



Operation/Reference Guide

NetLinx Controllers

X100-Series Integrated Controllers

NI-2100, NI-3100, and NI-4100

(Firmware build 330 or higher)



AMX Limited Warranty and Disclaimer

AMX warrants its products to be free of defects in material and workmanship under normal use for three (3) years from the date of purchase from AMX, with the following exceptions:

- Electroluminescent and LCD Control Panels are warranted for three (3) years, except for the display and touch overlay components that are warranted for a period of one (1) year.
- Disk drive mechanisms, pan/tilt heads, power supplies, and MX Series products are warranted for a period of one (1) year.
- AMX Lighting products are guaranteed to switch on and off any load that is properly connected to our lighting products, as long as the AMX Lighting products are under warranty. AMX does guarantee the control of dimmable loads that are properly connected to our lighting products. The dimming performance or quality cannot be guaranteed due to the random combinations of dimmers, lamps and ballasts or transformers.
- Unless otherwise specified, OEM and custom products are warranted for a period of one (1) year.
- AMX Software is warranted for a period of ninety (90) days.
- Batteries and incandescent lamps are not covered under the warranty.

This warranty extends only to products purchased directly from AMX or an Authorized AMX Dealer.

All products returned to AMX require a Return Material Authorization (RMA) number. The RMA number is obtained from the AMX RMA Department. The RMA number must be clearly marked on the outside of each box. The RMA is valid for a 30-day period. After the 30-day period the RMA will be cancelled. Any shipments received not consistent with the RMA, or after the RMA is cancelled, will be refused. AMX is not responsible for products returned without a valid RMA number.

AMX is not liable for any damages caused by its products or for the failure of its products to perform. This includes any lost profits, lost savings, incidental damages, or consequential damages. AMX is not liable for any claim made by a third party or by an AMX Dealer for a third party.

This limitation of liability applies whether damages are sought, or a claim is made, under this warranty or as a tort claim (including negligence and strict product liability), a contract claim, or any other claim. This limitation of liability cannot be waived or amended by any person. This limitation of liability will be effective even if AMX or an authorized representative of AMX has been advised of the possibility of any such damages. This limitation of liability, however, will not apply to claims for personal injury.

Some states do not allow a limitation of how long an implied warranty last. Some states do not allow the limitation or exclusion of incidental or consequential damages for consumer products. In such states, the limitation or exclusion of the Limited Warranty may not apply. This Limited Warranty gives the owner specific legal rights. The owner may also have other rights that vary from state to state. The owner is advised to consult applicable state laws for full determination of rights.

EXCEPT AS EXPRESSLY SET FORTH IN THIS WARRANTY, AMX MAKES NO OTHER WARRANTIES, EXPRESSED OR IMPLIED, INCLUDING ANY IMPLIED WARRANTIES OF MERCHANTABILITY OR FITNESS FOR A PARTICULAR PURPOSE. AMX EXPRESSLY DISCLAIMS ALL WARRANTIES NOT STATED IN THIS LIMITED WARRANTY. ANY IMPLIED WARRANTIES THAT MAY BE IMPOSED BY LAW ARE LIMITED TO THE TERMS OF THIS LIMITED WARRANTY.

Table of Contents

Introduction	1
NI-2100 Specifications	2
NI-3100 Specifications	6
NI-4100 Specifications	10
Installation and Upgrading	17
Installing NetLinx Control Cards (NI-4100 Only)	17
Setting the NetLinx Control Card Addresses (NI-4100 Only)	18
Device:Port:System (D:P:S)	18
Removing NetLinx Control Cards (NI-4100 Only)	19
ICSNet Daughter Card Installation (NI-2100/3100 Only)	19
Removing the Outer Housing.....	20
Installing the ICSNet Card.....	21
Replacing the Outer Housing.....	23
Compact Flash Upgrades.....	24
Accessing the internal components on an Integrated Controller.....	24
Installation of Compact Flash upgrades.....	24
Closing and Securing the Integrated Controller	26
Installing into an Equipment Rack	26
Connections and Wiring	29
Setting the Configuration DIP Switch (for the Program Port)	29
Baud rate settings	29
Program Run Disable (PRD) mode.....	29
Working with the Configuration DIP switch	30
Setting the CardFrame DIP Switch (NI-4x00 Only)	30
Program Port Connections and Wiring	30
Modes and Front Panel LED Blink Patterns.....	31
Port Assignments and Functionality	31
AXlink Port and LED.....	32
Wiring Guidelines	32
Wiring length guidelines	32
Preparing captive wires.....	33
Wiring a power connection.....	33
Using the 4-pin mini-Phoenix connector for data and power	34
Using the 4-pin mini-Phoenix connector for data with external power	34

DB9 Device Port: Connections and Wiring	35
ICSNet Port: Connections and Wiring	36
ICSHub OUT Port: Connections and Wiring	37
Relay Port: Connections and Wiring	37
Relay connections.....	37
Input/Output (I/O) Port: Connections and Wiring	38
IR/Serial Port: Connections and Wiring.....	39
NetLinx Control Card Slot Connector (NI-4x00 Series only)	39
Ethernet/RJ-45 Port: Connections and Wiring	40
Ethernet ports used by the Integrated Controllers	41
Configuration and Firmware Update	43
Communicating with the Master via the Program Port.....	43
Setting the System Value.....	44
Using multiple NetLinx Masters.....	46
Changing the Device Address of a NetLinx Device	46
Recommended NetLinx Device numbers.....	47
Using the ID Button to Change the Controller’s Device Value	47
Resetting the Factory Default System and Device Values.....	48
Obtaining the Master’s IP Address (using DHCP)	49
Assigning a Static IP to the NetLinx Master	50
Communicating with the NI Device via an IP	51
Verifying the current version of NetLinx Master Firmware	53
Upgrading the On-board Master Firmware via an IP	54
Upgrading the NI Controller Firmware via IP	57
Upgrading the NXC Card Firmware via IP (NI-4x00 ONLY)	59
NetLinx Security within the Web Server	63
NetLinx Security Terms.....	64
Accessing an Unsecured Master via an HTTP Address	65
Browser Application Frames	65
Default Security Configuration	66
Master Firmware Security Access Parameters	68
Web Control	68
Managing WebControl Connections	68

Security Features	70
Security - System Level Security page	71
Setting the system security options for a NetLinx Master	74
ICSP Authentication	75
Security - Group Level Security page	76
Adding a new Group	78
Modifying the properties of an existing Group.....	78
Deleting an existing Group.....	79
Security - User Level Security page.....	79
Adding a new User.....	81
Modifying the properties of an existing User	82
Deleting an existing User	83
System Settings	84
System Settings - Manage System page	84
Manage System - System Menu Buttons	87
System Menu - Modifying the Date/Time	87
System Menu - Changing the System Number.....	87
System Menu - Rebooting the Master.....	88
System Menu - Controlling/Emulating Devices on the Master	88
Manage System - Diagnostics	91
Setting up and removing a Diagnostic Filter	92
Setting the Master's Port Configurations.....	94
Manage System - Server	94
Modifying the Server Port Settings.....	96
SSL Server Certificate Creation Procedures.....	98
Server - Display SSL Server Certificate Information	100
Server - Creating a self-generated SSL Certificate	100
Server - Regenerating an SSL Server Certificate Request.....	101
Server - Creating a Request for an SSL Certificate	101
Common Steps for Requesting a Certificate from a CA.....	102
Communicating with the CA.....	102
Server - Exporting an SSL Certificate Request.....	103
Server - Importing a CA created SSL Certificate	105
Manage System - Device Menu Buttons	106
Device Menu - Configuring the Network Settings	106
Device Menu - Developing a URL List	107
Device Menu - Changing the Device Number.....	109
Device Menu - Controlling or Emulating a device	109
Device Menu - Viewing the Log	109
Device Menu - Running a Diagnostic Filter.....	110

System Settings - Manage License.....	110
Adding a new license	111
Removing a license.....	111
System Settings - Manage NetLinx Devices	112
Manage NetLinx Devices - Displaying NDP-capable devices	114
Manage NetLinx Devices - Binding/Unbinding - Explained.....	114
Manage NetLinx Devices - Obtaining NetLinx Device information.....	115
System Settings - Manage Other Devices - Dynamic Device Discovery Pages	116
What is Dynamic Device Discovery?	119
What is the difference between Program and Run-time defined binding?	120
Manage Other Devices - Manage Device Bindings	121
Configuring application-defined devices	121
What are Application Devices and their association status?.....	123
Manage Other Devices Menu - Viewing Discovered Devices.....	125
Manage Other Devices Menu - Creating a new User-Defined Device.....	126
How do I write a program that uses Dynamic Device Discovery.....	128
How do I configure a Run-time installation.....	129
Accessing an SSL-Enabled Master via an IP Address	130
Using your NetLinx Master to control the G4 panel	133
What to do when a Certificate Expires	135
NetLinx Security with a Terminal Connection	137
NetLinx Security Features.....	137
Initial Setup via a Terminal Connection.....	138
Establishing a Terminal connection via the RS-232 Program Port	138
Accessing the Security configuration options.....	138
Option 1 - Set system security options for NetLinx Master (Security Options Menu)	139
Option 2 - Display system security options for NetLinx Master.....	141
Option 3 - Add user.....	141
Option 4 - Edit User.....	142
Option 5 - Delete user	144
Option 6 - Show the list of authorized users	145
Option 7 - Add Group.....	145
Option 8 - Edit Group	147
Option 9 - Delete Group.....	148
Option 10 - Show List of Authorized Groups.....	148
Option 11 - Set Telnet Timeout in seconds.....	148
Option 12 - Display Telnet Timeout in seconds	149
Option 13 - Make changes permanent by saving to flash.....	149

Main Security Menu.....	150
Default Security Configuration.....	151
Help menu.....	152
Logging Into a Session.....	154
Logout	155
Help Security.....	155
Setup Security.....	155
Programming	157
Converting Axxcess Code to NetLinx Code.....	157
Master Send_Commands.....	157
Master IP Local Port Send_Commands	159
Using the ID Button	159
Device:Port:System (D:P:S).....	160
Program Port Commands.....	160
ESC Pass Codes.....	171
Notes on Specific Telnet/Terminal Clients	172
Windows™ client programs.....	172
Linux Telnet client	172
LED Disable/Enable Send_Commands	172
RS-232/422/485 Send_Commands	173
RS-232/422/485 Send_String Escape Sequences	177
IR / Serial Ports Channels	178
IR/Serial Send_Commands.....	178
Input/Output Send_Commands.....	184
Troubleshooting	185

Introduction

NetLinX Integrated Master Controllers (X000 and X100-Series) can both be programmed to control RS-232/422/485, Relay, IR/Serial, and Input/Output devices through the use of both the NetLinX programming language and the NetLinX Studio application (version 2.x or higher). Another key feature of this products is the ability to easily access the configuration switches without having to remove a cover plate.

NetLinX Integrated Master Controller Features	
NI-2100 (FG2105-04)	<ul style="list-style-type: none"> • 1 RS-232 Program port • 3 RS-232/RS-422/RS-485 ports • 4 IR/Serial Output ports • 4 Digital Input/Output ports • 4 Relays
NI-2100 Kit (FG2105-14)	<ul style="list-style-type: none"> • In addition to the options listed above, this Kit includes a pre-installed ICSNet daughter card (FG2105-10)
NI-3100 (FG2105-05)	<ul style="list-style-type: none"> • 1 RS-232 Program port • 7 RS-232/RS-422/RS-485 ports • 8 IR/Serial Output ports • 8 Digital Input/Output ports • 8 Relays
NI-3100 Kit (FG2105-15)	<ul style="list-style-type: none"> • In addition to the options listed above, this Kit includes a pre-installed ICSNet daughter card (FG2105-10)
NI-4100 (FG2105-06)	<ul style="list-style-type: none"> • Support for up to 4 NetLinX control cards (such as NXC-COM2, NXC-IRS4, etc.) • 1 ICSNet Hub port (part of the included pre-installed ICSNet card) • 1 RS-232 Program port • 2 ICSNet ports (part of the included pre-installed ICSNet card) • 7 RS-232/RS-422/RS-485 ports • 8 IR/Serial Output ports • 8 Digital Input/Output ports • 8 Relays



References within this manual to NI X100-Series Controllers are used to describe the NI-2100/3100/4100 Integrated Controllers. When there is an overlap of information with other related NI Controllers, an X will be used to refer to both sets of units. As an example, if a feature is shared by both the NI-4000 and the NI-4100 Controller, the term NI-4x00 Series is used.

These NI Controllers are shipped with Duet firmware and can not be downgraded to earlier Non-Duet firmware (< build 300).

These NI Controllers are Duet-compatible and can be upgraded via firmware. Duet is a dual-interpreter firmware platform from AMX which combines the proven reliability and power of NetLinX with the extensive capabilities of the *Java[®]2 MicroEdition (J2ME)* platform. Duet simplifies the programming of a system that includes the NI-900 and other third party devices by standardizing device and function definitions, defaulting touch panel button assignments, and controlling feedback methods. Dynamic Device Discovery makes integration even easier by automatically identifying and communicating with devices which support this new beaconing technology. Refer to the *System Settings - Manage Other Devices - Dynamic Device Discovery*

Pages section on page 116 for more detailed information on the use of *Dynamic Device Discovery* (DDD).

These NI Controllers use a combination lithium battery and clock crystal package called a *Timekeeper*. Only one *Timekeeper* unit is installed within a given NI controller. The battery can be expected to have up to 3 years of usable life under very adverse conditions. Actual life is appreciably longer under normal operating conditions. This calculation is based on storing the unit without power in 50° C (120° F) temperature until battery levels are no longer acceptable. The part number for a replacement battery is 57-0032.

NI-2100 Specifications

The NI-2100 (FIG. 1) provides support for **3** RS-232/RS-422/RS-485 Ports, **4** IR/Serial Output ports, **4** Digital Input/Output ports, and **4** Relays. The NI-2100 can be upgraded to provide **1** ICSHub and **2** ICSNet ports by either installing the optional ICSNet daughter card (**FG2105-10**) or purchasing this upgrade as an included feature of the NI-2100 Kit (**FG2105-14**).



FIG. 1 NI-2100 NetLinX Integrated Controller (front view)

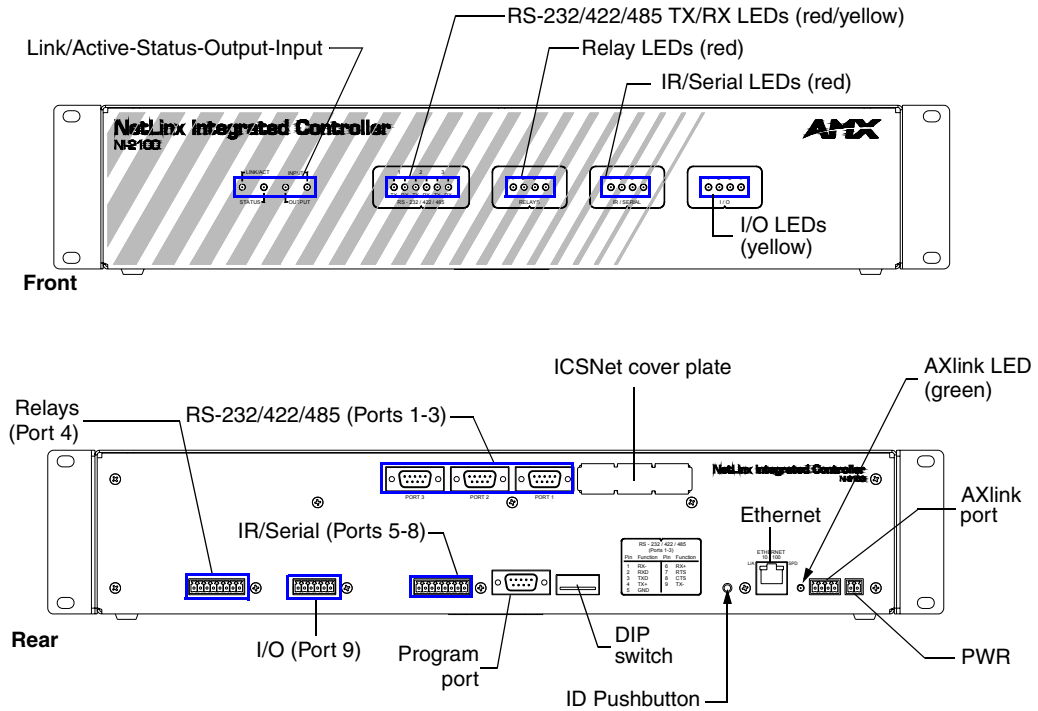

FIG. 2 NI-2100 front and rear panel connectors and components

NI-2100 Specifications	
Dimensions (HWD):	<ul style="list-style-type: none"> • 3.47" x 17.00" x 3.47" (8.81 cm x 43.18 cm x 8.82 cm) • 2 RU (rack unit) high
Power Requirement:	<ul style="list-style-type: none"> • 700 mA @ 12 VDC
Memory:	<ul style="list-style-type: none"> • 64 MB SDRAM • 1 MB Non-volatile (NV) SRAM
Compact Flash:	<ul style="list-style-type: none"> • 128 MB Card (upgradeable) (refer to the Other AMX Equipment section for more information)
Weight:	<ul style="list-style-type: none"> • 4.50 lbs (2.04 kg)
Enclosure:	<ul style="list-style-type: none"> • Metal with black matte finish
Certifications:	<ul style="list-style-type: none"> • FCC Part 15 Class B, CE, and IEC 60950
Front Panel Components:	
LINK/ACT	<ul style="list-style-type: none"> • Green LED blinks when the Ethernet cable is connected and an active link is established. This LED also blinks when receiving Ethernet data packets.
Status	<ul style="list-style-type: none"> • Green LED blinks to indicate that the system is programmed and communicating properly.
Output	<ul style="list-style-type: none"> • Red LED blinks when the Controller transmits data, sets channels On/Off, sends data strings, etc.
Input	<ul style="list-style-type: none"> • Yellow LED blinks when the Controller receives data from button pushes, strings, commands, channel levels, etc.
RS-232/422/485 LEDs	<ul style="list-style-type: none"> • Three sets of red and yellow LEDs light to indicate the rear DB9 Ports 1 - 3 are transmitting or receiving RS-232, 422, or 485 data: <ul style="list-style-type: none"> - TX LEDs (red) light when transmitting data - RX LEDs (yellow) light when receiving data - LED activity reflects transmission and reception activity
Relay LEDs	<ul style="list-style-type: none"> • Four red LEDs light to indicate the rear relay channels 1 - 4 are active (closed). • These LEDs reflect the state of the relay on Port 4 • If the relay is engaged = LED On and if the relay is Off = LED Off
IR/Serial LEDs	<ul style="list-style-type: none"> • Four red LEDs light to indicate the rear IR/Serial channels 1 - 4 are transmitting control data on Ports 5 - 8 • LED indicator for each IR port remains lit for the length of time that IR/Serial data is being generated
I/O LEDs	<ul style="list-style-type: none"> • Four yellow LEDs light when the rear I/O channels 1 - 4 are active • LED indicator for each I/O port reflects the state of that particular port
Rack-mount brackets	<ul style="list-style-type: none"> • Provide an installation option for the Integrated Controller to be mounted into an equipment rack, when used with the Installation Kit (KA2105-01).

NI-2100 Specifications (Cont.)	
Rear Panel Connectors:	
RS-232/422/485 (Ports 1 - 3)	<ul style="list-style-type: none"> • Three RS-232/422/485 control ports using DB9 (male) connectors with XON/XOFF (transmit On/transmit Off), CTS/RTS (clear to send/ready to send), and 300-115,200 baud. • Channel range = 1-255 • Channels 1-254 provide feedback • Channel 255 (CTS Push channel): Reflects the state of the CTS Input if a 'CTSPSH' command was sent to the port • Output data format for each port is selected via software • Three DB9 connectors provide RS-232/422/485 termination
ICSNet	<ul style="list-style-type: none"> • Two RJ-45 connectors for ICSNet interface (provided by the optional ICSNet daughter card)
ICSHub Out	<ul style="list-style-type: none"> • RJ-45 connector provides data to another Hub connected to the Controller (provided by the optional ICSNet daughter card)
Relay (Port 4)	<ul style="list-style-type: none"> • Four-channel single-pole single-throw relay ports • Each relay is independently controlled. • Supports up to 4 independent external relay devices • Channel range = 1-4 • Each relay can switch up to 24 VDC or 28 VAC @ 1 A • 8-pin 3.5 mm mini-Phoenix (female) connector provides relay termination
Digital I/O (Port 9)	<ul style="list-style-type: none"> • Four-channel binary I/O port for contact closure • Each input is capable of voltage sensing. Input format is software selectable. • Interactive power sensing for IR ports • Channel range = 1-4 • All inputs are assigned to respective IR/Serial ports for "automatic" power control through the use of software commands. Power control is provided via commands such as: 'PON', 'POF', 'POD', 'DELAY', I/O Link etc.). • Contact closure between GND and an I/O port is detected as a PUSH • When used as voltage input - I/O port detects a low signal (0- 1.5 VDC) as a PUSH and a high signal (3.5 - 5 VDC) as a RELEASE • When used as an output - each I/O port acts as a switch to GND and is rated at 200 mA @ 12 VDC • 6-pin 3.5 mm mini-Phoenix (female) connector provides I/O port termination <p>Note: This IO port uses 5V logic but can handle up to 12V without harm. It can handle up to 12V on the input. At higher voltages you run a higher risk of surge damage.</p>
IR/Serial (Ports 5 - 8)	<ul style="list-style-type: none"> • Four IR/Serial control ports support high-frequency carriers of up to 1.142 MHz. • Each output is capable of three electrical formats: IR, Serial, and Data • Four IR/Serial data signals can be generated simultaneously. • Channel range = 1-32,767 • Channels 1-128 (output): IR commands • Channels 129-253: used as reference channels • Channel 254 (feedback): Power Fail (used with 'PON' and 'POF' commands) • Channel 255 (feedback): Power status (when IO Link is set) • IR ports support data mode (at limited baud rates and wiring distances). • 8-pin 3.5 mm mini-Phoenix (female) connector provides IR/Serial port termination

NI-2100 Specifications (Cont.)	
Rear Panel Connectors (Cont.):	
Program port	<ul style="list-style-type: none"> • RS-232 DB9 connector (male) can be connected to a DB9 port on a computer; used with serial commands, NetLinx programming commands, other DB9 capable devices, and to upload/download information from the NetLinx Studio 2.4 program.
Configuration DIP switch	<ul style="list-style-type: none"> • Sets the communication parameters for the Program port.
ID pushbutton	<ul style="list-style-type: none"> • Provides the NetLinx ID (Device only) assignment for the device. Refer to the <i>Changing the Device Address of a NetLinx Device</i> section on page 46. • The D notation is used to represent a device number. • The S notation is used to represent the System number of the Master.
Ethernet port	<ul style="list-style-type: none"> • RJ-45 port for 10/100 Mbps communication. This port automatically negotiates the connection speed (10 Mbps or 100 Mbps) and whether to use half duplex or full duplex mode.
Ethernet Link/Activity LED	<ul style="list-style-type: none"> • LEDs show communication activity, connection status, speeds, and mode information: <ul style="list-style-type: none"> SPD (speed) - Yellow LED lights On when the connection speed is 100 Mbps and turns Off when the speed is 10 Mbps. L/A (link/activity) - Green LED lights On when the Ethernet cables are connected/terminated correctly, and blinks when receiving Ethernet data packets.
AXlink LED	<ul style="list-style-type: none"> • Green LED indicates the state of the AXlink connector port. • Normal AXlink activity = 1 blink/second • Abnormal AXlink activity = cycle of 3 consecutive blinks and then Off
AXlink port	<ul style="list-style-type: none"> • 4-pin 3.5 mm mini-Phoenix (male) connector provides data and power to external control devices.
Power port	<ul style="list-style-type: none"> • 2-pin 3.5 mm mini-Phoenix (male) connector
Included Accessories:	<ul style="list-style-type: none"> • 2-pin 3.5 mm mini-Phoenix (female) PWR connector (41-5025) • 4-pin 3.5 mm mini-Phoenix (female) AXlink connector (41-5047) • 6-pin 3.5 mm mini-Phoenix (female) I/O connector (41-5063) • 8-pin 3.5 mm mini-Phoenix (female) Relay connector (41-5083) • Installation Kit (KA2105-01): <ul style="list-style-type: none"> 8-pin Relay Common Strip Four rack mount screws Four washers • NI-2100 Quick Start Guide • Two CC-NIRC IR Emitters • Two removable rack ears (62-2105-07)
Other AMX Equipment:	<ul style="list-style-type: none"> • 2-pin 3.5 mm mini-Phoenix male connector (41-5026) • CC-NIRC IR cables (FG10-000-11) • CC-NSER IR/Serial cables (FG10-007-10) • CSB Cable Support Bracket (FG517) • ICSNet daughter card (FG2105-10) • NCK, NetLinx Connector Kit (FG2902) • STS, Serial To Screw Terminal (FG959) • Upgrade Compact Flash (factory programmed with firmware): <ul style="list-style-type: none"> NXA-CF2NI256M - 256 MB compact flash card (FG2116-47) NXA-CF2NI512M - 512 MB compact flash card (FG2116-48) NXA-CF2NI1G - 1 GB compact flash card (FG2116-49)

NI-3100 Specifications

The NI-3100 (FIG. 3) provides support for 7 RS-232/RS-422/RS-485 Ports, 8 IR/Serial Output ports, 8 Digital Input/Output ports, and 8 Relays. The NI-3100 can be upgraded to provide 1 ICSHub and 2 ICSNet ports by either installing the optional ICSNet daughter card (FG2105-10) or purchasing this upgrade as an included feature of the NI-3100 Kit (FG2105-15).

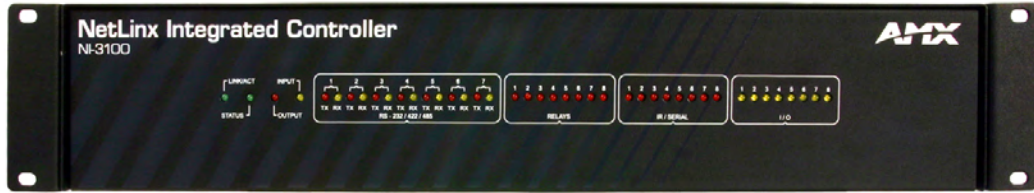

FIG. 3 NI-3100 NetLinX Integrated Controller (front view)

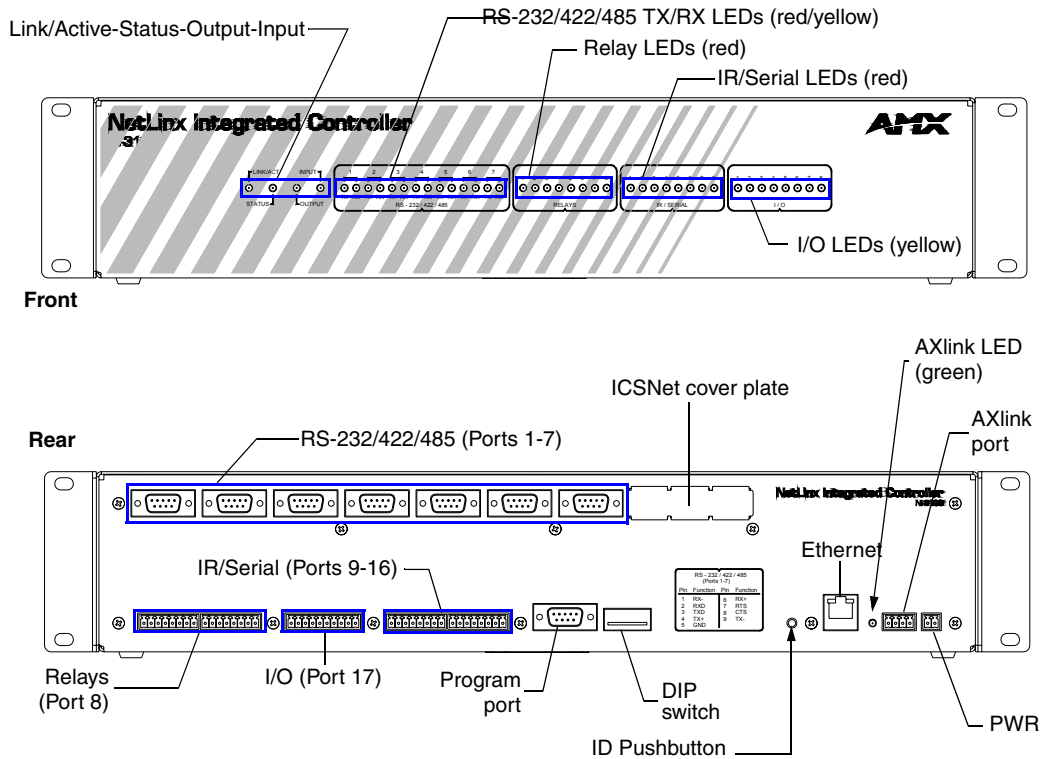

FIG. 4 NI-3100 front and rear panel connectors and components

NI-3100 Specifications (Cont.)	
Dimensions (HWD):	<ul style="list-style-type: none"> • 3.47" x 17.00" x 3.47" (8.81 cm x 43.18 cm x 8.82 cm) • 2 RU (rack unit) high
Power Requirement:	<ul style="list-style-type: none"> • 900 mA @ 12 VDC
Memory:	<ul style="list-style-type: none"> • 64 MB SDRAM • 1 MB Non-volatile (NV) SRAM
Compact Flash:	<ul style="list-style-type: none"> • 128 MB Card (upgradeable) (refer to the Other AMX Equipment section for more information)
Weight:	<ul style="list-style-type: none"> • 4.55 lbs (2.06 kg)
Enclosure:	<ul style="list-style-type: none"> • Metal with black matte finish
Certifications:	<ul style="list-style-type: none"> • FCC Part 15 Class B, CE, and IEC 60950
Front Panel Components:	
LINK/ACT	<ul style="list-style-type: none"> • Green LED blinks when the Ethernet cable is connected and an active link is established. This LED also blinks when receiving Ethernet data packets.
Status	<ul style="list-style-type: none"> • Green LED blinks to indicate that the system is programmed and communicating properly.
Output	<ul style="list-style-type: none"> • Red LED blinks when the Controller transmits data, sets channels On/Off, sends data strings, etc.
Input	<ul style="list-style-type: none"> • Yellow LED blinks when the Controller receives data from button pushes, strings, commands, channel levels, etc.
RS-232/422/485 LEDs	<ul style="list-style-type: none"> • Seven sets of red and yellow LEDs light to indicate the rear DB9 Ports 1 - 7 are transmitting or receiving RS-232, 422, or 485 data: <ul style="list-style-type: none"> - TX LEDs (red) light when transmitting data - RX LEDs (yellow) light when receiving data - LED activity reflects transmission and reception activity
Relay LEDs	<ul style="list-style-type: none"> • Eight red LEDs light to indicate the rear relay channels 1 - 8 are active (closed) • These LEDs reflect the state of the relay on Port 8 • If the relay is engaged = LED On and if the relay is Off = LED Off
IR/Serial LEDs	<ul style="list-style-type: none"> • Eight red LEDs light to indicate the rear IR/Serial channels 1 - 8 are transmitting control data on Ports 9 - 16 • LED indicator for each IR port remains lit for the length of time that IR/Serial data is being generated
I/O LEDs	<ul style="list-style-type: none"> • Eight yellow LEDs light when the rear I/O channels 1-8 are active • LED indicator for each I/O port reflects the state of that particular port
Rack-mount brackets	<ul style="list-style-type: none"> • Provide an installation option for the Integrated Controller to be mounted into an equipment rack, when used with the Installation Kit (KA2105-01).

NI-3100 Specifications (Cont.)	
Rear Panel Connectors:	
RS-232/422/485 (Ports 1 - 7)	<ul style="list-style-type: none"> • Seven RS-232/422/485 control ports using DB9 (male) connectors with XON/XOFF (transmit on/transmit off), CTS/RTS (clear to send/ready to send), and 300-115,200 baud. • Channel range = 1-255 • Channels 1-254 provide feedback • Channel 255 (CTS Push channel): Reflects the state of the CTS Input if a 'CTSPSH' command was sent to the port • Output data format for each port is selected via software • Seven DB9 connectors provide RS-232/422/485 termination
ICSNet	<ul style="list-style-type: none"> • Two RJ-45 connectors for ICSNet interface (provided by the optional ICSNet daughter card)
ICSHub Out	<ul style="list-style-type: none"> • RJ-45 connector provides data to another Hub connected to the Controller (provided by the optional ICSNet daughter card)
Relay (Port 8)	<ul style="list-style-type: none"> • Eight-channel single-pole single-throw relay ports • Each relay is independently controlled. • Supports up to 8 independent external relay devices • Channel range = 1-8 • Each relay can switch up to 24 VDC or 28 VAC @ 1 A • Two 8-pin 3.5 mm mini-Phoenix (female) connectors provide relay termination
Digital I/O (Port 17)	<ul style="list-style-type: none"> • Eight-channel binary I/O port for contact closure • Each input is capable of voltage sensing. Input format is software selectable. • Interactive power sensing for IR ports • Channel range = 1-8 • All inputs are assigned to respective IR/Serial ports for "automatic" power control through the use of software commands. Power control is provided via commands such as: 'PON', 'POF', 'POD', 'DELAY', I/O Link etc.). • Contact closure between GND and an I/O port is detected as a PUSH • When used as voltage input - I/O port detects a low signal (0- 1.5 VDC) as a PUSH and a high signal (3.5 - 5 VDC) as a RELEASE • When used as an output - each I/O port acts as a switch to GND and is rated at 200 mA @ 12 VDC • 10-pin 3.5 mm mini-Phoenix (female) connector provides I/O port termination <p>Note: This IO port uses 5V logic but can handle up to 12V without harm. It can handle up to 12V on the input. At higher voltages you run a higher risk of surge damage.</p>

NI-3100 Specifications (Cont.)	
Rear Panel Connectors (Cont.):	
IR/Serial (Ports 9 - 16)	<ul style="list-style-type: none"> • Eight IR/Serial control ports support high-frequency carriers up to 1.142 MHz • Each output is capable of three electrical formats: IR, Serial, and Data • Eight IR/Serial data signals can be generated simultaneously. • Channel range = 1-32,767 • Channels 1-128 (output): IR commands • Channels 129-253: used as reference channels • Channel 254 (feedback): Power Fail (used with 'PON' and 'POF' commands) • Channel 255 (feedback): Power status (when IO Link is set) • IR ports support data mode (at limited baud rates and wiring distances). • Two 8-pin 3.5 mm mini-Phoenix (female) connectors provide IR/Serial port termination
Program port	<ul style="list-style-type: none"> • RS-232 DB9 connector (male) can be connected to a DB9 port on a computer; used with serial commands, NetLinx programming commands, other DB9 capable devices, and to upload/download information from the NetLinx Studio 2.4 program.
Configuration DIP switch	<ul style="list-style-type: none"> • Sets the communication parameters for the Program port.
ID pushbutton	<ul style="list-style-type: none"> • Provides the NetLinx ID (Device only) assignment for the device. Refer to the <i>Changing the Device Address of a NetLinx Device</i> section on page 46. • The D notation is used to represent a device number.
Ethernet port	<ul style="list-style-type: none"> • RJ-45 port for 10/100 Mbps communication. This port automatically negotiates the connection speed (10 Mbps or 100 Mbps) and whether to use half duplex or full duplex mode.
Ethernet Link/Activity LED	<ul style="list-style-type: none"> • LEDs show communication activity, connection status, speeds, and mode information: SPD (speed) - Yellow LED lights On when the connection speed is 100 Mbps and turns Off when the speed is 10 Mbps. L/A (link/activity) - Green LED lights On when the Ethernet cables are connected/terminated correctly, and blinks when receiving Ethernet data packets.
AXlink LED	<ul style="list-style-type: none"> • Green LED indicates the state of the AXlink connector port. • Normal AXlink activity = 1 blink/second • Abnormal AXlink activity = cycle of 3 consecutive blinks and then Off
AXlink port	<ul style="list-style-type: none"> • 4-pin 3.5 mm mini-Phoenix (male) connector provides data and power to external control devices.
Power port	<ul style="list-style-type: none"> • 2-pin 3.5 mm mini-Phoenix (male) connector

NI-3100 Specifications (Cont.)	
Included Accessories:	<ul style="list-style-type: none"> • 2-pin 3.5 mm mini-Phoenix (female) PWR connector (41-5025) • 4-pin 3.5 mm mini-Phoenix (female) AXlink connector (41-5047) • 10-pin 3.5 mm mini-Phoenix (female) I/O connector (41-5107) • Installation Kit (KA2105-01): <ul style="list-style-type: none"> 8-pin Relay Common Strip Four rack mount screws Four washers • NI-3100 Quick Start Guide • Two 8-pin 3.5 mm mini-Phoenix (female) Relay connectors (41-5083) • Two CC-NIRC IR Emitters • Two removable rack ears (62-2105-07)
Other AMX Equipment:	<ul style="list-style-type: none"> • 2-pin 3.5 mm mini-Phoenix male connector (41-5026) • CC-NIRC IR cables (FG10-000-11) • CC-NSER IR/Serial cables (FG10-007-10) • CSB Cable Support Bracket (FG517) • ICSNet daughter card (FG2105-10) • NCK, NetLinX Connector Kit (FG2902) • STS, Serial To Screw Terminal (FG959) • Upgrade Compact Flash (factory programmed with firmware): <ul style="list-style-type: none"> NXA-CF2NI256M - 256 MB compact flash card (FG2116-47) NXA-CF2NI512M - 512 MB compact flash card (FG2116-48) NXA-CF2NI1G - 1 GB compact flash card (FG2116-49)

NI-4100 Specifications

The NI-4100 unit (FIG. 5) is geared toward those advanced control and automation requirements associated with most complex commercial and residential installations. The NI-4100 provides support for up to **4** NetLinX control cards (such as NXC-COM2, NXC-IRS4, etc.), **7** RS-232/RS-422/RS-485 Ports, **8** IR/Serial Output ports, **8** Digital Input/Output ports, and **8** Relays. The NI-4100's on-board Master also provides the ability to update installed control card firmware.



FIG. 5 NI-4100 NetLinX Integrated Controller (front view)

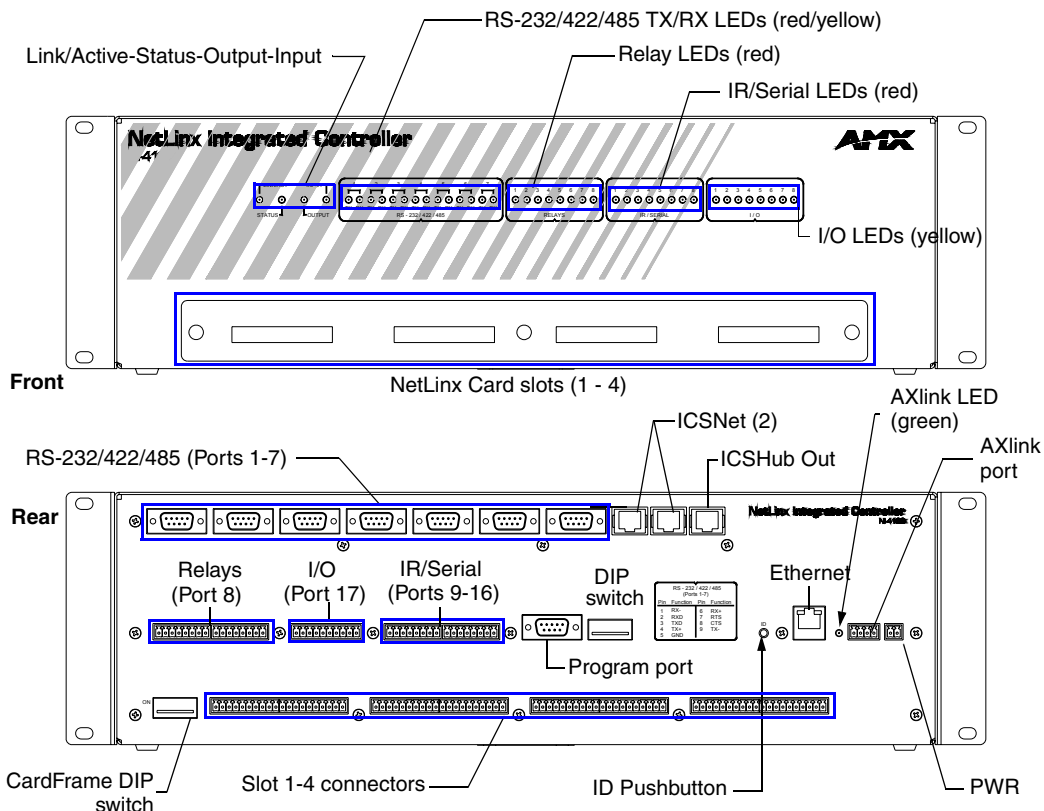

FIG. 6 NI-4100 front and rear panel connectors and components

NI-4100 Specifications	
Dimensions (HWD):	<ul style="list-style-type: none"> • 5.21" x 17.00" x 9.60" (13.23 cm x 43.18 cm x 24.27 cm) • 3 RU (rack unit) high
Power Requirement:	<ul style="list-style-type: none"> • 900 mA @ 12 VDC (no cards)
Memory:	<ul style="list-style-type: none"> • 64 MB SDRAM • 1 MB Non-volatile (NV) SRAM
Compact Flash:	<ul style="list-style-type: none"> • 128 MB Card (upgradeable) (refer to the Other AMX Equipment section for more information)
Weight:	<ul style="list-style-type: none"> • 9.15 lbs (4.15 kg)
Enclosure:	<ul style="list-style-type: none"> • Metal with black matte finish
Certifications:	<ul style="list-style-type: none"> • FCC Part 15 Class B, CE, and IEC 60950

NI-4100 Specifications (Cont.)	
Front Panel Components:	
LINK/ACT	<ul style="list-style-type: none"> Green LED blinks when the Ethernet cable is connected and an active link is established. This LED also blinks when receiving Ethernet data packets.
Status	<ul style="list-style-type: none"> Green LED blinks to indicate that the system is programmed and communicating properly.
Output	<ul style="list-style-type: none"> Red LED blinks when the Controller transmits data, sets channels On/Off, sends data strings, etc.
Input	<ul style="list-style-type: none"> Yellow LED blinks when the Controller receives data from button pushes, strings, commands, channel levels, etc.
RS-232/422/485 LEDs	<ul style="list-style-type: none"> Seven sets of red and yellow LEDs light to indicate the rear DB9 Ports 1-7 are transmitting or receiving RS-232, 422, or 485 data: <ul style="list-style-type: none"> - TX LEDs (red) light when transmitting data - RX LEDs (yellow) light when receiving data - LED activity reflects transmission and reception activity
Relay LEDs	<ul style="list-style-type: none"> Eight red LEDs light to indicate the rear relay channels 1-8 are active (closed) These LEDs reflect the state of the relay on Port 8 If the relay is engaged = LED On and if the relay is Off = LED Off
IR/Serial LEDs	<ul style="list-style-type: none"> Eight red LEDs light to indicate the rear IR/Serial channels 1-8 are transmitting control data on Ports 9-16 LED indicator for each IR port remains lit for the length of time that IR/Serial data is being generated
I/O LEDs	<ul style="list-style-type: none"> Eight yellow LEDs light when the rear I/O channels 1-8 are active LED indicator for each I/O port reflects the state of that particular port
NetLinx Control Card slots 1- 4	<p>Accepts up to 4 compatible NetLinx Control Cards:</p> <ul style="list-style-type: none"> NXC-COM2 Dual COM Port Control Card (FG2022) NXC-I/O10 Input/Output Control Card (FG2021) NXC-IRS4 4-Port IR/S Control Card (FG2023) NXC-REL10 Relay Control Card (FG2020) NXC-VAI4 Analog Voltage Control Card (FG 2025) NXC-VOL4 Volume Control Card (FG2024)
Rack-mount brackets	<ul style="list-style-type: none"> Provide an installation option for the Integrated Controller to be mounted into an equipment rack, when used with the Installation Kit (KA2105-01).

NI-4100 Specifications (Cont.)	
Rear Panel Connectors:	
RS-232/422/485 (Ports 1 - 7)	<ul style="list-style-type: none"> • Seven RS-232/422/485 control ports using DB9 (male) connectors with XON/XOFF (transmit on/transmit off), CTS/RTS (clear to send/ready to send), and 300-115,200 baud. • Channel range = 1-255 • Channels 1-254 provide feedback • Channel 255 (CTS Push channel): Reflects the state of the CTS Input if a 'CTSPSH' command was sent to the port • Output data format for each port is selected via software • Seven DB9 connectors provide RS-232/422/485 termination
ICSNet	<ul style="list-style-type: none"> • Two RJ-45 connectors for ICSNet interface
ICSHub Out	<ul style="list-style-type: none"> • RJ-45 connector provides data to another Hub connected to the Controller
Relay (Port 8)	<ul style="list-style-type: none"> • Eight-channel single-pole single throw relay ports • Each relay is independently controlled. • Supports up to 8 independent external relay devices • Channel range = 1-8 • Each relay can switch up to 24 VDC or 28 VAC @ 1 A • Two 8-pin 3.5 mm mini-Phoenix (female) connectors provide relay termination
Digital I/O (Port 17)	<ul style="list-style-type: none"> • Eight-channel binary I/O port for contact closure • Each input is capable of voltage sensing. Input format is software selectable. • Interactive power sensing for IR ports • Channel range = 1-8 • All inputs are assigned to respective IR/Serial ports for "automatic" power control through the use of software commands. Power control is provided via commands such as: 'PON', 'POF', 'POD', 'DELAY', I/O Link etc.). • Contact closure between GND and an I/O port is detected as a PUSH • When used as voltage input - I/O port detects a low signal (0- 1.5 VDC) as a PUSH and a high signal (3.5 - 5 VDC) as a RELEASE • When used as an output - each I/O port acts as a switch to GND and is rated at 200 mA @ 12 VDC • 10-pin 3.5 mm mini-Phoenix (female) connector provides I/O port termination <p>Note: This IO port uses 5V logic but can handle up to 12V without harm. It can handle up to 12V on the input. At higher voltages you run a higher risk of surge damage.</p>

NI-4100 Specifications (Cont.)	
Rear Panel Connectors (Cont.): IR/Serial (Ports 9 - 16)	<ul style="list-style-type: none"> • Eight IR/Serial control ports support high-frequency carriers of up to 1.142 MHz. • Each output is capable of three electrical formats: IR, Serial, and Data • Eight IR/Serial data signals can be generated simultaneously. • Channel range = 1-32,767 • Channels 1-128 (output): IR commands • Channels 129-253: used as reference channels • Channel 254 (feedback): Power Fail (used with 'PON' and 'POF' commands) • Channel 255 (feedback): Power status (when IO Link is set) • IR ports support data mode (at limited baud rates and wiring distances). • Two 8-pin 3.5 mm mini-Phoenix (female) connectors provide IR/Serial port termination
Program port	<ul style="list-style-type: none"> • RS-232 DB9 connector (male) can be connected to a DB9 port on a computer; used with serial commands, NetLinx programming commands, other DB9 capable devices, and to upload/download information from the NetLinx Studio 2.4 program.
Configuration DIP switch	<ul style="list-style-type: none"> • Sets the communication parameters for the Program port.
ID pushbutton	<ul style="list-style-type: none"> • Provides the NetLinx ID (Device only) assignment for the device. Refer to the <i>Changing the Device Address of a NetLinx Device</i> section on page 46. • The D notation is used to represent a device number.
Ethernet port	<ul style="list-style-type: none"> • RJ-45 port for 10/100 Mbps communication. This port automatically negotiates the connection speed (10 Mbps or 100 Mbps) and whether to use half duplex or full duplex mode.
Ethernet Link/Activity LED	<ul style="list-style-type: none"> • LEDs show communication activity, connection status, speeds, and mode information: SPD (speed) - Yellow LED lights On when the connection speed is 100 Mbps and turns Off when the speed is 10 Mbps. L/A (link/activity) - Green LED lights On when the Ethernet cables are connected/terminated correctly, and blinks when receiving Ethernet data packets.
AXlink LED	<ul style="list-style-type: none"> • Green LED indicates the state of the AXlink connector port. • Normal AXlink activity = 1 blink/second • Abnormal AXlink activity = cycle of 3 consecutive blinks and then Off
AXlink port	<ul style="list-style-type: none"> • 4-pin 3.5 mm mini-Phoenix (male) connector provides data and power to external control devices.
Power port	<ul style="list-style-type: none"> • 2-pin 3.5 mm mini-Phoenix (male) connector
CardFrame Number DIP switch	<ul style="list-style-type: none"> • Sets the starting address for the Control Cards in the CardFrame. (Factory default CardFrame DIP switch value = 0). • The Control Card address range is 1-3064.
NetLinx Control Card connectors (1 - 4)	<ul style="list-style-type: none"> • Four 20-pin (male) connectors that bridge the gap between the Control Cards in the CardFrame and external equipment.

NI-4100 Specifications (Cont.)	
Included Accessories:	<ul style="list-style-type: none"> • 2-pin 3.5 mm mini-Phoenix (female) PWR connector (41-5025) • 4-pin 3.5 mm mini-Phoenix (female) AXlink connector (41-5047) • 10-pin 3.5 mm mini-Phoenix (female) I/O connector (41-5107) • Installation Kit (KA2105-01): <ul style="list-style-type: none"> 8-pin Relay Common Strip Four rack mount screws Four washers • NI-4100 Quick Start Guide • Two 8-pin 3.5 mm mini-Phoenix (female) Relay connectors (41-5083) • Two CC-NIRC IR Emitters • Two removable rack ears (62-2105-07)
Other AMX Equipment:	<ul style="list-style-type: none"> • 2-pin 3.5 mm mini-Phoenix male connector (41-5026) • CC-NIRC IR cables (FG10-000-11) • CC-NSER IR/Serial cables (FG10-007-10) • CSB Cable Support Bracket (FG517) • NCK, NetLinx Connector Kit (FG2902) • STS, Serial To Screw Terminal (FG959) • Upgrade Compact Flash (factory programmed with firmware): <ul style="list-style-type: none"> NXA-CF2NI256M - 256 MB compact flash card (FG2116-47) NXA-CF2NI512M - 512 MB compact flash card (FG2116-48) NXA-CF2NI1G - 1 GB compact flash card (FG2116-49) • NXC cards (see the <i>Card Slot</i> section (page 12) of this Specification table for more detailed information)

Installation and Upgrading

Installing NetLinx Control Cards (NI-4100 Only)

NetLinx Cards can be installed into the front card slots. The cards mount horizontally through the card slot openings on the front of the enclosure. To install a NetLinx Card:

1. Discharge the static electricity from your body, by touching a grounded object.
2. Remove the three screws by turning them in a counter-clockwise direction and then remove the faceplate (FIG. 7).

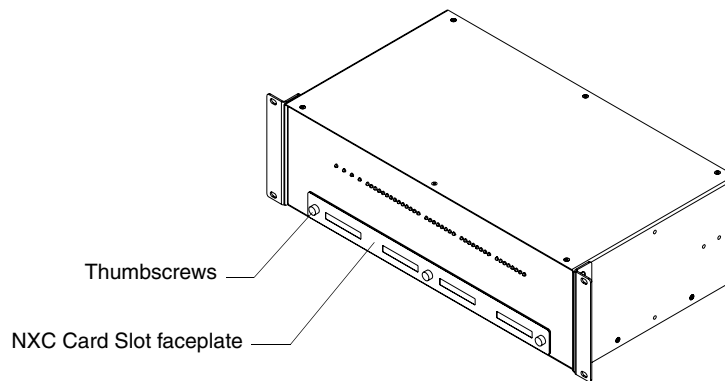

FIG. 7 NI-4100 front faceplate

3. Align the edges of the card with the internal guide slots and gently slide the card all the way into the slot (FIG. 8).

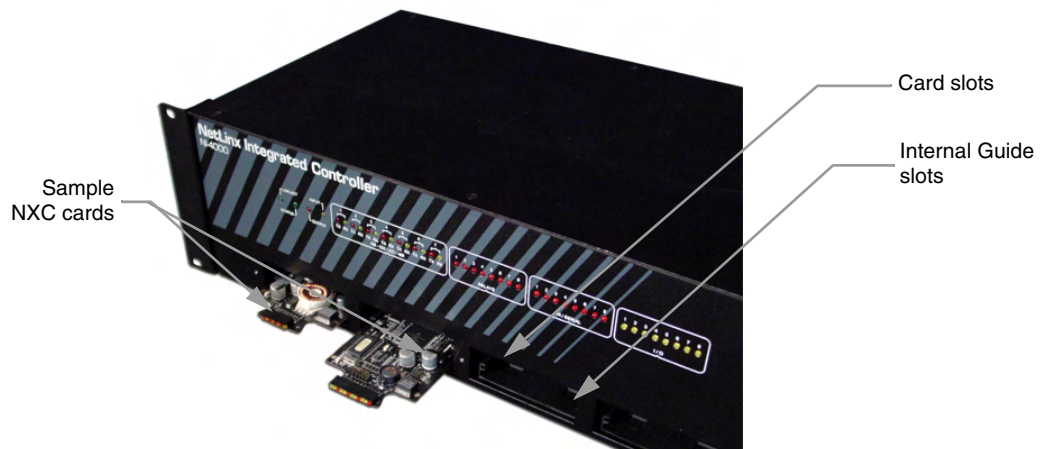

FIG. 8 Sample NXC cards inserted into an NI-4100 unit

4. Carefully apply a small amount of force to insert the cards into their respective connectors. If the cards have LEDs on them, those LEDs will initiate a lighting sequence to indicate they are receiving power and are communicating with the Controller.
5. Re-align the faceplate and secure it to the chassis by inserting the three screws by turning them in a clockwise direction and securing the front plate to the Integrated Controller.
6. Install all rear connectors and apply power.



NOTE

If the cards do not appear in the Workspace window for the selected Master System number: give the system time to detect the inserted cards (and refresh the system) and/or cycle power to the NI-4100 unit.

Setting the NetLinx Control Card Addresses (NI-4100 Only)

The 8-position CardFrame Number DIP switch, located on the rear of the Integrated Controller, sets the starting address (the device number in the D:P:S specification) for the Control Cards installed in the CardFrame. The address range is 1-3064. The factory default CardFrame DIP switch value = 0 (All CardFrame DIP switches in the OFF position). The formula for setting the starting address is:

$$(\text{DIP switch address} \times 12) + \text{Card slot Number (1-12)} = \text{Card address}$$

For example:

- DIP switch setting, 00010101: $(0 + 0 + 0 + 96 + 0 + 384 + 1536) + \text{SLOT \#(ex:1)} = 2017$.
- A card in slot number 1 would be device address 2017.

1. Set the CardFrame Number DIP switch based on the information listed in the table below.

Position	1	2	3	4	5	6	7	8
Value	12	24	48	96	192	384	768	1536

ON position

2. Cycle power to the unit for approximately 5 seconds. This allows the unit to read the new device number settings.

Device:Port:System (D:P:S)

A device is any hardware component that can be connected to an AXlink or ICSNet bus. Each device must be assigned a unique number to locate that device on the bus. The NetLinx programming language allows numbers in the range 1-32,767 for ICSNet (255 for AXlink).

Only the Device value can be set through the DIP switch settings mentioned above.

NetLinx requires a Device:Port:System (D:P:S) specification. This D:P:S triplet can be expressed as a series of constants, variables separated by colons, or a DEV structure. For example:

```
STRUCTURE DEV
{
  INTEGER Number // Device number
  INTEGER Port   // Port on device
  INTEGER System // System the device belongs to
}
```

The D:P:S notation is used to explicitly represent a device number, port and system.

For example, 128:1:0 represents the first port on device 128 on this system.

If a device is declared in a NetLinx program with just the Device number (**System and Port are omitted**), the NetLinx Compiler assumes it has a **Port number of 1 and a System number of 0**. However, you should convert all existing device declarations using the D:P:S (Device:Port:System) notation. This enables certain NetLinx specific debugging features and can help pinpoint other possibly obscure errors.

Here's the syntax:

NUMBER : PORT : SYSTEM

where:

NUMBER: 16-bit integer represents the device number
 PORT: 16-bit integer represents the port number (in the range 1 through the number of ports on the Controller or device)
 SYSTEM: 16-bit integer represents the system number (0 = this system)

Removing NetLinx Control Cards (NI-4100 Only)

To install NetLinx Control Card:

1. Discharge any static electricity from your body, by touching a grounded object and unplug all connectors (if any) from the unit.
2. Remove the three faceplate screws by turning them in a counter-clockwise direction.
3. Remove the faceplate from the front plate (FIG. 7 on page 17).
4. Gently grasp the rear edge of the control card and gently pull it out from the unit (along the internal guide slots).
5. Re-secure the faceplate by inserting the three faceplate screws by turning them in a clockwise direction and securing the front plate to the Integrated Controller.
6. Re-apply power and other connections as necessary.

ICSNet Daughter Card Installation (NI-2100/3100 Only)

The ICSNet Daughter Card (FG2105-10) is used to provide ICSNet connectivity for those NI-2100 and NI-3100 units (FIG. 9) that are not already ICSNet-ready. Although this card is already installed within the NI-4100 NetLinx Integrated Controller, it is an optional accessory to both the baseline NI-2100 and NI-3100 units.

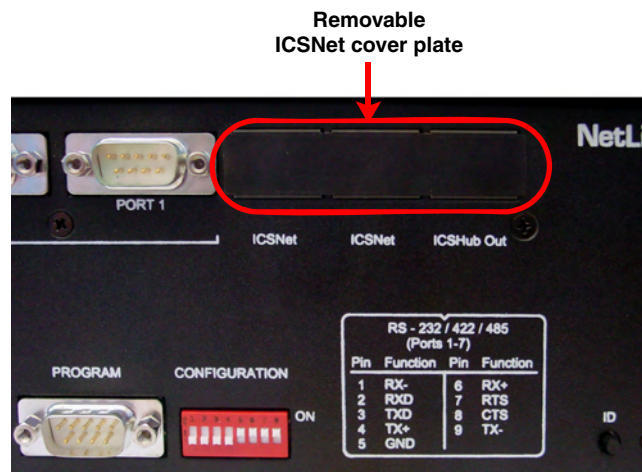

FIG. 9 Identifying upgradeable units (not ICSNet-ready)

The NI-2100 (FG2105-04) can be upgraded to provide 1 ICSHub and 2 ICSNet ports through either a field installation of the optional ICSNet Daughter Card or by purchasing this upgrade as a pre-installed component within the NI-2100 Kit (FG2105-14).

The NI-3100 (FG2105-05) can also be upgraded to provide 1 ICSHub and 2 ICSNet ports through either a field installation of the optional ICSNet Daughter Card or by purchasing this upgrade as a pre-installed component within the NI-3100 Kit (FG2105-15).

For the purposes of the installation procedures, the NI-2100 and NI-3100 upgrade procedures are identical.

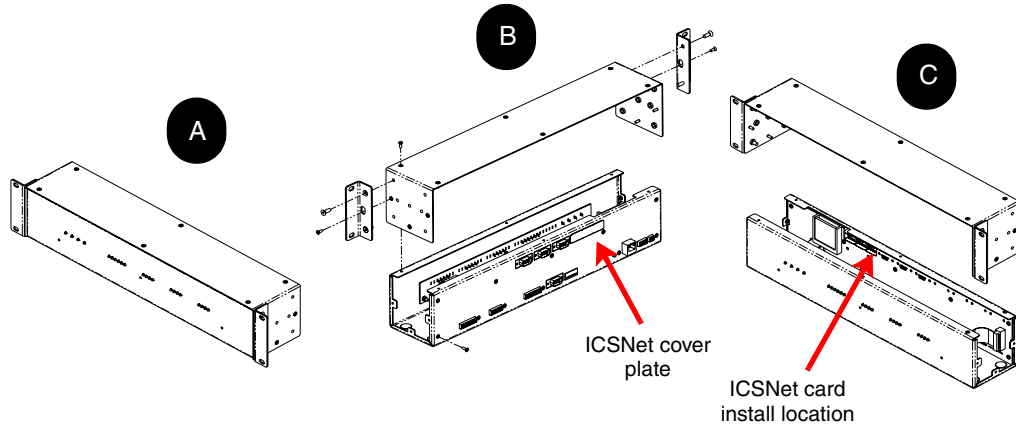

FIG. 10 Chassis removal overview for NI-2100 and NI-3100 units

Removing the Outer Housing

1. CAREFULLY DETACH ALL CONNECTORS from the rear of the unit.
2. Remove the chassis housing screws from both the sides and top of the NI-2100/3100 Controllers, as shown in both FIG. 10 and FIG. 11 by using a grounded screwdriver. The NI-2100/3100 units each have six screws on top and three at either side.

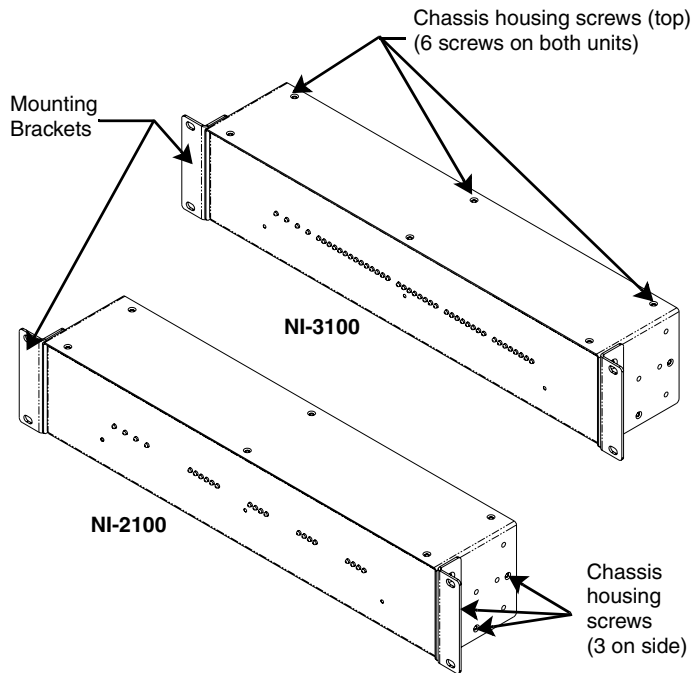

FIG. 11 Chassis screw locations

- You can choose to also remove the factory-installed mounting brackets by using a grounded screwdriver to remove the two sets of screws securing these brackets (**B** in FIG. 10).
3. Carefully pull-up and remove the housing from the Controller to expose the internal circuit board (**B** and **C** in FIG. 10).
 4. Place the housing aside for later re-installation and continue with the procedures in the following sections to both remove the ICSNet cover plate and install the ICSNet Daughter Card upgrade component.

Installing the ICSNet Card

1. Discharge any static electricity from your body by first touching a grounded metal object.



The ICSNet cover plate is composed of material which allows it to be easily malleable. The plate is made so that the flaps can be easily bent without using any tools.

2. Locate the three internal ICSNet cover plate security flaps (FIG. 12).

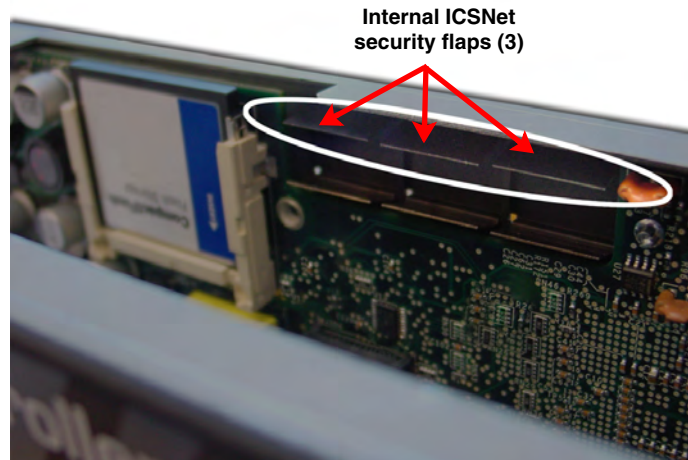

FIG. 12 ICSNet security flaps

3. Reach inside the unit and squeeze together the flap closest to the Compact Flash card.
4. Carefully repeat this process for the remaining two flaps.



Do not use a metal tool to assist in this removal process. This plate can be easily bent and can become damaged if reshaped in excess.

5. Push out the ICSNet cover plate from the inside of the unit. This action dislodges the cover plate and reveals the three ICSNet connector openings (FIG. 13).

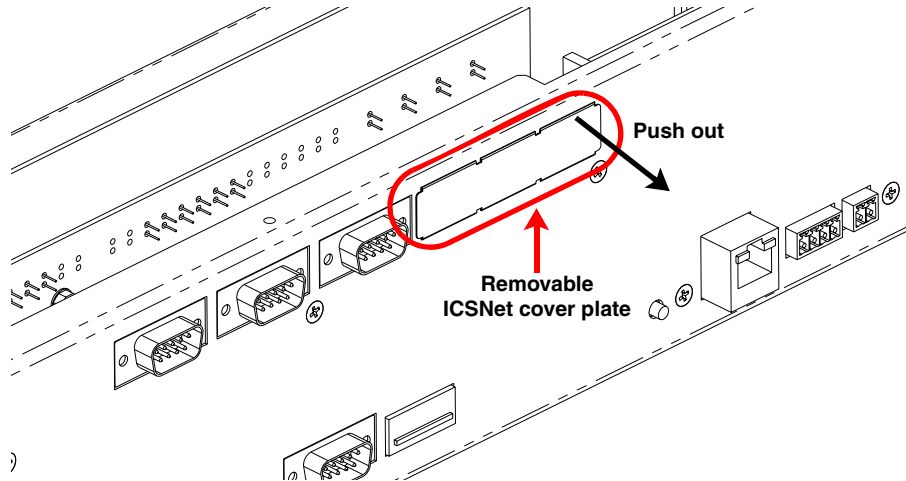

FIG. 13 ICSNet cover plate location

6. On the main board, locate both the ICSNet card's counterpart connector and standoff installation holes. These standoffs are located just under the main board cutout used for the card's RJ-45 connectors (FIG. 14).

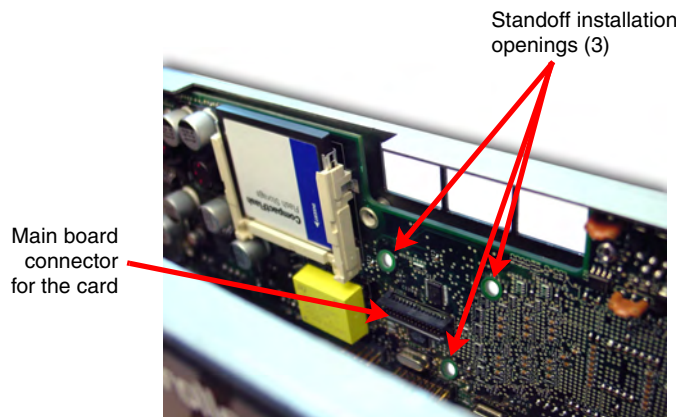

FIG. 14 Main board ICSNet card connection locations

7. Take the ICSNet card and prepare it for connection by:
 - Aligning its three pre-installed plastic standoffs (FIG. 15) to their three corresponding standoff installation openings on the main board (FIG. 14).
 - Aligning the card's three ICSNet connectors through the three openings on the chassis made by the removal of the connector plate (step 3).
 - Aligning the connector on the ICSNet card (FIG. 15) with its main board counterpart (FIG. 14).

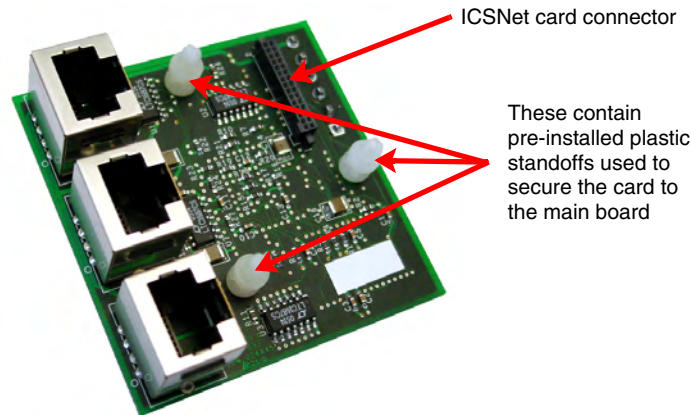

FIG. 15 ICSNet Daughter Card components

8. Carefully secure the card to the main board by pressing the top of each standoff (on the card) toward the main board until each standoff snaps into place.
9. Verify the ICSNet card connector was properly inserted into its main board counterpart by applying gentle force to the base of the card (FIG. 16).

The finished product is an upgraded NI-X100 Controller with **1** new ICSHub and **2** new ICSNet ports available at the rear of the unit (FIG. 8).



FIG. 16 ICSNet Daughter Card connectors

Replacing the Outer Housing

1. Align the chassis back over the unit and gently slide it down until the chassis housing openings are aligned over their respective openings along both the sides and top of the unit.
2. Insert and secure the chassis housing screws back into their respective locations on both the sides and top of the NI-2100/3100 Controllers, as shown in both FIG. 10 and FIG. 11 by using a grounded screwdriver. The NI-2100/3100 units each have six screws on top and three at either side.
 - You can choose to also re-install the mounting brackets by using a grounded screwdriver to resecure the two sets of screws securing these brackets (**B** in FIG. 10).
3. Re-install all connectors and apply power to the unit.

Compact Flash Upgrades

The NetLinx Integrated Controllers are shipped with a default 128 MB Compact Flash module.



NOTE

*It is recommended that **ANY MEMORY UPGRADE should be done prior to any installation.** Refer to the following accessing and installation sections for more information.*

The Compact Flash card is factory programmed with specific Controller firmware. These cards can be ordered from AMX in several different upgrade sizes (see the following table):

Optional Compact Flash Upgrades	
Product Name	Description
NXA-CF2NI256M	256 MB compact flash card (FG2116-47)
NXA-CF2NI512M	512 MB compact flash card (FG2116-48)
NXA-CF2NI1G	1 GB compact flash card (FG2116-49)

Accessing the internal components on an Integrated Controller

- CAREFULLY DETACH ALL CONNECTORS** from the rear of the unit.
- Remove the chassis housing screws from both the sides and top of the Controller, as shown in FIG. 17 by using a grounded screwdriver turning in a counter-clockwise rotation.
The NI-4100 has six screws on top and four on each side.
The NI-2100/3100 units have six screws on top and three on each side.
- Carefully pull-up and remove the housing up and away from the Controller to expose the internal circuit board (FIG. 17).
- Refer to the following *Installation of Compact Flash upgrades* for detailed replacement information.

Installation of Compact Flash upgrades

- Discharge any static electricity from your body by touching a grounded metal object.
- Locate the existing Compact Flash card on the main board. For more detailed information on component locations, refer to FIG. 17.
- Insert the tip of a grounded flathead screwdriver into one of the Card Removal Grooves (located on either side of the card), and gently pry the card out of the slot. Repeat this process on the opposite card removal groove. This alternating action causes the card to "wobble" away from the on-board connector pins.
- Slip your finger into the opening between the connector pins and the card, and push the card out to remove it.
- Remove the upgrade card from its anti-static bag.

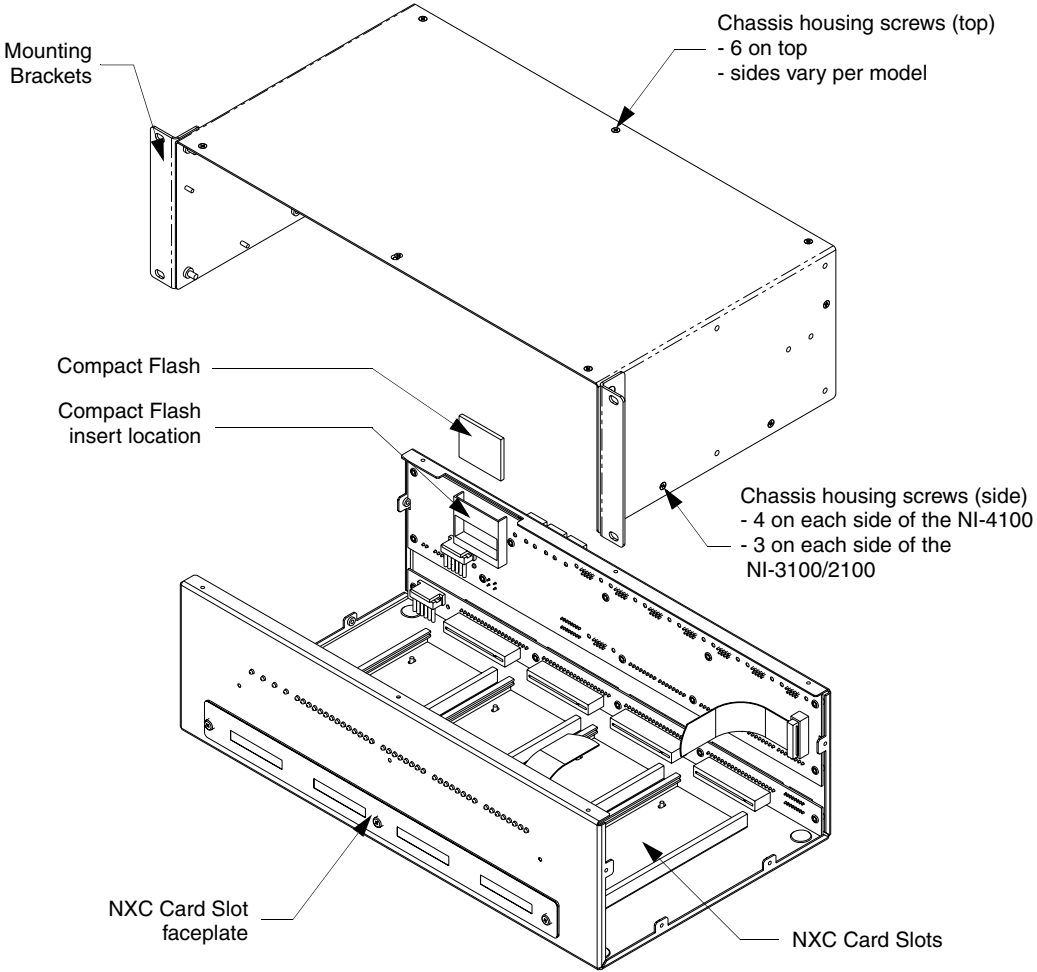

FIG. 17 Location of the Compact Flash within a sample Integrated Controller

- 6. Insert the upgrade card into the connector opening with the arrow facing towards the pins, then push it in firmly until the contact pins are completely inside the flash card and securely attached to the connector (FIG. 18).

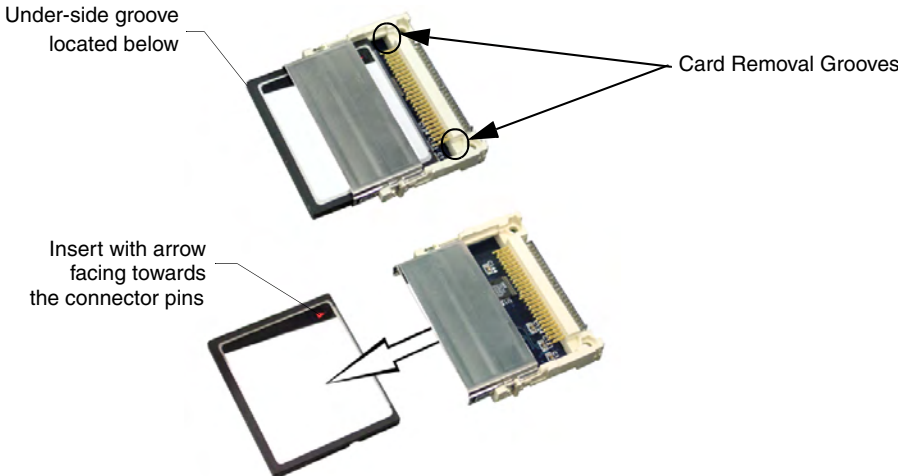

FIG. 18 Removing the Compact Flash card

7. To complete the upgrade process, close and re-secure the Integrated Controller enclosure by using the procedures outlined in the following section.



Any new internal card upgrade is detected by the Controller only after power is cycled.

Closing and Securing the Integrated Controller

Once the card has been replaced, close and re-secure the outer housing:

1. Align the cover over the unit and gently slide-down the cover until the chassis housing openings are aligned over their respective openings along both the sides and top of the unit.
2. Begin pushing-down the housing until the cover is securely positioned over circuit board.
3. Insert the chassis housing screws into their respective locations, as shown in FIG. 17.
4. Securely tighten these screws by using a grounded screwdriver turning in a clockwise direction.
5. Re-install all connectors and apply power.

Installing into an Equipment Rack

Use the rack-mounting brackets (supplied with the NI-2100/3100/4100 controller) for equipment rack installations. Remove the mounting brackets for flat surface installations.



Before completing the install process, it is recommended that you complete any firmware upgrade of the NetLinx Control Cards. This upgrade involves physically cycling power to the unit and can become cumbersome if the unit is already installed into a rack. Refer to the Upgrading the NXC Card Firmware via IP (NI-4x00 ONLY) section on page 59 for more detailed information.

1. Discharge the static electricity from your body by touching a grounded object.
2. Position and install the mounting brackets, as shown in FIG. 19, using the screws supplied with the unit. The mounting brackets can be rotated to accommodate your mounting needs.
3. Thread the cables through the opening in the equipment rack. Allow for enough slack in the cables to accommodate for movement during the installation process.
4. Reconnect all cables to their appropriate source/terminal locations. Refer to the *Connections and Wiring* section on page 29 for more detailed wiring and connection information.
 - Verify that the terminal end of the power cable is not connected to the a power supply before plugging in the 2-pin power connector.

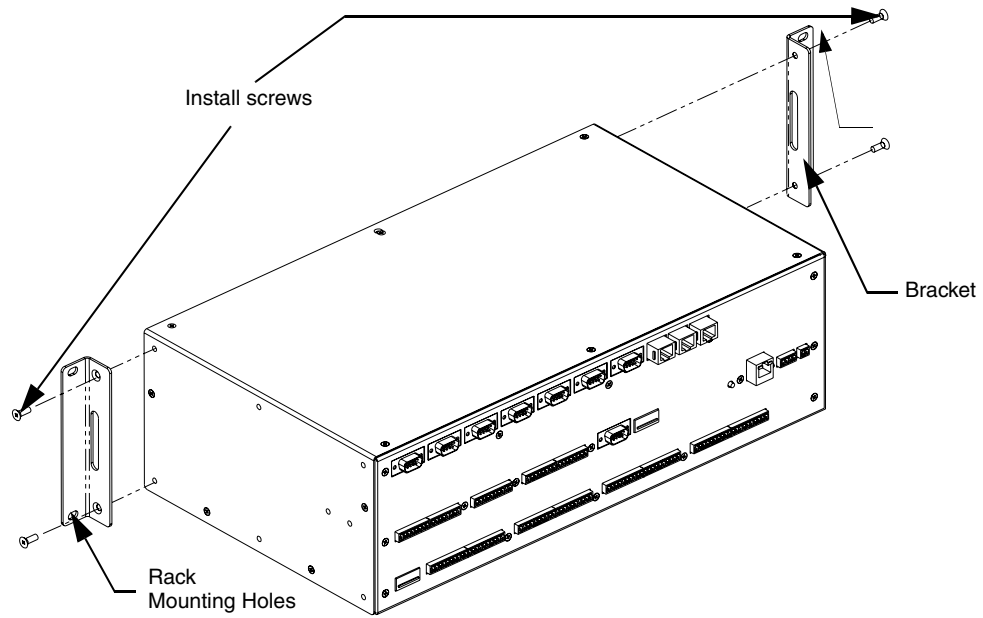

FIG. 19 Mounting Integrated Controller into an equipment rack



To prevent repetition of the installation, test the incoming wiring by connecting the Controller's connectors to their terminal locations and applying power. Verify that the unit is receiving power and functioning properly. Disconnect the terminal end of the power cable from the connected 12 VDC-compliant power supply.

5. Slide the unit into the rack until the attachment holes, along both sides, align to their corresponding locations on the mounting brackets, as shown in FIG. 19.
6. Secure the AC-RK to the rack by using the four #10-32 screws (80-0186) and four #10 washers (80-0342) supplied in the kit.
7. Apply power to the unit to complete the installation.

Connections and Wiring

Setting the Configuration DIP Switch (for the Program Port)

Prior to installing the Controller, use the Configuration DIP switch to set the baud rate used by the Program port for communication. The Configuration DIP switch is located on the rear of the NI Integrated Controllers.

Baud rate settings

Before programming the on-board Master, make sure the baud rate you set matches the communication parameters set on both your PC's COM port or and those set through your NetLinX Studio v2.x. By default, the baud rate is set to 38,400 (bps).

Baud Rate Settings on the Configuration DIP Switch				
Baud Rate	Position 5	Position 6	Position 7	Position 8
9600 bps	OFF	ON	OFF	ON
38,400 bps (default)	OFF	ON	ON	ON
57,600 bps	ON	OFF	OFF	OFF
115,200 bps	ON	ON	ON	ON

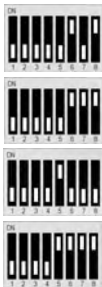

NOTE

Note the orientation of the Configuration DIP Switch and the ON position label. DIP switches 2,3, and 4 must remain in the OFF position at all times.

Program Run Disable (PRD) mode

You can also use the Program port's Configuration DIP switch to set the on-board Master to Program Run Disable (**PRD**) mode according to the settings listed in the table below.

PRD Mode Settings	
PRD Mode	Position 1
Normal mode (default)	OFF
PRD Mode	ON

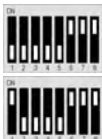

The **PRD** mode prevents the NetLinX program stored in the on-board Master from running when you power up the Integrated Controller. This mode should only be used when you suspect the resident NetLinX program is causing inadvertent communication and/or control problems. If necessary, place the on-board Master in PRD mode and use the NetLinX Studio v 2.x program to resolve the communication and/or control problems with the resident NetLinX program. Then download the new NetLinX program and try again.



Think of the PRD Mode (On) equating to a PC's SAFE Mode setting. This mode allows a user to continue powering a unit, update the firmware, and download a new program while circumventing any problems with a currently downloaded program. Power must be cycled to the unit after activating/deactivating this mode on the Program Port DIP switch #1.

Working with the Configuration DIP switch

1. Disconnect the power supply from the 2-pin PWR (green) connector on the rear of the NetLinx Integrated Controller.
2. Set DIP switch positions according to the information listed in the *Baud Rate Settings on the Configuration DIP Switch* and *PRD Mode Settings* tables.
3. Reconnect the 12 VDC power supply to the 2-pin 3.5 mm mini-Phoenix PWR connector.

Setting the CardFrame DIP Switch (NI-4x00 Only)

Refer to the *Setting the NetLinx Control Card Addresses (NI-4100 Only)* section on page 18 for a detailed explanation on this process.

Program Port Connections and Wiring

The Integrated Controllers are equipped with a Program port located on the rear of the unit. Use an RS232 programming cable to establish a connection between this Program port to your PC's COM port. This connection provides communication with the NetLinx Integrated Controller. Then you can download NetLinx programs to this on-board Master using the NetLinx Studio v 2.4 software program. Refer to the *NetLinx Studio* instruction manual for programming instructions. The following table shows the rear panel Program Port connector (male), pinouts, and signals.

Program Port, Pinouts, and Signals		
Program Port Connector	Pin	Signal
<p style="text-align: center;">Male</p>	2	RX
	3	TX
	5	GND
	7	RTS
	8	CTS

Modes and Front Panel LED Blink Patterns

The following table lists the modes and blink patterns for the front panel LEDs associated with each mode. These patterns are not evident until after the unit is powered.

Modes and LED Blink Patterns				
Mode	Description	LEDs and Blink Patterns		
		STATUS (green)	OUTPUT (red)	INPUT (yellow)
OS Start	Starting the operating system (OS).	On	On	On
Boot	On-board Master is booting.	On	Off	On
Contacting DHCP server	On-board Master is contacting a DHCP server for IP configuration information.	On	Off	Fast Blink
Unknown DHCP server	On-board Master could not find the DHCP server.	Fast Blink	Off	Off
Downloading Boot firmware	Downloading Boot firmware to the Master's on-board flash memory. <i>Do not cycle power during this process!</i>	Fast Blink	Fast Blink	Fast Blink
No program running	There is no program loaded, or the program is disabled.	On	Normal	Normal
Normal	On-board Master is functioning normally.	1 blink per second	Indicates activity	Indicates activity

Port Assignments and Functionality

The rear Port Assignments are as follows:

NI-2x00 Port Assignments	
Port	ICSP Port #
Serial Port #1	1
Serial Port #2	2
Serial Port #3	3
Relays Ports (1-4)	4
IR/Serial Port #1	5
IR/Serial Port #2	6
IR/Serial Port #3	7
IR/Serial Port #4	8
I/O Port	9

NI-3x00/4x00 Port Assignments	
Port	ICSP Port #
Serial Port #1	1
Serial Port #2	2
Serial Port #3	3
Serial Port #4	4
Serial Port #5	5
Serial Port #6	6
Serial Port #7	7
Relays Ports (1-8)	8
IR Serial Port #1	9
IR Serial Port #2	10
IR Serial Port #3	11
IR Serial Port #4	12
IR Serial Port #5	13
IR Serial Port #6	14
IR Serial Port #7	15
IR Serial Port #8	16
I/O Port	17

AXlink Port and LED

All NI units have an AXlink port and adjacent status LED (FIG. 20). This port allows the NI to support AMX Legacy AXlink devices such as G3 touch panels (*ex: CP4/A*) and PosiTrack Pilot devices. A green LED shows AXlink data activity. When the AXlink port is operating normally, blink patterns include:

- **Off** - No power, or the controller is not functioning properly
- **1 blink per second** - Normal operation.
- **3 blinks per second** - AXlink bus error. Check all AXlink bus connections.

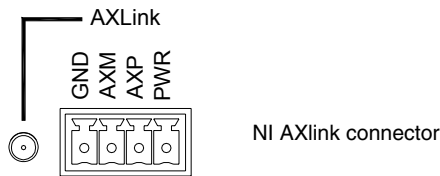

FIG. 20 AXlink connector and LED

The AXlink port can be used to supply power to downstream AXlink-compatible devices as long as both the power required is LESS THAN 2 Amps total and the external power supply feeding the NI unit has the necessary power capability.

Wiring Guidelines

The Integrated Controllers use a 12 VDC-compliant power supply to provide power through the rear 2-pin 3.5 mm mini-Phoenix PWR connector. Use the power requirements referenced in the product’s Specifications table to determine the power draw.

The incoming PWR and GND cable from the power supply must be connected to the corresponding locations within the PWR connector.



This unit should only have one source of incoming power.

Using more than one source of power to the Controller can result in damage to the internal components and a possible burn out.

Apply power to the unit only after installation is complete.

Wiring length guidelines

Refer to the following tables for the wiring length information used with the different types of NetLinx Integrated Controllers:

Wiring Guidelines - NI-3000 & NI-4000@ 900 mA	
Wire size	Maximum wiring length
18 AWG	120.41 feet (39.70 meters)
20 AWG	76.45 feet (23.30 meters)
22 AWG	49.36 feet (15.04meters)
24 AWG	30.08 feet (9.17 meters)

Wiring Guidelines - NI-3100 & NI-4100 @ 900 mA	
Wire size	Maximum wiring length
18 AWG	120.41 feet (39.70 meters)
20 AWG	76.45 feet (23.30 meters)
22 AWG	49.36 feet (15.04 meters)
24 AWG	30.08 feet (9.17 meters)

Wiring Guidelines - NI-2000 @ 700 mA	
Wire size	Maximum wiring length
18 AWG	154.83 feet (47.19 meters)
20 AWG	98.30 feet (29.96 meters)
22 AWG	63.40 feet (19.32 meters)
24 AWG	38.68 feet (11.79 meters)

Wiring Guidelines - NI-2100 @ 700 mA	
Wire size	Maximum wiring length
18 AWG	154.83 feet (47.19 meters)
20 AWG	98.30 feet (29.96 meters)
22 AWG	63.40 feet (19.32 meters)
24 AWG	38.68 feet (11.79 meters)

Preparing captive wires

You will need a wire stripper and flat-blade screwdriver to prepare and connect the captive wires.



Never pre-tin wires for compression-type connections.

1. Strip 0.25 inch (6.35 mm) of insulation off all wires.
2. Insert each wire into the appropriate opening on the connector (according to the wiring diagrams and connector types described in this section).
3. Tighten the screws to secure the wire in the connector. ***Do not tighten the screws excessively, doing so may strip the threads and damage the connector.***

Wiring a power connection

To use the 2-pin 3.5 mm mini-Phoenix connector with a 12 VDC-compliant power supply, the incoming PWR and GND cables from the external source must be connected to their corresponding locations on the connector (FIG. 21).

1. Insert the PWR and GND wires on the terminal end of the 2-pin 3.5 mm mini-Phoenix cable. ***Match the wiring locations of the +/- on both the power supply and the terminal connector.***
2. Tighten the clamp to secure the two wires. ***Do not tighten the screws excessively; doing so may strip the threads and damage the connector.***
3. Verify the connection of the 2-pin 3.5 mm mini-Phoenix to the external 12 VDC-compliant power supply.

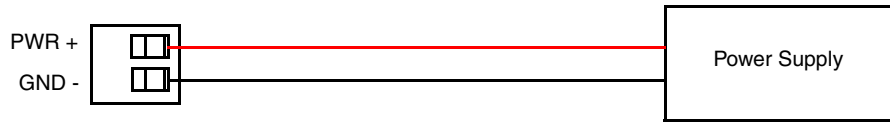

To the Integrated Controller

FIG. 21 2-pin mini-Phoenix connector wiring diagram (direct power)

Using the 4-pin mini-Phoenix connector for data and power

Connect the 4-pin 3.5 mm mini-Phoenix (female) captive-wire connector to an external NetLinx device as shown in FIG. 22.

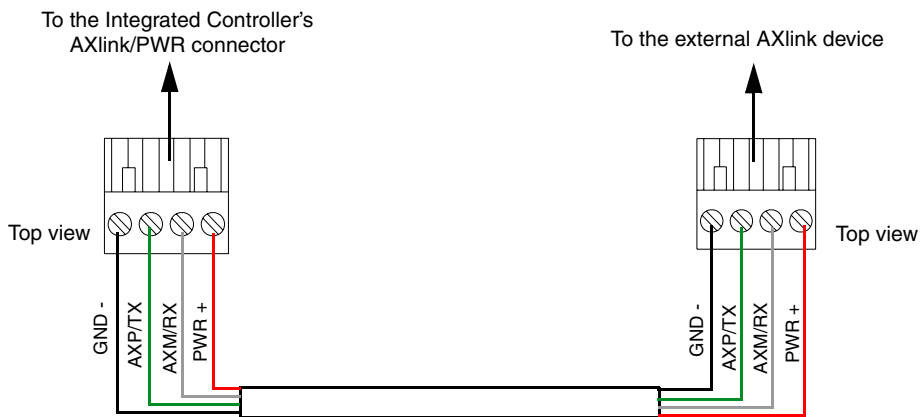

FIG. 22 Mini-Phoenix connector wiring diagram (direct data and power)

Using the 4-pin mini-Phoenix connector for data with external power

To use the 4-pin 3.5 mm mini-Phoenix (female) captive-wire connector for data communication and power transfer, the incoming PWR and GND cable from the 12 VDC-compliant power supply must be connected to the AXlink cable connector going to the Integrated Controller. FIG. 23 shows the wiring diagram. Always use a local power supply to power the Integrated Controller unit.

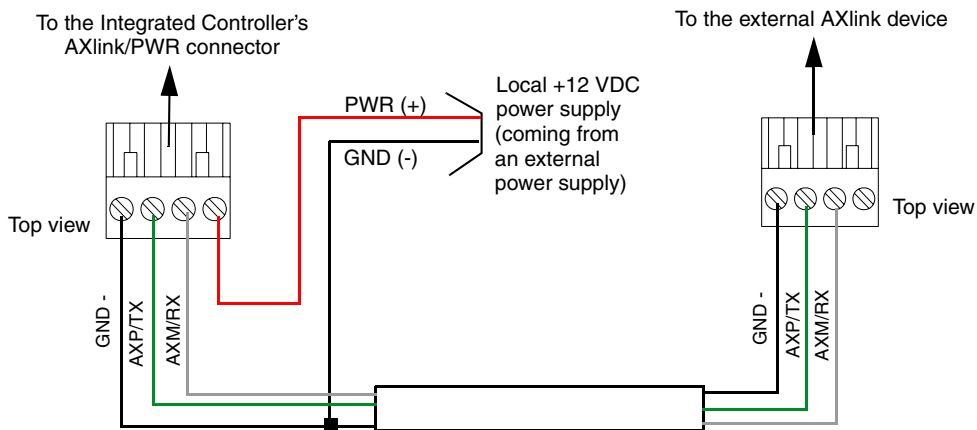

FIG. 23 4-pin mini-Phoenix connector wiring diagram (using external power source)



When you connect an external power supply, do not connect the wire from the PWR terminal (coming from the external device) to the PWR terminal on the Phoenix connector attached to the Controller unit. Make sure to connect **only** the AXM, AXP, and GND wires to the Controller's Phoenix connector when using an external power supply.

Make sure to connect **only** the GND wire on the AXlink/PWR connector when using a separate 12 VDC power supply. Do not connect the PWR wire to the AXlink connector's PWR (+) opening.

DB9 Device Port: Connections and Wiring

FIG. 24 shows the connector pinouts for the rear RS-232/RS-422/RS-485 (DB9) Device Ports. These ports support most standard RS-232 communication protocols for data transmission. This figure gives a visual representation of the wiring specifications for the RS-232/422/485 Device connectors. Refer to the rear of the unit for more detailed connector pinout information.

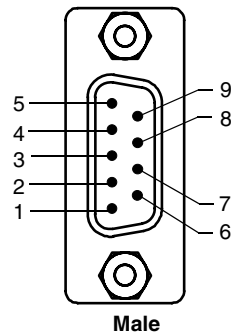

DB9 Serial Port pinouts (male connector)

RS-232	RS-422	RS-485
Pin 2: RX signal	Pin 1: RX -	Pin 1: A (strap to 9)
Pin 3: TX signal	Pin 4: TX +	Pin 4: B (strap to 6)
Pin 5: GND	Pin 5: GND	Pin 5: GND
Pin 7: RTS	Pin 6: RX +	Pin 6: B (strap to 4)
Pin 8: CTS	Pin 9: TX -	Pin 9: A (strap to 1)

FIG. 24 RS-232/422/485 DB9 (male) connector pinouts for the rear Device Ports

The table below provides information about the connector pins, signal types, and signal functions. This table's wiring specifications are applicable to the rear RS-232/422/485 Device Port connectors on the: NI-4000/NI-3000 (Ports 1-7), NI-4100/NI-3100 (Ports 1-7), NI-2000 (Ports 1-3), and NI-2100 (Ports 1-3).

RS-232/422/485 Device Port Wiring Specifications					
Pin	Signal	Function	RS-232	RS-422	RS-485
1	RX-	Receive data		X	X (strap to pin 9)
2	RXD	Receive data	X		
3	TXD	Transmit data	X		
4	TX+	Transmit data		X	X (strap to pin 6)
5	GND	Signal ground	X	X	
6	RX+	Receive data		X	X (strap to pin 4)
7	RTS	Request to send	X		
8	CTS	Clear to send	X		
9	TX-	Transmit data		X	X (strap to pin 1)

ICSNet Port: Connections and Wiring

The NI Controller must be equipped with the available ICSNet connectors for this functionality to be active. The following tables show the signal and pinouts/pairing information:

ICSNet RJ-45 Signals		
Pin	Signal-Master	Signal-Device
1	TX +	RX +
2	TX -	RX -
3	N/A	N/A
4	GND	GND
5	N/A	N/A
6	N/A	N/A
7	RX +	TX +
8	RX -	TX -

RJ-45 Pinout Information (EIA/TIA 568 B)			
Pin	Wire Color	Polarity	Function
1	Orange/White	+	Transmit
2	Orange	-	Transmit
3	Green/White	-	Mic
4	Blue	-	Ground
5	White/Blue	+	12 VDC
6	Green	+	Mic
7	White/Brown	+	Receive
8	Brown	-	Receive

TIA 568B

RJ-45 connector - pin configurations

The FIG. 25 illustrates the location of the ICSNet and ICSHub Out connectors on the rear panel.

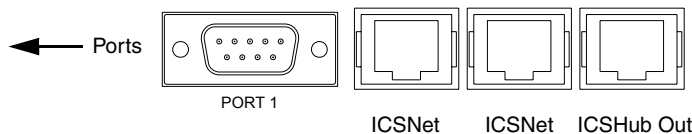

FIG. 25 Location of ICSNet and ICSHub Out connectors



Unlike the ICSNet ports, the ICSHub connections require a specific polarity. The IN/OUT configuration, on the hub ports, was implemented to use the same cables as ICSNet, but these ports need TX and RX crossed. You must connect an OUT to an IN, or an IN to an OUT port.

This is done simply to keep the polarity straight. The Hub bus is still a bus. All Hub connections are bi-directional.

ICSHub OUT Port: Connections and Wiring

The NI Controller must be equipped with the available ICSNet connectors for this functionality to be active. The following table describes the pinout/signal information for the ICSHub OUT port located on the rear panel of the Integrated Controller (as shown in FIG. 25).

ICSHub OUT Pinouts and Signals		
Pin	Signal	Color
1	RX +	orange-white
2	RX -	orange
3	-----	-----
4	-----	-----
5	-----	-----
6	-----	-----
7	TX +	brown-white
8	TX -	brown

Relay Port: Connections and Wiring

You can connect up to 8 independent external relay devices on both the NI-4x00 Series and NI-3x00 Series units (4 on the NI-2000 and NI-2100) to the Relay connectors on the Integrated Controller.

- Connectors labeled A are for common; B are for output.
- Each relay is isolated and normally open.
- A metal commoning strip is supplied with each Integrated Controller to connect multiple relays.

Relay connections

Use A for common and B for output (FIG. 26). Each relay is isolated and normally open. A metal connector strip is also provided to common multiple relays.

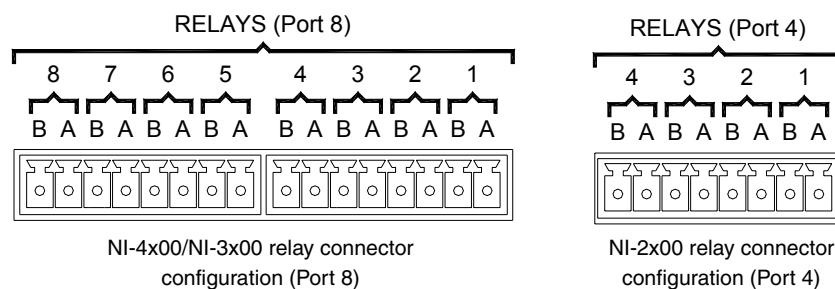

FIG. 26 RELAY connector (male) (NI-4x00/3x00/2x00)

Input/Output (I/O) Port: Connections and Wiring

The I/O port responds to either switch closures, voltage level (high/low) changes, or it can be used for logic-level outputs.

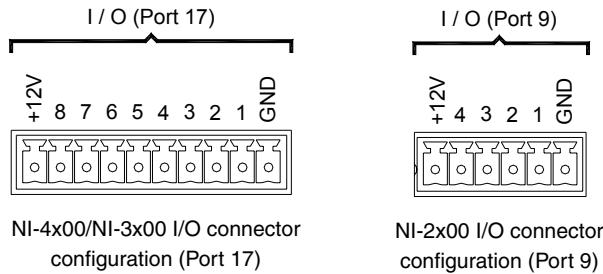

FIG. 27 INPUT/OUTPUT connector (male)

You can connect up to eight devices to the I/O connectors on the NI-4x00/3x00 Series (*four on the NI-2000 and NI-2100*) (FIG. 27). A contact closure between the GND and an I/O port is detected as a Push.

- When used for voltage inputs, the I/O port detects a low signal (0 - 1.5 VDC) as a Push, and a high signal (3.5 - 5 VDC) as a Release (*this IO port uses 5V logic but can handle up to 12V without harm*).
- When used for outputs, the I/O port acts as a switch to GND and is rated for 200 mA @ 12 VDC. This device can use up to 8 I/O ports (NI-4x00/3x00) and up to 4 I/O ports (NI-2x00).
- The PWR pin provides +12 VDC @ 200 mA and is designed as a power output for the PCS Power Current Sensors, VSS2 Video Sync Sensors (or equivalent).
- The GND connector is a common ground and is shared by all I/O ports. A common ground is shared with I/O ports 1 - 8 (NI-4x00/NI-3x00) or with I/O ports 1 - 3 (NI-2x00).

I/O Port Wiring Specifications NI-4x00 and NI-3x00		
Pin	Signal	Function
1	GND	Signal GND
2	I/O 1	Input/Output
3	I/O 2	Input/Output
4	I/O 3	Input/Output
5	I/O 4	Input/Output
6	I/O 5	Input/Output
7	I/O 6	Input/Output
8	I/O 7	Input/Output
9	I/O 8	Input/Output
10	12 VDC	PWR

I/O Port Wiring Specifications NI-2x00		
Pin	Signal	Function
1	GND	Signal GND
2	I/O 1	Input/Output
3	I/O 2	Input/Output
4	I/O 3	Input/Output
5	I/O 4	Input/Output
6	12 VDC	PWR

IR/Serial Port: Connections and Wiring

You can connect up to **eight** IR- or Serial-controllable devices to the IR/Serial connectors on the rear of the NI-4x00 and NI-3x00 and up to **four** on the NI-2x00 (FIG. 28). These connectors accept an IR Emitter (CC-NIRC) that mounts onto the device's IR window, or a mini-plug (CC-NSER) that connects to the device's control jack. You can also connect a data 0 - 5 VDC device. These units come with two CC-NIRC IR Emitters (**FG10-000-11**).

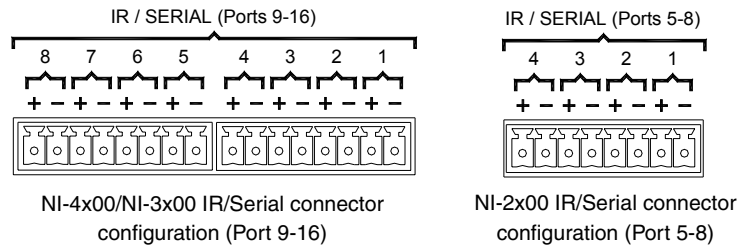

FIG. 28 IR/SERIAL (male)

The IR/Serial connector wiring specifications are listed in the following table.

IR/Serial Connector Wiring Specifications (per Port)				
Number of IR connections	NI-4x00/3x00 Port #	NI-2x00 Port #	Signal	Function
1	9	5		GND (-) Signal 1 (+)
2	10	6		GND (-) Signal 2 (+)
3	11	7		GND (-) Signal 3 (+)
4	12	8		GND (-) Signal 4 (+)
5	13	N/A		GND (-) Signal 5 (+)
6	14	N/A		GND (-) Signal 6 (+)
7	15	N/A		GND (-) Signal 7 (+)
8	16	N/A		GND (-) Signal 8 (+)

NetLinX Control Card Slot Connector (NI-4x00 Series only)

FIG. 29 shows the 20-pin (male) connector that provides connection to the NetLinX Control Cards.

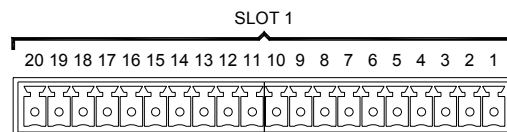

FIG. 29 NetLinX Control Card 20-pin connector

Ethernet/RJ-45 Port: Connections and Wiring

The following table lists the pinouts, signals, and pairing for the Ethernet connector.

Ethernet RJ-45 Pinouts and Signals				
Pin	Signals	Connections	Pairing	Color
1	TX +	1 ----- 1	1 ----- 2	Orange-White
2	TX -	2 ----- 2		Orange
3	RX +	3 ----- 3	3 ----- 6	Green-White
4	no connection	4 ----- 4		Blue
5	no connection	5 ----- 5		Blue-White
6	RX -	6 ----- 6		Green
7	no connection	7 ----- 7		Brown-White
8	no connection	8 ----- 8		Brown

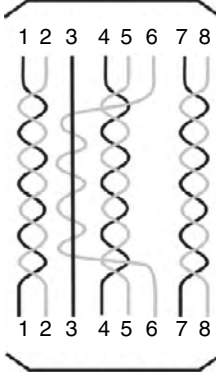

FIG. 30 diagrams the RJ-45 pinouts and signals for the Ethernet RJ-45 connector and cable.

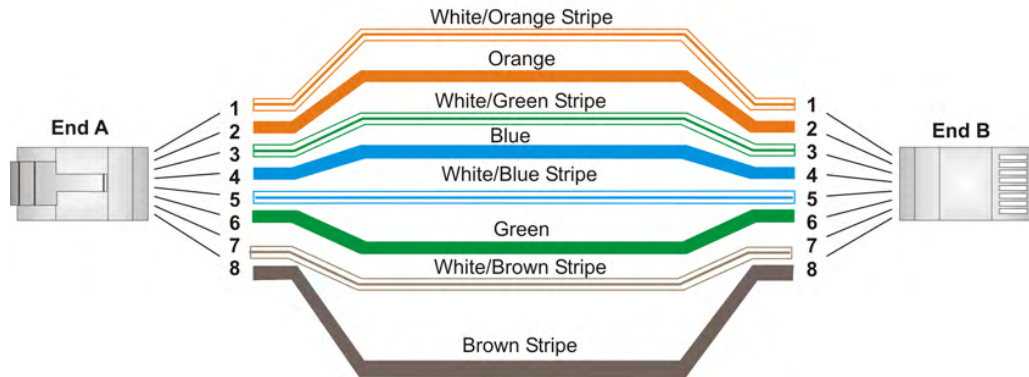
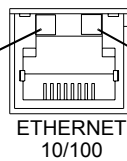

FIG. 30 RJ-45 wiring diagram

Ethernet LEDs

L/A - Link/Activity LED lights (green) when the Ethernet cables are connected and terminated correctly.



SPD - Speed LED lights (yellow) when the connection speed is 100 Mbps and turns Off when speed is 10 Mbps.

FIG. 31 Ethernet LEDs

Ethernet ports used by the Integrated Controllers

Ethernet Ports Used by the NetLinX Integrated Controllers		
Port type	Description	Standard Port #
FTP	The on-board Master has a built-in FTP server.	21/20 (TCP)
SSH	The SSH port functions using the same interface as Telnet but over a secure shell where it uses SSL as a mechanism to configure and diagnose a NetLinX system. This port value is used for secure Telnet communication. Note: SSH version 2 is only supported.	22 (TCP)
Telnet	The NetLinX Telnet server provides a mechanism to configure and diagnose a NetLinX system. For maximum flexibility, the Master can be configured to utilize a different port than 23, or disable Telnet completely from either Telnet or the Program Port located on the rear of the Master itself. Once disabled, the only way to enable Telnet again is from the Master's Program port.	23 (TCP)
HTTP	The Master has a built-in web server that complies with the HTTP 1.0 specification and supports all of the required features of HTTP v1.1. This port is used for unsecure HTTP Internet communication between the web browser's UI and the target Master.	80 (TCP)
HTTPS/SSL	This port is used by a web browser to securely communicate between the web server UI and the target Master. This port is also used to simultaneously encrypt this data using the SSL certificate information on the Master as a key.	443 (TCP)
ICSP	Peer-to-peer protocol used for both Master-to-Master and Master-to-device communications. For maximum flexibility, the Master can be configured to utilize a different port than 1319, or disable ICSP over Ethernet completely from either Telnet or the Program Port located on the rear of the Master itself. This type of communication is used by the various AMX product for communication amongst themselves.	1319 (UDP/TCP)
integration! Solutions	This feature on the Master uses, by default, port 10500 for the XML based communication protocol. This port is connected to by the client web browser's JVM when integration! Solutions control pages are retrieved from the on-board Master's web server. For maximum flexibility, the on-board Master can be configured to utilize a different port than 10500 or to disable integration! Solutions completely.	10500 (TCP)

Configuration and Firmware Update

This section refers to steps necessary to both communicate and upgrade the various NI Controller components.



**Before commencing, verify you are using the latest firmware Kit file (this file contains both the NI Integrated Controller and on-board Master firmware).
The NI-4000/3000/2000 Kit file begins with 2105_X000.
The NI-4100/3100/2100 Kit file begins with 2105_04_X100.
The NI-700/900 Kit file begins with 2105_03_NI-X00 and 2105_09_NI-X00 respectively.
Verify you are using the latest version of NetLinx Studio.**

Before beginning:

1. Setup and configure your Integrated Controller. Refer to the previous *Installation and Upgrading* section.
2. Verify you have installed the latest version of NetLinx Studio on your PC.
3. If an update is necessary, download the latest Studio software by first logging in to **www.amx.com** and then navigate to **Tech Center > Downloadable Files > Application Files > NetLinx Studio 2.x**. This program is used to setup a System number, obtain/assign the IP/URL for the connected NetLinx Master, and transfer firmware Kit files to the Master.
4. Verify that an Ethernet/ICSNet cable is connected from the Controller to the Ethernet Hub.
5. Connect an RS-232 programming cable from the Program Port on the unit to the rear COM port connector on the PC being used for programming (*this step establishes DB9 communication*).
6. Verify that any control cards (*NI-4000 and NI-4100 only*) are inserted and their respective connectors are attached to the rear of the Controller unit before continuing.
7. Verify that the NetLinx Master is receiving power and is turned On. Refer to the previous Wiring a power connection section for more information.



If you have previously setup communication with your Controller via an IP Address, continue with the firmware update procedures outlined in the Communicating with the NI Device via an IP section on page 51.

Communicating with the Master via the Program Port

1. Launch NetLinx Studio 2.x (default location is **Start > Programs > AMX Control Disc > NetLinx Studio 2 > NetLinx Studio 2**).
2. Select **Settings > Master Communication Settings**, from the Main menu, to open the Master Communication Settings dialog (FIG. 32).
3. Click the **Communications Settings** button to open the Communications Settings dialog (FIG. 32).
4. Click the **NetLinx Master** radio button (*from the Platform Selection section*) to indicate you are working with a NetLinx Master (such as the NXC-ME260/64 or NI-Series of Integrated Controllers).

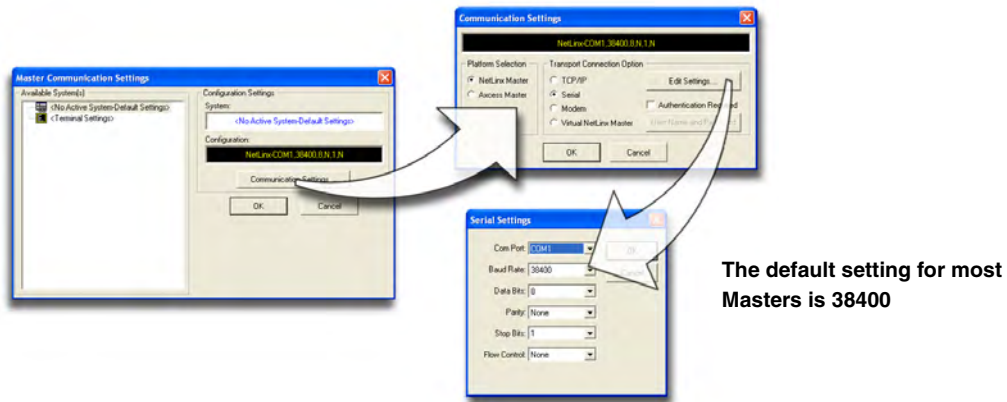

FIG. 32 Assigning Master Communication Serial Settings and Baud Rates

5. Click the **Serial** radio button (*from the Transport Connection Option section*) to indicate you are connecting to the on-board Master via a (Serial) COM port.
6. Click the **Edit Settings** button to open the Serial Settings dialog (FIG. 32).



No authentication username or password information is required with a direct connection such as: USB or Serial.

7. Set the COM port parameters for the selected COM port used for communication to the NetLinx Master. *Default parameters are: COM1, 38400, 8 Data Bits, No Parity, 1 Stop Bit, and No Flow Control.*
 - *If communication fails on a known COM port, change the baud rate to 115200 and try again.*
8. Click **OK** three times to close the open dialogs and save your settings.



*If the connection fails to establish: Select a different COM port, press the **Retry** button to reconnect using the same communication parameters, or press the **Change** button to alter your communication parameters and repeat steps 2 thru 8.*

Setting the System Value

1. Access/open the Device Addressing dialog (FIG. 33) by either one of these two methods:
 - Right-click on any System item listed (such as the NI Master entry) in the **OnLine Tree** tab of the Workspace and select **Device Addressing** (from the popup list).
 - Select **Diagnostics > Device Addressing** from the Main menu.



This process should be done while communicating to the Master via a Serial connection.

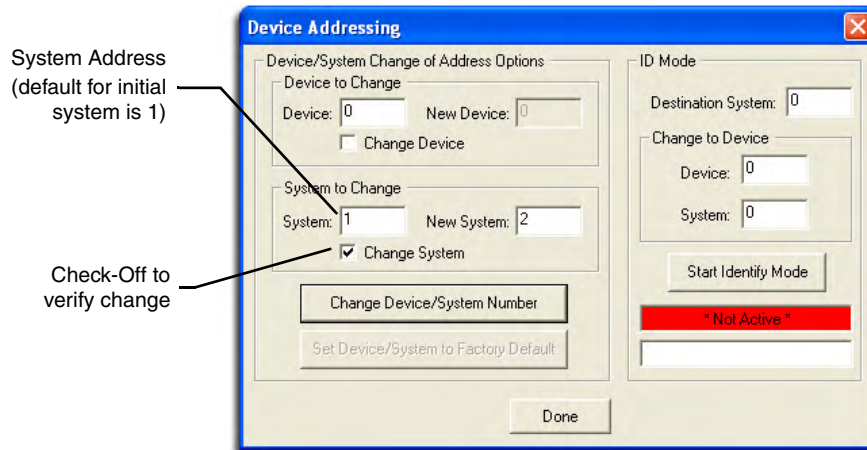

FIG. 33 Device Addressing tab (changing the system value)



NOTE

This tab represents the only way to change the System Number associated to the active on-board NI Master. **The Master must have it's power cycled to incorporate the new System number (often a simple reboot via Studio will not be enough to incorporate this new number).**

2. Select the **Change System** selection box from the *System to Change* section.
3. Enter both the current and new system address values (this example uses 2).
4. Click the **Change Device/System Number** button. This configures the on-board NI Master to accept the new value and incorporate the information. *The system information (in the OnLine Tree tab of the Workspace window) refreshes and then displays the new information.*
5. Click **Done** to close the Device Addressing dialog and return to the main program.
6. Click **Reboot** (from the *Tools > Reboot the Master Controller* dialog) and wait for the System Master to reboot. *The STATUS and OUTPUT LEDs should begin to alternately blink during the incorporation. Wait until the STATUS LED is the only LED to blink.*
7. Press **Done** once until the *Master Reboot Status* field reads **Reboot of System Complete**.
8. Click the **OnLine Tree** tab in the Workspace window to view the devices on the System. *The default System value is one (1).*
9. Right-click the associated System number (or anywhere within the tab itself) and select **Refresh System**. This establishes a new connection to the specified System and populates the list with devices on that system.
10. Use **Ctrl+S** to save your existing NetLinx Project with the new changes.



NOTE

If the NetLinx device does not appear within the OnLine Tree tab, make sure that the Integrated Controller's on-board Master System Number (from within the Device Addressing tab) is correctly assigned.

If there is a problem, use a system value of zero (0) on the NetLinx device.



NOTE

The Master by default is set to DEVICE 0. Connected NetLinx device addresses can only be changed through the Protected Setup page. The new address is reflected within the OnLine Tree tab of the Workspace window only after the devices are rebooted and the system is refreshed.



The system value on a Modero touch panel can NOT be changed from the Device Addressing dialog and MUST be altered through the panel Protected Setup page.

Using multiple NetLinx Masters

When using more than one Master, each unit must be assigned to a separate System value.

A Master’s System value can be changed but **it’s device Address must always be set to zero (00000)**. The Device Addressing dialog will not allow you to alter the NetLinx Master address value.

Example: Using NetLinx Studio v 2.x to work with an NXC-ME260/64 and NI-4x00:

- The NXC-ME260/64 could be assigned to **System 1** (with a value of 00000).
- The NI-4x00 could be assigned to **System 2** (with a value of 00000).

Changing the Device Address of a NetLinx Device

1. Access the Device Addressing dialog (FIG. 34) by either one of these two methods:
 - Right-click on any system device (*such as a Modero panel*) listed in the **OnLine Tree** tab of the Workspace and select **Device Addressing** (from the popup list).
 - Select **Diagnostics > Device Addressing** from the Main menu.

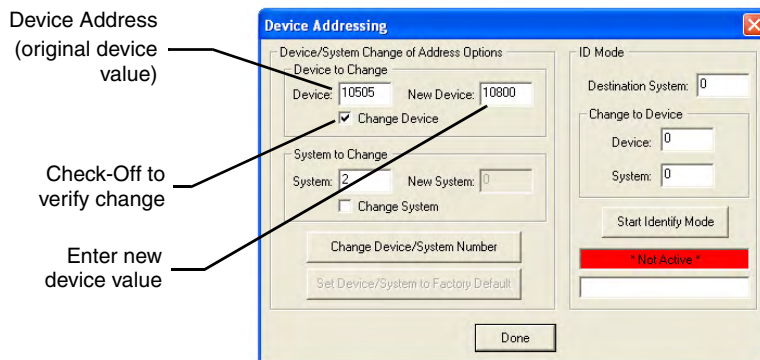

FIG. 34 Device Addressing dialog (changing the device value)



This dialog represents the only way to change the device value of a selected NetLinx device. Modero panels are one of the only devices that can have their **Device values** changed within both this dialog and through the on-board firmware page.

2. Select the **Change Device** checkbox from the *Device to Change* section.
3. Verify the **Current** value and enter the **New Device** value for the target NetLinx device.
4. Click the **Change Device/System Number** button. This configures the specified Master to accept the new value for the NetLinx device and incorporate the information (the system information in the Workspace window refreshes and then displays the new information).
5. Click **Done** to close the Device Addressing dialog.

6. Click **Reboot** (from the Tools > Reboot the Master Controller dialog) and wait for the System Master to reboot. The STATUS and OUTPUT LEDs should begin to alternately blink during the incorporation. Wait until the STATUS LED is the only LED to blink.
7. Press **Done** once until the Master Reboot Status field reads *Reboot of System Complete*.
8. Click the **OnLine Tree** tab in the Workspace window to view the devices on the System. The default System value is one (1).
9. Right-click the associated System number (or anywhere within the tab itself) and select **Refresh System**. This establishes a new connection to the specified System and populates the list with devices on that system.
10. Use **Ctrl+S** to save your existing NetLinX Project with the new changes.



If the Master does not appear in the Workspace window, make sure that the Master's System Number (from within the Device Addressing tab) is correctly assigned. If there is a problem, use a system value of zero (0) on the Master.

Recommended NetLinX Device numbers

- 1 - 255
- 301 - 3072
- 5001 - 5999
- 6001 - 6999
- 7001 - 7999
- 8001 - 8999
- 10000 - 31999
- 33001 - 36863
- 32001 - 32767
- 32768 - 36863
- Access Devices use Access standards
- NetLinX CardFrames start at frame number 25 - (frame# * 12) + Card #
- ICSNet NetLinX devices: NXI, NXM-COM2, NXM-IRS4, etc.
- ICSNet Landmark devices: PLH-VS8, PLH-AS16, PLB-AS16
- InConcert Devices
- PCLink Device: PCLink devices are PC programs
- ICSNet Panels: DMS, IMS, and future panels
- Virtual devices: these start at 33001
- Dynamic devices: the actual range used by Master
- Virtual devices: the actual range used by Master

Using the ID Button to Change the Controller's Device Value

1. Access the Device Addressing dialog (FIG. 35) by selecting **Diagnostics > Device Addressing** from the Main menu.

Enter the new Controller value

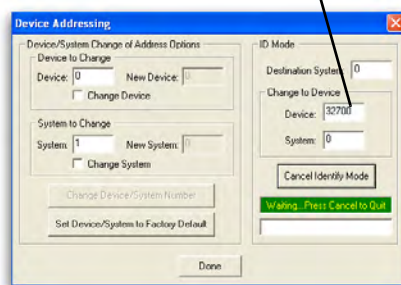

A

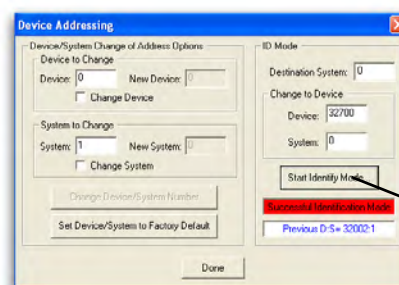

B

Assign the new value to the Controller

FIG. 35 Device Addressing dialog (using the ID mode to set the NI Controller device value)



NOTE

This dialog represents the another way to change the Device value of the NI Controller. This ID mode section of the Device Addressing dialog can be used only by Masters with an ID button (which apply to all NI-Series Masters).

2. Locate the *Device* field (A in FIG. 35) and enter the new value for the NI Controller.
This value must fall within a range of 0 - 32767.
3. Press the on-screen **Start Identify Mode** button.
 - This action causes a previously red **Not Active** field to now display a green *Waiting...Press Cancel to Quit.* field.
 - This green field indicates that Studio is waiting to detect the device value of the NI Controller associated with the **ID** button on the target NI.
4. Press the target NI unit's **ID** button to begin process of reading the current device value of the NI Controller and then assigning it to the new value entered in step 2.
 - Once the swap has been successfully made, a red *Successful Identification Made* field appears.
 - The previous Device value and associated System number of the targeted NI Controller are then displayed below the red field, as an example *Previous D:S=32002:1*, where 32002 was the previous device value of the Controller (**D**) and 1 was the on-board Master's System value (**S**).

Resetting the Factory Default System and Device Values

1. Access the Device Addressing dialog (FIG. 34 on page 46) by either one of these two methods:
 - Right-click on any system device listed in the Workspace and select **Device Addressing**.
 - Select **Diagnostics > Device Addressing** from the Main menu.
2. Click the **Set Device/System to Factory Default** button. This resets both the system value and device addresses (for definable devices) to their factory default settings. The system information (in the **OnLine Tree** tab of the Workspace window) refreshes and then displays the new information.



NOTE

*By setting the system to its default value (#1), Modero panels that were set to connect to the Master on another System value will not appear in the **OnLine Tree** tab of the Workspace window.*

For example: A Modero touch panel was previously set to System #2. The system is then reset to its default setting of System #1 and then refreshed from within the Workspace window. The panel will not reappear until the system is changed (from within the System Connection page on the Modero) to match the new value and both the Master and panel are rebooted.

3. Click **Done** to close the Device Addressing dialog.
4. Click **Reboot** (from the **Tools > Reboot the Master Controller** dialog) and wait for the System Master to reboot. *The STATUS and OUTPUT LEDs should begin to alternately blink during the incorporation. Wait until the STATUS LED is the only LED to blink.*
5. Press **Done** once until the *Master Reboot Status* field reads **Reboot of System Complete**.

6. Click the **OnLine Tree** tab in the Workspace window to view the devices on the System. *The default System value is one (1).*
7. Right-click the associated System number (*or anywhere within the tab itself*) and select **Refresh System**. This establishes a new connection to the specified System and populates the list with devices on that system.
8. Use **Ctrl+S** to save your existing NetLinx Project with the new changes.

Obtaining the Master's IP Address (using DHCP)



NOTE

Verify there is an active Ethernet connection on the Ethernet port of the NI-Series Controller before beginning these procedures.

1. Select **Diagnostics > Network Addresses** from the Main menu to access the Network Addresses dialog (FIG. 36).

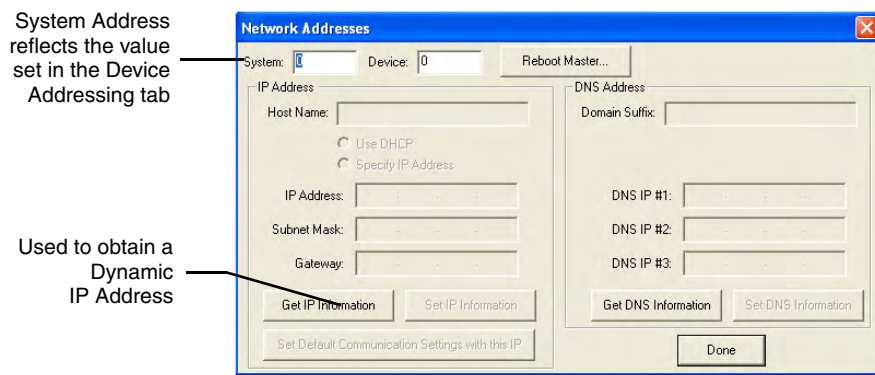

FIG. 36 Network Addresses dialog (for a DHCP IP Address)

2. Verify that both the **System** number corresponds to the System value previously assigned within the Device Addressing dialog and that zero (0) is entered into the *Device* field.



NOTE

The system value must correspond to the Device Address entered in the Device Addressing dialog. Refer to the Setting the System Value section on page 44 for more detailed instructions on setting a system value.

3. Click the **Get IP Information** button to configure the on-board Master for DHCP usage and then read the IP Address obtained from the DHCP Server.



NOTE

DO NOT enter ANY IP information at this time; this step only gets the System Master to recognize that it should begin using an obtained DHCP Address.

4. Note the obtained IP Address (*greyed-out and read-only*). This information is later entered into the **Master Communication Settings** dialog and used by NetLinx Studio v 2.x to communicate to the Master via an IP. This address is reserved by the DHCP server and then given to the Master.



If the IP Address field is empty, give the Master a few minutes to negotiate a DHCP Address with the DHCP Server, and try again. The DHCP Server can take anywhere from a few seconds to a few minutes to provide the Master with an IP Address.

5. Verify that **NetLinx** appears in the *Host Name* field (if not, then enter it in at this time).
6. Click the **Use DHCP** radio button from the IP Address section (if not greyed-out).
7. Click the **Set IP Information** button to retain the IP Address from the DHCP server and assign it to the on-board Master. A popup window then appears to notify you that Setting the IP information was successful and it is recommended that the Master be rebooted.
8. Click **OK** to accept the change to the new IP/DNS information.
9. Click the **Reboot Master** button and select **Yes** to close the Network Addresses dialog.
10. Click **Reboot** (from the *Tools > Reboot the Master Controller* dialog) and wait for the System Master to reboot and retain the newly obtained DHCP Address. *The STATUS and OUTPUT LEDs should begin to alternately blink during the incorporation. Wait until the STATUS LED is the only LED to blink.*
11. Press **Done** once until the *Master Reboot Status* field reads **Reboot of System Complete**.



Verify that these IP values are also entered into the related fields within either the IP Settings section of the System Connection page (on the touch panel) or within the Address field on the web browser.

12. Complete the communication process by continuing on to the *Communicating with the NI Device via an IP* section on page 51.

Assigning a Static IP to the NetLinx Master



Verify there is an active Ethernet connection on the Ethernet port of the NI-Series Controller before beginning these procedures.

1. Select **Diagnostics > Network Addresses** from the Main menu to access the Network Addresses dialog (FIG. 37).

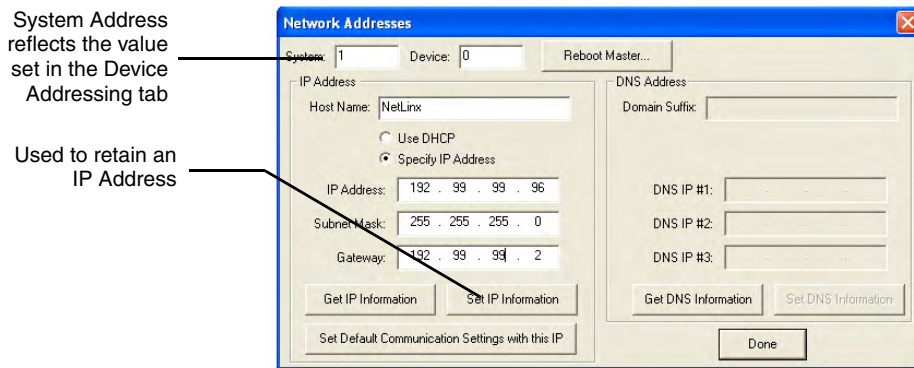

FIG. 37 Network Addresses dialog (for a pre-obtained Static IP Address)

2. Verify that both the **System** number corresponds to the System value previously assigned within the Device Addressing tab and that zero (0) is entered into the *Device* field.



The system value must correspond to the Device Address previously entered in the Device Addressing tab. Refer to the Setting the System Value section on page 44 for more detailed instructions on setting a system value.

3. Click the **Get IP Information** button to temporarily configure the on-board Master for DHCP usage and then read the IP Address obtained from the DHCP Server.
4. Click the **Specify IP Address** radio button from the IP Address section. With this action, all IP fields become editable.
5. Verify that **NetLinx** appears in the *Host Name* field (*if not, then enter it in at this time*).
6. Enter the IP Address, Subnet Mask, and Gateway information into their respective fields.
7. Click the **Set IP Information** button to cause the on-board Master to retain this new IP Address (pre-obtained from the System Administrator).
8. Click **OK** to accept the change to the new IP/DNS information.
9. Click the **Reboot Master** button and select **Yes** to close the Network Addresses dialog.
10. Click **Reboot** (*from the Tools > Reboot the Master Controller dialog*) and wait for the System Master to reboot and retain the newly obtained DHCP Address. *The STATUS and OUTPUT LEDs should begin to alternately blink during the incorporation. Wait until the STATUS LED is the only LED to blink.*
11. Press **Done** once until the *Master Reboot Status* field reads **Reboot of System Complete**.



Verify that these IP values are also entered into the related fields within either the IP Settings section of the System Connection page (on the touch panel) or within the Address field on the web browser.

12. Complete the communication process by continuing on to the *Communicating with the NI Device via an IP* section on page 51.

Communicating with the NI Device via an IP

Whether the on-board Master's IP Address was Static Set (Set IP Info) or Dynamically obtained (Get IP Info), use the IP Address information from the Network Addresses dialog to establish communication via the Ethernet-connected Integrated Controller.

1. Launch NetLinx Studio 2.4 (default location is **Start > Programs > AMX Control Disc > NetLinx Studio 2 > NetLinx Studio 2**).
2. Obtain the IP Address of the Master from your System Administrator or if you still do not have an IP Address:
 - Follow the steps outlined in either the *Obtaining the Master's IP Address (using DHCP)* section on page 49 or *Assigning a Static IP to the NetLinx Master* section on page 50.
3. Select **Settings > Master Communication Settings** from the Main menu to open the Master Communication Settings dialog (FIG. 38).
4. Click the **Communications Settings** button to open the Communications Settings dialog.

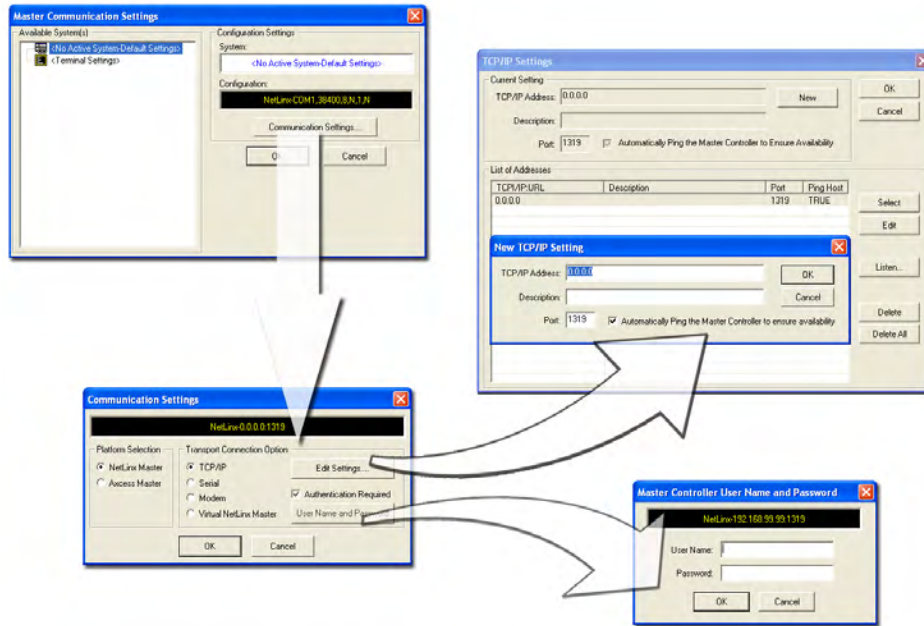

FIG. 38 Assigning Master Communication Settings and TCP/IP Settings

5. Click on the **NetLinx Master** radio button (from the *Platform Selection* section) to indicate you are working with a NetLinx Master (such as the NXC-ME260/64 or NI-Series of Integrated Controllers).
6. Click on the **TCP/IP** radio button (from the *Transport Connection Option* section) to indicate you are connecting to the Master via an IP Address.
7. Click the **Edit Settings** button (on the *Communications Settings* dialog) to open the TCP/IP Settings dialog (FIG. 38). This dialog contains a series of previously entered IP Address/URLs and their associated names, all of which are stored within Studio and are user-editable.
8. Click the **New** button to open the New TCP/IP Settings dialog where you can enter both a previously obtained DHCP or Static IP Address and an associated description for the connection into their respective fields.
9. Place a checkmark within the *Automatically Ping the Master Controller to ensure availability* radio box to make sure the Master is initially responding online before establishing full communication.
10. Click **OK** to close the current New TCP/IP Settings dialog and return to the previous TCP/IP Settings dialog where you must locate your new entry within the List of Addresses section.
11. Click the **Select** button to make that the currently used IP Address communication parameter.
12. Click **OK** to return to the Communications Settings dialog and place a checkmark within the *Authentication Required* radio box if your Master has been previously secured with a username/password.
13. Click on the **Authentication Required** radio box (if the Master is secured) and then press the **User Name and Password** button to open the Master Controller User Name and Password dialog.
14. Within this dialog, you must enter a previously configured username and password (with sufficient rights) before being able to successfully connect to the Master.

15. Click **OK** to save your newly entered information and return to the previous Communication Settings dialog where you must click **OK** again to begin the communication process to your Master.



If you are currently connected to the assigned Master, a popup asks whether you would want to temporarily stop communication to the Master and apply the new settings.

16. Click **Yes** to interrupt the current communication from the Master and apply the new settings.
17. Once the particular System Master is configured for communication via an IP Address, remove the DB9 connector from the Program port on the NI on-board Master.
18. Click **Reboot** (from the Tools > Reboot the Master Controller dialog) and wait for the System Master to reboot. *The STATUS and OUTPUT LEDs should begin to alternately blink during the incorporation. Wait until the STATUS LED is the only LED to blink.*
19. Press **Done** once until the Master Reboot Status field reads **Reboot of System Complete**.
20. Click the **OnLine Tree** tab in the Workspace window to view the devices on the System. *The default System value is one (1).*
21. Right-click the associated System number and select **Refresh System**. This establishes a new connection to the specified System and populates the list with devices on that system. *The communication method is then highlighted in green on the bottom of the NetLinx Studio window.*



*If the connection fails to establish, a Connection Failed dialog appears. Try selecting a different IP Address if communication fails. Press the **Retry** button to reconnect using the same communication parameters. Press the **Change** button to alter your communication parameters and repeat steps 4 thru 18.*

Verifying the current version of NetLinx Master Firmware

All NI Controllers contain both an on-board NI Master and an Integrated Controller. If you are using an NI-4000 or NI-4100 with installed NXC cards, these will also show up within the Online Tree tab.

- The on-board Master shows up within the Online Tree as **00000 NI Master**
- The Integrated Controller of the NI unit shows up as **0XXXX NI-XXXX** (ex: **050001 NI-700**)

Each of these components has its own corresponding firmware shown in parenthesis ().

1. After Studio has establish a connection to the target Master, click on the **OnLine Tree** tab in the Workspace window to view the devices on the System. *The default System value is one (1).*
2. Right-click the associated System number and select **Refresh System**. This establishes a new connection to the specified System and populates the list with devices on that system. *The communication method is highlighted in green on the bottom of the NetLinx Studio window.*



*The current installed firmware version of the on-board NI Master is displayed to the right of the device within the Online Tree tab as **00000 NI Master**.*

- After the Communication Verification dialog window indicates active communication between the PC and the Master, verify the NetLinx Master (**00000 NI Master**) appears within the **OnLine Tree** tab of the Workspace window (FIG. 39).

The default NI Master value is zero (00000) and cannot be changed.

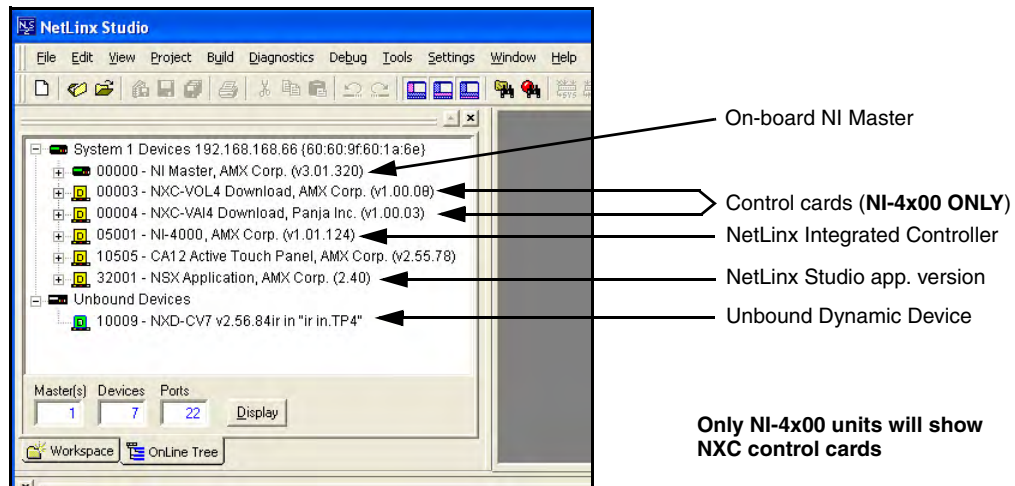

FIG. 39 Sample NetLinx Workspace window (showing OnLine Tree tab)

- If either the on-board NI Master or Integrated Controller is not the latest firmware version, follow the procedures outlined in the following sections to obtain these Kit files from **www.amx.com** and then transfer the new firmware Kit files to the device.

Upgrading the On-board Master Firmware via an IP

The on-board Master firmware Kit file is not the same as the Integrated Controller Kit file. Below is a table outlining the current sets of on-board Master and Integrated Controller Kit files used by the NI-Series of products:

Firmware Kit File usage for NI Controllers	
NI-4000 (FG2105)	On-board Master Kit file: 2105_NI-X000_Master
	Integrated Controller Kit file: 2105_NI-X000
NI-3000 (FG2105-02)	On-board Master Kit file: 2105_NI-X000_Master
	Integrated Controller Kit file: 2105_NI-X000
NI-2000 (FG2105-01)	On-board Master Kit file: 2105_NI-X000_Master
	Integrated Controller Kit file: 2105_NI-X000
NI-4100 (FG2105-06)	On-board Master Kit file: 2105_04_NI-X100_Master
	Integrated Controller Kit file: 2105_04_NI-X100
NI-3100 (FG2105-05/15)	On-board Master Kit file: 2105_04_NI-X100_Master
	Integrated Controller Kit file: 2105_04_NI-X100
NI-2100 (FG2105-04/14)	On-board Master Kit file: 2105_04_NI-X100_Master
	Integrated Controller Kit file: 2105_04_NI-X100
NI-700 (FG2105-03)	On-board Master Kit file: 2105-03_NI-X000_Master
	Integrated Controller Kit file: 2105-03_NI_X00
NI-900 (FG2105-09)	On-board Master Kit file: 2105-03_NI-X000_Master
	Integrated Controller Kit file: 2105-09_NI_X00



Only Master firmware Kit files use the word `_Master` in the Kit file name.

1. Follow the procedures outlined within the *Communicating with the NI Device via an IP* section on page 51 to connect to the target NI device via the web.
2. After Studio has established a connection to the target Master, click the **OnLine Tree** tab of the Workspace window to view the devices on the System. *The default System value is one (1).*
3. Right-click the associated System number and select **Refresh System**. This establishes a new connection to the specified System and populates the list with devices on that system. *The communication method is highlighted in green on the bottom of the NetLinx Studio window.*
4. After the Communication Verification dialog window verifies active communication between the PC and the Master, verify the NetLinx Master (**00000 NI Master**) appears in the **OnLine Tree** tab of the Workspace window. *The default NI Master value is zero (00000).*



First upgrade of the on-board Master using the Master's Kit file.

The Integrated Controller can later be upgraded using the Controller's Kit file.

BOTH Kits should be used when upgrading any firmware associated with the Integrated Controllers.

5. If the on-board Master firmware being used is not current, download the latest Kit file by first logging in to **www.amx.com** and then navigating to **Tech Center > Firmware Files**, where you can locate the desired file from within the NetLinx section of the web page.
6. Click on the desired Kit file link and after you've accepted the Licensing Agreement, verify you have downloaded the correct NI Master firmware (Kit) file to a known location.
7. From within Studio, select **Tools > Firmware Transfers > Send to NetLinx Device** from the Main menu to open the Send to NetLinx Device dialog (FIG. 40). Verify the target's System number matches the value listed within the active System folder in the **OnLine Tree** tab of the Workspace. **The Device number is always 0 for the NI Master.**
8. Select the NI Master's Kit file from the **Files** section (FIG. 40).

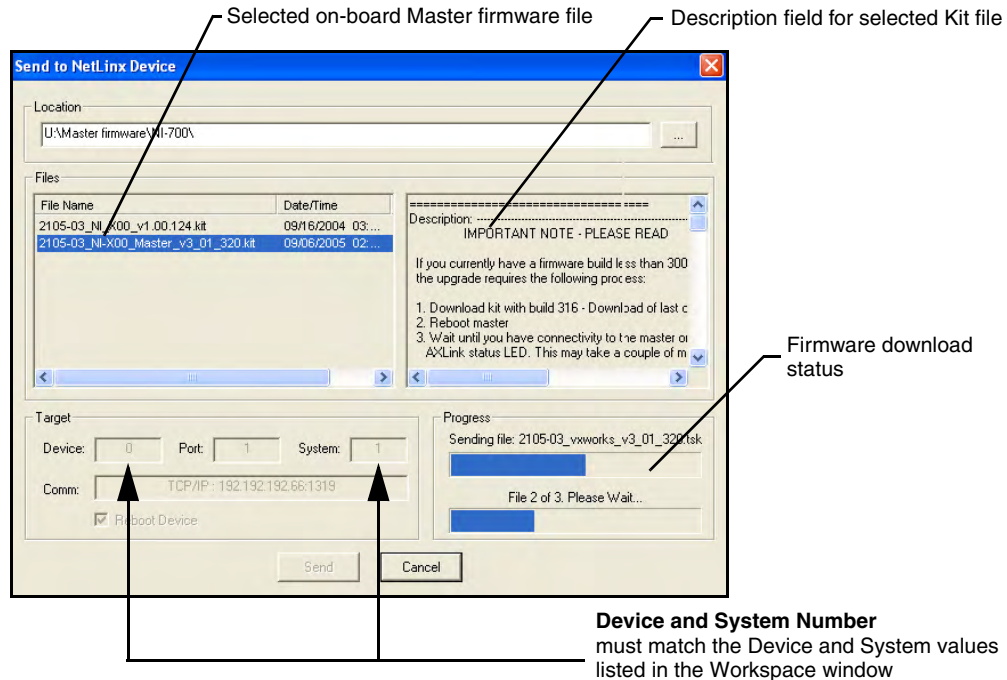

FIG. 40 Send to NetLinX Device dialog (showing on-board NI_Master firmware update via IP)



The Kit file for the NI-2000/3000/4000 Series of NI Masters begins with **2105_NI-X000_Master**.

The Kit file for the NI-2100/3100/4100 Series of NI Masters begins with **2105_04_NI-X100_Master**.

The Kit file for the NI-700/900 Series of NI Masters begins with **2105-03_NI-X000_Master**.

DO NOT use the 2105-03_NI_Master Kit file on anything other than an NI-700/900 since each Master Kit file is specifically configured to function on a specific NI unit.

9. Enter the **System** number associated with the target Master (listed in the *OnLine Tree* tab of the *Workspace* window) and verify the **Device** number value. The **Port** field is greyed-out.

- **The Device number is always 0 for the NI Master.**

10. Click the **Reboot Device** checkbox to reboot the NI unit after the firmware update process is complete.

11. Click **Send** to begin the transfer. The file transfer progress is indicated on the bottom-right of the dialog (FIG. 40).



Only upon the initial installation of a new Kit file to an on-board Master will there be a error message displayed indicating a failure of the last component to successfully download.

This is part of the NI Master update procedure and requires that the firmware be reloaded after a reboot of the unit. This consecutive process installs the final component of the new Kit file.

12. After the last components fails to install, click **Done**.

13. Click **Reboot** (from the *Tools > Reboot the Master Controller* dialog) and wait for the System Master to reboot. *The STATUS and OUTPUT LEDs should begin to alternately blink during the incorporation. Wait until the STATUS LED is the only LED to blink.*
14. Press **Done** once until the *Master Reboot Status* field reads **Reboot of System Complete**.
15. Repeat steps 5 - 9 again (the last component will now successfully be installed).
16. Click **Close** once the download process is complete.



The OUTPUT and INPUT LEDs alternately blink to indicate the on-board Master is incorporating the new firmware. Allow the Master 20 - 30 seconds to reboot and fully restart.

17. Right-click the System number and select **Refresh System**. This establishes a new connection to the System and populates the list with the current devices (*and their firmware versions*) on your system.

Upgrading the NI Controller Firmware via IP

1. Follow the procedures outlined within the *Communicating with the NI Device via an IP* section on page 51 to connect to the target NI device via the web.
2. After Studio has established a connection to the target Master, click the **OnLine Tree** tab of the Workspace window to view the devices on the System. *The default System value is one (1).*
3. Right-click the associated System number and select **Refresh System**. This establishes a new connection to the specified System and populates the list with devices on that system. *The communication method is highlighted in green on the bottom of the NetLinx Studio window.*
4. After the Communication Verification dialog window verifies active communication between the PC and the NI unit, verify the Integrated Controller (*NI-X00 or NI-Xx00*) appears in the **OnLine Tree** tab (FIG. 41) of the Workspace window (*ex: NI-4000 or NI-700*). This entry is different than the NI Master which uses a device value of *00000* (see below):

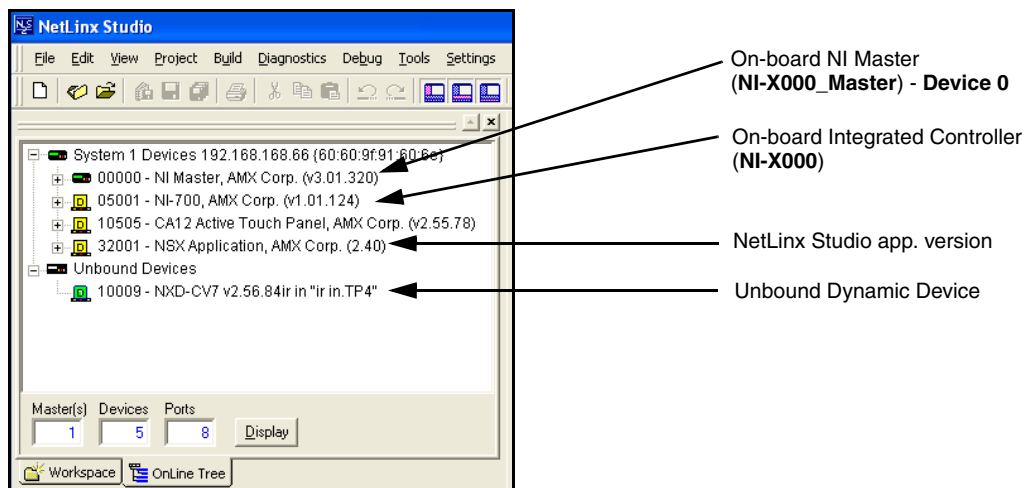

FIG. 41 Sample NetLinx Workspace window (showing SEPERATE NI-Master and Controller)

5. If the NI Controller firmware being used is not current, download the latest Kit file by first logging in to **www.amx.com** and then navigating to **Tech Center > Firmware Files**, where you can locate the desired file from within the *NI Series Device* (Integrated Controller) section of the web page.
6. Click on the desired Kit file link and after you've accepted the Licensing Agreement, verify you have downloaded the Integrated Controller firmware (Kit) file to a known location.
7. From within Studio, select **Tools > Firmware Transfers > Send to NetLinx Device** from the Main menu to open the Send to NetLinx Device dialog (FIG. 42). Verify the target's System number matches the value listed within the active System folder in the **OnLine Tree** tab of the Workspace. **The Device must match the entry for the on-board Integrated Controller (NI-X000/NI-X000) device.**

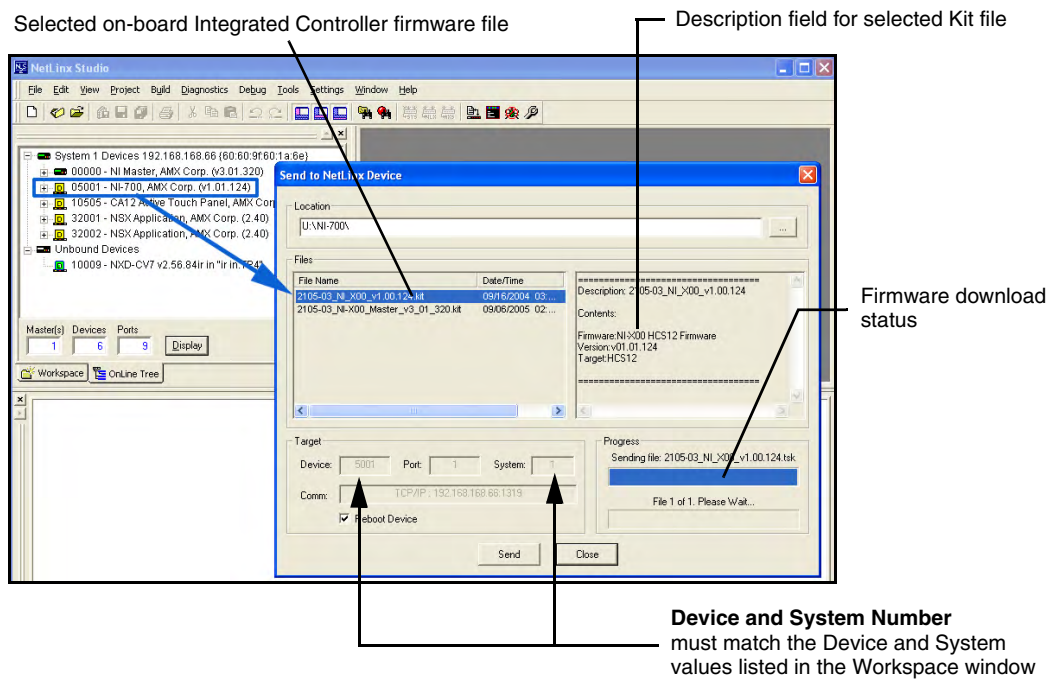

FIG. 42 Send to NetLinx Device dialog (showing on-board Integrated Controller firmware update via IP)



The Kit file for the Integrated Controller on the NI-2000/3000/4000 Series begins with **2105_NI_X000**.

The Kit file for the Integrated Controller on the NI-2100/3100/4100 Series begins with **2105_04_NI_X100**.

The Kit file for the NI-700/900 Series begins with **2105-03_NI_X000**

DO NOT use the 2105-03_NI_X00 Kit file on anything other than an NI-700/900 since each Kit file is specifically configured to function on a specific NI unit.

8. Select the Integrated Controller's (**_X00**) from the **Files** section (FIG. 42).
9. Enter the **System** and **Device** numbers associated with the target Master (*listed in the Workspace window*). *The Port field is greyed-out.*
10. Click the **Reboot Device** checkbox to reboot the NI unit after the firmware update process is complete.

11. Click **Send** to begin the transfer. The file transfer progress is indicated on the bottom-right of the dialog (FIG. 42).
12. Click **Close** once the download process is complete.



NOTE

The **OUTPUT** and **INPUT** LEDs alternately blink to indicate the unit is incorporating the new firmware. Allow the unit 20 - 30 seconds to reboot and fully restart.

13. Right-click the System number and select **Refresh System**. This establishes a new connection to the System and populates the list with the current devices (*and their firmware versions*) on your system.



NOTE

If the connection fails to establish, a *Connection Failed* dialog appears. Try selecting a different IP Address if communication fails. Press the **Retry** button to reconnect using the same communication parameters. Press the **Change** button to alter your communication parameters and repeat steps 2 thru 11.

Upgrading the NXC Card Firmware via IP (NI-4x00 ONLY)

Before beginning with this section, verify that both the on-board Master and on-board Integrated Controller have been updated with the latest firmware and that the NetLinx cards are securely inserted into the NI-4000 or NI-4100.

1. Follow the procedures outlined within the *Communicating with the NI Device via an IP* section on page 51 to connect to the target NI device via the web.
2. After Studio has established a connection to the target Master, click the **OnLine Tree** tab of the Workspace window to view the devices on the System. *The default System value is one (1).*
3. Right-click the associated System number and select **Refresh System**. This establishes a new connection to the specified System and populates the list with devices on that system. *The communication method is highlighted in green on the bottom of the NetLinx Studio window.*
4. After the Communication Verification dialog window verifies active communication between the PC and the NI unit, verify the NetLinx NXC Control Cards appear in the **OnLine Tree** tab of the Workspace window (FIG. 43).

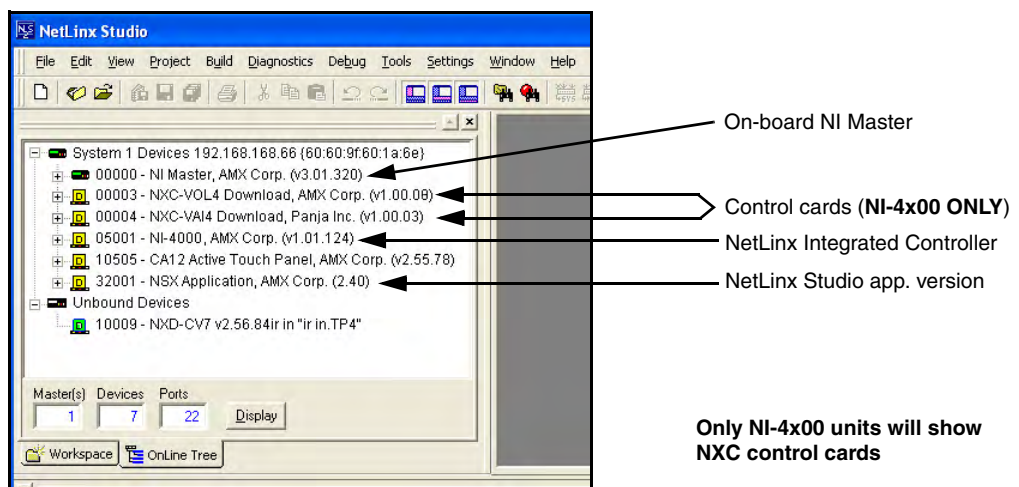

FIG. 43 Sample NetLinx Workspace window (showing OnLine Tree tab)



If the control card firmware is not up to date; download the latest firmware file from **www.amx.com > Tech Center > Downloadable Files > Firmware Files > NXC-XXX**.

In this example, the NXC-VOL card contains out-of-date firmware and requires build 1.00.09.

5. If the NXC card firmware being used is not current, download the firmware file by first logging in to **www.amx.com** and then navigate to **Tech Center > Firmware Files** and from within the NetLinX section of the web page locate the NXC card entries.
6. Click on the desired Kit file link and after you've accepted the Licensing Agreement, verify you have downloaded the NetLinX NXC card firmware (Kit) file to a known location.
7. Verify you have downloaded the latest NetLinX Control Card firmware (Kit) file to a known location.
8. Select **Tools > Firmware Transfers > Send to NetLinX Device** from the Main menu to open the Send to NetLinX Device dialog (FIG. 44). Verify the target's **Device and System** numbers matches the value listed within the System folder in the Workspace window.

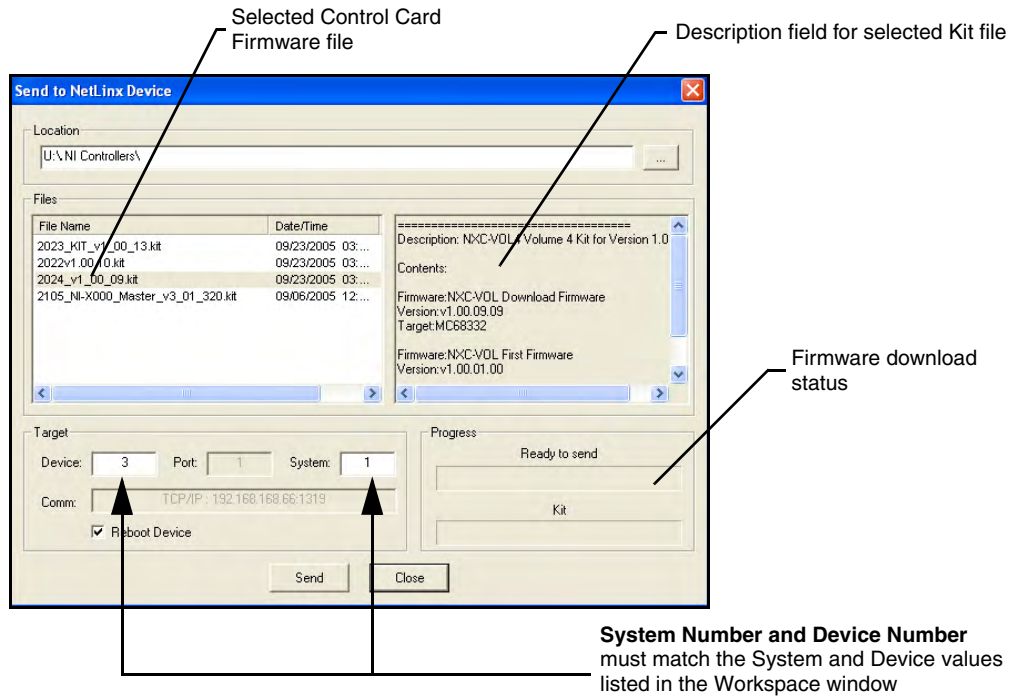

FIG. 44 Select Control Card firmware file for download page (via IP)

9. Select the Control Card's Kit file from the **Files** section (FIG. 44) (in our above example we chose to update the NXC-VOLA card).
10. Enter the **System** and **Device** numbers associated with the desired Master (listed in the Workspace window). A device value of **00003** is the same as a value of **3**.
11. Click the **Reboot Device** checkbox to reboot the NI unit after the firmware update process is complete and then re-detect the new NXC card firmware.
12. Click **Send** to begin the transfer. The file transfer progress is indicated on the bottom-right of the dialog (FIG. 44).

13. Click **Close** once the download process is complete.
14. Click **Reboot** (from the *Tools > Reboot the Master Controller* dialog) and wait for the System Master to reboot. *The STATUS and OUTPUT LEDs should begin to alternately blink during the incorporation. Wait until the STATUS LED is the only LED to blink.*
15. Press **Done** once until the *Master Reboot Status* field reads **Reboot of System Complete**.
16. Cycle power to the Integrated Controller (unplug and reconnect power to the unit).



This process of cycling power acts to reset the updated NetLinx Control Card and detect its new firmware update. It also serves to allow the Integrated Controller to detect and reflect the new firmware on the card to the NetLinx Studio display on the Workspace window.

17. After Studio has establish a connection to the target Master, click the **OnLine Tree** tab of the Workspace window to view the devices on the System. *The default System value is one (1).*
18. Right-click the associated System number and select **Refresh System**. This establishes a new connection to the specified System and populates the list with devices on that system. *The communication method is highlighted in green on the bottom of the NetLinx Studio window.*

NetLinX Security within the Web Server

NetLinX Masters (installed with firmware **build 300** or higher) incorporate new built-in security for: HTTPS and Terminal sessions (*enhanced with SSL and SSH respectively*), ICSP data verification/encryption, and Server Port configuration. By using both SSL certificate verification and encryption over a *secured HTTP* (HTTPS) connection; this version of NetLinX firmware provides users with a more convenient web-based method of securing both the Master and its data communications. Additional features in this release are the use of both authentication protocols and the ability to perform online NetLinX Diagnostics via the web server.

Terminal setup and security configuration is still valid and supported in this build of the NetLinX Master firmware.



*After the installation of **build 300 or higher** to your Master, Telnet security configuration access is disabled and the Master becomes capable of communicating via an HTTPS connection. This new build migrates the NetLinX Master security setup from a TELNET environment to a secure web-based application.*

If your Master is using a lower firmware version, please review the related product documentation located within the Archived Manuals section of the AMX Technical Publications support page.

This NetLinX Web Server is used to power Master security, data encryption, and SSL certificate/encryption features on current AMX Masters such as the ME260/64 and NI-Series of Controllers. This web server not only provides username and password security for the target Master, but also a new level of secure encryption for ICSP data communication among the various AMX software and hardware components. New security features for the Masters include:

- Enhanced Username and Password requirements
- HTTPS and SSL certificate interaction
- Use of a pre-installed AMX SSL certificate
- ICSP communication and encryption

The first layer of security for the Master is to prompt a user to enter a valid username and password before gaining access to a secured feature on the target Master. This data is pre-configured by the administrator within the Group and User Level pages of the Security section. **If an option is enabled within the System Security page**, a user is prompted to enter a valid username and password before gaining access to the corresponding feature. This access is only granted if their information matches a previously created profile assigned sufficient rights for that action. An already logged in user can enter a new profile by using the *Login* field to enter a new profile's username and profile.

- This username and password information is also used by both G4 touch panels (within the System Connection firmware page) and AMX software applications such as NetLinX Studio v 2.4 (via the Master Communications dialog) to communicate securely with a Master using encrypted communication.

The second layer of security uses a combination of *secure HTTP* (HTTPS) communication and SSL encryption to secure data being transferred from the web server application and the target Master.

To ensure this higher degree of security on the Master, an administrator can disable the HTTP Port access, enable HTTPS Port access (both from within the same **Manage System > Server** page), and then alter the level of encryption on the current SSL Certificate to meet their security needs.

- **SSL (Secure Sockets Layer)** is a protocol that works by encrypting data being transferred over an HTTPS connection. URLs that require a secure connection begin with **https:** instead of **http:** (in the browser's *Address* field). These security capabilities are configured to function via a web session within your browser. The encryption level (64 or 128-bit) achieved over the HTTPS Port is done via the SSL Certificate currently in use on the target Master. Whereas SSL creates a secure connection between a client and a server, over which any amount of data can be sent securely, HTTPS is designed to transmit individual messages securely. Therefore both HTTPS and SSL can be seen as complementary and are configured to communicate over the same port on the Master.

The third layer of protection is an SSL Certificate (specifically identifying the target Master and using a unique key to encrypt data). SSL works by using a private key to encrypt data that's transferred over the SSL connection. By default, current Masters are shipped with a default AMX SSL certificate called *sslexample.amx.com*. This pre-configured certificate can be used as a road-map to create your own certificate. The Master's SSL certificate can be either requested (from an external CA) or self-generated, and then installed/imported onto the target Master (*this action adds the certificate to the trusted site certificate listing within the computer's Internet browser*).

A fourth layer of security enables the encryption of data communication amongst the various AMX hardware and software components (such as between NetLinx Studio and the Master, or TPDesign4 and the touch panel (*communicating through the Master*)). Refer to the *Security Features* section on page 70 for more information.

NetLinx Security Terms

The following table lists some commonly used NetLinx Security terms:

NetLinx Security Terms	
User	A user is a single potential client of the NetLinx Master.
Administrator	An administrator has privileges to modify existing NetLinx Master access groups, users, and their rights. The administrator can also assign NetLinx communication access rights for different users or groups (ex: Telnet and HTTP access) and configure the Master's SSL server certificate.
Group	A group is a logical collection of users. Note that any properties possessed by a group (ex: access rights, directory associations, etc.) are inherited by all members of that group.
Username	A username is a valid character string (4 - 20 alpha-numeric characters) defining the user. This string is case sensitive and each username must be unique.
Group name	A group name is a valid character string (4 - 20 alpha-numeric characters) defining the group. This string is case sensitive and each group name must be unique.
Password	A password is a valid character string (4 - 20 alpha-numeric characters) to supplement the username in defining the potential client. This string is also case sensitive .
Access Rights	Each of the NetLinx Master's features has pre-defined security procedures. The access right for a particular feature determines if a user or group has access to that feature by entering a valid username and password.



NOTE

The maximum length of a username or password is 20 characters. The minimum length of a username or password is four characters. Characters such as # (pound) & (ampersand) and ' " (single and double quotes) are invalid and should not be used in usernames, group names, or passwords.

Accessing an Unsecured Master via an HTTP Address

Refer to the *Upgrading the On-board Master Firmware via an IP* section on page 54 for more detailed information on how to download the latest firmware from **www.amx.com**. This firmware build enables SSL certificate identification and encryption, HTTPS communication, ICSP data encryption, and disables the ability to alter the Master security properties via a TELNET session.



NOTE

Although Telnet security configuration access can no longer be used on a Master with this firmware, a Terminal connection (using HyperTerminal) can still be established using the Master's RS232 Program port (if the Telnet Port is enabled via the **Manage System > Server** page).

Once the Master's IP Address has been set through NetLinX Studio version 2.4 or higher:

1. Launch your web browser.
2. Enter the IP Address of the target Master (*ex: **http://198.198.99.99***) into the web browser's *Address* field.
3. Press the **Enter** key on your keyboard to begin the communication process between the target Master and your computer.
 - Initially, the Master Security option is disabled (from within the **System Security** page) and no username and password is required for access or configuration.
 - Both HTTP and HTTPS Ports are enabled by default (via the **Manage System > Server** page).
4. The first active page displayed within your open browser page is **Manage WebControl Connections**.



NOTE

Once HTTP Access is enabled for a Master; certificate verification and username and password verification must occur. Refer to the *Accessing an SSL-Enabled Master via an IP Address* section on page 130 for more information.

Browser Application Frames

A web page (FIG. 45) can be divided into separate sections or frames, each of which can be independent of one another and display their own information.

Located on the left side of the populated Browser window is the Navigation frame which allows a user to navigate throughout the application. Located on the right side of the Browser window is the Active frame which displays the pages corresponding to the currently selected option from within the Navigation frame.

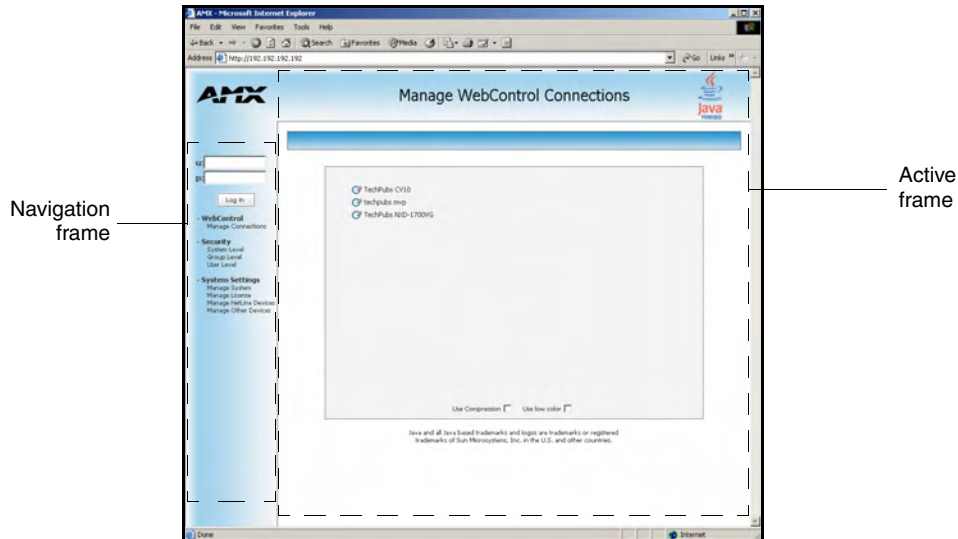

FIG. 45 Browser Application frames

The first Active frame displayed within the Browser is the Manage WebControl Connections page.

Default Security Configuration

Security for web pages is separated into two access groups: HTTP and Configuration:

- **HTTP Access** allows an authorized user to view these web pages by first requiring the entry of a username and password at the beginning of every connection session with the target Master. If **Master Security** is not enabled, the *username* and *password* fields are not displayed and the Master is openly accessible. *The Master Security configuration prevents users from altering any security or operational parameters. Unless this option is enabled, all subordinate options are inaccessible and greyed-out.*
- **Configuration** access is initially greyed-out until the Master Security option is enabled. This feature requires an authorized user provide a valid username and password before being granted access to change configuration and communication parameters on the target Master. *Only with this type of access can a user begin to alter security or operational parameters such as access rights, Port assignments, System values, and SSL certificate usage.*

If a user is not currently logged-into the Master (*via the initial Login screen*) and they attempt to access a feature wherein authentication is required, they are prompted with a message to log into the Master (*via the **Log In** button*) (FIG. 46). After the user's information and rights are confirmed, the login process is successfully completed and the button changes state and displays **Log Out**. A user must be logged into the system before their associated rights can be activated for the current session.

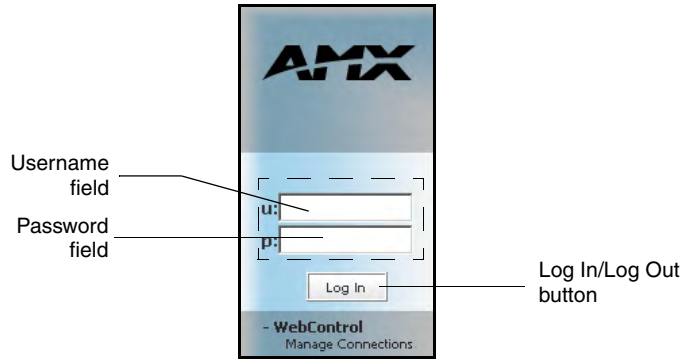

FIG. 46 Log In/Log Out fields



Authentication is based upon matching the user's data to pre-configured username and password information, and then assigning the rights assigned to that user. The maximum length of a username or password is 20 characters. The minimum length of a username or password is four characters. Characters such as # (pound) & (ampersand) and ' " (single and double quotes) are invalid and should not be used in usernames, group names, or passwords.

There is no limit to the number of concurrent logins allowed for a single user. This feature facilitates the creation of a single user (which is really an ICSP device such as a touch panel) that is provided to a number of ICSP devices using the same login to obtain access to the Master.

- As an example, if you had 50 devices connected to a Master, you would not have to create 50 individual user accounts—one for each device. Instead, you only need to create one to which all 50 devices use for access.

By default, the NetLinx Master creates the following accounts, access rights, directory associations, and security options:

Default Security Configuration (case-sensitive)		
Account 1	Account 2	Group 1
Username: administrator	Username: NetLinx	Group: administrator
Password: password	Password: password	Rights: All
Group: administrator	Group: none	Directory Association: /*
Rights: All	Rights: FTP Access	
Directory Association: /*	Directory Association: none	

Security Options: **FTP Security - Enabled**
 Admin Change Password Security - Enabled
 All other options - Disabled



By default, Master Security (and all subordinate options) are disabled. If the user/group is given FTP access rights by the administrator, all directories can become accessible (read/write/modify).

- The *administrator* user account cannot be deleted or modified with the exception of its password. Only a user with both **Configuration** access and administrator rights can alter the administrator's password.

- The *NetLinx* user account was created to be compatible with previous NetLinx Master firmware versions. This account is initially created by default and can later be deleted or modified.
- The *administrator* group account cannot be deleted or modified.

Master Firmware Security Access Parameters

- **Master Security Configuration**
- **Terminal (RS232 Program port) security**
- **HTTP (Web Server) Security** (*allows for access via a secure HTTP connection (if enabled) by requiring a username and password*)
- **Telnet Security**
- **Configuration** (*allows the alteration of current communication, system, and security settings by requiring a username and password*)
- **ICSP Connectivity** (*for AMX product communication*)
- **Encryption Requirement** (*only used if ICSP Connectivity is enabled - encrypts the data being transferred among the different AMX products*)



Installation of SSL functionality onto your Master causes security setup via Telnet to be disabled. Although Telnet security configuration access can no longer be used on the Master, a Terminal connection (using HyperTerminal) can still be established using the Master's RS232 Program port.

Web Control

This section of the Navigation frame contains the Manage Connections feature which allows control of compatible devices communicating with the target Master.

Managing WebControl Connections

This page (FIG. 47) is accessed by clicking on the **Manage connections** link. Once activated, this page displays links to G4 panels running the latest G4 Web Control feature.

If the **Master Security** and **HTTP Access** options have not been previously enabled on the target Master, a user does not need to Log into the Master to gain access to the Manage WebControl Connections page. This page allows a user to view all G4 enabled touch panels running G4 WebControl.

- To establish a secure connection between the touch panel and the target Master, the panel must be using a valid username and password (*that can be matched to a previously configured user on the target Master*) and the **ICSP Connectivity** option must be enabled within the System Level page.
- If at some later point, that user profile is removed from the Master, reboot both the panel and Master. After reboot, the connection status of the panel (from with the firmware Setup page) shows "No Encryption".

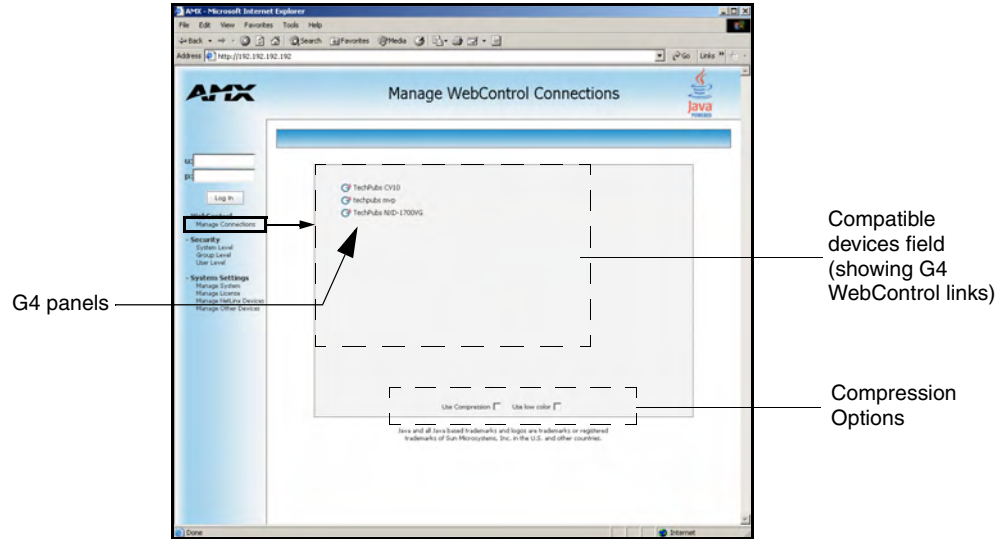

FIG. 47 Manage WebControl Connections page (populated with compatible panels)

Clicking on a G4 WebControl link opens a separate browser window which is configured to display the current information from the panel using the native resolution of the target panel.

An example is a CA15 panel link opening a new window using an 800 x 600 resolution.

The following table lists the Manage WebControl Connections page features that an administrator or other authorized user can select from:

Manage WebControl Connection Page Features	
Feature	Description
Compatible Devices Field:	This area displays G4 icons (with associated links) if a G4 panel running Web Control is communicating with the target Master.
Communication Compression Options:	Allows you to choose from among two compression options: <ul style="list-style-type: none"> • These compression settings are most useful when working either over a bandwidth-restricted network or over the Internet. • Use Compression allows the user to specify that the transmitted data packets be compressed. This speeds up the visual responses from the panel by minimizing the size of the information relayed through the web and onto the screen. • Use Low Color allows the user to specify the number of colors used to display the image from the panel be reduced. By reducing the numbers of colors, both the size of the information is reduced and the response delay is decreased.

Security Features

This section of the Navigation frame (FIG. 48) contains the NetLinx system security parameter links which allow an authorized user to define access rights at the system level and those for the various groups or users.

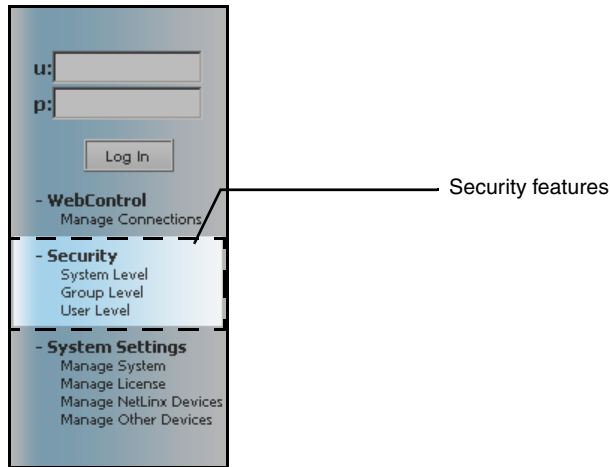

FIG. 48 System Level Security - Enable/Disable System Security page



*Security settings on related pages (such as the System Level, Group Level, and User Level) require that an authorized user be logged into the Master and have **Configuration Access** rights either directly assigned with that user or associated with the related Group.*

The following table lists the NetLinx System Security options an administrator (or other authorized user) can grant or deny access to:

Security Features	
Feature	Description
System Level:	Provides an authorized user with the ability to alter the current security options of the system assigned to the target Master.
Group Level:	Provides an authorized user with the ability to assign and alter group properties such as creating, modifying, or deleting a group's rights, and also allows for the definition of the files/directories accessible by a particular group. <ul style="list-style-type: none"> Any properties possessed by a group (access rights/directory associations, etc.) are inherited by all members of that group.
User Level:	Provides an authorized user with the ability to assign and alter user properties such as creating, modifying, or deleting a users' communication rights, and defining the files/directories accessible by a particular user.



It is recommended that the Master Security option be enabled after the groups, users, and passwords have been setup. If not, when the user accesses the Master from within another session, the default administrator username and password must be used for access.

Security - System Level Security page

To access this page, click the **Security Level** link from within the Security section of the Navigation frame. This page is strictly used to require a valid username and password be entered prior to gaining access to the listed features and options.



If the Master Security option is not selected, the Master is completely open and can be modified by anyone accessing the target Master via the web server's UI.

The options on the NetLinx Master Security page (FIG. 49) are only accessible and configurable if the **Master Security** checkbox is selected. The **Master Security** checkbox selection toggles the appearance of the NetLinx Master security options and makes them accessible. Enabling an option on this page requires that a user enter a valid username and password before they are granted access to the specific feature. Some examples are:

- Requiring verification before accessing the Master - **HTTP Access** must be enabled.
- Requiring verification before altering a current Master security setting - **Master Security** and **Configuration** must be enabled.
- Requiring verification from a communicating AMX software (such as NetLinx Studio v 2.4 or TPD4 v 2.5) before accepting communication for file/firmware transfers, the **Configuration, ICSP Connectivity** and **Require Encryption** options must be enabled.

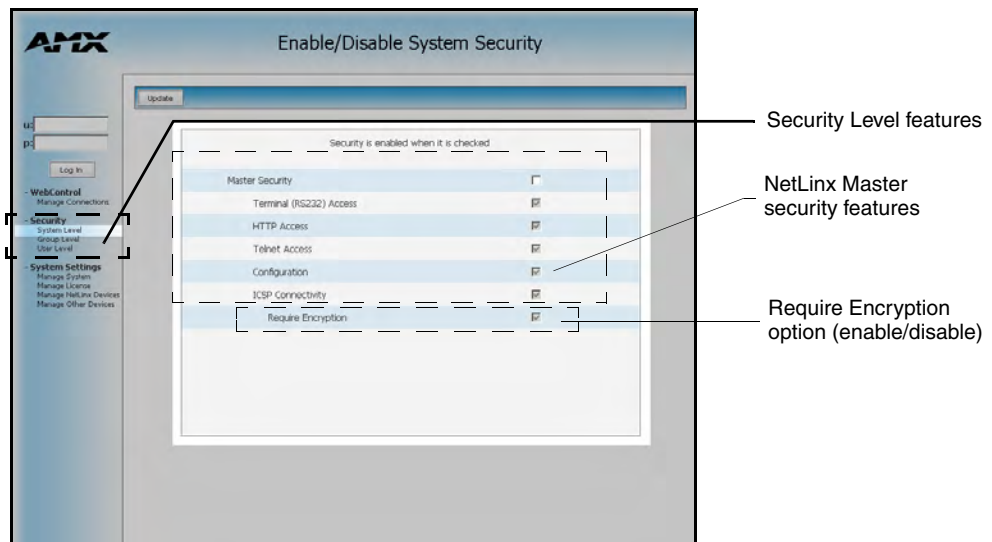

FIG. 49 System Level Security - Enable/Disable System Security page

System Level Security Page	
Feature	Description
Master Security:	<p>This option allows an authorized user to require that a valid username and password be required for access to a feature listed on this page.</p> <ul style="list-style-type: none"> • These are global options that enable or disable the login requirement for both users and groups. • If the Master Security checkbox is not enabled, all subordinate options are greyed-out and not selectable, meaning that the Master is completely unsecured and can be altered by any user (regardless of their rights).

System Level Security Page (Cont.)	
Feature	Description
Terminal (RS232) Access:	<p>This selection determines if a username and password is required for Terminal communication (<i>through the RS232 Program port</i>).</p> <ul style="list-style-type: none"> • If Terminal Security is enabled, a user must have sufficient access rights to login to a Terminal session and communicate with the Master.
HTTP Access:	<p>This selection determines if a username and password is required for communication over HTTP or HTTPS Ports (see FIG. 50).</p> <ul style="list-style-type: none"> • If enabled, a user must have sufficient access rights to browse to the NetLinx Master via a Web Browser. • Enabling this field requires the user (within a new session) submit a valid username and password before being able to view the web server pages. • If disabled, the Master is open for viewing and does not ask for this information during any consecutive sessions (until the user attempts to access a feature which is enabled within this page). • This requirement of a valid username and password affects both HTTP and HTTPS communication with the target Master using the web server.
Telnet Access:	<p>This selection determines if a username and password is required for Telnet Access (see FIG. 50).</p> <ul style="list-style-type: none"> • If Telnet access is enabled, a username and password is required before allowing communication over either the Telnet and/or SSH Ports. SSH version 2 is only supported. • This authorized user must have sufficient access rights to login through a Telnet session to the Master. • To establish a secure Telnet connection, an administrator can decide to disable the Telnet Port and then enable the SSH Port. Refer to the <i>Setting the Master's Port Configurations</i> section on page 94.
Configuration (security):	<p>This selection determines if a username and password is required before allowing a group/user to alter the current Master's security configuration and communication settings (see FIG. 50).</p> <ul style="list-style-type: none"> • Configuration access provides the user with the ability to perform configuration functions on the NetLinx system through NetLinx Studio. This includes such things as: IP configuration/Reset, URL list settings, Master communication settings, and security parameters. • If security Configuration is enabled, a user/group must have sufficient access rights to access the Main Security Menu. • Any time a configuration operation is performed, the Master verifies the current access rights for that feature and then requires a valid username and password (<i>if not already logged in</i>). - An example would be if you are trying to add a New User or modify the rights of an existing Group.

System Level Security Page (Cont.)	
Feature	Description
ICSP Connectivity:	<p>This selection determines if a username and password is required prior to communication with a target NetLinx Master via an ICSP connection using any transport method (TCP/IP, UDP/IP, and RS-232) (see FIG. 50).</p> <ul style="list-style-type: none"> • If this access is enabled and the user is not logged-in, when the user attempts to connect, the authentication fails and displays an "Access not allowed" message. • This feature allows communication amongst various AMX hardware and software components. This feature works in-tandem with the Require Encryption option to require that any application or hardware communicating with the Master must provide a valid username and password. • Refer to the <i>ICSP Authentication</i> section below for more detailed information on how the Master authenticates.
Require Encryption:	<p>Requires that any data being transmitted or received via an ICSP connection (among the various AMX products) be encrypted and that any application or hardware communicating with the Master over ICSP must provide a valid username and password.</p>

- The following graphic illustrates the Ports which can be enabled for the validation of rights by using a valid username and password. When one of the above options is enabled, the Master then requires the entry of a valid username and password to validate rights for that action and then grant or deny access.

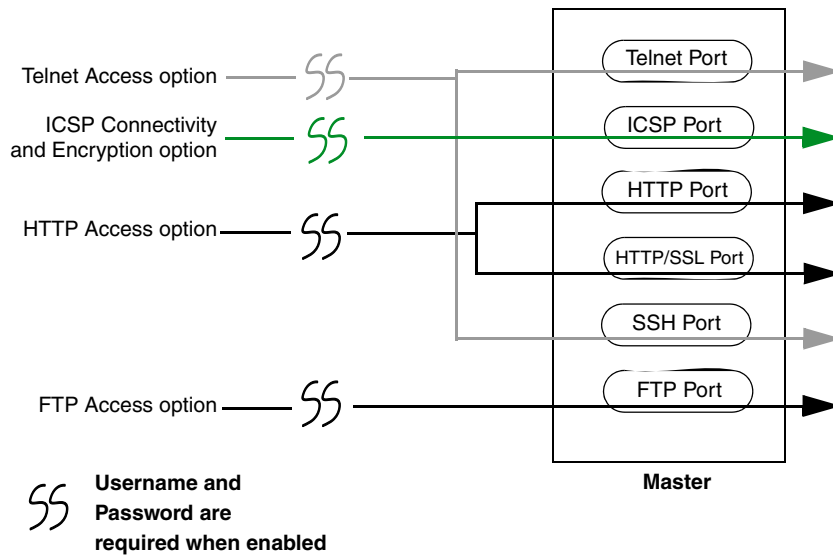

FIG. 50 Port Communication Settings

Setting the system security options for a NetLinx Master

This page simply toggles the requirement of a user to enter a valid username and password before gaining access to a particular feature. For every action, the Master validates whether a username and password are required and whether the user has sufficient rights. Refer to the *Security - Group Level Security page* section on page 76 for more information on the assignment of the Group/User rights. For example, if the user were attempting to modify the configuration parameters of the Master, their username and password must be associated with a profile which was previously granted Configuration Access privileges within the web server. If they their profile didn't have enough rights to accomplish their action an "Insufficient Rights..." message appears on top of the active page.

1. Enter the URL/IP Address of the target Master into the *Address/URL* field within the web browser. *Initially the connection is unsecured and communication can be made via an HTTP connection.* Refer to the *Accessing an Unsecured Master via an HTTP Address* section on page 65 for more detailed instructions.
2. Click the **Security Level** link (*from within the Security section of the Navigation frame*) to open the System Security page. The **Master Security** checkbox selection (FIG. 51) toggles the appearance of the NetLinx Master security options.
3. Click on the **Master Security** checkbox to access to the security parameters on the target Master and allow an authorized user (*with configuration access rights such as an Administrator*) the ability to alter the subordinate security parameters. Refer to the *Security - System Level Security page* section on page 71 for more detailed field descriptions.



Each selection simply toggles the security setting from enabled to disabled. By default, the Master Security option is disabled (unchecked), including the subordinate Master Security components (even though they might show a checkmark, they are greyed-out). An open Master does not require a user to enter a valid username and password.

4. Click on (*enable*) the desired access parameters and configuration checkboxes necessary to require user validation prior to usage.

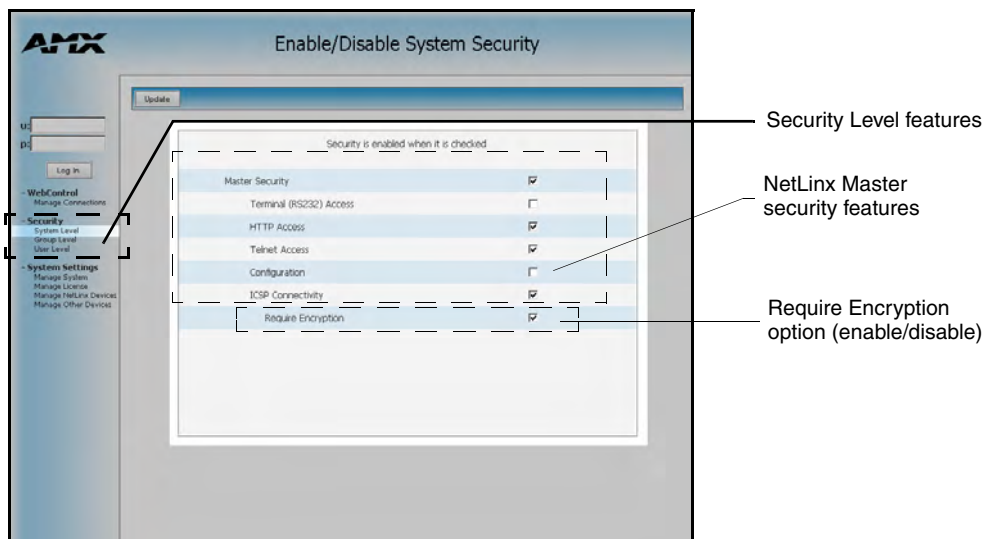

FIG. 51 System Level Security - Enable/Disable System Security page with selections

- Enabling the Terminal, HTTP, and Telnet Access options require that a valid username and password be entered prior to gaining access to the desired action. **If the HTTP Access option is enabled, upon the initial connection to the Master (via the web browser) the Login page appears and requires a valid username and password be entered before allowing access to the web server pages.**
 - Enabling the Configuration option requires that the user be logged in and their rights validated before allowing any modification to the current Master security configuration and communication parameters. **If the Configuration option is enabled and the user wants to modify the Master's IP Address; they would either be prompted to log in (via the Login button) or if already logged in, notified whether their rights are sufficient to allow them to change the current parameter.**
 - The **ICSP Connectivity** option is required to allow authenticated and/or secure communication between the Master and other AMX hardware/software. To establish an authenticated ICSP connection (where the external AMX hardware/software would have to provide a valid username and password). This option **must be enabled** (checked).
5. Click on the checkbox next to **Require Encryption** to enable the requirement of data encryption over the ICSP connection. Note that this is optional and if enabled, requires more processor cycles to maintain.
 6. Click the **Update** button to accept and save any changes on this page back to the Master. Updating these changes is instantaneous and does not require a reboot. Successful incorporation of the changes to the Master's security configurations results in an on-screen message stating: *"Security is enabled when it is checked"*.



NOTE

A Group represents a logical collection of individual users. Any properties possessed by a group (ex: access rights, directory associations, etc.) are inherited by all members of that group.

The "administrator" group account cannot be deleted or modified.

ICSP Authentication

In a Master-to-Master system, the Master which accepts the IP connection initiates the authentication process. This configuration provides compatibility with existing implementations and provides more flexibility for the implementation of other devices.

Security - Group Level Security page

To access this page, click the **Group Level** link (from within the Security section of the Navigation frame). This page (FIG. 52) allows an authorized user to both select and modify an existing group, delete an existing group, or add a new group. *Unless you are logged in with administrator privileges, you will not be allowed to modify the default administrator profile.*

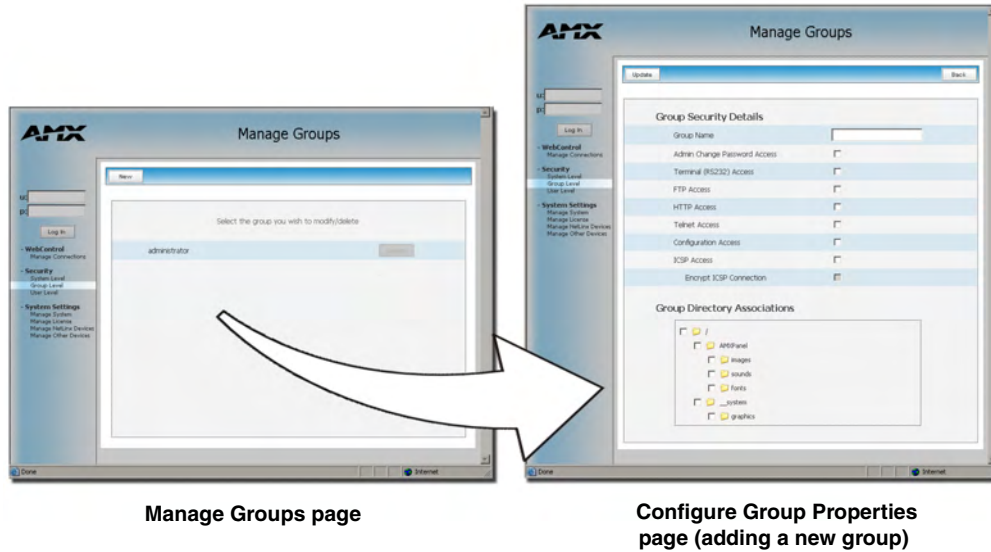

FIG. 52 Group Level Security - Manage Groups Security page

Manage Group Page	
Feature	Description
Manage Groups page:	This page allows a user to either modify the rights for a group available from the displayed list or use the New button to access a secondary window where a user can modify the rights for either the new or existing group.
New	<ul style="list-style-type: none"> Clicking this button allows a user to add a new group and configure its settings through the Configure Group Properties page.
Select	<ul style="list-style-type: none"> Clicking this button takes you to the selection's corresponding Configure Group Properties page. This button is greyed-out if the current user doesn't have the right to modify the rights for that group. <p>Note: The "administrator" group can't be modified unless you are logged in as a user with Configuration Access rights.</p>

Configure Group Properties Page	
Feature	Description
Configure Group Properties:	This page allows an authorized user to configure the options for either a pre-existing or new group. Configuration on this page consists of both the options and directories the group is granted access to.
Update	<ul style="list-style-type: none"> This button submits the modified page (form) information back to the server. If the group was successfully added after pressing the Update button; a status message of "Group XYZ was successfully added" is displayed.
Back	<ul style="list-style-type: none"> This button returns the user to the Manage Groups page.
Delete	<ul style="list-style-type: none"> This button is only available when modifying/deleting an existing group.
Group Security Details:	<ul style="list-style-type: none"> This section provides the user with several rights which can either be enabled or disabled.
Group Name	<ul style="list-style-type: none"> A valid character string defining the name of the group (4 - 20 alpha-numeric characters). The string is case sensitive and must be unique.
Admin Change Password Access	<ul style="list-style-type: none"> This selection enables or disables the group's right to change the administrator's user passwords. <p>Note: Once the Administrator's password has been changed, the default password can no longer be used to gain access.</p>
Terminal (RS232) Access	<ul style="list-style-type: none"> This selection enables or disables Terminal (RS232 Program port) Security Access for the target group.
FTP Access	<ul style="list-style-type: none"> This selection enables or disables FTP Access for the target group.
HTTP Access	<ul style="list-style-type: none"> This selection enables or disables Web Server access for the target group.
Telnet Access	<ul style="list-style-type: none"> This selection enables or disables Telnet Security access for the target group.
Configuration Access	<ul style="list-style-type: none"> This selection enables or disables the ability of a group to alter the security Configuration settings such as: - IP configuration/Reset, URL list settings, Master communication settings, and file transfers.
ICSP Access	<ul style="list-style-type: none"> This selection grants the members of this Group ICSP access. ICSP communication allows a user to connect to the target NetLinx Master via ICSP connection using any transport method (TCP/IP, UDP/IP, and RS-232).
Encrypt ICSP Connection	<ul style="list-style-type: none"> This selection enables encryption of the ICSP communication. This checkbox is greyed-out until ICSP Access is enabled.
Group/Directory Associations:	<ul style="list-style-type: none"> Provides an authorized user with a view of current directories on the target Master that are available to the selected group. A Directory Association defines the directory paths and files a particular user or group can access via the Web Server on the NetLinx Master. The displayed folders are the directory pathnames present on the target Master. These folder/files can be placed on the target Master via an FTP connection to the target Master.



NOTE

A **User** represents a single potential client of the NetLinx Master, while a **Group** represents a logical collection of users. Any properties possessed by groups (example: access rights, directory associations, etc.) are inherited by all the members of the group.

Adding a new Group

1. Click the **Group Level** link (*from within the Security section of the Navigation frame*) to open the Manage Groups page.
2. Click the **New** button to be transferred to the Configure Group Properties page (FIG. 52).
3. From within the Group Security Details section, enter a unique name for the new group. The name must be a valid character string consisting of 4 - 20 alpha-numeric characters. **The word administrator cannot be used for a new group name since it already exists by default.**
4. Enable the security access rights you want to provide to the group. By default, all of these options are disabled.
5. From within the Group Directory Associations section, place a checkmark next to the directories (available on the target Master) to provide an authorized group with access rights to the selected directories. *If you select a group directory note that all lower groups in that tree will be selected.*
6. Click the **Update** button to save your changes to the target Master. If there are no errors within any of the page parameters, a “Group added successfully” is displayed at the top of the page.
7. Click the **Back** button to return to the Manage Groups page.



NOTE

Any security changes made to the Master from within the web browser are instantly reflected within a Terminal session without the need to reboot. Security changes made to the Master from within a Terminal window are not reflected within the web browser until the Master is rebooted and the web browser connection is refreshed.

Modifying the properties of an existing Group

1. Click the **Group Level** link (*from within the Security section of the Navigation frame*) to open the Manage Groups page.



NOTE

*The fields displayed when modifying groups are the same as those available when adding a new group, except for the Group Name field which is pre-populated. The Administrator's rights are not editable and its **Select** button is greyed-out.*

2. Click the **Select** button (*next to the selected Group name*) to open the Configure Group Properties page for the particular group.
3. From within the Group Security Details section, modify the previously configured access rights by either enabling or disabling any of the available checkboxes shown within the Configure Group Properties page.
4. From within the Group Directory Associations section, place or remove any checkmarks next to the available directories to modify an authorized group's directory access rights.
5. Click the **Update** button to save your changes to the target Master. If there are no errors with the modification of any of this page's parameters, a “Group updated successfully” is displayed at the top of the page.
6. Click the **Back** button to return to the Manage Groups page.

Deleting an existing Group

1. Click the **Group Level** link (from within the Security section of the Navigation frame) to open the Manage Groups page.
2. Press the **Select** button (next to the selected Group name) to open the Configure Group Properties page (FIG. 52) for the particular group.
3. Click the **Delete** button to remove the selected group and return to the Manage Groups page.
 - If you are not logged into the Master, you receive a reminder message: "You must login before Security Settings can be changed".
 - Log into the Master and repeat the previous steps.
 - If the group is associated with several users, you might get an error while trying to delete the group. If this happens, change the group association of those specific users utilizing the old group and either give them a new group or assign them (none) as a group. When you return to delete the desired group, you receive a message saying "Group deleted successfully".

Security - User Level Security page

To access this page, click on the **User Level** link (from within the Security section of the Navigation frame). This page (FIG. 53) allows an authorized user to add a user account (FIG. 30) and then assign that user's current access rights.

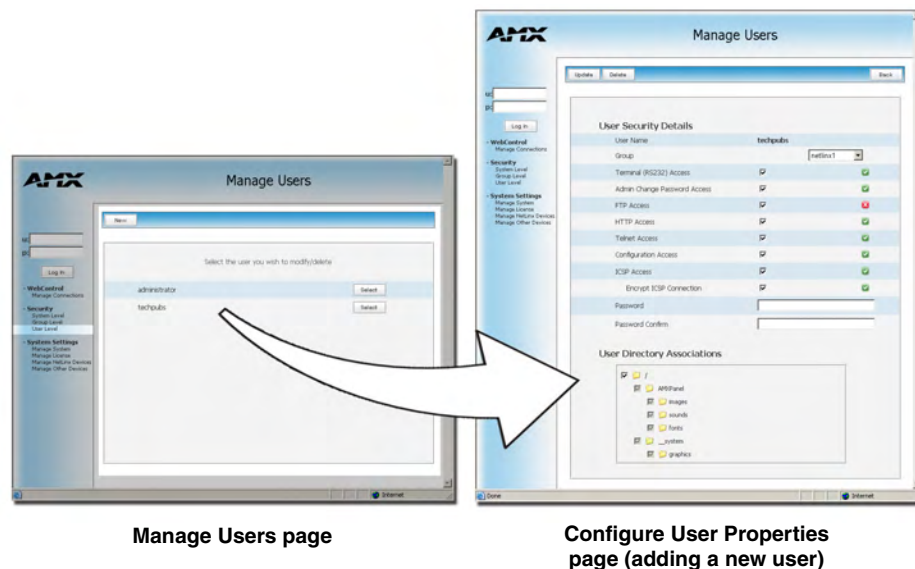

FIG. 53 User Level Security - Manage Users Security page

Manage Users Page	
Feature	Description
Manage Users page:	This page allows a user to either modify the rights for an existing user (<i>available from the displayed list</i>) or use the New button to access a secondary window where they can create a new user.
New	<ul style="list-style-type: none"> Clicking this button allows an authorized user to add a new user and configure their settings through the Configure User Properties page.
Select	<ul style="list-style-type: none"> Clicking this button takes you to the selection's corresponding Configure User Properties page. This button is greyed-out if the current authorized user doesn't have the right to modify the rights for that user.

Configure User Properties Page	
Feature	Description
Configure User Properties:	This page allows an authorized user to configure the options for either a pre-existing or new user. Configuration on this page consists of both the options and directories the user is granted access to.
Update	<ul style="list-style-type: none"> This button submits the modified page (form) information back to the server. If the user was successfully added after pressing the Update button; a status message of "User XYZ was successfully added" is displayed. Always press the Update button after making any changes to this page.
Back	<ul style="list-style-type: none"> This button returns the user to the Manage Users page.
Delete	<ul style="list-style-type: none"> This button is only available when modifying/deleting an existing user.
User Security Details:	<ul style="list-style-type: none"> This section provides the user with several rights which can either be enabled or disabled.
User Name	<ul style="list-style-type: none"> A valid character string defining the name of the user (4 - 20 alpha-numeric characters). If a user is selected from the Manage Users page, this row is populated with the name of the selected user. The string is case sensitive and must be unique.
Group	<ul style="list-style-type: none"> This drop-down list allows the user to associate a pre-defined series of Group rights to the current user profile. Once the Update button is clicked, the group rights then are transferred to the user by placing a checkmark next to those rights which are available to the associated group. Any properties possessed by groups (ex: access rights, directory associations, etc.) are inherited by users assigned to a particular group. Unchecking a security option (which is available within the associated group) does not remove that right from the user. The only way to remove a group's available security right from a target user is to either NOT associate a group to a user or to alter the security rights of the group being associated.
Terminal (RS232) Access	<ul style="list-style-type: none"> This selection enables or disables Terminal (RS232 Program port) Security Access for the target user.

Configure Users Properties Page (Cont.)	
Feature	Description
User Security Details (Cont.):	
Admin Change Password Access	<ul style="list-style-type: none"> This selection enables or disables the user's right to change the administrator's user passwords. <p>Note: Once the Administrator's password has been changed, the default password can no longer be used to gain access.</p>
FTP Access	<ul style="list-style-type: none"> This selection enables or disables FTP Access for the target user.
HTTP Access	<ul style="list-style-type: none"> This selection enables or disables Web Server access for the target user.
Telnet Access	<ul style="list-style-type: none"> This selection enables or disables Telnet Security access for the target group.
Configuration Access	<ul style="list-style-type: none"> This selection enables or disables the ability of a user to alter the global Configuration settings. Example: IP, Reset URL, etc.
ICSP Access	<ul style="list-style-type: none"> This selection grants this user ICSP access. ICSP communication allows a user to connect to the target NetLinx Master via ICSP connection using any transport method (TCP/IP, UDP/IP, and RS-232).
Encrypt ICSP Connection	<ul style="list-style-type: none"> This selection enables encryption of the ICSP communication. This checkbox is greyed-out until ICSP Access is enabled.
Password/Password Confirm	<p>Enter a password for the new user.</p> <ul style="list-style-type: none"> A user password is a valid character string (4 - 20 alpha-numeric characters) that is used to supplement the username/ID in defining the potential client. The string is case sensitive and must be unique. If this field is left blank (<i>during a user modification</i>) the current password is left unchanged. If a new alpha-numeric string is entered during modification of the user; it becomes incorporated as the new password after pressing the OK button.
User/Directory Associations:	<ul style="list-style-type: none"> Provides an authorized user with a view of current directories on the target Master that are available to the selected group. A Directory Association is a path that defines the directories and files a particular user or group can access via the Web Server on the NetLinx Master. The displayed folders are the directory pathnames present on the target Master.

Adding a new User

The information entered within this page can be used by Modero touch panels to verify and establish a secure connection by encrypting the data being transmitted between the Master and the panel. This information must be entered into the System Connection page of the panel's firmware.

1. Click the **User Level** link (*from within the Security section of the Navigation frame*) to open the Manage Users page.
2. Click the **New** button to be transferred to the Configure User Properties page (FIG. 53).
3. From within the User Security Details section, enter a unique name for the new group. The name must be a valid character string consisting of 4 - 20 alpha-numeric characters.
The usernames, administrator and NetLinx cannot be used since they already exist.
4. From within the Group drop-down list, choose from a list of pre-configured Groups and associate these rights to the new user.



NOTE

Any properties possessed by groups (ex: access rights, update rights, directory associations, etc.) are inherited by users assigned to that particular group. Unchecking a security option (which is available within the associated group) does not remove that right from the user. The only way to remove a group's available security right from a target user is to either NOT associate a group to a user or to alter the security rights of the group being associated.

5. Enable any additional security access rights you want to provide to the user. *By default, all of these options are disabled.*
6. Enter a user password within both the *Password* and *Password Confirm* fields. This password is a valid character string (4 - 20 alpha-numeric characters) that is used to supplement the username/ID in defining the potential client. The string is case sensitive.
7. From within the User Directory Associations section, place a checkmark next to the directories (on the target Master) to provide an authorized user with access rights to them.
8. Click the **Update** button to save your changes to the target Master. If there are no errors within any of the page parameters, a “*User added successfully*” is displayed at the top of the page.
9. Click the **Back** button to return to the Manage User page.

Modifying the properties of an existing User

1. Click the **User Level** link (*from within the Security section of the Navigation frame*) to open the Manage Users page.



NOTE

The fields displayed when modifying users are the same as those available when adding a new user, except for the User Name field which is pre-populated.

2. Click the **Select** button next to the selected User's name to open the Configure User Properties page for the particular user (FIG. 54).

- From within the User Security Details section, modify any previously configured access rights by either placing or removing a checkmark from within any of the available checkboxes (FIG. 54).

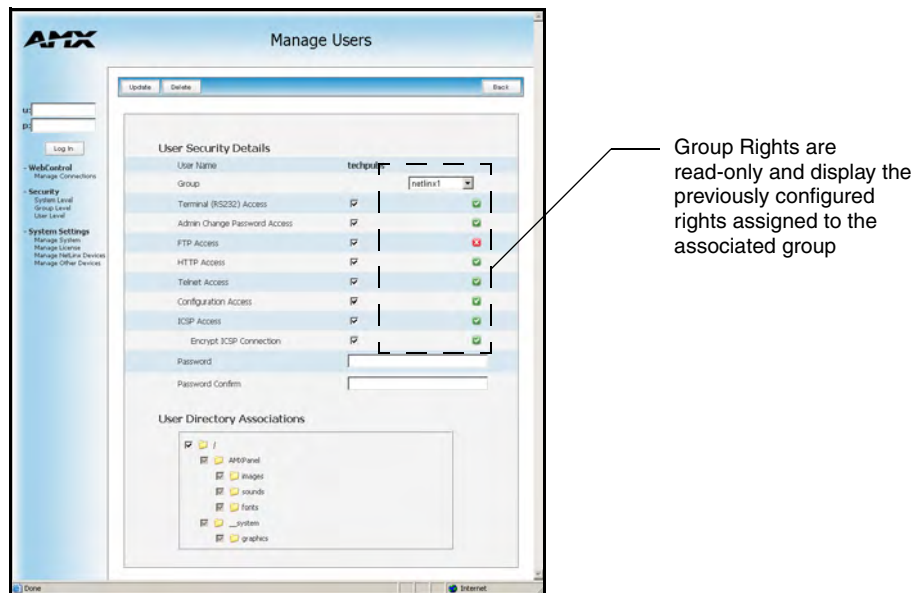

FIG. 54 User Level Security - Modifying a User's Security rights

- From within the User Directory Associations section, place or remove any checkmarks next to the available directories to modify an authorized user's directory access rights. *Removing a checkmark from any folder prohibits that user from accessing any files contained therein via the Web Server.*
- Enter the same password for the user into both the *Password* and *Password Confirm* fields, if you want to change the password. *Leaving this field blank retains the current or previous password.*
 - A user password is a valid character string (4 - 20 alpha-numeric characters) that is used to supplement the Username/ID in defining the potential client. The string is case sensitive.
- Click the **Update** button to save your changes to the target Master. If there are no errors with the modification of any of this page's parameters, a "*User updated successfully*" is displayed at the top of the page.
- Click the **Back** button to return to the Manage Users page.

Deleting an existing User

- Click on the **User Level** link (*from within the Security section of the Navigation frame*) to open the Manage Users page.
- Press the **Select** button next to the selected Username to open the Configure User Properties page (FIG. 53) for the particular user.
- Click the **Delete** button to remove the selected user and return to the Manage Users page.



The **NetLinx** account can be deleted from **Manage User** page. **The administrator account can not be deleted nor can it have it's directory associations modified.**

System Settings

This section of the Navigation frame (FIG. 55) provides the ability to both manage existing and pending license keys, manage the active NetLinx system communication parameters, and configure/modify the SSL certificates on the target Master.

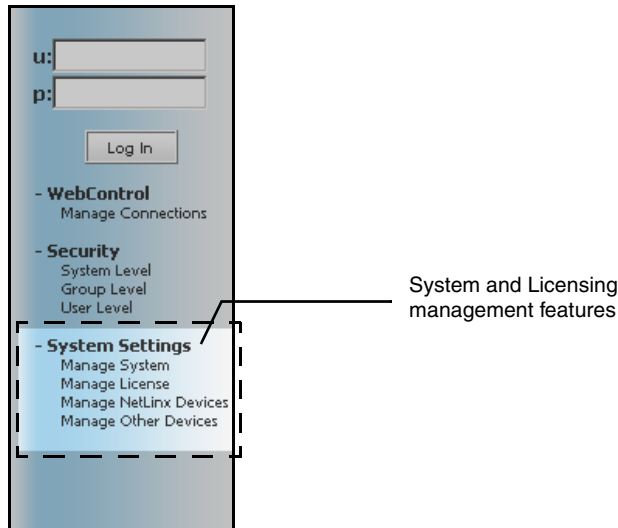

FIG. 55 System Settings - System an Licensing Management

System Settings - Manage System page

To view all of the available options within the right frame, it is recommended that you maximize the browser window.

To access this page (FIG. 56), click on the **Manage System** link (from within the **System Settings** section of the **Navigation** frame).

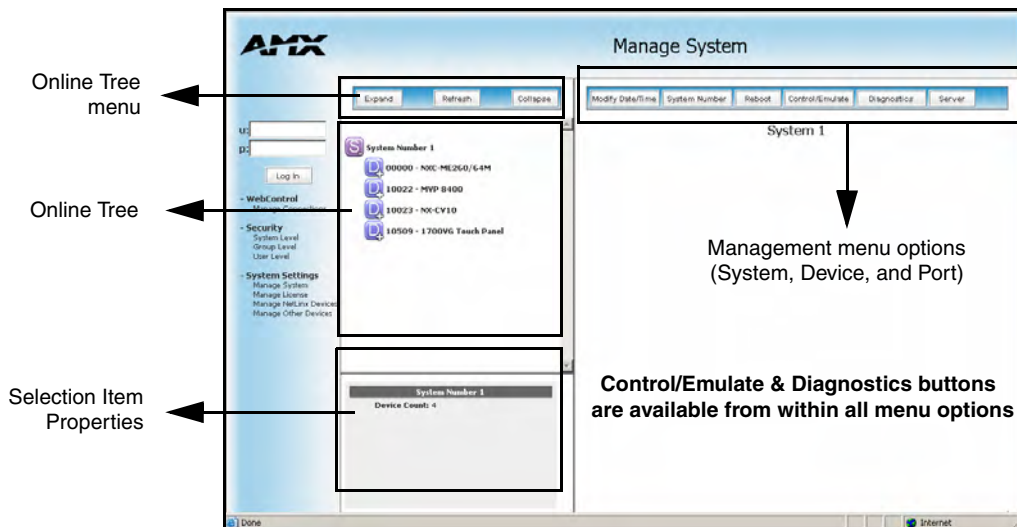

FIG. 56 System Settings - Manage System page

Manage System Page Components	
Feature	Description
Online Tree menu:	<p>The Online Tree menu contains button options relating to the entries within the Online Tree.</p> <ul style="list-style-type: none"> • Expand - Expands the selected level to expose any subfolders. • Refresh - Refreshes the contents of the Online Tree frame. • Collapse - Collapses the selected level to hide any subfolders.
Online Tree:	<p>This frame displays a snapshot list of devices detected as currently online by the Master (<i>and the firmware version for each</i>).</p> <ul style="list-style-type: none"> • By default, the Tree view begins fully collapsed. • The online devices are organized according to the System they belong to. • Double-click any System icon (FIG. 57) to display a list of devices that are currently online, within that System. • Double-clicking on any of the colored blocks causes that section of the Tree to expand. <p><i>Note: Sub-devices are hardware components contained within a parent device, which may require their own firmware. Refreshing/Rebooting the Master updates this Online Tree.</i></p>
Selection Item Properties:	<p>This frame displays the properties of the last selected (clicked) item from the Online Tree.</p> <ul style="list-style-type: none"> • Commands and Strings are not displayed, but a user is directed to the Control/Emulate window. • Channel properties show a list of all channels within the range available to the port. Clicking a channel takes the user to the Control/Emulate window where information such as the channel, System, Device, and Port are already pre-populated.

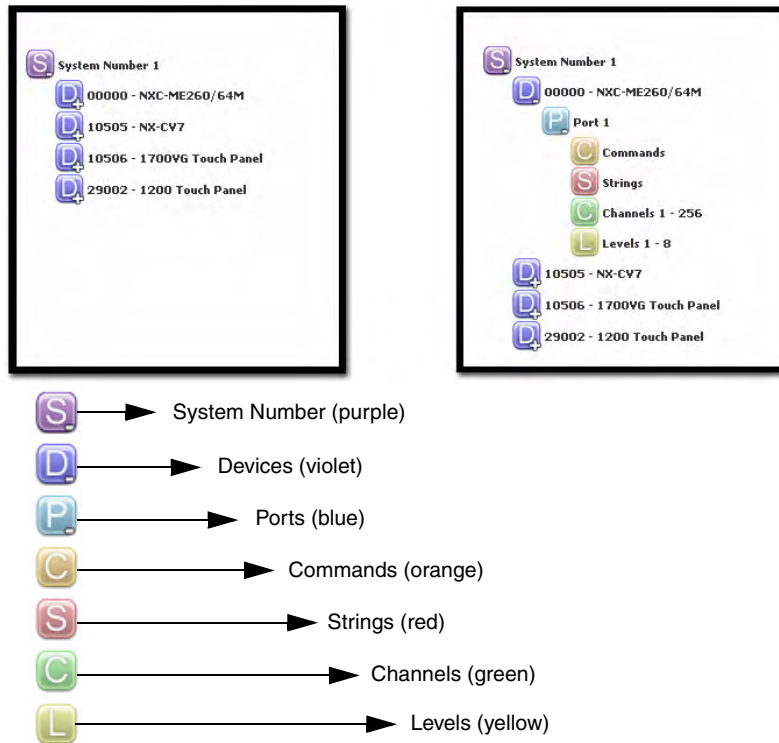

FIG. 57 System - Online Tree frame

Manage System Page Components (Cont.)	
Feature	Description
Management menu options:	<p>These management buttons change depending on the source chosen from the Online Tree.</p> <ul style="list-style-type: none"> • There are three menu groupings available: <ul style="list-style-type: none"> - System Menu (to configure Master properties). - Device Menu (to configure device specific properties). - Port Menu (to configure specific Port settings).
System menu buttons:	<p>The selected system number is displayed below these menu buttons.</p>
Modify Date/Time	<ul style="list-style-type: none"> • Allows a user to set the date and time on the target Master.
System Number	<ul style="list-style-type: none"> • Allows a user to change the current system number (value).
Reboot	<ul style="list-style-type: none"> • Allows a user to reboot the target Master.
Control/Emulate	<ul style="list-style-type: none"> • Allows a user to both control and emulate devices on a target Master. • This is done by allowing the user to control a device's channels, levels, and send both send commands and strings to the target device. • This button is available from within all Management menus.
Diagnostics	<ul style="list-style-type: none"> • Allows a user to watch the system activity to/from a selected device. • This button is available from within all Management menus.
Server	<ul style="list-style-type: none"> • Allows a user to both change the port numbers (<i>used for various Web services</i>) and configure the SSL settings used on the Master.
Device menu buttons:	<p>The selected system number: device number are displayed below these menu buttons.</p>
Network Settings	<ul style="list-style-type: none"> • Allows a user to configure the network IP/DNS settings.
URL List	<ul style="list-style-type: none"> • Allows a user to setup the URL List for the specified device. • <i>Not all devices allow this functionality.</i>
Device Number	<ul style="list-style-type: none"> • Allows a user to change the device number of a selected device.
Control/Emulate	<ul style="list-style-type: none"> • Allows a user to both control and emulate devices on a target Master. • This is done by allowing the user to control a device's channels, levels, and send both send commands and strings to the target device. • This button is available from within all Management menus.
Log	<ul style="list-style-type: none"> • Allows a user to view the log for the selected device. • <i>Not all devices allow this functionality.</i>
Diagnostics	<ul style="list-style-type: none"> • Allows a user to watch the system activity to/from a selected device. • This button is available from within all Management menus.
Port menu buttons:	<p>The selected system number:device & number:port number are displayed below these menu buttons.</p>
Control/Emulate	<ul style="list-style-type: none"> • Allows a user to both control and emulate devices on a target Master. • This button is available from within all Management menus.
Diagnostics	<ul style="list-style-type: none"> • Allows a user to watch the system activity to/from a selected device. • This button is available from within all Management menus.

Manage System - System Menu Buttons

These buttons appear (on the right) when a user clicks on the purple System icon from within the Online Tree. The selected system number is displayed below these System menu buttons.

System Menu - Modifying the Date/Time

1. Click the **Manage System** link (from within the System Settings section of the Navigation frame).
2. Click on the purple System icon from within the Online Tree to open the System menu buttons within the right frame.
3. Click the **Modify Date/Time** button to open the Modify System Date/Time dialog (FIG. 58). This dialog shows the current Date and Time settings for the target Master.

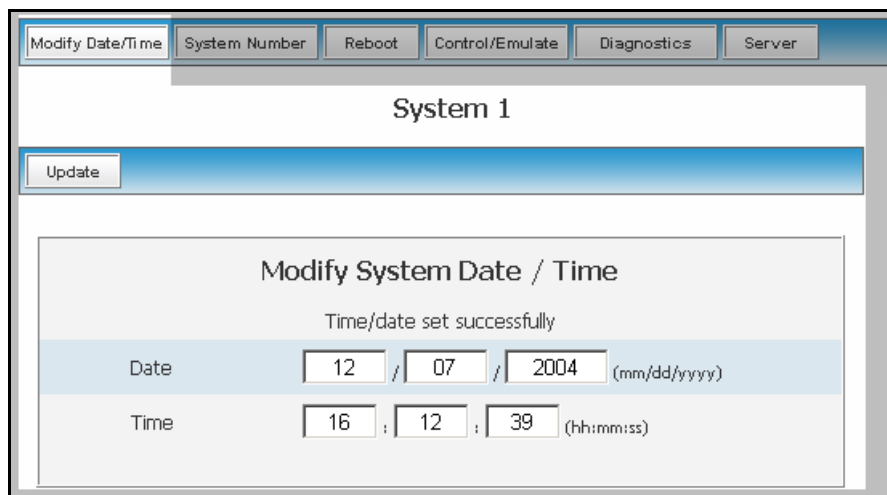

FIG. 58 Modify System/Date dialog

4. Alter any of these values by selecting the appropriate field and entering a new numeric value.
 - If you highlight any of the *Date* fields, a small popup calendar window appears to assist you with selecting a new date.
 - Navigate through the calendar and click on a new date which is then reflected back within the Modify System Date/Time dialog.
 - Any of the *Time* fields can be modified by either manually entering the new values or highlighting a field and using the arrow keys.
5. Click the **Update** button to save these settings to the target Master. If there were no problems with the update process, the following message is displayed: "Time/date set successfully".

System Menu - Changing the System Number

1. Click the **Manage System** link (from within the System Settings section of the Navigation frame).
2. Click on the purple System icon from within the Online Tree to open the System menu buttons within the right frame.
3. Click the **System Number** button to open the Change System Number dialog (FIG. 59). This dialog shows the current system number (read-only) on the target Master.

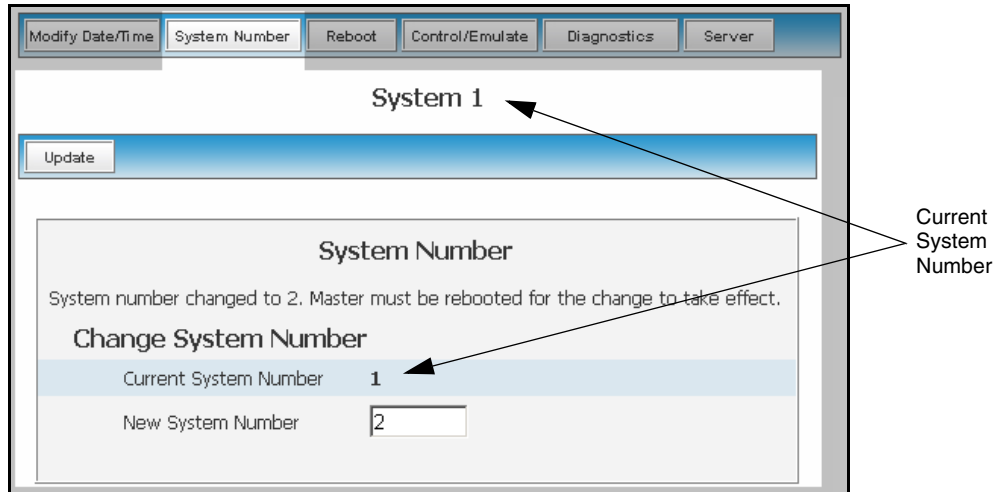

FIG. 59 Change System Number dialog

- The current system number is also shown just below the System menu buttons.
4. Enter a new numeric value into the *New System Number* field.
 5. Click the **Update** button to save this new value to the system on the target Master. The following message; "System number changed to X. Master must be rebooted for the change to take effect.", reminds the user the Master must first be rebooted before the new settings take effect. **Once the Master is rebooted, the IP Address must be re-entered and an authorized user must re-establish communication with the target Master.**

System Menu - Rebooting the Master

1. Click the **Manage System** link (from within the System Settings section of the Navigation frame).
2. Click on the purple System icon from within the Online Tree to open the System menu buttons within the right frame.
3. Click the **Reboot** button to remotely reboot the target Master. No dialog appears while using this button. The Online Tree then reads "Rebooting...". After a few seconds, the Online Tree refreshes with the current system information (showing the newly updated system number).
 - If the Online Tree contents do not refresh within a few minutes, press the browser's **Refresh** button and reconnect to the Master.

System Menu - Controlling/Emulating Devices on the Master

This button allows a user to either Control a device or Emulate a device. This is done by controlling a device's channels, levels, and sending both send commands and strings to the target device.



The Control/Emulate and Diagnostics buttons are common to all menus. These fields are populated depending on the items selected from the Online Tree (left frame). An example is: if you navigate down to a specific channel on a device, the Control/Emulate page then populates the D:P:S and Channel Code fields.

1. Click the **Manage System** link (from within the System Settings section of the Navigation frame).

2. Clicking on any of the Online Tree items opens menu items with the Control/Emulate button option available.
3. Click the **Control/Emulate** button to open the Control/Emulate dialog (FIG. 60).
4. Click the **Update Status** button to query the Master for the status of the currently entered level and channel.



The System Number, Device Number, and Port Number value fields are read-only (disabled) if you are brought to this window from a selection of an Online Tree item. By default these fields are otherwise editable.

5. Select either the **Control** or **Emulate** option.

FIG. 60 Control/Emulate dialog

- To **Control** a device means that the program generates messages which appear to a specified device to have come from the Master. The options in this frame allow you to specify the <D:P:S> combination for the device you want to control.
- To **Emulate** a device means that the program generates messages which appear to the Master to have come from a specified <D:P:S> combination (real or fictitious). The options in this frame allow you to specify the <D:P:S> combination for the device you want to emulate.
 - Selecting this option adds a **Push** button with the Channel Code section of this page.

6. Enter a System Number, Device Number, and Port Number into the appropriate fields. These values correspond to the device you wish to control (real or fictitious).
 - The Device, Port, and System value ranges are **1 - 65535**.
7. Within the Channel Code section, enter a valid Channel number to emulate Channel messages (i.e., Push/Release, CHON, and CHOFF) for the specified <D:P:S>.
 - The Channel number range is **1 - 65535**.
8. Select the **On** or **Off** buttons to Emulate Channel ON (CHON) and Channel OFF (CHOFF) messages for the specified <D:P:S>.
9. Select the **Push** button to Emulate a push/release on the channel specified. You can click and hold down the **Push** button to see how the device/Master responds to the push message.
10. Within the Level Code section, enter a valid Level number and Level data value for the specified <D:P:S> and press the **Send** button to transmit this data.
 - The Level number range is **1 - 65535**.
 - The list below contains the valid Level data types and their ranges:

Valid Level Data Types and Ranges		
	Minimum Value	Maximum Value
CHAR	0	255
INTEGER	0	65535
SINTEGER	-32768	32767
LONG	0	429497295
SLONG	-2147483648	2147483647
FLOAT	-3.402823466e+38	3.402823466e+38

11. Within the *Command* and *String* fields, you can enter any number of messages that can be sent as either a String or Command.
12. To Emulate sending a String or Command, type a String or Command within the corresponding field and press the **Send** button to transmit this data.
 - When entering a send command (in the context of this dialog) do not include the "send c" or "send_command" in the statement - only type what would normally occur within the quotes, but don't include the quotes either. For example to send the "CALIBRATE" send command, simply type CALIBRATE (no quotes) rather than SEND_COMMAND <dev> "CALIBRATE".
 - String Expressions start and end with double quotes (" "). Double quotes are not escaped, rather they are embedded within single quotes. String expressions may contain string literals, decimal numbers, ASCII characters and hexadecimal numbers (prepending with a \$), and are comma-delimited.
 - String Literals start and end with single quotes ('). To escape a single quote, use ''' (three single quotes).

Manage System - Diagnostics

This page allows an authorized user to setup and monitor diagnostic messages coming from and going to devices available on the Online Tree. This dialog also allows the user to watch the ICSP commands being sent to/from a device. There are several different types of asynchronous notifications that can be selected for a device:port:system (D:P:S) combination. Each notification type is represented by a column in the table. All messages are displayed in the Notifications tab of the Output Display window within NetLinx Studio v 2.4.

1. Click the **Manage System** link (from within the System Settings section of the Navigation frame).
2. Clicking on any of the Online Tree items opens menu items with the Diagnostics button option available.
3. Click the **Diagnostics** button to open the Diagnostics dialog (FIG. 61).

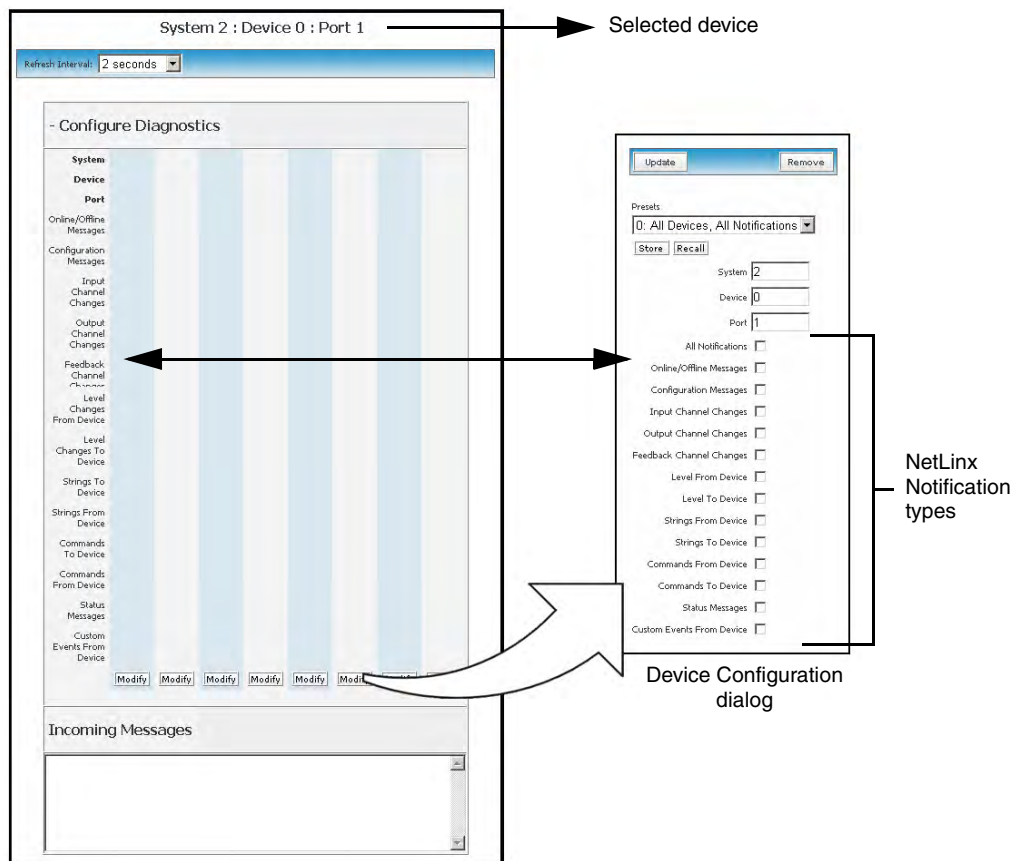

FIG. 61 Diagnostics dialog (showing modify popup)

4. Use the **Refresh Interval** drop-down to select from the following values: 2 seconds, 5 seconds, or 10 seconds. This refresh interval allows you to select how often your messages are updated.

Setting up and removing a Diagnostic Filter

1. Setup a diagnostic filter by scrolling down the page and clicking the **Modify** button below the first empty column. This action opens the Device Configuration dialog as a secondary popup window.



Up to 8 concurrent diagnostic filter slots can be simultaneously active using any eight of the 10 available user-configurable Presets available through the Device Configuration dialog.

2. Configure a diagnostic filter using the parameters available within the Diagnostic Configuration dialog.
 - The **Diagnostic Configuration** dialog allows you to select both the notifications you wish to receive and the target devices (within the Online Tree) for these notifications. There are several different types of asynchronous notifications that can be selected for a device:port:system (D:P:S) combination. Each notification type is represented by a column in the table. All messages are displayed in the Notifications tab of the Output Display window within NetLinx Studio v 2.4.
3. A user can choose to either store these selections to a profile or recall a previously stored profile configuration by either:
 - Select an open Preset number entry from within **Presets** drop-down list. Make all desired notification selection and press the **Store** button. Pressing this button opens a popup field labeled *Explorer User Prompt - Preset Name?* where you enter the name associated with this new Preset.
 - Press **OK** to return to the previous Device Configuration popup dialog.
 - Click **Cancel** to exit this popup and return to the previous dialog without making any changes.
 - Press the down arrow (*adjacent to the Preset drop-down list*) to display a listing of all currently available Presets. Select a previously configured Preset and press the **Recall** button to populate all available fields and radio buttons with the selections associated with this chosen Preset.
 - This preset mechanism is done via cookies so it does not persist across multiple browsers/computers.
4. Once you have made your modifications/selections within this dialog, press the **Update** button to save your changes and return to the Diagnostics dialog.

Diagnostic Configuration Dialog	
Feature	Description
Update:	Click this button once you have completed setting up your filter. The popup then closes and returns you to the Diagnostics window. <ul style="list-style-type: none"> • Watch the bottom Incoming Message pane for messages to begin coming in from the target device(s).
Remove:	Click this button to remove a selected Preset from being available within the Presets drop-down list.

Diagnostic Configuration Dialog (Cont.)	
Feature	Description
Presets:	<p>This list of up to 10 presets comes defaulted with Preset 0: All Devices, All Notifications</p> <ul style="list-style-type: none"> • Store: Save the current notification selections to a Preset profile. Pressing this button opens a popup field labeled <i>Explorer User Prompt - Preset Name?</i> where you enter the name associated with this new Preset. <ul style="list-style-type: none"> - Click OK to save both the Preset parameters and name, and then return to the Diagnostic Configuration Dialog. - Click Cancel to exit this popup and return to the previous dialog without making any changes. • Recall: Allows a user to recall a previously existing Preset. This action then populates every field and radio button with the selections associated with the chosen Preset. <ul style="list-style-type: none"> - This preset mechanism is done via cookies so it does not persist across multiple browsers/computers. <p>Note: A Preset MUST be Recalled before clicking the Update button. If you do not press this button, none of the fields or checkboxes are modified or selected. In essence, all options become disabled.</p> <p>Note: The All Devices entry cannot be removed.</p> <p>Note: The only way to modify the information within a Diagnostic filter is to remove the assigned Preset, change the information, and assign a new Preset. Refer to step 5 of this section for more information.</p>
System/Device/Port:	<p>Device, Port, System: Use these fields to enter a device:port:system (D:P:S) combination for the device that you want to enable notifications for.</p> <ul style="list-style-type: none"> • The specified device then appear in the Device field within the Diagnostic Configuration Dialog. • A value of 0 for any option gives you all of the systems, devices, or ports. This dialog also allows you to store/recall presets.
NetLinx Notification Types:	<p>All Notifications: Enables (selects) every notification field.</p> <ul style="list-style-type: none"> • Online/Offline Messages: Generates a message when there is a change in the target device's online/offline status. • Configuration Messages: Generates a message when there is a change in the target device's configuration. • Input Channel Changes: Generates a message when there is an input channel change (i.e. Push/Release) in the target device. • Output Channel Changes: Generates a message when there is an output channel change (i.e. CHON/CHOFF) in the target device. • Feedback Channel Changes: Generates a message when there is a feedback channel change in the target device. • Level Changes From Device: Generates a message when there is a level channel change from the target device. • Level Changes To Device: Generates a message when there is a level channel change to the target device. • String From Device: Generates a message when there is a string from the target device. • String To Device: Generates a message when there is a string sent to the target device. • Command From Device: Generates a message when there is a command from the target device. • Command To Device: Generates a message when there is a command to the target device. • Status Messages: Generates a message when there is a change in the target device's status. • Custom Events From Device: Generates a message there is a custom event occurring from the target device.

5. Remove a diagnostic filter by clicking the **Modify** button below it (from the Diagnostics dialog), then pressing the **Remove** button to delete this filter from the Diagnostics dialog.
 - Once a Preset is assigned to a specific Diagnostic filter "slot" (**up to 8**), its *System:Device:Port* fields are greyed-out, and can't be modified unless the Preset in that slot is removed and replicated with new information within these fields.
 - If you need to modify a Diagnostic filter's information (such as System/Device/Port) you can:
 - Navigate to an empty Diagnostic filter slot and click the **Modify** button below the filter.
 - Select a previously unused Preset and store it with a new name.
 - Click the **Remove** button to remove this duplicate Preset from the specific filter slot.
 - Re-open the empty slot by clicking the **Modify** button, select the duplicated Preset and click **Recall**.
 - Change the necessary information (such as the System/Device/Port), then save it as the original Preset name, and click the **Update** button.
6. Use the *Incoming Message* field to view all the internal system diagnostic messages that are generated by a NetLinx Master controller. This message field is a text box where you can select all the text within it and then copy/paste it for storage.

Setting the Master's Port Configurations

Manage System - Server

This page allows a user to both change the port numbers (*used for various Web services*) and configure the SSL settings used on the Master by bringing up a submenu of options such as:

Server Submenu Options	
Feature	Description
Port Settings:	Allows a user to modify the server settings; specifically those port assignments associated with individual services. <ul style="list-style-type: none"> • All items can be either enabled/disabled via the adjacent checkbox. • The port number values can also be modified (except the FTP port). • The default port for each service is listed to the right.
Create SSL Certificate:	Takes the an authorized user to the Server Certificate page where they can create a self-generated SSL certificate. <ul style="list-style-type: none"> • This dialog provides the ability to display an installed certificate, create a certificate request, self-generate, and regenerate SSL Server Certificates.
Export SSL Certificate Request:	Takes the user to the Server Certificate page where they can view a previously created certificate. <ul style="list-style-type: none"> • An authorized user can also copy the raw text from a generated Certificate request into their clipboard and then send it to the CA.
Import SSL Certificate:	Takes the user to the Import Certificate page where they can import and paste the raw text from a CA issued Certificate.

1. Click on the **Manage System** link (from within the System Settings section of the Navigation frame).
2. Click on the purple System icon from within the Online Tree to open the System menu buttons within the right frame.
3. Click the **Server** button to open the Server dialog and its associated submenu options (FIG. 62).

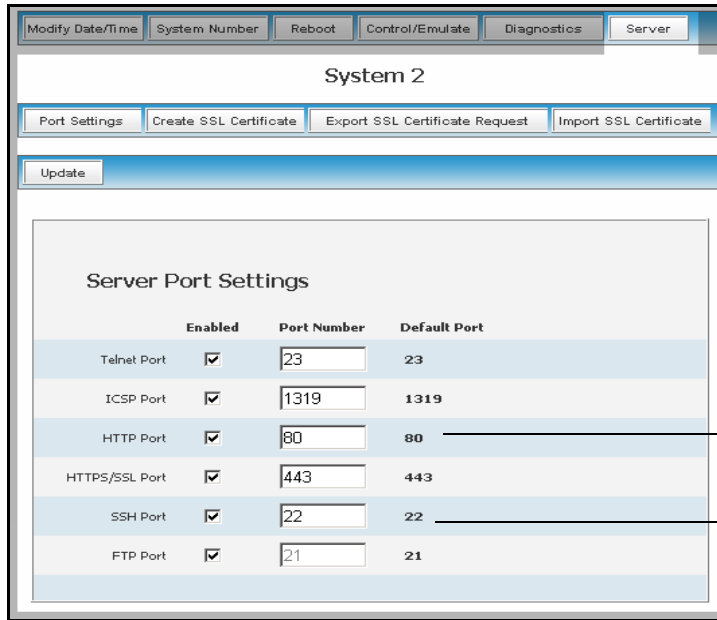

Disabling the HTTP Port requires that an authorized user access the Master ONLY via a secure HTTPS connection.

SSH version 2 is only supported.

FIG. 62 Server dialog and associated submenu options

- The following graphic illustrates the Ports which can be enabled for validation using a valid username and password and what method of communication is used with each.

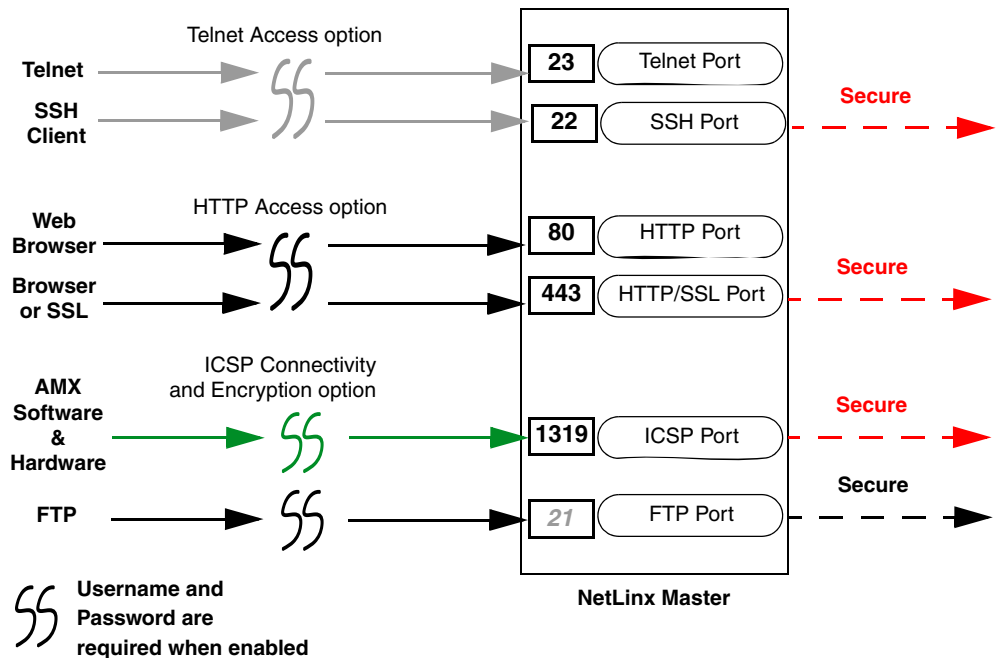

FIG. 63 Port Communication Settings

Modifying the Server Port Settings

1. From within the Server submenu, press the **Port Settings** button to open the Server Port Settings dialog seen above in FIG. 62.
2. Uncheck any services (and corresponding ports) to disable their functionality.
3. Modify any preset service port value by first enabling that service with a checkmark within the **Enabled** checkbox and then entering a value within the *Port Number* field.

Server Port Settings	
Feature	Description
Telnet Port:	<p>The port value used for Telnet communication to the target Master.</p> <ul style="list-style-type: none"> • The default port value is 23. • Enabling this feature allows future communication with the Master via a separate Telnet application (such as HyperTerminal). • Refer to the <i>NetLinx Security with a Terminal Connection</i> section for more information on the related procedures.
ICSP Port:	<p>The port value used for ICSP data communication among the different AMX software and hardware products.</p> <ul style="list-style-type: none"> • The default port value is 1319. • This type of communication is used by the various AMX product for communication amongst themselves. Some examples would be: NetLinx Studio communicating with a Master (for firmware or file information updates) and TPDesign4 communicating with a touch panel (for panel page and firmware updates). <p>Note: <i>To further ensure a secure connection within this type of communication, a user can enable the Require Encryption option which requires additional processor cycles. Enabling of the encryption feature is determined by the user.</i></p>
HTTP Port:	<p>The port value used for unsecure HTTP Internet communication between the web browser's UI and the target Master.</p> <ul style="list-style-type: none"> • The default port value is 80. • By default, the Master does not have security enabled and must be communicated with using http:// in the <i>Address</i> field. • One method of adding security to HTTP communication would be to change the port value. <ul style="list-style-type: none"> - If the port value is changed, any consecutive session to the target Master has to add the port value at the end of the address (within the <i>Address</i> field). An example is if the port were changed to 99, the new address information would be: http://192.192.192.192:99. • By disabling this port, the administrator (or other authorized user) can require that any consecutive sessions between the UI and the target Master are done over a more secure HTTPS connection.

Server Port Settings (Cont.)	
Feature	Description
HTTPS/SSL Port:	<p>The port value used by web browser to securely communicate between the web server UI and the target Master. This port is also used to simultaneously encrypt this data using the SSL certificate information on the Master as a key.</p> <ul style="list-style-type: none"> • The default port value is 443. • This port is used not only used to communicate securely between the browser (using the web server UI) and the Master using HTTPS but also provide a port for use by the SSL encryption key (embedded into the certificate). • Whereas SSL creates a secure connection between a client and a server, over which any amount of data can be sent securely, HTTPS is designed to transmit individual messages securely. Therefore both HTTPS and SSL can be seen as complementary and are configured to communicate over the same port on the Master. • These two methods of security and encryption are occurring simultaneously over this port as data is being transferred. • Another method of adding security to HTTPS communication would be to change the port value. <ul style="list-style-type: none"> - If the port value is changed, any consecutive session to the target Master has to add the port value at the end of the address (within the <i>Address</i> field). An example is if the port were changed to 99, the new address information would be: http://192.192.192.192:99.
SSH Port:	<p>The port value used for secure Telnet communication.</p> <p>Note: SSH version 2 is only supported.</p> <ul style="list-style-type: none"> • The default port value is 22. • A separate secure SSH Client would handle communication over this port. • When using a secure SSH login, the entire login session (including the transmission of passwords) is encrypted; therefore it is secure method of preventing an external user from collecting passwords. <p>Note: If this port's value is changed, make sure to use it within the Address field of the SSH Client application.</p>
FTP Port:	<p>The port value used for FTP communication. This port can be disabled/enabled but the value can not be changed.</p> <ul style="list-style-type: none"> • The default port value is 21. • When an application such as TPDesign uploads information to the target Master via an FTP connection; it is this port which is used by default.

4. Once an authorized user has modified any of the server port settings, press the **Update** button to save these changes to the Master. Once these changes are saved, the following message appears: *"Unit must be rebooted for the change to take effect"*.
5. Click the **Reboot** button (*from the top of the page*) to remotely reboot the target Master. No dialog appears while using this button. The Online Tree then reads *"Rebooting...."*. After a few seconds, the Online Tree refreshes with the current system information (showing the newly updated system number).
 - If the Online Tree contents do not refresh within a few minutes, press the browser's **Refresh** button and reconnect to the Master.

SSL Server Certificate Creation Procedures

Initially, a NetLinx Master is not equipped with any installed certificates. **In order to prepare a Master for later use with CA (officially issued) server certificates**, it is necessary to:

- **First create a self-generated certificate** which is automatically installed onto the Master.
- **Secondly, enable the SSL feature** from the Enable Security page. Enabling SSL security after the certificate has been self-generated insures that the target Master is utilizing a secure connection during the process of importing a CA server certificate over the web.



NOTE

A self-generated certificate has lower security than an external CA generated certificate.

A certificate consists of two different Keys:

- **Master Key** is generated by the Master and is incorporated into the text string sent to the CA during a certificate request. It is unique to a particular request made on a specific Master.
- **Public Key** is part of the text string that is returned from the CA as part of an approved SSL Server Certificate. This public key is based off the submitted Master key from the original request.
- **Regenerating a previously requested and installed certificate invalidates that certificate because the Master Key has been changed.**

1. Navigate to the Server Certificate page by clicking **System Settings > Manage System > Server > Create SSL Certificate** to open the Server Certificate page (FIG. 64).

FIG. 64 Create an SSL Certificate dialog

This page allows an authorized user to display an installed certificate, create a certificate request, self-generate, and regenerate SSL Server Certificates.

Server Certificate Entries	
Feature	Description
Server Certificate Field Information:	
Update	Updates the target Master with the information entered on this page. <ul style="list-style-type: none"> • This process can take a few minutes.
Bit Length	Provides a drop-down selection with three available public key lengths: 512, 1024, and 2048. <ul style="list-style-type: none"> • Longer key lengths result in increased certificate processing times. • A longer key length results in more secure certificates.
Common Name	The Common Name of the certificate MUST be the URL Domain Name used. <ul style="list-style-type: none"> • Example: If the address used is www.amxuser.com, that must be the Common name and format used. • The Common Name can not be an IP Address. • If the server is internal, the Netbios name must be used. • For every website using SSL that has a distinct DNS name, there must be a certificate installed. Each website (external or Internet) for SSL MUST also have a distinct IP Address.
Organization Name	Name of your business or organization. This is an alpha-numeric string (1 - 50 characters in length).
Organizational Unit	Name of the department using the certificate. This is an alpha-numeric string (1 - 50 characters in length).
City/Location	Name of the city where the certificate is used. This is an alpha-numeric string (1 - 50 characters in length).
State/Province	Name of the state or province where the certificate is used. This is an alpha-numeric string (1 - 50 characters in length).
Country Name	Provides a drop-down selection with a listing of currently selectable countries.
Action	Provides a drop-down selection with a listing of available certificate options: <ul style="list-style-type: none"> • Display Certificate - Populates the Server Certificate fields with the information from the certificate currently installed on the Master. <i>This action is used only to display the information contained in the certificate on the target Master.</i> • Create Request - Takes the information entered into the previous fields and formats the certificate so it can be exported to the external Certificate Authority (CA) for later receipt of an SSL Certificate. <i>This action is used to request a certificate from an external source.</i> • Self Generate Certificate - Takes the information entered into the previous fields and generates its own SSL Certificate. <i>This action is used when no previous certificate has been installed on the target Master, or a self-signed certificate is desired.</i> • Regenerate Certificate - Takes the information entered into the previous fields and regenerates an SSL Certificate. This action changes the Master Key. <i>This method of certificate generation is used to modify or recreate a previously existing certificate already on the Master.</i>

Server - Display SSL Server Certificate Information

1. Navigate to the Server Certificate page by clicking **System Settings > Manage System > Server > Create SSL Certificate** to open the Server Certificate page.



By default, the Display Certificate Action is selected and these fields are populated with information from an installed certificate. If the Master does not have a previously installed certificate, these fields are blank.

2. Click the down arrow from the *Action* field to open a drop-down listing of available certificate generation options.
3. Choose **Display Certificate** from the drop-down list.
4. Click **Update** to accept the action and populate the fields with the certificate information presently on the Master.

Server - Creating a self-generated SSL Certificate

1. Navigate to the Server Certificate page by clicking **System Settings > Manage System > Server > Create SSL Certificate** to open the Server Certificate page.
2. Click the down arrow from the *Bit length* field to open a drop-down listing of available public key lengths.
 - The three available public key lengths are: 512, 1024, and 2048. Higher selected key lengths result in increased certificate processing times. A longer key length results in more secure certificates.
3. Enter the used Domain Name into the *Common Name* field.
 - Example: If the address being used is www.amxuser.com, that must be the Common name and format used in the *Common Name* field. This string provides a unique name for the desired user.
 - **This domain name must be associated to a resolvable URL Address when creating a request for a purchased certificate. The address does not need to be resolvable when obtaining a free certificate.**
4. Enter the name of the business or organization into the *Organization Name* field. This is an alpha-numeric string (1 - 50 characters in length).
5. Enter the name of the department using the certificate into the *Organizational Unit* field. This is an alpha-numeric string (1 - 50 characters in length).
6. Enter the name of the city where the certificate resides into the *City/Location* field. This is an alpha-numeric string (1 - 50 characters in length).
7. Enter the name of the state or province where the certificate resides into the *State/Province* field. This is an alpha-numeric string (1 - 50 characters in length).
The state/province name must be fully spelled out.
8. Click the down arrow from the *Country Name* field to open a drop-down listing of listing of currently selectable countries.
9. Click the down arrow from the *Action* field to open a drop-down listing of available certificate generation options.

10. Choose **Self Generate Certificate** from the drop-down list. *When this request is submitted, the certificate is generated and installed into the Master in one step.*
11. Click **Update** to save the new encrypted certificate information to the Master.



CAUTION

*ONLY use the Regenerate certificate option when you have Self Generated your own certificate. **DO NOT** regenerate an external CA-generated certificate.*

Server - Regenerating an SSL Server Certificate Request

1. Navigate to the Server Certificate page by clicking **System Settings > Manage System > Server > Create SSL Certificate** to open the Server Certificate page.



NOTE

This method of certificate generation is used to modify or recreate a previously existing certificate already on the Master.

By default, if a certificate is already present on the target Master, the Display Certificate Action is selected and these fields are populated with information. EX: if the company has moved from Dallas to Houston, all of the information is reentered exactly except for the City.

2. Enter any new or changed information into its respective field.
3. Click the down arrow from the *Action* field to open a drop-down listing of available certificate generation options.
4. Choose **Regenerate Certificate** from the drop-down list.



NOTE

When this request is submitted, the certificate is generated and installed into the Master in one step.

5. Click **OK** to save the newly modified certificate information to the Master or click **Cancel** to void any changes made within this page and exit without making changes to the target Master.
6. **Before exiting the Master and beginning another session:**
 - Verify that all users have been assigned the correct rights, and are using the correct passwords.
 - In the Enable Security window of the Security tab, verify that the Master Security and HTTP Access are enabled. Enabling HTTP Access prompts users to enter pre-configured usernames and passwords.

Server - Creating a Request for an SSL Certificate

1. Navigate to the Server Certificate page by clicking **System Settings > Manage System > Server > Create SSL Certificate** to open the Server Certificate page.
2. Click the down arrow from the *Bit length* field to open a drop-down listing of available public key lengths.
 - The three available public key lengths are: 512, 1024, and 2048. Higher selected key lengths result in increased certificate processing times. A longer key length results in more secure certificates.

3. Enter the used Domain Name into the *Common Name* field.
 - Example: If the address being used is `www.amxuser.com`, that must be the Common name and format used in the *Common Name* field. This string provides a unique name for the desired user.
 - **This domain name must be associated to a resolvable URL Address when creating a request for a purchased certificate. The address does not need to be resolvable when obtaining a free certificate.**
4. Enter the name of the business or organization into the *Organization Name* field. This is an alpha-numeric string (1 - 50 characters in length).
5. Enter the name of the department using the certificate into the *Organizational Unit* field. This is an alpha-numeric string (1 - 50 characters in length).
6. Enter the name of the city where the certificate resides into the *City/Location* field. This is an alpha-numeric string (1 - 50 characters in length).
7. Enter the name of the state or province where the certificate resides into the *State/Province* field. This is an alpha-numeric string (1 - 50 characters in length).
The state/province name must be fully spelled out.
8. Click the down arrow from the *Country Name* field to open a drop-down listing of currently selectable countries.
9. Click the down arrow from the *Action* field to open a drop-down listing of available certificate generation options.
10. Choose **Create Request** from the drop-down list.
11. Click the **Update** button to accept the information entered into the above fields and generate a certificate file. Refer to the *Server - Exporting an SSL Certificate Request* section on page 103.
 - This refreshed the Server Certificate page and if the certificate request was successful, displays a "*Certified request generated*" message.
12. Follow the exporting and importing an SSL certificate procedures outlined within the following section.

Common Steps for Requesting a Certificate from a CA

Once the request has begun, a user has the choice to either remain using their self-generated SSL certificate or obtain a CA created certificate by exporting their request for the certificate and then, once received, import the returned certificate information onto the Master.

Communicating with the CA

A certificate is a cryptographically signed object that associates a public key and an identity. Certificates also include other information in extensions such as permissions and comments. A "CA" is short for Certification Authority and is an internal entity or trusted third party that issues, signs, revokes, and manages these digital certificates.

1. Navigate to the Web Server Certificate HTML page on your CA's web site.
 - A Web Server certificate allows you to authenticate through a Web browser via SSL. In order to successfully verify other certificates it is also necessary to import the CA key into the Web Server. Refer to the *Server - Creating a Request for an SSL Certificate* section on page 101.
 - This is done as part of the process of receiving your Web Server certificate.
 - **Only a user with administrator privileges can request a server certificate.**
2. Enter in the company information, such as: name, e-mail, address, state, and country.
3. Agree to any licensing agreements and continue to the next part of the registration process.
4. Enter the name of the server being used (this is the Master).
 - The server name is the name as it shows up in the URL of the Master you are securing with this server certificate. For example, if the URL of the Master is **https://www.myNetLinxMaster.com/**, then enter the server name as **www.myNetLinx Master.com**.
5. Send the CA the text created by your certificate request through the Master by exporting this information within the Server Certificate page. Refer to the *Server - Creating a Request for an SSL Certificate* section on page 101 for the procedures necessary to generate the certificate text file.
6. Follow the procedures outlined in the following section to export the data to the CA.

Server - Exporting an SSL Certificate Request

1. First follow the procedures outlined in the *Server - Creating a Request for an SSL Certificate* section on page 101 to begin the process of requesting an SSL by creating a session-specific Master certificate.
2. Click the **Export Certificate Request** button to display the certificate text file within the Server Certificate page (FIG. 65).
3. Place your cursor within the certificate text field.
4. Press the **Ctrl + A** keys simultaneously on your keyboard (this selects all the text within the field).

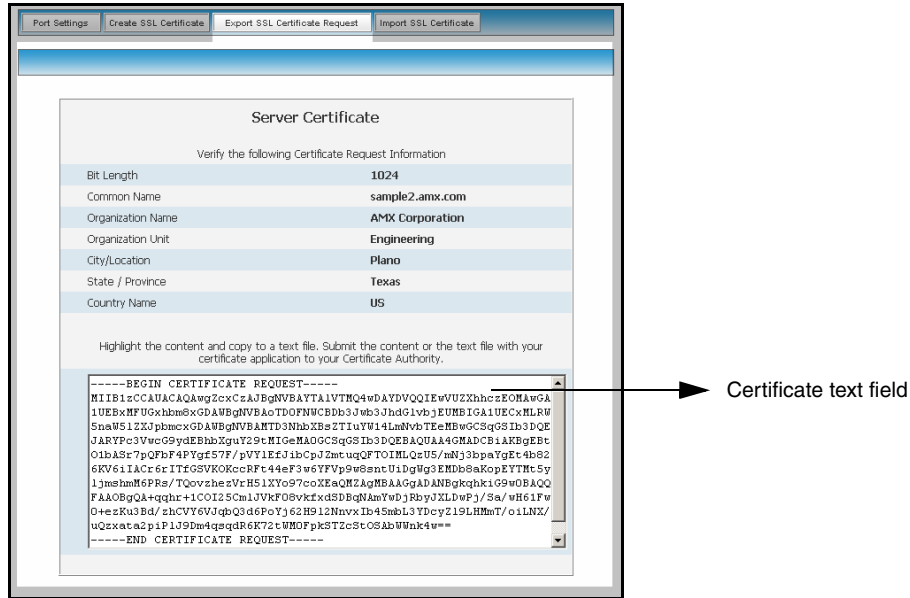

FIG. 65 Export SSL Certificate dialog



YOU MUST COPY ALL OF THE TEXT within this field, including the **-----BEGIN CERTIFICATE REQUEST-----** and the **-----END CERTIFICATE REQUEST-----**. Without this text included in the CA submission, you will not receive a CA-approved certificate.

5. Press the **Ctrl + C** keys simultaneously on your keyboard (this takes the blue selected text within the field and copies it to your temporary memory/clipboard).
6. Paste this text into the *Submit Request* field on the CA's Retrieve Certificate web page.
7. Choose to view the certificate response in raw DER format.
8. Note the **Authorization Code** and **Reference Number** (for use in the e-mail submission of the request).
9. Submit the request.
10. Paste this certificate text field (copied from steps 4 & 5 above) into your e-mail document and then send that information to a CA with its accompanying certificate application.



*When a certificate request is generated, you are creating a private key on the Master. **YOU CAN NOT REQUEST ANOTHER CERTIFICATE UNTIL THE PREVIOUS REQUEST HAS BEEN FULFILLED.** Doing so voids any information received from the previously requested certificate and it becomes nonfunctional if you try to use it.*

11. Once you have received the returned CA certificate, follow the procedures outlined in the following section to import the returned certificate (*over a secure connection*) to the target Master.

Server - Importing a CA created SSL Certificate

Before importing a CA server certificate, you must:

- **First**, have a self-generated certificate installed onto your target Master.
 - **Secondly**, enable the SSL security feature from the Enable Security page, to establish a secure connection to the Master prior to importing the encrypted CA certificate. Refer to the *Security - System Level Security* page section on page 71 for more information about enabling SSL security.
1. Take the returned certificate (signed by the CA and encrypted with new information which makes it different from the text string that was previously sent) and copy it into your clipboard.
 2. Navigate to the Server Certificate page by clicking **System Settings > Manage System > Server > Import SSL Certificate** to open the Import Certificate page (FIG. 66).

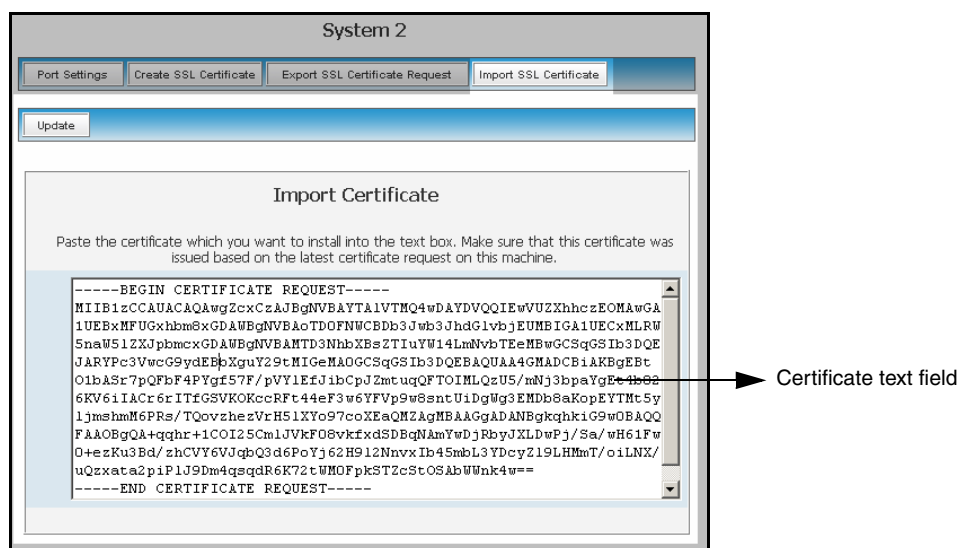

FIG. 66 Import SSL Certificate dialog

3. Place your cursor within the empty window and paste the raw text data (in its entirety) into the field.
4. Click the **Update** button to enter the new encrypted certificate information and save it to the Master.



Once a certificate has been purchased from an external CA and then installed onto a specific Master, **DO NOT regenerate the certificate or alter its properties** (example: bit length, city, etc.). If the purchased certificate is regenerated, it becomes invalid.

A certificate consists of two different Keys:

- **Master Key** is generated by the Master and is incorporated into the text string sent to the CA during a certificate request. It is specific to a particular request made on a specific Master.
 - **Public Key** is part of the text string that is returned from the CA as part of an approved SSL Server Certificate. This public key is based off the submitted Master key from the original request.
 - **Regenerating a previously requested and installed certificate, invalidates the previously purchased certificate because the Master Key has been changed.**
5. Use the **Server > Create SSL Certificate > Display Certificate** option to confirm the new certificate was imported properly to the target Master.



A CA server certificate can only be imported to a target Master only after both a self-generated certificate has been created and the SSL Enable feature has been selected on the Master. These actions configure the Master the secure communication necessary during the importing of the CA certificate.

Manage System - Device Menu Buttons

Appear when a user clicks on any violet Device icon from within the Online Tree. The selected system number: device number are displayed below these menu buttons.

Device Menu - Configuring the Network Settings

1. Click the **System Settings > Manage System** link from within the System Settings section of the Navigation frame.
2. Click on a violet Device icon from within the Online Tree to open the Device menu buttons within the right frame.
3. Click the **Network Settings** button to open the Network Settings dialog (FIG. 67). This dialog allows a user to setup the network settings for the specified device. The fields are populated with the current settings (when initially loaded).

FIG. 67 Network Settings dialog

Network Settings Dialog	
Feature	Description
IP Address:	
Host Name	Use this field to view/edit the target Master's current Host Name.
DHCP/Specify IP Address	Use these radio buttons to specify an address for the target Master: <ul style="list-style-type: none"> • DHCP - obtained from a DHCP Server. • Specify an IP Address - typically obtained from a System Administrator.
IP Address	Use this field to view/edit the target Master's current IP Address.
Subnet Mask	Use this field to view/edit the target Master's current Subnet Mask assignment.
Gateway	Use this field to view/edit the target Master's current Gateway assignment.
DNS Address:	
Domain Suffix	Use this field to view/edit the target Master's current Domain Suffix.
DNS IP #1, #2, #3	Use these fields to view/edit the target Master's current DNS IP addresses.

4. Enter a new or updated name within the *Host Name* field. This entry can be 1 - 50 alphanumeric characters in length.
5. Select either the **DHCP** or **Specify and IP Address** checkbox to chose the source of the IP Address information being used within the remaining fields.
6. Enter or change any IP Address or DNS Address information within the remaining fields.
7. Click **Update** to save any changes. If your changes are successfully updated to the Master, the following message appears. "*Network Settings updated. Device must be rebooted for the setting to take effect*".
8. Return to the System menu by clicking on the purple System icon from within the Online Tree, click the **Reboot** button, and then allow the Master a short time to reboot itself.
9. Click on the **Refresh** macro from the browser's menu bar. If no security is currently enabled on the target Master, you are directed back to the Manage WebControl Connections page. If security is enabled, you are directed to the initial Username/Password page to enter your access information.

Device Menu - Developing a URL List

1. Click the **System Settings > Manage System** link from within the System Settings section of the Navigation frame.
2. Click on a violet Device icon from within the Online Tree to open the Device menu buttons within the right frame.
3. Click the **URL List** button to open the URL List dialog (FIG. 68). This dialog allows the user to view, add, and remove URLs from the specified devices URL list.
4. Add a new URL to the list by pressing the **New** button which opens the Add New URL dialog.
5. Enter either an IP Address or a resolvable name (ex: **www.amx.com**) into the *URL* field.
6. Enter the Port number used to connect to the other device within the *Port* field. The default port provided is 1319, which is used for ICSP communication. Refer to the *Manage System - Server* section on page 94 for more information on the default Ports used for communication.

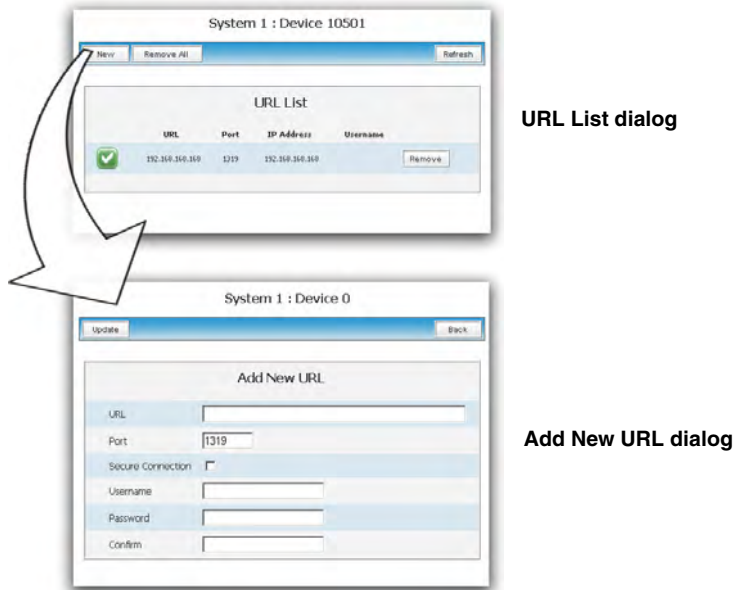

FIG. 68 URL List dialog

7. If a Username and/or Password is required for successful communication with the target URL, place a checkmark in the **Secure Connection** checkbox and enter the necessary information within the Username, Password, and Confirm (password) fields.
 - If this box is unchecked, the fields are greyed-out and the user is prevented from entering any text into any of the remaining fields.



These fields are not greyed-out within Internet Explorer even though they become read-only.

8. Click the **Update** button to accept and save your changes. If you are able to enter your information, a "URL added successfully" message is displayed at the top of the Add New URL dialog.
9. Click the **Back** button to return to the main URL List dialog.
10. Confirm your newly added URLs appear within the URL List dialog (FIG. 69).

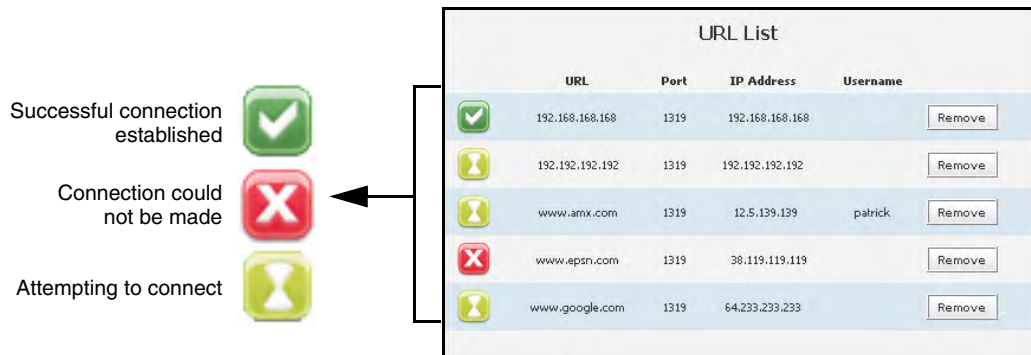

FIG. 69 URL List dialog (with entries)

- If your newly added URL doesn't appear on this page, click the **Refresh** button.

11. URL entries can be removed either individually or as a whole:

- Remove an individual URL entry by pressing the **Remove** button on that URL's row listing within the URL List dialog (FIG. 69).
- Remove all previously entered URLs by pressing the **Remove All** button. To confirm the removal of all items, press the **Refresh** button.

Device Menu - Changing the Device Number

1. Click the **System Settings > Manage System** link from within the System Settings section of the Navigation frame.
2. Click on a violet Device icon from within the Online Tree to open the Device menu buttons within the right frame.
3. Click the **Device Number** button to open the Device Number (FIG. 70). This dialog allows the user to change the device number for the selected device.

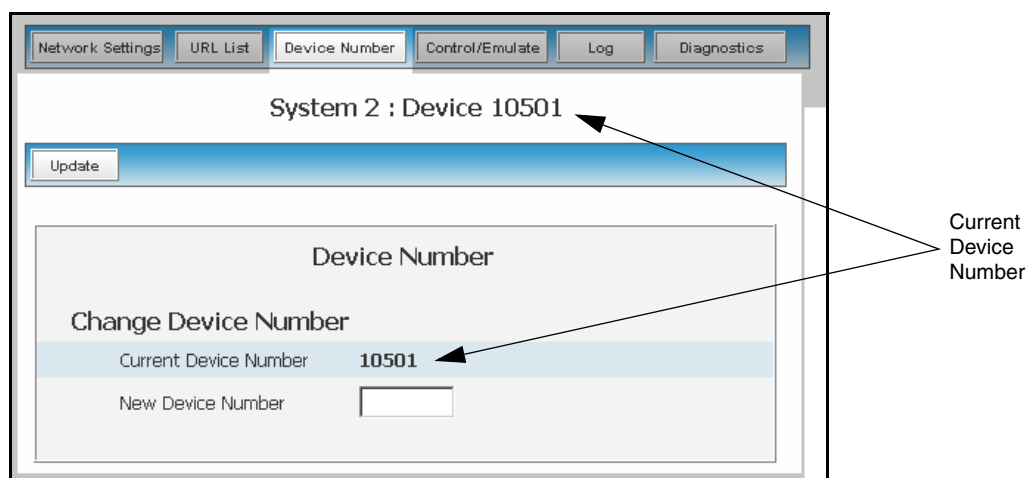

FIG. 70 Device Number dialog

- The current device number is also shown just below the System menu buttons.
4. Enter a new numeric value into the *New Device Number* field.
 5. Click the **Update** button to save this new value to the device. The following message; "*Device number changed to XXX. Device must be rebooted for the change to take effect.*", reminds the user that the Master must first be rebooted before the new settings take effect.

Device Menu - Controlling or Emulating a device

Refer to the procedures outlined within the *System Menu - Controlling/Emulating Devices on the Master* section on page 88 for more information.

Device Menu - Viewing the Log

1. Click on the **System Settings > Manage System** link from within the System Settings section of the Navigation frame.
2. Click on a violet Device icon from within the Online Tree to open the Device menu buttons within the right frame.

- Click the **Log** button (FIG. 71). This dialog allows the user to view the log for the selected device (*currently only the Master supports this feature*).

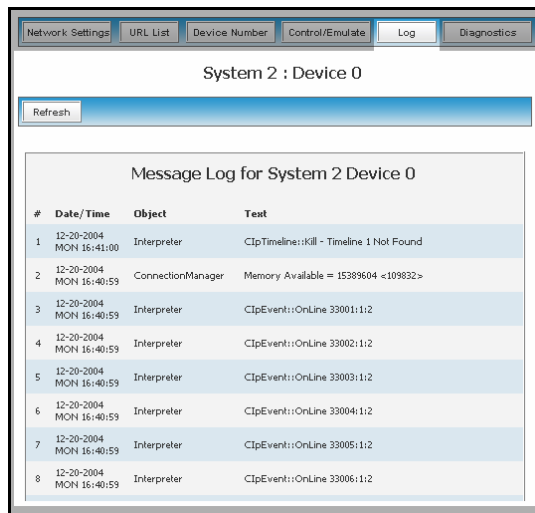

FIG. 71 Log dialog

- Click the **Refresh** button to update the information on-screen.

Device Menu - Running a Diagnostic Filter

Refer to the procedures outlined within the *Manage System - Diagnostics* section on page 91 for more information.

System Settings - Manage License

This page (FIG. 72) displays both the currently used license keys, as well as pending keys.

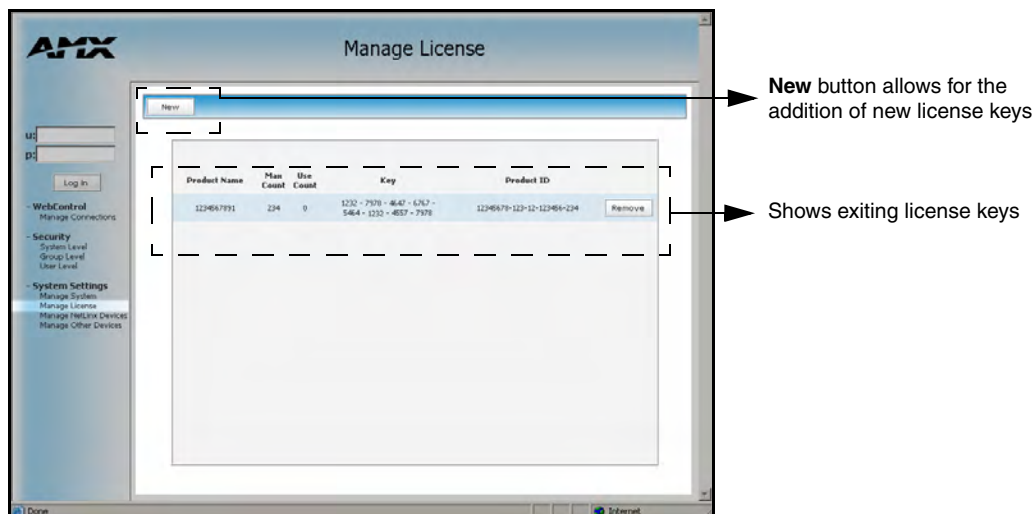

FIG. 72 System Settings - Manage License page

- The **New** button allows for the addition of new license keys associated with currently used modules/products.
- Adding new License Keys requires the use of both a Product ID and a Serial Key.

- An example of this type of product is i!-Voting. The Master confirms this registration information before running the module.

Adding a new license

1. Click on the **System Settings** > **Manage License** link from within the System Settings section of the Navigation frame.
2. Click the **New** button to be transferred to the Add new License Key page (FIG. 73).

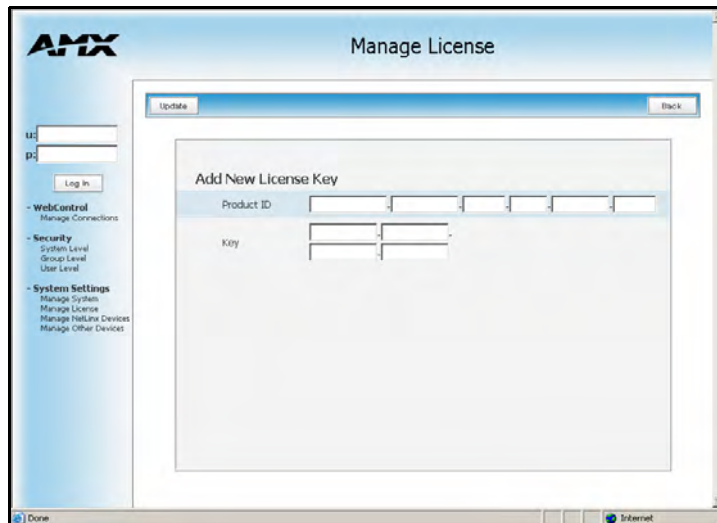

FIG. 73 System Settings - Add New License Key page

3. Enter the Product ID (certificate number) provided with the product into the *Product ID* fields.
4. Contact the AMX Sales department with both the product serial number (or certificate number) and the serial number of target Master to register your product and in turn receive the necessary Key information (typically 32 to 36 digits in length) which is then entered into the *Key* fields on this page.
 - The Key is Master specific and is typically provided by AMX upon registration.
 - Ex: AMX Meeting Manger and i!-Voting applications are examples of products that would require both a Product serial number and a Master-specific key prior to usage.
5. Press the **Update** button to save the information. If there are no errors with the information on this page, a “*Key successfully added for Product ID XXXX*” is displayed at the top of the page.
6. Press the **Back** button to return to the previously active Manage License page.

Removing a license

1. Click on the **System Settings** > **Manage License** link from within the System Settings section of the Navigation frame.
2. Click the **Remove** button.
3. Click **OK** from the “*Are you sure you want to remove this?*” popup.

System Settings - Manage NetLinX Devices

To access this page, click on the **Manage NetLinX Devices** link (*from within the System Settings section of the Navigation frame*). These pages (FIG. 74) have some additions that have been incorporated as part of **build 323 (or higher)**. These features include the display the device status as well as some background color changes which indicate system groupings. These enhancements are visual changes which allow for easier recognition of the information on a visual basis. IP connections are then able to utilize a network’s higher layers of multicast to broadcast their existence.

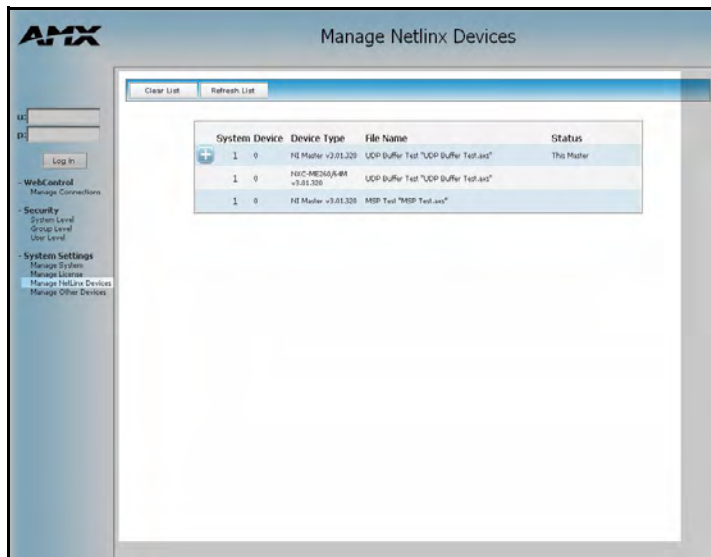

FIG. 74 System Settings - Manage NetLinX Devices page

Manage NetLinX Devices Page	
Feature	Description
Clear List:	Clicking this button causes the entries to be temporarily deleted from the page until either the user chooses to refresh the entries (using the Refresh List button) or the Master begins to detect any multi-cast transmissions as devices send out their announcements.
Refresh List:	<ul style="list-style-type: none"> Clicking this button allows the target Master to regenerate the listing by looking for broadcasting devices. The button causes the Master to send out a message asking devices to resend their NDP device announcements. The list is then updated as those devices send back their announcements to the “listening” Master. Due to system delays, message collisions, and multicast routing, not all devices may respond immediately. The information displayed can not only include Masters and devices on this system but Masters and devices on other systems as well. By default, the target Master always appears in the list.



A large number of NDP-capable devices on the network can result in a large amount of network traffic occurring at the same time.

Manage NetLinx Devices Page (Cont.)	
Feature	Description
Device Listings:	<ul style="list-style-type: none"> This page (<i>in addition to the target Master which is typically the first entry</i>) lists those NetLinx Masters which have sent out NetLinx Discovery Master Announce packets (NDPs). Each entry contains the data necessary to describe the devices detected by the system. If a Master has a '+' icon next to it, this indicates that this Master is reading the presence of a NDP-capable devices currently connected to it. This state can be toggled closed to show a '-' icon.
System	Displays the System value being used by the listed NetLinx Master.
Device	<ul style="list-style-type: none"> Displays the assigned device value of the listed unit. This Device entry applies to both the Master and those NDP-capable devices currently connected to that Master.
Device Type	<ul style="list-style-type: none"> Displays a description of the target Master or connected device, and its current firmware version. An example is: NI Master v3.01.323.
File Name	Displays the program name and/or file resident on the device.
Status	<p>Displays the Master or device state. Those states include:</p> <ul style="list-style-type: none"> This Master: Indicates its the target Master currently being used and being browsed to. Its this Master's web pages which are currently being viewed. Orphan: Indicates that the device is currently not yet "bound" or assigned to communicate with a particular Master. <ul style="list-style-type: none"> This state shows an adjacent Bind button which is used to the bind the device to the Master whose web pages are currently being viewed. Searching: Indicates that the device is trying to establish communication with it's associated Master. Bound: Indicates that the device has established communication with it's associated Master. <ul style="list-style-type: none"> This state shows an adjacent Unbind button which is used to release/disassociate the device from communicating with its current Master. Lost: Indicates that the device has tried to establish communication with it's associated or "bound" Master, but was after a period of time, unable to establish communication.

Manage NetLinX Devices - Displaying NDP-capable devices

You'll note in the previous example (FIG. 74), the first NetLinX Master has a "+" icon next to it, which shows that this Master is indicating the presence of NDP-capable devices currently connected to it.

1. Click the "+" icon to expand the particular Master's listing and reveal those NDP-capable devices connected to it, as shown below in FIG. 75.

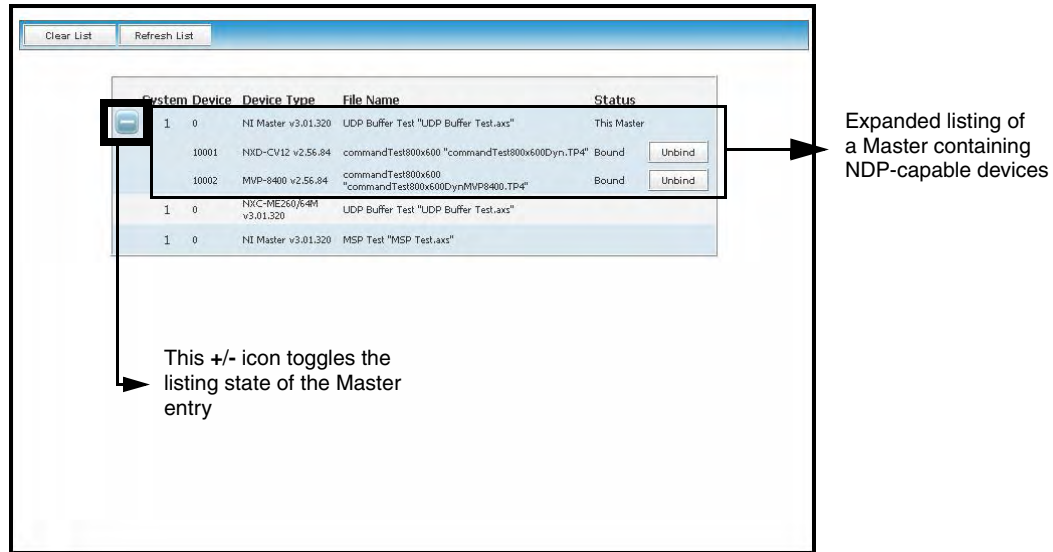

FIG. 75 Manage NetLinX Devices page - showing an expanded view

- Note that in this example the currently active Master's Status description reads - **This Master** and that the sub-devices are **Bound** to communicate with that Master. Even though they are currently bound, clicking the adjacent **Unbind** button will release them from communication with a particular Master.

2. Click the "-" icon to collapse the particular Master's listing.

Manage NetLinX Devices - Binding/Unbinding - Explained

From below the **Status** column (which displays the Master or device state) you can determine whether a device is Bound or Orphaned. For more information, refer to the *What is Dynamic Device Discovery?* section on page 119.

- A **Bound** device is one which has established communication with its associated Master. This device was previously bound to communicate with a specific Master.
 - This state shows an adjacent **Unbind** button which is used to release/disassociate the device from its current Master.
 - Once this button is pressed, the device then shows up as **Orphaned** (within the Status column).
- An **Orphan** is an NDP-capable device which has not yet been assigned to communicate (bound) with a specific Master.
 - This state shows an adjacent **Bind** button which is used to then bind the device to the Master whose pages are currently being viewed (displayed as **This Master** within the Status column).

- Once this button is pressed, the device then shows up as Bound (*within the Status column*).

Manage NetLinx Devices - Obtaining NetLinx Device information

To obtain more description than is provided by the listing:

1. Use your mouse to hover the cursor over a particular device within the listing and display a mouse-over popup dialog (FIG. 76).

System	Device	Device Type	File Name	Status
1	0	NI Master v3.01.320	UDP Buffer Test "UDP Buffer Test.axs"	This Master
1	0	NXC-ME260/64M v3.01.320	UDP Buffer Test	Address Type: IPv4MacAddress
0	10001	NXD-CV12 v2.56.84	commandTest800x600 "Port: 1319;1900x600Dyn_TP4"	Lost Unbind
0	10002	MVP-8400 v2.56.84	commandTest800x600 "commandTest800x600DynMVP8400_TP4"	Lost Unbind

This field illustrates the MAC Address of the Master.

NetLinx Master's associated property information (displayed via a mouse-over popup dialog)

FIG. 76 Manage NetLinx Devices page - showing a sample mouse-over popup dialog

- The previous popup dialog shows the Master's IP settings including the IP Address, ICSP Port, and a MAC Address.
- If the device is one that is bound to a Master, the popup also displays an additional Master *MAC Address* field, which should match the MAC Address information for the bound target Master (FIG. 77). **Notice that the Master MAC Address in FIG. 77 should match the MAC Address of the Master in FIG. 76.**

System	Device	Device Type	File Name	Status
1	0	NXC-ME260/64M v3.01.320	UDP Buffer Test "UDP Buffer Test.axs"	
1	0	NI Master v3.01.320	UDP Buffer Test "UDP Buffer Test.axs"	This Master
	10002	MVP-8400 v2.56.84	commandTest800x600 "commandTest800x600DynMVP8400_TP4"	Bound Unbind
0	10001	NXD-CV12 v2.56.84	commandTest800x600 "commandTest800x600DynMVP8400_TP4"	Lost Unbind

This field illustrates the MAC Address of the Master bound to this device

NDP device's associated property information (displayed via a mouse-over popup dialog)

FIG. 77 Manage NetLinx Devices page - showing a sample mouse-over popup dialog

- In the above example, the moused-over device is bound to an NI Master on System 1 running firmware v3.01.320. The device's popup shows the MAC Address of the Master with which it is bound (00:90:9f:90.....).
- *If this device is ever unbound from this Master (using the Unbind button), its Master MAC Address would be blank.*

System Settings - Manage Other Devices - Dynamic Device Discovery Pages



Before you begin to manage any other devices, the target Master must be loaded with the program which defines the new devices and modules. In addition to this code, all IP/Serial devices must be pre-configured and connected to the system.

To access this page, click on the **Manage Other Devices** link (from within the System Settings section of the Navigation frame). This page (FIG. 78) (*within build 323 or higher*) is used as the entry point for the management of all 3rd party Dynamically Discovered Devices.

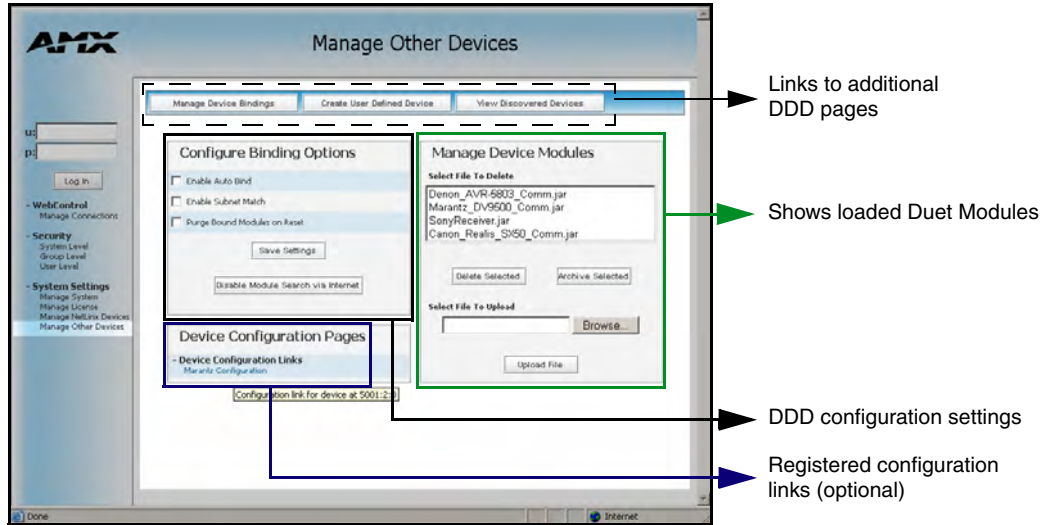

FIG. 78 System Settings - Manage Other Devices page

Manage Other Devices Page	
Feature	Description
<p>Dynamic Device Discovery links:</p>	<p>These links direct the user to additional Dynamic Device Discovery (DDD) configuration pages which include:</p> <ul style="list-style-type: none"> • Manage Device Bindings page is used for configuring application-defined Duet virtual devices by using discovered physical devices. <ul style="list-style-type: none"> - If your current NetLinx program (<i>running on the target Master</i>) has been written, and you have notified the Master of a set of Dynamic Devices on your system, you will then want to start by managing those devices through this page. • Create User Defined Device page provides a Web interface used in creating and managing the values necessary to add a dynamic physical device to the system. The devices added on this page do not support the DDD beaconing technology. <ul style="list-style-type: none"> - If after you have confirmed the presence of your programmed Dynamic Devices (<i>provided to the Master via your NetLinx code</i>), and have allowed the Master to confirm the presence of any other Dynamic Devices, its then time to manually enter in those remaining devices on your system via the User Defined Device page. <p>Note: IR-controlled devices (such as a VCR or Receiver) must always be User-Defined devices.</p> • View Discovered Devices page displays a listing of all the dynamic devices that have been discovered within the system. <ul style="list-style-type: none"> - After you have confirmed the presence of those previously coded Dynamic Devices within the Manage Device Bindings page, it is then recommended that you navigate to the View Discovered Devices page to continue the process of detecting Dynamic Devices which have been detected by the system, and then assign Module/drivers to those devices via the View Discovered Devices page.
<p>Configure Binding Options:</p> <p>Enable Auto Bind</p>	<p>This section contains configuration settings regarding the DDD process.</p> <ul style="list-style-type: none"> • This selection allows an end-user to toggle the state of the automatic binding for DDD (On/Off). • When auto-binding is enabled, the Master automatically attempts to connect any newly discovered device with an associated application device (<i>defined in the running NetLinx application</i>). • Auto-binding can only be accomplished if the Master's firmware determines a one-to-one correlation between the newly discovered device and a single entry within the list of defined application devices (<i>accessed by pressing the Manage Device Bindings button at the top of the page</i>). • For example, if the application only has one VCR defined and a VCR is detected in the system, auto-binding can then be accomplished. <ul style="list-style-type: none"> - If there were two VCRs defined within the application, auto-binding could not be completed due to the lack of a clearly defined one-to-one correspondence. • When the Enable Auto Bind option is not selected, no auto-binding activity takes place and all binding of the newly discovered devices must be accomplished manually via the Web control interface <i>Manage Other Devices - Manage Device Bindings</i> section on page 121.

Manage Other Devices Page (Cont.)	
Feature	Description
Configure Binding Options (Cont.):	
Enable Subnet Match	This selection allows an end-user to toggle whether or not IP devices should only be detected/discovered if they are on the same IP Subnet as the Master.
Purge Bound Modules on Reset	<ul style="list-style-type: none"> This selection indicates that all modules should be deleted from the /bound directory upon the next reboot. During the binding process, the associated Duet modules for a device are copied from the /unbound directory into a protected /bound area. Due to the dynamic nature of Java class loading, it is not safe to delete a running .JAR file. Therefore, this selection provides the administrator the capability of removing existing modules upon reboot by forcing a re-acquisition of the module at bind time. This selection is a one-time occurrence. Upon the next reboot, the selection is cleared.
Save Settings	Clicking this button causes the current selected checkbox values to be saved into the system.
Enable/Disable Module Search via Internet	<ul style="list-style-type: none"> Clicking this button toggles the capability of searching the Internet (<i>either AMX's site or a device specified site</i>) for a device's compatible Duet modules. This capability is automatically disabled if the Master does not have Internet connectivity. Upon enabling Internet connectivity, the AMX License Agreement is displayed for acceptance (FIG. 79). The AMX License Agreement must be accepted (<i>by pressing the Accept button on the upper-right of the page</i>) for the Internet Module search to be enabled. When the Internet search for modules feature is enabled (the button then reads Disable Module Search via Internet), the Master queries either AMX's Online database of device Modules and/or pulls Modules from a separate site specified by the manufacturer's device. You can later disable this feature by toggling this button's state.
Device Configuration Pages:	<p>This section is optional and is only present when either configuration links have been previously registered by a running Duet Module or if a discovered device supplies configuration link information.</p> <ul style="list-style-type: none"> If present, this section displays each link along with a mouse-over tool-tip. For Duet Modules this tool-tip describes the module configuration link. For discovered devices this tool-tip indicates the physical device the configuration link is associated with.

Manage Other Devices Page (Cont.)	
Feature	Description
Manage Device Modules:	This section displays a list of all currently loaded Duet Modules/.JAR files on the Master (<i>resident within the /unbound directory</i>); as well as providing those interfaces necessary to delete, add, and retrieve these modules.
Select File to Delete	<ul style="list-style-type: none"> This field provides the listing of loaded Modules/.JAR files. These entries can be selected for deletion or archiving.
Delete Selected	<ul style="list-style-type: none"> Clicking this button causes the deletion of a selected module from the /unbound directory. Any corresponding module within the /bound directory will NOT be deleted. Bound modules must be deleted via the Purge Bound Modules on Reset selection described within the previous <i>Configure Device Bindings</i> section.
Archive Selected	<ul style="list-style-type: none"> Clicking this button copies the selected JAR file to the PC which the user is browsing from. This option allows an administrator to archive those Duet Modules resident on a target Master back to a PC.
Select File to Upload	<ul style="list-style-type: none"> This section allows a user to browse for a target Module/.JAR file and then upload it to a target Master. Browse: Allows the user to browse for Duet Modules on the PC/Network. Upload File: Copies the specified Duet Module to the target Master's /unbound directory. <ul style="list-style-type: none"> If a file of the same specified name already exists within the /unbound directory; a prompt is displayed to confirm the over-write of the existing .JAR file. Only JAR file types are allowed for Upload to the target Master.

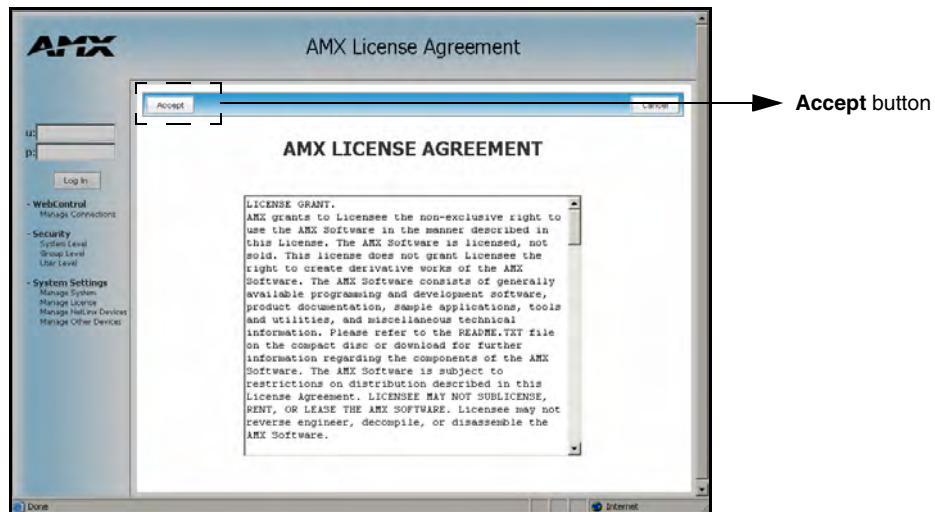

FIG. 79 System Settings - AMX License Agreement page

What is Dynamic Device Discovery?

The Dynamic Device Detector (DDD) monitors the system for newly connected devices. New devices can be detected via either an external discovery protocol manager (*built into firmware build 320 or higher*), Multicast reception of a Dynamic Device Beacon, or via the receipt of a beacon response on an application specified list of serial devices. This DDD process begins by detecting new devices within a NetLinx/Duet system, binding those devices to application instances, and then starting a Duet module to control those new devices.

Dynamic Device Discovery was created to take advantage of Java's Dynamic Class Loading and the Duet Standard NetLinx API (SNAPI). Java loads classes as they are needed. Therefore it is feasible to load a Duet control/protocol module on the fly as each new device is discovered. SNAPI provides a fixed interface for communicating with a certain type of device. The "glue code" refers to the developer defined NetLinx program that runs on a Master and controls a system.

Take for example a VCR. The majority of control features are common to all VCRs (play, stop, pause, etc.). SNAPI provides the "glue code" developer the ability to write common code that will control any type of VCR having an associated Duet module. The underlying Duet module could be swapped in and out based on the actual physical device with no changes needed to the higher level "glue code".

Dynamic Device Discovery Concepts	
Feature	Description
Application Device:	<ul style="list-style-type: none"> A Duet Device (41000-42000) that is used as a control interface to a physical device. This is also referred to as the <i>Duet virtual device</i>. All control requests are made to the application device rather than to the physical device.
Binding:	<ul style="list-style-type: none"> In concrete programming, the application device is forever associated with the NetLinx physical device. In DDD, this association is dynamic. The act of associating an application device with a physical device is called "binding".
Device Discovery:	<ul style="list-style-type: none"> In DDD, physical devices are detected in the system at run-time. There are two different methods of detection: via Dynamic Device Discovery Protocol (DDDP) or via user definition within the Master's Web interface (page 126).
SDK Class:	<ul style="list-style-type: none"> Each application device in the DDD world is associated with a particular device type as defined by SNAPI. When using a VCR or a Receiver as an example, each of these device types would correspond with a Java Interface within the Duet Device Software Development Kit (SDK). When writing programs for DDD, the developer specifies the device type of a particular application device by using one of these SDK Class names.
Polling:	<ul style="list-style-type: none"> Dynamic physical devices can be detected by DDDP through both Serial and IP interfaces. But whereas IP connections are then able to utilize the network's higher layers of multicast to broadcast their existence, Serial devices speak a fixed protocol that is incompatible with DDDP. Serial devices are passive and will only broadcast their existence if polled to do so. The program developer must specify which NetLinx interfaces/ports (i.e. serial ports) should be polled for devices.

What is the difference between Program and Run-time defined binding?

In DDD, the device discovery activity is always dynamic because the devices will always be detected at run-time. Note that DDD splits the binding activity into two different categories:

- **Program defined binding** (also known as static)
- **Run-time defined binding** (also known as dynamic).

With program defined/static binding, the developer specifies a permanent binding between an application device and a physical port, such as a particular serial or IR port. At run-time, any device detected on that port is automatically associated with the designated application device. This binding type would be used when the developer wants to hard code what port is used for a device, but does not know what manufacturer's device will actually be connected. Static binding is not available for IP connected devices, since the IP Address value of a device is subject to change due to IP network topology.

- An example of its use would be if DHCP is enabled for the peripheral device. A hard-coded IP Address within the NetLinx "glue-code" would be inadequate due to the nature of the dynamically acquired DHCP IP Addresses. Only actual NetLinx D:P:S values are allowed for static binding of physical ports.

With run-time defined/dynamic binding, the application device and the physical port are completely disassociated (in a program sense). The developer defines the application devices and their associated SDK class but does not specify what physical port they are bound to. At run-time, as those devices are discovered, the new physical devices are then bound to an application device either automatically or via the Master's Web access. Dynamic binding is the only binding option available for IP-connected peripheral devices due to the dynamic nature of IP Addresses as discussed earlier.

Manage Other Devices - Manage Device Bindings

To access this page, click on the **Manage Device Bindings** button (*from within the Manage Other Device page*). This page is used to configure application-defined Duet virtual devices with discovered physical devices. The on-screen table (FIG. 81) displays a list of all application-defined devices (including the defined "friendly name"), the Duet virtual D:P:S, and the associated Duet Device SDK class (indicating the type of the device). This information would have been pre-coded into the NetLinx file currently on the target Master (FIG. 80).

Configuring application-defined devices

Elements such as `DUET_DEV_TYPE_DISC_DEVICE` and `DUET_DEV_POLLED` are defined within the NetLinx `axi`. The latest version of the NetLinx.`axi` file contains both the new API definitions, as well as the pre-defined constants that are used as some of the API arguments (ex: `DUET_DEV_TYPE_DISC_DEVICE`). Sample code can be found within the `DEFINE_START` section seen in FIG. 80:



Physical device names are typically prefixed with "dv" and Virtual device names are typically prefixed with "vdv". It is recommended that anyone working with these modules should become familiar with this naming convention.

```
PROGRAM_NAME='DDD'
DEFINE_DEVICE
COM1 = 5001:1:0
COM2 = 5001:2:0
dvRECEIVER1 = 41000:1:0
dvDiscDevice = 41001:1:0

DEFINE_CONSTANT
DEFINE_TYPE
DEFINE_VARIABLE
```

```

DEFINE_START

STATIC_PORT_BINDING(dvDiscDevice, COM1, DUET_DEV_TYPE_DISC_DEVICE,
    'My DVD', DUET_DEV_POLLED)

DYNAMIC_POLLED_PORT(COM2)

DYNAMIC_APPLICATION_DEVICE(dvRECEIVER1, DUET_DEV_TYPE_RECEIVER,
    'My Receiver')

(*****
 *           THE EVENTS GO BELOW           *
*****)
DEFINE_EVENT

DATA_EVENT [dvRECEIVER1]
{
    // Duet Virtual device data events go here
}
    
```

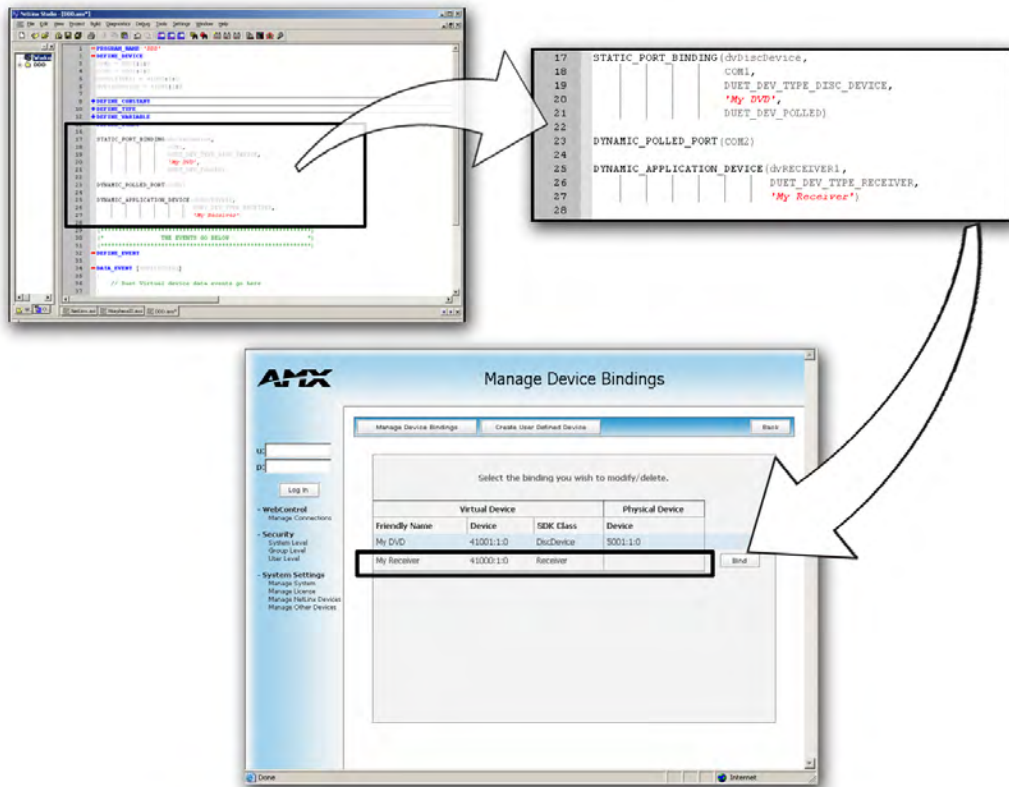

FIG. 80 Manage Device Bindings page - showing the NetLinx code relation

This code would have given the Master a previous “heads-up” notification to look for those devices meeting the criteria outlined within the code.

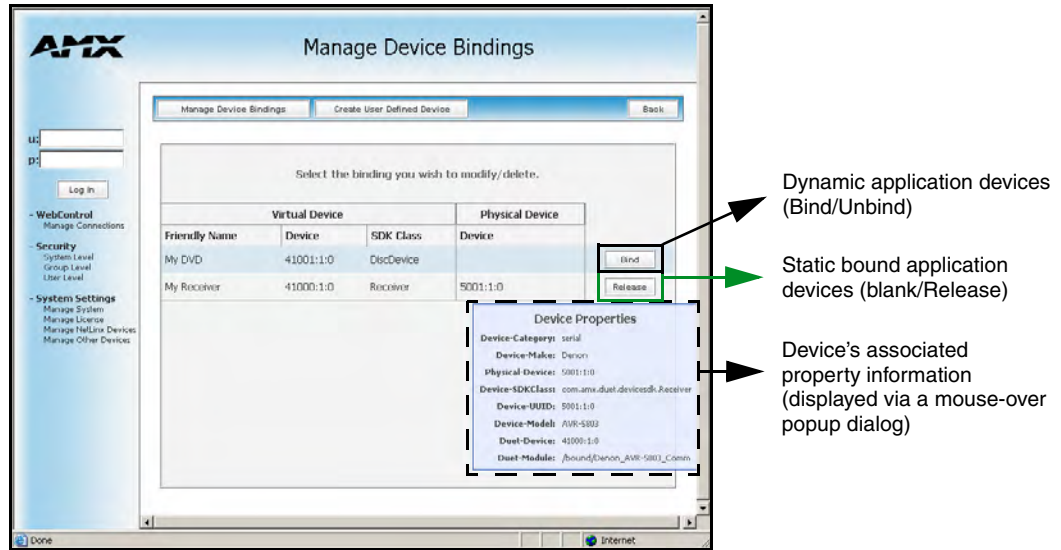

FIG. 81 Manage Device Bindings page

What are Application Devices and their association status?

There are two types of application devices: Static Bound application devices and Dynamic application devices.

- **Static Bound application devices** specify both a Duet virtual device and its associated Device SDK class type, as well as a NetLinx physical device port to which the application device is **ALWAYS** associated (i.e. statically bound).
- **Dynamic application devices** specify both the Duet virtual device and its associated Device SDK with no association to a physical port. Binding of an application device to a physical device/port occurs at run-time either via auto-binding or manual binding.

Application devices that have a "bound" physical device display their physical device ID within the **Physical Device** column. If an associated Duet module has been started to communicate with the device, its associated property information is then displayed in a mouse-over popup dialog when the cursor hovers over the physical device ID.

Each entry in the table has one of four values appear within the far right of the Manage Device Bindings page (FIG. 81).

- **Static bound application devices** will either be *blank* or display a **Release** button.
 - Static application devices that have not yet detected a physical device attached to their associated port are left *blank*. Once a physical device is detected and its associated Duet module has been started, a **Release** button is then displayed.
 - By selecting **Release**, the administrator is forcing the associated Duet module to be destroyed and the firmware then returns to detecting any physical devices attached to the port.
- **Dynamic application devices** either display a **Bind** or **Unbind** button.
 - Dynamic application devices that have been bound display an **Unbind** button. When the user selects **Unbind**, any associated Duet module is then destroyed and the "link" between the application device and the physical device is then broken.

- Dynamic application devices that have not been bound to a physical device display a **Bind** button. When this button is selected, a secondary display appears with a listing of all available unbound physical devices that match the application device's Device SDK class type (FIG. 82).
- If a currently bound device needs to be replaced or a Duet Module needs to be swapped out, the device should be unbound and the new module/driver should then be bound.

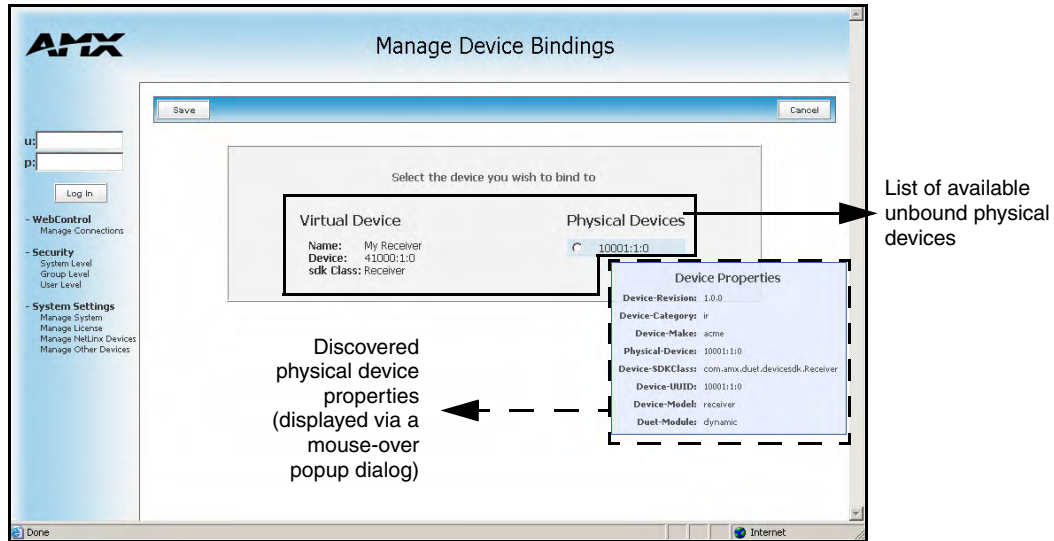

FIG. 82 Manage Device Bindings - showing a listing of all unbound devices

- The administrator/user can then select one of the available physical devices to bind with the associated application device. When the **Save** button is selected, the binding is created and a process begins within the target Master to find the appropriate Duet Module driver. Once a driver is found, the Duet Module is then started and associated with the specified application device (Duet virtual device). If the **Cancel** button is selected, the binding activity is then aborted.
- A mouse-over popup dialog is provided to display the properties associated with each discovered physical device that is listed (FIG. 82).



If the manufacturer device does not support Dynamic Device Discovery (DDD) beaconing, you must use the Add New Device page to both create and manage those values necessary to add a dynamic physical device. This process is described in detail within the following section.

Manage Other Devices Menu - Viewing Discovered Devices

This page (FIG. 83) provides a listing with all of the dynamic devices that have been discovered in the system.

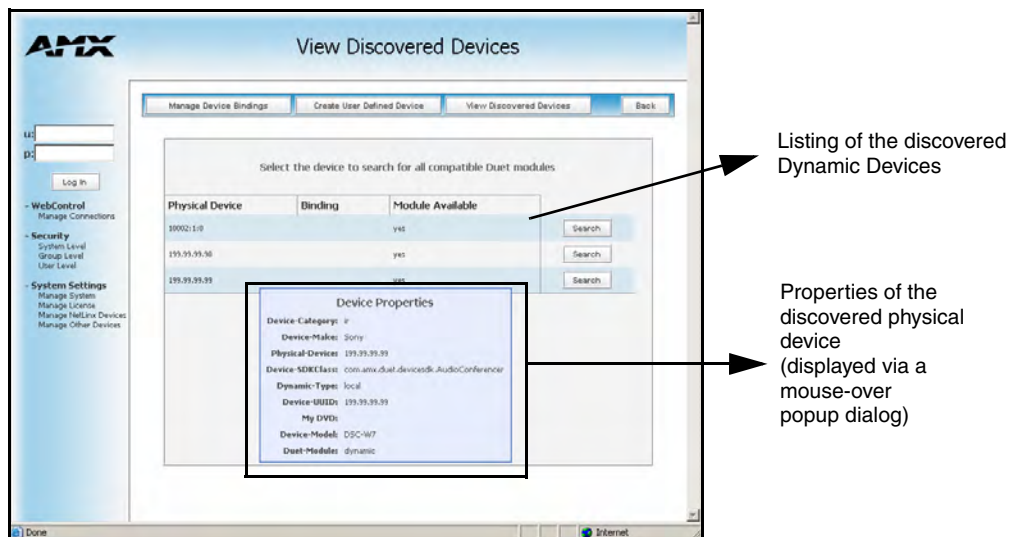

FIG. 83 View Discovered Devices page

Mousing-over a listed entry presents a popup which displays all of the properties associated with the physical device. If the physical device is bound to an application device, the associated application device's "friendly name" will be displayed in the **Binding** column. The **Module Available** column indicates if a Duet module is currently available on the system for the target physical device (the results are: **yes**, **no**, or **unknown**).

For each physical device, a **Search** button is provided which initiates a search for compatible modules.

- If the **Module Search via the Internet** option has been previously *enabled* (via the corresponding button within the *Configure Binding Options* section of the *Manage Other Devices* page), the search includes a query of the AMX online database for a compatible module based on the device's properties.
- If the device specified a **URL** in its DDD beacon, the file is retrieved from the URL either over the Internet or from the physical device itself, provided the device has an inboard HTTP or FTP server.
- If **Module Search via Internet** is *NOT enabled*, the search does NOT query the AMX online database nor will it pull any manufacturer specified URLs that do not match the IP Address of the physical device itself.

Modules that are retrieved from either the Internet or from the manufacturer's device are then placed into the **/unbound** directory and automatically overwrite any existing module of the same name.

Once a list of all compatible modules is compiled, the Select Device Module page (FIG. 84) is then displayed with a listing of each module along with its calculated "match" value. The greater the "match" value, the better the match between the Duet Module's properties and the physical device's properties.

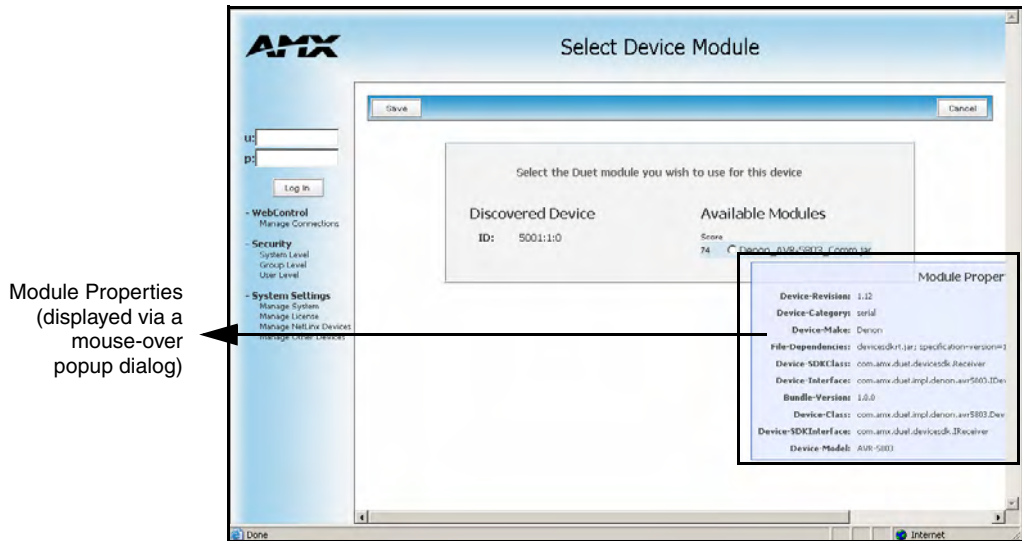

FIG. 84 Select Device Module page

Mousing-over a listed module entry presents a popup which displays the properties associated with the selected module.

By selecting the module and clicking the **Save** button, the administrator can assign a Duet module to be associated with the physical device.



This action will NOT affect any currently running Duet module associated with the physical device. The module is associated with the device upon reboot.

Clicking the **Cancel** button aborts the association of a Duet module with the physical device **BUT** it does not undo the process of pulling new modules from the Internet/device into the **/unbound** directory on the target Master. These modules will remain resident in the **/unbound** directory until they are manually deleted via the Manage Other Devices main web page. Refer to the *System Settings - Manage Other Devices - Dynamic Device Discovery Pages* section on page 116.

Manage Other Devices Menu - Creating a new User-Defined Device

This page provides the ability to both add and remove any user-defined devices. Existing user-defined devices are listed at the bottom of the display along with a corresponding **Remove** button alongside each new entry. Although FIG. 85 shows a populated page, by default, all fields are blank and no devices are pre-populated.

1. Click on the **Create User Defined Device** button (from within the *Manage Other Device page*).
2. Begin by entering the address of the physical device within the *Address* field. This information can be either the NetLinX Master port value (D:P:S) or an IP Address (###.###).
3. From within the *Device Category* field, use the drop-down list to select the control method associated with the physical target device (IR, IP, Serial, Relay, Other).
4. From within the *SDK Class* field, use the drop-down list to select the closest Device SDK class type match for the physical target device. The following table provides a listing of the available choices.

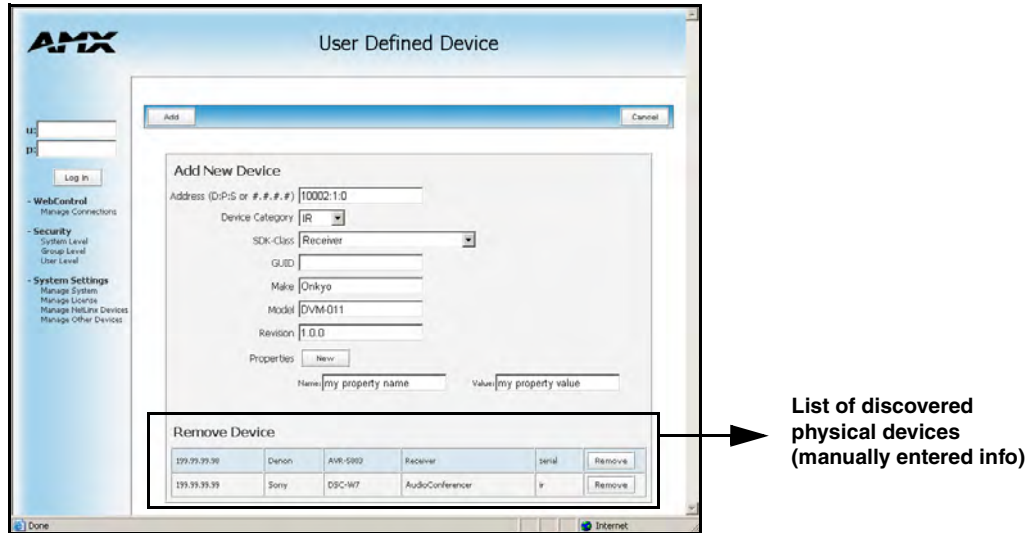

FIG. 85 Add New Device page

SDK-Class Types		
Amplifier	DocumentCamera	SlideProjector
AudioConferencer	HVAC	Switcher
AudioMixer	Keypad	Text Keypad
AudioProcessor	Light	TV
AudioTape	Monitor	Utility
AudioTunerDevice	Motor	VCR
Camera	MultiWindow	VideoConferencer
Digital Media Decoder	PoolSpa	VideoProcessor
Digital Media Encoder	PreAmpSurroundSoundProcessor	VideoProjector
Digital Media Server	Receiver	VideoWall
Digital Satellite System	Security System	VolumeController
Digital Video Recorder	Sensor Device	Weather
Disc Device	SettopBox	

5. Use the *GUID* field to enter the manufacturer-specified device’s Global Unique Identification information. *Either the GUID or Make/Model must be specified within this field.*
6. Enter the name of the manufacturer for the device being used (up to 55 alpha-numeric characters) (ex: Sony, ONKYO, etc..) into the *Make* field. *Either the GUID or Make/Model must be specified within this field. Note that spaces in the name will be converted to underscores.*
7. Enter the model number of the device being used (up to 255 alpha-numeric characters) (ex: Mega-Tuner 1000) into the *Model* field. *Either the GUID or Make/Model must be specified within this field.*
8. Enter the firmware version used by the target device into the *Revision* field. *Text is required within this field.*
 - The version must be in the format: **major.minor.micro** (where major, minor, and micro are numbers). An example is: *1.0.0* (revision 1.0.0 of the device firmware).

9. Once you are done creating the profile for the new device, click the **New** button to assign additional **Name** and **Value** property information for association with the new User Defined Device.
 - When the **Add** button is selected, the user-defined device is then inserted into the list of discovered physical devices which appears within the lower section of the display (FIG. 85).
 - When the **Cancel** button is selected, the addition of the user defined device is aborted, no amendment to the existing list is made, and the user is returned back to the Manage Device Bindings page.
10. Once you have finished entering your devices, click the **Back** button (from within the Manage Device Bindings page) and then navigate to the View Discovered Devices page to view the listing of all Dynamic Devices discovered in the system.

How do I write a program that uses Dynamic Device Discovery

These procedures assume the NetLinx developer does not have the Manufacturer device information necessary at the time of the initial setup. For more detailed UI information refer to the *Manage Other Devices - Manage Device Bindings* section on page 121. For information on the referenced NetLinx calls, refer to the NetLinx Keywords Help file (found within Studio).

1. Decide whether the application interface is to be Dynamic or Static bound and how the device will be connected to the system (Serial, IP, IR, etc).
 - Refer to page 123 for a definition of Static and Dynamic Application devices.



IP devices cannot be statically bound because they do not have an associated NetLinx D:P:S port value to associate with the application device.

2. To configure a Static application interface:
 - Add the NetLinx `STATIC_PORT_BINDING` API call to the section of the NetLinx program (FIG. 80 on page 122) containing the: Duet Virtual Device D:P:S, the NetLinx physical device D:P:S, the Duet Device type constant, and the associated friendly name string.
 - ***STATIC_PORT_BINDING*** designates an application device along with its SDK class and the physical interface it is bound to. The complete API is:

```
STATIC_PORT_BINDING (DEV duetDevice, DEV netlinxDevice, char[] deviceType, char[] friendlyName, integer polled)
```
 - Determine whether the physical device D:P:S should be polled to discover the connected devices. ***Only serial ports should be polled. Polled is a boolean integer which is part of the NetLinx AXI file.***

3. To configure a Dynamic application interface:
 - Add the `DYNAMIC_APPLICATION_DEVICE` API call to the section of the NetLinx program (FIG. 80 on page 122) containing the Duet Virtual Device D:P:S, the Duet Device type constant, and the associated friendly name string.
 - ***DYNAMIC_APPLICATION_DEVICE*** specifies a Duet device that is completely dynamic. A dynamically discovered device matching the specified deviceType could be bound to the duetDevice from anywhere in the system.

```
DYNAMIC_APPLICATION_DEVICE (DEV duetDevice, char[] deviceType,
char[] friendlyName)
```
 - Add the `DYNAMIC_POLLED_PORT` API call for any NetLinx physical device D:P:S's that should be polled to discover connected devices.
 - ***DYNAMIC_POLLED_PORT*** designates a NetLinx serial port that should be polled for dynamic device detection. This API must be called for each serial port that can dynamically have a device plugged into it.

```
DYNAMIC_POLLED_PORT (DEV netlinxDevice)
```
4. Write the remainder of the NetLinx application to communicate with the device via the Duet Virtual Device (D:P:S) using the Standard NetLinx API for that device type.
5. Compile the program file and then download it to the target Master via the Tools > File Transfer dialog,
6. Run the NetLinx application on the target Master.

How do I configure a Run-time installation

To utilize Dynamic binding execute step 1 then step 2 then proceed to Step 3.

To utilize Static binding execute step 2 then step 1 because the static bindings will try to bring up the Duet module as soon as the device is discovered and it's best if the module is already available on the Master.

1. Connect the device to the system.
 - If the device is a DDD enabled Serial or IP device, then the device will be automatically discovered and show up in the Master's View Discovered Devices UI page under Manage Other Devices. (FIG. 83 on page 125).
 - If the device is not DDD enabled and/or cannot be automatically discovered (ex. IR device) the installer must enter the device information into the Master via the User Defined Device Web page under manage Other Devices. (FIG. 85 on page 127)
2. Verify the appropriate Duet module is available.
 - If the Master is connected to the Internet, the **Module Search via Internet** button (FIG. 78 on page 116) can be enabled (*via toggling*).
 - From within the View Discovered Devices UI page, click the **Search** button adjacent to the appropriate device to begin the search of an appropriate module.

- Any available modules on either the amx.com, AMX's partner website, or within the physical device itself are downloaded to the Master and then displayed back within the Select Device Module page (FIG. 84 on page 126). The discovered device is then shown with an adjacent listing of available modules ranked with associated "match" score.
 - The location of these modules can be either indeterminate (in which case they will reside on the amx.com website) or in some cases be required by the manufacturer to reside in their own specific source location (such as the manufacturer's own website or found within the target unit itself).
- The installer can then select which module to use with that discovered device by selecting the corresponding radio box and then clicking the upper-left **Save** button. This action then returns the installer back to the View Discovered Devices page.



NOTE

If the installer has the Duet module on a PC, the file can be downloaded to the Master via the Manage Device Modules section of the Manage Other Devices web page (FIG. 78 on page 116).

3. For Dynamically bound modules:
 - Begin the process of binding the Dynamic application device with the newly discovered physical device by navigating to the Manage Other Devices > Manage Device Bindings page. Dynamic application devices that have not been bound to a physical device display a **Bind** button.
 - Click the **Bind** button adjacent to the desired device.
 - From the secondary window, choose the appropriate physical device from the listing of all available unbound physical devices which matches the application device's Device SDK class type (FIG. 82 on page 124).

The Duet Module is started immediately after being "bound" which then causes an ONLINE event to be received by the NetLinx program for the Duet Virtual device.

Accessing an SSL-Enabled Master via an IP Address

Once the target Master has been fully configured with an SSL certificate, user/group access rights, and System level security parameters, the administrator (or comparably authorized user) can decide to require additional security on the Master by making any consecutive access to the Master be done via a HTTPS (*a secure version of HTTP communication*). Refer to the *Setting the Master's Port Configurations* section on page 94 for more information on this process.

1. Launch your web browser.
2. Enter the IP Address of the target Master into the web browser's *Address* field, but preface this information with the word **https** (*ex: https://198.198.99.99*). This https is used to communicate with the target Master via the pre-configured HTTPS/SSL Port.
3. Press the **Enter** key on your keyboard to begin the communication process between the target Master and your computer.

- The user is then presented with a Security Alert popup window and Certificate information (FIG. 86).

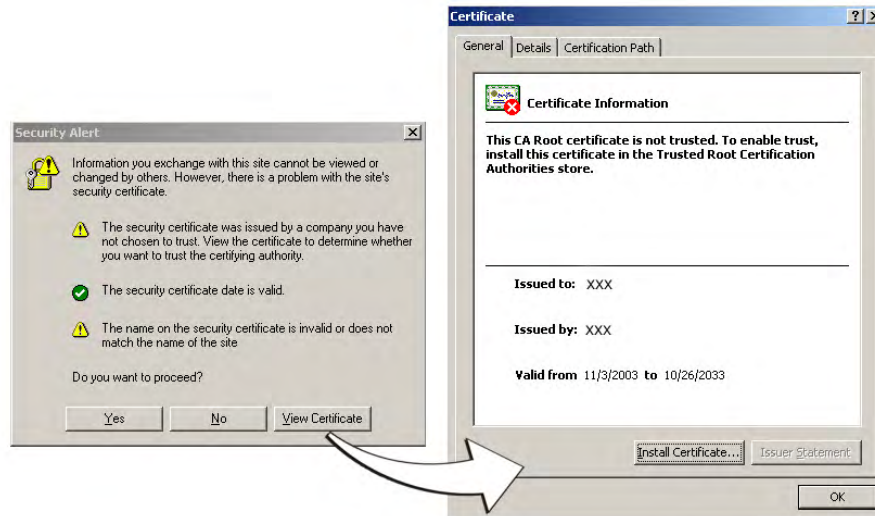

FIG. 86 Security Alert and Certificate popups



NOTE

The above alert only appears if an SSL Server Certificate has been installed on the target Master, the SSL Enable options has been enabled, from within the Enable Security window of the Security tab, and there is a problem with the site's certificate.

Problems with the certificate can result from:

- The default AMX certificate, self generated, or self-signed certificate hasn't been approved by a CA.
 - The above mentioned certificates are not part of that computer's web browser list of trusted sites. This changes after the certificate is installed into the user's browser list of trusted sites.
 - The date period given to the certificate has expired. CA-approved certificates typically come with a 2 year window of validity. Self generate certificates come defaulted with a 30 year window of validity (FIG. 86).
 - The name on the security certificate site information doesn't match the domain name of the target Master.
- Click the **View Certificate** button on the Security Alert popup to view more detailed information about the certificate. A secondary Certificate popup window is then displayed.
 - Review the information presented within the certificate and if you trust that both the site and certificate information are correct, click the **Install Certificate** button to begin installing the certificate into computer's web browser list of trusted sites.

- The user is then presented with a Certificate Import Wizard that begins the process of adding the certificate (FIG. 87).



FIG. 87 Certificate Import Wizard

- Click **Next** to proceed with the certificate store process.

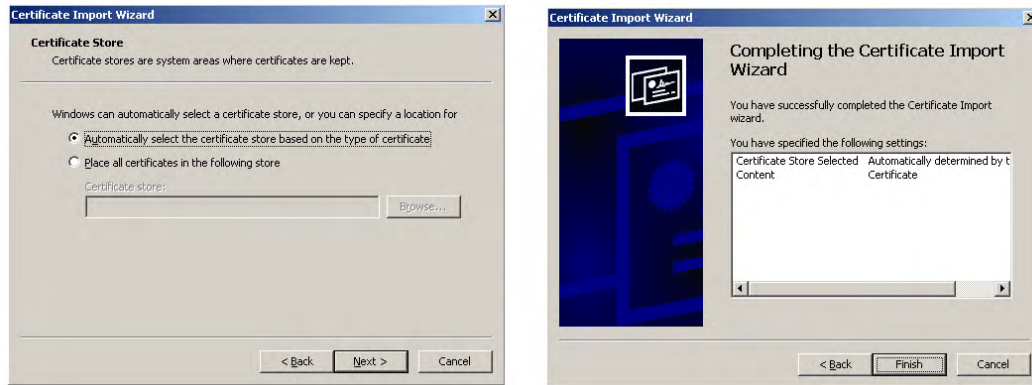

FIG. 88 Certificate Import Wizard- storing the certificate

- Click **Next** to automatically use the default certificate store settings and locations (FIG. 88).
- Click **Finish** button to finalize the certificate installation process.
- Click **Yes**, from the next popup window to "...ADD the following certificate to the Root Store?". After a successful importing of the certificate into Internet Explorer's list of trusted sites, another popup window appears to inform you of the success.
- Click **OK** from the Import was successful popup window.
- To close the still open Certificate popup window click **OK**.
- To close the still open Security Alert popup window, click **Yes**.
- From the Network Password window, click the down arrow from the *username* field to select a username.
- Enter a valid password into the *password* field.
- Click the *save password* check mark field if you want to have your web browser remember this password during consecutive login sessions.
- Click **OK** to access the target Master.

19. The first page displayed within your open browser window is Manage WebControl Connections page.

Using your NetLinx Master to control the G4 panel

Refer to the specific panel instruction manual for detailed information on configuring and enabling WebControl. This firmware build enables SSL certificate identification and encryption, HTTPS communication, ICSP data encryption, and disables the ability to alter the Master security properties via a TELNET session.



NOTE

In order to fully utilize the SSL encryption, your web browser should incorporate the an encryption feature. This encryption level is displayed as a Cipher strength.

Once the Master's IP Address has been set through NetLinx Studio version 2.4 or higher:

1. Launch your web browser.



NOTE

In order to fully utilize the SSL encryption, your web browser should incorporate the an encryption feature. This encryption level is displayed as a Cipher strength.

2. Enter the IP Address of the target Master (*ex: **http://198.198.99.99***) into the web browser's *Address* field.
3. Press the **Enter** key on your keyboard to begin the communication process between the target Master and your computer.
 - Initially, the Master Security option is disabled (from within the **System Security** page) and no username and password is required for access or configuration.
 - Both HTTP and HTTPS Ports are enabled by default (via the **Manage System > Server** page).
 - If the Master has been previously configured for secured communication, click **OK** to accept the AMX SSL certificate (*if SSL is enabled*) and then enter a valid username and password into the fields within the *Login* dialog.
4. Click **OK** to enter the information and proceed to the Master's Manage WebControl Connections window.
5. Enter a valid username and password into the fields within the Login dialog.
6. Click **OK** to enter the information and proceed to the Master's Manage WebControl Connections window.
7. This Manage WebControl Connections page (FIG. 89) is accessed by clicking on the **Manage connections** link (*within the Web Control section within the Navigation frame*). Once activated, this page displays links to G4 panels running the latest G4 Web Control feature (*previously setup and activated on the panel*).

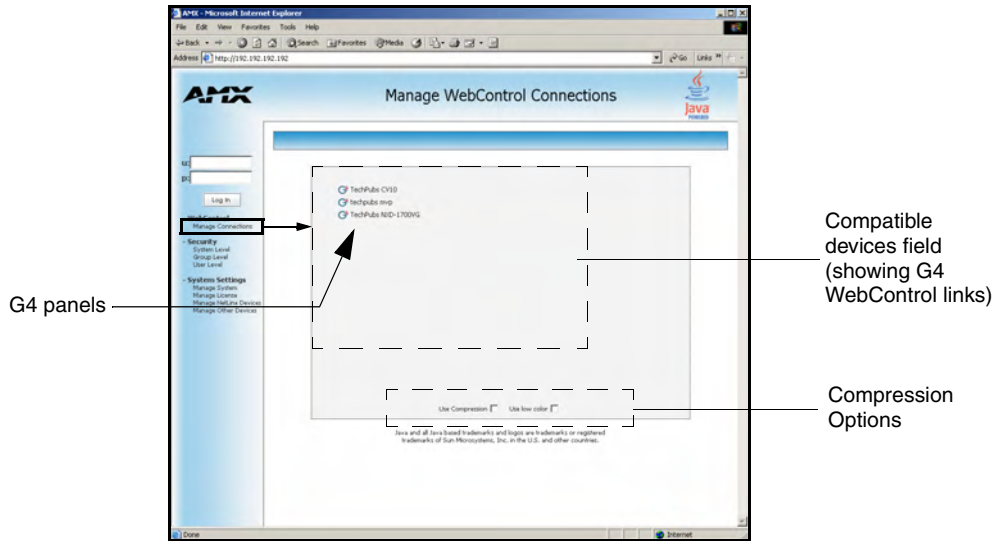

FIG. 89 Manage WebControl Connections page (populated with compatible panels)

8. Click on the G4 panel name link associated with the target panel. A secondary web browser window appears on the screen (FIG. 90).

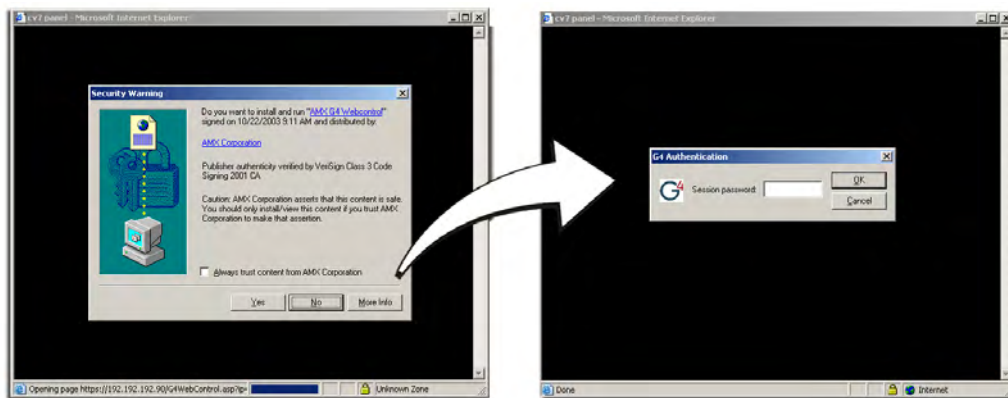

FIG. 90 WebControl VNC installation and Password entry screens

9. Click **Yes** from the Security Alert popup window to agree to the installation of the G4 WebControl application on your computer. This application contains the necessary Active X and VNC client applications necessary to properly view and control the panel pages from your computer.



NOTE

The G4 WebControl application is sent by the panel to the computer that is used for communication. Once the application is installed, this popup no longer appears. This popup only appears if you are connecting to the target panel using a different computer.

10. In some cases, you might get a Connection Details dialog (FIG. 91) requesting a VNC Server IP Address. This is the IP Address not the IP of the Master but of the target touch panel. Depending on which method of communication you are using, it can be found in either the:
 - **Wired Ethernet** - System Connection > IP Settings section within the *IP Address* field.
 - **Wireless** - Secondary Connection > IP Settings section within the *IP Address* field.

- If you do not get this field continue to step 11.

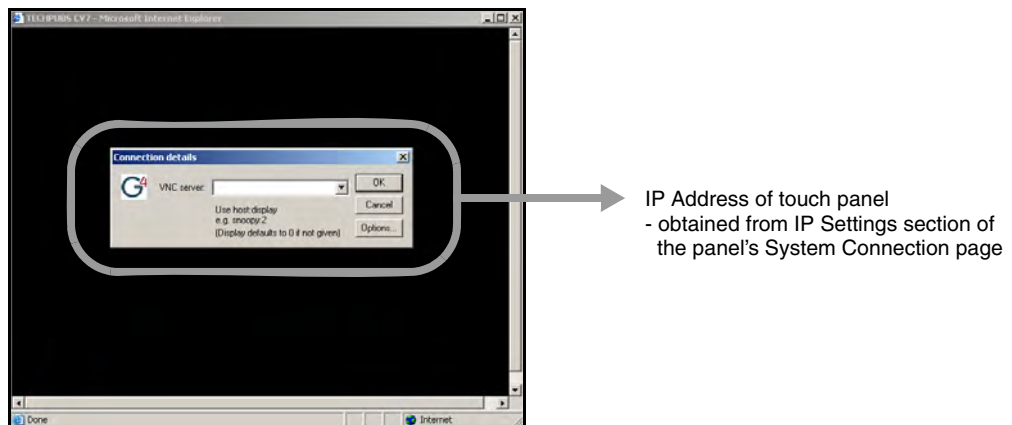

FIG. 91 Connection Details dialog

11. If a WebControl password was setup on the G4 WebControl page, a G4 Authentication Session password dialog box appears on the screen within the secondary browser window.
12. Enter the WebControl session password into the *Session Password* field (FIG. 90). *This password was previously entered into the Web Control Password field within the G4 Web Control page on the panel.*
13. Click **OK** to send the password to the panel and begin the session. A confirmation message appears stating *"Please wait, Initial screen loading.."*.

The secondary window then becomes populated with the same G4 page being displayed on the target G4 panel. A small circle appears within the on-screen G4 panel page and corresponds to the location of the mouse cursor. A left-mouse click on the computer-displayed panel page equates to an actual touch on the target G4 panel page.

What to do when a Certificate Expires

Self-generated certificates have a duration period of approximately 30 years. Most externally requested CA certificates are generally valid for a period of approximately 1 - 5 years.

The only way to avoid a CA certificate becoming invalid due to a time expiration is to request a new certificate from your current CA.

Refer to the *Server - Creating a Request for an SSL Certificate* section on page 101 for more information on how to request an externally generated certificate.

NetLinx Security with a Terminal Connection

NetLinx Masters currently have built-in security capabilities. They require a user enter a valid username and password to access the NetLinx System's Telnet, HTTP, ICSP, and FTP services.

The security capabilities are configured and applied via a Telnet connection or the NetLinx Master's RS-232 terminal interface (the RS232 Program port).



NOTE

Always use the RS232 Program port when entering potentially sensitive security information. The Telnet server interface exposes this security information to the network in clear text format, which could be intercepted by an unauthorized network client. By using the RS232 Program port, there is security during the configuration of the database due to the physical proximity of the user to the system.

NetLinx Security Features

NetLinx security allows you to define access rights for users or groups.



NOTE

A "User" represents a single potential client of the NetLinx Master, while a "Group" represents a logical collection of users. Any properties possessed by groups (i.e., access rights, directory associations, etc.) are inherited by all the members of the group.

The following table lists the NetLinx features that the administrator (or other 'qualified' user) may grant or deny access to.

NetLinx Security Features	
NetLinx Master Security Configuration	The user has access to the security configuration commands of the Master. Only those users with security configuration access rights granted will have access to the security configuration commands.
Telnet Security	The user has access to the Telnet server functionality. All basic commands are available to the user.
Terminal (RS232) Security	The user has access to the Terminal (RS232 Program port) server functionality. All basic commands are available to the user.
HTTP (web server) Security	The user has access to the HTTP server functionality. Directory associations assign specific directories/files to a particular user.
FTP Security	The user has access to the FTP server functionality. Only the administrator account has access to the root directory; all other 'qualified' clients are restricted to the /user/ directory and its 'tree'.
ICSP	The user has access to the ICSP communication functionality. Communication and encryption rights are available to an authorized user.
ICSP Encryption	The user has access to the ICSP data encryption functionality. Enabling encryption of ICSP data requires that both: <ul style="list-style-type: none"> - AMX hardware or software communicating with the target Master provide a valid username and password. - All communication is encrypted.

Initial Setup via a Terminal Connection

Security administration and configuration is done via a Terminal communication through the RS232 Program port on the NetLinx Master. If you connect to the target Master via the *TCP/IP (Winsock)* option, you will find that some command sets (such as the security setup) will not be available. *If you have a valid IP connection method to the Master, it is recommended that you make your changes to the parameters via the browser-based UI pages.*



NOTE

*Although these procedures are written for a Terminal connection, a user can also connect to a Master via a Telnet connection. Do this by going to Start > Run, enter **cmd** within the Run dialog's Open field and click **OK**. Then from within the CMD command prompt use the IP Address info to type **>telnet XXX.XXX.XXX.XXX** <Enter>.*

Establishing a Terminal connection via the RS-232 Program Port

1. Launch the HyperTerminal application from its' default location (**Start > Programs > Accessories > Communications**).
2. Apply power to the NetLinx Master and allow it to boot up.
3. Connect the PC COM (RS232) port from your computer to the RS232 Program port on the NetLinx Master. *Note the baud rate settings for the Master.*
4. Enter any text into the *Name* field of the HyperTerminal Connection Description dialog window and click **OK** when done.
5. From the *Connect Using* field, click the down-arrow and select the PC COM port being used for communication by the target Master and click **OK** when done.
6. From the *Bits per second* field, click the down-arrow and select the baud rate being used by the target Master.
 - Configure the remaining communication parameters as follows: Data Bits: **8**, Parity: **None**, Stop bits: **1**, and **Flow control: None** (*default is Hardware*).
 - Click **OK** to complete the communication parameters and open a new Terminal window.
7. Type **echo on** to view the characters while entering commands. If that does not work, press <Enter> key on your keyboard.



NOTE

It is very important for a user properly execute the 'logout' command prior to disconnecting from a Master. Simply removing the RS-232 connector from the Program Port maintains your logged-in status until you either return to logout via a new session or reboot the target Master.

Accessing the Security configuration options

1. In the Terminal session, type **help security** to view the available security commands. Here is a listing of the security help:

```
---- These commands apply to the Security Manager and Database ----
logout                Logout and close secure session
setup security        Access the security setup menus
```



NOTE

The 'help security' and 'setup security' functions are only available via a direct RS232 Program port connection. They are not available under telnet (such as via a TCP/IP (Winsock) connection).

2. Type **setup security** to access the Main Security Menu, shown below:

```
>setup security

--- These commands apply to the Security Manager and Database ----
 1) Set system security options for NetLinx Master
 2) Display system security options for NetLinx Master
 3) Add user
 4) Edit user
 5) Delete user
 6) Show the list of authorized users
 7) Add group
 8) Edit group
 9) Delete group
10) Show list of authorized groups
11) Set Telnet Timeout in seconds
12) Display Telnet Timeout in seconds
13) Make changes permanent by saving to flash

Or <ENTER> to return to previous menu

Security Setup ->
```

3. The Main Security Menu shows a list of choices and a prompt. To select one of the listed choices, simply enter the number of the choice (**1 - 13**) at the prompt and press <Enter>.



NOTE

Options 14 and 15 are only visible to the System Administrator. Refer to the Table , "Main Security Menu (Cont.)," on page 151.

4. Each option in the Main Security Menu displays a submenu specific to that option.

The following subsection describe using each of the Main Security Menu options.

For a detailed description of each option in the Main Security Menu, refer to *Main Security Menu on page 150*.

Option 1 - Set system security options for NetLinx Master (Security Options Menu)

Type **1** and <Enter> at the Security Setup prompt (at the bottom of the Main Security Menu) to display the **Security Options Menu**.

The Security Options Menu sets the "global" options for the NetLinx Master. It is accessed by the Set Security system options of the Main Security Menu. This first thing that will happen is you will be asked one of two questions. If NetLinx Master security is enabled, you will see the following:

```
NetLinx Master security is Enabled
Do you want to keep NetLinx Master security enabled? (y or n):
```

- If you answer **y** for yes, security will remain enabled and you will be taken to the Security Options Menu.
- If you answer **n** for no, all security settings (except FTP security) will be disabled and you will be taken back to the Main Security Menu.

If NetLinx Master security is not enabled, you will see the following:

```
NetLinx Master security is Disabled
Do you want to enable security for the NetLinx Master? (y or n):
```

- If you answer **y** for yes, security will be enabled and you will be taken to the Security Options Menu.
- If you answer **n** for no, all security settings (except FTP security) will remain disabled and you will be taken back to the Main Security Menu.

The Security Options Menu is displayed as follows:

```
Select to change current security option
1) Terminal (RS232) Security..... Enabled
2) HTTP Security..... Disabled
3) Telnet Security..... Enabled
4) Configuration Security..... Enabled
5) ICSP Security..... Enabled
6) ICSP Encryption Required..... Enabled
Or <ENTER> to return to previous menu
```

```
Security Options ->
```

The selection listed will display what the current settings. To change an option, select the number listed next to the option.

For example, if selection 2) is selected (from the Select to change current security option listing), the security options for the Master are listed and HTTP Security becomes enabled. The listing is then displayed as follows:

```
Select to change current security option
1) Terminal (RS232) Security..... Enabled
2) HTTP Security..... Enabled
3) Telnet Security..... Enabled
4) Configuration Security..... Enabled
5) ICSP Security..... Enabled
6) ICSP Encryption Required..... Enabled
Or <ENTER> to return to previous menu
```

```
Security Options ->
```

Each selection simply toggles the security setting selected. Press <Enter> to exit the menu and return to the Main Security Menu.



Changes made to the target Master from within the Terminal window are not reflected within the web browser, until the Master is rebooted and the web browser connection is refreshed.

Any changes made to the Master, from within the web browser are instantly reflected within the Terminal session without the need to reboot.

The items in the Security Options Menu are described below:

Security Options Menu	
Command	Description
1) Terminal (RS232) Security (Enabled/Disabled)	This selection enables/disables Terminal (RS232 Program port) Security. If Terminal Security is enabled, a user must have sufficient access rights to login to a Terminal session.
2) HTTP Security (Enabled/Disabled)	This selection enables/disables HTTP (Web Server) Security. If HTTP Security is enabled, a user must have sufficient access rights to browse to the NetLinx Master with a Web Browser.
3) Telnet Security (Enabled/Disabled)	This selection enables/disables Telnet Security. If Telnet Security is enabled, a user must have sufficient access rights to login to a Telnet session.
4) Configuration Security (Enabled/Disabled)	This selection enables/disables Configuration Access rights for the target Master. If the Configuration Security is enabled, a user must have sufficient access rights to access the Main Security Menu and make changes to the Master's security parameters.
5) ICSP Security (Enabled/Disabled)	This selection enables/disables security of ICSP data being transmitted between the target Master and external AMX components (software and hardware such as TPD4 and a Modero Touch Panel).
6) ICSP Encryption Required (Enabled/Disabled)	This selection enables/disables the need to require encryption of the ICSP communicated data. If enabled: - All communicating AMX components must authenticate with a valid username and password before beginning communication with the Master. - All communication must be encrypted.

Option 2 - Display system security options for NetLinx Master

Type 2 and <Enter> at the Security Setup prompt (at the bottom of the Main Security Menu) to display the current security options, and their current state (Enabled/Disabled). For example:

```
Master Security.....Disabled
Terminal.....Disabled
HTTP.....Disabled
Telnet.....Disabled
Configuration.....Disabled
ICSP.....Disabled
ICSP Encryption.....Disabled
```

Press <ENTER> key to continue

Option 3 - Add user

1. Type 3 and <Enter> at the Security Setup prompt (at the bottom of the Main Security Menu) to create a new user account. A sample session response is:

```
The following users are currently enrolled:
administrator
Fred
techpubs

Enter username ->
```

2. At the **Enter username** prompt, enter a new username (for example "techpubs"). A username is a valid character string (4 - 20 alpha-numeric characters) defining the user. This string is *case sensitive*. Each username must be unique.
3. Press <Enter> to enter the new username. The session then prompts you for a password for the new user.
4. Enter a password for the new user. A password is a valid character string (4 - 20 alpha-numeric characters) to supplement the username in defining the potential client. This string is also *case sensitive*.
5. The session then prompts you to verify the new password. Enter the password again, and press <Enter>.
6. Assuming the password was verified, the session then displays the Edit User menu (*see below*).

Option 4 - Edit User

1. Type 4 and <Enter> at the Security Setup prompt (at the bottom of the Main Security Menu) to edit an existing user account. A sample session response is:

```
Select from the following list of enrolled users:
```

```
1) administrator
2) NetLinx
3) techpubs
4) Pat
Select User ->
```

2. Select the user account (1-X) that you want to edit, and press <Enter> to display the Edit User Menu (described below).

Any changes made via the Edit User menu will affect the selected user account.

Edit User Menu

The Edit User Menu is accessed whenever you enter the Add user, or Edit user selections from the Main Security Menu. The Edit User Menu is displayed as follows:

```
Please select from the following options:
```

```
1) Change User Password
2) Change Inherits From Group
3) Add Directory Association
4) Delete Directory Association
5) List Directory Associations
6) Change Access Rights
7) Display User Record Contents
Or <ENTER> to return to previous menu
```

```
Edit User ->
```

Each selection (1-7) accesses the named option. Press <Enter> by itself to exit the menu and return to the Main Security Menu.

The Edit User Menu options are described in the following table:

Edit User Menu	
Command	Description
1) Change User Password	This selection prompts you to enter the new password (twice) for the user. Once the new password is entered, the user must use the new password from that point forward.
2) Change Inherits From Group	This selection will display the current group the user is assigned to (if any). It will then display a list of current groups and prompts you to select the new group.
3) Add Directory Association	This selection will display any current Directory Associations assigned to the user, and then will prompt you for a path for the new Directory Association.
4) Delete Directory Association	This selection will display any current Directory Associations assigned to the user, and then will prompt you to select the Directory Association you want to delete.
5) List Directory Associations	This selection will display any current Directory Associations assigned to the user.
6) Change Access Rights	This selection will display access the Access Rights Menu for the user, which allows you to set the rights assigned to the user.
7) Display User Record Contents	This selection will display the group the user is assigned to and the current Access Rights assigned to the user.

Access Rights Menu

The Access Rights Menu is accessed whenever you select Change Access Rights (option **6**) from the Edit User Menu, or Change Access Rights from the Edit Group Menu. The Access Rights Menu is displayed as follows:

```
Select to change current access right
 1) Terminal (RS232) Access..... Disabled
 2) Admin Change Password Access..... Disabled
 3) FTP Access..... Disabled
 4) HTTP Access..... Enabled
 5) Telnet Access..... Enabled
 6) Configuration Access..... Enabled
 7) ICSP Access..... Enabled
 8) ICSP Encryption Required..... Enabled
Or <ENTER> to return to previous menu
Set Rights ->
```

The above listing displays the current access rights. Entering a selection value simply toggles the access right selected (if for example you enter **4**, the HTTP Access rights toggle from disabled to enabled upon a refresh of the listing).

Press <Enter> to exit the menu and return to the previous menu. The Access Rights Menu is described in the following table:

Access Rights Menu	
Command	Description
1) Terminal (RS232) Access (Enable/Disable)	Enables/disables Terminal (RS232 Program port) Access. The account has sufficient access rights to login to a Terminal session if this option is enabled.
2) Admin Change Password Access (Enable/Disable)	Enables/disables Administrator Change Password Access. The account has sufficient access rights to change the administrator password if this option is enabled.
3) FTP Access (Enable/Disable)	Enables/disables FTP Access. The account has sufficient access rights to access the NetLinx Master's FTP Server if this option is enabled.
4) HTTP Access (Enable/Disable)	This selection enables/disables HTTP (Web Server) Access. The account has sufficient access rights to browse to the NetLinx Master with a Web Browser if this option is enabled.
5) Telnet Access (Enable/Disable)	This selection enables/disables Telnet Access. The account has sufficient access rights to login to a Telnet session if this option is enabled.
6) Configuration Access (Enable/Disable)	This selection enables/disables Configuration Access rights for the target Master. The account has sufficient access rights to access the Main Security Menu if this option is enabled.
5) ICSP Security (Enabled/Disabled)	This selection enables/disables ICSP communication access. The account has sufficient access rights to initiate ICSP data communication.
6) ICSP Encryption Required (Enabled/Disabled)	This selection enables/disables the need to require encryption of the ICSP communicated data. If enabled: - All communicating AMX components must authenticate with a valid username and password before beginning communication with the Master. - All communication must be encrypted.

Option 5 - Delete user

1. Type 5 and <Enter> at the Security Setup prompt (at the bottom of the Main Security Menu) to delete an existing user account. A sample session response is:

```
Select from the following list of enrolled users:
1) administrator
2) NetLinx
3) techpubs
4) Pat
Select User ->
```

2. Enter the value associated to the user you want to delete and press <Enter>. This action deletes the user account and returns you to the Security Setup menu.



Changes made to the target Master from within the Terminal window are not reflected within the web browser, until the Master is rebooted and the web browser connection is refreshed.

Any changes made to the Master, from within the web browser are instantly reflected within the Terminal session without the need to reboot.

Option 6 - Show the list of authorized users

1. Type **6** and <Enter> at the Security Setup prompt (at the bottom of the Main Security Menu) to view a list of currently enrolled users.
2. Press <Enter> to return to the Security Setup menu.

Option 7 - Add Group

1. Type **7** and <Enter> at the Security Setup prompt (at the bottom of the Main Security Menu) to add a group account. A sample session response is:

```
The following groups are currently enrolled:
administrator
```

```
Enter name of new group:
```

2. Enter a name for the group. A group name is a valid character string (4 - 20 alpha-numeric characters) defining the group. This string is *case sensitive*, and each group name must be unique.
3. Press <Enter> to display the following Edit Group menu:

Edit Group Menu

```
Please select from the following options:
```

- ```
1) Add Directory Association
2) Delete Directory Association
3) List Directory Associations
4) Change Access Rights
5) Display Access Rights
Or <ENTER> to return to previous menu
```

```
Edit Group ->
```

**Edit Group Menu: Add directory association**

1. At the Edit Group prompt, type **1** to add a new directory association. A sample session response is:

```
There are currently no directories associated with this account
New directory:
```

A Directory Association is a path that defines the directories and/or files that a particular user or group can access via the HTTP (Web) Server on the NetLinx Master. This character string can range from 1 to 128 alpha-numeric characters. This string is *case sensitive*. This is the path to the file or directory you want to grant access. Access is limited to the user (i.e. doc:user) directory of the Master. All subdirectories of the user directory can be granted access.

A single '/' is sufficient to grant access to all files and directories in the user directory and its sub-directory. The '\*' wildcard can also be added to enable access to all files. All entries should start with a '/'. Here are some examples of valid entries:

| Path                      | Notes                                                                                                                                                                                           |
|---------------------------|-------------------------------------------------------------------------------------------------------------------------------------------------------------------------------------------------|
| /                         | Enables access to the user directory and all files and subdirectories in the user directory.                                                                                                    |
| /*                        | Enables access to the user directory and all files and subdirectories in the user directory.                                                                                                    |
| /user1                    | If user1 is a file in the user directory, only the file is granted access. If user1 is a subdirectory of the user directory, all files in the user1 and its sub-directories are granted access. |
| /user1/                   | user1 is a subdirectory of the user directory. All files in the user1 and its sub-directories are granted access.                                                                               |
| /Room1/iWebControlPages/* | /Room1/iWebControlPages is a subdirectory and all files and its subdirectories are granted access.                                                                                              |
| /results.txt              | results.txt is a file in the user directory and access is granted to that file.                                                                                                                 |

By default, all accounts that enable HTTP Access are given a '/'/\*' Directory Association if no other Directory Association has been assigned to the account.

When you are prompted to enter the path for a Directory Association, the NetLinx Master will attempt to validate the path. If the directory or file is not valid (i.e. it does not exist at the time you entered the path), the NetLinx Master will ask you whether you were intending to grant access to a file or directory. From the answer, it will enter the appropriate Directory Association. The NetLinx Master will not create the path if it is not valid. That must be done via another means, most commonly by using an FTP client and connecting to the FTP server on the NetLinx Master.

### Edit Group menu: Delete directory association

1. At the Edit Group prompt, type **2** to delete an existing directory association. A sample session response is:

```
Select a directory association from the following:
1) /directory1/*
2) /directory2/*
Select Directory ->
```

2. Select the directory association to be deleted, and press <Enter> to delete the directory association, and return to the Edit Group menu.

### Edit Group menu: List directory associations

1. At the Edit Group prompt, type **3** to list all existing directory associations. A sample session response is:

```
The following directory associations are enrolled:
/directory1/*
/directory2/*

Press <ENTER> key to continue
```

2. Press <Enter> to return to the Edit Group menu.

## Edit Group menu: Change Access Rights

1. At the Edit Group prompt, type **4** to change the current access rights for the selected group account. A sample session response is:

```
Select to change current access right
 1) Terminal (RS232) Access..... Disabled
 2) Admin Change Password Access..... Disabled
 3) FTP Access..... Disabled
 4) HTTP Access..... Enabled
 5) Telnet Access..... Enabled
 6) Configuration Access..... Enabled
 7) ICSP Access..... Enabled
 8) ICSP Encryption Required..... Enabled
Or <ENTER> to return to previous menu
```

```
Set Rights ->
```

2. Each selection simply toggles the security setting selected. <Enter> is entered by itself to exit the menu and return to the Main Security Menu.



*Changes made to the target Master from within the Terminal window are not reflected within the web browser, until the Master is rebooted and the web browser connection is refreshed.*

*Any changes made to the Master, from within the web browser are instantly reflected within the Terminal session without the need to reboot.*

## Edit Group menu: Display Access Rights

1. At the Edit Group prompt, type **5** to view the current access rights for the selected group account. A sample session response is:

```
Terminal (RS232).....Disabled
Admin. Password Change.....Disabled
FTP.....Disabled
HTTP.....Disabled
Telnet.....Disabled
Configuration.....Disabled
ICSP.....Disabled
```

```
Press <ENTER> key to continue
```

2. Press <Enter> to return to the Edit Group menu.

### Option 8 - Edit Group

1. Type **8** and <Enter> at the Security Setup prompt (at the bottom of the Main Security Menu) to edit an existing group account. A sample session response is:

```
Select from the following list:
 1) administrator
 2) Group 1
 3) Group 2
Select group ->
```

2. Select a group from the list of currently enrolled groups and press <Enter> to open the Edit Group Menu. This is the same Edit Group Menu that was access via the Add Group option:

```

1) Add Directory Association
2) Delete Directory Association
3) List Directory Associations
4) Change Access Rights
5) Display Access Rights
Or <ENTER> to return to previous menu

```

```
Edit group ->
```

This menu is described on the previous pages (see *Edit Group Menu on page 145*).

### Option 9 - Delete Group

1. Type **9** and <Enter> at the Security Setup prompt (at the bottom of the Main Security Menu) to delete an existing group account. A sample session response is:

```

Select from the following list:
1) Group 1
2) Group 2
Select group ->

```

2. Select the group account to be deleted, and press <Enter> to delete the group and return to the Security Setup menu.



NOTE

*Changes made to the target Master from within the Terminal window are not reflected within the web browser, until the Master is rebooted and the web browser connection is refreshed.*

*Any changes made to the Master, from within the web browser are instantly reflected within the Terminal session without the need to reboot.*

### Option 10 - Show List of Authorized Groups

1. Type **10** and <Enter> at the Security Setup prompt (at the bottom of the Main Security Menu) to display a list of all authorized group accounts. A sample session response is:

```

The following groups are currently enrolled:
administrator
Group 1

```

```
Press <ENTER> key to continue
```

2. Press <Enter> to return to the Security Setup Menu.

### Option 11 - Set Telnet Timeout in seconds

*This feature is disabled after the installation of firmware build 130 or higher onto your target Master.*

1. Type **11** and <Enter> at the Security Setup prompt (at the bottom of the Main Security Menu) to set the Telnet Timeout value, in seconds. A sample session response is:

```
Specify Telnet Timeout in seconds:
```

2. Enter the number of seconds before you want The Telnet session to timeout, and press <Enter> to return to the Security Setup Menu.

### **Option 12 - Display Telnet Timeout in seconds**

*This feature is disabled after the installation of firmware build 130 or higher onto your target Master.*

1. Type **12** and <Enter> at the Security Setup prompt (at the bottom of the Main Security Menu) to view the current Telnet Timeout value (in seconds). A sample session response is:

```
Telnet Timeout is 10 seconds.
```

2. Press <Enter> to return to the Security Setup Menu.

### **Option 13 - Make changes permanent by saving to flash**

When changes are made to the security settings of the Master, they are initially only changed in RAM and are not automatically saved permanently into flash. This selection saved the current security settings into flash. Also, if you attempt to exit the Main Security Menu and the security settings have changed but not made permanent, you will be prompted to save the settings at that time.

Type **13** and <Enter> at the Security Setup prompt to (permanently) save all changes to flash.



*Changes made to the target Master from within the Terminal window are not reflected within the web browser, until the Master is rebooted and the web browser connection is refreshed.*

*Any changes made to the Master, from within the web browser are instantly reflected within the Terminal session without the need to reboot.*

## Main Security Menu

The Main Security menu is described below:

| Main Security Menu                                    |                                                                                                                                                                                                                                                                                                                                                                                                                                                                                                                                                                                                                                   |
|-------------------------------------------------------|-----------------------------------------------------------------------------------------------------------------------------------------------------------------------------------------------------------------------------------------------------------------------------------------------------------------------------------------------------------------------------------------------------------------------------------------------------------------------------------------------------------------------------------------------------------------------------------------------------------------------------------|
| Command                                               | Description                                                                                                                                                                                                                                                                                                                                                                                                                                                                                                                                                                                                                       |
| 1) Set system security options for NetLinx Master     | This selection will bring up the Security Options Menu that allows you to change the security options for the NetLinx Master (refer to the <i>Security Options Menu</i> section on page 141 for details). These are "global" options that enable rights given to users and groups. For instance, if you want to disable Telnet security for all users, you would simply go to this menu and disable Telnet security for the entire Master. This would allow any user, whether they have the rights to Telnet or not. These options can be thought of as options to turn on security for different features of the NetLinx Master. |
| 2) Display system security options for NetLinx Master | This selection will display the current security options for the NetLinx Master.                                                                                                                                                                                                                                                                                                                                                                                                                                                                                                                                                  |
| 3) Add user                                           | This selection will prompt you for a username and password for a user you would like to create. After the user is added, you will be taken to the Edit User Menu to setup the new users rights (see the <i>Edit User Menu</i> section on page 143 for details).                                                                                                                                                                                                                                                                                                                                                                   |
| 4) Edit user                                          | This selection will prompt you select a user. Once you have selected the user you want to edit, it will take you to the Edit User Menu so you can edit the user's rights (see the <i>Edit User Menu</i> section on page 143 for details).                                                                                                                                                                                                                                                                                                                                                                                         |
| 5) Delete user                                        | This selection will prompt you select a user to delete.                                                                                                                                                                                                                                                                                                                                                                                                                                                                                                                                                                           |
| 6) Show the list of authorized users                  | This selection displays a list of users.                                                                                                                                                                                                                                                                                                                                                                                                                                                                                                                                                                                          |
| 7) Add group                                          | This selection will prompt you for a group name from a group you would like to create. After the group is added, you will be taken to the Edit Group Menu to setup the new users right (see the <i>Edit Group Menu</i> section on page 145 for details).                                                                                                                                                                                                                                                                                                                                                                          |
| 8) Edit group                                         | This selection will prompt you select a group. Once you have selected the group you want to edit, it will take you to the Edit Group Menu so you can edit the group's rights (see the <i>Edit Group Menu</i> section on page 145 for details).                                                                                                                                                                                                                                                                                                                                                                                    |
| 9) Delete group                                       | This selection will prompt you select a group to delete. A group can only be deleted if there are no users assigned to that group.                                                                                                                                                                                                                                                                                                                                                                                                                                                                                                |
| 10) Show list of authorized groups                    | This selection displays a list of groups.                                                                                                                                                                                                                                                                                                                                                                                                                                                                                                                                                                                         |
| 11) Set Telnet Timeout in seconds                     | This selection allows you to set the time a telnet session waits for a user to login. When a Telnet client connects to the NetLinx Master, it is prompted for a username. If the client does not enter a users name for the length of time set in this selection, the session will be closed by the NetLinx Master.                                                                                                                                                                                                                                                                                                               |
| 12) Display Telnet Timeout in seconds                 | This selection allows you to display the time a telnet session waits for a user to login.                                                                                                                                                                                                                                                                                                                                                                                                                                                                                                                                         |

| Main Security Menu (Cont.)                            |                                                                                                                                                                                                                                                                                                                                                                                                        |
|-------------------------------------------------------|--------------------------------------------------------------------------------------------------------------------------------------------------------------------------------------------------------------------------------------------------------------------------------------------------------------------------------------------------------------------------------------------------------|
| Command                                               | Description                                                                                                                                                                                                                                                                                                                                                                                            |
| 13) Make changes permanent by saving to flash         | When changes are made to the security settings of the Master, they are initially only changed in RAM and are not automatically saved permanently into flash. This selection saved the current security settings into flash. Also, if you attempt to exit the Main Security Menu and the security settings have changed but not made permanent, you will be prompted to save the settings at that time. |
| 14) Reset Database<br>(administrator only function)   | These functions are only visible to administrators. If a user has been given "administrator rights", this additional menu option is displayed. This selection will reset the security database to its Default Security Configuration settings, erasing all users and groups that were added. This is a permanent change and you will be asked to verify this before the database is reset.             |
| 15) Display Database<br>(administrator only function) | These functions are only visible to administrators. If a user has been given "administrator rights", this additional menu option is displayed. This selection will display the current security settings to the terminal (excluding user passwords). It also displays all users (minus passwords), their group assignment (if any) and their rights, as well as all groups and their rights.           |

## Default Security Configuration

By default, the NetLinx Master will create the following accounts, access rights, directory associations, and security options.

```
Account 1: User Name: administrator
Password: password
Group: administrator
Rights: All
Directory Association: /*
```

```
Account 2: User Name: NetLinx
Password: password
Group: none
Rights: FTP Access
Directory Association: none
```

```
Group 1: Group: administrator
Rights: All
Directory Association: /*
```

```
Security Options: FTP Security Enabled
 Admin Change Password Security Enabled
 All other options disabled
```

- The *administrator* user account cannot be deleted or modified with the exception of its password. Only a user with "Change Admin Password Access" rights can change the administrator password.
- The *NetLinx* user account is created to be compatible with previous NetLinx Master firmware versions.

- The *administrator* group account cannot be deleted or modified.
- The FTP Security and Admin Change Password Security are always enabled and cannot be disabled.

**Help menu**

Type **help** at the prompt in the Telnet session to display the following help topics:

| Help Menu Options           |                                                                                                                                                                                                                                                                                                                                                                                                                                                                                                                                                                              |
|-----------------------------|------------------------------------------------------------------------------------------------------------------------------------------------------------------------------------------------------------------------------------------------------------------------------------------------------------------------------------------------------------------------------------------------------------------------------------------------------------------------------------------------------------------------------------------------------------------------------|
| Command                     | Description                                                                                                                                                                                                                                                                                                                                                                                                                                                                                                                                                                  |
| ----- Help ----- <D:P:S>    | (Extended diag messages are OFF)<br><D:P:S>: Device:Port:System. If omitted, assumes Master.                                                                                                                                                                                                                                                                                                                                                                                                                                                                                 |
| ? or Help                   | Displays this list.                                                                                                                                                                                                                                                                                                                                                                                                                                                                                                                                                          |
| DATE                        | Displays the current date.                                                                                                                                                                                                                                                                                                                                                                                                                                                                                                                                                   |
| DEVICE HOLDOFF ON OFF       | Sets the Master to holdoff devices (i.e. does not allow them to report ONLINE) until all objects in the NetLinx program have completed executing the DEFINE_START section.<br><br>If set to ON, any messages to devices in DEFINE_START will be lost, however, this prevents incoming messages being lost in the Master upon startup. When DEVICE_HOLDOFF is ON, you must use ONLINE events to trigger device startup SEND_COMMANDS.<br><br>By default, DEVICE_HOLDOFF is OFF to maintain compatibility with Access systems where f devices are initialized in DEFINE_START. |
| DEVICE STATUS <D:P:S>       | Provides information about the specified device.                                                                                                                                                                                                                                                                                                                                                                                                                                                                                                                             |
| DNS LIST <D:P:S>            | Displays the DNS configuration of a device.                                                                                                                                                                                                                                                                                                                                                                                                                                                                                                                                  |
| DISK FREE                   | Displays the amount of free space on the disk.                                                                                                                                                                                                                                                                                                                                                                                                                                                                                                                               |
| ECHO ON OFF                 | Enables/Disables echo of typed characters.                                                                                                                                                                                                                                                                                                                                                                                                                                                                                                                                   |
| GET DEVICE HOLDOFF          | Displays the state of the Master's device holdoff setting.                                                                                                                                                                                                                                                                                                                                                                                                                                                                                                                   |
| GET DUET MEMORY             | Display the amount of memory allocated for Duet Java pool. This is the current Java memory heap size as measured in Megabytes. An example is a value of 5 = 5 MB.                                                                                                                                                                                                                                                                                                                                                                                                            |
| GET IP <D:P:S>              | Displays the IP configuration of a device.                                                                                                                                                                                                                                                                                                                                                                                                                                                                                                                                   |
| HELP SECURITY               | Displays security related commands.                                                                                                                                                                                                                                                                                                                                                                                                                                                                                                                                          |
| IP STATUS                   | Provides information about NetLinx IP Connections.                                                                                                                                                                                                                                                                                                                                                                                                                                                                                                                           |
| MEM                         | Shows size of the largest block of available memory.                                                                                                                                                                                                                                                                                                                                                                                                                                                                                                                         |
| MSG ON OFF                  | Enables/Disables extended diagnostic messages.                                                                                                                                                                                                                                                                                                                                                                                                                                                                                                                               |
| OFF [D:P:S or NAME, CHAN]   | Turns off the specified channel.                                                                                                                                                                                                                                                                                                                                                                                                                                                                                                                                             |
| ON [D:P:S or NAME, CHAN]    | Turns on the specified channel.                                                                                                                                                                                                                                                                                                                                                                                                                                                                                                                                              |
| PASS [D:P:S or NAME]        | Puts the Session in pass mode to the specified device.<br><ul style="list-style-type: none"> <li>• Mode is exited by ++ ESC ESC.</li> <li>• Display Format is set by ++ ESC n<br/>                     - If n is A, format = ASCII, D, format = Decimal, and H = Hex</li> </ul>                                                                                                                                                                                                                                                                                              |
| PING [ADDRESS]              | Pings an address (IP or URL).<br>Specify -a option for reverse lookup.                                                                                                                                                                                                                                                                                                                                                                                                                                                                                                       |
| PROGRAM INFO                | Displays a list of program modules loaded.                                                                                                                                                                                                                                                                                                                                                                                                                                                                                                                                   |
| PULSE [D:P:S or NAME, CHAN] | Pulses the specified channel.                                                                                                                                                                                                                                                                                                                                                                                                                                                                                                                                                |
| REBOOT <D:P:S>              | Reboots the device.                                                                                                                                                                                                                                                                                                                                                                                                                                                                                                                                                          |
| RELEASE DHCP                | Releases the current DHCP lease.                                                                                                                                                                                                                                                                                                                                                                                                                                                                                                                                             |
| ROUTE MODE DIRECT NORMAL    | Sets the Master-Master route mode.                                                                                                                                                                                                                                                                                                                                                                                                                                                                                                                                           |



| Help Menu Options (Cont.)           |                                                                                                                                                                                                                                                                                                                                                                                                                                                                                                                                                                                                                                                      |
|-------------------------------------|------------------------------------------------------------------------------------------------------------------------------------------------------------------------------------------------------------------------------------------------------------------------------------------------------------------------------------------------------------------------------------------------------------------------------------------------------------------------------------------------------------------------------------------------------------------------------------------------------------------------------------------------------|
| Command                             | Description                                                                                                                                                                                                                                                                                                                                                                                                                                                                                                                                                                                                                                          |
| SEND_COMMAND D:P:S or NAME, COMMAND | Sends the specified command to the device. The Command uses NetLinx string syntax. <ul style="list-style-type: none"> <li>• Ex: send_command 1:1:1,"This is a test',13,10"</li> <li>• Ex: send_command RS232_1,"This is a test',13,10"</li> </ul>                                                                                                                                                                                                                                                                                                                                                                                                    |
| SEND_STRING D:P:S or NAME, STRING   | Sends the specified string to the device.                                                                                                                                                                                                                                                                                                                                                                                                                                                                                                                                                                                                            |
| SET DATE                            | Sets the current date.                                                                                                                                                                                                                                                                                                                                                                                                                                                                                                                                                                                                                               |
| SET DNS <D:P:S>                     | Sets up the DNS configuration of a device.                                                                                                                                                                                                                                                                                                                                                                                                                                                                                                                                                                                                           |
| SET DUET MEMORY                     | Set the amount of memory allocated for Duet Java pool. This is the current Java memory heap size as measured in Megabytes. This feature is used so that if a NetLinx program requires a certain size of memory be allotted for its currently used Duet Modules, it can be reserved on the target Master.<br><br>Valid values are 1 - 16 for 32 MB systems and 1 - 48 for a 64 MB system. This setting does not take effect until the next reboot.<br><br><b>Note:</b> If you are trying to accomplish this setting of the Duet Memory size via a NetLinx program, the program command "DUET_MEM_SIZE_SET(int)" should call REBOOT() following a set. |
| SET FTP PORT                        | Enables/Disables the IP port listened to for FTP connections.                                                                                                                                                                                                                                                                                                                                                                                                                                                                                                                                                                                        |
| SET HTTP PORT                       | Sets the IP port listened to for HTTP connections.                                                                                                                                                                                                                                                                                                                                                                                                                                                                                                                                                                                                   |
| SET HTTPS PORT                      | Sets the IP port listened to for HTTPS connections.                                                                                                                                                                                                                                                                                                                                                                                                                                                                                                                                                                                                  |
| SET ICSP PORT                       | Sets the IP port listened to for ICSP connections.                                                                                                                                                                                                                                                                                                                                                                                                                                                                                                                                                                                                   |
| SET ICSP TCP TIMEOUT                | Sets the timeout period for ICSP and i!-WebControl TCP connections.                                                                                                                                                                                                                                                                                                                                                                                                                                                                                                                                                                                  |
| SET IP <D:P:S>                      | Setup the IP configuration of a device.                                                                                                                                                                                                                                                                                                                                                                                                                                                                                                                                                                                                              |
| SET LOG COUNT                       | Sets the number of entries allowed in the message log.                                                                                                                                                                                                                                                                                                                                                                                                                                                                                                                                                                                               |
| SET SSH PORT                        | Sets the IP port listened to for SSH connections.                                                                                                                                                                                                                                                                                                                                                                                                                                                                                                                                                                                                    |
| SET TELNET PORT                     | Sets the IP port listened to for Telnet connections.                                                                                                                                                                                                                                                                                                                                                                                                                                                                                                                                                                                                 |
| SET THRESHOLD                       | Sets the Master's internal message thresholds.                                                                                                                                                                                                                                                                                                                                                                                                                                                                                                                                                                                                       |
| SET TIMELINE LOOPCNT                | Sets the Master's timeline/event max loopcount.                                                                                                                                                                                                                                                                                                                                                                                                                                                                                                                                                                                                      |
| SET TIME                            | Sets the current time.                                                                                                                                                                                                                                                                                                                                                                                                                                                                                                                                                                                                                               |
| SET UDP BC RATE                     | Sets the UDP broadcast rate. A broadcast message is sent by the Master to allow devices to discover the Master. This command allows the broadcast frequency to be changed or eliminate the broadcast message.                                                                                                                                                                                                                                                                                                                                                                                                                                        |
| SET URL <D:P:S>                     | Setup the initiated connection list URLs of a device.                                                                                                                                                                                                                                                                                                                                                                                                                                                                                                                                                                                                |
| SHOW COMBINE                        | Displays a list of devices, levels, and channels that are currently combined.                                                                                                                                                                                                                                                                                                                                                                                                                                                                                                                                                                        |
| SHOW DEVICE <D:P:S>                 | Displays a list of devices connected and attributes.                                                                                                                                                                                                                                                                                                                                                                                                                                                                                                                                                                                                 |
| SHOW LOG <START>                    | Displays the message log. <start> specifies message to begin the display. 'all' will display all messages.                                                                                                                                                                                                                                                                                                                                                                                                                                                                                                                                           |
| SHOW MEM                            | Displays the memory usage for all memory types.                                                                                                                                                                                                                                                                                                                                                                                                                                                                                                                                                                                                      |
| SHOW NOTIFY                         | Displays the Notify Device List (Master-Master).                                                                                                                                                                                                                                                                                                                                                                                                                                                                                                                                                                                                     |
| SHOW REMOTE                         | Displays the Remote Device List (Master-Master).                                                                                                                                                                                                                                                                                                                                                                                                                                                                                                                                                                                                     |
| SHOW ROUTE                          | Displays the Master's routing information.                                                                                                                                                                                                                                                                                                                                                                                                                                                                                                                                                                                                           |
| SHOW SYSTEM <S>                     | Displays a list of devices in a system.                                                                                                                                                                                                                                                                                                                                                                                                                                                                                                                                                                                                              |
| TCP LIST                            | Displays a list of active TCP connections.                                                                                                                                                                                                                                                                                                                                                                                                                                                                                                                                                                                                           |
| TIME                                | Displays the current time.                                                                                                                                                                                                                                                                                                                                                                                                                                                                                                                                                                                                                           |
| URL LIST <D:P:S>                    | Displays the initiated connection list URLs of a device.                                                                                                                                                                                                                                                                                                                                                                                                                                                                                                                                                                                             |

## Logging Into a Session

Until Telnet security is enabled, a session will begin with a welcome banner.

```
Welcome to NetLinx v3.01.320 Copyright AMX Corp. 1999-2005
>
```



*The welcome banner is not displayed for Terminal sessions.*

***It is very important for a user properly execute the 'logout' command prior to disconnecting from a Master. Simply removing the RS-232 connector from the Program Port maintains your logged-in status until you either return to logout via a new session or reboot the target Master.***

When Terminal security is enabled, the user should type in the word **login** to then be prompted for a username and password before they will be allowed to access any commands available from Telnet. No welcome banner will be displayed until a valid login is made. When the session is started, the user will see a login prompt as seen below:

```
Login:
```

The user (Login) name is case sensitive. The username must be entered with the exact combination of upper and lower letters as was assigned to them by the security administrator. The username must be at least 4 characters long and no more than 20 characters. Any combination of letters, numbers, or other characters may be used.

The user would enter their username and then would be prompted for a password:

```
Login: User1
Password:
```

The password is case sensitive. The password must be entered with the exact combination of upper and lower letters as was assigned to them by the security administrator. The password must be at least 4 characters long and no more than 20 characters. Any combination of letters, numbers, or other characters may be used.

After the password is entered, if the password is correct you will see a welcome banner as shown below:

```
Login: User1
Password: *****
Welcome to NetLinx v3.01.320 Copyright AMX Corp. 1999-2005
>
```

If the password is incorrect, the following will be displayed:

```
Login: User1
Password: *****
Login not authorized. Please try again.
```

After a delay, another login prompt will be displayed to allow the user to try again. If after 5 prompts, the login is not done correctly the following will be displayed and the connection closed:

```
Login not allowed. Goodbye!
```

If a user opens a connection but does not enter a username or password (i.e. they just sit at a login prompt), the connection will be closed after 1 minute.

## Logout

The logout command will log the user out of the current secure telnet session. For a Terminal session, the user will be logged out and to access Terminal commands again the user will first have to login.



***It is very important for a user properly execute the 'logout' command prior to disconnecting from a Master. Simply removing the RS-232 connector from the Program Port maintains your logged-in status until you either return to logout via a new session or reboot the target Master.***

### ***Help Security***

The help security command will display the security menu as shown previously.

### ***Setup Security***

The security command displays a series of menus that allow the security administrator to create and edit users, create and edit groups, and setup directory associations for the Web Server.

A user must be given rights to access this command. Any user that does not have rights to Security Configuration will see the following message when trying to access the setup security command:

```
>setup security
You are not authorized to access security commands
```

If a user is authorized, or if Configuration Security is not enabled, the Main Security Menu will be displayed.



# Programming

This section describes the `Send_Commands`, `Send_Strings`, and `Channel` commands you can use to program the Integrated Controller. The examples in this section require a declaration in the `DEFINE_DEVICE` section of your program to work correctly. Refer to the *NetLinx Programming Language* instruction manual for specifics about declarations and `DEFINE_DEVICE` information.

## Converting Access Code to NetLinx Code

In order to compile your existing Access code to NetLinx code, minor modifications will be required. These modifications include identifier names that conflict with NetLinx identifiers, warning on variable type conversions, and stricter syntax rules.

For more information on NetLinx standards and conversion recommendations, go to [www.amx.com](http://www.amx.com) and click on **Dealers > Tech Center > Tech Notes**. You can either search for the documents (such as *NetLinx Programming Standards* and *Converting Access Code to NetLinx Code*) or Tech Notes (TN numbers: 186, 249, 261, and 310).

Refer to the *NetLinx Programming* Instruction Manual for more detailed information on the differences between the two codes and how they can be re-written. The section is called *Converting Access Code to NetLinx Code*.

## Master Send\_Commands

These commands are specific to the Master and not the Controller. These commands are sent to the DPS 0:1:0 (the Master). A device must first be defined in the NetLinx programming language with values for the Device: Port: System.

In these programming examples, `<DEV>` = Device. The term `<D:P:S>` = Device:Port:System.

| Master Send_Commands                                 |                                                                                                                                                                                                                                                                                                                                                                                                                                                                                                                   |
|------------------------------------------------------|-------------------------------------------------------------------------------------------------------------------------------------------------------------------------------------------------------------------------------------------------------------------------------------------------------------------------------------------------------------------------------------------------------------------------------------------------------------------------------------------------------------------|
| Command                                              | Description                                                                                                                                                                                                                                                                                                                                                                                                                                                                                                       |
| <b>CLOCK</b><br>Set the date and time on the Master. | The date and time settings are propagated over the local bus.<br>Syntax:<br><pre>SEND_COMMAND &lt;DEV&gt;, "'CLOCK &lt;mm-dd-yyyy&gt; &lt;hh:mm:ss&gt;' "</pre> Variables:<br>mm-dd-yyyy = Month, day, and year. Month and day have 2 significant digits. Year has 4 significant digits.<br>hh-mm-ss = Hour, minute, and seconds. Each using only 2 significant digits.<br>Example:<br><pre>SEND_COMMAND 0, "'CLOCK 04-12-2005 09:45:31' "</pre> Sets the Master's date to April 12, 2005 with a time of 9:45 am. |

| Master Send_Commands (Cont.)                                                                                                                                |                                                                                                                                                                                                                                                                                                                                                                                                                                                                                                                                                                                                                                                                                                                                                                                                                                                                                                                                                                                                                                                                                   |
|-------------------------------------------------------------------------------------------------------------------------------------------------------------|-----------------------------------------------------------------------------------------------------------------------------------------------------------------------------------------------------------------------------------------------------------------------------------------------------------------------------------------------------------------------------------------------------------------------------------------------------------------------------------------------------------------------------------------------------------------------------------------------------------------------------------------------------------------------------------------------------------------------------------------------------------------------------------------------------------------------------------------------------------------------------------------------------------------------------------------------------------------------------------------------------------------------------------------------------------------------------------|
| Command                                                                                                                                                     | Description                                                                                                                                                                                                                                                                                                                                                                                                                                                                                                                                                                                                                                                                                                                                                                                                                                                                                                                                                                                                                                                                       |
| <p><b>G4WC</b></p> <p>Add G4 Web Control devices to Web control list displayed by the Web server in a browser.</p>                                          | <p>The internal G4WC Send command (to Master 0:1:0) has been revised to add G4 WebControl devices to Web control list displayed in the browser.</p> <p>Syntax:</p> <pre>SEND_COMMAND &lt;D:P:S&gt;, " 'G4WC "Name/Description", IP Address/URL, IP Port, Enabled' "</pre> <p>Variables:</p> <p>Name/Description = A string, enclosed in double quotes, that is the description of the G4 Web Control instance. It is displayed in the browser.</p> <p>IP Address/URL = A string containing the IP Address of the G4 Web Control server, or a URL to the G4 Web Control server.</p> <p>IP Port = A string containing the IP Port of the G4 Web Control Server.</p> <p>Enabled = 1 or 0. If it is a 1 then the link is displayed. If it is a 0 then the link is disabled.</p> <p><b><i>The combination of Name/Description, IP Address/URL, and IP Port are used to determine each unique listing.</i></b></p> <p>Example:</p> <pre>SEND_COMMAND 0:1:0, "'G4WC "Bedroom", 192.168.1.2, 5900, 1' "</pre> <p>Adds the BEDROOM control device using the IP Address of 192.168.1.2.</p> |
| <p><b>~IGNOREEXTERNAL-CLOCKCOMMANDS</b></p> <p>Set the Master so that it cannot have it's time set by another device which generates a 'CLOCK' command.</p> | <p>Syntax:</p> <pre>SEND_COMMAND &lt;D:P:S&gt;, " ' ~IGNOREEXTERNALCLOCKCOMMANDS' "</pre> <p>Example:</p> <pre>SEND_COMMAND 0:1:0, " ' ~IGNOREEXTERNALCLOCKCOMMANDS' "</pre>                                                                                                                                                                                                                                                                                                                                                                                                                                                                                                                                                                                                                                                                                                                                                                                                                                                                                                      |

## Master IP Local Port Send\_Commands

These commands are specific to the Master and not the Controller. These commands are sent to the DPS 0:1:0 (the Master). A device must first be defined in the NetLinx programming language with values for the Device: Port: System.

In these programming examples, <DEV> = Device. The term <D:P:S> = Device:Port:System.

| Master IP Local Port Send_Commands                                                                            |                                                                                                                                                                                                                                                                                                                                                                                                                                                                                                                                                                                                                                                                                                                                                                                                                                                                                                                                                                                                                                                                                             |
|---------------------------------------------------------------------------------------------------------------|---------------------------------------------------------------------------------------------------------------------------------------------------------------------------------------------------------------------------------------------------------------------------------------------------------------------------------------------------------------------------------------------------------------------------------------------------------------------------------------------------------------------------------------------------------------------------------------------------------------------------------------------------------------------------------------------------------------------------------------------------------------------------------------------------------------------------------------------------------------------------------------------------------------------------------------------------------------------------------------------------------------------------------------------------------------------------------------------|
| Command                                                                                                       | Description                                                                                                                                                                                                                                                                                                                                                                                                                                                                                                                                                                                                                                                                                                                                                                                                                                                                                                                                                                                                                                                                                 |
| <b>UDPSENDTO</b><br>Set the IP and port number of the UDP local ports destination for sending future packets. | <p>This is only available for Type 2 and Type 3 Local Ports. Type 2 and Type 3 are referring to the protocol type that is part of the IP_CLIENT_OPEN call (4th parameter).</p> <p>Type 1 is TCP.<br/>           Type 2 is UDP (standard)<br/>           Type 3 is UDP (2 way)</p> <p>The NetLinx.axi defines constants for the protocol types:</p> <pre>CHAR IP_TCP = 1 CHAR IP_UDP = 2 CHAR IP_UDP_2WAY = 3</pre> <p>Syntax:</p> <pre>SEND_COMMAND &lt;D:P:S&gt;, "'UDPSENDTO-&lt;IP or URL&gt;:&lt;UDP Port Number&gt;'"</pre> <p>Variables:</p> <p>IP or URL = A string containing the IP Address or URL of the desired destination.</p> <p>UDP Port Number = A String containing the UDP port number of the desired destination.</p> <p>Example 1:</p> <pre>SEND_COMMAND 0:3:0, "'UDPSENDTO-192.168.0.1:10000'"</pre> <p>Any subsequent SEND_STRING to 0:3:0 are sent to the IP Address 192.168.0.1 port 10000.</p> <p>Example 2:</p> <pre>SEND_COMMAND 0:3:0, "'UDPSENDTO-myURL.com:15000'"</pre> <p>Any subsequent SEND_STRING to 0:3:0 are sent to the URL myURL.com port 15000.</p> |

## Using the ID Button

The ID Button on the rear panel of the Integrated Controller is used in conjunction with the NetLinx Studio 2.x software program to allow you to assign new Device and System numbers for the Integrated Controller.

1. Using NetLinx Studio 2.x, place the system in Identity (ID) Mode. ID Mode means the entire system is put on hold while it waits for an event from any NetLinx device in the named system (for example, pushing the ID button on the Integrated Controller). The device that generates the first event is the identified device.
2. Press the ID Mode button to generate an event from the Integrated Controller and assign new device and system numbers in NetLinx Studio.



**Only the Device number can be changed on the Controllers using the ID button. Port and System can not be defined.**

### **Device:Port:System (D:P:S)**

A device is any hardware component that can be connected to an AXlink or ICSNet bus. Each device must be assigned a unique number to locate that device on the bus. The NetLinx programming language allows numbers in the range 1-32,767 for ICSNet (255 for AXlink).

NetLinx requires a Device:Port:System (D:P:S) specification. This D:P:S triplet can be expressed as a series of constants, variables separated by colons, or a DEV structure.

For example:

```
STRUCTURE DEV
{
 INTEGER Number // Device number
 INTEGER Port // Port on device
 INTEGER System // System the device belongs to
}
```

The D:P:S notation is used to explicitly represent a device number, port and system. For example, 128:1:0 represents the first port on device 128 on this system. If the system and Port specifications are omitted, (e.g. 128), system 0 (indicating this system) and port 1 (the first port) is assumed.

Here's the syntax:

```
NUMBER:PORT:SYSTEM
```

where:

- NUMBER: 16-bit integer represents the device number
- PORT: 16-bit integer represents the port number (in the range 1 through the number of ports on the Controller or device)
- SYSTEM: 16-bit integer represents the system number (0 = this system)

## **Program Port Commands**

The Program port commands listed in the following table can be sent directly to the Master Card using a terminal program (i.e. Telnet). Be sure that your PC's COM port and terminal program's communication settings match those in the table below:

| <b>PC COM Port Communication Settings</b> |                 |
|-------------------------------------------|-----------------|
| Baud                                      | 38400 (default) |
| Parity                                    | None            |
| Data Bits                                 | 8               |
| Stop Bits                                 | 1               |
| Flow Control                              | None            |



Each of the NetLinx Integrated Controllers has specific port assignments:

| Port Assignments (NI-4x00 & NI-3x00) |                      |
|--------------------------------------|----------------------|
| Serial                               | Ports 1 - 7          |
| Relays                               | Port 8               |
| IR                                   | Ports 9 -16          |
| I/Os                                 | Port 17              |
| Count                                | 8 relays and 8 I/O's |

| Port Assignments (NI-2x00) |                      |
|----------------------------|----------------------|
| Serial                     | Ports 1 - 3          |
| Relays                     | Port 4               |
| IR                         | Ports 5 -8           |
| I/Os                       | Port 9               |
| Count                      | 4 relays and 4 I/O's |

In your terminal program, type "Help" or a question mark ("?") and <Enter> to display the Program port commands listed in the following table.

| Program Port Commands |                                                                                                                                                                                                                                                                                                                                                                                                                                                                                                                                                                                                                                                                                                                                                                                                                                                                                                                               |
|-----------------------|-------------------------------------------------------------------------------------------------------------------------------------------------------------------------------------------------------------------------------------------------------------------------------------------------------------------------------------------------------------------------------------------------------------------------------------------------------------------------------------------------------------------------------------------------------------------------------------------------------------------------------------------------------------------------------------------------------------------------------------------------------------------------------------------------------------------------------------------------------------------------------------------------------------------------------|
| Command               | Description                                                                                                                                                                                                                                                                                                                                                                                                                                                                                                                                                                                                                                                                                                                                                                                                                                                                                                                   |
| DATE                  | <p>Displays the current date and day of the week.</p> <p>Example:</p> <pre>&gt;DATE 10/31/2004 Wed</pre>                                                                                                                                                                                                                                                                                                                                                                                                                                                                                                                                                                                                                                                                                                                                                                                                                      |
| DEVICE HOLDOFF ON OFF | <p>Sets the Master to holdoff devices and not allow them to report online until the NetLinx program has completed executing the DEFINE_START section.</p> <p>Example:</p> <pre>&gt;Device Holdoff ON Device Holdoff Set.</pre> <p>This command sets the state of the device holdoff. The GET DEVICE HOLDOFF command reveals whether the state is On or Off.</p>                                                                                                                                                                                                                                                                                                                                                                                                                                                                                                                                                               |
| DEVICE STATUS <D:P:S> | <p>Displays a list of all active (on) channels for the specified D:P:S. Enter DEVICE STATUS without the D:P:S variable, the Master displays ports, channels, and version information.</p> <p>Displays status of the specified Master.</p> <p>Example (on a local Master):</p> <pre>&gt;Device 0 AMX Corp.,NI-2000,v3.00.312 contains 1 Ports. Port    1 - Channels:256 Levels:8 MaxStringLen=64 Types=8 bit MaxCommandLen=64 Types=8 bit The following input channels are on:None The following output channels are on:None The following feedback channels are on:None Level 1=0 Supported data types=UByte,UInt Level 2=0 Supported data types=UByte,UInt Level 3=0 Supported data types=UByte,UInt Level 4=0 Supported data types=UByte,UInt Level 5=0 Supported data types=UByte,UInt Level 6=0 Supported data types=UByte,UInt Level 7=0 Supported data types=UByte,UInt Level 8=0 Supported data types=UByte,UInt</pre> |

| Program Port Commands (Cont.) |                                                                                                                                                                                                                                                                                                                                              |
|-------------------------------|----------------------------------------------------------------------------------------------------------------------------------------------------------------------------------------------------------------------------------------------------------------------------------------------------------------------------------------------|
| Command                       | Description                                                                                                                                                                                                                                                                                                                                  |
| DISK FREE                     | Displays the total bytes of free space available on the Master.<br>Example:<br>>DISK FREE<br>The disk has 2441216 bytes of free space.                                                                                                                                                                                                       |
| DNS LIST <D:P:S>              | Displays:<br>• Domain suffix<br>• Configured DNS IP Information<br>Example:<br>>DNS LIST [0:1:0]<br>Domain suffix:amx.com<br>The following DNS IPs are configured<br>Entry 1-192.168.20.5<br>Entry 2-12.18.110.8<br>Entry 3-12.18.110.7                                                                                                      |
| ECHO OFF                      | Disables terminal character's echo (display) function.                                                                                                                                                                                                                                                                                       |
| ECHO ON                       | Enables terminal character's echo (display) function.                                                                                                                                                                                                                                                                                        |
| GET DEVICE HOLDOFF            | Displays the state of the device holdoff setting in the Master.<br>Example:<br>>GET DEVICE HOLDOFF<br>Device Holdoff is off.<br>This command reveals the state of the device holdoff set using the DEVICE HOLDOFF ONIOFF command.                                                                                                            |
| GET IP <D:P:S>                | Displays the Master's D:P:S, Host Name, Type (DHCP or Static), IP Address, Subnet Mask, Gateway IP, and MAC Address.<br>Example:<br>>GET IP [0:1:50]<br>IP Settings for 0:1:50<br>HostName MLK_INSTRUCTOR<br>Type DHCP<br>IP Address 192.168.21.101<br>Subnet Mask 255.255.255.0<br>Gateway IP 192.168.21.2<br>MAC Address 00:60:9f:90:0d:39 |
| HELP SECURITY                 | Displays the related security commands:<br>Example:<br>>HELP SECURITY<br>>logout Logout and close secure session<br>>setup security Access the security setup menus                                                                                                                                                                          |
| IP STATUS                     | Provides information about the current NetLinx IP Connections:<br>Example:<br>>IP STATUS<br>NetLinx IP Connections<br>No active IP connections                                                                                                                                                                                               |
| MEM                           | Displays the largest free block of the Master's memory.<br>Example:<br>>MEM<br>The largest free block of memory is 11442776 bytes.                                                                                                                                                                                                           |
| MSG ON or MSG OFF             | MSG On sets the terminal program to display all messages generated by the Master. MSG OFF disables the display.<br>Example:<br>> MSG ON<br>Extended diagnostic information messages turned on.<br>> MSG OFF<br>Extended diagnostic information messages turned off.                                                                          |

| Program Port Commands (Cont.) |                                                                                                                                                                                                                                                                                                                                                                                                                                                                                                                                                                                             |
|-------------------------------|---------------------------------------------------------------------------------------------------------------------------------------------------------------------------------------------------------------------------------------------------------------------------------------------------------------------------------------------------------------------------------------------------------------------------------------------------------------------------------------------------------------------------------------------------------------------------------------------|
| Command                       | Description                                                                                                                                                                                                                                                                                                                                                                                                                                                                                                                                                                                 |
| OFF <D:P:S, or NAME, CHAN>    | <p>Turns off a channel on a device. The device can be on any system the Master you are connected to can reach. You can specify the device number, port, and system, or the name of the device that is defined in the DEFINE_DEVICE section of the program.</p> <p>Syntax:</p> <pre>OFF[name, channel]</pre> <p>-or-</p> <pre>OFF[D:P:S, channel]</pre> <p>Example:</p> <pre>&gt;OFF[5001:7:4] Sending Off[5001:7:4]</pre>                                                                                                                                                                   |
| ON <D:P:S, NAME, CHAN>        | <p>Turns on a channel on a device. The device can be on any system the Master you are connected to can reach. You can specify the device number, port, and system; or the name of the device that is defined in the DEFINE_DEVICE section of the program.</p> <p>Syntax:</p> <pre>ON[name, channel]</pre> <p>or</p> <pre>ON[D:P:S, channel]</pre> <p>Example:</p> <pre>&gt;ON[5001:7:4] Sending On[5001:7:4]</pre>                                                                                                                                                                          |
| PASS <D:P:S or NAME>          | <p>Sets up a pass through mode to a device. In pass through mode, any string received by the device is displayed on the screen, and anything typed is sent as a string to the device. The device can be on any system the Master you are connected to can reach. You can specify the device number, port, and system, or the name of the device that is defined in the DEFINE_DEVICE section of the program.</p> <p>Example:</p> <pre>&gt;pass[5001:7:4] Entering pass mode.</pre> <p>To exit pass mode, type ++ esc esc. Refer to the ESC Pass Codes on page 171 for more information.</p> |
| PING <IP ADDRESS>             | <p>Tests network connectivity to and confirms the presence of another networked device. The syntax is just like the PING application in Windows or Linux.</p> <p>Example:</p> <pre>&gt;ping 192.168.29.209 192.168.29.209 is alive.</pre>                                                                                                                                                                                                                                                                                                                                                   |
| PROGRAM INFO                  | <p>Displays the name of the NetLinx program residing on the Master.</p> <p>Example:</p> <pre>&gt;PROGRAM INFO -- Program Name Info -- Module Count = 1    1  Name is i!-PCLinkPowerPointTest  -- File Names = 2    1  = C:\Program Files\AMX Applications\i!-PCLinkPowerPoint    2  = C:\Program Files\Common Files\AMXShare\AXIs\NetLinx.axi    2  = Name is MDLPP  -- File Names = 2    1  C:\AppDev\i!-PCLink-PowerPoint\i!-PCLinkPowerPointMod.axs    2  C:\Program files\Common Files\AMXShare\AXIs\NetLinx.axi</pre>                                                                  |

| Program Port Commands (Cont.)          |                                                                                                                                                                                                                                                                                                                                                                                                                                                                                                                                                                                                                                                                                                  |
|----------------------------------------|--------------------------------------------------------------------------------------------------------------------------------------------------------------------------------------------------------------------------------------------------------------------------------------------------------------------------------------------------------------------------------------------------------------------------------------------------------------------------------------------------------------------------------------------------------------------------------------------------------------------------------------------------------------------------------------------------|
| Command                                | Description                                                                                                                                                                                                                                                                                                                                                                                                                                                                                                                                                                                                                                                                                      |
| PULSE <D:P:S, or<br>NAME, CHAN>        | <p>Pulses a channel on a device on and off. The device can be on any system the Master you are connected to can reach. You can specify the device number, port, and system; or the name of the device that is defined in the DEFINE_DEVICE section of the program.</p> <p>Example:</p> <pre>&gt;PULSE[50001:8:50,1] Sending Pulse[50001:8:50,1]</pre>                                                                                                                                                                                                                                                                                                                                            |
| REBOOT <D:P:S>                         | <p>Reboots the Master or specified device.</p> <p>Example:</p> <pre>&gt;REBOOT [0:1:0] Rebooting...</pre>                                                                                                                                                                                                                                                                                                                                                                                                                                                                                                                                                                                        |
| RELEASE DHCP                           | <p>Releases the DHCP setting for the Master.</p> <p>Example:</p> <pre>&gt;RELEASE DHCP The Master must be rebooted to acquire a new DHCP lease.</pre>                                                                                                                                                                                                                                                                                                                                                                                                                                                                                                                                            |
| ROUTE MODE<br>DIRECT   NORMAL          | <p>Sets the Master-to-Master route mode:</p> <ul style="list-style-type: none"> <li>• Normal mode - allows a Master to communicate with any Master accessible via the routing tables (shown with the SHOW ROUTE command). This includes a directly-connected Master (route metric =1) and indirectly connected masters (route metric greater than 1, but less than 16).</li> <li>• Direct mode - allows communication only with masters that are directly connected (route metric = 1). Indirectly connected masters cannot be communicated within this mode.</li> </ul> <p>Examples:</p> <pre>&gt;ROUTE MODE DIRECT Route Mode "Direct" Set &gt;ROUTE MODE NORMAL Route Mode "Normal" Set</pre> |
| SEND_COMMAND D:P:S or<br>Name, Command | <p>Sends a specified command to a device. The device can be on any system the Master you are connected to can reach. You can specify the device number, port, and system; or the name of the device that is defined in the DEFINE_DEVICE section of the NetLinX Program. The data of the string is entered with NetLinX string syntax. The Command uses the following NetLinX string syntax:</p> <p>Example:</p> <pre>&gt;Ex: send_command 1:1:1,"'This is a test',13,10" Ex: send_command RS232_1,"'This is a test',13,10"</pre>                                                                                                                                                                |
| SEND_STRING D:P:S or<br>Name, String   | <p>Sends a string to a device. The device can be on any system the Master you are connected to can reach. You can specify the device number, port, and system; or the name of the device defined in the DEFINE_DEVICE section of the NetLinX Program. The data of the string is entered with NetLinX string syntax.</p>                                                                                                                                                                                                                                                                                                                                                                          |
| SET DATE                               | <p>Prompts you to enter the new date for the Master.</p> <p>When the date is set on the Master, the new date will be reflected on all devices in the system that have clocks (i.e. touch panels). By the same token, if you set the date on any system device, the new date will be reflected on the system's Master, and on all connected devices.</p> <p>This will not update clocks on devices connected to another Master (in Master-to-Master systems).</p> <p>Example:</p> <pre>&gt;SET DATE Enter Date: (mm/dd/yyyy) -&gt;</pre>                                                                                                                                                          |

| Program Port Commands (Cont.) |                                                                                                                                                                                                                                                                                                                                                                                                                                                                                                                                                                                                                                                                                                                                       |
|-------------------------------|---------------------------------------------------------------------------------------------------------------------------------------------------------------------------------------------------------------------------------------------------------------------------------------------------------------------------------------------------------------------------------------------------------------------------------------------------------------------------------------------------------------------------------------------------------------------------------------------------------------------------------------------------------------------------------------------------------------------------------------|
| Command                       | Description                                                                                                                                                                                                                                                                                                                                                                                                                                                                                                                                                                                                                                                                                                                           |
| SET DNS <D:P:S>               | <p>Prompts you to enter a Domain Name, DNS IP #1, DNS IP #2, and DNS IP #3. Then, enter Y (yes) to approve/store the information in the Master. Entering N (no) cancels the operation.</p> <p>Example:</p> <pre>&gt;SET DNS [0:1:0] -- Enter New Values or just hit Enter to keep current settings --  Enter Domain Suffix: amx.com Enter DNS Entry 1 : 192.168.20.5 Enter DNS Entry 2 : 12.18.110.8 Enter DNS Entry 3 : 12.18.110.7  You have entered: Domain Name: amx.com                   DNS Entry 1: 192.168.20.5                   DNS Entry 2: 12.18.110.8                   DNS Entry 3: 12.18.110.7  Is this correct? Type Y or N and Enter -&gt; Y Settings written. Device must be rebooted to enable new settings</pre> |
| SET FTP PORT                  | <p>Enables/Disables the IP port listened to for FTP connections.</p> <p>Example:</p> <pre>&gt;SET FTP PORT FTP is enabled Do you want to enable (e) or disable (d) FTP (enter e or d) : FTP enabled, reboot the master for the change to take affect.</pre>                                                                                                                                                                                                                                                                                                                                                                                                                                                                           |
| SET HTTP PORT                 | <p>Sets the IP port listened to for HTTP connections.</p> <p>Example:</p> <pre>&gt;SET HTTP PORT Current HTTP port number = 80 Enter new HTTP port number (Usually 80) (0=disable HTTP) : Setting HTTP port number to New HTTP port number set, reboot the master for the change to take affect.</pre>                                                                                                                                                                                                                                                                                                                                                                                                                                |
| SET HTTPS PORT                | <p>Sets the IP port listened to for HTTPS connections.</p> <p>Example:</p> <pre>&gt;SET HTTPS PORT Current HTTPS port number = 443 Enter new HTTPS port number (Usually 443) (0=disable HTTPS) :</pre> <p>Once you enter a value and press the ENTER key, you get the following message:</p> <pre>Setting HTTPS port number to New HTTPS port number set, reboot the master for the change to take affect.</pre>                                                                                                                                                                                                                                                                                                                      |
| SET ICSP PORT                 | <p>Sets the IP port listened to for ICSP connections.</p> <p>Example:</p> <pre>&gt;SET ICSP PORT Current ICSP port number = 1319 Enter new ICSP port number (Usually 1319) (0=disable ICSP) :</pre> <p>Once you enter a value and press the ENTER key, you get the following message:</p> <pre>Setting ICSP port number to New ICSP port number set, reboot the master for the change to take affect.</pre>                                                                                                                                                                                                                                                                                                                           |

| Program Port Commands (Cont.) |                                                                                                                                                                                                                                                                                                                                                                                                                                                                                                                                                                                                                                                                                                                                    |
|-------------------------------|------------------------------------------------------------------------------------------------------------------------------------------------------------------------------------------------------------------------------------------------------------------------------------------------------------------------------------------------------------------------------------------------------------------------------------------------------------------------------------------------------------------------------------------------------------------------------------------------------------------------------------------------------------------------------------------------------------------------------------|
| Command                       | Description                                                                                                                                                                                                                                                                                                                                                                                                                                                                                                                                                                                                                                                                                                                        |
| SET ICSP TCP TIMEOUT          | <p>Sets the timeout period for ICSP and i!-WebControl TCP connections.</p> <p><b>Example:</b></p> <pre>&gt;SET ICSP TCP TIMEOUT This will set the timeout for TCP connections for both ICSP and i!-WebControl. When no communication has been detected for the specified number of seconds, the socket connection is closed. ICSP and i!-WebControl have built-in timeouts and reducing the TCP timeout below these will cause undesirable results. The default value is 45 seconds. The current ICSP TCP timeout is 45 seconds Enter new timeout (in seconds):</pre> <p>Once you enter a value and press the ENTER key, you get the following message:</p> <pre>New timeout value set (in affect immediately).</pre>              |
| SET IP <D:P:S>                | <p>Prompts you to enter a Host Name, Type (DHCP or Fixed), IP Address, Subnet Mask, and Gateway IP Address. Enter Y (yes) to approve/store the information into the Master. Entering N (no) cancels the operation.</p> <p><b>Example:</b></p> <pre>&gt;SET IP [0:1:0] --- Enter New Values or just hit Enter to keep current settings ---  Enter Host Name:   MLK_INSTRUCTOR Enter IP type. Type D for DHCP or S for Static IP and then Enter: DHCP Enter Gateway IP:  192.168.21.2  You have entered: Host Name  MLK_INSTRUCTOR                   Type      DHCP                   Gateway IP 192.168.21.2 Is this correct? Type Y or N and Enter -&gt; y Settings written. Device must be rebooted to enable new settings.</pre> |
| SET LOG COUNT                 | <p>Sets the number of entries allowed in the message log.</p> <p><b>Example:</b></p> <pre>&gt;SET LOG COUNT Current log count = 1000 Enter new log count (between 50-10000) :</pre> <p>Once you enter a value and press the ENTER key, you get the following message:</p> <pre>Setting log count to New log count set, reboot the Master for the change to take affect.</pre>                                                                                                                                                                                                                                                                                                                                                      |
| SET SSH PORT                  | <p>Sets the IP port listened to for SSH connections.</p> <p><b>Example:</b></p> <pre>&gt;SET SSH PORT Current SSH port number = 22 Enter new SSH port number (Usually 22) (0=disable SSH) :</pre> <p>Once you enter a value and press the ENTER key, you get the following message:</p> <pre>Setting SSH port number to 22 New SSH port number set, reboot the Master for the change to take affect.</pre>                                                                                                                                                                                                                                                                                                                         |

| Program Port Commands (Cont.) |                                                                                                                                                                                                                                                                                                                                                                                                                                                                                                                                                                                                                                                                                                                                                                                                                                                                                                             |
|-------------------------------|-------------------------------------------------------------------------------------------------------------------------------------------------------------------------------------------------------------------------------------------------------------------------------------------------------------------------------------------------------------------------------------------------------------------------------------------------------------------------------------------------------------------------------------------------------------------------------------------------------------------------------------------------------------------------------------------------------------------------------------------------------------------------------------------------------------------------------------------------------------------------------------------------------------|
| Command                       | Description                                                                                                                                                                                                                                                                                                                                                                                                                                                                                                                                                                                                                                                                                                                                                                                                                                                                                                 |
| SET TELNET PORT               | <p>Sets the IP port listened to for Telnet connections.</p> <p>Example:</p> <pre>&gt;SET TELNET PORT Current telnet port number = 23 Enter new telnet port number (Usually 23) (0=disable Telnet) :</pre> <p>Once you enter a value and press the ENTER key, you get the following message:</p> <pre>Setting telnet port number to 23 New telnet port number set, reboot the Master for the change to take affect.</pre>                                                                                                                                                                                                                                                                                                                                                                                                                                                                                    |
| SET THRESHOLD                 | <p>Sets the Master's internal message thresholds.</p> <p>Example:</p> <pre>&gt;SET THRESHOLD  -- This will set the thresholds of when particular tasks are pended. The threshold is the number of messages queued before a task is pended.-- --Use extreme caution when adjusting these values.-- Current Interpreter Threshold = 2000 Enter new Interpreter Threshold (Between 1 and 2000) (Default=10) :</pre> <p>Once you enter a value and press the ENTER key, you get the following message:</p> <pre>Current Lontalk Threshold = 50 Enter new Lontalk Threshold (Between 1 and 2000) (Default=50):50 Current IP Threshold = 600 Enter new IP Threshold (Between 1 and 2000) (Default=200): 600 Setting Thresholds to: Interpreter 2000                         Lontalk      50                         IP           600  New thresholds set, reboot the Master for the changes to take affect.</pre> |
| SET TIME                      | <p>Prompts you to enter the new time for the Master.</p> <p>When the time is set on the Master, the new time will be reflected on all devices in the system that have clocks (i.e. touch panels). By the same token, if you set the time on any system device, the new time will be reflected on the system's Master, and on all connected devices.</p> <p>This will not update clocks on devices connected to another Master (in Master-to-Master systems).</p> <p>Example:</p> <pre>&gt;SET TIME Enter Date: (hh:mm:ss) -&gt;</pre>                                                                                                                                                                                                                                                                                                                                                                       |
| SET UPD BC RATE               | <p>Set UDP broadcast rate. A broadcast message is sent by the Master to allow devices to discover the Master. This command allows the broadcast frequency to be changed or eliminate the broadcast message.</p> <p>Example:</p> <pre>&gt;SET UPD BC RATE Current broadcast message rate is 5 seconds between messages. Enter broadcast message rate in seconds between messages (off=0 ; default=5) (valid values 0-300) :</pre> <p>Once you enter a value and press the ENTER key, you get the following message:</p> <pre>Setting broadcast message rate to 300 seconds between messages New broadcast message rate set.</pre>                                                                                                                                                                                                                                                                            |





| Program Port Commands (Cont.) |                                                                                                                                                                                                                                                                                                                                                                                                                                                                                                                                                                                                                                                                                                                                                                                                                                                                                                                                                                                                                                                                                                                                                                                                                                                                                                                                                                                                                                                                                                                                                                                                                                                                                                                                                                                                                                                                                                                                                                                                                                                                                                                                                                                                                                                                                                                                                                        |
|-------------------------------|------------------------------------------------------------------------------------------------------------------------------------------------------------------------------------------------------------------------------------------------------------------------------------------------------------------------------------------------------------------------------------------------------------------------------------------------------------------------------------------------------------------------------------------------------------------------------------------------------------------------------------------------------------------------------------------------------------------------------------------------------------------------------------------------------------------------------------------------------------------------------------------------------------------------------------------------------------------------------------------------------------------------------------------------------------------------------------------------------------------------------------------------------------------------------------------------------------------------------------------------------------------------------------------------------------------------------------------------------------------------------------------------------------------------------------------------------------------------------------------------------------------------------------------------------------------------------------------------------------------------------------------------------------------------------------------------------------------------------------------------------------------------------------------------------------------------------------------------------------------------------------------------------------------------------------------------------------------------------------------------------------------------------------------------------------------------------------------------------------------------------------------------------------------------------------------------------------------------------------------------------------------------------------------------------------------------------------------------------------------------|
| Command                       | Description                                                                                                                                                                                                                                                                                                                                                                                                                                                                                                                                                                                                                                                                                                                                                                                                                                                                                                                                                                                                                                                                                                                                                                                                                                                                                                                                                                                                                                                                                                                                                                                                                                                                                                                                                                                                                                                                                                                                                                                                                                                                                                                                                                                                                                                                                                                                                            |
| SHOW LOG                      | <p>Displays the log of messages stored in the Master's memory. The Master logs all internal messages and keeps the most recent messages. The log contains:</p> <ul style="list-style-type: none"> <li>• Entries starting with first specified or most recent</li> <li>• Date, Day, and Time message was logged</li> <li>• Which object originated the message</li> <li>• The text of the message</li> </ul> <pre>SHOW LOG [start] [end] SHOW LOG ALL</pre> <p>If start is not entered, the most recent message will be first. If end is not entered, the last 20 messages will be shown. If ALL is entered, all stored messages will be shown, starting with the most recent.</p> <p>Example:</p> <pre>&gt;SHOW LOG Message Log for System 50 Version: v2.10.75 Entry      Date/Time      Object Text ----- 1: 11-01-2001 THU 14:14:49 ConnectionManager    Memory Available = 11436804 &lt;26572&gt; 2: 11-01-2001 THU 14:12:14 ConnectionManager    Memory Available = 11463376 &lt;65544&gt; 3: 11-01-2001 THU 14:10:21 ConnectionManager    Memory Available = 11528920 &lt;11512&gt; 4: 11-01-2001 THU 14:10:21 TelnetSvr    Accepted Telnet connection:socket=14 addr=192.168.16.110 port=2979 5: 11-01-2001 THU 14:05:51 Interpreter    CIPEvent::OnLine 10002:1:50 6: 11-01-2001 THU 14:05:51 Interpreter    CIPEvent::OnLine 128:1:50 7: 11-01-2001 THU 14:05:51 Interpreter    CIPEvent::OffLine 128:1:50 8: 11-01-2001 THU 14:05:51 Interpreter    CIPEvent::OnLine 96:1:50 9: 11-01-2001 THU 14:05:51 Interpreter    CIPEvent::OffLine 96:1:50 10: 11-01-2001 THU 14:05:51 Interpreter    CIPEvent::OnLine 128:1:50 11: 11-01-2001 THU 14:05:51 Interpreter    CIPEvent::OnLine 96:1:50 12: 11-01-2001 THU 14:05:51 Interpreter    CIPEvent::OnLine 5001:16:50 13: 11-01-2001 THU 14:05:51 Interpreter    CIPEvent::OnLine 5001:15:50 14: 11-01-2001 THU 14:05:51 Interpreter    CIPEvent::OnLine 5001:14:50 15: 11-01-2001 THU 14:05:51 Interpreter    CIPEvent::OnLine 5001:13:50 16: 11-01-2001 THU 14:05:51 Interpreter    CIPEvent::OnLine 5001:12:50 17: 11-01-2001 THU 14:05:51 Interpreter    CIPEvent::OnLine 5001:11:50 18: 11-01-2001 THU 14:05:51 Interpreter    CIPEvent::OnLine 5001:10:50 19: 11-01-2001 THU 14:05:51 Interpreter    CIPEvent::OnLine 5001:9:50 20: 11-01-2001 THU 14:05:51 Interpreter    CIPEvent::OnLine 5001:8:50</pre> |
| SHOW NOTIFY                   | <p>Displays a list of devices (up to 1000) that other systems have requested input from and the types of information needed. Note that the local system number is 1061.</p> <p>Example:</p> <pre>&gt;SHOW NOTIFY  Device Notification List of devices requested by other Systems  Device:Port      System  Needs ----- 00128:00001     00108  Channels Commands Strings Levels 33000:00001     00108  Channels Commands</pre>                                                                                                                                                                                                                                                                                                                                                                                                                                                                                                                                                                                                                                                                                                                                                                                                                                                                                                                                                                                                                                                                                                                                                                                                                                                                                                                                                                                                                                                                                                                                                                                                                                                                                                                                                                                                                                                                                                                                          |



| Program Port Commands (Cont.) |                                                                                                                                                                                                                                                                                                                |
|-------------------------------|----------------------------------------------------------------------------------------------------------------------------------------------------------------------------------------------------------------------------------------------------------------------------------------------------------------|
| Command                       | Description                                                                                                                                                                                                                                                                                                    |
| TCP LIST                      | Lists all active TCP/IP connections.<br>Example:<br><pre>&gt;TCP LIST The following TCP connections exist(ed): 1: IP=192.168.21.56:1042 Socket=0 (Dead) 2: IP=192.168.21.56:1420 Socket=0 (Dead)</pre>                                                                                                         |
| TIME                          | Displays the current time on the Master.<br>Example:<br><pre>&gt;TIME 13:42:04</pre>                                                                                                                                                                                                                           |
| URL LIST <D:P:S>              | Displays the list of URL addresses programmed in the Master (or another system).<br>Example:<br><pre>&gt;URL LIST The following URLs exist in the URL connection list -&gt;Entry 0-192.168.13.65:1319 IP=192.168.13.65 State=Connected Entry 1-192.168.13.200:1319 IP=192.168.13.200 State=Issue Connect</pre> |

## ESC Pass Codes

There are 'escape' codes in the pass mode. These codes can switch the display mode or exit pass mode. The following 'escape' codes are defined.

| Escape Pass Codes |                                                                                                                                                                                                                                                                                                                                                                              |
|-------------------|------------------------------------------------------------------------------------------------------------------------------------------------------------------------------------------------------------------------------------------------------------------------------------------------------------------------------------------------------------------------------|
| Command           | Description                                                                                                                                                                                                                                                                                                                                                                  |
| + + ESC ESC       | Exit Pass Mode:<br>Typing a plus (shift =) followed by another plus followed by an ESC (the escape key) followed by another escape exits the pass mode. The Telnet session returns to "normal".                                                                                                                                                                              |
| + + ESC A         | ASCII Display Mode:<br>Typing a plus (shift =) followed by another plus followed by an ESC (the escape key) followed by an 'A' sets the display to ASCII mode. Any ASCII characters received by the device will be displayed by their ASCII symbol. Any non-ASCII characters will be displayed with a \ followed by two hex characters to indicate the characters hex value. |
| + + ESC D         | Decimal Display Mode:<br>Typing a plus (shift =) followed by another plus followed by an ESC (the escape key) followed by a 'D' sets the display to decimal mode. Any characters received by the device will be displayed with a \ followed by numeric characters to indicate the characters decimal value.                                                                  |
| + + ESC H         | Hex Display Mode:<br>Typing a plus (shift =) followed by another plus followed by an ESC (the escape key) followed by an 'H' sets the display to hexadecimal mode. Any characters received by the device will be displayed with a \ followed by two hex characters to indicate the characters hex value.                                                                     |

## Notes on Specific Telnet/Terminal Clients

Telnet and terminal clients will have different behaviors in some situations. This section states some of the known anomalies.

### *Windows™ client programs*

Anomalies occur when using a Windows client if you are not typing standard ASCII characters (i.e. using the keypad and the ALT key to enter decimal codes). Most programs will allow you to enter specific decimal codes by holding ALT and using keypad numbers.

For example, hold ALT, hit the keypad 1, then hit keypad 0, then release ALT. The standard line feed code is entered (decimal 10). Windows will perform an ANSI to OEM conversion on some codes entered this way because of the way Windows handles languages and code pages.

The following codes are known to be altered, but others may be affected depending on the computer's setup.

Characters 15, 21, 22, and any characters above 127.

This affects both Windows Telnet and Terminal programs.

### *Linux Telnet client*

The Linux Telnet client has three anomalies that are known at this time:

- A null (\00) character is sent after a carriage return.
- If an ALT 255 is entered, two 255 characters are sent (per the Telnet RAFT).
- If the code to go back to command mode is entered (ALT 29 which is ^), the character is not sent, but Telnet command mode is entered.



NOTE

**THE FOLLOWING SECTIONS ONLY APPLY TO THE INTEGRATED CONTROLLER COMPONENT OF THE NIs.**

## LED Disable/Enable Send\_Commands

The following commands enable or disable the LEDs on the Integrated Controller.

In these examples: <DEV> = Port 1 of the device. Sending to port 1 of the NI-Controller (affects all ports).

| LED Send_Commands                                                   |                                                                                                                                                                                                                                                                                                                                                                                                            |
|---------------------------------------------------------------------|------------------------------------------------------------------------------------------------------------------------------------------------------------------------------------------------------------------------------------------------------------------------------------------------------------------------------------------------------------------------------------------------------------|
| Command                                                             | Description                                                                                                                                                                                                                                                                                                                                                                                                |
| <b>LED-DIS</b><br>Disable all LEDs (on 32 LED hardware) for a port. | Regardless of whether or not the port is active, the LED will not be lit. Issue this command to port 1 to disable all the LEDs on the Controller. When activity occurs on a port(s) or Controller, the LEDs will not illuminate.<br>Syntax:<br><pre>SEND_COMMAND &lt;DEV&gt;, "'LED-DIS'"</pre> Example:<br><pre>SEND_COMMAND Port_1, "'LED-DIS'"</pre> Disables all the LEDs on Port 1 of the Controller. |

| LED Send_Commands (Cont.)                                                     |                                                                                                                                                                                                                                                                                                                                                                                                                |
|-------------------------------------------------------------------------------|----------------------------------------------------------------------------------------------------------------------------------------------------------------------------------------------------------------------------------------------------------------------------------------------------------------------------------------------------------------------------------------------------------------|
| Command                                                                       | Description                                                                                                                                                                                                                                                                                                                                                                                                    |
| <b>LED-EN</b><br>Enable the LED (on 32 LED hardware) for a port (by default). | When the port is active, the LED is lit. When the port is not active, the LED is not lit. Issue the command to port 1 to enable the LEDs on the Controller (default setting). When activity occurs on a port(s) or Controller, the LEDs illuminate.<br>Syntax:<br><pre>SEND_COMMAND &lt;DEV&gt;, 'LED-EN'</pre> Example:<br><pre>SEND_COMMAND System_1, 'LED-EN'</pre> Enables the System_1 Controller's LEDs. |

## RS232/422/485 Ports Channels

RS232/422/485 ports are Ports 1-7 (NI-4X00/3X00) and Ports 1-3 (NI-2X00).

| RS232/422/485 Ports Channels  |                                                                                 |
|-------------------------------|---------------------------------------------------------------------------------|
| <b>255 - CTS push channel</b> | Reflects the state of the CTS input if a 'CTSPSH' command was sent to the port. |

## RS-232/422/485 Send\_Commands

In these examples: <DEV> = device.

| RS-232/422/485 Send_Commands                                                                                                                     |                                                                                                                                                                                                                                                                                                                                                                                                           |
|--------------------------------------------------------------------------------------------------------------------------------------------------|-----------------------------------------------------------------------------------------------------------------------------------------------------------------------------------------------------------------------------------------------------------------------------------------------------------------------------------------------------------------------------------------------------------|
| Command                                                                                                                                          | Description                                                                                                                                                                                                                                                                                                                                                                                               |
| <b>B9MOFF</b><br>Set the port's communication parameters for stop and data bits according to the software settings on the RS-232 port (default). | Disables 9-bit in 232/422/455 mode. By default, this returns the communication settings on the serial port to the last programmed parameters. This command works in conjunction with the 'B9MON' command.<br>Syntax:<br><pre>SEND_COMMAND &lt;DEV&gt;, "'B9MOFF'"</pre> Example:<br><pre>SEND_COMMAND RS232_1, "'B9MOFF'"</pre> Sets the RS-232 port settings to match the port's configuration settings. |
| <b>B9MON</b><br>Override and set the current communication settings and parameters on the RS-232 serial port to 9 data bits with one stop bit.   | Enables 9-bit in 232/422/455 mode. This command works in conjunction with the 'B9MOFF' command.<br>Syntax:<br><pre>SEND_COMMAND &lt;DEV&gt;, "'B9MON'"</pre> Example:<br><pre>SEND_COMMAND RS232_1, "'B9MON'"</pre> Resets the RS-232 port's communication parameters to nine data bits, one stop bit, and locks-in the baud rate.                                                                        |
| <b>CHARD</b><br>Set the delay time between all transmitted characters to the value specified (in 100 Microsecond increments).                    | Syntax:<br><pre>SEND_COMMAND &lt;DEV&gt;, "'CHARD-&lt;time&gt;'"</pre> Variable:<br>time = 0 - 255. Measured in 100 microsecond increments.<br>Example:<br><pre>SEND_COMMAND RS232_1, "'CHARD-10'"</pre> Sets a 1-millisecond delay between all transmitted characters.                                                                                                                                   |

| RS-232/422/485 Send Commands (Cont.)                                                                                                               |                                                                                                                                                                                                                                                                                                                                                                                                                                                |
|----------------------------------------------------------------------------------------------------------------------------------------------------|------------------------------------------------------------------------------------------------------------------------------------------------------------------------------------------------------------------------------------------------------------------------------------------------------------------------------------------------------------------------------------------------------------------------------------------------|
| Command                                                                                                                                            | Description                                                                                                                                                                                                                                                                                                                                                                                                                                    |
| <p><b>CHARDM</b></p> <p>Set the delay time between all transmitted characters to the value specified (in 1 Millisecond increments).</p>            | <p>Syntax:</p> <pre>SEND_COMMAND &lt;DEV&gt;, "'CHARDM-&lt;time&gt;' "</pre> <p>Variable:</p> <p>time = 0 - 255. Measured in 1 millisecond increments.</p> <p>Example:</p> <pre>SEND_COMMAND RS232_1, "'CHARDM-10' "</pre> <p>Sets a 10-millisecond delay between all transmitted characters.</p>                                                                                                                                              |
| <p><b>CTSPSH</b></p> <p>Enable Pushes, Releases, and Status information to be reported via channel 255 using the CTS hardware handshake input.</p> | <p>This command turns On (enables) channel tracking of the handshaking pins. If Clear To Send (CTS) is set high, then channel 255 is On.</p> <p>Syntax:</p> <pre>SEND_COMMAND &lt;DEV&gt;, "'CTSPSH' "</pre> <p>Example:</p> <pre>SEND_COMMAND RS232_1, "'CTSPSH' "</pre> <p>Sets the RS232_1 port to detect changes on the CTS input.</p>                                                                                                     |
| <p><b>CTSPSH OFF</b></p> <p>Disable Pushes, Releases, and Status information to be reported via channel 255.</p>                                   | <p>This command disables tracking. Turns CTSPSH Off.</p> <p>Syntax:</p> <pre>SEND_COMMAND &lt;DEV&gt;, "'CTSPSH OFF' "</pre> <p>Example:</p> <pre>SEND_COMMAND RS232_1, "'CTSPSH OFF' "</pre> <p>Turns off CTSPSH for the specified device.</p>                                                                                                                                                                                                |
| <p><b>GET BAUD</b></p> <p>Get the RS-232/422/485 port's current communication parameters.</p>                                                      | <p>The port sends the parameters to the device that requested the information.</p> <p>The port responds with:</p> <pre>&lt;port #&gt;,&lt;baud&gt;,&lt;parity&gt;,&lt;data&gt;,&lt;stop&gt; 485 &lt;ENABLED   DISABLED&gt;</pre> <p>Syntax:</p> <pre>SEND_COMMAND &lt;DEV&gt;, "'GET BAUD' "</pre> <p>Example:</p> <pre>SEND_COMMAND RS232_1, "'GET BAUD' "</pre> <p>System response example:</p> <pre>Device 1,38400,N,8,1 485 DISABLED</pre> |
| <p><b>HSOFF</b></p> <p>Disable hardware handshaking (default).</p>                                                                                 | <p>Syntax:</p> <pre>SEND_COMMAND &lt;DEV&gt;, "'HSOFF' "</pre> <p>Example:</p> <pre>SEND_COMMAND RS232_1, "'HSOFF' "</pre> <p>Disables hardware handshaking on the RS232_1 device.</p>                                                                                                                                                                                                                                                         |
| <p><b>HSON</b></p> <p>Enable RTS (ready-to-send) and CTS (clear-to-send) hardware handshaking.</p>                                                 | <p>Syntax:</p> <pre>SEND_COMMAND &lt;DEV&gt;, "'HSON' "</pre> <p>Example:</p> <pre>SEND_COMMAND RS232_1, "'HSON' "</pre> <p>Enables hardware handshaking on the RS232_1 device.</p>                                                                                                                                                                                                                                                            |
| <p><b>RXCLR</b></p> <p>Clear all characters in the receive buffer waiting to be sent to the Master.</p>                                            | <p>Syntax:</p> <pre>SEND_COMMAND &lt;DEV&gt;, "'RXCLR' "</pre> <p>Example:</p> <pre>SEND_COMMAND RS232_1, "'RXCLR' "</pre> <p>Clears all characters in the RS232_1 device's receive buffer waiting to be sent to the Master.</p>                                                                                                                                                                                                               |

| RS-232/422/485 Send_Commands (Cont.)                                                                         |                                                                                                                                                                                                                                                                                                                                                                                                                                                                                                                                                                                                                                                                                                                                                                                                                                                      |
|--------------------------------------------------------------------------------------------------------------|------------------------------------------------------------------------------------------------------------------------------------------------------------------------------------------------------------------------------------------------------------------------------------------------------------------------------------------------------------------------------------------------------------------------------------------------------------------------------------------------------------------------------------------------------------------------------------------------------------------------------------------------------------------------------------------------------------------------------------------------------------------------------------------------------------------------------------------------------|
| Command                                                                                                      | Description                                                                                                                                                                                                                                                                                                                                                                                                                                                                                                                                                                                                                                                                                                                                                                                                                                          |
| <p><b>RXOFF</b></p> <p>Disable the transmission of incoming received characters to the Master (default).</p> | <p>Syntax:</p> <pre>SEND_COMMAND &lt;DEV&gt;, " 'RXOFF' "</pre> <p>Example:</p> <pre>SEND_COMMAND RS232_1, " 'RXOFF' "</pre> <p>Stops the RS232_1 device from transmitting received characters to the Master.</p>                                                                                                                                                                                                                                                                                                                                                                                                                                                                                                                                                                                                                                    |
| <p><b>RXON</b></p> <p>Start transmitting received characters to the Master (default).</p>                    | <p>Enables sending incoming received characters to the Master. This command is automatically sent by the Master when a 'CREATE_BUFFER' program instruction is executed.</p> <p>Syntax:</p> <pre>SEND_COMMAND &lt;DEV&gt;, " 'RXON' "</pre> <p>Example:</p> <pre>SEND_COMMAND RS232_1, " 'RXON' "</pre> <p>Sets the RS232_1 device to transmit received characters to the Master.</p>                                                                                                                                                                                                                                                                                                                                                                                                                                                                 |
| <p><b>SET BAUD</b></p> <p>Set the RS-232/422/485 port's communication parameters.</p>                        | <p>Syntax:</p> <pre>SEND_COMMAND &lt;DEV&gt;, " 'SET BAUD &lt;baud&gt;,&lt;parity&gt;,&lt;data&gt;,&lt;stop&gt; [485 &lt;Enable   Disable&gt;]' "</pre> <p>Variables:</p> <p>baud = baud rates are: 115200, 76800, 57600, 38400, 19200, 9600, 4800, 2400, 1200, 600, 300, 150.</p> <p>parity = N (none), O (odd), E (even), M (mark), S (space).</p> <p>data = 7 or 8 data bits.</p> <p>stop = 1 and 2 stop bits.</p> <p>485 Disable = Disables RS-485 mode and enables RS-422.</p> <p>485 Enable = Enables RS-485 mode and disables RS-422.</p> <p><b>Note: The only valid 9 bit combination is (baud),N,9,1.</b></p> <p>Example:</p> <pre>SEND_COMMAND RS232_1, " 'SET BAUD 115200,N,8,1 485 ENABLE' "</pre> <p>Sets the RS232_1 port's communication parameters to 115,200 baud, no parity, 8 data bits, 1 stop bit, and enables RS-485 mode.</p> |

| RS-232/422/485 Send_Commands (Cont.)                                                                                |                                                                                                                                                                                                                                                                                                                                                                                                                                                                                                                                                                                                                                                                                                                                                                                                                                                                                                                                                                                                                  |
|---------------------------------------------------------------------------------------------------------------------|------------------------------------------------------------------------------------------------------------------------------------------------------------------------------------------------------------------------------------------------------------------------------------------------------------------------------------------------------------------------------------------------------------------------------------------------------------------------------------------------------------------------------------------------------------------------------------------------------------------------------------------------------------------------------------------------------------------------------------------------------------------------------------------------------------------------------------------------------------------------------------------------------------------------------------------------------------------------------------------------------------------|
| Command                                                                                                             | Description                                                                                                                                                                                                                                                                                                                                                                                                                                                                                                                                                                                                                                                                                                                                                                                                                                                                                                                                                                                                      |
| <p><b>TSET BAUD</b></p> <p>Temporarily set the RS-232/422/485 port's communication parameters for a device.</p>     | <p>TSET BAUD works the same as SET BAUD, except that the changes are not permanent, and the previous values will be restored if the power is cycled on the device.</p> <p>Syntax:</p> <pre>SEND_COMMAND &lt;DEV&gt;, "'TSET BAUD &lt;baud&gt;,&lt;parity&gt;,&lt;data&gt;,&lt;stop&gt; [485 &lt;Enable   Disable&gt;]'"</pre> <p>Variables:</p> <p>baud = baud rates are: 115200, 57600, 38400, 19200, 9600, 4800, 2400, 1200, 600, 300.</p> <p>parity = N (none), O (odd), E (even), M (mark), S (space).</p> <p>data = 7, 8, or 9 data bits.</p> <p>stop = 1 or 2 stop bits.</p> <p>485 Disable = Disables RS-485 mode and enables RS-422.</p> <p>485 Enable = Enables RS-485 mode and disables RS-422.</p> <p><b>Note: The only valid 9 bit combination is (baud),N,9,1.</b></p> <p>Example:</p> <pre>SEND_COMMAND RS232_1, "'TSET BAUD 115200,N,8,1 485 ENABLE'"</pre> <p>Sets the RS232_1 port's communication parameters to 115,200 baud, no parity, 8 data bits, 1 stop bit, and enables RS-485 mode.</p> |
| <p><b>TXCLR</b></p> <p>Stop and clear all characters waiting in the transmit out buffer and stops transmission.</p> | <p>Syntax:</p> <pre>SEND_COMMAND &lt;DEV&gt;, "'TXCLR'"</pre> <p>Example:</p> <pre>SEND_COMMAND RS232_1, "'TXCLR'"</pre> <p>Clears and stops all characters waiting in the RS232_1 device's transmit buffer.</p>                                                                                                                                                                                                                                                                                                                                                                                                                                                                                                                                                                                                                                                                                                                                                                                                 |
| <p><b>XOFF</b></p> <p>Disable software handshaking (default).</p>                                                   | <p>Syntax:</p> <pre>SEND_COMMAND &lt;DEV&gt;, "'XOFF'"</pre> <p>Example:</p> <pre>SEND_COMMAND RS232_1, "'XOFF'"</pre> <p>Disables software handshaking on the RS232_1 device.</p>                                                                                                                                                                                                                                                                                                                                                                                                                                                                                                                                                                                                                                                                                                                                                                                                                               |
| <p><b>XON</b></p> <p>Enable software handshaking.</p>                                                               | <p>Syntax:</p> <pre>SEND_COMMAND &lt;DEV&gt;, "'XON'"</pre> <p>Example:</p> <pre>SEND_COMMAND RS232_1, "'XON'"</pre> <p>Enables software handshaking on the RS232_1 device.</p>                                                                                                                                                                                                                                                                                                                                                                                                                                                                                                                                                                                                                                                                                                                                                                                                                                  |



## RS-232/422/485 Send\_String Escape Sequences

This device also has some special SEND\_STRING escape sequences:

If any of the 3 character combinations below are found anywhere within a SEND\_STRING program instruction, they will be treated as a command and not the literal characters.

In these examples: <DEV> = device.

| RS-232/422/485 Send_String Escape Sequences                                                        |                                                                                                                                                                                                                                                                                       |
|----------------------------------------------------------------------------------------------------|---------------------------------------------------------------------------------------------------------------------------------------------------------------------------------------------------------------------------------------------------------------------------------------|
| Command                                                                                            | Description                                                                                                                                                                                                                                                                           |
| <b>27,17,&lt;time&gt;</b><br>Send a break character for a specified duration to a specific device. | Syntax:<br><pre>SEND_STRING &lt;DEV&gt;, "27,17,&lt;time&gt;"</pre> Variable:<br>time = 1 - 255. Measured in 100 microsecond increments.<br>Example:<br><pre>SEND_STRING RS232_1, "27,17,10"</pre> Sends a break character of 1 millisecond to the RS232_1 device.                    |
| <b>27,18,0</b><br>Clear the ninth data bit by setting it to 0 on all character transmissions.      | Used in conjunction with the 'B9MON' command.<br>Syntax:<br><pre>SEND_STRING &lt;DEV&gt;, "27,18,0"</pre> Example:<br><pre>SEND_STRING RS232_1, "27,18,0"</pre> Sets the RS232_1 device's ninth data bit to 0 on all character transmissions.                                         |
| <b>27,18,1</b><br>Set the ninth data bit to 1 for all subsequent characters to be transmitted.     | Used in conjunction with the 'B9MON' command.<br>Syntax:<br><pre>SEND_STRING &lt;DEV&gt;, "27,18,1"</pre> Example:<br><pre>SEND_STRING RS232_1, "27,18,1"</pre> Sets the RS232_1 device's ninth data bit to 1 on all character transmissions.                                         |
| <b>27,19,&lt;time&gt;</b><br>Insert a time delay before transmitting the next character.           | Syntax:<br><pre>SEND_STRING &lt;DEV&gt;, "27,19,&lt;time&gt;"</pre> Variable:<br>time = 1 - 255. Measured in 1 millisecond increments.<br>Example:<br><pre>SEND_STRING RS232_1, "27,19,10"</pre> Inserts a 10 millisecond delay before transmitting characters to the RS232_1 device. |
| <b>27,20,0</b><br>Set the RTS hardware handshake's output to high (> 3V).                          | Syntax:<br><pre>SEND_STRING &lt;DEV&gt;, "27,20,0"</pre> Example:<br><pre>SEND_STRING RS232_1, "27,20,0"</pre> Sets the RTS hardware handshake's output to high on the RS232_1 device.                                                                                                |
| <b>27,20,1</b><br>Set the RTS hardware handshake's output to low/inactive (< 3V).                  | Syntax:<br><pre>SEND_STRING &lt;DEV&gt;, "27,20,1"</pre> Example:<br><pre>SEND_STRING RS232_1, "27,20,1"</pre> Sets the RTS hardware handshake's output to low on the RS232_1 device.                                                                                                 |

## IR / Serial Ports Channels

| IR / Serial Ports Channels |                                                  |
|----------------------------|--------------------------------------------------|
| 00001 - 00229              | IR commands.                                     |
| 00229 - 00253              | May be used for system call feedback.            |
| 00254                      | Power Fail. (Used w/ 'PON' and 'POF' commands).  |
| 00255                      | Power status. (Shadows I/O Link channel status). |



NOTE

*IR ports - Ports 9 - 16 (NI-4X000/3X00) and Ports 5 - 8 (NI-2X00).  
The NI series of NetLinx Masters support Serial control via the IR port when using firmware version 300 or greater.*

## IR/Serial Send\_Commands

The following IR and IR/Serial Send\_Commands generate control signals for external equipment. In these examples: <DEV> = device.

| IR/Serial Send_Commands                                                             |                                                                                                                                                                                     |
|-------------------------------------------------------------------------------------|-------------------------------------------------------------------------------------------------------------------------------------------------------------------------------------|
| Command                                                                             | Description                                                                                                                                                                         |
| <b>CAROFF</b><br>Disable the IR carrier signal until a 'CARON' command is received. | Syntax:<br><code>SEND_COMMAND &lt;DEV&gt;, "'CAROFF' "</code><br>Example:<br><code>SEND_COMMAND IR_1, "'CAROFF' "</code><br>Stops transmitting IR carrier signals to the IR_1 port. |
| <b>CARON</b><br>Enable the IR carrier signals (default).                            | Syntax:<br><code>SEND_COMMAND &lt;DEV&gt;, "'CARON' "</code><br>Example:<br><code>SEND_COMMAND IR_1, "'CARON' "</code><br>Starts transmitting IR carrier signals to the IR_1 port.  |

| IR/Serial Send_Commands (Cont.)                                                                                                  |                                                                                                                                                                                                                                                                                                                                                                                                                                                                                                                                                                                                                                                                                                                                                                                                                                                                                                                                                                                                                                                                                                                                                                                    |
|----------------------------------------------------------------------------------------------------------------------------------|------------------------------------------------------------------------------------------------------------------------------------------------------------------------------------------------------------------------------------------------------------------------------------------------------------------------------------------------------------------------------------------------------------------------------------------------------------------------------------------------------------------------------------------------------------------------------------------------------------------------------------------------------------------------------------------------------------------------------------------------------------------------------------------------------------------------------------------------------------------------------------------------------------------------------------------------------------------------------------------------------------------------------------------------------------------------------------------------------------------------------------------------------------------------------------|
| Command                                                                                                                          | Description                                                                                                                                                                                                                                                                                                                                                                                                                                                                                                                                                                                                                                                                                                                                                                                                                                                                                                                                                                                                                                                                                                                                                                        |
| <p><b>CH</b><br/>Send IR pulses for the selected channel.</p>                                                                    | <p>All channels below 100 are transmitted as two digits. If the IR code for ENTER (function #21) is loaded, an Enter will follow the number. If the channel is greater than or equal to (<math>\geq</math>) 100, then IR function 127 or 20 (whichever exists) is generated for the one hundred digit. Uses 'CTON' and 'CTOF' times for pulse times.</p> <p>Syntax:<br/> <code>SEND_COMMAND &lt;DEV&gt;, "'CH', &lt;channel number&gt;"</code></p> <p>Variable:<br/> channel number = 0 - 199.</p> <p>Example:<br/> <code>SEND_COMMAND IR_1, "'CH', 18"</code></p> <p>This device performs the following:</p> <ul style="list-style-type: none"> <li>• Transmits IR signals for 1 (IR code 11). The transmit time is set with the CTON command.</li> <li>• Waits until the time set with the CTOF command elapses.</li> <li>• Transmits IR signals for 8 (IR code 18).</li> <li>• Waits for the time set with the CTOF command elapses.</li> <li>• If the IR code for Enter (IR code 21) is programmed, the Controller performs steps 5 and 6.</li> <li>• Transmits IR signals for Enter (IR code 21).</li> <li>• Waits for the time set with the CTOF command elapses.</li> </ul> |
| <p><b>CP</b><br/>Halt and Clear all active or buffered IR commands, and then send a single IR pulse.</p>                         | <p>You can set the Pulse and Wait times with the 'CTON' and 'CTOF' commands.</p> <p>Syntax:<br/> <code>SEND_COMMAND &lt;DEV&gt;, "'CP', &lt;code&gt;"</code></p> <p>Variable:<br/> code = IR port's channel value 0 - 252 (253 - 255 reserved).</p> <p>Example:<br/> <code>SEND_COMMAND IR_1, "'CP', 2"</code></p> <p>Clears the active/buffered commands and pulses IR_1 port's channel 2.</p>                                                                                                                                                                                                                                                                                                                                                                                                                                                                                                                                                                                                                                                                                                                                                                                    |
| <p><b>CTOF</b><br/>Set the duration of the Off time (no signal) between IR pulses for channel and IR function transmissions.</p> | <p>Off time settings are stored in non-volatile memory. This command sets the delay time between pulses generated by the 'CH' or 'XCH' send commands in tenths of seconds.</p> <p>Syntax:<br/> <code>SEND_COMMAND &lt;DEV&gt;, "'CTOF', &lt;time&gt;"</code></p> <p>Variable:<br/> time = 0 - 255. Given in 1/10ths of a second. Default is 5 (0.5 seconds).</p> <p>Example:<br/> <code>SEND_COMMAND IR_1, "'CTOF', 10"</code></p> <p>Sets the off time between each IR pulse to 1 second.</p>                                                                                                                                                                                                                                                                                                                                                                                                                                                                                                                                                                                                                                                                                     |
| <p><b>CTON</b><br/>Set the total time of IR pulses transmitted and is stored in non-volatile memory.</p>                         | <p>This command sets the pulse length for each pulse generated by the 'CH' or 'XCH' send commands in tenths of seconds.</p> <p>Syntax:<br/> <code>SEND_COMMAND &lt;DEV&gt;, "'CTON', &lt;time&gt;"</code></p> <p>Variable:<br/> time = 0 - 255. Given in 1/10ths of a second. Default is 5 (0.5 seconds).</p> <p>Example:<br/> <code>SEND_COMMAND IR_1, "'CTON', 20"</code></p> <p>Sets the IR pulse duration to 2 seconds.</p>                                                                                                                                                                                                                                                                                                                                                                                                                                                                                                                                                                                                                                                                                                                                                    |

| IR/Serial Send_Commands (Cont.)                                                                                                                                |                                                                                                                                                                                                                                                                                                                                                                                                                                                                                                                                                                                                                                                                                                                                                                                                                                                                                                                                                                                                                                                                                                                                 |
|----------------------------------------------------------------------------------------------------------------------------------------------------------------|---------------------------------------------------------------------------------------------------------------------------------------------------------------------------------------------------------------------------------------------------------------------------------------------------------------------------------------------------------------------------------------------------------------------------------------------------------------------------------------------------------------------------------------------------------------------------------------------------------------------------------------------------------------------------------------------------------------------------------------------------------------------------------------------------------------------------------------------------------------------------------------------------------------------------------------------------------------------------------------------------------------------------------------------------------------------------------------------------------------------------------|
| Command                                                                                                                                                        | Description                                                                                                                                                                                                                                                                                                                                                                                                                                                                                                                                                                                                                                                                                                                                                                                                                                                                                                                                                                                                                                                                                                                     |
| <p><b>GET BAUD</b></p> <p>Get the IR port's current DATA mode communication parameters.</p>                                                                    | <p>The port sends the parameters to the device that requested the information. Only valid if the port is in Data Mode (see SET MODE command).</p> <p>The port responds with:</p> <p><i>&lt;port #&gt; &lt;baud&gt;,&lt;parity&gt;,&lt;data bits&gt;,&lt;stop bits&gt;</i></p> <p>Syntax:</p> <pre>SEND_COMMAND &lt;DEV&gt; , " 'GET BAUD' "</pre> <p>Example:</p> <pre>SEND_COMMAND IR_1 , " 'GET BAUD' "</pre> <p>System response example:</p> <pre>PORT 9 IR, CARRIER, IO LINK 0</pre>                                                                                                                                                                                                                                                                                                                                                                                                                                                                                                                                                                                                                                        |
| <p><b>GET MODE</b></p> <p>Poll the IR/Serial port's configuration parameters and report the active mode settings to the device requesting the information.</p> | <p>The port responds with: <i>&lt;port #&gt; &lt;mode&gt;,&lt;carrier&gt;,&lt;io link channel&gt;</i>.</p> <p>Syntax:</p> <pre>SEND_COMMAND &lt;DEV&gt; , " 'GET MODE' "</pre> <p>Example:</p> <pre>SEND_COMMAND IR_1 , " 'GET MODE' "</pre> <p>The system could respond with:</p> <pre>PORT 4 IR, CARRIER, IO LINK 0</pre>                                                                                                                                                                                                                                                                                                                                                                                                                                                                                                                                                                                                                                                                                                                                                                                                     |
| <p><b>IROFF</b></p> <p>Halt and Clear all active or buffered IR commands being output on the designated port.</p>                                              | <p>Syntax:</p> <pre>SEND_COMMAND &lt;DEV&gt; , " 'IROFF' "</pre> <p>Example:</p> <pre>SEND_COMMAND IR_1 , " 'IROFF' "</pre> <p>Immediately halts and clears all IR output signals on the IR_1 port.</p>                                                                                                                                                                                                                                                                                                                                                                                                                                                                                                                                                                                                                                                                                                                                                                                                                                                                                                                         |
| <p><b>POD</b></p> <p>Disable previously active 'PON' (power on) or 'POF' (power off) command settings.</p>                                                     | <p>Channel 255 changes are enabled. This command is used in conjunction with the I/O Link command.</p> <p>Syntax:</p> <pre>SEND_COMMAND &lt;DEV&gt; , " 'POD' "</pre> <p>Example:</p> <pre>SEND_COMMAND IR_1 , " 'POD' "</pre> <p>Disables the 'PON' and 'POF' command settings on the IR_1 device.</p>                                                                                                                                                                                                                                                                                                                                                                                                                                                                                                                                                                                                                                                                                                                                                                                                                         |
| <p><b>POF</b></p> <p>Turn Off a device connected to an IR port based on the status of the corresponding I/O Link input.</p>                                    | <p>If at any time the IR sensor input reads that the device is ON (such as if someone turned it on manually at the front panel), IR function 28 (if available) or IR function 9 is automatically generated in an attempt to turn the device back OFF. If three attempts fail, the IR port will continue executing commands in the buffer.</p> <p>If there are no commands in the buffer, the IR port will continue executing commands in the buffer and trying to turn the device OFF until a 'PON' or 'POD' command is received. If the IR port fails to turn the device OFF, a PUSH and RELEASE is made on channel 254 to indicate a power failure error. You can only use the 'PON' and 'POF' commands when an IR device has a linked I/O channel. Channel 255 changes are disabled after receipt of this command.</p> <p>You can only use the 'PON' and 'POF' commands when an IR device has a linked I/O channel.</p> <p>Syntax:</p> <pre>SEND_COMMAND &lt;DEV&gt; , " 'POF' "</pre> <p>Example:</p> <pre>SEND_COMMAND IR_1 , " 'POF' "</pre> <p>Sends power down IR commands 28 (if present) or 9 to the IR_1 device.</p> |

| IR/Serial Send_Commands (Cont.)                                                                                            |                                                                                                                                                                                                                                                                                                                                                                                                                                                                                                                                                                                                                                                                                                                                                                                                                                                                                                                                                                                                       |
|----------------------------------------------------------------------------------------------------------------------------|-------------------------------------------------------------------------------------------------------------------------------------------------------------------------------------------------------------------------------------------------------------------------------------------------------------------------------------------------------------------------------------------------------------------------------------------------------------------------------------------------------------------------------------------------------------------------------------------------------------------------------------------------------------------------------------------------------------------------------------------------------------------------------------------------------------------------------------------------------------------------------------------------------------------------------------------------------------------------------------------------------|
| Command                                                                                                                    | Description                                                                                                                                                                                                                                                                                                                                                                                                                                                                                                                                                                                                                                                                                                                                                                                                                                                                                                                                                                                           |
| <p><b>PON</b></p> <p>Turn On a device connected to an IR port based on the status of the corresponding I/O Link input.</p> | <p>If at any time the IR sensor input reads that the device is OFF (such as if one turned it off manually at the front panel), IR function 27 (if available) or IR function 9 is automatically generated in an attempt to turn the device back ON. If three attempts fail, the IR port will continue executing commands in the buffer and trying to turn the device On.</p> <p>If there are no commands in the buffer, the IR port will continue trying to turn the device ON until a 'POF' or 'POD' command is received. If the IR port fails to turn the device ON, a PUSH and RELEASE is made on channel 254 to indicate a power failure error.</p> <p>You can only use the 'PON' and 'POF' commands when an IR device has a linked I/O channel. Channel 255 changes are disabled after receipt of this command.</p> <p>Syntax:</p> <pre>SEND_COMMAND &lt;DEV&gt;,"'PON' "</pre> <p>Example:</p> <pre>SEND_COMMAND IR_1,"'PON' "</pre> <p>Sends power up IR commands 27 or 9 to the IR_1 port.</p> |
| <p><b>PTOF</b></p> <p>Set the time duration between power pulses in .10-second increments.</p>                             | <p>This time increment is stored in permanent memory. This command also sets the delay between pulses generated by the 'PON' or 'POF' send commands in tenths of seconds. It also sets the delay required after a power ON command before a new IR function can be generated. This gives the device time to power up and get ready for future IR commands.</p> <p>Syntax:</p> <pre>SEND_COMMAND &lt;DEV&gt;,"'PTOF',&lt;time&gt;"</pre> <p>Variable:</p> <p>time = 0 - 255. Given in 1/10ths of a second. Default is 15 (1.5 seconds).</p> <p>Example:</p> <pre>SEND_COMMAND IR_1,"'PTOF',15"</pre> <p>Sets the time between power pulses to 1.5 seconds for the IR_1 device.</p>                                                                                                                                                                                                                                                                                                                     |
| <p><b>PTON</b></p> <p>Set the time duration of the power pulses in .10-second increments</p>                               | <p>This time increment is stored in permanent memory. This command also sets the pulse length for each pulse generated by the 'PON' or 'POF' send commands in tenths of seconds.</p> <p>Syntax:</p> <pre>SEND_COMMAND &lt;DEV&gt;,"'PTON',&lt;time&gt;"</pre> <p>Variable:</p> <p>time = 0 - 255. Given in 1/10ths of a second. Default is 5 (0.5 seconds).</p> <p>Example:</p> <pre>SEND_COMMAND IR_1,"'PTON',15"</pre> <p>Sets the duration of the power pulse to 1.5 seconds for the IR_1 device.</p>                                                                                                                                                                                                                                                                                                                                                                                                                                                                                              |

| <b>IR/Serial Send_Commands (Cont.)</b>                                                                                                     |                                                                                                                                                                                                                                                                                                                                                                                                                                                                                                                                                                                                                                                                                             |
|--------------------------------------------------------------------------------------------------------------------------------------------|---------------------------------------------------------------------------------------------------------------------------------------------------------------------------------------------------------------------------------------------------------------------------------------------------------------------------------------------------------------------------------------------------------------------------------------------------------------------------------------------------------------------------------------------------------------------------------------------------------------------------------------------------------------------------------------------|
| <p><b>SET BAUD</b><br/>Set the IR port's DATA mode communication parameters.</p>                                                           | <p>Only valid if the port is in Data Mode (see SET MODE command).</p> <p>Syntax:<br/>SEND_COMMAND &lt;DEV&gt;, "'SET BAUD &lt;baud&gt;, &lt;parity&gt;, &lt;data&gt;, &lt;stop&gt;' "</p> <p>Variables:<br/>baud = baud rates are: 19200, 9600, 4800, 2400, and 1200.<br/>parity = N (none), O (odd), E (even), M (mark), S (space).<br/>data = 7 or 8 data bits.<br/>stop = 1 and 2 stop bits.</p> <p><b>Note: AMX does not recommend using a cable longer than 10 feet (3.05 meters) for the IR Ports.</b></p> <p>Example:<br/>SEND_COMMAND IR_1, "'SET BAUD 9600,N,8,1' "</p> <p>Sets the IR_1 port's communication parameters to 9600 baud, no parity, 8 data bits, and 1 stop bit.</p> |
| <p><b>SET IO LINK</b><br/>Link an IR or Serial port to a selected I/O channel for use with the 'DE', 'POD', 'PON', and 'POF' commands.</p> | <p>The I/O status is automatically reported on channel 255 on the IR port. The I/O channel is used for power sensing (via a PCS or VSS). A channel of zero disables the I/O link.</p> <p>Syntax:<br/>SEND_COMMAND &lt;DEV&gt;, "'SET IO LINK &lt;I/O number&gt;' "</p> <p>Variable:<br/>I/O number = 1 - 8. Setting the I/O channel to 0 disables the I/O link.</p> <p>Example:<br/>SEND_COMMAND IR_1, "'SET IO LINK 1' "</p> <p>Sets the IR_1 port link to I/O channel 1. The IR port uses the specified I/O input as power status for processing 'PON' and 'POF' commands.</p>                                                                                                            |
| <p><b>SET MODE</b><br/>Set the IR/Serial ports for IR or Serial-controlled devices connected to a CardFrame or NetModule.</p>              | <p>Sets an IR port to either IR, Serial, or Data mode.</p> <p><b>Note: IR DATA Mode works best when using both a lower baud rate and a short cable length (&lt; 10 feet).</b></p> <p>Syntax:<br/>SEND_COMMAND &lt;DEV&gt;, 'SET MODE &lt;mode&gt;' "</p> <p>Variable:<br/>mode = IR, SERIAL, or DATA.</p> <p>Example:<br/>SEND_COMMAND IR_1, "'SET MODE IR' "</p> <p>Sets the IR_1 port to IR mode for IR control.</p>                                                                                                                                                                                                                                                                      |
| <p><b>SP</b><br/>Generate a single IR pulse.</p>                                                                                           | <p>You can use the 'CTON' to set pulse lengths and the 'CTOF' for time Off between pulses.</p> <p>Syntax:<br/>SEND_COMMAND &lt;DEV&gt;, "'SP', &lt;code&gt;' "</p> <p>Variable:<br/>code = IR code value 1 - 252 (253-255 reserved).</p> <p>Example:<br/>SEND_COMMAND IR_1, "'SP', 25' "</p> <p>Pulses IR code 25 on IR_1 device.</p>                                                                                                                                                                                                                                                                                                                                                       |

| IR/Serial Send_Commands (Cont.)                                                                                       |                                                                                                                                                                                                                                                                                                                                                                                                                                                                                                                                                                                                                                                                                                                                                                                                                                                                                                                                                                                                                                                                                                                                                                                                                                                                                                                                                                                                                                                                                                                                                                                                                                                      |
|-----------------------------------------------------------------------------------------------------------------------|------------------------------------------------------------------------------------------------------------------------------------------------------------------------------------------------------------------------------------------------------------------------------------------------------------------------------------------------------------------------------------------------------------------------------------------------------------------------------------------------------------------------------------------------------------------------------------------------------------------------------------------------------------------------------------------------------------------------------------------------------------------------------------------------------------------------------------------------------------------------------------------------------------------------------------------------------------------------------------------------------------------------------------------------------------------------------------------------------------------------------------------------------------------------------------------------------------------------------------------------------------------------------------------------------------------------------------------------------------------------------------------------------------------------------------------------------------------------------------------------------------------------------------------------------------------------------------------------------------------------------------------------------|
| Command                                                                                                               | Description                                                                                                                                                                                                                                                                                                                                                                                                                                                                                                                                                                                                                                                                                                                                                                                                                                                                                                                                                                                                                                                                                                                                                                                                                                                                                                                                                                                                                                                                                                                                                                                                                                          |
| <p><b>XCH</b></p> <p>Transmit the selected channel IR codes in the format/pattern set by the 'XCHM' send command.</p> | <p>Syntax:<br/>SEND_COMMAND &lt;DEV&gt;, "'XCH &lt;channel&gt;' "</p> <p>Variable:<br/>channel = 0 - 999.</p> <p>Example:<br/>For detailed usage examples, refer to the 'XCHM' command.</p>                                                                                                                                                                                                                                                                                                                                                                                                                                                                                                                                                                                                                                                                                                                                                                                                                                                                                                                                                                                                                                                                                                                                                                                                                                                                                                                                                                                                                                                          |
| <p><b>XCHM</b></p> <p>Changes the IR output pattern for the 'XCH' send command.</p>                                   | <p>Syntax:<br/>SEND_COMMAND &lt;DEV&gt;, "'XCHM &lt;extended channel mode&gt;' "</p> <p>Variable:<br/>extended channel mode = 0 - 4.</p> <p>Example:<br/>SEND_COMMAND IR_1, "'XCHM 3' "</p> <p>Sets the IR_1 device's extended channel command to mode 3.</p> <p><b>Mode 0 Example (default): [x][x]&lt;x&gt;&lt;enter&gt;</b><br/>SEND_COMMAND IR_1, "'XCH 3' "</p> <p>Transmits the IR code as 3-enter.</p> <p>SEND_COMMAND IR_1, "'XCH 34' "</p> <p>Transmits the IR code as 3-4-enter.</p> <p>SEND_COMMAND IR_1, "'XCH 343' "</p> <p>Transmits the IR code as 3-4-3-enter.</p> <p><b>Mode 1 Example: &lt;x&gt; &lt;x&gt; &lt;x&gt; &lt;enter&gt;</b><br/>SEND_COMMAND IR_1, "'XCH 3' "</p> <p>Transmits the IR code as 0-0-3-enter.</p> <p>SEND_COMMAND IR_1, "'XCH 34' "</p> <p>Transmits the IR code as 0-3-4-enter.</p> <p>SEND_COMMAND IR_1, "'XCH 343' "</p> <p>Transmits the IR code as 3-4-3-enter.</p> <p><b>Mode 2 Example: &lt;x&gt; &lt;x&gt; &lt;x&gt;</b><br/>SEND_COMMAND IR_1, "'XCH 3' "</p> <p>Transmits the IR code as 0-0-3.</p> <p>SEND_COMMAND IR_1, "'XCH 34' "</p> <p>Transmits the IR code as 0-3-4.</p> <p>SEND_COMMAND IR_1, "'XCH 343' "</p> <p>Transmits the IR code as 3-4-3.</p> <p><b>Mode 3 Example: [[100][100]...] &lt;x&gt; &lt;x&gt;</b><br/>SEND_COMMAND IR_1, "'XCH 3' "</p> <p>Transmits the IR code as 0-3.</p> <p>SEND_COMMAND IR_1, "'XCH 34' "</p> <p>Transmits the IR code as 3-4.</p> <p>SEND_COMMAND IR_1, "'XCH 343' "</p> <p>Transmits the IR code as 100-100-100-4-3.</p> <p><b>Mode 4:</b><br/>Mode 4 sends the same sequences as the 'CH' command. Only use Mode 4 with channels 0 - 199.</p> |

## Input/Output Send\_Commands

The following Send\_Commands program the I/O ports on the Integrated Controller.  
 In these examples: <DEV> = device.



*I/O ports: Port 17 (NI-4X00/3X00) and Port 9 (NI-2X00).  
 Channels: 1 - 8 I/O channels.*

| I/O Send_Commands                                                                                |                                                                                                                                                                                                                                                                                                                                                                                                                                                                                                                                                                                                                                                                                                   |
|--------------------------------------------------------------------------------------------------|---------------------------------------------------------------------------------------------------------------------------------------------------------------------------------------------------------------------------------------------------------------------------------------------------------------------------------------------------------------------------------------------------------------------------------------------------------------------------------------------------------------------------------------------------------------------------------------------------------------------------------------------------------------------------------------------------|
| <p><b>GET INPUT</b><br/>                     Get the active state for the selected channels.</p> | <p>An active state can be high (logic high) or low (logic low or contact closure). Channel changes, Pushes, and Releases generate reports based on their active state. The port responds with either 'HIGH' or 'LOW'.</p> <p>Syntax:<br/> <code>SEND_COMMAND &lt;DEV&gt;, "'GET INPUT &lt;channel&gt;'"</code></p> <p>Variable:<br/>                     channel = Input channel 1 - 8.</p> <p>Example:<br/> <code>SEND_COMMAND IO, "'GET INPUT 1'"</code></p> <p>Gets the I/O port's active state.</p> <p>The system could respond with:<br/>                     INPUT1 ACTIVE HIGH</p>                                                                                                         |
| <p><b>SET INPUT</b><br/>                     Set the input channel's active state.</p>           | <p>An active state can be high (logic high) or low (logic low or contact closure). Channel changes, Pushes, and Releases generate reports based on their active state. Setting an input to ACTIVE HIGH will disable the ability to use that channel as an output.</p> <p>Syntax:<br/> <code>SEND_COMMAND &lt;DEV&gt;, "'SET INPUT &lt;channel&gt; &lt;state&gt;'"</code></p> <p>Variable:<br/>                     channel = Input channel 1 - 8.<br/>                     state = Active state HIGH or LOW (default).</p> <p>Example:<br/> <code>SEND_COMMAND IO, "'SET INPUT 1 HIGH'"</code></p> <p>Sets the I/O channel to detect a high state change, and disables output on the channel.</p> |



# Troubleshooting

This section describes the solutions to possible hardware/firmware issues that could arise during the common operation of a NetLinx device.

| Troubleshooting Information                                                                                                      |                                                                                                                                                                                                                                                                                                                                                                                                                                                                                                                                                                                                                                                                                                                                                                                                                                                            |
|----------------------------------------------------------------------------------------------------------------------------------|------------------------------------------------------------------------------------------------------------------------------------------------------------------------------------------------------------------------------------------------------------------------------------------------------------------------------------------------------------------------------------------------------------------------------------------------------------------------------------------------------------------------------------------------------------------------------------------------------------------------------------------------------------------------------------------------------------------------------------------------------------------------------------------------------------------------------------------------------------|
| Symptom                                                                                                                          | Solution                                                                                                                                                                                                                                                                                                                                                                                                                                                                                                                                                                                                                                                                                                                                                                                                                                                   |
| <p><b>My NI Controller can't obtain a DHCP Address.</b></p>                                                                      | <p>In requesting a DHCP Address, the DHCP Server can take up to a few minutes to provide the address to the on-board Master.</p> <ul style="list-style-type: none"> <li>• Verify there is an active Ethernet connection attached to the rear of the NI-Series Controller before beginning these procedures.</li> <li>• Select <b>Diagnostics &gt; Network Address</b>, from the Main menu and verify the System number.</li> <li>• If the IP Address field is still empty, give the NI Controller a few minutes to negotiate a DHCP Address and try again.</li> </ul>                                                                                                                                                                                                                                                                                      |
| <p><b>My NI Controller shows the same IP Address after selecting DHCP Server and clicking the GET IP Information button.</b></p> | <p>In requesting a DHCP Address, the DHCP Server can take up to a few minutes to provide the address to the on-board Master.</p> <p>When using a controller that has previously been used; there may be an instance where the IP Address was set as a fixed IP. In this case, the address would need to be released so a new user could use a DHCP server provided address.</p> <ul style="list-style-type: none"> <li>• Access the HyperTerminal application and try to communicate to the controller via the COM port.</li> <li>• Type <b>echo on</b> and press ENTER to send the information to the unit.</li> <li>• Type <b>get ip</b> to display the actual IP Address used by the unit.</li> <li>• Release the static/fixed IP Addresses.</li> <li>• Recycle power to the unit and retry obtaining a DHCP address through NetLinx Studio.</li> </ul> |
| <p><b>My NI Controller still can't obtain a DHCP Address even after completing the above troubleshooting tip.</b></p>            | <p>If the NI Controller is not connected directly to an open Ethernet wall connector, but is rather connected to an Ethernet Hub</p> <ul style="list-style-type: none"> <li>• Contact Technical Support for a resolution to issues with this type of connection scenario.</li> </ul>                                                                                                                                                                                                                                                                                                                                                                                                                                                                                                                                                                       |
| <p><b>I can't detect the NI Controller and my Status LED is blinking irregularly.</b></p>                                        | <p>The on-board Master is trying to establish communication.</p> <ul style="list-style-type: none"> <li>• Give it a few moments and retry establishing communication using the latest NetLinx Studio.</li> <li>• If the problem persists, cycle power to the unit and repeat the above procedure. Another solution is to attempt communication via another method (Program Port or IP).</li> <li>• Refer to the <i>Configuration and Firmware Update</i> section on page 43 for more information.</li> </ul>                                                                                                                                                                                                                                                                                                                                               |
| <p><b>NetLinx Studio only detects one of my connected Masters.</b></p>                                                           | <p>Each Master is give a Device Address of 00000.</p> <ul style="list-style-type: none"> <li>• Only one Master can be assigned to a particular System number. If you want to work with multiple Masters, open different instances of NetLinx Studio and assign each Master its own System value.</li> <li>• Example: A site has an NXC-ME260/64 and an NI-4x00. In order to work with both units. The ME260/64 can be assigned System #1 and the NI-4X00 can then be assigned System #2 using two open sessions of NetLinx Studio.</li> </ul>                                                                                                                                                                                                                                                                                                              |

| Troubleshooting Information (Cont.)                                                                                           |                                                                                                                                                                                                                                                                                                                                                                                                                                                                                                                                                                                                                                                                                                                                                                                                                                                  |
|-------------------------------------------------------------------------------------------------------------------------------|--------------------------------------------------------------------------------------------------------------------------------------------------------------------------------------------------------------------------------------------------------------------------------------------------------------------------------------------------------------------------------------------------------------------------------------------------------------------------------------------------------------------------------------------------------------------------------------------------------------------------------------------------------------------------------------------------------------------------------------------------------------------------------------------------------------------------------------------------|
| Symptom                                                                                                                       | Solution                                                                                                                                                                                                                                                                                                                                                                                                                                                                                                                                                                                                                                                                                                                                                                                                                                         |
| I can't connect to my NI Controller via the rear Program Port using a DB9 cable.                                              | <p>A DB9 cable is used for Serial communication between the PC and the Master.</p> <ul style="list-style-type: none"> <li>• Verify the DB9 connectors are securely inserted into their respective ports on both the rear Program Port (on the NI) and the COM Port (on the PC).</li> <li>• The NI-series of Integrated Controllers comes factory defaulted to a communication Baud Rate of 38400. Verify that the rear Program Port DIP switch is set to the user selected communication speed. Refer to the <i>Setting the Configuration DIP Switch (for the Program Port)</i> section on page 19 for more information.</li> <li>• If a higher Communication speed is being used (115200), try going to the lower Baud Rate of 38400. Refer to the <i>Configuration and Firmware Update</i> section on page 43 for more information.</li> </ul> |
| My NetLinx devices drop offline periodically when communicating over Ethernet.                                                | <p>The benefit of setting the Ethernet mode is to keep the Master (NI Controller) from having to auto negotiate with the Network.</p> <p>On NetLinx Masters (such as those onboard the NIs), from Telnet or Terminal, you can send the <b>SET ETHERNET MODE</b> command.</p> <p>Examples:</p> <pre> SET ETHERNET MODE 10 HALF SET ETHERNET MODE 10 FULL SET ETHERNET MODE 100 HALF SET ETHERNET MODE 100 FULL SET ETHERNET MODE AUTO                     </pre> <p>The NI Controllers can utilize all of the above Ethernet modes.</p>                                                                                                                                                                                                                                                                                                           |
| When plugging the Master into a fixed speed hub or switch; (i.e. 10-BaseT Hub or Switch); the hub or switch acts erratically. | (see above for resolution)                                                                                                                                                                                                                                                                                                                                                                                                                                                                                                                                                                                                                                                                                                                                                                                                                       |
| I'm unable to connect to the NetLinx Master from a PC over TCP/IP.                                                            | (see above for resolution)                                                                                                                                                                                                                                                                                                                                                                                                                                                                                                                                                                                                                                                                                                                                                                                                                       |
| I've inserted my NXC cards into my NI-4X00 but NetLinx Studio doesn't detect them.                                            | <p>The NI-4000 and NI-4100 Integrated Controller are the only NI-series Controllers that utilizes NXC Control Cards.</p> <ul style="list-style-type: none"> <li>• Verify that the cards have been firmly inserted into open slots within the NI-4X00 until the cards connectors "snap" into the rear connector. Without this proper connection of the cards to the rear of the slot, the NI Controller might not detect them properly.</li> <li>• From the Main NetLinx Studio menu, go to <b>Tools &gt; Reboot the Master Controller &gt; Continue</b>. This reboots the on-board Master and makes it re-detect the inserted cards.</li> <li>• If NetLinx Studio still does not detect the cards, cycle power to the Controller and repeat the above steps.</li> </ul>                                                                          |

| Troubleshooting Information (Cont.)                                                                     |                                                                                                                                                                                                                                                                                                                                                                                                                                                                                                                                                                                                                                                                                                                                                                                                                                                                                                                                                                                           |
|---------------------------------------------------------------------------------------------------------|-------------------------------------------------------------------------------------------------------------------------------------------------------------------------------------------------------------------------------------------------------------------------------------------------------------------------------------------------------------------------------------------------------------------------------------------------------------------------------------------------------------------------------------------------------------------------------------------------------------------------------------------------------------------------------------------------------------------------------------------------------------------------------------------------------------------------------------------------------------------------------------------------------------------------------------------------------------------------------------------|
| Symptom                                                                                                 | Solution                                                                                                                                                                                                                                                                                                                                                                                                                                                                                                                                                                                                                                                                                                                                                                                                                                                                                                                                                                                  |
| <p><b>During the firmware upgrade process, NetLinx Studio failed to install the last component.</b></p> | <p>This occurs when initially upgrading the on-board Master from a previous firmware (build 117 or lower), to the new Web Security firmware (build 300 or higher).</p> <ul style="list-style-type: none"> <li>• Only upon the initial installation of the new build there will be a failure of the last component to successfully download. This is part of the initial update procedure and will not occur during uploads of later firmware.</li> <li>• After the last components fails to install, click <b>Close</b> and reboot the on-board Master by selecting <b>Tools &gt; Reboot the Master Controller &gt; Continue</b> to continue the process.</li> <li>• After the last components fails to install, click Close and reboot the Master by selecting <b>Tools &gt; Reboot the Master Controller &gt; Continue</b> to begin the process.</li> <li>• Refer to the <i>Upgrading the On-board Master Firmware via an IP</i> section on page 54 for detailed procedures.</li> </ul> |



It's Your World - Take Control™