

Siemens Industry, Inc.

USER'S MANUAL

UM353-1B
Rev. 4 (SR r2)
April 2012



PROCESS AUTOMATION CONTROLLER

This User's Manual is for Design
Level "B" PAC 353 Controllers.

IMPORTANT

Refer to this manual, UM353-1B, to install, configure, operate, or service a Design Level “B” Siemens 353 Process Automation Controller.

Refer to UM353-1 to install, configure, operate, or service a Design Level “A” Siemens or Moore Products Co. 353 Process Automation Controller.

Refer to the controller nameplate and the Model Designation and Specifications section of the manual for the Design Level character. The Design Level is specified by the next to last character in the model designation.

TABLE OF CONTENTS

SECTION AND TITLE	PAGE
PREFACE	vii
1.0 INTRODUCTION	1-1
1.1 PRODUCT DESCRIPTION	1-2
1.2 FUNCTION BLOCKS	1-4
1.2.1 LOOP Function Block Types	1-4
1.2.2 Power Up Initialization	1-5
1.2.3 Configuration	1-5
1.3 CUSTOMER/PRODUCT SUPPORT	1-7
1.4 EQUIPMENT DELIVERY AND HANDLING	1-8
1.4.1 Factory Shipment	1-8
1.4.2 Receipt of Shipment	1-8
1.4.3 Storage	1-8
1.4.4 Typical Shipment Contents	1-8
2.0 CONFIGURATION OVERVIEW	2-1
2.1 STATION FUNCTION BLOCKS	2-1
2.2 STATION HARDWARE I/O BLOCKS	2-1
2.3 LOOP FUNCTION BLOCKS	2-1
2.4 ETHERNET DATA I/O FUNCTION BLOCKS	2-3
2.5 CONFIGURATION PROCEDURE	2-3
2.6 OPERATION DURING LOCAL ON-LINE CONFIGURATION	2-5
3.0 FUNCTION BLOCKS	3-1
3.1 STATION FUNCTION BLOCKS	3-2
3.1.1 CONFIGS – Configurations Library	3-2
3.1.2 SECUR - Security	3-3
3.1.3 STATN - Station Parameters	3-4
3.1.4 CLOCK - Real Time Clock	3-6
3.1.5 ETHERNET - Ethernet Communication Network	3-6
3.2 I/O AND LOOP FUNCTION BLOCKS	3-7
3.2.1 A/M - A/M Transfer	3-7
3.2.2 ACS - ARCCOSINE	3-9
3.2.3 ADD_ - Addition	3-9
3.2.4 AG3 - AGA 3 Orifice Metering of Natural Gas	3-10
3.2.5 AG7 - AGA 7 Measurement of Gas by Turbine Meters	3-12
3.2.6 AG8 - AGA 8 Compressibility Factors of Natural Gas	3-13
3.2.7 AIE_ - Analog Input - Ethernet	3-14
3.2.8 AIN_ - Analog Inputs	3-16
3.2.9 AINU_ - Analog Inputs, Universal	3-17
3.2.10 ALARM - Alarm	3-19
3.2.11 AND_ - AND Logic	3-21
3.2.12 AOE_ - Analog Output- Ethernet	3-21
3.2.13 AOUT_ - Analog Outputs	3-22
3.2.14 ASN_ - ARCSINE	3-23
3.2.15 ATD_ - Analog Trend Display	3-23
3.2.16 ATN_ - ARCTANGENT	3-24
3.2.17 AWE_ - Analog Write Ethernet	3-25
3.2.18 BATOT - Batch Totalizer	3-26
3.2.19 BATSW - Batch Switch	3-28
3.2.20 BIAS - Bias	3-29
3.2.21 CIE_ - Coil Inputs - Ethernet	3-30
3.2.22 CHR_ - Characterizer	3-31

3.2.23 CMP_ - Comparator	3-31
3.2.24 COS_ - COSINE	3-32
3.2.25 CWE_ - Coil Write Ethernet	3-32
3.2.26 DAM_ - Deviation Amplifier	3-33
3.2.27 DIE_ - Digital Input - Ethernet	3-34
3.2.28 DIN_ - Digital Inputs	3-35
3.2.29 DINU_ - Digital Inputs, Universal	3-36
3.2.30 DIV_ - Division	3-37
3.2.31 DNC_ - Divide by N Counter	3-37
3.2.32 DOE_ - Digital Output - Ethernet	3-38
3.2.33 DOUT_ - Digital Outputs	3-38
3.2.34 DTM_ - Dead Time Table	3-39
3.2.35 DWE_ - Digital Write Ethernet	3-40
3.2.36 DYT_ - Delay Timer	3-41
3.2.37 E/I - External/Internal Transfer Switch	3-42
3.2.38 ESL - Events Sequence Logger	3-43
3.2.39 EXP_ - NATURAL EXPONENTIATION	3-44
3.2.40 EXT_ - EXPONENTIATION	3-44
3.2.41 FTG_ - Falling Edge Trigger	3-45
3.2.42 GB_ - Gain & Bias	3-45
3.2.43 HLD_ - Hold	3-45
3.2.44 ID - ID Controller	3-46
3.2.45 LL_ - Lead/Lag	3-47
3.2.46 LMT_ - Limit	3-47
3.2.47 LN_ - NATURAL LOGARITHM	3-48
3.2.48 LOG_ - LOGARITHM BASE 10	3-48
3.2.49 MTH_ - Math	3-49
3.2.50 MUL_ - Multiplication	3-50
3.2.51 NND_ - NAND Logic	3-50
3.2.52 NOR_ - NOR Logic	3-51
3.2.53 NOT_ - NOT Logic	3-51
3.2.54 ODA - Operator Display for Analog Indication & Alarming	3-52
3.2.55 ODC - Operator Display for Controllers	3-54
3.2.56 ODD - Operator Display for Discrete Indication & Control	3-56
3.2.57 ODP - Operator Display for PushButtons	3-58
3.2.58 ODS - Operator Display for Sequencer	3-60
3.2.59 ON/OFF - On/Off Controller	3-62
3.2.60 OR_ - OR Logic	3-63
3.2.61 ORSL - Override Selector	3-63
3.2.62 OST_ - One Shot Timer	3-64
3.2.63 PB1SW - PB1 Switch	3-65
3.2.64 PB2SW - PB2 Switch	3-66
3.2.65 PB3SW - PB3 Switch	3-67
3.2.66 PCOM - Phase COMMunication	3-68
3.2.67 PD - PD Controller	3-70
3.2.68 PID - PID Controller	3-72
3.2.69 PIDAG - PIDAG Controller	3-74
3.2.70 PRSEQ - Program Sequencer	3-76
3.2.71 QHD_ - Quickset Hold	3-78
3.2.72 RATIO - Ratio	3-79
3.2.73 RCT_ - Repeat Cycle Timer	3-80
3.2.74 RLM_ - Rate Limiter	3-81
3.2.75 ROT_ - Retentive On Timer	3-82
3.2.76 ROUT_ - Relay Outputs	3-82
3.2.77 RSF_ - RS Flip-Flop	3-83
3.2.78 RTG_ - Rising Edge Trigger	3-83
3.2.79 RTT_ - Real Time clock Trip	3-84

3.2.80 SCL_ - Scaler	3-85
3.2.81 SEL_ - Signal Selector	3-85
3.2.82 SETPT - Setpoint	3-86
3.2.83 SIN_ - SINE	3-87
3.2.84 SPLIM - Setpoint Limit	3-87
3.2.85 SRF_ - SR Flip-Flop	3-88
3.2.86 SRT_ - Square Root	3-88
3.2.87 SUB_ - Subtraction	3-89
3.2.88 TAN_ - TANGENT	3-89
3.2.89 TH_ - Track & Hold.....	3-90
3.2.90 TOT_ - Totalizer	3-90
3.2.91 TSW_ - Transfer Switch	3-91
3.2.92 XOR_ - Exclusive OR Logic	3-91
4.0 FACTORY CONFIGURED OPTIONS	4-1
4.1 FCO101 - Single Loop Controller w/ Tracking Setpoint.....	4-2
4.2 FCO102 - Single Loop Controller w/ Fixed Setpoint.....	4-3
4.3 FCO103 - External Set Controller with Tracking Local Setpoint	4-4
4.4 FCO104 - External Set Controller with Non-Tracking Local Setpoint	4-6
4.5 FCO105 - Ratio Set Control w/ Operator Setpoint Limits.....	4-8
4.6 FCO106 - Single Loop Controller w/ Operator Setpoint Limits	4-10
4.7 FCO107 - Dual Loop Controller.....	4-11
4.8 FCO121 - Cascade Control.....	4-13
4.9 FCO122 - Cascade Control w/ Operator Setpoint Limits	4-15
5.0 NETWORK COMMUNICATIONS.....	5-1
5.1 MODBUS DATA MAPPING	5-1
6.0 DATA MAPPING.....	6-1
6.1 CONNECTING TO i ware PC.....	6-1
6.2 STATION DATA	6-2
6.2.1 Integer Data (16-bit Integer)	6-2
6.2.2 Station String Data (8-bit ASCII Char - 2/Word)	6-4
6.2.3 Station Coil Data (1-bit).....	6-4
6.3 LOOP DATA.....	6-5
6.3.1 Dynamic Loop Integer Data.....	6-5
6.3.2 Variable Loop Integer Data.....	6-6
6.3.3 Static Loop Integer Data	6-8
6.3.4 Dynamic Loop Floating Point Data (32-bit IEEE).....	6-9
6.3.5 Variable Loop Floating Point Data (32-bit IEEE)	6-10
6.3.6 Static Loop Floating Point Data (32-bit IEEE)	6-11
6.3.7 String Loop Data (8-bit ASCII Char - 2/Word).....	6-13
6.3.8 Coil Loop Data (1-bit).....	6-16
6.3.9 PCOM Block Status	6-21
6.3.10 Sequencer Loop I/O Coil Data (1-bit).....	6-22
6.3.11 Trend Data (Loop Defined by MLTP)	6-23
6.3.12 Configuration Data Sequencer Loop.....	6-26
7.0 INSTALLATION	7-1
7.1 INSTALLATION CONSIDERATIONS.....	7-1
7.2 ENVIRONMENTAL CONSIDERATIONS	7-1
7.3 MECHANICAL INSTALLATION.....	7-3
7.3.1 Removable Connectors and Covers	7-3
7.3.2 Panel and Rack Mounting Guidelines.....	7-4
7.3.3 Station Mounting.....	7-5
7.4 ELECTRICAL INSTALLATION.....	7-6
7.4.1 Wiring Guidelines	7-6

7.4.2 Analog Signal Input Wiring (4-20 mA, 1-5 Vdc, and mV)	7-10
7.4.3 Analog Output Wiring (4-20 mA, 1-5 Vdc)	7-12
7.4.4 Digital Input and Output Wiring	7-13
7.4.5 Thermocouple Input Wiring	7-15
7.4.6 RTD Input Wiring	7-16
7.4.7 Ohms and Slidewire Input Wiring	7-17
7.4.8 Relay Output Wiring	7-17
7.4.9 Modbus Wiring	7-18
7.4.10 Ethernet Wiring	7-18
7.4.11 Wiring to a Siemens SIREC D Recorder	7-20
7.4.12 Power Wiring	7-20
7.5 FACTORY CALIBRATION	7-22
8.0 LOCAL FACEPLATE OPERATION	8-1
8.1 NORMAL OPERATION MODE	8-1
8.2 CONFIGURATION MODE	8-3
8.3 AUTOTUNE PROCEDURE	8-4
9.0 CONTROLLER AND SYSTEM TEST	9-1
9.1 CONTROLLER CONFIGURATION AND TEST	9-1
9.1.1 Connections and Power	9-1
9.1.2 Configuration	9-2
9.1.3 Input/Output	9-2
9.1.4 Auto/Manual	9-2
9.1.5 Modifying an FCO	9-2
9.1.6 Alarms	9-4
9.1.7 TAG	9-5
9.1.8 QUICK	9-5
9.1.9 TUNE	9-6
9.1.10 View mode	9-7
9.2 SYSTEM CHECKOUT	9-7
10.0 MAINTENANCE	10-1
10.1 TOOLS AND TEST EQUIPMENT	10-1
10.2 PREVENTIVE MAINTENANCE	10-2
10.2.1 Environmental Considerations	10-2
10.2.2 Visual Inspection	10-2
10.2.3 Cleaning	10-2
10.2.4 Circuit Board Handling	10-3
10.3 TROUBLESHOOTING	10-4
10.4 ERROR CODES	10-6
10.4.1 Off-Line Error Codes	10-6
10.4.2 On-Line Error Codes and Status Codes	10-7
10.4.3 MultiMediaCard Error Codes	10-9
10.5 ASSEMBLY REPLACEMENT	10-9
10.5.1 Fuse	10-9
10.5.2 Display Assembly	10-10
10.5.3 MPU Controller Board	10-12
10.5.4 I/O Expander Board	10-12
10.5.5 Ethernet Cable	10-13
10.6 MULTIMEDIACARD – FORMATTING AND FILE NAMES	10-14
11.0 CALIBRATION	11-1
11.1 ANALOG INPUT (AIN1-4)	11-2
11.2 ANALOG OUTPUT (AOUT1-3)	11-3
11.3 UNIVERSAL ANALOG INPUTS (AINU1 AND AINU2)	11-3
12.0 CIRCUIT DESCRIPTION	12-1

12.1 OVERVIEW	12-1
12.2 MPU CONTROLLER BOARD	12-2
12.3 I/O EXPANDER BOARD.....	12-3
13.0 MODEL DESIGNATION AND SPECIFICATIONS	13-1
13.1 MODEL DESIGNATION	13-1
13.2 ACCESSORIES.....	13-3
13.3 SERVICE PARTS KITS	13-3
13.4 MECHANICAL SPECIFICATIONS	13-5
13.5 POWER INPUT REQUIREMENTS.....	13-5
13.6 MPU CONTROLLER BOARD SPECIFICATIONS.....	13-5
13.7 I/O EXPANDER BOARD SPECIFICATIONS	13-6
13.8 ENVIRONMENTAL SPECIFICATIONS	13-9
13.8.1 Standard Mounting.....	13-9
13.8.2 Enclosure Mounting.....	13-9
13.8.3 Electromagnetic Compatibility (EMC)	13-9
13.9 AGENCY APPROVALS	13-10
13.9.1 CSA Hazardous Locations Precautions	13-10
13.9.2 Special Conditions for Safe Use	13-11
14.0 ABBREVIATIONS AND ACRONYMS	14-1

SOFTWARE RELEASE MEMO

LIST OF ILLUSTRATIONS

FIGURE AND TITLE	PAGE
1-1 Siemens 353, Exploded View	1-2
1-2 Ethernet Architecture Example	1-3
2-1 Configuration Road Map.....	2-6
2-2 MultiMediaCard Road Map	2-7
3-1 PCOM Logic	3-69
7-1 Cover Installation and Removal.....	7-4
7-2 Panel Cutout Dimensions	7-4
7-3 Siemens 353 Dimensions	7-5
7-4 Case Mounting Clip	7-5
7-5 Rear Terminal Layout and Terminal Assignments.....	7-8
7-6 Analog Input AIN1, 2-Wire Transmitter.....	7-10
7-7 Analog Inputs AIN1, 2, and 3; 4-Wire Transmitters.....	7-11
7-8 Universal Analog Input AINU1	7-11
7-9 Analog Output AOUT 1, Current Output	7-12
7-10 Analog Output AOUT1, Voltage Output	7-12
7-11 Digital Inputs DIN and DINU	7-13
7-12 Digital Output DOUT1, Resistive and Inductive Loads	7-14
7-13 Universal Analog Input AINU1, Thermocouple Input	7-15
7-14 Reference Junction Lead Formation	7-15
7-15 Universal Analog Input AINU1; 2, 3, and 4-Wire RTD Inputs.....	7-16
7-16 Universal Analog Input, AINU1 Shown.....	7-17
7-17 Universal Relay Outputs ROUT1 and 2, Resistive Load.....	7-17
7-18 Modbus Communications, 353 to APACS™ ACM or Personal Computer.....	7-19
7-19 Model 353 to Siemens SIREC D Recorder Analog Input Wiring	7-20
7-20 Controller Power Wiring.....	7-20
7-21 Suggested Power Wiring.....	7-21
7-22 Daisy Chained Power Wiring.....	7-21
8-1 Chart 1, Autotune	8-5

8-2 Chart 2, Autotune 8-6
 10-1 Siemens 353 Exploded View, Design Level B 10-3
 10-2 MPU Controller Board 10-5
 10-3 MultiMediaCard (MMC), Inserting and Ejecting 10-5
 10-4 Display Assembly Repair 10-11
 10-5 I/O Expander Board 10-13
 10-6 Ethernet Cable Installation 10-14
 12-1 Siemens 353, Design Level B, Block Diagram 12-1

LIST OF TABLES

TABLE AND TITLE	PAGE
3-1 Security Level vs. Accessible Operations	3-3
3-2 Modbus Port Baud Rate Parameters.....	3-5
3-3 Board Description and ID with Example Hardware and Software Revisions.....	3-5
3-4 Floating Point Number Formats, AIE Block.....	3-15
3-5 Integer Default Values, AIE Block.....	3-15
3-6 FB Numbers vs. Modbus Registers, AIE Block.....	3-15
3-7 Input Types, AINU Block.....	3-18
3-8 Calibration Input Values, AINU Block.....	3-18
3-9 SEN MIN/MAX and MIN/MAX SCALE Parameters, AINU Block	3-18
7-1 Rear Terminal Assignments	7-9
7-2 Factory Calibration.....	7-22
8-1 Autotune Errors.....	8-6
8-2 Autotune Warnings	8-6
10-1 Off-Line Error Codes	10-6
10-2 On-Line Error and Status Codes	10-7
13-1 Siemens 353 Model Designation.....	13-2

Changes for Rev 4, April 2012

Section	Change
Cover	Manual Rev number and date updated; page dates changed throughout manual
3 Function Blocks	Section 3.2.8 AIN_ - Analog Inputs: Verify mode description revised Section 3.2.9 AINU_ - Analog Inputs, Universal: First paragraph revised Section 3.2.13 AOUT_ - Analog Outputs: Verify mode description and block parameters drawing revised Twelve function blocks and block diagrams amended
8 Local Faceplate Operation	Section 8.3 Autotune Procedure – Charts 1 and 2, and associated text, revised
11 Calibration	Section 11.1 Analog Input: Verification steps revised.
Addendum	SR353-15, Rev 2 replaces SR353-15, Rev 1

Procidia, i/pac, i/config, i/station, i/ware PC, APACS, PAC 353, and 352Plus are trademarks of Siemens Industry, Inc. Other trademarks are the property of their respective owners. All product designations may be trademarks or product names of Siemens Industry, Inc. or other supplier companies whose use by third parties for their own purposes could violate the rights of the owners.

Siemens Industry, Inc. assumes no liability for errors or omissions in this document or for the application and use of information included in this document. The information herein is subject to change without notice.









Procedures in this document have been reviewed for compliance with applicable approval agency requirements and are considered sound practice. Neither Siemens Industry, Inc. nor these agencies are responsible for product uses not included in the approval certification(s) or for repairs or modifications made by the user.

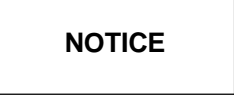
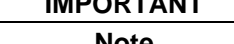

PREFACE

Conventions and Symbols

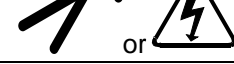
The following symbols may appear in this manual and may be applied to the equipment. The reader should become familiar with the symbols and their meaning. Symbols are provided to quickly alert the user to safety related situations, issues, and text.

Symbol	Meaning
	Indicates an immediate hazardous situation which, if not avoided, <i>will</i> result in death or serious injury.
	Indicates a potentially hazardous situation which, if not avoided, <i>could</i> result in death or serious injury.
	Indicates a potentially hazardous situation which, if not avoided, <i>may</i> result in minor or moderate injury.
	Indicates a potentially hazardous situation which, if not avoided, may result in property damage.
	Indicates a potential situation which, if not avoided, may result in an undesirable result or state.
	Identifies an action that should be taken to avoid an undesirable result or state.
	Identifies additional information that should be read.
	Electrical shock hazard. The included Warning text states that the danger of electrical shock is present.
	Explosion hazard. Indicates that the danger of an explosion hazard exists.
	Electrostatic discharge. The presence of this symbol indicates that electrostatic discharge can damage the electronic assembly.

Conventions and Usage Notes:

- In this User's Manual, the Siemens 353 can be referred to as a Model 353 or simply a 353. The terms controller and station are also used to prevent repetition.
- This manual describes the functionality provided by Design Level "B" MPU Controller board firmware, version 4.0.
- Part numbers are for items ordered from the Process Instrumentation Business Unit (PIBU) of Siemens Industry, except as noted.
- Date format is Month-Day-Year, except as noted.
- Time format is 12 hour (a.m./p.m.), except as noted.

Scope

This publication does not purport to cover all details or variations in equipment, nor to provide for every possible contingency to be met in connection with installation, operation, or maintenance. Should further information be desired or should particular problems arise which are not covered sufficiently for the purchaser's purposes, the matter should be referred to one of the support groups listed in the Customer/Product Support section of this manual.

The contents of this manual shall not become part of or modify any prior or existing agreement, commitment or relationship.

Warranty

The sales contract contains the entire obligation of Siemens. The warranty contained in the contract between the parties is the sole warranty of Siemens. Any statements continued herein do not create new warranties or modify the existing warranty.

Qualified Persons

The described equipment should be installed, configured, operated, and serviced only by qualified persons thoroughly familiar with this publication. An electronic copy of this publication, furnished on CD ROM, is shipped with the equipment. The current version, in Portable Document Format (PDF), is available at the Siemens Internet site; refer to Section 1.3 Customer/Product Support for the URL.

For the purpose of this publication and product labels, a qualified person is one who is familiar with the installation, construction, and operation of the equipment, and the involved hazardous. In addition, he or she has the following qualifications:

- Is trained and authorized to energize, de-energize, clear, ground and tag circuits and equipment in accordance with established safety practices.
- Is trained in the proper care and use of protective equipment such as rubber gloves, hard hat, safety glasses or face shields, flash clothing, etc., in accordance with established safety practices.
- Is trained in rendering first aid.

General Warnings and Cautions



This equipment contains hazardous voltages, and it has been certified for use in the hazardous locations specified on the product nameplate and in Section 13 Model Designation and Specifications. Death, serious personal injury, or property damage can result if safety instructions are not followed. Only qualified personnel should work on or around this equipment after becoming thoroughly familiar with all warnings, safety notices, and maintenance procedures contained herein. The successful and safe operation of this equipment is dependent upon proper handling, installation, operation, and maintenance.

The perfect and safe operation of the equipment is conditional upon proper transport, proper storage, installation and assembly, as well as, on careful operation and commissioning.

The equipment may be used only for the purposes specified in this publication.

CAUTION

Electrostatic discharge can damage or cause the failure of semiconductor devices such as integrated circuits and transistors. The symbol at right may appear on a circuit board or other electronic assembly to indicate that special handling precautions are needed.



- A properly grounded conductive wrist strap must be worn whenever an electronics module or circuit board is handled or touched. A service kit with a wrist strap and static dissipative mat is available from mail order and local electronic supply companies.
- Electronic assemblies must be stored in anti-static protective bags when not installed in equipment.



1.0 INTRODUCTION

This User's Manual contains configuration, installation and service information for the Siemens 353 Process Automation Controller. It is divided into fourteen sections.

- Section 1, Introduction, has general information about the organization of this manual, the controller, product support, and the contents of a typical shipment.
- Section 2, Configuration Overview, contains a list of the functions blocks available for use in configuring the controller and a procedure for configuration. A configuration road map and a MultiMediaCard road map are included.
- Section 3, Function Blocks, contains a detailed description of each function block.
- Section 4, Factory Configured Options, provides a graphical presentation of the function blocks used in FCOs and a listing of changes made to default function block parameters.
- Section 5, Network Communications, furnishes overviews of Modbus and Modbus/TCP Ethernet communication data.
- Section 6, Data Mapping, contains network data details for Modbus and Modbus/TCP Ethernet.
- Section 7, Installation, contains drawings and steps detailing mechanical and electrical installation. Electrical connections to the controller are identified and numerous wiring diagrams are included.
- Section 8, Local Faceplate Operation, describes and illustrates the Display Assembly's operator controls and displays. Use of these for on-line operation, for configurations and for autotuning is described.
- Section 9, Controller and System Test, has procedures for testing the controller and the installation.
- Section 10, Maintenance, lists the tools and test equipment to service a controller. It also has preventive maintenance and servicing procedures, including error codes.
- Section 11, Calibration, provides step-by-step procedures for calibration of analog input and output circuits.
- Section 12, Circuit Description, furnishes a block diagram level description of the controller's circuits.
- Section 13, Model Designation and Specifications, shows controller model numbers; a list of accessories; mechanical, electrical, and environmental specifications; and a list of current agency approvals.
- Section 14, Abbreviations and Acronyms, is a convenient reference for new users that explains many abbreviations and acronyms appearing in this manual.



1.1 PRODUCT DESCRIPTION

The Siemens 353 offers the control system designer the ultimate in flexibility and capability for the implementation of continuous solutions and batch solutions. An exploded view of the controller appears in Figure 1-1.

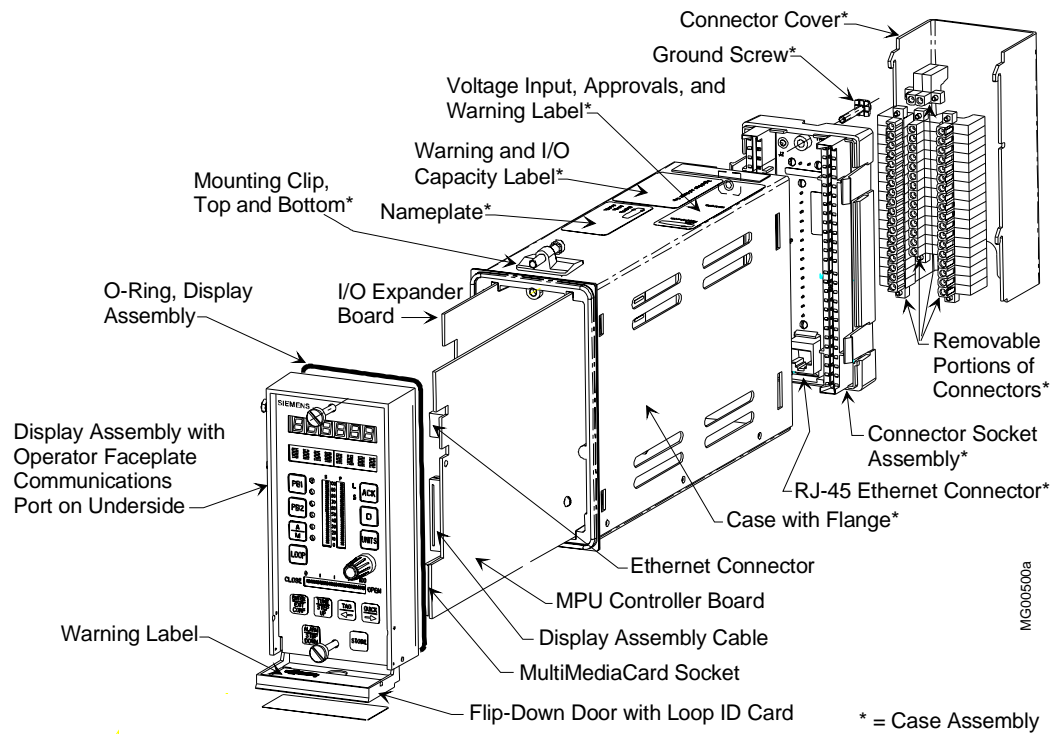

Figure 1-1 Siemens 353, Exploded View

At the heart of the 353 is a powerful MPU Controller board that uses the latest in microprocessor technology. It includes on-board I/O and reusable function blocks, and it is capable of solving a vast array of control implementations including single loop, cascade, and dual loop. Available MPU board I/O is listed in the table below.

Modbus and Modbus/TCP Ethernet are standard networking communication options that are used to connect multiple controllers to an operator workstation, Human/Machine Interface (HMI), or DCS, enabling integration of controllers into a plant-wide system. A popular HMI is the Procidia™ i|station™ running i|ware PC™ operator interface software. A communication port (RS232) on the underside of the Display Assembly is available for configuration and/or debugging when using i|config™, the optional PC-based Graphical Configuration Utility.

An optional I/O Expander Board can be added to the base Siemens 353. It includes direct thermocouple, RTD, and frequency inputs and additional I/O for direct process measurement of temperature and frequency variables, improving accuracy and control. Available Expander board I/O is listed below.

I/O on MPU Controller Board	I/O on Expander Board
Analog Inputs 1, 2, and 3	Analog Input 4
Analog Outputs 1 and 2	Analog Output 3
Digital Inputs 1 and 2	Digital Inputs 3 and 4
Digital Outputs 1 and 2	---
---	Analog Inputs Universal 1 and 2
---	Digital Inputs Universal 1 and 2
---	Relay Outputs 1 and 2

When even more I/O is needed for multiple-loop applications, advanced control, or batch sequencing, Modbus/TCP Ethernet can be used to connect remote I/O. The standard Ethernet capability of the 353 provides connectivity to a large selection of standard Modbus/TCP Ethernet I/O products that provide analog inputs and outputs and digital inputs and outputs using solid state technology.

Although the Siemens 353 can be connected to and operated entirely from a central operator workstation, such as i|station, a controller faceplate is included. This local operator interface is for applications where loops need individual attention during startup, troubleshooting, maintenance, or emergency conditions. The convenient faceplate layout and sophisticated software allow process and configuration changes to be made quickly and easily.

The controller can be completely configured from the operator faceplate or, as mentioned above, configured remotely using i|config, the optional PC-based Graphical Configuration Utility. A MultiMediaCard (MMC) can be used to transfer a configuration from one controller to another or between a PC running i|config and a controller when downloading a configuration over a network is not available.

Network communication options are listed in the following table.

Protocols	Available	Connection	Option Board Needed
Modbus	Standard	Rear Terminals, NCA and NCB	None
Modbus/TCP Ethernet	Standard	Rear Panel, RJ-45 (case option 4)	None

Ethernet supports uploading and downloading of controller configurations over the Ethernet LAN. For example, if i|config Graphical Configuration Utility is loaded on the local client shown in Figure 1-2, controller configurations can be developed on the client, or uploaded from the controller for editing, and then downloaded to the controller. Data can also be acquired from remote servers for the purpose of archiving and/or data mining.

The Ethernet-Modbus Bridge in Figure 1-2 accepts an Ethernet data command from the controller and outputs an equivalent Modbus command to a Modbus device at address 1. The returning Modbus data is embedded by the bridge in an Ethernet packet to be sent to the requesting controller.

Regardless of the selected communication option, the RS232 port on the underside of the Display Assembly will communicate using Modbus.

For small retrofit applications, the Siemens 353 with operator faceplate is a replacement for a simple stand-alone single-loop controller. It is easily upgraded with additional local I/O for advanced control strategies. Ethernet can extend the I/O capability of the controller ever further in data acquisition applications.

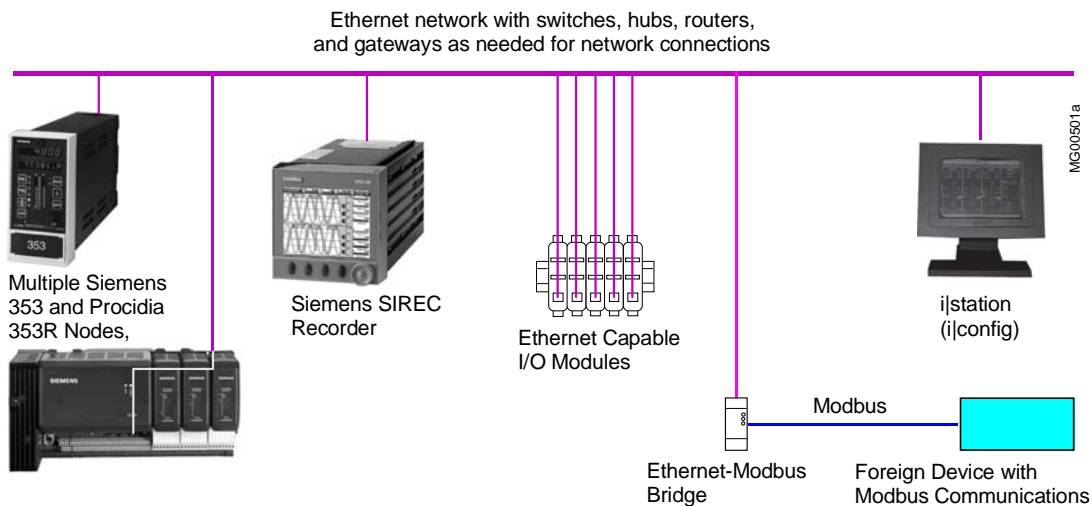

Figure 1-2 Ethernet Architecture Example

Often in this publication, reference is made to the labels on the controller to ensure that the controller being installed has the correct power input, I/O, communication options, and approvals. This is particularly important when non-incendive requirements are present or a critical process is involved where a custom configuration or calibration has been created. Label locations are shown in Figure 1-1 and typical labels are shown in Section 13 Model Designation and Specifications.

1.2 FUNCTION BLOCKS

Controller software is built on proven function block designs from previous controller products. In many cases, the controller has been enhanced with features only now possible with state of the art technology.

Function blocks are selected for use within a LOOP. Multiple loops can be configured, and each loop can be associated with an operator faceplate. Certain blocks are used once within each loop (e.g. controller, setpoint, auto/manual), others can be used as many times as needed. Some notable features include Auto Tuning within the PID function blocks, an expandable Sequencer that allows configuration of up to 250 steps, and up to 256 discrete inputs and outputs. In addition, the Graphical Configuration Utility, *i|config*, can be used to design the logic in a ladder diagram. Combining these features with continuous control loops within the same controller offers a well-integrated solution for small batch operations.

Several function blocks are available at the station level for configuration of STATION level parameters, such as the station address and station tag name. Function blocks include the CLOCK block and the ETHERNET block to configure parameters such as the IP address. All other function blocks are used for configuration within an individual LOOP. Control implementations are configured in the Siemens 353 by first creating a loop, then entering a unique loop tag name and selecting function blocks for use within that loop. A number of loops can be configured in the Siemens 353 and a number of function block types are available as described in the sections that follow.

1.2.1 LOOP Function Block Types

Local I/O Function Blocks are provided on both the MPU Controller Board and the I/O Expander Board. These blocks can be used in any LOOP, but as fixed resources are expendable. When used within a loop, the unique block name becomes <loop>.<block> (e.g. TC2053.AIN1 for Analog Input 1 used in loop TC2053).



Fixed Loop Function Blocks can be selected once for use within each configured LOOP. The operator display function block (e.g. ODC Operator Display for Controllers) defines the loop type, the function of the local faceplate, as well as the processing of commands coming from a remote workstation. A single controller function block can be selected from one of five available choices (ID, ON_OFF, PD, PIDAG, and PID) within each loop. When used within a loop the unique block name becomes <loop>.<block> (e.g. TC2053.PID for the PID controller used in loop TC2053).

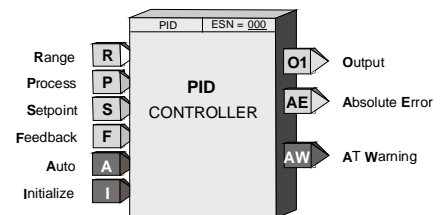

Arithmetic Function Blocks are also designated as LOOP function blocks and can be used as many times as needed in each loop. Each use of a block is automatically assigned a unique name (i.e. MATH01, MATH02) within each loop so that the unique block name becomes <loop>.<block> (e.g. TC2053.MATH01).

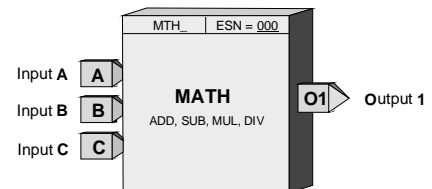

Logic Function Blocks are also designated as LOOP function blocks and can be used as many times as needed in each loop. Each use of a block is automatically assigned a unique name (i.e. AND01, AND02) within each loop so that the unique block name becomes <loop>.<block> (e.g. TC2053.AND01).

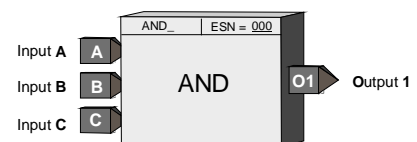

General Purpose Function Blocks are also designated as LOOP function blocks and include blocks that do not fall into the arithmetic or logic categories. These can be used as many times as needed and each use will automatically be assigned a unique name (e.g. HLD01, HLD02) within each loop so that the unique block name becomes <loop>.<block> (e.g. TC2053.HLD01).

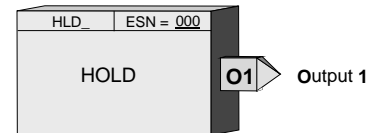

Ethernet Function Blocks are used as needed within a LOOP for communication over Ethernet. They will automatically be assigned a unique name (e.g. AIE01, DIE01) within each loop when it is configured so that the unique block name becomes <loop>.<block> (e.g. TC2053.AIE01).

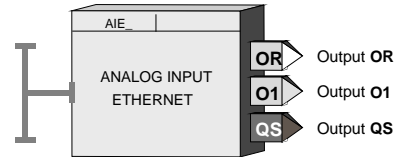

1.2.2 Power Up Initialization

The Siemens 353 will retain, in the station NVRAM, calculated block values (e.g. outputs, elapsed time, last input/output logic states), including the time since power was lost. Three power-up modes are used in the 353: hot, warm, and cold. These affect the initialization of function blocks and are configured by two power up timers (warm and cold), included in STATION parameters. The station will initialize a hot start when power up occurs prior to the expiration of the warm timer. A cold start will occur when power up occurs after the expiration of the cold timer and a warm start will take place when the station powers up after the expiration of the warm timer but prior to the expiration of the cold timer.

Hot Start - All function block execution continues from the last state prior to a power fail.

Warm Start - Function blocks that have a power up in a last state feature, either by design or by configuration selection, will power up as defined in the individual block descriptions. All other function blocks will initialize at cold start conditions.

Cold Start - All function block outputs will initialize at 0 unless otherwise stated in individual block descriptions.

1.2.3 Configuration

The Siemens 353 can be configured either locally or remotely. Local configuration is accomplished through the controller faceplate. The local faceplate includes buttons located behind a flip-down door for complete configuration including the addition/deletion of loops and function blocks and the editing of function block parameters. The local faceplate is required to enter an address in the controller so network communication can take place. Section 2 Configuration Overview includes a road map for stepping through configuration. Certain block parameters (e.g. gains, constants) can be edited while on-line but design changes (e.g. block interconnections, block additions) will put the station in “configuration hold” which will hold outputs at the current value until the Exit button is pressed. This will enable bumpless changes to be made while on-line. Note that new blocks will be initialized at default values which may affect final outputs.

Remote configuration can be accomplished through several methods. A configuration can be created on a PC running i|config and downloaded to a controller by way of: (1) the port on the underside of the local faceplate, (2) a network connection at the controller rear terminals, either Modbus or Modbus/TCP Ethernet, or (3) a MultiMediaCard (MMC). During a download, the controller will hold all outputs and it will retain all intermediate calculations by all blocks it was running prior to the download. After the download, all function block parameters with the same tag name as those held will be used to initialize the downloaded function block parameters, thus providing a bumpless download under these conditions. If a loop tag name is changed, the tag names of all function blocks within that loop will change and will, therefore, require re-initialization of all of these blocks. However, the loop tag can be changed from the local faceplate without causing re-initialization, providing a bumpless tag change.

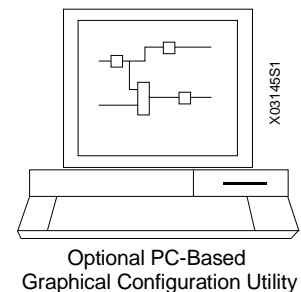

The MultiMediaCard (MMC) mentioned in the preceding paragraph is a small memory card that plugs into an MMC socket on the Controller board. A card can be used to:

- Transfer configurations from a PC running i|config to a series of controllers (at the PC, a compatible card reader or PC card slot is required)
- Transfer a configuration from a controller to a PC running i|config (at the PC, a compatible card reader or PC card slot is required)
- Transfer the operating configuration from a removed controller to the replacement controller
- Save an operating configuration prior to making changes to that configuration



The operating configuration in the controller is written to the MMC root directory, with the station serial number as the file name, whenever:

- The MMC is inserted in the MMC socket
- The MMC is removed from the MMC socket
- The controller is powered up
- The controller is powered down
- The configuration is edited and stored from the faceplate (i.e. display assembly)

Any of the above five actions will cause a previously saved configuration file to be over written by the current configuration.

IMPORTANT

To save a particular version of a configuration prior to making configuration edits, select a unique 8-character file name and then press STORE to save the configuration – refer to Figure 2-2 MultiMediaCard Road Map to change the file name.

After saving a configuration with a unique file name, subsequent configuration edits will again be saved to the MMC root directory with the controller serial number as the file name unless you save them with a new file name. Multiple file directories can be created on the MMC.

To transfer a configuration from one controller to another, the controllers must have the same firmware revision level. If the firmware levels differ, an error message will be displayed on the alphanumeric display of the receiving controller. An error message will be displayed if the receiving controller does not have the correct hardware (circuit boards) for the new configuration or if the configuration contains function blocks that are not valid for the controller design level. See Section 10.4.3 MultiMediaCard Error Codes for details.

A configuration created at the controller faceplate consists of a database file with a .V3C extension. A 353 configuration created at a PC running i|config consists of two files: a database file with a .V3C extension and a graphical file with a .353 extension. When a configuration is saved to a MultiMediaCard from i|config, both files are stored ensuring that both are available for merging by i|config should the configuration require editing. Downloading a configuration from i|config to a controller will transfer only the .V3C database file.

1.3 CUSTOMER/PRODUCT SUPPORT

Support is available through an online Support Request service; a link is provided in the table at the end of this section.

When contacting Siemens for support:

- Please provide complete product information:
 - For hardware, this information is provided on the product nameplate (part number or model number, serial number, and/or version).
 - For most software, this information is given in the Help > About screen.
- If there is a problem with product operation:
 - Is the problem intermittent or repeatable? What symptoms have been observed?
 - What steps, configuration changes, loop modifications, etc. were performed before the problem occurred?
 - What status messages, error messages, or LED indications are displayed?
 - What troubleshooting steps have been performed?
 - Is the installation environment (e.g. temperature, humidity) within the product's specified operating parameters? For software, does the PC meet or exceed the minimum requirements (e.g. processor, memory, operating system)?
- A copy of the product Service Instruction, User's Manual, or other technical publication should be at hand. The Siemens public Internet site (see the table) has current revisions of technical literature, in Portable Document Format, for downloading.
- To send an instrument to Siemens for warranty or non-warranty service, call Repair Service and request a Return Material Authorization (RMA).

IMPORTANT

An instrument must be thoroughly cleaned (decontaminated) to remove any process materials, hazardous materials, or blood-borne pathogens prior to return for repair. Read and complete the Siemens RMA form(s).

The Siemens public Internet site has current revisions of technical literature, in Portable Document Format (.pdf), for downloading.

For support and the location of your local Siemens representative, refer to the table below for the URL of the Process Instrumentation portion of the Siemens public Internet site. Once at the site, click **Support** in the right column and then **Product Support**. Next select the type of support desired: sales, technical (see the table below), documentation, or software.

Online Support Request	http://www.siemens.com/automation/support-request
Technical Support	1-800-333-7421; 8 a.m. to 4:45 p.m. eastern time, Monday through Friday (except holidays)
Customer Service & Returns	1-800-365-8766 (warranty and non-warranty)
Public Internet Site	http://www.usa.siemens.com/pi
Technical Publications in PDF	Click the above link to go to the Siemens Internet site and then click Process Instrumentation . In the column to the right, click Support > Manuals . In the column to the left, select the product line (e.g. Pressure or Temperature or Controllers) to open navigation and search panes. Note: Navigation may change as the site evolves.

1.4 EQUIPMENT DELIVERY AND HANDLING

1.4.1 Factory Shipment

Prior to shipment, a controller is fully tested and inspected to ensure proper operation. It is then packaged for shipment. Most accessories are shipped separately. Shown below are some of the items shipped with a controller. Actual items included in a shipment will depend upon controller model number. A printed copy of the 353 Installation Guide, IG353-1 is also supplied.

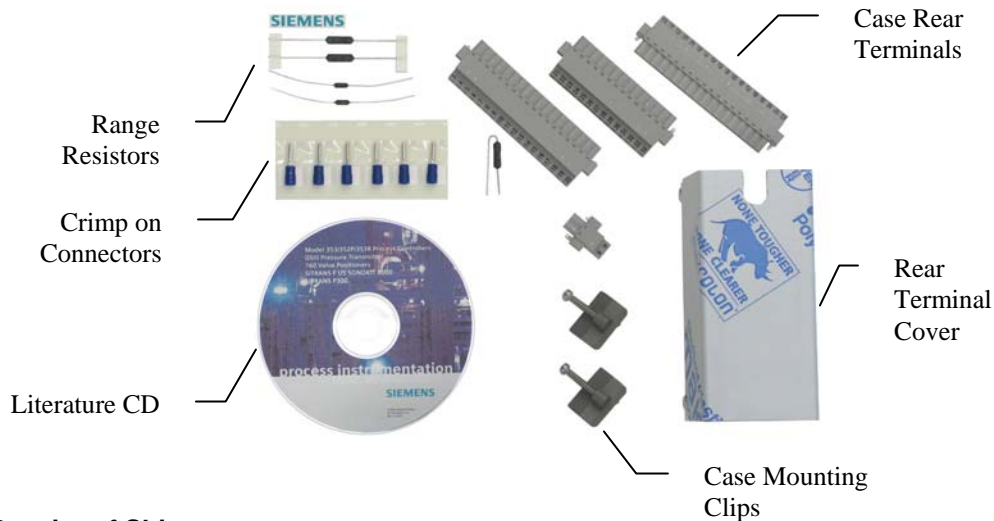

1.4.2 Receipt of Shipment

Inspect each carton at the time of delivery for possible external damage. Any visible damage should be immediately recorded on the carrier's copy of the delivery slip.

Carefully unpack each carton and check the contents against the enclosed packing list. Inspect each item for any hidden damage that may or may not have been accompanied by exterior carton damage.

If it is found that some items have been damaged or are missing, notify the Process Instrumentation Division of Siemens Energy and Automation immediately and provide full details. In addition, damages must be reported to the carrier with a request for their on-site inspection of the damaged item and its shipping carton.

1.4.3 Storage

If a controller is to be stored for a period prior to installation, review the environmental specifications in Section 13 Model Designation and Specifications.

1.4.4 Typical Shipment Contents

The items listed below are those typically included in a shipment and are subject to change.

1. Siemens 353 Process Automation Controller, model number per order, qty. 1
2. MMC or MMC*plus*TM memory card (inserted in MMC socket on MPU Controller board), qty 1
3. Power Input and Range Resistor Kit, PN 16354-30, qty. 1

DESCRIPTION	QUANTITY
Resistor, 250Ω, 0.1%, 3W, WW	3
Sleeving	3
Crimp-On Connector	6
Kit Installation Instruction	1
Shunt (Not used in Design Level B controller)	1

4. Mounting Clip Kit, no part number, qty. 1. Kit contains 2, Mounting Clips and 2, 8-32 x 1 Screws (see the Parts List at back of this manual for part numbers)
5. I/O Expander Board Kits

PN16353-52 I/O Expander Board Kit - The I/O Expander Board is factory installed when a Siemens 353 with Expansion Board option 1 is ordered.

- For field installation of this kit, see the supplied Kit Installation Instruction (15900-390).

DESCRIPTION	QUANTITY
I/O Expander Board - Do not remove Board from static shielding bag until it is to be installed.	1
Range Resistor and Reference Junction Kit, see below	1

PN16353-49 Range Resistor and Reference Junction Kit - This kit is supplied with the above I/O Expander Board Kit and with a factory shipped Siemens 353 with Expansion Board option 1.

DESCRIPTION	QUANTITY
4-20 mA to 1-5V Range Resistor, 250Ω, 0.1%, 3W, WW	1
4-20 mA to 15-75 mV Range Resistor, 3.75Ω, 0.1%, 3W, WW	2
Sleeving	5
Crimp-On Connector	6
TC Reference Junction, 100Ω	2
Kit Installation Instruction	1

6. Process Instrumentation User Manual CD ROM, qty. 1
7. Installation Guide IG353-1
8. Two warning labels that are to be placed in a highly visible location near the case rear terminals.
9. Additional items as required by your order. Refer to the packing list accompanying a shipment.



2.0 CONFIGURATION OVERVIEW

Configuration enables a user to select function blocks, stored in the controller, from an available list and enter appropriate block parameters to implement a specific control strategy. Although configuration affects the entire station, the controller partitions related control implementations into LOOPS. A maximum of 99 loops can be configured and 25 can have operator displays that are mapped to network communications¹.

Each LOOP can contain the function blocks listed in the following paragraphs. Signals can be connected between function blocks within the LOOP as well as between loops. Also, there are several STATION function blocks that are fixed and available in the STATION menu for setting station related values.

Section 3 Function Blocks fully describes all available function blocks. For tuning guidelines refer to Section 8.3 Autotune Procedure or request AD353-119 Digital Controller Tuning.

NOTE

This User's Manual includes the functionality provided by MPU Controller Board Design Level "B" and firmware Version 4.0

2.1 STATION FUNCTION BLOCKS

Function blocks that are permanent and accessible at the STATION menu level:

CONFIGS.....**Configuration Library** (includes FCOs and configuration on a MultiMediaCard)
STATN.....**Station Parameters**
SECUR**Security**
CLOCKreal time **CLOCK**
ETHERNETModbus/TCP **Ethernet** Communications

2.2 STATION HARDWARE I/O BLOCKS

Function blocks that are available during configuration depend on the hardware installed in the controller. These blocks can be selected within a LOOP but as fixed resources, once selected, are no longer available. The left column shows the minimum and maximum quantities of each block and the right column shows the quantity for each circuit board.

AINI-4**Analog Input**.....MPU Controller Board (3), I/O Expander Board (1)
AINU-2**Analog Input, Universal**I/O Expander Board (2)
AOUTI-3**Analog Output**.....MPU Controller Board (2), I/O Expander Board (1)
DINI-4**Digital Input**MPU Controller Board (3), I/O Expander Board (1)
DINU-2**Digital Input, Universal**I/O Expander Board (2)
DOUI-2**Digital Output**.....MPU Controller Board (2)
ROUTI-2**Relay Output**I/O Expander Board (2)

2.3 LOOP FUNCTION BLOCKS

The following blocks are available as needed within each loop in the quantities indicated (the quantity is one if no number is shown). Some blocks (e.g. A/M, BIAS) can be used only once within each LOOP. Others (e.g. ADD) are reusable within a LOOP and can be used up to the maximum number indicated. Each time a reusable block is selected within a LOOP, a new instance number will automatically be assigned (i.e. ADD01, ADD02). Each LOOP can have one operator display block (i.e. ODC, ODA, ODD, ODP, or ODS). The display block defines how the loop will be displayed on the local faceplate when that loop is selected and also how loop data will be mapped on the Modbus network interface. Each LOOP can have one controller function block (i.e. ID, ONOFF, PD, PID, or PIDAG).

¹ Subject to available memory in the controller.

A/M	Auto/Manual	ODC	Operator Display for Controllers
ACS01-99	ARCCosine	ODS	Operator Display for Sequencers
ADD01-99	Addition	ODA	Op Disp for Analog Ind. & Alarm
AG3	AGA3	ODD	Op Disp for Discrete Ind & Control
AG7	AGA7	ODP	Operator Display for Pushbuttons
AG8	AGA8	ONOFF	ON OFF Controller
ALARM	Alarm	OR01-99	OR Logic
AND01-99	AND Logic	ORSL	Override Selector
ASN01-99	Arcsine	OST01-99	One Shot Timer
ATN01-99	Arctangent	PB1SW	PB1 Switch
ATD01-99	Analog Trend Display	PB2SW	PB2 Switch
BATOT	Batch Totalizer	PB3SW	PB3 Switch
BATSW	Batch Switch	PCOM	Phase Communication
BIAS	Bias	PD	PD Controller
CHR01-99	Characterizer	PID	PID Controller
CMP01-99	Comparator	PIDAG	PIDAG Controller
COS01-99	Cosine	PRSEQ	Program Sequencer
DAM01-99	Deviation Amplifier	QHD01-99	Quickset Hold
DIV01-99	Division	RATIO	Ratio
DNC01-99	Divide by N Counter	RCT01-99	Repeat Cycle Timer
DTM01-99	Dead Time Table	RLM01-99	Rate Limiter
DYT01-99	Delay Timer	ROT01-99	Retentive On Timer
E/I	External/Internal Transfer	RSF01-99	RS Flip-Flop
ESL	Events Sequence Logger	RTG01-99	Rising Edge Trigger
EXP01-99	Natural Exponentiation	RTT01-99	Real Time clock Trip
EXT01-99	Exponentiation	SCL01-99	Scaler
FTG01-99	Falling Edge Trigger	SEL01-99	Signal Selector
GB01-99	Gain & Bias	SETPT	Setpoint
HLD01-99	Hold	SIN01-99	Sine
ID	ID Controller	SPLIM	Setpoint Limit
LL01-99	Lead/Lag	SRF01-99	SR Flip-Flop
LMT01-99	Limit	SRT01-99	Square Root
LN_01-99	Natural Logarithm	SUB01-99	Subtraction
LOG01-99	Logarithm Base 10	TAN01-99	Tangent
MTH01-99	Math	TH01-99	Track & Hold
MUL01-99	Multiplication	TOT01-99	TOTALizer
NND01-99	NAND Logic	TSW01-99	Transfer Switch
NOR01-99	NOR Logic	XOR01-99	Exclusive OR Logic
NOT01-99	NOT Logic		

2.4 ETHERNET DATA I/O FUNCTION BLOCKS

These function blocks are available in the quantities indicated within a controller. These blocks can be selected for use within individual loops but block names are unique station wide.

AIE01-32 Analog Input – Ethernet
AOE01-32 Analog Output – Ethernet
AWE01-32 Analog Write – Ethernet
CIE01-32 Coil Input - Ethernet

CWE01-32 Coil Write – Ethernet
DIE01-32 Discrete Input – Ethernet
DOE01-32 Digital Output – Ethernet
DWE01-32 Digital Write – Ethernet

2.5 CONFIGURATION PROCEDURE

Each controller must be configured to perform the desired control strategy. The arrangement of functions and the numerical data required for a particular control circuit are referred to as the controller configuration. Local and remote configurations are accommodated.

Local configuration involves the configuration pushbuttons and the pulser knob on the Display Assembly's faceplate. Section 8.2 Configuration Mode shows the faceplate and provides brief descriptions of control functions.

Remote configuration requires a personal computer running the i|config™ Graphical Configuration Utility and either a configuration cable or a Modbus or Modbus/TCP Ethernet network connection. The configuration can be created at and downloaded from the personal computer. A network connection is made at the controller's terminals or the Ethernet RJ45 connector. The configuration cable plugs into the configuration port in the underside of a 353 Display Assembly. The other end of this cable connects to a personal computer's serial port or to a modem.



Explosion hazard

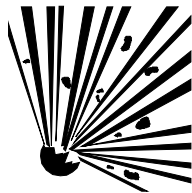

Explosion can cause death or serious injury.

In a potentially explosive atmosphere, remove power from the equipment before connecting or disconnecting power, signal or other circuits.

Comply with all pertinent regulations regarding installation in a hazardous area.

A configuration is designed by first arranging the needed function blocks in a fashion similar to that of a PI & D drawing. Parameter and calibration values are determined next and then entered on a Configuration Documentation Form or into i|config, the Graphical Configuration Utility. The controller may then be configured locally by entering the information on the form into the controller's configuration memory, by way of the controller faceplate. Alternatively, a configuration developed in i|config can be downloaded directly from the personal computer or transferred using the MultiMediaCard.

Nine common controller configurations have been stored in a built-in library that can be entered from the CONFIGS function block at the STATION level. Simple changes can then be made to accommodate individual needs. As an example, FCO101 Single Loop Controller includes the setpoint tracking feature but by simply disconnecting the TC input to the SETPT function block, it becomes a fixed setpoint Single Loop Controller. These FCOs are fully documented in Section 4 Factory Configured Options.

- FCO101** - Single Loop Controller w/ Tracking Setpoint
- FCO102** - Single Loop Controller with Fixed Setpoint
- FCO103** - External Set Controller with Tracking Local Setpoint
- FCO104** - External Set Controller with Non-Tracking Local Setpoint
- FCO105** - Ratio Set Controller with Operator Setpoint Limits
- FCO106** - Single Loop Controller w/Operator Setpoint Limits
- FCO107** - Dual Loop Controller
- FCO121** - Cascade Loop Controller
- FCO122** - Cascade Loop Controller with Operator Setpoint Limits

Unless otherwise specified on the order, FCO101 is installed at the factory. Use the following procedure to change the factory configured option. Refer to Figure 2-1 Configuration Road Map to move to, and then through, the selected FCO and to enter or edit parameter values.

1. Press the ENTER/EXIT CONF button. LOOP will appear on the alphanumeric display.
2. Rotate the Pulser Knob until STATION appears on alphanumeric display.
3. Press the STEP DOWN button to display CONFIGS.
4. Press the STEP DOWN button to display FCO in the lower display.
5. Press the STEP DOWN button until the FCO number appears in numeric display.
6. Rotate the Pulser Knob to display the desired FCO number in the upper display.
7. Press the STORE button to load the new FCO.
8. Edit the FCO as needed. In addition to the material in this section, refer to:
 - Section 3 Function Blocks for details about configurable parameters
 - Section 4 Factory Configured Options for FCO diagrams and parameters
 - Sections 5 and 6 for Modbus (also Modbus/TCP) mapping
 - Section 8 Local Faceplate Operation for operating controls and displays

Where an FCO is not suitable, a complete configuration can be designed to suit individual needs. Section 4 can be used as a guide for documenting a user-created or used-edited configuration. i|config, the PC-based Graphical Configuration Utility, can be used to design, document, and save configurations as well as download them to the controller, through either the configuration port or using a Modbus or Modbus/TCP Ethernet network connection.

The above steps are illustrated in Figure 2-1 Configuration Road Map. The map also provides a broad overview of the configuration procedure.

- Press the ENTER CONF button to enter the configuration mode. Press the button again to exit configuration.
- After entering the configuration mode, LOOP or STATION can be selected.

- At the STATION level, a factory configured option can be loaded, station parameters can be configured, security passwords can be entered, the clock can be set, communication parameters can be configured, and inputs and outputs can be calibrated.
- Calibration can also be performed within individual loops containing the input or output function blocks used in the LOOP.
- At the LOOP level, new loops can be added, loops can be deleted, or an existing loop can be edited.

When a new loop is created at the controller faceplate, the controller will assign a default name (e.g. LOOP01). The default loop name can be changed to a new name that is up to 12 ASCII characters in length. It is suggested that loop names be limited to 6-characters so that the complete loop name will appear in the alphanumeric display during normal operation.

A loop can be edited by stepping down from the EDIT menu. If more than one loop has been configured, press the STEP DOWN button and turn the Pulser Knob to step through the list of configured loops. From the selected loop, stepping down will provide various options within the specific loop.

- The current value of all configured block outputs can be viewed.
- The current tag name of the loop and the ESN (Execution Sequence Number) can be changed. ESNs are automatically assigned by the controller in the order of creation, either a loop or individual block. An ESN should be changed when it is important that one loop be executed prior to another (e.g. cascade primary executes prior to the cascade secondary).
- Function blocks can be added to or deleted from the loop. Existing function blocks can be edited. Use the step up and step down buttons to move between the function block, parameter, and value levels within the EDIT FB menu.

Once all configuration entries have been made and stored, press EXIT CONIF to exit the configuration mode. The configuration will be written to the root directory of the MultiMediaCard with a file name that is the serial number of the controller. Each time the configuration is edited and the EXIT CONF button pressed, the configuration is again written to the root directory of the card overwriting the stored file. The current version of the configuration is always stored on the MMC. If an archive copy of a particular configuration version is desired, create a new file and save it with a new file name; refer to Figure 2-2, Note 6 to create a new file name.

If no configuration entries are made for about three minutes, the mode will time out and the controller will exit the configuration mode. The STATN function block has a CONFIG TO (Configuration Timeout) parameter to enable or disable timeout.

2.6 OPERATION DURING LOCAL ON-LINE CONFIGURATION

Changing a controller's configuration parameters while the station is on-line can affect its operation and output values. Configuration parameters are divided into four types: HARD, SOFT, READ, and CALIBRATION.

HARD - When a HARD parameter is STORED the controller will suspend execution of all function blocks and will hold all outputs until the EXIT button is pressed. A HARD parameter is identified with each '(H)' notation in a function block parameter listing in Section 3 Function Blocks. When a loop or function block is added or deleted, the station enters a HARD configuration mode.

SOFT - A SOFT function block parameter can be changed while the function blocks are executing. A SOFT parameter is identified with each '(S)' notation in a function block parameter listing in Section 3. All QUICKSET changes also fall into this category.

READ - These parameters are not changeable and therefore can be read while the station function blocks are executing. A READ parameter is identified with each '(R)' notation in a function block parameter listing in Section 3. The configuration VIEW mode also falls into this category.

CALIBRATION – To calibrate a parameter, enter CONFIGURATION mode, navigate to CAL, select a function block, and finally select a parameter to calibrate. At this point, the station will suspend execution of all function blocks and it will hold all outputs until the EXIT button is pressed. If an output block is being calibrated its output will be adjusted during the calibration procedure. A calibration parameter is identified with a ‘(C)’ notation in a function block parameter listing in Section 3 Function Blocks.

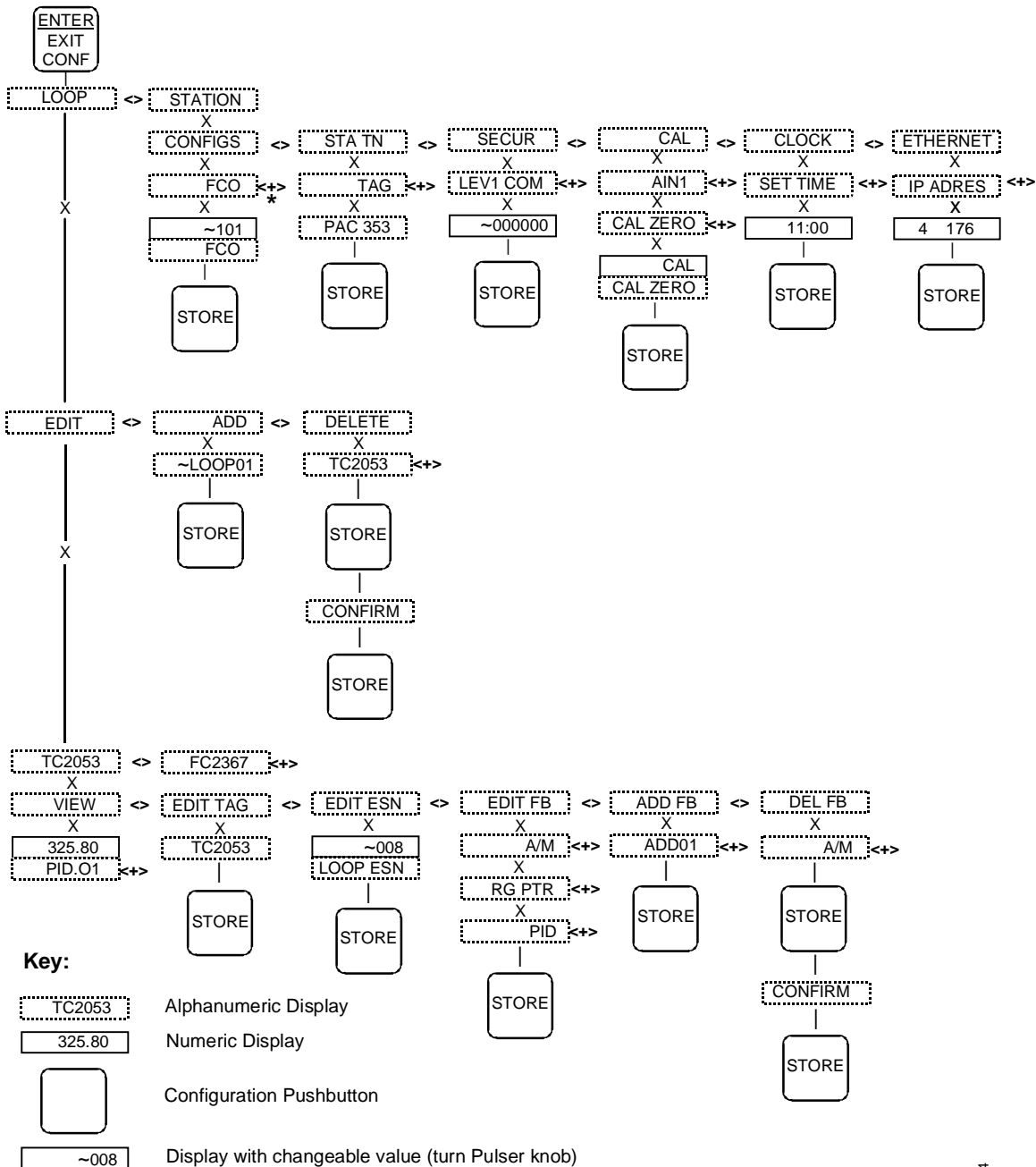

- <-> Turn Pulser to select new parameter or value (move horizontally across map)
- <-+> Turn Pulser to select additional menu items (items not shown)
- X Use Step Up or Step Down pushbutton (move vertically across map)
- * Model 353 Design Level B only - Refer to Figure 2-2 MultiMediaCard Road Map for additional selections. A formatted MMC must be installed in the socket on the Controller board to access these selections.

X0313754

Figure 2-1 Configuration Road Map

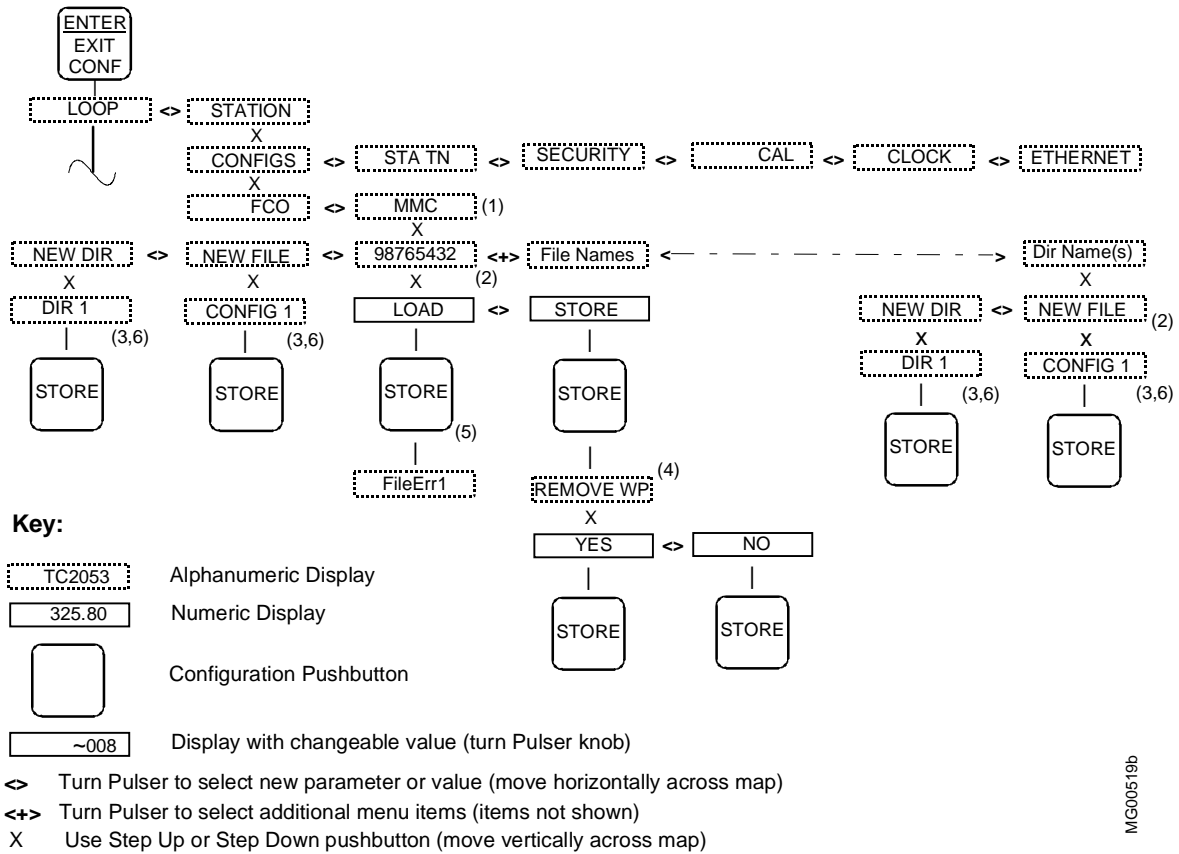

M/C00519b

Notes:

- (1) MMC will display only when a valid MultiMediaCard is installed in the socket on the Controller board.
- (2) If one or more .V3C files or sub-directories exist, the name of the first file or sub-directory listed in the directory will be displayed. Additional files or sub-directories can be displayed by turning the pulser knob clockwise. If no files exist OR the pulser is turned counterclockwise, NEW FILE or NEW DIR (respectively) will be displayed.
- (3) This is the default directory or file name. A unique name of up to 8 characters can be stored.
- (4) When storing a file with the write protect file attribute is set, this additional menu option will be presented.
- (5) When loading a file, if an error is found, an error code will display.
- (6) A directory or file can be renamed before it is stored. To change a displayed directory name or file name, use the left/right arrow keys to select the character to change, then rotate the pulser knob to select a new character.

Stored files and directories can be deleted and renamed at a PC running Windows Explorer or |jconfig.

Press STORE to save a new or edited configuration to the root directory of the MMC. The default file name will be the serial number of the controller (8 characters plus a .V3C extension; the extension is not displayed at the 353 faceplate). A previously saved file will be overwritten.

Figure 2-2 MultiMediaCard Road Map



3.0 FUNCTION BLOCKS

This section contains a detailed description of each function block (FB) available for configuration. Each function block description is supplemented by: (1) a drawing of the block showing data inputs and outputs and control lines, (2) a block parameter table. Most blocks are further described by a block diagram that shows the block's circuitry in a simplified or equivalent circuit form.

NOTES

This User's Manual includes the functionality provided by MPU Controller Board Design Level "B" and firmware Version 4.0.

Keep your controller firmware current by subscribing to updates. The latest firmware version will often provide performance options (e.g. additional function blocks, parameter selections) not available in an earlier version.

Function blocks have three types of inputs/outputs: digital, analog, and special data structure.

- Arrows with dark shading and white letters are digital (outputs are displayed as 0 and 1 in the VIEW mode when using the local faceplate). Digital outputs are typically used to designate function block status, logical outputs, and on/off function block outputs. Some examples are:
 - Function block status: E/I status (IS, ES, SI), A/M status (AS, NA, MS, ES, SS), and Quality Status (QS)
 - Logical Outputs: AND (01), OR (01), NOR (01), or NOT (01)
 - On/Off function blocks: One Shot Timer (01), Retentive On Timer (01), Rising Edge Trigger (01), Alarms (A1, A2, A3, and A4), and Comparator (01)
- Arrows with medium shading and black letters are analog. Internally they are REAL floating point numbers and outputs of these types will be displayed in the VIEW mode when using the local faceplate with the decimal point located to allow greatest resolution between 0.00000 and 999999 or -0.0000 and -99999. Numbers outside this resolution will blink.

Analog outputs are typically output (01) for analog I/O blocks and math functions. Analog outputs may also be specific to a particular function block such as the Analog Output (AO), Step Number (SN), Step Time (ST), Remaining Time (RT), and Current Recipe (CR) outputs of the Program Sequencer.

- Arrows with medium shading and black letters but with a white tip are special data structures for range scaling information and will not be displayed in the VIEW mode). Range scaling information is used when there is a conversion of units within a function block, for example, the Alarm block scales the alarm limits into process engineering units when the range pointer is configured to the process analog input block. If unconfigured the units default to 0-100%. The output range (OR), typically used on analog input function blocks, includes MIN and MAX SCALE, the DPP (Decimal Point Position), and the ENGUNITS (Engineering Units).

The output range is connected to the Range Pointer (input R) of functions blocks requiring scaling other than the default 0-100. For example, an Analog input block could be scaled 0-5000 psig with output (01) connected to the AOUT input (S) and the AIN (OR) connected to the AOUT input (R). The Analog output would then output 4 mA at a minscale of 0 psig and 20 mA at a maxscale of 5000 psig. In contrast, if AOUT input (R) were left unconfigured the output would equal 4 mA at a minscale of 0 psig, 20 mA at a maxscale of 100 psig and over ranged for any input over 100 psig.

Some users may prefer to use normalized 0-1 analog inputs for math calculations and scale outputs for display only; in this case, the Scaler function block may be used to provide an output range (OR) for the ODC (Operator display block).

Note how the range pointers are used in the following Factory Configured Options (FCOs). FCOs are described in detail in Section 4 Factory Configured Options.

- FCO101 Single Loop Controller – The process output range AIN1 (OR) is connected to the range pointer of the SETPT block, the PID block, the ALARM block and the process variable range of the ODC block. As a result these blocks will be automatically rescaled when the minscale and the maxscale or the

engineering units of the Process is changed. For example, if AIN1 is rescaled from the default of 0-100 to 0-5000, the 0-100% bargraph on the display will now represent 0-5000 when displaying the process. The A/M block, AOUT1 (Valve) output, and the Valve input of the ODC block are scaled based on the output of the PID block.

- FCO104 External-Set PID controller – The external setpoint is displayed as variable X in the ODC block. Therefore, the ODC (RX) input uses the range output of the external setpoint AIN2 (OR) for scaling. The 0-100% bargraph will represent the range of AIN1 when displaying the process variable and the range of AIN2 when displaying the X variable.
- FCO105 Ratio Set Control – AIN1 and AIN2 are scaled 0-100% of flow. The ratio of these flows is displayed on variable Y and the scaler function block is used to define the engineering units as a dimensionless ratio CF/WF scaled from 0.50 –1.50.

Connections between blocks are allowed only with similar data types.

To help you quickly locate a function block:

- In this section, function blocks are listed alphabetically by the block ID (e.g. AIN for Analog Input).
- In Section 2, function blocks are listed by broad function (e.g. station hardware I/O).

3.1 STATION FUNCTION BLOCKS

Station function blocks include stored configurations such as FCOs, security, clock setup, Ethernet settings, and station parameters. Each is described in the following subsections.

3.1.1 CONFIGS – Configurations Library

The CONFIGS function block provides a selection of applications either stored in the controller memory as FCOs or stored on a plug-in MMC memory card.

An FCO can be selected from the library and loaded as a complete controller configuration, as defined by the FCO documentation (see Section 4). This erases the current configuration in the controller. Station parameters (STATN, SECUR, ETHERNET blocks) and Calibration are retained when a new FCO or a configuration from an MMC is loaded. This enables a user to quickly configure the controller without having to re-calibrate or re-enter the Station parameter values. The Time and Date in the CLOCK block are retained and the SRCE ADD (Source Address) is reset to 0.

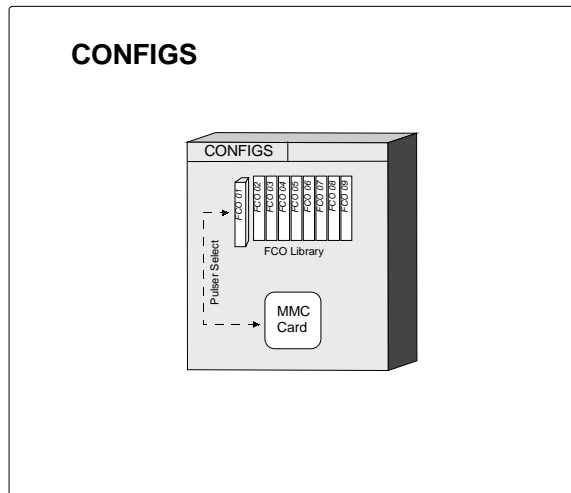

Upon stepping down to the FCO parameter, the last FCO that was loaded in the controller will be displayed. Turning the pulser knob will then display other FCOs that are available in the FCO library. The configuration installed at the factory will be either FCO 101 or a custom configuration that was ordered and defined by the user. FCO 101 is a basic single loop PID controller. An FCO can be loaded at any time in the field and used as is or modified (edited) to meet individual requirements. The FCO library file is not modified when the FCO selected for controller configuration is edited.

In a similar manner a configuration on the MultiMediaCard can be loaded as a complete controller configuration. Controller configurations can be stored on the MMC either in folders or in the card root directory. Pressing ENTER at the controller faceplate and stepping down until MMC appears in the alphanumeric display will provide access to the folders and files stored on the card; see the MultiMediaCard Roadmap, Figure 2-2. If a file name is displayed, stepping down will display either a load or save option. File names and folder names are limited to 8 characters.

A copy of the current configuration running in the controller is stored as a file on the MMC. This file is updated as changes are made at the local faceplate or as parameter changes are downloaded. The file is stored in the root directory of the MMC using the serial number of the controller as the file name. The MMC can be used to transfer a configuration from a controller that may have failed to a replacement controller. The firmware levels of the two controllers must be the same.

3.1.2 SECUR - Security

The SECUR function block enables a user to lock out portions or all of the faceplate configuration functions. Five levels of security are available; see Table 3-1. Each level is factory set to 000000 (no security), and can be changed by the user in the field to any number up to 999999.

A security combination should be assigned to each security level (1-highest, 5-lowest). A level that remains at the default 000000 combination will have no security for the involved function(s) regardless of the security assigned to the other levels. For example, assume that level 1 is assigned a security combination but level 4 remains at 000000. If a controller calibration is performed, the station will not prompt the user for the security combination and anyone will be able to store new calibration values.

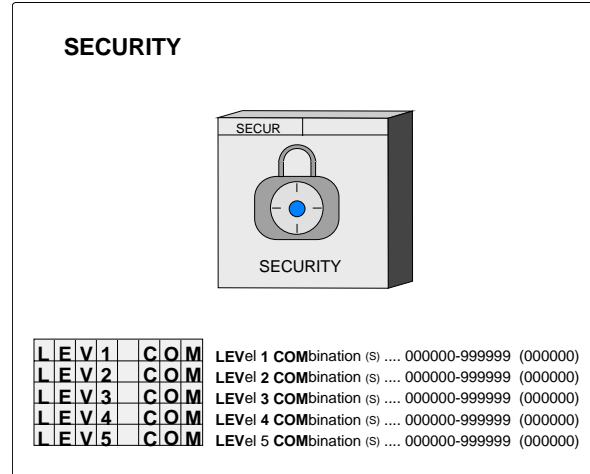

If security is desired, all 5 levels of security should be set with either the same value or different values when different individuals are granted access to only certain functions. The functions that can be accessed at the various security levels are listed in Table 3-1. The security combination will be required when the user attempts to store a parameter or attempts to view a security combination. The faceplate alphanumeric will display “ENTR COM” and allow the user to enter and store the combination. A combination is entered by selecting one digit at a time using the ← and → keys and setting the number for that digit using the pulser. When all digits have been set, press STORE. If incorrect, the alphanumeric will display “ACCESS/DENIED” and then return to the parameter level. Once a combination has been entered correctly, access will be provided for all functions within that level until the user exits configuration. If a combination is lost, contact Siemens technical support to obtain a method to enter configuration and change the security codes. Refer to Section 1.3 Customer/Product Support for contact information.

The PC-based i|config Graphical Configuration Utility may also have security options similar to the above. However, there is no security in the download procedure itself. At the controller, there are parameters in function block STA_PARM that will lock out all downloads and all parameter writes from a PC.

Table 3-1 Security Level vs. Accessible Operations

FUNCTION	LEVEL 1	LEVEL 2	LEVEL 3	LEVEL 4	LEVEL 5
Station Function Block Edit	X	X			
Loop/Function Block Add/Delete	X	X			
Loop/Function Block Edit	X	X	X		
Security Configuration	X				
Calibration of Input/Outputs	X			X	
Quick Faceplate Access*	X	X	X		X
Configuration of NEW FCO and MMC	X	X			
Change CLOCK	X	X			

* Security does not apply to continuously adjustable quickset parameters that include RATIO, BIAS, and QHLD.

The Cycle Time of the station can be viewed as a parameter within the STATN block. In addition, a bias can be added to increase the total cycle time of the station. This may be necessary when significant communications activities are taking place, causing communication overrun errors. Adding bias will allow the processor more time during each scan cycle for completing the communication chores.

The station can be configured to time out of the configuration mode after 1 minute of no faceplate operations by setting the CONFIG TO parameter to YES (default).

Table 3-2 Modbus Port Baud Rate Parameters

PARAMETERS	SETTINGS
Data Formatting	8 bits, no parity, and 1 stop bit
Baud Rate Selections	1 – 300 2 – 1200 3 – 2400 4 – 4800 5 – 9600 (default, rear port) 6 – 19200 (default, front port) 7 – 38400
Handshaking Selections	1. No handshaking is used (default). 2. The station port will turn on the RTS line when it's ready to send data but will not wait for a responding CTS from the receiving device. 3. The station port will turn on the RTS line when it's ready to send data and will wait for a responding CTS from the receiving device before transmitting.

A list of the installed controller hardware and software can be viewed within the STATN block using the HW PRES read only parameter. As shown in Table 3-3, each board has an ID and a hardware revision, and most also have a software revision. The controller's operating Kernel and operating code reside on the MPU Controller board and there is an entry in the table for each. The table lists the hardware and software revisions. For example, in Table 3-3, the MPU Controller board would be shown in the numeric display as '13 4.00'.

Table 3-3 Board Description and ID with Example Hardware and Software Revisions

BOARD DESCRIPTION	BOARD ID	HARDWARE REVISION	SOFTWARE REVISION
Kernel	0	3	2.00
MPU Controller	1	3	4.00
Display Assembly, Faceplate Display	2	1	4.00
I/O Expander	3	1	4.00
MultiMediaCard Installed	7	1	4.00

Check the NVRAM battery condition by reading the BAT OK parameter. The NVRAM, on the MPU Controller Board, uses a sealed lithium battery. Typical battery life is 10-20 years, depending on the total power off time and operating temperature of the controller. The battery powers the Clock and a portion of memory that stores operating data when external power is removed from the controller. When external power is next applied, the controller will read this data and return to the stored operating conditions, when a Hot start condition is encountered. The Clock will retain the correct time. If the battery fails the station will power up in a Cold start using the controller configuration stored in permanent FLASH memory and the Clock will be reset. Battery condition has no effect on normal operation while external power is applied. The RTT function block includes a Battery Status output (BS) that provides a high (1) signal when the battery is low.

3.1.4 CLOCK - Real Time Clock

This function block enables the current time and date to be viewed when using the local faceplate. As shipped, the clock is set to Greenwich Mean Time. When the Step Down Button is pressed to view the parameter value, the current TIME or DATE at that instant is displayed. The value can be changed using the pulser and the <-- and --> arrow buttons to enter a new value. The new value will initialize the clock when the STORE button is pressed. To accommodate scheduled local time changes such as Daylight Savings Time, which varies from country to country, the clock is either manually changed as described above or synchronized to a master as described below.

The time and date cannot be changed locally if the SRCE ADD parameter has been configured to a value other than 0 to have the time synchronized with a master station on the Ethernet network. Using the IP MASK of 255.255.255.0, the first three octets of the IP address (e.g. 192.168.1.xxx) must be the same for all controllers. The SRCE ADD parameter is used to set the last octet of the master controller on the network.

When the SRCE ADD parameter has been configured to synchronize the time with a master controller on the Ethernet network, the controller will query the master controller at 12 midnight and synchronize its time with the master. The time is also available in Modbus registers for display on the operator display (e.g. i|ware). The clock is powered by the controller battery when shut down. Battery condition can be checked from the faceplate using the BAT OK parameter in the STATN (Station) function block. In addition, the RTT function block has a battery status output that can be used to trip an alarm, or force a loop to a desired state (e.g. manual, standby, hold).

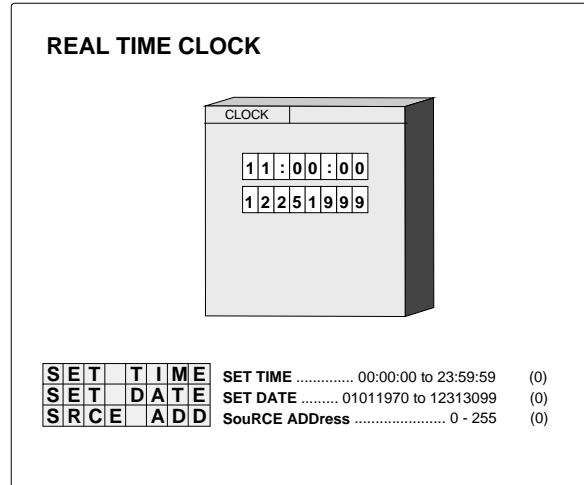

3.1.5 ETHERNET - Ethernet Communication Network

Use this function block to configure Ethernet communication parameters. The default IP addresses shown are used for factory testing in a network environment and should be changed to meet individual system requirements. All 353 controllers that will be communicating with each other or the HMI must reside on the same subnet. Consult your company's network administrator for assistance in determining IP addresses. Also, consider any network security issues that can arise when networking plant areas.

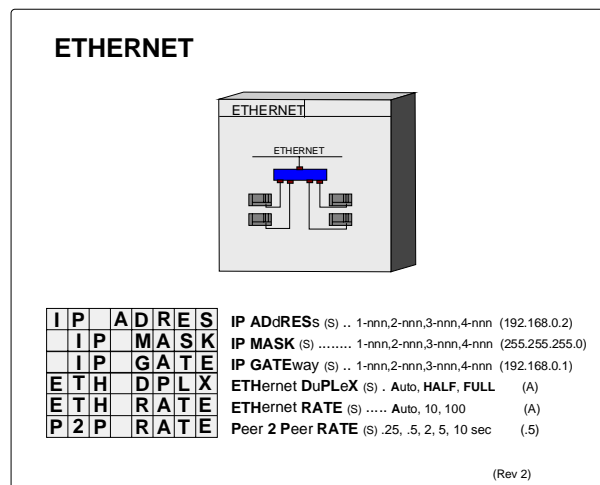

3.2 I/O AND LOOP FUNCTION BLOCKS

This section provides a detailed description of each input/output and loop function block. Blocks are listed alphabetically.

3.2.1 A/M - A/M Transfer

One A/M function block can be used per loop and it is normally used on the output of controller blocks to enable auto/manual operation of the loop. It is separate from the controller block allowing the option of inserting other function blocks (e.g. override, feedforward) between the controller and the A/M Transfer. If function block PB3SW has been used, the A/M block is not available.

AUTO allows the signal from the controller (input A) to become the output of the A/M Transfer unless EMER MAN or STANDBY is active. Auto ONLY forces the operator pushbutton to be locked in the AUTO position, but EMEG MAN and STANDBY will function normally.

MANual allows the operator to adjust the manual value unless STANDBY is active. The manual value tracks the block output when in AUTO or STANDBY. The manual value can be adjusted when in MAN, provided the displayed variable is the process or the valve (e.g. TC2053.P or TC2053.V). When a loop is switched to MANual the display will automatically show the valve (e.g. TC2053.V). The range pointer (input Range) lets the A/M function block know the range of the auto input signal and enables the A/M block to properly process pulser changes from the operator faceplate. The range pointer also defines the range of the manual function as -10% to 110%. This can be useful to prevent inadvertent changes from an operator workstation that might set the manual value well beyond the local operator's changeable range. In most cases, the Range input (range pointer) will connect to the controller function block. An unconfigured range pointer will default the range to 0.00 - 100.00.

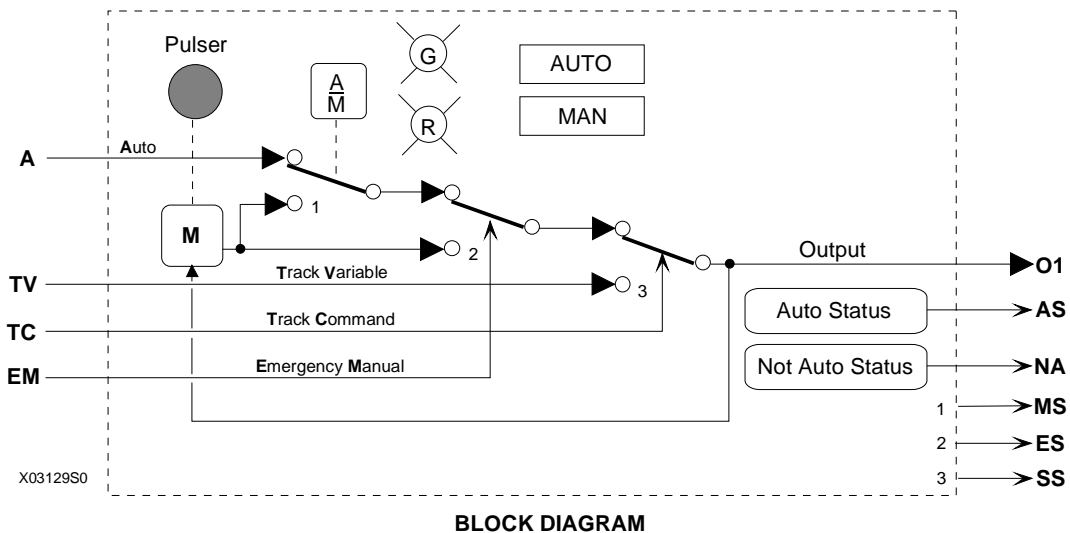
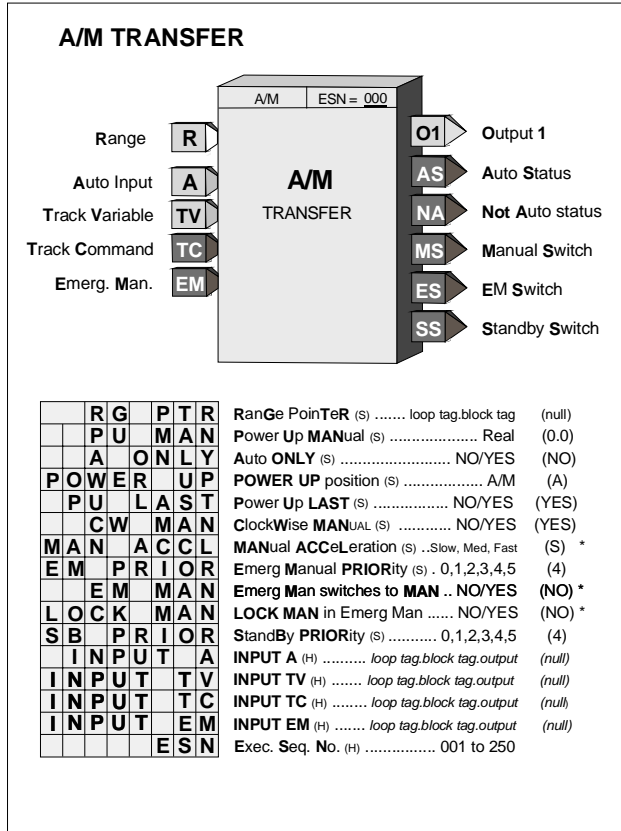

EMERGENCY MANUAL will be asserted when input EM is high (1). This causes the output to hold at the last position and permits the operator to adjust the manual value under the conditions listed for MANUAL. It will also assert an EM MAN status, at the configured priority, to the operator display.

STANDBY will be asserted when input TC is high (1). This causes the A/M block output to track input TV thus placing the loop in a standby condition. This feature can be used to enable one loop to track another for either redundancy applications or optional control schemes. It will also assert a STANDBY status, at the configured priority, to the operator display.

STATUS OUTPUTS - Output **AS** (Auto Status) goes high (1) when output O1 is the Auto input; output **NA** will go high when output O1 is not the Auto input, output **MS** goes high when the A/M switch is in the manual position; output **ES** goes high when the Emergency Manual switch is in the manual position; and **SS** goes high when the standby switch is in the Track Variable position. Two LEDs on the display identify the position of the A/M switch.

POWER UP - The A/M function block can be configured to power up under various conditions during a warm or cold start. If **PU LAST** has been configured as **YES**, during a warm start all outputs are initialized at previous values and the block will power up in the same condition (i.e. same A/M switch position). When powering up in auto, the A/M block will execute in the manual mode for the first two scan cycles, allowing a controller block to track the last value. When **PU LAST** is set to **NO**, the A/M block does not power up in last position during a warm start and will power up as configured by the **POWER UP** parameter, either **AUTO** or **MAN**. During a cold start, the A/M block will always power up as configured by the **POWER UP** parameter. When the **POWER UP** parameter is used and the block powers up in **MAN**, the manual value can be set using the **PU MAN** parameter.

Clock Wise MANUAL configured as **YES**, the default position, will cause the manual value to increase with clockwise rotation of the knob. This feature is useful when clockwise rotation is desired to always open a valve whether the valve is direct or reverse acting.

EMERGENCY MANUAL allows the position of the A/M block Manual Switch (switch 1 in the block diagram) and the associated light to be configured. When the EM input goes high (1), the Emergency Manual Switch (switch 2) switches to manual. If **EM MAN** is configured as **YES**, the Manual Switch (switch 1) and the indicator light will switch to the manual position, assuming that switch 1 is in Auto, and will remain in the manual position until the operator presses the A/M button or a command is received from an HMI to switch to Auto. The EM Switch (switch 2) will remain in the manual position until the EM status clears regardless of the position of the Manual Switch (switch 1). If the **EM MAN** parameter is configured as **NO**, the Manual Switch (switch 1) and associated indicator light will not change position when the EM input goes high (1).

LOCK MAN, can be set to **YES** to lock the loop in manual when Emergency Manual has been activated. The operator can switch the loop to Auto only when the EM condition has cleared. This feature is available only when the **EM MAN** parameter is configured as **YES**.

The **MAN ACCL** parameter enables setting the acceleration rate applied to the pulser knob. It can be configured for Slow, Medium, or Fast. Slow is the default.

PRIORITIES - The priority assigned to EM or SB PRIOR will affect the operation as follows (the outputs ES and SS will go high with all priority assignments, including 0, when event is active):

1. Bargraphs, event LEDs, and condition will flash. ACK button must be used to stop flashing.
2. Bargraphs, event LEDs, and condition will flash. Flashing will stop if ACK or if event clears.
3. Event LEDs and condition will flash. ACK button must be used to stop flashing.
4. Event LEDs and condition will flash. Flashing will stop if ACK or event clears.
5. Event LEDs and condition will turn on when event is active and off when the event clears.
0. No local display action occurs when event is active.

3.2.2 ACS - ARCCOSINE

ACS_ function blocks accept an input between -1.0 and 1.0. Each provides an output signal in radians of which the input is the cosine.

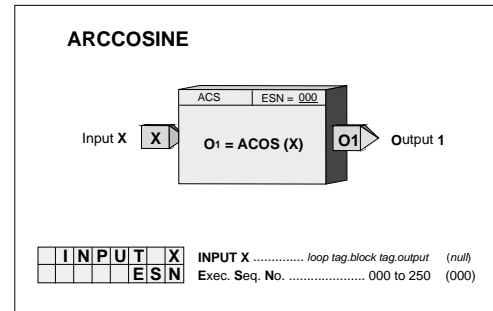
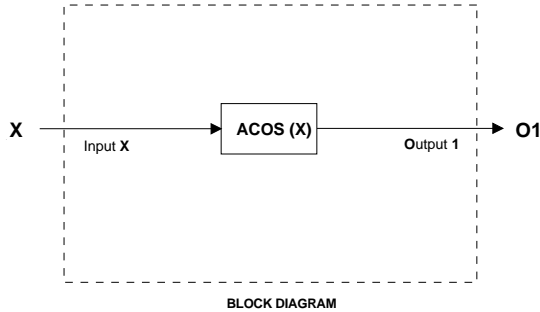

3.2.3 ADD_ - Addition

ADD_ function blocks perform arithmetic addition on three input signals. Any unused input will be set to 0.0 and will have no affect on the output.

All inputs should have the same engineering units. If units are not consistent, an SCL (Scaler) function block can be used or an alternative is to use a MATH function block that has built-in scaling functions.

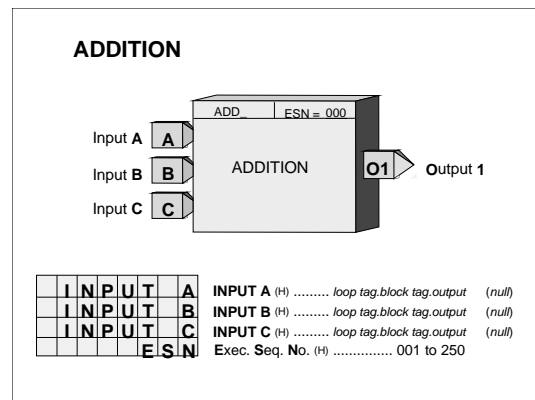
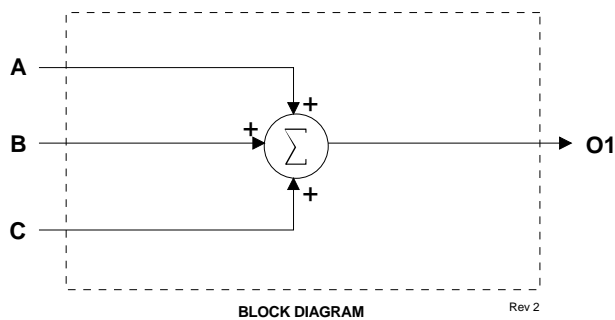

3.2.4 AG3 - AGA 3 Orifice Metering of Natural Gas

AG3 function blocks can be used on a one per loop basis. This block uses the AGA 3 (American Gas Association Report #3) calculation to accurately measure the flow of natural gas using an orifice meter with flanged taps. The basic equations calculated by this block, in accordance with AGA Report No. 3, Orifice Metering of Natural Gas, Part 3, November 1992 (AGA Catalog No. XQ9210), are:

$$Q_b = C' \sqrt{P_{f1} h_w}$$

$$C' = F_n(F_c + F_{s1})Y_1 F_{pb} F_{tb} F_{tf} F_{gr} F_{pv}$$

where: Q_b = volume flow rate at base conditions

- C' = composite orifice flow factor
- P_{f1} = absolute flowing pressure(upstream tap)
- h_w = orifice differential pressure
- F_n = numeric conversion factor
- F_c = orifice calculation factor
- F_{s1} = orifice slope factor
- Y_1 = expansion factor (upstream tap)
- F_{pb} = base pressure factor
- F_{tb} = base temperature factor
- F_{tf} = flowing temperature factor
- F_{gr} = real gas relative density factor
- F_{pv} = supercompressibility factor

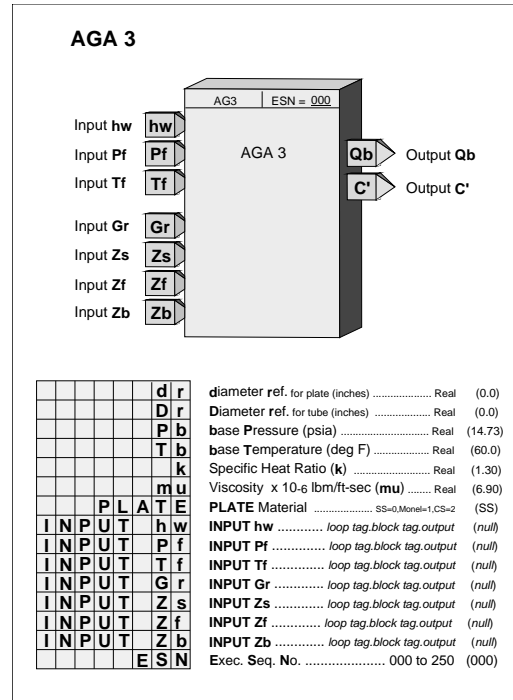

Output Q_b is updated every scan cycle. Output C' is updated continuously for temperature effects and periodically for other effects. The following conditions are considered in the calculations:

- Standard Conditions are: $P_s = 14.73$ psia, $T_s = 60^\circ\text{F}$, $Z_{sair} = 0.999590$.
- Nominal pipe size is 2" or larger, Beta is 0.1 - 0.75, and Re (Reynolds Number) is 4000 or larger.
- Y (expansion factor) and absolute flowing pressure P_f are referenced to upstream tap (i.e. Y_1 & P_{f1}).
- h_w is in inches H_2O and P_f is in psia. $0 < [h_w / (27.707 * P_f)] \leq 0.2$.

The following parameters are configuration entries:

- d_r = orifice plate bore diameter in inches at a reference temperature of 68°F
- D_r = meter tube internal diameter in inches at a reference temperature of 68°F
- P_b = base pressure (psia)
- T_b = base temperature (°F)

The following are analog inputs to the AGA 3 function block:

- h_w = orifice differential pressure (in H_2O)
- P_f = flowing pressure at upstream tap - P_{f1} (psia)
- T_f = flowing temperature (°F)
- G_r = real gas relative density (specific gravity)

- Z_s = compressibility at standard conditions
 Z_f = compressibility at flowing conditions at upstream tap - Z_{f1}
 Z_b = compressibility at base conditions

The specific gravity factor (G_r) and the compressibility factors (Z_s , Z_f , Z_b) can be entered manually using HLD (Hold) function blocks, computed, and then downloaded from a host device, or calculated in the controller using the AG8 (AGA 8 Compressibility Factors of Natural Gas) function block.

The following are analog outputs of the AGA 3 function block:

- Q_b = volume flow rate at base conditions (SCFH - Standard Cubic Feet per Hour)
 C' = composite orifice flow factor [SCFH/ $\sqrt{\text{psia}}(\text{in H}_2\text{O})$]

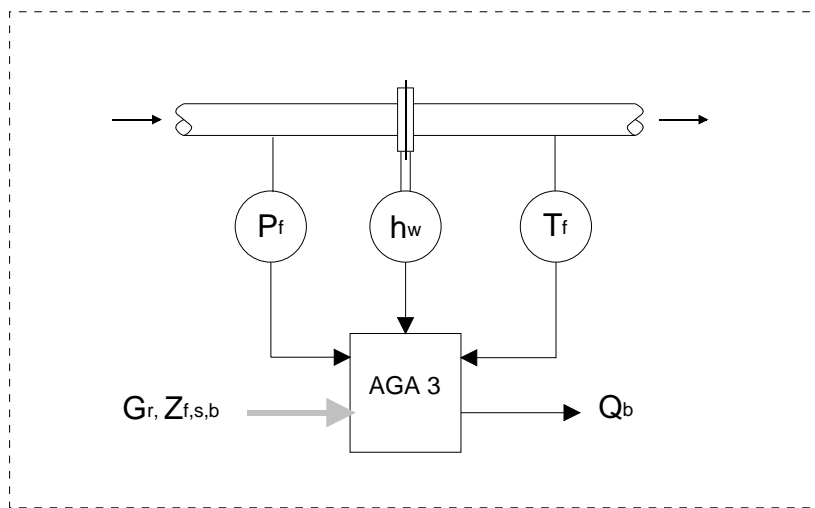

Application Diagram

3.2.5 AG7 - AGA 7 Measurement of Gas by Turbine Meters

AG7 function blocks can be used on a one per loop basis. This block uses the AGA 7 (American Gas Association Report #7) calculation to accurately measure the volume flow of gas at base conditions using a turbine meter. The basic equations calculated by this block in accordance with AGA Turbine Meter Report No. 7, 1985 (AGA Catalog No. XQ0585) are:

$$Q_b = Q_f (T_b/T_f)(P_f/P_b)(Z_b/Z_f)$$

- where:
- Q_f = volume flow at standard conditions
 - Q_b = volume flow rate at base conditions
 - P_f = flowing pressure (psia)
 - T_f = flowing temperature
 - Z_f = compressibility at flowing conditions
 - P_b = base pressure (psia)
 - T_b = base temperature (°F)
 - Z_b = compressibility at base conditions

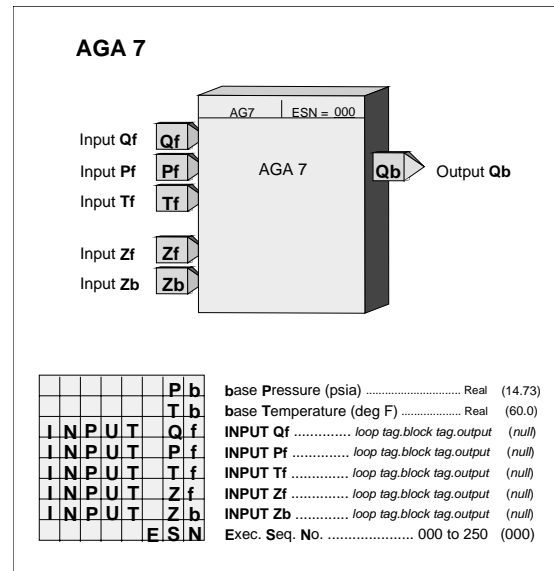

Block output Q_b is updated continuously and is the volume flow rate at base conditions in the same units as input Q_f . T_b and T_f are converted within the block from °F to °R (adds 459.67 to the °F input value) for the actual calculation. Compressibility factors (Z_f , Z_b) can be entered manually using HLD (Hold) function blocks, computed and downloaded from a host device, or calculated in the controller using the AG8 (AGA 8 Compressibility Factors of Natural Gas) function block.

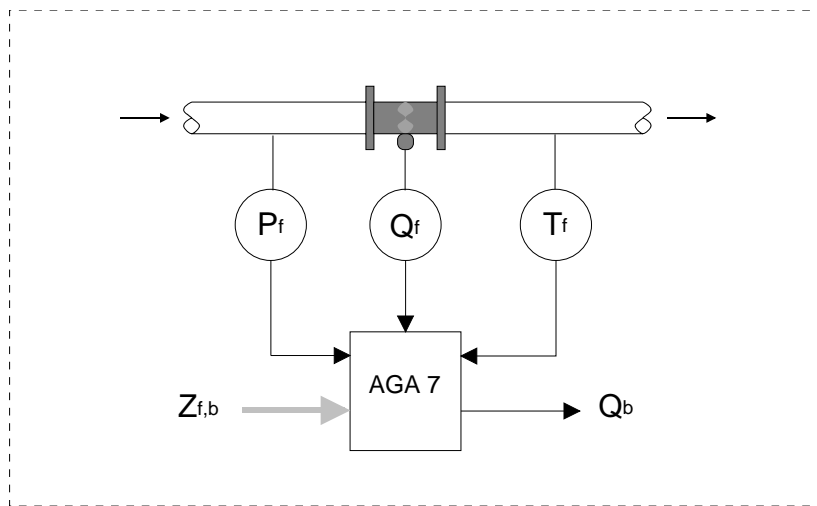

Application Diagram

3.2.6 AG8 - AGA 8 Compressibility Factors of Natural Gas

AG8 function blocks can be used on a one per loop basis. This block calculates the compressibility factors of natural gas in accordance with AGA 8 Report No. 8, July 1994 (AGA Catalog No. XQ9212). It computes various compressibility factors and the specific gravity (relative density) using the detailed characterization method described in the report. The mole percentage of the gas components and the base temperature and pressure are entered in the configuration and the flowing temperature and pressure are provided as block inputs. Parameter MOL% SUM provides a read only value that is the total of all the gas compounds that have been entered. The AGA8 computation is time consuming and is calculated over a total of 100 scan cycles so as not to have any significant effect on the controller cycle time.

Z_s (compressibility at standard conditions) is calculated after a power-up or after a configuration change is made. Z_b and Z_f are calculated on a periodic basis with the actual update time dependent on the number of gas components and the scan cycle of the controller.

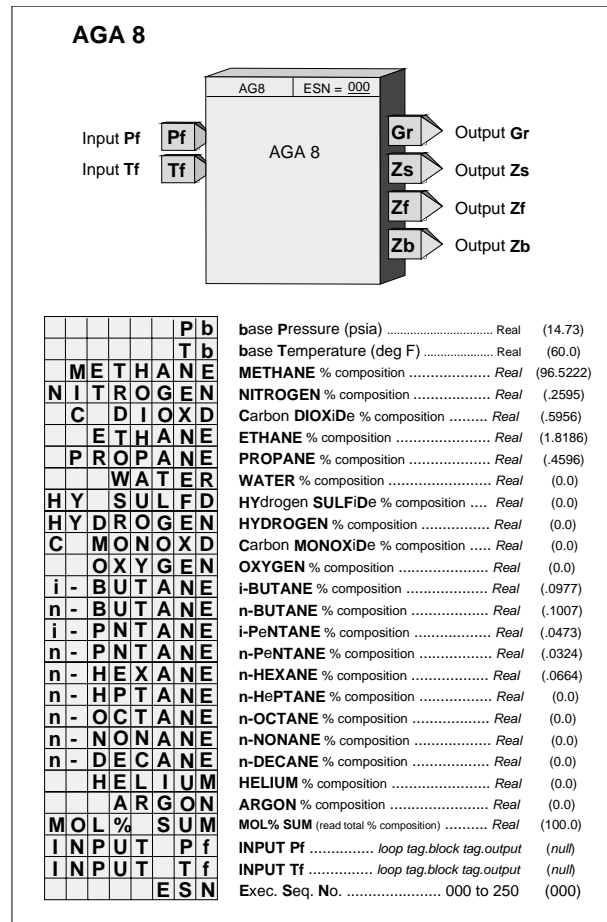

3.2.7 AIE_ - Analog Input - Ethernet

AIE_ function blocks use Modbus command 04 “Read Input Registers” to enable the controller to read analog data from other stations over the Ethernet network.

Up to 32 AIE_ blocks are available. Blocks are assigned in sequence (e.g. AIE01, AIE02...), controller wide, with each use.

Data can be received as a real floating-point number and is passed to block output O1 directly or it can be obtained as a 16-bit integer. A Floating Point number can be formatted in one of four methods as shown in Table 3-4 on the next page. An integer is converted to floating point as scaled by MIN INT and MAX INT and MINSCALE and MAXSCALE parameters. Both Unsigned Integer (Uint) and Signed Integer (Sint) options are available. See Table 3-5 on the next page.

When a DATA TYP is selected, range limits are automatically entered (see Table 3-5). This ensures that the user-entered integer values fall within the correct range. MIN INT and MAX INT values must be entered whenever a DATA TYP is changed.

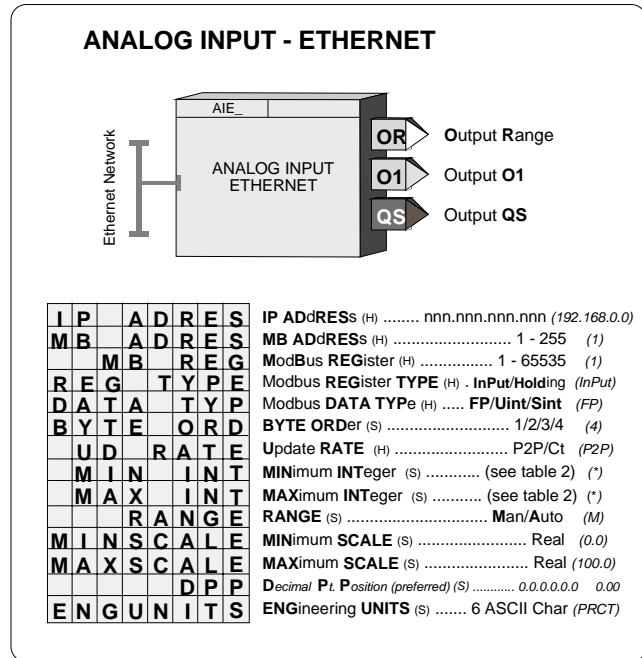

Output OR contains the range scaling for the floating point block output O1. The OR output is a special data type that includes the MINSCALE, MAXSCALE, DPP, and the ENGUNITS and can be connected to other blocks having a Range (RG PTR) input. Range scaling information can be automatically obtained from the source of the data over Ethernet if the device has the scaling information packaged with the data. This is a feature provided by AOE function blocks from other Siemens 353 controllers. AIE blocks are connected to AOE blocks by using the Modbus Registers from Table 3-6 below. If the automatic range scaling feature is not available, the default setting of the RANGE parameter "MAN" should be used. In this case, range parameters are entered manually. When the auto range feature is used, the range in the AIE block may be out of sync for several seconds if on line changes are made to the AOE range.

The IP ADRES parameter is used to configure the IP address of the source device. The MB ADRES parameter allows a Modbus address to be configured. When connecting to other Siemens controllers the Modbus address is set to 1. In some cases, other devices may use a different address or when going through a Modbus TCP/IP gateway a Modbus network may have multiple devices, each having a unique address. The REG TYP parameter allows setting the source register as a Holding Register or an Input Register. For many Modbus devices, this setting does not matter since the device will treat them as identical registers. The DATA TYP parameter will enable the AIE block to acquire floating point or integer data. When floating point is selected the controller will request two consecutive registers starting with the MB REG parameter. The UD RATE parameter configures the rate at which the block will request data. The P2P setting will update the data at the rate set by the P2P RATE parameter in the ETHERNET block. The Ct setting will update the data at the cycle time of the controller. The Ct parameter should normally be used only when the analog input is the process variable in a PID control loop

Output QS indicates the quality of the received data and will go high (1) when the data is bad. This is normally associated with failure to receive data due to a communication failure or a misconfiguration of the source.

Table 3-4 Floating Point Number Formats, AIE Block

BYTE ORD	Type Description	Byte Order	Comments
1	Big Endian FP Format	4, 3,2, 1	IEEE
2	Big Endian FP w/ bytes swapped	3, 4, 1, 2	
3	Little Endian FP Format	1, 2, 3, 4	
4	Little Endian FP w/ bytes swapped	2, 1, 4, 3	Model 353 Usage

Table 3-5 Integer Default Values, AIE Block

Selection	Parameter	Default Value
Uint	MIN INT	0
Uint	MAX INT	65535
Sint	MIN INT	-32768
Sint	MAX INT	+32767

Table 3-6 FB Numbers vs. Modbus Registers, AIE Block

FB Number	MB Register	FB Number	MB Register	FB Number	MB Register	FB Number	MB Register
AOE01	30961	AOE09	30977	AOE17	30993	AOE25	31009
AOE02	30963	AOE10	30979	AOE18	30995	AOE26	31011
AOE03	30965	AOE11	30981	AOE19	30997	AOE27	31013
AOE04	30967	AOE12	30983	AOE20	30999	AOE28	31015
AOE05	30969	AOE13	30985	AOE21	31001	AOE29	31017
AOE06	30971	AOE14	30987	AOE22	31003	AOE30	31019
AOE07	30973	AOE15	30989	AOE23	31005	AOE31	31021
AOE08	30975	AOE16	30991	AOE24	31007	AOE32	31023

Note: Registers listed in Table 3-6 are Extended Modbus Registers and are not supported by all Modbus devices.

3.2.8 AIN_ - Analog Inputs

AIN_ function blocks convert a voltage input, having a range defined during calibration, into a block output signal that is scaled in engineering units. The output is then interconnected to other function blocks within the controller.

A 6-character ASCII value can be entered to identify the engineering units of the output signal. The scaled output range is configurable and has a factory default of 0.0 to 100.0 PRCT. Ranges such as 300.0 to 500.0, representing engineering units in degrees C, can also be configured. The Output Range is a special data type that includes the MIN and MAX SCALE, the DPP, and the ENGUNITS that can be connected to other blocks with a Range (RG PTR) input.

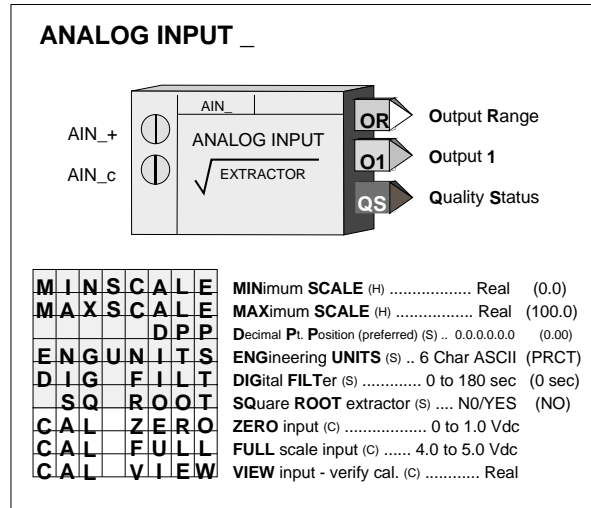

Analog Input blocks are available on the MPU Controller Board (CB) and on the I/O Expander Board (EB). Block names (IDs) are listed in Section 7.4 Electrical Installation together with the case rear terminal numbers. Power for 2-wire transmitters is available at the rear terminals.

A digital filter (time constant) is available to dampen process noise. A square root extractor is also available to linearize a flow signal from a ΔP transmitter, allowing the block output to be configured for flow units. Output QS indicates the quality of the analog output signal O1, and will be high (1) when output O1 is bad, and low (0) when good. Bad quality signifies an A/D conversion failure or a 1-5Vdc input signal that falls below 0.7 Vdc indicating an open circuit or failure of a 2-wire transmitter.

A verify mode (CAL VIEW) is available during calibration to view the block output over the full calibrated range. The input is factory calibrated for 1-5 Vdc and should not require field calibration. However, field calibration can be performed if another range is required or to match the exact transmitter calibration. Current inputs are accommodated using precision dropping resistors connected across the input terminals (250Ω resistors are supplied with the controller for conversion of 4-20mA inputs).

Power Up - During a hot, a warm or a cold start, the function block will temporarily by-pass the digital filter to enable the output to initialize at the actual hardware input signal.

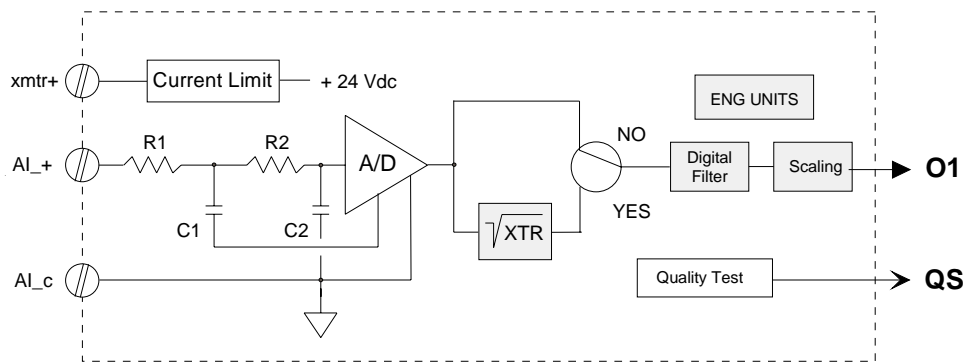

BLOCK DIAGRAM

3.2.9 AINU_ - Analog Inputs, Universal

AINU_ function blocks are available on the optional I/O Expander Board. These function blocks convert sensor inputs such as T/C (thermocouple), RTD (resistance temperature detector), millivolt, ohm, and slidewire sources into block outputs. Current inputs (i.e. 4-20 mA) are accommodated by using the WMV type and connecting a 3.75Ω resistor across the input. An output bias can be used to nullify any known offset in the sensor circuit and a digital filter (time constant) is included, to dampen process noise. Output QS indicates the quality status of the output signal O1 and will go high (1) when the output is of bad quality. Bad quality indicates an A/D conversion failure or an open circuit T/C.

The scaling function is used to establish an output range, in engineering units, for the selected sensor range (e.g. 0-10 mv or 50.0-150.0 amperes). Direct Temperature Measurements (i.e. T/C and RTD) bypass sensor and range scaling and the block output units are selected from Table 3-7. When selected, the proper read only ASCII characters corresponding to the type units selected will automatically be placed in the ENG UNITS parameter.

When OHMs or MVs are selected, the ENG UNITS parameter can be configured to correspond to the process engineering units. The default SEN MIN and MIN SCALE are set to the minimum operating value and SEN MAX and MAX SCALE are set to the maximum operating value. SEN MIN and SEN MAX always indicate the sensor range limits in degrees C. However, it is important to enter the actual intended operating range in the MINSSCALE, MAXSCALE, and DPP parameters so that other function blocks, such as the controller, operator faceplate, and workstation interface, can point to this block for range and display information. Block names (IDs). Input terminations (terminal numbers) are listed in Section 7.4 Electrical Installation.

All input types are factory calibrated and do not require field calibration. However, for those cases where outputs must be adjusted to meet a local standard, a field calibration feature is available to override the factory calibration for the input type selected. The factory calibration is retained so that the input can be returned to the factory calibration at any time by storing 'FAC' in the calibration selection. Table 3-8 provides the input values that are used to perform a field calibration. A verify mode is available during calibration to view the sensor input over the full range. The signal that is viewed, in the calibration verify mode, is in the basic units of measure (e.g. °C for temperature, mv for millivolts) and is not affected by the temperature units conversion, digital filter, scaling, or the output bias adjustment. The full block output with these parameters applied can be viewed in the VIEW mode within loop configuration. During a hot, a warm or a cold start, the function block will temporarily by-pass the digital filter to enable the output to initialize at the actual hardware input signal. Note that the field calibration is erased when the SENSOR TYPE is changed.

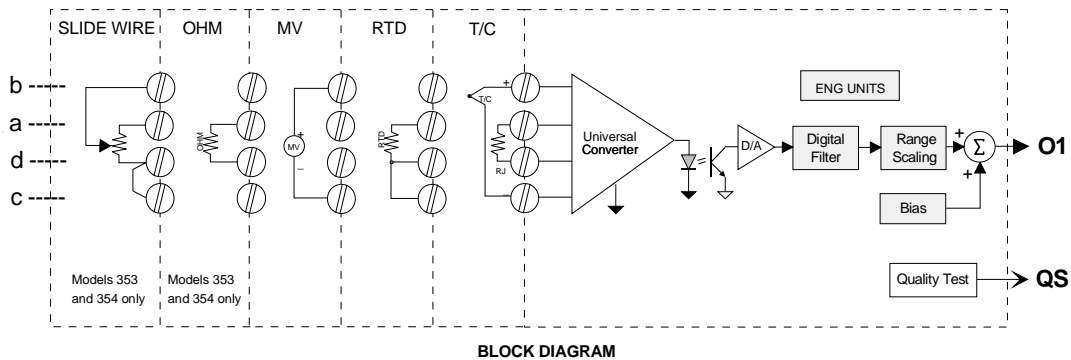
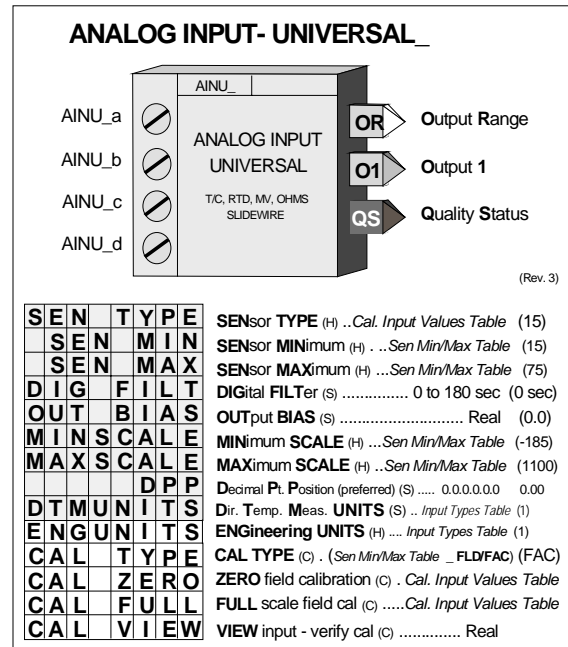

Table 3-7 Input Types, AINU Block

#	ENGINEERING UNITS	AVAILABLE ON INPUT TYPES
1	Deg C (degrees Celsius)	JT/C, KT/C, TT/C, ET/C, ST/C, RT/C, BT/C, NT/C, DRTD, URTD, JRTD
2	Deg F (degrees Fahrenheit)	JT/C, KT/C, TT/C, ET/C, ST/C, RT/C, BT/C, NT/C, DRTD, URTD, JRTD
3	Deg R (degrees Rankine)	JT/C, KT/C, TT/C, ET/C, ST/C, RT/C, BT/C, NT/C, DRTD, URTD, JRTD
4	K (Kelvin)	JT/C, KT/C, TT/C, ET/C, ST/C, RT/C, BT/C, NT/C, DRTD, URTD, JRTD
*****	6 Character ASCII	OHM, SLW, NMV, WMV

Table 3-8 Calibration Input Values, AINU Block

#	TYPE	DESCRIPTION	OPERATING RANGE	FIELD CAL 'FLD' POINTS
1	JT/C	Type J Thermocouple	-185°C to 1100°C (-300°F to 2010°F)	0°C & 800°C
2	KT/C	Type K Thermocouple	-185°C to 1370°C (-300°F to 2500°F)	0°C & 1000°C
3	TT/C	Type T Thermocouple	-200°C to 370°C (-400°F to 698°F)	-100°C & 300°C
4	ET/C	Type E Thermocouple	-185°C to 1000°C (-300°F to 1830°F)	0°C & 800°C
5	ST/C	Type S Thermocouple	-18°C to 1650°C (0°F to 3000°F)	400°C & 1400°C
6	RT/C	Type R Thermocouple	-18°C to 1610°C (0°F to 2930°F)	400°C & 1400°C
7	BT/C	Type B Thermocouple	-18°C to 1815°C (0°F to 3300°F)	800°C & 1600°C
8	NT/C	Type N Thermocouple	-185°C to 1300°C (-300°F to 2370°F)	0°C & 1000°C
9	DRTD	DIN 43760/IEC 751 RTD alpha 0.003850	-185°C to 622°C (-300°F to 1152°F)	100Ω (0°C) & 280.98Ω (500.0°C)
10	URTD	US (NBS 126) RTD alpha 0.003902	-185°C to 613°C (-300°F to 1135°F)	100Ω (0°C) & 283.36Ω (500.0°C)
11	JRTD	JIS C-1604 RTD alpha 0.003916	-185°C to 610°C (-300°F to 1130°F)	100Ω (0°C) & 285Ω (502.94°C)
12	OHM*	Resistance	0Ω to 5000Ω	0Ω & 5000Ω
13	SLW*	Slidewire	500Ω to 5000Ω	<i>Field cal not available</i>
14	NMV	Narrow Millivolt	- 19.0 mV to 19.0 mV	0 mV & +15 mV
15	WMV	Wide Millivolt	-30.0 mV to 77 mV	0 mV & +75 mV

- Not available in Model 352Plus.

Table 3-9 SEN MIN/MAX and MIN/MAX SCALE Parameters, AINU Block

SEN TYPE (1)	SEN MIN	SEN MAX	MIN SCALE	MAX SCALE
1-12,14,15	[min. operating value]	[max. operating value]	[min. range scale value]	[max. range scale value]
13	0 (%)	100 (%)	0.0 PRCT (2)	100.0 PRCT (2)

Note:

(1) When changing SEN TYPE, type number should blink after pressing STORE. Use STEP UP and then STEP DOWN to verify that sensor type has changed.

(2) Range scaling of the AINU output when the Slidewire sensor type is selected can be accomplished using a SCL_Scaler function block connected to the output (O1) of the AINU function block.

3.2.10 ALARM - Alarm

ALARM function blocks can be used on a one per loop basis and contain four (4) alarms associated with Input P (normally the process input to the controller function block). Each alarm can be configured as NONE, HI, LO, HDEV, LDEV, DEV, and OR.

Deviation type alarms compare Input P with Input D, the deviation input, normally the loop setpoint (i.e. the setpoint to the controller function block), having the same range as Input P. An Out of Range (OR) alarm compares the process input with the range limits specified by the range pointer parameter (input R). This parameter must point to a function block that includes MINSCALE and MAXSCALE configuration parameters (e.g. Analog Input) for proper scaling. If not configured, 0.0-100.0 will be used as a default range.

Alarms have priorities 1 to 5, with 1 the highest and are reported to the operator faceplate in order of priority first and then in order of occurrence. Priority 1 causes the station bargraphs and condition (e.g. A1 HI) to flash and requires acknowledgment to stop flashing. Priority 2 also flashes the bargraphs and condition but stops flashing when the alarm clears (i.e. Self Clearing). Priority 3 causes the event LEDs (L and S) and condition to flash. Flashing stops only when the alarm is acknowledged. Priority 4 also causes the event LEDs and condition to flash but stops when the alarm clears. Priority 5 displays the alarm but does not require that it be acknowledged.

Alarm limits are in engineering units. A quickset ALARM feature is also available allowing alarm limits to be set quickly during operation. The settings are in engineering units but will also be displayed in % of range on the bargraph. Alarms are displayed as defined by the range pointer parameter. Alarms can be set to any engineering value within -10% to 110% of the range defined by the pointer. If a range is changed, the current alarm settings will be changed to be the same % within the new range. For example, if a HI alarm is currently set at 100.0 with a range of 0.0 to 100.0 and the range is changed to 300.0 to 400.0, the HI alarm will be moved to 400.0.

Each alarm can be enabled or disabled when in the quickset ALARM mode. The configuration allows an alarm to be enabled or disabled on a cold start. When an alarm is disabled, it will not operate but will retain settings for return to the enabled mode. Operator faceplate functions, relating to alarms, are described in the sections describing the specific faceplate controls and displays. All alarms have the following features:

Deadband - requires that the signal either drop below or exceed the limit setting by the amount of the deadband before the alarm clears (goes low). The alarm deadband is set as a fixed % of the range pointer scale.

Delay-In Time - requires that the input remain above (or below) the limit setting for the delay time before the alarm trips (goes high). This can help prevent nuisance alarms that may be tripping due to process noise.

Delay-Out Time - requires that the input remain below (or above) the limit setting plus deadband for the delay time before the alarm will clear (goes low). This can help prevent inadvertent clearing of alarms due to process noise.

Ringback - causes a previously acknowledged alarm to require acknowledgment (priorities 1-4) when the alarm clears.

ALARM

	R	G	P	T	R	RanGe	PoinTeR	(S)	loop tag,block tag	(null)	
A 1	L	I	M	I	T	Alarm 1	LIMIT	(S)	Real	(110.0)	
A 2	L	I	M	I	T	Alarm 2	LIMIT	(S)	Real	(-10.0)	
A 3	L	I	M	I	T	Alarm 3	LIMIT	(S)	Real	(100.0)	
A 4	L	I	M	I	T	Alarm 4	LIMIT	(S)	Real	(0.0)	
A 1	D	B	A	N	D	Alarm 1	DeadBAND	(S)	0.1/0.5/1.0/5.0%	(0.5)	
A 2	D	B	A	N	D	Alarm 2	DeadBAND	(S)	0.1/0.5/1.0/5.0%	(0.5)	
A 3	D	B	A	N	D	Alarm 3	DeadBAND	(S)	0.1/0.5/1.0/5.0%	(0.5)	
A 4	D	B	A	N	D	Alarm 4	DeadBAND	(S)	0.1/0.5/1.0/5.0%	(0.5)	
A 1	P	U	E	N		Alarm 1	Power Up	ENabled	(S)	NO/YES (YES)	
A 2	P	U	E	N		Alarm 2	Power Up	ENabled	(S)	NO/YES (YES)	
A 3	P	U	E	N		Alarm 3	Power Up	ENabled	(S)	NO/YES (YES)	
A 4	P	U	E	N		Alarm 4	Power Up	ENabled	(S)	NO/YES (YES)	
A 1	P	R	I	O	R	Alarm 1	PRIORity	(S)	1/2/3/4/5	(3)	
A 2	P	R	I	O	R	Alarm 2	PRIORity	(S)	1/2/3/4/5	(3)	
A 3	P	R	I	O	R	Alarm 3	PRIORity	(S)	1/2/3/4/5	(3)	
A 4	P	R	I	O	R	Alarm 4	PRIORity	(S)	1/2/3/4/5	(3)	
A 1		T	Y	P	E	A1	TYPE	(S)	none,HI,LO,HdEV,LdEV,dEV,or	(HI)	
A 2		T	Y	P	E	A2	TYPE	(S)	none,HI,LO,HdEV,LdEV,dEV,or	(LO)	
A 3		T	Y	P	E	A3	TYPE	(S)	none,HI,LO,HdEV,LdEV,dEV,or	(dEV)	
A 4		T	Y	P	E	A4	TYPE	(S)	none,HI,LO,HdEV,LdEV,dEV,or	(none)	
A 1		D	L	I	N	A1	DeLay	IN	(S)	0/.4/1/2/5/15/30/60	Sec (0)
A 2		D	L	I	N	A2	DeLay	IN	(S)	0/.4/1/2/5/15/30/60	Sec (0)
A 3		D	L	I	N	A3	DeLay	IN	(S)	0/.4/1/2/5/15/30/60	Sec (0)
A 4		D	L	I	N	A4	DeLay	IN	(S)	0/.4/1/2/5/15/30/60	Sec (0)
A 1		D	L	O	U	A1	DeLay	OUT	(S)	0/.4/1/2/5/15/30/60	Sec (0)
A 2		D	L	O	U	A2	DeLay	OUT	(S)	0/.4/1/2/5/15/30/60	Sec (0)
A 3		D	L	O	U	A3	DeLay	OUT	(S)	0/.4/1/2/5/15/30/60	Sec (0)
A 4		D	L	O	U	A4	DeLay	OUT	(S)	0/.4/1/2/5/15/30/60	Sec (0)
A 1		R	G	B	C	K	Alarm 1	RinGBaCK	(S)	NO/YES (NO)	
A 2		R	G	B	C	K	Alarm 2	RinGBaCK	(S)	NO/YES (NO)	
A 3		R	G	B	C	K	Alarm 3	RinGBaCK	(S)	NO/YES (NO)	
A 4		R	G	B	C	K	Alarm 4	RinGBaCK	(S)	NO/YES (NO)	
		I	N	P	U	T	INPUT	P	(H)	loop tag,block tag,output (null)	
		I	N	P	U	T	INPUT	D	(H)	loop tag,block tag,output (null)	
				E	S	N	Exec. Seq. No	(H)	001 to 250		

Alarm Types

HI compares the process input with the limit setting and it will trip the alarm status high (1) when the process is equal to or higher than the limit setting. The alarm status will clear (0) when the process is less than the limit setting minus the deadband.

LO compares the process input with the limit setting and it will trip the alarm status high (1) when the process is equal to or less than the limit setting. The alarm status will clear (0) when the process is greater than the limit setting plus the deadband.

HI DEV compares the difference between the process input and the deviation input (P-D) with the limit setting and it will trip the alarm status high (1) when (P-D) is equal to or greater than the limit setting. The alarm status will clear (0) when (P-D) is less than the limit setting minus the deadband.

LO DEV compares the difference between the deviation input and the process input (D-P) with the limit setting and it will trip the alarm status high (1) when (D-P) is equal to or greater than the limit setting. The alarm status will clear (0) when (D-P) is less than the limit setting minus the deadband.

DEV compares the absolute difference between the process input and the deviation input $|P-D|$ with the limit setting and it will trip the alarm status high (1) when $|P-D|$ is equal to or greater than the limit setting. The alarm status will clear (0) when $|P-D|$ is less than the limit setting minus the deadband.

OR compares the process input with the range limits referenced by the range pointer parameter and will trip the alarm status high (1) when the process is equal to or greater than the high limit or equal to or less than the low limit. The alarm status will clear (0) when the process is less than the high limit minus the deadband or greater than the low limit plus the deadband.

POWER UP - During a warm start, all alarms will be handled the same as during a hot start: outputs are initialized at the last state, all previously acknowledged alarms are treated as acknowledged, and any new alarms will be processed on the first scan cycle. On a cold start, all alarm outputs are initialized at 0, all alarms are reset and any new alarms, based on the block inputs, will be processed during the first scan cycle. Also, during a cold start, alarms will be enabled or disabled as determined by the PU ENable parameters.

Alarm Status

Alarm status is available with Modbus or Modbus/TCP Ethernet for alarm management at a remote location. The alarm status is available in coils. Detailed information can be found in Section 5 Network Communications.

An overview of a Loop alarm status coil definitions are shown below.

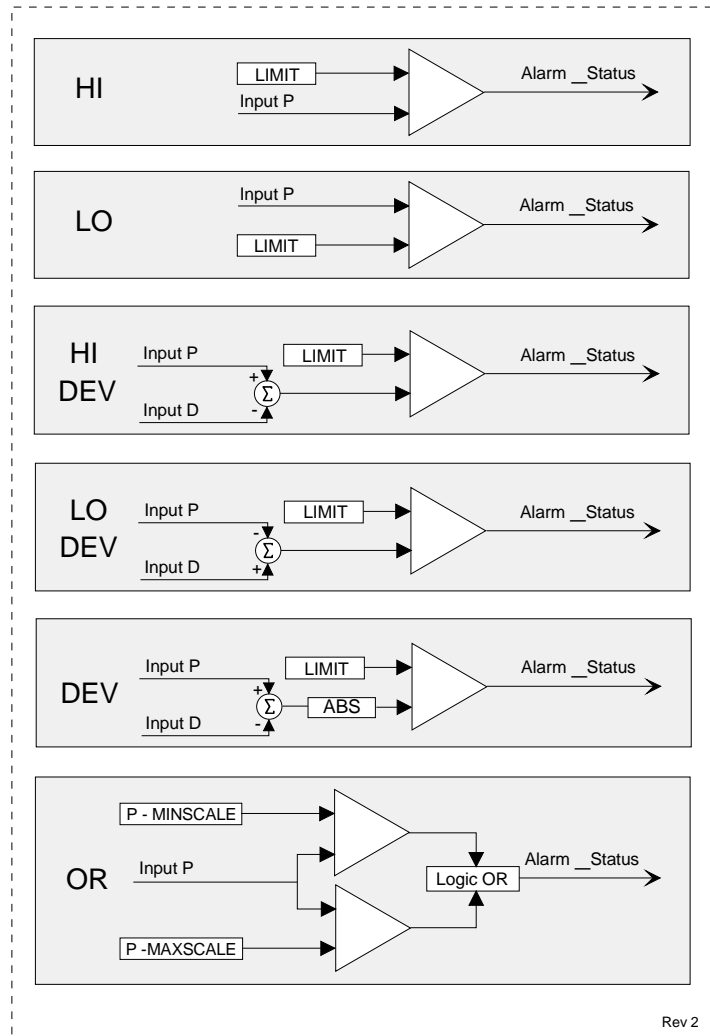

BLOCK DIAGRAM

L#A=1 when Loop # alarm__ is active
 L#N=1 when Loop # alarm__ is Not acknowledged
 L#E=1 when Loop # alarm__ is enabled (when the alarm is disabled the E, N, and A bits are set to 0)
 L#OS=1 indicates that all Loop # alarms are identified as Out of Service which means that all alarms function normally but the OS flag indicates to a higher level device that they can be ignored. OS cannot be set locally.

3.2.11 AND_ - AND Logic

AND_ function blocks perform a logical AND on the three inputs. Any unused input will be set high (1).

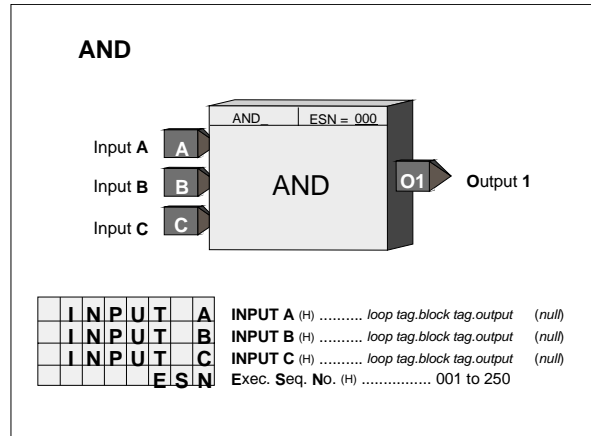
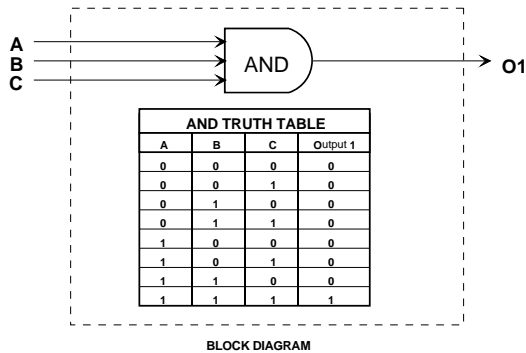

3.2.12 AOE_ - Analog Output- Ethernet

AOE_ function blocks are available and are assigned in sequence with each use, station wide. Up to 32 AOE blocks are available.

The range pointer parameter (Input R) enables the block to pass the range scaling to AIE function blocks in other Siemens 353 controllers connected over the Ethernet network.

Each AOE block is automatically assigned Modbus registers that can be accessed from any device having Modbus/TCP Ethernet capability. See Table 3-6 in Section 3.2.7 AIE_-Analog Input - Ethernet for a listing of these registers.

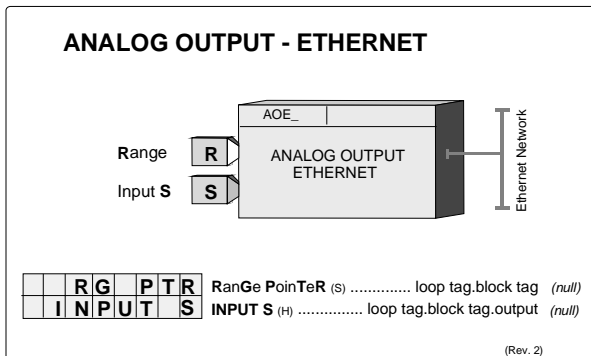

3.2.13 AOUT_ - Analog Outputs

AOUT_ function blocks convert function block interconnection signals, connected to input S, to a block output having a range of 4-20 mAdc. Input D can be used to disconnect the output from the load when asserted high (1). This feature is useful when two or more controllers are connected to a common load. When one controller is connected to the load, others are disconnected using the disconnect feature. The function block includes scaling to range the 4-20 mA output with the block input signal. The range pointer parameter (input R) tells the block where to obtain scaling information. If this parameter is not configured the block will use a range of 0.00 to 100.00.

Two analog output function blocks are available on the Controller Board and one additional on the Expander Board. Function block names and terminal identifications are listed below. The output is factory calibrated for 4-20 mAdc and should not require field calibration. However, field calibration can be performed if desired. The output is calibrated by adjusting the pulser until the desired output (i.e. 4.0 mA for zero) is obtained and then pressing the store button. A verify mode (CAL VIEW) is available during calibration that will show the 0-100% signal driving the output circuit in the numeric display as the pulser adjusts the output over the full range.

Output QS is the Quality Status output. It will go high if the output driver detects a high impedance or an open circuit. The alphanumeric will flash AOUT_.OC when an open circuit condition is detected. The QS output could also be used to switch to a second output circuit in a redundancy application.

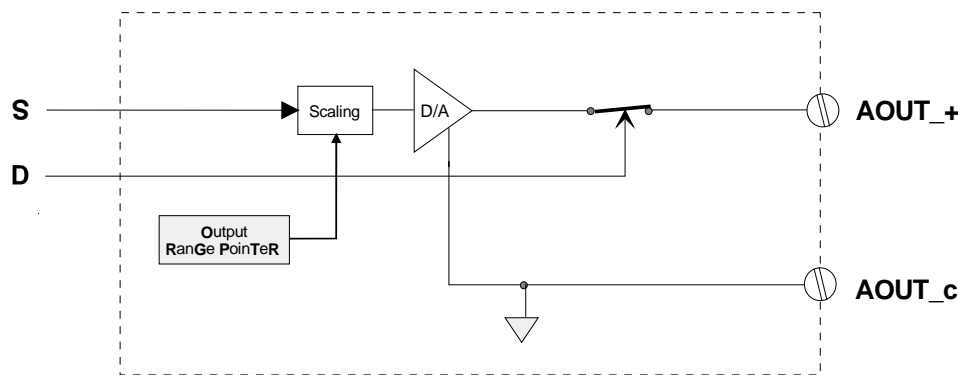
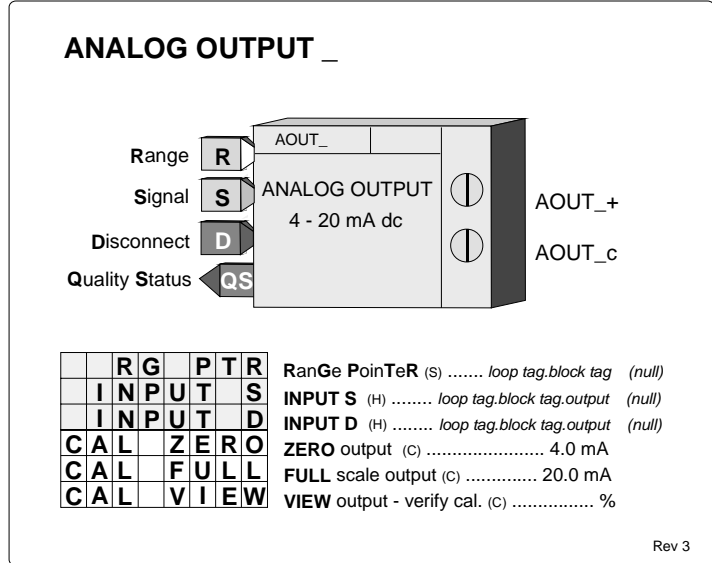

BLOCK DIAGM

3.2.14 ASN_ - ARCSINE

ASN__ function blocks accept an input between -1.0 and 1.0 and provide an output signal in radians of which the input is the sine.

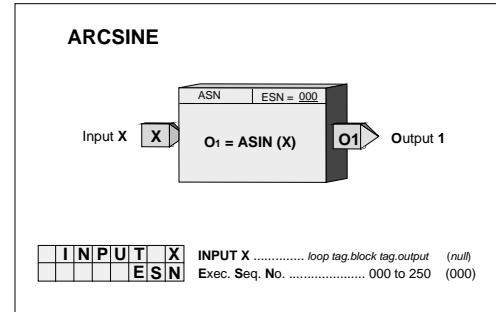
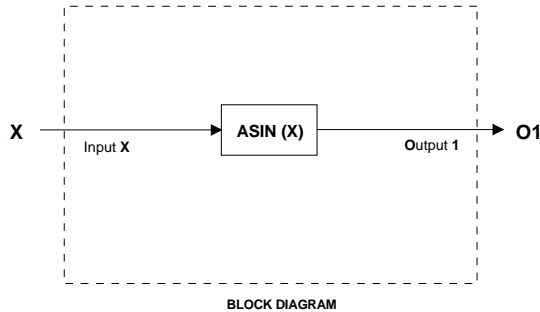

3.2.15 ATD_ - Analog Trend Display

ATD_ blocks can be used as needed in loops (up to a maximum of 5 per loop) to trend an analog variable connected to input A. The block can store up to 170 data points depending upon the use of the enable/disable function (see below). A trend can be displayed using Modbus commands. Data can be retrieved and displayed by a remote operator station that can retrieve, interpret, and display data packets from the station. A PC or i|station running i|warePC operator interface software can display trend data on a Loop Detail screen or Analog Detail screen.

Parameter TRND TYP allows data to be stored in one of two formats: the average over each sample time or the peak/peak values of the data over each sample time. All data is stored in a normalized form based on the value of the RG PTR (range pointer) input. The range information will be part of the data packet when retrieved over the network communications. When this input is unconfigured, a range of 0.0 - 100.0 will be used.

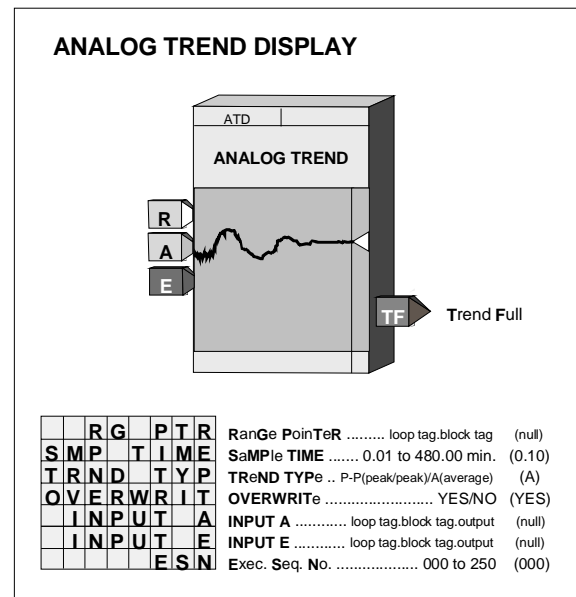

Several inputs can control the operation of the ATD function block. Input E (enable) can be used to enable the trend function when high (1) or unconfigured. Trend action can be disabled by setting E low (0). Each time the function block is enabled a new trend packet will be created.

The block also includes parameter OVERWRIT that, when set to YES, will cause the block to overwrite old data (i.e. circular file). When the parameter is set to NO, the block will stop trending when full and retain the data until reset. When the full state is reached, output TF (Trend Full) will go high (1). This function can be used to enable a second ATD block.

3.2.16 ATN_ - ARCTANGENT

ATN_ function blocks output a signal in radians of which the input is the tangent.

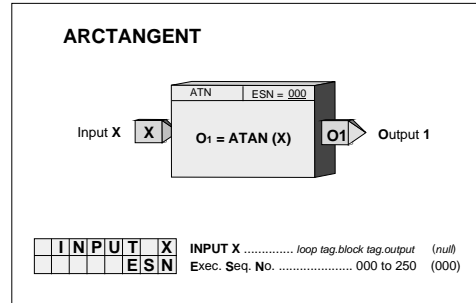
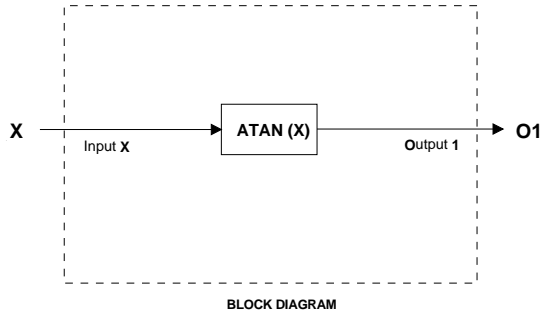

3.2.17 AWE_ - Analog Write Ethernet

AWE_ function blocks use Modbus command 16 “Preset Multiple Registers” to enable the controller to write analog data to other Modbus devices over the Ethernet network.

Up to 32 AWE_ blocks are available. Blocks are assigned in sequence (e.g. AWE01, AWE02, ...), controller wide, with each use.

Data can be written as a real floating-point number or as a 16-bit integer as configured by the DATA TYP parameter. A Floating point number can be selected to have one of four byte orders (BYTE ORD) with 1 being the most common (see Table 3-4 under AIE block description). An integer is converted from the block input S, which is a floating point number, by the MIN INT and MAX INT parameters using the range scaling information obtained from the source function block in the controller with the range pointer input R. Both Unsigned Integer (Uint) and Signed Integer (Sint) options are available. See the table listing parameters and default values below right.

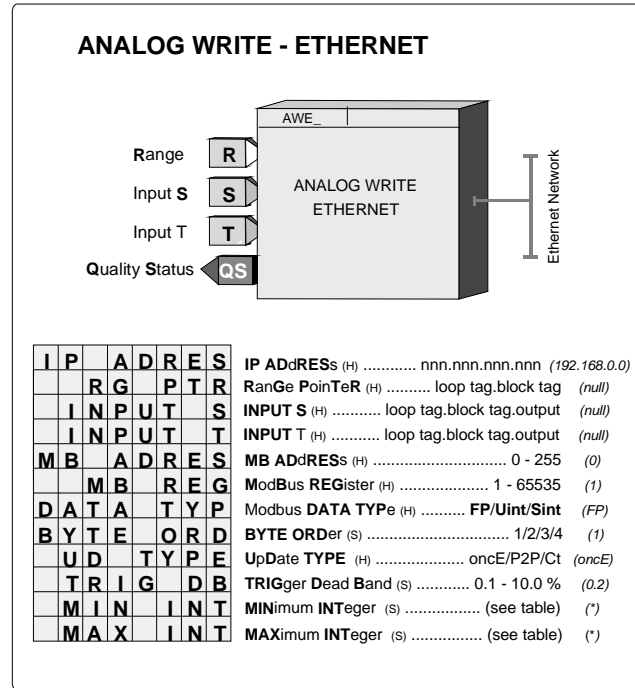

The IP ADRES parameter is used to configure the IP address of the destination Modbus device. The MB ADRES parameter allows a Modbus address to be configured. When connecting to other Siemens 353 controllers the Modbus address is set to 1. In some cases, other devices may use a different address or when going through a Modbus/TCP gateway a Modbus network may have multiple devices, each having a unique Modbus address.

Selection	Parameter	Default Value
Uint	MIN INT	0
Uint	MAX INT	65535
Sint	MIN INT	-32768
Sint	MAX INT	+32767

There are three write update options that can be configured by the UD TYPE parameter.

1. oncE will write once to the MB REG (Modbus Register). The controller will write when the input value changes by more than the value set with the TRIG DB parameter. This parameter is set based on a percentage of the range determined by the range pointer input R.
2. P2P will update at the controller peer to peer rate set in the ETHERNET block.
3. Ct will update at the cycle time of the controller.

The Ct option is normally only used when writing to I/O outputs in a PID control loop. Input T can be used to trigger a write. This would be used in cases where the oncE option has been selected, Input S does not change so as to trigger a write based on the trigger dead band, and there may be a concern that the receiving device has lost the value.

Output QS indicates the quality of the write operation and will go high (1) when the write is not completed successfully. This is normally associated with failure of the destination device to receive data due to a communication failure or a misconfiguration of the device.

3.2.18 BATOT - Batch Totalizer

BATOT function blocks can be used on a one per loop basis and integrate an analog input. Each provides an output signal representing a total integrated value over the time base selected. For example, if the time base is minutes and input A is 5.0 for 60 minutes, output TL would equal 300.0. The total can be displayed on the operator faceplate as <loop tag>.T if the configuration parameter DISP TOT is set to YES. A 6-character maximum name (e.g. GAL) is entered in configuration under TOT UNIT to identify the totalizer units.

Input S asserted high (1) will stop the integrator action. Input R will cause the integrator function to reset to the initial value (INIT VAL). These inputs do not affect the PuLse output. The integrator output is summed with the INITIAL VALue entered in configuration to provide the count total. The INIT VAL is used as the total when the BATOT is reset.

DIR ACT set to YES will cause the integrator to increase its output while NO will cause the integrator output to decrease. When INIT VAL is set to a predetermined batch amount, decreasing action will provide a count down counter. This is sometimes preferred since the count output then represents the amount remaining in a batch.

ZDO is used for setting a small positive value, insuring that the integrator will stop when the flow is shut off, which might not otherwise happen if a flowmeter zero is out of calibration.

The function block has two trip presets: PRESET 1 and PRESET 2. These can be set to cause a high output (1) from A1 or A2 when the count total equals or exceeds the preset values. The preset values, entered in configuration, can also be set using the QUICK button if the parameter QUICKSET has been set to YES. The QS DPP parameter allows fixing the decimal point during quickset to speed up changes to these settings. A parameter value with no decimal point position, the default, is for applications dealing with the totalizer count as whole units. An external preset can be used by providing an input to T1 and/or T2 and when used, the internal preset will be ignored. If an external preset is used, the value can be viewed but not changed in QUICKSET.

The action of the presets is also determined by the action setting of the integrator. When DIR ACT is set to YES the presets will be direct acting and will cause outputs A1 or A2 to go high when the integrated total is equal to or higher than the preset. If set to NO the total will cause A1 or A2 to go high when the total is equal to or lower than the preset. The actual preset value is available on outputs T1 and T2.

The function block can also provide a pulse output to drive a remote counter. The pulse output function integrates the input signal using the same time base and output pulses at a rate determined by the PUL SCAL configuration parameter. This parameter determines the change to the integrator total that must occur to cause a new output pulse. In the above example, if PUL SCAL equals 10, a total of 30 pulses will have occurred in the same time period. The PUL SCAL value is also the multiplier that would be used to read the exact value of gallons to a remote counter. The pulse output function operates on the absolute value of the analog input. When both negative and positive values are to be totalized, a CoMParator block can be used to sense the polarity of the analog input and the CMP output can then indicate a direction to the counter.

Be sure that the PUL SCAL setting does not require a pulse rate output greater than the scan cycle time of the controller under the maximum input conditions. Using the same example, if the maximum A input is 60.0 and the cycle time is 0.1 sec, the maximum required pulse rate is 0.1/sec. The condition is satisfied since the maximum

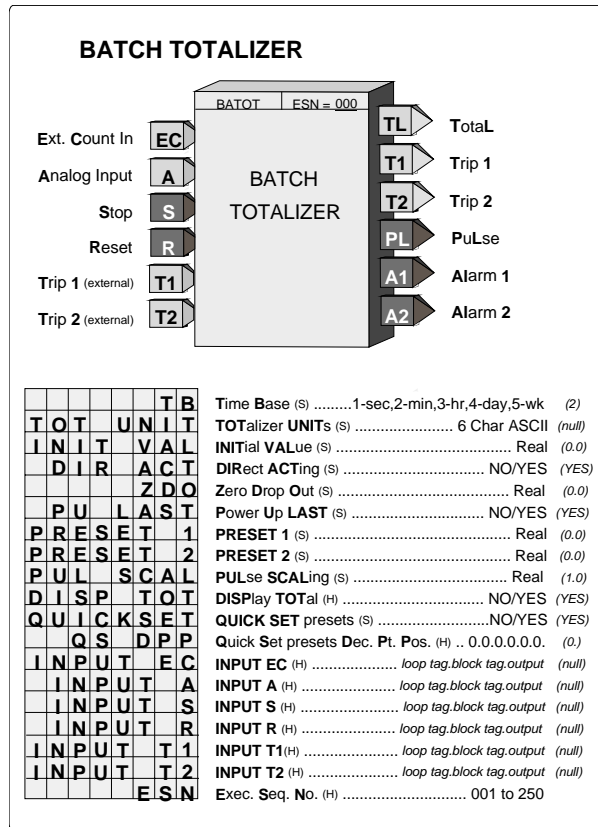

output requirement is less than the maximum pulse rate of 5/sec available with a 0.1 sec cycle time. The requirement would also be satisfied if a PUL SCAL of 1 was selected which would have required a maximum pulse rate of 1/sec.

POWER UP - During a warm start, if the configuration parameter PU LAST was set to YES, the integrator function will initialize with the last value prior to power down and all outputs will be initialized to the last value prior to power down. If set to NO, or during a cold start, the integrator and all outputs will initialize to 0.

Input EC allows the batch totalizer block to be used with another function block, such as the DINU that provides a count signal. When input A is not configured it will be set to (0.0). The EC input is summed with the initial value for use as the total. This value will now be displayed as the total on the operator faceplate and the presets will act on this value to provide outputs A1 and A2.

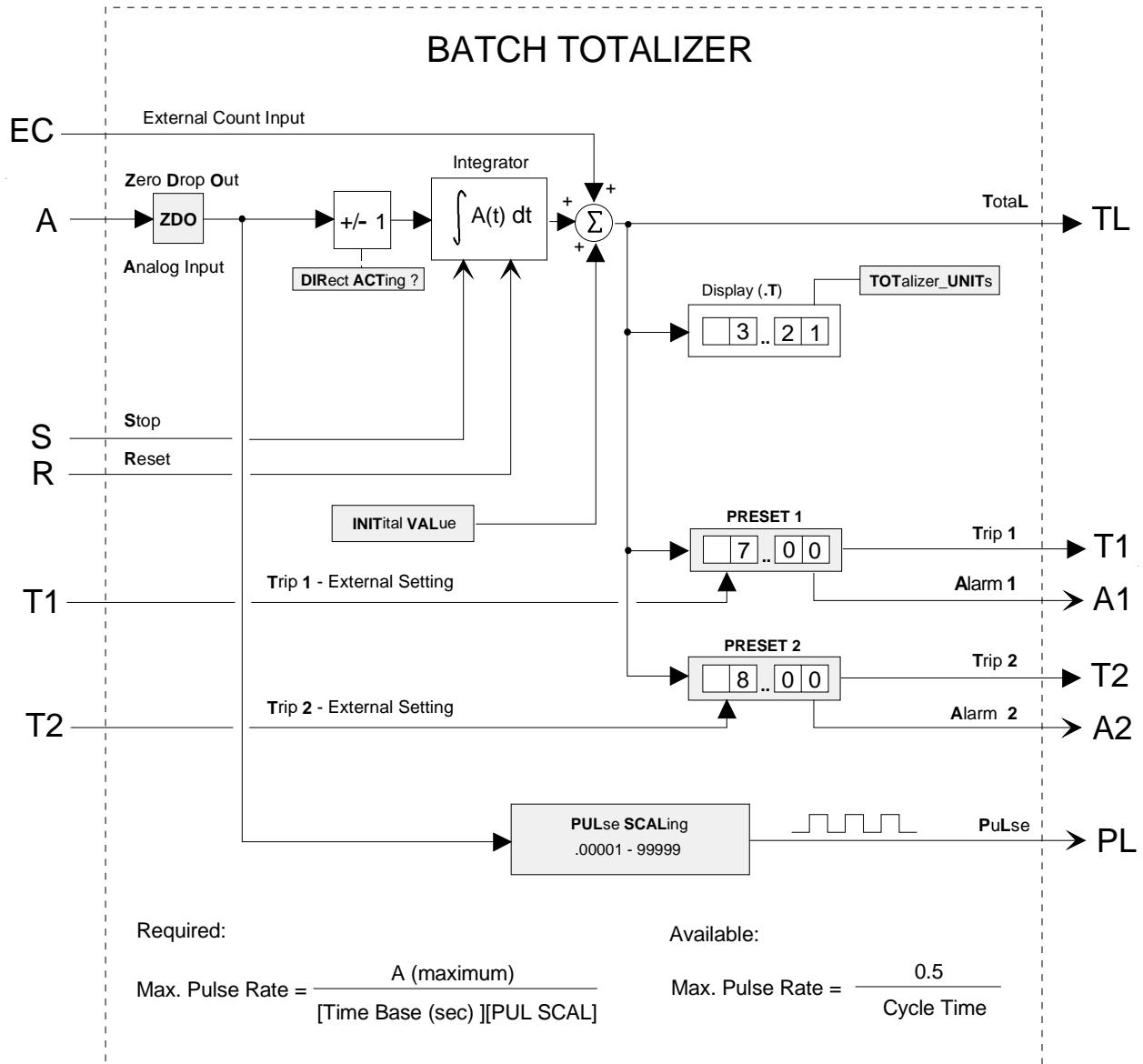

BLOCK DIAGRAM

Rev 2

3.2.19 BATSW - Batch Switch

BATSW function blocks can be used on a one per loop basis. Each is used with a PID function block to eliminate overshoot during startup conditions. When placed in the feedback path of the controller it causes the reset component of the controller to be reduced (if controller action is Rev). Without the use of a batch switch during startup, the controller output ($O1 = GE + R$) will equal full output since the reset will wind up. This requires the process to overshoot the setpoint in order to bring the controller output back down. With a batch switch in the feedback path, a lower reset value will be present when crossover occurs, thus reducing or eliminating overshoot.

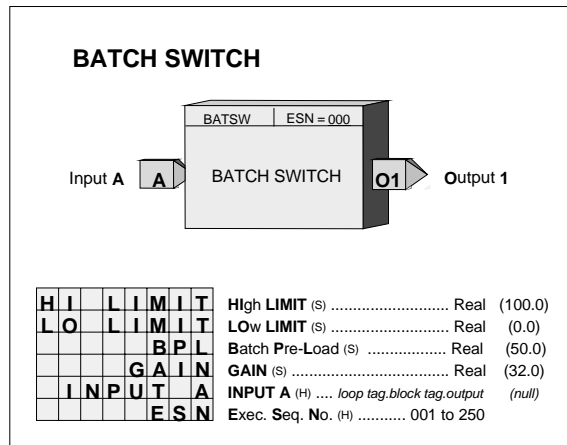

As input A equals or exceeds the HI or LO LIMIT setting, the output of the batch switch will be either decreased (HI LIMIT) or increased (LO LIMIT), changing the feedback signal and therefore the controller reset signal. This maintains controller output at the batch switch limit setting and eliminates reset windup.

If a controller has a large proportional gain setting, the reset can be modified too much, such that the process may under shoot the setpoint during a startup condition. The BPL (Batch Pre-Load) is adjusted to optimize the controller for startup conditions by limiting how much the batch switch can adjust the controller feedback signal.

When the controller output is within its normal operating output, the batch switch has no effect on the controller. This allows the controller to be tuned optimally for normal operating conditions and the batch switch to add additional compensation, very similar to derivative action, only during startup.

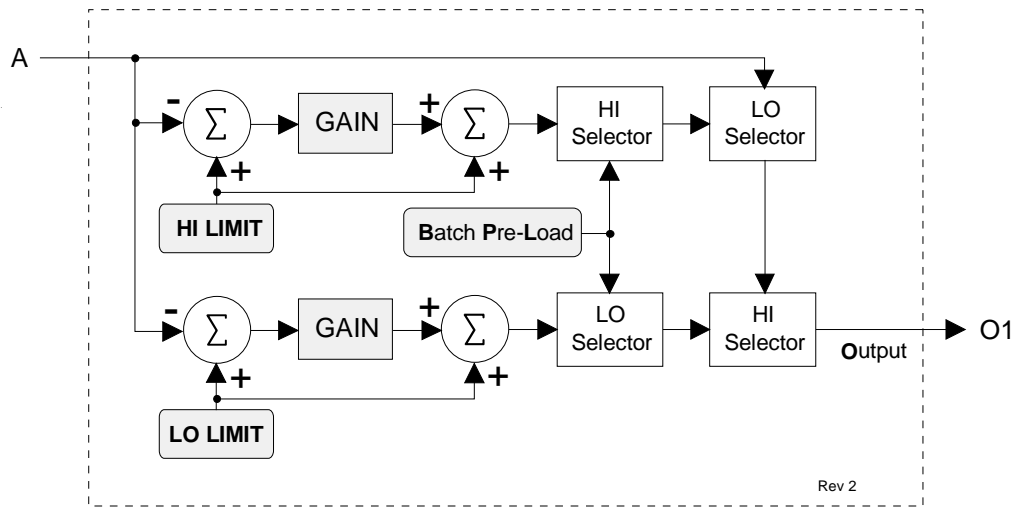

BLOCK DIAGRAM

3.2.20 BIAS - Bias

BIAS function blocks can be used on a one per loop basis and provide a means to bias a signal, such as the setpoint in an external set application. Inputs A and E (external bias) are summed and then added to the operator adjustable bias B.

Track Command input TC, asserted high (1), will cause the block output to track input TV and BIAS to be recalculated as $B = TV - (A+E)$. The value of B will be clamped at the HI and LO LIMIT settings. It is important to realize that the inputs and outputs are in engineering units and the limits must be adjusted accordingly with the expected minimum and maximum required range values. The default values have been set to -150.00 and +150.00, which might be the normal expected limits when using the default range of 0.0 to 100.0. These values can be set lower but have a maximum setting of +/-150% of the range pointer value. The default range is 0.00 to 100.00 if the pointer is not configured.

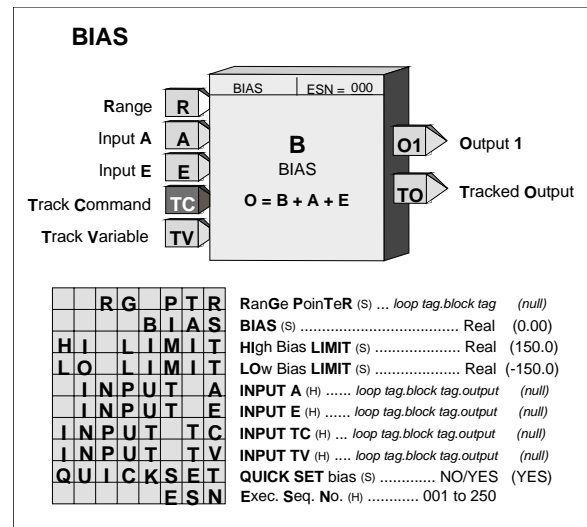

If, for example, the BIAS block is used to bias a flow setpoint with a range pointer (input R) of 0-6.00 GPM, the maximum bias adjustments would be +/-9.00. If limit adjustments of +/-50% of this range are desired, then the BIAS block LO LIMIT should be set at -3.00 and the HI LIMIT at +3.00. If a range change is made the current LIMIT settings and the current BIAS value will be changed to be the same % value within the new range.

The BIAS can be adjusted using the QUICKSET feature if the parameter QUICKSET is set to YES. The BIAS value will continuously change as the knob is adjusted but the STORE button must be pressed when the final value is reached to insure that the new BIAS setting will be retained on a Cold power up condition.

Any unused inputs to the block will be set equal to 0.

The TO (Tracked Output) is normally used in applications where an external device is being used to set a bias in place of the BIAS parameter (B is then set to 0.0). When it is desired to have the output of the BIAS block track the TV variable, the external device is forced to track TO. Input E will then equal $TV - [A+(0.0)]$ and, therefore, the BIAS block output O1 will equal TV.

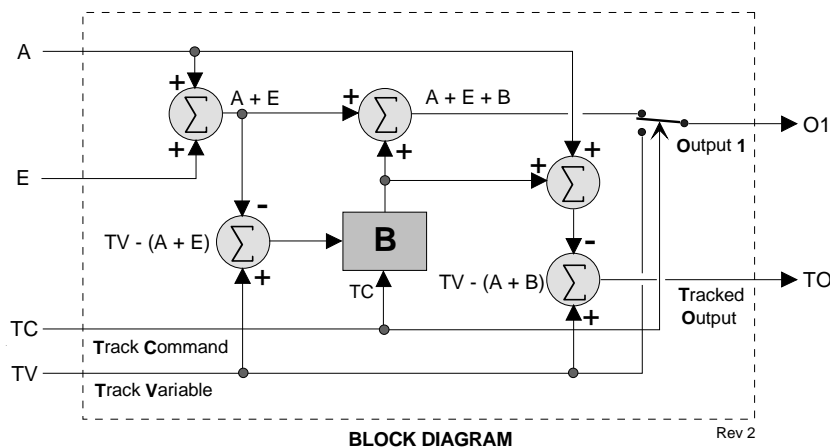

When a configuration containing the BIAS function block is edited in i/config and then downloaded to an on-line controller, the controller will ignore a change to the BIAS parameter value and continue to run with the pre-download value.

3.2.21 CIE_ - Coil Inputs - Ethernet

CIE_ function blocks use Modbus command 01 “Read Coil Status” to enable the controller to obtain Coil data from other stations over the Ethernet network.

Up to 32 CIE_ blocks are available. Blocks are assigned in sequence, controller wide, with each use. Up to 16 Coils can be obtained from a Modbus device. Each Coil is assigned to block outputs C0 – CF.

The IP ADRES parameter is used to configure the IP address of the source Modbus device. The MB ADRES parameter allows a Modbus address to be configured. When connecting to other Siemens 353 controllers, the Modbus address is set to 1. In some cases, other Modbus devices may use a different address or when going through a Modbus/TCP gateway a Modbus network may have multiple devices, each having a unique address.

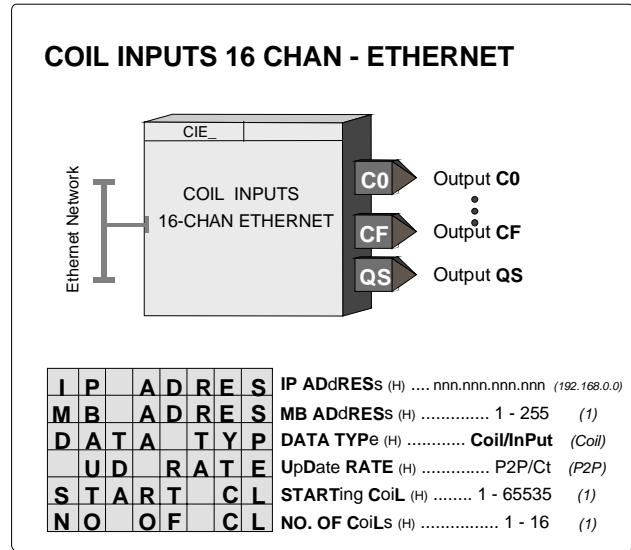

The START CL parameter identifies the location of the first Coil. Subsequent Coils, up to 16, can be obtained by setting the NO OF CL parameter to a value greater than 1. The DATA TYP parameter enables reading of Coils (Modbus Function Code 01) or Inputs (Modbus Function Code 02). Both are treated the same but the Coil type is the most common usage. The UD RATE parameter configures the rate at which the block will request data. The P2P setting will update the data at the rate set by the P2P RATE parameter in the ETHERNET block. The Ct setting will update the data at the cycle time of the controller.

Output QS indicates the quality of the received data and will go high (1) when the data is bad. This is normally associated with failure to receive data due to a communication failure or a misconfiguration of the source.

3.2.22 CHR_ - Characterizer

CHR_ function blocks provide 10 segments that can be used to characterize the X input signal. Individual segments are configured by entering the Xn, Yn and Xn+1, Yn+1 points for each segment. All Xn+1 points must be greater than the associated Xn points. Input X is in engineering units and the Y points should be in the engineering units desired for the characterizer output.

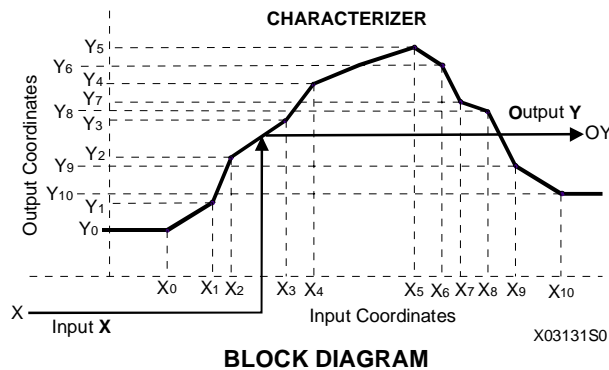

CHARACTERIZER

		X 0	Input Coordinate X0 (S)	Real	(0.0)
		X 1	Input Coordinate X1 (S)	Real	(10.0)
		X 2	Input Coordinate X2 (S)	Real	(20.0)
		X 3	Input Coordinate X3 (S)	Real	(30.0)
		X 4	Input Coordinate X4 (S)	Real	(40.0)
		X 5	Input Coordinate X5 (S)	Real	(50.0)
		X 6	Input Coordinate X6 (S)	Real	(60.0)
		X 7	Input Coordinate X7 (S)	Real	(70.0)
		X 8	Input Coordinate X8 (S)	Real	(80.0)
		X 9	Input Coordinate X9 (S)	Real	(90.0)
		X 10	Input Coordinate X10 (S)	Real	(100.0)
		Y 0	Output Coordinate Y0 (S)	Real	(0.0)
		Y 1	Output Coordinate Y1 (S)	Real	(10.0)
		Y 2	Output Coordinate Y2 (S)	Real	(20.0)
		Y 3	Output Coordinate Y3 (S)	Real	(30.0)
		Y 4	Output Coordinate Y4 (S)	Real	(40.0)
		Y 5	Output Coordinate Y5 (S)	Real	(50.0)
		Y 6	Output Coordinate Y6 (S)	Real	(60.0)
		Y 7	Output Coordinate Y7 (S)	Real	(70.0)
		Y 8	Output Coordinate Y8 (S)	Real	(80.0)
		Y 9	Output Coordinate Y9 (S)	Real	(90.0)
		Y 10	Output Coordinate Y10 (S)	Real	(100.0)
		INPUT X	INPUT X (H)	loop tag.block tag.output	(null)
		ESN	Exec. Seq. No. (H)	001 to 250	

3.2.23 CMP_ - Comparator

CMP_ function blocks compare analog input A with an external or internal limit setting and provide a high (1) output when the limit is exceeded.

ACTION - the CMP block can be configured as direct or reverse action. Direct action will cause the output to go high when input A is equal to or greater than the limit. Reverse action will cause the output to go high when input A is equal to or less than the limit.

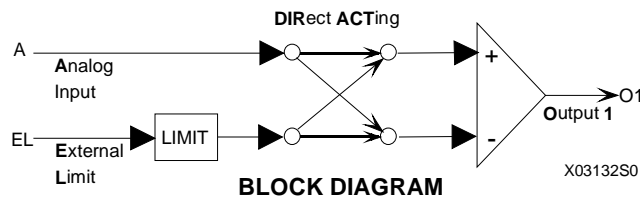

COMPARATOR

		LIMIT	Comparator LIMIT (S)	Real	(0.0)
		DBAND	Dead BAND (S)	Real	(0.5)
		DIRECT	DIRECT ACTing (S)	NO/YES	(YES)
		INPUT A	INPUT A (H)	loop tag.block tag.output	(null)
		INPUT EL	INPUT EL (H)	loop tag.block tag.output	(null)
		ESN	Exec. Seq. No. (H)	001 to 250	

DEAD BAND - the output will return from a high (1) output to a low (0) output when input A is less than the limit - Dead BAND setting for direct action or greater than the limit + Dead BAND for reverse action.

EXTERNAL LIMIT - When input EL is configured, the LIMIT setting will be ignored and the value of input EL will be used as the limit value.

3.2.24 COS_ - COSINE

COS_ function blocks accept radian inputs and output the cosine of that angle.

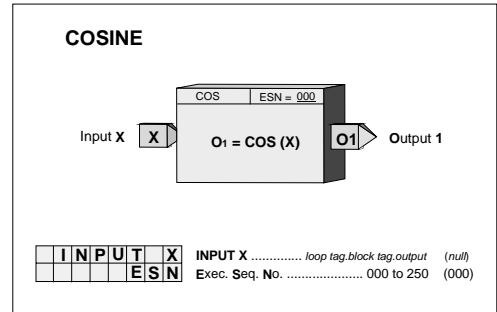
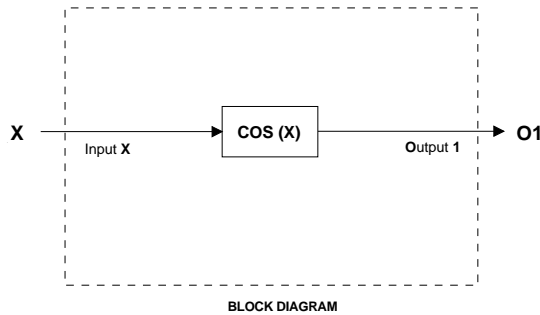

3.2.25 CWE_ - Coil Write Ethernet

CWE_ function blocks use Modbus command 15 “Force Multiple Coils” to enable the controller to write Coil data to other stations over the Ethernet network.

Up to 32 CWE_ blocks are available. Blocks are assigned in sequence, controller wide, with each use. Up to 16 ON/OFF block inputs, I0 to IF, can write to 16 consecutive coil locations in a destination Modbus device.

The IP ADRES parameter is used to configure the IP address of the destination Modbus device. The MB ADRES parameter allows a Modbus address to be configured. When connecting to other Siemens 353 controllers, the Modbus address is set to 1. In some cases, other Modbus devices may use a different address or when going through a Modbus/TCP gateway a Modbus network may have multiple devices, each having a unique address.

The START CL parameter identifies the location of the first Coil. The NO OF CL parameter identifies the total number of coils, up to 16, to write.

There are three write update options that can be configured by the UD TYPE parameter.

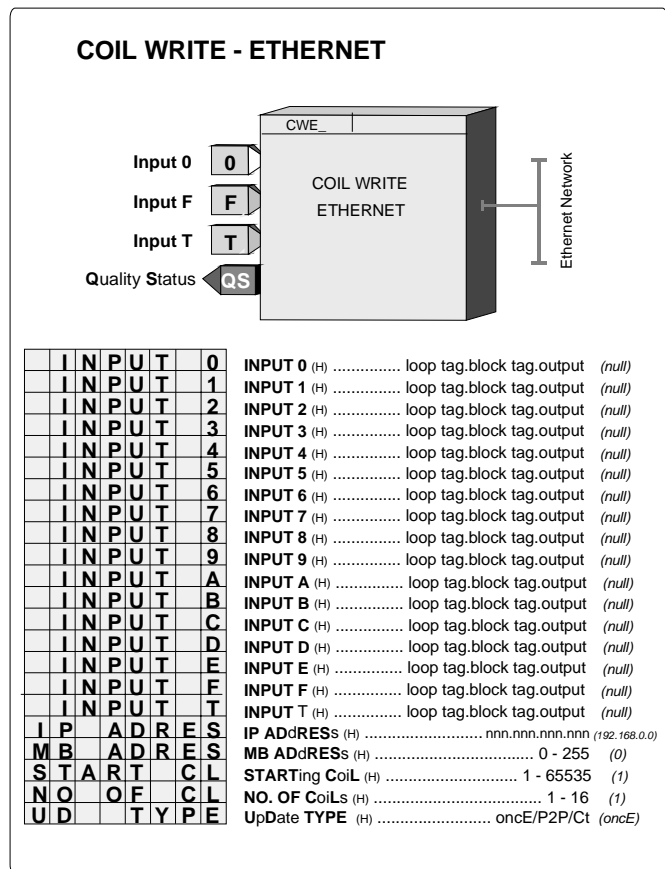

1. oncE will write once to the START CL (Modbus Starting Coil. The controller will write when any block input value changes state.
2. P2P will update at the controller peer to peer rate set in the ETHERNET block.
3. Ct will update at the cycle time of the controller.

The Ct option is normally only used when writing time critical changes. Input T can be used to trigger a write. This would be used in cases where the oncE option has been selected, input values do not change, and there may be a concern that the receiving device has lost the values.

Output QS indicates the quality of the write operation and will go high (1) when the write is not completed successfully. This is normally associated with failure of the destination device to receive data due to a communication failure or a misconfiguration of the device.

3.2.26 DAM_ - Deviation Amplifier

DAM_ function blocks compute the difference between inputs A and B, amplify the difference signal, and sum the resultant with an internal BIAS and an external signal at input C. Unused inputs are set to 0.0.

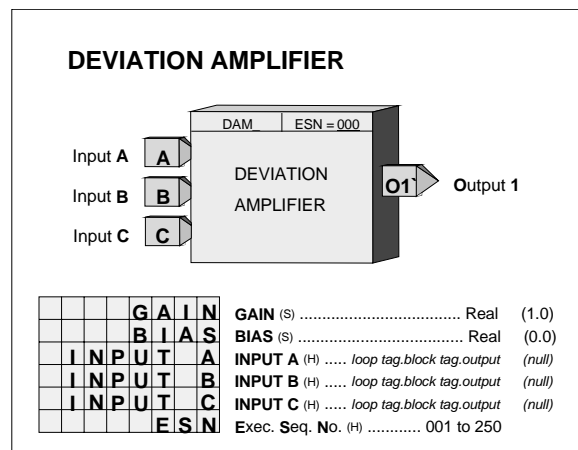
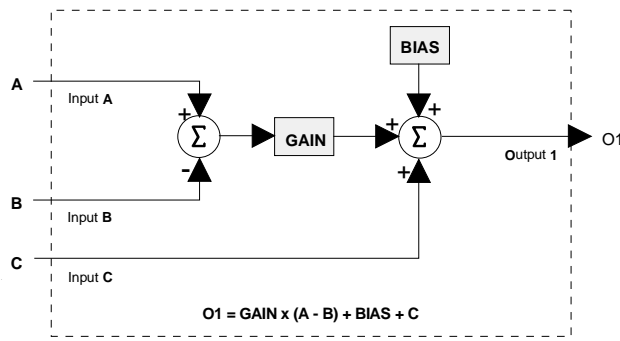

3.2.27 DIE_ - Digital Input - Ethernet

DIE_ function blocks use Modbus command 04 “Read Input Registers” to enable the controller to read digital data from other stations over the Ethernet network.

Up to 32 DIE_ blocks are available. Blocks are assigned in sequence, controller wide, with each use. Digital data is On/Off data packed into a 16-bit word. This data is fanned out to block outputs D0 – DF.

The IP ADRES parameter is used to configure the IP address of the source device. The MB ADRES parameter allows a Modbus address to be configured. When connecting to other Siemens 353 controllers, the Modbus address is set to 1. In some cases, other devices may use a different address or, when going through a Modbus/TCP gateway, a Modbus network may have multiple devices, each having a unique address.

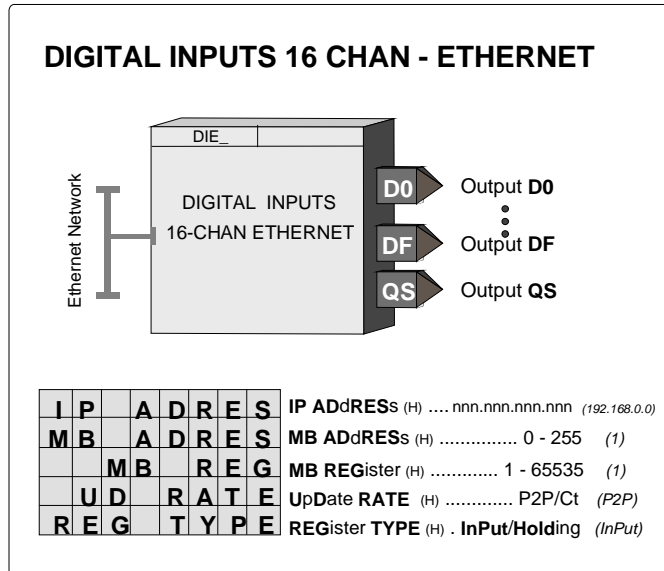

The MB REG parameter identifies the location of the digital data in the source device. The REG TYP parameter enables reading of Holding Registers (Modbus Function Code 03) or Input Registers (Modbus Function Code 04). Both are treated the same in most Modbus devices but the Input type is the most common usage. The use of DOE blocks in other Siemens 353 controllers as the input source is defined by using the Modbus Registers from the table below. The UD RATE parameter configures the rate at which the block will request data. The P2P setting will update the data at the rate set by the P2P RATE parameter in the ETHERNET block. The Ct setting will update the data at the cycle time of the controller.

Output QS indicates the quality of the received data and will go high (1) when the data is bad. This is normally associated with failure to receive data due to a communication failure or a misconfiguration of the source.

FB Number	MB Register	FB Number	MB Register	FB Number	MB Register	FB Number	MB Register
DOE01	31025	DOE09	31033	DOE17	31041	DOE25	31049
DOE02	31026	DOE10	31034	DOE18	31042	DOE26	31050
DOE03	31027	DOE11	31035	DOE19	31043	DOE27	31051
DOE04	31028	DOE12	31036	DOE20	31044	DOE28	31052
DOE05	31029	DOE13	31037	DOE21	31045	DOE29	31053
DOE06	31030	DOE14	31038	DOE22	31046	DOE30	31054
DOE07	31031	DOE15	31039	DOE23	31047	DOE31	31055
DOE08	31032	DOE16	31040	DOE24	31048	DOE32	31056

Note: Registers listed are Extended Modbus Registers. Not all Modbus devices support them

3.2.28 DIN_ - Digital Inputs

DIN_ function blocks can be used to sense a discrete signal from an external source and provide a block output representing the state of this signal. Blocks are available on the Controller Board and on the Expander Board. Function block names (IDs) and terminal designators are listed in Section 7.4 Electrical Installation.

The block output is high (1) when the input is on and low (0) when off.

Output QS indicates the quality status of the output signal O1 and will be high (1) when the output is of bad quality. Bad quality indicates any hardware failure of the input converter.

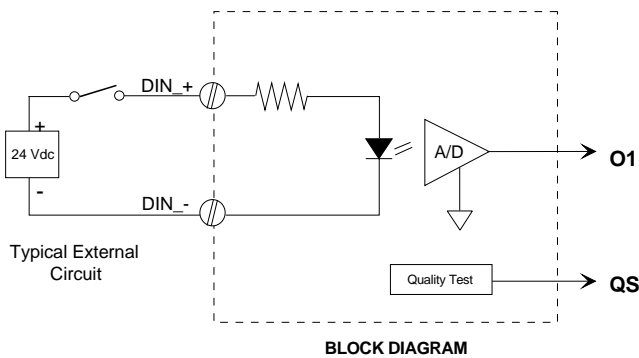
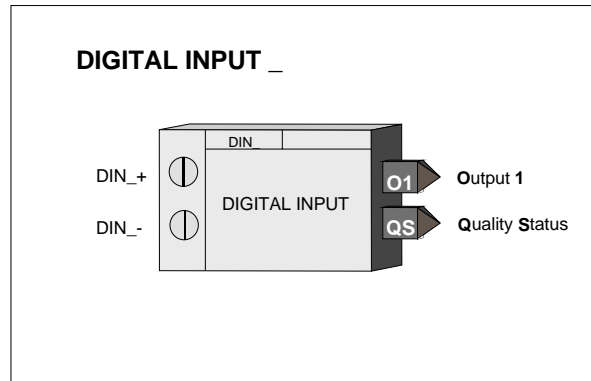

3.2.29 DINU_ - Digital Inputs, Universal

DINU_ blocks have multi-function capability:

- sensing a discrete input and providing a high (1) or low (0) output representing the state of the input
- totalizing and scaling the count of input pulses
- converting the rate of input pulses to a scaled analog frequency output

Two DINU_ blocks are available on the I/O expander board. The fixed names (IDs) of these blocks and their terminal designations are listed in Section 7.4 Electrical Installation.

Output CT represents the scaled (actual count x K) total of input pulses that occurred since the last reset. This output is a real number and can be used in a number of applications, such as a direct count input to the BAT batch totalizer function block or in math operations, such as computing the difference between counts in a ratio trim circuit.

Output IS is the current state of the input at the time the block is executed at the start of each controller scan cycle. It will be low (0) when the input is low and high (1) when the input is high.

Output SF is a scaled frequency (using the FREQ MIN and MAX parameters) that can represent flow rate, speed, or other transmitter variable that has a frequency signal. When the FREQ MAX parameter is set to 25 or less, a 20 msec contact debounce is used. When contact debounce is used, a pulse input must remain on for 20 msec to be recognized as a valid pulse. Output SF is linear with frequency and can be characterized using the CHR function block if necessary. An engineering range and units are assigned to this signal using the MINSCALE, MAXSCALE, DPP, and ENGUNITS parameters. They are available to other blocks using the OR output connection.

Input R resets output CT to 0.0. Input D controls the direction of the count. When direction input D is low (0), the count will move backwards, including negative values. The direction input feature enables the use of count down counters and it allows duplication of functions performed by previous computer pulse interfaces having a Pulse/Direction format. Input TC asserted high (1) will force the scaled count to track an external signal. This can be used in applications where the CT output is being used to set a value (e.g. setpoint) that can be changed from another source.

The quality status output QS indicates the quality of the block outputs and is high (1) when outputs CT, IS, or SF are of bad quality. Bad quality indicates a failure in the hardware conversion circuit.

POWER UP - With PU LAST set to YES, the CT output will power up at the last value during a hot or warm start. If set to NO, during a warm or a cold start, it will be set to 0.0. The digital filter will be temporarily bypassed during a hot, a warm or a cold start.

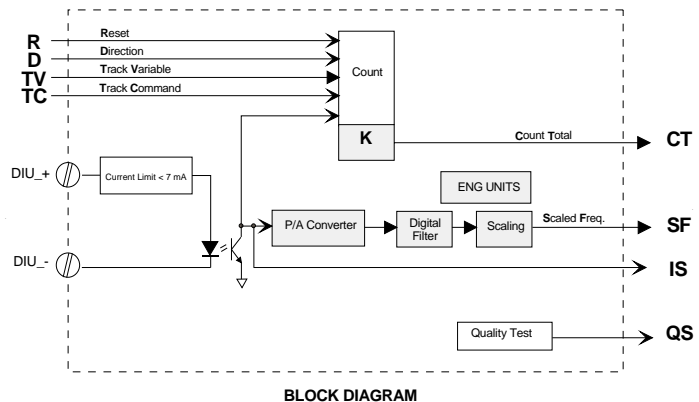
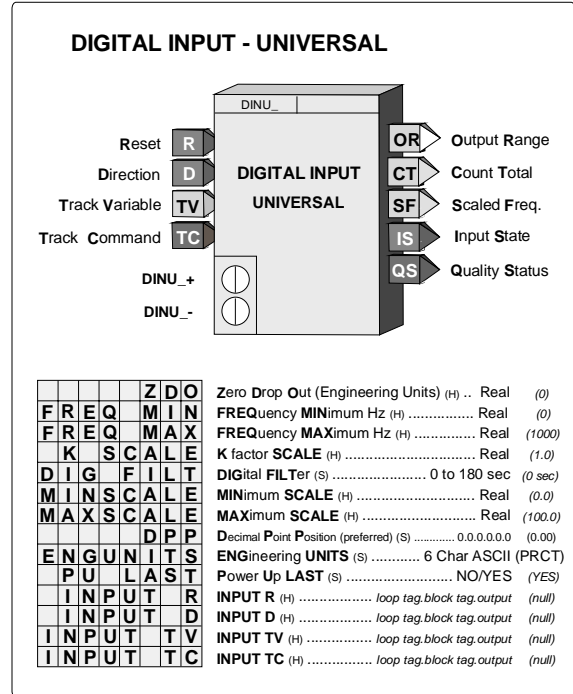

3.2.30 DIV_ - Division

DIV_ function blocks perform simple arithmetic division. The output will be the quotient of the two configured inputs N/D. The output will be limited to the maximum real number and, if the divisor is 0.0, the output will go to the maximum real number with the sign determined by the numerator. If the numerator is 0.0, the output will be 0.0.

Any unconfigured inputs will be set equal to 1.0.

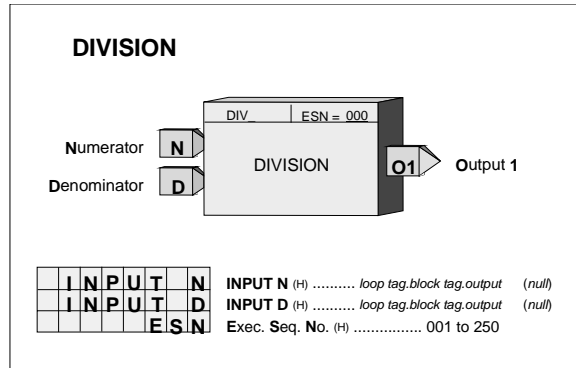
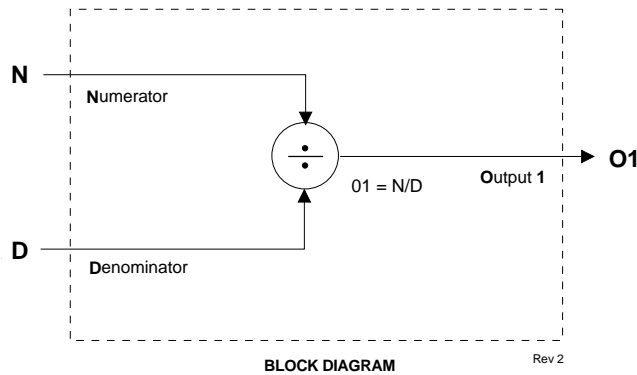

3.2.31 DNC_ - Divide by N Counter

DNC_ function blocks provide a single output pulse for a pre-selected number of input pulses. The output will go high (1) with a positive transition of the input P, edge triggered, and will return to a low (0) output on the succeeding positive transition.

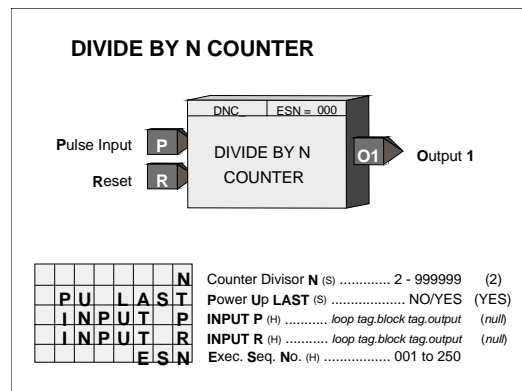
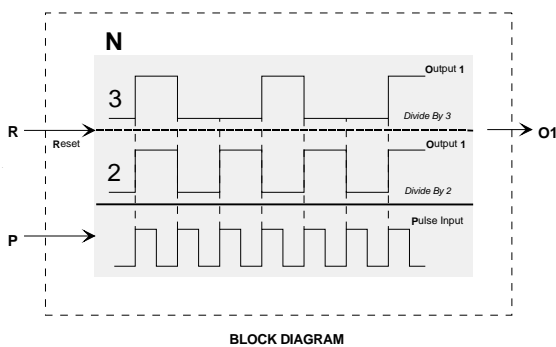

POWER UP - During a hot or a warm start, with **PU LAST** set to YES, the block will retain the last count and continue at the last input/output states. If set to NO, during a warm or a cold start, the output and count will be initialized to 0.

3.2.32 DOE_ - Digital Output - Ethernet

DOE_ function blocks are assigned in sequence with each use, station wide. Up to 32 blocks are available.

Up to 16 digital inputs can be configured. The block will pack inputs I0 - IF into a single integer word which can be accessed from another controller having Ethernet communication capability.

Each DOE block is automatically assigned Modbus registers that can be accessed from any device having Modbus/TCP Ethernet capability. See the DIE function block (Section 3.2.27) for a listing of these registers.

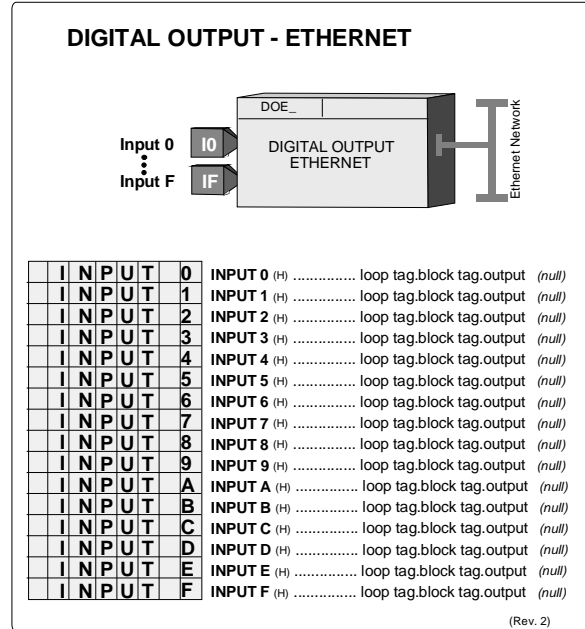

3.2.33 DOUT_ - Digital Outputs

DOUT_ function blocks are used to turn on remote devices powered from an external source. The negative terminal of the external power source must be connected to station common. The transistor switch will turn on when the block input S is high (1) and will turn off when low (0). Two digital output function blocks are available on the Controller Board.

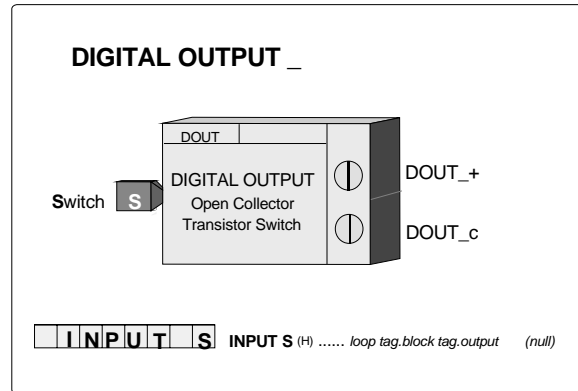
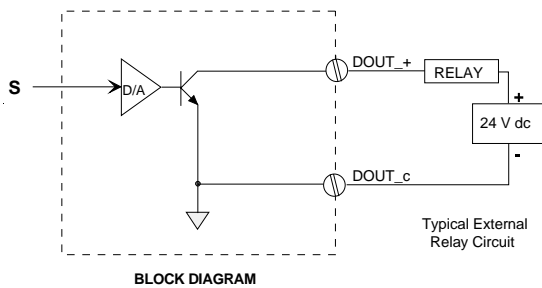

Terminal Connections:

DOUT1 ----- DOUT1+ (8) -- DOUT1c (9)

DOUT2 ----- DOUT2+ (10) -- DOUT2c (9)

3.2.34 DTM_ - Dead Time Table

DTM_ function blocks provide shift registers to hold the analog input signal A for a period of time and shift it from register to register to provide an overall delay between input and output as configured in parameter DEADTIME.

Input AT can be used to adapt the DEADTIME to an external signal. The actual shift register used as the block output will equal the whole value of input AT (e.g. 0.184 = register 0, 1.897 = register 1).

Output MA will provide the moving average of register 0 to the output register divided by the number of registers [e.g. output register = 50, MA = (R0+R1+R2+.....+R50)/51].

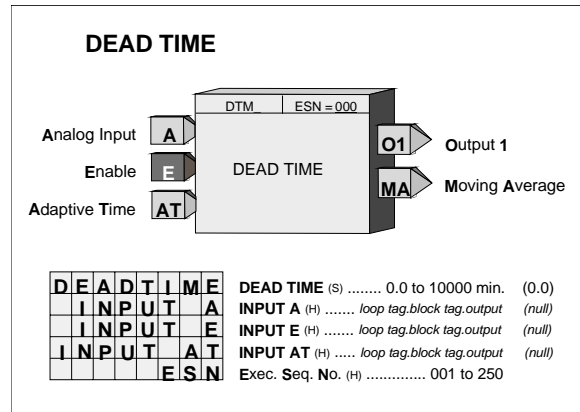

Input E asserted high (1) will enable the operation of the DTM block. When this input is not configured, it will be set high. A low (0) input will cause all registers and the outputs to equal the input A.

POWER UP - During a warm or cold start, all outputs will be initialized at 0 and all registers will be initialized to the value of the input on the first scan.

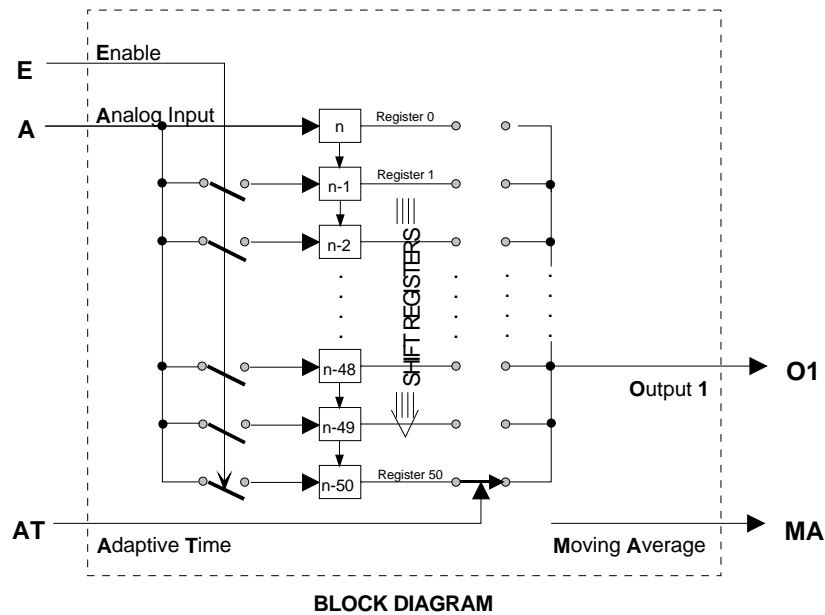

3.2.35 DWE_ - Digital Write Ethernet

DWE_ function blocks use Modbus command 16 “Preset Multiple Registers” to enable the controller to write a word, based on 16 discrete inputs to the function block, to other stations over the Ethernet network.

Up to 32 DWE_ blocks are available. Blocks are assigned in sequence, controller wide, with each use. Digital data is On/Off data packed into a 16-bit word.

The IP ADRES parameter is used to configure the IP address of the destination Modbus/TCP device. The MB ADRES parameter allows a Modbus address to be configured. When connecting to other Siemens controllers the Modbus address is set to 1. In some cases, other Modbus devices may use a different address or, when going through a Modbus/TCP gateway, a Modbus network may have multiple devices, each having a unique address. The MB REG parameter identifies the location of the register in the Modbus device.

There are three write update options that can be configured by the UD TYPE parameter.

1. oncE will write once to the START CL (Modbus Starting Coil. The controller will write when any block input value changes state.
2. P2P will update at the controller peer to peer rate set in the ETHERNET block.
3. Ct will update at the cycle time of the controller.

The Ct option is normally used only when writing time critical changes. Input T can be used to trigger a write. This would be used in cases where the oncE option has been selected, input values do not change, and there may be a concern that the receiving device has lost the values.

Output QS indicates the quality of the write operation and will go high (1) when the write is not completed successfully. This is normally associated with failure of the destination device to receive data due to a communication failure or a misconfiguration of the device.

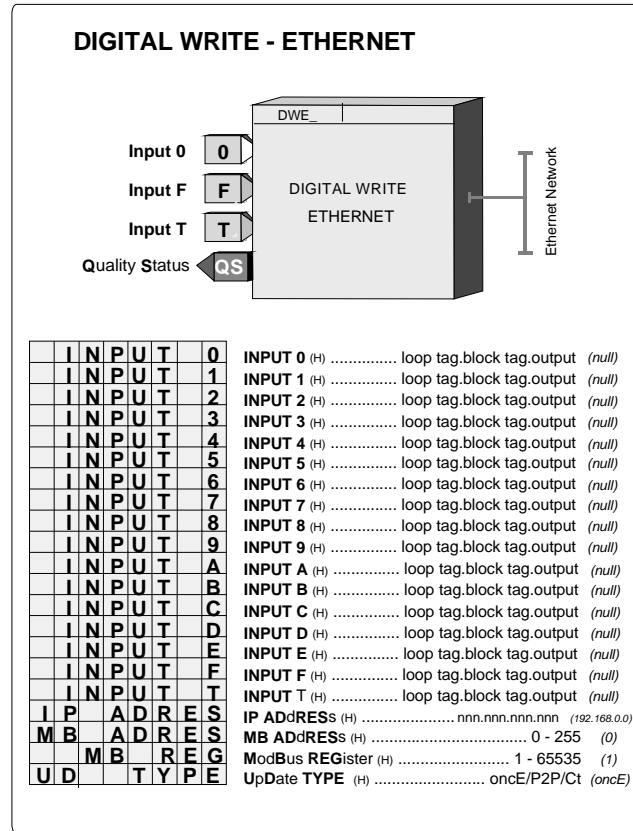

3.2.36 DYT_ - Delay Timer

DYT_ function blocks perform either an ON or OFF output delay as determined by the TYPE configuration parameter.

ON Delay - When input P is low (0), output O1 is low. If P goes high (1), the elapsed timer starts and sets O1 high upon reaching the DLY TIME, provided P is still high.

OFF Delay - When input P is high (1) the output is high. If P goes low (0), the elapsed timer starts and sets O1 low upon reaching the DLY TIME, provided P is still low.

The DLY TIME is adjustable over the full range of the display, which is 0.00000 to 999999. If the delay time is set to less than the scan time of the station, the delay time will equal the scan time.

Output ET (elapsed time) will ramp from 0.0 to the value of DLY TIME and remain there until P resets the output. Output RT (remaining time) equals DLY TIME - ET.

POWER UP - During a warm or a hot start, with PU LAST set to YES, the block will initialize with the input/output states and elapsed time in effect at the instant power down occurred. A cold start, with PU LAST set to NO, will initialize the input/output states and elapsed time to 0.

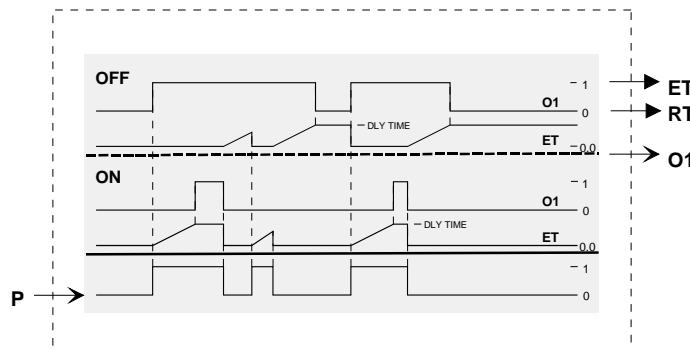
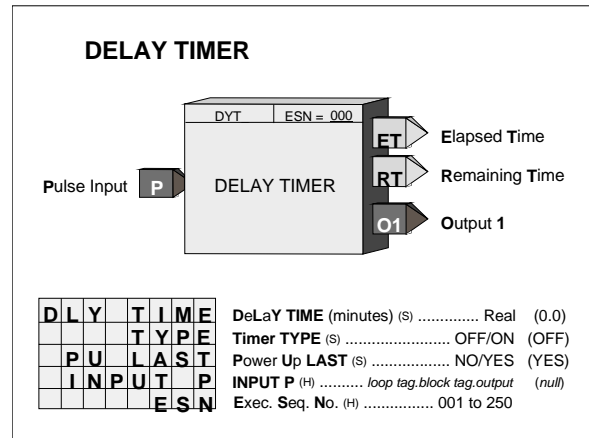

BLOCK DIAGRAM

3.2.37 E/I - External/Internal Transfer Switch

E/I function blocks can be used on a one per loop basis to select an analog signal, connected to input E (External) or input I (Internal), as a setpoint for the loop controller.

The position of the E/I switch can be changed on each positive transition of input ST and will normally be connected to the PS output of pushbutton block PB2SW, configured for momentary action. The SE output will normally be connected to the MD input of pushbutton block PB2SW. E/I switch position will be shown on the operator faceplate by a lighted LED: green for E, red for I.

The E/I switch position can also be changed by an operator HMI command over the Modbus RS485 or Modbus/TCP Ethernet networks.

When PU LAST is set to YES, the E/I switch will power up in the last position during a hot or a warm start. During a cold start, it will power up in the position set by the POWER UP parameter. If PU LAST is set to NO, the E/I switch will power up in the last position during a hot start, but during a warm or cold start will power up in the position set by the POWER UP parameter.

The IO (Internal Override) input enables a HI (1) input to temporarily select the Internal Input as the function block output O1. This input does not affect the position of the E/I switch.

Outputs SE and SI indicate the actual position of the E/I switch. SE is HI (1) when in the E position and LO (0) when in the I position. SI is HI when in the I position and LO when in the E position. Outputs IS and ES indicate the actual source of the block output. IS is HI when O1 is the Internal input and is LO when O1 is the External input. ES is HI when O1 is the External input and is LO when O1 is the Internal input.

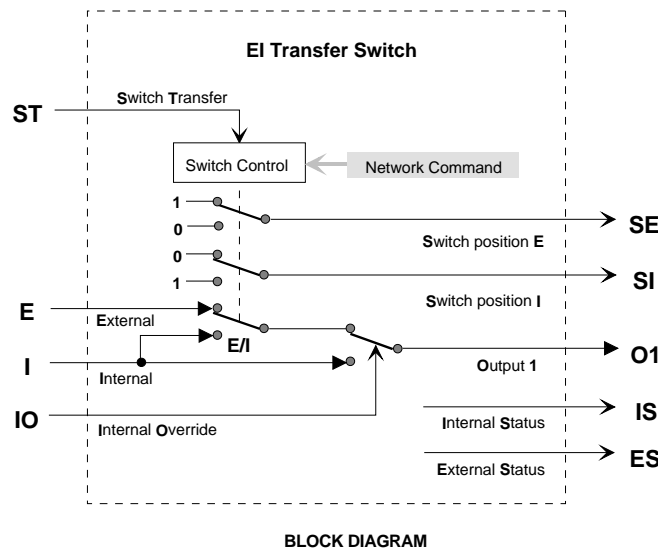
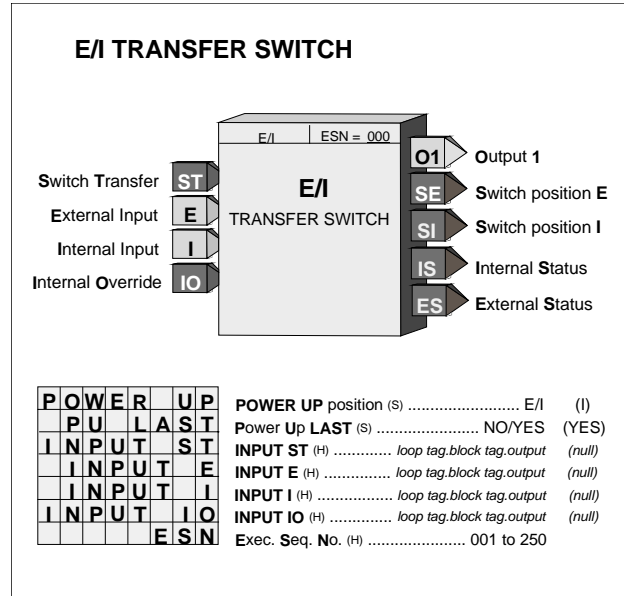

3.2.38 ESL - Events Sequence Logger

ESL function blocks can be used on a one per loop basis to log events within the loop. Each ESL input can be assigned a user tag (up to 8 ASCII characters) that will be displayed when viewing the logged events from the front panel. Events, once triggered by a positive transition 0>1 input, will remain in the logger until reset. Reset can be initiated either by setting input R high (this input is edge sensitive and will reset the events on the leading edge) or by entering configuration and setting the parameter RESET to YES.

Events logged to the ESL function block can be viewed at the operator faceplate by pressing the ACK pushbutton when displaying the loop containing an ESL function block having logged events. The alphanumeric display will first step through any active alarms, status conditions or errors and then all the logged events that occurred since the last reset. The configured 8-character name will be shown in the alphanumeric display and the order of occurrence (ESL-1, ESL-2...) will appear in the numeric display when stepping through the event log. Other events such as alarms, status conditions, or errors can be similarly viewed if logged to the ESL function block.

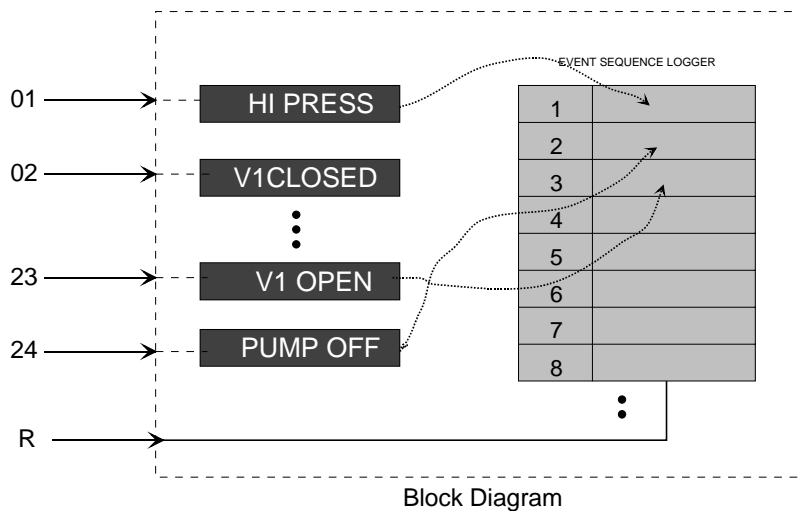
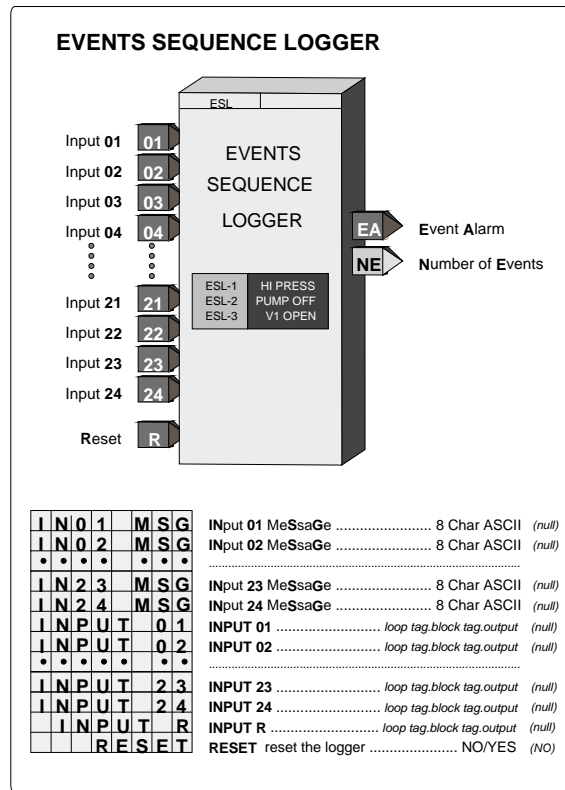

3.2.39 EXP_ - NATURAL EXPONENTIATION

EXP_ function blocks perform the natural exponentiation function, base “e”. The output will be the value “e” raised to the power of input X.

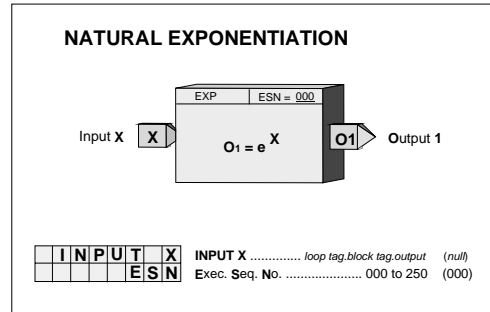
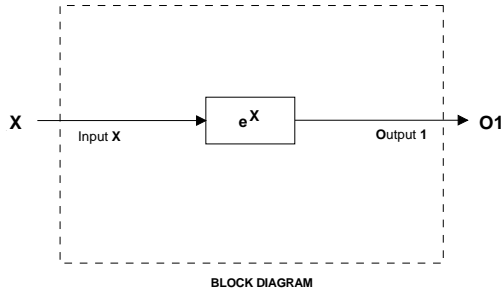

3.2.40 EXT_ - EXPONENTIATION

EXT_ function blocks will provide an output that equals the Y input raised to the power of X input. All negative values of input Y will be treated as 0.0. When input Y is 0.0 and X is negative, the output will be set to the maximum number (i.e. 1.17...e38).

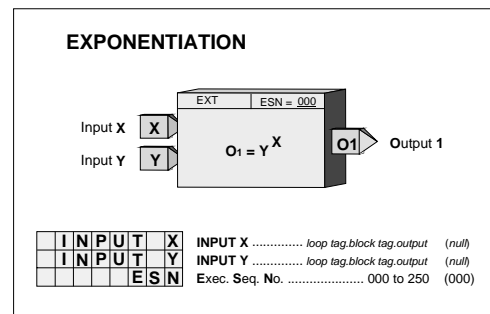
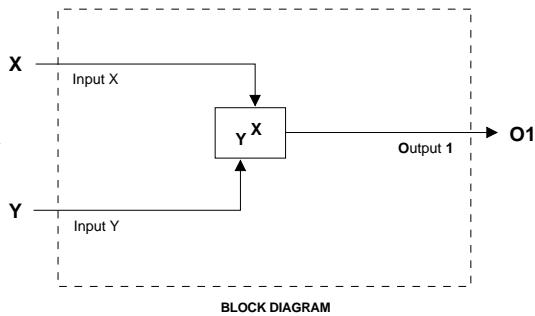

3.2.41 FTG_ - Falling Edge Trigger

FTG_ function blocks provide a high (1) output for one scan cycle each time input P transitions from a high (1) input to a low (0) input.

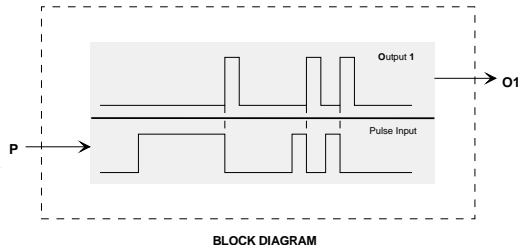

FALLING EDGE TRIGGER

I	N	P	P	E	S	N	INPUT P (H) loop tag.block tag.output (null) Exec. Seq. No. (H) 001 to 250
---	---	---	---	---	---	---	---

3.2.42 GB_ - Gain & Bias

GB_ function blocks provide action, gain, and bias adjustments to input signal A. Although this block can provide signal scaling, it should not be used if needed as a reference for a range pointer. The SCL function block should be used when scaling is required for this purpose.

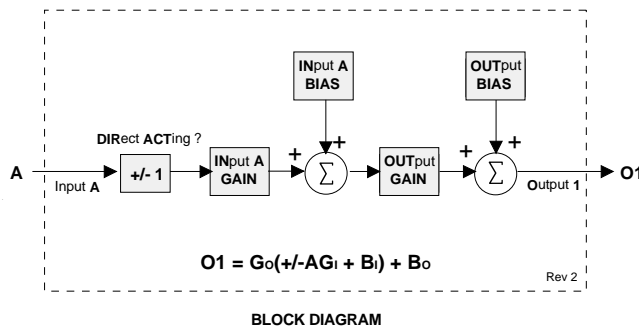

GAIN & BIAS

I	N	A	G	A	I	N	INPUT A GAIN (S) Real (1.0)
O	U	T	G	A	I	N	OUTput GAIN (S) Real (1.0)
I	N	A	B	I	A	S	INput A BIAS (S) Real (0.0)
O	U	T	B	I	A	S	OUTput BIAS (S) Real (0.0)
D	I	R	E	C	T	I	DIRect ACTing (S) NO/YES (YES)
I	N	P	U	T	A	E	INput A (H) loop tag.block tag.output (null)
I	N	P	U	T	A	E	Exec. Seq. No. (H) 001 to 250

3.2.43 HLD_ - Hold

HLD_ function blocks provide an output equal to the HOLD VAL set in configuration for interconnection to other function blocks.

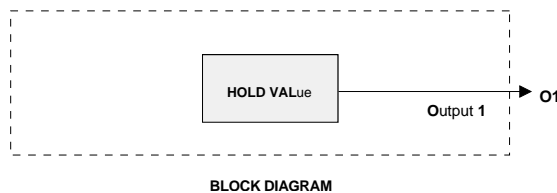

HOLD

H	O	L	D	V	A	L	HOLD VALue (S) Real (null)
---	---	---	---	---	---	---	----------------------------------

3.2.44 ID - ID Controller

ID is an integral only controller and one of five controller types that can be used on a one per loop basis. It uses external feedback to provide integral action and, therefore, allows interaction with other function blocks or external devices, such as pneumatic controllers and shutoff switches while eliminating windup that can occur with other controller types. Derivative action is provided when the parameter TD is non-zero.

When input A is high (1), the controller will operate in the normal auto mode and when low (0) will cause the output of the lag function to track the feedback signal. This will cause the controller output to track the feedback within the limits. When the controller is switched back to auto, the value at the input of the lag (GE+FB), if the GE is non-zero, will cause the output to integrate to a new output at the TI time constant.

The process range pointer parameter points to a function block that has range scaling, such as the analog input that is providing the process variable signal. This enables the controller to normalize the tuning parameters for the range of the process input. If this parameter is not configured, the controller will use a range scaling of 0.00 - 100.00.

POWER UP - During a warm or cold start, the output will be initialized to the value of the MINSCALE parameter and all dynamic states will be initialized to their current input value on the first scan cycle.

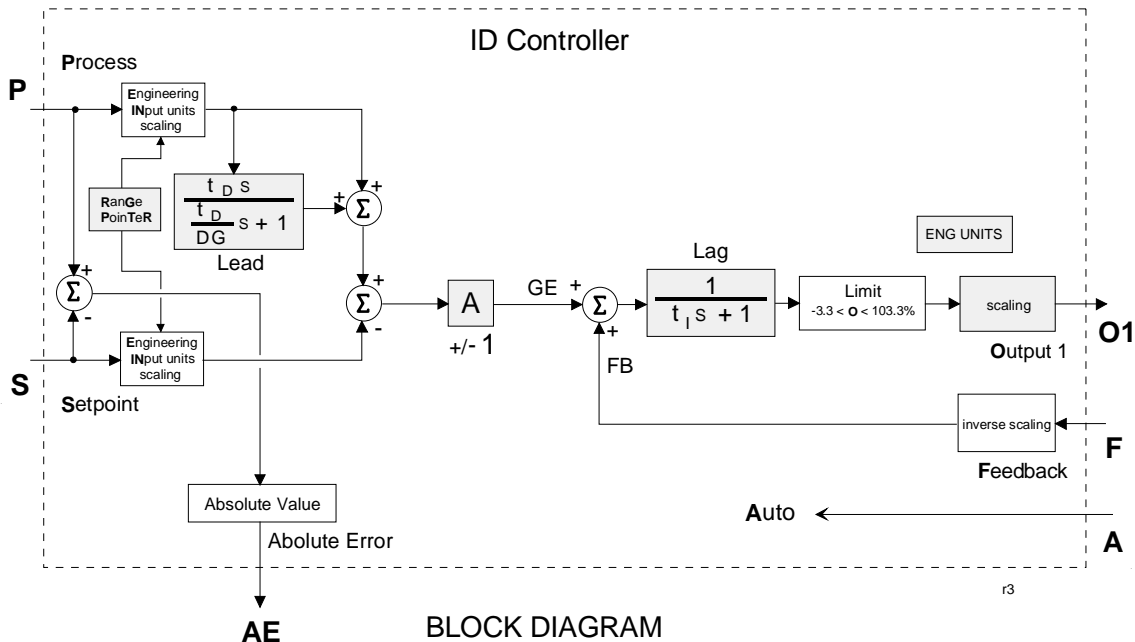
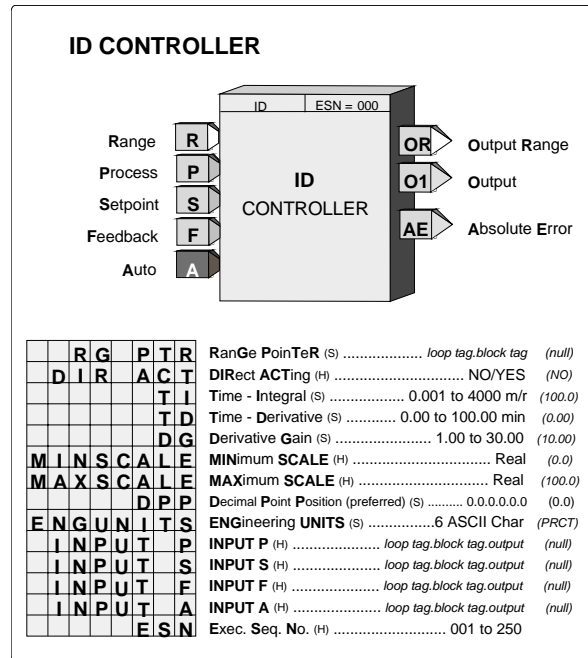

3.2.45 LL_ - Lead/Lag

LL_ function blocks provide both lead and lag functions. The block can function as lag only by setting the TLEAD time to 0.0. The lag function is always active and has a minimum setting of 0.01 minutes.

Input E asserted high (1) will enable the Lead/Lag function. When asserted low (0), the Lead/Lag function will be bypassed and the output will be set equal to the input. If input E is not configured, the block will be enabled.

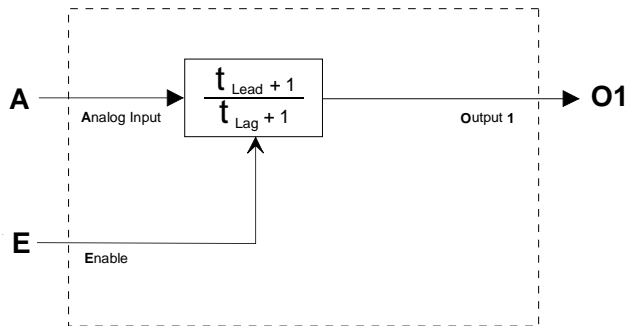

BLOCK DIAGRAM

POWER UP - During a warm or cold start, the dynamic elements and the output will be initialized to the value of the current input on the first scan.

LEAD/LAG

				T	L	A	G	Time - LAG (min) (S)	0.01 - 10000.0	(0.10)
				T	L	E	A	Time - LEAD (min) (S)	0.00 - 10000.0	(0.00)
				I	N	P	A	INPUT A (H)	loop tag.block tag.output	(null)
				I	N	P	E	INPUT E (H)	loop tag.block tag.output	(null)
				E	S	N		Exec. Seq. No. (H)	001 to 250	

3.2.46 LMT_ - Limit

LMT_ function blocks are used to limit a real signal. Input A will normally pass through the function block to the output O1. If the input exceeds one of the limits, the block will output the limit value.

If the HI LIMIT is set lower than the LO LIMIT, the block will output the high limit value. The output statuses will be high (1) when the block is in a limit condition.

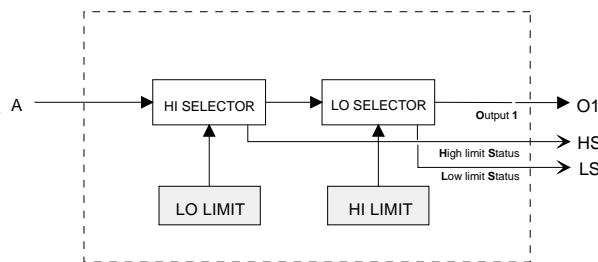

BLOCK DIAGRAM

LIMIT

				H	I	L	I	M	I	T	High LIMIT (S)	Real	(100.00)
				L	O	L	I	M	I	T	Low LIMIT (S)	Real	(0.00)
				I	N	P	U	T	A		INPUT A (H)	loop tag.block tag.output	(null)
				E	S	N					Exec. Seq. No. (H)	001 to 250	

3.2.47 LN_ - NATURAL LOGARITHM

LN_ function blocks will output the natural logarithm of input X. When the input is ≤ 0.0 , the input will be treated as the smallest number greater than 0.0 (i.e. $1.17 \dots e-38$) and the LN will be computed accordingly.

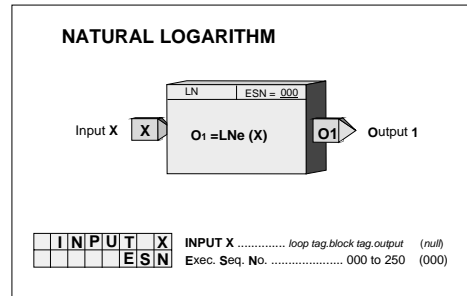
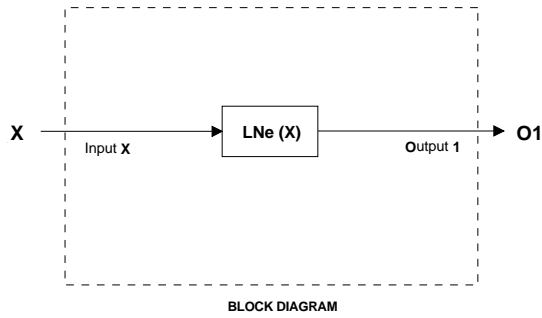

3.2.48 LOG_ - LOGARITHM BASE 10

LOG_ function blocks will output the logarithm to the base 10 of input X. When the input is ≤ 0.0 , the input will be treated as the smallest number greater than 0.0 (i.e. $1.17 \dots e-38$) and the LOG will be computed accordingly.

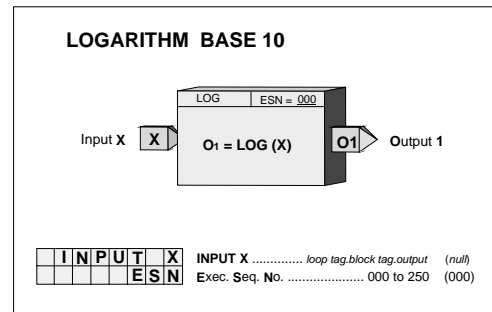
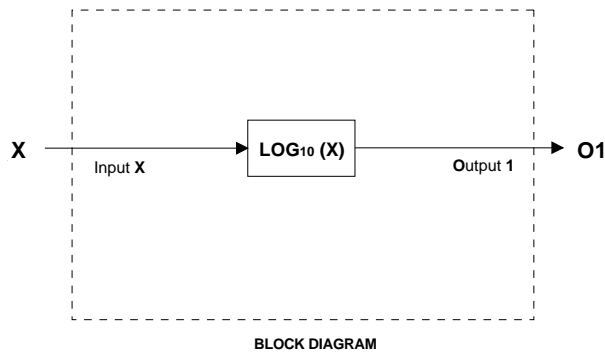

3.2.49 MTH_ - Math

MTH_ function blocks provide universal arithmetic capability. As shown in the block diagram, each input has gain and bias scaling. The resulting signals are then applied to configurable math operations (DIV, MUL, ADD and SUB). Operation A will be performed first on inputs A and B. Operation B will be performed next on the resultant and input C.

Unused inputs to a MUL or DIV operation will be set to 1.0 and those to an ADD or SUB operation will be set equal to 0.0. The operation of those inputs will function normally so it is important to insure that the bias and gain settings are set properly.

In a DIV operation, when a divisor is 0.0 the output will go to the maximum Real number with the sign determined by the numerator. If the numerator is 0 the output will be 0.

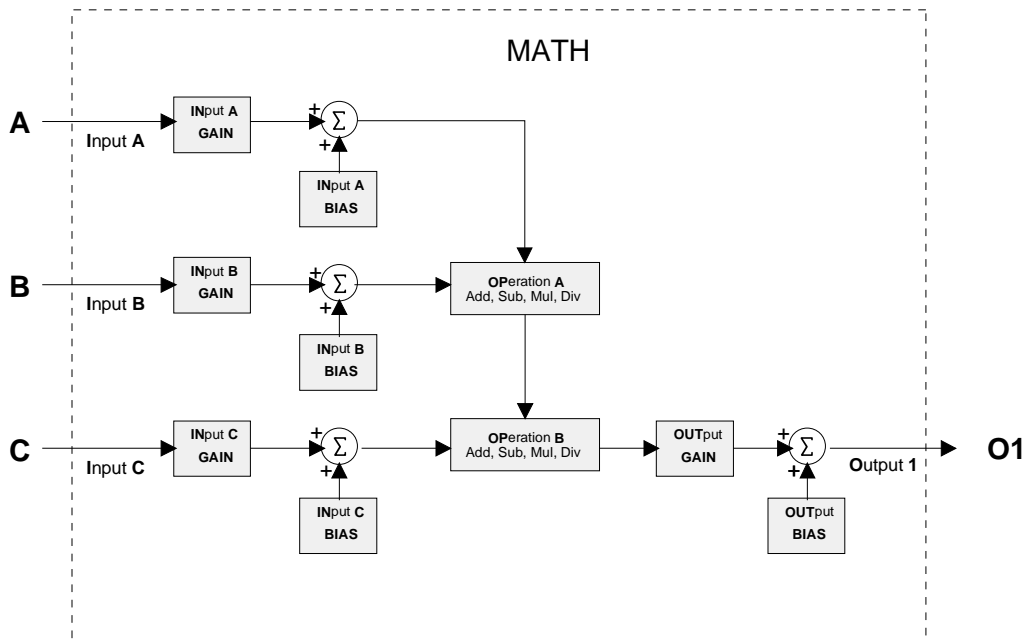
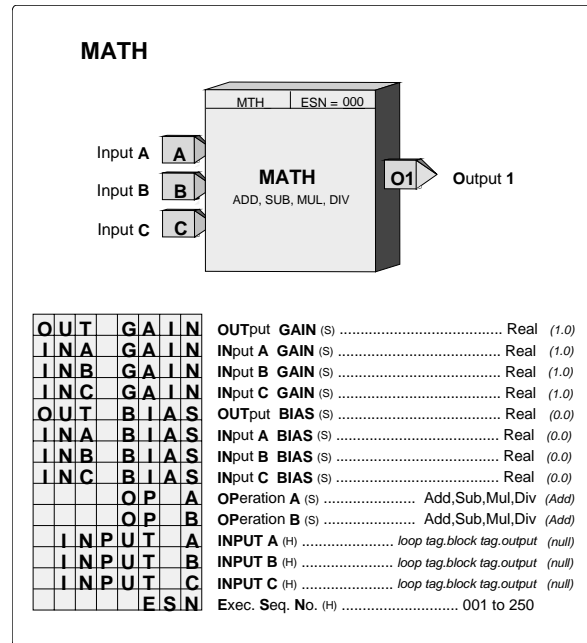

BLOCK DIAGRAM

Rev2

3.2.50 MUL_ - Multiplication

MUL_ function blocks perform arithmetic multiplication on the three input signals. Any unused input will be set to 1.0 and will therefore have no affect on the output.

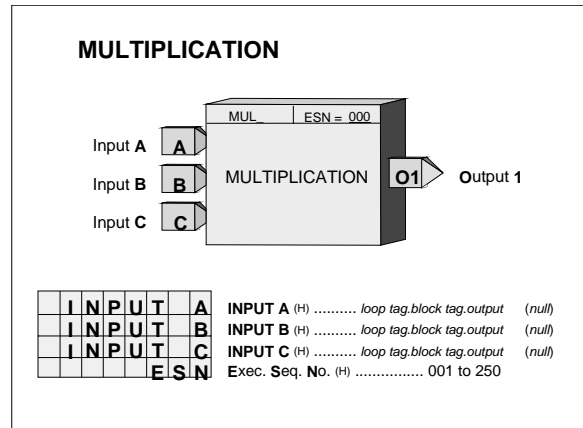
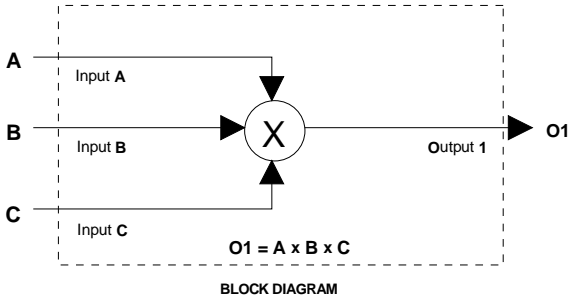

3.2.51 NND_ - NAND Logic

NND_ function blocks perform a logical NAND on the three inputs. Any unused input will be set high (1).

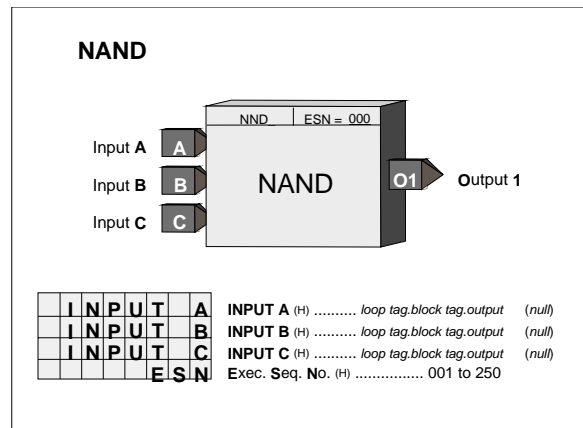
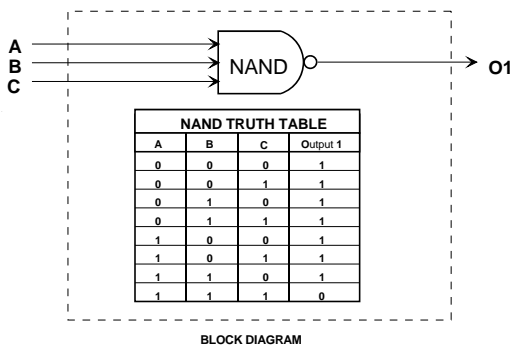

3.2.52 NOR_ - NOR Logic

NOR_ function blocks perform a logical NOR on the three inputs. Any unused input will be set low (0).

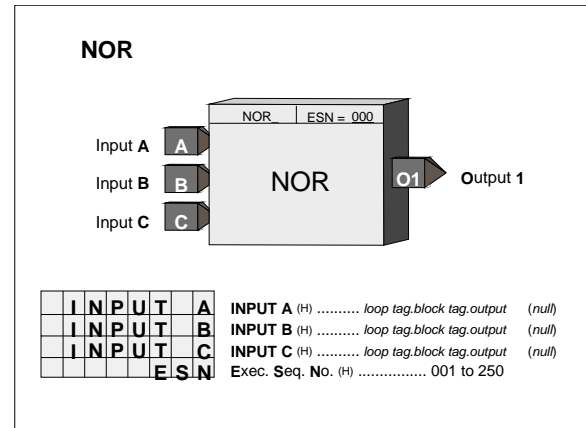
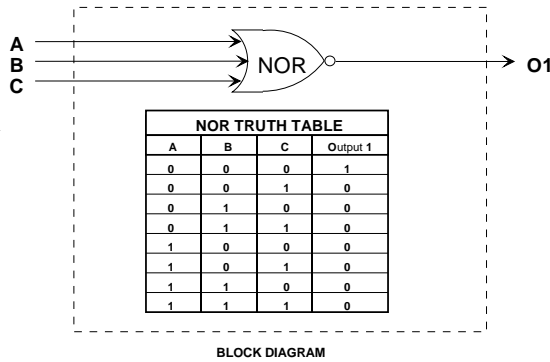

3.2.53 NOT_ - NOT Logic

NOT_ function blocks perform a logical NOT on input A. Any unused input will be set low (0).

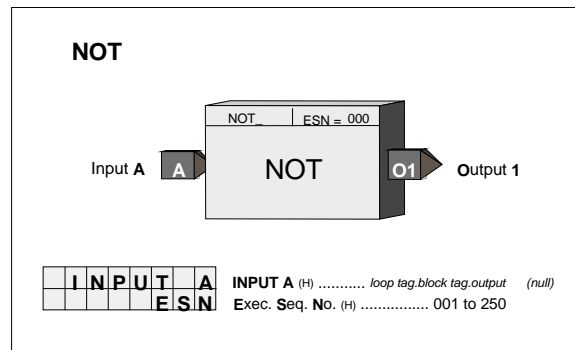
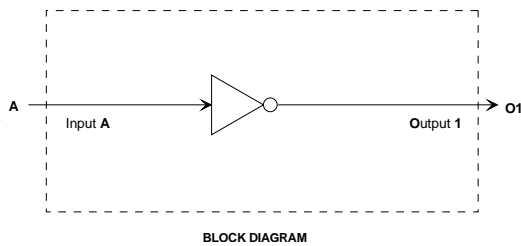

3.2.54 ODA - Operator Display for Analog Indication & Alarming

ODA blocks are one of five operator displays that are used on a one per loop basis to configure the local operator display functions and network parameters. See the i|ware PC faceplate on the next page.

The block will display up to four process variables P1 to P4 in both analog bargraph and digital form. Two alarms are associated with each process variable. They can be configured as HI or LO alarms. Each alarm function has associated block outputs that are high (1) when the alarm is active. Output LE is high (1) when a loop event is active. Output SE is high when a station error is active. LOOP # parameters are used to index reads and writes to Modbus network parameters. See Section 5 for network parameters.

The VIEW OD parameter, when set to YES, enables the operator display to be viewed and accessed locally. In cases where it is desired to view display or operation parameters only from a network workstation, the parameter should be set to NO.

Range pointers (i.e. R1 to R4) for all four process inputs must be configured to define the range of each variable input (i.e. P1 to P4). If these parameters are not configured, the bargraphs will be scaled using the engineering range of 0.00 to 100.00. This information also defines the scaling of the loop information provided to a remote workstation over the network (i.e. Modbus or Modbus/TCP Ethernet).

Each process variable can be displayed on the local faceplate using the D button. When first stepping into a loop using the Loop button, the loop tag will be displayed (e.g. AnDisp1). However, if there is a point within the loop that has an unacknowledged alarm, that point will be displayed alternating between the point tag and the alarm condition (e.g. PI693/3B LO). Press the D button to scroll through the analog points displaying the point tag (e.g. TI712) in the alphanumeric and the value of the point in the digital display (e.g. 348.47). Press the UNITS button to display the units of the point. Press the Loop tag to return to displaying the loop tag.

Alarm Types

HI compares the process input with the limit setting and trips the alarm status high (1) when the process is equal to or higher than the limit setting. The alarm status will clear (0) when the process is less than the limit setting minus the deadband.

LO compares the process input with the limit setting and trips the alarm status high (1) when the process is equal to or less than the limit setting. The alarm status will clear (0) when the process is greater than the limit setting plus the deadband.

OR compares the process input with the range limits referenced by the range pointer parameter. It will trip the alarm status high (1) when the process is equal to or greater than the high limit, or equal to or less than the low limit. The alarm status will clear (0) when the process is less than the high limit minus the deadband or greater than the low limit plus the deadband.

Operator Display for Analog indication & alarming

Process Range 1	R1	Operator Display for Analog Indication & Alarming	A1	Alarm A P1
Process 1	P1		B1	Alarm B P1
Process Range 2	R2		A2	Alarm A P2
Process 2	P2		B2	Alarm B P2
Process Range 3	R3		A3	Alarm A P3
Process 3	P3		B3	Alarm B P3
Process Range 4	R4		A4	Alarm A P4
Process 4	P4		B4	Alarm B P4
			LE	Loop Event
			SE	Station Error
			WD	Watch Dog

P1	R1	PTR	Process 1 - RanGe PoiNtEr (S)	loop tag.block tag	(null)
P2	R2	PTR	Process 2 - RanGe PoiNtEr (S)	loop tag.block tag	(null)
P3	R3	PTR	Process 3 - RanGe PoiNtEr (S)	loop tag.block tag	(null)
P4	R4	PTR	Process 4 - RanGe PoiNtEr (S)	loop tag.block tag	(null)
	P1	TAG	Process 1 TAG (S)	8 ASCII Char (P1 TAG)	
	P2	TAG	Process 2 TAG (S)	8 ASCII Char (P2 TAG)	
	P3	TAG	Process 3 TAG (S)	8 ASCII Char (P3 TAG)	
	P4	TAG	Process 4 TAG (S)	8 ASCII Char (P4 TAG)	
1	A	LIMIT	Process 1 Alarm A LIMIT(S)	Real	(10.0)
1	B	LIMIT	Process 1 Alarm B LIMIT(S)	Real	(-10.0)
2	A	LIMIT	Process 2 Alarm A LIMIT(S)	Real	(10.0)
2	B	LIMIT	Process 2 Alarm B LIMIT(S)	Real	(-10.0)
3	A	LIMIT	Process 3 Alarm A LIMIT(S)	Real	(10.0)
3	B	LIMIT	Process 3 Alarm B LIMIT(S)	Real	(-10.0)
4	A	LIMIT	Process 4 Alarm A LIMIT(S)	Real	(10.0)
4	B	LIMIT	Process 4 Alarm B LIMIT(S)	Real	(-10.0)
1	A	DBAND	Process 1 Alarm A DeadBAND (S)	0.10.5/1.0/5.0%	(0.5)
1	B	DBAND	Process 1 Alarm B DeadBAND (S)	0.10.5/1.0/5.0%	(0.5)
2	A	DBAND	Process 2 Alarm A DeadBAND (S)	0.10.5/1.0/5.0%	(0.5)
2	B	DBAND	Process 2 Alarm B DeadBAND (S)	0.10.5/1.0/5.0%	(0.5)
3	A	DBAND	Process 3 Alarm A DeadBAND (S)	0.10.5/1.0/5.0%	(0.5)
3	B	DBAND	Process 3 Alarm B DeadBAND (S)	0.10.5/1.0/5.0%	(0.5)
4	A	DBAND	Process 4 Alarm A DeadBAND (S)	0.10.5/1.0/5.0%	(0.5)
4	B	DBAND	Process 4 Alarm B DeadBAND (S)	0.10.5/1.0/5.0%	(0.5)
1	A	PUEN	Process 1 Alarm A Power Up ENabled (S)	NO/YES	(YES)
1	B	PUEN	Process 1 Alarm B Power Up ENabled (S)	NO/YES	(YES)
2	A	PUEN	Process 2 Alarm A Power Up ENabled (S)	NO/YES	(YES)
2	B	PUEN	Process 2 Alarm B Power Up ENabled (S)	NO/YES	(YES)
3	A	PUEN	Process 3 Alarm A Power Up ENabled (S)	NO/YES	(YES)
3	B	PUEN	Process 3 Alarm B Power Up ENabled (S)	NO/YES	(YES)
4	A	PUEN	Process 4 Alarm A Power Up ENabled (S)	NO/YES	(YES)
4	B	PUEN	Process 4 Alarm B Power Up ENabled (S)	NO/YES	(YES)
1	A	PRIOR	Process 1 Alarm A PRIORity (S)	1/2/3/4/5	(3)
1	B	PRIOR	Process 1 Alarm B PRIORity (S)	1/2/3/4/5	(3)
2	A	PRIOR	Process 2 Alarm A PRIORity (S)	1/2/3/4/5	(3)
2	B	PRIOR	Process 2 Alarm B PRIORity (S)	1/2/3/4/5	(3)
3	A	PRIOR	Process 3 Alarm A PRIORity (S)	1/2/3/4/5	(3)
3	B	PRIOR	Process 3 Alarm B PRIORity (S)	1/2/3/4/5	(3)
4	A	PRIOR	Process 4 Alarm A PRIORity (S)	1/2/3/4/5	(3)
4	B	PRIOR	Process 4 Alarm B PRIORity (S)	1/2/3/4/5	(3)
1	A	TYPE	Process 1 Alarm A TYPE (S)	none/HI/LO/or	(HI)
1	B	TYPE	Process 1 Alarm B TYPE (S)	none/HI/LO/or	(LO)
2	A	TYPE	Process 2 Alarm A TYPE (S)	none/HI/LO/or	(HI)
2	B	TYPE	Process 2 Alarm B TYPE (S)	none/HI/LO/or	(LO)
3	A	TYPE	Process 3 Alarm A TYPE (S)	none/HI/LO/or	(HI)
3	B	TYPE	Process 3 Alarm B TYPE (S)	none/HI/LO/or	(LO)
4	A	TYPE	Process 4 Alarm A TYPE (S)	none/HI/LO/or	(HI)
4	B	TYPE	Process 4 Alarm B TYPE (S)	none/HI/LO/or	(LO)
1	A	DLIN	Proc 1 Alarm A DeLay IN (S)	0/4/12/5/15/30/60	(0)
1	B	DLIN	Proc 1 Alarm B DeLay IN (S)	0/4/12/5/15/30/60	(0)
2	A	DLIN	Proc 2 Alarm A DeLay IN (S)	0/4/12/5/15/30/60	(0)
2	B	DLIN	Proc 2 Alarm B DeLay IN (S)	0/4/12/5/15/30/60	(0)
3	A	DLIN	Proc 3 Alarm A DeLay IN (S)	0/4/12/5/15/30/60	(0)
3	B	DLIN	Proc 3 Alarm B DeLay IN (S)	0/4/12/5/15/30/60	(0)
4	A	DLIN	Proc 4 Alarm A DeLay IN (S)	0/4/12/5/15/30/60	(0)
4	B	DLIN	Proc 4 Alarm B DeLay IN (S)	0/4/12/5/15/30/60	(0)
1	A	DLOUT	Proc 1 Alarm A DeLay OUT (S)	0/4/12/5/15/30/60	(0)
1	B	DLOUT	Proc 1 Alarm B DeLay OUT (S)	0/4/12/5/15/30/60	(0)
2	A	DLOUT	Proc 2 Alarm A DeLay OUT (S)	0/4/12/5/15/30/60	(0)
2	B	DLOUT	Proc 2 Alarm B DeLay OUT (S)	0/4/12/5/15/30/60	(0)
3	A	DLOUT	Proc 3 Alarm A DeLay OUT (S)	0/4/12/5/15/30/60	(0)
3	B	DLOUT	Proc 3 Alarm B DeLay OUT (S)	0/4/12/5/15/30/60	(0)
4	A	DLOUT	Proc 4 Alarm A DeLay OUT (S)	0/4/12/5/15/30/60	(0)
4	B	DLOUT	Proc 4 Alarm B DeLay OUT (S)	0/4/12/5/15/30/60	(0)
1	A	RGBCK	Process 1 Alarm A RiNg BaCK (S)	NO/YES	(NO)
1	B	RGBCK	Process 1 Alarm B RiNg BaCK (S)	NO/YES	(NO)
2	A	RGBCK	Process 2 Alarm A RiNg BaCK (S)	NO/YES	(NO)
2	B	RGBCK	Process 2 Alarm B RiNg BaCK (S)	NO/YES	(NO)
3	A	RGBCK	Process 3 Alarm A RiNg BaCK (S)	NO/YES	(NO)
3	B	RGBCK	Process 3 Alarm B RiNg BaCK (S)	NO/YES	(NO)
4	A	RGBCK	Process 4 Alarm A RiNg BaCK (S)	NO/YES	(NO)
4	B	RGBCK	Process 4 Alarm B RiNg BaCK (S)	NO/YES	(NO)
		VIEW OD	VIEW Operator Display (H)	NO/YES	(YES)
		LOOP #	LOOP # (S)	01 to 25	(null)
		INPUT P1	INPUT P1 (H)	loop tag.block tag.output	(null)
		INPUT P2	INPUT P2 (H)	loop tag.block tag.output	(null)
		INPUT P3	INPUT P3 (H)	loop tag.block tag.output	(null)
		INPUT P4	INPUT P4 (H)	loop tag.block tag.output	(null)

Alarms have priorities 1 to 5, with 1 the highest. Alarms are reported to the operator faceplate in order of priority first and then in order of occurrence. Priority 1 causes the station bargraphs and condition (e.g. A1 HI) to flash and requires acknowledgment to stop flashing. Priority 2 also flashes the bargraphs and condition but stops flashing when the alarm clears (i.e. Self Clearing). Priority 3 causes the event LEDs (L and S) and condition to flash. Flashing stops only when the alarm is acknowledged. Priority 4 causes the event LEDs and condition to flash but flashing stops when the alarm clears. Priority 5 displays the alarm but does not require that it be acknowledged.

Alarm limits are in engineering units. A quickset ALARM feature is also available allowing alarm limits to be set quickly during operation. The settings are in engineering units but will also be displayed in % of range on the setpoint bargraph when viewing a point. Alarms are displayed as defined by the range pointer parameter. Alarms can be set to any engineering value within -10% to 110% of the range defined by the pointer. If a range is changed, the current alarm settings will be changed to be the same % within the new range. For example, if a HI alarm is currently set at 100.0 with a range of 0.0 to 100.0 and the range is changed to 300.0 to 400.0, the HI alarm will be moved to 400.0.

Each alarm can be enabled or disabled when in the quickset ALARM mode. The configuration allows an alarm to be enabled or disabled on a cold start. When an alarm is disabled, it will not operate but will retain settings for return to the enabled mode. Operator faceplate functions, relating to alarms, are described in the sections describing the specific faceplate controls and displays. All alarms have the following features:

Deadband - requires that the signal either drop below or exceed the limit setting by the amount of the deadband before the alarm clears (goes low). The alarm deadband is set as a fixed % of the range pointer scale.

Delay-In Time - requires that the input remain above (or below) the limit setting for the delay time before the alarm trips (goes high). This can help prevent nuisance alarms that may be tripping due to process noise.

Delay-Out Time - requires that the input remain below (or above) the limit setting plus deadband for the delay time before the alarm will clear (goes low). This can help prevent inadvertent clearing of alarms due to process noise.

Ringback - causes a previously acknowledged alarm to require acknowledgment (priorities 1-4) when the alarm clears.

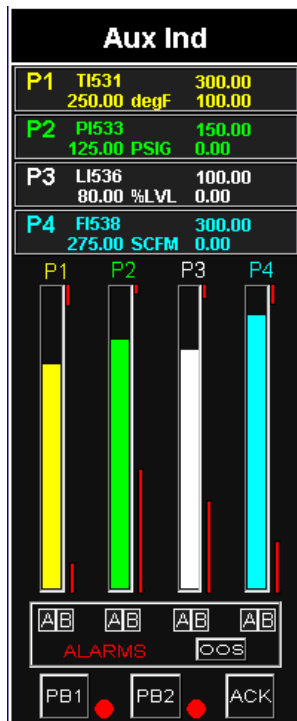

iWare PC Faceplate Display

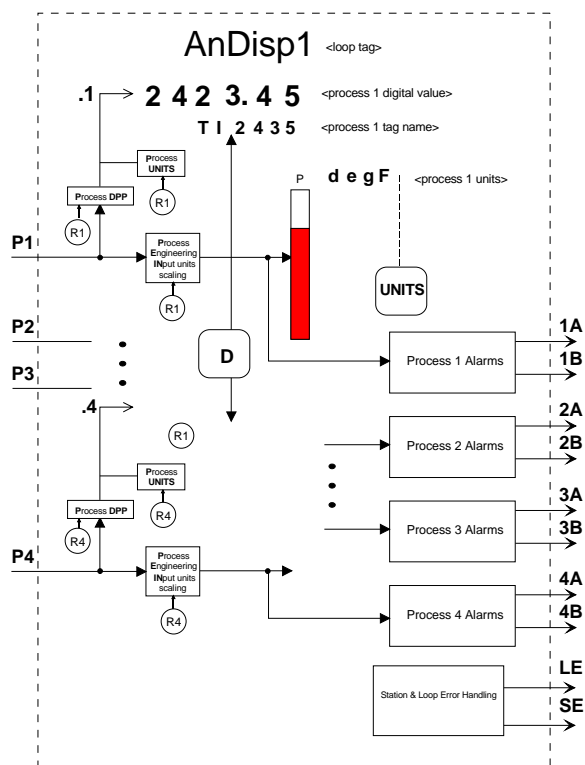

BLOCK DIAGRAM

3.2.55 ODC - Operator Display for Controllers

ODC blocks are one of five operator displays that are used on a one per loop basis to configure the local operator display functions and network parameters from a remote operator workstation associated with the loop. See the i|ware PC faceplate on the next page.

1. Parameter VIEW OD, when set to YES, the default setting, enables the operator display to be viewed and accessed locally using the LOOP button. In some cases, it may be desired to view only display or operation parameters with a network workstation and not allow operation or viewing of the control loop from the local display. Here the parameter should be set to NO.
2. Output LE is high (1) when a loop event is active. Output SE is high when a station error is active.
3. LOOP # is used to index reads and writes to Modbus parameters. The LOOP# must be entered to enable Modbus and Modbus/TCP communications.

Range pointers for both the process/setpoint and valve bargraphs must be configured to define the range of the variable inputs to P, S, and V. If these parameters are not configured, the bargraphs will be scaled using the engineering range of 0.00 to 100.00. The range pointer for X and Y define the displayed decimal point position and the units code. This information also defines the scaling of the loop information provided to a remote workstation over the network.

Input variables P, S, V, X, and Y are shown in the numeric display, using the engineering UNITS and the preferred DPP of the range pointer. The Total from the BATOT will also be displayed when configured within the BATOT block. If a value is greater than allowed by the DPP parameter, the decimal point will be shifted to allow the display to show the full number, until it exceeds the maximum available digits, at which time it will indicate over range.

When input U1 or U2 goes high (1), the 8-character user status (U_STATUS) will be displayed as configured by the status priority (U_PRIOR). A priority of 0 will disable that status function setting the bits in the status word to 0. See Section 8 Local Faceplate Operation for a description of display actions using priorities 1 to 5.

The horizontal bargraph can be selected as direct or reverse acting. This feature allows it to always indicate an OPEN valve when fully lit. The labels on the basic faceplate are fixed, but paste on labels can be used to change the indications. The V NET AC parameter allows the LxVI network parameter to be set for direct or reverse action. This enables the valve bar on the HMI to operate similar to the valve bar on the faceplate. The left and right bar labels should be set accordingly (e.g. Left = "OPEN & Right" = "CLOSE").

An operator display must be configured to map controller loop data to network data. Loop network data is mapped into registers or coils. Mappings for Modbus are listed in the tables included in Section 5 Network Communications. The 'LOOP #' parameter enables configuration of a loop index number (x) for Modbus data.

Input CL controls local arbitration of changes to loop data from the network. When input CL is not configured, the three status outputs LO, CN, and CM will be set high (1) and changes can be made from a network command or the local faceplate. When CL is configured, it can be changed locally from a pushbutton switch such as PB1SW output PS (configured as momentary) and will change from local to console or console/computer to local with each positive transition of the input. Also, when output LO goes high, output CN will also go high and CM will go low, indicating that the control source will change to Console whenever Local is disabled, either by a positive transition

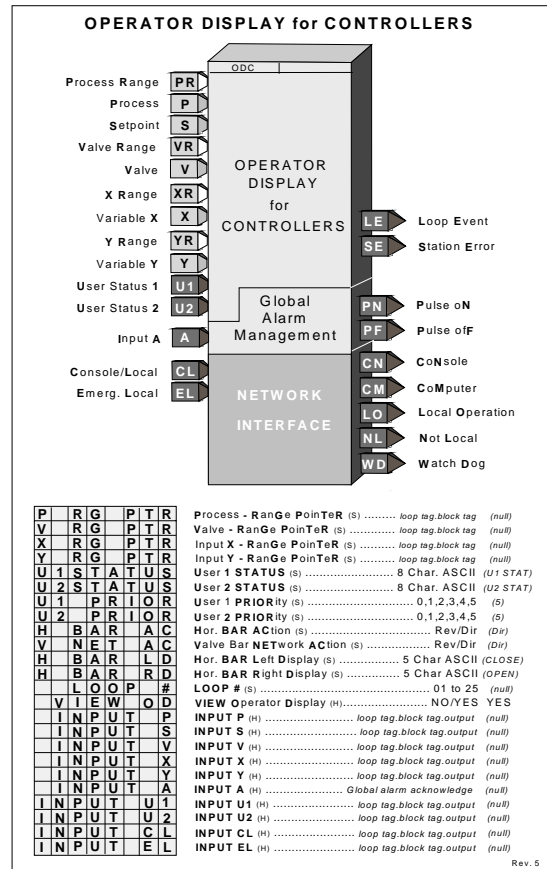

on input CL or from a network command. The Computer CM state can be set high using a network command. The NL output will normally be connected to the MD input of pushbutton block PB1SW to indicate the C/L switch position on the operator faceplate, a green LED for C and a red LED for LO.

Output WD will go high (1) when the controller fails to receive a command within the watchdog time. The watchdog time is set in the STATN (Station Parameters) function block. Input A can be used to acknowledge all the alarms in all of the loops in a controller. Output PN (Pulse oN) will go high for 0.5 seconds (or one scan cycle whichever is longer) whenever the bargraph flashes. Bargraph flashing is controlled by the priority setting of alarms or events. Output PF (Pulse ofF) will go high for 0.5 sec when the flashing bargraph is stopped (e.g. pressing the ACK button).

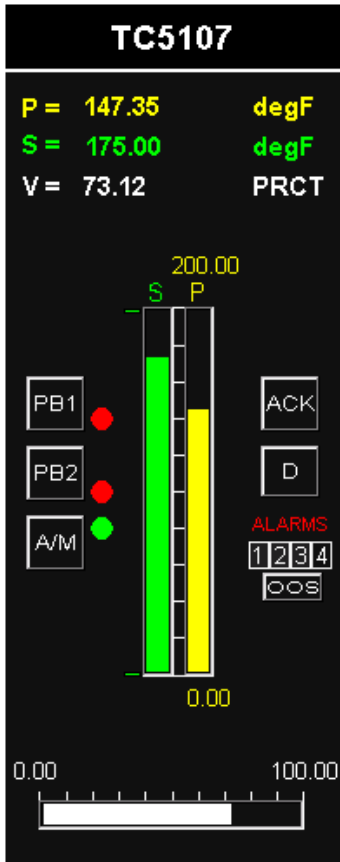

i|ware PC Faceplate Display

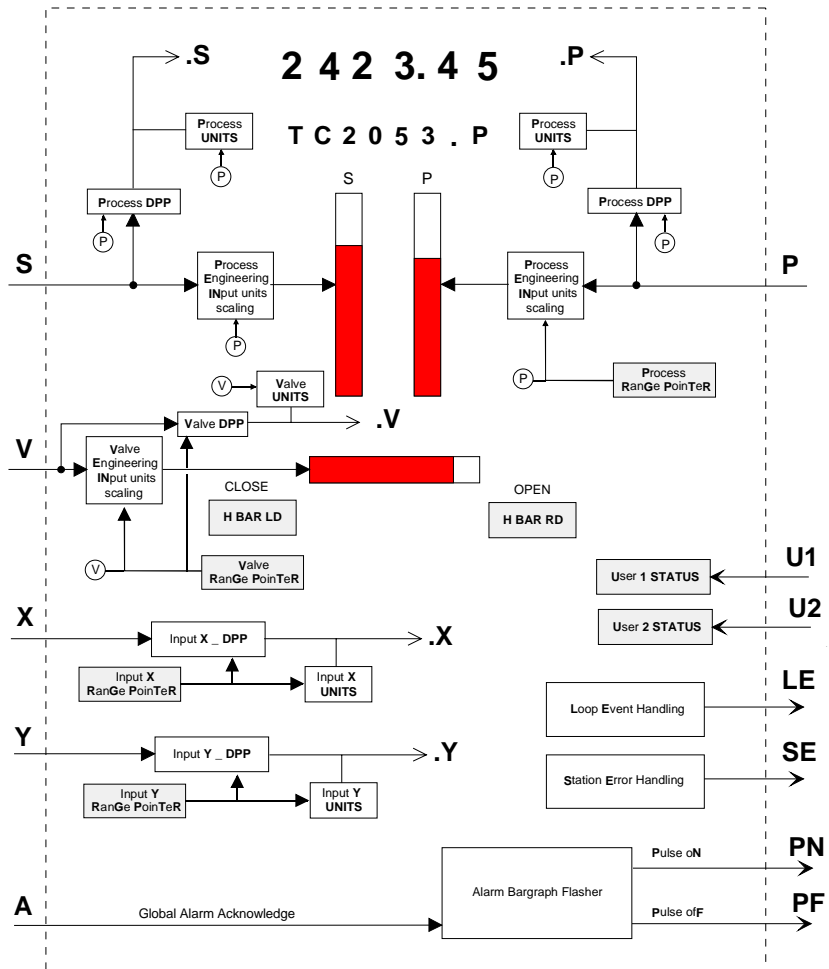

BLOCK DIAGRAM

Rev. 3

3.2.56 ODD - Operator Display for Discrete Indication & Control

ODD function blocks are one of five operator displays that can be used on a one per loop basis to configure the local operator display functions as well as network parameters. See the i|ware PC faceplate example on the next page.

The ODD function block displays up to 16 discrete variables. Each input has a corresponding block output that is equal to the input when the variable mode is in Auto. Each input variable can be assigned a mode. The value of the output can be changed while in Man by using the pulser and pressing the ACK button. When a variable is switched to Manual it will always equal the input value until changed.

The LOOP # parameter is used to index reads and writes to Modbus parameters. See Section 5 for more information on network parameters.

The VIEW OD parameter, when set to YES enables the operator display to be viewed and accessed locally. In cases where it is desired to view display or operation parameters only from a network workstation, the parameter should be set to NO.

During a cold or warm start, each input variable will power up in the auto mode. During a hot start, the mode and manual value will equal the value prior to power down.

Each discrete input variable can be displayed on the local faceplate using the D button. When first stepping into a loop using the Loop button, the loop tag will be displayed (e.g. DigDisp1). Pressing the D button will scroll through the discrete points displaying the point tag (e.g. SV-103) in the alphanumeric and the value of the input on the left 3 positions of the digital display (e.g. On) and the output in the right most 3 positions (e.g. OFF).

The A/M button will display the point mode and enable switching the point between auto & manual using the A/M button. The manual value can be changed by turning the pulser and pressing the ACK button. If the ACK button is not pressed within 4-5 seconds, the display will return to the actual output value.

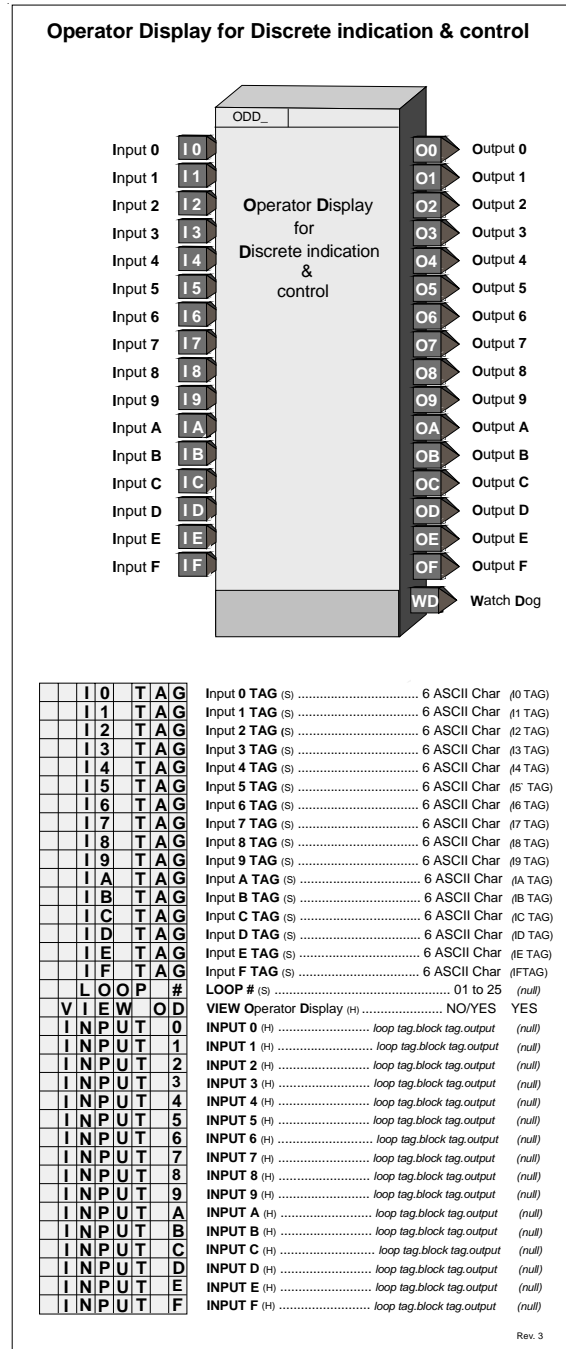

DigDisp1				
#	TAG	IN	MODE	OUT
0	SV101	ON	A	ON
1	SV102	ON	M	OFF
2	SV103	ON	M	ON
3	LS103	OFF	M	ON
4	PS105	ON	A	ON
5	MS106	ON	A	ON
6	SV107	ON	A	ON
7	LS109	OFF	A	OFF
8	SV110	ON	A	ON
9	PS115	OFF	M	ON
A	SV117	ON	A	ON
B	PS118	ON	A	ON
C	SV120	ON	A	ON
D	LS124	ON	A	ON
E	MS128	ON	A	ON
F	MS129	OFF	A	OFF

PB1	●	PB2	●
CONFIGURATION HOLD			

i|ware PC Faceplate Display

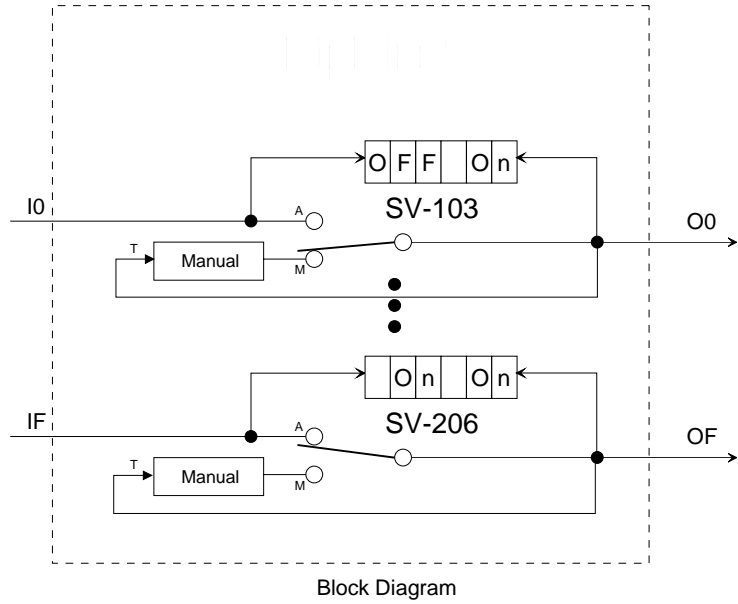

3.2.57 ODP - Operator Display for PushButtons

ODP function blocks are one of five operator displays that can be used on a one per loop basis to configure local operator display functions as well as network parameters. See the i|ware PC faceplate example on the next page.

The ODP function block can provide up to 8 groups of two pushbuttons and one selector switch. Each group includes:

- One normally open pushbutton, identified as PB1, on the local faceplate. It can have a 6-character tag to identify the button function on a HMI display.
- One normally closed pushbutton, identified as PB2 on the local faceplate. It can have a 6-character tag for display on an HMI.
- One two-position selector switch identified as A/M on the local faceplate. It can have a 6-character tag for switch position identification on an HMI.

Each group also has a set of 6-character messages associated with the status of a feedback signal (1/0).

Each pushbutton has a configuration parameter that controls how long the button function will be held in the pressed position. The default value is 1 second but can be set from 0.1 (or scan time if greater than 0.1) to 10 seconds.

The LOOP # parameter is used to index reads and writes to Modbus parameters. See Section 5 for more information on network parameters.

The VIEW OD parameter, when set to YES enables the operator display to be viewed and accessed locally. In cases where it is desired to view display or operation parameters only from a network workstation, the parameter should be set to NO.

During a cold or warm start, the A/M switch will power up in the Auto position. During a hot start, the A/M switch will power up in the position prior to power down.

Each group can be displayed on the local faceplate using the D button. When first stepping into a loop using the Loop button, the loop tag will be displayed (e.g. PBDISP1). Pressing the D button will scroll through the groups displaying the group tag (e.g. MS1036) in the alphanumeric and the value of the feedback in the digital display (e.g. 1). The feedback message associated with this feedback value can be viewed on the local faceplate using the UNITS button. The A/M button will display the position of the group selector switch and enable switching the group selector switch between auto and manual.

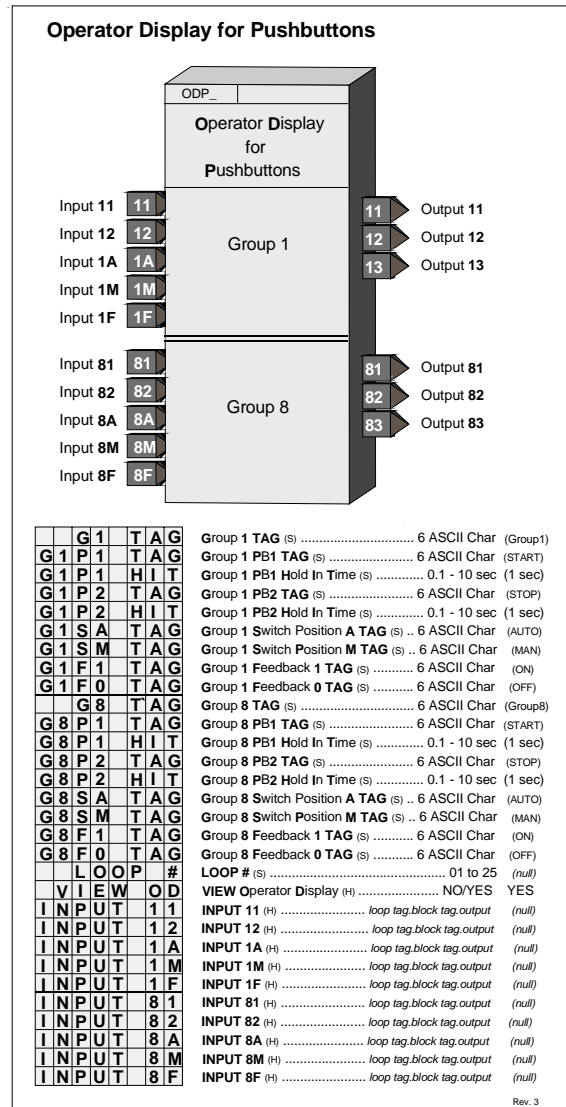

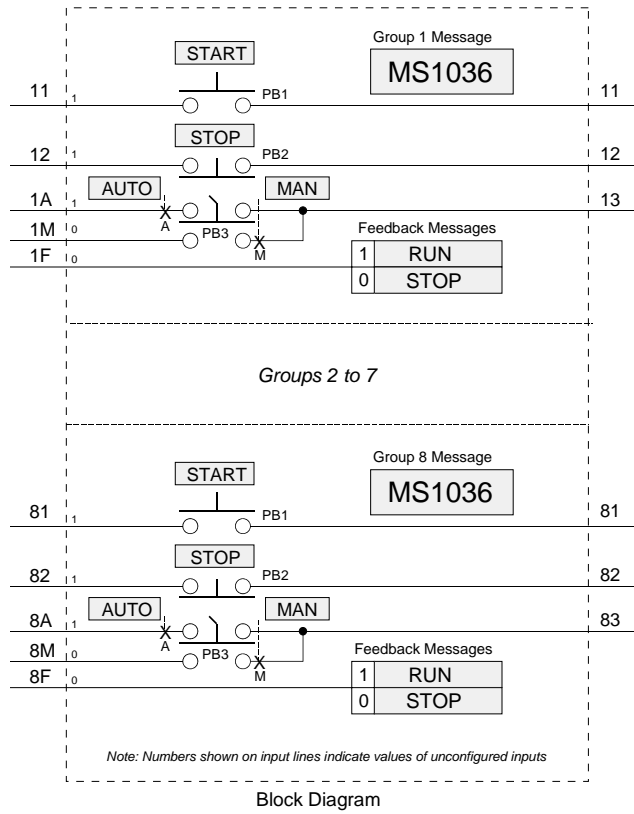
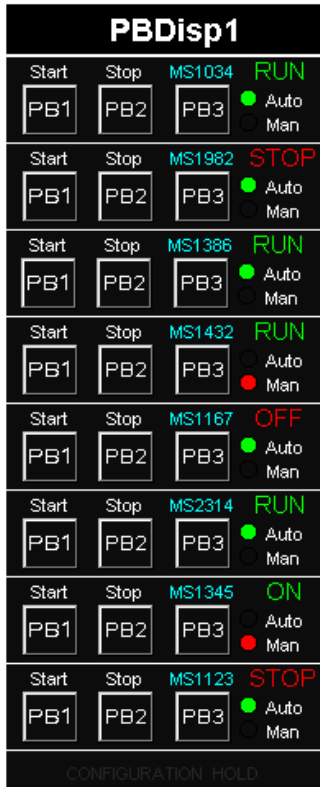

i|ware PC Faceplate Display

3.2.58 ODS - Operator Display for Sequencer

ODS function blocks are one of five operator displays available on a one per loop basis to configure the local operator display functions as well as the network commands from an operator workstation associated with the loop. See the i|ware PC faceplate example on the following page.

The VIEW OD parameter, when set to YES, the default value, enables the operator display to be viewed and accessed locally using the LOOP button. Set the parameter to NO to view the display or operation parameters only with a network workstation and not allow operation from the local display. This may be desired with a sequence/logic loop where local operation is not needed but a workstation needs access to force I/O or sequence parameters for recipe changes.

Messages will be available over Modbus and Modbus/TCP. Refer to Section 5 Network Communications for mapped data points.

1. The # of Recipe messages can be set to 0 so that a Recipe Message does not appear in the message list.
2. Messages will function as follows with the local faceplate display:

When the local display first enters a loop, the convention loop tag and sequence step number will be displayed. When the D button is pressed, the Numeric display will show MSG and the alphanumeric display will show the first message it comes to in the order shown below.

- Conditional messages will be displayed in the order in which they occurred.
- The latest message will be displayed first.
- A new message will override the current message.

The ACK button can be used to scroll through active messages. It will stay on the last message until a new message overrides it or the ACK button is again pressed. When an active message clears, the message display will loop back and start at the top and display the first message it comes to. Events that require acknowledgment will return the display to the normal mode (i.e. <loop tag>.S) and will flash the message. When events have been acknowledged they can be viewed using the ACK button. The display can be returned to the MSG mode using the D button and will then display the first message in the Queue.

Output LE is high (1) when a loop event is active. Output SE is high when a station error is active.

The LOOP # will be used to index reads and writes to Modbus parameters. The LOOP# must be entered to enable Modbus and Modbus/TCP communications.

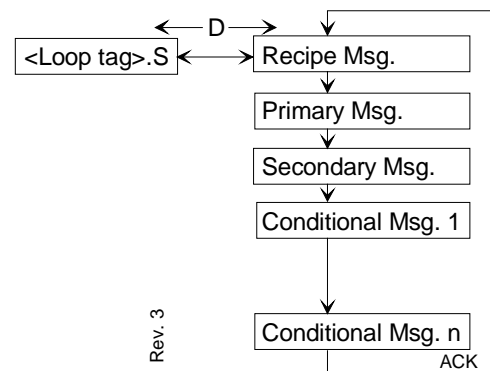
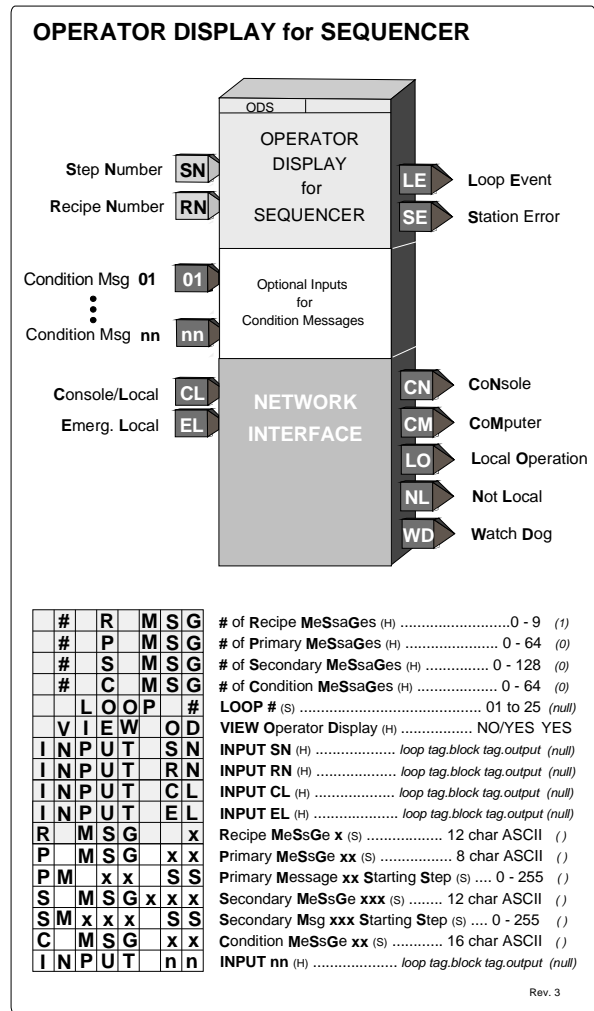

An operator display must be configured in order to properly map station loop data to network data. Sequencer loop network data is mapped onto registers or coils

Input CL controls local arbitration of changes to loop data from the network. When input CL is not configured, the three status outputs LO, CN, and CM will be set high (1) and changes can be made from a network command or the local faceplate. When CL is configured, it can be toggled locally from a pushbutton switch, such as PB1SW (output PS), and will change from local to console or from console/computer to local each time the input is toggled. Also, when output LO goes high, output CN will also go high and CM will go low, indicating that the control source will change to Console whenever Local is disabled, either by toggling input CL or from a network command. The Computer CM state can be set high using a network command. The NL output will normally be connected to the MD input of the pushbutton block PB1SW to indicate the C/L switch position on the operator faceplate using the green LED for C and the red LED for LO.

Output WD will go high (1) when the station fails to receive a Modbus network command within the watchdog period. The watchdog time is set in the STATN (Station Parameters) function block.

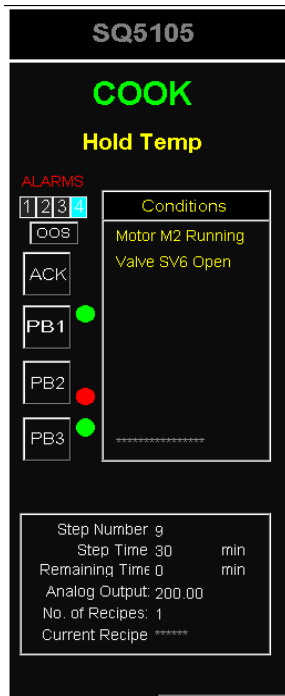

i|ware PC Faceplate Display

3.2.59 ON/OFF - On/Off Controller

ON/OFF is an on/off controller with deviation function. It is one of five controller types that can be used on a one per loop basis.

When P-S (Process - Setpoint) reaches the HDEV limit, the Boolean output HO will go high (1) and when S-P (Setpoint - Process) reaches the LDEV limit, the output LO will go high (1). When the deviation drops to less than the DEADBAND setting, the outputs will go low (0). Derivative action is added to the process variable when the TD parameter is other than 0.0.

When single ended action (gap action) is desired, set the DEADBAND equal to the gap and the HDEV parameter for half the gap. For example, if DEADBAND = 20.0, set HDEV to 10. If the setpoint S is 50.0, output HO will go high (1) when P equals 60.0 and HO will go low (0) when P equals 40.0.

Input E asserted high (1) will enable the block outputs; when low (0) all outputs will be set low (0).

The process range pointer parameter points to another function block that has range scaling, such as the analog input that is providing the process variable. This enables the controller to normalize the tuning parameters for the range of the process input. If this parameter is not configured, the controller will use a range scaling of 0.0 - 100.0.

POWER UP - During a warm start, outputs and comparator functions will be initialized at the state prior to power down and all dynamic elements will be initialized at the current input on the first scan. During a cold start all outputs and comparator states will be set to zero, to be activated by the block functions. All dynamic elements will be initialized at the current input on the first scan.

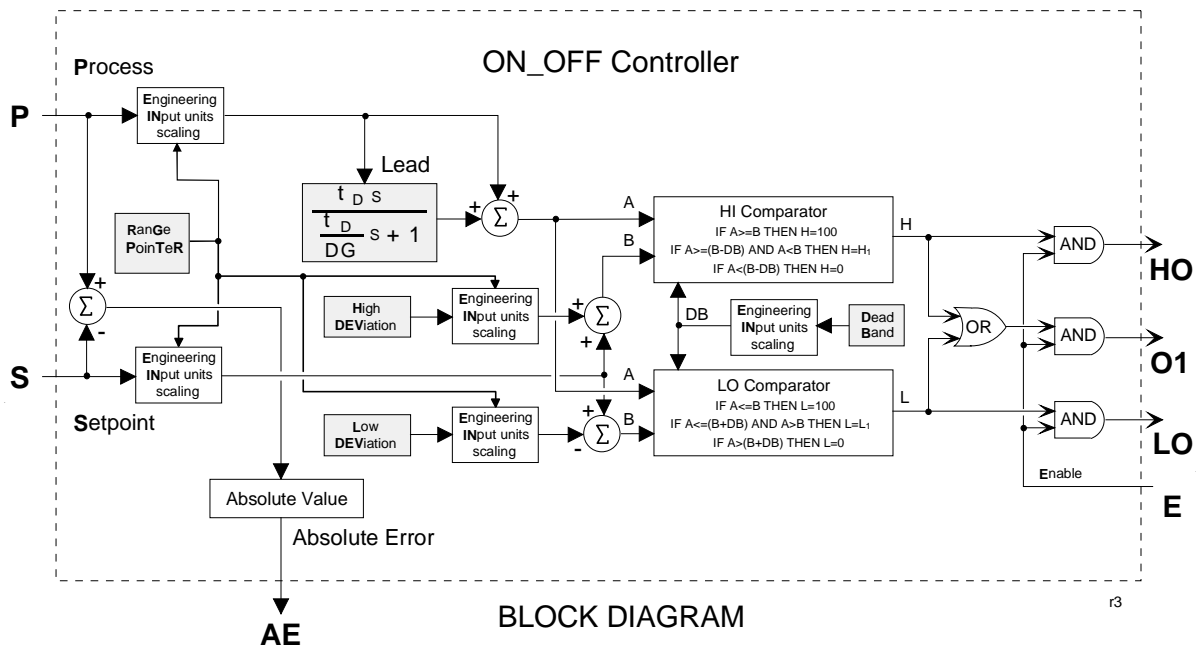
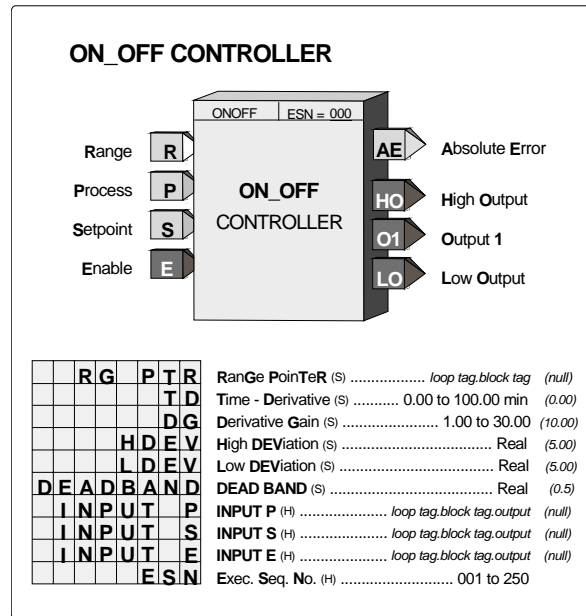

3.2.60 OR_ - OR Logic

OR_ function blocks perform a logical OR on the three inputs. Any unused input will be set low (0).

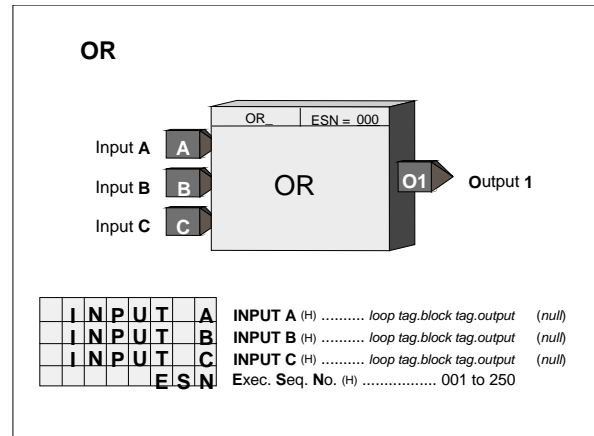
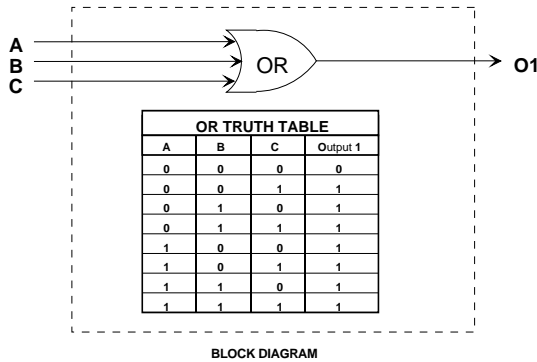

3.2.61 ORSL - Override Selector

ORSL function blocks are used on a one per loop basis and they enable a primary input signal, such as the output from a controller, to be overridden by other signals. For a selector configured as LO, the function block outputs the lower of the primary or override inputs. For a selector configured as HI, the function block will output the higher of the primary or override inputs. Override signals can be hard limits, coming from HOLD blocks, or signals coming from other controllers. Block override inputs 1 and 2 can be used as HI or LO selector functions. Additional override inputs can be accommodated by connecting these inputs to signal selector (SEL) blocks.

When the output of the ORSL block is not the primary input, the output OS will be high (1). In addition, the block can cause the operator faceplate to display 'OVERRIDE' status when a priority level higher than 0, the default, has been selected.

If an override input is not configured the individual selector will output the other input. When no inputs are configured, the block will output 0.0 and the OS status will be set low (0).

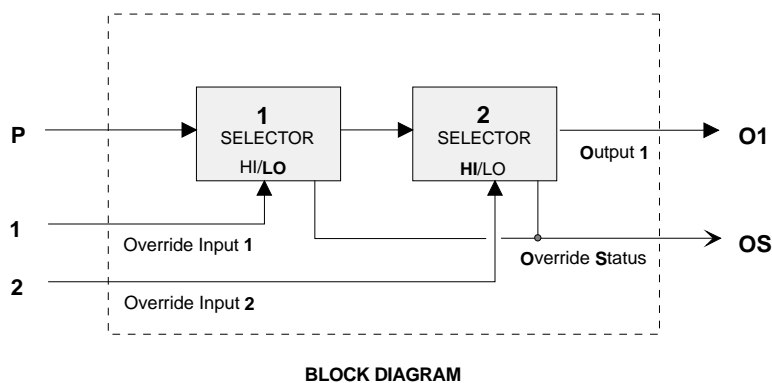
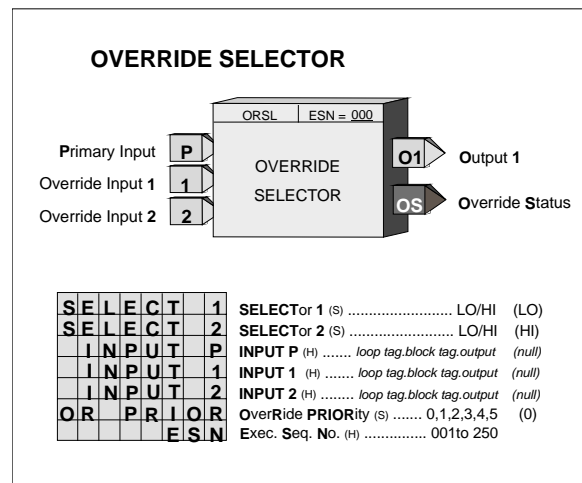

3.2.62 OST_ - One Shot Timer

OST_ function blocks provide a high (1) output for a predetermined time, set by ON TIME, when input P goes high (1). If input P goes low (0), the output will remain high until the time expires. If input P goes high during the on time, the elapsed timer will be re-triggered if RETRIG is set to YES.

ON TIME is adjustable over the full range of the display which is 0.00000 to 999999. If the delay time is set to less than the scan time of the station the delay time will equal the scan time.

Output ET (elapsed time) will ramp from 0.0 to the value of ON TIME and remain there until P goes low (0). Output RT (remaining time) equals ON TIME - ET.

POWER UP - During a warm start, when PU LAST is set to YES, the block will initialize at the input/output states and elapsed time in effect at the instant power down occurred. A cold start will initialize the input/output states and elapsed time to 0.

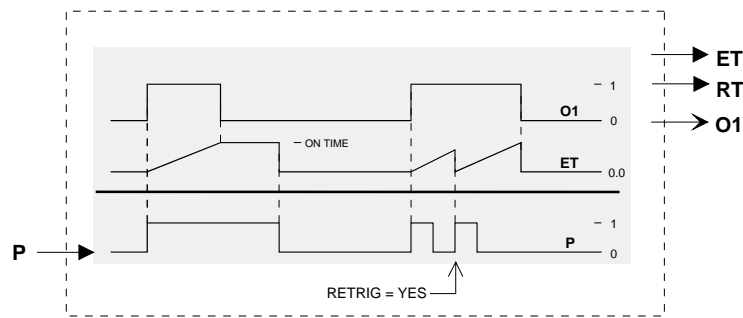
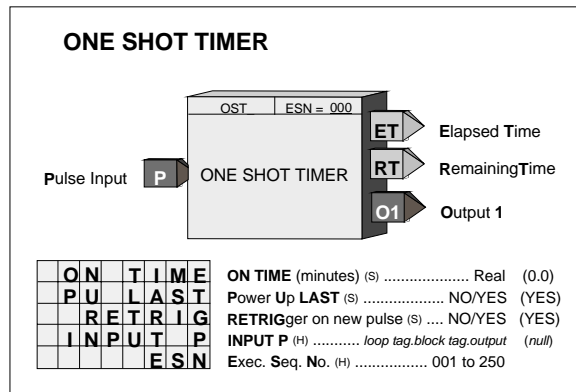

BLOCK DIAGRAM

3.2.63 PB1SW - PB1 Switch

PB1SW is one of three general purpose switches available in each loop. It can be utilized for switching Boolean signals in such applications as: toggling Console/Local operation of the ODC or ODS function blocks, Start/Stop, controlling the position of a TSW (Transfer Switch) function block for switching analog signals, or other operator initiated actions.

PB1SW can be configured for momentary or sustained operation. As momentary, the switch will transfer to the NO position when the button is pressed and will return when released. Momentary action is used in toggle applications such as changing the function of the ODC or ODS function blocks. In the sustained mode, the switch will alternate positions each time the button is pressed. An unconfigured NC input defaults to 0 and an unconfigured NO input to 1. The button can be remotely activated through a command over Modbus or Modbus/TCP.

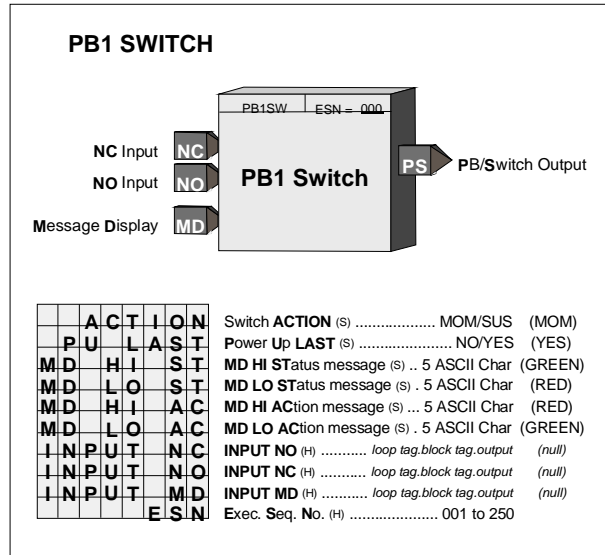

This block operates with an operator faceplate that includes green and red LEDs that are turned on using input MD. A HI (1) input will turn on the Green LED and a LO the Red LED. The default connection will be the PS output of the block but should be changed as required to display the correct status. The message parameters do not apply to the current product.

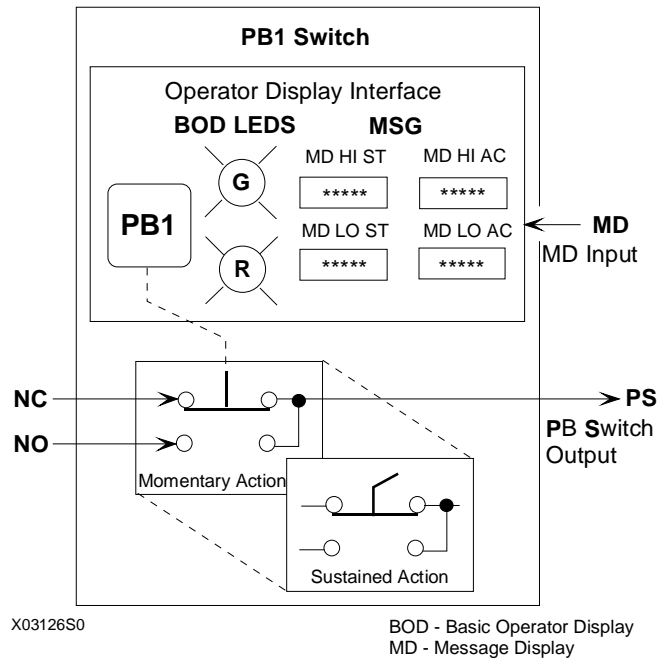

POWER UP - When the switch is configured for momentary action, it will always power up in the NC position. For sustained action, with the POWER UP parameter set to YES, the switch will power up in the last position during a hot or warm start, and during a cold start will power up in the NC position. When the POWER UP parameter is set to NO, the switch will power up in the last position during a hot start. During a warm or cold start, it will power up in the NC position.

3.2.64 PB2SW - PB2 Switch

PB2SW is one of three general purpose switches available in each loop. It can be utilized for switching Boolean signals in such applications as: toggling the E/I (External/Internal setpoint Transfer Switch) function block, Start/Stop, controlling the position of a TSW (Transfer Switch) function block for switching analog signals, or other operator initiated actions.

The switch can be configured for momentary or sustained operation. As momentary, the switch will transfer to the NO position when the button is pressed and will return when released. Momentary action is used in toggle applications such as changing the function of the E/I function block. In the sustained mode, the switch will alternate positions each time the button is pressed. An unconfigured NC input defaults to 0 and an unconfigured NO input to 1. The button can be remotely activated through a command over Modbus or Modbus/TCP.

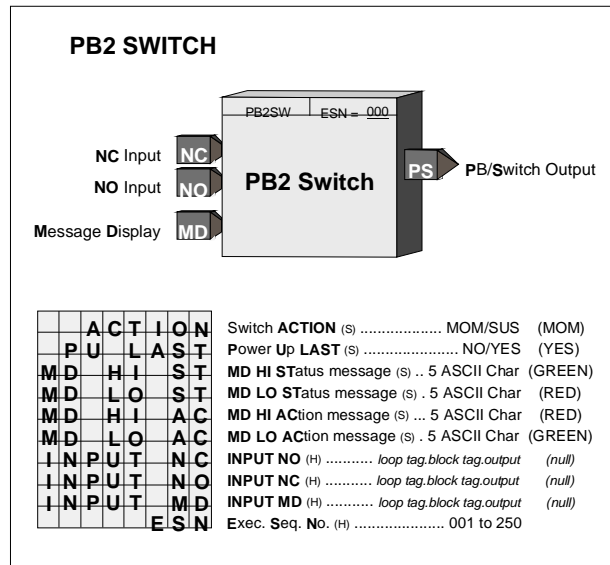

This block operates with an operator faceplate that includes green and red LEDs that are turned on using input MD. A HI (1) input will turn on the Green LED and a LO the Red LED. The default connection will be the PS output of the block but should be changed as required to display the correct status. The message parameters do not apply to the current product.

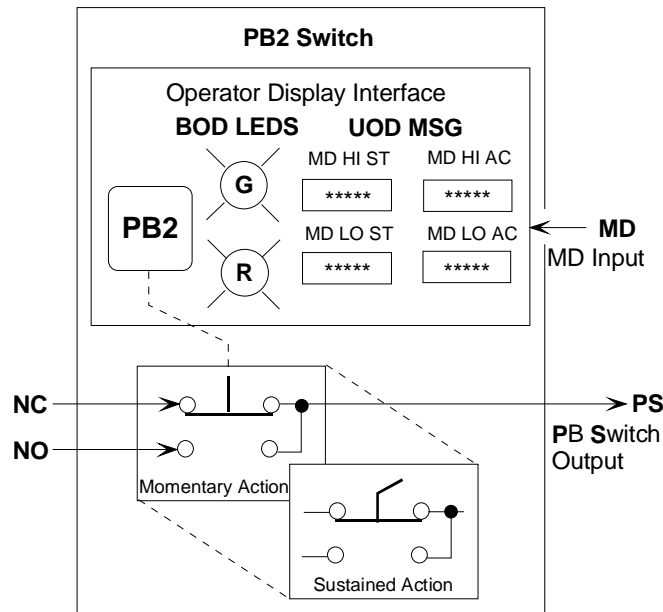

POWER UP - When the switch is configured for momentary action, it will always power up in the NC position. For sustained action, with the **POWER UP** parameter set to YES, the switch will power up in the last position during a hot or warm start, and during a cold start will power up in the NC position. When the **POWER UP** parameter is set to NO, the switch will power up in the last position during a hot start. During a warm or cold start, it will power up in the NC position.

X03127S0

BOD - Basic Operator Display
 MD - Message Display
 UOD - Universal Operator Display

BLOCK DIAGRAM

3.2.65 PB3SW - PB3 Switch

PB3SW is one of three general purpose switches, available in each loop. It can be utilized for switching Boolean signals in such applications as: Start/Stop, controlling the position of a TSW (Transfer Switch) function block for switching analog signals, or other operator initiated actions. PB3SW can only be operated from the front panel when the A/M function block has not been configured.

PB3SW can be configured for momentary or sustained operation. As momentary, the switch will transfer to the NO position when the button is pressed and it will return when released. In the sustained mode, the switch will alternate positions each time the button is pressed. An unconfigured NC input defaults to 0 and an unconfigured NO input to 1. The button can be remotely activated through a command over Modbus or Modbus/TCP, where explicitly stated in Section 6 Data Mapping.

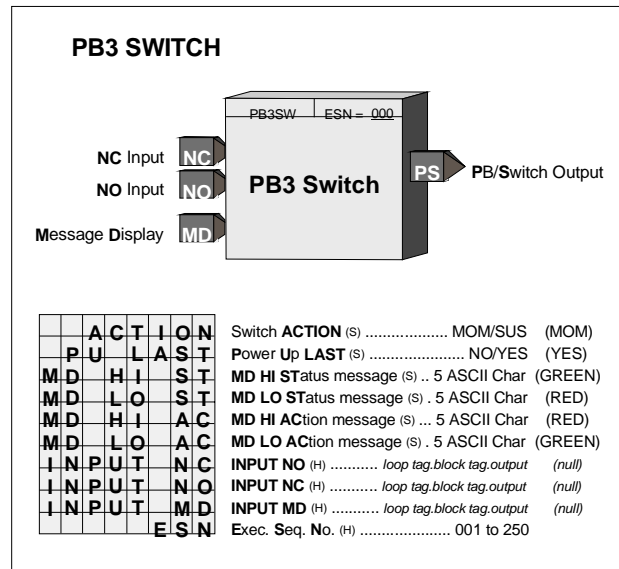

This block operates with an operator faceplate that includes green and red LEDs that are turned on using input MD. A HI (1) input will turn on the Green LED and a LO the Red LED. The default connection will be the PS output of the block but should be changed as required to display the correct status. The message parameters do not apply to the current product.

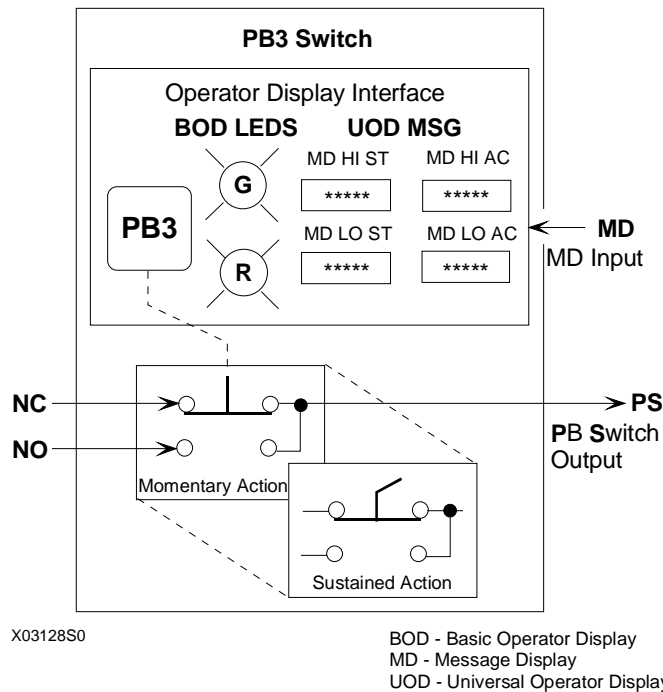

POWER UP - When the switch is configured for momentary action, it will always power up in the NC position. For sustained action, with the **POWER UP** parameter set to YES, the switch will power up in the last position during a hot or warm start, and during a cold start it will power up in the NC position. When the **POWER UP** parameter is set to NO, the switch will power up in the last position during a hot start. During a warm or cold start will power up in the NC position.

3.2.66 PCOM - Phase COMMunication

The Phase Communication **PCOM** function block is available on a one per loop basis to enable communication with a higher level device, such as a PC running a batch management software program. When the controller configuration is structured such that logic operations are partitioned in small phase operations, the PCOM block facilitates the interface between the logic controlling the overall phase operations for the batch and the logic performing the control logic for each phase.

The logic performed by the **PCOM** block is detailed in Boolean form in Figure 3-1. Network communication can be either Modbus or Modbus/TCP. Details are listed in Section 5 Network Communications. The LOOP # configured in the ODC or ODS function block for the loop determines the location of the status coils in the Modbus mapping. Communication states are represented in Figure 3-1, on the next page, using the symbols shown below. Modbus states are mapped in coils as defined in Section 6.3.9 PCOM Block Status.

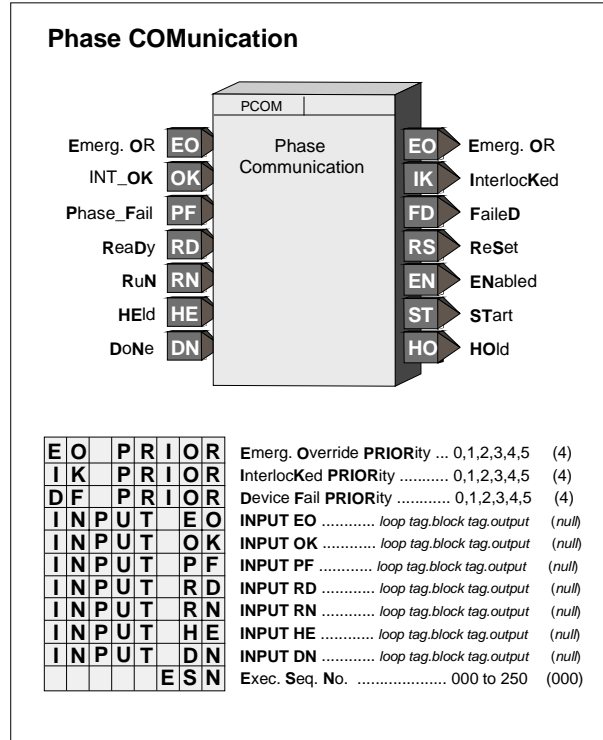

Read/Write States



Read States



Each communication state is read as a 1 or 0. Using Modbus, a write of a 1 (W1) or a 0 (W0) will affect the communication state as defined by the associated logic in Figure 3-1. All unconfigured inputs will be treated as low (0) except OK, RD, RN and HE which will be treated as high (1). Three of the output states, EO (“EMERG”), IK (“INTRLK”), and FD (“FAILED”) can be configured for priorities 0-5. This will affect the flashing, etc. as previously described for other controller status conditions. These states also have unacknowledged bits as detailed in status word 2. Conditions that require acknowledging can be acknowledged by either using the local faceplate ACK button or by writing to the individual not acknowledged bit or the Not Ack’d PCOM bit.

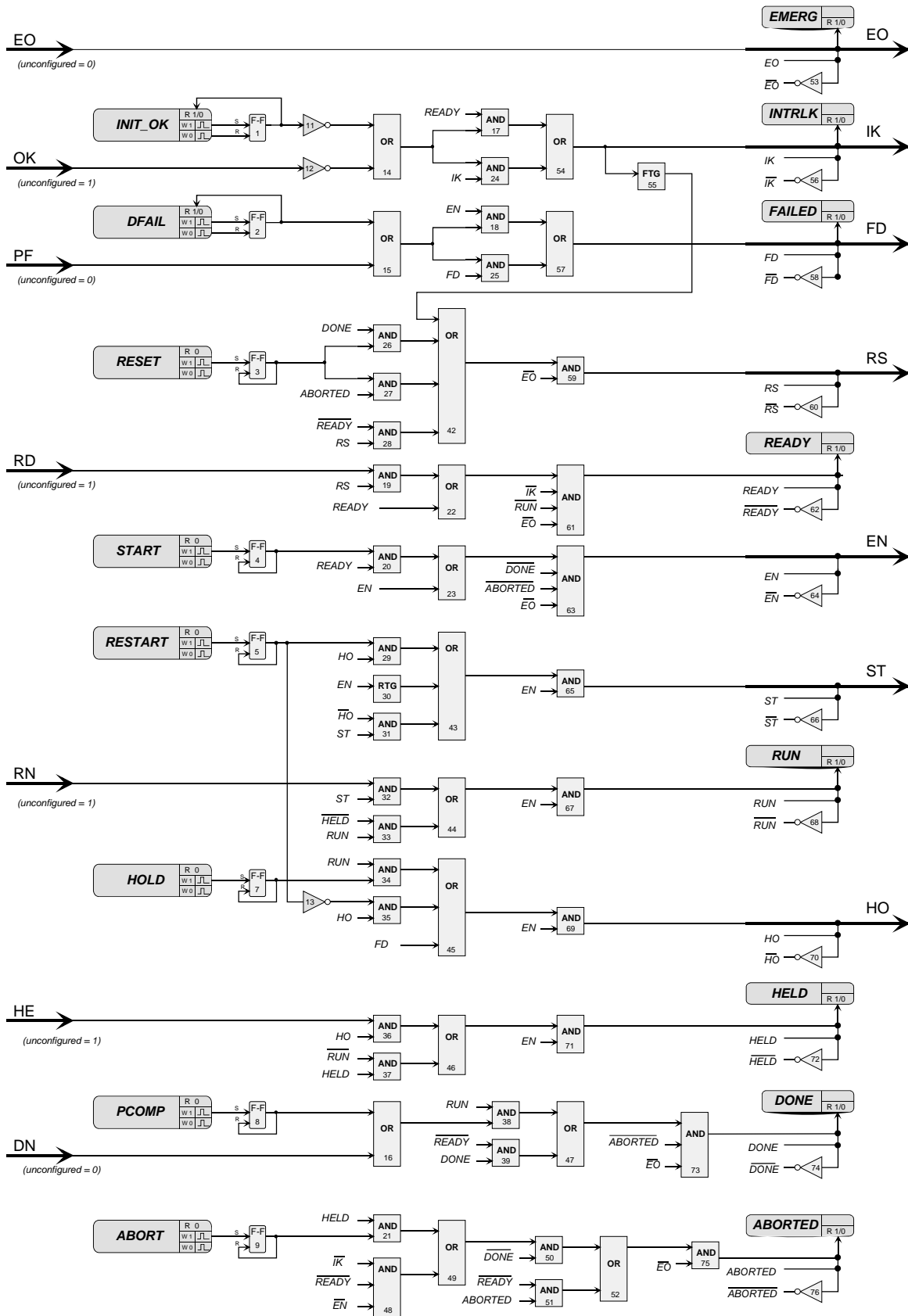

Figure 3-1 PCOM Logic

3.2.67 PD - PD Controller

PD is a proportional only controller with manual reset. It is one of five controller types that can be used on a one per loop basis.

Manual reset allows the output of the controller to be set for a normal operating value (i.e. the desired output when the process equals setpoint under a given load condition). Derivative action is provided when the parameter TD is non-zero. The controller includes an autotune feature that can be initiated from the operator faceplate using the quick TUNE feature.

When input A is high (1) the controller will operate in the normal auto mode and when low (0) causes the controller output to track the feedback signal to eliminate bumping the output when switching to auto. This is accomplished by forcing the reset component R to a value that will keep (GE+R) equal to the feedback value. When the controller is switched to auto the value of the reset component will change back to the manual reset MR value at a rate determined by the MR TLAG setting. When MRTRCK is set to YES the manual reset MR will also track the feedback signal when input A is low.

Input I, when changed from low (0) to high (1) or high to low, will cause the controller to initialize (i.e. eliminate any proportional gain action during that scan cycle). This can be used to prevent bumping the output when changes are made to the setpoint through a switch block.

PD CONTROLLER

Range **R**

Process **P**

Setpoint **S**

Feedback **F**

Auto **A**

Initialize **I**

PD

ESN = 000

PD

CONTROLLER

OR Output Range

O1 Output

AE Absolute Error

AW AT Warning

	R	G	P	T	R	RanGe PoinTeR (S) loop tag.block tag (null)
	D	I	R	A	C	DIRect ACTing (H) NO/YES (NO)
					P	Proportional Gain (S) 0.001 to 100.0 (1.000)
					T	Time - Derivative (S) 0.00 to 100.00 min (0.00)
					D	Derivative Gain (S) 1.00 to 30.00 (10.00)
					M	Manual Reset (S) 0.00 to 100.00 (0.00)
					R	Manual Reset Time LAG (S) . 0.001 to 4000 min (0.010)
					T	Manual Rest TRACKing (S) NO/YES (NO)
					M	MINimum SCALE (H) Real (0.0)
					M	MAXimum SCALE (H) Real (100.0)
					D	Decimal Point Position (preferred) (S) 0.0,0.0,0.0 (0.0)
					E	ENGINEERING UNITS (S) 6 ASCII Char (PRCT)
					A	AUTOTUNE (S) NO/YES (YES)
					%	% DEVIation during Autotune (S) AUTO, 2.5 to 25.0 (AUTO)
					%	% HYSteresis during Autotune (S) .. AUTO, 0.5 to 10.0 (AUTO)
					%	% output STEP on first Autotune (S) 5% to 40% (10)
					A	AT DYNAMic settings (S) Fast, Medium, Slow (M)
					A	AT RESET (S) NO/YES (YES)
					P	POST Autotune Transfer (S) NO/YES (NO)
					I	INPUT P (H) loop tag.block tag.output (null)
					I	INPUT S (H) loop tag.block tag.output (null)
					I	INPUT F (H) loop tag.block tag.output (null)
					I	INPUT A (H) loop tag.block tag.output (null)
					I	INPUT I (H) loop tag.block tag.output (null)
					E	Exec. Seq. No. (H) 001 to 250

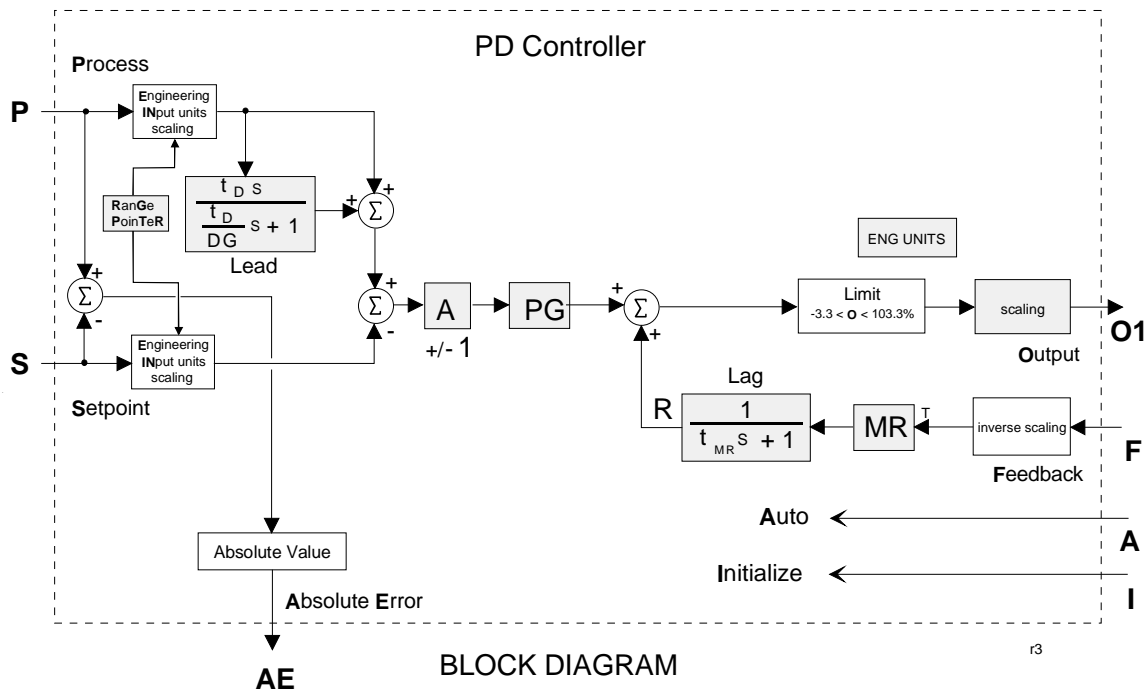

The process range pointer parameter should point to another function block that contains range scaling, such as an analog input that is the source of the process variable. This enables the controller to normalize tuning parameters for the process range. If this parameter is not configured, the controller will use a range scaling of 0.00-100.00. During a warm or cold power up the output will be initialized to MINSCALE and all dynamic elements will be initialized at the current input on the first scan.

The controller output has MINSCALE and MAXSCALE parameters allowing the output signal to be scaled for engineering ranges other than the default of 0 - 100 PRCT. This may be necessary when the controller output is the setpoint to another controller.

The Autotune feature is accessible using the TUNE pushbutton when AUTOTUNE is set to YES. It can be initiated while the loop is in Auto or Manual. The autotuner, when initiated, replaces the PD controller with an on-off control function, places the A/M block in Auto (if in Man), and cycles the control loop through six on-off cycles while learning the process dynamics which it uses to provide tuning recommendations for the PD controller.

The % DEV parameter is the maximum amount in % that the process should deviate from the setpoint during the on-off cycles. This parameter can be set manually or can be configured as AUTO. When AUTO is configured, the autotuner will set the % DEV to 4 times the % HYS. This is the minimum value needed to provide good autotuning results.

The % HYS parameter is the amount that the process must deviate from setpoint before switching the output in the opposite direction. This value must be equal to or slightly greater than any process noise band. If the noise band can not be determined, the autotuner will compute it at the start of an autotuning exercise when the % HYS parameter has been configured as AUTO.

The % STEP parameter is the amount that the valve will change on the first 1.5 on-off cycles. After the first cycles the autotuner will adjust the step to keep the process within the value of the % DEV parameter. On subsequent autotune exercises, the step will use the value computed from the previous exercise unless the AT RESET parameter is set to YES or the controller has been power cycled. The dynamic response recommended by the autotuner can be configured as Fast, Medium, or Slow. The Medium setting will normally provide a response that has no or little overshoot to a setpoint step response.

When the POST AT parameter is set to YES, the control loop will be returned to Auto using the recommended tuning values unless a warning occurred during the test.

More details on autotuning can be found in Section 8 Local Faceplate Operation.

3.2.68 PID - PID Controller

PID is a proportional + integral controller and one of five controller types that can be used on a one per loop basis. It uses external feedback to provide integral action. The block allows interaction with other function blocks or external devices, such as pneumatic controllers and shutoff switches, to eliminate the windup that can occur with other controller types. Derivative action is provided when the parameter TD is non-zero. The controller includes an autotune feature that can be initiated from the operator faceplate using the QUICK access feature.

When input A is high (1) the controller operates in the normal auto mode and when low (0) causes reset R to track (F-GE). This will force the controller output to track the feedback within the controller limits and allow the controller to switch back to auto without bumping the output.

The process range pointer parameter points to another function block that has range scaling, such as an analog input that is the process variable. This enables the controller to normalize the tuning parameters for the process range. If this parameter is not configured, the controller will use a range scaling of 0.00-100.00.

Input I, when changed from low (0) to high (1) or from high to low, will cause the controller to initialize (i.e. eliminate any proportional gain action during that cycle). This can be used to prevent bumping the output when changes are made to the setpoint using a switch block.

POWER UP - During a warm or cold power up, the output will be initialized to MINSCALE and all dynamic elements will be initialized at the current input on the first scan.

PID CONTROLLER

Range **R**

Process **P**

Setpoint **S**

Feedback **F**

Auto **A**

Initialize **I**

PID | ESN = 000

PID CONTROLLER

OR Output Range

O1 Output

AE Absolute Error

AW AT Warning

R	G	P	T	R	RanGe PoinTeR (S)	loop tag.block tag (null)
D	I	R	A	C	DIRect ACTing (H)	NO/YES (NO)
				P	Proportional Gain (S)	0.001 to 100.0 (1.000)
				T	Time - Integral (S)	0.001 to 4000 m/r (100.0)
				D	Time - Derivative (S)	0.00 to 100.00 min (0.00)
				D	Derivative Gain (S)	1.00 to 30.00 (10.00)
M	I	N	S	C	MINimum SCALE (H)	Real (0.0)
M	A	X	S	C	MAXimum SCALE (H)	Real (100.0)
				D	Decimal Point Position (preferred) (S)	0.0,0.0,0.0,0 (0.0)
E	N	G	U	N	ENGINEERING UNITS (S)	6 ASCII Char (PRCT)
A	U	T	O	T	AUTOTUNE (S)	NO/YES (YES)
				%	DEVIATION during Autotune (S)	AUTO, 2.5 to 25.0 (AUTO)
				%	HYSteresis during Autotune (S)	AUTO, 0.5 to 10.0 (AUTO)
				%	output STEP on first Autotune (S)	5% to 40% (10)
A	T	D	Y	N	AT DYNAMIC settings (S)	Fast, Medium, Slow (M)
A	T	R	E	S	AT RESET (S)	NO/YES (YES)
				P	POST Autotune Transfer (S)	NO/YES (NO)
				I	INPUT P (H)	loop tag.block tag.output (null)
				I	INPUT S (H)	loop tag.block tag.output (null)
				I	INPUT F (H)	loop tag.block tag.output (null)
				I	INPUT A (H)	loop tag.block tag.output (null)
				I	INPUT I (H)	loop tag.block tag.output (null)
				E	Exec. Seq. No. (H)	001 to 250

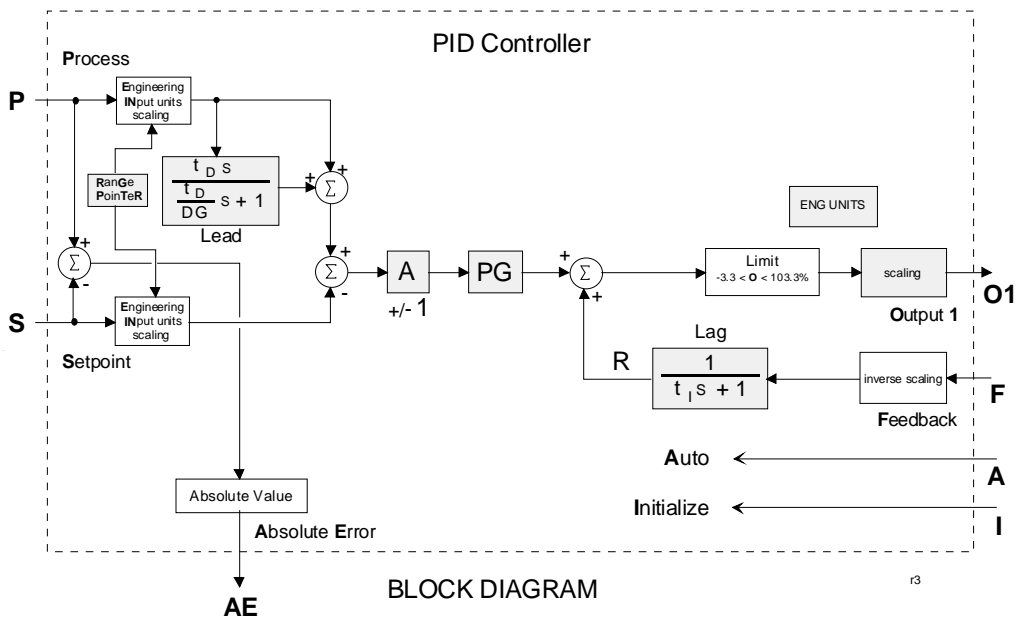

The controller output has MINSCALE and MAXSCALE parameters allowing the output signal to be scaled for engineering ranges other than the default of 0-100 PRCT. This may be necessary when the controller output is the setpoint to another controller.

The Autotune feature is accessible using the TUNE pushbutton when AUTOTUNE is set to YES and can be initiated while the loop is in Auto or Manual. The autotuner, when initiated, replaces the PID with an on-off control function, places the A/M block in Auto (if in Man) and cycles the control loop through six on-off cycles while learning the process dynamics which it uses to provide tuning recommendations for the PID controller.

The % DEV parameter is the maximum amount in % that the process should deviate from the setpoint during the on-off cycles. This parameter can be set manually or can be configured as AUTO. When AUTO is configured, the autotuner will set the % DEV to 4 times the % HYS. This is the minimum value needed to provide good autotuning results.

The % HYS parameter is the amount that the process must deviate from setpoint before switching the output in the opposite direction. This value must be at least equal to or slightly greater than any process noise band. If the noise band cannot be determined, the autotuner will compute it at the start of an autotuning exercise when the % HYS parameter has been configured as AUTO.

The % STEP parameter is the amount that the valve will change on the first on-off cycle. After the first cycle, the autotuner will adjust the step to keep the process within the value of the % DEV parameter. On subsequent autotune exercises, the step will use the value computed from the previous exercise unless the AT RESET parameter is set to YES or the controller has been power cycled. The dynamic response recommended by the autotuner can be configured as Fast, Medium, or Slow. The Medium setting will normally provide a response that has no or little overshoot to a setpoint step response.

When the POST AT parameter is set to YES, the control loop will be returned to Auto using the recommended tuning values unless a warning occurred during the test.

More details on autotuning can be found in Section 8 Local Faceplate Operation.

3.2.69 PIDAG - PIDAG Controller

PIDAG is an adaptive gain proportional + integral controller and is one of five controller types that can be used on a one per loop basis. It uses external feedback to provide integral action that allows interaction with other function blocks or external devices, such as pneumatic controllers, shutoff switches. PIDAG eliminates windup that can occur with other controller types. Derivative action is provided when the parameter TD is non-zero. The controller includes an autotune feature that can be initiated from the operator faceplate using the quick TUNE feature.

When input A is high (1) the controller will operate in the normal auto mode and when low (0) causes reset R to track (F-GE). This forces the controller output to track the feedback within controller limits and allow the controller to be switched back to auto without bumping the output.

The process range pointer parameter (input R) points to a function block that has range scaling, such as the analog input that is providing the process variable. This enables the controller to normalize the tuning parameters for the process range. If this parameter is not configured, the controller will use a range scaling of 0.00-100.00.

Input I, when changed from low (0) to high (1) or from high to low, will cause the controller to initialize (i.e. eliminate any proportional gain action during that scan cycle). This can be used to prevent bumping the output when changes are made to the setpoint using a switch block.

PIDAG CONTROLLER

Range **R**

Process **P**

Setpoint **S**

Feedback **F**

Auto **A**

Initialize **I**

Adaptive Gain **AG**

PIDAG | ESN = 000

PIDAG

CONTROLLER

OR Output Range

O1 Output

AE Absolute Error

AW AT Warning

R	G	P	T	R	RanGe PoiNtEr (S)	loop tag.block tag	(null)
D	I	R	A	C	DIRect ACTing (H)	NO/YES	(NO)
				P	Proportional Gain (S)	0.001 to 100.0	(1.00)
				T	Time - Integral (S)	0.001 to 4000 m/r	(100.0)
				D	Time - Derivative (S)	0.00 to 100.00 min	(0.0)
				D	Derivative Gain (S)	1.00 to 30.00	(10.00)
M	I	N	S	C	MINimum SCALE (H)	Real	(0.0)
M	A	X	S	C	MAXimum SCALE (H)	Real	(100.0)
				D	Decimal Point Position (preferred) (S)	0.0,0.0,0.0	(0.0)
E	N	G	U	N	ENGINEERING UNITS (S)	6 ASCII Char	(PRCT)
A	U	T	O	T	AUTOTUNE (S)	NO/YES	(YES)
				%	DEVIATION during Autotune (S) ... AUTO, 2.5 to 25.0		(AUTO)
				%	HYSTERESIS during Autotune (S) . AUTO, 0.5 to 10.0		(AUTO)
				%	output STEP on first Autotune (S)	5% to 40%	(10)
A	T	D	Y	N	AT DYNAMIC settings (S) .. Fast, Medium, Slow		(M)
A	T	R	E	S	AT RESET (S)	NO/YES	(YES)
				P	POST Autotune Transfer (S)	NO/YES	(NO)
I	N	P	U	T	INPUT P (H)	loop tag.block tag.output	(null)
I	N	S	U	T	INPUT S (H)	loop tag.block tag.output	(null)
I	N	F	U	T	INPUT F (H)	loop tag.block tag.output	(null)
I	N	A	U	T	INPUT A (H)	loop tag.block tag.output	(null)
I	N	I	U	T	INPUT I (H)	loop tag.block tag.output	(null)
I	N	A	G	U	INPUT AG (H)	loop tag.block tag.output	(null)
				E	Exec. Seq. No. (H)	001 to 250	

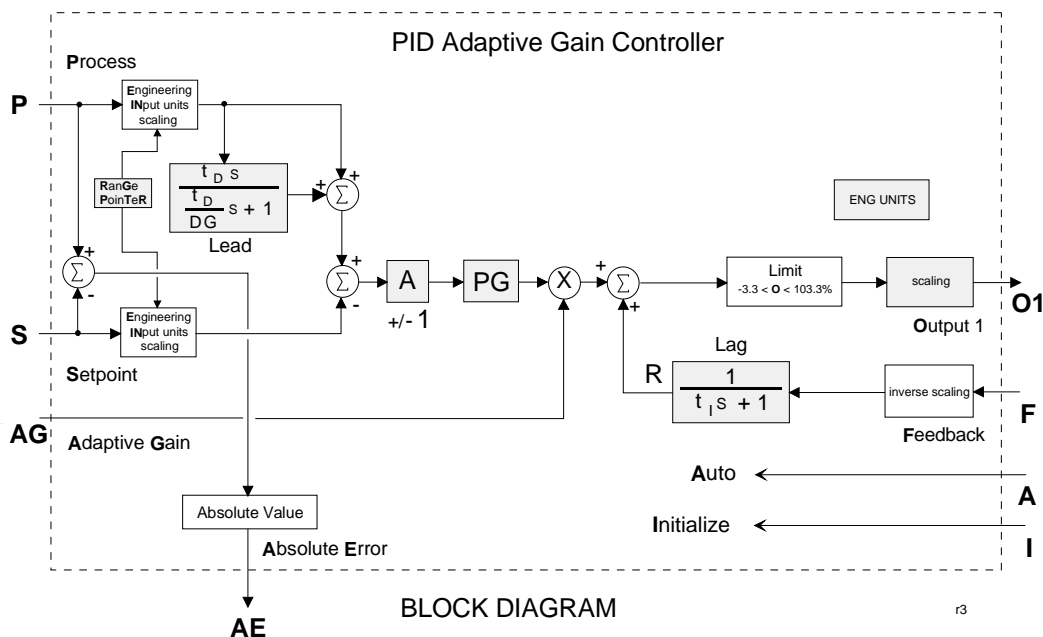

POWER UP - During a warm or cold power up, the output will be initialized to MINSCALE and all dynamic elements will be initialized at the current input on the first scan.

Input AG is multiplied by the gain error (GE). An unconnected AG input will be set to 1.0.

The controller output has MINSCALE and MAXSCALE parameters allowing the output signal to be scaled for engineering ranges other than the default of 0 - 100 PRCT. This may be necessary when the controller output is the setpoint to another controller.

The Autotune feature is accessible using the TUNE pushbutton when AUTOTUNE is set to YES and can be initiated while the loop is in Auto or Manual. The autotuner, when initiated, replaces the PIDAG with an on-off control function, places the A/M block in Auto (if in Man) and cycles the control loop through six on-off cycles while learning the process dynamics which it uses to provide tuning recommendations for the PIDAG controller.

The % DEV parameter is the maximum amount in % that the process should deviate from the setpoint during the on-off cycles. This parameter can be set manually or can be configured as AUTO. When AUTO is configured, the autotuner will set the % DEV to 4 times the % HYS. This is the minimum value needed to provide good autotuning results.

The % HYS parameter is the amount that the process must deviate from setpoint before switching the output in the opposite direction. This value must be at least equal to or slightly greater than any process noise band. If the noise band cannot be determined, the autotuner will compute it at the start of an autotuning exercise when the % HYS parameter has been configured as AUTO.

The % STEP parameter is the amount that the valve will change on the first on-off cycle. After the first cycle, the autotuner will adjust the step to keep the process within the value of the % DEV parameter. On subsequent autotune exercises, the step will use the value computed from the previous exercise unless the AT RESET parameter is set to YES or the controller has been power cycled. The dynamic response recommended by the autotuner can be configured as Fast, Medium, or Slow. The Medium setting will normally provide a response that has no or little overshoot to a setpoint step response.

When the POST AT parameter is set to YES, the control loop will be returned to Auto using the recommended tuning values unless a warning occurred during the test.

More details on autotuning can be found in Section 8 Local Faceplate Operation.

3.2.70 PRSEQ - Program Sequencer

PRSEQ function blocks are available on a one per loop basis. They can be used to generate a simple setpoint profile or a complex batch sequence involving multiple discrete input and output logic operations as well as setpoint profiles.

The number of steps is configurable using the STEPS parameter and the number of discrete inputs/outputs using the GROUPS parameter. Sixteen (16) discrete inputs/outputs are provided for each group. If these parameters are increased after the function block is initially configured, the values of all previously entered step parameters will be retained. If however, a configuration is downloaded from the PC-based Graphical Configuration Utility, the parameter values are determined by the download which includes the entire block configuration. The PRSEQ can store from 1 to 9 recipes. Each recipe will have the same number of steps and groups but all of the parameters can be configured differently.

Recipes can also be managed from the i|ware HMI. See application document AD353-133 for additional information. Refer to Section 1.3 Customer/Product Support for the Siemens Web site URL to download the publication.

Input RN will accept a recipe number and input LR on a positive transition will select the recipe number which is the RN input. The RN input will round the number to the nearest integer value. A recipe number that is out of range will have no effect and the current recipe will remain. The recipe number set by the RN and LR inputs will be retained during HOT and WARM starts. During a COLD start, the recipe will revert to the recipe set by the configuration parameter "Recipe."

Input SN will accept a step number and input GS, on a positive transition, will select the step number, which is the SN input. The SN input will round the number to the nearest integer value. A step number that is out of range will have no effect and the sequencer will remain at the current step.

Output AO (analog output) will track input TV when input TC is high (1). If input TC goes low (0), AO will remain at the tracked values unless either a timed step ramps AO to the AEP (analog end point) for the step or an event completes the step at which time AO will go to the AEP value for the completed step.

The current sequencer step can be changed by any of the following six events:

1. the Reset input R going high (1) moving it to step 1
2. Goto Step input GS going high (1) forcing the sequencer to the step indicated by the whole value of input SN
3. the Step Forward input SF going high (1) moving it to the next higher step unless on the last step
4. the Step Backward input SB going high (1) moving back to the previous step unless on the first step
5. a step time expiring advancing to the next step
6. all the discrete inputs nn are True (1) that match the input mask (a mask value of '0' is a 'don't care' condition) advancing to the next step

Input H will hold the remaining time of the current step and disable advancing of the sequencer by operations 5 and 6 but will allow operations 1, 2, 3, and 4 to move the sequencer to the starting position of a new step.

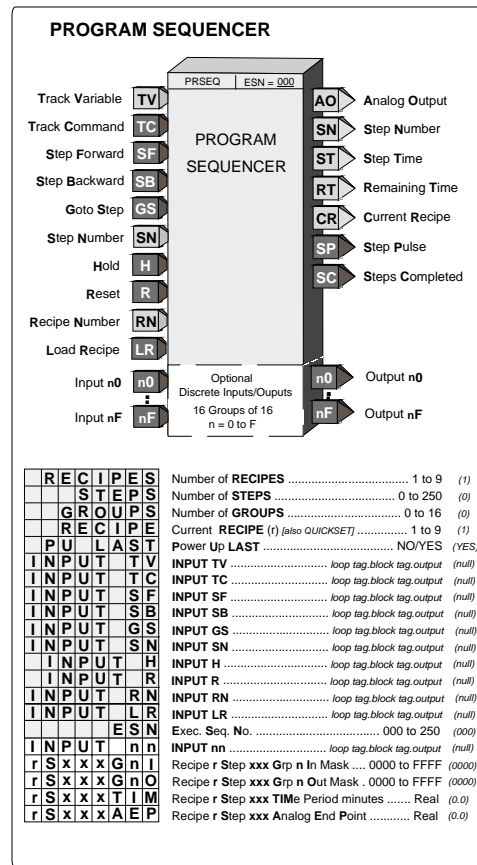

When the last sequencer step is completed, SC will be set high (1). The sequencer cannot be moved past the last step unless the reset input R goes high (1) forcing it to position 1. The sequencer can be moved forward only when in position 1. Network communications will allow the sequencer to be moved to a new step and the remaining time of the current step to be changed to a new value.

When discrete groups are used and a step is desired as 'timed only', one discrete input should be used to prevent the input mask from moving the sequencer to the next step. This can be accomplished by requiring a high (1) input and then not connecting that input, since unconnected inputs will be treated as 0.

When discrete groups are used and a step is desired as 'event only', the TIME parameter for the step should be set to 0.0. The Analog Output will remain at the AEP value of the previous step or, if at step 1, the Analog value will be 0.0. When the sequencer advances to the next step, the Analog Output will go to the AEP value for the completed step.

POWER UP - During a warm start, if PU LAST is set to YES, all outputs, step number, track variable, and remaining step time will be initialized at the last values prior to power fail. During a cold start all outputs are initialized to 0 and the PRSEQ is in a reset condition.

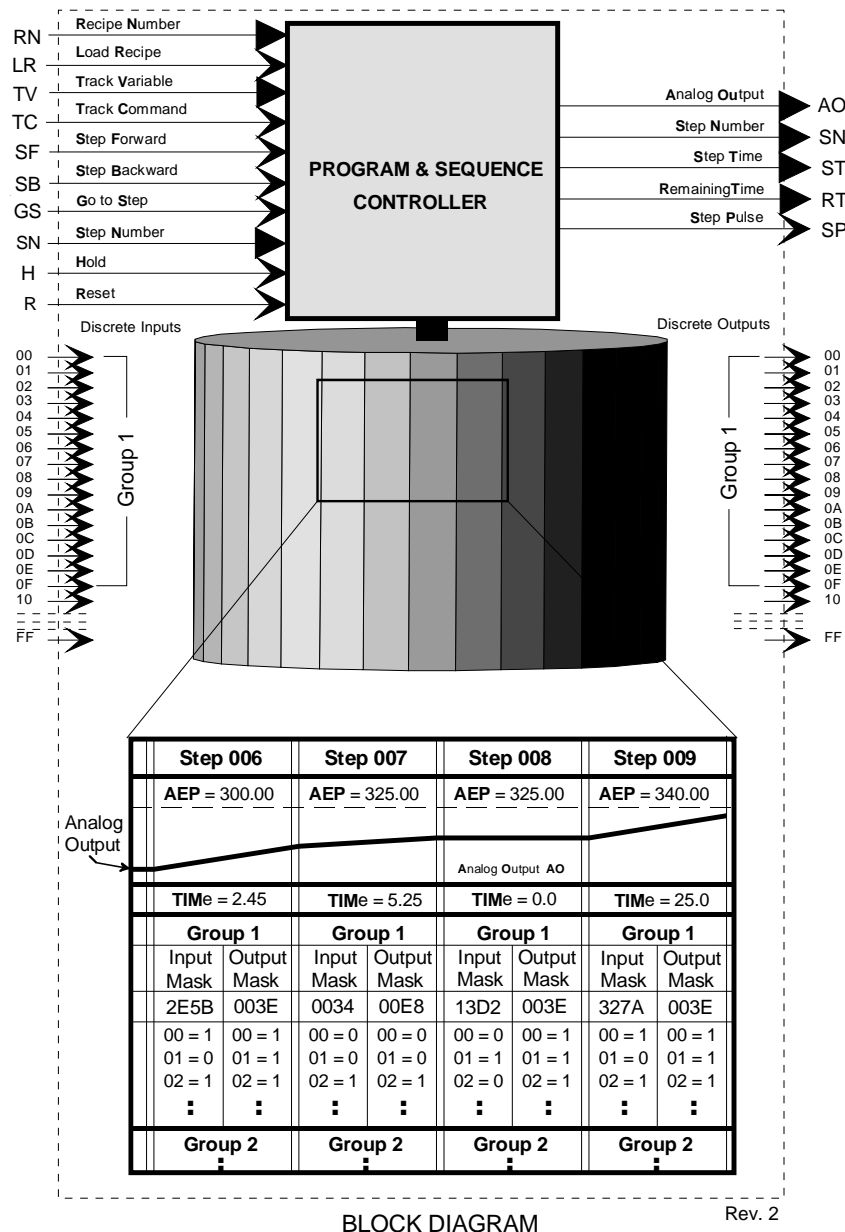

BLOCK DIAGRAM

Rev. 2

3.2.71 QHD_ - Quickset Hold

QHD_ function blocks enable a real value to be changed on-line using the QUICKSET feature. The block is identified by an 8-character name that will be displayed in the QUICKSET mode. The block is configured with a range entered as MIN SCALE and MAX SCALE to set a usable range, and a Decimal Point Position parameter can set the allowed precision. The hold value can not be changed beyond the -10% to 110% value of these limits and will change continuously as the pulser is turned. The MAX value must always be set greater than the MIN value. The block can also be forced to track input TV by asserting input TC high (1).

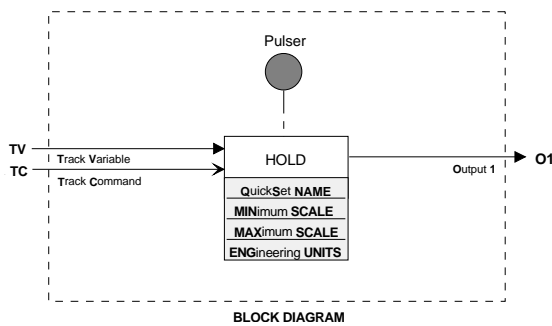

QUICKSET HOLD

Track Variable

TV

QHD_ ESN = 000

QUICKSET HOLD

OR

O1

Output Range

Output 1

Q	S	N	A	M	E	QuickSet NAME (S)	8 ASCII Char	(null)			
M	I	N	S	C	A	L	E	MINimum SCALE (H)	Real	(0.00)	
M	A	X	S	C	A	L	E	MAXimum SCALE (H)	Real	(100.00)	
						D	P	P	Decimal Point Position (preferred) (S) ...	0.0.0.0.0.0	(0.00)
E	N	G	U	N	I	T	S	ENGINEERING UNITS (S)	6 ASCII Char (PRCT)		
Q	S	C	H	A	N	G	E	Quick Set CHANGE ...	Continuous/Store	(C)	
P	U	V	A	L	U	E		Power Up VALUE (S)	Real	(0.00)	
P	U	L	A	S	T			Power Up LAST (S)	No/Yes	(YES)	
I	N	P	U	T	T	V		INPUT TV (H)	loop tag.block tag.output	(null)	
I	N	P	U	T	T	C		INPUT TC (H)	loop tag.block tag.output	(null)	
						E	S	N	Exec. Seq. No. (H)	001 to 250	Rev. 2

QSCHANGE enables the block output to either update continuously in the Quickset mode as the pulser knob is turned or to only update the output with the value in the numeric display when the STORE button is pressed.

When configuring the DPP (Decimal Point Position) it is important to keep the resolution to the minimum necessary for operation changes. It will take the operator longer turning the pulser if the resolution is too high. For example, if only 0.1% changes are needed, configure a 0-100 range as 0.0 – 100.0 and not 0.000 – 100.000.

During Hot or Warm start, the QHD will power-up in the last position during a Cold start at the -10% range value.

3.2.72 RATIO - Ratio

RATIO function blocks can be used on a one per loop basis. They provide a means of setting a ratio in an external setpoint application, for example, controlling a captive flow while maintaining the ratio between a wild flow and the captive flow at the desired value. Inputs A and E (external ratio) and the operator set ratio R value are multiplied and become the function block output O1.

Track Command input TC, asserted high (1), causes the ratio block to track the input variable TV. The ratio value to be recalculated is then $R = TV / (A \times E)$. The value of R will be limited at the HI or LO LIMIT range settings. The factory default settings of the ratio limits are 0.00 - 30.00.

The RATIO can be adjusted using the QUICKSET feature if parameter QUICKSET is set to YES. The RATIO will continuously change as the knob is adjusted. Press the STORE button when the final value is reached to insure that the new RATIO setting will be retained on a Cold power up condition. The QS DPP parameter enables setting of the Ratio adjustment resolution when in the QUICKSET mode.

If input A or E is not configured, its value will be set to 1. When input TC or TV is not configured, its value will be set to 0.

The TO (Tracked Output) is normally used in applications where an external device is being used to set a ratio in place of the RATIO parameter (R is then set to 1.0). When it is desired to have the output of the RATIO block track the TV variable, the external device is forced to track TO. Input E will then equal $TV/[A \times (1.0)]$ and, therefore, the RATIO block output O1 will equal TV.

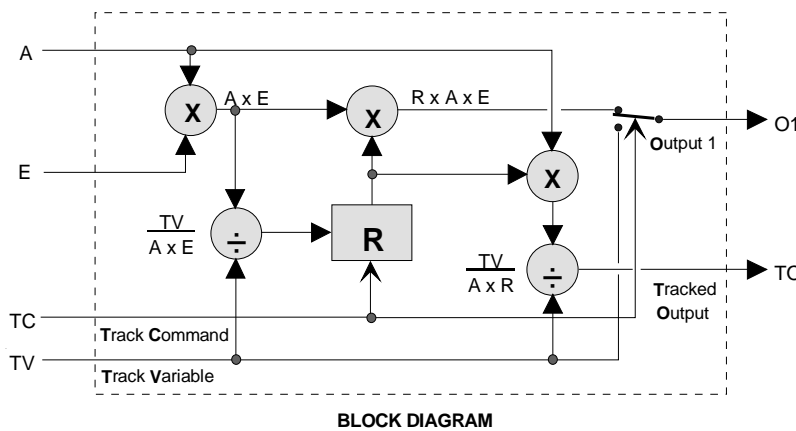
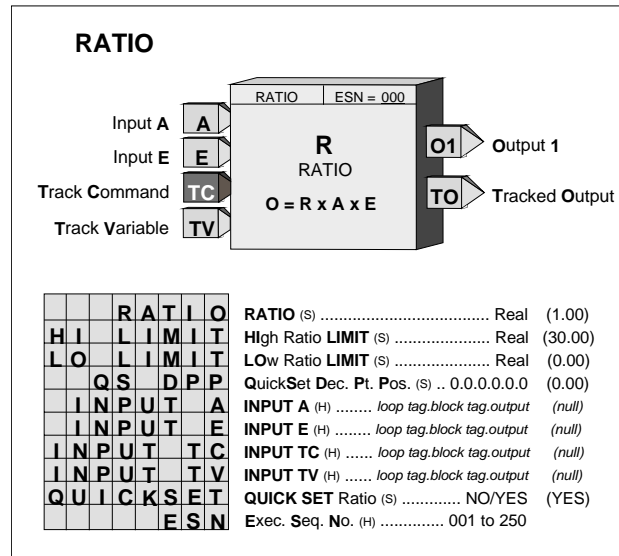

When a configuration containing the RATIO function block is edited in i/config and then downloaded to an on-line controller, the controller will ignore a change to the RATIO parameter value and continue to run with the pre-download value.

3.2.73 RCT_ - Repeat Cycle Timer

RCT_ function blocks provide repeat time cycles that can be used in logic timing operations or with PID blocks to provide adaptive on times controlled by the PID block. Output ET will provide the time in minutes that has elapsed during the current cycle (ON + OFF). Output RT is the remaining time in the current cycle and will equal the total cycle time (ON + OFF) when the timer has not been started.

The ON and OFF TIME is adjustable over the full range of the display which is 0.00000 to 999999. If the delay time is set to less than the scan time of the station the delay time will equal the scan time.

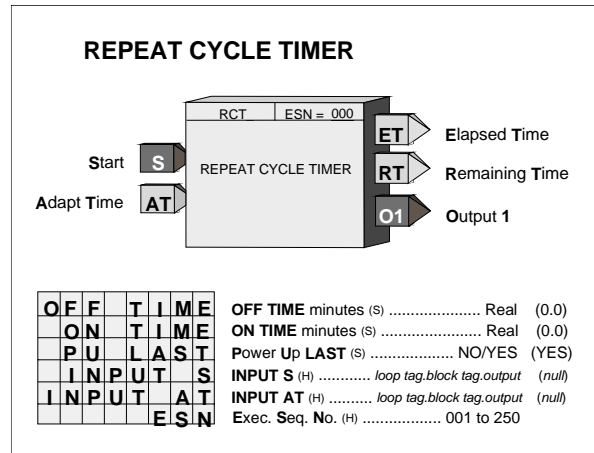

Input S, asserted high (1), will cause the RCT block to start the timing cycle. Output O1 will first go high (1) for a time set by ON TIME and then it will go low (0) for a time set by OFF TIME. It will continue to repeat this cycle until input S is asserted low (0) which forces O1 low (0) and ends the timing cycle.

ADAPTIVE ON TIME - this feature is active only when input AT is configured. It has a valid range of 0.0 to 1.0 and there are two separate modes of adaptive on time depending on the configuration of the OFF TIME parameter.

- OFF TIME = 0.0 - The time cycle will remain fixed and equal to the value of ON TIME. The output will be high for a period equal to ON TIME x AT.
- OFF TIME > 0.0 - The output will be low (0) for a period equal to OFF TIME and will be high for a period equal to ON TIME x AT. The time cycle equals [(ON TIME x AT) + OFF TIME].

POWER UP - With the PU LAST parameter set to YES, during a hot or warm power up the block will initialize the input/output states and elapsed time at the last values. During a cold start, they will be set to 0. With PU LAST set to NO, during a hot start the block will initialize the input/output states and elapsed time at the last values. During a warm or cold start, they will be set to 0.

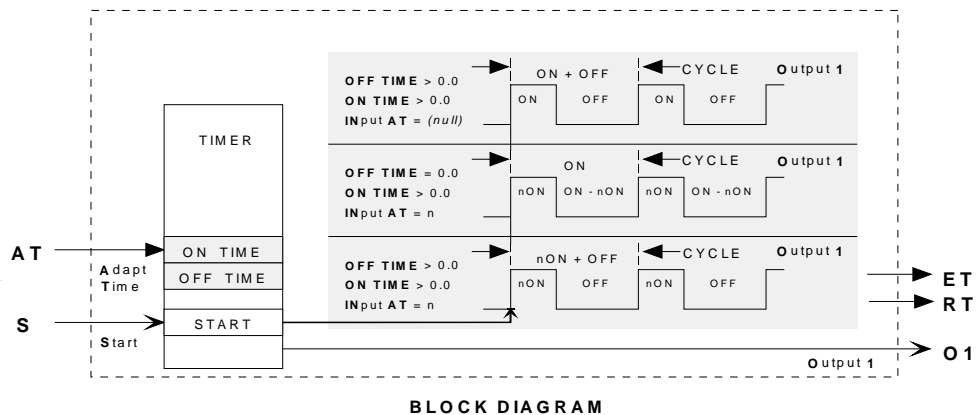

3.2.74 RLM_ - Rate Limiter

RLM_ function blocks limit the rate of change of analog input A. Separate up and down rates are entered in configuration, in engineering units per minute. Output RL will be high (1) if the block is limiting a rising input signal and output FL will be high when the block is limiting a falling input signal.

The Adaptive Rate inputs will vary the configured adaptive rate between 0 – 100% as the input varies from 0 to 100%. When the input is not configured the adaptive rate will not apply.

Input E asserted high (1) will enable the limit action of the block. When input E is low (0), the output will track the analog input. If input E is not configured, the limit action of the block will be enabled

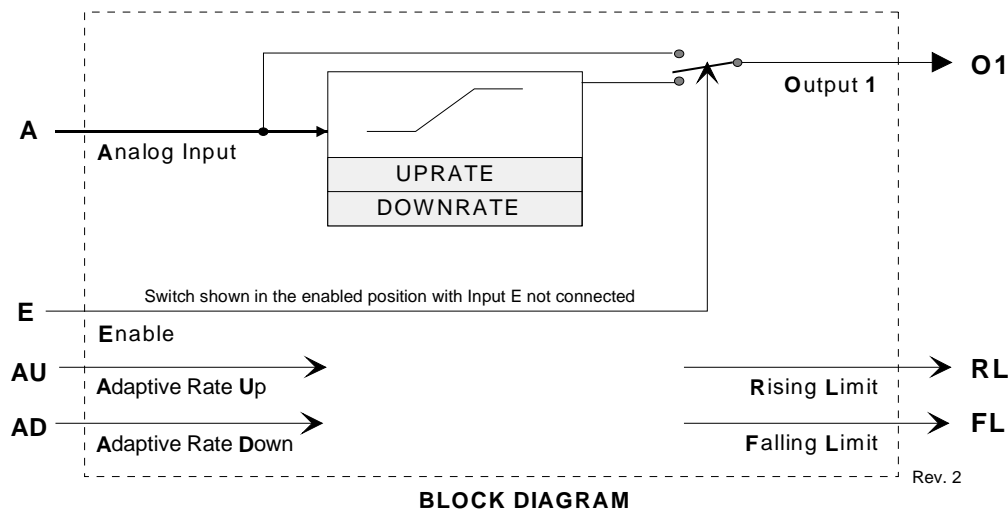
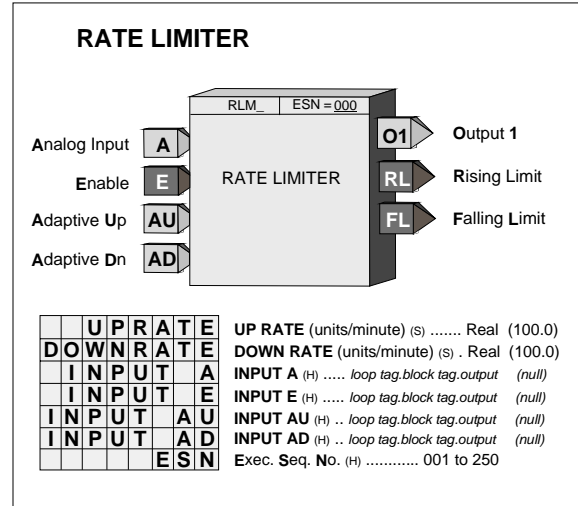

3.2.75 ROT_ - Retentive On Timer

ROT_ function blocks perform an on-delay timing function with output states determined by inputs ON and EN.

When input EN is low (0) outputs D and ND are low and when input EN is high (1), the outputs will be determined by the ON input and the elapsed time.

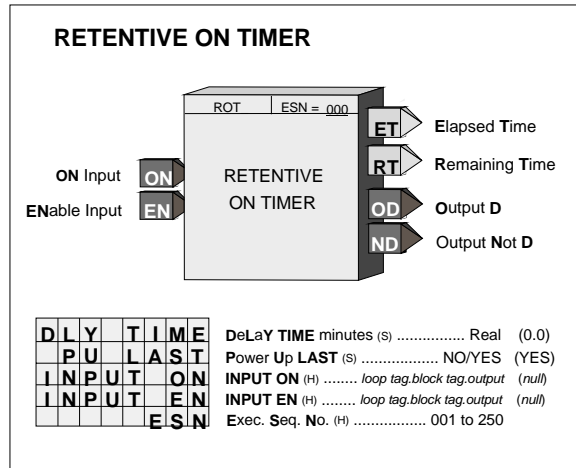
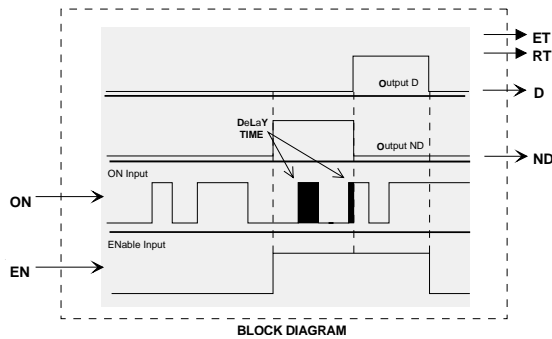

When ON goes high the elapsed time will start. Output D will go high after ET (elapsed time) equals or exceeds the DLY TIME. Output RT (remaining time) equals DLY TIME - ET.

If ON goes low, the elapsed time will stop at the current value and will continue when ON returns to a high state. The elapsed time returns to 0.0 when input EN goes low. Output ND will be high (1) if input EN is high and output D is not high. The DLY TIME is adjustable over the full range of the display which is 0.00000 to 999999. If the delay time is set to less than the scan time of the station the delay time will equal the scan time.

POWER UP - During a warm start, when PU LAST is set to YES, the block will initialize at the input/output states and elapsed time at the instant power down occurred. A cold start will initialize the input/output states and elapsed time to 0.

3.2.76 ROUT_ - Relay Outputs

ROUT_ function blocks provide SPDT contacts activated by function block input C. The relay will turn on when the block input is high (1) and will turn off when low (0). Two relay outputs are available on the Expander Board.

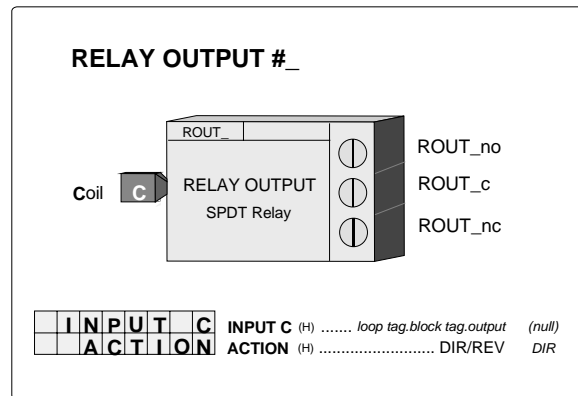
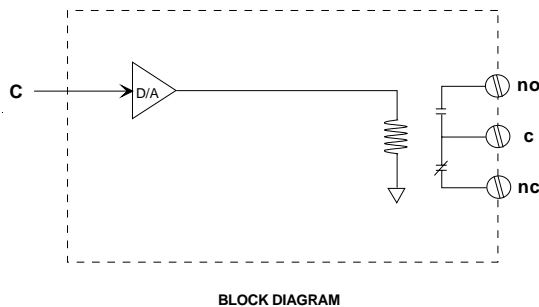

Terminal Connections are listed in Section 7.4 Electrical Installation.

3.2.77 RSF_ - RS Flip-Flop

RSF_ function blocks perform a reset dominant flip-flop function as detailed in the truth table. An unused S input will be set high (1) and an unused R input will be set low (0).

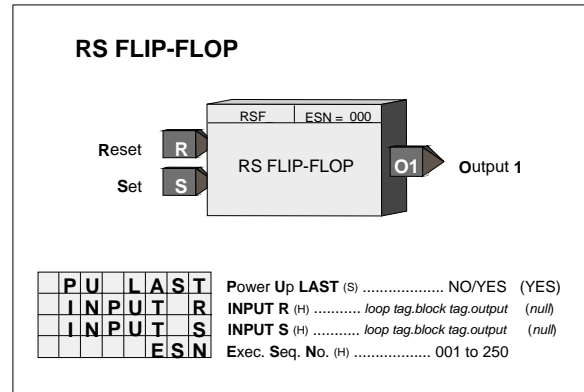
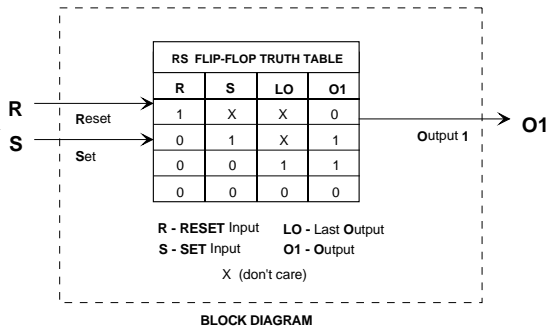

POWER UP - During a warm start, when PU LAST is set to YES, the block will initialize at the input/output states at the instant power down occurred. A cold start will initialize the input/output states to 0.

3.2.78 RTG_ - Rising Edge Trigger

RTG_ function blocks provide a high (1) output for one scan cycle each time input P transitions from a low (0) to a high (1).

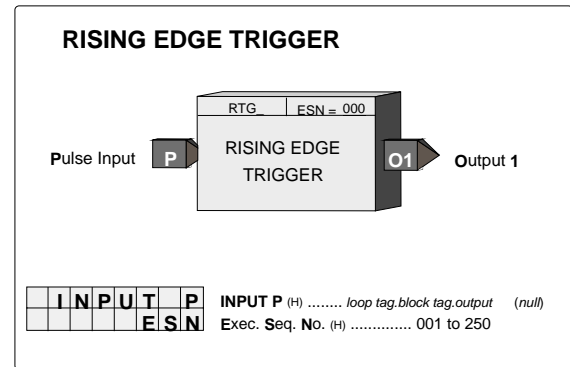
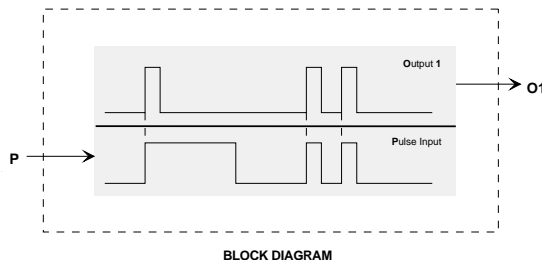

3.2.79 RTT_ - Real Time clock Trip

RTT_ function blocks provide high (1) outputs when time from the **CLOCK** block coincides with the **TIME**, **DATE**, & **DAYS** of the Week **TRIP** settings. The block outputs will remain high while the **CLOCK** coincides with the settings.

Output **TM** will go high when the **TIME** coincides with the **TIME TRP** setting. It will remain high for 1 second.

Output **DT** will go high when the **MONTH**, **DAY**, & **YEAR** coincides with the **MNTH TRP**, **DAY TRP**, & **YEAR TRP**. It will remain high for one day.

Output **DY** will go high when the Day of the Week, calculated by the 353, corresponds to the **MONTH**, **DAY**, & **YEAR**.

The **Clock Status** output will go high if there is a problem with the clock or the clock has been reset. The **Battery Status** will go high if the battery is low. The battery low condition could also cause a clock reset when the power is cycled. These outputs can be used to trip a **User Status** alarm condition or in logic to force a loop to manual, standby, hold, etc. Status outputs could be intermittent and may require configuration of function block logic to latch the status and operator interaction using pushbutton switches to clear.

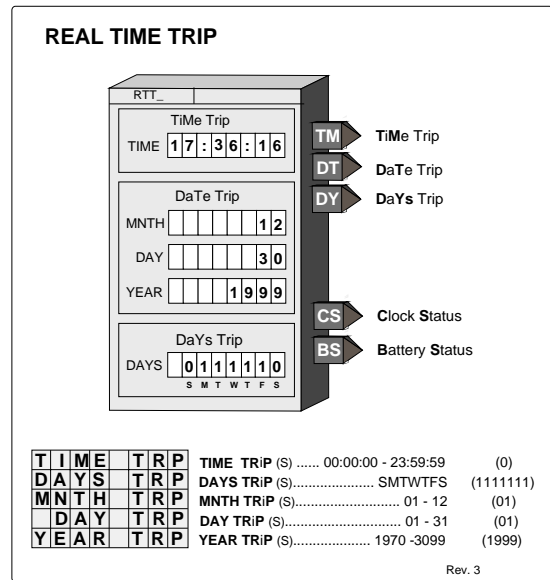

3.2.80 SCL_ - Scaler

SCL_ function blocks provide a means to scale an analog signal. It will re-range a signal by using the range pointer to reference the function block with the original range. When the range pointer (input R) is not configured, the function block will not re-scale the input signal but will pass it directly to the output. The purpose, under this situation, would be to provide minimum and maximum scale, preferred decimal point position, and units for another block (e.g. operator display) to reference.

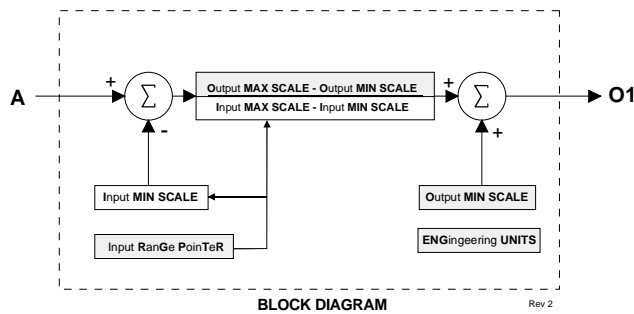

SCALER

	R	G	P	T	R	RanGe PoiNteR (S)	loop tag.block tag	(null)		
M	I	N	S	C	A	L	E	Output MINimum SCALE (H)	Real	(0.00)
M	A	X	S	C	A	L	E	Output MAXimum SCALE (H)	Real	(100.00)
					D	P	P	Decimal Pt. Position (preferred) (S) ...	0.0.0.0.0.0	(0.00)
E	N	G	U	N	I	T	S	ENGINEERING UNITS (S)	6 ASCII Char	(PRCT)
I	N	P	U	T	A			INPUT A (H)	loop tag.block tag.output	(null)
					E	S	N	Exec. Seq. No. (H)	001 to 250	

3.2.81 SEL_ - Signal Selector

SEL_ function blocks can provide a high or low signal selection on the three input signals. Unused inputs will be set equivalent to the lowest real value when configured as a HI selector and to the highest real value when configured as a LO selector.

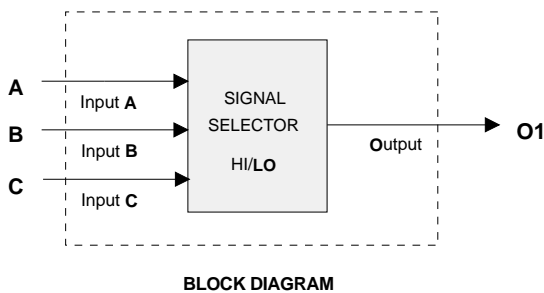

SIGNAL SELECTOR

S	E	L	T	Y	P	E	S	E	L	E	c	T	O	R	T	Y	P	E	(S)	LO/HI	(LO)
I	N	P	U	T	A														INPUT A (H)	loop tag.block tag.output	(null)
I	N	P	U	T	B														INPUT B (H)	loop tag.block tag.output	(null)
I	N	P	U	T	C														INPUT C (H)	loop tag.block tag.output	(null)
					E	S	N												Exec. Seq. No. (H)	001 to 250	

3.2.82 SETPT - Setpoint

SETPT function blocks can be used on a one per loop basis to permit operator adjustment of the controller setpoint within the loop. The on-line setpoint is adjustable, using the pulser knob, while <loop tag>.S is the displayed variable; unless the track command TC is high (1), at which time the setpoint will track the TV input.

A setpoint ramping feature allows the setpoint to ramp to a TARGET value. The start of a ramp can be initiated using a communication command asserting input SR high (the ramp starts on a positive transition of the SR input), or using the RAMP ON/OFF function in the QUICKSET mode. Both ramp RATE and ramp TIME can be set in configuration. Setting configuration parameter USE RATE to YES will cause the setpoint to change at the rate setting and ignore a configured ramp time. The RTIME or RRATE, TARGET, and PU SETPT values can be set using the QUICKSET feature if the QUICKSET parameter is set to YES.

The RG PTR, range pointer, parameter determines the normal operating range of the function block. If the pointer is not configured the block will use 0.00 to 100.00. The range of the setpoint block will be limited to -10% to 110% of the range parameter. If a range change is made the current setpoint, ramp rate, target setpoint, and power up setpoint will be moved to be the same % values within the new range.

The setpoint block also has two inputs LU and LD that can be used to limit pulser changes in one direction. This can be used if another function block is limiting the setpoint and it is desired not to allow the operator to adjust the setpoint block to a value beyond the external limit.

POWER UP - The function block can be configured to power up in various conditions during a warm start. If the PU LAST parameter is set to YES, the block will power up with the last setpoint. When SETPT does not power up in last position or on a cold start, it will power up using the PU SETPT parameter.

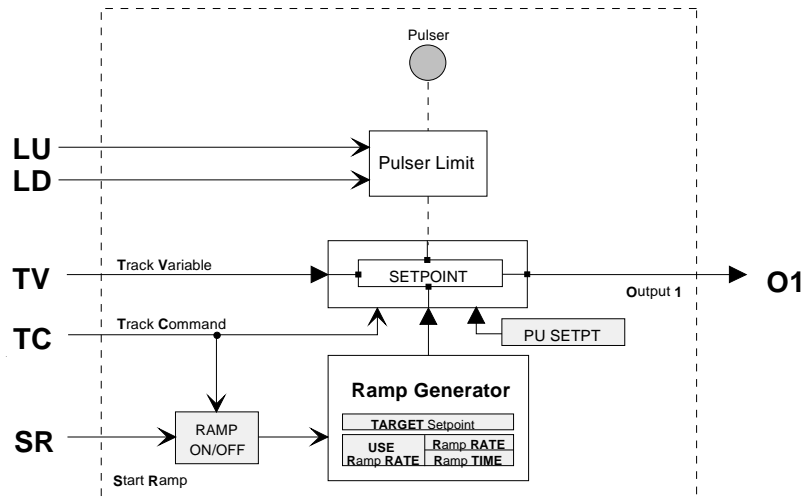
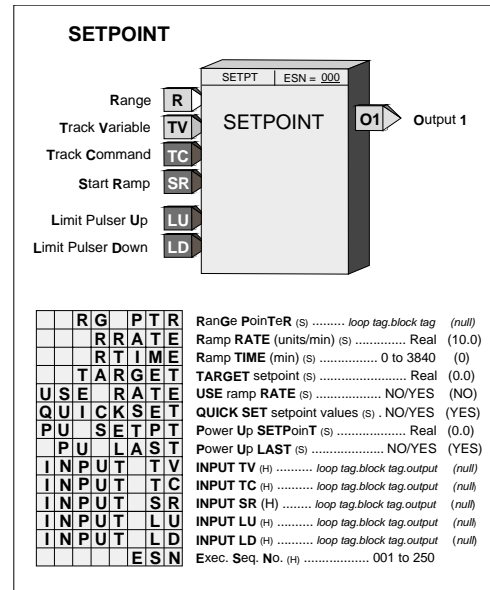

3.2.83 SIN_ - SINE

SIN__ function blocks accept a radian input and output the sine of that angle.

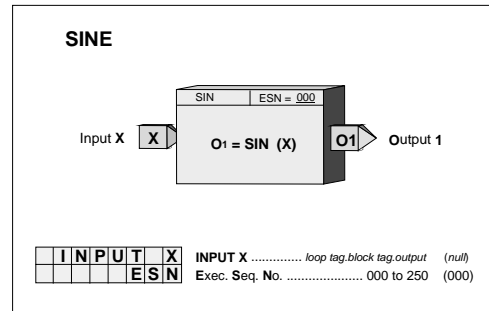
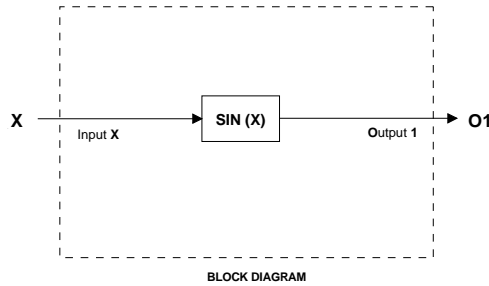

3.2.84 SPLIM - Setpoint Limit

SPLIM function blocks can be used on a one per loop basis to limit the setpoint of the loop controller. Input A will pass through the function block to output O1 unless it equals or exceeds the High limit setting or exceeds the Low limit setting at which time the block will output the limit value.

If the HI LIMIT is set lower than the LO LIMIT, the block will always output the high limit value.

Output status HS or LS will be high (1) if the block is in a limit condition. The status event 'S HI LIM' or 'S LO LIM' will be displayed in the alphanumeric if the SL PRIOR is greater than 0. A priority of 0 disables the reporting of the limit function and sets the bits in the status word to 0. See the table on the next page for additional details regarding priorities.

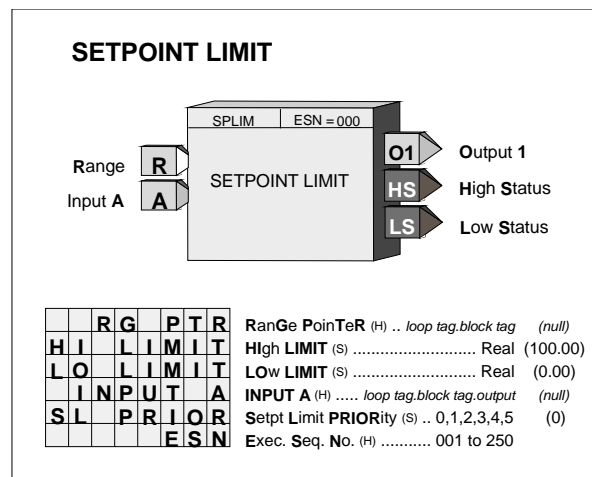

The SPLIM function block has an RG PTR parameter (input R) that defines the normal operating range of the block. Limit settings can be made within -10% to 110% of the range pointer values. If the range pointer is not configured, a range of 0.0 to 100.0 will be used. If a range change is made the current limit value will be moved to be the same % value within the new range.

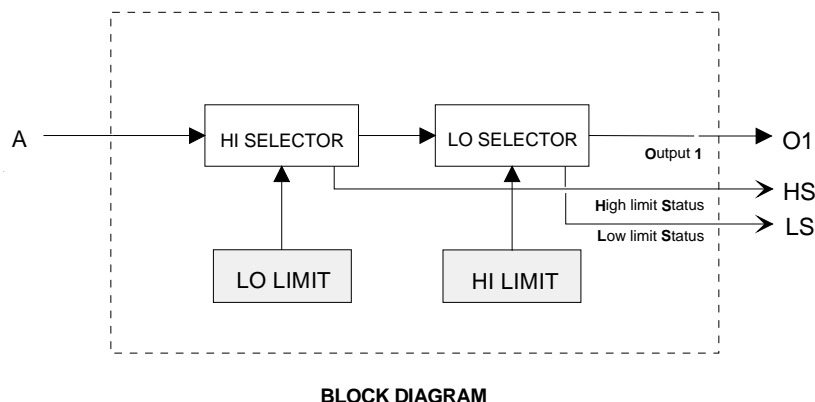

PRIORITIES - The priority assigned to SL PRIOR will affect the operation as follows (the outputs HS and LS will go high with all priority assignments, including 0, when event is active):

1. Bargraphs, event LEDs, and condition will flash. ACK button must be used to stop flashing.
2. Bargraphs, event LEDs, and condition will flash. Flashing will stop if ACK or if event clears.
3. Event LEDs and condition will flash. ACK button must be used to stop flashing.
4. Event LEDs and condition will flash. Flashing will stop if ACK or event clears.
5. Event LEDs and condition will turn on when event is active and off when the event clears.
0. No display action occurs when event is active. The HL and LL status bits are always set to 0.

3.2.85 SRF_ - SR Flip-Flop

SRF_ function blocks perform a set dominant flip-flop function as detailed in the truth table. An unused R input will be set high (1) and an unused S input will be set low (0).

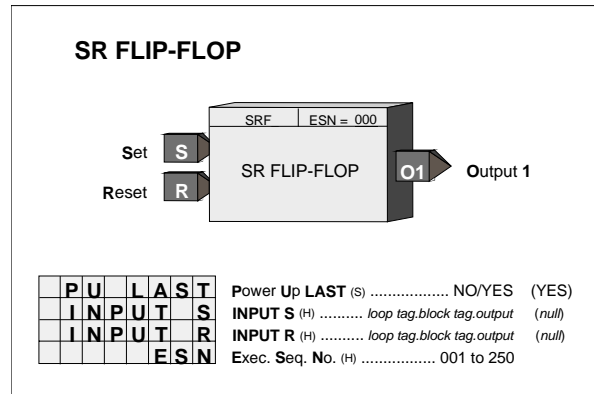
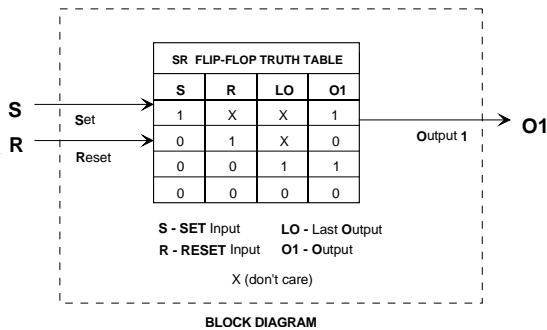

POWER UP - During a warm start, when PU LAST is set to YES, the block will initialize at the input/output states at the instant power down occurred. A cold start will initialize the input/output states to 0.

3.2.86 SRT_ - Square Root

SRT_ function blocks compute the square root of input signal A. The input has a built-in low limit that will limit the signal to the square root computation to 0.0.

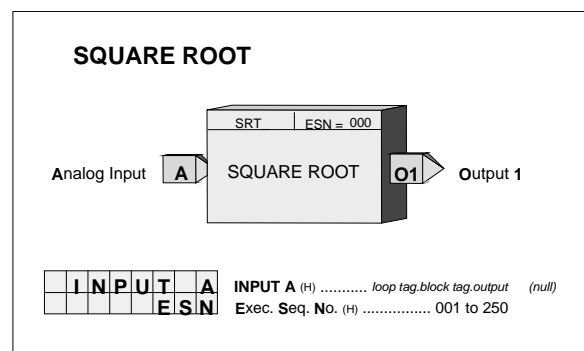
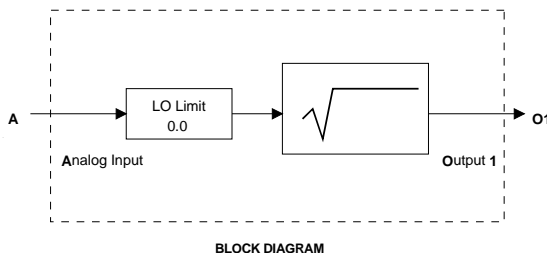

3.2.87 SUB_ - Subtraction

SUB_ function blocks perform arithmetic subtraction on the two input signals. Any unused input will be set to 0.0.

All inputs should have the same engineering units. If units are not consistent, a SCL function block can be used or an alternative is to use a MTH function block that has built-in scaling functions.

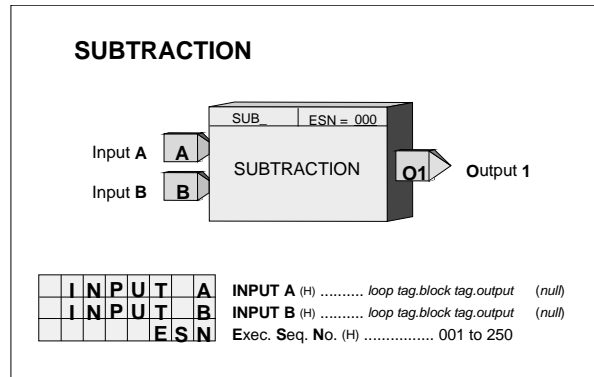
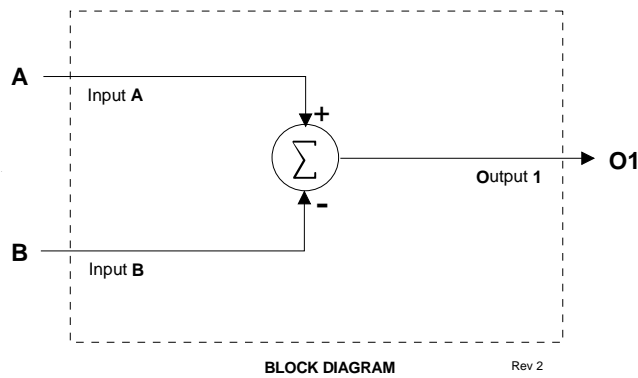

3.2.88 TAN_ - TANGENT

TAN_ function blocks accept a radian input and output the tangent of that angle.

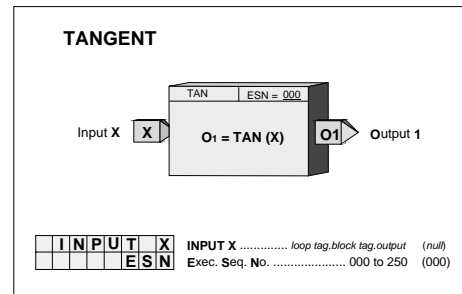
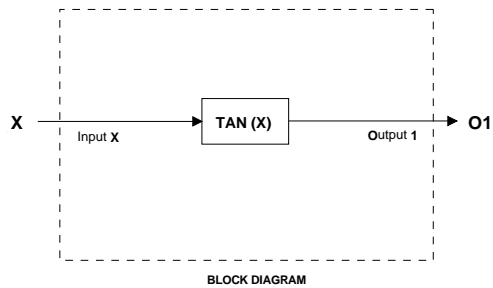

3.2.89 TH_ - Track & Hold

TH_ function blocks can hold an initial value that will transfer to the block output O1 on power up and it can be used to track the TV input when input TC is high (1).

The HOLD value can be changed on line, using the pulser, when the TH_.O1 block output is directly connected to X or Y inputs in an ODC block. The range and resolution used by the pulser making on line changes will be determined by the X Range or Y Range inputs.

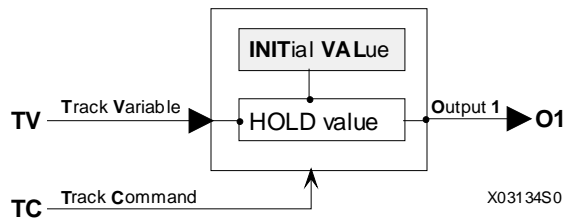

BLOCK DIAGRAM

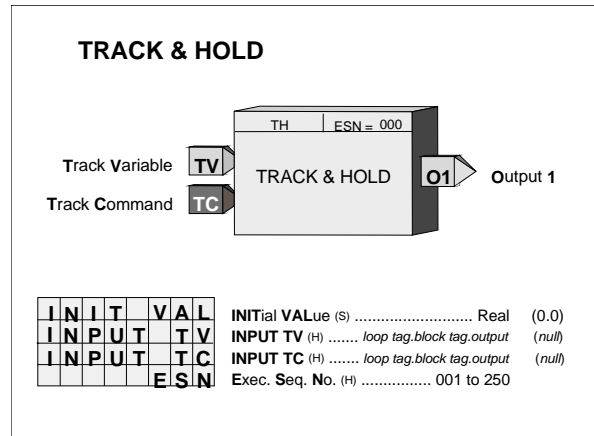

3.2.90 TOT_ - Totalizer

TOT_ function blocks accept a Boolean input and they will retain a running total of the input transitions as the block output as a real value for interconnection to other blocks in the controller. The running total can be reset when input R goes high (1). Input R is executed prior to reading input S on each scan cycle.

Unconfigured inputs will be set to 0. When the EDGETRIG parameter is set to 1, the total will increment on each 0 to 1 transition on input S. When the EDGETRIG parameter is set to 0, the total will increment on each 1 to 0 transition.

The total will be retained during a WARM & HOT start and will be initialized to 0.0 on a COLD start.

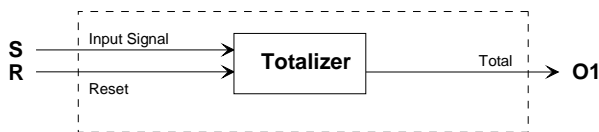

BLOCK DIAGRAM

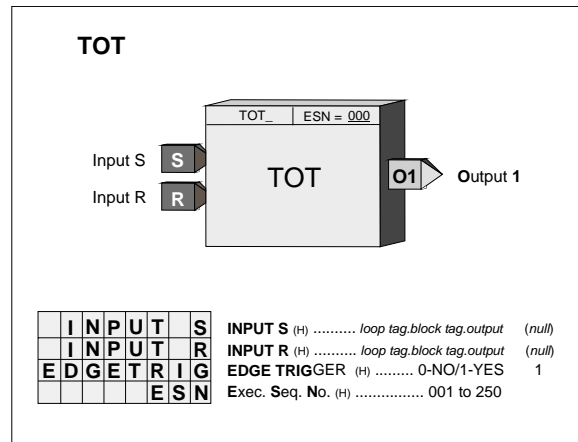

3.2.91 TSW_ - Transfer Switch

TSW_ function blocks select one of two analog input signals as the output signal. Input A becomes the output when input SC is low (0) and input B will be the output when input SC goes high (1).

Unconfigured inputs will default to SC=low(0), A=0.0, B=100.0.

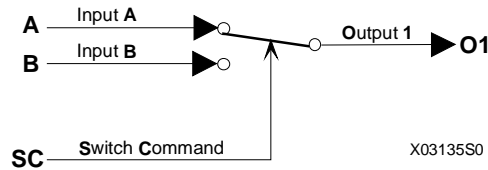

BLOCK DIAGRAM

TRANSFER SWITCH

I	N	P	U	T	A	INPUT A (H)	loop tag.block tag.output	(null)	
I	N	P	U	T	B	INPUT B (H)	loop tag.block tag.output	(null)	
I	N	P	U	T	S	C	INPUT SC (H)	loop tag.block tag.output	(null)
				E	S	N	Exec. Seq. No. (H)	001 to 250	

3.2.92 XOR_ - Exclusive OR Logic

XOR_ function blocks perform a logical exclusive OR function on all three inputs. An unused input will cause the block to function as a two input XOR. The XOR output will be low (0) when all configured inputs are low (0) or when all configured inputs are high (1).

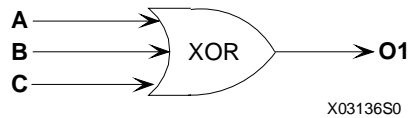

X03136S0

XOR TRUTH TABLE			
A	B	C	Output 1
0	0	0	0
0	0	1	1
0	1	0	1
0	1	1	1
1	0	0	1
1	0	1	1
1	1	0	1
1	1	1	0

XOR

I	N	P	U	T	A	INPUT A (H)	loop tag.block tag.output	(null)
I	N	P	U	T	B	INPUT B (H)	loop tag.block tag.output	(null)
I	N	P	U	T	C	INPUT C (H)	loop tag.block tag.output	(null)
				E	S	N	Exec. Seq. No. (H)	001 to 250

4.0 FACTORY CONFIGURED OPTIONS

Factory Configured Options provide an easy way to configure a Model 353. In most cases a Factory Configured Option (FCO) will provide a complete, functional loop controller, once the proper I/O connections are made. Changes can be made to an FCO to meet individual requirements. The FCO listings on the following pages document the parameters that are different than the default values listed in Section 3 Function Blocks. Some things to keep in mind when making changes are:

- a) All analog signals have been configured for an engineering range of 0.00 to 100.00. In most cases converting to other engineering units will require changing only the range at the source (e.g. Analog Input function block). All other blocks (i.e. Controller, Operator Display, Alarm, and Setpoint) that require knowledge of the range have range pointers that point to the signal source (e.g. Analog Input block) for this information.
- b) A number of function blocks have parameters that may be affected by range pointers. The range pointer limits the setting of parameter values to within -10% to 110% of the range. If a range is changed, the current parameter values will be changed to the same % within the new range. For example, if the range is 0.0-100.0 and the Alarm 1 Limit setting is 90.0 and the range is changed to 400.0-500.0 the alarm setting will be changed to 490.0.
- c) All controller (i.e. ID, PID, PD, PIDAG) outputs have an engineering range of 0.0-100.0 which will be satisfactory in most cases since outputs normally convert to a 4-20 mA signal to drive a valve 0-100% Open or Closed. However, when a controller is used in a cascade configuration, the primary controller output must be configured for the same engineering range as the secondary controller process.
- d) FCOs do not change Station parameters or calibration.
- e) FCO 0 deletes all loops and sets all parameters in the STATN & SECUR function blocks to default values. Calibration is not affected. As new loops and function blocks are added, parameters will appear at default values.

4.1 FCO101 - Single Loop Controller w/ Tracking Setpoint

Factory Configured Option FCO101 provides a single loop controller configured in Loop01. A block diagram of the loop configuration is shown below along with any *changes* to the default parameter values of the configured blocks. This configuration provides setpoint tracking which will cause the setpoint to track the process when the loop is not in Auto (NA). If the loop tag 'Loop01' is changed, all configured references within the station will automatically be changed to the new tag.

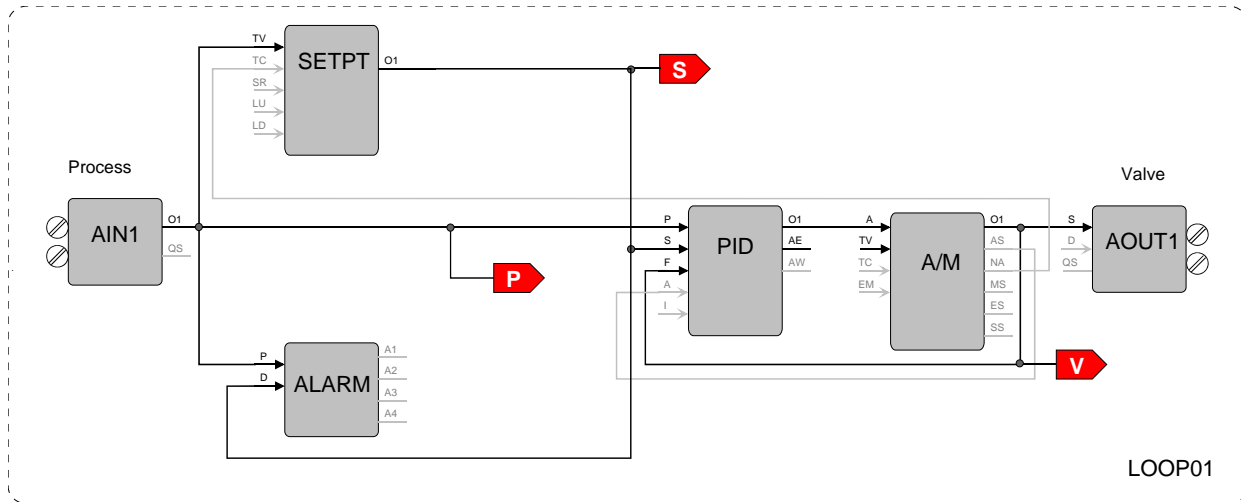

SETPT - Setpoint Function Block

RG PTR - Range Pointer ----- Loop01.AIN1.OR
 INPUT TV - Input TV ----- Loop01.AIN1.O1
 INPUT TC - Input TC ----- Loop01.A/M.NA
 ESN - Exec. Seq. No.----- 5

ALARM - Alarm Function Block

RG PTR - Range Pointer ----- Loop01.AIN1.OR
 INPUT P - Input P ----- Loop01.AIN1.O1
 INPUT D - Input D ----- Loop01.SETPT.O1
 ESN - Exec. Seq. No. ----- 10

PID - PID Controller Function Block

RG PTR - Range Pointer ----- Loop01.AIN1.OR
 INPUT P - Input P ----- Loop01.AIN1.O1
 INPUT S - Input S ----- Loop01.SETPT.O1
 INPUT F - Input F ----- Loop01.A/M.O1
 INPUT A - Input A ----- Loop01.A/M.AS
 ESN - Exec. Seq. No.----- 15

A/M - Auto/Manual Function Block

RG PTR - Range Pointer ----- Loop01.PID.OR
 INPUT A - Input A ----- Loop01.PID.O1
 ESN - Exec. Seq. No. ----- 20

AOUT1 - Analog Output 1 Function Block

RG PTR - Range Pointer ----- Loop01.PID.OR
 INPUT S - Input S ----- Loop01.A/M.O1

ODC - Operator Display for Controllers

P RG PTR - P Range Pointer ----- Loop01.AIN1.OR
 V RG PTR - V Range Pointer ----- Loop01.PID.OR
 INPUT P - Input P (Process) ----- Loop01.AIN1.O1
 INPUT S - Input S (Setpoint) ----- Loop01.SETPT.O1
 INPUT V - Input V (Valve) ----- Loop01.A/M.O1
 LOOP #- Loop # ----- 01

4.2 FCO102 - Single Loop Controller w/ Fixed Setpoint

Factory Configured Option FCO102 provides a single loop controller configured in Loop01. A block diagram of the loop configuration is shown below along with any *changes* to the default parameter values of the configured blocks. If the loop tag 'Loop01' is changed, all configured references within the station will automatically be changed to the new tag.

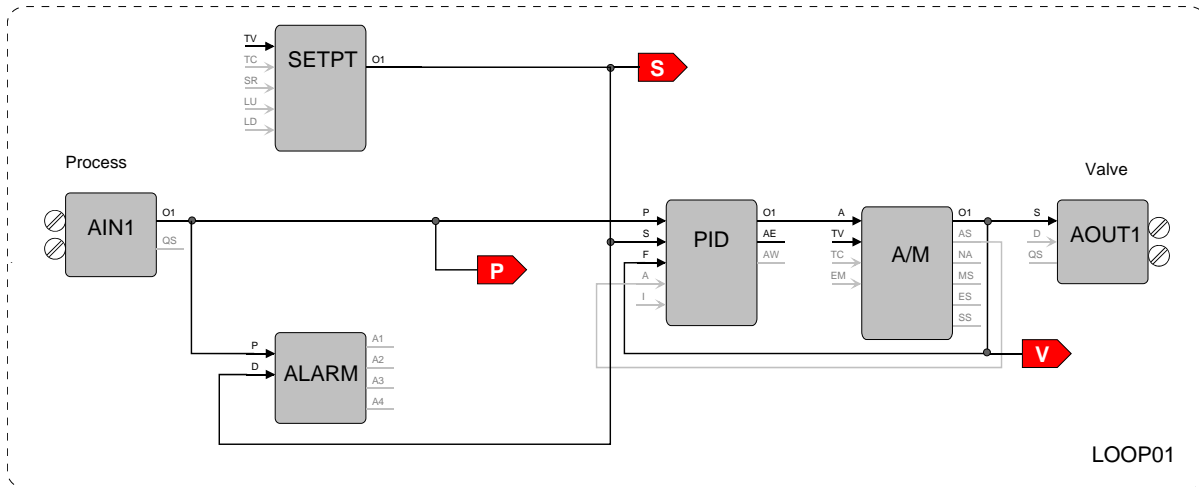

SETPT - Setpoint Function Block

RG PTR - Range Pointer ----- Loop01.AIN1.OR
 ESN - Exec. Seq. No.----- 5

ALARM - Alarm Function Block

RG PTR - Range Pointer ----- Loop01.AIN1.OR
 INPUT P - Input P ----- Loop01.AIN1.O1
 INPUT D - Input D ----- Loop01.SETPT.O1
 ESN - Exec. Seq. No. ----- 10

PID - PID Controller Function Block

RG PTR - Range Pointer ----- Loop01.AIN1.OR
 INPUT P - Input P ----- Loop01.AIN1.O1
 INPUT S - Input S ----- Loop01.SETPT.O1
 INPUT F - Input F ----- Loop01.A/M.O1
 INPUT A - Input A ----- Loop01.A/M.AS
 ESN - Exec. Seq. No.----- 15

A/M - Auto/Manual Function Block

RG PTR - Range Pointer ----- Loop01.PID.OR
 INPUT A - Input A ----- Loop01.PID.O1
 ESN - Exec. Seq. No. ----- 20

AOOUT1 - Analog Output 1 Function Block

RG PTR - Range Pointer ----- Loop01.PID.OR
 INPUT S - Input S ----- Loop01.A/M.O1

ODC - Operator Display for Controllers

P RG PTR - P Range Pointer ----- Loop01.AIN1.OR
 V RG PTR - V Range Pointer ----- Loop01.PID.OR
 INPUT P - Input P (Process) ----- Loop01.AIN1.O1
 INPUT S - Input S (Setpoint) ----- Loop01.SETPT.O1
 INPUT V - Input V (Valve) ----- Loop01.A/M.O1
 LOOP # - Loop # ----- 01

4.3 FCO103 - External Set Controller with Tracking Local Setpoint

Factory Configured Option FCO103 provides a single loop controller with external setpoint configured in Loop01. A block diagram of the loop configuration is shown below along with any *changes* to the default parameter values of the configured blocks. This configuration provides setpoint tracking. If a fixed setpoint is desired, the TC input to the SETPT function block can be set to UNCONFIG. If the loop tag 'LOOP01' is changed, all configured references will automatically be changed to the new tag.

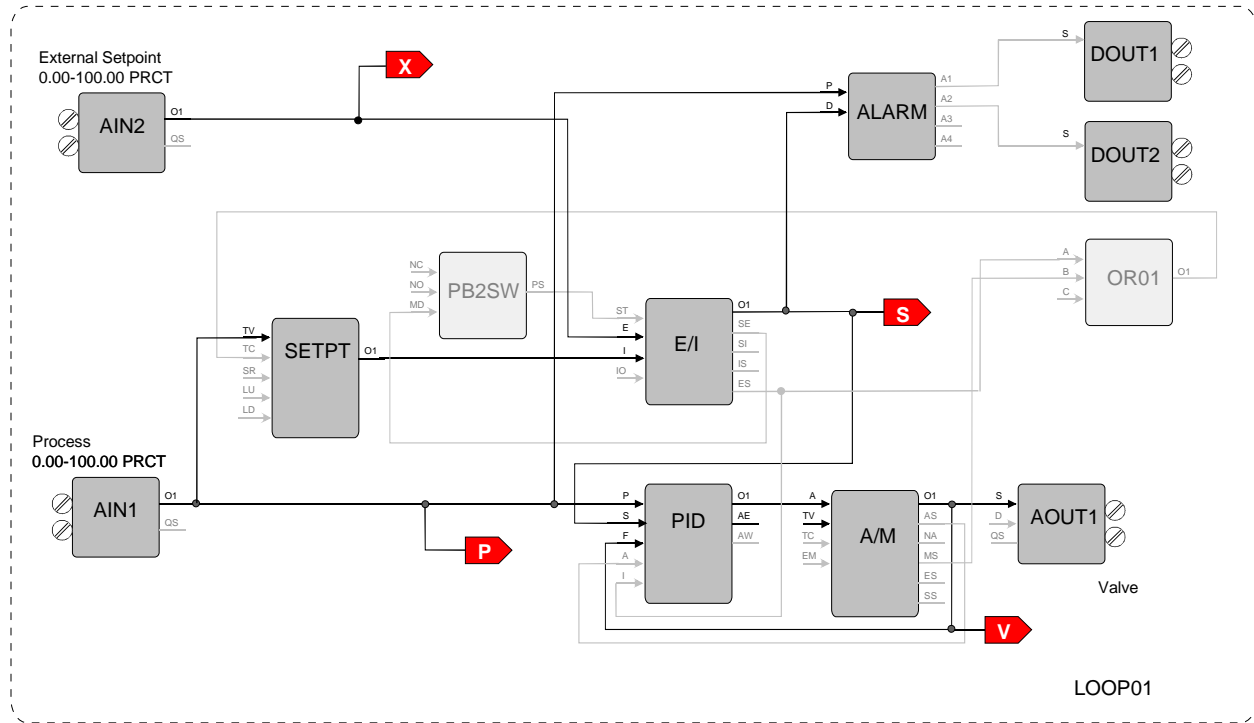

SETPT - Setpoint Function Block

RG PTR - Range Pointer ----- Loop01.AIN1.OR
 INPUT TV - Input TV ----- Loop01.AIN1.O1
 INPUT TC - Input TC ----- Loop01.OR01.O1
 ESN - Exec. Seq. No.----- 10

PB2SW - PB2 Switch Function Block

INPUT MD - Input MD ----- Loop01.E/I.SE
 ESN - Exec. Seq. No. ----- 5

ALARM - Alarm Function Block

RG PTR - Range Pointer ----- Loop01.AIN1.OR
 INPUT P - Input P ----- Loop01.AIN1.O1
 INPUT D - Input D ----- Loop01.E/I.O1
 ESN - Exec. Seq. No. ----- 20

PID - PID Controller Function Block

RG PTR - Range Pointer ----- Loop01.AIN1.OR
 INPUT P - Input P ----- Loop01.AIN1.O1
 INPUT S - Input S ----- Loop01.E/I.O1
 INPUT F - Input F ----- Loop01.A/M.O1
 INPUT A - Input A ----- Loop01.A/M.AS
 INPUT I - Input I ----- Loop01.E/I.ES
 ESN - Exec. Seq. No.----- 25

E/I - Ext/Int Transfer Switch Function Block

INPUT ST - Input ST ----- Loop01.PB2SW.PS
 INPUT E - Input E ----- Loop01.AIN2.O1
 INPUT I - Input I ----- Loop01.SETPT.O1
 ESN - Exec. Seq. No. ----- 15

A/M - Auto/Manual Function Block

RG PTR - Range Pointer ----- Loop01.PID.OR
 INPUT A - Input A ----- Loop01.PID.O1
 ESN - Exec. Seq. No. ----- 30

OR01 - OR Function Block

INPUT A - Input A ----- Loop01.E/I.ES
 INPUT B - Input B ----- Loop01.A/M.MS
 ESN - Exec. Seq. No. ----- 35

AOUT1 - Analog Output 1 Function Block

RG PTR - Range Pointer ----- Loop01.PID.OR
 INPUT S - Input S ----- Loop01.A/M.O1

ODC - Operator Display for Controllers

P RG PTR - P Range Pointer ----- Loop01.AIN1.OR
V RG PTR - V Range Pointer ----- Loop01.PID.OR
X RG PTR - X Range Pointer ----- Loop01.AIN2.OR
INPUT P - Input P (Process) ----- Loop01.AIN1.O1
INPUT S - Input S (Setpoint) ----- Loop01.E/I.O1
INPUT V - Input V (Valve) ----- Loop01.A/M.O1
INPUT X - Input X (X-Variable) - Loop01.AIN2.O1
LOOP # - Loop # ----- 01

DOUT1 - Digital Output 1 Function Block

INPUT S - Input S ----- Loop01.ALARM.A1

DOUT2 - Digital Output 2 Function Block

INPUT S - Input S ----- Loop01.ALARM.A2

4.4 FCO104 - External Set Controller with Non-Tracking Local Setpoint

Factory Configured Option FCO104 provides a single loop controller with external setpoint configured in Loop01. A block diagram of the loop configuration is shown below along with any *changes* to the default parameter values of the configured blocks. If the loop tag 'LOOP01' is changed, all configured references will automatically be changed to the new tag.

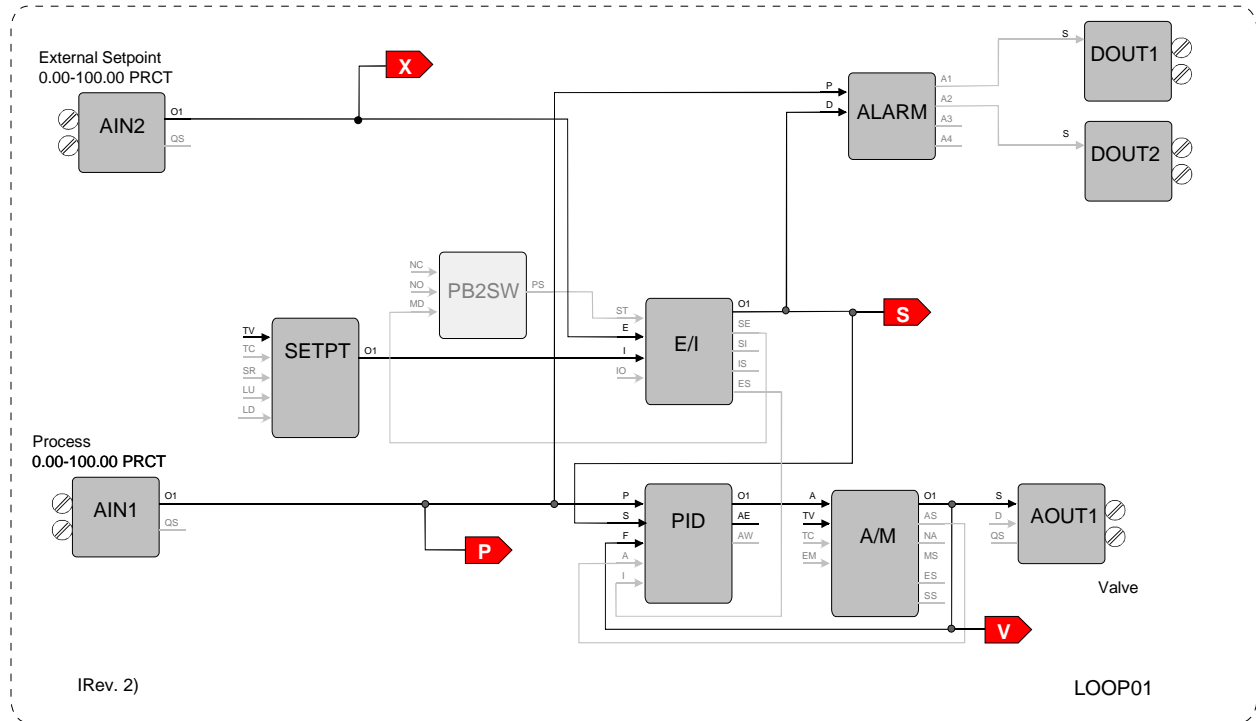

PB2SW - PB2 Switch Function Block

INPUT MD - Input MD ----- Loop01.E/I.SE
 ESN - Exec. Seq. No. ----- 5

ALARM - Alarm Function Block

RG PTR - Range Pointer ----- Loop01.AIN1.OR
 INPUT P - Input P ----- Loop01.AIN1.O1
 INPUT D - Input D ----- Loop01.E/I.O1
 ESN - Exec. Seq. No. ----- 20

PID - PID Controller Function Block

RG PTR - Range Pointer ----- Loop01.AIN1.OR
 INPUT P - Input P ----- Loop01.AIN1.O1
 INPUT S - Input S ----- Loop01.E/I.O1
 INPUT F - Input F ----- Loop01.A/M.O1
 INPUT A - Input A ----- Loop01.A/M.AS
 INPUT I - Input I ----- Loop01.E/I.ES
 ESN - Exec. Seq. No.----- 25

E/I - Ext/Int Transfer Switch Function Block

INPUT ST - Input ST ----- Loop01.PB2SW.PS
 INPUT E - Input E ----- Loop01.AIN2.O1
 INPUT I - Input I ----- Loop01.SETPT.O1
 ESN - Exec. Seq. No. ----- 15

A/M - Auto/Manual Function Block

RG PTR - Range Pointer ----- Loop01.PID.OR
 INPUT A - Input A ----- Loop01.PID.O1
 ESN - Exec. Seq. No. ----- 30

SETPT - Setpoint Function Block

RG PTR - Range Pointer ----- Loop01.AIN1.OR
 ESN - Exec. Seq. No. ----- 10

AOUT1 - Analog Output 1 Function Block

RG PTR - Range Pointer ----- Loop01.PID.OR
 INPUT S - Input S ----- Loop01.A/M.O1

ODC - Operator Display for Controllers

P RG PTR - P Range Pointer ----- Loop01.AIN1.OR
V RG PTR - V Range Pointer ----- Loop01.PID.OR
X RG PTR - X Range Pointer ----- Loop01.AIN2.OR
INPUT P - Input P (Process) ----- Loop01.AIN1.O1
INPUT S - Input S (Setpoint) ----- Loop01.E/I.O1
INPUT V - Input V (Valve) ----- Loop01.A/M.O1
INPUT X - Input X (X-Variable) - Loop01.AIN2.O1
LOOP # - Loop # ----- 01

DOU1 - Digital Output 1 Function Block

INPUT S - Input S ----- Loop01.ALARM.A1

DOU2 - Digital Output 2 Function Block

INPUT S - Input S ----- Loop01.ALARM.A2

4.5 FCO105 - Ratio Set Control w/ Operator Setpoint Limits

Factory Configured Option FCO105 provides a ratio set controller in Loop01. The setpoint to the Captive Flow controller can be maintained as a ratio of the Captive Flow to Wild Flow. The controller has complete setpoint tracking as well as ratio tracking. The local setpoint will track the Captive Flow signal when the loop is not in auto (NA) OR is in External (Ratio) Set (ES). The value of the RATIO will be computed as $\text{Captive Flow}_{\text{setpoint}} / \text{Wild Flow}$ while in the tracking mode which occurs whenever the loop is not in auto (NA) OR is in Internal Set (IS). The tracking features can be removed by setting the TC inputs to UNCONFIG. The Wild Flow signal will be displayed on Variable X and the actual Ratio CF/WF will be displayed on Variable Y.

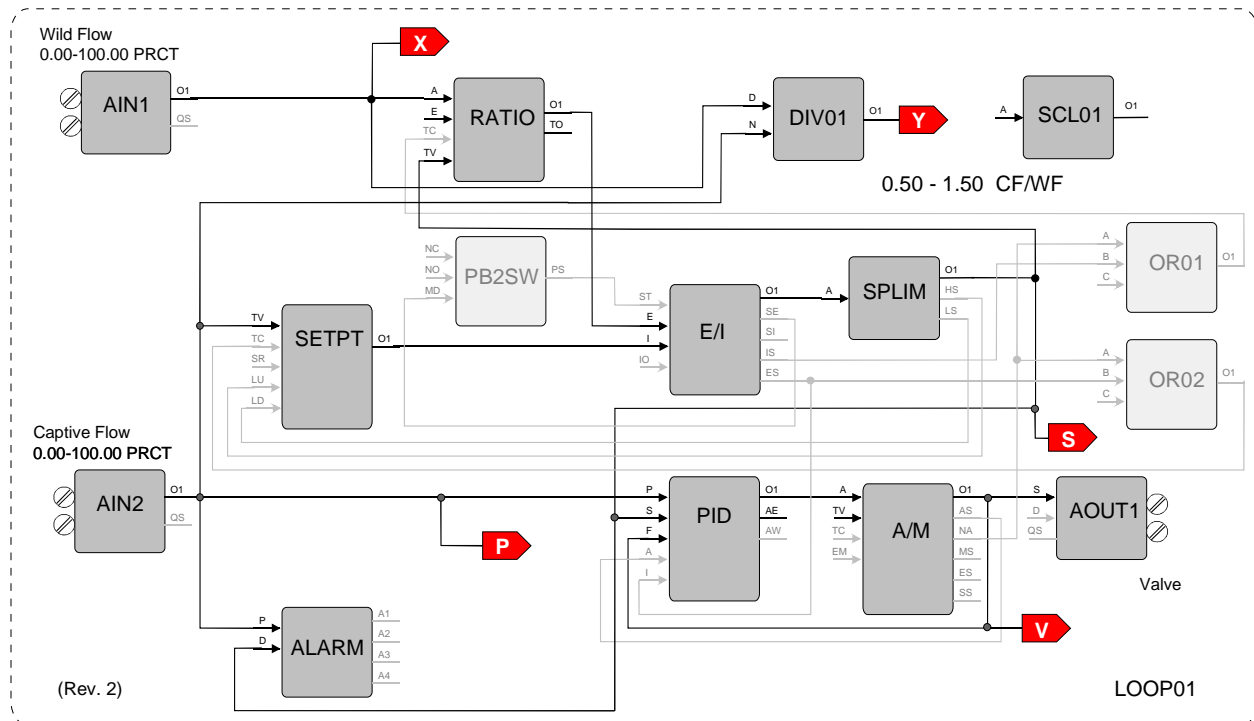

SETPT - Setpoint Function Block

RG PTR - Range Pointer ----- Loop01.AIN2.OR
 INPUT TV - Input TV ----- Loop01.AIN2.O1
 INPUT TC - Input TC ----- Loop01.OR02.O1
 INPUT LU - Input LU ----- Loop01.SPLIM.HS
 INPUT LD - Input LD ----- Loop01.SPLIM.LS
 ESN - Exec. Seq. No.----- 5

PB2SW - PB2 Switch Function Block

INPUT MD - Input MD ----- Loop01.E/I.SE
 ESN - Exec. Seq. No. ----- 10

ALARM - Alarm Function Block

RG PTR - Range Pointer ----- Loop01.AIN2.OR
 INPUT P - Input P ----- Loop01.AIN2.O1
 INPUT D - Input D ----- Loop01.SPLIM.O1
 ESN - Exec. Seq. No. ----- 15

RATIO - Ratio Function Block

HI LIMIT - HI Range LIMIT ----- 1.50
 LO LIMIT - LO Range LIMIT ---- 0.50
 INPUT A - Input A ----- Loop01.AIN1.O1
 INPUT TC - Input TC ----- Loop01.OR01.O1
 INPUT TV - Input TV ----- Loop01.SPLIM.O1
 ESN - Exec. Seq. No.----- 20

E/I - Ext/Int Transfer Switch Function Block

INPUT ST - Input ST ----- Loop01.PB2SW.PS
 INPUT E - Input E ----- Loop01.RATIO.O1
 INPUT I - Input I ----- Loop01.SETPT.O1
 ESN - Exec. Seq. No. ----- 25

SPLIM - Setpoint Limit Function Block

RG PTR - Range Pointer ----- Loop01.AIN2.OR
 INPUT A - Input A ----- Loop01.E/I.O1
 ESN - Exec. Seq. No. ----- 30

PID - PID Controller Function Block

RG PTR - Range Pointer ----- Loop01.AIN2.OR
 INPUT P - Input P ----- Loop01.AIN2.O1
 INPUT S - Input S ----- Loop01.SPLIM.O1
 INPUT F - Input F ----- Loop01.A/M.O1
 INPUT A - Input A ----- Loop01.A/M.AS
 INPUT I - Input I ----- Loop01.E/I.ES
 ESN - Exec. Seq. No.----- 35

A/M - Auto/Manual Function Block

RG PTR - Range Pointer ----- Loop01.PID.OR
 INPUT P - Input A ----- Loop01.PID.O1
 ESN - Exec. Seq. No. ----- 40

AOUT1 - Analog Output 1 Function Block

RG PTR - Range Pointer ----- Loop01.PID.OR
 INPUT S - Input S ----- Loop01.A/M.O1

ODC - Operator Display for Controllers

P RG PTR - P Range Pointer ----- Loop01.AIN2.OR
 V RG PTR - V Range Pointer ----- Loop01.PID.OR
 X RG PTR - X Range Pointer ----- Loop01.AIN1.OR
 Y RG PTR - Y Range Pointer ----- Loop01.SCL01.OR
 INPUT P - Input P (Process) ----- Loop01.AIN2.O1
 INPUT S - Input S (Setpoint) ----- Loop01.SPLIM.O1
 INPUT V - Input V (Valve) ----- Loop01.A/M.O1
 INPUT X - Input X (X-Variable) - Loop01.AIN1.O1
 INPUT Y - Input Y (Y-Variable)-- Loop01.DIV01.O1
 LOOP # - Loop # ----- 01

DIV01 - Division Function Block

INPUT N - Input N ----- Loop01.AIN2.O1
 INPUT D - Input D ----- Loop01.AIN1.O1
 ESN - Exec. Seq. No. ----- 45

SCL01 - Scaler Function Block

MINSCALE - Output MIN ----- 0.50
 MAXSCALE - Output MAX ----- 1.50
 ENGUNITS - ENGINEERING UNITS ---CF/WF
 ESN - Exec. Seq. No. ----- 50

OR01 - OR Function Block

INPUT A - Input A ----- Loop01.A/M.NA
 INPUT B - Input B ----- Loop01.E/I.IS
 ESN - Exec. Seq. No. ----- 55

OR02 - OR Function Block

INPUT A - Input A ----- Loop01.A/M.NA
 INPUT B - Input B ----- Loop01.E/I.ES
 ESN - Exec. Seq. No. ----- 60

4.6 FCO106 - Single Loop Controller w/ Operator Setpoint Limits

Factory Configured Option FCO106 provides a single loop controller configured in Loop01. This is similar to FCO101 but with a SPLIM block added to the output of the SETPT block. A block diagram of the loop configuration is shown below along with any *changes* to the default parameter values of the configured blocks. This configuration provides setpoint tracking. If a fixed setpoint is desired, the TC input to the SETPT function block can be set to UNCONFIG. If the loop tag 'LOOP01' is changed, all configured references will automatically be changed to the new tag.

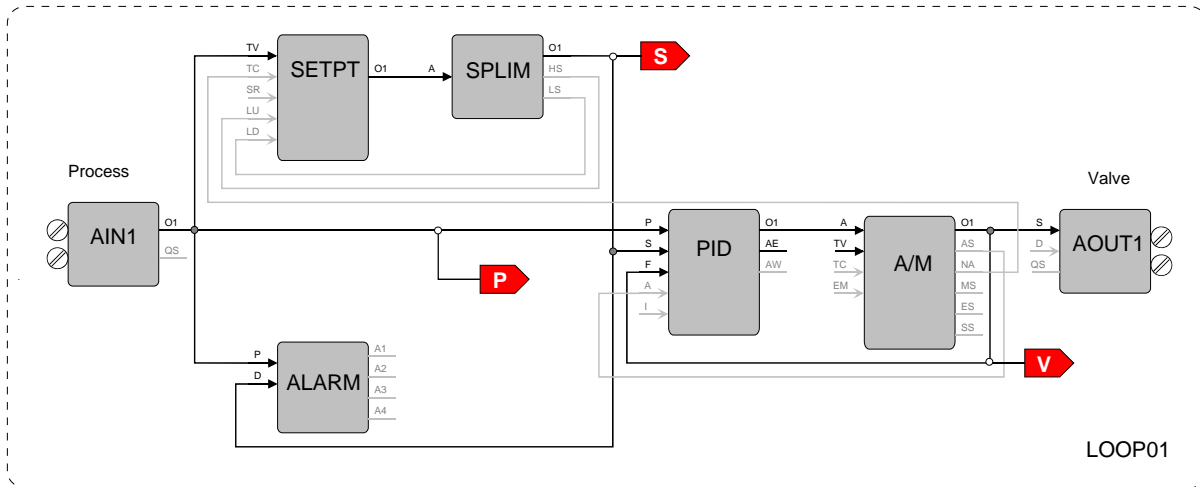

SETPT - Setpoint Function Block
 RG PTR - Range Pointer ----- Loop01.AIN1.OR
 INPUT TV - Input TV ----- Loop01.AIN1.O1
 INPUT TC - Input TC ----- Loop01.A/M.NA
 INPUT LU - Input LU ----- Loop01.SPLIM.HS
 INPUT LD - Input LD ----- Loop01.SPLIM.LS
 ESN - Exec. Seq. No.----- 5

SPLIM - Setpoint Limit Function Block
 RG PTR - Range Pointer ----- Loop01.AIN1.OR
 INPUT A - Input A ----- Loop01.SETPT.O1
 ESN - Exec. Seq. No. ----- 10

ALARM - Alarm Function Block
 RG PTR - Range Pointer ----- Loop01.AIN1.OR
 INPUT P - Input P ----- Loop01.AIN1.O1
 INPUT D - Input D ----- Loop01.SPLIM.O1
 ESN - Exec. Seq. No. ----- 15

PID - PID Controller Function Block
 RG PTR - Range Pointer - _----- Loop01.AIN1.OR
 INPUT P - Input P ----- Loop01.AIN1.O1
 INPUT S - Input S ----- Loop01.SPLIM.O1
 INPUT F - Input F ----- Loop01.A/M.O1
 INPUT A - Input A ----- Loop01.A/M.AS
 ESN - Exec. Seq. No.----- 20

A/M - Auto/Manual Function Block
 RG PTR - Range Pointer ----- Loop01.PID.OR
 INPUT A - Input A ----- Loop01.PID.O1
 ESN - Exec. Seq. No. ----- 25

AOUT1 - Analog Output 1 Function Block
 RG PTR - Range Pointer ----- Loop01.PID.OR
 INPUT S - Input S ----- Loop01.A/M.O1

ODC - Operator Display for Controllers
 P RG PTR - P Range Pointer ----- Loop01.AIN1.OR
 V RG PTR - V Range Pointer ----- Loop01.PID.OR
 INPUT P - Input P (Process) ----- Loop01.AIN1.O1
 INPUT S - Input S (Setpoint) ----- Loop01.SPLIM.O1
 INPUT V - Input V (Valve) ----- Loop01.A/M.O1
 LOOP # - Loop # ----- 01

4.7 FCO107 - Dual Loop Controller

Factory Configured Option FCO107 provides two independent loops with tracking setpoints. The block diagram of the configuration of the two loops is shown below along with the *changes* made to the default parameter values of the configured blocks. This configuration provides setpoint tracking. If a fixed setpoint is desired, the TC input to the SETPT function block can be set to UNCONFIG. The process range of the first loop can be changed in Analog Input 1 and the range of the Second loop in Analog Input 2.

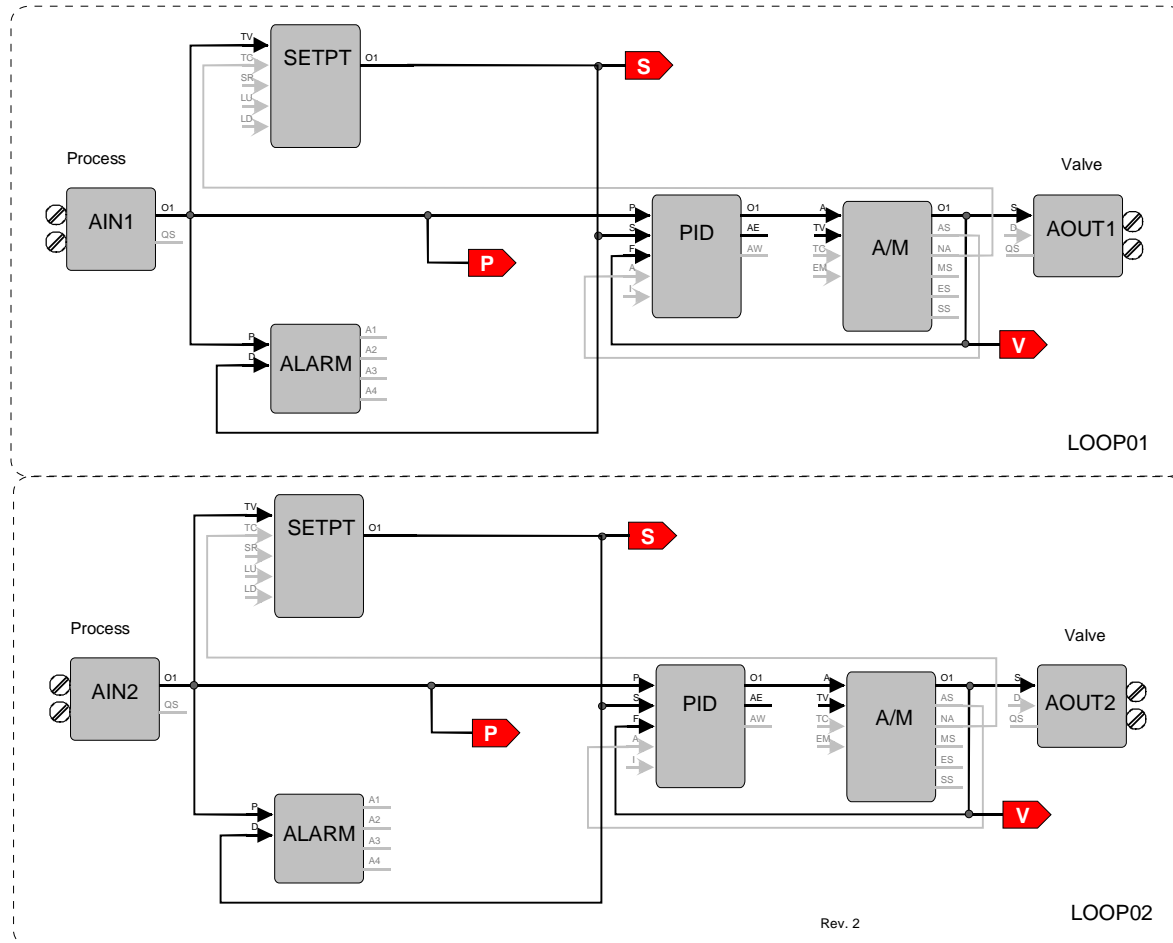

Loop 01

SETPT - Setpoint Function Block

RG PTR - Range Pointer ----- LOOP01.AIN1.OR
 INPUT TV - Input TV ----- LOOP01.AIN1.O1
 INPUT TC - Input TC ----- LOOP01.A/M.NA
 ESN - Exec. Seq. No.----- 5

ALARM - Alarm Function Block

RG PTR - Range Pointer ----- LOOP01.AIN1.OR
 INPUT P - Input P ----- LOOP01.AIN1.O1
 INPUT D - Input D ----- LOOP01.SETPT.O1
 ESN - Exec. Seq. No. ----- 10

PID - PID Controller Function Block

RG PTR - Range Pointer ----- LOOP01..AIN1.OR
 INPUT P - Input P ----- LOOP01.AIN1.O1
 INPUT S - Input S ----- LOOP01.SETPT.O1
 INPUT F - Input F ----- LOOP01.A/M.O1
 INPUT A - Input A ----- LOOP01..A/M.AS
 ESN - Exec. Seq. No.----- 15

A/M - Auto/Manual Function Block

RG PTR - Range Pointer ----- LOOP01.PID.OR
 INPUT A - Input A ----- LOOP01.PID.O1
 ESN - Exec. Seq. No. ----- 20

Loop 01 (cont)**ODC - Operator Display for Controllers**

P RG PTR - P Range Pointer ----- LOOP01.AIN1.OR
V RG PTR - V Range Pointer ---- LOOP01.PID.OR
INPUT P - Input P (Process) ----- LOOP01.AIN1.O1
INPUT S - Input S (Setpoint) ---- LOOP01.SETPT.O1
INPUT V - Input V (Valve) ----- LOOP01.A/M.O1
LOOP # - Loop# ----- 01

AOUT1 - Analog Output 1 Function Block

RG PTR - Range Pointer ----- LOOP01.PID.OR
INPUT S - Input S ----- LOOP01.A/M.O1

Loop 02**SETPT - Setpoint Function Block**

RG PTR - Range Pointer ----- LOOP02.AIN2.OR
INPUT TV - Input TV ----- LOOP02.AIN2.O1
INPUT TC - Input TC ----- LOOP02.A/M.O1
ESN - Exec. Seq. No.----- 5

ALARM - Alarm Function Block

RG PTR - Range Pointer ----- LOOP02.AIN2.OR
INPUT P - Input P ----- LOOP02.AIN2.O1
INPUT D - Input D ----- LOOP02.SETPT.O1
ESN - Exec. Seq. No. ----- 10

PID - PID Controller Function Block

RG PTR - Range Pointer ----- LOOP02.AIN2.OR
INPUT P - Input P ----- LOOP02.AIN2.O1
INPUT S - Input S ----- LOOP02.SETPT.O1
INPUT F - Input F ----- LOOP02.A/M.O1
INPUT A - Input A ----- LOOP02.A/M.AS
ESN - Exec. Seq. No.----- 15

A/M - Auto/Manual Function Block

RG PTR - Range Pointer ----- LOOP02.PID.OR
INPUT A - Input A ----- LOOP02.PID.O1
ESN - Exec. Seq. No. ----- 20

ODC - Operator Display for Controllers

P RG PTR - P Range Pointer ----- LOOP02.AIN2.OR
V RG PTR - V Range Pointer ---- LOOP02.PID.OR
INPUT P - Input P (Process) ----- LOOP02.AIN2.O1
INPUT S - Input S (Setpoint) ---- LOOP02.SETPT.O1
INPUT V - Input V (Valve) ----- LOOP02.A/M.O1
LOOP # - Loop # ----- 02

AOUT2 - Analog Output 2 Function Block

RG PTR - Range Pointer ----- LOOP02.PID.OR
INPUT S - Input S ----- LOOP02.A/M.O1

4.8 FCO121 - Cascade Control

Factory Configured Option FCO121 provides two loops configured for Cascade control. The block diagram of the configuration of the two loops is shown below along with the *changes* made to the default parameter values of the configured blocks. The process range of the Primary loop can be changed in Analog Input 1 and the range of the Secondary loop in Analog Input 2. Also, the output range of the primary PID controller must be changed to match any new range in the secondary loop. If the loop tag 'PRIM' or 'SEC' is changed, all configured references will automatically be changed to the new tag.

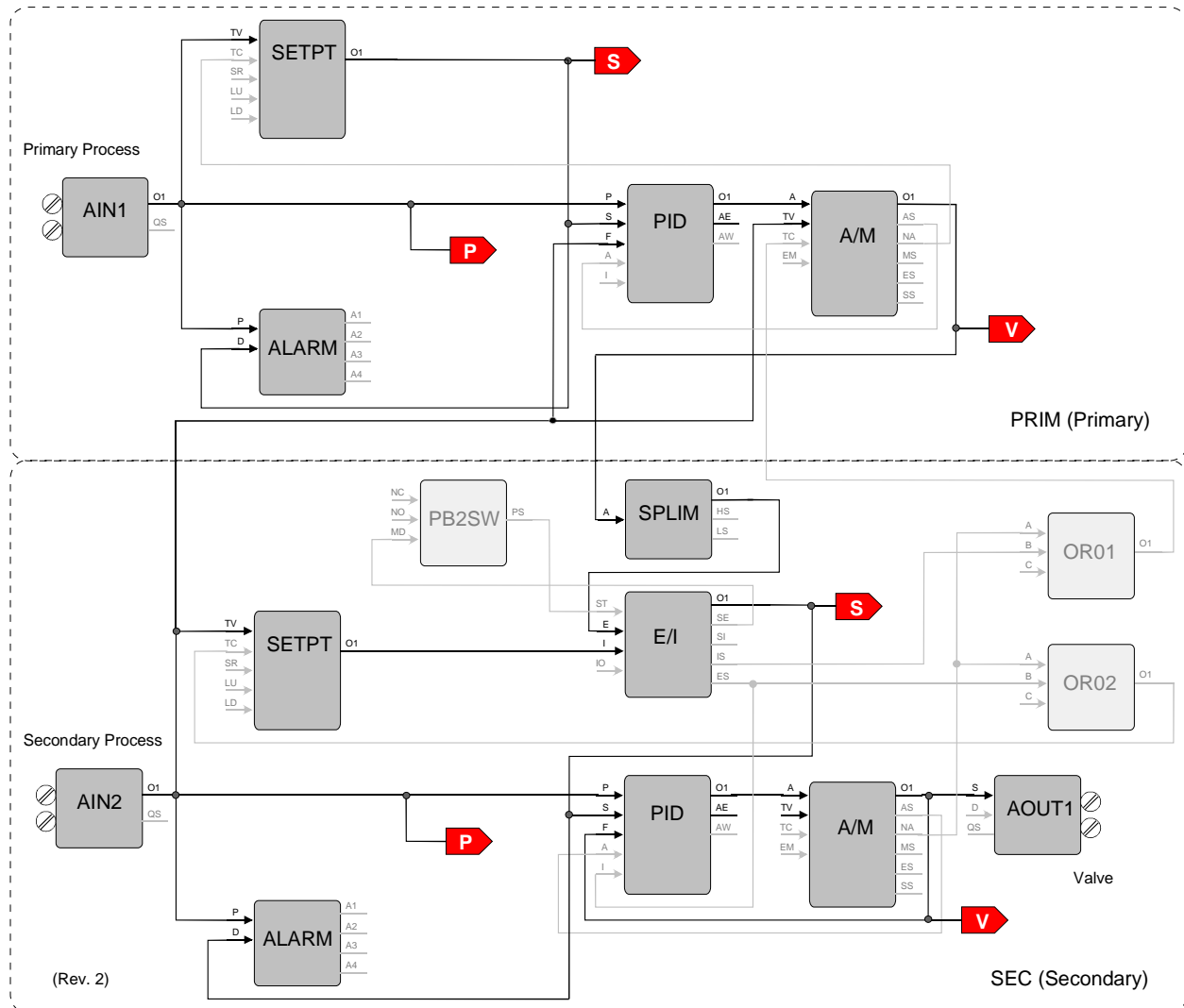

Primary Loop

SETPT - Setpoint Function Block
 RG PTR - Range Pointer ----- PRIM.AIN1.OR
 INPUT TV - Input TV ----- PRIM.AIN1.O1
 INPUT TC - Input TC ----- PRIM.A/M.NA
 ESN - Exec. Seq. No.----- 5

ALARM - Alarm Function Block
 RG PTR - Range Pointer ----- PRIM.AIN1.OR
 INPUT P - Input P ----- PRIM.AIN1.O1
 INPUT D - Input D ----- PRIM.SETPT.O1
 ESN - Exec. Seq. No. ----- 10

Primary Loop (cont)**PID - PID Controller Function Block**

RG PTR - Range Pointer ----- PRIM.AIN1.OR
 INPUT P - Input P ----- PRIM.AIN1.O1
 INPUT S - Input S ----- PRIM.SETPT.O1
 INPUT F - Input F ----- SEC.AIN2.O1
 INPUT A - Input A ----- PRIM.A/M.AS
 ESN - Exec. Seq. No.----- 15

A/M - Auto/Manual Function Block

RG PTR - Range Pointer ----- PRIM.PID.OR
 INPUT A - Input A ----- PRIM.PID.O1
 INPUT TV - Input TV ----- SEC.AIN2.O1
 INPUT TC - Input TC ----- SEC.OR01.O1
 ESN - Exec. Seq. No. ----- 20

ODC - Operator Display for Controllers

P RG PTR - P Range Pointer ---- PRIM.AIN1.OR
 V RG PTR - V Range Pointer ---- PRIM.PID.OR
 INPUT P - Input P (Process) ---- PRIM.AIN1.O1
 INPUT S - Input S (Setpoint) ---- PRIM.SETPT.O1
 INPUT V - Input V (Valve) ----- PRIM.A/M.O1
 LOOP# - Loop # ----- 01

Secondary Loop**SETPT - Setpoint Function Block**

RG PTR - Range Pointer ----- SEC.AIN2.OR
 INPUT TV - Input TV ----- SEC.AIN2.O1
 INPUT TC - Input TC ----- SEC.OR02.O1
 ESN - Exec. Seq. No.----- 5

ALARM - Alarm Function Block

RG PTR - Range Pointer ----- SEC.AIN2.OR
 INPUT P - Input P ----- SEC.AIN2.O1
 INPUT D - Input D ----- SEC.E/I.O1
 ESN - Exec. Seq. No. ----- 10

PB2SW - PB2 Switch Function Block

INPUT MD - Input MD ----- SEC.E/I.SE
 ESN - Exec. Seq. No. ----- 15

SPLIM - Setpoint Limit Function Block

RG PTR - Range Pointer ----- SEC.AIN2.OR
 INPUT A - Input A ----- PRIM.A/M.O1
 ESN - Exec. Seq. No. ----- 20

E/I - Ext/Int Transfer Switch Function Block

INPUT ST - Input ST ----- SEC.PB2SW.PS
 INPUT E - Input E ----- SEC.SPLIM.O1
 INPUT I - Input I ----- SEC.SETPT.O1
 ESN - Exec. Seq. No. ----- 25

PID - PID Controller Function Block

RG PTR - Range Pointer ----- SEC.AIN2.OR
 INPUT P - Input P ----- SEC.AIN2.O1
 INPUT S - Input S ----- SEC.E/I.O1
 INPUT F - Input F ----- SEC.A/M.O1
 INPUT A - Input A ----- SEC.A/M.AS
 INPUT I - Input I ----- SEC.E/I.ES
 ESN - Exec. Seq. No.----- 30

A/M - Auto/Manual Function Block

RG PTR - Range Pointer ----- SEC.PID.OR
 INPUT P - Input A ----- SEC.PID.O1
 ESN - Exec. Seq. No. ----- 35

OR01 - OR Function Block

INPUT A - Input A ----- SEC.A/M.NA
 INPUT B - Input B ----- SEC.E/I.IS
 ESN - Exec. Seq. No. ----- 40

OR02 - OR Function Block

INPUT A - Input A ----- SEC.A/M.NA
 INPUT B - Input B ----- SEC.E/I.ES
 ESN - Exec. Seq. No. ----- 45

AOUT1 - Analog Output 1 Function Block

RG PTR - Range Pointer ----- SEC.PID.OR
 INPUT S - Input S ----- SEC.A/M.O1

ODC - Operator Display for Controllers

P RG PTR - P Range Pointer ---- SEC.AIN2.OR
 V RG PTR - V Range Pointer ---- SEC.PID.OR
 INPUT P - Input P (Process) ---- SEC.AIN2.O1
 INPUT S - Input S (Setpoint) ---- SEC.E/I.O1
 INPUT V - Input V (Valve) ----- SEC.A/M.O1
 LOOP # - Loop # ----- 02

4.9 FCO122 - Cascade Control w/ Operator Setpoint Limits

Factory Configured Option FCO122 provides two loops configured for Cascade control. The block diagram of the configuration of the two loops is shown below along with the *changes* made to the default parameter values of the configured blocks. The process range of the Primary loop can be changed in Analog Input 1 and the range of the Secondary loop in Analog Input 2. Also, the output range of the primary PID controller must be changed to match any new range in the secondary loop. If the loop tag 'PRIM' or 'SEC' is changed, all configured references will automatically be changed to the new tag.

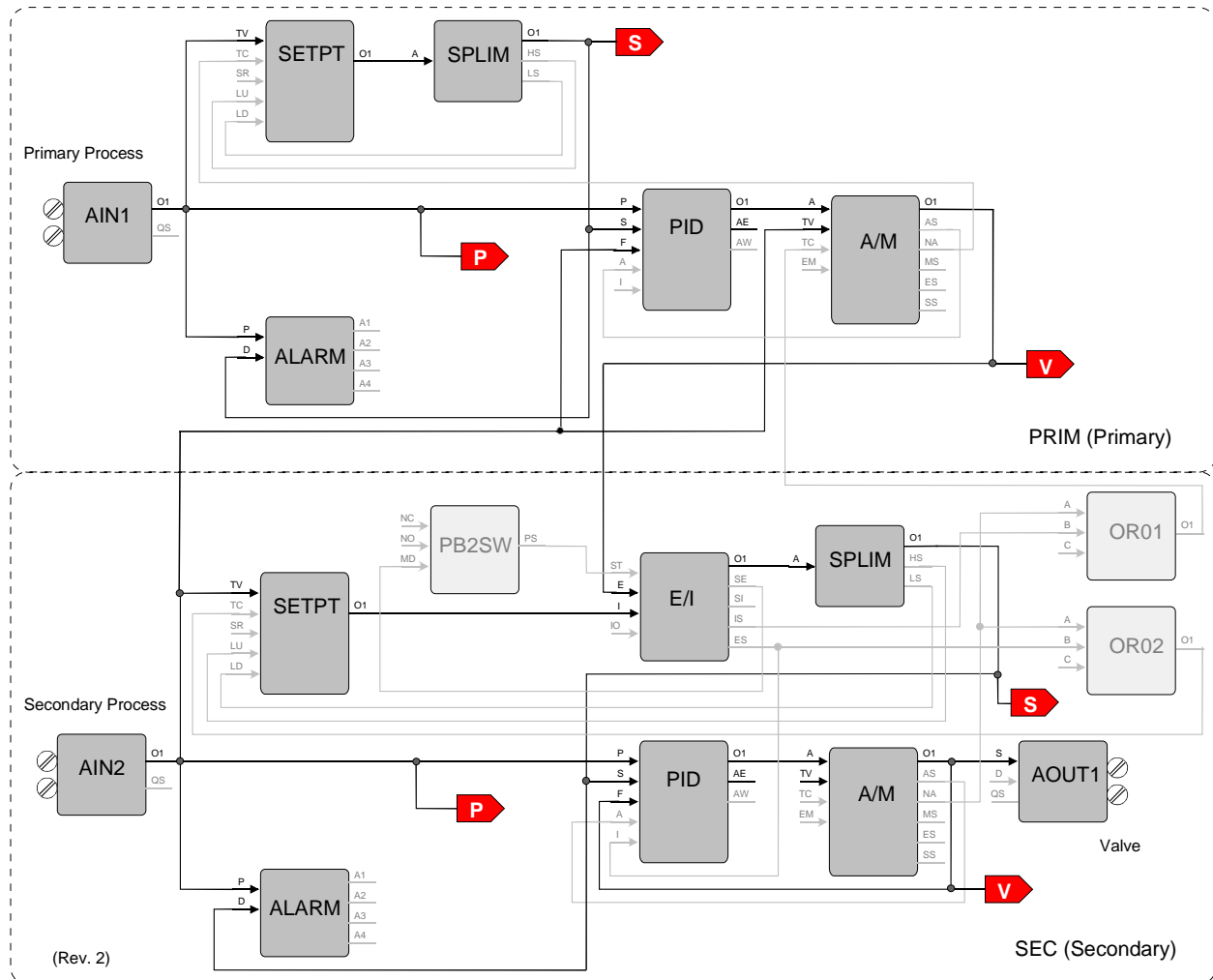

Primary Loop

SETPT - Setpoint Function Block
 RG PTR - Range Pointer ----- PRIM.AIN1.OR
 INPUT TV - Input TV ----- PRIM.AIN1.O1
 INPUT TC - Input TC ----- PRIM.A/M.NA
 INPUT LU - Input LU ----- PRIM.SPLIM.HS
 INPUT LD - Input LD ----- PRIM.SPLIM.LS
 ESN - Exec. Seq. No.----- 5

SPLIM- Setpoint Limit Function Block
 RG PTR - Range Pointer ----- PRIM.AIN1.OR
 INPUT A - Input A ----- PRIM.SETPT.O1
 ESN - Exec. Seq. No.----- 10

Primary Loop (cont)

ALARM - Alarm Function Block

RG PTR - Range Pointer ----- PRIM.AIN1.OR
 INPUT P - Input P ----- PRIM.AIN1.O1
 INPUT D - Input D ----- PRIM.SPLIM.O1
 ESN - Exec. Seq. No. ----- 20

PID - PID Controller Function Block

RG PTR - Range Pointer ----- PRIM.AIN1.OR
 INPUT P - Input P ----- PRIM.AIN1.O1
 INPUT S - Input S ----- PRIM.SPLIM.O1
 INPUT F - Input F ----- SEC.AIN02.O1
 INPUT A - Input A ----- PRIM.A/M.AS
 ESN - Exec. Seq. No.----- 30

A/M - Auto/Manual Function Block

RG PTR - Range Pointer ----- PRIM.PID.OR
 INPUT A - Input A ----- PRIM.PID.O1
 INPUT TV - Input TV ----- SEC.AIN2.O1
 INPUT TC - Input TC ----- SEC.OR01.O1
 ESN - Exec. Seq. No. ----- 60

ODC - Operator Display for Controllers

P RG PTR - P Range Pointer ----- PRIM.AIN1.OR
 V RG PTR - V Range Pointer ----- PRIM.PID.OR
 INPUT P - Input P (Process) ----- PRIM.AIN1.O1
 INPUT S - Input S (Setpoint) ----- PRIM.SPLIM.O1
 INPUT V - Input V (Valve) ----- PRIM.A/M.O1
 LOOP # - Loop # ----- 01

Secondary Loop

SETPT - Setpoint Function Block

RG PTR - Range Pointer ----- SEC.AIN2.OR
 INPUT TV - Input TV ----- SEC.AIN2.O1
 INPUT TC - Input TC ----- SEC.OR02.O1
 INPUT LU - Input LU ----- SEC.SPLIM.HS
 INPUT LD - Input LD ----- SEC.SPLIM.LS
 ESN - Exec. Seq. No.----- 5

ALARM - Alarm Function Block

RG PTR - Range Pointer ----- SEC.AIN2.OR
 INPUT P - Input P ----- SEC.AIN2.O1
 INPUT D - Input D ----- SEC.SPLIM.O1
 ESN - Exec. Seq. No. ----- 10

PB2SW - PB2 Switch Function Block

INPUT MD - Input MD ----- SEC.E/I.SE
 ESN - Exec. Seq. No. ----- 15

E/I - Ext/Int Transfer Switch Function Block

INPUT ST - Input ST ----- SEC.PB2SW.PS
 INPUT E - Input E ----- PRIM.A/M.O1
 INPUT I - Input I ----- SEC.SETPT.O1
 ESN - Exec. Seq. No. ----- 20

SPLIM - Setpoint Limit Function Block

RG PTR - Range Pointer ----- SEC.AIN2.OR
 INPUT A - Input A ----- SEC.E/I.O1
 ESN - Exec. Seq. No. ----- 25

PID - PID Controller Function Block

RG PTR - Range Pointer ----- SEC.AIN2.OR
 INPUT P - Input P ----- SEC.AIN2.O1
 INPUT S - Input S ----- SEC.SPLIM.O1
 INPUT F - Input F ----- SEC.A/M.O1
 INPUT A - Input A ----- SEC.A/M.AS
 INPUT I - Input I ----- SEC.E/I.ES
 ESN - Exec. Seq. No.----- 30

A/M - Auto/Manual Function Block

RG PTR - Range Pointer ----- SEC.PID.OR
 INPUT A - Input A ----- SEC.PID.O1
 ESN - Exec. Seq. No. ----- 35

OR01 - OR Function Block

INPUT A - Input A ----- SEC.A/M.NA
 INPUT B - Input B ----- SEC.E/I.IS
 ESN - Exec. Seq. No. ----- 40

OR02 - OR Function Block

INPUT A - Input A ----- SEC.A/M.NA
 INPUT B - Input B ----- SEC.E/I.ES
 ESN - Exec. Seq. No. ----- 45

AOUT1 - Analog Output 1 Function Block

RG PTR - Range Pointer ----- SEC.PID.OR
 INPUT S - Input S ----- SEC.A/M.O1

ODC - Operator Display for Controllers

P RG PTR - P Range Pointer ---- SEC.AIN2.OR
 V RG PTR - V Range Pointer -- SEC.PID.OR
 INPUT P - Input P (Process) ----- SEC.AIN2.O1
 INPUT S - Input S (Setpoint) ---- SEC.SPLIM.O1
 INPUT V - Input V (Valve) ----- SEC.A/M.O1
 LOOP # - Loop# ----- 02



5.0 NETWORK COMMUNICATIONS

This section provides an overview of the data that can be obtained from the 353 using Modbus, or Modbus/TCP Ethernet, which provides Modbus over Ethernet protocol. In the Modbus/TCP protocol all listed Modbus items are available and are embedded in the Modbus/Ethernet protocol frame. Refer to Section 6 Data Mapping for detailed list of the actual data. Go to the Modbus-IDA Website <http://www.modbus.org/> for more information on Modbus and access to Modbus technical specifications.

5.1 MODBUS DATA MAPPING

Modbus is a master/slave protocol where a master device (e.g. PC-based operator workstation) sends commands to one slave (i.e. Siemens 353 Process Automation Controller) and waits for a response. When using RS485 network communication, each station has a unique network address (1-32), configured as part of the station parameters. When using Modbus/TCP protocol each station has a unique IP address. Ethernet enables all 353 controllers on the Ethernet network to be masters, thus providing peer-to-peer network relationships between controllers.

Data is assigned to either a register (16-bit word) or a coil (1-bit). An IEEE floating point number (Real) is assigned to 2 consecutive registers with the first containing the most significant and the second the least significant portion of the floating point number. The 353 uses an IEEE reverse format. See Table 3-4 in Section 3.2.7 AIE_- Analog Input – Ethernet for more information on floating point formats.

The station supports Modbus function codes 01, 02, 03, 04, 05, 06, 08, and 16. Section 6 Data Mapping provides a listing of available data and specific locations within the Modbus map. The following is the overview for the complete 353 series controllers Modbus data mapping.

Station Coils.....	x0001 - x0071
Loop Coils.....	x0296 - x1495
Extended Loop Coils (ODD Pushbuttons).....	x8701 - x9100
Sequencer Loop I/O Coils (ref. MSLCP pointer)	x1496 - x2263
LonWorks Remote I/O Coils (352P, 353”A”, & 354/354N).....	x2401 - x3976*
Ubus Discrete I/O States & Forcing (353R)	x4001 - x5500
(spares).....	x5501 - x9100
Loop PCOM Block Coils.....	x9101 - x9999
Station Data (16-bit integer).....	x0001 - x0100
Station String Data (ASCII).....	x0101 - x0200
Loop Dynamic Data (16-bit integer).....	x0201 - x0450
Loop Variable Data (16-bit integer).....	x0451 - x1200
Loop Static Data (16-bit integer)	x1201 - x1950
Loop Dynamic Data (32-bit floating point)	x1951 - x2450
Loop Variable Data (32-bit floating point)	x2451 - x3950
Loop Static Data (32-bit floating point).....	x3951 - x5450
Loop String Data (ASCII).....	x5451 - x7950
Ubus Module Types (353R).....	x7951 - x8000*
Loop Trend Data (ref. MLTP pointer)	x8001 - x9000
(spares).....	x9001 - x9999

* Areas of the map that apply to other 353 products and do not apply to the 353 Design Level B.

EXTENDED MODBUS REGISTERS: The traditional addressing of Modbus Holding Registers has been limited to 9999. However, since the actual address is contained in a 16-bit word, addresses above 9999 are available. Many Modbus Masters support this extended addressing. Configuration data for a Sequencer & Timers contained in a single sequencer loop can be accessed in this space. The actual loop that can be accessed is contained in the Modbus parameter MSLCP Modbus Sequencer & Timers Configuration Pointer located in register 40041. This register contains the Modbus Index for the loop that can be configured with these extended parameters. A small number of these parameters have also been mapped in the areas listed within the actual loop area for those Masters that cannot access the extended area.

In addition, there are a number of registers reserved for the mappings of Modbus registers used in the Peer-to-Peer functionality of the Ethernet function blocks.

Sequencer Mask Configurations	x10001 – x18000
Real Time Trip Block Configurations.....	x19001 – x19021
Sequencer Time & Analog Configurations	x20001 – x20999
Timer Function Block Configurations	x21001 – x21009
Reserved – Modbus/TCP Block Register.....	x29001 – x29019
Reserved – Modbus/TCP Analog Inputs Static Data	x30001 – x30352
Reserved – Modbus/TCP Analog Outputs Static Data.....	x30353 – x30608
Reserved – Modbus/TCP Digital Inputs Static Data.....	x30609 – x30704
Reserved – Modbus/TCP Coil Inputs Static Data	x30705 – x30832
Reserved – Modbus/TCP Analog Inputs Dynamic Data.....	x30833 – x30896
Reserved – Modbus/TCP Digital Inputs Dynamic Data	x30897 – x30928
Reserved – Modbus/TCP Coil Inputs Dynamic Data.....	x30929 – x30960
Reserved – Modbus/TCP Analog Outputs Dynamic Data	x30961 – x31024*

* Refer to the AIE function block in Section 3 Function Blocks for details.

6.0 DATA MAPPING

This section provides loop and station data mapping for Modbus and Modbus/TCP Ethernet. With Ethernet communication, data is accessed using Modbus commands embedded within the TCP protocol. This is becoming known within the industry as the Open Modbus/TCP Protocol.

The controller has an RS232 port that always communicates via Modbus. It is located on the underside of the operator faceplate.

The use of a network permits data to be uploaded from the station to a computer or workstation (i|station). This data is typically used for process and alarm monitoring, and with additional processing of the data, for inventory management and accounting, and for process and equipment troubleshooting. Data can be downloaded to the station to change setpoint or valve value, change control mode, and acknowledge alarms.

Proprietary data transfers associated with configuration upload/download or on-line monitoring associated with the i|config™ Graphical Configuration Utility are not described.

6.1 CONNECTING TO i|ware PC

Modbus OPC Server

The i|ware PC Operator Interface software includes a Modbus OPC server that, when communicating with a station, can auto-populate its database with the number and type of loops configured in the station. All tag names used in the OPC database will be the same as listed in this manual.

Ethernet OPC Server

The i|ware PC Operator Interface software is an OPC Client and can be connected to an OPC server. An Ethernet OPC server using the Open Modbus/TCP Protocol is available to obtain data from single or multiple controllers and serve the data to OPC clients. It also auto-populates its database with the number and type of loops configured in the controller.

Modbus Application Note: Refer to application document AD353-108 for information on using Modbus communications with controller products. See Section 1.3 Customer/Product Support for access to the Siemens Website to download the current versions of publications referenced in this manual.

6.2 STATION DATA

A station contains some data that pertains to the entire station and some to individual loops. Station data, available over the network, is part of the station function block (STATN) configuration and is mapped to fixed locations in Modbus registers or coils. Loop data (detailed in the next section) can be associated with an ODC “Controller,” an ODS “Sequencer,” an ODA “Analog Indication”, an ODD “Discrete Indication”, or an ODP “Pushbutton Operation” operator display.

Much of the analog data is available in two formats. The first is 16-bit values, scaled consistent with previous legacy controller products, enabling integration into existing legacy systems. This data type also provides Modbus masters, unable to handle 32-bit floating point, a method for obtaining data from the station.

The second is the standard 32-bit IEEE floating point format consistent with the actual data in the station. This data type is contained in two consecutive registers or parameters.

- The LSW is first and the MSW second.
- Boolean values are available in coils.
- String data, formatted as 2 ASCII characters per word with the left-most character in the most significant byte, containing tag, units, and message information.

Most Station data is ‘Read Only’ except as noted in Section 6.2.1 Integer Data.

6.2.1 Integer Data (16-bit Integer)

<u>Code</u>	<u>R/W</u>	<u>Description</u>	<u>Range</u>	<u>Register (MB)</u>
GDS	R	Global Data Size (LIL)*	7-256 (\$0007-\$0100)	n/a
ST	R	Station Type	6 (\$0006)	40001
SSW	R/W	Station Status Word	(see Station Status Word)	(see coils)
SE	R/W	Station Error	0-32767(\$00000-\$7FFF)	40002
NCL	R	No. of Control Loops (# of ODC)	0-255(\$0000-\$00FF)	40003
NSL	R	No. of Seq. Loops (# of ODS)	0-255(\$0000-\$00FF)	40004
RAM	R	RAM Size (size in K bytes)	0-65535(\$0000-\$FFFF)	40005
CBT	R	Controller Board Type	(see below)	40006
CBSR	R	Controller Board Software Rev. #	(see below)	40007
EBT	R	Expander I/O Board Type	(see below)	40008
EBSR	R	Exp. I/O Board Software Rev. #	(see below)	40009
RBT	R	Remote I/O Board Type (A-1)*	(see below)	40010
RBSR	R	Remote I/O (A-1) Software Rev. #*	(see below)	40011
NBT	R	Network Board Type (B-1)*	(see below)	40012
NBSR	R	Network (B-1) Software Rev. #*	(see below)	40013
OAT	R	Option Board A Type (A-2)*	(see below)	40014
OASR	R	Option A (A-2) Software Rev. #*	(see below)	40015
OBT	R	Option Board B Type (B-2)*	(see below)	40016
OBSR	R	Option B (B-2) Rev #*	(see below)	40017
OFT	R	Operator Faceplate Type	(see below)	40018
DRN	R	Model 353 Database Rev. No.	0-32767(\$0000-\$7FFF)	40019
CWT	R	Computer Watchdog Timer (sec)	0-1000 (\$0000-\$03F8)	40020
KSR	R	Kernel Software Rev. #	(see below)	40021
CT	R	Cycle Time (msec)	0-32767(\$00000-\$7FFF)	40022
L \bar{x} T	R	Loop - Type (0-none, 1-controller, 2-sequencer, 3-analog ind., 4-discrete ind., 5-pushbuttons)	(0-5)	40023-40047
MSLCP	R/W	Modbus Seq. Loop Config. Pt	0-25 (\$0000-\$0019)	40048
SA	R/W	Station Address	0-250 (\$0000-\$00FA)	40049

* Station Data that applies to other 353 controllers and does not apply the 353 “Design Level B.”

RTS	R/W	Front Port (Display Assembly) RTS	1-3 (\$0001-\$0003)	40050
		reserved		40051-40057
MLTP	R/W	Modbus Loop Trend Pointer	0-25 (\$0000-\$0019)	40058
NLTB	R	Number of Loop Trend Blocks	0-5 (\$0000-\$0005)	40059
AASEL	R/W	Active Ack'd Station Error Log	0-33767(\$0000-\$7FFF)	40060
STY	R/W (1)	Standard Time in Years	2000-2099	40061
STM	R/W (1)	Standard Time in Months	1-12	40062
STD	R/W (1)	Standard Time in Days	1-31	40063
STH	R/W (1)	Standard Time in Hours	0-23	40064
STMN	R/W (1)	Standard Time in Minutes	0-59	40065
STSC	R/W (1)	Standard Time in Seconds	0-59	40066
NAL	R	No of Analog Ind. Loops (ODA)	0-255(\$0000-\$00FF)	40067
NDL	R	No of Discrete Ind. Loops (ODD)	0-255(\$0000-\$00FF)	40068
NDP	R	No of Pushbutton Loops (ODP)	0-255(\$0000-\$00FF)	40069
IPA1	R	IP Address (2)	1: 0-255, 2: 0-255	40070
IPA2	R	IP Address (2)	3: 0-255, 4: 0-255	40071
IPG1	R	IP Gateway Address (4)	1: 0-255, 2 0-255	40072
IPG2	R	IP Gateway Address (4)	3: 0-255, 4: 0-255	40073
IPM1	R	IP Mask (3)	1: 0-255, 2: 0-255	40074
IPM2	R	IP Mask (3)	3: 0-255, 4: 0-255	40075
EBS	R	Ethernet Board Speed	0-auto, 1-10M, 2-100M	40076
EBD	R	Ethernet Board Duplex	0-auto, 1-half duplex, 2-full duplex	40077
PPR	R	Ethernet Board Peer-to-Peer Rate	0.25, 0.5, 1, 2, 5, 10 sec	40078
Spares				40079-40100

Software Revisions:

Development Release	MSB 128 to 255 (\$80-\$FF)
Major Rev.	MSB 1 to 127 (\$00-\$7F) (5)
Minor Rev.	LSB 0 to 255 (\$00-\$FF)

Hardware Type and Revisions:

Type	MSB1 to 15 (\$01-\$0F) (5)
Rev.	LSB 1 to 15 (\$01-\$0F)

- (1) The controller time should be changed one parameter at a time and then verified before writing the next parameter (i.e. for Modbus use command 06 and not command 16). Write the year only (i.e. for 2006 write a 6). The change to each parameter will take approximately 1 to 2 seconds each.
- (2) IP Address format (nnn.nnn.nnn.nnn) 1,2,3,4 (default 192.168.0.2)
- (3) IP Mask format (nnn.nnn.nnn.nnn) 1,2,3,4 (default 255.255.255.0)
- (4) IP Gateway format (nnn.nnn.nnn.nnn) 1,2,3,4 (default is 192.168.0.1)
- (5) A major software Rev. of 0 = no software included and a hardware type of 0 = not installed.

6.2.2 Station String Data (8-bit ASCII Char - 2/Word)

Code	R/W	Description	Range	Register (MB)
STAG	R	Station Tag	12 ASCII Char	40101-40106
CFNR	R	Configuration File Name Reduced	8 ASCII Char	n/a
CFN	R	Configuration File Name	20 ASCII Char	40107-40116
SN	R	Station Serial No.	8 ASCII	40117-40120
		Spares	0(\$0000)	40121-40199

6.2.3 Station Coil Data (1-bit)

Code	R/W	Description	Range	Coil (MB)
ASE	R	1-Active Station Event	1/0	00001
SEN	R/W	1-Station Event Not Ack'd	1/0	00002
FSB	R	1- Flashing Station Bargraph	1/0	00003
SDV	R	1- Station Database Valid	1/0	00004
CCL	R	Config Change Counter LSB (bit)	1/0	n/a
CCH	R	Config Change Counter MSB (bit)	1/0	n/a
SCH	R	1-Station Configuration Hold	1/0	00007
SRB	R/W	1-Station Run Bit	1/0	00008
OOS	R/W	1-Station Alarms Out of Service	1/0	00009
		(spares)	0	00010-00014
CC1	R/W	Config Change Bit #1	1/0	n/a
CC2	R/W	Config Change Bit #2	1/0	n/a
CC3	R/W	Config Change Bit #3	1/0	n/a
SEB	R	1-Station Error Bit	1/0	00015
		(spare)	0	00016
		spares	0(\$0000)	00017-00071

6.3 LOOP DATA

Loop data is grouped into several categories. When using Modbus, the groupings enable single data requests (up to 60 Words/Registers or 48 Coils) to obtain similar data with a single command. The loop will have different data if assigned as a controller type (i.e. using the ODC block), a sequencer type (i.e. using the ODS block), an Analog Indicator Display (i.e. using the ODA block), or a Discrete Indicator Display (i.e. using the ODD block), or Pushbutton/Switch Operation (i.e. using the ODP block).

- a) Dynamic data may change value on each controller scan and/or is not identified as being changed by the data base change bit (coil). This category of data usually needs to be updated by a workstation every few seconds.
- b) Variable data changes periodically. It is usually associated with on-line operation at a workstation but may only need to be updated on a lower periodic basis or when a data base change is indicated.
- c) Static data is similar to variable data but has a lower update requirement. The data may only need updating when a change is indicated or to verify a previous change made to a parameter.
- d) String data contains tag names, units, and messages.

6.3.1 Dynamic Loop Integer Data

Controller [ODC]

Code	R/W	Description	Range	Register (MB)
L#PI	R	Process (%)	-3.3 to 103.3 (\$0-\$0FFF)	40201+10(#-1)
L#SI	R/W	Setpoint (%)	-3.3 to 103.3 (\$0-\$0FFF)	40202+10(#-1)
L#VI	R/W	Valve (%)	-3.3 to 103.3 (\$0-\$0FFF)	40203+10(#-1)
L#XI	R	X Variable (%)	-3.3 to 103.3 (\$0-\$0FFF)	40204+10(#-1)
L#YI	R	Y Variable (%)	-3.3 to 103.3 (\$0-\$0FFF)	40205+10(#-1)
L#RI	R/W	Ratio	0.00 to 38.40(\$80-\$0F80)	40206+10(#-1)
L#BI	R/W	Bias	100-0-100 (\$80-\$0F80)	40207+10(#-1)
L#TmI	R	Totalizer - 3 ms (whole) digits	0-999 (\$0000-\$03E7)	40208+10(#-1)
L#TlI	R	Totalizer - 3 ls (whole) digits	0-999 (\$0000-\$03E7)	40209+10(#-1)
L#PCSW	R	PCOM Block Status Word (VI.3)	1-7 (\$0001-\$0007)	40210+10(#-1)

Sequencer [ODS]

Code	R/W	Description	Range	Register (MB)
L#SSNI	R	Sequencer Step No.	0-250 (\$0000-\$00FA)	40201+10(#-1)
L#SNSI	R	Sequencer Number of Steps	0-250 (\$0000-\$00FA)	40202+10(#-1)
L#SNGI	R	Sequencer Number of Groups	0-16 (\$0000-\$0010)	40203+10(#-1)
L#SLS	R/W	Sequencer Loop Status	(see SLS)	(see coils)
L#SNRI	R	Sequencer Number of Recipes	0-9 (\$0000-\$0009)	40204+10(#-1)
L#CRNI	R/W	Current Recipe Number	0-9 (\$0000-\$0009)	40205+10(#-1)
L#PCSW	R	PCOM Block Status Word	1-7 (\$0001-\$0007)	40206+10(#-1)
L#TACM	R	Total Active Conditional Msgs	0-64 \$0000-\$0040)	40207+10(#-1)
		(spare)	0 (\$0000)	40208+10(#-1)
.....
		(spare)	0 (\$0000)	40210+10(#-1)

Analog Indicator [ODA]

Code	R/W	Description	Range	Register (MB)
L#P1I	R	Process 1 (%)	-3.3 to 103.3 (\$0-\$0FFF)	40201+10(#-1)
L#P2I	R	Process 2 (%)	-3.3 to 103.3 (\$0-\$0FFF)	40202+10(#-1)
L#P3I	R	Process 3 (%)	-3.3 to 103.3 (\$0-\$0FFF)	40203+10(#-1)
L#P4I	R	Process 4 (%)	-3.3 to 103.3 (\$0-\$0FFF)	40204+10(#-1)

6.3.2 Variable Loop Integer Data

Controller [ODC]

Code	R/W	Description	Range	Register (MB)
L#TSPI	R/W	Target Setpoint (%)	-3.3 to 103.3 (\$0-\$0FFF)	40451+30(#-1)
L#HLI	R/W	Setpoint High Limit (%)	-3.3 to 103.3 (\$0-\$0FFF)	40452+30(#-1)
L#LLI	R/W	Setpoint Low Limit (%)	-3.3 to 103.3 (\$0-\$0FFF)	40453+30(#-1)
L#RTI	R/W	Setpoint Ramp Time (min)	0-3840(\$0080-\$0F80)	40454+30(#-1)
L#RRI	R/W	Setpoint Ramp Rate (%/min)	-3.3 to 103.3 (\$0-\$0FFF)	40455+30(#-1)
L#A1LI	R/W	Alarm 1 Limit (%)	-3.3 to 103.3 (\$0-\$0FFF)	40456+30(#-1)
L#A2LI	R/W	Alarm 2 Limit (%)	-3.3 to 103.3 (\$0-\$0FFF)	40457+30(#-1)
L#A3LI	R/W	Alarm 3 Limit (%)	-3.3 to 103.3 (\$0-\$0FFF)	40458+30(#-1)
L#A4LI	R/W	Alarm 4 Limit (%)	-3.3 to 103.3 (\$0-\$0FFF)	40459+30(#-1)
L#T1mI	R/W	Tot. Preset 1 - 3 ms whole digits	0-999 (\$0000-\$03E7)	40460+30(#-1)
L#T1I	R/W	Tot. Preset 1 - 3 ls whole digits	0-999 (\$0000-\$03E7)	40461+30(#-1)
L#T2mI	R/W	Tot. Preset 2 - 3 ms whole digits	0-999 (\$0000-\$03E7)	40462+30(#-1)
L#T2I	R/W	Tot. Preset 2 - 3 ls whole digits	0-999 (\$0000-\$03E7)	40463+30(#-1)
L#A1TI	R/W	Alarm 1 Type	0-6 (\$0000-\$0006)	40464+30(#-1)
L#A2TI	R/W	Alarm 2 Type	0-6 (\$0000-\$0006)	40465+30(#-1)
L#A3TI	R/W	Alarm 3 Type	0-6 (\$0000-\$0006)	40466+30(#-1)
L#A4TI	R/W	Alarm 4 Type	0-6 (\$0000-\$0006)	40467+30(#-1)
L#A1PI	R/W	Alarm 1 Priority	1-5 (\$0001-\$0005)	40468+30(#-1)
L#A2PI	R/W	Alarm 2 Priority	1-5 (\$0001-\$0005)	40469+30(#-1)
L#A3PI	R/W	Alarm 3 Priority	1-5 (\$0001-\$0005)	40470+30(#-1)
L#A4PI	R/W	Alarm 4 Priority	1-5 (\$0001-\$0005)	40471+30(#-1)
L#CAI	R/W	Controller Action	1-DIR, 0-REV	40472+30(#-1)
		(spare)	0 (\$0000)	40473+30(#-1)
.....
		(spare)	0 (\$0000)	40480+30(#-1)

Sequencer [ODS] - (MASK Configurations)

Code	R/W	Description	Range	Register (MB)
L#S001G0I	R/W	Step 1 Group 0 Input Mask	\$0000-\$FFFF	40451+30(#-1)
L#S001G0O	R/W	Step 1 Group 0 Output Mask	\$0000-\$FFFF	40452+30(#-1)
L#S001G1I	R/W	Step 1 Group 1 Input Mask	\$0000-\$FFFF	40453+30(#-1)
L#S001G1O	R/W	Step 1 Group 1 Output Mask	\$0000-\$FFFF	40454+30(#-1)
L#S001G2I	R/W	Step 1 Group 2 Input Mask	\$0000-\$FFFF	40455+30(#-1)
L#S001G2O	R/W	Step 1 Group 2 Output Mask	\$0000-\$FFFF	40456+30(#-1)
L#S002G0I	R/W	Step 2 Group 0 Input Mask	\$0000-\$FFFF	40457+30(#-1)
L#S002G0O	R/W	Step 2 Group 0 Output Mask	\$0000-\$FFFF	40458+30(#-1)
.....
L#S005G0O	R/W	Step 5 Group 0 Output Mask	\$0000-\$FFFF	40476+30(#-1)
L#S005G1I	R/W	Step 5 Group 1 Input Mask	\$0000-\$FFFF	40477+30(#-1)
L#S005G1O	R/W	Step 5 Group 1 Output Mask	\$0000-\$FFFF	40478+30(#-1)
L#S005G2I	R/W	Step 5 Group 2 Input Mask	\$0000-\$FFFF	40479+30(#-1)
L#S005G2O	R/W	Step 5 Group 2 Output Mask	\$0000-\$FFFF	40480+30(#-1)

Analog Indicator [ODA] - (V2.2)

Code	R/W	Description	Range	Register (MB)
L#P1ALI	R/W	Process 1 Alarm A Limit (%)	-3.3 to 103.3 (\$0-\$0FFF)	40451+30(#-1)
L#P1BLI	R/W	Process 1 Alarm B Limit (%)	-3.3 to 103.3 (\$0-\$0FFF)	40452+30(#-1)
L#P2ALI	R/W	Process 2 Alarm A Limit (%)	-3.3 to 103.3 (\$0-\$0FFF)	40453+30(#-1)
L#P2BLI	R/W	Process 2 Alarm B Limit (%)	-3.3 to 103.3 (\$0-\$0FFF)	40454+30(#-1)
L#P3ALI	R/W	Process 3 Alarm A Limit (%)	-3.3 to 103.3 (\$0-\$0FFF)	40455+30(#-1)
L#P3BLI	R/W	Process 3 Alarm B Limit (%)	-3.3 to 103.3 (\$0-\$0FFF)	40456+30(#-1)
L#P4ALI	R/W	Process 4 Alarm A Limit (%)	-3.3 to 103.3 (\$0-\$0FFF)	40457+30(#-1)
L#P4BLI	R/W	Process 4 Alarm B Limit (%)	-3.3 to 103.3 (\$0-\$0FFF)	40458+30(#-1)
L#P1ATI	R/W	Process 1 Alarm A Type	0-3 (\$0000-\$0003)	40459+30(#-1)
L#P1BTI	R/W	Process 1 Alarm B Type	0-3 (\$0000-\$0003)	40460+30(#-1)
L#P2ATI	R/W	Process 2 Alarm A Type	0-3 (\$0000-\$0003)	40461+30(#-1)
L#P2BTI	R/W	Process 2 Alarm B Type	0-3 (\$0000-\$0003)	40462+30(#-1)
L#P3ATI	R/W	Process 3 Alarm A Type	0-3 (\$0000-\$0003)	40463+30(#-1)
L#P3BTI	R/W	Process 3 Alarm B Type	0-3 (\$0000-\$0003)	40464+30(#-1)
L#P4ATI	R/W	Process 4 Alarm A Type	0-3 (\$0000-\$0003)	40465+30(#-1)
L#P4BTI	R/W	Process 4 Alarm B Type	0-3 (\$0000-\$0003)	40466+30(#-1)
L#P1API	R/W	Process 1 Alarm A Priority	1-5 (\$0001-\$0005)	40467+30(#-1)
L#P1BPI	R/W	Process 1 Alarm B Priority	1-5 (\$0001-\$0005)	40468+30(#-1)
L#P2API	R/W	Process 2 Alarm A Priority	1-5 (\$0001-\$0005)	40469+30(#-1)
L#P2BPI	R/W	Process 2 Alarm B Priority	1-5 (\$0001-\$0005)	40470+30(#-1)
L#P3API	R/W	Process 3 Alarm A Priority	1-5 (\$0001-\$0005)	40471+30(#-1)
L#P3BPI	R/W	Process 3 Alarm B Priority	1-5 (\$0001-\$0005)	40472+30(#-1)
L#P4API	R/W	Process 4 Alarm A Priority	1-5 (\$0001-\$0005)	40473+30(#-1)
L#P4BPI	R/W	Process 4 Alarm B Priority	1-5 (\$0001-\$0005)	40474+30(#-1)
.....
		(spare)	0 (\$0000)	40480+30(#-1)

6.3.3 Static Loop Integer Data

Controller [ODC]

Code	R/W	Description	Range	Register (MB)
L#PGI	R/W	Proportional Gain	-9.99 to -0.01 (\$1419-\$17FF) 0.01 to 9.99 (\$1801-\$1BE7) -100.0 to -10.0 (\$2418-\$279C) 10.0 to 100.0 (\$2864-\$2BE8)	41201+30(#-1)
L#TII	R/W	Integral Time (min)	0.01 to 9.99 (\$2081-\$2467) 10.0 to 99.9 (\$10E4-\$1467) 100 to 3967 (\$30E4-\$3FFF)	41202+30(#-1)
L#TDI	R/W	Derivative Time (min)	0.00 to 9.99 (\$2080-\$2467) 10.0 to 100.0 (\$10E4-\$1468)	41203+30(#-1)
L#DGI	R/W	Derivative Gain	1.00 to 39.67 (\$20E4-\$2FFF)	41204+30(#-1)
L#MRI	R/W	Manual Reset (%)	0.0 to 100.0 (\$0080-\$0F80)	41205+30(#-1)
L#RHI	R	Range High	-1 to -32768 (\$FFFF-\$8000) 0 to 32767 (\$0000-\$7FFF)	41206+30(#-1)
L#RLI	R	Range Low	-1 to -32768 (\$FFFF-\$8000) 0 to 32767 (\$0000-\$7FFF)	41207+30(#-1)
L#DPPI	R	Decimal Point Position	0 to 5 (\$0000-\$0005)	41208+30(#-1)
L#PDPP	R	Process DPP	0 to 5 (\$0000-\$0005)	41209+30(#-1)
L#VDPP	R	Valve DPP	0 to 5 (\$0000-\$0005)	41210+30(#-1)
L#XDPP	R	Variable X DPP	0 to 5 (\$0000-\$0005)	41211+30(#-1)
L#YDPP	R	Variable Y DPP	0 to 5 (\$0000-\$0005)	41212+30(#-1)
		(spare)	0 (\$0000)	41213+30(#-1)
.....
		(spare)	0 (\$0000)	41230+30(#-1)

Sequencer [ODS] - (MASK Configurations)

Code	R/W	Description	Range	Register (MB)
L#S006G0I	R/W	Step 6 Group 0 Input Mask	\$0000-\$FFFF	41201+30(#-1)
L#S006G0O	R/W	Step 6 Group 0 Output Mask	\$0000-\$FFFF	41202+30(#-1)
L#S006G1I	R/W	Step 6 Group 1 Input Mask	\$0000-\$FFFF	41203+30(#-1)
L#S006G1O	R/W	Step 6 Group 1 Output Mask	\$0000-\$FFFF	41204+30(#-1)
L#S006G2I	R/W	Step 6 Group 2 Input Mask	\$0000-\$FFFF	41205+30(#-1)
L#S006G2O	R/W	Step 6 Group 2 Output Mask	\$0000-\$FFFF	41206+30(#-1)
L#S007G0I	R/W	Step 7 Group 0 Input Mask	\$0000-\$FFFF	41207+30(#-1)
L#S007G0O	R/W	Step 7 Group 0 Output Mask	\$0000-\$FFFF	41208+30(#-1)
.....
L#S009G2I	R/W	Step 9 Group 2 Input Mask	\$0000-\$FFFF	41223+30(#-1)
L#S009G2O	R/W	Step 9 Group 2 Output Mask	\$0000-\$FFFF	41224+30(#-1)
L#S010G0I	R/W	Step 10 Group 0 Input Mask	\$0000-\$FFFF	41225+30(#-1)
L#S010G0O	R/W	Step 10 Group 0 Output Mask	\$0000-\$FFFF	41226+30(#-1)
L#S010G1I	R/W	Step 10 Group 1 Input Mask	\$0000-\$FFFF	41227+30(#-1)
L#S010G1O	R/W	Step 10 Group 1 Output Mask	\$0000-\$FFFF	41228+30(#-1)
L#S010G2I	R/W	Step 10 Group 2 Input Mask	\$0000-\$FFFF	41229+30(#-1)
L#S010G2O	R/W	Step 10 Group 2 Output Mask	\$0000-\$FFFF	41230+30(#-1)

6.3.4 Dynamic Loop Floating Point Data (32-bit IEEE)

Controller [ODC]

Code	R/W	Description	Range	Register (MB)
L#PF	R	Process	Real	41951+20(#-1)
L#SF	R/W	Setpoint	Real	41953+20(#-1)
L#VF	R/W	Valve	Real	41955+20(#-1)
L#XF	R	X Variable	Real	41957+20(#-1)
L#YF	R	Y Variable	Real	41959+20(#-1)
L#RF	R/W	Ratio	Real	41961+20(#-1)
L#BF	R/W	Bias	Real	41963+20(#-1)
L#TLF	R	Totalizer	Real	41965+20(#-1)
		(spare)	(\$00000000)	41967+20(#-1)
		(spare)	(\$00000000)	41969+20(#-1)

Sequencer [ODS]

Code	R/W	Description	Range	Register (MB)
L#SSNF	R/W	Sequencer Step No.*	Real	41951+20(#-1)
L#SAOF	R	Sequencer Analog Output	Real	41953+20(#-1)
L#SAEPF	R	Step Analog End Point	Real	41955+20(#-1)
L#SRTF	R/W	Step Remaining Time*	Real	41957+20(#-1)
L#SSTF	R	Sequencer Step Time	Real	41959+20(#-1)
L#SNSF	R	Sequencer Number of Steps	Real	41961+20(#-1)
L#SNGF	R	Sequencer Number of Groups	Real	41963+20(#-1)
L#SNRF	R	Sequencer Number of Recipes	Real	41965+20(#-1)
L#CRNF		Current Recipe Number @	Real	41967+20(#-1)
R/W		(spare)	0(\$00000000)	41969+20(#-1)

Analog Indicator [ODA]

Code	R/W	Description	Range	Register (MB)
L#P1F	R	Process 1	Real	41951+20(#-1)
L#P2F	R	Process 2	Real	41953+20(#-1)
L#P3F	R	Process 3	Real	41955+20(#-1)
L#P4F	R	Process 4	Real	41957+20(#-1)
		(spare)	0(\$00000000)	41959/69+20(#-1)

* A Write command will force the Step or Remaining Time to the write value.

@ The current recipe can be changed if the Sequencer is in the HOLD mode.

6.3.5 Variable Loop Floating Point Data (32-bit IEEE)

Controller [ODC]

<u>Code</u>	<u>R/W</u>	<u>Description</u>	<u>Range</u>	<u>Register (MB)</u>
L#TSPF	R/W	Target Setpoint	Real	42451+60(#-1)
L#HLF	R/W	Setpoint High Limit	Real	42453+60(#-1)
L#LLF	R/W	Setpoint Low Limit	Real	42455+60(#-1)
L#RTF	R/W	Setpoint Ramp Time (min)	Real	42457+60(#-1)
L#RRF	R/W	Setpoint Ramp Rate (units/min)	Real	42459+60(#-1)
L#A1LF	R/W	Alarm 1 Limit	Real	42461+60(#-1)
L#A2LF	R/W	Alarm 2 Limit	Real	42463+60(#-1)
L#A3LF	R/W	Alarm 3 Limit	Real	42465+60(#-1)
L#A4LF	R/W	Alarm 4 Limit	Real	42467+60(#-1)
L#T1F	R/W	Totalizer Preset 1	Real	42469+60(#-1)
L#T2F	R/W	Totalizer Preset 2	Real	42471+60(#-1)
L#Q1F	R/W	Quickset Hold 1	Real	42473+60(#-1)
L#Q2F	R/W	Quickset Hold 2	Real	42475+60(#-1)
L#BHLF	R/W	Batch Switch High Limit	Real	42477+60(#-1)
L#BLLF	R/W	Batch Switch Low Limit	Real	42479+60(#-1)
L#BPLF	R/W	Batch Switch Pre-Load	Real	42481+60(#-1)
L#BGF	R/W	Batch Switch Gain (spares)	Real (\$00000000)	42483+60(#-1) 42485-42509+60(#-1)

Sequencer (Timers - Running Values) [ODS]

<u>Code</u>	<u>R/W</u>	<u>Description</u>	<u>Range</u>	<u>Register (MB)</u>
L#DYT01ET	R	DYT01 Elapsed Time	Real	42451+60(#-1)
L#DYT01RT	R/W	DYT01 Remaining Time	Real	42453+60(#-1)
L#OST01ET	R	OST01 Elapsed Time	Real	42455+60(#-1)
L#OST01RT	R/W	OST01 Remaining Time	Real	42457+60(#-1)
L#RCT01ET	R	RCT01 Elapsed Time	Real	42459+60(#-1)
L#RCT01RT	R/W	RCT01 Remaining Time	Real	42461+60(#-1)
L#ROT01ET	R	ROT01 Elapsed Time	Real	42463+60(#-1)
L#ROT01RT	R/W	ROT01 Remaining Time	Real	42465+60(#-1)
L#DYT02ET	R	DYT02 Elapsed Time	Real	42467+60(#-1)
L#DYT02RT	R/W	DYT02 Remaining Time	Real	42469+60(#-1)
L#OST02ET	R	OST02 Elapsed Time	Real	42471+60(#-1)
L#OST02RT	R/W	OST02 Remaining Time	Real	42473+60(#-1)
L#RCT02ET	R	RCT02 Elapsed Time	Real	42475+60(#-1)
L#RCT02RT	R/W	RCT02 Remaining Time	Real	42477+60(#-1)
L#ROT02ET	R	ROT02 Elapsed Time	Real	42479+60(#-1)
L#ROT02RT	R/W	ROT02 Remaining Time	Real	42481+60(#-1)
L#DYT03ET	R	DYT03 Elapsed Time	Real	42483+60(#-1)
L#DYT03RT	R/W	DYT03 Remaining Time	Real	42485+60(#-1)
L#OST03ET	R	OST03 Elapsed Time	Real	42487+60(#-1)
L#OST03RT	R/W	OST03 Remaining Time	Real	42489+60(#-1)
L#RCT03ET	R	RCT03 Elapsed Time	Real	42491+60(#-1)
L#RCT03RT	R/W	RCT03 Remaining Time	Real	42493+60(#-1)
L#ROT03ET	R	ROT03 Elapsed Time	Real	42495+60(#-1)
L#ROT03RT	R/W	ROT03 Remaining Time (spares)	Real	42497+60(#-1) 42499-42509+60(#-1)

Analog Indicator [ODA]

<u>Code</u>	<u>R/W</u>	<u>Description</u>	<u>Range</u>	<u>Register (MB)</u>
L#P1ALF	R/W	Process 1 Alarm A Limit	Real	42451+60(#-1)
L#P1BLF	R/W	Process 1 Alarm B Limit	Real	42453+60(#-1)
L#P2ALF	R/W	Process 2 Alarm A Limit	Real	42455+60(#-1)
L#P2BLF	R/W	Process 2 Alarm B Limit	Real	42457+60(#-1)
L#P3ALF	R/W	Process 3 Alarm A Limit	Real	42459+60(#-1)
L#P3BLF	R/W	Process 3 Alarm B Limit	Real	42461+60(#-1)
L#P4ALF	R/W	Process 4 Alarm A Limit	Real	42463+60(#-1)
L#P4BLF	R/W	Process 4 Alarm B Limit	Real	42465+60(#-1)
L#Q1F	R/W	Quickset Hold 1	Real	42467+60(#-1)
L#Q2F	R/W	Quickset Hold 2	Real	42469+60(#-1)
L#Q3F	R/W	Quickset Hold 3	Real	42471+60(#-1)
L#Q4F	R/W	Quickset Hold 4 (spares)	Real (\$00000000)	42473+60(#-1) 42475-42509+60(#-1)

6.3.6 Static Loop Floating Point Data (32-bit IEEE)**Controller [ODC]**

<u>Code</u>	<u>R/W</u>	<u>Description</u>	<u>Range</u>	<u>Register (MB)</u>
L#PGF	R/W	Proportional Gain	0.001 - 100.0	43951+60(#-1)
L#TIF	R/W	Integral Time	0.001 - 4000.0 min	43953+60(#-1)
L#TDF	R/W	Derivative Time	0.00 - 100.00 min	43955+60(#-1)
L#MRF	R/W	Manual Reset	0.00 - 100.00	43957+60(#-1)
L#ADF	R/W	Autotune Deviation	auto(0), 2.5-25%	43959+60(#-1)
L#AHF	R/W	Autotune Hysteresis	auto(0), 0.5 - 10.0%	43961+60(#-1)
L#ASF	R/W	Autotune Step (initial)	5 - 40%	43963+60(#-1)
L#APGF	R	Autotune Proportional Gain	0.001 - 1000.0	43965+60(#-1)
L#ATIF	R	Autotune Integral Time	0.001 - 4000.0 min	43967+60(#-1)
L#ATDF	R	Autotune Derivative Time	0.00 - 100.00 min	3969+60(#-1)
L#HDF	R/W	On-Off Controller HI Deviation	Real	43971+60(#-1)
L#LDF	R/W	On-Off Controller LO Deviation	Real	43973+60(#-1)
L#DBF	R/W	On-Off Controller DEADBAND	Real	43975+60(#-1)
L#PMNF	R/W	Process MIN SCALE	Real	43977+60(#-1)
L#PMXF	R/W	Process MAX SCALE	Real	43979+60(#-1)
L#VMNF	R/W	Valve MIN SCALE	Real	43981+60(#-1)
L#VMXF	R/W	Valve MAX SCALE	Real	43983+60(#-1)
L#XMNF	R/W	X Variable MIN SCALE	Real	43985+60(#-1)
L#XMXF	R/W	X Variable MAX SCALE	Real	43987+60(#-1)
L#YMNF	R/W	Y Variable MIN SCALE	Real	43989+60(#-1)
L#YMXF	R/W	Y Variable MAX SCALE	Real	43991+60(#-1)
L#Q1MNF	R/W	Quickset 1 MIN SCALE	Real	43993+60(#-1)
L#Q1MXF	R/W	Quickset 1 MAX SCALE	Real	43995+60(#-1)
L#Q2MNF	R/W	Quickset 2 MIN SCALE	Real	43997+60(#-1)
L#Q2MXF	R/W	Quickset 2 MAX SCALE	Real	44009+60(#-1)
L#DGF	R/W	Derivative Gain (spares)	1.00 - 30.00 (\$00000000)	44001+60(#-1) 44003-44009+60(#-1)

Sequencer [ODS]

Code	R/W	Description	Range	Register (MB)
L#S001TIM	R/W	Step 1 Time Period (min)	Real	43951+60(#-1)
L#S001AEP	R/W	Step 1 Analog End Point	Real	43953+60(#-1)
L#S002TIM	R/W	Step 2 Time Period (min)	Real	43955+60(#-1)
L#S002AEP	R/W	Step 2 Analog End Point	Real	43957+60(#-1)
L#S003TIM	R/W	Step 3 Time Period (min)	Real	43959+60(#-1)
L#S003AEP	R/W	Step 3 Analog End Point	Real	43961+60(#-1)
L#S004TIM	R/W	Step 4 Time Period (min)	Real	43963+60(#-1)
L#S004AEP	R/W	Step 4 Analog End Point	Real	43965+60(#-1)
L#S005TIM	R/W	Step 5 Time Period (min)	Real	43967+60(#-1)
L#S005AEP	R/W	Step 5 Analog End Point	Real	43969+60(#-1)
L#S006TIM	R/W	Step 6 Time Period (min)	Real	43971+60(#-1)
L#S006AEP	R/W	Step 6 Analog End Point	Real	43973+60(#-1)
L#S007TIM	R/W	Step 7 Time Period (min)	Real	43975+60(#-1)
L#S007AEP	R/W	Step 7 Analog End Point	Real	43977+60(#-1)
L#S008TIM	R/W	Step 8 Time Period (min)	Real	43979+60(#-1)
L#S008AEP	R/W	Step 8 Analog End Point	Real	43981+60(#-1)
L#S009TIM	R/W	Step 9 Time Period (min)	Real	43983+60(#-1)
L#S009AEP	R/W	Step 9 Analog End Point	Real	43985+60(#-1)
L#S010TIM	R/W	Step 10 Time Period (min)	Real	43987+60(#-1)
L#S010AEP	R/W	Step 10 Analog End Point (spares)	Real	43989+60(#-1) 44991-44009+60(#-1)

Controller [ODA]

Code	R/W	Description	Range	Register (MB)
L#Q1MNF	R/W	Quickset 1 MIN SCALE	Real	43951+60(#-1)
L#Q1MXF	R/W	Quickset 1 MAX SCALE	Real	43953+60(#-1)
L#Q2MNF	R/W	Quickset 2 MIN SCALE	Real	43955+60(#-1)
L#Q2MXF	R/W	Quickset 2 MAX SCALE	Real	43957+60(#-1)
L#Q3MNF	R/W	Quickset 3 MIN SCALE	Real	43959+60(#-1)
L#Q3MXF	R/W	Quickset 3 MAX SCALE	Real	43961+60(#-1)
L#Q4MNF	R/W	Quickset 4 MIN SCALE	Real	43963+60(#-1)
L#Q4MXF	R/W	Quickset 4 MAX SCALE	Real	43965+60(#-1)
L#P1MNF	R	Process 1 MIN SCALE	Real	43967+60(#-1)
L#P1MXF	R	Process 1 MAX SCALE	Real	43969+60(#-1)
L#P2MNF	R	Process 2 MIN SCALE	Real	43971+60(#-1)
L#P2MXF	R	Process 2 MAX SCALE	Real	43973+60(#-1)
L#P3MNF	R	Process 3 MIN SCALE	Real	43975+60(#-1)
L#P3MXF	R	Process 3 MAX SCALE	Real	43977+60(#-1)
L#P4MNF	R	Process 4 MIN SCALE	Real	43979+60(#-1)
L#P4MXF	R	Process 4 MAX SCALE	Real	43981+60(#-1)
	(spares)		(\$00000000)	43983-44009+60(#-1)

6.3.7 String Loop Data (8-bit ASCII Char - 2/Word)**Controller [ODC]**

<u>Code</u>	<u>R/W</u>	<u>Description</u>	<u>Range</u>	<u>Register (MB)</u>
L#TAG	R	Loop Tag	12 ASCII Char	45451+100(#-1)
L#PUR	R/W	Process Units - Reduced	4 ASCII Char	45457+100(#-1)
L#PU	R/W	Process Units	6 ASCII Char	45459+100(#-1)
L#VU	R/W	Valve Units	6 ASCII Char	45462+100(#-1)
L#XU	R/W	X Variable Units	6 ASCII Char	45465+100(#-1)
L#YU	R/W	Y Variable Units	6 ASCII Char	45468+100(#-1)
L#TLU	R/W	Totalizer Units	6 ASCII Char	45471+100(#-1)
L#Q1N	R	Quickset Hold 1 Name	8 ASCII Char	45474+100(#-1)
L#Q1U	R/W	Quickset Hold 1 Units	6 ASCII Char	45478+100(#-1)
L#Q2N	R	Quickset Hold 2 Name	8 ASCII Char	45481+100(#-1)
L#Q2U	R/W	Quickset Hold 2 Units	6 ASCII Char	45485+100(#-1)
L#LHM	R/W	Left Horizontal Bar Message	5 ASCII Char	45488+100(#-1)
L#RHM	R/W	Right Horizontal Bar Message (spares)	5 ASCII Char (\$0000)	45491+100(#-1) 45492-45550+100(#-1)

Sequencer [ODS]

<u>Code</u>	<u>R/W</u>	<u>Description</u>	<u>Range</u>	<u>Register (MB)</u>
L#TAG	R	Loop Tag)	12 ASCII Char	45451+100(#-1)
L#PMSG	R	Primary Message	8 ASCII Char	45457+100(#-1)
L#SMSG	R	Secondary Message	12 ASCII Char	45461+100(#-1)
L#MSGa	R	Conditional Message a *	16 ASCII Char	45467+100(#-1)
L#MSGb	R	Conditional Message b *	16 ASCII Char	45475+100(#-1)
L#MSGc	R	Conditional Message c *	16 ASCII Char	45483+100(#-1)
L#MSGd	R	Conditional Message d *	16 ASCII Char	45491+100(#-1)
L#MSGe	R	Conditional Message e *	16 ASCII Char	45499+100(#-1)
L#MSGf	R	Conditional Message f *	16 ASCII Char	45507+100(#-1)
L#MSGg	R	Conditional Message g *	16 ASCII Char	45515+100(#-1)
L#MSGh	R	Conditional Message h *	16 ASCII Char	45523+100(#-1)
L#MSGi	R	Conditional Message I *	16 ASCII Char	45531+100(#-1)
L#RMSG	R	Recipe Message (spares)	12 ASCII Char (\$0000)	45539+100(#-1) 45545-45550+100(#-1)

* Conditional messages are stacked in the order of occurrence. The 9 most recent active conditional messages can be viewed.

Analog Indicator [ODA]

<u>Code</u>	<u>R/W</u>	<u>Description</u>	<u>Range</u>	<u>Register (MB)</u>
L#TAG	R	Loop Tag	12 ASCII Char	45451+100(#-1)
L#P1T	R	Process 1 Tag	6 ASCII Char	45457+100(#-1)
L#P1U	R/W	Process 1 Units	6 ASCII Char	45460+100(#-1)
L#P2T	R	Process 2 Tag	6 ASCII Char	45463+100(#-1)
L#P2U	R/W	Process 2 Units	6 ASCII Char	45466+100(#-1)
L#P3T	R	Process 3 Tag	6 ASCII Char	45469+100(#-1)
L#P3U	R/W	Process 3 Units	6 ASCII Char	45472+100(#-1)
L#P4T	R	Process 4 Tag	6 ASCII Char	45475+100(#-1)
L#P4U	R/W	Process 4 Units	6 ASCII Char	45478+100(#-1)
L#Q1N	R	Quickset Hold 1 Name	8 ASCII Char	45481+100(#-1)
L#Q1U	R/W	Quickset Hold 1 Units	6 ASCII Char	45485+100(#-1)
L#Q2N	R	Quickset Hold 2 Name	8 ASCII Char	45488+100(#-1)
L#Q2U	R/W	Quickset Hold 2 Units	6 ASCII Char	45492+100(#-1)
L#Q3N	R	Quickset Hold 3 Name	8 ASCII Char	45495+100(#-1)
L#Q3U	R/W	Quickset Hold 3 Units	6 ASCII Char	45499+100(#-1)
L#Q4N	R	Quickset Hold 4 Name	8 ASCII Char	45502+100(#-1)
L#Q4U	R/W	Quickset Hold 4 Units (spares)	6 ASCII Char (\$0000)	45506+100(#-1) 45509-45550+100(#-1)

Discrete Indicator [ODD]

<u>Code</u>	<u>R/W</u>	<u>Description</u>	<u>Range</u>	<u>Register (MB)</u>
L#TAG	R	Loop Tag	12 ASCII Char	45451+100(#-1)
L#I0T	R	Input 0 Tag	6 ASCII Char	45457+100(#-1)
L#I1T	R	Input 1 Tag	6 ASCII Char	45460+100(#-1)
L#I2T	R	Input 2 Tag	6 ASCII Char	45463+100(#-1)
L#I3T	R	Input 3 Tag	6 ASCII Char	45466+100(#-1)
L#I4T	R	Input 4 Tag	6 ASCII Char	45469+100(#-1)
L#I5T	R	Input 5 Tag	6 ASCII Char	45472+100(#-1)
L#I6T	R	Input 6 Tag	6 ASCII Char	45475+100(#-1)
L#I7T	R	Input 7 Tag	6 ASCII Char	45478+100(#-1)
L#I8T	R	Input 8 Tag	6 ASCII Char	45481+100(#-1)
L#I9T	R	Input 9 Tag	6 ASCII Char	45484+100(#-1)
L#IAT	R	Input A Tag	6 ASCII Char	45487+100(#-1)
L#IBT	R	Input B Tag	6 ASCII Char	45490+100(#-1)
L#ICT	R	Input C Tag	6 ASCII Char	45493+100(#-1)
L#IDT	R	Input D Tag	6 ASCII Char	45496+100(#-1)
L#IET	R	Input E Tag	6 ASCII Char	45499+100(#-1)
L#IFT	R	Input F Tag (spares)	6 ASCII Char (\$0000)	45502+100(#-1) 45505-45550+100(#-1)

Discrete Indicator [ODP] - (V2.2)

<u>Code</u>	<u>R/W</u>	<u>Description</u>	<u>Range</u>	<u>Register (MB)</u>
L#TAG	R	Loop Tag	12 ASCII Char	45451+100(#-1)
L#G1Tag	R	Group 1 Tag	6 ASCII Char	45457+100(#-1)
L#G1P1T	R	Group 1 PB1 Tag	6 ASCII Char	45460+100(#-1)
L#G1P2T	R	Group 1 PB2 Tag	6 ASCII Char	45463+100(#-1)
L#G1SAT	R	Group 1 Switch Position A Tag	6 ASCII Char	45466+100(#-1)
L#G1SMT	R	Group 1 Switch Position M Tag	6 ASCII Char	45469+100(#-1)
L#G1F1T	R	Group 1 Feedback 1 Tag	6 ASCII Char	45472+100(#-1)
L#G1F0T	R	Group 1 Feedback 0 Tag	6 ASCII Char	45475+100(#-1)
L#G2Tag	R	Group 2 Tag	6 ASCII Char	45478+100(#-1)
L#G2P1T	R	Group 2 PB1 Tag	6 ASCII Char	45481+100(#-1)
L#G2P2T	R	Group 2 PB2 Tag	6 ASCII Char	45484+100(#-1)
L#G2SAT	R	Group 2 Switch Position A Tag	6 ASCII Char	45487+100(#-1)
L#G2SMT	R	Group 2 Switch Position M Tag	6 ASCII Char	45490+100(#-1)
L#G2F1T	R	Group 2 Feedback 1 Tag	6 ASCII Char	45493+100(#-1)
L#G2F0T	R	Group 2 Feedback 0 Tag	6 ASCII Char	45496+100(#-1)

L#G3Tag	R	Group 3 Tag	6 ASCII Char	45499+100(#-1)
L#G3P1T	R	Group 3 PB1 Tag	6 ASCII Char	45502+100(#-1)
L#G3P2T	R	Group 3 PB2 Tag	6 ASCII Char	45505+100(#-1)
L#G3SAT	R	Group 3 Switch Position A Tag	6 ASCII Char	45508+100(#-1)
L#G3SMT	R	Group 3 Switch Position M Tag	6 ASCII Char	45511+100(#-1)
L#G3F1T	R	Group 3 Feedback 1 Tag	6 ASCII Char	45514+100(#-1)
L#G3F0T	R	Group 3 Feedback 0 Tag	6 ASCII Char	45517+100(#-1)
L#G4Tag	R	Group 4 Tag	6 ASCII Char	45520+100(#-1)
L#G4P1T	R	Group 4 PB1 Tag	6 ASCII Char	45523+100(#-1)
L#G4P2T	R	Group 4 PB2 Tag	6 ASCII Char	45526+100(#-1)
L#G4SAT	R	Group 4 Switch Position A Tag	6 ASCII Char	45529+100(#-1)
L#G4SMT	R	Group 4 Switch Position M Tag	6 ASCII Char	45532+100(#-1)
L#G4F1T	R	Group 4 Feedback 1 Tag	6 ASCII Char	45535+100(#-1)
L#G4F0T	R	Group 4 Feedback 0 Tag	6 ASCII Char	45538+100(#-1)
L#G5Tag	R	Group 5 Tag	6 ASCII Char	40451+30(#-1)
L#G5P1T	R	Group 5 PB1 Tag	6 ASCII Char	40454+30(#-1)
L#G5P2T	R	Group 5 PB2 Tag	6 ASCII Char	40457+30(#-1)
L#G5SAT	R	Group 5 Switch Position A Tag	6 ASCII Char	40460+30(#-1)
L#G5SMT	R	Group 5 Switch Position M Tag	6 ASCII Char	40463+30(#-1)
L#G5F1T	R	Group 5 Feedback 1 Tag	6 ASCII Char	40466+30(#-1)
L#G5F0T	R	Group 5 Feedback 0 Tag	6 ASCII Char	40469+30(#-1)
		Spares		40472-40480

Note: These Modbus groupings normally used for Variable Loop Integer Data with displays other than ODP

L#G6Tag	R	Group 6 Tag	6 ASCII Char	41201+30(#-1)
L#G6P1T	R	Group 6 PB1 Tag	6 ASCII Char	41204+30(#-1)
L#G6P2T	R	Group 6 PB2 Tag	6 ASCII Char	41207+30(#-1)
L#G6SAT	R	Group 6 Switch Position A Tag	6 ASCII Char	41210+30(#-1)
L#G6SMT	R	Group 6 Switch Position M Tag	6 ASCII Char	41213+30(#-1)
L#G6F1T	R	Group 6 Feedback 1 Tag	6 ASCII Char	41216+30(#-1)
L#G6F0T	R	Group 6 Feedback 0 Tag	6 ASCII Char	41219+30(#-1)
		spares		41222-41230

Note: These Modbus groupings normally used for Static Loop Integer Data with displays other than ODP

L#G7Tag	R	Group 7 Tag	6 ASCII Char	42451+60(#-1)
L#G7P1T	R	Group 7 PB1 Tag	6 ASCII Char	42454+60(#-1)
L#G7P2T	R	Group 7 PB2 Tag	6 ASCII Char	42457+60(#-1)
L#G7SAT	R	Group 7 Switch Position A Tag	6 ASCII Char	42460+60(#-1)
L#G7SMT	R	Group 7 Switch Position M Tag	6 ASCII Char	42463+60(#-1)
L#G7F1T	R	Group 7 Feedback 1 Tag	6 ASCII Char	42466+60(#-1)
L#G7F0T	R	Group 7 Feedback 0 Tag	6 ASCII Char	42469+60(#-1)
L#G8Tag	R	Group 8 Tag	6 ASCII Char	42472+60(#-1)
L#G8P1T	R	Group 8 PB1 Tag	6 ASCII Char	42475+60(#-1)
L#G8P2T	R	Group 8 PB2 Tag	6 ASCII Char	42478+60(#-1)
L#G8SAT	R	Group 8 Switch Position A Tag	6 ASCII Char	42481+60(#-1)
L#G8SMT	R	Group 8 Switch Position M Tag	6 ASCII Char	42484+60(#-1)
L#G8F1T	R	Group 8 Feedback 1 Tag	6 ASCII Char	42487+60(#-1)
L#G8F0T	R	Group 8 Feedback 0 Tag	6 ASCII Char	42490+60(#-1)
		spares		42493-42509

Note: These Modbus groupings normally used for Variable Loop Floating Point Data with displays other than ODP

6.3.8 Coil Loop Data (1-bit)

Controller [ODC]

<u>Code</u>	<u>R/W</u>	<u>Description</u>	<u>Range</u>	<u>Coil(MB)</u>
L#A	R/W	1-Auto 0-Manual	1/0	00296+48(#-1)
L#L	R/W	1-Local	1/0	00297+48(#-1)
L#SS	R	1-AM block in STANDBY	1/0	00298+48(#-1)
L#E	R/W	1-External Set	1/0	00299+48(#-1)
L#CN	R/W	1-Console	1/0	00300+48(#-1)
L#CM	R/W	1-Computer	1/0	00301+48(#-1)
L#RS	R/W	1-Ramping Setpoint	1.0	00302+48(#-1)
L#OR	R	1-Override	1/0	00303+48(#-1)
L#EM	R	1-Emergency Manual	1/0	00304+48(#-1)
L#CH	R	1-Configuration Hold	1/0	00305+48(#-1)
L#HL	R	1-HI Setpoint Limit	1/0	00306+48(#-1)
L#LL	R	1-LO Setpoint Limit	1/0	00307+48(#-1)
L#OS	R/W	1-Alarms - Out of Service	1/0	00308+48(#-1)
L#U1S	R	1-U1 Status Active	1/0	00309+48(#-1)
L#U2S	R	1-U2 Status Active	1/0	00310+48(#-1)
L#AT	R/W	1-Autotune	1/0	00311+48(#-1)
L#A1	R	1-Alarm 1 is Active	1/0	00312+48(#-1)
L#N1	R/W	1-Alarm 1 is Not Acknowledged	1/0	00313+48(#-1)
L#E1	R/W	1-Alarm 1 is Enabled	1/0	00314+48(#-1)
L#A2	R	1-Alarm 2 is Active	1/0	00315+48(#-1)
L#N2	R/W	1-Alarm 2 is Not Acknowledged	1/0	00316+48(#-1)
L#E2	R/W	1-Alarm 2 is Enabled	1/0	00317+48(#-1)
L#A3	R	1-Alarm 3 is Active	1/0	0318+48(#-1)
L#N3	R/W	1-Alarm 3 is Not Acknowledged	1/0	00319+48(#-1)
L#E3	R/W	1-Alarm 3 is Enabled	1/0	00320+48(#-1)
L#A4	R	1-Alarm 4 is Active	1/0	00321+48(#-1)
L#N4	R/W	1-Alarm 4 is Not Acknowledged	1/0	00322+48(#-1)
L#E4	R/W	1-Alarm 4 is Enabled	1/0	00323+48(#-1)
L#OS2	R/W	1-Alarms - Out of Service	1/0	00324+48(#-1)
L#CC	R	1-Configuration has Changed	1/0	00325+48(#-1)
L#NA	R/W	1-Unacknowledged Loop Event	1/0	00326+48(#-1)
L#AE	R	1-Active Loop Event	1/0	00327+48(#-1)
L#NSS	R/W	1-Not Ack'd STANDBY	1/0	00328+48(#-1)
L#NOR	R/W	1-Not Ack'd Override	1/0	00329+48(#-1)
L#NEM	R/W	1-Not Ack'd Emergency Man	1/0	00330+48(#-1)
L#NHL	R/W	1-Not Ack'd HI Setpoint Limit	1/0	00331+48(#-1)
L#NLL	R/W	1-Not Ack'd LO Setpoint Limit	1/0	00332+48(#-1)
L#NU1	R/W	1-Not Ack'd U1 Status	1/0	00333+48(#-1)
L#NU2	R/W	1-Not Ack'd U2 Status	1/0	00334+48(#-1)
L#NW1	R/W	1-Not Ack'd W1 Status	1/0	00335+48(#-1)
L#NW2	R/W	1-Not Ack'd W2 Status	1/0	00336+48(#-1)
L#NW3	R/W	1-Not Ack'd W3 Status	1/0	00337+48(#-1)
L#NE1	R/W	1-Not Ack'd E1 Status	1/0	00338+48(#-1)
L#NE2	R/W	1-Not Ack'd E2 Status	1/0	00339+48(#-1)
L#NE3	R/W	1-Not Ack'd E3 Status	1/0	00340+48(#-1)
L#XAT	W	1-Transfer Autotune Parameters	1/0	00341+48(#-1)
L#PB1C	R/W	PB1SW Input MD (*)	1/0	00342+48(#-1)
L#PB2C	R/W	PB2SW Input MD (*)	1/0	00343+48(#-1)

* These bits indicate the status of the switch input MD. A write of a "1" will have the same effect as pressing and releasing the button on the faceplate. If the action of the switch is sustained the switch will change position. If the action is momentary the switch will close for one scan cycle.

Sequencer Loop [ODS]

Code	R/W	Description	Range	Coil (MB)
L#HS	R	1-Hold Sequencer	1/0	00296+48(#-1)
L#L	R/W	1-Loop Local	1/0	00297+48(#-1)
L#RSQ	W	1-Reset Sequencer	1/0	00298+48(#-1)
L#TC	R	1-Track	1/0	00299+48(#-1)
L#CN	R/W	1-Console	1/0	00300+48(#-1)
L#CM	R/W	1-Computer	1/0	00301+48(#-1)
L#SSF	W	1-Step Forward (normal 0)	1/0	00302+48(#-1)
L#SSB	W	1-Step Backward (normal 0)	1/0	00303+48(#-1)
		(spare)	1/0	00304+48(#-1)
L#CH	R	1-Configuration Hold	1/0	00305+48(#-1)
L#SSC	R	1-Steps Completed	1/0	00306+48(#-1)
		(spare)	0	00307+48(#-1)
		(spare)	0	00308+48(#-1)
L#PB1	R	PB1SW Input MD (*)	1/0	00309+48(#-1)
L#PB2	R	PB2SW Input MD (*)	1/0	00310+48(#-1)
L#PB3	R	PB3SW Input MD (*)	1/0	00311+48(#-1)
L#A1	R	1-Alarm 1 is Active	1/0	00312+48(#-1)
L#N1	R/W	1-Alarm 1 is Not Acknowledged	1/0	00313+48(#-1)
L#E1	R/W	1-Alarm 1 is Enabled	1/0	00314+48(#-1)
L#A2	R	1-Alarm 2 is Active	1/0	00315+48(#-1)
L#N2	R/W	1-Alarm 2 is Not Acknowledged	1/0	00316+48(#-1)
L#E2	R/W	1-Alarm 2 is Enabled	1/0	00317+48(#-1)
L#A3	R	1-Alarm 3 is Active	1/0	00318+48(#-1)
L#N3	R/W	1-Alarm 3 is Not Acknowledged	1/0	00319+48(#-1)
L#E3	R/W	1-Alarm 3 is Enabled	1/0	00320+48(#-1)
L#A4	R	1-Alarm 4 is Active	1/0	00321+48(#-1)
L#N4	R/W	1-Alarm 4 is Not Acknowledged	1/0	00322+48(#-1)
L#E4	R/W	1-Alarm 4 is Enabled	1/0	00323+48(#-1)
L#OS2	R/W	1-Alarms - Out of Service	1/0	00324+48(#-1)
L#CC	R	1-Configuration has Changed	1/0	00325+48(#-1)
L#NA	R/W	1-Unacknowledged Loop Event	1/0	00326+48(#-1)
L#AE	R	1-Active Loop Event	1/0	00327+48(#-1)
		(spare)	0	00328+48(#-1)

* These bits indicate the status of the switch input MD. A write of a "1" will have the same effect as pressing and releasing the button on the faceplate. If the action of the switch is sustained the switch will change position. If the action is momentary, the switch will close for one scan cycle.

Analog Indicator [ODA]

Code	R/W	Description	Range	Coil(MB)
L#P1AA	R	1-Process 1 Alarm A is Active	1/0	00296+48(#-1)
L#P1AN	R/W	1-Process 1 Alarm A is Not Acknowledged	1/0	00297+48(#-1)
L#P1AE	R/W	1-Process 1 Alarm A is Enabled	1/0	00298+48(#-1)
L#P1BA	R	1-Process 1 Alarm B is Active	1/0	00299+48(#-1)
L#P1BN	R/W	1-Process 1 Alarm B is Not Acknowledged	1/0	00300+48(#-1)
L#P1BE	R/W	1-Process 1 Alarm B is Enabled	1/0	00301+48(#-1)
L#P2AA	R	1-Process 2 Alarm A is Active	1/0	00302+48(#-1)
L#P2AN	R/W	1-Process 2 Alarm A is Not Acknowledged	1/0	00303+48(#-1)
L#P2AE	R/W	1-Process 2 Alarm A is Enabled	1/0	00304+48(#-1)
L#P2BA	R	1-Process 2 Alarm B is Active	1/0	00305+48(#-1)
L#P2BN	R/W	1-Process 2 Alarm B is Not Acknowledged	1/0	00306+48(#-1)
L#P2BE	R/W	1-Process 2 Alarm B is Enabled	1/0	00307+48(#-1)
L#OS1	R/W	1-Alarms - Out of Service	1/0	00308+48(#-1)
L#PB1	R/W	PB1SW Input MD (*)	1/0	00309+48(#-1)
L#PB2	R/W	PB2SW Input MD (*)	1/0	00310+48(#-1)
L#PB3	R/W	PB3SW Input MD (*)	1/0	00311+48(#-1)
L#P3AA	R	1-Process 3 Alarm A is Active	1/0	00312+48(#-1)
L#P3AN	R/W	1-Process 3 Alarm A is Not Acknowledged	1/0	00313+48(#-1)
L#P3AE	R/W	1-Process 3 Alarm A is Enabled	1/0	00314+48(#-1)
L#P3BA	R	1-Process 3 Alarm B is Active	1/0	00315+48(#-1)
L#P3BN	R/W	1-Process 3 Alarm B is Not Acknowledged	1/0	00316+48(#-1)
L#P3BE	R/W	1-Process 3 Alarm B is Enabled	1/0	00317+48(#-1)
L#P4AA	R	1-Process 4 Alarm A is Active	1/0	00318+48(#-1)
L#P4AN	R/W	1-Process 4 Alarm A is Not Acknowledged	1/0	00319+48(#-1)
L#P4AE	R/W	1-Process 4 Alarm A is Enabled	1/0	00320+48(#-1)
L#P4BA	R	1-Process 4 Alarm B is Active	1/0	00321+48(#-1)
L#P4BN	R/W	1-Process 4 Alarm B is Not Acknowledged	1/0	00322+48(#-1)
L#P4BE	R/W	1-Process 4 Alarm B is Enabled	1/0	00323+48(#-1)
L#OS	R/W	1-Alarms - Out of Service	1/0	00324+48(#-1)
L#CC	R	1-Configuration has Changed	1/0	00325+48(#-1)
L#NA	R/W	1-Unacknowledged Loop Event	1/0	00326+48(#-1)
L#AE	R	1-Active Loop Event	1/0	00327+48(#-1)

* These bits indicate the status of the switch input MD. A write of a “1” will have the same effect as pressing and releasing the button on the faceplate. If the action of the switch is sustained the switch will change position. If the action is momentary, the switch will close for one scan cycle.

Digital Indicator [ODD]

<u>Code</u>	<u>R/W</u>	<u>Description</u>	<u>Range</u>	<u>Coil(MB)</u>
L#D0I	R	Discrete 0 Input 1-ON 0-OFF	1/0	00296+48(#-1)
L#D1I	R	Discrete 1 Input 1-ON 0-OFF	1/0	00297+48(#-1)
L#D2I	R	Discrete 2 Input 1-ON 0-OFF	1/0	00298+48(#-1)
L#D3I	R	Discrete 3 Input 1-ON 0-OFF	1/0	00299+48(#-1)
L#D4I	R	Discrete 4 Input 1-ON 0-OFF	1/0	00300+48(#-1)
L#D5I	R	Discrete 5 Input 1-ON 0-OFF	1/0	00301+48(#-1)
L#D6I	R	Discrete 6 Input 1-ON 0-OFF	1/0	00302+48(#-1)
L#D7I	R	Discrete 7 Input 1-ON 0-OFF	1/0	00303+48(#-1)
L#D8I	R	Discrete 8 Input 1-ON 0-OFF	1/0	00304+48(#-1)
L#D9I	R	Discrete 9 Input 1-ON 0-OFF	1/0	00305+48(#-1)
L#DAI	R	Discrete A Input 1-ON 0-OFF	1/0	00306+48(#-1)
L#DBI	R	Discrete B Input 1-ON 0-OFF	1/0	00307+48(#-1)
L#DCI	R	Discrete C Input 1-ON 0-OFF	1/0	00308+48(#-1)
L#DDI	R	Discrete D Input 1-ON 0-OFF	1/0	00309+48(#-1)
L#DEI	R	Discrete E Input 1-ON 0-OFF	1/0	00310+48(#-1)
L#DFI	R	Discrete F Input 1-ON 0-OFF	1/0	00311+48(#-1)
L#D0S	R/W	Discrete 0 Status 1-Auto 0-Manual (*)	1/0	00312+48(#-1)
L#D1S	R/W	Discrete 1 Status 1-Auto 0-Manual (*)	1/0	00313+48(#-1)
L#D2S	R/W	Discrete 2 Status 1-Auto 0-Manual (*)	1/0	00314+48(#-1)
L#D3S	R/W	Discrete 3 Status 1-Auto 0-Manual (*)	1/0	00315+48(#-1)
L#D4S	R/W	Discrete 4 Status 1-Auto 0-Manual (*)	1/0	00316+48(#-1)
L#D5S	R/W	Discrete 5 Status 1-Auto 0-Manual (*)	1/0	00317+48(#-1)
L#D6S	R/W	Discrete 6 Status 1-Auto 0-Manual (*)	1/0	00318+48(#-1)
L#D7S	R/W	Discrete 7 Status 1-Auto 0-Manual (*)	1/0	00319+48(#-1)
L#D8S	R/W	Discrete 8 Status 1-Auto 0-Manual (*)	1/0	00320+48(#-1)
L#D9S	R/W	Discrete 9 Status 1-Auto 0-Manual (*)	1/0	00321+48(#-1)
L#DAS	R/W	Discrete A Status 1-Auto 0-Manual (*)	1/0	00322+48(#-1)
L#DBS	R/W	Discrete B Status 1-Auto 0-Manual (*)	1/0	00323+48(#-1)
L#DCS	R/W	Discrete C Status 1-Auto 0-Manual (*)	1/0	00324+48(#-1)
L#DDS	R/W	Discrete D Status 1-Auto 0-Manual (*)	1/0	00325+48(#-1)
L#DES	R/W	Discrete E Status 1-Auto 0-Manual (*)	1/0	00326+48(#-1)
L#DFS	R/W	Discrete F Status 1-Auto 0-Manual (*)	1/0	00327+48(#-1)
L#D0O	R/W	Discrete 0 Output 1-ON 0-OFF	1/0	00328+48(#-1)
L#D1O	R/W	Discrete 1 Output 1-ON 0-OFF	1/0	00329+48(#-1)
L#D2O	R/W	Discrete 2 Output 1-ON 0-OFF	1/0	00330+48(#-1)
L#D3O	R/W	Discrete 3 Output 1-ON 0-OFF	1/0	00331+48(#-1)
L#D4O	R/W	Discrete 4 Output 1-ON 0-OFF	1/0	00332+48(#-1)
L#D5O	R/W	Discrete 5 Output 1-ON 0-OFF	1/0	00333+48(#-1)
L#D6O	R/W	Discrete 6 Output 1-ON 0-OFF	1/0	00334+48(#-1)
L#D7O	R/W	Discrete 7 Output 1-ON 0-OFF	1/0	00335+48(#-1)
L#D8O	R/W	Discrete 8 Output 1-ON 0-OFF	1/0	00336+48(#-1)
L#D9O	R/W	Discrete 9 Output 1-ON 0-OFF	1/0	00337+48(#-1)
L#DAO	R/W	Discrete A Output 1-ON 0-OFF	1/0	00338+48(#-1)
L#DBO	R/W	Discrete B Output 1-ON 0-OFF	1/0	00339+48(#-1)
L#DCO	R/W	Discrete C Output 1-ON 0-OFF	1/0	00340+48(#-1)
L#DDO	R/W	Discrete D Output 1-ON 0-OFF	1/0	00341+48(#-1)
L#DEO	R/W	Discrete E Output 1-ON 0-OFF	1/0	00342+48(#-1)
L#DFO	R/W	Discrete F Output 1-ON 0-OFF	1/0	00343+48(#-1)
L#PB1	R/W	PB1SW Input MD (**)	1/0	08701+16(#-1)
L#PB2	R/W	PB2SW Input MD (**)	1/0	08702+16(#-1)
		(spares)		08703-08716+16(#-1)

(*) L#DnS - writing a "1" toggles the switch, Reading "1" indicates Auto Status; reading "0" indicate Man status.

(**) L#PB1 & L#PB2 - writing a "1" to the controller will have the same affect as pushing the button on the faceplate of the controller. If the action of the switch is sustained the switch will change position. If the action is momentary, the switch will close for one scan cycle. Reading the bits indicates the status of the switch MD input.

Pushbutton/Switch Indicator [ODP]

<u>Code</u>	<u>R/W</u>	<u>Description</u>	<u>Range</u>	<u>Coil(MB)</u>
L#G1P1	W	Group 1 - Press PB1 (**)	1	00296+48(#-1)
L#G1P2	W	Group 1 - Press PB2 (**)	1	00297+48(#-1)
L#G1S3	R/W	Group 1 - Auto/Man Switch (*)	1/0	00298+48(#-1)
L#G1FS	R	Group 1 Feedback Status	1/0	00299+48(#-1)
L#G2P1	W	Group 2 - Press PB1 (**)	1	00300+48(#-1)
L#G2P2	W	Group 2 - Press PB2 (**)	1	00301+48(#-1)
L#G2S3	R/W	Group 2 - Auto/Man Switch (*)	1/0	00302+48(#-1)
L#G2FS	R	Group 2 - Feedback Status	1/0	00303+48(#-1)
L#G3P1	W	Group 3 - Press PB1 (**)	1	00304+48(#-1)
L#G3P2	W	Group 3 - Press PB2 (**)	1	00305+48(#-1)
L#G3S3	R/W	Group 3 - Auto/Man Switch (*)	1/0	00306+48(#-1)
L#G3FS	R	Group 3 - Feedback Status	1/0	00307+48(#-1)
L#G4P1	W	Group 4 - Press PB1 (**)	1	00308+48(#-1)
L#G4P2	W	Group 4 - Press PB2 (**)	1	00309+48(#-1)
L#G4S3	R/W	Group 4 - Auto/Man Switch (*)	1/0	00310+48(#-1)
L#G4FS	R	Group 4 - Feedback Status	1/0	00311+48(#-1)
L#G5P1	W	Group 5 - Press PB1 (**)	1	00312+48(#-1)
L#G5P2	W	Group 5 - Press PB2 (**)	1	00313+48(#-1)
L#G5S3	R/W	Group 5 - Auto/Man Switch (*)	1/0	00314+48(#-1)
L#G5FS	R	Group 5 - Feedback Status	1/0	00315+48(#-1)
L#G6P1	W	Group 6 - Press PB1 (**)	1	00316+48(#-1)
L#G6P2	W	Group 6 - Press PB2 (**)	1	00317+48(#-1)
L#G6S3	R/W	Group 6 - Auto/Man Switch (*)	1/0	00318+48(#-1)
L#G6FS	R	Group 6 - Feedback Status	1/0	00319+48(#-1)
L#G7P1	W	Group 7 - Press PB1 (**)	1	00320+48(#-1)
L#G7P2	W	Group 7 - Press PB2 (**)	1	00321+48(#-1)
L#G7S3	R/W	Group 7 - Auto/Man Switch (*)	1/0	00322+48(#-1)
L#G7FS	R	Group 7 - Feedback Status	1/0	00323+48(#-1)
L#G8P1	W	Group 8 - Press PB1 (**)	1	00324+48(#-1)
L#G8P2	W	Group 8 - Press PB2 (**)	1	00325+48(#-1)
L#G8S3	R/W	Group 8 - Auto/Man Switch (*)	1/0	00326+48(#-1)
L#G8FS	R	Group 8 - Feedback Status	1/0	00327+48(#-1)

* L#GnS3 - reading a "1" indicates a switch position of Auto and reading a "0" indicates Man. Writing a "1" to the controller will toggle the state of the Auto/Man switch.

** L#GnP1 & L#GnP2 - writing a "1" to the controller will have the same affect as pushing the button on the faceplate of the controller. If the action of the switch is sustained the switch will change position. If the action is momentary the switch will close for one scan cycle.

6.3.9 PCOM Block Status

Controller/Sequencer

<u>Code</u>	<u>R/W</u>	<u>Description</u>	<u>Range</u>	<u>Coil(MB)</u>
L#INIT_OK	R/W	1-INIT_OK	1/0	09101+32(#-1)
L#DFAIL	R/W	1-DFAIL	1/0	09102+32(#-1)
L#RESET	W	1-RESET	1/0	09103+32(#-1)
L#START	W	1-START	1/0	09104+32(#-1)
L#RESTART	W	1-RESTART	1/0	09105+32(#-1)
L#HOLD	W	1-HOLD	1/0	09106+32(#-1)
L#PCOMP	W	1-PCOMP	1/0	09107+32(#-1)
L#ABORT	W	1-ABORT	1/0	09108+32(#-1)
L#READY	R	1-READY	1/0	09109+32(#-1)
L#RUN	R	1-RUN	1/0	09110+32(#-1)
L#HELD	R	1-HELD	1/0	09111+32(#-1)
L#DONE	R	1-DONE	1/0	09112+32(#-1)
L#ABORTED	R	1-ABORTED	1/0	09113+32(#-1)
spare	R		1/0	09114+32(#-1)
spare	R		1/0	09115+32(#-1)
spare	R		1/0	09116+32(#-1)

<u>Code</u>	<u>R/W</u>	<u>Description</u>	<u>Range</u>	<u>Coil(MB)</u>
L#EMERG (EO)	R	1-Emerg. Override	1/0	09117+32(#-1)
L#NotAck'dEO	R/W	1-EO Not Ack'd	1/0	09118+32(#-1)
L#INTRLK (IK)	R	1-INTRLK	1/0	09119+32(#-1)
L#NotAck'd IK	R/W	1- IK Not Ack'd	1/0	09120+32(#-1)
L#FAILED (FD)	R	1-FAILED	1/0	09121+32(#-1)
L#NotAck'dFD	R/W	1- FD Not Ack'd	1/0	09122+32(#-1)
spare	R	1/0		09123+32(#-1)
spare	R		1/0	09124+32(#-1)
spare	R		1/0	09125+32(#-1)
spare	R		1/0	09126+32(#-1)
spare	R		1/0	09127+32(#-1)
spare	R		1/0	09128+32(#-1)
spare	R		1/0	09129+32(#-1)
spare	R		1/0	09130+32(#-1)
L#NotAck'dPCOM	R/W	1-PCOM Evnt Not Ack'd	1/0	09131+32(#-1)
L#ACTIVEPCOM	R	1-PCOM Event is Active	1/0	09132+32(#-1)

6.3.10 Sequencer Loop I/O Coil Data (1-bit)**Sequencer:**

<u>Code</u>	<u>R/W</u>	<u>Description</u>	<u>Range</u>	<u>Coil (MB)</u>
SG0KI0	R	Seq. Group 0 (cur. step) masK for Input 0	1/0	01496
SG0KIF	R	Seq. Group 0 (cur. step) masK for Input F	1/0	01511
SG0SI0	R	Seq. Group 0 (cur. step) State of Input 0	1/0	01512
SG0SIF	R	Seq. Group 0 (cur. step) State of Input F	1/0	01527
SG0SO0	R	Seq. Group 0 (cur. step) State of Output 0	1/0	01528
SG0SOF	R	Seq. Group 0 (cur. step) State of Output F	1/0	01543
SGFKI0	R	Seq. Group F (cur. step) masK for Input 0	1/0	02216
SGFKIF	R	Seq. Group F (cur. step) masK for Input F	1/0	02231
SGFSI0	R	Seq. Group F (cur. step) State of Input 0	1/0	02232
SGFSIF	R	Seq. Group F (cur. step) State of Input F	1/0	02247
SGFSO0	R	Seq. Group F (cur. step) State of Output 0	1/0	02248
SGFSOF	R	Seq. Group F (cur. step) State of Output F	1/0	02263

6.3.11 Trend Data (Loop Defined by MLTP)

<u>Code</u>	<u>R/W</u>	<u>Description</u>	<u>Range</u>	<u>Register (MB)</u>
A1RMN	R	ATD01 MIN SCALE	Real	48001
A1RMX	R	ATD01 MAX SCALE	Real	48003
A1DPP	R	ATD01 Decimal Point Position	0-5	48005
A1EU	R	ATD01 Engineering Units	6 ASCII Char	48006
A1YR	R	ATD01 Year V2.0 (5)	1997-	48009
A1MT	R	ATD01 Month V2.0 (5)	1-12	48010
A1DY	R	ATD01 Day V2.0 (5)	1-31	48011
A1HR	R	ATD01 Hour V2.0 (5)	0-23	48012
A1MN	R	ATD01 Minute V2.0 (5)	0-59	48013
A1SC	R	ATD01 Second V2.0 (5)	0-59	48014
A1ST	R/W*	ATD01 Sample Time x0.01=min	1-48000	48015
A1STC	R	ATD01 % Sample Time Complete	0-1000 (x.1=%)	48016
A1D1	R	ATD01 Data 1 (latest) 0-100%	128-3968	48017
A1D2	R	ATD01 Data 2 0-100%	128-3968	48018
A1D3	R	ATD01 Data 3 0-100%	128-3968	48019
.....				
A1D168	R	ATD01 Data 168 0-100%	128-3968	48184
A1D169	R	ATD01 Data 169 0-100%	128-3968	48185
A1D170	R	ATD01 Data 170 0-100%	128-3968	48186

* Writing to the sample time will reset all data points A1D1 through A1D170 to \$0.

A2RMN	R	ATD02 MIN SCALE	Real	48201
A2RMX	R	ATD02 MAX SCALE	Real	48203
A2DPP	R	ATD02 Decimal Point Position	0-5	48205
A2EU	R	ATD02 Engineering Units	6 ASCII Char	48206
A2YR	R	ATD02 Year V2.0 (5)	1997	48209
A2MT	R	ATD02 Month V2.0 (5)	1-12	48210
A2DY	R	ATD02 Day V2.0 (5)	1-31	48211
A2HR	R	ATD02 Hour V2.0 (5)	0-23	48212
A2MN	R	ATD02 Minute V2.0 (5)	0-59	48213
A2SC	R	ATD02 Second V2.0 (5)	0-59	48214
A2ST	R/W*	ATD02 Sample Time x0.01=min	1-48000	48215
A2STC	R	ATD02 % Sample Time Complete	0-1000 (x.1=%)	48216
A2D1	R	ATD02 Data 1 (latest) 0-100%	128-3968	48217
A2D2	R	ATD02 Data 2 0-100%	128-3968	48218
A2D3	R	ATD02 Data 3 0-100%	128-3968	48219
.....				
A2D168	R	ATD02 Data 168 0-100%	128-3968	48384
A2D169	R	ATD02 Data 169 0-100%	128-3968	48385
A2D170	R	ATD02 Data 170 0-100%	128-3968	48386

* Writing to the sample time will reset all data points A2D1 through A2D170 to \$0.

Code	R/W	Description	Range	Register (MB)
A3RMN	R	ATD03 MIN SCALE	Real	48401
A3RMX	R	ATD03 MAX SCALE	Real	48403
A3DPP	R	ATD03 Decimal Point Position	0-5	48405
A3EU	R	ATD03 Engineering Units	6 ASCII Char	48406
A3YR	R	ATD03 Year V2.0 (5)	1997-	48409
A3MT	R	ATD03 Month V2.0 (5)	1-12	48410
A3DY	R	ATD03 Day V2.0 (5)	1-31	48411
A3HR	R	ATD03 Hour V2.0 (5)	0-23	48412
A3MN	R	ATD03 Minute V2.0 (5)	0-59	48413
A3SC	R	ATD03 Second V2.0 (5)	0-59	48414
A3ST	R/W*	ATD03 Sample Time x0.01=min	1-48000	48415
A3STC	R	ATD03 % Sample Time Complete	0-1000 (x.1=%)	48416
A3D1	R	ATD03 Data 1 (latest) 0-100%	128-3968	48417
A3D2	R	ATD03 Data 2 0-100%	128-3968	48418
A3D3	R	ATD03 Data 3 0-100%	128-3968	48419
.....				
A3D168	R	ATD03 Data 168 0-100%	128-3968	48584
A3D169	R	ATD03 Data 169 0-100%	128-3968	48585
A3D170	R	ATD03 Data 170 0-100%	128-3968	48586

* Writing to the sample time will reset all data points A3D1 through A3D170 to \$0.

A4RMN	R	ATD04 MIN SCALE	Real	48601
A4RMX	R	ATD04 MAX SCALE	Real	48603
A4DPP	R	ATD04 Decimal Point Position	0-5	48605
A4EU	R	ATD04 Engineering Units	6 ASCII Char	48606
A4YR	R	ATD04 Year V2.0 (5)	1997-	48609
A4MT	R	ATD04 Month V2.0 (5)	1-12	48610
A4DY	R	ATD04 Day V2.0 (5)	1-31	48611
A4HR	R	ATD04 Hour V2.0 (5)	0-23	48612
A4MN	R	ATD04 Minute V2.0 (5)	0-59	48613
A4SC	R	ATD04 Second V2.0 (5)	0-59	48614
A4ST	R/W*	ATD04 Sample Time x0.01=min	1-48000	48615
A4STC	R	ATD04 % Sample Time Complete	0-1000 (x.1=%)	48616
A4D1	R	ATD04 Data 1 (latest) 0-100%	128-3968	48617
A4D2	R	ATD04 Data 2 0-100%	128-3968	48618
A4D3	R	ATD04 Data 3 0-100%	128-3968	48619
.....				
A4D168	R	ATD04 Data 168 0-100%	128-3968	48784
A4D169	R	ATD04 Data 169 0-100%	128-3968	48785
A4D170	R	ATD04 Data 170 0-100%	128-3968	48786

* Writing to the sample time will reset all data points A4D1 through A4D170 to \$0.

<u>Code</u>	<u>R/W</u>	<u>Description</u>	<u>Range</u>	<u>Register (MB)</u>
A5RMN	R	ATD05 MIN SCALE	Real	48801
A5RMX	R	ATD05 MAX SCALE	Real	48803
A5DPP	R	ATD05 Decimal Point Position	0-5	48805
A5EU	R	ATD05 Engineering Units	6 ASCII Char	48806
A5YR	R	ATD05 Year V2.0 (5)	1997-	48809
A5MT	R	ATD05 Month V2.0 (5)	1-12	48810
A5DY	R	ATD05 Day V2.0 (5)	1-31	48811
A5HR	R	ATD05 Hour V2.0 (5)	0-23	48812
A5MN	R	ATD05 Minute V2.0 (5)	0-59	48813
A5SC	R	ATD05 Second V2.0 (5)	0-59	48814
A5ST	R/W*	ATD05 Sample Time x0.01=min	1-48000	48815
A5STC	R	ATD05 % Sample Time Complete	0-1000 (x.1=%)	48816
A5D1	R	ATD05 Data 1 (latest) 0-100%	128-3968	48817
A5D2	R	ATD05 Data 2 0-100%	128-3968	48818
A5D3	R	ATD05 Data 3 0-100%	128-3968	48819
.....				
A5D168	R	ATD05 Data 168 0-100%	128-3968	48984
A5D169	R	ATD05 Data 169 0-100%	128-3968	48985
A5D170	R	ATD05 Data 170 0-100%	128-3968	48986

* Writing to the sample time will reset all data points A5D1 through A5D170 to \$0.

Notes:

1. A read of any Time Stamp Data (i.e. Year, Month, Day, Hour, Minute, Second, or Sample Time) will update all Loop data registers. Additional data reads of Trend data within the same block should only request data so as to obtain a complete set of time synchronized data.
2. Trend data are obtained from the loop referenced by the MLTP parameter (register 40058). This parameter can also be written to change the loop.
3. Parameter NTTB will indicate the number of ATD Analog Trend Display blocks that are available in the loop specified by the MLTP.
4. Undefined data (e.g. unconfigured inputs, period station was in HOLD or powered down) are represented by a value of \$0.

6.3.12 Configuration Data Sequencer Loop

The Modbus registers on this page refer to configuration parameters of function blocks within a specific loop previously defined by Modbus parameter MSLCP (40048). For example, to read or write the Step 1 Group 0 Input Mask for the PRSEQ block that is in a loop with a Modbus Index of 3, write a 3 to 40048, then read or write to register 410001.

Sequencer (MASK Configurations)

<u>Code</u>	<u>R/W</u>	<u>Description</u>	<u>Range</u>	<u>Register (MB)</u>
S001G0I	R/W	Step 1 Group 0 Input Mask	\$0000-\$FFFF	410001
S001G0O	R/W	Step 1 Group 0 Output Mask	\$0000-\$FFFF	410002
S001G1I	R/W	Step 1 Group 1 Input Mask	\$0000-\$FFFF	410003
S001G1O	R/W	Step 1 Group 1 Output Mask	\$0000-\$FFFF	410004
S001G2I	R/W	Step 1 Group 2 Input Mask	\$0000-\$FFFF	410005
S001G2O	R/W	Step 1 Group 2 Output Mask	\$0000-\$FFFF	410006
S001G3I	R/W	Step 1 Group 3 Input Mask	\$0000-\$FFFF	410007
S001G3O	R/W	Step 1 Group 3 Output Mask	\$0000-\$FFFF	410008
.....				
S250GEI	R/W	Step 250 Group E Input Mask	\$0000-\$FFFF	417997
S250GEO	R/W	Step 250 Group E Output Mask	\$0000-\$FFFF	417998
S250GFI	R/W	Step 250 Group F Input Mask	\$0000-\$FFFF	417999
S250GFO	R/W	Step 250 Group F Output Mask	\$0000-\$FFFF	418000

Real Time Trip Block Configurations

<u>Code</u>	<u>R/W</u>	<u>Description</u>	<u>Range</u>	<u>Register (MB)</u>
RTT01Y	R/W	Year	1999-	419001
RTT01M	R/W	Month	1-12	419002
RTT01D	R/W	Day	1-31	419003
RTT01HR	R/W	Hour	0-23	419004
RTT01MN	R/W	Minute	0-59	419005
RTT01SC	R/W	Second	0-59	419006
RTT01DA	R/W	Day	0000 0000 0SMT WTFS	419007
RTT02Y	R/W	Year	1999-	419008
RTT02M	R/W	Month	1-12	419009
RTT02D	R/W	Day	1-31	419010
RTT02HR	R/W	Hour	0-23	419011
RTT02MN	R/W	Minute	0-59	419012
RTT02SC	R/W	Second	0-59	419013
RTT02DA	R/W	Day	0000 0000 0SMT WTFS	419014
RTT03Y	R/W	Year	1999-	419015
RTT03M	R/W	Month	1-12	419016
RTT03D	R/W	Day	1-31	419017
RTT03HR	R/W	Hour	0-23	419018
RTT03MN	R/W	Minute	0-59	419019
RTT03SC	R/W	Second	0-59	419020
RTT03DA	R/W	Day	0000 0000 0SMT WTFS	419021

Sequencer Time & Analog Configurations

<u>Code</u>	<u>R/W</u>	<u>Description</u>	<u>Range</u>	<u>Register (MB)</u>
S001TIM	R/W	Step 1 Time Period (min)	Real	420001
S001AEP	R/W	Step 1 Analog End Point	Real	420003
S002TIM	R/W	Step 2 Time Period (min)	Real	420005
S002AEP	R/W	Step 2 Analog End Point	Real	420007
S003TIM	R/W	Step 3 Time Period (min)	Real	420009
S003AEP	R/W	Step 3 Analog End Point	Real	420011
S004TIM	R/W	Step 4 Time Period (min)	Real	420013
S004AEP	R/W	Step 4 Analog End Point	Real	420015
.....				
S246TIM	R/W	Step 246 Time Period (min)	Real	420981
S246AEP	R/W	Step 246 Analog End Point	Real	420983
S247TIM	R/W	Step 247 Time Period (min)	Real	420985
S247AEP	R/W	Step 247 Analog End Point	Real	420987
S248TIM	R/W	Step 248 Time Period (min)	Real	420989
S248AEP	R/W	Step 248 Analog End Point	Real	420991
S249TIM	R/W	Step 249 Time Period (min)	Real	420993
S249AEP	R/W	Step 249 Analog End Point	Real	420995
S250TIM	R/W	Step 250 Time Period (min)	Real	420997
S250AEP	R/W	Step 250 Analog End Point	Real	420999

Timer Function Block Configurations

<u>Code</u>	<u>R/W</u>	<u>Description</u>	<u>Range</u>	<u>Register (MB)</u>
DYT01T	R/W	Delay Timer 01 Time (min)	Real	421001
OST01T	R/W	One Shot Timer 01 Time (min)	Real	421003
RCT01NT	R/W	Rept Cy Timer 01 ON Time (min)	Real	421005
RCT01FT	R/W	Rept Cy Timer 01 OFF Time (min)	Real	421007
ROT01T	R/W	Retentive On Timer 01 Time (min)	Real	421009
.....				
DYT21T	R/W	Delay Timer 21 Time (min)	Real	421201
OST21T	R/W	One Shot Timer 21 Time (min)	Real	421203
RCT21NT	R/W	Rept Cy Timer 21 ON Time (min)	Real	421205
RCT21FT	R/W	Rept Cy Timer 21 OFF Time (min)	Real	421207
ROT21T	R/W	Retentive On Timer 21 Time (min)	Real	421209

■

7.0 INSTALLATION

This section describes installation of a Siemens 353 Process Automation Controller. Topics include: installation considerations and mechanical and electrical installation.

IMPORTANT

The installation must conform to the National Electrical Code and all other applicable construction and electrical codes.

Section 1.4.4 has lists of the items in a typical controller shipment. If the Display Assembly or a circuit board(s) must be installed in the case, go to Section 10.5 Assembly Replacement for installation information.

Refer to Section 13.9 Agency Approvals as necessary. CSA Hazardous Location Precautions and Special Conditions for Safe Use are included in this section. Use of the equipment in a manner not specified by the manufacturer may impair the protection provided by the equipment.

A warning label, shown at right, is included with the controller. Install the label in a highly visible location near the rear terminals of the controller to insure that all plant personnel with access to controller terminals are aware of a potential electrical shock hazard and, if installation is in a hazardous area, possible explosion hazard.



7.1 INSTALLATION CONSIDERATIONS

A Siemens 353 is intended for flush panel mounting in a vibration free instrument panel or rack in an indoor or sheltered location. Mount a single controller in a single-station panel cutout or mount several controllers in a row in a multiple-station panel cutout. For a watertight panel, mount each controller in a single-station cutout.

The controller can be mounted in a user-supplied enclosure located out-of-doors or in a location whose environmental parameters exceed controller operating specifications. A thin bead of silicon sealant is often applied between the controller's Display Assembly and the mounting panel to prevent air or liquid leakage at this joint.

Do not mount the controller where direct sunlight can strike the faceplate or case. Direct sunlight can make the displays difficult to read and will interfere with heat dissipation.

Mount the controller either horizontally or with a backward tilt (i.e. the front of the case higher than the rear). If the controller is to be mounted with some electronic recorders or with pneumatic recorders or stations, tilt back restrictions for these units may have a bearing on panel design and layout.

Route electrical power to the controller through a clearly labeled circuit breaker, fuse, or on-off switch that is located near the controller and is accessible by the operator. The breaker or switch should be located in a non-explosive atmosphere unless suitable for use in an explosive atmosphere.

Thermocouple inputs are accommodated with an optional I/O Expander board and a Reference Junction temperature sensor. At the factory, two Reference Junctions are included in a Range Resistor and Reference Installation Kit.

For troubleshooting and assembly replacement, see Section 10 Maintenance. Refer to this material when installing or storing a controller or an MPU Controller board.

7.2 ENVIRONMENTAL CONSIDERATIONS

Operate a controller within its environmental specifications to help ensure reliable, trouble-free operation with minimum down time. Refer to Section 13 Model Designation and Specifications for controller operating temperatures limits, operating humidity, and maximum moisture content.

TEMPERATURE

Maintain the temperature of the air surrounding an operating controller below 50°C (122°F). Check air temperature periodically to ensure that this specification is not being exceeded.

CAUTION

Exceeding the specified operating temperature limits can adversely affect performance and may cause damage to the controller.

Forced air ventilation is recommended when controllers are mounted in a partially or completely enclosed panel or cabinet (e.g. NEMA 1); as shown at right. When clean air is present, exhaust fans are often mounted across the top of a panel and louvers formed in the panel bottom. Air is then drawn upward between the station cases. When air contains particulate matter, fans and filters are generally located at the panel bottom and louvers at the top. Filtered air is now forced upward between the station cases. Filters must be serviced periodically.

Only high quality, quiet running fans should be used. Also, the fans should not generate electrical noise which could interfere with electronic instruments.

A sealed cabinet (e.g. NEMA 12 or 4X) housing 353s must not contain other equipment that generates significant heat and must contain a fan to force air to flow around equipment and throughout the cabinet preventing hot spots from developing. Forced air conditioning may be required in high density panels or consoles. Periodically change or clean air filters.

CONTAMINANTS

The controller case is slotted to permit circulation of clean cooling air. Liquids and corrosive gases must not be allowed to enter the case. Whether the controller is in a control room or field mounted it must be protected from rain, air conditioning condensate, and plant and process related fluids and gases. Extended exposure to contaminants can result in malfunctions.

Industrial environments often contain airborne particulate contaminants. Particulate matter, usually dust and dirt, is abrasive and can cause intermittent connections. A layer of dust on circuit boards can interfere with component heat dissipation and can absorb other airborne contaminants. Extended exposure to these contaminants may result in malfunctions.

Although 353 boards have a protective coating, the following steps can reduce contaminant related equipment malfunctions:

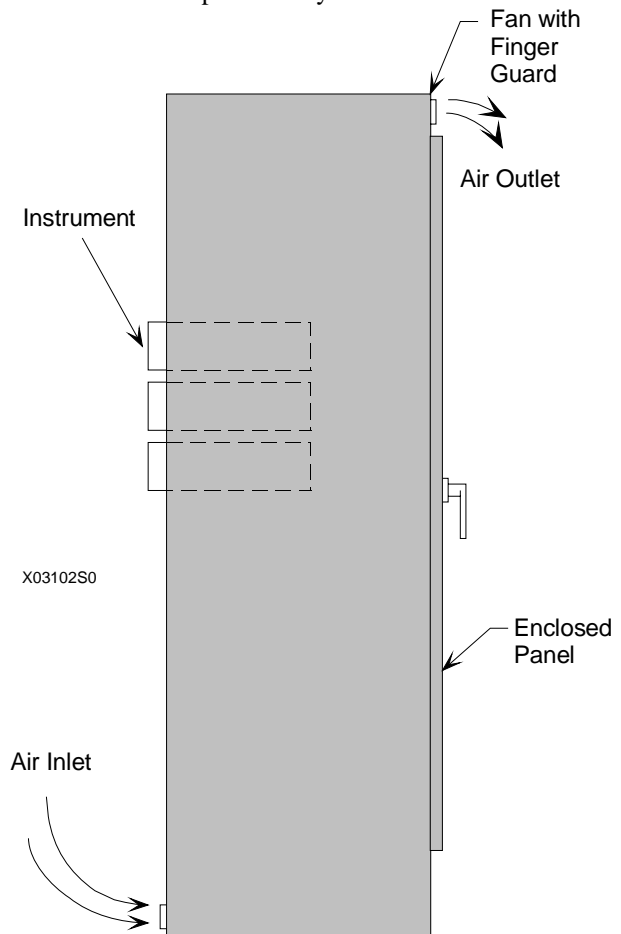

No. of Fans: One for each 16 stations or 3 ft. of panel width.

Air Inlet: 30 in² for each fan. If filters are used, they must be changed periodically (increase inlet to 50 in²).

Forced Air Ventilation for Enclosed Panels

1. Identify contaminants and implement methods to reduce their presence.
2. Install protective housing for field mounted controllers.
3. When cleaning equipment and surrounding area, especially the floor, either vacuum away all dust and dirt or use a dampened rag or mop. Sweeping or dry dusting recirculates dust and dirt.
4. Clean or replace all air conditioning filters, room air filters, and equipment filters regularly.
5. Inform all personnel with access to the equipment of the need for cleanliness.

7.3 MECHANICAL INSTALLATION

The following subsections provide guidelines and procedures for mounting controllers in a panel or rack. The installation should be structurally rigid and the controllers should be squared in the panel or rack.

7.3.1 Removable Connectors and Covers

To gain access to the case mounted connectors, a cover may need to be removed. Reinstall the cover when wiring is completed. As discussed above, each connector has a removable portion that can be separated from the case mounted portion, wired, and then reattached. This section will describe cover removal, connector separation, and connector installation.

COVER AND CONNECTOR REMOVAL AND INSTALLATION

Removal

1. Squeeze the cover slightly about 2" (5 mm) down from the top and push the cover upward. See Figure 7-1. As shipped from the factory, the cover is not installed on the case.
2. Locate the connector to be removed. As necessary, disconnect, unclamp, or unbundle wires connected to the connector to be removed. Be sure there is sufficient slack in the wiring for connector removal.
3. Loosen the two captive screws securing the removable portion of the connector to the fixed portion.
4. Grasp the removable portion and pull it from the fixed portion. Be careful not to stress or damage connected wires and components.

Installation

1. Align the removable portion of the connector with the fixed portion.
2. Press the removable portion onto the fixed portion.
3. Tighten the two captive screws. Do not over tighten. Check that wires and components remain connected securely.
4. Install the cover as shown in Figure 7-1.

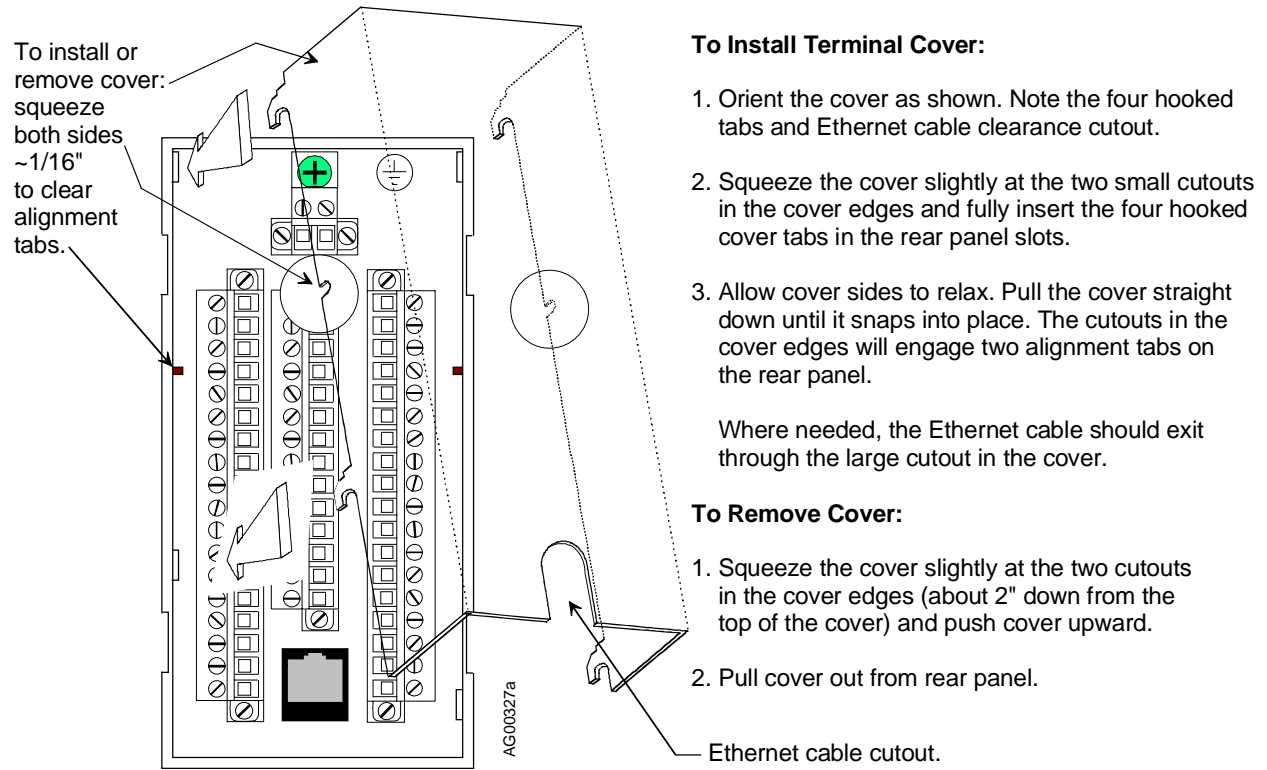
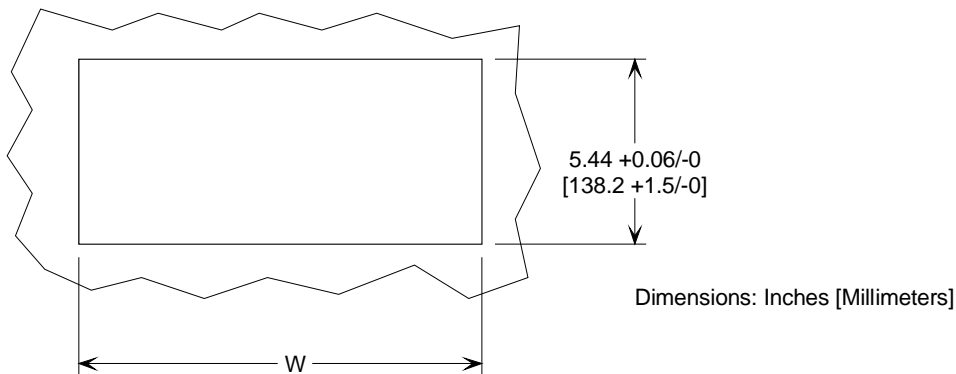

Figure 7-1 Cover Installation and Removal

7.3.2 Panel and Rack Mounting Guidelines

The panel face should provide a flat and rigid mounting surface. Reinforce the back of the panel if there is a possibility that the panel face will bow. Raceways, conduit, and wiring should not interfere with the removal or accessibility of the instruments, control devices, alarms, and related equipment. See Figure 7-2 for panel cutout dimensions and Figure 7-3 for controller dimensions.



X03100S1

Panel Cutout Dimensions: Tolerances +0.06/-0 [+1.5/-0]
 Height = 5.44 [138.2]
 Width = (2.84 X A) - 0.16 inches
 [(72.0 X A) - 4.1] mm

Where: A= Number of 353 Stations and 353R or ilpac Faceplates

Figure 7-2 Panel Cutout Dimensions

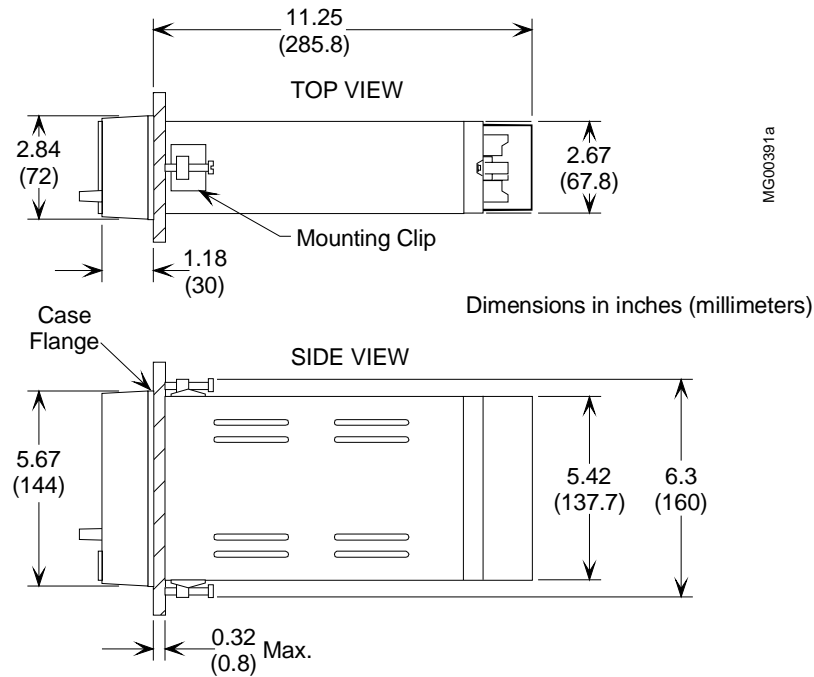

Figure 7-3 Siemens 353 Dimensions

7.3.3 Station Mounting

A straight slot screwdriver with at least a 10" (254 mm) shank is needed to tighten the two mounting clip screws.

1. Locate the supplied Mounting Clip Kit. It contains two mounting clips and two 8-32 x 1" fillister head screws. Thread the mounting screws into the mounting clips. See Figure 7-4.
2. From in front of the panel, insert the controller case into the panel cutout.
3. Slightly rotate the top mounting clip to fit it into the case cutout. Then straighten the clip and partially tighten the mounting screw. Insert, straighten and partially tighten the bottom clip.
4. Square the controller with the panel.
5. Alternately tighten top and bottom mounting clip screws until the controller is secured to the panel. Do not over tighten and distort the case.

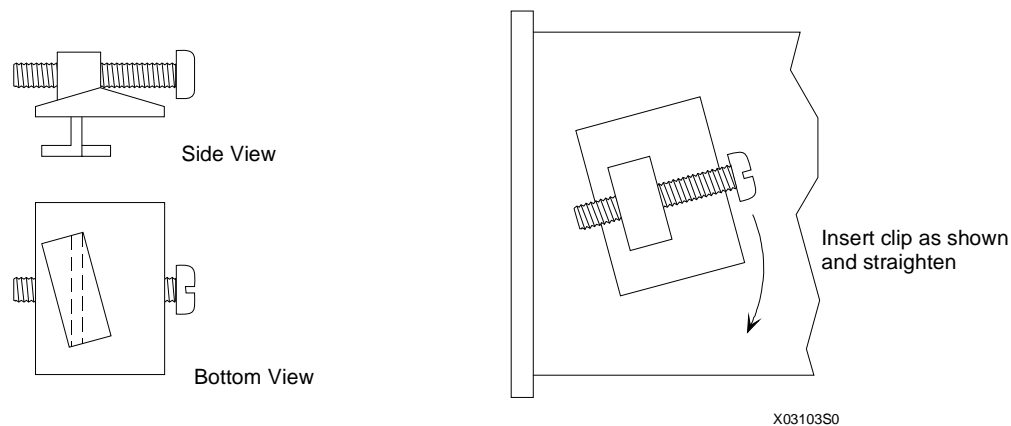





Figure 7-4 Case Mounting Clip

7.4 ELECTRICAL INSTALLATION

These sections contain electrical connection details for wiring a Siemens 353. Each case rear connector and terminal is identified. Connector cover removal and separation of the removable portion of a connector from the fixed portion is described in section 7.3.

Section 7.4.1 Wiring Guidelines contains specific information about connector removal for wiring, wire size, wire stripping and other details that will be needed while wiring. Read this section before beginning to wire a controller. Sections 7.4.2 through 7.4.11 contain wiring diagrams and, where needed, step-by-step procedures to describe I/O and network wiring. Section 7.4.12 provides power input wiring information. Single controller and daisy chained power wiring are illustrated.

 WARNING		
	<p>Electrical shock hazard Explosion hazard</p> <p>Can cause death or injury</p> <ul style="list-style-type: none"> • Remove power from all wires and terminals before working on equipment. • In potentially hazardous atmosphere, remove power from equipment before connecting or disconnecting power, signal, or other circuit. • Observe all pertinent regulations regarding installation in hazardous area. 	

7.4.1 Wiring Guidelines

Electrical Connections - Power, I/O, and Modbus network connections to a basic controller are completed through removable connectors with terminals H, N, and 3-26. When the controller includes an I/O Expander board, connectors with terminals 27-52 are also used. The case has an RJ45 connector for use when Ethernet networking is utilized. Connector locations are shown in Figure 7-5. Individual terminals functions are also identified in Table 7-1.

Connectors - Power terminals are identified by a letter: Hot and Neutral. The ground connection is made to a green case/safety ground screw located between connectors. Signal I/O terminals are identified by a number: 3 through 52. A connector terminal will accept the following wire(s).

- one 14-22 AWG (2.1-0.38 mm²)
- two 16 AWG (1.3 mm²)
- three 18 AWG (0.96 mm²)

Wire Size Recommendations:

- signal wiring - 18 AWG (0.96 mm²)
- power wiring - 18 AWG (0.96 mm²)

Wire Stripping Recommendations:

- connector terminal wiring - 1/4" (6 mm) to 5/16" (8 mm)
- green ground screw wiring - 1/8" (10 mm) to 1/2" (13 mm)

Be careful not to nick the conductor or cut away strands.

Wire Selection - Stranded wire is recommended for most connections, however, solid wire is typically used for thermocouple extension wire. Carefully select wire size, conductor material, and insulation. Some selection considerations are:

- current and voltage to be carried
- total length of each wire run
- whether wire will be bundled or run singly
- indoor or outdoor installation
- temperature extremes (Use supply wires suitable for 5°C (10°F) above ambient temperature.)
- exposure to sunlight
- vibration
- types of contaminants

Station Common (COM), Terminal 6:

- Connect station common to the user's instrument bus common at only one point
- Station common is electrically isolated from case/safety ground, the green ground screw
- Terminals 6, 9, 18, 21, 24, 34, 40 and 42 are electrically connected. Use the terminals that allow the best wire routing and the least stress on components, such as range resistors

Digital Input Commons (DIN#-) – Digital input commons are isolated from the station common and case/safety ground.

Connector Terminal and Ground Screw Torque Specifications:

- connector terminals - 5 in. lbs (0.56 N m)
- green case/safety ground screw - 20 in. lbs (2.26 N m)

Crimp-On (solderless) Connectors - A pin-style crimp-on connector can be used when two or more wires or a combination of wires and component leads are to be inserted into a connector terminal at the rear of the case. Wires and leads are crimped in the connector and the connector pin inserted in the selected connector terminal. The connector can provide a more secure connection when multiple leads are involved. An example of its use is shown at right. Several crimp-on connectors are provided in various Siemens 353 installation kits, and they are available from most electrical supply sources.

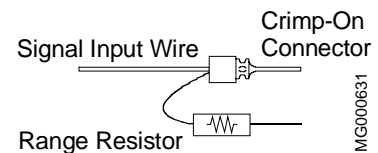

Wire Routing and Conduit - DC wiring should be separated from AC wiring and away from AC powered pushbuttons, alarms, annunciators, motors, solenoids, and similar devices. Conduit and raceways are commonly used for routing panel wiring. Wiring not installed in conduit or raceway should be clamped or supported approximately every 12 inches (300 mm).

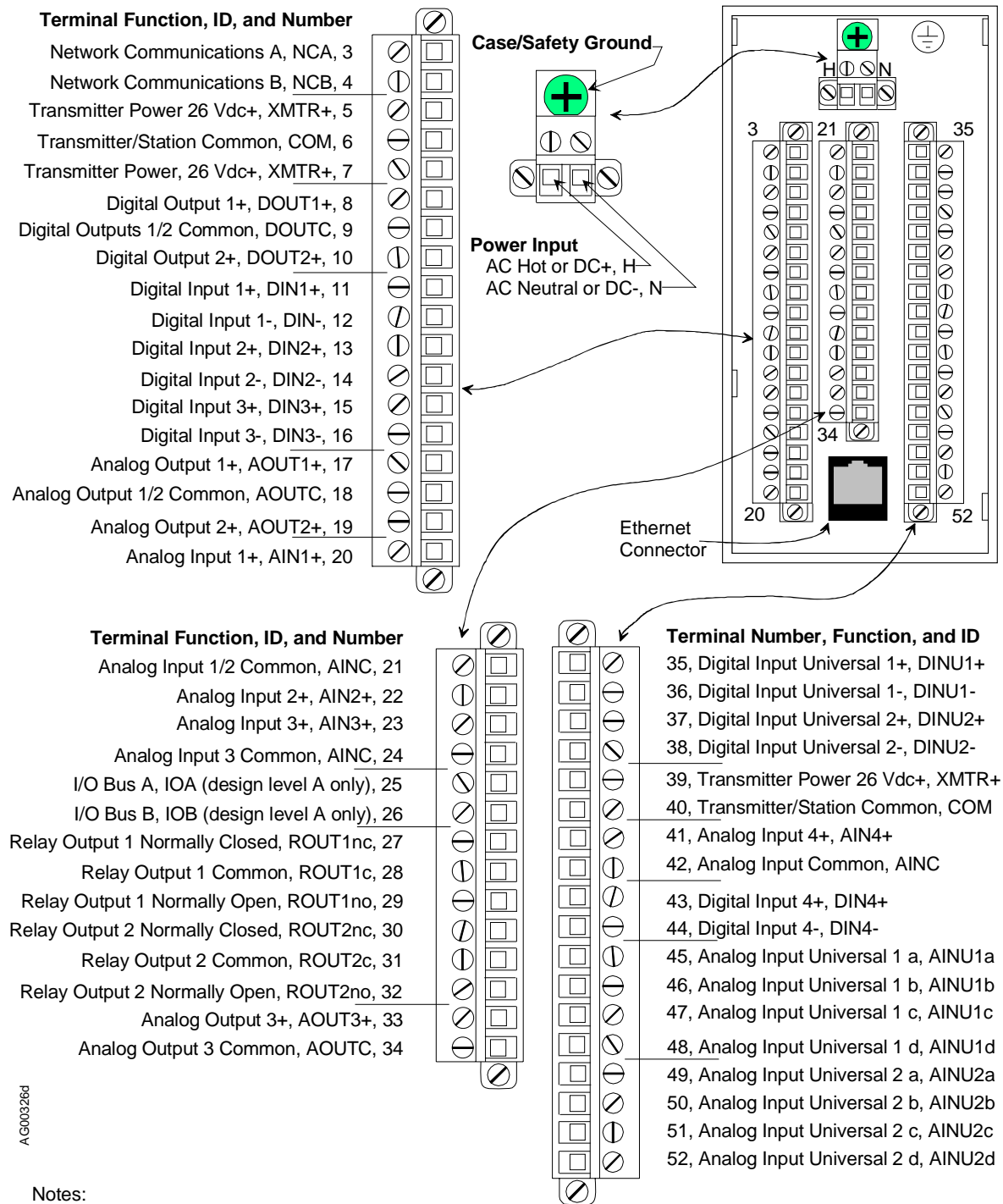

AG00326d

Notes:

1. Terminal numbers are shown on each connector. The plug-in portions of the connectors are packed with a case. The connectors are keyed.
2. Case/Safety Ground - Connect to green screw at top center of rear terminal area.
3. NCA and NCB - Connect Modbus cable or twisted pair wiring. Refer to UM353-1B, Section 7.4.9 for additional details.
4. IOA and IOB - No connection
5. Ground Bus - An external, user-supplied ground bus can ease connection of multiple grounds, particularly when twinaxial cable shields are to be grounded.
6. Terminals 6, 9, 18, 21, 24, 34, 40, and 42 are electrically connected. Use the terminals that allow the best wire routing and the least stress on components, such as range resistors.

Figure 7-5 Rear Terminal Layout and Terminal Assignments

Table 7-1 Rear Terminal Assignments

CONTROLLER BOARD			I/O EXPANDER BOARD		
Description	ID	#	#	ID	Description
Power - AC Hot/ DC +	ACH/DC+	H	27	ROUT1nc	Relay Output 1 Normally Closed
Power - AC Neutral/DC -	ACN/DC-	N	28	ROUT1c	Relay Output 1 Common
Network Communication A	NCA	3	29	ROUT1no	Relay Output 1 Normally Open
Network Communication B	NCB	4	30	ROUT2nc	Relay Output 2 Normally Closed
Transmitter Power 26Vdc +	XMTR+	5	31	ROUT2c	Relay Output 2 Common
Transmitter/Station Common	COM	6	32	ROUT2no	Relay Output 2 Normally Open
Transmitter Power 26Vdc +	XMTR+	7	33	AOUT3+	Analog Output 3 +
Digital Output 1 +	DOUT1+	8	34	AOUTC	Analog Output 3 Common
Digital Outputs 1/2 Common	DOUTC	9	35	DINU1+	Digital Input Universal 1 +
Digital Output 2 +	DOUT2+	10	36	DINU1-	Digital Input Universal 1 -
Digital Input 1 +	DIN1+	11	37	DINU2+	Digital Input Universal 2 +
Digital Input 1 -	DIN1-	12	38	DINU2-	Digital Input Universal 2 -
Digital Input 2 +	DIN2+	13	39	XMTR+	Transmitter Power 26Vdc +
Digital Input 2 -	DIN2-	14	40	COM	Transmitter/Station Common
Digital Input 3 +	DIN3+	15	41	AIN4+	Analog Input 4 +
Digital Input 3 -	DIN3-	16	42	AINC	Analog Input Common
Analog Output 1 +	AOUT1+	17	43	DIN4+	Digital Input 4 +
Analog Output 1/2 Common	AOUTC	18	44	DIN4-	Digital Input 4 -
Analog Output 2 +	AOUT2+	19	45	AINU1a	Analog Input Universal 1 a
Analog Input 1 +	AIN1+	20	46	AINU1b	Analog Input Universal 1 b
Analog Input 1/2 Common	AINC	21	47	AINU1c	Analog Input Universal 1 c
Analog Input 2 +	AIN2+	22	48	AINU1d	Analog Input Universal 1 d
Analog Input 3 +	AIN3+	23	49	AINU2a	Analog Input Universal 2 a
Analog Input 3 Common	AINC	24	50	AINU2b	Analog Input Universal 2 b
Not Used	IOA	25	51	AINU2c	Analog Input Universal 2 c
Not Used	IOB	26	52	AINU2d	Analog Input Universal 2 d
Ethernet	Separate RJ-45 Connector				

Notes:

1. Safety/Case Ground - Wire to green screw at top center of rear terminal area.
2. Ground Bus - An external, user-supplied ground bus can ease connection of multiple grounds, particularly when twinaxial cable shields are to be grounded.
3. Terminals 6, 9, 18, 21, 24, 34, 40 and 42 are electrically connected. Use the terminals that allow the best wire routing and the least stress on components, such as range resistors.

7.4.2 Analog Signal Input Wiring (4-20 mA, 1-5 Vdc, and mV)

Siemens 353 analog signal input terminals are connected to software function blocks AIN and AINU within the controller. Table 7-1 correlates function blocks and input terminals. These terminals will accept several input signal types with the appropriate wiring and components. A 4-20 current input signal to an AIN function block must be converted to 1-5 Vdc signal and a 4-20 current input signal to an AINU function block must be converted to a 15-75 mVdc signal.

INPUT TYPE	FUNCTION BLOCKS ⁽¹⁾	RANGE RESISTOR ⁽²⁾	FIGURE(S)
4-20 mA	AIN1, 2, 3 and 4	250Ω	7-6 and 7-7
	AINU1 and AINU2	3.75Ω	7-8A
1-5 Vdc	AIN1, 2, 3 and 4	Not Required	7-6 and 7-7
Millivolt	AINU1 and AINU2	Not Required	7-8B

Notes:

- (1) Function blocks AIN4, AINU1, and AINU2 are available only when an I/O Expander Board is installed.
- (2) Range resistors listed are supplied in Installation Kits. For other current values, select a range resistor that will provide a 1-5 Vdc input. For example, for 10-50 mA, install a 100Ω range resistor.

Crimp-on connectors are provided for use when a range resistor and a signal input wire are to be inserted in the same connector terminal. A connector should also be used when two wires of significantly different gauges would otherwise be inserted in a single connector terminal.

Perform the following steps for each analog input.

1. Select an analog input terminal pair for connection of the input signal wiring. Refer to Table 7-1 and the following illustrations as necessary.

For a 4-20 mA input, go to step 2. For a 1-5 Vdc or millivolt input, go to step 4.

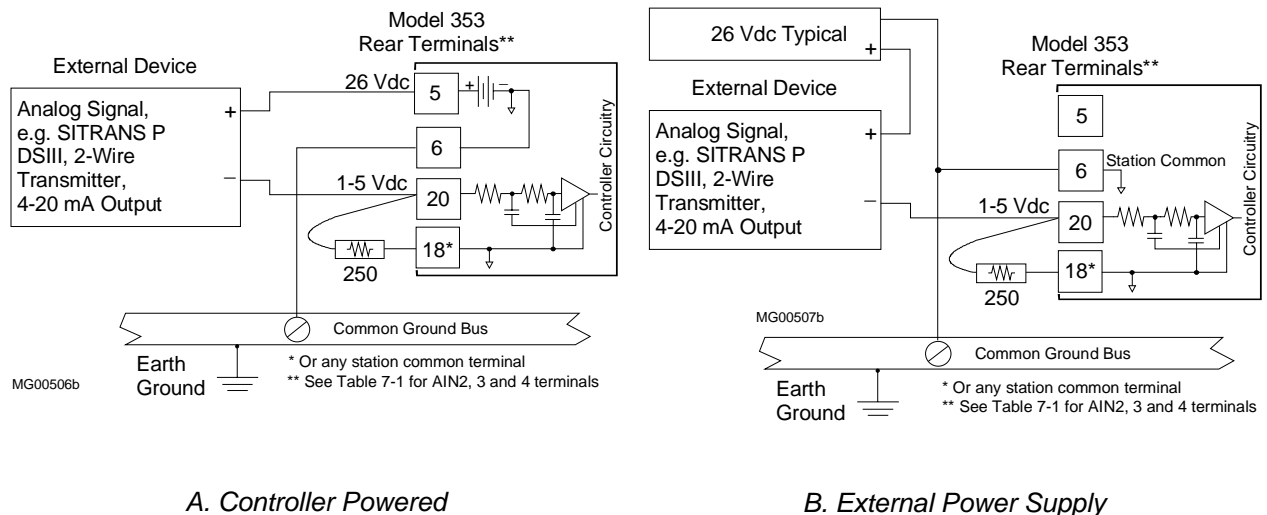

Note: Terminals 6, 9, 18, 21, 24, 34, 40 and 42 are electrically connected. Use the terminals that allow the best wire routing and least stress on components, such as range resistors.

Figure 7-6 Analog Input AIN1, 2-Wire Transmitter

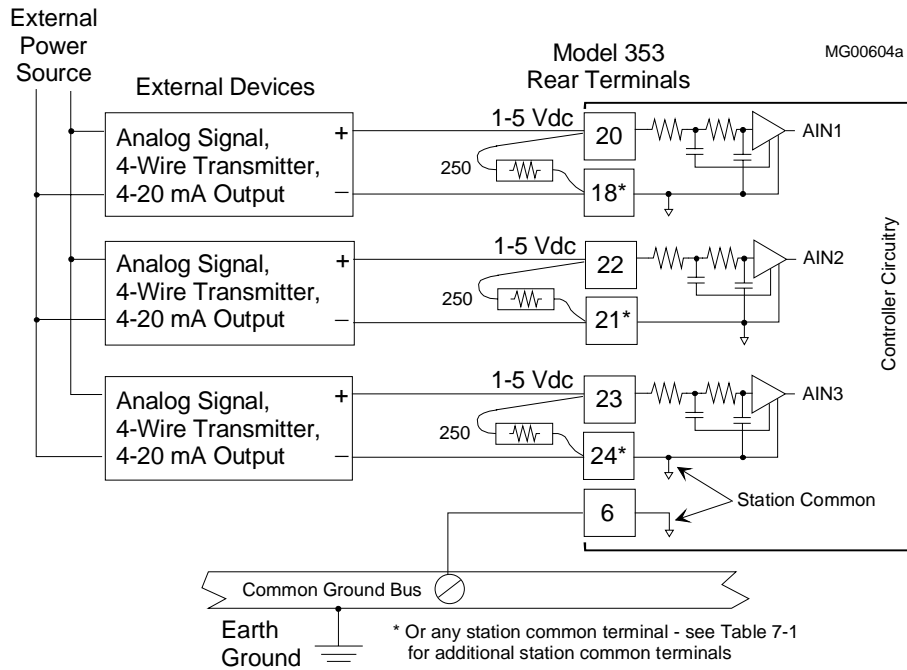
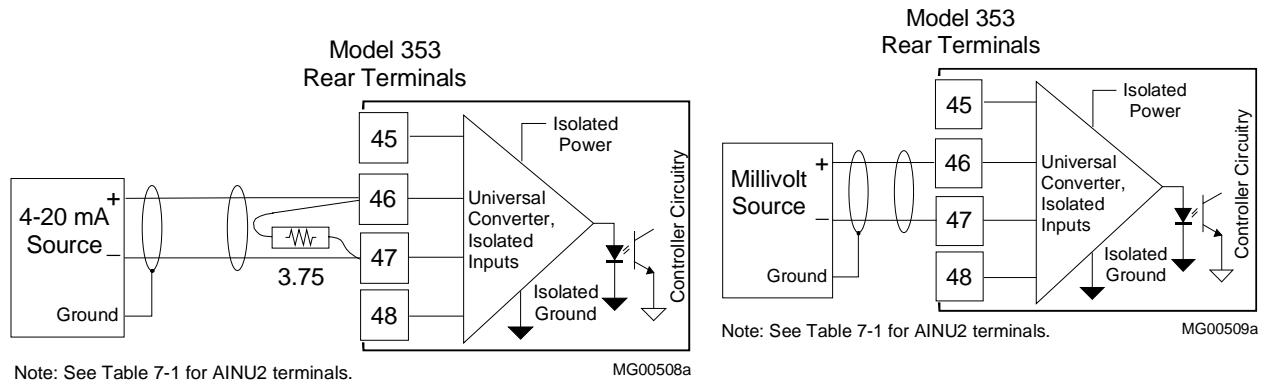

Figure 7-7 Analog Inputs AIN1, 2, and 3; 4-Wire Transmitters



A. 4-20 mA Input

B. Millivolt Input

Figure 7-8 Universal Analog Input AINU1

- 4-20 mA Input Only - Select a precision (0.1%) 250Ω (for AIN#) or 3.75Ω (for AINU#) resistor from the installation kit and insulate the bent resistor lead with a piece of sleeving. At the lead end, approximately 1/4" (6 mm) to 5/16" (8 mm) of bare resistor lead should be exposed.

If a crimp-on connector is to be used, go to step 3. Otherwise, go to step 4.

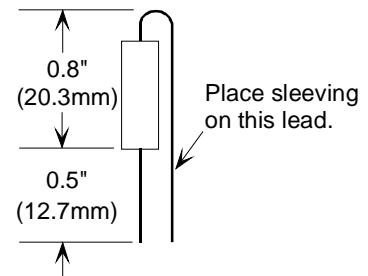

3. Crimp-On Connector - Insert the resistor lead and any signal wiring into the connector until the wire ends are visible at the pin end of the connector. Use a standard electrical connector crimp tool to crimp the connection. Be certain that all resistor leads and signal input wires are inserted in the connector before crimping.
4. Loosen the two terminal screws using a straight blade screwdriver with a 1/8" (3 mm) blade width. Insert wires, resistor leads, or a crimp-on connector pin into the two openings in the side of the connector adjacent to the selected terminal numbers.
5. Check that all involved components and station wiring are fully inserted and carefully tighten the screws to 5 in. lbs. Do not over tighten.
6. Repeat steps 1-5 for each 4-20 mA, 1-5 Vdc and millivolt input.
7. Carefully dress resistors and wiring so that excessive stress is not placed on a component, wire, or connection.

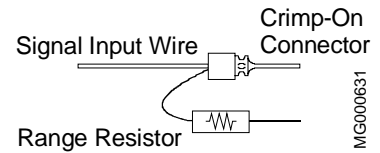

MG000631

7.4.3 Analog Output Wiring (4-20 mA, 1-5 Vdc)

Analog output functions blocks are AOUT1, AOUT2, and AOUT3. Figure 7-9 shows connections for an external device that accepts 4-20 mA. For an external device that needs 1-5 Vdc, see Figure 7-10. Refer to Section 7.4.1 for wiring guidelines.

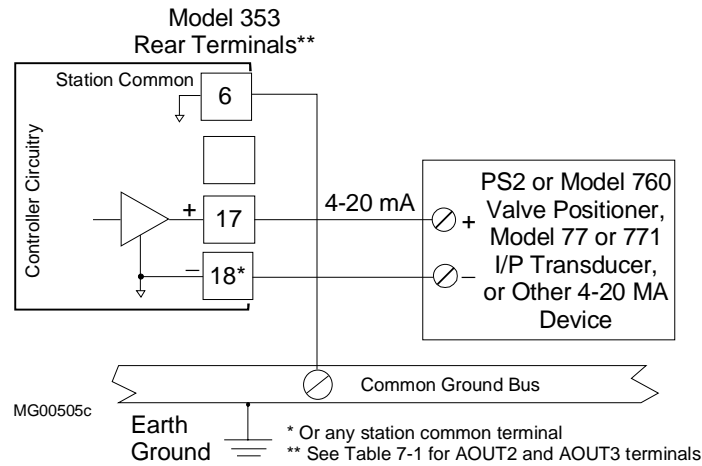

Figure 7-9 Analog Output AOUT 1, Current Output

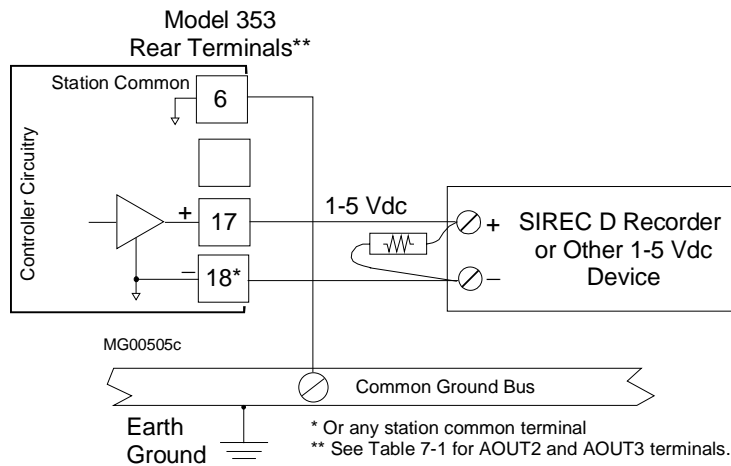

Figure 7-10 Analog Output AOUT1, Voltage Output

7.4.4 Digital Input and Output Wiring

Connections to Digital Input and Digital Input Universal function blocks are shown in Figure 7-11. Wiring for internal and external power sources is shown. Semiconductor devices can replace the mechanical switches shown. Wiring guidelines are found in Section 7.4.1.

Digital input commons, e.g. DIN1 (-), are isolated from station common and from case/safety ground.

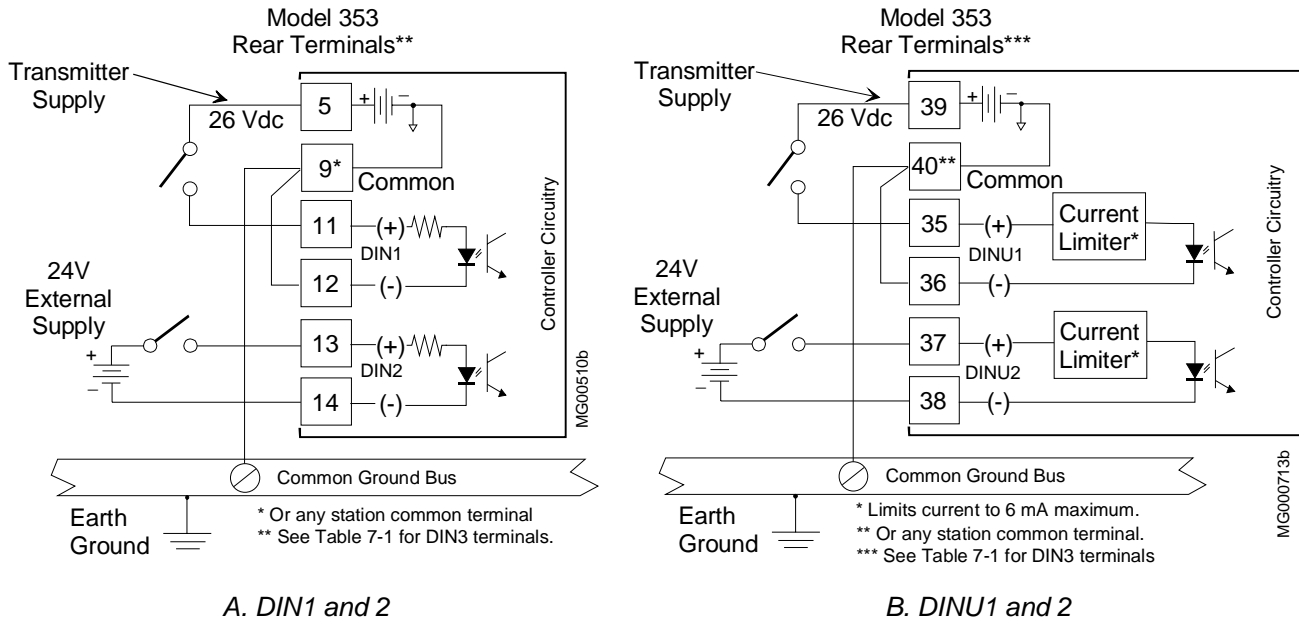
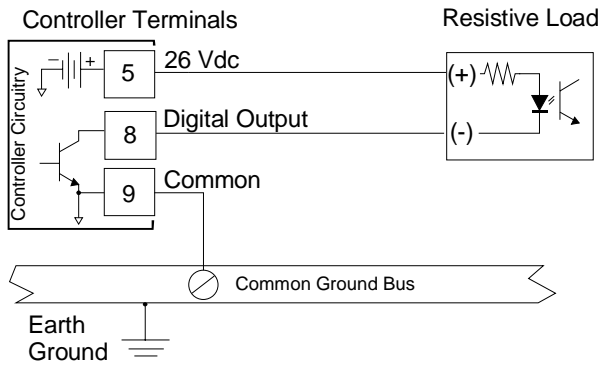

Figure 7-11 Digital Inputs DIN and DINU

Digital output wiring is shown in Figure 7-12. Three diagrams are provided showing current and voltage outputs. Note the use of transient suppression diodes in Figure 7-12C. Always install a transient suppression component across a reactive component, such as a relay coil, to protect the semiconductor devices in the Siemens 353.

Digital output common, DOUTC, is connected to station common.

MG00511b



A. Current Output, Isolated

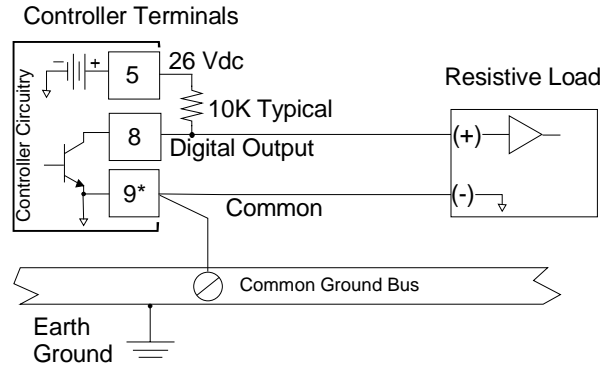

B. Voltage Output, Non-Isolated

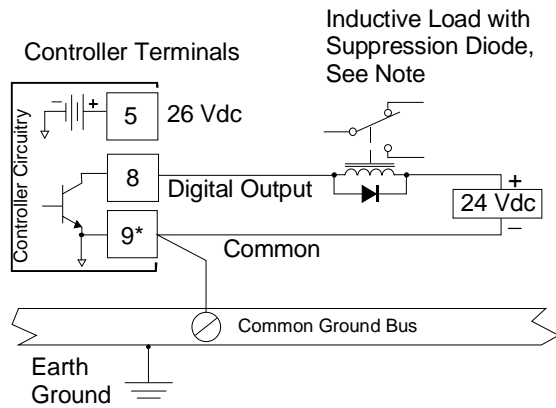

C. Current Output, Isolated

Notes:

1. Inductive load must be shunted with a transient suppression diode (1N4005 or equiv.) to prevent damage to station output circuit.
 2. See Table 7-1 for DOUT2 terminal numbers.
- * Or any station common terminal

Figure 7-12 Digital Output DOUT1, Resistive and Inductive Loads

7.4.5 Thermocouple Input Wiring

Function blocks AINU1 and AINU2 can be configured for thermocouple or RTD input.

Thermocouple input wiring is shown in Figure 7-13. Shown is a typical grounded tip thermocouple. If an ungrounded thermocouple is used, the thermocouple wire shield can be grounded at the Siemens 353. Thermocouple wire often has a solid conductor. Make connections as outlined in Section 7.4.1. Be sure that the solid conductor is satisfactorily clamped by the terminal screw and pressure plate. Two reference junctions (RJ) are supplied in the I/O Expander board installation kit. Install as outlined below.

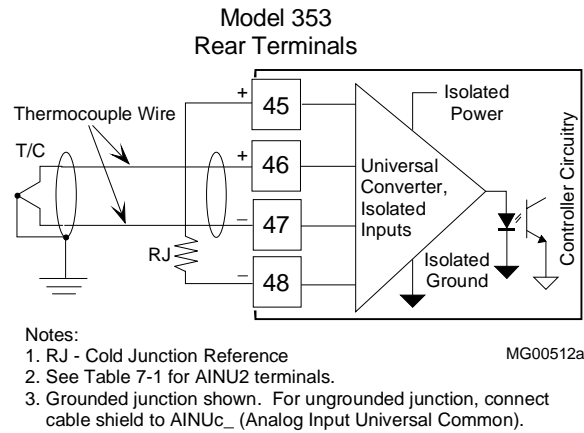

Figure 7-13 Universal Analog Input AINU1, Thermocouple Input

Thermocouple reference junction (RJ) installation:

1. Slip a length of insulating sleeving over the portion of each reference junction lead that will remain exposed after installation. Carefully form the leads as shown in Figure 7-14.

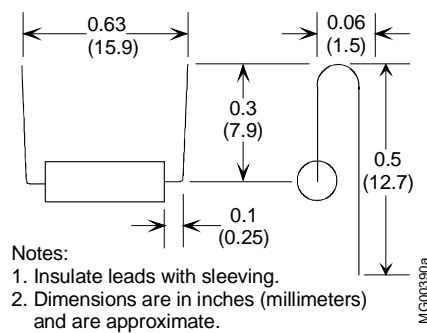
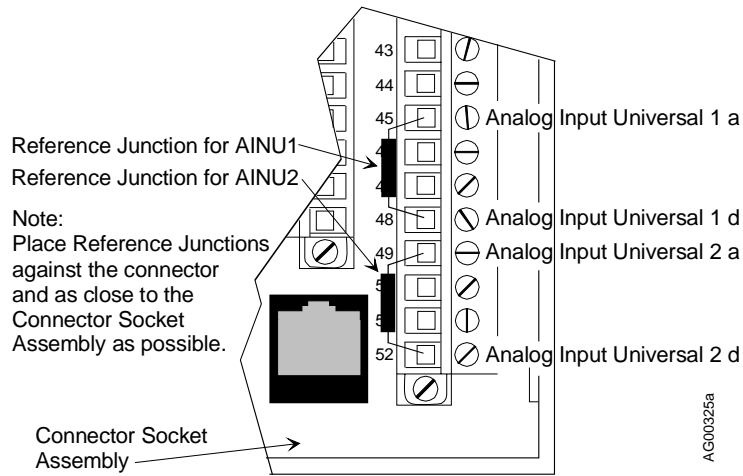

Figure 7-14 Reference Junction Lead Formation

2. Loosen the two terminal screws using a straight blade screwdriver with a 1/8" (3 mm) blade width. Insert the reference junction leads into the two openings in the side of the connector adjacent to the selected terminal numbers.

Carefully press the reference junction down between the connectors, as shown below.



3. Check that all involved components and station wiring are fully inserted. Carefully tighten the terminal screws to 5 in. lbs.
4. Repeat the above steps if the other AINU function block is to be used as a thermocouple input.

7.4.6 RTD Input Wiring

Wiring for 2-, 3-, and 4-wire RTDs is shown in Figure 7-15. Make connections as outlined in Section 7.4.1. Note the wire jumper between terminals 47 and 48 when a 2-wire RTD is installed.

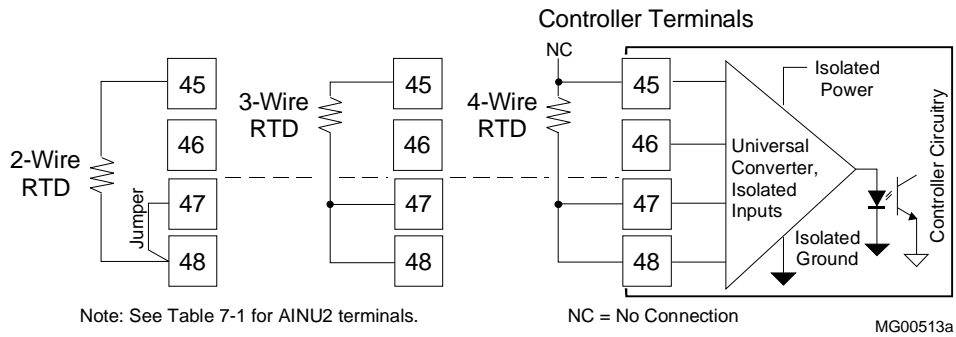

Figure 7-15 Universal Analog Input AINU1; 2, 3, and 4-Wire RTD Inputs

7.4.7 Ohms and Slidewire Input Wiring

Function blocks AINU1 and AINU2 can be configured for ohm or slidewire inputs. Figure 7-16 shows the needed connections for Ohm and Slidewire inputs.

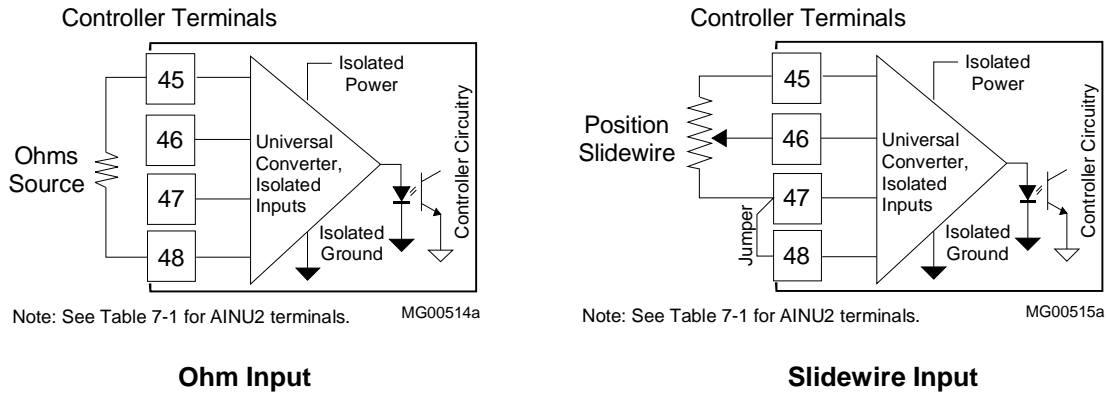

Figure 7-16 Universal Analog Input, AINU1 Shown

7.4.8 Relay Output Wiring

Function blocks ROUT1 and ROUT2 are located on the I/O Expander board. They provide two single-pole, double-throw relay outputs, as shown in Figure 7-17. Relay contact ratings are stated in Section 13.6 MPU Controller Board Specifications.

The load connected to a closed contact should draw a current between the minimum and maximum contact ratings. A resistive load is recommended. An inductive or capacitive load can cause high peak currents or contact arcing which can pit or otherwise damage contacts. The arcing associated with an inductive load can be limited by connecting a voltage transient suppressor, such as a 1N4005 diode, across the load.

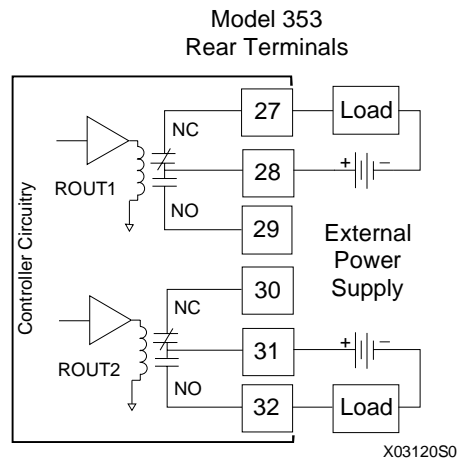

Figure 7-17 Universal Relay Outputs ROUT1 and 2, Resistive Load

7.4.9 Modbus Wiring

This section describes the wiring needed to connect a host device to a Siemens 353's Modbus network interface. When connected, the host can read data from and write data to a Siemens 353 in a command/response format.

Most host devices communicate using RS232 while the Modbus network interface is RS485. As shown in Figure 7-18, a 2-wire RS485 to RS232 converter is installed to perform the protocol conversion and adapt the connection hardware. A shielded RS232 cable with either DB9 or DB25 connectors is installed between the host device and the converter. An RS485 shielded, twisted-pair cable connects the converter to a Siemens 353. Up to 32 Siemens 353s can be connected since RS485 is a multi-drop network.

Shown below are the jumper locations and identifiers for the Entrelec® Isolated Converter shown in Figure 7-18.

For access to jumpers carefully remove the side of the module that has the jumper label.

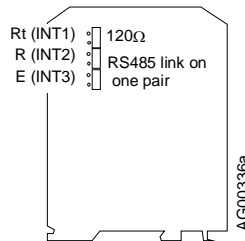

Entrelec ILPH 084.233.11 Isolated Converter

7.4.10 Ethernet Wiring

A sample architecture and a brief description are presented in the Introduction section of this manual. An RJ-45 Ethernet connector is located on the back of the case. Ethernet cables external to the controller must be rated Category 5 or better. Shielded cable or the use of fiber optic transmission is highly recommended outside the panel or cabinet, as shown at right. Many Ethernet switches offer fiber optic ports as an option.

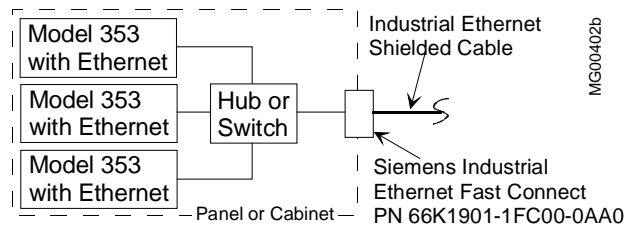

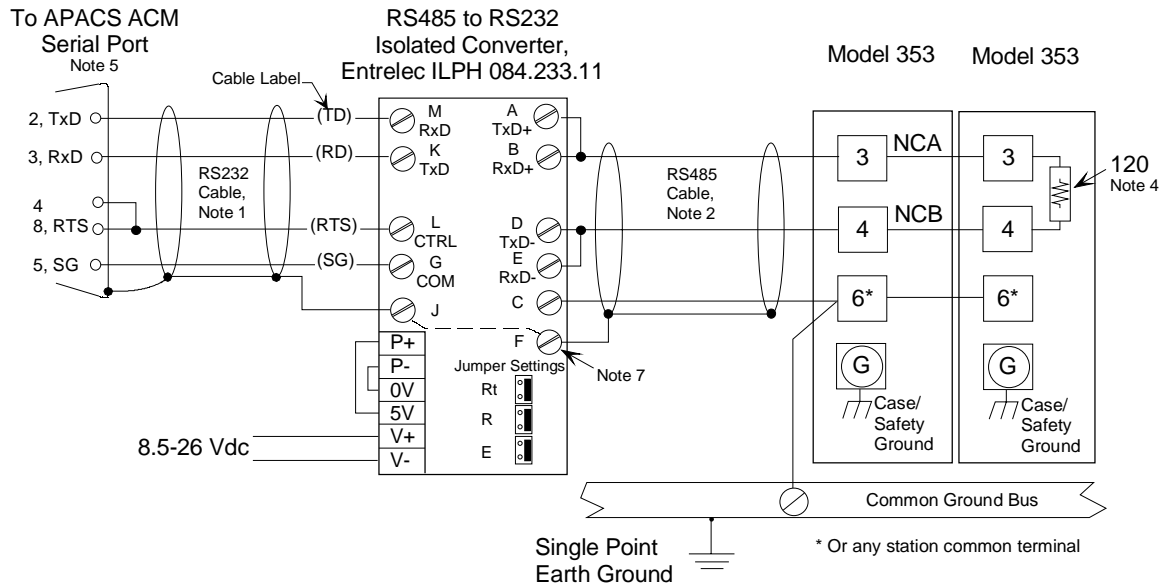

A. Modbus Communications, APACS ACM to Model 353

MG00503b

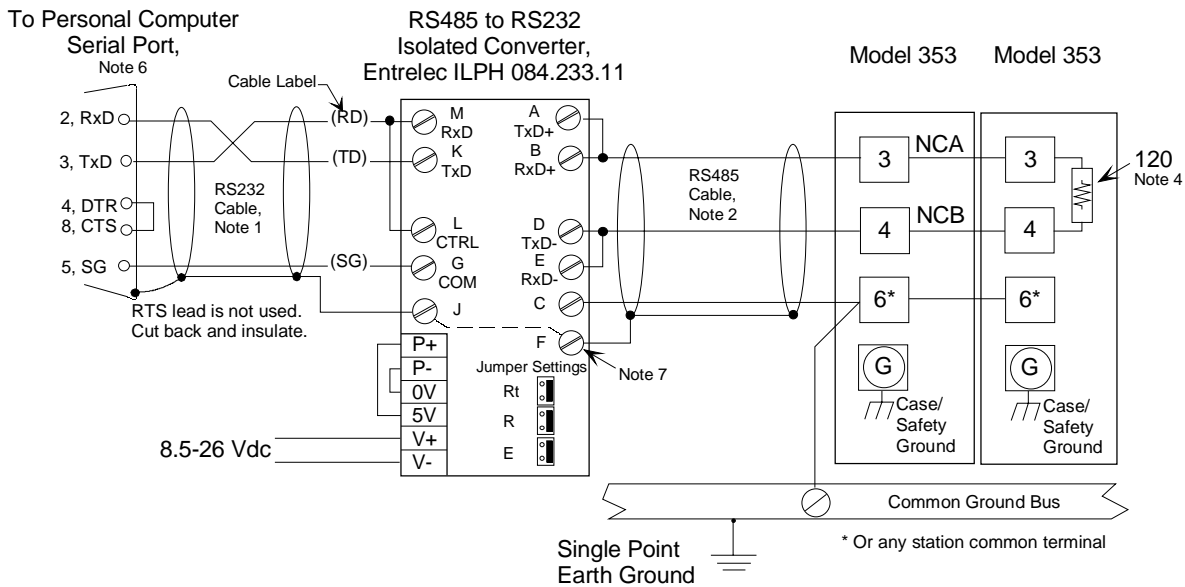

B. Modbus Communications, Personal Computer to Model 353

Notes:

1. RS232 cable must be shielded and less than 50 feet (15 meters) in length. Recommended cable is Belden 9927, 24 AWG, or equivalent. For an assembled cable, order Siemens PN 16137-191.
2. RS485 recommended cable is Belden 9842, 24 AWG, 120 Ohms or equivalent cable.
3. Up to 32 controllers (Model 352P, Model 353, and Model 353R or i|pac) can be connected.
4. A user-supplied 120 Ohm network termination resistor should be installed on the last device on the network.
5. In APACS™ ACM, set SERIAL Function Block Flow Control to 1.
6. Assembled cable above has DB9 (plug) connector. Connection to computer serial port may require a DB9 (socket/receptacle) gender adapter.
7. Connection between F and J provided by Entrelec converter.

Figure 7-18 Modbus Communications, 353 to APACS™ ACM or Personal Computer

7.4.11 Wiring to a Siemens SIREC D Recorder

Figure 7-19 shows the wiring needed to connect a SIREC D analog input to a Model 353 analog input. As shown, a 1-5 Vdc transmitter input to the Model 353 is also routed the recorder's Analog Input 1.

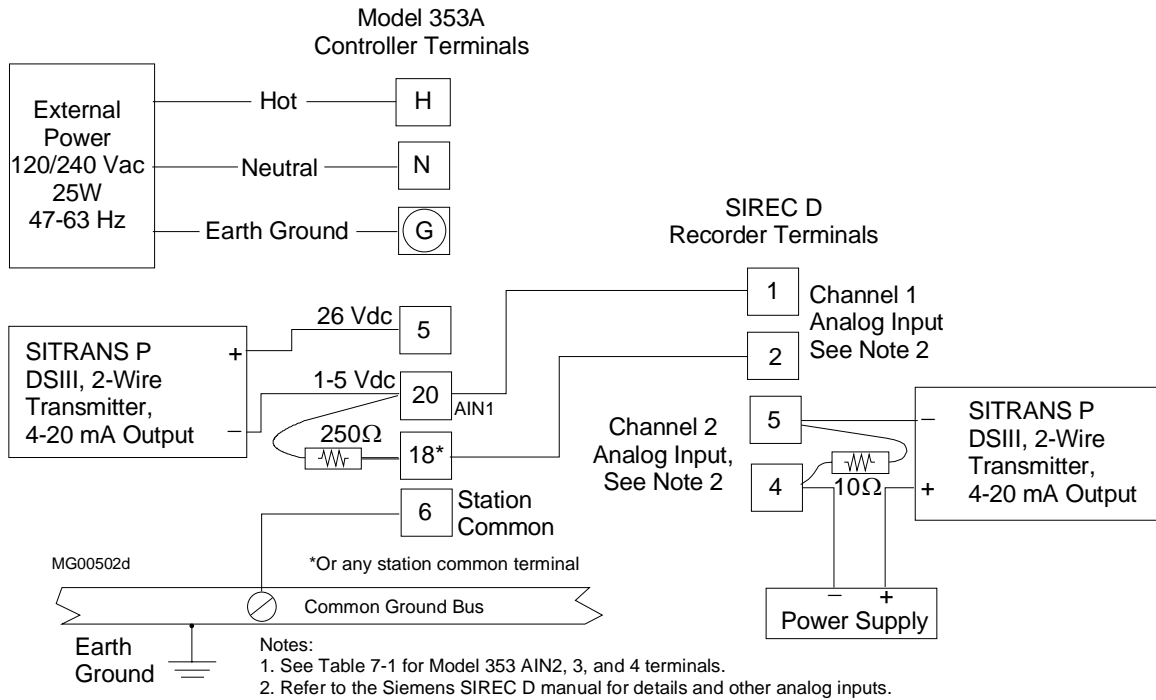

Figure 7-19 Model 353 to Siemens SIREC D Recorder Analog Input Wiring

7.4.12 Power Wiring

Basic connections for AC and DC power input are shown in Figure 7-20. Wiring guidelines are given in Section 7.4.1.

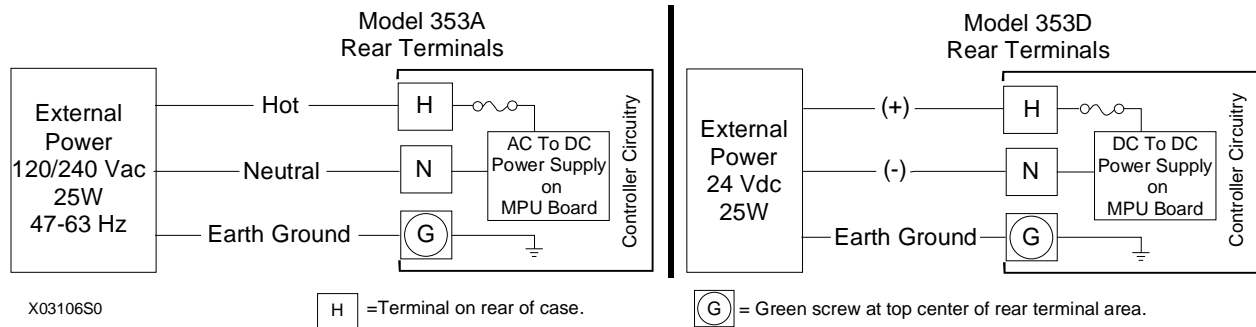

Figure 7-20 Controller Power Wiring

Power input to a Siemens should be routed through a clearly labeled circuit breaker, fuse or on-off switch that is located near the controller and is accessible by the operator. The protective device should be located in a non-explosive atmosphere unless suitable for use in an explosive atmosphere. This type of wiring is shown in Figure 7-21. It will permit removal of controller power without affecting the on-line status of adjacent controllers.

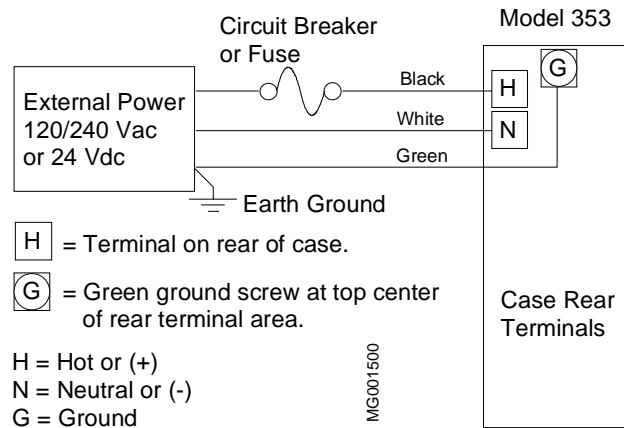

Figure 7-21 Suggested Power Wiring

Where separate wiring is not required, power input wiring can daisy chain together a series of controllers. Here, each controller, except for the last controller on the daisy chain, will have two wires (18 AWG recommended) inserted in terminal H and in terminal N. If a larger gauge is to be used, the two wires can be inserted in a crimp-on connector and the connector inserted in the terminal, for a more secure installation. Daisy chained wiring is shown in Figure 7-22. Perform the following steps at H, N, and G terminals at each involved controller.

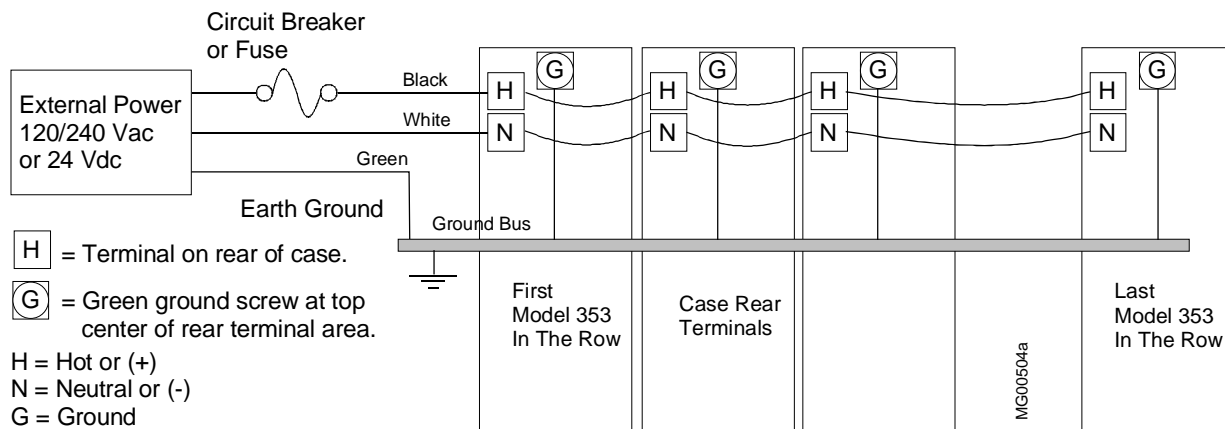

Figure 7-22 Daisy Chained Power Wiring

1. Strip ground wire(s) 3/8" (10 mm) to 1/2" (13 mm). Clamp the ground wire(s) under the green, square pressure plate and ground screw (case/safety ground) at top center of each rear terminal area. Tighten the ground screw to 20 in. lbs.
2. Remove 1/4" (6 mm) to 5/16" (8 mm) from each Hot and Neutral wire to be inserted in a terminal or crimp-on connector.
3. Crimp-On Connector only - Insert the wires into the crimp-on connector until the wires are visible at the pin end of the connector. Use a standard electrical connector crimp tool to crimp the connection. Be certain that both power input wires are fully inserted in the connector before crimping.
4. Loosen the terminal screw using a straight blade screwdriver with a 1/8" (3 mm) blade width.
5. Insert the striped wire or crimp-on connector pin into the terminal and tighten the screw to 5 in. lbs.

7.5 FACTORY CALIBRATION

Unless a special calibration is ordered, the factory calibration is as follows:

Table 7-2 Factory Calibration

ANALOG INPUT OR OUTPUT	FACTORY CALIBRATION
Analog input function blocks	1 to 5 Vdc
Analog output function blocks	4 to 20 mA
Thermocouple	Type J, Upscale Break
RTD	CAL ZERO - 0°C CAL FULL - 500°C CAL VIEW - -3.3 to 103.3%
Slidewire	CAL ZERO - 0% CAL FULL - 100% CAL VIEW - Contact factory
Ohms	CAL ZERO - 0 Ohms CAL FULL - 5000 Ohms CAL VIEW - Contact factory
Millivolt	CAL ZERO - -19.0 mV CAL FULL - +19.0 mV CAL VIEW - 0% TO 100%

Section 11.0 provides calibration procedures that may be used to check or change factory calibration.



8.0 LOCAL FACEPLATE OPERATION

Controller operation is described in this section. Each faceplate display, pushbutton, and knob will be discussed first in normal operation mode and then in configuration mode. This section contains many references to function blocks. As necessary, refer to Section 3 for details about a function block.

Most operator controls are shown on the faceplate below. Several additional pushbuttons are located behind the flip-down door at the bottom of the faceplate. These will be discussed in the configuration mode portion of this section.

8.1 NORMAL OPERATION MODE

- 6-Digit Numeric Display** - displays the numeric value of the variable identified by the 8-character alphanumeric display. Numbers can be displayed from 0.00000 to 999999 or -0.0000 to -99999. Any input exceeding these limits will be shown as the maximum or minimum displayable value and cause the display to flash.
- 8-Character Alphanumeric Display** - normally displays the loop tag with the dot suffix of the variable currently showing in the 6-digit numeric display (e.g. **TC2053.P** is the **P**rocess variable for loop **TC2053**). A loop tag that is displayed is called the *Active Loop* and all operator controls (e.g. PB1, PB2, A/M, ACK, D, UNITS, ALARM, TUNE, TAG, QUICK) will affect the function blocks within the *Active Loop*.
- PB1 Pushbutton** - controls the operation of the **PB1SW** (**PB 1** transfer **SW**itch) function block when the block has been configured for use within the *Active Loop*. See the function block details in Section 3 for more information on **PB1SW**.
- PB2 Pushbutton** - controls the operation of the **PB2SW** (**PB 2** transfer **SW**itch) function block when the block has been configured for use within the *Active Loop*. See the function block details for more information on **PB2SW**.
- A/M Pushbutton** - controls the operation of an **A/M** (Auto/Manual) function block when the block has been configured for use within the *Active Loop*. See the function block details for more information on **A/M**. When the A/M is switched to Auto the numeric display will show the Setpoint value, as indicated by **.S** in the alphanumeric display, and when switched to Manual, the Valve value and **.V** will be shown.
- LOOP Pushbutton** – selects the *Active Loop* when more that one loop has been configured. When more than one loop has been configured, the **LOOP** button will advance the operator display to the next *Active Loop*. All operator controls now affect the *Active Loop* that is currently shown in the alphanumeric display (e.g. **FC2367**). When a loop is first displayed, the loop tag will appear in the alphanumeric and the displayed variable will be the same as when the loop was last viewed.
- ACK Pushbutton** - this button is used together with the **L** and **S** status LEDs to manage events (e.g. alarm, status, and error conditions) within the controller. Events have user assigned priorities 1-5 (with 1 the highest) and will be organized within the controller, first by priority and then by order of occurrence.
 - S Status LED** - Indicates that event is active (unacknowledged) in the Station. A flashing LED indicates that the event needs to be acknowledged.
 - L Status LED** - Indicates that event is active in the displayed Loop. A flashing LED indicates that the event needs to be acknowledged.

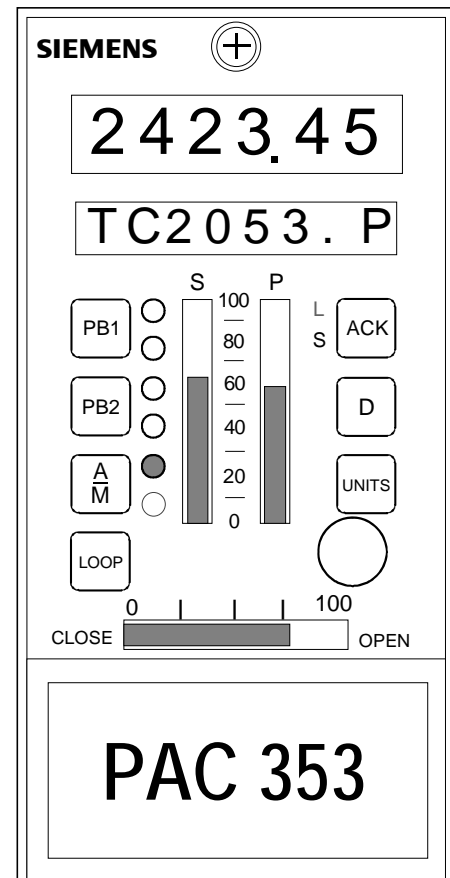

Priority:

- Priority 1 causes the station bargraphs and event LEDs to flash and requires acknowledgment to stop flashing. This is the highest priority.
- Priority 2 also flashes the bargraphs but stops flashing when the event clears (i.e. Self Clearing).
- Priority 3 causes the event LEDs L & S to flash and stops only when the event is acknowledged.
- Priority 4 also causes the event LEDs to flash but stops when the event clears.
- Priority 5 displays the event but does not require that it be acknowledged. This is the lowest priority.

If the event is in the active loop, the alphanumeric display will alternate between the loop tag and the unacknowledged condition (e.g. 'TC2053.P' <---> 'A3 HI'). Press the ACK button to acknowledge this condition and stop the flashing.

The ACK button, after all events have been acknowledged, can then be used to scroll through any active alarm or status conditions within the *Active Loop*. Pressing the ACK button will scroll through the list of active events and wrap around to the start of the list when more than one event is active. This function will time out if the ACK button is not pressed for 3 seconds and return to the normal display mode.

If an unacknowledged event is not within the active loop, press the LOOP button to page through the loops.

- **D** Pushbutton - changes the variable currently displayed. Pressing this pushbutton steps the display one position in the sequence P, S, V, X and Y from any starting point within the display select group.
- **UNITS** Pushbutton - displays the units of the variable shown in the alphanumeric display. When the button is pressed the units that apply to the displayed variable will appear in the alphanumeric (e.g. 'TC2053.P' 'deg F', 'TC2053.V' 'PRCT'). After 3 seconds, the alphanumeric display will return to the variable tag.
- **S** Bargraph - this vertical bargraph displays the scaled range of the controller setpoint in the *Active Loop*. Bargraph height shows the setpoint as the % of range value. The setpoint in engineering units can be viewed by pressing the **D** button to display the dot S parameter (e.g. **TC2053.S**).
- **P** Bargraph - this vertical bargraph displays the scaled range of the controller process in the *Active Loop*. Bargraph height shows the process as the % of range value. The process in engineering units can be viewed by pressing the **D** button to display the dot P parameter (e.g. **TC2053.P**).
- **Pulser Knob** - rotate the Pulser to change the value in the numeric display (e.g. Setpoint, Valve, or other variable configured for normal operator display changes such as **Ratio**, **Bias**). The Pulser knob is also used in configuration to change values in the alphanumeric display.

An accelerator is included. Turning the knob faster multiplies the rate of change of the displayed parameter. Large value changes then require fewer knob rotations.

- **V** Bargraph - this horizontal bargraph displays the scaled range of the controller output in the *Active Loop*. The output/valve signal is shown as the % of range value. The value in engineering units can be viewed by pressing the **D** button to display the dot V parameter (e.g. **TC2053.V**).
- **STORE** Pushbutton (behind the flip-down door on the lower quarter of the faceplate) – activates display test lighting all elements in the 6-digit numeric display, the 8-character alphanumeric display, the horizontal and vertical bargraphs, and individual LEDs.

8.2 CONFIGURATION MODE

Configuration pushbuttons are located behind the flip-down door on the lower quarter of the faceplate. Note that many of these buttons are used in both the normal operation mode and configuration mode, as described below.

- **ENTER/EXIT CONF** - press to enter configuration when the station is in the normal operation mode or to exit configuration when in the configuration mode.
- **ALARM/STEP DOWN** - has a dual purpose. When in the normal operation mode, pressing the button will scroll through the alarm configuration parameters if the ALARM function block has been configured in the *Active Loop*. The alarm setting is displayed in engineering units and the % of range value will also be displayed on the setpoint bargraph by flashing a single segment equal to the % of range value. If security clearance is satisfied, the parameters can also be changed. See the ALARM function block description for details on the parameters. Press the ENTER/EXIT CONFIG button to return to the on-line displays.

When in the configuration mode, this button will step down to the next configuration level. See Section 2 Configuration Overview for details on typical levels of the configuration mode.

- **TUNE/STEP UP** - has a dual purpose. When in the normal operation mode, pressing the button will scroll through the controller tuning parameters and allow activating the AUTOTUNE algorithm, if configured for the loop controller. If security clearance is satisfied, the parameters can also be changed. Press the ENTER/EXIT CONFIG button to return to the on-line displays.

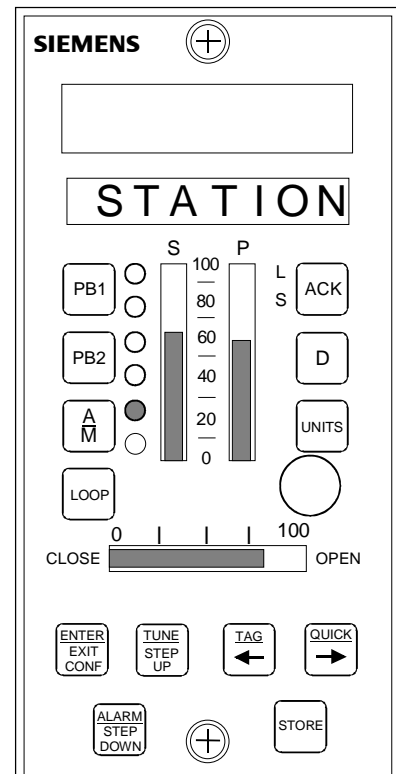

X03141S2

When in the configuration mode, this button will step up to the next configuration level.

- **TAG/<---** - has a dual purpose. When in the normal operation mode, pressing the button will scroll the complete tag name of the *Active Loop* in the alphanumeric display. The tag will scroll one character at a time starting on the right (e.g. -----T, -----TI, ----TIC).

When in the configuration mode, this button will provide a shift left function for configurable items (e.g. will shift the decimal point left).

- **QUICK/--->** - has a dual purpose. When in the normal mode this button will step through and access either previously selected configuration parameters in the quick hold blocks configured within the *Active Loop* (e.g. the HOLD value in **QHOLD03** which was labeled to display **TEMP_LIM** having a range of 300.0 to 600.0) or parameters defined as **QUICKSET**² in certain function blocks (e.g. **RATIO**). Press the ENTER/EXIT CONFIG button to return to the on-line displays.

When in the configuration mode, this button will provide a shift right function for configurable items (e.g. will shift the decimal point right).

- **STORE** - will store the configuration parameter to memory. All configuration changes, except for **QUICK**, 'BIAS', 'RATIO', and (quickset hold), require a store before the change is applied to the configuration. However, the **QUICK** functions will also require a store for the value to be placed in permanent memory, otherwise, it will only remain in battery RAM. Values in battery RAM will be used on a hot or warm start. A cold start will use the value in permanent memory.

² ALARM, TUNE, and QUICK are QUICKSET functions.

8.3 AUTOTUNE PROCEDURE

If the AUTOTUNE parameter in the controller function block is set to YES, the autotune procedure can be initiated using the TUNE pushbutton located behind the flip-down door. The Autotuner will substitute an ON_OFF controller for the PD or PID function. By making +/- step changes to the valve position, the controller will control the process at the current setpoint while it learns about the process dynamics. The controller then uses this knowledge to derive recommended P, I, and, D settings.

Press the TUNE button to step through the following parameters and, if desired, initiate autotune:

PG Proportional Gain setting - (view or change)
TI Integral Time setting - PID/PIDAG controllers only (view or change)
MR Manual Reset setting - PD controller only (view or change)
TD Derivative Time setting - (view or change)
% DEV The peak/peak % process deviation that the autotuner will maintain during test
% HYS The % process change needed before the valve output will switch
AUTOTUNE Set to YES and STORE to start autotune.
 Press EXIT CONF to return to normal operator faceplate operation.
AT PG Proportional Gain setting recommended by the autotuner
AT TI Integral Time setting recommended by the autotuner
AT TD Derivative Time setting recommended by the autotuner
STORE AT Pressing STORE transfers autotuner recommended settings to controller

While autotuning, the controller will continue normal operation. Pressing the A/M button to switch the controller to Manual will terminate autotune. While in autotune, the alphanumeric display will alternate between 'AUTOTUNE' and the loop tag name and will stop alternating when the autotune program has been completed. Once completed, the controller will return to the mode prior to autotune initiation. When the POST AT (in the controller block) is set to auto transfer, the recommended tuning parameters will automatically be transferred to the controller and it will return to automatic control. To review the AT parameters before initiating autotune, press TUNE and then press STORE at the STORE AT prompt to transfer the recommended settings.

Chart 1 (0-100% range) illustrates a typical autotune exercise. The process has a small amount of noise (approximately 1% P-P). The autotuner was set with fast response, the %HYS was set to A, and the %Dev was set to A. The autotuner provided recommended settings of P=1.84 and I=0.38. These settings were entered into the controller and a step change was made to the setpoint to review the response with the new controller settings.

The autotuner will use the initial valve step size (set as % STEP in the controller function block) during the first 1-1/2 cycles to learn the approximate gain of the process. It will then adjust the valve step size during the remainder of the autotuning exercise to maintain the % DEV setting. When this test concludes, the recommended settings are transferred to the controller and a 20% setpoint change is made to illustrate the controller tuning.

When the autotuner is started for the next autotune exercise, it will use the process gain learned during the previous exercise to determine the valve step size unless: the parameter AT RESET in the controller block has been stored as YES, warnings occurred during the first test, or the station has been power cycled.

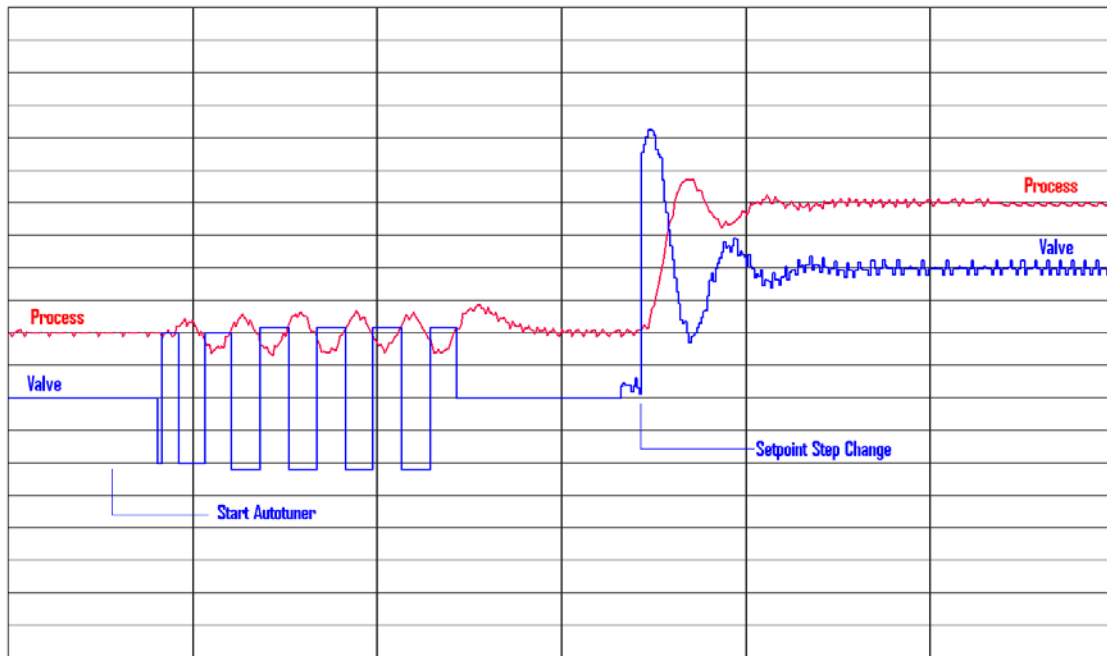
Autotuning Considerations:**Figure 8-1 Chart 1, Autotune**

Process Noise – could have an effect on the autotuner. Chart 2 illustrates the same process as Chart 1 but more significant noise. The autotuner settings were the same but the results of this test produced a warning W3 and recommended settings of $P=1.40$ & $I=0.42$. In most cases with warnings, the autotuner will provide tuning recommendations but they may be more conservative. Manual settings for the %HYS and %DEV can be considered as described in the section Autotuner Warnings.

Steady State Conditions - must be established for the process and controller prior to starting an autotune exercise. The autotuner can be initiated while in manual or auto. Steady state is reached when the present valve signal has brought the process to its present value, and the setpoint is equal to the process. When not at steady state, valve cycles will not be symmetrical as illustrated in the second tuning exercise in chart 2 or, as a worse case situation, the valve may not cycle at all. If the valve does cycle, although not symmetrically, adequate tuning results will still be obtained.

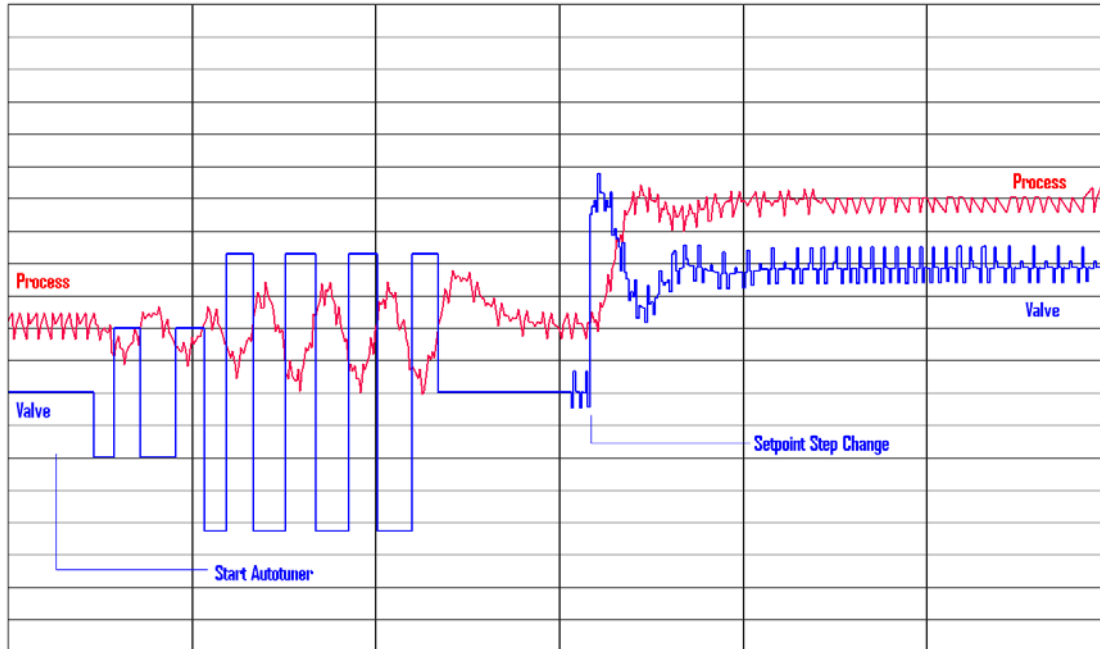

Figure 8-2 Chart 2, Autotune

Autotuner Errors - terminate the autotune exercise and returns the control loop to the point prior to the start of autotune. An Error message can be cleared by pressing the ACK button.

Table 8-1 Autotune Errors

ERROR	DESCRIPTION
E1	A zero crossing did not occur within 120 minutes. Most likely caused by the control loop not being in a steady state condition when the autotuner was started.
E2	Process went out of range twice (<0%, >100%). The first time an out of range occurs, the autotuner will cut the valve step size in half and restart the exercise.
E3	When the autotune algorithm has been set to HYS = A and it calculates a required hysteresis value greater than 10%. Process filtering should be added to reduce the noise seen by the autotuner.

Autotuner Warnings - do not terminate the autotune exercise and are normally eliminated by increasing the % HYS and/or the % DEV settings. In some cases, they may have been caused by load changes that occurred during the autotune exercise. The autotuner will still derive recommended tuning values but they will not automatically be transferred to the controller, if that feature was requested. The warnings can be cleared by pressing the ACK button.

Table 8-2 Autotune Warnings

WARNING	DESCRIPTION
W1	Indicates that the % DEV setting is not greater than 4 times the % HYS setting.
W2	Indicates that the process deviations during the first one and a half cycles, where the autotuner first learns about the process gain, were inconsistent.
W3	Indicates that the average % DEV values during the final phase of the autotuning exercise were not greater than 4 times the % HYS setting. If this warning occurs while the % DEV selection was set to A (auto selection of deviation setting), the use of manual entry should be considered.

9.0 CONTROLLER AND SYSTEM TEST

This section presents a series of steps to verify controller operation and to help a user become familiar with the functionality of the controller. A new controller is shipped factory configured with either Factory Configured Option FCO101 Single Loop Controller or a user-specified custom configuration. The following procedure is for FCO101 with factory set parameter values. If a custom configuration was installed, or if you have configured the controller, it may be necessary to modify the procedure to test all function blocks in that configuration.

To determine the current configuration of a controller, either:

- refer to your configuration documentation for that controller
- upload the configuration to a PC running the Graphical Configuration Utility where the configuration can be viewed
- enter the configuration mode and step through the configuration recording the configured function blocks and entered parameter values



In the following steps, 'press' indicates a faceplate button (key).

9.1 CONTROLLER CONFIGURATION AND TEST

The purpose of this section is to configure and test the controller and to familiarize the user with the controller's faceplate pushbuttons, pulser, and displays. This section also introduces several configuration topics.

9.1.1 Connections and Power

1. Connect power to the controller. Refer to Controller nameplate for model number and then to Section 13 Model Designation and Specifications for power requirements. Refer to Section 7 Installation for connections.

 WARNING		
	Electrical shock hazard Explosion hazard Can cause death or injury	
<ul style="list-style-type: none"> • Remove power from all wires and terminals before working on equipment. • In potentially hazardous atmosphere, remove power from equipment before connecting or disconnecting power, signal, or other circuit. • Observe all pertinent regulations regarding installation in hazardous area. 		

2. Depending upon the configuration, connect test equipment to the I/O terminals.

FCO101 - This FCO has one 1-5 Volt analog input (AIN1), and one 4-20 mA analog output (AOUT1) configured. To verify both of these outputs, and to simulate an analog input for subsequent steps, jumper the terminals shown below. Connect a 250 ohm range resistor across the terminals shown below to convert the 4-20 mA output to a 1-5 volt input. This will tie the valve output (horizontal bargraph) back in the loop as the process input (P bargraph). Refer to Section 7 Installation as necessary.

CONTROLLER	JUMPER TERMINAL	INSTALL 250Ω AT TERMINALS
Model 353	17 to 20	From 18 to 20

Custom Configuration - Refer to Section 7 Installation as necessary for any additional connections.

3. Apply power to the controller. Refer to Section 10.3 Troubleshooting for the display sequence during start up, while the controller performs power-up diagnostics.

If a power-up diagnostic test fails, an error code will be displayed on the alphanumeric display. Refer to Sections 10.3 and 10.4 for troubleshooting error codes.

If WAIT remains displayed for more than 1 minute, the controller is not powering up correctly and power connections should be checked for loose wiring.

9.1.2 Configuration

1. Determine the current configuration; refer to Section 9.0 above. Then perform one of the following steps.

To load FCO101, go to step 2.

IMPORTANT

Loading FCO101 will overwrite the current configuration and any entries made since shipment. *Skip step 2 if the installed configuration is to be retained.*

To proceed with the installed configuration, go to Section 9.1.3.

2. To load FCO101 locally or to download it from a PC running the Graphical Configuration Utility, refer to Section 2.5 Configuration Procedure as necessary and to Section 4 Factory Configured Options for the block diagram and parameter values.
3. Edit the configuration as desired. Refer to Section 9.1.5 Modifying an FCO.

9.1.3 Input/Output

Press the D button on the faceplate to scroll through Loop01.S (Setpoint), Loop01.V (Valve Output), and Loop01.P (Process Input). Note from the FCO101 block diagram, that INPUT P is configured as the output from function block AIN1, INPUT S is configured as the output of function block SETPT, and INPUT V is configured as the output of function block A/M.

9.1.4 Auto/Manual

In FCO101, the A/M block is configured to switch Valve control from the PID controller in AUTO, to the Pulser Knob in Manual. Press the A/M button to toggle the display between the (Loop01.S) setpoint parameter and the (Loop01.V) valve parameter. Turn the pulser knob while displaying the valve parameter in manual to change the value on the numeric display as well as the horizontal bargraph; turn the pulser knob while displaying the setpoint parameter in Auto to change the numeric value and the vertical S bargraph.

9.1.5 Modifying an FCO

In addition to FCO101, Single Loop Control, there are several other factory configured options available, such as Ratio Set Control (FCO105) and Cascade Control (FCO121). To download another FCO, follow the steps in Section 2.5.

Changes to an FCO may be made either by adding and deleting function blocks or by changing the default parameter values. A Configuration Road Map is shown in Figure 2-1. Note that an X represents pressing the STEP DOWN or STEP UP button and a <> represents turning the pulser knob. For example, to add a function block you would do the following steps:

1. Press ENTER/EXIT CONF.
2. Press STEP DOWN until VIEW is displayed.
3. Turn the pulser knob until ADD FB is displayed.
4. Press STEP DOWN for the function block menu.
5. Turn the pulser knob to scroll through the available function blocks and press STORE to add the function block to the configuration.
6. To make changes to a function block parameter turn the Pulser Knob to EDIT FB.

7. Press STEP DOWN for the function Block menu.
8. Turn the pulser knob to the desired Function Block and Press STEP DOWN.
9. The first function block parameter will be displayed. For example, RG PTR for the A/M Transfer Block or MINSCALE for the Analog Input Block. Press STEP DOWN to display current parameter value or use the pulser knob to select a different parameter. Press STORE to save any changes.
10. Press EXIT to return to normal operation mode.

Notice that the SETPT, ALARM, PID, and ODC function blocks in FCO101 all refer to AIN1 as the RG PTR (range pointer) to determine the operating range of the function block. Be aware that making changes to a configuration may require changing referenced RG PTRs. For example, in FCO105 (Ratio Set Control), the PID controller output range is determined by the range of AIN2.

Try changing the default 0-100% range of analog input #1 (AIN1) to 100.0-500.0°F using the Configuration Road Map in Figure 2-1 or the following steps:

1. Press ENTER/EXIT CONF to display LOOP.
2. Press STEP DOWN twice to display VIEW.
3. Turn pulser knob or use arrow button to display EDIT FB.
4. Press STEP DOWN to display Function Block menu.
5. Turn the pulser knob or use right arrow button to display AIN1.
6. Press STEP DOWN to display MINSCALE.
7. Press STEP DOWN to display current 0% of range.
8. Turn the pulser knob to display 1 in the last digit. Display should read “0.00001”.
9. Now press the left arrow (TAG) button. Notice that the decimal place will move one place every time the button is pressed. Press the arrow button until the display reads “100.000” and then press the STORE button.
10. Press STEP UP.
11. Turn the pulser knob or use the arrow button to display MAXSCALE.
12. Press STEP DOWN to display “100.000”.
13. Press the right arrow button until display reads “0.00001”.
14. Turn the pulser knob to change the last digit to 5. Display should read “0.00005”.
15. Press left arrow button until display reads “500.000” and press store.
16. Press STEP UP.
17. Turn the pulser knob or the use arrow button to display DPP.
18. Press STEP DOWN. Notice “0.00” or 2 decimal places is the default. Turn the pulser knob to set the number of decimal places to 0.0 or to show 1 decimal place on the display and press STORE button.
19. Press STEP UP and turn the pulser knob or use the arrow button to display ENGUNITS.
20. Press STEP DOWN. Notice that the default units are PRCT.
21. Use the arrow buttons to move the flashing cursor to the space before the P. Now turn the pulser knob to display “D”. Use the arrow button to move to the next position and turn the pulser knob to select “E”. Repeat until display reads DEG F and press the STORE button.
22. Press ENTER/EXIT CONF to return to normal operation.

Try displaying the process and setpoint. Notice that these are now displayed in engineering units scaled 100 to 500 DEG F, or 300 at 50%. Press the UNITS button to display the engineering units configured above.

9.1.6 Alarms

Upon power up, FCO101 has 4 alarms enabled:

- Hi alarm at 110% on AIN1
 - Lo alarm at -10% on AIN1
 - Deviation alarm of 110% between AIN1 and SETPT
 - No alarm
1. Press the ALARM/STEP DOWN button to step through the Alarm limits and Enable/Disable Status. Notice all the alarms are enabled and the alarm limits are displayed in engineering units on the numeric display and as a percentage of range by a flashing LED on the S bargraph. If security clearance is satisfied, the alarm limits can be changed by rotating the pulser knob. Try changing the alarm limit A1 to 50% (300 DEG F) and press STORE to save the new value.
 2. Press EXIT to return to normal operation mode.
 3. Enter manual mode to display Loop01.V.
 4. Turn the pulser knob until both the valve output and process input are greater than 50%. Note that the alphanumeric display will flash "A1 HI" and the L and S LEDs will flash. Press the ACK button to acknowledge the alarm.

Alarms have a default priority of 3 (see Alarm block in Section 3.2.10), meaning that the alarms must be acknowledged to clear the flashing. Alarms may also be configured as self clearing. Try changing the alarm priority to 4 using the Configuration Road Map in Figure 2-1 or the following steps:

1. Press ENTER/EXIT CONF. LOOP should be displayed.
2. Press STEP DOWN twice until VIEW appears on the display.
3. Press the right arrow button 3 times or turn the pulser knob until EDIT FB appears on the display.
4. Press STEP DOWN. A/M will be displayed.
5. Press the right arrow button 3 times or the turn pulser knob until ALARM appears on the display.
6. Press STEP DOWN to display RG PTR.
7. Press the right arrow button or turn the pulser knob until A1 PRIOR appears on the display.
8. Press STEP DOWN to display 3 on the numeric display.
9. To change the priority of alarm 1 from 3 to 4, rotate the pulser knob until 4 appears on the numeric display.
10. Press STORE to save the configuration change.
11. Press ENTER/EXIT CONF to return to normal operation.

Try adjusting the process above and below 50% (300 DEG F). Notice that the alarm will clear without pressing the ACK button if the process drops below the alarm limit - deadband. Use the ALARM QUICK button to return the Alarm Limit A1 to the default 110% (540 DEG F) and press STORE to save. Other alarm parameters referenced in the ALARM function block description may be changed in a similar manner.

9.1.7 TAG

Press the TAG button. Note that Loop01.* (*= P, S, V, X or Y) will scroll across the screen. To change the tag, refer to the Configuration Road Map in Figure 2-1 or the following instructions.

Note that although 12 characters are available for the tag, it is suggested that loop names be limited to 6 characters so that the complete tag name will be displayed during normal operation. The additional 6 characters can be displayed by scrolling the tag. The last two digits of the alphanumeric displayed during normal operation will be used to identify the variable currently being displayed, P, S, V, X or Y.

1. Press ENTER/EXIT CONF. LOOP will be displayed.
2. Press STEP DOWN twice until VIEW appears on display.
3. Press the right arrow button or the turn pulser knob until EDIT TAG appears on the display.
4. Press STEP DOWN. LOOP01 will appear on the display with the 1 digit flashing. Use the pulser knob to change the value of the flashing character and press store to save the change. Use the arrow buttons to move to another character. Try changing the TAG to TC101.
5. Press ENTER/EXIT CONF to return to normal operation mode.
6. Press TAG to view tag names longer than 6 characters.

9.1.8 QUICK

When in normal operation mode the QUICK button can be used to step through the QUICK SET parameters of any function block which has this feature enabled. In FCO101, the SETPT function block has the QUICK SET feature enabled as a default. Press the QUICK button and note that you can scroll through the following Setpoint features: RAMP ON/OFF, Ramp RATE, TARGET setpoint, and POWER UP SETPOINT. The ramp feature can either use a ramp TIME or a ramp RATE. USE RATE is set to YES as the default (see SETPT function block details in Section 3.2.82).

To see how the Ramp rate works, make sure the controller is in AUTO mode and do the following steps.

1. Press QUICK to display RRATE.
2. Rotate the pulser knob to set the ramp RATE to 300 and press STORE. Since the SETPT range pointer is configured for AIN1 scaled 100 to 500 DEG F, 300 will represent a ramp rate of 300 DEG F/min.
3. Press QUICK to display TARGET. Set the target to 250% and press STORE.
4. Press QUICK to display R ON OFF. Turn the pulser knob to change the setting to ON and press STORE.
5. Press ENTER/EXIT to display the setpoint on the numeric display. The setpoint should ramp to 25% in 30 seconds.

To change from a Ramp RATE to a Ramp TIME do the following steps.

1. Press ENTER/EXIT CONF to display LOOP.
2. Press STEP DOWN twice to display VIEW.
3. Press the right arrow button or turn the pulser knob to display EDIT FB.
4. Press STEP DOWN to display A/M.
5. Turn the pulser knob to display SETPT.
6. Press STEP DOWN to display RG PTR.
7. Turn the pulser knob to display USE RATE.
8. Press STEP DOWN to display YES.
9. Turn the pulser knob to change to NO, and press STORE. Press STEP UP.
10. Turn pulser knob counterclockwise or use left arrow button to display RTIME.

11. Press **STEP DOWN** to display ramp **TIME**.
12. Turn the pulser knob to set the desired Ramp **TIME**, and press **STORE**.
13. Press **EXIT** to return to normal operation mode.

Now press the **QUICK** button. Note that the **RTIME** parameter will now be displayed instead of the **RRATE** parameter. Setting **R ON OFF** parameter to “**ON**” will now ramp the setpoint to the **TARGET** setpoint in the specified time rather than at a particular rate. See the **SETPT** description in Section 3.2.82 for more details on setpoint functions.

Quickset parameters for other function blocks such as **RATIO** and **BIAS** may be changed in a similar fashion. See specific function block descriptions in Section 3 Function Blocks for more details.

9.1.9 TUNE

When in normal operation mode, pressing the **TUNE** button will scroll through the controller tuning parameters and allow activating the **AUTOTUNE** algorithm. **FCO101** is configured for **PID** control with the **AUTOTUNE** feature enabled. Press the **TUNE** button and note that the default values for **Proportional Gain (PG)**, **Time-Integral (TI)**, **Time-Derivative (TD)**, and the **Derivative Gain (DG)** will be displayed. In addition, the **AUTOTUNE** parameters **% Deviation**, **% Hysteresis**, and **Autotune YES/NO** will be displayed.

It is difficult to simulate the autotune feature without simulating a process signal but increasing the digital filter parameter on the **AIN1** will help make the process seem more realistic. To change the digital filter to a value around 10 follow the Configuration Road Map in Figure 2-1 or do the following steps.

1. Press **ENTER/EXIT CONF**.
2. Press **STEP DOWN** twice to display **VIEW**.
3. Use the right arrow button or the pulser knob to display **EDIT FB**.
4. Press **STEP DOWN** for **Function Block** menu.
5. Use the right arrow button or the pulser knob to display **AIN1**.
6. Press **STEP DOWN** for **parameter** menu.
7. Use the right arrow button or the pulser knob to display **DIG FILT** and Press **STEP DOWN**.
8. Rotate the pulser knob to set the digital filter to 10 and press **STORE**.
9. Press **ENTER/EXIT CONF** to return to normal operation.

Before initiating **AUTOTUNE** bring the process to steady state. This can be done by placing the instrument in manual mode and bringing the valve to approximately mid-scale using the pulser knob. Display the process and wait a minute or two for the process to stabilize.

To activate the **AUTOTUNE** feature:

1. Press the **TUNE Quick Button** to display **AUTOTUNE**.
2. Set this parameter to **YES**; press **STORE** and then press **EXIT**. The controller is now set to **AUTO** and “**AUTOTUNE**” will flash until the **AUTOTUNE** is finished. Tuning warnings may occur; refer to Section 8.3 **Autotune Procedure**. Since this is only a simulation, press **ACK** to clear any warnings.
3. Press the **TUNE** button to display the default controller parameters and the resulting **AUTOTUNE (ATUNE)** parameters. After viewing the parameters, **STORE AT** will be displayed. Press the **STORE** button to change the controller parameters to the new values or press the **ENTER/EXIT CONF** button to keep the defaults.

To cancel the **AUTOTUNE** before the tuning operation is complete, press the **A/M** button to enter **MANUAL** mode. Refer to Section 8.3 for more details on the **AUTOTUNE** feature.

9.1.10 View mode

When troubleshooting a configuration, it is often helpful to be able to view the intermediate outputs of function blocks that are not configured as display variables during normal operation. This can be accomplished via the VIEW mode. To enter VIEW mode:

1. Press ENTER/EXIT CONF to display LOOP.
2. Press STEP DOWN to display VIEW.
3. Press STEP DOWN to display the first output of the first configured function block.
4. Use the pulser knob or arrow buttons to scroll through the function block outputs. Note that analog outputs are in engineering units and discrete/status outputs (represented by the black shaded arrows in the Function Block diagrams) are either low (0) or high (1).
5. Press EXIT to return to normal operation mode.

9.2 SYSTEM CHECKOUT

1. Check that the correct circuit boards are installed and fully seated in the case as follows. The controller model number on the P&I drawing should match the model number on the controller's case. Compare the model number to the Model Designation table in Section 13 to be sure the proper boards are installed.

NOTE

When power is applied to the controller, an installed hardware list can be viewed in the STATN function block. Refer to Section 3.1.3 for board description and ID.

2. Check all wiring between the controller and external equipment (e.g. transmitters, recorders, power supplies). Check for correct and secure connections, correct wire gauge and insulation, adequate support (ties, raceways, conduit), and protection from damage (sharp edges, moving equipment, chemicals, abrasion).
3. Test all equipment connected to the controller for proper operation. Refer to the equipment manufacturer's literature as necessary.
4. Apply power to the controller and note the faceplate displays during power up. See Section 10.3 for a list of the faceplate displays during power up.
5. Based on the controller hardware present, the current configuration in the controller, and the external equipment, exercise the system in a systematic manner to ensure proper operation.





10.0 MAINTENANCE

Controller maintenance requirements are minimal. Activities such as cleaning and visual inspections should be performed at regular intervals. The severity of the controller's operating environment will determine the frequency of maintenance. Additional topics including troubleshooting, assembly replacement, and software compatibility are also covered. Figure 10-1 shows an exploded view of the controller.

Before servicing or calibration the equipment, note the following statements.

- Maintenance should be performed only by qualified personnel. Failure to properly maintain the equipment can result in death, serious injury, or product failure. This manual should be carefully reviewed, understood, and followed.
- The steps in the Preventive Maintenance section below should be performed regularly.
- The procedures in this section do not represent an exhaustive survey of maintenance steps necessary to ensure safe operation of the equipment. Particular applications may require further procedures. Should further information be desired or should particular problems arise which are not covered sufficiently for the purchaser's purposes, the matter should be referred to the local Siemens sales office.
- The use of unauthorized parts in the repair of the equipment or tampering by unqualified personnel will result in dangerous conditions that can cause death, serious injury, or equipment damage. Follow all safety instructions contained herein.

 WARNING		
	Electrical shock hazard Explosion hazard Can cause death or injury	
<ul style="list-style-type: none"> • Remove power from all wires and terminals before working on equipment. • In potentially hazardous atmosphere, remove power from equipment before connecting or disconnecting power, signal, or other circuit. • Observe all pertinent regulations regarding installation in hazardous area. 		

10.1 TOOLS AND TEST EQUIPMENT

The following tools and equipment are necessary for servicing:

- A. Common hand tools for servicing electronic equipment
- B. Digital Multimeter (DMM)
 - Voltmeter section:
 - Accuracy +/-0.01% of reading
 - Resolution 1.0 millivolt input
 - Impedance 10 Megohms
 - Ammeter section:
 - Accuracy +/- 0.1% of reading
 - Resolution 100 microamperes
- C. Maintenance Kit, P/N 15545-110, containing wrist strap and conductive mat. This kit or an equivalent is required when a circuit board assembly is handled for any reason.

10.2 PREVENTIVE MAINTENANCE

The objective for establishing a preventive maintenance program is to provide maximum operating efficiency. Every preventive maintenance operation should assist in realizing this objective. Unless a preventive measure reduces a Station's down time, it is unnecessary.

10.2.1 Environmental Considerations

The controller has been designed to operate within specified environmental parameters (temperature and humidity). These parameters are listed in Section 13 Model Designation and Specifications. Additional information concerning environmental contaminants is covered in Section 7 Installation.

10.2.2 Visual Inspection

As part of a periodic maintenance program, the controller should be visually inspected. When viewing the station, scan for abnormalities such as loose, broken or stressed ribbon cables. Look for damaged circuitry and heat stressed parts. Check for excessive dirt or dust build-up which may impede air flow and inhibit proper heat dissipation.

10.2.3 Cleaning

Circuit boards are conformal coated for protection against contaminants and should not be cleaned unless accumulated foreign material is causing a problem. If cleaning becomes necessary:

1. Protect the station's electronic components from electrostatic discharge. Fasten a conductive wrist strap around your wrist and ground the strap to the station's case, the panel, or a static dissipative work mat. See the next section for circuit board handling guidelines.
2. Loosen the Display Assembly's two faceplate screws. One screw is above the numeric display, the other behind the flip-down door at the bottom of the faceplate. See Figure 10-1 as needed.
3. Pull the Assembly from the panel about 1.5" (38 mm).
4. Look behind the Assembly and locate the display cable, then open the connector locking levers on the Assembly mounted connector to eject the cable-mounted connector.
5. Clean the bezel with a mild, nonabrasive liquid cleaner and a soft, lint-free cloth - do not use a paper towel. Set the Display Assembly aside.
6. Pull the board(s) from the case by grasping a board by an exposed edge. Do not use the display cable to pull the MPU Controller board from the case. Since the board edge connector mates with a connector at the back of the case, a moderate pull will be needed to extract the board.
7. Remove debris from case and board(s) using a soft brush or low velocity deionized air.
8. Insert removed board(s) into the case and *carefully guide* the connector end of a board to mate with the connector(s) at the back of the case. Only when the connectors are mated should additional force be applied to seat the board.
9. Hold the Display Assembly close to the open case and mate the display cable with the connector on the Display Assembly circuit board. The cable is keyed.
10. Align the Display Assembly with the case and *finger tighten* the two faceplate screws. To ensure water tightness, use a torque screwdriver set to 6 inch-pounds to tighten the screws. Alternatively, use a screwdriver to tighten the screws until a slight resistance is felt - then tighten an additional ½ turn. **DO NOT OVERTIGHTEN.**
11. Remove the wrist strap.



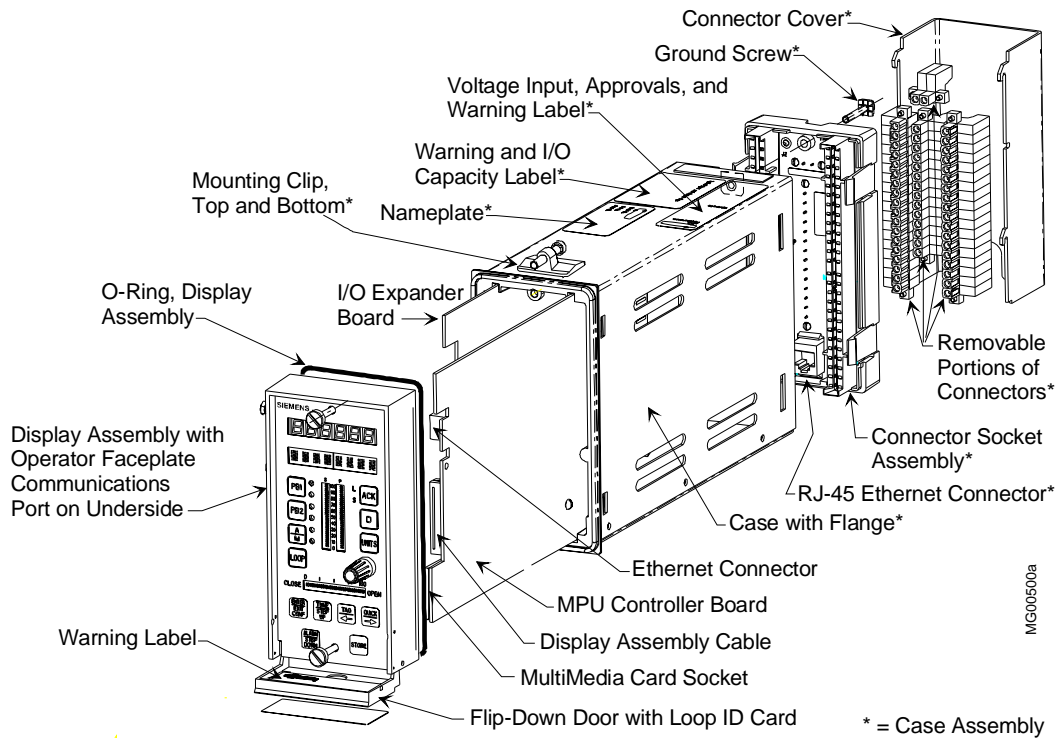

Figure 10-1 Siemens 353 Exploded View, Design Level B

10.2.4 Circuit Board Handling

ELECTROSTATIC DISCHARGE, ALL ELECTRONIC ASSEMBLIES



Semiconductor devices must be protected from electrostatic discharge. A properly grounded conductive wrist strap must be worn whenever a circuit board assembly is handled or touched. A service kit with a wrist strap and static dissipative work mat is available from mail order and local electronic supply companies.

LITHIUM BATTERY PRECAUTIONS

Each MPU Controller board has a lithium battery that is not field replaceable. Note the following when handling or disposing of either board.

- Properly dispose of an un-repairable circuit board with a lithium battery
- Do not burn the battery
- Do not place the circuit board on a metal surface or otherwise short circuit battery terminals
- Do not attempt to charge the battery
- If electrolyte is exposed, wear safety glasses and rubber gloves when handling the battery
- For details contact the battery manufacturer

10.3 TROUBLESHOOTING

Troubleshooting the controller is primarily done by error codes. Error codes are indicated on the alphanumeric display in response to a failed power-up diagnostic test or to an on-line controller error. Section 10.4 Error Codes lists each code and the type of test or error check, controller response, problem confirmation, and corrective action.

The normal controller power-up display sequence is:

- DRAMTest appears for several seconds on the alphanumeric display
- SRAMTest appears in the alphanumeric display
- ROM Test appears in the alphanumeric display
- WAIT may appear in the alphanumeric display
- A display test of the 6-digit display, horizontal and vertical bargraphs, and individual LEDs is performed followed by a test of the 8-character alphanumeric display
- Values determined by the configuration and process state are displayed

In the event a malfunction within the controller is suspected, troubleshooting by assembly substitution is recommended to get the controller back on-line in the shortest possible time. The plug-in design of controller assemblies permits rapid removal and replacement to isolate a defect. Figure 10-1 shows controller assemblies.

If a problem appears upon initial installation of the controller, check the installation wiring and the controller's configuration. Also, check the wiring and operation of connected external process devices (e.g. process transmitter, sensor, valve positioner). Field servicing experience indicates that most initial service incidents are of this nature.

Additional troubleshooting avenues are also possible. For example, a series of test configurations may be created and implemented to 'exercise' various function blocks within the controller. Section 3 describes each function block. This type of troubleshooting analysis is intended to be implemented in an off-line test bench situation.

On-line checks of the controller input and output signals (i.e. analog and digital) can be performed without affecting station operation. Signal tracing is usually carried out behind an instrument panel. Refer to the Installation section, Table 7-1, for rear terminal assignments.

There are no user settable jumpers or switches on either the Controller or I/O Expander board.

ETHERNET ACTIVITY LED

The Ethernet LED is located on the exposed edge of the MPU Controller board, as shown in Figure 10-2. The LED will blink with each received communication.

MMC ACTIVITY LED

The MultiMediaCard LED is located on the exposed edge of the MPU Controller board, see Figure 10-2. The LED blinks when a file is being written to or read from the MMC. The card or the file being transferred may be corrupted if the MMC is ejected from the MMC Socket while the LED is blinking.

Inserting a card into the MMC Socket (see Figure 10-3) on the front edge of the Controller board will cause the MMC LED to flash indicating that the controller software is accessing the card. To remove an MMC, press the eject button on the MMC socket; see Figure 10-3. Do not eject the card while the LED is flashing.

If an MMC FAIL or FileErr# message appears on the alphanumeric display, refer to Section 10.4.3 for MultiMediaCard error code descriptions.

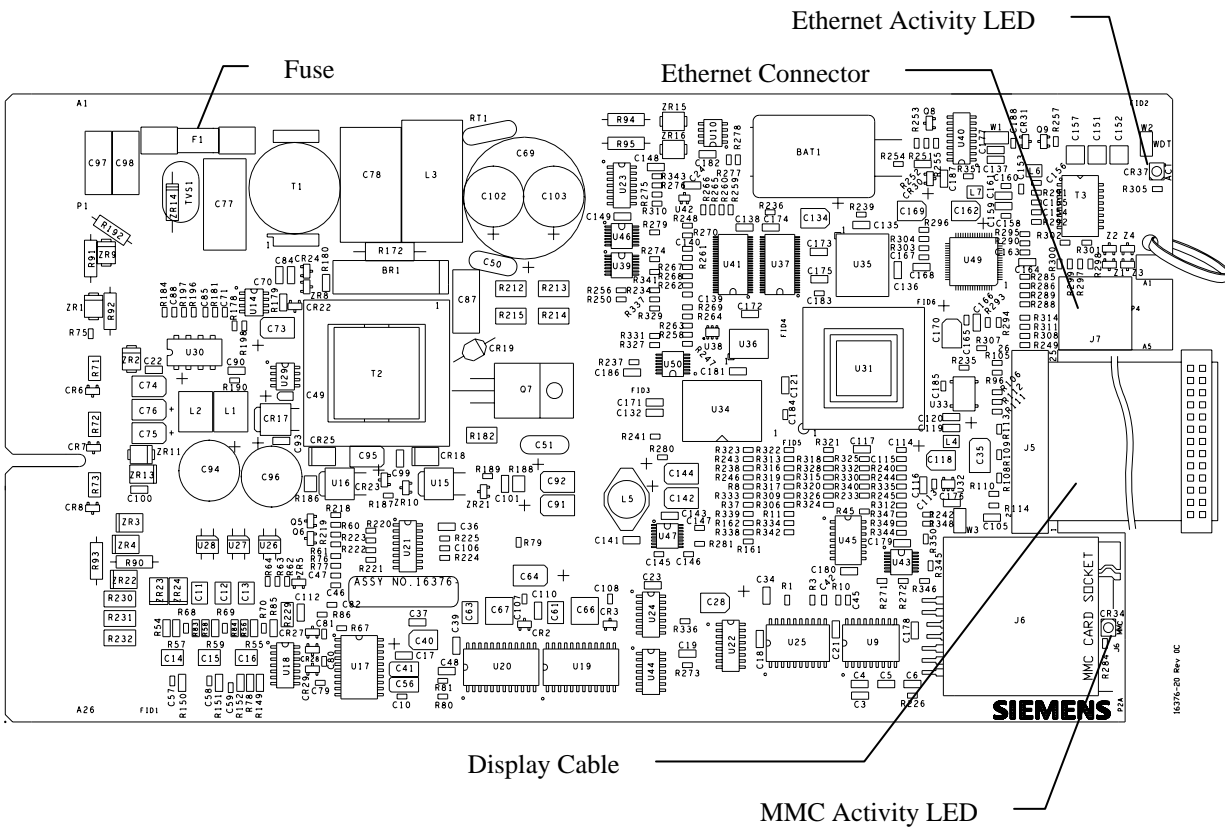

Figure 10-2 MPU Controller Board

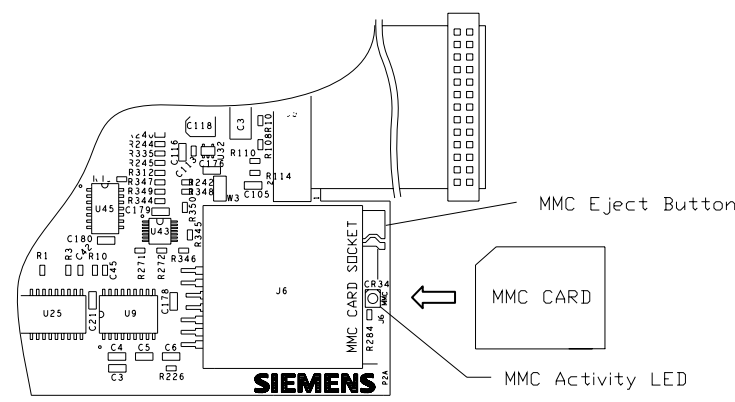

Figure 10-3 MultiMediaCard (MMC), Inserting and Ejecting

10.4 ERROR CODES

This section describes off-line error codes, on-line error codes, and on-line status codes. Typically, a code will point to a failed internal assembly or a failed peripheral device. Note that a configuration error can also cause an error code or multiple error codes to be produced. For example, an error will occur when attempting to run a configuration that includes an I/O Expander board hardware I/O block (i.e. AINU 1, AINU2, DINU1, DINU2, ROUT1 or ROUT2) in a controller that does not have an I/O Expander board installed.

10.4.1 Off-Line Error Codes

Off-line error messages are displayed while the 353 is powered but not running function block code and therefore not actively controlling a process. Depending on the message, user intervention will most likely be required.

Corrective action can be initiated via the Ethernet or Modbus ports as appropriate. Parameter “SE” located at Modbus register 40002 will contain the hexadecimal form of the error number currently displayed (e.g., ERR: 213 would be sent as \$00D5). An Error message can be acknowledged over the network by writing a 0 to the Modbus register. Messages are displayed one at a time, in order of occurrence, and a message cannot be cleared until the error condition is corrected.

Table 10-1 Off-Line Error Codes

ERROR CODE	DESCRIPTION	CORRECTIVE ACTION
101	Board type test	Replace Controller board.
102	DRAM error	Replace Controller board.
103	SRAM error	Replace Controller board.
104	Flash CRC error	Press ENTER to reset and retest controller. If error remains, replace Controller board or reinstall firmware.
202	Constant Data CRC Test	Controller operation suspended. Press ENTER to load Controller board default constant data.
203	Calibration Data CRC Test	Controller operation suspended. Press ENTER to load Controller board default calibration data.
205	Database Compatibility Test	Controller operation suspended. Press ENTER to, if possible, convert the database or load Controller board default constant data.
208	Board Compatibility Test	Install compatible Controller board.
213	Calibration Data CRC Test	Controller operation suspended. Press ENTER to load I/O Expander board default calibration data.
214	Software Compatibility Test	Controller operation suspended. Replace I/O Expander board or press ENTER to remove from the configuration all references to blocks relating to the Expander board.
215	Database Compatibility Test	Controller operation suspended. Replace I/O Expander board or press ENTER to, if possible, convert the database or load Expander board default constant data.
216	Board Not Present	Controller operation suspended. Install I/O Expander board or press ENTER to remove from the configuration all references to the missing board.
218	Board Compatibility Test	Install compatible I/O Expander board.

10.4.2 On-Line Error Codes and Status Codes

These codes can be produced while the controller is running function block and may be actively controlling a process. Depending on the message and its priority level, user intervention may be required or the message may simply be informational in nature. Parameter “SE” located at Modbus register \$40002 will reflect unacknowledged error or status messages present in the controller. Messages are displayed according to priority until all active messages have been acknowledged. If no link code has been assigned to the active message, the “SE” code will remain at its last value.

Table 10-2 lists on-line error and status codes. For most error codes, replace the involved circuit board to repair the controller. For most status codes, acknowledge or otherwise respond to the situation.

Table 10-2 On-Line Error and Status Codes

DISPLAYED CODE	LINK/MODBUS CODE (Hex/Dec)		DESCRIPTION
MPU A/D	\$0001	1	MPU Controller board A/D Error
EXP A/D	\$0002	2	I/O Expander Board A/D Error
AOUT1 OC	\$0003	3	MPU Controller board D/A #1 Open Circuit
AOUT2 OC	\$0004	4	MPU Controller board D/A #2 Open Circuit
AOUT3 OC	\$0005	5	MPU Controller board D/A #3 Open Circuit
AINU1 AD	\$0006	6	I/O Expander Board Universal Analog Input #1 A/D Error
AINU1 TC	\$0007	7	I/O Expander Board Universal Analog Input #1 T/C Burnout
AINU1 RJ	\$0008	8	I/O Expander Board Universal Analog Input #1 Reference Junction Error
AINU2 AD	\$0009	9	I/O Expander Board Universal Analog Input #2 A/D Error
AINU2 TC	\$000A	10	I/O Expander Board Universal Analog Input #2 T/C Burnout
AINU2 RJ	\$000B	11	I/O Expander Board Universal Analog Input #1 Reference Junction Error
UDIN E1	\$000C	12	I/O Expander Board Universal Digital Input #1 Underflow Error
UDIN E2	\$000D	13	I/O Expander Board Universal Digital Input #2 Underflow Error
MOD ERR	\$0010	16	Modbus Port Error
Watchdog	\$0013	19	Watchdog Timeout
LOW BAT	\$0014	20	Low NVRAM Battery Voltage
MMC→MEM	\$0015	21	Press STORE to load MMC configuration into MPU memory
CYCLTIME	\$0016	22	Cycle Time Overrun – see STATN block – add Cycle Time bias
BURNFAIL	\$0017	23	Flash Memory burn failed
NO EXPBD	\$0019	25	Expander board is not installed
MB OVRUN	\$001C	28	Modbus communication error
A1 HI	None		Alarm A1 High
A1 LO	None		Alarm A1 Low
A1 HI D	None		Alarm A1 High Deviation
A1 LO D	None		Alarm A1 Low Deviation
A1 DEV	None		Alarm A1 Deviation
A1 OR	None		Alarm A1 Overrange
A2 HI	None		Alarm A2 High
A2 LO	None		Alarm A2 Low
A2 HI D	None		Alarm A2 High Deviation
A2 LO D	None		Alarm A2 Low Deviation
A2 DEV	None		Alarm A2 Deviation
A2 OR	None		Alarm A2 Overrange
A3 HI	None		Alarm A3 High
A3 LO	None		Alarm A3 Low
A3 HI D	None		Alarm A3 High Deviation
A3 LO D	None		Alarm A3 Low Deviation

DISPLAYED CODE	LINK/MODBUS CODE (Hex/Dec)	DESCRIPTION
A3 DEV	None	Alarm A3 Deviation
A3 OR	None	Alarm A3 Overrange
A4 HI	None	Alarm A4 High
A4 LO	None	Alarm A4 Low
A4 HI D	None	Alarm A4 High Deviation
A4 LO D	None	Alarm A4 Low Deviation
A4 DEV	None	Alarm A4 Deviation
A4 OR	None	Alarm A4 Overrange
B1 HI	None	Alarm B1 High
B1 LO	None	Alarm B1 Low
B1 OR	None	Alarm B1 Out of Range
B2 HI	None	Alarm B2 High
B2 LO	None	Alarm B2 Low
B2 OR	None	Alarm B2 Out of Range
B3 HI	None	Alarm B3 High
B3 LO	None	Alarm B3 Low
B3 OR	None	Alarm B3 Out of Range
B4 HI	None	Alarm B4 High
B4 LO	None	Alarm B4 Low
B4 OR	None	Alarm B4 Out of Range
Emeg Man	None	Emergency Manual
Em Local	None	Emergency Local
Standby	None	Standby Sync
Override	None	Override
EMERG OR	None	Emergency Override - PCOM block
INTRLK	None	Interlocked – PCOM block
DFAIL	None	Device Failed – PCOM block
MAX LOOP	None	Maximum Loop Size
S HI Lim	None	Setpoint HI Limit
S LO Lim	None	Setpoint LO Limit
U1 Status	None	User Status #1
U2 Status	None	User Status #2
ATUNE W1	None	Autotuner Warning: hys/desamp >0.2; see Section 8.3 for ‘W#’ details
ATUNE W2	None	Autotuner Warning: Deviation Ratio is HI; see Autotune procedure
ATUNE W3	None	Autotuner Warning: Avg. Deviation is LO; see Autotune procedure
ATUNE E1	None	Autotuner Error: limit cycle timeout
ATUNE E2	None	Autotuner Error: process out of range
ATUNE E3	None	Autotuner Error: Only applies when % HYS set to A. Process too noisy.
E In RAM	None	Insufficient Volatile Memory Available
E In Con	None	Insufficient Constant Memory Available
E Db CRC	None	Database CRC/Checksum Error
E P Qual	None	Poor I/O quality
AIEnn NU	None	AIEnn Function Block Not Updating
CIEnn NU	None	CIEnn Function Block Not Updating
DIEnn NU	None	DIEnn Function Block Not Updating

10.4.3 MultiMediaCard Error Codes

If MMC FAIL appears on the alphanumeric display, an error has occurred. Flashing will continue until the event is acknowledged by pressing the ACK button or the card is removed from the socket. Some possible reasons for the error are:

- Card is defective
- Card is not formatted or format (e.g. FAT32) is not supported
- Corrupt or missing file structure
- Card is write-protected
- Card is full

The following error codes can be shown on the alphanumeric display. The configuration file being read cannot be further processed until the file error corrected.

- FileErr1 – The file does not conform to the defined structure of a configuration file and is unusable. The file may be corrupted.
- FileErr2 – The file contains one or more function blocks associated with Model 353R or Procidia i|pac. Remove those function blocks to allow the file to be loaded.
- FileErr3 – The file contains one or more unknown function blocks. This is most likely caused by the presence of LIL or LON function blocks in the file (the configuration may have been created for a design level A 353). Remove the unknown function blocks to allow the file to be loaded.
- FileErr4 – The file contains function blocks that require hardware that is not present in the station. This is most likely caused by the absence of an I/O Expander board. Either remove the function blocks that require the Expander board from the file or install the Expander board.
- FileErr5 – The file contains a database revision that is not supported. The file is not usable. The database revision must be Rev 4.00 or higher.

10.5 ASSEMBLY REPLACEMENT

The following describes replacement of the controller's assemblies. The subsections below are organized in the sequence of controller disassembly and reassembly. Most subsections have Removal and Installation paragraphs. Controller disassembly is described by the Removal paragraphs and controller assembly is described by the Installation paragraphs.

Each circuit board assembly has a part number label and a serial number label. Label locations shown herein may differ from actual assemblies.

TOOLS:

Common hand tools for electronic equipment servicing are needed and a torque screwdriver, calibrated in inch-pounds, is recommended. Before handling an assembly, refer to Section 10.2.4 for electrostatic discharge prevention procedures. See Figure 10-1 for an exploded view of the controller that shows field replaceable assemblies and individual parts.



FIELD UPGRADES:

The procedures below are provided for servicing an assembled controller. When installing a circuit board in the controller to add or change performance features, always refer to the Kit Installation Instruction supplied in the circuit board kit for details specific to the supplied board.

10.5.1 Fuse

A power input fuse is located on the MPU Controller board as shown in Figure 10-2. This is the controller's power input fuse. A replacement fuse can be obtained from a local electronics supplier or can be ordered from the factory. See the Parts List for fuse part number and description.

To replace the fuse:

1. Refer to Section 10.5.2 and remove the Display Assembly
2. Refer to Section 10.5.3 and remove the MPU Controller board.
3. While the controller is apart, visually inspect the assemblies for overheated or otherwise damaged components.
4. Remove the failed fuse and read the fuse ratings. Install a replacement fuse.
 - 120/240 Vac MPU Controller board – A 0.5A fuse may be replaced with a 0.4A or 0.5A, 250V, SloBlo fuse. A 0.4A fuse must be replaced with a 0.4A, 250V, SloBlo fuse.
 - 24 Vdc MPU Controller board – Install a 2A, 250V, SloBlo fuse.
5. Reassemble the controller. Refer to the above referenced sections as necessary.
6. Apply power to the controller. Operate the controller off-line for several minutes to be sure that a condition does not exist that will cause the replacement fuse to fail.

10.5.2 Display Assembly

To replace a Display Assembly, see Section 10.5.2.1. To replace the bezel or the circuit board, perform the procedures in Sections 10.5.2.1 and 10.5.2.2.

10.5.2.1 To Replace a Display Assembly

REMOVAL:

1. In a hazardous area, remove power from the Controller.
2. Protect the station's electronic components from electrostatic discharge. Fasten a conductive wrist strap around your wrist and ground the strap to the ground screw on the Controller's case, an unpainted area on the panel, or a grounded static dissipative work mat. 
3. Loosen the Display Assembly's two faceplate screws. One is above the numeric display and one behind the flip-down door at the bottom of the faceplate.
4. Pull the Assembly from the panel about 1.5" (38 mm).
5. Look behind the Assembly and locate the display cable from the MPU Controller board. Open the connector locking levers on the Assembly mounted connector to eject the cable mounted connector.
6. Place the Display Assembly in a static shielding bag and set it aside.
7. Go to the following sections to remove a circuit board or replace the power input fuse.

INSTALLATION

1. Hold the Display Assembly close to the open case and mate the display cable with the connector on the Display Assembly circuit board. Check that the locking levers on the connector fully engaged the cable mounted connector. The cable is keyed.
2. Align the Display Assembly with the case. To ensure water tightness, use a torque screwdriver set to 6 inch-pounds to tighten the two faceplate screws. Alternatively, use a screwdriver to tighten the screws until a *slight resistance* is felt, then tighten an additional ½ turn. **DO NOT OVERTIGHTEN.**
3. Remove the wrist strap.

NOTE

When changing a Display Assembly with the controller powered-up and an error code present, the displays will light in a random pattern except for the alphanumeric display which will show the error code. Clear the error to clear the displays.

10.5.2.2 To Replace the Bezel or Circuit Board

REMOVAL

1. Place a properly grounded wrist strap on your wrist and remove the Display Assembly as described above.
2. Refer to Figure 10-4. Notice that the circuit board is captured by a Fixed Retainer at the top of the bezel and a Flexible Retainer at the bottom. Grasp the body of the connector at (1) and at the same time press the Flexible Retainer downward slightly. Pull gently on the connector to lift the bottom edge of the board above the Flexible Retainer.



Note

The board is a snug fit. Do not squeeze the bezel sides and make removal more difficult.

3. Remove the board from the bezel by carefully continuing to lift board while pulling the board out from under to Fixed Retainer at the top of the assembly.
4. If the bezel is being replaced:
 - 1) Remove the two Display Assembly mounting screws. Turn the Assembly face up and lift each mounting screw upward until the threaded portion contacts the bezel. Turn each screw counterclockwise to unscrew it from the bezel. A screwdriver may be needed once a screw is started.
 - 2) Remove the flip-down door by pressing on the door near its pivot point to free the door from the bezel.

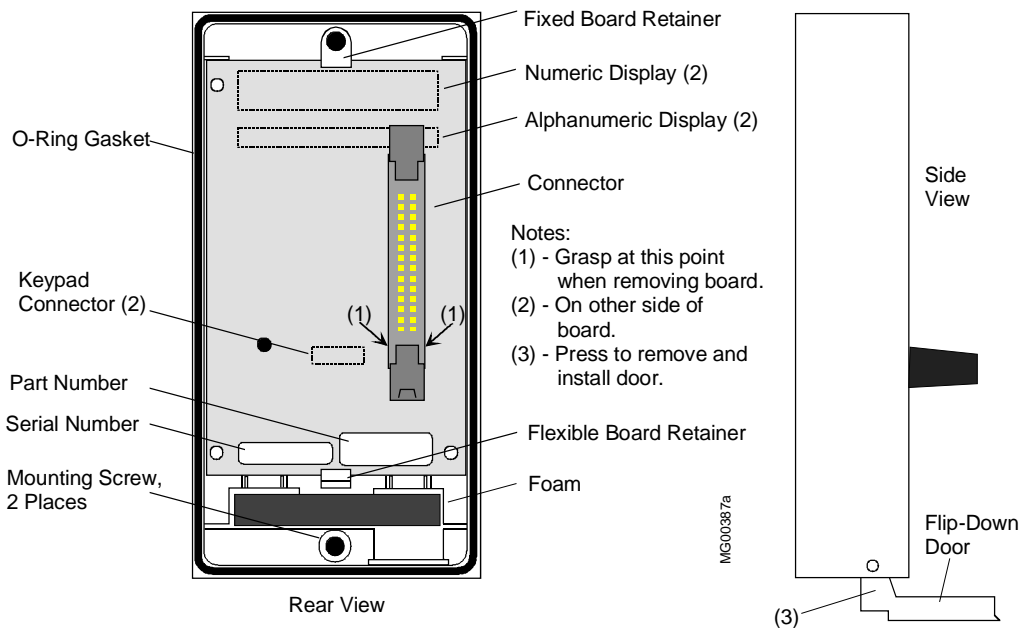

Figure 10-4 Display Assembly Repair

INSTALLATION

1. Place an anti-static wrist strap on your wrist and connect the ground lead.
2. Get the replacement bezel, or get the replacement circuit board and remove it from the anti-static bag.
3. If the bezel is being replaced, start threading each Faceplate mounting screw into the bezel. Use a screwdriver to complete screw installation. Install the flip-down door; see Figure 10-4.
4. Turn the bezel over.



5. Install the circuit board in the bezel by slightly inserting the top edge of board under the Fixed Retainer. The top edge is nearest the Numeric and Alphanumeric Displays.
6. Continue to ease the board under the Fixed Retainer while lowering the bottom edge of the board into the bezel. Be sure that the keypad connector mates with the connector on the keypad. The board is fully inserted when it snaps under the Flexible Retainer.
7. Install the Display Assembly on the case as described above.

10.5.3 MPU Controller Board

This board has a lithium battery; refer to Section 10.2.4 Board Handling Precautions. When replacing an MPU Controller board, configuration parameters must either be re-entered manually, read from a MultiMediaCard, or downloaded from the PC running i|config.™ Refer to Sections 2 and 3 and to Section 11 Calibration as needed. Factory repaired controllers must also be configured.

To replace the MPU Controller board or the station fuse use the following procedure:

REMOVAL:

1. Remove input power from Controller.
2. Remove Display Assembly as described in previous section.
3. If installed, remove the MultiMediaCard. See Figures 10-2 and 10-3.
4. Disconnect the Ethernet cable from J7 on the MPU Controller board by pressing the locking tab toward the Controller board and withdrawing the connector from the socket.
5. Grasp the loop in the front edge of the MPU Controller board and pull the board straight out of the case.
6. Place the MPU Controller board in a static shielding bag.

INSTALLATION:

1. While wearing a grounded wrist strap, remove MPU Controller board from static shielding bag.
2. Partially insert the MPU Controller board into the case and connect the Ethernet cable.
3. Carefully guide the connector end of the board until it mates with the connector at the back of the case. Only when the connectors are mated should additional force be applied to seat the board.
4. Disconnect wrist strap.
5. Insert a MultiMediaCard with the desired configuration into the MMC Socket.
6. Install Display Assembly as described in the previous section.

10.5.4 I/O Expander Board

REMOVAL:

1. In a hazardous area, remove input power from Controller.
2. Remove Display Assembly and MPU Controller board as described in previous sections.
3. Refer to Figure 10-5. Grasp the edge of the I/O Expander Board and pull the Board straight out of the case.
4. Place the Board in a static shielding bag.

INSTALLATION

1. While wearing a grounded wrist strap, remove the I/O Expander Board from its static shielding bag.
2. Insert the I/O Expander Board into the case and carefully guide the connector end of the board until it mates with the connector at the back of the case. Only when the connectors are mated should additional force be applied to seat the board.

3. Disconnect wrist strap.
4. Install MPU Controller board and Display Assembly as described in previous sections.

IMPORTANT

After **replacing** an I/O Expander board in a controller whose configuration includes an AINU function block: assemble the controller, apply power, ENTER configuration and STORE the SEN TYPE parameter. This must be done even if the SEN TYPE displays the desired type. This will ensure that the function block loads the correct calibration from the new Expander board. If desired, a FIELD CAL can then be performed.

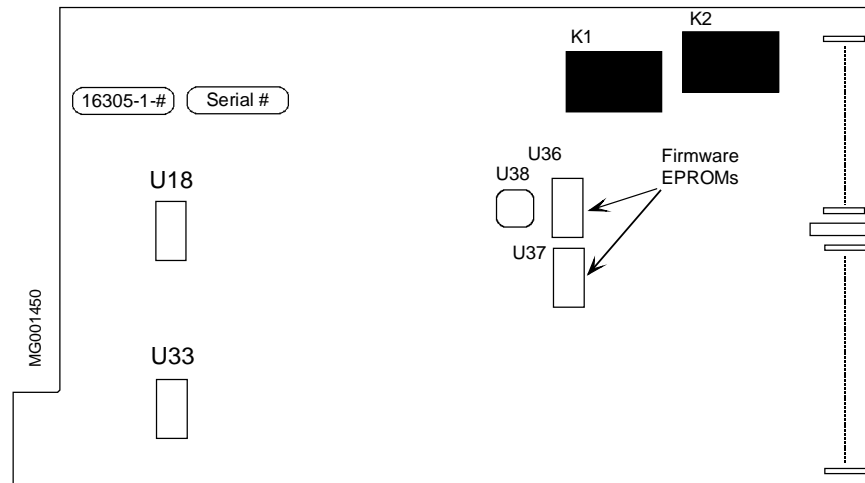

Figure 10-5 I/O Expander Board

10.5.5 Ethernet Cable

Figure 10-6 shows the Ethernet cable.

REMOVAL

1. At the Ethernet connection on the MPU Controller board, press the locking tab on the cable-mounted RJ-45 connector toward the circuit board and withdraw the connector from the board-mounted connector.
2. Remove the Controller board and I/O Expander board, if present, as described in preceding sections.
3. Inside the case, at the rear panel, press the locking tab on the cable-mounted connector upward and withdraw the connector from the rear panel mounted connector. A long flat-blade screwdriver may be needed to press the locking tab upward and release the connector.

INSTALLATION

1. Referring to Figure 10-6, perform the steps under Case Connection to install the cable in the case.
2. Install the I/O Expander board as described in a preceding section. Partially install the MPU Controller board; the Ethernet connector should be accessible. The Ethernet cable must lie on the floor of the case, between the Expander and Controller boards.
3. In Figure 10-6, refer to the steps under MPU Controller Board Connection to mate the free end of the Ethernet cable with the connector on the MPU Controller board. Dress the cable so that it will not interfere with the Display Assembly.
4. Fully install the MPU Controller board and reassemble the controller as described in preceding sections.

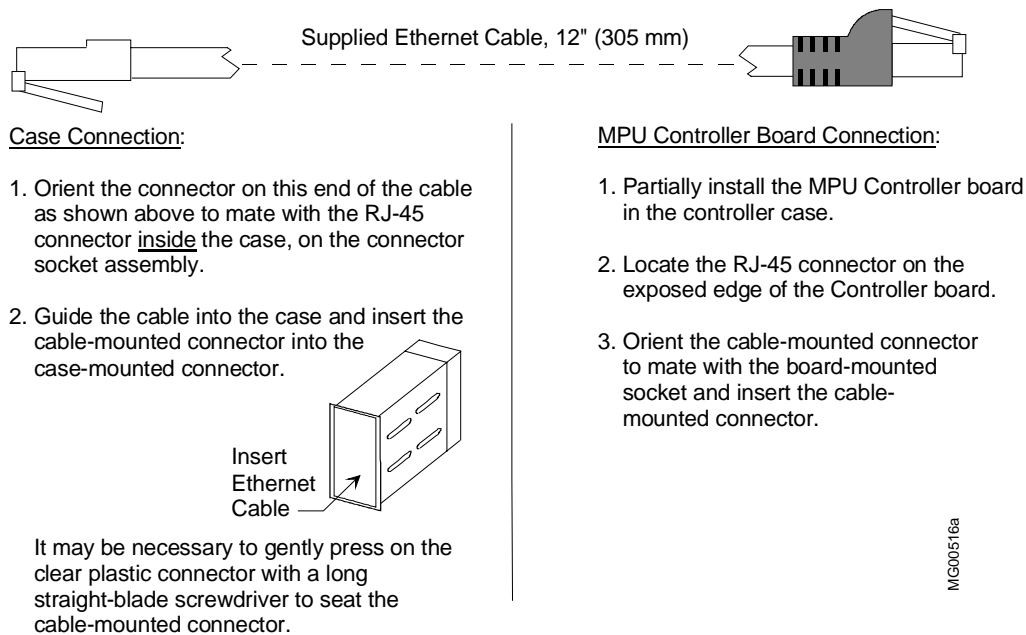

Figure 10-6 Ethernet Cable Installation

10.6 MULTIMEDIACARD – FORMATTING AND FILE NAMES

Formatting a MultiMediaCard (MMC)

Siemens supplied MultiMediaCards are formatted for use in a 353. A MultiMediaCard from another source can be formatted in a Windows-based PC that has either a built-in MMC card slot or a user-supplied external MMC card reader. Current Windows operating systems are capable of formatting a card. If the formatting program asks you to select a FAT (File Allocation Table) file system, select FAT16 for cards from 48 MB to 2 GB. Smaller cards are formatted to FAT12 by default. FAT 32 and cards larger than 2 GB were not supported at the time this manual was produced.

Configuration File Names

A configuration created and saved at a 353 faceplate will be stored on the MultiMediaCard with the controller's 8-character serial number, and a 3-character extension, as the file name. This file name can be edited; see the notes in Figure 2-2.

A configuration designed in `i|config` can be saved to the PC and to the MultiMediaCard with a long file name or an 8.3 short file name, in accordance with the Windows file naming convention. If a long file name is typed and saved, Windows will also save a short 8.3 file name. When the card is inserted in a 353 and the file name viewed on the 353 faceplate, the 8.3 file name (8 characters and a 3 character extension) will be shown. Typically a tilde (~) and an incrementing number replace the characters following the initial 6 characters of the file name; the 3-character extension is not affected. For example, if a configuration named `Boiler01DraftFanSafety` is created in `i|config` and saved to an MMC, the short file name may be contracted to, for example, `Boiler~1`. If additional similarly named Boiler configurations with long file names are saved to the same MMC, the contracted file names may make it difficult to identify a specific configuration. The contracted file names may be `Boiler~1Boiler~2`, `Boiler~3` and so on. Before saving the configuration to the MMC, examine the file name and create a file name that places the characters critical to configuration identification at the beginning of the file name.

11.0 CALIBRATION

A controller is factory calibrated to either the standard values listed in Section 7.5 Factory Calibration or to values specified by the purchaser at time of order. Field calibration should not be necessary.

For those cases where inputs or outputs must be adjusted either to meet a local standard or for a more critical application, a field calibration can be performed. The field calibration becomes the default calibration.

A CAL VIEW mode is available in calibration to view the sensor input over the full range. The signal that is viewed, in the calibration verify mode, is 0 to 100% of span in basic units of measure (e.g., °C for temperature, mv for millivolts) and is not affected by the temperature units conversion, digital filter, scaling, or the output bias adjustment. The full block output in engineering units with these parameters applied can be seen in the VIEW mode within loop configuration.

This section describes calibration and calibration verification of the following function blocks:

AIN1-4 - Analog **I**nput MPU board (3) and I/O Expander board (1)
AOUT1-3 - Analog **O**utput MPU board (2) and I/O Expander board (1)

When field calibrating a controller for a critical application, consider the following:

- If the input is a current signal (e.g., 4-20 mA), use a precision current source. The 250 ohm precision range resistor installed across the input terminals for calibration should remain with the station, connected across that set of terminals, to eliminate the voltage drop variation due to resistor tolerance.
- Allow the Station to warm-up for an hour prior to calibration. The ambient temperature should be close to normal operating conditions.

The controller must be off-line during calibration. Factory calibration values are listed in Section 7.5.

Refer to Table 7-1 and to the installation wiring figures in Section 7 Installation for power input, signal input and signal output terminals.

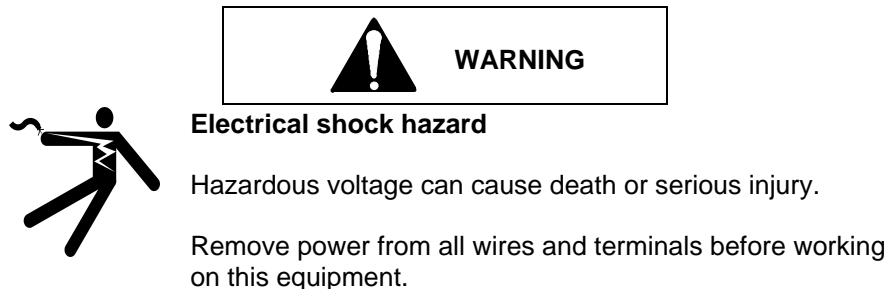

Security, Calibration of Inputs/Outputs: If level 1 and level 4 security are enabled, the user-determined six-digit security combination (e.g. 000025) for either level 1 or level 4 must be entered before new calibration parameters can be stored. Once the security combination has been entered, access will be provided to all functions with that security level until the user exits configuration. For additional information, refer to function block SECUR - Security in Section 3.1.2.

Bargraphs: The bargraphs on the Display Assembly are not used during the calibration procedure. Ignore any bargraph indications during calibration.

Calibration and calibration verification are described in the following procedures.

11.1 ANALOG INPUT (AIN1-4)

Analog input function blocks have been factory calibrated for 1 to 5 Vdc inputs. Recalibration should not be required unless calibration parameters are to be changed. Periodic recalibration should not be necessary. To calibrate an analog input, use the following procedure.

1. At the controller's rear terminals, connect an electronic calibrator or precision reference source capable of supplying a voltage between 0.000 and 5.000 Vdc to the selected analog input terminals (e.g. AIN1 or AIN2). Refer to Section 7 Installation for terminal numbers and wiring guidelines. Ensure that terminal screws are tight.
2. If security is enabled, a level 1 or level 4 security combination will be needed to store the results of a calibration. Refer to SECUR-Security in Section 3.1.2 for additional information.
3. Apply power to the station.
4. Press the ENTER CONF button to enter the configuration mode at the MENU level. Rotate the Pulser Knob to select 'STATION' on the alphanumeric (lower) display.
5. Press the STEP DOWN button to choose options at the station level and rotate the Pulser Knob to select 'CAL' on the alphanumeric display.
6. Press the STEP DOWN button to enter the FUNCTION BLOCK level. Rotate the Pulser Knob to select the desired input (e.g. AIN1 or AIN2).
7. Press the STEP DOWN button to enter the PARAMETER level.
8. Rotate the Pulser Knob to select the desired parameter, CAL ZERO, shown on the alphanumeric display.
9. Press the STEP DOWN button to enter the VALUE level ('CAL' appears on upper display).
10. Set the precision voltage source to the zero input value (0.000 to 1.000 Vdc).
11. Press STORE to lock-in the desired value. If ENTER COM appears in the alphanumeric display, security is enabled and steps 1) through 5) must be performed to store the calibration. Otherwise, go to step 14.
 - 1) The numeric display shows 000000 with the right-most digit flashing. Rotate the pulser knob to set the units digit to the correct number.
 - 2) Press the TAG/← key to select the next digit, the tens digit. Rotate the pulser knob to select a number for that digit.
 - 3) Move to and select the needed number for each remaining digit.
 - 4) Press ENTER. If the combination entered is incorrect, "ACCESS/DENIED" will be displayed and the controller will return to the parameter level. Otherwise, go to step 14.
12. Press the STEP UP button. Rotate the Pulser Knob to select the 'CAL FULL' parameter.
13. Press the STEP DOWN button to enter the VALUE level ('CAL' appears on upper display).
14. Set the voltage source to the full scale input value (4.000 to 5.000 Vdc).
15. Press STORE.
16. For verification perform the following steps:
 - 1) Press STEP UP button. Rotate Pulser Knob to select 'CAL VIEW' parameter.
 - 2) Press STEP DOWN button to enter VALUE level. Set precision voltage source to zero input voltage. The display should read the real number at the block output.
 - 3) Set source to full scale voltage. The display should read the real number at the block output.
17. If all points have been calibrated and verified, press EXIT button to leave the calibration mode and enter the operation mode. If additional function blocks are to be calibrated and verified, press the STEP UP button to enter the FUNCTION BLOCK level. Perform steps 2 -19 for each function block.

If security is enabled, exiting the configuration mode will lock out the calibration mode until the security combination is re-entered.

11.2 ANALOG OUTPUT (AOUT1-3)

Analog output function blocks have been factory calibrated to 4-20 mA outputs. If recalibration is necessary use the following procedure.

1. At the controller's rear terminals, connect an electronic calibrator or digital multimeter capable of displaying 4.00 and 20.00 mA to the selected analog output terminals (AOUT1 or AOUT2). Refer to Section 7 Installation for terminal numbers and wiring guidelines. Ensure that terminal screws are tight.
2. If security is enabled, a level 1 or level 4 security combination will be needed to store the results of a calibration. Refer to SECUR-Security in Section 3.1.2 for additional information.
3. Apply power to the station.
4. Press the ENTER CONF button to enter the configuration mode at the MENU level.
5. Rotate the Pulser Knob to select 'STATION' on the alphanumeric (lower) display.
6. Press the STEP DOWN button to choose options at the station level and rotate the Pulser Knob to select 'CAL' on the alphanumeric display.
7. Press the STEP DOWN button to enter the FUNCTION BLOCK level. Rotate the Pulser Knob to select the desired output (e.g. AOUT1).
8. Press the STEP DOWN button to enter the PARAMETER level. Rotate the Pulser Knob to select the desired parameter, CAL ZERO, shown on the alphanumeric display.
9. Press the STEP DOWN button to enter the VALUE level ('CAL' appears on display).
10. Rotate the Pulser Knob to set the zero output to 4.00 mA on the digital multimeter or electronic calibrator.
11. Press the STORE button to lock-in the desired value. (If "ENTER COM" appears in the alphanumeric display, go to Section 11.1, step 13 for entering a level 1 or level 4 security combination.)
12. Press the STEP UP button. Rotate the Pulser Knob to select the 'CAL FULL' parameter.
13. Press the STEP DOWN button to enter the VALUE level ('CAL' appears on display).
14. Rotate the Pulser Knob to set the full scale output to 20.00 mA.
15. Press STORE.
16. For verification perform the following steps:
 - 1) Press STEP UP button and rotate Pulser Knob to select 'CAL VIEW' parameter.
 - 2) Press STEP DOWN button to enter VALUE level.
 - 3) Rotate Pulser Knob to set display to 0.0%. Output current should be 4.00 mA.
 - 4) Rotate Pulser Knob to set 100.0%. Output current should be 20.00 mA.
17. If all points have been calibrated and verified, press EXIT button to leave calibration mode and enter operation mode. If additional function blocks are to be calibrated and verified, press STEP UP button to enter FUNCTION BLOCK level. Perform steps 2-19 for each function block.

If security is enabled, the exiting the configuration mode will lock out the calibration mode until the security combination is re-entered.

11.3 UNIVERSAL ANALOG INPUTS (AINU1 AND AINU2)

For calibration of the universal analog inputs, refer to Section 3.2.9 AINU_.



12.0 CIRCUIT DESCRIPTION

This section provides a block diagram level circuit description of the Siemens 353 Controller.

12.1 OVERVIEW

Controller hardware architecture is shown in Figure 12-1. An exploded view of the controller showing individual assemblies is provided in Figure 1-1.

The Display Assembly is used for operation and configuration. The MPU-based Controller Board performs many of the controller’s signal processing and process control functions in addition to overseeing internal operations. The Controller Board’s on-board power supply furnishes DC operating voltages to all plug-in assemblies and to external process transmitters connected to the rear terminals. The I/O Expander board provides additional I/O. Ethernet communications is standard.

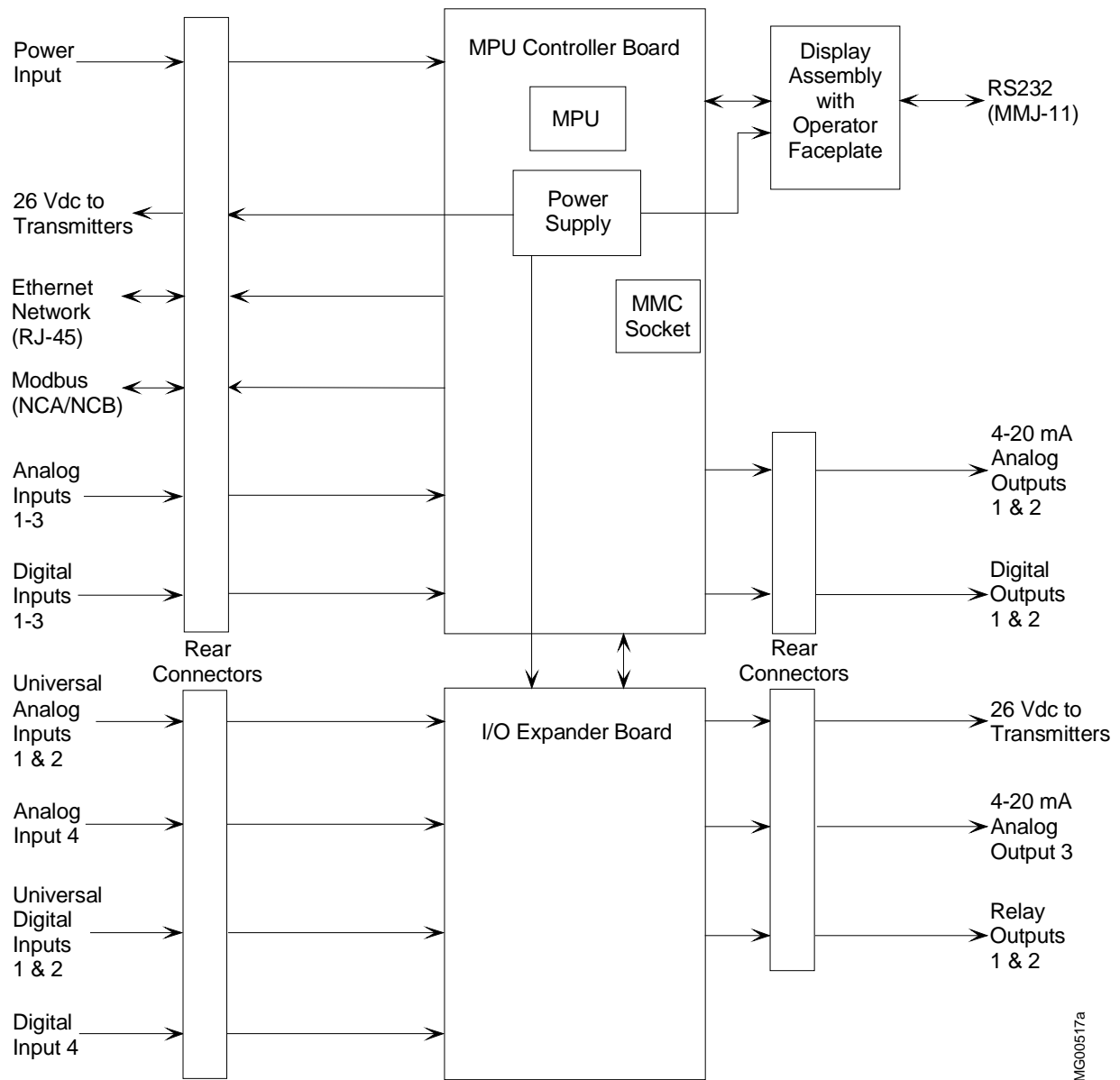

Figure 12-1 Siemens 353, Design Level B, Block Diagram

MG00517a

12.2 MPU CONTROLLER BOARD

The heart of the 353 is the powerful, microprocessor-based MPU Controller Board. The flexible software supports reusable function blocks beneficial in solving a vast array of control strategies such as single loop, cascade and dual loop.

The Controller Board assembly contains both analog and digital circuits. The analog circuitry operates in real time while the microprocessor based digital circuitry operates at high speed under program control. The MPU (microprocessor unit) contains a 32-bit core, a System Integration Unit (SIU), a Communications Processor Module (CPM), a Serial Peripheral Interface module (SPI), UARTs, timer modules, and a Fast Ethernet Controller (FEC). The MPU is capable of arithmetic, logical, and support circuit control functions and interacts with surrounding on-board and off-board circuitry to control the internal operation of the 353. The MPU Board also contains 32-bit SDRAM, 16-Bit NVRAM, and 16-bit ROM, a 2-wire RS485 connection, a RS232 connection, and an Ethernet connection.

The MPU communicates with the RAM, ROM via the SIU. All communication between the MPU and the I/O, display and expander board is done via the SPI. The SPI is a full-duplex, synchronous serial interface for receive and transmit data. Communication consists of timing, control, data, and sequencing information.

The Controller Board has three analog inputs, 3 digital inputs, 2 analog outputs and 2 digital outputs. The configuration in use determines the active inputs and outputs. For example, Factory Configured Option FCO101 is configured to accept one analog input for the process signal and one analog output for the valve signal. The two analog outputs are 4 to 20 mA current sources with shutdown control for use in redundant control systems. The two digital outputs are open collector devices with over-voltage protection. The board also contains a MultiMediaCard interface and a real-time clock.

Two serial ports are available for bi-directional asynchronous communications. Terminals NCA and NCB provide an RS485 connection for Modbus network communications. An MMJ-11 connector on the underside of the Display Assembly provides an RS232 connection for creating and editing configurations using the optional PC-Based Graphical Configuration Utility. Since both ports are independent UARTs, communications with one serial port will not interfere with communications to the other. Parameters in the STATN function block allow setting of the Modbus baud rate and transmission characteristic for the Display Assembly MMJ-11 configuration port and Modbus terminals NCA/NCB. (See STATN-Station Parameters in Section 3.1.3.) Additional information on Modbus network communications and data mapping can be found in Section 5 and Section 6.

The RS-232 connection uses a DEC MMJ connector with the following six connections:

- RTS - Handshaking output from MPU
- TXD - Data output from MPU
- Common
- Common
- RXD - Data input to MPU
- CTS - Handshaking input to MPU

Ethernet communications is standard. It enables peer-to-peer communications, using Modbus RTU protocol, with other Siemens controllers, Procidia™ i|pac™ controllers, and other devices having Ethernet functionality.³ Ethernet supports transferring configurations between a 353 and a PC running i|config™ Graphical Configuration Utility. The Ethernet-Modbus Bridge in Figure 1-2 accepts an Ethernet data command from the controller and outputs an equivalent Modbus command. The returning Modbus data is embedded by the bridge in an Ethernet packet to be sent to the requesting controller.

A short Ethernet cable connects the Controller board to the Connector Socket Assembly at the rear of the case. The Connector Assembly has an RJ-45 connector for connecting to the external Ethernet network. An Ethernet Activity LED is located on the exposed (with the faceplate loosened) edge of the Controller board. It will flash with received Ethernet communications.

³ Compatible with Design Level A Siemens 353 and Moore Products Co. 353 controllers that include an Ethernet option board.

A MultiMediaCard socket is located on the exposed edge (when the display assembly is freed) of the Controller board. When the controller is configured from the faceplate, the configuration is stored to an EEPROM and to the MultiMediaCard, using the station serial number as the file name. Each time the configuration is changed and stored, the revised configuration is written to the EEPROM and to the MMC so a copy of the current configuration is always available. The MMC can be removed from the controller, inserted in another 353 (design level B) controller, and the configuration loaded into that controller. The card can also be used to transfer a configuration between a controller and a PC running i|config, the Graphical Configuration Utility. Each MMC has sufficient space for numerous configurations.

A configuration created at the 353 faceplate will be stored in the root directory of the MultiMediaCard with an 8-character file name and a .V3C extension. Supported MMC file structures are FAT (file allocation table) 12 and FAT 16. FAT 32 is not supported and MMC FAIL will be displayed on the controller faceplate should an MMC formatted as FAT 32 be inserted in the controller. Refer to Section 10.5 MultiMediaCard – Formatting and File Names for additional information.

A configuration created on a PC running i|config can be saved with a long file name (more than 8 characters). When the file is saved at the PC, Windows will also create a short file name of 8 characters. This short 8 character file name, generated from the long file name, will be displayed by the 353.

The on-board Power Supply circuit provides the power sources necessary for system power, internal analog output power and transmitter power.

12.3 I/O EXPANDER BOARD

The I/O Expander Board communicates with the Controller Board and contains hardware that increases station capability. Additional direct connected I/O includes two isolated universal analog inputs with thermocouple, RTD, resistance, slidewire, mA and voltage conversions, two additional digital inputs that can be used as discrete or frequency inputs, an additional analog output and two relay outputs. All calibration data for the Expander Board is stored in the board's nonvolatile EEPROM making recalibration unnecessary when interchanging Expander and Controller Boards.

Expander circuitry operates under the control of the MPU-based Controller Board, and like the Controller Board, it contains both analog and digital circuitry. The analog circuitry operates in real time while the digital circuitry operates at high speed under program control.

Relay 1 and Relay 2 are triggered by the off-board MPU to provide relay contact type outputs. Each SPDT relay output can be connected in a normally open or normally closed contact state.

13.0 MODEL DESIGNATION AND SPECIFICATIONS

This section provides model designation information, lists of controller accessories and service parts, detailed controller specifications and hazardous area installation information.

IMPORTANT

Before installing or servicing a controller, refer to the controller labels and the applicable specifications and hazardous area classifications in this section to ensure that the correct model with the needed certifications is at hand.

Every controller is identified by several labels. Labels are located on the case and inside the drop-down door on the Display Assembly, as shown in Figure 1-1. Typical labels are shown below.

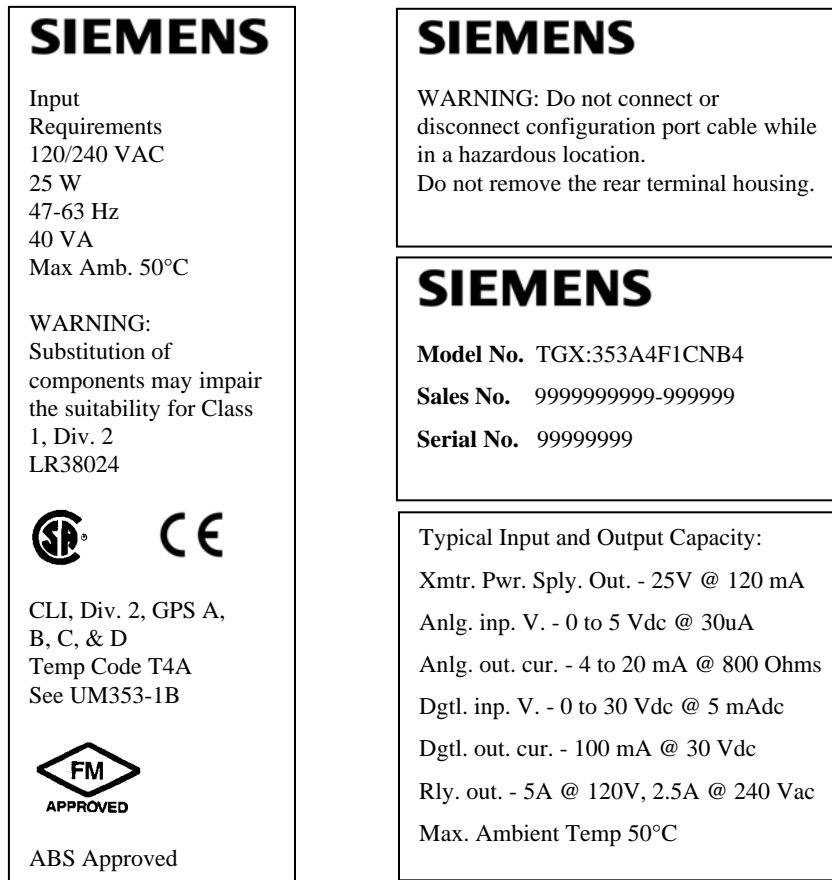

13.1 MODEL DESIGNATION

Table 13-1 shows the controller's model number sequence. The model designation is shown on a nameplate on the top of the case. The nameplate and other labels carry important information about the controller, such as Model Number, Bill of Material number (P/N No.), Serial Number, and Certifications.

IMPORTANT

Confirm a controller's model number and hazardous area certifications before installing, applying power, or servicing.

When circuit boards are added to a controller in the field, nameplate information will not reflect the current physical configuration.

Table 13-1 Siemens 353 Model Designation⁴

Sample Order Number	TGX:353	A	4	F	1	C	N	B	4
MPU Controller Board									
120/240 Vac (85-264 Vac), 47-63 Hz		A							
24 Vdc, + 20%, - 15%		D							
Mounting Case									
Case with 52 Terminals and Ethernet Connector			4						
High Shock and Vibration Case with Ethernet Connector			5						
Operator Display Panel									
Fixed Analog and Digital Displays				F					
I/O Expansion									
Not Required					N				
Local I/O Expander (e.g. TC, RTD, Freq, Relay)					1				
MultiMediaCard									
MMC						C			
Modification Options									
Not Required							N		
Controller modified per order Bill of Material							X		
Design Level									
Design Level 'B'								B	
Electrical Approval									
Not Required									N
FM/CSA Div. 2 Class 1 Groups A, B, C & D suitable for non-incendive (CE compliant)									4
FM/CSA Div. 2 Class 1 Groups A, B, C & D suitable for non-incendive (CE compliant and ABS approved)									X

⁴ Contact Siemens Industry, Inc., Process Instrumentation Division for the latest model designation information, availability of certain options, and current electrical approvals. Always refer to the labels on the controller case for approvals and certifications before installing, configuring, connecting data transfer cables, or servicing a controller.

13.2 ACCESSORIES

The following two tables list the accessories currently available.

ACCESSORY	PART NUMBER	DESCRIPTION
i config Graphical Configuration Utility	iCONFIG-Vn.nn	Windows® 98, NT, 2000, and XP compatible software for PC-based controller configuration and creation of a function block diagram. Transfer configuration to and from controller via Modbus or Ethernet. Vn.nn - the latest software version will be supplied. Includes: 16353-61 Cable - see description below 16353-63 Adapter - see description below
Transmitter Power Supply	15124-1	Acopian Model B24G210M, 24 Vdc, 2.0A
Adapter Bezel	15738-123	A panel cutout adapter for mounting a controller in a 3" x 6" panel cutout.
Blank Filler Panel	15738-168	Enhances control room appearance by covering a panel cutout intended for future mounting of a controller.
Loop Identification Card	-----	Custom printed loop identification for flip-down access door. Specify up to 5 lines with 24 characters per line.
Permanent Instrument Tag	-----	Stainless steel tag permanently attached to the controller case. One line with up to 24 characters can be specified.
Display Assembly Remote Mounting Kit	16353-54	For remote panel mounting of a Display Assembly. Includes: Flange Assembly Mounting Clips and Screws Display (Ribbon) Cable, 48 inches (1219 mm) long Installation Instruction Does not include the Display Assembly.
Communications Cable, MMJ11 to MMJ11	16353-61	Connects MMJ11 on adapter (connected to a personal computer's serial port) to MMJ11 on a Display Assembly. Select one of the following adapters.
Adapter, DB25 to MMJ11	16353-62	Adapts personal computer serial port to above Communications Cable.
Adapter, DB9 to MMJ11	16353-63	
Faceplate Labels	-----	Discontinued.

13.3 SERVICE PARTS KITS

Exploded view drawings of the Siemens 353 appear in Section 1 Introduction and Section 10 Maintenance.

SERVICE PART DESCRIPTION	PART NO.
MultiMediaCard	TGX:16353-304
- FIRMWARE UPDATE KITS -	
Controller upgrade Utility and Controller Firmware for Models 352P, 353, 353R, 354 and IPAC Download file fw400.zip, the file/firmware revision at the time this manual was prepared, or order a firmware CD	15939-71V4.00 Contact Siemens for current version.

SERVICE PART DESCRIPTION	PART NO.
- ELECTRONIC ASSEMBLIES AND RELATED PARTS -	
Display Assembly Kit, for Model 353 __ F _ _ _ _ _	16353-53*
Display Assembly Bezel Replacement Kit Contains gray bezel, keypad, pulsar knob, and installation instruction Does not contain Display Board or black Display Assembly mounting screws	16353-163
MPU Controller Board Kit for 120/240 Vac Power Input, for Model 353A _ _ _ _ _	TGX:16353-302*
MPU Controller Board Kit for 24 Vdc Power Input, for Model 353D _ _ _ _ _	TGX:16353-303*
I/O Expander Board Kit, for Model 353 _ _ _ 1 _ _ _ _ . Contains I/O Expander Board and Range Resistor and Reference Junction Kit. Does not include terminals 27-52; Case supplied with all needed connectors.	16353-52*
Spare Parts Kit, includes: Power Input and Range Resistor Kit, includes: 250 Ohm, 0.1%, 3W, WW resistor and insulating sleeving, qty 3 each Crimp-on connector, qty 6 Range Resistor and Reference Junction Kit, includes: 250 Ohm, 0.1%, 3W, WW resistor, qty 1 3.75 Ohm, 1%, 3W, WW resistor, qty 2 Insulating sleeving, qty 5 Crimp-on connector, qty 6 100 Ohm reference junction for TC inputs, qty 2 Crimp-on Connector, qty 18 O-Ring, Display Assembly, qty 1 Fuse, 120/240 Vac MPU Controller board: 0.4A or 0.5A, 250V, SloBlo, qty 1 Fuse, 24 Vdc MPU Controller board: 2A, 250V, SloBlo, qty 1 Case Mounting Clip and 8-32 x 1 Fillister Hd. Screw, qty 2 each Case Ground Screw (Green), qty 1	16353-131*
- CASE AND CASE MOUNTED CONNECTORS -	
Standard Case with Ethernet Connector and Case-Mounted Connectors, Case Option 4 (Model 353_4...), includes: Flange and Case Assembly, qty 1 Expanded Connector Socket Assembly with Ethernet Connector and 52 Case-Mounted Connectors and plug mating connectors Connector Cover Case Mounting Clip and 8-32 x 1 Fillister Hd. Screw, qty 2 each Ground Screw, Green, qty 1	15353-206
Replacement Ethernet Cable Kit, for an Option 4 case.	15720-368

Notes to Kits:

- Refer to User’s Manual UM353-1B for accessory part numbers and for servicing a controller.
- See drawing(s) on previous page for disassembly and item reference numbers.
- “*” Identifies a recommended on-hand spare part for the indicated model. Include nameplate information when ordering.
- Sample model number: TGX:353 A 4 F 1 C N B 4
- NS = Not Shown

13.4 MECHANICAL SPECIFICATIONS

Panel Cutout Dimensions	See Figure 7-2
Controller Dimensions.....	See Figures 7-3

13.5 POWER INPUT REQUIREMENTS

Voltage Input	
Model 353A	85-264 Vac, 47-63 Hz
AC power ride through time.....	25 msec. (minimum)
Model 353D	24 Vdc, +20%, -15%
Power	25 Watts, 40 VA (maximum)
Wire Size, Recommended	18 AWG (0.96 mm ²)
Rear Terminals	H - Hot; N - Neutral; G - Ground, Green Screw
Over-current Protection.....	User supplied 20A maximum fuse or circuit breaker

13.6 MPU CONTROLLER BOARD SPECIFICATIONS

Analog Inputs: (3)

Input Range	0-5 Vdc (standard calibration 1-5 Vdc)
Zero	0-1 Vdc
Span	4-5 Vdc
Type	Single ended
Accuracy	0.10 %
Resolution	0.024 %
Software Output Type.....	Analog [configurable (default 0.0-100.0)]
Normal Mode Rejection.....	>50dB @ 60Hz
Input Impedance.....	>1 megohm
Maximum Continuous Input	
Without Crosstalk	+7, -30 Vdc
Without Damage	±30 Vdc

Analog Outputs: (2)

Standard Calibration.....	4-20 mAdc
Zero	4 mAdc +/- trim
Span	16 mAdc +/- trim
Current Limits	2.4 mA to 21.6 mA
Accuracy:	0.1%
Resolution:	0.003%
Software Input Type.....	Analog [configurable (default 0.0-100.0)]
Signal Reference	Neg. (-) output tied to station common
Output Load	800 Ohms
Over-voltage Protection	30 Vdc

Digital Inputs: (3)

Logic "1" Range.....	15-30 Vdc
Logic "0" Range.....	0-1 Vdc
Over-voltage.....	+/-30 Vdc
Minimum Required ON time	>Scan Time
Software Output Type	Digital
Isolation.....	100 Vdc

Digital Outputs: (2)

Type	Open Collector Transistor (emitter tied to station common)
Load Voltage.....	+30Vdc maximum
Load Current	100 mA maximum

Off State Leakage Current.....< 200 uA @ 30 Vdc
 Transmitter Power25 Vdc +/-3V, 120 mA, short circuit protected
 MultiMediaCardMMC or MMC*plus*™ up to 2 GB; must support SPI mode

13.7 I/O EXPANDER BOARD SPECIFICATIONS

Analog Inputs, Universal: (2)

Type 'J' Thermocouple:

Range Limits.....-185°C to 1100°C (-300°F to 2010°F)
 Performance Range.....0 to 1100°C
 Accuracy+/-0.5°C
 Conformity<= 0.06°C
 Software Output Type.....Analog (configurable °C, °F, °R, °K)
 Ambient Temperature Effect:+/- 0.08°C/°C

Type 'K' Thermocouple:

Range Limits.....-185°C to 1370°C (-300°F to 2500°F)
 Performance Range.....0 to 1370°C
 Accuracy+/-0.6°C
 Conformity<= 0.06°
 Software Output Type.....Analog (configurable °C, °F, °R, °K)
 Ambient Temperature Effect:+/- 0.10°C/°C

Type 'T' Thermocouple:

Range Limits.....-240°C to 370°C (-400°F to 698°F)
 Performance Range.....-100 to 370°C
 Accuracy+/-0.5°C
 Conformity<= 0.06°
 Software Output Type.....Analog (configurable °C, °F, °R, °K)
 Ambient Temperature Effect:+/- 0.07°C/°C

Type 'E' Thermocouple:

Range Limits.....-185°C to 1000°C (-300°F to 1830°F)
 Performance Range.....0 to 1000°C
 Accuracy+/-0.5°C
 Conformity<= 0.06°
 Software Output Type.....Analog (configurable °C, °F, °R, °K)
 Ambient Temperature Effect:+/- 0.07°C/°C

Type 'S' Thermocouple:

Range Limits.....-18°C to 1650°C (0°F to 3000°F)
 Performance Range.....200 to 1650°C
 Accuracy+/-0.7°C
 Conformity<= 0.06°
 Software Output Type.....Analog (configurable °C, °F, °R, °K)
 Ambient Temperature Effect:+/- 0.14°C/°C

Type 'R' Thermocouple:

Range Limits.....-18°C to 1610°C (0°F to 2930°F)
 Performance Range.....200 to 1610°C
 Accuracy+/-0.7°C
 Conformity<= 0.06°
 Software Output Type.....Analog (configurable °C, °F, °R, °K)
 Ambient Temperature Effect:+/- 0.15°C/°C

Type 'B' Thermocouple:

Range Limits-18°C to 1815°C (0°F to 3300°F)
 Performance Range800 to 1815°C
 Accuracy+/-0.7°C
 Conformity<= 0.06°
 Software Output Type.....Analog (configurable °C, °F, °R, °K)
 Ambient Temperature Effect:+/- 0.15°C/°C

Type 'N' Thermocouple:

Range Limits-200°C to 1300°C (-325°F to 2370°F)
 Performance Range0 to 1300°C
 Accuracy+/-0.5°C
 Conformity<= 0.06°
 Software Output Type.....Analog (configurable °C, °F, °R, °K)
 Ambient Temperature Effect:+/- 0.10°C/°C

Type DIN 43760/ IEC 751 RTD ($\alpha = 0.003850$):

Range Limits-185°C to 622°C (-300°F to 1152°F)
 Accuracy+/-0.4 °C
 Software Output Type.....Analog (configurable °C, °F, °R, °K)
 Ambient Temperature Effect:+/- 0.04°C/°C

Type US (NBS126) RTD ($\alpha = 0.003902$):

Range Limits185°C to 613°C (-300°F to 1135°F)
 Accuracy+/-0.4°C
 Software Output Type.....Analog (configurable °C, °F, °R, °K)
 Ambient Temperature Effect:+/- 0.04°C/°C

Type JIS C-1604 RTD ($\alpha = 0.003916$):

Range Limits-185°C to 610°C (-300°F to 1130°F)
 Accuracy+/-0.4°C
 Software Output Type.....Analog (configurable °C, °F, °R, °K)
 Ambient Temperature Effect:+/- 0.04°C/°C

Slidewire

Resistance Range500-5000 Ω
 Software Output Type.....Analog (% slidewire 0.0 to 100.0)
 Accuracy:+/- 0.1%
 Ambient Temperature Effect:+/- 0.01°C/°C

Ohms

Resistance Range0-5000 Ω
 Software Output Type.....Analog (ohms)
 Accuracy:+/- 0.1%
 Ambient Temperature Effect:+/- 0.01°C/°C

Millivolt

Narrow Range-19.0 to 19.0 mVdc
 Accuracy+/-5.0 uV
 Ambient Temperature Effect1.0 uV/°C
 Wide Range.....-30.0 to 77 mVdc
 Accuracy+/-8.0 uV
 Ambient Temperature Effect2.5 uV/°C
 Software Output Type.....Analog (millivolts)
 Overvoltage.....See Table on next page

Millivolt Overvoltage

Case Rear Terminals AINU1	Case Rear Terminals AINU2	Maximum
46 to 47	50 to 51	+/- 30 Vdc
45 to 47 48 to 47	49 to 51 52 to 51	+5/-0.7 Vdc
45, 46, 47, or 48 to station common	49, 50, 51, or 52 to station common	+/- 30 Vdc

Analog Input: (1)

Input Range0-5 Vdc (standard calibration 1-5 Vdc)
 Zero0-1 Vdc
 Span4-5 Vdc
 TypeSingle ended
 Accuracy0.10 %
 Resolution0.024 %
 Software Output TypeAnalog [configurable (default 0.0 - 100.0)]
 Normal Mode Rejection>50dB @ 60Hz.
 Input Impedance>1 megohm
 Maximum Continuous Input+/-30 Vdc

Analog Output: (1)

Standard Calibration4-20 mA dc
 Zero4 mA dc +/- trim
 Span16 mA dc +/- trim
 Accuracy0.10 %
 Resolution0.003 %
 Software Input TypeAnalog [configurable (default 0.0 - 100.0)]
 Current Range Limits2.4 to 21.6 mA dc
 Signal ReferenceNeg. (-) output tied to station common
 Output Load800 Ohms
 Overvoltage Protection30 Vdc

Digital Input: (1)

Logic "1" Range15-30 Vdc
 Logic "0" Range0-1 Vdc
 Overvoltage+/-30 Vdc
 Minimum Required ON Time>Scan Time
 Software Output TypeDigital
 Isolation100 Vdc

Universal Digital Inputs: (2)

Logic "1" Range4-30 Vdc
 Input Current<7 mA @ 30 V
 Logic "0" Range0-1 Vdc
 Overvoltage+/-30 Vdc
 Frequency Range0 to 25,000 Hz.
 Accuracy0.03 % of reading
 Minimum Operating Frequency0.05 Hz.
 Pulse Width20 µsec (minimum)
 Signal TypesSine Square, Pulse, Triangle, or Contact Closure
 (contacts require external power)

Software Output Types:(a) Scaled Frequency: Analog
 (b) Scaled Count: Analog
 (c) Current Input State: Digital
 Isolation..... 100 Vdc

Relay Outputs: (2)

TypeSealed (meets requirements of Division 2 applications)
 Software Input Type.....Digital
 Contact ConfigurationSPDT
 Contact Rating.....5A @ 115 Vac; 2.5A @ 230 Vac (resistive load)
 Minimum Current..... 100 mA @ 10 mVdc or 150 mA @ 50 mVac

13.8 ENVIRONMENTAL SPECIFICATIONS

13.8.1 Standard Mounting

Mounting, Typical Location.....Control room or other protected area

Temperature Limits:

Operating.....0° to 50°C (32° to 122°F)
 Storage-40° to 85°C (-40° to 185°F)

Climatic Conditions.....IEC 60654-1 (Class B3)
 Corrosive Conditions.....IEC 60654-4 (Class 2)

13.8.2 Enclosure Mounting

Mounting:

Typical LocationOut-of-doors or other area without environmental controls
 Enclosure.....User supplied
 Model 353 Case.....Installed inside enclosure
 Model 353 DisplayExposed through enclosure to external environment
 Installation Requirements.....Refer to Section 7 Installation

Temperature Limits:

Enclosure Internal, Operating0° to 50°C (32° to 122°F)
 Enclosure External, Operating-40° to 50°C (-40° to 122°F)
 Controller Storage-40° to 85°C (-40° to 185°F)

Climatic Conditions:.....IEC 60654-1 (Class B3)
 Corrosive Conditions:.....IEC 60654-4 (Class 2)

13.8.3 Electromagnetic Compatibility (EMC)

EN 61000-6-2 Generic Standard, Immunity for Industrial Environments	IEC 61000-4-3 (EM Field)
EN 61000-6-4 Generic Standard, Emissions for Industrial Environments	IEC 61000-4-4 (EFT/Burst)
	IEC 61000-4-5 (Surge)
IEC 61000-3-2 (Current Harmonics)	IEC 61000-4-6 (Conducted RF)
IEC 61000-3-3 (Voltage Fluctuation)	
IEC 61000-4-2 (ESD)	IEC 61000-4-11 (Voltage Dip/Short Interruption)

ABS Rules for Building and Classing Steel Vessels: 2007, Part 4, Chapter 9

13.9 AGENCY APPROVALS

The Siemens 353 has been designed to meet various agency approvals. Contact the factory or your local Siemens (Process Instrumentation Business Unit) representative for current approvals. Labels on each Siemens 353 list the agency approvals that apply to that particular instrument.

FM/CSA

Class I, Division 2, Groups A, B, C, and D

CE - see Section 13.10.2

ABS Type Approval; meets ABS Rules for Building and Classing Steel Vessels: 2007, Part 4, Chapter 9

13.9.1 CSA Hazardous Locations Precautions

This section provides CSA hazardous location precautions that should be observed by the user when installing or servicing the equipment described in this Instruction. These statements supplement those given in the preceding section.



Explosion Hazard

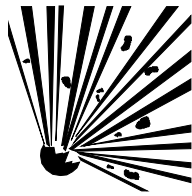

Explosion can cause death or serious injury.

In a potentially explosive atmosphere, remove power from the equipment before connecting or disconnecting power, signal or other wiring.

All pertinent regulations regarding installation in a hazardous area must be observed.

Precautions - English

For Class I, Division 1 and Class I, Division 2 hazardous locations,

- Use only factory-authorized replacement parts. Substitution of components can impair the suitability of this equipment for hazardous locations.

For Division 2 hazardous locations:

When the equipment described in this Instruction is installed without safety barriers, the following precautions should be observed. Switch off electrical power at its source (in non-hazardous location) before connecting or disconnecting power, signal, or other wiring.

Précautions - Français

Emplacements dangereux de classe I, division 1 et classe I, division 2:

- Les pièces de rechange doivent être autorisées par l'usine. Les substitutions peuvent rendre cet appareil impropre à l'utilisation dans les emplacements dangereux.

Emplacement dangereux de division 2:

Lorsque l'appareil décrit dans la notice ci-jointe est installé sans barrières de sécurité, on doit couper l'alimentation électrique à la source (hors de l'emplacement dangereux) avant d'effectuer les opérations suivantes branchement ou débranchement d'un circuit de puissance, de signalisation ou autre.

13.9.2 Special Conditions for Safe Use

Always refer to the labels on the controller case for approvals and certifications applicable to that instrument.

FM

Enclosure Requirements:

- The apparatus must be mounted within an enclosure or assembly to prevent personal injury resulting from accessibility to live parts. The enclosure is typically user-supplied and, therefore, was not examined as part of this Approval but shall comply with the requirements of this section.
- Accessibility - The system must be installed within the enclosure so that its circuits are accessible by the use of a tool only. A part is accessible when either a.) the IEC articulate accessibility probe applied in every possible position to the exterior or exposed surfaces, including the bottom; or b.) the IEC rigid accessibility probe applied with a maximum force of 30 Newtons (6.75 lbs force) in every possible position to the exterior or exposed surface, including the bottom, touches the part.
- Protection from Fire - If the enclosure is non-metallic, it shall have the proper flammability rating.
- Grounding - A metallic enclosure must have a protective grounding terminal and be marked as such. All accessible non-current conductive parts must be bonded to the protective grounding terminal.
- General Construction - The equipment enclosure, or parts of the enclosure, required to be in place to comply with the requirements for protection from electric shock, personal injury, protection of internal parts and wiring and external cord and cable assembly strain relief shall comply with the following tests for mechanical strength:
 - Impact Tests - The equipment shall be held firmly against a rigid support and shall be subjected to sets of three blows with 6.6 Joules (4.9 pound force-inch) from a spring-operated impact hammer. The hammer shall be applied to any external part that when broken is likely to expose live parts. A window of an indicating device shall withstand an impact of 0.085 Newton-meter (0.753 pound force-inch) from a hollow steel impact sphere 50.8 mm (2 inches) in diameter and an approximate mass of 113.4 grams (4 ounces).
 - Pressure Tests - A force of 90 Newtons (20 pounds) shall be applied from a metal rod 12.7 mm (0.50 inch) in diameter, the end of which is rounded. The force shall be applied for one minute to any point on the overall enclosure except the bottom. The bottom shall sustain a force of 65 Newtons (15 pounds).
 - Tip Stability Test - Equipment having a weight of 11 kilograms (24 pounds) or more shall not tip over when placed at the center of an inclined plane that makes an angle of 10 degrees with the horizontal and then turned to the position (with all doors, drawers, and other openable and sliding parts in the least stable position) most likely to cause tip-over.
 - Sharp Edges - An accessible edge, projection, or corner of an enclosure, opening, frame, guard, handle, or the like shall be smooth and well rounded, and shall not cause a cut-type injury during normal use of the equipment.

CE

- Use of the equipment in a manner not specified by the manufacturer may impair the protection or performance provided by the equipment.
- Route the power to the controller through a clearly labeled circuit breaker or on-off switch that is located near the controller and is accessible by the operator. The breaker or switch should be located in a non-explosive atmosphere unless suitable for use in an explosive atmosphere.
- Following is a Declaration of Conformance with the standards or other normative documents stated on the certificate.
- For critical applications using thermocouples and RTDs where improved performance is necessary at the frequencies of use, other Siemens solutions are available. The Siemens Sitrans T series of Temperature Transmitters with 4-20 ma outputs can be used as the input signal to the Model 353.
- When using the contact closure as the frequency input to the Universal Digital Input, the debounce feature for low frequencies may not function in an area of high Electrical Fast Transients. The use of flow meters that provide solid state switches or contacts that do not bounce are recommended for these applications.

SIEMENS

EC Declaration of Conformity EG-Konformitätserklärung

No. Sho011- 11/07

Manufacturer: <i>Hersteller:</i>	Siemens Energy & Automation, Inc.
Address: <i>Anschrift:</i>	Spring House Pennsylvania, 19477 USA
Product description: <i>Produktbezeichnung</i>	Multi-Loop Controller Type / Typ TGX:353abFcdeBf mit a=A,D, b=4,5, c=N,1, d=N,C, e=N,X, f=4,W

The product described above in the form as delivered is in conformity with the provisions of the following European Directives:

Das bezeichnete Produkt stimmt in der von uns in Verkehr gebrachten Ausführung mit den Vorschriften folgender Europäischer Richtlinien überein:

- | | |
|--------------------|--|
| 2004/108/EG
EMC | Council Directive on the approximation of the laws of the Member States relating to electromagnetic compatibility.
<i>Richtlinie des Rates zur Angleichung der Rechtsvorschriften der Mitgliedstaaten über die elektromagnetische Verträglichkeit..</i> |
| 2006/95/EG
LVD | Directive of the European Parliament and of the Council of 12 December 2006 on the harmonization of the laws of Member States relating to electrical equipment designed for use within certain voltage limits.
<i>Richtlinie des Europäischen Parlaments des Rates zur Angleichung der Rechtsvorschriften der Mitgliedstaaten betreffend elektrische Betriebsmittel zur Verwendung innerhalb bestimmter Spannungsgrenzen.</i> |

Spring House, 16.11.2007

Siemens Energy & Automation, Inc.

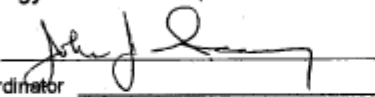
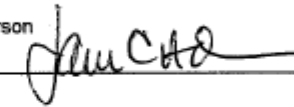
John Sweeney Approvals Coordinator		Lawrence Anderson PLM Manager	
Name, function <i>Name, Funktion</i>	signatur <i>Unterschrift</i>	Name, function <i>Name, Funktion</i>	signatur <i>Unterschrift</i>

Annex A is integral part of this declaration.
Anhang A ist integraler Bestandteil dieser Erklärung.
This declaration certifies the conformity to the specified directives but contains no assurance of properties.
The safety documentation accompanying the product shall be considered in detail.
Diese Erklärung bescheinigt die Übereinstimmung mit den genannten Richtlinien, ist jedoch keine Zusicherung von Eigenschaften
Die Sicherheitshinweise der mitgelieferten Produktdokumentation sind zu beachten.

Page 1 / 2

EC Declaration of Conformity

SIEMENS

Annex A to the EC Declaration of Conformity Anhang A zur EG-Konformitätserklärung

No. Sho011- 11/07

Product description: Multi-Loop Controller
 Produktbezeichnung Type / Typ TGX:353abFcdeBf mit a=A,D, b=4,5, c=N,1, d=N,C, e=N,X,
 f=4,W

Conformity to the Directives indicated on page 1 is assured through the application of the following standards (depending on versions):

Die Konformität mit den auf Blatt 1 angeführten Richtlinien wird nachgewiesen durch die Einhaltung folgender Normen (variantenabhängig):

Direktive Richtlinie	Standard / Reference number Norm / Referenznummer	Edition Ausgabedatum
2004/108/EG	EN 61000-6-2	2005
2004/108/EG	EN 61000-6-4	2001
2006/95/EG	EN 61010-1	2001

A representative Model 353 controller was tested. Individual test results may vary. Radiated Immunity tests caused deviations beyond the standard performance specifications of the Universal Analog Inputs [thermocouple (Type K) and RTD (DIN)] at certain frequencies as listed in Table 1. All tests on the 353 were conducted with a field strength listed in Table 1. However, CE allows tests in the ITU bands (87-108M 174-230M, & 470-790M) to be conducted with a field strength of 3 V/m. This will effectively reduce the deviations within these bands by a factor of approximately 8:1

Field Strength	Frequency	Process Input	Deviations °C
10 Volts/meter	275M	RTD	+1.4
10 Volts/meter	500M - 750M	RTD	+5.2 / -19.4
10 Volts/meter	750M - 850M	RTD	+9.0 / -7.2
10 Volts/meter	850M - 950M	RTD	+5.2 / -6.2
10 Volts/meter	1G - 1.8G	RTD	+6.0
10 Volts/meter	2.0G	RTD	+1.2
3 Volts/meter	2.0G - 2.1G	RTD	+0.6
10 Volts/meter	500M - 950M	Thermocouple	+14.0
10 Volts/meter	500M - 750M	Thermocouple	-0.7
10 Volts/meter	750M - 950M	Thermocouple	-3.3
10 Volts/meter	1G - 1.8G	Thermocouple	+21.1 / -5.8
10 Volts/meter	2.0G	Thermocouple	+0.7
3 Volts/meter	2.0G - 2.1G	Thermocouple	+0.6

Table 1

Annex A to the EC Declaration of Conformity

14.0 ABBREVIATIONS AND ACRONYMS

This section contains definitions for many of the abbreviations and acronyms that frequently appear in this User's Manual. Less frequently used terms are defined where they appear. Where a term has more than one meaning, context will usually indicate the meaning. Terms that identify a function block are indicated by (FB).

A - ampere(s)	DLY - delay
AC - action, alternating current	DMM - digital multimeter
ACS - Arccosine (FB)	DNC - Divide by N Counter (FB)
ACT - acting	DOD - Digital Output Discrete (FB)
ADD - Addition (FB), address	DOE - Digital Output -Ethernet (FB)
AIE - Analog Input - Ethernet (FB)	DOS - Digital Output_State (FB)
AIN - Analog Input (FB)	DOUT - Digital Output (FB)
AINU - Analog Input Universal (FB)	DPP - decimal point position
A/M - auto/manual	DRAM - Dynamic Random Access Memory
AOE - Analog Output - Ethernet (FB)	DTM - Dead Time Table (FB)
APACS - Advanced Process Automation and Control System	DWNLD - download
ASCII - American Standard Code for Information Interchange	DYT - Delay Timer (FB)
ASN - Arcsine (FB)	E/I - External/Internal Transfer Switch (FB)
AT - adaptive time, autotune transfer	EM - EMER MAN - emergency manual
ATD - Analog Trend Display (FB)	EN - enable, enabled
ATN - Arctangent (FB)	ENG - engineering (units)
AWG - American Wire Gauge	ERR - error
	ESL - Events Sequence Logger (FB)
BAT - battery	ESN - Execution Sequence Number
BATSW - Batch Switch (FB)	ET - elapsed time
BATOT - Batch Totalizer (FB)	EXP - Natural Exponent (FB)
BPL - batch pre-load	EXT - Exponentiation (FB)
BOD - Basic Operator Display	
	F - Fahrenheit
C - centigrade	FAC - factory
CAL - calibrate, calibration	FB - function block
CHN - channel	FCO - Factory Configured Option
CHR - Characterizer (FB)	FREQ - frequency
CHAN - channel	ft. - feet
CIE - Coil Input - Ethernet (FB)	FTG - Falling Edge Trigger (FB)
CL - console/local	
CMP - Comparator (FB)	GB - Gain & Bias (FB)
COS -Cosine (FB)	GS - go to step
CRC - Cyclical Redundancy Check	
	H - hold
D - deviation, denominator	HART - Highway Addressable Remote Transducer
DAM - Deviation Amplifier (FB)	HI - high
DC - direct current	HLD - Hold (FB)
DEG - degrees	HYS - hysteresis
DEV - deviation	Hz - Hertz
DG - derivative gain	
DIE - Digital Input -Ethernet (FB)	ICI - Independent Computer Interface (Model 320)
DID - Digital Input Discrete (FB)	ID - ID Controller (FB), identity
DIG - digital	in. - inch
DIN - Digital Input (FB)	INIT - initial
DINU - Digital Input Universal (FB)	I/O - input/output
DIR - direct	IO - internal override
DIS - Digital Input_State	k - kilo (prefix) 10 ⁺³
DISP - display	K - Kelvin
DIV - Division (FB)	
	lb. - pound(s)

LED - Light Emitting Diode
 LIB - library
 LL - Lead/Lag (FB)
 LMT - Limit (FB)
 LN_ - Natural Logarithm (FB)
 LO - low, lockout
 LOG - Logarithm Base 10 (FB)

m - milli (prefix) 10^{-3} , meter
 M - mega (prefix) 10^{+6}
 MA - moving average
 MAX - maximum
 MB - Modbus
 MD - Message Display
 MIN - minimum
 MMC - MultiMediaCard
 MR - manual reset
 MSG - Message
 MTH - Math (FB)
 MUL - Multiplication (FB), multiply, multiplication

N - number, numerator
 NC - normally closed
 NND - NAND Logic (FB)
 NO - normally open
 NOR - NOR Logic (FB)
 NOT - NOT Logic (FB)
 NUM - number
 NV - network variable
 NVRAM - non-volatile random access memory

ODC - Operator Display for Controllers (FB)
 ODS - Operator Display for Sequencer (FB)
 ON/OFF - On/Off Controller (FB)
 OP - operation
 OR - OR Logic (FB), override
 ORSL - Override Select (FB)
 OST - One Shot Timer (FB)

P - process
 PAC - Process Automation Controller
 PARM - parameter
 PB - Pushbutton
 PB#SW - Pushbutton # Switch (FB)
 PC - personal computer
 PCOM - Phase Communication (FB)
 PD - PD Controller (FB)
 PG - proportional gain
 PID - PID Controller (FB),
 proportional/integral/derivative
 PIDAG - PIDAG Controller (FB),
 proportional/integral/derivative/adaptive gain
 PRSEQ - Program Sequencer (FB)
 PTR - pointer
 PU - Power Up
 PUL - pulse

Q - quality
 QHD - Quickset Hold (FB)
 QS - quick set, quality status
 QSPI - Queued Serial Peripheral Interface

R - reset, Rankine
 RCT - Repeat Cycle Timer (FB)
 RD - received data
 Rev - revision
 RG - range
 RLM - Rate Limiter (FB)
 RN - recipe number
 ROT - Retentive On Timer (FB)
 ROUT - Relay Output (FB)
 RSF - RS Flip-Flop (FB)
 RT - remaining time
 RTD - resistance temperature detector
 RTG - Rising Edge Trigger (FB)

S - setpoint, set
 SCL - Scaler (FB)
 SEN - sensor
 SB - step backward
 SEL - Signal Selector (FB)
 SETPT - Setpoint (FB)
 SF - step forward
 SIN_ - Sine (FB)
 SL - setpoint limit
 SLTA - Serial Link Talk Adapter
 SN - step number
 SPLIM - Setpoint Limit (FB)
 SQ - square root
 SR - start ramp
 SRAM - Static Random Access Memory
 SRF - SR Flip-Flop (FB)
 SRT - Square Root (FB)
 SS - stainless steel, standby synchronization
 ST - status
 STA - station
 STATN - station
 SUB - Subtraction (FB), subtract
 SW - switch

TAN_ - Tangent (FB)
 TC - thermocouple, track command
 TD - time derivative
 TH - Track & Hold (FB)
 TI - time integral
 TIM - timer
 TO - tracked output
 TOT - totalizer
 TSW - Transfer Switch (FB)
 TV - track variable

V - valve, volt(s)
VAL - value

XOR - Exclusive OR Logic (FB)

W - watts
WD - watchdog

ZDO - zero drop out



XMTR - transmitter

Model 353 Process Automation Controller
Design Level “B”
MPU Controller Board Firmware Version 4.03

PRODUCT(S) INVOLVED

Model 353, Design Level B¹, Process Automation Controller (e.g. TGX:353_____B_)

INTRODUCTION

This Software Release memo discusses the enhancements and operational considerations for version 4.03 of MPU Controller board firmware. This firmware is intended for a Design Level “B” Model 353 with 4.00, 4.01, or 4.02 firmware.

Firmware is installed using the Controller Firmware Upgrade Utility, version 4.03, available for download from <http://support.automation.siemens.com/US/view/en/51785815>. The download includes the Upgrade Utility and controller firmware. *For more information about the utility and firmware installation steps, refer to Software Release memo SR15939-71-6.*

ENHANCEMENTS

The following enhancements are included in version 4.03 firmware:

Universal T/C inputs – At power up, a design level “B” 353 controller with an I/O Expander Board will now correctly clear an error status retained from the previous session.

Faceplate buttons UNITS and TAG now require only a single press to update the faceplate display. Previously more than one press could be needed.

OPERATIONAL CONSIDERATIONS

In the STATN - Station Parameters function block, parameters CONFIG LO and PARAM LO can have a value of either 0 or 1, 2, or 3: a 0 allows writes, a 1, 2, or 3 prevents writes. (There is no difference in operation in selecting a 1, 2, or 3.) Earlier User’s Manuals list “write” values as YES/NO, which was correct for earlier firmware. Later manuals list values (1, 2, or 3) incorrectly. Reads are always enabled.

Simultaneously pressing faceplate buttons PB1 and PB2 will cause the loop A/M status to toggle, even if the PB1 and PB2 function blocks are not configured.

¹ The design level is indicated by the next to last character in the model number. The characters shown are those required to identify an involved instrument. See the Siemens Process Instruments catalog or the instrument’s User’s Manual (UM353-1B) for complete model designation information.

UPGRADE CONSIDERATIONS AND MATERIALS

None. Note that this firmware release is for use with design level “B” Model 353 controllers only.

INSTALLING VERSION 4.03

Refer to Software Release memo SR15939-71-6 for a brief list of needed hardware and the firmware installation steps.

CUSTOMER/PRODUCT SUPPORT

For support and the location of your local Siemens representative, refer to the table below for the URL of the Process Instrumentation (PI) portion of the Siemens public Internet site. Once at the site, click **Support** in the right column and then **Product Support**. Next select the type of support desired: sales, technical (see the table below), documentation, or software.

Online Support Request	http://www.siemens.com/automation/support-request
Technical Support	1-800-333-7421; 8 a.m. to 4:45 p.m. eastern time, Monday through Friday (except holidays)
Customer Service & Returns	1-800-365-8766 (warranty and non-warranty)
Public Internet Site	http://www.usa.siemens.com/pi
Technical Publications in PDF	Click the above link to go to the Siemens Internet site and then click Process Instrumentation . In the column to the right, click Support > Manuals . In the column to the left, select the product line (e.g. Pressure or Temperature or Controllers) to open navigation and search panes.

All product designations may be trademarks or product names of Siemens Industry, Inc. or other supplier companies whose use by third parties for their own purposes could violate the rights of the owners.

Siemens Industry, Inc assumes no liability for errors or omissions in this document or for the application and use of information included in this document. The information herein is subject to change without notice.

Procedures in this document have been reviewed for compliance with applicable approval agency requirements and are considered sound practice. Neither Siemens Industry, Inc. nor these agencies are responsible for product uses not included in the approval certification(s) or for repairs or modifications made by the user.

© Copyright 2012, Siemens Industry, Inc. All rights reserved.