



Rushmore Touch Controller

Summary Specification

Document Version 1.2.10

Cirque Corporation is a wholly owned subsidiary of Alps Electric Co., Ltd.

JULY 2017
GP140306



ALPS ELECTRIC CO., LTD

This document highlights the electrical and mechanical specifications of Cirque's AFE Touch Controller, Rushmore. Sample hardware and firmware are available upon request.

This document supersedes all previous versions.

Part marking (see [Rushmore Part Number Explanation on page 17](#)):

- Manufacturer: Cirque
- IC Marking Number (1CA037), Major/minor revision (B0)
- Lot Code: YM (Year/Month date code), S (Assemble site code)
- Lot trace code: LLLL , G4(Gen4)
Pre-Production, if on package (P)

The Rushmore platform is developed by Cirque for Alps Electric Co., Ltd.

Document Version History

Date	Current Version	Description
MARCH 2014	1.0	Initial Documentation created.
MARCH 2014	1.1	Added Specific customer requested information - Schematics for both track-pad and touchpanel.
MARCH 2014	1.2	Updated AFE drawings and Pin order.
OCTOBER 2014	1.2.1	Added ESD information and ASIC part number explanation.
APRIL 2015	1.2.2	Updated copyright and patent information. Added packaging information.
AUGUST 2015	1.2.3	Added packaging information and clarified the ESD information.
DECEMBER 2015	1.2.4	Added "ALPS ELECTRIC CO., LTD" to the Footer.
JANUARY 2016	1.2.5	Minor text and formatting changes
MAY 2016	1.2.6	Removed the "Cirque Confidential" text from the footer.
NOVEMBER 2016	1.2.7	Corrected issue with the ESD Absolute Maximum Ratings table.
DECEMBER 2016	1.2.8	Swapped the ESD_CDM and ESD_MM rows in the ESD Absolute Maximum Ratings table.
APRIL 2017	1.2.9	Updated the footprint drawing to include radius.
JULY 2017	1.2.10	Minor change to description of part marketing number, minor formatting changes.

Notice

This document is the sole property of Cirque Corporation. The information contained within is proprietary to Cirque Corporation.

Note to Purchasers: All specifications subject to change without notice. Cirque shall not be liable for any damages whether non-specified, direct, indirect, special, incidental or consequential (including downtime, loss of profit or goodwill) regardless of the legal theory asserted. This document supersedes all previous versions.

Copyright, Trademark, and Patent Information

Copyright© 2017 Cirque Corporation. All Rights Reserved. Cirque®, the Cirque logo, GlidePoint®, GlideTouch®, the GlidePoint logo, and GlideExtend® are trademarks of Cirque Corporation. All other brand names or trademarks are the property of their respective owners.

Cirque's touch controller platforms and technology solutions are protected by patents and additional U.S. and International patents pending. Contact Cirque for more information.

Table of Contents

Overview	4
Electrical Specifications	5
Mechanical Interface	7
Cirque Analog Front-End.....	7
Physical Dimensions	9
Cirque’s AFE Footprint	10
Rushmore AFE Reference Designs	11
With Microcontroller PS/2, Internal SPI, and Button Interface	11
Multi-Rushmore Example	12
Example Schematic	14
Touch Panel Schematic	15
Trackpad Schematic.....	16
Rushmore Part Number Explanation	17
Packaging Information	18
Rushmore Tape and Reel Information.....	18
Reel Box Dimensions	19
Shipping Box Information	20
Contact Information	21

Overview

This document highlights the electrical specifications of Cirque’s application-specific integrated circuit (ASIC) also called “Rushmore.” The Rushmore ASIC is a low-cost high-performance analog front-end (AFE) touch controller that requires a companion microcontroller to manage the measurements and process the data into touch point locations.

Note: The information in this document only applies to the Rushmore ASIC.

The block diagram shown below in [Figure 1](#) highlights Rushmore’s flexible electrode I/O architecture.

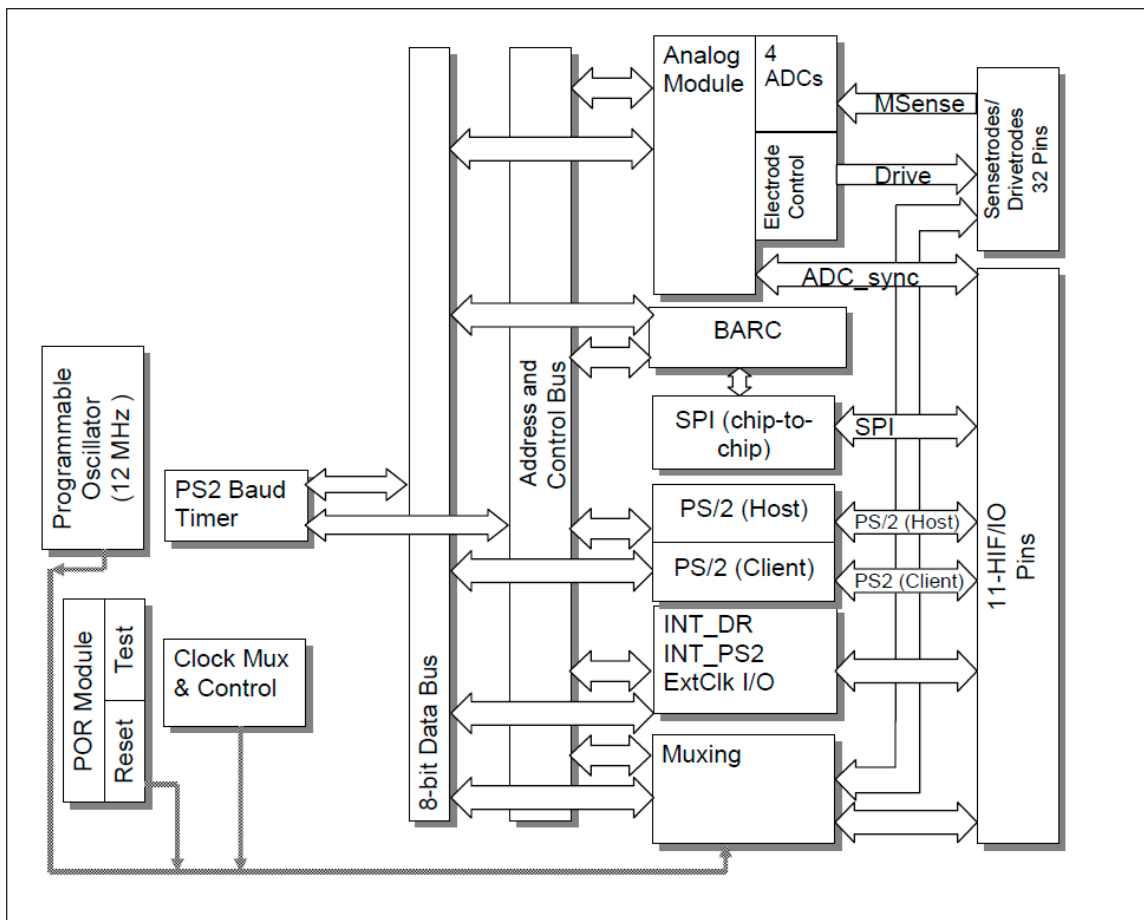

Figure 1: Rushmore ASIC Block Diagram

Electrical Specifications

This section describes the electrical specifications for the Rushmore ASIC. The electrical voltage range details are provided in [Table 1](#), temperature and humidity ranges are provided in [Table 2](#). These settings must be followed to ensure proper performance. IC operation cannot be guaranteed if any one of the recommended operating conditions listed below is exceeded.

Table 1. Rushmore Voltage Ranges

Symbol	Parameter	Minimum	Typical	Maximum	Unit
V _{DD}	Power Supply	2.4	3.3	3.6	V
V _{IO}	Input or Output Voltage	-0.3		3.6	V

Table 2. Rushmore Temperature and Humidity Ranges

Symbol	Parameter	Value	Unit
T _{A FE}	Temperature range for Cirque Analog Front End	-40 to +85 degrees	C
T _{stg}	Storage Temperature	-40 to 125 degrees	C
R H	Relative Humidity	5 to 95	%

The absolute limits are provided in [Table 3](#). The values listed in this table must not be exceeded. The life and dependability of the product are jeopardized if the maximum value is exceeded even if only for an instant.

Table 3. Maximum Ratings

Symbol	Description	Ratings	Unit
DVDD	Power Supply	-0.3 to 3.6	V
AVDD	Power Supply	-0.3 to 3.6	V
V _{in} / V _{out}	Input or Output Voltage	-0.3 to DVDD+0.3*	V
	Input or Output Voltage (PS/2)	-0.3 to 5.5*	V
T _{opr}	Operating Temperature	-40 to 85 degrees	C
T _{stg}	Storage Temperature	-40 to 125 degrees	C
R H	Relative Humidity	5 to 95	%

*All I/O's except the PS/2 pins are limited to the 3.6 V power rail. The PS/2 pins include the following: PS2H_HCsnc, PS2H_HD, PS2C_HC, and PS2C_HD. When the PS/2 pins are used in over voltage mode, the internal pull up resistors should be disabled to prevent extra current paths between power supplies and to prevent DVDD from being pulled up.

Table 4. ESD Absolute Maximum Ratings

Symbol	Parameter	Maximum	Unit
-	Module Level: Properly installed in a module	15	kV
ESD_HBM	IC only: Human Body model	2000	V
ESD_CDM	IC only: Charge Device model	750	V
*ESD_MM	IC only: Machine model	200	V

*Obsolete specification, checked for informational purpose only

Cirque’s Rushmore ASIC is a low-cost, high-performance, analog front-end touch controller. This section describes the pin order and function for the Rushmore ASIC.

Cirque offers a high-performance companion microcontroller that is used to manage the measurements and process the data into touch point locations. Contact your Cirque representative for more information (see [Contact Information on page 21](#)).

Cirque Analog Front-End

This section describes the requirements associated with the Cirque AFE. An example of the 48-Pin QFN Package is shown in [Figure 2](#), the dimensions are shown in [Table 5](#). The pin number, name, and description are provided in [Table 6 on page 8](#).

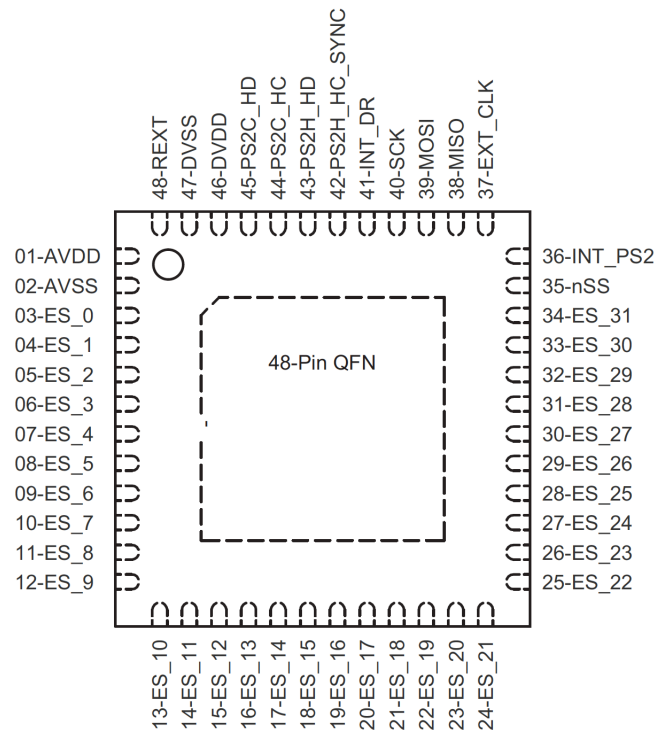

Figure 2: The 48-Pin QFN Package

Table 5. Dimensions for Rushmore

Dimension	Value
Length	7.0 mm (±0.10)
Width	7.0 mm (±0.10)
Overall Height	0.9 mm (±0.10)

Table 6. Pin Assignments for Cirque AFE

Pin Number	Pin Name	Description
1	AVDD	Analog Power
2	VSS	Ground
3 - 34	ES_0-ES-31	Programmable Sense / Drive Electrodes
35	nSS	SPI Slave Select Input
36	INT_PS2	PS/2 Interrupt Output
37	EXT_CLK	Programmable Clock (input or output) Note Used when multiple Rushmore ICs are in a common circuit.
38	MISO	SPI Slave Output
39	MOSI	SPI Slave Input
40	SCK	SPI Clock Input
41	INT_DR	Data Ready Interrupt output Note This is asserted at measurement completion.
42	PS2H_HC_sync	PS/2 Host Clock or the Sync Pulse Note Used for cascading multiple Rushmore ICs.
43	PS2H_HD	PS/2 Host Data
44	PS2C_HC	PS/2 Client Clock
45	PS2C_HD	PS/2 Client Data
46	DVDD	Digital Power
47	DVSS	Ground
48	REXT	External Gain Resistor Note The connection to the external gain resistor that sets the input sensitivity. Layout should ensure low parasitic capacitance to this pin and isolation from noise coupling.

Physical Dimensions

This section describes the physical size of Rushmore as well as information about the thermal pad.

Rushmore is available in a 48-pin QFN package. The dimensions for Rushmore are shown below in [Figure 3](#).

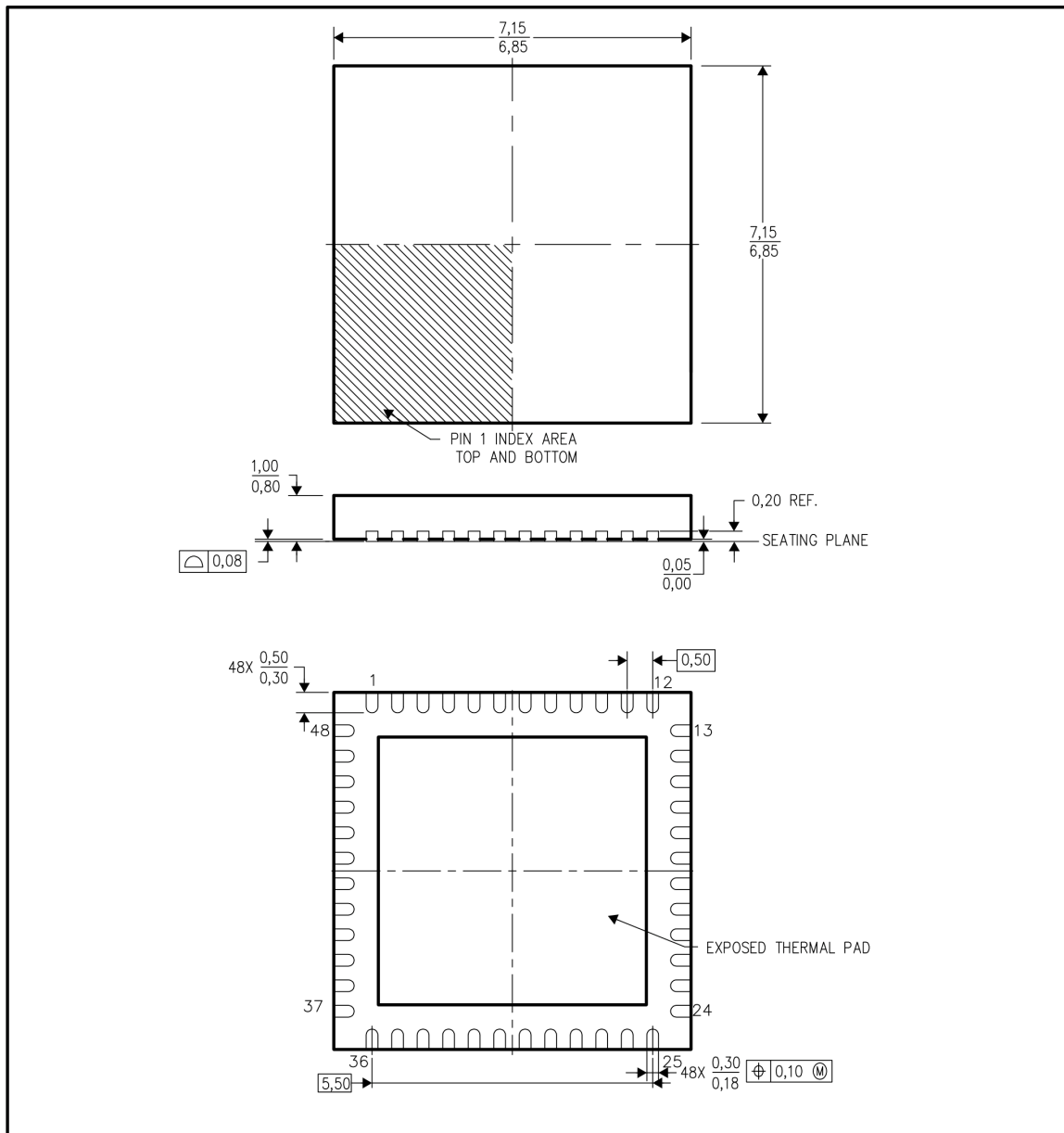

Figure 3: Rushmore Package Dimensions

Cirque's AFE Footprint

The following example drawings are land patterns used for Cirque circuit boards. The thermal pad should be soldered for mechanical reliability, even though it is not required for heat transfer. The AFE footprint (48-pin QFN) is shown in [Figure 4](#).

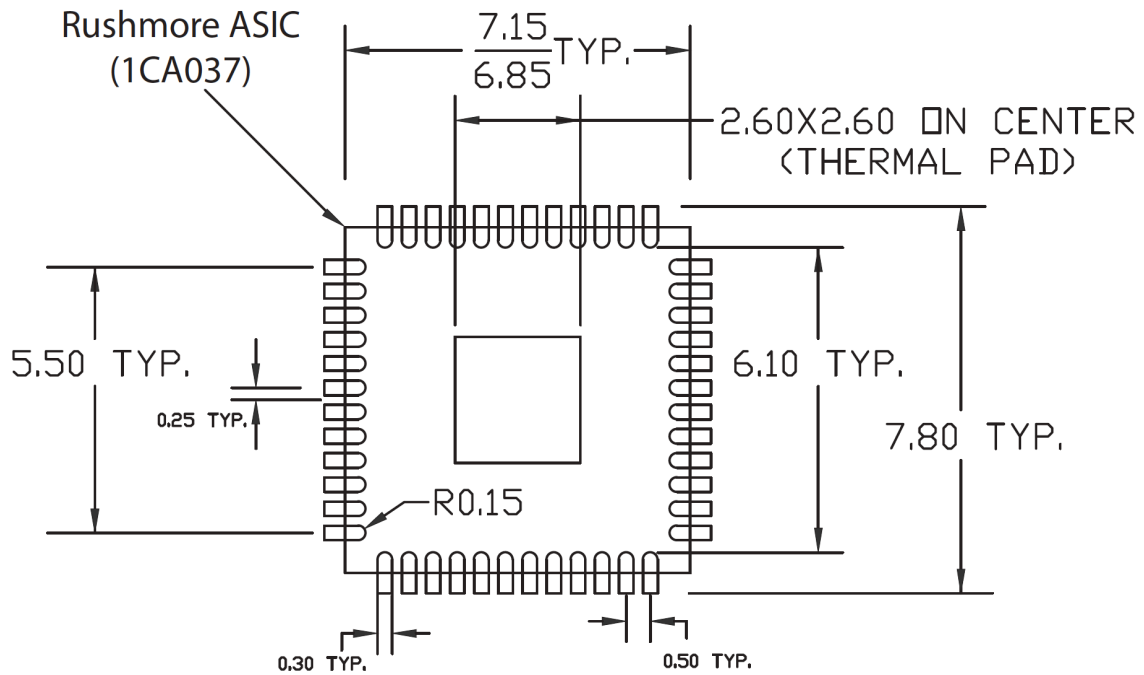

Figure 4: Cirque AFE Thermal Pad- Bottom View

Rushmore AFE Reference Designs

This section has example reference designs.

- Rushmore AFE with Microcontroller PS/2, Internal SPI, and Button Interface.
- Multi-Rushmore example.

Rushmore can work with a variety of microcontrollers. These examples are generic; however, regardless of micro controller, the following pins must be connected:

- MISO (Master In Slave Out)
- MOSI (Master Out Slave In)
- CLK (clock)
- Dr_Int (Drive Interrupt)
- Slave Select

With Microcontroller PS/2, Internal SPI, and Button Interface

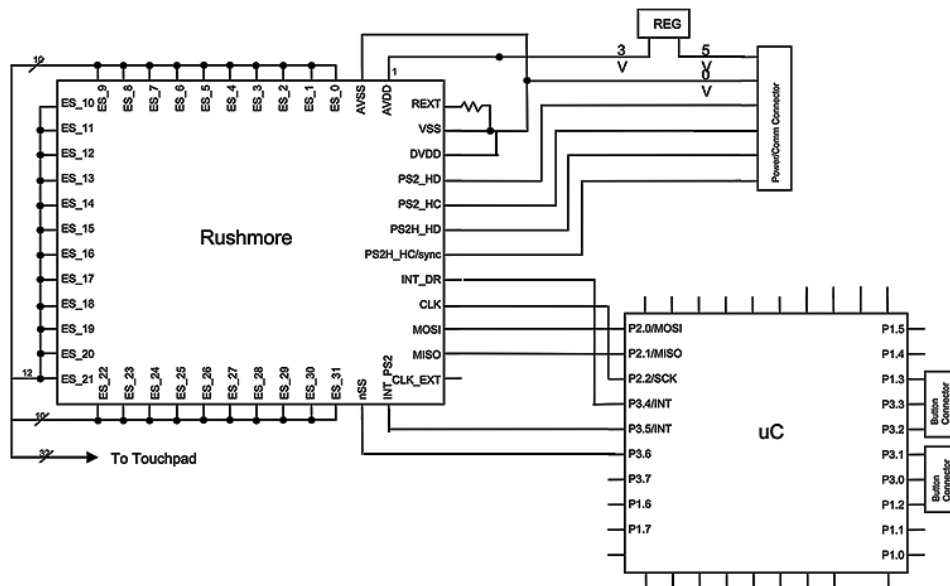

Figure 5: Rushmore with Microcontroller PS/2, Internal SPI, and Button Interface

Multi-Rushmore Example

Note: Master/Slave configuration is configured in the ADC section of the register map in the firmware.

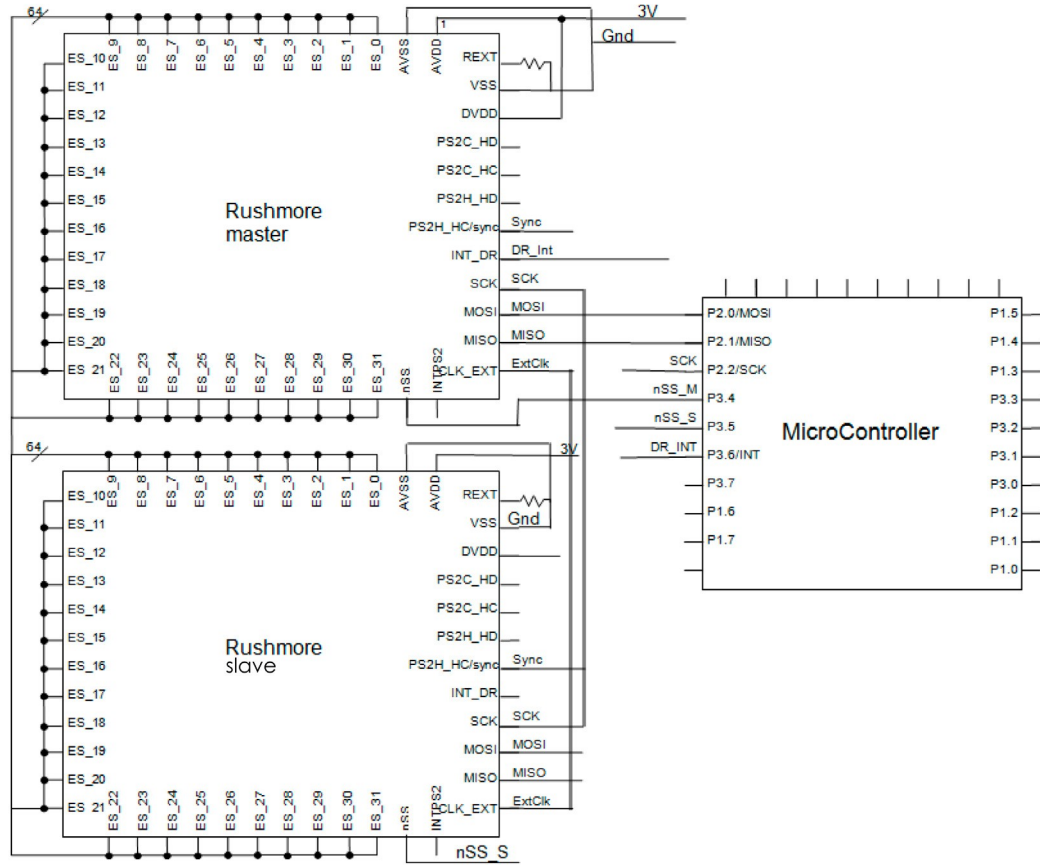

Figure 6: Multi-Rushmore Example, Emphasizing 'sync', 'ExtClk,' and 'nSS' Connections

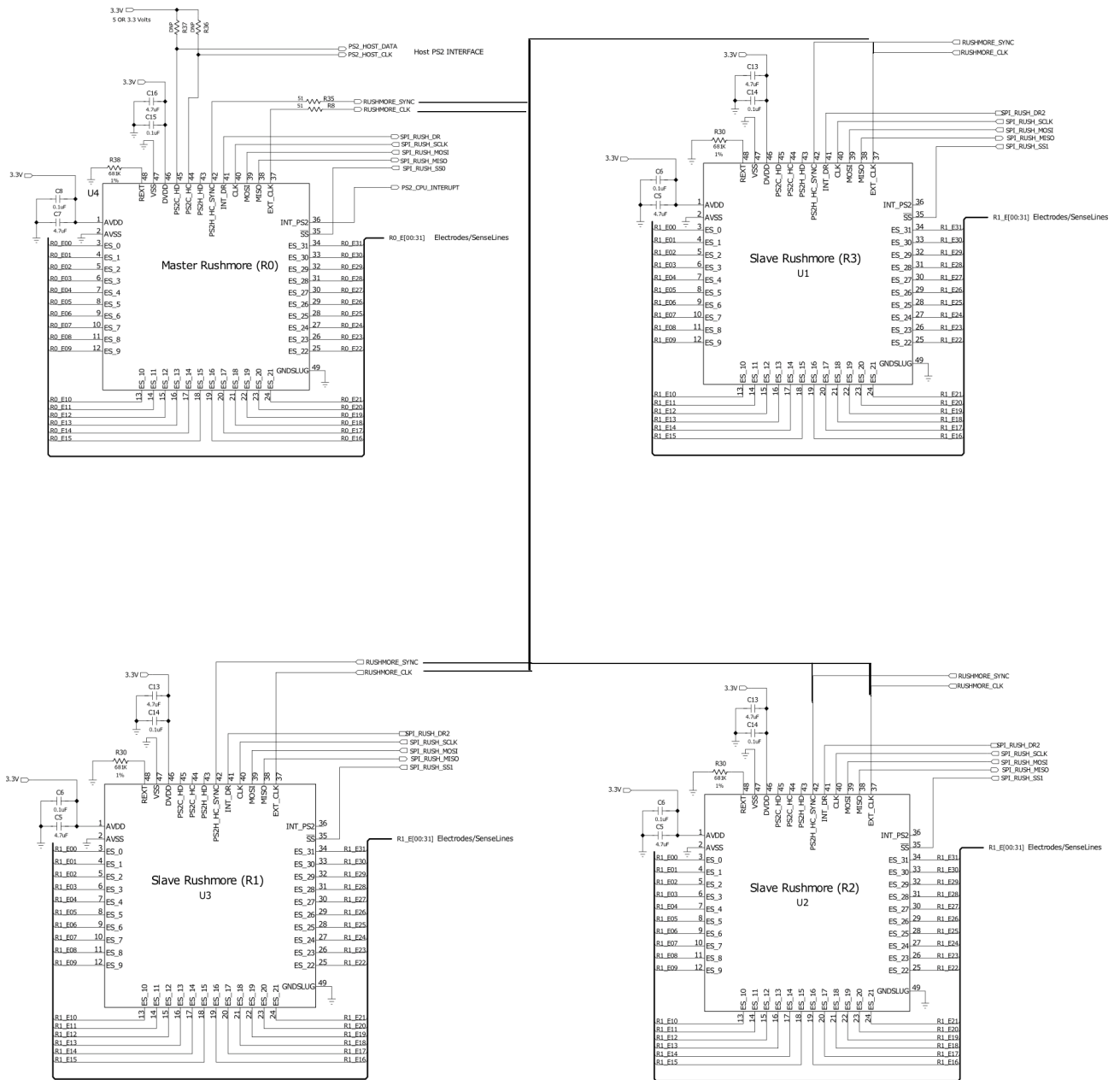

Figure 7: Multi-Rushmore Example

Example Schematic

This section has example schematics for the type of products in which Rushmore may be used. Contact your Cirque representative for more information.

- [Example Schematic: Touch Panel Using Rushmore](#) on page 15
- [Example Schematic: Trackpad Using Rushmore](#) on page 16

Touch Panel Schematic

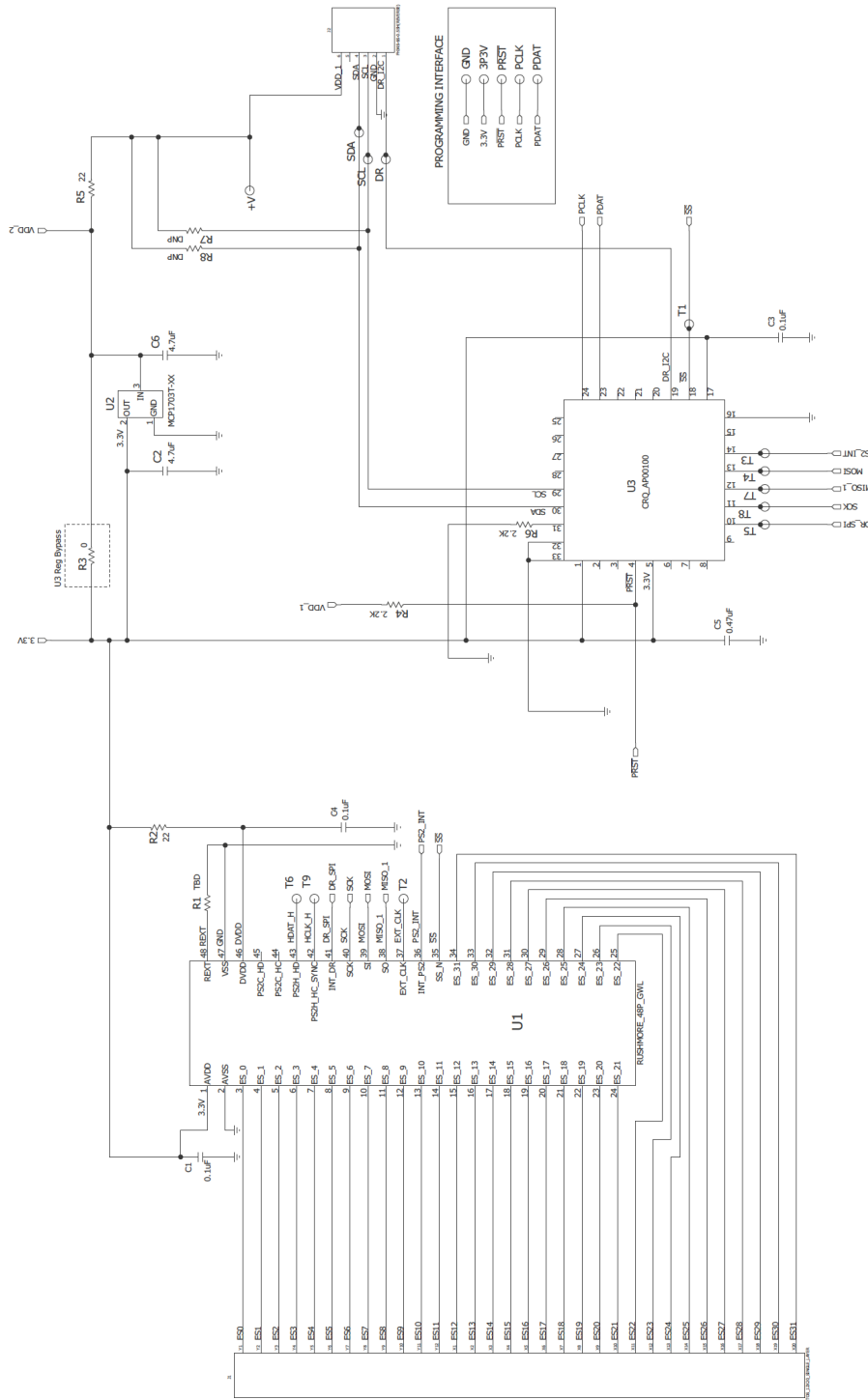

Figure 9. Example Schematic: Touch Panel Using Rushmore

Rushmore Part Number Explanation

This section explains the markings on the Rushmore ASIC.

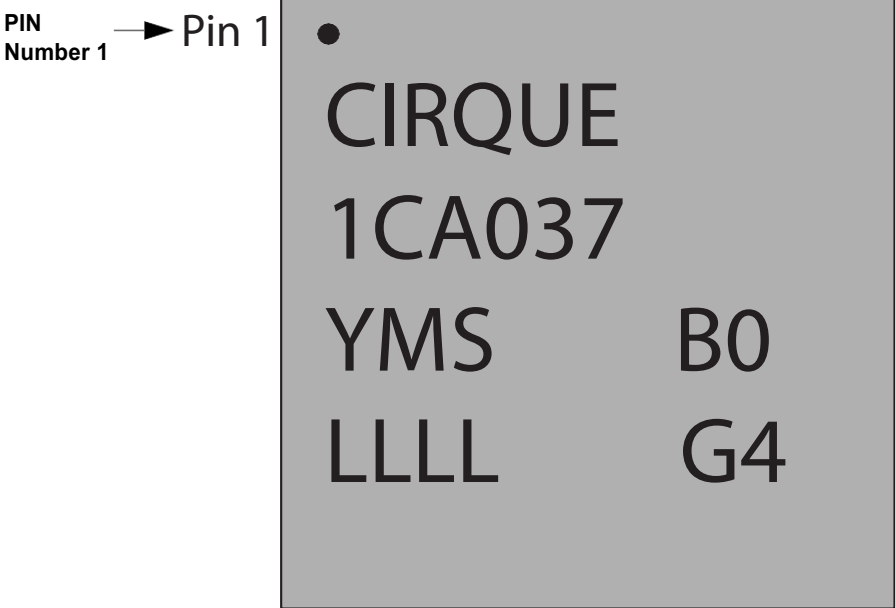

Figure 10: Example Rushmore ASIC

Table 7. Rushmore Part Marking Legend

Marking	Description
CIRQUE	Manufacturer
1CA037	IC marking number
YMS*	Lot code: YM (Year/6-week period), S (Assemble site code)
B0	Major/minor revision
LLLL	Lot tracking code
G4	Green rated, pre-plated, lead (Pb) free
P	Pre-Production, if on package

*M in the date code is a 6-week period instead of month. 1 is work weeks 06 - 11.....8 is 48 - 51. 9 is 52 - 05. 0 is not used.

Packaging Information

The Rushmore ASIC and the Cirque microcontroller are shipped on tape and stored on a reel. This section covers the information about the reels, reel boxes, and shipping boxes that are used when sending Rushmore.

Note: All drawings are subject to change without notice.

Rushmore Tape and Reel Information

This section provides the tape and reel dimensions. The capacity for each reel is 2,500 pcs. The tape and reel information is in [Figure 11](#). The box information is in [Figure 12 on page 19](#).

Tape, Reel, and Box Dimensions

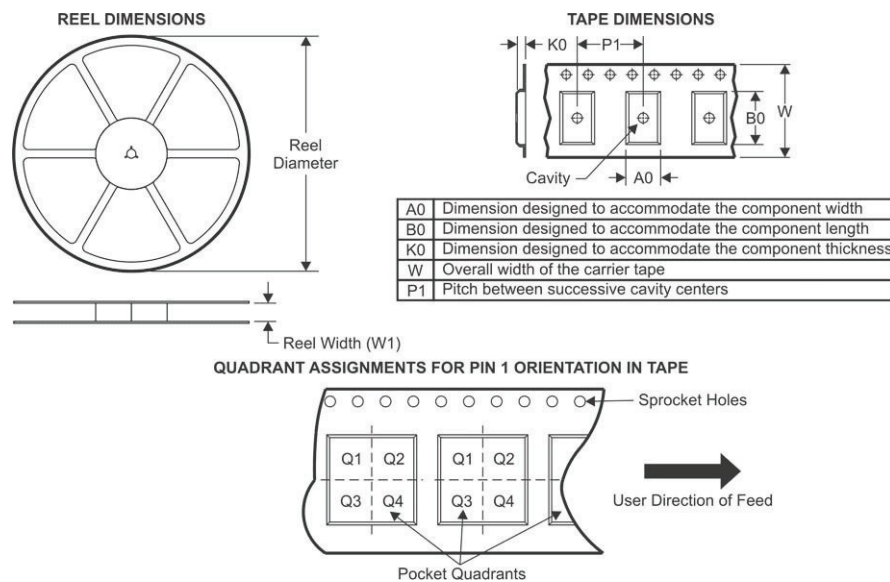

Figure 11. Rushmore Tape and Reel Information

Table 8. Tape and Reel Information

Cirque Part Number	Package Type	Package Drawing	Pins	Reel Diameter (mm)	Reel Width W1 (mm)	A0 (mm)	B0 (mm)	K0 (mm)	P1 (mm)	W (mm)	Pin 1 Quadrant
Rushmore 10-020150-020	QFN	RGZ	48	330.0	16.8	9.6	9.6	1.5	12.0	12.0	Q2

Note: All dimensions are nominal.

Reel Box Dimensions

This section provides the reel box dimensions.

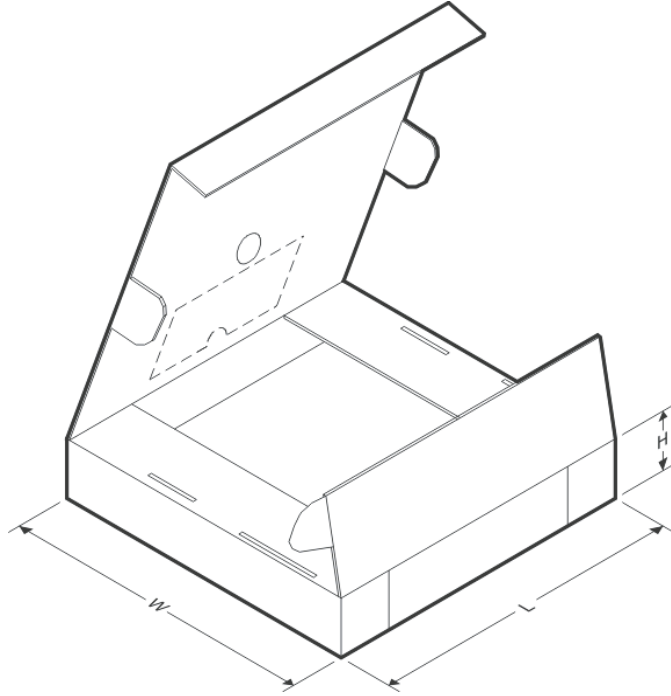

Figure 12. Box Dimensions

Table 9. Box Dimensions and other Information for Reels

Cirque Part Number	Pins	SPQ	Length (mm)	Width (mm)	Height (mm)
Rushmore 10-020150-020	48	2500	346.0	346.0	33.0

Note: All dimensions are nominal.

Shipping Box Information

This section provides information about the box in which the reel boxes will be sent to customers. The shipping box (Figure 13) will be a corrugated fiberboard container. The size of the box is determined by the number of the reel boxes. Filler, such as cushion, is added if space exists inside the shipping box after the reel boxes have been added.

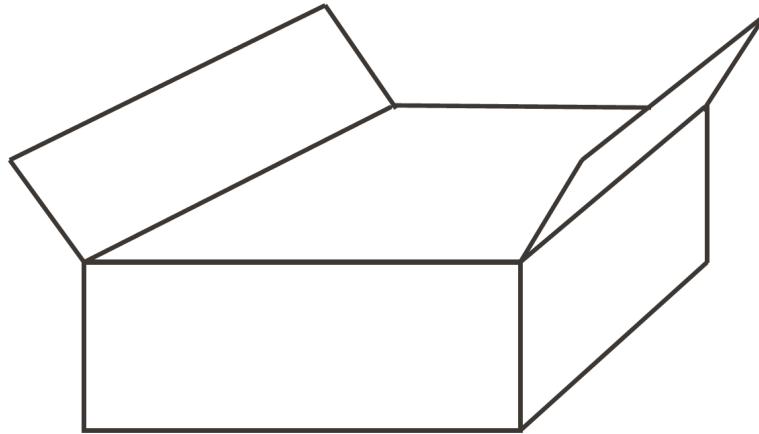

Figure 13. Example Shipping Box

Contact Information

Contact a Cirque sales representative for a complete list of Cirque's OEM products.

- In United States & Canada** (800) GLIDE-75 (454-3375)
- Outside US & Canada** (801)467-1100
- Fax** (801) 467-0208
- Web site** <http://www.cirque.com>