

This Field Service Bulletin replaces bulletin, "Grade Gripper Solenoid, Replacement", (USA70297) PV729-FSB593-013_M, dated (05.2015).

Date	Group	No.	Release	Page
1.2016	593	013	04	1(14)

Grade Gripper Solenoid, Replacement
CHU, CXU, GU, TD

FSB 593-013, Grade Gripper Solenoid, Replacement

(January 2015)

On some MACK CHU, CXU, GU, and TD truck models built between 04/31/2008 and 11/30/2015, the solenoid valve for the grade gripper feature is prone to internal contamination in harsh environments. The internal contamination of the solenoid valve is caused by the buildup of grime, salt, road debris and other solid contaminants. In some cases, the buildup of solid contaminants caused the solenoid valve to malfunction. A similar malfunction is possible if the solenoid valve is equipped with a vent fitting that freezes over. The malfunction causes the trailer brake circuit to maintain trailer brake pressure after a grade gripper event. Replacement of the existing solenoid valve, elbow, and the addition of a new tube fitting and tube will ensure proper functionality of the grade gripper feature.

Note: This bulletin does not apply to MACK Trucks Australia.

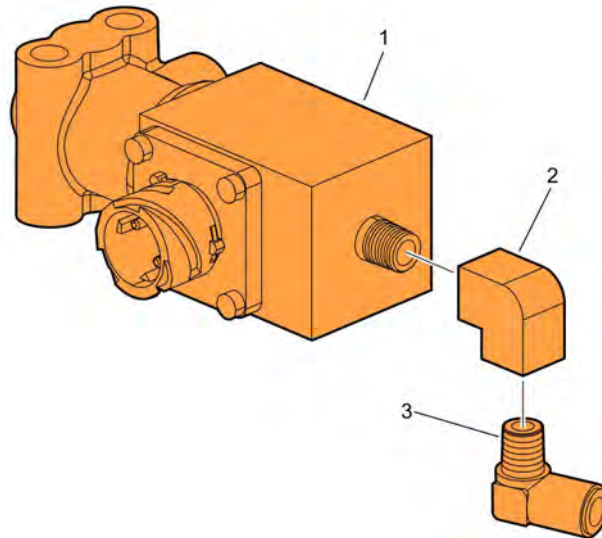

W5100449

Required Parts

Grade Gripper Solenoid Replacement Parts			
Item	Description	Part Number	Qty
1	Solenoid Valve	21396762	1
2	Elbow	3082873	1
3	Tube Fitting	8397697	1
4	Tubing, Bulk	1113569	N/A

Repair Procedure

You must read and understand the precautions and guidelines in Service Information, group 5, "General Safety Practices, Brakes" before performing this procedure. If you are not properly trained and certified in this procedure, ask your supervisor for training before you perform it.

DANGER

Do not attempt to repair or service this vehicle without having sufficient training, the correct service literature and the proper tools. Failure to follow this could make the vehicle unsafe and lead to serious personal injury or death.

- 1 Park vehicle on a flat and level surface.
- 2 Apply the parking brake.
- 3 Place the transmission in neutral or park.
- 4 Install the wheel chocks.

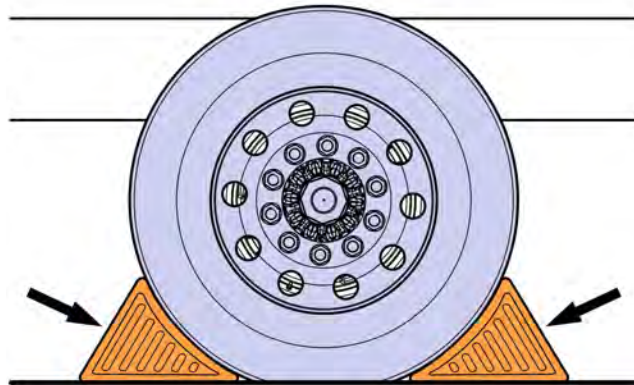

W7086748

- 5 Disconnect the cable from the battery's negative terminal.

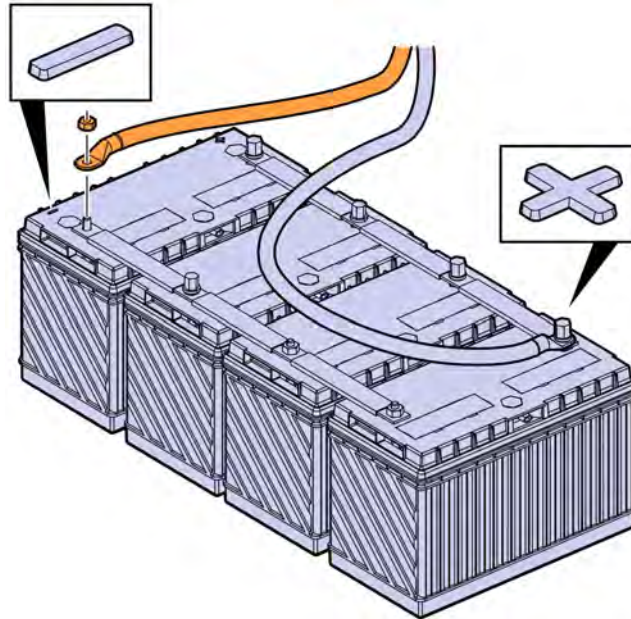

W3086747

- 6 If applicable, slide the fifth wheel to the rear most position to gain access to the solenoid valve.

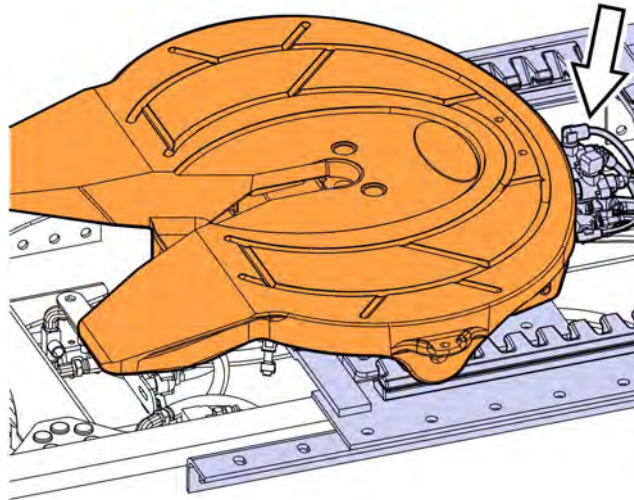

W9090990

- 7 Verify whether or not the Grade Gripper solenoid is equipped with vent fitting (part number 25164397) as shown in the figure below.

Note: If the solenoid is equipped with a vent fitting, remove the vent fitting and proceed to step 24 for elbow fitting and tube installation instructions only.

Note: If the solenoid is not equipped with a vent fitting, proceed to step 8 for Grade Gripper Solenoid, Replacement instructions.

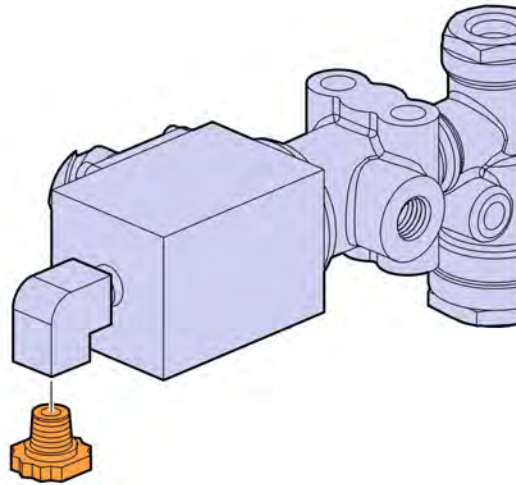

W5091002

- 8 Disconnect the harness from the solenoid.

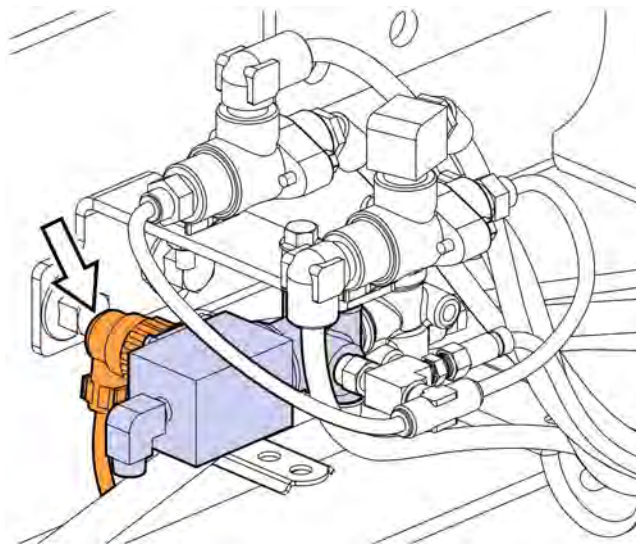

W5090991

9 Disconnect the air lines shown.

Note: Note the position of the air lines before removal.

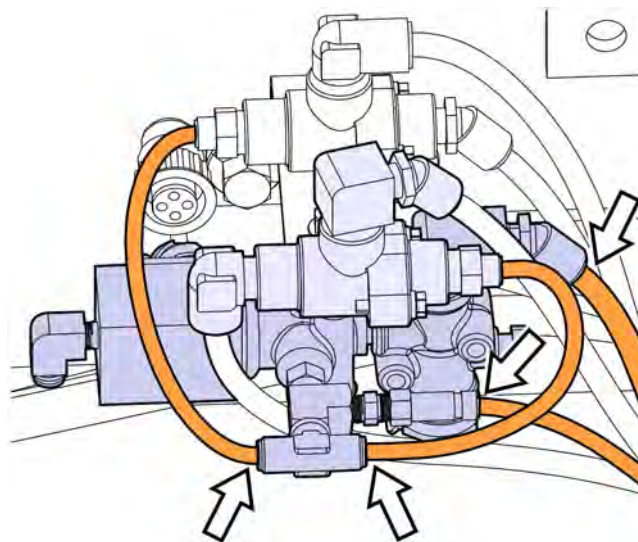

W5090993

10 Remove the solenoid valve assembly.

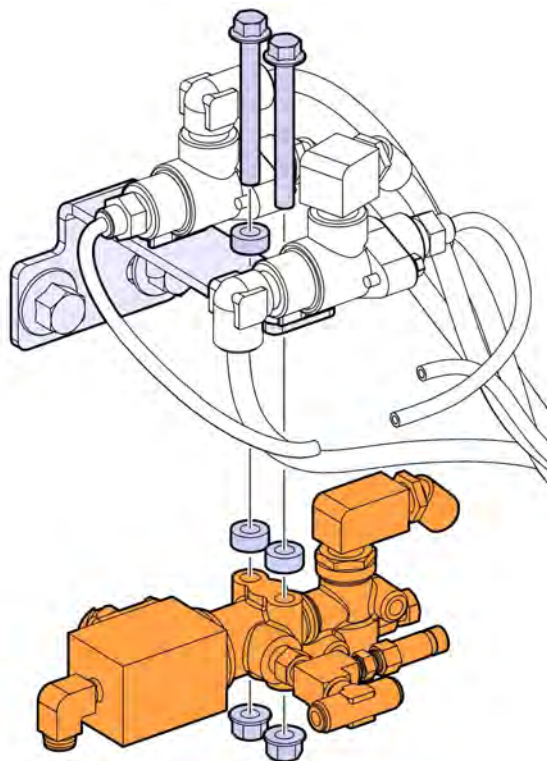

W5090994

11 Remove the fittings from the solenoid valve.

Note: Note the position of the fittings for installation.

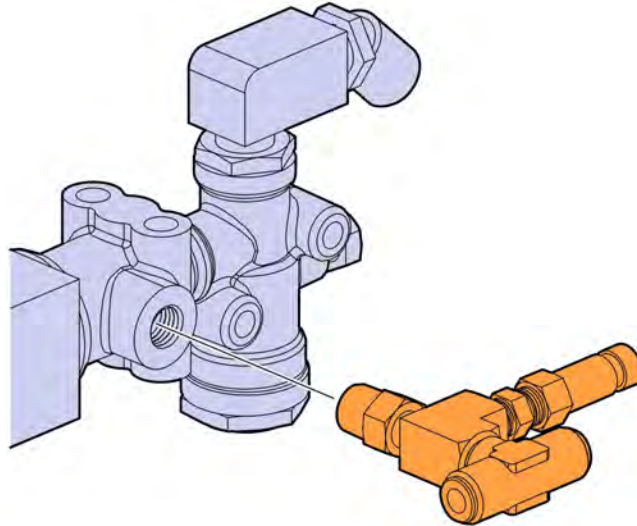

W5090995

12 Remove the elbow fitting from the solenoid valve.

Note: Note the position of the elbow fitting for installation.

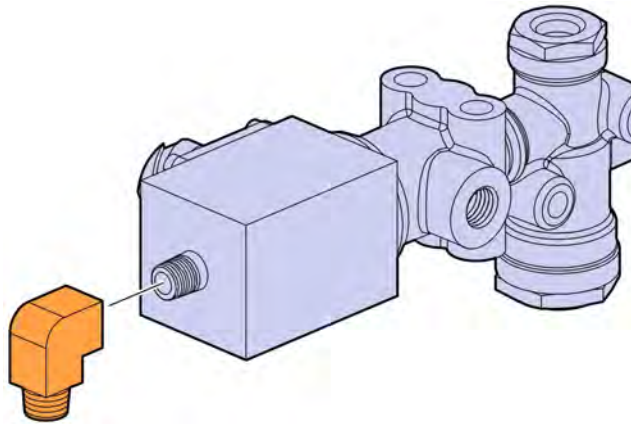

W5090996

13 Position and clamp the solenoid in a vise by the valve body as shown.

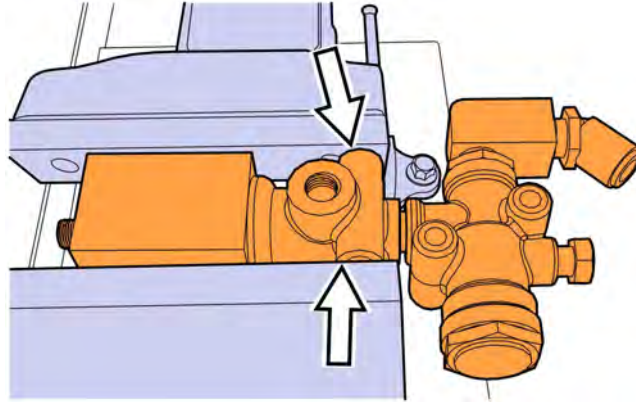

W5090997

14 Remove the valve (1) from the solenoid valve (2).

Note: Note the position of the valve (1) for later installation.



CAUTION

Removal of the union fitting (3) from the solenoid valve (2) will cause damage to the fitting.

Note: If the union fitting (3) is removed with the valve, clean and store both for installation.

Note: If the union fitting (3) is fixed in the solenoid valve after removal of the valve, discard the solenoid valve and the union fitting, then clean and store the valve for installation.

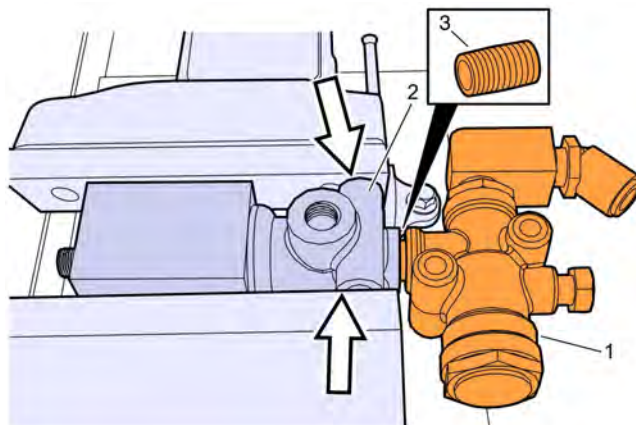

W5090998

15 Remove the existing solenoid from the vise.

16 Position and clamp the replacement solenoid in a vise by the valve body as shown.



CAUTION

To prevent damage to the solenoid valve, do not clamp the electrical portion of the solenoid.

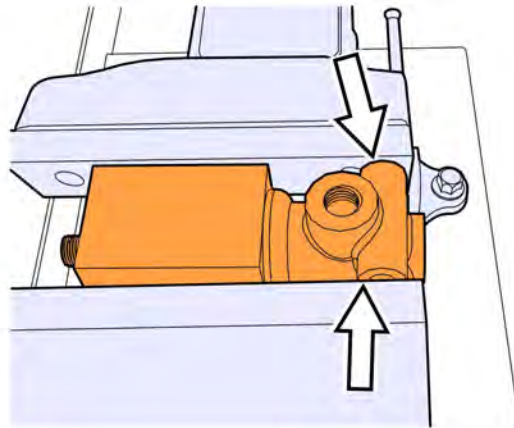

W5090999

17 Assemble the replacement solenoid valve (2), valve (1), and union fitting (3).

Note: Apply thread sealant to the fitting before assembly.

Note: if applicable, assemble a new union fitting (part number 25089731) and valve prior to assembly with the solenoid valve.

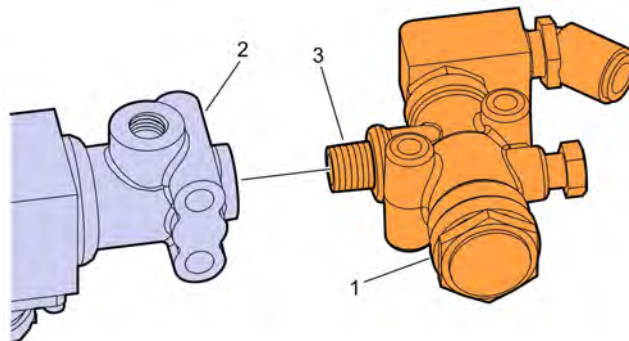

W5091000

18 Remove the replacement solenoid from the vise.

19 Install the replacement elbow fitting (part number 3082873) to the solenoid valve.

Note: Apply thread sealant to the solenoid before installing elbow fitting.

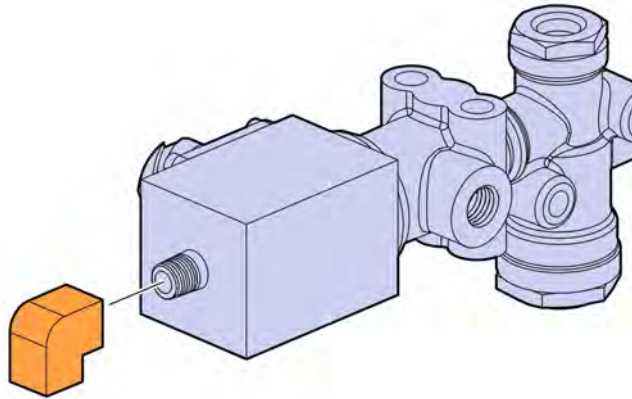

W5091001

20 Install the solenoid valve fittings as shown.

Note: Apply thread sealant to the fitting before assembly.

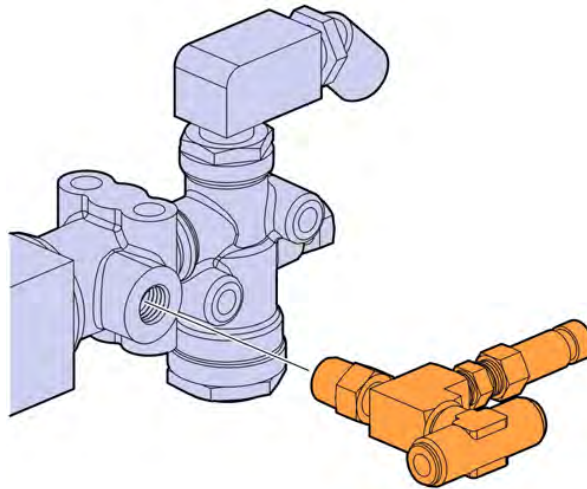

W5090995

- 21 Position the solenoid valve assembly.
- 22 Install the fasteners securing the solenoid valve assembly.
- 23 Tighten the fasteners to 24 ± 4 Nm (18 ± 3 ft-lb).

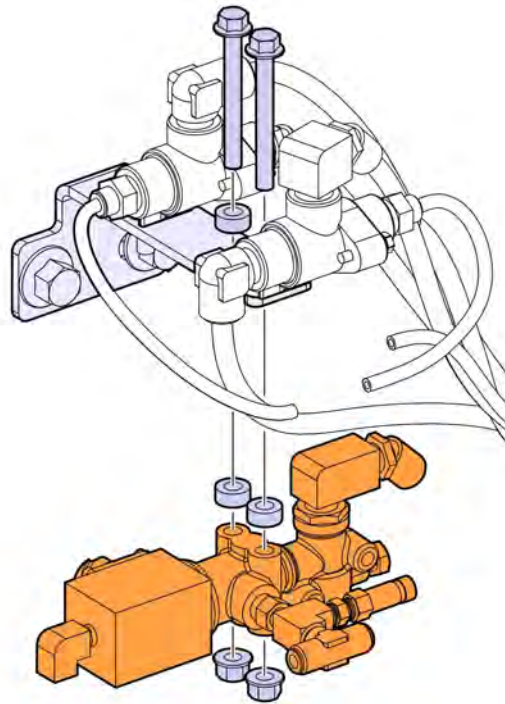

W5100451

- 24 Install the tube fitting (part number 8397697) on the elbow fitting.

Note: Ensure the inside and outside of the tube fitting is clean and free of any solid contaminants before installation.

Note: Apply thread sealant to the tube fitting before assembly.

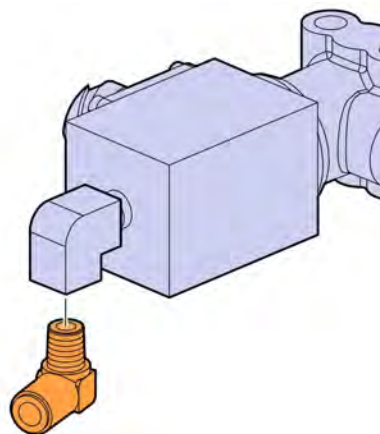

W5100450

- 25 Cut approximately, 914 mm (36 in) of bulk tubing (part number 1113569).
- 26 Connect the 914 mm (36 in) section of bulk tubing to the tub fitting as shown in the figure below.

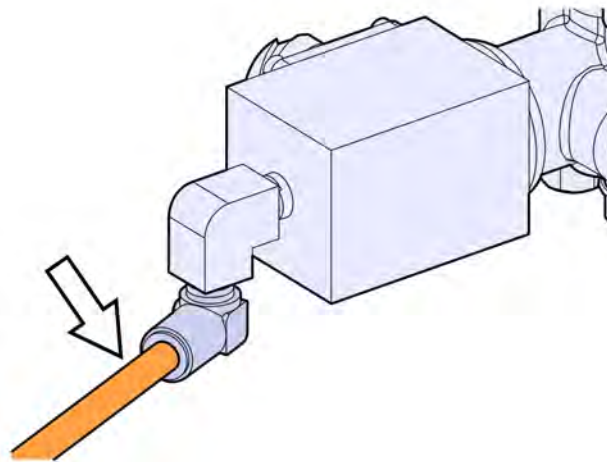

W5100452

- 27 Route the tubing from the tube fitting along the chassis harness and air line bundle. See the figure below.

Note: The air line tubing must be routed inside chassis harness bundle.

Note: Use cable ties to secure the tubing to the chassis harness and air line bundle as shown below.

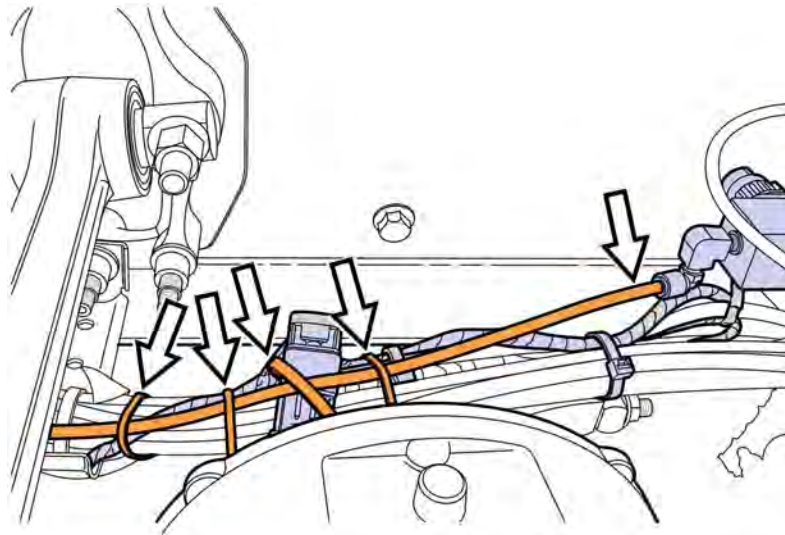

W5100453

28 Connect the remaining air lines.

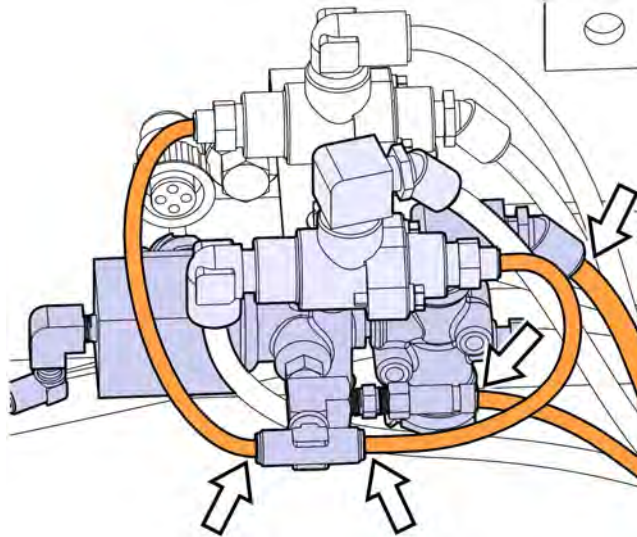

W5100454

29 Connect the harness.

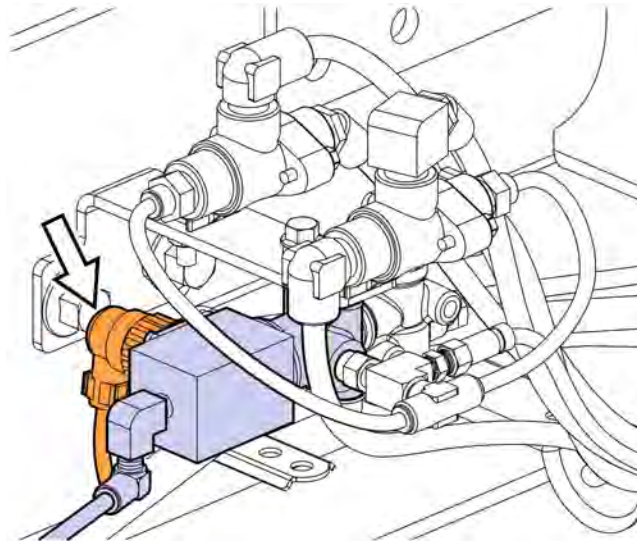

W5100455

30 If applicable, return the fifth wheel to it's original position.

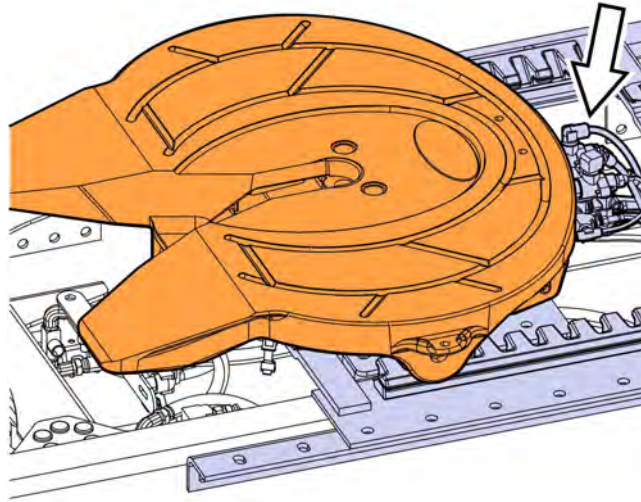

W9090990

31 Connect the battery cable to the negative (ground) terminal.

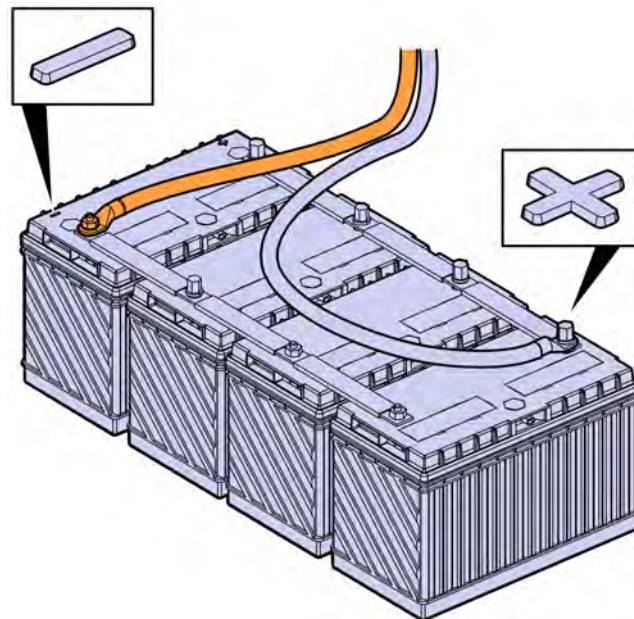

W3086758

32 Remove the wheel chocks.

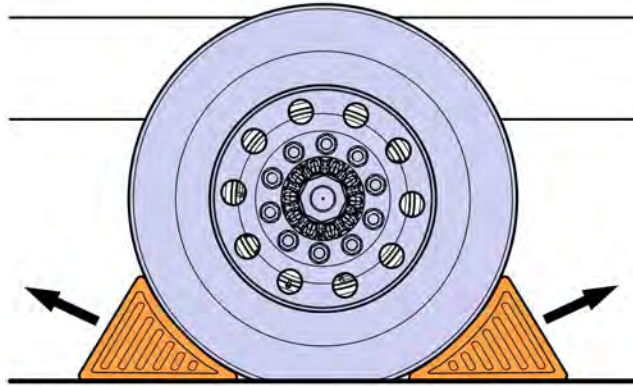

W7086759

Reimbursement

This repair may be eligible for reimbursement if a product failure was experienced within time and mileage limits of the applicable Warranty coverage. Reimbursement is obtained via the normal claim handling process.	UCHP Reimbursement	eWarranty Reimbursement
Claim Type (used only when uploading from the Dealer Bus. Sys.)	01	01
Labor Code		
Primary Labor Code (Grade Gripper Solenoid, Replacement)	5939-03-09-02 0.4 hrs.	5332E-01-80 0.4 hrs.
Causal Part	21396762	21396762

MACK Trucks North America reserves the right to make any changes in design or to make additions to or upon its products without incurring any obligations to install the same on vehicles previously built.