

H BRAKE SPECIFICATIONS

SUBJECT: Consolidated Certificate of
Compliance for Air Actuated Brakes

LIT NO: L809

DATE: January 2014

REVISION: I

Hendrickson Consolidated Certificate of Compliance for Air Actuated Brakes used on Hendrickson INTRAAX[®] and VANTRAAX[®] integrated suspension systems and TRLAXLE[®] non-integrated axles in North America.

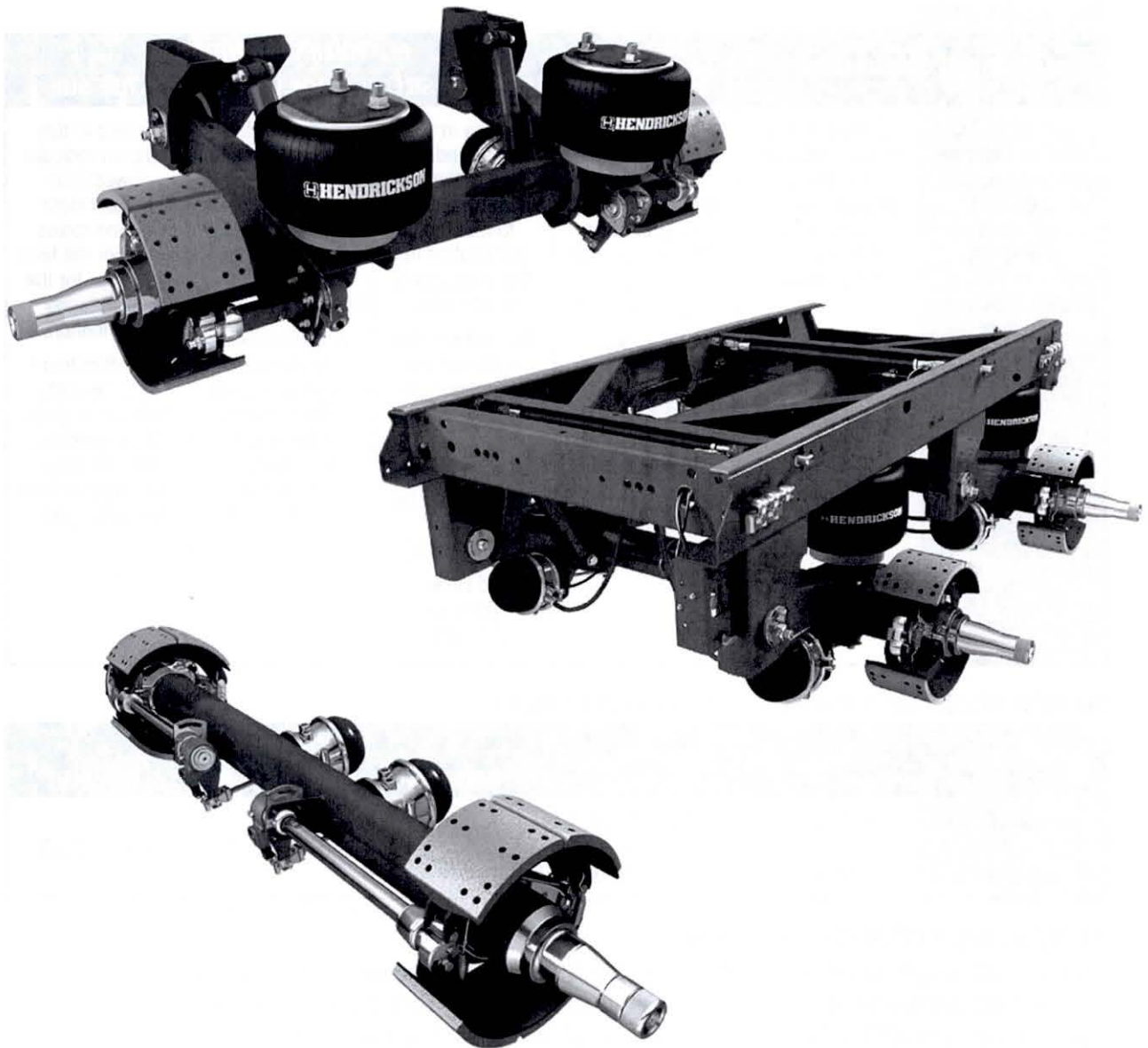

H HENDRICKSON
The World Rides On Us[®]



Notes Regarding Brake Certifications

Federal Motor Vehicle Standards specify that the original equipment manufacturer (OEM) is responsible for compliance to Federal Motor Vehicle Safety Standard (FMVSS)-121 for air actuated brakes. In the United States, OEMs are self-certifying to the standard. In Canada, test data must be submitted to Transport Canada either directly or indirectly through the Canadian Transport Equipment Association’s (CTEA) brake database (Note - CTEA database is available to CTEA members only).

As a service to our customers, Hendrickson Trailer Commercial Vehicle Systems provides this **Consolidated Certificate of Compliance** for use with Hendrickson INTRAAX® and VANTRAAX® integrated suspension systems and TRLAXLE® non-integrated axles. For every entry in the table, Hendrickson has data showing compliance to FMVSS-121 requirements. As an additional service to Canadian customers who must provide parking test compliance data to Transport Canada, FMVSS/CMVSS-121 parking data is also available upon request for every table entry. This data is a part of the CTEA database. **For certifications other than those listed in these tables, please contact Hendrickson Brake Engineering for an application specific approval.**

Reading the tables:

BRAKE MODEL	LINING	BRAKE RATING	WHEN USED WITH:		
			CHAMBER SIZE	SLACK LENGTH	TIRE SLR
<p>Entries in this column indicate the brake model, size (drum diameter and shoe width) and identifies the Friction Materials Standards Institute (FMSI) code for the brake.</p>	<p>Entries in this column indicate the lining manufacturer’s name and lining formula designation.</p>	<p>Entries in this column indicate the lowest and highest Gross Axle Weight Rating (GAWR) in pounds for the given lining certification.</p> <p>The given certification is valid at any GAWR at or between the two stated values.</p>	<p>Entries in this column indicate size of the air chamber required to meet the certification for the given lining certification.</p> <p>The first number is the service chamber area (square inch).</p> <p>The second number is the Parking Chamber area # (square inch).</p> <p>Rated stroke is listed in [brackets].</p>	<p>Entries in this column indicate length of the slack adjuster in inches required to meet the certification for the given lining certification.</p> <p>Note that there may be splits between a given GAWR and the slack length necessary to meet the certification.</p>	<p>Entries in this column indicate lowest and highest static loaded radius (SLR) for the tires in inches for the given lining certification.</p> <p>Note that there may be splits between a given GAWR and the tire SLR range necessary to meet the certification.</p>

Example: (Always read across the table for valid combinations)

BRAKE MODEL	LINING	BRAKE RATING	WHEN USED WITH:		
			CHAMBER SIZE	SLACK LENGTH	TIRE SLR
<p>HENDRICKSON 16.5" × 7" HXS® (F.M.S.I. 4707)</p>	H20167XF	17,000 – 20,000	<p>30/30 [2.5" stroke]</p>	<p>5.5" or 6.0"</p>	<p>17.0" – 20.8"</p>
	H23167XF	17,000 – 23,000			

Example interpretations of the table entries:

- 16.5" × 7" HXS using H20167XF at 17,000 GAWR with 30/30 chamber, 5.5" slack and 20.8" SLR is valid.
- 16.5" × 7" HXS using H20167XF at 20,000 GAWR with 30/30 chamber, 5.5" slack and 19.3" SLR is valid.
- 16.5" × 7" HXS using H20167XF at 20,000 GAWR with 30/30 chamber, 5.5" slack and 17" SLR is valid.
- 16.5" × 7" HXS using H20167XF at 17,000 GAWR with 30/30 chamber, 6" slack and 17" SLR is valid.
- 16.5" × 7" HXS using H23167XF at 17,000 GAWR with 30/30 chamber, 5.5" slack and 17" SLR is valid.
- 16.5" × 7" HXS using H23167XF at 23,000 GAWR with 30/30 chamber, 5.5" slack and 20.8" SLR is valid.
- 16.5" × 7" HXS using H23167XF at 23,000 GAWR with 30/30 chamber, 5.5" slack and 17" SLR is valid.
- 16.5" × 7" HXS using H23167XF at 23,000 GAWR with 30/30 chamber, 5.5" slack and 20.8" SLR is valid.



12.25" x 5.5" Brake Certificate of Compliance

This table certifies that the Hendrickson TRLAXLE® non-integrated axles described below comply with the current revision of DOT 49 CFR 571.121 and Canadian Motor Vehicle Safety Standards, Service Brakes, Par. S5.4 and Parking Brakes, Par.5.6.1 when equipped as noted. For certifications other than those listed below, please contact Hendrickson Brake Engineering for an application specific approval.

BRAKE MODEL	LINING	BRAKE RATING	WHEN USED WITH:		
			CHAMBER SIZE	SLACK LENGTH	TIRE SLR
Bendix Spicer 12.25" x 5.5" (F.M.S.I. 4536E)	Bendix Spicer ES600 / 931-162	10,000 – 15,000	24/30 [2.5" stroke]	5.5" or 6.0"	14.3" – 15.6"

12.25" x 7.5" Brake Certificate of Compliance

This table certifies that the Hendrickson TRLAXLE non-integrated axles described below comply with the current revision of DOT 49 CFR 571.121 and Canadian Motor Vehicle Safety Standards, Service Brakes, Par. S5.4 and Parking Brakes, Par.5.6.1 when equipped as noted. For certifications other than those listed below, please contact Hendrickson Brake Engineering for an application specific approval.

BRAKE MODEL	LINING	BRAKE RATING	WHEN USED WITH:		
			CHAMBER SIZE	SLACK LENGTH	TIRE SLR
Bendix Spicer 12.25" x 7.5" (F.M.S.I. 4692)	Bendix Spicer ES600 / 931-162	15,000 – 17,500	24/30 [2.5" stroke]	5.5" or 6.0"	14.3" – 15.6"
		17,500 – 20,000	30/30 [3.0" stroke]	6.0"	14.3" – 15.6"
HENDRICKSON 12.25" x 7.5" HXS® (F.M.S.I. 4692)	H20127XF	15,000 – 17,500	24/24 [2.5" stroke]	5.5" or 6.0"	14.3" – 15.6"
		17,500 – 20,000	30/30 [3.0" stroke]	6.0"	14.3" – 15.6"



15" x 8.625" HXS® Brake Certificate of Compliance

This table certifies that the Hendrickson INTRAAX® and VANTRAAX® integrated suspension systems and TRLAXLE® non-integrated axles described below comply with the current revision of DOT 49 CFR 571.121 and Canadian Motor Vehicle Safety Standards, Service Brakes, Paragraph S5.4, and Parking Brakes, Paragraph 5.6.1, when equipped as noted. **For certifications other than those listed below, please contact Hendrickson Brake Engineering for an application specific approval.**

BRAKE MODEL	LINING	BRAKE RATING	WHEN USED WITH:		
			CHAMBER SIZE	SLACK LENGTH	TIRE SLR
HENDRICKSON 15" x 8.625" HXS® (F.M.S.I. 4710)	H20158XF	13,700 – 18,750	24/24 ² [2.5" stroke]	5.5" or 6.0"	14.9" – 16.3"
		17,000 – 20,000	or 24/30 ² [2.5" stroke]	6.0"	
		17,000 – 20,000	30/30 [2.5" stroke]	5.5" or 6.0"	

15" x 8.625" Extended Service Brake Certificate of Compliance

This table certifies that the Hendrickson TRLAXLE non-integrated axles described below comply with the current revision of DOT 49 CFR 571.121 and Canadian Motor Vehicle Safety Standards, Service Brakes, Par. S5.4 and Parking Brakes, Par.5.6.1 when equipped as noted. **For certifications other than those listed below, please contact Hendrickson Brake Engineering for an application specific approval.**

BRAKE MODEL	LINING	BRAKE RATING	WHEN USED WITH:		
			CHAMBER SIZE	SLACK LENGTH	TIRE SLR
Bendix Spicer 15" x 8.625" (F.M.S.I. 4710)	Bendix Spicer ES460 / 3030-197	13,700 – 17,000	24/24 ² [2.5" stroke]	5.5" or 6.0"	14.9" – 17.3"
		13,700 – 18,750	or 24/30 ² [2.5" stroke]	6.0"	14.9" – 17.3"
		17,000 – 20,000	30/30 [2.5" stroke]	5.5" or 6.0"	14.9" – 17.3"

1. 15" brakes are usually used with 19.5" wheel equipment. Users should review tractor brake configurations to assure correct brake balance.
2. Do not use older Type 24 service chambers rated at 1.75" stroke.



16.5" x 7" Standard Model Brake Certificate of Compliance

This table certifies that the Hendrickson INTRAAX® and VANTRAAX® integrated suspension systems and TRLAXLE® non-integrated axles described below comply with the current revision of DOT 49 CFR 571.121 and Canadian Motor Vehicle Safety Standards, Service Brakes, Paragraph S5.4, and Parking Brakes, Paragraph 5.6.1, when equipped as noted.

For certifications other than those listed below, please contact Hendrickson Brake Engineering for an application specific approval. All tests were performed on 112-pound cast drums.

BRAKE MODEL	LINING	BRAKE RATING	WHEN USED WITH:		
			CHAMBER SIZE	SLACK LENGTH	TIRE SLR
HENDRICKSON 16.5" x 7" Standard (F.M.S.I. 4515)	H20167SF	17,000 – 20,000	30/30 [2.5" stroke]	5.5" or 6.0"	17" – 20.8"
	H23167SF	17,000 – 23,000			

16.5" x 7" Standard Model Brake Certificate of Compliance

This table certifies that the Hendrickson TRLAXLE non-integrated axles described below comply with the current revision of DOT 49 CFR 571.121 and Canadian Motor Vehicle Safety Standards, Service Brakes, Par. S5.4 and Parking Brakes, Par. 5.6.1 when equipped as noted. **For certifications other than those listed below, please contact Hendrickson Brake Engineering for an application specific approval.**

BRAKE MODEL	LINING	BRAKE RATING	WHEN USED WITH:		
			CHAMBER SIZE	SLACK LENGTH	TIRE SLR
Bendix Spicer 16.5" x 7" (F.M.S.I. 4515)	Bendix Spicer ES460 / 3030-197	17,000 – 20,000	30/30 [2.5" stroke]	5.5" or 6.0"	17" – 20.3"
	Bendix Spicer ES600 / 931-162	17,000 – 20,000		5.5" or 6.0"	17" – 20.8"
		20,000 – 22,500		6.0"	



16.5" x 7" HXS® Brake Certificate of Compliance

This table certifies that the Hendrickson INTRAAX® and VANTRAAX® integrated suspension systems and TRLAXLE® non-integrated axles described below comply with the current revision of DOT 49 CFR 571.121 and Canadian Motor Vehicle Safety Standards, Service Brakes, Paragraph S5.4, and Parking Brakes, Paragraph 5.6.1, when equipped as noted. **For certifications other than those listed below, please contact Hendrickson Brake Engineering for an application specific approval.** All test were performed on 112-pound cast drums. 120-pound heavy duty drums are required for applications greater than 23,000 lbs.

BRAKE MODEL	LINING	BRAKE RATING	WHEN USED WITH:		
			CHAMBER SIZE	SLACK LENGTH	TIRE SLR
HENDRICKSON 16.5" x 7" HXS® (F.M.S.I. 4707)	H20167XF	17,000 – 20,000	30/30 [2.5" stroke]	5.5" or 6.0"	17" – 20.8"
	H23167XF	17,000 – 23,000			
	Hendrickson ULTRA20™	17,000 – 20,000	30/30 [2.5" stroke]	5.5" or 6.0"	17" – 20.3"
	Abex NAB456	23,000 – 26,000		6.0"	17" – 20.8"

16.5" x 7" Extended Service Brake Certificate of Compliance

This table certifies that the Hendrickson TRLAXLE non-integrated axles described below comply with the current revision of DOT 49 CFR 571.121 and Canadian Motor Vehicle Safety Standards, Service Brakes, Par. S5.4 and Parking Brakes, Par.5.6.1 when equipped as noted. **For certifications other than those listed below, please contact Hendrickson Brake Engineering for an application specific approval.**

BRAKE MODEL	LINING	BRAKE RATING	WHEN USED WITH:		
			CHAMBER SIZE	SLACK LENGTH	TIRE SLR
Bendix Spicer 16.5" x 7" (F.M.S.I. 4707)	Bendix Spicer ES460 / 3030-197	17,000 – 20,000	30/30 [2.5" stroke]	5.5" or 6.0"	17" – 20.3"
	Bendix Spicer ES600 / 931-162	17,000 – 20,000		5.5" or 6.0"	17" – 20.8"
		20,000 – 22,500		6.0"	



16.5" x 8.625" HXS® Brake Certificate of Compliance

This table certifies that the Hendrickson INTRAAX® and VANTRAAX® integrated suspension systems and TRLAXLE® non-integrated axles described below comply with the current revision of DOT 49 CFR 571.121 and Canadian Motor Vehicle Safety Standards, Service Brakes, Paragraph S5.4, and Parking Brakes, Paragraph 5.6.1, when equipped as noted.

For certifications other than those listed below, please contact Hendrickson Brake Engineering for an application specific approval. All tests were performed on 123-pound cast drums.

BRAKE MODEL	LINING	BRAKE RATING	WHEN USED WITH:		
			CHAMBER SIZE	SLACK LENGTH	TIRE SLR
HENDRICKSON 16.5" x 8.625" HXS® (F.M.S.I. 4711)	H20168XF	17,000 – 20,000	30/30 [2.5" stroke]	5.5" or 6.0"	17" – 20.8"
		20,000 – 22,500		6.0"	
	H23168XF	17,000 – 23,000		5.5" or 6.0"	
		23,000 – 25,000		6.0"	
	Hendrickson ULTRAA20™	17,000 – 23,000	30/30 [2.5" stroke]	5.5" or 6.0"	17" – 20.8"
	Abex NAB456	23,000 – 25,000	30/30 [2.5" stroke]	5.5" or 6.0"	17" – 20.8"
		25,000 – 27,500	30/30 [3.0" stroke]	6.0"	17" – 20.8"



Air Disc Brake Certificate of Compliance

This table certifies that the Hendrickson INTRAAX® and VANTRAAX® integrated suspension systems and TRILAXLE® non-integrated axles described below comply with the current revision of DOT 49 CFR 571.121 and Canadian Motor Vehicle Safety Standards, Service Brakes, Par. S5.4 and Parking Brakes, Par. 5.6.1 when equipped as noted. **For certifications other than those listed below, please contact Hendrickson Brake Engineering for an application specific approval.**

BRAKE MODEL	BRAKE ROTOR	LINING	BRAKE RATING	WHEN USED WITH:	
				CHAMBER SIZE	TIRE SLR
Haldex DB22 Caliper	430mm x 45mm Rotor	Jurid 539	17,000 – 23,000	20/30	17" – 20.8"
Bendix Spicer (Knorr) ADB22X Caliper	430mm x 45mm Rotor	Jurid 539 (BX235)	17,000 – 23,000	18/24	17" – 20.8"
Meritor Wabco PAN22	430mm x 45mm Rotor	Wabco 230	17,000 – 23,000	20/24	17" – 20.8"

Important Air Disc Application Information

- 1. Wheel and Valve Stem Packaging** Great care must be taken in selecting combinations of wheel and valve stem products that are compatible with air disc brakes. OEM customers will need to review wheel-end and valve stem packaging with the selected disc brake manufacturer to confirm adequate running clearances. Hendrickson Brake Engineering will assist customers in discussions with the disc brake manufacturer.
- 2. ABS Sensors** Hendrickson fully dressed air disc brake suspensions require straight ABS sensors. Depending on caliper model, ABS sensing may be via hub-mounted tone rings or rotor-mounted tone rings.
- 3. Air Chamber Selection and Vehicle Balance** Default air chamber selection is based on the choice of caliper brand and lining. Additional sizes are available if necessary. Trailer OEM customers are encouraged to work with end customers to review mating tractor brake specifications and determine if combined vehicle brake balance is correct for the application. Hendrickson Brake Engineering will assist customers in discussions with the disc brake manufacturer.
- 4. Air Disc Application Form** Required by air disc manufacturer for North American applications — See *L895 ORDERING GUIDE / APPLICATION FORM — AIR DISC BRAKES*

Call your trailer dealer or Hendrickson at 330.489.0045 or 866.RIDEAIR (743.3247) for additional information.



www.hendrickson-intl.com

TRAILER COMMERCIAL VEHICLE SYSTEMS
 2070 Industrial Place SE
 Canton, OH 44707-2641 USA
 866.RIDEAIR (743.3247)
 330.489.0045 • Fax 800.696.4416

Hendrickson Canada
 250 Chrysler Drive, Unit #3
 Brampton, ON Canada L6S 6B6
 800.668.5360
 905.789.1030 • Fax 905.789.1033

Hendrickson Mexicana
 Circuito El Marqués Sur #29
 Parque Industrial El Marqués
 Pob. El Colorado, Municipio El Marqués,
 Querétaro, México C.P. 76246
 +52 (442) 296.3600 • Fax +52 (442) 296.3601