

NEXT-GEN ALL-TEMP



LOW PROFILE UNIT COOLER

AIR, ELECTRIC & HOT GAS DEFROST MODELS
2,700 to 45,900 BTUH

SMALL TO MEDIUM WALK-INS
COOLER & FREEZER APPLICATIONS



Features

Kramer Low Profile Unit Coolers feature an air draw-through design and are available in air, electric and hot gas defrost configurations. We've taken these all-purpose unit coolers to the next level with the release of the Next-Gen All-Temp models. The units feature a new fan guard design and deep draw venturi to achieve optimal airflow, easy access for serviceability, and can be used with multiple refrigerants.

SIZES

There are a wide array of sizes available with capacities ranging from 2,700 to 45,900 BTUH at a 10° TD. One through six fan models are available with air flow spanning a range of 800 to 4,650 CFM.

HOUSING

The embossed aluminum casing is lightweight yet durable. Each fan section is baffled to prevent short cycling of the discharge air. The units are designed to mount flush to the ceiling and are compliant with NSF requirements. The top panel includes 1/2" wide slotted mounting points to simplify installation. The removable drain fitting is installed into the bottom of the drain pan for easy field connection and it can be quickly replaced without changing out the entire drain pan. End panels can be slid out from the front of the unit providing easy serviceability from the front or side of the unit, allowing convenient access to the roomy electrical and piping compartments.

COIL

Copper hairpins consist of high efficiency 3/8" enhanced copper tubes which are staggered and mechanically expanded into corrugated aluminum fins achieving maximum heat transfer while reducing refrigerant charge. Die formed fin collars provide even fin spacing. Models are available in 4 and 6 fins per inch (FPI). Sweat connections are standard on all models.

MOTORS

Standard models feature highly efficient Dual Speed Electronically Commutated (EC) motors. Dual Speed EC motors are available for 115V or 208/230V and are compliant with California Title 24 regulations. All motors include thermal overload protection.

FANS

Heavy duty 12" aluminum fans are balanced to provide vibration-free operation. Improved black plastic fan guard design and deep draw venturi achieve optimal air pattern.

ELECTRICAL

Available for 115V and 208/230V. A large electrical compartment is supplied internal to the unit to house the electrical components and is easily accessible by removing the slide out end panel. All models are UL and cUL listed and are available for 60 Hz or 50 Hz applications.

AIR DEFROST

Air Defrost models (KL6A) are designed for use in coolers 35°F and warmer. All components are factory wired to convenient screw-type terminal strips.

ELECTRIC DEFROST

Electric Defrost 6 FPI models (KL6E) are designed for use in coolers and freezers between 34°F to -20°F. Electric Defrost 4 FPI models (KL4E) are designed for use in freezers between 32°F to -20°F. Defrost heaters are mounted on the air intake side of the unit for optimal performance and easy maintenance. A lower heater is installed inside the drain pan for fast, reliable drainage. A defrost termination fan delay thermostat (DTFD) terminates the defrost cycle when the temperature is satisfied. The fan delay allows the warm coil to cool after a defrost cycle prior to the fans turning on. A heater safety thermostat is installed to prevent overheating.

HOT GAS DEFROST

There are two types of Hot Gas Defrost models available: 3-pipe Hot Gas models (KL*H) and 2-pipe Hot Gas Reverse Cycle units (KL*G) (see pages 8 and 9 for more details). Hot Gas Defrost 6 FPI models (KL6H, KL6G) are designed for use in coolers and freezers between 34°F and -20°F. Hot Gas Defrost 4 FPI models (KL4H, KL4G) are designed for use in freezers between 32°F and -20°F. All Hot Gas units include a fixed DTFD factory wired and an electric drain pan heater.

Optional Features

- EcoNet® Enabled Controller¹ factory-installed
- EcoNet® Command Center (loose)
- Thermostat - Mechanical or Electric (mounted or loose)
- Thermostatic Expansion Valve (mounted or loose)
- Electronic Expansion Valve (mounted or loose)
- Liquid Line Solenoid Valve (mounted or loose)
- Insulated Drain Pan
- Painted Cabinet (White or Black)
- Coated Cabinet
- Stainless Steel Cabinet
- Coated Coil (Russproof, Heresite, Bronz-Glow, or Electrofin®)
- Heat Exchanger (loose)

Note

¹ EcoNet Control Package includes: EEV; suction pressure transducer; suction, entering air coil temp. thermistors; local on-board two-row LCD display and push-button adjustments. (Controller replaces TXV, liquid line solenoid valve, room thermostat, defrost termination and fan delay, and time clock.) EcoNet is not available in 208-230/3/60.

Highlighted Features and Options

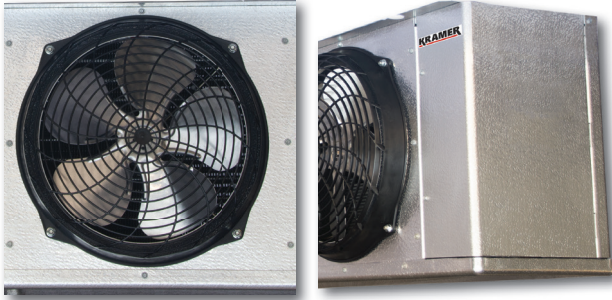

FANS AND HOUSING

- 12" heavy duty aluminum fans are balanced for vibration-free operation
- High efficiency fan guard design and deep draw venturi provide optimal air flow
- Mounts flush to ceiling
- Slide out end panels
- NSF approved



COILS AND DEFROST HEATERS

- Available in 4 or 6 fins per inch (FPI)
- Electric defrost heaters are mounted on the air intake coil face to provide optimal performance and easy service access
- The drain pan heater is affixed to the drain pan and is easily removable for service or cleaning



ECONET ENABLED UNIT COOLERS (Optional)

- Developed in conjunction with Rheem Manufacturing specifically for walk-in coolers and freezers — it builds on the reliability and efficiency of Rheem's EcoNet technology
- Saves energy in refrigeration systems through precise superheat and space temperature control, fan cycling, and controlling how often the system goes into defrost based on compressor runtime
 - Eliminates unnecessary defrosts
 - Maximizes energy efficiency with less compressor runtime
 - Reduces fan speed to 50% during off cycle for energy savings
- Can be used with a condensing unit in single and multiple evaporator installations as a group
- Optional **EcoNet Command Center** with intuitive graphical interface controls up to 32 devices (including the Command Center) through one display, provides continuous communication between system components, and the remote mount display allows for EcoNet Enabled Unit Coolers to be programmed, monitored and troubleshoot outside of the space being cooled

ELECTRICAL AND PIPING

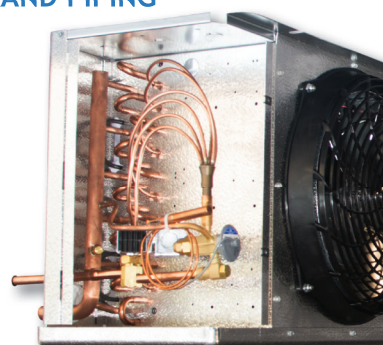

Unit shown with optional components installed

- End panels slide out for easy service from the front or sides of the unit
- Ample room in electrical and piping compartments for easy access

MODEL NUMBER NOMENCLATURE

CONFIGURABLE BASE MODEL								PRE-CONFIGURATION CODES ²	
K	L	6	E	042	D	D	A	A	L
Brand	Connections ¹	Fins Per Inch	Defrost Type	BTUH in Hundreds	Unit Voltage	Motor Type	Revision	Refrigerant	Pre-assembly Code
K = Kramer	L = Standard U = Reverse	6 FPI 4 FPI	A = Air E = Electric H = Hot Gas 3-Pipe G = Hot Gas Reverse Cycle		A = 115/1/60 D = 208-230/1/60 E = 208-230/3/60	D - Dual Speed EC		A = R404A R = EcoNet Approved Refrigerants ³ S = R407A, R448A, R449A/B	E = EcoNet Control Package ⁴ L = Mounted TXV, LLSV & Mechanical Thermostat ⁵

Note(s):

- Refrigerant and electrical connection locations have been changed for the Next-Gen All-Temp design. Standard connections "L" are now opposite of the legacy All-Temp models. Mirror connections "U" are the same end as legacy All-Temp models and are available only as built-to-order base units with no installed options.
- Pre-Configuration Codes are used to show common Factory Mounted options. Pre-Configuration Codes are not available for every model. For specific model availability, see the respective Pre-Configuration pricing tables in the Russell List Price or contact your local Russell sales representative.
- EcoNet approved refrigerants are: R404A, R407A, R407C, R448A, R449A/B, R450A, R507A, R513A.
- EcoNet Control Package includes: EEV; suction pressure transducer; suction, entering air coil temp. thermistors; local on-board two-row LCD display and push-button adjustments. (Controller replaces TXV, liquid line solenoid valve, room thermostat, defrost termination and fan delay, and time clock.)
- Models with Pre-configured Mechanical Components (TXV, LLSV and Thermostat) are rated for +25°FSS/10°FDT (Air Defrost) and -20°FSS/10°FDT (Electric Defrost).
- CO₂ and Glycol Next-Gen All-Temp Unit Coolers available. If required, please contact factory.

EVAPORATOR APPLICATION RATINGS

Multiple conditions combine to determine the application capacity of an evaporator. Walk-in space temperature, relative humidity, saturated suction temperature difference, and outdoor ambient temperature. All of the factors are considered when calculating an evaporator application rating. These ratings are considerably higher than the net capacity value used for DOE ratings (AWEF).

The AWEF of an evaporator is calculated using the dry coil capacity and the daily evaporator power consumption. Power consumption included fan and defrost power. Evaporator net capacity reported to the DOE database is dry coil capacity less the full power fan watts. DOE test conditions are at 10°F evaporator/SST temperature difference and less than 50% relative humidity and 96°F liquid temperature. These conditions create a uniform test method, but should not be used for equipment selection. The equipment selected would be too large for the application.

Kramer's published application ratings are a guideline for proper equipment selection. They account for true operating conditions experienced by equipment.

Application Rating and Electrical Data - Air Defrost Models - 6 FPI

Model Number	BTUH Capacity @ 25°F S.T. & 10°F TD		CFM	No. of Fans	Total Fan Motor AMPS - 1 Phase		MCA	MOPD
	R404A/CO ₂ DX	R407A/R448A/R449A/B [^]			EC Motors [†]			
					115V	208-230V	115V/208-230V	115V/208-230V
KL6A041*DA	4,100	4,800	800	1	0.8	0.5		
KL6A052*DA	5,200	6,000	785	1	0.8	0.5	15.0	20
KL6A066*DA	6,600	7,800	775	1	0.8	0.5		
KL6A073*DA	7,300	8,500	1,600	2	1.6	1.0		
KL6A094*DA	9,400	10,900	1,570	2	1.6	1.0	15.0	20
KL6A117*DA	11,700	13,600	1,550	2	1.6	1.0		
KL6A130*DA	13,000	15,300	1,550	2	1.6	1.0		
KL6A141*DA	14,100	16,300	2,355	3	2.4	1.5		
KL6A161*DA	16,100	18,800	2,355	3	2.4	1.5	15.0	20
KL6A181*DA	18,100	21,200	2,325	3	2.4	1.5		
KL6A195*DA	19,500	22,500	3,140	4	3.2	2.0		
KL6A235*DA	23,500	27,800	3,140	4	3.2	2.0	15.0	20
KL6A260*DA	26,000	30,400	3,100	4	3.2	2.0		
KL6A295*DA	29,500	36,100	3,875	5	4.0	2.5	15.0	20
KL6A330*DA	33,000	38,800	4,650	6	4.8	3.0	15.0	20
KL6A390*DA	39,000	45,900	4,650	6	4.8	3.0		

* Each asterisk represents a variable character based on voltage ordered. See page 4 for nomenclature.

[^] Refrigerants with large glides are rated at dew point temperature. Use R407A capacity ratings for R407C and R407F.

[†] Dual-speed EC motors are compliant with California Title 24 regulations.

Models were designed in anticipation of the July 2020 Department of Energy AWEF regulations for evaporators for Walk-in Coolers and Freezers in boxes less than 3,000 sq. ft. See page 14 for AWEF compliance ratings.

Mounts flush to the ceiling to maximize storage space

UL certified for use with multiple refrigerants

Single fan through six fan models are available



Application Rating and Electrical Data - Electric Defrost Models - 6 FPI

Model Number	BTUH Capacity @ -20°F S.T. & 10°F TD ¹		CFM	No. of Fans	Total Fan Motor AMPS - 1 Phase	208-230V/1			
	R404A / CO ₂ DX	R407A/ R448A/ R449A/B [^]				MCA		MOPD	
					230V	Base Model ²	EcoNet Enabled ³	Base Model ²	EcoNet Enabled ³
KL6E035DDA	3,500	4,000	800	1	0.5				
KL6E042DDA	4,200	4,900	785	1	0.5	15.0	15.0	20	20
KL6E049DDA	4,900	5,600	775	1	0.5				
KL6E066DDA	6,600	7,600	1,600	2	1.0				
KL6E077DDA	7,700	8,800	1,570	2	1.0	15.0	15.0	20	20
KL6E090DDA	9,000	10,600	1,550	2	1.0				
KL6E105DDA	10,500	12,400	1,550	2	1.0				
KL6E121DDA	12,100	14,200	2,355	3	1.5	15.0	15.0	20	20
KL6E142DDA	14,200	16,600	2,325	3	1.5				
KL6E162DDA	16,200	18,700	3,140	4	2.0	15.0	19.2	20	20
KL6E182DDA	18,200	21,000	3,100	4	2.0				
KL6E200*DA	20,000	22,800	3,925	5	2.5	15.0	24.1	20	30
KL6E244*DA	24,400	27,900	4,710	6	3.0	15.0	29.0	20	30
KL6E281*DA	28,100	33,000	4,650	6	3.0				

Model Number	208-230V/3		Heater Amps		Heater Watts
	MCA	MOPD	230V		
	Base Model ²	Base Model ²	1PH	3PH	
KL6E035DDA			4.9	-	1,125
KL6E042DDA	-	-	4.9	-	1,125
KL6E049DDA			4.9	-	1,125
KL6E066DDA			9.8	-	2,250
KL6E077DDA	-	-	9.8	-	2,250
KL6E090DDA			9.8	-	2,250
KL6E105DDA			9.8	-	2,250
KL6E121DDA	-	-	14.3	-	3,300
KL6E142DDA			14.3	-	3,300
KL6E162DDA	-	-	19.2	-	4,425
KL6E182DDA			19.2	-	4,425
KL6E200*DA	15.0	20	24.1	14.0	5,550
KL6E244*DA	15.0	20	29.0	16.8	6,675
KL6E281*DA			29.0	16.8	6,675

See notes on page 7.

Application Rating and Electrical Data - Electric Defrost - 4 FPI

Model Number	BTUH Capacity @ -20°F S.T. & 10°F TD ¹		CFM	No. of Fans	Total Fan Motor AMPS - 1 Phase	208-230V/1				
	R404A / CO ₂ DX	R407A/ R448A/ R449A/B [^]				EC Motors [†]		MCA		MOPD
					230V		Base Model ²	EcoNet Enabled ³	Base Model ²	EcoNet Enabled ³
KL4E027DDA	2,700	3,100	800	1	0.5					
KL4E032DDA	3,200	3,800	785	1	0.5	15.0	15.0	20	20	
KL4E038DDA	3,800	4,400	775	1	0.5					
KL4E051DDA	5,100	5,900	1,600	2	1.0					
KL4E064DDA	6,400	7,300	1,570	2	1.0	15.0	15.0	20	20	
KL4E080DDA	8,000	9,500	1,550	2	1.0					
KL4E094DDA	9,400	11,000	2,355	3	1.5	15.0	15.0	20	20	
KL4E110DDA	11,000	12,800	2,325	3	1.5					
KL4E125DDA	12,500	14,400	3,140	4	2.0	15.0	19.2	20	20	
KL4E141DDA	14,100	16,300	3,100	4	2.0					
KL4E155*DA	15,500	17,700	3,925	5	2.5	15.0	24.1	20	30	
KL4E195*DA	19,500	22,300	4,710	6	3.0	15.0	29.0	20	30	
KL4E230*DA	23,000	27,000	4,650	6	3.0					

Model Number	208-230V/3		Heater Amps		Heater Watts
	MCA	MOPD	230V		
	Base Model ²	Base Model ²	1PH	3PH	
KL4E027DDA			4.9	–	1,125
KL4E032DDA	–	–	4.9	–	1,125
KL4E038DDA			4.9	–	1,125
KL4E051DDA			9.8	–	2,250
KL4E064DDA	–	–	9.8	–	2,250
KL4E080DDA			9.8	–	2,250
KL4E094DDA			14.3	–	3,300
KL4E110DDA	–	–	14.3	–	3,300
KL4E125DDA			19.2	–	4,425
KL4E141DDA	–	–	19.2	–	4,425
KL4E155*DA	15.0	20	24.1	14.0	5,550
KL4E195*DA	15.0	20	29.0	16.8	6,675
KL4E230*DA	15.0	20	29.0	16.8	6,675

Notes: 1.

Capacity Correction for Electric and Hot Gas Defrost Evaporators					
S.S.T. (Dew)	20°F	0°F	-10°F	-20°F	-30°F
Multiply Capacity by:	1.15	1.075	1.0375	1	0.9625

2. Base Model MCA/MOPD Represents Motor Circuit since Defrost Heaters are powered via the Condensing Unit.

3. EcoNet Enabled Units are not powered by Condensing Unit so Defrost Heaters are incorporated into shown MCA/MOPD. EcoNet is not available on 208-230/3/60.

* Each asterisk represents a variable character based on voltage ordered. See page 4 for nomenclature.

[^] Refrigerants with large glides are rated at dew point temperature. Use R407A capacity ratings for R407C and R407F.

[†] Dual Speed EC motors are compliant with California Title 24 regulations.

– Model not available.

Models were designed in anticipation of the July 2020 Department of Energy AWEF regulations for evaporators for Walk-in Coolers and Freezers in boxes less than 3,000 sq. ft. See pages 14-15 for AWEF compliance ratings.

Application Rating and Electrical Data - Hot Gas Defrost - 6 FPI

Hot Gas 3-Pipe Model Number	Hot Gas Reverse Cycle 2-Pipe Model Number	BTUH Capacity @ -20°F S.T. & 10°F TD ¹		CFM	No. of Fans	Total Fan Motor AMPS - 1 Phase		115V/ 208-230V	
		R404A / CO ₂ DX	R407A / R448A / R449A/B [^]			EC Motors [†]		MCA ²	MOPD ²
						115V	208-230V		
KL6H035*DA	KL6G035*DA	3,500	4,000	800	1	0.8	0.5	15.0	20
KL6H042*DA	KL6G042*DA	4,200	4,900	785	1	0.8	0.5		
KL6H049*DA	KL6G049*DA	4,900	5,600	775	1	0.8	0.5		
KL6H066*DA	KL6G066*DA	6,600	7,600	1,600	2	1.6	1.0	15.0	20
KL6H077*DA	KL6G077*DA	7,700	8,800	1,570	2	1.6	1.0		
KL6H090*DA	KL6G090*DA	9,000	10,600	1,550	2	1.6	1.0		
KL6H105*DA	KL6G105*DA	10,500	12,400	1,550	2	1.6	1.0		
KL6H121*DA	KL6G121*DA	12,100	14,200	2,355	3	2.4	1.5	15.0	20
KL6H142*DA	KL6G142*DA	14,200	16,600	2,325	3	2.4	1.5		
KL6H162*DA	KL6G162*DA	16,200	18,700	3,140	4	3.2	2.0	15.0	20
KL6H182*DA	KL6G182*DA	18,200	21,000	3,100	4	3.2	2.0		
KL6H200*DA	KL6G200*DA	20,000	22,800	3,925	5	4.0	2.5	15.0	20
KL6H244*DA	KL6G244*DA	24,400	27,900	4,710	6	4.8	3.0	15.0	20
KL6H281*DA	KL6G281*DA	28,100	33,000	4,650	6	4.8	3.0		

Hot Gas 3-Pipe Model Number	Hot Gas Reverse Cycle 2-Pipe Model Number	Drain Pan Heater Amps		Drain Pan Heater Watts
		115V	230V	
		1PH	1PH	
KL6H035*DA	KL6G035*DA	3.1	1.7	375
KL6H042*DA	KL6G042*DA	3.1	1.7	375
KL6H049*DA	KL6G049*DA	3.1	1.7	375
KL6H066*DA	KL6G066*DA	6.3	3.3	750
KL6H077*DA	KL6G077*DA	6.3	3.3	750
KL6H090*DA	KL6G090*DA	6.3	3.3	750
KL6H105*DA	KL6G105*DA	6.3	3.3	750
KL6H121*DA	KL6G121*DA	9.3	4.8	1,100
KL6H142*DA	KL6G142*DA	9.3	4.8	1,100
KL6H162*DA	KL6G162*DA	12.3	6.4	1,475
KL6H182*DA	KL6G182*DA	12.3	6.4	1,475
KL6H200*DA	KL6G200*DA	15.4	8.1	1,850
KL6H244*DA	KL6G244*DA	18.5	9.7	2,225
KL6H281*DA	KL6G281*DA	18.5	9.7	2,225

See notes on page 9.

Hot Gas 3-Pipe Model

The system uses 3 pipes — 1 for liquid line, 1 for suction line and 1 for hot gas. The hot gas is taken from the discharge line, between the compressor and the condenser, through a hot-gas solenoid valve to the distributor tee then through the coil.

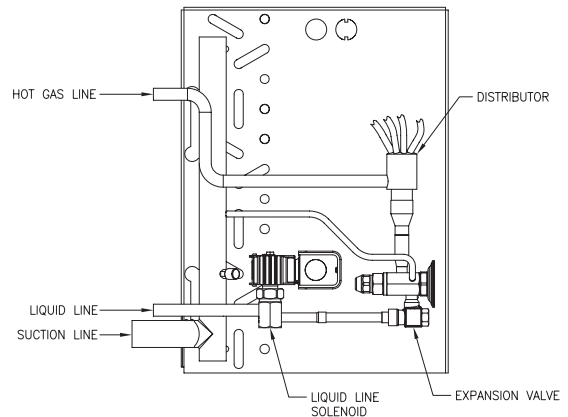

Application Rating and Electrical Data - Hot Gas Defrost - 4 FPI

Hot Gas 3-Pipe Model Number	Hot Gas Reverse Cycle 2-Pipe Model Number	BTUH Capacity @ -20°F S.T. & 10°F TD ¹		CFM	No. of Fans	Total Fan Motor AMPS - 1 Phase		115V/ 208-230V	
		R404A / CO ₂ DX	R407A/ R448A/ R449A/B [^]			EC Motors [†]		MCA ²	MOPD ²
						115V	208-230V		
KL4H027*DA	KL4G027*DA	2,700	3,100	800	1	0.8	0.5		
KL4H032*DA	KL4G032*DA	3,200	3,800	785	1	0.8	0.5	15.0	20.0
KL4H038*DA	KL4G038*DA	3,800	4,400	775	1	0.8	0.5		
KL4H051*DA	KL4G051*DA	5,100	5,900	1,600	2	1.6	1.0		
KL4H064*DA	KL4G064*DA	6,400	7,300	1,570	2	1.6	1.0	15.0	20.0
KL4H080*DA	KL4G080*DA	8,000	9,500	1,550	2	1.6	1.0		
KL4H094*DA	KL4G094*DA	9,400	11,000	2,355	3	2.4	1.5		
KL4H110*DA	KL4G110*DA	11,000	12,800	2,325	3	2.4	1.5	15.0	20.0
KL4H125*DA	KL4G125*DA	12,500	14,400	3,140	4	3.2	2.0		
KL4H141*DA	KL4G141*DA	14,100	16,300	3,100	4	3.2	2.0	15.0	20.0
KL4H155*DA	KL4G155*DA	15,500	17,700	3,925	5	4.0	2.5	15.0	20.0
KL4H195*DA	KL4G195*DA	19,500	22,300	4,710	6	4.8	3.0		
KL4H230*DA	KL4G230*DA	23,000	27,000	4,650	6	4.8	3.0	15.0	20.0

Hot Gas 3-Pipe Model Number	Hot Gas Reverse Cycle 2-Pipe Model Number	Drain Pan Heater Amps		Drain Pan Heater Watts
		115V	230V	
		1PH	1PH	
KL4H027*DA	KL4G027*DA	3.1	1.7	375
KL4H032*DA	KL4G032*DA	3.1	1.7	375
KL4H038*DA	KL4G038*DA	3.1	1.7	375
KL4H051*DA	KL4G051*DA	6.3	3.3	750
KL4H064*DA	KL4G064*DA	6.3	3.3	750
KL4H080*DA	KL4G080*DA	6.3	3.3	750
KL4H094*DA	KL4G094*DA	9.3	4.8	1,100
KL4H110*DA	KL4G110*DA	9.3	4.8	1,100
KL4H125*DA	KL4G125*DA	12.3	6.4	1,475
KL4H141*DA	KL4G141*DA	12.3	6.4	1,475
KL4H155*DA	KL4G155*DA	15.4	8.1	1,850
KL4H195*DA	KL4G195*DA	18.5	9.7	2,225
KL4H230*DA	KL4G230*DA	18.5	9.7	2,225

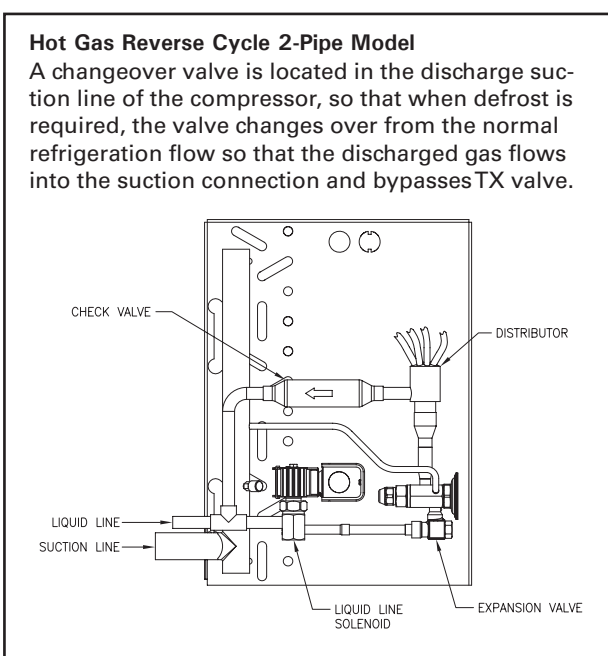

Notes: 1.

Capacity Correction for Electric and Hot Gas Defrost Evaporators					
S.S.T. (Dew)	20°F	0°F	-10°F	-20°F	-30°F
Multiply Capacity by:	1.15	1.075	1.0375	1	0.9625

2. Base Model MCA/MOPD Represents Motor Circuit since Defrost Heaters are powered via the Condensing Unit.

* Each asterisk represents a variable character based on voltage ordered. See page 4 for nomenclature.

^ Refrigerants with large glides are rated at dew point temperature. Use R407A capacity ratings for R407C and R407F.

† Dual Speed EC motors are compliant with California Title 24 regulations.

Models were designed in anticipation of the July 2020 Department of Energy AWEF regulations for evaporators for Walk-in Coolers and Freezers in boxes less than 3,000 sq. ft. See page 15 for AWEF compliance ratings.

Distributor Nozzle and Expansion Valves - Air Defrost Models

Model Number	Part Numbers						No. of Circuits
	Nozzle @ Liq. Temp.		TXV^ @ Liq. Temp.		EEV @ Liq. Temp.		
	50°F	100°F	50°F	100°F	50°F	100°F	

R404A

6 FPI	KL6A041*DA	-	-	SBFSE-AAA-C	SBFSE-AA-C	SER-AA	SER-AA	1
	KL6A052*DA	-	-	SBFSE-AA-C	SBFSE-AA-C	SER-AA	SER-A	1
	KL6A066*DA	L, #1/4	L, #3/4	SBFSE-AA-C	SBFSE-A-C	SER-A	SER-A	2
	KL6A073*DA	L, #1/4	L, #3/4	SBFSE-AA-C	SBFSE-A-C	SER-A	SER-A	2
	KL6A094*DA	L, #1/4	L, #1	SBFSE-A-C	SBFSE-A-C	SER-A	SER-B	2
	KL6A117*DA	L, #1/3	L, #1-1/2	SBFSE-A-C	SBFSE-A-C	SER-A	SER-B	3
	KL6A130*DA	L, #1/2	L, #1-1/2	SBFSE-A-C	SBFSE-B-C	SER-B	SER-B	3
	KL6A141*DA	L, #1/2	L, #1-1/2	SBFSE-A-C	SBFSE-B-C	SER-B	SER-B	4
	KL6A161*DA	L, #1/2	L, #1-1/2	SBFSE-A-C	SBFSE-B-C	SER-B	SER-C	3
	KL6A181*DA	L, #1/2	L, #2	SBFSE-B-C	SBFSE-B-C	SER-B	SER-C	4
	KL6A195*DA	L, #3/4	L, #2	SBFSE-B-C	SBFSE-B-C	SER-B	SER-C	4
	KL6A235*DA	L, #3/4	L, #2-1/2	SBFSE-B-C	SBFSE-C-C	SER-C	SER-C	6
	KL6A260*DA	L, #3/4	L, #2-1/2	SBFSE-B-C	SBFSE-C-C	SER-C	SER-C	6
	KL6A295*DA	L, #1	L, #3	SBFSE-B-C	SBFSE-C-C	SER-C	SER-C	8
	KL6A330*DA	L, #1	L, #4	SBFSE-C-C	EBSSE-6-C	SER-C	SER-C	7
KL6A390*DA	L, #1-1/2	L, #4	SBFSE-C-C	EBSSE-6-C	SER-C	SER-C	8	

R407A/ R448A/ R449A/B†

6 FPI	KL6A041*DA	-	-	SBFDE-AA-C	SBFDE-AA-C	SER-AA	SER-AA	1
	KL6A052*DA	-	-	SBFDE-AA-C	SBFDE-AA-C	SER-AA	SER-AA	1
	KL6A066*DA	L, #1/4	L, #3/4	SBFDE-AA-C	SBFDE-AA-C	SER-A	SER-A	2
	KL6A073*DA	L, #1/4	L, #3/4	SBFDE-AA-C	SBFDE-AA-C	SER-A	SER-A	2
	KL6A094*DA	L, #1/3	L, #1	SBFDE-AA-C	SBFDE-A-C	SER-A	SER-A	2
	KL6A117*DA	L, #1/2	L, #1-1/2	SBFDE-A-C	SBFDE-A-C	SER-A	SER-B	3
	KL6A130*DA	L, #1/2	L, #1-1/2	SBFDE-A-C	SBFDE-A-C	SER-B	SER-B	3
	KL6A141*DA	L, #1/2	L, #1-1/2	SBFDE-A-C	SBFDE-A-C	SER-B	SER-B	4
	KL6A161*DA	L, #3/4	L, #1-1/2	SBFDE-A-C	SBFDE-B-C	SER-B	SER-B	3
	KL6A181*DA	L, #3/4	L, #2	SBFDE-A-C	SBFDE-B-C	SER-B	SER-B	4
	KL6A195*DA	L, #3/4	L, #2	SBFDE-A-C	SBFDE-B-C	SER-B	SER-B	4
	KL6A235*DA	L, #1	L, #2-1/2	SBFDE-B-C	SBFDE-B-C	SER-B	SER-C	6
	KL6A260*DA	L, #1	L, #2-1/2	SBFDE-B-C	SBFDE-C-C	SER-C	SER-C	6
	KL6A295*DA	L, #1-1/2	L, #3	SBFDE-B-C	SBFDE-C-C	SER-C	SER-C	8
	KL6A330*DA	L, #1-1/2	L, #3	SBFDE-B-C	SBFDE-C-C	SER-C	SER-C	7
KL6A390*DA	L, #1-1/2	L, #4	SBFDE-C-C	SBFDE-C-C	SER-C	SER-C	8	

Distributor lines are 3/16" diameter and 14" long. Distributor connection size is 1/2" for all air defrost models.

* Each asterisk represents a variable character based on voltage ordered. See page 4 for nomenclature.

- Single feed circuit coils do not get a distributor/nozzle. Line breaks in the table above are per number of fans.

^ TXV selections are based on +25°F suction temp., 8°F to 12°F evaporator TD. Contact factory for operating conditions outside of this range.

† SBFDE expansion valves are compatible with R407A, R448A and R449A/B. For other valves, follow manufacturers selection guidelines.

Base models (no factory-mounted components) include nozzles sized for 100°F liquid shipped loose.

Distributor Nozzle and Expansion Valves - Electric Defrost Models

Model Number	Part Numbers						No. of Circuits	
	Nozzle @ Liq. Temp.		TXV [^] @ Liq. Temp.		EEV @ Liq. Temp.			
	50°F	100°F	50°F	100°F	50°F	100°F		
R404A								
6 FPI	KL6E035DDA	-	-	SBFSE-AAA-ZP	SBFSE-AA-ZP	SER-AA	SER-AA	1
	KL6E042DDA	L, #1/3	L, #3/4	SBFSE-AA-ZP	SBFSE-AA-ZP	SER-AA	SER-AA	2
	KL6E049DDA	L, #1/2	L, #1	SBFSE-AA-ZP	SBFSE-A-ZP	SER-AA	SER-A	2
	KL6E066DDA	L, #1/2	L, #1	SBFSE-AA-ZP	SBFSE-A-ZP	SER-A	SER-A	2
	KL6E077DDA	L, #3/4	L, #1-1/2	SBFSE-A-ZP	SBFSE-A-ZP	SER-A	SER-A	3
	KL6E090DDA	L, #3/4	L, #1-1/2	SBFSE-A-ZP	SBFSE-A-ZP	SER-A	SER-A	5
	KL6E105DDA	L, #1	L, #2	SBFSE-A-ZP	SBFSE-B-ZP	SER-A	SER-B	6
	KL6E121DDA	L, #1	L, #2	SBFSE-A-ZP	SBFSE-B-ZP	SER-B	SER-B	6
	KL6E142DDA	L, #1-1/2	L, #2-1/2	SBFSE-A-ZP	SBFSE-B-ZP	SER-B	SER-B	6
	KL6E162DDA	L, #1-1/2	L, #2-1/2	SBFSE-B-ZP	SBFSE-C-ZP	SER-B	SER-B	6
KL6E182DDA	L, #1-1/2	L, #3	SBFSE-B-ZP	SBFSE-C-ZP	SER-B	SER-C	6	
KL6E200*DA	L, #1-1/2	L, #3	SBFSE-B-ZP	SBFSE-C-ZP	SER-B	SER-C	6	
KL6E244*DA	L, #2	L, #4	SBFSE-C-ZP	EBSSSE-6-ZP	SER-C	SER-C	9	
KL6E281*DA	G, #2-1/2	G, #5	SBFSE-C-ZP	EBSSSE-6-ZP	SER-C	SER-C	12	
4 FPI	KL4E027DDA	-	-	SBFSE-AAA-ZP	SBFSE-AA-ZP	SER-AA	SER-AA	1
	KL4E032DDA	-	-	SBFSE-AA-ZP	SBFSE-AA-ZP	SER-AA	SER-AA	1
	KL4E038DDA	L, #1/3	L, #3/4	SBFSE-AA-ZP	SBFSE-AA-ZP	SER-AA	SER-AA	2
	KL4E051DDA	L, #1/2	L, #1	SBFSE-AA-ZP	SBFSE-A-ZP	SER-AA	SER-A	2
	KL4E064DDA	L, #1/2	L, #1-1/2	SBFSE-AA-ZP	SBFSE-A-ZP	SER-A	SER-A	3
	KL4E080DDA	L, #3/4	L, #1-1/2	SBFSE-A-ZP	SBFSE-A-ZP	SER-A	SER-A	6
	KL4E094DDA	L, #3/4	L, #2	SBFSE-A-ZP	SBFSE-A-ZP	SER-A	SER-B	6
	KL4E110DDA	L, #1	L, #2	SBFSE-A-ZP	SBFSE-B-ZP	SER-A	SER-B	6
	KL4E125DDA	L, #1	L, #2-1/2	SBFSE-A-ZP	SBFSE-B-ZP	SER-B	SER-B	6
	KL4E141DDA	L, #1	L, #2-1/2	SBFSE-A-ZP	SBFSE-B-ZP	SER-B	SER-B	6
KL4E155*DA	L, #1-1/2	L, #2-1/2	SBFSE-A-ZP	SBFSE-C-ZP	SER-B	SER-B	6	
KL4E195*DA	L, #2	L, #4	SBFSE-B-ZP	SBFSE-C-ZP	SER-B	SER-C	9	
KL4E230*DA	G, #2	G, #4	SBFSE-C-ZP	SBFSE-C-ZP	SER-B	SER-C	12	
R407A/ R448A/ R449A/B†								
6 FPI	KL6E035DDA	-	-	SBFDE-AA-ZP	SBFDE-AA-ZP	SER-AA	SER-AA	1
	KL6E042DDA	L, #1/3	L, #3/4	SBFDE-AA-ZP	SBFDE-AA-ZP	SER-AA	SER-AA	2
	KL6E049DDA	L, #1/3	L, #3/4	SBFDE-AA-ZP	SBFDE-AA-ZP	SER-AA	SER-AA	2
	KL6E066DDA	L, #1/2	L, #1	SBFDE-AA-ZP	SBFDE-A-ZP	SER-A	SER-A	2
	KL6E077DDA	L, #3/4	L, #1	SBFDE-A-ZP	SBFDE-A-ZP	SER-A	SER-A	3
	KL6E090DDA	L, #3/4	L, #1-1/2	SBFDE-A-ZP	SBFDE-B-ZP	SER-A	SER-A	5
	KL6E105DDA	L, #1	L, #2	SBFDE-A-ZP	SBFDE-B-ZP	SER-A	SER-B	6
	KL6E121DDA	L, #1	L, #2	SBFDE-A-ZP	SBFDE-B-ZP	SER-A	SER-B	6
	KL6E142DDA	L, #1-1/2	L, #2	SBFDE-B-ZP	SBFDE-B-ZP	SER-B	SER-B	6
	KL6E162DDA	L, #1-1/2	L, #2-1/2	SBFDE-B-ZP	SBFDE-C-ZP	SER-B	SER-B	6
KL6E182DDA	L, #1-1/2	L, #2-1/2	SBFDE-B-ZP	SBFDE-C-ZP	SER-B	SER-B	6	
KL6E200*DA	L, #1-1/2	L, #3	SBFDE-B-ZP	SBFDE-C-ZP	SER-B	SER-B	6	
KL6E244*DA	L, #2	L, #4	SBFDE-C-ZP	SBFDE-C-ZP	SER-B	SER-C	9	
KL6E281*DA	G, #2-1/2	G, #4	SBFDE-C-ZP	SBFDE-C-ZP	SER-C	SER-C	12	
4 FPI	KL4E027DDA	-	-	SBFDE-AA-ZP	SBFDE-AA-ZP	SER-AA	SER-AA	1
	KL4E032DDA	-	-	SBFDE-AA-ZP	SBFDE-AA-ZP	SER-AA	SER-AA	1
	KL4E038DDA	L, #1/3	L, #3/4	SBFDE-AA-ZP	SBFDE-AA-ZP	SER-AA	SER-AA	2
	KL4E051DDA	L, #1/2	L, #3/4	SBFDE-AA-ZP	SBFDE-A-ZP	SER-AA	SER-AA	2
	KL4E064DDA	L, #1/2	L, #1	SBFDE-AA-ZP	SBFDE-A-ZP	SER-A	SER-A	3
	KL4E080DDA	L, #3/4	L, #1-1/2	SBFDE-A-ZP	SBFDE-A-ZP	SER-A	SER-A	6
	KL4E094DDA	L, #3/4	L, #1-1/2	SBFDE-A-ZP	SBFDE-B-ZP	SER-A	SER-A	6
	KL4E110DDA	L, #1	L, #2	SBFDE-A-ZP	SBFDE-B-ZP	SER-A	SER-B	6
	KL4E125DDA	L, #1	L, #2	SBFDE-A-ZP	SBFDE-B-ZP	SER-A	SER-B	6
	KL4E141DDA	L, #1	L, #2	SBFDE-B-ZP	SBFDE-B-ZP	SER-B	SER-B	6
KL4E155*DA	L, #1-1/2	L, #2-1/2	SBFDE-B-ZP	SBFDE-B-ZP	SER-B	SER-B	6	
KL4E195*DA	L, #1-1/2	L, #3	SBFDE-B-ZP	SBFDE-C-ZP	SER-B	SER-B	9	
KL4E230*DA	G, #2	G, #4	SBFDE-B-ZP	SBFDE-C-ZP	SER-B	SER-C	12	

Distributor lines are 3/16" diameter and 14" long. Distributor connection size is 1/2" for electric defrost models with "L" nozzle and 7/8" for models with "G" nozzle.

* Each asterisk represents a variable character based on voltage ordered. See page 4 for nomenclature.

- Single feed circuit coils do not get a distributor/nozzle. Line breaks in the table above are per number of fans.

^ TXV selections are based on -20°F suction temp., 8°F to 12°F evaporator TD. Contact factory for operating conditions outside of this range.

Do not use pressure limiting TXVs when the condensing unit includes a CPR valve.

† SBFDE expansion valves are compatible with R407A, R448A and R449A/B. For other valves, follow manufacturers selection guidelines.

Base models (no factory-mounted components) include nozzles sized for 100°F liquid shipped loose.

Distributor Nozzle and Expansion Valves Hot Gas Defrost Models

	Hot Gas 3-Pipe Model Number	Hot Gas Reverse Cycle 2-Pipe Model Number	Part Numbers						No. of Circuits
			Nozzle @ Liq. Temp.		TXV [^] @ Liq. Temp.		EEV @ Liq. Temp.		
			50°F	100°F	50°F	100°F	50°F	100°F	
R404A									
6 FPI	KL6H035*DA	KL6G035*DA	-	-	SBFSE-AAA-ZP	SBFSE-AA-ZP	SER-AA	SER-AA	1
	KL6H042*DA	KL6G042*DA	L, #1/3	L, #3/4	SBFSE-AA-ZP	SBFSE-AA-ZP	SER-AA	SER-AA	2
	KL6H049*DA	KL6G049*DA	L, #1/2	L, #1	SBFSE-AA-ZP	SBFSE-A-ZP	SER-AA	SER-A	2
	KL6H066*DA	KL6G066*DA	L, #3/4	L, #1-1/2	SBFSE-AA-ZP	SBFSE-A-ZP	SER-A	SER-A	2
	KL6H077*DA	KL6G077*DA	L, #3/4	L, #1-1/2	SBFSE-A-ZP	SBFSE-A-ZP	SER-A	SER-A	3
	KL6H090*DA	KL6G090*DA	L, #3/4	L, #2	SBFSE-A-ZP	SBFSE-A-ZP	SER-A	SER-A	5
	KL6H105*DA	KL6G105*DA	L, #1	L, #2	SBFSE-A-ZP	SBFSE-B-ZP	SER-A	SER-B	6
	KL6H121*DA	KL6G121*DA	L, #1	L, #2-1/2	SBFSE-A-ZP	SBFSE-B-ZP	SER-B	SER-B	6
	KL6H142*DA	KL6G142*DA	L, #1-1/2	L, #2-1/2	SBFSE-A-ZP	SBFSE-B-ZP	SER-B	SER-B	6
	KL6H162*DA	KL6G162*DA	L, #1-1/2	L, #3	SBFSE-B-ZP	SBFSE-C-ZP	SER-B	SER-B	6
	KL6H182*DA	KL6G182*DA	L, #1-1/2	L, #4	SBFSE-B-ZP	SBFSE-C-ZP	SER-B	SER-C	6
	KL6H200*DA	KL6G200*DA	L, #2	L, #4	SBFSE-B-ZP	SBFSE-C-ZP	SER-B	SER-C	6
KL6H244*DA	KL6G244*DA	E, #2	E, #5	SBFSE-C-ZP	EBSSSE-6-ZP	SER-C	SER-C	9	
KL6H281*DA	KL6G281*DA	E, #2-1/2	E, #5	SBFSE-C-ZP	EBSSSE-6-ZP	SER-C	SER-C	12	
4 FPI	KL4H027*DA	KL4G027*DA	-	-	SBFSE-AAA-ZP	SBFSE-AA-ZP	SER-AA	SER-AA	1
	KL4H032*DA	KL4G032*DA	-	-	SBFSE-AA-ZP	SBFSE-AA-ZP	SER-AA	SER-AA	1
	KL4H038*DA	KL4G038*DA	L, #1/3	L, #3/4	SBFSE-AA-ZP	SBFSE-AA-ZP	SER-AA	SER-AA	2
	KL4H051*DA	KL4G051*DA	L, #1/2	L, #1	SBFSE-AA-ZP	SBFSE-A-ZP	SER-AA	SER-A	2
	KL4H064*DA	KL4G064*DA	L, #3/4	L, #1-1/2	SBFSE-AA-ZP	SBFSE-A-ZP	SER-A	SER-A	3
	KL4H080*DA	KL4G080*DA	L, #3/4	L, #1-1/2	SBFSE-A-ZP	SBFSE-A-ZP	SER-A	SER-A	6
	KL4H094*DA	KL4G094*DA	L, #3/4	L, #2	SBFSE-A-ZP	SBFSE-A-ZP	SER-A	SER-B	6
	KL4H110*DA	KL4G110*DA	L, #1	L, #2	SBFSE-A-ZP	SBFSE-B-ZP	SER-A	SER-B	6
	KL4H125*DA	KL4G125*DA	L, #1	L, #2-1/2	SBFSE-A-ZP	SBFSE-B-ZP	SER-B	SER-B	6
	KL4H141*DA	KL4G141*DA	L, #1-1/2	L, #2-1/2	SBFSE-A-ZP	SBFSE-B-ZP	SER-B	SER-B	6
	KL4H155*DA	KL4G155*DA	L, #1-1/2	L, #3	SBFSE-A-ZP	SBFSE-C-ZP	SER-B	SER-B	6
	KL4H195*DA	KL4G195*DA	E, #2	E, #4	SBFSE-B-ZP	SBFSE-C-ZP	SER-B	SER-C	9
KL4H230*DA	KL4G230*DA	E, #2	E, #5	SBFSE-B-ZP	SBFSE-C-ZP	SER-B	SER-C	12	
R407A/ R448A/ R449A/B†									
6 FPI	KL6H035*DA	KL6G035*DA	-	-	SBFDE-AA-ZP	SBFDE-AA-ZP	SER-AA	SER-AA	1
	KL6H042*DA	KL6G042*DA	L, #1/3	L, #3/4	SBFDE-AA-ZP	SBFDE-AA-ZP	SER-AA	SER-AA	2
	KL6H049*DA	KL6G049*DA	L, #1/2	L, #3/4	SBFDE-AA-ZP	SBFDE-AA-ZP	SER-AA	SER-AA	2
	KL6H066*DA	KL6G066*DA	L, #1/2	L, #1	SBFDE-AA-ZP	SBFDE-A-ZP	SER-A	SER-A	2
	KL6H077*DA	KL6G077*DA	L, #3/4	L, #1-1/2	SBFDE-A-ZP	SBFDE-A-ZP	SER-A	SER-A	3
	KL6H090*DA	KL6G090*DA	L, #3/4	L, #1-1/2	SBFDE-A-ZP	SBFDE-B-ZP	SER-A	SER-A	5
	KL6H105*DA	KL6G105*DA	L, #1	L, #2	SBFDE-A-ZP	SBFDE-B-ZP	SER-A	SER-B	6
	KL6H121*DA	KL6G121*DA	L, #1	L, #2	SBFDE-A-ZP	SBFDE-B-ZP	SER-A	SER-B	6
	KL6H142*DA	KL6G142*DA	L, #1-1/2	L, #2-1/2	SBFDE-B-ZP	SBFDE-B-ZP	SER-B	SER-B	6
	KL6H162*DA	KL6G162*DA	L, #1-1/2	L, #2-1/2	SBFDE-B-ZP	SBFDE-B-ZP	SER-B	SER-B	6
	KL6H182*DA	KL6G182*DA	L, #1-1/2	L, #3	SBFDE-B-ZP	SBFDE-C-ZP	SER-B	SER-B	6
	KL6H200*DA	KL6G200*DA	L, #2	L, #3	SBFDE-B-ZP	SBFDE-C-ZP	SER-B	SER-B	6
KL6H244*DA	KL6G244*DA	E, #2	E, #4	SBFDE-C-ZP	SBFDE-C-ZP	SER-B	SER-C	9	
KL6H281*DA	KL6G281*DA	E, #2-1/2	E, #5	SBFDE-C-ZP	SBFDE-C-ZP	SER-C	SER-C	12	
4 FPI	KL4H027*DA	KL4G027*DA	-	-	SBFDE-AA-ZP	SBFDE-AA-ZP	SER-AA	SER-AA	1
	KL4H032*DA	KL4G032*DA	-	-	SBFDE-AA-ZP	SBFDE-AA-ZP	SER-AA	SER-AA	1
	KL4H038*DA	KL4G038*DA	L, #1/3	L, #3/4	SBFDE-AA-ZP	SBFDE-AA-ZP	SER-AA	SER-AA	2
	KL4H051*DA	KL4G051*DA	L, #1/2	L, #1	SBFDE-AA-ZP	SBFDE-A-ZP	SER-AA	SER-AA	2
	KL4H064*DA	KL4G064*DA	L, #1/2	L, #1	SBFDE-AA-ZP	SBFDE-A-ZP	SER-A	SER-A	3
	KL4H080*DA	KL4G080*DA	L, #3/4	L, #1-1/2	SBFDE-A-ZP	SBFDE-A-ZP	SER-A	SER-A	6
	KL4H094*DA	KL4G094*DA	L, #3/4	L, #2	SBFDE-A-ZP	SBFDE-B-ZP	SER-A	SER-A	6
	KL4H110*DA	KL4G110*DA	L, #1	L, #2	SBFDE-A-ZP	SBFDE-B-ZP	SER-A	SER-B	6
	KL4H125*DA	KL4G125*DA	L, #1	L, #2	SBFDE-A-ZP	SBFDE-B-ZP	SER-A	SER-B	6
	KL4H141*DA	KL4G141*DA	L, #1-1/2	L, #2-1/2	SBFDE-B-ZP	SBFDE-B-ZP	SER-B	SER-B	6
	KL4H155*DA	KL4G155*DA	L, #1-1/2	L, #2-1/2	SBFDE-B-ZP	SBFDE-B-ZP	SER-B	SER-B	6
	KL4H195*DA	KL4G195*DA	E, #1-1/2	E, #3	SBFDE-B-ZP	SBFDE-C-ZP	SER-B	SER-B	9
KL4H230*DA	KL4G230*DA	E, #2	E, #4	SBFDE-B-ZP	SBFDE-C-ZP	SER-B	SER-C	12	

Distributor lines are 1/4" diameter and 14" long. Distributor connection size is 1/2" for all hot gas defrost models with "L" nozzle and 1-1/8" for models with "E" nozzle.

* Each asterisk represents a variable character based on voltage ordered. See page 4 for nomenclature.

- Single feed circuit coils do not get a distributor/nozzle. Line breaks in the table above are per number of fans.

^ TXV selections are based on -20°F suction temp., 8°F to 12°F evaporator TD. Contact factory for operating conditions outside of this range.

Do not use pressure limiting TXVs when the condensing unit includes a CPR valve.

† SBFDE expansion valves are compatible with R407A, R448A and R449A/B. For other valves, follow manufacturers selection guidelines.

Base models (no factory-mounted components) include nozzles sized for 100°F liquid shipped loose.

Specifications

Models		TXV [†] Type	Refrigerant Connections			No. of Hanger Slot Locations	Dimensions (Inches)				Est. Ship Wt. (Lbs.)
			Liquid Line [^]	KL6A Suction	KL*E/ KL*G/H Suction		A ¹	B ¹	C ¹	W	
KL6A	KL*E/G/H										

6 FPI

KL6A041*DA	KL6*035*DA	EXT	3/8	5/8	5/8	2	17-1/4	-	-	27-1/8	41
KL6A052*DA	KL6*042*DA	EXT	3/8	5/8	5/8	2	17-1/4	-	-	27-1/8	44
KL6A066*DA	KL6*049*DA	EXT	3/8	5/8	5/8	2	17-1/4	-	-	27-1/8	47
KL6A073*DA	KL6*066*DA	EXT	3/8	5/8	7/8	2	33-1/4	-	-	43-5/8	52
KL6A094*DA	KL6*077*DA	EXT	3/8	5/8	7/8	2	33-1/4	-	-	43-5/8	55
KL6A117*DA	KL6*090*DA	EXT	3/8	5/8	7/8	2	33-1/4	-	-	43-5/8	58
KL6A130*DA	KL6*105*DA	EXT	3/8	5/8	7/8	2	33-1/4	-	-	43-5/8	62
KL6A141*DA	-	EXT	3/8	5/8	-	2	49-1/4	-	-	60-1/8	72
KL6A161*DA	KL6*121*DA	EXT	3/8	5/8	1-1/8	2	49-1/4	-	-	60-1/8	78
KL6A181*DA	KL6*142*DA	EXT	3/8	7/8	1-1/8	2	49-1/4	-	-	60-1/8	85
KL6A195*DA	-	EXT	3/8	7/8	-	2	65-1/4	-	-	76-5/8	115
KL6A235*DA	KL6*162*DA	EXT	3/8	7/8	1-1/8	2	65-1/4	-	-	76-5/8	124
KL6A260*DA	KL6*182*DA	EXT	3/8	7/8	1-1/8	2	65-1/4	-	-	76-5/8	147
-	KL6*200*DA	EXT	3/8	-	1-1/8	3	81-1/4	32-5/8	48-5/8	93-1/8	195
KL6A295*DA	-	EXT	3/8	1-1/8	-	3	81-1/4	32-5/8	48-5/8	93-1/8	218
-	KL6*244*DA	EXT	3/8	-	1-1/8	3	97-1/4	48-5/8	48-5/8	109-5/8	238
KL6A330*DA	-	EXT	3/8	1-1/8	-	3	97-1/4	48-5/8	48-5/8	109-5/8	257
KL6A390*DA	KL6*281*DA	EXT	3/8	1-1/8	1-1/8	3	97-1/4	48-5/8	48-5/8	109-5/8	262

4 FPI

-	KL4*027*DA	EXT	3/8	-	5/8	2	17-1/4	-	-	27-1/8	40
-	KL4*032*DA	EXT	3/8	-	5/8	2	17-1/4	-	-	27-1/8	42
-	KL4*038*DA	EXT	3/8	-	5/8	2	17-1/4	-	-	27-1/8	46
-	KL4*051*DA	EXT	3/8	-	7/8	2	33-1/4	-	-	43-5/8	50
-	KL4*064*DA	EXT	3/8	-	7/8	2	33-1/4	-	-	43-5/8	52
-	KL4*080*DA	EXT	3/8	-	7/8	2	33-1/4	-	-	43-5/8	55
-	KL4*094*DA	EXT	3/8	-	1-1/8	2	49-1/4	-	-	60-1/8	79
-	KL4*110*DA	EXT	3/8	-	1-1/8	2	49-1/4	-	-	60-1/8	84
-	KL4*125*DA	EXT	3/8	-	1-1/8	2	65-1/4	-	-	76-5/8	124
-	KL4*141*DA	EXT	3/8	-	1-1/8	2	65-1/4	-	-	76-5/8	144
-	KL4*155*DA	EXT	3/8	-	1-1/8	3	81-1/4	32-5/8	48-5/8	93-1/8	191
-	KL4*195*DA	EXT	3/8	-	1-1/8	3	97-1/4	48-5/8	48-5/8	109-5/8	257
-	KL4*230*DA	EXT	3/8	-	1-1/8	3	97-1/4	48-5/8	48-5/8	109-5/8	262

* Each asterisk represents a variable character based on defrost and voltage ordered. See page 4 for nomenclature.

- Not available.

[†] Externally equalized.

[^] For units with mounted TXV components. See Nozzle/TXV table for distributor connection size when TXV is field installed.

¹ Dimensions listed are the distance between hanger slots. Hanger slots are 3/4" deep x 1/2" wide.

Specifications - All Models - Continued

Department of Energy Annual Walk-In Energy Factor (AWEF) Ratings			
Base Model Number	Defrost Type	FPI	AWEF

Cooler Models¹ - Air and Electric Defrost Models

K*6A041*DA	Air Defrost	6	9.00
K*6A052*DA	Air Defrost	6	9.00
K*6A066*DA	Air Defrost	6	9.00
K*6A073*DA	Air Defrost	6	9.00
K*6A094*DA	Air Defrost	6	9.00
K*6A117*DA	Air Defrost	6	9.00
K*6A130*DA	Air Defrost	6	9.00
K*6A141*DA	Air Defrost	6	9.00
K*6A161*DA	Air Defrost	6	9.00
K*6A181*DA	Air Defrost	6	9.00
K*6A195*DA	Air Defrost	6	9.00
K*6A235*DA	Air Defrost	6	9.00
K*6A260*DA	Air Defrost	6	9.00
K*6A295*DA	Air Defrost	6	9.00
K*6A330*DA	Air Defrost	6	9.00
K*6A390*DA	Air Defrost	6	9.00
K*6E035DDA	Electric Defrost	6	9.00
K*6E042DDA	Electric Defrost	6	9.00
K*6E049DDA	Electric Defrost	6	9.00
K*6E066DDA	Electric Defrost	6	9.00
K*6E077DDA	Electric Defrost	6	9.00
K*6E090DDA	Electric Defrost	6	9.00
K*6E105DDA	Electric Defrost	6	9.00
K*6E121DDA	Electric Defrost	6	9.00
K*6E142DDA	Electric Defrost	6	9.00
K*6E162DDA	Electric Defrost	6	9.00
K*6E182DDA	Electric Defrost	6	9.00
K*6E200*DA	Electric Defrost	6	9.00
K*6E244*DA	Electric Defrost	6	9.00
K*6E281*DA	Electric Defrost	6	9.00

Department of Energy Annual Walk-In Energy Factor (AWEF) Ratings			
Base Model Number	Defrost Type	FPI	AWEF

Freezer Models² - Electric Defrost

K*6E035DDA	Electric Defrost	6	4.15
K*6E042DDA	Electric Defrost	6	4.15
K*6E049DDA	Electric Defrost	6	4.15
K*6E066DDA	Electric Defrost	6	4.15
K*6E077DDA	Electric Defrost	6	4.15
K*6E090DDA	Electric Defrost	6	4.15
K*6E105DDA	Electric Defrost	6	4.15
K*6E121DDA	Electric Defrost	6	4.15
K*6E142DDA	Electric Defrost	6	4.15
K*6E162DDA	Electric Defrost	6	4.15
K*6E182DDA	Electric Defrost	6	4.15
K*6E200*DA	Electric Defrost	6	4.15
K*6E244*DA	Electric Defrost	6	4.15
K*6E281*DA	Electric Defrost	6	4.15
K*4E027DDA	Electric Defrost	4	3.94
K*4E032DDA	Electric Defrost	4	3.95
K*4E038DDA	Electric Defrost	4	3.96
K*4E051DDA	Electric Defrost	4	3.96
K*4E064DDA	Electric Defrost	4	3.99
K*4E080DDA	Electric Defrost	4	4.01
K*4E094DDA	Electric Defrost	4	4.03
K*4E110DDA	Electric Defrost	4	4.06
K*4E125DDA	Electric Defrost	4	4.07
K*4E141DDA	Electric Defrost	4	4.09
K*4E155*DA	Electric Defrost	4	4.10
K*4E195*DA	Electric Defrost	4	4.15
K*4E230*DA	Electric Defrost	4	4.15

* Each asterisk represents a variable character based upon connection and voltage ordered. See page 4 for nomenclature.

1. If the model has a numerical value in the table above, the following statement applies: "The refrigeration system is designed and certified for use in walk-in cooler applications."
2. If the model has a numerical value in the table above, the following statement applies: "The refrigeration system is designed and certified for use in walk-in freezer applications."

Specifications - All Models -Continued

Department of Energy Annual Walk-In Energy Factor (AWEF) Ratings			
Base Model Number	Defrost Type	FPI	AWEF

Cooler Models¹ - Hot Gas Defrost

K*6*035*DA	Hot Gas Defrost	6	9.00
K*6*042*DA	Hot Gas Defrost	6	9.00
K*6*049*DA	Hot Gas Defrost	6	9.00
K*6*066*DA	Hot Gas Defrost	6	9.00
K*6*077*DA	Hot Gas Defrost	6	9.00
K*6*090*DA	Hot Gas Defrost	6	9.00
K*6*105*DA	Hot Gas Defrost	6	9.00
K*6*121*DA	Hot Gas Defrost	6	9.00
K*6*142*DA	Hot Gas Defrost	6	9.00
K*6*162*DA	Hot Gas Defrost	6	9.00
K*6*182*DA	Hot Gas Defrost	6	9.00
K*6*200*DA	Hot Gas Defrost	6	9.00
K*6*244*DA	Hot Gas Defrost	6	9.00
K*6*281*DA	Hot Gas Defrost	6	9.00

* Each asterisk represents a variable character based upon connection, defrost and voltage ordered. See page 4 for nomenclature.

1. If the model has a numerical value in the table above, the following statement applies: "The refrigeration system is designed and certified for use in walk-in cooler applications."
2. If the model has a numerical value in the table above, the following statement applies: "The refrigeration system is designed and certified for use in walk-in freezer applications."

Department of Energy Annual Walk-In Energy Factor (AWEF) Ratings			
Base Model Number	Defrost Type	FPI	AWEF

Freezer Models² - Hot Gas Defrost

K*6*035*DA	Hot Gas Defrost	6	4.15
K*6*042*DA	Hot Gas Defrost	6	4.15
K*6*049*DA	Hot Gas Defrost	6	4.15
K*6*066*DA	Hot Gas Defrost	6	4.15
K*6*077*DA	Hot Gas Defrost	6	4.15
K*6*090*DA	Hot Gas Defrost	6	4.15
K*6*105*DA	Hot Gas Defrost	6	4.15
K*6*121*DA	Hot Gas Defrost	6	4.15
K*6*142*DA	Hot Gas Defrost	6	4.15
K*6*162*DA	Hot Gas Defrost	6	4.15
K*6*182*DA	Hot Gas Defrost	6	4.15
K*6*200*DA	Hot Gas Defrost	6	4.15
K*6*244*DA	Hot Gas Defrost	6	4.15
K*6*281*DA	Hot Gas Defrost	6	4.15
K*6*027*DA	Hot Gas Defrost	4	3.94
K*6*032*DA	Hot Gas Defrost	4	3.95
K*6*038*DA	Hot Gas Defrost	4	3.96
K*6*051*DA	Hot Gas Defrost	4	3.96
K*6*064*DA	Hot Gas Defrost	4	3.99
K*6*080*DA	Hot Gas Defrost	4	4.01
K*6*094*DA	Hot Gas Defrost	4	4.03
K*6*110*DA	Hot Gas Defrost	4	4.06
K*6*125*DA	Hot Gas Defrost	4	4.07
K*6*141*DA	Hot Gas Defrost	4	4.09
K*6*155*DA	Hot Gas Defrost	4	4.10
K*6*195*DA	Hot Gas Defrost	4	4.15
K*6*230*DA	Hot Gas Defrost	4	4.15



Applications

Physical Dimensions

Installation Notes:

- (1) Install 12" away from back wall.
- (2) Drain connection is located in the center/rear of the drain pan.
- (3) Standard refrigerant connections are located at the left rear (facing air discharge).

All dimensions are in inches.

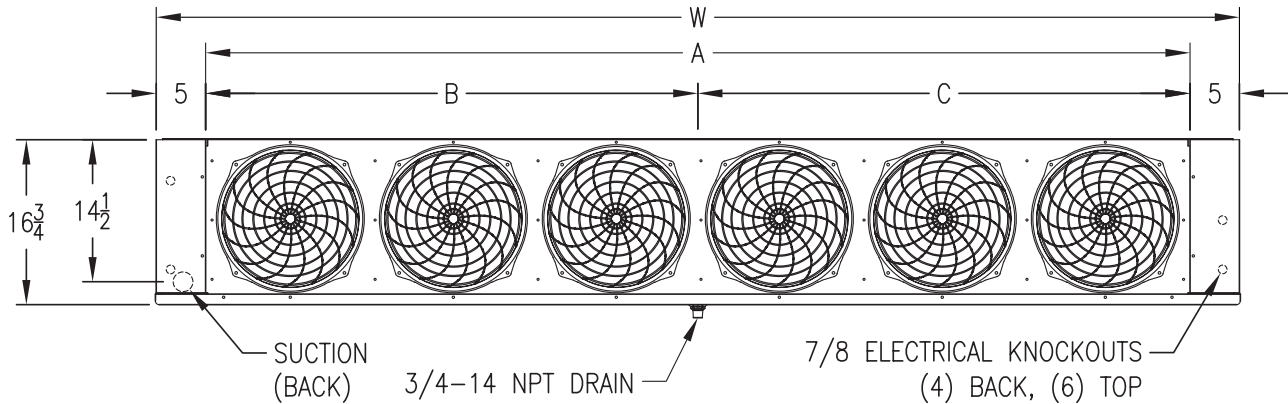
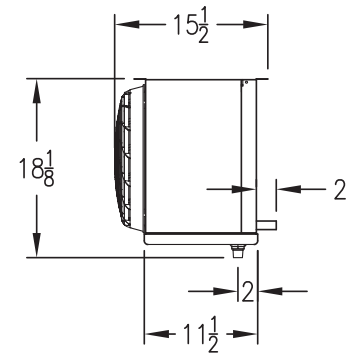

NOTE: Refrigerant and electrical connection locations have been changed for the Next-Gen All-Temp design. Standard connections are now opposite of the legacy LP models.



Kramer's Next-Gen All-Temp Low Profile Unit Cooler can be used in combination with Next-Gen K-Series Condensing Units to provide complete refrigeration solutions for small to medium walk-ins

Due to continuing product development, specifications are subject to change without notice.