

Data Sheet

FUJITSU Software ServerView® Suite ServerView® Virtual-I/O Manager Version 4.0.07

SERVERVIEW VIRTUAL-IO MANAGER
DYNAMIZATION AND VIRTUALIZATION IN THE DATACENTER

Brief Description

Fujitsu ServerView Virtual-I/O Manager is a function extension for the ServerView Operations Manager. It simplifies the virtualization of the I/O links for the Fujitsu PRIMERGY BX900, BX400 and BX600 blade servers and for a variety of Fujitsu PRIMERGY rack servers, thus enabling resources to be used more dynamically and efficiently.

The ServerView Virtual-I/O Manager provides a central control instance, which enables the administration of a large number of PRIMERGY blade and rack servers via virtualization and storage of the corresponding server I/O parameters (MAC addresses, WWNs, I/O connections and boot parameters) in a server profile, which is independent of the hardware.

This profile is used to easily allocate the servers in the managed pool irrespective of location. A failover to a spare server can be easily automated. This helps the administrator to construct a dynamic data center which can react automatically to events and thus always guarantee the required service level.

The customer is able to define profiles for all his applications and store them centrally in the profile store irrespective of the hardware, especially when used together with the remote boot function (PXE/SAN/iSCSI).

The required application (boot image) can be started on the already defined network addresses (MAC, WWN and iSCSI-initiator, -target) without further configuration effort in LAN and SAN by simply assigning a specific profile (containing all the required parameters) to a rack/tower or blade server, or also as an extension to a blade server slot that is not used.

All this without any restrictions regarding the number of rack servers, server blades or chassis. Generation-spanning profiles, which include BX900, BX400, BX600 blade and rack servers, can also be created.

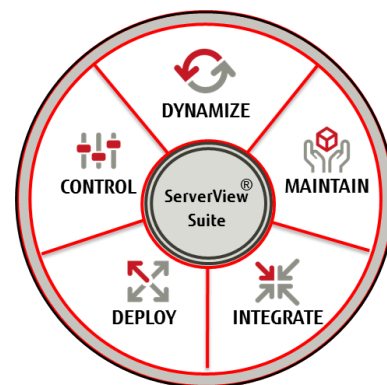

ServerView®

Resourceful Server Management

FUJITSU Software ServerView® Suite provides all the necessary elements for professionally managing server systems during their lifecycle.

For information on other ServerView products please visit www.fujitsu.com/fts/serverview



Features and Benefits

| Main features | Benefits |
|--|---|
| <ul style="list-style-type: none">■ Separates server management from LAN and SAN management | <ul style="list-style-type: none">■ Significantly reduces administration effort, time and costs. Entire SAN and LAN pools are pre-configured only once and pre-assignment of I/O addresses make servers ready for "plug and go". Any operational changes of VIOM managed servers are now performed without involving LAN or SAN administration. |
| <ul style="list-style-type: none">■ Separates and virtualizes server I/O parameters in a hardware independent profile repository | <ul style="list-style-type: none">■ Minimizes administration effort, time and costs to deploy, maintain and recover VIOM managed servers |
| <ul style="list-style-type: none">■ Supports Fujitsu PRIMERGY rack and blade servers | <ul style="list-style-type: none">■ Simplifies for a wide range of Fujitsu PRIMERGY servers the I/O virtualization enabling resources to be used more dynamically and efficiently |
| <ul style="list-style-type: none">■ Operates completely independent from operating system; transparent to any application, network, storage system | <ul style="list-style-type: none">■ Requires no certification: VIOM works with any operating system and hypervisor |
| <ul style="list-style-type: none">■ Comprises provisions to easily add servers to the VIOM managed environment prior to their actual availability. | <ul style="list-style-type: none">■ Speeds up deployment, saves effort, time and costs |
| <ul style="list-style-type: none">■ Reallocates application (images) by simply moving profiles between similar servers | <ul style="list-style-type: none">■ Increases server utilization, ensures flexibility and fast adaptation to business needs. Using the same hardware for different applications which are not required at the same time reduces costs and increases efficiency |
| <ul style="list-style-type: none">■ Simple spare server definition and manual failover function for server blades | <ul style="list-style-type: none">■ Supports an easy and secure recovery after server failure. |
| <ul style="list-style-type: none">■ Scales up to hundreds of rack servers and server blades | <ul style="list-style-type: none">■ Increases administrator's efficiency and reduces costs |
| <ul style="list-style-type: none">■ Provides in blade server a pass-thru like connectivity / direct connection architecture | <ul style="list-style-type: none">■ Reduces costs and risk for failures by cable consolidation; ensures high throughput |
| <ul style="list-style-type: none">■ Supports Emulex Universal Multi-Channel (UMC) operation | <ul style="list-style-type: none">■ Enables and manages flexible bandwidth allocation of Converged Network Adapters (CNA) in a very comprehensive and comfortable manner |

ServerView Virtual-I/O Manager Version 4.0.07

Traditional I/O infrastructure – inflexible and costly

LAN and FC ports of individual servers are connected to the customer’s LAN and SAN infrastructure via switches, which are traditionally viewed as network components. This means that up to three administrators responsible for servers, LAN and SAN must coordinate their work when changing the configuration, for example when replacing a server due to a hardware problem – regardless, whether such switches are integrated in a blade server chassis:

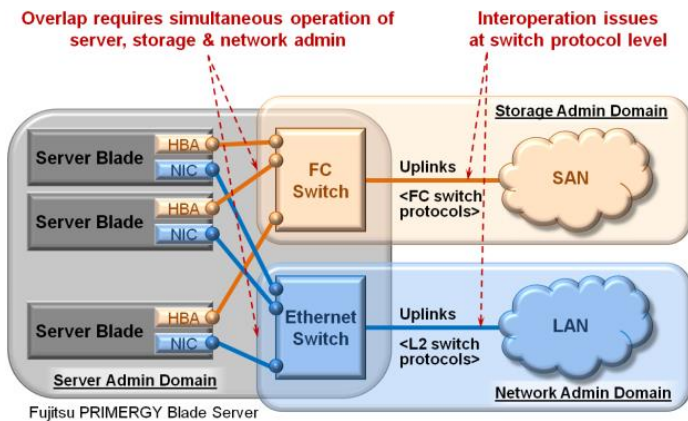

or in case of rack servers external switches are used:

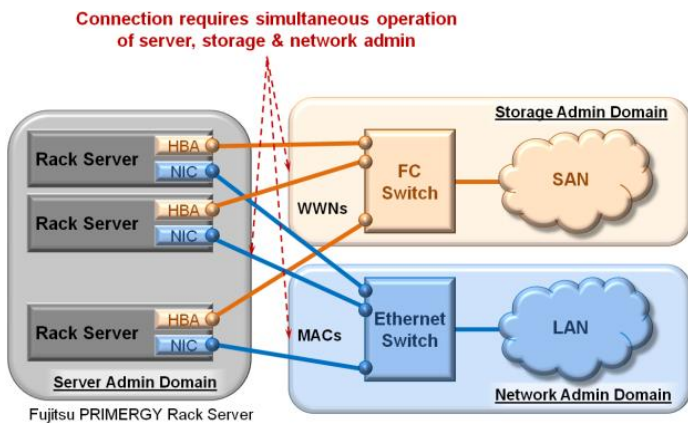

Another major issue is MAC addresses and WWNs, which are hard-coded in NICs and HBAs – regardless whether these are installed in a rack or blade server. Whenever a server has to be replaced or an image or application needs to be moved to a different server, these hard-coded addresses require administrative changes in the server, LAN and SAN configurations.

I/O virtualization with Virtual-I/O Manager – dynamic and simple

ServerView Virtual-I/O Manager (VIOM) is a comprehensive and user-friendly application for administration of virtual addresses and the required LAN connection. All the parameters of a server blade or a rack server are grouped together in a so-called server profile. As these profiles only contain virtual addresses, they can be relocated and assigned to any server blade in any chassis or to any rack server, respectively, as long as the respective server is still connected to the required LAN and SAN networks.

ServerView Virtual-I/O Manager for Blade Server

In Fujitsu PRIMERGY blade server chassis BX900, BX400 and BX600 switches can be replaced with special I/O connection blades that offer a simple means of grouping specific server blade I/O channels (port grouping, cable consolidation), but which do not have the complexity of a switch. Different I/O connection blades are available for this purpose: The Fibre Channel Access Gateway (FC AG) to link storage systems and the Intelligent Blade Panel (IBP) for the LAN connection.

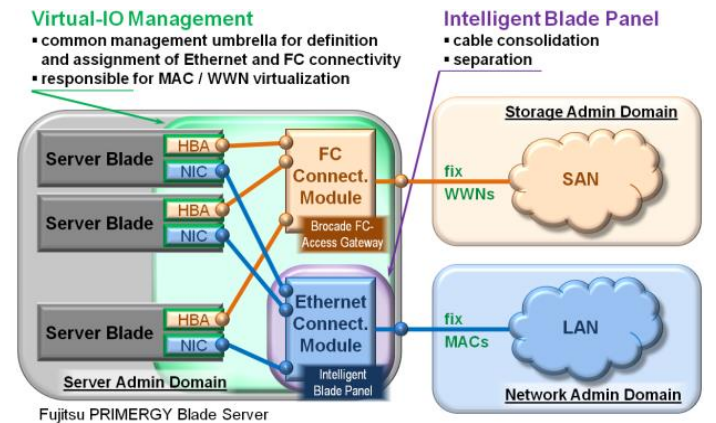

In PRIMERGY BX900 and BX400 these are not different hardware modules, but simply an additional FW mode, providing the flexibility to use the connection modules either in traditional switch-mode or in FC AG and IBP mode. In the first case the administrator is responsible for managing the I/O connections; in the latter case VIOM manages the I/O connectivity as part of the profile.

Instead of hard-coded MAC addresses and WWNs, virtual, customer-defined addresses are used which can be individually assigned to specific server blades and can retain the same slot assignment even if the server blade has been removed.

ServerView Virtual-I/O Manager Version 4.0.07

ServerView Virtual-I/O Manager for rack server

For a range of Fujitsu PRIMERGY rack servers the same well-proven principle of I/O virtualization is now available. In the same way as with PRIMERGY blade servers, virtual, customer-defined addresses are used instead of hard-coded MAC addresses and WWNs:

Virtual-I/O Management

- common management umbrella for definition and assignment of Ethernet and FC connectivity
- responsible for MAC / WWN virtualization

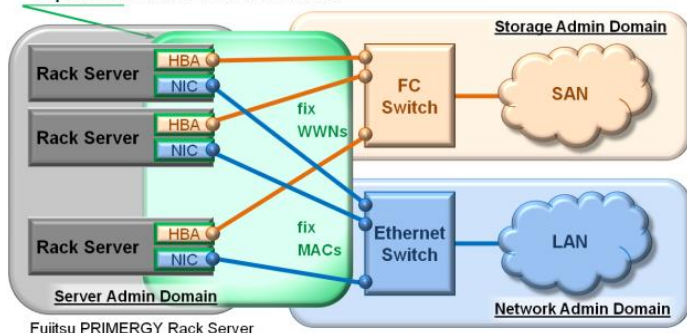

Management concept and function features

1. PRIMERGY Blade Server Chassis configuration

- With ServerView Virtual-I/O Manager (VIOM), compatible BX900, BX400 and BX600 blade server chassis can be identified via the standard discovery service of ServerView Operations Manager.
- After successful identification all chassis compatible with VIOM can be easily imported into VIOM. Each server blade configuration is checked for VIOM compliance and the user can select those to be run under VIOM control.
- With PRIMERGY BX900, BX400, the LAN switches CB18/6, CB36/12, CB36/8+2 and CB18/8 can be operated as required in IBP or switch mode; the role can be switched via the firmware command at any time.
- When using IBP: Definition of all external LAN connections for each VIOM-controlled chassis.
- The network connections (including VLAN connections) for the individual chassis and uplinks of the integrated LAN I/O connection blade (IBP) have already been defined by the server and LAN administrators during the hardware installation. These network connections are documented in VIOM by assigning symbolic names, which are used to define LAN links in server profiles.

2. PRIMERGY rack server configuration

- With ServerView Virtual-I/O Manager (VIOM), compatible rack servers can be identified via the standard discovery service of ServerView Operations Manager.
- After successful identification all rack servers compatible with VIOM can be easily imported into VIOM. Each rack server configuration is checked for VIOM compliance and the user can select those to be run under VIOM control.

3. Profile definition

- A profile is a quantity of data for a specific server blade or rack server, consisting of the virtual MAC addresses and WWNs, the boot parameters (up to 4 boot devices) and the LAN connections of all I/O channels of a server blade, if connected to a connection blade running in IBP mode.
- All profiles are held in a data memory (independent of the installed hardware), which is located in the Central Management Station (CMS). For each profile individual IDs can be defined which, for example, provide information about the application or the service provided by the respective profile.
- Profiles may be created, copied, removed and assigned to a server.

4. Profile assignment

- **Defining / cancelling the profile assignment** to a slot in a VIOM-controlled chassis or to a VIOM-controlled rack/tower server.
On allocation, VIOM checks whether the number and the I/O channel concepts match that of the installed server blade or rack server and whether the required LAN connections are provided by the IBP uplinks on the chassis.
With blade servers a server blade pre-assignment can be made by allocating the profiles to empty slots.
As the profile assignment is server specific and includes all "individual server parameters", failed server blades or rack servers can then be replaced without incurring any problems or making any configuration changes.
- **Switching the server on / off** (boot / shutdown)
- **Failover configuration (within a blade server chassis)**
Individual server blades can be defined as "spare servers" so that in the event of a fault the failover command can be used to simply and securely replace a failed server with a similar spare server.

ServerView Virtual-I/O Manager Version 4.0.07

5. Profile assignment

- **Defining / cancelling the profile assignment** to a slot in a VIOM-controlled chassis or to a VIOM-controlled rack/tower server.

On allocation, VIOM checks whether the number and the I/O channel concepts match that of the installed server blade or rack server and whether the required LAN connections are provided by the IBP uplinks on the chassis.

With blade servers a server blade pre-assignment can be made by allocating the profiles to empty slots.

As the profile assignment is server specific and includes all "individual server parameters", failed server blades or rack servers can then be replaced without incurring any problems or making any configuration changes.

- **Switching the server on / off** (boot / shutdown)
- **Failover configuration (within a blade server chassis)**
Individual server blades can be defined as "spare servers" so that in the event of a fault the failover command can be used to simply and securely replace a failed server with a similar spare server.

6. Command Line Interface (CLI)

All the important VIOM functions can also be used via a command interface. This provides the customer with the option of running self-written scripts and the systems can be distributed or deactivated according to current requirements or in order to reduce costs. Day/night operation can thus be easily implemented.

7. XML Import / Export of VIOM profile definitions

In both user interfaces GUI and CLI there are functions to export and import the VIOM profile definition in/from a text file in XML format. This supports user in effective creation and maintaining larger amounts of profiles.

8. Support of Multiple VLAN Groups in „tagged“ Mode

VIOM supports VLAN groups of the Intelligent Blade Panels (IBP) in "tagged" mode. This allows running applications simultaneously at a Hypervisor and a physical Blade Server in one chassis using the same VLAN (concurrent operation of a VLAN on different downlinks, tagged and untagged).

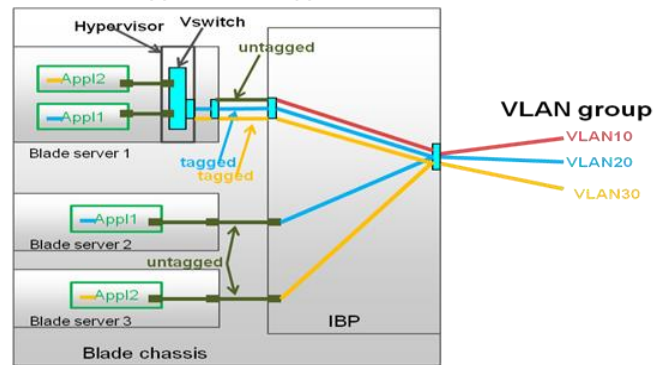

IBP: Untagged VLAN group

9. Support of iSCSI Data Center Bridging (DCB) Settings

VIOM supports the optional setting of the iSCSI DCB parameter for loss-less iSCSI operation. For this the SBAX iSCSI configuration can be set via VIOM.

10. Support of BROCADE VDX 2730 and AMPP

In PRIMERGY blade server BX900 and BX400 the Ethernet Fabric Switch 10Gbit/s 18/6+6 (BROCADE VDX 2730) is released. This switch allows (AMPP) Automatic Migration of Port Profiles, a function which is supported by VIOM from version 3.2.

11. VIOM upgrade to newer version

When upgrading the VIOM software on the Management Station any running servers are not affected and need not to be rebooted. The newer VIOM version supports the existing BIOS and FW versions of the blade and rack server components to ensure uninterrupted operation).

1) Important Note:

ServerView Virtual-I/O Manager Version 4.0.07 usage on CNA may require a blade server BIOS update; for further details please refer to the tables below.

ServerView Virtual-I/O Manager Version 4.0.07

TECHNICAL DETAILS

1. MANAGEMENT STATION

1.1. Released Operating Systems on Management Station

| Operating System for Virtual-I/O Manager and VIOM CLI |
|---|
| Microsoft Windows Server® 2012 |
| Microsoft Windows Server® 2012 R2 |
| Microsoft Windows Server® 2016 |
| Microsoft Windows Server® 2019 |
| RedHat Enterprise Linux (RHEL) 6.10 |
| RedHat Enterprise Linux (RHEL) 7.x (7.5 / 7.6 / 7.7) |
| SUSE® Linux Enterprise Server (SLES) 12 (SP4 / SP5) |
| SUSE® Linux Enterprise Server (SLES) 15 (SP1) |

1.2. High Availability (HA) Support

| Operating System for Management Station in Virtual Machines (VM) for VIOM Manager and VIOM CLI |
|--|
| Microsoft Windows Server® 2012 |
| Microsoft Windows Server® 2012 R2 |

ServerView Suite Management Station running as Virtual Machine (VM) in
 - Microsoft Windows Hyper-V Cluster, or
 - VMware Cluster supported with VMware Infrastructure 3 or higher, or
 - VMware Cluster supported with vSphere.

1.3. Released Web-Browser

| Operating System | Web Browser |
|------------------|----------------------------------|
| Windows | as delivered by Operating System |
| RedHat LINUX | as delivered by operating system |
| SUSE® Linux | as delivered by operating system |

1.4. Software Dependencies on Management Station

| Operating System | Software Product | Version |
|------------------|---|---|
| Windows | ServerView Operations Manager Java Runtime | v8.41.01, JRE ≥ 1.8.0_172 |
| LINUX | ServerView Operations Manager Java Runtime | v8.41.01, JRE ≥ 1.8.0_172 |
| Windows | ServerView Operations Manager Java Runtime | v8.50.02 for Windows 2019, JRE ≥ 1.8.0_191 |
| Windows/Linux | ServerView Operations Manager OpenJDK | V9.10.03 (Windows) V9.10.04 (Linux) JDK 8u222-b10-JRE |

- In 64 bit Operating Systems both Java Runtime (x32 & x64) has to be installed.
- After Java Update it is absolute necessary to clear the Java Cache.

ServerView Virtual-I/O Manager Version 4.0.07

2. SUPPORTED HARDWARE - Fujitsu PRIMERGY Blade Server

2.1 PRIMERGY BX900 S1 / BX900 S2 / BX400 S1

| System / Component | |
|--|----|
| Fujitsu PRIMERGY BX400 S1 with MMB S1 | #1 |
| Fujitsu PRIMERGY BX900 S1/S2 with MMB S1 | #1 |

2.2 PRIMERGY BX Server Blades

| Server Blades | | |
|---------------|----|--------------------|
| - BX920 S1 | | D2860 1.21 |
| - BX960 S1 | #2 | D2873 3C20 |
| - BX920 S2 | | D3030 3D99 |
| - BX922 S2 | | D2861 3D99 |
| - BX924 S2 | | D2952 3D99 |
| - BX920 S3 | | D3142 A1 v4.6.5.3 |
| - BX924 S3 | | D3143 A1 v4.6.5.3 |
| - BX920 S4 | | D3142 B1 v4.6.5.4 |
| - BX924 S4 | | D3143 B1 v4.6.5.4 |
| - BX2560 M1 | | D3320 A1 v5.0.0.9 |
| - BX2580 M1 | | D3321 A1 v5.0.0.9 |
| - BX2560 M2 | | D3320 B1 v5.0.0.11 |
| - BX2580 M2 | | D3321 B1 v5.0.0.11 |

| Onboard Controller | | |
|----------------------|----|-----------------------|
| - 4x 1 GbE | #3 | Intel®: ZOAR / KAWELA |
| - 2x 10 GbE | #3 | Intel®: NIANTEC |
| - CNA LoM "OCI11102" | | Emulex (BE3) |
| - CNA LoM "OCI14102" | | Emulex (Skyhawk) |

| Daughter Cards (Mezzanine) | | |
|-----------------------------|----|-----------------------|
| - LAN Mezz.Card 4x 1 GbE | #3 | Intel®: ZOAR / KAWELA |
| - LAN Mezz.Card 2x 10 GbE | #3 | Intel®: NIANTEC |
| - FC Mezz.Card 2x 8Gb | | Emulex: MC-FC82E |
| - FC Mezz.Card 2x 16Gb | | Emulex: MC-FC162E |
| - CNA Mezz.Card 10Gb 2 Port | | Emulex: MC-CNA102E |
| - CNA Mezz.Card 10Gb 2 Port | | Emulex: MC-CNA112E |

Note:

- Certain firmware dependencies might apply; please contact us for details (support.ts.fujitsu.com)
- SMUX setting support via VIOM profile has specific requirements for BIOS, iRMC firmware and MMB firmware.
- #1 The MAC and WVN Virtualization feature strongly depends on corresponding features in MMB, Server Blades and Mezz.Cards.
- #2 No support for CNA Mezz.Card (MC-CNA102E/MC-CNA112E)
- #3 Not supported with PY CB DCB VDX 2730 (Brocade)

ServerView Virtual-I/O Manager Version 4.0.07

2.3 PRIMERGY BX Connection Blades

| LAN Connection Blades | |
|--|---------------|
| - PY CB ETH Switch/IBP 1Gb 18/6 | SB6 |
| - PY CB ETH Switch/IBP 1Gb 36/12 | SB11a #2 |
| - PY CB ETH Switch/IBP 1Gb 36/8+2 | SB11 #1 #2 |
| - PY CB ETH Switch/IBP 10Gb 18/8 | SBAX2 #3 |
| - PY CB DCB Switch 10Gb 18/8+2 | SBAX3 #4 |
| | |
| - PY CB Eth Pass Thru 10Gb (18/18) | LAN Pass Thru |
| - PY CB 10Gb FEX Nexus B22F (16/8) | Cisco FEX |
| - PY CB 10Gb DCB VDX2730 (18/6+6) | BROCADE #5 |
| FC Connection Blades | |
| - PY CB 8GB FC Connection Blade (Brocade 5450) | BROCADE |
| - PY CB Fibre Channel 16GB (Brocade 6545) | BROCADE |

Note:

- Older BIOS and Firmware support only SV-VIOM 2.1 features (Please have a look in the SV-VIOM Readme)
- SMUX setting support via VIOM profile has specific requirements for BIOS, iRMC firmware and MMB firmware.
- #1 Only on BX900: support of SB11 Stacking feature (SB11) using of IBP FW ≥ 2.18 and Switch FW ≥ 2.14 is necessary!
- #2 SB-PRI-11018 – PRIMERGY BX900 CB SB11 (a) losing telnet access after update
- #3 only plain port-groups and extended vLANs groups should be used for DCB Config
- #4 C-FABRIC mode supported but can't be managed by SV-VIOM (shown as supported component)
- #5 Supported but can't be managed by SV-VIOM (shown as supported component)

2.4 PRIMERGY BX600 S3

| System / Component | |
|--|------------------|
| Fujitsu PRIMERGY BX600 S3 with MMB S3 #1 | |
| Server Blades: | |
| - BX620 S4 | D2571 |
| - BX620 S5 | D2686 |
| - BX620 S6 | D3051 |
| - BX630 S2 | D2537 / D2931 |
| Daughter Cards (Mezzanine): | |
| - 2x FC 4Gb PCIe | Emulex: MC FC42E |
| LAN Switch Blades: | |
| - BX600 IBP 10/6 | SB9v |
| - BX600 IBP 30/12 | SB9i |
| - BX600 GbE 10/6 | SB9/SB9a |
| - BX600 GbE 30/12 | SB9f |
| - BX600 LAN Pass-Thru Blades | LAN PassThru |
| FC Switch Blades: | |
| - BX600 4GB FC Switch (BROCADE) | SW4016-D4 |
| - BX600 4Gbit FC Pass-Thru Blade | FC PassThru |

Note:

#1 certain firmware dependencies might apply; please contact us for details (support.ts.fujitsu.com)

ServerView Virtual-I/O Manager Version 4.0.07

2.5 Supported Boot Methods

2.5.1 Legacy mode

| Server Blades PRIMERGY | Onboard | |
|---------------------------|---------|----------|
| | Intel® | |
| | PXE | iSCSI #1 |
| - BX620 S4 (D2571) | ✓ | - |
| - BX620 S5 (D2686) | ✓ | - |
| - BX620 S6 (D3051) | ✓ | ✓ |
| - BX630 S2 (D2537) | ✓ | - |
| - BX630 S2 (D2931) | ✓ | - |

| Daughter Cards (Mezzanine) | | | | | |
|----------------------------|-------|-----|------|-------|----|
| LAN | | BE2 | | | FC |
| PXE | iSCSI | PXE | FCoE | iSCSI | |
| ✓ | - | - | - | - | ✓ |
| ✓ | - | - | - | - | ✓ |
| ✓ | - | - | - | - | ✓ |
| ✓ | - | - | - | - | ✓ |
| ✓ | - | - | - | - | ✓ |

| Server Blades PRIMERGY | Onboard | |
|---------------------------|---------|-------|
| | Intel® | |
| | PXE | iSCSI |
| - BX920 S1 (D2860) | ✓ | ✓ |
| - BX920 S2 (D3030) | ✓ | ✓ |
| - BX922 S2 (D2861) | ✓ | ✓ |
| - BX924 S2 (D2952) | ✓ | - |
| - BX960 S1 (D2873) | ✓ | ✓ #3 |

| PCIe | | | | | |
|------|-------|-----|------|-------|----|
| LAN | | BE2 | | | FC |
| PXE | iSCSI | PXE | FCoE | iSCSI | |
| ✓ | - | ✓ | - | - | ✓ |
| ✓ | - | ✓ | ✓ | - | ✓ |
| ✓ | - | ✓ | ✓ | - | ✓ |
| ✓ | - | ✓ | ✓ | - | ✓ |
| ✓ | - | - | - | - | ✓ |

| Server Blades PRIMERGY | Onboard | | |
|---------------------------|---------|------|-------|
| | BE3 #2 | | |
| | PXE | FCoE | iSCSI |
| - BX920 S3 (D3142) | ✓ | ✓ | ✓ |
| - BX920 S4 (D3142B) | ✓ | ✓ | ✓ |
| - BX924 S3 (D3143) | ✓ | ✓ | ✓ |
| - BX924 S4 (D3143B) | ✓ | ✓ | ✓ |

| PCIe | | | | | |
|------|-------|-----|------|-------|----|
| LAN | | BE3 | | | FC |
| PXE | iSCSI | PXE | FCoE | iSCSI | |
| ✓ | - | ✓ | ✓ | ✓ | ✓ |
| ✓ | - | ✓ | ✓ | ✓ | ✓ |
| ✓ | - | ✓ | ✓ | ✓ | ✓ |
| ✓ | - | ✓ | ✓ | ✓ | ✓ |

| Server Blades PRIMERGY | Onboard | | |
|---------------------------|------------|------|-------|
| | Skyhawk #2 | | |
| | PXE | FCoE | iSCSI |
| - BX2560 M1 (D3320) | ✓ | ✓ | ✓ |
| - BX2580 M1 (D3321) | ✓ | ✓ | ✓ |
| - BX2560 M2 (D3320B) | ✓ | ✓ | ✓ |
| - BX2580 M2 (D3321B) | ✓ | ✓ | ✓ |

| PCIe | | | | | |
|------|-------|-----|------|-------|----|
| LAN | | BE3 | | | FC |
| PXE | iSCSI | PXE | FCoE | iSCSI | |
| ✓ | - | ✓ | ✓ | ✓ | ✓ |
| ✓ | - | ✓ | ✓ | ✓ | ✓ |
| ✓ | - | ✓ | ✓ | ✓ | ✓ |
| ✓ | - | ✓ | ✓ | ✓ | ✓ |

Note:

- iSCSI boot support for LAN ports on this mezzanine card must be checked in BIOS release notes.
- #1 Only W2K3 SP2 / R2 SP2 (x86/x64); W2K8 SP2 (x86/x64); W2K8 Core SP2; RHEL5.5; SLES10 SP3; SLES 11 SP1 are supported!
- #2 iSCSI Boot only in CNA/UMC Mode of EMULEX CNA (BE3) Onboard OCI11102-LOM (no iSCSI Boot in CNA 1GB Mode)
- #3 please refer to Service documentation SB-PRI-12078: Workaround is necessary!

ServerView Virtual-I/O Manager Version 4.0.07

SUPPORTED HARDWARE - Fujitsu PRIMERGY Blade Server (continued) Supported Boot Methods

2.5.2 UEFI mode

| Server Blades PRIMERGY | Onboard | | | PCIe | | | | | |
|---------------------------|------------|------|-------|------|-------|-----|------|-------|----|
| | Skyhawk #2 | | | LAN | | BE3 | | | FC |
| | PXE | FCoE | iSCSI | PXE | iSCSI | PXE | FCoE | iSCSI | |
| - BX2560 M1 (D3320) | ✓ | ✓ | ✓ | ✓ | - | ✓ | ✓ | ✓ | ✓ |
| - BX2580 M1 (D3321) | ✓ | ✓ | ✓ | ✓ | - | ✓ | ✓ | ✓ | ✓ |
| - BX2560 M2 (D3320B) | ✓ | ✓ | ✓ | ✓ | - | ✓ | ✓ | ✓ | ✓ |
| - BX2580 M2 (D3321B) | ✓ | ✓ | ✓ | ✓ | - | ✓ | ✓ | ✓ | ✓ |

Note:

- Boot with iSCSI software initiator is not supported in UEFI mode

#2 iSCSI Boot only in CNA/UMC Mode of EMULEX CNA (BE3) Onboard OCI11102-LOM (no iSCSI Boot in CNA 1GB Mode)

3 SUPPORTED HARDWARE - Fujitsu PRIMERGY Rack / Tower Server

3.1 PRIMERGY RX/TX System / Component

| PRIMERGY RX/TX server | |
|--|---|
| - RX200 S7 - RX300 S7 - RX350 S7 / TX300 S7 | D3032 D2939 D2949 |
| - RX100 S8 - RX200 S8 - RX300 S8 - RX350 S8 / TX300 S8 | D3229 D3302 D2939 B1 D2949 B1 |
| - RX1330 M1 / RX1330 M2 / RX1330 M3 - RX2520 M1 - RX2530 M1 / RX2530 M2 / RX2530 M4 / RX2530 M5 - RX2540 M1 / RX2540 M2 / RX2540 M4 / RX2540 M5 - RX2560 M1 / TX2560 M1 / RX2560 M2 - RX4770 M1 / RX4770 M2 / RX4770 M3 / RX4770 M5 | D3229 / D3375 / D3375 D3169 D3279 A1/ D3279 B1 / D3383 A1 / D3383 B1 D3289 A1/ D3289 B1 / D3384 A1 / D3384 B1 D3289 A1/ D3289 A1/ D3289 B1 D3342 / D3349 / D3749 A1 / D3753-C1 |

ServerView Virtual-I/O Manager Version 4.0.07

| Controller | |
|---|---|
| Fibre Channel | |
| - Emulex 32/16Gb FC 1-port HBA | LPe32000 / LPe31000 |
| - Emulex 32/16Gb FC 2-port HBA | LPe32002 / LPe31002 |
| - Emulex 16Gb FC 1-port HBA #2 | LPe16000 |
| - Emulex 16Gb FC 2-port HBA #2 | LPe16002 |
| - Emulex 8Gb FC HBA | LPe12002 / LPe1250 |
| - QLogic 2x32 Gb FC HBA | QLE 2740/2 1/2 |
| - QLogic 2x16 Gb FC HBA | QLE 2690/2 1/2 |
| LAN #1 | |
| - INTEL PLAN EP 4x10Gbit | X710-DA4 ¹⁾ |
| - INTEL PLAN EP 2x10Gbit | X710-DA2 ¹⁾ |
| - INTEL PLAN EP 2x25Gbit | XXV710-DA2 ¹⁾ |
| - INTEL PLAN EP 4x10Gbit | X710-T4 ¹⁾ |
| - INTEL 2-port 10GbE | X550-T2 ¹⁾ / X540-T2 ¹⁾ |
| - Emulex PLAN EP 2x 10 Gb | OCe14102 ¹⁾ |
| - INTEL PLAN CP 2x1Gbit | I350-T2 ¹⁾ |
| - INTEL PLAN CP 4x1Gbit | I350-T4 ¹⁾ |
| - INTEL 2-port 1GbE | D2735 ¹⁾ |
| - INTEL 2-port 10GbE | D2755 ¹⁾ |
| - INTEL 4-port 1GbE | D2745 ¹⁾ |
| - INTEL 2-port 1GbE | D3035 ¹⁾ |
| - INTEL 4-port 1GbE | D3045 ¹⁾ |
| - Mellanox 25/40/100 Gbit | MCX4 ¹⁾ |
| ¹⁾ It is recommended to disable the virtualization on the NIC and to reset it to factory defaults before reusing it in any other system which does not support VIOM. | |
| CNA | |
| - Emulex PCNA 10GbE (BE2) | OCe10102 |
| - Emulex PCNA 10GbE (Skyhawk) | OCe14102 |
| - Emulex PCNA 40GbE (Skyhawk) | OCe14401 |
| Onboard Controller | |
| - Emulex 10GbE (Skyhawk) | OCI14000 |
| - PLAN EM 4x1Gb T OCP | Intel OCP I357-T4 |
| - PLAN EM 2x10Gb T OCP | Intel OCP X557-T2 |
| - PLAN EM 2x10Gb SFP+ OCP | Intel OCP X557-DA2 |
| - PLAN EM 4x10Gb SFP+ OCP | Intel OCP X557-DA4 |
| - PLAN EP XXV710-DA2 25Gb 2p SFP28 OCP | Intel OCP |
| - PLAN EP MCX4-LX 25Gb 2p SFP28 OCP | Mellanox OCP |

- Note:**
- **Certain firmware dependencies might apply; please contact us for details (support.ts.fujitsu.com)**
 - #1 iSCSI software boot is not supported for LAN PCIe Controller!
 - #2 Support LP16k (FW ≥ 1.1.35.0) with RX200 S7 (needs BIOS ≥ R2.21.0) and RX300 S7, RX350 S7, TX300 S7 (needs BIOS ≥ R1.24.0)
RX2530 M1 / RX2540 M1: Adapter-FW 10.2.405.13 necessary

ServerView Virtual-I/O Manager Version 4.0.07

3.2 Supported Boot Methods

3.2.1 Legacy mode

| PRIMERGY | | Onboard Intel® | | | PCIe | | | | | |
|-----------|--------|----------------|--|-------|------|-------|-----|------|-------|----|
| | | LAN | | | LAN | | BE2 | | | FC |
| | | PXE | | iSCSI | PXE | iSCSI | PXE | FCoE | iSCSI | |
| RX100 S8 | D3229 | ✓ | | ✓ | ✓ | - | ✓ | ✓ | ✓ | ✓ |
| RX1330 M1 | D3229 | ✓ | | ✓ | ✓ | - | ✓ | ✓ | ✓ | ✓ |
| RX1330 M2 | D3375 | ✓ | | | ✓ | | - | | | ✓ |
| RX1330 M3 | D3375 | ✓ | | | ✓ | | - | | | ✓ |
| RX200 S7 | D3032 | ✓ | | ✓ | ✓ | - | ✓ | ✓ | ✓ | ✓ |
| RX200 S8 | D3302 | ✓ | | ✓ | ✓ | - | ✓ | ✓ | ✓ | ✓ |
| RX2520 M1 | D3169 | ✓ | | ✓ | ✓ | - | ✓ | ✓ | ✓ | ✓ |
| RX300 S7 | D2939 | ✓ | | ✓ | ✓ | - | ✓ | ✓ | ✓ | ✓ |
| RX300 S8 | D2939B | ✓ | | ✓ | ✓ | - | ✓ | ✓ | ✓ | ✓ |
| RX350 S7 | D2949 | ✓ | | ✓ | ✓ | - | ✓ | ✓ | ✓ | ✓ |
| RX350 S8 | D2949B | ✓ | | ✓ | ✓ | - | ✓ | ✓ | ✓ | ✓ |
| TX300 S7 | D2949 | ✓ | | ✓ | ✓ | - | ✓ | ✓ | ✓ | ✓ |
| TX300 S8 | D2949B | ✓ | | ✓ | ✓ | - | ✓ | ✓ | ✓ | ✓ |

| PRIMERGY | | Onboard Intel® | | | PCIe | | | | | |
|-----------|----------|----------------|------|-------|------|-------|---------|------|-------|----|
| | | LAN | | | LAN | | Skyhawk | | | FC |
| | | PXE | FCoE | iSCSI | PXE | iSCSI | PXE | FCoE | iSCSI | |
| RX4770 M1 | D3342 | ✓ | - | - | ✓ | - | ✓ | ✓ | ✓ | ✓ |
| RX4770 M2 | D3349 | ✓ | - | - | ✓ | - | ✓ | ✓ | ✓ | ✓ |
| RX4770 M3 | D3749 | ✓ | - | - | ✓ | - | ✓ | ✓ | ✓ | ✓ |
| RX4770 M4 | D3753-C1 | ✓ | - | - | ✓ | - | - | - | - | ✓ |

| PRIMERGY | | Onboard | | | PCIe | | | | | |
|-------------------------|--------|---------|------|-------|------|-------|---------|------|-------|----|
| | | Skyhawk | | | LAN | | Skyhawk | | | FC |
| | | PXE | FCoE | iSCSI | PXE | iSCSI | PXE | FCoE | iSCSI | |
| RX/TX2560 M1 | D3289 | - | - | - | ✓ | - | ✓ | ✓ | ✓ | ✓ |
| + D3245 (2 x 1Gb) | | ✓ | - | - | ✓ | - | ✓ | ✓ | ✓ | ✓ |
| + D3255 (4 x 1Gb) | | ✓ | - | - | ✓ | - | ✓ | ✓ | ✓ | ✓ |
| + D3265 (2 x 10Gb SFP+) | | ✓ | ✓ | ✓ | ✓ | - | ✓ | ✓ | ✓ | ✓ |
| + D3275 (2 x 10Gb - T) | | ✓ | - | - | ✓ | - | ✓ | ✓ | ✓ | ✓ |
| RX/TX2560 M1 | D3289B | - | - | - | ✓ | - | ✓ | ✓ | ✓ | ✓ |
| + D3245 (2 x 1Gb) | | ✓ | - | - | ✓ | - | ✓ | ✓ | ✓ | ✓ |
| + D3255 (4 x 1Gb) | | ✓ | - | - | ✓ | - | ✓ | ✓ | ✓ | ✓ |
| + D3265 (2 x 10Gb SFP+) | | ✓ | ✓ | ✓ | ✓ | - | ✓ | ✓ | ✓ | ✓ |
| + D3275 (2 x 10Gb - T) | | ✓ | - | - | ✓ | - | ✓ | ✓ | ✓ | ✓ |

ServerView Virtual-I/O Manager Version 4.0.07

| PRIMERGY | Onboard | | | PCIe | | | | | |
|-------------------------|---------|------|-------|------|-------|---------|------|-------|----|
| | Skyhawk | | | LAN | | Skyhawk | | | FC |
| | PXE | FCoE | iSCSI | PXE | iSCSI | PXE | FCoE | iSCSI | |
| RX2530 M1 D3279 | - | - | - | ✓ | - | ✓ | ✓ | ✓ | ✓ |
| + D3245 (2 x 1Gb) | ✓ | - | - | ✓ | - | ✓ | ✓ | ✓ | ✓ |
| + D3255 (4 x 1Gb) | ✓ | - | - | ✓ | - | ✓ | ✓ | ✓ | ✓ |
| + D3265 (2 x 10Gb SFP+) | ✓ | ✓ | ✓ | ✓ | - | ✓ | ✓ | ✓ | ✓ |
| + D3275 (2 x 10Gb - T) | ✓ | - | - | ✓ | - | ✓ | ✓ | ✓ | ✓ |
| RX2530 M2 D3279B | - | - | - | ✓ | - | ✓ | ✓ | ✓ | ✓ |
| + D3245 (2 x 1Gb) | ✓ | - | - | ✓ | - | ✓ | ✓ | ✓ | ✓ |
| + D3255 (4 x 1Gb) | ✓ | - | - | ✓ | - | ✓ | ✓ | ✓ | ✓ |
| + D3265 (2 x 10Gb SFP+) | ✓ | ✓ | ✓ | ✓ | - | ✓ | ✓ | ✓ | ✓ |
| + D3275 (2 x 10Gb - T) | ✓ | - | - | ✓ | - | ✓ | ✓ | ✓ | ✓ |
| RX2530 M4 D3383 A1 | ✓ | - | - | ✓ | - | ✓ | ✓ | ✓ | - |
| RX2530 M5 D3383 B1 | ✓ | - | - | ✓ | - | - | - | - | - |
| RX2540 M1 D3289 | - | - | - | ✓ | - | ✓ | ✓ | ✓ | ✓ |
| + D3245 (2 x 1Gb) | ✓ | - | - | ✓ | - | ✓ | ✓ | ✓ | ✓ |
| + D3255 (4 x 1Gb) | ✓ | - | - | ✓ | - | ✓ | ✓ | ✓ | ✓ |
| + D3265 (2 x 10Gb SFP+) | ✓ | ✓ | ✓ | ✓ | - | ✓ | ✓ | ✓ | ✓ |
| + D3275 (2 x 10Gb - T) | ✓ | - | - | ✓ | - | ✓ | ✓ | ✓ | ✓ |
| RX2540 M2 D3289B | - | - | - | ✓ | - | ✓ | ✓ | ✓ | ✓ |
| + D3245 (2 x 1Gb) | ✓ | - | - | ✓ | - | ✓ | ✓ | ✓ | ✓ |
| + D3255 (4 x 1Gb) | ✓ | - | - | ✓ | - | ✓ | ✓ | ✓ | ✓ |
| + D3265 (2 x 10Gb SFP+) | ✓ | ✓ | ✓ | ✓ | - | ✓ | ✓ | ✓ | ✓ |
| + D3275 (2 x 10Gb - T) | ✓ | - | - | ✓ | - | ✓ | ✓ | ✓ | ✓ |
| RX2540 M4 D3384 A1 | ✓ | - | - | ✓ | - | ✓ | ✓ | ✓ | - |
| RX2540 M5 D3384 B1 | ✓ | - | - | ✓ | - | - | - | - | - |

Note:

- iSCSI boot support for LAN ports on this mezzanine card must be checked in BIOS release notes.
- PXE & iSCSI supported for Linux operating system (incl. VMware ESX4.1 and ESX5)

ServerView Virtual-I/O Manager Version 4.0.07

3.2.2 UEFI mode

| PRIMERGY | Onboard | | | PCIe | | | | | |
|-------------------------|------------|------|-------|------|-------|------------|------|-------|----|
| | Skyhawk #2 | | | LAN | | Skyhawk #2 | | | FC |
| | PXE | FCoE | iSCSI | PXE | iSCSI | PXE | FCoE | iSCSI | |
| RX2530 M1 D3279 | - | - | - | ✓ | - | ✓ | ✓ | ✓ | ✓ |
| + D3245 (2 x 1Gb) | ✓ | - | - | ✓ | - | ✓ | ✓ | ✓ | ✓ |
| + D3255 (4 x 1Gb) | ✓ | - | - | ✓ | - | ✓ | ✓ | ✓ | ✓ |
| + D3265 (2 x 10Gb SFP+) | ✓ | ✓ | ✓ | ✓ | - | ✓ | ✓ | ✓ | ✓ |
| + D3275 (2 x 10Gb - T) | ✓ | - | - | ✓ | - | ✓ | ✓ | ✓ | ✓ |
| RX2530 M2 D3279B | - | - | - | ✓ | - | ✓ | ✓ | ✓ | ✓ |
| + D3245 (2 x 1Gb) | ✓ | - | - | ✓ | - | ✓ | ✓ | ✓ | ✓ |
| + D3255 (4 x 1Gb) | ✓ | - | - | ✓ | - | ✓ | ✓ | ✓ | ✓ |
| + D3265 (2 x 10Gb SFP+) | ✓ | ✓ | ✓ | ✓ | - | ✓ | ✓ | ✓ | ✓ |
| + D3275 (2 x 10Gb - T) | ✓ | - | - | ✓ | - | ✓ | ✓ | ✓ | ✓ |
| RX2530 M4 D3383 A1 | ✓ | - | - | ✓ | - | ✓ | ✓ | ✓ | - |
| RX2530 M5 D3383 B1 | ✓ | - | - | ✓ | - | - | - | - | ✓ |
| RX2540 M1 D3289 | - | - | - | ✓ | - | ✓ | ✓ | ✓ | ✓ |
| + D3245 (2 x 1Gb) | ✓ | - | - | ✓ | - | ✓ | ✓ | ✓ | ✓ |
| + D3255 (4 x 1Gb) | ✓ | - | - | ✓ | - | ✓ | ✓ | ✓ | ✓ |
| + D3265 (2 x 10Gb SFP+) | ✓ | ✓ | ✓ | ✓ | - | ✓ | ✓ | ✓ | ✓ |
| + D3275 (2 x 10Gb - T) | ✓ | - | - | ✓ | - | ✓ | ✓ | ✓ | ✓ |
| RX2540 M2 D3289B | - | - | - | ✓ | - | ✓ | ✓ | ✓ | ✓ |
| + D3245 (2 x 1Gb) | ✓ | - | - | ✓ | - | ✓ | ✓ | ✓ | ✓ |
| + D3255 (4 x 1Gb) | ✓ | - | - | ✓ | - | ✓ | ✓ | ✓ | ✓ |
| + D3265 (2 x 10Gb SFP+) | ✓ | ✓ | ✓ | ✓ | - | ✓ | ✓ | ✓ | ✓ |
| + D3275 (2 x 10Gb - T) | ✓ | - | - | ✓ | - | ✓ | ✓ | ✓ | ✓ |
| RX2540 M4 D3384 A1 | ✓ | - | - | ✓ | - | ✓ | ✓ | ✓ | - |
| RX2540 M5 D3384 B1 | ✓ | - | - | ✓ | - | - | - | - | ✓ |

Note:
 - Boot with iSCSI software initiator is not supported in UEFI mode
 #2 UEFI boot mode from Skyhawk is only supported with one LAN and one Storage function (excludes UMC and custom mode).

| PRIMERGY | Onboard | | | PCIe | | | | | |
|-------------------------|------------|------|-------|------|-------|------------|------|-------|----|
| | Skyhawk #2 | | | LAN | | Skyhawk #2 | | | FC |
| | PXE | FCoE | iSCSI | PXE | iSCSI | PXE | FCoE | iSCSI | |
| RX/TX2560 M1 D3289 | - | - | - | ✓ | - | ✓ | ✓ | ✓ | ✓ |
| + D3245 (2 x 1Gb) | ✓ | - | - | ✓ | - | ✓ | ✓ | ✓ | ✓ |
| + D3255 (4 x 1Gb) | ✓ | - | - | ✓ | - | ✓ | ✓ | ✓ | ✓ |
| + D3265 (2 x 10Gb SFP+) | ✓ | ✓ | ✓ | ✓ | - | ✓ | ✓ | ✓ | ✓ |
| + D3275 (2 x 10Gb - T) | ✓ | - | - | ✓ | - | ✓ | ✓ | ✓ | ✓ |
| RX/TX2560 M2 D3289 B1 | - | - | - | ✓ | - | ✓ | ✓ | ✓ | ✓ |
| + D3245 (2 x 1Gb) | ✓ | - | - | ✓ | - | ✓ | ✓ | ✓ | ✓ |
| + D3255 (4 x 1Gb) | ✓ | - | - | ✓ | - | ✓ | ✓ | ✓ | ✓ |
| + D3265 (2 x 10Gb SFP+) | ✓ | ✓ | ✓ | ✓ | - | ✓ | ✓ | ✓ | ✓ |
| + D3275 (2 x 10Gb - T) | ✓ | - | - | ✓ | - | ✓ | ✓ | ✓ | ✓ |

ServerView Virtual-I/O Manager Version 4.0.07

| PRIMERGY | Onboard Intel® | | | | PCIe | | | | | |
|--------------------|----------------|------|-------|--|------|-------|------------|------|-------|----|
| | LAN | | | | LAN | | Skyhawk #2 | | | FC |
| | PXE | FCoE | iSCSI | | PXE | iSCSI | PXE | FCoE | iSCSI | |
| RX4770 M1 D3342 | ✓ | - | - | | ✓ | - | ✓ | ✓ | ✓ | ✓ |
| RX4770 M2 D3349 | ✓ | - | - | | ✓ | - | ✓ | ✓ | ✓ | ✓ |
| RX4770 M3 D3749 | ✓ | - | - | | ✓ | - | ✓ | ✓ | ✓ | ✓ |
| RX4770 M5 D3753-C1 | ✓ | - | - | | ✓ | - | - | - | - | ✓ |
| RX1330 M2 D3375 | ✓ | - | - | | ✓ | - | ✓ | ✓ | ✓ | ✓ |
| RX1330 M3 D3375 | ✓ | - | - | | ✓ | - | ✓ | ✓ | ✓ | ✓ |

Note:
 - Boot with iSCSI software initiator is not supported in UEFI mode
 #2 UEFI boot mode from Skyhawk is only supported with one LAN and one Storage function (excludes UMC and custom mode).

DISTRIBUTION; IMPLEMENTATION; DOCUMENTATION & SUPPORT

| | |
|------------------------------|---|
| User Interface | English |
| Installation | VIOM - as other ServerView Suite modules - can easily be installed by the customer; optionally an installation service can be provided by Fujitsu professional service. |
| Documentation | User manuals can be downloaded from manuals.ts.fujitsu.com/serverbooks/serverview-suite |
| User Skills | Basic knowledge of Windows/LINUX and Fujitsu Blade and Rack/tower server administration is presumed. |
| Conditions | This software product is supplied under conditions described in our current license agreement. |
| Warranty | Class: A Purchase of a Service and Support Pack available from Fujitsu Technology Solutions is mandatory. |
| Media | The ServerView Suite DVD contains all necessary software components. |
| Ordering and Delivery | ServerView Virtual-I/O Manager Right-to-Use licenses have to be purchased on a per server base to be managed by VIOM. Besides a single server license (U15000-C311) also two bundles are available for 8 or 18 servers (8 licenses: U15000-C312; 18 licenses: U15000-C313). Purchase of a Service and Support Pack available from Fujitsu Technology Solutions is mandatory. |

More information

Fujitsu OPTIMIZATION Services

In addition to FUJITSU Software ServerView® Suite, Fujitsu provides a range of platform solutions. They combine reliable Fujitsu products with the best in services, know-how and worldwide partnerships.

Fujitsu Portfolio

Built on industry standards, Fujitsu offers a full portfolio of IT hardware and software products, services, solutions and cloud offering, ranging from clients to datacenter solutions and includes the broad stack of Business Solutions, as well as the full stack of Cloud offerings. This allows customers to select from alternative sourcing and delivery models to increase their business agility and to improve their IT operation's reliability..

Computing products

www.fujitsu.com/global/services/computing/

Software

www.fujitsu.com/software/

More information

Learn more about FUJITSU Software ServerView® Suite, please contact your Fujitsu sales representative or Fujitsu business partner, or visit our website.
www.fujitsu.com/fts/serverview

Fujitsu green policy innovation

Fujitsu Green Policy Innovation is our worldwide project for reducing burdens on the environment. Using our global know-how, we aim to contribute to the creation of a sustainable environment for future generations through IT. Please find further information at www.fujitsu.com/global/about/environment/



Copyrights

All rights reserved, including intellectual property rights. Changes to technical data reserved. Delivery subject to availability. Any liability that the data and illustrations are complete, actual or correct is excluded. Designations may be trademarks and/or copyrights of the respective manufacturer, the use of which by third parties for their own purposes may infringe the rights of such owner. For further information see www.fujitsu.com/fts/resources/navigation/terms-of-use.html
©2019 Fujitsu Technology Solutions GmbH

Disclaimer

Technical data is subject to modification and delivery subject to availability. Any liability that the data and illustrations are complete, actual or correct is excluded. Designations may be trademarks and/or copyrights of the respective manufacturer, the use of which by third parties for their own purposes may infringe the rights of such owner.

Contact

FUJITSU LIMITED

Website: www.fujitsu.com
2019-12-13 CE-EN

All rights reserved, including intellectual property rights. Changes to technical data reserved. Delivery subject to availability. Any liability that the data and illustrations are complete, actual or correct is excluded. Designations may be trademarks and/or copyrights of the respective manufacturer, the use of which by third parties for their own purposes may infringe the rights of such owner. For further information see www.fujitsu.com/fts/resources/navigation/terms-of-use.html
Copyright 2019 FUJITSU LIMITED