

peerless®

Installation and Assembly: VESA® extension kit for up to 200x100mm mounting patterns

Model: ACC-V2X1

Parts List

	Description	Qty	Part No.
A	VESA® adaptor plate	2	095-1590
B	M5 x 6mm Phillips screw	4	520-1023
C	No. 10 flat washer	4	540-9400

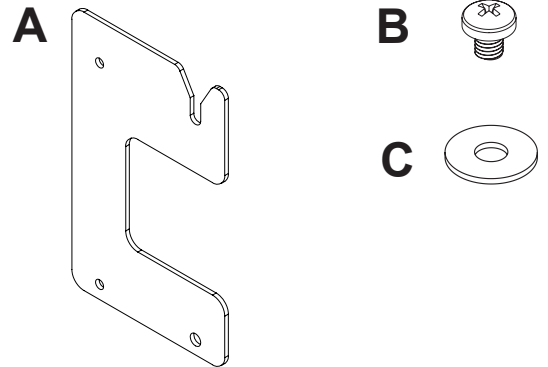

⚠ WARNING

- If screws do not get three complete turns in the screen inserts, or if screws bottom out and the wall mount is still not tightly secured, damage may occur to screen or the product may fail.

This extension kit allows a Peerless mount with an existing fixed (non-scalable) VESA® 100x100mm mounting pattern to be extended to accommodate screens with VESA® 200x100mm mounting patterns.

1 ATTACHING ADAPTOR PLATES TO EXISTING TILT PLATE

Attach Adaptor Plates (A) to the existing tilt plate of arm assembly using four M5 x 6mm screws (B) and four No. 10 flat washers (C).

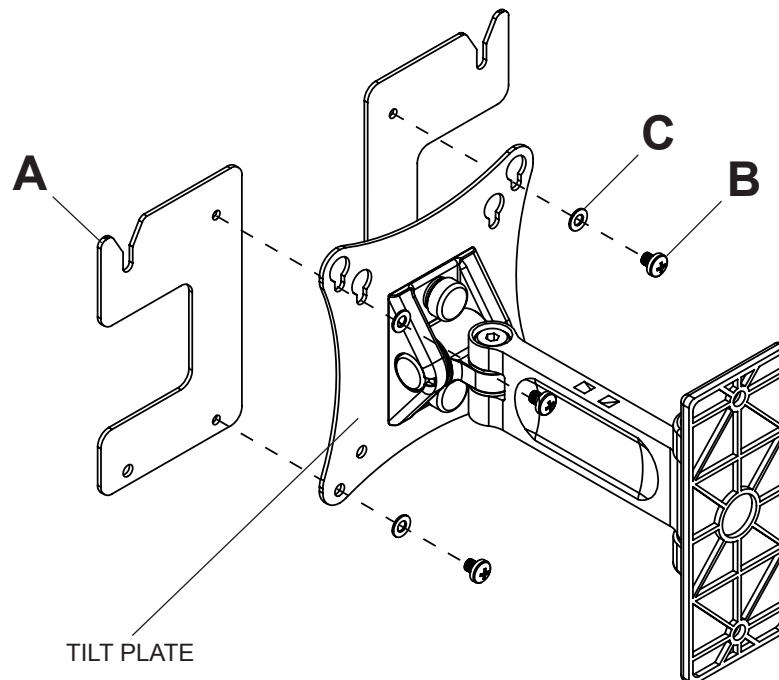

Visit Peerless at www.peerless-av.co.uk

For Technical Support call +44 (0)1923 200 100

ACC-V2X1 ISSUED 10-06-30 REV1

2 ATTACHING ADAPTOR PLATE TO REAR OF SCREEN

Using the screws supplied with your existing wall mount, insert two screws into the top holes of screen, leaving approximately 6.3mm (1/4") of exposed thread. Hook screws onto slots of adaptor plates (A) as shown below.

NOTE: If hole pattern is in a pocket, insert two 20mm screws with two retaining spacers (supplied with existing wall mount) into top two holes of screen.

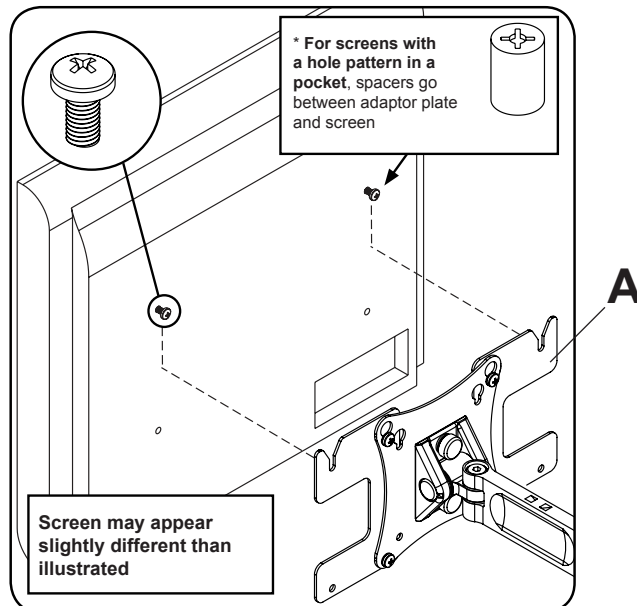

Depending on the make of your screen, insert one M4 x 10mm, M5 x 10mm or M6 x 10mm screw through each bottom hole of the adaptor plate (A) as shown below.

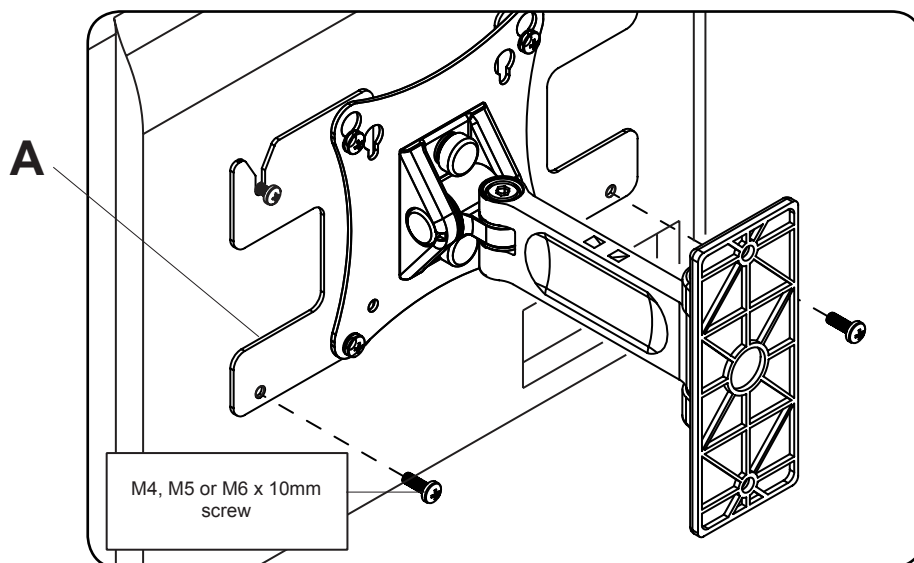

peerless-AV
uk

Peerless-AV UK

Unit 3 Watford Interchange, Colonial Way, Watford, Herts WD24 4WP, United Kingdom

Tel: +44 (0)1923 200 100 Fax: +44 (0)1923 200 101

Email: info@peerless-av.co.uk Web: www.peerless-av.co.uk

BBG Distribution Ltd, trading as Peerless-AV UK

peerless-AV
europe

Peerless-AV Europe

Unit 3 Watford Interchange, Colonial Way, Watford, Herts WD24 4WP, United Kingdom

Tel: +44 (0)1923 200 100 Fax: +44 (0)1923 200 101

Email: info@peerless-av.eu.com Web: www.peerless-av.eu.com

BBG Distribution Ltd, trading as Peerless-AV Europe