



INSTALLATION AND MAINTENANCE INSTRUCTIONS

MHP4-12/14 Series

Heat Pump / Electric Heat Packaged Unit

Save these instructions for future reference



This is a safety alert symbol and should never be ignored. When you see this symbol on labels or in manuals, be alert to the potential for personal injury or death.

Installation

WARNING

These units are not approved for mobile home applications. Such use could result in property damage, personal injury, or death.

Table of Contents

Installation	1
Operation	12
Maintenance	13
Accessories	14
Wiring Diagrams	16

WARNING

Improper installation, adjustment, alteration, service or maintenance can cause property damage, personal injury or loss of life. Installation and service must be performed by a licensed professional installer (or equivalent), service agency or the gas supplier.

General

These instructions explain the recommended method of installation of the MagicPak All-In-One™ HVAC system model MHP4 electric cooling unit and associated electrical wiring.

These instructions, and any instructions packaged with mating components and/or accessories, should be carefully read prior to beginning installation. Note particularly any **CAUTIONS** or **WARNINGS** in these instructions and all labels on the units.

Manufactured By
Allied Air Enterprises LLC
A Lennox International Inc. Company
215 Metropolitan Drive
West Columbia, SC 29170



(P) 508346-01

CAUTION

The installation of this appliance must conform to the requirements of the National Fire Protection Association; the National Electrical Code, ANSI/NFPA No. 70 (latest edition) in the United States; the Canadian Electrical Code Part 1, CSA 22.2 (latest edition) in Canada; and any state or provincial laws or local ordinances. Local authorities having jurisdiction should be consulted before installation is made. Such applicable regulations or requirements take precedence over the general instructions in this manual.

Check that equipment complies with all applicable building codes, laws, and regulations for its intended use prior to installation.

The MHP4 unit is a self-contained electric heating and cooling unit with optional epoxy-coated coils. This unit has been examined for compliance with Canadian Standards Association CAN/CSA-C22.2 No. 236 (latest edition) and Underwriters Laboratories UL 1995. This unit is also in compliance with AHRI Performance Standard 210/240. Any alterations of internal wiring will void these listings and warranties.

These instructions are intended as a general guide only, for use by qualified personnel and do not supersede any national or local codes in any way. Compliance with all local, state, provincial, or national codes pertaining to this type of equipment should be determined prior to installation.

Units certified for less than 2% cabinet leakage using ANSI/ASHRAE 193 (complies with IECC 2015) are identified on the rating plate.

⚠ WARNING

Installation and servicing of air conditioning equipment can be hazardous due to internal refrigerant pressure and live electrical components. Only trained and qualified service personnel should install or service this equipment. Installation and service performed by unqualified persons can result in property damage, personal injury, or death.

⚠ WARNING

For your safety, do not store or use gasoline or other flammable vapors and liquids in the vicinity of this or any other appliance. Such actions could result in property damage, personal injury, or death.

⚠ WARNING

The unit must be installed with approved wall sleeve and louver accessories for safe operation. Improper installations could result in property damage, personal injury, or death.

Inspection

Upon receipt of equipment, carefully inspect it for possible shipping damage. If damage is found, it should be noted on the carrier's freight bill. Take special care to examine the unit inside the carton if the carton is damaged. File a claim with the transportation company. **If any damage is discovered and reported to the carrier, do not install the unit, as claim may be denied.**

Check the unit rating plate to confirm specifications are as ordered.

Limitations

The unit should be installed in accordance with all national and local safety codes.

Limitations of the unit and appropriate accessories must also be observed.

The outdoor fan is designed to operate against no more than .10" w.c. static pressure.

Minimum and maximum operation conditions must be observed to assure proper system performance. Refer to Table 1 for the ambient operating limitations of the unit.

Outdoor Ambient Air Temperature °F		
Minimum DB		Maximum DB
Cool		Heat
65		115 / 75

Indoor Ambient Air Temperature °F			
Minimum		Maximum	
DB/WB	DB	DB/WB	DB
Cool	Heat	Cool	Heat
62/57	50	90/72	80

DB = Dry Bulb
WB = Wet Bulb

Table 1. Ambient Temperature Limitations

Location

For information on wall sleeves and louver accessories, see the **Accessories** section.

This unit is designed to be installed in up to the wall (exterior wall) installation only. Refer to Figure 2 for additional details. **Accessibility clearances must take precedence over fire protection clearances.**

The outside of the unit may be flush with the face of the exterior wall, and it should not be obstructed with trees, landscape materials, or building structure. Unit can be installed recessed with appropriate wall sleeve accessories. There is no minimum clearance required on locating the unit to an interior corner of a building.

If the unit is installed in a residential garage, it must be located or protected to avoid physical damage by vehicles. The unit must be installed so that no electrical components are exposed to water.

⚠ CAUTION

This unit must be installed level to allow for proper drainage of the unit base pan and indoor drain pan.

Use of Unit During Construction

Use of this unit as a construction heater or air conditioner is not recommended during any phase of construction. Very low return air temperature, harmful vapors and operation of the unit with clogged or misplaced filters will damage the unit.

Units may be used for heating or cooling of buildings or structures under construction if the following conditions are met or the warranty will be void:

- The unit must be permanently installed per these installation instructions.
- A room thermostat must control the unit. The use of fixed jumpers that will provide continuous heating is not allowed.
- Supply and return air duct must be provided and sealed to the unit.
- Return air temperature range between 60°F (16°C) and 80°F (27°C) must be maintained.
- MERV 11 or greater air filters must be installed in the system and must be regularly inspected and maintained (e.g., regular static checks and replaced at end of life) during construction.
- Air filters must be replaced upon construction completion.
- The input rate and temperature rise must be set per the unit rating plate.
- One hundred percent (100%) outdoor air must be provided for combustion air requirements during construction.
- The heat exchanger, components, duct system, air filters and evaporator coils must be thoroughly cleaned following final construction cleanup.
- The unit operating conditions (including airflow, cooling operation, ignition, input rate, temperature rise and venting) must be verified according to these installation instructions.

Unit Dimensions (in.)

Model	A	B*	C	D	E	F	G	H	J	K	L	M	N
*MHP4-12-091*P *MHP4-12-121*P	43-7/8	16-7/8	25-1/4	21-1/2	18-5/8	19-1/4	6	8	16	17-1/16	3/4	2-1/4	24-5/8
*MHP4-12-181*P	47-7/8	18-7/8	27-1/4	21-1/2	20-5/8	21-1/4	6	8	16	17-1/16	3/4	2-1/4	26-5/8
*MHP4-12-241*P	55-7/8	22-7/8	31-1/4	24-3/8	24-5/8	25-1/4	6	8	16	22-7/16	3/4	1	30-5/8
*MHP4-12-301*P	55-7/8	22-7/8	31-1/4	24-3/8	24-5/8	25-1/4	6	11-3/8	10-7/16	22-7/16	3-3/4	1	30-5/8
*MHP4-14-361*P	67-7/8	26-7/8	35-1/4	24-3/8	28-5/8	29-1/4	10	11-3/8	10-7/16	22-7/16	3-3/4	1	38-5/8

* Dimension B represents the height of the optional front return air duct opening

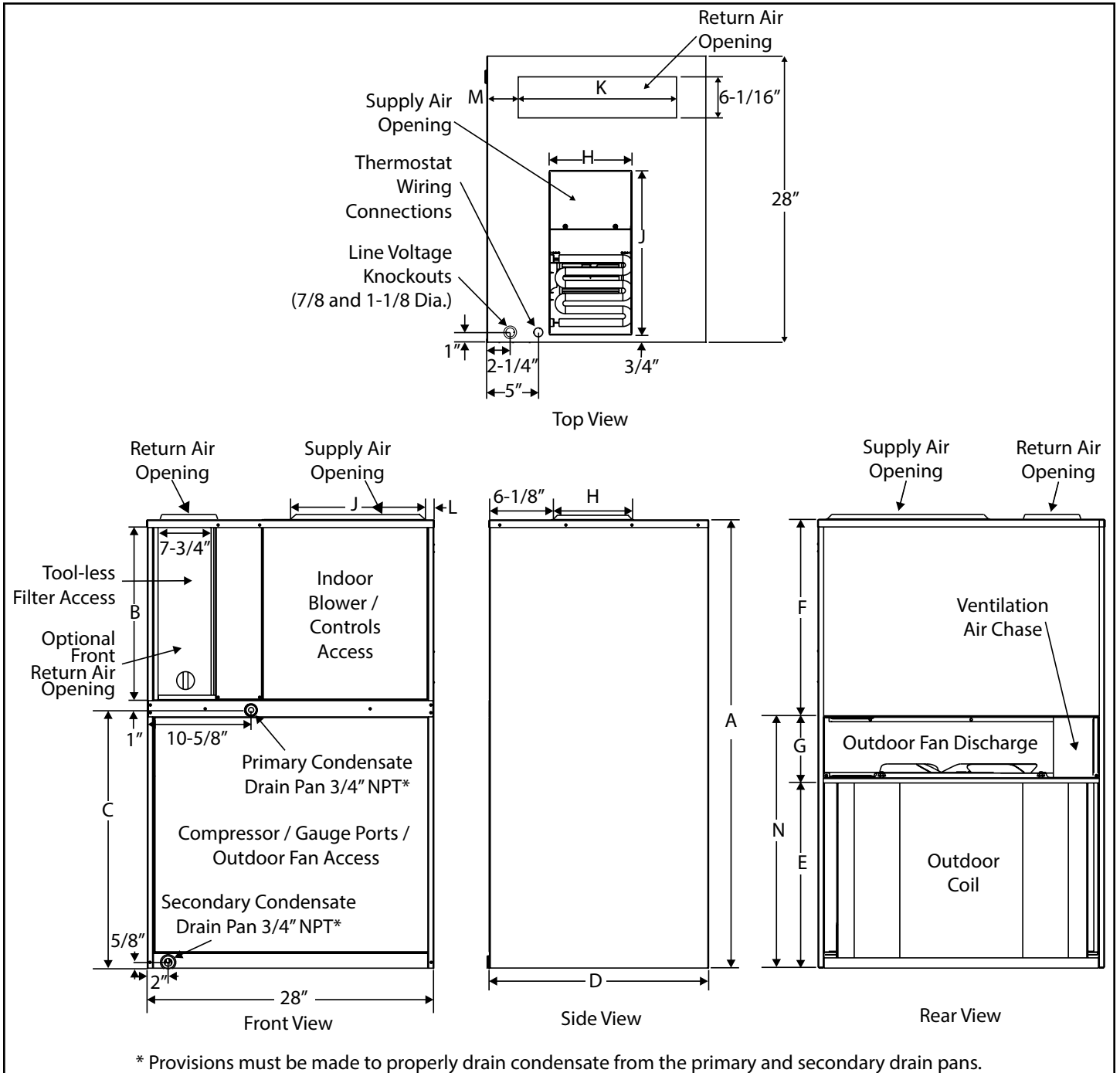

Figure 1.

Accessibility Clearances

The front of the unit must be accessible for service. A minimum clearance of 30" in front of unit is required for service.

If the unit is enclosed, a door or access panel aligned with the front of the unit is the preferred method of providing access. The door or access panel opening must be a minimum of 30" wide (centered on the unit) and be as tall as the unit.

IMPORTANT

The unit must be installed with approved wall sleeve and louver accessories for safe operation. Improper installations could result in property damage, personal injury, or death.

Supply Duct Clearances

Minimum Clearances to Combustible Materials ¹		
Front	Sides	Top
0"	0"	0"

1 Accessibility clearances take precedence

Unit Clearances

Return Duct Configuration	Unit Height	Minimum Clearances ¹	
		Front	Sides ³
Ducted Top Opening	All	Note 2	1"
Ducted Front Opening ⁵	All	Notes 2 & 4	1"
Non-Ducted/ Free Return	43"	4"	1"
	48" - 68"	5"	1"

1 Accessibility clearances take precedence

2 Clearance must accommodate field-installed condensate drain line / drain trap

3 Additional clearance required if field-installed condensate drain line/drain trap is routed alongside unit

4 Consult local codes for other clearance requirements

5 If ductwork is attached to the optional front return opening, provisions to service unit filter must be provided

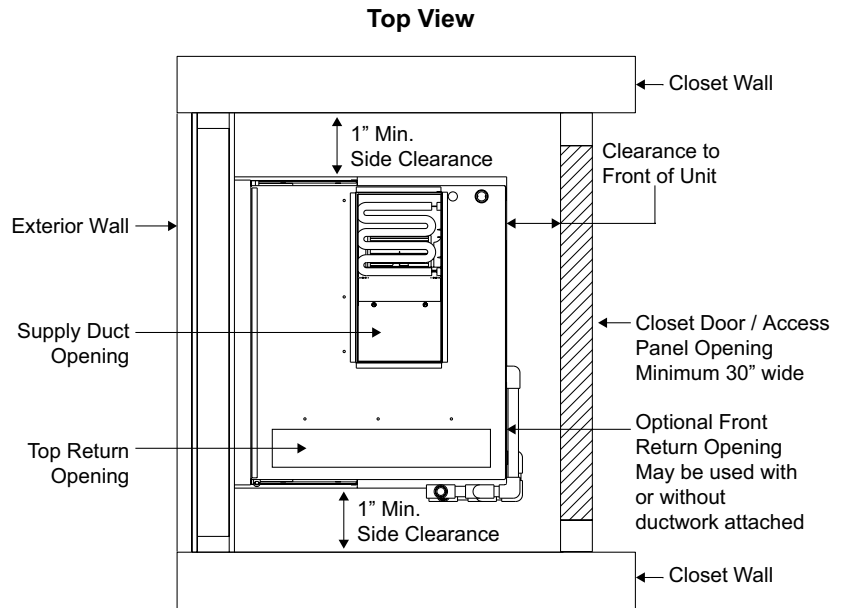

Side View

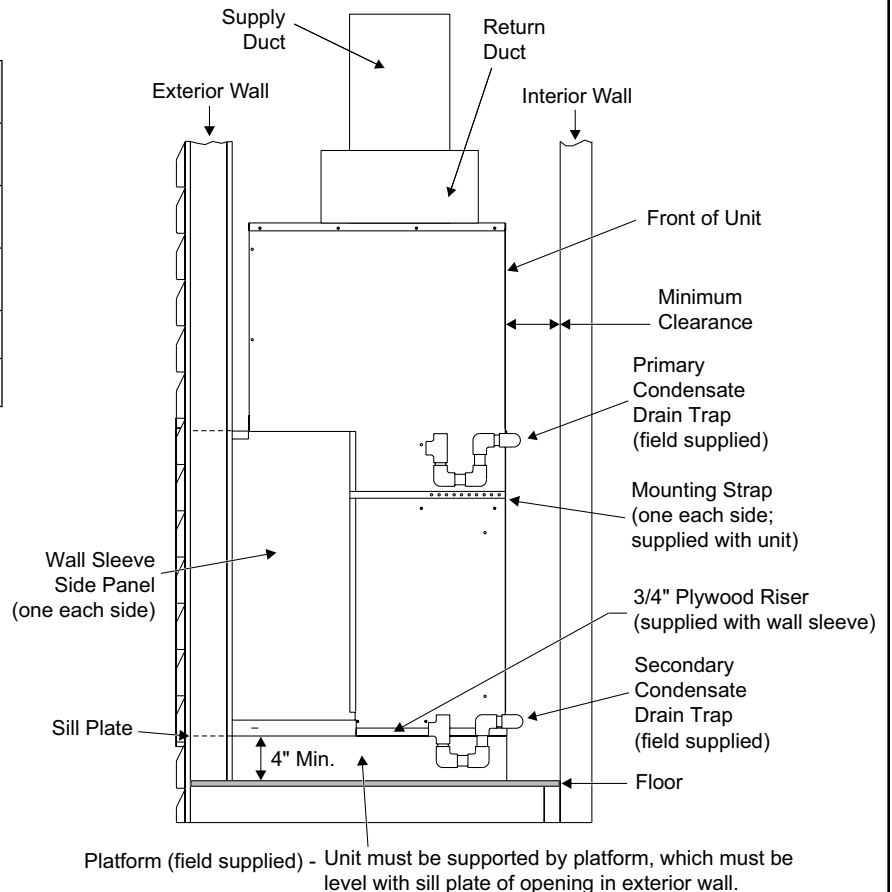

Figure 2. Minimum Clearances

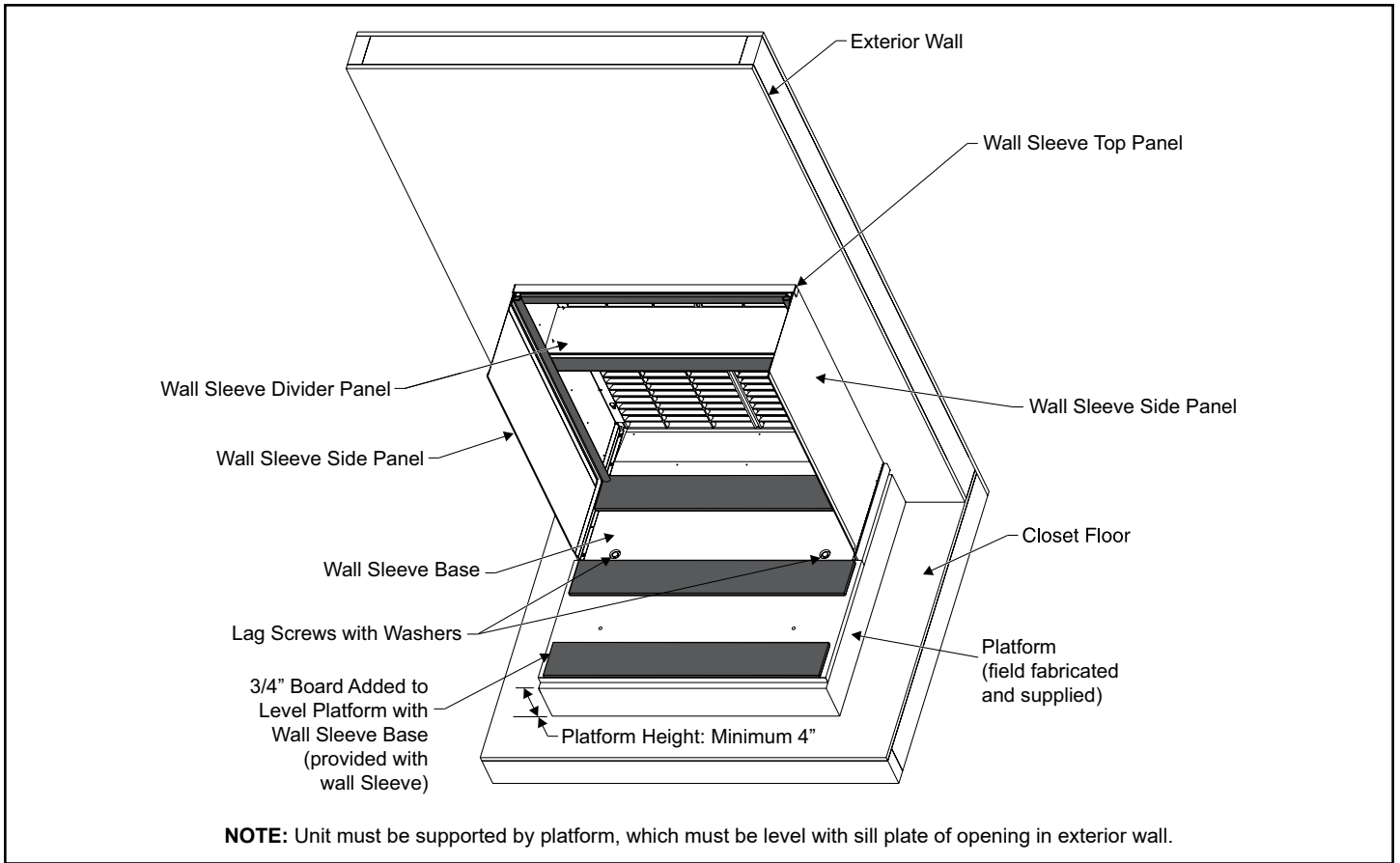

Figure 3. Wall Sleeve and Louver Kit Installation

Wall Sleeve and Louver Installation

Refer to installation instructions included with the wall sleeve kit and the louver kit along with Figure 3 for guidance in assembling and installing the wall sleeve and louver.

⚠ CAUTION

The sleeve is not intended as the sole support for the unit. An additional support must be provided for adequate support (see Figure 3).

Installing and Securing Unit to Wall Sleeve

1. Before installing and securing the unit to the wall sleeve, make sure that the proper louver is installed.
2. Make sure the gaskets attached to the sleeve are not damaged.
3. Verify divider panel is positioned properly. Refer to Table 2 for wall sleeves that allow for multiple divider panel locations.

Model	ASLEEVE** -2	ASLEEVE** -5	Orientation of Flange
	Two Positions	Three Positions	
MHP4-12-09,12	Lower	Lower	Down
MHP4-12-18			Up
MHP4-12-24, 30	Upper	Middle	
MHP4-14-36	N/A	Upper	

Table 2.

4. Place the unit into the wall sleeve. **Lift leading end of unit and walk unit onto the sleeve.** Once in the wall sleeve, lower the unit into position. This prevents damage to the base pads. Assure that the unit is level and completely seated against the gaskets on the wall sleeve. The unit must be supported by a field supplied base platform.

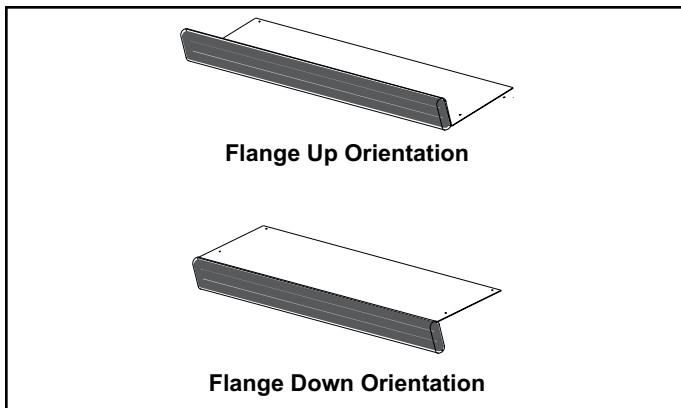

Figure 4. Positioning Divider Panel

5. Use the two installation brackets to secure the unit to the wall sleeve (see Figure 5). The units are shipped with the brackets placed in the return air compartment. Hook each bracket into the front edge of the wall sleeve side. Position the bracket so it can be bent around the front corner of the unit. Remove one of the two screws in that position on the unit. Line up one of the holes in the installation bracket with the screw hole and attach the bracket to the unit with that screw. Make sure to fasten tight enough that the seal is maintained. Trim off excess bracket if applicable.

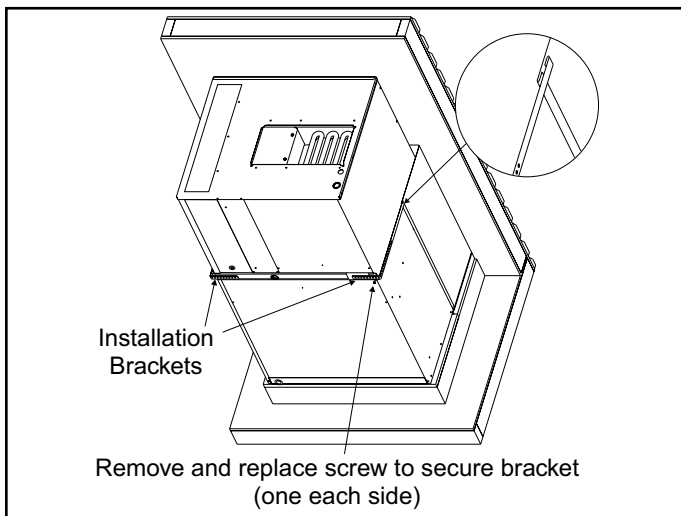

Figure 5. Securing Unit

⚠ CAUTION

Do not screw into the side of the drain pan, the indoor coil or the heat strip, which is located above the installation bracket.

6. Inspect the fit up of the unit to the wall sleeve. Verify that the gaskets of the wall sleeve make a complete seal to the unit paying particular attention to top and bottom corners of unit to sleeve seal. Caulk if needed.

Ductwork

Ductwork should be designed and sized according to the methods in Manual Q of the Air Conditioning Contractors of America (ACCA).

Check unit supply and return air outlets for debris before making ductwork connections.

It is recommended that supply and return duct connections at the unit be made with flexible joints. If flexible ducts are used, a 6" sheet metal starter collar is required.

The supply and return air duct systems should be fabricated per the designed CFM and static requirements of the job (see Table 3). **Ductwork should not be sized to match the dimensions of the duct connections on the unit.** The return duct should be sealed to the unit casing and terminate outside the space containing the unit.

Optional Front Return

As shipped, units are configured for attaching supply and return ductwork to the top of the unit. Return air may be brought in through the optional front return opening. To open the optional front return and close off the top return opening, perform the following steps.

1. Rotate knob to release filter access panel and remove panel.
 - a. For all units except 3-ton models, position filter access panel to close off top return opening. Secure at rear using two sheet metal screws. Secure in front using knob. See Figure 6.
 - b. For 3-ton models, field fabricate a sheet metal panel to close off the top return opening.
2. Seal panel to top of unit with tape or mastic.

NOTE: If ductwork is attached to the optional front return opening, provisions to service unit filter must be provided. Filter may need to be relocated to a suitable location outside the cabinet for ease of service.

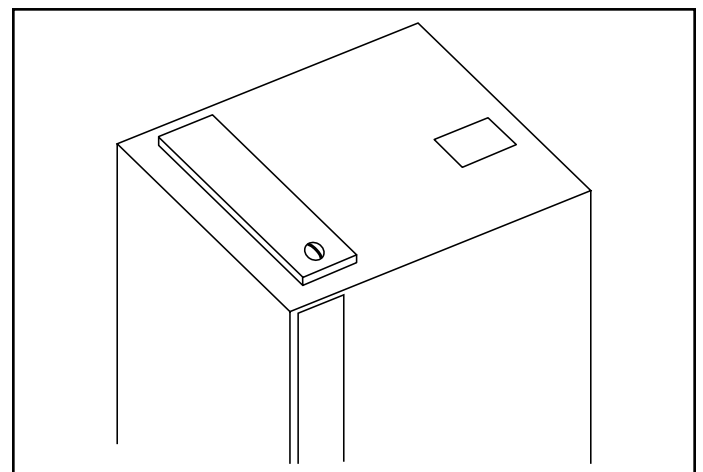

Figure 6. Secure Filter Access Panel

Airflow Performance as a Function of External Static Pressure																	
Model	Indoor Blower Speed	0.1 "w.c.			0.2 "w.c.			0.3 "w.c.			0.4 "w.c.			0.5 "w.c.			
		SCFM	Watts	HP	SCFM	Watts	HP	SCFM	Watts	HP	SCFM	Watts	HP	SCFM	Watts	HP	
*MHP4-12-091*P	TAP 1 (FAN)	365	28	0.04	330	31	0.04	275	35	0.05	225	38	0.05	180	41	0.05	
	TAP 2 (COOL/HP)	375	28	0.04	325	32	0.04	275	35	0.05	N/A	N/A	N/A	N/A	N/A	N/A	
	TAP 3 (COOL/HP)†	N/A	N/A	N/A	N/A	N/A	N/A	352	38	0.05	319	42	0.06	279	46	0.06	
	3 kW	TAP 4 (AUX HEAT)*	515	55	0.07	485	58	0.08	450	62	0.08	N/A	N/A	N/A	N/A	N/A	N/A
		TAP 5 (AUX HEAT)	600	73	0.10	570	78	0.10	545	84	0.11	515	88	0.12	475	92	0.12
	5 kW	TAP 4 (AUX HEAT)*	570	69	0.09	545	73	0.10	515	77	0.10	N/A	N/A	N/A	N/A	N/A	N/A
TAP 5 (AUX HEAT)		660	92	0.12	635	98	0.13	605	104	0.14	580	109	0.15	550	114	0.15	
*MHP4-12-121*P	TAP 1 (FAN)	365	28	0.04	330	31	0.04	275	35	0.05	225	38	0.05	180	41	0.05	
	TAP 2 (COOL/HP)	490	50	0.07	460	55	0.07	420	59	0.08	N/A	N/A	N/A	N/A	N/A	N/A	
	TAP 3 (COOL/HP)†	N/A	N/A	N/A	501	59	0.08	469	63	0.08	440	68	0.09	408	72	0.10	
	3 kW	TAP 4 (AUX HEAT)*	515	55	0.07	485	58	0.08	450	62	0.08	N/A	N/A	N/A	N/A	N/A	N/A
		TAP 5 (AUX HEAT)	600	73	0.10	570	78	0.10	545	84	0.11	515	88	0.12	475	92	0.12
	5 kW	TAP 4 (AUX HEAT)*	570	69	0.09	545	73	0.10	515	77	0.10	N/A	N/A	N/A	N/A	N/A	N/A
TAP 5 (AUX HEAT)		660	92	0.12	635	98	0.13	605	104	0.14	580	109	0.15	550	114	0.15	
*MHP4-12-181*P	TAP 1 (FAN)	365	32	0.04	335	35	0.05	280	39	0.05	235	42	0.06	175	46	0.06	
	TAP 2 (COOL/HP)	615	103	0.14	590	108	0.14	555	112	0.15	530	117	0.16	500	121	0.16	
	TAP 3 (COOL/HP)†	705	118	0.16	680	124	0.17	650	129	0.17	620	135	0.18	595	140	0.19	
	3 kW	TAP 4 (AUX HEAT)*	615	93	0.12	590	97	0.13	555	101	0.14	N/A	N/A	N/A	N/A	N/A	N/A
		TAP 5 (AUX HEAT)	715	127	0.17	685	134	0.18	655	140	0.19	630	146	0.20	600	151	0.20
	5 kW	TAP 4 (AUX HEAT)*	665	110	0.15	635	114	0.15	605	118	0.16	N/A	N/A	N/A	N/A	N/A	N/A
		TAP 5 (AUX HEAT)	750	148	0.20	725	154	0.21	700	160	0.21	675	166	0.22	650	171	0.23
	7 kW	TAP 4 (AUX HEAT)*	725	137	0.18	705	144	0.19	675	150	0.20	N/A	N/A	N/A	N/A	N/A	N/A
		TAP 5 (AUX HEAT)	N/A	N/A	N/A	800	200	0.27	780	205	0.27	755	209	0.28	725	213	0.29
	10 kW	TAP 4 (AUX HEAT)*	750	148	0.20	725	154	0.21	700	161	0.22	N/A	N/A	N/A	N/A	N/A	N/A
TAP 5 (AUX HEAT)		N/A	N/A	N/A	N/A	N/A	N/A	805	224	0.30	780	228	0.31	750	232	0.31	
*MHP4-12-241*P	TAP 1 (FAN)	460	43	0.06	420	47	0.06	380	51	0.07	350	54	0.07	290	59	0.08	
	TAP 2 (COOL/HP)	815	150	0.20	785	161	0.22	760	165	0.22	740	172	0.23	715	178	0.24	
	TAP 3 (COOL/HP)†	854	124	0.17	828	132	0.18	797	139	0.19	775	145	0.19	750	150	0.20	
	5 kW	TAP 4 (AUX HEAT)*	800	146	0.20	775	152	0.20	750	157	0.21	N/A	N/A	N/A	N/A	N/A	N/A
		TAP 5 (AUX HEAT)	905	201	0.27	880	207	0.28	855	212	0.28	825	216	0.29	800	219	0.29
	7 kW	TAP 4 (AUX HEAT)*	855	174	0.23	830	179	0.24	800	183	0.25	N/A	N/A	N/A	N/A	N/A	N/A
		TAP 5 (AUX HEAT)	N/A	N/A	N/A	930	231	0.31	900	235	0.32	875	239	0.32	850	243	0.33
	10 kW	TAP 4 (AUX HEAT)*	855	174	0.23	830	179	0.24	800	183	0.25	N/A	N/A	N/A	N/A	N/A	N/A
		TAP 5 (AUX HEAT)	N/A	N/A	N/A	930	231	0.31	900	235	0.32	875	239	0.32	850	243	0.33

N/A: Do not operate unit using this blower speed at this external static pressure.

† As shipped speed for Cooling operation. Blower speed must be field adjusted to Speed Tap 2 for lower duct static applications.

* As shipped speed for Heating operation. Blower speed must be field adjusted to Speed Tap 5 for higher duct static applications.

Table 3. Blower Performance (208V or 230V)

Airflow Performance as a Function of External Static Pressure																	
Model	Indoor Blower Speed	0.1 "w.c.			0.2 "w.c.			0.3 "w.c.			0.4 "w.c.			0.5 "w.c.			
		SCFM	Watts	HP	SCFM	Watts	HP	SCFM	Watts	HP	SCFM	Watts	HP	SCFM	Watts	HP	
*MHP4-12-30†*P	TAP 1 (FAN)	590	43	0.06	535	48	0.06	430	55	0.07	380	60	0.08	315	65	0.09	
	TAP 2 (COOL/HP)	1040	161	0.22	1005	169	0.23	970	177	0.24	935	185	0.25	900	193	0.26	
	TAP 3 (COOL/HP)†	N/A	N/A	N/A	1030	162	0.22	1005	171	0.23	980	180	0.24	955	189	0.25	
	5 kW	TAP 4 (AUX HEAT)*	1075	151	0.20	1040	159	0.21	1005	168	0.23	N/A	N/A	N/A	N/A	N/A	N/A
		TAP 5 (AUX HEAT)	N/A	N/A	N/A	N/A	N/A	N/A	1100	205	0.27	1065	216	0.29	1025	225	0.30
	7 kW	TAP 4 (AUX HEAT)*	1075	151	0.20	1040	159	0.21	1005	168	0.23	N/A	N/A	N/A	N/A	N/A	N/A
		TAP 5 (AUX HEAT)	N/A	N/A	N/A	N/A	N/A	N/A	1100	205	0.27	1065	216	0.29	1025	225	0.30
	10 kW	TAP 4 (AUX HEAT)*	1075	151	0.20	1040	159	0.21	1005	168	0.23	N/A	N/A	N/A	N/A	N/A	N/A
		TAP 5 (AUX HEAT)	N/A	N/A	N/A	N/A	N/A	N/A	1100	205	0.27	1065	216	0.29	1025	225	0.30
*MHP4-14-36†*P	TAP 1 (FAN)	680	61	0.08	630	68	0.09	575	74	0.10	525	79	0.11	460	86	0.12	
	TAP 2 (COOL/HP)	1235	260	0.35	1200	272	0.36	1165	284	0.38	1135	295	0.40	1100	305	0.41	
	TAP 3 (COOL/HP)†	N/A	N/A	N/A	N/A	N/A	N/A	1106	263	0.35	1073	272	0.36	1043	282	0.38	
	5 kW	TAP 4 (AUX HEAT)*	1240	232	0.31	1205	248	0.33	1170	262	0.35	N/A	N/A	N/A	N/A	N/A	N/A
		TAP 5 (AUX HEAT)	N/A	N/A	N/A	N/A	N/A	N/A	1260	315	0.42	1230	328	0.44	1200	338	0.45
	7 kW	TAP 4 (AUX HEAT)*	1240	232	0.31	1205	248	0.33	1170	262	0.35	N/A	N/A	N/A	N/A	N/A	N/A
		TAP 5 (AUX HEAT)	N/A	N/A	N/A	N/A	N/A	N/A	1260	315	0.42	1230	328	0.44	1200	338	0.45
	10 kW	TAP 4 (AUX HEAT)*	1240	232	0.31	1205	248	0.33	1170	262	0.35	N/A	N/A	N/A	N/A	N/A	N/A
		TAP 5 (AUX HEAT)	N/A	N/A	N/A	N/A	N/A	N/A	1260	315	0.42	1230	328	0.44	1200	338	0.45

N/A: Do not operate unit using this blower speed at this external static pressure.
† As shipped speed for Cooling operation. Blower speed must be field adjusted to Speed Tap 2 for lower duct static applications.
* As shipped speed for Heating operation. Blower speed must be field adjusted to Speed Tap 5 for higher duct static applications.

Table 3. Blower Performance (208V or 230V)

Filter

All return air must be filtered. A washable filter is furnished with the unit, located in the return air compartment. If the optional front return opening is used and a duct is installed, provisions must be made to accommodate filter servicing. **If a filter is installed at a separate central return location, then the factory furnished filter must be removed from the unit.**

The washable filter may be replaced with a disposable filter. Avoid filter with paper frame and media; if it gets wet, it could collapse and block the coil, restricting airflow and causing issues with unit operation. Table 4 lists filter sizes that fit the unit.

When proper duct design is applied, field-provided filters up to MERV 6 can typically be installed in the unit's factory filter location in lieu of a washable filter. If a higher resistance filter is field installed in the unit, the added resistance must be included in the external static pressure and must not exceed 0.5 in. w.c., including ductwork.

If an installation is made in which it is more desirable to mount the filter exterior to the unit, in the return duct work or elsewhere, the washable filter can be used or replaced with a disposable filter. If a disposable filter is used, in lieu of washable filter, use the information provided in Table 5 when sizing the disposable filter.

Model Number	Filter Size (in.)
MHP4-12-09 *MHP4-12-12*	18 x 20 x 1
MHP4-12-18	20 x 20 x 1
MHP4-12-24 *MHP4-12-30*	22 x 24 x 1
MHP4-14-36	22 x 28 x 1

Table 4. Filter Sizes

Model Number	Filter Area (in ²)
MHP4-12-09 *MHP4-12-12*	265
3MHP4-12-18* 5MHP4-12-18*	310
7MHP4-12-18* 10MHP4-12-18*	360
MHP4-12-24	400
MHP4-12-30	515
MHP4-14-36	600

Table 5. Minimum Required Surface Area for Disposable Filters

Condensate Drain

Provisions must be made to properly drain the primary and secondary drain pans of this appliance.

Primary drain and secondary drain connection: 3/4" NPT to 3/4" PVC fitting (schedule 40 minimum). Both drains must be trapped as shown in Figure 7. The drain line should pitch gradually downward at least 1" per 10' of horizontal run to an open drain.

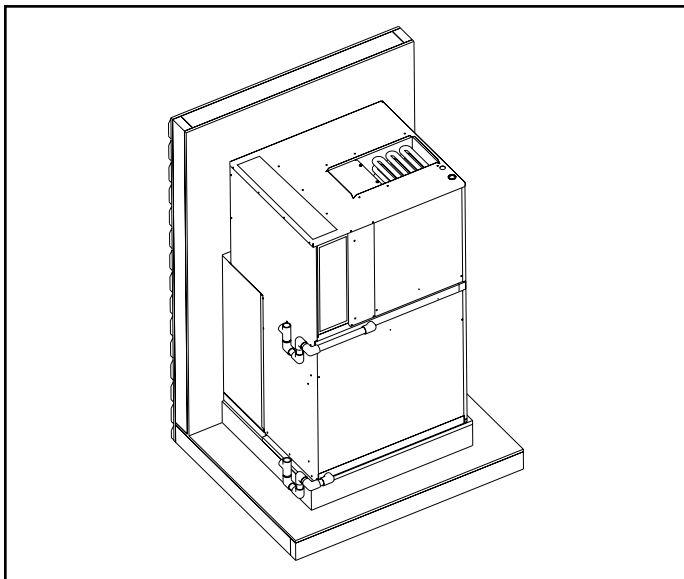

Figure 7. Condensate Drain Installation

If local codes require the use of metal condensate lines, do not thread metal fittings into the unit drain pans. Thread a PVC fitting into the unit drain pans and make the field connection to the PVC fitting.

NOTE: These units are designed with a redundant drain system to handle condensate without the need for an emergency drain pan. Should the indoor coil condensate drain system fail, all water is contained within the unit and the flow is directed into the unit base pan. From there it will drain into the condensate riser. If for some reason the water cannot drain into the main condensate riser, all water

is contained in the unit, and the design will allow drainage out through the wall sleeve and louver to the outside of the building.

CAUTION

Use thread sealant on the threaded fittings. Install threaded fittings by hand only. **Do not over torque the fittings.**

Do not thread metal condensate fittings to unit drain pans.

Ventilation Air

Units ship with a panel installed that seals the return air compartment at the ventilation air intake. Installers can choose to remove the factory-installed panel and use the field-provided ventilation damper if introduction of ventilation air is desired.

NOTE: If ventilation air is introduced, the quantity of air and conditions of this air must be accounted for in the load calculations.

The auxiliary panel has nine knockouts to configure ventilation air flow to installation requirements. Use Table 6 and Figure 8 to determine which knockouts to remove from the auxiliary panel in order to achieve the desired ventilation air flow. Use a flat head screw driver to remove the knockouts. Set the factory-installed panel aside for possible future changes.

WARNING

The location of ventilation air capable models must conform to the requirements of National Fire Protection Association NFPA No. 54 in regards to proximity of forced air inlets to flue gas terminals. Improper installation could result in personal injury or death.

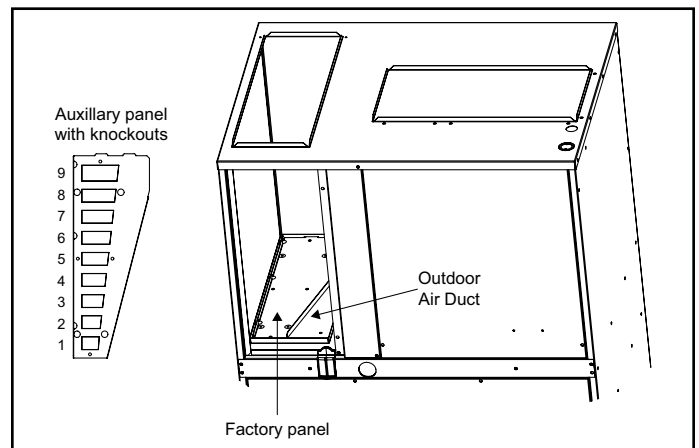

Figure 8. Auxiliary and Factory Panel for Ventilation Air

		Ventilation Air (CFM) *					
		Cumulative Knockouts Removed	Total External Static Pressure (supply + return) **				
			0.1	0.2	0.3	0.4	0.5
0.75, 1.0, 1.5 TON	# 1 Only	7	9	12	15	18	
	#1 thru #2	10	15	20	24	28	
	#1 thru #3	12	18	25	32	38	
	#1 thru #4	18	28	36	45	54	
	#1 thru #5	23	35	46	57	69	
	#1 thru #6	27	41	54	67	80	
	#1 thru #7	32	48	63	78	93	
	#1 thru #8	37	55	73	90	107	
	#1 thru #9	41	61	80	100	118	

2.0, 2.5, 3.0 TON	# 1 Only	21	20	19	17	16
	#1 thru #2	28	27	25	24	22
	#1 thru #3	35	33	32	30	28
	#1 thru #4	45	42	40	38	35
	#1 thru #5	55	52	49	46	43
	#1 thru #6	66	62	59	55	52
	#1 thru #7	79	75	71	66	62
	#1 thru #8	91	86	81	76	71
	#1 thru #9	105	99	94	88	82

* Assumes proper speed tap adjustments to maintain nominal supply air CFM
 ** Assumes equal supply and return static pressures

Table 6.

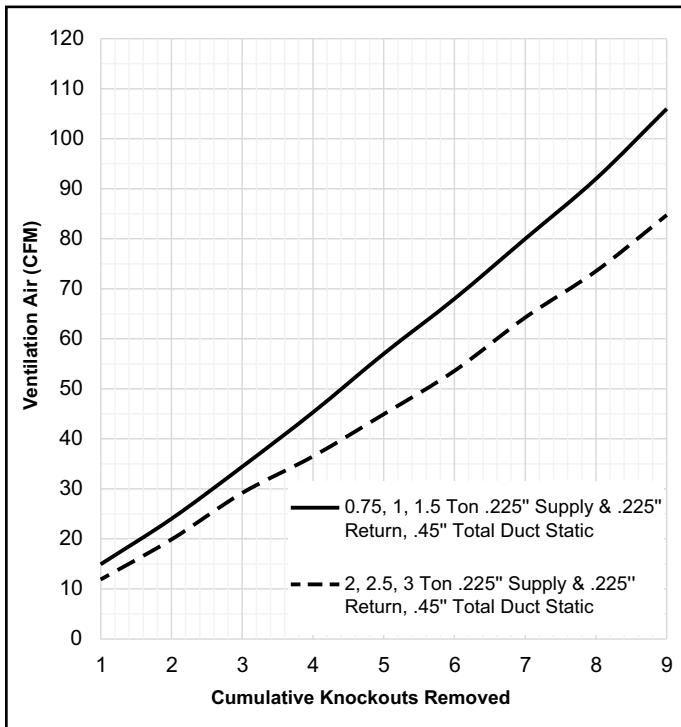

Figure 9. Ventilation Air CFM

Thermostat

The room thermostat should be located on an inside wall where it will not be subject to drafts, sun exposure, or heat from electrical fixtures or appliances. Follow manufacturer's instructions enclosed with the thermostat for general installation procedures. Color-coded insulated wires (#18 AWG) should be used to connect the thermostat to the unit.

Electrical Connections

The unit must be electrically grounded in accordance with local codes or, in the absence of local codes, with the National Electrical Code ANSI/NFPA No. 70 (latest edition) or CSA C22.2 Part 1 (latest edition). Any alteration of internal wiring will void certification and warranty.

Units are factory wired for a 230 volt power supply. If power supply is 208 volts, it will be necessary to change a wire connection on unit transformer from 240 volt terminal to 208 volt terminal as shown on the wiring diagram.

Use wiring with a temperature limitation of 75°F minimum. Run the 208 or 230 volt, single phase, 60 hertz electric power supply through a fused disconnect switch to the control box of the unit and connect as shown in the unit's wiring diagram.

The power supply to the unit must be NEC Class 1 and must comply with all applicable codes. A fused disconnect switch should be field provided for the unit, and must be separate from all other circuits. If any of the wire supplied with the unit must be replaced, replacement wire must be of the type shown on the wiring diagram.

Electrical wiring must be sized to minimum circuit ampacity (MCA) marked on the unit. **Use copper conductors only.** Each unit must be wired with a separate branch circuit and be properly fused.

NOTE: Some models require two separate power supply circuits. See the unit wiring diagrams and rating plates for specifications.

Operation

Sequence of Operation

Upon initial "power up" to unit, there is a 3-minute time delay to the compressor contactor (R to Y). Any 24V interrupt (R, C) to the defrost control will initiate the 3-minute delay to the contactor.

Cooling

When the thermostat is in the cooling mode, the O circuit is powered which energizes the reversing valve. Upon cooling demand, the thermostat closes circuit R to Y and G. Closing R to Y closes the unit contactor, starting the compressor and outdoor fan, and signaling the indoor blower to run at cooling speed. Upon satisfying cooling demand, the thermostat will open the above circuits and open the main contactor, stopping the compressor and outdoor fan. The unit is equipped with a blower OFF delay; the blower will continue to operate for a fixed 90 seconds after the thermostat is satisfied.

Heating

Upon heating demand, the thermostat closes circuit R to Y, which closes the unit contactor, starting the compressor and outdoor fan. The reversing valve is not energized in the heating mode. The Y signal from the thermostat brings the indoor blower on at heat pump speed. The second stage of the thermostat closes circuit R to W, which closes the unit sequencers, bringing the auxiliary electric heat on. The W signal from the thermostat brings the indoor blower on at electric heat speed. Upon satisfying heating demand, the thermostat opens the above circuits and stops unit operation.

The unit is equipped with a blower OFF delay; the blower will continue to operate for a fixed 90 seconds (heat pump) or 120 seconds (electric heat) after the thermostat is satisfied.

NOTE: The 7.2 and 10 kW heats strips offer a W1 and W2 thermostat connection. Taking advantage of the two heat strip circuits requires a 3-stage thermostat (Y for heat pump, W1 for electric heat stage 1, and W2 for electric heat stage 2). If a 2-stage thermostat is used, "pigtail" W1 and W2 wires together when connecting the thermostat wires at the unit.

Defrost Cycle

If the outdoor ambient conditions are such that frost forms on the outdoor coil, the defrost control monitors the need for, initiates, and terminates defrost cycles as necessary to maintain system performance.

The defrost control is time/temperature initiated and temperature terminated with a maximum defrost time (time-out) of 14 minutes. The time between defrost cycles is preset at 90-minute intervals at the factory, but can be

field adjusted to 30 or 60 minutes. To field adjust time between defrost cycles, place defrost time plug in the proper position (see Figure 11).

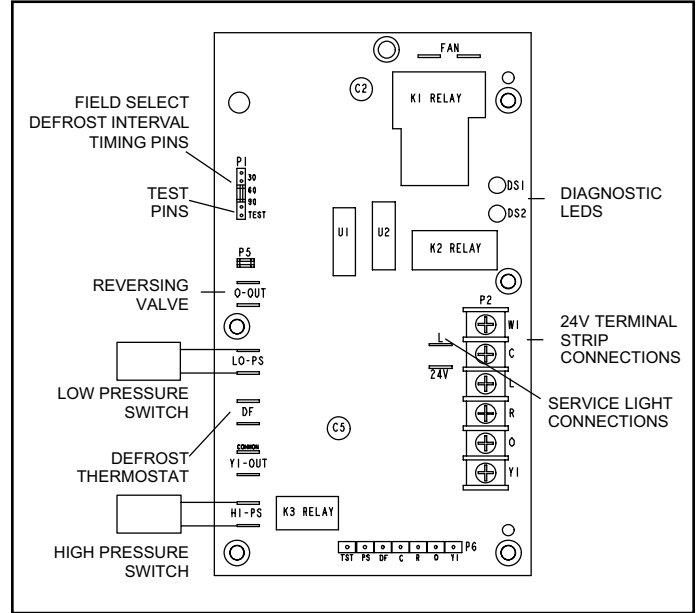

Figure 10. Defrost Control

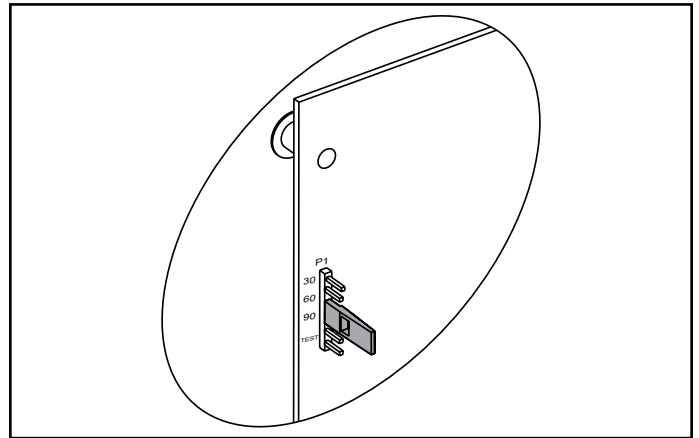

Figure 11. Defrost Interval Timing Jumper

Defrost control will initiate a defrost cycle if the time period has elapsed and the defrost sensor sees a temperature below freezing. At the start of a defrost cycle, the defrost control will energize the reversing valve solenoid, shifting the reversing valve and de-energizing the outdoor fan. The defrost control will also energize auxiliary heat for increased comfort during defrost. The unit will remain in defrost until the defrost sensor has determined that the frost has been removed from the coil or a 14-minute time period has elapsed.

The defrost control is also equipped with a set of pins to aid in the troubleshooting of the defrost system (see Figure 11). The following is a brief outline of the testing of the defrost system.

1. Defrost sensor must be closed, 32°F or below. If temperatures are such that the switch will not close, jumper between defrost sensor terminals on the defrost control.
2. Start system in heating operation.
3. Place the defrost pin jumper on the test pins for a brief second, then place back on the proper defrost time setting (30, 60, or 90). This will speed up defrost time interval as shown in Table 7.

Defrost Control Setting	Defrost Test Cycle Time
30 minutes	7 seconds
60 minutes	14 seconds
90 minutes	21 seconds

Table 7. Defrost Test Cycle Time

The reversing valve will then shift to defrost mode and the outdoor fan should stop. After 2 seconds of defrost operation, the reversing valve should shift back to heating operation and the outdoor fan should start.

Diagnostic LEDs

The state (Off, On, Flashing) of two LEDs on the defrost board (DS1 [Red] and DS2 [Green]) indicate diagnostics conditions that are described in Table 8.

Mode	Green LED (DS2)	Red LED (DS1)
No power to control	Off	Off
Normal operation / power to control	Simultaneous slow flash	
Timed lockout	Alternating slow flash	
Low pressure switch fault	Off	Slow flash
Low pressure switch lockout	Off	On
High pressure switch fault	Slow flash	Off
High pressure switch lockout	On	Off

Table 8.

Maintenance

WARNING

Disconnect all electrical power to the unit before conducting any maintenance procedures. Failure to disconnect the power could result in personal injury or death.

The refrigeration system normally requires no maintenance since it is a closed, self-contained system.

Periodic inspection and maintenance normally consists of changing or cleaning filters and (under some conditions) cleaning the coils.

Filter

Inspect the filter once a month. Replace disposable filter or clean the washable filter as necessary (a minimum of three times each heating or cooling season is recommended).

To clean the washable filter, shake filter to remove excess dirt and/or use a vacuum cleaner. Wash filter in soap or detergent water and replace after filter is dry.

Motors

The indoor and outdoor fan motors are permanently lubricated and require no maintenance.

Outdoor Coil

Foreign material should not be allowed to accumulate on the outdoor coil surface or other parts in the air circuit. Cleaning should be as often as necessary to keep the coil clean. To clean the coil, remove the lower access panel and blow out debris by using compressed air or water. **Be sure power to unit is shut off before using water to clean the coil.**

Care should be used when cleaning the coils so that the coil fins are not damaged.

Primary and Secondary Condensate Drain

Foreign material should not be allowed to clog the drain hole. Inspect and clear drain opening prior to each heating and cooling season.

Accessories

WARNING

The unit must be installed with approved wall sleeve and louver accessories for safe operation. Improper installations could result in property damage, personal injury, or death.

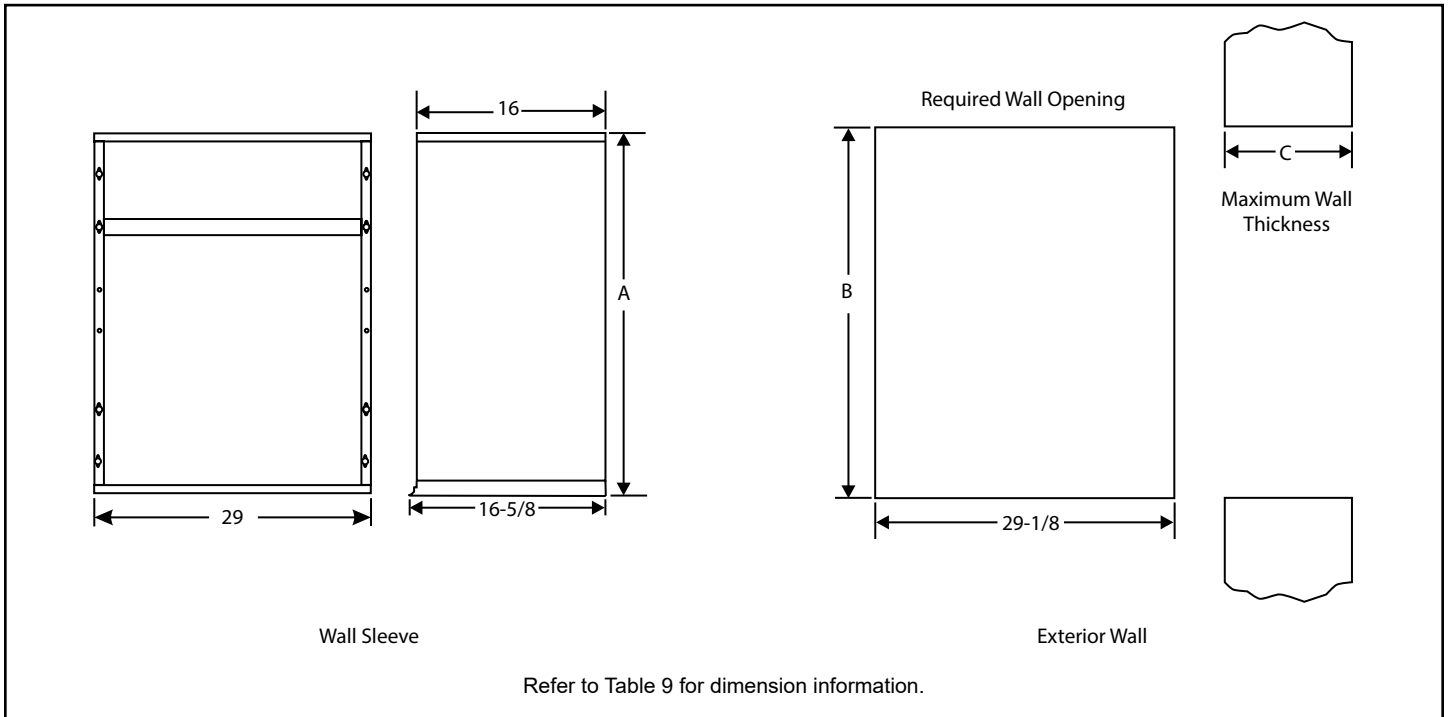

Figure 12.

Wall Sleeves		Louvers			Model						Dimensions (in.)			
											Wall Sleeve	Wall Opening		
Wall Sleeve	Wall Sleeve Extension	Polypropylene Louvers	Aluminum Louvers	Impact Louvers	*MHP4-12-091*P	*MHP4-12-121*P	*MHP4-12-181*P	*MHP4-12-241*P	*MHP4-12-301*P	*MHP4-14-361*P	Height (A)	Height (B)	Depth (C)	
													Sleeve Only	Sleeve Plus Extension
ASLEEVE6-1	---	ALVRP***-1	ALVRAL-1^	ALVRALC-1^	•	•	•				29	29-1/8	6	---
ASLEEVE8-1	---	ALVRP***-1	ALVRAL-1^	ALVRALC-1^	•	•	•				29	29-1/8	8	---
ASLEEVE10-1	ASLEEVEEXT4-1	ALVRP***-1	ALVRAL-1^	ALVRALC-1^	•	•	•				29	29-1/8	10	14
ASLEEVE12-1	ASLEEVEEXT4-1	ALVRP***-1	ALVRAL-1^	ALVRALC-1^	•	•	•				29	29-1/8	12	16
ASLEEVE6-2	---	ALVRP***-2	ALVRAL-2^	ALVRALC-2^				•	•		32-3/4	32-7/8	6	---
ASLEEVE8-2	---	ALVRP***-2	ALVRAL-2^	ALVRALC-2^				•	•		32-3/4	32-7/8	8	---
ASLEEVE10-2	ASLEEVEEXT4-2	ALVRP***-2	ALVRAL-2^	ALVRALC-2^				•	•		32-3/4	32-7/8	10	14
ASLEEVE12-2	ASLEEVEEXT4-2	ALVRP***-2	ALVRAL-2^	ALVRALC-2^				•	•		32-3/4	32-7/8	12	16
ASLEEVE6-2	---	ALVRP***-2	ALVRAL-7^	ALVRALC-7^	◦	◦	◦				32-3/4	32-7/8	6	---
ASLEEVE8-2	---	ALVRP***-2	ALVRAL-7^	ALVRALC-7^	◦	◦	◦				32-3/4	32-7/8	8	---
ASLEEVE10-2	ASLEEVEEXT4-2	ALVRP***-2	ALVRAL-7^	ALVRALC-7^	◦	◦	◦				32-3/4	32-7/8	10	14
ASLEEVE12-2	ASLEEVEEXT4-2	ALVRP***-2	ALVRAL-7^	ALVRALC-7^	◦	◦	◦				32-3/4	32-7/8	12	16
ASLEEVE6-5	---	ALVRP***-3	---	---	◦	◦	◦	◦	◦	•	45	45-1/8	6	---
ASLEEVE8-5	---	ALVRP***-3	---	---	◦	◦	◦	◦	◦	•	45	45-1/8	8	---
ASLEEVE10-5	ASLEEVEEXT4-3	ALVRP***-3	---	---	◦	◦	◦	◦	◦	•	45	45-1/8	10	14
ASLEEVE12-5	ASLEEVEEXT4-3	ALVRP***-3	---	---	◦	◦	◦	◦	◦	•	45	45-1/8	12	16
ASLEEVE6-5	---	---	ALVRAL-3^	ALVRALC-3^	◦	◦	◦				45	45-1/8	6	---
ASLEEVE8-5	---	---	ALVRAL-3^	ALVRALC-3^	◦	◦	◦				45	45-1/8	8	---
ASLEEVE10-5	ASLEEVEEXT4-3	---	ALVRAL-3^	ALVRALC-3^	◦	◦	◦				45	45-1/8	10	14
ASLEEVE12-5	ASLEEVEEXT4-3	---	ALVRAL-3^	ALVRALC-3^	◦	◦	◦				45	45-1/8	12	16
ASLEEVE6-5	---	---	ALVRAL-4^	ALVRALC-4^				◦	◦	•	45	45-1/8	6	---
ASLEEVE8-5	---	---	ALVRAL-4^	ALVRALC-4^				◦	◦	•	45	45-1/8	8	---
ASLEEVE10-5	ASLEEVEEXT4-3	---	ALVRAL-4^	ALVRALC-4^				◦	◦	•	45	45-1/8	10	14
ASLEEVE12-5	ASLEEVEEXT4-3	---	ALVRAL-4^	ALVRALC-4^				◦	◦	•	45	45-1/8	12	16

Note: Wall Sleeve and Louver size must be coordinated
*** Louver colors: WHT = white, SAN = sandstone, BGE = beige, TPST = taupestone
^ -P: Option to paint standard, aluminum, and impact-resistant louver
• Wall sleeve and louver sizes equal to the required wall opening dimensions for the unit size
◦ Optional: Wall sleeves and louvers can be oversized to maintain a uniform appearance

Table 9. Accessories

Wiring Diagrams

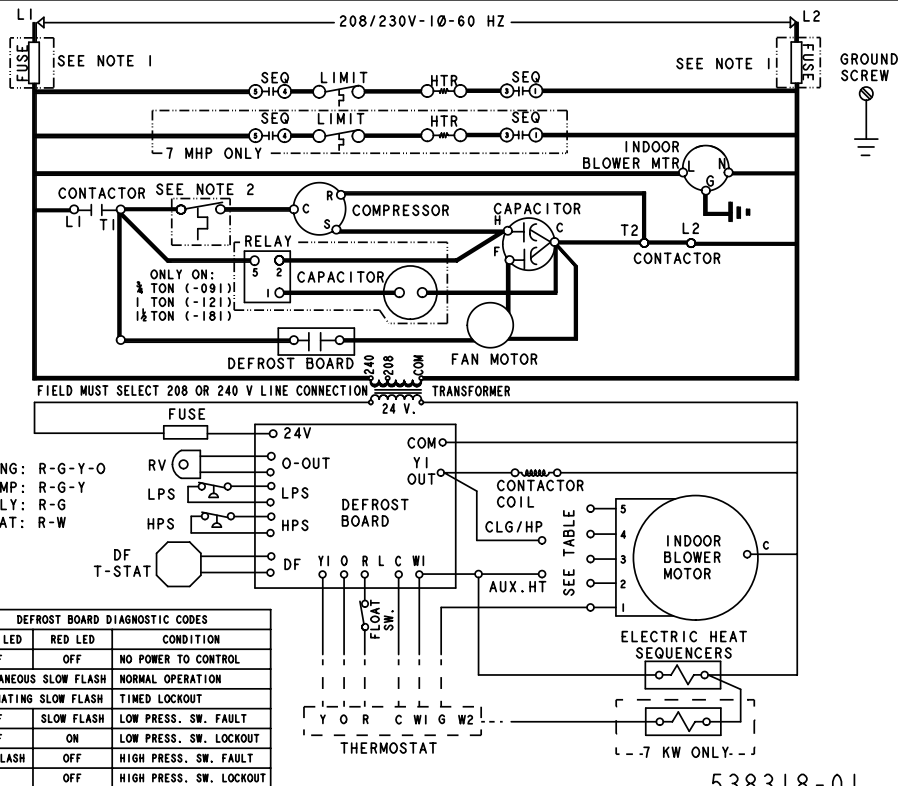
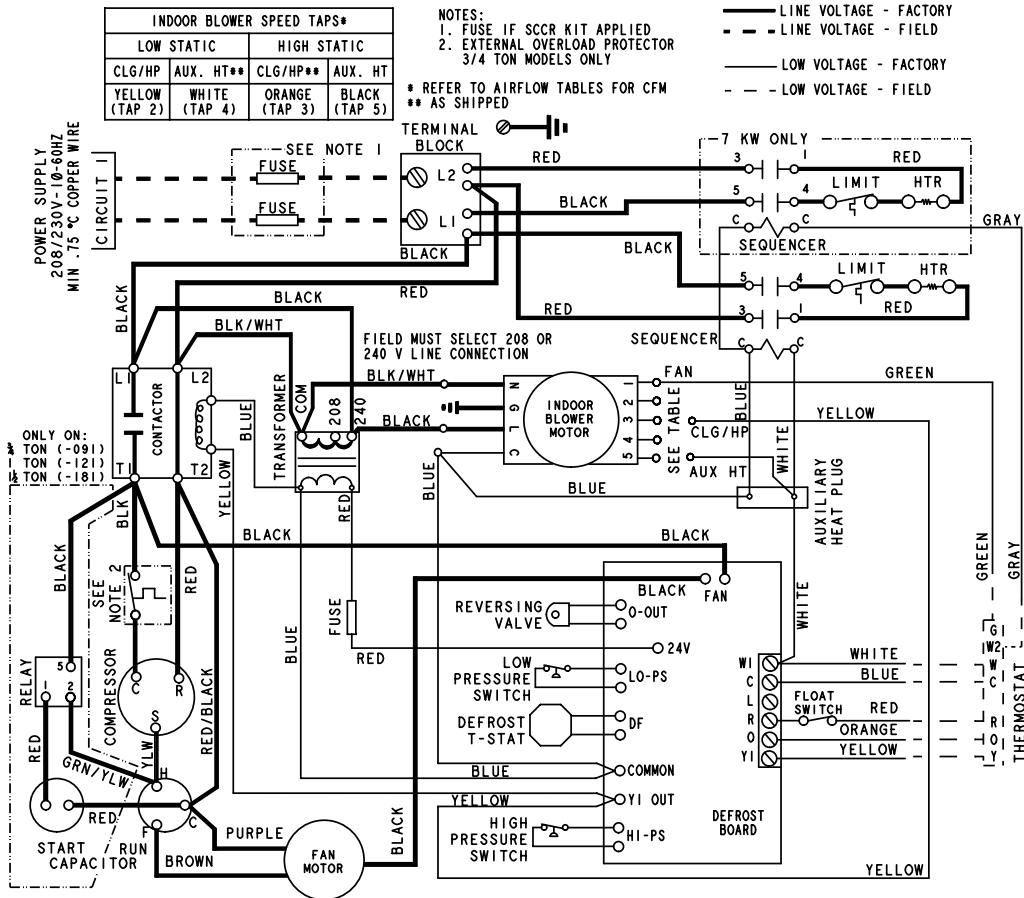

Figure 13. Wiring Diagram - MHP with Single Circuit and Hard Start Enabled (0.75 Ton through 2.5 Ton)

INDOOR BLOWER SPEED TAPS*			
LOW STATIC		HIGH STATIC	
CLG/HP	AUX. HT**	CLG/HP**	AUX. HT
YELLOW (TAP 2)	WHITE (TAP 4)	ORANGE (TAP 3)	BLACK (TAP 5)

NOTES:
1. FUSE IF SCCR KIT APPLIED

* REFER TO AIRFLOW TABLES FOR CFM
** AS SHIPPED

— LINE VOLTAGE - FACTORY
- - - LINE VOLTAGE - FIELD
— LOW VOLTAGE - FACTORY
- - - LOW VOLTAGE - FIELD

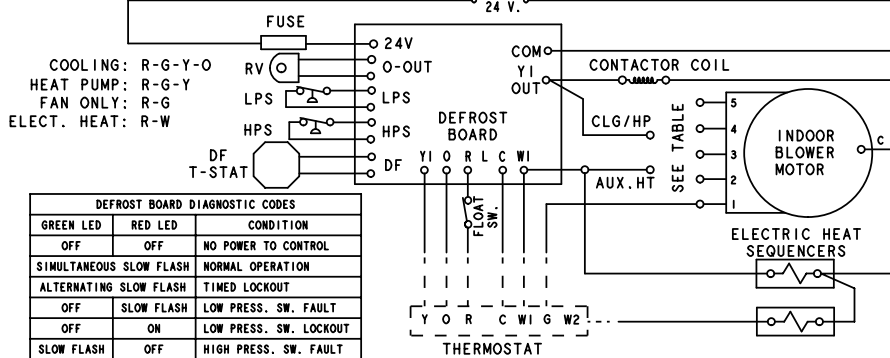
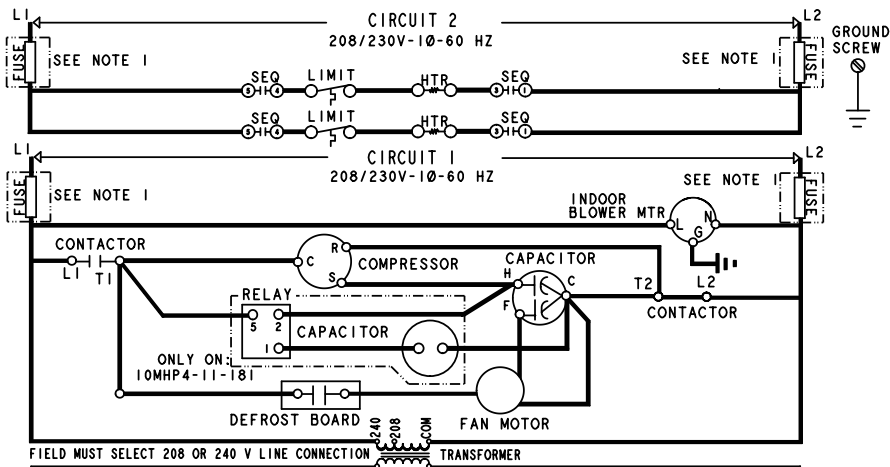
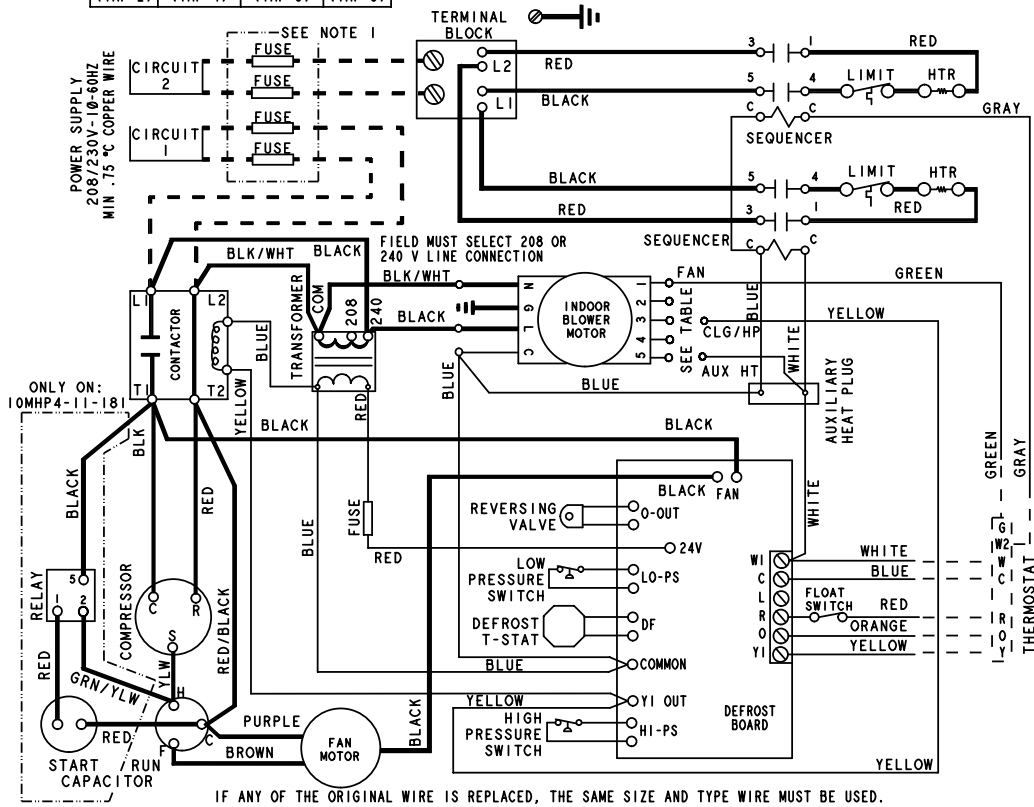

DEFROST BOARD DIAGNOSTIC CODES		
GREEN LED	RED LED	CONDITION
OFF	OFF	NO POWER TO CONTROL
SIMULTANEOUS SLOW FLASH		NORMAL OPERATION
ALTERNATING SLOW FLASH		TIMED LOCKOUT
OFF	SLOW FLASH	LOW PRESS. SW. FAULT
OFF	OH	LOW PRESS. SW. LOCKOUT
SLOW FLASH	OFF	HIGH PRESS. SW. FAULT
ON	OFF	HIGH PRESS. SW. LOCKOUT

538318-02

Figure 14. Wiring Diagram - MHP with Dual Circuit and Hard Start Enabled (1.5 Ton through 3 Ton)

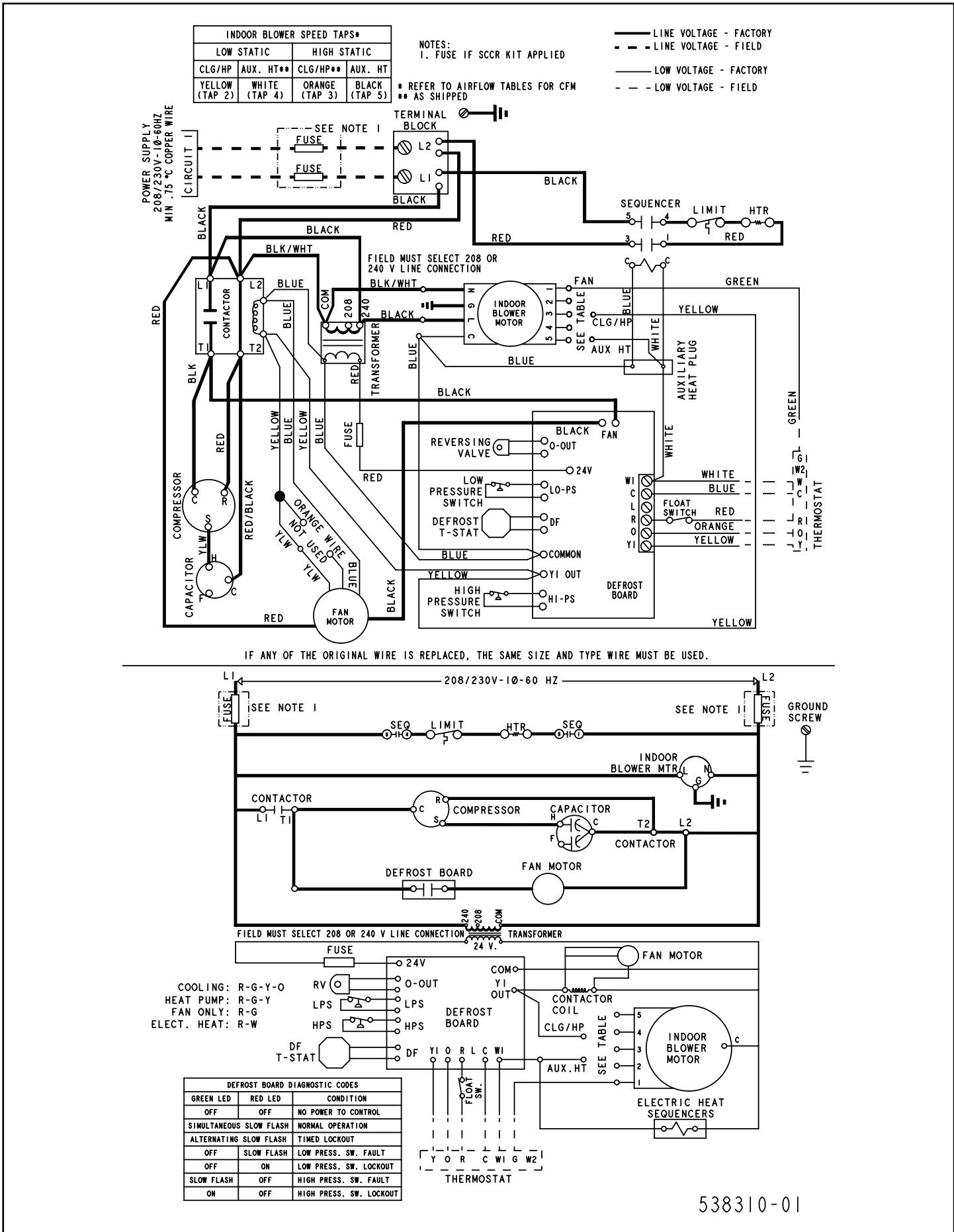

Figure 15. Wiring Diagram - MHP with Single Circuit (3 Ton)

INDOOR BLOWER SPEED TAPS*			
LOW STATIC		HIGH STATIC	
CLG/HP	AUX. HT**	CLG/HP**	AUX. HT
YELLOW (TAP 2)	WHITE (TAP 4)	ORANGE (TAP 3)	BLACK (TAP 5)

NOTES:
1. FUSE IF SCCR KIT APPLIED

* REFER TO AIRFLOW TABLES FOR CFM
** AS SHIPPED

— LINE VOLTAGE - FACTORY
- - - LINE VOLTAGE - FIELD
— LOW VOLTAGE - FACTORY
- - - LOW VOLTAGE - FIELD

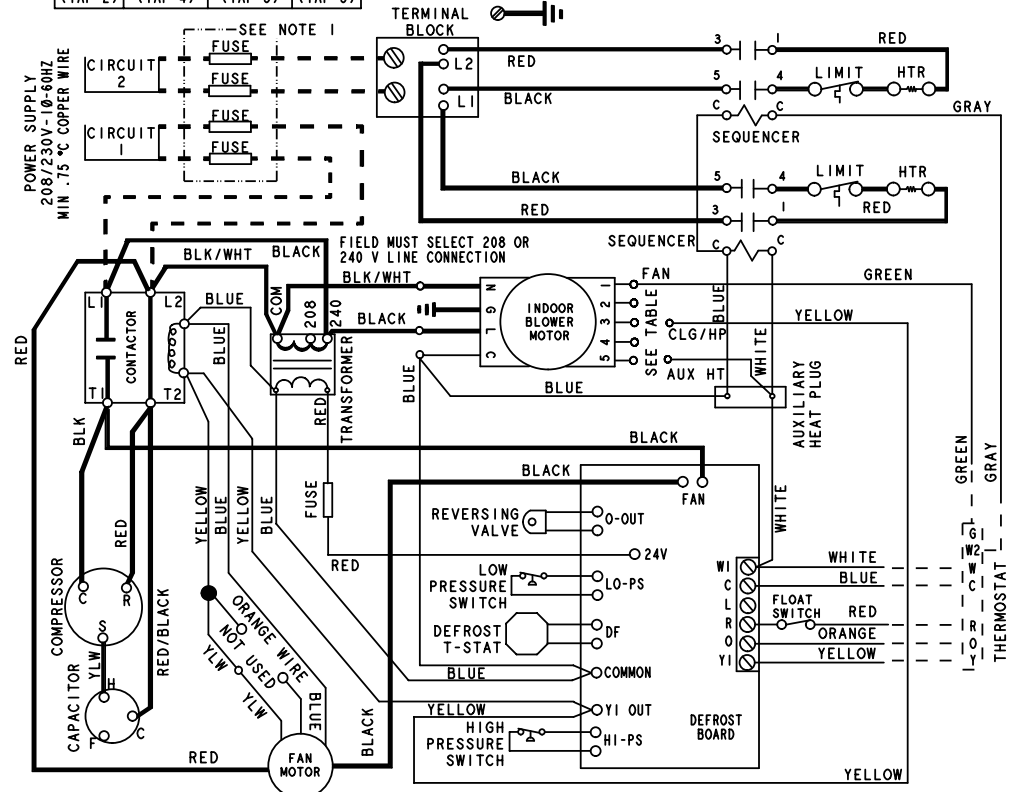

IF ANY OF THE ORIGINAL WIRE IS REPLACED, THE SAME SIZE AND TYPE WIRE MUST BE USED.

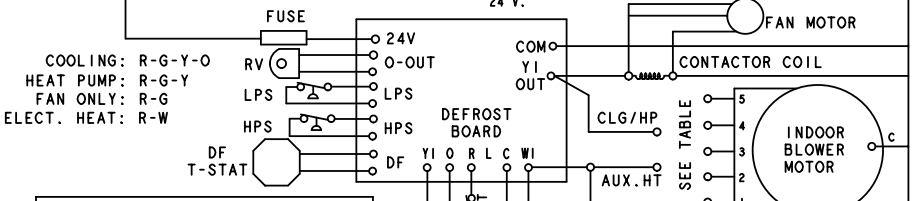
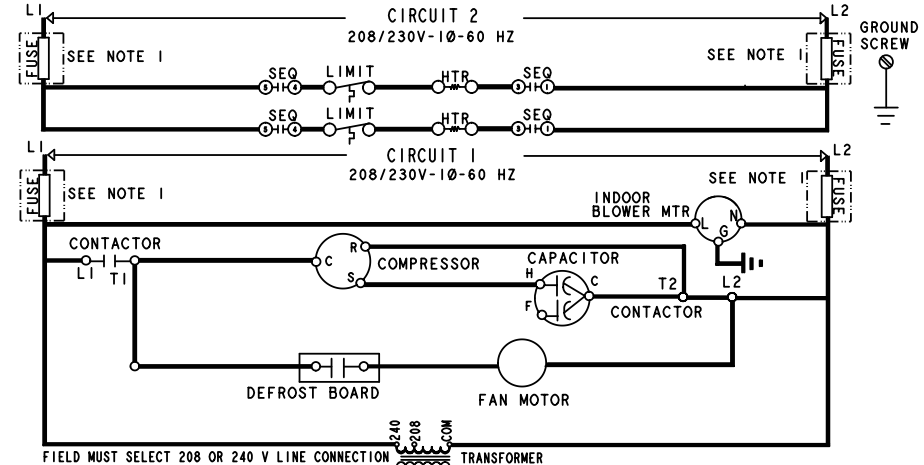

DEFROST BOARD DIAGNOSTIC CODES		
GREEN LED	RED LED	CONDITION
OFF	OFF	NO POWER TO CONTROL
SIMULTANEOUS SLOW FLASH		NORMAL OPERATION
ALTERNATING SLOW FLASH		TIMED LOCKOUT
OFF	SLOW FLASH	LOW PRESS. SW. FAULT
OFF	ON	LOW PRESS. SW. LOCKOUT
SLOW FLASH	OFF	HIGH PRESS. SW. FAULT
ON	OFF	HIGH PRESS. SW. LOCKOUT

538310-02

Figure 16. Wiring Diagram - MHP with Dual Circuit (3 Ton)