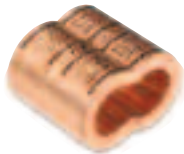


## Table of Contents

Thomas & Betts offers a complete range of grounding products including mechanical, compression and exothermic systems. Whatever the application, there is a Thomas & Betts grounding solution to meet your requirements.



Introduction .....	D2–D3
SnapTap® Connectors .....	D4
Signal Reference Grid Connectors .....	D5
Clamps .....	D6–D18
Service Post Connectors .....	D19–D20
Transformer Tank Ground Connectors .....	D21
Conduit Hubs .....	D22
Lay-In Lug Connectors .....	D23
Ground Plates .....	D24
Figure 6, Figure 8 .....	D25
Figure 6 to 8, Figure 6 to 6 .....	D26
Cable-to-Cable or Cable-to-Rod Connectors .....	D27
Two Cables to Ground Rod .....	D28
Grounding Grid Connectors .....	D29
C-Taps .....	D30–D31
Pigtail Connectors .....	D32
Grounding Studs .....	D33
Bus Bar Connectors .....	D34
Ground Rods .....	D35–D37
Ground Rod Drivers .....	D38
Flexible Braid .....	D39
Exothermic Welding System .....	D40–D92
Competitive Cross Reference .....	D93–D95



This installation method results in a long-lasting low-installed cost connection. You can install it and forget it.

Before compression, typical cable connector cross section of cable and connector consists of about 75% metal and 25% air. After Thomas & Betts method compression, the cross section shows 100% metal with virtually no air spaces.

## Introduction

### Compression Method Grounding Connectors save 50 – 75% in time and labor costs

- Eliminates exothermic welding
- Reduces time and labor costs
- Minimizes possibility of poor connections

Thomas & Betts introduces a method of compression to replace exothermic welding and its associated disadvantages. This compression method is designed to provide quick, reliable connections for grid grounding at significantly lower installed costs because compression connectors install in less time, in any weather, and are unaffected by moisture, reducing downtime. In addition, our compression connectors for grid grounding require no special training for installation. They are made of high-conductivity wrought and cast copper, and are used for connecting and tapping cross grid, loop lines and ground rods for direct burial or concrete embedded ground grid systems. The Thomas & Betts compression system uses standard electrical connector installation tools.

### Meets all applicable specifications

Thomas & Betts grid and ground rod connectors satisfy the requirements of CEC SECTION 10 for connecting to the Grounding Electrode System. They also meet the requirements of UL and CSA standards being acceptable as grounding and bonding equipment suitable for direct burial. Thomas & Betts grid and ground rod connectors also satisfy the recommended practice for the selection of grounding connector joints described in IEEE 837 standard for qualifying permanent connections used in substation grounding. The connectors conform to the following IEEE Standard 837 requirements:

- 350°C current cycling
- Freeze-thaw test
- Accelerated aging – nitric acid/salt spray
- Mechanical, tensile and electromagnetic force (EMF) criteria
- Install in any weather – cut downtime
- Enhance safety
- Easy to install – no special training



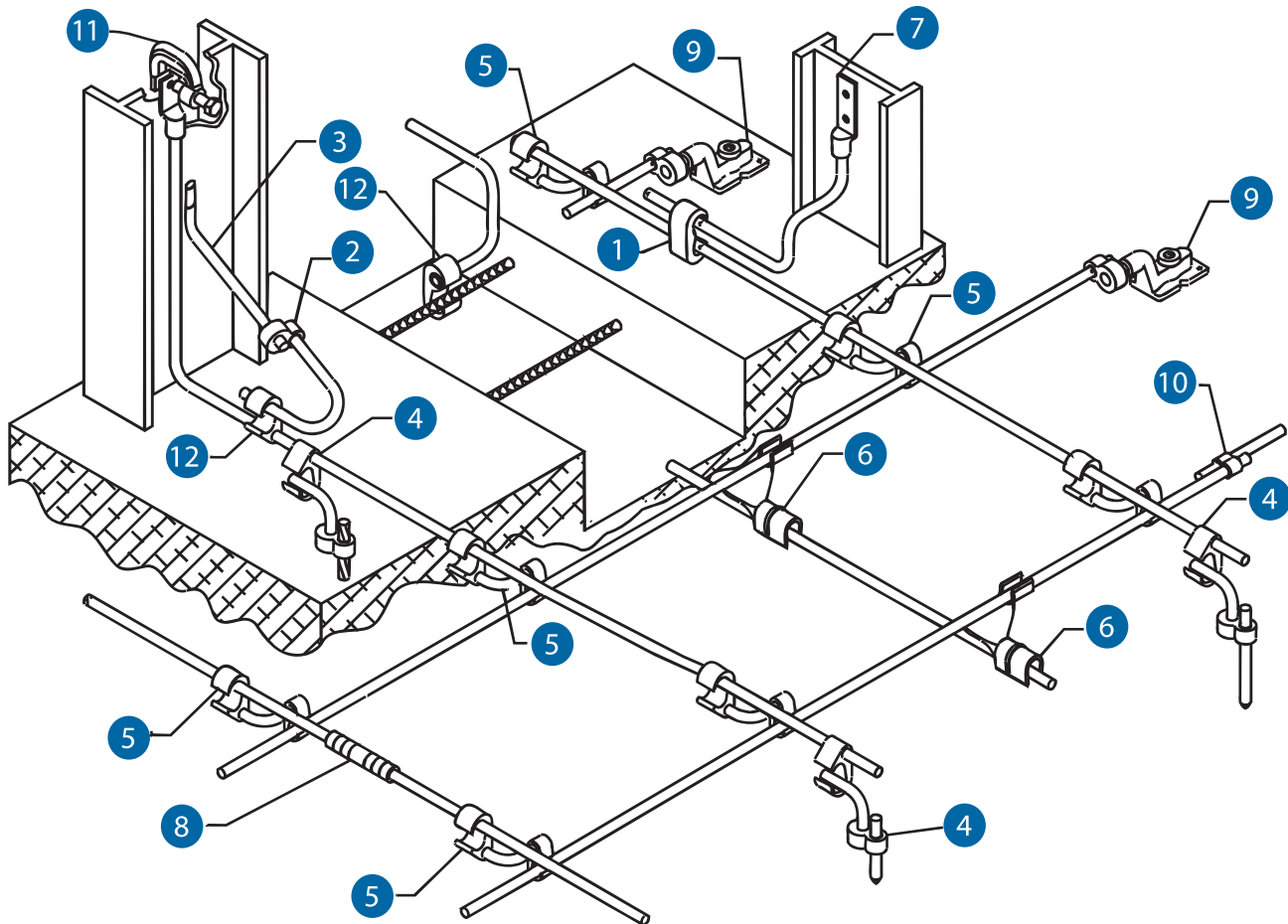
**TBM14M**  
(Suggested tool for E-Z-Ground connectors to ground rods up to 5/8 in. diameter.)

### Reliable installations through compression connections

Dies that are used in Thomas & Betts hand and hydraulic tools contain the die code numbers which are engraved on the compression surface of the die. Under compression, this number becomes embossed on the completed connection for inspection purposes.

The inspector compares the die code number embossed on the connector with the die table to ensure that the proper connector was compressed with the correct die for that particular size conductor.

## Introduction



Thomas & Betts offers a complete line of grid-ground compression connectors. Our E-Z-Ground® connectors are designed for direct burial and offer a safe, efficient alternative to exothermic welding products. Grid ground installations do not require explosive charges, and can be installed in various climate conditions. These range-taking products will reduce the number of connectors and dies needed for your installation.

Thomas & Betts E-Z-Ground® products meet all applicable standards (IEEE837, UL, CSA). Connectors are prefilled with oxide inhibitors and sealed.

- |  |  |                               |
|--|--|-------------------------------|
| <b>1</b> C-Taps                          | <b>5</b> Figure 6-6 Connectors             | <b>9</b> Ground Plates        |
| <b>2</b> Figure 8 Connector              | <b>6</b> GG Connectors<br>(Grid to Ground) | <b>10</b> Figure 8 Connector  |
| <b>3</b> Steel Grounding Stud TBG Series | <b>7</b> Lug                               | <b>11</b> I-Beam Clamp        |
| <b>4</b> Figure 6-8 Connectors           | <b>8</b> Splice/Two-Way Connectors         | <b>12</b> Figure 6 Connectors |



## SnapTap® Connectors

### A “Snap” to assemble — no special tools required

- Designed for bonding and grounding applications using copper, steel strand and ground rod
- Easily installed with channel locks or pliers
- Made from high-strength aluminum alloy with tin-plated
- Offer excellent electrical and mechanical characteristics
- UL Listed – exceed performance requirements
- CSA Certified

With the SnapTap® Connectors, you can achieve an electrically superior, pressure-fit connection in seconds without expensive tooling. The connectors are also easy to disassemble, requiring only a flat-head screwdriver to release the connected body. A one-piece design keeps parts together, minimizing loss of components prior to assembly. Simply separate the pieces and snap them in place for installation. An audible “Snap” indicates that the connection is complete and properly installed.

### General Usage Instructions

#### Separate

No special tools required. Use ordinary parallel jaw pliers to separate the connector into two parts. Hold one side of connector with pliers and bend opposite side back and forth until parts separate (see Fig. 1).

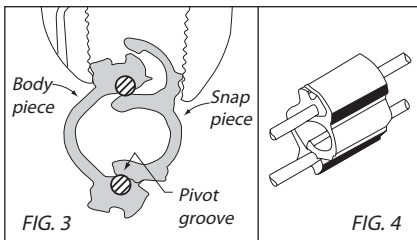
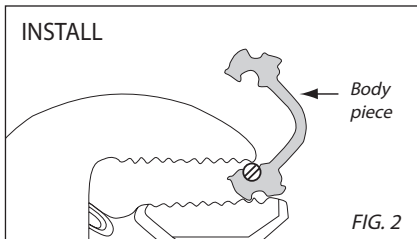
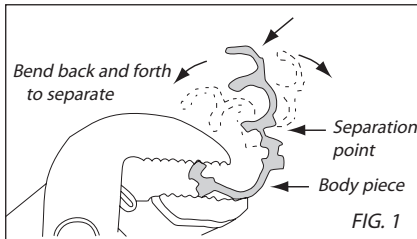
Caution: Be careful not to pinch fingers or thumb when separating parts. Keep fingers out of bend part when bending part against plier jaws.

#### Installation

1. Strip the insulation from each conductor. Be careful not to nick the conductor. Clean the conductor ends with a wire brush or emery cloth if necessary.
2. Place each conductor into the grooves in BODY piece. Press conductors with pliers to align and seat into grooves (see Fig. 2).
3. Hold the conductors and BODY piece until it closes. Use parallel jaw pliers and grip the SNAP and BODY pieces as shown (see Fig. 3). Apply pressure until connector “snaps” into place. Visually inspect snap to verify full insertion. The connection is now complete (see Fig. 4).

#### Removal

The connectors can be disassembled using a flat-head screwdriver to pry the SNAP piece from BODY piece.



Cat. No.	Conductor Description		Packaging		Std. Qty.
	Main	Branch	Inner Pack	Outer Pack	
JP62*	#2 AWG Sol. Copper	#6 AWG Sol. Copper	20	200	200
JP66-TB*	#6 AWG Sol. Copper				
JP146	1/4 in. Steel Strand				
JP5166	5/8 in. Steel Strand				
JP386	3/8 in. Steel Strand				
JP126	1/2 in. Steel Strand				
JP126G	1/2 in. Ground Rod				
JP2614	1/4 in. Steel Strand	2-#6 AWG Sol. Copper			
JP26516	5/16 in. Steel Strand				
JP2638	3/8 in. Steel Strand				
JP2612G*	1/2 in. Ground Rod				

\* CSA Certified.

## Signal Reference Grid Connectors

### Compress #8 AWG through 4/0 AWG cable

- Clamp onto pedestal posts up to 1 diameter square and 1-1/4 in. round
- Can be used as “X” or “T” configuration cable to post
- High-conductivity wrought-copper construction



Cat. No.	Conductor Range	Installing Tools and Die Codes TBM14M and TBM15I		
		Die Cat No.	Die Code	Colour Code
SRG8-4	#8	15527	29	Grey
	#6 to #4	15528	33	Brown
SRG2-1	#2 and #1	15508	42	Pink
SRG10-20	1/0 and 2/0	15530	50	Orange
SRG30-40	3/0 and 4/0	15511	54	Purple



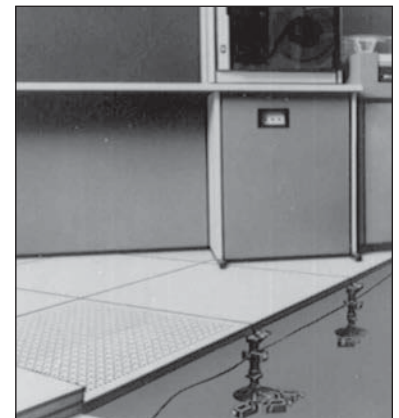
## Signal Reference Grid Clamps

### Secure signal reference grid wires to raised-floor support posts

- Range-taking design accepts #4 to #8 AWG grid wire and fits 3/4 in. square to 1 in. round
- Lay-in feature means no kinks or bends
- Quick, easy installation
- Only one screw to tighten
- Enable grid wire to make direct, low-resistance contact with support posts
- Stamped-steel construction, zinc plated

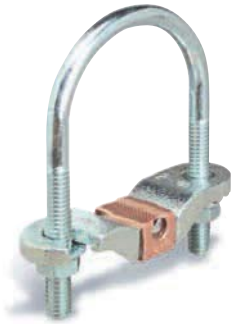


Cat. No.	Description	Wire Range
3900 (Unit)	3/4 in. square to 1 in. round	#8-#4
3900BP (Bulk Pack)		



## Clamps

### Waterpipe Ground Clamps



Cat. No.	Ground Wire Size	Water Pipe Size
<b>2-TB</b>	#6, #4, #2 AWG	1/2 in., 3/4 in., 1 or rebar 4-10
<b>3-TB</b>		1-1/4 in., 1-1/2 in. or 2 in.
<b>4</b>		2-1/2 in., 3 in. or 3-1/2 in.
<b>5-TB</b>		4 in., 4-1/2 in. or 5 in.
<b>6</b>		6 in.

Malleable iron crossbar, steel U-Bolt c/w copper cable clamp with serrations.



Cat. No.	Ground Wire Size	Water Pipe Size
<b>3902</b>	#4-4/0 AWG	1/2 in.-1
<b>3903</b>		1-1/4 in.-2 in.
<b>3904</b>		2-1/2 in.-3-1/2 in.
<b>3905-TB</b>		4 in.-5 in.
<b>3906-TB</b>		6 in.
<b>3907</b>		8 in.
<b>3908</b>		10 in.
<b>3909-TB</b>		12 in.

Material: Steel U-bolt and nut c/w bronzed aluminum cap and crossbar cadmium plated plus gold chromate finish.



Cat. No.	Ground Wire Size	Water Pipe Size
<b>3902BU*</b>	#4-4/0 AWG	1/2 in.-1
<b>3903BU*</b>		1-1/4 in.-2 in.
<b>3904BU*</b>		2-1/2 in.-3-1/2 in.
<b>3905BU*</b>		4 in.-5 in.
<b>3906BU*</b>		6 in.
<b>3907BU*</b>		8 in.
<b>3908BU*</b>		10 in.
<b>3909BU*</b>		12 in.

Material: Bronze U-bolt and nut c/w bronzed aluminum cap and crossbar with a brite dip finish.

\*UL Listed for Direct Burial.

## Clamps

### Ground Clamps



Cat. No.	Material	Water Pipe, Copper Tubing Size	Ground Rod Size
3826*	Malleable Iron	1/2 in., 3/4 in.	1/2 in.-1
3846*	Bronze		
3849**	Brass	1/2 in.-1	-
3840-TB•	Malleable Iron	1/2 in., 3/4 in. or 1	

\* For unarmored copper wires #6, #4 AWG.  
 \*\* For copper and aluminum conductors; for #14 thru #2 AWG unarmored copper wires for corrosive and outdoor use. UL approved for direct burial.  
 • #8 thru #4 AWG. Not CSA Certified.



3849



3825



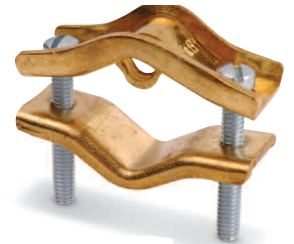
3840

### Ground Clamps for K&L Grade Copper Tubing Only



Cat. No.	Ground Wire Size	Water Pipe, Copper Tubing Size
3844*	#8-#4 AWG	1/2 in.-1
3888**		1/2 in.-1 also rebar 4-10

\* With Steel Screws.  
 \*\* UL approved for direct burial. Silicon Bronze Screws.



3844

For armored and unarmored wires.

### Ground Clamp Accessories

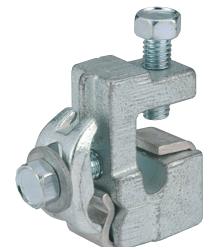


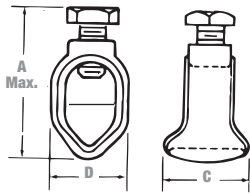
Cat. No.	Description	For use with
10102-TB	1-1/4 to 1-1/2 in. cables	#8-#2 Ground wire

Material: Malleable iron, zinc plated.



Cat. No.	For use with
10105	Single conductors #4 solid to 2/0 str.
10109	Single conductors 2/0 solid to 4/0 str.





## Clamps

### Type JAB — Ground Rod Clamps

- Cast of high-strength corrosion resistant copper alloy
- Both hex head and socket set screws available
- Long bearing surface of clamp on ground wire secures ground connection
- Listed for direct burial



Cat. No.		Nominal Rod Dia.		Wire Range				Dimensions (in.)						
Socket Set Screw	Hex Head Bolt	(in.)	(mm)	Max.	Min.	Max. (mm <sup>2</sup> )	Min. (mm <sup>2</sup> )	A (Max.) Socket Screw	A (Max.) Hex Bolt	Screw Thread Size UNC-2A	B	C	D	
JAB12*	JAB12H	1/2	12.7	2 str.	10 sol.	33.6	5.2	1-19/32	2-3/32	7/16-14	27/32	7/8	19/32	
JAB58	JAB58H	5/8	15.8	1/0 str.	8 sol.	53.4	8.3	1-27/32	2-13/64		29/32	1	11/16	11/16
JAB34	JAB34H	3/4	19.0					2	2-11/32		11/16		51/64	
-	JAB34C	3/4 + 5/8	15.8 to 19.0	3/0 str.				95.0	-		1-1/8	1-1/32	13/16	
JAB1	JAB1H	1	25.0		107.1	2-1/4	3	1-11/32	1-1/16		1			

\* CSA not applicable.  
Add suffix P to Cat. No. for tin-plated clamp.

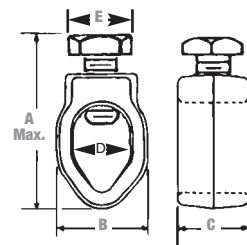
### Type G — Budget Line Ground Clamps

- A dependable ground connection offered at a substantial saving
- Cast of high-strength corrosion-resistant copper alloy
- Hex head bolts
- Simplified compact design will make a lasting, trouble-free connection
- Listed for direct burial



Cat. No.	Nominal Rod Dia.		Wire Range				Dimensions (in.)					
	(in.)	(mm)	Max.	Min.	Max. (mm <sup>2</sup> )	Min. (mm <sup>2</sup> )	A (Max.) Bolt	Screw Thread Size UNC-2A	B	C	D	E
G3*	3/8	9.5	4 str.	10 sol.	21.1	5.2	1-3/8	5/16-18	11/16	1/2	27/64	3/8
G4	1/2	12.7	2 str.				-	3/8-16	27/32	3/8	37/64	
G5	5/8	15.8					29/32	43/64				
G6	3/4	19.0					1-1/16	13/16				

\* Not U.L. Listed and CSA not applicable.  
Add suffix P to Cat. No. for tin-plated clamp.

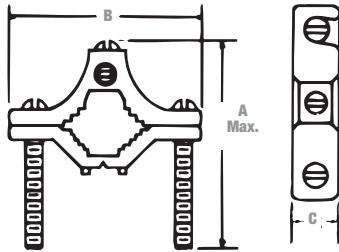




## Clamps

### Budget Price Cast Bronze Clamp

Similar to aluminum water pipe clamp but lighter in construction



Cat. No.	Water Pipe Size (in.)	Conductor Range		Dimensions (in.)		
		Max.	Min.	A	B	C
JJR	1/2 to 1	1/2	12.7	1-19/32	27/32	7/8

Add suffix C to Cat. No. to specify plating.



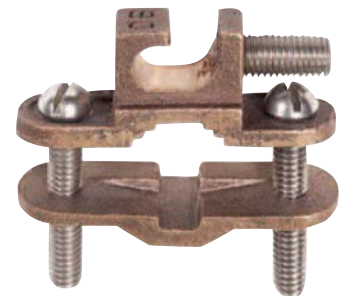
### Type JDLI — Direct Burial Ground Clamp

Lay-in feature reduces installation time for difficult bends or continuous loops of ground wire

- UL Listed for direct burial in earth/concrete
- UL Listed for connection to ground rod, pipe or rebar up to 1
- Constructed from bronze alloy and high-performance stainless steel bolts
- Designed for easy installation of difficult bends or continuous loops



Cat. No.	Pipe Size	Rebar Size	Ground Rod Size	Conductor Range	Mech. Conn./Splice (UL Listed)
JDLI	1/2 in.-1	3/8 in.-1	1/4 in.-1	#10 sol.-#2 Str.	(2) #8 sol.

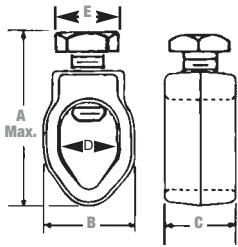




## Clamps

### Type JWR — Wide-Range Ground Rod Clamp

- Listed for direct burial in earth/concrete
- Constructed from bronze alloy and high-performance stainless steel bolt
- Provides wide range of connection sizes
- More than 300 lb. torque capacity

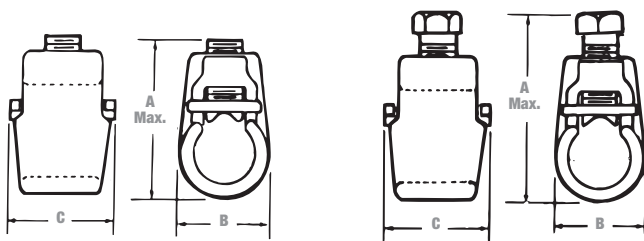
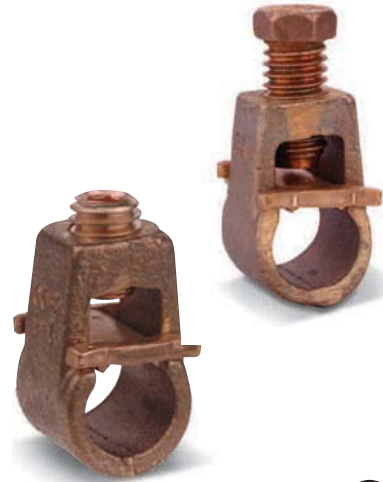


Cat. No.	Nominal Rod Dia.		Wire Range				Dimensions (in.)			
	(in.)	(mm)	Max.	Min.	Max. (mm <sup>2</sup> )	Min. (mm <sup>2</sup> )	A (Max.) Bolt	B	C	D
JWR	3/8*	9.5	1/0 str.	10 sol.	53.4	5.2	1.535	1.050	0.812	0.652
	1/2	12.7								
	5/8	15.8								
	3/4	19.0								

\* 3/8 in. rod CSA not applicable/Listed by UL.

### Types GG and GGH — Heavy Duty Ground Rod Clamps

- Cast of high-strength corrosion-resistant copper alloy; two types of screws available
- Type GG has a socket set screw
- Type GGH has a hex head bolt
- Floating pressure bar distributes pressure evenly over a large area of the ground wire
- Axial groove keeps wire and rod in perfect alignment



Cat. No.		Nominal Rod Dia.		Wire Range				Dimensions (in.)				
Socket Set Screw	Hex Head Bolt	(in.)	(mm)	Max.	Min.	Max. (mm <sup>2</sup> )	Min. (mm <sup>2</sup> )	A (Max.) Socket Screw	A (Max.) Hex Bolt	Screw Thread Size UNC-2A	B	C
GG12	GG12H	1/2	12.7	2 str.	8 sol.	33.6	8.3	1-13/64	1-13/16	7/16-14	27/32	15/16
GG58	GG58H	5/8	15.8	2/0 str.		53.6		1-51/64	2-7/32		61/64	
—	GG34H**	3/4	19.0	4/0 str.		120.6		—	3	1/2-14	1-3/8	1-1/4

\*\* CSA not applicable.  
GG34H has no pressure bar or axial groove.  
Add suffix P to Cat. No. for tin-plated clamp.

## Clamps

### Budget Price Cast Bronze Clamps

Type swings 360° for ease of alignment

- Pipe clamping portion identical to “JA” clamp
- Pressure-bar type conduit hub adjusts to fit 1/2 in. or 3/4 in. EMT, or 1/2 in. rigid conduit
- Brass washer provides positive contact with grounding conductor
- Furnished with zinc-plated screws



Cat. No.	Conduit Size	Water Pipe Size	Conductor Range	
			Max.	Min.
JPT	1/2 in. or 3/4 in. EMT 1/2 in. Rigid	1/2 in. to 1	#6 Sol.	#10 Sol.
JPT2		1-1/4 in. to 2 in.		
JPT4		2-1/2 in. to 4 in.		

### Cast Bronze Clamps

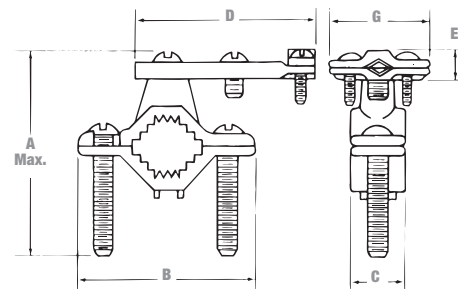
For connecting armored cable to water pipe

- Clamping portion similar to standard “J” clamp
- Special pressure bar grips armor or outer cable insulation to reduce chance of grounding conductor being pulled out
- Furnished with zinc-plated screws



Cat. No.	Water Pipe Size (in.)	Conductor Range		Dimensions (in.)					
		Max.	Min.	A	B	C	D	E	G
JA	1/2 to 1	#6 sol.	#10 sol.	2-3/4	2-11/32	25/32	2-9/32	15/32	1-3/8
JA-2	1-1/4 to 2			3-3/4	3-1/2	13/16			
JA-2124	2-1/2 to 4			6	6-5/16	1			

Add suffix C to Cat. No. to specify plating.



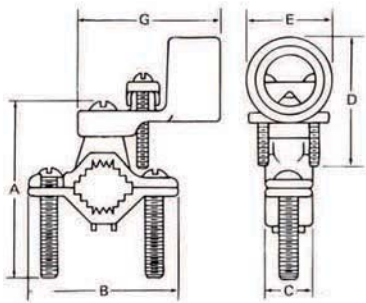


## Clamps

### Cast Bronze Clamps for Conduit

For grounding rigid conduit systems

- Continuity from rigid conduit system to ground provided by cast bronze threaded conduit hub
- Hub swings 360° for easy alignment
- Heavy brass washer protects clamped grounding conductor
- Furnished with zinc-plated screws
- Cast bronze pipe clamping portion identical to that used in “JA” clamp



Cat. No.	Conduit Size (in.)	Water Pipe Size (in.)	Conductor Range		Dimensions (in.)					
			Max.	Min.	A	B	C	D	E	G
JP-12	1/2	1/2 to 1	#6 sol.	#10 sol.	2-3/4	2-11/32	23/32	1-9/64	1	2-1/2
JP-212		1-1/4 to 2			3-3/4	3-1/2	13/16			
JP-212412		2-1/2 to 4			6	6-5/16	1			
JP-34	3/4	1/2 to 1	#2/0 str.	#10 sol.	2-3/4	2-11/32	23/32	2-5/16	1-1/4	2-3/16
JP-234		1-1/4 to 2			3-3/4	3-1/2	13/16			
JP-212434		2-1/2 to 4			6	6-5/16	1			
JP-1	1	1/2 to 1	#3/0 str.	#10 sol.	2-3/4	2-11/32	23/32	2-5/16	1-1/2	2-3/8
JP-21		1-1/4 to 2			3-3/4	3-1/2	13/16			
JP-21241		2-1/2 to 4			6	6-5/16	1			

Add suffix C to Cat. No. to specify plating.

### Cast Bronze Clamps with Copper Strap

Flexible copper strap makes alignment easy

- For grounding rigid conduit systems
- Same features as “JP” clamp plus flexible copper strap
- Strap helps protect conduit system from water system vibrations
- Furnished with zinc-plated screws



Cat. No.	Conduit Size (in.)	Water Pipe Size (in.)	Conductor Range	
			Max.	Min.
JPS-12	1/2	1/2 to 1	6 sol.	10 sol.
JPS-34	3/4		2/0 str.	
JPS-1	1		3/0 str.	

Add suffix C to Cat. No. to specify plating.



## Clamps

### Cast Bronze Ground Clamps

Connect copper ground wire to water pipe, copper tubing or ground rods

- High-strength, high-conductivity copper alloy (over 80% copper)
- UL Approved for direct burial



Cat. No.	Water Pipe Size (in.)	Conductor Range
J	1/2 to 1	#2 str.—#10 str.
J2D	1-1/4 to 2	

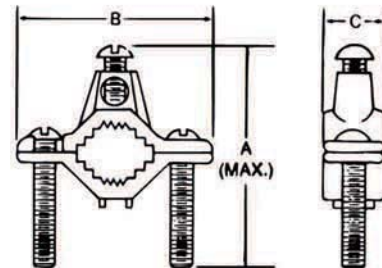


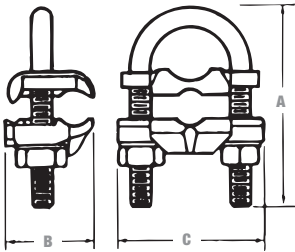
### Type J — Cast Bronze Ground Clamps

For connecting grounding conductor to water pipe or copper tube

- Cast of high-strength, highly conductive copper alloy
- Screws plated for corrosion resistance
- UL Listed

Cat. No.	Water Pipe Size (in.)	Conductor Range		Dimensions (in.)		
		Max.	Min.	A	B	C
J	1/2 to 1	2 str.	10 sol.	2-3/4	2-11/32	23/32
J2BB	1-1/4 to 2			3-3/4	3-1/2	13/16
J2124	2-1/2 to 4			6	6-5/16	1
J6	4-1/4 to 6			7-1/4	8-1/8	





## Clamps

### Type GUV — U-Bolt Clamps

- Listed for direct burial in earth or concrete
- For connecting copper or copper clad steel grounding conductor to ground rod or pipe or rebar
- Excellent for connecting multiple electrodes with a single cable as in substation grounding
- GUV body components are cast or forged from copper alloy and U-Bolts are stainless steel
- Specially designed spacer provides proper alignment between cable and electrode and affords more positive contact area



Cat. No.	Conductor Range (Cu)		Nominal Rod Size (in.)		IPS Pipe Size (in.)		Dimensions (in.)		
	Max.	Min.	Max.	Min.	Max.	Min.	A	B	C
<b>GUV584</b>	4	8	3/4	5/8	3/8	-	2-13/16	1-9/16	2-1/4
<b>GUV5821</b>	2/0	4							2-5/8
<b>GUV5825</b>	250	2/0							2-3/4
<b>GUV784</b>	4	8	1	7/8	3/4	1/2	2-3/4		2-3/4
<b>GUV7821</b>	2/0	4							2-15/16
<b>GUV7825</b>	250	2/0	1-1/4	1-1/8	1	-	3-5/16		2-3/4
<b>GUV1184</b>	4	8							2-15/16
<b>GUV11821</b>	2/0	4							3-3/16
<b>GUV1384</b>	4	8	1-1/2	1-3/8	1-1/4	-	3-7/16		2-15/16
<b>GUV13821</b>	2/0	4							3-3/16
<b>GUV13825</b>	250	2/0						3-3/16	
<b>GUV1584</b>	4	8	1-7/8	1-5/8	1-1/2	-	3-15/16	3-3/16	
<b>GUV15821</b>	2/0	4						3-11/16	
<b>GUV15825</b>	250	2/0						3-11/16	
<b>GUV204</b>	4	8	2-3/8	2	2	-	4-7/16	3-11/16	
<b>GUV2021</b>	2/0	4						4-3/16	
<b>GUV2025</b>	250	2/0						4-3/16	
<b>GUV21221</b>	2/0	4	2-7/8	2-1/2	2-1/2	-	4-15/16	4-3/16	
<b>GUV21225</b>	250	2/0						4-13/16	
<b>GUV3021</b>	2/0	4	3-1/2	3	3	-	5-9/16	4-13/16	
<b>GUV3025</b>	250	2/0						5-1/2	
<b>GUV31221</b>	2/0	4	4	3-1/2	3-1/2	-	6-1/16	5-1/2	
<b>GUV4021</b>	2/0	4						5-11/16	
<b>GUV4025</b>	250	2/0						5-11/16	

For tin-plated, add suffix TP to Cat. No.

## Clamps

### Technical Specifications



Cat. No.	Water Pipe Size (in.)	Ground Wire Size (AWG)		Galv. Steel	Copper Clad
		Min.	Max.		
<b>Ground Clamps (Zinc alloy body / Steel screws)</b>					
<b>CI3106</b>	1/2 to 1	10 sol.	2 str.	5/8 to 1*	N/A
<b>Ground Clamps (Zinc / Steel)</b>					
<b>CI3108</b>	1/2 to 1	10 sol.	2 str.	5/8 to 1*	N/A
For connecting grounding conductor to either galvanized steel rod or water pipe.					
<b>Ground Clamps (Brass body / Brass screws)</b>					
<b>CI3110U</b>	1/2 to 1	10 sol.	2 str.	5/8 to 1*	5/8 to 1
For connecting grounding conductor to either galvanized steel rod, copper clad or water pipe. CSA approved for wet locations and for direct burial.					
<b>Ground Clamps (Brass body / Brass screws)</b>					
<b>CI3112U</b>	1-1/4 to 2	10 sol.	2 str.	-	-
For connecting grounding conductor to water pipe. CSA approved for wet locations and for direct burial.					
<b>Ground Rod Clamps (Bronze body / Brass screws)</b>					
<b>CI3112U</b>	N/A	10 sol. 8 sol.	2 str. 1/0 str.	5/8 3/4	5/8 3/4
For connecting grounding conductor to either galvanized steel rod or copper clad rod. CSA approved for wet locations and for direct burial.					

\*Reversible.



CI3106



CI3108



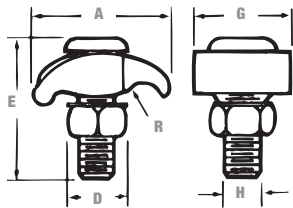
CI3110U



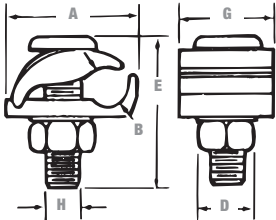
CI3112U



CI3112U



Type GTC 13 and 14



Type GTC 23 and 24

## Clamps

### Type GTC — Tower Ground Clamps

- Bolt has square shank to prevent turning and allow clamp to be tightened with one wrench
- GTC 23 and 24 are two-piece clamps for connecting ground lead cable to flat metal surface; ideal for grounding substations on tower footings
- Castings are of high-strength, corrosion resistant copper alloy
- GTC 13 and 14 are economical one-piece clamps which perform the same function as two-piece clamps except the under pad support is omitted and conductor is connected directly to tower
- Add suffix L to Cat. No. for 1/2 in. channel thickness



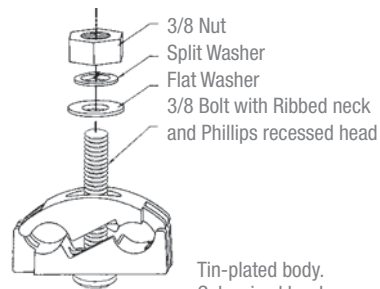
Cat. No.	Conductor Range				Channel Thickness (in.)	Dimensions (in.)						
	Max.	Min.	Max. (mm <sup>2</sup> )	Min. (mm <sup>2</sup> )		A	B	D	E	G	H	R
<b>GTC13</b>	2/0 str.	4 sol.	67.4	21.1	1/4	1-15/32	—	9/16	1-21/32	13/32	3/8	7/32
<b>GTC14</b>	250 kcmil	2/0 str.	126.6	67.4		1-15/16	—	3/4	1-15/16	1-13/32	1/2	5/16
<b>GTC23</b>	2/0 str.	4 sol.	67.4	21.1		1-41/64	7/16	9/16	2-21/32	1-3/32	3/8	—
<b>GTC24</b>	250 kcmil	2/0 str.	126.6			1-61/64	5/8	3/4	1-15/16	1-3/8	1/2	—

### CTG250 — Wide Range Tower Ground Clamp

- For use with aluminum or copper conductors and in aluminum or galvanized steel cable tray
- Ribbed neck on the bolt prevents rotation during tightening if 0.440 dia. hole is used



Cat. No.	Wire Range (2 sides)	Height (in.)	Width (in.)	Depth (in.)	Nut (Flats)
<b>CTG250</b>	#2 sol. (0.258 Dia.), 250 kcmil (0.575 Dia.)	1.95	2.00	1.13	0.560



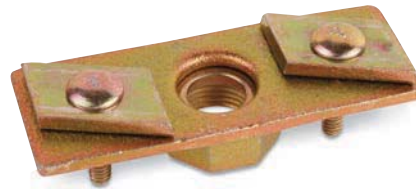


## Clamps

### I-Beam Ground Clamps

Connect ground cable to I-Beam or any 1 in. maximum structural steel member — without welding or drilling

- Breakaway bolt head shears at predetermined torque to ensure tight connection
- Heavy-duty compression lug provides excellent current carrying capabilities
- Surface of steel must be cleaned in accordance with installation instruction sheet provided with product
- Connector made of high-conductivity cast copper bright dip
- Clamp made of drop-forged high-grade steel, zinc-plated



Cat. No.	Wire Range	TBM15I, TBM15 Installing Tool, Die Code	Die Cat. No.
<b>IBG2-10</b>	2 thru 1/0 AWG	66H	15534 [2]
<b>IBG20-40</b>	2/0 thru 4/0 AWG	87H	15506 [2]
<b>IBG350-500</b>	350 kcmil thru 500 kcmil	115H	15504 [2]

Hydraulic tooling with hex crimp dies.  
Use 15500TB adaptor for TBM15-Ton Tool.

\* Number of crimps.

### Ground Clamps

For permanent, reliable connection

- Crimp to cable
- Clamp to ground rod and rebar
- Use standard Color-Keyed® hand and hydraulic tools
- Colour-coded for easy installation die selection
- Made from high-conductivity wrought copper
- Furnished with stainless steel hardware, 1/4 in. washers, bolts and nuts

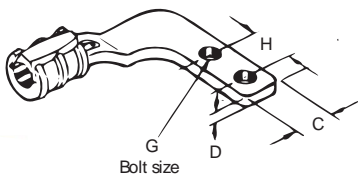


Cat. No.	Wire Size	Ground Rod Diameter (in.)	Rebar (in.)	Bolt Size (in.)	Die Code and Colour
<b>CC2C-45R</b>	#2-#3 AWG	1/2 or 5/8	0.80	0.25	<b>33 Brown</b>
<b>CC1C-45R</b>	#1 AWG				<b>37 Green</b>
<b>CC10C-56R</b>	1/0 AWG	5/8 or 3/4	0.83	0.38	<b>42 Pink</b>
<b>CC20C-56R</b>	2/0 AWG				<b>45 Black</b>
<b>CC40C-56R</b>	4/0 AWG				<b>54 Purple</b>

UL Approved for direct burial.



## Clamps



### Flat-Surface Ground Clamps

Terminate or connect continuous runs of copper cable to flat surfaces

- Captive “Keeper bar” design extends cable range and helps hold cable prior to crimping, facilitating installation
- Saddles marked with conductor size and die code
- Conductor can be assembled to saddle with standard dies and hydraulic tools
- Made from high-conductivity cast copper



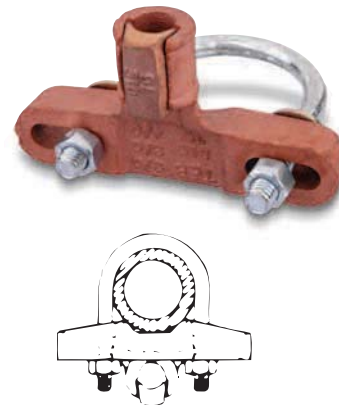
Cat. No.	Wire Range	Bolt Hole (in.)	Die Code No.	Qty.	Std. Pkg.	Wt. Per 100	Hex Die		Dimensions in. (mm)				
							Cat. No.	Die Code No.	L1	L2	D	C	H
53055FL	1/0–2/0 AWG	3/8	66	2	10	75	15534*	66	4.09 (103.9)	3.66 (93.0)	0.28 (7.1)	1.38 (35.1)	1.00 (25.4)
53065FL	4/0–250 kcmil		87H			15506**	87H	4.50 (114.3)	4.09 (103.9)	0.31 (7.9)			

\* TBM14M, 13100A, TBM15I with hex crimp dies.  
 \*\* TBM15I with hex crimp dies only.

### Grid-to-Fence Ground Clamps

Bond copper conductors to steel or aluminum fence post or top rail of round fence posts

- Provide quick, dependable installation at low installed cost
- Use no incendiary materials
- Body made from cast copper alloy with steel U-bolt



Cat. No.	Ground Cable Range	Die Code	Steel and Aluminum Line Post Range (in)
FG2040R2	2/0–3/0–4/0	76	2.00
FG2040R25			2.50
FG2040R3			3.00
FG210R2	2–1–1/0	66	2.00
FG210R25			2.50
FG210F3			3.00

Install with hydraulic tooling with hex crimp dies.

## Service Post Connectors

### Type DS — Service Post Connectors, Short Stud

#### Application

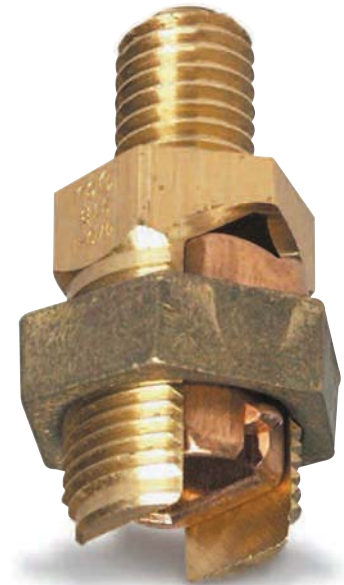
The Blackburn® line of Service Post Connectors is designed for applications including steel structure, fence post or transformer grounding involving one or two cables. Service Posts can also be used to tap one or two cables from bus bar.

#### Construction & Ratings

Bolts used in the Service Post are machined from high-conductivity bronze alloy while the nuts are cold-formed from high-strength, corrosion resistant copper alloy. Pressure bars are copper through 4/0 size, while copper alloy is used for 350 kcmil size and above. Bolts and nuts are of the traditional Blackburn® hex design for easy installation.

Service Post Connectors are available in sizes accommodating AWG copper conductor ranges of #12 – 500 kcmil stranded (4 mm<sup>2</sup> - 240 mm<sup>2</sup>) and #12-#2 solid (4 mm<sup>2</sup> - 35 mm<sup>2</sup>).

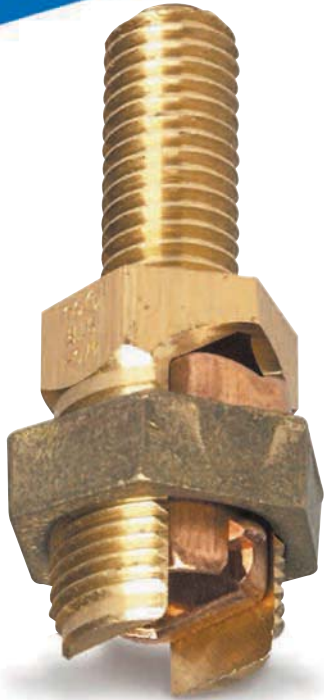
The line includes both short and long stud versions for single and double conductor connectors.



- For copper to copper connections
- For grounding of steel structures, fence posts or transformers using one or two cables
- For tapping one or two cables from bus bar
- Hex design bolts are machined from high-conductivity bronze alloy
- Nuts and pressure bars are cold-formed from high-strength copper or copper alloy



Cat. No.		Conductor Range Stranded (AWG/mm <sup>2</sup> )		Conductor Range Solid (AWG/mm <sup>2</sup> )		Maximum Diameter Range (in.)	Stud Size (in.)
Double Conductor	Single Conductor	Max.	Min.	Max.	Min.		
SP0DS	SP0SS	8 6 mm <sup>2</sup>	12 4 mm <sup>2</sup>	8 6 mm <sup>2</sup>	12 4 mm <sup>2</sup>	0.146–0.080	1/4–20 x 1/2
SP1DS	SP1SS	7 10 mm <sup>2</sup>	10 6 mm <sup>2</sup>	6 10 mm <sup>2</sup>	10 6 mm <sup>2</sup>	0.170–0.102	
SP2DS	SP2SS	5 16 mm <sup>2</sup>		4 16 mm <sup>2</sup>		2 35 mm <sup>2</sup>	8 10 mm <sup>2</sup>
SP3DS	SP3SS	3 25 mm <sup>2</sup>	1 35 mm <sup>2</sup>	1 35 mm <sup>2</sup>	8 10 mm <sup>2</sup>		
SP4DS	SP4SS	1 35 mm <sup>2</sup>				2 35 mm <sup>2</sup>	2 35 mm <sup>2</sup>
SP5DS	SP5SS	1/0 50 mm <sup>2</sup>	4/0 95 mm <sup>2</sup>	4/0 95 mm <sup>2</sup>	–		
SP6DS	SP6SS	2/0 70 mm <sup>2</sup>				1 35 mm <sup>2</sup>	1 35 mm <sup>2</sup>
SP8DS	SP8SS	4/0 95 mm <sup>2</sup>	1/0 70 mm <sup>2</sup>	1/0 70 mm <sup>2</sup>	–		
SP9DS	SP9SS	350 150 mm <sup>2</sup>				3/0 95 mm <sup>2</sup>	3/0 95 mm <sup>2</sup>
SP10DS	SP10SS	500 240 mm <sup>2</sup>					



## Service Post Connectors

### Type SP — Service Post Connectors, Long Stud

- For copper to copper connections
- For grounding of steel structures, fence posts, transformers using one or two cables
- For tapping one or two cables from bus bar
- Hex design bolts are machined from high-conductivity bronze alloy
- Nuts and pressure bars are cold-formed from high-strength copper or copper alloy
- Pressure bars are copper through 4/0 size; copper alloy is used for 350 kcmil size and above
- Available in sizes accommodating AWG copper conductor ranges of #12–500 kcmil stranded (4 mm<sup>2</sup>–240 mm<sup>2</sup>) and #12–#2 solid (4 mm<sup>2</sup>–35 mm<sup>2</sup>)
- Line includes single conductor and double conductor connectors

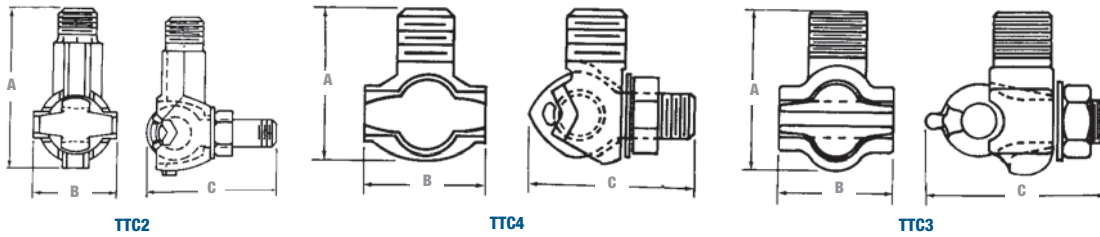


Cat. No.		Conductor Range Stranded (AWG/mm <sup>2</sup> )		Conductor Range Solid (AWG/mm <sup>2</sup> )		Maximum Diameter Range (in.)	Stud Size (in.)
Double Conductor	Single Conductor	Max.	Min.	Max.	Min.		
SP0DL	SP0SL	8 6 mm <sup>2</sup>	12 4 mm <sup>2</sup>	8 6 mm <sup>2</sup>	12 4 mm <sup>2</sup>	0.146–0.080	1/4–20 x 1/2
SP1DL	SP1SL	7 10 mm <sup>2</sup>	10 6 mm <sup>2</sup>	6 10 mm <sup>2</sup>	10 6 mm <sup>2</sup>	0.170–0.102	1/4–20 x 1/2
SP2DL	SP2SL	5 16 mm <sup>2</sup>		4 16 mm <sup>2</sup>		8 10 mm <sup>2</sup>	0.217–0.102
SP3DL	SP3SL	3 25 mm <sup>2</sup>	8 6 mm <sup>2</sup>	2 35 mm <sup>2</sup>	8 10 mm <sup>2</sup>		0.271–0.102
SP4DL	SP4SL	1 35 mm <sup>2</sup>				2 35 mm <sup>2</sup>	8 10 mm <sup>2</sup>
SP5DL	SP5SL	1/0 50 mm <sup>2</sup>	2 35 mm <sup>2</sup>	8 10 mm <sup>2</sup>	8 10 mm <sup>2</sup>		
SP6DL	SP6SL	2/0 70 mm <sup>2</sup>				1 35 mm <sup>2</sup>	8 10 mm <sup>2</sup>
SP8DL	SP8SL	4/0 95 mm <sup>2</sup>	1 35 mm <sup>2</sup>	8 10 mm <sup>2</sup>	8 10 mm <sup>2</sup>		
SP9DL	SP9SL	350 150 mm <sup>2</sup>				1/0 70 mm <sup>2</sup>	8 10 mm <sup>2</sup>
SP10DL	SP10SL	500 240 mm <sup>2</sup>	3/0 95 mm <sup>2</sup>	–	–		

## Transformer Tank Ground Connectors

### Type TTC — Transformer Tank Ground Connectors

- Transformer Grounding Connectors are cast of high-conductivity bronze; 1/2 in.–13 stud fits all standard EEI-NEMA distribution transformers
- Eye bolt on TTC2 rotates to accommodate cable in either vertical or horizontal direction
- One size connector to handle full range of grounding conductors from #8 through 2/0 str.
- No special tools required



Cat. No.	Conductor Range				Stud Thread Size UNC-2A	Dimensions (in.)		
	Max.	Min.	Max. (mm <sup>2</sup> )	Min. (mm <sup>2</sup> )		A	B	C
TTC2	2/0 str.	8 sol.	67.4	8.3	1/2 in.–13	1-51/64	1-9/64	1-21/32
TTC3	1 str.	10 sol.	42.4	5.2		1-3/8	1-3/64	1-9/16
TTC4+						1-1/4	7/8	1-3/8
TTC2P+	2/0 str.	8 sol.	67.4	8.3		1-51/64	1-9/64	1-21/32
TTC3P*	1 str.	10 sol.	42.4	5.2		1-3/8	1-3/64	1-9/16
TTC4P*						1-1/4	7/8	1-3/8

\* Tin-Plated.  
+ Rus Listed.

## Conduit Hubs



Cat. No.	Ground Wire Size (AWG)	Conduit/Wire Size
<b>3930</b>	#8 to #2	1/2 in. Conduit
<b>3940</b>		3/4 in. Conduit
<b>3950</b>	#8 to #3/0	1 Conduit
<b>3951</b>	#8 to #4/0	1-1/4 in. Conduit
<b>3960</b>	#8 to #4	Armored Wire

Material: Malleable iron.



## Type CH — Bronze Conduit Hubs

- Rugged cast bronze threaded hub
- Provide positive connection between rigid conduit and water system in conjunction with “J” clamp

Cat. No.	Conduit Size (in.)	Conductor Range	
		Max.	Min.
<b>CH12</b>	1/2	6 sol.	10 sol.
<b>CH34</b>	3/4	2/0 str.	
<b>CH1</b>	1	3/0 str.	

## Lay-In Lug Connectors

### Copper Lay-In Lug Connectors

- Ideal for swimming pool grounding applications
- Carries “DB” marking for direct burial
- Open-faced design enables installer to quickly lay-in grounding conductor as jumper to multiple conduits with no break in ground conductor

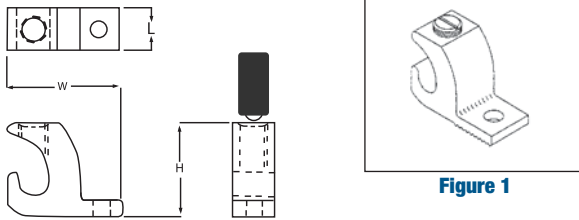


Figure 1



Cat. No.	Conductor Range		Stud Size		Dimensions					
	AWG	mm <sup>2</sup>	in.	mm	H		W		L	
					in.	mm	in.	mm	in.	mm
<b>CULL414</b>	4-14	16-1.5	0.22	5.59	0.78	19.81	0.38	9.65	1.07	27.18
<b>CULL414TP*</b>								9.65		

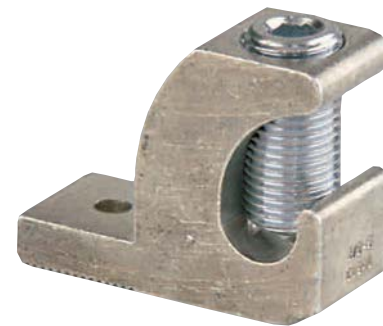
\* Tin-plated.  
90°C Rating.

### Blackburn® Lay-In Lug



Cat. No.	Conductor Range AWG		Stud Size	
	in.	mm <sup>2</sup>	in.	mm <sup>2</sup>
<b>LL414</b>	4-14	16-1.5	0.22	5.59
<b>LL1014</b>	1/0-14	50-1.5	0.27	6.86
<b>LL306</b>	3/0-6	70-16	0.33	8.38
<b>LL2506</b>	250-6	120-16		

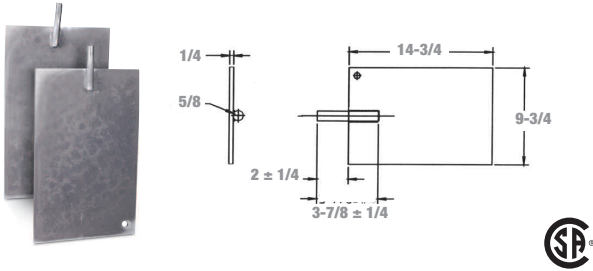
These grounding connectors are dual rated for aluminum and copper conductors. The opened face design allows the installer to quickly lay-in the grounding conductor as a jumper.



## Ground Plates

### Galvanized Grounding Plates

- Made of high-quality steel, hot dip galvanized
- Major time and cost savings vs ground rods



Cat. No.	Description	Wire Range	Std. Pkg.
1016TB	Galvanized grounding plate	8 sol. to 3/0 str.	1
1016BTB	Galvanized grounding plate (complete with JAB34C connector)		
1016TB-NG*	Grounding plate (not galvanized)		
1016BTB-NG*	Grounding plate (not galvanized) (complete with JAB34C connector)		

\* CSA not applicable.

### Type GP — Copper Pole Bottom Ground Plates for Multigrounded Neutral Construction

- More efficient than butt wrapping poles
- Made of electrolytic sheet copper
- Built-in high-pressure connector for ground lead, or supplied with #6 AWG copper pigtail pre-attached
- Plates are grooved for trapping moisture



Cat. No.	Pigtail Wire Range				Diameter of Plate	
	Min.	Max.	Min. (mm <sup>2</sup> )	Max. (mm <sup>2</sup> )	(in.)	(mm)
GP100	8	2 sol.	6.3	25.6	7-1/2	191
GP110					10	254
GP114					14	356
GP1003	#6 AWG solid Cu Pigtail with 18 in. conductor	-	-	-	7-1/2	191
GP1008						
GP1108						254

### Ground Electrode Boxes

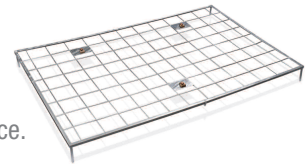


Cat. No.	Description
51628	Pregalvanized steel
51629	Hot dip galvanized steel

14 gauge steel 10 in. diameter, 12 in. depth.

### Metallic Gradient Control Mats

- To reduce risk and prevent build up of dangerous potential differences between high-voltage equipment or structures and the user standing on the ground surface. CEC Rule 36-308.



Cat. No.	Description	Std. Pkg.	Wt/100	
			lb.	kg
64663	Mat with connectors	1	3000	1363

4 ft. x 6 ft. hot dip galvanized mat is made from 6 in. x 6 in. welded mesh, 1/4 in. diameter. With hardware 3-1/2 x 1/2 galvanized bolts, 3 gal. washers and 3 gal. nuts.

### Type PB — Copper Pole Ground Plates

- Installed on butt end of utility poles to provide an economical, low resistance neutral ground
- Installed cost considerably less than butt-wrapped poles. Plate portion fabricated of 0.025 in. pure copper
- PBGW connector is eye-bolt type, cast of corrosion resistant aluminum bronze alloy, with silicon bronze nut and lock washer. Riveted all copper terminal lug is an integral part of the PBH, and provides the means of connection to the grounding conductor



Cat. No.	Wire Range		Finished Size (in.)	Surface Area (sq. in.)
	Max.	Min.		
PBGW	2/0 str.	10 sol.	7 x 7-5/8	56
PBH*	4 str.	14 sol.		

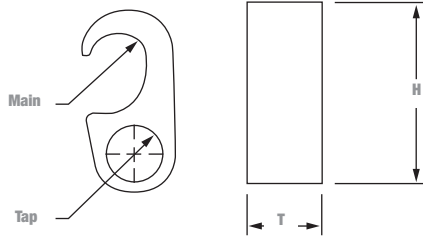
\* RUS Listed.



## Figure 6, Figure 8

### Figure 6 Compression Ground Tap Connectors

- Material: High-conductivity copper
- Acceptable for direct burial



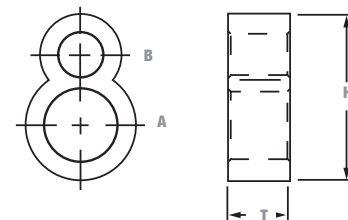
Cat. No.	Application		Cable to rebar application*		Dimensions in. (mm)		Dies for TBM14M, 13100A or TBM15I
	Main	Tap	Main	Tap	T	H	
54855	1/0 Str.–250 kcmil or 1/2 in.–5/8 in. Rod	#4 Sol.–#2 Str.	#3 Rebar 3/8 thru 1/2 in. #4 Rebar	#4 Sol.–#2 Str.	0.75 (19.1)	1.94 (49.3)	15G86A [1]
54860		1/0 Str.–2/0 Str.		1/0 Str.–2/0 Str.		2.19 (55.6)	15G86R [1]
54865-CK		3/0 Str.–250 kcmil		3/0 Str.–250 kcmil		2.19 (55.6)	15G86R [1]
54875	#6 Sol.–#2 Str.	#6 Sol.–#2 Str.	–	2.56 (65.0)		15501A [1]	
54885	250 kcmil–500 kcmil or 5/8 in.–3/4 in. Rod	#4 Sol.–#2 Str.	#5 Rebar 5/8 thru 3/4 in. #6 Rebar	#4 Sol.–#2 Str.		1.94 (49.3)	15G126R [1]
54890		1/0 Str.–2/0 Str.		1/0 Str.–2/0 Str.		2.13 (54.1)	15G126R [1]
54895		3/0 Str.–250 kcmil		3/0 Str.–250 kcmil	2.19 (55.6)	15G126R [1]	
54900		350 kcmil–500 kcmil		350 kcmil–500 kcmil	1.38 (35.1)	2.44 (62.0)	15G121R [3]

\* CSA not applicable.  
Tin-plated version of galvanized ground rods available. Add suffix -TP to Cat. No.  
Use 15500TB adaptor for TBM15-Ton Tool.

[1] Number of crimps.

### Figure 8 Compression Ground Rod Tap Connectors

- Material: High-conductivity copper
- Acceptable for direct burial



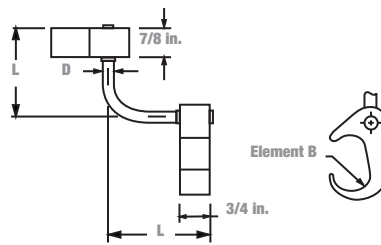
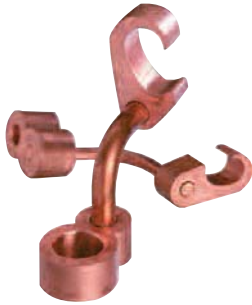
Cat. No.	A (in.) Ground Rod	B Cable Range	Dimensions in. (mm)		Dies for TBM14M 13100A or TBM15I
			T	H	
GR12-202*	1/2	2 AWG–2/0 AWG	0.88 (22.4)	1.94 (49.3)	15G121R [2]
GR58-202*	5/8			1.97 (50.0)	
GR34-202*	3/4			2.19 (55.6)	
GR1-202	1	2.56 (65.0)			
GR12-40250*	1/2	3/0 AWG–250 kcmil		1.94 (49.3)	
GR58-40250*	5/8			2.13 (54.1)	
GR34-40250*	3/4		2.19 (55.6)		
GR1-40250	1		2.44 (62.0)		
GR58-300500*	5/8	300–500 kcmil	2.13 (54.1)		
GR34-300500*	3/4		2.44 (62.0)		
GR1-300500	1		2.69 (68.3)		

\* Tin-plated version of galvanized ground rods available. Add suffix -TP to Cat. No.  
Use 15500TB adaptor for TBM15-Ton Tool.  
Optional Ground Rod Knurling die for 14- and 15-Ton tools: 15508.  
Knurling tool: 240-31565-94.

[2] Number of crimps.

## Figure 6 to 8, Figure 6 to 6

### Figure 6 to 8 Compression Ground Rod to Grid Connectors

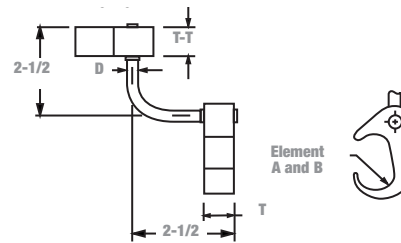
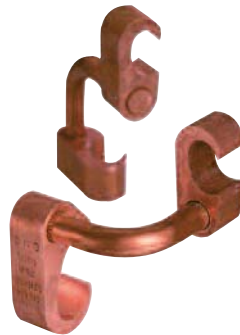


Cat. No.	A in. (mm) Ground Rod	B Cable Range	Dimensions in. (mm)		Dies for TBM14M, 13100A or TBM15I	
			D	L	Element A	Element B
54855LR12*	1/2 (12.7)	2 AWG–250 kcmil	0.31 (7.8)	2.50 (63.5)	15G121R	15G86R
54885LR12*		250 kcmil–500 kcmil				15G126R
54865LR58*	2 AWG–250 kcmil	15G86R				
54895LR58*	250 kcmil–500 kcmil	15G126R				
54875LR34*	3/4 (19.1)	2 AWG–250 kcmil	0.50 (12.7)	2.63 (66.8)		15G86R
54900LR34*		250 kcmil–500 kcmil				15G126R
54910LR100	1 (25.4)	2 AWG–250 kcmil				15G86R
54920LR100		250 kcmil–500 kcmil				15G126R

\*Tin-plated version available for galvanized ground rods. Add suffix -TP to Cat. No.

### Figure 6 to 6 Compression Ground Grid Connectors

- Material: High-conductivity copper
- Acceptable for direct burial



Cat. No.	Element A	Element B	Element A to Ground Rod (in.)	*Element B to Rebar (in.)	Dimensions in. (mm)			Die for TBM14M, 13100A or TBM15I	
	Cable to Cable				D	T	T-T	Element A	Element B
54855L	#6 Sol.–#2 Str.	#6 Sol.–#2 Str.	–	–	0.88 (22.4)	0.75 (19.1)	0.75 (19.1)	15501A	15501A
54865L	#1 Str.–250 kcmil	#6 Sol.–#2 Str.	1/2 – 5/8	3/8 – 1/2 #3–#4 Rebar				15501A	15G86R
54875L	#2 Str.–250 kcmil	#2 Str.–250 kcmil						15G86R	15G86R
54885L		#6 Sol.–#2 Str.	15501A	15G126R					
54895L	250 kcmil–500 kcmil	#2 Str.–250 kcmil	5/8 – 3/4	5/8 – 3/4 #3–#4 Rebar	15G86R	15G126R			
54900L		250 kcmil–500 kcmil			15G121R	15G121R			

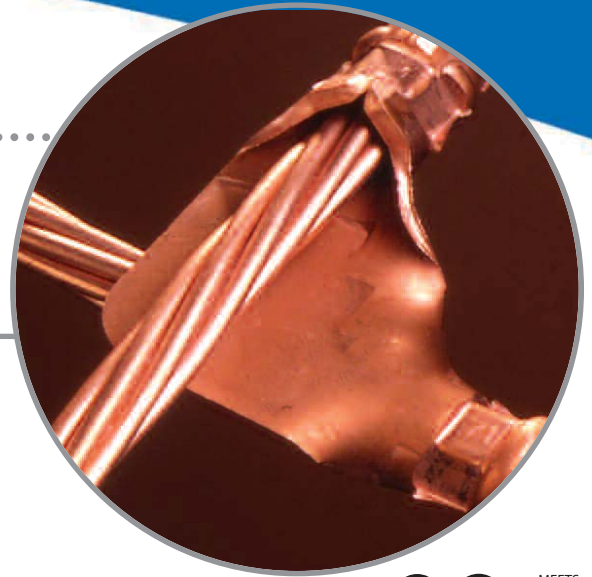
\*CSA not applicable.  
Use 15500TB adaptor for 15-Ton Tool TBM15I.

\* Number of crimps.

## Cable-to-Cable or Cable-to-Rod Connectors

One-piece construction for cable-to-cable, cable-to-rod, “T” and “X” connections

- Suitable for direct burial or in concrete
- Replaces exothermic welds
- Made from high-conductivity wrought copper



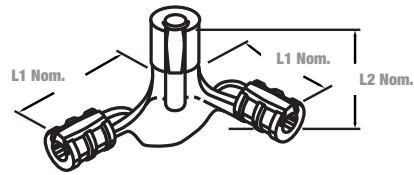
Cat. No.	Cable to Cable Range						Rod to Cable range								
	Main	Die Code	TBM14 and 15 Die Cat. No.	Branch	Die Code	TBM14 and 15 Die Cat. No.	Ground Rod (in.)	Die Code	TBM14 and 15 Die Cat. No.	Cable	Die Code	TBM14 and 15 Die Cat. No.			
GG21-21	#2 or #1	45	15526 [2]	#2 or #1	45	15526 [2]	-	-	-	-	-	-			
GG10-10	1/0	54	15511 [2]	1/0	54	15511 [2]									
GG2030-21	2/0 or 3/0	60	15532 [2]	#2 or #1	50-45	15526 [2] 15530 [2]									
GG2030-10				1/0	54H	15511 [2]									
GG2030-2030				2/0-3/0	60	15532 [2]									
GG40250-21	4/0 or 250 kcmil	71H	15514-CK [2]	#2	45 50	15526 [2] 15530 [2]	1/2 5/8	71 80H	15514-CK 15517	#2 or #1 #2 or #1	45 50	15526 15530			
GG40250-10				1/0 kcmil	54H	15511 [2]				1/0	54	15511			
GG40250-2030				2/0 or 3/0	60	15532-CK [2]				2/0 or 3/0	60	15532 15532			
GG40250-40250				4/0 or 250 kcmil	71H	15514-CK [2]				4/0 or 250 kcmil	71H	15514-CK [2]	4/0 or 250 4/0 or 250 4/0 or 250	71H 71H 71H	15514-CK 15514-CK
GG500-40250				500 kcmil	87H	15506 [2]				4/0 or 250 kcmil	71H	15514-CK [2]	3/4 5/8	87H	15506
GG500-500	500 kcmil	87H	15506 [2]				500	87H	15506						
GG500-350	350 kcmil	80H	15606 [2]				350	80H	15606						
GG500-2030	2/0 or 3/0	60	15532-CK [2]				2/0 or 3/0	60	15532CK						
GG350-350	350 kcmil	80H		350 kcmil	80H	15606 [2]	-	-	-	-	-	-			

Uses 15500TB adaptor for 15-Ton Tools.  
Optional ground rod knurling die or TBM14 and 15 tools: 15508.  
Optional ground rod knurling tool: 240-31565-94.

[2] Number of crimps.

## Two Cables to Ground Rod

For connecting perpendicular runs of stranded copper cable to ground rod



Cat. No.	Cable Size		Ground Rod Dia. (in.)	Cable and Rod Installing Dies for TBM14 and 15				Overall Dimensions in. (mm)			
	Main	Tap		Ground Cable		Ground Rod		L1	L2		
				Die Code	Cat. No.	Die Code	Cat. No.				
53065-58GR	250 or 4/0	250 or 4/0	5/8 and 1/2	87H	15506	2	87H	15506	2	4.94 (125.5)	3.25 (82.6)
53065-34GR			3/4		15515-CK	2	106H	15515	2		

Use T&B hydraulic tools with hex crimp dies.  
 Optional ground rod knurling die for TBM14 and 15 Tools: 15508.  
 Optional ground rod knurling Tool: 240-31565-94.  
 Use 15500TB adaptor for TBM15-Ton Tool.

\* Number of crimps.

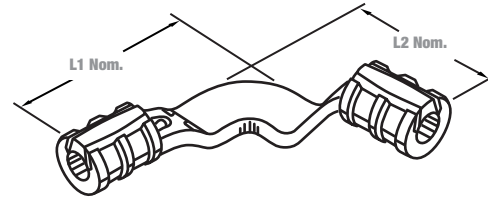
## Copperweld\* Conductors and Rebar For Use with Cast Copper Connectors

Cable Size	Reinforcing Rod Size	Copperweld* Conductor Size
2, 1 AWG	–	3 #8 or 3 #6
1/0, 2/0 AWG	#3	3/8 (7 #8) or 7/16 (7 #7)
4/0, 250 kcmil	#4	7/16 (19 #9) or (7 #5)
300–350	#5	21/32 (19 #8) or 5/8 (7 #4)
500 kcmil	#6	13/16 (19 #6)

\*Reg. Trademark Copperweld Corporation.  
 UL Listed for use with cast copper connectors.

## Grounding Grid Connectors

### Heavy-Duty Cast Copper\*\*



Cat. No.	Rod to Cable Range		Cable to Cable Range Rod		Cable and Rod Installing Dies for TBM14 and 15			Overall Dimensions in. (mm)			
	Rod Size (in.)	Cable Range	Main	Branch	Die Code	Cat. No.	Die Code	Cat. No.	L1	L2	
53055	—	—	1/0–2/0 AWG	1/0–2/0 AWG	—	—	66	15534	1	3.88 (98.6)	3.88 (98.6)
53059*	1/2–5/8	2–1 AWG	4/0–250 kcmil	2–1 AWG	87H	15506	54H	15511	2	4.16 (105.7)	4.56 (115.8)
53060*		1/0–2/0 AWG		1/0–2/0 AWG			87H	15506	2	4.44 (112.8)	4.44 (112.8)
53065*		4/0–250 kcmil		4/0–250 kcmil			87H	15506	2	4.44 (112.8)	4.44 (112.8)
53069*	3/4	1/0–2/0 AWG	300–350 kcmil	1/0–2/0 AWG	106H	15515-CK	66	15534	1	4.59 (116.6)	4.59 (116.6)
53071*		4/0–250 kcmil		4/0–250 kcmil			106H	15515-CK	2	5.25 (133.4)	4.78 (121.4)
53073*	1	1/0–2/0 AWG	500 kcmil	1/0–2/0 AWG	125H	15603	66	15534	1	4.81 (122.2)	4.88 (124.0)
53075*		4/0–250 kcmil		4/0–250 kcmil			87H	15506	2	6.56 (166.6)	5.00 (127.0)
53080*		500 kcmil		500 kcmil			125H	15603	3	5.19 (131.8)	5.19 (131.8)

\* 4/0–250 wire barrels suitable for 1/2 in. and 5/8 in. rod, 300–500 kcmil wire barrels suitable for 3/4 in. rods, 500 kcmil wire barrels suitable for 1 rods.

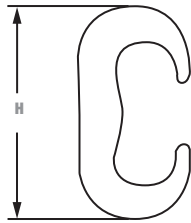
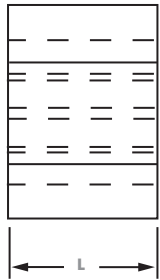
\*\* Do not meet IEEE837.

Cat. No. 15500TB adaptor is required for all 15500 Series dies, not for 15600 Series, crimp with 15-Ton Tools. Hydraulic tools only.

\* Number of crimps.



## C-Taps



Cat. No.	Main	Tap	Dimensions in. (mm)		Dies for TBM14M, 13100A or TBM15I*	Crimps
			H	L		
CTP22	#6 Sol.–#2 Str.	#6 Sol.–#2 Str.**	1.16 (29.5)	0.75 (19.1)	HBKC	1
CTP202	#1 Str.–2/0 Str.		1.41 (35.8)		15501A	
CTP2020	#1 Str.–2/0 Str.	#1 Str.–2/0 Str.	1.54 (39.1)		15G86R	
CTP25020	3/0 Str.–250 kcmil	#6 Sol.–2/0 AWG**	1.97 (50.0)	0.88 (22.4)	15G121R	2
CTP250250		3/0 Str.–250 kcmil	2.06 (52.3)			
CTP50020	300–500 kcmil	#6 Sol.–2/0 AWG**	2.42 (61.5)	1.10 (27.9)		3
CTP500250		3/0 Str.–250 kcmil	2.67 (67.8)			
CTP500500†		300–500 kcmil	2.91 (73.9)			

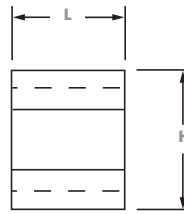
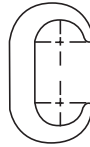
\* Cat. No. 15500 adaptor required if using TBM15I and 155XX series Dies.

\*\* #6 AWG branch must be doubled.

† Must use TBM15I tool

Material: High-Conductivity Copper.

## Copper C-Crimps Wire Combinations\*\*

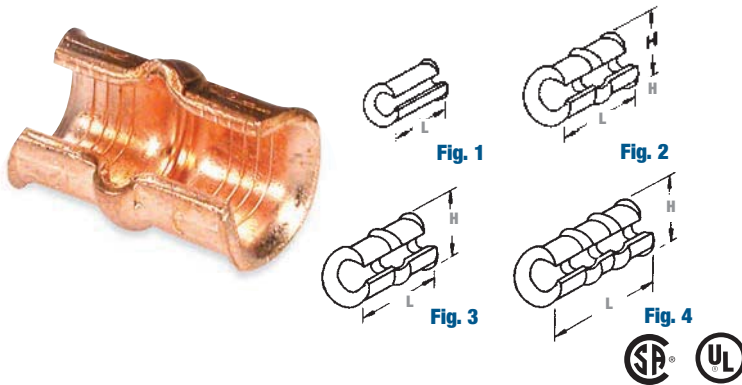


Cat. No.	Run	Tap	Die Index	Manual Tool OD Series	Installing Die 14- and 15-Ton Tools	Dimensions in. (mm)	
						L	H
BC48	6 Sol.–4 Str.	8 Sol.–8 Str.	BG or 5/8	BY31	B58CR	0.64 (16.3)	0.56 (14.2)
BC46-BB		6 Sol.–6 Str.					0.75 (19.1)
BC44		4 Sol.–4 Str.					0.80 (20.3)
BC24	2 Sol.–2 Str.	8 Sol.–4 Str.	C	BY33	HBKC	0.75 (19.1)	0.98 (24.9)
BC22		2 Sol.–2 Str.					1.05 (26.7)
BC202	1/0 Sol.–2/0 Str.	8 Sol.–2 Str.	E or O			0.94 (23.9)	1.31 (33.3)
BC2020-BB		1/0 Str.–2/0 Str.					1.34 (34.0)
BC402	3/0 Str.–4/0 Str.	6 Sol.–2 Str.	F or D3	-	HO	1.06 (26.9)	1.63 (41.4)
BC4020		1/0 Sol.–2/0 Str.					
BC4040		3/0 Sol.–4/0 Str.					

\*\*Do not meet IEEE 837.

## C-Taps

### Small Size

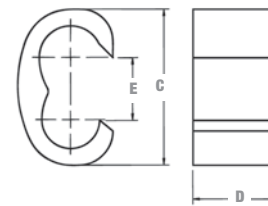


Cat. No.	Code Wire Comb. Cir. Area Range		Die			Group 2	Group 3	Insulation Choice		Dimensions in. (mm)		Colour Code
	Main	Branch	Group 1	TMB62BSCR	Smart™ Tools			Adhesive	Shrink Tubing	L	H	
54705	12	14	6TON21	TBM6221					HS12-6	0.31 (7.9)	0.31 (7.9)	Red
	14	16								0.56 (14.2)	0.44 (11.2)	Blue
54710	10	10	6TON24	TBM6224					HS12-6	0.56 (14.2)	0.63 (16.0)	Grey
	8	12								1.16 (29.5)	0.69 (17.5)	Brown
54715	6	10, 12	6TON29	TBM6229					HS12-6	0.56 (14.2)	0.81 (20.6)	Green
	8	8, 10, 12								1.16 (29.5)	0.84 (21.3)	Pink
54720	4 or 5	8, 10, 12	6TON33	TBM6233	TBM8-750C20				HS6-1	0.06 (1.5)	0.88 (22.4)	Black
	6	6, 8								1.69 (42.9)	0.97 (24.6)	Orange
54725	3	6, 8, 10, 12***	6TON37	TBM6237					HS6-1	1.69 (42.9)	1.06 (26.9)	Purple
	4 or 5	6, 5								1.69 (42.9)	1.19 (30.2)	Yellow
54730	2	6, 8, 10, 12	6TON42	TBM6242	TBM8-750C2530				HS4-30	1.69 (42.9)	1.06 (26.9)	Purple
	3	5								1.69 (42.9)	1.19 (30.2)	Yellow
54735	1	4, 5, 6, 8, 10, 12	6TON45	TBM6245					AC5X3	0.06 (1.5)	0.88 (22.4)	Black
	2	4, 5								1.69 (42.9)	0.97 (24.6)	Orange
54740	1/0	4, 5, 6, 8, 10, 12	6TON50	TBM6250					HS4-30	1.69 (42.9)	1.06 (26.9)	Purple
	1	3, 4								1.69 (42.9)	1.19 (30.2)	Yellow
54745	2/0	3, 4, 5, 6, 8, 10, 12	6TON54	TBM6254					HS4-30	1.69 (42.9)	1.06 (26.9)	Purple
	1/0	2, 3								1.69 (42.9)	1.19 (30.2)	Yellow
54750	3/0	2, 3, 4, 5, 6, 8, 10, 12	6TON62	TBM6262					HS4-30	1.69 (42.9)	1.06 (26.9)	Purple
	2/0	1, 2								1.69 (42.9)	1.19 (30.2)	Yellow
	1/0	1/0, 1										

\*\*\* When using 3 AWG on main and 12 AWG on branch with Smart™ Tools and dies, 12 AWG wire must be doubled (hair-pinned) and placed on branch for crimping.  
 Group 1 = TBM6H, TBM6BSCR.  
 Group 2 = TBM25S, TBM21E (require 2 compressions within each crimp area).  
 Group 3 = TBM4/4S, TBM5/5S, TBM6/6S, TBM8/8S, TBM6H (require 1 compression within each crimp area).

### Large Size for Certified to 600 V

- More economical than other taps and split bolts in terms of purchase, inventory, installation time, insulation and maintenance.
- Color-coded for easy matching with proper die
- Barely larger than conductor insulation once installed



**Material:** High-Conductivity Wrought Copper  
**Finish:** Plain



Cat. No.	Wire Size		Dimensions in. (mm)			Installing Die		Die Code	No. of Crimps	Colour Code
	Main	Branch	C	D	E	Tool	Cat. No.			
54755	#1	#1	1.93 (49.0)	0.75 (19.1)	0.53 (13.5)	TBM14M	15512	76	1	Blue
	1/0	1/0-#2					15512*	76		
	2/0	2/0-#3					TBM12D-4	76		
	3/0	4/0-#4					15512	76		
54760	4/0	2/0-#1	1.43 (36.3)	0.75 (19.1)	0.59 (15.0)	TBM14M	15506	87H	2	Brown
	250 kcmil	3/0-#3					15506*	87H		
		4/0-#4					TBM12D-3	87H		
		#1-#8					15506	87H		
54765	2/0	2/0-#1	1.68 (42.7)	1.00 (25.4)	0.64 (16.3)	TBM14M	15505	99H	2	Pink
	3/0	3/0-#2					15505*	99H		
	4/0	4/0-#4					TBM12D-2	99H		
	250 kcmil	3/0-#6					15505	99H		
54770	4/0	4/0-2/0	1.68 (42.7)	1.00 (25.4)	0.68 (17.3)	TBM14M	15515	106H	2	Black
	250 kcmil	250-#1					15515*	106H		
	300 kcmil	4/0-#4					TBM12D-2	106H		
	350 kcmil	3/0-#6					15515	106H		
54775**	250 kcmil	250 kcmil	1.88 (47.8)	1.25 (31.8)	0.81 (20.6)	TBM14M	15504	115H	2	Yellow
	300 kcmil	300-3/0					15504*	115H		
	350 kcmil	350-1/0					TBM12D-1	115H		
	400 kcmil	300-#2					15504	115H		
	450 kcmil	250-#4								
54780	350 kcmil	350-4/0	2.18 (55.4)	1.25 (31.8)	0.82 (20.08)	TBM15I	15603	125H	2	N/A
	400 kcmil	400-2/0								
	450 kcmil	450-#1								
	500 kcmil	500-#2								
54785	750 kcmil	4/0-#6	2.12 (53.8)	2.00 (50.8)	1.00 (25.4)	TBM15I	15603	125H	3	N/A
	54790	750 kcmil	750-4/0	2.68 (68.1)	2.00 (50.8)	1.31 (33.3)	TBM15I	15603	125H	3

UL approved for direct burial.  
 For covers see Section B.  
 Taps can be supplied tin-plated. Add suffix "TP" to any Cat. No. (i.e. 54725TP).  
 \* Cat. No. 15500TB adaptor required if using TBM15I and 155xx series dies.  
 \*\* #6 AWG branch must be doubled.  
 Tooling and Die Selector Chart see Section E.



## Pigtail Connectors

**Hex Compression intimately bonds directly to copper clad ground rod**

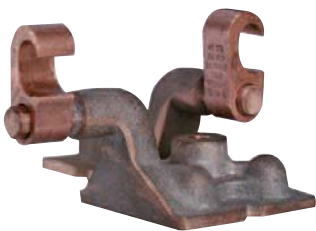
- Figure-8 connectors
- Conforms to IEEE 837 standard
- UL Listed

When connecting cable to copper clad ground rod for direct burial or in concrete, the connector shall be wrought copper with minimum conductivity of 99% I.A.C.S., such as Thomas & Betts series GR12-306. Hex compression with die code embossing shall be used.



Cat. No.	Cable Range	Copper Clad Ground Rod (in.)	Die Code for TBM14M, TBM15, 13100A or TBM15I	Die Cat. No. [2]
<b>GR12-306</b>	One Cable: 3/0 to 6 AWG Two Cables: 2 to 6 AWG	1/2	87H	15506 [2]
<b>GR58-406</b>	One Cable: 4/0 to 6 AWG Two Cables: 2 to 6 AWG	5/8		
<b>GR34-4010</b>	One Cable: 4/0 to 1/0 AWG	3/4	99H	15505

\* [2] Number of crimps.



## Ground Plates



Cat. No.	Fig.	Cable Range	H in. (mm)	Die Code for 14- and 15-Ton Tools
<b>GP2250-2</b>	1	2-250 kcmil	3.63 (92.2)	15G86R [1]
<b>GP2250-4</b>	2		4.22 (107.2)	15G86R [1]
<b>GP250500-2</b>	1	250-500 kcmil	3.63 (92.2)	15G126R [2]
<b>GP250500-4</b>	2		4.22 (107.2)	15G126R [2]

\* [2] Number of crimps.

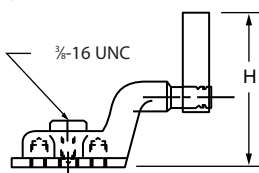
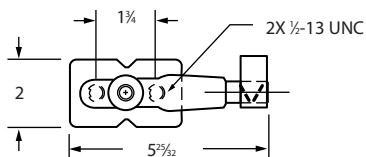


Fig. 1

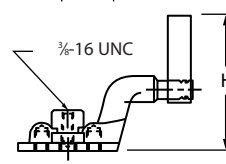
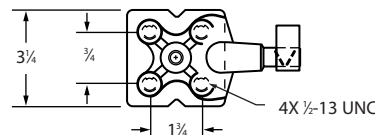
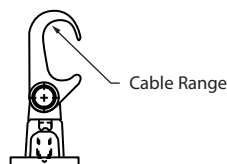
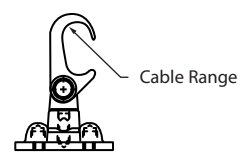


Fig. 2





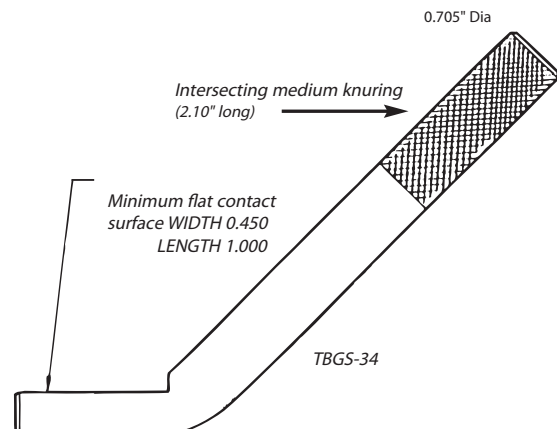
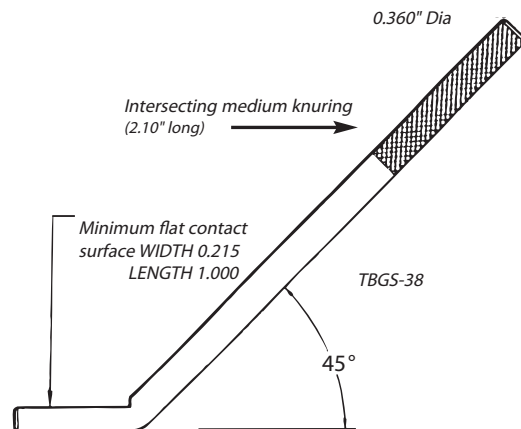
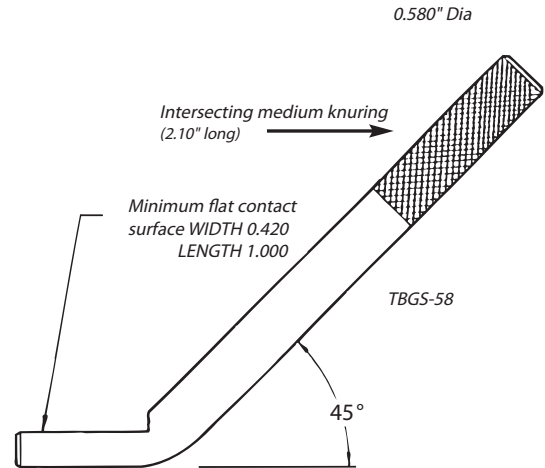
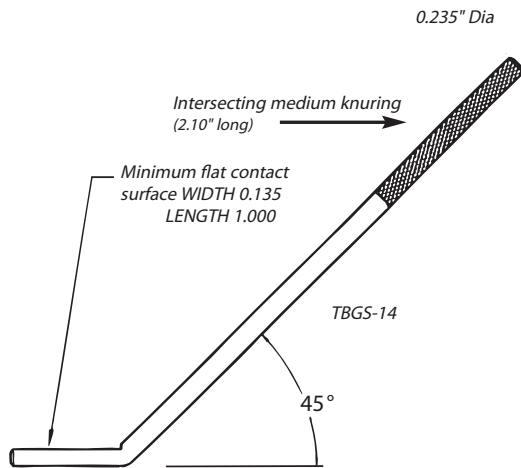
## Grounding Studs

### Type TBGS Structural Grounding Studs

Knurling ensures excellent mechanical pull-out and electrical continuity

- Easily welded to steel structures with minimal construction welding equipment
- Connect to grounding conductors with appropriate Thomas & Betts grounding connectors
- Knurled portion of stud resists pull-out and provides electrical continuity to ensure the integrity of the grounding circuit
- Constructed of high-strength steel and coated with corrosion-resistant copper cyanide

Cat. No.	Rod Size (in.)
<b>TBGS-14</b>	0.25
<b>TBGS-38</b>	0.38
<b>TBGS-58</b>	0.63
<b>TBGS-34</b>	0.75



## Bus Bar Connectors



**Cuts installation time in half – With results superior to conventional connectors**

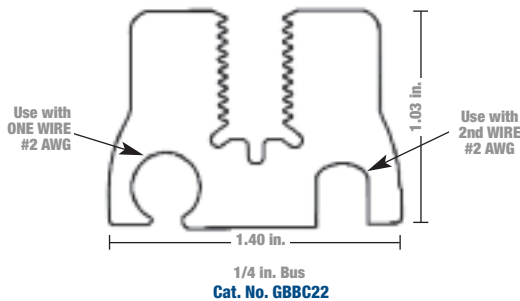
- Unique
- Fast and easy installation
- Superior low-resistance, high-conductivity connections
- Install with conventional compression tools
- Produce a permanent connection with any combination of copper from #6 to #2 solid or stranded conductors, to 1/4 in. copper bus bar
- Made from pure wrought copper and prefilled with oxide inhibitor
- CSA Certified and UL Listed
- Insulated with die HDF

Cat. No.	Ground Bus Bar (in.)	Conductor Range	Std. Pkg. Qty.
GBBC22	1/4	#2 AWG–#2 AWG	1
GBBC26		#6 AWG–#2 AWG	

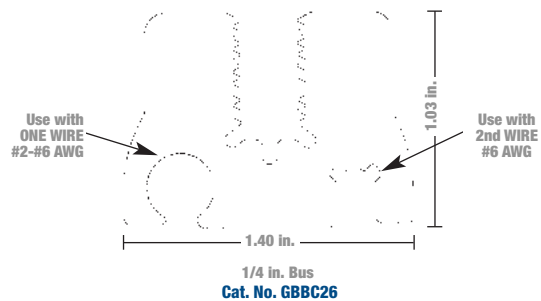
E-Z-Ground® Bus Bar Connectors install in less than 2 minutes with one easy crimp! The connector attaches directly to the bus, saving the labor-intensive process of drilling and tapping. The unique jaw interface of the E-Z-Ground® Bus Bar Connector grips the copper bus, resulting in a low-resistance, high-conductivity connection.

The E-Z-Ground® Bus Bar Connectors can be used in OEM applications or telecom applications – Cellular, PCS and others. They provide a continuous ground to the copper bus bar, making them ideal for tower applications. The design enables installation in virtually any position, horizontal or vertical, and is suitable for inside and outside plant use. Installation can be completed using any T&B compression tool that accepts U-shaped die sets and is rated 12-Ton or higher.

*Use this side of the connector when using only one wire.*



*Use this side of the connector only when using two wires.*



## Ground Rods

### Galvanized Ground Rods



- Made of high-strength quality cold drawn steel (1035) hot dip galvanized
- Meets ANSI C135.30-1979 requirements
- Stainless steel rods are also available (for more detailed information, contact your T&B Regional Sales Office)

Cat. No.	Trade Size		Rod Size (nominal diameter x length)		Plating Thickness	Standard Packaging	Weight per 100	
	in.	ft.	mm	m			lb.	kg
GR5006	1/2	6	12.7	1.8	4 mils	10	410	186
GR6256	5/8	8	15.8	1.8		5	600	272
GR6258		10		2.4			800	363
GR6250 (0.543 - 0.555)	3/4	10		19.0	3.0		10	1000
GR6260 (0.625 - 0.640)			1.8		700	318		
GR6250B* (0.618 - 0.623)			2.4		1200	545		
GR7506	1	6	25.4	1.8	1	2248	1020	
GR7508		8		2.4		1240	462	
GR7510		10		3.0		1500	681	

\* B suffix denotes black iron bare steel ground rod (CSA not applicable).  
CSA lists rods 1/2 in. and larger, 10 ft. and longer.

### Copper Bonded Steel Ground Rods



- All E-Z-Ground® ground rods have a heavy uniform covering of electrolytic copper bonded to a rigid steel core
- Copper ions are forced electrically to join with the steel core, establishing a corrosion-resistant bond between the copper and the steel

Cat. No.	Trade Size		Rod Size (nominal diameter x length)		Plating Thickness	Standard Packaging	Weight per 100	
	in.	ft.	mm	m			lb.	kg
5005	1/2	5	12.7	1.8	5 mils	10	305	138
5006		6		370		168		
5008		8		545		247		
5010		10		611		277		
6256	5/8	6	15.8	3.0	5	508	230	
6258*		8		678		308		
6260*		10		847		384		
7508*	3/4	8	19.0	2.4	10 mils	992	450	
7510*		10		1240		462		
1010*		1		2248		1020		

\* Ground rods are UL Listed, except for regular rods shorter than 8 ft. or less than 1/2 in.  
CSA lists rods 1/2 in. and larger, 10 ft. and longer.

### Knurling Dies for 14- & 15-Ton Tools

Cat. No.	Description
15508	For 5/8 in. and 3/4 in. ground rods

Used to knurl ground rods in order to increase the pullout value of the compression connection by as much as 20%.



Hand Knurling Tool  
for all Ground Rods

240-31565-94

## Ground Rods

### Sectional type Ground Rods



- Sectional type ground rods have the same high-quality as regular copper bonded steel ground rods and are threaded top and bottom



Cat. No.	Trade Size		Rod Size (nominal diameter x length)		Plating Thickness	Thread Size	Standard Packaging	Weight per 100	
	in.	ft.	mm	m				lb.	kg
5008LS	1/2	6	15.8	1.8	10 mils	9/16-12	5	546	248
5010LS		8		2.4				682	309
6258S	5/8	8		3.0	10 mils	5/8-11		670	308
6260S		10	837					384	
7506S	3/4	6	19.0	1.8	5 mils	3/4-10		774	160
7508S		8		2.4				992	450
7510S		10		3.0			1040	562	
1010S	1		25.4			8-1	1	2248	1020

CSA lists rods 1/2 in. and larger, 10 ft. and longer.

### Couplings

- Threaded couplings are made of high-strength, corrosion resistant alloy. Streamlined design reduces driving friction. Couplings are tapped for use on all standard threaded sectional rods



Cat. No.	Rod Size Diameter (in.)	Thread Size	Standard Packaging	Weight per 100 (lb.)
50LC	1/2	9/16 in. - 12 UNS	25	17
60C	5/8	5/8 in. - 11 UNS		25
70C	3/4	3/4 in. - 10 UNS		38
80C	1	1 - 8 UNS	10	75

### Driving Studs

- Driving Studs of high-strength steel
- May be used with all standard threaded couplings



Cat. No.	Rod Size Diameter (in.)	Thread Size	Standard Packaging	Weight per 100 (lb.)
50LDS*	1/2	9/16 in. - 12 UNS	10	16
60DS*+	5/8	5/8 in. - 11 UNS	25	23
70DS*	3/4	3/4 in. - 10 UNS	5	35
80DS	1	1 - 8 UNS	10	75

\* UL Listed  
+ CSA Certified

## Ground Rods

### Threadless Couplings and Driving Caps for Standard Copper Bonded Ground Rods

#### Threadless Couplings

- For joining non-threaded, sectional, copper bonded, steel ground rods
- Coupling is manufactured of a high-strength, corrosion resistant, silicone bronze

#### Threadless Driving Caps

- Prevent “mushrooming” of ground rod while driving to insure proper fit of coupling
- Driving cap is manufactured of high-strength, hardened steel



Cat. No.	Size (in.)	Dimensions (in.)		Standard Packaging	Weight per 100 (lb.)
		Length	Diameter		
<b>Threadless couplings</b>					
50CNT	1/2	3.0	0.78	25	34
60CNT2	5/8	2.5	0.69		
70CNT	3/4	3.0	0.97		
<b>Driving Caps</b>					
60DSNT *	5/8	4.0	0.88	10	43

\* UL not applicable

## Ground Rod Drivers

**For installing ground rods, there's no safer, simpler or more effective tool than the Thomas & Betts Ground Rod Driver. It can be used on all types of ground rods including copper-bonded, galvanized and stainless steel.**

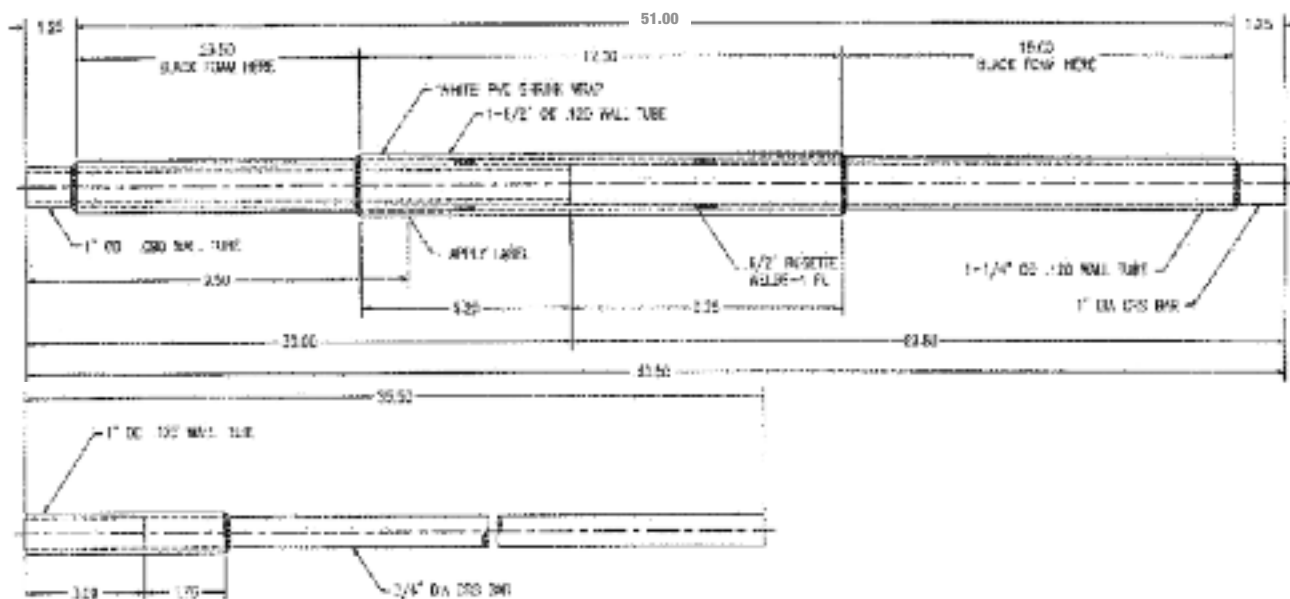
Integral inserts prevent the driver from slipping off the rod near ground level. The inserts are 5/8 in. and 3/4 in., and are interchangeable with the standard driver body. The convenient retaining collar holds the insert in the tool when not in use.

Thomas & Betts Ground Rod Drivers have a heavy-duty steel construction that allows maximum force for driving ground rods, while the efficient design ensures that minimal lifting force is required. The ground rod end is designed for high-impact applications to ensure quality connections.

- Unique design allows installation of 10-foot rods from ground level
- Heavy-duty steel construction
- Ergonomic grip provides ease and comfort with increased safety
- Complete with interchangeable parts that are range-taking for different diameter ground rods
- Two interchangeable inserts allow the same tool to be used with all sizes of rods
- Completely self-contained and easy to store

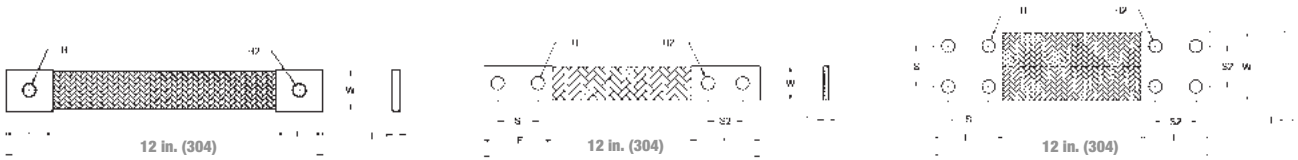


Photo includes ground rod driver and insert.



Cat. No.	Description	Weight (lb.)	Maximum Rod Diameter (in.)	Std. Pkg.
TBRD58	5 ft. Ground Rod Driver with 5/8 in. insert	25	0.63	1
TBRD34	5 ft. Ground Rod Driver with 3/4 in. insert		0.75	
TBS58	Replacement 5/8 in. insert	4	0.63	
TBS34	Replacement 3/4 in. insert		0.75	

## Flexible Braid



Cat. No.	Circular Mils	Bolt Hole (H or H2)	No. of Braids in Ferrule	Dimensions in. (mm)			
				(T) Thickness	(W) Width	(F) Ferrule Length	(S or S2) Distance Ctr. to Ctr.
<b>FBB12-1*</b>	24000	1/4	1	0.140 (3.6)	0.625 (15.9)	0.750 (19.1)	-
<b>FBC12-1*</b>	48000	7/16		0.148 (3.8)		1.000 (25.4)	
<b>FBD12-1*</b>	76800		0.200 (5.1)		2.500 (63.5)		1.25 (31.8)
<b>FBD12*</b>	76800			2		1.250 (31.8)	1.500 (38.1)
<b>FB2D12-1*</b>	153600		0.250 (6.4)		2.500 (63.5)		1.25 (31.8)
<b>FB2D12*</b>	153600			3		1.250 (31.8)	1.500 (38.1)
<b>FB3D12-1*</b>	230400		0.350 (8.9)		2.500 (63.5)		1.25 (31.8)
<b>FB3D12*</b>	230400			1		1.250 (31.8)	1.500 (38.1)
<b>FBXD12-1*</b>	105600		9/16		0.250 (6.4)		1.250 (31.8)
<b>FBXD12*</b>	105600			0.350 (8.9)		2.500 (63.5)	
<b>FB2XD12-1*</b>	211200				0.400 (10.2)		1.500 (38.1)
<b>FB2XD12*</b>	211200	1		1.250 (31.8)		2.500 (63.5)	
<b>FB3XD12-1*</b>	316800				0.500 (12.7)	1.500 (38.1)	1.25 (31.8)
<b>FB3XD12*</b>	316800	0.250 (6.4)		1.250 (31.8)			3.500 (88.9)
<b>FBE12-1*</b>	168000				9/16	0.500 (12.7)	1.250 (31.8)
<b>FBD12*</b>	168000	0.750 (19.1)		1.500 (38.1)			
<b>FB2E12-1*</b>	336000					1.000 (25.4)	1.500 (38.1)
<b>FB2E12*</b>	336000	2		1.500 (38.1)			
<b>FB3E12</b>	504000		0.300 (7.6)			1.500 (38.1)	1.25 (31.8)
<b>FB4E12</b>	672000	0.450 (11.4)		1.625 (41.2)			1.75 (44.5)
<b>FBF12</b>	230400		0.600 (15.2)			1.625 (41.2)	1.75 (44.5)
<b>FB2F12</b>	460800	0.750 (19.1)		1.500 (38.1)			1.75 (44.5)
<b>FB3F12</b>	691200		0.380 (9.7)			1.500 (38.1)	1.75 (44.5)
<b>FB4F12</b>	921600	0.630 (16.0)		1.625 (41.2)			1.75 (44.5)
<b>FBG12</b>	307200		0.850 (21.6)		1.625 (41.2)	1.75 (44.5)	
<b>FB2G12</b>	614400	1.000 (25.4)		1.880 (47.9)		1.75 (44.5)	
<b>FB3G12</b>	921600		1.000 (25.4)		1.880 (47.9)	1.75 (44.5)	
<b>FB4G12</b>	1228800						

\* UL Listed, CSA Certified as Grounding and Bonding Equipment.  
 Special lengths offered in 6, 18, 24, 30 and 36 in. (end to end).  
 Change the 12 in the above catalogue numbers to the desired length.  
 (-1) indicates 1 bolt hole per ferrule.  
 S2 and H2 measurements are used for customized braids only.

### Flexible Braids in a roll (10 feet minimum)\*

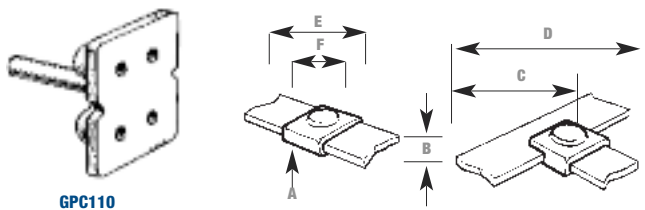
Cat. No.	Circular Mils	Thickness (in.)	Width (in.)
<b>FBBRL</b>	24000	0.140 (3.6)	0.625 (15.9)
<b>FBCRL</b>	48000	0.148 (3.8)	1.000 (25.4)
<b>FBDRL</b>	76800	0.200 (5.1)	
<b>FBXDRL</b>	105600	0.250 (6.4)	1.250 (31.8)

\*Ferrules or lugs not included.  
 Add suffix for desired length, i.e.: FBCRL "-10" for 10 ft. roll.

## Exothermic Welding System

### Earth Points

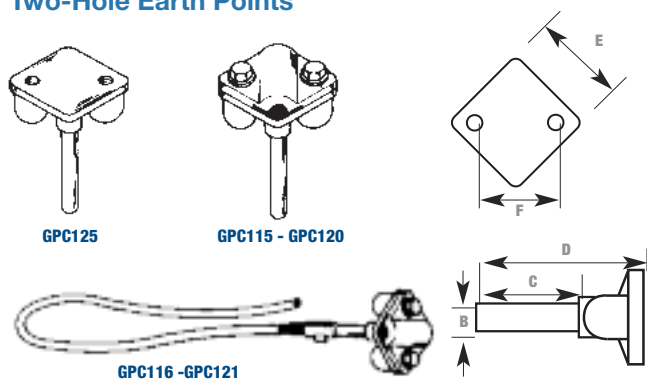
#### Four-Hole Earth Points



GPC110

Cat. No.	A Hole Size (in. dia.)	B (in. dia.)	C (in. dia.)	D (in. dia.)	E (in. dia.)	F (in. dia.)
GPC110	4 x 5/16 UNC x 9/16	27/64	2	3	2-1/2	1-13/32
GPC111	As GPC110 with a pre-welded 20 in. long tail of 2/0 AWG pvc insulated cable					

#### Two-Hole Earth Points



GPC125

GPC115 - GPC120

GPC116 - GPC121

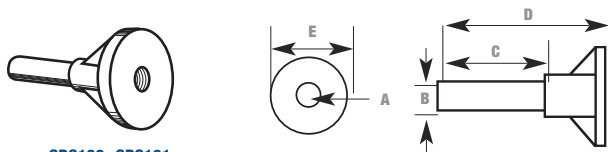
#### Complete with front plate

Cat. No.	Conductor Type	B (in. dia.)	C (in.)	D (in.)	E (in.)	F (in.)
GPC115	1 in. x 1/8 in. Tape or 2/0 AWG Cable	27/64	2	3-1/8	2-3/16	1-3/4
GPC116	As GPC115 with a pre-welded 20 in. long tail of 2/0 AWG pvc insulated cable					
GPC120	1 in. x 1/8 in. Tape or 5/16 in. dia. Solid	27/64	2	3-1/8	2-3/16	1-3/4
GPC121	As PC120 with a pre-welded 20 in. long tail of 2/0 AWG pvc insulated cable					

#### Without front plate

Cat. No.	Conductor Type	B (in. dia.)	C (in.)	D (in.)	E (in.)	F (in.)
GPC125	2 x 5/16 UNC x 1/2	27/64	2	3-1/8	2-3/16	1-3/4
GPC126	As PC125 with a pre-welded 20 in. long tail of 2/0 AWG pvc insulated cable					

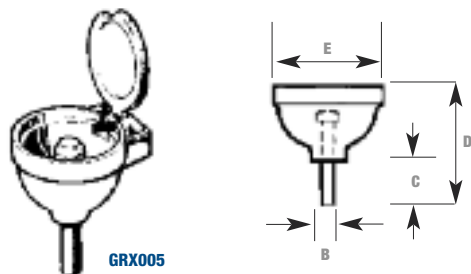
#### One-Hole Earth Points



GPC100 - GPC101

Cat. No.	A Hole Size	B (in. dia.)	C (in.)	D (in.)	E (in.)
GPC100	1 x 5/16 UNC x 5/8	27/64	2-3/16	3-1/8	1-3/8
GPC101	1 x 3/8 UNC x 5/8				
GPC105	As PC100 with a pre-welded 20 in. long tail of 2/0 AWG pvc insulated cable				
GPC106	As PC101 with a pre-welded 20 in. long tail of 2/0 AWG pvc insulated cable				

#### Static Earth Receptacle



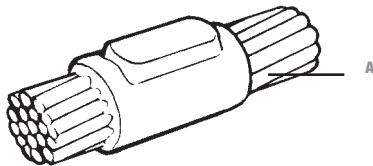
GRX005

Cat. No.	B (in. dia.)	C (in.)	D (in.)	E (in.)
GRX005	27/64	1-1/2	3-3/8	2-11/16



## Exothermic Welding System

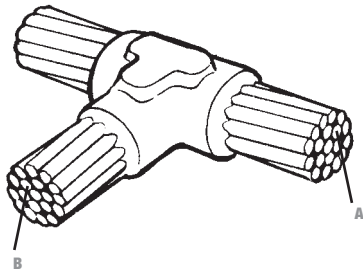
### Cable to Cable



- Stranded Conductor
- Solid Circular Conductor

#### CC1

Cat. No.	Wire Size (A)	Welding Powder size	Handle Clamp Type	Std. Qty.
CC1-3-#3	3	32BKB	HCPK3	1
CC1-3-#2	2			
CC1-3-#2S	2 solid			
CC1-3-#1	1			
CC1-3-#1S	1 solid	45BKB	HCPK4	
CC1-4-1/0	1/0			
CC1-4-1/0S	1/0 solid			
CC1-4-2/0	2/0			
CC1-4-3/0	3/0	90BKB	HCPK4	
CC1-4-4/0	4/0			
CC1-4-4/0S	4/0 solid	115BKB	HCPK4	
CC1-4-250K	250			
CC1-4-300K	300	150BKB	HCPK5	
CC1-4-350K	350			
CC1-4-500K	500	200BKB	HCPK5	
CC1-5-750K	750			
CC1-5-1000K	1000	2 X 150BKB	2 X 200BKB	



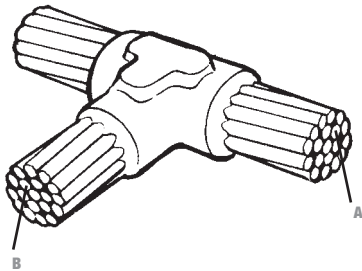
- Stranded Conductor
- Solid Circular Conductor

#### CC2

Cat. No.	Wire Size (A)	Wire Size (B)	Welding Powder size	Handle Clamp Type	Std. Qty.	Cat. No.	Wire Size (A)	Wire Size (B)	Welding Powder size	Handle Clamp Type	Std. Qty.
CC2-4-#4#4	4	4	32BKB	HCPK4	1	CC2-4-3/0#2	3/0	2	45BKB	HCPK4	1
CC2-4-#2S#2	2 solid	2	45BKB								
CC2-4-#2S#2S		2 solid									
CC2-4-#2S#4		4									
CC2-4-#2#2	2	2	90BKB								
CC2-4-#2#2S		2 solid									
CC2-4-#2#4		4									
CC2-4-#1#1	1	1	90BKB								
CC2-4-#1#2		2									
CC2-4-#1#2S		2 solid									
CC2-4-#1#4	1/0	4	45BKB								
CC2-4-1/01/0		1/0									
CC2-4-1/0#1		1									
CC2-4-1/0#2	1/0	2	90BKB								
CC2-4-1/0#2S		2 solid									
CC2-4-1/0#4		4									
CC2-4-1/0#4	2/0	4	90BKB								
CC2-4-2/02/0		2/0									
CC2-4-2/01/0		1/0									
CC2-4-2/0#1	2/0	1	45BKB								
CC2-4-2/0#2		2									
CC2-4-2/0#2S		2 solid									
CC2-4-2/0#4	3/0	4	115BKB								
CC2-4-3/03/0		3/0									
CC2-4-3/02/0		2/0									
CC2-4-3/01/0	3/0	1/0	90BKB								
CC2-4-3/0#1		1									
CC2-4-3/0#1		1									
CC2-4-3/0#2	250	3/0	150BKB								
CC2-4-250K4/0		4/0									
CC2-4-250K4/0		3/0									
CC2-4-250K2/0	250	2/0	90BKB								
CC2-4-250K1/0		1/0									
CC2-4-250K#1		1									
CC2-4-250K#2	300	2	200BKB								
CC2-4-250K#2S		2 solid									
CC2-4-250K#4		4									
CC2-4-300K300K	300	300	150BKB								
CC2-4-300K250K		250									
CC2-4-300K4/0		4/0									
CC2-4-300K3/0	300	3/0	90BKB								
CC2-4-300K2/0		2/0									
CC2-4-300K1/0		1/0									

## Exothermic Welding System

### Cable to Cable



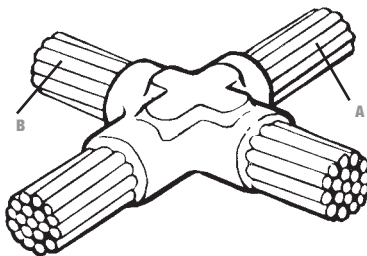
- Stranded Conductor
- Solid Circular Conductor

CC2 (cont'd)

Cat. No.	Wire Size (A)	Wire Size (B)	Welding Powder size	Handle Clamp Type	Std. Qty.	Cat. No.	Wire Size (A)	Wire Size (B)	Welding Powder size	Handle Clamp Type	Std. Qty.
CC2-4-300K#2	300	2	90BKB	HCPK4	1	CC2-4-750K300K	750	300	200BKB	HCPK4	1
CC2-4-300K#2S		2 solid				CC2-4-750K250		250			
CC2-4-300K#4		4				CC2-4-750K4/0		4/0			
CC2-4-350K350K	350	CC2-4-750K2/0	2/0								
CC2-4-350K300K	300	CC2-4-750K1/0	1/0								
CC2-4-350K250K	250	CC2-5-1000K1000K	1000			2 X 250BKB	HCPK5				
CC2-4-350K4/0	4/0	CC2-5-1000K750K	750								
CC2-4-350K3/0	3/0	CC2-5-1000K500K	500								
CC2-4-350K2/0	2/0	CC2-4-1000K350K	350			250BKB	HCPK4				
CC2-4-350K1/0	1/0	CC2-4-1000K300K	300			200BKB					
CC2-4-350K#1	1	CC2-4-1000K250K	250			HCPK4					
CC2-4-350K#2	2	CC2-4-1000K4/0	4/0								
CC2-4-350K#4	4	CC2-4-1000K2/0	2/0			150BKB					
CC2-4-500K500K	500	500	2 X 150BKB			HCPK4	1	CC2-4-1000K1/0	1/0	150BKB	
CC2-4-500K350K		350	200BKB								
CC2-4-500K300K		300									
CC2-4-500K250K		250									
CC2-4-500K4/0		4/0	150BKB								
CC2-4-500K2/0		2/0	90BKB								
CC2-4-500K1/0		1/0									
CC2-4-500K#1		1									
CC2-4-500K#2		2									
CC2-4-500K#4		4	HCPK5								
CC2-5-750K750K	750	2 X 250BKB									
CC2-5-750K500K	500	250BKB									
CC2-4-750K350K	350	250BKB	HCPK4								

## Exothermic Welding System

### Cable to Cable



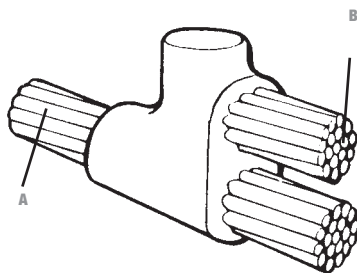
- Stranded Conductor
- Solid Circular Conductor

#### CC4

Cat. No.	Wire Size (A)	Wire Size (B)	Welding Powder size	Handle Clamp Type	Std. Qty.	Cat. No.	Wire Size (A)	Wire Size (B)	Welding Powder size	Handle Clamp Type	Std. Qty.
CC4-4-#4#4	4	4	45BKB	HCPK4	1	CC4-4-300K300K	300	300	250BKB	HCPK4	1
CC4-4-#2#2	2	2	65BKB			250					
CC4-4-#2#4		4				200BKB					
CC4-4-#2S#2S	2 solid	2 solid	2 solid					3/0			
CC4-4-#1#1	1	1	65BKB			2/0					
CC4-4-#1#2		2				150BKB					
CC4-4-#1#4		4									
CC4-4-1/01/0		1/0				1/0		90BKB	1/0		
CC4-4-1/0#1	1	200BKB									
CC4-4-1/0#2	2										
CC4-4-1/0#4	4										
CC4-4-2/02/0	2/0		2/0			115BKB	4/0				
CC4-42/01/0		1/0	2 X 250BKB								
CC4-4-2/0#1		1					2 X 200BKB				
CC4-4-2/0#2		2	2 X 150BKB								
CC4-4-3/03/0	3/0	3/0				150BKB	3/0				
CC4-4-3/02/0		2/0	250BKB								
CC4-4-3/01/0	1/0	150BKB									
CC4-4-3/0#1	1		115BKB								
CC4-4-3/0#2	2	115BKB									
CC4-4-4/04/0	4/0		4/0			200BKB	4/0				
CC4-4-4/03/0		3/0	2 X 150BKB								
CC4-4-4/02/0		2/0					250BKB				
CC4-4-4/01/0		1/0	150BKB								
CC4-4-4/0#1	1	115BKB									
CC4-4-4/0#2	2		115BKB								
CC4-4-250K250K	250	250				200BKB	2/0				
CC4-4-250K4/0		4/0	150BKB								
CC4-4-250K3/0		3/0				115BKB					
CC4-4-250K2/0		2/0	115BKB								
CC4-4-250K1/0		1/0				115BKB					
CC4-4-250K#1		1	115BKB								
CC4-4-250K#2		2				115BKB					
CC4-4-500K500K		500	500				2 X 250BKB	1/0			
CC4-4-500K350K			350			2 X 200BKB					
CC4-4-500K300K			300				2 X 150BKB				
CC4-4-500K250K	250		250BKB								
CC4-4-500K4/0	4/0					250BKB					
CC4-4-500K3/0	3/0		250BKB								
CC4-4-500K2/0	2/0					250BKB					
CC4-4-500K1/0	1/0		250BKB								
CC4-4-500K#1	1					250BKB					
CC4-4-500K#2	2		250BKB								

## Exothermic Welding System

### Cable to Cable



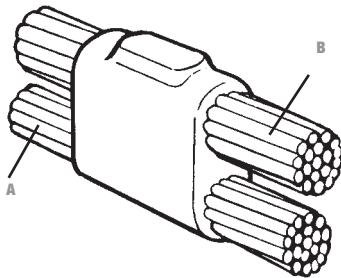
- Stranded Conductor
- Solid Circular Conductor

#### CC6

Cat. No.	Wire Size (A)	Wire Size (B)	Welding Powder size	Handle Clamp Type	Std. Qty.	
CC6-4-#4#4	4	4	45BKB	HCPK4	1	
CC6-4-#2#2	2	2	65BKB			
CC6-4-#2#4		4				
CC6-4-#2S#2S	2 solid	2 solid	90BKB			
CC6-4-#1#1	1	1				
CC6-4-#1#2		2				
CC6-4-#1#4		4				
CC6-4-1/01/0	1/0	1/0	115BKB			
CC6-4-1/0#1		1				
CC6-4-1/0#2		2				
CC6-4-1/0#4		4				
CC6-4-2/02/0	2/0	2/0	150BKB			
CC6-4-2/01/0		1/0				
CC6-4-2/0#1		1				
CC6-4-2/0#2		2				
CC6-4-3/03/0	3/0	3/0	200BKB			
CC6-4-3/02/0		2/0				
CC6-4-3/01/0		1/0				
CC6-4-3/0#1		1				
CC6-4-3/0#2	4/0	1/0	115BKB			
CC6-4-4/04/0						4/0
CC6-4-4/03/0						3/0
CC6-4-4/02/0						2/0
CC6-4-4/01/0	250	1/0	200BKB			
CC6-4-4/0#1		1				
CC6-4-4/0#2		2				
CC6-4-250K250K		250				
CC6-4-250K4/0	300	4/0	150BKB			
CC6-4-250K3/0		3/0				
CC6-4-250K2/0		2/0				
CC6-4-250K1/0		1/0				
CC6-4-250K#1	350	1	250BKB			
CC6-4-250K#2		2				
CC6-4-300K300K		300				
CC6-4-300K250K		250				
CC6-4-300K4/0	350	4/0	200BKB			
CC6-4-300K3/0		3/0				
CC6-4-300K2/0		2/0				
CC6-4-300K1/0		1/0				
CC6-4-300K#1	350	1	200BKB			
CC6-4-300K#2		2				
CC6-4-350K350K		350				
CC6-4-350K300K		300				
CC6-4-4350K250K	350	250	250BKB			
CC6-4-350K4/0		4/0				
CC6-4-350K3/0		3/0				
CC6-4-350K2/0		2/0				

## Exothermic Welding System

### Cable to Cable



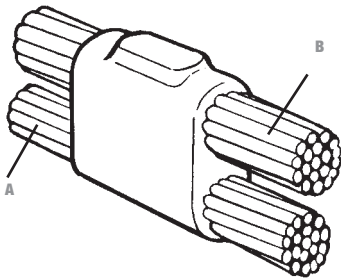
- Stranded Conductor
- Solid Circular Conductor

#### CC7

Cat. No.	Wire Size (A)	Wire Size (B)	Welding Powder size	Handle Clamp Type	Sleeve	Std. Qty.
CC7-4-#4#4	4	4	32BKB	HCPK4	-	1
CC7-4-#4#6		6			2 X SLEEVE#6	
CC7-4-#4#6S		6 solid			2 X SLEEVE#6S	
CC7-4-#4#8		8			2 X SLEEVE#8	
CC7-4-#2S#2	2 solid	2	65BKB		-	
CC7-4-#2S#2S		2 solid			2 X SLEEVE#6	
CC7-4-#2S#4		4			2 X SLEEVE#6S	
CC7-4-#2S#6		6			2 X SLEEVE#8	
CC7-4-#2S#6S	2	6 solid	45BKB		2 X SLEEVE#8S	
CC7-4-#2S#8		8			2 X SLEEVE#6	
CC7-4-#2S#8S		8 solid			2 X SLEEVE#6S	
CC7-4-#2#2		2			2 X SLEEVE#8	
CC7-4-#2#4	2	4	65BKB		-	
CC7-4-#2#6		6			2 X SLEEVE#6	
CC7-4-#2#6S		6 solid			2 X SLEEVE#6S	
CC7-4-#2#8		8			2 X SLEEVE#8	
CC7-4-#2#8S	1 solid	8 solid	45BKB		2 X SLEEVE#8S	
CC7-4-#1S#1		1			-	
CC7-4-#1S#2		2			2 X SLEEVE#6	
CC7-4-#1S#2S		2 solid			2 X SLEEVE#6S	
CC7-4-#1S#4	1	4	65BKB		2 X SLEEVE#8	
CC7-4-#1S#6		6			2 X SLEEVE#8S	
CC7-4-#1S#6S		6 solid			-	
CC7-4-#1S#8		8			2 X SLEEVE#6	
CC7-4-#1S#8S	1	8 solid	45BKB		2 X SLEEVE#6S	
CC7-4-#1#1		1			2 X SLEEVE#8	
CC7-4-#1#1S		1 solid			2 X SLEEVE#8S	
CC7-4-#1#2		2			-	
CC7-4-#1#2S	1/0 solid	2 solid	65BKB		2 X SLEEVE#6	
CC7-4-#1#4		4			2 X SLEEVE#6S	
CC7-4-#1#6		6			2 X SLEEVE#8	
CC7-4-#1#6S		6 solid			2 X SLEEVE#8S	
CC7-4-#1#8	1/0	8	45BKB		-	
CC7-4-#1#8S		8 solid			2 X SLEEVE#6	
CC7-4-1/0S1/0		1/0			2 X SLEEVE#6S	
CC7-4-1/0S1/0S		1/0 solid			2 X SLEEVE#8	
CC7-4-1/0S#1	1/0 solid	1	65BKB		2 X SLEEVE#8S	
CC7-4-1/0S#1S		1 solid			-	
CC7-4-1/0S#2		2			2 X SLEEVE#6	
CC7-4-1/0S#2S		2 solid			2 X SLEEVE#6S	
CC7-4-1/0S#4	1/0	4	90BKB		2 X SLEEVE#8	
CC7-4-1/0S#6		6			2 X SLEEVE#8S	
CC7-4-1/0S#6S		6 solid			-	
CC7-4-1/0S#8		8			2 X SLEEVE#6	
CC7-4-1/0S#8S	1/0	8 solid	90BKB		2 X SLEEVE#6S	
CC7-4-1/01/0		1/0			2 X SLEEVE#8	
CC7-4-1/01/0S	1/0 solid	2 X SLEEVE#8S				

## Exothermic Welding System

### Cable to Cable



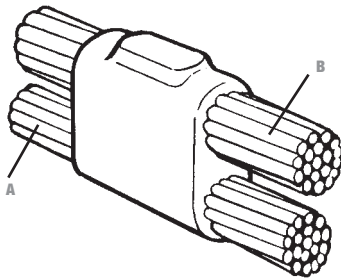
- Stranded Conductor
- Solid Circular Conductor

CC7 (cont'd)

Cat. No.	Wire Size (A)	Wire Size (B)	Welding Powder size	Handle Clamp Type	Sleeve	Std. Qty.				
CC7-4-1/0#1	1/0	1	65BKB	HCPK4	-	1				
CC7-4-1/0#1S		1 solid								
CC7-4-1/0#2		2								
CC7-4-1/0#2S		2 solid								
CC7-4-1/0#4		4								
CC7-4-1/0#6		6								
CC7-4-1/0#6S		6 solid								
CC7-4-1/0#8		8								
CC7-4-1/0#8S	8 solid									
CC7-4-2/02/0	2/0	2/0	115BKB	HCPK4	-	1				
CC7-4-2/01/0		1/0								
CC7-4-2/01/0S		1/0 solid	90BKB							
CC7-4-2/0#1		1								
CC7-4-2/0#1S		1 solid								
CC7-4-2/0#2		2								
CC7-4-2/0#4		4								
CC7-4-2/0#6		6								
CC7-4-2/0#6S		6 solid								
CC7-4-2/0#8		8								
CC7-4-2/0#8S		8 solid								
CC7-4-3/03/0		3/0	3/0				150BKB	HCPK4	-	1
CC7-4-3/02/0			2/0							
CC7-4-3/01/0			1/0				115BKB			
CC7-4-3/01/0S			1/0 solid							
CC7-4-3/0#1			1							
CC7-4-3/0#1S	1 solid									
CC7-4-3/0#2	2									
CC7-4-3/0#2S	2 solid									
CC7-4-3/0#4	4									
CC7-4-3/0#6	6									
CC7-4-3/0#6S	6 solid									
CC7-4-3/0#8	8									
CC7-4-3/0#8S	8 solid									
CC7-4-4/0S4/0	4/0 solid		4/0	200BKB	HCPK4	-	1			
CC7-4-4/0S4/0S			4/0 solid							
CC7-4-4/0S3/0			3/0	150BKB						
CC7-4-4/0S2/0			2/0							
CC7-4-4/0S1/0			1/0							
CC7-4-4/0S1/0S			1/0 solid							
CC7-4-4/0S#1			1							
CC7-4-4/0S#1S			1 solid							
CC7-4-4/0S#2			2							
CC7-4-4/0S#2S			2 solid							
CC7-4-4/0S#4			4							
CC7-4-4/0S#6		6								
CC7-4-4/0S#6S		6 solid								
CC7-4-4/0S#8		8								
CC7-4-4/0S#8S		8 solid								
CC7-4-4/0S#8S		8 solid	90BKB							

## Exothermic Welding System

### Cable to Cable



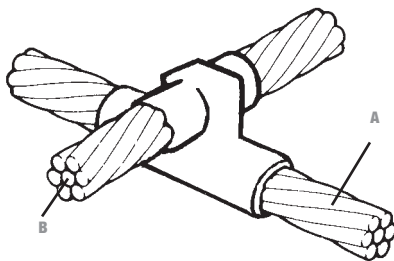
- Stranded Conductor
- Solid Circular Conductor

CC7 (cont'd)

Cat. No.	Wire Size (A)	Wire Size (B)	Welding Powder size	Handle Clamp Type	Sleeve	Std. Qty.
CC7-4-4/04/0	4/0	4/0	200BKB	HCPK4	-	1
CC7-4-4/04/0S		4/0 solid				
CC7-4-4/03/0		3/0				
CC7-4-4/02/0		2/0	150BKB			
CC7-4-4/01/0		1/0				
CC7-4-4/01/0S		1/0 solid				
CC7-4-4/0#1		1				
CC7-4-4/0#1S		1 solid				
CC7-4-4/0#2		2	90BKB			
CC7-4-4/0#2S		2 solid				
CC7-4-4/0#4		4				
CC7-4-4/0#6		6				
CC7-4-4/0#6S		6 solid				
CC7-4-4/0#8		8	2 X SLEEVE#6			
CC7-4-4/0#8S		8 solid				
					2 X SLEEVE#8	
					2 X SLEEVE#8S	

## Exothermic Welding System

### Cable to Cable



- Stranded Conductor
- Solid Circular Conductor

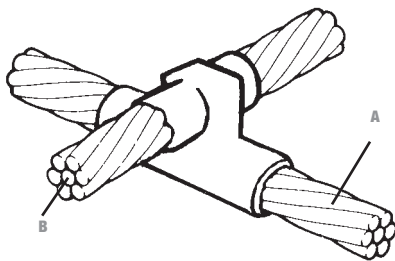
#### CC11

Cat. No.	Wire Size (A)	Wire Size (B)	Welding Powder size	Handle Clamp Type	Sleeve	Std. Qty.
CC11-7-#6S#6S	6 solid	6 solid	32BKB	HCPK7	4 X SLEEVE#6S	1
CC11-7-#6#6	6	6	45BKB		4 X SLEEVE#6	
CC11-7-#4#4	4	4	65BKB			
CC11-7-#2#2	2	2	90BKB			
CC11-7-#2#4	2	4	65BKB			
CC11-7-#2S#2S	2 solid	2 solid	90BKB			
CC11-7-#1#1	1	1	115BKB			
CC11-7-#1#2		2	90BKB			
CC11-7-#1#4		4				
CC11-7-1/0#1/0	1/0	1/0	150BKB			
CC11-7-1/0#1		1	115BKB			
CC11-7-1/0#2		2				
CC11-7-1/0#4		4				
CC11-7-2/0#2/0	2/0	2/0	200BKB			
CC11-7-2/0#1/0		1/0	150BKB			
CC11-7-2/0#1		1				
CC11-7-2/0#2		2				
CC11-7-3/0#3/0	3/0	3/0	250BKB			
CC11-7-3/0#2/0		2/0	200BKB			
CC11-7-3/0#1/0		1/0				
CC11-7-3/0#1		1			150BKB	
CC11-7-3/0#2	2					
CC11-7-4/0#4/0	4/0	4/0	250BKB			
CC11-7-4/0#3/0		3/0	200BKB			
CC11-7-4/0#2/0		2/0				
CC11-7-4/0#1/0		1/0				
CC11-7-4/0#1		1	150BKB			
CC11-7-4/0#2		2				
CC11-7-250K250K	250	250	2 X 150BKB			
CC11-7-250K4/0		4/0				
CC11-7-250K3/0		3/0	250BKB			
CC11-7-250K2/0		2/0				
CC11-7-250K1/0		1/0				
CC11-7-250K#1		1		200BKB		
CC11-7-250K#2		2		150BKB		



## Exothermic Welding System

### Cable to Cable



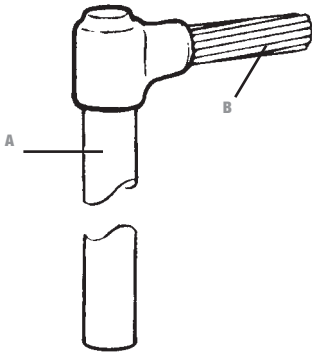
- Stranded Conductor
- Solid Circular Conductor

CC11 (cont'd)

Cat. No.	Wire Size (A)	Wire Size (B)	Welding Powder size	Handle Clamp Type	Sleeve	Std. Qty.	
CC11-8-300K300K	300	300	2 X 200BKB	HCPK8	-	1	
CC11-8-300K250K		250					
CC11-7-300K4/0		4/0	2 X 150BKB	HCPK7			
CC11-7-300K3/0		3/0					
CC11-7-300K2/0		2/0	250BKB	HCPK7			
CC11-7-300K1/0		1/0					
CC11-7-300K#1		1	200BKB	HCPK7			
CC11-7-300K#2		2	150BKB				
CC11-8-350K350K		350	350	2 X 250BKB			HCPK8
CC11-8-350K300K			300				
CC11-8-350K250K	250		2 X 200BKB	HCPK7			
CC11-8-350K4/0	4/0						
CC11-8-350K3/0	3/0		250BKB	HCPK7			
CC11-7-350K2/0	2/0						
CC11-7-350K1/0	1/0		200BKB				
CC11-7-350K#1	1		200BKB	HCPK7			
CC11-7-350K#2	2						
CC11-8-500K500K	500		500	3 X 250BKB	HCPK8		
CC11-8-500K350K		350	3 X 200BKB				
CC11-8-500K300K		300					
CC11-8-500K250K		250k	2 X 250BKB				
CC11-8-500K4/0		4/0					
CC11-8-500K3/0		3/0	2 X 200BKB				
CC11-8-500K2/0		2/0					
CC11-8-500K1/0		1/0	2 X 150BKB				

## Exothermic Welding System

### Cable to Ground Rod



- Stranded Conductor
- Solid Circular Conductor

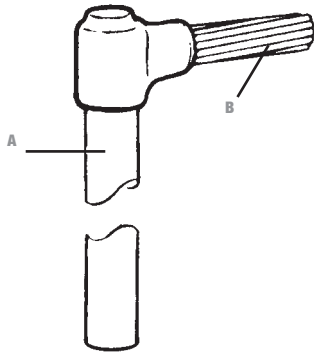
#### CR1

Cat. No.	Rod Size (A)	Wire Size (B)	Welding Powder size	Handle Clamp Type	Sleeve	Std. Qty.
CR1-3-500#6	1/2 Nominal Diameter Actual Shank Dia. 0.476 in. (Non UL Rod)	6	65BKB	HCPK3	1 X SLEEVE#6	1
CR1-3-500#6S		6 solid			1 X SLEEVE#6S	
CR1-3-500#4		4	45BKB			
CR1-3-500#4S		4 solid				
CR1-3-500#2		2	65BKB	HCPK4	-	
CR1-3-500#2S		2 solid				
CR1-4-500#1		1	90BKB			
CR1-4-5001/0		1/0				
CR1-4-5001/0S		1/0 solid				
CR1-4-5002/0		2/0				
CR1-4-5003/0	3/0					
CR1-4-5004/0	4/0					
CR1-4-500250K	250					
CR1-4-500300K	300					
CR1-3-500L#6	1/2 True Diameter Actual Shank Dia. 0.502 in. (UL Rod)	6	45BKB	HCPK3	1 X SLEEVE#6	1
CR1-3-500L#6S		6 solid			1 X SLEEVE#6S	
CR1-3-500L#4		4	65BKB			
CR1-3-500L#4S		4 solid				
CR1-3-500L#2		2	90BKB	HCPK4	-	
CR1-3-500L#2S		2 solid				
CR1-4-500L#1		1				
CR1-4-500L1/0		1/0				
CR1-4-500L1/0S		1/0 solid				
CR1-4-500L2/0		2/0				
CR1-4-500L3/0	3/0					
CR1-4-500L4/0	4/0					
CR1-4-500L250K	250					
CR1-4-500L300K	300					
CR1-3-625#6	5/8 Nominal Diameter Actual Shank Dia. 0.560 in.	6	65BKB	HCPK4	1 X SLEEVE#6	1
CR1-3-625#6S		6 solid			1 X SLEEVE#6S	
CR1-3-625#4		4	90BKB			
CR1-3-625#4S		4 solid				
CR1-4-625#2		2	115BKB	HCPK4	-	
CR1-4-625#2S		2 solid				
CR1-4-625#1		1				
CR1-4-6251/0		1/0				
CR1-4-6251/0S		1/0 solid				
CR1-4-6252/0		2/0				
CR1-4-6253/0	3/0					
CR1-4-6254/0	4/0					
CR1-4-625250K	250					
CR1-4-625300K	300					
CR1-4-625350K	350					
CR1-4-625500K	500	150BKB				

For Connections to Extensible (Threaded) Rods - Remove Top Threaded Section.

## Exothermic Welding System

### Cable to Ground Rod



- Stranded Conductor
- Solid Circular Conductor

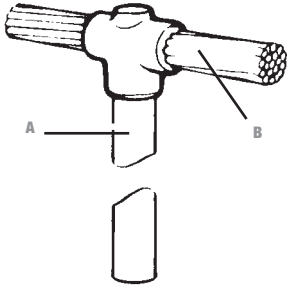
#### CR1 (cont'd)

Cat. No.	Rod Size (A)	Wire Size (B)	Welding Powder size	Handle Clamp Type	Sleeve	Std. Qty.
CR1-3-750#6	3/4 Nominal Diameter Actual Shank Dia. 0.678 in.	6	32BKB	HCPK3	1 X SLEEVE#6	1
CR1-3-750#6S		6 solid			1 X SLEEVE#6S	
CR1-3-750#4		4	45BKB	HCPK4		
CR1-3-750#4S		4 solid				
CR1-4-750#2		2	90BKB	HCPK4		
CR1-4-750#2S		2 solid				
CR1-4-750#1		1				
CR1-4-7501/0		1/0				
CR1-4-7501/0S		1/0 solid				
CR1-4-7502/0		2/0				
CR1-4-7503/0		3/0				
CR1-4-7504/0		4/0				
CR1-4-750250K		250				
CR1-4-750300K		300				
CR1-4-750350K		350				
CR1-4-750500K		500	150BKB			

For Connections to Extensible (Threaded) Rods - Remove Top Threaded Section.

## Exothermic Welding System

### Cable to Ground Rod



- Stranded Conductor
- Solid Circular Conductor

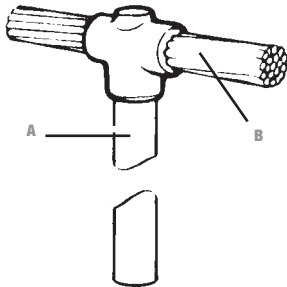
#### CR2

Cat. No.	Rod Size (A)	Wire Size (B)	Welding Powder size	Handle Clamp Type	Sleeve	Std. Qty.				
CR2-3-500#6	1/2 Nominal Diameter Actual Shank Dia. 0.476 in. (Non UL Rod)	6	65BKB	HCPK3	SLEEVE#6					
CR2-3-500#6S		6 solid			SLEEVE#6S					
CR2-3-500#4		4			90BKB		HCPK4			
CR2-3-500#4S		4 solid								
CR2-4-500#2		2	115BKB	HCPK4						
CR2-4-500#2S		2 solid								
CR2-4-500#1		1					200BKB		HCPK3	
CR2-4-5001/0		1/0								
CR2-4-5001/0S		1/0 solid								
CR2-4-5002/0		2/0								
CR2-4-5003/0		3/0	150BKB	HCPK4						
CR2-4-5004/0		4/0								
CR2-4-500250K		250	200BKB	HCPK4						
CR2-4-500300K		300								
CR2-3-500L#6		1/2 True Diameter Actual Shank Dia. 0.502 in. (UL Rod)	6	65BKB			HCPK3		SLEEVE#6	
CR2-3-500L#6S			6 solid						SLEEVE#6S	
CR2-3-500L#4	4		90BKB			HCPK4				
CR2-3-500L#4S	4 solid									
CR2-4-500L#2	2		115BKB	HCPK4						
CR2-4-500L#2S	2 solid									
CR2-4-500L#1	1				200BKB		HCPK3			
CR2-4-500L1/0	1/0									
CR2-4-500L1/0S	1/0 solid									
CR2-4-500L2/0	2/0									
CR2-4-500L3/0	3/0		150BKB	HCPK4						
CR2-4-500L4/0	4/0									
CR2-4-500L250K	250		200BKB	HCPK4						
CR2-4-500L300K	300									
CR2-3-625#6	5/8 Nominal Diameter Actual Shank Dia. 0.560 in.		6	32BKB	HCPK3		SLEEVE#6			
CR2-3-625#6S			6 solid				SLEEVE#6S			
CR2-3-625#4		4	90BKB				HCPK4			
CR2-3-625#4S		4 solid								
CR2-4-625#2		2	115BKB	HCPK4						
CR2-4-625#2S		2 solid								
CR2-4-625#1		1				200BKB	HCPK3			
CR2-4-6251/0		1/0								
CR2-4-6251/0S		1/0 solid								
CR2-4-6252/0		2/0								
CR2-4-6253/0		3/0	150BKB	HCPK4						
CR2-4-6254/0		4/0								
CR2-4-625250K		250	200BKB	HCPK4						
CR2-4-625300K		300								
CR2-4-625350K		350	200BKB	HCPK4						
CR2-4-625500K		500								

For Connections to Extensible (Threaded) Rods - Remove Top Threaded Section.

## Exothermic Welding System

### Cable to Ground Rod



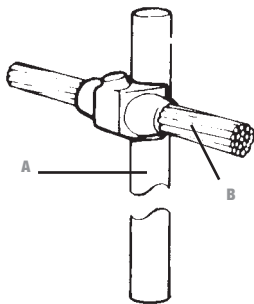
- Stranded Conductor
- Solid Circular Conductor

#### CR2 (cont'd)

Cat. No.	Rod Size (A)	Wire Size (B)	Welding Powder size	Handle Clamp Type	Sleeve	Std. Qty.
CR2-3-750#6	3/4 Nominal Diameter Actual Shank Dia. 0.678 in.	6	65BKB	HCPK3	SLEEVE#6	1
CR2-3-750#6S		6 solid			SLEEVE#6S	
CR2-3-750#4		4				
CR2-3-750#4S		4 solid				
CR2-4-750#2		2	90BKB	HCPK4		
CR2-4-750#2S		2 solid				
CR2-4-750#1		1				
CR2-4-7501/0		1/0	115BKB	HCPK4		
CR2-4-7501/0S		1/0 solid				
CR2-4-7502/0		2/0				
CR2-4-7503/0		3/0	150BKB			
CR2-4-7504/0		4/0				
CR2-4-750250K		250	200BKB			
CR2-4-750300K		300				
CR2-4-750350K		350				
CR2-4-750500K		500				

For Connections to Extensible (Threaded) Rods - Remove Top Threaded Section.

#### CR3



- Stranded Conductor
- Solid Circular Conductor

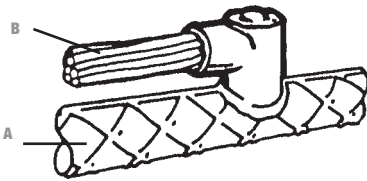
Cat. No.	Rod Size (A)	Wire Size (B)	Welding Powder size	Handle Clamp Type	Sleeve	Std. Qty.
CR3-9-5001/0	1/2 Nominal Diameter Actual Shank Dia. 0.476 in. (Non UL Rod)	1/0	115BKB	HCPK4 and FRAME1		
CR3-9-5001/0S		1/0 solid				
CR3-9-5002/0		2/0	150BKB			
CR3-9-5003/0		3/0				
CR3-9-5004/0		4/0	200BKB			
CR3-9-500250K	250					
CR3-9-500300K	300					
CR3-9-500L1/0	1/2 Nominal Diameter Actual Shank Dia. 0.502 in. (UL Rod)	1/0	115BKB			
CR3-9-500L1/0S		1/0 solid				
CR3-9-500L2/0		2/0	150BKB			
CR3-9-500L3/0		3/0				
CR3-9-500L4/0		4/0	200BKB			
CR3-9-500L250K	250					
CR3-9-500300K	300					
CR3-9-6251/0	5/8 Nominal Diameter Actual Shank Dia. 0.560 in.	1/0	115BKB			
CR3-9-6251/0S		1/0 solid				
CR3-9-6252/0		2/0	150BKB			
CR3-9-6253/0		3/0				
CR3-9-6254/0		4/0	200BKB			
CR3-9-625250K		250				
CR3-9-625300K		300				
CR3-9-625350K		350	250BKB			
CR3-10-625500K		500				
CR3-9-7501/0		3/4 Nominal Diameter Actual Shank Dia. 0.678 in.	1/0	115BKB	HCPK5 and FRAME2	
CR3-9-7501/0S	1/0 solid					
CR3-9-7502/0	2/0		HCPK4 and FRAME1			
CR3-9-7503/0	3/0					
CR3-9-7504/0	4/0		200BKB			
CR3-9-750250K	250					
CR3-9-750300K	300					
CR3-10-750350K	350		2 X 150BKB			
CR3-10-750500K	500					
				2 X 250BKB	HCPK5 and FRAME2	

For Connections to Extensible (Threaded) Rods - Remove Top Threaded Section.

## Exothermic Welding System

### Cable to Re-Bar

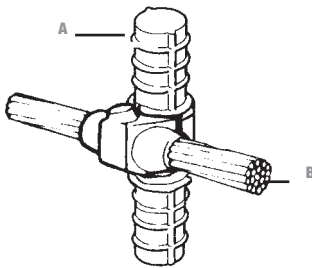
#### CRE1



- Stranded Conductor
- Solid Circular Conductor

Cat. No.	Rod Size (A)	Wire Size (B)	Welding Powder size	Handle Clamp Type	Sleeve	Pkg.	Std. Qty.	
CRE1-4-#43R	3	4	32BKB	HCPK4		-		
CRE1-4-#2S3R		2 solid	45BKB					
CRE1-4-#23R		2						
CRE1-4-#13R		1	65BKB					
CRE1-4-1/03R		1/0	90BKB					
CRE1-4-2/03R		2/0						
CRE1-4-3/03R		3/0	115BKB					
CRE1-3-#4Z		4 to 7	4					32BKB
CRE1-3-#2SZ	2 solid		45BKB					
CRE1-3-#2Z	2							
CRE1-3-#1Z	1		65BKB					
CRE1-3-1/0Z	1/0		90BKB					
CRE1-3-2/0Z	2/0							
CRE1-3-3/0Z	3/0		115BKB					
CRE1-3-4/0Z	4/0							
CRE1-3-#4Y	8 to 11		4	32BKB				
CRE1-3-#2SY			2 solid	45BKB				
CRE1-3-#2Y			2					
CRE1-3-#1Y			1	65BKB				
CRE1-3-1/0Y			1/0	90BKB				
CRE1-3-2/0Y			2/0					
CRE1-3-3/0Y			3/0	115BKB				
CRE1-3-4/0Y			4/0					

#### CRE3

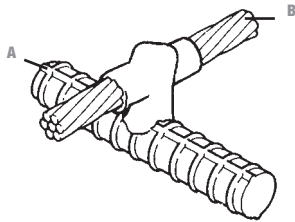


- Stranded Conductor
- Solid Circular Conductor

Cat. No.	Rod Size (A)	Wire Size (B)	Welding Powder size	Handle Clamp Type	Sleeve	Pkg.	Std. Qty.
CRE3-3-#4Z	4 to 7	4	90BKB	HCPK3A	-	Pack-A	1
CRE3-3#2SZ		2 solid					
CRE3-3-#2Z		2					
CRE3-4-#1Z		1	115BKB				
CRE3-4-1/0Z		1/0					
CRE3-4-2/0Z		2/0	150BKB				
CRE3-4-3/0Z		3/0					
CRE3-4-4/0Z		4/0	150BKB				
CRE3-3-#4Y	8 to 11	4	90BKB	HCPK3A	-	Pack-A	1
CRE3-3-#2SY		2 solid					
CRE3-3-#2Y		2					
CRE3-4-#1Y		1	115BKB				
CRE3-4-1/0Y		1/0					
CRE3-4-2/0Y		2/0	150BKB				
CRE3-4-3/0Y		3/0					
CRE3-4-4/0Y		4/0	150BKB				

## Exothermic Welding System

### Cable to Re-Bar

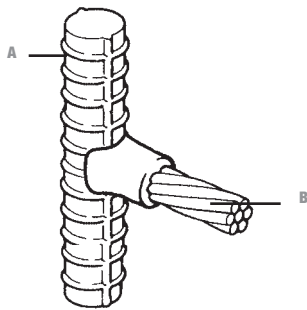


- Stranded Conductor
- Solid Circular Conductor

#### CRE4

Cat. No.	Rod Size (A)	Wire Size (B)	Welding Powder size	Handle Clamp Type	Cradle	Sleeve	Pkg.	Std. Qty.
CRE4-3-#4Z	4 to 7	4	65BKB	HCPK3B	HCPK3BMOD	-	Pack-A	1
CRE4-3-#2SZ		2 solid	90BKB					
CRE4-3-#2Z		2						
CRE4-3-#1Z		1	115BKB					
CRE4-3-1/OZ		1/0						
CRE4-3-2/OZ		2/0						
CRE4-3-3/OZ		3/0						
CRE4-3-4/OZ		4/0	65BKB					
CRE4-3-#4Y	4	90BKB						
CRE4-3-#2SY	2 solid							
CRE4-3-#2Y	2	115BKB						
CRE4-3-#1Y	1							
CRE4-3-1/OY	1/0							
CRE4-3-2/OY	2/0							
CRE4-3-3/OY	3/0	150BKB						
CRE4-3-4/OY	4/0							

#### CRE6

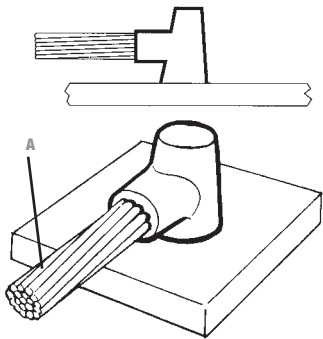


- Stranded Conductor
- Solid Circular Conductor

Cat. No.	Rod Size (A)	Wire Size (B)	Welding Powder size	Handle Clamp Type	Sleeve	Pkg.	Std. Qty.
CRE6-3-#4Z	4 to 7	4	65BKB	HCPK3A	-	Pack-A	1
CRE6-3-#2SZ		2 solid					
CRE6-3-#2Z		2	90BKB				
CRE6-3-#1Z		1					
CRE6-4-1/OZ		1/0	115BKB				
CRE6-4-2/OZ		2/0					
CRE6-4-3/OZ		3/0	150BKB				
CRE6-4-4/OZ		4/0					
CRE6-3-#4Y	8 to 11	4	65BKB				
CRE6-3-#2SY		2 solid	65BKB				
CRE6-3-#2Y		2					
CRE6-3-#1Y		1	90BKB				
CRE6-4-1/OY		1/0	115BKB				
CRE6-4-2/OY		2/0					
CRE6-4-3/OY		3/0	150BKB				
CRE6-4-4/OY		4/0					

## Exothermic Welding System

### Cable to Steel Surface and Pipe

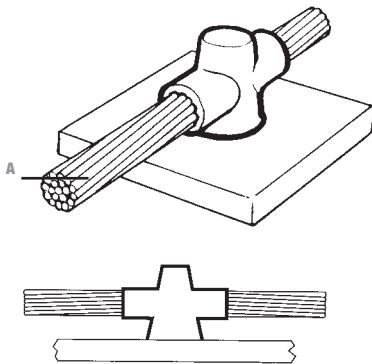


- Stranded Conductor
- Solid Circular Conductor

#### CS1 – For Flat Surfaces

Cat. No.	Wire Size (A)	Welding Powder size	Handle Clamp Type	Sleeve	Std. Qty.
CS1-4-1/0	1/0	90BKB	HCPK4	-	1
CS1-4-2/0	2/0				
CS1-4-3/0	3/0	115BKB			
CS1-4-4/0	4/0				
CS1-4-250K	250	150BKB			
CS1-4-300K	300				
CS1-4-350K	350	200BKB			
CS1-4-500K	500				
CS1-4-750K	750	2 X 150BKB			
CS1-4-1000K	1000	2 X 200BKB			

Mold Sealing Compound (MSC) will be required if surface is uneven.



- Stranded Conductor
- Solid Circular Conductor

#### CS2 – For Flat Surfaces

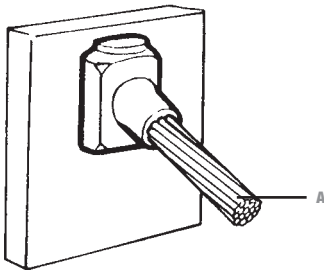
Cat. No.	Wire Size (A)	Welding Powder size	Handle Clamp Type	Sleeve	Std. Qty.
CS2-4-1/0	1/0	90BKB	HCPK4	-	1
CS2-4-2/0	2/0	115BKB			
CS2-4-3/0	3/0				
CS2-4-4/0	4/0	150BKB			
CS2-4-250K	250				
CS2-4-300K	300	200BKB			
CS2-4-350K	350	250BKB			
CS2-5-500K	500	2 X 150BKB			

Mold Sealing Compound (MSC) will be required if surface is uneven.



## Exothermic Welding System

### Cable to Steel Surface and Pipe



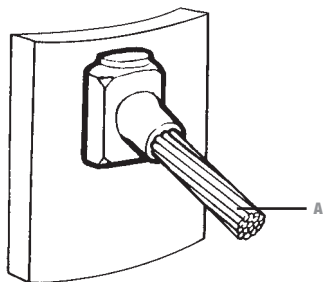
- Stranded Conductor
- Solid Circular Conductor

#### CS3 – For Flat Surfaces

Cat. No.	Wire Size (A)	Welding Powder size	Handle Clamp Type	Sleeve	Std. Qty.
CS3-4-#6	#6	45BKB	HCPK4	SLEEVE#6	1
CS3-4-#4	#4				
CS3-4-#2S	#2 solid				
CS3-4-#2	#2				
CS3-4-#1	#1	65BKB			
CS3-4-1/0	1/0	90BKB			
CS3-4-2/0	2/0				
CS3-4-3/0	3/0	115BKB			
CS3-4-4/0	4/0				
CS3-4-250K	250				
CS3-4-300K	300		150BKB		
CS3-4-350K	350	200BKB	HCPK5		
CS3-4-500K	500				
CS3-5-750K	750	2 X 150BKB			
CS3-5-1000K	1000	2 X 200BKB			

Mold Sealing Compound (MSC) will be required if surface is uneven.

#### CS3 – For Pipes



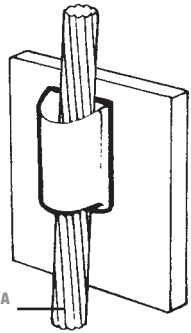
- Stranded Conductor
- Solid Circular Conductor

Cat. No.	Wire Size (A)	Pipe Size (in.)	Welding Powder size	Handle Clamp Type	Sleeve	Std. Qty.
CS3-4-#4C	#4	1-1/2 to 2-3/4	45BKB	HCPK4	-	1
CS3-4-#4D		2-3/4 to 6-1/2				
CS3-4-#4F		6-1/2 to 10				
CS3-4-#4G	10 to 14					
CS3-4-#2SC	#2 solid	1-1/2 to 2-3/4				
CS3-4-#2SD		2-3/4 to 6-1/2				
CS3-4-#2SF		6-1/2 to 10				
CS3-4-#2SG	10 to 14					
CS3-4-#2C	#2	1-1/2 to 2-3/4				
CS3-4-#2D		2-3/4 to 6-1/2				
CS3-4-#2F		6-1/2 to 10				
CS3-4-#2G	10 to 14					
CS3-4-#1C	#1	1-1/2 to 2-3/4	65BKB			
CS3-4-#1D		2-3/4 to 6-1/2				
CS3-4-#1F		6-1/2 to 10				
CS3-4-#1G	10 to 14					
CS3-4-#1/OC	1/0	1-1/2 to 2-3/4	90BKB			
CS3-4-#1/OD		2-3/4 to 6-1/2				
CS3-4-#1/OF		6-1/2 to 10				
CS3-4-#1/OG		10 to 14				
CS3-4-#2/OC	2/0	1-1/2 to 2-3/4				
CS3-4-#2/OD		2-3/4 to 6-1/2				
CS3-4-#2/OF		6-1/2 to 10				
CS3-4-#2/OG		10 to 14				
CS3-4-#3/OC	3/0	1-1/2 to 2-3/4	115BKB			
CS3-4-#3/OD		2-3/4 to 6-1/2				
CS3-4-#3/OF		6-1/2 to 10				
CS3-4-#3/OG		10 to 14				
CS3-4-#4/OC	4/0	1-1/2 to 2-3/4				
CS3-4-#4/OD		2-3/4 to 6-1/2				
CS3-4-#4/OF		6-1/2 to 10				
CS3-4-#4/OG		10 to 14				

OVER 14 in. USE CS3 FOR FLAT SURFACE  
Use Mold Sealing Compound (MSC) to ensure effective sealing.

## Exothermic Welding System

### Cable to Steel Surface and Pipe



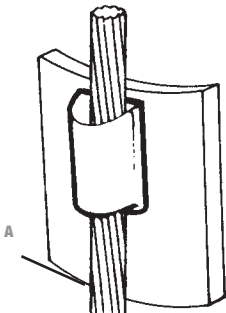
- Stranded Conductor
- Solid Circular Conductor

#### CS4 – For Flat Surfaces

Cat. No.	Wire Size (A)	Welding Powder size	Handle Clamp Type	Sleeve	Std. Qty.
CS4-4-#6	#6	90BKB	HCPK4	SLEEVE#6	1
CS4-4-#4	#4				
CS4-4-#2S	#2 solid	115BKB			
CS4-4-#2	#2				
CS4-4-#1	#1	200BKB	HCPK5	-	
CS4-5-1/0	1/0				
CS4-5-2/0	2/0				
CS4-5-3/0	3/0				
CS4-5-4/0	4/0	250BKB			
CS4-5-250K	250				

Mold Sealing Compound (MSC) will be required if surface is uneven.

#### CS4 – For Pipes



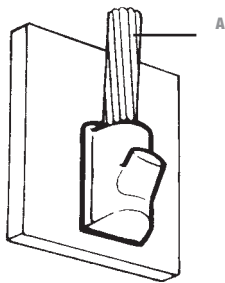
- Stranded Conductor
- Solid Circular Conductor

Cat. No.	Wire Size (A)	Pipe Size (in.)	Welding Powder size	Handle Clamp Type	Sleeve	Std. Qty.
CS4-4-#4C	#4	1-1/2 to 2-3/4	90BKB	HCPK4	-	1
CS4-4-#4D		2-3/4 to 6-1/2				
CS4-4-#4F		6-1/2 to 10				
CS4-4-#4G		10 to 14				
CS4-4-#2SC	#2 solid	1-1/2 to 2-3/4	115BKB			
CS4-4-#2SD		2-3/4 to 6-1/2				
CS4-4-#2SF		6-1/2 to 10				
CS4-4-#2SG		10 to 14				
CS4-4-#2C	#2	1-1/2 to 2-3/4		200BKB		
CS4-4-#2D		2-3/4 to 6-1/2				
CS4-4-#2F		6-1/2 to 10				
CS4-4-#2G		10 to 14				
CS4-4-#1C	#1	1-1/2 to 2-3/4	250BKB			
CS4-4-#1D		2-3/4 to 6-1/2				
CS4-4-#1F		6-1/2 to 10				
CS4-4-#1G		10 to 14				
CS4-5-1/0C	1/0	1-1/2 to 2-3/4		HCPK5		
CS4-5-1/0D		2-3/4 to 6-1/2				
CS4-5-1/0F		6-1/2 to 10				
CS4-5-1/0G		10 to 14				
CS4-5-2/0C	2/0	1-1/2 to 2-3/4	HCPK5			
CS4-5-2/0D		2-3/4 to 6-1/2				
CS4-5-2/0F		6-1/2 to 10				
CS4-5-2/0G		10 to 14				
CS4-5-3/0C	3/0	1-1/2 to 2-3/4		HCPK5		
CS4-5-3/0D		2-3/4 to 6-1/2				
CS4-5-3/0F		6-1/2 to 10				
CS4-5-3/0G		10 to 14				
CS4-5-4/0C	4/0	1-1/2 to 2-3/4	HCPK5			
CS4-5-4/0D		2-3/4 to 6-1/2				
CS4-5-4/0F		6-1/2 to 10				
CS4-5-4/0G		10 to 14				

OVER 14 in. USE CS4 FOR FLAT SURFACE  
Use Mold Sealing Compound (MSC) to ensure effective sealing.

## Exothermic Welding System

### Cable to Steel Surface and Pipe

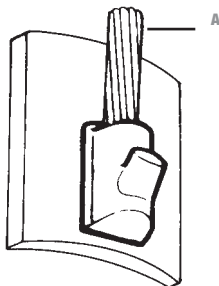


- Stranded Conductor
- Solid Circular Conductor

#### CS7 – For Flat Surfaces

Cat. No.	Wire Size (A)	Welding Powder size	Handle Clamp Type	Sleeve	Std. Qty.
CS7-4-#4	#4	65BKB	HCPK4	-	1
CS7-4-#2S	#2 solid				
CS7-4-#2	#2				
CS7-4-#1	#1	90BKB			
CS7-4-1/0	1/0				
CS7-4-2/0	2/0	150BKB			
CS7-5-3/0	3/0	200BKB	HCPK5	-	1
CS7-5-4/0	4/0				
CS7-5-250K	250				
CS7-5-300K	300	250BKB			
CS7-6-350K	350	2 X 150BKB			
CS7-6-500K	500	2 X 200BKB			

Use Mold Sealing Compound (MSC) to ensure effective sealing.



- Stranded Conductor
- Solid Circular Conductor

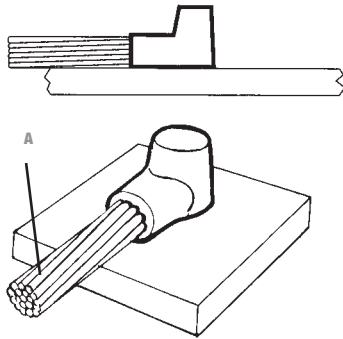
#### CS7 – For Pipes

Cat. No.	Wire Size (A)	Pipe Size (in.)	Welding Powder size	Handle Clamp Type	Sleeve	Std. Qty.
CS7-4-#4C	#4	1-1/2 to 2-3/4	65BKB	HCPK4	-	1
CS7-4-#4D		2-3/4 to 6-1/2				
CS7-4-#4F		6-1/2 to 10				
CS7-4-#4G	10 to 14					
CS7-4-#2SC	#2 solid	1-1/2 to 2-3/4				
CS7-4-#2SD		2-3/4 to 6-1/2				
CS7-4-#2SF		6-1/2 to 10				
CS7-4-#2SG		10 to 14				
CS7-4-#2C	#2	1-1/2 to 2-3/4	90BKB	HCPK4	-	1
CS7-4-#2D		2-3/4 to 6-1/2				
CS7-4-#2F		6-1/2 to 10				
CS7-4-#2G	10 to 14					
CS7-4-#1C	#1	1-1/2 to 2-3/4				
CS7-4-#1D		2-3/4 to 6-1/2				
CS7-4-#1F		6-1/2 to 10				
CS7-4-#1G		10 to 14				
CS7-4-1/0C	1/0	1-1/2 to 2-3/4	150BKB	HCPK4	-	1
CS7-4-1/0D		2-3/4 to 6-1/2				
CS7-4-1/0F		6-1/2 to 10				
CS7-4-1/0G	10 to 14					
CS7-4-2/0C	2/0	1-1/2 to 2-3/4				
CS7-4-2/0D		2-3/4 to 6-1/2				
CS7-4-2/0F		6-1/2 to 10				
CS7-4-2/0G		10 to 14				
CS7-5-3/0C	3/0	1-1/2 to 2-3/4	200BKB	HCPK4	-	1
CS7-5-3/0D		2-3/4 to 6-1/2				
CS7-5-3/0F		6-1/2 to 10				
CS7-5-3/0G	10 to 14					
CS7-5-4/0C	4/0	1-1/2 to 2-3/4				
CS7-5-4/0D		2-3/4 to 6-1/2				
CS7-5-4/0F		6-1/2 to 10				
CS7-5-4/0G		10 to 14				

Over 14 in. use CS7 for flat surface.  
Use Mold Sealing Compound (MSC) to ensure effective sealing.

## Exothermic Welding System

### Cable to Steel Surface and Pipe



- Stranded Conductor
- Solid Circular Conductor

#### CS8 – For Flat Surfaces

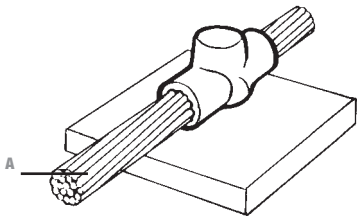
Cat. No.	Wire Size (A)	Welding Powder size	Handle Clamp Type	Sleeve	Std. Qty.
<b>CS8-2-#6</b>	#6	45BKB	HCPK2	SLEEVE#6	1
<b>CS8-2-#4</b>	#4				
<b>CS8-2-#2S</b>	#2 solid				
<b>CS8-2-#2</b>	#2				
<b>CS8-2-#1</b>	#1	65BKB			

Use Mold Sealing Compound (MSC) to ensure effective sealing.

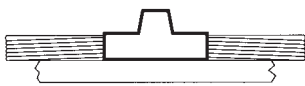
#### CS9 – For Flat Surfaces

Cat. No.	Wire Size (A)	Welding Powder size	Handle Clamp Type	Sleeve	Std. Qty.
<b>CS9-2-#6</b>	#6	45BKB	HCPK2	SLEEVE#6	1
<b>CS9-2-#4</b>	#4				
<b>CS9-2-#2S</b>	#2 solid				
<b>CS9-2-#2</b>	#2				
<b>CS9-2-#1</b>	#1	65BKB			

Use Mold Sealing Compound (MSC) to ensure effective sealing.

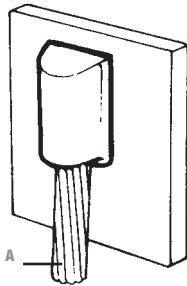


- Stranded Conductor
- Solid Circular Conductor



## Exothermic Welding System

### Cable to Steel Surface and Pipe

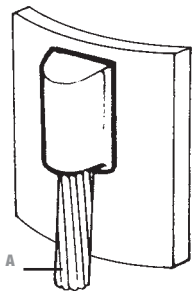


- Stranded Conductor
- Solid Circular Conductor

#### CS25 – For Flat Surfaces

Cat. No.	Wire Size (A)	Welding Powder size	Handle Clamp Type	Sleeve	Std. Qty.
CS25-4-#4	#4	65BKB	HCPK4	-	1
CS25-4-#2S	#2 solid				
CS25-4-#2	#2				
CS25-4-#1	#1	90BKB			
CS25-4-1/0	1/0	115BKB			
CS25-4-2/0	2/0				
CS25-4-3/0	3/0	150BKB			
CS25-4-4/0	4/0				
CS25-4-250K	250				
CS25-4-300K	300	250BKB			
CS25-4-350K	350				
CS25-4-500K	500				

Use Mold Sealing Compound (MSC) to ensure effective sealing.



- Stranded Conductor
- Solid Circular Conductor

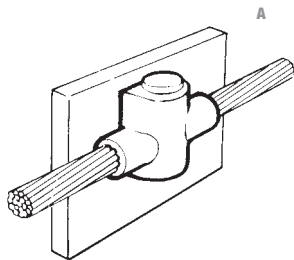
#### CS25 – For Pipes

Cat. No.	Wire Size (A)	Pipe Size (in.)	Welding Powder size	Handle Clamp Type	Sleeve	Std. Qty.				
CS25-4-#4C	#4	1-1/2 to 2-3/4	65BKB	HCPK4	-	1				
CS25-4-#4D		2-3/4 to 6-1/2								
CS25-4-#4F		6-1/2 to 10								
CS25-4-#4G	10 to 14									
CS25-4-#2SC	#2 solid	1-1/2 to 2-3/4								
CS25-4-#2SD		2-3/4 to 6-1/2								
CS25-4-#2SF		6-1/2 to 10								
CS25-4-#2SG	10 to 14									
CS25-4-#2C	#2	1-1/2 to 2-3/4					90BKB	HCPK4	-	1
CS25-4-#2D		2-3/4 to 6-1/2								
CS25-4-#2F		6-1/2 to 10								
CS25-4-#2G	10 to 14									
CS25-4-#1C	#1	1-1/2 to 2-3/4								
CS25-4-#1D		2-3/4 to 6-1/2								
CS25-4-#1F		6-1/2 to 10								
CS25-4-#1G	10 to 14									
CS25-4-1/0C	1/0	1-1/2 to 2-3/4	150BKB	HCPK4	-	1				
CS25-4-1/0D		2-3/4 to 6-1/2								
CS25-4-1/0F		6-1/2 to 10								
CS25-4-1/0G	10 to 14									
CS25-4-2/0C	2/0	1-1/2 to 2-3/4					200BKB	HCPK4	-	1
CS25-4-2/0D		2-3/4 to 6-1/2								
CS25-4-2/0F		6-1/2 to 10								
CS25-4-2/0G	10 to 14									
CS25-4-3/0C	3/0	1-1/2 to 2-3/4								
CS25-4-3/0D		2-3/4 to 6-1/2								
CS25-4-3/0F		6-1/2 to 10								
CS25-4-3/0G	10 to 14									
CS25-4-4/0C	4/0	1-1/2 to 2-3/4	250BKB	HCPK4	-	1				
CS25-4-4/0D		2-3/4 to 6-1/2								
CS25-4-4/0F		6-1/2 to 10								
CS25-4-4/0G	10 to 14									

Over 14 in. use CS25 for flat surface.  
Use Mold Sealing Compound (MSC) to ensure effective sealing.

## Exothermic Welding System

### Cable to Steel Surface and Pipe

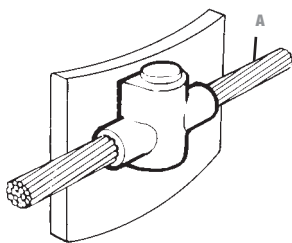


- Stranded Conductor
- Solid Circular Conductor

#### CS27 – For Flat Surfaces

Cat. No.	Wire Size (A)	Welding Powder size	Handle Clamp Type	Sleeve	Std. Qty.
CS27-4-#6	#6	45BKB	HCPK4	SLEEVE#6	1
CS27-4-#4	#4				
CS27-4-#2S	#2 solid				
CS27-4-#2	#2				
CS27-4-#1	#1	65BKB			
CS27-4-1/0	1/0	115BKB			
CS27-4-2/0	2/0				
CS27-4-3/0	3/0	150BKB			
CS27-4-4/0	4/0				
CS27-4-250K	250				

Use Mold Sealing Compound (MSC) to ensure effective sealing.



- Stranded Conductor
- Solid Circular Conductor

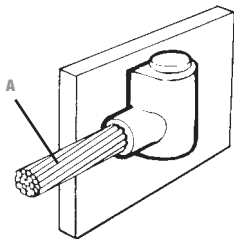
#### CS27 – For Pipes

Cat. No.	Wire Size (A)	Pipe Size (in.)	Welding Powder size	Handle Clamp Type	Sleeve	Std. Qty.	
CS27-4-#4C	#4	1-1/2 to 2-3/4	45BKB	HCPK4	-	1	
CS27-4-#4D		2-3/4 to 6-1/2					
CS27-4-#4F		6-1/2 to 10					
CS27-4-#4G		10 to 14					
CS27-4-#2SC	#2 solid	1-1/2 to 2-3/4					
CS27-4-#2SD		2-3/4 to 6-1/2					
CS27-4-#2SF		6-1/2 to 10					
CS27-4-#2SG		10 to 14					
CS27-4-#2C	#2	1-1/2 to 2-3/4					65BKB
CS27-4-#2D		2-3/4 to 6-1/2					
CS27-4-#2F		6-1/2 to 10					
CS27-4-#2G		10 to 14					
CS27-4-#1C	#1	1-1/2 to 2-3/4	115BKB				
CS27-4-#1D		2-3/4 to 6-1/2					
CS27-4-#1F		6-1/2 to 10					
CS27-4-#1G		10 to 14					
CS27-4-110C	1/0	1-1/2 to 2-3/4		150BKB			
CS27-4-110D		2-3/4 to 6-1/2					
CS27-4-110F		6-1/2 to 10					
CS27-4-110G		10 to 14					
CS27-4-210C	2/0	1-1/2 to 2-3/4			150BKB		
CS27-4-210D		2-3/4 to 6-1/2					
CS27-4-210F		6-1/2 to 10					
CS27-4-210G		10 to 14					
CS27-4-310C	3/0	1-1/2 to 2-3/4	150BKB				
CS27-4-310D		2-3/4 to 6-1/2					
CS27-4-310F		6-1/2 to 10					
CS27-4-310G		10 to 14					
CS27-4-410C	4/0	1-1/2 to 2-3/4		150BKB			
CS27-4-410D		2-3/4 to 6-1/2					
CS27-4-410F		6-1/2 to 10					
CS27-4-410G		10 to 14					

Over 14 in. use CS27 for flat surface.  
Use Mold Sealing Compound (MSC) to ensure effective sealing.

## Exothermic Welding System

### Cable to Steel Surface and Pipe

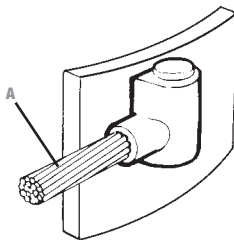


- Stranded Conductor
- Solid Circular Conductor

#### CS31 – For Flat Surfaces

Cat. No.	Wire Size (A)	Welding Powder size	Handle Clamp Type	Sleeve	Std. Qty.
CS31-4-#6	#6	45BKB	HCPK4	SLEEVE#6	1
CS31-4-#4	#4				
CS31-4-#2S	#2 solid				
CS31-4-#2	#2	65BKB		-	
CS31-4-#1	#1				
CS31-4-1/0	1/0	90BKB		-	
CS31-4-2/0	2/0				
CS31-4-3/0	3/0	115BKB		-	
CS31-4-4/0	4/0				
CS31-4-250K	250				

Add "R" or "L" to denote wire exiting left or right. (Example: CS31-6-#6R for #6 wire exiting on the right.)  
Use Mold Sealing Compound (MSC) to ensure effective sealing.



- Stranded Conductor
- Solid Circular Conductor

#### CS31 – For Pipes

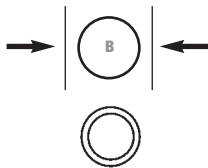
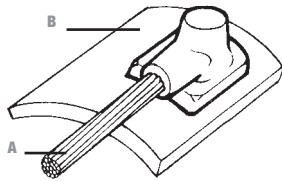
Cat. No.	Wire Size (A)	Pipe Size (in.)	Welding Powder size	Handle Clamp Type	Sleeve	Std. Qty.
CS31-4-#4C	#4	1-1/2 to 2-3/4	45BKB	HCPK4	-	1
CS31-4-#4D		2-3/4 to 6-1/2				
CS31-4-#4F		6-1/2 to 10				
CS31-4-#4G		10 to 14				
CS31-4-#2SC	#2 solid	1-1/2 to 2-3/4				
CS31-4-#2SD		2-3/4 to 6-1/2				
CS31-4-#2SF		6-1/2 to 10				
CS31-4-#2SG		10 to 14				
CS31-4-#2C	#2	1-1/2 to 2-3/4				
CS31-4-#2D		2-3/4 to 6-1/2				
CS31-4-#2F		6-1/2 to 10				
CS31-4-#2G		10 to 14				
CS31-4-#1C	#1	1-1/2 to 2-3/4	65BKB			
CS31-4-#1D		2-3/4 to 6-1/2				
CS31-4-#1F		6-1/2 to 10				
CS31-4-#1G		10 to 14				
CS31-4-1/0C	1/0	1-1/2 to 2-3/4	90BKB			
CS31-4-1/0D		2-3/4 to 6-1/2				
CS31-4-1/0F		6-1/2 to 10				
CS31-4-1/0G		10 to 14				
CS31-4-2/0C	2/0	1-1/2 to 2-3/4				
CS31-4-2/0D		2-3/4 to 6-1/2				
CS31-4-2/0F		6-1/2 to 10				
CS31-4-2/0G		10 to 14				
CS31-4-3/0C	3/0	1-1/2 to 2-3/4	115BKB			
CS31-4-3/0D		2-3/4 to 6-1/2				
CS31-4-3/0F		6-1/2 to 10				
CS31-4-3/0G		10 to 14				
CS31-4-4/0C	4/0	1-1/2 to 2-3/4				
CS31-4-4/0D		2-3/4 to 6-1/2				
CS31-4-4/0F		6-1/2 to 10				
CS31-4-4/0G		10 to 14				

Over 14 in. use CS31 for flat surface.  
Add "R" or "L" to denote wire exiting left or right. (Example: CS31-6-#6R for #6 wire exiting on the right.)  
Use Mold Sealing Compound (MSC) to ensure effective sealing.

## Exothermic Welding System

### Cable to Steel Surface and Pipe

#### CS32 – For Pipes



• Stranded Conductor

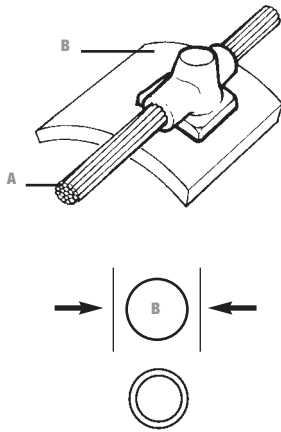
Cat. No.	Wire Size (A)	Pipe Size (B)	Welding Powder size	Handle Clamp Type	Sleeve	Std. Qty.
<b>OVER 14 in. USE CS8 FOR FLAT SURFACE</b>						
CS32-2-#4C	#4	1-1/2 to 2-3/4	45BKB	HCPK2	-	1
CS32-2-#4D		2-3/4 to 6-1/2				
CS32-2-#4F		6-1/2 to 10				
CS32-2-#4G	10 to 14					
CS32-2-#2SC	#2 solid	1-1/2 to 2-3/4				
CS32-2-#2SD		2-3/4 to 6-1/2				
CS32-2-#2SF		6-1/2 to 10				
CS32-2-#2SG	#2	10 to 14				
CS32-2-#2C	#2	1-1/2 to 2-3/4				
CS32-2-#2D		2-3/4 to 6-1/2				
CS32-2-#2F		6-1/2 to 10				
CS32-2-#2G	#1	10 to 14				
CS32-2-#1D	#1	2-3/4 to 6-1/2	65BKB			
CS32-2-#1F		6-1/2 to 10				
CS32-2-#1G		10 to 14				
<b>OVER 14 in. USE CS1 FOR FLAT SURFACE</b>						
CS32-4-#1/OD	1/0	2-3/4 to 6-1/2	90BKB	HCPK4	-	1
CS32-4-#1/OF		6-1/2 to 10				
CS32-4-#1/OG		10 to 14				
CS32-4-#2/OD	2/0	2-3/4 to 6-1/2				
CS32-4-#2/OF		6-1/2 to 10				
CS32-4-#2/OG		10 to 14				
CS32-4-#3/OD	3/0	2-3/4 to 6-1/2				
CS32-4-#3/OF		6-1/2 to 10				
CS32-4-#3/OG		10 to 14				
CS32-4-#4/OD	4/0	2-3/4 to 6-1/2				
CS32-4-#4/OF		6-1/2 to 10				
CS32-4-#4/OG		10 to 14				

Add "R" or "L" to denote wire exiting left or right. (Example: CS31-6-#6R for #6 wire exiting on the right.)  
Use Mold Sealing Compound (MSC) to ensure effective sealing.



## Exothermic Welding System

### Cable to Steel Surface and Pipe



• Stranded Conductor

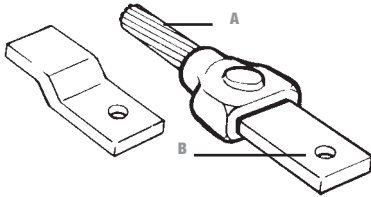
#### CS34 – For Pipes

Cat. No.	Wire Size (A)	Pipe Size (B)	Welding Powder size	Handle Clamp Type	Sleeve	Std. Qty.
<b>OVER 14 in. USE CS8 FOR FLAT SURFACE</b>						
CS34-2-#4C	#4	1-1/2 to 2-3/4	45BKB	HCPK2	-	1
CS34-2-#4D		2-3/4 to 6-1/2				
CS34-2-#4F		6-1/2 to 10				
CS34-2-#4G	10 to 14					
CS34-2-#2SC	#2S	1-1/2 to 2-3/4				
CS34-2-#2SD		2-3/4 to 6-1/2				
CS34-2-#2SF		6-1/2 to 10				
CS34-2-#2SG	10 to 14					
CS34-2-#2C	#2	1-1/2 to 2-3/4				
CS34-2-#2D		2-3/4 to 6-1/2				
CS34-2-#2F		6-1/2 to 10				
CS34-2-#2G	10 to 14					
CS34-2-#1D	#1	2-3/4 to 6-1/2	65BKB			
CS34-2-#1F		6-1/2 to 10				
CS34-2-#1G		10 to 14				
<b>OVER 14 in. USE CS1 FOR FLAT SURFACE</b>						
CS34-4-#1/OD	1/0	2-3/4 to 6-1/2	90BKB	HCPK4	-	1
CS34-4-#1/OF		6-1/2 to 10				
CS34-4-#1/OG		10 to 14				
CS34-4-#2/OD	2/0	2-3/4 to 6-1/2	115BKB			
CS34-4-#2/OF		6-1/2 to 10				
CS34-4-#2/OG		10 to 14				
CS34-4-#3/OD	3/0	2-3/4 to 6-1/2	150BKB			
CS34-4-#3/OF		6-1/2 to 10				
CS34-4-#3/OG		10 to 14				
CS34-4-#4/OD	4/0	2-3/4 to 6-1/2	150BKB			
CS34-4-#4/OF		6-1/2 to 10				
CS34-4-#4/OG		10 to 14				

Use Mold Sealing Compound (MSC) to ensure effective sealing.

## Exothermic Welding System

### Cable to Bar



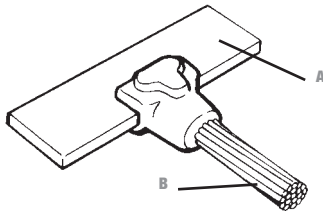
- Stranded Conductor
- Solid Circular Conductor
- Rectangular Tape or Bar

#### CB1 – For Pipes

Cat. No.	Wire Size (A)	Bar Size (B)	Welding Powder size	Handle Clamp Type	Sleeve	Std. Qty.
CB1-4-#4181	#4	1/8 X 1	45BKB	HCPK4	-	1
CB1-4-#2181	#2 solid					
CB1-4-#2181	#2					
CB1-4-#1181	#1					
CB1-4-1/0181	1/0	3/16 X 1	65BKB			
CB1-4-1/03161		1/4 X 1				
CB1-4-1/0141		1/8 X 1				
CB1-4-2/0181	2/0	3/16 X 1	90BKB			
CB1-4-2/03161		1/4 X 1				
CB1-4-2/0141		1/8 X 1				
CB1-4-3/018	3/0	3/16 X 1	115BKB			
CB1-4-3/0161		1/4 X 1				
CB1-4-3/0141		1/4 X 1				
CB1-4-4/03161	4/0	3/16 X 1	200BKB			
CB1-4-4/0141		1/4 X 1				
CB1-4-4/014112		1/4 X 1-1/2				
CB1-4-4/0142	250	1/4 X 2	2 X 150BKB			
CB1-4-4/0143		1/4 X 3				
CB1-4-250K3161		3/16 X 1				
CB1-4-250K141	300	1/4 X 1	HCPK5			
CB1-4-250K14112		1/4 X 1-1/2				
CB1-4-250K142		1/4 X 2				
CB1-4-250K143	350	1/4 X 3	HCPK5			
CB1-4-300K141		1/4 X 1				
CB1-4-300K14112		1/4 X 1-1/2				
CB1-4-300K142	500	1/4 X 2	HCPK5			
CB1-4-300K143		1/4 X 3				
CB1-4-350K141		1/4 X 1				
CB1-4-350K14112	750	1/4 X 1-1/2	HCPK5			
CB1-4-350K142		1/4 X 2				
CB1-4-350K143		1/4 X 3				
CB1-4-500K14112	1000	3/8 X 1-1/2	HCPK5			
CB1-4-500K142		1/4 X 2				
CB1-4-500K143		1/4 X 3				
CB1-5-750K142	750	1/4 X 2	HCPK5			
CB1-5-750K143		1/4 X 3				
CB1-5-750k38112		3/8 X 1-1/2				
CB1-5-750k382	1000	3/8 X 2	HCPK5			
CB1-5-750k383		3/8 X 3				
CB1-5-1000K143		1/4 X 3				
CB1-5-1000K382	1000	3/8 X 2	HCPK5			
CB1-5-1000K383		3/8 X 3				
CB1-5-1000K122		1/2 X 2				
CB1-5-1000K123		1/2 X 3				

## Exothermic Welding System

### Cable to Bar



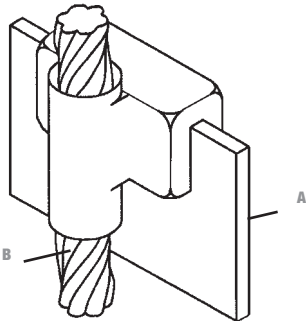
- Stranded Conductor
- Solid Circular Conductor
- Rectangular Tape or Bar

#### CB4 – For Flat Surfaces

Cat. No.	Bar Size (A)	Wire Size (B)	Welding Powder size	Handle Clamp Type	Sleeve	Std. Qty.
CB4-4-#2S14112	1/4 X 1-1/2 and wider	#2 solid	45BKB	HCPK4	-	1
CB4-4-214112		#2				
CB4-4-1/014112		1/0	90BKB			
CB4-4-2/014112		2/0				
CB4-4-3/014112		3/0				
CB4-4-4/014112		4/0				
CB4-4-250K14112		250	115BKB			
CB4-4-300K14112		300				
CB4-4-350K14112		350	150BKB			
CB4-4-500K1411		500	200BKB			
CB4-4-#2S38112	3/8 X 1-1/2 and wider	#2 solid	65BKB	HCPK4	-	1
CB4-4-#238112		#2				
CB4-4-1/038112		1/0	90BKB			
CB4-4-2/038112		2/0				
CB4-4-4/038112		4/0				
CB4-4-250K38112		250				
CB4-4-300K38112		300				
CB4-4-350K38112		350	200BKB			
CB4-4-500K38112		500	250BKB			
CB4-5-750K38112		750	2 X 150BKB			
CB4-5-1000K38112	1000	2 X 200BKB				
CB4-4-#2S12112	1/2 X 1-1/2 and wider	#2 solid	90BKB	HCPK4	-	1
CB4-4-#212112		#2				
CB4-4-1/012112		1/0	115BKB			
CB4-4-2/012112		2/0				
CB4-4-3/012112		3/0				
CB4-4-4/012112		4/0				
CB4-4-250K12112		250	200BKB			
CB4-4-300K12112		300				
CB4-4-350K12112		350	250BKB			
CB4-5-500K12112		500	2 X 150BKB			
CB4-5-750K12112	750	2 X 200BKB				
CB4-5-1000K12112	1000	2 X 250BKB				

## Exothermic Welding System

### Cable to Bar



#### CB29 – For Flat Surfaces

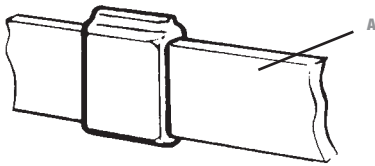
Cat. No.	Bar Size (A)	Wire Size (B)	Welding Powder size	Handle Clamp Type	Sleeve	Std. Qty.
CB29-9-#2S142	1/4 X 2 and wider	#2 solid	250BKB	HCPK4	-	1
CB29-9-#2142		#2				
CB29-10-#1142		#1	2 X 150BKB	HCPK5		
CB29-10-1/0142		1/0	2 X 200BKB			
CB29-10-2/0142		2/0				
CB29-10-4/0142		4/0	2 X 250BKB			
CB29-10-250K142		250				
CB29-10-500K142		500	3 X 200BKB			
CB29-10-750K142		750				
CB29-9-#2S382		3/8 X 2 and wider	#2 solid			
CB29-9-#2382	#2 solid					
CB29-10-#1382	#1		2 X 150BKB		HCPK5	
CB29-10-1/0382	1/0		2 X 200BKB			
CB29-102/0382	2/0					
CB29-104/0382	4/0		2 X 250BKB			
CB29-10-250K382	250					
CB29-10-500K382	500		3 X 200BKB			
CB29-10-750K382	750					
CB29-10-#2S122	1/2 X 2 and wider		#2 solid	2 X 150BKB		HCPK5
CB29-10-#2122		#2				
CB29-10-#1122		#1	2 X 200BKB			
CB29-10-1/0122		1/0	2 X 250BKB			
CB29-10-2/0122		2/0				
CB29-10-4/0122		4/0	3 X 200BKB			
CB29-10-250K122		250				
CB29-10-500K122		500	3 X 250BKB			
CB29-10-750K	750					

Use Mold Sealing Compound (MSC) to ensure effective sealing.

## Exothermic Welding System

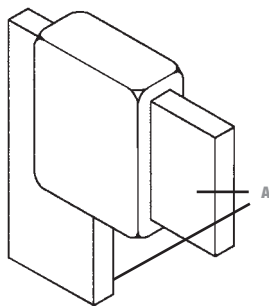
### Bar to Bar

#### BB1 – For Flat Surfaces



Cat. No.	Bar Size (A)	Welding Powder size	Handle Clamp Type	Sleeve	Std. Qty.
BB1-4-181	1/8 X 1	45BKB	HCPK4		
BB1-4-18112	1/8 X 1-1/2	65BKB			
BB1-4-182	1/8 X 2	90BKB			
BB1-4-183	1/8 X 3	200BKB			
BB1-4-184	1/8 X 4	250BKB			
BB1-4-3161	3/16 X 1	65BKB			
BB1-4-3162	3/16 X 2	115BKB			
BB1-4-141	1/4 X 1	90BKB			
BB1-4-14114	1/4 X 1-1/4	115BKB			
BB1-4-14112	1/4 X 1-1/2	150BKB			
BB1-4-142	1/4 X 2	200BKB			
BB1-4-14212	1/4 X 2-1/2	250BKB			
BB1-5-143	1/4 X 3	2 X 200BKB	HCPK5	-	1
BB1-5-144	1/4 X 4	2 X 250BKB			
BB1-4-381	3/8 X 1	150BKB	HCPK4		
BB1-4-38112	3/8 X 1-1/2	250BKB			
BB1-5-382	3/8 X 2	2 X 150BKB	HCPK5		
BB1-5-383	3/8 X 3	2 X 250BKB			
BB1-5-384	3/8 X 4	3 X 200BKB			
BB1-4-121	1/2 X 1	200BKB	HCPK4		
BB1-5-122	1/2 X 2	2 X 200BKB	HCPK5		

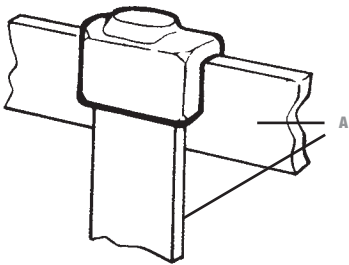
#### BB2 – For Flat Surfaces



Cat. No.	Bar Size (A)	Welding Powder size	Handle Clamp Type	Sleeve	Std. Qty.
BB2-4-181	1/8 X 1	45BKB	HCPK4		
BB2-4-18112	1/8 X 1-1/2	65BKB			
BB2-4-182	1/8 X 2	90BKB			
BB2-4-183	1/8 X 3	200BKB			
BB2-4-184	1/8 X 4	250BKB			
BB2-4-3161	3/16 X 1	65BKB			
BB2-4-3162	3/16 X 2	115BKB			
BB2-4-141	1/4 X 1	90BKB			
BB2-4-14114	1/4 X 1-1/4	115BKB			
BB2-4-14112	1/4 X 1-1/2	150BKB			
BB2-4-142	1/4 X 2	200BKB			
BB2-4-14212	1/4 X 2-1/2	250BKB			
BB2-5-143	1/4 X 3	2 X 200BKB	HCPK5	-	1
BB2-5-144	1/4 X 4	2 X 250BKB			
BB2-4-381	3/8 X 1	150BKB	HCPK4		
BB2-4-38112	3/8 X 1-1/2	250BKB			
BB2-5-382	3/8 X 2	2 X 150BKB	HCPK5		
BB2-5-383	3/8 X 3	2 X 250BKB			
BB2-5-384	3/8 X 4	3 X 200BKB			
BB2-4-121	1/2 X 1	200BKB	HCPK4		
BB2-5-122	1/2 X 2	2 X 200BKB	HCPK5		

## Exothermic Welding System

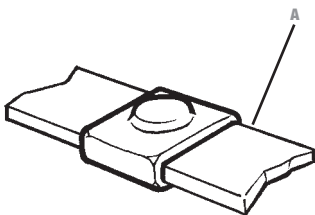
### Bar to Bar



BB3 – For Flat Surfaces

Cat. No.	Bar Size (A)	Welding Powder size	Handle Clamp Type	Sleeve	Std. Qty.	
BB3-4-181	1/8 X 1	45BKB	HCPK4	-	1	
BB3-4-18112	1/8 X 1-1/2	65BKB				
BB3-4-182	1/8 X 2	90BKB				
BB3-4-183	1/8 X 3	200BKB				
BB3-4-184	1/8 X 4	250BKB				
BB3-4-3161	3/16 X 1	65BKB				
BB3-4-3162	3/16 X 2	115BKB				
BB3-4-141	1/4 X 1	90BKB				
BB3-4-14114	1/4 X 1-1/4	115BKB				
BB3-4-14112	1/4 X 1-1/2	150BKB				
BB3-4-142	1/4 X 2	200BKB				
BB3-4-14212	1/4 X 2-1/2	250BKB				
BB3-5-143	1/4 X 3	2 X 200BKB				HCPK5
BB3-5-144	1/4 X 4	2 X 250BKB				
BB3-4-381	3/8 X 1	150BKB	HCPK4			
BB3-4-38112	3/8 X 1-1/2	250BKB				
BB3-5-382	3/8 X 2	2 X 150BKB	HCPK5			
BB3-5-383	3/8 X 3	2 X 250BKB				
BB3-5-384	3/8 X 4	3 X 200BKB				
BB3-4-121	1/2 X 1	200BKB	HCPK4	-	1	
BB3-5-122	1/2 X 2	2 X 200BKB	HCPK5			

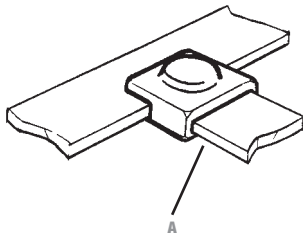
BB7 – For Flat Surfaces



Cat. No.	Bar Size (A)	Welding Powder size	Handle Clamp Type	Sleeve	Std. Qty.	
BB7-4-181	1/8 X 1	45BKB	HCPK4	-	1	
BB7-4-18112	1/8 X 1-1/2	65BKB				
BB7-4-182	1/8 X 2	90BKB				
BB7-4-183	1/8 X 3	200BKB				
BB7-4-184	1/8 X 4	250BKB				
BB7-4-3161	3/16 X 1	65BKB				
BB7-4-3162	3/16 X 2	115BKB				
BB7-4-141	1/4 X 1	90BKB				
BB7-4-14114	1/4 X 1-1/4	115BKB				
BB7-4-14112	1/4 X 1-1/2	150BKB				
BB7-4-142	1/4 X 2	200BKB				
BB7-4-14212	1/4 X 2-1/2	250BKB				
BB7-5-143	1/4 X 3	2 X 200BKB				HCPK5
BB7-5-144	1/4 X 4	2 X 250BKB				
BB7-4-381	3/8 X 1	150BKB	HCPK4			
BB7-4-38112	3/8 X 1-1/2	250BKB				
BB7-5-382	3/8 X 2	2 X 150BKB	HCPK5			
BB7-5-383	3/8 X 3	2 X 250BKB				
BB7-5-384	3/8 X 4	3 X 200BKB				
BB7-4-121	1/2 X 1	200BKB	HCPK4	-	1	
BB7-5-122	1/2 X 2	2 X 200BKB	HCPK5			

## Exothermic Welding System

### Bar to Bar

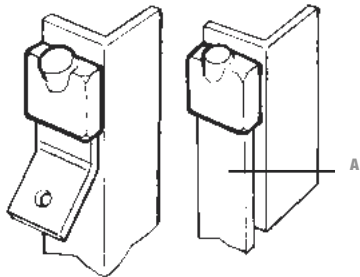


#### BB14 – For Flat Surfaces

Cat. No.	Bar Size (A)	Welding Powder size	Handle Clamp Type	Sleeve	Std. Qty.			
BB14-4-181	1/8 X 1	45BKB	HCPK4	-	1			
BB14-4-18112	1/8 X 1-1/2	65BKB						
BB14-4-182	1/8 X 2	90BKB						
BB14-4-183	1/8 X 3	200BKB						
BB14-4-184	1/8 X 4	250BKB						
BB14-4-3161	3/16 X 1	65BKB						
BB14-4-3162	3/16 X 2	115BKB						
BB14-4-141	1/4 X 1	90BKB						
BB14-4-14114	1/4 X 1-1/4	115BKB						
BB14-4-14112	1/4 X 1-1/2	150BKB						
BB14-4-142	1/4 X 2	200BKB						
BB14-4-14212	1/4 X 2-1/2	250BKB						
BB14-5-143	1/4 X 3	2 X 200BKB				HCPK5	-	1
BB14-5-144	1/4 X 4	2 X 250BKB						
BB14-4-381	3/8 X 1	150BKB	HCPK4					
BB14-4-38112	3/8 X 1-1/2	250BKB						
BB14-5-382	3/8 X 2	2 X 150BKB	HCPK5					
BB14-5-383	3/8 X 3	2 X 250BKB						
BB14-5-384	3/8 X 4	3 X 200BKB						
BB14-4-121	1/2 X 1	200BKB	HCPK4					
BB14-5-122	1/2 X 2	2 X 200BKB	HCPK5					

## Exothermic Welding System

### Bar to Steel Surface

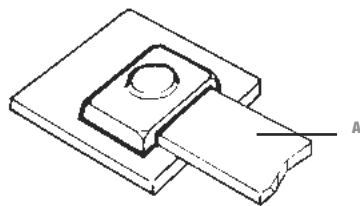


• Rectangular Tape or Bar

#### BS1 – For Flat Surfaces

Cat. No.	Bar Size (A)	Welding Powder size	Handle Clamp Type	Sleeve	Std. Qty.			
BS1-4-181	1/8 X 1	115RTB	HCPK4	4	1			
BS1-4-18112	1/8 X 1-1/2	150RTB						
BS1-4-182	1/8 X 2	200RTB						
BS1-4-3161	3/16 X 1	150RTB						
BS1-4-316112	3/16 X 1-1/2	200RTB						
BS1-4-3162	3/16 X 2	250RTB						
BS1-4-141	1/4 X 1	150RTB						
BS1-4-14114	1/4 X 1-1/4	200RTB						
BS1-4-14112	1/4 X 1-1/2	250RTB						
BS1-5-142	1/4 X 2	2 X 150RTB						
BS1-4-381	3/8 X 1	200RTB				HCPK5	5	
BS1-4-38112	3/8 X 1-1/2	250RTB				HCPK4		
BS1-5-382	3/8 X 2	2 X 200RTB				HCPK5	5	
BS1-4-121	1/2 X 1	250RTB				HCPK4	4	
BS1-5-12112	1/2 X 1-1/2	2 X 200RTB	HCPK5	5				
BS1-5-122	1/2 X 2	2 X 250RTB						

Mold Sealing Compound (MSC) will be required if surface is uneven.



• Rectangular Tape or Bar

#### BS2 – For Flat Surfaces

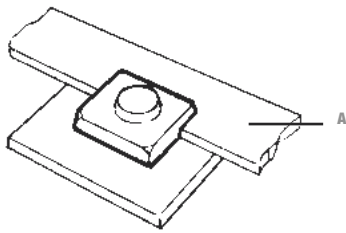
Cat. No.	Bar Size (A)	Welding Powder size	Handle Clamp Type	Sleeve	Std. Qty.			
BS2-4-181	1/8 X 1	115RTB	HCPK4	-	1			
BS2-4-18112	1/8 X 1-1/2	150RTB						
BS2-4-182	1/8 X 2	200RTB						
BS2-4-3161	3/16 X 1	150RTB						
BS2-4-316112	3/16 X 1-1/2	200RTB						
BS2-4-3162	3/16 X 2	250RTB						
BS2-4-141	1/4 X 1	150RTB						
BS2-4-14114	1/4 X 1-1/4	200RTB						
BS2-4-14112	1/4 X 1-1/2	250RTB						
BS2-5-142	1/4 X 2	2 X 150RTB						
BS2-4-381	3/8 X 1	200RTB				HCPK5	5	
BS2-4-38112	3/8 X 1-1/2	250RTB				HCPK4		
BS2-5-382	3/8 X 2	2 X 200RTB				HCPK5	5	
BS2-4-121	1/2 X 1	250RTB				HCPK4	4	
BS2-5-12112	1/2 X 1-1/2	2 X 200RTB	HCPK5	5				
BS2-5-122	1/2 X 2	2 X 250RTB						

Mold Sealing Compound (MSC) will be required if surface is uneven.



## Exothermic Welding System

### Bar to Steel Surface



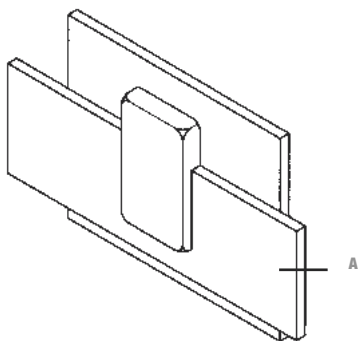
- Rectangular Tape or Bar

#### BS3 – For Flat Surfaces

Cat. No.	Bar Size (A)	Welding Powder size	Handle Clamp Type	Sleeve	Std. Qty.	
<b>BS3-4-181</b>	1/8 X 1	115RTB	HCPK4	-	1	
<b>BS3-4-18112</b>	1/8 X 1-1/2 and wider	150RTB				
<b>BS3-4-3161</b>	3/16 X 1	150RTB				
<b>BS3-4-316112</b>	3/16 X 1-1/2 and wider	200RTB				
<b>BS3-4-141</b>	1/4 X 1	150RTB				
<b>BS3-4-14114</b>	1/4 X 1-1/4	200RTB				
<b>BS3-4-14112</b>	1/4 X 1-1/2 and wider	250RTB				
<b>BS3-4-381</b>	3/8 X 1	200RTB				HCPK5
<b>BS3-4-38112</b>	3/8 X 1-1/2 and wider	250RTB				HCPK4
<b>BS3-4-121</b>	1/2 X 1	250RTB				HCPK5
<b>BS3-5-12112</b>	1/2 X 1-1/2 and wider	2 X 200RTB	HCPK5			

Mold Sealing Compound (MSC) will be required if surface is uneven.

#### BS4 – For Flat Surfaces



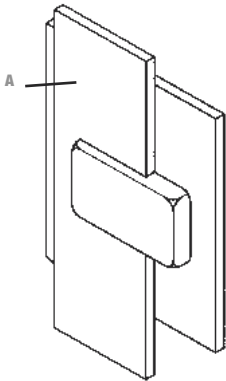
Cat. No.	Bar Size (A)	Welding Powder size	Handle Clamp Type	Sleeve	Std. Qty.
<b>BS4-4-181</b>	1/8 X 1	115RTB	HCPK4	-	1
<b>BS4-4-18112</b>	1/8 X 1-1/2	150RTB			
<b>BS4-4-182</b>	1/8 X 2	200RTB			
<b>BS4-4-3161</b>	3/16 X 1	150RTB			
<b>BS4-4-316112</b>	3/16 X 1-1/2	200RTB			
<b>BS4-4-3162</b>	3/16 X 2	250RTB			
<b>BS4-4-141</b>	1/4 X 1	150RTB			
<b>BS4-4-14114</b>	1/4 X 1-1/4	200RTB			
<b>BS4-4-14112</b>	1/4 X 1-1/2	250RTB			
<b>BS4-5-142</b>	1/4 X 2	2 X 150RTB			
<b>BS4-4-381</b>	3/8 X 1	200RTB	HCPK5		
<b>BS4-4-38112</b>	3/8 X 1-1/2	250RTB	HCPK4		
<b>BS4-5-382</b>	3/8 X 2	2 X 200RTB	HCPK5		
<b>BS4-4-121</b>	1/2 X 1	250RTB	HCPK4		
<b>BS4-5-12112</b>	1/2 X 1-1/2	2 X 200RTB	HCPK5		
<b>BS4-5-122</b>	1/2 X 2	2 X 250RTB			

Mold Sealing Compound (MSC) will be required if surface is uneven.

## Exothermic Welding System

### Bar to Steel Surface

#### BS5 – For Flat Surfaces

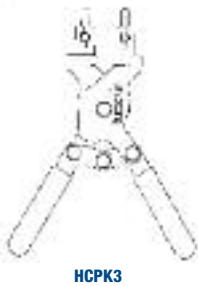


Cat. No.	Bar Size (A)	Welding Powder size	Handle Clamp Type	Sleeve	Std. Qty.
<b>BS5-4-181</b>	1/8 X 1	115RTB	HCPK4	-	1
<b>BS5-4-18112</b>	1/8 X 1-1/2	150RTB			
<b>BS5-4-182</b>	1/8 X 2 and wider	200RTB			
<b>BS5-4-3161</b>	3/16 X 1	150RTB			
<b>BS5-4-316112</b>	3/16 X 1-1/2	200RTB			
<b>BS5-4-3162</b>	3/16 X 2 and wider	250RTB			
<b>BS5-4-141</b>	1/4 X 1	150RTB			
<b>BS5-4-14114</b>	1/4 X 1-1/4	200RTB			
<b>BS5-4-14112</b>	1/4 X 1-1/2	250RTB			
<b>BS5-5-142</b>	1/4 X 2 and wider	2 X 150RTB			
<b>BS5-4-381</b>	3/8 X 1	200RTB	HCPK4		
<b>BS5-4-38112</b>	3/8 X 1-1/2	250RTB	HCPK5		
<b>BS5-5-382</b>	3/8 X 2 and wider	2 X 200RTB	HCPK4		
<b>BS5-4-121</b>	1/2 X 1	250RTB	HCPK5		
<b>BS5-5-12112</b>	1/2 X 1-1/2	2 X 200RTB			
<b>BS5-5-122</b>	1/2 X 2 and wider	2 X 250RTB			

Mold Sealing Compound (MSC) will be required if surface is uneven.

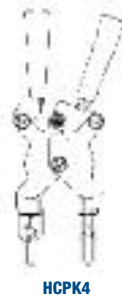
## Exothermic Welding System

### Handle Clamps, Tools and Accessories



#### Handle Clamps

Cat. No.	Description	Applications	Std. Qty.
HCPK1	Price Key 1 Handle	For use on price key 1 molds	1
HCPK2	Price Key 2 Handle	For use on price key 2 molds	
HCPK3	Price Key 3 Handle Clamp	For use on price key 3 molds	
HCPK3A	Price Key 3A Handle Clamp	Type 3A molds (connections to vertical rebars)	
HCPK3B	Price Key 3B Handle Clamp	Type 3B molds (connections to horizontal rebars)	
HCPK3BMOD	Price Key 3B Modified Clamp	Type 3B molds (cross connections to horizontal rebars)	
HCPK4	Price Key 4 Handle Clamp	For use on price key 4 molds	
HCPK5	Price Key 5 Handle Clamp	For use on price key 5 molds	
HCPK7	Price Key 7 Handle Clamp	For use on price key 7 molds	
HCPK8	Price Key 8 Handle Clamp	For use on price key 8 molds	
FRAME1	Price Key 9 Frame	For use with HCPK4 on price key 9 molds	1
FRAME2	Price Key 10 Frame	For use with HCPK5 on price key 10 molds	



#### Tools and Accessories

Cat. No.	Description	Applications	Std. Qty.
WWB1	Cable Cleaning Brush	Cleaning of stranded and other circular section conductors	6
WRB1	Replacement Elements (Pair)	-	3
BFC	Card Cloth Brush	Cleaning of conductors and surfaces	10
FGUN	Flint Ignitor Gun	Starting powder ignition	
BCM	Mold Cleaning Brush	Soft brush for mold cleaning	
STM1-TB	Mold Scraper Tool	Break up and removal of slag in mold crucible	5
MSC	Mold Sealing Compound	Mold sealing on uneven surfaces, and general mold sealing	
PACK-A	Packing	Mold sealing on rebar surfaces	50
SLEEVE#6	Sleeve for #6 wire	Prevents burning of small section wire	100
SLEEVE#6S	Sleeve for #6S wire		
SLEEVE#8	Sleeve for #8 wire		
SLEEVE#8S	Sleeve for #8S wire		
SHIM	Copper shim.	For sealing around undersize conductors	



## Exothermic Welding System



### Sure Shot™ Welding Mold

Thomas & Betts introduces a new approach to the perfect connection Sure Shot™ an extension of the Furseweld® line of exothermic welding products.

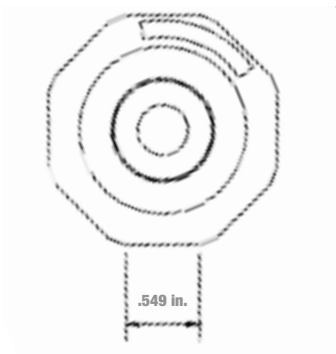
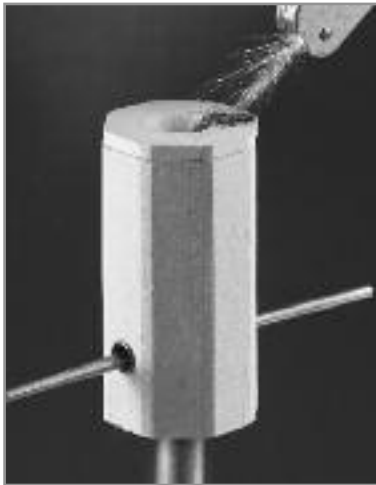
Sure Shot™ molds come completely packaged with everything necessary for a connection. They are fast and easy to use. The contractor simply positions the mold, adds the weld powder and starting powder, and ignites it with a flint gun.

Sure Shot™ molds are disposable, so there's no maintenance involved. And, it's not necessary to remove the mold in underground installations because Sure Shot™ molds are made from an "earth friendly" ceramic.

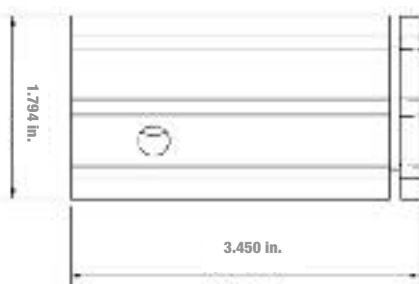
The hexagonal Sure Shot™ design is easy to grasp and hold without removing safety gloves, and it won't roll away if it's laid down while the installer prepares the connection.

#### Features and Benefits:

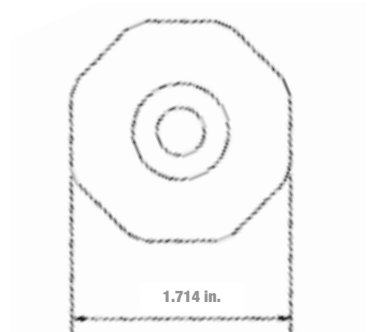
- Fast and easy to use
- Packaged with everything necessary for a connection
- Maintenance-free disposable molds
- Made of biodegradable ceramic
- Ergonomic hexagonal design



**Cover**



**Welding Mold**

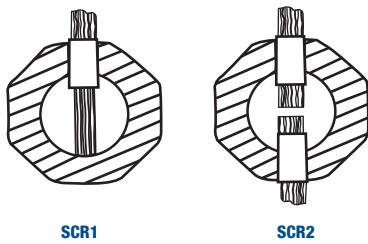


**Disk**

## Exothermic Welding System

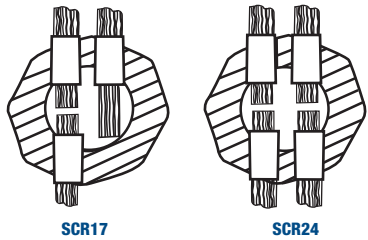
### Sure Shot™ Welding Mold

#### Wire Positioning



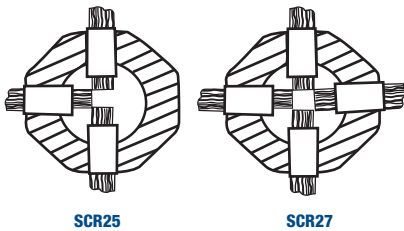
SCR1

SCR2



SCR17

SCR24



SCR25

SCR27

#### Product Specifications

Cat. No.	Ground Rod Size in.	Conductor Size	
		Solid	Stranded
<b>Furseweld Type SCR1</b>			
SCR1-58-6808	5/8	6,8	8
SCR1-58-3446		3,4	4,6
SCR1-58-1223		1,2	2,3
SCR1-58-2010		2/0,1/0	1/0,1
SCR1-58-0020		–	2/0
SCR1-34-6808		3/4	6,8
SCR1-34-3446	3,4		4,6
SCR1-34-1223	1,2		2,3
SCR1-34-2010	2/0,1/0		1/0,1
SCR1-34-0020	–		2/0
SCR1-34-0040	–		4/0
<b>Furseweld Type SCR2</b>			
SCR2-58-6808	5/8	6,8	8
SCR2-58-3446		3,4	4,6
SCR2-58-1223		1,2	2,3
SCR2-58-2010		2/0,1/0	1/0,1
SCR2-58-0020		–	2/0
SCR2-34-6808		3/4	6,8
SCR2-34-3446	3,4		4,6
SCR2-34-1223	1,2		2,3
SCR2-34-2010	2/0,1/0		1/0,1
SCR2-34-0020	–		2/0
SCR2-34-0040	–		4/0
<b>Furseweld Type SCR17</b>			
SCR17-58-6808	5/8	6,8	8
SCR17-58-3446		3,4	4,6
SCR17-58-1223		1,2	2,3
SCR17-34-6808	3/4	6,8	8
SCR17-34-3446		3,4	4,6
SCR17-34-1223		1,2	2,3
<b>Furseweld Type SCR24</b>			
SCR24-58-6808	5/8	6,8	8
SCR24-58-3446		3,4	4,6
SCR24-58-1223		1,2	2,3
SCR24-34-6808	3/4	6,8	8
SCR24-34-3446		3,4	4,6
SCR24-34-1223		1,2	2,3
<b>Furseweld Type SCR25</b>			
SCR25-58-6808	5/8	6,8	8
SCR25-58-3446		3,4	4,6
SCR25-58-1223		1,2	2,3
SCR25-34-6808	3/4	6,8	8
SCR25-34-3446		3,4	4,6
SCR25-34-1223		1,2	2,3
<b>Furseweld Type SCR27</b>			
SCR27-58-6808	5/8	6,8	8
SCR27-58-3446		3,4	4,6
SCR27-34-6808	3/4	6,8	8
SCR27-34-3446		3,4	4,6
SCR27-34-1223		1,2	2,3

\* The weight per 100 is 20 lb. and the standard carton/outer pack is 6 for all catalogue numbers.

## Exothermic Welding System

### Cross Reference

Cadweld Cat. No.	Thermoweld Cat. No.	Furseweld Cat. No.
BAC-JE	M-1135	BB1-4-121
BAC-EE	M-1122	BB1-4-141
BAC-EG	M-1124	BB1-4-14112
BAC-EF	M-1123	BB1-4-14114
BAC-EH	M-1125	BB1-4-142
BAC-EJ	M-6346	BB1-4-14212
BAC-CE	M-1118	BB1-4-181
BAC-CG	M-2557	BB1-4-18112
BAC-CH	M-1119	BB1-4-182
BAC-CK	M-6298	BB1-4-183
BAD-CM	M-5315	BB1-4-184
BAC-DE	M-1120	BB1-4-3161
BAC-DH	M-1121	BB1-4-3162
BAC-GE	M-1130	BB1-4-381
BAC-GG	M-1131	BB1-4-38112
BAD-JH	M-1136	BB1-5-122
BAD-EK	M-1126	BB1-5-143
BAD-EM	M-1127	BB1-5-144
BAD-GH	M-1132	BB1-5-382
BAD-GK	M-1133	BB1-5-38
BAD-GM	M-1134	BB1-5-384
EPC-JE	M-1247	BB2-4-121
EPC-EE	M-1234	BB2-4-141
EPC-EG	M-1236	BB2-4-14112
EPC-EF	M-1235	BB2-4-14114
EPC-EH	M-1237	BB2-4-142
EPC-EJ	M-6352	BB2-4-14212
EPC-CE	M-1230	BB2-4-181
EPC-CG	M-6347	BB2-4-18112
EPC-CH	M-1231	BB2-4-182
EPC-CK	M-6348	BB2-4-183
EPD-CM	M-6351	BB2-4-184
EPC-DE	M-1232	BB2-4-3161
EPC-DH	M-1233	BB2-4-3162
EPC-GE	M-1242	BB2-4-381
EPC-GG	M-1243	BB2-4-38112
EPD-JH	M-1248	BB2-5-122
EPD-EK	M-1238	BB2-5-143
EPD-EM	M-1239	BB2-5-144
EPD-GH	M-1244	BB2-5-382
EPD-GK	M-1245	BB2-5-383
EPD-GM	M-1246	BB2-5-384
BQC-EEEE	M-1102	BB3-4-141
BQC-EGEG	M-1104	BB3-4-14112
BQC-EFEF	M-1103	BB3-4-14114
BQC-CECE	M-1098	BB3-4-181
BQC-CHCH	M-1099	BB3-4-182
BQC-DEDE	M-1100	BB3-4-3161
BQC-DHDH	M-1101	BB3-4-3162
BQC-GEGE	M-1108	BB3-4-381
BQD-JEJE	M-1113	BB3-5-121

Cadweld Cat. No.	Thermoweld Cat. No.	Furseweld Cat. No.
BQD-JHJH	M-1114	BB3-5-122
BQD-EHEH	M-1105	BB3-5-142
BQD-GGGG	M-1109	BB3-5-38112
BQD-GHGH	M-1110	BB3-5-382
BQF-EKEK	M-1106	BB3-6-143
BQF-GKGK	M-1111	BB3-6-383
BWC-JE	M-1051	BS1-4-121
BWC-EE	M-1045	BS1-4-141
BWC-EG	M-1047	BS1-4-14112
BWC-EF	M-1046	BS1-4-14114
BWC-CE	M-1043	BS1-4-181
BWC-CG	M-6354	BS1-4-18112
BWC-CH	M-1044	BS1-4-182
BWC-DE	M-6056	BS1-4-3161
BWC-DG	M-6355	BS1-4-316112
BWC-DH	M-6356	BS1-4-3162
BWC-GE	M-1049	BS1-4-381
BWC-GG	M-6357	BS1-4-38112
BWD-JG	M-6358	BS1-5-12112
BWD-JH	M-1052	BS1-5-122
BWD-EH	M-1048	BS1-5-142
BWD-GH	M-1050	BS1-5-382
CGC-JE	M-1084	BS2-4-121
CGC-EE	M-1077	BS2-4-141
CGC-EG	M-1079	BS2-4-14112
CGC-EF	M-1078	BS2-4-14114
CGC-CE	M-1072	BS2-4-181
CGC-CG	M-1073	BS2-4-18112
CGC-CH	M-1074	BS2-4-182
CGC-DE	M-1075	BS2-4-3161
CGC-DG	M-6359	BS2-4-316112
CGC-DH	M-1076	BS2-4-3162
CGC-GE	M-1081	BS2-4-381
CGC-GG	M-1082	BS2-4-38112
CGD-JG	M-1085	BS2-5-12112
CGD-JH	M-1086	BS2-5-122
CGD-EH	M-1080	BS2-5-142
CGD-GH	M-1083	BS2-5-382
CHC-JE	M-1095	BS3-4-121
CHC-EE	M-1090	BS3-4-141
CHC-EF	M-1092	BS3-4-14112
CHC-CE	M-1091	BS3-4-14114
CHC-DE	M-1088	BS3-4-181
CHC-CG	M-1089	BS3-4-18112
CHC-CH	M-6353	BS3-4-3161
CHC-DG	M-7163	BS3-4-316112
CHC-GE	M-1093	BS3-4-381
CHC-GG	M-1094	BS3-4-38112
CHD-JG	M-1096	BS3-5-12112
CCC-JE	M-1060	BS4-4-121
CCC-EE	M-1056	BS4-4-141

Cadweld Cat. No.	Thermoweld Cat. No.	Furseweld Cat. No.
CCC-EG	M-6369	BS4-4-14112
CCC-EF	M-5566	BS4-4-14114
CCC-CE	M-1054	BS4-4-181
CCC-CG	M-6360	BS4-4-18112
CCC-CH	M-1055	BS4-4-182
CCC-DE	M-6361	BS4-4-3161
CCC-DG	M-6362	BS4-4-316112
CCC-DH	M-6367	BS4-4-3162
CCC-GE	M-1058	BS4-4-381
CCC-GG	M-6370	BS4-4-38112
CCD-JG	M-6372	BS4-5-12112
CCD-JH	M-1061	BS4-5-122
CCD-EH	M-1057	BS4-5-142
CCD-GH	M-1059	BS4-5-382
CFC-JE	M-1069	BS5-4-121
CFC-EE	M-1065	BS5-4-141
CFC-EG	M-6379	BS5-4-14112
CFC-EF	M-6377	BS5-4-14114
CFC-CE	M-1063	BS5-4-181
CFC-CF	M-6373	BS5-4-18112
CFC-CH	M-1064	BS5-4-182
CFC-DE	M-6374	BS5-4-3161
CFC-DG	M-6375	BS5-4-316112
CFC-DH	M-6376	BS5-4-3162
CFC-GE	M-1067	BS5-4-381
CFC-GG	M-6382	BS5-4-38112
CFD-JG	M-6383	BS5-5-12112
CFD-JH	M-1070	BS5-5-122
CFD-EH	M-1066	BS5-5-142
CFD-GH	M-1068	BS5-5-382
LAC-1YCE	M-977	CB1-4-#1181
LAC-1VCE	M-975	CB1-4-#2181
LAC-1TCE	-	CB1-4-#2S181
LAC-1LCE	M-971	CB1-4-#4181
LAC-2CEE	M-979	CB1-4-1/0141
LAC-2CCE	M-978	CB1-4-1/0181
LAC-2CDE	M-6075	CB1-4-1/03161
LAC-2GEE	M-981	CB1-4-2/0141
LAC-2GCE	M-980	CB1-4-2/0181
LAC-2GDE	M-6579	CB1-4-2/03161
LAC-2VEE	M-988	CB1-4-250K141
LAC-2VEG	M-990	CB1-4-250K14112
LAC-2VEH	M-8784	CB1-4-250K142
LAC-2VEK	M-1916	CB1-4-250K143
LAC-2VDE	M-8277	CB1-4-250K3161
LAC-2LEE	M-983	CB1-4-3/0141
LAC-2LCE	M-6284	CB1-4-3/0181
LAC-2LDE	M-982	CB1-4-3/03161
LAC-3AEE	M-991	CB1-4-300K141
LAC-3AEG	M-993	CB1-4-300K14112
LAC-3AEH	M-6288	CB1-4-300K142

## Exothermic Welding System

### Cross Reference

Cadweld Cat. No.	Thermoweld Cat. No.	Furseweld Cat. No.
LAC-3AEK	M-1917	CB1-4-300K143
LAC-3DEE	M-994	CB1-4-350K141
LAC-3DEG	M-996	CB1-4-350K14112
LAC-3DEH	M-6289	CB1-4-350K142
LAC-3DEK	M-1918	CB1-4-350K143
LAC-2QEE	M-985	CB1-4-4/0141
LAC-2QEG	M-987	CB1-4-4/014112
LAC-2QEH	M-5657	CB1-4-4/0142
LAC-2QEK	M-1915	CB1-4-4/0143
LAC-2QDE	M-984	CB1-4-4/03161
LAC-3QEG	M-1001	CB1-4-500K14112
LAC-3QEH	M-1002	CB1-4-500K142
LAC-3QEK	M-1920	CB1-4-500K143
LAC-3QGG	M-1004	CB1-4-500K38112
LAD-4YJH	M-1011	CB1-5-1000K122
LAD-4YJK	M-6295	CB1-5-1000K123
LAD-4YEK	M-6292	CB1-5-1000K143
LAD-4YGH	M-1009	CB1-5-1000K382
LAD-4YVK	M-1922	CB1-5-1000K383
LAD-4LEH	M-1006	CB1-5-750K142
LAD-4LEK	M-1921	CB1-5-750K143
LAD-4LGG	M-1007	CB1-5-750K38112
LAD-4LGH	M-1008	CB1-5-750K382
LAD-4LGK	M-6291	CB1-5-750K383
LQJ-JH1Y		CB29-10-#1122
LQJ-EH1Y		CB29-10-#1142
LQJ-GH1Y		CB29-10-#1382
LQJ-JH1V		CB29-10-#2122
LQJ-JH1T		CB29-10-#2S122
LQJ-JH2C		CB29-10-1/0122
LQJ-EH2C		CB29-10-1/0142
LQJ-GH2C		CB29-10-1/0382
LQJ-JH2G		CB29-10-2/0122
LQJ-EH2G		CB29-10-2/0142
LQJ-GH2G		CB29-10-2/0382
LQJ-JH2V		CB29-10-250K122
LQJ-EH2V		CB29-10-250K142
LQJ-GH2V		CB29-10-250K382
LQJ-JH2Q		CB29-10-4/0122
LQJ-EH2Q		CB29-10-4/0142
LQJ-GH2Q		CB29-10-4/0382
LQJ-JH3Q		CB29-10-500K122
LQJ-EH3Q		CB29-10-500K142
LQJ-GH3Q		CB29-10-500K382
LQJ-JH4L		CB29-10-750K122
LQJ-EH4L		CB29-10-750K142
LQJ-GH4L		CB29-10-750K382
LQE-EH1V		CB29-9-#2142
LQE-GH1V		CB29-9-#2382
LQE-EH1T		CB29-9-#2S142
LQE-GH1T		CB29-9-#2S382

Cadweld Cat. No.	Thermoweld Cat. No.	Furseweld Cat. No.
LJC-JG1V		CB4-4-#212112
LJC-EG1V		CB4-4-#214112
LJC-GG1V		CB4-4-#238112
LJC-JG1T		CB4-4-#2S12112
LJC-EG1T		CB4-4-#2S14112
LJC-GG1T		CB4-4-#2S38112
LJC-JG2C	M-1671	CB4-4-1/012112
LJC-EG2C	M-1651	CB4-4-1/014112
LJC-GG2C	M-1660	CB4-4-1/038112
LJC-JG2G	M-1672	CB4-4-2/012112
LJC-EG2G	M-1652	CB4-4-2/014112
LJC-GG2G	M-1661	CB4-4-2/038112
LJC-JG2V	M-1675	CB4-4-250K12112
LJC-EG2V	M-1655	CB4-4-250K14112
LJC-GG2V	M-1664	CB4-4-250K38112
LJC-JG2L	M-1673	CB4-4-3/012112
LJC-EG2L	M-1653	CB4-4-3/014112
LJC-GG2L	M-1662	CB4-4-3/038112
LJC-JG3A	M-1676	CB4-4-300K12112
LJC-EG3A	M-1656	CB4-4-300K14112
LJC-GG3A	M-1665	CB4-4-300K38112
LJC-JG3D	M-1677	CB4-4-350K12112
LJC-EG3D	M-1657	CB4-4-350K14112
LJC-GG3D	M-1666	CB4-4-350K38112
LJC-JG2Q	M-1674	CB4-4-4/012112
LJC-EG2Q	M-1654	CB4-4-4/014112
LJC-GG2Q	M-1663	CB4-4-4/038112
LJC-EG3Q	M-1659	CB4-4-500K14112
LJC-GG3Q	M-1668	CB4-4-500K38112
LJD-JG4Y	M-1681	CB4-5-1000K12112
LJD-GG4Y	M-1670	CB4-5-1000K38112
LJD-JG3Q	M-1679	CB4-5-500K12112
LJD-JG4L	M-1680	CB4-5-750K12112
LJD-GG4L	M-1669	CB4-5-750K38112
XBC-1Y1Y	M-2691	CC11-7-#1#1
XBC-1Y1V	M-2692	CC11-7-#1#2
XBC-1Y1L	M-2693	CC11-7-#1#4
XBC-1V1V	M-2689	CC11-7-#2#2
XBC-1V1L	M-2690	CC11-7-#2#4
XBC-1T1T	M-2689-S	CC11-7-#2S#2S
XBC-1L1L	M-2687	CC11-7-#4#4
XBP-1H1H	M-5432	CC11-7-#6#6
XBP-1G1G	M-5432-S	CC11-7-#6S#6S
XBM-2C1Y	M-2695	CC11-7-1/0#1
XBM-2C1V	M-2696	CC11-7-1/0#2
XBM-2C1L	M-2697	CC11-7-1/0#4
XBM-2C2C	M-2694	CC11-7-1/01/0
XBM-2G1Y	M-2700	CC11-7-2/0#1
XBM-2G1V	M-2701	CC11-7-2/0#2
XBM-2G2C	M-2699	CC11-7-2/01/0
XBM-2G2G	M-2698	CC11-7-2/02/0

Cadweld Cat. No.	Thermoweld Cat. No.	Furseweld Cat. No.
XBM-2V1Y	M-2718	CC11-7-250K#1
XBM-2V1V	M-2719	CC11-7-250K#2
XBM-2V2C	M-2717	CC11-7-250K1/0
XBM-2V2G	M-2716	CC11-7-250K2/0
XBM-2V2V	M-2713	CC11-7-250K250K
XBM-2V2L	M-2715	CC11-7-250K3/0
XBM-2V2Q	M-2714	CC11-7-250K4/0
XBM-2L1Y	M-2705	CC11-7-3/0#1
XBM-2L1V	M-2706	CC11-7-3/0#2
XBM-2L2C	M-2704	CC11-7-3/01/0
XBM-2L2G	M-2703	CC11-7-3/02/0
XBM-2L2L	M-2702	CC11-7-3/03/0
XBM-3A1Y	M-2726	CC11-7-300K#1
XBM-3A1V	M-2727	CC11-7-300K#2
XBM-3A2C	M-2725	CC11-7-300K1/0
XBM-3A2G	M-2724	CC11-7-300K2/0
XBM-3A2L	M-2723	CC11-7-300K3/0
XBM-3A2Q	M-2722	CC11-7-300K4/0
XBM-3D1Y	M-2735	CC11-7-350K#1
XBM-3D1V	M-2736	CC11-7-350K#2
XBM-3D2C	M-2734	CC11-7-350K1/0
XBM-3D2G	M-2733	CC11-7-350K2/0
XBM-2Q1Y	M-2711	CC11-7-4/0#1
XBM-2Q1V	M-2712	CC11-7-4/0#2
XBM-2Q2C	M-2710	CC11-7-4/01/0
XBM-2Q2G	M-2709	CC11-7-4/02/0
XBM-2Q2L	M-2708	CC11-7-4/03/0
XBM-2Q2Q	M-2707	CC11-7-4/04/0
XBM-3Q2C	M-2755	CC11-7-500K1/0
XBV-3A2V	M-2721	CC11-8-300K250K
XBV-3A3A	M-2720	CC11-8-300K300K
XBV-3D2V	M-2730	CC11-8-350K250K
XBV-3D2L	M-2732	CC11-8-350K3/0
XBV-3D3A	M-2729	CC11-8-350K300K
XBV-3D3D	M-2728	CC11-8-350K350K
XBV-3D2Q	M-2731	CC11-8-350K4/0
XBV-3Q2G	M-2754	CC11-8-500K2/0
XBV-3Q2V	M-2751	CC11-8-500K250K
XBV-3Q2L	M-2753	CC11-8-500K3/0
XBV-3Q3A	M-2750	CC11-8-500K300K
XBV-3Q3D	M-2749	CC11-8-500K350K
XBV-3Q2Q	M-2752	CC11-8-500K4/0
XBV-3Q3Q	M-2747	CC11-8-500K500K
SST-1Y	M-5626	CC1-3-#1
SST-1X	M-5626-S	CC1-3-#1S
SST-1V	M-5625	CC1-3-#2
SST-1T	M-5625-S	CC1-3-#2S
SST-1Q	M-5624	CC1-3-#3
-	-	CC1-4-#2
SSC-2C	M-205	CC1-4-1/0
SSC-2B	M-205-S	CC1-4-1/0S

## Exothermic Welding System

### Cross Reference

Cadweld Cat. No.	Thermoweld Cat. No.	Furseweld Cat. No.
SSC-2G	M-206	CC1-4-2/0
SSC-2V	M-209	CC1-4-250K
SSC-2L	M-207	CC1-4-3/0
SSC-3A	M-210	CC1-4-300K
SSC-3D	M-211	CC1-4-350K
SSC-2Q	M-208	CC1-4-4/0
SSC-2P	M-208-S	CC1-4-4/0S
SSC-3Q	M-213	CC1-4-500K
SSD-4Y	M-215	CC1-5-1000K
SSD-4L	M-214	CC1-5-750K
TAC-1Y1Y	M-225	CC2-4-#1#1
TAC-1Y1V	M-226	CC2-4-#1#2
TAC-1Y1T	M-5879	CC2-4-#1#2S
TAC-1Y1L	M-227	CC2-4-#1#4
TAC-1V1V	M-223	CC2-4-#2#2
TAC-1V1T	M-5869	CC2-4-#2#2S
TAC-1T1L	M-224	CC2-4-#2#4
TAC-1V1L	M-5859	CC2-4-#2#4
TAC-1T1V	M-5856	CC2-4-#2S#2
TAC-1T1T	M-223-S	CC2-4-#2S#2S
TAC-1L1L	M-221	CC2-4-#4#4
TAC-2C1Y	M-229	CC2-4-1/0#1
TAC-2C1V	M-230	CC2-4-1/0#2
TAC-2C1T	M-5311	CC2-4-1/0#2S
TAC-2C1L	M-231	CC2-4-1/0#4
TAC-2C2C	M-228	CC2-4-1/01/0
TAC-4Y2C	M-308	CC2-4-1000K1/0
TAC-4Y2G	M-307	CC2-4-1000K2/0
TAC-4Y2V	M-305	CC2-4-1000K250K
TAC-4Y3A	M-304	CC2-4-1000K300K
TAC-4Y3D	M-303	CC2-4-1000K350K
TAC-4Y2Q	M-306	CC2-4-1000K4/0
TAC-2G1Y	M-234	CC2-4-2/0#1
TAC-2G1V	M-235	CC2-4-2/0#2
TAC-2G1T	M-8093	CC2-4-2/0#2S
TAC-2G1L	M-5475	CC2-4-2/0#4
TAC-2G2C	M-233	CC2-4-2/01/0
TAC-2G2G	M-232	CC2-4-2/02/0
TAC-2V1Y	M-252	CC2-4-250K#1
TAC-2V1V	M-253	CC2-4-250K#2
TAC-2V1T	M-5889	CC2-4-250K#2S
TAC-2V1L	M-5425	CC2-4-250K#4
TAC-2V2C	M-251	CC2-4-250K1/0
TAC-2V2G	M-250	CC2-4-250K2/0
TAC-2V2V	M-247	CC2-4-250K250K
TAC-2V2L	M-249	CC2-4-250K3/0
TAC-2V2Q	M-248	CC2-4-250K4/0
TAC-2L1Y	M-239	CC2-4-3/0#1
TAC-2L1V	M-240	CC2-4-3/0#2
TAC-2L1T	M-5884	CC2-4-3/0#2S
TAC-2L1L	M-5574	CC2-4-3/0#4

Cadweld Cat. No.	Thermoweld Cat. No.	Furseweld Cat. No.
TAC-2L2C	M-238	CC2-4-3/01/0
TAC-2L2G	M-237	CC2-4-3/02/0
TAC-2L2L	M-236	CC2-4-3/03/0
TAC-3A1Y	M-260	CC2-4-300K#1
TAC-3A1V	M-261	CC2-4-300K#2
TAC-3A1T	M-5903	CC2-4-300K#2S
TAC-3A1L	M-6397	CC2-4-300K#4
TAC-3A2C	M-259	CC2-4-300K1/0
TAC-3A2G	M-258	CC2-4-300K2/0
TAC-3A2V	M-255	CC2-4-300K250K
TAC-3A2L	M-257	CC2-4-300K3/0
TAC-3A3A	M-254	CC2-4-300K300K
TAC-3A2Q	M-256	CC2-4-300K4/0
TAC-3D1Y	M-269	CC2-4-350K#1
TAC-3D1V	M-270	CC2-4-350K#2
TAC-3D1L	M-6398	CC2-4-350K#4
TAC-3D2C	M-268	CC2-4-350K1/0
TAC-3D2G	M-267	CC2-4-350K2/0
TAC-3D2V	M-264	CC2-4-350K250K
TAC-3D2L	M-266	CC2-4-350K3/0
TAC-3D3A	M-263	CC2-4-350K300K
TAC-3D3D	M-262	CC2-4-350K350K
TAC-3D2Q	M-265	CC2-4-350K4/0
TAC-2Q1Y	M-245	CC2-4-4/0#1
TAC-2Q1V	M-246	CC2-4-4/0#2
TAC-2Q1T	M-5348	CC2-4-4/0#2S
TAC-2Q1L	M-5021	CC2-4-4/0#4
TAC-2Q2C	M-244	CC2-4-4/01/0
TAC-2Q2G	M-243	CC2-4-4/02/0
TAC-2Q2L	M-242	CC2-4-4/03/0
TAC-2Q2Q	M-241	CC2-4-4/04/0
TAC-3Q1Y	M-288	CC2-4-500K#1
TAC-3Q1V	M-289	CC2-4-500K#2
TAC-3Q1L	M-8113	CC2-4-500K#4
TAC-3Q2C	M-287	CC2-4-500K1/0
TAC-3Q2G	M-286	CC2-4-500K2/0
TAC-3Q2V	M-284	CC2-4-500K250K
TAC-3Q3A	M-283	CC2-4-500K300K
TAC-3Q3D	M-282	CC2-4-500K350K
TAC-3Q2Q	M-285	CC2-4-500K4/0
TAC-3Q3Q	M-280	CC2-4-500K500K
TAC-4L2C	M-298	CC2-4-750K1/0
TAC-4L2G	M-297	CC2-4-750K2/0
TAC-4L2V	M-295	CC2-4-750K250K
TAC-4L3A	M-294	CC2-4-750K300K
TAC-4L3D	M-293	CC2-4-750K350K
TAC-4L2Q	M-296	CC2-4-750K4/0
TAD-4Y4Y	M-299	CC2-5-1000K1000K
TAD-4Y3Q	M-301	CC2-5-1000K500K
TAD-4Y4L	M-300	CC2-5-1000K750K
TAD-4L3Q	M-291	CC2-5-750K500K

Cadweld Cat. No.	Thermoweld Cat. No.	Furseweld Cat. No.
TAD-4L4L	M-290	CC2-5-750K750K
-	-	CC2HD-4-4/04/0
XAC-1Y1Y	M-427	CC4-4-#1#1
XAC-1Y1V	M-428	CC4-4-#1#2
XAC-1Y1L	M-429	CC4-4-#1#4
XAC-1V1V	-	CC4-4-#2#2
XAC-1V1L	-	CC4-4-#2#4
XAC-1T1T	-	CC4-4-#2S#2S
XAC-1L1L	-	CC4-4-#4#4
XAC-2C1Y	M-431	CC4-4-1/0#1
XAC-2C1V	M-432	CC4-4-1/0#2
XAC-2C1L	M-433	CC4-4-1/0#4
XAC-2C2C	M-430	CC4-4-1/01/0
XAC-2G1Y	M-436	CC4-4-2/0#1
XAC-2G1V	M-437	CC4-4-2/0#2
XAC-2G2C	M-435	CC4-4-2/01/0
XAC-2G2G	M-434	CC4-4-2/02/0
XAC-2V1Y	M-454	CC4-4-250K#1
XAC-2V1V	M-455	CC4-4-250K#2
XAC-2V2C	M-453	CC4-4-250K1/0
XAC-2V2G	M-452	CC4-4-250K2/0
XAC-2V2V	M-449	CC4-4-250K250K
XAC-2V2L	M-451	CC4-4-250K3/0
XAC-2V2Q	M-450	CC4-4-250K4/0
XAC-2L1Y	M-441	CC4-4-3/0#1
XAC-2L1V	M-442	CC4-4-3/0#2
XAC-2L2C	M-440	CC4-4-3/01/0
XAC-2L2G	M-439	CC4-4-3/02/0
XAC-2L2L	M-438	CC4-4-3/03/0
XAC-3A1Y	M-462	CC4-4-300K#1
XAC-3A1V	M-463	CC4-4-300K#2
XAC-3A2C	M-461	CC4-4-300K1/0
XAC-3A2G	M-460	CC4-4-300K2/0
XAC-3A2V	M-457	CC4-4-300K250K
XAC-3A2L	M-459	CC4-4-300K3/0
XAC-3A3A	M-456	CC4-4-300K300K
XAC-3A2Q	M-458	CC4-4-300K4/0
XAC-3D1Y	M-471	CC4-4-350K#1
XAC-3D1V	M-472	CC4-4-350K#2
XAC-3D2C	M-470	CC4-4-350K1/0
XAC-3D2G	M-469	CC4-4-350K2/0
XAC-3D2V	M-466	CC4-4-350K250K
XAC-3D2L	M-468	CC4-4-350K3/0
XAC-3D3A	M-465	CC4-4-350K300K
XAC-3D3D	M-464	CC4-4-350K350K
XAC-3D2Q	M-467	CC4-4-350K4/0
XAC-2Q1Y	M-447	CC4-4-4/0#1
XAC-2Q1V	M-448	CC4-4-4/0#2
XAC-2Q2C	M-446	CC4-4-4/01/0
XAC-2Q2G	M-445	CC4-4-4/02/0
XAC-2Q2L	M-444	CC4-4-4/03/0



## Exothermic Welding System

### Cross Reference

Cadweld Cat. No.	Thermoweld Cat. No.	Furseweld Cat. No.
XAC-2Q2Q	M-443	CC4-4-4/04/0
XAC-3Q2C	M-491	CC4-4-500K1/0
XAC-3Q2G	M-490	CC4-4-500K2/0
XAD-3Q2V	M-487	CC4-5-500K250K
XAD-3Q2L	M-489	CC4-5-500K3/0
XAD-3Q3A	M-486	CC4-5-500K300K
XAD-3Q3D	M-485	CC4-5-500K350K
XAD-3Q2Q	M-488	CC4-5-500K4/0
XAD-3Q3Q	M-483	CC4-5-500K500K
PCC-1Y1V	M-1282	CC6-4-#1#2
PCC-1Y1L	M-1283	CC6-4-#1#4
PCC-1Y1H	M-1284	CC6-4-#1#6
PCC-1Y1G	M-1285	CC6-4-#1#6S
PCC-1Y1D	M-1286	CC6-4-#1#8S
PCC-1V1V	M-1276	CC6-4-#2#2
PCC-1V1L	M-1277	CC6-4-#2#4
PCC-1V1H	M-1278	CC6-4-#2#6
PCC-1V1G	M-1279	CC6-4-#2#6S
PCC-1V1D	M-1280	CC6-4-#2#8S
PCC-1T1V		CC6-4-#2S#2
PCC-1T1T		CC6-4-#2S#2S
PCC-1T1H		CC6-4-#2S#6
PCC-1T1G		CC6-4-#2S#6S
PCC-1T2C		CC6-4-#2S1/0
PCC-1T2G		CC6-4-#2S2/0
PCC-1L1L		CC6-4-#4#4
PCC-1L1H		CC6-4-#4#6
PCC-1L1G		CC6-4-#4#6S
PCC-1L1D		CC6-4-#4#8S
PCC-2C1V	M-1289	CC6-4-1/0#2
PCC-2C1L	M-1290	CC6-4-1/0#4
PCC-2C1H	M-1291	CC6-4-1/0#6
PCC-2C1G	M-1292	CC6-4-1/0#6S
PCC-2C1D	M-1293	CC6-4-1/0#8S
PCC-2G1V	M-1297	CC6-4-2/0#2
PCC-2G1L	M-1298	CC6-4-2/0#4
PCC-2G1H	M-1299	CC6-4-2/0#6
PCC-2G1G	M-1300	CC6-4-2/0#6S
PCC-2G1D	M-1301	CC6-4-2/0#8S
-	-	CC6-4-2/02/0
PCC-2Q1Y	M-1305	CC6-4-4/0#1
PCC-2Q1V	M-1306	CC6-4-4/0#2
PCC-2Q1L	M-1307	CC6-4-4/0#4
PCC-2Q1H	M-1308	CC6-4-4/0#6
PCC-2Q1G	M-1309	CC6-4-4/0#6S
PCC-2Q1D	M-1310	CC6-4-4/0#8S
-	-	CC6-4-4/02/0
-	-	CC6-4-4/04/0
PTC-1Y1Y	M-1315	CC7-4-#1#1
PTC-1Y1X	M-6013	CC7-4-#1#1S
PTC-1Y1V	M-1316	CC7-4-#1#2

Cadweld Cat. No.	Thermoweld Cat. No.	Furseweld Cat. No.
PTC-1Y1T	M-6017	CC7-4-#1#2S
PTC-1Y1L	M-1317	CC7-4-#1#4
PTC-1Y1H	M-5636	CC7-4-#1#6
PTC-1Y1G	M-5637	CC7-4-#1#6S
PTC-1Y1E	M-5638	CC7-4-#1#8
PTC-1Y1D	M-5639	CC7-4-#1#8S
PTC-1X1Y	M-5998	CC7-4-#1S#1
PTC-1X1V	M-6001	CC7-4-#1S#2
PTC-1X1T	M-1316-S	CC7-4-#1S#2S
PTC-1X1H	M-6008	CC7-4-#1S#4
PTC-1X1H	M-6010	CC7-4-#1S#6
PTC-1X1G	M-5636-S	CC7-4-#1S#6S
PTC-1X1E	M-6012	CC7-4-#1S#8
PTC-1X1D	M-5638-S	CC7-4-#1S#8S
PTC-1V1V	M-1313	CC7-4-#2#2
PTC-1V1L	M-1314	CC7-4-#2#4
PTC-1V1H	M-5631	CC7-4-#2#6
PTC-1V1G	M-5632	CC7-4-#2#6S
PTC-1V1E	M-5634	CC7-4-#2#8
PTC-1V1D	M-5635	CC7-4-#2#8S
PTC-1T1V	M-5973	CC7-4-#2S#2
PTC-1T1T	M-1313-S	CC7-4-#2S#2S
PTC-1T1H	M-5987	CC7-4-#2S#4
PTC-1T1H	M-5989	CC7-4-#2S#6
PTC-1T1G	M-5631-S	CC7-4-#2S#6S
PTC-1T1E	M-5993	CC7-4-#2S#8
PTC-1T1D	M-5634-S	CC7-4-#2S#8S
PTC-1L1L	M-1311	CC7-4-#4#4
PTC-1L1H	M-5627	CC7-4-#4#6
PTC-1L1G	M-8882	CC7-4-#4#6S
PTC-1L1E	M-5629	CC7-4-#4#8
PTC-1L1D	M-5630	CC7-4-#4#8S
PTC-2C1Y	M-1319	CC7-4-1/0#1
PTC-2C1X	M-6036	CC7-4-1/0#1S
PTC-2C1V	M-1320	CC7-4-1/0#2
PTC-2C1T	M-6044	CC7-4-1/0#2S
PTC-2C1H	M-1321	CC7-4-1/0#4
PTC-2C1H	M-5642	CC7-4-1/0#6
PTC-2C1G	M-1208	CC7-4-1/0#6S
PTC-2C1E	M-5644	CC7-4-1/0#8
PTC-2C1D	M-5645	CC7-4-1/0#8S
PTC-2C2C	M-1318	CC7-4-1/01/0
PTC-2C2B	M-6035	CC7-4-1/01/0S
PTC-2B1Y	M-6019	CC7-4-1/0S#1
PTC-2B1X	M-1319-S	CC7-4-1/0S#1S
PTC-2B1V	M-6023	CC7-4-1/0S#2
PTC-2B1T	M-1320-S	CC7-4-1/0S#2S
PTC-2B1H	M-6026	CC7-4-1/0S#4
PTC-2B1H	M-6806	CC7-4-1/0S#6
PTC-2B1G	M-5462-S	CC7-4-1/0S#6S
PTC-2B1E	M-6028	CC7-4-1/0S#8

Cadweld Cat. No.	Thermoweld Cat. No.	Furseweld Cat. No.
PTC-2B1D	M-5644-S	CC7-4-1/0S#8S
PTC-2B2C	M-6227	CC7-4-1/0S1/0
PTC-2B2B	M-1318-S	CC7-4-1/0S1/0S
PTC-2G1Y	M-1324	CC7-4-2/0#1
PTC-2G1X	M-6052	CC7-4-2/0#1S
PTC-2G1V	M-1325	CC7-4-2/0#2
PTC-2G1L	M-5659	CC7-4-2/0#4
PTC-2G1H	M-5342	CC7-4-2/0#6
PTC-2G1G	M-5652	CC7-4-2/0#6S
PTC-2G1E	M-5668	CC7-4-2/0#8
PTC-2G1D	M-5943	CC7-4-2/0#8S
PTC-2G2C	M-1323	CC7-4-2/01/0
PTC-2G2B	M-6047	CC7-4-2/01/0S
PTC-2G2G	M-1322	CC7-4-2/02/0
PTC-2L1Y	M-1329	CC7-4-3/0#1
PTC-2L1X	M-6064	CC7-4-3/0#1S
PTC-2L1V	M-1330	CC7-4-3/0#2
PTC-2L1T	M-6065	CC7-4-3/0#2S
PTC-2L1L	M-6046	CC7-4-3/0#4
PTC-2L1H	M-5676	CC7-4-3/0#6
PTC-2L1G	M-5679	CC7-4-3/0#6S
PTC-2L1E	M-5680	CC7-4-3/0#8
PTC-2L1D	M-5682	CC7-4-3/0#8S
PTC-2L2C	M-1328	CC7-4-3/01/0
PTC-2L2B	M-6062	CC7-4-3/01/0S
PTC-2L2G	M-1327	CC7-4-3/02/0
PTC-2L2L	M-1326	CC7-4-3/03/0
PTC-2Q1Y	M-1335	CC7-4-4/0#1
PTC-2Q1X	M-6804	CC7-4-4/0#1S
PTC-2Q1V	M-1336	CC7-4-4/0#2
PTC-2Q1T	M-6805	CC7-4-4/0#2S
PTC-2Q1L	M-5340	CC7-4-4/0#4
PTC-2Q1H	M-5684	CC7-4-4/0#6
PTC-2Q1G	M-6552	CC7-4-4/0#6S
PTC-2Q1E	M-5686	CC7-4-4/0#8
PTC-2Q1D	M-5688	CC7-4-4/0#8S
PTC-2Q2C	M-1334	CC7-4-4/01/0
PTC-2Q2B	M-2551	CC7-4-4/01/0S
PTC-2Q2G	M-1333	CC7-4-4/02/0
PTC-2Q2L	M-1332	CC7-4-4/03/0
PTC-2Q2Q	M-1331	CC7-4-4/04/0
PTC-2Q2P	M-6803	CC7-4-4/04/0S
PTC-2P1Y	M-6089	CC7-4-4/0S#1
PTC-2P1X	M-1335-S	CC7-4-4/0S#1S
PTC-2P1V	M-6090	CC7-4-4/0S#2
PTC-2P1T	M-1336-S	CC7-4-4/0S#2S
PTC-2P1L	M-6109	CC7-4-4/0S#4
PTC-2P1H	M-6111	CC7-4-4/0S#6
PTC-2P1G	M-5684-S	CC7-4-4/0S#6S
PTC-2P1E	M-6112	CC7-4-4/0S#8
PTC-2P1D	M-5686-S	CC7-4-4/0S#8S

## Exothermic Welding System

### Cross Reference

Cadweld Cat. No.	Thermoweld Cat. No.	Furseweld Cat. No.
PTC-2P2C	M-6085	CC7-4-4/OS1/0
PTC-2P2B	M-1334-S	CC7-4-4/OS1/OS
PTC-2P2G	M-6082	CC7-4-4/OS2/0
PTC-2P2L	M-6081	CC7-4-4/OS3/0
PTC-2P2Q	M-6071	CC7-4-4/OS4/0
PTC-2P2P	M-1331-S	CC7-4-4/OS4/OS
GRT-14A1V	—	CR1-3-500#2
GRT-14A1T	—	CR1-3-500#2S
GRT-14A1L	M-8403	CR1-3-500#4
GRT-14A1K	M-8403-S	CR1-3-500#4S
GRT-14A1H	M-8402	CR1-3-500#6
GRT-14A1G	M-8402-S	CR1-3-500#6S
GRT-14B1V	—	CR1-3-500L#2
GRT-14B1T	—	CR1-3-500L#2S
GRT-14B1L	M-8403-T	CR1-3-500L#4
GRT-14B1K	M-8403-ST	CR1-3-500L#4S
GRT-14B1H	M-8402-T	CR1-3-500L#6
GRT-14B1G	M-8402-ST	CR1-3-500L#6S
GRT-161L	M-8415	CR1-3-625#4
GRT-161K	M-8415-S	CR1-3-625#4S
GRT-161H	M-8414	CR1-3-625#6
GRT-161G	M-8414-S	CR1-3-625#6S
GRP-181L	M-8426	CR1-3-750#4
GRP-181K	M-8426-S	CR1-3-750#4S
GRT-181H	M-8422	CR1-3-750#6
GRT-181G	M-8422-S	CR1-3-750#6S
GRC-151Y	M-496	CR1-4-500#1
GRC-152C	M-497	CR1-4-500#1/0
GRC-152B	M-497-S	CR1-4-500#1/OS
GRC-152G	M-498	CR1-4-500#2/0
GRC-152V	M-501	CR1-4-500#250K
GRC-152L	M-499	CR1-4-500#3/0
GRC-153A	M-502	CR1-4-500#300K
GRC-152Q	M-500	CR1-4-500#4/0
GRC-141Y	M-496-T	CR1-4-500L#1
GRC-142C	M-497-T	CR1-4-500L#1/0
GRC-142B	M-497-ST	CR1-4-500L#1/OS
GRC-142G	M-498-T	CR1-4-500L#2/0
GRC-142V	M-501-T	CR1-4-500L#250K
GRC-142L	M-499-T	CR1-4-500L#3/0
GRC-143A	M-502-T	CR1-4-500L#300K
GRC-142Q	M-500-T	CR1-4-500L#4/0
GRC-161Y	M-504	CR1-4-625#1
GRC-161V	M-503	CR1-4-625#2
GRT-161V	—	CR1-4-625#2
GRC-161T	—	CR1-4-625#2S
GRT-161T	—	CR1-4-625#2S
GRC-162C	M-505	CR1-4-625#1/0
GRC-162B	M-505-S	CR1-4-625#1/OS
GRC-162G	M-506	CR1-4-625#2/0
GRC-162V	M-509	CR1-4-625#250K

Cadweld Cat. No.	Thermoweld Cat. No.	Furseweld Cat. No.
GRC-162L	M-507	CR1-4-625#3/0
GRC-163A	M-510	CR1-4-625#300K
GRC-163D	M-511	CR1-4-625#350K
GRC-162Q	M-508	CR1-4-625#4/0
GRC-163Q	M-513	CR1-4-625#500K
GRC-181Y	M-514	CR1-4-750#1
GRC-181V	M-5781	CR1-4-750#2
GRC-181T	—	CR1-4-750#2S
GRC-182C	M-515	CR1-4-750#1/0
GRC-182B	M-515-S	CR1-4-750#1/OS
GRC-182G	M-516	CR1-4-750#2/0
GRC-182V	M-519	CR1-4-750#250K
GRC-182L	M-517	CR1-4-750#3/0
GRC-183A	M-520	CR1-4-750#300K
GRC-183D	M-521	CR1-4-750#350K
GRC-182Q	M-518	CR1-4-750#4/0
GRC-183Q	M-523	CR1-4-750#500K
—	—	CR17-4-750#4/0
GTT-14A1L	M-8435	CR2-3-500#4
GTT-14A1K	M-8435-S	CR2-3-500#4S
GTT-14A1H	M-8434	CR2-3-500#6
GTT-14A1G	M-8434-S	CR2-3-500#6S
GTT-14B1L	M-8435-T	CR2-3-500L#4
GTT-14B1K	M-8435-ST	CR2-3-500L#4S
GTT-14B1H	M-8434-T	CR2-3-500L#6
GTT-14B1G	M-8434-ST	CR2-3-500L#6S
GTT-161L	M-8442	CR2-3-625#4
GTT-161K	M-8442-S	CR2-3-625#4S
GTT-161H	M-8441	CR2-3-625#6
GTT-161G	M-8441-S	CR2-3-625#6S
GTP-181L	M-8454	CR2-3-750#4
GTP-181K	M-8454-S	CR2-3-750#4S
GTP-181H	M-8452	CR2-3-750#6
GTP-181G	M-8452-S	CR2-3-750#6S
GTC-151Y	M-538	CR2-4-500#1
GTC-151V	M-537	CR2-4-500#2
GTC-151T	—	CR2-4-500#2S
GTC-152C	M-539	CR2-4-500#1/0
GTC-152B	M-539-S	CR2-4-500#1/OS
GTC-152G	M-540	CR2-4-500#2/0
GTC-152V	M-543	CR2-4-500#250K
GTC-152L	M-541	CR2-4-500#3/0
GTC-153A	M-544	CR2-4-500#300K
GTC-152Q	M-542	CR2-4-500#4/0
GTC-141Y	M-538-T	CR2-4-500L#1
GTC-141V	M-537-T	CR2-4-500L#2
GTC-141T	—	CR2-4-500L#2S
GTC-142C	M-539-T	CR2-4-500L#1/0
GTC-142B	—	CR2-4-500L#1/OS
GTC-142G	M-540-T	CR2-4-500L#2/0
GTC-142V	M-543-T	CR2-4-500L#250K

Cadweld Cat. No.	Thermoweld Cat. No.	Furseweld Cat. No.
GTC-142L	M-541-T	CR2-4-500L#3/0
GTC-143A	M-544-T	CR2-4-500L#300K
GTC-142Q	M-542-T	CR2-4-500L#4/0
GTC-161Y	M-546	CR2-4-625#1
GTC-161V	M-545	CR2-4-625#2
GTC-161T	—	CR2-4-625#2S
GTC-162C	M-547	CR2-4-625#1/0
GTC-162B	M-547-S	CR2-4-625#1/OS
GTC-162G	M-548	CR2-4-625#2/0
GTC-162V	M-551	CR2-4-625#250K
GTC-162L	M-549	CR2-4-625#3/0
GTC-163A	M-552	CR2-4-625#300K
GTC-163D	M-553	CR2-4-625#350K
GTC-162Q	M-550	CR2-4-625#4/0
GTC-163Q	M-555	CR2-4-625#500K
GTC-181Y	M-557	CR2-4-750#1
GTC-181V	M-556	CR2-4-750#2
GTC-181T	—	CR2-4-750#2S
GTC-182C	M-558	CR2-4-750#1/0
GTC-182B	M-558-S	CR2-4-750#1/OS
GTC-182G	M-559	CR2-4-750#2/0
GTC-182V	M-562	CR2-4-750#250K
GTC-182L	M-560	CR2-4-750#3/0
GTC-183A	M-563	CR2-4-750#300K
GTC-183D	M-564	CR2-4-750#350K
GTC-182Q	M-561	CR2-4-750#4/0
GTC-183Q	M-566	CR2-4-750#500K
GYJ-163Q	M-1593	CR3-10-625#500K
GYJ-183D	M-1599	CR3-10-750#350K
GYJ-183Q	M-1601	CR3-10-750#500K
GYE-152C	M-1581	CR3-9-500#1/0
GYE-152B	M-1581-S	CR3-9-500#1/OS
GYE-152G	M-1582	CR3-9-500#2/0
GYE-152V	M-1584	CR3-9-500#250K
GYE-152L	M-6267	CR3-9-500#3/0
GYE-153A	M-1585	CR3-9-500#300K
GYE-152Q	M-1583	CR3-9-500#4/0
GYE-142C	M-1581-T	CR3-9-500L#1/0
GYE-142B	M-1581-ST	CR3-9-500L#1/OS
GYE-142G	M-1582-T	CR3-9-500L#2/0
GYE-142V	M-1584-T	CR3-9-500L#250K
GYE-142L	M-6267-T	CR3-9-500L#3/0
GYE-143A	M-1585-T	CR3-9-500L#300K
GYE-142Q	M-1583-T	CR3-9-500L#4/0
—	—	CR3-9-625#2
GYE-162C	M-1586	CR3-9-625#1/0
GYE-162B	M-1586-S	CR3-9-625#1/OS
GYE-162G	M-1587	CR3-9-625#2/0
GYE-162V	M-1589	CR3-9-625#250K
GYE-162L	M-8305	CR3-9-625#3/0
GYE-163A	M-1590	CR3-9-625#300K

## Exothermic Welding System

### Cross Reference

Cadweld Cat. No.	Thermoweld Cat. No.	Furseweld Cat. No.
GYE-163D	M-1591	CR3-9-625350K
GYE-162Q	M-1588	CR3-9-6254/0
GYE-182C	M-1594	CR3-9-7501/0
GYE-182B	M-1594-S	CR3-9-7501/0S
GYE-182G	M-1595	CR3-9-7502/0
GYE-182V	M-1597	CR3-9-750250K
GYE-182L	M-6608	CR3-9-7503/0
GYE-183A	-	CR3-9-750300K
GYE-182Q	M-1596	CR3-9-7504/0
RR	-	CRE1-3-#1Y
RR	-	CRE1-3-#1Z
RR	-	CRE1-3-#2SY
RR	-	CRE1-3-#2SZ
RR	-	CRE1-3-#2Y
RR	-	CRE1-3-#2Z
RR	-	CRE1-3-#4Y
RR	-	CRE1-3-#4Z
RR	-	CRE1-3-1/0Y
RR	-	CRE1-3-1/0Z
RR	-	CRE1-3-2/0Y
RR	-	CRE1-3-2/0Z
RR	-	CRE1-3-3/0Y
RR	-	CRE1-3-3/0Z
RR	-	CRE1-3-4/0Y
RR	-	CRE1-3-4/0Z
RRC-511Y	M-7503	CRE1-4-#13R
RRC-511V	M-7502	CRE1-4-#23R
RRC-511T	-	CRE1-4-#2S3R
RRC-511L	M-7501	CRE1-4-#43R
RRC-512C	M-7504	CRE1-4-1/03R
RRC-512G	M-7505	CRE1-4-2/03R
RRC-512L	M-7506	CRE1-4-3/03R
RRC-512Q	M-7507	CRE1-4-4/03R
RC	-	CRE3-3-#2SY
RC	-	CRE3-3-#2SZ
RC	-	CRE3-3-#2Y
RC	-	CRE3-3-#2Z
RC	-	CRE3-3-#4Y
RC	-	CRE3-3-#4Z
-	-	CRE3-3-1/0Y
-	-	CRE3-3-1/0Z
-	-	CRE3-3-2/0Y
-	-	CRE3-3-2/0Z
RC	-	CRE3-4-#1Y
RC	-	CRE3-4-#1Z
RC	-	CRE3-4-1/0Y
RC	-	CRE3-4-1/0Z
RC	-	CRE3-4-2/0Y
RC	-	CRE3-4-2/0Z
RC	-	CRE3-4-3/0Y
RC	-	CRE3-4-3/0Z

Cadweld Cat. No.	Thermoweld Cat. No.	Furseweld Cat. No.
RC	-	CRE3-4-4/0Y
RC	-	CRE3-4-4/0Z
RD	-	CRE4-3-#1Y
RD	-	CRE4-3-#1Z
RD	-	CRE4-3-#2SY
RD	-	CRE4-3-#2SZ
RD	-	CRE4-3-#2Y
RD	-	CRE4-3-#2Z
RD	-	CRE4-3-#4Y
RD	-	CRE4-3-#4Z
RD	-	CRE4-3-1/0Y
RD	-	CRE4-3-1/0Z
RD	-	CRE4-3-2/0Y
RD	-	CRE4-3-2/0Z
RD	-	CRE4-3-3/0Y
RD	-	CRE4-3-3/0Z
RD	-	CRE4-3-4/0Y
RD	-	CRE4-3-4/0Z
RJ	-	CRE6-3-#1Y
RJ	-	CRE6-3-#1Z
RJ	-	CRE6-3-#2SY
RJ	-	CRE6-3-#2SZ
RJ	-	CRE6-3-#2Y
RJ	-	CRE6-3-#2Z
RJ	-	CRE6-3-#4Y
RJ	-	CRE6-3-#4Z
RJ	-	CRE6-4-1/0Y
RJ	-	CRE6-4-1/0Z
RJ	-	CRE6-4-2/0Y
RJ	-	CRE6-4-2/0Z
RJ	-	CRE6-4-3/0Y
RJ	-	CRE6-4-3/0Z
RJ	-	CRE6-4-4/0Y
RJ	-	CRE6-4-4/0Z
HSC-2C	M-644	CS1-4-1/0
HSD-4Y	M-654	CS1-4-1000K
HSC-2G	M-645	CS1-4-2/0
HSC-2V	M-648	CS1-4-250K
HSC-2L	M-646	CS1-4-3/0
HSC-3A	M-649	CS1-4-300K
HSC-3D	M-650	CS1-4-350K
HSC-2Q	M-647	CS1-4-4/0
HSC-3Q	M-652	CS1-4-500K
HSD-4L	M-653	CS1-4-750K
HTC-2C	M-616	CS2-4-1/0
HTC-2G	M-617	CS2-4-2/0
HTC-2V	M-620	CS2-4-250K
HTC-2L	M-618	CS2-4-3/0
HTC-3A	M-621	CS2-4-300K
HTC-3D	M-622	CS2-4-350K
HTC-2Q	M-619	CS2-4-4/0

Cadweld Cat. No.	Thermoweld Cat. No.	Furseweld Cat. No.
VBC-1Y	M-5361	CS25-4-#1
VBC-1Y-V3	-	CS25-4-#1C
VBC-1Y-V5	-	CS25-4-#1D
VBC-1Y-V8	-	CS25-4-#1F
VBC-1Y-V21C	-	CS25-4-#1G
VBC-1V	M-2781	CS25-4-#2
VBC-1V-V3	-	CS25-4-#2C
VBC-1V-V5	-	CS25-4-#2D
VBC-1V-V8	-	CS25-4-#2F
VBC-1V-V21C	-	CS25-4-#2G
VBC-1T	-	CS25-4-#2S
VBC-1T-V3	-	CS25-4-#2SC
VBC-1T-V5	-	CS25-4-#2SD
VBC-1T-V8	-	CS25-4-#2SF
VBC-1T-V21	-	CS25-4-#2SG
VBC-1L	M-5359	CS25-4-#4
VBC-1L-V3	-	CS25-4-#4C
VBC-1L-V5	-	CS25-4-#4D
VBC-1L-V8	-	CS25-4-#4F
VBC-1L-V21	-	CS25-4-#4G
VBC-2C	M-2189	CS25-4-1/0
VBC-2C-V3	-	CS25-4-1/0C
VBC-2C-V5	-	CS25-4-1/0D
VBC-2C-V8	-	CS25-4-1/0F
VBC-2C-V20	-	CS25-4-1/0G
VBC-2G	M-2540	CS25-4-2/0
VBC-2G-V3	-	CS25-4-2/0C
VBC-2G-V5	-	CS25-4-2/0D
VBC-2G-V8	-	CS25-4-2/0F
VBC-2G-V20	-	CS25-4-2/0G
VBC-2V	M-8165	CS25-4-250K
VBC-2L	M-5362	CS25-4-3/0
VBC-2L-V3	-	CS25-4-3/0C
VBC-2L-V5	-	CS25-4-3/0D
VBC-2L-V8	-	CS25-4-3/0F
VBC-2L-V20	-	CS25-4-3/0G
VBC-3A	M-5363	CS25-4-300K
VBC-3D	M-9029	CS25-4-350K
VBC-2Q	M-8718	CS25-4-4/0
VBC-2Q-V3	-	CS25-4-4/0C
VBC-2Q-V5	-	CS25-4-4/0D
VBC-2Q-V8	-	CS25-4-4/0F
VBC-2Q-V20	-	CS25-4-4/0G
VBR-3Q	M-8512	CS25-4-500K
HTD-2Q	M-624	CS2-5-500K
VGC-1Y	M-6279	CS27-4-#1
VGC-1Y-V3	-	CS27-4-#1C
VGC-1Y-V5	-	CS27-4-#1D
VGC-1Y-V8	-	CS27-4-#1F
VGC-1Y-V21C	-	CS27-4-#1G
VGC-1V	M-5822	CS27-4-#2

## Exothermic Welding System

### Cross Reference

Cadweld Cat. No.	Thermoweld Cat. No.	Furseweld Cat. No.
VGC-1V-V3		CS27-4-#2C
VGC-1V-V5		CS27-4-#2D
VGC-1V-V8		CS27-4-#2F
VGC-1V-V21C		CS27-4-#2G
VGC-1T	-	CS27-4-#2S
VGC-1T-V3		CS27-4-#2SC
VGC-1T-V5		CS27-4-#2SD
VGC-1T-V8		CS27-4-#2SF
VGC-1T-V21		CS27-4-#2SG
VGC-1H	M-5245	CS27-4-#4
VGC-1L	M-5816	CS27-4-#4
VGC-1L-V3		CS27-4-#4C
VGC-1L-V5		CS27-4-#4D
VGC-1L-V8		CS27-4-#4F
VGC-1L-V21		CS27-4-#4G
VGC-2C	M-1168	CS27-4-1/0
VGC-2C-V3		CS27-4-1/0C
VGC-2C-V5		CS27-4-1/0D
VGC-2C-V8		CS27-4-1/0F
VGC-2C-V20		CS27-4-1/0G
VGC-2G	M-9242	CS27-4-2/0
VGC-2G-V3		CS27-4-2/0C
VGC-2G-V5		CS27-4-2/0D
VGC-2G-V8		CS27-4-2/0F
VGC-2G-V20		CS27-4-2/0G
VGC-2V	M-2520	CS27-4-250K
VGC-2L	M-6195	CS27-4-3/0
VGC-2L-V3		CS27-4-3/0C
VGC-2L-V5		CS27-4-3/0D
VGC-2L-V8		CS27-4-3/0F
VGC-2L-V20		CS27-4-3/0G
VGC-2Q	M-2177	CS27-4-4/0
VGC-2Q-V3		CS27-4-4/0C
VGC-2Q-V5		CS27-4-4/0D
VGC-2Q-V8		CS27-4-4/0F
VGC-2Q-V20		CS27-4-4/0G
VNC-1Y	M-6060	CS31-4-#1
VGC-1Y-V3		CS31-4-#1C
VGC-1Y-V5		CS31-4-#1D
VGC-1Y-V8		CS31-4-#1F
VGC-1Y-V21C		CS31-4-#1G
VNC-1V	M-2569	CS31-4-#2
VGC-1V-V3		CS31-4-#2C
VGC-1V-V5		CS31-4-#2D
VGC-1V-V8		CS31-4-#2F
VGC-1V-V21C		CS31-4-#2G
VNC-1T	-	CS31-4-#2S
VGC-1T-V3		CS31-4-#2SC
VGC-1T-V5		CS31-4-#2SD
VGC-1T-V8		CS31-4-#2SF
VGC-1T-V21		CS31-4-#2SG

Cadweld Cat. No.	Thermoweld Cat. No.	Furseweld Cat. No.
VNC-1L	M-2761	CS31-4-#4
VGC-1L-V3		CS31-4-#4C
VGC-1L-V5		CS31-4-#4D
VGC-1L-V8		CS31-4-#4F
VGC-1L-V21		CS31-4-#4G
VNC-1H	M-5910	CS31-4-#6
VNC-2C	M-5419	CS31-4-1/0
VGC-2C-V3		CS31-4-1/0C
VGC-2C-V5		CS31-4-1/0D
VGC-2C-V8		CS31-4-1/0F
VGC-2C-V20		CS31-4-1/0G
VNC-2G	M-2567	CS31-4-2/0
VGC-2G-V3		CS31-4-2/0C
VGC-2G-V5		CS31-4-2/0D
VGC-2G-V8		CS31-4-2/0F
VGC-2G-V20		CS31-4-2/0G
VNC-2V	M-2568	CS31-4-250K
VNC-2L	M-6072	CS31-4-3/0
VGC-2L-V3		CS31-4-3/0C
VGC-2L-V5		CS31-4-3/0D
VGC-2L-V8		CS31-4-3/0F
VGC-2L-V20		CS31-4-3/0G
VNC-3A	M-6061	CS31-4-300K
VNC-3D	M-6067	CS31-4-350K
VNC-2Q	M-9253	CS31-4-4/0
VGC-2Q-V3		CS31-4-4/0C
VGC-2Q-V5		CS31-4-4/0D
VGC-2Q-V8		CS31-4-4/0F
VGC-2Q-V20		CS31-4-4/0G
VNC-3Q	M-8359	CS31-4-500K
HAA-1Y-325C	M-6269	CS32-2-#1D
HAA-1Y-7C	M-6270	CS32-2-#1F
HAA-1Y-11C	M-6271	CS32-2-#1G
HAA-1V-162C	M-6016	CS32-2-#2C
HAA-1V-350C	M-2576	CS32-2-#2D
HAA-1V-7C	M-2514	CS32-2-#2F
HAA-1V-11C	M-2515	CS32-2-#2G
HAA-1T-162C		CS32-2-#2SC
HAA-1T-350C		CS32-2-#2SD
HAA-1T-7C		CS32-2-#2SF
HAA-1T-11C		CS32-2-#2SG
HAA-1L-162C	M-8014	CS32-2-#4C
HAA-1L-350C	M-8015	CS32-2-#4D
HAA-1L-7C	M-2516	CS32-2-#4F
HAA-1L-11C	M-2517	CS32-2-#4G
HAH-2C-350C	M-8504	CS32-4-1/0D
HAH-2C-8C	M-8505	CS32-4-1/0F
HAH-2C-20C	M-6272	CS32-4-1/0G
HAH-2G-350C	M-2776	CS32-4-2/0D
HAH-2G-8C	M-6273	CS32-4-2/0F
HAH-2G-20C	M-6274	CS32-4-2/0G

Cadweld Cat. No.	Thermoweld Cat. No.	Furseweld Cat. No.
HAH-2L-350C	M-6275	CS32-4-3/0D
HAH-2L-8C	M-6276	CS32-4-3/0F
HAH-2L-20C	M-6278	CS32-4-3/0G
HAH-2Q-350C	M-9236	CS32-4-4/0D
HAH-2Q-8C	M-9237	CS32-4-4/0F
HAH-2Q-20C	M-9238	CS32-4-4/0G
VSC-1Y	M-589	CS3-4-#1
VSC-1Y-V3C	M-2482	CS3-4-#1C
VSC-1Y-V5C	M-2483	CS3-4-#1D
VSC-1Y-V8C	M-2484	CS3-4-#1F
VSC-1Y-V21C	M-2485	CS3-4-#1G
VSC-1V	M-588	CS3-4-#2
VSC-1V-V3C	M-9233	CS3-4-#2C
VSC-1V-V5C	M-2480	CS3-4-#2D
VSC-1V-V8C	M-2583	CS3-4-#2F
VSC-1V-V21C	M-2481	CS3-4-#2G
VSC-1T		CS3-4-#2S
VSC-1T-V3C		CS3-4-#2SC
VSC-1T-V5C		CS3-4-#2SD
VSC-1T-V8C		CS3-4-#2SF
VSC-1T-V21C		CS3-4-#2SG
VSC-1L	M-586	CS3-4-#4
VSC-1L-V3C	M-2476	CS3-4-#4C
VSC-1L-V5C	M-2477	CS3-4-#4D
VSC-1L-V8C	M-2478	CS3-4-#4F
VSC-1L-V21C	M-2479	CS3-4-#4G
VSC-1H	M-585	CS3-4-#6
VSC-2C	M-590	CS3-4-1/0
VSC-2C-V3C	M-2486	CS3-4-1/0C
VSC-2C-V5C	M-2487	CS3-4-1/0D
VSC-2C-V8C	M-2488	CS3-4-1/0F
VSC-2C-V21C	M-2489	CS3-4-1/0G
HCA-1Y-350C		CS34-2-#1D
HCA-1Y-7C		CS34-2-#1F
HCA-1Y-11C		CS34-2-#1G
HCA-1V-162C		CS34-2-#2C
HCA-1V-350C		CS34-2-#2D
HCA-1V-7C		CS34-2-#2F
HCA-1V-11C		CS34-2-#2G
HCA-1T-162C		CS34-2-#2SC
HCA-1T-350C		CS34-2-#2SD
HCA-1T-7C		CS34-2-#2SF
HCA-1T-11C		CS34-2-#2SG
HCA-1L-162C		CS34-2-#4C
HCA-1L-350C		CS34-2-#4D
HCA-1L-7C		CS34-2-#4F
HCA-1L-11C		CS34-2-#4G
VSC-2G	M-591	CS3-4-2/0
VSC-2G-V3C	M-8833	CS3-4-2/0C
VSC-2G-V5C	M-2490	CS3-4-2/0D
VSC-2G-V8C	M-2491	CS3-4-2/0F

## Exothermic Welding System

### Cross Reference

Cadweld Cat. No.	Thermoweld Cat. No.	Furseweld Cat. No.
VSC-2G-V21C	M-2492	CS3-4-2/OG
VSC-2V	M-594	CS3-4-250K
VSC-2L	M-592	CS3-4-3/0
VSC-2L-V3C	M-2493	CS3-4-3/OC
VSC-2L-V5C	M-2494	CS3-4-3/OD
VSC-2L-V8C	M-2495	CS3-4-3/OF
VSC-2L-V21C	M-2496	CS3-4-3/OG
VSC-3A	M-595	CS3-4-300K
VSC-3D	M-596	CS3-4-350K
VSC-2Q	M-593	CS3-4-4/0
VSC-2Q-V3C	M-9021	CS3-4-4/OC
VSC-2Q-V5C	M-2497	CS3-4-4/OD
VSC-2Q-V8C	M-2498	CS3-4-4/OF
VSC-2Q-V21C	M-2499	CS3-4-4/OG
HTC-2C-350C		CS34-4-1/OD
HTC-2C-8C		CS34-4-1/OF
HTC-2C-20C		CS34-4-1/OG
HTC-2G-350C		CS34-4-2/OD
HTC-2G-8C		CS34-4-2/OF
HTC-2G-20C		CS34-4-2/OG
HTC-2L-350C		CS34-4-3/OD
HTC-2L-8C		CS34-4-3/OF
HTC-2L-20C		CS34-4-3/OG
HTC-2Q-350C		CS34-4-4/OD
HTC-2Q-8C		CS34-4-4/OF
HTC-2Q-20C		CS34-4-4/OG
VSC-3Q	M-598	CS3-4-500K
VSD-4Y	M-600	CS3-5-1000K
VSD-4L	M-599	CS3-5-750K
VVC-1Y	M-1219	CS4-4-#1
VVC-1Y-V3		CS4-4-#1C
VVC-1Y-V5		CS4-4-#1D
VVC-1Y-V8		CS4-4-#1F
VVC-1Y-V21		CS4-4-#1G
VVC-1V	M-1218	CS4-4-#2
VVC-1V-V3		CS4-4-#2C
VVC-1V-V5		CS4-4-#2D
VVC-1V-V8		CS4-4-#2F
VVC-1V-V21		CS4-4-#2G
VVC-1T		CS4-4-#2S
VVC-1T-V3		CS4-4-#2SC
VVC-1T-V5		CS4-4-#2SD
VVC-1T-V8		CS4-4-#2SF
VVC-1T-V21		CS4-4-#2SG
VVC-1L	M-1216	CS4-4-#4
VVC-1L-V3		CS4-4-#4C
VVC-1L-V5		CS4-4-#4D
VVC-1L-V8		CS4-4-#4F
VVC-1L-V21		CS4-4-#4G
VVC-1H	M-1215	CS4-4-#6
WVR-2C	M-1220	CS4-5-1/0

Cadweld Cat. No.	Thermoweld Cat. No.	Furseweld Cat. No.
WVR-2C-V3		CS4-5-1/OC
WVR-2C-V5		CS4-5-1/OD
WVR-2C-V8		CS4-5-1/OF
WVR-2C-V20		CS4-5-1/OG
WVR-2G	M-1221	CS4-5-2/0
WVR-2G-V3		CS4-5-2/OC
WVR-2G-V5		CS4-5-2/OD
WVR-2G-V8		CS4-5-2/OF
WVR-2G-V20		CS4-5-2/OG
WVR-2V	M-1224	CS4-5-250K
WVR-2L	M-1222	CS4-5-3/0
WVR-2L-V3		CS4-5-3/OC
WVR-2L-V5		CS4-5-3/OD
WVR-2L-V8		CS4-5-3/OF
WVR-2L-V20		CS4-5-3/OG
WVR-2Q	M-1223	CS4-5-4/0
WVR-2Q-V3		CS4-5-4/OC
WVR-2Q-V5		CS4-5-4/OD
WVR-2QV8		CS4-5-4/OF
WVR-2Q-V20		CS4-5-4/OG
VFC-1Y	M-1639	CS7-4-#1
VFC-1Y-V3		CS7-4-#1C
VFC-1Y-V5		CS7-4-#1D
VFC-1Y-V8		CS7-4-#1F
VFC-1Y-V21		CS7-4-#1G
VFC-1V	M-1638	CS7-4-#2
VFC-1V-V3		CS7-4-#2C
VFC-1V-V5		CS7-4-#2D
VFC-1V-V8		CS7-4-#2F
VFC-1V-V21		CS7-4-#2G
VFC-1T		CS7-4-#2S
VFC-1T-V3		CS7-4-#2SC
VFC-1T-V5		CS7-4-#2SD
VFC-1T-V8		CS7-4-#2SF
VFC-1T-V21		CS7-4-#2SG
VFC-1L	M-1636	CS7-4-#4
VFC-1L-V3		CS7-4-#4C
VFC-1L-V5		CS7-4-#4D
VFC-1L-V8		CS7-4-#4F
VFC-1L-V21		CS7-4-#4G
VFC-2C	M-1640	CS7-4-1/0
VFC-2C-V3		CS7-4-1/OC
VFC-2C-V5		CS7-4-1/OD
VFC-2C-V8		CS7-4-1/OF
VFC-2C-V20		CS7-4-1/OG
VFC-2G	M-1641	CS7-4-2/0
VFC-2G-V3		CS7-4-2/OC
VFC-2G-V5		CS7-4-2/OD
VFC-2G-V8		CS7-4-2/OF
VFC-2G-V20		CS7-4-2/OG
VFR-2V	M-1644	CS7-5-250K

Cadweld Cat. No.	Thermoweld Cat. No.	Furseweld Cat. No.
VFR-2L	M-1642	CS7-5-3/0
VFR-2L-V3		CS7-5-3/OC
VFR-2L-V5		CS7-5-3/OD
VFR-2L-V8		CS7-5-3/OF
VFR-2L-V20		CS7-5-3/OG
VFR-3A	M-1645	CS7-5-300K
VFR-2Q	M-1643	CS7-5-4/0
VFR-2Q-V3		CS7-5-4/OC
VFR-2Q-V5		CS7-5-4/OD
VFR-2Q-V8		CS7-5-4/OF
VFR-2Q-V20		CS7-5-4/OG
VFF-3D	M-1646	CS7-6-350K
VFF-3Q	M-1648	CS7-6-500K
HAA-1Y	M-631	CS8-2-#1
HAA-1V	M-630	CS8-2-#2
HAA-1T		CS8-2-#2S
HAA-1L	M-629	CS8-2-#4
HAA-1H	M-628	CS8-2-#6
HCA-1Y	M-605	CS9-2-#1
HCA-1V	M-604	CS9-2-#2
HCA-1T		CS9-2-#2S
HCA-1L	M-603	CS9-2-#4
HCA-1H	M-602	CS9-2-#6
15	15	15RTB
25	25	25RTB
32	32	32RTB
45	45	45RTB
65	65	65RTB
90	90	90RTB
115	115	115RTB
150	150	150RTB
200	200	200RTB
250	250	250RTB
L160	40-0106-00	HCPK4
L159	40-0107-00	HCPK5
T314	38-0135-00	WRB1
T314A	38-0135-01	WRB1
T313	38-0306-00	BFC
T320	38-0309-00	FGUN
T394	38-3922-00	BCM
B136A/B	40-0319-01/3/5/6	STM1
T403	38-4129-00	MSC
B144A/B/C/E	38-406-1/2/3/4-00	PACK-A

## Exothermic Welding System

### Sure Shot™ Cross Reference

Ground Rod Size (in.)	Conductor Size		Cadweld Cat. No.	Thermoweld Cat. No.	Furseweld Cat. No.
	Solid	Stranded	TYPE GR(CR1)	TYPE CR-1	TYPE CR1
1/2	6,8	8	GR1-141G	-	-
	3,4	4,6	GR1-141L		
	1,2	2,3	GR1-141V		
5/8	6,8	8	GR1-161G	M-2012	SCR1-58-6808
	3,4	4,6	GR1-161L	M-2013	SCR1-58-3446
	1,2	2,3	GR1-161V	M-2014	SCR1-58-1223
	2/0,1/0	1/0,1	GR1-162C	M-2015	SCR1-58-2010
	-	2/0	GR1-162G	M-2016	SCR1-58-0020
3/4	6,8	8	GR1-181G	M-2017	SCR1-34-6808
	3,4	4,6	GR1-181L	M-2018	SCR1-34-3446
	1,2	2,3	GR1-181V	M-2019	SCR1-34-1223
	2/0,1/0	1/0,1	GR1-182C	M-2020	SCR1-34-2010
	-	2/0	GR1-182G	M-2021	SCR1-34-0020
	-	4/0	GR1-182Q	-	SCR1-34-0040
Size (in.)	Solid	Stranded	TYPE GT(CR2)	TYPE CR-2	TYPE CR2
1/2	6,8	8	GT1-141G	-	-
	3,4	4,6	GT1-141L		
	1,2	2,3	GT1-141V		
5/8	6,8	8	GT1-161G	M-2027	SCR2-58-6808
	3,4	4,6	GT1-161L	M-2028	SCR2-58-3446
	1,2	2,3	GT1-161V	M-2029	SCR2-58-1223
	2/0,1/0	1/0,1	GT1-162C	M-2030	SCR2-58-2010
	-	2/0	-	-	SCR2-58-0020*
3/4	6,8	8	GT1-181G	M-2031	SCR2-34-6808
	3,4	4,6	GT1-181L	M-2032	SCR2-34-3446
	1,2	2,3	GT1-181V	M-2033	SCR2-34-1223
	2/0,1/0	1/0,1	GT1-182C	M-2034	SCR2-34-2010
	-	2/0	-	-	SCR2-34-0020*
	-	4/0	-	-	SCR2-34-0040*
Size (in.)	Solid	Stranded	TYPE NT(CR17)		TYPE CR17
1/2	6,8	8	NT1-141G	-	-
	3,4	4,6	NT1-141L		
	1,2	2,3	-		
5/8	6,8	8	NT1-161G	-	SCR17-58-6808
	3,4	4,6	NT1-161L		SCR17-58-3446
	1,2	2,3	NT1-161V		SCR17-58-1223
	2/0,1/0	1/0,1	-		SCR17-58-2010*
	-	2/0	-		SCR17-58-0020*
3/4	6,8	8	NT1-181G	-	SCR17-34-6808
	3,4	4,6	NT1-181L		SCR17-34-3446
	1,2	2,3	NT1-181V		SCR17-34-1223
	2/0,1/0	1/0,1	-		SCR17-34-2010*
	-	2/0	-		SCR17-34-0020*
	-	4/0	-		SCR17-34-0040*
Size (in.)	Solid	Stranded	TYPE NX(CR24)		TYPE CR24
1/2	6,8	8	NX1-141G	-	-
	3,4	4,6	NX1-141L		
	1,2	2,3	-		
5/8	6,8	8	NX1-161G	-	SCR24-58-6808
	3,4	4,6	NX1-161L		SCR24-58-3446

\* Future development.

## Exothermic Welding System

### Sure Shot™ Cross Reference

Ground Rod	Conductor Size		Cadweld Cat. No.	Thermoweld Cat. No.	Furseweld Cat. No.
Size (in.)	Solid	Stranded	TYPE GR(CR1)	TYPE CR-1	TYPE CR1
3/4	3,4	4,6	NX1-181L	-	<a href="#">SCR24-34-3446</a>
	1,2	2,3	NX1-181V		<a href="#">SCR24-34-1223</a>
	2/0,1/0	1/0,1			<a href="#">SCR24-34-2010*</a>
5/8	-	2/0	-		<a href="#">SCR24-34-0020*</a>
		4/0			<a href="#">SCR24-34-0040*</a>
Size (in.)	Solid	Stranded		TYPE CR-25	TYPE CR25
	6,8	8		M-2006	<a href="#">SCR25-58-6808</a>
	3,4	4,6		M-2007	<a href="#">SCR25-58-3446</a>
	1,2	2,3		M-2008	<a href="#">SCR25-58-1223</a>
3/4	2/0,1/0	1/0,1	-	M-2023	<a href="#">SCR25-58-12010</a>
	6,8	8		M-2068	<a href="#">SCR25-34-6808</a>
	3,4	4,6		M-2069	<a href="#">SCR25-34-3446</a>

\* Future development.

## Exothermic Welding System

### Additional Tables

#### Conductor Properties

Size (AWG or kcmil)	Area		Quantity	Conductors						Direct-Current Resistance at 75°C (167°F)					
				Stranding				Overall		Copper				Aluminum	
	mm <sup>2</sup>	Circular mils		Diameter		Diameter		Area		Uncoated		Coated		ohm/km	ohm/kFT
				mm	in.	mm	in.	mm <sup>2</sup>	in. <sup>2</sup>	ohm/km	ohm/kFT	ohm/km	ohm/kFT		
18	0.823	1620	1	—	—	1.02	0.040	0.823	0.001	25.5	7.77	26.5	8.08	42.0	12.8
			7	0.39	0.015	1.16	0.046	1.06	0.002	26.1	7.95	27.7	8.45	42.8	13.1
16	1.31	2580	1	—	—	1.29	0.051	1.31	0.003	16.0	4.89	16.7	5.08	26.4	8.05
			7	0.49	0.019	1.46	0.058	1.68	0.003	16.4	4.99	17.3	5.29	26.9	8.21
14	2.08	4110	1	—	—	1.63	0.064	2.08	0.004	10.1	3.07	10.4	3.19	16.6	5.06
			7	0.62	0.024	1.85	0.073	2.68	0.004	10.3	3.14	10.7	3.26	16.9	5.17
12	3.31	6530	1	—	—	2.05	0.081	3.31	0.005	6.34	1.93	6.57	2.01	10.45	3.18
			7	0.78	0.030	2.32	0.092	4.25	0.006	6.50	1.98	6.73	2.05	10.69	3.25
10	5.261	10380	1	—	—	2.588	0.102	5.26	0.008	3.984	1.21	4.148	1.26	6.561	2.00
			7	0.98	0.038	2.95	0.116	6.76	0.011	4.070	1.24	4.226	1.29	6.679	2.04
8	8.367	16510	1	—	—	3.264	0.128	8.37	0.013	2.506	0.764	2.579	0.786	4.125	1.26
			7	1.23	0.049	3.71	0.146	10.76	0.017	2.551	0.778	2.653	0.809	4.204	1.28
6	13.30	26240	7	1.56	0.061	4.67	0.184	17.09	0.027	1.608	0.491	1.671	0.510	2.652	0.808
4	21.15	41740		1.96	0.077	5.89	0.232	27.19	0.042	1.010	0.308	1.053	0.321	1.666	0.508
3	26.67	52620		2.20	0.087	6.60	0.260	34.28	0.053	0.802	0.245	0.833	0.254	1.320	0.403
2	33.62	66360		2.47	0.097	7.42	0.292	43.23	0.067	0.634	0.194	0.661	0.201	1.045	0.319
1	42.41	83690	19	1.69	0.066	8.43	0.332	55.80	0.087	0.505	0.154	0.524	0.160	0.829	0.253
1/0	53.49	105600		1.89	0.074	9.45	0.372	70.41	0.109	0.399	0.122	0.415	0.127	0.660	0.201
2/0	67.43	133100		2.13	0.084	10.62	0.418	88.74	0.137	0.3170	0.0967	0.329	0.101	0.523	0.159
3/0	85.01	167800		2.39	0.094	11.94	0.470	111.9	0.173	0.2512	0.0766	0.2610	0.0797	0.413	0.126
4/0	107.2	211600	37	2.68	0.106	13.41	0.528	141.1	0.219	0.1996	0.0608	0.2050	0.0626	0.328	0.100
250	—	—		2.09	0.082	14.61	0.575	168	0.260	0.1687	0.0515	0.1753	0.0535	0.2778	0.0847
300	—	—		2.29	0.090	16.00	0.630	201	0.312	0.1409	0.0429	0.1463	0.0446	0.2318	0.0707
350	—	—		2.47	0.097	17.30	0.681	235	0.364	0.1205	0.0367	0.1252	0.0382	0.1984	0.0605
400	—	—	61	2.64	0.104	18.49	0.728	268	0.416	0.1053	0.0321	0.1084	0.0331	0.1737	0.0529
500	—	—		2.95	0.116	20.65	0.813	336	0.519	0.0845	0.0258	0.0869	0.0265	0.1391	0.0424
600	—	—		2.52	0.099	22.68	0.893	404	0.626	0.0704	0.0214	0.0732	0.0223	0.1159	0.0353
700	—	—		2.72	0.107	24.49	0.964	471	0.730	0.0603	0.0184	0.0622	0.0189	0.0994	0.0303
750	—	—	61	2.82	0.111	25.35	0.998	505	0.782	0.0563	0.0171	0.0579	0.0176	0.0927	0.0282
800	—	—		2.91	0.114	26.16	1.030	538	0.834	0.0528	0.0161	0.0544	0.0166	0.0868	0.0265
900	—	—		3.09	0.122	27.79	1.094	606	0.940	0.0470	0.0143	0.0481	0.0147	0.0770	0.0235
1000	—	—		3.25	0.128	29.26	1.152	673	1.042	0.0423	0.0129	0.0434	0.0132	0.0695	0.0212

FPN: The construction information is per NEMA WC8-1992 or ANSI/UL 1581-1998. The resistance is calculated per National Bureau of Standards Handbook 100, dated 1966, and Handbook 109, dated 1972. 70-625 TABLES.

NATIONAL ELECTRICAL CODE, 2002 Edition.



## Exothermic Welding System

### Additional Tables

#### Metric Conductors

Wire Size		Circ Mils	# of Strands	Strand Diameter	Diameter		Colour Code	Die Code
MM	AWG				MM	Inch		
10	8	19,73	1	3.57	3.57	0.140	Red	21
			7	1.35	4.05	0.159		
16	6	31,558	1	4.50	4.50	0.177	Blue	24
			7	1.70	5.10	0.200		
25	2	49,325	7	2.14	6.42	0.253	Gray	29
				1.35	6.75	0.266	Brown	33
35	1	69,055	19	1.53	7.65	0.300	Green	37
50	1/0	98,65		1.78	8.90	0.350	Pink	42
70	2/0	138,11	37	2.14	10.70	0.421	Black	45
95	3/0	187,5		2.52	12.60	0.496	Orange	50
	3/0		1.78	12.46	0.490			
120	250	236,76	61	2.03	14.21	0.560	Purple	54
150	300	295,95		2.25	15.75	0.620	White	66
185	–	365	91	2.52	17.64	0.695	Red	71
240	500	473,5		2.25	20.25	0.797	Brown	87
300	–	591,9	127	2.52	22.68	0.893	Green	94
400	–	789,2		2.85	25.65	1.000	Black	106
			2.36	25.96	1.022			
500	–	986,5	61	3.20	28.80	1.134	–	125
			91	2.65	29.15	1.148		
630	–	1,243,000	127	2.52	32.76	1.290	–	–
800	–	1,578,400		2.85	37.05	1.459		
1000	–	1,973,000		3.20	41.60	1.638		

Table B.310.1 Ampacities of Two or Three Insulated Conductors, Rated 0 Through 2000 V, Within an Overall Covering (Multiconductor Cable), in Raceway in Free Air Based on Ambient Air Temperature of 30°C (86°F)

#### Temperature Rating of Conductor

Size (AWG or kcmil)	60°C (140°F)	75°C (167°F)	90°C (194°F)	60°C (140°F)	75°C (167°F)	90°C (194°F)	Size (AWG or kcmil)
	Types TW, UF	Types RHW, THHW, THW, THWN, XHHW, ZW	Types THHN, THHW, THW-2, THWN-2, RHH, RW-2, USE-2, XHHW, XHHW-2, ZW-2	Type TW	Types RHW, THHW, THW, THWN, XHHW	Types THHN, THHW, THW-2, THWN-2, RHH, RW-2, USE-2, XHHW, XHHW-2, ZW-2	
14	16*	18*	21*	–	–	–	14
12	20*	24*	27*	16*	18*	21*	12
10	27*	33*	36*	21*	25*	28*	10
8	36	43	48	28	33	37	8
6	48	58	65	38	45	51	6
4	66	79	89	51	61	69	4
3	76	90	102	59	70	79	3
2	88	105	119	69	83	93	2
1	102	121	137	80	95	106	1
1/0	121	145	163	94	113	127	1/0
2/0	138	166	186	108	129	146	2/0
3/0	158	189	214	124	147	167	3/0
4/0	187	223	253	147	176	197	4/0
250	205	245	276	160	192	217	250
300	234	281	317	185	221	250	300
350	255	305	345	202	242	273	350
400	274	328	371	218	261	295	400
500	315	378	427	254	303	342	500
600	343	413	468	279	335	378	600
700	376	452	514	310	371	420	700
750	387	466	529	321	384	435	750
800	397	479	543	331	397	450	800
900	415	500	570	350	421	477	900
1000	448	542	617	382	460	521	1000

#### Correction Factors

Ambient Temp. (°C)	For ambient temperatures other than 30°C (86°F), multiply the ampacities shown above by the appropriate factor shown below.						Ambient Temp. (°C)
21–25	1.08	1.05	1.04	1.08	1.05	1.04	70–77
26–30	1.00	1.00	1.00	1.00	1.00	1.00	79–86
31–35	0.91	0.94	0.96	0.91	0.94	0.96	88–95
36–40	0.82	0.88	0.91	0.82	0.88	0.91	97–104
41–45	0.71	0.82	0.87	0.71	0.82	0.87	106–113
46–50	0.58	0.75	0.82	0.58	0.75	0.82	115–122

\*Unless otherwise specifically permitted elsewhere in this Code, the overcurrent protection for these conductor types shall not exceed 15 A for 14 AWG, 20 A for 12 AWG, and 30 A for 10 AWG copper; or 15 A for 12 AWG and 25 A for 10 AWG aluminum and copper-clad aluminum.

NATIONAL ELECTRICAL CODE, 2002 Edition.

## Exothermic Welding System

### Additional Tables

**Table C1 Maximum Number of Conductors or Fixture Wires in Electrical Metallic Tubing (EMT) (Based on Table 1, Chapter 9)**

Type	CONDUCTORS										
	Conductor Size (AWG/kcmil)	Metric Designator (Trade Size)									
		16 (1/2)	21 (3/4)	27 (1)	35 (1-1/4)	41 (1-1/2)	53 (2)	63 (2-1/2)	78 (3)	91 (3-1/2)	103 (4)
<b>RHH, RHW, RHW-2</b>	14	4	7	11	20	27	46	80	120	157	201
	12	3	6	9	17	23	38	66	100	131	167
	10	2	5	8	13	18	30	53	81	105	135
	8	1	2	4	7	9	16	28	42	55	70
	6	1	1	3	5	8	13	22	34	44	56
	4	1	1	2	4	6	10	17	26	34	44
	3	1	1	1	4	5	9	15	23	30	38
	2	1	1	1	3	4	7	13	20	26	33
	1	0	1	1	1	3	5	9	13	17	22
	1/0	0	1	1	1	2	4	7	11	15	19
	2/0	0	1	1	1	2	4	6	10	13	17
	3/0	0	0	1	1	1	3	5	8	11	14
	4/0	0	0	1	1	1	3	5	7	9	12
	250	0	0	0	1	1	1	3	5	7	9
	300	0	0	0	1	1	1	3	5	6	8
	350	0	0	0	1	1	1	3	4	6	7
	400	0	0	0	1	1	1	2	4	5	7
500	0	0	0	0	1	1	2	3	4	6	
600	0	0	0	0	1	1	1	3	4	5	
700	0	0	0	0	0	1	1	2	3	4	
750	0	0	0	0	0	1	1	2	3	4	
800	0	0	0	0	0	1	1	2	3	4	
900	0	0	0	0	0	1	1	1	3	3	
1000	0	0	0	0	0	1	1	1	2	3	
<b>TW, THHW, THW, THW-2</b>	14	8	15	25	43	58	96	168	254	332	424
	12	6	11	19	33	45	74	129	195	255	326
	10	5	8	14	24	33	55	96	145	190	243
	8	2	5	8	13	18	30	53	81	105	135
	14	6	10	6	28	39	64	112	169	221	282
<b>RHH*, RHW*, RHW-2*</b>	12	4	8	13	23	31	51	90	136	177	227
	10	3	6	10	18	24	40	70	106	138	177
	8	1	4	6	10	14	24	42	63	83	106

\* Types RHH, RHW, and RHW-2 without outer covering.

Type	CONDUCTORS										
	Conductor Size (AWG/kcmil)	Metric Designator (Trade Size)									
		16 (1/2)	21 (3/4)	27 (1)	35 (1-1/4)	41 (1-1/2)	53 (2)	63 (2-1/2)	78 (3)	91 (3-1/2)	103 (4)
<b>RHH*, RHW*, RHW-2*, TW, THHW, THW, THW-2</b>	6	1	3	4	8	11	18	32	48	63	81
	4	1	1	3	6	8	13	24	36	47	60
	3	1	1	3	5	7	12	20	31	40	52
	2	1	1	2	4	6	10	17	26	34	44
	1	1	1	1	3	4	7	12	18	24	31
	1/0	0	1	1	2	3	6	10	16	20	26
	2/0	0	1	1	1	3	5	9	13	17	22
	3/0	0	1	1	1	2	4	7	11	15	19
	4/0	0	0	1	1	1	3	6	9	12	16
	250	0	0	1	1	1	3	5	7	10	13
	300	0	0	1	1	1	2	4	6	8	11
	350	0	0	0	1	1	1	4	6	7	10
	400	0	0	0	1	1	1	3	5	7	9
	500	0	0	0	1	1	1	3	4	6	7
	600	0	0	0	1	1	1	2	3	4	6
	700	0	0	0	0	1	1	1	3	4	5
	750	0	0	0	0	1	1	1	3	4	5
800	0	0	0	0	1	1	1	3	3	5	
900	0	0	0	0	0	1	1	2	3	4	
1000	0	0	0	0	0	1	1	2	3	4	
<b>THHN, THWN, THWN-2</b>	14	12	22	35	61	84	138	241	364	476	608
	12	9	16	26	45	61	101	176	266	347	443
	10	5	10	16	28	38	63	111	167	219	279
	8	3	6	9	16	22	36	64	96	126	161
	6	2	4	7	12	16	26	46	69	91	116
	4	1	2	4	7	10	16	28	43	56	71
	3	1	1	3	6	8	13	24	36	47	60
	2	1	1	3	5	7	11	20	30	40	51
	1	1	1	1	4	5	8	15	22	29	37
	1/0	1	1	1	3	4	7	12	19	25	32
	2/0	0	1	1	2	3	6	10	16	20	26
	3/0	0	1	1	1	3	5	8	13	17	22
	4/0	0	1	1	1	2	4	7	11	14	18
	250	0	0	1	1	1	3	6	9	11	15
	300	0	0	1	1	1	3	5	7	10	13
	350	0	0	1	1	1	2	4	6	9	11
	400	0	0	0	1	1	1	4	6	8	10
500	0	0	0	1	1	1	3	5	6	8	
600	0	0	0	1	1	1	2	4	5	7	
700	0	0	0	1	1	1	2	3	4	6	
750	0	0	0	0	1	1	1	3	4	5	
800	0	0	0	0	1	1	1	3	4	5	
900	0	0	0	0	1	1	1	3	3	4	
1000	0	0	0	0	1	1	1	2	3	4	

NATIONAL ELECTRICAL CODE, 2002 Edition

\* Types RHH, RHW, and RHW-2 without outer covering.

## Exothermic Welding System

### Additional Tables

**Table C4 Maximum Number of Conductors or Fixture Wires in Intermediate Metal Conduit (IMC) (Based on Table 1, Chapter 9)**

Type	CONDUCTORS										
	Conductor Size (AWG/kcmil)	Metric Designator (Trade Size)									
		16 (1/2)	21 (3/4)	27 (1)	35 (1-1/4)	41 (1-1/2)	53 (2)	63 (2-1/2)	78 (3)	91 (3-1/2)	103 (4)
<b>RHH, RHW, RHW-2</b>	14	4	8	13	22	30	49	70	108	144	186
<b>RHH, RHW, RHW-2</b>	12	4	6	11	18	25	41	58	89	120	154
	10	3	5	8	15	20	33	47	72	97	124
	8	1	3	4	8	10	17	24	38	50	65
	6	1	1	3	6	8	14	19	30	40	52
	4	1	1	3	5	6	11	15	23	31	41
	3	1	1	2	4	6	9	13	21	28	36
	2	1	1	1	3	5	8	11	18	24	31
	1	0	1	1	2	3	5	7	12	16	20
	1/0	0	1	1	1	3	4	6	10	14	18
	2/0	0	1	1	1	2	4	6	9	12	15
	3/0	0	0	1	1	1	3	5	7	10	13
	4/0	0	0	1	1	1	3	4	6	9	11
	250	0	0	1	1	1	1	3	5	6	8
	300	0	0	0	1	1	1	3	4	6	7
	350	0	0	0	1	1	1	2	4	5	7
	400	0	0	0	1	1	1	2	3	5	6
	500	0	0	0	1	1	1	3	4	5	5
	600	0	0	0	0	1	1	1	2	3	4
	700	0	0	0	0	1	1	1	2	3	4
	750	0	0	0	0	1	1	1	1	3	4
800	0	0	0	0	0	1	1	1	3	3	
900	0	0	0	0	0	1	1	1	2	3	
1000	0	0	0	0	0	1	1	1	2	3	
1250	0	0	0	0	0	1	1	1	1	2	
1500	0	0	0	0	0	0	1	1	1	1	
1750	0	0	0	0	0	0	1	1	1	1	
2000	0	0	0	0	0	0	1	1	1	1	
<b>TW, THHW, THW, THW-2</b>	14	10	17	27	47	64	104	147	228	304	392
	12	7	13	21	36	49	80	113	175	234	301
	10	5	9	15	27	36	59	84	130	174	224
	8	3	5	8	15	20	33	47	72	97	124
<b>RHH,* RHW,* RHW-2*</b>	14	6	11	18	31	42	69	98	151	202	261
<b>RHH,* RHW,* RHW-2*</b>	12	5	9	14	25	34	56	79	122	163	209
<b>RHH,* RHW,* RHW-2*</b>	10	4	7	11	19	26	43	61	95	127	163
<b>RHH,* RHW,* RHW-2*</b>	8	2	4	7	12	16	26	37	57	76	98
<b>RHH,* RHW,* RHW-2*</b>	6	1	3	5	9	12	20	28	43	58	75
<b>RHH,* RHW,* RHW-2*</b>	4	1	2	4	6	9	15	21	32	43	56

\* Types RHH, RHW, and RHW-2 without outer covering.

Type	CONDUCTORS											
	Conductor Size (AWG/kcmil)	Metric Designator (Trade Size)										
		16 (1/2)	21 (3/4)	27 (1)	35 (1-1/4)	41 (1-1/2)	53 (2)	63 (2-1/2)	78 (3)	91 (3-1/2)	103 (4)	
<b>TW, THHW, THW, THW-2</b>	3	1	1	3	6	8	13	18	28	37	48	
	2	1	1	3	5	6	11	15	23	31	41	
	1	1	1	1	3	4	7	11	16	22	28	
	1/0	1	1	1	3	4	6	9	14	19	24	
	2/0	0	1	1	2	3	5	8	12	16	20	
	3/0	0	1	1	1	3	4	6	10	13	17	
	4/0	0	1	1	1	2	4	5	8	11	14	
	250	0	0	1	1	1	3	4	7	9	12	
	300	0	0	1	1	1	2	4	6	8	10	
	350	0	0	1	1	1	2	3	5	7	9	
	400	0	0	0	1	1	1	3	4	6	8	
	500	0	0	0	1	1	1	2	4	5	7	
	600	0	0	0	1	1	1	1	3	4	5	
	700	0	0	0	0	1	1	1	3	4	5	
	750	0	0	0	0	1	1	1	2	3	4	
	800	0	0	0	0	1	1	1	2	3	4	
	900	0	0	0	0	1	1	1	2	3	4	
	1000	0	0	0	0	0	1	1	1	3	3	
	<b>THHN, THWN, THWN-2</b>	14	14	24	39	68	91	149	211	326	436	562
		12	10	17	29	49	67	109	154	238	318	410
10		6	11	18	31	42	68	97	150	200	258	
8		3	6	10	18	24	39	56	86	115	149	
6		2	4	7	13	17	28	40	62	83	107	
4		1	3	4	8	10	17	25	38	51	66	
3		1	2	4	6	9	15	21	32	43	56	
2		1	1	3	5	7	12	17	27	36	47	
1		1	1	2	4	5	9	13	20	27	35	
1/0		1	1	1	3	4	8	11	17	23	29	
2/0		1	1	1	3	4	6	9	14	19	24	
3/0		0	1	1	2	3	5	7	12	16	20	
4/0		0	1	1	1	2	4	6	9	13	17	
250		0	0	1	1	1	3	5	8	10	13	
300		0	0	1	1	1	3	4	7	9	12	
350		0	0	1	1	1	2	4	6	8	10	
400		0	0	1	1	1	2	3	5	7	9	
500		0	0	0	1	1	1	3	4	6	7	
600		0	0	0	1	1	1	2	3	5	6	
700		0	0	0	1	1	1	1	3	4	5	
750	0	0	0	1	1	1	1	3	4	5		
800	0	0	0	0	1	1	1	3	4	5		
900	0	0	0	0	1	1	1	2	3	4		
1000	0	0	0	0	1	1	1	2	3	4		

Note: This table is for concentric stranded conductors only. For compact stranded conductors, Table C4(A) should be used. \*Types RHH, RHW, and RHW-2 without outer covering.

NATIONAL ELECTRICAL CODE, 2002 Edition

## Exothermic Welding System

### Additional Tables

**Table C8 Maximum Number of Conductors or Fixture Wires in Rigid Metal Conduit (RMC) (Based on Table 1, Chapter 9)**

		CONDUCTORS											
Type	Conductor Size (AWG/kcmil)	Metric Designator (Trade Size)											
		16 (1/2)	21 (3/4)	27 (1)	35 (1-1/4)	41 (1-1/2)	53 (2)	63 (2-1/2)	78 (3)	91 (3-1/2)	103 (4)	129 (5)	155 (6)
<b>RHH, RHW, RHW-2</b>	14	4	7	12	21	28	46	66	102	136	176	276	398
	12	3	6	10	17	23	38	55	85	113	146	229	330
	10	3	5	8	14	19	31	44	68	91	118	185	267
	8	1	2	4	7	10	16	23	36	48	61	97	139
	6	1	1	3	6	8	13	18	29	38	49	77	112
	4	1	1	2	4	6	10	14	22	30	38	60	87
	3	1	1	2	4	5	9	12	19	26	34	53	76
	2	1	1	1	3	4	7	11	17	23	29	46	66
	1	0	1	1	1	3	5	7	11	15	19	30	44
	1/0	0	1	1	1	2	4	6	10	13	17	26	38
	2/0	0	1	1	1	2	4	5	8	11	14	23	33
	3/0	0	0	1	1	1	3	4	7	10	12	20	28
	4/0	0	0	1	1	1	3	4	6	8	11	17	24
	250	0	0	0	1	1	1	3	4	6	8	13	18
	300	0	0	0	1	1	1	2	4	5	7	11	16
	350	0	0	0	1	1	1	2	4	5	6	10	15
	400	0	0	0	1	1	1	1	3	4	6	9	13
	500	0	0	0	1	1	1	1	3	4	5	8	11
	600	0	0	0	0	1	1	1	2	3	4	6	9
	700	0	0	0	0	1	1	1	1	3	4	6	8
750	0	0	0	0	0	1	1	1	3	3	5	8	
800	0	0	0	0	0	1	1	1	2	3	5	7	
900	0	0	0	0	0	1	1	1	2	3	5	7	
1000	0	0	0	0	0	1	1	1	1	3	4	6	
<b>TW, THHW, THW, THW-2</b>	14	9	15	25	44	59	98	140	216	288	370	581	839
	12	7	12	19	33	45	75	107	165	221	284	446	644
<b>RHH,* RHW,* RHW-2*</b>	10	5	9	14	25	34	56	80	123	164	212	332	480
	8	3	5	8	14	19	31	44	68	91	118	185	267
<b>RHH,* RHW,* RHW-2*</b>	14	6	10	17	29	39	65	93	143	191	246	387	558
	12	5	8	13	23	32	52	75	115	154	198	311	448
<b>RHH,* RHW,* RHW-2*</b>	10	3	6	10	18	25	41	58	90	120	154	242	350
	8	1	4	6	11	15	24	35	54	72	92	145	209

NATIONAL ELECTRICAL CODE, 2002 Edition

		CONDUCTORS												
Type	Conductor Size (AWG/kcmil)	Metric Designator (Trade Size)												
		16 (1/2)	21 (3/4)	27 (1)	35 (1-1/4)	41 (1-1/2)	53 (2)	63 (2-1/2)	78 (3)	91 (3-1/2)	103 (4)	129 (5)	155 (6)	
<b>RHH,* RHW,* RHW-2*, TW, THHW, THW, THW-2</b>	6	1	3	5	8	11	18	27	41	55	71	111	160	
	4	1	1	3	6	8	14	20	31	41	53	83	120	
	3	1	1	3	5	7	12	17	26	35	45	71	103	
	2	1	1	2	4	6	10	14	22	30	38	60	87	
	1	1	1	1	3	4	7	10	15	21	27	42	61	
	1/0	0	1	1	2	3	6	8	13	18	23	36	52	
	2/0	0	1	1	2	3	5	7	11	15	19	31	44	
	3/0	0	1	1	1	2	4	6	9	13	16	26	37	
	4/0	0	0	1	1	1	3	5	8	10	14	21	31	
	250	0	0	1	1	1	3	4	6	8	11	17	25	
	300	0	0	1	1	1	2	3	5	7	9	15	22	
	350	0	0	0	1	1	1	3	5	6	8	13	19	
	400	0	0	0	1	1	1	3	4	6	7	12	17	
	500	0	0	0	1	1	1	2	3	5	6	10	14	
	600	0	0	0	1	1	1	1	3	4	5	8	12	
	700	0	0	0	0	1	1	1	2	3	4	7	10	
	750	0	0	0	0	1	1	1	1	2	3	4	7	10
	800	0	0	0	0	1	1	1	1	2	3	4	6	9
	900	0	0	0	0	1	1	1	1	1	3	4	6	8
	1000	0	0	0	0	0	1	1	1	1	2	3	5	8
<b>THHN, THWN, THWN-2</b>	14	13	22	36	63	85	140	200	309	412	531	833	1202	
	12	9	16	26	46	62	102	146	225	301	387	608	877	
	10	6	10	17	29	39	64	92	142	189	244	383	552	
	8	3	6	9	16	22	37	53	82	109	140	221	318	
	6	2	4	7	12	16	27	38	59	79	101	159	230	
	4	1	2	4	7	10	16	23	36	48	62	98	141	
	3	1	1	3	6	8	14	20	31	41	53	83	120	
	2	1	1	3	5	7	11	17	26	34	44	70	100	
	1	1	1	1	4	5	8	12	19	25	33	51	74	
	1/0	1	1	1	3	4	7	10	16	21	27	43	63	
	2/0	0	1	1	2	3	6	8	13	18	23	36	52	
	3/0	0	1	1	1	3	5	7	11	15	19	30	43	
	4/0	0	1	1	1	2	4	6	9	12	16	25	36	
	250	0	0	1	1	1	3	5	7	10	13	20	29	
	300	0	0	1	1	1	3	4	6	8	11	17	25	
	350	0	0	1	1	1	2	3	5	7	10	15	22	
	400	0	0	1	1	1	2	3	5	7	8	13	20	
	500	0	0	0	1	1	1	2	4	5	7	11	16	
	600	0	0	0	1	1	1	1	3	4	6	9	13	
	700	0	0	0	1	1	1	1	3	4	5	8	11	
750	0	0	0	0	1	1	1	3	4	5	7	11		
800	0	0	0	0	1	1	1	2	3	4	7	10		
900	0	0	0	0	1	1	1	2	3	4	6	9		
1000	0	0	0	0	1	1	1	1	3	4	6	8		

Note: This table is for concentric stranded conductors only. For compact stranded conductors, Table C8(A) should be used. \*Types RHH, RHW, and RHW-2 without outer covering.

## Competitive Cross Reference

**Figure 6 — Compression Ground Tap Connectors**

E-Z-Ground®	Burndy	IlSCO
54855	YGHP29C2	GGC-2
54860	YGHP29C26	GGC-3
54865	YGHP29C29	GGC-4
54875	YGHP2C2	GGC-1
54885	YGHP34C2	GGC-5
54890	YGHP34C26	GGC-6
54895	YGHP34C29	GGC-7
54900	YGHP34C34	GGC-8

**Figure 6 to Figure 6 — Compression Ground Grid Connectors**

E-Z-Ground®	Burndy	IlSCO
54855L	YGL2C2	-
54855LR12	YGLR29C12	-
54865L	YGL29C2	GGA-2
54865LR58	YGLR29C58	-
54875L	YGL29C29	GGA-3
54875LR34	YGLR29C34	-
54885L	YGL34C2	GGA-4
54885LR12	YGLR34C12	-
54895L	YGL34C29	GGA-5
54895LR58	YGLR34C58	-
54900L	YGL34C34	GGA-6
54900LR34	YGLR34C34	-
54910LR100	YGLR29C100	-
54920LR100	YGLR34C100	-

**C-Crimp Series BC**

E-Z-Ground®	Burndy	IlSCO
BC202	YC26C2	-
BC2020-BB	YC26C26	-
BC22	YC2C2	ULT-7-Z
BC24	YC2C4	ULT-6-Z
BC402	YC28C2	-
BC4020	YC28C26	-
BC4040	YC28C28	ULT-12-Z
BC44	YC4C4	ULT-5-Z
BC46-BB	YC4C6	ULT-4-Z
BC48	YC4C8	-

**C-Taps**

EZ Ground®	Burndy	IlSCO
CTG250	GCM28CG3	-

**Type SP — Service Post Connectors**

Blackburn®	Penn Union	Burndy	IlSCO/Utilco	Kupler
SP0DL	SCS-0A1	K2C15B1		
SP1DL	SCS-1A1	K2C17B1		
SP2DL	SCS-2A1	K2C20B1		
SP3DL	SCS-3A1	K2C22B1		
SP4DL	SCS-4A1	K2C23B1		
SP5DL	SCS-5A1	K2C25B1		
SP6DL	SCS-6A1	K2C26B1		
SP8DL	SCS-8A1	K2C28B1		
SP9DL	SCS-9A1	K2C31B1		
SP10DL	SCS-10A1	K2C34B1		
SPOSL	SSS-0A1	KC15B1	-	-
SP1SL	SSS-1A1	KC17B1		
SP2SL	SSS-2A1	KC20B1		
SP3SL	SSS-3A1	KC22B1		
SP4SL	SSS-4A1	KC23B1		
SP5SL	SSS-5A1	KC25B1		
SP6SL	SSS-6A1	KC26B1		
SP8SL	SSS-8A1	KC28B1		
SP9SL	SSS-9A1	KC31B1		
SP10SL	SSS-10A1	KC34B1		

**Flexible Braids**

Blackburn®	Penn Union	Burndy	IlSCO/Utilco	Penn-Union	Anderson	Dossert	Gedney
FB2D12		B2D12N		FXB2A-12-Q			
FB2E12		B2E12N		FXB2C-12N-Q			
FB2F12		B2F12N		FXB2D-12N-Q			
FB3D12		B3D12N		FXB3A-12-Q			
FB3E12		B3E12N		FXB3C-12N-Q			
FB3F12		B3F12N					
FB3XD12		B4D12N		-			
FB4E12		B4E12N		FXB4C-12N-Q			
FB4F12		B4F12N		FXB4D-12N-Q			
FBD12		BD12N		FXBA-12-Q			
FBD18				FXBA-18-Q			
FBD24				FXBA-24-Q			
FBE12		BE12N		FXBB-12N-Q			
FBF12		BF12N		FXBD-12N-Q			
FBG12				FXBE-12N-Q			
FBG18				FXBE-18S-Q			
FBG24				FXBE-24S-Q			

## Competitive Cross Reference

Ground Plates							
E-Z-Ground®	Burndy						
GP2250-2	YGF29-2N	-	-	-	-	-	-
GP2250-4	YGF29-4N						
GP250500-2	YGF34-2N						
GP250500-4	YGF34-4N						
Figure 8 — Compression Tap Connectors for Copper Ground Rods							
E-Z-Ground®	Burndy						
GR1-202	YGHR26C100						
GR12-202	YGHR26C12						
GR12-40250	YGHR29C12						
GR1-300500	YGHR34C100						
GR1-40250	YGHR29C100	-	-	-	-	-	-
GR34-202	YGHR26C34						
GR34-300500	YGHR34C34						
GR34-40250	YGHR29C34						
GR58-202	YGHR26C58						
GR58-300500	YGHR34C58						
GR58-40250	YGHR29C58						
Type TBGS — Structural Grounding Studs							
E-Z-Ground®	Burndy						
TBGS14	GSTUD14HY	-	-	-	-	-	-
TBGS34	GSTUD34HY						
TBGS38	GSTUD38HY						
TBGS58	GSTUD916HY						
Type JAB — Ground Rod Clamps							
Blackburn®	Penn Union	Burndy	IlSCO	Eritech	Anderson	Joslyn	Dossert
JAB12	CAB-1	GRC12	CGRC48	HDC12		J8391AB	GNA50
JAB58	CAB-2	GRC58	CGRC58	-		J8392AB	GNA62
JAB34	CAB-3	-	-	HDC34		J8393AB	GNA75
JAB34C	-	GRC3426	CGRC68	-		-	-
JAB1	-						
JAB12H	CAB-1			HDC12	GC-103-01	J8491AB	GN-50
JAB58H	CAB-2			HDC58R	GC-103-02	A8393AB	GN-62
JAB34H	CAB-3			HDC34	GC-103-03	J8493AB	GN-75
JAB1H	-						
Type G — Budget Line Ground Rod Clamps							
Blackburn®	Penn Union	Burndy	IlSCO	Eritech	Anderson	Joslyn	Dossert
G3	CAB-1	GRC12	-	CP38	-		-
G4	CEB-1	GRC-12	GRC-48	CP12	GC-4		GNL50
G5	CEB-2	GRC-58	GRC-58	CP58	GC-5		GNL62
G6	CEB-3	GRC34	GRC-68	CP34	GC-6		GNL75

Blackburn and E-Z-Ground are registered trademarks for Thomas & Betts Corporation.  
 All other trademarks are the property of their respective owners.

## Competitive Cross Reference

Type GUV — U-Bolt Clamps								
Blackburn®	Penn Union	Burndy	Ilco/Utilco	Homac®	Anderson	Dossert	Gedney	
GUV4021	-	GAR2226	-	-	-	-	-	
GUV4025		GAR2229						
GUV584	-	GAR644C						
GUV5821		GAR6426						
GUV5825		GAR6429						
GUV784		GPL-8						GAR144C
GUV7821		GPL-9						GAR1426
GUV7825	GPL-10	GAR1429						
GUV1184	GPL-14	GAR154C						
GUV11821	GPL-15	GAR1526						
GUV1384	GPL-20	GAR164C						
GUV13821	-	GAR1626						
GUV13825	GPL-22	GAR1629						
GUV1584	GPL-26	GAR174C						
GUV15821	GPL-27	GAR1726						
GUV15825	GPL-28	GAR1729						
GUV204	GPL-32	GAR184C						
GUV2021	GPL-33	GAR1826						
GUV2025	GPL-34	GAR1829	-	-	-	-	-	
GUV21221	GPL-39	GAR1926						
GUV21225	GPL-40	GAR1929						
GUV3021	GPL-45	GAR2026						
GUV3025	GPL-46	GAR2029						
GUV31221	GPL-51	GAR2126						

Type GTC — Tower Ground Clamps							
Blackburn®	Penn Union	Burndy	Ilco/Utilco	Homac®	Anderson	Dossert	Gedney
GTC13	GMS-2	GBM26	-	-	GC140-01	GFM-13	-
GTC14	GMS-3	GBM29			GC-140-02	GFM-25	
GTC23	GM-2	GB26			GC141-01	GF13	
GTC24	GM-3	GB29			-	GF25	

Type TTC — Transformer Tank Ground Connectors							
Blackburn®	Penn Union	Burndy	Ilco/Utilco	Homac®	Anderson	Dossert	Eritech
TTC2	HGSE-020	EQC632C	-	-	GTCL-34A	-	TGC210
TTC3	HGSE-C1	-			GTCL-23A	TGC8-50	
TTC4	-				-	-	
TTC2P	-				-	-	
TTC3P	GSE-C1TN				GTCL23A-TP	TGC8-50SN	
TTC4P	-				-	-	

Type GP — Copper Pole Bottom Ground Plates							
Blackburn®	Penn Union	Burndy	Ilco/Utilco	Homac®	Anderson	Dossert	Eritech
GP100	-	-	-	5575	-	-	EGP100

Blackburn and Homac are registered trademarks for Thomas & Betts Corporation.  
 All other trademarks are the property of their respective owners.