

BUICK PARTS

1930 and UP



908-369-3666
oldbuickparts.com

BUICK PARTS: GROUP NUMBERS

Engine • Clutch • Decals.....	Group 0
Cooling • Oiling • Grills	Group 1
Electrical • Lamps	Group 2
Fuel • Carburetion • Exhaust	Group 3
Transmission • Brakes	Group 4
Wheels • Propeller Shaft • Rear Axle	Group 5
Front Suspension • Steering	Group 6
Frame • Springs • Shocks • Bumpers	Group 7
Hood • Front Fenders • Running Boards	Group 8
Heater • Air Conditioner • Firewall • Radio • Antenna	Group 9
Glass • Doors • Cowl • Weatherstrip • Wiper • Dash	Group 10
Rear 1/4 Glass • Seats • Door Sills • Dome Lenses	Group 11
Rocker Panels • Rear Sheet Metal • Deck Lid.....	Group 12
Convertible Tops and Parts	Group 13
Door Panels • Misc. Interior • Headlinings	Group 14
Carpet • Floor Mats • Trunk Linings	Group 15
Literature.....	Group 16

-ATTENTION-

This catalog pertains to
1930's and Up All models ONLY

We also have catalogues and stock Buick parts for:

1961 and Up Special, Skylark, Sportwagon and Gran Sport

1961 and Up LeSabre, Invicta, Wildcat, Electra 225,
Centurion, Century and Apollo

1973 and Up Regal, Grand National, T-Type and GNX

Please inquire about separate catalogs for the above Buicks

www.oldbuickparts.com

All rights reserved. No part of this publication may be reproduced without prior written permission from CARS, Inc. Illustrations in this catalog are representations only and may not exactly depict any particular part or part number. Prices subject to change without notice.



We Rebuild:

Alternators

Brake Boosters

Brake Shoes

Carburetors

Convertible Top Pumps

Drive Shaft Supports

Generators

Motor Mounts

Pressure Plate Assembly

Rocker Assembly

Starter Motors

Voltage Regulators

Wheel Cylinders

Ball Joints

Brake Cables

Camshafts

Clutch Discs

Distributors

Fuel Pumps

Master Cylinders

Oil Pumps

Transmission Mounts

Shocks

Vacuum Advances

Water Pumps

Vacuum Wiper Motors

Please Inquire.

We are a full service company.



CARS, LLC

205 Pearl St. • Neshanic Station, NJ 08853

(908) 369-3666 • (908) 369-7595 Fax

www.oldbuickparts.com

Motor Mounts Sold Outright



1933-1938 Front Motor Support Pads.
1933-1936 All (2 pair needed)
1937-1938 All (1 pair needed)
 MM368\$9.75 pr.

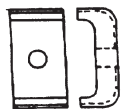

1934-1938 Front Motor Mounts.
1934-1935 Specials;
1936 All Except Convertibles,
1937-1938 All.
 MM367\$89.50 pr.



1948-1953
1948-1952 All;
1953 Specials.
 MM483.....\$77.50 pr.

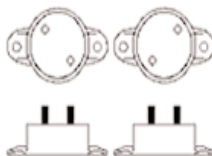

1953-1956 All V-8 Engines.
 MM536\$77.50 pr.

Motor Mount Rebuilding Service (0.027)

We now offer you complete revulcanization of your motor mounts. Fresh, new rubber will insure safe and smooth running. The mounts listed below are sold on an exchange basis only. If we have your needed mount ready to ship we will charge you an additional core deposit of \$50.00 per item. This charge is fully refundable upon receiving your rebuildable cores. We prefer you send your mounts for rebuilding. Please allow at least 2 weeks for this process. See NOS section, Group .027 for outright sales.

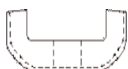

1934-1935 Series 50 and 60. Front.
 Series 50 - 2nd type after frame #2727014;
 Series 60 - used after frame #2728021.
 MM345FRS.....\$129.50 pr.

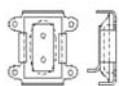

1934-1935 Series 40. Rear.
 1934 All series 40.
 1935 All Series 40 up to frame #2789239.
 MM345RS\$368.00 pr.

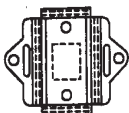

1935 Series 50. Rear.
 MM35RS\$124.25 pr.

1935 Series 60 (Century) Rear.
 MM35CRS\$122.50 pr.

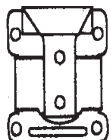

1935-1936. Rear.
 1935 Series 40 after frame #2789239.
 1936 series 40 all exc. model 46C.
 MM356RS\$169.50 pr.

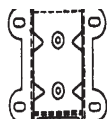

1936 Series 80-90 exc. 80C. Rear.
 MM36BRS.....\$275.75 pr.

1936 Series 60. Closed Body Styles.
 MM36RS\$230.00 pr.



1937-1938 Special. Rear Motor Mounts.
 MM378RS\$219.00 pr.



1937-1938 Century and Roadmaster. Rear Motor Mounts.
 MM378BRS.....\$244.25 pr.

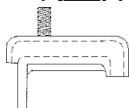

1939 Special and Century. Front motor mounts.
 MM39FRS.....\$162.25 pr.



1939 Series 80-90. Front Motor Mounts.
 MM39BRS.....\$139.50 pr.

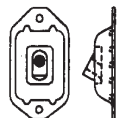

1939 All Rear Motor Mounts.
 MM39RS\$168.75 pr.

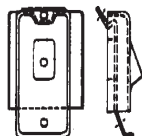

1940 Special and Century, Rear.
 MM40SRS.....\$194.00 pr.

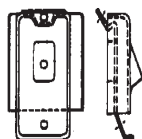

1940 Super and Roadmaster. Rear Motor Mounts.
 MM40BRS.....\$192.25 pr.

1940 Series 80-90. Rear Motor Mounts.
 MM40LRS\$201.25 pr.

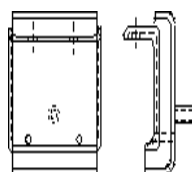

1940-1947 Front, Except Series 90.
 (Sold Outright - no core charge)
 MM407.....sold outright.....\$99.00 pr.
 MM407RS.....rebuilding service.....\$143.75 pr.

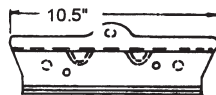

1941-1942 Series 90. Front Motor Mounts.
 MM412RS\$123.25 pr.

1941-1947 Rear Motor Mount.
 MM417RS.....\$114.25 ea.



1957-1958 All Front.
 Sold outright, No core charge.
 MM578.....\$111.00 pr.
 MM578RS.....rebuilding service.....\$124.25 pr.



1959-1960 All Front.
 Sold outright, No core charge.
 MM590\$75.50 pr.

Exhaust Valves (.0297)

1936-1952 Roadmaster, Century and Limited. EV362.....	\$16.25 ea.
1936-1953 Special and Super. EV363.....	\$16.25 ea.
1953 All V-8. EV53.....	\$16.25 ea.
1954 All. EV54.....	\$16.25 ea.
1955 Exhaust Valve. EV55.....	\$16.25 ea.
1956 Exhaust Valve. EV56.....	\$16.25 ea.
1957-1958 Exhaust Valve. EV578.....	\$16.25 ea.
1959-1960 With 401 Engine. EV596.....	\$16.50 ea.



(.303) Valve Springs (.306)

1937-1947 All; 1948-1949 Special and Super; 1950 thru 1953 Special with Standard Trans. (outer). VS473.....	\$4.25 ea.
VS473S.....(Set of 16).....	\$65.00 set
1953-1960 All V-8. (inner). VS536.....	\$5.00 ea.
VS536S.....(Set of 16).....	\$58.00 set
1953-1960 All V-8. (outer). VS596.....	\$4.75 ea.
1953-1960 All V-8. Complete Set of 16. VS596S.....	\$52.25 ea.



Hydraulic Valve Lifters

1936-1953 All Mechanical Lifters. (Outright). VL360.....	\$16.50 ea.
1948-1953 All Straight-8 Engines. Hydraulic Valve Lifter. New, not rebuilt. VL483.....	\$19.25 ea.
VL483S.....Full Set of 16.....	\$319.00 set
1953-1955 Hydraulic Valve Lifters (Outright). VL535.....	\$11.25 ea.
1956-1960 Hydraulic Valve Lifters (Outright). VL567.....	\$9.50 ea.
VL567S.....Full Set of 16.....	\$139.50 set

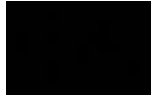

Valve Spring Retainers (keepers) (.310)



1936-1965 All. VR365.....	\$3.00 pr.
Valve Spring Retainer Set VR365S.....(Set of 32).....	\$42.50 set

Intake Valves (.296)

1936-1952 Roadmaster, Century and Limited. IV362.....	\$16.25 ea.
1936-1953 Special and Super. IV363.....	\$16.25 ea.
1953 All V-8. IV53.....	\$16.25 ea.
1954-1956 All. IV546.....	\$16.25 ea.
1957-1958 All. IV578.....	\$15.75 ea.
1959-1960 With 401 Engine. IV596.....	\$14.25 ea.



Valve Guides and Seals (.283)

1934-1952 Series 40, 50; 1953 Series 40 Exhaust and Intake Valve Guides. VG384.....	\$4.75 ea.
VG384S.....(Set of 16).....	\$69.50 set
1936-1952 320 Engines Exhaust and Intake Valve Guides. VG407.....	\$4.75 ea.
1953-1960 Intake and Exhaust Valve Guides. VG733.....	\$4.00 ea.
1953-1960 All V-8 Valve Stem Seals. VSG536.....	\$2.75 ea.



Valve Seat Inserts

1955-1956 All (Exhaust). VSI557.....	\$4.50 ea.
1957-1958 All (Exhaust). VSI572.....	\$4.50 ea.
1959-1960 All 364 and 401 Engines (Intake). VSI592.....	\$4.75 ea.
1959-1960 All 364 and 401 engines (Exhaust). VSI590.....	\$4.75 ea.

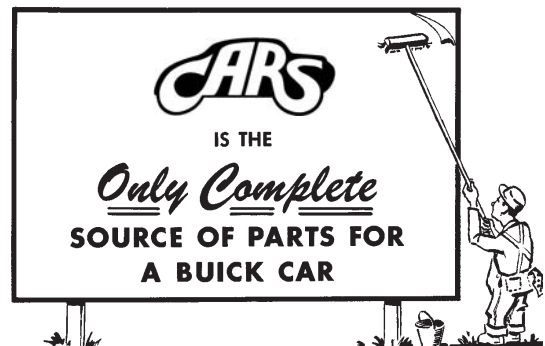

Engine Parts (Group 0)



Main Bearing Sets (.096)

Sets are available in standard .010, .020, .030, and .040 undersized. Please specify when ordering.

1937-1938 Special.
MBS378.....\$279.50 set

1937-1952 Series 60, 70, 80, 90.
MBS372.....\$232.50 set

1939-1950
1939-1949: Special and Super;
1950: Special.
MBS390.....\$222.50 set

1950-1953
1950-1952: Super;
1951-1953: Special.
MBS503.....\$147.50 set

1953-1956 All V-8.
MBS536.....\$139.00 set

1957-1960 All with 364 Engine.
MBS571.....\$126.50 set

1959-1960 All with 401 Engine.
MBS596.....\$129.75 set

Camshafts Regrinding Service

1935-1953 All Straight 8 Engines.
CS353R.....\$296.50 ea.

1957-1960 All Engines.
CS576R.....\$296.50 ea.



New Camshafts - Sold Outright (.519)

1953-1956 All V-8.
CS536.....\$324.00 ea.

1957-1960 All Engines.
CS576.....\$154.50 ea.

All Years. All Engines. Cam break-in lube.
CL300.....\$6.75 ea.



Connecting Rods (.603)

1959-1960 All with 401 Engine.
CR596.....\$43.25 ea.

Connecting Rod Bearings (.604)

1936-1950 248 Engines
1936-1949: Special and Super;
1950: Special.
RBS360.....\$94.50 set

1937-1952 Series 60, 70, 80, 90, 320 Engines
RBS372.....\$119.75 set

1950-1953 263 Engines
1950-1952: Super;
1951-1953: Special.
RBS503.....\$94.50 set

1953-1956 All V-8.
RBS536.....\$74.50 set

1957-1960 All.
RBS576.....\$79.50 set



Camshaft Bearings (.546)

1936-1952 Straight-8 engines.
1936-1952 All Series 60, 70, 80, 90 320 C.I. Engines.
CBS362.....\$78.50 set

1936-1953 All. Straight-8 Engines.
1936-1952 All;
1953: Special.
CBS363.....\$78.50 set

1953-1956 All. V-8 Camshaft Bearing Set.
CBS536.....\$78.50 set

1957-1960 All.
CBS576.....\$38.50 ea.



www.oldbuickparts.com

908-369-3666

Pistons (0.629)

We also have oversize pistons

1938-1950 All 248 Engines.

P380\$39.75 ea.
P380S.....(Set of 8).....\$268.50 set

1938-1952 All 320 Engines.

P382\$59.50 ea.
P382S..... (Set of 8).....\$429.50 set

1950-1953 All 263 Engines.

P503\$39.75 ea.
P503S.....(Set of 8).....\$268.50 set

1953 All 322 V-8 Engines.

P53\$43.00 ea.
P53S.....(Set of 8).....\$288.50 set

1954-1955 Special with 264 Engine.

P545.....\$59.50 ea.
P545S.....(Set of 8).....\$424.50 set

1954-1956 Super, Century, Skylark and Roadmaster with 322 Engine.

P546\$43.00 ea.
P546S.....(Set of 8).....\$288.50 set

**1957-1958 All;
1959-1961 LeSabre. 364 Engines**

P571\$43.00 ea.
P571S.....(Set of 8).....\$288.50 set

All others PLEASE INQUIRE

Harmonic Balancer Rebuilding Service



Balancers are completely disassembled, shot peened and inspected. Threaded holes are repaired and new seal saver is installed. (non-rope seal apps.) New silicone rubber is injected, then vulcanized for proper bonding. Please remove any bolted pulleys before sending. For those not listed, please inquire.

1953-1956 All 322 V-8 Engines.

HB322RS\$154.00 ea.

1954-1955 All Special, 264 Engine. No Rubber Type.

HB264RS\$56.00 ea.

1954-1955 All Special, 264 Engine. Riveted Type.

HB264RRS.....\$154.00 ea.

1957-1960 All 364 Engine. Riveted. 75% of weight removed from ring. External Balanced.

HB364RS\$154.00 ea.

1959-1960 All 401 Engine. Riveted type.

HB401RS\$155.50 ea.

Piston Ring Sets (0.643)

1937-1950 All 248 Engines.

PRS380\$109.00 set

1938-1952 All 320 Engines.

PRS382\$112.00 set

1951-1953 Special and Super with Straight-8 Engine.

PRS513\$99.50 set

1953-1956 All with 322 Engine, Cast Iron.

PRS322C.....\$59.00 set

1953-1956 All with 322 Engine, Moly Set.

PRS322M\$117.00 set

1954-1955 All Special with 264 Engine.

PRS264\$88.50 set

1957-1960

**1957-1958: All;
1959-1960: with 364. Cast Iron.**

PRS364C.....\$68.50 set

1959-1960 All with 401 Engine, Cast Set.

PRS401C.....\$94.50 set

1959-1960 All with 401 Engine, Moly Set.

PRS401M\$195.00 set

1957-1960

**1957-1958: All;
1959-1960: with 364. Moly Set.**

PRS364M\$129.50 set

Push Rods (0.426)

1941-1949 Special with Solid Lifters. 12 13/16"

PR419\$15.50 ea.

1949 Super:

1950 Special. For Cars with Hydraulic Lifters. 11"

PR490\$15.50 ea.

1950-1953 For Dynaflo Cars.

1950-1952 Super;

1951-1953 Special .

PR503\$14.00 ea.

1950-1953 Special. All with Standard Transmission 12-1/8" length.

PR503S\$15.50 ea.

1953-1955 All V-8.

PR535\$7.25 ea.

1956 All.

PR56\$7.25 ea.

1957-1961 364 Engine.

PR573\$7.25 ea.
PR535S.....(Set of 16)\$74.25 set

1959-1960 All with 401 Engine.

PR597\$5.75 ea.

1959-1960 All with 401 Engine. (16)

PR597S\$78.00 set.

Engine Parts (Group 0)

Timing Chains (0.724)

1934-1949 Special;
1940-1949 Super.
 TC349.....\$91.50 ea.

1936-1949 Series 60, 70, 80, 90
 TC369.....\$84.75 ea.

1950-1952 Special and Super;
1953 Special. 49 Links.
 TC503.....\$78.50 ea.

1950-1952 Roadmaster.
 TC502.....\$78.50 ea.

1953-1960 All V-8.
 TC536.....\$34.50 ea.

Timing Chain Sets with Iron Cam Gear (Includes chain and 2 gears)



1934-1949
 1934-1938: Special;
 1939-1949: All Special and Super.
 TS349.....\$179.50 set

1936-1949 Series 60, 70, 80 and 90.
 TS369.....\$169.50 set

1950-1952 Roadmaster.
 TS502.....\$168.50 set

1950-1953 Specials and Super with Straight-8 Engine
 TS503.....\$189.50 set

1953-1956 All V-8.
 TS536.....\$104.50 set

1957-1960 All.
 TS576.....\$108.50 set

Aluminum Valve Covers



1953-1960 All V-8 Engines. Grooved with "BUICK" as original. Nice reproduction! Matte finish.
 AVC536\$199.00 pr.



1953-1960 All V-8 Engines. Grooved with "BUICK" as original. Nice reproduction! Bright finish. Includes oil cap, PCV grommet, bolts and gaskets
 AVC536B.....\$199.00 pr.



1963-1966 All with Aluminum Valve Covers. Chrome Plated.
 WRS636\$36.00 pr.



"AC OIL" Chrome twist on cap.
 OC647\$31.00 ea.



ORDER BY PHONE!
908-369-3666

Rocker Arm Assembly Rebuilding Service

- 1937-1953** All Straight 8 Engines with mechanical or hydraulic lifters.
RAA373\$390.50 ea.
- 1953-1958** All. V-8.
RAA538\$353.00 pr.
- 1959-1960** All.
RAA596\$296.50 pr.

Rocker Arm Shafts (.353)

- 1953-1960** All. V-8, rocker arm shaft.
RS536\$48.50 ea.
RS536P.....Pair.....\$88.50 pr.



Rocker Arms (0.333)

- 1953-1960** All V8 Reproduced in **steel**.
Set includes 16 arms.
RAS536\$208.50 set



Rocker Arm Adjusting Ball (0.276)

- 1924 thru 1952** All;
1953 Special. NOT for Hydraulic Lifter Applications.
AB243.....\$4.25 ea.

- 1953-1955** V8 Rocker Arms
RA536L.....L.H.....\$16.00 ea.
RA536R.....R.H.....\$16.00 ea.

Valve Cover and Spark Plug Cover Hardware (.416)

- 1934-1938 series 40**;
1936-1953 All. Straight 8 Engines. Rocker Cover Studs.
RS343\$4.00 ea.



- 1934-1935 series 40**;
1936-1940 All. Straight 8 Engines. Spark Plug Cover Studs.
CS340\$4.00 ea.



- 1936-1955** Rocker Cover Nuts.
(Also fits 1939-1953 Spark Plug Covers).
RN395\$3.00 ea.
W6.....\$.50 ea.
(Fiber washer for use under RN395)



- 1953-1956** Spark Plug Cover Nuts.
Also fits Rocker Covers. (.416)
SN536\$3.00 ea.
W6.....\$.50 ea.
(Fiber washer for use under SN536)



- 1957-1960** Valve Rocker Cover Bolt Grommet. (4 per car).
VCG572\$3.50 ea.



Freeze Plug Kits (.553) (enough for complete overhaul)

- 1927-1953** All. Straight 8.
FPK273\$17.50 kit
1953-1960 All V-8.
FPK536\$18.50 kit

Cars, Inc. World Leader in



Engine Parts (Group 0)

Clutch Parts (0.886)

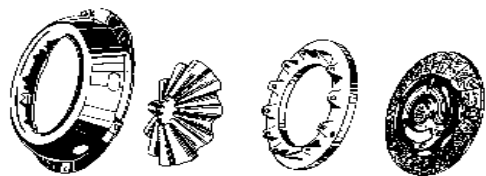

Clutch Pressure Plate Replacement Kit

1939-1955

1939 -1955: Series 40;

1939 -1953: Series 50.

Includes NEW Clutch, Pressure Plate, throw out bearing (old collar must be used) Pilot bearing and alignment tool. Features improved 10 1/2" clutch disc.

CPA395.....\$285.00 kit

Clutch Disc Rebuilding Service

1931-1937

1931-1935: Series 50;

1934-1937: Series 40.

CD317.....10" - 1 1/4.....\$98.50 ea.

1931-1935 Century. 9 7/8" - 1 1/2".

CD315.....\$98.50 ea.

1936-1937 Series 60, 70, 90.

CD367.....11" - 1 1/4.....\$98.50 ea.

1938 Special.

CD38.....10" - 1 1/8".....\$97.50 ea.

1938-1948 10 1/2" - 1 1/8" discs. Series 60, 70, 80 and 90.

CD388.....\$97.50 ea.

1939-1955 All. 10" x 1 1/8".

1939-1952: Special and Super;

1953-1955: Special.

CD395.....\$97.50 ea.

CD395R.....New Replacement.....\$89.50 ea.

1953-1960

1953-1955: Super and Century;

1956-1960: All.

CD530.....\$97.50 ea.

Clutch Pressure Plate Assembly Rebuilding Service

1934-1956 All.

PP366.....\$167.75 ea.

1957-1963 All.

PP573.....\$197.50 ea.

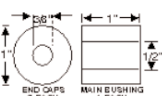

1941-1953 All Standard trans. Kit, clutch equalizer. Kit includes metal sleeved rubber bushing and 2 end seals. (0.806)

EB413.....\$37.25 kit

1941-1949 All models. Bumper, clutch pedal stop at toe board. (.832)

PS419.....\$12.00 ea.

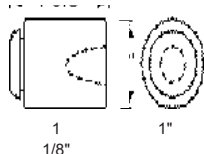

Clutch Arm Boot

1940-1955 All.

CB405.....\$12.50 ea.

Clutch Throw Out Bearings (.799)

1932 thru 1935 series 50;

1936 series 60-80-90;

1937 All.

TB327.....\$79.50 ea.



1938 All.

TB38.....\$51.00 ea.



1939-1955

1939-1952: All Special and Super;

1953-1955: All Specials.

TB395.....(Bearing only).....\$37.50 ea.

TB395A.....(Assembly).....\$94.50 ea.



1939-1960 Bearing

1939-1952: Series 60, 70, 80 and 90;

1953-1955: Super and Century;

1956-1960: All.

TB416.....\$41.25 ea.



Clutch Pilot Bearings (.649)

1932-1956

1932-1933 series 50;

1934-1935 series 40,50;

1936-1956 All. Except 1938 Specials and 1939.

PB366.....\$19.50 ea.



1938 Special; 1939 all.

PB389.....\$19.50 ea.



1957-1960 Clutch pilot bearing.

PB570.....\$8.00 ea.

Stop Light Switches (2.447)

1936-1940 All.

SLS360.....\$17.50 ea.



1941-1955 All.

SLS415.....\$9.75 ea.



1956-1960 All.

SLS563.....\$9.75 ea.



1936-1980 Brake adjuster hole plug. (4 per car).

BC340.....\$1.00 ea.



1936-1958 All, brake and clutch pedal return grommets.(9.775) (2 per car)

PG365.....\$7.75 ea.



Decal and Detail Kits



This kit includes 12-20 decals but is not limited to Valve Covers, Glove Box, Jack Instruction, Oil Filter and Air Cleaner decals. Priced to **SAVE!**

Sets include decals that originally came with car. Standard equipment only.

DK36	1936	\$44.00
DK37	1937	\$49.00
DK38	1938	\$49.00
DK39	1939Series 50, 60, 70.....	\$49.00
DK39S	1939Series 40.....	\$49.00
DK40	1940Series 50, 60, 70.....	\$49.00
DK40S	1940Series 40.....	\$49.00
DK41	1941	\$49.00
DK42	1942	\$49.00
DK46	1946	\$49.00
DK47	1947	\$49.00
DK48	1948	\$49.00
DK49	1949	\$49.00
DK50	1950	\$49.00
DK51	1951	\$49.00
DK52	1952	\$49.00
DK53	1953Series 50 & 70.....	\$49.00
DK53S	1953Series 40.....	\$33.00
DK54	1954	\$33.00
DK55	1955	\$65.00
DK56	1956	\$65.00
DK57	1957	\$65.00
DK58	1958	\$65.00
DK59	1959	\$65.00
DK60	1960	\$65.00

Individual kit decals are not returnable.



D37



D40



D41

Owners Manual Envelopes

D37	1936-1940	\$3.50
D38	1941	\$3.25
D39	1942-1950	\$3.25
D40	1951-1954	\$3.25
D41	1955-1957	\$3.25
D145	1958 All(Beautifully Embossed).....	\$5.75

Engine Compartment Decals/Tags

D1	1931-1960	Generator Warning Tag	\$2.00
D86	1936-1960	Antifreeze Tag.....	\$2.50
D19	1937-1953	Oil Filler Cap Decal	\$3.25
D31	1941-1958	Trico Washer Pump Decal	\$4.50
D202	1941-1958	GM Windshield Washer Bracket Decal.....	\$3.75
D22	1952-1956	Power Steering Pump Decal.....	\$3.50
D230	1941-1958	GM Auto. Windshield Washer Decal (yellow).....	\$4.50
D375	1954-1960	Electric Antenna.....	\$4.50
D172	1954-1960	Air Conditioning Compressor Warning Decal.....	\$5.00
D72	1955-1960	Harrison A.C. Tag Metal	\$5.75
D296	1959-1960	Optikleen Bottle Label	\$3.00
D178	1959-1960	Cooling System Decal.....	\$5.00
D370	1960	New Car Price Booklet	\$3.50



D1



D5

Oil Filter Decals

D3	1930-36	A.C. (W6).....	\$3.50
D4	1937-47	A.C. (L11)	\$4.00
D5	1948-53	A.C. (P127).....	\$3.75
D73	1946-48	A.C.	\$4.00
D74	1953-58	A.C. (PF122).....	\$4.00



D71



D 111



D 117

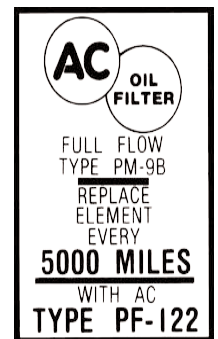

D74

Miscellaneous

D108	Old Style Buick Logo (blue and white)	\$7.50
D111	All Years "Genuine Buick 8 Parts".....(H2O).....	\$3.25
D112	All Years "Buick 8" logo.....(H2O).....	\$3.25
D117	"Authorized Buick Service" (10" diameter red, white and blue decal)	\$6.00
D118	"Authorized Buick Service" (5" diameter red, white and blue decal)	\$4.75
D379	1953-1960 "Air Conditioned" window decal	\$5.00
D75	"Authorized Buick" Lube Sticker.....	\$2.25

Buick Decals • Tags • Etc. (Group 0)



D10

D12



D21



D16



D17



D85

Valve Cover Decals

D6	1936-37 "Valve/Head Silent Oil Cushion"	\$7.25
D19	1937-1953 Oil Filler Cap decal (silver)	\$3.25
D7	1938 "Buick 8 Dynafash Oil Cushion"	\$7.25
D8	1939-1940 Ser. 40 "Dynafash Oil"	\$7.25
D9	1939-1940 Ser. 60-70 " Dynafash Oil"	\$7.25
D10	1941-1948 "Valve in Head Fireball". Please state Black (D10B), Red (D10R), or Blue (D10U).....	\$7.25
D21	1948-1953 "Hydraulic Lifter" decal.....	\$4.75
D10R	1949-1952; 1953 Ser. 40 "Valve in Head"	\$7.25
D13	1950-1953 263 Cubic Inch decal	\$4.50
D12	1953-1955 V8 w/ raised covers. (set of two).....	\$6.50
D184	1953-60 V-8 Oil Filler Cap decal (orange)	\$3.00



D30



D44



D165

Air Cleaner Decals

D14	1932-1936 (Dry Element).....	\$4.00
D20	1936-1946 Oil type or Dry style warning	\$4.00
D15	1936-1946(Oil Bath Type).....	\$4.00
D419	1941-1948 Dry style air cleaner	\$4.50
D16	1946-1953 (All straight 8); 1953 Super	\$4.50
D17	1953-1958 4bbl. Carb. (orange. Oil Bath Type) ..	\$4.00
D16	1954-1956 2bbl. Carb. (orange).....	\$4.00
D18	1957-1958 2BBL Oil Bath Type (white).....	\$4.00
D173	1958 2bbl. Dry Style Air Cleaner (white).....	\$4.75
D162	1958 4 bbl. Dry Style Air Cleaner decal (red).....	\$4.50
D174	1958 4 bbl. Air Poise Suspension decal (red).....	\$5.00
D85	1959-1960 Wildcat 445 (2 piece set on lid).....	\$12.25
D368	1959-1960 4bbl Service Inst. on side. A63C	\$4.50
D182	1959-1960 2bbl Service Inst. on side. A86C.....	\$4.50

Interior Decals/Tags

D24	1936 Glove Box Tire Pressure	\$2.75
D23	1936-1960 Owners I.D. Card	\$3.25
D76	1936-1937 Battery Warrantee	\$3.50
D208	1936-1954 Buick Service Policy.....	\$3.25
D30	1934-1958 Glove Box Key Sticker	\$2.75
D25	1937 Glove Box Tire Pressure	\$2.75
D81	1937-1953 Tire and Wheel Balance Tag	\$3.25
D82	1937-1953 Oil and Tire Instruction Tag.....	\$2.75
D79	1937-1960 Compass Directions	\$3.50
D367	1937-1960 New Car Break-in Tag	\$3.50
D26	1938 Glove Box Sticker.....	\$2.75
D27	1939-1947 Glove Box Sticker	\$2.75
D209	1939-54 Buick Battery Warranty Cert.	\$3.50
D206	1940 Electric Clock Instructions	\$3.50
D207	1940 Buick New Car Inspection/Adjustment Sheet	\$2.50
D211	1940-1954 Chrome Care Instructions	\$3.50
D71	1940-1963 Casco Auto. Lighter Tag Interior Decal.....	\$4.00
D28	1948-1950 Glove Box Sticker	\$2.75
D29	1951-1954 Glove Box Sticker	\$2.75
D385	1955-1960 Battery Certificate	\$3.00
D44	1956-1960 Glove Box Door Sticker.....	\$4.00
D124	1957-1958 2-Speed Windshield Wiper Tag.	\$4.25
D165	1957-1960 Glove Box "Lacquer Paint".....	\$3.50
D36	1958-1959 Autronic Eye Instructions	\$4.50



D33

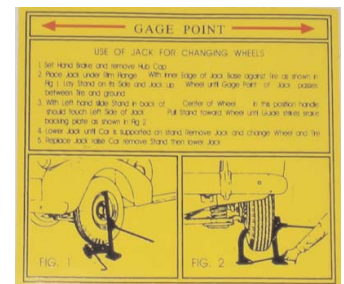

D93

Trunk Decals/Tags

D93	1938-1941 Jack Instructions	\$3.00
D110	1942-1948 Jack Instructions	\$3.00
D245	1949 Jack Instructions	\$4.50
D32	1955 Jack Instructions	\$4.00
D33	1956 Jack Instructions	\$3.00
D34	1957 Jack Instructions	\$4.50
D113	1958 Jack Instructions	\$4.50
D35	1958-1960 Air Suspension.....	\$4.50
D356	1959 Jack Instructions	\$4.25
D170	1959-1960 Jack Decal (on Jack).....	\$4.50
D360	1960 Jack Instructions	\$4.25

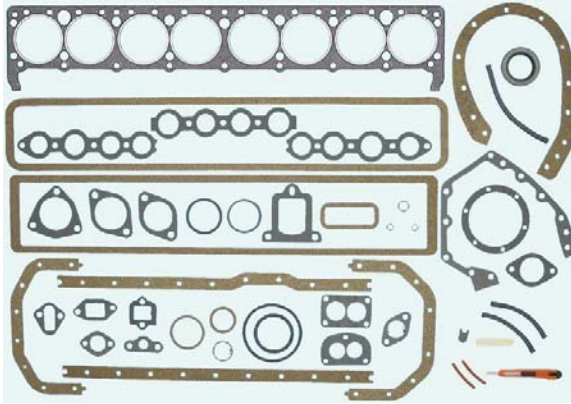

Full Engine Gasket Sets, Head Rebuilding Sets and Head Gaskets

1931-1935 Series 50, 60, 80, 90. Inc composition head gasket.
FGS315.....Full Rebuilding Set.....\$325.00 ea.
HG315.....Head Gasket, Series 50.....\$84.50 ea.
HG315B.....Head Gasket Series 60, 80, 90.....\$97.50 ea.

1934-1949 All Special and Super;
1950 Special. for 233 and 248 engines. prg-346 not included.
FGS340.....Full Rebuilding Set.....\$145.00 ea.
HGS349.....Head Rebuilding Set.....\$95.50 ea.
HG349.....Head Gasket Only.....\$59.50 ea.

1950-1953 All Special and Super. 263 engines.
FGS503.....Full Rebuilding Set.....\$137.50 ea.
HGS503.....Head Rebuilding Set.....\$95.50 ea.
HG503S.....Head Gasket Only. .015.....\$59.50 ea.

1936-1952 Series 60, 70, 80, 90. 320 engines.
FGS362.....Full Rebuilding Set.....\$189.50 ea.
HGS362.....Head Rebuilding Set.....\$95.50 ea.
HG362.....Head Gasket Only. .015.....\$63.50 ea.

1953-1953 All V-8 engines. Includes .045 head gaskets.
*FGS536.....Full Rebuilding Set.....\$139.00 ea.
HGS536.....Head Rebuilding Set.....\$89.50 ea.
HG536.....Head Gaskets Only.....\$52.50 pr.

1953-1953 All V-8 engines. Includes .015 head gaskets.
*FGS536S.....Full Rebuilding Set.....\$115.00 ea.
HGS536S.....Head Rebuilding Set.....\$89.50 ea.
HG536S.....Head Gaskets Only.....\$52.50 pr.

1957-1960 All V-8 engines. Includes .045 head gaskets.
*FGS576.....Full Rebuilding Set.....\$129.50 ea.
HGS576.....Head Rebuilding Set.....\$74.50 ea.
HG576.....Head Gaskets Only.....\$67.50 pr.

* Contains new "rubber lip" timing cover seal!



Timing Cover Gasket Sets

1934-1941 All 248 and 263 straight-8 engines.
TCS341.....(includes rope seal).....\$26.00 ea.
1942-1953 All 248 and 263 straight-8 engines.
TCS423.....(includes rubber lip seal).....\$29.50 ea.
1942-1949 All 320 Roadmaster straight-8 engines.
TCS429.....(includes rubber lip seal).....\$26.00 ea.
1950-1952 All 320 Roadmaster straight-8 engines.
TCS502.....(includes rubber lip seal).....\$29.50 ea.
1953-1960 All V-8.
TCS536.....(includes rubber lip seal).....\$19.50 ea.

Timing Cover Gaskets and Seals

1934-1953 All 248 and 263 straight-8 engines. Cover gasket.
BG13022.....(cork/rubber gasket).....\$9.50 ea.
1934-1953 All 248 and 263 straight-8 engines. Back plate.
BG10038.....(paper gasket).....\$7.75 ea.
1936-1952 All 60, 70, 80, 90, 320 Engines. Cover gasket.
BG13023.....(cork/rubber gasket).....\$9.50 ea.
1936-1952 All 60, 70, 80, 90, 320 Engines. Back plate.
BG10037.....(paper gasket).....\$6.50 ea.
1937-1953 All straight-8 engines. Front rope seal.
BG7056.....\$9.50 ea.
1942-1953 All 248 and 263 straight-8 engines;
1942-1949 All 60, 70, 80, 90, 320 Engines. Modern lip seal.
BG3494.....\$19.50 ea.
1950-1952 Roadmaster, 320 Engines. Modern lip seal.
BG3495.....\$14.50 ea.
1953-1960 All V-8. Cover gasket.
BG12060.....\$9.50 ea.
1953-1960 All V-8. Front seal. Modern lip seal.
TCS536L.....\$11.75 ea.

Rear Main Seals

1934-1953 All straight-8 engines;
1957-1960 All. Rear main rope seal.
RMS346.....\$15.50 ea.
1939-1953 All. Special and Super; **1953** Special. Lip seal.
RMS343M.....\$39.50 ea.
1953-1956 All. V-8 engines. Rope seal set.
RMS536.....\$16.00 ea.
1957-1960 All. V-8 engines. Rubber lip type seal.
RMS576.....\$19.50 ea.

Distributor Base Gaskets

1934-1952 All; **1953** Special. Crankcase vent gasket.
BG4225.....\$4.50 ea.
1934-1952 All; **1953** Special. Distributor base gasket.
BG1272.....\$3.50 ea.
1953-1960 All V-8. Distributor base gasket.
BG1634.....\$3.50 ea.

Engine Gaskets (Group 0)



Valve Cover Gaskets

- 1934-1953;**
1934-1952 All Special and Super;
1953 Special.
 VCG343.....\$16.95 ea.
1936-1952 All Series 60, 70, 80, 90. 320 engines.
 VCG362.....\$16.95 ea.
1953-1960 All V-8 engines.
 VCG536.....\$16.50 pr.
 VCG572.....(Bolt grommets, 4 needed).....\$3.50 ea.

Push Rod Cover Gaskets

- 1934-1936** All Series 40.
 PRG346.....\$16.50 ea.
1937-1949 All Special and Super;
1950 Special.
 PRG370.....\$15.00 ea.
1951-1953 All Special.
1950-1952 Super.
 PRG503.....\$15.00 ea.
1936-1952 All Series 60, 70, 80, 90. 320 engines.
 PRG362.....\$15.00 ea.
1936-1953 All straight-8 engines. Push rod nut gasket.
 PRG363.....(8 req. per car).....\$1.00 ea.









- 1953-1956** All V-8 engines.
 PRG536.....\$9.75 ea.
1957-1960 All V-8 engines.
 PRG576.....\$9.75 ea.

Misc. Oil Gaskets

- 1934-1958** All engines. Oil pan drain plug gasket.
 ODG348.....\$2.50 ea.
1934-1952 Special & Super; **1953** Special. Oil pump cover.
 BG3381.....\$4.50 ea.
1934-1952 Special & Super; **1953** Special. Oil pump/block.
 BG3292.....\$4.50 ea.
1936-1952 Ser. 60, 70, 80, 90. 320 engines. Oil pump mtg.
 BG3871.....\$4.75 ea.
1953-1956 All V-8 engines. Oil pump inlet. Tri-angular.
 BG3484.....\$4.75 ea.
1953-1960 All V-8 engines. Oil pump body.
 BG2380.....\$4.75 ea.
1953-1960 All V-8 engines. Oil filter housing to block.
 BG3486.....(except 1957-1958).....\$4.75 ea.
 BG3595.....(1957-1958 only).....\$4.75 ea.
1953-1960 All except 1959. Oil pump inlet.
 BG2324.....(All except 1959).....\$4.75 ea.
 BG1479.....(1959 only).....\$4.75 ea.
1957-1958 All engines. Oil pump body.
 BG2469.....\$4.75 ea.

Thermostat Related Gaskets

-  **1933-1953** All straight 8 engines. Water outlet.
 WOG330.....\$2.50 ea.
 **1934-1940** All Special and Super. Thermostat housing.
 BG2172.....\$2.75 ea.
 **1936-1940** All 60, 70, 80, 90 320 engines;
1941-1949 All engines. Thermostat housing.
 BG2173.....\$2.75 ea.
 **1950-1953** All straight 8 engine. Thermostat housing/head.
 BG3386.....\$2.75 ea.
 **1934-1953** All straight 8 engines. Therm. Hsg. bolt seals.
 BG134.....(2 needed per car).....\$1.00 ea.
 **1953-1960** All V-8 Engines. Water outlet.
 WOG536.....\$2.25 ea.

Water Pump and Manifold Gaskets

- 1934-1940** All Special and Super. Water pump backing plate.
 WPG340.....\$6.50 ea.
1941-1953 All straight-8 eng. Water pump backing plate.
 WPG413.....\$6.50 ea.
1934-1940 All Special and Super. Water pump to block.
 BG2204.....\$2.50 ea.
1936-1940 All 60, 70, 80, 90 320 engines w/ pump to block;
1941-1949 All engines water pump to block;
1950-1953 All straight-8. Water pump to elbow.
 BG2140.....\$2.50 ea.
1950-1953 All straight-8 eng. Water pump elbow to block.
 BG3015.....\$3.00 ea.
1953-1955 All V-8 engines. Water pump mounting gasket.
 WPG535.....\$4.50 ea.
1953-1960 All V-8 engines. Water manifold seal kit.
 Contains two end gaskets and center "o" ring.
 WMK536.....\$8.50 ea.
1956-1960 All V-8 engines. Water pump mounting gasket.
 WPG561.....\$4.75 ea.



Oil Pan Gaskets

- 1934-1952** All Special and Super; **1953** Special.
 OPG343.....\$16.25 ea.
1936-1952 All series 60, 70, 80, 90. 320 engines.
 OPG362.....\$16.25 ea.
1953-1956 All V-8 engines.
 OPG536.....\$13.50 ea.
1957-1960 All V-8 engines.
 OPG576.....\$14.50 ea.

Original Colors to Authenticate your Engine.
 Our Enamels are the Finest available. Heat
 Resistant to 700° F. Can be Easily Brushed or
 Sprayed to Obtain a Rich Deep Gloss.
 Sold in Quart or Spray Cans.

* Note: Spray cans can NOT be shipped by Air.

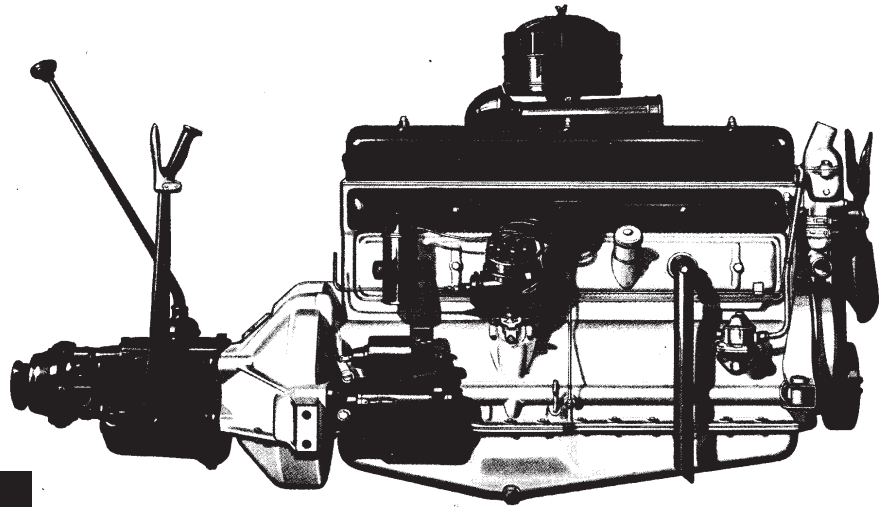

Please Note:
 Spray Cans cannot be shipped by Air.

YEARS	APPLICATION	Quart Cans	12 oz. Spray Can
1932	Black	EP1.....\$24.50	EP1S\$14.00
1933-1938	Forest green engine paint	EP298.....\$27.50	EP298S\$14.00
1939-1940	Gray engine paint	EP390.....\$27.50	EP390S.....\$14.00
1941	Dante red engine paint	EP41.....\$27.50	EP41S\$14.00
1942-1952	Turquoise engine paint	EP423.....\$27.50	EP423S\$14.00
Also 1953	Series 40 buick turquoise	EP535.....\$27.50	EP536S.....\$14.00
1953-1960	All V8 buick green		



Spray Gun for Engine Enamels

Self-propelled unit enables you to spray up to 16 oz. of paint. Great for use on engine enamels listed above that are not available in spray cans.

- SG220.....\$12.50 ea.
- Refill cartridge.
- SGR220\$6.50 ea.

Engine Compartment and Chassis Paint

All years satin black paint. This is correct enamel for frame and engine compartments. Authentic for all years. Excellent for use on fan, radiator, air cleaner, side pans, shroud, etc.

- EP2.....(Quart).....\$24.50 ea.
- EP2S.....(12 oz. spray can)\$14.00 ea.



Cast Iron Paint

Extremely High Temperature - 1800 degrees. Excellent for manifolds and exhaust systems. **Will not burn OFF.**

- EP3.....(pint).....\$32.00 ea.
- EP3S.....(spray can).....\$19.50 ea.

All years universal gloss black. Excellent for engine dress-up, chassis and general use.

- EP1.....(Quart).....\$24.50 ea.
- EP1S.....(12 oz. spray can)\$14.00 ea.

Optional Dante Red Wheel Paint

Our EP41 and EP41S is also used as a correct replacement for the optional wheel color - Dante red used from 1938 thru 1960.



Grille Emblems • Mouldings (Group 1)



1937
Grille Emblem
GO37....\$68.00 ea.

1939
Vertical Grille Moulding. All Models.
GM39.....\$149.50 ea.

1940
GE40.....\$115.00 ea..



1941
Grille Emblem
GE41...\$149.75 ea.

Cooling • Oiling (Group 1)

Water Pump Exchange or Rebuilding Services (1.069)

Water pumps are freshly re-built to assure long lasting performance. If in stock, they are sold on an exchange basis with a core charge, or send in your pump for fresh rebuild. Core charge will be refunded after your OEM rebuildable pump is returned. **1934-1949** ball bearing type pumps can also be rebuilt on a case by case basis. Allow about 2-4 weeks.

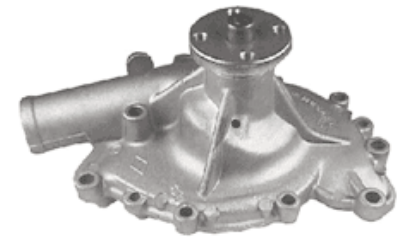

Years	Part No.	Price
1953-1955 All V-8 engines - New Water Pump Sold Outright.	WP535.....	\$129.50 ea
1956 All.....	WP56.....	\$148.50 ea.
1957 All.....	WP578.....	\$148.50 ea.
1958 All w/o AC	WP578.....	\$148.50 ea.
1958 All with AC Except 5 Bladed Fan.....	WP578.....	\$148.50 ea.

Water Pumps (New!) Sold Outright

Years	Part No.	Core Charge	Price
1934-1939 Series 40; 1940 Series 40-50.....	WP340EI.....	\$100.00.....	\$118.50 ea.
1936-1940 Series 60-70-80-90; 1941-1949 All.....	WP369EI.....	\$50.00.....	\$109.50 ea.
1950-1952 All; 1953 Specials.....	WP503EI.....	\$50.00.....	\$109.50 ea.
1953-1955 All V-8 engines.....	WP535EI.....	\$50.00.....	\$99.50 ea.
1956 All.....	WP56EI.....	\$50.00.....	\$99.50 ea.
1957-1958 All. (state size of outlet, hub, a.c., etc.).....	WP578EI.....	\$50.00.....	\$99.50 ea.
1959-1960 All.....	WP591EI.....	\$50.00.....	\$99.50 ea.

Water Pump Covers (1.113)

"Backing Plates" includes gasket and bolts.
1934 thru **1940** all straight 8.
 WPC340.....\$19.50 ea
1941 thru **1953** all straight 8.
 WPC413.....\$19.50 ea

Water Pump Hardware Kits

You never have to worry about breaking another bolt.
 High strength stainless steel bolts will never rust.

1934-1939 Special; 1940 Special and Super.
 WPH340.....\$4.25 kit
1950-1953 All Straight-8 engines.
 WPH503.....\$4.25 kit
1953-1958 all V-8.
 WPH538.....\$11.75 kit



Radiator Hoses

Our radiator hoses are pre-formed as the originals, (no flex type), to fit and look authentic. Some may come longer and need minor trimming.

	Year	(1.159)	Upper Hose Part No.	Lower Hose Part No.		
	1934-1938 Specials		UH360	LH360	\$11.50	\$18.50
UH 360	1936-1938 Series 60-70-90		UH360	LH360	\$11.50	\$18.50
	1936-1953 By-pass hose		BP363			\$ 4.00
LH 360	1939-1940 Specials and Supers..		UH393	LH393	\$12.75	\$18.50
	1939-1940 Series 60-70		UH393	LH393	\$12.75	\$18.50
	1939-1940 Series 80-90		UH360	LH360	\$11.50	\$18.50
	1941 Specials and Supers		UH413	LH41	\$13.50	\$18.50
LH 41	1941 All 320 engines		UH413	LH393	\$13.50	\$18.50
	1942-1947 Series 40-50 to frame #14717304		LH429	LH429	\$18.50	\$18.50
	1942-1947 Series 60-70-90		UH478	LH393	\$18.50	\$18.50
LH 429	1947 Series 40-50 after frame #14717304		UH478	LH429	\$18.50	\$18.50
	1948-1949 Special and Super.		UH478	LH429	\$18.50	\$18.50
UH 478	1948 Roadmaster before frame #14710654.....		UH478	LH393	\$18.50	\$18.50
	1948 Ser. 70 after #14710654.....		UH478	LH393	\$18.50	\$18.50
	1949-1952 Roadmaster.		UH428	LH393	\$18.50	\$18.50
UH 428	1950-1952 Series 40-50; 1953 Series 40.....		UH413	LH393	\$13.50	\$18.50
	1953 Super, Roadmaster and Skylark		UH428	LH536	\$18.50	\$18.50
UH 54	1954-1956 All.....		UH54	LH536	\$18.50	\$18.50
	1957 All.....		UH57	LH570	\$16.50	\$18.50
UH 57	1958 All.....		UH58	LH570	\$18.75	\$18.50
	1959 All.....		UH590	LH570	\$17.75	\$18.50
UH 58	1960 All.....		UH590		\$17.75	
						
UH 590						

Radiator Hose Clamps

These are the correct "Wittek Tower Top" hose clamps. They are correct for all 1941-1960 models.

2 1/16" Diameter fits most upper hose. This is a stock size.

RC216.....\$2.75 ea.

2" Diameter fits most upper hose. Smaller than stock.

RC200.....\$2.75 ea.

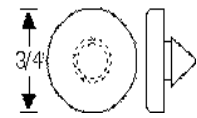

1956-1959 Bumper, radiator fan shroud as required.

HB429.....\$2.25 ea.

Cooling System Seal Tabs

Developed by GM for sealing and stabilization of your cooling system. Highly recommended by Buick engineers for all older cars. Pack of 6 non-toxic tabs.

CT300.....\$6.00 pack



Wire Hose Clamps



For 9/16" diameter hose.

HC916W.....\$ 1.00 ea.

HC916WP.....(5 Pack).....\$ 3.25 ea.

For 3/4" diameter hose.

HC340W.....\$ 0.75 ea.

HC340WP.....(5 Pack).....\$ 3.25 ea.

For 13/16" diameter hose.

HC1316W.....\$ 1.00 ea.

HC1316WP.....(5 Pack).....\$ 4.25 ea.

For 15/16" diameter hose.

HC1516W.....\$ 0.75 ea.

HC1516WP.....(5 Pack).....\$ 4.25 ea.

For 1" diameter hose.

HC100W.....\$ 1.00 ea.

HC100WP.....(5 Pack).....\$ 4.25 ea.

For 1-1/4" diameter hose.

HC114W.....\$ 1.00 ea.

HC114WP.....(5 Pack).....\$ 5.00 ea.

For 2" diameter hose.

HC200W.....\$ 2.75 ea.

HC200WP.....(5 Pack).....\$12.25 ea.

Buick Fan Belts, Power Steering,

AC Belts (1.416)



Please note that 1953-1960 belts are also offered as 100% authentically correct. They feature a flat un-cogged surface for a smooth and quiet ride, comes with the original GM numbers, stamped right into the belt.

		Cars	Part #	
1934-1939	*Specials.....		FB340.....	\$21.50 ea.
1936-1939	Series 60-80-90.....		FB369.....	\$32.00 ea.
1940	All Special & Super.....		FB40S.....	\$24.50 ea.
1940	Series 60-70-80-90.....		FB40B.....	\$28.50 ea.
1941-1949	Special & Super.....		FB419S.....	\$18.50 ea.
1941-1949	*Series 60-70-90.....		FB419B.....	\$36.50 ea.
1950	All Special & Super.....		FB340.....	\$21.50 ea.
1950	Roadmasters.....		FB50B.....	\$24.50 ea.
1951-1952	Roadmaster.....		FB512.....	\$13.50 ea.
1951-1952	Special & Super; 1953 Specials.....		FB513.....	\$15.00 ea.
1953	All V-8 Fan/Gen Belt		FB530.....	\$18.75 ea.
	Exact Reproduction.....		FB1343438.....	\$34.50 ea.
1953	All V-8 Power Steering Belt		FB530.....	\$18.75 ea.
	Exact Reproduction.....		FB1343438.....	\$34.50 ea.
1953	All V-8 Matched Pair Belt Set		FB53S.....	\$35.00 ea.
	Exact Reproduction.....		FB1343438S.....	\$65.00 pr.
1954-1957	All Fan/Gen Belt w/o AC ;			
1957	Fan/Gen Belt w/ AC Early..		FB548.....	\$19.75 ea.
1954	Power Steering Belt		FB548.....	\$19.75 ea.
	Exact Reproduction.....		FB1163447.....	\$34.50 pr.
1954 & 1956	All Fan/Gen Belts . Matched Pair.....		FB548S.....	\$37.50 ea.
	Exact Reproduction.....		FB1163447S.....	\$65.00 pr.
1955-1956	Power Steering Belt		FB556.....	\$21.50 ea.
1957	All Late Fan/Gen Belt w/ AC		FB578A	\$21.50 ea.
1957	All w/o AC and 1" type w/ AC Power Steering Belt		FB578.....	\$21.50 ea.
	Exact Reproduction.....		FB1163447.....	\$34.50 ea.
1957	All Early. AC Belt		FB57E.....	\$21.50 ea.
1957	All Late. AC Belt		FB57E.....	\$21.50 ea.
1958	All Fan/Gen Belt w/ AC		FB578A	\$21.50 ea.
1958	All Fan/Gen Belt w/o AC ..		FB548.....	\$19.75 ea.
	Exact Reproduction.....		FB1180978.....	\$34.50 ea.
1958	All w/o AC or Air Ride Power Steering Belt		FB578.....	\$21.50 ea.
1958	All AC Belts (uses 2 belts)		FB58.....	\$43.50 pr.
1959-1960	All Fan/Gen Belt w/o AC ...		FB530.....	\$18.75 ea.
	Exact Reproduction.....		FB1188358.....	\$34.50 ea.
1959-1960	All Fan/Gen/AC Belts 364 eng. Uses 2 belts.....		FB590.....	\$43.50 pr.
	Exact Reproduction.....		FB1180978.....	\$65.00 pr.
1959-1960	All Fan/Gen/AC Belts 401 eng. Uses 2 belts.....		FB590B.....	\$43.50 pr.
1959-1960	All Power Steering Belt ...		FB591.....	\$21.50 ea.

* Not as wide as original

Water Outlets (1.153)



1954-1957 Thermo. Housing water outlet and gasket.
WO547.....\$24.50 ea.

1958-1960 Thermo. Housing water outlet and gasket.
WO581.....\$25.00 ea.

Temperature Sending Unit



1960 All.
TSU608.....\$13.25 ea.

Thermostats (1.246)

All thermostats include gaskets



1933-1953 All except 1953 V-8.
T330180°.....\$9.75 ea.
T330L160°.....\$9.75 ea.
T330H195°.....\$9.75 ea.
WOG330.....Gasket for Above.....\$2.25 ea.

1953-1960 All V-8 Engines.
T536180°.....\$9.75 ea.
T536L160°.....\$9.75 ea.
T536H195°.....\$9.75 ea.
WOG536.....Gasket for Above.....\$2.25 ea.

Radiator Caps



Take a good look at these caps. They are identical to the originals. Correct in every detail, they feature the cap number, instructions and of course genuine "AC" identification stamped right into the cadmium plated surface. Show quality, approved and licensed by Buick.

1937-1939 All. Non-pressure. No detail.	
RC10	\$36.50 ea.
1940-1946 All;	
1947 up to frame 14717305 on Special and Super; up to frame 14710656 on Roadmaster. 7 lb.	
RC13	\$32.50 ea.
1947 after frame 14717305 on Special and Super; after frame 14710656 on Roadmaster; 4lb.	
1948 All	
RC509	\$32.50 ea.
1949 Roadmaster Early. 13lb. cap.	
RC559	\$32.50 ea.
1949 all Special and Super. Roadmaster Late;	
1950 thru 1956 All. 7 lb.	
RC549	\$32.50 ea.
1957-1960 All. 15 lb.	
RC15D	\$32.50 ea.

Replacement Radiator Caps



1937-1939 All. Non-pressure.	
RC379.....	\$10.50 ea.



1940-1947 All. 7 lb.	
RC407.....	\$10.50 ea.



1948-1949 All. 4 lb.	
RC489.....	\$10.50 ea.



1950-1956 All. 7 lb.	
RC506.....	\$10.50 ea.



1957-1960 All. 15 lb.	
RC579.....	\$16.50 ea.

Heater Hose



HH58.....5/8"	\$1.00 per foot
HH5850.....5/8"	\$39.00 per 50 feet
HH34.....3/4"	\$1.00 per foot
HH3450.....3/4"	\$39.00 per 50 feet

Heater Hose Clamps (1.066)



Buick used "Tower Top" Heater hose clamps on all cars from **1942-1960**. We supply a reproduction identical to the clamp made by the Wittek Company. They are authentic and correct. Measure your OD.

1942-1960 "Tower Top" Heater hose clamps. All GM.	
HC340.....(for 3/4" hose with 1 1/4" OD).....	\$2.75 ea.
HC340S.....(for 3/4" hose with 1 3/16" OD)	\$2.75 ea.
HC580.....(for 5/8" hose with 1 1/16" OD).....	\$2.75 ea.
HC580S.....(for 5/8" hose with 1" OD)	\$2.75 ea.



www.oldbuickparts.com

908-369-3666

Oil Pump Rebuilding Service

1936-1937 Specials.
OP367RS\$129.50 ea.

1938-1952
1938-1940: Series 60, 70, 80, 90;
1946-1952: Roadmaster.
OP382RS\$129.50 ea.

1938-1953
1938-1939: Special;
1940-1952: Special and Super;
1953: Special.
OP383RS\$129.50 ea.

1953 V-8 Oil pump.
OP53RS\$129.50 ea.

1954-1956 Oil pump.
OP546RS\$129.50 ea.

1957-1958 Oil pump rebuilt.
OP578RS.....Oil pump only.....\$299.00 ea.

1959-1960 With engine 401 engine oil pump.
OP591RS.....\$107.00 ea.

Oil Pump Kits (1.652)



1934-1939 Special and Super.
OPK349\$93.50 ea.

1936-1952 Century, Roadmaster w/ 320 eng, oil pump kit.
OPK362\$93.50 ea.

1940-1952 Special and Super; **1953** Special. Oil pump kit.
OPK403\$93.50 ea.

1953-1956 All V-8 engines. Oil pump kit.
OPK536\$71.50 ea.

1957-1958 Oil pump kit.
OPK578\$69.50 ea.

1959-1960 All. Oil pump kit.
OPK591\$69.50 ea.



GM Engine Lubricant (E.O.S.)

Genuine GM EOS provides excellent lubrication. Highly recommended. 16 oz.
EOS300.....\$20.00 ea.

Oil Filter Elements (1.836)



1939-1947 All. (AC-P112)
OF397\$17.50 ea.

1948 All except Roadmaster with hydraulic lifters. (AC-P115)
OF48\$15.50 ea.

1948-1953 (AC-P127)
1948: Roadmaster with hydraulic lifters;
1949-1952: All;
1953: Specials.
OF493\$14.75 ea.

1953-1958 All V-8. (AC-P122)
OF538\$11.50 ea.

1959-1960 All. (AC-PF24)
OF596\$9.75 ea.

Oil Pan Drain Plug and Gasket (1.453)

1929-1937 All. Self threading 11/16" oversize.
OP297\$4.00 set

1938-1958 All. Self threading 5/8" oversize.
OP388\$5.75 set

1934-1958 All engines. Oil pan drain plug gasket.
ODG348.....\$2.75 ea.

1959-1960 1/2", x 20 thread.
OP595\$5.50 set



Oil Pressure Switch



1960 All.
OPS606\$11.75 ea.

Oil Filter/Breather Caps (1.758)









1936-1960 All. Twist on type. Genuine "AC" reproduction with embossed letters. Show quality.
OC397.....Black.....\$26.50 ea.
OC647.....Chrome.....\$36.00 ea.

1939-1960 All. Twist on type. Aftermarket replacement.
OC397A\$9.75 ea.

1953-1955 V-8 All. Push in type. Aftermarket replacement.
OC535.....\$7.50 ea.

Thermostat Related Gaskets

-  **1933-1953** All straight 8 engines. Water outlet. WOG330\$2.25 ea.
-  **1934-1940** All Special & Super. Thermostat housing. BG2172.....\$2.75 ea.
-  **1936-1940** All 60, 70, 80, 90 320 engines; **1941-1949** All engines. Thermostat housing. BG2173.....\$3.00 ea.
-  **1950-1953** All straight 8 engine. Thermostat housing/head. BG3386.....\$2.75 ea.
-  **1934-1953** All straight 8 engines. Therm. Hsg. bolt seals. BG134.....(2 needed per car)\$1.00 ea.

-  **1953-1960** All V-8 engines. Water outlet. WOG536\$2.25 ea.

Water Pump & Manifold Gaskets

-  **1934-1940** All Special and Super. Water pump backing plate. WPG340.....\$4.95 ea.

- 1936-1940** Series 60, 70, 80, 90 engines w/ water pump backing plate;

-  **1941-1953** All straight-8 eng. Water pump backing plate. WPG413.....\$4.95 ea.

-  **1934-1940** All Special and Super. Water pump to block. BG2204\$2.75 ea.

- 1936-1940** All 60, 70, 80, 90 320 engines w/ pump to block;

- 1941-1949** All engines water pump to block;

-  **1950-1953** All straight-8 engines. Water pump to elbow. BG2140\$3.00 ea.

-  **1950-1953** All straight-8 eng. Water pump elbow to block. BG3015\$3.00 ea.

-  **1953-1955** All V-8 engines. Water pump mounting gasket. WPG535.....\$4.75 ea.

-  **1953-1960** All V-8 engines. Water manifold seal kit. Contains two end gaskets and center "o" ring. WMK536\$9.00 ea.









-  **1956-1960** All V-8 engines. Water pump mounting gasket. WPG561.....\$4.75 ea.



Oil Pan Gaskets

- 1934-1952** All Special and Super; **1953** Special. OPG343\$16.00 ea.
- 1936-1952** All series 60, 70, 80, 90. 320 engines. OPG362\$16.00 ea.
- 1953-1956** All V-8 engines. OPG536\$14.50 ea.
- 1957-1960** All V-8 engines. OPG576\$14.50 ea.

Misc. Oil Gaskets

-  **1934-1958** All engines. Oil pan drain plug gasket. ODG348.....\$2.75 ea.
-  **1934-1952** Special and Super; **1953** Special. Oil pump cover. BG3381.....\$4.50 ea.
-  **1934-1952** Special and Super; **1953** Special. Oil pump/block. BG3292.....\$4.50 ea.
-  **1936-1952** Ser. 60, 70, 80, 90. 320 engines. Oil pump mtg. BG3871.....\$4.50 ea.
-  **1953-1956** All V-8 engines. Oil pump inlet triangular. BG3484.....\$4.50 ea.
-  **1953-1960** All V-8 engines. Oil pump body. BG2380.....\$4.50 ea.
-  **1953-1960** All V-8 engines. Oil filter housing to block. BG3486.....(except 1957-1958)\$4.50 ea. BG3595.....(1957-1958 only)\$4.50 ea.
-  **1953-1960** All except 1959. Oil pump inlet. BG2324.....(All except 1959).....\$4.50 ea. BG1479.....(1959 only).....\$4.50 ea.
-  **1957-1958** All engines. Oil pump body. BG2469.....\$4.50 ea.

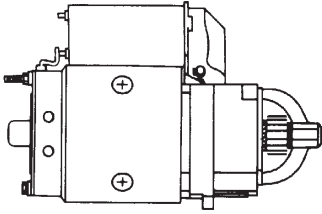

Starter Rebuilding Service

Includes Solenoid

1934-1938 Special.	
S348.....	\$194.50 ea.
1936-1938 Series 60-80-90.	
S368.....	\$194.50 ea.
1939-1950	
1939: Special;	
1940-1950: Special and Super.	
S390.....	\$194.50 ea.
1939-1950 Roadmaster.	
S390B.....	\$194.50 ea.
1951-1953	
1951-1952: Special and Super;	
1953: Special.	
S513.....	\$194.50 ea.
1951-1952 Roadmaster.	
S512.....	\$194.50 ea.
1953 Super and Roadmaster.	
S53.....	\$194.50 ea.
1954-1956 All.	
S546.....	\$194.50 ea.
1957-1958 All.	
S578.....	\$189.50 ea.
1959-1960 All.	
S590.....	\$189.50 ea.



Starter ID Tag

1931-1960 Delco, starter, gen., and distributor ID tag.	
ET6.....(ALL 6 VOLT).....	\$7.00 ea.
ET12.....(ALL 12 VOLT).....	\$7.00 ea.

Starter Brush Sets

1935-1952; 1953 Series 40.	
SBS353.....	\$5.50 set
1953-1960 All V-8.	
SBS539.....	\$6.50 set



Starter Solenoid Boots

1934-1950 All. Solenoid boot. Cover on starter motor solenoid. (2.140)	
SB420.....	\$7.50 ea.
1951-1956 Starter solenoid boot.	
SB516.....	\$11.25 ea.



Starter Solenoids (2.100)

1934-1941 All. (Rebuilding Service).	
SS341.....	\$132.50 ea.
1942-1950 All Engines. (Rebuilding Service).	
SS420.....	\$124.50 ea.
1951-1953	
1951-1952: Special and Super;	
1953: Special. (Sold Outright).	
SS513.....	\$104.50 ea.
1953 All V-8 Engines. (Rebuilding Service).	
SS53.....	\$95.50 ea.
1954-1956 All. (Sold Outright).	
SS546.....	\$64.50 ea.
1957-1960 All. (Sold Outright).	
SS575.....	\$38.50 ea.

Starter Solenoid Repair Kit



1957-1960 All.	
SRK570.....	\$24.50 kit

Starter Drives

1932-1953	
1932-1952: All;	
1953: Specials.	
SD393.....	\$48.00 ea.
1953 All V-8.	
SD53.....	\$49.50 ea.
1954-1956 All.	
SD546.....	\$41.00 ea.
1957-1960 Starter drive.	
SD571.....	\$57.00 ea.



Starter Relay (2.127)





1932-1953 All V-8 engines. (12V)	
Aftermarket replacement	
SR530.....	\$58.50 ea.

Horn Contact Separator

1938-1949 Special; 1940 Super.	
HS389.....	\$28.75 ea.



Ignition Parts (Group 2)

Years	POINT SET (2.384) 	CONDENSER (2.393) 	DIST. CAP (2.367) 	ROTOR (2.382) 	IGNITION COIL (2.170) 	COMPLETE TUNE UP KITS 8 Spark Plugs, Points, Rotor, Condenser, Cap, Wire Set. Complete \$89.50
1937-1950	D103.....\$11.50	D203...\$6.00	D302..\$16.50	D401...\$8.50	IC373...\$26.50	TK370
1951-53 ex.	D103.....\$11.50	D203...\$6.00	D302..\$16.50	D401...\$8.50	IC373...\$26.50	TK513
1953 (12 vt.)	D104.....\$13.50	D203...\$6.00	D305..\$16.50	D403...\$16.50	IC539...\$26.50	TK536
1954-1956	D104.....\$13.50	D203...\$6.00	D305..\$16.50	D403...\$16.50	IC539...\$26.50	TK536
1957-1960	D106.....\$16.50	D204...\$6.00	D308..\$13.50	D409...\$7.50	IC539...\$26.50	TK579



Spark Plugs (2.270)

SP86	1929-1937 All	\$2.95 ea.
SP45R	1938-1942 All	\$2.95 ea.
SP45R	1946-1949 All	\$2.95 ea.
SP45R	1950-1952; 1953 Series 40	\$2.95 ea.
SP45R	1953-1957 All V-8 (use #45)	\$2.95 ea.
SP45R	1958 All	\$2.95 ea.
SPR43S	1959-1960 All	\$2.95 ea.



Spark Plug Boots

SB536	1953-1956 All V-8.	\$3.00 ea.
SB577	1957-1960 Spark plug boots (8 per car). Use with original type copper core ignition wires.	\$3.00 ea.

Delco Ignition Points

IP373N	1937-1953 <u>Original</u> Delco Igniton Points.	\$21.50 ea.
IP536N	1953-1956 All V-8 <u>Original</u> Delco Ignitions Points.	\$21.50 ea.

Original Ignition Lock Cylinder With 2 Keys

IL359	1935-1939 All	\$19.50 ea.
IL413	1941-1950: All; 1951-1953: Super, Roadmaster and Skylark.	\$52.50 ea.
IL513	1951-1953 Specials; 1954-1956 Same	\$28.00 ea.
IL359	1957-1960 All	\$19.50 ea.
IL414	1941-1960 All, replacement type. (non original).	\$26.00 kit



Key Blanks-Genuine GM

KB10	1933-1960 Octagon.	\$3.50 ea.
KB11	1933-1960 Rounded.	\$3.50 ea.



KB10 KB11

Spark Plug Wire Sets

IW336	1936-1952 All; 1953 Series 40. Has copper core as original!	\$57.50 set
IW366	1953-1956 All V-8. Has copper core as original!	\$57.50 set
IW576	1957-1960 All.	\$29.50 set



(2.239)

Spark Plug Wire Grommets, etc.

WR363	1936-1953 All Straight-8 spark plug wire retainers. 4 piece set.	\$21.50 set
-------	--	-------------



WG53C	1953 Oblong for spark plug wire clip at right rear head. Uses two per car. Series 50 and 70.	\$17.75 pr
-------	--	------------



WG53	1953 Trapezoidal style under spark plug cover flange at right end of both sides. One pair per car. Series 50 and 70.	\$9.25 ea.
------	--	------------

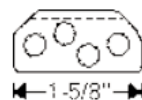

WG546	1954-1956 (4 per car).	\$7.50 ea.
-------	--------------------------	------------



WG578	1957-1958 (4 per car).	\$4.95 ea.
-------	--------------------------	------------



WR596	1959-1960 Ignition wire retainer.	\$4.25 ea.
-------	-----------------------------------	------------



Distributor Adjusting Tool

DT575	1957-1960 All .	\$10.00 ea.
-------	-----------------	-------------

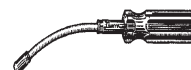

Distributor Vacuum Advance Controls

VC600	1961-1974 All. Oem replacement.	\$16.25 ea.
-------	---------------------------------	-------------



Universal Coil Bracket

CB350	With mount for Radio Capacitor	\$6.50 ea.
CB350C	Chrome	\$11.50 ea.

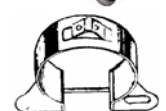



www.oldbuickparts.com

Never Change Points Again!

Upgrade to an electronic ignition. Fits entirely inside the distributor.

Installs as quickly as changing a set of points. No black boxes, complicated wiring or special brackets. Only two wires to connect.

IGNITOR ELECTRONIC IGNITION KITS	NO.	PRICE
8 CYLINDER		
1937-1953 All Straight 8, 6 volt, negative ground	PI1183N6	\$96.50
1937-1953 All Straight 8, 12 volt, negative ground (original distributor)	PI1183	\$96.50
1953-1956 All V-8 Mechanical advance under baseplate	PI1185LS	\$89.50
1957-1974 All V-8 Except 215, 300, 340 Engines	PI1181LS	\$89.50
1957-1974 All V-8	PI1181	\$89.50
1957-1974 All V-8 (Ignitor II)	PI91181	\$109.50
6 CYLINDER		
1968-1974 All	PI1162A	\$89.50
1962-1967 V-6 Engine	PI1164	\$89.50
1962-1967 V-6 Engine (Odd Fire)	PI1165	\$89.00
HIGH PERFORMANCE COIL		
1937-1953 All Straight 8, 6 volt, negative ground (Black)	PC45011	\$39.50
1937-1953 All Straight 8, 6 volt, negative ground (Chrome)	PC45001	\$49.50
1953-1974 All (Black)	PC40011	\$37.50
1953-1974 All (Chrome) 12 v	PC40001	\$46.50
1953-1974 All (For Ignitor II applications only - Chrome) 12 v	PC45001	\$49.50
1953-1974 All (For Ignitor II applications only - Black) 12 v	PC45011	\$39.50
Coil Bracket	CB350	\$6.50
Coil Bracket (Chrome)	CB350C	\$11.50
HIGH PERFORMANCE SPARK PLUG WIRES		
Low 500 ohm/ft. resistance with spiral wound alloy to suppress electromagnetic radiation plus redundant current paths.		
V-8 7.0mm Stock-Look Custom Set		
1953-1960 All	PW708103	\$44.50
1960-1967 Special, Skylark, GS (Ex 1967 GS 400)	PW708103	\$44.50
1967-1966 LeSabre, Wildcat, Invicta, Electra, Riviera All 364, 401, 425 Engines	PW708105	\$44.50
1967 GS-400	PW708102	\$44.50
1968-1974 All 350, 400, 430, 455 w/o HEI	PW708102	\$44.50
6 CYLINDER 7.0mm STOCK-LOOK Custom Set		
1968-1974 ALL	PW706101	\$44.50

Ignition Parts (Group 2)

Battery Cable Covers (2.343)

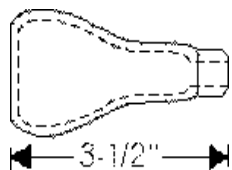

1931-1960 Battery cable cover. Two per car.
CC315\$6.25 ea.

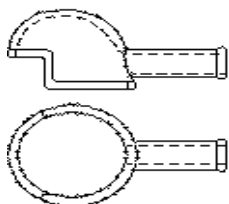

1932-1960 All. Battery cable cover. Located on switch side and junction block. (Two per car).
CC325\$6.25 ea.

Battery Cables

Ground Cables (-) (2.341)

- BC9 **1931-1932** All; **1933** series 60,80,90;
1934-1935 Series 40, 60, 90;
1936-1937 All;
1950-1951 Special and Super;
1953 Special.....\$12.25 ea.
- BC13 **1933-1935** Series 50;
1938-1949 All;
1950-1952 Roadmaster.....\$15.25 ea.
- BC19 **1953** Ser. 50-70; **1954-56**;
1958-60\$17.50 ea.
- BC24 **1957**\$19.50 ea.



Switch Cables (+) (2.342)

- BC48 **1933-1937** All
\$34.50 ea.
- BC17 **1938-1953** All Straight 8;
1958-1960 All\$16.50 ea.
- BC14 **1953** All V-8 engines;
1957 All\$17.00 ea.
- BC19 **1954-1956** All.\$17.50 ea.



See Wire Loom, page 25 cover some battery cables.

Switch to Starter Cable

- 1953-1960**
1953-1956: All;
1959-1960: All.
SC32\$27.75 ea.



Battery Hold Down Clamps (2.335)



- 1932-1937** All series 40 and 50.
BC327\$34.50 ea.
- 1939-1949** All with shield.
BC399\$59.00 ea.
- 1939-1953** All straight 8 w/o shield.
BC393\$37.50 ea.
- 1955-1957** All.
BC557\$54.50 ea.
- 1960** All. Rubber coated as original.
BC602\$39.50 ea.

Battery Parts (9.775) 2 per car



- 1939-1953**
1939-1952: All;
1953: Series 40 Battery hold down.
Grommet.
BG393.....\$3.00 ea.
- 1953-1958** Battery cushion. Attaches to battery hold. (4 per car).
BC548\$2.75 ea.

Battery Top Louvre

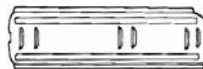

- 1953** Super, Roadmaster and Skylark.
BL53.....\$49.50 ea.

Battery Hold Down Bolts (2.334)



- 1939-1953** All. Battery hold down kits. Kit contains 2 bolts, 2 grommets, 2 wing nuts, and 2 washers.
BK393\$12.25 set
- 1954-1958** All. Battery hold down kits. Kit contains 2 bolts, 2 washers, 2 wing nuts, 4 (BC548) cushions.
BK548\$17.25 ea.

- 1960** All, two needed per car. Includes washer and wing nut.
BB602\$6.50 ea.

Generator Rebuilding Service

G356	1935-1936 Special and Super	\$266.75
G36	1936 Series 60, 80, and 90.....	\$266.75
G37	1937 Special	\$266.75
G3B	1937 Series 60, 80, and 90.....	\$266.75
G389	1938-1939 All.....	\$266.75
G409	1940-1948 All; 1949 Special.....	\$189.50
G491	1949 Super and Roadmaster; 1950-1951 All.....	\$189.50
G523	1952 All; 1953 Special	\$189.50
G536	1953-1956 All V-8	\$189.50
G57	1957 Without air conditioning	\$189.50
G57A	1957 All with air conditioning	\$189.50
G58	1958 Without air conditioning	\$189.50
G58A	1958 All with air conditioning	\$189.50
G59	1959 Without air conditioning	\$189.50
G59A	1959 All with air conditioning	\$189.50
G602	1960 Without air conditioning	\$189.50
G60A	1960 All with air conditioning	\$189.50

Generator Brush Sets (2.285)

Part No.	Years	
 GBS359	1935-1939 All.....	\$10.25 set
GBS401	1940-1951 All.....	\$5.75 set
GBS527	1952-1957 All.....	\$5.75 set
GBS401	1958-1960 All.....	\$5.75 set

Generator Bearings (2.306)



1941-1960 Generator front bearing.	
GEB412.....	\$8.75 ea.
1954-1957 Generator rear bearing. (2.298)	
GEB547	\$17.75 ea.
1958-1960 Generator rear bearing.	
GEB581	\$15.75 ea.

Generator Pulley (2.274)

1957-1960 All without air conditioning. Single Pulley.	
AP575.....	\$33.25 ea.

Generator Fan (2.274)



1958-1960 All. (Correct cadmium plating).	
AF585.....	\$17.50 ea.

Generator I.D. Tag



1931-1960 Delco, starter, generator and distributor ID tag.	
ET6.....(ALL 6 VOLT).....	\$7.00 ea.
ET12.....(ALL 12 VOLT).....	\$7.00 ea.

Voltage Regulators (2.500)



1940-1953 All 6 volt replacement.	
VR403	\$89.50 ea.
1953-1956 All, 12 volt replacement.	
VR536	\$79.50 ea.
1957-1960 1957 All ;1958-1960 All with out A.C.	
VR572	\$59.50 ea.
1958-1960 All with A.C. - replacement.	
VR582A	\$79.50 ea.

Voltage Regulator Cover "Delco Remy"

1940-1960 All "Delco Remy"	
VRC402.....	\$32.50 ea.

Coil Resistor



1953-1960 Coil resistor on firewall.	
CR533.....	\$11.50 ea.

Horn Relay (2.815)



1937-1953 All six volt replacement horn relay.	
HR373	\$17.00 ea.
1953-1956 All V-8.	
HR536	\$18.50 ea.
1957-1958 All.	
HR578	\$13.25 ea.
1959-1960 All.	
HR590	\$79.75 ea.

Electrical (Group 2)

Delco Ignition Points

1937-1953 Original Delco Ignition Points.

IP373N	\$10.25 ea.
1953-1956 All V-8 <u>Original</u> Delco Ignition Points.	
IP536N	\$14.00 ea.

Distributor Adjusting Tool

1957-1960 All.

DT575	\$10.00 ea.
-------------	-------------

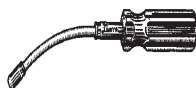

Universal Coil Bracket

With mount for Radio Capacitor.

CB350	\$6.50 ea.
CB350C.....Chrome	\$11.75 ea.

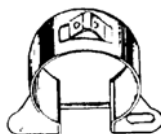

Distributor Rebuilding Service (2.361)

1934-1953

1934-1952: All;
1953: Special.

D343	\$167.50 ea.
1954-1958 All. Does not include vacuum.	
D548	\$167.50 ea.
1959-1960 All.	
D596	\$167.50 ea.

Distributor Vacuum Control Rebuilding Service (2.410)

1937-1952 All.

VC372RS	\$66.00 ea.
1953 Special.	
VC53RS	\$66.00 ea.
1953 Super, Roadmaster, Skylark; 1954-1956 All.	
VC536RS	\$66.00 ea.
1957-1959 All.	
VC579RS	\$66.00 ea.

1960 All. Sold outright.

VC600	\$16.25 ea.
-------------	-------------



Electronic Distributor



Now available for the Vintage Buick Straight 8 is the high performance DUI Distributor! This high powered ignition will light the fire in the straight 8 like never before. Built with our popular Street Strip DUI Coil, you can open the plug gaps to a massive .055"! Also included is the high dwell Dyna-Module

which allows the coil to produce a longer duration spark over stock ignitions. The advance curve is custom tuned to provide the most power throughout the RPM range with no pre-detonation. Additional benefits are quicker starting, smoother idle and it is all electronic - NO POINTS! Installation is easy with only one wire required for hookup Bring your straight 8 up to date by adding some serious firepower with the DUI! Comes with easy to follow instructions and is backed by a one year warranty.

- Simple One Wire Hookup
- Allows for Wider Plug Gaps
- All Electronic Ignition - No Points
- 50,000 Volt Coil and Dyna Module
- Performance Tuned Advance Curve
- Increased Horsepower and Fuel Mileage

1936-1953 (12 volt only) 248, 263, 320 engines.
DUI383

\$395.00 ea.

State cap color: Black, Red, Blue.

Live Wires



IW383B.....(Black).....	\$99.00 ea.*
IW383R.....(Red).....	\$99.00 ea.*
IW383U.....(Blue).....	\$99.00 ea.*

* For use with DUI383 ONLY.

Headlamp Doors (Rims) (2.728)

- 1940** All. stainless steel. Perfect reproduction.
 HD40.....\$49.75 ea.
1940 All. Completely assembled with our HR407 rubber seal and HC402 clips.
 HD40A.....\$59.75 ea.
1941 All. Headlamp door.
 HD41.....\$23.25 ea.
1942-1948 All. Headlamp door.
 HD428.....\$26.50 ea.
1942-1948; 1949 Special Headlamp spear.
 HS429.....\$10.50 ea.
1949-1952 Headlight door. Stainless steel.
 HD492.....\$44.50 ea.

NOTE: Our Headlamp doors have the correct width unlike other vendors selling doors that are too thin.

- 1958-1960** All;
 Headlamp adjusting screw assembly.
 HA582.....\$3.50 ea.
1940-1954 All;
1955 First type. Headlamp sealed beam retainer.
 Chrome plated. Beautiful!
 HR405.....\$27.50 ea.
1940-1960 Retainer screw.
 HS400.....\$1.25 ea.

Headlamp Seals

- 1940-1957**
1940 All;
1949 Super & Roadmaster;
1950-1957 all except 1955.
 HB407.....\$12.75 pr.
1941-1949. (For 9" dia. seals)
1941-1948 All;
1949 Specials.
 HB419.....\$14.50 pr.
1955 All.
 HB55.....\$25.25 pr.

Headlamp Bucket Grommet

- 1940 thru 1957** All.
 BG407.....\$5.75 ea.

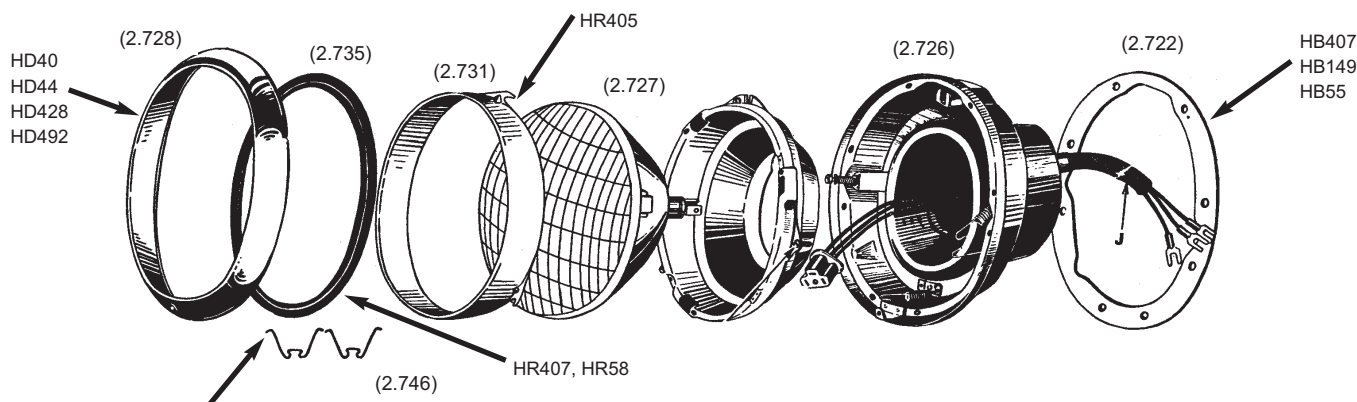

- 1936-1939** All. Headlamp retaining clips. 3 clips per set. Stainless steel. 2 sets per car.
 HC369.....\$5.50 set
1940-1952 All. Headlamp rim seal retaining clips. 4 clips per set. Stainless steel. Two sets per car.
 HC402.....\$6.25 set

- 1940-1957** Headlamp door seals. Smooth rubber skin with inner seal core for perfect fit.
 HR407.....\$18.50 pr.
1958 All.
 HR58.....\$33.00 pr.

- 1958** All.
 Headlamp to fender seals.
 HB58.....\$55.50 pr.

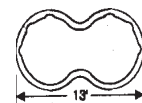

"Guide" Genuine T-3 Headlamps (2.727)

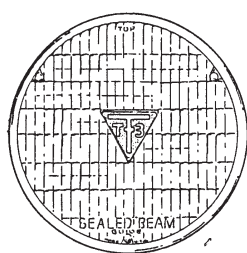

1956-1957
 Two Hi/Low Beams.
 SB567S.....TOS

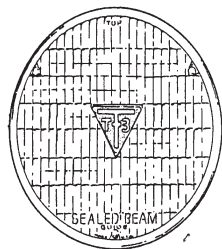

1958-1959
 Two Hi/Low Beams
 Two Hi Beams.
 SB589S.....TOS

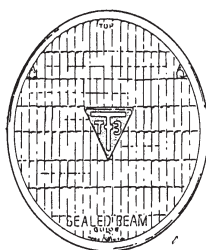

1960
 Two Hi/Low Beams
 Two Hi Beams.
 SB607S.....\$149.00 set

Replacement Sealed Beams (2.727)

- 1940-1953** Headlamp sealed beam, 6 volt.
 SB6.....\$12.50 ea.
1953-1957 12 volt.
 SB12.....\$11.00 ea.
1958-1960 All. Headlamp sealed beam. #1, high beam. Two terminals.
 SB1.....\$11.00 ea.
1958-1960 All. Headlamp sealed beam. #2, low beam. Three terminals.
 SB2.....\$11.00 ea.

Headlamps and Parts (Group 2)

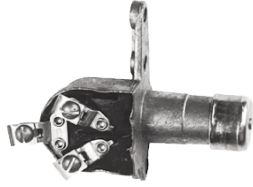

Headlamp Dimmer Switches

1934-1958

1934-1956 All;
1957-1958 All, except with Autronic Eye.

HDS348.....\$19.50 ea.

1959-1960 All, except with Autronic Eye.

HDS590.....\$24.50 ea.

Headlamp Terminal Junction Blocks



1936-1939 (6 prongs).

JB369.....\$21.50 ea.

1940-1951 (8 prongs).

JB401.....\$19.50 ea.

1952-1955

JB525.....\$21.00 ea.

Headlamp Mounting Pads



1934-1935 For 3 1/4" x 6 1/4" base, non-symmetrical. Series 50, 60 and 90.

HLP345B.....\$58.50 pr.

1934-1935 Headlight bracket to fender. Right and left. Series 40.

HLP345.....\$33.75 pr.

1936 All series.

HLP36.....\$33.50 pr.

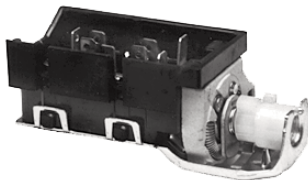

Headlamp Switches

1949-1953 All 6 volt aftermarket replacement type.

HS493.....\$49.50 ea.

1959-1960 All. OEM replacement type.

HS593.....\$49.50 ea.

Wire Loom

Asphalt coated fabric. Wire loom for battery cables, headlamps, wire etc.

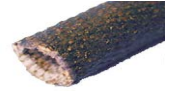

WL1801/8" ID\$1.55 ft.

WL3163/16" ID\$1.55 ft.

WL1401/4" ID\$1.80 ft.

WL5165/16" ID\$1.80 ft.

WL3803/8" ID\$1.80 ft.

WL7167/16" ID\$1.80 ft.

WL1201/2" ID\$1.80 ft.

WL9169/16" ID\$2.15 ft.

WL5805/8" ID\$2.15 ft.

WL3403/4" ID\$2.15 ft.

Woven Wire Mesh Split Loom



WWL3163/16" ID\$1.75 ft.

WWL3803/8" ID\$2.00 ft.

WWL1201/2" ID\$2.50 ft.

WWL3403/4" ID\$3.00 ft.

WWL1001" ID\$3.50 ft.

Headlamp Wiring Grommets



1936 Grommet, headlight wiring from headlight bulb through mounting brace. Series 40.

WG36.....\$26.25 pr.



1936-1941 Electric wire through body for head 1" and tail lights. 3/8" I.D. for 11/16" hole.

WG361.....\$2.25 ea.

New Xenon Headlamp Technology for Your Old Buick

One of the weakest systems in older cars is the quality of lighting. Night driving is particularly unsafe due to low levels of candlepower. Modern technology has developed state of the art **Xenon Head-lamps** now available for your model Buick.

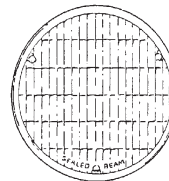

1940-1953

Two Hi/Low 6V
Haolgen Beams.

SB6h...\$86.50 set

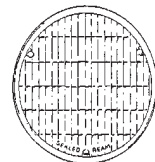

1953-1957

Two Hi/Low
Xenon 12V Beams.

SB12X...\$49.50 set

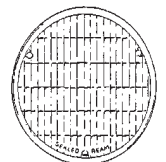

1958-1960

Two Hi/Low Beams
Two Hi Beams Xenon

SBXs.....TOS

Park Lamp Pads



1936 All. Parking lamp mounting pads.
PLP36.....\$40.75 pr.



1937 All. Parking lamp mounting pads.
PLP37.....\$34.50 pr.



1938 All. Parking lamp mounting pads.
PLP38.....\$31.00 pr.

1939 All. Parking lamp mounting pads.
PLP39.....\$35.25 pr.

1940 All. Parking lamp mounting pads.
PLP40.....\$43.50 pr.

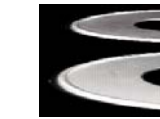

1941 All. Parking lamp mounting pads.
PLP41.....\$68.50 pr.



1942-1948 Super and Roadmaster parking lamp mounting pads.
PLP428.....\$14.50 pr.

1953-1954 All (Lamp to body gasket).

PLP534.....\$9.75 pr.



1936-1938 Replacement. These lamps are quality made but not exact reproductions.
PL300.....\$185.50 pr.

Fender Lights

Front Parking Lamp Lenses

1936 All.
PL36.....\$26.50 ea.



1937-1938 All. Includes gaskets
PL378.....\$26.50 ea

1939 All.
PL39TOS



1941 All.
PL41.....\$39.50 ea.



1946-1949
1946-1948 All;
1949 Specials.
PL469.....\$21.50 ea.



1949 All Super and Roadmaster.
PL49.....\$35.00 ea.



1950-1952 All. "Guide".
PL502.....\$18.00 ea.



1953-1954 All. "Guide".
PL534.....\$18.00 ea.



1955 Special and Century. "Guide".
PL55.....\$18.00 ea.



1955 Super and Roadmaster.
PL55B\$26.50 ea.



1956-1957 All. "Guide".
PL567.....\$24.00 ea.



1958 All. "Guide".
PL58.....\$26.50 ea.

Front Parking Lens Gaskets

1936-1938 All.
PLG368.....\$5.50 pr.

1939 All.
PLG39.....\$5.50 pr.



1941 All.
PLG41.....\$9.75 pr.



1946-1949
1946-1948: All; 1949: Specials.
PLG469.....\$4.50 pr.



1949 Super and Roadmaster.
Four gaskets for two lamps.
PLG49.....\$8.00 pr.



1950-1952 All.
PLG502.....\$5.00 pr.



1953-1954 All.
PLG534.....\$7.00 pr.



1955 All Special and Century.
PLG55.....\$5.75 pr.



1955 Super and Roadmaster.
PLG55B\$7.75 pr.



1956-1957 All.
PLG567.....\$6.00 pr.



1958 All.
PLG58.....\$6.50 pr.



1959 All.
PLG59.....\$22.50 pr.

Parking Lamp Doors

1946-1949 1946-1948 All; 1949 Special.
LD469.....\$16.50 ea.

1950-1952 1950 All; 1951-1952 Super & Roadmaster.
LD50.....\$18.00 ea.

Highly Polished Stainless Steel Screws
LDS503.....\$2.95 ea.

Tail Lamps (Group 2)

Tail Lamp Lenses (2.682)

All Cars; Blue dot glass lenses with chrome ring.
BD360.....\$12.75 pr.





1939-1940 Special & Centruy
Plastic Replacement
TL390.....\$29.50 pr.

1940 Super and Roadmaster. Glass as original.
TL40R.....(R.H. Side).....\$21.50 ea.
TL40L.....(L.H. Side).....\$21.50 ea.

1942-1948 Super and Roadmaster.
Both sides. Gaskets included.
TL428P.....\$69.50 pr.



 **1949** Super and Roadmaster.
TL49.....\$29.00 ea.

 **1950-1952** "Guide".
1950: All;
1951-1952: Super and Roadmaster.
TL502.....\$36.50 ea.

1951-1952 Specials.
TL512.....TOS

1957 All. Stop lamp lens.
SL57\$37.50 ea.

 **1953** All. Four per car. "Guide" imprint. Brass ferrules and deep red color as original. Licensed by GM. Beware of cheap imitations!
TL53.....\$15.00 ea.

 **1954** All except Skylark. "Guide" imprint. Brass ferrules and deep red color as originals. Four per car. Licensed by GM.
TL54\$18.00 ea.

 **1955** All. "Guide".
TL55\$41.00 ea.

 **1956** All. "Guide".
TL56\$36.00 ea.

 **1957** Special and Century.
TL57\$36.50 ea.

 **1959** All. Tail lamp lens.
TL59\$39.50 ea.

 **1960** All. Tail lamp lens.
TL60.....\$39.50 ea.

Tail Lamp Lens Gaskets (2.684)

1936 Tail lamp lens gasket.
TLG36.....\$5.00 pr.

1938-1940
1938: All;
1939-1940: Series 80-90.
TLG380.....\$7.75 pr.

 **1939-1940** Special and Century, Tail lamp lens gasket.
TLG390.....\$7.50 pr.

 **1942-1948** All.
TLG428.....\$12.50 pr.

1949 Super and Roadmaster, 4 piece tail lamp gasket set.
TLG49.....(For Two Lamps).....\$11.50 pr.



 **1950-1952**
1950: All;
1951-1952: Super and Roadmaster.
TLG502\$9.75 pr.

1951-1952 Special.
TLG512.....\$8.00 pr.

1953 All.
TLG53S.....(Set of 4).....\$9.75 set



1954 All except Skylark.
TLG54S.....(Set of 4).....\$9.75 set

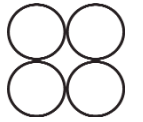

 **1955** Tail lamp lens gasket.
TLG55\$9.50 pr.

1956 Tail lamp lens gasket.
TLG56.....\$9.50 pr.



1957 Special and Century.
TLG57.....\$9.50 pr.

1957 Super and Roadmaster.
TLG57B.....\$9.00 pr.



 **1957** All. (for oval stop lamp lens).
SLG57\$7.25 pr.

 **1958** all Special and Century.
TLG58S.....\$30.25 pr.

 **1958** Super and Roadmaster.
TLG58B.....\$30.25 pr.

1960 All.
TLG60.....\$30.25 pr.



Tail Lamp Mounting Pads (2.660)



1933-1935 All Series.
TLP335\$41.75 pr.



1936 All Series.
TLP36\$32.50 pr.



1937 Special and Century.
TLP37\$33.25 pr.

1937 Series 80 and 90.
TLP37B\$64.25 pr.



1938 Special and Century.
TLP38\$34.50 pr.

1938-1940 Series 80 and 90.
TLP380\$52.25 pr.



1939-1940 Special and Century.
TLP390\$22.50 pr.



1939-1940 Super and Roadmaster.
TLP40\$42.50 pr.

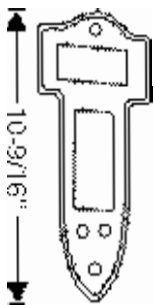

1941 Four door touring Sedan and four door convertible. Phaeton. Models 51, 51C, 71, 71C.
TLP41A\$74.00 pr.

1941 Series 50, 70 coupes and convertible coupes. Models 56, 56C, 56S, 76C, 76S.
TLP41B\$73.50 pr.

1941-1942 Series 90 only.
TLP41C\$90.50 pr.

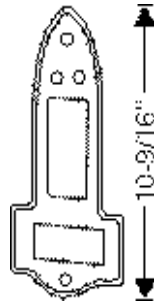

1941-1949
1941-1942: Model 41, 41 SE, 61;
1946-1949: Model 41.
TLP41D\$74.00 pr.

1941-1949
1941-1942: Series 40 and 60 coupes;
1946-1949: Model 46S.
TLP41E\$74.00 pr.



1942-1948 Super and Roadmaster.
TLP428\$49.50 pr.

1950-1952
1950: All Series;
1951-1952: Super and Roadmaster.
TLP502\$8.50 pr.



1951-1952 Specials.
TLP512\$23.50 pr.



1953 All. Seal, tail lamp bodies to fender. Four required per car. Four in set. (2.685)
TLP53\$103.75 set
1954 All. Tail lamp rubber mounting pad. Four required per car. (Except Skylark)
TLP54\$88.50 set



1954 Skylark. Seal, tail lamp to fender. (8.204)
TLP54S\$91.00 pr.

1955-1957 All.
TLP557\$21.00 pr.

1937-1959 Horn Contact Wire



1937-1959 All.
HCW379\$19.75 ea.

Signal Flashers



1941-1953 All. Six volt directional signal flasher.
SF413\$12.75 ea.
1953-1960 All 12 volt.
SF530\$10.75 ea.

Directional Signal Return Spring



1955-1960 All.
CS550\$12.75 ea.

Tail Lamp Parts (Group 2)



1949 Gasket junction block for taillight wiring. One pair per car. Series 50 & 70.
TWG49.....\$5.75 pr.

1950-1951 Boot and hose, tail lamp wiring. Four piece set includes end covers.

1950: all models;

1951: Series 50 and 70.

TWB501.....\$122.50 set

1942-1948 Tail Lamp Bezels



Die cast chrome. Fits either side.

1942-1948 Super & Roadmaster

These parts are sold as "seconds". They may have small pitting or imperfections in the chrome. Great for the "driver".

For Super and Roadmaster series.

TB428BS.....\$29.75 ea.

1953 Boot, tail lamp and turn signal wiring. Excellent quality tubing with correct molded ends. Order two pair per car.

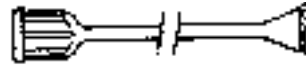

TWB53.....(All except Skylark).....\$74.00 pr.

TWB53X.....(Skylark - 4 piece set).....\$262.25 set

1954 All except Skylark.

Seal, reflector signal, between taillights. A smaller replacement for 1953.

RS534.....\$18.50 pr.

1950-1952 Tail Lamp Bezel



Die cast chrome. Fits either side.

Beautiful reproduction.

1950: All;

1951-1952: Super and Roadmaster.

TB502.....\$41.00 ea.

NOTICE

CAR SHOW ATTENDEES

CARS, Inc. will NOT bring the usual "yellow trailer" to the shows.

We will be happy to bring any parts you need.

Please call in advance of the show to place your order.

Look For Us!

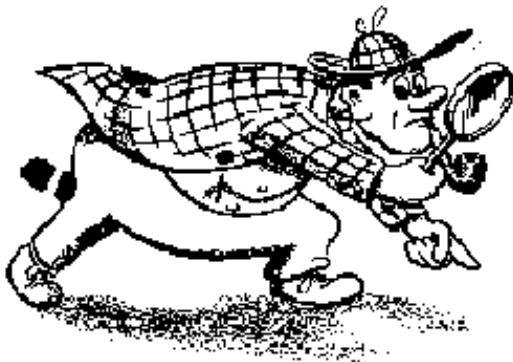

If your thinking of attending any of the shows listed below, be sure to stop by and say "Hello". We will be glad to discuss some of our newest items or simply talk about your **BUICK**.

Plan ahead by calling-in your order weeks ahead of time. We will be able to bring your entire order and save you shipping too.

GS Nationals

Buick Nationals

**Hershey*

GBM-12

near Lamp Post 93

Back-up Lenses (2.697)



1950-1953 "Guide".
1950: All;
1951-1953: Super, Roadmaster, Skylark.
BL503\$19.50 ea.



1951-1953 Special.
BL513\$18.50 ea.

1954 All except Skylark. "Guide"
BL54\$26.50 ea.



1955 All. "Guide"
BL55\$21.50 ea.



1956 All. "Guide".
BL56\$32.50 ea.



1957 all. "Guide".
BL57\$39.50 ea.

Back-up Lens Gaskets



1949 All Super and Roadmaster. Gaskets.
BLG49\$4.75 pr.



1950-1953
1950 all:
1951-1953: Super, Roadmaster, Skylark.
BLG503\$5.00 pr.



1951-1953 All Specials.
BLG513\$4.50 pr.



1955 Back-up lamp lens gaskets.
BLG55\$6.00 pr.



1956 Back-up lamp lens gaskets.
BLG56\$6.50 pr.



1957 All.
BLG57\$7.25 pr.

Back-up Lamp Parts



1949 Gasket, back up light housing.
One pair per car. All Super and Roadmasters (except station wagons).
BLP49\$28.75 pr.

1949 Series 50 and 70. Seal, backup lamp housing to inside of body. One pair per car.
BLS49.....\$5.00 pr.

1950-1963 Back-up lamp door chrome plated steel.



1950: All;
1951-1953: Super, Roadmaster and Skylark.
LD503.....\$19.50 ea.

Screws for the above. Correct highly polished stainless steel.
LDS503.....\$2.95 ea.



1951-1953 Special deluxe back-up light chrome ring.
BR513.....\$16.50 pr.



License Lenses

1956 License Lamp Lens

LL56\$21.50 ea.
LLG56.....(Gasket).....\$3.50 ea.



1959 License Lamp Lens

LL59\$51.00 ea.



Fog Lamp Kit

All years as required. Two 5 " 12 volt amber lamps in chrome housings. Easy mounting stud with wire.
FL300\$62.50 pr.

Bulbs and Fuses (Group 2)



Bulbs (8.991)



Year & Model	Head-light	Parking	Direction Front	Signal Rear	Tail	Stop	License Plate	Instru-ment	Indicator	Dome	Back-up
'35-'36	B2330/B2331	B55	----	----	B63	B87	B63	B55	B51	B81	----
'37, '38, '39	B2330/B2331	B55	-----	-----	B1154	B1154	B63	B55	B51	B81	----
'40	SB6	B1154	B1154	-----	B1154	B1154	B63	B55	B51	B81	-----
'41	SB6	B1154	B1154	-----	B1154	B1154	B63	B55	B51	B82	-----
'42	SB6	B1154	B1154	B1129	B1154	B1154	B63	B55	B51	B88	-----
'46-'49 (series 40)	SB6	B1154	B1154	B1129	B1154	B1154	B63	B55	B51	B81	B82
'46-'48 (ser. 50, 70)	SB6	B1154	B1154	B1154	B1154	B1154	B63	B55	B51	B81	B82
'49 (series 50 & 70)	SB6	B1154	B1154	B1154	B1154	B1154	B63	B55	B51	B88	B1129
'50	SB6	B1154	B1154	B1129	B1154	B1154	B63	B55	B51	B88	B1129
'51-'52	SB6	B63 B1154	B1154	B1129	B1154	B1154	B63	B55	----	B88	B1129 B1133
'53 (series 40)	SB6	B1154	B1154	B1129	B1154	B1154	B63	B55	B51	B210	B1133
'53 (ser. 50-70 12V)	SB12	B1034	B1034	B1073	B1034	B1034	B67	B57	B53	B1004	B1073
'54	SB12	B1034	B1034	B1073	B1034	B1034	B67	B57	B53	B90 B1004	B1073
'55	SB12	B1034	B1034	B1034	B1034	B1034	B67	B57	B53	B90 B1004	B1073
'56	SB12	B1034	B1034	B1034	B1034	B1034	B67	B57	B57	B90 B1004	B1073
'57	SB12	B1034	B1034	B1073	B67	B1073	B67	B57	B53	B90 B1004	B1073
'58	SB1, SB2	B1034	B1034	B1034	B1034	B1034	B67	B57	B57	B90 B1004	B1073
59	SB1, SB2	B1034	B1034	B1034	B1034	B1034	B67	B57	B57	B90 B1004	B1073
'60	SB1, SB2	B1034	B1034	B1034	B1034	B1034	B67	B5357	B57	B90 B1004	B1073

Prices: **B51**-\$1.50, **B53**-\$1.50, **B55**-\$1.50, **B57**-\$1.25, **B63**-\$1.25, **B67**-\$1.50, **B81**-\$1.75, **B82**-\$1.50, **B87**-\$2.00, **B88**-\$2.50, **B89**-\$2.00, **B90**-\$2., **B210**-\$5.25, **B1000**-\$5.75, **B1004**-\$2.75, **B1034**-\$2.75, **B1073**-\$2.75, **B1129**-\$2.75, **B1133**-\$4.00, **B1154**-\$2.00, **B1157**-\$2.00, **B2330**-\$8.75, **B2331** (High Intensity Bulb)-\$16.50, **SB1**-\$11.25, **SB2**-\$11.25, **SB6**-\$12.50, **SB12**-\$12.25.



www.oldbuickparts.com
908-369-3666

Headlamp Sockets



For 3 prong beam numbers SB6, 6006, SB12, 6012, SB2, 4000 and 4002.
PT6\$4.75 ea.



For 2 prong beam numbers SB1, 4001.
PT7\$4.25 ea.

Lamp Sockets and Pigtails



Single contact with lead. Fits bulb numbers 51, 53, 55 and 57.
PT1\$2.25 ea.



Single contact with lead. Fits bulb numbers 63, 67, 81, 87, 89, 1073, 1129, 1133, 1141 and 1156.
PT2\$2.25 ea.



Double contact with lead. For ears reversed. Bulbs numbers 82, 88, 90, 210, 1004, 1034, 1154 and 1157.
PT3\$2.75 ea.



Double contact with lead. For ears aligned bulbs.
PT4\$2.50 ea.

Parking and Tail Lamp Sockets

Single contact with lead. For 3/4" to 1 1/8" hole.
LS1\$4.25 ea.

Double contact with lead. For bulb numbers 1034 and 1154. Fits 1 1/8" hole.
LS5\$5.75 ea.

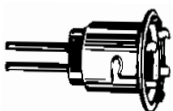

Double contact with leads. Fits 3/4" hole. For bulb numbers 1034, 1154 and 1157.
LS9\$5.75 ea.

Double contact with leads. Fits 3/4" to 1 1/8" hole. For bulb numbers 1034, 1154 and 1157.
LS2\$5.75 ea.



Double contact with leads. Fits 3/4" to 1 1/8" hole. For bulb numbers 82, 88, 90, 210 and 1004.
LS3\$6.85 ea.



Double contact with leads. Fits 1 1/8" hole. For bulb numbers 1034, 1154 and 1157.
LS4\$5.75 ea.

Interior/Dash Sockets



Single contact with lead for dome etc. For bulb numbers 63, 67, 81 89, 1073, 1129 and 1133.
PT8\$8.75 ea.



Double contact with lead. For dome and map lamps. Reversed ears. Bulb numbers 82, 88, 90, 210 and 1004.
PT9\$7.00 ea.



Double contact with lead for ears aligned bulbs.
PT10\$2.50 ea.

Back-Up and License Lamp Sockets

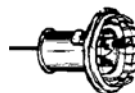

Single contact with lead. Fits 3/4" hole. Bulb numbers 63, 67, 81, 89 1129 and 1133.
LS6\$5.75 ea.



Single contact with lead. Fits 1 1/8" hole with ground wire. For bulb numbers 63, 67, 81, 89, 1129 and 1133.
LS7TOS



Single contact with lead. Fits 1 1/8" hole. For bulb numbers 63, 67, 81, 89, 1129 and 1133.
LS8\$6.00 ea.

Wiring Harnesses (Group 2)

Each harness is manufactured with factory color code specifications and made from patterns developed from original Buick harnesses. Each wire is tagged or identified individually for easy installation. We offer the largest selection of Buick harnesses found anywhere. Don't see your particular harness listed here? We can develop a new harness from your old one. Please call for more information.

[Early] 1936 BUICK Special / Series 40

[Headlight Switch had 8 Terminals]

WH3640EM.....Main Lighting Harness.....	\$573.30
WH3640EHG.....Horn Button Ground Wire	\$6.60
WH3640EDE..... Dash and Engine Harness	\$196.35
WH3640EI..... Instrument Light Wiring	\$8.80
WH3640ECL.....Cigar Lighter Wire	\$4.40
WH3640EC.....Clock Harness	\$46.20
WH3640EFT..... Fuel Tank Connector Wire	\$5.50
WH3640EGS..... Engine Ground Strap	\$27.50

[Late] 1936 BUICK Special / Series 40

[Headlight Switch had 10 Terminals]

WH3640LHB..... Headlight Bucket Wires [pair]	\$38.50
WH3640LFL..... Fender Light Bucket Wires [pair]	\$33.00
WH3640LM..... Main Lighting Harness	\$575.40
WH3640LHG.....Horn Button Ground Wire	\$6.60
WH3640LDE.....Dash and Engine Harness	\$196.35
WH3640LI..... Instrument Light Wiring	\$9.90
WH3640LCL.....Cigar Lighter Wire	\$5.50
WH3640LC.....Clock Harness	\$46.20
WH3640LFT.....Fuel Tank Connector Wire	\$5.50
WH3640LGS.....Engine Ground Strap	\$27.50

[Late] 1936 BUICK Century / Series 60

[Headlight Switch had 10 Terminals]

WH3660LHB..... Headlight Bucket Wires [pair]	\$38.50
WH3660LFL..... Fender Light Bucket Wires [pair]	\$34.10
WH3660LM.....Main Lighting Harness	\$553.35
WH3660LHG.....Horn Button Ground Wire	\$6.60
WH3660LDE..... Dash and Engine Harness	\$196.35
WH3660LI..... Instrument Light Wiring	\$9.90
WH3660LCL.....Cigar Lighter Wire	\$5.50
WH3660LC.....Clock Harness	\$46.20
WH3660LDL4.....Dome Light Wiring [4dr.sedan]	\$13.20
WH3660LDL2.....Dome Light Wiring [2dr.sedan]	\$13.20
WH3660LFT.....Fuel Tank Connector Wire	\$5.50

[Early] 1936 BUICK Roadmaster / Series 80

WH3680M..... Main Lighting Harness	\$583.80
WH3680DE..... Dash and Engine Harness	\$190.05

Wiring Harness Tape

Non-adhesive vinyl Harness wrap is same as used by GM.

1" wide, 100 foot roll.

WT100.....1" wide.	\$11.25 roll
-------------------------	--------------

1937 BUICK Special / Series 40

WH3740DEH..... Dash, Engine and Headlight Harness ..	\$600.60
WH3740I..... Instrument Light Wiring	\$34.10
WH3740C.....Clock and Glove Box Harness	\$55.65
WH3740BT.....Body and Taillights Harness [2dr.coupe] ..	\$242.55
WH3740BT4.....Body and Taillights Harness [4dr.sedan] ..	\$253.05
WH3740DLS..... Dome Light Wiring [4dr.sedan]	\$12.10
WH3740FT.....Fuel Tank Connector Wire	\$8.80
WH3740GS..... Engine Ground Strap	\$30.80

1937 BUICK Century / Series 60

WH3760DEH..... Dash, Engine and Headlight Harness ..	\$549.10
WH3760I..... Instrument Light Wiring	\$35.20
WH3760C..... Clock and Glove Box Harness	\$55.65
WH3760FT.....Fuel Tank Connector Wire	\$9.90
WH3760GS..... Engine Ground Strap	\$30.80

1937 BUICK Roadmaster / Series 80

WH3780DEH.....Dash, Engine and Headlight Harness	\$563.85
WH3780I..... Instrument Light Wiring	\$35.20
WH3780BT4.... Body and Taillights Harness [4dr.sedan] ..	\$274.05
WH3780FT.....Fuel Tank Connector Wire	\$9.90
WH3780GS..... Engine Ground Strap	\$30.80

1937 BUICK Limited / Series 90

WH3790DEH..... Dash, Engine and Headlight Harness ...	\$563.85
WH3790I..... Instrument Light Wiring	\$35.20
WH3790BT..... Body and Taillights Harness	\$179.55
WH3790IL..... Interior Light and Door Switch Wiring	\$113.40
WH3790FT.....Fuel Tank Connector Wire	\$9.90
WH3790GS.....Engine Ground Strap	\$30.80

1938 BUICK Special / Series 40

WH3840DEH..... Dash, Engine and Headlight Harness ...	\$646.80
WH3840BT.....Body and Taillights Harness [2dr.coupe] ..	\$270.90
WH3840BT4....Body and Taillights Harness [4dr.sedan] ..	\$281.40
WH3840BTC....Body and Taillights Harness [2dr.conv.] ..	\$260.40
WH3840FL.....Fender Light Bucket Wires [pair]	\$33.00
WH3840C..... Clock and Glove Box Harness	\$55.65
WH3840HB..... Headlight Bucket Wires [pair]	\$33.00
WH3840FT.....Fuel Tank Connector Wire	\$11.00
WH3840HS..... Heater Switch Wiring	\$31.90
WH3840TB.....Taillight Bucket Wires [pair]	\$44.00

1938 BUICK Century / Series 60

WH3860HB..... Headlight Bucket Wires [pair]	\$33.20
WH3860FL.....Fender Light Bucket Wires [pair]	\$34.10
WH3860DEH....Dash, Engine and Headlight Harn. [lhd]...	\$646.80
WH3860DEHR..Dash, Engine and Headlight Harn. [rhd]..	\$665.70
WH3860C..... Clock and Glove Box Harness	\$55.65
WH3860HS..... Heater Switch Wiring	\$31.90
WH3860BT4.....Body and Taillights Harness [4dr.sedan] ..	\$281.40
WH3860FT.....Fuel Tank Connector Wire	\$12.10
WH3860TB.....Taillight Bucket Wires [pair]	\$45.10

1938 BUICK Roadmaster / Series 80

WH3880HB.....	Headlight Bucket Wires [pair]\$35.20
WH3880FL.....	Fender Light Bucket Wires [pair]\$34.10
WH3880DEH.....	Dash, Engine and Headlight Harness	..\$694.05
WH3880BTL.....	Body Harness.....	\$418.95
WH3880HS.....	Heater Switch Wiring\$31.90
WH3880C.....	Clock and Glove Box Harness\$55.65
WH3880TB.....	Taillight Bucket Wires [pair]\$45.10
WH3880FT.....	Fuel Tank Connector Wire\$12.10

1938 BUICK Limited / Series 90

WH3890HB.....	Headlight Bucket Wires [pair]\$35.20
WH3890FL.....	Fender Light Bucket Wires [pair]\$34.10
WH3890DEH.....	Dash, Engine and Headlight Harness	..\$694.05
WH3890BTL.....	Body and Taillights Harness [4dr.limo]	..\$439.95
WH3890C.....	Clock and Glove Box Harness\$55.65
WH3890HS.....	Heater Switch Wiring\$31.90
WH3890TB.....	Taillight Bucket Wires [pair]\$45.10
WH3890FT.....	Fuel Tank Connector Wire\$12.10

1939 BUICK Special / Series 40

WH3940HB.....	Headlight Bucket Wires [pair]\$64.05
WH3940FL.....	Park and Turn Signal Bucket Wires [pair]\$71.93
WH3940DEH....	Dash, Engine and Headlight Harness\$543.90
WH3940BT2....	Body and Taillights Harness [2dr.coupe]	\$328.65
WH3940BT4S...	Body and Taillights Harness [4dr.sedan]	\$327.60
WH3940BTH...	Body and Taillights Harness [hearse]\$345.45
WH3940TS.....	Turn Signal Switch Harness\$85.05
WH3940C.....	Clock and Glove Box Harness\$58.80
WH3940FT.....	Fuel Tank Connector Wire\$12.10

1939 BUICK Century / Series 60

WH3960HB.....	Headlight Bucket Wires [pair]\$64.05
WH3960FL.....	Park and Turn Signal Bucket Wires [pair]\$57.75
WH3960TS.....	Turn Signal Switch Harness\$85.05
WH3960FT.....	Fuel Tank Connector Wire\$12.10
WH3960DEH....	Dash, Engine and Headlight Harness\$623.70
WH3960C.....	Clock and Glove Box Harness\$58.80
WH3960BT2C..	Body and Taillights Harness [2dr.conv.]	..\$328.65
WH3960BT2P..	Body and Taillights Harness [2dr.coupe]	..\$324.45
WH3960BTS...	Body and Taillights Harness [4dr.sedan]	..\$328.65
WH3960LL.....	License Light Wires\$8.80

1939 BUICK Roadmaster / Series 80

WH3980HB.....	Headlight Bucket Wires [pair]\$64.05
WH3980FL.....	Park and Turn Signal Bucket Wires [pair]\$57.75
WH3980DEH....	Dash, Engine and Headlight Harness\$643.65
WH3980TS.....	Turn Signal Switch Harness\$93.45
WH3980C.....	Clock and Glove Box Harness\$67.20
WH3980BT.....	Body/Taillights Harness w/o turns\$418.95
WH3980BTS.....	Body/Taillights Harness w/ turns\$466.20
WH3980FT.....	Fuel Tank Connector Wire\$12.10

1939 BUICK Limited / Series 90

WH3990HB.....	Headlight Bucket Wires [pair]\$64.05
WH3990FL.....	Park and Turn Signal Bucket Wires [pair]\$57.75
WH3990DEH....	Dash, Engine and Headlight Harness\$643.65
WH3990TS.....	Turn Signal Switch Harness\$93.45
WH3990C.....	Clock and Glove Box Harness\$67.20
WH3990BT.....	Body/Taillights Harness w/o turns\$407.40
WH3990BTS.....	Body/Taillights Harness w/ turns\$442.05
WH3990FT.....	Fuel Tank Connector Wire\$12.10

1940 BUICK Special / Series 40

WH4040HB.....	Headlight Bucket Wires [pair]\$58.80
WH4040FL.....	Park and Turn Signal Bucket Wires [pair]	..\$53.90
WH4040DEH....	Dash, Engine and Headlight Harness	..\$689.85
WH4040BT.....	Body and Taillights Harness [2dr.coupe]	\$328.65
WH4040BT4....	Body and Taillights Harness [4dr.sedan]	\$333.90
WH4040TS.....	Turn Signal Switch Harness\$65.10
WH4040C.....	Clock and Glove Box Harness\$59.85
WH4040I.....	Instrument Light Cluster\$52.80
WH4040CL.....	Cigar Lighter Feed Wire\$12.10
WH4040FT.....	Fuel Tank Connector Wire\$12.10
WH4040LL.....	License Light Wires\$9.90

1940 BUICK Super / Series 50

WH4050HB.....	Headlight Bucket Wires [pair]\$58.80
WH4050FL.....	Park and Turn Signal Bucket Wires [pair]\$53.90
WH4050DEH....	Dash, Engine and Headlight Harness	..\$655.20
WH4050I.....	Instrument Light Cluster\$53.90
WH4040IA.....	Instrument Light Cluster w/ Ashtray Lite\$55.00
WH4050TS.....	Turn Signal Switch Harness\$65.10
WH4050C.....	Clock and Glove Box Harness\$58.80
WH4050HD.....	Heater and Defroster Wiring\$30.80
WH4050CL.....	Cigar Lighter Feed Wire\$12.10
WH4050BTC.....	Body and Taillights Harness [conv.]\$328.65
WH4050BT.....	Body and Taillights Harness [2dr.coupe]	\$322.35
WH4050BT4....	Body and Taillights Harness [4dr.sedan]	\$328.65
WH4050FT.....	Fuel Tank Connector Wire\$12.10
WH4050LL.....	License Light Wires\$9.90

1940 BUICK Century / Series 60

WH4060HB.....	Headlight Bucket Wires [pair]\$58.80
WH4060FL.....	Park and Turn Signal Bucket Wires [pair]	..\$53.90
WH4060DEH....	Dash, Engine and Headlight Harness	..\$675.15
WH4060TS.....	Turn Signal Switch Harness\$67.20
WH4060C.....	Clock and Glove Box Harness\$58.80
WH4060I.....	Instrument Light Cluster\$52.80
WH4060CL.....	Cigar Lighter Feed Wire\$12.10
WH4060BT4...	Body and Taillights Harness [4dr.sedan]	..\$347.55
WH4060FT.....	Fuel Tank Connector Wire\$12.10
WH4060LL.....	License Light Wires\$9.90

Wiring Harnesses (Group 2)

1940 BUICK Roadmaster / Series 70

WH4070HB.....	Headlight Bucket Wires [pair]\$58.80
WH4070FL.....	Park and Turn Signal Bucket Wires [pair]	..\$53.90
WH4070DEH....	Dash, Engine and Headlight Harness\$683.55
WH4070BT4...	Body and Taillights Harn. [4dr.sedan]\$328.65
WH4070TS.....	Turn Signal Switch Harness\$65.10
WH4070C.....	Clock and Glove Box Harness\$58.80
WH4070CL.....	Cigar Lighter Feed Wire\$11.00
WH4070I.....	Instrument Light Cluster\$53.55
WH4070TB.....	Taillight Bucket Wires [pair]\$48.40
WH4070FT.....	Fuel Tank Connector Wire\$11.00
WH4070LL.....	License Light Wires\$7.70

1940 BUICK Limited / Series 80

WH4080HB.....	Headlight Bucket Wires [pair]\$58.80
WH4080FL.....	Park and Turn Signal Bucket Wires [pair]	..\$53.90
WH4080DEH....	Dash, Engine and Headlight Harness	..\$715.05
WH4080BT4	Body and Taillights Harn. [4dr.sedan/4819]	\$324.45
WH4080TS.....	Turn Signal Switch Harness\$65.10
WH4080C.....	Clock and Glove Box Harness\$58.80
WH4080I.....	Instrument Light Cluster\$53.90
WH4080TB.....	Taillight Bucket Wires [pair]\$42.90
WH4080CL.....	Cigar Lighter Feed Wire\$11.00
WH4080FT.....	Fuel Tank Connector Wire\$11.00
WH4080LL.....	License Light Wires\$7.70

1940 BUICK Limited / Series 90

WH4090HB.....	Headlight Bucket Wires [pair]\$58.80
WH4090FL.....	Park and Turn Signal Bucket Wires [pair]\$53.90
WH4090DEH....	Dash, Engine and Headlight Harness\$715.05
WH4090BT4..	Body & Taillights Harn. [4dr.sedan/4923]\$425.25
WH4090TS.....	Turn Signal Switch Harness\$66.15
WH4090C.....	Clock and Glove Box Harness\$58.80
WH4090I.....	Instrument Light Cluster\$53.90
WH4090TB.....	Taillight Bucket Wires [pair]\$42.90
WH4090CL.....	Cigar Lighter Feed Wire\$11.00
WH4090FT.....	Fuel Tank Connector Wire\$11.00
WH4090LL.....	License Light Wires\$7.70

1941 BUICK Special / Series 40

WH4140HB.....	Headlight Bucket Wires [pair]\$72.45
WH4140FL.....	Park and Turn Signal Bucket Wires [pair]	...\$65.10
WH4140DEH.	Dash, Eng. and Headlight Harness [41SE]	\$725.55
WH4140DEHS..	Dash, Eng. & Headlight Harn. [ex.41SE]	..\$725.55
WH4140C.....	Clock Harness\$71.40
WH4140I.....	Instrument Light Cluster\$47.30
WH4140HD.....	Heater and Defroster Wiring\$40.70
WH4140BT..	Body and Taillights Harness [2dr.sedanet]	..\$418.95
WH4140BTC...	Body and Taillights Harness [2dr.conv.]	..\$404.25
WH4140FT.....	Fuel Tank Connector Wire\$11.00
WH4140LL.....	License Light Bucket Wire\$7.70

1941 BUICK Super / Series 50

WH4150HB.....	Headlight Bucket Wires [pair]\$72.45
WH4150FL.....	Park and Turn Signal Bucket Wires [pair]	...\$65.10
WH4150DEH....	Dash, Eng. and Headlight Harness\$726.60
WH4150I.....	Instrument Light Cluster\$47.30
WH4150HD.....	Heater and Defroster Wiring\$40.70
WH4150BTC...	Body and Taillights Harness [2dr.conv.]	..\$404.25
WH4150BT... Body and Taillights Harness [4dr.sedan]	...\$442.05	
WH4150FT.....	Fuel Tank Connector Wire\$11.00
WH4150LL.....	License Light Bucket Wire\$7.70

1941 BUICK Century / Series 60

WH4160HB.....	Headlight Bucket Wires [pair]\$72.40
WH4160FL.....	Park and Turn Signal Bucket Wires [pair]	...\$65.10
WH4160DEH....	Dash, Eng. and Headlight Harness\$718.20
WH4160I.....	Instrument Light Cluster\$47.30
WH4160HD.....	Heater and Defroster Wiring\$40.70
WH4160BT... Body and Taillights Harness [4dr.sedan]	...\$408.45	
WH4160BTC...	Body and Taillights Harness [2dr.conv.]	..\$404.25
WH4160FT.....	Fuel Tank Connector Wire\$11.00
WH4160LL.....	License Light Bucket Wire\$7.70

1941 BUICK Roadmaster / Series 70

WH4170HB.....	Headlight Bucket Wires [pair]\$72.40
WH4170FL.....	Park and Turn Signal Bucket Wires [pair]	...\$65.10
WH4170DEH....	Dash, Eng. and Headlight Harness\$718.20
WH4170I.....	Instrument Light Cluster\$47.30
WH4170HD.....	Heater and Defroster Wiring\$40.70
WH4170BTC...	Body and Taillights Harness [2dr.conv.]	..\$408.45
WH4170BT... Body and Taillights Harness [4dr.sedan]	...\$442.05	
WH4170BTP..	Body and Taillights Harness [4dr.phaeton]	..\$590.10
WH4170FT.....	Fuel Tank Connector Wire\$11.00
WH4170LL.....	License Light Bucket Wire\$7.70

1941 BUICK Limited / Series 90

WH4190HB.....	Headlight Bucket Wires [pair]\$72.40
WH4190FL.....	Park and Turn Signal Bucket Wires [pair]	...\$65.10
WH4190DEH....	Dash, Eng. and Headlight Harness\$718.20
WH4190I.....	Instrument Light Cluster\$47.30
WH4190HD.....	Heater and Defroster Wiring\$40.70
WH4190FT.....	Fuel Tank Connector Wire\$11.00

1942 BUICK Roadmaster / Series 70

WH4270HB.....	Headlight Bucket Wires [pair]\$74.55
WH4270FL.....	Park and Turn Signal Bucket Wires [pair]	...\$63.00
WH4270DEH.....	Dash, Eng. and Headlight Harness\$595.35
WH4270I.....	Instrument Light Cluster\$47.30
WH4270C.....	Clock Harness\$71.40
WH4270GB.....	Glove box Harness\$7.90
WH4270HD.....	Heater and Defroster Wiring\$15.40
WH4270PT.....	Power Top Control Harness\$297.15
WH4270BT..	Body and Taillights Harness [2dr.sedanet]	..\$350.70
WH4270BTC...	Body and Taillights Harness [2dr.conv.]	..\$529.20
WH4270FT.....	Fuel Tank Connector Wire\$11.00

1947 BUICK Super / Series 50

WH4750HB.....	Headlight Bucket Wires [pair]\$74.55
WH4750DEH.....	Dash, Eng. and Headlight Harness\$665.70
WH4750I.....	Instrument Light Cluster\$46.20
WH4750FT.....	Fuel Tank Connector Wire\$11.00

1948 BUICK Special / Series 40

WH4840HB.....	Headlight Bucket Wires [pair]\$74.55
WH4840FL.....	Park and Turn Signal Bucket Wires [pair]	...\$61.95
WH4840DEH.....	Dash, Eng. and Headlight Harness\$757.05
WH4840C.....	Clock Harness\$71.40
WH4840I.....	Instrument Light Cluster\$46.20
WH4840BT..	Body and Taillights Harness [2dr.sedanet]	..\$413.70
WH4840FT.....	Fuel Tank Connector Wire\$11.00

1948 BUICK Super / Series 50

WH4850HB.....	Headlight Bucket Wires [pair]\$74.55
WH4850FL.....	Park and Turn Signal Bucket Wires [pair]	...\$61.95
WH4850DEH.....	Dash, Eng. and Headlight Harness\$760.20
WH4850I.....	Instrument Light Cluster\$52.80
WH4850BT..	Body and Taillights Harness [2dr.sedan]\$403.20
WH4850FT.....	Fuel Tank Connector Wire\$11.00
WH4850HD.....	Heater and Defroster Wiring\$15.40
WH4850TS.....	Turn Signal Switch Harness\$76.65
WH4850BTS...	Body and Taillights Harness [4dr.sedan]	..\$662.55
WH4850BTC.....	Body and Taillights Harness [conv.]\$540.75
WH4850PT....	Power Window & Top Control Harness\$321.30
WH4850PS.....	Power Seat Control Harness (conv.)\$68.25
WH4850FT.....	Fuel Tank Connector Wire\$11.00
WH4850LL.....	License Light Bucket Wire\$12.10

1948 BUICK Roadmaster / Series 70

WH4870HB.....	Headlight Bucket Wires [pair]\$74.55
WH4870FL.....	Park and Turn Signal Bucket Wires [pair]	...\$61.95
WH4870DEHS.	Dash, Eng. & Headlight Harn. (std.trans)	..\$761.25
WH4870DEH..	Dash, Eng. & Headlight Harn. (auto.trans)	..\$770.70
WH4870I.....	Instrument Light Cluster\$51.70
WH4870C.....	Clock Harness\$75.60
WH4870BT.....	Body and Taillights Harness [conv.]\$540.75
WH4870PT..	Power Window & Top Control Harn. (conv)	..\$322.35
WH4870PS.....	Power Seat Control Harness (conv.)\$68.25
WH4870FT.....	Fuel Tank Connector Wire\$11.00
WH4870BL.....	Back-up Light Bucket Wires\$33.00

1949 BUICK Super / Series 50

WH4950HB.....	Headlight Bucket Wires [pair]\$59.85
WH4950FL.....	Park and Turn Signal Bucket Wires [pair]\$57.75
WH4950SH.....	Starter to Ignition Harness. (auto trans)\$150.15
WH4950SHS...	Starter to Ignition Harness. (std. trans)\$150.15
WH4950HR.....	Horn Realy to Horn Wiring.....\$12.10
WH4950DEH.	Dash, Eng. & Headlight Harn. (auto trans)	..\$649.95
WH4950DEHS.	Dash, Eng. & Headlight Harn. (std. trans)	..\$649.95
WH4950TS.....	Turn Signal Switch Harness\$76.65
WH4950BTC.....	Body and Taillights Harness [conv.]\$438.90
WH4950BTS..	Body and Taillights Harness [4dr.sedan]	..\$475.65
WH4950BTW....	Body and Taillights Harness [wagon]\$498.75
WH4950FT.....	Fuel Tank Connector Wire\$8.80
WH4950LL.....	License Light Bucket Wire\$12.10

1949 BUICK Roadmaster / Series 70

WH4970HB.....	Headlight Bucket Wires [pair]\$59.85
WH4970FL.....	Park and Turn Signal Bucket Wires [pair]\$57.75
WH4970SH.....	Starter to Ignition Harness. (auto trans)\$150.15
WH4970HR.....	Horn Realy to Horn Wiring.....\$11.00
WH4970TS.....	Turn Signal Switch Harness\$76.65
WH4970DEH.	Dash, Eng. & Headlight Harn. (auto trans)	..\$649.95
WH4970DEHS.	Dash, Eng. & Headlight Harn. (std. trans)	..\$649.95
WH4970BTC.....	Body and Taillights Harness [conv.]\$464.10
WH4970BTR....	Body and Taillights Harn. [2-dr. ht]\$555.45
WH4970BTS..	Body and Taillights Harness [4dr.sedan]	..\$542.85
WH4970BTA....	Body and Taillights Harness [ambul]\$374.85
WH4970PT....	Power Window & Top Control Harness\$563.85
WH4970PS...	Power Seat Control Harness (4-dr sedan)	...\$68.25
WH4970FT.....	Fuel Tank Connector Wire\$8.80
WH4970LL.....	License Light Bucket Wire\$12.10

1950 BUICK Special / Series 40**(Early Models, heater & blower switches are side by side)**

WH5040HB.....	Headlight Bucket Wires [pair]\$60.90
WH5040FL.....	Park and Turn Signal Bucket Wires [pair]\$55.00
WH5040DEH.	Dash, Eng. & Headlight Harn. (auto trans)	..\$778.05
WH5040DEHS.	Dash, Eng. & Headlight Harn. (std. trans)	..\$778.05
WH5040TS.....	Turn Signal Switch Harness. (pair)\$78.75
WH5040GB.....	Glove box Light Switch Wire\$6.60
WH5040ML.....	Map Light Wiring\$13.20
WH5040BT.....	Body and Taillights Harness\$223.65
Note: Tail Lamp Wiring requires the purchase of our TWB501		
WH5040IL..	Interior light & Door Switch 43,43D,46,46S\$385.35
WH5040FT.....	Fuel Tank Connector Wire\$7.70
WH5040BL.....	Back-up Light Bucket Wires\$30.80
WH5040LL.....	License Light Bucket Wire\$30.80

Wiring Harnesses (Group 2)

1950 BUICK Special / Series 40

(Late Models, heater & blower switches are separated)

WH5040LHB.....	Headlight Bucket Wires [pair]\$60.90
WH5040LFL...	Park and Turn Signal Bucket Wires [pair]	...\$59.85
WH5040LDH..	Dash, Eng. & Headlight Harn. (auto trans)	..\$781.20
WH5040LDHS..	Dash, Eng. & Headlight Harn. (std. trans)	..\$781.20
WH5040LTS.....	Turn Signal Switch Harness. (pair)\$79.80
WH5040LGB.....	Glove box Light Switch Wire\$6.60
WH5040LML.....	Map Light Wiring\$14.30
WH5040LBT.....	Body and Taillights Harness\$223.65

Note: Tail Lamp Wiring requires the purchase of our TWB501

WH5040LIL..	Interior light & Door Switch 43,43D,46,46S	..\$385.35
WH5040LFT.....	Fuel Tank Connector Wire\$7.70
WH5040LBL.....	Back-up Light Bucket Wires\$31.90
WH5040LLL.....	License Light Bucket Wire\$31.90

1950 BUICK Super / Series 50

WH5050HB.....	Headlight Bucket Wires [pair]\$60.90
WH5050DEH..	Dash, Eng. & Headlight Harn. (auto trans)	..\$786.45

1950 BUICK Roadmaster / Series 70

WH5070HB.....	Headlight Bucket Wires [pair]\$60.90
WH5070DEH..	Dash, Eng. & Headlight Harn. (auto trans)	..\$788.55
WH5070IL.....	Interior light and Door Switch (4-dr. sedan)	..\$430.50
WH5070B.....	Body Harness [4dr.sedan]\$137.55
WH5070T.....	Tail Lamp Harness [4dr.sedan]\$124.95

Note: Tail Lamp Wiring requires the purchase of our TWB501

1951 BUICK Special / Series 40

WH5140DEH..	Dash, Eng. & Headlight Harn. (auto trans)	..\$796.95
WH5140BT...	Body and Taillights Harness, model 46S\$487.20

1951 BUICK Super / Series 50

WH5150HB.....	Headlight Bucket Wires [pair]\$60.90
WH5150DEH..	Dash, Eng. & Headlight Harn. (auto trans)	..\$796.95
WH5150BTW....	Body and Tail Lamp Harness [wagon]	...\$277.20

Note: Tail Lamp Wiring requires the purchase of our TWB501

WH5150ILW....	Interior light & Door Switch (wagon)\$408.45
WH5150T.....	Tail Lamp Harness [4dr.sedan]\$121.80

Note: Tail Lamp Wiring requires the purchase of our TWB501

1953 BUICK Special / Series 40

WH5340DEH..	Dash, Eng. & Headlight Harn. (std trans)\$763.35
WH5340DEHA..	Dash, Eng. & Headlight Harn. (auto trans)	..\$791.75
WH5340BTC.....	Body and Tail Lamp Harness [conv]\$698.25
WH5340G.....	Generator Harness\$53.90
WH5340LGB.....	Glove box Light Switch Wire\$6.60
WH5340ML.....	Map Light Wires\$6.60
WH5340PB.....	Parking Brake Warning Light Wires\$14.30
WH5340CL.....	Courtesy Light Harness (convertible)\$38.50
WH5340HM.....	Heater Motor Feed Wire\$31.90
WH5340LL.....	License Light Bucket Wire\$6.60

1953 BUICK Super / Series 50

WH5350HB.....	Headlight Bucket Wires [pair]\$68.25
WH5350FL....	Park and Turn Signal Bucket Wires [pair]	...\$59.85
WH5350DEH..	Dash, Eng. & Headlight Harn. (auto trans)	..\$927.13
WH5350BTW....	Body and Tail Lamp Harness [wagon]	...\$280.35
WH5350ILW....	Interior light and Door Switch (wagon)\$405.30
WH5350FT.....	Fuel Tank Connector Wire\$8.80

1953 BUICK Roadmaster / Series 70

WH5370HB.....	Headlight Bucket Wires [pair]\$68.25
WH5370FL....	Park and Turn Signal Bucket Wires [pair]	...\$59.85
WH5370DEH..	Dash, Eng. & Headlight Harn. (auto trans)	..\$926.10
WH5370BTC....	Body & Tail Lamp Harness [conv]\$655.20
WH5370BTW....	Body and Tail Lamp Harness [wagon]	...\$280.35
WH5370P...Power Window, Seat, Top Control Harness	...	\$625.80
WH5370PT.....	Power Top Feed Cable\$65.10
WH5370TS.....	Turn Signal Switch Harness\$75.60
WH5370SR.....	Starter to Relay Harness\$31.90
WH5370ILW....	Interior light & Door Switch (wagon)\$404.25
WH5370FT.....	Fuel Tank Connector Wire\$8.80

1953 BUICK Skylark / Model 76X

WH53XHB.....	Headlight Bucket Wires [pair]\$68.25
WH53XFL....	Park and Turn Signal Bucket Wires [pair]	...\$58.55
WH53XDEH.....	Dash, Eng. and Headlight Harn\$716.00
WH53XBT....	Body & Tail Lamp Harness [conv]\$655.20
WH53XP...Power Window, Seat, Top Control Harness	...	\$624.75
WH53XPT.....	Power Top Feed Cable\$65.10
WH53XTS.....	Turn Signal Switch Harness\$75.60
WH53XSR.....	Starter to Relay Harness\$31.90
WH53XFT.....	Fuel Tank Connector Wire\$8.80

1954 BUICK Special / Series 40

WH5440HB.....	Headlight Bucket Wires [pair]\$67.20
WH5440FL....	Park and Turn Signal Bucket Wires [pair]	...\$14.30
WH5440DEH..	Dash, Eng. & Headlight Harn. (auto trans)	..\$912.45
WH5440BT....	Body & Tail Lamp Harness [2-dr. sedan]	..\$555.45
WH5440BTS... Body & Tail Lamp Harness [4-dr. sedan]	..	\$555.45
WH5440GB.....	Glove box Light Switch Wire\$6.60
WH5440ML.....	Map Light Switch Wire\$6.60
WH5440TS.....	Turn Signal Switch Harness\$80.85
WH5440DL....	Dome Light/Switch Wire (2-dr. sedan)\$80.85
WH5440LBL.....	Back-up Light Bucket Wires (pair)\$12.10
WH5440LL.....	License Light Bucket Wires (pair)\$50.60

1954 BUICK Roadmaster / Series 70

WH5470HB.....	Headlight Bucket Wires [pair]\$66.15
WH5470DEH..	Dash, Eng. & Headlight Harn. (auto trans)	..\$1017.45
WH5470SS.....	Starter Solenoid Harness\$28.60
WH5470DLC.....	Dome Light Harness (conv)\$67.20
WH5470TS.....	Turn Signal Switch Harness\$81.90
WH5470BTC.....	Body and Tail Lamp Harness [conv]\$635.25
WH5470P.....	Power Window, Seat Control Harness\$712.95
WH5470SC.....	Verticle Seat Control Harness\$68.25

1954 BUICK Skylark / Series 100

WH54XTS.....Turn Signal Switch Harness.\$80.85

1955 BUICK Special / Series 40

WH5540HB..... Headlight Bucket Wires [pair]\$67.20
 WH5540DEH.....Dash, Eng. and Headlight Harn.\$991.20
 WH5540BT..... Body & Tail Lamp Harness [2-dr. ht]\$517.65
 WH5540TS.....Turn Signal Switch Harness.....\$82.95
 WH5540LL.....License Light Bucket Wires (pair)\$37.40

1955 BUICK Century / Series 60

WH5560HB..... Headlight Bucket Wires [pair]\$67.20
 WH5560DEH.Dash, Eng. & Headlight Harn. (auto trans)..\$991.20
 WH5560BTC.... Body & Tail Lamp Harness [conv]\$660.45
 WH5560BTH.... Body & Tail Lamp Harness [4-dr. ht]\$518.70
 WH5560TS.....Turn Signal Switch Harness.....\$86.10
 WH5560PW....Power Window Control Harn (conv)\$170.10
 WH5560PSW....Power Seat Control Harn w/ pwr. wind.\$93.45
 WH5560PS....Power Seat Control Harn w/o pwr. wind.\$93.45
 WH5560ILR.....Rear Interior Light (4-dr. ht).....\$143.85
 WH5560RC.....Rear Seat Cigar Lighter\$28.60

1955 BUICK Roadmaster / Series 70

WH5570HB..... Headlight Bucket Wires [pair]\$66.15
 WH5570DEH.Dash, Eng. & Headlight Harn. (auto trans)\$1017.45
 WH5570BTC.... Body and Tail Lamp Harness [conv]\$628.95
 WH5570PW.....Power Window Control Harn. conv).\$660.45
 WH5570SS.....Starter Solenoid Harness.....\$28.60
 WH5570DLC..... Dome Light Harness (conv).....\$46.20

1957 BUICK Special / Series 40

WH5740HB..... Headlight Bucket Wires [pair]\$67.20
 WH5740EH.....Engine and Headlight Harn.....\$368.55
 WH5740HH.....Horn Bucket Wires (pair)\$15.40

1957 BUICK Century / Series 60

WH5760HB..... Headlight Bucket Wires [pair]\$67.20
 WH5760EH.....Engine and Headlight Harn.....\$368.55
 WH5760DH.....Dash Harness.....\$542.85
 WH5760HH.....Horn Bucket Wires (pair)\$15.40
 WH5760SS.....Starter Solenoid Harness.....\$34.10
 WH5760DLW..... Dome Light Harness (wagon).....\$51.70

1957 BUICK Roadmaster / Series 70

WH5770CLC..... Dome Light Harness (conv).....\$46.20

1959 BUICK Lesabre

WH59LEH.....Engine and Headlight Harn.....\$376.95
 WH59LSS.....Starter Solenoid Harness.....\$31.90
 WH59LDH.....Dash Harness.....\$899.85
 WH59LCB.....Circuit Breaker Wires.....\$57.75
 WH59LGB.....Glove Box Light Harness.....\$7.70
 WH59LBHC.....Body Harness. (conv).....\$295.05
 WH59LTL.....Tail Lamp Harness\$224.70
 WH59LWM.....Windshield Wiper Motor Harness\$96.60
 WH59LRFW.....Window Harness. (RH Front)\$140.70
 WH59LLFW.....Window Harness. (LH Front).....\$166.95
 WH59LRRW.....Window Harness. (RH Rear).....\$138.60
 WH59LLRW.....Window Harness. (LH Rear).....\$150.15
 WH59LPW.....Power Window Connector Harness\$107.10
 WH59LML.....Map Light Wire.....\$11.00
 WH59LH.....Heater Harness\$40.70
 WH59LHBW.....Hand Brake Wiring\$38.50
 WH59LCLR.....Courtesy Lamp Harness (RH Rear)\$95.55

1957-1960 Wiring Harness Straps



1957-1960 All as required. 2" overall length. Metal.
 WS1\$3.75 ea



1957-1960 All as required. 1/4" high. Metal.
 WS2\$3.75 ea



1957-1960 All as required. 5/8" high. Metal.
 WS3\$3.75 ea



www.oldbuickparts.com
908-369-3666

Carburetor Rebuilding and Restoration Service (3.725)

Each carburetor is totally disassembled and cleaned in a hot tank solution. Then, each component is correctly plated, painted and colored to duplicate it's original factory finish. The carburetor is reassembled using all proper gaskets, pumps, needles and seats, etc. and new correct screws. Finally, all bench adjustments are made to factory specs. This includes correct shimming of the start switch. The result, the best rebuilt and restored carburetor available in the Hobby Allow about 4 weeks.

NOTE: *This is not an area to skimp on your restoration. Demand the best!*

- 1932-1938** Marvel Carburetors.
CRS328M.....\$425.00 ea.
- 1935-1936** Stromberg Carburetors.
CRS356.....\$390.00 ea.
- 1937-1938** Stromberg Carburetors.
CRS378.....without choke.....\$325.00 ea.
CRS378C.....with choke.....\$345.00 ea.
- 1939-1948** All with Diaphragm type starter switch.
CRS398.....\$355.00 ea.
- 1939-1960** All 2bbl Carburetors w/ Bakelite switch.
CRS390.....\$329.00 ea.
- 1952-1960** 4bbl. Carburetor rebuilding service.
CRS520.....\$389.00 ea.

Others by inspection and quotation

Carter Carburetor Rebuilding Kits

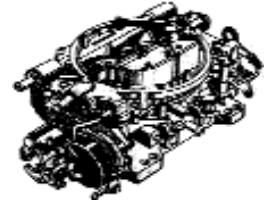

- 1936-1940** All models. WDO 2 BBL.
Numbers: 419, 440, 448, 474.
CKC360.....\$42.75 ea.
- 1941-1942** All 40-90. WCD 2BBL.
Numbers: 487, 549, 551.
CKC412.....\$42.75 ea.
- 1941-1942** Dual Carbs. WCD 2 BBL.
Numbers: 528, 529, 533, 534, 543, 544. For both kits.
CKC412D.....\$58.50 ea.
- 1946-1949** Models 40-50-70. WCD 2 BBL. Numbers: 608, 609, 663, 664.
CKC469.....\$41.50 ea.
- 1950-1955**
1950-1951: Roadmaster. WCD 2 BBL. Numbers: 725, 726, 882, 883, 2017, 2081, 2179.
1950-1955: Models 40-50. WCD 2 BBL. Numbers: 725, 726, 882, 883, 2017, 2081.
CKC505.....\$41.50 ea.
CKC505A.....(#2179 only).....\$41.50 ea.
- 1952-1953** Roadmaster. WCFB 4 BBL.
Numbers 894, 996, 2053, 2083.
CKC523.....\$44.75 ea.
- 1954-1956** Super and Skylark WCFB 4 BBL.
Numbers: 2082, 2197, 2347, 2358.
CKC546.....\$42.75 ea.
- 1955-1960** Special and LeSabre. WGD 2 BBL.
Numbers: 2292, 2378, 2400, 2536, 2529, 2548, 2674, 2675, 2682, 2837, 2838, 2845, 2979, 2980.
CKC550.....\$42.75 ea.
- 1957-1960** All AFB 4 BBL.
Numbers: 2507, 2800, 2840, 2877, 2981, 2982.
CKC570.....\$42.75 ea.



Remember!

Check to see that the carburetor number matches that of the part you are ordering. Any letters after the main number are also included in our kits.

Carter numbers after 1937 are stamped on the bottom of the throttle body.
Stromberg numbers from 1939 are stamped on the top bowl cover.

Fuel • Carburetion • Exhaust (Group 3)

Rochester Carburetor Kits

- 1955** All models. 4 GC 4 BBL.
Numbers: 7006200, 7009100.
CKR55.....\$41.50 ea.
- 1956** All models. 4 GC 4 BBL.
Numbers: 7009200.
CKR56.....\$41.50 ea.
- 1957-1958** All models. 4 GC 4 BBL.
Numbers: 7010070, 7011570, 7011600.
CKR578.....\$41.50 ea.
- 1958 Late** All models. 4 GC 4 BBL.
Numbers: 7013100.
CKR58.....\$41.50 ea.
- 1959-1960** All 4 GC 4 BBL. Numbers: 7013044, 7015040, 7019040, 7020040, 7020041.
CKR592.....\$41.50 ea.

Stromberg Carburetor Kits

- 1934-1936** Model 40. EE-1, 2 BBL.
Numbers: 7-1, 7-2, 7-4, 7-5, 7-7, 7-9.
CKS346.....\$57.50 ea.
- 1936** 60-80-90. EE-22,2 BBL.
Numbers: 7-6, 7-8, 7-10.
CKS36.....\$44.50 ea.
- 1937-1949** 40-50. AA 2 BBL.
Numbers: 7-12, 7-17, 7-19, 7-24, 7-31, 7-32, 7-66, 7-69, 7-74, 7-75, 7-79, 7-81, 7-82,
CKS379.....\$49.50 ea.
- 1937-1955**
1937-1951: 60-70-80-90. AA 2 BBL.
Numbers: 7-13, 7-15, 7-18, 7-20, 7-22, 7-23, 7-33, 7-34, 7-36.
1953-1955: Special and Super. AA 2 BBL.
Numbers: 7-57, 7-70, 7-77, 7-80, 7-89, 7-91, 7-95, 7-96, 7-102, 380150.
CKS375.....\$49.50 ea.
- 1941-1942** All with Dual Carbs. AA 2 BBL.
Numbers: 7-39, 41, 42, 43, 44, 45, 46, 47, 55, 59 and 60. Contains parts for both carbs.
CKS412D.....\$64.50 ea.
- 1950-1953**
1950-1952: Special and Super. AA 2 BBL.
Numbers: 7-88, 7-90.
1953: Special. AA 2 BBL. Numbers: 7-88, 7-90.
CKS503.....\$47.50 ea.
- 1952-1954** Roadmaster and Skylark. 4A 4 BBL.
Numbers: 7-92, 7-94, 7-98.
CKS524.....\$54.50 ea.
- 1955-1956** Special. WW 2 BBL.
Numbers: 7-103, 7-104, 7-105.
CKS556.....\$57.50 ea.
- 1957** Special with Dynaflo. WW 2 BBL.
Numbers: 7-106.
CKS57.....\$57.50 ea.
- 1958-1960** Special and LeSabre. WW 2 BBL.
Numbers: 7-109, 7-112, 7-113.
CKS580.....\$59.50 ea.

Carburetor Bowl Floats

- 1934-1936** Stromberg EE1. Brass.
CF346S.....\$ ea.
- 1936-1940** Carter WDO. Brass.
CF346C.....\$37.50 ea.
- 1937-1953** Stromberg AA 2BBL. Brass.
CF373S.....\$47.50 ea.
- 1941-1955** Carter WCD. Brass.
CF415C.....\$47.50 ea.
- 1955-1956** Rochester 4GC. Brass.? (2 needed per car)
CF556R.....\$ ea.
- 1955-1961** Stromberg WW. Plastic.
CF551S.....\$24.00 ea.
- 1957-1960** Carter AFB 4BBL. Brass.(2 needed per car)
CF576C.....\$ ea.

Fuel Bowl Gaskets



- 1936-1940** Special & Super. Fuel bowl gasket.
BG2002.....\$2.25 ea.
- 1941-1953** All straight. Fuel bowl gasket.
BG2088.....\$2.25 ea.

Carburetor to Intake Manifold Gaskets

- 1935-1939** Special;
1940-1949 Special and Super.
Use 2 on dual carb set-ups.
CMG359.....\$3.75 ea.
CI3.....(Thick Insulator).....\$14.75 ea.
- 1936-1949** All 320 engines;
1950-1952 Special and Super;
1953 Special;
1954-1955 All 2bbl carbs.
CMG395.....\$3.75 ea.
CI4.....(Thick Insulator).....\$14.25 ea.
- 1953** Roadmaster;
1954 Century, Roadmaster, Skylark;
1955-1956 Century, Super, Roadmaster
For 4bbl carbs.
CMG536.....\$4.25 ea.
- 1955** Late Carter and Rochester 2bbl;
1956-1960 All carter and Rochester 2bbl.
CMG554.....\$4.50 ea.
- 1957-1960** All 4bbl.
CMG576.....\$4.75 ea.



Carburetor to Air Cleaner Gaskets



- 1953-1960 All 2bbl carbs. ACG535.....\$3.50 ea.
- 1952-1956 All Carter and Stromberg 4bbl; 1957-1960 All 4bbl Carburetors. ACG526.....\$3.50 ea.

Carter Baffle Plates

Stainless Steel Plate between carb. and intake manifold. This plate is essential for protection against disintegration of aluminum base of carb. It is also necessary for proper idle and smooth running.



- 1954-1956 All with 4bbl. carbs. BP546.....\$15.25 ea.
- 1957-1960 All with Carter AFB 4bbl. BP576.....\$16.25 ea.



Exhaust Manifold (3.601)

- 1939-1953
1939-1952: All Special and Super; 1953: Special. Exhaust manifold. EM393\$695.00 ea.



- 1939-1953 All Straight 8. Valve body. No Butterfly. (3.645)
1939-1952 Special and Super; 1953: Special. For 248 and 263 engines. VB413\$389.00 ea.



- 1934-1953 Special and Super valve body to exhaust, manifold ring.(3.657) VBR343\$7.75 ea.

Exhaust Manifold Gaskets (3.270)

- 1934-1953 Special and Super (Straight eight). Intake - exhaust manifold gaskets. MG363.....(Composite material).....\$16.00 set
- MG363C.....(Copper shielded material).....\$39.50 set
- FG363.....(Flange gasket exc. dual carb).....\$4.50 ea.
- BG4516.....(Flange 1941-1942 dual carb).....\$4.00 ea.

Valve Body Gaskets (3.657)



- 1934-1953 Special and Super, valve body to exhaust manifold gasket. Triangular. VBG343\$4.50 ea.
- 1937-1953 Valve body to intake manifold gasket. All except dual carburetor set-ups. VBI373\$6.00 ea.

Manifold Parts

- 1936-1956 All. Exhaust manifold valve body return spring. (3.678) MS366\$3.50 ea.



- 1940-1956 All. Exhaust manifold valve body thermostatic coil. MT406\$9.75 ea.

- 1936-1953 Exhaust manifold valve body stud. (3.275) MS363.....(2 per car).....\$2.75 ea.

- 1934-1953 Manifold to engine block threaded studs. Nine per car. Not a generic STUD. 100% correct. MS363\$2.75 ea.
- N14.....(nuts for above).....\$.75 ea.



- Brass Nuts. Tall. 3/8-16. All years as required. For manifolds, pipes, trim etc. N6P.....\$3.75 pr.



- 1936-1952 Series 60, 70, 80 and 90. Rear manifold section. MR362\$395.00 ea.



- 1937-1938 Series 60-80-90. Center section. (Can be altered for use on 1936). MC378\$395.00 ea.
- 1939-1951 Series 60-70-80-90. Center section. MC391\$450.00 ea.

Exhaust Manifold Valve Body (3.645)

- 1937-1951 Series 60-70-80-90. VB391.....\$415.00 ea.



- 1936-1952 Roadmaster and Limited valve body to exhaust manifold ring. (3.657) VBR361.....\$7.75 ea.

Exhaust Manifold Gaskets (3.270)

- 1936-1952 Century, Roadmaster, Limited. Intake - Exhaust manifold gaskets. MG362.....16.50 set
- MG362C.....(Copper shielded material).....\$39.50 set
- FG360.(1936-1940 flange gasket. 2 needed).....\$3.75 ea.
- FG412.(1941-1942 flange gasket. 2 needed).....\$4.75 ea.
- FG462.....(1946-1952 flange gasket).....\$4.00 ea.

- 1936-1951 Century, Roadmaster, Limited. Valve body to exhaust manifold gasket. Triangular.(3.657) VBG361\$4.50 ea.

- 1937-1953 Valve body to intake manifold gasket. All except dual carb. set-ups. VBI373\$6.00 ea.

Fuel • Carburetion • Exhaust (Group 3)

Cast Iron Paint



Extremely high temp. Excellent for manifolds and exhaust systems. Will not burn off.

EP3.....\$32.00 pt.
EP3S...(16 oz spray can).....\$19.50 ea.

V-8 Exhaust Manifold Gaskets

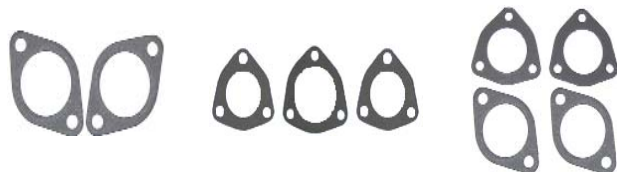

1953-1955 All V-8.

EMG536.....(To Engine block).....\$13.50 set
FG535.....(3 pc. Flange set)\$11.75 set

1956 All

EMG536.....(To Engine block).....\$13.50 set
FG56.....(4 pc. Flange set)\$12.50 set

1957-1960 All.

EMG576\$11.75 set
FG576.....(Flange gasket)\$8.75 set

Exhaust Manifold French Locks

The best restoration can be ruined by rust spreading from original unsightly locks to your engine block and manifolds. We made these from lifetime rust-free **stainless steel**.

1953-1956 All V-8.

FL536\$2.75 ea.



1957-1960 All.

FL576.....\$3.50 ea.

Choke Stove Pipe Replacement Kits (3.545)



1935-1953 all Straight-8 engines.

All as required. Includes PI300.

CSK350.....\$15.50 kit

1935-1960 all V-8 engines.

All as required. Includes PI300.

CSK530.....\$18.25 kit

Choke Stove Pipe Insulator



This modern aramid fiber sleeve greatly resembles the original. It is heat resistant up to 650°F. Also, excellent for wrapping vapor locked fuel lines. Sold by the foot. All years.
PI300.....\$5.25 ft.

Intake Manifold Gaskets

1936-1953

1936-1953: Straight-8

(See Exhaust Manifold Gaskets);

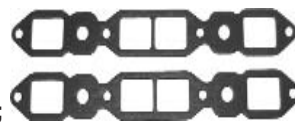

1953-1956: All V-8.

IMG536\$13.25 pr.

1957-1960

IMG576\$11.75 pr.

Intake Manifold Pilots

1934-1953

1934-1939: Specials;

1940-1952: Special and Super;

1953: Special.



MP253\$2.50 ea.

1931-1952

1931-1935: Series 60;

1936-1939: Series 60, 80, 90;

1940-1952: Series 60, 70, 80, 90 (For 320 Engines).

MP312\$2.50 ea.

Intake Manifold/Carburetor Studs

1935-1949:

1935-1942: Special;

1937: Series 60, 80, 90;

1941-1942: All with dual carbs. front carb;

1942-1949: All with single carb.

S13\$3.75 ea.

Intake Manifold Plugs

This plug is often rusted out and sometimes missing. Leakage around this plug causes poor carburetion.

1957-1960

1957-1958: All;

1959-1960: LeSabre with 2bbl carburetor.



MP579\$11.50 ea.



1959-1960: All with 4-bbl. carburetor.

MP596\$12.75 ea.



1955-1956: All manifold plug gasket.

BG3780\$4.75 ea.

Carburetor Mounting Insulators (3.726)



1935-1939 Special;
1940-1949 Special and Super
 (use 2 on dual carb. set-ups.)
 CI3.....Insulator\$14.25 ea.
 CMG359.....Gasket.....\$3.75 ea.



1939-1949 all 320 engines exc. dual carb set-ups;
1950-1952 Special and Super;
1953 Special; **1954-1955** all 2bbl.
 CI4.....Insulator\$14.25 ea.
 CMG395.....Gasket...\$3.75 ea.

Accelerator Return Springs (3.459)

1939-1947 All except dual carburetor set-up.
 AS397.....(stainless steel).....\$7.50 ea.



1948-1956 Accelerator return spring.
1948-1952: All;
1953: Specials;
1955-1956 All.
 AS483.....(stainless steel).....\$7.00 ea.



Gas Filters



1957-1960 Gas filter replacement element.
 GF572\$7.50 ea.



1957-1960 AC replacement. Gas filter assembly with element.
 GF572A.....\$29.50 ea.



All years replacement. Clear in-line gas filter. Great for near gas tank or frame installation. Important for insuring clean fuel to fuel pump.
 GF100\$4.50 ea.

In Line Gas Filters



GF140.....For 1/4" ID Hose.....\$9.25 ea.

GF516.....For 5/16" IDHose.....\$9.25 ea.



GF516C..For 5/16" ID Hose(clear).\$6.50 ea.

GF380.....For 3/8" ID Hose.....\$9.25 ea.



Air Cleaner Wing Nut (3.920)

1953-1960 Replacement air cleaner wing nut.
 WN530\$1.75 ea.

Carter Baffle Plates



Stainless steel plate between carb. and intake manifold. This plate is essential for protection against disintegration of aluminum base of carb. It is also necessary for proper idle and smooth running.



1954-1956 All with 4bbl. carbs.
 BP546\$15.25 ea.
1957-1960 All with Carter AFB 4bbl.
 BP576\$16.25 ea.

Linkage Rod Clips



1946-1960 Carburetor throttle rod clip. 1/4" rod diameter.
 RC460.....\$0.75 ea.

Linkage Rod Bushing



Carburetor throttle rod bushing and grommet. 1/4" rod diameter.
 RB460.....\$6.00 ea.

Carburetor Dash Pots



1954-1956 All. (3.440)
 DP546.....\$18.25 ea.

1957-1960 All.
 DP573\$18.25 ea.

Air Filters (3.410)



1958-1960
1958: All;
1959-1960: with 4 bbl. carb., air filter.
 AF582.....\$15.50 ea.
1959 All with 2 bbl. carburetor, air filter.
 AF59.....\$14.50 ea.
1960 All with 2 bbl. carburetor, air filter.
 AF607.....\$15.00 ea.

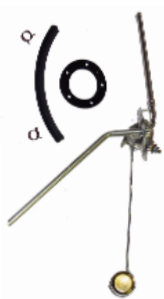

Gas Tank Sending Units 1939-1958

1939-1958 A complete quality re-production. Our units are tested and calibrated before shipment. Gasket included. Some minor modifications may be required. Instructions included with unit.

- 1939 thru 1956 All.**
- SU416\$69.50 ea.
- 1954 thru 1956 All.** Complete with correct brass fittings.
- SU546\$74.50 ea.
- 1957 All.**
- SU57\$69.50 ea.
- 1958 All.**
- SU58\$69.50 ea.



- 1946-1958** Brass gas tank float.
- TF468.....\$8.50 ea.

Gas Tank Gasket and Parts



- 1935-1960** Gas tank fuel gauge gasket.
- GG355\$3.75 ea.

- 1935-1960** Fuel gauge screws and washers kit. (5)
- GG355.....\$4.50 kit.



- 1935-1960 All.** Gas tank strap cushions.
- SC350\$12.75 pr.

Gas Tank Cleaner/Degreaser

- Cleans and degreases. 1 Qt.
- TC1.....\$12.25 ea.



Gas Tank Etch

- Removes light rust and will prep for sealer/liner. 16oz.
- TE1\$16.00 ea.



Gas Tank Sealer/Liner

- Alcohol resistant. Quart can.
- TS1\$30.00 ea.



Lead Additive

- All Buick engines needing leaded gas.
- LA1.....\$13.50 ea.



GC366A



GC366R

Gas Caps

- 1932-1956 All.** Cadmium as original. Aftermarket.
- GC366\$8.00 ea.
- 1930-1956 All.** Stainless steel. AC accessory type.
- GC366R\$9.25 ea.
- 1932-1956 All.** Authentic reproduction. Cadmium.
- GC366A.....\$19.75 ea.
- 1957-1960** Gas cap.
- GC575\$9.00 ea.

Gas Filler Grommets



- 1933-1935** Gas filler grommet.
- 1933:** All Series 50 and 60 except Victoria Coupe;
- 1934-1935** All Models 66C, 66S, 67, 68.
- GF335.....\$45.25 ea.



- 1933-1935** Gas filler grommet.
- 1933:** All Model 58, 68, 86, 90, 90L, 91;
- 1934-1935** All Models 61, 68C.
- GF335B\$45.25 ea.



- 1936-1937** Gas filler grommet.
- 1936:** All;
- 1937:** Series 80-90.
- GF367.....\$17.50 ea.



- 1937** Gas filler grommet. Special and Century.
- GF37\$17.50 ea.



- 1937-1938** Rubber cover, automatic choke cable at carburetor.
- CC378\$32.50 ea.

Gas Pedals (3.451)

1931-1935 Full slip-over type. Sold outright.

1931-1932 Series 60, 80, 90;

1933 All;

1934-1935 Series 50, 60, 90,

GP315.....(Black).....\$48.00 ea.

GP315N.....(Brown).....\$47.25 ea.

1934-1935 Series 40. Send in your old core to have fresh rubber vulcanized. 3 week service.

GP345\$83.75 ea.

1936-1937 Pad, accelerator pedal. Slip-over type with heavy retainer lip to fit over original pedal after stripping old rubber off.

1936: Series 80 and 90;

1937: All.

GP367\$38.00 ea.



1938-1940 Pad, accelerator pedal.

Rubber flanges all around as original to over pedal carcass.

1938: All;

1939-1940: All Series 80 and 90.

GP380\$38.00 ea.

1939-1940 Special and Century

GP390B.....(Black - Sold outright)\$44.50 ea.

GP390V..(Black/Brown - Rebuilding service).....\$77.00 ea.

1940-1942 Pad, accelerator pedal.

Slip over type old carcass, perfect copy.

1940: Series 50 and 70;

1941-1942: All.

1946-1948: Series 50, 70;

1948-1949: All.

GP402\$35.00 ea.



1946-1954 Made with steel core as original.

(Black).

GP464\$24.50 ea.



1948-1958 All; Accelerator pedal bellows. Fits behind gas pedal. Often missing.

AB488\$7.25 ea.



1955-1956 (Black).

GP556\$32.50 ea.

1955-1956 (Blue).

GP556U\$34.50 ea.



1957-1958 Gas pedal with steel core (Black).

GP578.....\$34.50 ea.

1957-1958 Gas pedal with steel core (Blue).

GP578U\$36.50 ea.

Universal Exhaust Hangers (3.616)



Fits 1 1/2" - 2" O.D. Twists or bends to any position. Absorbs road vibrations.

EH1\$5.75 ea.

Use with any 1 1/8" - 3" size muffler clamp. Rotates 360°. Absorbs road vibrations.

EH2.....\$6.50 ea.



Universal hanger.

EH3.....\$4.00 ea.



Authentic Hangers/Supports

1937-1952 All; 1953 Special; 1954 Special, Century, Skylark. Muffler, exhaust pipe and tail pipe clamp.

MC374\$15.00 ea.

1939 Special and Century tail pipe hangers.

TPH39F.....(Front)\$24.50 ea.

TPH39R.....(Rear Over Axle).....\$24.50 ea.

MS39R.....(Rear Muffler Support).....\$38.50 ea.

1940 Super and Roadmaster; **1941** All. Muffler support.

MS401.....(Fits Front or Rear)\$42.50 ea.

1941 All; **1942-1949** Special; **1950** All. Tail pipe hangers.

TPH410F.....(Front)\$24.50 ea.

TPH418R.....(Rear Over Axle).....\$24.50 ea.

Exhaust Deflectors



1936-1955 Original accessory. Stainless steel, complete with hardware.

ED365\$33.50 ea.



1954-1955 All: Tubular type. Chrome plated steel.

ED545\$19.50 ea.

1957 Exhaust Deflector

1957 All Models: Stamped steel. Looks identical to original. Correct for judging.

ED57\$74.50 ea.



Fuel Pumps



1930-1953 All 6 volt. Universal replacement electric fuel pump.

FP6\$79.50 ea.

1953-1960 All V-8. Universal replacement electric fuel pump.

FP12\$68.50 ea.

1957-1960 Replacement fuel pump. Sold outright no exchange necessary.

FP575\$39.75 ea.

Fuel Pump Rebuilding

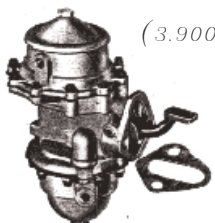

(3.900) Send in your fuel pump for the best quality rebuilding service available. Pumps are completely disassembled, refurbished and guaranteed. Allow about 3-5 weeks. If in stock, some are sold on an exchange basis - with core charge refundable after your old OEM is deemed rebuildable.

We buy old Pumps...Please inquire.

1934-1935 Series 40.

FP345RS.....(core \$50.00)\$89.25 ea.

1936-1937 Specials; (State filtered or non-filtered type).

1938: Specials (early production).

FP368RS.....(core \$50.00)\$89.25 ea.

1938-1939 1938: Specials (late production);

1939: Specials. Inverted type.

FP389RS.....(core \$50.00)\$89.25 ea.

1936-1939 Series 60-80-90.

FP369RS.....(core \$150.00)\$89.25 ea.

1940-1951 Special and Super.

FP401RS.....(core \$100.00)\$99.50 ea.

1940-1951 Series 60-70-80-90.

FP401LRS.....(core \$50.00)\$99.50 ea.

1952-1953 1952: Special and Super;

1953: Special.

FP523RS.....(core \$50.00)\$99.50 ea.

1952 Roadmaster.

FP52RS.....(core \$50.00)\$99.50 ea.

1953-1955 1953-1954: All;

1955: Early. (Top mounts with 6 screws).

FP535RS.....(core \$100.00)\$99.50 ea.

1955-1956 1955: Late;

1956: All. (Top mounts with 1 screw).

FP556RS.....(core \$100.00)\$99.50 ea.

1957-1958 All.

FP578RS.....(core \$50.00)\$89.25 ea.

1959-1960 All.

FP595RS.....(core \$50.00)\$89.25 ea.

Fuel Pump Gaskets



1934-1935 series 40, 50 fuel pump mounting gasket.
BG2085\$2.50 ea.

1936-1960 All fuel pump mounting gasket.
BG2306\$2.50 ea.

Fuel Pump Rebuilding Kits (3.925)

1935-1938 Specials with single action (pump #421).

FPK358\$49.00 ea.

1936-1938 Series 60-80-90. Double action (pump #422).

FPK368\$86.50 ea.

1938-1939 Specials. For single action pumps (#518).

FPK389\$54.00 ea.

1938-1951 All double action pumps. (#519, 529, 530, 843).

FPK381\$85.00 ea.

1939 Series 60-80-90. Double action pump (#518).

FPK39\$85.00 ea.

1952-1953

1952: All;

1953: Specials.

FPK523\$87.00 ea.

1953-1955 All V-8 engine, double action pump.

FPK535.....(Top mounts with 6 screws).....\$86.00 ea.

1955-1956 All.

FPK556.....(Top mounts with 1 screw)\$86.00 ea.

1957-1958 All.

FPK578\$59.50 ea.

1959-1960 All.

FPK575\$59.50 ea.

Cover Plate Assembly

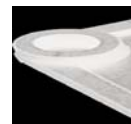

Used for cars with electric fuel pumps.

CP300.....\$10.75 ea.

Fuel Pump Hardware Kits

1940-1960 all engines. Correct bolts/washers.

FPH406.....\$2.75 ea.

Gas Lines (3.158)



1940-1953 Gas line to pump hose.

1940-1952: All;

1953: Specials.

GL403.....\$17.50 ea.

1953-1956 All V-8, gas line to fuel pump hose.

GL536.....\$18.50 ea.

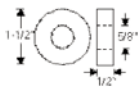

1933-1936 Transmission support pad. Lower.
1933-1935 All;
1936 Series 40. Sold outright!
 TM336\$10.50 ea.

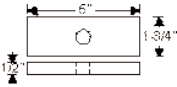

1934-1936 Series 40. Transmission support pa. Upper. Sold outright!
 TM346\$12.75 ea.

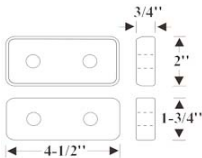

1936-1937 Pad set, transmission support. Use your original channel, plate and cap. One set (2 pad per set) per car. Series 60, 80 and 90. Sold outright!
 TM367\$90.00 set



1937 Series 40. Pad, transmission support. Two per car. Sold outright!
 TM37.....\$24.00 pr.

1938-1939 Insulator blocks, transmission support, upper and lower. These blocks are not vulcanized to steel, but are installed in shells at time of assembly like the original.
1938: Series 60, 80, and 90;
1939: Series 80 and 90. Sold outright!
 TI389.....\$69.25 pr.

1948-1958 All Dynaflow except 1953 Super, Roadmaster, Skylark. Sold outright!
 TM488.....\$32.00 ea.



1948-1956 All Standard; 1953 Super, Roadmaster and Skylark. Sold outright!
 TM486S.....\$51.00 ea.



1948-1956 All. (Thrust Pad). outright!
 Includes Nuts & Washers
 TP486.....\$39.50 ea.



1957-1959 All. Ex. flight pitch. (Thrust pad).
 TP579.....\$59.50 ea. outright



Transmission Mount Rebuilding

We now offer you complete revulcanization of your transmission mounts. Fresh, new rubber will insure safe and smooth running. If we have your needed mount ready to ship we will charge you an additional core deposit of \$50.00 per item. This charge is fully refundable upon receiving your rebuildable cores. We prefer you send your mounts for rebuilding. Please allow at least 2-3 weeks for this process. See NOS section, group 4.085 for outright sales.

1938 Special, with standard transmission. Pad, transmission mounting upper and lower.
 TM38RS.....\$111.75 set

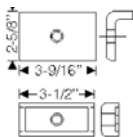
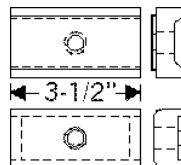

1938-1940 Special with semi-auto trans.
 TM380RS.....\$132.95 set

1940-1942 (Exchange).

1940: Series 40, 50, 60, 70;

1941: Series 60, 70, 90; 1942:

Series 90.

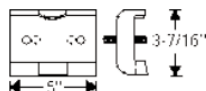

TM402RS.....\$115.00 ea.

1941-1947 (Exchange).

1941: Series 40, 50;

1942-1947: All except Series 90.

TM417RS.....\$115.00 ea.

1958-1959 All flight pitch transmissions.
 TM589FRS.....\$176.75 pr.

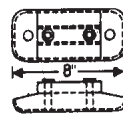
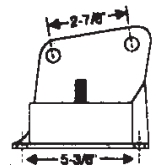

1959-1960 All with automatic transmission.
 TM590RS.....\$112.00 ea.

Shift Rod Insulators

1941-1954 (4.019)

1941-1948 All;

1949-1953 Series 40-50;

1954 Series 40-50-60. All

standard trans. (3 per car) Shift Lever Insulator.

SLI400.....\$4.25 ea.

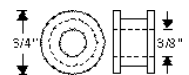

Shift Boots

1934-1938 Shift Boot

1934-1935 Series 40-60;

1936-1938 Series 40.

SB348.....(Black).....\$17.00 ea.

SB348N.....(Brown).....\$32.50 ea.



Transmission (Group 4)

Automatic Transmission Kits (4.005)

Model	Year	Master Overhaul Kit	Banner Kit	Paper, Rubber, Rings & Seals	External Seal-up Kit	Torque Ball Seal Kit
Buick Dynaflow	1948-1952	TOK482 \$234.50 ea.	TKB482 \$208.00 ea.	TRK482 \$174.50 ea.	TSK482 \$95.00 ea.	TBK482 \$89.50 ea.
Buick Dynaflow	1953-1956	TOK536 \$249.00 ea.	TKB536 \$193.00 ea.	TRK536 \$189.50 ea.	TSK536 \$95.50 ea.	TBK538 \$89.50 ea.
Buick Dynaflow	1957-1958	TOK570 \$247.00 ea.	TKB570 \$222.75 ea.	TRK570 \$174.50 ea.	TSK570 \$95.50 ea.	TBK538 \$89.50 ea.
Buick Dynaflow	1959-1960	TOK570 \$247.00 ea.	TKB570 \$222.75 ea.	TRK570 \$174.50 ea.	TSK570 \$95.50 ea.	TBK590 \$89.50 ea.
Buick Flightpitch	1958-1959	N/A N/A	N/A N/A	TRK589 \$445.00 ea.	TSK589 \$134.50 ea.	TBK538 \$89.50 ea.

Master Overhaul Kit: Gaskets, Friction (lined) Clutches, Lip Seals, Steel Clutches, "O" Rings, Front Pump Seal, Metal Sealing Rings and Extension Housing Seal.

Paper, Rubber, Rings & Seals: All gaskets, Lipseals, O-Rings, Sealing Rings, Front Pump Seal and Ext. Hsg. Seal.

Banner Kit: Same as Master Kit, but w/o Steel Clutches.



External Seal-up Kit: Stops any external Leaks. Contains Front Pump Seal, Extension Housing Seal, Selector Lever Seal and External Gaskets (including Pan Gasket and Converter Gasket or O-Ring).

Torque Ball Kit: Torque Ball Retainer with seal, rear transmission seal, gasket and seal.





Standard Transmission Gasket Kits

1934-1938 Special. TGK348	\$14.00 ea.	
1936-1939 Century, Roadmaster, Limited. TGK379	\$22.25 ea.	
1939-1955 Special and Super. TGK395	\$14.50 ea.	

Dynaflow Transmission Pan Gaskets

 1948-1960 All. TPG483	\$10.00 ea.	
1958-1960 All. Flight pitch. TPG589	\$19.00 ea.	

Transmission Seals

 1939-1954 All standard trans. Front main drive seal. (4.354) TS394	\$11.75 ea.	
1940-1952: 1940-1942 Series 60 and 70; 1946-1952 All. Rear. (serves as propeller shaft seal also). TS482	\$15.25 ea.	
 1951-1960 All. converter pump seal. "O" Ring". PS513	\$10.75 ea.	
1948-1960 Dynaflow front pump seal. Exc. 3T. TS483F	\$14.00 ea.	
1953-1958 All. Rear. (serves as propeller shaft seal also). TS538	\$11.50 ea.	
1959-1960 All. Rear. (serves as propeller shaft seal also). TS590	\$11.50 ea.	

Transmission Bands

1948-1960 All. Rebuilding service only. TB483	\$75.75 ea.
--	-------------

Speedometer Cables



1937-1955 Speedometer cable with casing. SC378	\$33.50 ea.
1956-1960 Speedometer cable with casing. SC560	\$49.50 ea.
1936-1960 All. Speedometer cable repair kit. SRK360	\$16.00 ea.
All Years. Speedometer cable lubricant. SCL300	\$5.00 ea.

See Group 5 for Torque Ball Sealing Kits.

We prefer you send **your** master cylinder for resleeving. This process takes about two weeks. Units are cleaned, honed or sleeved as necessary. They are returned with a fresh repair kit ready for assembly. Please note, we can re-sleeve any master cylinder, but, we can only supply kits as listed in the "Repair Kit" section. Please keep your filler cap, end caps, internal parts and push rod. We can also send you a master cylinder on an exchange basis. If we have your needed part ready to ship we will charge you an additional core deposit of \$100.00 refundable upon receiving your original equipment and rebuildable core. Previously sleeved units are \$25 additional.

Master Cylinder Resleeving Regular Brakes (4.650)

1936 Special.	
MC36RS.....	\$132.50 ea.
1936 Century, Roadmaster, Limited.	
MC36BRS.....	\$137.50 ea.
1937-1938 Special.	
MC378SRS.....	\$137.50 ea.
1937-1938 Century.	
MC378CRS.....	\$137.50 ea.
1937 thru 1940 Roadmaster and Limited.	
MC370RS.....	\$137.50 ea.
1939-1949	
1939-1940: Except Limited;	
1941-1949 All.	
MC399RS.....	\$137.50 ea.
**Also see MC399 and MC503 below, a brand new unit	
1950-1953	
1950-1952 All;	
1953 Special.	
MC503RS.....	\$137.50 ea.
1953 Super, Roadmaster with dynaflo.	
MC53RS.....	\$137.50 ea.
1954-55 All.	
MC545RS.....	\$147.50 ea.
1956 All regular brakes.	
MC56RS.....	\$194.50 ea.
1957 Regular brakes.	
MC57RS.....	\$137.50 ea.
1958 Regular brakes.	
MC58RS.....	\$137.50 ea.
1959 Regular brakes.	
MC59RS.....	\$137.50 ea.
1960 Regular brakes.	
MC60RS.....	\$137.50 ea.

1939-1953 New Master Cylinders

Fully assembled, ready to install

1939-1940: Except Limited;	
1941-1949 all.	
MC399.....	\$148.50 ea.
1950-1952 All;	
1953 Special	
MC503.....	\$164.00 ea.



Master Cylinder Cap for Above
MCC393.....\$12.00 ea.

Master Cylinders - Repair Kits (4.649)

1936 Special, Series 40. 1"	
MK36S.....	\$29.50 ea.
1936 Series 60, 80, 90. 1 1/8"	
MK36.....	\$32.50 ea.
1937-1940 Series 80, 90. 1 1/8" diameter	
MK370.....	\$32.50 ea.
1937-1955	
1937-1940: All except 80 and 90;	
1941-1955: All regular brakes.	
MK375.....(1" Diameter).....	\$23.50 ea.
1956 All with standard brakes	
MK56.....	\$59.50 ea.
1957 All with standard brakes	
MK57.....	\$23.50 ea.
1958-1960 All with regular brakes.	
MK596.....	\$26.25 ea.
1960 All with power brakes.	
MK602.....	\$22.25 ea.

Power Brake Master Cylinder Rebuilding Kits and Parts (4.649)

 1955-1959 Moraine power brake overhaul kit.	
PBK559.....	\$98.50 ea.

1953-1960 Moraine power brake leather piston seal.	
BL530.....	33.50 ea.



Master Cylinders Power Brakes Power Brake Unit Rebuilding Service

1954-1960 All Delco Moraine and Bendix Treadlevac.	
MC530.....	\$325.00 ea.
1953-1954 All Kelsey Hayes. Note. It is our understanding that the 1953 kelsey hayes units were recalled by Buick and replaced with 1954 units. They can be identified by a 6 1/2" piston chamber as opposed to 4" on 1954 units. We cannot rebuild the early 1953 models (cast #37002).	
MC534K.....	\$548.50 ea.

Moraine Brake Shafts (Pistons)

1955 All.	
BS55.....	\$70.25 ea.
1956 All.	
BS56.....	\$70.25 ea.
1957-1959 All.	
BS579.....	\$70.25 ea.

Brakes (Group 4)

Wheel Cylinders (4.665)

FRONT:

1937-1942:

1937-1939 Special and Century;

1940-1941 All except 80 and 90;

1942 All except series 90.

FWC372R.....R.H. Side\$39.00 ea.

FWC372L.....L.H. Side\$39.00 ea.

1942-1957 All.

FWC427R.....R.H. Side\$39.00 ea.

FWC427L.....L.H. Side\$39.00 ea.

1958-1960 All

FWC580R.....R.H. Side\$48.50 ea.

FWC580L.....L.H. Side\$48.50 ea.

REAR:

1938-1942:

1938-1939 Special and Century;

1940 Special, Super, Century, Roadmaster;

1941 All;

1942 Series 90.

RWC380.....Fits Either Side\$39.50 ea.

1942-1949 All.

RWC429R.....R.H. Side\$35.00 ea.

RWC429L.....L.H. Side\$35.00 ea.

1950-1960 All.

RWC500R.....R.H. Side\$35.00 ea.

RWC500L.....L.H. Side\$35.00 ea.



Wheel Cylinder Repair Kits (4.667)

Front

1936 Series 40, front. 1 1/16"

FK36\$8.50 ea.

1936-1940

1936: Series 60, 80, and 90;

1937-1940: Series 80 and 90. Front. 1 1/4"

FK360.....\$11.00 ea.

1937-1941 All, except 80-90, front. 1 3/32"

FK371.....\$10.50 ea.

1942-1960 All. Front. 1 1/8"

FK426.....\$10.25 ea.

Rear

1936 Series 60-80-90;

1937-1940 Series 80 and 90, rear. 1 3/16"

RK360\$11.25 ea.

1936-1960 All Except above listed.

RK370\$9.50 ea.



Wheel Cylinder Re-Sleeving Service

1936-1941 We re-sleeve your cylinders with brass.

WCS361\$89.50 ea.

Brake Overhaul Kits

Our complete kits include the following:

- 4 Wheel cylinder kits
- * • 1 Master cylinder kit. Standard brakes only
- 4 Brake shoe sets
- 3 Hydraulic brake hoses
- 2 Brake spring hardware kits

* Not available for 1956

1936 Special.

BOK36S\$189.50 ea.

1937-38 Special with 1-3/4" shoes.

BOK378.....\$189.50 ea.

1937-38 Century and Roadmaster with 2" shoes.

BOK378B\$189.50 ea.

1939 All except 80 - 90 and Convertibles;

1940 Series 50, 70;

1941 All except convertibles.

BOK391.....\$189.50 ea.

1940 Special.

BOK40S\$189.50 ea.

1941-1949 Roadmaster.

BOK419.....\$189.50 ea.

1942-1949 Special and Super.

BOK429.....\$189.50 ea.

1950-51 Special and Super.

BOK501.....\$189.50 ea.

1950-51 Century and Roadmaster. All w/o power brakes.

BOK501B\$189.50 ea.

1952 Super.

BOK52.....\$189.50 ea.

1952-55 Special.

BOK525.....\$189.50 ea.

1952 Roadmaster Early;

1953-1956 all Roadmaster.

BOK526R.....\$189.50 ea.

1953-55 Super, Century;

1954 Skylark.

BOK535.....\$189.50 ea.

1956 Special, Super, Century.

BOK56.....\$239.50 ea.

1957 Special, Super, Century.

BOK57.....\$189.50 ea.

1958 All.

BOK58.....\$189.50 ea.

1959 All.

BOK59.....\$189.50 ea.

1960 All.

BOK60.....\$189.50 ea.



Silicone Brake Fluid

One Gallon Size

SF360.....\$63.00 gal.

Brake Shoes (5.017)

Years	Part No.	Width	Price
FRONT (set is enough for 2 wheels)			
1936-1951	1936-1951 Special and Super.....	BS29.....1 3/4".....	\$64.50 set
1937-1938	1937-1938 Century, Roadmaster w/ 2" shoes.....	BS340.....2".....	\$59.50 set
1940-1957	1940-51 Ser. 60-70; 1952-57 Sr 40,50,60,100.....	BS197.....2 1/4".....	\$49.50 set
1952-1957	52 sr. 70 late; 53-57 all Roadmaster.	BS64.....2 1/2".....	\$52.75 set (rebuilding service)
1958-1960	1952 Roadmaster early; 1958-1960 all.....	BS65.....2 1/2".....	\$58.00 set
REAR (set is enough for 2 wheels)			
1936-1955	1936-1955 Series 40; 1940-1952 Series 50.....	BS29.....1 3/4".....	\$64.50 set
1940-1960	1940-1952 Series 60-70; 1953-1955 Series- 50-60-70-100; 1956-1960 All.....	BS197.....2 1/4".....	\$49.50 set

**Brake Hoses** (4.680)

Years	Part No.	Price
FRONT		
1936-1940	1936 All; 1937-1940 Series 80-90 Front.....	FH360.....\$18.00 ea.
1937-1938	1937-1938 Series 40-60 Front.....	FH378.....\$20.00 ea.
1939-1949	1939 Series 40-60; 1940 Series 50-70; 1941-1949 All. Front.....	FH399.....\$17.00 ea.
	New Modern Stainless Steel Braided	FH399SS...\$29.50 ea.
1950-1956	1950-1956 All. Front.....	FH506.....\$17.50 ea.
1957-1960	1957-1960 All. Front.....	FH575.....\$18.50 ea.

REAR		
1936-1941	1936-1939 All except convertibles; 1941 All except convertibles. Rear.....	RH361.....\$18.00 ea.
	New Modern Stainless Steel Braided	RH361SS..\$34.00 ea.
1940-1949	1940 Series 80-90; 1940 Series 40-60 except convertibles; 1941-1949 All. Rear....	RH409.....\$18.50 ea.
1950-1955	All. Rear.....	RH505.....\$17.50 ea.
1956-1958	All. Rear.....	RH568.....\$24.50 ea.
1959-1960	All. Rear.....	RH590.....\$24.50 ea.

Brake Spring Kits (5.023) Kits are per one axle

1936-1955	1936-1951 All Front or Rear, exc. 89,90; 1952-1955 Special, Rear.....	BSK365.....\$22.50 ea.
1952-1960	1952-1957 All Roadmaster, Front; 1956-1960 All Front.....	BSK520F.....\$22.50 ea.
1952-1960	1952-1957 All exc. Roadmaster, Front; 1952-1955 Roadmaster, Rear; 1952-1955 Super, Century, Skylark, Rear; 1956-1960 All Rear.....	BSK520.....\$22.50 ea.



BAS362

1936-1960	All. Brake Adjusting Screw. Fits front & rear...BAS362.....	\$10.75 ea.
------------------	---	-------------

**Brake Drums** (5.809)

Brand New! Cast Iron replacements.
(When replacing aluminum front
drums - purchase in pairs.)

Front 1 3/4"

1936-1951 Super;
1936-1951 Special.
BD365..... \$114.50 ea.

Rear 1 3/4"

1936-1952 Super exc. wagons;
1936-1955 Special
BD365..... \$114.50 ea.

Front 2 1/4"

1942-1951 Roadmaster;
1942-1957 Century;
1952-1957 Super exc. wagons;
1952-1957 Special;
BD420.....\$114.50 ea.

Rear 2 1/4"

1942-1957 Century and Roadmaster;
1953-1957 Super;
1956-1957 Special;
1958-1960 All.
BD420.....\$114.50 ea.

Front 2 1/2"

1952-1957 Roadmaster;
1958-1960 All
BD520.....\$114.50 ea.

Brakes (Group 4)

Brake Pedal Pads (4.630)



1932-1940 Pad, brake and clutch pedals full slip-over type as original.

1936: Series 60, 80 and 90;

1937-1940: Series 80 and 90.

PC320.....(Black).....\$48.00 pr.

PC320N.....(Brown).....\$49.00 pr.

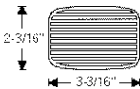

1936-1955

1936: Series 40;

1937-1939: Series 40-60;

1940-1947: All except 80-90;

1948-1952: All Park brake pedal;

1953: Early models, park brake pedal;

1948-1955: Standard transmission. Three

per car.

PC345.....(Black).....\$7.50 ea.

PC345N.....(Brown).....\$8.50 ea.



1948-1952 All Brake pedal pads with dynaflo transmission. (Black).

PC482\$15.00 ea.



1953-1954 Park brake pedal pad.

1953: All. Late models;

1954: All.

PC534\$21.25 ea.



1953-1955 Brake pedal pad. All with dynaflo and regular brakes.

PC535R\$18.75 ea.



Stop on a Dime!
With Brake Parts From Cars, Inc.

Brake Pedal Pads



1953-1955 All with power brakes.

PC535P.....("Power Brake").....\$18.50 ea.

PC535.....(no letters on pad).....\$22.25 ea.



1955-1958 Park Brake pedal pad.

PC558.....(Black).....\$10.50 ea.

PC558U.....(Blue).....\$13.50 ea.

PC558G.....(Green).....\$13.50 ea.



1956 All with power brakes.

PC56\$19.50 ea.



1956 All with regular brakes.

PC56R\$19.00 ea.

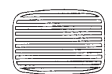

1956-1958 All with manual trans. Clutch and brake pedal.

PC568S.....(Black).....\$36.50 pr.



1957-1958 Power brake pedal cover.

PC578B.....(Black).....\$23.25 ea.

PC578PY.....(Gray).....\$28.25 ea.



1957-1958 All with regular brakes and auto trans.

PC578S.....(Black).....\$23.50 ea.

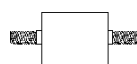

1953-1954 Vacuum pump mount.

PM534\$4.75 ea.

Stop Light Switches (2.447)



1936-1940 All.

SLS360\$17.50 ea.



1941-1955 All.

SLS415\$9.75 ea.



1956-1960 All.

SLS563\$9.75 ea.



1936-1980 Brake adjuster hole plug. (4 per car).

BC340.....\$1.00 ea.



1936-1958 All, brake and clutch pedal return grommets.(9.775) (2 per car)

PG365.....\$7.75 ea.

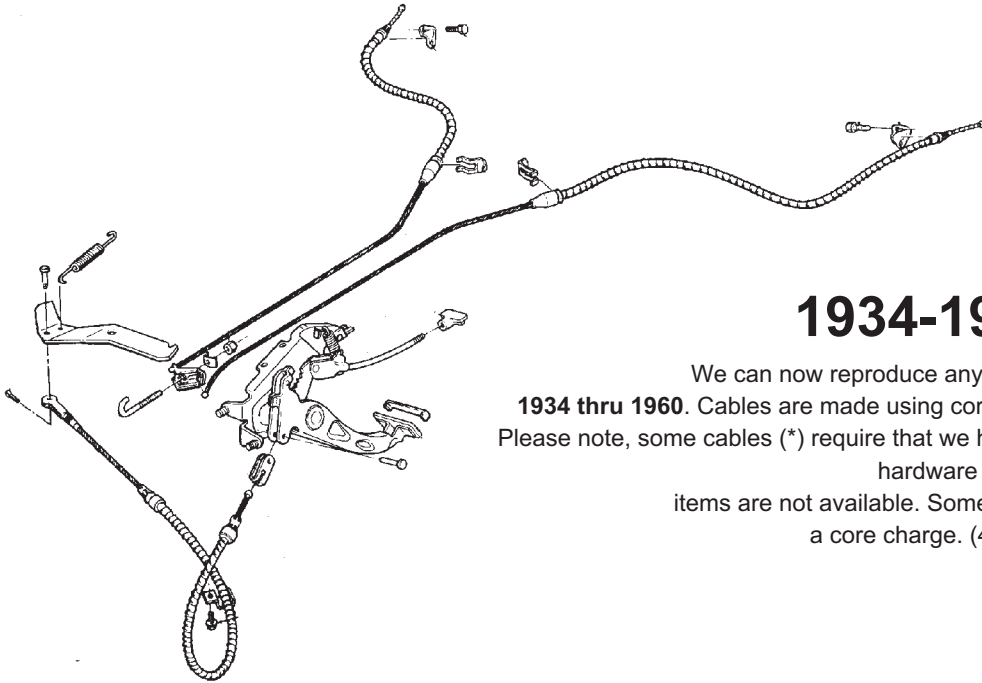

1934-1960

We can now reproduce any cable listed from
1934 thru 1960. Cables are made using correct conduit, cable and hardware.
 Please note, some cables (*) require that we have your old unit for parts as some
 hardware
 items are not available. Some are available with
 a core charge. (4.779)

Year & Model	Front	Cost	Rear	Cost
1934-1935 (40)	R1266724 (2)	\$90.25 ea.	R1267082 (2)	\$78.50 ea.
1934-1935 (50)	R1282837 (2)	\$90.25 ea.	R1284204 (2)	\$78.50 ea.
1934-1935 (60)	R1282594 (2)	\$90.25 ea.	R1284205 (2)	\$78.50 ea.
1934-1935 (90)	R1282538 (2)	\$90.25 ea.	R1284205 (2)	\$78.50 ea.
1936 (40)	R1293175 (1)	\$90.25 ea.	R1289833 (2)	\$78.50 ea.
1936 (60)	R1294332 (1)	\$90.25 ea.	R1294331 (2)	\$78.50 ea.
1936 (80)	R1293288 (1)	\$90.25 ea.	R1290372 (2)	\$78.50 ea.
1936 (90)	R1293288 (1)	\$90.25 ea.	R1290319 (2)	\$78.50 ea.
1937 (40, 60)	R1298782 (1)	\$90.25 ea.	R1299321 (2)	\$78.50 ea.
1937 (80)	R1298783 (1)	\$90.25 ea.	R1299322 (2)	\$78.50 ea.
1937 (90)	R1298783 (1)	\$90.25 ea.	R1299323 (2)	\$78.50 ea.
1938 (40, 60)	R1304324 (1)	\$90.25 ea.	R1304326 (1)	\$78.50 ea.
1938 (80)	R1305200 (1)	\$90.25 ea.	R1305229 (1)	\$78.50 ea.
1938 (90)	R1305201 (1)	\$90.25 ea.	R1305229 (1)	\$78.50 ea.
1939 (40, 60)	R1308610 (1)	\$90.25 ea.	R1308315 (1)	\$78.50 ea.
1939 (80)	R1309111 (1)	\$90.25 ea.	R1309114 (1)	\$78.50 ea.
1939 (90)	R1309112 (1)	\$90.25 ea.	R1310348 (1)	\$78.50 ea.
1940 (40, 50, 60, 70)	R1315857 (1)	\$90.25 ea.	R1315855 (1)	\$78.50 ea.
1940 (80)	R1314860 (1)	\$90.25 ea.	R1310348 (1)	\$78.50 ea.
1940 (90)	R1314861 (1)	\$90.25 ea.	R1310348 (1)	\$78.50 ea.
1941 (44,44C,46S,47)	R1321478 (1)	\$90.25 ea.	R1316875 (1)	\$78.50 ea.
1941 (41, 41SE, 46, 46S, 46SSE, 49, 50, 60, 70)	R1315857 (1)	\$90.25 ea.	R1316815 (1)	\$78.50 ea.
1941 (90)	R1319737 (1)	\$90.25 ea.	R1310348 (1)	\$78.50 ea.
1942 (44, 44C, 47, 48, 48S)	R1325350 (1)	\$90.25 ea.	R1316875 (1)	\$78.50 ea.

Brake Cables (Group 4)

Year & Model	Front	Cost	Rear	Cost
1942 (41, 41SE, 46, 46s, 46SSE, 49);				
1942 all Century;				
1946-1949 (Specials)	R1339588 (1)	\$90.25 ea.	R1316875 (1)	\$78.50 ea.
1942-1948 (50, 70)	R1323639 (1)	\$90.25 ea.	R1322613 (1)	\$78.50 ea.
1949 (50, 70)	R1339589 (1)	\$90.25 ea.	R1316875 (1)	\$78.50 ea.
1950 all except models 52 and 72;				
1951-1953 all Super, Roadmaster and Skylark, except models				
(52,72,72R)	R1338927 (1)	\$85.00 ea.	R1316875 (1)	\$78.50 ea.
1951-1953 (Specials)	R1338927 (1)	\$85.00 ea.	R1342444 (1)	\$78.50 ea.
1950-1953 (52, 72, 72R)	R1339434 (1)	\$85.00 ea.	R1316875 (1)	\$78.80 ea.
1954-1956 Special, Century,				
Skylark	R1166151 (1)	\$85.00 ea.	R1163029 (1)	\$78.50 ea.
1954-1956 Super and Rdmst. ..	R1173411 (1)	\$85.00 ea.	R1162575 (1)	\$78.50 ea.
1957-1958 Special -				
standard trans.	R1178540 (1)	\$85.00 ea.	R1174857 (1)	\$78.50 ea.
1957-1958 Special and				
Century A.T.	R1175039 (1)	\$85.00 ea.	R1174857 (1)	\$78.50 ea.
1957-1958 Super, Limited,				
Roadmaster	R1175040 (1)	\$85.00 ea.	R1174857 (1)	\$78.50 ea.
1959 LeSabre, Invicta	R1187115 (1)	\$85.00 ea.	R1187358 (1)	\$78.50 ea.
1959 Electra	R1187116 (1)	\$85.00 ea.	R1187358 (1)	\$78.50 ea.
1960 LeSabre and Invicta	R1193879 (1)	\$85.00 ea.	R1193782 (1)	\$78.50 ea.
1960 Electra	R1193880 (1)	\$85.00 ea.	R1193782 (1)	\$78.50 ea.

* Old cable needed or \$25 core charge

 **1934-1935** Boot or collar for hand brake lever.
HB345.....\$56.50 ea.

 **1934-1948** Brake cable anti-rub cover.
CB348.....\$4.00 ea.

 **1938-1958** All. Parking brake cable rubber
buffer.
CB388.....\$7.75 ea.

 **1959-1960** All. Parking brake cable rubber
buffer.
CB590.....\$6.75 ea.

1940-1959 Parking Brake Return Spring.
BRS409.....\$15.00 ea.



www.oldbuickparts.com

908-369-3666

Torque Ball Seal (5.560)



1934-1948 Torque ball packing (cork seal).
TS348\$22.75 ea.



1936-1948 Sealing kit - includes seal, gaskets and instructions. All models except 1939.
TBK348\$35.50 ea.

Torque Ball Retainer



Developed by Buick in 1960 to fit all Dynaflow from 1948 thru 1960. Does not have lip, so dust boot now rests against retainer.

1948-1960 (5.560)
1948-1960: All Dynaflow;
1953-1960: All Standard.
TBR480.....\$59.50 ea.

Dynaflow Torque Ball Sealing Kits

The common cause of transmission leakage can now be corrected with the installation of these kits. Kit contains: Retainer with seal (TBR480) featured above, rear transmission seal, and shims.



1948-1953 All Dynaflow.
1948-1952: All;
1953: Specials.
TBK482.....\$89.50 ea.



1953-1958 All Dynaflow.
1953 Super and Roadmaster;
1954 thru 1958 all.
TBK538.....\$89.50 ea.



1959-1960 All Dynaflow.
TBK590.....\$89.50 ea.

Torque Ball Boots (5.565)



1939 Series Special and Century.
TB39\$28.50 ea.

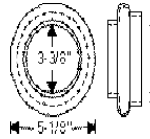

1948-1952 All;
1953 Compare with TB535.
TB482\$36.50 ea.



1953 Some - compare TB482;
1954-1955 All.
TB535\$23.25 ea.

Torque Ball Outer Seals (5.560)



1956-1960 All. Located on outer retainer, 4 7/8" dia.
TBS560\$6.00 ea.
1957-1960 All. Seals torque ball flange. 5" dia.
TBS570\$6.00 ea.

Torque Ball Supports (5.565)

1939 Special and Century.
New rubber vulcanized to your old cores.
TM39.....\$222.25 pr.

Note: You must send in your core to be revulcanized.

Torque Ball • Propeller Shaft (Group 5)

Torque Ball Bushings (5.566)



1948-1955 Bronze Bushing.
(Can be used to back to 1940)
TBB485.....\$79.50 ea.



1956-1957
1956: All;
1957: Early Dynaflow.
TBB567\$94.50 ea.



1957-1959
1957: Late;
1958-1959: Dynaflow.
TBB579\$94.50 ea.

Drive Shaft Front Sealer



1940-1952:
1940-1942 Series 60 and 70;
1946-1952 All. Rear.
(serves as propeller shaft seal also).
TS482.....\$15.25 ea.

1953-1958 All. Rear.
(serves as propeller shaft seal also).
TS538.....\$11.50 ea.



1959-1960 All. Rear.
(serves as propeller shaft seal also).
TS590.....\$11.50 ea.



Torque Tube Gaskets-Shims (5.560)



1940-1960 All. Torque tube to torque ball.
TBG400.....\$3.00 ea.



1940-1955 All. Torque tube to rear axle.
TTG405\$8.00 ea.

Drive Shaft Bearing (5.506)

1957-1960 All.
DSB570\$59.50 ea.

Propeller Shaft

1946-1953 All. Spline Seal.
PS463.....\$10.00 ea.

Torque Ball Shim Kits (5.560)

1934-1938;
1940-1956 All with standard
transmission.
TBG345.....\$8.00 ea.



1936-1948 ser. 60, 70, 80, 90 with
standard transmission;
1948-1960 All Dynaflow.
TBG480.....\$8.00 ea.

Driveshaft Universal Joints



1957-1960 All. Rear drive shaft U-joint.
For saginaw type. 1 1/8" O.D. cap.
UJ574.....\$20.00 ea.



1957-1960 All. Rear drive shaft U-joint.
Spicer type. 1 1/16" O.D. cap.
UJ573.....\$20.00 ea.

Rear Axle Rubber Parts

1932-1936 Bumpers, rubber, rear axle to frame.

1932-1933: Series 50;
1934-1935: Series 40 and 50;
1936: Series 40. (5.395)

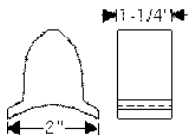

AB326.....\$43.00 pr.

1936-1937 Bumper, rubber, rear axle to frame.

1936: Series 60, 80, and 90.
1937: Series 80, and 90.

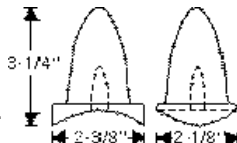

AB367.....\$51.50 pr.



1936-1937 Pad, rear spring insulator for 2-1/4" wide springs. Four per car.

1936: Series 60, 80 and 90;
1937: Series 80 and 90.

SI367.....\$28.75 ea.



1937 Series 40 and 60. Bumper, rear axle to frame. Two per car. (5.395)

AB37.....\$62.50 pr.

1938 All. Bumper, rear spring, rubber. Right and left.

AB38.....\$67.25 pr.

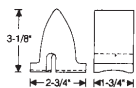

1954-1958 All models. Rear axle differential vent.

DV548.....\$8.75 ea.

1938-1958 All. Insulator, rear coil spring clamp bolt (upper end). Fabric reinforced rubber as original. Two per car.

SI389.....\$20.50 ea.



1938-1960 Insulator, rear coil spring. Fabric reinforced rubber as original. Two per car.

SI380.....\$19.50 pr.



1941-1957 Bumper, rear axle.

1941: Series 40, 50, 60 and 70;

1942: Series 40 and 60;

1946-1948: Model 40;

1949-1957: All.

AB417.....\$121.75 pr.



1958 Bumper, rear axle. All modes except Air Poise. New rubber on new steel cores.

AB58.....\$110.75 pr.

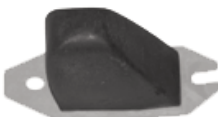

Rear Axle Radius Rod Bushings (5.417)

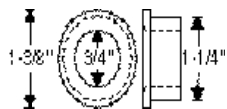

1938-1940 Series 80 and 90. Four per car.

AB380.....(Set of 4).....\$38.00 set

1938-1958 All. Four per car.

AB388.....(Set of 4).....\$14.00 set

1960 Rear All. 1 set per car.

RRB600.....\$49.50 set

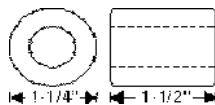

1940-1941 Series 40, 50, 60 and 70. Bushing, rear stabilizer bar mounting. Fits original bracket.

SB401.....\$45.75 pr.

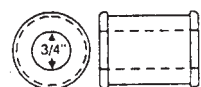

1956-1960 All models. Bushing, strut rod at drive shaft tube. Two per car.

SB560.....\$15.00 pr.

1951-1958 Bumper, rear axle stop. Molded left and right. Send in your old units for revulcanization.

1951-1952: Series 40 only;

1953-1958: All Series.

AB518.....\$67.00 pr.



Cars LLC., recognized leader in Buick Parts and Service since 1973

Rear Axle (Group 5)

Pinion Bearings



1936 Special;
1937-1939 Special and Century; (Rear)
PBR369\$90.25 ea.

1936-1954 Front.

1936: Series 60, 80, 90;
1937-1939: Series 80, 90;
1940-1955: All.

PBF414\$67.00 ea.

1936-1954 Rear.

1936: Series 60, 80;
1937-1939: Series 80, 90;
1941-1954: All.

PBR414\$96.50 ea.

1955 All. Rear.

PBR55\$45.00 ea.

1956-1962 All. Front.

PBF562\$34.00 ea.

1956-1962 All. Rear.

PBR562\$79.50 ea.

Carrier Side Differential Bearings

(5.536)

1932-1937

1932-1933: Series 50;
1934-1935: Series 40-50;
1936 Special;
1937 Special and Century; 1939 Century.

DB327\$94.50 ea.

1938-1955

1938-1939: Series 40, 60;
1940-1942: 40, 50, 60, 70;
1946-1955: All.

DB385
\$57.50 ea.



1958-1960 All

DB562\$434.50 ea.



Rear Wheel Bearings *(5.855)*

1934-1955

1934-1936: Series 40;
1937-1955: All, except 80-90.

RWB345\$42.50 ea.

1935-1955 All, except 80-90 (inner race) *(5.855)*

RAR345\$24.25 ea.

1956-1960 All.

RWB562\$74.50 ea.

Rear Axle Cover Gaskets *(5.399)*

1931-1955

1931-1935: Series 50;
1936-1939: Series 40 and 60;
1940-1942: Series 40, 50, 60 and 70;
1946-1955: All.

RAG305\$9.25 ea.

1936-1942

1936: Series 60 and 80;

Pinion Seals *(5.455)*

1940-1955 All.

PS535\$22.50 ea.



1956-1960 All. Front.

PS562\$26.50 ea.

Rear Axle Seals *(5.822)*



1936-1955 (Inner).

1934-1936: Series 40;
1937-1939: Series 40-60;
1940-1955: All exc. 80-90.

IOS375\$11.50 ea.

1937-1941 (Outer).

1937-1941: Series 80-90

OOS371\$15.00 ea.

1936-1955 (Outer).

1934-1936: Series 40;
1937-1939: Series 40-60;
1940-1955: All exc. 80-90.

OOS375\$12.00 ea.

1956-1960 All. Outer.

OS560\$12.50 ea.

Backing Plate Gaskets-Shims *(5.8.19)*

1934-1955 Axle housing to brake backing plate. Four or more per car.

1934-1936: Specials;
1941-1955: All. *(5.560)*

AG345\$4.00 ea.



1956-1960 All. Axle housing to brake backing plate and between wheel bearing retainer. Four or more per car (.015)

AG562\$4.50 ea.

ABG560.....(3 1/4" Diameter).....\$4.00 ea.

Rear Axle Carrier Gaskets

1931-1955

1931-1935: Series 50;
1936-1939: Series 40 and 60;
1940-1942: Series 40, 50, 60 and 70;
1946-1955: All.

RCG305\$9.00 ea.

1936-1942

1936: Series 60 and 80;
1937-1942: Series 80 and 90.

RCG362\$9.00 ea.

1956-1960 All.

RCG560\$9.00 ea.

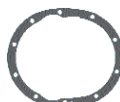

1953-1955 Wire Wheels

A beautiful reproduction of the wheels that came as original equipment on 1953-1954 Skylarks and as optional equipment on all 1953-1955 Buicks. These wheels will fit many years up to and beyond 1960. Wheels measure 15" x 6". (5 on 5, 3" rear spacing.) They are produced with safety Rims so tubless can be used.



Wire Wheel Spinners and Inserts



Metal as Original. Beautiful!
S536.....\$70.25 ea.

Plastic Reproduction. Snap in style.
Does not require SR535.
S536P\$28.50 ea.

Plain Tri-Shield. Red, white and blue. Metal as original with mounting tabs. For use on S536 or original spinners only. 100 point show quality!
SI536\$36.00 ea.



"Skylark" Red, white and blue insert. Metal as original with mounting tabs. For use on S536 or original spinners only. 100 point show quality!
SI536S.....\$36.00 ea.

Chrome Wheel with Chrome Spokes.
WW536.....\$699.00 ea.

Chrome Wheel with Stainless Steel Spokes.
WW536S\$870.00 ea.

Wire Wheel Chrome Bolts (6.335)



1953-1955 All.
WB536.....\$8.50 ea.
WB536S..... (Set of 20).....\$157.50 set

1957-1960 As required for use on aluminum front drums only where longer bolt is needed.
WB570.....\$9.25 ea.
WB570S..... (Set of 10).....\$83.75 set



Wheel Spinner Gasket Set
SG536.....(Set of 4).....\$15.50 set

Spinner Retainers

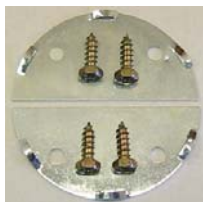

1953-1955 Stamped steel as original (For original spinners only). Includes screws, one set needed per wheel.
SR535.....\$9.50 set



www.oldbuickparts.com
908-369-3666

Wheels (Group 5)

Hubcaps

We take pride in offering you these reproduction **BUICK** Hubcaps. Each hubcap is highly polished as the originals.

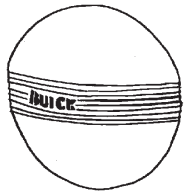

1936 All.
 HC36\$72.50 ea.



1937 All.
 HC37\$70.00 ea.



1939-1940 All.
 HC390\$70.00 ea.



1941-1950 All.
 HC410\$69.75 ea.
 HNC410S.....(set of 4)\$272.00 set

NOTE: We have a few **1941-1950** later style caps on hand. These are the same as our HC410 but have a tri-shield in the center. Original, made by Buick. May have shop wear.
 HC410T\$25.75 ea.



1955; 1956-1957 Wheel Cover Inserts

(6.871)

Red Plastic with chrome letters. Show quality. Licensed by GM.

1955 All. Wheel cover center emblem, red plastic.
 WP55.....\$23.75 ea.
 WP55S(set of 4)\$83.75 set

1956-1957 All. Wheel cover emblem.
 WP561.....\$23.75 ea.
 WP561S(set of 4)\$83.75 set

1958 Wheel Cover Inserts

(5.871)

These long sought after plastic inserts are now available.

WP58.....\$68.00 ea.



Hubcap Clips (5.864)

1936-1940 1 1/2" Tall. Not for 3 clip style wheels.

HC360\$3.00 ea.



1935-1954 As required.

HC364\$3.00 ea.

Curb Feelers



All Years. Accessory.

CF300\$13.00 pr.

Wheel Trim Rings

1936-1954 Stainless Steel 15".
 Except 1948-1949 "Wide Style".

TR15.....\$32.50 ea.

TR15S.....(set of 4).....\$118.50 ea.



1936-1941 Stainless Steel 16".

TR16.....\$32.50 ea.

TR16S.....(set of 4).....\$118.50 ea.

1934-1960 Valve Stem Caps

Needed for BACH point judging. Use metal caps thru 1950.

Use rubber caps 1951 and up.



VC300.....(Chrome Octagonal).....\$4.75 set of five



VC301.....(Stem Type).....\$5.50 set of five



VC511.....(Rubber Type).....\$3.75 set of five

Wheel Bolts

1935-1960

1935-1956: Front;

1957-1960 Front ext alum. drums:

1941-1958: Rear.

WB350.....\$4.00 ea.



Front Suspension (Group 6)

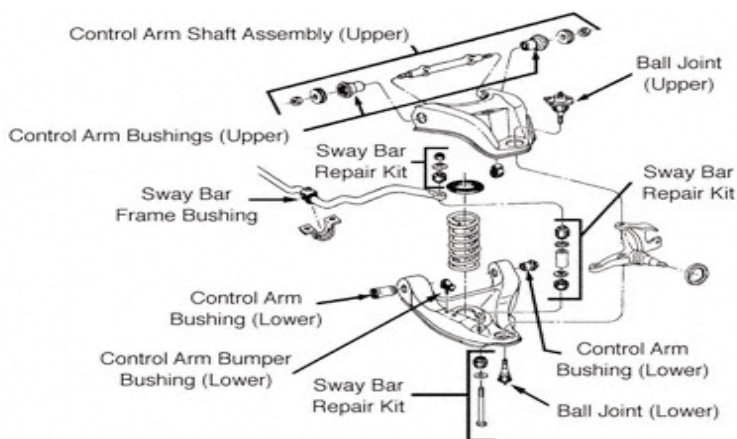

Lower Control Arm

-  **1937-1952** Lower knuckle support pin ser. 1937-1939 sr. 40-60; 1940 All ex. 80, 90; 1941 thru 1952 Series 60, 70, 90 (6.174)
K102\$59.50 ea.
K71\$44.25 ea.
- 1937-1938** Series 40-60; 1946-1957: All.
Lower control arm shaft kit.
SK377\$70.00 ea.
- 1940-1942.** 1940 All ex 80-90; 1941-1942 all.
Lower control arm shaft kit.
SK402\$110.00 ea.
- 1958-1960** All. Lower control arm shaft kit.
SK580\$79.50 ea.
- 1937-1960** All, except 1939 and 1940. Lower control arm bushing kit. 1 side.
BK370.....(with rubber).....\$36.50 pr.
- 1937-1960** All. Lower control arm shaft seal. (Rubber dirt seal).
SS370\$3.50 ea.
- 1939** Series 40 and 60. Rubber bushings, lower suspension arm, inner.
AB39\$31.50 pr.
- 1934-1940** Front spring bumpers. Our new bumpers include lower metal clamps.
1934-1936: Series 40; 1936 All;
1937-1940: Series 80, 90.
LB340\$39.50 pr.
- 1937-1940** Bumper, front lower arm. (7.422)
1937-1939: Series 40 and 60;
1940: Series 40, 50, 60, 70 (except series 50 and 70 convertibles).
LB370\$36.75 pr.
- 1939-1956** Lower control arm bumper.
LB396\$31.00 ea.
- 1957** All. Lower left side ball joint.
LBJ57L.....(rebuild service)\$349.50 ea.
- 1957** All. Lower right side ball joint.
LBJ57R.....(rebuild service)\$349.50 ea.
- 1958-1960** Lower ball joint. Fits either side.
LBJ580.....\$89.50 ea.
- 1957-1960** Lower control arm bumper.
LB570.....\$19.25 ea.

Upper Control Arm

- 1937-1939** Upper knuckle support pin series 40-60;
1940-1948: All.
K101\$41.50 ea.
 - 1949-1956** All.
K60\$41.50 ea.
 - 1937-1956** Upper and lower outer support pin seals.
SS376\$3.25 ea.
 - 1954-1956** Upper inner shaft kit.
UI546\$84.25 ea.
 - 1957-1960** All. Upper inner shaft kit.
UI570\$86.50 ea.
 - 1954-1960** Upper control arm bushing and rubber kit. For one side.
BK543.....\$39.50 pr.
 - 1934-1940** Rebound pad, front suspension, upper arm, on frame.
1934-1935: Series 50,60, and 90;
1936-1940: Series 80 and 90.
UB340.....\$72.75 pr.
 - 1934-1936** Series 40. Bumper, steering knuckle support upper arm (for front shock absorber arm).
UB346.....\$101.75 pr.
 - 1937-1956** All except 80. Upper a-frame bumper.
UB376\$8.25 ea.
 - 1957-1960** All.
UB573\$8.50 ea.
 - 1957** All. Upper left side ball joint.
UBJ57L.....(rebuild service)\$272.25 ea.
 - 1957** All. Upper right side ball joint.
UBJ57R.....(rebuild service)\$272.25 ea.
- (Core Charge \$100.00)**
- 1958-1960** Upper ball joint.
UBJ580\$82.50 ea.



1934-1956 King pin kit. (6.203)
1934-1936: Series 40;
1937-1956: All except series 80, 90.
K89.....(Enough for entire car)\$81.50 ea.



1941-1942 King pin kit. Series 90. (6.203)
K351...(Enough for entire car) ..\$133.75 ea.



1954-1956 Idler arm frame bracket and bushing.
IA546\$59.50 ea.

1957-1960 Idler arm frame bracket and bushing.
IA570\$60.00 ea.

Tie Rod Ends

1937-1940
1937: All;
1938-1940: 80, 90 (2 needed per car, R.H. outer and L.H. inner)
TE372R.....\$29.50 ea.



1937-1952
1937-1941 All;
1942-1952: Series 60, 70, 90. (2 needed per car, R.H. inner and L.H. outer).
TE372L\$29.50 ea.



Check your car for left hand or right hand threads. Throughout the years many were changed.

1942-1948 Series 40-50. Fits either side.
TE468\$33.50 ea.



1949-1958 Tie rod end.
1949-1952: Series 40-50;
1953-1956: All. L.H. and R.H.
1957-1958 All. L.H. and R.H.
TE492\$31.00 ea.



1959-1960 Tie rod end. Either side outer.
TE591\$43.75 ea.



1937-1960 All. Dust cover, tie rod ends.
EC372.....\$3.25 ea.

Tie Rod End Adjusting Sleeve

(6.234)



1950-1958 All. Fits either side.
AS506\$14.50 ea.

1959-1960 All. Fits either side.
AS590\$30.25 ea.



Grease Fittings

All models as required. Sold in packs of 10.
GF360S.....(1/4" diameter).....\$7.75 pack
GF360B.....(3/8" diameter).....\$8.75 pack



Front End Rebuilding Kits

(1939-1940, state rubber or metal bushings, shafts n/a)

1937-1956 Kits include;
• 2 Lower inner shafts with bushings
• 1 King pin kit with bushings
• Upper and Lower outer support pin kits
• 2 Outer tie rod ends
• 2 Stabilizer link kits

1957-1960 Kits include;
• 2 Lower inner shafts with bushings
• 2 Upper inner shafts with bushings
• 2 Upper ball joints
• 2 Lower ball joints
• 2 Outer tie rod ends
• 2 Stabilizer link kits

1937-1939 Special and Century with threaded LCA shafts and bushings.
FEK379\$354.00 kit
1939 Special and Century with rubber bushings on lower control arms.
FEK39R\$299.00 kit
1940 All; 1941-42 Series 60-70-90.
FEK402\$462.00 kit
1941-1942 Special and Super.
FEK412\$462.00 kit
1946-1952 Roadmaster.
FEK462\$354.00 kit
1946-1948 Special and Super.
FEK468\$354.00 kit
1949-1952 Special and Super.
1953 All.
FEK4953\$354.00 kit
1954-1956 All.
FEK546\$412.00 kit
1957 All. Ball joint cores needed. Rebuild only.
FEK57\$1599.00 kit
1958 All.
FEK58\$548.00 kit
1959-1960 All.
FEK590\$579.00 kit

Centerlink Repair Kits

1941 Special and Super;
1941 thru 1952 series 60, 70, 80, 90.
1953 Series 50 - 70
CRK412.....\$197.50 ea.
1942 thru 1952 Special and Super;
1953 Special.
CRK423\$101.50 ea.
1954 thru 1956 All.
CRK546\$73.50 ea.
1957-1958 All with power steering.
CRK578P\$179.50 ea.
1957-1958 All with regular steering.
CRK578R\$185.50 ea.
1959-1960 All.
CRK590\$167.50 ea.



Front Suspension (Group 6)



(6.326)

Front Wheel Grease Seals

- 1934-1940** All Series 40, 50, 60, 70.
 GS340.....\$12.50 ea.
1941-1956 All
 GS416.....\$16.00 ea.
1957-1960 All.
 GS570.....\$18.50 ea.
1956-1960 Steering column coupling disc repair kit.
 SD570.....\$22.25 ea.



Power Steering Hoses

Replacements for all 1952-1960 models. Some hoses may have a slightly different appearance than original.



- 1952-1953**
1952: All;
1953: Special. Pressure hose (long).
 SH523P.....\$37.50 ea.
1952 Power steering return hose (short).
 SH52R.....\$37.50 ea.
1953 Special. Power steering return hose (short).
 SH53R.....\$37.50 ea.
1953-1955 V-8, pressure hose.
 SH535P.....\$49.75 ea.
1953-1955 V-8, return hose.
 SH535R.....\$49.75 ea.
1956 All, pressure hose.
 SH56P.....\$46.50 ea.
1956 All, return hose.
 SH56R.....\$11.75 ea.
1957-1958 All pressure hose (exc. air ride).
 SH578P.....\$48.75 ea.
1957 All, return hose.
 SH57R.....\$12.75 ea.
1957-1958 All pressure hose (exc. air ride).
 SH578P.....\$48.75 ea.
1958 All; 1959 All LeSabre 1st type, return hose.
 SH589R.....(20").....\$37.50 ea.
1959 LeSabre 2nd type;
1959 All Invicta & Electra; **1960** All, return hose.
 SH592R.....\$26.75 ea.

Wheel Grease Caps (6.330)

- 1934-1960**
1934-1940 Series 40.
1937-1940 Series 40, 50, 60,70.
 2 3/32" D:9.
 GC340.....\$16.00 ea.
1941-1960 All 2 7/32"OD.
 GC410.....\$15.00 ea.

1938-1957 Front Backing Plate Leather Seals

- 1939-1940** Series 40-60;
1940-1942 All Except 80-90;
1946-1957 All.
 PS397.....\$13.50 ea.

Power Steering Pump (Rebuilt)

- 1959-1960** All. \$50 core.
 SP594.....\$89.00 ea.



Power Steering Pump Reservoir Cap

- 1959-1960** All.
 RC596.....\$46.50 ea.

Power Steering Pump Seal Kits

- 1953-1954** All.
 SPK534.....\$39.50 ea.
1955 All.
 SPK55.....\$39.50 ea.
1956 All.
 SPK56.....\$39.50 ea. 
1957-1958 All.
 SPK578.....\$39.50 ea.
1959-1960 All.
 SPK596.....\$34.50 ea.

1960 Steering Gear Box Rebuilding Kit

- SBK606.....\$82.75 ea.

Pitman Shaft Seal Kit

-  **1957 thru 1960** all with power steering.
 PSK577.....\$20.00 ea.

Front Wheel Bearings

Outer

- 1932-1960** (6.313)
1932-1935: Series 50-60;
1941-42: All except 80-90;
1946-1960: All. 
 OWB320.....\$38.50 ea.
1934-1940
1934-1936: Series 40;
1937-1939: Series 40-60;
1940: All except 80-90.
 OWB340.....\$31.50 ea.

Inner

- 1937-1940** (6.311)
1937-1939: Series 40-60;
1940: except 80-90. 
 IWB370.....\$46.50 ea.
1941-1956
1941-1942: except 80-90;
1946-1956: All.
 IWB416.....\$49.50 ea.
1957-1960 All.
 IWB570.....\$39.50 ea.

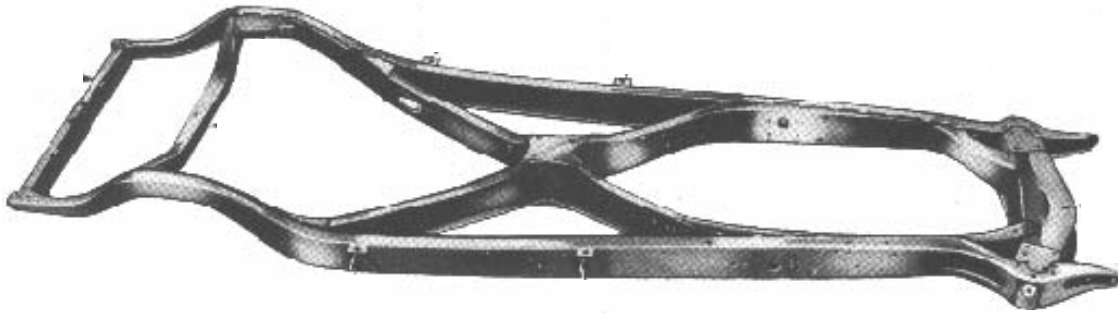

Stabilizer Repair Kits (7.240)



- 1937-1953** All Front;
1940-1941: All Rear.
SK373\$17.00 pr.
- 1954-1956** All Front.
SK373\$17.00 pr.
- 1957-1960** All Front.
SK373\$17.00 pr.



- 1937-1960** All. Stabilizer link bushing.
(8 needed per car).
SB376\$1.25 ea.

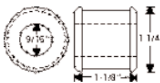

- 1934-1935** All. Stabilizer link bushing.
SB316\$8.25 ea.

Stabilizer Bar to Frame Bushings



- 1937** Front stabilizer bar bushing. Two per car.
Series 40 and 60.
SB37\$51.00 pr.

- 1937-1938** Bushing, stabilizer bracket.
1937: Series 80 and 90 only;
1938: Series 40 and 60 only.
SB378\$38.25 pr.



- 1941-1947** Front stabilizer bar bushing.
Two per car. Series 40, 50, 60 and 70.
SB417\$39.75 pr.



- 1948-1958** All. Front stabilizer bar bushing.
Two per car.
SB488\$11.50 pr.

- 1959-1960** All.
SB593\$15.25 pr.

Coil Springs



- 1935-1960** Front coil springs. (7.412)
CS350F\$195.00 pr.

- 1935-1960** Rear coil springs. (7.503)
CS350R\$185.00 pr.

- 1938-1960** Pad, front coil spring
insulator, upper. Two per car.
5 1/8" O.D. (7.420)
1938: All models;
1939-1941: Series 80 and 90;
1954-1960: All. (7.420)
SI381\$15.25 pr.



- 1939-1953** Insulators,
front coil spring. Fabric
reinforced rubber as original. One pair
required per car. (7.420)
1939-1940: Exc. Limited;
1941-53: All.
SI395\$10.00 pr.



- 1938-1958** Insulators, rear coil spring
clamp bolt (upper end). Two per car. Fabric
reinforced rubber as original. All models. 7.545
SI389\$20.50 pr.



- 1938-1960** Insulators, rear coil springs,
upper. Fabric reinforced rubber. One pair
per car.
SI380\$23.50 pr.

Spring Insulator Pad



- 1936-1937** Series 60, 80, 90.
Pad, rear spring insulator for 2 1/4" wide springs. 4 per car.
SI367\$28.75 ea.

Frame • Springs • Shocks (Group 7)



All Years: Satin Black paint: This is the correct enamel for frame and engine compartment, and is authentic for all years;

EP2\$24.50 qt.
 EP2S.....(12 oz. spray can)\$14.00 ea.

All Years: Universal gloss black: (Excellent for chassis, and general sse).
 EP1.....\$19.50 qt.



"Miracle Paint" Tough stuff!

Hirsch brand, works very well as tested by our personnel. Bonds to rust, will not crack chip or peel. Impervious to gasoline, thinner, salt. Can be applied by brush or spray.

MP300B.....Black (quart)\$35.00 ea.
 MP300S.....Silver (quart).....\$35.00 ea.
 MP300C.....Clear (quart)\$35.00 ea.
 MP300BG.....Black (gallon).....\$101.00 ea.
 MP300SG.....Silver (gallon).....\$101.00 ea.
 MP300CG.....Clear (gallon).....\$101.00 ea.

Tubing and Wiring Clip

FC1.....\$2.50 ea.



License Plate Frame



1940-1956 Front or rear. Genuine GM repro
 LF406\$36.00 ea.



1920-1960 License plate bolt kit.
 Two bolts and two nuts per kit.
 LB300.....\$2.50 kit

Rear Bumper Fillers (Gravel Deflectors)



1937-1938 All Special and Century.
 BF378R\$95.00 ea.

1939 All Special and Century.
 BF39R\$210.00 pr.

1940 All Special and Century.
 BF40R\$220.00 ea.



www.oldbuickparts.com

908-369-3666

Send in your lever shocks for the best quality rebuilding service available. Shocks are disassembled and refurbished as necessary to guarantee correct performance. Allow only about 3 days. If in stock, they are sold on an exchange basis with core charge - refundable after receipt of your old rebuildable core. Add "EI" for exchange, "RS" for rebuilding service.

Lever Type Shocks	Front		Rebuild Price Each	Rear		Rebuild Price Each
	Right	Left		Right	Left	
1935 Ser. 40.....	S1932B	1932A	\$149.00	1431C.....	1431D	\$144.50
1936 Ser. 40.....	S1932B	1932A	\$149.00	1439E.....	1439F	\$144.50
1937 Ser. 40-60.....	S1947A	1947B	\$149.00	1713A.....	1713B	\$144.50
1938 Ser. 40-60.....	S1947A	1947B	\$149.00	*1754C.....	*1754D	\$144.50
1938 Ser. 80-90.....	S1933B	1933A	\$172.25	See Tube Section..		
1939 Ser. 40-60.....	S1948A	1948A	\$144.50	2103A, E.....	2103B, F	\$144.50
1939-40 Ser. 80-90.....	S1933B,D	1933A,C	\$163.25	1751R.....	1751S	\$144.50
1940 Ser. 40-50-60-70..	S1948A	1948A	\$144.50	2105A.....	2105B	\$144.50
1941 Ser. 40-50-60-70..	S1948AX	1948AX	\$144.50	2105C.....	2105D	\$144.50
1941-42 Ser. 90.....	S1948A	1948A	\$144.50	1757A.....	1758B	\$144.50
1942 Ser. 40-50-60-70..	S1948A	1948A	\$144.50	2105C.....	2105D	\$144.50
1946-53 Ser. 40-50-70.....	S1948A	1948A	\$144.50	2105C.....	2105D	\$144.50
1954-55 Ser. 40-50-60-70-100 (tube section)				2105X.....	2105Y	\$144.50

*1754C,D are knee action, see tube section for tube type

TUBE SHOCKS



Tube Shocks are state of the art Gas shocks, developed specifically for your Buick. We can also supply shocks in:

CS540.....COIL BOOSTER....\$136.00 pr.
AS540.....AIR SHOCKS.....\$149.00 pr.

	Front	Rear
1938 All rear, tube type.....		RS38 \$109.00 pr.
1954-55 All.....	FS107G \$93.50 pr.....	(see lever section)
1956 All.....	FS107G \$93.50 pr.	RS94G \$68.25 pr.
1957 All.....	FS132G \$93.50 pr.	RS94G \$68.25 pr.
1958 All.....	FS155G \$93.50 pr.	RS94G \$68.25 pr.
1959-60 All.....	FS144G \$103.50 pr.....	RS145G \$98.75 pr.



Rear Shock Links

1937 Special and Century.

SL37.....\$58.00 pr.
N11S2.....Locknut kit for above.....\$1.75 kit

1939-1940

1939 All;
1940 Series 80 and 90.

SL390.....\$51.00 pr.
N11S2.....Locknut kit for above.....\$1.75 kit

1940 Special, Super, Century, Roadmaster

SL40.....\$55.00 pr.
N11S2.....Locknut kit for above.....\$1.75 kit

1941-1953 All except 1951-1953 Special;
1954-1955 Super and Roadmaster.

SL413.....\$42.50 pr.
N10S4.....Locknut kit for above.....\$3.75 kit

1951-1955

1951-1953 Special;
1954-1955 Special, Century, Skylark.

SL515.....\$42.50 pr.
N10S4.....Locknut kit for above.....\$3.75 kit

1934-1935 Rear shocks and brackets mounting kit. 18 piece hardened steel hardware kit.
SBK568R\$17.00 ea.

1931-1936 Shock absorber link bushing.

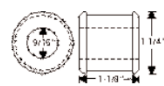

1931-1933 series 60, 80, 90.

1934-1935 series 50, 60, 90.

1936 All.

SB316\$8.25 ea.

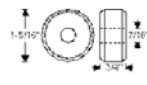

1934-1935 Shock absorber link bushing. Some models as req. 1 5/16" OD, 7/16" ID.

SB345\$7.00 ea.

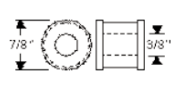

1934-1935 Shock absorber arm bushing. Series 40. 3/8" ID, 7/8" OD, 13/16" long.

SB345S\$4.00 ea.

1938 All Rear. Shock absorber bushing. Eight required per car.

SB38\$2.25 ea.

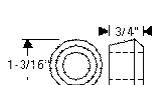

1955-1960 Grommet/bushing, shock absorber mounting 5/8" hole, 1-3/16" O.D., 3/4" thick. Double cone style. Rear.

SB556\$2.50 ea.

Bumpers (Group 7)



(7.799)

1953 Front Bumper "Special" Plastic Emblem.
BE53L.....\$98.50 ea.



1953 Front Bumper "Super" Plastic Emblem.
BE53S.....\$98.50 ea.



1946-1949 Bumper Emblems

1946-1949 All. "Special".
BE468L.....\$39.00 ea.

1946-1948 "Super".
BE468.....\$39.00 ea.

1949 All. "Super".
BE49S.....\$43.00 ea.



1949 All. "Roadmaster".
BE49R.....\$43.00 ea.



(7.799)

1953 Front Bumper "Roadmaster" Plastic Emblem.
BE53R.....\$98.50 ea.



ORDER BY PHONE!

Call 908-369-3666

Bumper Details

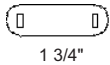

1 3/4"

1940-1949 Anti-rattle, front or rear bumper gravel shield.

1940: Series 50, 70, Rear, 3 per car;

1941-1948: All, front, 2 or 4 per car;

1949: Series 40 front two or four per car.

HB379.....\$7.50 ea.

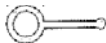

1941-1948 Anti-squeak, gravel shield-to-rear bumper, bulb type seal. 12 foot strip. Some models.

GS418.....\$40.50 ea.



1941-1953 Bumper, rear car bumper gravel deflector (anti-rattle), rubber. Five or more used per car.

1941: All (except style 49);

1942-1953: All.

DB413.....\$3.00 ea.



1936-1960 All cars. License plate mounting bolts. (two bolts - 2 nuts).

LB300.....\$2.50 set

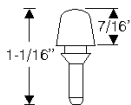

1950-1953 All. Bumper, license plate.
LB505.....\$7.50 pr.

1946-1960 Gasket set, rear license lamp assembly. One rubber ring and one cork rubber gasket comprise set.



1946-1947: Series 50 and 70;

1950-1953: All series;

1958: Roadmaster;

1959: Station Wagons.

LG462.....\$6.75 set

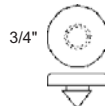

3/4"

1951-1952 Super and Roadmaster. Bumper, front gravel deflector as required.

HB429.....\$3.50 ea.



1955-1960 All front license plate rubber bumper. (two per car).

LB552.....\$2.75 pr.



1957 All. Gas lid rubber bumper.

GB57.....\$7.75 pr.



1957 "Fuel" door. Beautiful reproduction.

GD57.....\$79.00 ea.



1957 All. Grill to front bumper Insulators.

GI57.....\$39.75 pr.

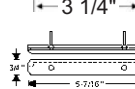

1959-1960 All except wagons. Fuel filler door bumper.

GB590.....\$17.50 pr

1933-1935 Most models.

BGR335.....(Most models without luggage rack)\$115.50 pr.
 BGR335L.....(Most models with luggage rack)\$92.00 pr.

1934-1935 Series 40.

BGR345\$69.75 pr.

1936 All. Front bumper grommets.

BGF36\$37.50 pr.

1937-1938 Series 40-60. Front bumper grommets.

BGF378\$42.50 pr.

1939-1941 All except 80-90. Front bumper grommets.

BGF391\$40.00 pr.

1939-1941 Front Bumper. **1939-1940:** Series 80, 90; **1941:** Series 90.

BGF391B\$52.50 pr.

1936 All round type. Rear bumper grommets.

BGR36\$28.00 pr.

1936-1937 Rear bumper grommets. Series 80 and 90.

BGR367\$77.50 pr.

1937-1940 Series 40-60, except **1938**. Rear bumper grommets.

BGR379\$39.50 pr.

1938 Series 40-60. Rear bumper grommets.

BGR38\$68.50 pr.

1938-1940 Rear bumper grommets. Excellent copy. Series 80 and 90.

BGR380\$93.25 pr.

1940 All except Series 80-90. Rear bumper grommets.

BGR40\$38.50 pr.

1942-1946 Series 50-70. Rear bumper grommets.

BGR426\$64.00 pr.

1951-1952 All. Seal, bumper arm. One pair per car. (7.829)

BGF512\$45.00 pr.



BGF36



BGF391



BGR379

Bumper Bolts (7.859)

1937-1938 All front and rear.

BB378.....\$7.25 ea.

1939-1941

1939-1940: Front and rear;

1941: Rear only.

BB391\$2.75 ea.

1942-1949

1942-1948: All;

1949: Special.

BB429\$7.75 ea.

1949 Series 50-70 rear only.

BB490\$2.75 ea.

1949-1953

1949: Series 50-70 front and rear;

1950-1953: Front;

1951-1953 Super & Roadmaster, Skylark rear.

BB493\$5.00 ea.

1954-1960 All. (1/2-13 x 1 1/4).

BB490\$2.75 ea.



Rear Bumper Fillers (7.834)

1954-1955 All Special, Century, Skylark.

BF545.....\$35.00 pr.

1956 40-60. Rear bumper to body rubber seal.

BF56\$24.50 ea.

1956 50-70. Rear bumper to body rubber seal.

BF56B\$24.50 ea.

1954

BF54B\$35.00 ea.



1959

BF59\$34.25 pr.

1960 All, except wagons.

BF60\$25.00 pr.

Retaining Clips for Above Fillers

MC12\$0.50 ea.

Make Your Own Fillers

Correct composition rubber material is excellent for duplication using your old aprons as a pattern.

MR4812.....(48" x 12").....\$40.75 ea.

MR4824.....(48" x 24").....\$81.50 ea.

MR4836.....(48" x 36").....\$122.25 ea.

MR4848.....(48" x 48").....\$163.00 ea.

Hood Ornaments (Group 8)

1937, 1938, 1940 and 1955 Hood Ornaments



HO37.....(1937)....\$139.50



These quality reproductions are in detail, highly polished and triple chrome plated for long lasting beauty. They have already enhanced many trophy winning **BUICKS**. We have a few "seconds" please ask.

HO558.....**1955** All Chrome....\$69.50 ea.
HO558G....**1955** All Gold.....
Hood Ornament Base - COMING SOON!



HO40....(1940)....\$90.00



HO38.....(1938)....\$149.50

Hood Letters

Hood letters are die cast and heavy chrome plated as the originals. Mounting pins are in correct locations for easy fit. *(We recommend silicone rubber for attaching letters) or, check page 59 for mounting clips.*



1939 Hood letters.
HL39.....\$51.25 set

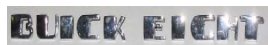

1940 Hood letters.
HL40.....\$39.50 set



1941 Hood letters.
HL41.....\$38.50 set



1954 Hood letters.
HL54.....\$52.75 set



1955 Hood letters.
HL55.....\$52.75 set



1956 Hood letters.
HL56.....\$52.75 set



1957 Hood letters. Includes "ARROWS".
HL57.....\$52.75 set



1958 Hood letters.
HL58.....\$52.75 set



Hood Emblems (8.005)

1939 Hood emblem (Cloisonne).
HE39.....TOS

1948-1949 Hood plastic emblem.
1948 All;
1949 Special.
HE489\$85.00 ea.



1949 Hood plastic emblem.
Super and Roadmaster.
HE49.....\$85.00 ea.



1950 Hood plastic emblem.
HE50.....\$85.00 ea.



1951-1952 Hood plastic emblem.
HE512.....\$85.00 ea.



1953 Hood plastic emblem.
HE53.....\$85.00 ea.



1935-1940 Fisher Body I.D. Plate (oval metal).
FP320.....\$9.00 ea.



1936-1937 All. Pads, rear hood corners.
Original style with metal core and metal
fastening tabs.
HP367R\$46.25 pr.



1937-1949 Pad, hood rest. Metal core with tab.
All models.
1937-1938: Six per car;
1939-1949: Up to 12 per car.
HB379\$8.75 ea.



1939-1940 All. Hood bumper.
Vulcanized to metal (6 per car).
HB390\$7.00 ea.

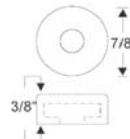

1938-1958 Bumper, hood rest, cap type for
adjustable screw, 7/8" O.D., 3/8" thick. Some
models as required.
TB415.....\$1.75 ea.



1941 All. Pad, hood side center rest.
HB41A.....\$37.75 pr.



1941 All. Bumper for bracket, radiator upper
panel to grill. One per car. Rubber only. Use
original steel bracket.
HB41B.....\$5.25 ea.

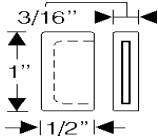

1941 All models. Bumper, hood front. Two
required per car. Slips over metal bracket as
shown.
HB41C.....\$5.25 ea.



1941 All models. Bumper, hood side pilot. Set
of four. Steel washer vulcanized in rubber.
HB41D.....\$52.50 ea.



1941 All. Bumper, hood to cowl, for 1/4" hole.
HB426\$2.75 ea.

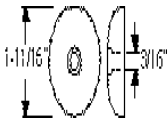

1942-1949 All models. Bumper, hood,
fastened to cowl at rear of hood. 1-11/16"
diameter. Two per car.
HFB429\$3.75 ea.



1942-1959 Bumper, hood two uses. Hood to
radiator shell at side panel, six per car. Hood
to fender and hood rail as required. 1956-1959
All on radiator shroud.
1942-1959: All;
HB429\$3.50 ea.



1948 Bumper, hood front in grille. 3/4"
diameter X 5/16" thick, self-retaining for 1/4"
hole, two per car. Series 50 and 70.
HB48\$2.75 ea.



1948-1953 Many models. Hood to fender
bumper.
HFB483.....\$3.75 ea.



1949 Series 50-70. Also fits other years. Hood
to fender bumper.
HFB49R.....\$4.50 ea.



1949 Super, Roadmaster. Seal plate, hood
fastener control, cable through firewall.
Rubber with steel core.
FWG49.....\$46.25 ea.



1949 Super, Roadmaster. Hood to fender
bumper.
HFB49B\$3.50 ea.



1949-1953 Bumper, rubber, hood ledge corner
at shroud. Two per car. Some as required.
HB493.....\$10.75 ea.



1949-1955
1949 Super, Roadmaster;
1950-1955 All. Hood to radiator grill frame
bumper.
GB495.....\$3.00 ea.

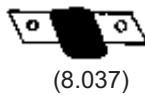

1950-1952 Bumper, hood side to fender ledge.
Metal core molded in as original.
1950: All models;
1951-1952: All Super, Roadmaster
HFB502.....\$8.25 ea.

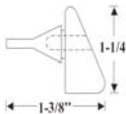

1953-1954 Bumper, hood to fender. Uses four
per car for most models.
HFB534.....\$5.00 ea.

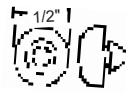

1953-1955 Most models. Bumper, fan shroud.
SB535\$2.50 ea.



1955-1958 Bumper, hood side, self-retaining
type. Six per car.
HFB558.....\$5.50 ea.



1958 Bumper, hood side on fender ledge.
HFB58.....\$11.00 ea.



1959-1960 All. Front hood rubber bumper.
HB595.....\$2.50 ea.



1958-1960 Many models. Bumper and stud,
adjustable type, hood front. Cadmium plated
bolt 8 mm x 1-1/4", rubber bumper 1-1/8" in
diameter, 5/8" thick.
HB585.....\$4.00 ea.
HS585.....Stud Only.....\$2.50 ea.

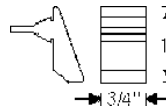

1959-1960 Bumper, hood to fender ledge. All
models as required.
HFB591R\$5.00 ea.

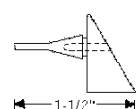

1959-1960 All full size models. Bumper hood
to fender ledge.
HFB591\$7.75 ea.

Hood • Running Boards (Group 8)

Hood Insulation 1941-1960 (8.021)

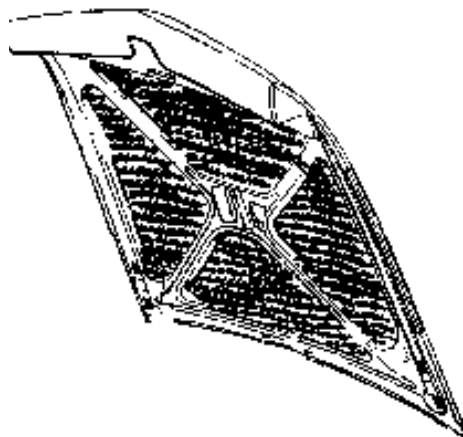

1953 Super & Roadmaster.
HI53\$37.50 ea.

Below listed insulators are pre-cut, ready to install. Should you not see your car and or model listed, please send us your old items to make new patterns. You will receive a discounted new insulator. See spray adhesive below for application. Our hood pads are in stock, ready to ship.

1954 All.
HI54\$37.50 ea.
1955-1956 All.
HI556\$37.50 ea.
1957 All.
HI57\$37.50 ea.
1958 All.
HI58\$37.50 ea.
1959 All
HI59\$37.50 ea.
1960 All
HI60\$37.50 ea.

For years and models not listed above

Generic hood insulation pad. Gray fiberglass. Easy to trim and apply. 48" x 55" x 1"

HI415.....\$39.50 ea.

Spray adhesive for application of hood Insulation

SA360.....(20 oz).....\$18.00 ea.

Hood Insulation Retainers (Sombreros)

1954-1956 All
HIR546.....\$11.50 ea.



Hood Corner Pads



1934-1935 All. Pads, hood corners, front.
HP345F\$46.25 pr.



1934-1935 Series 40. Pads, hood corners, rear.
HP345R\$64.50 pr.

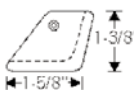

1934-1935 Series 50, 60, 90. Pads, hood corners, rear.
HP345RB\$64.50 pr.



1936-1937 All. Pads, hood corners, front. Original type with metal carcass and retaining tab.
HP367.....Front\$46.25 pr.
HP367R.....Rear\$46.25 pr.

1946-1960 Accessory Jack Cases (8.820)



A genuine Buick accessory, part # 981521, 981161. These cases were made from excess materials left over from the upholstery shops at GM. They came in assorted colors and trim.
JC460BT.....(Black with Tan Trim).....\$34.75 ea.
JC460BR.....(Black with Red Trim).....\$34.75 ea.
JC460BY.....(Black with Gray Trim).....\$34.75 ea.
JC460B.....(Black with White Trim).....\$34.75 ea.

Fender Splash Aprons



1960 All models. Fender apron set. Includes All factory holes required for installation.
FA60\$113.25 ea.

Make You Own Fender Splash Aprons

Correct composition rubber material is excellent for duplication using your old aprons as a pattern.
MR4812.....(48" x 12").....\$40.75 ea.
MR4824.....(48" x 24").....\$81.50 ea.
MR4836.....(48" x 36").....\$122.25 ea.
MR4848.....(48" x 48").....\$163.00 ea.

1942-1948 Hood Handle Frame



This item is often split or broken to a degree that the opening mechanism will not function. Die cast chrome. Triple plated. Fits either side. Does not include handle.

HF428\$85.00 ea.



Winged speed nut. For fastening 1/8" hood letters and other ornaments. Pack of 25.

MC38\$1.25 ea.



Tool necessary for removing and installing MC38 clips without damaging studs or paint.

CT555\$29.25 ea.

Hood Cables and Springs



1949 Hood release cables. Super and Roadmaster.
HC49\$37.00 pr.



1949 Super and Roadmaster, hood cable return spring. (Stainless steel).
AS397\$8.00 ea.



1950-1952 Hood cable return spring (Stainless steel).
CS502\$7.00 ea.



1950-1952 Hood release cable.
1950: All;
1951-1952: Super and Roadmaster.
HC502\$37.00 pr.



1951-1952 Special. Hood release cable.
HC512\$37.00 pr.



1950-1952 Hood cable spring protective sleeve.
SL502\$7.75 pr.



1949-1952 Hood cable pull handle. "HOOD"
HH492\$54.00 ea.



(9.784)

1950-1952 Air Intake tube end seals. (2 per car).
AS502\$19.25 pr.

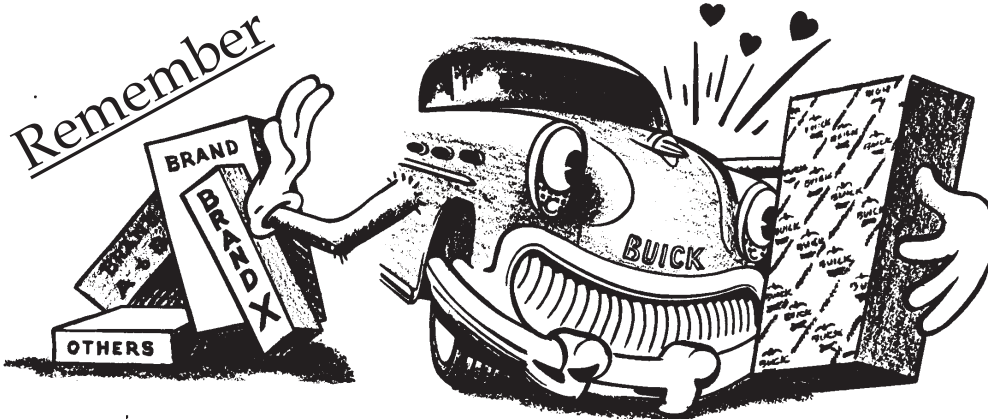

Your Buick is mighty "Choosy" about the company it keeps.....Treat it to the Best! Use only Cars Quality Original and Reproduction Parts.

Fenders (Group 8)

Portholes

Throughout the years, one of **BUICK'S** most distinguishable trademarks has been the "Porthole" or "venti-port". We are proud to preserve this tradition in offering the following examples. Each is made identical to the original. (8.147)

PH49	1949 ALL Models.....	\$33.50 ea.
PH512	1951-1952 Specials and Supers;	
	PHL512 Left hand set.....	\$35.50 ea.
	PHR512 Right hand set.....	\$35.50 ea.
PH512R	1951-1952 Roadmasters.....	\$35.50 ea.

1952 Roadmaster Porthole Inserts

Replacement insert for worn or missing parts. Stainless.

PI512R.....	\$9.75 ea.
PH53	1953 All Models..(includings mounting bracket)...\$39.50 ea.
PH54	1954 All Models.....\$35.50 ea.
PH55	1955 All Models.....\$49.50 ea.
PH56	1956 All Models.....\$39.50 ea.

1948-1952 Scripts. The detail and workmanship on these three scripts is magnificent. The chrome plating is beautiful. Our scripts come complete with correct "speed nuts" for mounting on fenders.

SS480	1948-1950 Series 50.....(Super)	\$30.00 ea.
RS480	1948-1950 Series 70.....(Roadmaster).....	\$38.50 ea.
DS482	1948-1952 All Dyna. Trans.(Dynaflow).....	\$30.00 ea.



PH-54



PH-55



PH-56



1955-1956 Rear Fender and Rear Door Scripts

SS55.....	1955 All "Special".....	\$53.00 ea.
SS56.....	1956 All "Special".....	\$53.00 ea.
CS56.....	1956 All "Century".....	\$53.00 ea.
SS56U.....	1956 All "Super".....	\$53.00 ea.

1959 Front Fender Monograms



FM59E.....	"Electra".....	\$33.50 ea.
FM59225.....	"225".....	\$19.00 ea.
FM59I.....	"Invicta".....	\$33.50 ea.

Fender Hardware

We had these pieces fabricated to be as close to the original as possible. All are finished with correct plating. These apply to All 1936-1960 Models.



1936-1960 Fender bolt. Zinc plated 5/16-18 thread, 25 pack. Correct head.	
FB1.....(1").....	\$8.00 pk.
FB12.....(1/2").....	\$8.00 pk.
FB34.....(3/4").....	\$8.00 pk.



1936-1960 Fender washer. Zinc 25 pack. 5/16 ID, 7/8 OD. Correct reproduction	
FW78	\$7.00 pk.
1936-1960 Fender star washer. 5/16 ID, 7/8 OD. 25 pack.	
FS78	\$.00 ea.



1936-1953 Rear. Fender case nuts. (Also other uses).	
CN363	\$1.75 ea.

Curb Feelers for All Years



CF300.....	\$13.00 pr.
------------	-------------

1958 Front Fender Ornaments



Beautiful cast chrome, two per car.	
HO558.....	\$69.50 ea.
HO558G....	1955 All Gold
Hood Ornament Base - COMING SOON!	

(Group 8) **Rear Fender • Running Boards**

1935-1960 Rear fender inner seal.
(between deflector and fender-36" length)
AS502.....\$16.50 ea.



1959 and 1960 Rear Fender Fin Clips

1959 All. For peak molding on rear fender.
MC79\$2.50 ea.

1960 All. For peak molding on rear fender.
MC80\$2.50 ea.

1955-1956 Rear Fender and Rear Door Scripts

SS55.....**1955 "Special"**.....\$53.00 ea.
SS56.....**1956 "Special"**.....\$53.00 ea.
SS56U.....**1956 "Super"**.....\$53.00 ea.
CS56.....**1956 "Century"**.....\$53.00 ea.

1958 Buick Limited Rear Fender Louvers

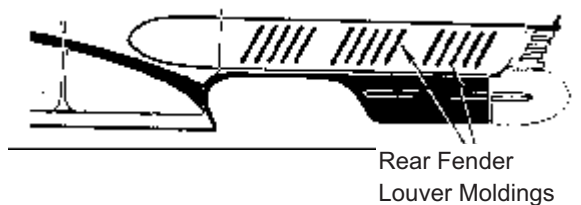

1958 Limited rear fender louvers. Beautiful die cast reproduction. Chrome plated. Complete with hardware.
L58.....\$9.50 ea.
L58S.....(set of 30).....\$247.00 set

1958 Rocker Panel Clips (8.309)

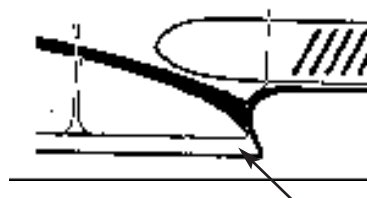

1958 All Roadmaster and Limited. 20 per car.
MC6.....\$2.50 ea.

1960 All. 18 per car.
MC81.....\$2.50 ea.

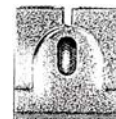

Running Board Matting (8.299)

1934-1935 Running board matting, exact copy using parallel ribbed pattern. Extruded width 8 1/4", so butting is required. Give required dimensions. Series 40.

RB345.....\$318.25 set



1936 Specials. Made in one piece with steel backs and bend over tabs.
RB36.....\$499.50 pr.

1941 All. 5" wide x 41" long.
RB41.....\$189.50 pr.



1937-1938 Running board matting. Special original design, molded in solid aluminum molds, right and left. Size includes stock for apron riser and outer radius. Some splicing necessary. Subject to batching so order early. Series 40.
RB378.....\$670.75 set

1939 Running board matting, original pattern with material to come down over ends and sides. Super workmanship, made in solid aluminum molds, each in one piece; no splicing required. Series 40.
RB39.....\$666.25 set

1938-1949 All. Gas door return spring.
GDS389.....\$9.75 pr

Body to Frame Mounting Pads (Group 9)



1937 All Series 40 and 60 (except convertibles). Shim, body sill, for #3, #5, and #7 body bolts. Six per car.
BM37\$6.25 ea.



1937-1938 All Series 40 and 60 (except convertibles). Shim, body sill, for #2, #4 and #6 body bolts. Six per car.
BM378A\$6.75 ea.

1937-1940 Shim, body sill. For #1 bolt holding body.

1937-1939: Series 40 and 60 (except convertibles);
1940: Series 40, 50, 60 and 70 (except convertibles).



BM370\$8.25 ea.

1938-1939 Insulator, body bolt.

1938: All 40 and 60 closed models.
For #2-3 bolts;
1939: All 40 and 60 closed models.
For #2-3-4-5 bolts;
1939: All 40 and 60 convertibles.
For #6 bolts.



BM389\$8.50 ea.



1940 Cushion washer, body bolt, 5/16" x 1-3/4". As required.
BM40R\$6.25 ea.



1940 Pad, body mounting, 5/16" x 1-3/4" x 2-1/4" with locating boss.
BM40\$6.50 ea.



1940 Pad, body mounting, 3/8" x 2" x 2". with locating collar. As required.
BM40A\$5.75 ea.



1940 Cushion washer, body bolt, 3/8" x 2". As required.
BM40B\$5.75 ea.



1940-1949 Insulator, cushion body mounting to frame. 1/2" thick. Up to 20 required per car. Check number needed for your particular body.
BM409\$6.75 ea.

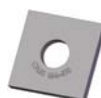

1940-1958 Pad, body mounting. 2" square with 7/8" hole. Most convertible models as required.
BM408\$6.00 ea.



1941-1958 Rubber washer, body bolt pad. Under frame bracket for holddown nut. 3/4" thick. See also BM418B.
BM418\$5.50 ea.



1941-1958 Pads, body mounting, 2" square type, with locating boss and steel core.
BM418A\$8.00 ea.



1941-1958 Cushions, body mounting bolt, 2" round x 1/2" thick rubber. 15/16" hole. Up to 20 required, for closed cars.
BM418B\$6.00 ea.
BM418C
Same as 418B but 3/4" hole.\$7.00 ea.



1942-1956 Insulator, body mounting pad with metal insert. 1-7/8" round and 1/2" thick x 3/4" metal sleeve. Most models as required.
BM426\$7.75 ea.



1952-1956 All Series 50 and 70. Insulator, body mounting pad (#7 position). Two per car. 1953-1956: Some.
BM52\$7.25 ea.



1958-1960 Insulator, body bolt. 1-7/8" O.D. x 7/8" I.D. x 3/4" high, with 7/16" nut and washer molded in. Used on some models as required.
BM580\$8.75 ea.



1958-1960 Pad, body mounting. 1-7/8" O.D. x 11/16" with 1-1/8" diameter collar, washer and 7/8" O.D. sleeve. Number used varies.
1958-1960: All (except convertibles).
BM584\$8.75 ea.



1959-1960 Insulator, body hold down bolt. 2" O.D. x 7/8" I.D. Number used as required.
1959: All Models;
1960: Some Models;
BM595\$6.50 ea.



1957-1960 Al as required. 2 1/4" square x 7/16" thick. Hole size is 3/4".
BM570\$8.75 ea.

(Group 9) Body to Frame Mounting Pads

Universal Body Mounts

These body mounts are made from original GM molds. They were used in many Buick applications, however, parts books will not identify them by number. Many can be cut, doubled-up, or shaved to fit your needs.



Diameter - 1 11/16"
Thickness - 11/16"
Hole Size - 15/16"
BM2.....\$6.50 ea.



Diameter - 1 15/16"
Thickness - 3/4"
Hole Size - 1"
BM3.....\$8.75 ea.



Diameter - 2 5/8"
Thickness - 1"
Hole Size - 7/8"
Includes metal insert.
BM4.....\$8.75 ea.



Diameter - 2"
Thickness - 1/2"
Hole Size - 1/2"
BM5.....\$8.75 ea.



Diameter - 2 1/2"
Thickness - 3/4"
Hole Size - 9/16"
Includes metal insert.
BM6.....\$8.75 ea.



Diameter - 2 1/2"
Thickness - 13/16"
Hole Size - none.
Solid rubber.
Insert diameter - 1 5/16"
BM7.....\$8.75 ea.



Diameter - 1 5/8"
Thickness - 7/16"
Hole Size - 3/4"
BM9.....\$8.75 ea.



Diameter - 2 1/16"
Thickness - 13/16"
Hole Size - none.
Solid rubber.
Insert diameter - 1 5/16"
BM11.....\$8.75 ea.



Diameter - 2"
Thickness - 13/16"
Hole Size - 7/8"
BM12.....\$8.75 ea.



Diameter - 2"
Thickness - 7/8"
Hole Size - 9/16"
Includes metal insert.
BM13.....\$8.75 ea.



Diameter - 1 3/4"
Thickness - 1 11/16"
Hole Size - 7/8"
BM15.....\$8.75 ea.

Body Mount Bolts



7/16-14 x 2". Grade 5.
B1.....\$0.75 ea.
B1B.....(Box of 25).....\$12.75 ea.

7/16-14 x 2 1/2". grade 5
B2.....\$1.00 ea.
B2B.....(Box of 25).....\$15.00 ea.

**Don't See Your
Body Mounts Listed?**

If you send your old mounts
and bolts, we will try and make
a complete kit for you at a
discounted price!

Body Mount Washers



Diameter - 1 7/8"
Thickness - 1/8"
Hole Size - 0.45"
Extra thick.
W4.....\$1.00 ea.

Diameter - 1 3/8"
Thickness - 7/64"
Hole Size - 9/16"
Insert diameter - 1 5/16"
W5.....\$0.50 ea.
W5B...(box of 50)...\$15.00 ea.

Diameter - 1 1/16"
Thickness - 7/64"
Hole Size - 9/16"
W7.....\$0.50 ea.
W7B...(box of 50)...\$15.00 ea.

Diameter - 1 1/4"
Thickness - 5/64"
Hole Size - 1/2"
W9.....\$0.50 ea.
W9B...(box of 50)...\$15.00 ea.

Diameter - 13/16"
Thickness - 1/16"
Hole Size - 13/32"
W10.....\$0.50 ea.
W10B...(box of 50)...\$15.00 ea.

Diameter - 7/8"
Thickness - 1/16"
Hole Size - 3/8"
W2.....\$0.50 ea.
W2B...(box of 50)...\$15.00 ea.

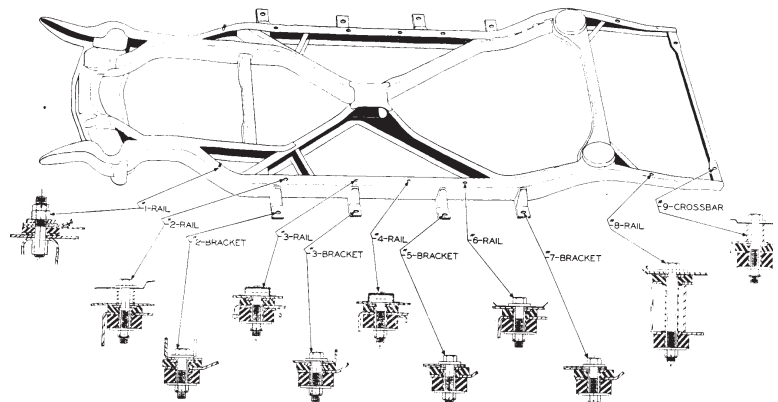

Radio • Antenna • Under Dash (Group 9)

1941-1953 Roof Mounted Antennas (9.645)

Our antenna assembly is an exact reproduction of that used on all **BUICKS** from 1940-1953.

AM403	Antenna Mast. 1940-1953 All, except convertibles.....	\$26.00
AM423	Antenna Mast. 1942-1953 (3 sections) 1942-1949 All convertibles; 1950-1953 All 2 dr. hardtop & convert.	\$26.00 ea.
AB413	Antenna Base 1941-1953 . Sedans.....	\$32.00 ea.
AA413	Antenna Assembly (mast and base) 1941-1953	\$57.00 ea.
AG403	Antenna Rubber Grommet- 1940-1960 ...(9.622).....	\$3.25 ea.

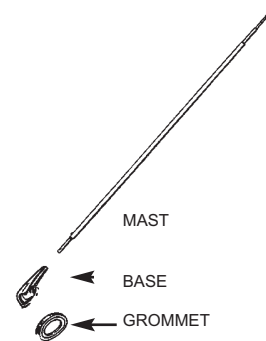

1954-1960 Front Fender Mounted Antenna Hardware



1954-1960 Chrome antenna retaining nut.
AN544.....\$15.00 ea.



1954-1960 Antenna mounting pad.
AG403.....\$3.75 ea.



1954-1956 Antenna adaptor (Spacer).
AA546.....\$13.00 ea.

1953-1960 Cigar Lighter Fuse (9.712)

1953-1960 All Casco lighters.

CF532.....	\$13.00 ea.
------------	-------------

Air Duct Hose

Sturdy, wire reinforced defroster and air duct made like the original with rubber impregnated cloth covering. Specify inner diameter and length. Sold in 1 foot increments only.



AD150.....	1 1/2".....	\$8.00 ft.
AD200.....	2".....	\$9.50 ft.
AD250.....	2 1/2".....	\$11.25 ft.
AD300.....	3".....	\$12.00 ft.
AD350.....	3 1/2".....	\$12.25 ft.
AD375.....	3 3/4".....	\$12.25 ft.
AD400.....	4" (4' max.).....	\$12.50 ft.
AD500.....	5".....	\$13.25 ft.
AD538.....	5 3/8".....	\$14.00 ft.

A.C. Clutch Bearing (8.846)

1958-1960 All.

ACB585.....	\$41.00 ea.
-------------	-------------

A.C. Refrigerant for R-12 and 134-a

5 oz. standard can. Includes red dye for leak detection. A drop-in replacement for CFC-12 and HFC-134a. **No system evacuation needed.** Up to 30% more efficient than CFC-12 and far more efficient than HFC-134a.

ACR360.....	\$10.00 ea.
-------------	-------------



1937-1938 Antenna Insulators

1937-1938 All Factory Installations. 2 pair per running board needed, or buy set of 8.
RI378.....\$34.00 ea.
RI378S.....(Set of 8).....\$239.00 set.



1948-1953 Heater Hose

1948-1953 All. Heater hose at cowl "U" shaped when installed. (8.846)
HH503.....\$11.25 ea.

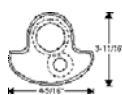

Steering Column Jackets (6.518)

1937-1939 Series 40 and 60.
CJ379.....(Black).....\$40.75 ea.
CJ379N.....(Brown).....\$48.00 ea.
1940 All. Steering column jacket.
CJ40.(Special & Century **Black**)...\$62.75 ea.
CJ40N.(Special & Century **Brown**)...\$62.25 ea.
CJ40B...(Series 80,90 **Black**).....\$40.25 ea.
CJ40BN...(Series 80,90 **Brown**)...\$43.50 ea.

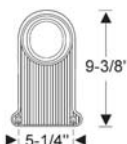
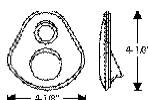

1941 All Series 60-70-90.
CJ41.....(Black).....\$140.25 ea.
CJ41N.....(Brown).....\$147.25 ea.



1953 Models 56C, 76C and 76R.
CJ53.....(Black).....\$130.75 ea.
CJ53N.....(Brown).....\$118.25 ea.



1954-1955 Models 56C, 76C and 76R. Steering column jacket.
CJ545.....(Black).....\$117.00 ea.
CJ545N.....(Brown).....\$118.00 ea.



1954-1956
CJ546..(Series 40,60,100 **Black**)...\$147.50 ea.
CJ546B...(Series 57-70 **Black**).....\$258.25 ea.

1957-1958 All. Steering column jacket.
CJ578.....\$115.00 ea.



1929-1937 Grommet, water temperature indicator pipe through dash. 3-angle hole oval grommet, 15/16" x 1 7/8".
FG297\$21.75 ea.



1936 Grommet, firewall for wiring harness and other usage.
FG36\$13.50 ea.

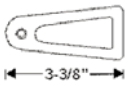

1936-1938 All as required. Radio antenna end loop. Cord reinforced rubber. On runningboard.
AR368\$27.75 ea.

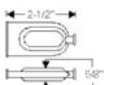

1936-1939 All as required. Boot for antenna connection on runningboard.
RB369\$25.50 ea.



1937-1941 All. Firewall grommets. Two piece set. Located on firewall.
FG371\$16.75 set



1937-1948 All. Coil wire grommet. (on firewall).
CWG379\$5.25 ea.



1939-1941 Grommet, firewall, parking brake cable, has 3/8" angular hole through 1 3/8" diameter grommet.
FG391\$11.50 ea.



1939-1949 Grommet, speedometer cable through firewall (lower).
1939: Series 40;
1940: Series 50 (except convertible);
1941-1942: All; 1946-1949: Series 40.
FG399\$12.75 ea.



1939-1948 Speedometer cable grommet.
1939-1940: Series 60-70-80-90;
1941: Models 51-51C-56-56S;
1942-1948: All.
SG398\$8.50 ea.



1939-1949 Grommet, oil pressure, water temp, and vacuum line through firewall.
1939-1940: Super, Century, Roadmaster and Limited only;
1941-1942: All models;
1946-1948: Special;
1949: All.
FG399T\$8.75 ea.



1937-1949 Wiring harness grommet.
1937-1948: All;
1949: Specials.
FWG379\$21.00 ea.



1940 Grommet, 2 holes for oil pressure and water temperature lines through firewall. Series 40 and 50.
FG40\$10.00 ea.



1940-1941 Grommet for ignition switch conduit through firewall.
FG401\$11.00 ea.



1940-1949 Grommet, parking brake cable through firewall. Most models.
FG409\$4.50 ea.



1940-1958 Grommet, hand brake cable through firewall. Fits all models.
FG408\$2.25 ea.



1940-1960 Cowl plug, for 1" hole.
BP360\$3.00 ea.



1942-1953 Grommet, parking brake release rod.
FG423\$2.75 ea.



1942-1955 Grommet, parking brake release rod.
FG425\$4.25 ea.



1942-1960 Grommet, wiring harness through fender skirts, or hood latch low mounting panels. All series.
FG420\$3.75 ea.



1946-1957 Grommet, windshield wiper control cable or gas gauge wire through rear compartment pan.
1946-49: Models 50, 59, 70-79; 1951-53: Series 50 and 70; 1954-1957: All series.
FG467\$2.50 ea.



1949 Grommet, speedometer cable and windshield washer lines through firewall. Series 50 and 70.
FG49\$13.50 ea.



1949 Super and Roadmaster. Seal plate, hood fastener control cable through firewall. Rubber with steel core.
FWG49\$46.25 ea.

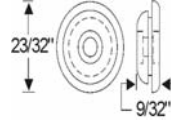

1950-1953 Grommet, firewall, vent control cable.
1950: All Series; 1951-1952: Series 50 and 70; 1953: All Series (except Skylark).
FWG503\$2.75 ea.



1950-1953 All. Grommet for oil pressure and water, or vacuum lines.
FWG503A\$8.50 ea.

Firewall (Group 9)



1950-1953 Grommet, firewall, windshield washer hose.
FG503\$7.50 ea.



1950-1956 Grommet, park brake cable through frame.
1950-1953 Super, Roadmaster, Skylark;
1954-1956 All.
FG506C\$10.75 ea.



1950-1958 Most models. Firewall grommet. Houses oil and temperature gauge lines.
FWG506\$6.50 ea.



1950-1958 Most models. Firewall grommets. Separates vacuum lines.
FG506\$9.00 ea.



1950-1960 Plug, shroud or cowl upper panel gauge holes and for various holes requiring plug. For 1/2" hole. Amount as needed.
CP416\$2.75 ea.



1951-1953 Seal, heater control valve. High quality sponge rubber designed to cushion heater control valve and keep out noise and water.
HVG513\$11.00 ea.



1953 Grommet, wiring harness through firewall.
FWG53\$29.25 ea.

1954-1955 Grommet, underseat heater to ranco valve through frame. Used on convertibles with underseat heaters.
FG545\$21.25 ea.

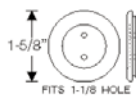

1954-1956 Grommet, oil pressure and temp lines through firewall. All as required.
FWG546T\$11.25 ea.



1954-1956 Grommet, speedometer cable through firewall. All as required.
FWG546S\$11.25 ea.



1954-1956 Grommet, vacuum lines & ignition resistor wire through firewall. All as required.
FWG546V\$13.00 ea.



1954-1956 Grommet, parking brake cable through firewall. All as required.
FWG546B\$13.50 ea.



1954-1956 Grommet, main wiring harness through firewall. All as required.
FWG546W\$18.00 ea.



1954-1956 Body plug used in various locations through sheet metal. All as required 7/8" hole.
BP780\$2.25 ea.



1954-1956 Body plug used in various locations through sheet metal. All as required 1" hole.
BP100\$1.75 ea.



1954-1957 All. Firewall gasket. Sponge rubber.
FG547\$5.00 ea.

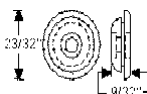

1956 Grommet, air conditioning cable.
FG56A\$2.25 ea.



1957-1958 All. Firewall grommet. Water temp. wire.
FWG577\$6.50 ea.



1959-1960 All. Grommet, antenna lead through sheet metal.
FG599\$8.75 ea.

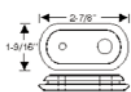

1960 Grommet, for heater control cabled wiring harness through firewall. All as required.
FWG60\$21.75 ea.

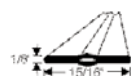

1928-1939 Cowl lacing. Hollow center for which to run electrical wires. Fastens with rivets.
CL289H\$10.25 ft.



1928-1939 Cowl lacing. Solid cross-section. Fastens with rivets.
CL289\$10.25 ft.

Heater Control Valves (9.795)

1942-1960 Rebuilt and restored.
HV420\$153.50 ea.

Heater Hose at Cowl

1950-1953 "U" shaped heater hose at cowl.
HH503\$11.25 ea.



All years as required. For view of traffic lights hidden by roof. A reproduction of a genuine Buick accessory.
LF300\$39.75 ea.



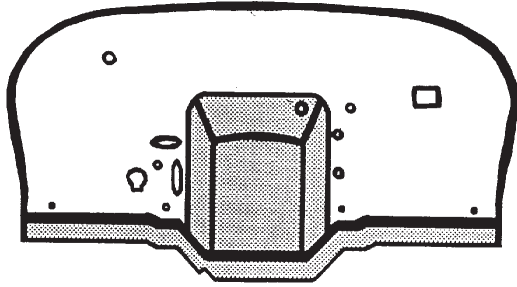

Our **Firewall Insulators** are fabricated and contour molded from strong ABS material.

Each one is formed to fit and look like the original. Holes are already cut. Insulation material is also included and fastened to the back side.

Where applicable, the rubber draft seal is installed and sewn on as original. Some minor modifications may be necessary to adapt special needs such as air conditioning, etc. If you do not see your car listed please call. We are continually adding to the list! We can also fabricate an insulator from your old pattern.

Firewall Insulator Retainer.
1950 thru 1960 all as required.
IR500.....\$1.75 ea.



www.oldbuickparts.com
908-369-3666

<u>Item #</u>	<u>Description</u>	<u>Price</u>
FI27A	1927 Buick Series 50.....	\$199.50 ea.
FI30A	1930 Buick Series 60.....	\$224.50 ea.
KP30	1930 All. Cowl Kick Panels.....	\$89.50 ea.
FI31A	1931 Series 50	\$277.50 ea.
FI31B	1931 Elec. Grommet.....	\$29.50 ea.
FI31C	1931 Series 60	\$227.50 ea.
FI31D	1931 Series 80-90	\$227.50 ea.
CJ312	1931-32 All. Steering Column Jacket	\$51.50 ea.
FI32A	1932 Series 50	\$277.50 ea.
FI32B	1932 Series 60	\$227.50 ea.
FI32C	1932 Series 80-90	\$227.50 ea.
FI33A	1933 Series 50-60	\$217.50 ea.
FI345A	1934-1935 Series 40	\$267.50 ea.
FI345B	1934-1935 Series 60-80-90.....	\$227.50 ea.
FI36A	1936 Series 40-60	\$277.50 ea.
FI36B	1936 Series 80-90	\$267.50 ea.
FI37A	1937 Series 40-60	\$257.50 ea.
FI37B	1937 Series 80-90	\$237.50 ea.
KP37	1937 All. Side Cowl Kick Panels.....	\$74.50 ea.
FI38A	1938 Series 40-60	\$267.50 ea.
FI38B	1938 Series 80-90	\$279.50 ea.
KP38	1938 Series 40-60, Cowl Kick Panels	\$74.50 ea.
FI39A	1939 Series 40-60	\$279.50 ea.
FI39B	1939 Series 60-90	\$279.50 ea.
FI40A	1940 Series 40-60	\$267.50 ea.
FI40B	1940 Series 50-70	\$267.50 ea.
FI40C	1940 Series 80-90	\$279.50 ea.
KP40	1940 All. Side Cowl Kick Panels.....	\$74.50 ea.
FI41A	1941 Series 40-60	\$267.50 ea.
FI41B	1941 Series 50-70	\$267.50 ea.
FI41C	1941 Series 80-90	\$279.50 ea.
FI428B	1942-1948 Series 40-60	\$267.50 ea.
FI428A	1942-1948 Series 50-70	\$267.50 ea.
FI49A	1949 Series 50-70	\$237.50 ea.
FI502A	1950-1953 Special	\$279.50 ea.
FI503A	1950-53 Super, Rdmstr, Skylark	\$237.50 ea.
FI545A	1954-1955 Super and Rdmaster	\$237.50 ea.
FI545B	1954-55 Spec., Cent. and Sky.	\$237.50 ea.
KP545	1954-55 Spec. and Cn Kick Panels.....	\$74.50 ea.
FI56A	1956 Special and Century	\$279.50 ea.
FI56B	1956 Super and Roadmaster	\$279.50 ea.
FI578A	1957-1958 All	\$237.50 ea.
FI590A	1959-1960 All	\$217.50 ea.

Cowl (Group 10)

Hood to Cowl Weatherstrips (9.127)

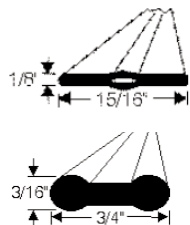

1928-1939 Hood to cowl lace webbing. Has hollow center to accept wires if needed. Fastens with rivets as original. CL289H\$10.25 ft.

1928-1939 Hood to cowl lace webbing. Does not have hollow center as above. Fastens with rivets as original.

- CL289\$10.25 ft.
- 1940** Weatherstrip, hood-to-cowl, right and left. Super and Roadmaster.
- CS40B\$113.75 ea.
- 1941** Weatherstrip, hood-to-cowl, right and left.
- CS41B.....(All Super and Roadmaster).....\$113.75 ea.
- 1941** Weatherstrip, hood-to-cowl. Series 40, 60, 90 (except models 44C, 44S, and 47).
- CS41\$118.75 ea.
- CS41S.....(Models 44, 44C, 44S, and 47).....\$108.00 ea.
- 1942-1948** Weatherstrip, hood-to-cowl, right and left. Super and Roadmaster.
- CS428\$120.25 ea.
- 1949** Super. Two piece, right and left. Held by carrot retainers. Uniform 4" retainer spacing.
- CS49.....(All Super Models).....\$120.00 pr.
- 1949-1952** Weatherstrip, hood-to-cowl, with self-retainer stems. 56-1/2" long.
- 1949** Roadmaster.
- 1950** Some. (also see CS502P)
- 1950-1952** Super and Roadmaster. (also see CS502P)
- CS492\$96.50 ea.
- 1950-1952** Weatherstrip, hood-to-cowl. Uniform 4-1/8" retainer spacing. Left and right strips 31" each. Used on some models, compare to CS492.
- CS502P\$115.50 pr.
- 1951-1952** Special. Weatherstrip, hood-to-cowl.
- CS512\$113.75 ea.
- 1953** Special All 2 and 4-door Sedans.
- CS53S\$84.25 ea.
- 1953** Special except sedans. See CP538 or CF540 for retaining plugs. 60-1/2" long.
- CS53\$49.00 ea.
- 1957** Special and Century.
- CS57S\$54.00 ea.
- 1957** Super and Roadmaster.
- CS57B\$55.00 ea.
- 1953-1958** Cowl lacing.
- 1953:** Series 50-70;
- 1954-1958:** Most. Located top of cowl.
- See CP538 for retaining plugs. See CF540 for fasteners.
- CL538\$39.50 ea.
- 1959-1960** All models. Hood-to-cowl weatherstrip.
- CS590\$22.25 ea.

Cowl Parts

1934-1935 Windshield frame to cowl mounting pad. 2 parts with jointed center. Canvas base as original. For all convertible coupes and sedans exc. 1935 series 40 convertible coupe.

WP345\$107.00 ea.
WP35..(1935 Ser. 40 Conv't Cpe)..\$118.00 ea.

1934-1935 All cowl vent seal.
CV345.....\$20.00 ea.

1936-1937 Cowl vent seal.
1936: All;
1937: Series 80 and 90.
CV367.....\$20.00 ea.

1937-1941 Cowl vent seal.
1937: Series 40-60;
1938-1940: All;
1941: Series 40, models 44, 44C, 44S, 47;
1941 All Super and Roadmaster.
CV371.....\$17.00 ea.

1941 Cowl vent seal.
Series 40, 60, 90 except models 44, 44C, 44S, 47.
CV41.....\$36.75 ea.

1939-1941 Cowl vent drain tube.
1939-1940 Special and Century;
1941 Special exc. Estate Wagon;
1941 All Series 60 and 90

CT391\$30.75 ea.
1941-1960 Most models. Cowl plug. Located top of cowl.
CP416.....\$2.75 ea.

1953-1958 Cowl lacing rubber retaining Plug. Used on CL538.
CP538.....\$2.25 ea.

1953-1954 Grommet, cowl gutter drain hose. For 3/4" hole through cowl side wall. 5/16" I.D.
1953: Skylark;
1954: All.

HG534\$5.00 ea.

1954-1960 Fastener, hood to cowl weatherstrip (and other uses), self-retaining steel button, 11/16" head, for 5/16" hole but will fit down to 1/4" hole.
CF540\$1.65 ea.

1947-1953. Windshield wiper trans. link grommet.
1947-1952: All;
1953: Special.
WLG473.....\$2.25 ea.

1932-1940 Fisher body I.D. plate (oval metal).
FP320\$10.00 ea.

1941-1958 Fisher body I.D. plate (oval metal).
FP418\$11.25 ea.

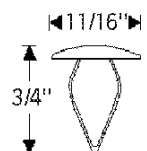
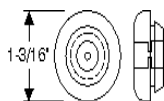
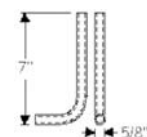
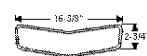
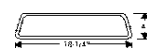

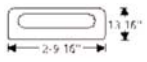

1933-1935. Some Models as required.

WW335\$19.00 pr.



1936-1937 Mounting gasket, windshield Wiper transmission.

1936: All;

1937: Series 80 and 90 (except convert).

WW367\$9.75 pr.



1937-1938 Mounting gasket, windshield wiper transmission. Carefully made to proper outline with smooth radius at edge. Mounted on cowl. Series 40 and 60.

WW378\$9.50 pr.



1938-1940 Gasket, windshield wiper transmission mounting. Series 80 and 90.

WW380\$9.00 pr.



1939 Gasket, wiper transmission mounting. About 7/8" x 1 1/8". Early 1939 cars only. Series 40 and 60.

WW39\$8.25 pr.



1939-1940 Mounting gasket, windshield wiper transmission.

1939: Series 40 and 60 (later type with larger transmission);

1940: Series 40 and 60.

WW390\$10.50 pr.



1940-1949 Gasket, windshield wiper transmission mounting. 1 1/4" x 1 1/2" inside dimension.

1940: All Series 50 and 70;

1941: Series 40, Style 4409, 09D, 27, 27B, 27D; All Series 50, 60, 70 & 90;

1942: Series 40, Style 4407, 07B, 09; Series 60, Style 4607, 09; Series 90;

1946-1949: Series 40, Style 4406, 09.

WW409\$9.00 pr.



1942-1948 Mounting pad, wiper transmission. Most closed models, Series 50 and 70.

WW428\$8.75 pr.



1947-1953 Grommet, wiper control connection link. 11/32" ID x 19/32" OD Series 40.

WG473.....\$5.00 ea.



1951-1953 Specials, gasket, windshield wiper transmission to cowl.

WW513\$6.50 pr.

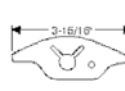

1950-1953 Super, Roadmaster and Skylark. Wiper transmission gasket.

WW503\$10.00 pr



1959 Cap or seal, wiper motor crank. For two speed wiper motors only.

WS59.....\$44.75 pr.



1936-1940 Windshield wiper acorn nuts.

WN360.....\$2.95 ea.

1950-1953 Windshield Escutcheons.

WE503.....\$38.50 pr.

Wiper Transmission Nuts

1950 All.

1951-1953 Super, Roadmaster, Skylark.

WN503.....\$14.50 pr.

1954-1957 All.

WN547.....\$14.50 pr.

1958 All.

WN58.....\$14.50 pr.

1954-1958 Windshield wiper escutcheon chrome unit.

WN548.....\$14.50 pr.

1954-1958 Wiper nut removal tool.

WT548\$17.25 ea.



Wiper Transmission Escutcheons

1954 Super & Roadmaster.

WTE54B.....\$89.00 pr.

1955-1956

1955: Roadmaster;

1956: Super & Roadmaster.

WTE556.....\$89.00 pr.

1957 Super & Centruy .

WTE57S.....\$75.00 pr.

Windshield wiper hose. (7/64").

VH764.....\$1.50 per foot

Windshield wiper hose. (5/32").

VH532.....\$1.50 per foot

Windshield wiper hose. (7/32").

VH732.....\$1.50 per foot

Windshield wiper hose. (1/4").

VH14.....\$1.50 per foot

*****We have a limited supply of **NOS 1/4"** vacuum hose. It features correct outside diameter and "draw" lines for that authentic look.*****

VH14OEM.....\$3.50 ft.

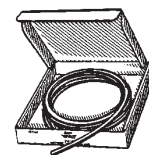

1957-1958 Windshield wiper control handle.

WH578\$22.25 ea.



1959-1960 Windshield washer pump repair kit.

WRK594\$12.25 ea.



Air Duct Hose

AD150..... 1 1/2".....\$8.00 ft.

AD200.....2".....\$9.50 ft.

AD250..... 2 1/2".....\$11.25 ft.

AD300.....3".....\$12.00 ft.

AD350.....3 1/2".....\$12.25 ft.

AD375..... 3 3/4".....\$12.25 ft.

AD400..... 4".....\$12.50 ft.

AD500..... 5".....\$13.25 ft.

AD538..... 5 3/8".....\$14.00 ft.



(9.784) - (9.786)

Windshield Wiper Parts (Group 10)

Wiper Motor Rebuilding Service 1935 - 1958

WR358\$118.75 ea.

Wiper Arms

1941-1948 All;

1949 Special. Uses our WB360 blade.

WA419\$16.50 ea.



1954-1956. All models except Cam-o-Matic. Has flat end. Accepts our WB546 only.

WA546L.....Left Hand Side\$36.75 ea.

WA546R.....Right Hand Side.\$36.75 ea.

1959-1960 LeSabre, Invicta.

WA592L.....(Left Hand Side)\$30.25 ea.

WA592R.....(Right Hand Side)\$30.25 ea.

Wiper Blades

1936-1948 All. 1949 Special 9" or cut to length).

WB360\$ 6.25 ea.

1949 Super & Roadmaster;

1950-1954 All, except Skylark. Hook end as original.

WB11.....11" blade\$16.50 ea.

WB12.....12" blade\$16.50 ea.

WB503.....(Genuine 12" Trico reproduction)\$32.50 ea.

1954-1956 All. with flat ended wiper arm.

WB546.....(Genuine Trico reproduction)\$34.50 ea.

1959-1960 All.

WB15\$16.50 ea.

1936-1948 All.

1949 Special Link Retainer.

WL369\$4.00 ea.

Windshield Washer Nozzles

1953-1960 All. Can be used back to 1941.

WN540\$7.00 pr.



Windshield Wiper Switch

1959 All.

WS592\$59.50 ea.



Windshield Washer Jars and Lids

1951-1958 All as required.

WJ518.....\$55.00 ea.



1951-1956 All. Does not include pump.

JL516\$59.00 ea.

1957-1958 All. Does not include pump

JL578\$59.00 ea.

Trico Lid Decal

D31.....\$4.75 ea.



GM Lid Decal

D230.....\$4.75 ea.



Windshield Washer Repair Kits



1951-1956 All. Matches our JL514 lid.

WRK516\$45.00 ea.

WPS516.....(Pump spring)\$25.25 ea.

1957-1958 All. Matches our JL568 lid.

WRK578\$53.00 ea.

WPS578.....(Pump spring)\$21.50 ea.



1959-1960 Optikleen Bottles and Caps

Bottle assembly. Includes stainless steel bracket and cap.
OB598.....\$36.50 ea.

Cap only. Includes stenciled writing.

OC598.....\$6.75 ea.

Optikleen bottle label.

D46.....\$3.75 ea.

Optikleen bottle cap label.

D107.....\$4.00 ea.



(Group 10) **Vulcanized Windshield Seals**

1934-1935 Series 40 closed bodies **WITHOUT** reveal molding.
 WS345\$93.50 ea.

1936 Series 40 and 60 closed bodies **WITHOUT** reveal molding.
 (Order DP356 division post seal separate).
 WS36\$86.50 ea.

1936 Special & Century convertible coupes, models 46C, 66C.
 (Order DP356 division post seal separately).
 WS36C\$139.00 ea.

1936-1937 Model 80C and 90.
 (Order DP378 division post seal separately).
 WS367R....(Model 80C 4-dr. Sport Phaeton)....\$163.00 ea.
 WS367.....(Series 90 with reveal molding).....\$95.00 ea.

1937-1938 Series 40 and 60 except convertibles. For cars **WITHOUT** reveal molding. (Order DP378 division post seal separately).
 WS378\$106.50 ea.

1937-1938 Series 40 and 60 convertibles **WITHOUT** reveal molding. (Order DP378 division post seal separately).
 WS378C\$93.50 ea.

1938-1940
1938-1939: Series 80 and 90 convertible;
1940: Series 80 convertible.
 WS380\$100.25 ea.

1939; Special and Century closed cars
 (Order DP39 post seal separately).
 WS39.....(For cars **without** reveal molding).....\$106.50 ea.
 WS39M.....(For cars **with** reveal molding).....\$78.25 ea.

1939; Special convertible **WITHOUT** reveal molding.
 (Order DP39C post seal separately).
 WS39C\$117.25 ea.

1939-1940 Models **WITH** reveal molding.
1939: Series 40 and 60 Convertible; All Series 80 and 90 (except convertible).
1940: All Series 80 and 90 (exc. conv't.) Order division post seal DP39C for Ser. 40 and 60.
 WS390\$115.75 ea.

1940 Special & Century **WITH** reveal molding. Inc. division seal
 WS40C.....(Convertible Models).....\$129.75 ea.
 WS40M.....(Except Convertible Models).....\$130.50 ea.

1940-1941 Series 50 and 70 convertibles **WITH** reveal molding.
 (Order PW419 pinchweld seal and DR418 division post retainer for 1941 models only).
 WS40BC\$150.00 ea.

1940-1948;
1940-1941: Series 50, 70 closed cars;
1942: Models 51, 71; 1946: Models 51, 71, 59;
1947-1948: Models 51, 71, 59, 79
 (For **1941-1948**, Order PW419 pinchweld seal and DR418 division post retainer separately).
 WS408\$152.25 ea.

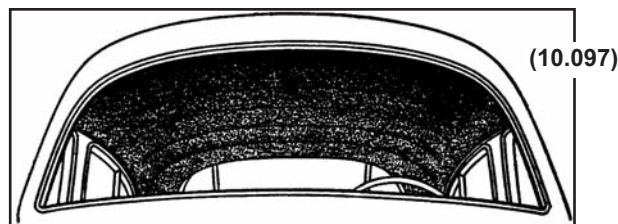

1941-1942;
1941: Models 44, 44S, 44C, and 47
1942: Models 44, 44C, and 47 (Order PW419 pinchweld seal and DR418 division post retainer separately).
 WS412\$101.75 ea.

1941-1949; For cars with reveal molding.
1941: Models 41, 41SE, 46, 46S, 46SSE;
 ALL Series 60,90;
1942: Models 41, 46, 46S, 46SSE,
 ALL Series 60, 90;
1946-1949: Models 41, 46S .
 (order DR418 division post seal separately)
 WS419\$145.00 ea.

1942-1948 Super and Roadmaster with reveal molding. Models 56S and 76S. Order PW419 pinchweld seal and DR418 division post retainer separately.
 WS428S\$161.75 ea.

1942-1948 Model 56C and 76C convertible **WITH** reveal molding.
 (Order PW419 pinchweld seal and DR418 division post retainer separately).
 WS428\$159.75 ea.

1949 Super and Roadmaster 2-door HT and converts.
 WS49\$327.50 set

1949 Model 56S and 76S (lockstrip included).
 WS49S\$265.25 set

1949 Models 51, 59, 71 and 79 (lockstrip type).
 WS49B\$292.50 set

1950 Models 41, 41D, 43, 43D, 46 and 46D **WITH** reveal molding.
 WS50\$271.50 ea.

1950-1953 Models **WITH** reveal molding.
1950: Models 51, 56S, 59, 71, 76S, 79;
1951: Models 51, 56S, 59, 79R;
1952-1953: Models 59, 79R.
 WS503S\$219.75 ea.

1950-1953 Models **WITH** reveal molding.
1950: Models 56C, 56R, 75R, 76C,76R;
1951: Models 56C, 56R, 56RD, 76C, 76MR,
 76R; 1952-1953: Models 56C, 56R, 76C, 76R.
 WS503C\$210.25 ea.

1950-1953; 1950: Models 52, 52X, 72, 72X; **1951-1953:** Models 52, 52X, 72R, 72RX.
 WS503\$227.75 ea.

Vulcanized Windshield Seals (Group 10)

Vulcanized Windshield Seals (con't)

1951-1953 Models 45R and 46C (Special Riviera Hardtop and Convertible).

WS513C\$108.75 ea.

1951-1953 Models 41D and 48D.

WS513S\$108.75 ea.

1953 Model 76X (Skylark).

WS53X\$210.25 ea.

1954-1956 (For models with reveal molding).

1954: Special, Century, Skylark;

1955-1956: All Series 40, 60 Convertibles and closed models exc. mod 43 and 63. Slotted for chrome across top only, remainder chrome lays on top. 1st type.

WS546\$142.25 ea.

1955-1956 (For models with reveal molding).

1955-1956: Series 40, 60 Closed models and models 43 and 63. 2nd type Slotted for chrome on top and bottom left and right. The remainder is not slotted.

WS556\$163.50 ea.

1954-1956

1954: Models 52, 72R;

1955-1956: Models 52, 72

WS546BS\$152.75 ea.

1954-1956;

1954: 56C, 56R, 76CX, 76RX;

1955: Models 56C, 56R, 76C, 76R;

1956: Models 53, 56C, 56R, 73, 76C, 76R

WS546B\$129.50 ea.

1957-1958;

1957: Models 53, 73, 73A, 75;

1958: Models 53, 75, 750

WS578B\$146.25 ea.

1957-1958;

1957-1958: Models 41, 43, 46R, 48, 49, 49D,

56R, 61, 63, 66R, 69, 75R, 76A, 76R, 755

WS578\$146.25 ea.

1957-1958 All convertibles.

WS578C\$152.00 ea.

1959-1960 All models.

WS590\$122.75 ea.

Windshield Division Post Seals



1935-1936 Most models. Inner and outer seals. Two piece set.

DP356\$18.00 set



1936-1937

1936 All series 40, 60.

1936-1937 model 80C.

DP367\$70.50 set

Windshield Division Post Seals

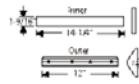

1937 Series 90. Includes steel core. Acts as retainer for outer chrome. Similar to out DP378 but shorter. 12".

DP37\$67.25 set.

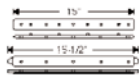

1938-1940 Series 80, 90 except convertibles. 2 piece set with screw holes.

DP380\$51.25 set



1937-1938 Most models. Inner and outer seals. Steel core, threaded as original. 13 1/2"

DP378\$49.50 set



1939 Series 40 and 60. (except convertible).

DP39\$27.25 set

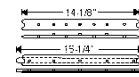

1939 Series 40 and 60 convertibles. Inner and outer seals.

DP39C\$50.25 set



1939-1940 Some models. Two piece set.

DP390.....(17" to 20")\$17.50 ea.



1941-1948 All models. Windshield center post, "H" section, requires fitting to top and bottom, not drilled. (Already molded in vulcanized seals purchased from CARS).

DP418\$23.75 ea.



1941-1948 Retainer, rubber, for outside windshield center post stainless molding. Use w/ original stainless molding and clips.

DR418\$17.50 ea.

Windshield Rubber Extrusions



1935-1936 Some models. For windows without chrome reveal molding. 12 ft. strip. **NOTE:** For **1935-1936** cars with two piece windshields, use division post seal DP36, ordered separately.

WR356\$34.50 ea.

1937-1940 Some models. For windows without chrome reveal molding. (For cars with two piece windshield, select seal for division post).

12 ft. strip.

WR370\$48.50 ea.



1937-1948 Most models. For windows with chrome reveal molding. Plain channel for 1/4" glass. 12 ft. strip.

WR378\$58.25 ea.

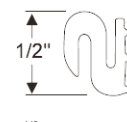

1941-1948 Some models. Pinchweld seal. To seal and retain outer reveal molding. 12 ft. strip.

PW419\$39.75 ea.

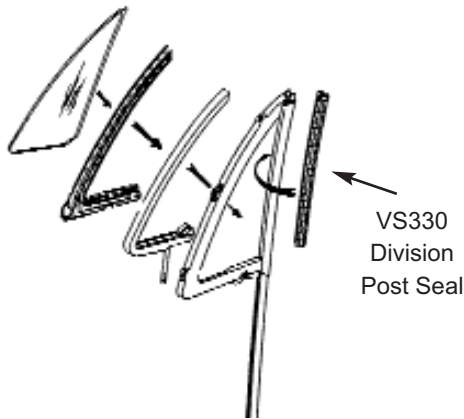

1934-1960 All models. Front vent window division post vertical seal. (see above).

VS3309.75 pr.

1934-1935 Series 40 except convertibles.

VW345\$129.50 pr.

1934-1935 All Series. (For convertibles).

VW345C\$131.75 pr.

1934-1935 Series 50, 60, 90 except convertibles

VW345B.....\$135.75 pr.

1936 Series 40 and 60 closed models.

VW36\$134.75 pr.

1936-1937

1936: 46C, 66C, 80C;

1937: 80C.

VW367C\$131.75 pr.

1936-1937

1936: 81, 91, 90, 90L, Sedans;

1937: All closed models 80 and 90.

VW367B.....\$129.50 pr.

1937-1938 Series 40 and 60 except convertibles.

VW378\$94.50 pr.

1937-1938 Series 40 and 60 convertibles.

VW378C\$124.25 pr.

1938-1940 Series 80 and 90 convertibles.

VW380C\$132.00 pr.

1938-1940 Series 80 and 90 except convertibles.

VW380\$139.00 pr.

1939-1940 Series 40 and 60 convertibles.

VW390C\$94.50 pr.

1939-1940 Series 40 and 60 except convertibles.

VW390\$82.50 pr.

1940 Series 80-90 convertibles.

VW40C\$122.50 pr.

1940 Series 80-90 Closed Cars.
VW40L.....\$139.00 pr.

1940-1941 Series 50 and 70 convertibles.
VW401C.....\$74.50 pr.

1940-1941 Series 50, 70 except convertibles.
VW401\$94.50pr.

1941-1942 All Special convertibles.
VW412C.....\$124.50 pr.

1941-1942
1941: Model 44S, 46, 47;
1942: Model 44,47.
VW412\$118.00 pr.

1941-1949
1941 Models 41, 41SE, 44, 44S, 46S, 46SSE; All Series 60, 90;
1942: Models 41, 41SE, 46, 46S, 46SSE, 61, 66S, All Series 90;
1946-1949 Specials.
VW419\$111.50 pr.

1942 Model 48 and 48S.
VW42\$129.50 pr.

1942-1948 Series 50, 70 convertibles.
VW428C.....\$74.50 pr.

1942-1948 Series 50, 70 except convertibles.
VW428\$94.50 pr.

1949 Models 56C, 76R and 76C.
VW49\$94.50 pr.

1949 Model 51, 59, 71 and 79.
VW49B.....\$127.75 pr.

1950-1953;
1950: Model 52, 52X, 72, 72X;
1951-1953: Model 52, 52X, 72R, 72RX.
VW503S\$135.25 pr.

1950-1953 All Super and Roadmaster two door hardtop and convertibles except Skylark.
VW503C.....\$158.00 pr.

1949-1953;
1949: Models 56S, 76S;
1950: All Series 40's; Models 51, 56S, 71, 76S;
1950-1953: Models 59, 79, 79R;
1951: Models 51, 56S.
VW493.....\$134.50 pr.

Windshield Drain Tubes

 1957-1958 All.
DT578F\$37.50 pr.

Front Vent Window Seals (Group 10)

1951-1953;

1951-1952: Model 41, 41D, 46S, 48D;

1953: Models 41D, 48D.

VW513\$124.25 pr.

1951-1953 Models 45R and 46C.

VW513C.....\$217.75 pr.



1951-1958 Cushion, side window glass in vent frame at top. All hardtop and convertibles.

WC518\$37.50 pr.

1953 Skylark Model 76X.

VW53X\$206.00 pr.

1954-1956 Special, Century, Skylark, two door hardtop and convertibles.

VW546\$147.50 pr.

VWB546.(Seals at bottom of vent window).\$48.00 pr.

1954-1956 Models 52, 72, 72R.

VW546B\$121.50 pr.

1954-1956;

1954: Models 56C, 56R, 76CX, 76RX;

1955-1956: Models 56, 56C, 76C, 56R, 76R;

1956: Models 53, and 73.

VW546BC\$216.25 pr.



1954-1956

1954: Models 41D, 48D, 49, 69, 61;

1955:Models 41, 48, 49, 61, 69;

1956: Models 41, 48, 49, 69.

VW546S\$113.00 pr.

1955-1956; Special and Century 4 door hardtop.

VW556H.....\$139.00 pr.

1957-1958 1957: Models 56C, 56R, 75R, 76A, 76C, 76R;1958: Models 56R, 76C, 75R, 755, 756.

VW578C.....\$163.00 pr.



1957-1958 Special and Century two door hardtop and convertibles.

VW578.....\$121.50 pr.

1957-1958 1957: Models 41, 48, 49 and 61;

1958: Special Estate Wagon.

VW578S\$174.50 pr.

1957-1958 Super, Roadmaster and Limited four door hardtop.

VW578H.....\$208.00 pr.

1957-1958

1957 Four door hardtop and Riviera Wagons. Models 43, 49D, 63, 69;

1958 Riviera Wagons, models 49D and 69

VW578W\$163.00 pr.

1958 Models 41, 48, and 61.

VW58\$166.00 pr.

1958 Models 43 and 63 Riviera 4-dr. H.T.

VW58A.....\$171.00 pr.



1959 All four door Sedans and Wagons.

VW590S\$95.00 pr.

1959-1960 All convertible and hardtop models, except 4829. Includes vehicle seals.

VW590.....\$95.00 pr.

1959-1960 Electra 225 four door hardtop, Model 4829.

VW590H.....\$158.00 pr.

1959-1960 Cushion, side window glass. Two and four door hardtop.

WC590H.....\$39.75 pr.

1960 All four door Sedans and Wagons.

VW60S\$99.75 pr.



Vent Window Lock Repair Kit

1939-1958 All except convertibles.

VLR398\$16.50 ea.

We are proud to offer you the MIRRORS listed below. They represent complete coverage of all model **BUICKS** from **1939 - 1960**. Exact in detail, they are manufactured to be identical to the originals. They come to you in a kit. This kit includes, mirror(s), gaskets, and hardware. 1939-1953 mirrors can be attached to vent frame with kit provided or "clipped on" with MC393.



1939-1947

- MK397 Left and Right Hand Mirror Kits\$149.50 pr.
- MKL397 Left Hand Mirror Kit\$79.50 ea.
- MKR397 Right Hand Mirror Kit.....\$77.50 ea.
- MC393 Mirror Clip (fits all G.M. 1939-1953)\$5.75 ea.
- MG393 Mirror Gasket 1939-1953 Fits either side\$3.75 ea.
- MGK393 Mirror Mounting Kit 1939-1953 Fits either side\$5.50 ea.
- MG397 Mirror Glass Replacement.....\$9.25 ea.

Universal curved arm peep mirror features chrome arm with stainless steel 4" mirror head. Complete with mounting hardware. Fits either side. Clips to drip rail.
PM200.....\$28.50 ea.



1948-1953

- Left and Right Hand Mirror Kits.
- MK483.....\$92.50 pr.
- Left Hand Mirror Kit.
- MKL483.....\$53.50 ea.
- Right Hand Mirror Kit.
- MKR483\$51.00 ea.
- Mirror Clip (fits all G.M. 1939-1953).
- MC393.....\$5.75 ea.
- Mirror Gasket. 1948-1953 Fits either side.
- MG393\$3.75 ea.



1954-1956 Special, Century and Skylark.

- MK546S Left and Right Hand Mirror Kits....\$153.00 pr.
- MKL546S Left Hand Mirror Kit.....\$84.00 ea.
- MKR546S Right Hand Mirror Kit.....\$78.50 ea.
- MG546SL Mirror gasket Left hand side.....\$3.75 ea.
- MG546SR Mirror gasket Right hand side.....\$3.75 ea.



1954-1956 Super and Roadmaster.

- MK546B Left and Right Hand Mirror Kits....\$153.00 pr.
- MKL546B Left Hand Mirror Kit.....\$84.50 ea.
- MKR546B Right Hand Mirror Kit.....\$78.50 ea.
- MG546BL Mirror gasket Left hand side.....\$3.75 ea.
- MG546BR Mirror gasket Right hand side.....\$3.75 ea.



1957-1958 All Models.

- MK578 Left and Right Hand Mirror Kits...\$153.00 pr.
- MKL578 Left Hand Mirror Kit.....\$84.50 ea.
- MKR578 Right Hand Mirror Kit.....\$79.50 ea.
- MG578L Mirror gasket Left hand side.....\$3.75 ea.
- MG578R Mirror gasket Right hand side.....\$3.75 ea.



Replacement Mirror Head

- 1954-1958** All. Will fit our reproduction exactly, or drill and fill as necessary for original.
- MH548.....\$19.75 ea.



1959-1960 All Models ("BUICK") engraved on back.

- MK590 Left or Right Hand Mirror Kit.....\$149.00 ea.
- MG590 Mirror gasket and hardware kit.....\$9.75 ea.

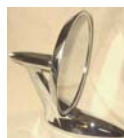

Glass Channels and Supplies (Group 10)

Complete Window Channel Kits

Each kit listed below contains enough channels and sweepers to complete one car. Clips, cushions and vertical seals are sold separately. Rivets, staples or screws can be obtained locally. See the next page for individually priced items and other necessities.

1933-1939 All Convertible Coupes.
WCK339C\$80.25 set

1933-1939 All 4-door Sedans with sliding rear 1/4 window.
WCK339S\$164.50 set

1933-1939 All 2-door Sedans and Coupes with sliding rear window.
WCK339S2\$136.50 set

1933-1939 All 2-door Sedans and Coupes with 4 roll-up windows and 4-dr. Sedans with fixed rear 1/4 window.
WCK339S4\$136.50 set

1936-1939 All 2-door Business Coupes.
WCK369B\$74.50 set

1940-1941 All 2-door Business Coupes.
WCK401B\$74.50 set

1940-1949 All Convertible Coupes;
1949 All Super and Roadmaster 2-dr. Hardtops;
1954-1956 All 2-dr. Hardtop and Convertible models.
WCK406C\$69.50 set

1940-1954 All 4-door Sedans and all Wagons.
WCK404S\$179.50 set

1940-1956 All 2-door Sedans and Coupes with sliding rear window.
WCK406S2\$119.50 set

1940-1956 All 2-door Sedans and Coupes with 4 roll-up windows.
WCK406S4\$137.50 set

1950-1953 All 2-dr. Hardtop and Convertible models.
WCK503C\$69.50 set

1955-1956 All 4-dr. Hardtops and Hardtop Wagons.
WCK556H\$95.00 set

1955-1956 All 4-door Sedans and Wagons. For 4 roll-up windows.
WCK556S\$169.50 set

1957-1960 All 2-dr. Hardtop and Convertible models.
WCK570C\$107.50 set

1957-1960 All 4-dr. Hardtops and Hardtop Wagons.
WCK570H\$85.25 set

1957-1960 All 4-door Sedans and Wagons. For 4 roll-up windows
WCK570S\$224.50 set

1957-1960 All 2-door Sedans and Coupes with sliding rear window.
WCK570S2\$133.50 set

1957-1960 All 2-door Sedans and Coupes with 4 roll-up windows.
WCK570S4\$149.50 set



www.oldbuickparts.com

908-369-3666

(Group 10) **Glass Channels and Supplies**



—5/16"—

1925-1938 (All GM) side window glass run channel. Comes in 14" lengths.
WC358\$11.75 ea.



—1/2"—

1936-1960 All front and rear upper. Rigid glass channel. Two 18" lengths.
WC360\$16.50 pr.



—5/8"—

1933-1960 All side windows. Six foot lengths. Flexible glass channel. For sides and top of window. Most closed models.
WC330.....(1) 72" length.....\$27.50 ea.
WC330A.....(2) 36" lengths.....\$22.00 pr.



—1/2"—

1940-1960 All front and rear lower. Rigid glass channel. Two 16" lengths.
WC400\$11.25 pr.

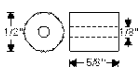

1931-1953 Most models. Anti-rattle rollers, side window.
WC313\$2.75 ea.



1928-1960 Channel, side window glass. U-shaped steel channel attach your own window regulator cam to underside as required. Sold in 4 foot strips. 3/8" at top. 9/16" at bottom.
WC280\$18.50 ea.

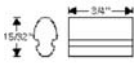

1936-1938 Anti-rattle bumpers, side window.
WC368\$3.75 ea.

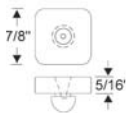

1941-1960 As required. Cushion (stem bumper), window stop, lower. Front and rear door, rear side quarter windows as required. Compare with WC414.
WC411\$5.50 ea.



1941-1960 Cushion (stem bumper), window stop, lower. For front and rear door, rear side and quarter windows as required. 15/16" square, 1/2" thick. Compare with WC411.
WC414\$6.00 ea.



—7/16"—

1933-1956 Flexible sweeper used on inner and outer frames. 64" length.
WS330\$20.00 ea.
WS330A.....(2) 32" lengths\$18.25 pr.
WS330B.....(2) 36" lengths\$18.25 pr.



Sweeper Clip for fastening WS330. Six clips required per door.
SC330\$0.75 ea.



—9/16"—

1957-1960 Flexible sweeper used on inner and outer frames. 64" length. (Wider than WS330).
WS575\$26.50 ea.
WS575A.....(2) 32" lengths\$26.50 pr.
WS575B.....(2) 48" lengths\$26.50 pr.

1933-1960 All. Vent window vertical seals. Fits front and rear doors. One or two pair required.
VS330\$9.75 pr.



1933-1960 All. Glass setting tape.
ST330\$0.85/ft.



1957-1958 Flexible snap-in channel. Front and rear doors.
WC578.....64" length.....\$39.50 ea.
WC578A.....(2) 32" length.....\$36.50 pr.
WC578B.....(2) 48" length.....\$36.50 pr.

Chrome Edge



1958-1972 All inner belt line window sash sweeper. Rigid rubber covered weatherstrip with flock lining. 1/4" flat chrome edge. Re-seal on front and rear doors quarter windows. As required.
WS582.....64" length\$29.50 ea.
WS582A.....(2) 32" length\$27.50 pr.
WS582B.....(2) 48" length\$29.50 pr.
WS582C.....(2) 24" length\$22.50 pr.

Glass Channels and Supplies (Group 10)

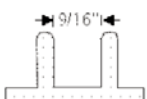

1925-1932 Side window channel. Flocked 9/16" wide. As required.
CC252\$7.25 ft.

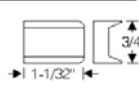

1925-1936 Lower window rest pad. 2 needed per window. For all closed cars.
WC256\$5.50 ea.



1926-1936 Lower window outer glass seal. Fastens to door. All as required. 3/4" tall.
WS266\$2.50 ft.

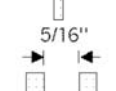

1925-1938 Side window channel. Flocked 5/16" wide for 1/4" glass. As required.
CC258\$6.75 ft.

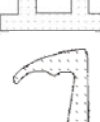

1927-1936 Lower window outer glass seal. 3/8" tall. Retained by metal strip in side of channel.
WS276\$2.50 ft.

1930-1940 Channel pad, window carrier, weatherstrip. Used for some side window lower channel.
WS300\$3.75 ft.

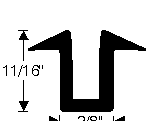

1931-1940 Weatherstrip, side window, double-lip seal type, used as filler for 1/4" glass in metal carrier channel.
WS310\$3.75 ft.

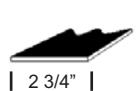

1932-1960 Mohair liner with rubber backing. Apply to division bars and channels as req.
ML325.....\$11.00 (3) ft.

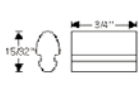

1936-1938 Window anti-rattlepad. Fits into slots on inner and outer sides. As required
WP368\$3.75 ea.



1939-1955 Some models. Filler channel weatherstrip, door window sash channel. Special type with wide weatherstrip edge. 3 ft. lengths. Trim as necessary.
WS392\$12.25 ea.

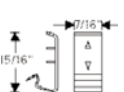

1939-1956 Side window channel clip. Standard GM. Compare to your original.
CC396A\$2.25 ea.

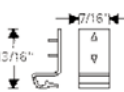

1939-1956 Side window channel clip. Standard GM. Compare to your original.
CC396B\$2.25 ea.

All Years. The best weatherstrip adhesive we have found. 3M Brand.
WA360\$12.00 ea.

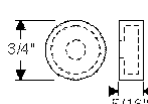
1940-1958 Window cushion. Six required per car. Snaps over pedestal as pictured.
WC408\$2.00 ea.

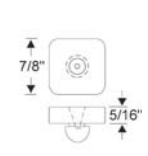

1941-1960 As required. Cushion (stem bumper), window stop, lower. Front and rear door, rear side quarter windows as required. Compare with WC414.
WC411\$5.50 ea.



1941-1960 Cushion (stem bumper), window stop, lower. For front and rear door, rear side and quarter windows as required. 15/16" square, 1/2" thick. Compare with WC411.
WC414\$6.00 ea.



1942-1955 Weatherstrip, sash channel, outer, for side windows, 1/2" wide weatherstrip (cross section).
WS425\$2.25 ft.



1953 Weatherstrip, door window sash channel. Please order by foot. Known to fit Skylark (76X), may fit other models.
WS53\$4.00 ft.



1959-1960 Weatherstrip, upper vertical on rear body lock pillar, 11" long steel core, cloth facing. Style 4829 (Electra 225 four door Riviera Sedan) only.
WS590E.....\$101.50 pr.

Upper Window Frames

Chrome plated, pre-drilled, ready to install.

1954-1956 Special, Century, Skylark Converts.
WF546C\$172.50 pr.

1954-1956 Super and Roadmaster 2 dr. HT.
WF546BH\$172.50 pr.

1954-1956 Super and Roadmaster Convertibles.
WF546BC\$172.50 pr.

Adhesive Backed Bow Drill

Cloth tape used to cover roof rail weather-strip rear 1/4 window seals, etc. as req. Waterproof and sunproof. Comes in 5 foot rolls.

BD250B.....(Black 2 1/2" wide).....\$11.00 ea.
BD250T.....(Tan 2 1/2" wide).....\$9.00 ea.
BD500B.....(Black 5" wide).....\$22.00 ea.
BD500T.....(Tan 5" wide).....\$22.00 ea.



(Group 10) Door Weatherstrip Sets

1935-1936 All closed models.

DWS356A.....(Front Doors).....\$83.75 set
DWS356B.....(Rear Doors).....\$56.00 set

1937-1938 Special and Century Convertibles. **Front doors.**

Set includes 14 feet of DW378S, 7 feet of DW369, 20 WC391 clips and 40 WC378 clips.

DWS378A.....\$143.75 set

1937-1938 Special and Century convertibles. **Rear doors.**

Set includes 10 feet of DW378, 4 feet of DW369, 20 WC369 clips and 30 WC378 clips.

DWS378B.....\$108.75 set

1937-1938 All Special and Century closed models. **Front doors.**

Set includes 22 feet of DW378S, 7 feet of DW369, 20 WC369 clips and 70 WC378 clips.

DWS378C.....\$164.25 set

1937-1938 All Special and Century closed models. **Rear doors.**

Set includes 20 feet of DW378S, 5 feet of DW369, 20 WC369 clips and 70 WC378 clips.

DWS378D.....\$154.00 set

1939 Special and Century convertibles. **Front doors.** Set

Includes 14 feet DW379, 7 feet DW369, 20 WC369 clips.

DWS39A.....\$92.00 set

1939 Special and Century convertibles. **Rear door.** Set includes 10 feet of DW379, 6 feet of DW369 and 20 WC369 clips.

DWS39B.....\$70.75 set

1939 All Special and Century closed models. **Front doors.**

Set includes 22 feet of DW378S, 7 feet of DW369 and 20 WC369 clips.

DWS39C.....\$121.25 set

1939 All Special and Century closed models. **Rear doors.**

Set includes 20 feet of DW379, 5 feet of DW369 and 20 WC369 clips.

DWS39D.....\$111.50 set

1940-1941 For closed models.

1940: All. **Front or rear doors;**

1941: Series 50, 70. **Front or rear doors.**

Set includes 28' of DW379.

DWS401A.....\$66.50 set

1940-1941 Convertibles. **For front and rear doors.**

1940-1941: Special and Century convertibles. front and rear

1940-1941: Super and Roadmaster Convertibles. Rear

Set includes 20' of DW379.

DWS401B.....\$56.50 set

1940-1941 Super and Roadmaster two and four door convertibles. **Front doors.** Set includes 20' of DW379 and one pair AW401.

DWS401C.....\$89.50 set

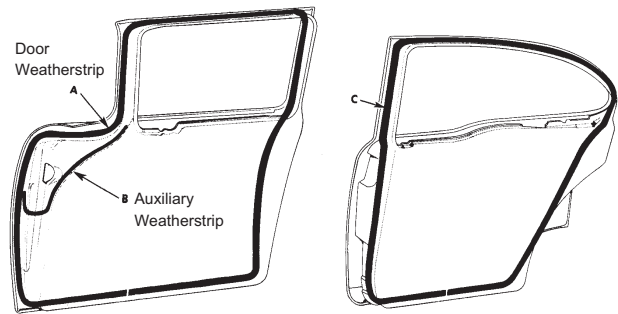

1941 Special, Century, Limited closed models. **Front doors.**

Set includes 20' of DW379, one DW418 and moulded corners.

DWS41A.....\$145.75 set

1941-1949 **Rear doors.** Closed cars.

1941-1942: Series 40, 60, 90;

1946-1949: All Specials.

Set includes 20' of DW379, one DW418 and moulded corners.

DWS419A.....\$134.25 set

1942-1949 **Front doors.** Closed models.

1942: Series 40, 60 and 90;

1946-1949: Specials.

Set includes one set AW429H, one DW418 and moulded corners.

DWS429A.....\$294.25 set

1942-1948 Super and Roadmaster closed models. **Front**

doors. Set includes one set AW429H, one DW418 and moulded corners.

DWS428A.....\$283.75 set

1942-1948 Super and Roadmaster closed models. **Rear**

doors. Set includes one pair of AW429H, one strip of DW418 and moulded corners.

DWS428B.....\$279.50 set

1950-1951 Super and Roadmaster sedans.

1950: All;

1951: (1st type);

Front doors. Set includes one pair AW503B, one pair AW501, one pair AW503A, and one pair DB503.

DWS501A.....\$400.00 set

1950-1953 Super and Roadmaster sedans. **Rear doors.**

Set includes all components to correctly surround doors.

DWS503B.....\$202.50 set

1950-1953 All Series 50 and 70 hardtops and convertibles.

Front doors. Set includes one pair of AW503U, one pair of DW523, one pair of DW513L, one pair of DB503, and one pair of AW503A.

DWS503.....\$514.75 set

Door Weatherstrip Sets (Group 10)

1951-1953 Special, 2-door hardtop and convertibles.

Front doors. Comes ready to install with molded ends.

DWS513\$277.00 pr.

1951-1953 Super and Roadmaster sedans.

1951: (2nd type); 1952-1953: All.

Front doors. Set includes one pair AW503B, one pair DW513L, one pair AW503A, one pair DB503.

DWS513A\$393.25 set

1953 Special two door Sedans. Sufficient footage for complete door circumference.

DWS53A\$110.50 pr.

1954 Front doors. Full circumference sets. glue-on style.

1954 models 41, 48, 49, 61, 69, 52, 72

DWS54\$90.00 set

1954-1955 Special, Century, and Skylark 2-door hardtop and convertibles. **Front doors.** Comes ready to install with molded ends. Glue on type.

DWS545\$141.00 pr.

1954-1955 Full circumference set for both **rear doors**, includes molded clearance for power window lines and button fasteners. 1954: Models 52 and 72; 1955: Models 52 and 72 (early type).

DWS545B\$145.25 set

1954-1956 Special and Century. **Front or rear doors.** Full circumference sets. Clip-on style.

1954-1956 models 41, 48, 61 front doors;

1955-1956 models 49 and 69 wagons front or rear doors;

1954 models 52, 72 front doors;

DWS546\$90.00 set

1954-1955 models 41, 48, 61 rear doors;

1956 models 41, 48 rear doors.

DWS546R\$90.00 set

1954-1956 Super and Roadmaster two door hardtops.

Front doors. Complete, with molded ends. Includes 8 fasteners.

DWS546A\$137.75 set

1955-1956 Special and Century 2 door hardtops and convertibles. Molded end pieces and inserted clips as originals. Remove if not needed.

DWS556\$117.00 pr.

1955-1956 Special and Century 4 door hardtops models.

Front Doors. Molded end pieces and inserted clips as originals.

DWS556F\$130.25 pr.

1955-1956 Special and Century 4-door hardtop models.

Rear Doors. Molded end pieces and inserted clips as originals.

DWS556R\$138.00 pr.

1954-1956 Super and Roadmaster convertible. **Front**

doors. Complete with molded ends. (8 fasteners).

DWS546B\$137.75 set

1955 Super and Roadmaster four door sedans. **Front**

doors. Full circumference set for both front doors, includes button type fasteners.

DWS55A\$69.75 set

1956 Super & Roadmaster 4-door hardtop. Moulded ends.

DWS56A(**Front Doors**)\$148.25 pr.

DWS56B(**Rear Doors**)\$175.00 pr.

1957 Special two door Sedan model 48.

DWS57A\$147.50 pr.

1957-1958 Special and Century two door hardtop and convertible. Moulded end pieces and inserted clips.

DWS578\$121.25 pr.

1957-1958 Special and Century four door hardtops and hardtop wagons. **Front doors**, moulded end pieces and inserted clips. Models 43, 49D, 63, 69.

DWS578C\$170.75 pr.

1957 Special and Century four door hardtops and hardtop wagons. **Rear doors**, moulded end pieces and inserted clips. Models 43, 49D, 63, 69.

DWS57B\$150.75 pr.

1958 Special and Century four door hardtops and hardtop wagons. **Rear doors**, moulded end pieces and inserted clips. Models 43, 49D, 63, 69.

DWS58B\$177.75 pr.

1957-1958 Super, Roadmaster, and Limited four door hardtops. **Front doors**, moulded end pieces with inserted clips.

DWS58A\$208.50 pr.

1957-1958 Super, Roadmaster, and Limited two door hardtop. Moulded end pieces and inserted clips.

DWS578B\$141.00 pr.

1957-1958 Super, Roadmaster, and Limited convertibles. Moulded end pieces and inserted clips.

DWS578A\$146.00 pr.

1957-1958 Super, Roadmaster, and Limited four door hardtops. **Rear doors**, moulded end pieces with inserted clips.

DWS58C\$167.00 pr.

Continued on Next Page

1958 All Special two door Sedans model 48.
DWS58S.....\$138.00 pr.

1958 All Special & century four door Sedans. **Front doors**
DWS58D.....\$185.50 pr.

1959-1960 LeSabre 2-door sedan. **Front doors**. Moulded ends.
DWS590G\$141.25 pr.

1959-1960 Electra 4-door sedan. **Front doors**. Moulded ends.
DWS590F\$138.00 pr.

1959-1960 LeSabre, Invicta four door hardtop. **Front doors**.
Molded ends and inserted clips.
DWS590A.....\$128.75 pr.

1959-1960 All four door hardtops. **Rear doors**.
Moulded end pieces with inserted pins.
DWS590B.....\$128.25 pr.

1959-1960 Electra four door hardtop. **Front doors**.
Moulded end pieces with inserted pins.
DWS590C.....\$126.50 pr.

1959-1960 4-door sedans, models 4419, 4619, 4434,
4445, 4635, 4645. **Front doors**. Moulded ends.
DWS590D.....\$119.50 pr.

1959-1960 All sedans. **Rear doors**. Moulded ends.
DWS590E.....\$129.25 pr.



1959-1960 All two door hardtops and convertibles. Moulded ends and pins.
DWS590\$153.25 pr.

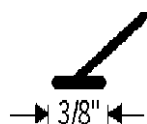

1935-1936 Seal, door top, fits in light metal track. Closed cars. Two door styles need about 5 ft. per door. Four door styles need about 7 ft. per side.
DW356\$2.25/ft.



1936-1938 Clip, door bottom weatherstrip retaining. As required. Doors usually require one clip every 6".
WC369\$1.50 ea.

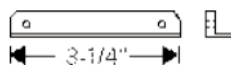

1936 All; 1937 Series 80-90 ex. convertible. Weather seals, front door upper hinge with steel core as original.
WS367H.....\$41.25 pr.

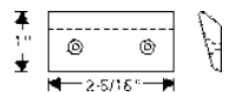

1937 Models 46C, 66C;
1938 All Special and Century Convertibles. Weather seals, hinge post at instrument panel.
WS378H.....\$53.75 pr.

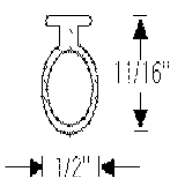

1936-1939 Door bottom seal, held by metal track or by clips. (see WC369 for clips). Two door styles need about 3 1/2' per door. Four door styles need about 5 ft. per side.
1936-1937: All;
1938: Special and Century.
DW369.....\$3.75/ft.

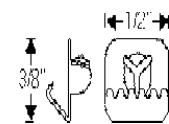

1937-1938 Metal clip for attaching door edge weatherstrips. For 1/4" holes. Doors usually require 1 clip every 6".
WC378.....\$1.00 ea

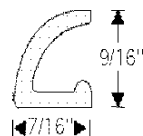

1937-1938 Weatherstrip, door opening, sides and top. Full profile of superior grade sponge, made for use of clips: WC378.
DW378.....\$4.25 ft.

1937-1949
1937-1938 Can be substituted easily for DW378 and DW369 to fit around entire door. Smooth skinned sponge rubber.
1939-1948: All;
1949: Specials.
DW379.....\$2.50/ft.

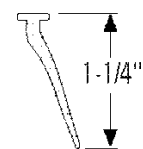

1938-1941 Weatherstrip, door opening, fits retainer under edge of body sill to form seal when door is closed. 6 foot strips. Series 80 and 90.
DW381\$77.00 pr.

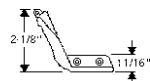

1940-1941 Auxiliary Front door hinge pillar, right and left. Metal core, located at top front of front door, under door flange. Series 50, 70 convertibles.
AW401\$59.75 pr.

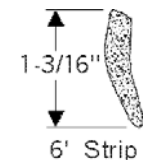

1941-1948 Weatherstrip, door bottom, sponge constant section, solid skin surface, excellent quality. 6 foot strips as required on most models.
DW418.....\$29.25 ea.



1942-1948 Weatherstrip, door at lock pillar, 40" long with molded ends. All Super and Roadmaster convertibles.
AW428C.....\$89.75 pr.

Door Weatherstrips (Group 10)



1942-1950 weatherstrip, hinge post on door or body opening. Bend and trim to fit. 4' length.
AW420\$16.75 ea.



1949-1952 All. Door bottom seal. Fits into retainer.
DW492.....4' length.....\$15.75 ea.



1949-1953
1949 Super and Roadmaster.
1950-1953 Most models. Please compare profile. * For lighter seal, DW379 can be used.
DW493\$2.25/ft.



1949 Weatherstrip, windshield post to vent window frame, fits steel retainer rail, right and left. Riviera hardtops and convertibles.
AW49\$101.00 pr.

1950-1951 Weatherstrip, front door bottom. Molded right and left hand ends.



1950: Most models;
1951: 50 and 70 1st type doors (see DW513L for 2nd type).
DW501\$139.75 pr.



1950-1953 Weatherstrip, body hinge pillar to door, bellows type seal. 8" x 27" nylon reinforced rubber, 1/16" thick. All models.
DB503.....\$56.75 pr.

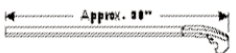

1950-1951 Super and Roadmaster 2-door Hardtops and Coupes. Rear side door weatherstrip.
AW501R\$133.75 pr.

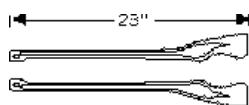

1950-1953 All Super, Roadmaster, and Skylark, two door hardtop and convertible. Weatherstrip, front door. Upper on edge of door or body opening. Special ends, right and left.
AW503U\$118.25 pr.

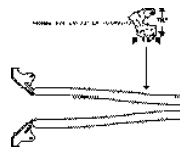

1950-1951 Weatherstrip, front door bottom. Molded right and left ends.
1950: Most models;
1951: 50 and 70 1st type doors. (order AW513 for second type)
AW501\$139.75 pr.

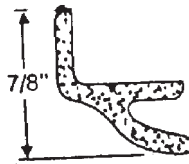

1950-1953 Weatherstrip, front door opening, front body hinge pillar, lower. Extruded sponge. Original config.
1950: Model 56C, 56R, 75R, 76C, and 76R;
1951-1953: All Series 50, 70 including **1953** Skylark 76X.
AW503A.....\$30.50 pr.

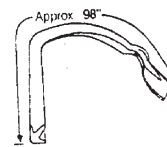

1950-1953 Weatherstrip, front door. Includes molded ends. With steel screw retainer as original.
1950: Models 41, 41D, 43D, 46, 46D, 51, 52, 52X, 56S, 59, 71, 72, 72X, 76S, 79; (43 and 46S 2nd type)
1951-1953: Models 51, 52, 52X, 56S, 59, 71, 72, 72X and 79.
AW503B.....\$142.75 pr.

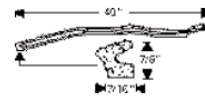

1951-1953 Door bottom weatherstrip. Molded left and right, overall length 40 inches.
1951: Models 50 and 70 second type, except 56S;
1952-1953: Models 50-70.
AW513\$133.00 pr.

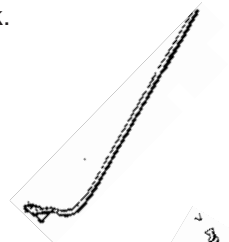

1951-1953 Door bottom weatherstrip. Molded left and right, overall length 40 inches. All 1951 second type model 50 and 70 (except 1951: 56S) and all 1952-1953 models 50 and 70.
DW513L\$133.00 pr.

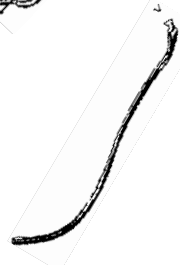

1952-1953 Weatherstrip, front door lock pillar. Ready to install with molded ends. All hardtop coupes and convertibles including '53 Skylark.
DW523\$133.75 pr.



1951-1954 all; 1955 Most models. Please compare profile with DW550. Can also be used from 1951-1953
DW515\$2.50/ft.

(Group 10) **Door Weatherstrips**

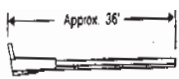

1952-1953 Front door lock pillar, with molded ends. All 2 dr. hardtops and convertibles including 1953 Skylark.
AW523\$133.75 pr.

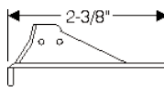

1952-1953 Super and Roadmaster 2-door hardtop models 56R and 76R.
Seal, roof rail at vent.
AW523A.....\$37.25 pr.



1954-1956 Special, Century and Skylark weatherstrip, front door, auxiliary on door front at belt line, right and left. Includes bottom fastener.
AW546\$48.25 set

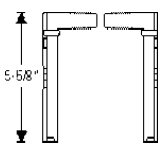

1954-1956 Weatherstrip, front door upper corner, outer (at front end of flipper). Right and left, steel core. Models 46R and 66R 2-door hardtop.
AW546A.....\$75.50 pr.

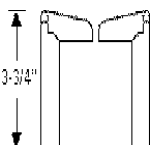

1954-1956 Weatherstrip, upper front door hinge pillar at roof rail. Molded rubber with brass core. Fits 56R, 76R and 76RX Riviera hardtop coupes.
AW546B.....\$68.75 pr.

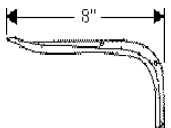

1954-1956 Super and Roadmaster, front door opening, auxiliary on cowl at belt line. Right and left steel core.
AW546C.....\$120.75 pr.



1954-1957 Most Models. Weatherstrip, windshield post, upper to door. Two strips approximately 15" long. Compare with PS548.
AW547\$15.00 pr.

1954-1958;

1954-1956 Super and Roadmaster, may need trimming;

1957-1958 All. weatherstrip, front door, auxiliary on door front at belt line, right and left. Includes bottom fasteners.



AW548\$18.50 set



1954-1960 Fastener, door edge weatherstrip, steel. 1/2" long, 13/32" diameter head, black finish. All models as required.
WF1\$1.00 ea.

1954-1958 Seal, roof rail, outer at 1/4 window.

1954-1956: Century and Special, Riviera with hardtop coupes;
1957-1958: Super and Roadmaster, Riviera with hardtop coupes;
1957: Roadmaster Riviera hardtop coupes wrap around and 3 piece window.
1958: Limited Riviera Coupe.

RR548A\$19.75 pr.

1955-1960

1955-1956: Correct configuration, most models. Compare with DW515
1957-1960: Excellent glue on replacement.

DW550\$1.75/ft.

1956 Roof rail Filler w/s. Attaches to body. Made with metal core as original.

AW56\$57.50 pr.

1955-1960 All. Correct configuration with inserted pins. Remove pins for glue apps.
DW577\$2.75 ft.

1957-1960 All as required. Door weatherstrip retainer.
WR577\$0.50 ea.

1954-1958 Front door, auxiliary on body above belt line. Two strips 15" long.

1954-1958: Compare with AW547;
1958: Models 43, 46C, 46R, 49D, and 63.
PS549\$44.50 pr.

1954-1958 Same as above. Sponge stick-on replacement.
PS548\$8.50 pr.

1959-1960 Most models. Weatherstrip, front door opening. Auxillary on door hinge pillar at belt line, right and left. Set includes four button type fasteners.

AW591\$29.25 set

1959-1960 Gutter, cowl side drain, left and right. Rubber with metal core as original. All post models.

AW590\$98.00 pr.

1959-1960 Electra 225 4-door model 4829. Upper vertical weatherstrip at rear body lock pillar. 11: long.

AW590A.....\$101.50 pr.

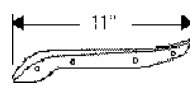
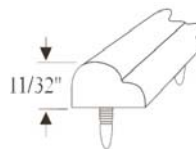

Door Bumpers (Group 10)

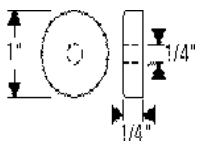

1932-1936 bumper, front and rear body hinge pillar, 1" diameter x 1/4" thick, held by screw, steel core. Auxiliary, used only where needed to prevent door rattle.
DB326.....\$5.50 ea.

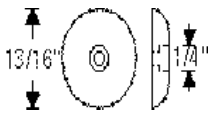

1932-1948 Bumper, front door above the upper hinge on the upper radius of the door. Stiff-backed, retained by screw, mounted on door. All closed GM models.
DB328.....\$5.00 ea.



1933-1939 Pad, door jamb (door side bumper). Heavily used all models 1933-1936, also on some convert. thru 1939.
DB339.....\$9.00 ea.



1936-1939 Bumper, door center post, upper, fits 1/4" hole, 5/16" thick, self-retaining. Most closed bodies as required.
DB360.....\$1.75 ea.

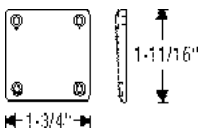

1937-1953 Bumper, door side. Square type held by 4 screws, metal core as original. Convertibles and hardtops.
DB373\$46.25 pr.



1940 Super 4-door sedan. Rear door vent grommets. Set of 4.
VG40.....\$44.50 set

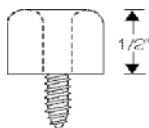

1941-1960 Door post bumper. Most models. Hollowed center. Used with screw.
DB411.....(Steel Core)\$2.25 ea.



1941-1960 Door pillar bumper. All, except convertibles.
DB410.....\$1.75 ea.

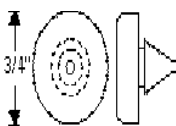

1937-1956 Bumper, door hinge pillar upper. 3/4" diameter, 3/16" thick, for 1/4" hole. Most models, as required.
DB426\$2.00 ea.

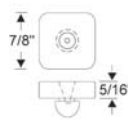

1941-1960 As required. Cushion (stem bumper), window stop, lower. Front and rear door, rear side quarter windows as required. Compare with WC414.
WC411\$5.50 ea.



1941-1960 Cushion (stem bumper), window stop, lower. For front and rear door, rear side and quarter windows as required. 15/16" square, 1/2" thick. Compare with WC411.
WC414\$6.00 ea.



Door Adjustment Hole Plug

1941-1948 convertible. Fits a 5/8" wide x 1" long hole.
DAP418.....\$5.50 ea.

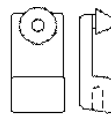

1949 Door bumper, lower, held by one screw and one carrot retainer. All Super and Roadmaster. Two door models.
DB49\$13.25 ea.



1949 Bumpers, front door, upper. Approximately 5/8" square, 3/8" I.D. Steel core, retained by screw. Super and Roadmaster including Estate Wagon.
DB49F.....\$29.00 pr.

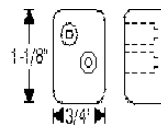

1949 Bumpers, rear door upper, right and left. 1/2" X 3/4" X 1", steel core, retained by two screws. Models 51, 71.
DB49R\$42.25 pr.



1949-1960 Door pillar bumper.
DB500A-3/8" W. x 1/2" H.\$2.75 ea.
DB500B-3/8" W. x 5/8" H.\$2.75 ea.
DB500C-1/2" W. x 7/16" H.\$2.75 ea.



1957-1960 Door bumper. Most models.
DB570\$2.75 ea.



1959-1960 Bumper, door, used upper and/or lower as required.
DB595\$2.75 ea.



1937-1960 Door panel repair clip.
PN370\$0.65 ea.



Door Panel Retainers

1959-1975 All as required.
DPR598\$1.00 ea.

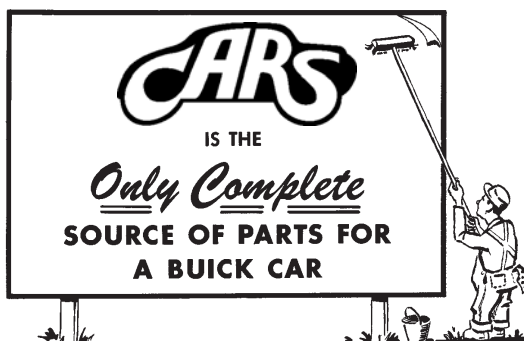

Outer Door Handle Parts



1937-1939 Special, Century.
Stainless steel outside door handle.
DH378\$176.50 ea.

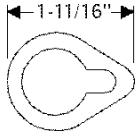

1939-1949 Mounting pad, door lock cylinder,
1939: Series 40 and 60;
1940: Series 40, 50, 60 and 70;
1941-1949: All. Fits either side.
KLG399\$2.75 ea.



1950-1953 Gasket set, door handle, Front and rear door if necessary. One set for two doors.
1950: All (exc. 59, 76C, 76R, and 79);
1951: All 40 and 50 (exc. 59);
1952-1953: All (exc. 59, 79R).
HG503\$8.75 set



1954-1956 Door handles. Special, Century, Skylark 2-door models. Pair. Includes buttons
DH546S\$129.00 pr.



1954-1956 Door handle gaskets. Special, Century, Skylark 2-door models. For 2 handles
HG5462\$9.75 per set



1954-1956 Door handle gaskets. Special, Century, Skylark 4-door models. Front and rear. One set for two doors.
HG5464\$9.00 set

1950-1958 Door handle button seals / cushions.
BS508\$1.00 ea



1954-1960 Gasket, door lock cylinder. Exact reproduction. 7/8" I.D.
1954: 40, 60, 100;
1955-1960: As required.
KLG540\$1.25 ea.



1954-1956 Gasket, door handle. Super and Roadmaster 2 door models.
HG546B2\$20.25 set



1954-1956 Gasket, door handle. Models 52 & 72. One set for 2 handles.
HG546B\$19.75 set

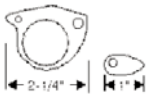

1957-1958 Gasket set, outside door handle. Four piece set for two handles.
1957: All Front doors;
1957: All Special and Century rear doors;
1958: All Special and Century front doors.
HG578\$8.50 set

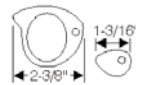

1958 Gaskets, door handle, four piece set for two handles. Some models, as required.
HG58\$9.50 set



1959-1960 Outside chrome door handles. Includes buttons and springs.
DH590S\$85.25 pr.



1959-1960 Gasket set, outside door handles. Four piece set for two handles.
HG590\$10.00 set

Door Handle Ferrules



1926-1937 Ferrule, for 3/4" outside door handle. Chrome plated brass (includes grommet). All models.
HF307.....\$8.00 ea.



1938-1940 Ferrule, outside door handle. Chrome plated brass. Includes grommet.
1938-1939: All;
1940: All (exc. 50 and 70)
HF380.....\$8.00 ea.



1940-1948 Ferrule, outside door handle with rubber sleeve.
1940: Series 50 and 70;
1941-1948: All models.
HF408.....\$8.00 ea.



1935-1948 Installing tool, door and trunk handle ferrule. This tool does a quick, neat and efficient job of installing ferrules staking them internally to keep them in place.
FT358.....\$45.00 ea.



Key Blanks

1935-1960 All. Octagon.
KB10.....\$3.75 ea.



1935-1960 All. Rounded.
KB11.....\$3.75 ea.

Door Lock Pairs with 2 Keys



1954 Special, Century, Skylark;
1955-1956 Special, Century and Wagons exc. 43, 63. Change forks as necessary.
DLS546\$37.75 set

1955-1956 Special and Century, models 43 and 63.
DLS556A.....\$50.50 set

1959 All except 2 door Sedans.
DLS596\$36.00 set

1959 All 2 door Sedans.
DLS59\$39.50 set

1960 All 2 door Sedans.
DLS608\$36.00 set

1960 All 4 door models.
DLS604\$37.75 set

Door Handles and Parts (Group 10)

1939-1958 Inner Door Handles (10.512)

1939 thru 1953 ALL;

1954 thru 1958 Super, Roadmaster, Limited. Die cast and beautifully chrome plated as original. (Note these will replace 1939-1940 with plastic insert type but will not look original.



DH398\$17.00 ea.

1939-1958 Window Cranks (10.797)

Same application as above. Includes chrome knob.



WC398.....(Window Crank).....\$19.50 ea.

VC398.....(Vent Crank).....\$19.50 ea.

1951-1953 Window Cranks

Includes black knob w/ stainless steel cap.

WC512.....(Window Crank).....\$26.50 ea.

VC512.....(Vent Crank).....\$26.50 ea.

Door Handle & Window Handle Escutcheons

1940-1952 All smooth finish 1 piece.

HE402.....\$11.50

1940-1952 All smooth finish 2 pieces.(Spring loaded)

HE402S.....\$15.25

1952-1953 All "Starburst". 1 piece.

HE523.....\$13.50

1952-1953 All "Starburs". 2 pieces.(Spring loaded)

HE523S.....\$17.50

1954-1958 Inner Door Handles (10.512)



Fits Special, Century, Skylark. Chrome plated. 5" "Drumstick" style.

DH542\$24.50 ea.

1959-1960 All

DH594\$16.50 ea.

1954-1958 Window Cranks (10.797)

Special & Century. These new items are correct in everyway including black knobs as per original. They are not generic replacements such as you might see elsewhere.

WC548.....(Window Crank).....\$27.25 ea.

VC548.....(Vent Crank).....\$27.25 ea.

1959-1960 Window Cranks



1959-1960 all as required. Front and rear.

WH594.....\$16.50 ea.

Inner Door Handle Parts



1931-1953 Door handle retaining clip. All. (10 Pack).

HRC318.....\$2.25 pack



1933-1948 All;

1949 Special. Tapered screw for securing outer door handles to lock mechanism.

HS339.....\$3.25 ea.



1954-1960 All. Door handle retaining clip. (10 Pack).

HRC540.....\$2.25 pack



1937-1960 Interior door handle tension spring.

HS395.....\$1.50 ea.



1935-1960 Door handle removal tool. All.

HT360.....\$7.75 ea.

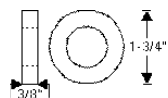

1935-1958 Sponge rubber, interior door handle escutcheon.

2" O.D. X 3/8" thick. Some models.

EW353.....\$2.75 ea.



1954-1960 Door handle washers.

HW552.....\$3.00 ea.



1957-1960 All as required. Window regulator roller and rivet.

WR576.....\$3.25 ea.



Rear Ash Trays

1959-1960 LeSabre, Invicta, Electra 2-dr. ht.;
1959-1960 All convertibles.
 AT597.....\$22.25 ea.



1959-1960 Vent Cranks

1959-1960 all as required.
 VC594.....\$16.50 ea.

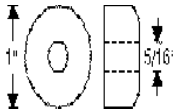

1930-1940 Cushion, door check link. 1" diameter X 3/8" thick with 5/16" hole. All models using rod type door check.
 CB300.....\$4.25 ea.

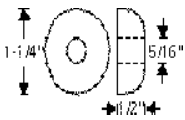

1930-1940 End stop and cushion, door check link rod. Rubber with embedded steel plate, 5/16" diameter thread. Most models with rod type door checks.
 CB301.....\$9.50 ea.

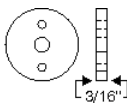

1931-1940 Rubber washer, door check link stop.
1931-1939: All;
1940: Series 40, 60, 80, and 90.
 CB310.....\$5.50 ea.

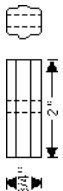

1939-1949 Check link end nut, (rubber bar with steel bar insert).3/4" x 3/4" x 2" threaded.
1939: All Series 40, 60 rear;
1940: Series 40 and 60 rear; Series 50 and 70 front and rear;
1941-1948: All, front and rear;
1949: Series 40, front.
 LN399.....\$19.50 ea.



1931-1960 All as required. Door hinge pin correct 11/32" O.D. 4" length. Cut to shorten if necessary.
 HP310.....\$3.00 ea.



1931-1960 Door hinge bushing. Two per hinge pin. Bronze.
 HB310.....\$1.00 ea.



1946-1948 Conduit (double rubber hose), body to door, for hydraulic and electrical lines to power window. Convertible only.
 DC468.....\$28.75 pr.



1950-1952 Conduit, hydraulic line and power window wire. Front doors Two pieces 9 1/2".
1950: 52X, 56C, 72X, 76C, 76R;
1951: 52X, 56C, 72RX, 76C, 76R;
1952: 59, 79R.
 DC502.....\$31.00 pr.



1940-1949 Seal, door lock, front and rear. Protects lock mechanism from dust & weather.
Front door: 1940: Series 50 and 70;



1941-1948: All;
1949: Models, 41, 46S.



Rear door: 1942: Series 40, 60 and 90;
1946-1947: All.
 LS409.....\$24.50 pr.

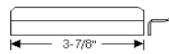

1941-1948 Door bottom drain seals.
 DG418.....\$5.00 ea.



1954-1956 Special, Century, Skylark. Door bottom drain hole seal.
 HS546.....\$4.50 ea.



1949-1953 Door striker screws. Pack of 6
 SS506.....\$9.75 ea.

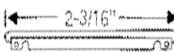

1954-1960 Door striker.
1954-56: All Special, Cent. and Skylark;
1956: Super and Road. 4 dr. hardtop;
1957-1960: All.
 DS542.....\$40.75 pr.

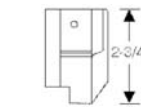

1956-1958 Weatherstrip, door bottom drain hole seal. Also used on tailgate of station wagon. (2 required for this use).
1956: Series 50 and 70;
1957-58: All including station wagon.
 HS568.....\$3.50 ea.

1957 Super and Roadmaster 4-door hardtop models. Weatherstrip, rear door hinge pillar.

PS57.....\$59.75 pr.

1959-1960 All Models.

Weatherstrip, door bottom drain hole seal.

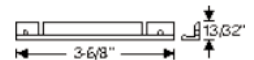

HS591.....\$4.00 pr.

Door Lock Buttons



1936-1941 Brown.....LB361.....\$5.25 ea.
1937-1942 Chrome.....LB372.....\$9.75 ea.
1942-60 LB427.....(Black).....\$3.50 ea.
1942-60 LB427N.....(Brown).....\$6.00 ea.
1942-60 LB427R.....(Red).....\$4.50 ea.
1942-60 LB427G.....(Green).....\$4.50 ea.
1942-60 LB427U.....(Lt. Blue).....\$3.00 ea.
1946-1958 Chrome.....LB468.....\$7.75 ea.

1954-1960 Power window motors. Includes 12 tooth gear. See Group 10.783 for used motors.

Left front or left rear quarter.
 WM540L.....\$119.50 ea.



Right hand front or rear quarter.
 WM540R.....\$119.50 ea.



Power Window Switches (Group 10)



1949-1953 all with hydraulic windows. 4 button assembly
Includes chrome Escutcheon.
WS493A\$195.00 ea.



1949-1953 all with hydraulic windows. 4 button switch
Does not include chrome Escutcheon.
WS493\$149.00 ea.

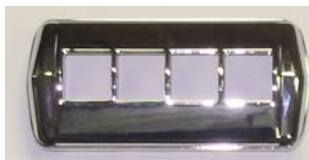

1949-1953 All.
4-button
chrome Escutcheon.
WSE493\$49.00 ea.

1949-1953 all. Fits R.H. door and either side
rear. Assy. Includes chrome Escutcheon.
WS493SA.....\$95.00 ea.



1949-1953 all. Fits R.H. Door and either side rear. Switch.
Does not include chrome Escutcheon.
WS493S\$67.00 ea.

1949-1953 All. Single button chrome
Escutcheon.
WSE493S.....\$35.00 ea.



1949-1953 All. Button only. Fits
all hydraulic switches.
WSB493\$15.00 ea.



1954 Century and Skylark with hydraulic windows.
4 button assembly. Includes chrome Escutcheon.
WS54A\$225.00 ea.
WS54SA.....(Single Button Assembly)\$95.00 ea.



1954-1957 All with electric windows. 4 button assembly
Includes chrome Escutcheon.
WS547A\$179.00 ea.

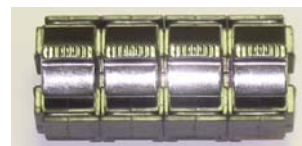

1954-1957 All with electric windows. 4 button switch.
Does not include chrome Escutcheon.
WS547\$135.00 ea.

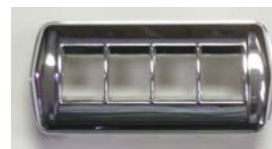

1954-1957 All. 4-Button chrome Escutcheon.
WSE547\$49.00 ea.

1954-1957 All. Fits R.H. door and either side
rear. Assy. Includes chrome Escutcheon.
WS547SA.....\$95.00 ea.



1954-1957 All. Fits R.H. door
and either side rear. Switch.
Does not include chrome Escutcheon.
WS547S\$67.00 ea.

1954-1957 All. Button only. For Single button
switches.
WSB547.....\$15.50 ea.
WSB547M.....(For 4-button switches)\$15.00 ea.



1954-1957 All. Single button chrome
Escutcheon.
WSE547S\$35.00 ea.



1958-1960 Window with contact. All "4 in a row type"
WSC583\$89.00 ea.

1958-1960 All. Contact for all single button switches
WSC584\$29.50 ea.

Inside Rear View Mirror (10.185)

1939-1953 Chrome backed with stud.
IM393\$27.00 ea.

1939-1953 Chrome backed. Day-nite with bent threaded stud mirror is 9" wide.
IM393D.....\$70.25 ea.



1948-1953 Straight threaded stud to mount. Day-nite.
IM483\$66.00 ea.

1950-1953 Day/night w/ flatend stem/screw mount.
IM503.....\$79.00 ea.



1954-1956 Day-nite.
IM546\$88.50 ea.

1957-1960 Day-nite.
IM572\$76.50 ea.



Mirror Screw

1953-1960 As required.
MS532\$2.75 ea.



Tissue Dispenser Emblem
All Years. Adhesive backed. Also can be used on our seat belts.
TBE550\$7.50 ea.

Vanity Mirrors



1936-1949 All. A "GM" dealer installed accessory. Can be written on. Clips on visor.
VM369.....\$30.50 ea.



1942-1960 All. Odometer reset knob.
RK425.....\$3.75 ea.



1939-1960 Coat hook - chrome.
CH396\$11.25 pr.



1937-1942 Sunvisor end plug.
VP372.....(Black).....\$2.75 ea.
VP372N.....(Brown).....\$4.00 ea.



1938-1955 Many models. Bumper, rubber, glove box door, for 1/8" to 5/32" thick pad, 5/16" diameter. Compare with GDB410.
GDB385.....\$1.00 ea.



1938-1955 Many models. Bumper, rubber, glove box door, for 1/8" to 5/32" hole, 1/4" thick pad, 5/16" diameter. Compare with GDB385.
GDB410\$1.25 ea.



1937-1939 Many models. Grommet, glove box door check link, for 1 1/8" slot in dash.
GG379\$14.00 ea.



1940 All. Grommet, glove box door check link.
GG40\$3.50 ea.

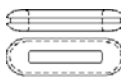

1949 Some models. Grommet, glove box door check link, for 1" slot in dash.
GG49\$17.25 ea.

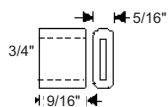

1950-1960 Bumper or grommet, glove box check link. Fits on glove box door arm as required.
GG503\$6.00 ea.

1956-1958 Grommet, glove box door cushion. Used on all models as required.
GG568\$9.75 ea.



Vanity Mirror

1954-1960 Vanity mirror is an exact reproduction. Clips to sunshade as original.
VM549\$40.75 ea.

Interior Parts (Group 10)

Glove Boxes



1934-1935 Series 40.	
GB345	\$34.75 ea.
1934-1935 Series 50-60-90.	
GB345B	\$34.75 ea.
1936 All. Felt lined as original.	
GB36	\$32.50 ea.
1937 All except Limited. Felt lined as original.	
GB37S	\$31.50 ea.
1937 Limited. Felt lined as original.	
GB37B	\$33.75 ea.
1938 All. Felt lined as original.	
GB38	\$31.50 ea.
1939 Special and Century. Felt lined as original.	
GB39S	\$31.50 ea.
1940 Special, Century, Limited. Felt lined as original.	
GB40S	\$31.50 ea.
1940 Super and Roadmaster. Felt lined as original.	
GB40B	\$31.50 ea.
1941 All. Felt lined as original.	
GB41	\$33.75 ea.
1942-1948 Super and Roadmaster.	
GB428	\$32.50 ea.
1942-1949	
1942: Models 41, 41SE, 46, 46S, 46SSE, 61, 66S, all series 90;	
1946-1949: All Specials.	
GB429	\$33.50 ea.

1949 Super and Roadmaster.	
GB49	\$32.50 ea.
1950-1952	
1950: All;	
1951-1952: Super and Roadmaster.	
GB502	\$32.50 ea.
1951-1953 Special.	
GB513	\$32.50 ea.
1953 Super, Roadmaster and Skylark.	
GB53	\$32.50 ea.
1954-1955 Super and Roadmaster.	
GB545	\$32.50 ea.
1954-1955 Special, Century and Skylark.	
GB545S	\$32.50 ea.
1956 Special and Century.	
GB56S	\$32.50 ea.
1956 Super and Roadmaster.	
GB56	\$32.50 ea.

Glove Box Lock with Two Keys (10.266)



1941-1953 All.	
GBL415	\$29.25 set
1954-1956 All.	
GBL546	\$29.25 set
1959 All.	
GBL59	\$27.75 set



www.oldbuickparts.com

908-369-3666



Roof Rail Weatherstrip (10.721)

1949 Riviera Roadmaster hardtops.
RR49\$326.75 set

1950 Models 56R, 75R and 76R for early models.
RR50\$207.25 set

1950-1951
 1950: Models 56R, 75R, 76R (Later models);
 1951: Models 56R, 56RD, 76MR, 76R.
RR501\$149.50 pr.

1952-1953 Super and Roadmaster two door hardtop.
(Flipper seals). 2, 30" pieces
RR523F\$32.50 pr.

1952-1953 Special two door hardtops. Two extruded
pieces for both front doors.
RR523\$98.50 pr.

1954-1958 Flipper stops. Mounts at rear of door for 2 door
hardtop models.
1954-1956 Special and Century;
1957-1958 Super, Roadmaster, Limited.
FS548.....\$35.50 pr.

1955-1956 All four door hardtops. Two 6' lengths.
RR556\$59.00 pr.

1955-1956 Special and Century 4 door hardtops.
Includes metal core as original.
RR556M\$480.00 pr.

1955-1956 Super and Roadmaster 4 door hardtops.
Includes metal core as original.
RR556BM.....\$492.50 pr.

1957-1958 Special and Century. Four door hardtops and
hardtop wagons. Two 6' lengths.
RR578\$69.50 pr.

1957-1958 All. Two door hardtops. Two 40" pieces.
RR578A.....\$79.50 pr.

1957-1958 Super, Roadmaster and Limited four door hardtops.
RR578B.....\$146.25 pr.

1959-1960 Electra four door "Flat Tops". Models
4739-4839. Includes molded ends and inserted clips.
RR590F\$179.25 pr.

1959-1960 All two door hardtop. Two piece set includes
R and L molded sections for body hinge pillar and R and L
sponge weatherstrips with inserted clips.
RR590H.....\$150.75 set

1959-1960 LeSabre, Invicta four door "Flat Tops". Models
4439-4639. Includes molded ends and inserted clips.
RR590S\$175.00 pr.

1959-1960 Electra four door "Flat Tops". Model 4829.
Includes molded ends and inserted clips.
RR590SE\$164.50 pr.

1959-1960 All four door hardtops. Two 8' lengths of
extruded rubber. Does not have molded ends as original.
An inexpensive substitute.
RR590\$67.50 pr.

Spray adhesive for application of bow drill cloth.
SA360.....(20 oz.).....\$18.00 can

Adhesive Backed Bow Drill

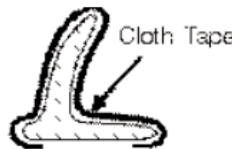

Cloth tape used to cover roof rail
weatherstrip rear 1/4 window seals,
etc. as req. Waterproof and sun-
proof. Comes in 5 foot rolls.

BD250B.....(Black 2 1/2" wide).....\$11.00 ea.
BD250T.....(Tan 2 1/2" wide).....\$9.00 ea.
BD500B.....(Black 5" wide).....\$22.00 ea.
BD500T.....(Tan 5" wide).....\$22.00 ea.

Bow Drill Cloth

54" width and is sold by the yard. Not adhesive backed.
Please order black or tan.

1935-1960 All. Black.
BD360B\$22.75 yd.

1935-1960 All. Tan.
BD360T.....\$22.75 yd.

Rear Vent Window Seals (Group 10)

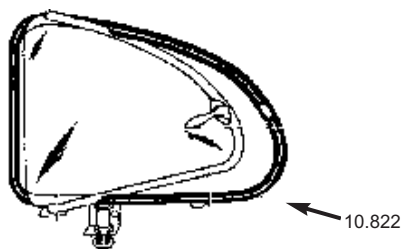

- 1934-1960** All Models. Rear vent window division post vertical seal.
VS330.....\$9.75 pr.
- 1934-1935** Model 61 and 91 four door sedans.
RVW345\$162.25 pr.
- 1934-1935** Models 47, 57, 58, 67, 68, 90, 90L, 97, 98.
RVW345A.....\$161.50 pr.
- 1934-1935** Model 41 four door sedans.
RVW345B.....\$131.00 pr.
- 1936** Special and Century four door sedans.
RVW356\$109.50 pr.
- 1936-1937** Model 81 and 81F.
RVW367F\$131.00 pr.
- 1936-1937** Models 90, 90L, and 91.
RVW367L\$155.25 pr.
- 1937-1938** Model 41 and 61 four door Sedans. Full swing types.
RVW378\$146.50 pr.
- 1937-1938** Model 47 and 67 plain back Sedans. (splicing required).
RVW378S.....\$157.75 pr.
- 1938-1940** Series 90. Includes division bar seals and run channel.
RVW380B.....\$205.50 st.
- 1940-1942;**
 1940-1941: Model 51 and 71;
 1942: Model 47.
RVW402\$123.75 pr.
- 1942-1948** Model 51 and 71.
RVW428\$130.50 pr.
- 1949** Model 51 and 71.
RVW49\$157.75 pr.

1949-1960 Grommet, rear quarter window lift hose.

1949-1950: Models 56C, 76C, 76R;

1951: Models 46C, 56C, 76C, 76MR, 76R;

1952: Models 46C, 56C, 76C, 76R;

1953: Models 56C, 76C, 76R, 76X;

1954: Model 66C and 100.



QG490\$2.50 ea.

1950-1953;

1950: Model 52, 52X, 72, and 72X;

1951-1953: Models 52, 52X, 72R, and 72RX.

RVW503S.....\$146.50 pr.

1951-1953 Special four door Sedans.

RVW513\$115.00 pr.

1954 Super & Roadmaster 4-door Sedan models 52 & 72R

RVW54\$167.75 pr.

1954-1956 Special and Century four door Sedans with opening vent windows.

RVW546\$122.75 pr.

1955-1956 Model 52 and 72.

RVW556S.....\$166.25 pr.

1958 Vent window weatherstrip, rear door. Models 53, 75 and 750.

RVW58H.....\$161.50 pr.

**Fax Us
Your Order**

Save Time!

When sending us a long order
it is easier to just fax it.

908-369-7595

(Group 10) Rear Window Vulcanized Seals

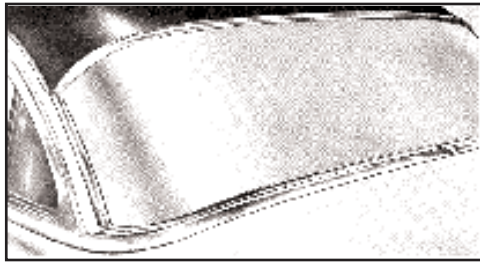

1937-1940 Channel, back window, for windows without chrome reveal molding. Eight foot strip.
WR370A.....\$30.25 ea.

1937-1948 Most models. Channel, back window, for windows with chrome reveal molding. Plain channel for 1/4" glass. Eight foot strip.
BS378B\$30.25 ea.

1938-1940 Series 90 All closed cars.
BS380.....\$121.00 ea.

1939-1940 Specials. For closed models.
BS390.....\$92.00 ea.

1938-1940 Models 81 and 81F.
BS380A\$126.00 ea.

1939-1949;
1939-40: All series 40, 60 with reveal molding;
1941-1949: All Special and Century.
1946-1948 Super and Roadmaster Sedans, 56S, 76S.
 BS399.\$104.50 ea.

1940 All Closed 50 and 70 Series Models;
1941 Series 50, 70, 90 (except convertibles)
 Models **WITH** reveal molding.
 BS401.....\$93.25 ea.

1941-1948 Pinchweld seal, back window, to seal and retain outer reveal molding. Used in conjunction with BS378 and BS401. Some models. 12 foot strip.
 PW419\$39.75 ea.

1942-48 All Super and Roadmaster. 4 door sedans.
 BS428A\$98.25 ea.

1949 Model 56S, and 76S (lock strip included).
 BS49S\$156.50 set

1949 Model 76R (Roadmaster two door hardtop).
 BS49R\$342.50 set

1949 Model 51 and 71.
 BS49B.\$161.25 ea.

1950 Model 43, 46, 46S. For cars **WITHOUT** reveal molding.
 BS50S\$118.00 ea.

1950-1951 Models **WITH** reveal molding.
1950: Models 41, 41D, 51, 71;
1951: Model 51.
 BS501.....\$282.25 ea.

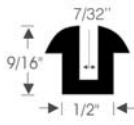
 **1926-1931** Mounting channel for fixed back window. Double weatherstrip type for 1/2" glass. 7' 3" strip. Most closed bodies.
 BS261\$42.00 ea.

 **1928-1932** Setting channel for fixed back window. Plain style. 7' 6" strip.
 BS282\$43.00 ea.

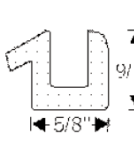
 **1933-1934** Some models. Channel, back window, for windows with or without chrome reveal molding. Most cars require 8 ft.
 BS334\$3.75 ft.

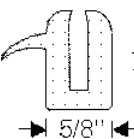
 **1935-1936** Some models. Channel, back window, for window without chrome reveal molding. Eight foot strip.
 BS356.....\$31.75 ea.

1936 Model 41, 48, 61, and 68 w/o reveal molding.
 BS36\$77.50 ea.

1936 Models 81, 90, 90L, 91. (Order DP367R divider pads, separately).
 BS36A\$81.25 ea.

1936 Special and Century Coupes without reveal molding.
 BS36H.....\$83.75 ea.

1937 All 80 and 90 Series except convertibles. (Order DP367R divider pads, separately).
 BS37\$84.25 pr.

1937-1938 Special and Century models **WITHOUT** reveal molding. Models 44, 47, 64 and 67.
 BS378\$104.50 pr

1937-1938 Special and Century models **WITHOUT** reveal molding. Models 41, 48, 46, 46s, 61, 66s, 68
 BS378A\$104.50 ea.

Rear Window Vulcanized Seals (Group 10)

1950-1951 Models WITH reveal molding.
1950: Models 46D, 46S, 43D, 56S, 76S;
1951: Model 56S.
 BS501S\$139.25 ea.

1950-1952 Model 52, 72R.
 BS502S\$285.50 ea.

1950-1952 Models WITH reveal molding.
1950: Model 56R, 75R, 76R;
1951: Model 56R, 76MR, 76R;
1952: Model 56R, 76R.
 BS502R\$317.75 ea.

1951-1952 Model 41, 41D, 48D. Models WITH reveal molding.
 BS512\$268.00 ea.

1951-1952 Model 45R (Special Riviera).
 Molded with divider bars for 3 piece window.
 BS512H\$243.25 ea.

1951-1952 Special model 46S
 BS512S\$140.00 ea.

1953 Model 48D, 45R, 41D
 BS53S\$118.50 ea.

1953 Model 52, 52X, 72R, 72RX.
 BS53B\$137.00 ea.

1953 Model 56R and 76R.
 BS53H\$234.25 ea.

1954 Model 52, 72R.
 BS54B\$136.25 ea.

1954-1956;
1954: Model 41D, 48D, 61
1955: Model 41, 48, 61;
1956: Model 48, 41.
 BS546S\$160.75 ea.

1954-1956 Model 46R, 66R.
 BS546H\$171.00 ea.

1954-1956;
1954-1955: 56R, 76R;
1956: 56R, 53, 76R, 73.
 BS546B\$130.50 ea.

1954-1956 Models 49 and 69. (Estate Wagon).
 BS546W\$62.75 ea.

1955-1956 Special and Century four door hardtops.
 BS556\$127.00 ea.

1955-1956 Model 52, 72.
 BS556B\$130.50 ea.

1957 Special and Century 2 and 4 door Sedans.
 3 piece set.
 BS57\$226.00 ea.

1957 Special and Century 2 dr and -dr. HT (3 piece set).
 BS57H\$187.50 st.

1957 Model 53, 73, 73A, 75.
 BS57B\$143.50 ea.

1957 Models 56R, 75R, 76A, 76R.
 BS57BH\$143.50 ea.

1957-1958 Wagon.
 BS578W\$228.75 ea.

1958 Special and Century.
 BS58\$143.50 ea.

1958 Model 53, 75, 750.
 BS58B\$127.25 ea.

1958 Super, Roadmaster, Limited models 56R, 75R, 755.
 BS58H\$140.25 ea.

1959 LeSabre Sedans WITHOUT inside garnish molding.
 BS59LS\$167.25 ea.

1959 LeSabre 2 door Hard Top WITHOUT inside garnish molding.
 BS59LH\$158.50 ea.

1959 1960 All 2 door hardtops with garnish molding,
 models 44, 46, 4737.
 BS590H\$128.75 ea.

1959-1960 All LeSabre and Invicta 4-dr. HT.; All Electra
 4 dr. H.T. with panorama back windows. Models 4439,
 4639, 4739, 4839.
 BS590\$207.50 ea.

1959-1960 All four door Sedan models WITH inside garnish molding.
 BS590S\$132 50 ea.

Rear Window Clips



1954 Models. 41D, 48, 61. Maybe others.
 MC88\$3.25 ea.



1954-1956 Models. 52, 72;
1957-1958 all Special, Super and Roadmaster. Maybe others.
 MC89\$1.50 ea.

Rear Window Drain Tubes



1957-1958 All Sedan Models. Maybe others.
 DT578\$37.50 pr.

Rear Quarter Window to Front Window Seals



1942-1960 All two door hardtop and convertibles.
 QS490\$17.00 pr.
1955-1960 All four door hardtop and station wagons.
 QS550\$17.00 pr.

Adhesive Backed Bow Drill

Cloth tape used to cover roof rail weatherstrip rear 1/4 window seals, etc. as req. Waterproof and sunproof. Comes in 5 foot rolls.

BD250B.....(Black 2 1/2" wide).....\$9.75 ea.
 BD250T.....(Tan 2 1/2" wide).....\$8.75 ea.
 BD500B.....(Black 5" wide).....\$21.25 ea.
 BD500T.....(Tan 5" wide).....\$21.25 ea.

Rear Quarter Window Fixed Seals

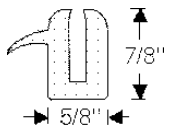

1935-1940 Channel, fixed quarter window (type without chrome reveal molding). Four ft. strip. Some models.
 RQS350.....\$13.75 ea.

1937-1938 Channel, fixed quarter window. One piece. No splicing required. All coupes except convertibles.



RQS378\$77.50 pr.

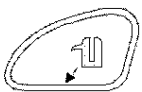

1939-1940 Weatherstrip, fixed rear quarter window. One piece.
 1939: Model 46;
 1940: Models 46 and 66.

RQS390\$79.00 pr.

1952-1960 Rear 1/4 window pivot Kit.
1952-1953 All Hardtops and Convertibles;
1954-1960 All Convertibles.



QPK520\$26.50 ea.

Rear Quarter Window Upper Chrome Frames

1954-1956 Special, Century and Skylark Convertibles.
 QWF546.....\$135.00 pr.

1954-1956 All 2-door hardtop models.
 QWF546H\$135.00 pr.

1939-1949 Weatherstrip, sliding quarter window. Mounted vertically in body where leading edge of sliding window fits when closed. Right and left rubber.

1939: Models 41, 46S, 61, 66S. Series 80;
1940: Models 41, 46S, 61, 66S, 76S. Series 80;
1941: Models 41, 41SE, 46, 56, 56S, 76S. Ser. 80;
1942: Models 41, 41SE, Series 90;
1946-1949: Model 41.

RQS399\$44.00 pr.



1939-1950 Weatherstrip, inner and outer for sliding quarter window, chrome beaded, mohair faced, flexible stock. May be formed to required outline 64" strip.
 WS330\$18.25 ea.

1954-1956 Filler channel with lip for stationary rear side windows and tailgate windows.

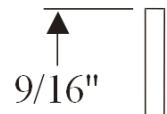

WR546\$3.50 ft.



1954-1956 Models 41 and D. Weatherstrip, fixed quarter window.
 RQS546\$127.25 pr.

1957-1958 4-dr. hardtop wagons - models 49, 49D, 69. Rear side glass. Fully molded.



RQS578W\$212.75 pr.

1959-1960 Electra 225 6-window hardtop model 4829 Weatherstrip, fixed quarter window.

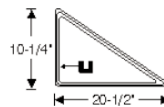

RQS590E\$124.25 pr.

1959-1960 All 4-door sedan models 4419, 4619, 4719. Weatherstrip, fixed quarter window.

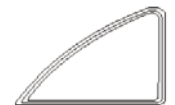



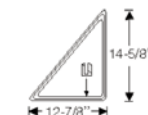

RQS590A.....\$86.50 pr.

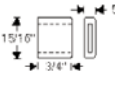
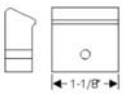

1959-1960 2 door, 4 door and wagon models with fixed triangular quarter window.
 RQS590B\$82.00 pr.

Rear Quarter Seals (Group 11)

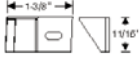
Rear Quarter Window Parts

-  **1942-1953** Bumper, rear 1/4 window lower.
Models 44C, 56C, 56R, 76C, 76R, 76X.
QB423L.....\$3.25 ea.
-  **1942-1953** Bumper, rear 1/4 window upper.
Models 44C, 56C, 56R, 76C, 76R, 76X.
QB423U.....\$3.75 ea.
-  **1952-1953** Bumper, 1/4 window at lock pillar.
All 2-dr. hardtop and convertibles.
QB523.....\$23.00 pr.
-  **1954-1956** All Super and Roadmaster.
convertibles, Rear 1/4 window rubber bumper
w/ steel core.
QB546.....\$21.75 pr.
-  **1954-1956** All Super and Roadmaster models
56r, 76r, 76rx. Rear 1/4 window/roof rail seals.
QS546.....\$36.00 pr.
-  **1957-1958** Division post upper bumper.
1957 all sedans and riviera wagon;
1958 Super, Road. Riviera HT & Lim. Riv. Sed.
WB578.....\$41.75 pr.

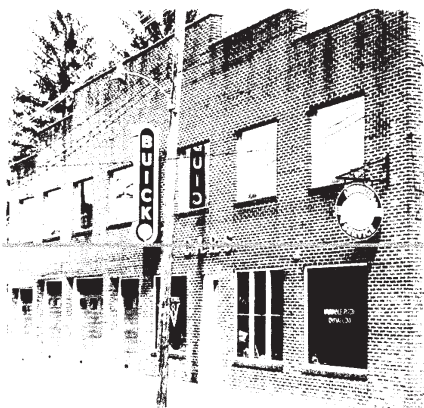

Visit us at our Worldwide Headquarters

We're located in a small village amongst the
vast farmland in western New Jersey

Lock Pillar Seals



- 1954-1956** Special and Century two door hardtops.
LPS546\$56.50 pr.
- 1954-1956** Super and Roadmaster two door hardtops.
LPS546B\$44.00 pr.
- 1954-1956** All convertibles. Screws included.
LPS546C\$25.75 pr.
-  **1954-1956** Models 46C, 66C
1954 Model 100 Lock pillar
weatherstrip under window.
LPW546C\$68.75 pr.
- 1957-1958** Super, Roadmaster, Limited 2-Door hardtop.
LPS578\$45.25 pr.
- 1957-1958** Special and Century 2-Door hardtops.
LPS578A\$47.50 pr.
- 1957-1958** Super, Roadmaster, and Limited convertibles.
LPS578C\$44.25 pr.
- 1958** All 4-dr. hardtops and hardtop wagons for front doors.
LPS58F\$32.50 pr.
- 1958** All 4-dr. hardtops and hardtop wagons for rear doors.
LPS58R\$37.50 pr.
- 1957-1960** Convertibles.
1957: Special and Century;
1959-1960: All.
LPS570\$34.00 pr.
-  **1957** Convertibles.
Lock pillar weatherstrip under window.
LPW57\$69.75 pr.
- 1959-1960** Electra 4 door hardtop model 4829.
LPS590A\$47.50 pr.
- 1959-1960** All 2 door hardtops.
LPS590\$42.50 pr.
- 1959-1960** All 4 door hardtop. On rear door.
hinge pillar.
LPS590S\$43.25 pr.
- 1959-1960** All 4 door hardtop. (For front doors).
LPS590F\$36.75 pr.

Dome Lenses - Courtesy Lenses

(11.927, 11.928)



1939-1940 All closed cars, dome lamp lens.
DL390\$14.25 ea.



1940-1949 All convertibles, on top bow.
DL409\$8.50 ea.

1940-1949 Convertible top bow lens rim.
DR409.....\$18.50 ea.

1941-1949 Except convertibles. Dome lens.
DL419\$18.00 ea.

1950-1956 All except convertibles. Has hole for switch.
DL506\$11.75 ea.

1950-1956 Except convertibles. Chrome dome lens rim.
Has square hole for switch.
DR506.....\$19.50 ea.

1950-1956 All convertibles. 1954-1956 Series
50-70 convertibles located on top bow.
DL506C\$10.00 ea.

Housing for above lens. Complete.
DLH506C.....\$33.00 ea. 

1950-1960 All with side roof courtesy lens.
CL502\$9.25 ea.



1954-1960 All convertibles. Rear courtesy
lamp housings.
CLH542\$27.00 ea.



1954-1960 All convertibles and 2 door
hardtop (at rear armrest).
CL544.....\$6.00 ea.



1957-1960 All round style (3 7/8").
DL578\$11.00 ea.

Seat Parts

1936-1940 Pads, folding front seat
rest, steel core. Also used as bumper,
slat iron to compartment on convertibles.
SP360\$49.25 pr. 

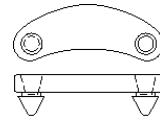

1941-1949 Rest pads, seat back, outer, on
two door styles with folding seats. Specify
color when ordering.

1941-1948: All as required;
1949: Style 4407 only.

SP419.....(Black)\$30.50 pr.
SP419N.....(Brown)\$35.75 pr.



1953-1958 Seat rest bumper. Used on all
2-door models. 4 needed per car.
SB538\$7.75 ea.

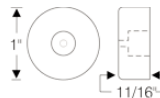

1959-1960 Seat rest bumper. Used on all
2-door models. 2 needed per car.
SB590\$8.75 ea.

Hog Rings

For attaching seat covers to frame.
HR360.....Bag of 100.....\$8.75 ea. 

Hog Ring Pliers

For attaching hog rings to seat covers.
HRP360.....\$30.25 ea. 

Door Jamb Switches

1930-1958:
1930 thru 1956 All front and rear.
1957-1958 All rear.
DJS308\$18.00 ea. 

1959-1960 All
DJS590\$24.25 ea.

Power Seat Switches

1957-1958 All 6-way power seats.
Includes chrome Escutcheon.
SS578A.....\$187.00 ea. 

1957-1958 All 6-way power seats.
Does not include chrome Escutcheon.
SS578\$149.00 ea.

1957-1958 All 6-way power seats. Chrome Escutcheon.
SSE578.....\$99.00 ea.

Door Sills (Group 11.175)

YEAR	MODELS	CARS #	PRICE
1909	4-Door Touring Model 17 (aluminum)	DS0917A	\$217.75 set
1918-1920	4-Door Touring, 7-Passenger E-49, H-49, K-49	DS180	\$217.75 set
1922	2-Door Sport Roadster Model 54 3 passenger.....	DS22	\$217.75 set
1923	2-Door Models 39, 44	DS23	\$217.75 set
1923	4-Door Touring Models 35, 45, 49.....	DS23A	\$247.50 set
1925	2-Door Master Series Coupe Model 40.....	DS25	\$217.75 set
1925	4-Door Standard and Master Models 255, 45, 47, 47A.....	DS25A	\$247.50 set
1926	2-Door Master Series Models 44, 48.....	DS26	\$217.75 set
1926	4-Door Master Series Touring 5-Passenger Model 45.....	DS26B	\$247.50 set
1927	2-Door Master Series Sport Roadster Model 54 4-Passenger.....	DS27	\$217.75 set
1927	4-Door Standard and Master Series Models 25, 50	DS27A	\$247.50 set
1928	2-Door Standard and Master Series Models 24, 26S, 54.....	DS28	\$242.50 set
1928	4-Door Standard Series Sedan 5-Passenger Model 20	DS28A	\$242.50 set
1928	4-Door Standard Series Models 25, 27, 47	DS28B	\$267.25 set
1929	2-Door Models 20, 26S, 44, 46, 48, 54CC, 58	DS29	\$227.75 set
1929	4-Door Touring Series 116 Australian Body.....	DS29A	\$267.25 set
1929	4-Door Sedan Models 27, 47, 51, 57 Series 121	DS29B	\$267.25 set
1929	4-Door Sedan McLaughlin 7-Passenger Model 50 Series 129	DS29M	\$267.25 set
1929	4-Door Closed Coupe Sedan 5-Passenger Model 41 Series 121	DS29N	\$267.25 set
1930	2-Door Models 40, 44, 46, 46S	DS30	\$227.75 set
1930	4-Door Sedan Models 47, 57, 67	DS30A	\$267.25 set
1931	2-Door Models 56C, 56S, 64, 66, 66S, 86, 94, 96S, 96C	DS31	\$227.75 set
1931	4-Door Models 55, 57, 67, 95.....	DS31A	\$267.25 set
1932	2-Door Convertible Models 68C, 86, 96C	DS32	\$227.75 set
1932	4-Door Sedan Models 57, 67, 87, 90, 90L	DS32A	\$267.25 set
1932	4-Door Sport Phaeton 7-Passenger Model 95, Series 90	DS32B	\$316.75 set
1933	2-Door Models 56S, 58, 68, 96	DS33	\$227.75 set
1933	4-Door Sedan Models 57, 67, 87, 88C.....	DS33A	\$267.25 set
1934	2-Door Convertible Coupe Model 96C, Series 90.....	DS34	\$227.75 set
1934	4-Door Sedan Models 47, 67, 91, 98C, 90L.....	DS34A	\$267.25 set
1935	2-Door Convertible Coupe Model 66C, Series 60.....	DS35	\$227.75 set

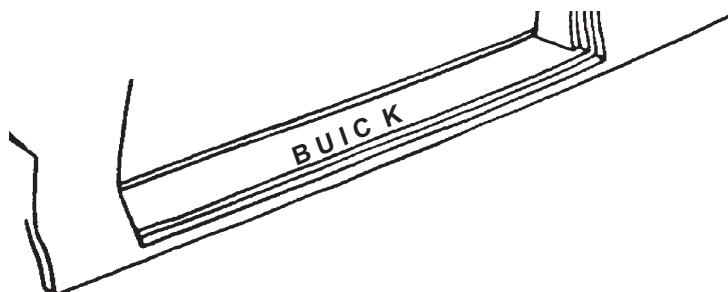

Door Sills are Custom made one set at a time, delivery may take up to 7 mo. or longer.

We do stock some for immediate delivery - () or add "P" to the item to check availability.*

IF YOU DO NOT SEE YOUR MODEL LISTED, PLEASE ASK. WE CAN CUSTOM MAKE ANY SILL.

YEAR	MODELS	CARS #	PRICE	SCREW SET	PRICE
1936	2-Door Century Models 66S, 68	DS36	\$217.75 set	DSS555.....	\$5.25 set
1936	4-Door Special and Century Sedan Models 41, 61	DS36A	\$267.25 set		
1936	4-Door Roadmaster Sedan Models 80C, 81	DS36B	\$267.25 set		
1937	4-Door McLaughlin Special	DS36M	\$267.25 set		
1937	4-Door Roadmaster Phaeton Model 80C	DS37SC	\$267.50 set		
1937-1938	2-Door Sedans Model 44, 48, 64, 68	DS378S	\$217.75 set		
1937-1938	2-Door Coupes and Conv't. Model 46, 46C, 46S, 66C, 66S	DS378C	\$217.75 set		
1937-1938	4-Door Roadmaster Series 80 and 90.....	DS378B	\$299.00 set		
1937-1938	4-Door Sedan and Conv't. Model 40C, 41, 47, 60C, 61, 67	DS378	\$277.25 set		
1939	4-Door Touring Sedan (5 pass.) Model 41	DS39TS	\$314.75 set		
1939	4-Door Sport Phaeton Model 80C	DS39SP	\$299.00 set		
1939	4-Door Convertible Sedan Model 81C	DS39CV	\$299.00 set		
1939-1940	4-Door Special Century Phaeton Model 41C, 61C.....	DS390	\$316.75 set		
1939-1940	2-Door Convertible & Coupe Models 46,46C,46S,66,66C,66S.....	DS390C	\$288.50 set		
1939-1940	2-Door Special Model 48.....	DS40P	\$267.50 set		
1940	4-Door Sedan Special Series 40 Model 41	DS40SS	\$288.50 set		
1940	2-Door Business Coupe Model 46	DS40SC	\$288.50 set		
1940	2-Door Convertible and Coupe Models 56C, 56S, 76C, 76S	DS40C	\$262.50 set		
1940	4-Door Super Convertible Sedan Model 51C.....	DS40E	\$292.00 set		
1940	4-Door Roadmaster Convertible Sedan Model 71C.....	DS40F	\$292.00 set		
1940	4-Door Super Woody Wagon Model 59	DS40D	\$292.00 set		
1940	4-Door Series 80	DS40B	\$299.00 set		
1940	4-Door Super Sedan Model 51 (6 pieces).....	DS40M	\$320.00 set		
1940	4-Door Century Series 60 Model 61	DS40BC	\$287.00 set		
1940	4-Door Roadmaster Sedan Model 71.....	DS40BS	\$314.75 set		
1940	4-Door Flxble Ambulance.....	DS40A	\$404.00 set		
1941-1949	4-Door Special and Century Sedans Models 41, 47, 61.....	DS419	\$299.00 set		
1941	2-Door Special Sport Coupe Model 44S	DS41SC	\$236.00 set		
1941	2-Door Convertible and Coupe 56C, 56S, 76C, 76S.....	DS41CC	\$288.50 set		
1941 & 1946	2-Door Convertible Special 44C (left and right diff.)	DS41CS	\$288.50 set		
1941	4-Door Convertible Series 51, 51C, 71, 71C (6 pieces).....	DS41BC	\$309.50 set		
1941-1942	4-Door Estate Wagon Model 49	DS41W	\$320.00 set		
1941-1948	2-Door Sedanette 46SSE, 66S, 46S	DS41W	\$272.75 set		
1942	2-Door Super Convertible Coupe 56C - no etch	DS42CC	\$320.00 set		
1942	2-Door Super and Roadmaster Conv't. Models 56C, 76C	DS42BC	\$341.00 set		

Door Sills (Group 11.175)

**Door Sills are Custom made one set at a time, delivery may take up to 7 mo. or longer.
We do stock some for immediate delivery - (*) or add "P" to the item to check availability.**

IF YOU DO NOT SEE YOUR MODEL LISTED, PLEASE ASK. WE CAN CUSTOM MAKE ANY SILL.

YEAR	MODELS	CARS #	PRICE	SCREW SET	PRICE
1946-1948	4-Door Estate Wagon (no etch).....	DS48W\$320.00	set	
1946-1948	2-Door Convertible 56C, 76C (left and right diff.)	DS468C\$327.50	set	
1947-1948	2-Door Super and Roadmaster Sedanette Models 56S, 76S.....	DS47S\$299.00	set	
1946-1948	4-Door Super and Road. Sedans & Wag. Mod 51, 59, 71, 79.....	DS468B\$309.50	set	
1949	4-Door Super and Road. Sedans & Wag. Mod 51, 59, 71, 79.....	DS49B\$296.00	set	
1949	2-Door Super and Roadmaster Sedanette Models 56S, 76S9.....	DS49S\$288.50	set	
1949	2-Door Super and Road. Conv. Models 56C,76C, 76R.....	DS49BC\$309.50	set	
1950	2-Door Special Models 46D, 46S. No Etch	DS50\$278.25	set	
1950	4-Door Special Models 41, 41D ,43, 43D.....	DS50A\$292.00	set	
1950	2-Door Super and Road. Mod 56S,56R,56C,75R,76S,76C,76R...DS50C\$272.25	set		
1950	4-Door Super and Roadmaster Sedans Models 52, 72.....	DS50B\$329.50	set	
1950	4-Door Super and Road. Sedans & Wag. Mod 51, 59, 71, 79.....	DS50D\$296.00	set	
1950	2-Door Super and Road. 56R, 56C, 56S, 76R, 76C..5" at widest.	DS51C\$272.25	set	
1951	2-Door Sup & Road. 56R, 56C, 56S, 76R, 76C 3 3/4" at widest....	DS51D\$330.75	set	
1951	4-Door Special Sedan Models 41, 41D	DS51S\$296.00	set	
1951	4-Door Super & Road. Sedan & Wag Mod 51, 59, 71, 79.....	DS51W\$309.50	set	
1951	4-Door Super Mod 52 no etch, Front sill 4 1/8" at widest part.....	DS51BX\$299.00	setDSS555.....\$5.25 set
1951	4-Door Super Model 52 no etch, Front sill 3 3/8" at widest	DS51BS\$299.00	set	
1952-1953	4-Door Special Sedan Models 41, 41D	DS523\$292.00	set	
1952-1953	4-Door Super and Road. Sedans & Wag Mod 52, 59, 72R, 79	DS52W\$330.75	set	
1952-1953	2-Door Super and Roadmaster Models 56C, 56R, 76C, 76R.....	DS523BC\$299.00	set	
1952-1953	2-Door Special Models 45R, 46C, 46S, 48D (4 piece set).....	DS513S\$272.25	set	
1953	Skylark.....	DS53X\$231.00	set	
1954	4-Door Special and Century Sedan Models 41D, 61, 69.....	DS54A\$302.00	set	
1954	4-Door Super and Roadmaster Sedan Models 52, 72R.....	DS54B\$302.00	set	
1954	2-Door Skylark.....	DS54X\$262.25	set	
1954	2-Door Special and Century Mod 46R, 46C, 48D, 66R, 66C	DS54C\$293.75	set	
1954	2-Door Super and Road Cpe & Conv. mod 56R, 56C76R, 76C...DS54BC\$297.50	set		
1955-1956*	2-Door Special and Century Mod 46R, 46C, 48, 66R, 66C	DS556\$96.00	set	
1955-1956*	4-Door Special and Century Hardtop Models 43, 49, 63, 69	DS556RS\$98.50	set	
1955-1956*	4-Door Special and Century Sedan Models 41, 61	DS556S\$98.50	set	
1955-1956	2-Door Super and Roadmaster Models 56R, 56C, 76R, 76C.....	DS556R\$272.25	set	
1955-1956	4-Door Super and Roadmaster Models 52, 72R	DS556RB\$321.75	set	
1957-1958*	2-Door Special and Century Models 46R, 46C, 48, 66R, 66C	DS578\$94.00	set	
1957-1958	4-Door Special and Century Models 41, 43, 49, 49D, 63, 69	DS578D\$220.25	set	
1957-1958	2-Door All Super, Roadmaster and Limited Models	DS578B\$262.25	set	
1957-1958	4-Door Super, Roadmaster and Limited Hardtops	DS578A\$307.50	set	
1959-1960*	All 2-Door Models.....	DS590\$117.50	set	
1959-1960	4-Door LeSabre, Invicta and Wagon Models.....	DS590A\$272.25	set	
1959-1960	4-Door Electra 225 Models.....	DS590B\$272.25	set	



All floor pans, trunk pans and inner rocker panels are made of 18 gauge coated steel. Outer rocker panels are made of 20 gauge coated steel. Panels are custom made and usually take a week or so to fabricate.

1937-1940 All Special

Floor Pans (Front and Rear) (12.980)

FP370FFL.....(FRONT LEFT)	\$60.50 ea.
FP370FFR.....(FRONT RIGHT)	\$60.50 ea.
FP370RFL.....(REAR LEFT)	\$60.50 ea.
FP370RFR.....(REAR RIGHT)	\$60.50 ea.

1939-1940 All Super and Roadmaster

Floor Pans (Front and Rear) (12.980)

FP390FFL.....(FRONT LEFT)	\$65.00 ea.
FP390FFR.....(FRONT RIGHT)	\$65.00 ea.
FP390RFL.....(REAR LEFT)	\$65.00 ea.
FP390RFR.....(REAR RIGHT)	\$65.00 ea.

1940-1941 All Super and Roadmaster

Rocker Panels for 4-dr. Models. (12.934)

RP401L4..... (L.H.OUTER PANEL)	\$51.00 ea.
RP401R4..... (R.H.OUTER PANEL)	\$51.00 ea.
RP401IL..... (L.H. INNER PANEL)	\$51.00 ea.
RP401IR.....(R.H. INNER PANEL)	\$51.00 ea.

1941-1949 All Special

Rocker Panels (12.934)

RP409L..... (L.H.OUTER PANEL)	\$51.00 ea.
RP409R..... (R.H.OUTER PANEL)	\$51.00 ea.

1941-1949 All Models

Floor Pans (Front and Rear) (12.980)

FP419FFL.....(FRONT LEFT)	\$60.00 ea.
FP419FFR.....(FRONT RIGHT)	\$60.00 ea.
FP419RFL.....(REAR LEFT)	\$60.00 ea.
FP419RFR.....(REAR RIGHT)	\$60.00 ea.

1942-1948 All Super and Roadmaster

Rocker Panels for 4-dr. Models. (12.934)

RP428L4..... (L.H.OUTER PANEL)	\$51.00 ea.
RP428R4..... (R.H.OUTER PANEL)	\$51.00 ea.

1949 All Super and Roadmaster

Rocker Panels for 2-dr. Models. (12.934)

RP49L..... (L.H.OUTER PANEL)	\$51.00 ea.
RP49R..... (R.H.OUTER PANEL)	\$51.00 ea.

Rocker Panels for 4-dr. Models. (12.934)

RP49L4..... (L.H.OUTER PANEL)	\$51.00 ea.
RP49R4..... (R.H.OUTER PANEL)	\$51.00 ea.

1950 All;

1951-1953 Super, Roadmaster, Skylark.

Front Toeboards (12.980)

TB503L.....(LEFT)	\$60.00 ea.
TB503R.....(RIGHT)	\$60.00 ea.

Floor Pans (Front and Rear) (12.980)

FP503FFL.....(FRONT LEFT)	\$60.00 ea.
FP503FFR.....(FRONT RIGHT)	\$60.00 ea.
FP503RFL.....(REAR LEFT)	\$60.00 ea.
FP503RFR.....(REAR RIGHT)	\$60.00 ea.

Under Seats (Front and Rear) (12.980)

FP503FSL.....(13" FRONT LEFT).....	\$85.00 ea.
FP503FSR.....(13" FRONT RIGHT)	\$85.00 ea.
FP503RSL.....(REAR LEFT).....	\$135.00 ea.
FP503RSR.....(REAR RIGHT).....	\$135.00 ea.

Rocker Panels for 2-dr. Models. (12.934)

RP503L..... (L.H.OUTER PANEL)	\$60.00 ea.
RP503R..... (R.H.OUTER PANEL)	\$60.00 ea.
RP503I..... (L.H or R.H INNER PANEL)	\$60.00 ea.

Rocker Panels for 4-dr. Models. (12.934)

RP503L4..... (L.H.OUTER PANEL)	\$60.00 ea.
RP503R4..... (R.H.OUTER PANEL)	\$60.00 ea.

Sill Panels. For 2-dr. Models. (12.934)

SP503L.....(LEFT ANGLE)	\$28.00 ea.
SP503R.....(RIGHT ANGLE)	\$28.00 ea.

Floorpans • Rocker Panels • Trunk Pans (Group 12)

1951-1953 Special.

Front Toeboards (12.980)

TB513L.....(LEFT)	\$90.25 ea.
TB513R.....(RIGHT)	\$90.25 ea.

Floor Pans (Front & Rear) (12.980)

FP513FFL.....(FRONT LEFT)	\$60.00 ea.
FP513FFR.....(FRONT RIGHT)	\$60.00 ea.
FP513RFL.....(REAR LEFT)	\$60.00 ea.
FP513RFR.....(REAR RIGHT)	\$60.00 ea.

Rocker Panels for 2-dr. Models. (12.934)

RP513L(L.H. OUTER PANEL)	\$25.25 ea.
RP513R(R.H. OUTER PANEL)	\$25.25 ea.
RP513I.....(INNER PANEL)	\$85.25 ea.

Rocker Panels for 4-dr. Models. (12.934)

RP513L4(L.H. OUTER PANEL)	\$60.00 ea.
RP513R4(R.H. OUTER PANEL)	\$60.00 ea.
RP513I.....(INNER PANEL)	\$60.00 ea.

1954 - 1956 Special, Century, Skylark

Front Toeboard (12.980)

TB546L.....(LEFT).....	\$60.00 ea.
TB546R.....(RIGHT).....	\$60.00 ea.

Floor Pans (Front & Rear) (12.980)

FP546FL.....(FRONT LEFT)	\$60.00 ea.
FP546FR.....(FRONT RIGHT)	\$60.00 ea.
FP546RL.....(REAR LEFT)	\$60.00 ea.
FP546RR.....(REAR RIGHT)	\$60.00 ea.

Side Extension pc (connects front & rear floor pans. 5" x 22")

SE546L.....(LEFT).....	\$60.00 ea.
SE546R.....(RIGHT).....	\$60.00 ea.

Wiring Covers (12.934)

WC546L.....(LEFT)	\$65.00 ea.
WC546R.....(RIGHT)	\$65.00 ea.

Rocker Panels for 2-dr. Models. (12.934)

RP546L.....(OUTER LEFT).....	\$60.00 ea.
RP546R.....(OUTER RIGHT).....	\$60.00 ea.
RP546I.....(INNER PANEL)	\$60.00 ea.

Rocker Panels for 4-dr. Models. (12.934)

RP546L4.....(OUTER LEFT).....	\$60.00 ea.
RP546R4.....(OUTER RIGHT).....	\$60.00 ea.
RP546I.....(INNER PANEL)	\$60.00 ea.

Trunk Floor Pan. (12.980)

TP546.....	\$247.00 ea.
------------	--------------

1954 - 1956 Super and Roadmaster (12.980)

Front Toeboard

TB546BL.....(LEFT)	\$60.00 ea.
TB546BR.....(RIGHT)	\$60.00 ea.

Floor Pans (Front & Rear) (12.980)

FP546BFL.....(FRONT LEFT).....	\$60.00 ea.
FP546BFR.....(FRONT RIGHT).....	\$60.00 ea.
FP546BRL.....(REAR LEFT).....	\$60.00 ea.
FP546BRR.....(REAR RIGHT).....	\$60.00 ea.

Under Front Seat (12.980)

FP546BL.....(LEFT)	\$80.25 ea.
FP546BR.....(RIGHT)	\$80.25 ea.

Rocker Panels for 2-dr. models. (12.934)

RP546BL.....(OUTER LEFT)	\$60.00 ea.
RP546BR.....(OUTER RIGHT)	\$60.00 ea.
RP546I.....(INNER PANEL)	\$60.00 ea.

Rocker Panels for 4-dr. models. (12.934)

RP546BL4.....(OUTER LEFT)	\$60.00 ea.
RP546BR4.....(OUTER RIGHT)	\$60.00 ea.
RP546I.....(INNER PANEL)	\$60.00 ea.

Top of Rocker Panel for 2-dr. models. (12.934)

RP546BTL.....(LEFT)	\$51.00 ea.
RP546BTR.....(RIGHT)	\$51.00 ea.

Wiring Covers (for on top of rockers 2-dr. models).

WC546BL.....(LEFT)	\$65.00 ea.
WC546BR.....(RIGHT)	\$65.00 ea.

Conv. Rear Seat Channels

RSC546BL.....(LEFT)	\$80.25 ea.
RSC546BR.....(RIGHT)	\$80.25 ea.



www.oldbuickparts.com

908-369-3666

(Group 12) **Floorpans • Rocker Panels • Trunk Pans**

1957-1958 All models (12.980)

Front Toeboard

TB578L.....(LEFT).....\$90.25 ea.
 TB578R.....(RIGHT).....\$90.25 ea.

Floor Pans (Front) (12.980)

FP578FL (FRONT LEFT)\$60.00 ea.
 FP578FR (FRONT RIGHT)\$60.00 ea.

Side of Front Seat (12.980)

FP578SL.....(LEFT)\$80.25 ea.
 FP578SR.....(RIGHT)\$80.25 ea.

1957-1958 Special & Century

Rocker Panels for 2-dr. Models. (12.934)

RP578L.....(OUTER LEFT).....\$60.00 ea.
 RP578R.....(OUTER RIGHT).....\$60.00 ea.
 RP578IL.....(INNER LEFT)\$60.00 ea.
 RP578IR.....(INNER RIGHT)).....\$60.00 ea.

Rocker Panels for 4-dr. Models. (12.934)

RP578L4.....(OUTER LEFT).....\$60.00 ea.
 RP578R4.....(OUTER RIGHT).....\$60.00 ea.
 RP578IL4.....(INNER LEFT)\$60.00 ea.
 RP578IR4.....(INNER RIGHT)).....\$60.00 ea.

Floor Pans (Front & Rear) (12.980)

FP578FL(FRONT LEFT)\$60.00 ea.
 FP578FR(FRONT RIGHT)\$60.00 ea.
 FP578RL(REAR LEFT)\$60.00 ea.
 FP578RR(REAR RIGHT)\$60.00 ea.

1957-1958 Super, Roadmaster & Limited

Rocker Panels for 2-dr. Models. (12.934)

RP578BL.....(OUTER LEFT)\$60.00 ea.
 RP578BR.....(OUTER RIGHT)\$60.00 ea.
 RP578BIL.....(INNER LEFT).....\$60.00 ea.
 RP578BIR.....(INNER RIGHT)).....\$60.00 ea.

Rocker Panels for 4-dr. Models. (12.934)

RP578BL4.....(OUTER LEFT)\$60.00 ea.
 RP578BR4.....(OUTER RIGHT)\$60.00 ea.
 RP578BIL4.....(INNER LEFT).....\$60.00 ea.
 RP578BIR4.....(INNER RIGHT).....\$60.00 ea.

Rocker Panel Extensions for 4-dr. Models. (12.934)

RPE578BL4.....(LEFT).....\$65.75 ea.
 RPE578BR4.....(RIGHT).....\$65.75 ea.

1959-1960

Front Toeboard

TB590L.....(LEFT).....\$70.25 ea.
 TB590R.....(RIGHT).....\$70.25 ea.

Floor Pans (Front & Rear) (12.980)

FP590FL.....(FRONT LEFT)\$60.00 ea.
 FP590FR.....(FRONT RIGHT)\$60.00 ea.
 FP590RL\$60.00 ea.
 FP590RR.....\$60.00 ea.

Outer Rocker Panels for 2-dr. Models. (12.934)

RP590L.....(OUTER LEFT).....\$60.00 ea.
 RP590R.....(OUTER RIGHT).....\$60.00 ea.

Outer Rocker Panels for 4-dr. Models. (12.934)

RP590L4.....(OUTER LEFT).....\$60.00 ea.
 RP590R4.....(OUTER RIGHT).....\$60.00 ea.

Inner Rocker Panels for All Models.

RP590I.....(INNER PANEL)\$25.50 ea.

Trunk Floor Pan. (12.980)

TP590.....\$346.00 ea.

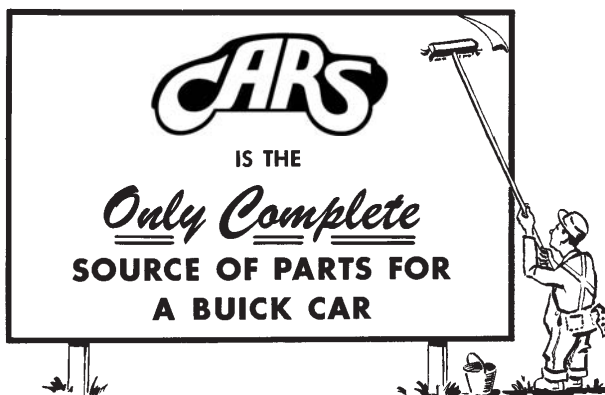

Rear Fender (Group 12)



1936-1955 Fender welt.
 FW25.....(25 ft. roll).....\$23.25 ea.
 FW50.....(50 ft. roll).....\$44.00 ea.



1938-1940 Gas door bumper.
 GDB385\$1.00 ea.



1941-1961 All. Gas door bumper.
 GDB410\$1.25 ea.

1951-1956 Gas door bumper.
1951-1953 Specials;
1954-1956 All (Two per car).
 GB516\$4.75 pr.

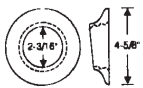

1933-1935 Gas filler grommet.
1933 All series 50 and 60 exc. Vic. Coupe
1934-1935 All Series 40-50-90;
1934-1935 models 66c, 66s, 67, 68
 GF335\$42.00 ea.

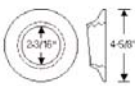

1933-1935 Gas filler grommet.
1933 Models 58, 68, 86, 90, 90L, 91;
1934-1935 Models 61, 68C
 GF335B\$39.25 ea.



1936-1937 Gas filler grommet.
 1936 All;
 1937 Series 80-90.
 GF367\$18.00 ea.



1937 Gas filler grommet. Special and Century.
 GF37\$18.00 ea.

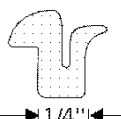

1935-1960 Rear fender inner seal.
 (between deflector and fender). (36" length).
 AS502.....\$19.25 ea.

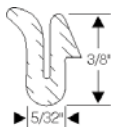

1936-1941 Fender skirt seals. Some pre-war cars with removable fender skirts.
 FS361\$48.75 pr.

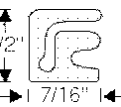

1941-1948 Fender skirt seals. Similar to FS361, but thicker. Known to fit Super and Roadmaster. Approx. 2- 5 foot strips.
 FS418\$42.25 pr.

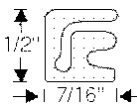

1941-1950 Fender skirt seals. Exact copy. Trim notch for skirt lock at installation. Most models. Compare to picture. 2- 5 foot strips.
 FS410\$45.50 pr.

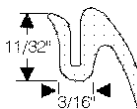

1947-1950 Fender skirt seal. Compare to picture. 1-10 foot strip.
 FS470.....\$45.50 ea.

1952 Mounting pads, rear fender crown molding Two per car. Models 41D, 45R, 46C and 48D.
 OP52S.....\$76.75 pr.

1942-1948 All and 1955 Rear fender reflex.
 TR425.....\$12.50 pr.

1940 Super and Roadmaster. Rubber stone shield, rear fender, right and left hand. Fully molded to original contour with attaching tabs but without steel backing plate. Will fit fender contour perfectly.
 GS40\$374.50 pr.



1940-1941 Super and Roadmaster. Rubber gravel guard between body and rear fender, right and left steel core.
 GG401\$122.25 pr.

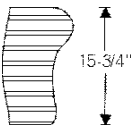

1941 Super and Roadmaster. Gravel shield, rear fender. Molded with metal backing and holding tabs as original.
 GS41.....\$374.50 pr.

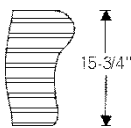

1941-1949 Gravel guard, rear fender. Fully molded with metal backing and attaching tabs as original.
1941: All 40, 60, & 90 Series except 40 Series 118" wheelbase models 44, 44C, 44S, 47;
1942: All 121" Series 40 and All 60 Series without factory fenderskirts;
1946-1949: All Series 40 without factory fenderskirts.
 GS419.....\$374.50 pr.

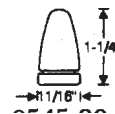

1957 All. Rear fender extension bumper.
 FEB57\$3.75 ea.

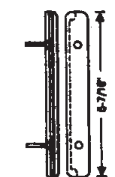

1959-1960 All except wagons. Fuel filler door bumper.
 FDB590.....\$15.25 ea.

Trunk Weatherstrips (12.269)

1936 Special and Century. Rumbleseat lid, lower, approximately 37" long.
RW36\$48.75 ea.

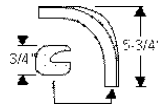

1949-1953 Molded wide corners to use with TW413 center section for across front of trunk opening. Molded corners made with each leg approximately 5-3/4" long. Some models as required.
TA493.....\$47.25 pr.

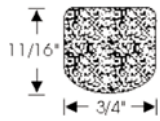

1936-1937 In gutter. 3/4" x 3/4" x 14'. Found in some sedan models. Sponge.
TW367\$70.00 ea.



1949-1953 Roadmasters, Series 70.
TW493R.....\$2.50/ft.



1936-1937 In gutter. 5/8" x 1/8" x 13'. Found in gutter of some sedan models. Sponge.
TW367A\$17.00 ea.

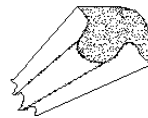

1949-1956
1949-1953 Special and Super.
1954-1956 Special, Century, Skylark. Located on trunk lid.
TW496.....\$2.75/ft.

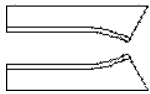

1937-1938 Convertible coupes. Rumbleseat lid, lower corner, RH and LH.
RW378\$48.75 ea.



1936-1940 Coupes and convertibles. Use as required.
TW360A.....3/4" x 1/2" x 16'.....\$49.00
TW360B.....1" x 1/2" x 16'.....\$51.00
TW360C.....1" x 5/8" x 16'.....\$78.00

Weatherstrip Adhesive

All Years. The Best weatherstrip adhesive we have found. 3M brand. 5 oz tube.



WA360.....\$11.75 ea.

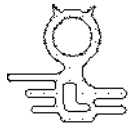

1937-1941 All Sedans, and convertible Sedans.
TW371.....15' length\$55.25 ea.



1954-1956 Super and Roadmaster. Located in gutter of body. Compare with TW542.
TW546.....\$4.25/ft.



1940-1949
1940: Super and Roadmaster;
1941: All;
1942-1949: Special.
TW408\$2.75/ft.



1954-1960
1954-1956: Series 50-70; Compare/TW546
1957-1960: All. In gutter. Compare/TW582.
TW542.....\$2.25/ft.



1941-1953 Used on Body for 5/8" to 3/4" gutter. Compare with TW493. Measure gutter width for correct weatherstrip.
TW413\$4.00/ft.



1958-1960 Located in gutter of body. Note "laid-over" configuration of sealing lip. Compare with TW542.
TW58218.....(18' length).....\$60.50 ea.
TW58220.....(20' length).....\$65.75 ea.



1940-1953
Used on body for 7/8" to 1" gutter. Compare with TW413.
TW493\$4.50/ft.



1942-1948 Super and Roadmaster. Available in 15 foot lengths.
TW428\$36.25 ea.

Fax Us Your Order
Save Time!
When sending us a long order
it is easier to just fax it.
908-369-7595

Trunk (Group 12)

Trunk Lid Bumpers



1937-1940 Bumper, decklid. Steel core, screw held. Two per car.

1937-1938: Series 40 and 60 coupes;

1939-1940: Series 40 and 60 coupe and convertibles.

TB370.....\$39.00 pr.

1940 Pads, decklid lower stop, right and left. Series 40 and 50.

TB40.....\$43.25 pr.



1941-1949 bumper, decklid opening on lid.



Metal core, as original, screw held. Two per car.

1941-1948: All;
1949: Series 40.

TB419.....\$9.50 pr.

1942-1950 Bumper, rubber, for decklid.

Molded with clearance for screw.

1942: All (except Series 90, station wagon, 44C Special convertible coupe).

1946-1950: All.



TB420.....\$1.50 ea.

1941-1960 All. Deck lid Bumper. Deck lid rests on pedestal type.

TB415.....\$1.75 ea.



1949-1960 All. Deck lid Bumper.

Plug in type on lid.

TB495.....\$2.75 ea.

1948-1953 Bumper, rubber, for tailgate on station wagon.

HFB483.....\$4.00 ea.



1950-1953 Bumper, tail gate. Metal core molded in as original. Series 59 and 79 wagons.

HFB502.....\$5.50 ea.

1951-1955 T-nut, rubber, decklid bumper ingutter at sides. Steel core, two required per car.

TB515.....\$13.50 ea.



1957-1958 Tailgate support bumper. 4 needed per car. Applies to all wagons.

TB578.....\$7.50 ea.



1957-1958 Tailgate anti-rattle bumper. Mounts on jamb area. Applies to all wagons.

TB578W.....\$9.00 ea.



1959 Tailgate bumper. Applies to all wagons.

TB59.....\$9.25 ea.

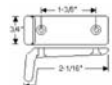

1959-1960 Tailgate weatherstrip. Applies to all wagons.

TW590.....\$20.50 pr.



1959-1960 Tailgate bumper. All wagons.

TB598.....\$3.00 ea.

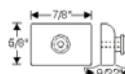

Trunk Floor Plugs



1940-1948 Plug, trunk floor pan construction holes, also rest pad for spare wheel area. 1 1/8" O.D., fits 7/8" diameter holes. 6-8 per car, as required. Series 50 and 70. FP408.....\$2.50 ea.



1950-1955 Plug, trunk floor pan. For 3/4" hole in sheet metal.

1950-1953 All;

1954-1955 Special, Century, Skylark FP505A.....\$3.00 ea.



1950-1960 Plug, trunk and floor pan drain hole. For 1/2" hole in sheet metal. Many models.

FP505.....\$2.25 ea.



1950-1957 Plug, floor pan, rear compartment and body, for 3/4" sheet metal hole. Many models.

FP507.....\$2.25 ea.



1959-1960 Plug, floor pan, rear compartment and body, for 3/4" sheet metal hole. Up to 12 per car.

FP596.....\$1.75 ea.



1936-1960 Rubber body hole plug. For 1" hole.

BP360.....\$3.00ea.

Body Plugs/Trunk Plugs

BP120 1/2" Hole Diameter.....\$1.75 ea.

BP580 5/8" Hole Diameter.....\$1.75 ea.

BP340 3/4" Hole Diameter.....\$2.25 ea.

BP780 7/8" Hole Diameter.....\$2.25 ea.

BP100 1" Hole Diameter.....\$1.75 ea.

BP114 1 1/4" Hole Dia.\$1.75 ea.

BP112 1 1/2" Hole Dia.\$2.25 ea.

BP118 1 1/8" Hole Dia.\$2.50 ea.

1935-1960 Plug, body sheet metal holes. Used in various places. For 1 1/2" hole in body. Many models.

BP355.....\$3.25 ea.

1959-1960 Plug, floor pan, rear compartment and body, for 3/4" sheet metal hole. 12 per car.

BP598.....\$2.25 ea.

1950-1960 Trunk Hinge to Lid bolt Set.

Set of 4 correct bolts and scalloped washers. TB500.....\$19.00 set



Trunk Lid Parts

1930-1937 Ferrule for 3/4" outside decklid handle. Chrome plated brass. Includes grommet.

HF307.....\$8.00 ea.

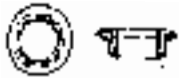

1938-1940 All. Ferrule, decklid handle, chrome with rubber sleeve.

HF380.....\$8.00 ea.

1940-1948 Ferrule and grommet set, outside decklid handle. Chrome plated brass with rubber sleeve.

1940: Series 50 and 70;

1941: All.

HF408.....\$8.00 ea.

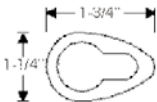

1951-1955 Trunk lock gasket as required. Tear drop shaped.

KLG399.....\$2.75 ea.



1954-1960 As required. Gasket, trunk lock cylinder. Exact reproduction. 7/8" I.D.

KLG540.....\$1.25 ea.

Trunk Area Parts



1936 All. Rumble step plate.

RP36\$28.50 ea.

1937-1938 All. Rumble step plate.

RP378\$10.75 ea.



1936 Pads, rumbleseat lid corners original style, rounded triangular shape. Some models.

LC36\$21.50 pr.



1939-1940 All. Gasket, turn signal bulb housing. 1/8" die cut sponge rubber.

DHG390\$19.00 pr.



1938-1942 Most models. Grommet, license lamp socket.

LG382.....\$6.75 ea.

Trunk Kit

1937 All. Trunk Kit

TPK37.....\$149.00 ea.



1941-1948 Most models. Grommet, license light wire through decklid inner panel. 1 1/4" O.D. x 3/8" I.D. 1/4" thick for 1" hole in sheet metal.

LG418\$1.75 ea.



1946-1960 Gasket set, rear license lamp assembly. One rubber ring and one cork rubber gasket set.

1946-1947: Series 50 and 70;

1950-1953: All Series;

1958: Roadmaster;

1959: Station wagons.

LG462.....\$6.50 set



Trunk Locks (with 2 keys)

1955-1958 All Except Wagons.

TLS558.....\$25.50 set

1959-1960 All Except Wagons.

TLS590.....\$27.75 set

Sound Deadening Material

Used under floor matting, on inside of outer sheet metal panels, between trunk inner panels etc.

Heavy, black, tar type material.

SD300.....44" x 64".....\$44.75 ea.

Waffle pattern, Dark Brown, more paper type.

SD301.....27"x 36".....\$25.25 ea.

Closed-cell Foam. Adhesive-backed. Form-fitting.

Light and soft. Nice underpadding.

SD302.....42" x 72".....\$37.50 ea.



1946-1960 Jack Case

A genuine Buick accessory, part # 981521, 981161.

These cases were made from excess materials left over from the upholstery shops at GM. They came in assorted colors and trim.

JC460BT.....(Black with Tan Trim).....\$34.75 ea.

JC460BR.....(Black with Red Trim).....\$34.75 ea.

JC460BY.....(Black with Gray Trim).....\$34.75 ea.

JC460BY.....(Black with White Trim).....\$34.75 ea.

Trunk Mounting Pads (Group 12)

Trunk Emblems and Hinge Pads



DLP37



DLP390



DLP428



DLP502

1937 Models 41, 48, 61, 68 and all Ser 80-90. Deck Lid Emblem Pad.	
DLP37.....	\$23.25 ea.
1937 Models 40c, 44, 47, 60c, 64, 67 Plainback. Deck Lid Emblem Pad.	
DLP37S.....	\$23.50 ea.
1938 All. Deck Lid Emblem Pad.	
DLP38.....	\$14.00 ea.
1939-1940 All. Deck Lid Emblem Pad.	
DLP390.....	\$18.00 ea.
1941 All. Deck Lid Emblem Pad.	
DLP41.....	\$18.00 ea.
1942-1948 Series 50-70. Deck Lid Emblem Pad.	
DLP428.....	\$32.50 ea.
1949 All. Deck Lid Emblem Pad.	
DLP49.....	\$25.25 ea.
1950-1952 All. Deck Lid Emblem Pad.	
DLP502.....	\$22.25 ea.
1953 All. Deck Lid Emblem Pad.	
DLP53.....	\$18.00 ea.
1954 All. Deck Lid Emblem Pad.	
DLP54.....	\$32.50 ea.
1955 All. Deck Lid Emblem Pad.	
DLP55.....	\$26.25 ea.
1956 All. Deck Lid Emblem Pad.	
DLP56.....	\$45.75 ea.



DLP37S



DLP41



DLP49



DLP53

Deck Handle Mounting Pads



DH381

1938-1941 All; 1942-1949 Specials. Deck Handle Mounting Pad.	
DH381.....	\$15.00 ea.
1942-1948 All Super and Roadmaster Models. Deck Handle Mounting Pad.	
DH429.....	\$15.00 ea.
1955-1958 Deck Handle Mounting Pad .	
1955-1957: Super and Roadmaster;	
1958: Special, Super and Century exc. wagons.	
DH558.....	\$9.75 ea.



DH429

Trunk Hinge Pads



TH36

1936 All. Trunk Hinge Pads. (4 piece set).	
TH36.....	\$19.00 set
1937 Roadmaster and Limited. Non-beaded as original. (4 piece set).	
TH37.....	\$25.75 set
1937-1938 Models 41,41C,48,61,61C,68. Trunk Hinge Pads. (4 piece set).	
TH378.....	\$28.25 set
1939-1940 All except 1940 Series 50-70 Coupe and Convertibles. Trunk Hinge Pads. (4 piece set).	
TH390.....	\$29.25 set
1940 Series 50-70 Coupe and Convertibles. Trunk Hinge Pads. (4 piece set).	
TH390C.....	\$25.25 set
1940-1942:	
1940 models, 56S, 56C, 56S, 76C Coupes;	
1941 models, 44, 44C, 44S, 56, 56S, 56C, 76S, 76C Coupes; 1942 models,	
44 Coupe.	
TH402.....	\$21.25 set



TH378



TH390

(Group 12) **Trunk Lid Ornaments**



1939-1941
Trunk Emblem.
TE391.....\$36.00 ea.

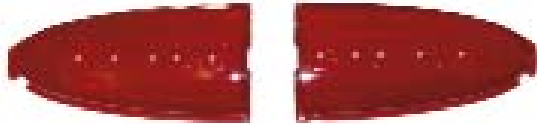

1940
Trunk Plastics. (For letter use TPL391).
TP40.....\$51.00 pr.

1939-1941
"BUICK EIGHT" Chrome letters.
TPL391.....\$23.25 set

1939-1940 Deck Lid Emblem, Lens Gasket.
DLG390.....(2 per car).....\$7.50 pr.



1941
Trunk Plastics (for letters, use TPL-391).
TP41.....\$42.25 pr.



1942-1948 All; 1949 Special
Trunk Base (die cast chrome)
TB428.....\$80.25 ea.



1942-1948 All; 1949 Special
TE429.....\$42.25 ea.



1942-1948 Trunk Plastics
TP428.....\$50.50 pr.



1948 "Dyna Flow" Trunk Plastics
TP48.....\$60.00 pr.



1949 Trunk Plastics. Series 50-70.
TP49.....\$120.00 set.



1950-1952 Trunk Plastics. For auto trans. cars
TP502.....\$95.50 pr.



1950-1952 Trunk Plastics. For standard trans. cars
TP502S.....\$120.00 pr.



1953 Trunk Plastics.



TP53.....\$62.50 pr.
1955 Trunk Plastic
TP55\$69.75 ea.



1958 Limited Trunk "Whiskers"
TW58\$33.50 ea.
TW58S.....(Set of 4).....\$119.50 set

Convertible Tops (Group 13)

Convertible Tops (13.347)

Our convertible tops are designed and manufactured by a large company responsible for thousands of trophy winning classic cars in the past 15 years. *Each top is Custom made for perfect appearance and fit.* All seams are sewn with matching bond thread, dielectrically or latex sealed for long lasting water protection. Tops are guaranteed against defects for a full 54 months. All tops come with heavy duty clear vinyl window. A solid rear panel can also be ordered for installation of your framed glass window. Hardware also included. We recommend Haartz Cloth for 1936-1953 **BUICKS** and Vinyl for 1954-1960 **BUICKS**. **When ordering**, keep in mind, the second color listed is the color inside the car.

HAARTZ Stayfast Cloth Tops: The best top available, made with 4 bonded layers of waterproof fabric.
Available Colors: Black/Black, Black/Tan, Dark Blue/Black, Medium Blue/Black, Medium Blue/Tan, Dark Brown/Black, Tan/Tan, Tan/Black, Lt. Neutral/Black, Lt. Neutral/Tan, Dk. Beige/Black, True Burgundy/Black, Charcoal/Black, Medium Gray/Black, Pepper/Black, Red Berry/Black.
 1941 thru 1960 only. No patterns for 1940 back.
 CT360HS.....\$571.25 kit

Stayfast by the yard. 58" wide. State color.
 SC300.....\$80.25 yd.

Bow Drill Cloth

Used to make convertible Top Wells. 66" wide.
 BD360B (Black).....\$22.75 per yd.
 BD360T (Tan).....\$22.75 per yd.



Convertible Top Frame Rebuilding Kits

Our kits contain all necessary bolts, bushings, nuts, washers, and rivets to completely rebuild your frame. TFK546 has 119 pieces, TFK546B has 125 pieces. You will need a 21/64" drill bit and a cold chisel to stake rivets.

1954-1956 All Special, Century, Skylark.
 TFK546.....\$167.75 ea.

1954-1956 All Super and Roadmaster.
 TFK546B.....\$212.25 ea.



Heavy Duty Vinyl: Quality Sateen Back 32 ounce durable vinyl. *Available Colors:* Black/Black, Tan/Tan, White/Black, Brown/Black, Beige/Sliver Tan, Red/Black, Maroon/Black, Green/Green, Dark Green/Black, Buckskin/Black, Pale Blue/Black, Med Blue/Black, Dark Blue/Black.
 CT360V32.....\$237.00 kit

Deluxe Heavy Duty Vinyl: Superior Sateen Back 38 ounce durable vinyl. *Available Colors:* Black over Black, White over Black.
 CT360V38.....\$335.50 kit

Convertible Top Pad Kit: For all convertible tops listed above. (13.349)
 TP360B.....(Black).....\$59.75 kit
 TP360T.....(Tan).....\$59.75 kit
 TP360D.....(Durable).....\$59.75 kit
 TP360S.....(Stayfast).....\$149.50 kit



Convertible Boots (13.450)

We have many patterns for boots in stock. We can also reproduce a boot from your old boot or pattern.
 TB400.....\$169.50 ea.

Convertible Well Liners (13.450)

We have patterns for the cars listed below at this time. We can also make a new well liner from your old one. Please inquire about this procedure.

1950-1952 Super and Roadmaster.
 WL502B.....\$104.50 ea.

1954-1958 Special, Century, Skylark.
 WL548.....\$104.50 ea.

1959-1960 All.
 WL590.....\$64.00 ea.

Seat Belts

Quality made aftermarket seat belts come in various colors and styles. Colored belts: add \$3 and code, are custom made and not returnable. Please see our website for colors. 74" recommended for fronts, 60" for rears. Per person.

Chrome Lift Lever Style



Lap belts come standard with authentic style chrome buckle. Black (B), tan (T), rust (R), dark brown (DB), orange (O), glove red (GR), maroon (M), charcoal (C), navy blue (NB), powder blue (PB), turquoise (TQ), ivory (I), white (W), gray (G), silver (S), dark green (DG).

- SB20074B.....(74" Black).....\$30.25 ea.
- SB20060B.....(60" Black).....\$30.25 ea.
- SBH200.....(Hardware Kit).....\$5.25 ea.

Plastic Push Button Style



Lap belts with push-button plastic buckle. Black (B), Taupe (T), Maroon (M), Light Gray (LG), Blue (U). Sizes available are 60" and 74" for the black, light gray and taupe. The blue and maroon are available in 74" only. Colored belts, (add \$3 and code), are custom made and not returnable.

- SB200P74B.....(74" Black).....\$30.25 ea.
- SB200P60B.....(60" Black).....\$30.25 ea.
- SBH200.....(Hardware Kit).....\$5.25 ea.

Metal Push Button Style



Lap belts with push-button metal buckle. Black (B), Taupe (T), Gray (G), Colored belts, (add \$3 and code), are custom made and not returnable.

- SB200M74B.....(74" Black).....\$30.25 ea.

Seatbelt Hardware Kit



- SBH200\$5.25 ea.

Dress-up Your Seat Belts



Buick Red, white and blue tri-shield. Fits well on our lift lever seat belts.

- D418\$3.75 ea.



Old style Buick coat of arms. Fits well on our lift lever seat belts.

- TBE550\$7.50 ea.



GM mark of excellence. Fits well on our lift lever seat belts.

- D55\$3.75 ea.



GM Mark of excellence. Embossed. Fits well on our lift lever seat belts.

- D55E\$6.50 ea.



www.oldbuickparts.com

908-369-3666

Convertible Top Hydro-lectric Systems (Group 14)

Firewall Pump Rebuilding Service (14.481)

1946-1954 Firewall pump rebuilding service. Our pumps are 100% remanufactured to operate better than new. Pumps are even returned with stainless steel screws. Add \$75.00 for 100 point restoration. See NOS section for pumps sold outright. * Five (5) year warranty.
 FPR464.....\$494.00 ea.

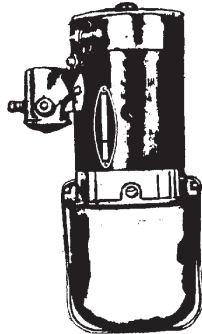

* Always use ATF. Brake fluid will reduce your warranty to one year.

1946-1953 6 Volt pumps firewall. Sold outright. These replacement pumps will fit in the original mounting location, but do not look original.
 TP463.....\$787.00 ea.

1953-1960 12 Volt firewall pump replacement.
 TP534.....\$787.00 ea.

Control Valves

(14.465)

Control Valve Rebuilding Service
Valves are cleaned, re-sealed and tested.



1946-1949 Under dash or on firewall bakelite valve type. New part! Sold outright.
 CV469\$296.00 ea.

1946-1950 Under dash or on firewall bakelite valve type. Rebuilding service.
 CVS465\$149.50 ea.

1950-1954 Under seat twin solenoid control valve. Direct replacement available in 6 or 12 volt.
 CV503.....(6 volt)\$692.00 ea.
 CV534.....(12 volt)\$692.00 ea.

1950-1954 Under seat twin solenoid type. Rebuilding service.
 CVS504\$321.75 ea.
 New cover\$95.00 ea.

Firewall Pump Solenoid (14.465)



PS464.....(6 Volt).....\$36.75 ea.



PS464H.....(12 Volt).....\$52.75 ea.

Firewall Pump Reservoir and Bails (14.486)

Duro/Hydro (Aluminum pump body): Short style reservoir. Zinc plated steel. Includes gasket.
 PR464S\$107.00 ea.
 Bail clip for above.
 RB464S\$27.25 ea.

Duro/Hydro: Steel tall style reservoir. Includes gasket.
 PR464S\$100.00 ea.
 Bail clip for above.
 RB464T\$27.75 ea.

GM/Moraine (Cast iron pump): Reservoir. Includes gasket.
 PR464T\$100.00 ea.
 Bail clip for above.
 RB464T\$27.75 ea.

Delco/Moraine rotary vane at 90° angle aluminum pump. Reservoir. Includes gasket.
 PR464D.....\$61.50 ea.

Convertible Top Frame Rebuilding Hardware Kit

1954-1956 Special, Century, Skylark. 119 piece kit.
 TFK546.....\$167.75 ea.
1954-1956 Super and Roadmaster. 125 piece kit.
 TFK546B\$212.25 ea.

Convertible Top Instruction Manuals

CTM49.....**1949**.....\$8.75 ea.
 CTM54.....**1954**.....\$8.75 ea.
 CTM55.....**1955**.....\$8.75 ea.

(Group 14) **Convertible Top Hydro-lectric Systems**

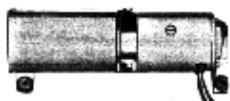

Convertible Top Motor/Pump.
 Universal 12V replacement.
1955-1960. Includes mounts. (14.481)
 TP553.....\$232.75 ea.



Convertible Top Motor/Pump mounts.
1946-1954. Three per car.
 PM464\$8.75 ea.



1953-1960 Grommet, folding top hydraulic pump mount. Special design to hold pump mounting bracket to floor pan. Four per car.
 PM531\$1.75 ea.



Convertible Top Cylinders (14.475)

1946-1960 Convertible top cylinders. Absolutely the Best obtainable. Five (5) year warranty. Always use ATF.
 TIP! Always lubricate the shafts and seals with ATF after winter storage.
 TC460.....\$138.00 ea.



Convertible Top Hose Sets
 For years 1954 and earlier, please supply length and fittings information

1955-1956 All. Correct black rubber hose as original.
 CHS556.....\$107.00 set

1957-1960 All. Correct black rubber hose as original.
 CHS571.....\$107.00 set

Individual hoses are available for all applications. These replacement hoses do not look authentic, but they will function as original.
 CH460\$42.50 ea.

1946-1961 All. Folding top hydraulic cylinder support spacers. 4 used per car.
 CS461\$3.00 ea.



Window and Seat Cylinders

1946-1954 Includes solenoid. (Stainless steel shafts).
 Five (5) year warranty with ATF. One (1) year with brake fluid.

1946-1954 Door window cylinder.
 DC464\$149.00 ea.

1946-1954 Quarter window cylinder.
 QC464\$129.50 ea.

1946-1954 Seat cylinder. (Back and forth).
 SC464\$149.50 ea.

1946-1954 Seat cylinder. (Up and down). Rebuild.
 SC464P\$187.00 ea.

1957-1960 Chrome convertible top locking handles.
 TH570\$100.50 pr.

1949-1953 Convertible top locking handle with hardware.
 TH493\$65.75

Tacking Strips

1936-1960 Convertible top front tacking strip. 1/8" x 5/8".
 TSF360\$3.00/ft.

1936-1960 Convertible top rear tacking strip. 3/16" x 1/2".
 TSR360\$3.00/ft.

Convertible Top Parts (Group 14)

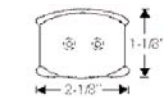

1936-1937 Detachable center post pad. Top and bottom 4/set.
PP367\$142.50 set.

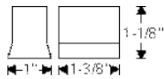

1936-1937 Model 80C Conv. top rest blocks.
RB367\$32.75 pr.

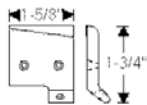

1936-1937 Model 80C Conv. top 3rd bow rest pads.
RP367\$47.75 pr.

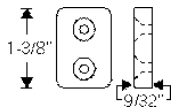

1936-1940 All. Slat iron to compartment pads.
SP360\$49.25 pr.

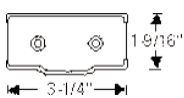

1937-1938 Models 40C and 60C. Detachable center post pad. Top and bottom 4/set.
PP378\$146.25 set.

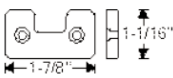

1937-1938 Special and Century convertibles. Folding post bottom pads.
PP378B.....\$55.50 pr.

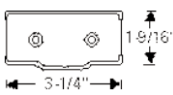

1938-1940 Series 80 convertible sedan. Detachable center post pad. Top and bottom 4/set.
PP380\$185.25 set.

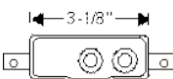

1939-1940 Models 41C and 61C. Detachable center post pad. Top and bottom 4/set.
PP390\$250.50 set.

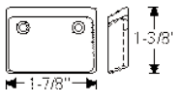

1940 Special and Century convertibles. Folding post pads.
PP40\$59.00 pr.

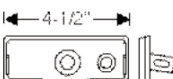

1940-1941 Models 51C and 71C. Detachable center post pad. Top and bottom 4/set.
PP401\$202.25 set.

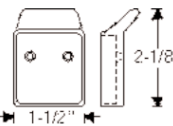

1940-1941 Convertibles. Top folding post bottom pads.
PP401CS..(For Convertible Sedans)\$52.00 pr.
PP401CC.(For Convertible Sedans)\$47.25 pr.

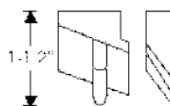

1941-1942 Model 44C. Side roof rail to front roof rail corner fillers. Metal core with threaded holes for screws. Pair.
TF412\$60.00 pr.



1941-1952 Top Cushions. 1941-1948 top end of folding pillar to side of roof rail at rear.
1941-1952 folding post on female hinge for folding top.
TC412.....\$23.50 pr.

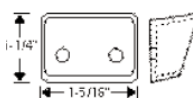

1942 Convertibles. Top folding post bottom pads. Metal core. Fastens with two screws.
PP42.....\$52.75 pr.

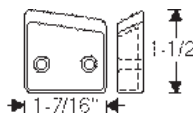

1942-1948 All convertibles. Bumper, folding top bow folding post on bottom of post, held by 2 screws. Steel core.
TB428C\$47.75 pr.



1942-1948 56C and 76C. Fillers, folding top to side roof rail to front roof rail. Metal core as original. Right and left sides.
TF428C\$47.25 pr.

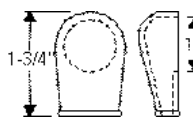

1949 Super and Roadmaster convertibles, side roof rail bumper caps. (Gray rubber, four per car). Set of 4.
TC49\$50.50 set

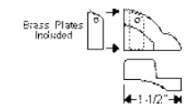

1949 Super and Roadmaster convertibles. Fillers, folding top front corners.
TF49\$39.75 pr.

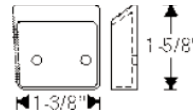

1949 Super and Roadmaster convertibles. Bumpers at rear quarter window.
TB49\$39.75 pr.

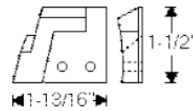

1950-1953 Super and Roadmaster. convertibles. Folding post hinge bumpers.
TB503.....\$54.75 pr.

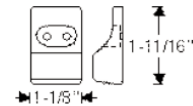

1951-1953 Roadmaster. Top rest pads.
RP513.....\$20.75 ea.

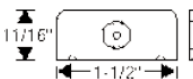

1953-1956 Side roof rail bumpers. 2-4/car
1953 model 46R;
1954-1956 All convertibles.
TB536.....\$31.75 pr.



1932-1933 Most Models. Extruded T-rubber.
RR323\$4.50 ft.

1933-1941 All. Fits into metal channel retainer. Sold in 12 ft. lengths. Enough for both sides.
RR341\$72.00 ea.

1942 Special. Eight (8) piece set for right and left sides, including windshield post strip.
RR42C.....\$234.00 ft.

1942-1948 Super and Roadmaster convertible sedan. Eight (8) piece set.
RR428\$328.25 set

1949 All. Six (6) piece set consists of right and left hand sections over door window quarter window, and folding top post. Does not include bow seal.
RR49C.....\$295.50 set

1950-1953 Super and Roadmaster. Eight (8) piece set for Right and Left side consists of: rubber sections for front corners, over door window, quarter window, and folding top post. Does not include windshield stanchion seals.
RR503\$383.25 set

1951-1952 Special. Six (6) piece set.
RR512\$206.00 set

1953 Specials. Nine (9) piece set includes left and right side (3 pieces per side), front corners, and front bow strip.
RR53\$260.00 set

1953 Skylark. Eight (8) piece set consists of right and left sections for front corners, door window upper quarter window upper, and folding top post.
RR53X.....\$521.50 set

1954-1956 Super and Roadmaster. Nine (9) piece set includes: metal cores, proper studs, and front bow weatherstrip.
RR546\$394.25 set.

1954-1956 Nine (9) piece set includes: front bow and two front corner sections.
1954-1956: Special and Century;
1954: Skylark.
RR546C.....\$418.50 set

1957-1958 Nine (9) piece set for right and left side includes: steel shank running full length with staked in studs as original, front corner pieces, and front bow seal.
1957: Super and Roadmaster;
1958: Roadmaster and Limited.
RR578BC\$370.50 set

1957-1958 Special and Century. Weatherstrip, convertible roof rail. Nine(9) piece set complete with metal core, proper studs and front bow with strip.
RR578C.....\$394.00 set

1959-1960 LeSabre and Invicta. Weatherstrip, roof rail. Set includes front bow seal, metal core and studs.
RR590B\$271.00 set

1959-1960 Electras. Seven (7) piece set includes: metal core, front bow seal and studs.
RR590C.....\$270.25 set

Adhesive Backed Bow Drill



Cloth tape used to cover roof rail weatherstrip rear 1/4 window seals, etc. as req. Waterproof and sunproof. Comes in 5 foot rolls.

BD250B.....(Black 2 1/2" wide).....\$9.75 ea.
BD250T.....(Tan 2 1/2" wide).....\$8.75 ea.
BD500B.....(Black 5" wide).....\$21.25 ea.
BD500T.....(Tan 5" wide).....\$21.25 ea.

Convertible Top Parts (Group 14)

Pillar Seals

- 1949** All Convertibles. Weatherstrip, windshield post to vent window frame, fits steel retainer rail, right and left. PS49.....\$91.50 pr.
- 1950-1953** Super, Roadmaster and Skylark convertibles. PS503.....\$118.25 pr.
- 1959-1960** Weatherstrip, front body hinge pillar, upper. Molded right and left, with retaining clips. Convertibles only. PS590.....\$94.00 pr.

Convertible Front Bow Seals (14.060)

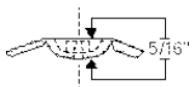

- 1932-1935** Weatherstrip, front bow-to-windshield, soft rubber with correct holes and hinged flaps. Convertibles. BS325.....\$118.00 ea.



- 1936-1937** Seal, convertible top front bow-to-windshield with integral end pads. Must be modified slightly. **1936:** All; **1937:** Series 80 and 90. BS367.....\$107.25 ea.

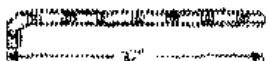

- 1937-1940** Weatherstrip, front bow-to-windshield, outer, right and left, molded with end hook, screw holes and clearances. Convertibles. BS370.....\$76.50 pr.

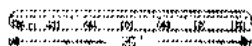

- 1937-1940** Weatherstrip, front bow-to-windshield, inner, right and left. Convertibles. BS370I.....\$73.00 pr.

- 1937-1940** Clip w/s fastener for front bow. Approx. 30 per car. Fits in 1/4" hole. Convertibles. Cadmium plated. BSC370.....\$2.00 ea.

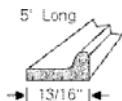

- 1939-1942** Weatherstrip and pad, front bow to windshield, inner. Approximately four (4) ft. 10" strip for one car. **1939-1941:** Sport Phaeton and all convertibles; **1942:** Series 40 convertibles. BS392.....\$28.25 ea.

- 1939-1948** Weatherstrip, front bow-to-windshield, outer, four (4) ft. 10" strip. All convertibles. BS398A.....\$35.25 ea.

- 1951-1953** Weatherstrip, front bow of convertible. Sponge rubber extrusion with correct dimensions. 5' length. BS513E.....\$17.00 ea.

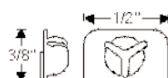

- 1942-1948** Super and Roadmaster. Weatherstrip, windshield header fo folding top. BS428.....\$149.00 ea.

- 1949** Super and Roadmaster convertibles. Weatherstrip, windshield header to convertible front bow. Molded replacement with correct holes for locking pins. BS49.....\$146.50 ea.

- 1951-1953** Weatherstrip, front bow with strip. With metal core in center section as original. **1951:** 56C after body #6528; **1951:** 76C after body #2508; **1952-1953:** All 56C and 76C. BS513.....\$152.50 ea.

- 1954-1956** Series 40-60-100 convert. top bow seal. BS546.....\$16.00 ea.

Drain Tubes and Grommets



- 1957** Special and Century convertible drain tubes. DT57.....\$34.50 pr.



- 1957** Special and Century convertible drain tube grommets. TG57.....\$20.00 pr.



- 1957** All convertibles. Lock pillar weatherstrip. Located under rear 1/4 window. LPW57.....\$69.75 pr.

Convertible Top Molding Clips



- 1957** Special and Century convertibles. For belt molding. Up to 20 per car. MC90.....\$3.75 ea.



www.oldbuickparts.com

908-369-3666

Our Headliners are the finest quality, manufactured by the same company that supplies G.M. All Headliners are custom made from original patterns to guarantee perfect fit and easy installation. All kits include: detailed instructions and contain extra material to cover the sun visors. Samples of materials are available upon request by sending SASE.

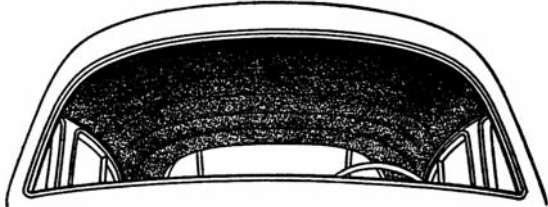

Headliner Trim Kits

Our Trim Kits come complete with the proper amount of windlace, wire-on, and instructions. (extra wire-on may be needed on some 1935-1949 cars. *Please order* WO359.....\$11.00 yd.)

HTK3582.....	1935-1948	2-dr. Models.....	\$ 93.50
HTK3584.....	1935-1950	4-dr. Models.....	\$167.75
HTK4902.....	1949-1960	2-dr. Models.....	\$ 98.50
HTK4904.....	1949-1960	4-dr. Models.....	\$167.75

Original style cloth covered windlace. Available in 14 colors. Black, Cashmere, Taupe, Antique Taupe, Brown, Dark Brown, Gray, Antique Gray, Green, Dark Green, Blue, Dark Blue, Red, Maroon.
WL360\$10 yd.

When ordering Headliner or Headliner Trim Kits, please give all information about the car, including **Model** and **Style** Number. This number is stamped on the I.D. plate on the firewall. These items are custom made. Allow two to three weeks for delivery.

Windlace Stops

1930's thru 1960's all as required.
WLS360.....\$11.75 pr.



1935-1958 Napped Cloth Headliners

Cloth Colors Available: Gray, Dark Taupe, Dark Tan, Black, Med. Blue, Lt. Green, Dk. Green, Aqua, Ivory, Red, Maroon. Other colors available upon request (please send SASE for samples) (Extra Cloth Headlining Material. 54" wide - \$22.00 yard). Add \$15 for wagons.

HL357.....	1935-1947	\$167.75
HL488.....	1948-1958	\$197.75

1954-1960 Leatherette Headliners

VINYL COLORS AVAILABLE: White, Off White, Black, Brown, Beige, Tan, Dark Blue, Maroon, Green, Red, Turquoise, Yellow, Black or White Perforated. (Extra Leatherette Material. 54" wide - \$16.00 yard).

HL540.....	\$169.50
HL540P.....(Perforated).....	\$169.50

Package Shelf Material

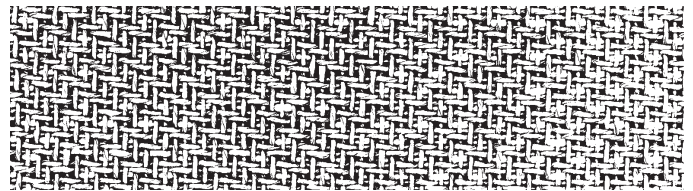

Woven straw material duplicates the texture and appearance of the original. Comes in 18" x 64" roll. It can be applied to hardboard with spray adhesive (SA360), then trimmed to fit. Paint to match. All models as required.
PS300.....\$59.50 ea.

Carpets • Mats (Group 15)

1949-1960 Front and Rear Carpet Sets



Our carpets are cut and sewn from manufacturers specifications for correct fit and easy installation. All sets include matching vinyl heel pad on drivers side, bound edges, and jute underpadding. 500 Series is 80/20 Ralon. 600 and 800 Series is 100% nylon.

Full Set (front & rear) 500 Series Nylon Loop.....\$151.50
 Full Set (front & rear) 600 Series Nylon Loop.....\$151.50
 Full Set (front & rear) 800 Series Nylon Cut Pile...\$151.50

When ordering, specify color and number, year, model and style of car. Colors listed are "names" only and do not imply any exact shade, color or trim code that may have been originally offered. **We strongly suggest that you receive a sample before you purchase any carpet.** FREE samples are available by sending S.A.S.E. Sorry, no returns on custom made items.

Carpet by the yard - 36" x 40" (for kick panels, doors, etc. (Two (2) yard minimum).

Nylon Loop\$51.50 yd.
 Nylon Cut Pile.....\$51.50 yd.

NYLON LOOP

SC501 - Black
 SC601 - Black
 SC622 - Light Blue
 SC540 - Navy Blue
 SC602 - Dark Blue
 SC508 - Turquoise
 SC608 - Turquoise
 SC609 - Forest Green
 SC565 - Bright Red
 SC615 - Deep Red
 SC525 - Burgundy
 SC625 - Maroon
 SC557 - Gunmetal Gray
 SC521 - Saddle
 SC621 - Saddle
 SC610 - Chocolate Brown

NYLON CUT PILE

SC801 - Black
 SC8170 - Lapis Blue
 SC840 - Navy Blue
 SC8075 - Medium Green
 SC815 - Deep Red
 SC825 - Maroon/Burgundy
 SC897 - Charcoal Gray
 SC853 - Silver Gray
 SC854 - Caramel
 SC851 - Biscuit
 SC810 - Chocolate Brown

1937-1938 Front Floor Mats

1937-1938 All. Brown

FM378\$232.75 ea.

1937-1938 All. Black

FM378B.....\$222.75 ea.

1950-1956 Front Floor Mats (15.292)

An excellent reproduction of a Genuine Buick Accessory. These mats come in colors and apply to all models. They feature the Buick logo licensed by Buick. They can also be used in the rear depending upon your size requirements. They are 18" wide and 16 1/2" tall.



1950-1956 All models. Black with Buick logo. Oem #981116
 FM506\$41.00 pr.

1950-1956 All models. Blue with Buick logo. Oem #981118
 FM506U\$29.00 pr.

1950-1956 All models. Red with Buick logo. Oem #981510
 FM506R\$41.00 pr.

1950-1956 All models. Maroon w/Buick logo. Oem #981117
 FM506M\$41.00 pr.

1950-1956 All models. Green w/ Buick logo. Oem #981119
 FM506G\$41.00 pr.

All years. Carpet Under Padding. 27 oz. (36" x 72")

JP360.....\$14.00 ea.

All Years. Sound Deadening material. Heavy rubberized material. 39" x 72".

SD300.....\$44.75 ea.

All Years. Sound Deadening material. Lighter, dark brown more paper-type material. 27" x 36".

SD301.....\$25.25 ea.

All Years. Sound Deadening material. Closed-cell foam, adhesive backed. Very light and soft. Easy cut. 42" x 72".

SD302.....\$37.50 ea.

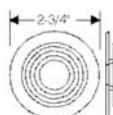

1936-1960 Grommet for dimmer Switch on carpet floor. 1" hole.

SG360\$7.00 ea.



1946-1956 Most Special, Century, Super.
TM466.....(56" Wide)\$59.50 yard



1950-1958 Roadmaster, Skylark, Limited
some others. Cross Stich\$69.50 yard
TM508G - 43" widegreen backing-green thread
TM508TB - 48" widetaupe backing-brown thread
TM508TV - 48" widetaupe backing-violet thread
TM508OO - 44" wideorange backing-orange thread

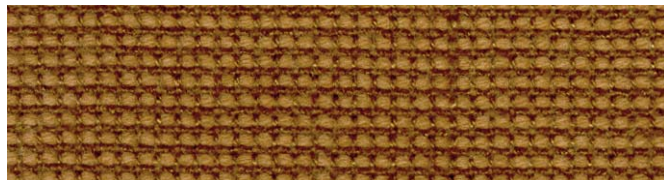

All years Universal. An inexpensive substitute for non-authentic trunk dress-up. High quality gold backing with darker gold thread.
TM6.....(60" Wide)\$47.50 yard

Sound Deadener Kit

Sound Deadeners help insulate your vehicle from road noise and engine heat. They are available in EVA, foil back or mastic with jute and are custom made to fit each model perfectly. ACC sound deadeners meet federal standards for flammability retardation. It's the perfect beginning when replacing your carpet and to increase its durability. 7 piece kit.

1955-1957 Century, Special and Roadmaster.
SD557.....\$100.00

1959-1960 LeSabre, Invicta and Electra.
SD590.....\$100.00



Trunk Cardboard Panel Kits (Group 15.222)

Below listed are new trunk panel kits that we have completed. These panel kits will complement our trunk lining material seen on previous pages. Panel Kits are available in the following colors and ordered by adding the corresponding letters to the part number. Example: if you want TPK546B in metallic green, order TPK546BMG. Of course, they may be custom sprayed the color of your choice.

We will continue to make more kits as we receive samples from our customers. Please let us know if you have patterns from your car that we can use. In turn we will supply you with a discounted new kit.

Color	Add Letters
Black	B
Brown	N
Gray	A
Maroon	M
Pebble Beige	PB
Off White	OW
Metallic Green	MG



TPK546A



TPK590C



1937 All.

TPK37.....\$125.00 set

1954-1956 All Super and Roadmaster exc. convt. 3 pieces.

TPK546A\$59.00 set

1954-1956 All Special and Century except convertibles and wagons. 3 pieces.

TPK546B\$59.00 set

1956 Super 4-dr. Hardtop.

TPK56A\$59.00 set

1956 Super 4-dr. Sedan.

TPK56B\$59.00 set

1957 All Special and Century 2-door Sedan models.

TPK186.....\$59.00 set

1959-1960 Electra 225 4-dr. hardtop.

TPK590A\$59.00 set

1959-1960 All Convertibles.

TPK590C\$59.00 set

SHOP MANUALS: A Shop Manual is *essential*. This should be your very first purchase after buying your car. These fully illustrated books were originally developed by **BUICK** for trained **BUICK** mechanics. They offer in detail, description and analysis as well as maintenance and step by step overhaul procedures. All of our Shop Manuals are *Full Size* as originals with the clearest print and pictures available in a "xerox" type copy form. The covers are "in color" and protected by a heavy clear plastic to keep them clean. As an additional feature, each manual is spiral bound in plastic for long lasting use.

OWNERS MANUALS: Originally placed in the glove compartment of each car. They contain a wealth of information on awareness, instruction and maintenance of your newly purchased car.

FISHER BODY MANUALS: These books are "Shop Manuals" for the Body of the car. Topics include Doors, Panels, Weatherstripping, Glass, Glass Channels and all interior. Fisher Body Manuals through 1948 deal with all G.M. Fisher Bodied Cars. Later years deal specifically with **BUICK** only.

CHASSIS AND BODY PARTS BOOKS: These books were sent to **BUICK** dealerships for their Parts Department Staff to recognize and identify parts. The illustrations within, enable you to find the "group" and "part number" of each part - then identify.

All items listed below are quality copied from genuine Buick originals. They are provided as informative tools for restoration purposes.

Shop Manuals		Fisher Manuals		Owners Manuals		Chassis & Body Parts Books	
1936 ALL.....	SM36..... \$43.75	BM36.....	\$20.00	OM36*....	\$14.75	PB2846..(740 pg.)...	\$68.50
1937 ALL.....	SM37..... \$43.75	BM378.....	\$20.00	OM37.....	\$14.75	PB2846..(740 pg.)...	\$68.50
1938 ALL.....	SM38..... \$43.75	BM378.....	\$20.00	OM38*...	\$14.75	PB2846..(740 pg.)...	\$68.50
1939 ALL.....	SM39..... \$43.75	BM390.....	\$20.00	OM39.....	\$14.75	PB2846..(740 pg.)...	\$68.50
NOTE: 1938 Shop Manuals is needed to supplement 1939 Shop Manual							
1940 ALL.....	SM40..... \$43.75	BM390.....	\$20.00	OM40*...	\$14.75	PB2846..(740 pg.)...	\$68.50
1941 ALL.....	SM41..... \$37.00	BM412.....	\$13.25	OM41*...	\$14.75	PB2846..(740 pg.)...	\$68.50
1942 ALL.....	SM42..... \$37.00	BM412.....	\$13.25	OM42.....	\$14.75	PB2846..(740 pg.)...	\$68.50
1946 ALL.....	SM46..... \$27.75	BM468.....	\$20.00	OM46.....	\$14.75	PB2846..(740 pg.)...	\$68.50
1947 ALL.....	SM47..... \$	BM468.....	\$20.00	OM47.....	\$14.75	PB429..(1435 pg.)	\$136.75
1948 ALL.....	SM489.... \$54.50	BM468.....	\$20.00	OM48*...	\$14.75	PB429..(1435 pg.)	\$136.75
1949 SPECIAL.....	SM489.... \$54.50	BM468.....	\$20.00	OM49.....	\$14.75	PB429..(1435 pg.)	\$136.75
1949 SUPER, ROADMASTER.....	SM489.... \$54.50	BM49.....	\$20.00	OM49*...	\$14.75	PB429..(1435 pg.)	\$136.75
1950 SPECIAL.....	SM50..... \$54.50	INC. IN SM50		OM50S...	\$14.75	PB429..(1435 pg.)	\$136.75
1950 SUPER, ROADMASTER.....	SM50..... \$54.50	INC. IN SM50		OM50*...	\$14.75	PB429..(1435 pg.)	\$136.75
1951 ALL.....	SM51..... \$54.50	INC. IN SM51		OM51*...	\$14.75	PB51.....	\$33.50
1952 ALL.....	SM52..... \$54.50	INC. IN SM52		OM52*...	\$14.75	PB52.....	\$33.50
1953 SPECIAL.....	SM52..... \$54.50	INC. IN SM52		OM53	\$14.75	PB53.....	\$33.50
1953 ALL V-8.....	SM53..... \$42.25	INC. IN SM53		OM53*...	\$14.75	PB53.....	\$33.50
1954 ALL.....	SM54..... \$54.50	INC. IN SM54		OM54.....	\$14.75	PB54.....	\$33.50
1955 ALL.....	SM55..... \$54.50	INC. IN SM55		OM55.....	\$14.75	PB55.....	\$33.50
1956 ALL.....	SM56..... \$54.50	INC. IN SM56		OM56.....	\$14.75	PB56.....	\$33.50
1957 ALL.....	SM57..... \$54.50	BM57....\$33.50		OM57*...	\$14.75	PB57.....	\$33.50
1958 ALL.....	SM58..... \$54.50	BM58....\$33.50		OM58.....	\$14.75	PB58.....	\$33.50
1959 ALL.....	SM59..... \$64.50	BM59....\$33.50		OM59.....	\$14.75	PB59.....	\$33.50
1960 ALL.....	SM60..... \$64.50	BM60....\$33.50		OM60.....	\$14.75	PB60.....	\$33.50

* Available in Full Color as original at \$22.75 ea. Add "c" to end part number

We also have Shop manuals available on CD ROM Disc - Ask your sales agent for details

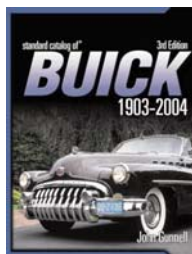

1903-2000 (Second Edition)
 Standard Catalog for Buick.
 CD ROM. Illustrated features,
 articles and specifications.
 Includes grading system and
 price guide.
 SG1CD.....\$20.00 ea.

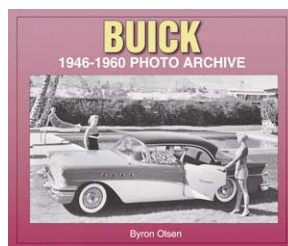

1946-1960
 Buick Photo Archive. 130 pages.
 Cleanly reproduced photos from
 General Motors archives and
 other sources. Great gift idea.
 PA1\$30.75 ea.

Shop Manuals on CDROM Disc

These computerized shop manuals will allow you to view the actual Buick publications on your computer screen or print them out for use in the shop. Most CD's also contain facts and figures for the model year(s) they cover. Our Cd's also include Chassis and Body Parts books at no extra charge.

1940 ALL: 1940 Shop manual, 1928-1954 Buick Parts, 1940-1970 Buick Parts	
SM40CD.....	\$49.75
1942-1947 ALL: 1942 Shop Manual, 1946-47 Shop Manual Supplement, 1928-1954 Buick Parts Book, 1940-1960 Buick Parts Book	
SM427CD.....	\$49.75
1948-1949 ALL: 1948 Buick Shop Manual, 1949 Supplement, 1948-1950 Dynaflo Manual 1928-1954 Buick Parts Book, 1940-1960 Buick Parts Book	
SM489CD.....	\$49.75
1950 ALL: 1950 Buick Shop Manual, 1948-1950 Dynaflo Manual, 1928-1954 Buick Parts Book 1940-1960 Buick Parts Book	
SM50CD.....	\$49.75
1951 ALL: 1951 Buick Shop Manual, 1928-1954 Buick Parts Book, 1940-1960 Buick Parts Book 1948-1950 Dynaflo Manual	
SM51CD.....	\$49.75
1952-1953 ALL: 1952 Buick Shop Manual, 1953 Supplement, 1928-1954 Buick Parts Book 1940-1960 Buick Parts Book	
SM523CD.....	\$51.25
1954 ALL: 1954 Buick Shop Manual, 1928-1954 Buick Parts Book, 1940-1960 Master Body Parts	
SM54CD.....	\$51.25
1955 ALL: 1955 Buick Shop Manual, 1940-1960 Buick Parts Book	
SM55CD.....	\$51.25
1956 ALL: 1956 Buick Shop Manual, 1940-1960 Buick Master Body Parts Book	
SM56CD.....	\$51.25
1957 ALL: 1957 Buick Shop Manual, 1957 Buick Body Manual, 1940-1960 Buick Parts Book	
SM57CD.....	\$51.25
1958 ALL: 1958 Buick Shop Manual, 1958 Buick Body Manual, 1940-1960 Buick Parts Book	
SM58CD.....	\$51.25
1959 ALL: 1959 Buick Shop Manual, 1959 Buick Body Manual, 1940-1960 Buick Parts Book	
SM59CD.....	\$51.25
1960 ALL: 1960 Buick Shop Manual, 1959 Buick Body Manual, 1940-1960 Buick Parts Book	
SM60CD.....	\$51.25

Sales Brochures, Technical Books, Guides, Lists, etc. (16.700)

YEAR	DESCRIPTION	ITEM #	PRICE
1936	Dealer Service Bulletins. 70 pages of problem fixers.....	DSB36.....	\$12.75
1936-1941	"Good Housekeeping In Your Car". 11 page booklet on upholstery care	GH361	\$ 5.50
1936-1952	GM Interchange Book	IB52.....	\$18.25
1936-1953	"Users Guide". 65 page booklets containing over 80 topics and 196 suggestions, to get the most out of your BUICK. (Was put in glove box of all GM cars in this era).	UG363.....	\$ 11.75
1937	Dealer Service Bulletins. 92 pages of problem fixers.....	DSB37	\$15.25
1937	"1937 Buick Delivered Price List"	PS37.....	\$ 2.25
1937	"1937 Buick Accessories" card. A listing of accessories and retail prices.....	DC37	\$ 3.25
1938	Dealer Service Bulletins. 95 pages of "problem fixers".....	DSB38.....	\$17.00
1938	"1938 Buick Delivered Price List". Price card for all models & accessories.....	DC38	\$ 3.25
1939	"1939 Buick Delivered Price List". Price card for all models & accessories.....	DC39	\$ 3.25
1940	"1940 Buick Delivered Price List". Price card for all models & accessories.....	DC40	\$ 3.25
1941	"1941 Buick Delivered Price List". Price card for all models & accessories.....	DC41	\$ 3.25
1941	1941 Buick Restoration Facts by William C. Anderson. 204 page book - great.....	RFB41	\$ 42.25
1946	1946 Models and Accessories Price List	PS46.....	\$ 2.75
1948-1950	Dynaflow Drive Repair Manual (can be used through 1953)	DDB480.....	\$15.00
1949	"1949 Buick Delivered Price List". Price card for all models and accessories	DC49	\$ 3.25
1949	"Features" sales booklet. Illustrates outstanding features of 1949 Buicks	SB49.....	\$ 9.00
1949-1955	Ionia Body Parts book for Buick Estate Wagons.....	WPB495	\$15.00
1949-1957	GM Interchange book.....	IB57	\$18.50
1950	1950 Models and Accessories Price List.	PS50.....	\$ 2.75
1950	"Engineer Approved Accessories for 1950"	AL50	\$11.25
1951	"1951 Buick Delivered Price List"	PS51.....	\$2.25
1952	1952 Models and Accessories Price List.	PS52.....	\$ 2.25
1952	"Engineer Approved Accessories for 1952"	AL52	\$ 11.25
1953	Shop Manual. Same as previous page but bound poorly. Great for a working manual. This is the manual your not afraid to get greasy. 1/3 the price	SM53S.....	\$14.50
1953	1953 Models and Accessories Price List	PS53.....	\$ 2.50
1953	"Engineer Approved Accessories for 1953"	AL53	\$ 11.25
1953-1955	Air Conditioning Manual.	ACB534	\$11.00
1953-1960	Kelsey-Hayes Power Brake repair pamphlet	BB530.....	\$ 11.25
1954	1954 Models and Accessories Price List	PS54.....	\$ 2.50
1954	"Engineer Approved Accessories for 1954".	AL54	\$ 11.25
1955	1955 Models and Accessories Price List	PS55.....	\$ 2.50
1955	"Engineer Approved Accessories for 1955"	AL55	\$ 11.25
1956	1956 Models and Accessories Price List	PS56.....	\$ 2.75
1956	Power Steering System Repair Manual.	PSB56	\$ 10.00
1959	1959 Models and Accessories Price List	PS59.....	\$ 2.50

Hardware • Push-In Wire Clips (Group 17)



1/4" - 3/16" Hole size.
1/2" x 1/2".
MC3\$0.25 ea.
MC3B Box 100\$8.50 ea.



3/4" x 15/16" Head.
5/16" Hole size.
MC17\$0.50 ea.
MC17B Box 100\$24.00 ea.



1/2" Head diameter.
5/16" Hole size.
MC5\$0.50 ea.
MC5B Box 100\$24.00 ea.



A11/16" x 9/16" Head.
5/16" Hole size.
MC20\$0.25 ea.
MC20B Box 100.....\$17.00 ea.



1/2" Head diameter.
1/4" Hole size.
MC12\$0.25 ea.
MC12B Box 100\$12.25 ea.



1" x 7/8" Head.
5/16" - 3/8" Hole size.
MC21\$0.50 ea.



5/8" x 5/8" Head.
5/16" Hole size.
MC13\$0.25 ea.
MC13B Box 50\$8.50 ea.



7/8" x 7/8" Head.
5/16" - 3/8" Hole size.
MC22\$0.25 ea.
MC22B Box 50\$8.50 ea.



3/4" Head diameter.
5/16" - 3/8" Hole size
MC16\$0.50 ea.
MC16B Box 100\$39.00 ea.



1" x 1 1/8" Head.
5/16" - 3/8" Hole size.
MC24\$0.50 ea.





www.oldbuickparts.com

908-369-3666

Moulding Clips Threaded Type, (Nuts Included)

Door Panel Fasteners

- 

7/8" | 10 - 24 x 3/4" stud.
MC63.....\$0.75 ea.
- 

1 1/8" | 10 - 24 x 3/4" stud.
MC66.....\$0.75 ea.
- 

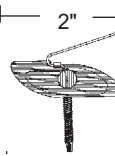
1 3/4" | 12 - 24 x 3/4" stud.
MC69.....\$1.00 ea.
- 

2" | 8 - 32 x 1" stud.
MC72.....\$0.50 ea.
- 

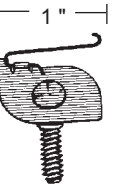
1 3/4" | 10 - 24 x 1/2" stud.
MC75.....\$2.75 ea.
- 

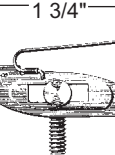
1" | 10 - 24 x 5/8" stud.
MC64.....\$0.75 ea.
- 

1 3/4" | Adjustable.
10 - 24 x 5/8" stud.
MC70\$1.25 ea.

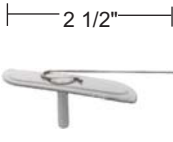
- 

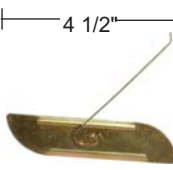
2 1/2" | 12 - 24 x 7/8" stud.
MC73.....\$1.00 ea.
- 

4 1/2" | 10 - 24 x 3/4" stud.
MC76.....\$3.50 ea.
- 

1 5/16" | 10 - 24 x 3/4" stud.
MC68.....\$0.75 ea.
- 

1 7/8" | 10 - 24 x 5/8" stud.
MC71.....\$0.75 ea.

Universal Break-Off Type

- 

10 - 24 x 3/4" stud.
MC1\$1.00 ea.

- 

Head Dia.3/4"
Stem Length.....1/2"
Fits Hole Size.....1/4"
DPF1.....\$0.50 ea.
- 

Head Dia.7/8"
Stem Length.....3/4"
Fits Hole Size.....1/4"
DPF2.....\$0.50 ea.
- 

Head Dia.3/4"
Stem Length.....3/4"
Fits Hole Size.....1/4"
DPF3.....\$0.50 ea.
- 

Head Dia.15/16"
Stem Length.....1 1/4"
Fits Hole Size.....1/4"
DPF4.....\$0.50 ea.
- 

Head Dia.15/16"
Stem Length.....5/16"
Fits Hole Size....11/16"
DPF5.....\$0.50 ea.
- 

Head Width.7/16"
DPF6.....\$1.00 ea.
- 

Head Width.5/8"
DPF7.....\$1.00 ea.
- 

Head Dia.1/2"
Stem Length.....3/4"
Fits Hole Size.....1/4"
DPF8.....\$0.25 ea.

Misc. Retainers

- 

Head Dia.7/16"
Stem Length.....7/16"
Fits Hole Size.....1/8"
WF2.....\$0.75 ea.
- 

Head Dia.7/16"
Stem Length.....5/8"
Fits Hole Size.....1/8"
WF3.....\$1.00 ea.
- 

Head Dia.9/16"
Stem Length.....3/4"
Fits Hole Size.....1/8"
WF4.....\$0.75 ea.

Push-In Clips

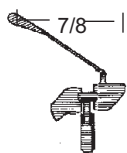

For 5/16" - 3/8" hole.
MC47\$0.75 ea.

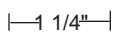

5/16" hole.
MC49\$0.75 ea.

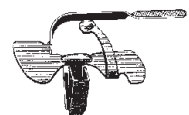
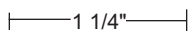

For 3/8" hole.
MC50\$0.75 ea.

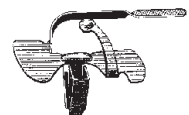
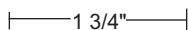

For 3/8" hole.
MC51\$2.25 ea.

Universal Wire Moulding Clips Push-in Type



5/16" - 1/2" Moulding.
3/8" Hole size.
MC29\$0.25 ea.
MC29B..Box 50..\$12.25 ea.

Nylon Clips

Push into oval holes in panels, then moulding snap over them.



MC84\$2.25 ea.



MC85\$2.25 ea.

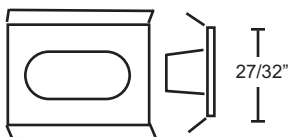

MC86\$2.25 ea.

Chrome Trim Screws



#6 Chrome Plated Phillips Oval Head

TS612.....	6x1/2"\$0.25
TS658.....	6x5/8"\$0.25
TS634.....	6x3/4"\$0.25
TS678.....	6x7/8"\$0.25
TS6100.....	6x1"\$0.50
TS6114.....	6x1 1/4"\$0.50

#8 Chrome Plated Phillips Oval Head

TS8386.....	8x3/8" w/ #6 Head.....	\$0.25
TS812.....	8x1/2".....	\$0.25
TS8126.....	8x1/2" w/ #6 Head.....	\$0.50
TS858.....	8x5/8".....	\$0.25
TS8586.....	8x5/8" w/ #6 Head.....	\$0.25
TS834.....	8x3/4".....	\$0.50
TS8346.....	8x3/4" w/ #6 Head.....	\$0.50
TS83410.....	8x3/4" w/ #10 Head.....	\$0.50
TS878.....	8x7/8".....	\$0.50
TS8786.....	8x7/8" w/ #6 Head.....	\$0.50
TS8100.....	8x1".....	\$0.50
TS81006.....	8x1" w/ #6 Head.....	\$0.50
TS8118.....	8x1 1/8".....	\$0.50
TS81186.....	8x1 1/8" w/ #6 Head.....	\$0.50
TS8114.....	8x1 1/4".....	\$0.50
TS81146.....	8x1 1/4" w/ #6 Head.....	\$0.50
TS8112.....	8x1 1/2".....	\$0.50
TS81126.....	8x1 1/2" w/ #6 Head.....	\$0.50
TS81346.....	8x1 3/4" w/ #6 Head.....	\$0.75

#10 Chrome Plated Phillips Oval Head

TS1012.....	10x1/2".....	\$0.50
TS10128.....	10x1/2" w/ #8 Head.....	\$0.50
TS1058.....	10x5/8".....	\$0.50
TS1034.....	10x3/4".....	\$0.50
TS1000.....	10x1".....	\$0.50
TS10008.....	10x1" w/ #8 Head.....	\$0.50
TS10114.....	10x1 1/4".....	\$0.50
TS101126.....	10x1 1/2" w/ #6 Head.....	\$0.50
TS10134.....	10x1 3/4" w/ #6 Head.....	\$0.75
TS10200.....	10x2.....	\$0.50
TS10348.....	10x3/4" w/ #8 Head.....	\$0.50

Windshield and Backglass Moulding Clips



1969-1975
1969-1970: LeSabre and Wildcat two door models. Backglass. 22 per car;
1971-1972: All Electra, LeSabre and Wildcat four door hardtops. Backglass. As required;
1971-1972: All Electra. Backglass. As required;
1973-1975: All windshield. Backglass and 1/4" glass. As required.
 MC32.....\$0.75 ea.



1968-1971
 1968: All with soft roof trim. Windshield upper and side. Backglass. As required;
1969-1971: All windshield and backglass. As required.
 MC33.....\$0.75 ea.
1968-1973 All windshield and Backglass (Emergency) As required.
 MC35.....\$1.00 ea.



1965-1968
 All windshield and Backglass. As required.
 MC34.....\$1.00 ea.



1966-1975
 All as required. Windshield and Backglass. (Emergency - screw-on type).
 MC37.....\$1.75 ea.

Other Windshield - Backglass Clips (Use as required)



Windshield & backglass clips. Use as required.
 MC43.....\$0.75 ea.



Windshield & backglass clips. Use as required.
 MC41\$0.75 ea.



Windshield & backglass clips. Use as required.
 MC44\$0.75 ea.



Windshield & backglass clips. Use as required.
 MC42.....\$0.75 ea.



Windshield & backglass clips. Use as required.
 MC39.....\$1.00 ea.

Window Rollers (see also window bearings on next page)



1957 thru 1972 all as required.
 WR576\$3.25



1978 thru 1995 all as required. 5/16 wide.
 WR785.....\$4.75 ea.



1969-1974 as required. 11/32" wide
 WR694.....\$5.50 ea.



1968 thru 1978 all as required. 7/16 wide.
 WR682\$4.75 ea.

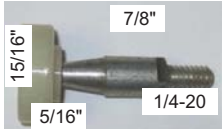

1968-1975 as required. 5/16 w.
 WR685.....\$3.75 ea.



1979-2004 as req. With metal insert.
 WR790.....\$3.75 ea.



1972 thru 1999 all as required. .11/64" id
 WR727\$2.25 ea.



1971-1980 as required. 5/16" w.
 WR710.....\$4.75 ea.

Hardware Section (Group 17)



Tubular Nuts (8.921)



For attaching monograms, emblems, etc. with studs. Measure your pin diameter and the size of the hole. Consider nylon tubular nuts. Although not original, they will not rust or chip paint.

Stud size 1/16" Hole size 9/64"
 TN1.....Nylon\$0.50 ea.
 TN1P.....Pack of 25\$7.75

Stud size 3/32" Hole size 1/8"
 TN2.....Steel\$0.25 ea.
 TN2P.....Pack of 25\$6.75

Stud size 1/8" Hole size 5/32"
 TN3.....Steel\$0.25 ea.
 TN3P.....Pack of 25\$6.75

Stud size 5/64" Hole size 5/32"
 TN4.....Nylon\$0.50 ea.
 TN4P.....Pack of 25\$7.75

Stud size 1/8" Hole size 11/64"
 TN5.....Nylon\$0.50 ea.
 TN5P.....Pack of 25\$9.75

Stud size 1/8" Hole size 3/16"
 TN6.....Steel\$0.50 ea.
 TN6P.....Pack of 25\$9.75

Stud size 1/8" Hole size 1/4"
 TN7.....Steel\$0.50 ea.
 TN7P.....Pack of 25\$8.75

Stud size 5/32" Hole size 7/32"
 TN8.....Steel\$0.50 ea.
 TN8P.....Pack of 25\$12.75

Stud size 5/32" Hole size 3/16"
 TN9.....Nylon\$0.50 ea.
 TN9P.....Pack of 25\$7.75

Stud size 3/16" Hole size 7/32"
 TN10.....Steel\$0.50 ea.
 TN10P.....Pack of 25\$8.75

Stud size 3/16" Hole size 13/64"
 TN11.....Steel\$0.50 ea.
 TN11P.....Pack of 25\$8.75

Stud size 1/4" Hole size 5/16"
 TN12.....Steel\$0.50 ea.
 TN12P.....Pack of 25\$9.75



Flat Nuts (8.921)

For attaching monograms, emblems, etc. with studs.

Measure your stud diameter.

FN1.....1/16"\$0.25 ea.
 FN1P.....Pack of 25\$4.75

FN2.....3/32"\$0.25 ea.
 FN2P.....Pack of 25\$4.75

FN3.....1/8"\$0.25 ea.
 FN3P.....Pack of 25\$4.75

FN4.....5/32"\$0.25 ea.
 FN4P.....Pack of 25\$4.75

FN5.....3/16"\$0.25 ea.
 FN5P.....Pack of 25\$4.75

FN6.....1/4"\$0.25 ea.
 FN6P.....Pack of 25\$5.75

FN7.....5/16"\$0.25 ea.
 FN7P.....Pack of 25\$5.75

Round Flat Nuts (8.921)



FN8.....1/8"\$0.25 ea.
 FN8P.....Pack of 25\$5.75

FN9.....3/16"\$0.25 ea.
 FN9P.....Pack of 25\$5.75

1935-1960 All as required. Cage nut.

Cage Nuts /"U" Nuts

(8.155)



CN363\$1.75 ea.

For 5/16"-18 Screw.
 Range - .025" - .060"
 Center of hole to edge
 - 9/16"

UN1\$0.50 ea.
 UN1B.....Box of 50\$17.00 ea.

For 3/8"-16 Screw.
 Range - .050" - .200"
 Center of hole to edge
 - 3/4"

UN2\$0.75 ea.
 UN2B.....Box of 25\$15.00 ea.

Thread Cutting Nuts



Sold in packs of 25 pieces (8.921)

5/16" Hex. For 1/4" stud.
 7/16" washer OD. Zinc plated.
 TCN516\$4.25 pack

3/8" Hex. For 3/16" stud.
 1/2" washer OD. Zinc plated.
 TCN38\$4.25 pack

11/32" Hex. For 5/32" stud.
 9/16" washer OD. Zinc plated.
 TCN1132\$4.50 pack

7/16" Hex. For 1/4" stud.
 11/16" washer OD. Zinc plated.
 TCN716\$4.50 pack
 1968-1974 as required. low profile.

Window Bearings



1 7/32" dia.
 WB684A.....\$3.75



1968-1974 as required.
 1" dia.
 WB684B.....\$3.75



1968-1974 as required.
 1" dia. high cap.
 WB684C\$3.75

Buick License Plates

Laser Cut License Plates

These beautiful license plates are made of durable high impact acrylic and are approximately 3/16" thick. Hand inlaid design.

1913 Buick Logo



Black acrylic with bright red square. The "Buick" is shiny mirror like. LP1\$25.75

Buick Tri-Shield - Gold



Black acrylic with gold mirror lettering. Tri-Shield is red, white and blue inlay. LP9\$25.75

Buick Tri-Shield - Silver



Black acrylic with silver mirror lettering. Tri-Shield is red, white and blue inlay. LP8\$25.75

T-Type Turbo 6



Black acrylic with bright yellow/red laser cut and inlaid insignia. LP7\$25.75

Silk Screened License Plates

Heavy gauge embossed aluminum plate.

Buick Tri-Shield



Black with white shield and red "BUICK" lettering. LP2\$8.00

Buick Gold Hawk



Black with gold BUICK Hawk. Sharp! LP3\$8.25

GS by Buick



Black with red "GS" and white "Fast with Class" LP4\$7.25

Grand National



Black plate, red and yellow "6" with gold lettering. LP6\$7.75

Buick License Plates - Frames and Accessories

License Plate Frame Solid Brass



These heavy, **solid brass** frames have "BUICK" stamped in the center flanked by the buick tri-shield. Gold & Chrome (pictured) available.

- Gold - LP13\$25.75
- Chrome - LP12\$25.75

License Plate Grand National



Bad to the

- bone.
- LP19\$7.25

License Plate Cover Bubble Cover

Protect your License plate with this clear see-thru bubble cover.

- LP14\$15.50

"GO BUICK"



These were found recently in the back room of an old Buick Dealership in Bayonne, NJ. Estimates are that these were from the 1970's.

- LP18\$6.25

Stainless Steel License Plates



Shiny **Stainless Steel** license plate with clear lettering. Tri-Shield is red, white and blue.

- LP10 (Clear Letters)\$25.75
- LP11 (GOLD Letters)\$25.75
- LP20 (BLACK Letters)\$25.75

Fender Covers

GSX Beats You in Stages



Heavy gauge with tool ridge

- FC5.....\$27.25

GS by Buick



A Quality fender cover with tool ridge

- FC3.....\$16.50

Index

B

Body to Frame Mounting Pads 73

- Body Mount Bolts 74
- Universal Body Mounts 74

Brakes 48

- 1939-1953 New Master Cylinders 48
- Drums 50
- Hoses 50
- Master Cylinder Resleeving Regular Brakes 48
- Master Cylinders Power Brakes 48
- Master Cylinders - Repair Kits 48
- Moraine Brake Shafts (Pistons) 48
- Overhaul Kits 49
- Pedal Pads 51
- Power Brake Master Cylinder Rebuilding Kits & Parts 48
- Power Brake Unit Rebuilding Service 48
- Shoes 50
- Silicone Brake Fluid 49
- Spring Kits 50
- Stop Light Switches 49
- Wheel Cylinder Re-Sleeving Service 49
- Wheel Cylinder Repair Kits 49
- Wheel Cylinders 49

Bumpers 65

- 1946-1949 Bumper Emblems 65
- Bolts 66
- Details 65
- Fillers 66
- Make Your Own Fillers 66
- Retaining Clips 66

C

Carpets • Mats 129

- Carpet Sets 129
- Front Floor Mats 129

Chrome Bolts 57

Complete Window Channel Kits 87

Convertible Roof Rail Weatherstrip 126

- Adhesive Backed Bow Drill 126
- Drain Tubes and Grommets 127
- Front Bow Seals 127
- Front Header Strips 127
- Pillar Seals 127
- Top Molding Clips 127

Convertible Top Hydro-lectric Systems 123

- Control Valves 123
- Firewall Pump Rebuilding Service 123
- Firewall Pump Solenoid 123
- Pump Reservoir and Bails 123
- Tacking Strips 124
- Top Cylinders 124
- Top Frame Rebuilding Hardware Kit 123
- Top Hose Sets 124
- Top Instruction Manuals 123
- Window and Seat Cylinders 124

Convertible Top Parts 125

Convertible Tops 121

- Boots 121
- Bow Drill Cloth 121
- Convertible Top Pad Kit 121
- Deluxe Heavy Duty Viny 121

- HAARTZ Stayfast Cloth Tops 121
- Heavy Duty Vinyl 121
- Top Frame Rebuilding Kits 121
- Well Liners 121

Cooling 14

- Cooling System Seal Tabs 15
- Fan Belts 16
- Heater Hose 16
- Heater Hose Clamp 16
- Radiator Cap 16
- Radiator Hose 15
- Radiator Hose Clamp 15
- Temperature Sending Unit 16
- Thermostat 16
- Water Outlet 16
- Water Pum 14
- Water Pump Cover 14
- Water Pump Hardware Kits 14

Cowl 79

- Cowl Parts 79
- Hood to Cowl Weatherstrips 79

D

Decals 9

Dome Lamps 108

- Dome Lenses - Courtesy Lenses 108

Door Bumpers 95

- Door Panel Retainers 95

Door Handles 96

- 1939-1958 Inner Door Handles 97
- 1939-1958 Window Cranks 97
- 1954-1958 Inner Door Handles 97
- 1954-1958 Window Cranks 97
- 1959-1960 Vent Cranks 97
- 1959-1960 Window Cranks 97
- Door Handle Ferrules 96
- Door Lock Pairs with 2 Keys 96
- Inner Door Handle Parts 97
- Key Blanks 96
- Outer Door Handle Parts 96
- Rear Ash Trays 97

Door Parts 98

- 24 Tooth Adaptor 98
- Door Lock Buttons 98
- Power Window Motor Rebuilding Service 98

Door Sills 109

Door Weatherstrip Sets 90

E

Engine 2

- Aluminum Valve Covers 6
- Camshaft Bearings 4
- Camshafts Regrinding Service 4
- Clutch Disc Rebuilding Service 8
- Clutch Parts 8
- Clutch Pilot Bearings 8
- Clutch Pressure Plate Assembly 8
- Clutch Throw Out Bearings 8
- Connecting Rod Bearings 4
- Connecting Rods 4
- Freeze Plug Kits 7
- Harmonic Balancer Rebuilding Service 5

Index

Intake Valves 3
Main Bearing Sets 4
Motor Mounts 2
New Camshafts 4
Piston Ring Sets 5
Pistons 5
Push Rods 5
Rocker Arm Adjusting Ball 7
Rocker Arm Assembly Rebuilding Service 7
Rocker Arm Shafts 7
Rocker Arms 7
Timing Chain Sets with Iron Cam Gear 6
Timing Chains 6
Valve Cover & Spark Plug Cover Hardware 7
Valve Guides & Seals 3
Valve Seat Inserts 3

Engine Enamel 13

Cast Iron Paint 13
Engine Compartment and Chassis Paint 13
Optional Dante Red Wheel Paint 13
Spray Gun 13

Engine Gaskets 11

Misc. Oil Gaskets 12
Oil Pan Gaskets 12
Push Rod Cover Gaskets 12
Rear Main Seals 11
Thermostat Related Gaskets 12
Timing Cover Gasket Sets 11
Timing Cover Gaskets & Seals 11
Valve Cover Gaskets 12
Water Pump & Manifold Gaskets 12

Exhaust 44

1957 Exhaust Deflector 44

V-8 Exhaust Manifold Gaskets 41

Authentic Hangers/Supports 44
Exhaust Deflectors 44
Exhaust Manifold 40
Exhaust Manifold Valve Body 40
Exhaust Manifold French Locks 41
Exhaust Manifold Gaskets 40
Universal Exhaust Hangers 44

F

Fender Cover 143

Fenders 71

1955-1956 Rear Fender and Rear Door Scripts 71
1958 Front Fender Ornaments 71
1959 Front Fender Monograms 71
Curb Feelers for All Years 71
Fender Hardware 71
Porthole Inserts PB 71
Portholes 71

Firewall 76

Heater Control Valves 77

Heater Hose at Cowl 77

Firewall Insulators 78

Floorpans • Rocker Panels • Trunk Pans 112

Frame 62

License Plate Frame 63
Miracle Paint 63

Rear Bumper Fillers (Gravel Deflectors) 63
Stabilizer Bar to Frame Bushings 62
Stabilizer Repair Kits 62
Tubing & Wiring Clip 63

Front Suspension 59

1934-1960 Wheel Grease Cap 61
1960 Steering Gear Box Rebuilding Kit 61
Centerlink Repair Kits 60
Front End Rebuilding Kits 60
Front Wheel Bearings 61
Front Wheel Grease Seals 61
Lower Control Arm 59
Pitman Shaft Seal Kit 61
Power Steering Hoses 61
Power Steering Pump Reservoir Cap 61
Power Steering Pump Seal Kits 61
Tie Rod End Adjusting Sleeve 60
Tie Rod Ends 60
Upper Control Arm 59

Front Vent Window Seals 84

Vent Window Lock Repair Kit 85
Windshield Drain Tubes 84

Fuel • Carburetion 38

1935-1953 Carburetor Mounting Insulators 42
1957-1958 Vacuum Pump 45
Accelerator Return Springs 42
Air Filters 42
Carburetor Dash Pots 42
Carburetor Rebuilding and Restoration Service 38
Carburetor to Air Cleaner Gaskets 39
Carburetor to Intake Manifold Gaskets 39
Carter Baffle Plates 39, 42
Carter Carburetor Rebuilding Kits 38
Cast Iron Paint 40, 41
Choke Stove Pipe Replacement Kits 71
Choke Stove Pipe Insulator 41
Cover Plate Assembly 45
Fuel Bowl Gaskets 39
Fuel Pump Hardware Kits 45
Fuel Pump Rebuilding 45
Fuel Pump Rebuilding Kits 45
Gas Caps 43
Gas Filler Grommets 43
Gas Filters 42
Gas Lines 45
Gas Pedals 44
Gas Tank Gasket & Parts 43
Gas Tank Sealer/Liner 43
Gas Tank Sending Units 1939-1958 43
Intake Manifold Gaskets 41
Intake Manifold Pilots 41
Intake Manifold Plugs 41
Intake Manifold/Carburetor Studs 41
Lead Additive 43
Linkage Rod Clips 42
Manifold Parts 40
Rochester Carburetor Kits 39
Stromberg Carburetor Kits 39
Valve Body Gaskets 40

G

Glass Channels and Supplies 89

Index

Adhesive Backed Bow Drill 89
Upper Window Frames 89

Grille Emblem 14

H

Hardware • Push-In Wire Clips 136

"U" Nuts 140
Backglass Clips 139
Cage Nuts 140
Chrome Trim Screws 138
Door Panel Fasteners 137
Flat Nuts 140
Misc. Retainers 137
Moulding Clips Threaded Type 137
Nylon Clips 138
Push-In Clips 138
Push-In Wire Clips 136
Round Flat Nuts 140
Thread Cutting Nuts 140
Tubular Nuts 140
Universal Break-Off Type 137
Universal Wire Moulding Clips Push-in Type 138
Window Bearings 140
Window Rollers 139
Windshield and Backglass Moulding Clips 139

Headlinings 128

Package Shelf Material 128
Trim Kits 128
Windlace Stops 128

Hood • Running Boards 69

Die Cut, Pre-formed Hood Insulation 69
Hood Corner Pads 69
Hood Insulation 69
Hood Insulation 1941-1960 69
Hood Insulation Retainers (Sombros) 69
Jack Case 69
Make You Own Fender Splash Aprons 69

Hood Bumpers 68

Hood Ornaments 67

Emblems 67
Letters 67

Hood Parts 70

1942-1948 Hood Handle Frame 70
Hood Cables and Springs 70

I

Interior Parts 100

"GM" Tissue Dispenser 100
Adhesive Backed Bow Drill 102
Bow Drill Cloth 102
Glove Box Lock with Two Original Keys 101
Glove Boxes 101
Inside Rear View Mirror 100
Tissue Dispenser Emblem 100
Vanity Mirrors 100

L

License Plate 141

License Plate Frame 142

Literature 132

Guides 134
Lists 134

Manuals 132
Parts Book 132
Sales Brochures 134
Technical Books 134

M

Mirrors 86

Replacement Mirror Head 86

Moulding 14

O

Oiling 17

GM Engine Lubricant 17
Oil Filter Element 17
Oil Filter/Breather Cap 17
Oil Pan Drain Plug and Gasket 17
Oil Pressure Switch 17
Oil Pump 17

Oiling Gasket 18

Oil Pan 18
Thermostat 18
Water Pump & Manifold 18

P

Power Window Switches 99

R

Radio • Antenna • Under Dash 75

1937-1938 Antenna Insulators 75
1941-1953 Roof Mounted Antennas 75
1948-1953 Heater Hose 75
1953-1960 Cigar Lighter Fuse 75
1954-1960 Front Fender Mounted Antenna Hardware 75
A.C. Clutch Bearing 75
A.C. Refrigerant for R-12 and 134-a 75
AC Compressor Bracket 75
Air Duct Hose 75
Steering Column Jackets 75

Rear Axle 55

Backing Plate Gaskets-Shims 56
Differential Bearings 56
Pinion Bearings 56
Pinion Seals 56
Radius Rod Bushings 55
Rear Axle Carrier Gaskets 56
Rear Axle Cover Gaskets 56
Rear Axle Seals 56
Rear Wheel Bearings 56
Rubber Parts 55

Rear Fender 115

Rear Fender • Running Boards 72

1954 Skylark Rear 1/4 Emblems 72
1955-1956 Rear Fender and Rear Door Scripts 72
1958 Rear Fender Louvers 72
1958 Rocker Panel Clips 72
1959 & 1960 Rear Fender Fin Clips 72
Running Board Matting 72

Rear Quarter Seals 106

Adhesive Backed Bow Drill 106
Fixed Seals 106
Lock Pillar Seals 107
Seals 106
Upper Chrome Frames 106

Index

Window Parts 107

Rear Window Vulcanized Seals 104

Clips 105
Drain Tubes 105
Seals 105

S

Seat Belts 122

Chrome Lift Lever Style 122
Dress-up your Seat Belts 122
Hardware Kit 122
Metal Push Button Style 122
Plastic Push Button Style 122

Seat Parts 108

Door Jamb Switches 108
Hog Ring Pliers 108
Hog Rings 108
Power Seat Switches 108

Shocks 63

Lever Type Shocks 64
Rear Shock Links 64
Rebuild 64

Spinner Retainers 57

Spinners & Inserts 57

Springs 62

Coil Springs 62
Insulator Pad 62

T

Torque Ball • Propeller Shaft 54

Boots 54
Bushings 54
Drive Shaft Bearing 54
Driveshaft Universal Joints 54
Dynaflow Torque Ball Sealing Kits 54
Outer Seals 54
Propeller Shaft 54
Retainer 54
Seal 54
Shim Kits 54
Supports 54
Tube Gaskets-Shims 54

Transmission 46

Automatic Transmission Kits 47
Bands 47
Dynaflow Transmission Pan Gaskets 47
Seals 47
Shift Boots 46
Shift Rod Insulators 46
Speedometer Cables 47
Standard Transmission Gasket Kits 47
Transmission Mount Rebuilding 46

Trunk 116

Body Plugs 117
Floor Plugs 117
Lid Bumpers 117
Lid Parts 118
Sound Deadening Material 118
Trunk Area Parts 118
Trunk Locks (with 2 keys) 118
Trunk Plugs 117
Weatherstrips 116

Trunk Cardboard Panel Kits 131

Trunk Lid Ornaments 120

Trunk Lining Materials 130

Trunk Mounting Pads 119

Deck Handle Mounting Pads 119
Hinge Pads 119
Trunk Emblems 119

V

Vulcanized Windshield Seals 83

Division Post Seals 83
Rubber Extrusions 83

W

Wheels 58

1934-1960 Valve Stem Caps 58
1955; 1956-1957 Wheel Cover Inserts 58
1958 Wheel Cover Inserts 58
Curb Feelers 58
Hubcap Clips 58
Hubcaps 58
Trim Rings 58
Wheel Bolts 58

Windshield Wiper Parts 80

1959-1960 Optikleen Bottles & Caps 81
Air Duct Hose 80
Blades 81
GM Lid Decal 81
Repair Kits 81
Trico Lid Decal 81
Washer Jars & Lids 81
Washer Nozzles 81
Wiper Motor Rebuilding Service 1935 thru 1958 81
Wiper Switch 81

Wire Wheels 57



www.oldbuickparts.com

NEVER CHANGE POINTS AGAIN!

UPGRADE TO AN ELECTRONIC IGNITION. FITS ENTIRELY INSIDE THE DISTRIBUTOR.
 INSTALLS AS QUICKLY AS CHANGING A SET OF POINTS. NO BLACK BOXES,
 COMPLICATED WIRING OR SPECIAL BRACKETS. ONLY TWO WIRES TO CONNECT.

IGNITOR ELECTRONIC IGNITION KITS

NO.

PRICE

8 CYLINDER

1937-1953 ALL Straight 8, 6 volt, negative ground.....	PI1183N6	\$82.25
1937-1953 ALL Straight 8, 12 volt, negative ground (original distributor)	PI1183	\$74.75
1953-1956 ALL V-8 Mechanical advance under baseplate	<i>New Design - No Magnet Ring</i> PI1185LSC	\$69.50
1957-1974 ALL V-8 Except 215, 300, 340 Engines	<i>New Design - No Magnet Ring</i> PI1181LSC	\$69.50
1957-1974 ALL V-8	PI1181	\$67.50
1957-1974 ALL V-8 (IGNITOR II)	PI91181	NEW \$95.25

6 CYLINDER

1968-1974 All	PI1162A	\$67.50
1962-1967 V-6 Engine.....	PI1164	\$67.50
1962-1967 V-6 Engine (Odd Fire)	PI1165	\$67.50

HIGH PERFORMANCE COILS (40,000 VOLT WITH STOCK APPEARANCE)



1937-1953 ALL Straight 8, 6 volt, negative ground (BLACK).....	PC45011	\$35.75
1937-1953 ALL Straight 8, 6 volt, negative ground (CHROME)	PC45001	\$44.00
1953-1974 ALL (BLACK)	PC40011	\$29.50
1953-1974 ALL (CHROME) 12 v.....	PC40001	\$37.50
1953-1974 ALL (FOR IGNITOR II APPLICATIONS ONLY)(CHROME) 12 v.....	PC45001	NEW \$44.00
1953-1974 ALL (FOR IGNITOR II APPLICATIONS ONLY)(BLACK) 12 v.	PC45011	NEW \$35.75
Coil Bracket	CB350	\$6.75
Coil Bracket (CHROME).....	CB350C	\$9.50

HIGH PERFORMANCE SPARK PLUG WIRES

Low 500 ohm/ft. resistance with spiral wound alloy to suppress electromagnetic radiation plus redundant current paths.

V-8 7.0MM STOCK-LOOK CUSTOM SET

1960-1967 Special, Skylark, GS (Ex 1967 GS 400)	PW708103	\$39.50
1953-1960 All	PW708103	\$39.50
1967-1966 Lesabre, Wildcat, Invicta, Electra, Riviera All 364,401,425 Engines.....	PW708105	\$39.50
1967 GS -400.....	PW708102	\$39.50
1968-1974 All 350, 400, 430, 455 w/o HEI	PW708102	\$39.50

6 CYLINDER 7.0MM STOCK-LOOK CUSTOM SET

1968-1974 ALL.....	PW706101	\$39.50
--------------------	----------	---------



BUICK CLUB OF AMERICA

PO Box 360775, Columbus, Ohio 43236

[Home](#)

Note: Complete and **"PRINT"** this form then send it to the BCA at address or fax at the bottom of the page. For online secure Membership Form [Click Here](#)

The Buick Club of America is a non-profit membership corporation dedicated to the preservation and restoration of those vehicles built by the Buick Motor Division of General Motors Corporation. BCA Membership (includes spouse and minor children only) offers the following:

- Monthly issue of **The Buick Bugle** published by the BCA,
- Advertising privileges in **The Buick Bugle** for Buick-Related items,
- Participation in all club events and opportunity to join local chapters and divisions,
- Membership card and, as a new members, one BCA decal. (Additional decals can be purchased from the San Gabriel Valley Chapter.)

Dues Schedule	US 2nd Class	US 1st Class	Canada & Mexico Periodical	Canada & Mexico Priority	International Surface	International Air
1 Year	<input checked="" type="radio"/> \$35	<input type="radio"/> \$55	<input type="radio"/> \$53	<input type="radio"/> \$83	<input type="radio"/> \$53	<input type="radio"/> \$83
2 Years	<input type="radio"/> \$65	<input type="radio"/> \$105	<input type="radio"/> \$106	<input type="radio"/> \$154	<input type="radio"/> \$106	<input type="radio"/> \$164
3 Years	<input type="radio"/> \$95	<input type="radio"/> \$155	<input type="radio"/> \$155	<input type="radio"/> \$230	<input type="radio"/> \$155	<input type="radio"/> \$245

The USA annual membership is \$35 - of this amount, \$34 is for subscription to **The Buick Bugle**. All foreign country remittances must be a bank draft or money order drawn on a USA bank and payable in USA currency, payable to Buick Club of America or Visa, Mastercard, or Discover (see below).

YOU AND YOUR BUICKS

Please enter your Name, Address, City, State, Zip+4, Phone, and E-Mail Address

OFFICE USE ONLY
Check /M.O. #
Visa - Mastercard - Discover
Date Processed
Expire Date
First Class - Surface - Air

New Or Renewal: BCA No.

(If you are a renewing member please include your most current mailing label.)

BUICKS CURRENTLY OWNED (ownership not a prerequisite for membership)

Year, Model Number or Type, Body Style (4 Dr/ 2 Dr), Vin #

Please Enter Sponsoring Member's Name Here

We occasionally make the membership list available to carefully screened companies whose products or services might interest you. If you would prefer to have your name withheld, place a mark in this box.

PAYMENT AND REMITTANCE

Check or Money Order made payable to **Buick Club of America** (Foreign country applicants must use bank draft or money order drawn on USA bank and payable in USA currency.) OR

Visa Mastercard Discover

Card Number and Exp. Date

Mail or fax this application to:

Officer Manager - **Buick Club of America**
PO Box 360775
Columbus, Ohio
43236

614-472-3939
614-472-3222 Fax

email: [Buick Club Office](#)

Telephone Number: 908-369-3666 Fax: 908-369-7595

Catalog Order Form

YEAR _____ CARB. _____

NAME _____ TRANS. _____

SUPER, ROADMASTER

SERIES _____ POWER BRAKES _____

40,50,70,4800,ETC.

BODY STYLE _____ POWER STEERING _____

ENGINE, CU. IN. _____ AIR CONDITIONING _____

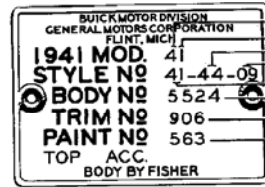

CREDIT CARD BILLING ADDRESS

SHIPPING ADDRESS (if different)

COMPANY _____
NAME _____
ADDRESS _____
CITY _____ STATE _____ ZIP _____
DAYTIME TELEPHONE _____

COMPANY _____
NAME _____
ADDRESS _____
CITY _____ STATE _____ ZIP _____
EVENING TELEPHONE _____

NOTE: ALWAYS GIVE STREET ADDRESS: UPS AND TRUCK LINES CANNOT DELIVER TO POST OFFICE BOXES.

QTY	GROUP NUMBER	PART NUMBER	DESCRIPTION	PRICE EACH	TOTAL PRICE OF ITEMS

Credit Card Information

Visa Mastercard Discover

IMPORTANT: COPY ACCOUNT NUMBER FROM YOUR CREDIT CARD

□□□□ □□□□ □□□□ □□□□

EXPIRATION DATE MONTH □□ YEAR □□ CVV2 □□□

3 Digits on Back

SIGNATURE _____

NOTE: ADDRESS ABOVE MUST BE EXACTLY AS IT APPEARS ON YOUR STATEMENT

SUB TOTAL	
US Shipping Add 10% (\$9.50 Min.)	
US Residential Delivery (\$1.50/\$2.50)*	
NJ Addresses Add 7% Sales Tax	
TOTAL AMOUNT	

*Note: UPS charges extra for residential type delivery (\$1.10) as well as an extended rural area delivery fee (\$1.50). These charges are not well defined by UPS and may affect your order total. We suggest you include these charges if you are unsure. We will gladly refund your money if not required.

Ordering Instructions

ORDER BY TELEPHONE, FAX or INTERNET

Monday through Friday, 8:30AM to 5:00PM.

Telephone: 908-369-3666

Fax: 908-369-7595

Website: www.oldbuickparts.com

ORDER BY MAIL. Please use Catalog Item Order Form, giving complete information requested. Order by Group and Part numbers where applicable. If you do not have enough space use back of the form or a plain piece of paper.

Shipping and Handling Charges

Shipping and Handling charges are 10% for orders under \$750.00 but not less than our \$8.00 minimum. Additional delivery charges for residential (\$1.50) and extended rural area delivery (\$1.50) as determined by UPS will also be added. We pay shipping on in stock orders over \$750.00 by UPS Ground within the 48 states (Not included are custom made items, rebuilt or special orders, large "ticket" items used parts and some NOS). Large items (fenders, hood, etc.) are shipped freight collect by common carrier and must be pre-paid by check. Foreign Customers please add 20% to order for shipping and handling. Additional shipping charges will apply to large or heavy items. (All Air Shipments, Blue Label, etc. are additional). We ship UPS unless specified.

Means of Payment



Personal Checks: We reserve the right to hold personal checks pending their clearance. Returned checks are subject to \$25 charge.

Visa-Mastercard:

Foreign: All orders are payable in U.S. funds only. Any extra charges applied such as foreign interchange, duties, customs fees etc. are the responsibility of the customer and will be passed on accordingly.

Damages in Shipment

Damage in transit is the responsibility of the delivering carrier. Retain all packing materials and immediately contact the carrier to file your claim. Do not return damaged items to us as further shipping will result in the loss of claim settlement.



Guarantee - Returns

Your satisfaction is very important to us. If you are not satisfied with an item please phone and tell us why. We will accept any returnable item **within 30 days of the sale** (call first for authorization) provided it is in good unused condition and is returned prepaid with a copy of our receipt. We will then replace the item or refund the original cost. **Parts returned through no fault of CARS, Inc. will be subject to a restocking charge.** Not included in this policy are custom made items such as yard goods, carpets etc., electrical items, and some used parts. Custom items, if made incorrectly with be repaired, not refunded. Labor charges are not refundable. Returns will effect discount and free shipping programs. Expedited delivery charges are not returnable under any circumstances. Computer Software is not returnable.

Back Orders

In the event an item is not in stock at the time of the order, we will back order until the item comes in or for 30 days at which time you may request a refund.

Subject to Change

All prices, part numbers, specifications, policies and terms are subject to change without notice. All parts subject to prior sale. Always double-check when ordering. Availability is not guaranteed.

Quantity Discount

We will extend a quantity discount of 10% on orders of new parts totalling over \$1,000.00 paid for by cash, check, or postal money order. Excluded are NOS, custom made items and all services. Friends and club members should find this advantageous by combining their orders to meet the quantity discount. All items, however, will be shipped to one address. Actual shipping charges will apply.

DEALER INQUIRIES WELCOME

Come visit our Showroom

CARS, Inc.

P.O. Box 5

205 Pearl Street

Neshanic Station, NJ 08853

Main: 908-369-3666

Fax: 908-369-7595

Website: www.oldbuickparts.com



CARS, Inc.

205 Pearl St.

Neshanic Station, NJ 08853

(908) 369-3666 Phone

(908) 369-7595 Fax



www.oldbuickparts.com

