



# HARADA HOUSE

**3356 Lemon Street  
Riverside, CA 92501**

April 30, 2018

## STRUCTURAL ENGINEERING ASSESSMENT REPORT

## Intent and Scope of Report

Over the past several years, Structural Focus has provided consulting structural engineering services on the National Historic Landmark Harada House in Riverside, CA. Several years of minimal activity has led to several occasions where temporary measures were implemented to address obvious building deficiencies. While these temporary measures have prolonged the life of the Harada House, it became clear during a meeting with City of Riverside personnel in April of 2017 that a revised approach was needed to finally undertake a full renovation of the Harada House. This Structural Assessment Report summarizes the efforts that have been completed and provides recommendations for immediate, short term, and long term actions necessary to stabilize the Harada House.



*Figure 1: Harada House  
Photo from 2015*

During a meeting on April 27, 2017 at the Riverside City Hall, the project team agreed it was time to step back and take a fresh look at the existing structure of the Harada House. This involved assessing structural deficiencies that need to be identified, documented and addressed. Several items were on the list of things to review:

- 1) Existing Foundation Damage - Revisit the extent and severity of the deterioration to the existing brick and concrete foundations.
- 2) Condition of Existing Perimeter Wood Framing - Exploratory dismantling of the exterior siding on all four elevations of the house was required to fully understand the condition of the wood framed structure. Assembling a set of Harada House Exterior Siding Dismantling and Reconstruction Drawings was necessary to bring a contractor on board to perform the work that would allow for a thorough observation of the condition of the existing perimeter wood framing.
- 3) Non-uniform Movement of House - While the findings from a monitoring survey in 2016 and 2017 did not indicate the house moved in a significant way over the six-month period between surveys, visual observations indicate movement of the house over its lifetime have not been uniform. These visual observations included identification of areas in the house that have moved several inches vertically as well as horizontal movement in both directions (north-south and east-west). It is also very clear that the house is out-of-level and no longer plumb. Therefore, exploring the non-uniform movement of the house needed to be investigated.
- 4) New Items - The Assessment was intended to identify any existing but not previously identified items that are of structural concern for the project moving forward.

After observing the condition of the existing perimeter wood framing (Item #2 above), it was determined that the condition of the interior wood framing should be assessed as well. However, that would require removal of the existing historic plaster finishes on at least one side of the interior walls. Based on direction from the Director of the Riverside Metropolitan Museum, we were directed to assume the worst-case scenario for the condition of the interior framing without

direct observation of those structural elements. All interior framing recommendations are based on the worst-case scenario assumption. No interior framing was exposed and observed.

### Limitations

Structural Focus' observations at the site were limited to the structural elements for which access was available. No interior building finishes were disturbed during site visits. In addition, no structural information in the form of structural drawings was available for the original building construction. Assumptions were made where necessary.

### Methodology

The following documents were reviewed and used in assembling this Structural Engineering Assessment Report:

- Long Range Conservation Plan/Historic Structure Report, Historic Resources Group, LLC, Dated January 11, 2007 (Structural portion prepared by Structural Focus.)
- Harada House Seismic Retrofit Drawings, Prepared by Structural Focus, S0.1A through S8.2 (11 sheets total), Dated February 5, 2008
- Harada House Monitoring Survey, Cornerstone Land Surveying Inc., First Survey Letter dated July 25, 2016, Second Survey Letter dated February 14, 2017
- Harada House Exterior Siding Dismantling and Reconstruction Drawings, Prepared by Structural Focus, S1.0 through S5.0 (5 sheets total), Dated August 7, 2017
- Plaster Observation Report, Prepared by Donna Williams at Williams Art Conservation, Inc., Dated 26 November 2017, Revised 4 December 2017, 2<sup>nd</sup> Revision 12 February 2018

While at the site, Structural Focus observed the condition of the existing structure, where visible, from the subterranean partial cellar, the crawl space below the house, around the perimeter from the exterior of the house during the siding removal process, and from the attic space through an access hatch in the second-floor hallway adjacent to the bathroom. The floor plans on the following page (Figure 2 and Figure 3) identify the location of these areas.

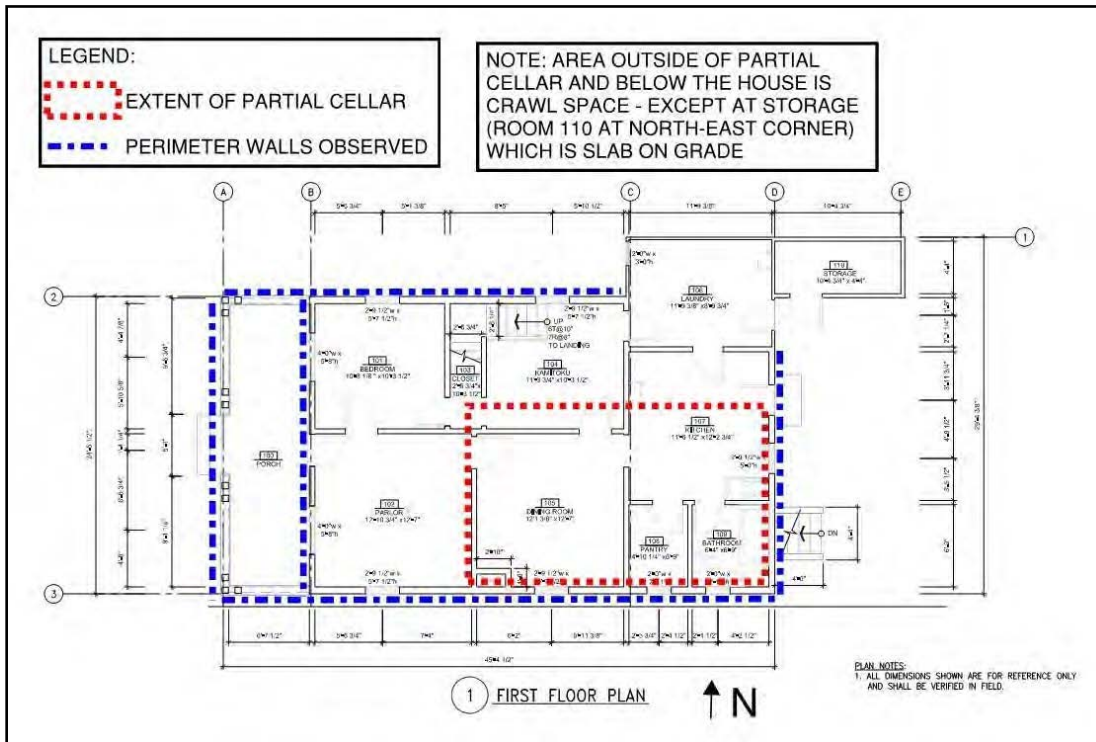

Figure 2 - First Floor Plan

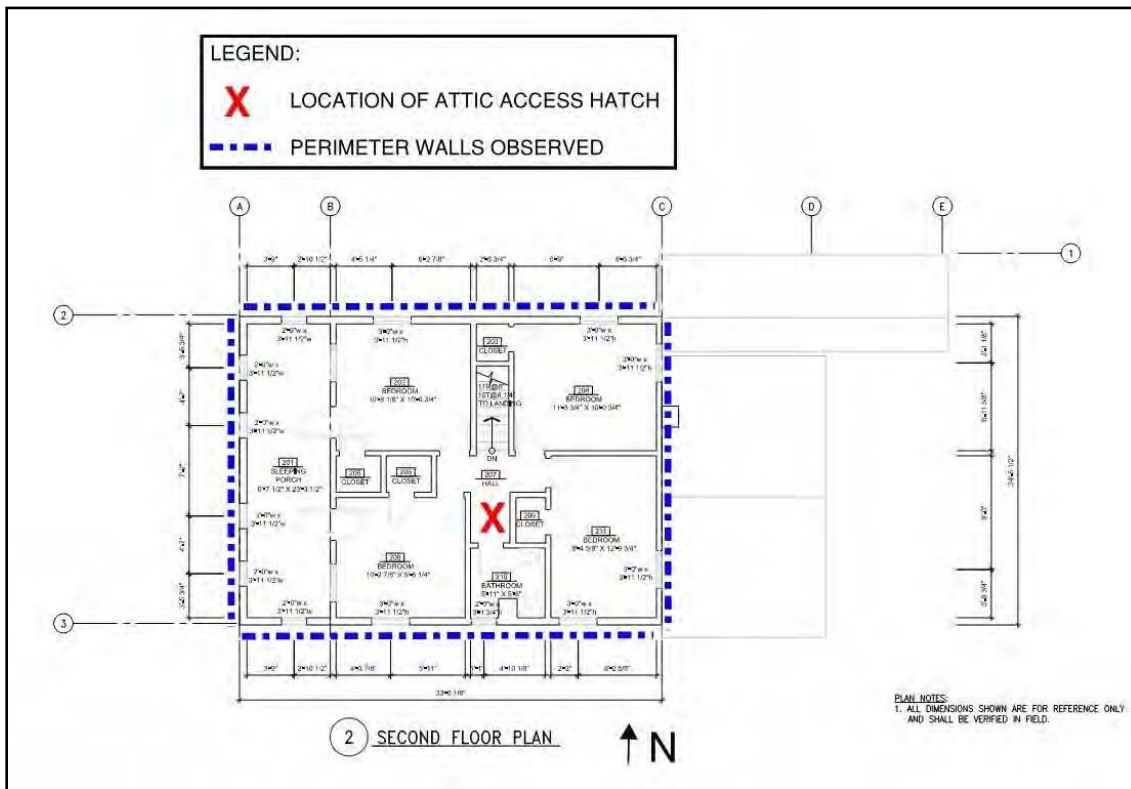

Figure 3 - Second Floor Plan

## Objectives

This Structural Assessment Report provides an overview of findings and recommendations related to the structural systems, including the following: general building observations; structural repair and seismic retrofit needs of internal and external structure including, but not limited to, the foundations, walls, floors, ceilings, and roof. A seismic retrofit of the Harada House is needed because the building structure does not currently have an adequate system for resisting structural loads from earthquakes and strong wind storms.

## Applicable Codes and Standards

As a National Historic Landmark, the Harada House qualifies for the use of the California Historical Building Code (CHBC) as the governing code. The state historical building code is intended to provide a minimum level of structural integrity for building structures without imposing the much more stringent requirements of the current building code. Upgrading historic structures in accordance with the current building code is simply not feasible in many cases. The CHBC recognizes that and was developed to keep our existing historic structures in service, where applicable.

## Description of Structure

### Building and Site

Located on a relatively flat site on the east side of Lemon St. in Riverside, CA, the Harada House was originally constructed in the late 1870's or early 1880's as a single-story house. A second-floor addition was completed in 1916, and the house is now a two-story wood framed structure of approximately 1,800 total square feet (excluding the front porch and rear storage portion). The laundry room, kitchen, and bathroom are located at the rear of the building in a single-story portion that was not covered by the second-floor addition. The house has three chimneys constructed of unreinforced brick masonry, one on the south elevation, one small chimney extending from the low roof above the kitchen along the exterior of the wall past the high roof on the rear (east) elevation, and one extending a few feet above the low roof of the laundry room in the northeast corner of the house. The kitchen and laundry room chimneys are supported on wood framing in the walls and do not extend to a brick foundation. The main chimney on the south elevation and the laundry room chimney were disassembled above the roof line as part of temporary stabilization work in 2006, and the chimney over the kitchen was enclosed and braced at the same time.

### Structural System

Building structures have three components that form the Structural System: 1) *Foundation System*, 2) *Vertical Load Resisting System*, and 3) *Lateral Load Resisting System*. The Foundation System is the base of the structure and is the critical component for supporting all levels of a building. Without a sturdy foundation, a structure will not be stable. The Vertical Load Resisting System supports a structure for gravity forces that act in the vertical direction. The Lateral Load Resisting System resists horizontal loads on a structure like forces from wind and seismic events. For a wood framed building, the lateral force resisting system consists of horizontal floor and roof diaphragms as well as vertical shear walls properly supported by the foundation system.



1) Foundation System

The Foundation System is the base of the structure and is the critical component for supporting all levels of a building. The Harada House is supported on wood posts on individual concrete and small brick pad foundations (spread footings) at the building interior in the crawl space (see Figure 4 below) and on straight line brick foundations (linear strip footings) around the perimeter of the building. A partial cellar was reportedly excavated in about 1915 and a new concrete foundation wall was constructed at that time. Figure 5 below shows the severely cracked concrete cellar wall located at the south-west corner of the house.

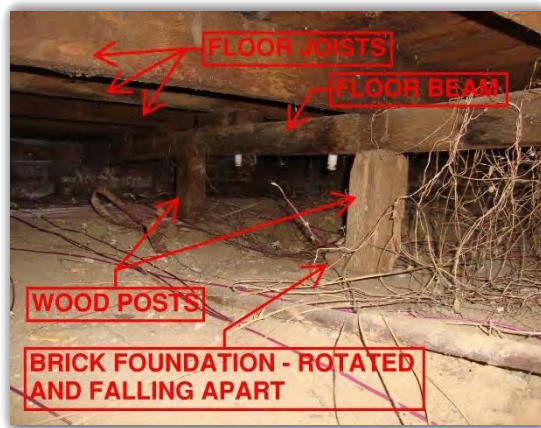

Figure 4 - Crawl Space Framing  
(June 20, 2017)



Figure 5 - Cellar Foundation Wall  
(July 27, 2016)

Although not verified with exploratory excavation, it appears that the perimeter wall foundations consist of double wide (two wythes) unreinforced brick. The depth of the brick foundation walls is unknown. The 2x wood sill plate typically bears on the top of the brick and the floor joists bear on the sill plate. The wall studs bear on the floor plate over the ends of the floor joists. There is typically no rim joist or blocking between the floor joists at the Ground Floor. There is no anchorage of the framing to the foundations. The condition of the brick foundation as observed from the interior side at the southwest corner cellar is very poor. The mortar joints are very soft and the bond between the bricks and mortar has released. The top course of brick on the south wall of the cellar have rotated and displaced due to rotation of the concrete retaining wall below. See Figure 6 for a photo of this condition.



Figure 6 - Rotated Brick Foundation below South Wall  
(June 20, 2017)

At the southeast corner, the crawlspace has been deepened to create a cellar and the south wall is a concrete retaining wall supporting the top three courses of brick. According to some records, the concrete wall was constructed in approximately 1915 to provide the space for the cellar and the bottom of the concrete foundation is approximately 6 inches below the floor of the cellar. However, the cellar floor elevation and therefore the bottom of the concrete wall is now unknown. In this location, the retaining wall is cracked in several locations and is leaning inward toward the building. In the remaining areas of the building there is a crawlspace roughly 24 inches tall (See Figure 4 above).

### 2) Vertical Load Resisting System

The Vertical Load Resisting System supports a structure for gravity forces that act in the vertical direction. For the Harada House, this system consists of wood framing. The walls are 2x4 wood studs and the hip roof is framed with 2x joists bearing on the perimeter walls. The original roof had skip sheathing that was retained where possible during the re-roofing project completed in 2006. The interior walls consist of 2x4 stud framing and the ceilings and walls are covered with wood lath and plaster. The floors are framed with 2x joists and sheathed with straight wood sheathing.

The roof is a hip roof and is framed of 2x4 roof rafters at approximately 30 inches on center. There are some vertical posts near the center of the roof to help support the roof framing and the posts are supported on the interior walls below. The ceiling is also framed of 2x joists and span between the interior and exterior walls.

### 3) Lateral Load Resisting System

The Lateral Load Resisting System resists horizontal loads on a structure like forces from wind and seismic events. The existing lateral load resisting system in the Harada House consists of the roof and floor horizontal diaphragms spanning to the interior and exterior wood framed walls. At the roof level, as part of the re-roofing project completed in 2006, new 5/16" plywood was installed on top of the ceiling joists to provide a horizontal diaphragm at the roof level. The plywood is blocked at the perimeter and anchored with framing hardware and nails to the top plates of the perimeter walls. The second floor and first floor diaphragms consist of straight wood sheathing and have not been modified or strengthened.



The original vertical lateral force resisting elements consist of the existing 2x4 wood stud walls. The interior walls are covered with wood lath and plaster on both faces, and the exterior perimeter walls have lath and plaster on the interior face and 1x horizontal clapboard siding on the exterior face. As part of this Structural Assessment project, the original siding was removed and replaced with plywood sheathing as shown in Figure 7 at the left. There is little

*Figure 7: Harada House with Plywood Sheathing  
(March 20, 2018)*

blocking between joists and plates at the floor levels and no mechanical connections observed other than some occasional toenails. The interior walls do not bear on foundations so the lateral loads transfer horizontally through the diaphragms to the perimeter walls. The perimeter wall framing is not anchored to the perimeter brick foundations that are in a state of disrepair.

### Findings, Recommendations, and Conclusions

The following excerpt was taken from the Historic Structures Report for the Harada House that was completed in 2007 (see pages 43 and 44).

#### Existing Conditions

The following field observations were made regarding the existing condition of the building:

- The concrete retaining wall in the cellar in the southwest corner on the south wall is leaning several inches into the building and has cracked severely in several locations, including one major horizontal crack at about half-height. The brick wythes on top of the retaining wall have rotated outward due to the weight of the wood stud wall on top. It appears that the much of the foundation damage is due to the lack of adequate drainage around the building leading to excessive water infiltration under and through the foundation walls into the crawlspace and cellar. Temporary shoring to prevent further damage at this location has been designed and installed. Shoring is exterior as well as interior. The exterior shoring also functions as a “cricket” that diverts rain and surface water away from the area in an effort to reduce hydrostatic pressure.
- The wood mudsill on top of the brick foundation wall along the south wall is significantly decayed and has crushed due to the weight of the wall above. Where the retaining wall is leaning and the bricks have rotated, the sill plate has begun to displace toward the exterior of the building. Although access to the sill plate at the other portions of the perimeter wall is very limited, it can be assumed that the sill plate is in poor condition around the entire perimeter of the building.
- Several of the wood floor joists in the cellar area are badly decayed and termite-damaged especially concentrated at the ends of the joists. Some joists are no longer supported on the foundation walls and have been shored recently to support vertical loads. Some of the wood bearing beams at the center of the house have failed due to decay and/or termite damage.
- Several of the interior wood support posts have completely displaced from the floor framing above due to erosion of the soil during flooding of the crawlspace and cellar area. Temporary shoring has recently been installed to provide vertical support in these areas.
- The remainder of the crawl space areas are largely inaccessible but it can be assumed that there is decay and termite damage.



- The chimneys were found to be in poor condition. The chimneys on the south elevation and in the laundry room were removed above the roof line, and the kitchen chimney was boxed and braced as part of the early stabilization work performed on the structure.
- On the south elevation, some temporary shoring has been installed to laterally and vertically support the area of the south wall immediately above the leaning retaining wall in the southwest corner. Where the retaining wall is leaning, the brick foundation wall has rotated allowing the wall framing to slide toward the exterior of the building. There is some separation of the framing noted at the interface between the lower roof over the kitchen and bathroom and rear wall of the building.
- Throughout the interior of the building the plaster has cracked significantly due to movement of the structural framing and water infiltration. Temporary shoring to hold the plaster in place has been installed.
- In some areas of the building, notably the Kamitoku, kitchen, and dining room, the wood subfloor has decayed and weakened.

All of our observations from the Historic Structures Report are still accurate, and many of them have continued to deteriorate over the last 10+ years.

### **Current Findings, Recommendations, and Conclusions**

The Dismantling and Reconstruction Drawings divided the exterior elevations of the Harada House into zones that were labeled in the drawing elevations. A copy of the drawings can be found at the end of this report. Removing the exterior siding in zones was necessary to preserve the stability of the house during the dismantling process while allowing access to observe the condition of the exterior wall framing. The dismantling of the siding started on the south elevation and proceeded around the house to the east elevation, north elevation, and finally the west elevation. Figure 2 and Figure 3 indicate the wall elevations of the house that were investigated (see previous pages and end of report for the Figures).

Our findings from the assessment effort are summarized below along with recommendations and conclusions for each specific item. Recommendations have been broken down into three categories:

- Immediate Future - This category includes items that have already been addressed as part of the temporary immediate repairs completed through this assessment as well as items that need to be addressed within the next six months. It's important to note that several of these items are being addressed in an urgent and temporary manner and a permanent fix will need to be completed as part of the permanent restoration of the Harada House.

- Short Term - Items in this category need to be addressed in the next two years.
  - Permanent Solution - These items need to be addressed as part of the permanent renovation of the Harada House.
1. Based on our observations of the Harada House structure, it has become clear that the existing wood framing and foundation system have deteriorated to a level that requires limited access to the house. In our professional opinion, we recommend the City of Riverside limits access to the house to City employees for essential purposes only. No public access should be allowed to the house. This recommendation falls under the **Immediate Future category**, and City personnel was notified of this recommendation while on site on March 20, 2018 and via email on March 27, 2018.
  2. Temporary Immediate Repairs - During the assessment discovery process, several conditions were found that required immediate measures to stabilize the Harada House. These items fall under the **Immediate Future category**, and the stabilization details provided to the contractor are documented in sketches at the end of this report. Figures 8 and 9 below illustrate where each of the repair sketches were implemented.

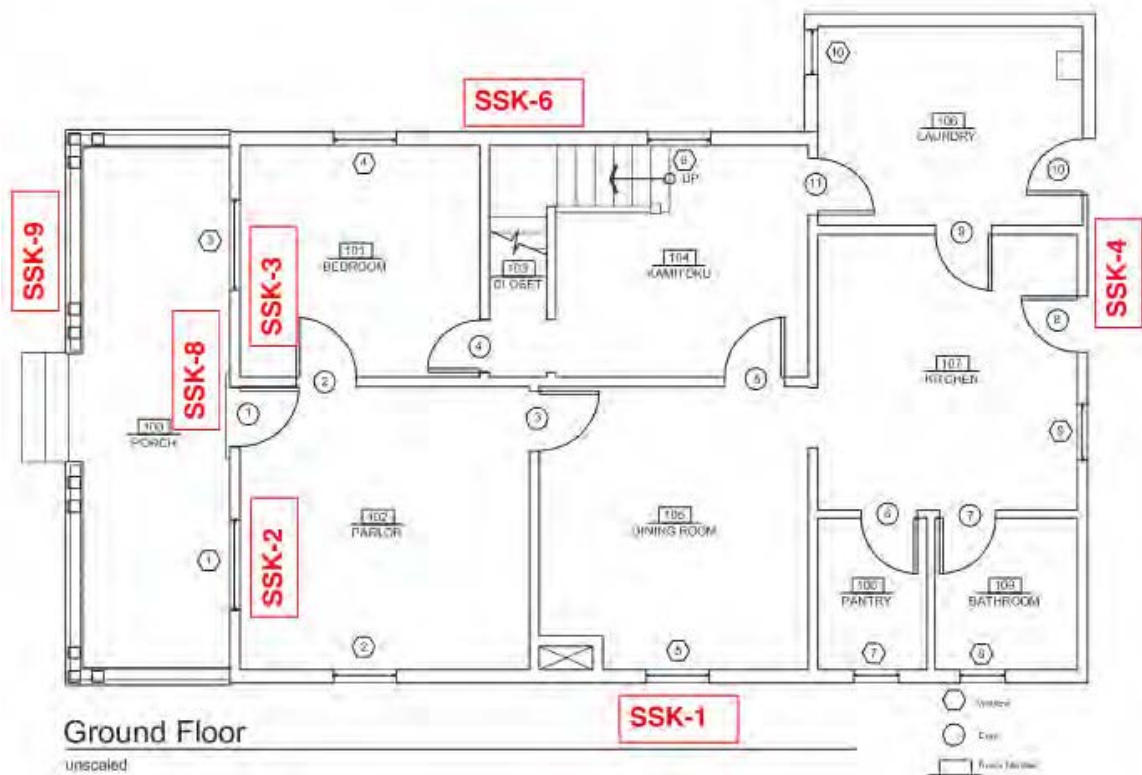

Figure 8 - Ground Floor Temporary Immediate Repair Sketch Locations

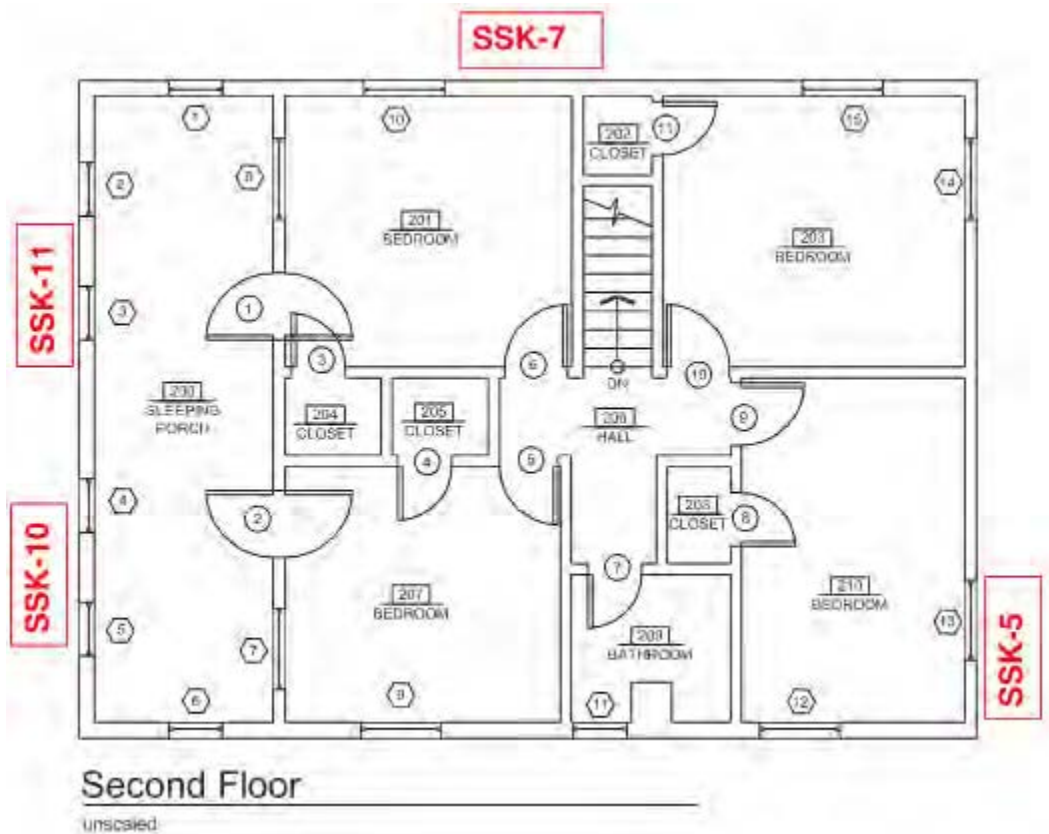

Figure 9 - Second Floor Temporary Immediate Repair Sketch Locations

A description of the Temporary Immediate Repairs that were addressed are described below:

- a. Severe damage was found at the base of the wall on the south elevation in the middle portion of the house. The damage included deteriorated wood framing from termites, dry rot, and water damage (Figure 8 at right). In addition, the removal of the siding exposed a framing condition where load bearing studs were only supported by the bottom plate of the wall. This is not an adequate way to properly support wall studs



Figure 10 - South Wall Deteriorated Wood Framing (November 9, 2017)

and is known as a discontinuous load bearing condition (Figure 9 at right).

The **Immediate Future category** repair for this condition was addressed with the implementation of sketch *SSK-1 Blocking at Base of Zone SIC*. The sketch can be found at the end of this report and provided new wood blocks at the base of the wall to provide direct support between load bearing exterior wall studs and the existing brick foundation. A permanent solution to this structural deficiency will be addressed with the construction of a new foundation for the building.

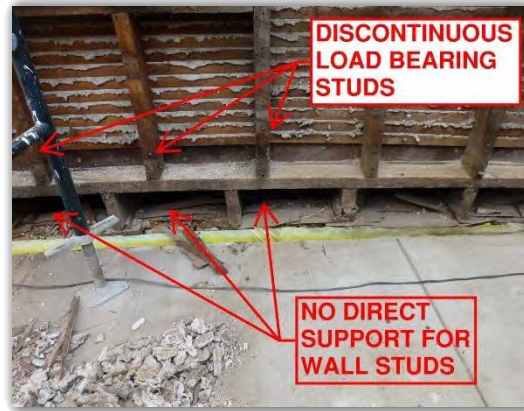

*Figure 11 - South Wall Discontinuous Load Bearing Condition (November 9, 2017)*

- b. The wood beam under the First Floor that supports the front door elevation (Grid B – see drawings on page 3 or drawings at end of this report) was found to be severely deteriorated at the south end. Upon further investigation, we discovered the beam contained severe deterioration along its full length, and the north end of the beam was in bad shape when the north elevation was exposed.

The **Immediate Future category** repair for this condition was addressed through the implementation of sketches *SSK-2 New Wood Beam at Grid B* and *SSK-3 Section at Grid B*. The sketches provided a new wood beam to restore the required strength and stiffness necessary to support the front door wall elevation.

- c. The east elevation of the house on the north side of the back door was not originally included in the Dismantling Plan because it was a small area and there were no visible signs of deterioration in that area. However, after observing the condition at the base of the east elevation on the south side of the back door, it was decided that the north side needed to be looked at as well. Water intrusion all along the base of the east elevation and the crumbling brick foundation has resulted in severe deterioration and damage to the wood framing.

*SSK-4 New Zone EIC* was issued as an **Immediate Future category** repair in order to add this zone to the areas of the exterior wall where the siding needed to be dismantled.



- d. Severe termite damage was found in two studs that support the south-east corner of the high roof. The most severely damaged stud was a header support stud (called a king stud) on the south side of the second-floor window. Approximately half of the stud width had been eaten away by termites, and the remaining portion of the stud was so compromised a nail could be pushed completely through with a bare hand. The photo at the right (Figure 12) shows this stud.



Figure 12 - Severely Compromised King Stud (November 29, 2017)

The repair for this condition involved replacing the severely damaged stud with a new stud. **Immediate Future** category repair SSK-5 Stud Replacement at Zone E2A shows the most severely damaged wood stud on the south side of the Second Floor window was removed and replaced with a new stud. The next stud to the south was supplemented by screwing a new stud to the side of the damaged one.

- e. The north elevation had two conditions that required immediate repair measures. The bottom plate of the ground floor wall was so badly damaged by termites that support for the north wall was compromised. In addition, the ground floor joist tails were irregularly framed and needed to be modified to facilitate the repair. At the second floor, the rim joist contained severe termite damage as well. Figure 12 and Figure 13 at the right show the extent of the damage.



Figure 13 - Second Floor Rim Joist with Termite Damage (December 7, 2017)

Two **Immediate Future** category repair sketches were issued to address the inadequate framing on the north elevation: SSK-6 Temp Repair at North Wall Bottom Plate and SSK-7 North Wall 2<sup>nd</sup> Floor Rim Joist. The bottom



Figure 14 - Back side of Second Floor rim joist after being removed (January 23, 2018)

plate of the ground floor wall was replaced, and the ground floor joist tails were supplemented with a new 2x joist screwed to the side and then trimmed to facilitate the repair. At the Second Floor, the rim joist was replaced.

- f. The front door elevation (Grid B) on the west side contained several conditions that were inconsistent with currently accepted framing practices. In addition to the severely deteriorated wood beam below the ground floor framing (see Item b. above), the front door and two window headers on each side of the front door were framed in a manner that does not provide adequate support for the Second Floor.

Sketch SSK-8 *Front Door Elevation* was implemented as an **Immediate Future category** repair that provided new 3x6 wood headers over the door and window openings. In addition, a continuous coil strap was added, with blocking where required, over the full length of the front door elevation just above the windows. The coil strap is necessary to tie all of the framing together along the front door elevation of the house.

- g. When initially looking at the front (west) elevation of the Harada House, the west elevation appeared to be properly supported by several posts. But after further investigation it was discovered that several of the posts were aesthetic in nature (false posts) and did not contain adequate structural elements to properly support the Second Floor. Where support for the second floor was provided, it was found to be a single 2x4 stud acting as a post. Once again, this is not consistent with modern framing practices and would not be adequate when strong lateral loads from a wind storm or an earthquake push on the Second Floor of the house. Therefore, the condition needed to be addressed with a repair that was in the **Immediate Future category**.

The repairs were addressed through sketch SSK-9 *West Elevation – Temporary Immediate Repairs*. Proper support for the Second Floor Sleeping Porch was added with the addition of new wood posts placed in the false post spaces at the north-west and south-west corner. The existing single 2x4 support posts were supplemented with new 2x4 studs screwed to the existing post. The strengthening of the posts fit within the architectural trim boards that surrounded the post location.

- h. The upper portion of the west elevation was found to be inadequately framed. Posts supporting the second-floor header and roof header did not exist. This leads to overstressed structural elements and excessive deflections that have a damaging effect on the structure and finishes in the building. While wood framed buildings tend to be resilient and find ways to stay standing, this condition only contributed to the deterioration that is abundant at the Harada House.

The inadequate framing led to sketch SSK-10 *West Elevation – Upper Portion* being implemented as an **Immediate Future** category repair. Similar to the repair work done at the Ground Floor of the west elevation, new wood posts were added and existing insufficient 2x4 wood studs were supplemented with new doubled (sistered) 2x4 studs.

- i. The second-floor header on the west elevation contained a problematic framing condition. The header was originally built as a let-in 2x header creating a notch in the studs that the porch ceiling joists hang from. Figure 15 illustrates this condition.

This condition was mitigated by SSK-11 *Detail at (E) Let-In Header (West Elevation)* as an **Immediate Future** category repair. The detail adds new posts from the foundation of the west elevation to the roof, special detailing was required to pass around the existing let-in header at the second-floor.

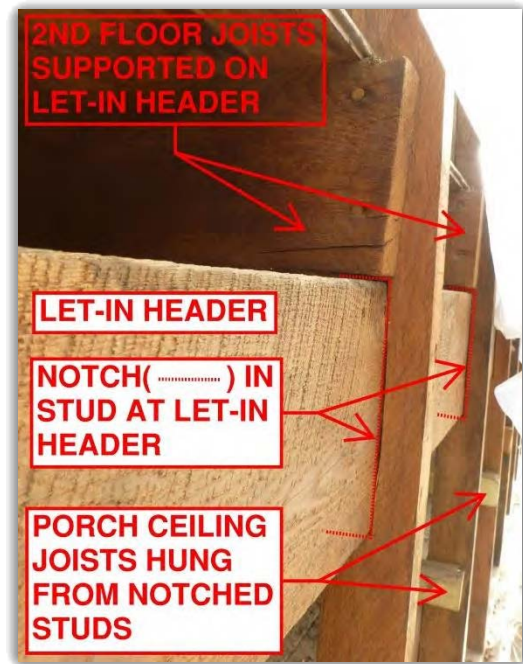

Figure 15 - Porch Ceiling Joists Hung from Notched Studs (January 16, 2018)

3. As noted in several of the Temporary Immediate Repairs listed above, severe termite damage was found in every exterior wall elevation when exposed. The ground floor framing and floor boards as observed from the partial cellar are also severely deteriorated from termite damage to the point that several holes through the floor were found. Additional photos of the most severe termite damage are provided in the photos at the end of this report. See Photos 1, 2, 4, 8, 10, and 11.

All structural elements that have been compromised by termite damage need to be replaced or supplemented with new wood members. This includes a large portion of the exterior wall framing that was observed during this structural assessment and is assumed to include the interior framing as mandated by the Director of the Riverside Metropolitan Museum since access was not provided to assess the interior wood framing. In addition, a robust termite inspection and treatment program by a qualified pest control professional shall be implemented and maintained immediately. The Termite Monitoring Program falls under the **Immediate Future** category.

Some of the termite damage was addressed as a temporary immediate repair in the Immediate Future category. The remainder of the termite damage needs to be addressed as part of the **Permanent Solution category** as long as the termite inspection and treatment program is initiated and maintained immediately in order to avoid further termite damage.

4. Several indicators of non-uniform movement in the house were observed. This included several level and plumb readings taken in the attic space over the second-floor, the second-floor walls and floors, and some areas of the ground floor. While the findings from a monitoring survey in 2016 and 2017 did not indicate the house moved in a significant way over the six-month period between surveys, visual observations indicate movement of the house over its lifetime have not been uniform. These visual observations included identification of areas in the house that have moved several inches vertically as well as horizontal movement in both directions (north-south and east-west). It is also very clear that the house is out-of-level and no longer plumb.

Differential movements in the house were found to be extensive and irregular. No clear conclusions could be formed to explain the movement that has occurred, but it is reasonable to expect two major contributing factors are the severe termite damage in the house (Item #3 above) and the crumbling foundation system (Item #5 below).

Continuing the monitoring survey as part of a **Short Term category** item should be done. The survey program will need to be revisited to address the following: 1) Re-establish the baseline for future surveys - Several of the previous survey points were lost during the dismantling and reconstruction of the exterior siding project. This means that the next survey of the house will establish the new baseline; 2) Establish number and location of survey points - After conducting our investigation and discovering the extent of the non-uniform movement in the house, it is clear additional survey points are needed. 3) Frequency of surveys - Monitoring surveys shall be conducted every 6 months for the next two years. In addition to a revamped monitoring survey program, annual visits by a structural engineer shall be made to visually observe the condition of the house.

Restoring the house to a level and plumb condition should be part of the **Permanent Solution category** for the renovation of the Harada House. Wood framed structures that are not level and not plumb show signs of distress due to the internal forces that result from this condition. This is obviously not ideal, and the Harada House is displaying signs of distress in many areas. Several of the temporary shoring measures that have been taken over the last 10+ years were intended to relieve the stress from the house being out-of-level and out-of-plumb. This condition can be corrected as part of the house stabilization when a new foundation is built to properly support the house.



5. The original brick and concrete basement foundations are severely damaged and need to be replaced. In addition to the most visible damage at the south-east corner of the house in the partial cellar (see Figure 16 and Figure 17 below), there are loose bricks in several areas around the entire perimeter of the house.

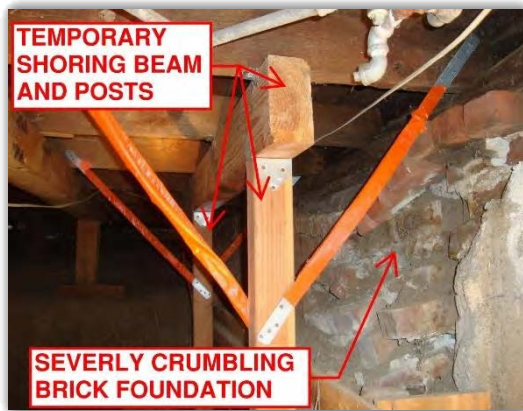

Figure 16 – Crumbling Foundation below East Wall (June 20, 2017)



Figure 17 – Unstable Brick Foundation below South Wall (June 20, 2017)

The Foundation System is the base of the structure and is the critical component for supporting all levels of a building. New code compliant foundations are needed to properly support the Harada House and anchor the wood framed building to the foundation. Structural Focus previously completed construction documents for new foundations to support the house, but the documents will need to be updated to include leveling the house. Replacing the foundation system will require a specialty contractor that can provide temporary support for the house and lift it to allow for construction of the new foundation system. The process will be a complex and risky undertaking that will likely involve major excavation work under the house. Figure 18 shows an example of a different historic house in Claremont, CA that was lifted and relocated on a new foundation. The photo is taken during construction when the holes for the new foundation were dug and steel reinforcing bars have been placed in the excavation in preparation for placement of new concrete foundations.



Our recommendation for the Harada House is to construct the new foundation level and set the house on the foundation to restore the house back to a level condition. This will require removal of some of the temporary immediate repair work that was done in order to allow the house to properly sit on the new foundation. While time is of the essence when it comes to stabilizing the house on a proper foundation, this recommendation falls under the **Permanent Solution category**.

6. Several framing conditions were found during the assessment that need to be corrected. Correcting each poorly framed condition should be done as part of **Permanent Solution category** repairs after the house has been leveled on a new foundation system. This will allow for the corrective framing measures to be constructed properly in a level and plumb condition. A description of the condition and our recommendations for each item follows:
  - a. Several poorly framed header conditions were found throughout the exterior walls. The headers often consist of a double, flat 2x4 that is end nailed to the closest adjacent stud. In some cases, the header is a single, flat 2x member. Figure 19 shows a typical header condition in the house.

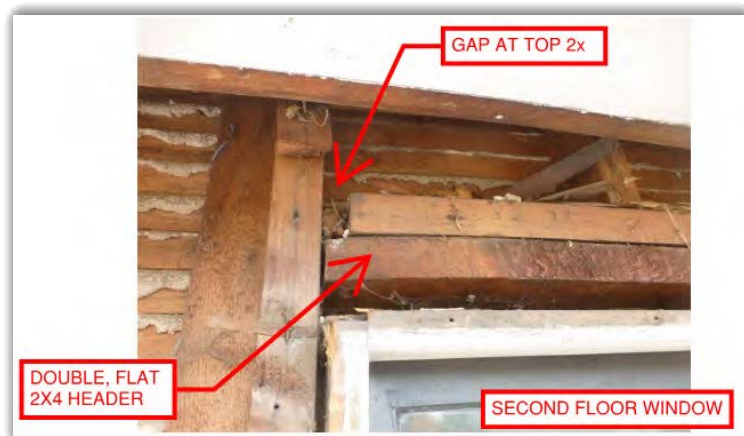

Figure 19 - Harada House Typical Header Condition (November 6, 2017)

The **Permanent Solution category** repair for this condition is to remove the existing header and replace it with a properly designed and connected header. Modifications to the adjacent king studs as well as the addition of jack studs will also be required. Figure 20 shows a properly framed header condition using current construction practices.

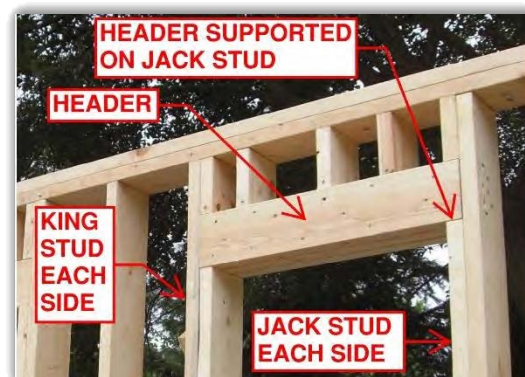

Figure 20 - Standard Header Framing

- b. The base of the stairs in the house are not properly supported. Standard construction practice would provide supplemental support framing at the base of the stair due to the critical nature of the stair as the sole exit option from the Second Floor. Providing supplemental framing at the ground floor is a **Permanent Solution category** repair to properly support the stairs.
- c. The framing for the front porch is severely deteriorated and poorly laid out. It does not properly support the second-floor sleeping porch. The porch ceiling appears to be framed with ceiling joists that were made from scrap wood on site at the time the ceiling was built. This is a dangerous condition. Several of the joists are short and have been split for splicing another member alongside to span the required length. This condition can be seen in Figure 21 at the right.



Figure 21 - Inadequate Porch Ceiling Framing  
(December 7, 2017)

Rebuilding the front porch and the ceiling over the front porch is a necessary **Permanent Solution category** repair. Until this can be done, access to the space over the porch ceiling should be restricted.

7. Cracked Wood Blocks in Attic - As part of the re-roofing project completed in 2006, horizontal wood blocks were added to properly connect the new plywood sheathing on the second-floor ceiling joists with the top plate of the perimeter walls. While assessing the condition of the house, it was observed that several of the blocks had cracked through the length of the block at the south-east corner of the house and along the north wall at the east end. Figure 22 shows this condition.



Figure 22 - Cracked Wood Blocking

Restoring the load path between the second-floor ceiling diaphragm and the exterior walls will need to be completed as part of the **Permanent Solution category** repairs. This can be done with standard wood framing details for residential construction

once the base of the house is stabilized on a proper foundation and the house is brought to a level and plumb condition.

### Overall Conclusions

The Harada House has deteriorated to the level that it is no longer safe to occupy the building. The condition of the crumbling foundation system and severely termite damaged perimeter (as observed) and interior (based on worst-case scenario assumption) wood framing leave the house at a point where almost all the existing structure needs to be supplemented or replaced. But that work will only stabilize the building structure.

The future of the house as an occupiable building requires the services of an Architect of Record and Historic Preservationist to form a consulting team that can provide the professional design services necessary to perform a proper historic preservation of the Harada House.

### Details

Drawings, Photos and Sketches of the project can be found on the following pages:

1. Harada House Exterior Siding Dismantling and Reconstruction Drawings
2. Photo 1 - South Elevation - Ground Floor
3. Photo 2 - East Elevation - Second Floor
4. Photo 3 - East Elevation - Damaged Stud
5. Photo 4 - North Elevation - 2<sup>nd</sup> Floor Rim Joist
6. Photo 5 - North Elevation - Damaged Rim Joist
7. Photo 6 - North Elevation - Damaged Rim Joist (after Removal)
8. Photo 7 - North Elevation - Damaged Rim Joist (after Removal)
9. Photo 8 - Drop Ceiling over Dining Room (Middle of House on South Side)
10. Photo 9 - South Elevation - Header Condition
11. Photo 10 - Dining Room - Hole in Floor Board
12. Photo 11 - Ground Floor - Termite Damaged Floor Beam
13. Photo 12 - Inadequate Porch Ceiling Framing
14. SSK-1 BLOCKING AT BASE OF ZONE S1C
15. SSK-2 NEW WOOD BEAM AT GRID B
16. SSK-3 SECTION AT GRID B
17. SSK-4 NEW ZONE E1C
18. SSK-5 STUD REPLACEMENT AT ZONE E2A
19. SSK-6 TEMP REPAIR AT NORTH WALL BOTTOM PLATE
20. SSK-7 NORTH WALL 2<sup>ND</sup> FLOOR RIM JOIST
21. SSK-8 FRONT DOOR ELEVATION
22. SSK-9 WEST ELEVATION - TEMPORARY IMMEDIATE REPAIRS
23. SSK-10 WEST ELEVATION - UPPER PORTION
24. SSK-11 DETAIL AT (E) LET-IN HEADER (WEST ELEVATION)



# GENERAL STRUCTURAL NOTES

## I. GENERAL

- MATERIALS AND WORKMANSHIP TO CONFORM WITH THE 2016 EDITION OF THE CALIFORNIA HISTORICAL BUILDING CODE AND THE REQUIREMENTS OF THE CONTRACT DOCUMENTS.
- THESE GENERAL NOTES SUPPLEMENT THE REQUIREMENTS OF THE PROJECT SPECIFICATIONS. IN CASE OF CONFLICT BETWEEN THE PLANS AND SPECIFICATIONS, CONTACT THE OWNER'S REPRESENTATIVE.
- REFERENCE TO CODES, RULES, REGULATIONS, STANDARDS, MANUFACTURER'S INSTRUCTIONS OR REQUIREMENTS OF REGULATORY AGENCIES IS TO THE LATEST PRINTED EDITION OF EACH IN EFFECT AT THE DATE OF SUBMISSION OF BID UNLESS THE DOCUMENT DATE IS SHOWN.
- DRAWINGS INDICATE GENERAL AND TYPICAL DETAILS OF CONSTRUCTION. WHERE CONDITIONS ARE NOT SPECIFICALLY INDICATED BUT ARE OF SIMILAR CHARACTER TO DETAILS SHOWN, USE SIMILAR DETAILS OF CONSTRUCTION, SUBJECT TO REVIEW BY THE OWNER'S REPRESENTATIVE.
- DETAILS AND SHEETS TITLED "TYPICAL" APPLY TO SITUATIONS OCCURRING ON THE PROJECT THAT ARE THE SAME OR SIMILAR TO THOSE SPECIFICALLY REFERENCED. SUCH DETAILS ARE NOT NOTED AT EACH LOCATION THAT THEY OCCUR.
- THE CONTRACTOR IS RESPONSIBLE FOR COORDINATING THE WORK OF ALL TRADES AND FOR CHECKING DIMENSIONS. NOTIFY THE OWNER'S REPRESENTATIVE OF ANY DISCREPANCIES AND RESOLVE BEFORE PROCEEDING WITH THE WORK.
- DO NOT SCALE THE DRAWINGS.
- PROVIDE MEASURES NECESSARY TO PROTECT THE STRUCTURE DURING CONSTRUCTION. SUCH MEASURES INCLUDE, BUT MAY NOT BE LIMITED TO, BRACING AND SHORING FOR LOADS DURING CONSTRUCTION.
- INFORMATION SHOWN ON THE DRAWINGS RELATED TO EXISTING CONDITIONS REPRESENTS THE PRESENT KNOWLEDGE, BUT WITHOUT GUARANTEE OF ACCURACY. REPORT CONDITIONS THAT CONFLICT WITH THE CONTRACT DOCUMENTS TO THE OWNER'S REPRESENTATIVE. DO NOT DEVIATE FROM THE CONTRACT DOCUMENTS WITHOUT WRITTEN DIRECTION FROM THE OWNER'S REPRESENTATIVE.
- THE CONTRACTOR IS SOLELY RESPONSIBLE FOR PROVIDING A SAFE PLACE TO WORK AND MEETING THE REQUIREMENTS OF ALL APPLICABLE JURISDICTIONS. EXECUTE WORK TO ENSURE THE SAFETY OF PERSONS AND ADJACENT PROPERTY AGAINST DAMAGE BY FALLING DEBRIS AND OTHER HAZARDS IN CONNECTION WITH THIS WORK.

## II. ROUGH CARPENTRY

- FRAMING LUMBER: DOUGLAS FIR (COAST REGION) GRADED AND MARKED IN ACCORDANCE WITH THE STANDARD GRADING RULES NO. 17 OF THE WEST COAST LUMBER INSPECTION BUREAU (W.C.L.I.B.) OR WESTERN LUMBER GRADING RULES, OF THE WESTERN WOOD PRODUCTS ASSOCIATION (W.W.P.A.). USE LUMBER OF THE FOLLOWING GRADES:

MEMBER	MOISTURE CONTENT	WOOD/GRADE
SILLS	15%	D.F. #1 PRESSURE OR PRESERVATIVE TREATED OR FOUNDATION GRADE REDWOOD
STUDS	15%	D.F. #2
JOISTS, PLANKS AND PLATES	12%	D.F. #1
BEAMS, 5" & WIDER	GREEN	D.F. SELECT STRUCTURAL
BEAMS, 4" & NARROWER	GREEN	D.F. #1
POSTS, 6x6 & LARGER	GREEN	D.F. SELECT STRUCTURAL
POSTS, 4x6 & SMALLER	15%	D.F. #1
FRAMING BLOCKING & BRIDGING	12%	D.F. #2
PLYWOOD BLOCKING	15%	D.F. #1
FRAMING BLOCKING & BRIDGING	15%	CONSTRUCTION

- PANEL SHEATHING: IDENTIFY WOOD STRUCTURAL PANELS WITH THE APPROPRIATE TRADEMARK OF APA—THE ENGINEERED WOOD ASSOCIATION AND MEET THE REQUIREMENTS OF THE VOLUNTARY PRODUCT STANDARD PS-1 OR PS-2 AND APA PRP-108 PERFORMANCE STANDARD.

A. PANEL SHEATHING TO BE EXPOSURE 1.

B. PLYWOOD PANELS TO BE 5-PLY MINIMUM, EXCEPT 3/8" PANELS TO BE 3-PLY MINIMUM.

C. PLYWOOD TO BE CC GRADE AT LOCATIONS EXPOSED TO WEATHER; CD GRADE ELSEWHERE.

D. PROVIDE THE FOLLOWING GRADE AND SPAN RATINGS:

PANEL THICKNESS	MINIMUM GRADE	ROOF/FLOOR RATING
3/8	STRUCTURAL 1	24/0
7/16	STRUCTURAL 1	24/16
15/32	STRUCTURAL 1	32/16
19/32 & 5/8	CD/CC	40/20
3/4	CD/CC	48/24
7/8 & 1	CD/CC	54/32
1 1/8	CD/CC	60/48

## 3. ROUGH HARDWARE:

A. BOLTS AND THREADED RODS: ASTM A307, SQUARE OR HEXAGONAL HEAD MACHINE BOLTS WITH ASTM A563 NUTS. USE MALLEABLE IRON WASHERS UNDER HEAD AND NUT WHEN IN CONTACT WITH WOOD. AT SILL PLATES USE 2 1/2" X 2 1/2" "X 1/4" MINIMUM PLATE WASHERS.

B. LAG SCREWS: ASTM A307, ANSI/ASME STANDARD B18.2.1. USE ANSI B18.22.1 WASHERS UNDER HEAD WHEN IN CONTACT WITH WOOD.

C. SCREWS: ASTM A307, ANSI/ASME STANDARD B18.6.1. USE CADMIUM-PLATED PAN OR ROUND HEADED SCREWS AT STEEL TO WOOD AND WOOD TO WOOD CONNECTIONS.

D. MISCELLANEOUS STEEL: ASTM A36.

E. BOLTS, NUTS, WASHERS, STRAPS AND OTHER HARDWARE EXPOSED TO THE WEATHER TO BE HOT-DIPPED GALVANIZED OR STAINLESS STEEL.

F. FRAMING CLIPS, SHEET METAL STRAPS, ETC.: SIMPSON, UNIVERSAL, OR SILVER, WITH ICBO REPORTS. DESIGNATIONS ON DRAWINGS ARE BASED ON SIMPSON CATALOGUE NUMBERS.

## 4. FASTENERS

A. ALL FASTENERS SHALL BE WOOD SCREWS IN ORDER TO MINIMIZE THE IMPACT ON THE EXISTING HISTORIC STRUCTURE. NO NAILS ARE ALLOWED. WHERE NAILS ARE SPECIFIED SUBSTITUTE ALL NAILS WITH THE FOLLOWING WOOD SCREWS:  
8d = #6, 10d = #7, 16d = #8, 20d = #10, 30d = #12, 40d = #14

B. MINIMUM FASTENERS TO BE AS FOLLOWS, UNLESS OTHERWISE NOTED:

BLOCKING BETWEEN STUDS TOENAILS EACH END 3-#6 EACH SIDE

PROVIDE MINIMUM FASTENERS PER TABLE 2304.9.1 OF THE CODE U.O.N. SUBSTITUTE ALL NAILS WITH WOOD SCREWS PER NOTE A.

## 5. BOLT AND SCREW INSTALLATION:

A. DRILL BOLT HOLES A MAXIMUM OF 1/16 INCH LARGER IN DIAMETER THAN THE BOLT NOMINAL DIAMETER.

B. DRILL PRE-BORED LEAD HOLES FOR WOOD SCREWS AS FOLLOWS.

1. DRILL LEAD HOLE FOR THE SHANK TO A DEPTH EQUAL TO THE LENGTH OF THE UNTHREADED PORTION IN THE MAIN MEMBER. USE A DRILL BIT 7/8 THE DIAMETER OF THE WOOD SCREW.

2. EXTEND THE LEAD HOLE FOR THE THREADED PORTION OF THE SCREW WITH A DRILL BIT WHOSE DIAMETER IS 7/8 THE DIAMETER OF THE SCREW AT THE ROOT OF THE THREAD.

3. INSERT THE SCREW INTO LEAD HOLE BY TURNING. DO NOT DRIVE WITH A HAMMER.

4. LUBRICATE WITH SOAP OR BEESWAX TO FACILITATE INSTALLATION.

C. DRILL PRE-BORED LEAD HOLES FOR LAG SCREWS AS FOLLOWS.

1. DRILL LEAD HOLE FOR THE SHANK TO A DEPTH EQUAL TO THE LENGTH OF THE UNTHREADED PORTION IN THE MAIN MEMBER. USE A DRILL BIT OF THE SAME DIAMETER AS THE LAG SCREW.

2. EXTEND THE LEAD HOLE FOR THE THREADED PORTION OF THE LAG SCREW WITH A DRILL BIT WHOSE DIAMETER IS 60 PERCENT OF THE NOMINAL LAG SCREW DIAMETER.

3. INSERT LAG SCREW INTO LEAD HOLE BY TURNING. DO NOT DRIVE WITH A HAMMER.

4. LUBRICATE WITH SOAP OR BEESWAX TO FACILITATE INSTALLATION.

6. INSTALL SOLID BLOCKING BETWEEN JOISTS AT ENDS AND OVER SUPPORTS. PROVIDE 2 INCH BY 3 INCH CROSS BRIDGING, METAL BRIDGING, OR SOLID BLOCKING BETWEEN JOISTS IN SPANS EQUALLY SPACED 8 FEET ON CENTER MAXIMUM AND WHERE INDICATED.

7. DO NOT USE WOOD SHINGLE SHIMS UNDER STUDS, JOISTS, BEAMS, OR POSTS.

## PROJECT DESCRIPTION

THE PURPOSE OF THIS PROJECT IS TO DISMANTLE THE EXTERIOR SIDING ON THE HARADA HOUSE TO PERFORM AN INVESTIGATION OF THE EXISTING HOUSE STRUCTURE. IT IS ANTICIPATED THAT STRUCTURAL DEFICIENCIES WILL BE FOUND, SOME OF WHICH MAY REQUIRE IMMEDIATE ATTENTION. ONCE REMOVED, THE HISTORIC SIDING WILL BE STORED AND REPLACED WITH PLYWOOD SHEATHING THAT WILL REMAIN IN PLACE FOR AN UNDETERMINED PERIOD OF TIME.

THE HARADA HOUSE IS A DESIGNATED HISTORIC LANDMARK. EXTREME CAUTION SHALL BE USED WHEN WORKING ON THE HOUSE TO PROTECT THE HISTORIC FEATURES OF THE BUILDING.

## DRAWING INDEX

- S1.0 GENERAL STRUCTURAL NOTES AND DRAWING INDEX
- S2.0 DISMANTLING PLAN NOTES & RECONSTRUCTION PLAN NOTES
- S3.0 HOUSE ELEVATIONS
- S4.0 DETAILS
- S5.0 FLOOR PLANS (FOR REFERENCE)

## REVISIONS

NO. REVISION OR ISSUE DATE

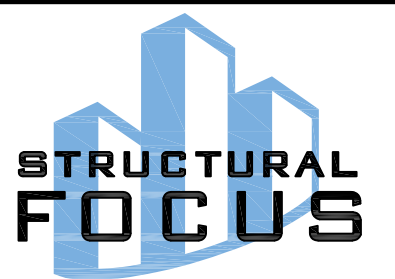

19210 S. Vermont Ave.  
Building B, Suite 210  
Gardena, CA 90248  
310.323.9924  
structuralfocus.com

PROJECT

## HARADA HOUSE

3356 LEMON STREET  
RIVERSIDE, CA 92501

SHEET TITLE

GENERAL  
STRUCTURAL NOTES  
AND DRAWING INDEX

SCALE NOT TO SCALE

JOB NUMBER 17126

DRAWN BY SF

DESIGN BY SF

CHECKED BY RK

DATE 8/7/2017

SHEET NO.

# S1.0

1 OF 5 SHEETS

## A. GENERAL

### A. GENERAL

- 1) THE HARADA HOUSE IS A DESIGNATED HISTORIC LANDMARK. EXTREME CAUTION SHALL BE USED WHEN WORKING ON THE HOUSE TO PROTECT THE HISTORIC FEATURES OF THE BUILDING.
- 2) THE PURPOSE OF THIS PROJECT IS TO DISMANTLE THE EXTERIOR SIDING ON THE HARADA HOUSE TO PERFORM A STRUCTURAL INVESTIGATION OF THE EXISTING HOUSE STRUCTURE. IT IS ANTICIPATED THAT STRUCTURAL DEFICIENCIES WILL BE FOUND, SOME OF WHICH MAY REQUIRE IMMEDIATE ATTENTION.
- 3) SEE SPECIFICATIONS FOR REQUIREMENTS REGARDING IMPLEMENTATION OF THE PROTECTION PLAN.
- 4) HAZARDOUS MATERIALS ARE KNOWN TO BE PRESENT AND SHALL BE PROPERLY ADDRESSED BY THE CONTRACTOR DURING CONSTRUCTION. SEE SPECIFICATIONS FOR HAZARDOUS MATERIAL REPORT.
- 5) THE FOLLOWING DISMANTLING PLAN NOTES AND RECONSTRUCTION PLAN NOTES SHALL BE FOLLOWED FOR EACH ZONE DESIGNATED ON THE HARADA HOUSE ELEVATIONS (SEE S3.0). DEVELOP A SCHEDULE FOR DISMANTLING AND RECONSTRUCTION TO BE SHARED WITH STRUCTURAL FOCUS FOR ON-SITE OBSERVATION PURPOSES. ON-SITE OBSERVATION BY STRUCTURAL FOCUS WILL BE REQUIRED DURING THE DISMANTLING PROCESS, SO CAREFUL COORDINATION WILL BE REQUIRED.
- 6) DISMANTLING AND RECONSTRUCTION SHALL BE COMPLETED FOR EACH ZONE PRIOR TO MOVING TO THE NEXT ZONE.

## B. DISMANTLING PLAN NOTES

- 1) THE HARADA HOUSE IS A DESIGNATED HISTORIC LANDMARK. EXTREME CAUTION SHALL BE USED WHEN WORKING ON THE HOUSE TO PROTECT THE HISTORIC FEATURES OF THE BUILDING.
- 2) REMOVAL OF THE SIDING SHALL BE DONE IN ZONES AS DESIGNATED ON THE HOUSE ELEVATIONS (S3.0). THE FOLLOWING ZONE ORDER SHALL BE FOLLOWED FOR DISMANTLING THE HARADA HOUSE SIDING:
  - a) SOUTH ELEVATION – S2B (INSCRIPTION WALL – USE EXTREME CARE), S1D, S1C, S2C, S1B (NOTE – S1E IS NOT INCLUDED)
  - b) SOUTH ELEVATION – S2A, S1A (BREAK OUT BID AS ADD-ALTERNATE 'SOUTH PORCH')
  - c) EAST ELEVATION – E2A, E2B, E1A (NOTE – E1B IS NOT INCLUDED)
  - d) NORTH ELEVATION – N2A, N2B, N1A, N1B (BREAK OUT BID AS ADD-ALTERNATE 'NORTH')
  - e) NORTH ELEVATION – N2C, N1D (BREAK OUT BID AS ADD-ALTERNATE 'NORTH PORCH')
  - f) WEST ELEVATION FRONT DOOR (GRID B) – W1C, W1D, W1E (BREAK OUT BID AS ADD-ALTERNATE 'FRONT DOOR')
  - g) WEST ELEVATION – W2A, W2B, W1A, W1B (BREAK OUT BID AS ADD-ALTERNATE 'WEST')
- 3) CAREFULLY REMOVE ALL TRIM BOARDS AND BATTENS – STORE IN ACCORDANCE WITH WILLIAMS ART CONSERVATION REQUIREMENTS
- 4) CAREFULLY REMOVE ALL SIDING BOARDS – BOARDS SHALL BE REMOVED IN FULL LENGTH SEGMENTS; STORE IN ACCORDANCE WITH WILLIAMS ART CONSERVATION REQUIREMENTS
- 5) CONTACT STRUCTURAL FOCUS TO DETERMINE IF ON-SITE OBSERVATION WILL BE REQUIRED FOR EACH ZONE.

## C. RECONSTRUCTION PLAN NOTES

- 1) THE HARADA HOUSE IS A DESIGNATED HISTORIC LANDMARK. EXTREME CAUTION SHALL BE USED WHEN WORKING ON THE HOUSE TO PROTECT THE HISTORIC FEATURES OF THE BUILDING.
- 2) CONTRACTOR TO SUBMIT WATERPROOFING AND FLASHING DETAILS FOR REVIEW BY OWNER.
- 3) PRIOR TO PLACING NEW PLYWOOD SHEATHING, CONTACT STRUCTURAL FOCUS TO CONFIRM THAT ON-SITE OBSERVATION REQUIREMENTS HAVE BEEN MET.
- 4) USE T1-11 PLYWOOD SHEATHING FOR COVERING THE EXPOSED EXTERIOR WALL FRAMING. SEE HOUSE ELEVATIONS (S3.0) FOR SHEATHING PANEL TYPES AND DETAIL 5/S4.0 FOR PLYWOOD SHEATHING REQUIREMENTS.
- 5) PAINT T1-11 PLYWOOD SHEATHING – SEE PROJECT SPECIFICATIONS.

NO.	REVISION OR ISSUE	DATE
REVISIONS		



19210 S. Vermont Ave.  
Building B, Suite 210  
Gardena, CA 90248  
310.323.9924  
structuralfocus.com

PROJECT

**HARADA  
HOUSE**

3356 LEMON STREET  
RIVERSIDE, CA 92501

SHEET TITLE

**DISMANTLING PLAN  
NOTES &  
RECONSTRUCTION  
PLAN NOTES**

SCALE NOT TO SCALE

JOB NUMBER 17126

DRAWN BY SF

DESIGN BY SF

CHECKED BY RK

DATE 8/7/2017

SHEET NO.

**S2.0**

4 OF 5 SHEETS



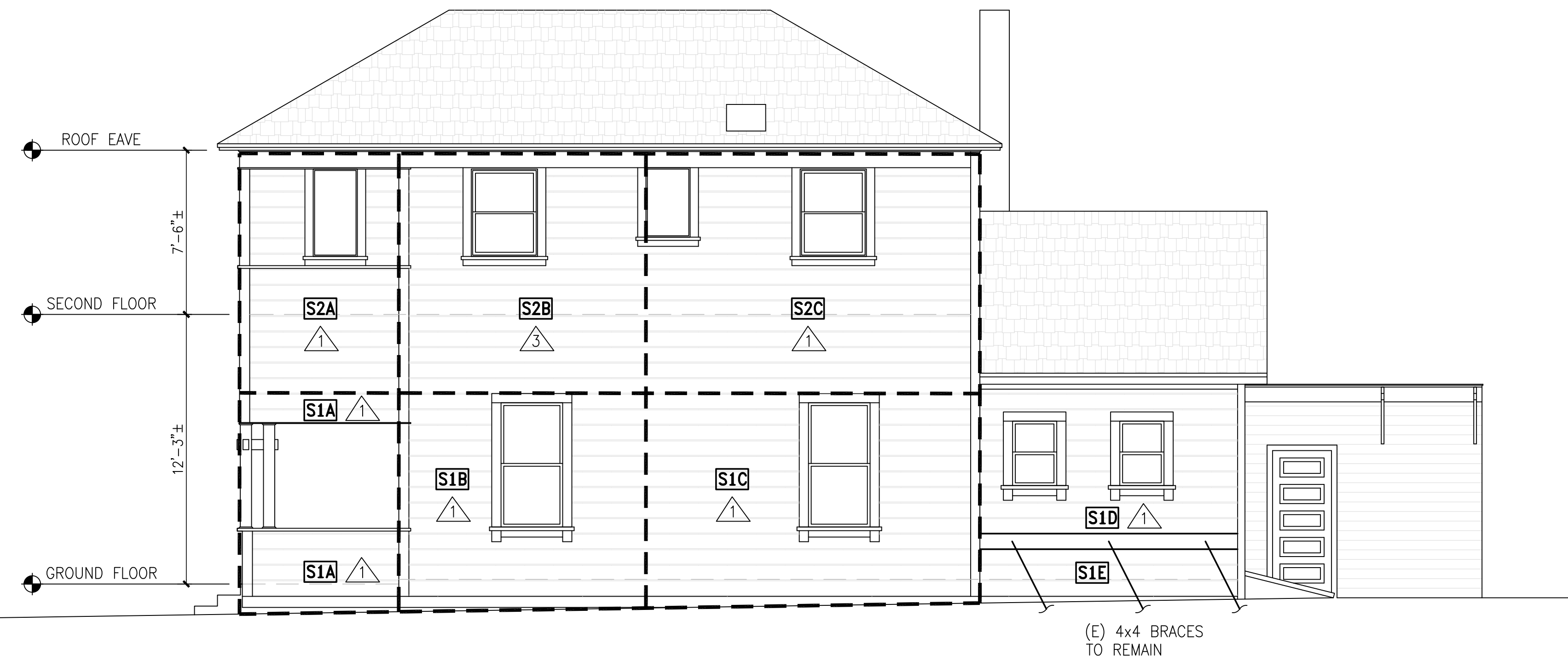

- NOTES:
- 1) DISMANTLING AND RECONSTRUCTION SHALL BE COMPLETED FOR EACH ZONE PRIOR TO MOVING TO THE NEXT ZONE.
  - 2) SEE S5.0 FOR REFERENCE FLOOR PLANS OF THE HARADA HOUSE
  - 3)  $\triangle$  INDICATES PLYWOOD SHEATHED SHEARWALL OF TYPE '#'  
PER TYPICAL SHEAR WALL FRAMING DETAIL 5/S4.0.
  - 4) BREAK OUT BID FOR ZONES S2A AND S1A ON SOUTH ELEVATION AS ADD-ALTERNATE 'SOUTH PORCH'
  - 5) ALL EXISTING BRACING SHALL REMAIN IN PLACE. DISMANTLING OF THE SIDING IN ZONE S1E IS NOT INCLUDED.

3 SIDE (SOUTH) ELEVATION  
1/4"=1'-0"

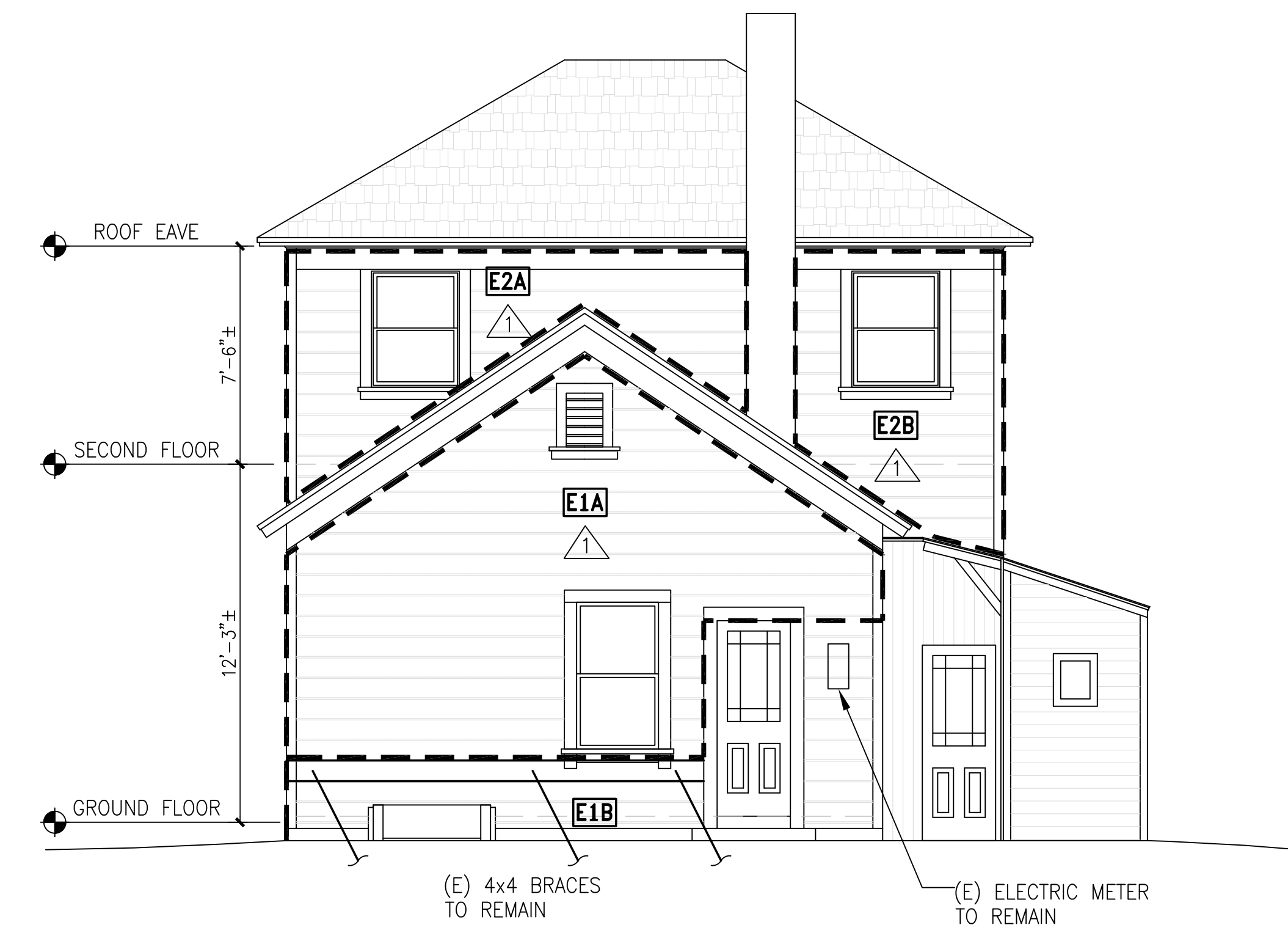

- NOTES:
- 1) DISMANTLING AND RECONSTRUCTION SHALL BE COMPLETED FOR EACH ZONE PRIOR TO MOVING TO THE NEXT ZONE.
  - 2) SEE S5.0 FOR REFERENCE FLOOR PLANS OF THE HARADA HOUSE
  - 3)  $\triangle$  INDICATES PLYWOOD SHEATHED SHEARWALL OF TYPE '#'  
PER TYPICAL SHEAR WALL FRAMING DETAIL 5/S4.0.
  - 4) ALL EXISTING BRACING SHALL REMAIN IN PLACE. DISMANTLING OF THE SIDING IN ZONE E1B IS NOT INCLUDED.

4 REAR (EAST) ELEVATION  
1/4"=1'-0"



- NOTES:
- 1) DISMANTLING AND RECONSTRUCTION SHALL BE COMPLETED FOR EACH ZONE PRIOR TO MOVING TO THE NEXT ZONE.
  - 2) SEE S5.0 FOR REFERENCE FLOOR PLANS OF THE HARADA HOUSE
  - 3)  $\triangle$  INDICATES PLYWOOD SHEATHED SHEARWALL OF TYPE '#'  
PER TYPICAL SHEAR WALL FRAMING DETAIL 5/S4.0.
  - 4) BREAK OUT BID FOR ZONES N2A, N2B, N1A AND N1B ON NORTH ELEVATION AS ADD-ALTERNATE 'NORTH'
  - 5) BREAK OUT BID FOR ZONES N2C AND N1D ON NORTH ELEVATION AS ADD-ALTERNATE 'NORTH PORCH'

2 SIDE (NORTH) ELEVATION  
1/4"=1'-0"



- NOTES:
- 1) DISMANTLING AND RECONSTRUCTION SHALL BE COMPLETED FOR EACH ZONE PRIOR TO MOVING TO THE NEXT ZONE.
  - 2) SEE S5.0 FOR REFERENCE FLOOR PLANS OF THE HARADA HOUSE
  - 3)  $\triangle$  INDICATES PLYWOOD SHEATHED SHEARWALL OF TYPE '#'  
PER TYPICAL SHEAR WALL FRAMING DETAIL 5/S4.0.
  - 4) BREAK OUT BID FOR ZONES W1C, W1D AND W1E ON WEST ELEVATION AS ADD-ALTERNATE 'FRONT DOOR'
  - 5) BREAK OUT BID FOR ZONES W2A, W2B, W1A AND W1B ON WEST ELEVATION AS ADD-ALTERNATE 'WEST'

1 FRONT (WEST) ELEVATION  
1/4"=1'-0"

NO.	REVISION OR ISSUE	DATE
REVISIONS		

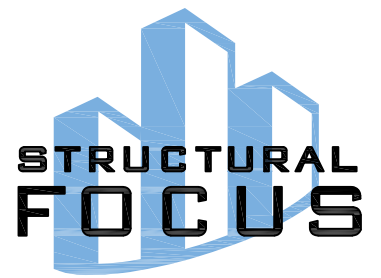

19210 S. Vermont Ave.  
Building B, Suite 210  
Gardena, CA 90248  
310.323.9924  
structuralfocus.com

PROJECT  
**HARADA HOUSE**  
3356 LEMON STREET  
RIVERSIDE, CA 92501

SHEET TITLE  
**HOUSE ELEVATIONS**

SCALE NOT TO SCALE  
JOB NUMBER 17126  
DRAWN BY SF  
DESIGN BY SF  
CHECKED BY RK  
DATE 8/7/2017

SHEET NO.  
**S3.0**

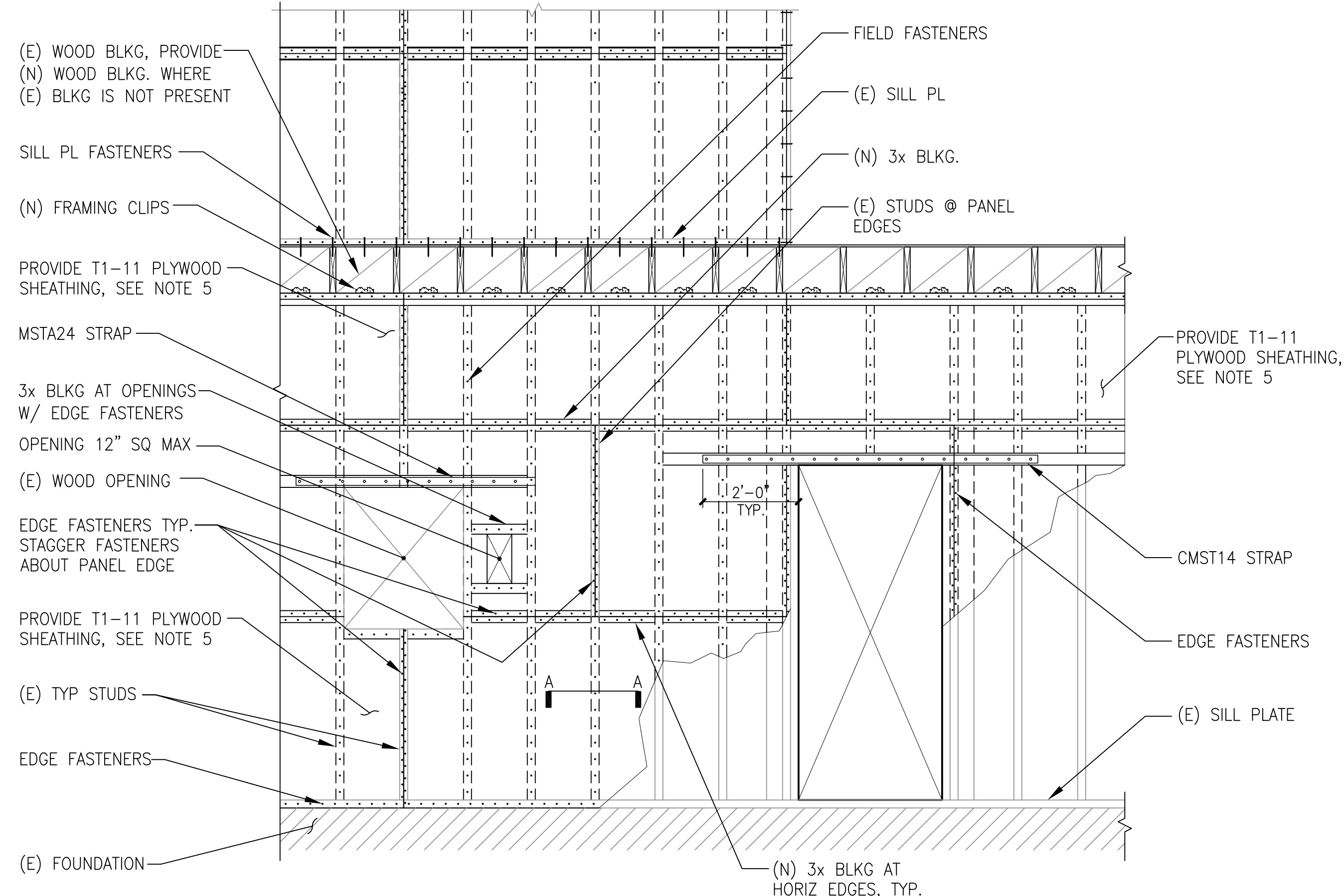

- NOTES:
1. USE T1-11 PLYWOOD SHEATHING. RUN PLYWOOD SHEETS AND T1-11 GROOVES HORIZONTAL.
  2. INDIVIDUAL PANEL PIECES SHALL NOT BE LESS THAN 2'-0" IN LEAST DIMENSION NOR LESS THAN 8 SQ FEET, U.O.N.
  3. PLACE PANELS ON EXTERIOR SIDE OF WALL.
  4. ALL FASTENERS SHALL BE WOOD SCREWS. IN ORDER TO MINIMIZE THE IMPACT ON THE EXISTING HISTORIC STRUCTURE, NO NAILS ARE ALLOWED. WHERE NAILS ARE SPECIFIED, SUBSTITUTE ALL NAILS WITH EQUIVALENT WOOD SCREWS AS INDICATED IN THE GENERAL NOTES SECTION II.3.G
  5. PROVIDE T1-11 PLYWOOD SHEATHING ABOVE AND BELOW ALL WALL OPENINGS.

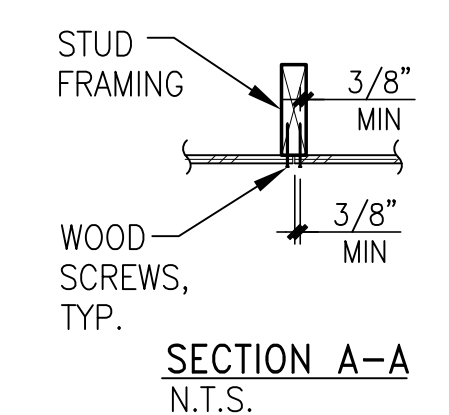

SHEAR PANEL SCHEDULE								
PANEL TYPE	SHEATHING	EDGE FASTENERS	FIELD FASTENERS	SILL PLATE FASTENERS AT 2ND FLOOR	SILL PLATE	STUDS AND HORIZONTAL BLKG AT PANEL EDGES	TYP STUDS	FRAMING CLIPS
△	3/8" STRUCT 1	#6 @ 6" O.C.	#6 @ 12" O.C.	#10 @ 6" O.C.	(E)	2x4	(E) 2x4 @ 16" O.C.	A35 @ 16" O.C.
△	3/8" STRUCT 1	#6 @ 4" O.C.	#6 @ 12" O.C.	#12 @ 4" O.C.	(E)	3x4	(E) 2x4 @ 16" O.C.	A35 @ 16" O.C.
△	1" STRUCT 1	#7 @ 4" O.C.	#7 @ 12" O.C.	#12 @ 4" O.C.	(E)	3x4	(E) 2x4 @ 16" O.C.	A35 @ 16" O.C.

**5** TYPICAL SHEAR WALL FRAMING  
N.T.S.

NO.	REVISION OR ISSUE	DATE
REVISIONS		

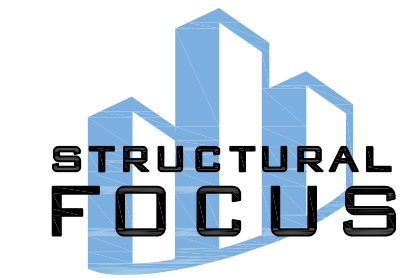

19210 S. Vermont Ave.  
Building B, Suite 210  
Gardena, CA 90248  
310.323.9924  
structuralfocus.com

PROJECT  
**HARADA HOUSE**

3356 LEMON STREET  
RIVERSIDE, CA 92501

SHEET TITLE  
**DETAILS**

SCALE NOT TO SCALE  
JOB NUMBER 17126  
DRAWN BY SF  
DESIGN BY SF  
CHECKED BY RK  
DATE 8/7/2017

SHEET NO.  
**S4.0**





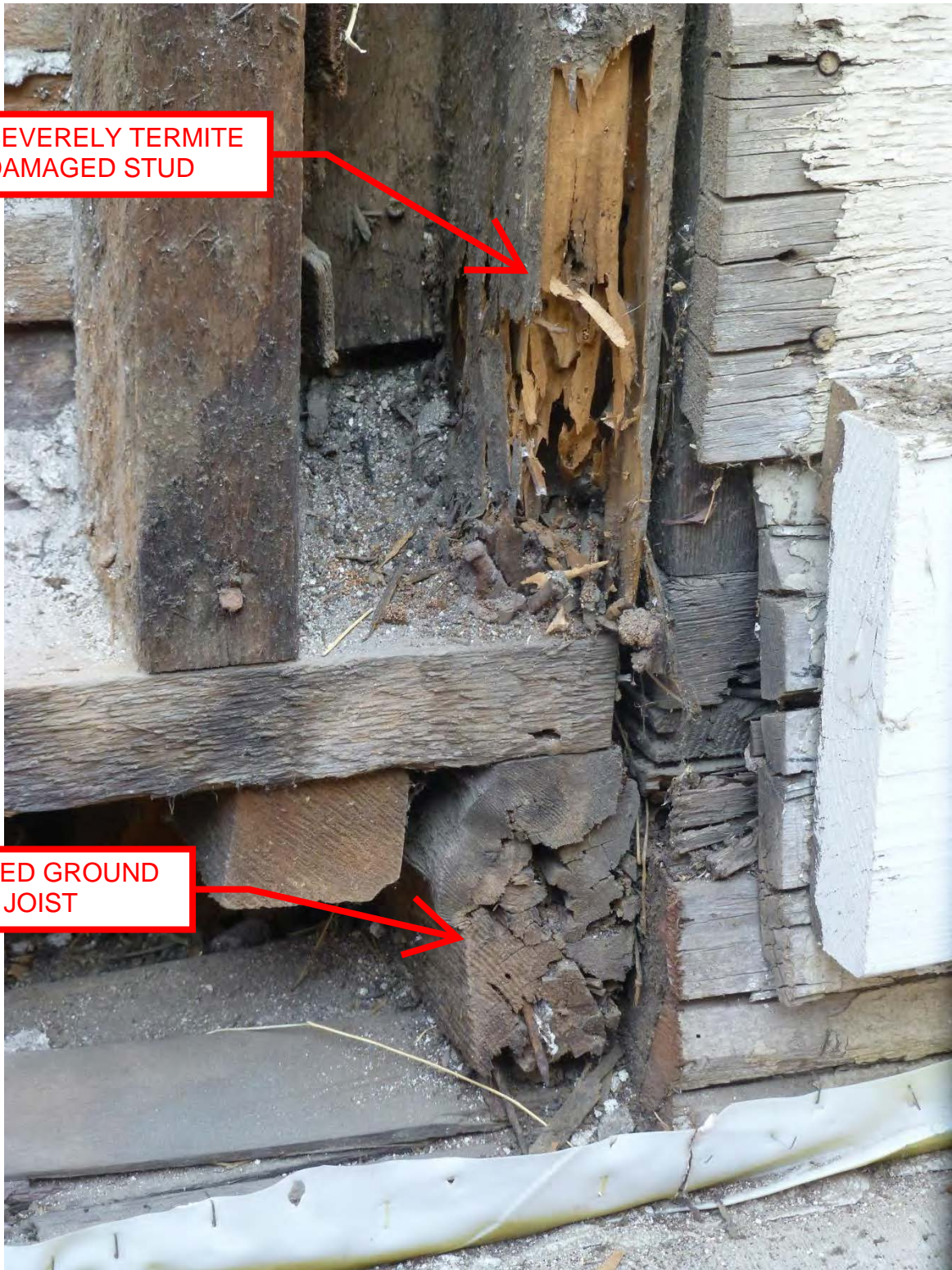
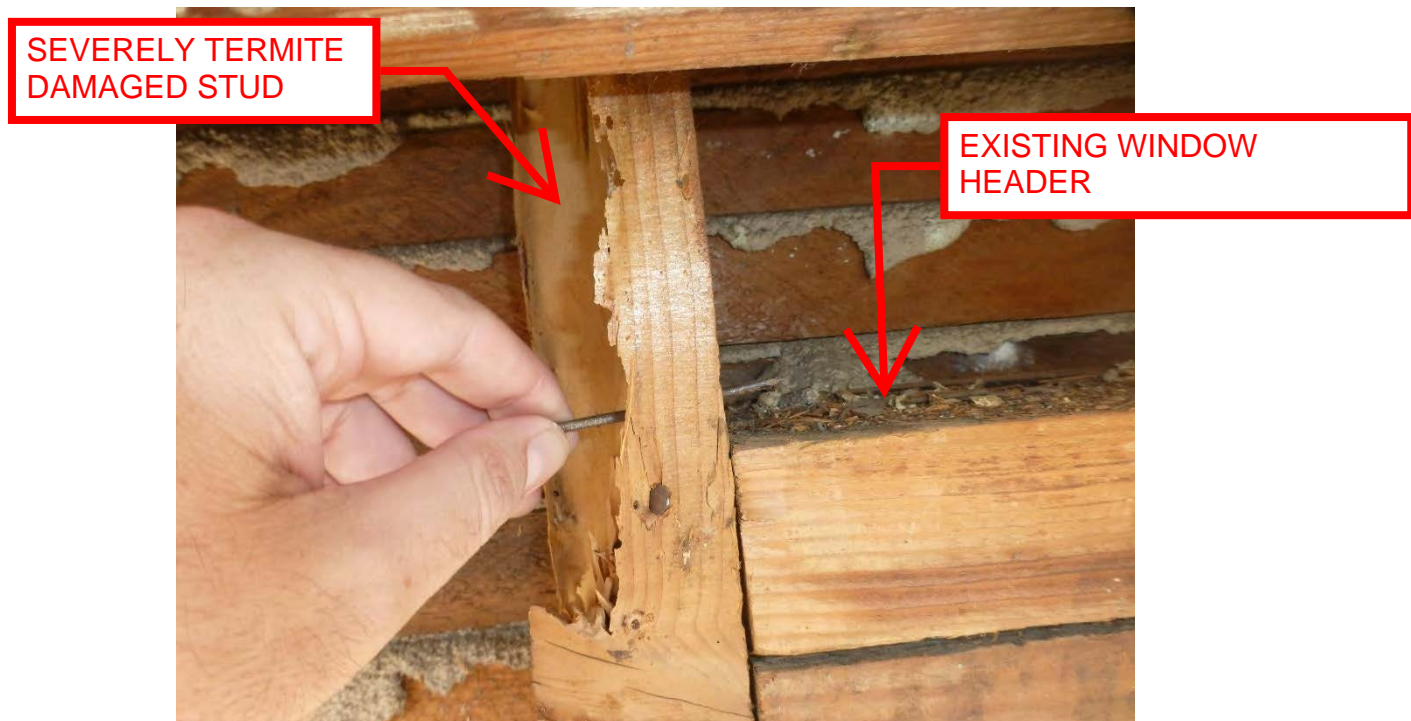

**PHOTO 1: SOUTH ELEVATION – GROUND FLOOR**





**PHOTO 2: EAST ELEVATION – SECOND FLOOR**



**PHOTO 3: EAST ELEVATION – DAMAGED STUD**

SEVERELY TERMITE  
DAMAGED RIM JOIST



PHOTO 4: NORTH ELEVATION – 2ND FLOOR RIM JOIST

TERMITE DAMAGE



PHOTO 5: NORTH ELEVATION – DAMAGED RIM JOIST



SEVERELY TERMITE DAMAGED  
RIM JOIST - EXTERIOR SIDE  
AFTER REMOVAL



PHOTO 6: NORTH ELEVATION – DAMAGED RIM JOIST

SEVERELY TERMITE DAMAGED  
RIM JOIST - INTERIOR SIDE  
AFTER REMOVAL

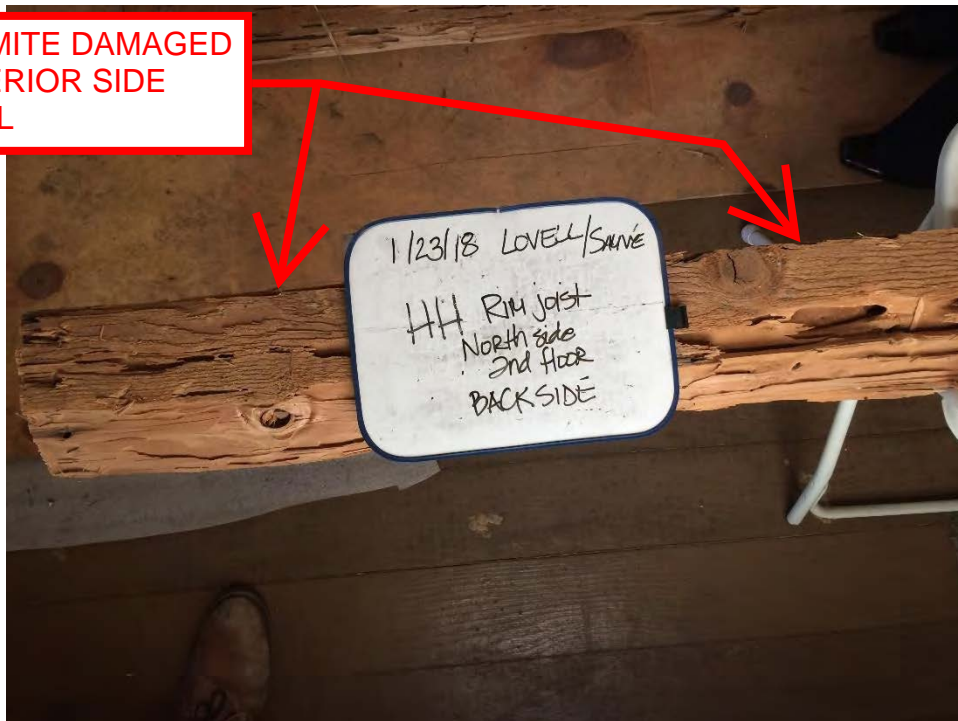
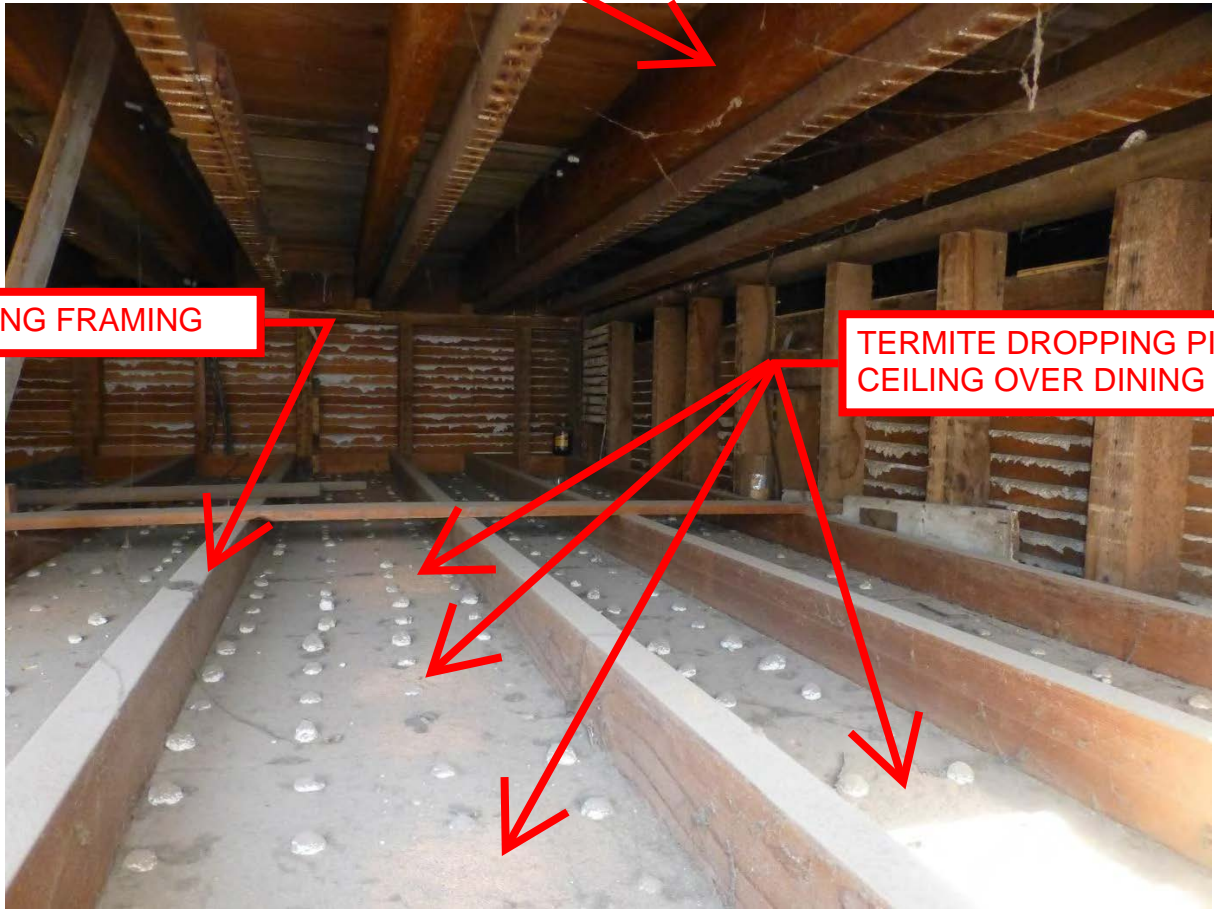

PHOTO 7: NORTH ELEVATION – DAMAGED RIM JOIST

SECOND FLOOR FRAMING



DROP CEILING FRAMING

TERMITE DROPPING PILES ON  
CEILING OVER DINING ROOM

PHOTO 8: DROP CEILING OVER DINING ROOM  
(MIDDLE OF HOUSE ON SOUTH SIDE)

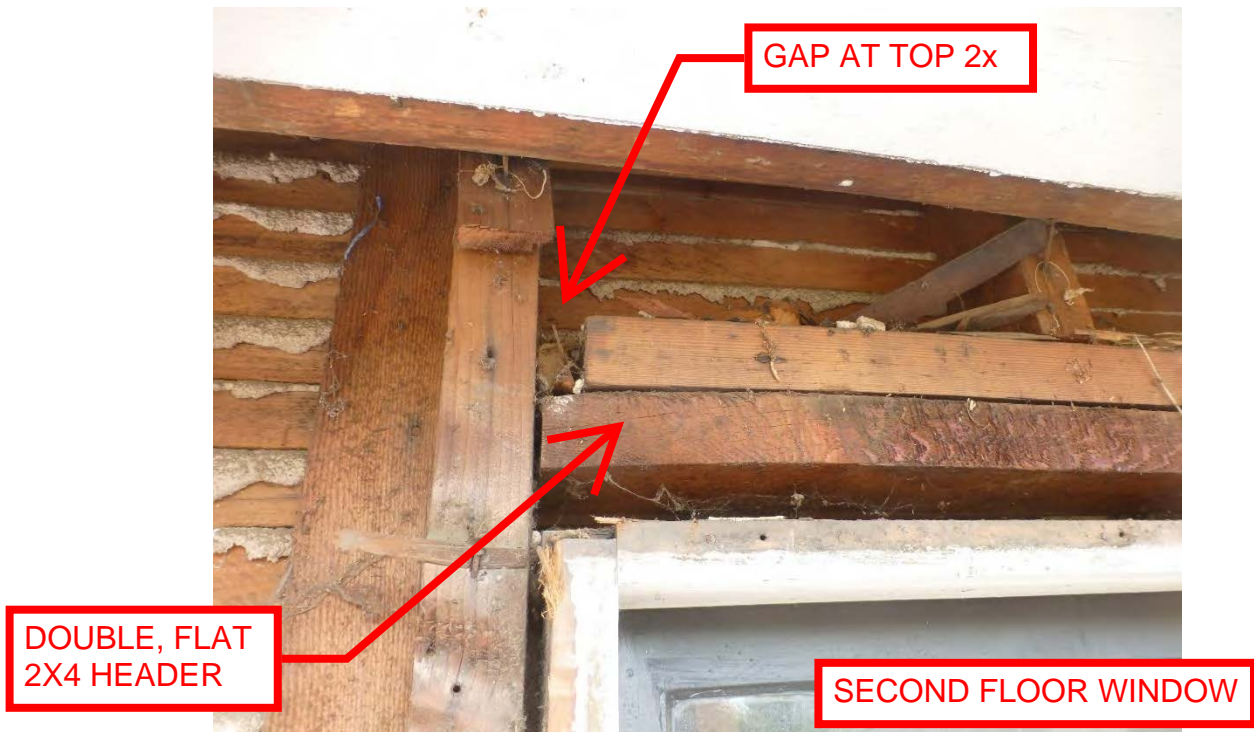

**PHOTO 9: SOUTH ELEVATION – HEADER CONDITION**

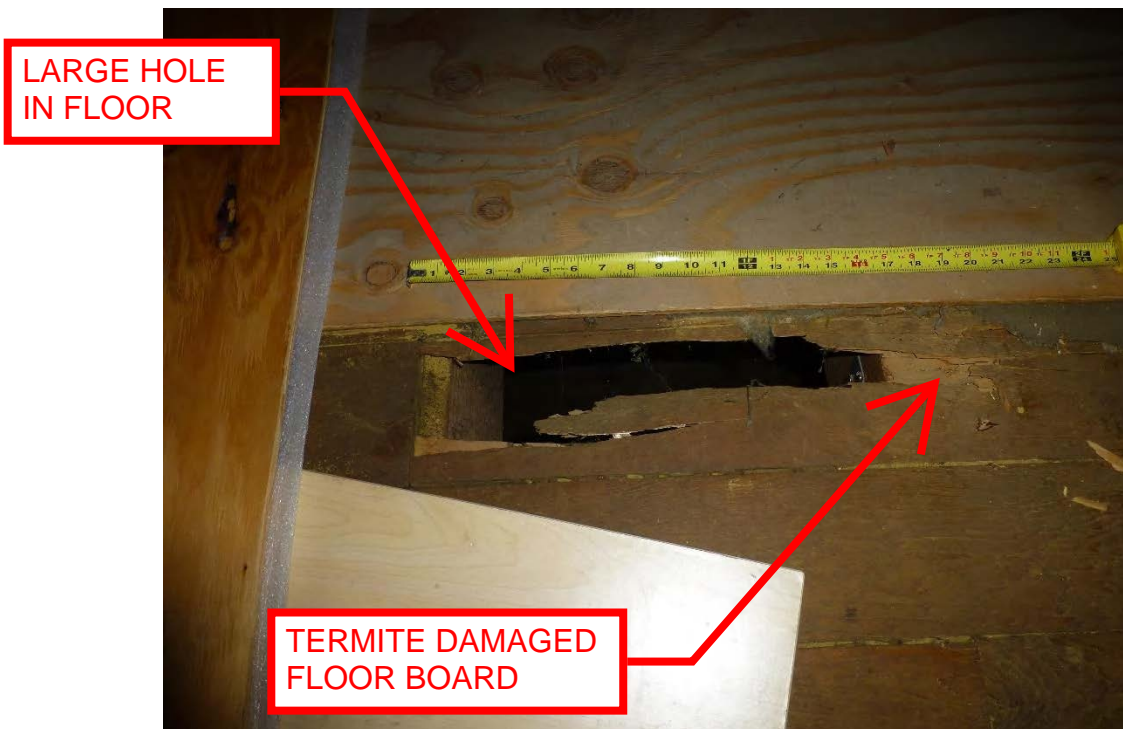

**PHOTO 10: DINING ROOM – HOLE IN FLOOR BOARD**





**PHOTO 11: GROUND FLOOR –  
TERMITE DAMAGED FLOOR BEAM**



**PHOTO 12: INADEQUATE PORCH CEILING FRAMING**



PROJECT Harada House

DATE 11/21/2017

PROJECT NUMBER 17126

SECTION

BY RK

CHECKED BY

PAGE OF

SUBJECT SSK-1 Blocking at Base of Zone S1C

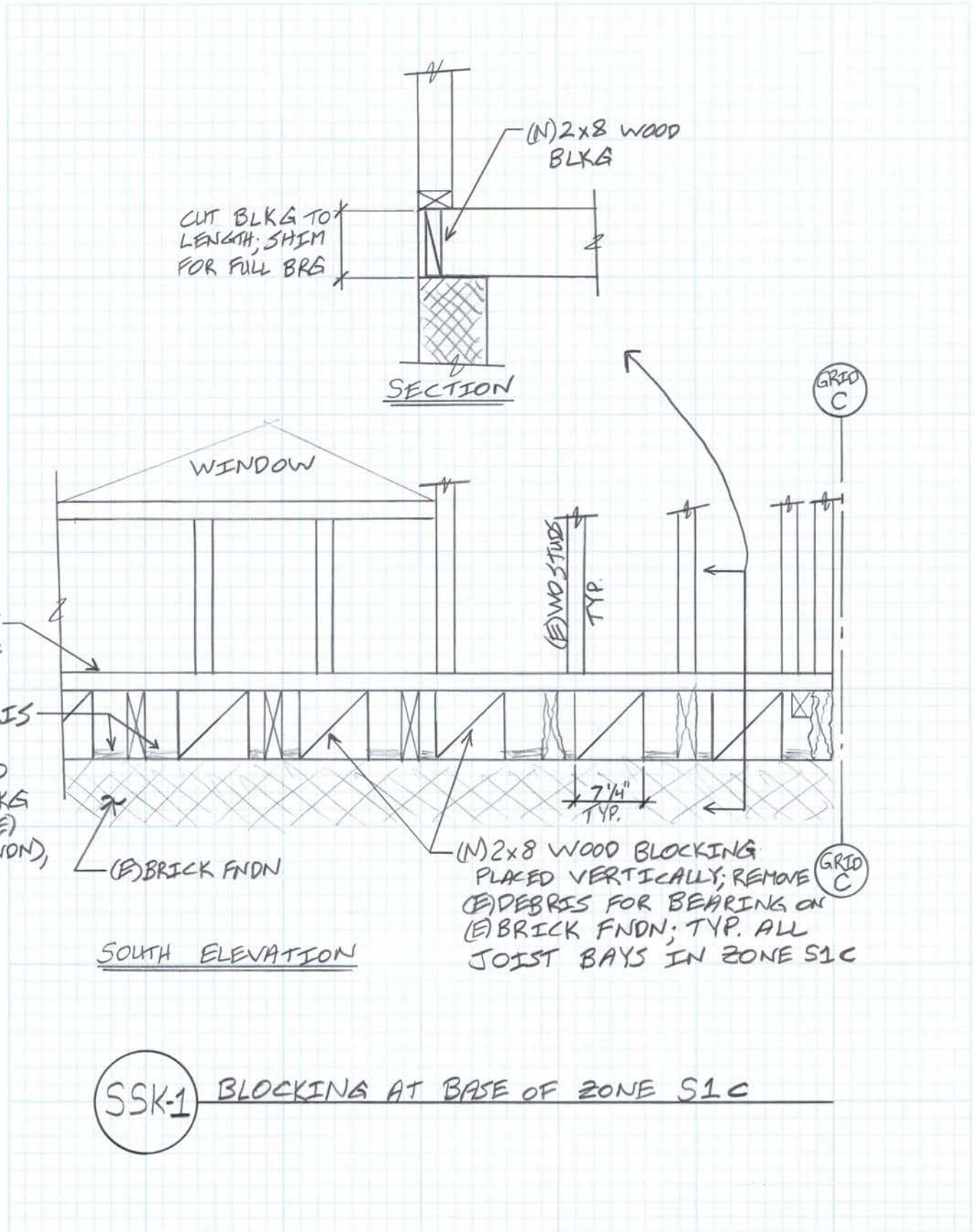

SSK-1 BLOCKING AT BASE OF ZONE S1C

Structural Focus  
 RK 11/21/2017  
 Harada House #17126

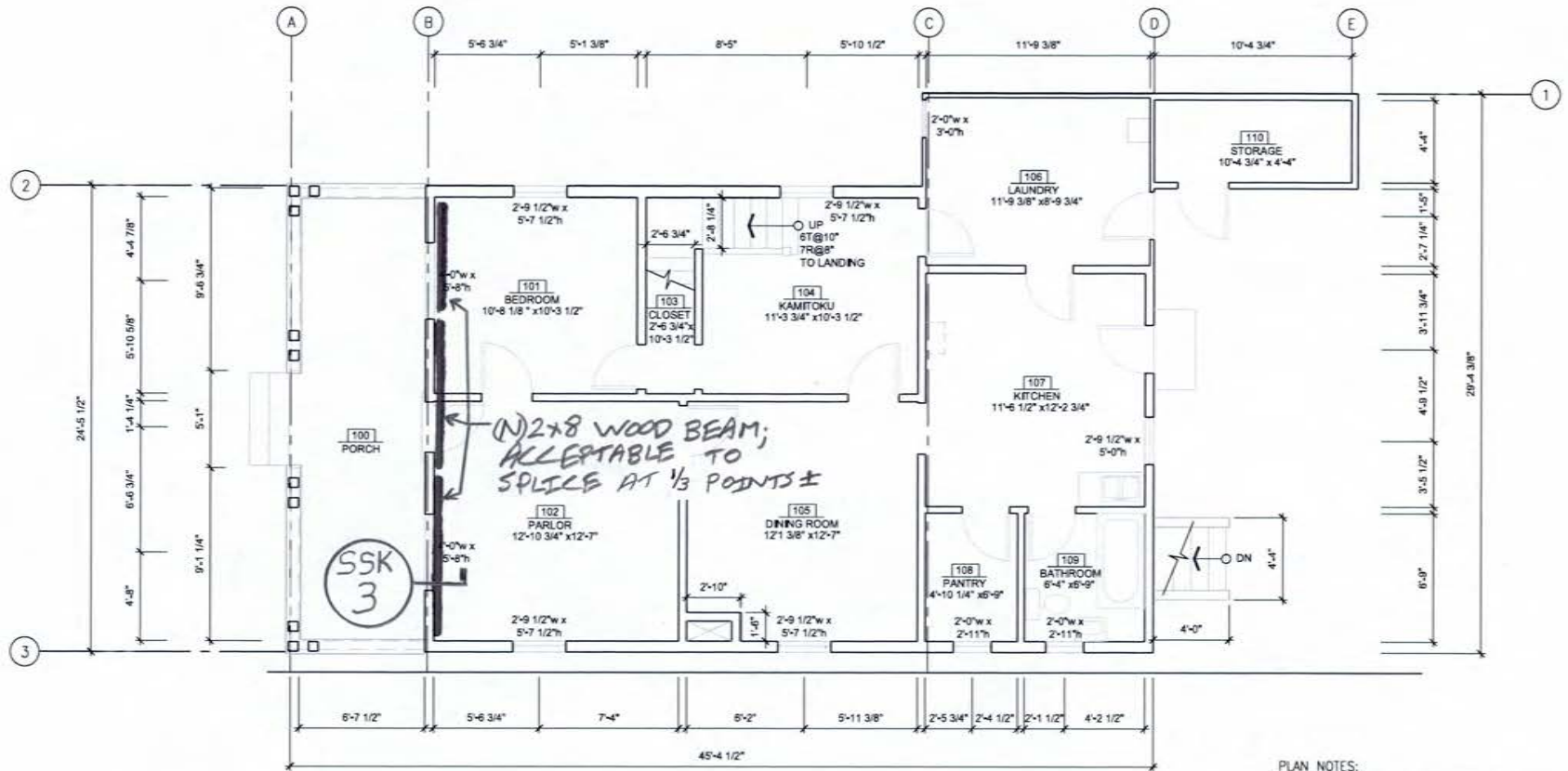

PLAN NOTES:  
 1. ALL DIMENSIONS SHOWN ARE FOR REFERENCE ONLY AND SHALL BE VERIFIED IN FIELD.

FIRST FLOOR PLAN (FOR REFERENCE)

SSK 2 NEW WOOD BEAM AT GRID B

PROJECT Harada House

DATE 11/21/2017

PROJECT NUMBER 17126

SECTION

BY RK

CHECKED BY

PAGE OF

SUBJECT SSK-3 Section at Grid B

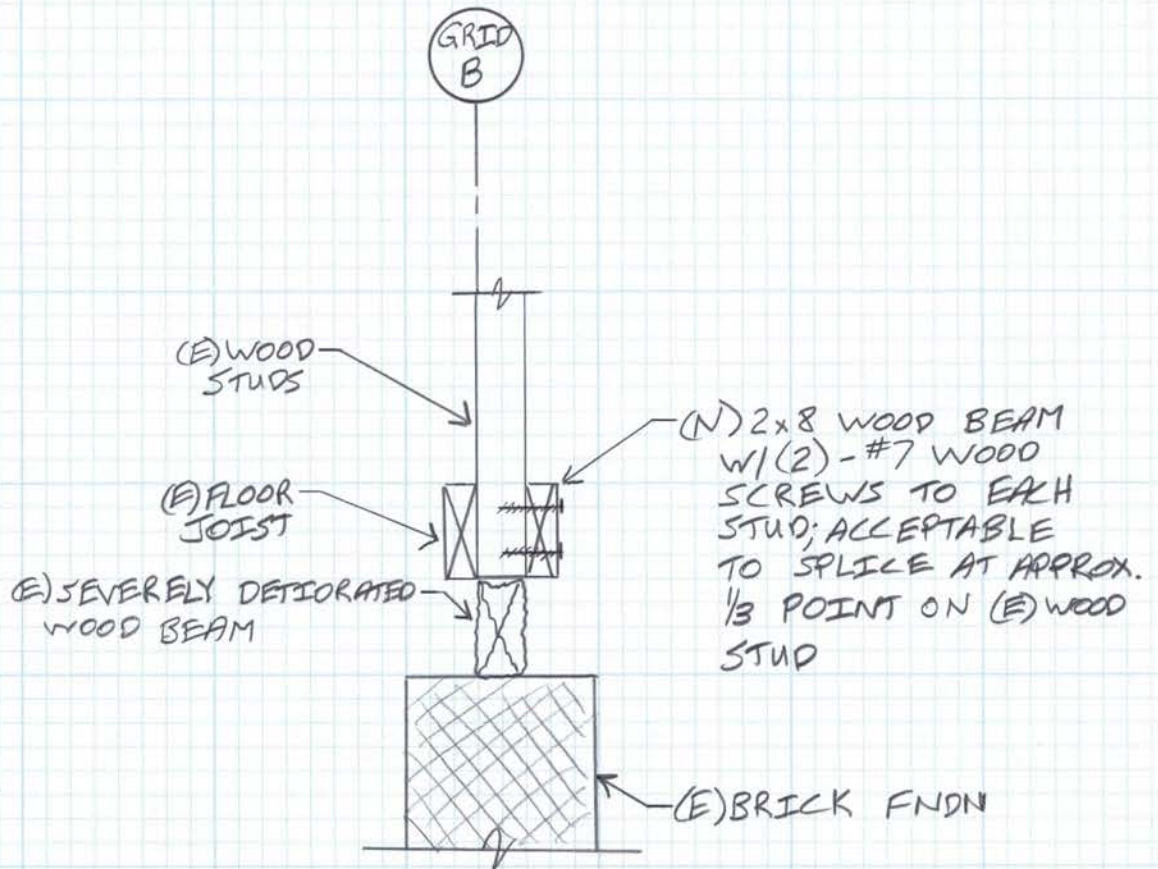

SSK  
3

SECTION AT GRID B



STRUCTURAL FOCUS  
RK 11/28/2017  
HARADA HOUSE #17126

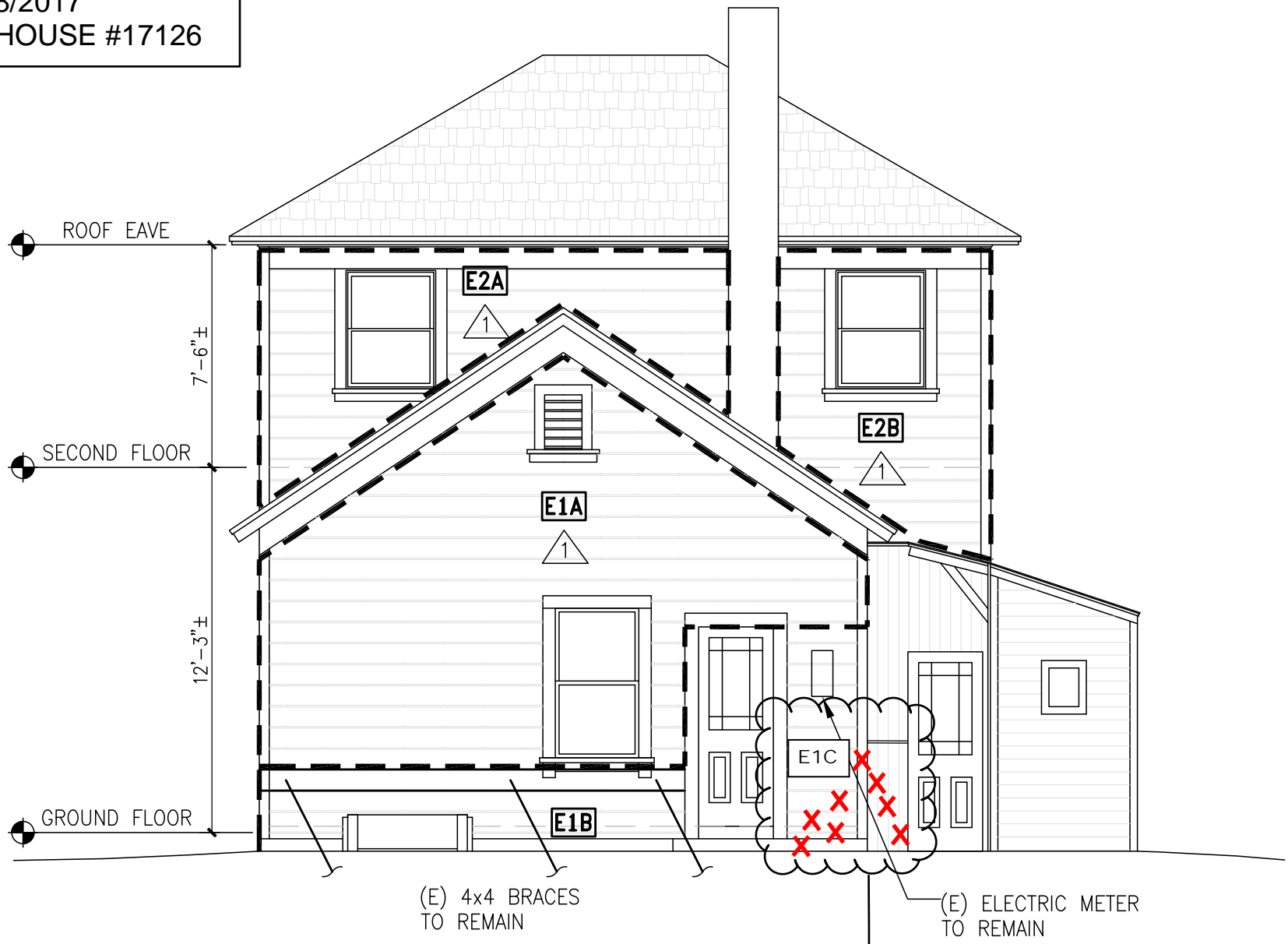

SSK  
4

NEW ZONE E1C

AREA OF NEW ZONE E1C:  
- REMOVE SIDING/TRIM BOARDS MARKED WITH AN 'X'  
- LEAVE OPEN FOR OBSERVATION BY STRUCTURAL FOCUS



11/29/2017

Structural Focus  
Harada House #17126

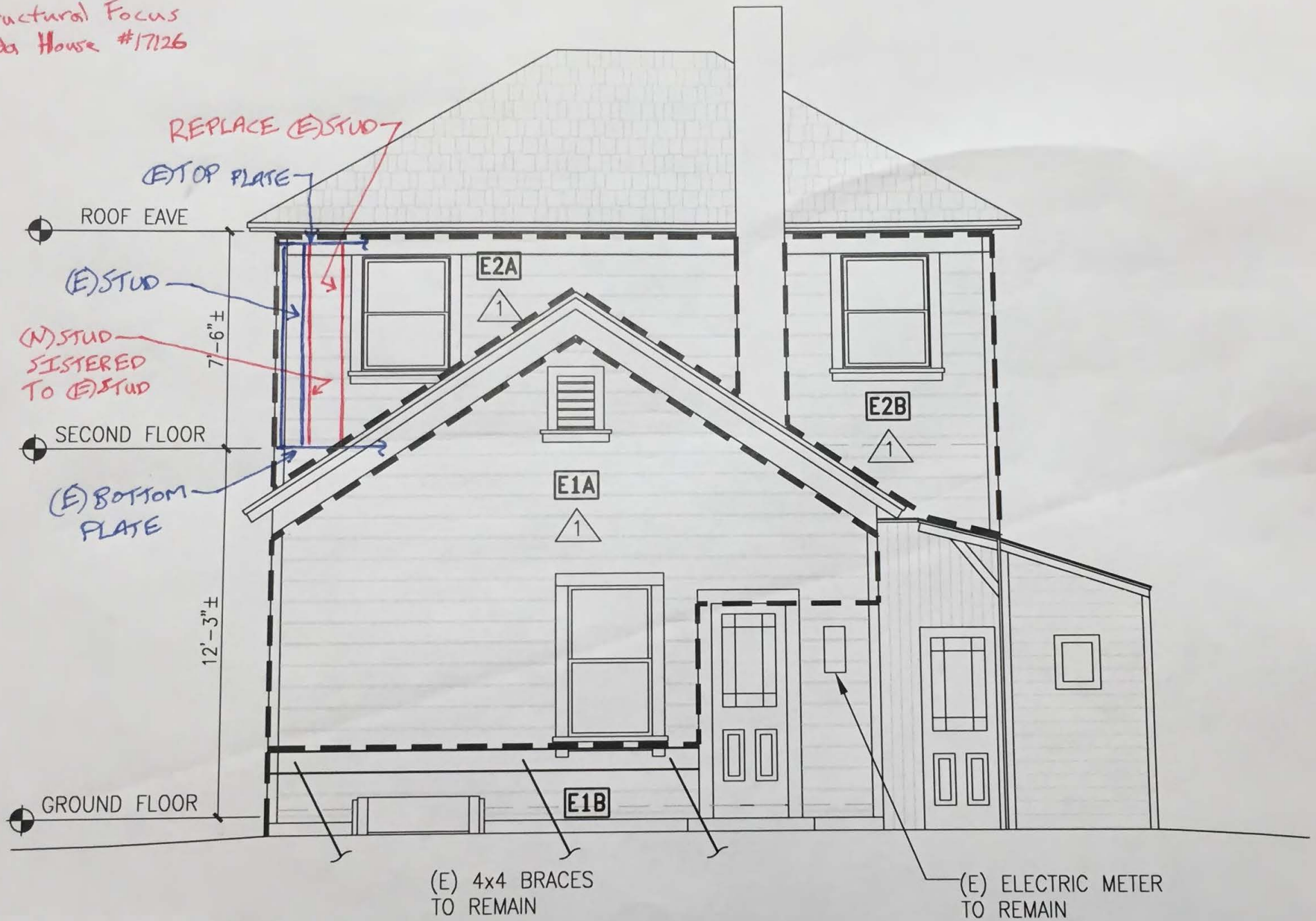

SSK 5 STUD REPLACEMENT AT ZONE E2A

PROJECT Harada House

DATE 12/8/2017

PROJECT NUMBER 17126

SECTION

BY RK

CHECKED BY

PAGE OF

SUBJECT SSK-6 NORTH WALL BOTTOM PLATE



TEMP REPAIR SEQUENCE:

- ① - INSTALL (N) 2x12 SHORING BEAM WITH (2) - #7 WOOD SCREWS TO EACH STUD
- ② - REPLACE (E) BOTTOM PLATE
- ③ - TRIM (E) FLOOR JOIST TAIL AND BLOCK FLUSH WITH WALL
- ④ - INSTALL (N) 2x JOIST AND BLOCKING
- ⑤ - INSTALL (N) T1-11 PLYWOOD SHEATHING PER CONSTRUCTION DOCUMENTS

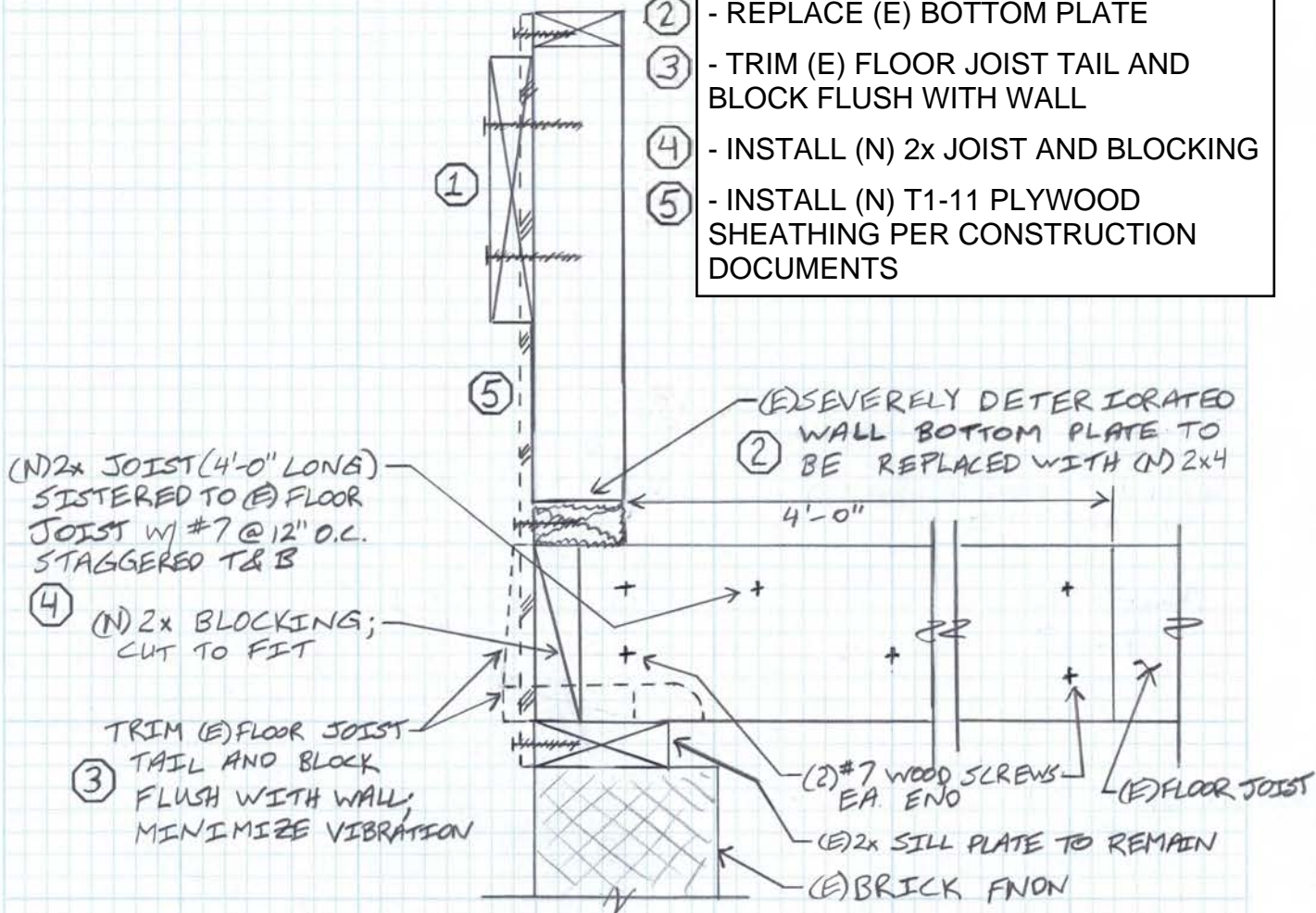

NOTE: USE #7 WOOD SCREWS WHERE SHOWN AND FOR INSTALLATION OF (N) BLOCKING

CONTRACTOR TO SUBMIT WATERPROOFING AND FLASHING DETAILS FOR REVIEW BY OWNER PER S2.0, SECTION C, NOTE 2.

SSK  
6

TEMP REPAIR AT NORTH WALL BOTTOM PLATE



SEQUENCE

- ① INSTALL (N) 2x12 SHORING BEAM WITH (2) -#7 WOOD SCREWS TO EACH STUD

- ② REPLACE (E) SEVERELY DETERIORATED RIM JOIST W/ (N) 3x RIM JOIST CUT TO FIT; REPLACE IN 8'-0" SECTIONS MAX AND 4'-0" SECTIONS MIN; SHIM FOR FULL BEARING; PROVIDE M5T36 STRAP AT (N) RIM JOIST BUTT JOINTS

- ③ INSTALL (N) T1-11 PLYWOOD SHEATHING PER CONSTRUCTION DOCUMENTS

- ④ PROVIDE (3) -#7 WOOD SCREWS BETWEEN (N) RIM JOIST AND (E) FLOOR JOIST TO REPLACE (E) NAILS TO BE REMOVED; (2) OF THE (N) WOOD SCREWS SHALL PENETRATE THRU THE (N) PLYWOOD SHEATHING; 2" MIN PENETRATION INTO (E) FLOOR JOIST

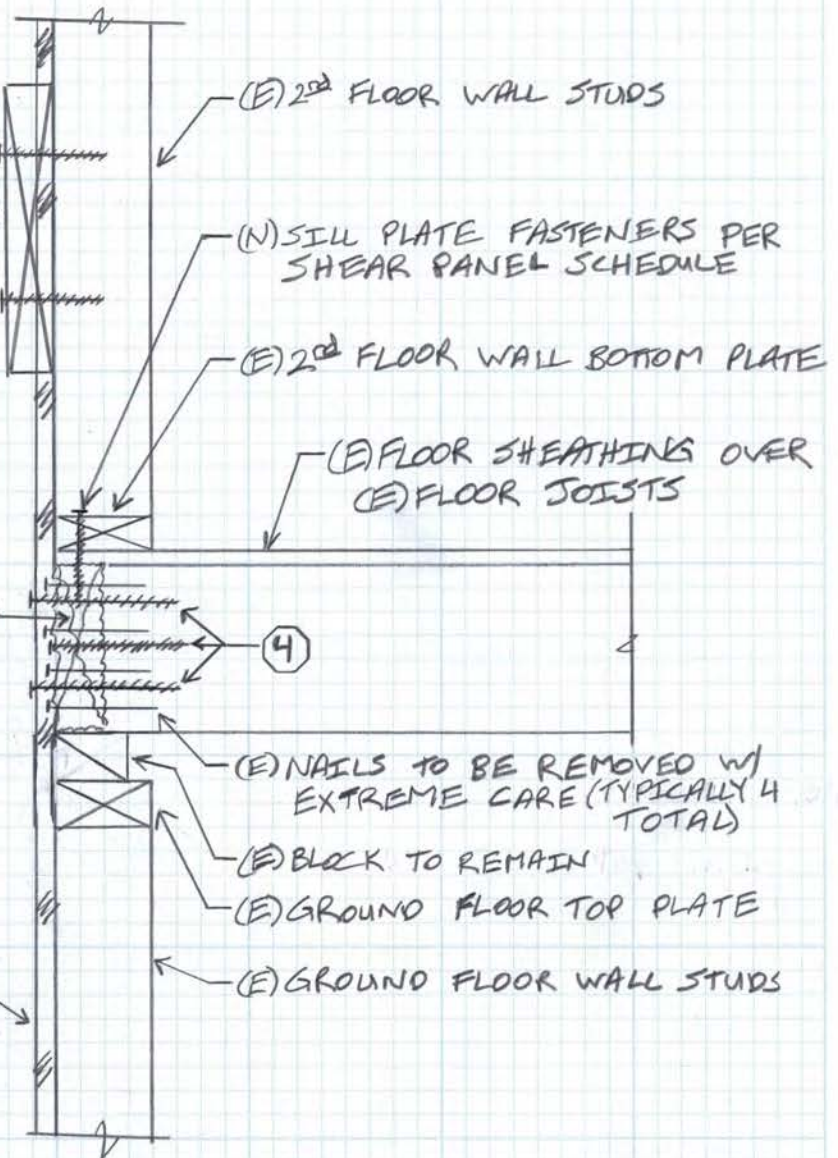

SSK

7

NORTH WALL 2<sup>nd</sup> FLOOR RIM JOIST

N.T.S.

STRUCTURAL FOCUS  
RK 12/5/2018  
HARADA HOUSE #17126

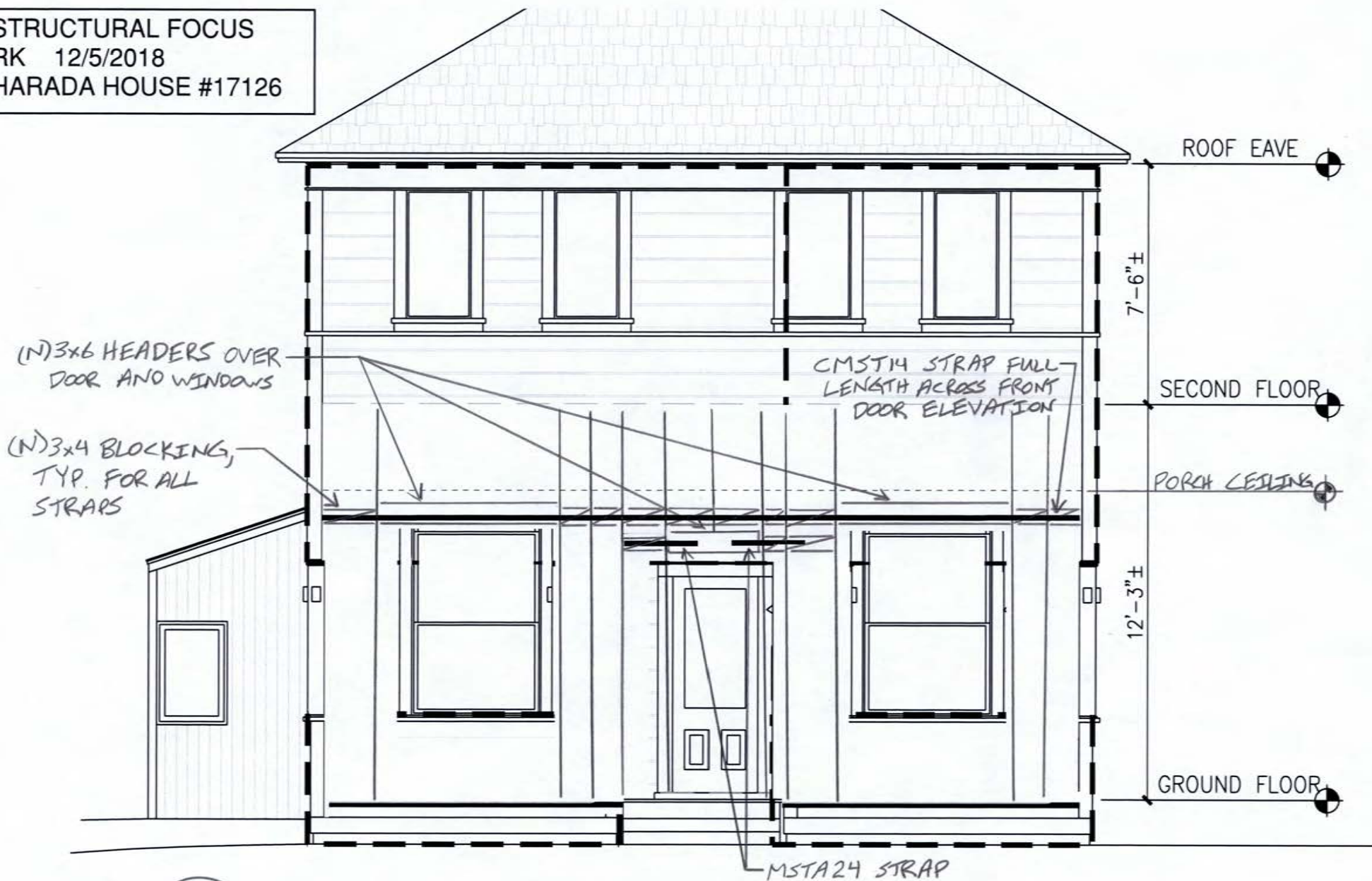

SSK  
8

FRONT DOOR ELEVATION



STRUCTURAL FOCUS  
RK 11/28/2017  
HARADA HOUSE #17126

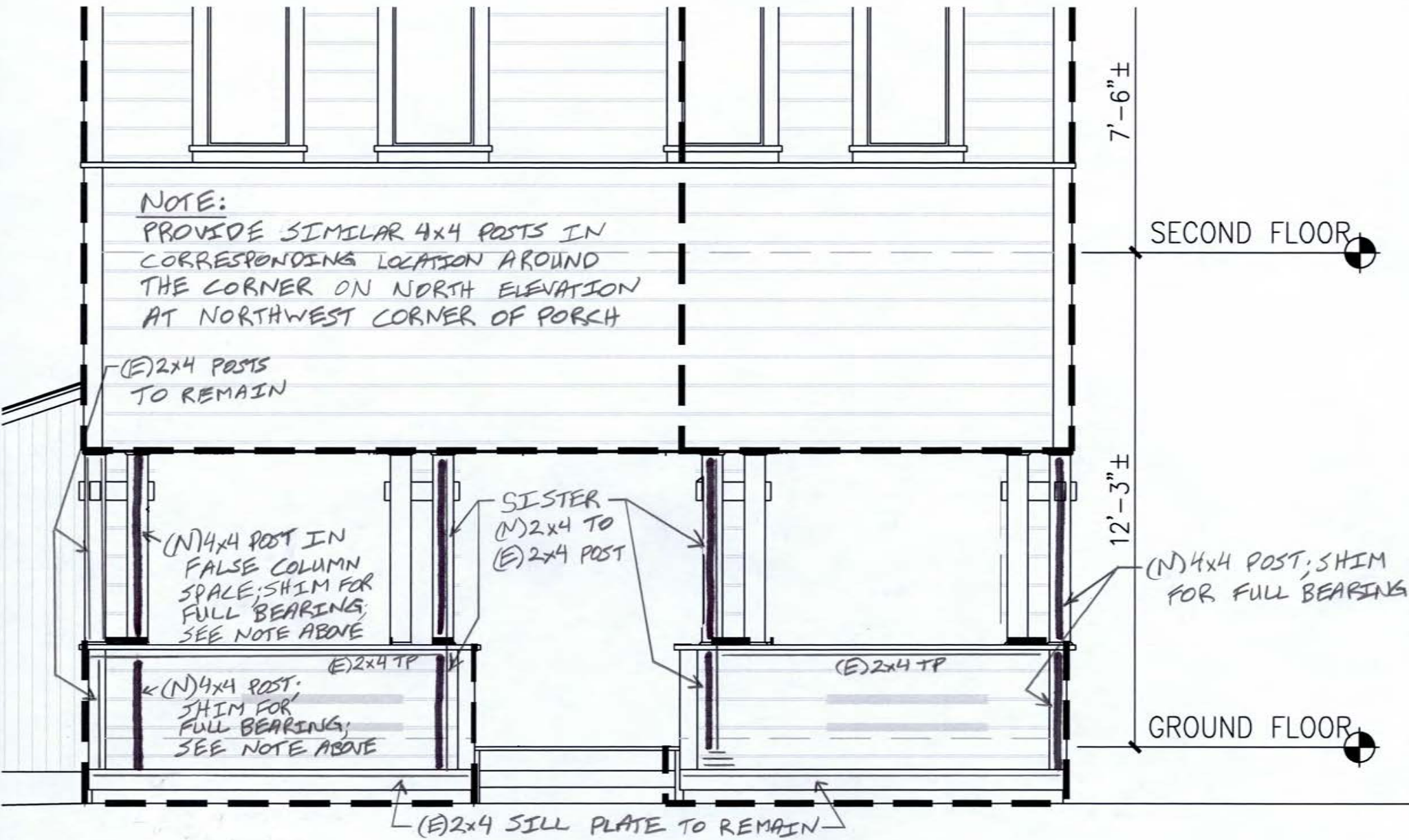

SSK  
9

WEST ELEVATION - TEMPORARY IMMEDIATE REPAIRS

STRUCTURAL FOCUS  
 RK 1/23/2018  
 HARADA HOUSE #17126

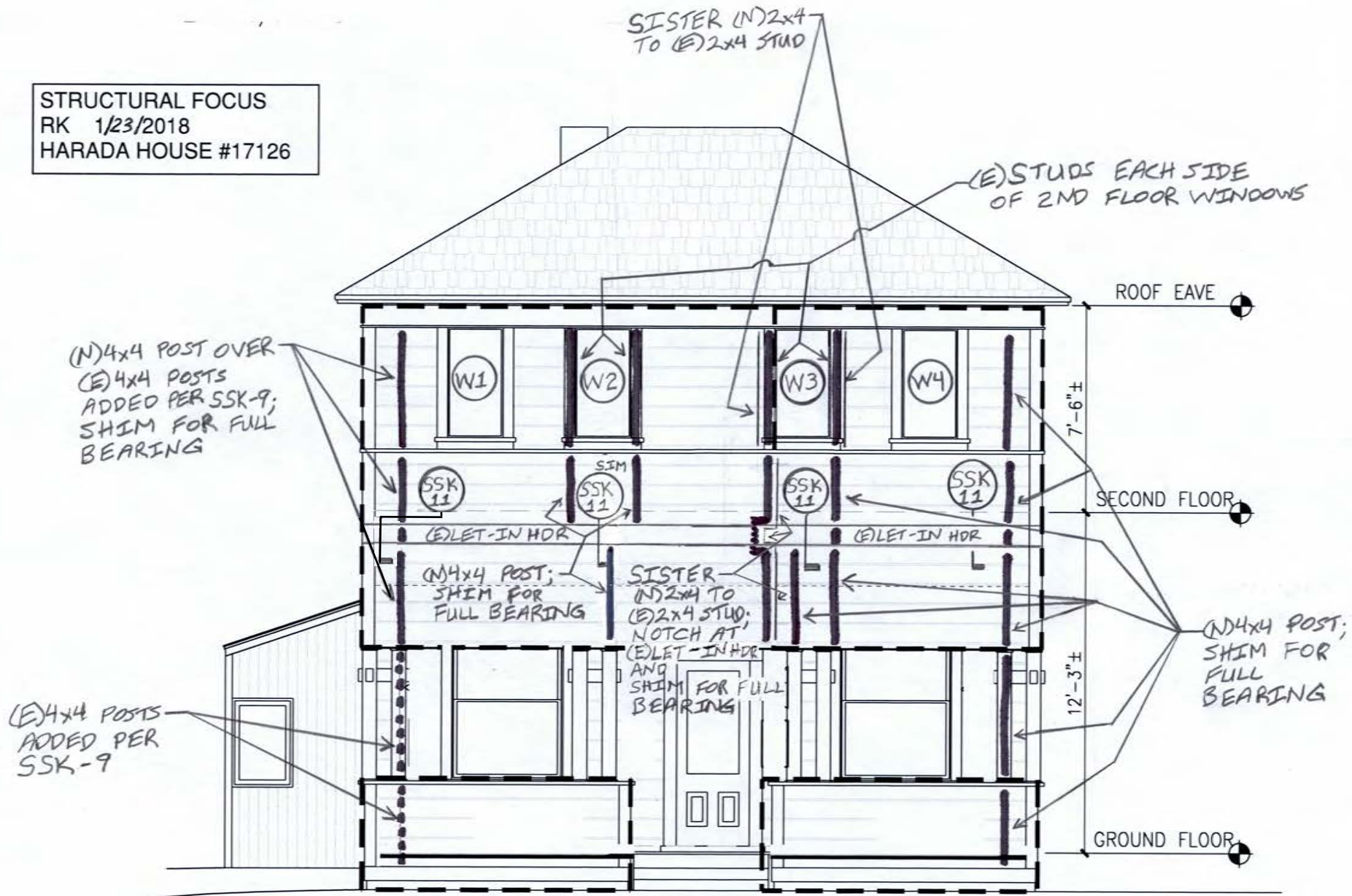

SSK 10 WEST ELEVATION - UPPER PORTION



PROJECT Harada House

DATE 1/23/2018

PROJECT NUMBER 17126

SECTION

BY RK

CHECKED BY

PAGE OF



SUBJECT SSK-11 Detail at (E) Let-in Header (West Elevation)

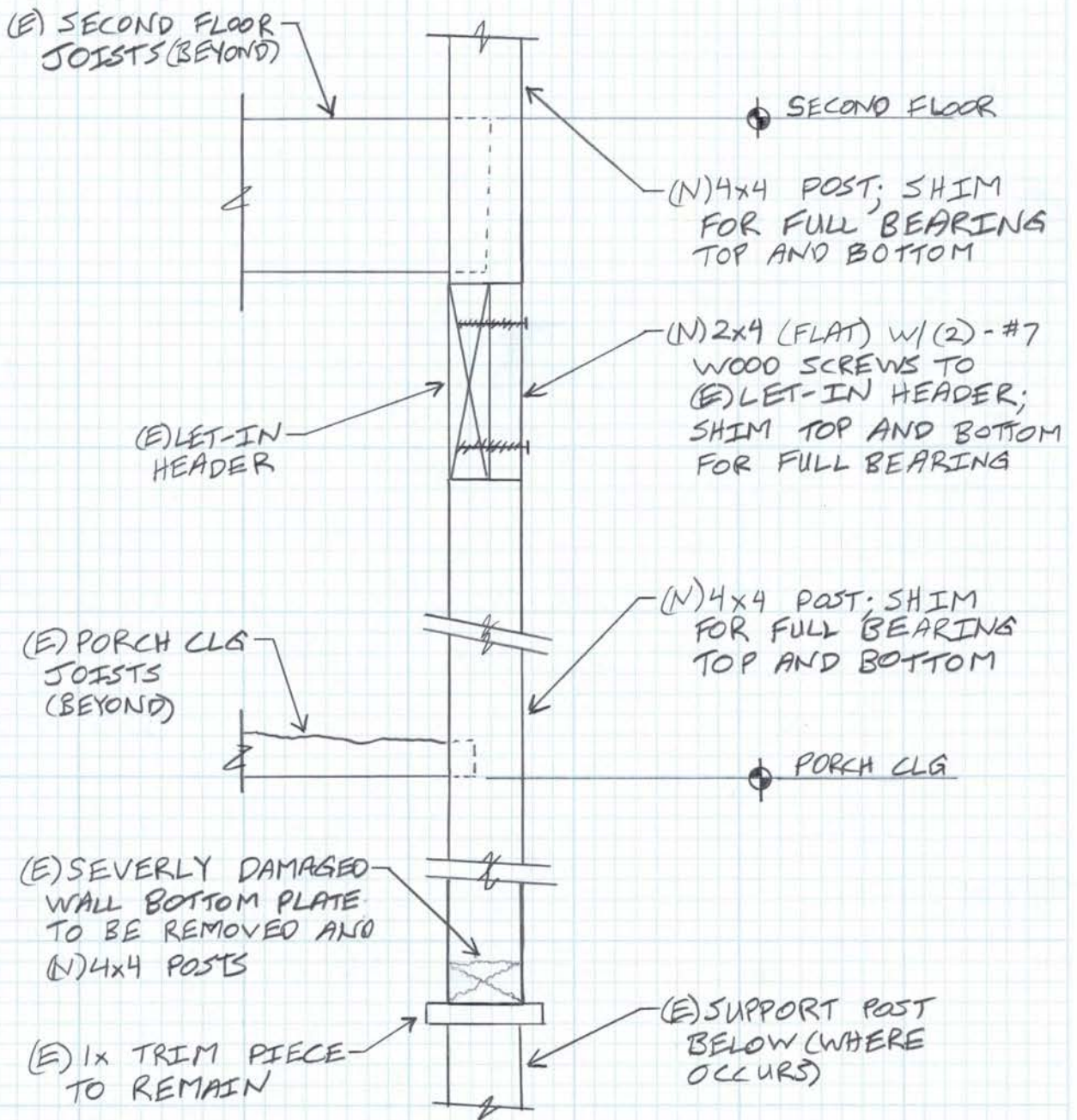

SSK  
11

DETAIL AT (E) LET-IN HEADER (WEST ELEVATION)