

Short Range Wireless Switch System HD 900 MHz Installation Guide

CHECK ALL WIRING CONNECTIONS BEFORE APPLYING POWER

Operation

The Short Range Wireless Switch System (SRWSS) HD 902-928 MHz System uses a 1, 2, 4 or 8 button handheld transmitter and a 1, 2, 4 or 8 output receiver to provide wireless control of multiple devices. The transmitter is used to send a coded set of instructions to the receiver activating corresponding relay outputs.

A 12-position DIP switch allows the user to digitally code the receiver to match the transmitter input. Multiple transmitters can be programmed to one receiver, and a single transmitter can operate multiple receivers.

The receiver output relay has two modes that control how the relays function. The relay output modes are selectable using a 1, 2 or 4 position DIP switch on the receiver. Each relay is a SPDT Class C rated for 5 amps@ 250VAC (or 5A @ 30 VDC) with Normally Open (NO), Normally Closed (NC), and Common (C) contacts.

The receivers and transmitters use fast frequency hopping (FFH) to allow up to eight receivers to be used in the same area. No interference or jamming will occur.

Both transmitters and receivers use a dual digital coding technology to provide secure, interference-free operation. The operator has a choice between using the 12-position DIP switch and encrypted coding. The 12-position DIP switch allows for simple programming and involves simply matching the 12-position dip switch on both the transmitter and receiver. The encrypted coding is a random generated code, which is programmed wirelessly to the transmitter and receiver. The encrypted code is usually used when more codes are required for high security applications.

Heavy Duty Hand-Held Transmitters

Heavy Duty Hand-Held Transmitters include:

- (1) 900 MHz Antenna (not shown) (1) Battery Cover (1) 9 Volt Alkaline Battery (1) Belt Clip



9109THD-001-001
 1-Push Button Heavy
 Duty Transmitter



9209THD-001-001
 2-Push Button Heavy
 Duty Transmitter



9409THD-001-001
 4-Push Button Heavy
 Duty Transmitter



9809THD-001-001
 8-Push Button Heavy
 Duty Transmitter

Key components of the receiver are:

- Supply Connections
- SMA and Terminal Block Antenna Connections
- Position Relay Mode DIP Switch(es)
- 902-928MHz Receiver
- 12 Position Receiver Code DIP Switch
- Relay Connections
- Signal Strength Indicator (see below)
- Receiver Status Indicator
- Output Relay Test Button

By default, the receivers code in preset and the relay output mode is set to Momentary mode. This must be taken into consideration when setting up the receiver.

Note: Bench test the system prior to the final installation to ease setup and to gain a better understanding of how the system functions.

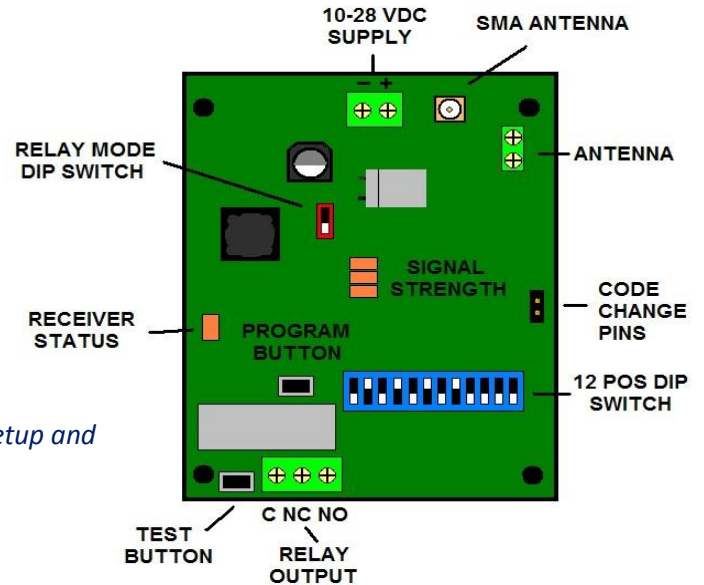

Signal Strength Indicator

Most receivers in the 902-928MHz series include a signal strength indicator*, which is useful for antenna location and troubleshooting.

1-Relay Output Receiver – Three yellow LEDs

2-Relay Output Receiver – Three yellow LEDs

The three LEDs indicate different levels of signal strength.

3 LEDs	-80dBm	Very Strong Signal	Very Reliable Operating Conditions
2 LEDs	-90dBm	Strong Signal	Very Reliable Operating Conditions
1 LED	-100dBm	Good Signal	Reliable Operating Conditions

4-Relay Output Receiver – No signal strength LEDs

8-Relay Output Receiver – One red “signal acknowledgement” LED

*Subject to change

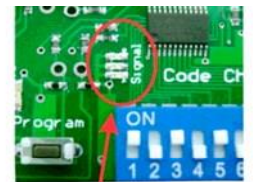

Signal Strength Indicator

Relay Output Modes

Relay outputs on the receivers can function in either Momentary or Flip-Flop (Toggle) mode. By default the mode is set to Momentary. The relay output modes are selectable using the (red and white) DIP switch(s).

- **Momentary** – Output is active for as long as the transmitter button is pressed. This is a standard mode on most automatic gates or garage door openers.
- **Flip-Flop** – Output remains active until next press of the transmitter button. Similar to switching “on” and “off” a light.

9112RHD-001-001 1-Relay Output Receiver

The 1-relay output receiver has two modes that control how the relay output functions. These modes are user selectable using the 1 Position DIP switch on the receiver. The two Modes functions as follows:

Momentary

Move the switch position to “OFF” to set the selected relay(s) in momentary mode. In momentary mode, the selected relay(s) will change its state and maintain it for the duration of the transmission received. Once the transmission is terminated, the relay will change back to its original state.

Flip-Flop

Move the switch position to “ON” to set the selected relay(s) in Flip-Flop mode. In Flip-Flop mode, the selected relay(s) will change its state and maintain it until a matching transmission is received. Every time a transmission is received the relay will change its state and maintain it until another transmission is received.

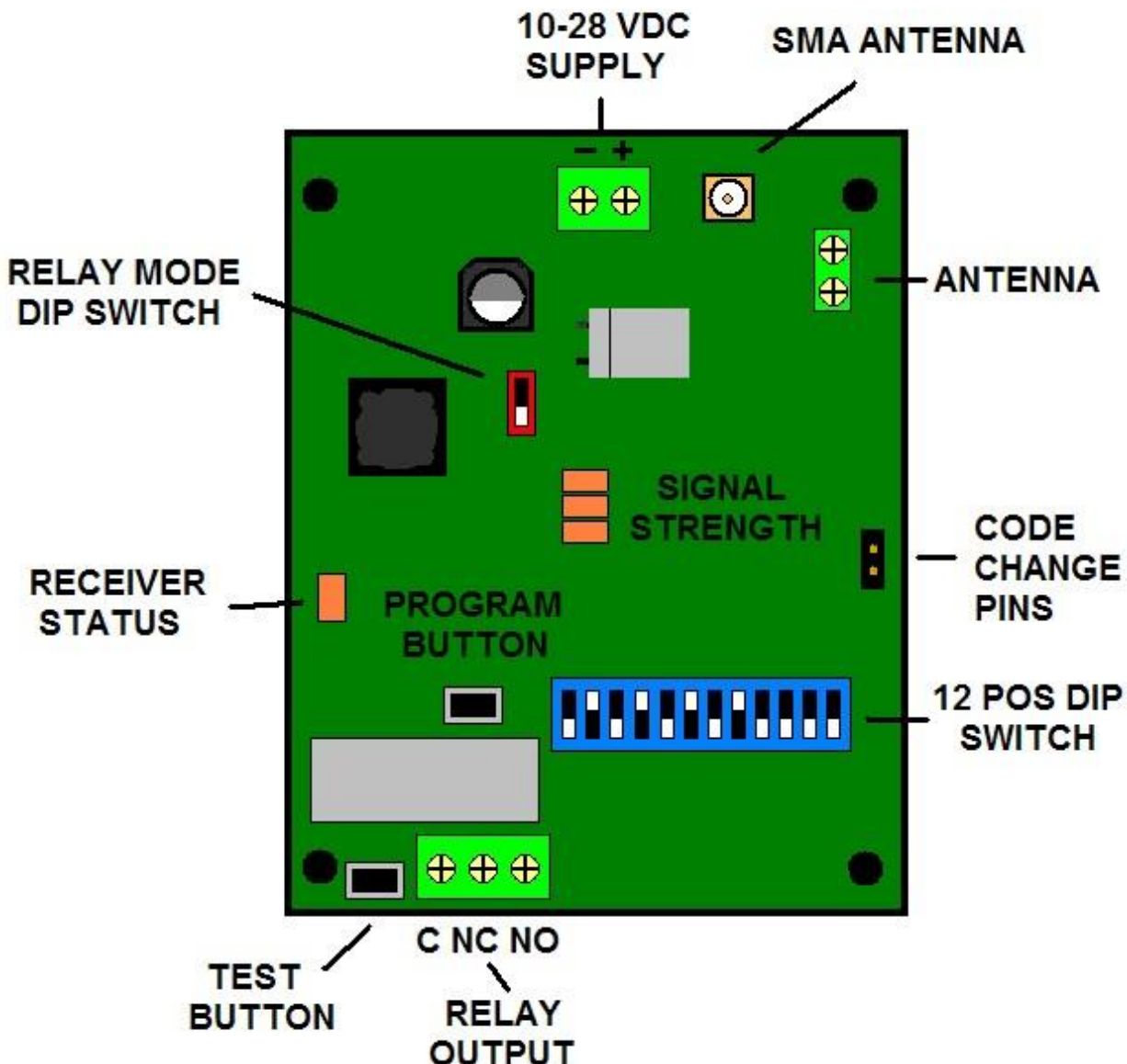

9212RHD-001-001 2-Relay Output Receiver

The 2-relay output receiver has two modes that control how they relay outputs function. These modes are user selectable using the 2 Position DIP switch on the receiver. The number on the 2 Position DIP switch corresponds to the relay that switch controls. Position 1 controls relay one; position two controls relay two. The two modes function as follows:

Momentary

Move the switch position to "OFF" to set the selected relay(s) in momentary mode. In momentary mode, the selected relay(s) will change its state and maintain it for the duration of the transmission received. Once the transmission is terminated, the relay will change back to its original state.

Flip-Flop

Move the switch position to "ON" to set the selected relay(s) in Flip-Flop mode. In Flip-Flop mode, the selected relay(s) will change its state and maintain it until a matching transmission is received. Every time a transmission is received the relay will change its state and maintain it until another transmission is received.

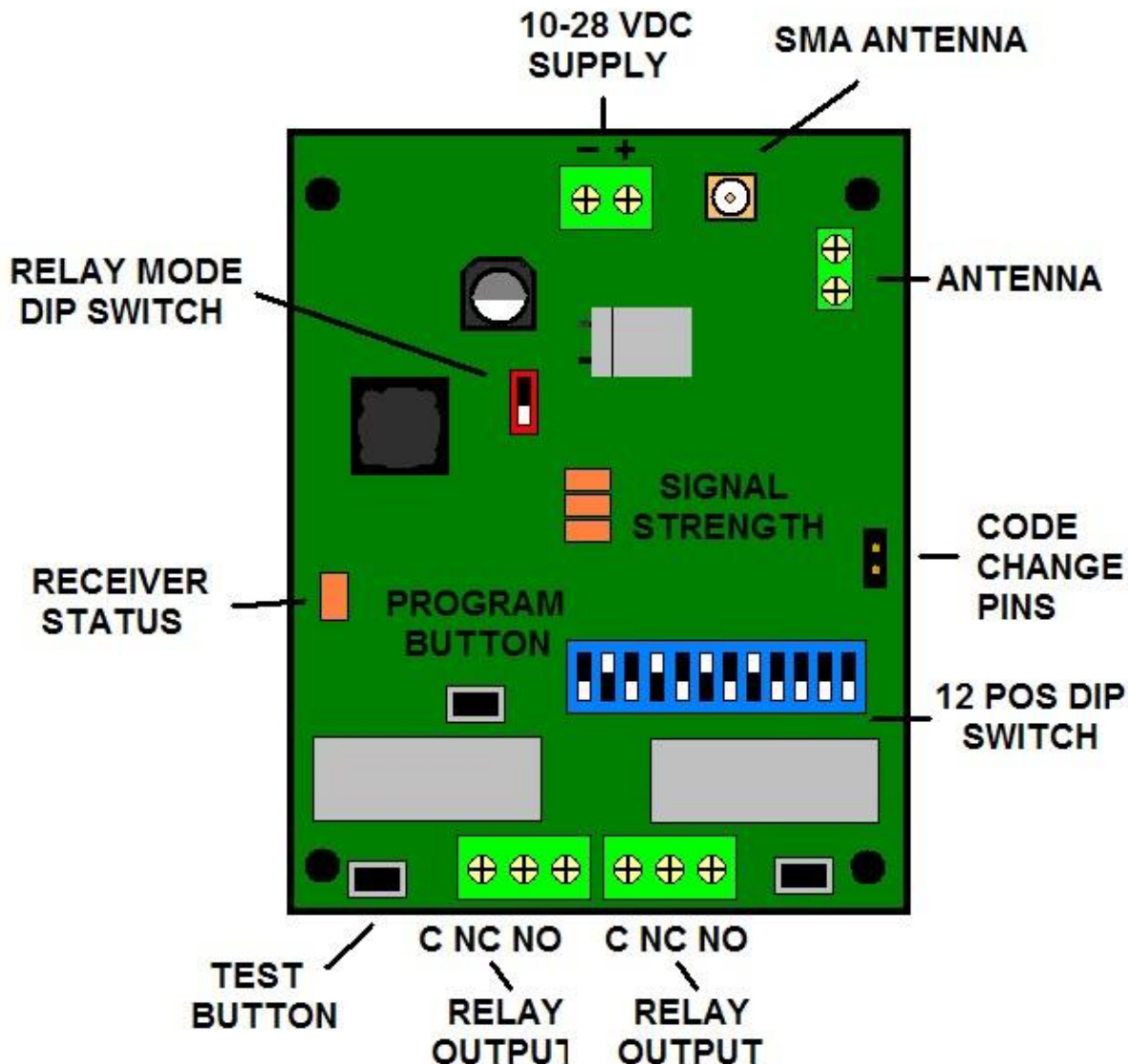

9412RHD-001-001 4-Relay Output Receiver

The 4-relay output receiver has two modes that control how the relay output functions. These modes are user selectable using the 4 Position DIP switch on the receiver. The number on the 4 Position DIP switch corresponds to the relay that switch controls. Position 1 controls relay one; position 2 controls relay two, etc. The two modes function as follows:

Momentary

Move the switch position to "OFF" to set the selected relay(s) in momentary mode. In momentary mode, the selected relay(s) will change its state and maintain it for the duration of the transmission received. Once the transmission is terminated, the relay will change back to its original state.

Flip-Flop

Move the switch position to "ON" to set the selected relay(s) in Flip-Flop mode. In Flip-Flop mode, the selected relay(s) will change its state and maintain it until a matching transmission is received. Every time a transmission is received the relay will change its state and maintain it until another transmission is received.

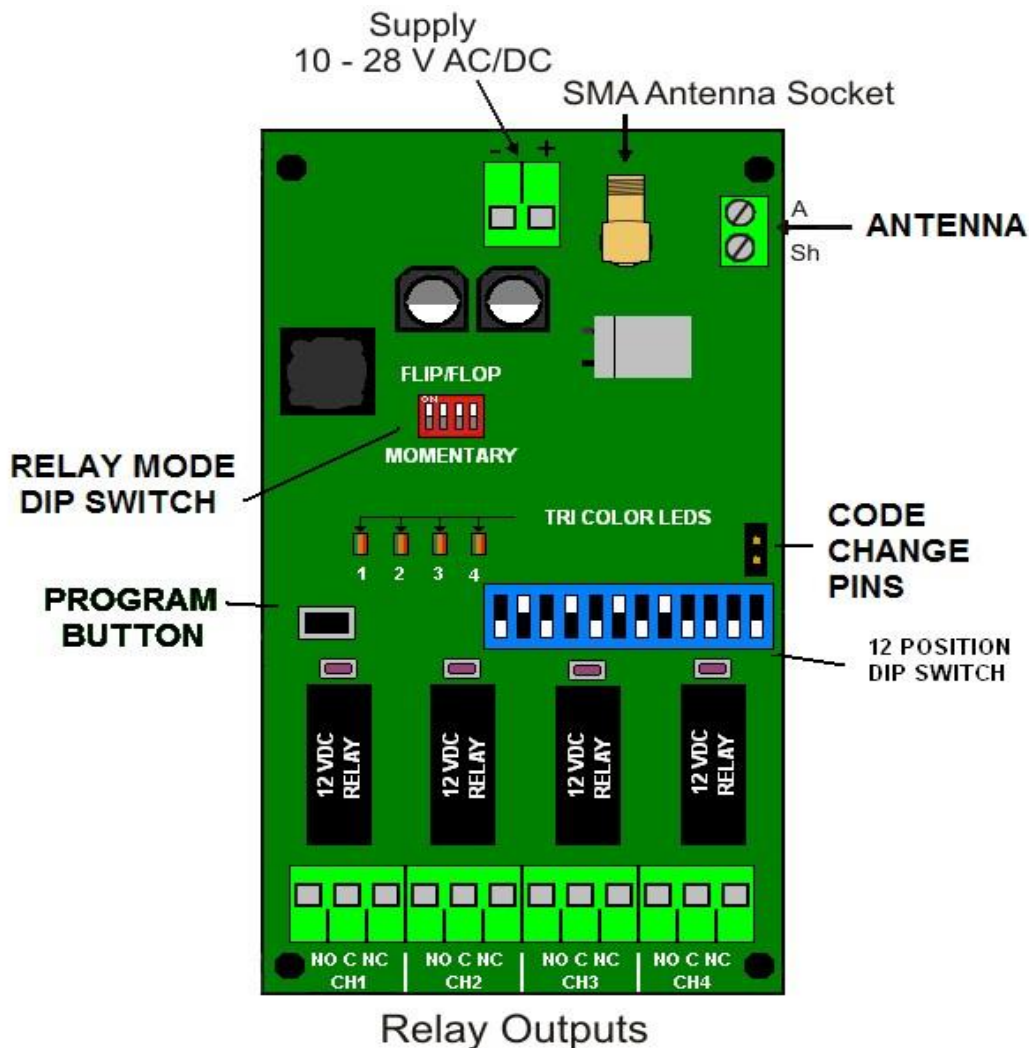

9812RHD-001-001 8-Relay Output Receiver

The 8-relay output receiver has eight modes that control how the relay output functions. These modes are user selectable using the 4 Position DIP switch on the receiver. The chart below displays the DIP switch position accompanied by a description of the relay functions.

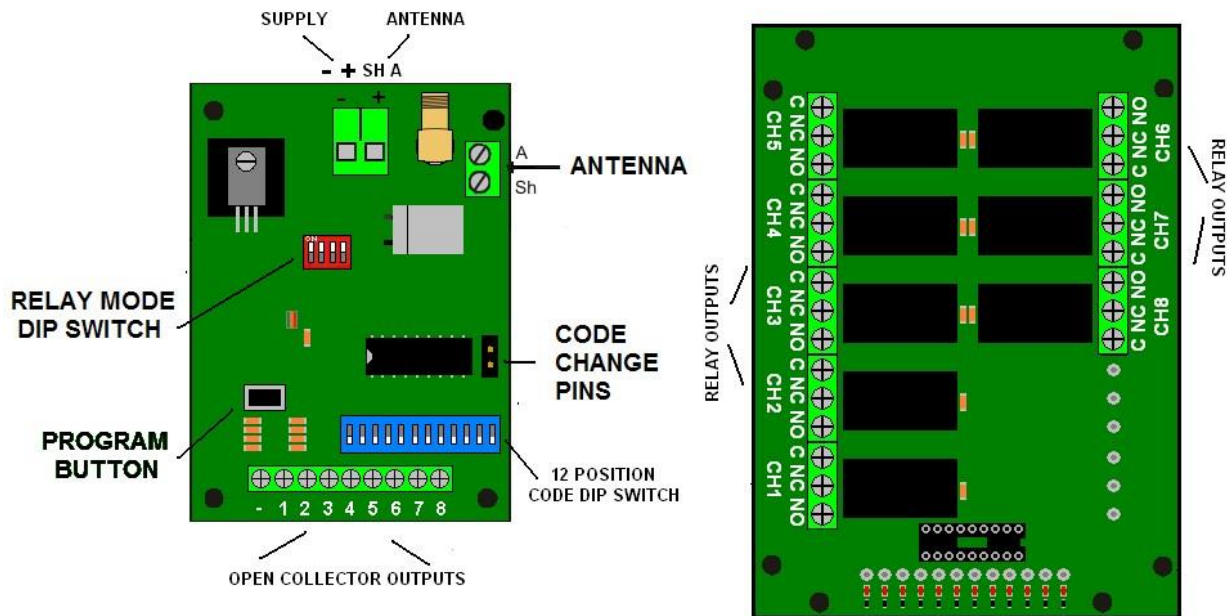

4 Position DIP Switch Mode Settings

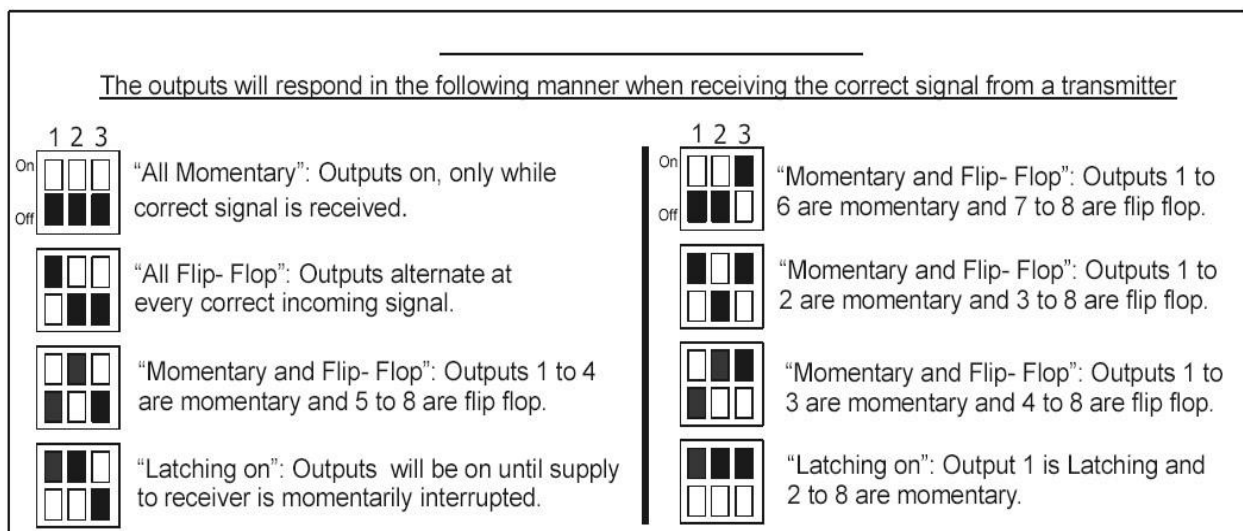

NOTE: The 4th position of the DIP switch is not used

Receiver Installation

The Receiver is designed for mounting on a wall or in a larger enclosure. As with any RF receiver, care must be taken in choosing the installation location. Installing the receiver in a location with variable frequency drives (VFDs), large power transformers, other radio equipment, or any unshielded electrical device may cause interference with the operation of the receiver. A good location would be 10-40 feet from any device that would cause interference, but this is not always possible. For those situations, further steps must be taken to shield the receiver from external interference. Here are a few suggestions to provide some additional shielding:

- Wire AC and DC wiring in separate bundles.
- Use a multi-conductor shielded cable to connect devices to the output relay and to the analog device.
- Provide a good earth ground to receiver power supply.
- Relocate the receiver antenna away from any device that would cause interference.
- Install the receiver in a metal enclosure and ground the enclosure to a good earth ground.

Receiver Installation Steps:

1. Affix the wall mounting brackets included with the system to the back of the enclosure and mount the receiver enclosure to a wall, pole, or another enclosure.
2. Connect a device to the 3 position terminal block(s). Position (NO) the Normally Open contact of the relay. Position (NC) the Normally Closed contact to the relay. Position (C) a Common contact of the relay.
3. Attach the antenna to the antenna mount assembly.
4. Connect the antenna to the coaxial cable provided, and connect the cable to the BNC connector on the top of the receiver enclosure.

Note: Do not loop excess coaxial cable into a coil. This will cause a radio frequency choke and reduce your signal range. Lay excess cable in a straight line or loosely route it back and forth in an "S" configuration

5. Connect a 110-220 VAC power source to the built-in power supply. Alternatively, connect a 12 VDC power source directly to the receiver.
6. Attach the lightning/surge suppressor and antenna (see below).

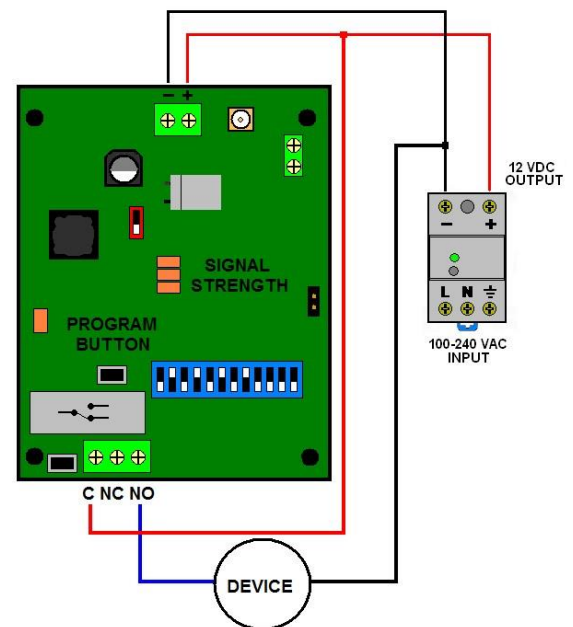

CAUTION:
Check all wiring connections prior to applying power.
Failure to do so can result in serious damage
to your product.

Antenna Installation

Clear Communication Path

Wireless communication can be hindered by radio interference and obstructions in the path between the transmitter and receiver. To achieve the best radio performance, carefully consider the installation locations for the receiver and select locations without obstructions in the path.

Increase the Height of the Receiver Antenna

Position the receiver antenna vertically for optimal RF communication. If necessary, consider changing the height of the receiver radio, or its antenna, to improve reception. For outdoor applications, mounting the antenna on top of a building or pole may help achieve a line-of-sight radio link with the other radios in the network. The receiver includes 25' of LMR-400 coaxial cable and the omni-directional antenna is suitable for mounting on a pole or the top of a building or structure. Longer and shorter cable lengths are available.

Line of Sight

Accurate radio transmission depends on a clear path between radio antennas known as “line of sight”. If any obstructions, including but not limited to buildings, trees, or terrain, interrupt the visual path between antennas, the obstructions may also interfere with the radio signal transmission, resulting in multi-path fade or increased signal attenuation.

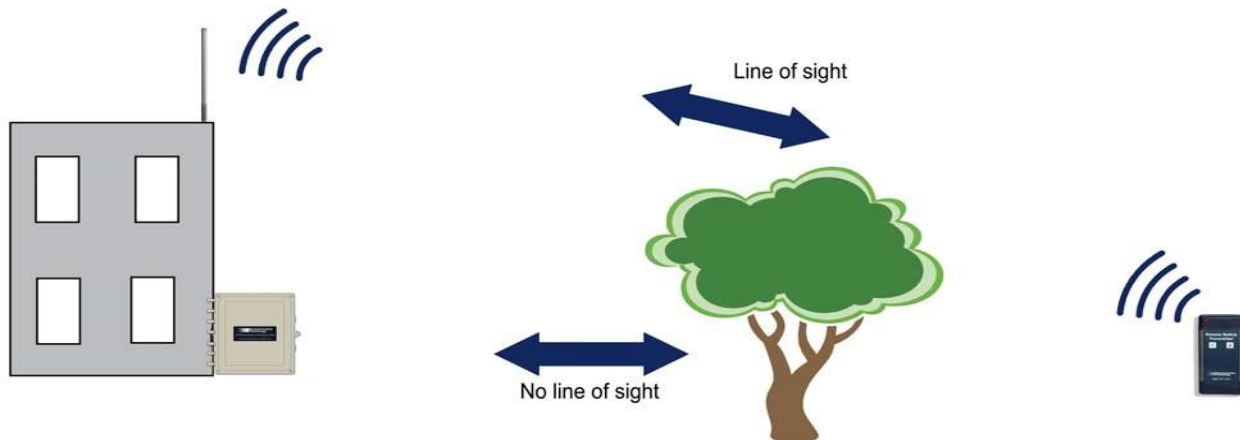

Multi-path fade is the result of radio signals reaching the receiver via two or more paths. In industrial settings, a received signal may include the line of sight signal in addition to signals reflected off buildings, equipment, trees, or outdoor terrain. Signal attenuation is the “decrease in signal strength as a result of travel through the medium; in this case the air.

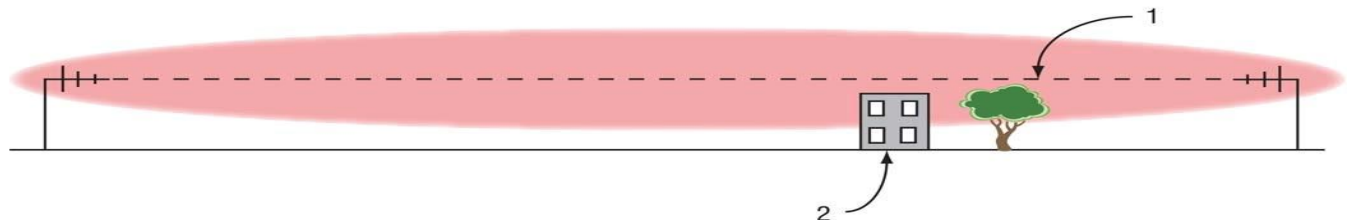

Line of sight may be preserved, but obstructions in the first lobe of the Fresnel zone may still cause reception problems.

Despite a clear line of sight, obstructions in the Fresnel zone, a three-dimensional ellipsoid formed with the two antennas as the foci, will still interfere with the radio signal and cause multi-path fade.

Raise the antennas high enough to clear any obstructions. Ideally there should be no obstructions anywhere in the Fresnel zone, even if line-of-sight is preserved.

Antenna Mounting and Specifications

The receiver antenna is a high performance omni-directional antenna designed for the 900 MHz ISM band. It is ideally suited for multipoint, Non Line of Sight (NLOS) and mobile applications where high gain and wide coverage is desired.

This antenna features an integral N-Female bulkhead type connector that mounts through the wall of an equipment enclosure. Included with the antenna is a mast mounting kit. Consisting of a heavy-duty steel bracket and a pair of U-bolts, this kit allows installation on masts up to 2.0" in diameter.

This omni-directional antenna's construction features a rugged 1.3" diameter white high intensity fiberglass radome for durability and aesthetics. It is designed for all weather operation.

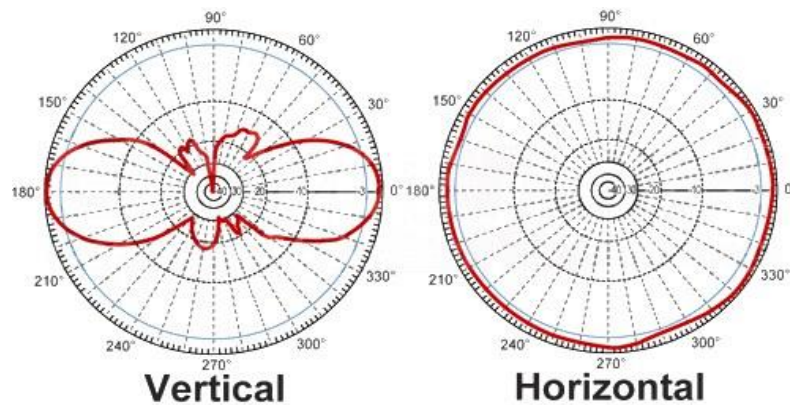

Electrical Specifications

Frequency	824 – 960 MHz
Gain	6 dBi
Vertical Beam Width	30 Degrees
Impedance	50 Ohms
Max Input Power	100 Watts
VSWR	<1.5:1 Avg.

Mechanical Specifications

Connector	Integral N-Female
Weight	2.4 lbs (1.1 kg)
Length	23.6 in. (600mm)
Diameter	1.3 in. (33mm)
Radome Material	White Fiberglass
Mounting	1.25" to 2" dia. Mast Max (31.7 mm to 50.8 mm dia.)
Polarization	Vertical
Operating Temperature	-40° to 85° C (-40° F to 105° F)
Rated Wind Velocity	108 MPH
ROHS Compliant	Yes

Following these guidelines will maximize range:

- Mount the antennas at least 40 feet away from electric motors, large power transformers, power lines, VFDs or any equipment that produces ambient electrical noise.
- Mount all antennas outdoors. The receiver and transmitter communicate in the RF (radio frequency) spectrum at 900 MHz. This frequency has great characteristics for long range. For best results, the antennas need line of sight. If equipment is to be located indoors, use an appropriate length of LMR400 coaxial cable for an antenna to be mounted outdoors. **NEVER WRAP EXCESS CABLE IN A COIL.**
- Mount antennas as high as possible, at least 3 feet away from vertical surfaces and avoid under roof awnings.
- Mount it at the apex or the highest point of the building.
- When mounting the antenna to a metal pole, mount the antenna at the top of the pole or at least 3 feet away from the pole.
- Avoid mounting the antenna on the same pole as the power service.
- Avoid mounting the antenna on or near a chain link fence. If necessary, the antenna can be mounted at least 3 feet above the fence.
- Use only high-quality antenna and cable connectors, which are available from Remote Control Technology.

Weatherproofing Antenna Installations

Prevent water damage to the cable and connections by sealing the connections with rubber splicing tape and electrical tape. To protect the connections, follow these steps:

1. Verify both connections are clean and dry before connecting the antenna cable to the antenna or other cable and hand-tighten.

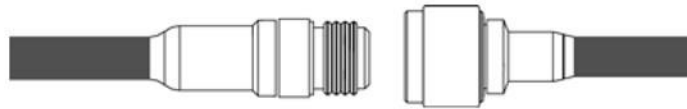

2. Tightly wrap the entire connection with rubber splicing tape. Begin wrapping the rubber splicing tape one inch away from the connection and continue wrapping until you are one inch past the other end of the connection. Each new round of tape should overlap about half the previous rounds.

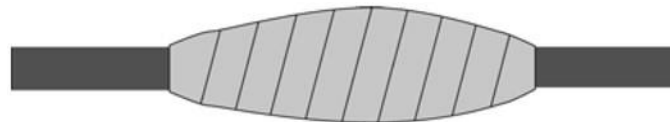

3. Protect the rubber splicing tape from UV damage by tightly wrapping electrical tape on top of the rubber splicing tape.



4. The electrical tape should completely cover the rubber splicing tape and overlap the rubber tape by one inch on each side of the connection.

Programming

Encrypted Coding Setup Instructions

The encrypted code is a randomly selected code out of 16 million different combinations.

The user can change the code by shorting out the Add/Delete pin on the receiver. The orange LED turns on when the Add/Delete pins are shorted to confirm the change of code was successful. Once this is done, all transmitters and receivers need to be programmed again with the new code.

Programming Steps

Receiver to Transmitter

1. Apply power to transmitter (install 9VDC battery)
2. Apply power to receiver (12VDC from power supply)
3. On the receiver's 12-Position DIP switch, make sure all twelve (12) switches are in the "OFF" position
4. Using the black plastic jumper, short the "Code Change" pins together on the receiver to create a random code; the receiver's orange LED comes on to confirm the change of code was successful
5. Remove the black plastic jumper from the Code Change pins and place it back over one pin

Note: Any previously programmed transmitters/receivers will need to be re-programmed at this point

6. To broadcast the receiver's code, turn DIP switch 12 "ON" and then "OFF" ...this is confirmed by the green LED being on for 10 seconds
7. While the receiver is broadcasting the code, press button 1 on the transmitter for 1 second and then release the button; the orange LED on the transmitter will flash twice to confirm successful programming

Note: If orange LED on transmitter did not flash twice, try again, but move closer to the broadcasting receiver

8. Once the green LED on the broadcasting receiver goes out, the system will be ready to use

Receiver to Receiver

1. Apply power to both receivers
2. On the broadcasting receiver's 12-Position DIP switch, make sure all twelve (12) switches are in the "OFF" position
3. Short the "Code Change" pins together on the receiver to select a random code; the receiver's orange LED turns on to confirm the change of code was successful

Note: Any previously programmed transmitters/receivers will need to be re-programmed at this point

4. To broadcast the receiver's code, turn DIP switch 12 "ON" and then "OFF"; this is confirmed by the green LED being on for 10 seconds
5. While the receiver is broadcasting the code, press the "Program" button on the additional receiver for 1 second and then release the button; the orange LED will flash twice to confirm successful programming





Note: If orange LED on target receiver did not flash twice, try again, but move closer to the broadcasting receiver

6. Once the green LED on the broadcasting receiver goes out, the system will be ready for use

During programming all channels are sequentially programmed; that is, Button 1 to Relay 1, etc.

This programming method allows a user to program unlimited number of transmitters to the receiver or vice versa.

900 MHz Antenna and Cable Accessories

Part Number	Description	Comments
01801-001-002	 Antenna, Omni, 902-928 MHz, 3 dBi, Rubber Swivel, SMA MALE	Used for applications less than 1 mile in length. Line of sight required
01800-001-001	 Antenna, Omni, 902-928 MHz, 6 dBi, N Type Female Connector, (Includes Mounting Hardware, Adapters Not Included)	Used for applications greater than 1 mile in length. Line of sight required
01920-001-001	 N-Male to N-Female Bulkhead Lightning/Surge Arrester Kit. (Includes cable, adapters, and mounting hardware)	Recommended when using an antenna other than the Whip Antenna (01801001-002).
01805-001-003	 BNC Male / SMA Female Coaxial Adapter	Used with: 01801-001-002 74-304-021 74-304-026 74-304-031
01805-001-004	 N Female / BNC Male Coaxial Adapter	Used with: 74-304-051 74-304-076 74-304-0100
Part Number	Description	
01803-001-002	902-928 MHz 9dBi Yagi Antenna Kit (Includes - Bulkhead Lightning Arrester, 25 FT LMR 400 Coaxial Cable, & Mounting Hardware)	
01803-002-002	902-928 MHz 6dBi Omni Antenna Kit (Includes - Bulkhead Lightning Arrester, 25 FT LMR 400 Coaxial Cable, & Mounting Hardware)	
74-304-021	LMR 195 Coaxial Cable, SMA Plug to N-Male, 20 ft Length	
74-304-026	LMR 400 Coax with N-Male to SMA Plug 25 ft Length	
74-304-031	LMR 400 Coax with N-Male to SMA Plug 30 ft Length	
74-304-051	LMR 400 Coax with N-Male to SMA Plug 50 ft Length	
74-304-076	LMR 400 Coax with N-Male to SMA Plug 75 ft Length	
74-304-0100	N-Male to N-Male LMR 600 Series Assembly 100 ft Length	

