

# Modulate Action

Safety Relief Valves

Series 433

Series 429



# CATALOG

**LESER**

The-Safety-Valve.com

LESER Safety Valves for every industrial application



## Modulate Action



**High Performance**

## Series 433

Type 431, 433



**Compact Performance**

Type 431, 433 PN 160



**API**



**High Efficiency**



**Clean Service**

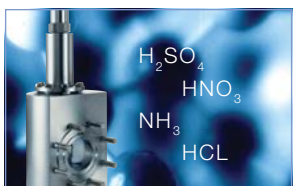

**Critical Service**

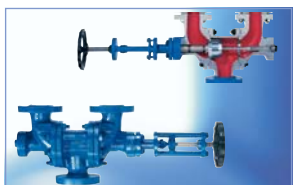

**Best Availability**

## Series 429

Type 427, 429

# General

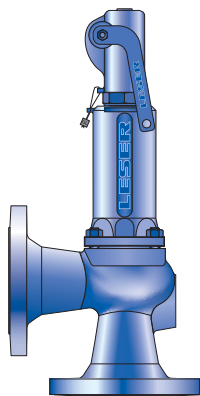

## Type 431, 433

DN 15 – DN 150  
Set pressure 0.2 – 40 bar

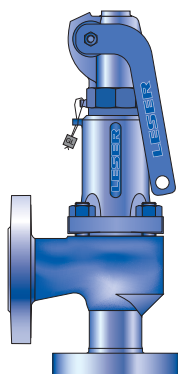

## Type 431, 433 PN 160

DN 15  
Set pressure 0.3 – 160 bar

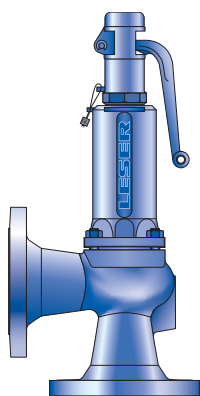

## Type 427, 429

DN 15 – DN 150  
Set pressure 1.5 – 40 bar

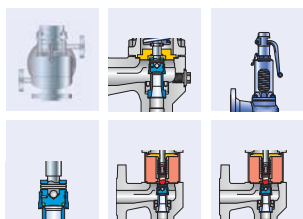

## Options

## Overview Chapter/Page

General	
General Information	00/01
Applications, General design features	00/02
Valve guide	00/03
Valve selection	00/05
How to use: Signs and symbols, Flange drillings and facings	00/07
How to use: Determination of coefficient of discharge $K_{dr}/\alpha_w$	00/08
How to use: Capacity sheets	00/09
LESER Effective Orifice $LEO_{S/G}$	00/11
LESER Effective Orifice $LEO_L$	00/12
NACE-Compliant Safety Valves	00/13

## LESER Type Chapter/Page

Type 431, 433		01/01
<b>Materials</b>		
• Conventional construction		01/02
• Balanced bellows construction		01/04
<b>How to order:</b>		
• Numbering system		01/06
• Article numbers		01/08
<b>Pressure temperature ratings</b>		
• Metric units		01/10
<b>Dimensions and weights</b>		
• Metric units		01/12
Approvals		01/13
Flange drillings		01/14
Flange facings		01/15
LESER Original Spare Parts Kits		01/16
Available options		01/18
<b>Capacities</b>		
• Steam	Metric units	01/19
• Air	Metric units	01/20
• Water	Metric units	01/21
Determination of coefficient of discharge $K_{dr}/\alpha_w$		01/22

## LESER Type Chapter/Page

Type 433 PN 160		02/01
<b>Materials</b>		
• Conventional design		02/02
• Balanced bellows design		02/04
<b>How to order:</b>		
• Numbering system		02/06
• Article numbers		02/08
<b>Pressure temperature ratings</b>		
• Metric units		02/09
<b>Dimensions and weights</b>		
• Metric units		02/10
Flange drillings and facings		02/11
Order information - spare parts		02/12
Available options		02/13
Approvals		02/14
<b>Capacities</b>		
• Steam, air, water	Metric units	02/15
Determination of coefficient of discharge $K_{dr}/\alpha_w$		02/16

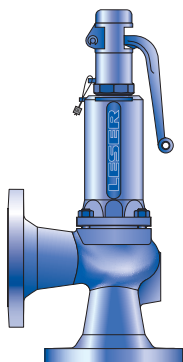

**Type 433**  
Plain lever H3  
Closed bonnet  
Conventional design

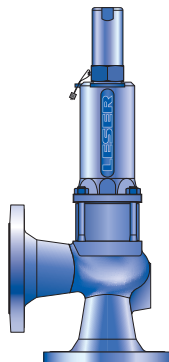

**Type 433**  
Cap H2  
Closed bonnet  
Balanced bellows design

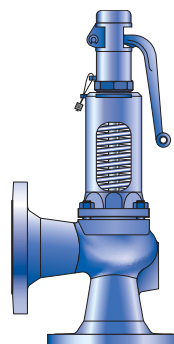

**Type 431**  
Plain lever H3  
Open bonnet  
Conventional design

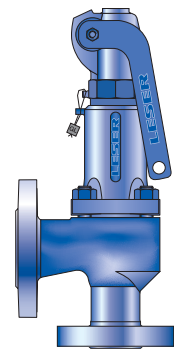

**Type 433 PN 160**  
Packed lever H4  
Closed bonnet  
Conventional design



LESER Type	Chapter/Page	
<b>Type 427, 429</b>	<b>03/01</b>	
<b>Materials</b>		
• Conventional design	03/02	
• Balanced bellows design	03/04	
<b>How to order:</b>		
• Numbering system	03/06	
• Article numbers	03/08	
<b>Pressure temperature ratings</b>		
• Metric units	03/10	
<b>Dimensions and weights</b>		
• Metric units	03/12	
Flange drillings	03/13	
Flange facings	03/14	
LESER Original Spare Parts Kits	03/15	
Available options	03/16	
Approvals	03/17	
<b>Capacities</b>		
• Steam	Metric units	03/18
• Air	Metric units	03/19
• Water	Metric units	03/20

Options	Chapter/Page
Overview	99/02
Caps and lever	99/04
Metal seat	99/06
Soft seal disc	99/08
Soft seal	99/10
Balanced bellows	99/12
Heating jacket	99/14
O-ring damper	99/16
Elastomer bellows	99/18
Lift indicator	99/19
Lift restriction	99/20

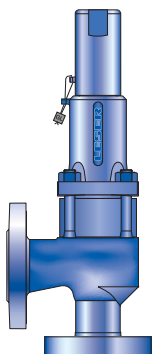

**Type 433 PN 160**  
Cap H2  
Closed bonnet  
Balanced bellows design

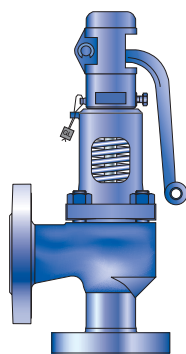

**Type 431 PN 160**  
Plain lever H3  
Open bonnet  
Conventional design

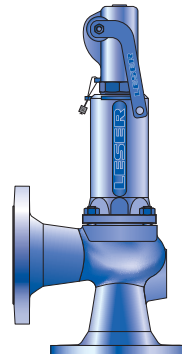

**Type 429**  
Packed lever H4  
Closed bonnet  
Conventional design

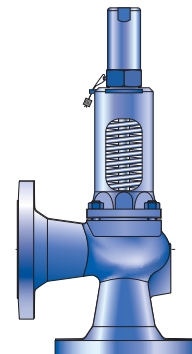

**Type 427**  
Cap H2  
Open bonnet  
Conventional design



## LESER – Modulate Action Safety Valves

The Modulate Action product group stands for

- ✓ Suitable solutions for all areas of applications, especially thermal expansion
- ✓ Lowest possible loss of medium
- ✓ Compact construction and low weight

### LESER Modulate Action Safety Valves

- are characterised by longstanding proof in service and are constantly optimised by service specialists.
- are available as standard safety valves or proportional safety valves.
- reach their full lift within a pressure increase of 10% above the set pressure
- are suitable for almost all industrial applications.
- are accepted by numerous rules and regulations and approved by leading classification societies.

Examples of this are:

- European Community: CE marking as per Pressure Equipment Directives 97/23/EG and DIN EN ISO 4126-1
- Germany: VdTÜV approval as per Pressure Equipment Directive, EN ISO 4126-1, TÜV SV 100 and AD 2000-Merkblatt A2
- China: AQSIQ based on the approvals as per AD 2000-Merkblatt A2
- Eurasian Custom Union: Approval acc. to Eurasian Custom Union (EAC - Eurasian Conformity)

Furthermore, all LESER Modulate Action safety valves are designed, marked, produced and approved according to the requirements of the following regulations (directives, codes, rules and standards): EN ISO 4126-7, EN 12266-1/-2, EN 1092 Part I and II Flange, ASME B 16.34 and ASME B16.5- Flange, AD 2000-Merkblatt A4, AD 2000-Merkblatt HP0.

LESER Modulate Action safety valves can be used for all steam, gas, and liquid applications and are characterised by their low loss of medium.

The Series 433 standard safety relief valves have component testing according to AD 2000-Merkblatt A2 for steam, gases, and liquids. For the Series 429 proportional safety valves, there is only component testing as per AD 2000-Merkblatt A2 for steam and gasses, because the required coefficient of discharge is not reached for liquids. Nevertheless, Series 429 can be used as per the rules and regulations for thermal expansion.

Furthermore, Series 429 proportional safety valves are used as overflow valves or in bypass systems.



## Applications

### LESER – Modulate Action Safety Valves

provide the ultimate solution for all industrial applications with steam, gasses, and liquids.

#### **Series 433 standard safety valves** **acc. to definition AD 2000-Merkblatt A2**

are ideal relief valves for medium mass flows. Their greater proportional range leads to a constant mode of operation and relief of pressure peaks for liquids in particular.

Typical applications for LESER Modulate Action Series 433 safety valves are:

- chemical industry
  - recycling facilities: Low medium loss
  - piping with long line lengths
  - two-phase flow
  - waste gas purification systems on the outlet side
- heat-transfer oil systems
- liquids protection
  - metering pumps
  - hydraulic systems
  - pulsating operating pressures
- machine building (OEM)
  - piston compressors with small and medium capacities
- overflow function
- thermal expansion
  - protection of pipeline segments
  - sealed storage tanks

#### **Series 429 proportional safety valves** **acc. to definition AD 2000-Merkblatt A2**

opens proportional to pressure increase. This is usually achieved by using a disc without a lifting aid. Proportional safety valves are normally used anywhere where only very small mass flows are to be expected and the medium loss is to be kept as low as possible (e. g. thermal expansion).

Both proportional as well as standard safety valves are characterised by particularly stable operation.

## General design feature

### LESER – Modulate Action Safety Valves

offer a large number of models, materials, and accessories for adaptation to any application:

- 11 valve sizes from DN 15 to DN 150 – 1/2" up to 6" with connection possibilities for the respective application
- Nominal pressure ratings from PN 16 to PN 160 / Class 150 to Class 600 fulfil most pressure requirements
- Orifice  $0.2 \times D$  to  $> 1.1 \times M$  cover all common performance requirements.
- The required material for the application can be chosen from the large choice of body materials, for example:
  - 0.6025 / cast iron (Series 433)
  - 0.7043 / ductile iron
  - 1.0619 / WCB
  - 1.4408 / CF8M
- centre to face dimensions acc. to DIN 3320
- set pressures from 0.2 to 160 bar qualify Modulate Action safety valves for all industrial systems
- operating temperatures from -270 to 450 °C make use possible in numerous applications
- compact construction and low weight for easy handling
- same nominal inlet and outlet diameter
- identical construction for steam, gasses and liquids (single trim) reduces the number of required spare parts and facilitates cost-effective maintenance
- construction without a blow down ring guarantees easy service and prevents incorrect settings of the blow down ring
- the one-part spindle reduces friction, guarantees optimal guidance and reliable operation under all operating conditions
- the self-emptying angle type body prevents residue and reduces corrosion

LESER – Modulate Action safety valves can be individually adapted to the applications with a multitude of accessories. Examples are:

- discs with soft seal (O-ring) fulfil increased demands of functional tightness
- stellited or hardened metal seat surfaces of disc and seat reduce the wear and increase the service life
- balanced bellows for compensation of the back pressure and to protect the moving parts
- heating jacket for heating the safety valve when protecting cold stiff media
- each component can be constructed of an alternative material according to customer specifications

## How to find the right Product Group

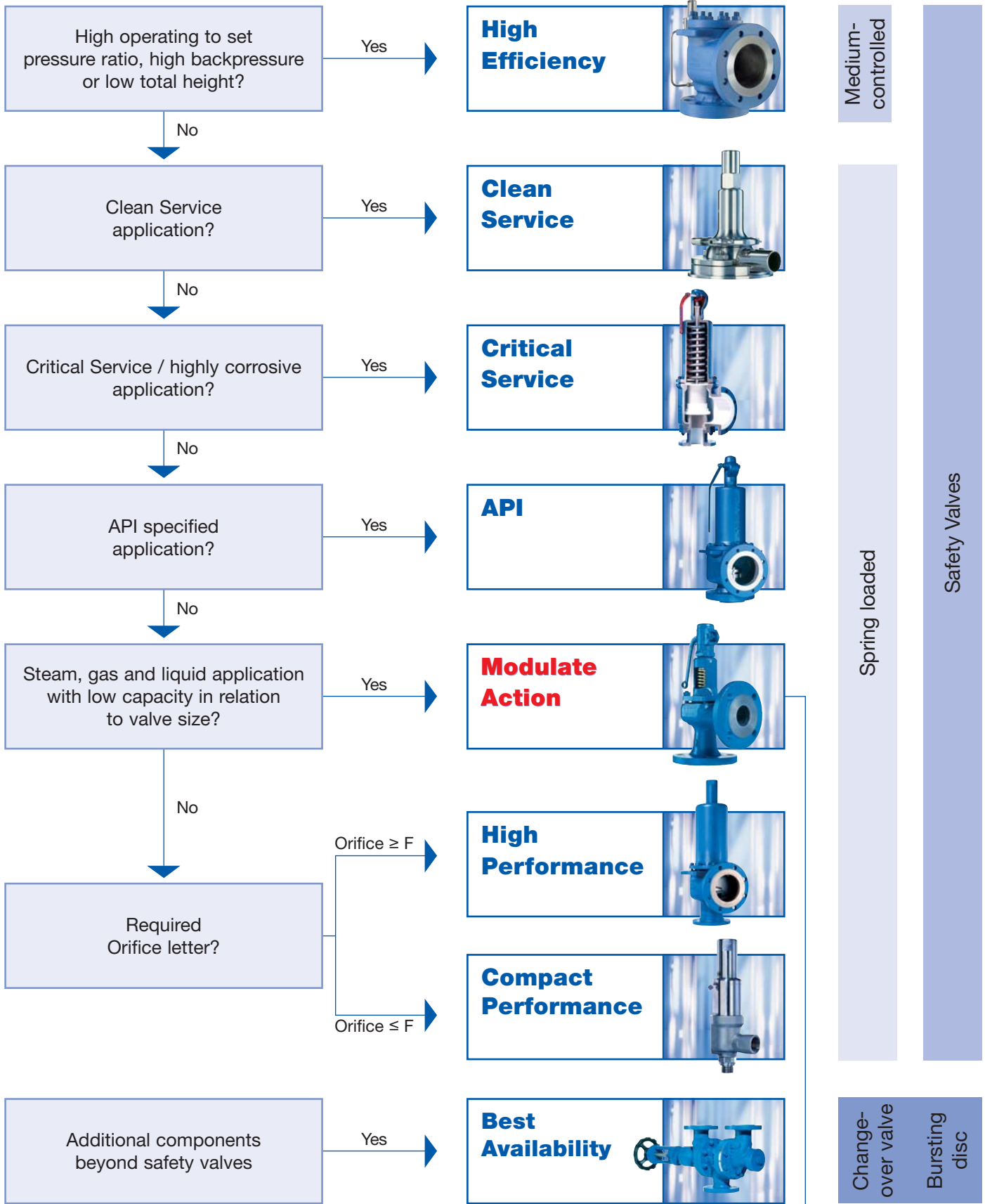

## How to find the right Modulate Action Safety Valve

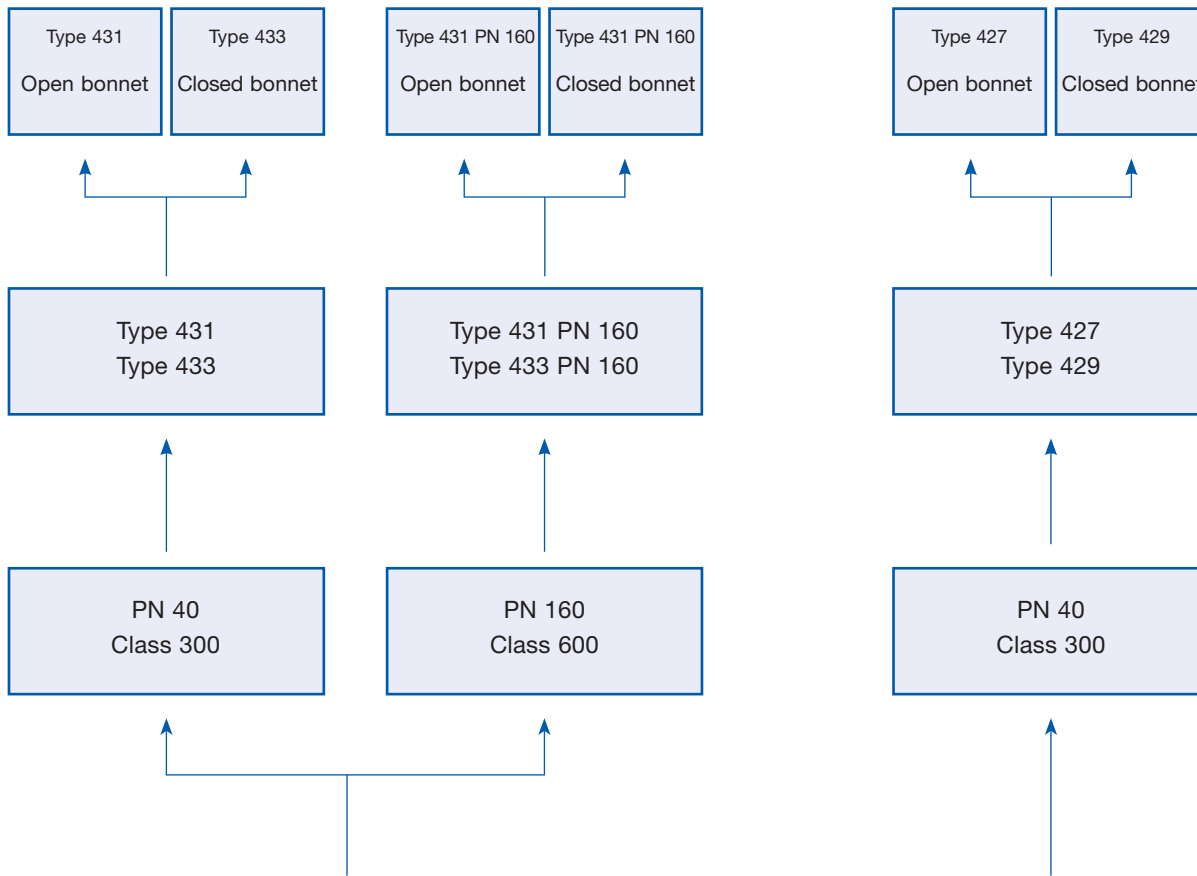

**Standard Safety Valve**  
 acc. to definition AD 2000-Merkblatt A2  
 for medium capacities with a large proportional range  
 Mainly used for thermal expansion.

**Proportional Safety Valve**  
 acc. to definition AD 2000-Merkblatt A2  
 with linear opening and closing characteristics  
 proportional to increasing or falling pressure  
 Mainly used with incompressible media

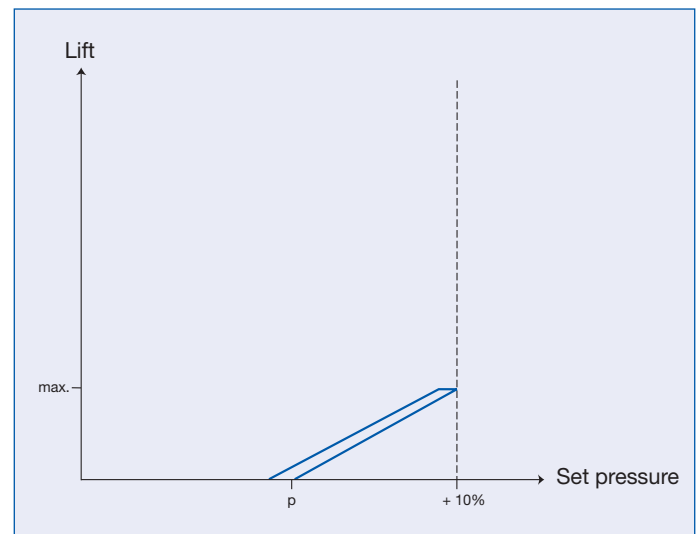
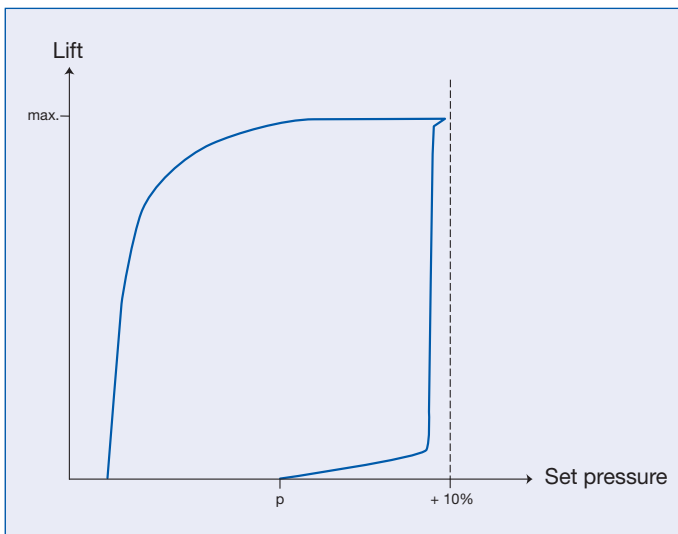

How to find the right  
 Modulate Action Safety Valve



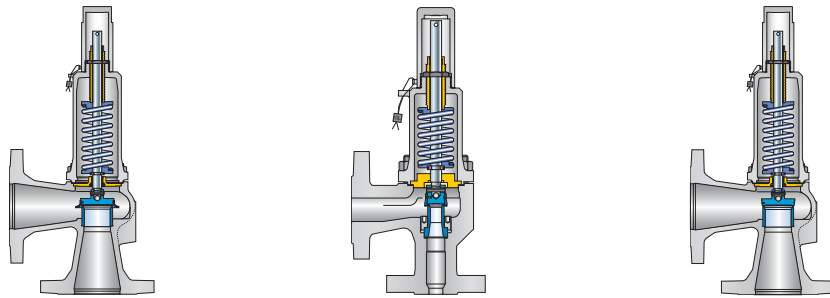

Valve size		431 / 433	433 PN 160	427 / 429
Type				
min.	DN 15			
	1/2"			
max.	DN 150			
	6"			

Materials		431 / 433	433 PN 160	427 / 429
Type				
0.6025	Cast iron	✓	-	-
0.7043	Ductile 60-40-18	✓	-	✓
1.0619	WCB	✓	✓	✓
1.4408	CF8M	✓	✓	✓

Set pressure		431 / 433	433 PN 160	427 / 429
Type				
Metric units min. [bar]		0.2	0.3	1.5
Metric units max. [bar]		40	160	40

Temperature application range		431 / 433	433 PN 160	427 / 429
Type				
According to DIN EN min. [°C]		-270	-270	-270
According to DIN EN max. [°C]		450	450	450

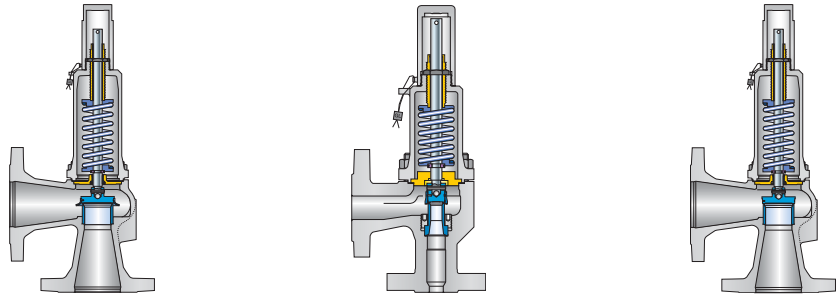

Capacity		Type	431 / 433	433 PN 160	427 / 429
<b>Attention: Series 433 and 429 are CE certified, however not according to ASME.</b>					
LEO <sub>S/G</sub>	min.		0.111	0.111	0.023
LEO <sub>S/G</sub>	max.		4.016	0.111	1.374
Orifice <sub>S/G</sub>	min.		1.0 x D	1.0 x D	1.0 x D
Orifice <sub>S/G</sub>	max.		1.1 x M	1.0 x D	1.07 x J
LEO <sub>L</sub>	min.		0.115	0.129	The required discharge coefficient for liquids of $\alpha_w$ 0,05 acc. to AD 2000-Merkblatt A2 is not reached, therefore a component test is not possible.
LEO <sub>L</sub>	max.		3.963	0.127	
Orifice <sub>L</sub>	min.		1.0 x D	1.2 x D	
Orifice <sub>L</sub>	max.		1.1 x M	1.2 x D	

Coefficient of discharge		Type	431 / 433				433 PN 160		427 / 429
			DN 15 O-ring disc	DN 15 Metal seat	DN 20	DN 25 - 150	DN 15 O-ring disc	DN 15 Metal seat	
Pressure increase acc. to DIN EN ISO 4126			10%	10%	10%	10%	10%	10%	10%
	$K_{dr} / \alpha_w$ S/G		0.59	0.62	0.29	0.38	0.59	0.62	0.13
	$K_{dr} / \alpha_w$ L		0.47	0.48	0.19	0.25	0.47	0.48	The required discharge coefficient for liquids of $\alpha_w$ 0,05 acc. to AD 2000-Merkblatt A2 is not reached, therefore a component test is not possible.

Approvals			Type	431 / 433	433 PN 160	427 / 429
Country	Code	Media			HDD	
Europe	DIN EN ISO 4126-1 CE marking	S/G/L	072020111Z0008/0/06	072020111Z0008/0/06	072020111Z0008/0/04	
Germany	AD 2000- Merkblatt A2	S/G/L	TÜV SV 577	TÜV SV 577	TÜV SV 610	
China	AQSIQ	S/G/L	✓	✓	-	
Eurasian Custom Union	EAC	S/G/L	✓	✓	✓	
Classification societies						
Bureau Veritas	BV		✓	✓	On request	
ClassNK NIPPON Kaiji Kyokai	NK		✓	✓		
Det Norske Veritas	DNV		✓	✓		
Germanischer Lloyd	GL		✓	✓		
Lloyd's Register EMEA	LREMEA		✓	✓		
Registro Italiano Navale	RINA		✓	✓		

General signs and symbols		Signs and symbols for flange drillings and flange facings	
<input type="checkbox"/> *	Standard	<input type="checkbox"/> *	Standard construction, specification of an option code not necessary
<input type="checkbox"/> ✓	Available	<input type="checkbox"/> (*)	Flange dimensions with exception of flange thickness as per flange standards (e.g. ASME B16.5) Flange thickness is less (max. 2 mm), see "Hole patterns valid for different pressure ratings"
<input type="checkbox"/> -	Not possible	<input type="checkbox"/> -	Flange hole pattern / sealing surface not possible

### Option code for flange drillings and dimensions, e.g. H50

<b>H50</b>	Flange drilling as specified in flange standard Outer flange diameter, flange thickness and height of flange facing may be larger, see "Dimensions"
<b>(H50)</b>	Flange dimensions except flange thickness are in accordance with standards (e.g. ASME B16.5) Flange thickness is smaller (max. 2 mm), see "Multiple pressure rating"
<b>Stock Fini</b>	Flange drilling as specified in standard. Flange thickness may be less than the flange outer diameter as specified in the standard, however complete nut support area is available

### Option code for flange sealing surfaces, e.g. L36

<b>L36</b>	Flange facing as specified in standard (e.g. Flange facing inlet Type B2 "smooth finish")
------------	-------------------------------------------------------------------------------------------

### General information concerning flange drillings and flange facings

<b>Multiple pressure rating</b>	The flange standard shows the same drilling, facing and outer diameter for several pressure ratings, e.g. from PN 16 to PN 40. Due to the pressure rating of the body, LESER fulfills the requirements for flange thickness, e.g. PN 16 but not PN 40.
<b>Smooth Finish</b>	In the applicable MSS SP-6 (Edition 2001), "Smooth Finish" is no longer mentioned. In MSS SP-6 (Edition 1980), "Smooth Finish" was defined as the surface quality of the flange with "250 µinch (6.3 µm) AARH max.". LESER supplies flange sealing surfaces according to ASME B16.5 – 1996, Paragraph 6.4.4.3: "Either a serrated concentric or serrated spiral finish resulting in service finish from 125 to 250 µinch average roughness shall be furnished" This finish meets the requirements of MSS SP-6 (Edition 1980), which is not valid anymore!
<b>Stock Finish</b>	"Stock Finish" is not defined in any technical standard. If "Stock Finish" is specified in the order, then LESER delivers standard flange sealing surfaces as per DIN or ASME (marked with * in the "Flange sealing surfaces" table for each series).

### Pressures – Symbols in use

Symbols	Name	Metric units
p	Set pressure	bar
p <sub>0</sub>	Absolute pressure in vessel = p · 1.1 + 1.013 = p · 1.1 + 14.5 The overpressure is 10% of the set pressure, but at least 0.2 bar	bar <sub>a</sub>
p <sub>a</sub>	Back pressure	bar
p <sub>a0</sub>	Absolute back pressure (= p <sub>a</sub> + 1.013) (= p <sub>a</sub> + 14.5)	bar <sub>a</sub>

### Materials

In the table below, you will find a list of the LESER material codes. Please take into consideration that

- material quality certificate 3.1 acc. to EN 10204 is available for each body material
- material quality certificate 3.1, which certifies different materials, is available for many materials.

Material code	Valve body with flanges	Body material is certified acc. to 3.1 (EN 10204) for the following materials	
		acc. to DIN EN	acc. to ASME
xxx1.xxxx	Grey iron	0.6025	Cast iron
xxx2.xxxx	Carbon steel	1.0619	WCB, WCC
xxx4.xxxx	Stainless steel	1.4408, 1.4581	CF8M (Charpy Test at -196°C), CF10M
xxx5.xxxx	Nodular cast iron	0.7043	Ductile Gr. 60-40-18
xxx7.xxxx	High temperature carbon steel	1.7357	WC6

## Example of determination of $K_{dr}/\alpha_w$ : Type 433 DN 25

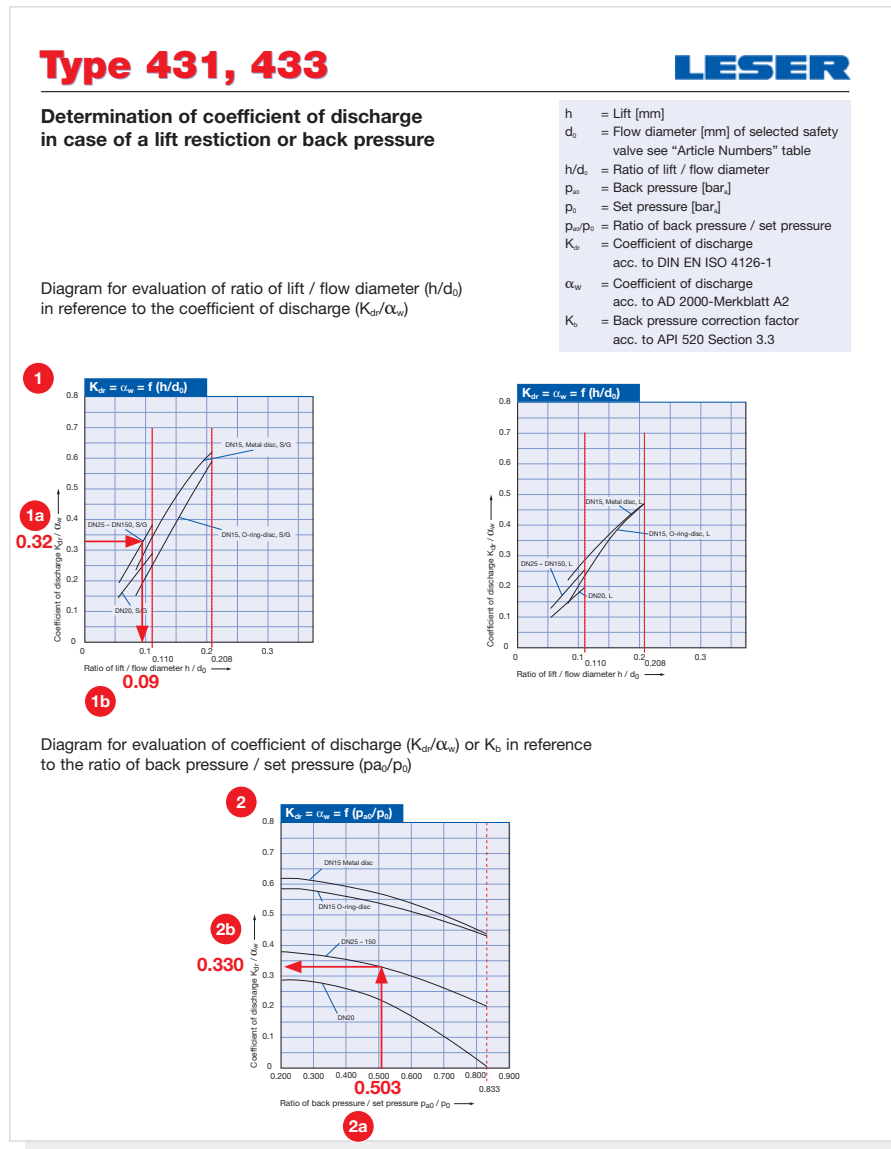

### Explanation

Example – Type 433, flow diameter  $d_0 = 13$  mm, Lift  $h = 3.0$  mm,  $K_{dr}/\alpha_w$  D/G = 0.81

1 Diagram 1 Determining the restricted lift due to reduced $K_{dr}/\alpha_w$			2 Diagram 2 Determination of reduced $K_{dr}/\alpha_w$ or $K_b$ due to back pressure		
Step	Description	Example	Step	Description	Example
1	Calculation of the necessary coefficient of discharge for the selected safety valve. The applicable formulas are to be taken from the codes and standards.	1a $K_{dr}/\alpha_w = 0.32$	1	Calculation of the back pressure $p_{a0}/p_0$ with the use of the set pressure $p_0$ [bar <sub>a</sub> ] 0.962 and the back pressure $p_{a0}$ [bar <sub>a</sub> ] 1.913	2a $p_{a0}/p_0 = 0.503$
2	Choose the starting point (0.3) on the Y-axis of the diagram		2	Choose the starting point (0.503) on the X-axis of the diagram	
3	Draw a horizontal line to determine the intersection point of the curves.		3	Draw a vertical line to determine the intersection point of the curves.	
4	Draw a vertical line through the intersection point on the X-axis to determine the ratio of lift / flow diameter ( $h/d_0$ ).	1b $h/d_0 = 0.09$	4	Draw a horizontal line through the intersection point on the Y-axis to determine the reduced coefficient of discharge $K_{dr}/\alpha_w$	2b $K_{dr}/\alpha_w = 0.330$
5	Calculation of the lift stopper with the formula $h = d_0 \times h/d_0$ . (To order the lift restriction, please choose option code J51; see page 99/20).	$h = 13 \times 0.09$ $h = 1.17$ mm	5	Calculation of the valve with the established coefficient of discharge $K_{dr}/\alpha_w$ or the correction factor for back pressure $K_b$	

## Sample capacity table – How to select capacities for steam: Type 433 DN 25

### Capacity table – steam

Capacities for saturated steam according to AD 2000-Merkblatt A2, based on set pressure plus 10% overpressure.

Metric units		AD 2000-Merkblatt A2 [kg/h]												
	O-ring disc	Metal seat												
DN <sub>I</sub>	15	15	20	25	32	40	50	65	80	100	125	150		
DN <sub>O</sub>	15	15	20	25	32	40	50	65	80	100	125	150		
Actual Orifice diameter d <sub>0</sub> [mm]	12	12	18	18	18	23	29	37	46	60	74	92		
Actual Orifice area A <sub>0</sub> [mm <sup>2</sup> ]	113	113	254	254	254	416	661	1075	1662	2827	4301	6648		
LEO <sub>S/G</sub> * [inch <sup>2</sup> ]	0.111	0.111	0.117	0.154	0.154	0.251	0.399	0.650	1.004	1.708	2.598	4.016		
Set pressure [bar]	Capacity [kg/h]													
0.2				34	34	55	88	142	220	375	570	880		
0.5	55	53	30	63	63	102	163	265	410	697	1060	1638		
1	78	78	67	101	101	165	263	428	661	1125	1711	2645		

Explanation		Type 433 DN 25		
No.	Name		Metric units	Example
1	Code			AD 2000-Merkblatt A2
2	Nominal inlet diameter	DN <sub>I</sub>		25
3	Nominal outlet diameter	DN <sub>O</sub>		25
4	Actual orifice diameter	d <sub>0</sub>	[mm]	18
5	Actual orifice area	A <sub>0</sub>	[mm <sup>2</sup> ]	254
6	LESER Effective Orifice	LEO <sub>S/G</sub>	[inch <sup>2</sup> ]	0.154
7	Set pressure		[bar <sub>g</sub> ]	1
8	Capacity		[kg/h]	101
9	Calculation basis			See table on page 00/10



**9**

Calculation basis		Metric units	
<b>Code</b>		Capacity calculation according to AD 2000-Merkblatt A2	
<b>Medium</b>			
<b>Steam</b> (Saturated steam)	Standard conditions	Steam table IAPWS-IF97 IAPWS Industrial Formulation for the Thermodynamic Properties of water and steam	[kg/h]
<b>Air</b>	Standard conditions	0 °C and 1013 mbar	[m <sub>n</sub> <sup>3</sup> /h]
<b>Water</b>	Standard conditions	20 °C	[10 <sup>3</sup> kg/h]
<b>All media</b>			
	Design pressure	Set pressure plus 10% overpressure	
	Design pressure for low set pressures	Capacity at 1 bar (14.5 psig) and lower are calculated at 0.1 bar (1.45 psig) overpressure.	

Example		Determining the design pressure	
Metric units			
Set pressure	Design pressure		
10 bar	10 bar + 10% overpressure = 11 bar		
0.5 bar	0.5 bar + 0.1 bar overpressure = 0.6 bar		

**6**

## LESER Effective Orifice

Pressure relief devices may be initially sized using the equations shown in API RP 520, Section 3.6 to 3.10 for steam, gasses, liquids, or two-phase flow. These equations use the coefficient of discharge (S/G 0.975, L 0.650) and the effective area (acc. to API Std. 526, Fifth Edition, June 2002, table 1), which are independent of the valve design.

This way, the designer can determine a preliminary valve size. By using the LESER Effective Orifice (LEO), the designer can select the safety valve directly according to the calculation. A verification with the selected actual orifice area and the accorded coefficient of discharge is not necessary.

<b>LEO<sub>S/G</sub></b>	<b>LESER Effective Orifice (for steam and gasses)</b>	<b>[inch<sup>2</sup>]</b>	see page 00/11
<b>LEO<sub>L</sub></b>	<b>LESER Effective Orifice (for liquids)</b>	<b>[inch<sup>2</sup>]</b>	see page 00/12

For further information refer to LESER ENGINEERING at [www.leser.com/engineering](http://www.leser.com/engineering).

The table is based on the accorded coefficient of discharge for steam and gases for ASME certified LESER safety valves.  
The associated K-values can be seen in the "K-values" column.

$$LEO_{S/G} [\text{inch}^2] = A_0 [\text{inch}^2] \cdot \left( \frac{K}{0.975} \right)$$

LEO <sub>S/G</sub>		LESER Effective Orifice (for steam, gas and vapor)						
Orifice acc. to API 526	LESER series	DN	Inlet size	d <sub>0</sub> [mm]	K <sub>dr</sub> /α <sub>w</sub> -values K-value <sup>1)</sup>	LEO <sub>S/G</sub> [inch <sup>2</sup> ]	% of next higher orifice	% of next lower orifice
	<b>429</b>	15	1/2"	12.0	0.130	<b>0.023</b>	21.2%	
	<b>429</b>	20	3/4"	18.0	0.130	<b>0.053</b>	47.8%	
	<b>429</b>	25	1"	18.0	0.130	<b>0.053</b>	47.8%	
	<b>429</b>	32	1 1/2"	18.0	0.130	<b>0.053</b>	47.8%	
	<b>429</b>	40	1 1/2"	23.0	0.130	<b>0.086</b>	78.1%	
	<b>433</b>	15 O-ring disc	1/2"	12.0	0.590	<b>0.106</b>	96.4%	
<b>D</b>						<b>0.110</b>	<b>100.0%</b>	<b>100.0%</b>
	<b>433</b>	15 Metal seat	1/2"	12.0	0.620	<b>0.111</b>	56.9%	101.3%
	<b>433</b>	20	3/4"	18.0	0.290	<b>0.117</b>	56.9%	106.7%
	<b>429</b>	50	2"	29.0	0.130	<b>0.137</b>	69.6%	124.1%
	<b>433</b>	25	1"	18.0	0.380	<b>0.154</b>	78.4%	139.8%
	<b>433</b>	32	1 1/2"	18.0	0.380	<b>0.154</b>	78.4%	139.8%
<b>E</b>						<b>0.196</b>	<b>100.0%</b>	<b>100.0%</b>
	<b>429</b>	65	2 1/2"	37.0	0.130	<b>0.222</b>	72.4%	113.4%
	<b>433</b>	40	1 1/2"	23.0	0.380	<b>0.251</b>	81.8%	128.1%
<b>F</b>						<b>0.307</b>	<b>100.0%</b>	<b>100.0%</b>
	<b>429</b>	80	3"	46.0	0.130	<b>0.343</b>	68.3%	111.9%
	<b>433</b>	50	2"	29.0	0.380	<b>0.399</b>	79.3%	130.0%
<b>G</b>						<b>0.503</b>	<b>100.0%</b>	<b>100.0%</b>
	<b>429</b>	100	4"	60.0	0.130	<b>0.584</b>	74.4%	116.2%
	<b>433</b>	65	2 1/2"	37.0	0.380	<b>0.650</b>	82.7%	129.1%
<b>H</b>						<b>0.785</b>	<b>100.0%</b>	<b>100.0%</b>
	<b>429</b>	125	5"	74.0	0.130	<b>0.889</b>	69.1%	113.2%
	<b>433</b>	80	3"	46.0	0.380	<b>1.004</b>	78.0%	127.9%
<b>J</b>						<b>1.287</b>	<b>100.0%</b>	<b>100.0%</b>
	<b>429</b>	150	6"	92.0	0.130	<b>1.374</b>	74.7%	106.7%
	<b>433</b>	100	4"	60.0	0.380	<b>1.708</b>	92.9%	132.7%
<b>K</b>						<b>1.838</b>	<b>100.0%</b>	<b>100.0%</b>
	<b>433</b>	125	5"	74.0	0.380	<b>2.598</b>	91.1%	141.4%
<b>L</b>						<b>2.853</b>	<b>100.0%</b>	<b>100.0%</b>
<b>M</b>						<b>3.600</b>	<b>100.0%</b>	<b>100.0%</b>
	<b>433</b>	150	6"	92.0	0.380	<b>4.016</b>	92.5%	116.3%
<b>N</b>						<b>4.340</b>	<b>100.0%</b>	<b>100.0%</b>

<sup>1)</sup> There is no ASME approval for the LESER Modulate Action Series 433 and 429. In order to be able to still use the LEO and hence obtain compatibility to the orifice acc. to API 526, the K<sub>dr</sub>/α<sub>w</sub>-value (approval acc. to DIN EN ISO 4126-1 and AD 2000-Merkblatt A2) was brought into the calculation.

The table is based on the accorded coefficient of discharge for liquids for ASME certified LESER safety valves.  
The associated K-values can be seen in the "K-values" column.

$$LEO_L [\text{inch}^2] = A_0 [\text{inch}^2] \cdot \left( \frac{K}{0.650} \right)$$

LEO <sub>L</sub>		LESER Effective Orifice (for liquids)						
Orifice acc. to API 526	LESER series	DN	Inlet size	d <sub>0</sub> [mm]	K <sub>dr</sub> /α <sub>w</sub> -values K-value <sup>1)</sup>	LEO <sub>L</sub> [inch <sup>2</sup> ]	% of next higher orifice	% of next lower orifice
<b>D</b>						<b>0.110</b>	<b>100.0%</b>	<b>100.0%</b>
	433	20	3/4"	18.0	0.190	<b>0.115</b>	58.8%	104.8%
	433	15 O-ring disc	1/2"	12.0	0.590	<b>0.127</b>	64.8%	115.5%
	433	15 Metal seat	1/2"	12.0	0.480	<b>0.129</b>	66.0%	117.7%
	433	25	1"	18.0	0.250	<b>0.152</b>	77.4%	137.9%
	433	32	1 1/2"	18.0	0.250	<b>0.152</b>	77.4%	137.9%
<b>E</b>						<b>0.196</b>	<b>100.0%</b>	<b>100.0%</b>
	433	40	1 1/2"	23.0	0.250	<b>0.248</b>	80.7%	126.4%
<b>F</b>						<b>0.307</b>	<b>100.0%</b>	<b>100.0%</b>
	433	50	2"	29.0	0.250	<b>0.394</b>	78.3%	128.3%
<b>G</b>						<b>0.503</b>	<b>100.0%</b>	<b>100.0%</b>
	433	65	2 1/2"	37.0	0.250	<b>0.641</b>	81.7%	127.4%
<b>H</b>						<b>0.785</b>	<b>100.0%</b>	<b>100.0%</b>
	433	80	3"	46.0	0.250	<b>0.991</b>	77.0%	126.2%
<b>J</b>						<b>1.287</b>	<b>100.0%</b>	<b>100.0%</b>
	433	100	4"	60.0	0.250	<b>1.686</b>	91.7%	131.0%
<b>K</b>						<b>1.838</b>	<b>100.0%</b>	<b>100.0%</b>
	433	125	5"	74.0	0.250	<b>2.564</b>	89.9%	139.5%
<b>L</b>						<b>2.853</b>	<b>100.0%</b>	<b>100.0%</b>
<b>M</b>						<b>3.600</b>	<b>100.0%</b>	<b>100.0%</b>
	433	150	6"	92.0	0.250	<b>3.963</b>	91.3%	110.1%
<b>N</b>						<b>4.340</b>	<b>100.0%</b>	<b>100.0%</b>

<sup>1)</sup> There is no ASME approval for the LESER Modulate Action Series 433. In order to be able to still use the LEO and hence obtain compatibility to the orifice acc. to API 526, the K<sub>dr</sub>/α<sub>w</sub>-value (approval acc. to DIN EN ISO 4126-1 and AD 2000-Merkblatt A2) was brought into the calculation.

## NACE-Compliant Safety Valves

### General requirements for safety valves in sour gas service

Media such as sour gas, which is especially common in oil and gas production, can have a corrosive effect on safety valves. The National Association of Corrosion Engineers (NACE) is a global association that deals with the development of corrosion control measures and defines these in standards such as NACE MR0175 and NACE MR0103. Both of these standards identify requirements for metallic materials used for piping and related components, to include safety valves, in the oil and gas industry.

The aim here is to protect the environment from escaping media. The focus is on the prevention of various types of corrosion (e.g. sulfur-induced stress corrosion cracking) of used materials that can be caused by acidic media.

Both standards define the maximum material hardness for prevention of corrosion damage because hardness increases corrosion resistance. NACE MR0175 provides requirements for materials used in oil and gas extraction (upstream) whereas NACE MR0103 specifies less stringent requirements for materials used in refinery processes (downstream).

Various components of LESER safety valves can be constructed in corrosion resistant materials using a level concept. This way, LESER can offer efficient safety valve solutions according to the requirements of NACE MR0175 and NACE MR0103 for different application conditions.

### Norms

NACE MR0175/ISO15156 – 2003

1 Scope: This part of NACE MR0175/ISO 15156 describes general principles and gives requirements and recommendations for the selection and qualification of metallic materials for service in equipment used in oil and gas production and in natural gas sweetening plants in H<sub>2</sub>S-containing environments, where the failure of such equipment could pose a risk to the health and safety of the public and personnel or to the environment.

NACE MR0103 – 2012

•1.1.1: This standard establishes material requirements for resistance to SSC in sour petroleum refining and related processing environments containing H<sub>2</sub>S either as a gas or dissolved in an aqueous (liquid water) phase with or without the presence of hydrocarbon.

•1.1.2: Specifically, this standard is directed at the prevention of SSC of equipment (including pressure vessels, heat exchangers, piping, valve bodies, and pump and compressor cases) and components used in the refining industry.

Works standard: LDeS 3001.91

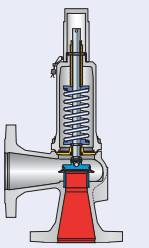
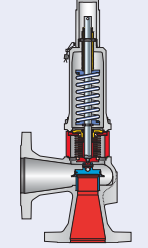
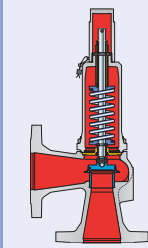
Part definition	Level 1		Level 2	
	Contact with the medium in closed position		Contact with the medium in opened position	
Contact surfaces	Conventional	Balanced bellows	Conventional	Balanced bellows
				
Safety valve operation	closed		opened	
Parts concerned	Body, seat, disc	Body, seat, disc	all	Body, seat, disc, bonnet spacer, bellows

LESER already uses NACE compliant materials as standard for many of its components. This means that material adjustments are required for only certain components – these are listed in the table below.

### Necessary material modification NACE MR0175/ISO 15156 – 2003 (Option code N78) and NACE MR0103 – 2012 (Option code N77)

Type	Body material	Design	Part	Material	Option code	Material	Option code
4292 4332 4332 PN 160	1.0619 (WCB)	Conventional	Disc	1.4404 / 316L stellite	L44 / J25	1.4404 / 316L stellite	L44 / J25
			Spring	No adjustment required		Please select balanced bellows design, as Inconel spring is not available	–
		Balanced bellows	Disc	1.4404 / 316L stellite	L44 / J25	1.4404 / 316L stellite	L44 / J25
			Balanced bellows	1.4571 / 316Ti	J78	1.4571 / 316Ti	J78
4294 4334 4334 PN 160	1.4408 (CF8M)	Conventional	Spring	No adjustment required		Please select balanced bellows design, as Inconel spring is not available	–
			Balanced bellows	Balanced bellows	1.4571 / 316Ti	J78	1.4571 / 316Ti



**Type 431**  
**Plain lever H3**  
**Open bonnet**  
**Conventional design**

# Type 431, 433

Type 433

## Flanged Safety Relief Valves - spring loaded



**Type 433**  
**Cap H2**  
**Closed bonnet**  
**Conventional design**

### Contents

### Chapter/Page

#### Materials

- Conventional design 01/02
- Balanced bellows design 01/04

#### How to order

- Numbering system 01/06
- Article numbers 01/08

#### Pressure temperature ratings

- Metric units 01/10

#### Dimensions and weights

- Metric units 01/12

#### Approvals

01/13

#### Flange drillings

01/14

#### Flange facings

01/15

#### LESER Original Spare Parts Kits

01/16

#### Available options

01/18

#### Capacities

- Steam [Metric units] 01/19
- Air [Metric units] 01/20
- Water [Metric units] 01/21

#### Determination of

01/22

coefficient of discharge  $K_{dr}/\alpha_w$



## Conventional design

Type 433

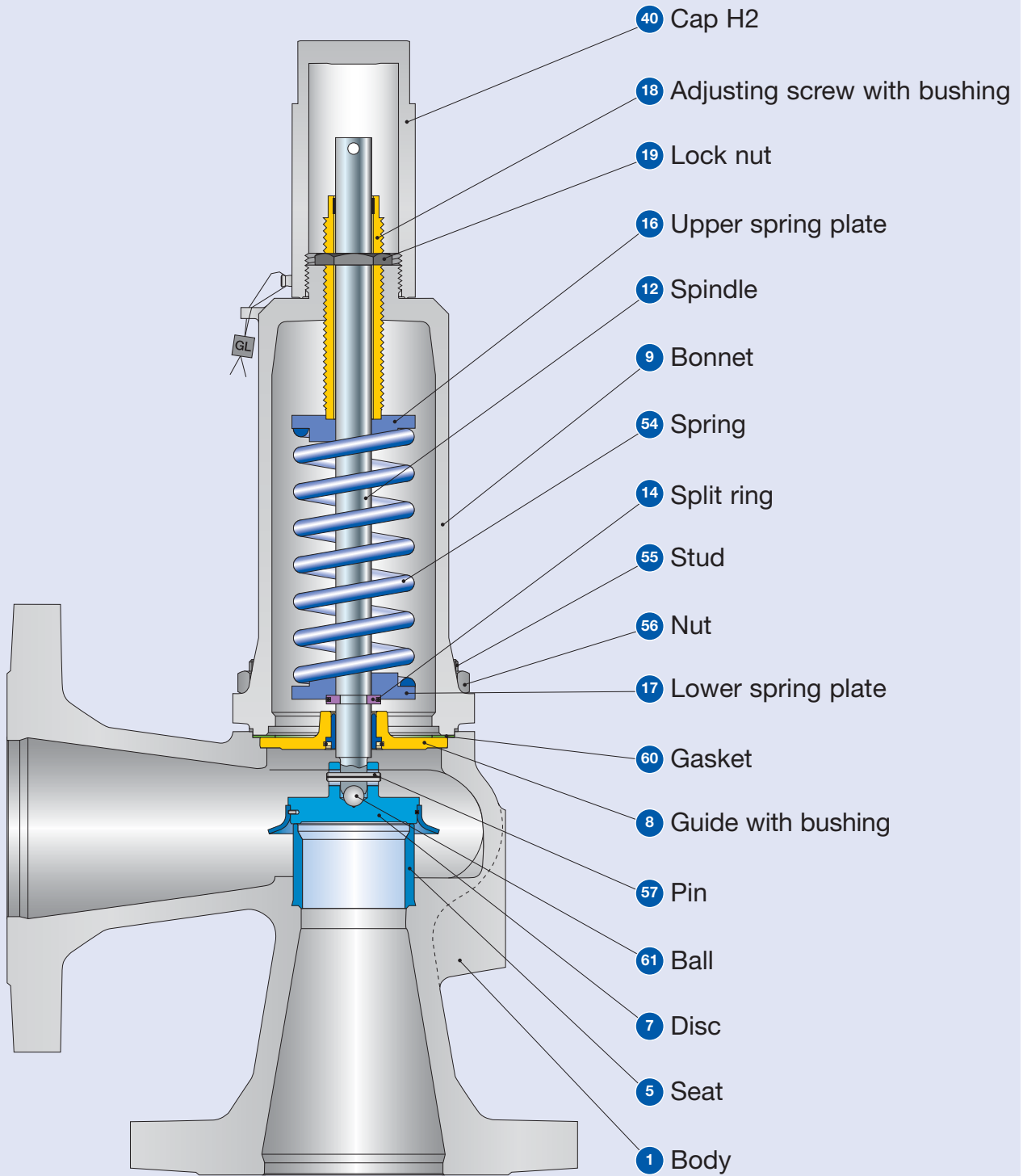

## Conventional design

Materials		Type 4311 / 4331	Type 4315 / 4335	Type 4312 / 4332	Type 4334
<b>1</b>	<b>Body</b>	0.6025	0.7043	1.0619	1.4408
		Cast iron	Ductile Gr. 60-40-18	SA 216 WCB	SA 351 CF8M
<b>5</b>	Seat	1.4404	1.4404	1.4404	1.4404
		316L	316L	316L	316L
<b>7</b>	Disc	1.4122	1.4122	1.4122	1.4404
		Hardened stainless steel	Hardened stainless steel	Hardened stainless steel	316L
<b>8</b>	Guide	1.4104, 1.0501	1.4104, 1.0501	1.4104, 1.0501, 1.0570	1.4404
		Chrome or carbon steel	Chrome or carbon steel	Chrome or carbon steel	316L
	with bushing	1.4104 tenifer	1.4104 tenifer	1.4104 tenifer	–
		Chrome steel tenifer	Chrome steel tenifer	Chrome steel tenifer	–
<b>9</b>	<b>Bonnet</b>	0.7040	0.7040	0.7040	1.4408
		Ductile Gr. 60-40-18	Ductile Gr. 60-40-18	Ductile Gr. 60-40-18	SA 351 CF8M
<b>12</b>	Spindle	1.4021	1.4021	1.4021	1.4404
		420	420	420	316L
<b>14</b>	Split ring	1.4104	1.4104	1.4104	1.4404
		Chrome steel	Chrome steel	Chrome steel	316L
<b>16/17</b>	Spring plate	1.0718	1.0718	1.0718	1.4404
		Steel	Steel	Steel	316L
<b>18</b>	Adjusting screw with bushing	1.4104 PTFE	1.4104 PTFE	1.4104 PTFE	1.4404 PTFE
		Chrome steel PTFE	Chrome steel PTFE	Chrome steel PTFE	316L PTFE
<b>19</b>	Lock nut	1.0718	1.0718	1.0718	1.4404
		Steel	Steel	Steel	316L
<b>40</b>	Cap H2	1.0460	1.0460	1.0460	1.4404
		SA 105	SA 105	SA 105	316L
<b>54</b>	Spring, standard	1.1200, 1.8159, 1.7102	1.1200, 1.8159, 1.7102	1.1200, 1.8159, 1.7102	1.4310
		Carbon steel	Carbon steel	Carbon steel	Stainless steel
	Spring, optional	1.4310	1.4310	1.4310	–
		Stainless steel	Stainless steel	Stainless steel	–
<b>55</b>	Stud	1.1181	1.1181	1.1181	1.4401
		Steel	Steel	Steel	B8M
<b>56</b>	Nut	1.0501	1.0501	1.0501	1.4401
		2H	2H	2H	8M
<b>57</b>	Pin	1.4310	1.4310	1.4310	1.4310
		Stainless steel	Stainless steel	Stainless steel	Stainless steel
<b>60</b>	Gasket	Graphite / 1.4401	Graphite / 1.4401	Graphite / 1.4401	Graphite / 1.4401
		Graphite / 316	Graphite / 316	Graphite / 316	Graphite / 316
<b>61</b>	Ball	1.3541	1.3541	1.3541	1.4401
		Hardened stainless steel	Hardened stainless steel	Hardened stainless steel	316

**Please note:**

- LESER reserves the right to make changes.
- If several materials are specified LESER defines the material.
- LESER may use higher quality materials without giving prior notice.
- Each component can be constructed of another material according to the customer's specification.
- All components exposed to pressure are highlighted in bold. The material will be specified according to DIN and ASTM here.

# Type 431, 433

LESER

Balanced bellows design

Type 433

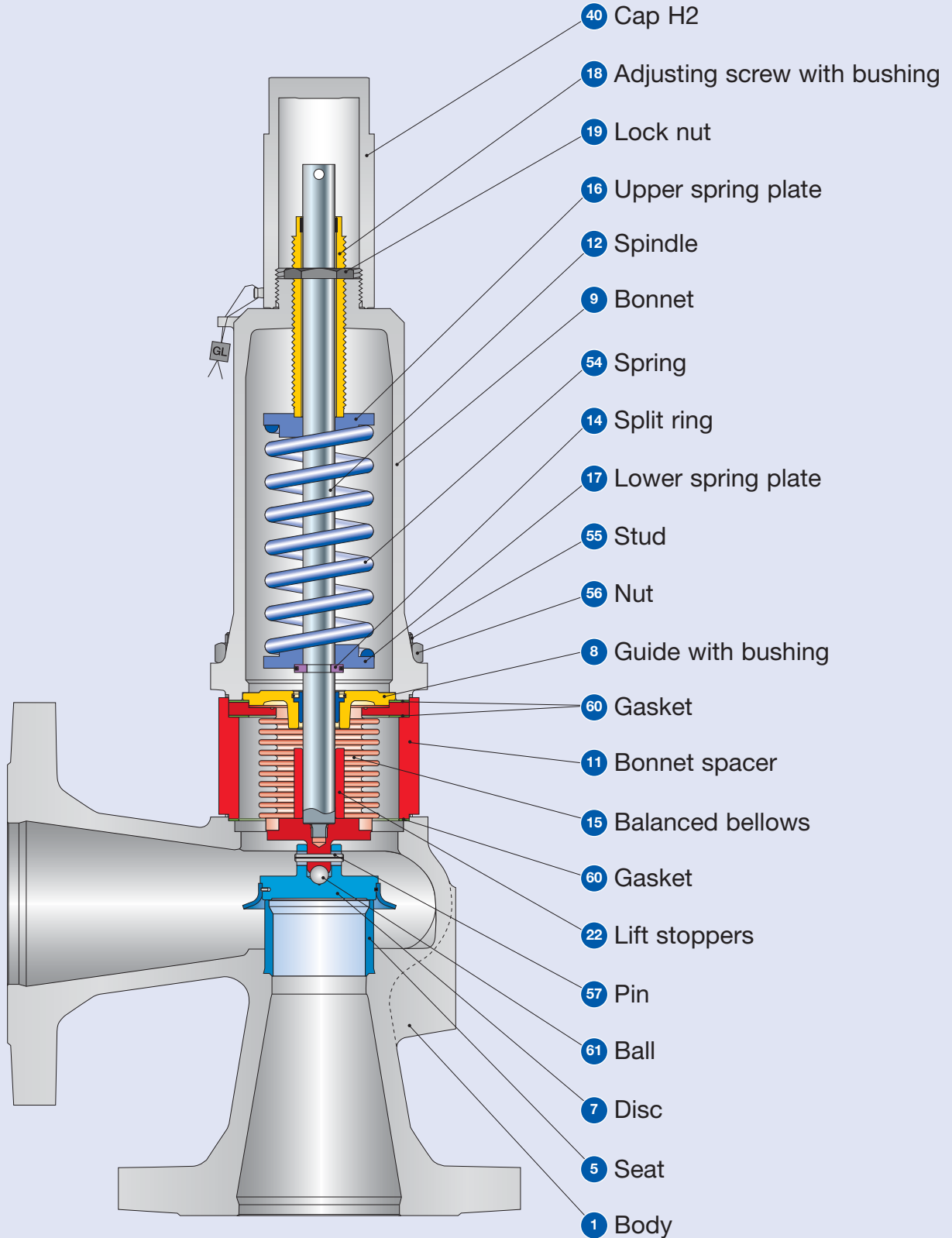

## Balanced bellows design

Materials					
Item	Component	Type 4311 / 4331	Type 4315 / 4335	Type 4312 / 4332	Type 4334
<b>1</b>	<b>Body</b>	0.6025	0.7043	1.0619	1.4408
		Cast iron	Ductile Gr. 60-40-18	SA 216 WCB	SA 351 CF8M
<b>5</b>	Seat	1.4404	1.4404	1.4404	1.4404
		316L	316L	316L	316L
<b>7</b>	Disc	1.4122	1.4122	1.4122	1.4404
		Hardened stainless steel	Hardened stainless steel	Hardened stainless steel	316L
<b>8</b>	Guide	1.4104, 1.0501	1.4104, 1.0501	1.4104, 1.0501, 1.0570	1.4404
		Chrome or stainless steel	Chrome or stainless steel	Chrome or stainless steel	316L
	with bushing	1.4104 tenifer	1.4104 tenifer	1.4104 tenifer	-
		Chrome steel	Chrome steel	Chrome steel	-
<b>9</b>	<b>Bonnet</b>	0.7040	0.7040	0.7040	1.4408
		Ductile Gr. 60-40-18	Ductile Gr. 60-40-18	Ductile Gr. 60-40-18	SA 351 CF8M
<b>11</b>	Bonnet spacer	1.4404	1.4404	1.4404	1.4404
		316L	3316L	316L	316L
<b>12</b>	Spindle	1.4404	1.4404	1.4404	1.4404
		316L	316L	316L	316L
<b>14</b>	Split ring	1.4104	1.4104	1.4104	1.4404
		Chrome steel	Chrome steel	Chrome steel	316L
<b>15</b>	Balanced bellows	1.4571	1.4571	1.4571	1.4571
		316Ti	316Ti	316Ti	316Ti
<b>16/17</b>	Spring plate	1.0718	1.0718	1.0718	1.4404
		Steel	Steel	Steel	316L
<b>18</b>	Adjusting screw with bushing	1.4104 PTFE	1.4104 PTFE	1.4104 PTFE	1.4404 PTFE
		Chrome steel PTFE	Chrome steel PTFE	Chrome steel PTFE	316L PTFE
<b>19</b>	Lock nut	1.0718	1.0718	1.0718	1.4404
		Steel	Steel	Steel	316L
<b>22</b>	Lift stoppers	1.4404	1.4404	1.4404	1.4404
		316L	316L	316L	316L
<b>40</b>	Cap H2	1.0460	1.0460	1.0460	1.4404
		SA 105	SA 105	SA 105	316L
<b>54</b>	Spring, standard	1.1200, 1.8159, 1.7102	1.1200, 1.8159, 1.7102	1.1200, 1.8159, 1.7102	1.4310
		Chrome steel	Chrome steel	Chrome steel	Stainless steel
	Spring, optional	1.4310	1.4310	1.4310	-
		Stainless steel	Stainless steel	Stainless steel	-
<b>55</b>	Stud	1.4401	1.4401	1.4401	1.4401
		B8M	B8M	B8M	B8M
<b>56</b>	Nut	1.4401	1.4401	1.4401	1.4401
		8M	8M	8M	8M
<b>57</b>	Pin	1.4310	1.4310	1.4310	1.4310
		Stainless steel	Stainless steel	Stainless steel	Stainless steel
<b>60</b>	Gasket	Graphite / 1.4401	Graphite / 1.4401	Graphite / 1.4401	Graphite / 1.4401
		Graphite / 316	Graphite / 316	Graphite / 316	Graphite / 316
<b>61</b>	Ball	1.3541	1.3541	1.3541	1.4401
		Hardened stainless steel	Hardened stainless steel	Hardened stainless steel	316

**Please note:**

- LESER reserves the right to make changes.
- If several materials are specified LESER defines the material.
- LESER may use higher quality materials without giving prior notice.
- Each component can be constructed of another material according to the customer's specification.
- All components exposed to pressure are highlighted in bold. The material will be specified according to DIN and ASTM here.

## How to order – Example for numbering system – Type 433

# 1

## Article Number

**4332.4192**

# 2

## Set Pressure

**5 bar<sub>g</sub>**

# 3

## Connections

**H45**

1
2
3
4

433
2
.
419
2

**1 Valve type 431, 433**  
 Type 433 – with closed bonnet  
 Type 431 – with open bonnet

**2 Material code**

Code	Body material
1	0.6025 (cast iron)
2	1.0619 (WCB)
4	1.4408 (CF8M)
5	0.7043 (Ductile Gr. 60-40-18)

**3 Valve code**  
 Automatically determines nominal diameter and body material (see page 01/09).

**4**

Code	Lifting device	
2	Gas-tight cap	H2
3	Plain lever	H3
4	Packed lever	H4
5	Plain lever with open bonnet	H3

Please enter the units (in gauge)!

The specified pressure range may not be exceeded!

See page 01/14.



## 4 Options

J22

Type 431, 433	Option code
• O-ring disc	
CR "K"	J21
EPDM "D"	J22
FKM "L"	J23
FFKM "C"	J20
• Disc 1.4404 / 316L	L44
• Disc 1.4404 / 316L stellited	J25
• Detachable lifting aid	J26
• Balanced bellows	
- Bonnet, open (Type 431)	J68
- Bonnet, closed (Type 433)	J78
• Elastomer bellows	J79
• High temperature alloy spring	X01
• Stainless steel spring	X04
• Adaptor for lift indicator H4	J39
• Lift indicator	J93
• Test gag	
- Cap H2	J70
- Packed lever H4	J69
• Heating jacket	
- Couplings G 3/8	H29
G 3/4	H30
- Flange DN 15	H31
DN 25	H32
• Drain hole G 1/4	J18
G 1/2	J19
• Oil and grease free	J85
• Materials	
- NACE MR0175	N78
- NACE MR0103	N77
Option code applies only if not standard	

## 5 Documentation

H01 L30

Please select the necessary documentation:

Tests, Certifications:	Option code
DIN EN 10204-3.2: TÜV-Nord Certification for set pressure	M33
<b>LESER CGA (Certificate for Global Application)</b>	H03
- Acceptance test certificate 3.1 acc. to DIN EN 10204	
- Declaration of conformity as per pressure equipment directive PED 97/23/EC	
<b>Material quality certificate:</b> DIN EN 10204-3.1	
<b>Component</b>	<b>Option code</b>
Body	H01
Bonnet	L30
Cap / lever cover	L31
Disc	L23
Screws	N07
Nuts	N08

## 6 Code and Medium

2.0

1	2
2	0
<b>1 Code</b>	
2. CE / VdTUEV	
3. ASME Section VIII + CE / VdTUEV	
<b>2 Medium</b>	
.0 steam / gases / liquids (only valid for CE / VdTUEV)	

# Type 431, 433

LESER

How to order – Article numbers

Type 433

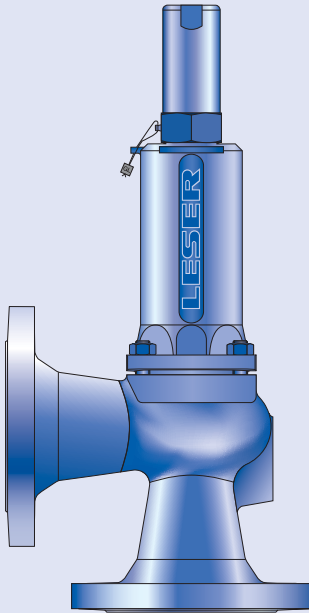

**Type 433**  
Cap H2  
Closed bonnet  
Conventional design

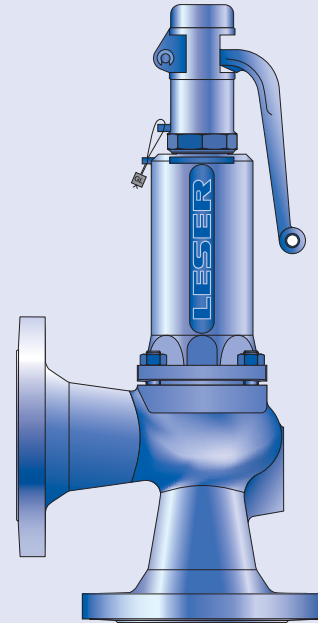

**Type 433**  
Plain lever H3  
Closed bonnet  
Conventional design

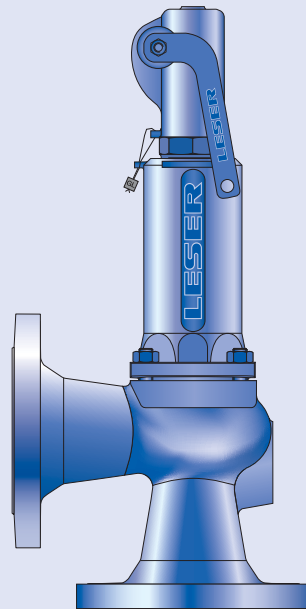

**Type 433**  
Packed lever H4  
Closed bonnet  
Conventional design

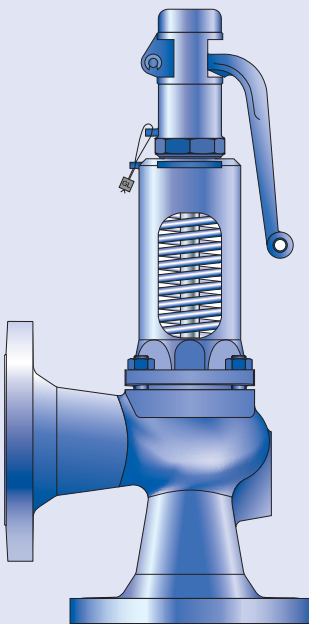

**Type 431**  
Plain lever H3  
Open bonnet  
Conventional design

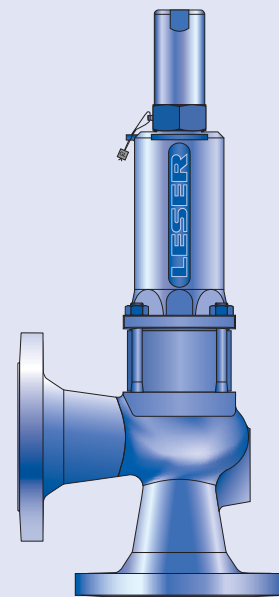

**Type 433**  
Cap H2  
Closed bonnet  
Balanced bellows design

## How to order – Article numbers

Article numbers														
		O-ring disc	Metal disc											
	DN <sub>i</sub>	15	15	20	25	32	40	50	65	80	100	125	150	
	DN <sub>o</sub>	15	15	20	25	32	40	50	65	80	100	125	150	
	Actual orifice diameter d <sub>o</sub> [mm]	12	12	18	18	18	23	29	37	46	60	74	92	
	Actual orifice area A <sub>o</sub> [mm <sup>2</sup> ]	113	113	254	254	254	416	661	1075	1662	2827	4301	6648	
<b>Body material: 0.6025 (cast iron)</b>														
Bonnet closed	H2	Art.-No. 4331.	8502	3992	4012	4022	4032	4042	4052	4062	4072	4082	-	-
	H3	Art.-No. 4331.	8503	3993	4013	4023	4033	4043	4053	4063	4073	4083	-	-
	H4	Art.-No. 4331.	8504	3994	4014	4024	4034	4044	4054	4064	4074	4084	-	-
open	H3	Art.-No. 4311.	8505	3995	4015	4025	4035	4045	4055	4065	4075	4085	-	-
<b>Body material: 0.7043 (Ductile Gr. 60-40-18)</b>														
Bonnet closed	H2	Art.-No. 4335.	8532	8752	8762	8772	8782	8792	8802	8812	8822	8832	-	-
	H3	Art.-No. 4335.	8533	8753	8763	8773	8783	8793	8803	8813	8823	8833	-	-
	H4	Art.-No. 4335.	8534	8754	8764	8774	8784	8794	8804	8814	8824	8834	-	-
open	H3	Art.-No. 4315.	8535	8755	8765	8775	8785	8795	8805	8815	8825	8835	-	-
<b>Body material: 1.0619 (WCB)</b>														
Bonnet closed	H2	Art.-No. 4332.	8512	4122	4142	4152	4162	4172	4182	4192	4202	4212	4222	4232
	H3	Art.-No. 4332.	8513	4123	4143	4153	4163	4173	4183	4193	4203	4213	4223	4233
	H4	Art.-No. 4332.	8514	4124	4144	4154	4164	4174	4184	4194	4204	4214	4224	4234
open	H3	Art.-No. 4312.	8515	4125	4145	4155	4165	4175	4185	4195	4205	4215	4225	4235
<b>Body material: 1.4408 (CF8M)</b>														
Bonnet closed	H2	Art.-No. 4334.	8522	4252	4272	4282	4292	4302	4312	4322	4332	4342	-	-
	H4	Art.-No. 4334.	8524	4254	4274	4284	4294	4304	4314	4324	4334	4344	-	-

## Pressure temperature ratings

### Metric units

	O-ring disc	Metal disc											
DN <sub>i</sub>	15	15	20	25	32	40	50	65	80	100	125	150	
DN <sub>o</sub>	15	15	20	25	32	40	50	65	80	100	125	150	
Actual orifice diameter d <sub>0</sub> [mm]	12	12	18	18	18	23	29	37	46	60	74	92	
Actual orifice area A <sub>0</sub> [mm <sup>2</sup> ]	113	113	254	254	254	416	661	1075	1662	2827	4301	6648	

#### Body material: 0.6025 (cast iron)

DIN flange	Inlet		PN 16										-	-	
	Outlet		PN 16												
<b>Minimum set pressure</b>	p [bar <sub>g</sub> ]	S/G/L	0.3	0.3	0.2	0.2	0.2	0.2	0.2	0.2	0.2	0.2	0.2	-	-
<b>Min. set pressure<sup>1)</sup></b> standard bellows	p [bar <sub>g</sub> ]	S/G/L	3.0	3.0	3.0	3.0	3.0	3.0	3.0	3.0	3.0	3.0	3.0	-	-
<b>Min. set pressure</b> low pressure bellows	p [bar <sub>g</sub> ]	S/G/L	-	-	2.0	2.0	2.0	1.8	1.9	1.8	1.8	1.2	-	-	-
<b>Maximum set pressure</b>	p [bar <sub>g</sub> ]	S/G/L	16	16	16	16	16	16	16	16	16	16	-	-	-
<b>Max. set pressure</b> with special spring	p [bar <sub>g</sub> ]	S/G/L	16	16	16	16	16	16	16	16	16	16	-	-	-
<b>Temperature<sup>2)</sup></b> acc. to DIN EN	min. [°C]	-10							-10				-	-	
	max. [°C]	+150							+300				-	-	

#### Body material: 0.7043 (Ductile Gr. 60-40-18)

DIN flange	Inlet		PN 40										-	-	
	Outlet		PN 40												
<b>Minimum set pressure</b>	p [bar <sub>g</sub> ]	S/G/L	0.3	0.3	0.2	0.2	0.2	0.2	0.2	0.2	0.2	0.2	0.2	-	-
<b>Min. set pressure<sup>1)</sup></b> standard bellows	p [bar <sub>g</sub> ]	S/G/L	3.0	3.0	3.0	3.0	3.0	3.0	3.0	3.0	3.0	3.0	3.0	-	-
<b>Min. set pressure</b> low pressure bellows	p [bar <sub>g</sub> ]	S/G/L	-	-	2.0	2.0	2.0	1.8	1.9	1.8	1.8	1.2	-	-	-
<b>Maximum set pressure</b>	p [bar <sub>g</sub> ]	S/G/L	40	40	40	40	40	40	40	35	35	30	-	-	-
<b>Max. set pressure</b> with special spring	p [bar <sub>g</sub> ]	S/G/L	40	40	40	40	40	40	40	40	35	30	-	-	-
<b>Temperature<sup>2)</sup></b> acc. to DIN EN	min. [°C]	-45							-60				-	-	
	max. [°C]	+150							+350				-	-	

<sup>1)</sup> Min. set pressure of standard bellows = max. set pressure of bellows for low set pressure.

<sup>2)</sup> The temperature is limited by the soft seal material (see page 99/10). The values given here are valid for EPDM. Between -10°C and the lowest specified application temperature, proceed acc. to AD 2000-Merkblatt W10.

## Pressure temperature ratings

Metric units															
		O-ring disc	Metal disc												
	DN <sub>i</sub>	15	15	20	25	32	40	50	65	80	100	125	150		
	DN <sub>o</sub>	15	15	20	25	32	40	50	65	80	100	125	150		
	Actual orifice diameter d <sub>0</sub> [mm]	12	12	18	18	18	23	29	37	46	60	74	92		
	Actual orifice area A <sub>0</sub> [mm <sup>2</sup> ]	113	113	254	254	254	416	661	1075	1662	2827	4301	6648		
<b>Body material: 1.0619 (WCB)</b>															
<b>DIN flange</b>		Inlet	PN 40												
		Outlet	PN 40												
<b>Minimum set pressure</b>	p [bar <sub>g</sub> ] S/G/L	0.3	0.3	0.2	0.2	0.2	0.2	0.2	0.2	0.2	0.2	0.2	0.2		
<b>Min. set pressure<sup>1)</sup> standard bellows</b>	p [bar <sub>g</sub> ] S/G/L	3.0	3.0	3.0	3.0	3.0	3.0	3.0	3.0	3.0	3.0	3.0	3.0		
<b>Min. set pressure low pressure bellows</b>	p [bar <sub>g</sub> ] S/G/L	–	–	2.0	2.0	2.0	1.8	1.9	1.8	1.8	1.2	1.2	on request		
<b>Maximum set pressure</b>	p [bar <sub>g</sub> ] S/G/L	40	40	40	40	40	40	40	35	35	30	32	16		
<b>Max. set pressure with special spring</b>	p [bar <sub>g</sub> ] S/G/L	40	40	40	40	40	40	40	40	35	30	32	16		
<b>Temperature<sup>2)</sup> acc. to DIN EN</b>	min. [°C]	-45						-85						–	–
	max. [°C]	+150						+450						–	–
<b>Body material: 1.4408 (CF8M)</b>															
<b>DIN flange</b>		Inlet	PN 40											–	–
		Outlet	PN 40											–	–
<b>Minimum set pressure</b>	p [bar <sub>g</sub> ] S/G/L	0.3	0.3	0.2	0.2	0.2	0.2	0.2	0.2	0.2	0.2	0.2	–	–	
<b>Min. set pressure<sup>1)</sup> standard bellows</b>	p [bar <sub>g</sub> ] S/G/L	3.0	3.0	3.0	3.0	3.0	3.0	3.0	3.0	3.0	3.0	3.0	–	–	
<b>Min. set pressure low pressure bellows</b>	p [bar <sub>g</sub> ] S/G/L	–	–	2.0	2.0	2.0	1.8	1.9	1.8	1.8	1.2	–	–		
<b>Maximum set pressure</b>	p [bar <sub>g</sub> ] S/G/L	40	40	40	40	40	40	31.6	20.2	25	22	–	–		
<b>Max. set pressure with special spring</b>	p [bar <sub>g</sub> ] S/G/L	40	40	40	40	40	40	40	26	25	22	–	–		
<b>Temperature<sup>2)</sup> acc. to DIN EN</b>	min. [°C]	-45						-270						–	–
	max. [°C]	+150						+400						–	–

<sup>1)</sup> Min. set pressure of standard bellows = max. set pressure of bellows for low set pressure.

<sup>2)</sup> The temperature is limited by the soft seal material (see page 99/10). The values given here are valid for EPDM. Between -10°C and the lowest specified application temperature, proceed acc. to AD 2000-Merkblatt W10.

## Dimensions and weights

### Metric units

		O-ring disc	Metal disc										
	DN <sub>i</sub>	15	15	20	25	32	40	50	65	80	100	125	150
	DN <sub>o</sub>	15	15	20	25	32	40	50	65	80	100	125	150
	Actual orifice diameter d <sub>0</sub> [mm]	12	12	18	18	18	23	29	37	46	60	74	92
	Actual orifice area A <sub>0</sub> [mm <sup>2</sup> ]	113	113	254	254	254	416	661	1075	1662	2827	4301	6648
<b>Weight</b> [kg]		5	5	6	6	8	9	12	15	20	33	48	65
	with bellows	6.3	6.3	6.4	6.4	8.4	9.6	13	16	21.6	35.6	52.1	78.4
<b>Centre to face</b> [mm]	Inlet a	90	90	95	100	105	115	125	145	155	175	200	225
	Outlet b	90	90	95	100	105	115	125	145	155	175	200	225
<b>Height (H4)</b> [mm]	Standard H max.	310	310	315	320	325	335	360	475	530	605	745	870
	Bellows H max.	362	362	345	350	360	390	425	535	600	680	825	965
<b>Support brackets</b> [mm]	A												277
	B												160
(Drilled only on request, option code H42)	C												Ø 18
	D												278
	E												21

### Body material: 0.6025 (cast iron)

<b>DIN flange<sup>1)</sup></b>	Inlet	PN 16	-	-
	Outlet	PN 16	-	-

### Body material: 0.7043 (Ductile Gr. 60-40-18)

<b>DIN flange<sup>1)</sup></b>	Inlet	PN 40	-	-
	Outlet	PN 40	-	-

### Body material: 1.0619 (WCB)

<b>DIN flange<sup>1)</sup></b>	Inlet	PN 40	-	-
	Outlet	PN 40	-	-

### Body material: 1.4408 (CF8M)

<b>DIN flange<sup>1)</sup></b>	Inlet	PN 40	-	-
	Outlet	PN 40	-	-

<sup>1)</sup> Standard flange class For other flange drillings, refer to page 01/14 and 01/15.

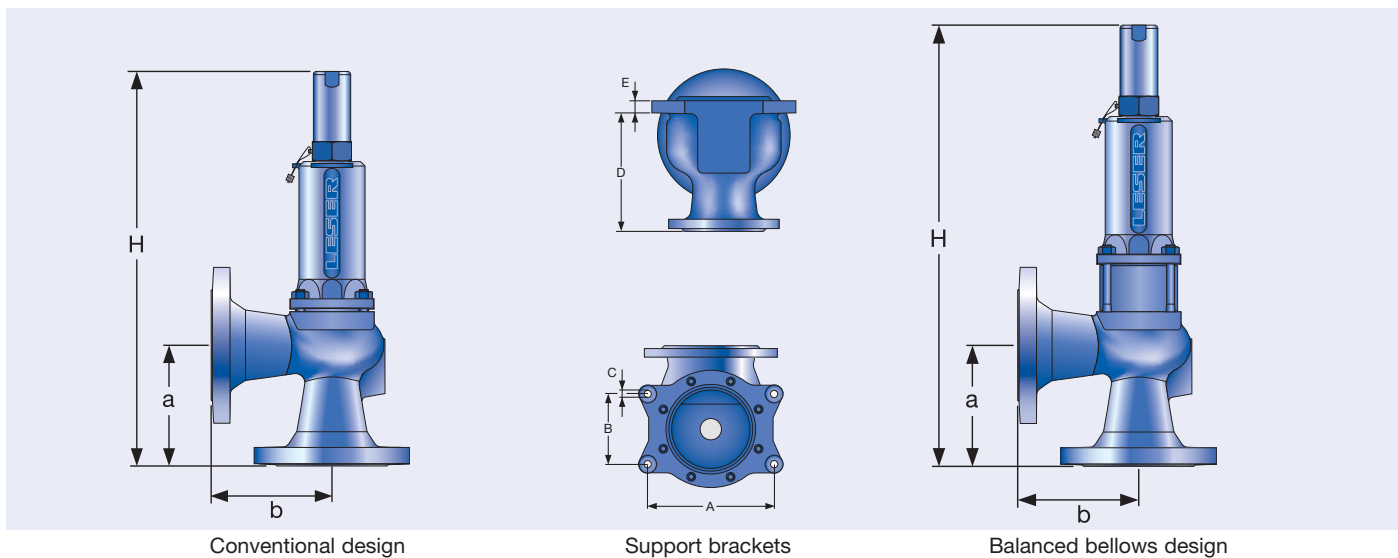

## Approvals

Approvals		O-ring disc	Metal disc		
	DN <sub>i</sub>	15	15	20	25 – 150
	DN <sub>o</sub>	15	15	20	25 – 150
	Actual orifice diameter d <sub>o</sub> [mm]	12	12	18	18 – 92
	Actual orifice area A <sub>o</sub> [mm <sup>2</sup> ]	113	113	254	254 – 6648
<b>Europe</b>		<b>Coefficient of discharge K<sub>dr</sub></b>			
PED / DIN EN ISO 4126-1	Approval-No.	072020111Z0008/0/06			
	S/G	0.59	0.62	0.29	0.38
	L	0.47	0.48	0.19	0.25
<b>Germany</b>		<b>Coefficient of discharge α<sub>w</sub></b>			
PED / AD 2000-Merkblatt A2 Standard safety valve	Approval-No.	TÜV SV 577			
	S/G	0.59	0.62	0.29	0.38
	L	0.47	0.48	0.19	0.25
<b>China</b>		<b>Coefficient of discharge α<sub>w</sub></b>			
AQSIQ	Approval-No.	For current Approval-No. see <a href="http://www.leser.com">www.leser.com</a>			
	S/G	0.59	0.62	0.29	0.38
	L	0.47	0.48	0.19	0.25
<b>Eurasian Custom Union</b>		<b>Coefficient of discharge α<sub>w</sub></b>			
EAC	Approval-No.	For current Approval-No. see <a href="http://www.leser.com">www.leser.com</a>			
	S/G	0.59	0.62	0.29	0.38
	L	0.47	0.48	0.19	0.25
<b>Classification societies</b>		<b>Homepage</b>			
Bureau Veritas	BV	<a href="http://www.bureauveritas.com">www.bureauveritas.com</a>			
ClassNK NIPPON Kaiji Kyokai	NK	<a href="http://www.classnk.or.jp">www.classnk.or.jp</a>			
Det Norske Veritas	DNV	<a href="http://www.dnv.com">www.dnv.com</a>			
Germanischer Lloyd	GL	<a href="http://www.gl-group.com">www.gl-group.com</a>			
Lloyd's Register EMEA	LREMEA	<a href="http://www.lr.org">www.lr.org</a>			
Registro Italiano Navale	RINA	<a href="http://www.rina.org">www.rina.org</a>			
		The valid Approval-No. changes with each renewal of the approval.			
		For a sample certificate including the valid certification number see <a href="http://www.leser.com">www.leser.com</a>			



## Flange drillings

### Flange drillings

		O-ring disc	Metal disc											
		DN <sub>i</sub>	15	20	25	32	40	50	65	80	100	125	150	
		DN <sub>o</sub>	15	20	25	32	40	50	65	80	100	125	150	
		Valve size	1/2" x 1/2"	1/2" x 1/2" 3/4" x 3/4"	1" x 1"	1 1/4" x 1 1/4"	1 1/2" x 1 1/2"	2" x 2"	2 1/2" x 2 1/2"	3" x 3"	4" x 4"	5" x 5"	6" x 6"	
		Actual orifice diameter d <sub>0</sub> [mm]	12	18	18	18	23	29	37	46	60	74	92	
		Actual orifice area A <sub>0</sub> [mm <sup>2</sup> ]	113	254	254	254	416	661	1075	1662	2827	4301	6648	
<b>Body material: 0.6025 (cast iron)</b>														
Inlet	DIN EN 1092	PN 10	*	*	*	*	*	*	*	*	*	*	*	
		PN 16	*	*	*	*	*	*	*	*	*	*	*	
		PN 25	-	-	-	-	-	-	-	-	-	-	-	
		PN 40	-	-	-	-	-	-	-	-	-	-	-	
Outlet	DIN EN 1092	PN 10	*	*	*	*	*	*	*	*	*	*	*	
		PN 16	*	*	*	*	*	*	*	*	*	*	*	
<b>Body material: 0.7043 (Ductile Gr. 60-40-18), 1.0619 (WCB), 1.4408 (CF8M)</b>														
Inlet	DIN EN 1092	PN 10	*	*	*	*	*	*	*	H44	H44	H44	H44	
		PN 16	*	*	*	*	*	*	*	H45	H45	H45	H45	
		PN 25	*	*	*	*	*	*	*	*	*	*	*	
		PN 40	*	*	*	*	*	*	*	*	*	*	*	
	ASME B16.5	CL150	H64	H64	H64	H64	H64	H64	H64	H64	H64	[H64]	H64	H64
		CL300	[H65]	[H65]	-	H65	H65	-	[H65]	[H65]	-	-	-	-
Outlet	DIN EN 1092	PN 10	*	*	*	*	*	*	*	H50	H50	H50	H50	
		PN 16	*	*	*	*	*	*	*	H51	H51	H51	H51	
		PN 25	*	*	*	*	*	*	*	*	*	*	*	
		PN 40	*	*	*	*	*	*	*	*	*	*	*	
	ASME B16.5	CL150	H79	H79	H79	H79	H79	H79	H79	H79	H79	[H79]	H79	H79
		CL300	H80	H80	-	H80	H80	-	[H80]	[H80]	-	-	-	-

For an explanation of the characters and symbols, refer to page 00/07.  
 Note: Flange drillings and facings always meet the requirements of the given flange standards.  
 Flange thickness and outside diameter may deviate from the standard.

## Flange facings

Flange facings										
Information	Standard	Inlet	Outlet	Remark						
<b>General</b>										
Flange, undrilled	–	H38	H39							
Linde-V-Nut, Form V48	Linde Standard 420-08	J07	J08	Groove: Rz = 16						
Linde-V-Nut, Form V48A	LDeS 3313.36	J05	J06	Groove: Rz = 4, e.g. for hydrogen						
Lens-shape seal form L (without lens-shape seal)	DIN 2696 LDeS 3313.35	J11	J12							
<b>According to DIN EN 1092</b>										
Flange facings		Inlet	Outlet	Remark						
DIN EN 1092 (also see LDeS 3313.40)		PN 10 – PN 40	PN 10 – PN 40	Rz specification acc. to DIN EN 1092 in µm						
Raised face	Form B1	*	*	Facing: Rz = 12.5 – 50						
	Form B2	L36	L38	Facing: Rz = 3.2 – 12.5						
Tongue, Form C <sup>1)</sup>		H94	H92	only for steel flange						
Groove, Form D <sup>1)</sup>		H93	H91							
Male, Form E		H96	H98							
Female, Form F		H97	H99							
O-ring Male, Form G		J01	J02							
O-ring Female, Form H		J03	J04							
<b>According to ASME B16.5</b>										
Body material	Inlet	Outlet	Smooth Finish <sup>2)</sup>		Serrated Finish		RTJ-Groove			
			Inlet	Outlet	Inlet	Outlet	Inlet		Outlet	
			Option code		Option code		ANSI Class	Option code	ANSI Class	Option code
0.7043	all	all	L52	L53	*	*	–	–	–	–
1.0619, 1.4408	all	all	L52	L53	*	*	150	H62	150	H63

<sup>1)</sup> LESER manufactures the groove at flanged valves by milling. If a customer demands a turned surface in the soil of the groove according to DIN EN 1092-1 an additional option code is necessary: "S01: soil of the groove drilled".

<sup>2)</sup> Smooth Finish is not defined in the effective standards.

For signs and symbols refer to page 00/07

Note: Flange drillings and facings meet always the requirements of mentioned flange standards.

Flange thickness and outer diameter may vary from flange standard.

## LESER Original Spare Parts Kits

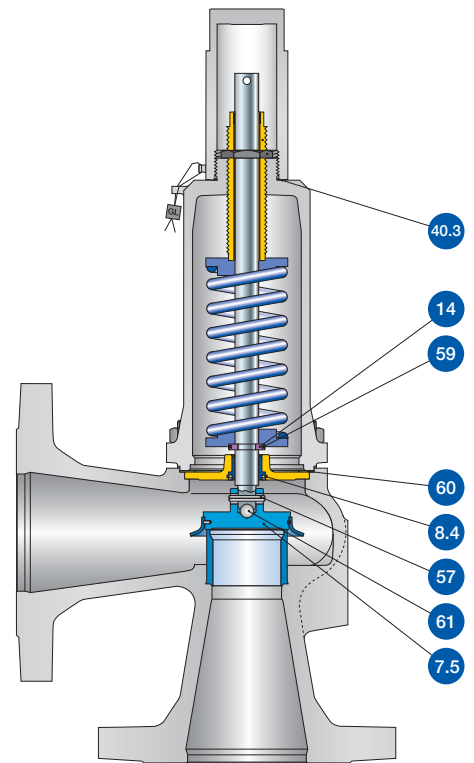

The LESER Spare Parts Kits contain all the spare parts recommended for the regular maintenance of a LESER safety valve.

### Contents

Item	Component	Material	Quantity
7.5	Securing ring (Disc)	1.4571 / 316Ti	1
8.4	Securing ring (Guide)	1.4571 / 316Ti	1
14	Split ring	1.4404 / 316L	2
40.3	Spacer	1.4571 / 316Ti	3
57	Pin	1.4310 / Stainless steel	1
59	Securing ring (Split ring)	1.4571 / 316Ti	1
60	Gasket	Graphite / 1.4401 Graphite / 316	3
61	Ball	1.4401 / 316	1
1.9	O-ring (Lifting device H4)	FKM	1

# Type 431, 433

## LESER Original Spare Parts Kits

### Article numbers

DN	15 – 20	25	32	40	50	65	80	100	125	150
Art.-No. 5012.	1201	1201	1201	1201	1212	1213	1204	1214	1215	1216



## Available options

For more information, also see  
"Accessories and Options" as of page 99/01.

### Heating jacket

H29, H30: Coupling G 3/8, G 3/4  
H31, H32: Flange DN15, DN25

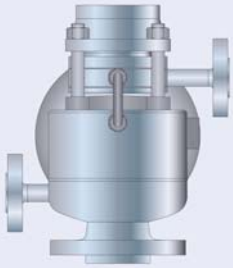

### Drain hole

J18: G 1/4  
J19: G 1/2

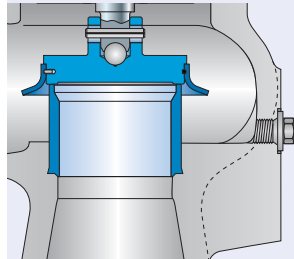

### Open bonnet

See Art.-No.

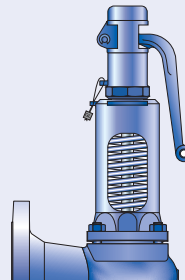

### O-ring disc

J20: FFKM "C"  
J21: CR "K"  
J22: EPDM "D"  
J23: FKM "L"

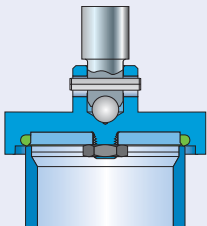

### Disc with sealing plate

J44: PTFE-FDA  
J48: PCTFE  
J49: SP

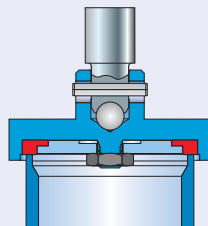

### Balanced bellows

J68: Open bonnet  
J78: Closed bonnet

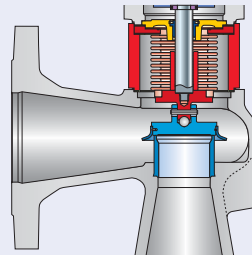

### Conversion kit for balanced bellows

Art.-No. see page 01/14

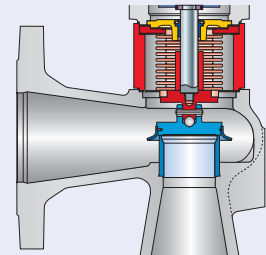

### Screwed cap H2

H2

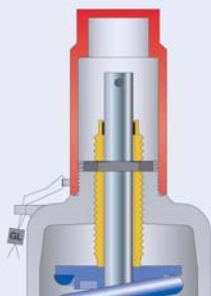

### Plain lever H3

H3

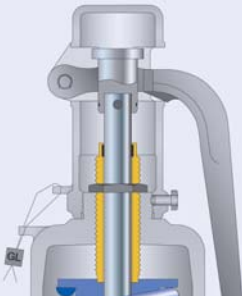

### Packed lever H4

H4

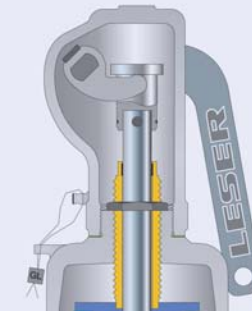

### O-ring damper H2

J65

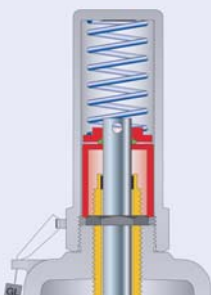

### O-ring damper H4

J66

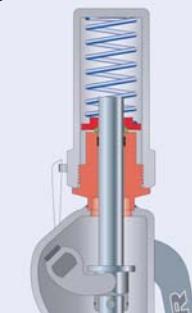

### Lift indicator

J39: Adaptor H4  
J93: Lift indicator

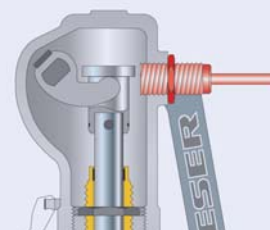

### Test gag

J69: H4  
J70: H4

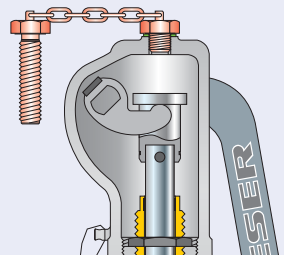

## Capacities – steam

Calculation of the capacity for saturated steam acc. to AD 2000-Merkblatt A2 with 10% overpressure.  
Capacities at 1 bar and lower are calculated at 0.1 bar overpressure.

Metric units		AD 2000-Merkblatt A2 [kg/h]										
		O-ring disc	Metal disc									
DN <sub>i</sub>	15	15	20	25	32	40	50	65	80	100	125	150
DN <sub>o</sub>	15	15	20	25	32	40	50	65	80	100	125	150
Actual orifice diameter d <sub>o</sub> [mm]	12	12	18	18	18	23	29	37	46	60	74	92
Actual orifice area A <sub>o</sub> [mm <sup>2</sup> ]	113	113	254	254	254	416	661	1075	1662	2827	4301	6648
LEO <sub>s/g</sub> <sup>*)</sup> [inch <sup>2</sup> ]	0.106	0.111	0.117	0.154	0.154	0.251	0.399	0.650	1.004	1.708	2.598	4.016
Set pressure [bar]	Capacity [kg/h]											
0.2				34	34	55	88	142	220	375	570	880
0.5	52	55	30	63	63	102	163	265	410	697	1060	1638
1	74	78	67	101	101	165	263	428	661	1125	1711	2645
2	118	125	129	170	170	278	442	720	1113	1893	2880	4452
3	161	168	177	232	232	379	603	981	1517	2581	3926	6068
4	200	210	221	290	290	473	752	1224	1892	3218	4895	7567
5		251	265	347	347	566	900	1465	2265	3853	5861	9058
6		293	308	404	404	659	1048	1706	2636	4485	6823	10545
7		333	350	459	459	750	1192	1940	2999	5102	7761	11996
8		374	394	516	516	842	1339	2179	3368	5730	8717	13473
9		415	437	572	572	934	1485	2418	3737	6358	9671	14948
10		456	480	629	629	1026	1632	2656	4105	6984	10624	16421
12		538	566	741	741	1210	1924	3132	4842	8237	12530	19366
14		618	650	852	852	1391	2211	3599	5563	9464	14395	22250
16		699	736	964	964	1574	2503	4074	6297	10714	16296	25189
18		781	822	1077	1077	1758	2795	4550	7033	11965	18200	28131
20		863	908	1190	1190	1942	3088	5027	7770	13218	20107	
22		942	991	1299	1299	2121	3372	5489	8484	14434	21956	
24		1024	1078	1412	1412	2306	3665	5967	9222	15690	23866	
26		1106	1164	1525	1525	2491	3959	6445	9962	16949		
28		1189	1251	1639	1639	2676	4254	6925	10704	18211		
30		1271	1338	1753	1753	2862	4550	7407	11449	19478		
32		1354	1425	1867	1867	3049	4847	7890	12195	20748		
34												
36												
38												
40												

<sup>\*)</sup> LEO<sub>s/g</sub> = LESER Effective Orifice steam/gases please refer to page 00/11

"How to use" capacity tables, refer to page 00/09

## Capacity table – air

Calculation of the capacity for air acc. to AD 2000-Merkblatt A2 with 10% overpressure.  
Capacities at 1 bar and lower are calculated at 0.1 bar overpressure.

Metric units		AD 2000-Merkblatt A2 [ $m_n^3/h$ ]											
		O-ring disc	Metal disc										
	DN <sub>i</sub>	15	15	20	25	32	40	50	65	80	100	125	150
	DN <sub>o</sub>	15	15	20	25	32	40	50	65	80	100	125	150
	Actual orifice diameter d <sub>0</sub> [mm]	12	12	18	18	18	23	29	37	46	60	74	92
	Actual orifice area A <sub>0</sub> [mm <sup>2</sup> ]	113	113	254	254	254	416	661	1075	1662	2827	4301	6648
	LEO <sub>s/g</sub> <sup>*)</sup> [inch <sup>2</sup> ]	0.106	0.111	0.117	0.154	0.154	0.251	0.399	0.650	1.004	1.708	2.598	4.016
Set pressure [bar]		Capacity [ $m_n^3/h$ ]											
0.2					39	39	63	101	165	255	431	660	1019
0.5	64	67	35	74	74	120	191	311	481	819	1245	1925	
1	93	93	80	121	121	197	313	510	788	1341	2039	3152	
2	151	151	156	206	206	336	534	870	1344	2287	3478	5377	
3	206	206	217	284	284	463	737	1199	1854	3153	4797	7414	
4	246	258	272	356	356	582	925	1505	2327	3958	6021	9306	
5	296	311	327	429	429	700	1113	1811	2800	4763	7245	11198	
6	346	363	382	501	501	818	1301	2117	3273	5568	8469	13091	
7	396	416	438	574	574	936	1489	2423	3746	6373	9694	14983	
8	446	468	493	646	646	1055	1677	2729	4219	7177	10918	16875	
9	496	521	548	718	718	1173	1865	3035	4692	7982	12142	18767	
10	546	573	604	791	791	1291	2053	3342	5165	8787	13366	20659	
12	646	679	714	936	936	1528	2429	3954	6111	10397	15815	24444	
14	746	784	825	1081	1081	1764	2805	4566	7057	12006	18263	28228	
16	846	889	935	1225	1225	2001	3181	5178	8003	13616	20711	32013	
18	946	994	1046	1370	1370	2237	3557	5790	8949	15226	23160		
20	1046	1099	1156	1515	1515	2474	3933	6402	9895	16835	25608		
22	1146	1204	1267	1660	1660	2710	4309	7014	10842	18445	28057		
24	1245	1309	1377	1805	1805	2947	4685	7626	11788	20055	30505		
26	1345	1414	1488	1950	1950	3183	5061	8238	12734	21664	32954		
28	1445	1519	1599	2095	2095	3420	5437	8851	13680	23274	35402		
30	1545	1624	1709	2240	2240	3656	5813	9463	14626	24883	37850		
32	1645	1729	1820	2384	2384	3893	6189	10075	15572		40299		
34	1745	1834	1930	2529	2529	4130	6565	10687	16518				
36	1845	1939	2041	2674	2674	4366	6941	11299					
38	1945	2044	2151	2819	2819	4603	7317	11911					
40	2045	2149	2262	2964	2964	4839	7693	12523					

<sup>\*)</sup> LEO<sub>s/g</sub> = LESER Effective Orifice steam/gases please refer to page 00/11

"How to use" capacity tables, refer to page 00/09



## Capacity table – water

Calculation of the capacity for water acc. to AD 2000-Merkblatt A2 with 10% overpressure at 20 °C.  
Capacities at 1 bar and lower are calculated at 0.1 bar overpressure.

Metric units		AD 2000-Merkblatt A2 [10 <sup>3</sup> kg/h]											
		O-ring disc	Metal disc										
DN <sub>i</sub>	15	15	20	25	32	40	50	65	80	100	125	150	
DN <sub>o</sub>	15	15	20	25	32	40	50	65	80	100	125	150	
Actual orifice diameter d <sub>0</sub> [mm]	12	12	18	18	18	23	29	37	46	60	74	92	
Actual orifice area A <sub>0</sub> [mm <sup>2</sup> ]	113	113	254	254	254	416	661	1075	1662	2827	4301	6648	
LEO <sub>L</sub> *) [inch <sup>2</sup> ]	0.127	0.129	0.115	0.152	0.152	0.248	0.394	0.641	0.991	1.686	2.564	3.963	
Set pressure [bar]	Capacity [10 <sup>3</sup> kg/h]												
0.2				1.77	1.77	2.89	4.60	7.50	11.6	19.7	30.0	46.3	
0.5	2.09	2.14	1.90	2.51	2.51	4.09	6.51	10.6	16.4	27.8	42.4	65.5	
1	2.84	2.90	2.58	3.39	3.39	5.54	8.81	14.3	22.2	37.7	57.4	88.7	
2	4.01	4.10	3.65	4.80	4.80	7.84	12.5	20.3	31.3	53.3	81.1	125	
3	4.91	5.02	4.47	5.88	5.88	9.60	15.3	24.8	38.4	65.3	99.3	154	
4	5.67	5.79	5.16	6.79	6.79	11.1	17.6	28.7	44.3	75.4	115	177	
5	6.34	6.48	5.77	7.59	7.59	12.4	19.7	32.1	49.6	84.3	128	198	
6	6.95	7.09	6.32	8.31	8.31	13.6	21.6	35.1	54.3	92.4	140	217	
7	7.50	7.66	6.82	8.98	8.98	14.7	23.3	37.9	58.6	99.8	152	235	
8	8.02	8.19	7.30	9.60	9.60	15.7	24.9	40.6	62.7	107	162	251	
9	8.51	8.69	7.74	10.2	10.2	16.6	26.4	43.0	66.5	113	172	266	
10	8.97	9.16	8.16	10.7	10.7	17.5	27.9	45.3	70.1	119	181	280	
12	9.82	10.0	8.93	11.8	11.8	19.2	30.5	49.7	76.8	131	199	307	
14	10.6	10.8	9.65	12.7	12.7	20.7	33.0	53.7	82.9	141	215	332	
16	11.3	11.6	10.3	13.6	13.6	22.2	35.2	57.4	88.7	151	229	355	
18	12.0	12.3	10.9	14.4	14.4	23.5	37.4	60.8	94.0	160	243		
20	12.7	13.0	11.5	15.2	15.2	24.8	39.4	64.1	99.1	169	257		
22	13.3	13.6	12.1	15.9	15.9	26.0	41.3	67.3	104	177	269		
24	13.9	14.2	12.6	16.6	16.6	27.1	43.2	70.2	109	185	281		
26	14.5	14.8	13.2	17.3	17.3	28.3	44.9	73.1	113	192	292		
28	15.0	15.3	13.6	18.0	18.0	29.3	46.6	75.9	117	200	304		
30	15.5	15.9	14.1	18.6	18.6	30.3	48.2	78.5	121	207	314		
32	16.0	16.4	14.6	19.2	19.2	31.3	49.8	81.1	125		324		
34	16.5	16.9	15.0	19.8	19.8	32.3	51.4	83.6	129				
36	17.0	17.4	15.5	20.4	20.4	33.2	52.9	86.0					
38	17.5	17.9	15.9	20.9	20.9	34.2	54.3	88.4					
40	17.9	18.3	16.3	21.5	21.5	35.0	55.7	90.7					

\*) LEO<sub>L</sub> = LESER Effective Orifice liquids, please refer to page 00/11

"How to use" capacity tables, refer to page 00/09

## Determination of coefficient of discharge in case of lift restriction or back pressure

- $h$  = Lift [mm]
- $d_0$  = Flow diameter [mm] of selected safety valve see "Article Numbers" table
- $h/d_0$  = Ratio of lift / flow diameter
- $p_{a0}$  = Back pressure [bar<sub>a</sub>]
- $p_0$  = Set pressure [bar<sub>a</sub>]
- $p_{a0}/p_0$  = Ratio of back pressure / set pressure
- $K_{dr}$  = Coefficient of discharge acc. to DIN EN ISO 4126-1
- $\alpha_w$  = Coefficient of discharge acc. to AD 2000-Merkblatt A2
- $K_b$  = Back pressure correction factor acc. to API 520 Section 3.3

Diagram for evaluation of ratio of lift / flow diameter ( $h/d_0$ ) in reference to the coefficient of discharge ( $K_{dr}/\alpha_w$ )

"How to use" refer to page 00/08

Type 433

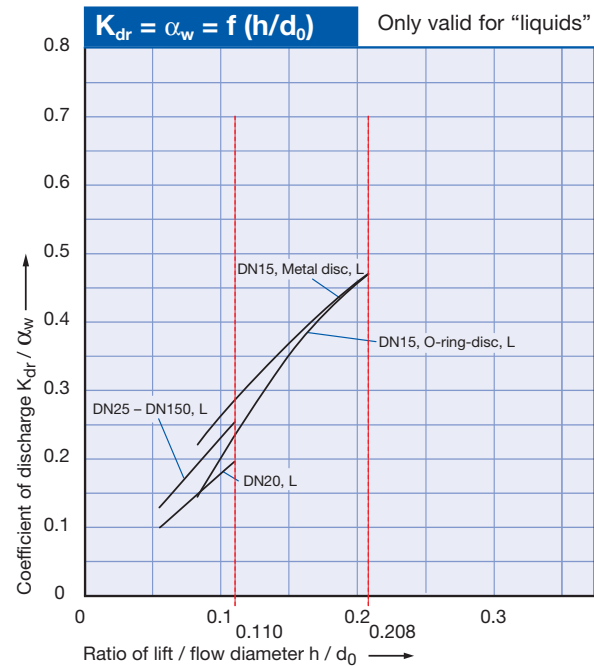
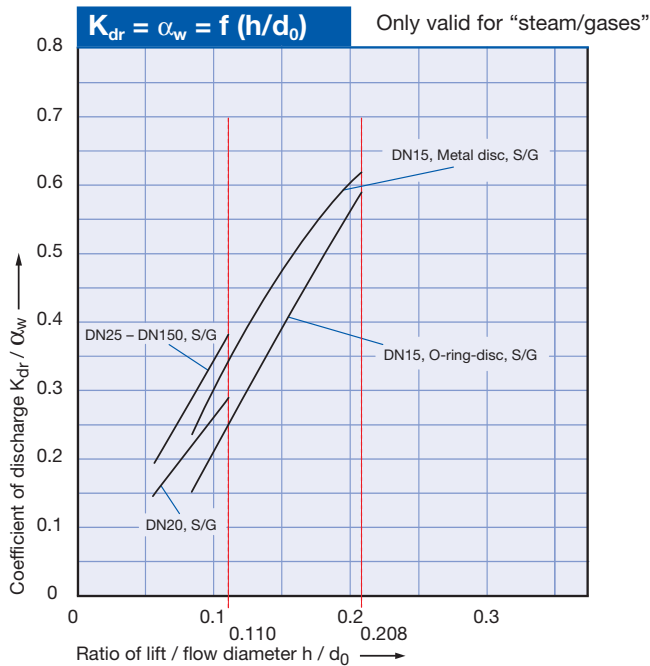
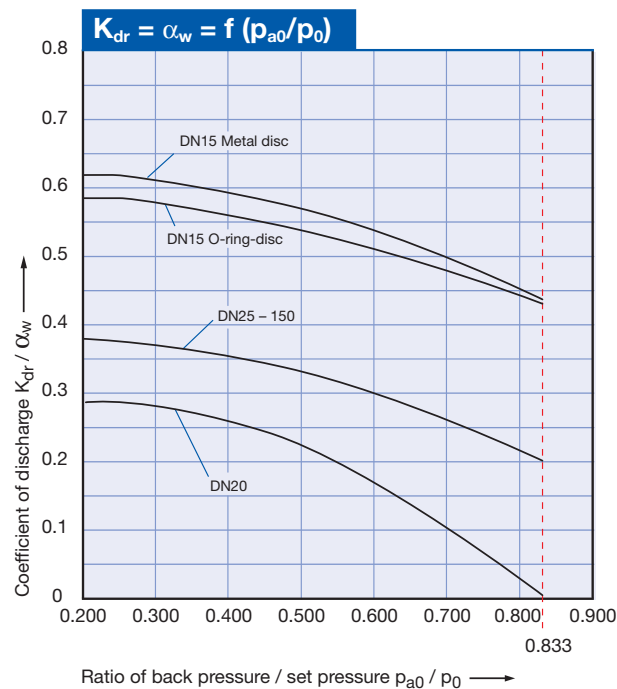

Diagram for evaluation of coefficient of discharge ( $K_{dr}/\alpha_w$ ) or  $K_b$  in reference to the ratio of back pressure / set pressure ( $p_{a0}/p_0$ )





**Type 431 PN 160**  
**Packed lever H4**  
**Open bonnet**  
**Conventional design**

# Type 431, 433 PN 160

**Flanged Safety Relief Valves**  
 - spring loaded



**Type 433 PN 160**  
**Cap H2**  
**Closed bonnet**  
**Conventional design**

**Contents**

**Chapter/Page**

**Materials**

- Conventional design 02/02
- Balanced bellows design 02/04

**How to order**

- Numbering system 02/06
- Article numbers 02/08

**Pressure temperature ratings**

- Metric units 02/09

**Dimensions and weights**

- Metric units 02/10

Flange drillings and Flange facings 02/11

Order information - spare parts 02/12

Available options 02/13

Approvals 02/14

**Capacities**

- Steam [Metric units] 02/15
- Air [Metric units] 02/15
- Water [Metric units] 02/15

Determination of coefficient of discharge  $K_{dr}/\alpha_w$  02/16

# Type 431, 433 PN 160

LESER

Conventional design

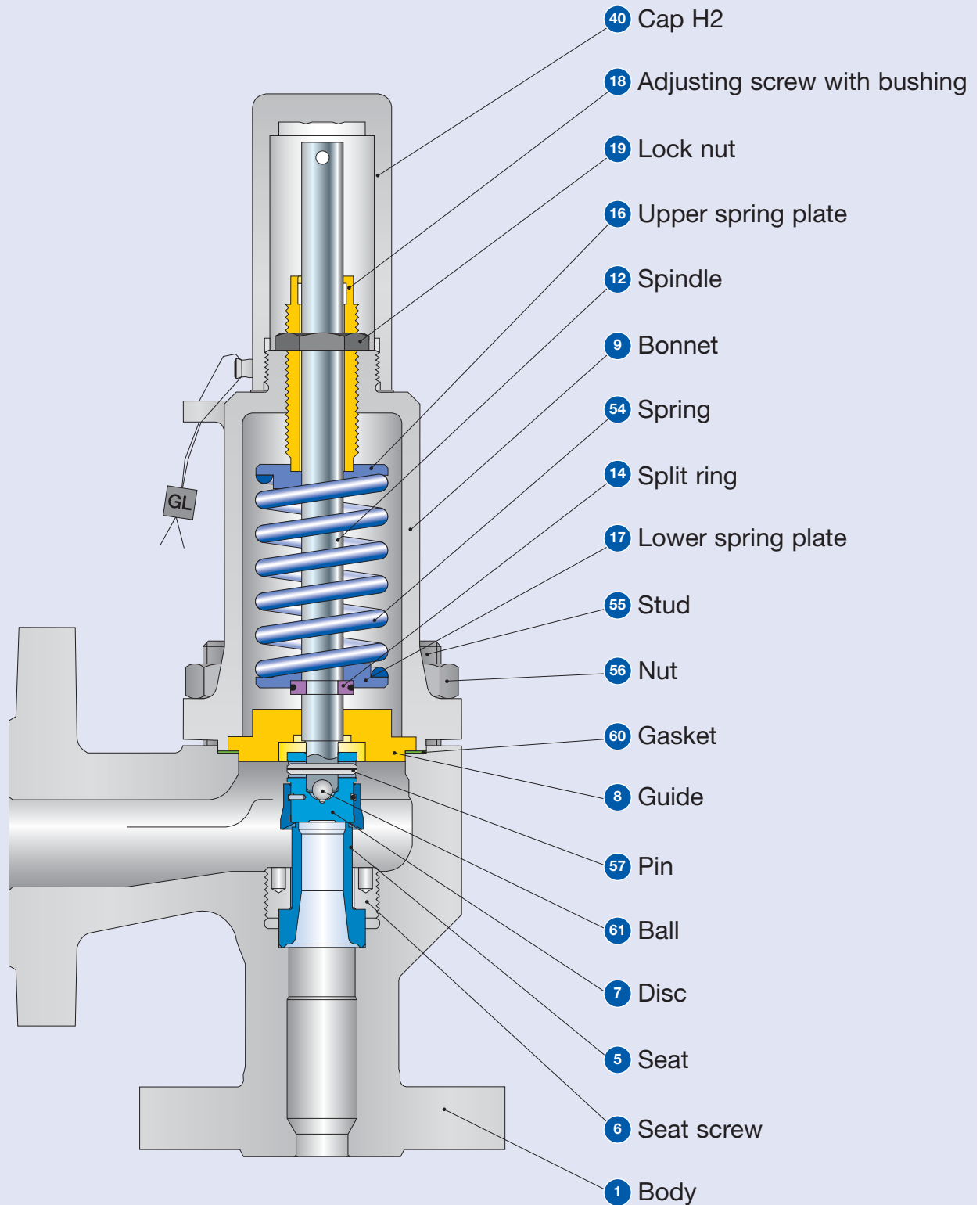

Type 433 PN 160

## Conventional design

Materials		O-ring disc	Metal disc	O-ring disc	Metal disc
Item	Component	Type 4312 / 4332	Type 4312 / 4332	Type 4334	Type 4334
<b>1</b>	<b>Body</b>	1.0619	1.0619	1.4408	1.4408
		SA 216 WCB	SA 216 WCB	SA 351 CF8M	SA 351 CF8M
<b>5</b>	Seat	1.4404	1.4404	1.4404	1.4404
		316L	316L	316L	316L
<b>6</b>	Seat screw	1.4404	1.4404	1.4404	1.4404
		316L	316L	316L	316L
<b>7</b>	Disc	1.4404	1.4122	1.4404	1.4404
		316L	Hardened stainless steel	316L	316L
<b>8</b>	Guide	1.4104 tenifer	1.4104, 1.0501, 1.0570	1.4404	1.4404
		Chrome steel tenifer	Chrome or stainless steel	316L	316L
<b>9</b>	<b>Bonnet</b>	0.7040	0.7040	1.4408	1.4408
		Ductile Gr. 60-40-18	Ductile Gr. 60-40-18	SA 351 CF8M	SA 351 CF8M
<b>12</b>	Spindle	1.4021	1.4021	1.4404	1.4404
		420	420	316L	316L
<b>14</b>	Split ring	1.4104	1.4104	1.4404	1.4404
		Chrome steel	Chrome steel	316L	316L
<b>16/17</b>	Spring plate	1.0718	1.0718	1.4404	1.4404
		Steel	Steel	316L	316L
<b>18</b>	Adjusting screw with bushing	1.4104 PTFE	1.4104 PTFE	1.4404 PTFE	1.4404 PTFE
		Chrome steel PTFE	Chrome steel PTFE	316L PTFE	316L PTFE
<b>19</b>	Lock nut	1.4104	1.4104	1.4404	1.4404
		Chrome steel	Chrome steel	316L	316L
<b>40</b>	Cap H2	1.0460	1.0460	1.4404	1.4404
		SA 105	SA 105	316L	316L
<b>54</b>	Spring, standard	1.1200, 1.8159, 1.7102	1.1200, 1.8159, 1.7102	1.4310	1.4310
		Steel	Steel	Stainless steel	Stainless steel
<b>54</b>	Spring, optional	1.4310	1.4310	-	-
		Stainless steel	Stainless steel	-	-
<b>55</b>	Stud	1.1181	1.1181	1.4401	1.4401
		Steel	Steel	B8M	B8M
<b>56</b>	Nut	1.0501	1.0501	1.4401	1.4401
		2H	2H	8M	8M
<b>57</b>	Pin	1.4310	1.4310	1.4310	1.4310
		Stainless steel	Stainless steel	Stainless steel	Stainless steel
<b>60</b>	Gasket	Graphite / 1.4401	Graphite / 1.4401	Graphite / 1.4401	Graphite / 1.4401
		Graphite / 316	Graphite / 316	Graphite / 316	Graphite / 316
<b>61</b>	Ball	1.3541	1.3541	1.4401	1.4401
		Hardened stainless steel	Hardened stainless steel	316	316

### Note:

- LESER reserves the right to make changes.
- If several materials are specified LESER defines the material.
- LESER may use higher quality materials without giving prior notice.
- Each component can be constructed of another material according to the customer's specification.
- All components exposed to pressure are highlighted in bold. The material will be specified according to DIN and ASTM here.

# Type 431, 433 PN 160

LESER

Balanced bellows design

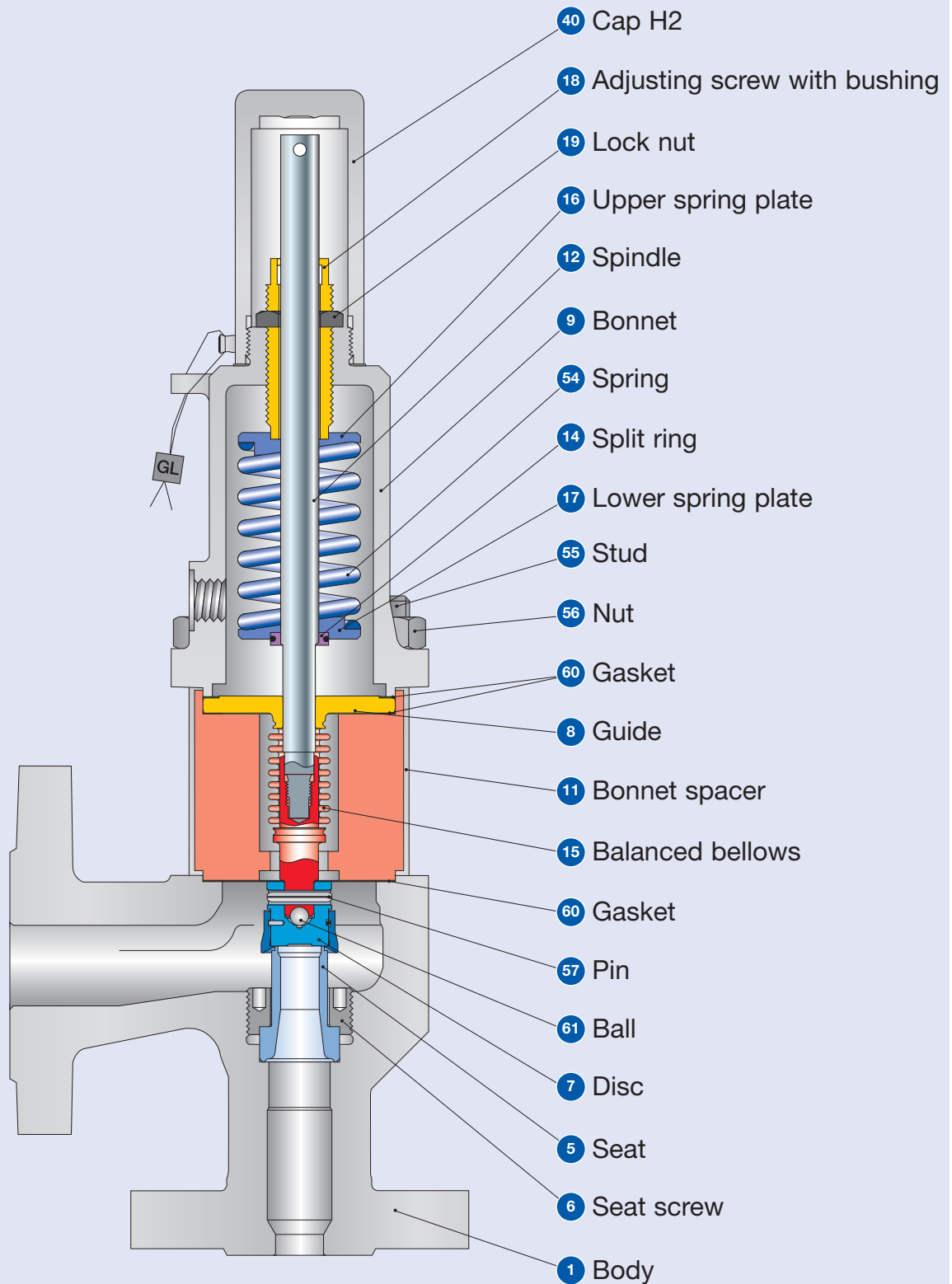

Type 433 PN 160

## Balanced bellows design

Materials		O-ring disc	Metal disc	O-ring disc	Metal disc
Item	Component	Type 4312 / 4332	Type 4312 / 4332	Type 4334	Type 4334
<b>1</b>	<b>Body</b>	1.0619	1.0619	1.4408	1.4408
		SA 216 WCB	SA 216 WCB	SA 351 CF8M	SA 351 CF8M
<b>5</b>	Seat	1.4404	1.4404	1.4404	1.4404
		316L	316L	316L	316L
<b>6</b>	Seat screw	1.4404	1.4404	1.4404	1.4404
		316L	316L	316L	316L
<b>7</b>	Disc	1.4404	1.4122	1.4404	1.4404
		316L	Hardened stainless steel	316L	316L
<b>8</b>	Guide Upper connection of balanced bellows	1.4404	1.4404	1.4404	1.4404
		316L	316L	316L	316L
<b>9</b>	<b>Bonnet</b>	0.7040	0.7040	1.4408	1.4408
		Ductile Gr. 60-40-18	Ductile Gr. 60-40-18	SA 351 CF8M	SA 351 CF8M
<b>11</b>	Bonnet spacer	1.4404	1.4404	1.4404	1.4404
		316L	316L	316L	316L
<b>12</b>	Spindle	1.4404	1.4404	1.4404	1.4404
		316L	316L	316L	316L
<b>14</b>	Split ring	1.4104	1.4104	1.4404	1.4404
		Chrome steel	Chrome steel	316L	316L
<b>15</b>	Balanced bellows	1.4571	1.4571	1.4571	1.4571
		316Ti	316Ti	316Ti	316Ti
<b>16/17</b>	Spring plate	1.0718	1.0718	1.4404	1.4404
		Steel	Steel	316L	316L
<b>18</b>	Adjusting screw with bushing	1.4104 PTFE	1.4104 PTFE	1.4404 PTFE	1.4404 PTFE
		Chrome steel PTFE	Chrome steel PTFE	316L PTFE	316L PTFE
<b>19</b>	Lock nut	1.4104	1.4104	1.4404	1.4404
		Chrome steel	Chrome steel	316L	316L
<b>40</b>	Cap H2	1.0460	1.0460	1.4404	1.4404
		SA 105	SA 105	316L	316L
<b>54</b>	Spring, standard	1.1200, 1.8159, 1.7102	1.1200, 1.8159, 1.7102	1.4310	1.4310
		Steel	Steel	Stainless steel	Stainless steel
<b>55</b>	Stud	1.4310	1.4310	–	–
		Stainless steel	Stainless steel	–	–
<b>55</b>	Stud	1.4401	1.4401	1.4401	1.4401
		8M	8M	B8M	B8M
<b>56</b>	Hex nut	1.4401	1.4401	1.4401	1.4401
		8M	8M	B8M	B8M
<b>57</b>	Roll pin	1.4310	1.4310	1.4310	1.4310
		Stainless steel	Stainless steel	Stainless steel	Stainless steel
<b>60</b>	Gasket	Graphite / 1.4401	Graphite / 1.4401	Graphite / 1.4401	Graphite / 1.4401
		Graphite / 316	Graphite / 316	Graphite / 316	Graphite / 316
<b>61</b>	Ball	1.3541	1.3541	1.4401	1.4401
		Hardened stainless steel	Hardened stainless steel	316	316

### Note:

- LESER reserves the right to make changes.
- If several materials are specified LESER defines the material.
- LESER may use higher quality materials without giving prior notice.
- Each component can be constructed of another material according to the customer's specification.
- All components exposed to pressure are highlighted in bold. The material will be specified according to DIN and ASTM here.



## How to order – Example for numbering system – Type 433 PN 160

# 1

### Article Number

4332.8552

# 2

### Set Pressure

60 bar

# 3

### Connections

H47

1	2	3	4
433	2	855	2

#### 1 Valve type 431, 433 PN 160

Type 433 – with closed bonnet  
Type 431 – with open bonnet

#### 2 Material code

Code	Body material
2	1.0619 (WCB)
4	1.4408 (CF8M)

#### 3 Valve code

Automatically determines nominal diameter and body material (see page 02/08).

#### 4

Code	Lifting device	
2	Gas-tight cap	H2
3	Plain lever	H3
4	Packed lever	H4
5	Plain lever with open bonnet	H3

Please enter the units (in gauge)!

The specified pressure range may not be exceeded!

Please refer to page 02/11.

## 4

### Options

J22

#### Type 431, 433 PN 160 Option code

- O-ring disc
 

CR	"K"	J21
EPDM	"D"	J22
FKM	"L"	J23
FFKM	"C"	J20
- Disc 1.4404 / 316L **L44**
- Disc 1.4404 / 316L stellited **J25**
- Detachable lifting aid **J26**
- Balanced bellows
  - Bonnet, open (Type 431) **J68**
  - Bonnet, closed (Type 433) **J78**
- High temperature alloy spring **X01**
- Stainless steel spring **X04**
- Adaptor for lift indicator H4 **J39**
- Lift indicator **J93**
- Test gag
  - Cap H2 **J70**
  - Packed lever H4 **J69**
- Heating jacket
  - Couplings G 3/8 **H29**
  - G 3/4 **H30**
  - Flange DN 15 **H31**
  - DN 25 **H32**
- Heating jacket - Bonnet spacer **H33**
- Drain hole G 1/4 **J18**
- G 1/2 **J19**
- Oil and grease free **J85**
- Materials
  - NACE MR0175 **N78**
  - NACE MR0103 **N77**

Option code applies only if not standard

## 5

### Documentation

H01

L30

Please select the necessary documentation:

**Tests, Certifications:** Option code  
 DIN EN 10204-3.2: TÜV-Nord Certification for set pressure **M33**

**LESER CGA (Certificate for Global Application)** **H03**  
 - Acceptance test certificate 3.1 acc. to DIN EN 10204  
 - Declaration of conformity as per pressure equipment directive PED 97/23/EC

**Material quality certificate:** DIN EN 10204-3.1

Component	Option code
Body	<b>H01</b>
Nozzle	<b>L59</b>
Bonnet	<b>L30</b>
Disc	<b>L23</b>
Screws	<b>N07</b>
Nuts	<b>N08</b>

## 6

### Code and Medium

2.0

1	2
2	0

- 1 Code**  
 2. CE / VdTUEV  
 3. ASME Section VIII + CE / VdTUEV
- 2 Medium**  
 .0 steam / gases / liquids (only valid for CE / VdTUEV)

## How to order – article numbers

Article numbers			O-ring disc	Metal disc
	DN <sub>i</sub>		15	15
	DN <sub>o</sub>		25	25
	Actual orifice diameter d <sub>0</sub> [mm]		12	12
	Actual orifice area A <sub>0</sub> [mm <sup>2</sup> ]		113	113
<b>Body material: 1.0619 (WCB)</b>				
Bonnet closed	H2	Art.-No. 4332.	8572	8552
	H3	Art.-No. 4332.	8573	8553
	H4	Art.-No. 4332.	8574	8554
open	H3	Art.-No. 4312.	8575	8555
<b>Body material: 1.4408 (CF8M)</b>				
Bonnet closed	H2	Art.-No. 4334.	8582	8562
	H4	Art.-No. 4334.	8584	8564

Type 433 PN 160

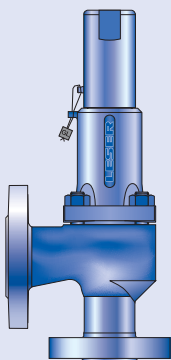

**Type 433 PN 160**  
Cap H2  
Closed bonnet  
Conventional design

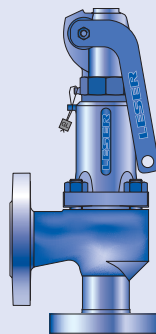

**Type 433 PN 160**  
Packed lever H4  
Closed bonnet  
Conventional design

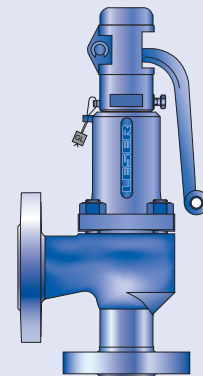

**Type 433 PN 160**  
Plain lever H3  
Closed bonnet  
Conventional design

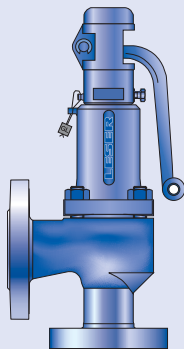

**Type 431 PN 160**  
Plain lever H3  
Open bonnet  
Conventional design

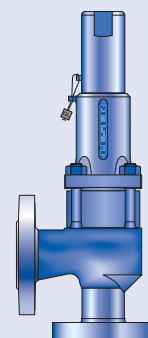

**Type 431 PN 160**  
Plain lever H3  
Closed bonnet  
Balanced bellows design

## Pressure temperature ratings

Metric units					
			O-ring disc		Metal disc
	DN <sub>i</sub>		15		15
	DN <sub>o</sub>		25		25
	Actual orifice diameter d <sub>0</sub> [mm]		12		12
	Actual orifice area A <sub>0</sub> [mm <sup>2</sup> ]		113		113
Body material: 1.0619 (WCB)					
DIN flange	Inlet		PN 160		
	Outlet		PN 40		
<b>Minimum set pressure</b>	p [bar <sub>g</sub> ] S/G/L		0.3		0.3
<b>Min. set pressure<sup>1)</sup></b> standard bellows	p [bar <sub>g</sub> ] S/G/L		3		3
<b>Maximum set pressure</b>	p [bar <sub>g</sub> ] S/G/L	“K”		“C”	
		“D”	142	85	144
		“L”			
<b>Max. set pressure</b> with special spring	p [bar <sub>g</sub> ] S/G/L	“K”		“C”	
		“D”	160	85	160
		“L”			
<b>Temperature<sup>2)</sup></b> acc. to DIN EN	min. [°C]		-45		-60
	max. [°C]		+150		+450
Body material: 1.4408 (CF8M)					
DIN flange	Inlet		PN 160		
	Outlet		PN 40		
<b>Minimum set pressure</b>	p [bar <sub>g</sub> ] S/G/L		0.3		0.3
<b>Min. set pressure<sup>1)</sup></b> standard bellows	p [bar <sub>g</sub> ] S/G/L		3		3
<b>Max. set pressure</b>	p [bar <sub>g</sub> ] S/G/L		85		85
<b>Max. set pressure</b> with special spring	p [bar <sub>g</sub> ] S/G/L	“K”		“C”	
		“D”	150	85	160
		“L”			
<b>Temperature<sup>2)</sup></b> acc. to DIN EN	min. [°C]		-45		-270
	max. [°C]		+150		+400

<sup>1)</sup> Min. set pressure of standard bellows = max. set pressure of bellows for low set pressure.

<sup>2)</sup> The temperature is limited by the soft seal material (see page 99/10). The values given here are valid for EPDM. Between -10°C and the lowest specified application temperature, proceed as per AD 2000-Merkblatt W10.

## Dimensions and weights

Metric units		
	DN <sub>i</sub>	15
	DN <sub>o</sub>	25
	Actual orifice diameter d <sub>0</sub> [mm]	12
	Actual orifice area A <sub>0</sub> [mm <sup>2</sup> ]	113
<b>Weight</b>		
[kg]		7
	with bellows	8.4
<b>Centre to face</b>		
[mm]	Inlet a	90
	Outlet b	90
<b>Height (H4)</b>		
[mm]	Standard H max.	307
	Bellows H max.	359
<b>Body material: 1.0619 (WCB)</b>		
<b>DIN flange<sup>1)</sup></b>	Inlet	PN 160
	Outlet	PN 40
<b>Body material: 1.4408 (CF8M)</b>		
<b>DIN flange<sup>1)</sup></b>	Inlet	PN 160
	Outlet	PN 40

<sup>1)</sup> Standard flange class. For other flange drillings, see page 02/11.

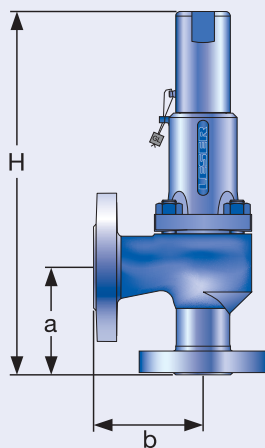

Conventional design

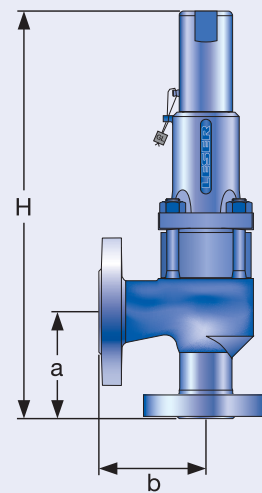

Balanced bellows design

## Flange drillings and facings

Flange drillings			
DN <sub>i</sub>	15		
DN <sub>o</sub>	25		
Valve size	1/2" x 1"		
Actual orifice diameter d <sub>o</sub> [mm]	12		
Actual orifice area A <sub>o</sub> [mm <sup>2</sup> ]	113		
<b>Body material: 1.0619 (WCB), 1.4408 (CF8M)</b>			
Inlet	DIN EN 1092	PN 16	H47
		PN 40	H47
		PN 63	*
		PN 160	*
	ASME B 16.5	CL300	H65
		CL600	H67
Outlet	DIN EN 1092	PN 16	*
		PN 40	*
	ASME B16.5 <sup>1)</sup>	CL150	H79
		CL300	H80

Flange facings		Information	Standard	Inlet	Outlet	Remark				
<b>General</b>										
		Flange, undrilled	–	H38	H39					
		Linde-V-Nut, Form V48	Linde Standard 420-08	J07	J08	Groove: Rz = 16				
		Linde-V-Nut, Form V48A	LDeS 3313.36	J05	J06	Groove: Rz = 4, e.g. for hydrogen				
		Lens-shape seal form L (without lens-shape seal)	DIN 2696 LDeS 3313.35	J11	J12					
<b>According to DIN EN 1092</b>										
Flange facings				Inlet	Outlet	Remark				
DIN EN 1092 (also see LDeS 3313.40)				PN 63 – PN 160	PN 40	Rz specification acc. to DIN EN 1092 in µm				
Raised face	Form B1			–	*	Facing: Rz = 12.5 – 50				
	Form B2			*	L38	Facing: Rz = 3.2 – 12.5				
	Tongue, Form C <sup>1)</sup>			H94	H92	only for steel flange				
	Groove, Form D <sup>1)</sup>			H93	H91					
	Male, Form E			H96	H98					
	Female, Form F			H97	H99					
	O-ring Male, Form G			J01	J02					
	O-ring Female, Form H			J03	J04					
<b>According to ASME B16.5</b>										
Body material	Inlet	Outlet	Smooth Finish <sup>2)</sup>		Serrated Finish		RTJ-Groove			
			Inlet	Outlet	Inlet	Outlet	Inlet		Outlet	
			Option code		Option code		ANSI Class	Option code	ANSI Class	Option code
1.0619, 1.4408	all	all	L52	L53	*	*	150	H62	150	H63

<sup>1)</sup> LESER manufactures the groove at flanged valves by milling. If a customer demands a turned surface in the soil of the groove according to DIN EN 1092-1 an additional option code is necessary: "S01: soil of the groove drilled".

<sup>2)</sup> Smooth Finish is not defined in the effective standards.

For signs and symbols refer to page 00/07

Note: Flange drillings and facings meet always the requirements of mentioned flange standards.  
Flange thickness and outer diameter may vary from flange standard.

## Order information – spare parts

### Spare parts

		O-ring disc	Metal disc
	DN <sub>i</sub>	15	15
	DN <sub>o</sub>	25	25
	Actual orifice diameter d <sub>0</sub> [mm]	12	12
	Actual orifice area A <sub>0</sub> [mm <sup>2</sup> ]	113	113
<b>Disc (item 7): Metal seat</b>		<b>Material-No. / Art.-No.</b>	
<b>Disc</b>	1.4122	–	230.9339.9000
Detachable lifting aid	1.4404	–	230.9349.9000
<b>Disc (item 7): Soft seal</b>		<b>Material-No. / Art.-No.</b>	
<b>Disc</b>	CR “K”	230.2949.9053	–
	EPDM “D”	230.2949.9042	–
	FKM “L”	230.2949.9073	–
	FFKM “C”	230.2949.9091	–
<b>O-ring (item 7.4): Soft seal</b>		<b>Material-No. / Art.-No.</b>	
<b>O-Ring</b>	CR “K”	502.0107.2653	–
	EPDM “D”	502.0107.2642	–
	FKM “L”	502.0107.2673	–
	FFKM “C”	502.0107.2691	–
<b>Bellows (item 15): 1.4571</b>		<b>Material-No. / Art.-No.</b>	
<b>Standard bellows</b>		400.6349.0000	400.6349.0000
<b>Conversion kit, standard<sup>1)</sup></b>		Please specify application conditions	
<b>Low pressure bellows</b>		–	–
<b>Conversion kit low pressure<sup>1)</sup></b>		–	–
<b>Gasket – body / bonnet (item 60)</b>		<b>Material-No. / Art.-No.</b>	
<b>Gasket</b>	Graphite + 1.4401	500.0407.0000	500.0407.0000
	Option code L68 Gylon (PTFE compliance)	500.0405.0000	500.0405.0000
<b>Ball (item 61):</b>		<b>Material-No. / Art.-No.</b>	
<b>Ball</b>	Ball Ø [mm]	6	6
	1.4404	510.0104.0000	510.0104.0000
<b>Split ring (item 14):</b>		<b>Material-No. / Art.-No.</b>	
<b>Split ring</b>	Spindle Ø [mm]	12	12
	1.4404	251.0149.0000	251.0149.0000
<b>Pin (item 57)</b>		<b>Material-No. / Art.-No.</b>	
<b>Pin</b>	1.4310	480.0505.0000	480.0505.0000
<b>O-ring damper</b>		<b>Material-No. / Art.-No.</b>	
	Conversion kit H2	5021.1060	5021.1060
	Conversion kit H4	5021.1064	5021.1064

Item.	Components	No.
8	Guide; upper connection of balanced bellows	1
11	Bonnet spacer	1
12	Spindle	1
15	Bellows	1
55	Stud	4
60	Gasket	2
	Instruction guide WI 3037.05	1

Refer to page page 02/04



## Available options

For more information, also see  
"Accessories and Options" as of page 99/01.

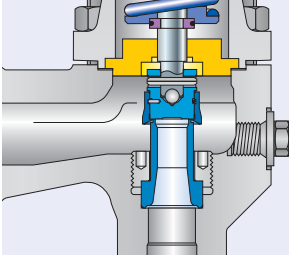
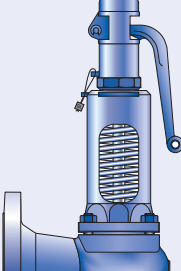
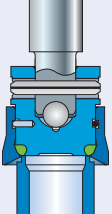
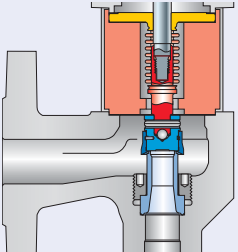
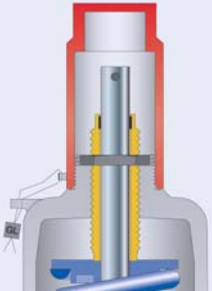
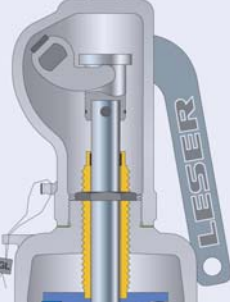
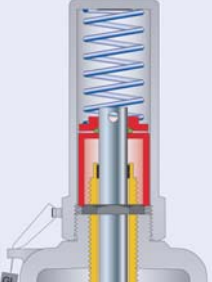
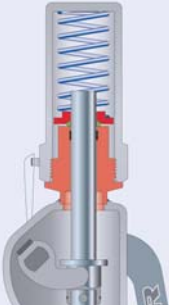
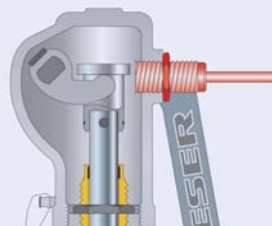
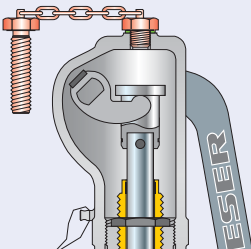
<p><b>Heating jacket</b> H29, H30: Coupling G 3/8, G 3/4 H31, H32: Flange DN15, DN25</p> 	<p><b>Drain hole</b> J18: G 1/4 J19: G 1/2</p> 	<p><b>Open bonnet</b> See Art.-No.</p> 	
<p><b>O-ring disc</b> J20: FFKM "C" J21: CR "K" J22: EPDM "D" J23: FKM "L"</p> 	<p><b>Balanced bellows</b> J68: Open bonnet J78: Closed bonnet</p> 	<p><b>Conversion kit for balanced bellows</b> Art.-No. see page 02/14</p> 	
<p><b>Screwed cap H2</b> H2</p> 	<p><b>Plain lever H3</b> H3</p> 	<p><b>Packed lever H4</b> H4</p> 	
<p><b>O-ring damper H2</b> J65</p> 	<p><b>O-ring damper H4</b> J66</p> 	<p><b>Lift indicator</b> J39: Adaptor H4 J93: Lift indicator</p> 	<p><b>Test gag</b> J69: H4 J70: H4</p> 

## Approvals

Approvals			
		O-ring disc	Metal disc
	DN <sub>i</sub>	15	15
	DN <sub>o</sub>	25	25
	Actual orifice diameter d <sub>o</sub> [mm]	12	12
	Actual orifice area A <sub>o</sub> [mm <sup>2</sup> ]	113	113
<b>Europe</b>			<b>Coefficient of discharge K<sub>dr</sub></b>
PED / DIN EN ISO 4126-1	Approval-No.	072020111Z0008/0/06	
	S/G	0.59	0.62
	L	0.47	0.48
<b>Germany</b>			<b>Coefficient of discharge α<sub>w</sub></b>
PED / AD 2000-Merkblatt A2 Standard safety valve	Approval-No.	TÜV SV 577	
	S/G	0.59	0.62
	L	0.47	0.48
<b>China</b>			<b>Coefficient of discharge α<sub>w</sub></b>
AQSIQ	Approval-No.	For current Approval-No. see <a href="http://www.leser.com">www.leser.com</a>	
	S/G	0.59	0.62
	L	0.47	0.48
<b>Eurasian Custom Union</b>			<b>Coefficient of discharge α<sub>w</sub></b>
EAC	Approval-No.	For current Approval-No. see <a href="http://www.leser.com">www.leser.com</a>	
	S/G	0.59	0.62
	L	0.47	0.48
<b>Classification societies</b>		<b>Homepage</b>	
Bureau Veritas	BV	<a href="http://www.bureauveritas.com">www.bureauveritas.com</a>	The valid Approval-No. changes with each renewal of the approval.
ClassNK NIPPON Kaiji Kyokai	NK	<a href="http://www.classnk.or.jp">www.classnk.or.jp</a>	
Det Norske Veritas	DNV	<a href="http://www.dnv.com">www.dnv.com</a>	
Germanischer Lloyd	GL	<a href="http://www.gl-group.com">www.gl-group.com</a>	For a sample certificate including the valid certification number see <a href="http://www.leser.com">www.leser.com</a>
Lloyd's Register EMEA	LREMEA	<a href="http://www.lr.org">www.lr.org</a>	
Registro Italiano Navale	RINA	<a href="http://www.rina.org">www.rina.org</a>	

## Capacities

Calculation of the capacity for steam, gases, and liquids acc. to AD 2000-Merkblatt A2 with 10% overpressure.  
Capacities at 1 bar and lower are calculated at 0.1 bar overpressure.

Metric units		AD 2000-Merkblatt A2					
		O-ring disc	Metal disc	O-ring disc	Metal disc	O-ring disc	Metal disc
DN		15	15	15	15	15	15
DN <sub>0</sub>		25	25	25	25	25	25
Actual orifice diameter d <sub>0</sub> [mm]		12	12	12	12	12	12
Actual orifice area A <sub>0</sub> [mm <sup>2</sup> ]		113	113	113	113	113	113
LEO <sub>S/G/L</sub> <sup>*)</sup> [inch <sup>2</sup> ]		0.106	0.111	0.106	0.111	0.127	0.129
Set pressure	Capacities	Capacities		Capacities		Capacities	
[bar]	Steam saturated [kg/h]	Air 0°C and 1013 mbar [m <sup>3</sup> /h]		Water 20°C [10 <sup>3</sup> kg/h]			
0.2							
0.5	52	55	64	67	2.09	2.14	
1	74	78	93	93	2.84	2.90	
2	118	125	151	151	4.01	4.10	
3	161	168	206	206	4.91	5.02	
4	200	210	246	258	5.67	5.79	
5		251	296	311	6.34	6.48	
6		293	346	363	6.95	7.09	
7		333	396	416	7.50	7.66	
8		374	446	468	8.02	8.19	
9		415	496	521	8.51	8.69	
10		456	546	573	8.97	9.16	
12		538	646	679	9.82	10.0	
14		618	746	784	10.6	10.8	
16		699	846	889	11.3	11.6	
18		781	946	994	12.0	12.3	
20		863	1046	1099	12.7	13.0	
22		942	1146	1204	13.3	13.6	
24		1024	1245	1309	13.9	14.2	
26		1106	1345	1414	14.5	14.8	
28		1189	1445	1519	15.0	15.3	
30		1271	1545	1624	15.5	15.9	
32		1354	1645	1729	16.0	16.4	
34		1433	1745	1834	16.5	16.9	
36		1517	1845	1939	17.0	17.4	
38		1600	1945	2044	17.5	17.9	
40		1684	2045	2149	17.9	18.3	
50		2109	2545	2674	20.1	20.5	
60		2537	3045	3200	22.0	22.4	
70		2981	3545	3725	23.7	24.2	
80		3430	4045	4250	25.4	25.9	
90		3901	4544	4775	26.9	27.5	
100			5044	5301	28.4	29.0	
120			6044	6351	31.1	31.7	
140			7044	7402	33.6	34.3	
160			8043	8452	35.9	36.6	

\*) LEO<sub>S/G/L</sub> = LESER Effective Orifice for steam, gases, and liquids, please refer to page 00/11  
"How to use" capacity tables, refer to page 00/09

## Determination of coefficient of discharge in case of lift restriction or back pressure

- h = Lift [mm]
- d<sub>0</sub> = Flow diameter [mm] of selected safety valve see "Article Numbers" table
- h/d<sub>0</sub> = Ratio of lift / flow diameter
- p<sub>a0</sub> = Back pressure [bar<sub>a</sub>]
- p<sub>0</sub> = Set pressure [bar<sub>a</sub>]
- p<sub>a0</sub>/p<sub>0</sub> = Ratio of back pressure / set pressure
- K<sub>dr</sub> = Coefficient of discharge acc. to DIN EN ISO 4126-1
- α<sub>w</sub> = Coefficient of discharge acc. to AD 2000-Merkblatt A2
- K<sub>b</sub> = Back pressure correction factor acc. to API 520 Section 3.3

Diagram for evaluation of ratio of lift / flow diameter (h/d<sub>0</sub>) in reference to the coefficient of discharge K<sub>dr</sub>/α<sub>w</sub>

"How to use" refer to page 00/08

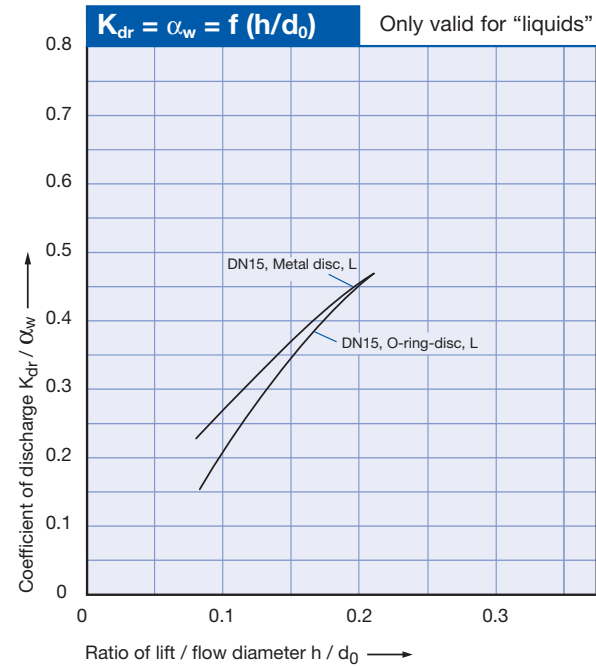
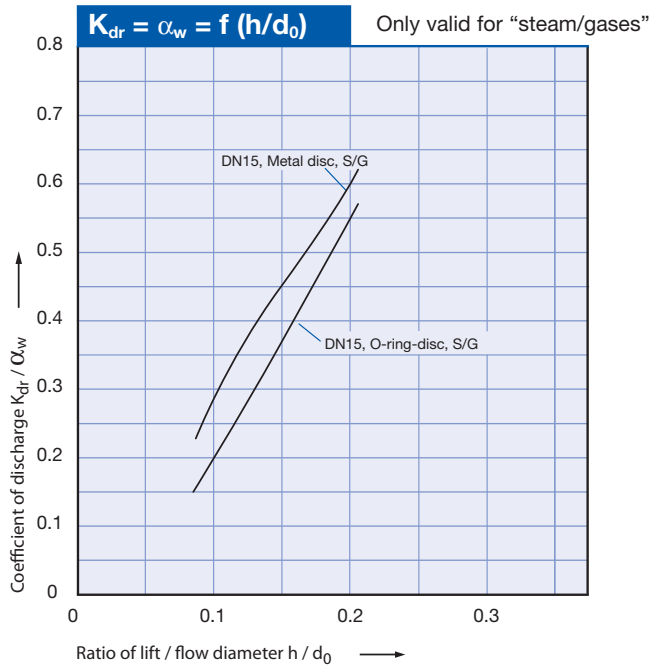
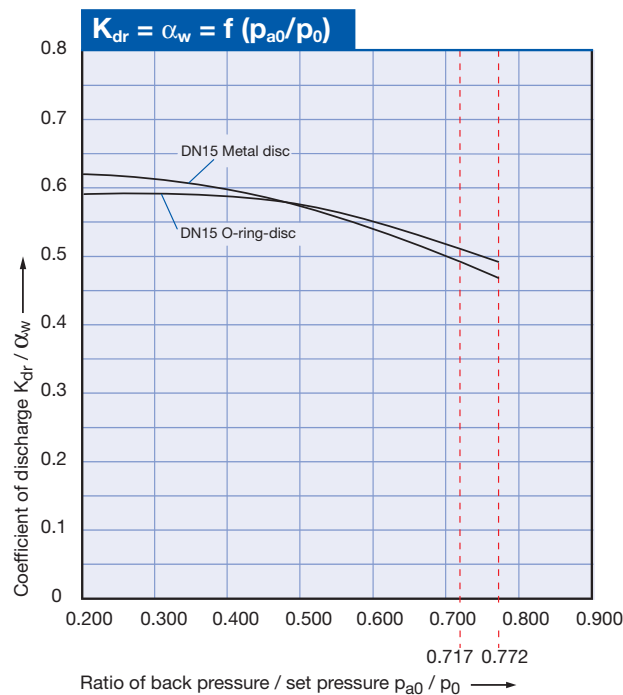

Diagram for evaluation of coefficient of discharge (K<sub>dr</sub>/α<sub>w</sub>) or K<sub>b</sub> in reference to the ratio of back pressure / set pressure (p<sub>a0</sub>/p<sub>0</sub>)



# Type 427, 429



Type 427  
Plain lever H3  
Open bonnet  
Conventional design



Type 429  
Cap H2  
Closed bonnet  
Conventional design

## Flanged Safety Relief Valves – spring loaded

### Contents

### Chapter/Page

#### Materials

- Conventional design 03/02
- Balanced bellows design 03/04

#### How to order

- Numbering system 03/06
- Article numbers 03/08

#### Pressure temperature ratings

- Metric units 03/10

#### Dimensions and weights

- Metric units 03/12

Flange drillings 03/13

Flange facings 03/14

LESER Original Spare Parts Kits 03/15

Available options 03/16

Approvals 03/17

#### Capacities

- Steam [Metric units] 03/18
- Air [Metric units] 03/19
- Water [Metric units] 03/20

# Type 427, 429

## Conventional design

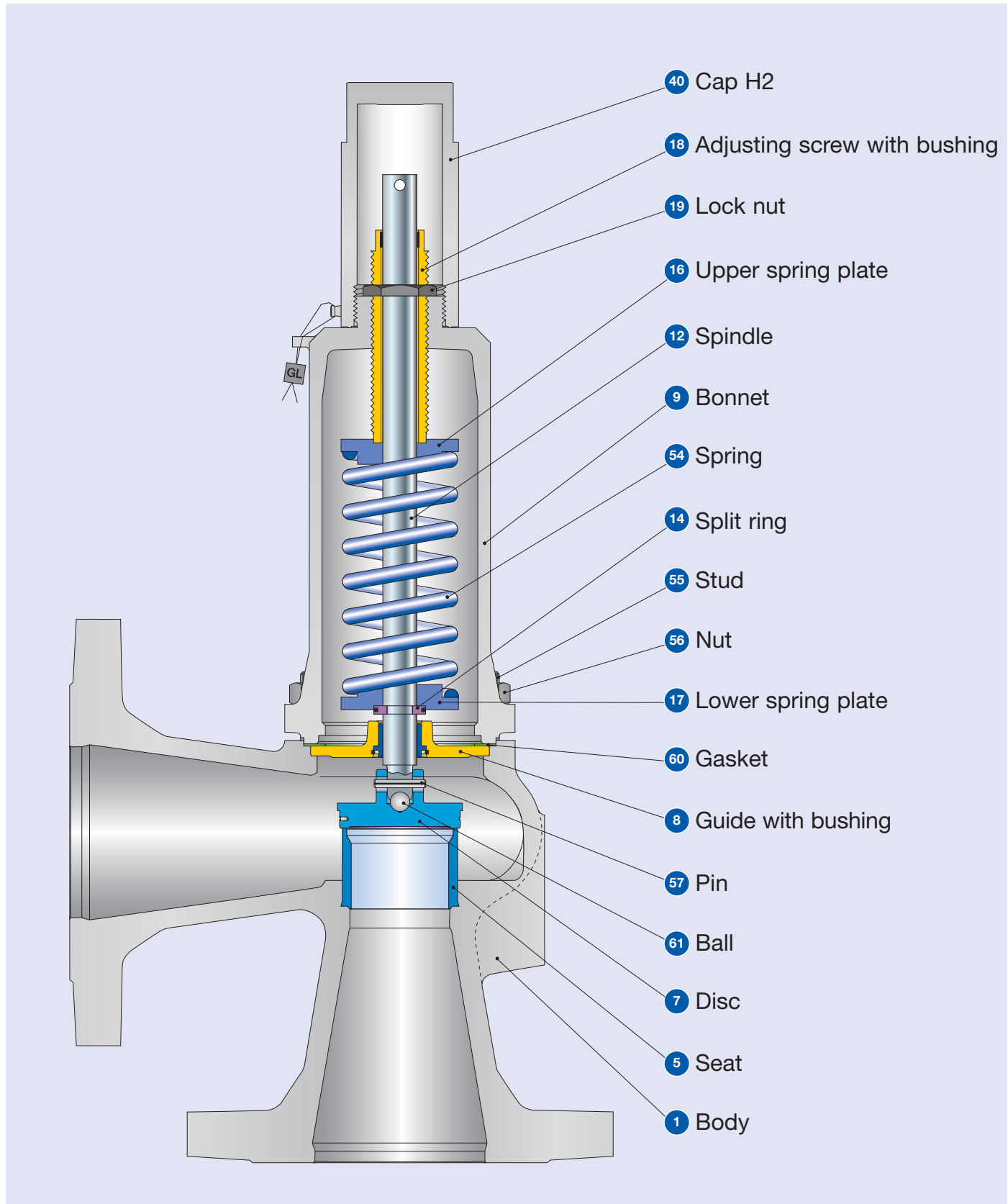

Type 429

## Conventional design

Materials				
Item	Component	Type 4275 / 4295	Type 4272 / 4292	Type 4294
<b>1</b>	<b>Body</b>	0.7043	1.0619	1.4408
		Ductile Gr. 60-40-18	SA 216 WCB	SA 351 CF8M
<b>5</b>	Seat	1.4404	1.4404	1.4404
		316L	316L	316L
<b>7</b>	Disc	1.4122	1.4122	1.4404
		Hardened stainless steel	Hardened stainless steel	316L
<b>8</b>	Guide	1.4104, 1.0501	1.4104, 1.0501, 1.0570	1.4404
		Chrome steel or steel	Chrome steel or steel	316L
	with bushing	1.4104 tenifer	1.4104 tenifer	-
		Chrome steel tenifer	Chrome steel tenifer	-
<b>9</b>	<b>Bonnet</b>	0.7040	0.7040	1.4408
		Ductile Gr. 60-40-18	Ductile Gr. 60-40-18	SA 351 CF8M
<b>12</b>	Spindle	1.4021	1.4021	1.4404
		420	420	316L
<b>14</b>	Split ring	1.4104	1.4104	1.4404
		Chrome steel	Chrome steel	316L
<b>16/17</b>	Spring plate	1.0718	1.0718	1.4404
		Steel	Steel	316L
<b>18</b>	Adjusting screw with bushing	1.4104 PTFE	1.4104 PTFE	1.4404 PTFE
		Chrome steel PTFE	Chrome steel PTFE	316L PTFE
<b>19</b>	Lock nut	1.0718	1.0718	1.4404
		Steel	Steel	316L
<b>40</b>	Cap H2	1.0460	1.0460	1.4404
		SA 105	SA 105	316L
<b>54</b>	Spring, standard	1.1200, 1.8159, 1.7102	1.1200, 1.8159, 1.7102	1.4310
		Steel	Steel	Stainless steel
	Spring, optional	1.4310	1.4310	-
		Stainless steel	Stainless steel	-
<b>55</b>	Stud	1.1181	1.1181	1.4401
		Steel	Steel	B8M
<b>56</b>	Nut	1.0501	1.0501	1.4401
		2H	2H	8M
<b>57</b>	Pin	1.4310	1.4310	1.4310
		Stainless steel	Stainless steel	Stainless steel
<b>60</b>	Gasket	Graphite / 1.4401	Graphite / 1.4401	Graphite / 1.4401
		Graphite / 316	Graphite / 316	Graphite / 316
<b>61</b>	Ball	1.3541	1.3541	1.4401
		Hardened stainless steel	Hardened stainless steel	316

### Note:

- LESER reserves the right to make changes.
- If several materials are specified LESER defines the material.
- LESER may use higher quality materials without giving prior notice
- Each component can be constructed of another material according to the customer's specification.
- All components exposed to pressure are highlighted in bold. The material will be specified according to DIN and ASTM here.

# Type 427, 429

LESER

Balanced bellows design

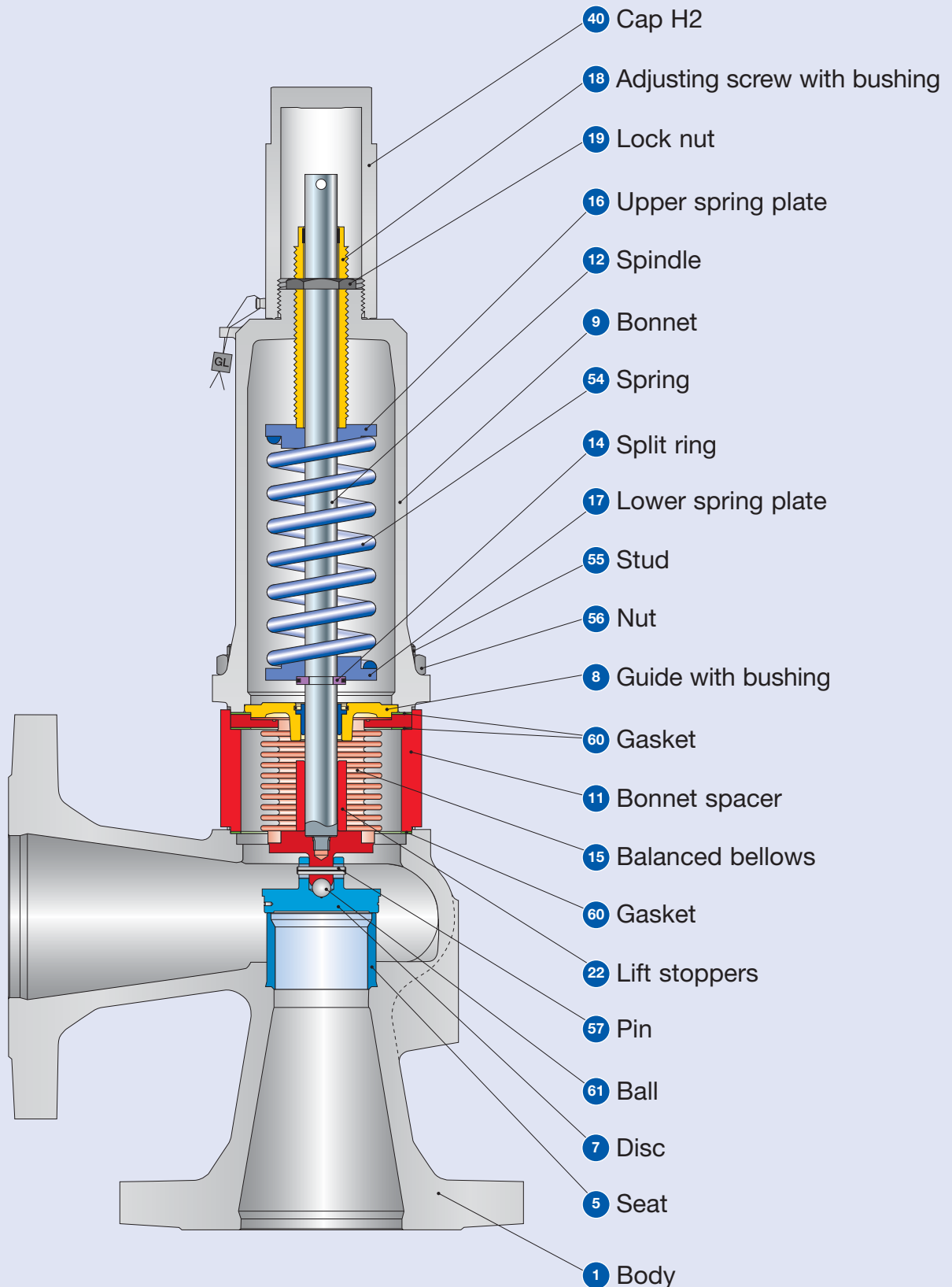

Type 429



## Balanced bellows design

Materials				
Item	Component	Type 4275 / 4295	Type 4272 / 4292	Type 4294
<b>1</b>	<b>Body</b>	0.7043	1.0619	1.4408
		Ductile Gr. 60-40-18	SA 216 WCB	SA 351 CF8M
<b>5</b>	Seat	1.4404	1.4404	1.4404
		316L	316L	316L
<b>7</b>	Disc	1.4122	1.4122	1.4404
		Hardened stainless steel	Hardened stainless steel	316L
<b>8</b>	Guide	1.4104, 1.0501	1.4104, 1.0501, 1.0570	1.4404
		Chrome steel or steel	Chrome steel or steel	316L
	with bushing	1.4104 tenifer	1.4104 tenifer	-
		Chrome steel tenifer	Chrome steel tenifer	-
<b>9</b>	Bonnet	0.7040	0.7040	1.4408
		Ductile Gr. 60-40-18	Ductile Gr. 60-40-18	SA 351 CF8M
<b>11</b>	Bonnet spacer	1.4404	1.4404	1.4404
		316L	316L	316L
<b>12</b>	Spindle	1.4404	1.4404	1.4404
		316L	316L	316L
<b>14</b>	Split ring	1.4104	1.4104	1.4404
		Chrome steel	Chrome steel	316L
<b>15</b>	Balanced bellows	1.4571	1.4571	1.4571
		316Ti	316Ti	316Ti
<b>16/17</b>	Spring plate	1.0718	1.0718	1.4404
		Steel	Steel	316L
<b>18</b>	Adjusting screw with bushing	1.4104 PTFE	1.4104 PTFE	1.4404 PTFE
		Chrome steel PTFE	Chrome steel PTFE	316L PTFE
<b>19</b>	Lock nut	1.0718	1.0718	1.4404
		Steel	Steel	316L
<b>22</b>	Lift stoppers	1.4404	1.4404	1.4404
		316L	316L	316L
<b>40</b>	Cap H2	1.0460	1.0460	1.4404
		SA 105	SA 105	316L
<b>54</b>	Spring, standard	1.1200, 1.8159, 1.7102	1.1200, 1.8159, 1.7102	1.4310
		Steel	Steel	Stainless steel
	Spring, optional	1.4310	1.4310	-
<b>55</b>	Stud	Stainless steel	Stainless steel	-
		1.4401	1.4401	1.4401
<b>56</b>	Nut	8M	B8M	B8M
		1.4401	1.4401	1.4401
<b>57</b>	Pin	8M	B8M	B8M
		1.4310	1.4310	1.4310
<b>60</b>	Gasket	Stainless steel	Stainless steel	Stainless steel
		Graphite / 1.4401	Graphite / 1.4401	Graphite / 1.4401
<b>61</b>	Ball	Graphite / 316	Graphite / 316	Graphite / 316
		1.3541	1.3541	1.4401
<b>61</b>	Ball	Hardened stainless steel	Hardened stainless steel	316
		Hardened stainless steel	Hardened stainless steel	316

**Note:**

- LESER reserves the right to make changes.
- If several materials are specified LESER defines the material.
- LESER may use higher quality materials without giving prior notice
- Each component can be constructed of another material according to the customer's specification.
- All components exposed to pressure are highlighted in bold. The material will be specified according to DIN and ASTM here.

## How to order – Example for numbering system – Type 429

# 1

**Article Number**

4292.7172

# 2

**Set Pressure**

5 bar

# 3

**Connections**

H45

1	2	3	4
429	2	717	2

**1 Valve type 427, 429**  
 Type 429 – with closed bonnet  
 Type 427 – with open bonnet

**2 Material code**

Code	Body material
2	1.0619 (WCB)
4	1.4408 (CF8M)
5	0.7043 (Ductile Gr. 60-40-18)

**3 Valve code**  
 Automatically determines nominal diameter and body material (see page 03/09).

**4**

Code	Lifting device	
2	Gas-tight cap	H2
3	Plain lever	H3
4	Packed lever	H4
5	Plain lever with open bonnet	H3

Please enter the units (in gauge!)  
  
 The specified pressure range may not be exceeded!

Please refer to page 03/13.

Type 429

## 4 Options

J22

Type 427, 429	Option code
• O-ring disc	
CR "K"	J21
EPDM "D"	J22
FKM "L"	J23
FFKM "C"	J20
• Disc 1.4404 / 316L	L44
• Disc 1.4404 / 316L stellited	J25
• Balanced bellows	
- Bonnet, open (Type 427)	J68
- Bonnet, closed (Type 429)	J78
• Elastomer bellows	J79
• High temperature alloy spring	X01
• Stainless steel spring	X04
• Adapter for lift indicator H4	J39
• Lift indicator	J93
• Test gag	
- Cap H2	J70
- Packed lever H4	J69
• O-ring damper	
- Cap H2	J65
- Packed lever H4	J66
• Heating jacket	
- Couplings G 3/8	H29
G 3/4	H30
- Flange DN 15	H31
DN 25	H32
• Drain hole G 1/4	J18
G 1/2	J19
• Oil and grease free	J85
• Materials	
- NACE MR0175	N78
- NACE MR0103	N77

Option code applies only if not standard

## 5 Documentation

H01 L30

Please select the necessary documentation:

Tests, Certifications:	Option code
DIN EN 10204-3.2: TÜV-Nord Certification for set pressure	M33
<b>LESER CGA (Certificate for Global Application)</b>	H03
- Acceptance test certificate 3.1 acc.to DIN EN 10204	
- Declaration of conformity as per pressure equipment directive PED 97/23/EC	
<b>Material quality certificate:</b>	
DIN EN 10204-3.1	
<b>Component</b>	<b>Option code</b>
Body	H01
Bonnet	L30
Cap / lever cover	L31
Disc	L23
Screws	N07
Nuts	N08

## 6 Code and Medium

2.0

1	2
2	0
<b>1 Code</b>	
2. CE / VdTUEV	
3. ASME Section VIII + CE / VdTUEV	
<b>2 Medium</b>	
.0 steam / gases / liquids (only valid for CE / VdTUEV)	

## How to order – Article numbers

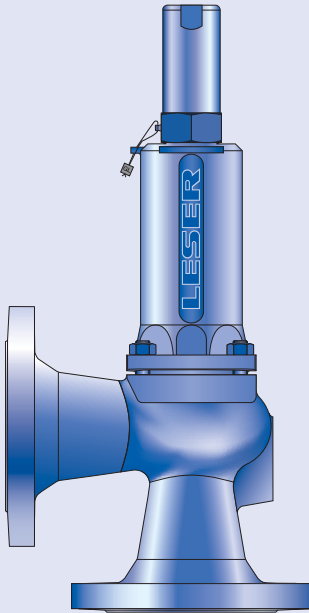

**Type 429**  
Cap H2  
Closed bonnet  
Conventional design

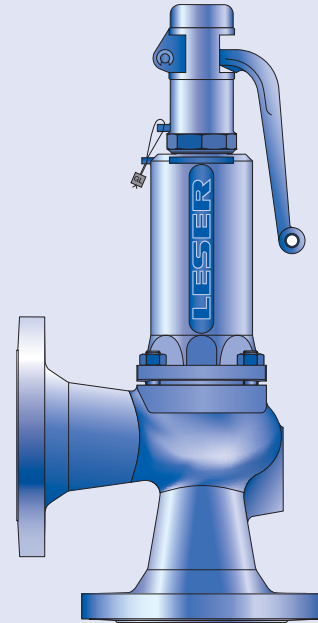

**Type 429**  
Plain lever H3  
Closed bonnet  
Conventional design

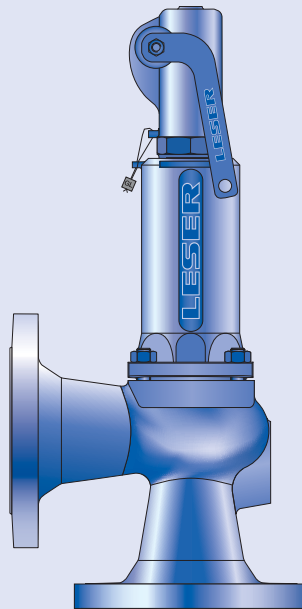

**Type 429**  
Packed lever H4  
Closed bonnet  
Conventional design

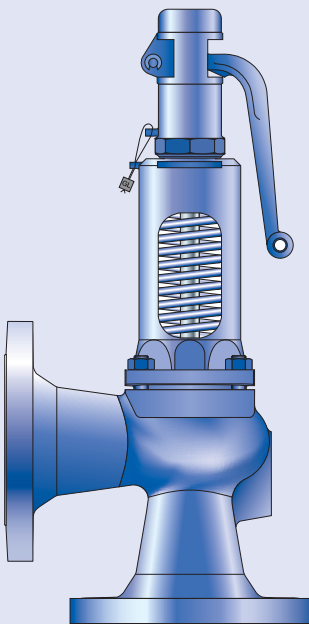

**Type 427**  
Plain lever H3  
Open bonnet  
Conventional design

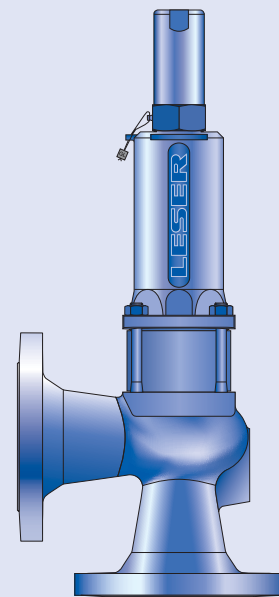

**Type 429**  
Cap H2  
Closed bonnet  
Balanced bellows design

## How to order – Article numbers

Article numbers													
	DN <sub>i</sub>		15	20	25	32	40	50	65	80	100	125	150
	DN <sub>o</sub>		15	20	25	32	40	50	65	80	100	125	150
	Actual orifice diameter d <sub>o</sub> [mm]		12	18	18	18	23	29	37	46	60	74	92
	Actual orifice area A <sub>o</sub> [mm <sup>2</sup> ]		113	254	254	254	416	661	1075	1662	2827	4301	6648
<b>Body material: 0.7043 (Ductile Gr. 60-40-18)</b>													
<b>Bonnet</b> closed	<b>H2</b>	Art.-No. 4295.	8612	8622	8632	8642	8652	8662	8672	8682	8692	-	-
	<b>H3</b>	Art.-No. 4295.	8613	8623	8633	8643	8653	8663	8673	8683	8693	-	-
	<b>H4</b>	Art.-No. 4295.	8614	8624	8634	8644	8654	8664	8674	8684	8694	-	-
open	<b>H3</b>	Art.-No. 4275.	8615	8625	8635	8645	8655	8665	8675	8685	8695	-	-
<b>Body material: 1.0619 (WCB)</b>													
<b>Bonnet</b> closed	<b>H2</b>	Art.-No. 4292.	7122	7132	7142	7152	7162	7172	7182	7192	7202	7212	7222
	<b>H3</b>	Art.-No. 4292.	7123	7133	7143	7153	7163	7173	7183	7193	4203	7213	7223
	<b>H4</b>	Art.-No. 4292.	7124	7134	7144	7154	7164	7174	7184	7194	4204	7214	7224
open	<b>H3</b>	Art.-No. 4272.	7125	7135	7145	7155	7165	7175	7185	7195	4205	7215	7225
<b>Body material: 1.4408 (CF8M)</b>													
<b>Bonnet</b> closed	<b>H2</b>	Art.-No. 4294.	7242	7252	7262	7272	7282	7292	7302	7312	7322	-	-
	<b>H4</b>	Art.-No. 4294.	7244	7254	7264	7274	7284	7294	7304	7314	7324	-	-

## Pressure temperature ratings

Metric units													
	DN <sub>i</sub>	15	20	25	32	40	50	65	80	100	125	150	
	DN <sub>o</sub>	15	20	25	32	40	50	65	80	100	125	150	
	Actual orifice diameter d <sub>o</sub> [mm]	12	18	18	18	23	29	37	46	60	74	92	
	Actual orifice area A <sub>o</sub> [mm <sup>2</sup> ]	113	254	254	254	416	661	1075	1662	2827	4301	6648	
Body material: 0.7043 (Ductile Gr. 60-40-18)													
DIN flange	Inlet	PN 16										-	-
	Outlet	PN 16										-	-
Minimum set pressure	p [bar <sub>g</sub> ] S/G/L	1.5	1.5	1.5	1.5	1.5	1.5	1.5	1.5	1.5	-	-	
Min. set pressure <sup>1)</sup> standard bellows	p [bar <sub>g</sub> ] S/G/L	3.0	3.0	3.0	3.0	3.0	3.0	3.0	3.0	3.0	-	-	
Min. set pressure low pressure bellows	p [bar <sub>g</sub> ] S/G/L	-	2.0	2.0	2.0	1.8	1.9	1.8	1.8	1.2	-	-	
Maximum set pressure	p [bar <sub>g</sub> ] S/G/L	40	40	40	40	40	40	35	35	30	-	-	
Max. set pressure with special spring	p [bar <sub>g</sub> ] S/G/L	40	40	40	40	40	40	40	35	30	-	-	
Temperature <sup>2)</sup> acc. to DIN EN	min. [°C]	-60										-	-
	max. [°C]	+350										-	-

<sup>1)</sup> Min. set pressure of standard bellows = max. set pressure of bellows for low set pressure.

<sup>2)</sup> The temperature is limited by the soft seal material (see page 99/10). The values given here are valid for EPDM. Between -10°C and the lowest specified application temperature, proceed acc. to AD 2000-Merkblatt W10.

Metric units													
	DN <sub>i</sub>	15	20	25	32	40	50	65	80	100	125	150	
	DN <sub>o</sub>	15	20	25	32	40	50	65	80	100	125	150	
	Actual orifice diameter d <sub>o</sub> [mm]	12	18	18	18	23	29	37	46	60	74	92	
	Actual orifice area A <sub>o</sub> [mm <sup>2</sup> ]	113	254	254	254	416	661	1075	1662	2827	4301	6648	
Body material: 1.0619 (WCB)													
DIN flange	Inlet	PN 40										-	-
	Outlet	PN 40										-	-
Minimum set pressure	p [bar <sub>g</sub> ] S/G/L	1.5	1.5	1.5	1.5	1.5	1.5	1.5	1.5	1.5	1.5	1.5	
Min. set pressure <sup>1)</sup> standard bellows	p [bar <sub>g</sub> ] S/G/L	3.0	3.0	3.0	3.0	3.0	3.0	3.0	3.0	3.0	3.0	3.0	
Min. set pressure low pressure bellows	p [bar <sub>g</sub> ] S/G/L	-	2.0	2.0	2.0	1.8	1.9	1.8	1.8	1.2	1.2	on request	
Maximum set pressure	p [bar <sub>g</sub> ] S/G/L	40	40	40	40	40	40	35	35	30	32	16	
Max. set pressure with special spring	p [bar <sub>g</sub> ] S/G/L	40	40	40	40	40	40	40	35	30	32	16	
Temperature <sup>2)</sup> acc. to DIN EN	min. [°C]	-85										-	-
	max. [°C]	+450										-	-

## Pressure temperature ratings

Metric units													
	DN <sub>i</sub>	15	20	25	32	40	50	65	80	100	125	150	
	DN <sub>o</sub>	15	20	25	32	40	50	65	80	100	125	150	
	Actual orifice diameter d <sub>0</sub> [mm]	12	18	18	18	23	29	37	46	60	74	92	
	Actual orifice area A <sub>0</sub> [mm <sup>2</sup> ]	113	254	254	254	416	661	1075	1662	2827	4301	6648	
Body material: 1.4408 (CF8M)													
DIN flange	Inlet											-	-
	Outlet											-	-
Minimum set pressure	p [bar <sub>g</sub> ] S/G/L	1.5	1.5	1.5	1.5	1.5	1.5	1.5	1.5	1.5	1.5	-	-
	Min. set pressure <sup>1)</sup> standard bellows	p [bar <sub>g</sub> ] S/G/L	3.0	3.0	3.0	3.0	3.0	3.0	3.0	3.0	3.0	-	-
Min. set pressure low pressure bellows	p [bar <sub>g</sub> ] S/G/L	-	2.0	2.0	2.0	1.8	1.9	1.8	1.8	1.2	-	-	
	Maximum set pressure	p [bar <sub>g</sub> ] S/G/L	40	40	40	40	40	31.6	31.0	30	22	-	-
Max. set pressure with special spring	p [bar <sub>g</sub> ] S/G/L	40	40	40	40	40	40	31	30	22	-	-	
	Temperature <sup>2)</sup> acc. to DIN EN	min. [°C]										-270	-
max. [°C]											+400	-	-

<sup>1)</sup> Min. set pressure of standard bellows = max. set pressure of bellows for low set pressure.

<sup>2)</sup> The temperature is limited by the soft seal material (see page 99/10). The values given here are valid for EPDM. Between -10°C and the lowest specified application temperature, proceed acc. to AD 2000-Merkblatt W10.

## Dimensions and weights

Metric units												
	DN <sub>i</sub>	15	20	25	32	40	50	65	80	100	125	150
	DN <sub>o</sub>	15	20	25	32	40	50	65	80	100	125	150
	Actual orifice diameter d <sub>0</sub> [mm]	12	18	18	18	23	29	37	46	60	74	92
	Actual orifice area A <sub>0</sub> [mm <sup>2</sup> ]	113	254	254	254	416	661	1075	1662	2827	4301	6648
<b>Weight</b> [kg]		5	6	6	8	9	12	15	20	33	48	65
	with bellows	6.3	6.4	6.4	8.4	9.6	13	16	21.6	35.6	52.1	78.4
<b>Centre to face</b> [mm]	Inlet a	90	95	100	105	115	125	145	155	175	200	225
	Outlet b	90	95	100	105	115	125	145	155	175	200	225
<b>Height (H4)</b> [mm]	Standard H max.	310	307	311	320	320	360	476	525	609	743	865
	Bellows H max.	359	337	341	355	355	425	536	595	684	823	960
<b>Support brackets</b> [mm]	A											277
	B											160
(Drilled only on request, option code H42)	C											Ø 18
	D											278
	E											21

### Body material: 0.7043 (Ductile Gr. 60-40-18)

<b>DIN flange<sup>1)</sup></b>	Inlet	PN 40	-	-
	Outlet	PN 40	-	-

### Body material: 1.0619 (WCB)

<b>DIN flange<sup>1)</sup></b>	Inlet	PN 40	-	-
	Outlet	PN 40	-	-

### Body material: 1.4408 (CF8M)

<b>DIN flange<sup>1)</sup></b>	Inlet	PN 40	-	-
	Outlet	PN 40	-	-

<sup>1)</sup> Standard flange class For other flange drillings, see page 03/13.

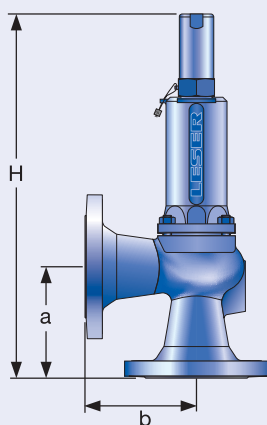

Conventional design

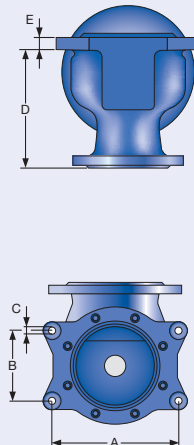

Support brackets

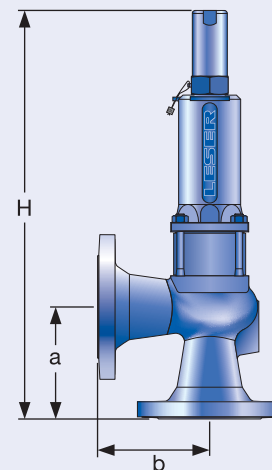

Balanced bellows design



## Flange drillings

Flange drillings														
	DN <sub>i</sub>	15	20	25	32	40	50	65	80	100	125	150		
	DN <sub>o</sub>	15	20	25	32	40	50	65	80	100	125	150		
	Valve size	1/2" x 1/2"	3/4" x 3/4"	1" x 1"	1 1/4" x 1 1/4"	1 1/2" x 1 1/2"	2" x 2"	2 1/2" x 2 1/2"	3" x 3"	4" x 4"	5" x 5"	6" x 6"		
	Actual orifice diameter d <sub>0</sub> [mm]	12	18	18	18	23	29	37	46	60	74	92		
	Actual orifice area A <sub>0</sub> [mm <sup>2</sup> ]	113	254	254	254	416	661	1075	1662	2827	4301	6648		
Body material: 0.7043 (Ductile Gr. 60-40-18), 1.0619 (WCB), 1.4408 (CF8M)														
Inlet	DIN EN 1092	PN 10	*	*	*	*	*	*	H44	H44	H44	H44	H44	
		PN 16	*	*	*	*	*	*	H45	H45	H45	H45	H45	
		PN 25	*	*	*	*	*	*	*	*	*	*	*	
		PN 40	*	*	*	*	*	*	*	*	*	*	*	
	ASME B16.5 <sup>1)</sup>	CL150	H64	H64	H64	H64	H64	H64	H64	H64	H64	[H64]	H64	H64
		CL300	[H65]	–	H65	H65	–	[H65]	[H65]	–	–	–	–	–
Outlet	DIN EN 1092	PN 10	*	*	*	*	*	*	H50	H50	H50	H50	H50	
		PN 16	*	*	*	*	*	*	H51	H51	H51	H51	H51	
		PN 25	*	*	*	*	*	*	*	*	*	*	*	
		PN 40	*	*	*	*	*	*	*	*	*	*	*	
	ASME B16.5 <sup>1)</sup>	CL150	H79	H79	H79	H79	H79	H79	H79	H79	H79	[H79]	H79	H79
		CL300	H80	–	H80	H80	–	[H80]	[H80]	–	–	–	–	–

## Flange facings

Flange facings										
Information	Standard	Inlet	Outlet	Remark						
<b>General</b>										
Flange, undrilled	–	H38	H39							
Linde-V-Nut, Form V48	Linde Standard 420-08	J07	J08	Groove: Rz = 16						
Linde-V-Nut, Form V48A	LDeS 3313.36	J05	J06	Groove: Rz = 4, e.g. for hydrogen						
Lens-shape seal form L (without lens-shape seal)	DIN 2696 LDeS 3313.35	J11	J12							
<b>According to DIN EN 1092</b>										
<b>Flange facings</b>		<b>Inlet</b>	<b>Outlet</b>	<b>Remark</b>						
<b>DIN EN 1092</b> (also see LDeS 3313.40)		PN 10 – PN 40	PN 10 – PN 40	Rz specification acc. to DIN EN 1092 in µm						
Raised face	Form B1	*	*	Facing: Rz = 12.5 – 50						
	Form B2	L36	L38	Facing: Rz = 3.2 – 12.5						
Tongue, Form C <sup>1)</sup>		H94	H92	only for steel flange						
Groove, Form D <sup>1)</sup>		H93	H91							
Male, Form E		H96	H98							
Female, Form F		H97	H99							
O-ring Male, Form G		J01	J02							
O-ring Female, Form H		J03	J04							
<b>According to ASME B16.5</b>										
Body material	Inlet	Outlet	Smooth Finish <sup>2)</sup>		Serrated Finish		RTJ-Groove			
			Inlet	Outlet	Inlet	Outlet	Inlet		Outlet	
			Option code		Option code		ANSI Class	Option code	ANSI Class	Option code
0.7043, 1.0619, 1.4408	all	all	L52	L53	*	*	–	–	–	–

<sup>1)</sup> LESER manufactures the groove at flanged valves by milling. If a customer demands a turned surface in the soil of the groove according to DIN EN 1092-1 an additional option code is necessary: "S01: soil of the groove drilled".

<sup>2)</sup> Smooth finish is not defined in the effective standards.

For an explanation of signs and symbols, refer to page 00/07.

Note: Flange drillings and facings always meet the requirements of mentioned flange standards.  
Flange thickness and outer diameter may deviate from flange standard.

## LESER Original Spare Parts Kits



The LESER Spare Parts Kits contain all the spare parts recommended for the regular maintenance of a LESER safety valve.

Contents			
Item	Component	Material	Quantity
7.5	Securing ring (Disc)	1.4571 / 316Ti	1
8.4	Securing ring (Guide)	1.4571 / 316Ti	1
14	Split ring	1.4404 / 316L	2
40.3	Spacer	1.4571 / 316Ti	3
57	Pin	1.4310 / Stainless steel	1
59	Securing ring (Split ring)	1.4571 / 316Ti	1
60	Gasket	Graphite / 1.4401 Graphite / 316	3
61	Ball	1.4401 / 316	1
1.9	O-ring (Lifting device H4)	FKM	1

Article numbers											
DN	15 – 20	25	32	40	50	65	80	100	125	150	
Art.-No. 5012.	1201	1201	1201	1201	1212	1213	1204	1214	1215	1216	

## Available options

For more information, also see  
"Accessories and options" as of page 99/01.

### Heating jacket

H29, H30: Coupling G 3/8, G 3/4  
H31, H32: Flange DN15, DN25

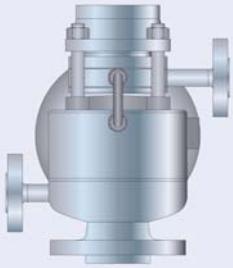

### Drain hole

J18: G 1/4  
J19: G 1/2

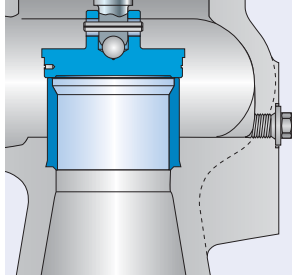

### Open bonnet

See Art.-No.

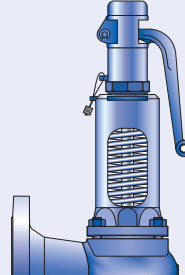

### O-ring disc

J20: FFKM "C"  
J21: CR "K"  
J22: EPDM "D"  
J23: FKM "L"

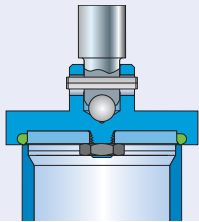

### Balanced bellows

J68: Open bonnet  
J78: Closed bonnet

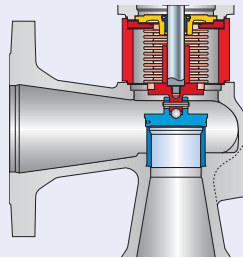

### Conversion set for balanced bellows

Art.-No. see page 02/14

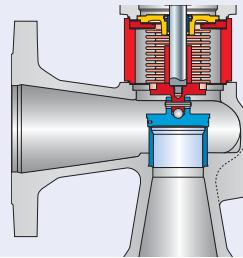

### Screwed cap H2

H2

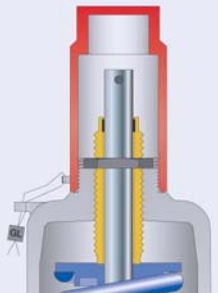

### Plain lever H3

H3

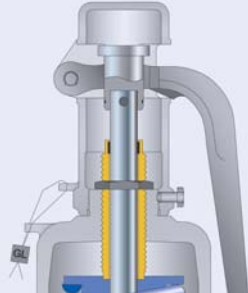

### Packed lever H4

H4

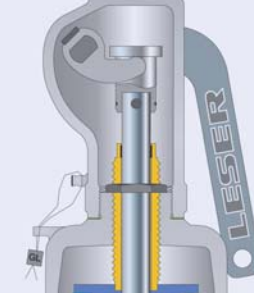

### O-ring damper H2

J65

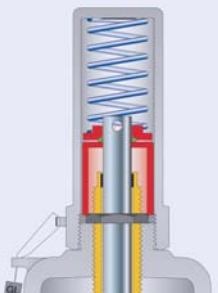

### O-ring damper H4

J66

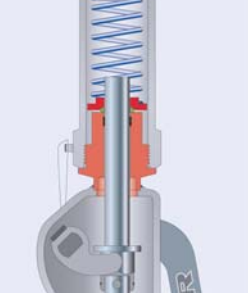

### Lift indicator

J39: Adaptor H4  
J93: Lift indicator

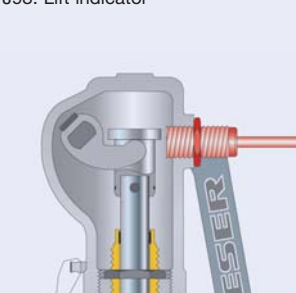

### Test gag

J69: H4  
J70: H4

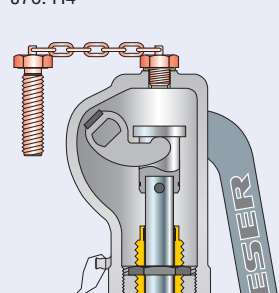

## Approvals

Approvals		
	DN <sub>E</sub>	15 – 150
	DN <sub>A</sub>	15 – 150
	Actual orifice diameter d <sub>0</sub> [mm]	12 – 92
	Actual orifice area A <sub>0</sub> [mm <sup>2</sup> ]	113 – 6648
Europa		Coefficient of discharge K <sub>dr</sub>
PED / DIN EN ISO 4126-1	Approval-No.	072020111Z0008/0/04
	S/G	0.13
	L	The valve is component tested for liquids with thermal expansion.
Germany		Coefficient of discharge α <sub>w</sub>
PED / AD 2000-Merkblatt A2 Proportional safety valve	Approval-No.	TÜV SV 610
	S/G	0.13
	L	The valve is component tested for liquids with thermal expansion.
China		Coefficient of discharge α <sub>w</sub>
AQSIQ	Approval-No.	For current Approval-No. see <a href="http://www.leser.com">www.leser.com</a>
	S/G	0.13
	L	The valve is component tested for liquids with thermal expansion.
Eurasian Custom Union		Coefficient of discharge α <sub>w</sub>
EAC	Approval-No.	For current Approval-No. see <a href="http://www.leser.com">www.leser.com</a>
	S/G	0.13
	L	The valve is component tested for liquids with thermal expansion.
Classification societies		
		on request

**Information:**

According to AD 2000-Merkblatt A2 Chap. 10.3, the discharge coefficient "... for normal or proportional safety valves, should not exceed the value  $\alpha_w = 0.08$  for S/G or the value  $\alpha_w = 0.05$  for L." Since the actual  $\alpha_w$  value for liquids is below the requirements of the AD 2000-Merkblatt for the Series 429, it is not possible to accord a discharge coefficient  $\alpha_w$ .

## Capacities – Steam

Calculation of the capacity for saturated steam acc. to AD 2000-Merkblatt A2 with 10% overpressure.  
Capacities at 1 bar and lower are calculated at 0.1 bar overpressure.

Metric units		AD 2000-Merkblatt A2 [kg/h]										
DN <sub>i</sub>		15	20	25	32	40	50	65	80	100	125	150
DN <sub>o</sub>		15	20	25	32	40	50	65	80	100	125	150
Actual orifice diameter d <sub>o</sub> [mm]		12	18	18	18	23	29	37	46	60	74	92
Actual orifice area A <sub>o</sub> [mm <sup>2</sup> ]		113	254	254	254	416	661	1075	1662	2827	4301	6648
LEO <sub>S/G</sub> <sup>*)</sup> [inch <sup>2</sup> ]		0.023	0.053	0.053	0.053	0.086	0.137	0.222	0.343	0.584	0.889	1.374
Set pressure [bar]	Capacity [kg/h]											
1.5		22	50	50	50	81	130	211	326	555	843	1304
2		27	60	60	60	98	155	253	391	665	1012	1564
3		35	79	79	79	130	206	336	519	883	1343	2076
4		44	99	99	99	162	257	419	647	1101	1675	2589
5		53	119	119	119	194	308	501	775	1318	2005	3099
6		61	138	138	138	225	358	584	902	1534	2334	3608
7		70	157	157	157	256	408	664	1026	1746	2655	4104
8		78	176	176	176	288	458	746	1152	1960	2982	4609
9		87	196	196	196	320	508	827	1278	2175	3308	5114
10		96	215	215	215	351	558	909	1404	2389	3635	5618
12		113	254	254	254	414	658	1072	1656	2818	4286	6625
14		130	291	291	291	476	756	1231	1903	3238	4925	7612
16		147	330	330	330	539	856	1394	2154	3665	5575	8617
18		164	368	368	368	601	956	1557	2406	4093	6226	
20		181	407	407	407	665	1056	1720	2658	4522	6879	
22		198	444	444	444	726	1154	1878	2903	4938	7511	
24		215	483	483	483	789	1254	2041	3155	5368	8165	
26		232	522	522	522	852	1355	2205	3408	5798	8820	
28		249	561	561	561	915	1455	2369	3662	6230	9477	
30		267	600	600	600	979	1557	2534	3917	6663	10136	
32		284	639	639	639	1043	1658	2699	4172		10797	
34												
36												
38												
40												

<sup>\*)</sup> LEO S/G = LESER Effective Orifice steam/gases please refer to page 00/11  
"How to use" capacity tables, refer to page 00/09

## Capacities – Air

Calculation of the capacity for air acc. to AD 2000-Merkblatt A2 with 10% overpressure at 0 °C and 1013 mbar.  
Capacities at 1 bar and below are calculated with 0.1 bar overpressure.

Metric units		AD 2000-Merkblatt A2 [m <sub>n</sub> <sup>3</sup> /h]										
DN <sub>i</sub>		15	20	25	32	40	50	65	80	100	125	150
DN <sub>o</sub>		15	20	25	32	40	50	65	80	100	125	150
Actual orifice diameter d <sub>0</sub> [mm]		12	18	18	18	23	29	37	46	60	74	92
Actual orifice area A <sub>0</sub> [mm <sup>2</sup> ]		113	254	254	254	416	661	1075	1662	2827	4301	6648
LEO <sub>S/G</sub> <sup>*)</sup> [inch <sup>2</sup> ]		0.023	0.053	0.053	0.053	0.086	0.137	0.222	0.343	0.584	0.889	1.374
Set pressure [bar]	Capacity [m <sub>n</sub> <sup>3</sup> /h]											
1.5		27	60	60	60	98	156	253	391	666	1013	1565
2		32	72	72	72	118	188	306	472	803	1222	1889
3		43	97	97	97	159	252	410	634	1079	1641	2536
4		54	122	122	122	199	316	515	796	1354	2060	3184
5		65	147	147	147	239	381	620	958	1629	2479	3831
6		76	171	171	171	280	445	724	1120	1905	2897	4478
7		87	196	196	196	320	509	829	1281	2180	3316	5126
8		98	221	221	221	361	574	934	1443	2455	3735	5773
9		109	246	246	246	401	638	1038	1605	2731	4154	6420
10		120	271	271	271	442	702	1143	1767	3006	4573	7068
12		142	320	320	320	523	831	1353	2091	3557	5410	8362
14		164	370	370	370	604	960	1562	2414	4107	6248	9657
16		186	419	419	419	684	1088	1771	2738	4658	7086	10952
18		208	469	469	469	765	1217	1981	3062	5209	7923	
20		230	518	518	518	846	1345	2190	3385	5759	8761	
22		252	568	568	568	927	1474	2400	3709	6310	9598	
24		274	617	617	617	1008	1603	2609	4033	6861	10436	
26		296	667	667	667	1089	1731	2818	4356	7411	11274	
28		318	717	717	717	1170	1860	3028	4680	7962	12111	
30		341	766	766	766	1251	1989	3237	5004	8513	12949	
32		363	816	816	816	1332	2117	3447	5327		13786	
34		385	865	865	865	1413	2246	3656	5651			
36		407	915	915	915	1494	2375	3865				
38		429	964	964	964	1575	2503	4075				
40		451	1014	1014	1014	1655	2632	4284				

\*) LEO S/G = LESER Effective Orifice steam/gases please refer to page 00/11  
"How to use" capacity tables, refer to page 00/09

## Capacities – water

Acc. to AD 2000-Merkblatt A2, the LESER safety valve type 427, 429 can be used for thermal expansion in spite of having no component testing for liquids. To calculate the water capacity table, a coefficient of discharge of  $\alpha_w = 0.05$  was used.

Calculation of the capacity for water as per AD 2000-Merkblatt A2 with 10% overpressure at 20 °C.  
Capacities at 1 bar and below are calculated with 0.1 bar overpressure.

Metric units		AD 2000-Merkblatt A2 [10 <sup>3</sup> kg/h]										
DN		15	20	25	32	40	50	65	80	100	125	150
DN <sub>o</sub>		15	20	25	32	40	50	65	80	100	125	150
Actual orifice diameter d <sub>o</sub> [mm]		12	18	18	18	23	29	37	46	60	74	92
Actual orifice area A <sub>o</sub> [mm <sup>2</sup> ]		113	254	254	254	416	661	1075	1662	2827	4301	6648
LEO <sub>L</sub> <sup>*)</sup> [inch <sup>2</sup> ]		0.009	0.020	0.020	0.020	0.033	0.053	0.085	0.132	0.225	0.342	0.528
Set pressure [bar]	Capacity [10 <sup>3</sup> kg/h]											
1.5	0.30	0.67	0.67	0.67	1.09	1.73	2.81	4.34	7.39	11.2	17.4	
2	0.34	0.77	0.77	0.77	1.25	1.99	3.24	5.02	8.53	13.0	20.1	
3	0.42	0.94	0.94	0.94	1.54	2.44	3.97	6.14	10.4	15.9	24.6	
4	0.48	1.09	1.09	1.09	1.77	2.82	4.59	7.09	12.1	18.4	28.4	
5	0.54	1.21	1.21	1.21	1.98	3.15	5.13	7.93	13.5	20.5	31.7	
6	0.59	1.33	1.33	1.33	2.17	3.45	5.62	8.69	14.8	22.5	34.7	
7	0.64	1.44	1.44	1.44	2.35	3.73	6.07	9.38	16.0	24.3	37.5	
8	0.68	1.54	1.54	1.54	2.51	3.99	6.49	10.0	17.1	26.0	40.1	
9	0.72	1.63	1.63	1.63	2.66	4.23	6.88	10.6	18.1	27.5	42.6	
10	0.76	1.72	1.72	1.72	2.80	4.46	7.26	11.2	19.1	29.0	44.9	
12	0.84	1.88	1.88	1.88	3.07	4.88	7.95	12.3	20.9	31.8	49.1	
14	0.90	2.03	2.03	2.03	3.32	5.27	8.58	13.3	22.6	34.3	53.1	
16	0.97	2.17	2.17	2.17	3.55	5.64	9.18	14.2	24.1	36.7	56.7	
18	1.02	2.30	2.30	2.30	3.76	5.98	9.73	15.0	25.6	38.9		
20	1.08	2.43	2.43	2.43	3.96	6.30	10.3	15.9	27.0	41.0		
22	1.13	2.55	2.55	2.55	4.16	6.61	10.8	16.6	28.3	43.0		
24	1.18	2.66	2.66	2.66	4.34	6.90	11.2	17.4	29.6	45.0		
26	1.23	2.77	2.77	2.77	4.52	7.19	11.7	18.1	30.8	46.8		
28	1.28	2.87	2.87	2.87	4.69	7.46	12.1	18.8	31.9	48.6		
30	1.32	2.97	2.97	2.97	4.86	7.72	12.6	19.4	33.0	50.3		
32	1.37	3.07	3.07	3.07	5.02	7.97	13.0	20.1		51.9		
34	1.41	3.17	3.17	3.17	5.17	8.22	13.4	20.7				
36	1.45	3.26	3.26	3.26	5.32	8.46	13.8					
38	1.49	3.35	3.35	3.35	5.47	8.69	14.1					
40	1.53	3.43	3.43	3.43	5.61	8.91	14.5					

<sup>\*)</sup> LEO<sub>L</sub> = LESER Effective Orifice liquids please refer to page 00/11

"How to use" capacity tables, refer to page 00/09



# Accessories and Options

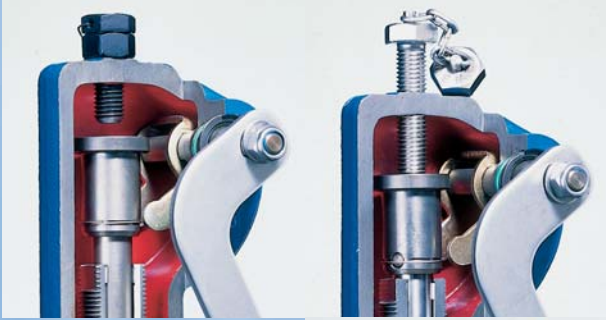
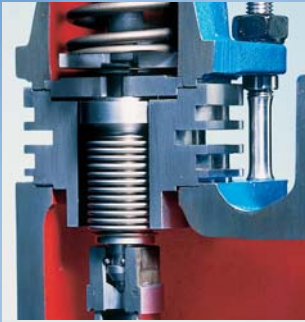

## Contents

## Chapter/Page

Overview	99/02
Caps and levers	99/04
Metal seat	99/06
Disc with soft seal	99/08
Soft seal disc	99/10
Balanced bellows	99/12
Heating jacket	99/14
O-ring damper	99/16
Elastomer bellows	99/18
Lift indicator	99/19
Lift stoppers	99/20

## Overview

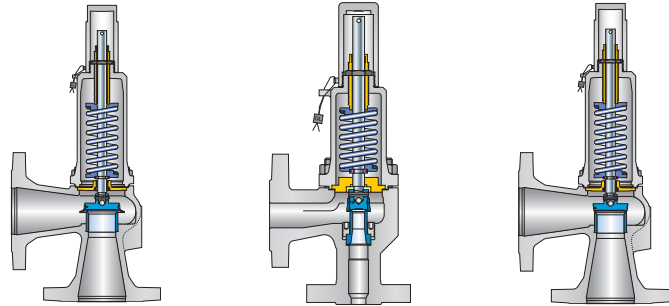

Options		Type	Option code	431, 433	431, 433 PN 160	427, 429
<b>Disc (item 7):</b>						
		Bull race disc	<b>J24</b>	✓	✓	✓
<b>Seal type (item 5 and 7)</b>						
<b>Metal seat</b>		Disc 1.4404	<b>L44</b>	✓	✓	✓
		Disc 1.4404 stellite	<b>J25</b>	✓	✓	✓
<b>Soft seal</b>	O-Ring	CR "K"	<b>J21</b>	✓	✓	✓
		NBR "N"	<b>J30</b>	✓	✓	✓
		EPDM "D"	<b>J22</b>	✓	✓	✓
		FKM "L"	<b>J23</b>	✓	✓	✓
		FFKM "C"	<b>J20</b>	✓	✓	✓
		Sealing plate	SP "T"	<b>J49</b>	✓	on request
PCTFE "G"	<b>J48</b>		✓	on request	–	
PTFE "A"	<b>J44</b>		✓	on request	–	
<b>Bellows (item 15, item 70)</b>						
<b>Open bonnet</b>		Standard bellows	<b>J68</b>	✓	✓	✓
		Low pressure bellows	<b>J68J63</b>	✓	–	✓
<b>Bonnet closed</b>		Standard bellows	<b>J78</b>	✓	✓	✓
		Low pressure bellows	<b>J78J63</b>	✓	–	✓
		Other materials	<b>J25 + Material name</b>	✓	✓	✓
<b>Elastomer bellows</b>		EPDM	<b>J79</b>	✓	–	✓
		NBR	<b>J87</b>	✓	–	✓
<b>Caps and levers (item 40)</b>						
		H2		✓	✓	✓
		H3		✓	✓	✓
		H4		✓	✓	✓
<b>Spring (item 54)</b>						
		High temperature alloy 1.8159 / 1.7102	<b>X01</b>	✓	✓	✓
		Stainless steel 1.4310	<b>X04</b>	✓	✓	✓

## Overview

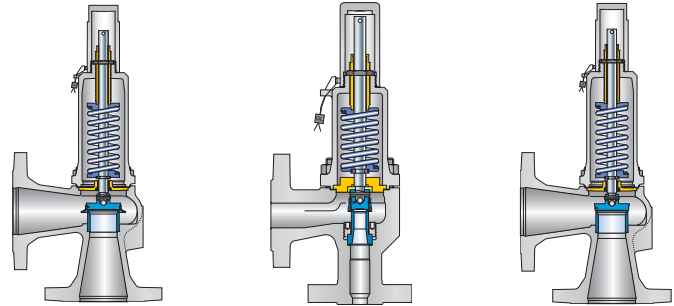

Options		Type	Option code	431, 433	431, 433 PN 160	427, 429
<b>Test gag</b>						
	H2		<b>J70</b>	✓	✓	✓
	H4		<b>J69</b>	✓	✓	✓
<b>Bonnet (item 9)</b>						
	closed			✓	✓	✓
	open			✓	✓	✓
<b>Heating jacket</b>						
				✓	✓	✓
<b>Lift indicator</b>						
	Lifting device H2, H4		<b>J39J93</b>	✓	✓	✓
<b>Lift stoppers</b>						
	Bush		<b>J51</b>	✓	✓	✓
	Gag H2		<b>J52</b>	✓	✓	✓
	Gag H4		<b>J50</b>	✓	✓	✓
<b>Drain hole</b>						
	G 1/4		<b>J18</b>	✓	✓	✓
	G 1/2		<b>J19</b>	✓	✓	✓
<b>O-ring damper (item 40)</b>						
	H2		<b>H65</b>	✓	✓	✓
	H4		<b>H66</b>	✓	✓	✓
<b>Bursting disc</b>						
	H2			✓	✓	✓

## Caps and levers – subassembly item 40

### Cap H2

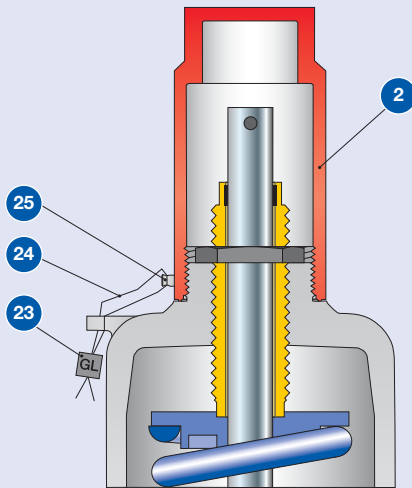

### Packed lever H4

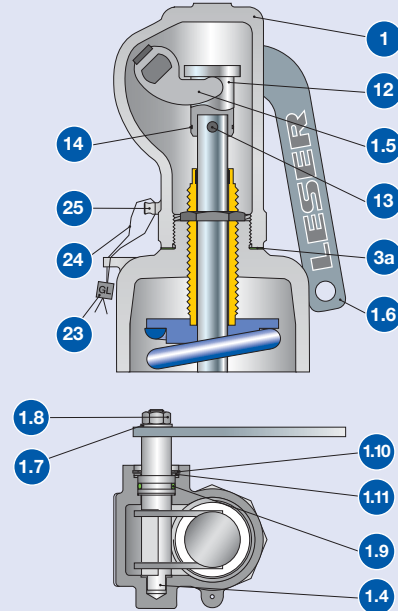

### Plain lever H3

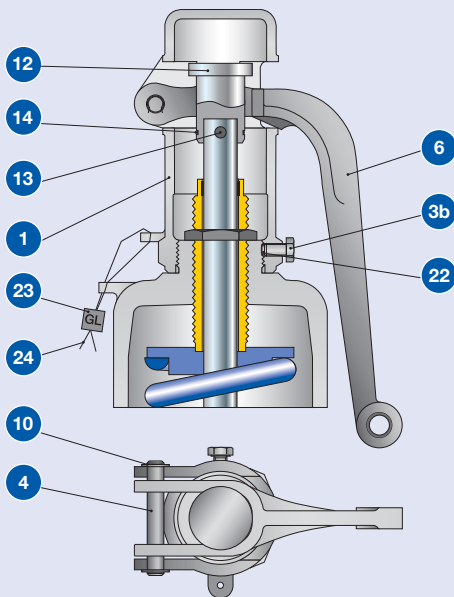

### Test gag

Cap H2: J70  
Packed lever H4: J69

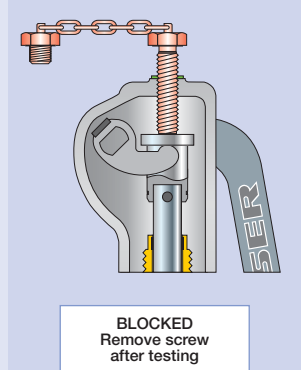
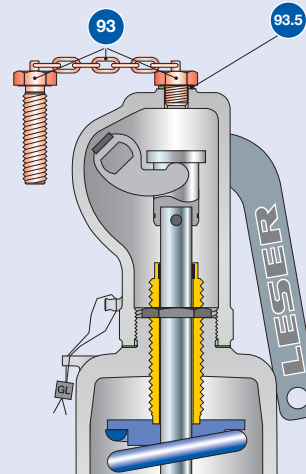

### Test gag

The test gag prevents the spindle from lifting and keeps the safety valve tight while the system pressure exceeds the set pressure.

### The test gag is used to:

- perform the pressure test in a system without disassembling the safety valve
- be able to make an adjustment to each individual valve in systems with multiple safety valves

The test gag must be removed after testing, otherwise the safety valve will not protect the system against impermissible overpressure.

## Caps and levers – subassembly item 40

Materials		Steel			Stainless steel	
Item.	Component	Cap H2	Plain lever H3	Packed lever H4	Cap H2	Packed lever H4
1	Lever cover	–	0.7040	0.7040	–	1.4408
		–	Gr. 60-40-18	Gr. 60-40-18	–	CF8M
2	Cap	1.0460	–	–	1.4404	–
		SA 105	–	–	316L	–
3a	Spacer	–	–	1.4571	–	1.4571
		–	–	316Ti	–	316Ti
3b	Hex screw	–	1.4401	–	–	–
		–	B8M	–	–	–
4 / 1.4	Shaft / bolt	–	1.4021	1.0718	–	1.4404
		–	420	Steel	–	316L
1.5	Lifting fork	–	–	1.0531	–	1.4571
		–	–	Steel	–	316Ti
6 / 1.6	Lever	–	0.7040	1.0036	–	1.4301
		–	Gr. 60-40-18	Steel	–	304
1.7	Washer	–	–	1.4401	–	1.4301
		–	–	316	–	304
1.8	Nut	–	–	A2/Poly	–	1.4401
		–	–	2H	–	8M
1.9	O-Ring	–	–	FKM	–	–
		–	–	FKM	–	–
1.9	Packing ring precast	–	–	–	–	Graphite
		–	–	–	–	Graphite
10/1.10	Retaining clip	–	Carbon steel	Carbon steel	–	–
		–	Carbon steel	Carbon steel	–	–
1.10	Nut	–	–	–	–	1.4104
		–	–	–	–	Chrome steel
1.10	Packing gland	–	–	–	–	1.4404
		–	–	–	–	316L
1.11	Support ring	–	–	Carbon steel	–	–
		–	–	Carbon steel	–	–
12	Spindle cap	–	1.0718	1.0718	–	1.4404
		–	Carbon steel	Carbon steel	–	316L
13	Pin	–	Steel	Steel	–	1.4401
		–	Steel	Steel	–	8M
14	Securing ring	–	1.4571	1.4571	–	1.4571
		–	316Ti	316Ti	–	316Ti
22	Plug	–	Plastic	–	–	–
		–	Plastic	–	–	–
23	Seal	Plastic	Plastic	Plastic	Plastic	Plastic
		Plastic	Plastic	Plastic	Plastic	Plastic
24	Seal wire	1.4541	1.4541	1.4541	1.4541	1.4541
		321	321	321	321	321
25	Sealing nose	1.4435	–	–	1.4435	1.4435
		316L	–	–	316L	316L
93	Test gag	1.4401	–	1.4401	1.4401	1.4401
		B8M	–	B8M	B8M	B8M
93.5	Washer	Fiber	–	Fiber	Fiber	Fiber
		Fiber	–	Fiber	Fiber	Fiber

**Note:**

- LESER reserves the right to make changes
- LESER may use higher quality materials without giving prior information
- Each component can be constructed of another material according to the customer's specification.

## Metal seat – seat / nozzle, item 5 and disc subassembly item 7

With LESER, the metal seat surfaces (disc and seat) are optically lapped planar to guarantee high seal tightness. LESER safety valves are delivered with a standard seal tightness acc. to API 527.

Improved tightness (Option code J86) is available on request.

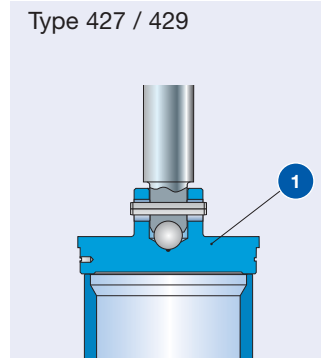
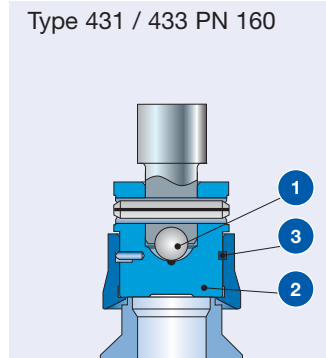
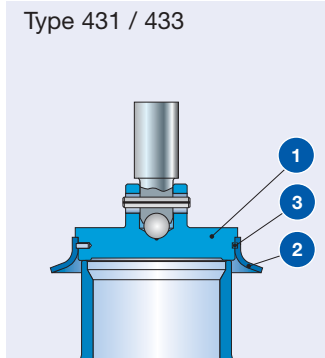

The detachable lifting aid is standard with safety valves of Type 431 / 433 and Type 431 / 433 PN 160. The benefit of the detachable lifting aid is the easy re-lapping of the disc sealing surface on one disc.

This makes it possible to have fast maintenance of the safety valve on site.

## Stellited sealing surface

The sealing surfaces of stainless steel discs and seats / nozzles can be stellited by weld cladding. Stellite is a cobalt-chrome non-ferrous alloy with increased hardness, corrosion resistance, and abrasion resistance even at high temperatures.

LESER recommends stellited sealing surfaces for Modulate Action safety valves (seat / nozzle and disc (1.4404 / 316L)) in the following applications:

- for high-pressure applications with highly stressed sealing surfaces
- for high-temperature applications in order to prevent permanent deformation of the sealing surface as a consequence of the material properties of the seat and disc
- use with abrasive media in order to increase the abrasion resistance of the sealing surface

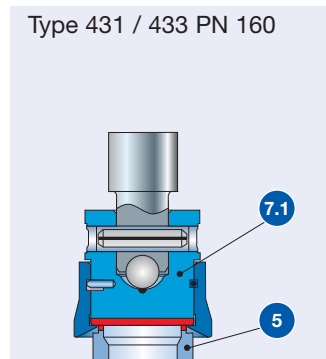
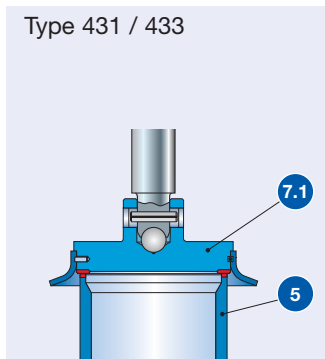

Materials for disc and seat / nozzle, see page 99/07.

Hardness		Metal seat		
Material		Hardness of the sealing surface		
EN	ASME	Value according to standard or manufacturer specification		Mean value LESER bearing material
EN 10088-3, 1.4122 hardened	Chrome steel, hardened	≥ 40 HRC	LDs 4325.01 hardening process	42 – 46 HRC
EN 10272, 1.4404	SA 479 316L	≤ 215 HBW	EN 10272 Table 7	16 – 19 HRC <sup>1)</sup>
EN 10272, 1.4404 stellited	SA 479 316L stellited	≥ 35 HRC	Manufacturer specification	40 HRC

HBW: BRINELL hardness acc. to DIN EN ISO 6506-1 / HRC: ROCKWELL hardness acc. to DIN EN ISO 6508-1

<sup>1)</sup> Rockwell hardnesses less than 20 HRC are not approved by the standard. LESER gives these values for better comparability.

## Metal seat – seat / nozzle, item 5 and disc subassembly item 7

### Standard and corrosiv service

Materials		Disc – subassembly item 7				
Item	Component	Steel			Stainless steel	
<b>Type 431 / 433</b>						
1	Disc	1.4122 hardened			1.4404	
		Hardened stainless steel			316L	
2	Lifting aid	DN 15	DN 20 - 50	≥DN 65	DN 15 - 50	≥DN 65
		1.4104	1.4404	1.4408	1.4404	1.4408
		430F	316L	CF8M	316L	CF8M
3	Circlip	1.4571			1.4571	
		316Ti			316Ti	
<b>Type 431 / 433 PN 160</b>						
1	Teller	1.4122 hardened			1.4404	
		Hardened stainless steel			316L	
2	Lifting aid	1.4104			1.4404	
		430F			316L	
3	Circlip	1.4571			1.4571	
		316Ti			316Ti	
<b>Type 427 / 429</b>						
1	Disc	1.4122 hardened			1.4404	
		Hardened stainless steel			316L	

Materials		Seat / nozzle item 5				
Item	Component	Steel			Stainless steel	
<b>All series</b>						
5	Seat / nozzle				1.4404	

### Stellited sealing surface

Materials		Seat / nozzle item 5, disc item 7				
Item	Component	Option code				
<b>Type 431 / 433, 431 / 433 PN 160</b>						
7.1	Disc	J25	1.4404 stellited			
			316L stellited			
5	Seat / nozzle	L61 / L62	1.4404 stellited			
			316L stellited			

### Bull race disc

To prevent damages to the sealing surfaces from frequent disassembly, in particular for safety valves with short or regular service intervals, the disc can be supplied in a bull race construction as a custom design.

Construction		431, 433			431, 433 PN 160			427, 429		
Construction										
Option code	J24			J24			J24			

## Disc with soft seal – subassembly item 7

### Features and Benefits

LESER soft seal solutions allow for superior tightness.

- Two different designs with o-ring or sealing plate for a wide variety application
- Large selection of soft seal materials to best adapt to the application
- Increased service life of sealing surfaces compared to a metal to metal seat

- Simple replacement of the soft seal reduces maintenance costs
- Standard ARP O-ring sizes for easy worldwide procurement
- One standard durometer per O-ring material for all set pressures to reduce stocking expenses

Design of soft seal			O-ring disc			
Type			431 / 433		433 PN 160	427 / 429
Nominal size			DN 15	DN 20 – DN 150	DN 15	DN 20 – DN 150
Pressure range			0.3 – 40 bar	0.2 – 20 bar	0.2 – 160 bar	1.5 – 40 bar
Option code						
CR	“K”	J21				
EPDM	“D”	J22				
FKM	“L”	J23				
FFKM	“C”	J20				

For temperature application limits, media resistance, and option codes, see selection table on page 99/10.  
Materials for soft sealing disc, see page 99/09

Materials		Disc – subassembly item 7					
Type		431 / 433		433 PN 160	427 / 429		
		DN 15	DN 20 – DN 150	DN 15	DN 20 – DN 150		
		0.3 – 40 bar	0.2 – 40 bar	0.2 – 160 bar	1.5 – 40 bar		
<b>Disc</b>	Item 7.1	1.4404	Item 7.1	1.4404	Item 7.1	1.4404	
		316L		316L		316L	
<b>Retainer</b>	Item 7.3	1.4404		–	Item 7.3	1.4404	
		316L		–		316L	
<b>Soft seal</b> Materials, see page 99/10	Item 7.4	O-ring	Item 7.5	O-ring	Item 7.4	O-ring	
<b>Lifting aid</b>		see Item 7.1	Item 7.2	1.4404		–	
		–		316L		–	
<b>Nut</b>	Item 7.5	1.4401		–	Item 7.5	1.4401	
		8M		–		8M	

For temperature application limits, media resistance and option codes, see selection table on page 99/10.



## Soft seal disc – subassembly item 7

Design of soft seal		Disc with sealing plate		
Type		431 / 433	433 PN 160	427 / 429
Option code		Pressure range		
SP "T"	J49	10 – 40 bar	–	–
PCTFE "G"	J48	1.0 – 30 bar	–	–
PTFE "A"	J44	1.0 – 10 bar	–	–
<b>Design</b>				On request
				Not available

Materials		Disc – subassembly item 7			
Type		431 / 433		433 PN 160	427 / 429
		DN 15 0.3 – 40 bar	DN 20 – DN 150 0.2 – 40 bar	DN 15 0.2 – 160 bar	DN 20 – DN 150 1.5 – 40 bar
<b>Disc</b>	Item 7.1	1.4404	–	–	–
		316L	–	–	–
<b>Retainer</b>	Item 7.3	1.4404	–	–	–
		316L	–	–	–
<b>Soft seal</b> Materials, see page 99/11	Item 7.4	Sealing plate	–	–	–
			–	–	–
<b>Lifting aid</b>		see Item 7.1	–	–	–
		–	–	–	–
<b>Nut</b>	Item 7.5	1.4401	–	–	–
		8M	–	–	–

For temperature application limits, media resistance and option codes, see selection table on page 99/11.

## Soft seal

Soft seal selection		O-ring				
Abbreviation ASTM 14	Trade name (Designation)	Code letter <sup>1)</sup>	Option code	T <sub>min</sub>	T <sub>max</sub>	Application <sup>2)</sup>
				[°C]	[°C]	
<b>O-ring</b>						
CR	Neoprene®	K	J21	-40	100	Paraffins, mineral oils, silicon oils and greases, water and aqueous solutions, refrigerants, ozone
NBR	Buna-N® (Nitrile-Butadiene)	N	J30	-25	100	Hydraulic oils, plant and animal fats and oils
EPDM	Buna-EP (Ethylene-Propylene-Diene)	D	J22	-45	150	Hot water and hot steam up to 150 °C, 302 °F, many organic and inorganic acids, silicon oils and greases FDA conforming compound
FKM	Viton® (Fluorocarbon)	L	J23	20	180	High temperatures (not hot steam), mineral oils and greases, silicon oils and greases, plant and animal oils and fats, ozone FDA conforming compound on request
FFKM	Kalrez® (Perfluor)	C	J20	0	250	Almost all chemicals, standard compound is Kalrez® 6375 with steam resistance FDA conforming compound on request

<sup>1)</sup> The code letters are stamped on the disc (Item 1)

<sup>2)</sup> The pressure and temperature application range must be observed in all cases. The chemical resistance is based on specifications from the soft seal manufacturer. LESER assumes no guarantee.

## Soft seal

Soft seal selection		Sealing plate				Application <sup>2)</sup>
Abbreviation ASTM 14	Trade name (Designation)	Code letter <sup>1)</sup>	Option code	T <sub>min</sub> [°C]	T <sub>max</sub> [°C]	
<b>Sealing plate</b>						
SP	VESPEL SP-1 <sup>®3)</sup> (Polyimide)	T	J49	-270	300	High-temperature and high-pressure applications (no steam), chemical resistance, see manufacturer's specifications
PCTFE	KEL-F <sup>®</sup> (Polychlorotrifluoroethylene)	G	J48	-240	204	Low-temperature and refrigeration system applications, flammable media, gaseous acid up to 50 bar, 725 psig at 60 °C, 140 °F
PTFE	Teflon <sup>®</sup> (Polytetrafluoroethylene)	A	J44	-184	150	Almost all chemicals
Other not listed materials		X	For other materials, please contact your local representative or sales@leser.com.			

<sup>1)</sup> The code letters are stamped on the disc (Item 1)

<sup>2)</sup> The pressure and temperature application range must be observed in all cases. The chemical resistance is based on specifications from the soft seal manufacturer. LESER assumes no guarantee.

<sup>3)</sup> Only for DN 25, 1" x 2".

## Balanced bellows – subassembly item 15

Balanced bellows are generally used for two applications:  
 – to compensate for back pressure  
 – to seal off the bonnet from the outlet chamber

### Compensation for back pressure

The back pressure acts on the reverse side of the disc, creating a force in the closing direction ( $F_C$ ). The balanced bellows constitutes an area equal to the seat area, creating a force acting in the opening direction ( $F_O$ ), thus compensating the force in closing direction.

A quantitative representation is shown in the table below:

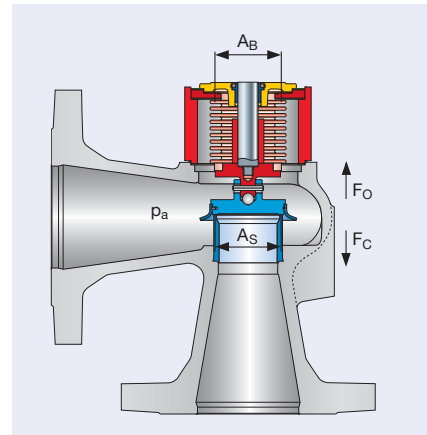

Actual area	Back pressure	Actual force	Direction of force	Compensation criteria
Seat area = $A_S$	$p_a$	$F_C = p_a \times A_S$	closing	$A_S = A_B$
Bellows area = $A_B$	$p_a$	$F_O = p_a \times A_B$	opening	$F_C = F_O$

### Sealing the bonnet from the outlet chamber

LESER's balanced bellows seal the spring chamber to the blow-off chamber. That way, they protect the guides, moving parts, and the spring against media-related affects such as dirt, corrosion, impurities, and also temperature.

#### Balanced bellows

Type	431 / 433	431 / 433 PN 160	427 / 429
Design			
Bonnet spacer	*	*	*
Bellows housing	-	*	-

The shield protects the bellows against flow turbulence when blowing off the valve. Vibrations in the bellows are reduced. This guarantees a longer service life of the bellows.

Control thread	DIN ISO 228-1, G 1/4	ASME B1.20.1 NPT 1/2"
	*	✓
	*	✓

To check the effectiveness of the bellows, an inspection connection G 1/4 is inserted into the bonnet as per DIN ISO 228-1. For safe discharge, especially of aggressive, toxic media, a discharge pipe G 1/4 can be installed if necessary.

Option code		431 / 433	431 / 433 PN 160	427 / 429
Bonnet open	Standard bellows	J68	J68	J68
	Low pressure bellows	J68, J63	-	J68, J63
	Special materials	S15 + material name	S15 + material name	S15 + material name
Bonnet closed	Standard bellows	J78	J78	J78
	Low pressure bellows	J78, J63	-	J78, J63
	Special materials	S15 + material name	S15 + material name	S15 + material name
	Control thread NPT 1/2"	J95	J95	J95

The following information can be found on the respective pages of the selected valve:

- dimensions and weights, see "Dimensions and weights" table
- set pressure, see "Pressure temperature ratings" table
- temperature ranges, see "Pressure temperature ratings" table

## Balanced bellows – subassembly item 15

Materials		Standard bellows
Item	Component	431 / 433, 431 / 433 PN 160, 427 / 429
15.1	Lower adaptor	1.4404
		316L
15.2	Upper adaptor	1.4404
		316L
15.3	Bellows	1.4571
		316Ti
11	Bonnet spacer	1.4404
		316L
55	Stud	1.4401
		B8M
60	Gasket	Graphite / 1.4401
		Graphite / 316

Bellows made of Hastelloy® or other special materials are available on request.

## Balanced bellows conversion kits

With the LESER bellows conversion set, conventional construction safety valves can be converted to a balanced bellows design quickly and easily. The conversion set contains all the components needed for the conversion as well as a conversion guide.

Conversion kits				
Item	Component	No.	Materials	Remark
8	Guide	1	1.4404	
			316L	
11	Bonnet spacer	1	1.4404	
			316L	
12	Spindle	1	1.4404	
			316L	
15	Bellows	1	1.4571	
			316Ti	
55	Stud	4, 8 dependant on valve size	1.4401	
			B8M	
60	Gasket	2, 3 dependant on valve size	Graphite / 1.4401	
			Graphite / 316	
	Installation Instructions	1		WI 3037.05

## Heating jacket

### Application and construction

To protect systems with viscous, crystallising or sticky media, LESER offers a heating jacket.

The heating jacket has a welded design and covers the angle type body such that it allows the hot media (steam, oil, and so on) to flow through the created space.

In order to protect the spindle and moving parts against sticking, a safety valve with a balanced bellows construction should be chosen for the heating jacket construction.

For safety valves with balanced bellows, the bonnet spacer needed to accommodate the bellows is equipped with an additional heating jacket. Both heating jackets are joined by a threaded pipe bend.

If there is no danger of the medium setting in the blowoff chamber of the valve, then the balanced bellows don't have to be used. The position of the heating connections is shown in figures 1 to 3.

### Specification for the heating jacket

The operating data of the heating jacket is placed on an additional heating jacket rating plate on the heating jacket.

### Slip-on flange

Heating connections with flanges are designed for better orientation than slip-on flanges.

Nominal pressure rating: PN 25 as per EN 1092-1  
Class 150 as per ANSI 16.5

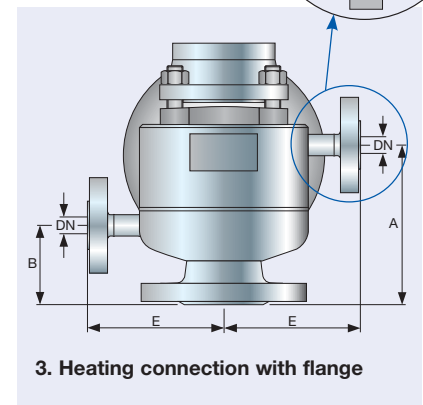
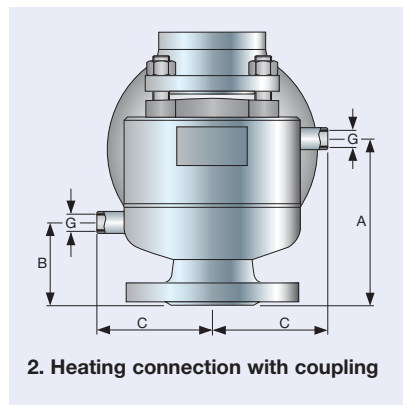
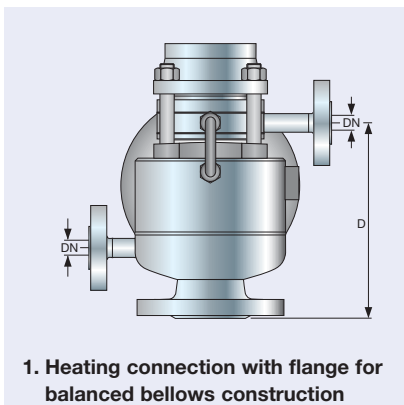

## Heating jacket

Heating jacket		DN <sub>i</sub>	15	15	20	25	32	40	50	65	80	100	125	150	
Inlet valve size			1/2" x 1/2"	1/2" x 1/2"	3/4" x 3/4"	1" x 1"	1 1/4" x 1 1/4"	1 1/2" x 1 1/2"	2" x 2"	2 1/2" x 2 1/2"	3" x 3"	4" x 4"	5" x 5"	6" x 6"	
Actual orifice diameter d <sub>0</sub> [mm]			12	12	18	18	18	23	29	37	46	60	74	92	
<b>Materials</b>															
<b>Body</b>		Series 429, 433	1.4408	1.4408	1.4408	1.4408	1.4408	1.4408	1.4408	1.0619 optional 1.4408	1.0619 optional 1.4408	1.0619 optional 1.4408	-	-	
<b>Heating jacket</b>									1.4541 321						
<b>Connections</b>															
Slip-on flange DIN	Option code	DN 15, PN 25	1.4571, 1.4404 316Ti, 316L									-	-	-	-
	H 31														
Slip-on flange ANSI	H 32	DN 25, PN 25	-									1.4571, 1.4404 316Ti, 316L	-	-	
	K 31	1/2", CL150	1.4404 316L									-	-	-	-
Coupling DIN 2986	K 32	1", CL150	-									1.4404 316L	-	-	
	H 29	G 3/8"	1.4571 316Ti									-	-	-	-
Heating jacket Bonnet spacer	H 30	G 3/4"	-									1.4571 316Ti	-	-	
	H 33		1.4404 316L											-	-

Metric units		DN <sub>E</sub>	15	15	20	25	32	40	50	65	80	100	125	150
Inlet valve size			1/2" x 1/2"	1/2" x 1/2"	3/4" x 3/4"	1" x 1"	1 1/4" x 1 1/4"	1 1/2" x 1 1/2"	2" x 2"	2 1/2" x 2 1/2"	3" x 3"	4" x 4"	5" x 5"	6" x 6"
Actual orifice diameter d <sub>0</sub> [mm]			12	12	18	18	18	23	29	37	46	60	74	92
<b>Series 433, 429</b>														
			<b>Dimensions</b>											
[mm]	A	95	95	95	95	105	120	130	150	170	165	-	-	-
	B	65	65	65	65	65	75	75	80	80	80	-	-	-
	C	83	83	83	83	95	95	95	110	120	145	-	-	-
	D	131	131	130	134	142	163	180	209	224	300	-	-	-
	E	110	110	110	110	120	121	121	136	150	176	-	-	-
	Slip-on flange DN	15	15	15	15	15	15	15	15	25	25	-	-	-
[inch]	Coupling G	3/8	3/8	3/8	3/8	3/8	3/8	3/8	3/8	3/8	3/4	3/4	-	-
<b>Series 433, 429</b>														
			<b>Operating pressure [bar]</b>											
Operating temperature	20°C	25	25	25	25	25	25	25	25	15	15	15	-	-
	300°C	18	18	18	18	18	18	18	18	11	11	11	-	-

## O-ring damper – subassembly item 40

The O-ring damper successfully prevents or reduces the vibrations of the moving parts of a safety valve.

### Background:

In each safety valve, the moving parts – the disc, spindle, bottom spring plate and spring – form a so-called spring-mass-system. As in all spring-mass-systems, the components can be stimulated to start vibrating under unfavourable conditions (e.g. loss of inlet pressure). Vibrations can also be triggered by external units and then transferred to the safety valve via the mechanical connection or the medium. In the event of resonances, the safety valve opens and closes in an uncontrolled way at a high frequency and can't discharge the accorded mass flow.

In general, there are two types of uncontrolled vibrations (definition as per ASME PTC 25-2001, Chapter 2.7):

**Chatter:** “Abnormal rapid reciprocating motion of the movable parts of a pressure relief valve in which the disc contacts the seat.” The reasons for chatter may include, among other things, too high inlet pressure loss, inadmissible back pressure, or operation in partial load ranges.

**Flutter:** “Abnormal rapid reciprocating motion of the movable parts of a pressure relief valve in which the disc does not contact the seat.” The causes of flutter with small and difficult to measure amplitudes are vibrations coming from external sources. Possible external sources are piston compressors or pumps. The vibration can be transferred to the safety valve mechanically via the connections or through the medium.

Based on extensive experience with safety valves, LESER developed the o-ring damper on its certified test benches. The o-ring damper prevents the vibration of moving parts or reduces them to a non-critical frequency and amplitude. Nevertheless, the safety valve operates within the limits of the rules and regulations and standards. Through a special design, the o-ring damper can be used for any type of vibrations.

LESER offers the o-ring damper integrated in the cap H2 and as a modified lifting device H4. For applications with friction-reducing media, e.g. oil, a balanced bellows design is provided to protect the o-ring damper against the medium.

### Available design

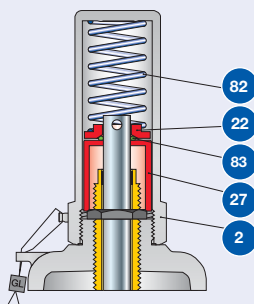
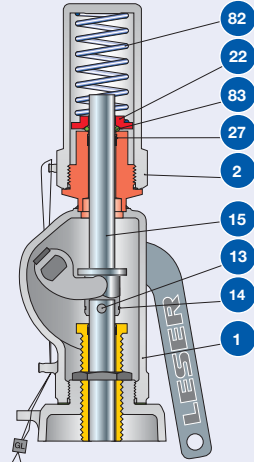
		Cap H2	Packed lever H4
<b>Design</b>			
<b>Option code</b>	Conventional design	J65	J66
	Balanced bellows design	J65, J78	J66, J78
<b>O-ring temperature range</b>		-20 °C to +180 °C	



## O-ring damper – subassembly item 40

Availability		Cap H2 and Packed lever H4	
Valve size		Pressure range	
<b>Series 433</b>			
DN 15 1/2"		0.5 – 40 bar 7.25 – 580 psig	
DN 20 – DN 50 3/4" – 2"		0.5 – 40 bar 7.25 – 580 psig	
DN 65 – DN 80 2 1/2" – 3"		0.5 – 35 bar 7.25 – 508psig	
DN 100 4"		0.5 – 30 bar 7.25 – 435 psig	
DN 15 PN 160 O-ring disc 1/2"		11.3 – 103 bar 164 – 1494 psig	
DN 15 PN 160 steel disc 1/2"		9.01 – 100 bar 131 – 1450 psig	
<b>Series 429</b>			
DN 15 – DN 50 1/2" – 2"		0.5 – 40 bar 7.25 – 580 psig	
DN 65 – DN 80 2 1/2" – 3"		0.5 – 35 bar 7.25 – 508 psig	
DN 100 4"		0.5 – 30 bar 7.25 – 435 psig	

LESER guarantees perfect operation of the o-ring damper through extensive testing on the certified test benches. If an o-ring damper is needed for a pressure level that is not given in the table, then further tests are necessary. This leads to longer delivery times. Please contact sales@leser.com.

Materials		Cap H2	Packed lever H4
Item.	Component		
1	Lever cover	–	1.4408
		–	CF8M
2	Cap H2	1.4404	1.4404
		316L	316L
13	Cylindrical pin	–	1.4401
		–	B8M
14	Securing ring	–	1.4571
		–	316Ti
15	Spindle	–	1.4404
		–	316L
22	Clamping ring	1.4404	1.4404
		316L	316L
27	Bush	1.4404	–
		316L	–
27	Nozzle	–	PFTE 15% Glass
		–	PFTE 15% Glass
82	Spring	1.4310	1.4310
		Stainless steel	Stainless steel
83	O-Ring	FKM	FKM
		FKM	FKM

### O-ring damper

### Conversion kit

see respective main parts list

## Elastomer bellows

### Application

Bellows seal the spring chamber to the blow-off chamber. That way, they protect the guides, moving parts, and the spring against media-related affects such as dirt, corrosion, and impurities. The elastomer bellows provides a cost-effective alternative to the balanced bellows.

The range of applications for the elastomer bellows is limited by:

- Chemical resistance
- Medium temperature
- Set pressure
- Back pressure

Elastomer bellows	
Design	
Construction	Easy, compact, and single-ply construction facilitates installation in small blow-off chambers. The one-piece design also facilitates easy replacement and extends the service life.
Flexibility	The special shape of the elastomer bellows provides good spindle mobility and prevents wear and tear.
Inspection hole	To check the effectiveness of the bellows, an inspection hole (Ø 10 mm) is put into the bonnet. This makes it possible to check the seal tightness of the bellows. In the event of a fault in the bellows, the medium leaks from this hole.
Construction height	No change

Materials		Valve size	DN 20 – 100	DN 20 – 150
		Option code	J79	J87 (DN 100 J87 + S70)
Item	Component			
70	Elastomer bellows		70 EPDM 281	45 NBR 670
			70 EPDM 281	45 NBR 670
71	Hose clamp		1.4301	1.4301
			304	304
72	Hose clamp		1.4301	1.4301
			304	304

Operating conditions		Valve size	DN 20 – 100	DN 20 – 150
Temperature ranges	[°C]		-50 to +130	-25 to +100
Set pressure	max. [bar <sub>g</sub> ]		10	
Built-up	[bar <sub>g</sub> ]		up to 3	

## Lift indicator

The lift indicator is used in the process technology to monitor the operating condition of a safety valve.

Depending on the type of valve, LESER equips the packed lever H4 or the bonnets with the receptacle for the lift indicator.

For safety valves with lift indicators, the opening of the valve during opening or the lifting operation is signalled as of a specific lift (min. 1mm).

LESER uses inductive DC lift indicators with two-wire technology Type DIN EN 60947-5-6 (NAMUR). The indicators are approved for use in explosion-prone areas of Zone 0 (Ex II 1 D Ex iaD 20 T6). Other indicators that meet customer specifications can be used.

Technical data for lift indicators can be found on the manufacturer's homepage:  
[www.pepperl-fuchs.com](http://www.pepperl-fuchs.com)

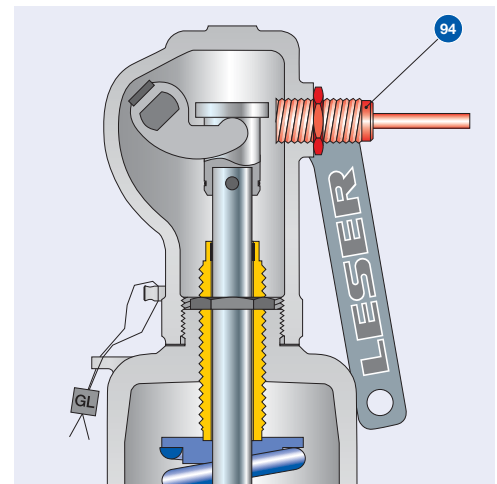

Packed lever H4

## Gas-tight construction on request

For installation instructions for lift indicators, see WI 3323.02.

### Availability

Item.	Name	Option code
40	Packed lever H4 with receptacle for lift indicator M18 x 1 [mm]	J39
94	Lift indicator M18 x 1, used type = PEPPERL+FUCHS NJ5-18GK-N	J93

### Functional diagram

**A, closed**

**B, open**

For a closed valve, the lift indicator is positioned on the side, in front of the coupling or the control sleeve.

If the safety valve opens or if the safety valve is vented **(in both cases, min. 1 mm)** the lift indicator changes its state and switches. If the lift indicator unscrews, e.g. due to vibrations, there is also a switching operation.

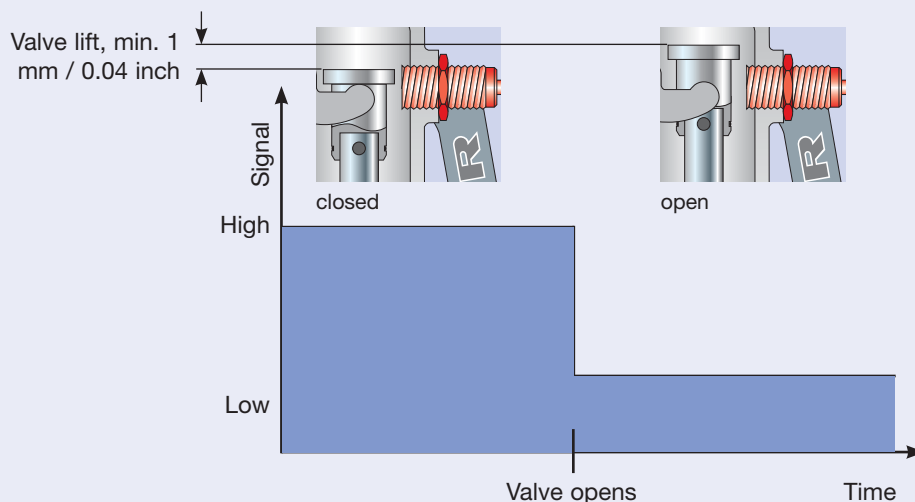

## Lift restriction

The Lift restriction is used to adjust the safety valve to the required discharge mass flow and does not affect the operation of the safety valve.

A lift stopper must meet the requirements of the following codes and standards.

Requirements			
Code / Standards	EN ISO 4126-1, Section 5.1.3	ASME Code case 1945-4	AD 2000-Merkblatt A2, Section 10.3
<b>Lift</b>	≥ 30% of the full lift not less than 1.0 mm	≥ 30% of the full lift not less than 2.0 mm	not less than 1.0 mm
<b>Coefficient of discharge</b>	-	-	$\alpha_w [S/G] \geq 0.08$
	-	-	$\alpha_w [L] \geq 0.05$
<b>Name plate marking</b>	Identification of the reduced coefficient of discharge	- Capacity replaced by "Limited capacity" - Limited lift = ___ mm	Identification of the reduced coefficient of discharge
<b>Design according to EN ISO 4126-1</b>	For valves with a lift stopper to adapt to the required discharge mass flow, this device must not have an adverse effect on the operation of the valve. If it is adjustable, the lift stopper device must be setup such that the adjustable part can be mechanically secured and sealed. The lift stopper device must be installed and sealed by the manufacturer.		

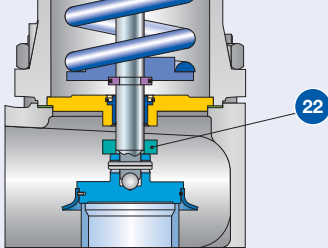
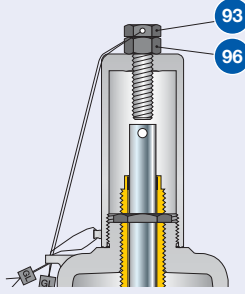
Lift restriction		Lift restriction by bush	Lift restriction by gag
<b>Design</b>			
<b>Option code</b>		J51	Cap H2: J52 Packed lever H4: J50
<b>Availability</b>			
<b>Series 433</b>		✓	✓
<b>Series 429</b>		-	-
<b>Materials</b>			
<b>Item.</b>	<b>Component</b>		
22	Bush	1.4404	-
		316L	-
93	Stud	-	1.4401
		-	B8M
96	Nut	-	1.4401
		-	8M

# LESER worldwide

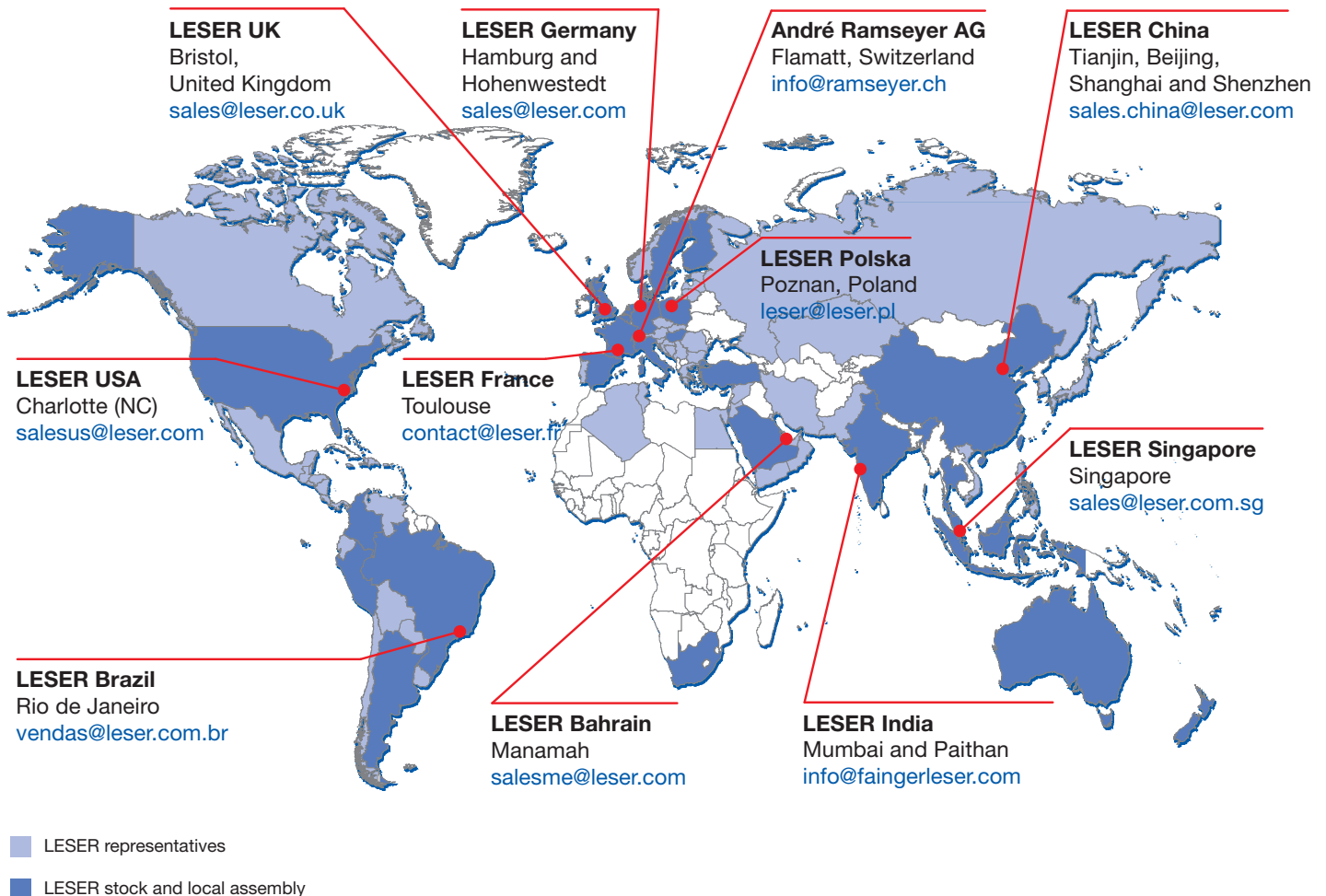

For More Information:



Relevant Solutions  
1.888.858.3647  
[relevantsolutions.com](http://relevantsolutions.com)

Modulate Action  
Edition August 2014 / 1000  
0777.5646

# LESER

[The-Safety-Valve.com](http://The-Safety-Valve.com)