

443
1943

TM 11-330

U.S. Dept. of Army

WAR DEPARTMENT.

TECHNICAL MANUAL.

TELEPHONE CENTRAL
OFFICE SET TC-12

January 18, 1943





U113
2

TM 11-336
1943

★ ★
TECHNICAL MANUAL

TELEPHONE CENTRAL OFFICE

TC-12

CHANGES }
No. 1 }

US WAR DEPARTMENT,
WASHINGTON, May 12, 1943.

TM 11-336, January 18, 1943, is changed as follows:

APPENDIX (ADDED)

MOBILE TELEPHONE CENTRAL OFFICE FOR DIVISIONS

	Paragraph
General.....	1
Construction.....	2
Installation of equipment.....	3
Operation in blackout.....	4

1. **General.**—*a.* This appendix covers a suggested method of constructing and operating a mobile telephone central office, using telephone central office set TC-12. Its use is not mandatory.

b. Provisions are included for transporting and operating the TC-12 in either the O-truck, 2½-ton, cargo, or in the O-truck, 1½-ton, cargo. When the 2½-ton truck is used, components of the telephone central office set TC-3 (teletypewriter) may also be transported and operated in the truck with the TC-12. The plan provides essential equipment for installation at a division command post or at a rear echelon of a division headquarters.

c. A copy of the loading plan for movement and a copy of the loading plan for operation should be kept in a clear plastic pocket or envelope and stored in a convenient place so as to be available for reference.

2. **Construction.**—*a.* The mobile telephone central office consists of an O-truck, 1½-ton, cargo, or an O-truck, 2½-ton, cargo, with all equipment loaded in packaged form (that is, so far as possible carried as units or in suitable chests). This will provide for the temporary installation of the telephone central office in the truck when conditions permit, or for the rapid removal of the equipment for installation on the ground or in shelter when necessary, or when the truck is required for other work. Three of these trucks may be thus equipped for each division signal company.

b. The list of equipment necessary for the construction of a mobile telephone central at the echelons of division headquarters is given in the loading tables following:

524993°-43

M558374

Signal Corps stock No.	Item	Number required when using			
		O—truck, 1½-ton, cargo		O—truck, 2½-ton, cargo	
		Rear echelon	First or second echelon	Rear echelon	First or second echelon
CENTRAL OFFICE SETS					
4C27012	Telephone central office set TC-12.	1	2	1	2
4A2788	Telegraph central office set TC-3 (teletypewriter).			1	1
NONEXPENDABLE ITEMS					
6Q1001	Axle LC-1	1	1	1	1
6H227 ()	Axle RL-27-()	1	1	1	1
	Blackout light (note 1)	2	2	2	2
1B1445	Cable assembly CC-345, 100 ft. long (5 pr.).	4	6	4	6
1B1445	Cable assembly CC-345, ¼ mile long (5 pr.).	2	3	2	3
1B1444	Cable stub CC-344, 10 ft. long (5 pr.).	6	10	6	10
6F705	Chest BC-5	2	3	2	3
6Z4002A.1	Flashlight TL-122-A	3	3	3	3
6Z4810	Gloves LC-10, pr.	3	3	3	3
6H2504	Reel DR-4	2	2	2	2
6H2505	Reel DR-5				1
6H2507	Reel DR-7	2	3	2	3
6H6231	Reel unit RL-31	1	1	1	1
	Sign (note 2)	1	1	1	1
4B5008A	Telephone EE-8-A	12	24	12	24
4E9304	Terminal strip TM-184	3	5	3	5
1B110B	Wire W-110-B, miles	1	1	1	2
EXPENDABLE ITEMS					
3A30	Battery BA-30	30	54	30	54
	Camouflage material (standard nets, chicken wire, etc.)				
	Log book	1	1	1	1
6Z6981	Marline RP-2, pounds			1	1
6Z7904	Rope RP-1, ball	20	20	20	20
1A16	Seizing wire W-16, spool	100	100	100	100
4Z7272	Tags MC-72	100	100	100	100
6N8594	Tape, rubber, TL-94, rolls	6	6	6	6
6N8583	Tape, friction, TL-83, rolls	6	6	6	6

NOTES

1. Improvise pending standardization. Self-contained battery source, such as BA-23, suggested.
2. Improvise pending standardization. Interior-lighted box suggested.

c. When the O-trucks, 2½-ton, cargo, are used, the following telegraph equipment may be carried in the O-trailer, 1-ton, 2-wheel, cargo, attached to the first echelon truck when a movement of the command post is being made:

- 2 teletypewriter sets EE-97-A.
- 2 telegraph sets TG-5-A.

d. The suggested loading plans are shown as follows:

Fig. No.	Loading plan for—	Using O-truck
18	Movement.....	1½-ton, cargo.
19	Operation.....	Do.
20	Movement.....	2½-ton, cargo.
21	Operation.....	Do.

The loading plan is the same for each of the three trucks of a company, except that in the case of a rear echelon truck, a reduced amount of equipment is carried in accordance with the table in b above.

e. Three chests BC-5 are provided for loading telephones and other small parts included in the list in b above, to permit easier transportation. All of the smaller component parts of the TC-12 are carried in the compartment provided in switchboard BD-91 except maintenance equipment ME-30, which is carried in case CS-78.

3. Installation of equipment.—a. The method of leading in the outside lines is a matter which the installation personnel must work out for individual cases. In general, it is desirable to “bunch” or tie the wires leading into the truck together for a short distance to the nearest support. The purpose of tying the field wire lines and field cables together is to prevent sagging of individual wires.

b. In order to permit personnel to enter or leave the truck under blackout conditions without extinguishing the lights, the use of paulin, duck, type I, furnished as part of telephone central office set TC-12, is suggested as follows (fig. 22): Tie the top part of the paulin over the top of the truck canopy, overlapping about 3 feet, and reaching the ground. Overlap the left-hand vertical edge of the paulin on the side of the truck about 3 feet. The right-hand edge of the paulin will then extend about 4 feet from the right rear end of the truck, and may be attached at the top corner to the top of the truck. Personnel desiring to enter the truck under blackout conditions first lift the flap on the right-hand side, walk under the paulin to the rear of the truck, allowing the paulin to fall back in place, and lastly, enter the body.

4. Operation in blackout.—a. Arrangements for operation during blackout conditions will differ, depending on the degree of security required.

(1) For extremely critical situations, blackout lights should be installed. Turn these lights off whenever entrance and exit of personnel is taking place. Use the improvised curtain shown in figure 22, and the end curtain of the truck. Ventilation at night is by means of natural convection of air currents through the openings between the canopy and end curtain.

(2) For normal restrictions, entrance and exit of personnel from the truck usually is permissible with the blackout light turned on, pro-

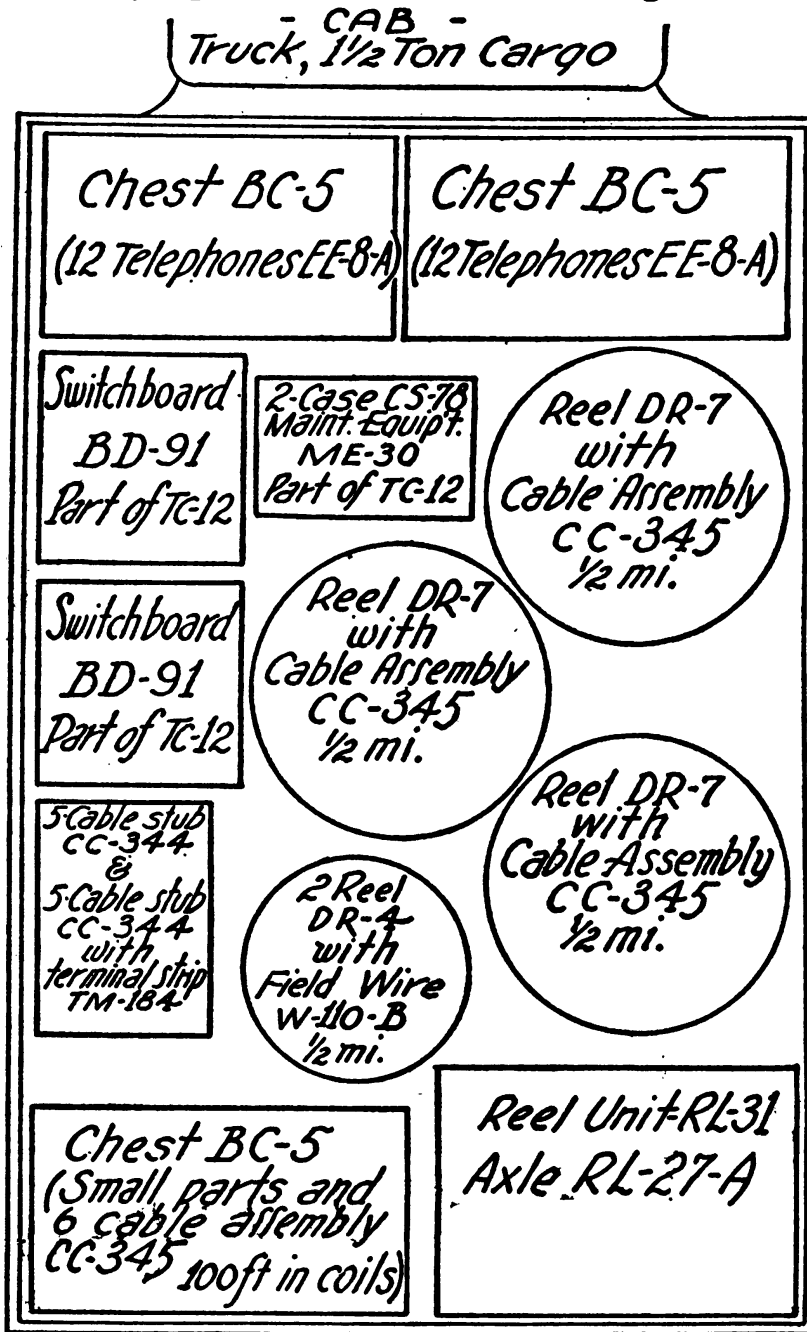

FIGURE 18.—Loading plan for movement, TC-12 in 1 1/2-ton truck.

vided the improvised curtain shown in figure 22 is used to seal the opening into the truck from direct view. In this case, the end curtain of the truck need not be used. Increased ventilation may be obtained by propping up the canvas canopy by means of short sticks and retying the ropes to prevent accidental lifting of the canvas by the wind.

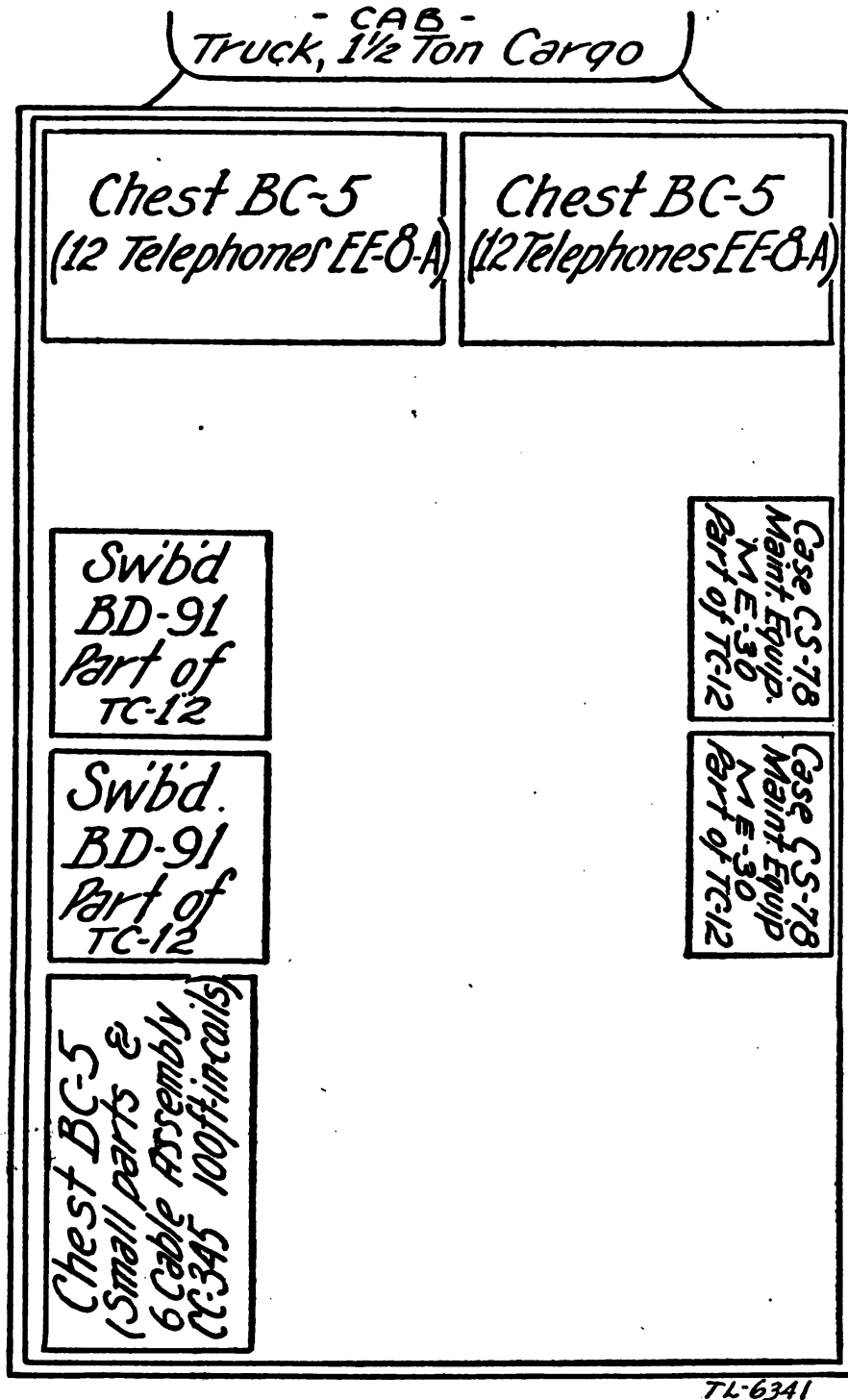

FIGURE 19.—Loading plan for operation, TC-12 in 1 1/2-ton truck.

(3) Where no enemy ground troops would be likely to observe the presence of the mobile telephone central office, and where security against observation by enemy aircraft only is required, the mobile telephone central office may be operated without the end curtain

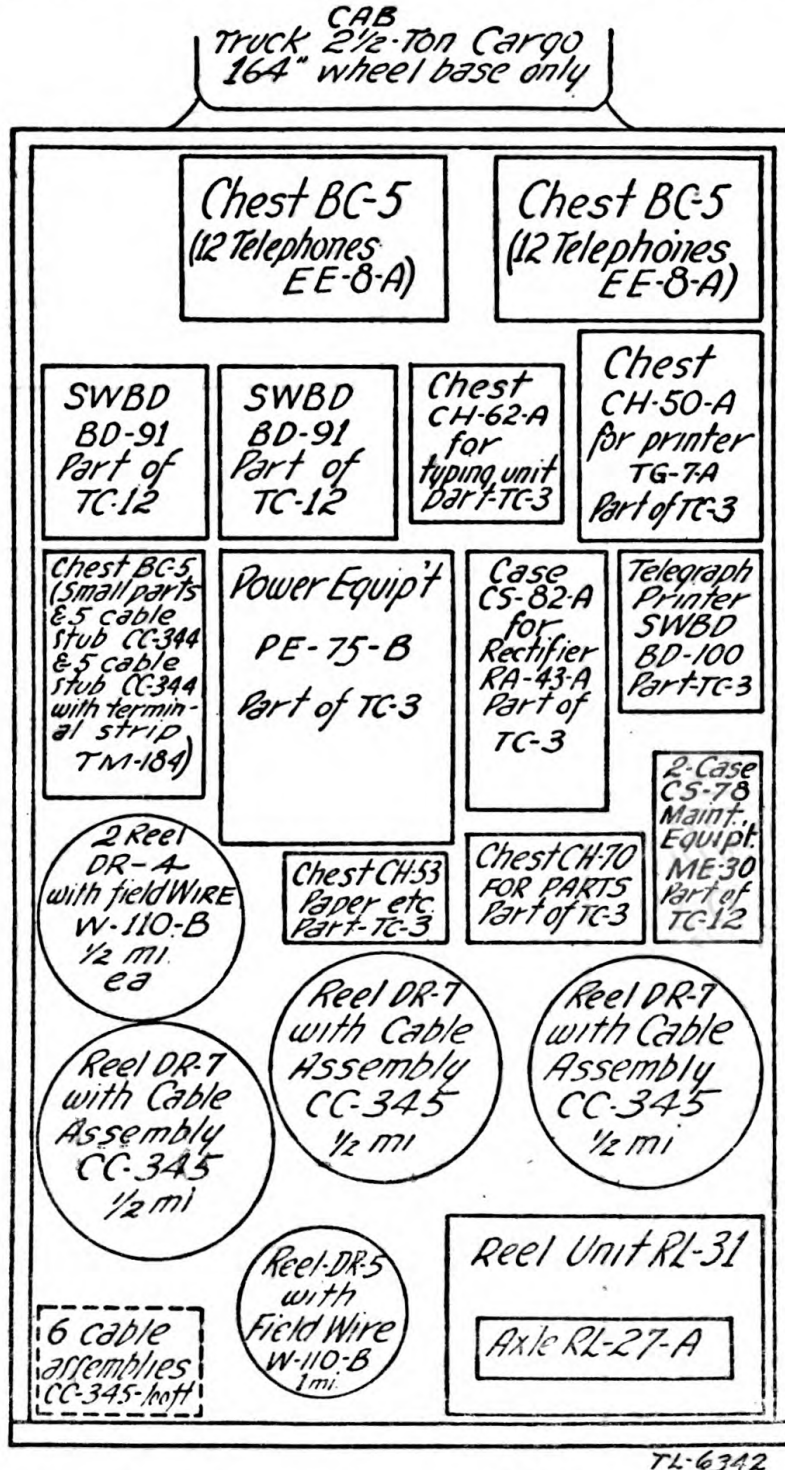

FIGURE 20.—Loading plan for movement, TC-12 in 2½-ton truck.

or the improvised entrance curtain in place. It is assumed that the blackout lamp used will provide an intensity of illumination so low that the direct ray of the lamp will not be visible at a distance of ap-

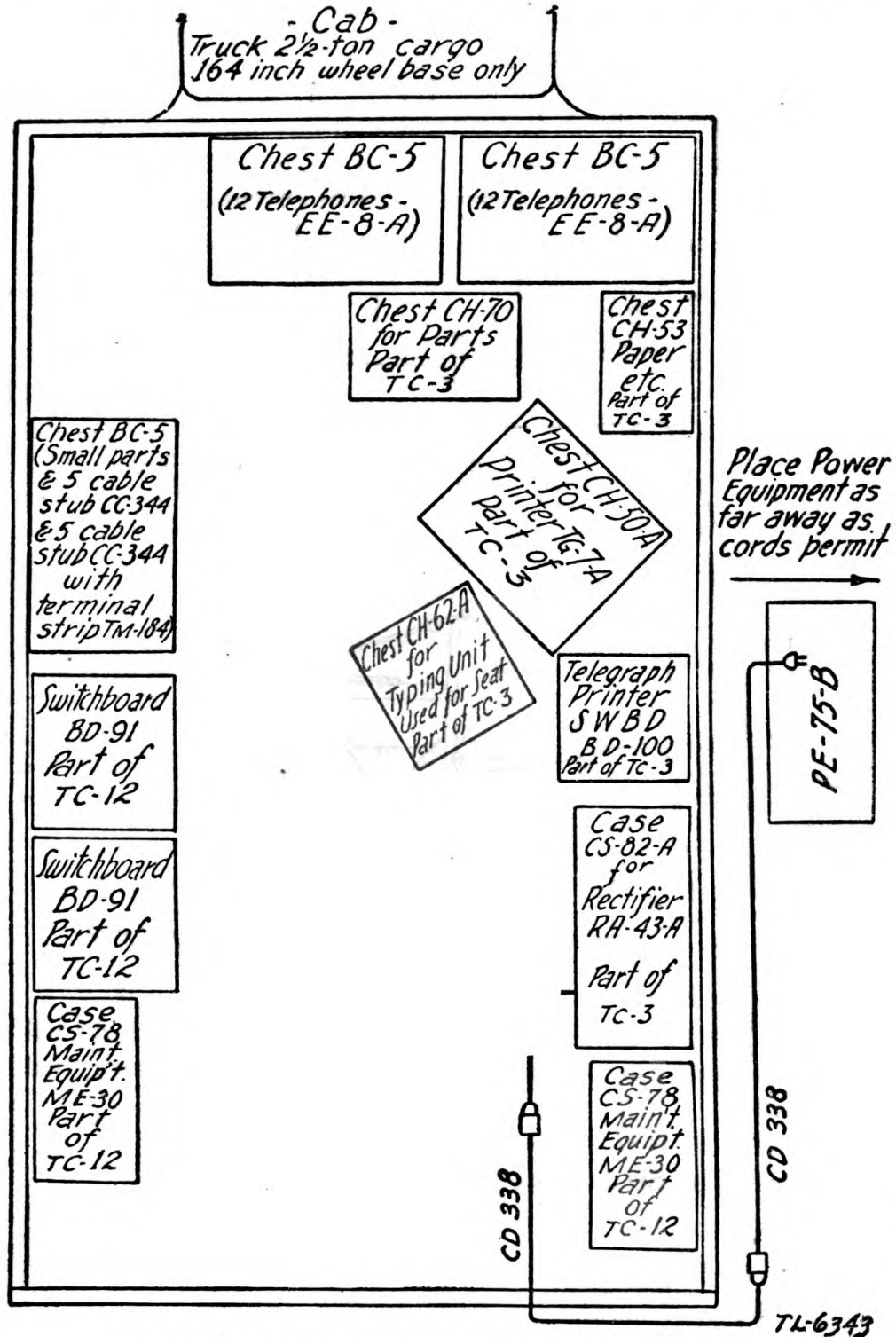
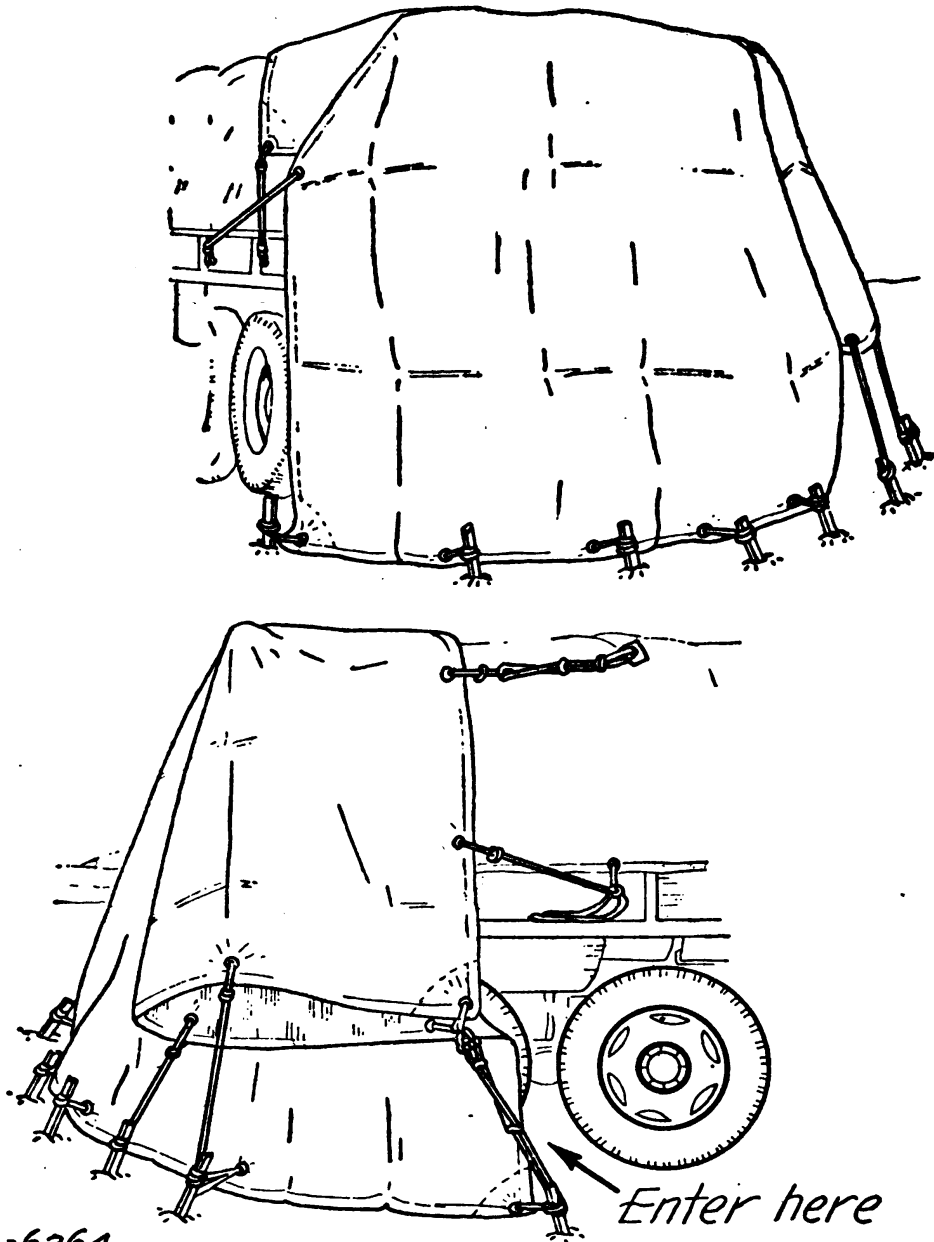

FIGURE 21.—Loading plan for operation, TC-12 in 2 1/2-ton truck.



TL-6264

FIGURE 22.—Entrance curtain using paulin, duck, type I, part of TC-12.

proximately 1,000 feet. Under this condition, any reflected light will be unobservable at a much shorter distance and adequate security will be maintained.

[A. G. 062.11 (4-15-43).] (C 1, May 12, 1943.)

BY ORDER OF THE SECRETARY OF WAR:

OFFICIAL:

J. A. ULIO,
Major General,
The Adjutant General.

G. C. MARSHALL,
Chief of Staff.

✓
L. War,

TM 11-336
C 2

TECHNICAL MANUAL
TELEPHONE CENTRAL OFFICE SET TC-12

CHANGES }
No. 2 }

WAR DEPARTMENT,
WASHINGTON 25, D. C., 17 July 1943.

TM 11-336, 18 January 1943, is changed as follows:

All references to Telegraph Central Office Set TC-3 appearing in C 1, 12 May 1943, are hereby rescinded.

[A. G. 300.7 (15 Jun 43).] (C 2, 17 Jul 43.)

BY ORDER OF THE SECRETARY OF WAR:

G. C. MARSHALL,
Chief of Staff.

OFFICIAL:

J. A. ULIO,
Major General,
The Adjutant General.

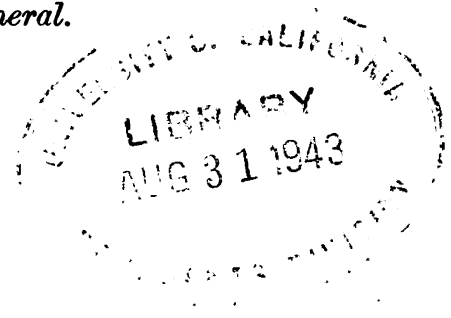

TECHNICAL MANUAL
TELEPHONE CENTRAL OFFICE SET TC-12

CHANGES }
No. 3 }

WAR DEPARTMENT,
WASHINGTON 25, D. C., 25 August 1944.

TM 11-336, 18 January 1943, is changed as follows:

1. Purpose.—Telephone central office * * * in paragraph 2.

COMPONENT PARTS

Quantity	Article	Approximate shipping size (inches)	Approximate unit weight (pounds)
* 1	* Ground rod GP-29	* 36 long x 1 $\frac{3}{8}$ diameter	* 10
2	Headset HS-30-($\&$) ¹		$\frac{3}{8}$
2	Chest set TD-1 ¹		$\frac{1}{8}$
1	Converter M-222	8 $\frac{1}{4}$ x 6 $\frac{3}{4}$ x 6 $\frac{5}{8}$	10 $\frac{1}{2}$
1	Switchboard BD-91 ²	17 $\frac{1}{4}$ x 18 $\frac{3}{4}$ x 25 $\frac{9}{16}$	215
	Total weight approximately		272

¹ If headset HS-30-($\&$) and chest set TD-1 are not available, head and chest set HS-19 or equal may be used. The sign ($\&$) following the nomenclature of an item indicates all models and procurements of that item.

² The nomenclature switchboard BD-91 is used in this manual to mean both switchboard BD-91 and BD-91-B.

Note. The telering has been deleted from the table of component parts since it is no longer furnished separately. The telering is now furnished as an integral part of switchboard BD-91.

TELEPHONE CENTRAL OFFICE SET TC-12

Figure 2 is rescinded and the following is substituted therefor:

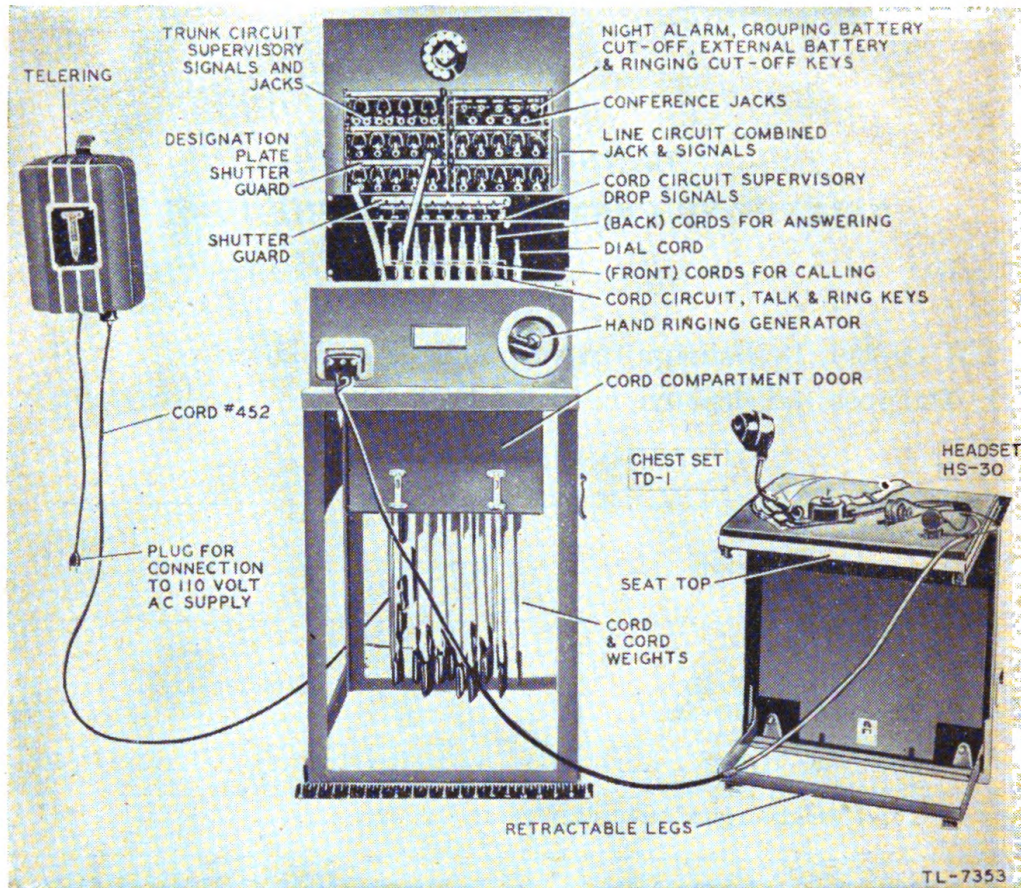

FIGURE 2.—Switchboard BD-91—ready for operation.

4. Setting up and connecting equipment.

* * * * *

m. Plug a headset **HS-30** (&) and chest set **TD-1** into the jack **JK-37** mounted in the front of the key shelf. Two headsets **HS-30** (&) and chest sets **TD-1** are normally carried in the compartments provided in the front cover.

7. Magneto line circuit (fig. 5).

* * * * *

c. Magneto line circuits in switchboards **BD-14**, **BD-71**, **BD-72**, **BD-80**, **BD-89**, **BD-91**, **BD-96**, **BD-110**, and in commercial switchboards.

TELEPHONE CENTRAL OFFICE SET TC-12

d. Line circuits equipped * * * in commercial switchboards.

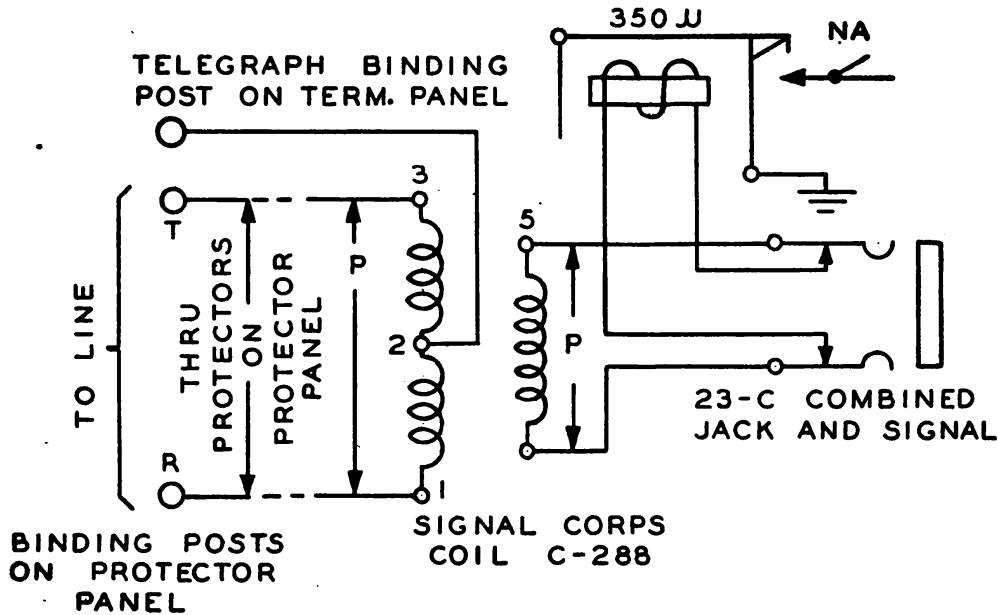

FIGURE 5.1.—Magneto line circuit equipped for telegraph.

* * * * *

7.1. (Added.) Magneto line circuit equipped for telegraph (fig. 5.1).—Line circuits 0, 1, 2, and 3 operate as covered in paragraph 7, except that ringing and talking take place through repeating coil C-288. Telegraph circuits connected to the telegraph binding posts operate without interference with the talking circuit if the two line wires are of equal resistance. Current entering the line at the telegraph binding post divides at terminal 2 of the repeating coil; half of the current flows through the 2-3 winding and the tip side of the line, the other half flows through the 2-1 winding and the ring side of the line. The 1-2 and 2-3 windings are identical. With equal currents flowing in opposite directions through these windings, the magnetic fields oppose each other and the voltage induced in the talking circuit (4-5 winding) is zero. At the opposite end of the line, the action is the same, except that the current flow will be from the line to the telegraph leg.

11. Operator's telephone circuit (fig. 9).—An antisidetone telephone * * * grouping cord CD-611. Headset **HS-30-(&)** and chest set **TD-1** may be connected to the operator's telephone circuit

TELEPHONE CENTRAL OFFICE SET TC-12

by means of a plug PL-58 and the jack JK-37 located on the left front of the key shelf.

Figure 12 is rescinded and the following is substituted therefor:

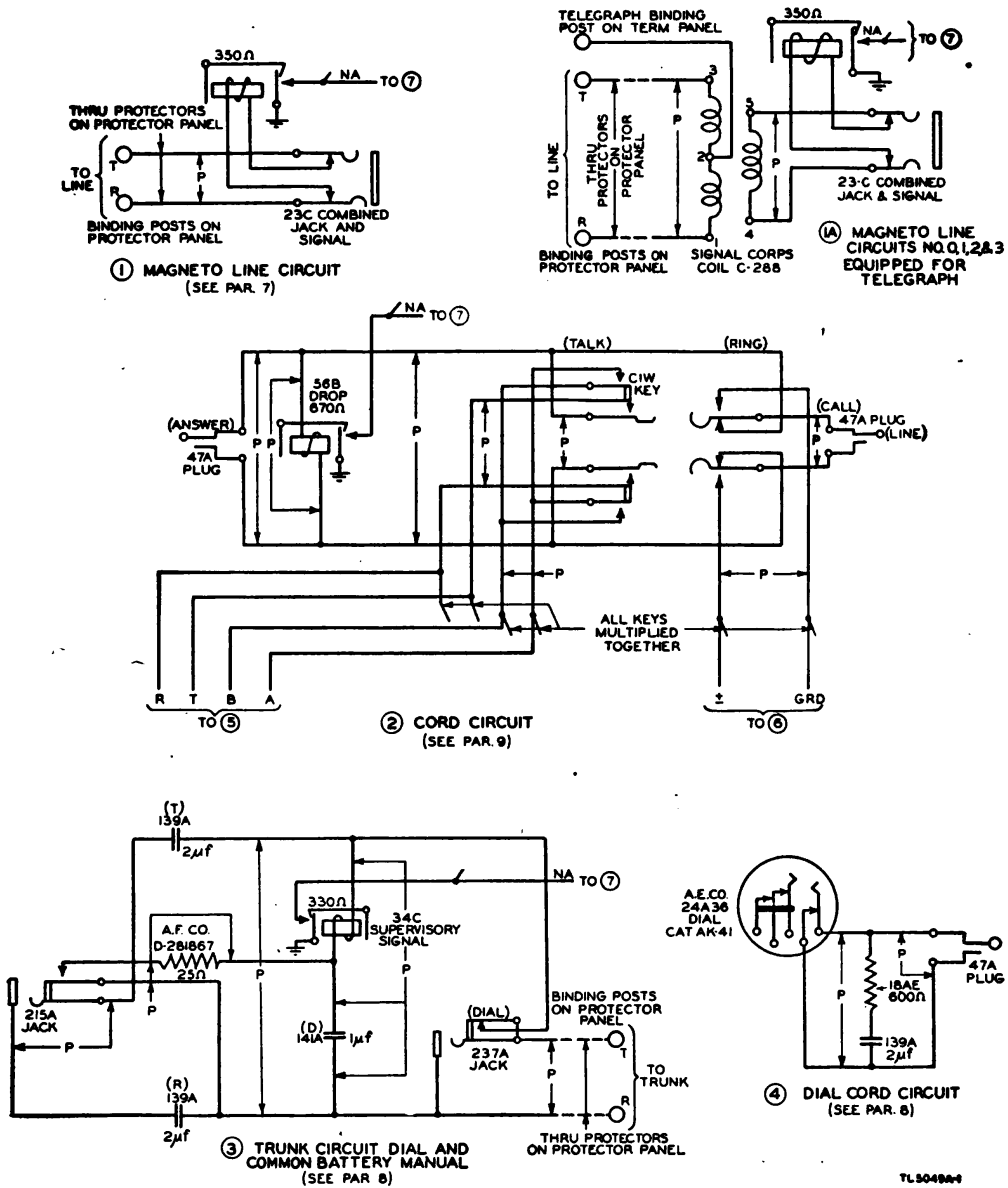
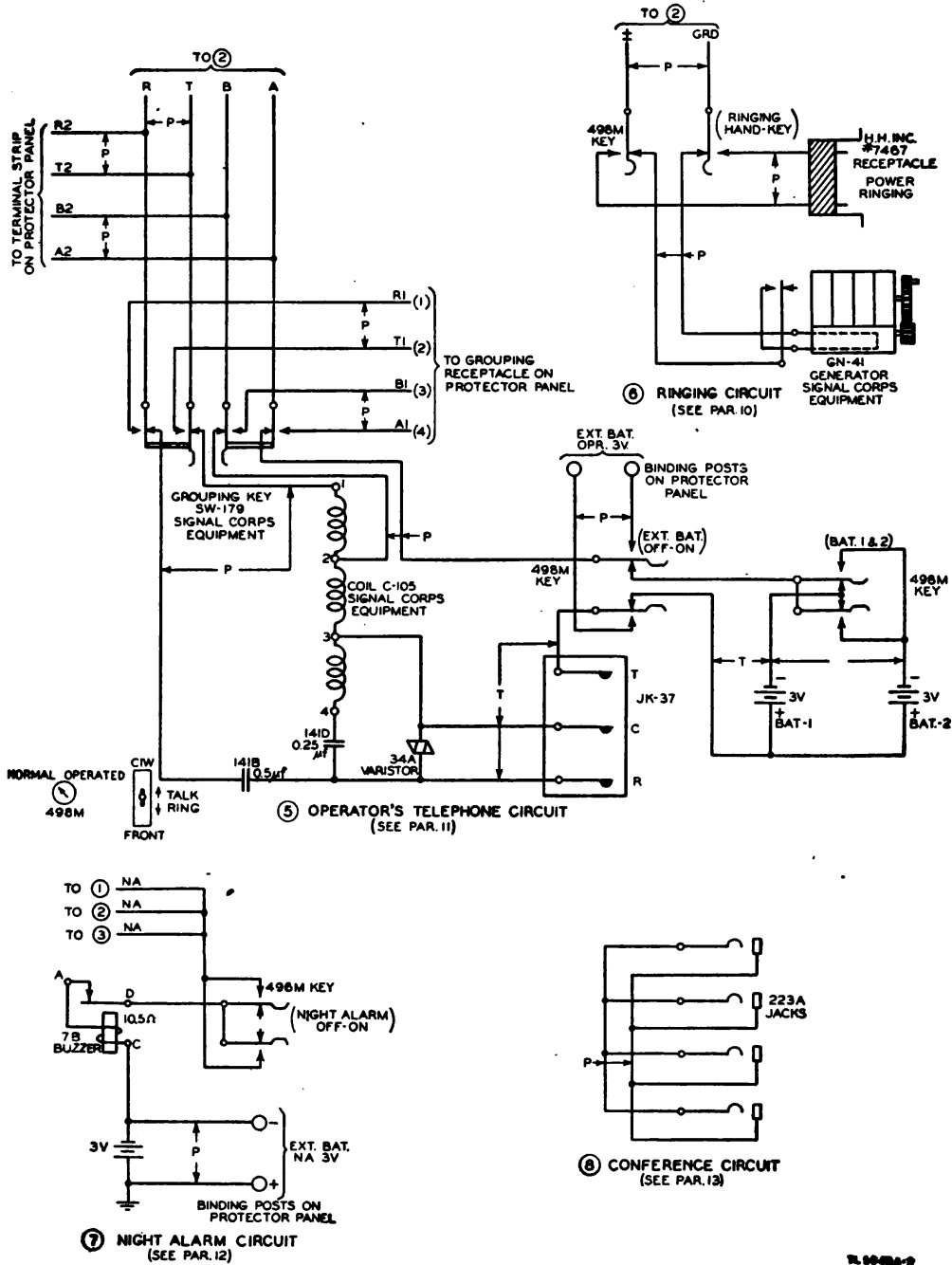

FIGURE 12.—Switchboard BD-91—master schematic diagram.

TELEPHONE CENTRAL OFFICE SET TC-12



(2)

FIGURE 12.—Switchboard BD-91—master schematic diagram—Continued.

17. (Superseded.) **Preventive maintenance.**—*a. General.*—The greatest single factor in trouble-free operation is careful handling

TELEPHONE CENTRAL OFFICE SET TC-12

of the equipment while packing and unpacking, transporting, and installing. Much potential trouble can be eliminated by routine checks. The frequency of the routine checks depends on the number of calls handled and the usage of the equipment.

b. Inspection and tests.—The following will serve as a guide to the inspections and tests to be made upon installation and for routine checks:

(1) Set up switchboard BD-91 in an operating position (par. 4).

(2) Inspect all sections of the switchboard for damaged or missing parts, giving particular attention to cords, plugs, keys, drops, operator's telephone equipment, and hand generator. While inspecting the cords make sure they are of the proper length and that the weights hang evenly.

(3) Connect one terminal of a test telephone EE-8 to the GRD terminal on the switchboard BD-91, and touch a wire from the other phone terminal to each line terminal binding post of the panel. Then ring from the test telephone. If the line is grounded, the generator will turn hard. Usually grounds occurring in the protector panel are caused by dirty or improperly mounted protector blocks.

(4) With the test telephone across each pair of line terminals at the protector panel at the rear of the switchboard, ring from the telephone on each pair in turn. The shutter should fall and the night alarm should ring.

(5) As each shutter is rung down, plug into the line jack of that line with one of the cords, thus restoring the shutter. Throw the listening key and talk to the man who is at the test phone.

(6) Ring the test phone by operating the appropriate key and turning the switchboard generator crank. In the course of these ringing and talking tests, use each cord of each cord circuit at least once, so as to test both sides of every cord circuit.

(7) Cause the test phone to ring on each cord to test the supervisory drops of the cord circuit.

c. Cleaning plugs.—To maintain high grade transmission through the cord circuits, all plugs should be cleaned as often as required to maintain brightness. Use polish, metal, paste (stock number 6G1516), or equal, for polishing the switchboard plugs. Take care to remove thoroughly all surplus polishing material.

d. Cleaning contacts and jacks.—(1) When it becomes necessary to clean the contacts of keys, drops, jacks, etc., burnish them with a burnishing tool, or its equivalent. The contact burnisher furnished

TELEPHONE CENTRAL OFFICE SET TC-12

with the telegraph set TG-5-A, or tool, switchboard, contact burnisher (stock number 6R41065B), a part of telephone electrician's tool equipment TE-49 (stock number 6R38049) may be used. To burnish, normally open contacts of keys, jacks, drops, etc., place the blade of the burnisher between the contacts and press them together or operate apparatus manually to get a slight pressure against the burnisher blade. Move the blade back and forth between the contacts. Repeat this process two or three times for the best results. In the case of normally closed contacts, the tension of the springs themselves usually will give sufficient pressure against the burnisher. When it is impossible to properly clean the contacts by ordinary burnishing, clean and flush the contacts by dipping the flat end of a toothpick into a cleaning fluid, such as carbon tetrachloride, solvent, dry cleaning, or a similar solvent, and place the fluid on the contacts (held slightly apart) without rubbing. Repeat this process to flush off the dirt. Then burnish the contacts. Do not permit the fluid to come in contact with insulators, spoolheads, etc.

(2) To clean the tripping latch, top notches of the shutter, and the shutter-hinge plate of the drops and signals (figs. 15.1 and 15.2), saturate a clean cloth or brush with carbon tetrachloride or solvent, dry cleaning, and apply to the parts to be cleaned. Then wipe the parts dry with a clean cloth.

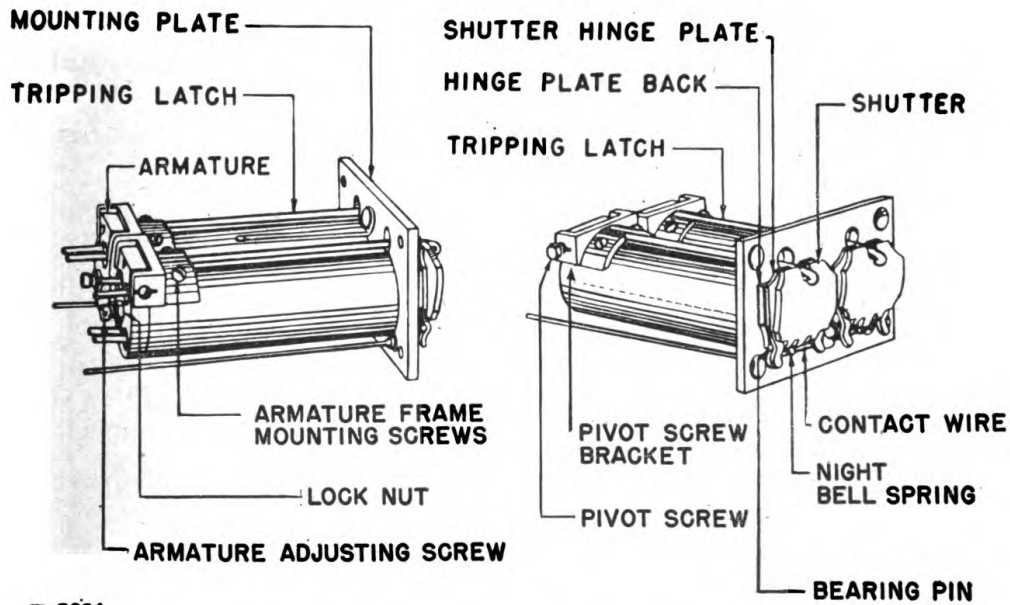

FIGURE 15.1.—Designation of parts of a 56B drop

AGO 358C

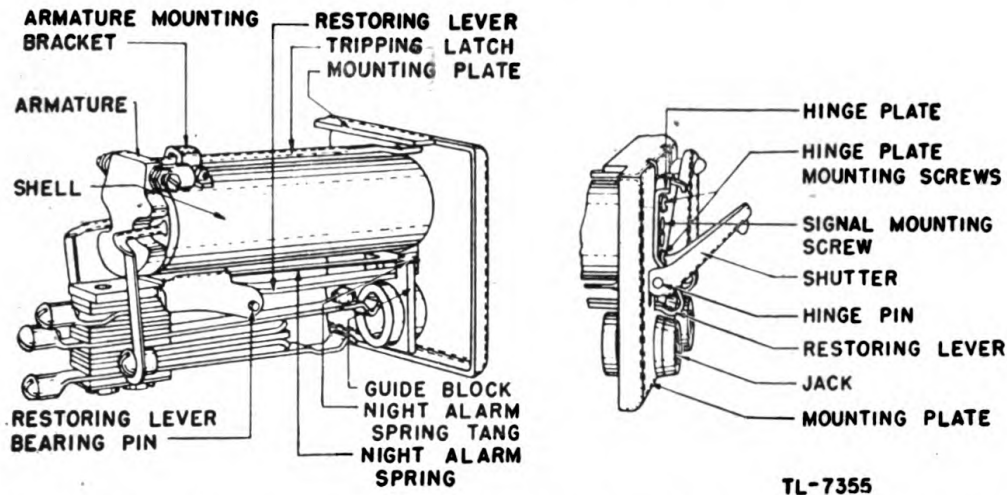

FIGURE 15.2.—Designation of parts of a 23C combined jack and signal and a 34C supervisory signal.

17.1. (Added.) Moistureproofing and fungiproofing.—a. General.—Communication failures commonly occur when Signal Corps equipment is operated in tropical areas where temperature and relative humidity are extremely high. The following problems are typical:

- (1) Resistors and capacitors fail.
- (2) Electrolytic action takes place in coils, chokes, transformer windings, etc., causing eventual break-down.
- (3) Hook-up wire and cable insulation break-down. Fungus growth accelerates deterioration.
- (4) Moisture forms electrical leakage paths on terminal boards and insulating strips, causing flash-overs and crosstalk.
- (5) Moisture provides leakage paths between battery terminals.

b. Treatment.—A moistureproofing and fungiproofing treatment has been devised which, if properly applied, provides a reasonable degree of protection against fungus growth, insects, corrosion, salt spray, and moisture. The treatment involves the use of a moisture-resistant and fungi-resistant varnish applied by means of a spray gun. A brief description of the method of application follows:

- (1) All repairs and adjustments necessary for the proper operation of the equipment are made.
- (2) Equipment to be processed is thoroughly cleaned of all dirt, dust, rust, fungus, oil, grease, etc.
- (3) Equipment is partially disassembled and certain points, such as

TELEPHONE CENTRAL OFFICE SET TC-12

relay contacts, open switches, air capacitors, sockets, bearings, etc., are covered with masking tape.

(4) Equipment is thoroughly dried by heat to expel moisture which the circuit elements have absorbed.

(5) All circuit elements and all parts of the equipment are sprayed or painted with three coats of moistureproofing and fungiproofing varnish.

(6) The equipment is given a final operational check.

c. Step-by-step instructions.—(1) Disassembly.—(a) Open rear door of switchboard by loosening two knurled screws. This will expose one side of the protector panel.

(b) Loosen latches on left edge of panel and open protector panel, exposing rear side.

(c) Raise panel at top of switchboard.

(d) Release lower panel and remove cords from the cord shelf.

(e) Remove four screws from front of each combined jack and drop mounting plate. Pull units forward until terminals are exposed.

(f) Open the large portion of the local cable running up the side of the frame to the rear panel.

(g) Loosen screw at right end of keyshelf. Open keyshelf and loosen screws holding the keys in place. Turn the clamp pieces so they will slide through the key mounting bars.

(h) On the right front of the plug shelf, remove the two screws holding a small section of phenolic plate. Lift out plate.

(i) Remove the two screws supporting the rear of the hand generator. Open keyshelf and remove two screws holding front of generator. Remove generator and disconnect the connected leads.

(2) Masking.—(a) Mask fuse connecting clip springs, carbon blocks, binding posts TM-198 and TM-85, and grouping and power plug receptacles located on protector panel.

(b) Mask dial-mounting opening on under side of top compartment.

(c) Mask cord terminal end of cord fasteners and buzzer.

(d) Place shield under supervisory drops.

(e) Mask the wire connecting screws and contact points of the spring pile-up on the generator.

*(3) Drying.—*Dry all parts for 2 or 3 hours at 160° F.

*(4) Varnishing.—*Apply three coats of moistureproofing and fungiproofing varnish according to the following instructions:

(a) Spray both sides of protector panel.

(b) Spray top compartment, including repeating coils.

(c) Spray cord shelf, capacitor mounting plate, and local cable on the under side of cord shelf.

(d) Use brush to apply varnish to the spring pile-ups of jacks, soldered connections, and ends of wire insulation in lower panel.

(e) While combined jacks and drops are drawn forward, spray the under side of the top compartment where the leads to the repeating coils are exposed.

(f) Spray the opened-up portion of the local cable running up the side of the frame to the rear panel.

(g) Brush varnish on the cable forms and individual conductors from the main cable form to the soldered jack and drop connections.

(h) Close the keyshelf and lift out the keys one at a time. Brush varnish on the spring pile-ups, the soldered connections, and on the insulation of the connected wires.

(i) Brush varnish on the local cable form and the conductors to the keys, generator, and operator's jacks. Do not varnish terminal ends of generator leads.

(j) Use brush to varnish spring pile-up on generator.

(k) Turn generator upside down and brush varnish on the coil winding of the armature. Revolve the armature and varnish the other side of the coil.

(5) *Reassembling and testing.*—(a) After varnish is dry, remove all masking.

(b) Check all contacts for traces of varnish and, if necessary, clean with varnish remover, and burnish.

(c) Reassemble and dress cabling. If varnish is broken during this operation, touch up with varnish.

(d) Replace the combined jack and drop mounting strip.

(e) Replace the keys in the keyshelf.

(f) Replace generator in switchboard.

(g) Test switchboard for proper operation in accordance with paragraph 17b.

(h) Mark MFP and date of treatment. This marking should be stencilled near the nameplate.

d. Reference.—For a full description of the varnish spray method of moistureproofing and fungiproofing, refer to TB SIG 13.

17.2. (Added.) Trouble location tests.—The following table provides a testing sequence for isolating switchboard troubles:

a. Ringing circuit test

Description and number	Condition	Indication	Probable location and procedure
1. Testing power ringing from switchboard through any or all cord circuits.	Ring nearby station or connect test set across line binding posts, RINGING key in KEY position.	Station ringer does not operate.	Proceed to test 2, to ascertain if trouble is in telephone equipment or in power equipment.
2. Testing hand-ringing generator from switchboard through any or all cord circuits.	Same as above with RINGING key in HAND position.	2A. Station ringer does not operate. 2B. Station ringer does not operate with power ringing supply, but does operate with hand generator.	Check switchboard ringing keys, associated wiring connections, and line fuses. Check telering, connecting-cable connections, a-c supply fuses, and connections.

b. Signaling test

1. Testing line and trunk signals through line protectors and fuses.	Connect a magneto test set across the line or trunk binding posts; then ring.	1A. Signal operates. 1B. Signal fails to operate, generator handle turns easily. 1C. Signal fails to operate, generator handle turns hard.	Trouble outside of switchboard; check line binding post to make certain connections are tight. Operate drops or signals manually to check mechanical operation; make adjustments, if required. If mechanically correct, proceed to test 2. Circuit shorted or crossed. Disconnect line wires and repeat test 1; if indication does not change, check local cable wiring and switchboard apparatus.
--	---	--	--

b. Signaling test (Cont'd)

Description and number	Condition	Indication	Probable location and procedure
2. Testing line and trunk signals at the switch board end of the line or trunk fuses.	Connect a magneto test set across the switchboard side of the line or trunk fuses; then ring.	2A. Signal operates. 2B. Signal fails to operate.	Blown fuse. Broken or unsoldered local cable lead at jack drop or protector, dirty jack or defective drop. Check for open in local cable.
3. Testing cord circuit supervisory signals.	Same as test 1, except insert cord-circuit plug in line or trunk jack.	3A. Cord supervisory signal fails to operate, generator handle turns easily. 3B. Cord supervisory signal fails to operate, generator handle turns hard.	Operate signal manually to check mechanical operation; make adjustments if required. If indication is still 3A, proceed to test 3B. Circuit shorted or crossed; check local wiring connections; check apparatus for foreign substances.

c. Transmission test

1. Testing operator's telephone, cord, line, and trunk circuits, when battery supply is derived from local dry cells.	Insert operator's telephone-set plug in jack and insert cord-circuit cord in line or trunk jack; ring a nearby station or test set; operate talking key and talk between test man and operator.	1A. Operator hears station, but station does not hear operator. 1B. Station hears operator but operator does not hear station. 1C. Both station and operator unable to hear each other.	Operate EXT. BAT. key to OFF position; operate battery key to switch from battery 1 to 2, or vice versa. If trouble persists, check battery and replace it, if dead. Try another cord circuit; check operator's headset; check local cable wiring for open or disconnected wiring; check apparatus, plugs, keys, etc. Try another cord-circuit cord; check operator's headset, cord circuit, and listening key local cable wiring for open or disconnected wiring, etc. Check position of grouping key (should be OFF). If indication is still the same, proceed with test 1A and 1B.
---	---	---	---

<p>2. Testing operator's telephone, cord, line, and trunk circuits when battery is derived from external battery.</p>	<p>Same as for test 1-----</p>	<p>2A. Operator hears station, but station does not hear operator. 2B. Station hears operator, but operator does not hear station. 2C. Both station and operator unable to hear each other.</p>	<p>Operate EXT. BAT. key to ON position; check external battery connections, binding post, etc. If trouble persists, insert internal dry batteries and proceed with test 1A. Same as 1B. Same as 1C.</p>
---	--------------------------------	---	--

AGO 358C

d. Dial circuit test

<p>1. Testing dial cord circuit----</p>	<p>Connect ohmmeter, voltmeter and battery, or receiver test set and battery on T and R trunk circuit line-binding post. Insert dial cord into trunk circuit "dial" jack and operate dial.</p>	<p>Meters or receiver test set fails to register impulses.</p>	<p>Check plug, jack, and circuit wiring for circuit continuity. Check dial; if out of order, replace with new dial.</p>
---	--	--	---

e. Night-alarm circuit test

<p>1. Testing night-alarm, internal battery.</p>	<p>Switch night-alarm key to ON position; cause a line or trunk drop signal to operate. Same as 1-----</p>	<p>Buzzer fails to sound----- Buzzer fails to sound-----</p>	<p>Operate other drop signals; check batteries and replace if dead. Check buzzer, key, and local wiring of circuit continuity. Operate other drop signals, check external battery connections, binding post, etc. Insert internal dry battery and proceed with test 1.</p>
<p>2. Testing night-alarm, circuit, external battery.</p>			

TM 11-336

C 3 TELEPHONE CENTRAL OFFICE SET TC-12

18. Packing for Army transportation.

* * * * *

b. Place the ringing * * * of the clamp. Place headsets **HS-30**-(&) and chest sets **TD-1** in the proper compartments in the front cover. Adjust the designation * * * supervisory drop shutters.

* * * * *

19. List of replaceable parts.—a. Telephone central office set TC-12 complete.

Stock No.	Name	Description	Function	Reference paragraph
3A23	Battery	BA-23	For ringing converter M-222.	
3A30	Battery	BA-30	Talking and night alarm circuit.	
3E1452	Cord	CD-452	Ringing cord	
3E2258	Cord	CD-258	Ground connection	
3Z3329	Ground rod	GP-29	Ground	
2B830	Headset*	HS-30	Operator's set	19d
4B417	Chest set*	TD-1	Operator's set	19c
4F222	Ringing converter.	M-222	Emergency ringing current.	
4C9991A	Switchboard	BD-91	Switching central	19b
6Q1104-52	Axe	4-lb head	Tool	

*If headset HS-30 and chest set TD-1 are not available, head and chest set HS-19 or equal may be used.

b. Switchboard BD-91.

Reference fig. No.	Reference symbol	Stock No.	Name	Description	Function	Manufacturer	Manufacturer's part No.	Signal Corps drawing No.
5		4C4623C-1	Jack and signal combined.	Self-restoring drop with jacks.	Line and signal jack	W. E. Co.	23-C	SC-D-5015.
5 and 6		4E882.1	Unit destroyer	Carbon protector blocks	Line protection	Cook	2612	SC-D-5027.
5 and 6		3Z298	Binding post	TM-198	Line and trunk	W. E. Co.		SC-D-5052.
6		4C9650.34C	Supervisory signal	Drop type signal	Trunk signal and holding bridge.	W. E. Co.	34-C	SC-D-5018.
6	(LINE)	2Z5514.2	Jack	Circuit closing	Trunk	do.	215-A	Do.
6	(DIAL)	2Z5514.1	do.	Cut-off	Dial	do.	237-A	Do.
6	(T) (R)	3DB2.39A	Capacitor	2 μ f, 200 volts d-c.	Blocking	do.	139-A	SC-D-5024.
6	(D)	3DB1.41A	do.	1 μ f, 200 volts d-c.	do.	do.	141-A	Do.
6		3Z6002E5-15	Resistor	25 ohms	Shunt (D) capacitor	A. E. Co.	D-281867	Do.
6		3C279-288	Coil	C-288	Repeating coil	do.		SC-D-5745.
6		4C6248	Plug	PL-48	Dial and cord circuits	W. E. Co.	47-A	SC-D-5005.
6		3ES24K	Cord ¹	5-ft, 2-conductor	do.	S-C. T. M.	S-24-K	Do.
6		3ES2A-6.3	Cord and plug ²	S2A cord, 5-ft, 2-conductor, 47A plug.	Dial and cord circuit	W. E. Co.	S2A47A	
6		4B795	Dial ³	A. E. Co. catalog No. AK-41.	Dialing on trunks	A. E. Co.	24A36	SC-D-5015.
6		4B794.8	Dial ⁴	W. E. Co. type LB	do.	W. E. Co.	LB	
6		3DB2.39A	Capacitor	2 μ f, 200 volts d-c.	Contact protection	W. E. Co.	134-A	SC-D-5024.
6		3Z5818AE	Resistor ⁵	600-ohm	Contact protection	W. E. Co.	18AE	SC-D-5024.
6		3Z6060-26	Resistor ⁶	600-ohm, moistureproof	Contact protection	W. E. Co.	18AE	
7		4C9914.5/16	Supervisory signal	Drop type signal	Recall and disconnect signal.	W. E. Co.	56-B	SC-D-5015.
7	(TALK) (RING)	4C5073C-1W	Key	Lever type	Talking and ringing	do.	C1W	SC-D-5020.
8		4B456	Crank	GC-12	Generator operation	do.		SC-D-1983.
8		4B841	Generator	GN-41	Ringing	do.		SC-D-816.
8	(RINGING)	4C5104.98M	Key	Turn-button type	do.	W. E. Co.	498M	SC-D-5017.
8	(POWER RINGING)	6Z516	Receptacle		Receptacle for power ringing.	H. H. I.	7467	SC-D-5027.
9		4C4277	Jack	JK-37	Operator's set	do.		SC-D-2586.
9		3E1611	Cord	CD-611	Grouping	do.		SC-D-5048.
9	(EXT. BAT.)	4C5104.98M	Key	Turn-button type	External battery key	W. E. Co.	498M	SC-D-5017.
9	(BAT. 1 and 2)	4C5104.98M	Key	do.	Battery key	do.		Do.
9			Key ⁷	SW-179	Grouping key	do.		SC-D-6704; fig. 1.
9		4C4909	Key ⁸	Turn-button type	Grouping key	W. E. Co.	498AJ	SC-D-2877 and Spec. 71-670.
9		3C105	Coil	C-105	Induction coil	do.		SC-D-5024.
9		3DA-500-20	Capacitor	0.5 μ f	Blocking	W. E. Co.	141-B	Do.
9		3DA-250-7	do.	0.25 μ f	By-pass	do.	141-D	Do.
9		4Z9730	Varistor	Receiver shunting	Acoustic shock protection.	do.	34-A ¹¹	Do.

Switchboard BD-91 (Cont'd.)

Reference fig. No.	Reference symbol	Stock No.	Name	Description	Function	Manufacturer	Manufacturer's part No.	Signal Corps drawing No.
9, 10		3Z9985	Terminal	TM-85	External battery and telegraph terminals.			RL-A-942.
10		4C5104.98M	Key	Turn-button type.	Night alarm release	W. E. Co.	498M	SC-D-5017.
10		4Z2810	Buzzer	D-c or a-c, 2-6 volts, 10.5 ohms, d-c.	Night alarm.	do	7B	SC-D-5023.
11		4C4823A	Jack	Mounted with keys	Conference circuit.	do	223A	SC-D-5017.
		4C29100	Cord weight ⁹	Flat, 8-11 ounces	Cord return.	S-C-T. M.	6	SC-D-5005.
		4C29419	Cord weight ¹⁰	Single pulley, 9.5 ounces	Cord return.	W. E. Co	119	SC-D-5027.
		3Z2432	Fuse	1 ampere	Line protection	Cook	A-12	SC-D-5023.
		3Z11087	Fastener, cord	Tinned brass.	Cord terminal	W. E. Co	9	SC-D-5023.
		4C2427B.3	Hook, cord	17 per strip	Cord hook	do	7B	D.O.
		3Z737-6	Binding posts	Knurled bakelite top	Telegraph simplex, battery tops.	H. H. E. Inc.	P-3	
		2Z8674.1	Chassis connector	4-conductor, female, metal case.	Grouping switchboards	A. P. Co.	PC4F	
		4E5805	Carbon-block protector mounting.	Bronze springs in insulating base.	Mount unit-discharger units.	Cook		
		4C9873	Designation plate	Steel, 6 11/16 in. long	Secure signals during shipment.	W. E. Co		SC-D-5016.
		4C9870	Designation strip	3/8 in. wide, 5 3/4 in. long	Trunk and line designations.	W. E. Co		
		4C9301	Drop retainer	Steel, 8 15/16 in. long	Secure 56 B drops during shipments.	W. E. Co		SC-D-5016.
		3Z1027	Fuse clip	Phosphor bronze spring clip.	Line and trunk fuse holder.	W. E. Co		SC-D-5029.
		4F2425	Telering	Vibrator type ringing generator, 110-volt, 60-cycle a-c to 90-volt, 20-cycle, a-c.	Ring power supply.	Telkor	H	

1 Supplied with BD-91 and may be used interchangeably with cord and plug (stock No. 3E52A-63).
 2 Supplied with BD-91-B and may be used interchangeably with cord (stock No. 3E52AK).
 3 Supplied with BD-91 and may be used interchangeably with dial (stock No. 4B794.8).
 4 Supplied with BD-91-B and may be used interchangeably with dial (stock No. 4B795).
 5 Supplied with BD-91 and may be used interchangeably with resistor (stock No. 3Z6060-26).
 6 Supplied with BD-91-B and may be used interchangeably with resistor (stock No. 3Z5818AE).
 7 Supplied with BD-91 and may be used interchangeably with key (stock No. 4C4909).
 8 Supplied with BD-91-B and may be used interchangeably with key supplied with BD-91.
 9 Supplied with BD-91 and may be used interchangeably with cord weight (stock No. 4C29419).
 10 Supplied with BD-91-B and may be used interchangeably with cord weight (stock No. 4C29419).
 11 Replaces 33-A varistor.

c. (Superseded.) *Chest set TD-1.*

Stock No.	Name	Description
4B418.....	Chest unit.....	T-26 including the following items:
(4Z6924).....	Strap.....	ST-24.
(4Z6925).....	Strap.....	ST-25.
(3Z8118).....	Switch.....	SW-118.
3E333.....	Cord.....	CC-333, 6 ft., 3-conductor.
4B2358.....	Plug.....	PL-58.

d. **Headset HS-30-(&).**

Stock No.	Name	Description
2B730.....	Headband.....	HB-30.
2B2030 (&).....	Receiver.....	R-30-(&).
2E1620 (&).....	Cord.....	CD-620-(&) 2-conductor.
2B1300.....	Inserts.....	M-300.

e. *Head and chest set HS-19.*

* * * * *

f. (Added.) *Switchboard plug cleaning material.*—The material in the following chart is used with, but is not a part of, telephone central office set TC-12.

Stock No.	Name	Description
6G1516.....	Polish, metal, paste.....	2-ounce box.

g. (Added.) *Tool list.*—The material in the following chart is used with, but is not a part of, telephone central office set TC-12.

Stock No.	Name	Manufacturer	Manufacturer's code No.
6R15461.....	Screw driver, 3'' cabinet.....	Stanley.....	1001-3''.
6R40835.....	Screw driver.....	W. E. Co.....	KS-6854.
6R15520.....	Screw driver.....	do.....	R-8210.
6R41020.....	Socket wrench, relay adjusting.....	do.....	220.
6R4710-6.5.....	Pliers, long-nose.....	do.....	KS-6267.
6R4735-6.1.....	Pliers, duck-bill.....	do.....	KS-6015.
6R41103.....	Adjuster.....	do.....	303.
6R41065B.....	Tool, switchboard (contact bur-nisher).	do.....	265B.
6R38348.....	Tool roll.....	do.....	R-1041.

20. List of manufacturers and their addresses.

Abbreviation	Name	Address
* * W. E. Co..... H. H. E. Inc..... Stanley.....	* * * Western Electric Co..... Hugh H. Eby, Inc..... Stanley Works.....	* * * Kearny, N. J. Philadelphia, Pa. New Britain, Conn.

[A. G. 300.7 (18 Jul 44).]

BY ORDER OF THE SECRETARY OF WAR:

G. C. MARSHALL,
Chief of Staff

OFFICIAL:

J. A. ULIO,
*Major General,
The Adjutant General.*

DISTRIBUTION:

As prescribed in paragraph 9a, FM 21-6: Armies (10); Corps (10); Sv C (10); Dept (10); Def Comd (2); D (2);

I Bn 1 (3); IC 11 (4); Tech Sv (2); Arm & Sv Board (2);

I Bn 1 (3); T/O & E 1-27, 1-37, 1-47, 1-67, 1-117, 1-127, 1-130-1, 1-137, 1-147, 1-167, 1-252, 1-267, 1-277S, 1-317, 1-487S, 1-547, 1-637, 1-757, 1-758, 1-759, 1-767, 1-768, 1-777S, 1-779, 1-1027;

IC 11 (4); T/O & E 11-885, 11-247, 11-18, 11-47, 11-517S, 11-237, 11-97, 11-267, 11-217, 11-107, 11-127, 11-77, 11-257, 11-287, 11-537S, 11-557.

For explanation of symbols, see FM 21-6.

TECHNICAL MANUAL }
 No. 11-336 }

WAR DEPARTMENT,
 WASHINGTON, January 18, 1943.

TELEPHONE CENTRAL OFFICE SET TC-12

SECTION I. General.	Paragraph
Purpose.....	1
Description.....	2
II. Employment.	
Equipment lay-out.....	3
Setting up and connecting equipment.....	4
Switchboard operation.....	5
III. Functioning of parts.	
Switchboard.....	6
Magneto line circuit.....	7
Trunk circuit, dial and common battery manual.....	8
Cord circuit.....	9
Ringing circuit.....	10
Operator's telephone circuit.....	11
Night alarm circuit.....	12
Conference circuit.....	13
Master schematic and wiring diagrams.....	14
Main distributing frame.....	15
Ringing equipment.....	16
IV. Maintenance.	
General.....	17
Packing for Army transportation.....	18
V. Supplementary data.	
List of replaceable parts.....	19
List of manufacturers and their addresses.....	20

SECTION I

GENERAL

	Paragraph
Purpose	1
Description	2

1. Purpose.—Telephone central office set TC-12 is for use at Army Air Forces squadron headquarters and at other headquarters which require one or more telephone switchboards of the capacity described in paragraph 2.

COMPONENT PARTS

Quantity	Article	Approximate shipping size (Inches)	Approximate unit weight (pounds)
4	Battery BA-23 (2 in use, 2 spare) -----	2½ diameter x 6½	2
12	Battery BA-30 (6 in use, 6 spare) -----	2¼ x 1¼ -----	¼
1	Cord CD-452 (10 ft long) -----		2
1	Cord CO-258 (50 ft long) -----		10
1	Ground rod GP-29 -----	36 long x 1½ diameter.	10
2	Head and chest set HS-19 -----		2
1	Maintenance equipment ME-30 in case CS-78.	19¼ x 12¼ x 6 -----	35
1	Converter M-222 -----	8¼ x 6¾ x 6⅝ -----	10½
1	Switchboard BD-91 -----	17 x 18 x 25 -----	215
1	Telering -----	11⅞ x 8⅞ x 4⅞ -----	11
	Total weight approximately -----		308½

2. Description (see figs. 1 and 2).—The switchboard is a complete, transportable, single position, manually operated telephone switchboard, with associated line protection equipment, for serving magneto lines as well as two-way trunks and tie lines. Ring-down trunk circuits are provided which may be used for connection to common battery lines of either manual or automatic central offices. Drop signals are associated with the lines and trunks for signaling incoming calls and also with each cord for recall signals. The line and trunk jacks are wired to commercial type fuses and unit dischargers (carbon protector blocks) mounted on a protector panel in the back of the switchboard. The protectors are in turn wired to binding posts of Signal Corps design which are furnished for terminating incoming lines. A grouping cord is provided for associating two switchboards BD-91 for use as a single installation. The batteries for the talking circuit and for the night alarm buzzer are inserted in a battery case in the rear of the switchboard, where space is also provided for two spare batteries. The remaining spare batteries BA-30 are carried in the CS-78 with maintenance equipment. Terminal facilities are furnished on the lower part of the back of the switchboard for ringing current and external battery. Four simplex coils are permanently included in the first four lines with the telegraph legs wired to binding posts on the rear of the board. A Telering model H ringing machine is mounted in the front cover to

furnish ringing current when 110-volt, 60-cycle a-c power is available, and converter M-222, a battery-operated ringing converter, is provided for emergency use. Each switchboard contains the following:

- 1 operator's position.
- 1 operator's telephone circuit with grouping key.
- 8 cord circuits.
- 1 ringing circuit.
- 20 line circuits, magneto.
- 4 trunk circuits, common battery, manual and dial.
- 1 dial cord circuit.
- 1 conference circuit (4 jacks).
- 1 night alarm circuit.

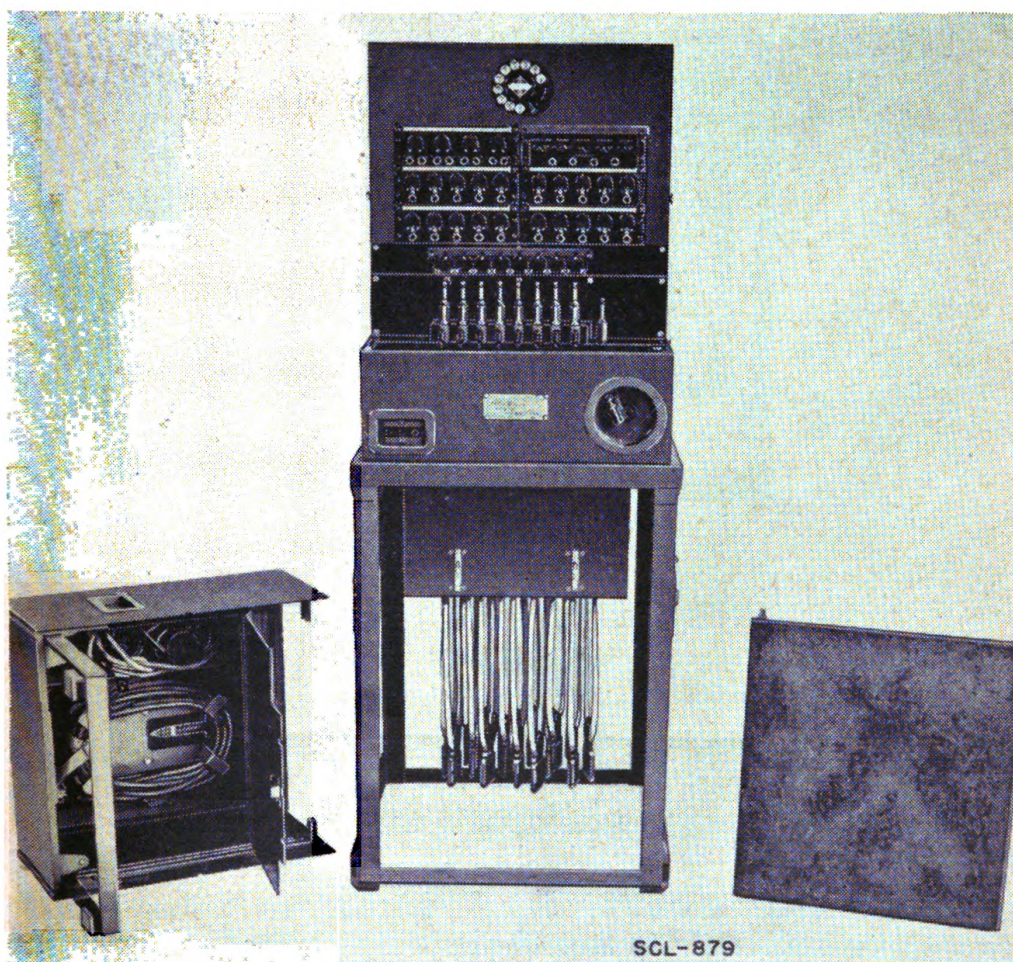

FIGURE 1.—Switchboard BD-91—components.

The over-all size of switchboard BD-91 when prepared for transportation is $17\frac{1}{4}$ by $18\frac{3}{4}$ inches by $25\frac{9}{16}$ inches high. In the operating position, the height of the switchboard is $47\frac{9}{16}$ inches. The approxi-

mate weight is 215 pounds. The switchboard is arranged to be packed within the angle iron base, so that a separate packing case is not necessary for Army transportation.

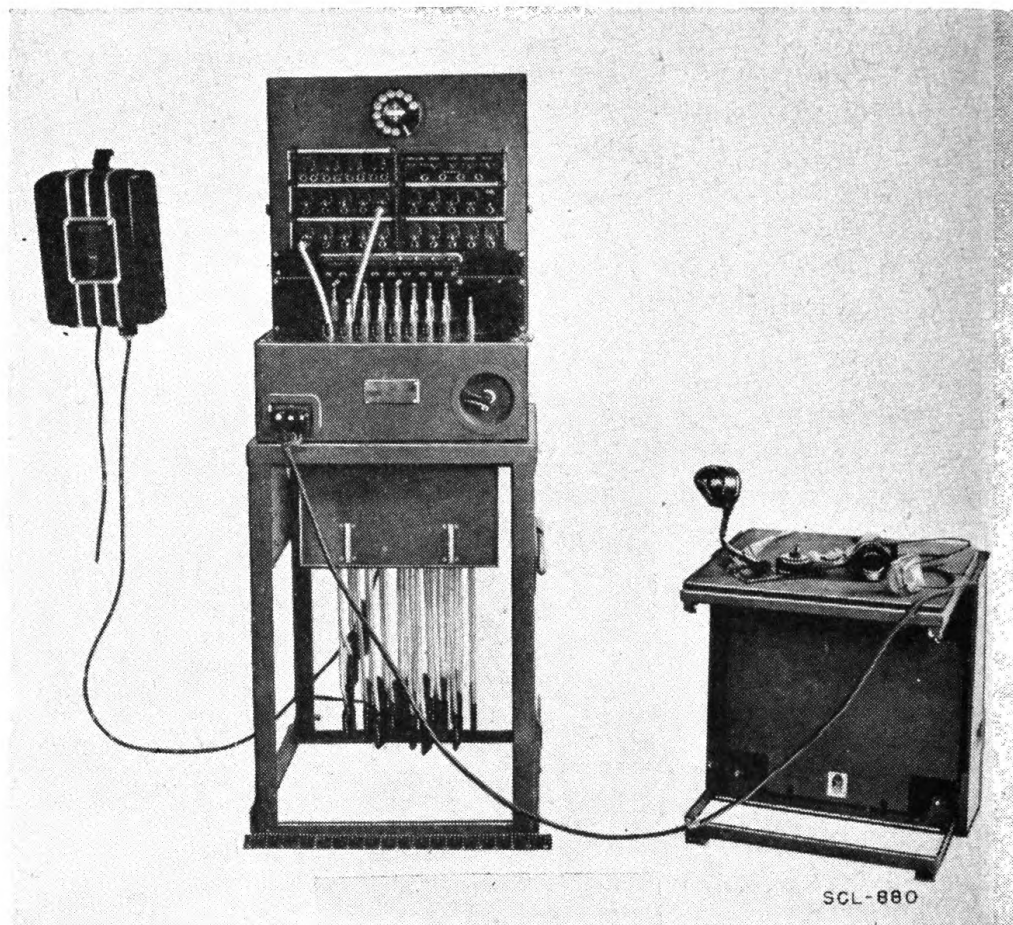

FIGURE 2.—Switchboard BD-91—ready for operation.

SECTION II

EMPLOYMENT

	Paragraph
Equipment lay-out.....	3
Setting up and connecting equipment.....	4
Switchboard operation.....	5

3. Equipment lay-out.—Before starting any installation, the general disposition of the equipment should be decided upon with a view to local conditions.

4. Setting up and connecting equipment.—*a.* Turn the angle iron framework containing the switchboard to an upside down position. Remove the seat top and draw out the extension legs of the base.

b. Turn the base to ease the switchboard outward upon the ground, and lift the base upward. Place the base in the desired operating location. Set the switchboard on the base making sure that the dowels on the switchboard fit into the holes in the top of the base.

c. Unfasten the cord compartment on the bottom of the switchboard and let the cords and weights drop into position. Clamp the switchboard to the base by means of the two wing nut bolts.

d. Remove the front cover of the switchboard and raise the designation strips to permit the drop shutters to fall.

e. Swing the retractable legs out from the open end of the switchboard cover until the side braces snap into the slots. Fit the hooks under the seat top into the holes in the angle brackets and fasten in place by means of the slide bolts for use as an operator's chair.

f. Install eight batteries BA-30 in the compartments in the lower back of the switchboard (see fig. 3). If external battery is to be used for the night alarm circuit, do not install any battery BA-30 in the compartment designated NA BATT.

g. Inspect the switchboard for damaged or loose parts.

h. Connect the incoming lines to the binding posts mounted on the protector panel at the rear of the switchboard (see fig. 4). The first four line circuits are equipped with simplex coils for use when simplex telegraph circuits are desired. The telegraph legs are brought to four binding posts on the back of the protector panel and are designated—

1	2
TELEGRAPH	
3	4

i. When two switchboards *A* and *B* are to be used together in adjacent positions and grouping is desired, connect the grouping cord CD-611 (fig. 4) of switchboard *A* to the receptacle designated **GROUPING** on switchboard *B* and connect the similar grouping cord of switchboard *B* to the receptacle designated **GROUPING** on switchboard *A*.

j. When 110-volt, 60-cycle a-c is available, plug the Telering cable into a convenient outlet. Extend ringing current from the Telering to the switchboard by means of the cord CD-452. The receptacle for this cord on the switchboard is located in the lower back and is designated **POWER RINGING**. The Telering may be removed from the switchboard cover and hung up in a convenient location if desired.

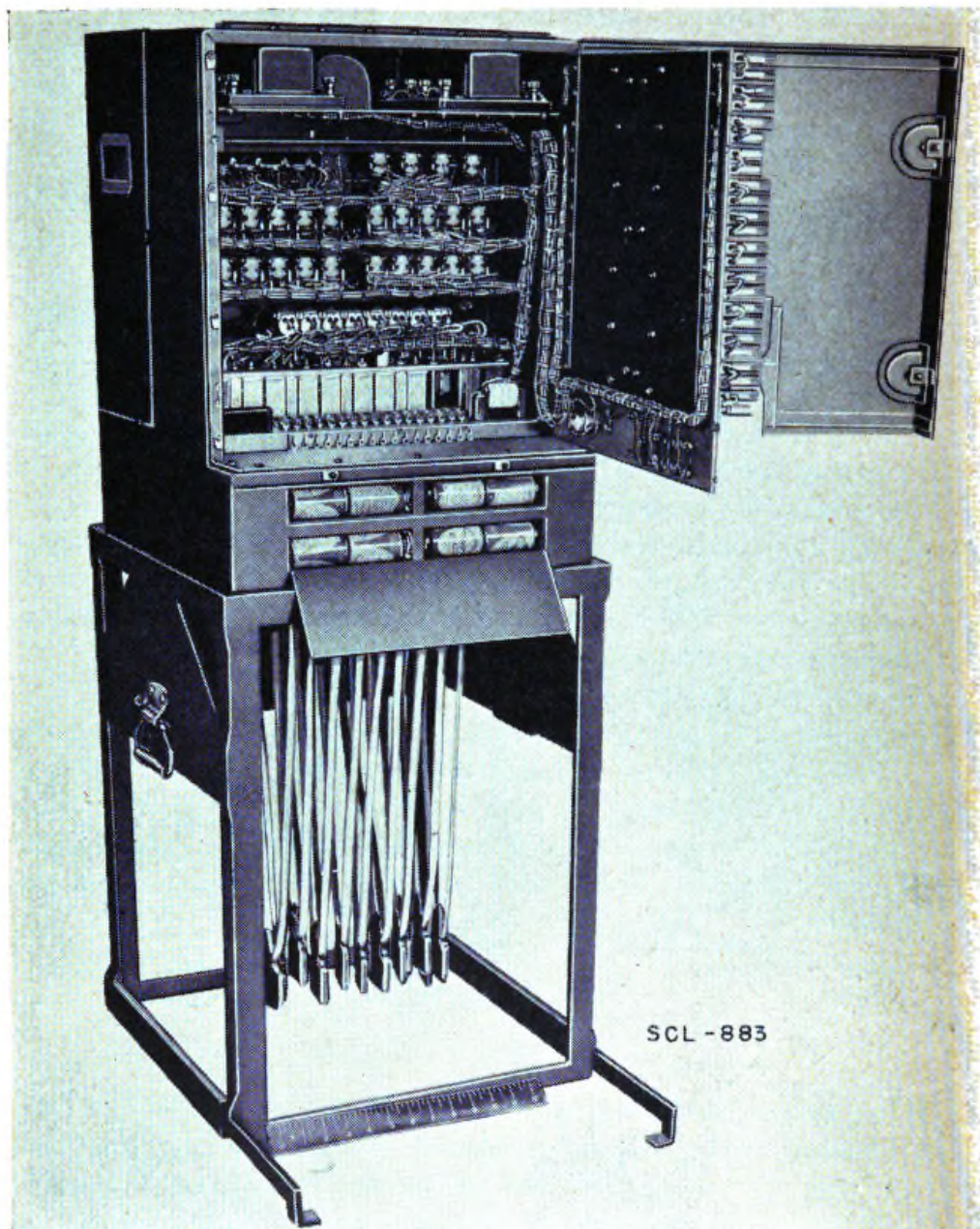

FIGURE 3.—Switchboard BD-91—rear view, showing equipment.

k. When 110-volt, 60-cycle a-c is not available, converter M-222 may be used. The operation of this ringing converter is covered in TM 11-344.

l. Connect cord CO-258 to the GRD terminal on the lower part of the back of the switchboard and to ground rod GP-29 driven into the ground.

m. Plug a head and chest set HS-19 into the jack JK-37 mounted in the front of the key shelf. Two head and chest sets are normally carried in the compartments provided in the front cover.

5. **Switchboard operation.**—The operation of switchboard BD-91 is characteristic of comparable commercial practice. It is to be understood that in station-to-station connections, trunk-to-station connections, etc., *associated* front and back cords must be used.

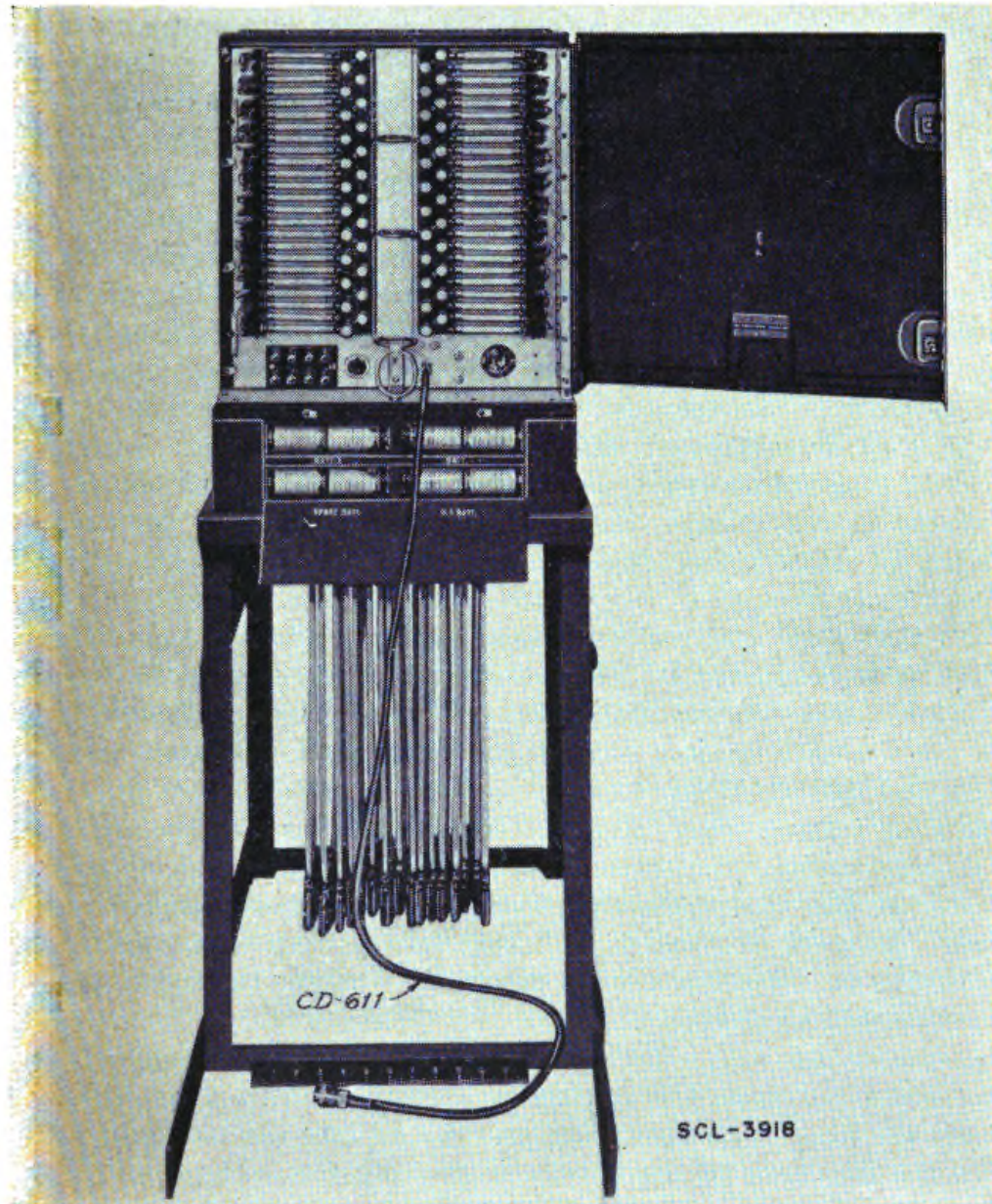

FIGURE 4.—Switchboard BD-91—rear view, covers open.

a. Incoming calls.—Incoming calls on lines or trunks are indicated by drop signals.

b. Answering calls.—When a drop signal operates indicating an incoming call, insert an answering (back) plug into the line or trunk jack associated with the operated drop. If the call is incoming over

a trunk circuit the jack designated L should receive the answering plug. Operate the key associated with the cord being used to the TALK position (away from the operator) and challenge.

c. Originating calls.—To make an outgoing call at the request of a station user, insert the calling (front) plug associated with the proper answering cord into a trunk or line jack in accordance with the following procedure:

(1) *Call to station.*—Insert a calling (front) plug into the line jack of the desired station. Operate the key associated with the cord circuit used to the nonlocking RING position (toward the operator). If the switchboard is supplied with power ringing, operation of the key will ring the station bell. If no power ringing is available, it is necessary to operate the hand generator while holding the key in the RING position. In either case, after each application of ringing current, operate the key to the locking TALK position and listen for an answer from the distant end.

(2) *Call over common battery manual trunk.*—Insert a calling (front) plug into a trunk jack designated L. This will signal the operator at the distant office. Operate the associated key to the TALK position (away from the operator) and await the distant operator's challenge.

(3) *Call over dial trunk.*—Insert a calling (front) plug into a trunk jack designated L. Operate the associated key to the TALK position and listen for dial tone. When dial tone is heard, plug the dial cord plug into the D jack associated with the selected jack, and dial the desired number. Remove the dial cord plug and listen for ringing tone. It is not necessary to ring on the trunk.

d. Supervision.—Supervision is provided by means of drop signals located on the face of the switchboard directly above the associated cords. Ring-off or recall is indicated by the drop shutters falling. Challenge on the connection to determine whether the signal means disconnection or recall.

e. Conference calls.—To connect a number of lines together for conference purposes, the conference circuit is utilized as follows: Insert the plug of an answering (rear) cord into the jack associated with the telephone of the person originating the conference. Then insert the plug of the associated calling (front) cord into a conference circuit jack. Make the other connections to the conference circuit with answering plugs inserted into the conference circuit jacks and the associated calling plugs connected to the desired line circuit jacks. Call each member of the conference in the usual manner.

f. Face equipment keys.—A strip of five turn-button keys is mounted on the face of the switchboard at the top of the right-hand panel (see fig. 1). These keys are designated NIGHT ALARM, RINGING, BATTERY, GROUPING, and EXT BAT, respectively. Their functions are as follows:

(1) *Night alarm key.*—With this key turned to the ON position, an incoming call will cause a buzzer to operate when the drop signal falls. To stop the buzzer, turn the key to the OFF position. If the operation of the buzzer is not desired, leave the key in the OFF position.

(2) *Ringling key.*—With the key turned to the position designated HAND, ringing current must be applied through the use of the hand generator. With the key turned to the position designated KEY, the switchboard is prepared for the application of power ringing current.

(3) *Battery key.*—Cord circuit and transmitter battery are supplied from battery 1 or battery 2. With the key thrown to position 1, energy is supplied from battery 1; in position 2, energy is supplied from battery 2.

(4) *Grouping key.*—When two adjacent switchboards BD-91 are used together as a single installation and it is desired that both boards be attended by one operator, operation of the GROUPING key on the unattended switchboard to the ON position associates the cord circuits of that switchboard with the operator's circuit of the attended switchboard.

(5) *External battery key.*—If battery supply is to be obtained from an external source, operate the EXT BAT key to the ON position.

g. Destruction of equipment.—In the event of danger of capture, this equipment will be destroyed with any hammer, ax, sledge, or other means of destruction available. Destruction will be accomplished in the following order: jacks, drops, keys, fuses, head and chest sets, batteries, and ringing equipment.

SECTION III

FUNCTIONING OF PARTS

	Paragraph
Switchboard.....	6
Magneto line circuit.....	7
Trunk circuit, dial and common battery manual.....	8
Cord circuit.....	9
Ringing circuit.....	10
Operator's telephone circuit.....	11
Night alarm circuit.....	12
Conference circuit.....	13
Master schematic and wiring diagrams.....	14
Main distributing frame.....	15
Ringing equipment.....	16

6. Switchboard.—*a. General.*—The switchboard cabinet, base, and miscellaneous mechanical details were designed for the mounting and assembly of standard telephone apparatus to form a telephone switchboard suitable for military use. The induction coil, operator's jack, head and chest set, and hand generator are of Signal Corps design and are used in other equipment. The remaining apparatus is composed of standard commercial parts.

b. Equipment.—The front equipment lay-out is shown in figures 1 and 2. The rear equipment lay-out is shown in figure 3. The operator's telephone circuit apparatus, dial cord apparatus, and trunk circuit equipment are mounted on a plate running horizontally across the back of the switchboard just above the cord shelf. This equipment can be conveniently removed or replaced after removing the guard on the under side of the plate. The upper part of the switchboard is occupied by the jack and signal equipment.

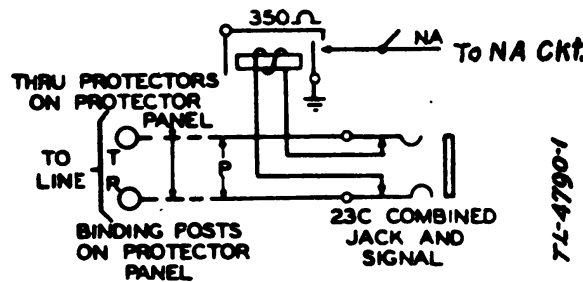

FIGURE 5.—Magneto line circuit.

c. Circuits.—The several circuits are designed to function as covered in paragraphs 7 to 13, inclusive.

7. Magneto line circuit (fig. 5).—This circuit is for use with equipment which furnishes 16- to 20-cycle ringing current for signaling. As direct current is not applied to the line through this circuit,

it cannot be used with telephones or circuits that require an external source of transmitter current or that require direct current for supervisory purposes. The application of ringing current to this circuit from the line causes the drop shutter to fall. When a plug is inserted into the jack, the shutter is automatically restored by mechanical means and the winding of the drop is disconnected from the line at the cut-off contacts in the jack. Contacts are furnished on the drop shutter which close a night alarm circuit and provide, when desired, for an audible signal when a shutter falls. This circuit may be connected to the following types of equipment or circuits:

- a. Military local battery (magneto) telephone such as telephones EE-3, EE-4, EE-5, and EE-8.
- b. Commercial local battery (magneto) telephones.
- c. Magneto line circuits in switchboards BD-14, BD-71, BD-72, BD-80, BD-89, BD-91, and BD-96 and in commercial switchboards.
- d. Line circuits equipped with ring-down relays and arranged for two-way ringing in switchboards BD-74 and BD-78 and in commercial switchboards.

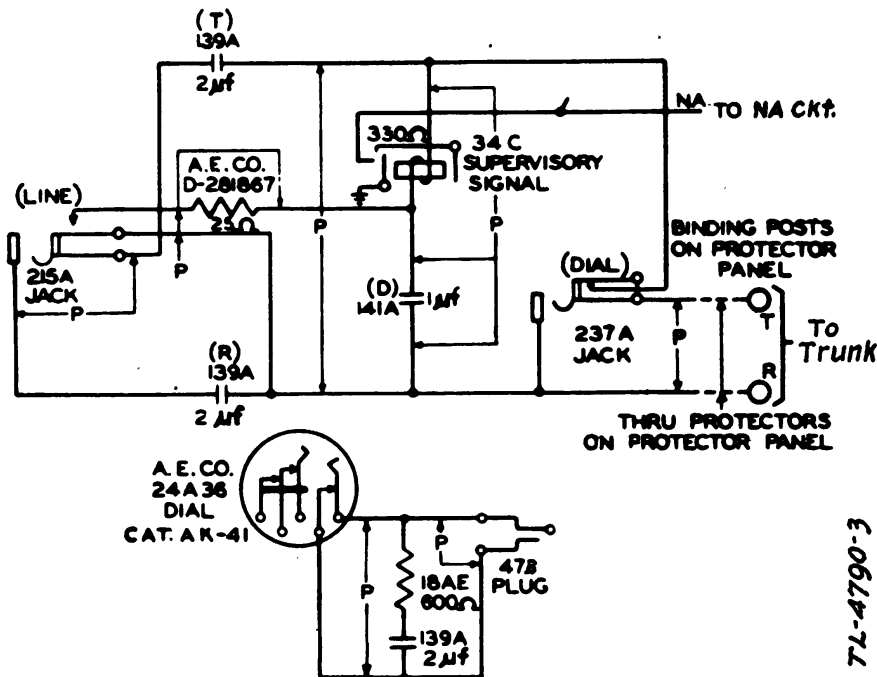

FIGURE 6.—Trunk circuit and dial cord circuit.

8. Trunk circuit, dial and common battery manual (fig. 6).—This circuit is for use with common battery central office equipment of either manual or dial type. It may be connected in place of any common battery manual or dial (automatic) telephone.

- a. The application of ringing current at the distant end of the line causes the associated drop shutter to fall. A contact on the shutter

connects ground to the NA lead to operate an audible signal. When an answering plug is inserted in the line jack, a circuit is closed to bridge the coil of the drop across the line as a holding bridge. This action extends supervision to the central office and cuts off automatic ringing current.

b. On outgoing common battery manual calls, the insertion of the calling plug in the line jack places the coil of the drop across the line which signals and extends supervision to the central office operator without the necessity of ringing on the line.

c. On outgoing dial (automatic) calls the insertion of the calling plug in the line jack and the subsequent connection of the coil across the line seizes the central office equipment. The operator then inserts the dial cord plug in the dial jack which disconnects the coil from the trunk and closes a holding bridge for the trunk through the dial impulse springs (see fig. 6). The operator dials the desired number, causing the switch train at the central office to complete the connection. After the dialing is completed the dial cord is removed from the dial jack and the trunk is again held through the drop.

d. When the plug is removed from the jack upon completion of a call, the trunk-holding bridge is opened, signaling the central office operator in the case of a manual call and allowing the central office equipment to release in the case of a dial call.

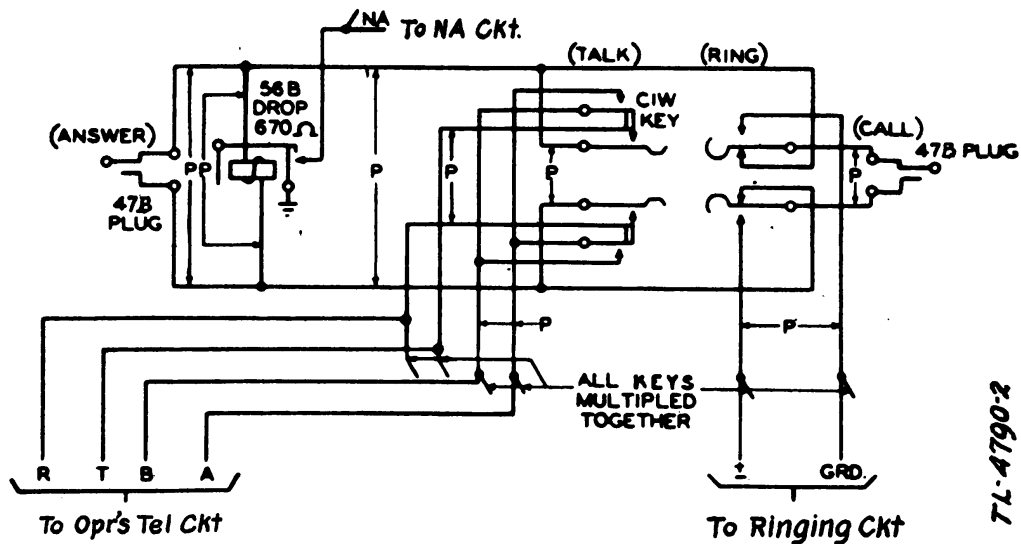

FIGURE 7.—Cord circuit.

9. **Cord circuit** (fig. 7).—These cord circuits are limited to use with magneto lines because ringing current must be applied to at least one of the lines connected to the cord circuit in order to actuate recall or disconnect signaling equipment. This signaling equipment consists of supervisory drops, one of which is associated with each pair of cords. The drops are located in the face of the switchboard.

a. When, on incoming calls, the plug of the answering cord is inserted in the line jack, the supervisory signal is bridged across the tip and ring of the line to provide for ring-off supervision. The operator answers the call with the TALK key in the operated position.

b. On outgoing calls the plug of the calling cord is inserted into the line jack. Upon operation of the ringing key, ringing current is applied to the line if the ringing machine is operating; if not, the circuit is prepared for the operation of the hand generator. Except when ringing, the TALK key is operated until connection has been made to the called line.

c. When a conversation is completed, ringing current should be applied to the line by the telephone user or distant switchboard operator. The ringing current from either source will operate the supervisory drop, thus providing a disconnect signal. When a common battery trunk is associated with the cord circuit, ringing current for the operation of the supervisory signal must be supplied over the magneto line which has been involved in the trunk connection.

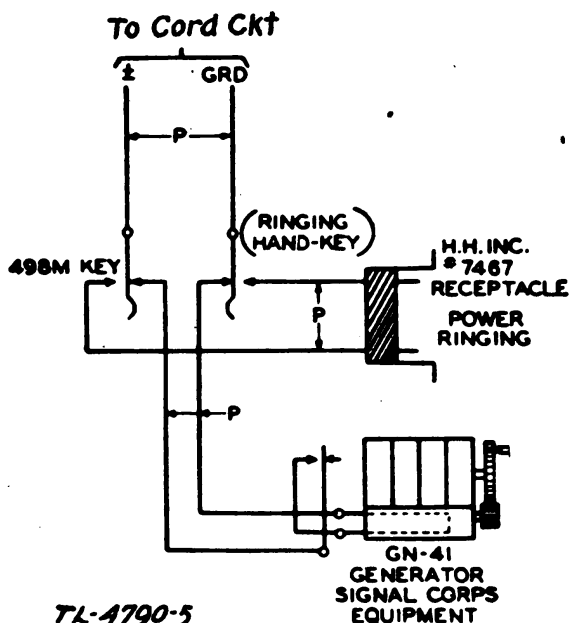

TL-4790-5

FIGURE 8.—Ringing circuit.

10. Ringing circuit (fig. 8).—This circuit provides a switching key and a receptacle to connect either hand or power ringing to the cord circuit. With the key in the HAND position, the circuit is prepared to supply ringing current from the hand generator GN-41. With the key in the KEY position and the ringing machine (Teleting or ringing converter M-222) connected through the power ringing receptacle, the circuit is prepared to supply ringing current

from a commercial power supply or from batteries. The receptacle for connecting to external ringing is located at the bottom of the protector panel.

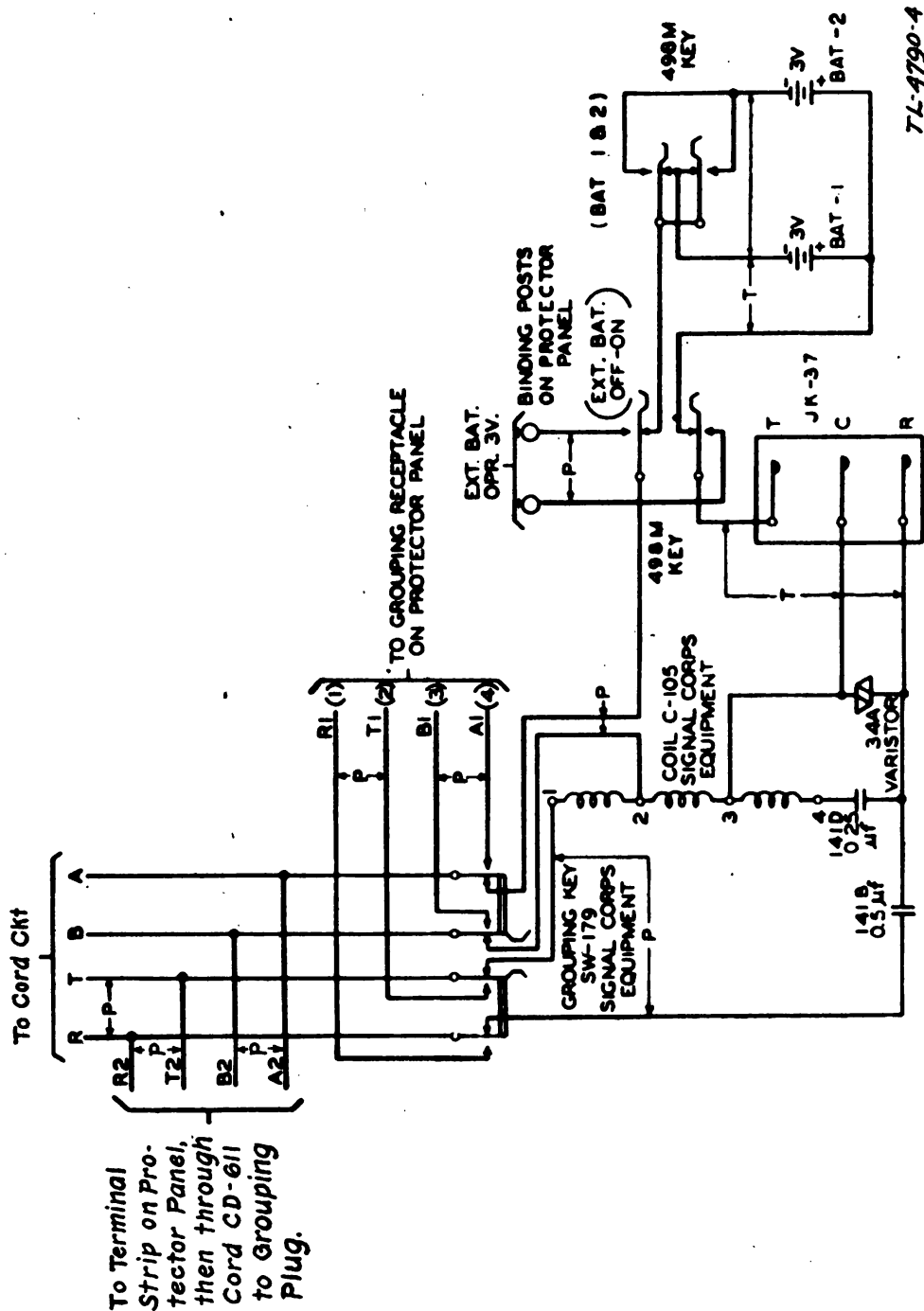

FIGURE 9.—Operator's telephone circuit.

11. Operator's telephone circuit (fig. 9).—An antisidetone telephone circuit using induction coil C-105 is used in this switch-board. Operation of the TALK key associated with the cord circuit closes the transmitting circuit through the A and B leads to provide

direct current talking battery to the operator's transmitter. A varistor is bridged across the receiver terminals to reduce the acoustic shock to the operator which might be caused by excessive voltages. The varistor consists of an arrangement of copper oxide disks the resistance of which decreases as the voltage increases, thus reducing the current through the receiver. Binding posts for the external battery terminals are mounted on the terminal strip on the bottom of the protector panel. A receptacle and a terminal strip for the grouping connections are provided on the protector panel. The A2, B2, T2, and R2 leads extend the talking battery leads and the T and R leads of the cord circuits to the terminal strip from the TALK key. The grouping cord (CD-611) is wired to the terminal strip and is provided with a locking plug to connect to the grouping receptacle of an adjacent switchboard BD-91. The receptacle is connected to the normally open contacts of the grouping key SW-179 by the A1, B1, T1, and R1 leads. When the grouping key is operated the cord circuits of that switchboard are associated with the operator's telephone circuit of an adjacent switchboard through the A1, B1, T1, and R1 leads and the grouping cord CD-611. Head and chest set HS-19 may be connected to the operator's telephone circuit by means of a plug PL-58 and the jack JK-37 located on the left front of the key shelf.

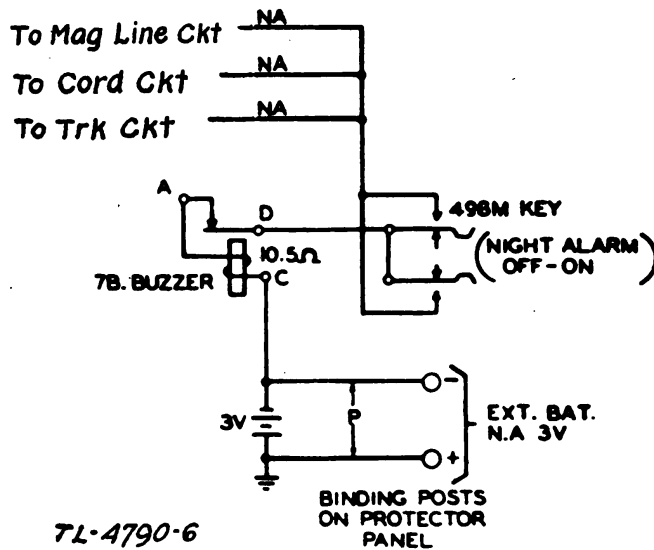

FIGURE 10.—Night alarm circuit.

12. Night alarm circuit (fig. 10).—This is a conventional night alarm circuit in which the operation of a drop signal completes a circuit from ground through the night alarm buzzer to negative battery, thereby giving an audible signal. The battery is normally in the battery compartment in the back of the switchboard. Ter-

minals are provided for an external battery. When an external battery is used, no battery should be left in the compartment. The key which controls the operation of the night alarm is located in the top of the face equipment.

13. Conference circuit (fig. 11).—This circuit consists of four jacks wired in parallel for connecting a maximum of four lines together for conference purposes. Cord circuits should be used for connecting the various lines to the conference circuit.

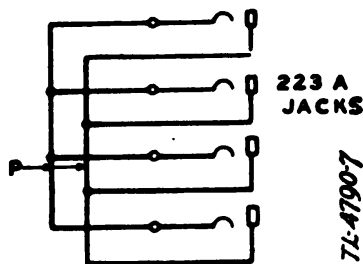
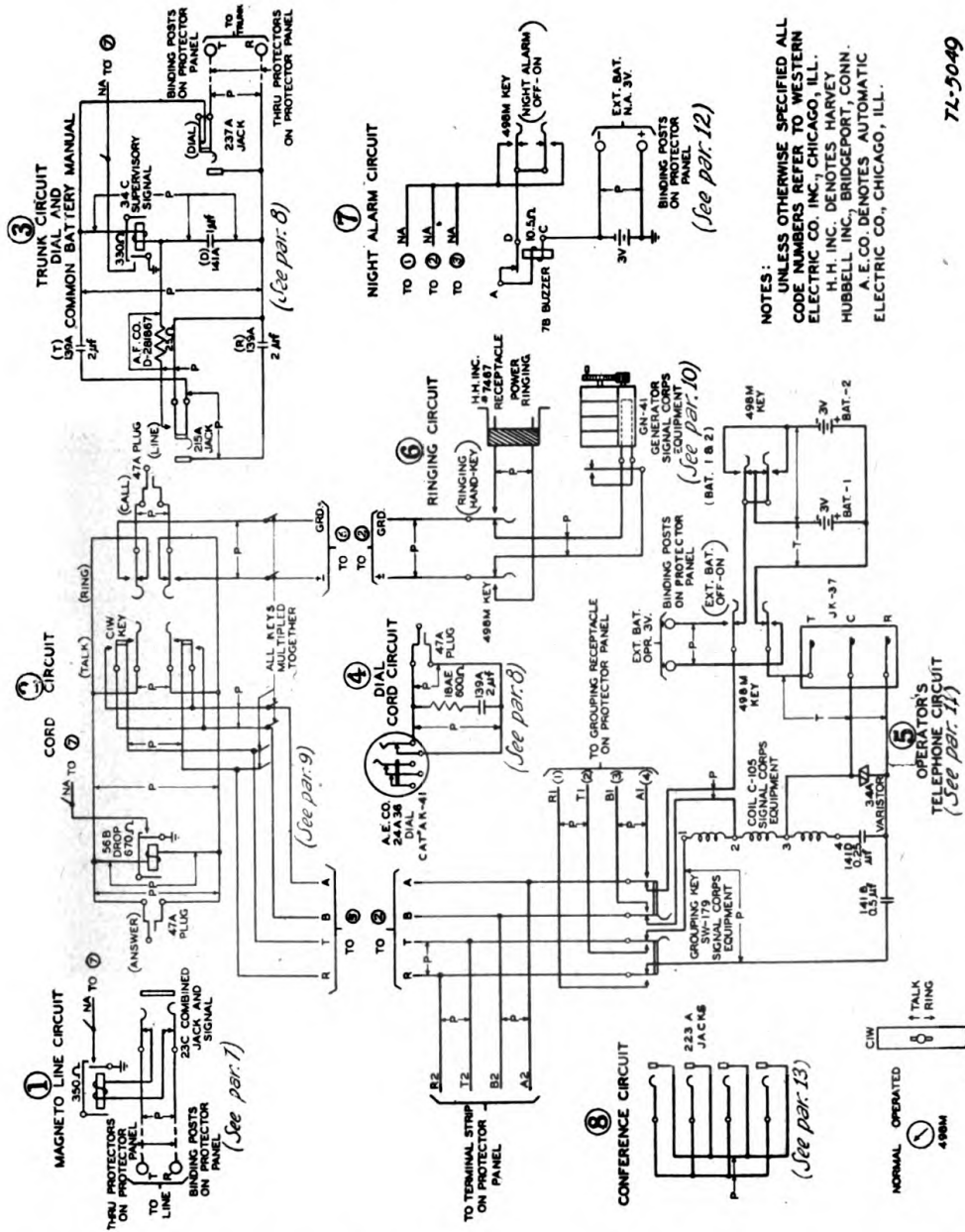

FIGURE 11.—Conference circuit.

14. Master schematic and wiring diagrams.—Figure 12 shows all the various circuits of switchboard BD-91 in schematic form and shows their interconnection. Figures 13 and 14 show the wiring diagrams for switchboard BD-91.

15. Main distributing frame.—*a.* The terminal equipment is mounted in the rear of the switchboard. The arrangement of the apparatus is shown in figure 4. An opening with a cover is provided in the bottom center of the rear door to permit the closing of the door while the switchboard is in use. Four simplex coils C-288 are permanently wired in the first four line circuits. The telegraph binding posts are mounted on the lower part of the panel with the binding posts for external batteries.

b. Two vertical rows of 12 pairs of 1-ampere fuses and 12 pairs of unit dischargers each are mounted on the protector panel. The unit dischargers consist of two carbon protector blocks for each line wire, one block connected to the ground strap and the other tapped on the wire from the fuse to the drop. A definite air gap between the two blocks is provided by a thin spacer of insulating material. The air gap is large enough to insulate the normal currents in the line wire from ground but provides a path to ground for foreign voltages high enough to damage the telephone equipment. Two terminal strips, each of 24 binding posts of Signal Corps design, are mounted in the center of the panel for connecting the incoming line wires. These terminals are permanently wired to the line side of the fuses and protector blocks.



NOTES:
UNLESS OTHERWISE SPECIFIED ALL
CODE NUMBERS REFER TO WESTERN
ELECTRIC CO. INC., CHICAGO, ILL.
H. H. INC. DENOTES HARTY,
HUBBELL INC., BRIDGEPORT, CONN.
A. E. CO. DENOTES AUTOMATIC
ELECTRIC CO., CHICAGO, ILL.

71-5049

FIGURE 12.—Switchboard BD-91—master schematic diagram.

16. Ringing equipment. — *a. Power ringer, 20-cycle (Telering).*—The Telering 20-cycle power ringer is a vibrating reed type of frequency converter. The reed vibrates between a contact screw and an electromagnet. The contact screw is set at the factory, and it is suggested that no change be made in the adjustment unless the reed vibrates in a surging manner or there is sparking at the contact. If sparking occurs, it requires only the slightest turn on the contact screw, either inward or outward, to correct it. However, it is seldom that any change will be necessary. The adjustment of the Telering contact is practically opposite to that of other vibrating type power

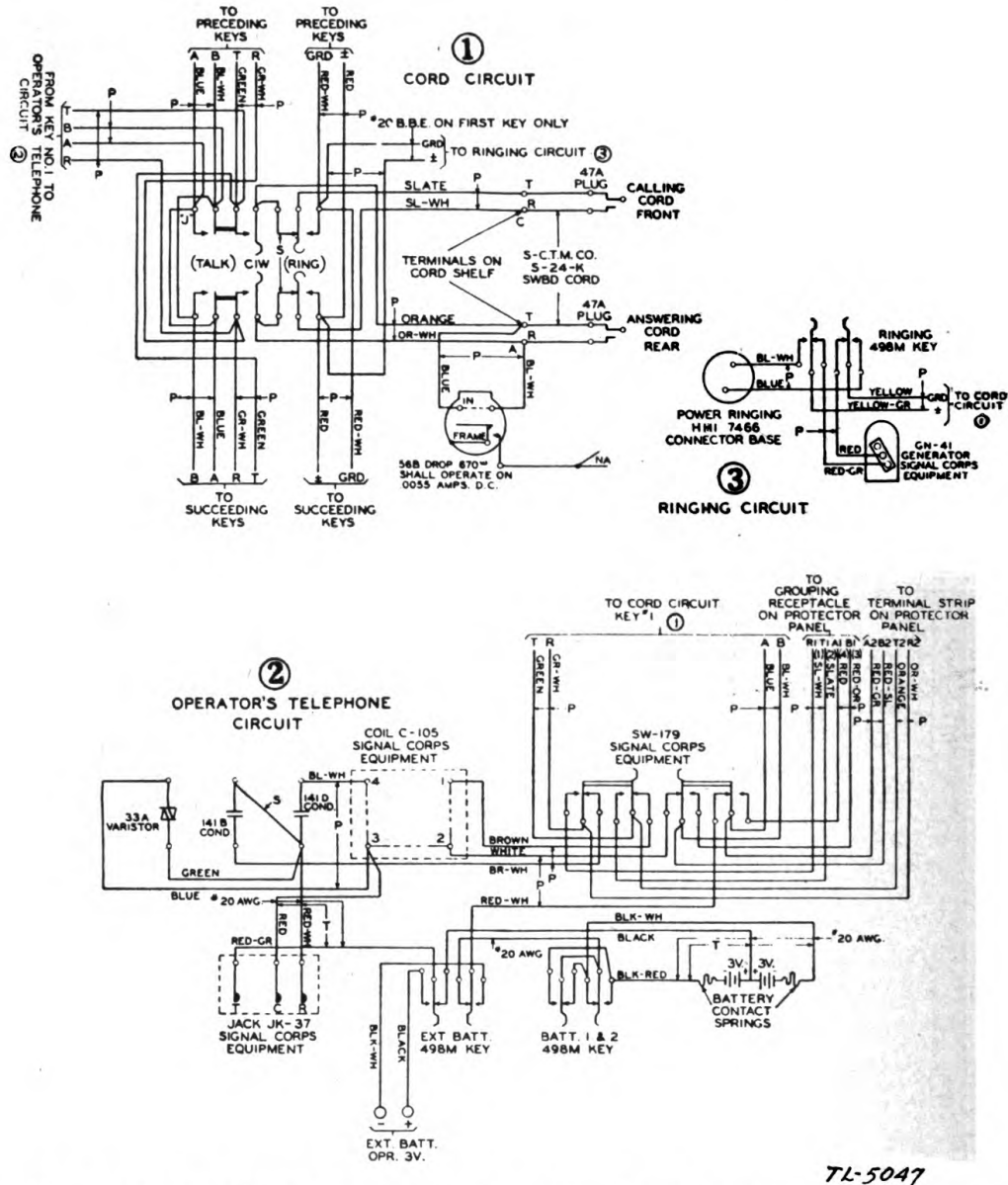

TL-5047

FIGURE 13.—Switchboard BD-91—wiring diagrams of cord, operator's telephone, and ringing circuits.

ringers, in that the contact gap in the Telering must be kept *as wide as possible*. Closing the contact gap does not increase the output, but instead will upset the adjustment, causing sparking, interference with radio reception, and may prevent starting. (See fig. 15.)

b. Converter M-222.—Converter M-222 is described in TM 11-344.

Generated on 2015-09-21 19:36 GMT / http://hdl.handle.net/2027/uc1.b3245457 Public Domain, Google-digitized / http://www.hathitrust.org/access_use#pd-google

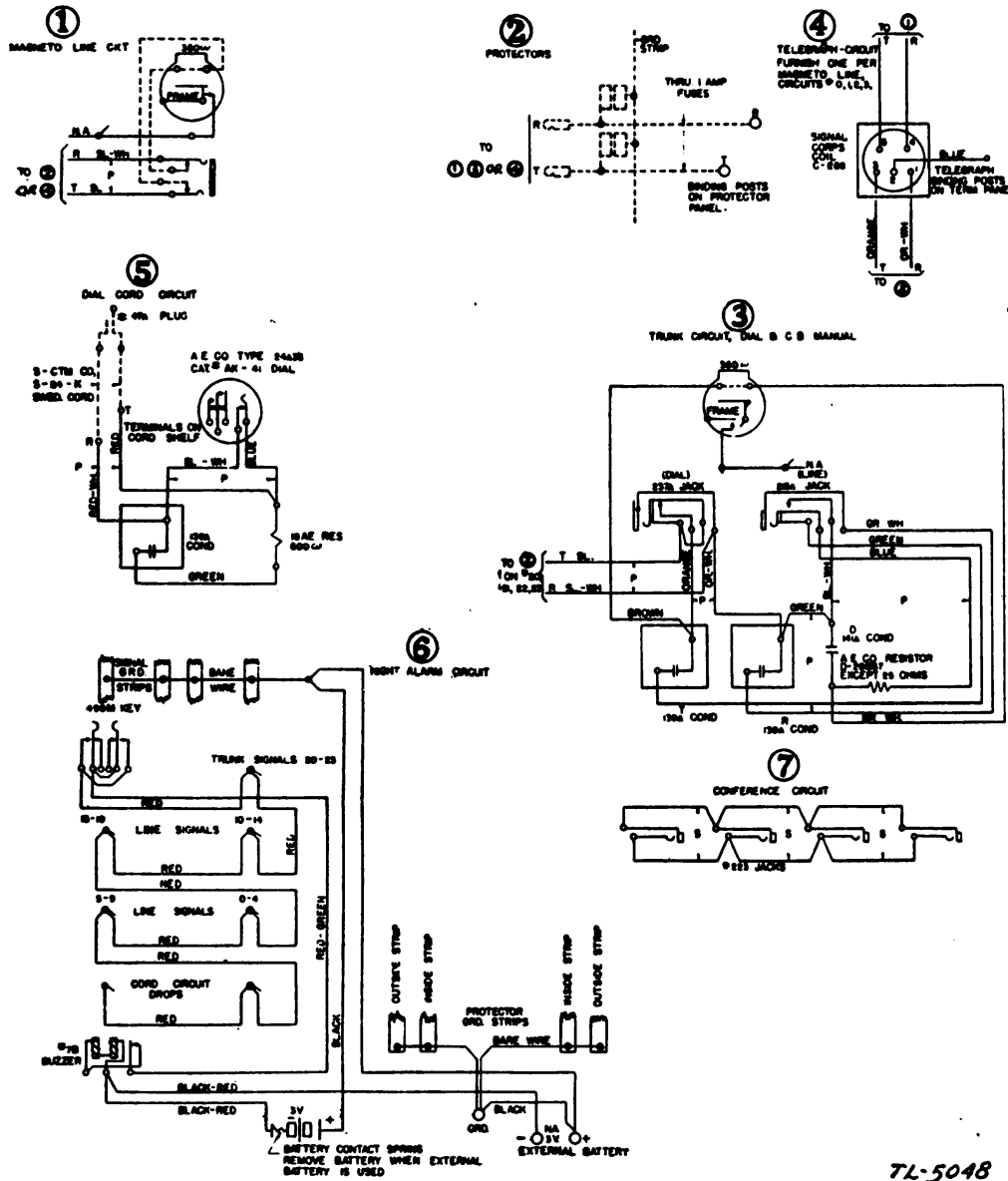

FIGURE 14.—Switchboard BD-91—wiring diagrams of line, trunk, and miscellaneous circuits.

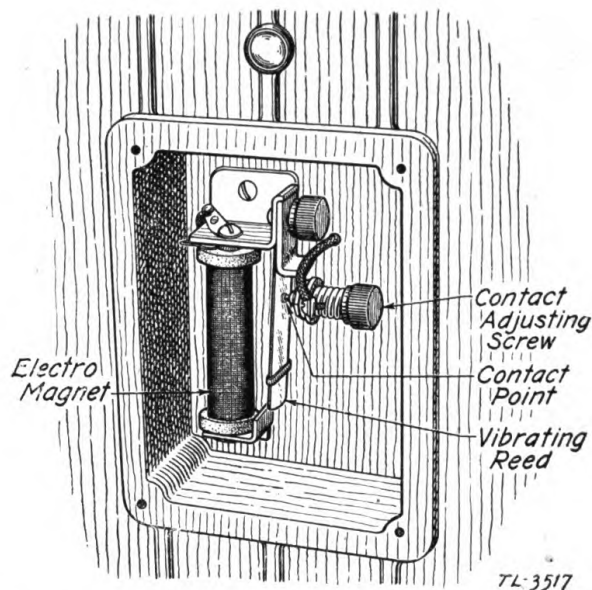

FIGURE 15.—Teling 20-cycle power ringer—cover removed, showing vibrator assembly.

SECTION IV

MAINTENANCE

	Paragraph
General	17
Packing for Army transportation	18

17. General.—The greatest single factor in trouble-free operation is careful handling of the equipment while packing and unpacking, transporting, and installing. After the installation has been completed, tests of all circuits should be made at least once each month or as often as required. Test the magneto line drops, the trunk drops, and the supervisory drops for proper operation by ringing through several miles of field wire. All fuses and carbon protector blocks should be inspected periodically with the circuits. In order to maintain high grade transmission through the cord circuits, all plugs should be cleaned as often as required to maintain brightness, using a light oil and cake rouge, and taking care to remove thoroughly all surplus polishing material.

18. Packing for Army transportation.—*a.* Remove the seat top from the front cover of the switchboard. Fold the retractable legs up into the cover. Disconnect the cords to the ringing machine from the power outlet and from the switchboard.

b. Place the ringing machine in the compartment provided in the front cover and fasten with the clamp and thumbscrews. Coil the ringing machine cord and cord CD-452 around the guides on top of the clamp. Place head and chest sets HS-19 in the proper compart-

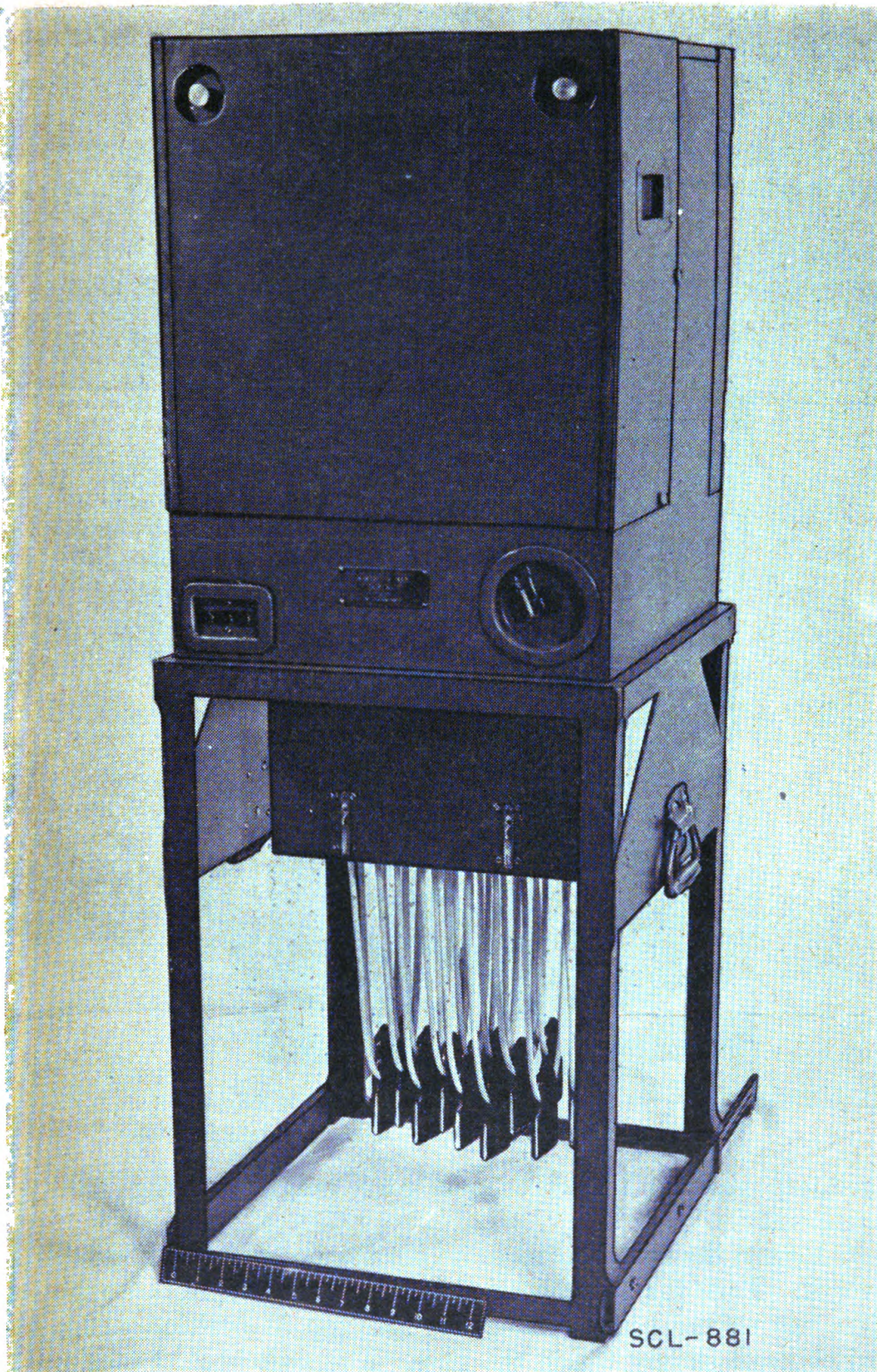

FIGURE 16.—Switchboard BD-91—front cover in place.

ments in the front cover. Adjust the designation strip mounting and the clamp over the supervisory drops to clamp the line, trunk, and supervisory drop shutters.

c. Fit the front cover in place and fasten the switchboard by tightening the two thumbscrews (fig. 16).

d. Remove the batteries from the battery compartment to prevent corrosion of the switchboard.

e. Separate the switchboard and base by loosening the wing nuts underneath the switchboard. Turn the switchboard upside down to

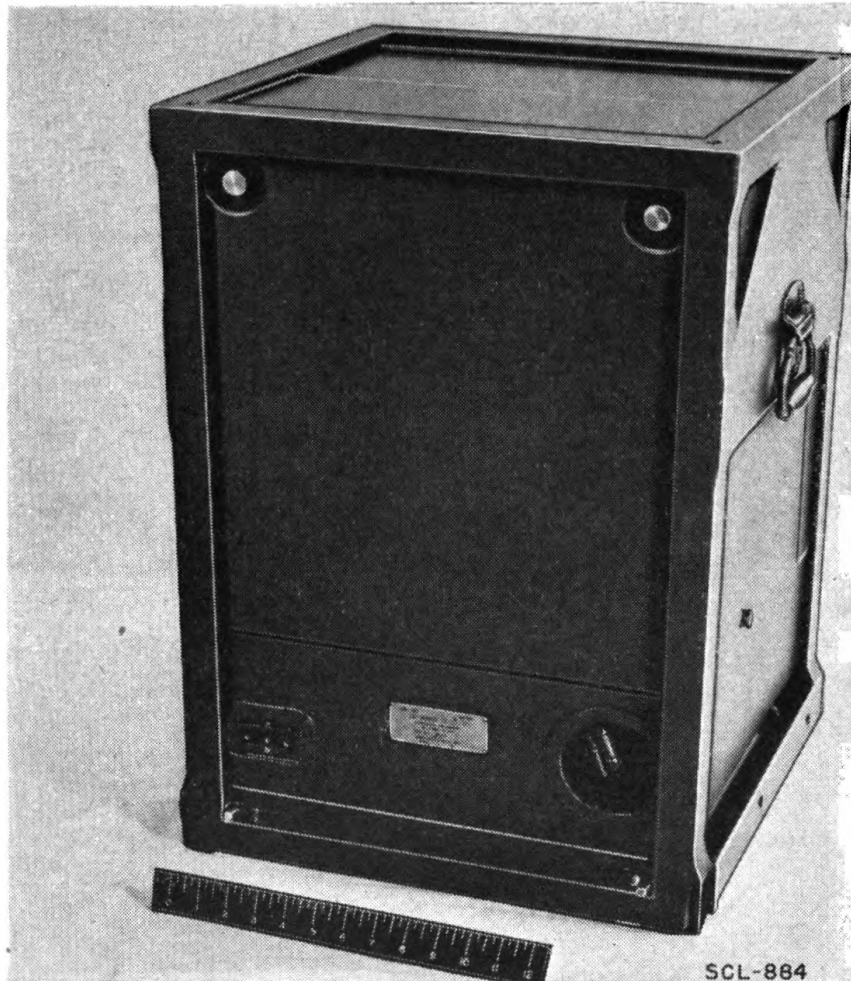

FIGURE 17.—Switchboard BD-91—packed for transportation.

facilitate packing the cords and cord weights in the cord compartment.

f. Return the switchboard to its normal position and slide the base over it. Turn the switchboard and base over and restore the extension legs on the base. Clamp the seat top in position to hold the switchboard snugly inside the base. The switchboard unit is then packed and ready for Army transportation (fig. 17).

SECTION V

SUPPLEMENTARY DATA

List of replaceable parts	Paragraph 19
List of manufacturers and their addresses	20

19. List of replaceable parts.—*a. Telephone central office TC-12 complete.*

Stock No.	Name	Description	Function	Reference paragraph
3A23	Battery	BA-23	For ringing converter M-222.	
3A30	Battery	BA-30	Talking and night alarm circuit.	
	Cord	CD-452	Ringing cord	
3E2258	Cord	CO-258	Ground connection	
3Z3329	Ground rod	GP-29	Ground	
4B1279	Head and chest set	HS-19	Operator's set	19d
	Maintenance equipment.	ME-30 (in case CS-78).	Maintenance	19c
	Ringing converter	M-222	Emergency ringing current.	
	Switchboard	BD-91	Switching central	19b
	Telering	Telkor model H	A-c power ringing	

SIGNAL CORPS

b. Switchboard BD-91.

Reference fig. No.	Reference symbol	Stock No.	Name	Description	Function	Manufacturer	Manu- facturer's part No.	Signal Corps drawing No.
5		4C4623C-1	Jack and signal combined.	Self-restoring drop with jacks.	Line signal and jack	W. E. Co.	23-C	SC-D-5015.
5 and 6			Unit discharger	Carbon protector blocks.	Line protection	Cook	2612	SC-D-5027.
5 and 6			Binding post	TM-198	Line and trunk			SC-D-5052.
6			Supervisory signal	Drop type signal	Trunk signal and holding bridge.	W. E. Co.	34-C	SC-D-5018.
6	(LINE)		Jack	Circuit closing	Trunk	do	215-A	Do.
6	(DIAL)		do	Cut-off	Dial	do	237-A	Do.
6	(T) (R)	3DB2.39A	Capacitor	2 μ f	Blocking	do	139-A	SC-D-5024.
6	(D)	3DB1.41A	do	1 μ f	do	do	141-A	Do.
6			Resistor	25-ohm	Shunt (D) capacitor	A. E. Co.	D281867	Do.
6		4C6248	Coil	C-288	Repeating coil	W. E. Co.	47-A	SC-D-5745.
6		3ES24K	Plug	PL-48	Dial cord circuit	S-C. T. M.	S-24-K	SC-D-5005.
6		4B795	Cord	5-ft., 2-conductor	do	A. E. Co.	24A36	Do.
6			Dial	A. E. Co. catalog No. A K-41.	do			SC-D-5015.
6		3DB2.39A	Capacitor	2 μ f	Contact protection	W. E. Co.	139-A	SC-D-5024.
6		3Z5818AE	Resistor	600-ohm	Contact protection	W. E. Co.	18A.E	SC-D-5024.
7			Plug	2-conductor	Cord circuit	do	47-B	SC-D-5005.
7		3ES24K	Cord	5-ft, 2-conductor	do	S-C. T. M.	S-24-K	Do.
7		4C9914.5/16	Supervisory signal	Drop type signal	Recall and disconnect signal	W. E. Co.	56-B	SC-D-5015.
7	(TALK) (RING)		Key	Lever type.	Talking and ringing	do	C1W	SC-D-5020.
8		4B456	Crank	GC-12	Generator operation			SC-D-1983.
8		4B841	Generator	GN-41	Ringing			SC-D-816.
8	(RINGING) (POWER RING- ING).		Key	Turn-button type.	do	W. E. Co.	498M	SC-D-5017.
8			Receptacle		Receptacle for power ringing	H. H. I.	7467	SC-D-5027.
9		4C4277	Jack	JK-37	Operator's set			SC-D-2586.
9			Cord	CD-611	Grouping			SC-D-5048.
9	(EXT. BAT.)		Key	Turn-button type.	External battery key	W. E. Co.	498M	SC-D-5017.
9	(BAT. 1 and 2)		Key	do.	Battery key	do	do	Do.

9.	Key	SW-179	Grouping key		SC-D-6704; fig. 1.
9.	Coil	C-105	Induction coil		SC-D-2877 and Spec. 71-670.
9.	Capacitor	0.5 μ f	Blocking	141-B	SC-D-5024.
9.	do	0.25 μ f	By-pass	141-D	Do.
9.	Varistor	Receiver shunting	Aconstic shock protection	34-A *	Do.
9, 10.	Terminal	TM-85	External battery and telegraph terminals.		RL-A-042.
10.	Key	Turn-button type	Night alarm release	498M	SC-D-5017.
10.	Buzzer		Night alarm	7B	SC-D-5023.
11.	Jack	Mounted with keys	Conference circuit	223A	SC-D-5017.
	Cord weight	Flat, 8-11 ounces	Cord return	6	SC-D-5005.
	Fuse	1 ampere	Line protection	A-12	SC-D-5027.
	Fastener, cord	Tinned brass	Cord terminal	9	SC-D-5023.
	Hook, cord	17 per strip	Cord hook	7B	Do.

* Replaces 33-A varistor.

c. Maintenance equipment ME-30.

Quantity	Stock No.	Name	Description	Manufacturer	Manufacturer's part No.	Signal Corps drawing No.
1		AX	Single edge, 4-lb head			
2	3A30	Battery				SC-A-535-C.
1		Case				SC-A-548-F, SC-D-5152-C.
50 ft.		Cordage	Rubber covered, black, 2-conductor No. 18 AWG.	G. E. Co.	Type S-J.	
1	6R24508	Copper, soldering	Without handle, 1/2-lb			
1	6Z4002	Flashlight	TL-122A			
1	6Q51185-5	Handle	Wood, 5', for soldering iron			
1	6Z6896	Lamp with extension cord.	60-watt, 120-volt with 25-ft cord equipped with plug of separable type, Edison base.	G. E. Co.	9X282	
32		Nut	Hex, for #8-32, electro-galvanized.			
1	6R4513	Pliers	TL-13			SC-A-534-D.
1	6R4603	do	TL-103			SC-A-533-B.
1	6R4626	do	TL-126			SC-A-902-A.
1		Scissors	Electrician's, 5'			
1	6R15210	Screw driver	TL-15			

32		Screw	Machine, #8-32, 3/4", RHB, electro-galvanized.	
10 ft.	6Nu531	Solder	M-31	
1	6R24617	Soldering iron	TL-117	
1 roll	6N8583	Tape	TL-83	
1	6R42167	Torch	TL-130	
1 lb	6Z8813	Twine	RP-13	
32		Washer	Kantlink spring washers for #8-32" machine screws.	M. M. & M.
1	6R55006	Wrench	TL-111	

d. Head and chest set HS-19.

Stock No.	Name	Description
4B418	Chest unit	T-26, composed of the following items (stock number in parentheses):
(4Z6924)	Strap	ST-24.
(4Z6925)	do	ST-25.
(3Z8118)	Switch	SW-118.
3E333	Cord	CC-333, 6-foot, 3-conductor.
3E337	do	CC-337, 20-inch, 2-conductor.
4C4153BA	Head band	
4C4153BA/1	Pad	Leather.
4B2358	Plug	PL-58.
4B2522	Receiver	R-22.

20. List of manufacturers and their addresses.

Abbreviation	Name	Address
A. E. Co	Automatic Electric Company	Chicago, Ill.
A. P. Co	American Phenolic Company	Chicago, Ill.
Cook	Cook Electric Company	Chicago, Ill.
E. L. I.	Electronic Laboratories, Inc.	Indianapolis, Ind.
G. E. Co	General Electric Company	Schenectady, N. Y.
H. H. I.	Harvey Hubbell, Inc.	Bridgeport, Conn.
M. M. & M.	Manning, Maxwell & Moore, Inc.	Bridgeport, Conn.
S-C. T. M.	Stromberg-Carlson Telephone & Manufacturing Company.	Rochester, N. Y.
Telkor	Telkor, Inc.	Elyria, Ohio.
W. E. Co	Western Electric Co.	Kearny, N. J.

[A. G. 062.11 (12-18-42).]

BY ORDER OF THE SECRETARY OF WAR:

G. C. MARSHALL,
Chief of Staff.

OFFICIAL:

J. A. ULIO,
Major General,
The Adjutant General.

DISTRIBUTION:

IBn 1 (3); IC 11 (4).
(For explanation of symbols see FM 21-6.)