



Level



Pressure



Flow



Temperature



Liquid  
Analysis



Registration



Systems  
Components



Services



Solutions

## Operating Instructions

# Prosonic S FMU90

Flow Measurement

Backwater and Dirt Detection

Totalizers and Counters

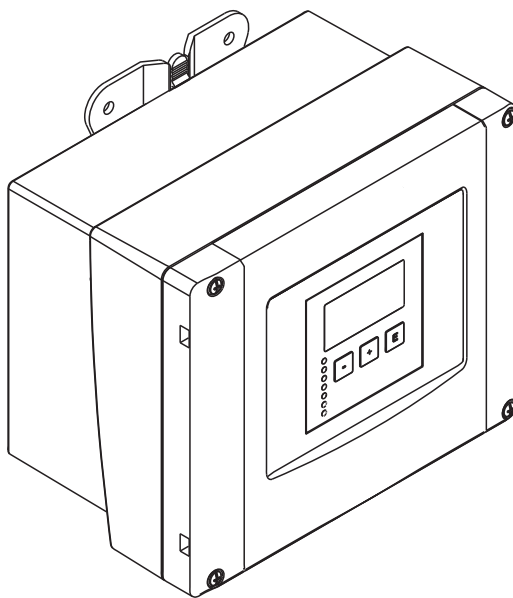
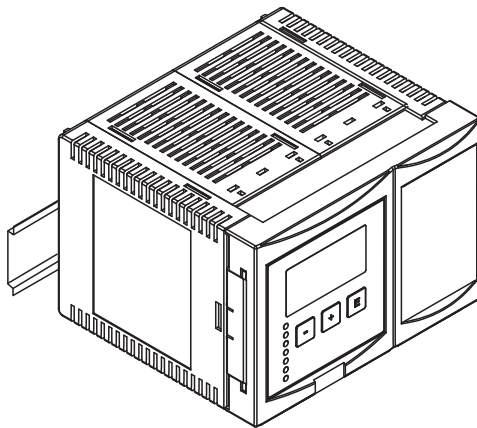

BA00289F/00/EN/13.12  
71164415

Valid as of software version  
V 02.01.00



## Table of Contents

<b>1</b>	<b>Safety Instructions</b>	<b>5</b>	6.5	Calibration of backwater and dirt detection	64
1.1	Designated use	5	6.6	Calibration for simultaneous level and flow measurement with one sensor	68
1.2	Installation, commissioning, operation	5	6.7	Parametrization of the counters	69
1.3	Operational safety and process safety	5	6.8	Envelope curve display	74
1.4	Notes on safety conventions and symbols	6	6.9	After the calibration	74
<b>2</b>	<b>Identification</b>	<b>7</b>	<b>7</b>	<b>The "display" menu</b>	<b>75</b>
2.1	Parts of the Prosonic S FMU90	7	7.1	"display"	75
2.2	Nameplate (Example)	8	7.2	"display format"	76
2.3	Product structure	9	7.3	"back to home"	77
2.4	Scope of delivery	10	<b>8</b>	<b>The "Relay/Controls" menu</b>	<b>78</b>
2.5	Certificates of approvals	10	8.1	Configuration of a limit relay	78
2.6	Registered trademarks	10	8.2	Configuration of an alarm or diagnostic relay	83
<b>3</b>	<b>Installation</b>	<b>11</b>	8.3	Configuration of a time pulse relay	86
3.1	Incoming acceptance, transport, storage	11	8.4	Configuration of a counting pulse relay	88
3.2	Mounting the field housing	11	<b>9</b>	<b>The "output/calculations" menu</b>	<b>93</b>
3.3	Mounting the DIN-rail housing	13	9.1	The "allocation/calculations" submenu	94
3.4	Mounting the remote display and operating module	16	9.2	The "extended calibration" submenu	95
3.5	Mounting of the sensors	17	9.3	"HART settings" submenu (only for current output 1)	98
3.6	Installation check	17	9.4	"Simulation" submenu	100
<b>4</b>	<b>Wiring</b>	<b>18</b>	<b>10</b>	<b>Troubleshooting</b>	<b>101</b>
4.1	Terminal compartment	18	10.1	System error messages	101
4.2	Terminal assignment	20	10.2	Possible calibration errors	105
4.3	Sensor connection	23	10.3	Envelope curve display	106
4.4	Connection of the sensor heater (for FDU90/FDU91)	25	10.4	Software history	109
4.5	Connection of external switches (for FMU90-*****B***)	27	<b>11</b>	<b>Maintenance</b>	<b>110</b>
4.6	Connection of a temperature sensor	27	11.1	Exterior cleaning	110
4.7	Shortening the sensor cable	29	11.2	Repairs	110
4.8	Synchronization line	30	11.3	Repairs to Ex-approved devices	110
4.9	Connection of the separate display and operating module	31	11.4	Replacement	110
4.10	Potential equalization	32	11.5	Replacing a sensor	110
4.11	Post-connection check	33	11.6	Spare Parts	111
<b>5</b>	<b>Operation</b>	<b>34</b>	11.7	Return	112
5.1	Operating options	34	11.8	Disposal	112
5.2	Operation via the display and operating module	34	11.9	Contact addresses of Endress+Hauser	112
5.3	Operation via Endress+Hauser operating tool "FieldCare"	47	<b>12</b>	<b>Accessories</b>	<b>113</b>
5.4	Operation via Field Xpert SFX100	47	12.1	Commubox FXA195 HART	113
5.5	Lock/unlock configuration	47	12.2	Commubox FXA291	113
5.6	Reset to the default configuration	49	12.3	Protection cover for the field housing	113
<b>6</b>	<b>Commissioning</b>	<b>50</b>	12.4	Mounting plate for the field housing	113
6.1	Structure and Functions of the Prosonic S	50	12.5	Mounting bracket	114
6.2	First setup	52	12.6	Adaption plate for remote display	115
6.3	Preparing the basic setup	53	12.7	Overvoltage protection (in IP66 housing)	115
6.4	Calibration of a flow measurement	54	12.8	Overvoltage protection HAW562	116
			12.9	Extension cable for sensors	118

---

12.10	Temperature sensor FMT131 .....	119
<b>13</b>	<b>Technical Data.....</b>	<b>120</b>
13.1	Technical data at a glance .....	120
<b>14</b>	<b>Operating menu .....</b>	<b>126</b>
14.1	"flow" .....	126
14.2	"safety settings" .....	128
14.3	"relay/controls" .....	130
14.4	"output/calculations" .....	132
14.5	"device properties" .....	133
14.6	"system information" .....	134
14.7	"display" .....	136
14.8	"sensor management" .....	136
<b>15</b>	<b>Appendix.....</b>	<b>137</b>
15.1	Pre-programmed flow curves .....	137
15.2	The formula for flow calculation .....	151
15.3	Default block configuration .....	155
<b>Index</b> .....	<b>158</b>	

# 1 Safety Instructions

## 1.1 Designated use

The Prosonic S FMU90 is a transmitter for the ultrasonic sensors FDU90, FDU91, FDU91F, FDU92, FDU93, FDU95 and FDU96. The sensors of the class FDU8x can be connected as well.

The transmitter version for level measurements (→  9, "Product structure": FMU90 - \*1\*\*\*\*\*\*) can be applied for different measuring tasks, e.g.:

- level measurement in tanks and silos
- conveyor belt measurement
- level limit detection
- (alternating) pump control, screen and rake control

The version for level and flow measurements (→  9, "Product structure": FMU90 - \*2\*\*\*\*\*\*) is usable for further measuring tasks, e.g.:

- flow measurement at open flumes and weirs
- (non-resettable) totalizers and (resettable) counters
- control of samplers by time or counting pulses
- backwater and dirt detection in flumes
- simultaneous measurement of level and flow in a stormwater overflow basin with only one sensor

## 1.2 Installation, commissioning, operation

The Prosonic S FMU90 is fail-safe and constructed to the state-of-the-art. It meets the appropriate standards and EC directives. However, if you use it improperly or other than for its designated use, it may pose application-specific hazards, e.g. product overflow due to incorrect installation or configuration. Installation, electrical connection, start-up, operation and maintenance of the measuring device must therefore be carried out exclusively by trained specialists authorised by the system operator. Technical personnel must have read and understood these operating instructions and must adhere to them. You may only undertake modifications or repair work to the device when it is expressly permitted by the operating instructions.

## 1.3 Operational safety and process safety

Alternative monitoring measures must be taken to ensure operational safety and process safety during configuration, testing and maintenance work on the device.

### Hazardous areas

Measuring systems for use in hazardous environments are accompanied by separate "Ex documentation", which is an integral part of this Operating Manual. Strict compliance with the installation instructions and ratings as stated in this Additional documentation is mandatory.

- Ensure that all personnel are suitably qualified.
- Observe the specifications in the certificate as well as national and local regulations.

The transmitter may only be installed in suitable areas.

Sensors with a certificate for hazardous areas may be connected to a transmitter without a certificate.



Warning!

The sensors FDU83, FDU84, FDU85 and FDU86 with an ATEX, FM or CSA certificate are not certified for connection to the FMU90 transmitter.

For installations in the USA:











Installation should be in accordance with the National Electrical Code NFPA 70 (NEC)

For installations in Canada:

Installation should be in accordance with the Canadian Electrical Code (CEC)

## 1.4 Notes on safety conventions and symbols

In order to highlight safety-relevant or alternative operating procedures in the manual, the following conventions have been used, each indicated by a corresponding symbol in the margin.

Safety conventions	
	<p><b>Warning!</b> A warning highlights actions or procedures which, if not performed correctly, will lead to personal injury, a safety hazard or destruction of the instrument</p>
	<p><b>Caution!</b> Caution highlights actions or procedures which, if not performed correctly, may lead to personal injury or incorrect functioning of the instrument</p>
	<p><b>Note!</b> A note highlights actions or procedures which, if not performed correctly, may indirectly affect operation or may lead to an instrument response which is not planned</p>
Explosion protection	
	<p><b>Device certified for use in explosion hazardous area</b> If the device has this symbol embossed on its name plate it can be installed in an explosion hazardous area</p>
	<p><b>Explosion hazardous area</b> Symbol used in drawings to indicate explosion hazardous areas. Devices located in and wiring entering areas with the designation “explosion hazardous areas” must conform with the stated type of protection.</p>
	<p><b>Safe area (non-explosion hazardous area)</b> Symbol used in drawings to indicate, if necessary, non-explosion hazardous areas. Devices located in safe areas still require a certificate if their outputs run into explosion hazardous areas</p>
Electrical symbols	
	<p><b>Direct voltage</b> A terminal to which or from which a direct current or voltage may be applied or supplied</p>
	<p><b>Alternating voltage</b> A terminal to which or from which an alternating (sine-wave) current or voltage may be applied or supplied</p>
	<p><b>Grounded terminal</b> A grounded terminal, which as far as the operator is concerned, is already grounded by means of an earth grounding system</p>
	<p><b>Protective grounding (earth) terminal</b> A terminal which must be connected to earth ground prior to making any other connection to the equipment</p>
	<p><b>Equipotential connection (earth bonding)</b> A connection made to the plant grounding system which may be of type e.g. neutral star or equipotential line according to national or company practice</p>
	<p><b>Temperature resistance of the connection cables</b> States, that the connection cables must be resistant to a temperature of at least 85 °C (185 °F).</p>

## 2 Identification

### 2.1 Parts of the Prosonic S FMU90

#### 2.1.1 FMU90 in the field housing

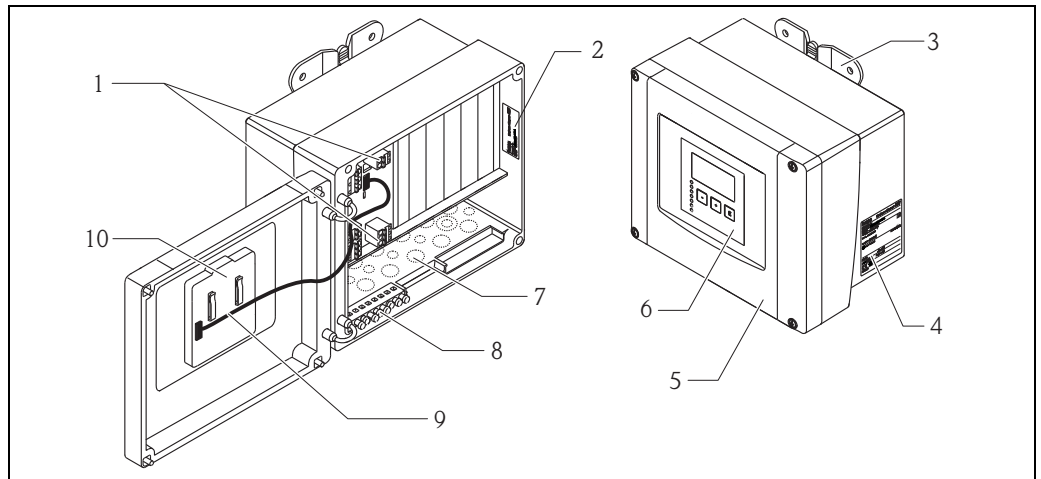

L00-FMU90xxx-03-00-00-xx-001

- |   |   |    |                                       |
|---|---|----|---------------------------------------|
| 1 | Terminals                                 | 6  | Display and operating module          |
| 2 | Instrument designation and identification | 7  | Prestamped openings for cable entries |
| 3 | Mounting help                             | 8  | Grounding terminals                   |
| 4 | Nameplate                                 | 9  | Display cable                         |
| 5 | Cover of the terminal compartment         | 10 | Short instructions                    |

#### 2.1.2 FMU90 in the DIN-rail housing

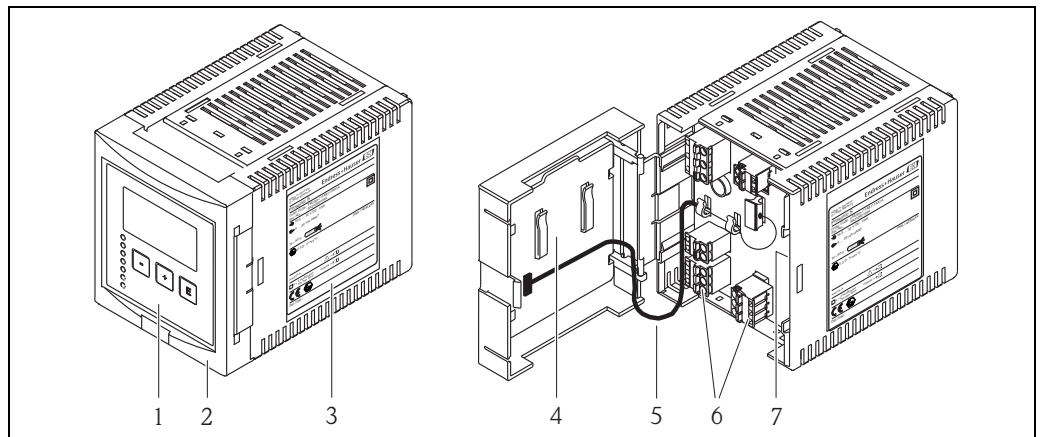

L00-FMU90xxx-03-00-00-xx-002

- |   |                                   |   |   |
|---|-----------------------------------|---|---|
| 1 | Display and operating module      | 5 | Display cable                             |
| 2 | Cover of the terminal compartment | 6 | Terminals                                 |
| 3 | Nameplate                         | 7 | Instrument designation and identification |
| 4 | Short instructions                |   |   |



**Note!**

The picture shows the smallest possible version of the DIN-rail housing. Depending on the version of the Prosonic S, the width of the housing may be larger.

### 2.1.3 FMU90 with remote display and operating module for cabinet door and switchboard mounting (96 x 96 mm (3.78 x 3.78 in))

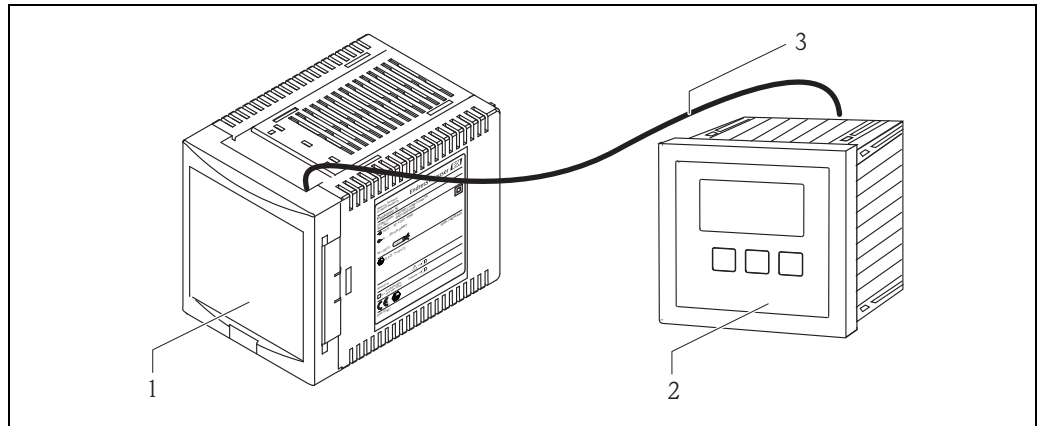

- 1 DIN-rail housing without display
- 2 Remote display and operating module for cabinet mounting
- 3 The cable (3 m (9.8 ft)) is supplied



Note!  
The picture shows the smallest possible version of the DIN-rail housing. Depending on the version of the Prosonic S, the width of the housing may be larger.

### 2.2 Nameplate (Example)

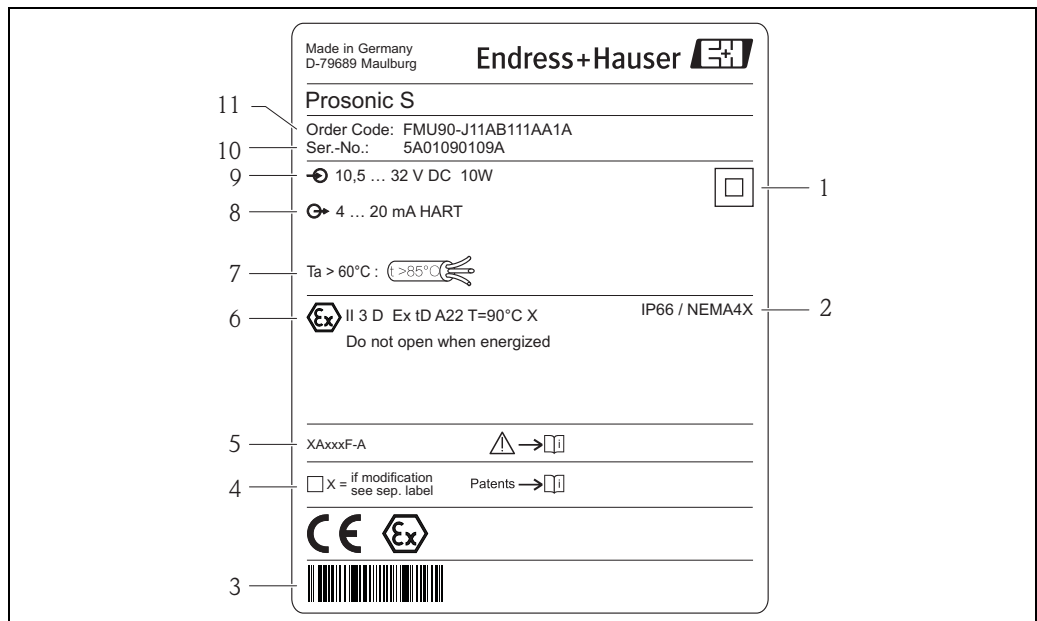

- 1 Specification of the electrical protection class (protective insulation)
- 2 Ingress protection
- 3 Barcode
- 4 Marked if a modification nameplate is present
- 5 Reference to additional safety-relevant documentation
- 6 Certificate-related data
- 7 Specification of required temperature resistance of the connection cables
- 8 Output signal
- 9 Power supply
- 10 Serial number
- 11 Order code (as defined by the product structure)



## 2.3 Product structure

<b>10</b>	<b>Approval</b>	
	R	Non-hazardous area
	J	ATEX II 3D
	N	CSA General Purpose
<b>20</b>	<b>Application</b>	
	1	Level + pump control, alternating
	2	Flow + totalizer + level + sample control + preprogrammed OCM flow curves
	3	Level + additional pump control
	4	Universal instrument (Level + Flow + Additional pump control)
<b>30</b>	<b>Housing, material</b>	
	1	Field mounting PC, IP66 NEMA 4x
	2	DIN rail mounting PBT, IP20
<b>40</b>	<b>Operation</b>	
	C	Illuminated display + keypad
	E	Illuminated display + keypad, 96x96, panel mounting, front IP65
	K	w/o display, via communication
<b>50</b>	<b>Power supply</b>	
	A	90-253 VAC
	B	10,5-32 VDC
<b>60</b>	<b>Level input</b>	
	1	1x sensor FDU9x/8x
	2	2x sensor FDU9x/8x
<b>70</b>	<b>Switch output</b>	
	1	1x relay, SPDT
	3	3x relay, SPDT
	6	6x relay, SPDT
<b>80</b>	<b>Output</b>	
	1	1x 0/4-20mA HART
	2	2x 0/4-20mA HART
	3	PROFIBUS DP
<b>90</b>	<b>Additional input</b>	
	A	w/o additional input
	B	4x limit switch + 1x temperature PT100/FMT131
<b>100</b>	<b>Datalog function</b>	
	A	Basic version
<b>110</b>	<b>Languages</b>	
	1	de, en, nl, fr, es, it, pt
	2	de, en, ru, pl, cs
	3	en, zh, ja, ko, th, id
<b>120</b>	<b>Additional option</b>	
	A	Basic version
	L	5-point linearity protocol only to order with FDU9x sensor + 5-point linearity protocol
<b>995</b>	<b>Marking</b>	
	1	Tagging (TAG)
	2	Bus address
FMU90 -		complete product designation

(\*): meaning of the language code:

cs: Czech; de: German; en: English; es: Spanish; fr: French; id: Bahasa (Indonesia, Malaysia); it: Italian; ja: Japanese; ko: Korean; nl: Dutch; pl: Polish; pt: Portuguese; ru: Russian; th: Thai; zh: Chinese

## 2.4 Scope of delivery

- Instrument according to the version ordered
- Endress+Hauser operating program on the enclosed CD-ROM
- For FMU90-\*\*\*E\*\*\*\*\*: remote display and operating module; retainers; connection cable (3 m (9.8 ft))
- For FMU90-\*21\*\*\*\*\* FMU and for FMU90-\*41\*\*\*\*\*: 2 slotted capstan screws (can be used to seal the housing)
- Accessories → 113
- Approval documentation: if this is not included in the operating manual (Refer to the nameplate for the names of the safety instructions that apply to your device version.)
- CD-ROM with further documentation, e.g.
  - Technical Information
  - Operating Instructions
  - Description of Instrument Functions
  - Slot/Index tables
- Brief operating instructions for quick commissioning, see the following table:

Brief operating instructions	Output	Application	Instrument version
KA01065F	HART	<ul style="list-style-type: none"> <li>■ level measurement</li> <li>■ alternating pump control</li> <li>■ screen and rake control</li> </ul>	FMU90 - *****1**** FMU90 - *****2****
KA01066F		<ul style="list-style-type: none"> <li>■ flow measurement</li> <li>■ backwater and dirt detection</li> <li>■ totalizers and counters</li> </ul>	FMU90 - *2*****1**** FMU90 - *4*****1**** FMU90 - *2*****2**** FMU90 - *4*****2****
KA01067F	PROFIBUS DP	<ul style="list-style-type: none"> <li>■ level measurement</li> <li>■ alternating pump control</li> <li>■ screen and rake control</li> </ul>	FMU90 - *****3****
KA01068F		<ul style="list-style-type: none"> <li>■ flow measurement</li> <li>■ backwater and dirt detection</li> <li>■ totalizers and counters</li> </ul>	FMU90 - *2*****3**** FMU90 - *4*****3****

## 2.5 Certificates of approvals

### CE mark, declaration of conformity

The device is designed to meet state-of-the-art safety requirements, has been tested and left the factory in a condition in which it is safe to operate. The device complies with the applicable standards and regulations as listed in the EC declaration of conformity and thus complies with the statutory requirements of the EC directives. Endress+Hauser confirms the successful testing of the device by affixing to it the CE mark.

## 2.6 Registered trademarks

HART®

Registered trademark of HART Communication Foundation, Austin, USA

ToF®

Registered trademark of the company Endress+Hauser GmbH+Co. KG, Maulburg, Germany

FieldCare®

Trademark of Endress+Hauser Process Solutions AG

## 3 Installation

### 3.1 Incoming acceptance, transport, storage

#### 3.1.1 Incoming acceptance

Check the packing and contents for any signs of damage.

Check the shipment, make sure nothing is missing and that the scope of supply matches your order.

#### 3.1.2 Transport, storage

Pack the measuring instrument so that it is protected against impacts for storage and transport. The original packing material provides the optimum protection for this.

Permissible storage temperature: -40 to +60 °C (-40 to +140 °F)

### 3.2 Mounting the field housing

#### 3.2.1 Dimensions of the field housing

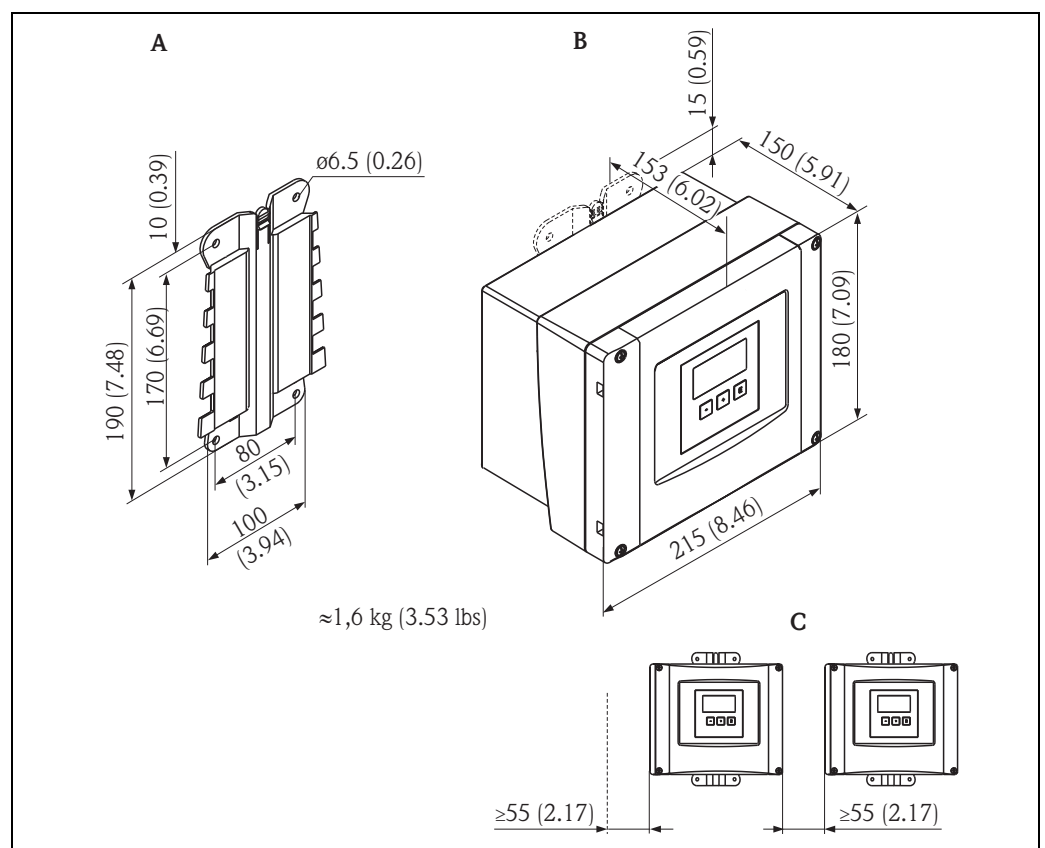

Dimensions in mm (in)

**A** Mounting help (supplied); can also be used as drilling template

**B** Field housing

**C** Minimum mounting distance

The dimensions of the field housing are the same for all instrument versions.

To open the housing, a minimum mounting distance of 55 mm (2.17 in) is required on the left.

### 3.2.2 Installation conditions

#### Weather protection

In order to avoid excessive sunlight exposure, the instrument should be mounted in a position which is protected against direct sunlight or a protection cover should be applied (→ 113, "Accessories").

#### Overvoltage protection

In order to protect the Prosonic against overvoltages (especially if mounted outdoors), connection of an overvoltage protection is recommended (→ 113, "Accessories").

#### Wall mounting

A mounting help for wall mounting is supplied. It also serves as drilling template. The mounting help should be mounted on a flat surface and may not become distorted.

#### Pipe mounting

A mounting plate is available for mounting of the field housing to 1" to 2" pipes (→ 113, "Accessories").

### 3.2.3 Installation

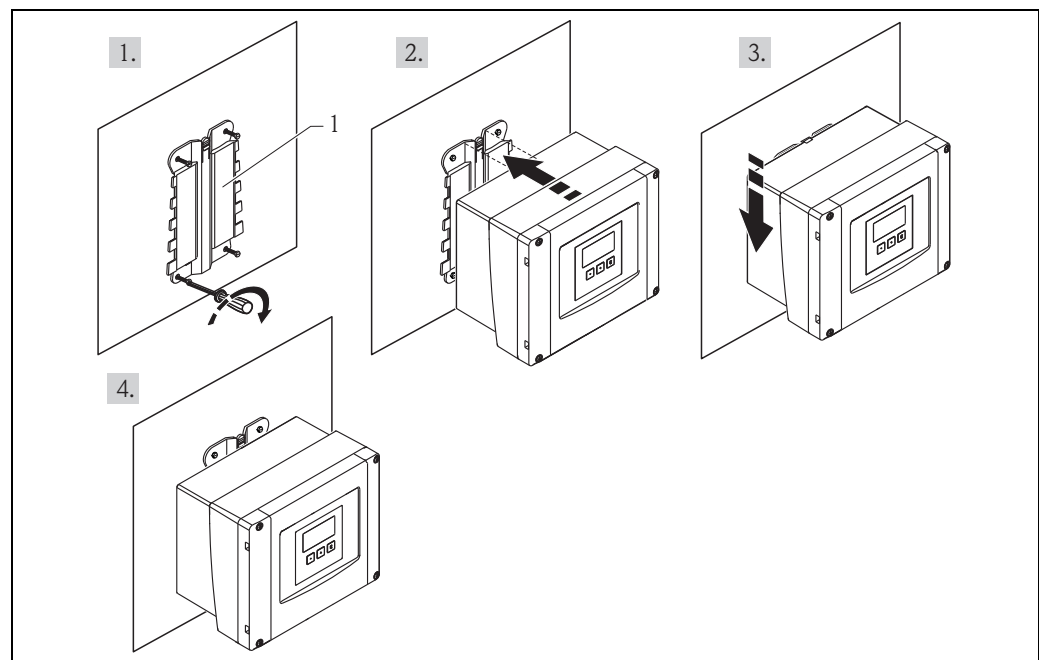

1 Wall mounting with mounting help



**Sum = 4**  
**(4 optional terminal areas)**

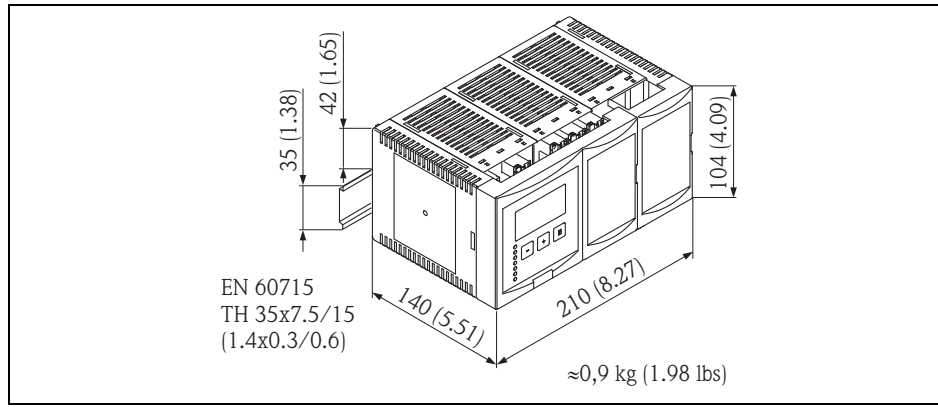

Dimensions in mm (in)

**Example**

		10	20	30	40	50	<b>60</b>	<b>70</b>	<b>80</b>	<b>90</b>	100	110	120
FMU90 -	R	1	2	A	A		2	3	2	A	A	1	A

feature and option of the product structure	corresponds to the following terminal area	present?
feature 60; option 2 and/or feature 80, option 2	2 sensor inputs and/or 2 analogue outputs	1 (yes)
feature 70, option 3 or 6	3 or 6 relays	1 (yes)
feature 80, option 3	PROFIBUS DP interface	0 (no)
feature 90, option B	inputs for external switches and external temperature sensor	0 (no)
	Sum =	2

Sum = 2  
 => 104 x 150 x 140 mm (4.09 x 5.91 x 5.51 in)

### 3.3.2 Installation conditions

- The DIN-rail housing must be mounted outside hazardous areas in a cabinet.
- The housing is mounted on a DIN rail EN 60715 TH 35x7,5 or TH 37x15.
- Do not install the instrument in the vicinity of high-voltage lines, motor lines, contactors or frequency converters. The installation regulations for high-voltage lines, motor lines, contactors or frequency converters must be observed.
- To ensure easy mounting and opening of the housing, a distance of approx. 10 mm (0.39 in) should be kept between the instruments.
- In order to avoid interference signals, the sensor cables must not be laid parallel to high voltage or electric power lines.
- The cables may not be laid in the proximity to frequency converters.

### 3.3.3 Mounting

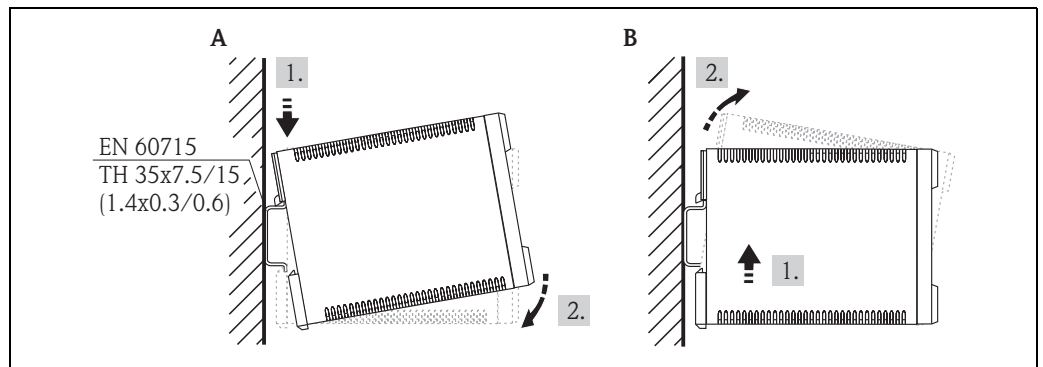

- A** Attaching the instrument to the rail  
**B** Detaching the instrument from the rail

### 3.4 Mounting the remote display and operating module

#### 3.4.1 Scope of delivery

If the Prosonic S is ordered with the display for cabinet door mounting, the following is contained in the scope of delivery:

- Display and operating module, 96 x 96 mm (3.78 x 3.78 in)
- 4 retainers (with nuts and screws)
- Connection cable (3 m (9.8 ft)) for connection to the transmitter (preassembled with suitable plugs).

#### 3.4.2 Dimensions of the separate display and operating module

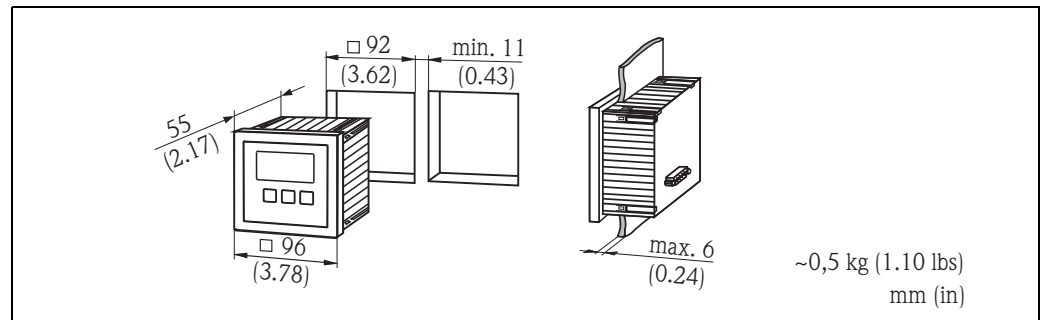

100-FM190xxx-06-00-00-xx-004

#### 3.4.3 Mounting

1. Cut an opening of 92 x 92 mm (3.62 x 3.62 in) into the intended mounting position (e.g. cabinet door).
2. Insert the remote display module into the opening and fix the retainers as shown in the following figure:

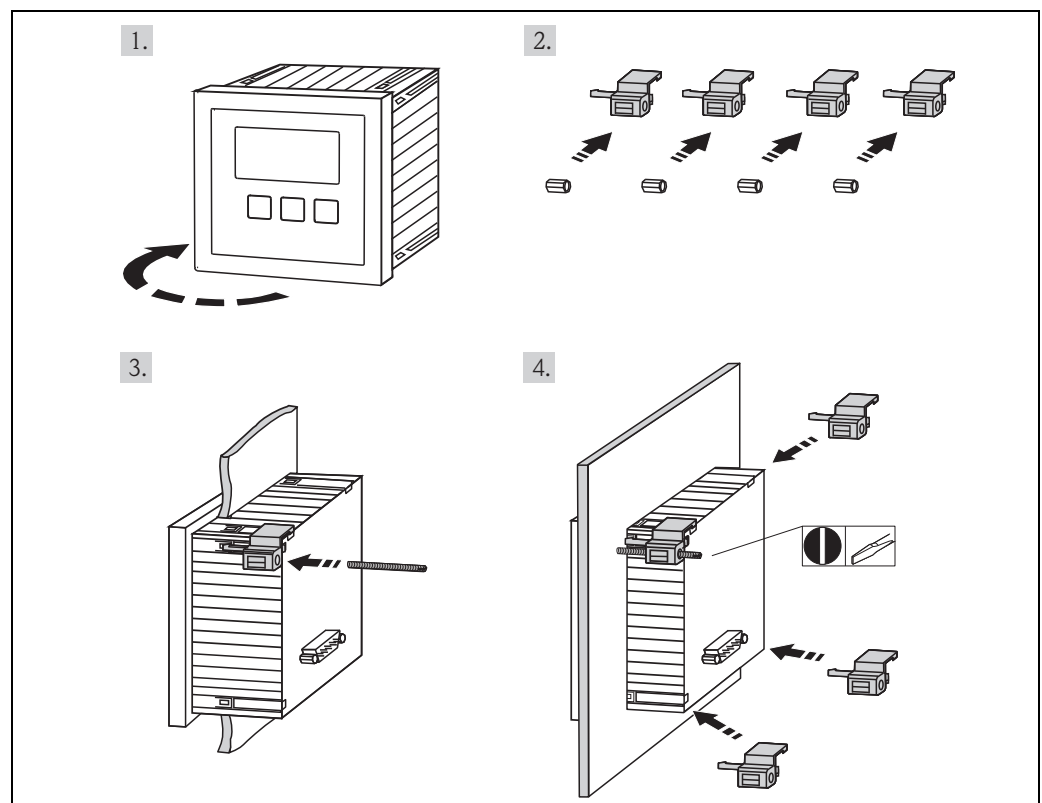

100-FM190xxx-17-00-00-xx-002



### 3.4.4 Adaption plate

If an opening of 138 x 138 mm (5.43 x 5.43 in) and the remote display of the Prosonic FMU860/861/862 are already present, you can use the adaption plate (Order Code: 52027441, → [113](#), "Accessories"). It is inserted into the remote display of the FMU860/861/862.



Note!

The adapter plate is mounted directly in the housing of the old remote display of the FMU86x series. The housing of the remote display of the FMU86x is the holder for the adapter plate and the new remote display of the FMU90/FMU95 in the format 96 x 96 mm (3.78 x 3.78 in).

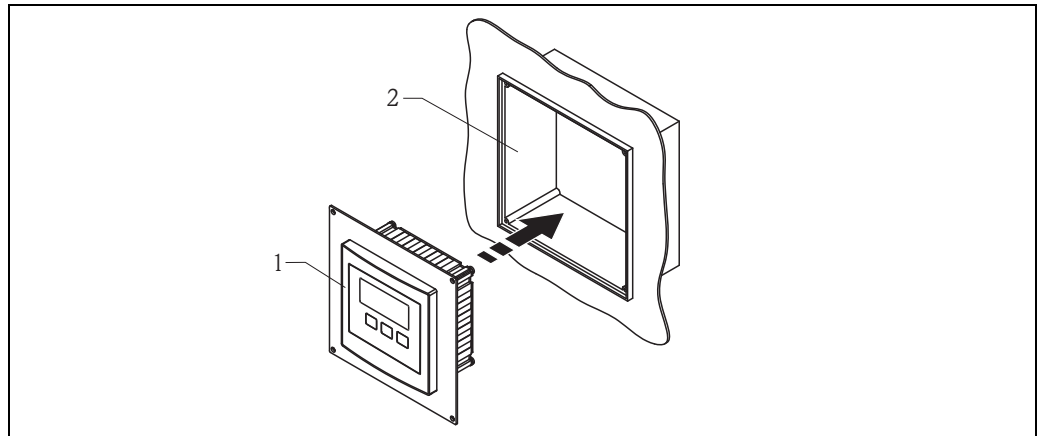

- 1 Remote display of the FMU90 with adaption plate  
2 Opening of the remote display of the FMU860/861/862

L00-FMU90xxx-06-00-00-xx-006

### 3.5 Mounting of the sensors

Information on the mounting of the sensors can be found in the following documents:

- Technical Information TI00189F/00 (for FDU8x)
- Technical Information TI00396F/00 (for FDU9x)

These documents are supplied with the sensors.



Caution!

Observe the mounting distances of the sensors as specified → [137](#), "Pre-programmed flow curves".

### 3.6 Installation check

After installing the device, carry out the following checks:

- Is the device damaged (visual inspection)?
- Does the device correspond to the measuring point specifications such as process temperature, process pressure, ambient temperature, measuring range etc?
- If available: Are the measuring point number and labelling correct?
- Is the instrument sufficiently protected against rainfall and direct sunlight?
- For the field housing: Are the cable glands tightened correctly?
- Is the instrument securely mounted to the DIN rail or the mounting help (visual inspection)?
- For the field housing: Are the screws of the terminal compartment cover securely tightened (visual inspection)?

## 4 Wiring



Warning!

The instrument may only be installed if the supply voltage is switched off.

### 4.1 Terminal compartment

#### 4.1.1 Terminal compartment of the field housing

The field housing has a separate terminal compartment. It can be opened after loosening the four screws of the lid.

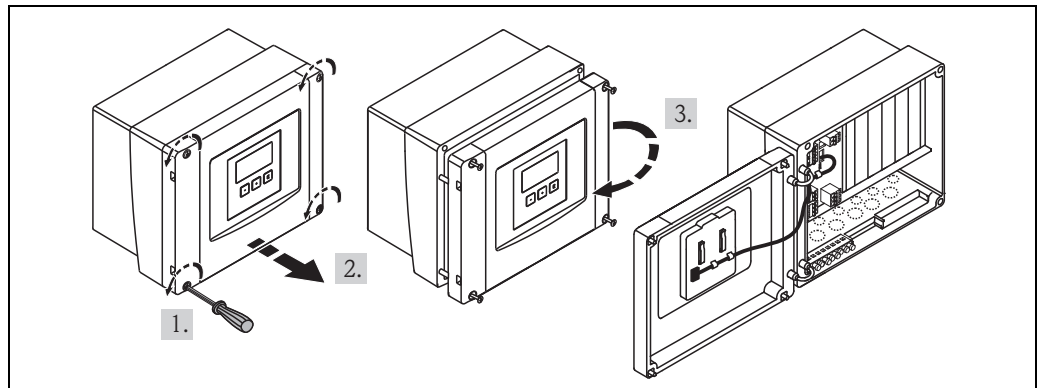

L00-FMU90xxx-04-00-00-xx-002

For easier wiring, the lid can be completely removed by unplugging the display plug and loosening the hinges:

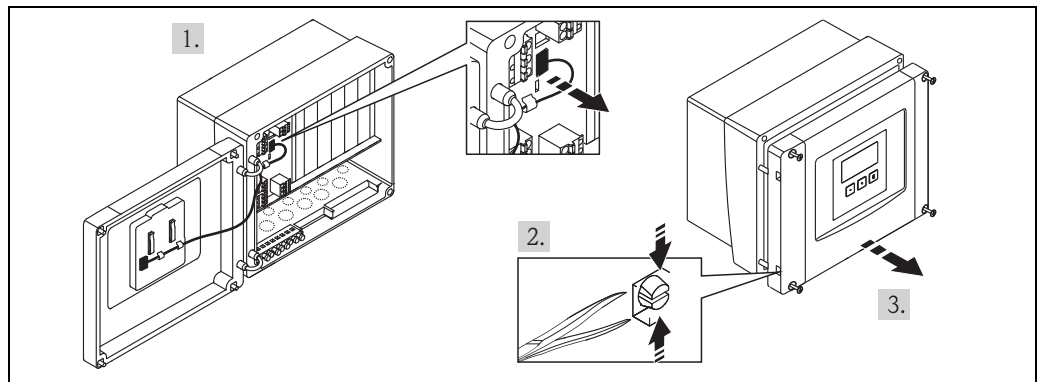

L00-FMU90xxx-04-00-00-xx-009

#### 4.1.2 Cable entries of the field housing

The following openings for cable entries are prestamped on the bottom of the housing :

- M20x1.5 (10 openings)
- M16x1.5 (5 openings)
- M25x1.5 (1 opening)

The required number and types of cable entries depend on the application at hand.

The prestamped openings can be removed by a suitable tool (e.g. knife or boring bit) or by punching them out cautiously.

### 4.1.3 Terminal compartment of the DIN-rail housing

#### Single instrument

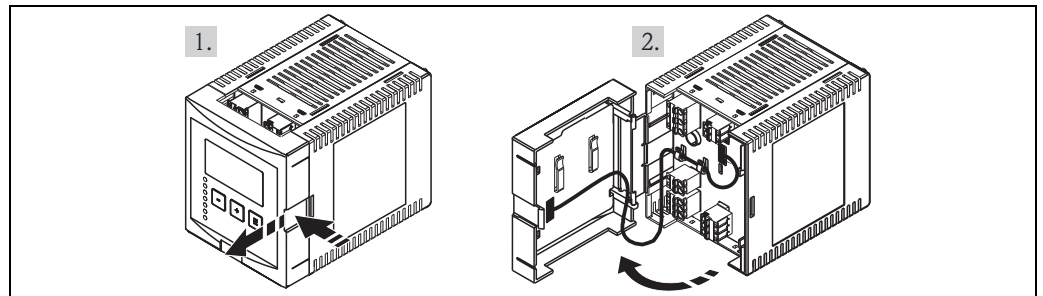

L00-FMU90xxx-04-00-00-xx-003

The catch can be unlocked by slightly pressing onto the clip. Then, the cover of the terminal compartment can be opened.

#### Several instruments mounted side by side

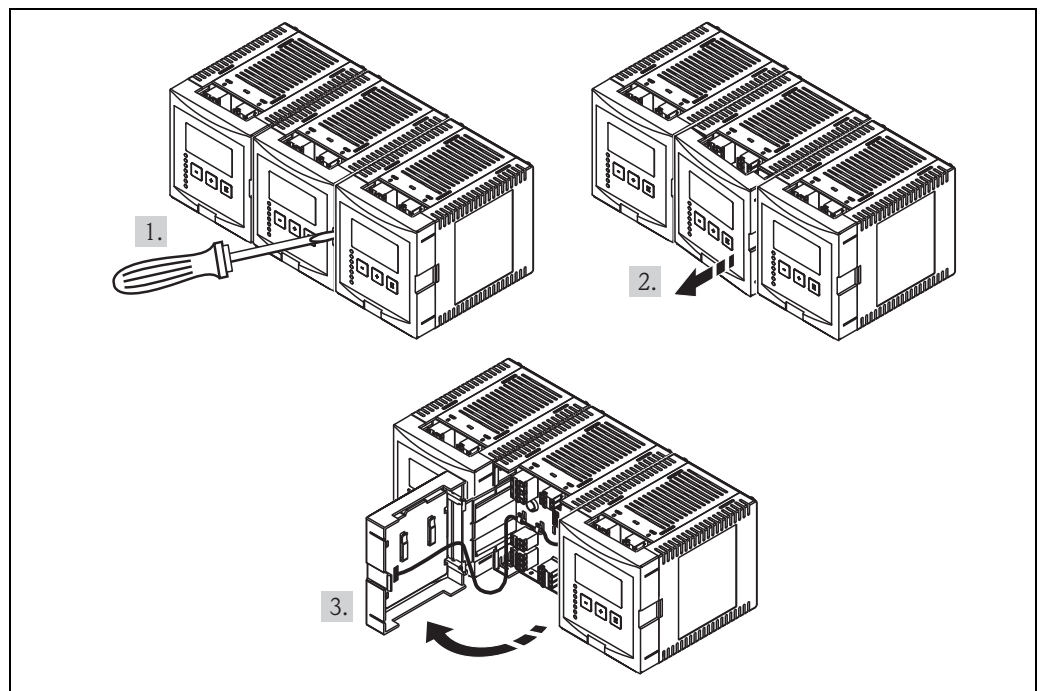

L00-FMU90xxx-04-00-00-xx-012

1. Open the catch of the cover (e.g. by a screwdriver).
2. Pull the cover out by approx. 20 mm (0.79 in) .
3. The cover can now be opened.



#### Note!

- The cables can be inserted into the housing from above or from below.
- The pictures show the smallest housing version but are valid for the larger versions as well.
- If the instruments are mounted next to each other and if the sensor cables run in parallel, the synchronization terminals (39 and 40) must be interconnected (→ 20 "Terminal assignment" and → 30 "Synchronization line").

## 4.2 Terminal assignment

Pluggable spring-force terminals for connection of the cables are supplied in the terminal compartment. Rigid conductors or flexible conductors with cable sleeve can directly be inserted and are contacted automatically.

Conductor cross section	0.2 mm <sup>2</sup> to 2.5 mm <sup>2</sup> (26 to 14 AWG)
Cable and sleeve cross section	0.25 mm <sup>2</sup> to 2.5 mm <sup>2</sup> (24 to 14 AWG)
min. stripping length	10 mm (0.39 in)

The terminal configuration depends on the instrument version ordered. There is a basic terminal area, which is present in every instrument version. Additional optional terminal areas are only present if the respective option has been selected in the product structure.

Terminal area	present for the following instrument versions	
Basic area	A	for all versions
	B	for instrument versions with 2 sensor inputs and/or 2 analogue outputs (FMU90 - *****2***** and/or FMU90 - *****2*****)
Optional areas	C	for instrument versions with 3 or 6 relays (FMU90 - *****3***** oder FMU90 - *****6*****)
	D	for instruments with external switch inputs and external temperature input (FMU90 - *****B****)
	E	for instrument versions with PROFIBUS DP interface (FMU90 - *****3*****)

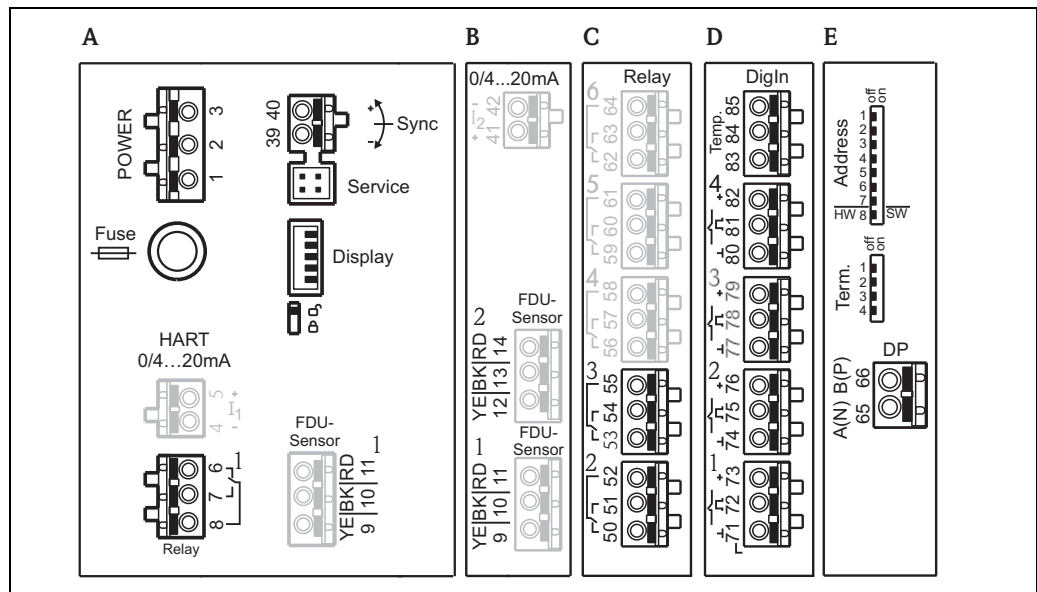

Terminals of the Prosonic S (the terminals depicted in grey are not present in every instrument version)

**A** Basic terminal area

**B-E** Optional terminal areas (present if the respective option has been selected in the product structure)



Note!

The depicted switching states of the relays refer to the de-energized state.

Terminals	Meaning	Terminal area	Remarks
<b>Auxiliary energy</b>			
1, 2	<ul style="list-style-type: none"> <li>■ L (für AC version)</li> <li>■ L+ (for DC version)</li> </ul>	A	depending on instrument version: <ul style="list-style-type: none"> <li>■ 90 ... 253 V<sub>AC</sub></li> <li>■ 10,5 ... 32 V<sub>DC</sub></li> </ul>
2	<ul style="list-style-type: none"> <li>■ N (for AC version)</li> <li>■ L- (for DC version)</li> </ul>	A	
3	Potential equalization	A	
Fuse		A	depending on instrument version: <ul style="list-style-type: none"> <li>■ 400 mA T (for AC)</li> <li>■ 2 A T (for DC)</li> </ul>
<b>Analog outputs (not available for PROFIBUS DP instruments)</b>			
4, 5	Analog output 1; 4 ... 20 mA with HART/ 0 ... 20 mA w/o HART	A	<b>not</b> present for the PROFIBUS DP version
41, 42	Analog output 2 (optional); 4 ... 20 mA/ 0 ... 20 mA	B	only for the version with two analog outputs; no HART signal at this output
<b>Relay outputs</b>			
6, 7, 8	Relay 1	A	
50, 51, 52	Relay 2 (optional)	C	only for the versions with 3 or 6 relays
53, 54, 55	Relay 3 (optional)	C	only for the versions with 3 or 6 relays
56, 57, 58	Relay 4 (optional)	C	only for the version with 6 relays
59, 60, 61	Relay 5 (optional)	C	only for the version with 6 relays
62, 63, 64	Relay 6 (optional)	C	only for the version with 6 relays
<b>Bus communication (only available for PROFIBUS DP instruments)</b>			
65	PROFIBUS A (RxT/TxD - N)	D	only for the PROFIBUS DP version
66	PROFIBUS B (RxT/TxD - P)	D	
<b>Synchronization</b>			
39, 40	Synchronization	A	→ 30, "Synchronization line"
<b>Level inputs</b>			
9 (YE), 10 (BK), 11 (RD)	Sensor 1 (FDU8x/9x) YE: yellow strand BK: black strand RD: red strand		<ul style="list-style-type: none"> <li>■ A: for versions with 1 sensor input</li> <li>■ B: for versions with 2 sensor inputs<sup>1)</sup></li> </ul>
12 (YE), 13 (BK), 14 (RD)	Sensor 2 (FDU8x/9x) (optional) YE: yellow strand BK: black strand RD: red strand	B	only for the version with 2 sensor inputs
<b>external switch inputs</b>			
71, 72, 73	external switch input 1	D	0: < 8 V or 72 and 73 interconnected 1: > 16 V or 72 and 73 not interconnected
74, 75, 76	external switch input 2	D	0: < 8 V or 75 and 76 interconnected 1: > 16 V or 75 and 76 not interconnected
77, 78, 79	external switch input 3	D	0: < 8 V or 78 and 79 interconnected 1: > 16 V or 78 and 79 not interconnected
80, 81, 82	external switch input 4	D	0: < 8 V or 81 and 82 interconnected 1: > 16 V or 81 and 82 not interconnected
<b>temperature input</b>			
83, 84, 85	temperature input: <ul style="list-style-type: none"> <li>■ PT100</li> <li>■ FMT131 (Endress+Hauser)</li> </ul>	D	→ 27, "Connection of a temperature sensor"

1) In this case, terminals 9/10/11 are not present on terminal area A.



**Warning!**

When using the public supply mains, an easily accessible power switch must be installed in the proximity of the device. The power switch must be marked as a disconnecter for the device (IEC/EN 61010)



**Note!**

- In order to avoid interference signals, the sensor cables should not be laid parallel to high voltage or electric power lines.
- The cables may not be laid in the proximity to frequency converters.

**Additional elements on the terminal areas**

Designation	Meaning/Remarks
Fuse	Fuse: 2 A T /DC or 400 mA T/AC
Display	Connection of the display or the remote display and operating module
Service	Service interface for connection of a PC/Notebook via Commubox FXA291
	Locking switch
Term.	Bus termination (only applicable for instruments with PROFIBUS interface)
Address	Bus address (only applicable for instruments with PROFIBUS interface)



**Warning!**

On wiring, the supply voltage must be switched off.

### 4.3 Sensor connection

#### 4.3.1 Connection diagram

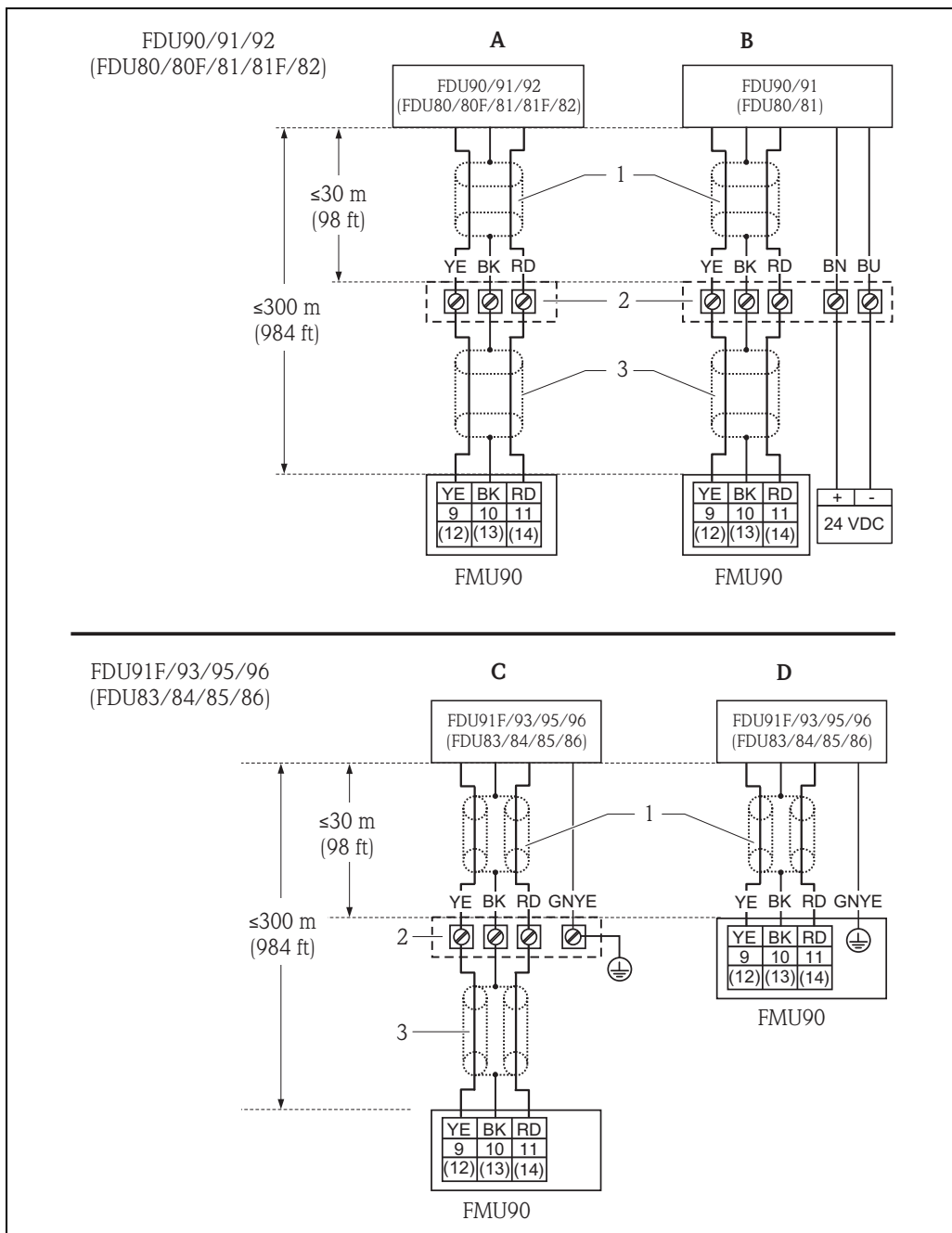

L00-FDU9xxxx-04-00-00-xx-002

**A** Without sensor heater

**B** With sensor heater

**C** Grounding at the terminal box

**D** Grounding at the transmitter FMU90

1 Screen of the sensor cable

2 Terminal box

3 Screen of the extension cable

Colours of the strands: YE = yellow; BK = black; RD = red; BU = blue; BN = brown; GNYE = green-yellow

### 4.3.2 Connection hints



#### Caution!

- In order to avoid interference signals, the sensor cables should not be laid parallel to high voltage electric power lines. The cables may not be laid in the proximity to frequency converters.
- The cable screen serves as a return cable and must be connected to the transmitter without any electrical break. With the pre-assembled cables, the screen ends in a black strand (BK). With the extension cable, the screen must be twisted together and connected to the "BK" terminal.



#### Warning!

- The sensors FDU83, FDU84, FDU85 and FDU86 with an ATEX, FM or CSA certificate are not certified for connection to the FMU90 transmitter.
- For the sensors FDU91F/93/95/96 and FDU83/84/85/86:  
The ground lead (GNYE) must be connected to the local potential equalization **after a maximum distance of 30 m (98 ft)**. This can be done
  - either at the terminal box
  - or at the transmitter FMU90 or in the cabinet (if the distance to the sensor does not exceed 30 m (98 ft)).



#### Note!

For easier mounting it is advisable to use the sensors FDU90/91/92 and FDU80/80F/81/81F/82 with a maximum cable length of 30 m (98 ft) as well. For longer distances an extension cable with a terminal box should be used.

### 4.3.3 Extension cables for the sensors

For distances up to 30 m (98 ft) the sensor can be directly connected by the sensor cable. For longer distances, it is recommended to use an extension cable. The extension cable is connected via a terminal box. The total length (sensor cable + extension cable) may be up to 300 m (984 ft).



#### Caution!

If the terminal box is installed in explosion hazardous areas, all applicable national guidelines must be observed.

Suitable extension cables can be obtained from Endress+Hauser (→ [113](#), "Accessories")  
Alternatively, cables with the following properties can be used:

- Number of cores according to the connection diagram (see above)
- Braided wire screen for the yellow (YE) and red (RD) core (no foil screen)
- Length: up to 300 m (984 ft), (sensor cable + extension cable)
- Cross section: 0.75 mm<sup>2</sup> to 2.5 mm<sup>2</sup> (18 to 14 AWG)
- Up to 8 Ω per core
- Max. 60 nF (between core and screen)
- For FDU91F/93/95/96 and FDU 83/84/85/86:  
The earth lead must not be within the screening.





#### 4.4.2 Connection in the DIN-rail housing

The supply voltage must be provided in the cabinet, e.g. by a terminal on the DIN-rail:

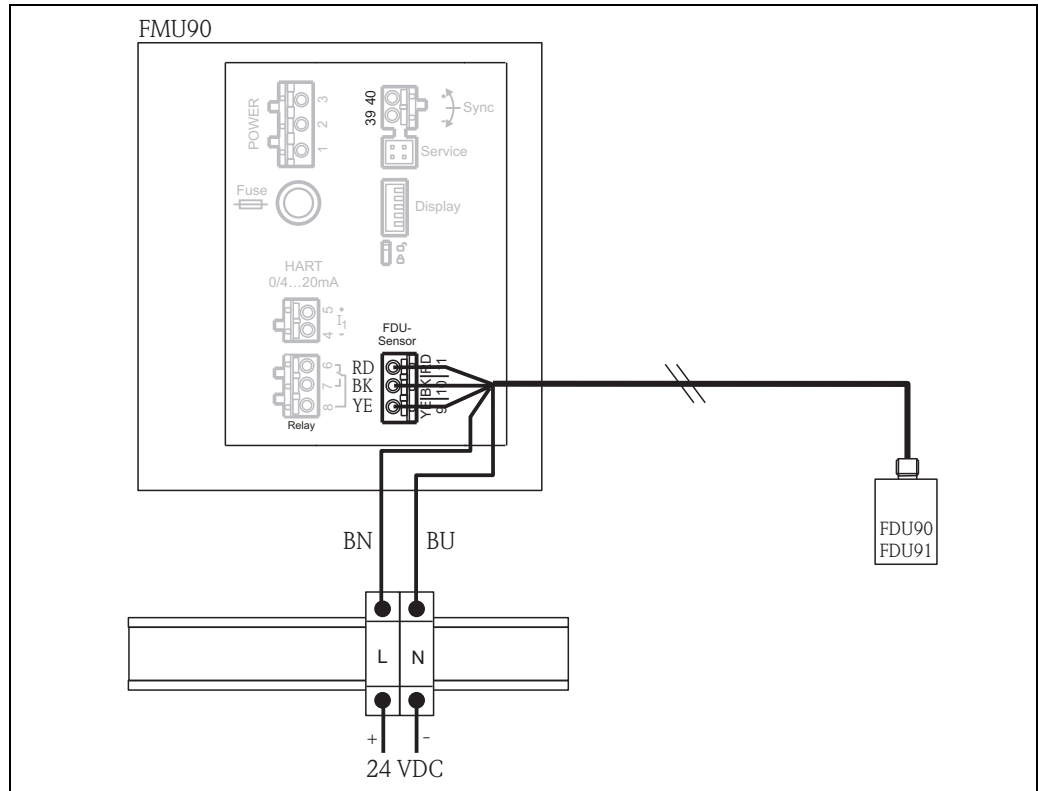

L00-FMU90xxx-04-00-00-xx-014



Note!

The terminal module supplied with the sensor can also be used for connection of the supply voltage. For the terminal assignment on this module → 25.

### 4.5 Connection of external switches (for FMU90-\*\*\*\*\*B\*\*\*)

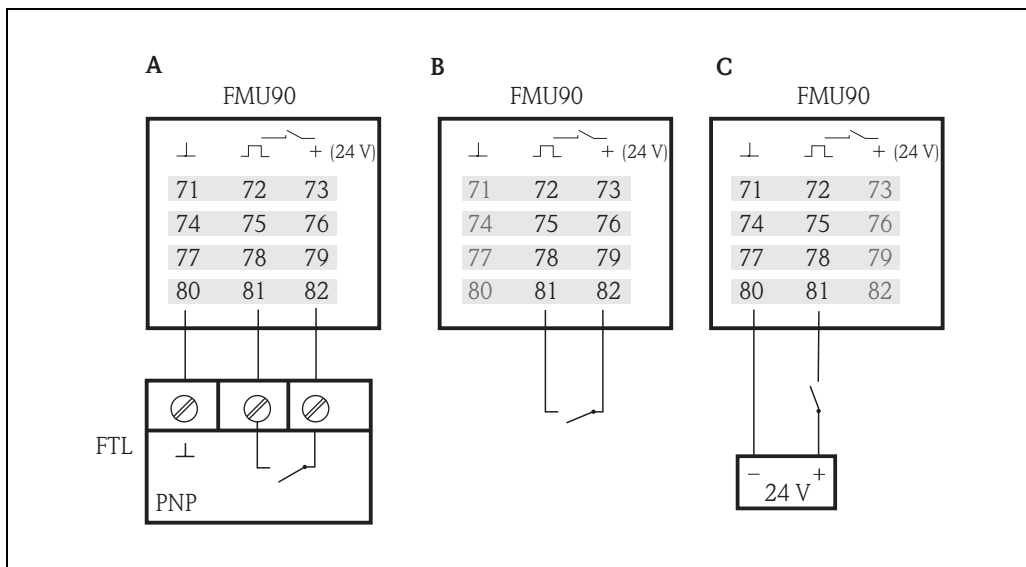

- A *Liquiphant*
- B *External switch*
- C *External switch with external supply voltage*

The maximum short-circuit current at 24 V is 20 mA.

### 4.6 Connection of a temperature sensor

The Prosonic S FMU90 transmitter has an optional input for an external temperature probe (in the product structure: feature 90 "Additional input", option B). The following probes can be connected:

- a FMT131 temperature probe from Endress+Hauser
- a Pt100 temperature probe



Note!

- After connecting an external temperature sensor, the following is required:
  1. The type of the connected sensor (Pt100 or FMT131) must be selected in "sensor management/ext. temp. sensor" in the "sensor type" parameter.
  2. The external temperature sensor must be assigned to an ultrasonic sensor in "sensor management/FDU sensor/US sensor N" in the "temp. measurement" parameter.
- If the option "alarm" has been selected for the case of an error in external temperature sensor, this alarm is indicated by the alarm relay.

### 4.6.1 FMT131 (Endress+Hauser) (connectable to FMU90-\*\*\*\*\*B\*\*\*)

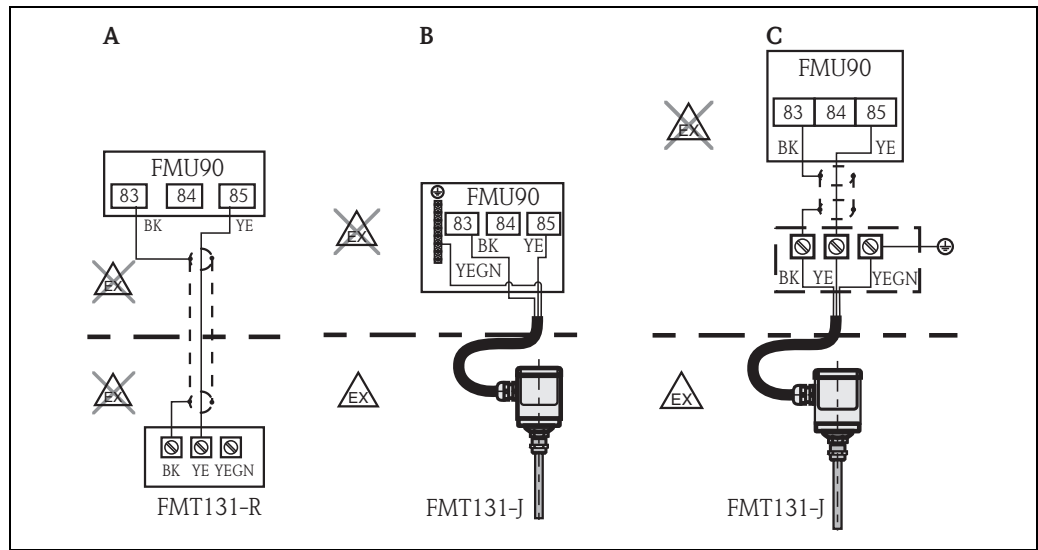

**A** Non-Ex area (FMT131-R)  
**B** Ex area (FMT131-J) with grounding in the FMU90  
**C** Ex area (FMT131-J) with grounding at a terminal box

BK black  
 YE yellow  
 YEGN yellow-green



Note!  
 For details refer to the Operating Instructions KA00019F/00.

### 4.6.2 Pt100 (connectable to FMU90-\*\*\*\*\*B\*\*\*)

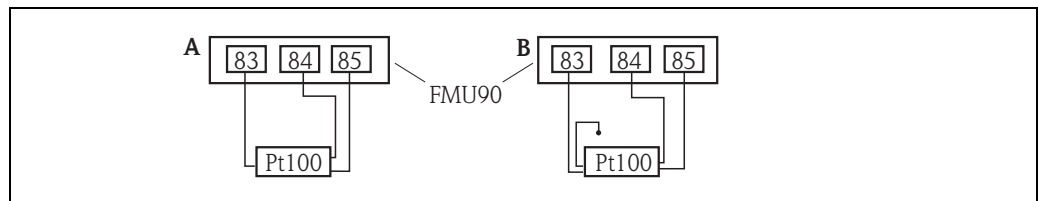

**A** Pt100 with 3-wire connection  
**B** Pt100 with 4-wire connection (one connector remains unused)



Note!  
 A Pt100 with 2-wire connection may not be used due to its insufficient measuring accuracy.



Warning!  
 A Pt100 may not be connected in explosion hazardous areas. A FMT131 must be used instead.

### 4.7 Shortening the sensor cable

If required, the sensor cable can be shortened. Please note:

- Do not damage the cores when removing the insulation.
- The cable is shielded by a metallic braiding. This shielding serves as a return cable and corresponds to the black (BK) strand of the unshortened cable. After shortening the cable, loosen the metallic braiding, twist it together securely and connect it to the "BK" terminal.



Caution!

The protective earth conductor (GNYE), which is present in some of the sensor cables, may not be electrically connected to the cable shield.

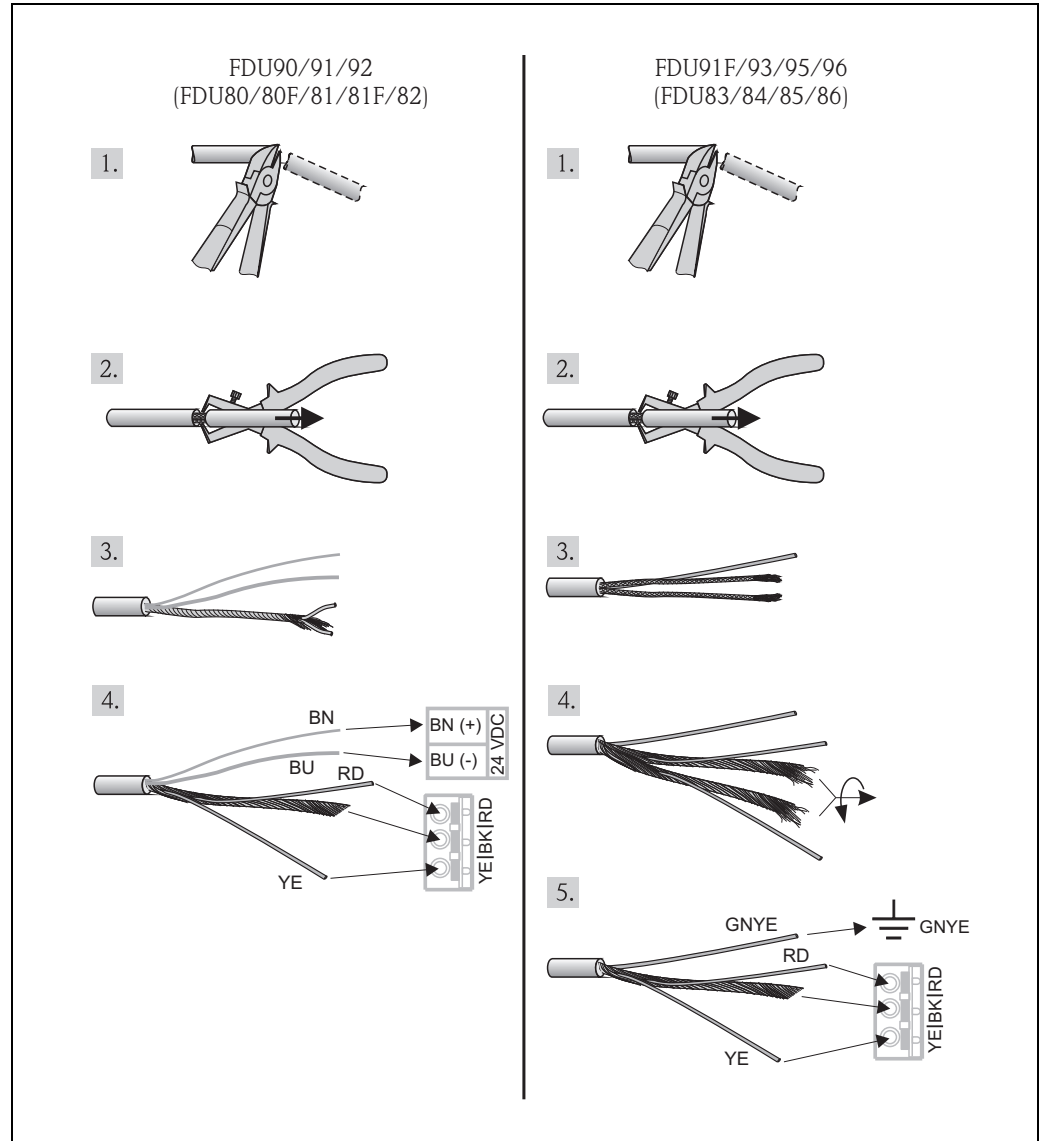

Colours of the strands: YE = yellow; BK = black; RD = red; BU = blue; BN = brown; GNYE = green-yellow



Note!

The blue (BU) and brown (BN) strands are only present for sensors with heater.

## 4.8 Synchronization line

- If wiring several Prosonic S (FMU90/FMU95) which are mounted in a common cabinet and if the sensor cables run in parallel, the synchronization terminals (39 and 40) must be interconnected.
- Up to 20 instruments can be synchronized in this way.
- The synchronization causes the evaluation units FMU9x to send the pulses simultaneously. Only after all sensors have received their signal, new simultaneous pulses are sent. This prevents pulses in the sensor cable of one sensor from influencing the received signal on the cable of a different sensor.
- If there are more than 20 instruments, groups must be formed, each containing a maximum of 20 instruments. For the instruments within each group, the sensor cables may run in parallel. The sensor cables of different groups must be separated from each other.
- Usual commercial screened cable can be used for synchronization
  - Max. length: 10 m (33 ft) between the individual instruments
  - Cross section: 2 x (0.75 to 2.5 mm<sup>2</sup> (18 to 14 AWG))
  - For lengths up to 1 m (3.3 ft), an unscreened cable can be used; for lengths exceeding 1 m (3.3 ft), screening is required. The screen must be connected to ground
- Instruments of the Prosonic FMU86x family can be connected to the synchronization line as well. In this case a maximum of 10 instruments can be connected to each synchronisation line.

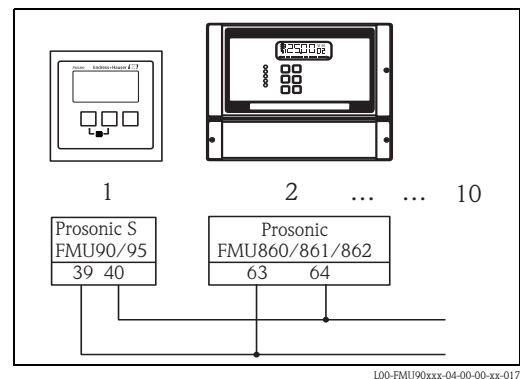
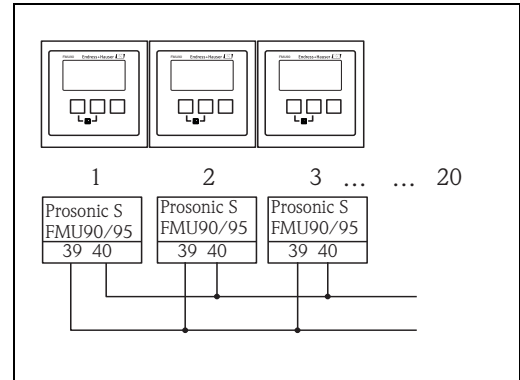

## 4.9 Connection of the separate display and operating module

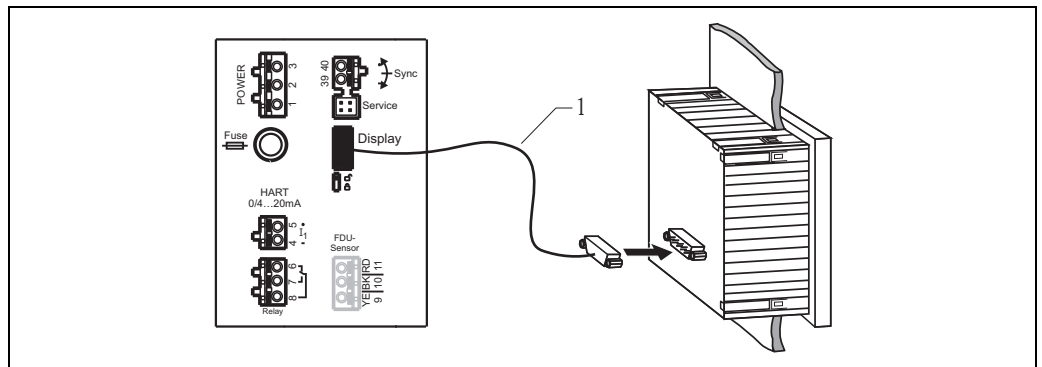

L00-FM190xxx-04-00-00-xx-005

1 Connection of the display plug with the cable (3 m (9.8 ft))

For the version of the Prosonic S with a separate display for panel mounting, a pre-assembled connecting cable (3 m (9.8 ft)) is supplied. The cable must be connected to the display plug of the Prosonic S.



Note!

Minimum diameter for cable bushing: 20 mm (0.79 in).





### 4.10.2 Potential equalization for the DIN-rail housing

If the DIN-rail housing is used, the potential equalization must be connected in the cabinet, e.g. at a metallic DIN rail:



Warning!

The grounding line of the sensors FDU91F/93/95/96 and FDU83/84/85/86 must be connected to the local potential equalization system **after a maximum of 30 m (98 ft)** (→ 23).

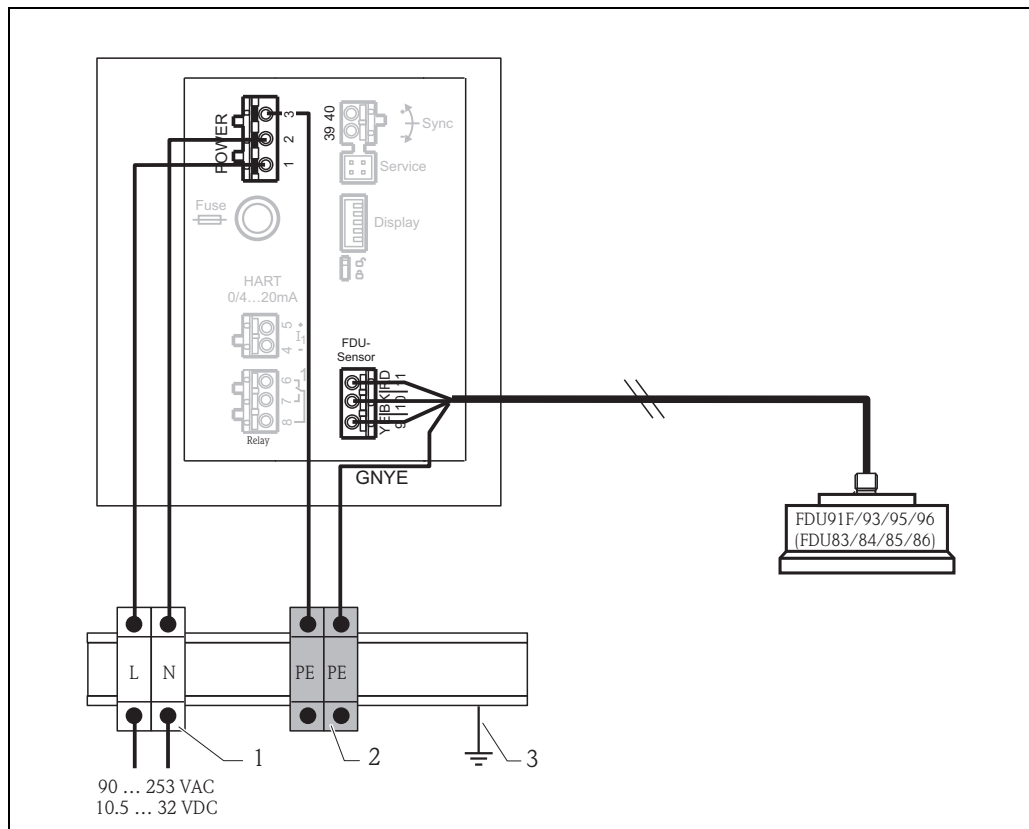

- 1 Terminal (isolated from the DIN rail)
- 2 Protective earth terminal (with contact to the DIN rail)
- 3 Protective ground via DIN rail



Caution!

The signal evaluation electronics and its direct connections (display interface, service interface etc.) are galvanically isolated from the supply voltage and the communication signals. Their electric potential is identical to the potential of the sensor electronics.

Pay attention to the potential difference if the sensors are connected to ground!



Note!

- The longest required distance has to be taken into account when removing the jacket of the sensor cable (GNYE in the above example).
- When shortening the sensor cable, comply to the notes → 29, "Shortening the sensor cable".

### 4.11 Post-connection check

After wiring the transmitter, carry out the following checks:

- Is the terminal assignment correct?
- For the field housing: Are the cable glands tight and is the cover of the terminal compartment securely closed?
- If auxiliary energy is switched on: Does a display appear on the display module (if available) and does the green LED light up?

## 5 Operation

### 5.1 Operating options

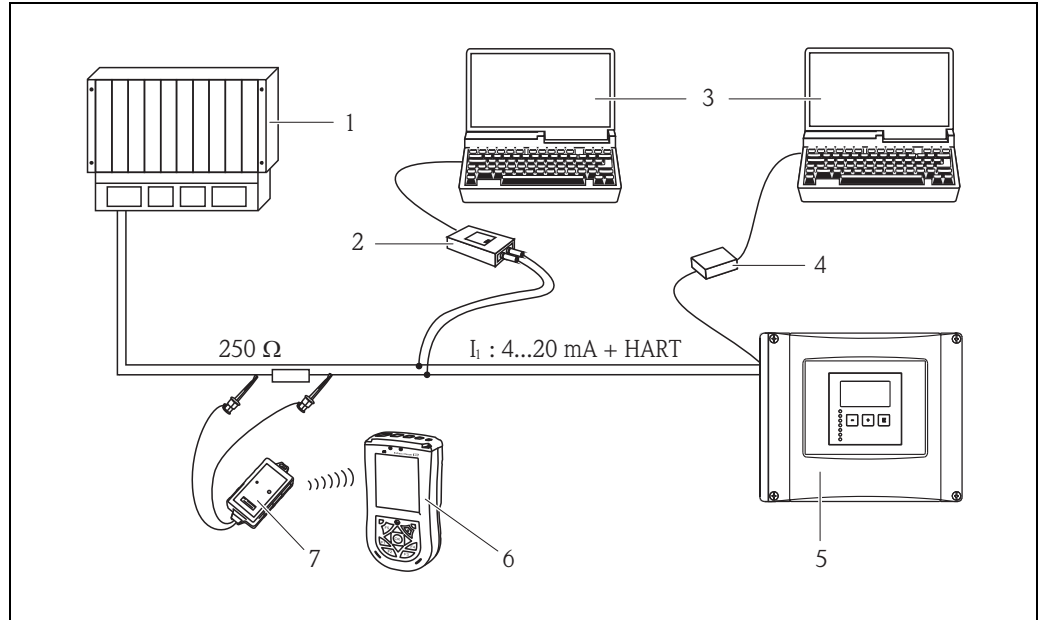

- 1 SPS, PLC, API  
 2 Commubox FXA195 (USB), HART-Protocol  
 3 FieldCare  
 4 Commubox FXA291 (service interface)  
 5 Operating and display module at the Prosonic S (if present)  
 6 Field Xpert SFX100  
 7 VIATOR Bluetooth-Modem with connection cable





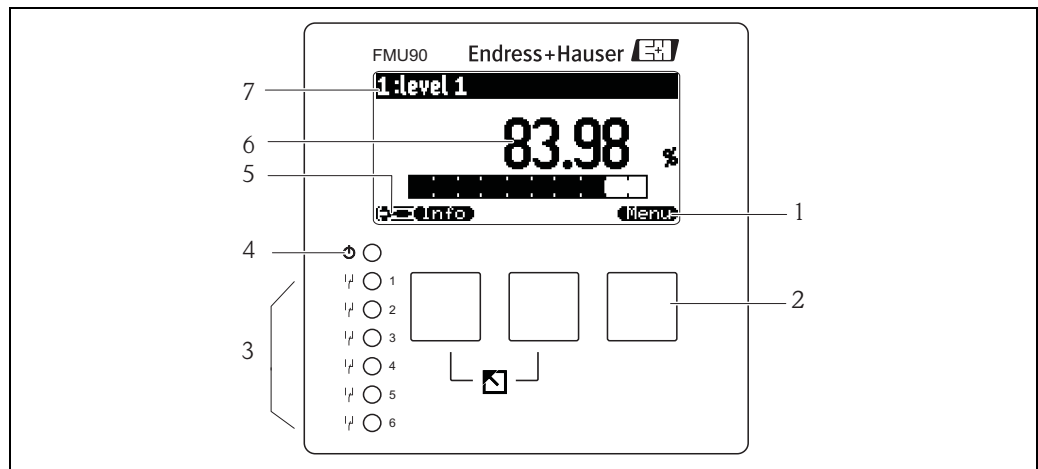







### 5.2 Operation via the display and operating module

#### 5.2.1 Display and operating elements



- 1 Softkey symbol  
 2 Key  
 3 LEDs indicating the switching states of the relays  
 4 LED indicating the operating state  
 5 Display symbols  
 6 Value of the parameter, including unit  
 7 Name of the parameter

## Display symbols

Symbol	Meaning
<b>Operating mode of the instrument</b>	
	<b>User</b> User parameters can be edited. Service parameters are locked.
	<b>Diagnosis</b> The service interface is connected.
	<b>Service</b> User and service parameters can be edited.
	<b>Locked</b> All parameters are locked.
<b>Locking state of the currently displayed parameter</b>	
	<b>Display parameter</b> The parameter can <b>not</b> be edited in the current operating mode of the instrument.
	<b>Editable parameter</b> The parameter can be edited.
<b>Scroll symbols</b>	
	<b>Scroll list available</b> Indicates that the list contains more parameters than can be represented on the display. By pressing  or  repeatedly, all parameters of the list can be accessed.
<b>Navigation in the envelope curve display</b>	
	<b>Move left</b>
	<b>Move right</b>
	<b>Zoom in</b>
	<b>Zoom out</b>

## LEDs

LED indicating the operating state (pos. 4 in the figure)	
green	normal measuring mode; no error detected
red (flashing)	Warning: An error is detected but the measurement continues. Reliability of the measured value is no longer ensured.
red	Alarm: An error is detected. The measurement is interrupted. The measured value assumes the value specified by the user (parameter "output on alarm").
off	supply voltage missing

LEDs for the relays (pos. 3 in the figure)	
yellow	The relay is activated.
off	The relay is de-activated (idle state).

### Keys (softkey operation)

The function of the keys depends on the current position within the operating menu (softkey functionality). The key functions are indicated by softkey symbols in the bottom line of the display.

Symbol	Meaning
	<b>Move downwards</b> Moves the marking bar downwards within a selection list.
	<b>Move upwards</b> Moves the marking bar upwards within a selection list.
	<b>Enter</b> <ul style="list-style-type: none"> <li>Opens the marked submenu, the marked parameter set or the marked parameter</li> <li>Confirms the edited parameter value</li> </ul>
	<b>Previous parameter set</b> Reopens the previous parameter set within the submenu.
	<b>Next parameter set</b> Opens the next parameter set within the submenu.
	<b>Confirm selection</b> Selects the option of a selection list which is currently marked by the bar.
	<b>Increase value</b> Increases the active digit of an alphanumeric parameter.
	<b>Decrease value</b> Decreases the active digit of an alphanumeric parameter
	<b>Error list</b> Opens the list of all errors which are currently detected. If a warning is present, this symbol flashes. If an alarm is present, the symbol is displayed continuously.
	<b>Change Display</b> Change to the next page of measured values (only available if more than one pages of measured values have been defined; see "display" menu)
	<b>Info</b> Opens the Shortcut Menu, which contains the most important information about the current state of the instrument
	<b>Menu</b> Opens the Main Menu, which contains <b>all</b> parameters of the Prosonic S

### General key combinations

The following key combinations do not depend on the menu position:

Key combination	Meaning
	<b>Escape</b> <ul style="list-style-type: none"> <li>While editing a parameter: Exit the editing mode without accepting the changes.</li> <li>Within the navigation: Move upwards to the previous layer of the menu.</li> </ul>
	<b>Increase contrast</b> Increases the contrast of the display module.
	<b>Decrease contrast</b> Decreases the contrast of the display module.

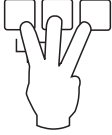
Key combination	Meaning
	<b>Locking</b> Locks the instrument against parameter changes. The instrument can only be unlocked again by the keys.

## 5.2.2 The operating menu

### Structure of the menu

The parameters of the Prosonic S are organized in an operating menu (consisting of a main menu and several submenus). Parameters which are related to each other are comprised in a common parameter set. To simplify the navigation within the menu, a five-digit position code is displayed with each parameter set.

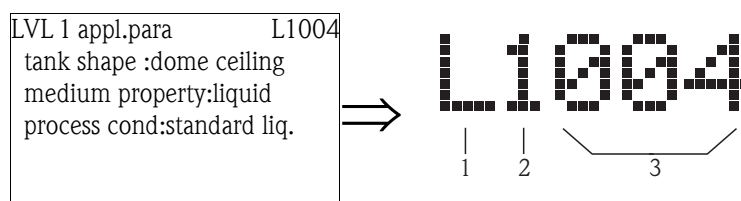

Identification of the parameter sets:

- 1 Submenu
- 2 Number of the associated input or output
- 3 Number of the parameter set within the submenus

- The **first digit (1)** specifies the submenu<sup>1)</sup>:
  - **L:** "level"
  - **F:** "flow"
  - **A:** "safety settings"
  - **R:** "relay/controls"
  - **O:** "output/calculations"
  - **D:** "device properties", "calibr. display" and "sensor management"
  - **I:** "system information"
  - **S:** "service" (only available if the service password has been entered)

Diagrams of the submenus can be found in the chapter "Operating menu".

- The **second digit (2)** is used if the parameter set occurs several times within the Prosonic S (e.g. for different inputs or outputs).

#### Example:

- O1201: "allocation current" for output 1
- O2201: "allocation current" for output 2

If the parameter set occurs only once within the Prosonic S, "X" is indicated at this position.

- The **last three digits (3)** specify the individual parameter sets within the submenu.

1) Depending on the instrument version, the installation environment and the selected operating mode, some of the submenus may not be present.

## Parameter types

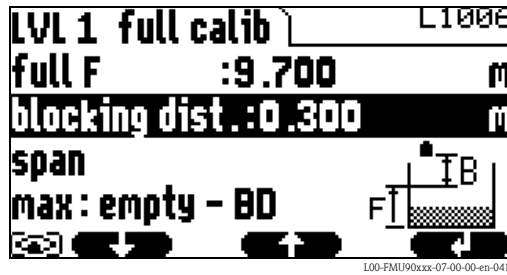

### Display parameters

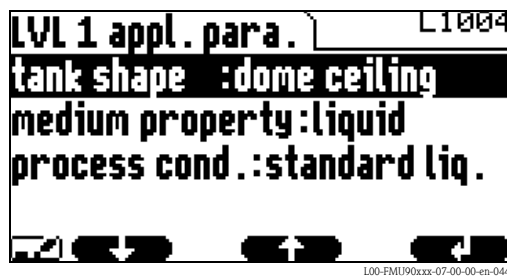

Parameters for which the  symbol is displayed in the left bottom corner of the display module, are either locked or display-only parameters.

### Editable parameters



Parameters, for which the  symbol is displayed in the left bottom corner of the display module, can be entered for editing by pressing .

The editing procedure depends on the type of parameter:

- when entering a **selection parameter**, the associated selection list appears (see below: "Editing a parameter with selection list").
- when entering a **numerical or alphanumeric parameter**, the text and number editor appears (see below: "Entering numbers and characters").

Navigation within the menu (Example)

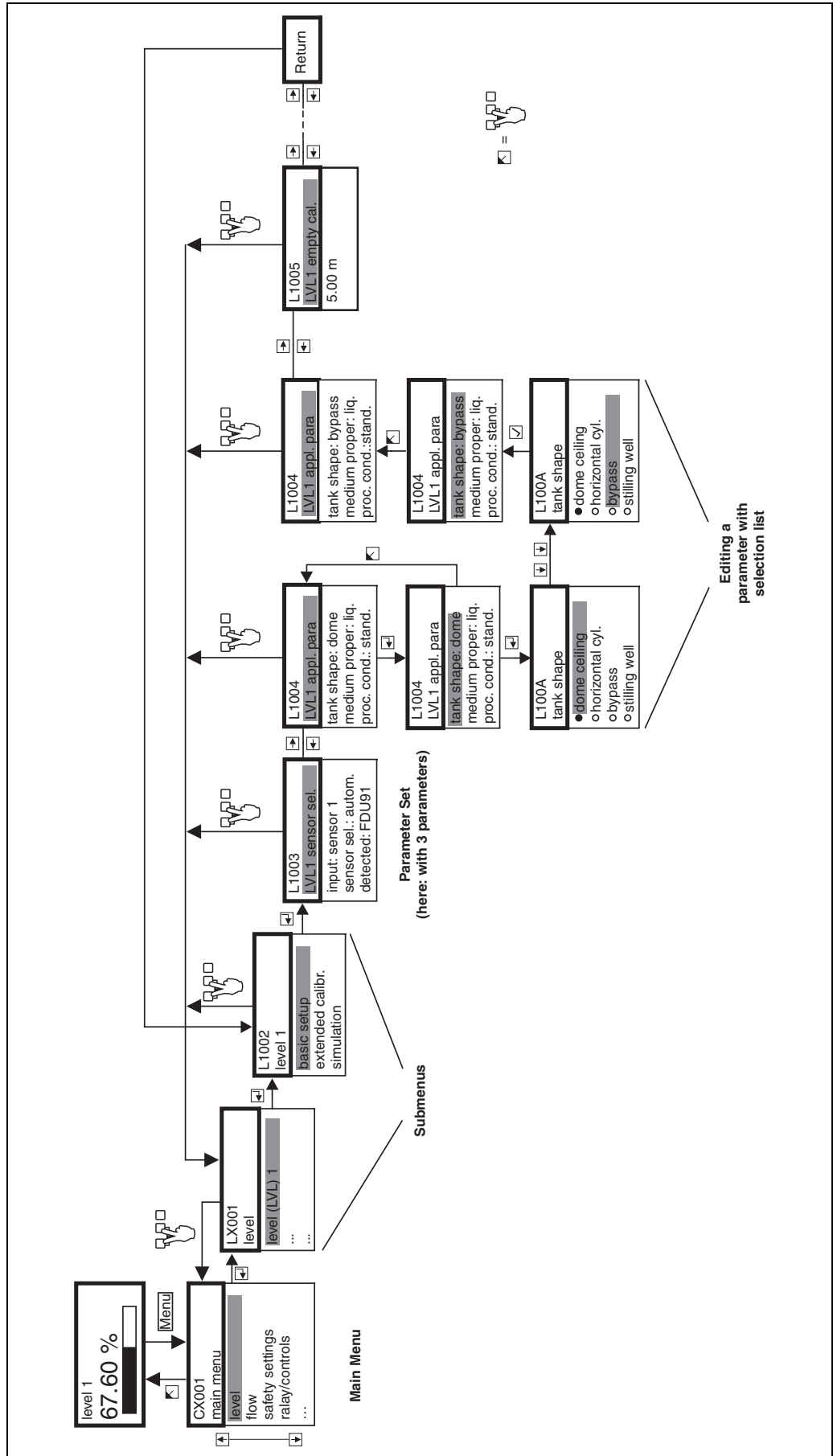

## Entering the menu

The navigation always starts from the main screen (measured value display<sup>2)</sup>). From there, the following menus can be opened by the keys:

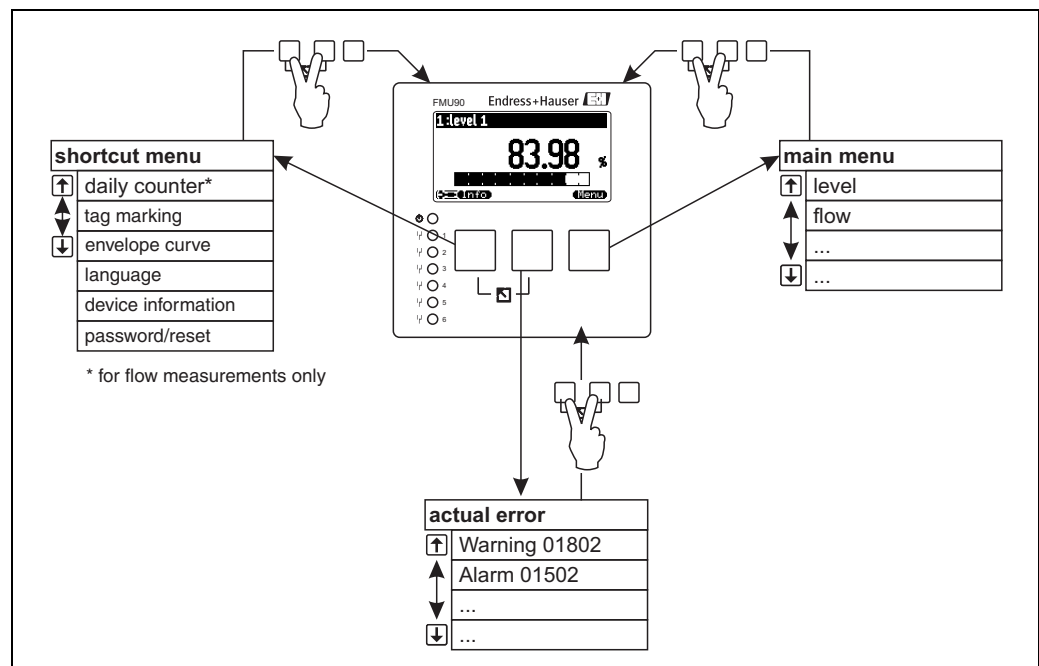

L00-FM190ccc-19-00-00-yy-038

### ■ shortcut menu

The shortcut menu is accessed via the **"Info"** key. It allows quick access to device information:

- daily counter (for flow measurements)
- tag marking
- envelope curve: used to check the signal quality
- language: sets the display language
- device information: serial number, versions of software and hardware
- password/reset: used to enter the password or reset code

All parameters of the shortcut menu are contained in the main menu as well.

### ■ main menu

The main menu is accessed via the **"Menu"** key. It contains all parameters of the Prosonic S. It is divided into submenus. Some of the submenus consist of further submenus. Which submenus are actually present, depends on the instrument version and the installation environment.

An overview of all submenus and parameters is given in the chapter "Operating menu".

### ■ actual error

If the self-monitoring of the Prosonic S detects an error, the  softkey symbol appears above the middle key.

If the softkey symbol flashes, only "warnings"<sup>3)</sup> are present.

If the softkey symbol is displayed permanently, at least one "alarm"<sup>3)</sup> is present.

After pressing the key, a list of all currently present errors appears.

2) Note: Depending on the configuration, the appearance of the measured value display may be different from the example in the figure.

3) The difference between "Warning" and "Alarm" → Chap. 10.1



### Selecting a submenu

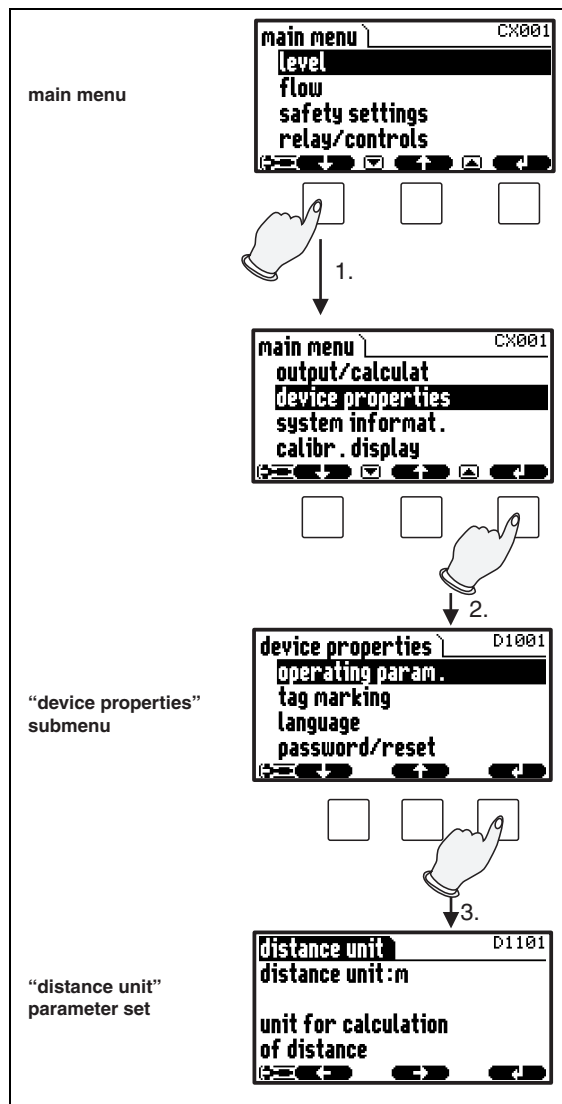

1. In the main menu, press or until the required submenu is marked by the bar.

**Note!**  
The symbols and indicate that the selection list contains more items than can be displayed on the module. Press or several times, to mark one of the hidden items.

2. Press , in order to enter the marked submenu.

3. If the submenu contains further submenus, continue until you reach the level of the parameter sets. This level is reached if the softkey symbols and appear.



**Note!**

If necessary, you can return to the previous level of the menu by pressing .

### Selecting a parameter

By pressing  $\leftarrow$  or  $\rightarrow$  you can switch between the parameter sets of the current submenu. For each parameter set the values of all its parameters are displayed. In order to change one of the values, proceed as follows:

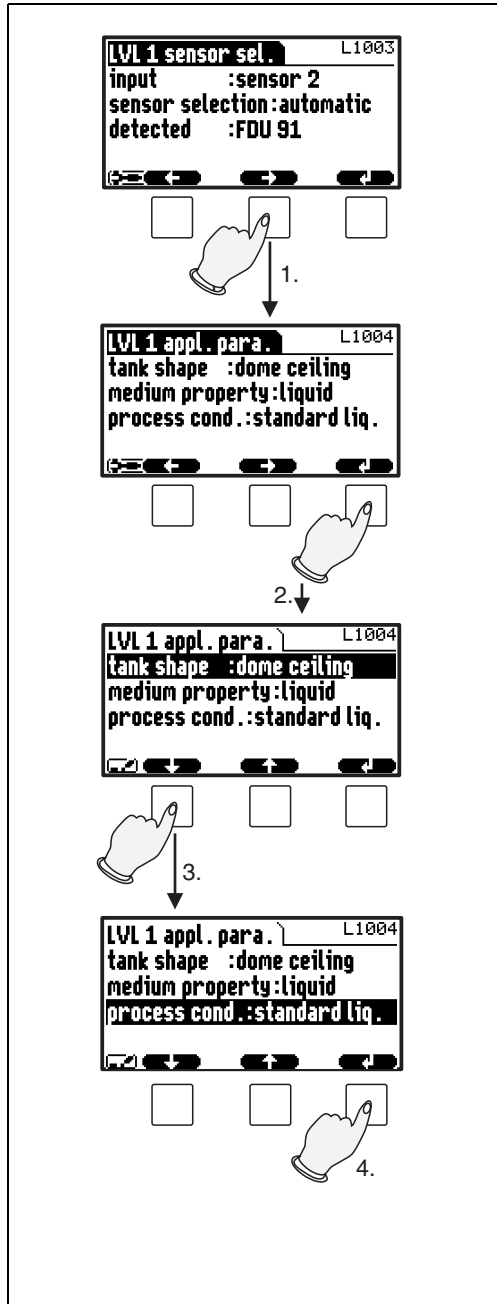

1. Press  $\leftarrow$  or  $\rightarrow$ , until you have reached the required parameter set.
2. Press  $\downarrow$ , in order to enter the parameter set.
3. Select the required parameter by pressing  $\leftarrow$  or  $\rightarrow$ .  
(This step is not required if the set contains only one parameter.)
4. Press  $\downarrow$ , in order to enter the editing mode of the parameter.  
The editing method depends on the type of parameter (selection list, numeric or alphanumeric parameter). For details refer to the following sections.

L00-FMU90xxx-19-00-00-en-040



Note!

If necessary, you can exit the parameter and parameter set by pressing  .

Editing a parameter with selection list

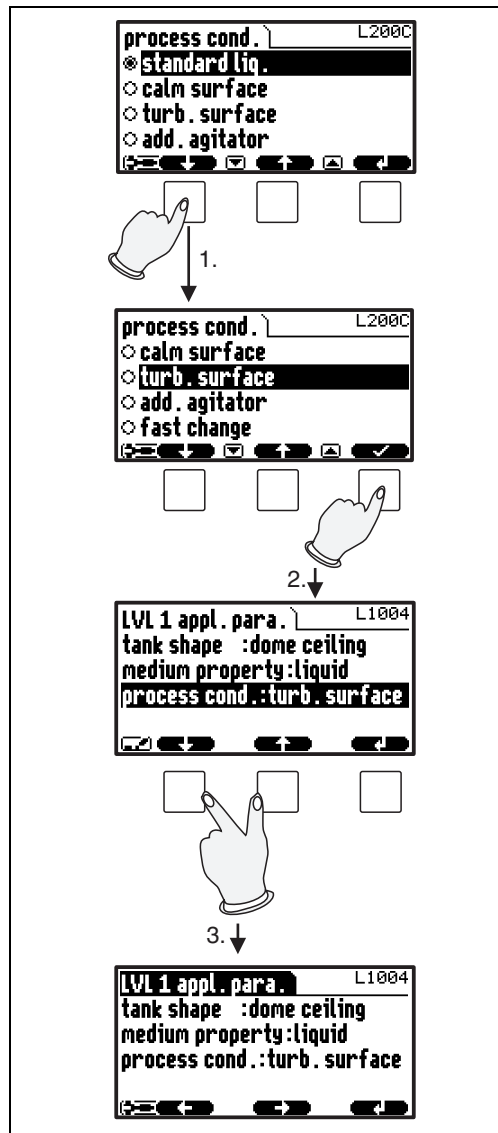

1. Press or , until the required option is marked by the bar (in the example: "turb. surface").

Note!

The symbols indicate that the selection list contains more items than can be displayed on the module. Press or several times, to mark one of the hidden items.

2. Press , in order to select the marked option. It is then stored in the instrument.

3. Press the left and middle keys simultaneously in order to quit the parameter.  
The software key symbols and reappear and you can switch to the next parameter set.



Note!

By pressing before you can quit the parameter without accepting your changes.

L00-FMI190xxx-19-00-00-en-041

Entering numbers and characters

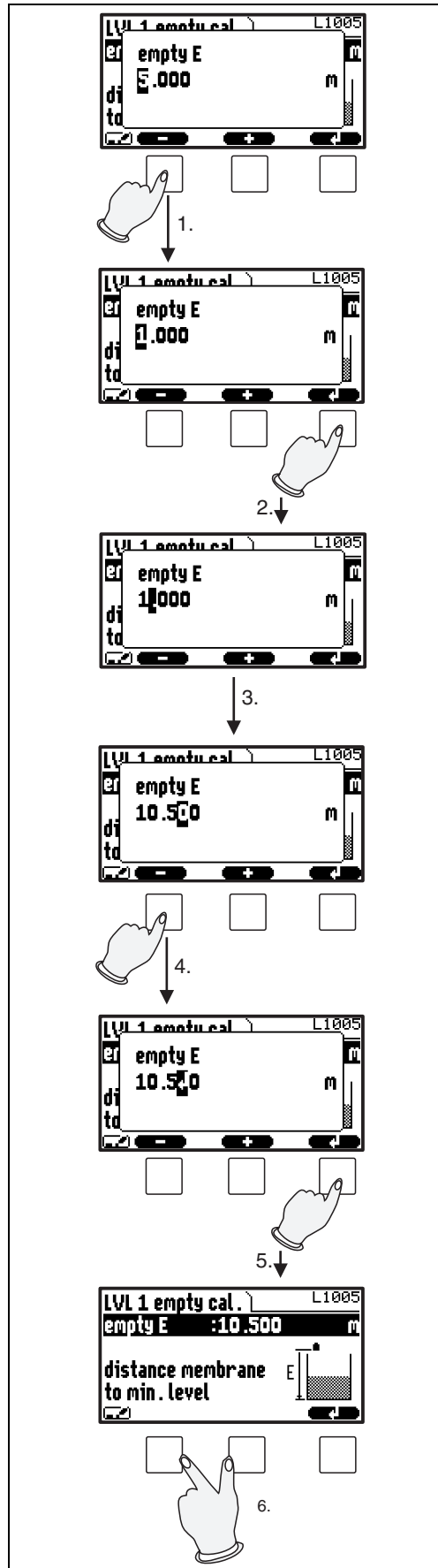

When you select a numeric parameter ("empty calibration", "full calibration" etc.) or an alpha-numeric parameter ("device marking" etc.), the editor for numbers and text strings appears. Enter the desired value in the following way:

1. The cursor is at the first digit. Press  $\square$  or  $\square$  until this digit has the required value.
2. Press  $\downarrow$  in order to confirm the value and to jump to the next digit.
3. Repeat the procedure for all relevant digits.
4. If all relevant digits have been entered: Press  $\square$  or  $\square$ , until  $\downarrow$  appears at the cursor.
5. Press  $\downarrow$  to store the complete value in the device.
6. Press the left and middle keys simultaneously in order to quit the parameter.

L00-FM190xxx-19-00-00-yy-042

### Special editing functions

Within the editor for alphanumeric characters, pressing  $\square$  or  $\oplus$  does not only lead to numbers and characters but also to the following symbols for special editing functions. They simplify the editing procedure.

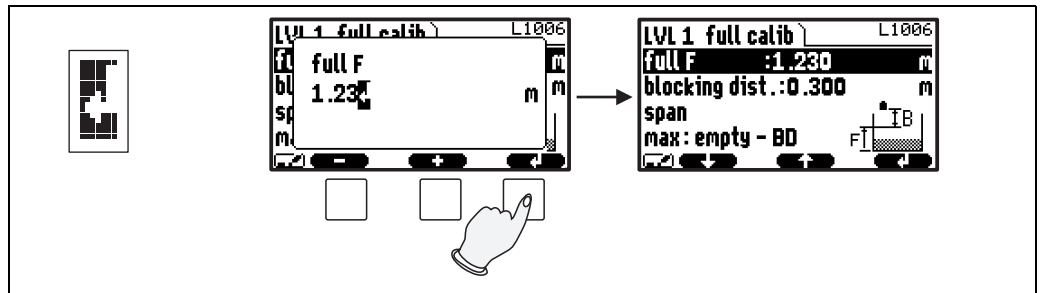

L00-FM190xxx-19-00-00-yy-043

**Enter:** The number left of the cursor is transferred to the instrument.

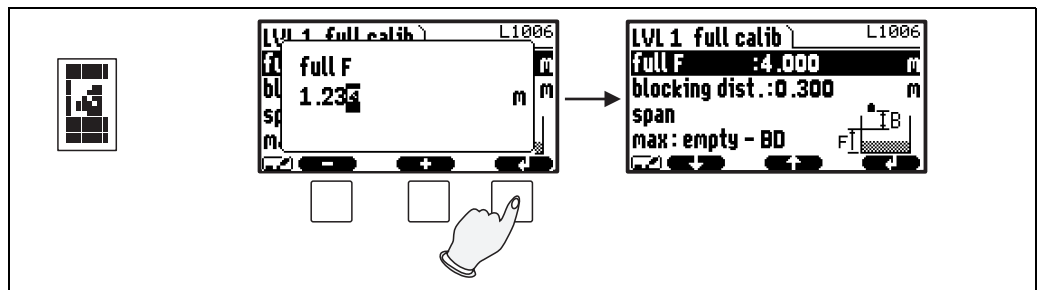

L00-FM190xxx-19-00-00-yy-044

**Escape:** The editor is closed. The parameter maintains its former value. The same behavior can be achieved by pressing the left and the middle key simultaneously ( $\square$ ).

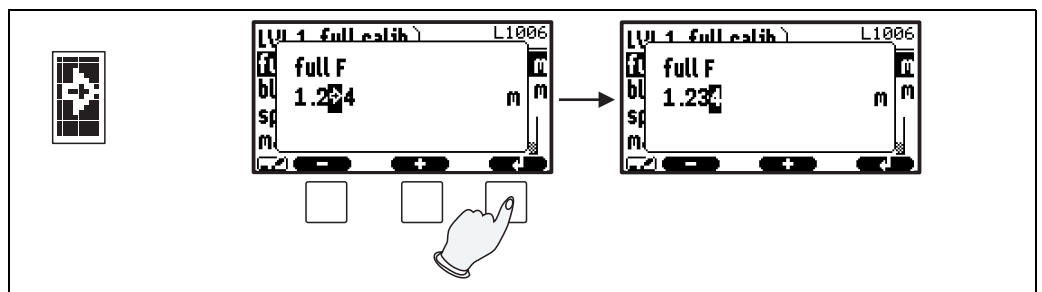

L00-FM190xxx-19-00-00-yy-045

**Next digit:** The cursor moves on to the next digit.

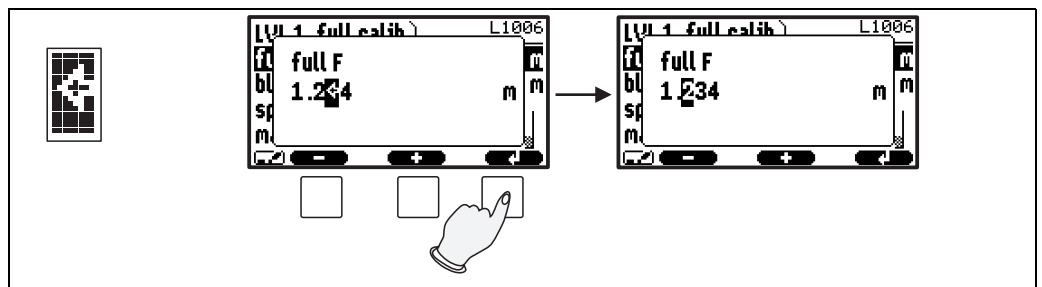

L00-FM190xxx-19-00-00-yy-046

**Previous digit:** The cursor moves back to the previous digit.

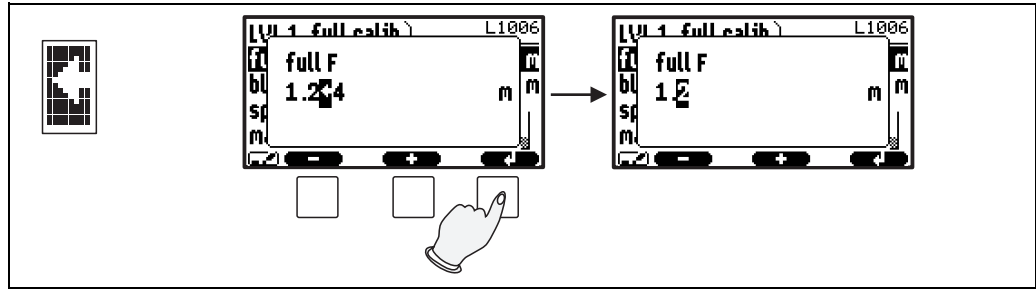

L00-FMU190xxx-19-00-00-yy-047

**Delete:** The current digit and all digits to its right are deleted.

**Return to the measured value display**

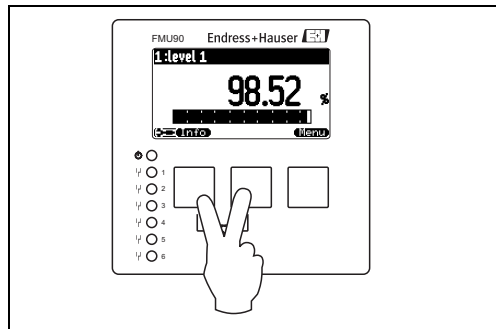

L00-FMU190xxx-19-00-00-en-048

By pressing the left and middle keys simultaneously you can return

- from a parameter to the parameter set
- from the parameter set to the submenu
- from the submenu to the main menu
- from the main menu to the measured value display

## 5.3 Operation via Endress+Hauser operating tool "FieldCare"

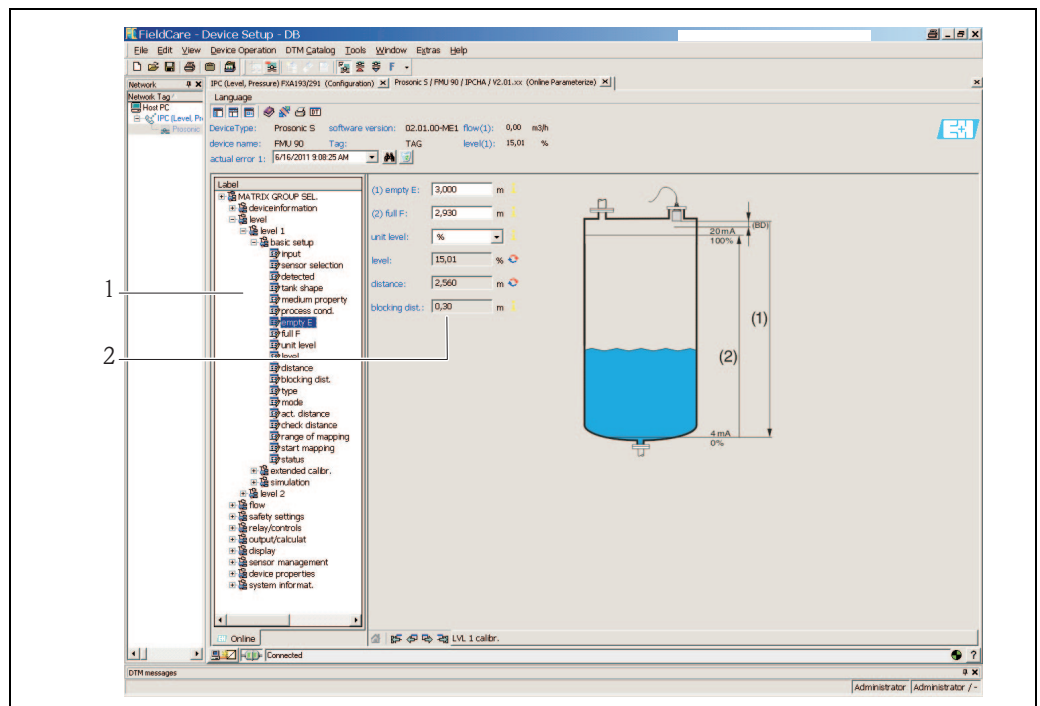

L00-FMU190xxx-19-00-00-en-087

Operation via the FieldCare is similar to the operation via the display module.

- The operating menu can be found in the **navigation bar (1)**.
- Input fields for the parameters can be found in the **parameter editor (2)**.
- When you click on a parameter name, the **help pages** appear. They contain a detailed description of the respective parameter.

## 5.4 Operation via Field Xpert SFX100

Compact, flexible and robust industry handheld terminal for remote parametrization and measured value inspection via the HART current output or FOUNDATION Fieldbus. For details refer to Operating Instructions BA00060S/04/EN.

## 5.5 Lock/unlock configuration

### 5.5.1 Software locking

#### Locking

Go to the parameter "device properties/password-reset/code" and enter a value  $\neq 100$ . The instrument is locked against parameter changes.

The  symbol appears on the display.

#### Unlocking

If you try to change a parameter, the "password-reset" parameter set appears. Select the "code" parameter and enter "100". Parameters can be changed again.

## 5.5.2 Locking by key combination

### Locking

Press all three keys simultaneously. The instrument is locked against parameter changes. The  symbol appears on the display.

### Unlocking

If you try to change a parameter, the "password/reset" parameter set appears. "key locked" is displayed in the "status" parameter. Press all three keys simultaneously. Parameters can be changed again.

## 5.5.3 Hardware locking

The instrument can be locked against parameter changes by the locking switch in the terminal compartment of the Prosonic S.

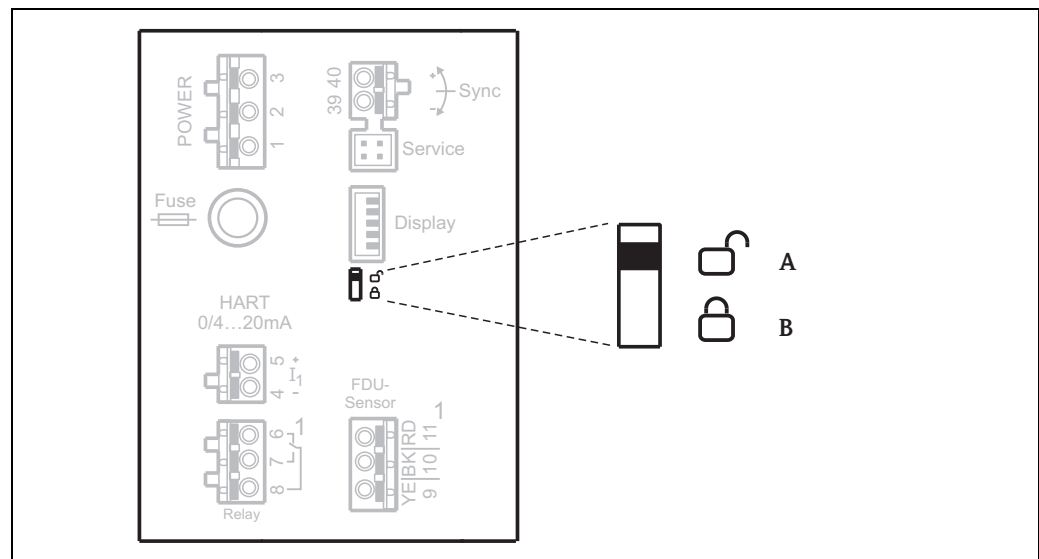

Switch position **A**: unlocked; parameters can be changed  
Switch position **B**: locked; parameters can not be changed.

If the switch is in position B,  appears on the display and parameters can not be changed. The instrument can only be unlocked by the switch.

## 5.5.4 Indication of the locking state

The current locking state of the instrument is displayed in the parameter "device properties/ password-reset/status". The following states may occur:

- **unlocked**  
All parameters (except of service parameters) can be changed.
- **code locked**  
The instrument has been locked via the operating menu. It can be unlocked by entering the unlocking code into the "code" parameter.
- **key locked**  
The key has been locked by a key combination. It can only be unlocked by pressing all three keys simultaneously.
- **switch locked**  
The instrument has been locked by the switch in the terminal compartment. It can only be unlocked by this switch.



## 5.6 Reset to the default configuration



### Caution!

A reset may lead to impairment of the measurement. As a rule, a basic calibration is required after a reset.

### Application of the Reset

It is advisable to reset the customer parameters if you want to use a device with an unknown history.

### Effects of the Reset

- All parameters are reset to their default values.
- The linearisation type is switched to "none". If a linearisation table is present, it is not deleted. If required, it can be reactivated at a later point of time.
- An interference echo curve is set "inactive". However, the curve is not deleted and can be reactivated at a later point of time.



### Note!

In the menu diagrams (→  126, "Operating menu") the default values of the parameters are printed in bold.

### Performing a Reset

In order to perform a reset, enter "333" into the parameter "device properties/password-reset/reset".

### 5-point linearity protocol



### Note!

The specified measuring accuracy is a typical value →  122, "Performance characteristics". With the production of the 5-point linearity protocol the measuring system (FDU9x sensor and FMU9x transmitter electronic) is adjusted exactly to one another and the measuring accuracy is optimized for the specified range.

To realize this, the parameter "zero distance" is fine adjusted. After a reset the value for the zero distance has to be re-parameterized in the service menu according to the data on the associated 5-point linearity protocol for the FDU9x sensor. Please contact the Endress+Hauser service.



### Note!

- To **delete a linearisation table**, use the parameter "basic setup/linearisation" → Chap. 6.4.3
- To **delete an interference echo mapping**, use the parameter "extended calibration/distance mapping/state" → Chap. 6.4.9

## 6 Commissioning



Warning!

For the version with field housing: The instrument may only be operated if the field housing is closed.

### 6.1 Structure and Functions of the Prosonic S

#### 6.1.1 Function blocks

The Prosonic S contains various function blocks. During the commissioning procedure the blocks are linked to each other in order to perform the desired measuring task. Depending on the instrument version and installation environment, the following function blocks may occur:

##### Signal inputs

- Sensor 1
- Sensor 2 (if selected in the product structure)

##### Signal evaluation (calculation of the measured value)

- Level 1
- Level 2 (for instruments with 2 current outputs)
- Flow 1 (for flow instruments)
- Flow 2 (for flow instruments)

##### Controls

- Pump control
- Rake control
- Backwater detection

##### Signal output

- Display
- Current output 1 with HART
- Current output 2 (if selected in the product structure)
- Relay 1
- Relay 2 (for instruments with 3 or 6 relays)
- Relay 3 (for instruments with 3 or 6 relays)
- Relay 4 (for instruments with 6 relays)
- Relay 5 (for instruments with 6 relays)
- Relay 6 (for instruments with 6 relays)

#### 6.1.2 Typical block configurations

##### 1-channel flow measurement

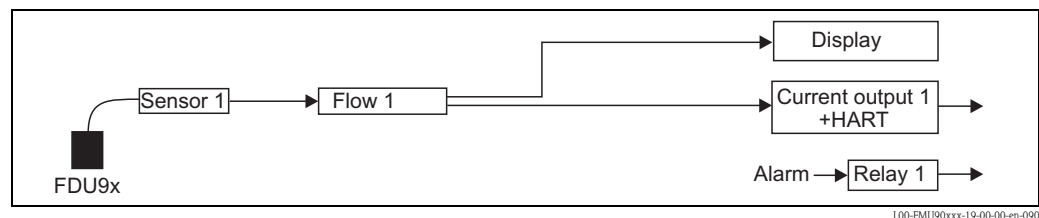

**2-channel flow measurement**

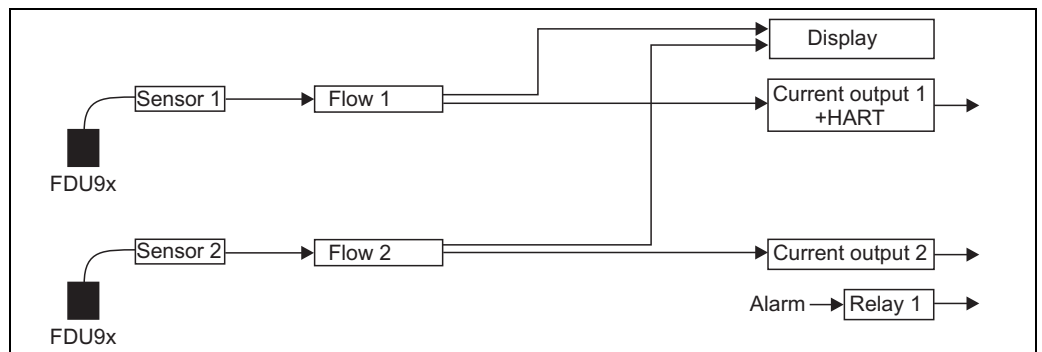

L00-FMU90xxx-19-00-00-en-080

**Level and flow measurement with 1 sensor**

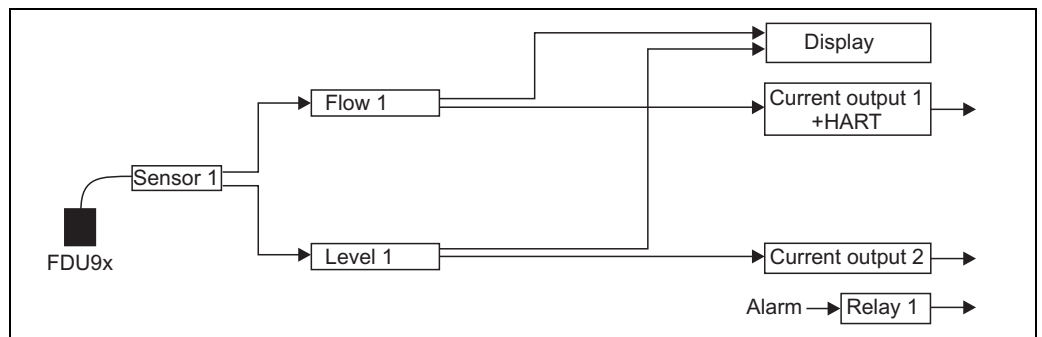

L00-FMU90xxx-19-00-00-en-092

**Backwater detection**

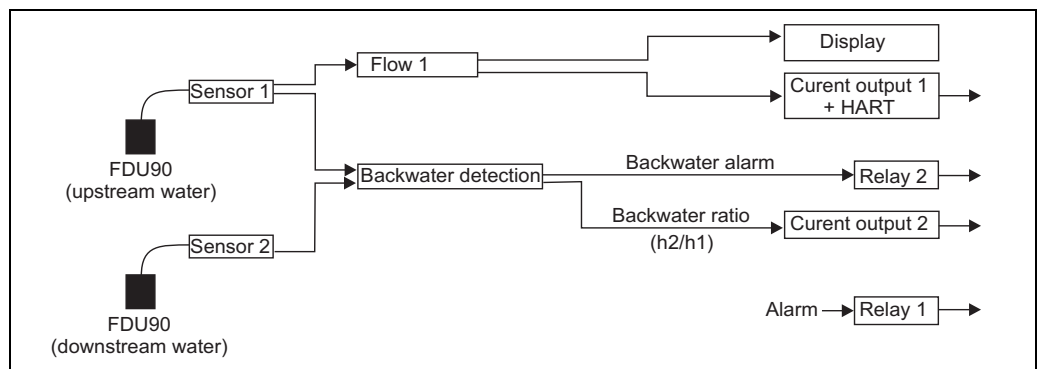

L00-FMU90xxx-19-00-00-en-093

*Note: The backwater alarm relay must be configured by the user. It is not part of the default configuration.*



**Note!**  
By default, relay 1 is always configured to be the alarm relay.

## 6.2 First setup



Note!

This chapter describes the commissioning of the Prosonic S via the display and operating module. Commissioning via FieldCare or the Field Xpert SFX100 is similar. For further instructions refer to the FieldCare Online Help or the Operating Instructions supplied with the Field Xpert SFX100.

After switching on the power supply for the first time, you are requested to define the basic operating parameters:

1. Select the display language.
  - a. Press ↓ or ↑ to move the marking bar above the desired language.
  - b. Press ↵ to confirm your selection.



2. Select the unit for distance measurements.

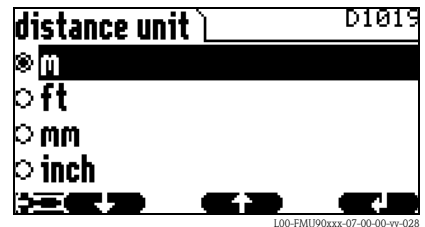

3. Select the temperature unit.

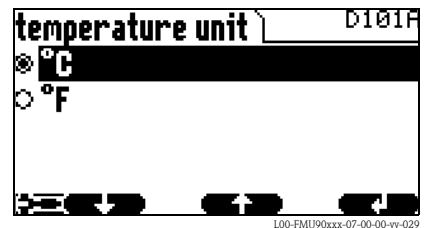

4. Select the operating mode.



Note!

The available options depend on the instrument version and the installation environment. If you want to configure a backwater detection, you must select the option "flow+backwater".

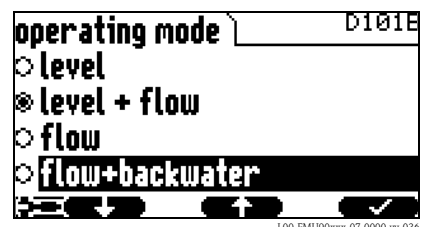

5. Select the control functions, which you are going to use.



Note!

This selection is not required for the "flow" and "flow+backwater" operating modes.



Note!



**By pressing** you can return to the previous parameter (e.g. in order to correct the value). All these parameters can also be changed at a later point of time in the "device properties/operating parameters" and "device properties/language" parameter sets.

### 6.3 Preparing the basic setup

1. After the first setup the main screen appears. However, the displayed values do not yet correspond to the real flows before you have performed the basic setup. To do so, enter the main menu by pressing "Menu" (right key).

 Note!

In the "calibr. display" menu you can adjust the display to your requirements (displayed values, display format). The figure shows an example for a 2-channel instrument.

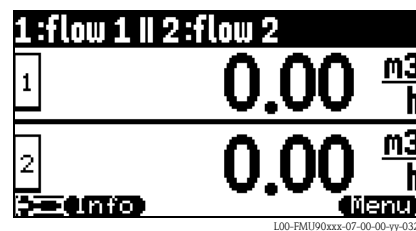

2. Select the "flow" submenu.
  - Select by ↓ and ↑
  - Confirm by ↵



The "flow" submenu is used for the calibration of

- flow measurements (1 or 2 channels)
- back water alarm
- flow counters

The structure of the submenu depends on the selected operating mode<sup>4</sup>:

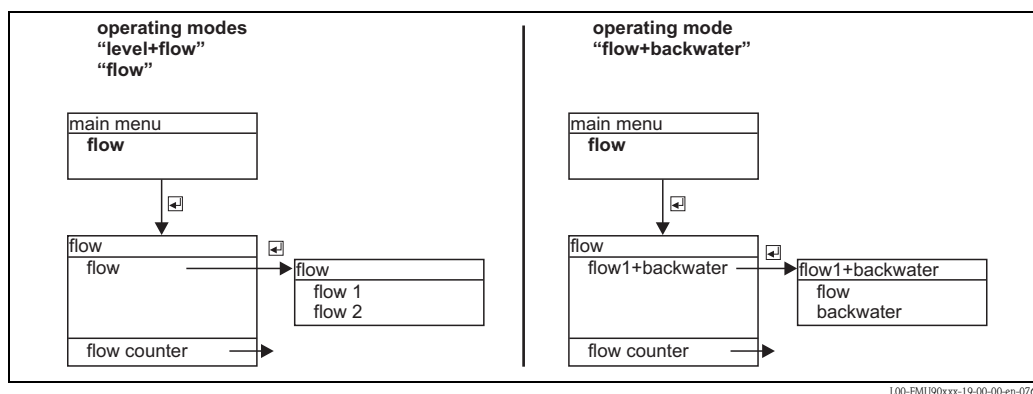

Always start by calibrating the first flow channel ("flow 1" submenu).

Thereafter, you can calibrate the following as required:

- the second flow channel ("flow 2" submenu)
- the backwater detection ("backwater" submenu)
- the flow counters ("flow counter" submenu)

4) The operating mode is selected during the first setup. Nevertheless, it can be changed at any time if required ("device properties" menu, "operating params" submenu, "operating mode" parameter set).

## 6.4 Calibration of a flow measurement

### 6.4.1 Overview

The following table gives an overview of the calibration of a flow measurement. Detailed information on the parameters can be found in sections 6.4.2 - 6.4.9.

Step	Parameter set	Parameter	Remarks	Section
1			Open the "flow 1" or "flow 2" submenu.	
2			Open the "basic setup" submenu.	
3	flow N sensor selection (N = 1 or 2)	input	Allocate a sensor to the channel.	→ Chap. 6.4.2
		sensor selection	Specify the type of sensor ("automatic" for FDU9x)	
		detected	only available for "sensor selection" = "automatic"; indicates the detected type of sensor.	
4	flow N linearisation (N = 1 or 2)	type	Select type of linearisation <sup>1)</sup> : <ul style="list-style-type: none"> <li>■ "flume/weir" (for the pre-programmed flumes and weirs)</li> <li>■ "table" (to enter a linearisation table manually)</li> <li>■ "formula" (for the flow formula <math>Q = C (h^\alpha + \gamma h^\beta)</math>)</li> </ul>	→ Chap. 6.4.3
		flow unit	Select the flow unit.	
		curve	Select the type of flume or weir; (only present for "type" = "flume/weir"); A second page appears in which the size of the respective flume and weir must be selected (for details refer to chapter → Chap. 15.1)	
		edit	Used to enter, change or delete a linearisation table; (only available for "type" = "table")	
		status table	Enables or disables the linearisation table; (only available for "type" = "table")	
		alpha	Specify the value of the parameter $\alpha$ ; (only available for "type" = "formula")	
		beta	Specify the value of the parameter $\beta$ ; (only available for "type" = "formula")	
		gamma	Specify the value of the parameter $\gamma$ ; (only available for "type" = "formula")	
		C	Specify the value of the parameter C; (only available for "type" = "formula")	
		max. flow	Specify the maximum flow of the flume or weir; (not available for "type" = "table")	
		5	flow N empty calibration (N = 1 or 2)	
blocking distance	indicates the blocking distance of the respective sensor; the maximum level may not project into the blocking distance.			
6	flow N (N = 1 or 2)	flow N (N = 1 or 2)	displays the currently measured flow (for checking purposes)	→ Chap. 6.4.5
		level	displays the currently measured level (for checking purposes)	
		distance	displays the currently measured distance between the reference point of the sensor and the liquid surface (for checking purposes)	

Step	Parameter set	Parameter	Remarks	Section
7	flow N check value (N = 1 or 2)	distance	displays the currently measured distance between the reference point of the sensor and the liquid surface.	→ Chap. 6.4.6 → Chap. 6.4.7
		check distance	Compare the displayed distance with the real value: <ul style="list-style-type: none"> <li>■ "distance = ok" → "flow N mapping" (see below)</li> <li>■ "distance too small" → "flow N mapping" (see below)</li> <li>■ "distance too big" → basic setup completed</li> <li>■ "distance unknown" → basic setup completed</li> <li>■ "manual" → "flow N mapping" (see below)</li> </ul>	
8	flow N mapping (N = 1 or 2)	distance	displays the currently measured distance between the reference point of the sensor and the liquid surface	→ Chap. 6.4.8
		range of mapping	Determines the range over which the mapping is recorded; confirm the predefined value or enter your own value.	
		start mapping	Select: <ul style="list-style-type: none"> <li>■ no: the mapping is not recorded</li> <li>■ yes: the mapping is recorded; after completion, the "flow N state" function appears (see below)</li> </ul>	
9	flow N state (N = 1 or 2)	level	displays the currently measured level	→ Chap. 6.4.9
		distance	displays the currently measured distance between the reference point of the sensor and the liquid surface. Check the value: <ul style="list-style-type: none"> <li>■ Value correct: → Basic calibration completed. Press  several times to return to the measured value display.</li> <li>■ Value incorrect: → go back to step 7 ("flow N check value")</li> </ul>	
		flow N (N = 1 or 2)	displays the currently measured flow	
		status	Used to enable, disable or delete a mapping	
10			Parametrization of the counters (in the operating menu: "flow/flowcounter")	→ Chap. 6.7

1) The type of linearisation determines the relationship between the measured level and the flow.

## 6.4.2 "flow N sensor selection" (N = 1 or 2)

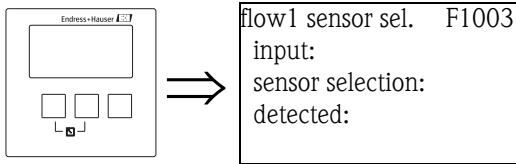

### "input"

Use this parameter to allocate a sensor to the channel.

#### Selection

- no sensor
- sensor 1
- sensor 2 (for instruments with 2 sensor inputs)
- average level <sup>5)</sup>

### "sensor selection"

Use this parameter to specify the type of the connected ultrasonic sensor.



Note!

- For the sensors **FDU9x**, the option "automatic" is recommended (default setting). With this setting the Prosonic S recognizes the type of sensor automatically.
- For the sensors **FDU8x**, the type has to be assigned explicitly. The automatic sensor recognition does not work for these sensors.



Caution!

After exchanging a sensor, observe the following:

The automatic sensor recognition is also active if a sensor has been exchanged <sup>6)</sup>. The Prosonic S recognizes the type of the new sensor automatically and changes the "detected" parameter to fit the new sensor. The measurement continues without break.

Nevertheless, in order to ensure perfect measurement, the following checks are required:

- Check the **"empty calibration"** parameter. Adjust this value if required. Take into account the blocking distance of the new sensor.
- Go to the **"flow N check value"** parameter set and check the displayed distance. If required, perform a new interference echo suppression.

### "detected" (only available for "sensor selection" = "automatic")

Indicates the type of the automatically detected sensor.

5) This option is only available if two level measurements have been calibrated. This is only possible for the "leve+flow" operating mode and a two channel instrument.

6) if the sensor is of the type FDU9x.



### 6.4.3 "flow N linearization" (N = 1 or 2)

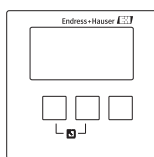

flow 1 linearizat F1004  
 type:  
 flow unit:



Note!  
 The selected linearization type determines which parameters are present.  
 Only the parameters "type" and "flow unit" are always present.

The "linearization" parameter set is used to calculate the flow from the measured level. The Prosonic S provides the following linearization types:

- pre-programmed flow curves for commonly used flumes and weirs
- a freely editable linearization table (up to 32 points)
- a flow formula  $Q = C(h^\alpha + \gamma h^\beta)$  with freely selectable parameters



Caution!

Flow measurement **always** requires a linearization.

#### "type"

Use this parameter to select the type of linearization.

##### Selection:

- **none**  
 No flow linearization is performed.



Note!

If this option has been selected, no further parameters are available. A flow measurement is only possible with one of the other options.

- **flume/weir**

In this type, the linearization is performed according to a preprogrammed linearization curve. The type of curve is selected in the "**curve**" parameter. Additionally, the "**flow unit**" has to be specified. The "**max. flow**" parameter displays the max. flow of the respective flume or weir. If required, this value can be adjusted (as well as the "**width**" of the weir).

- **table**

In this type, a linearization table consisting of up to 32 pairs of values "level - flow" is used. Additionally, the "**flow unit**" has to be specified. To enter and activate the table use the "**edit**" and "**status table**" parameters.

- **formula**

In this type, the linearization is performed according to the formula

$$Q = C(h^\alpha + \gamma h^\beta).$$

The "**alpha**", "**beta**", "**gamma**" and "**C**" parameters appear, which are used to specify the details of the curve. Additionally, the "**flow unit**" and the "**max. flow**" of the weir or flume have to be specified.

#### "flow unit"

Use this parameter to select the desired flow unit.



Note!

After a change of the flow unit, the switching points of the limit relays have to be checked and adjusted if required.

#### "curve"

This parameter is available for the "**flume/weir**" linearization type.

It is used to select the type of flume or weir. After the selection, a second list appears with different sizes of the flume or weir<sup>7)</sup>. When you have confirmed your selection, the Prosonic S returns to the "**linearization**" function.

7) Tables of the flume and weir parameters can be found in the Appendix.

**"width"**

This parameter appears for the curves **"rectangular weir"**, **"NFX"** and **"trapezoidal weir"**. It is used to specify the width of the respective weir.

**"edit"**

This parameter is used to enter or to view the linearization table. You have got the following options:

- **read:**  
The table editor appears. An existing table can be viewed but not changed.
- **manual:**  
The table editor appears. Table values can be entered and changed.
- **delete:**  
The linearization table is deleted.

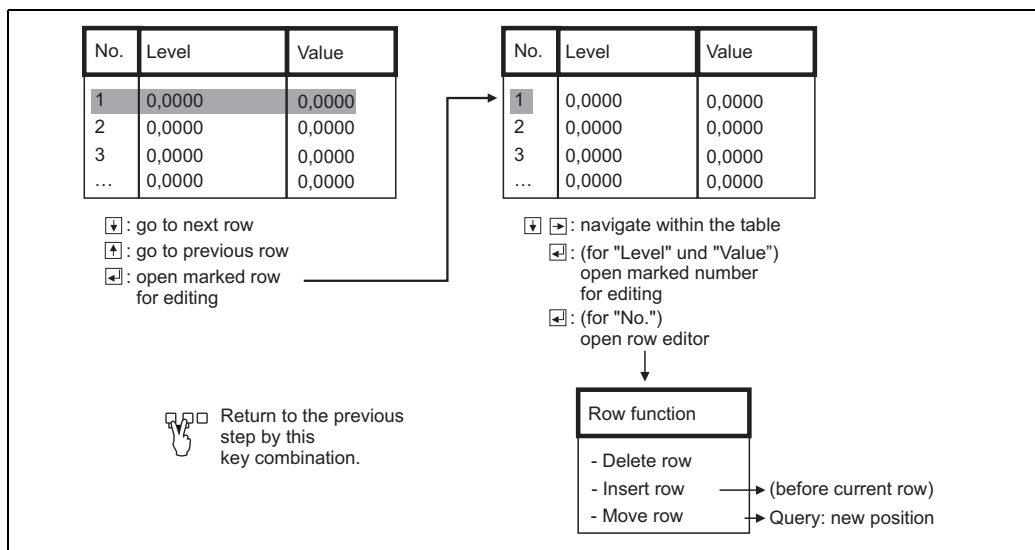
**The table editor**

L00-FMU190xxx-19-00-00-de-006

**"status"**

Use this parameter to specify if the linearization table is to be used or not.

**Selection:**

- **enabled**  
The table is used.
- **disabled**  
The table is not used. A flow value is not calculated.

**"alpha", "beta", "gamma" and "C"**

These parameters are available for the **"formula"** linearization type.

They are used to specify the parameters of the flow formula:

$$Q = C(h^\alpha + \gamma h^\beta)$$

**"max flow"**

This parameter is available for the linearization types **"flume/weir"** and **"formula"**. It is used to specify the maximum flow of the respective weir or flume. For each of the preprogrammed curves, a default value is preset. However, this value can be adjusted, e.g. if the weir/flume is applied for lower flows. The maximum flow corresponds to an output current of 20 mA.

**6.4.4 "flow N empty calibration" (N = 1 or 2)**

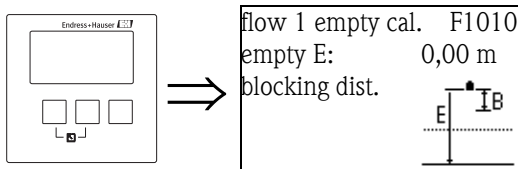

**"empty E"**

Use this parameter to enter the empty distance E, i.e. the distance between the reference point of the sensor and the zero point of the flume or weir.

For flumes, the zero point is the bottom of the flume at the narrowest position:

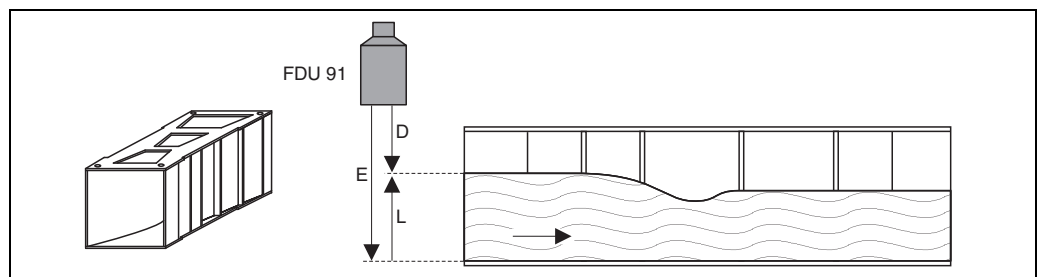

Example: Khafagi-Venturi flume  
E: empty distance; D: measured distance; L: level

For weirs, the zero point is the lowest point of the weir crest:

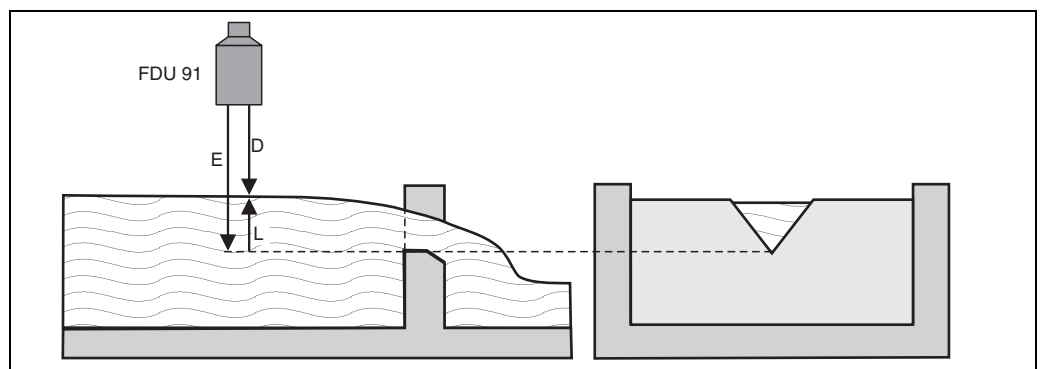

Example: Triangular weir  
E: empty distance; D: measured distance; L: level

**"blocking distance"**

Indicates the blocking distance of the respective sensor. The blocking distance is measured from the reference point of the sensor. The maximum level may not project into the blocking distance.

Type of sensor	blocking distance (BD)	maximum measuring distance <sup>1)</sup>
FDU90	0,07 (0.2)	3,0 (9.8) (for liquids)
FDU91/FDU91F	0,3 (1.0)	10 (33) (for liquids)
FDU92	0,4 (1.3)	20 (66) (for liquids)
FDU93	0,6 (2.0)	25 (82) (for liquids)
FDU95 - *1*** (low temperature version)	0,7 (2.3)	45 (148) (for solids)
FDU95 - *2*** (high temperature version)	0,9 (3.0)	45 (148) (for solids)
FDU96	1,6 (5.2)	70 (230) (for solids)
FDU80/FDU80F	0,3 (1.0)	5 (16) (for liquids)
FDU81/81F	0,5 (1.6)	10 (33) (for liquids)
FDU82	0,8 (2.6)	20 (66) (for liquids)
FDU83	1,0 (3.3)	25 (82) (for liquids)
FDU84	0,8 (2.6)	25 (82) (for solids)
FDU85	0,8 (2,6)	45 (148) (for solids)
FDU86	1,6 (5.2)	70 (230) (for solids)

m (ft)

1) valid for optimum process conditions

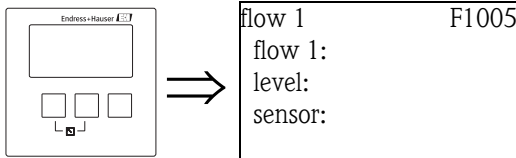
**6.4.5 "flow N" (N = 1 or 2)****"flow N" (N = 1 or 2)**

Displays the currently measured flow Q.

If the displayed value does not match the real flow, it is recommended to check the linearisation.

**"level"**

Displays the currently measured level L.

If the displayed value does not match the real level, it is recommended to check the empty calibration.

**"sensor"**

Displays the currently measured distance D between the reference point of the sensor and the liquid surface.

If the displayed value does not match the real distance, it is recommended to perform an interference echo suppression.

### 6.4.6 Interference echo suppressio: Basic principles

The "flow N check value" and "flow N mapping" parameter sets are used to configure the interference echo suppression of the Prosonic S. The following picture shows the operating principle of the interference echo suppression:

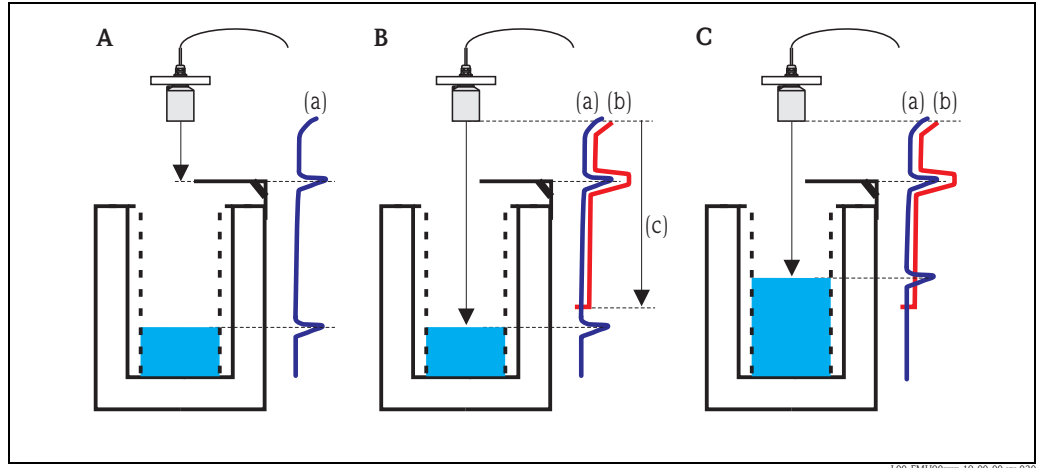

**A:** The envelope curve (a) contains the level echo and an interference echo. Without interference echo suppression, the interference echo is evaluated.  
**B:** The interference echo suppression generates the mapping curve (b). This curve contains all echos which are located within the range of mapping (c).  
**C:** From now on, only those echos are evaluated, which are higher than the mapping curve. The interference echo is ignored because it is lower than the mapping curve.



Note!

In order to include all interference echos, the interference echo suppression should be performed with the level as low as possible. If during the commissioning the channel can not be sufficiently emptied, it is advisable to repeat the interference echo suppression at a later point of time (as soon as the level reaches nearly 0%).

### 6.4.7 "flow N check value" (N = 1 or 2)

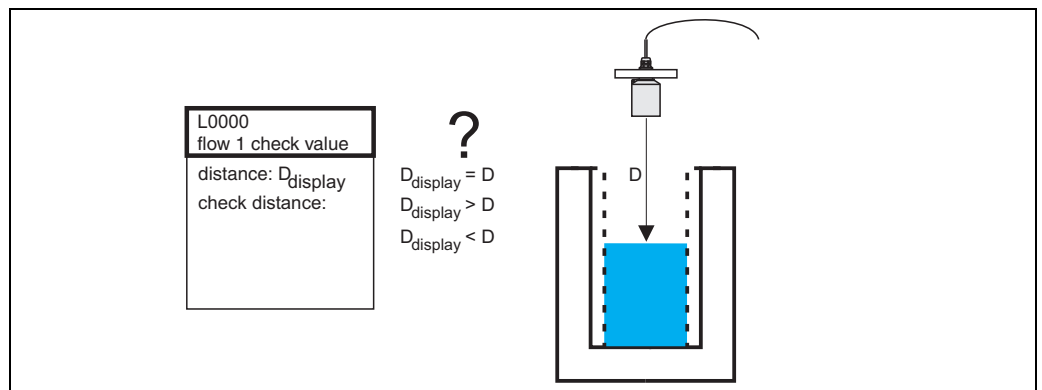
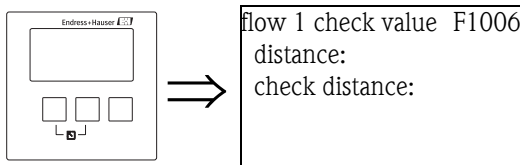

**"distance"**

Displays the currently measured distance  $D_{display}$ .

**"check distance"**

Use this parameter to state if the displayed distance  $D_{display}$  matches the real distance  $D$ . Based on your selection, the Prosonic S automatically proposes a suitable range of mapping.

You have got the following options:

- **distance = ok**

Choose this option if the displayed value matches the real distance.

After selecting this option, the **"flow N mapping"** parameter set appears. The preset range of mapping is equal to  $D$ . That means: all interference echos which are above the current product surface will be mapped out in the interference echo suppression.

- **distance too small**

Choose this option if the displayed value is smaller than the real distance  $D$ .

In this case, the currently evaluated echo is an interference echo.

After selecting this option, the **"flow N mapping"** parameter set appears. The preset range of mapping is slightly larger than  $D_{display}$ . Therefore, the currently evaluated interference echo will be mapped out by the interference echo suppression.

- **distance too big**

Choose this option if the displayed value  $D_{display}$  is larger than the real distance  $D$ .

This error is not caused by interference echos. Therefore, no interference echo suppression is performed and the Prosonic S returns to the "flow N" parameter set. Check the calibration parameters, especially the **"empty calibration"**.

- **distance unknown**

Choose this option if you do not know the real distance  $D$ .

In this case, an interference echo suppression can not be performed and the Prosonic S returns to the "flow N" parameter set.

- **manual**

Choose this option if you want to define the range of mapping manually.

The **"flow N mapping"** parameter set appears, where you can define the required range of mapping.

### 6.4.8 "flow N mapping" (N = 1 or 2)

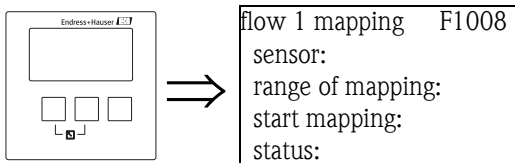
**"sensor"**

Displays the currently measured distance between the reference point of the sensor and the water surface. Compare this value to the real distance in order to find out if currently an interference echo is evaluated.

**"range of mapping"**

Use this parameter to specify the range of the mapping curve. Normally, a suitable value has already been entered automatically. Nevertheless, you can change this value if required.

**"start mapping"**

Select **"yes"** in this parameter in order to start the mapping. When the mapping is finished, the state is automatically changed to **"enable map"**.

The **"flow N state"** parameter set appears, in which the currently measured level, distance and flow are displayed. Compare the displayed distance to the real distance in order to decide if a further mapping is necessary.

If yes: Press the left-arrow key (←) in order to return to the "flow N mapping" parameter set.

If no: Press the right key (→) in order to return to the "flow N" submenu.

### "status"

see below ("flow N status")

## 6.4.9 "flow N state" (N = 1 or 2)"

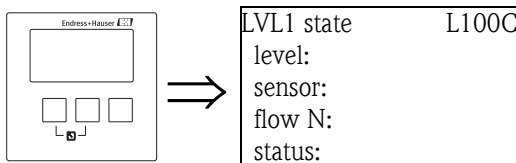

### "level"

Displays the currently measured level.

### "sensor"

Displays the currently measured distance between the reference point of the sensor and the liquid surface.

### "flow N" (N = 1 or 2)

Displays the currently measured flow.

### "status"

Use this parameter to define the status of the interference echo suppression.

#### ■ enable map

Choose this option in order to activate the interference echo suppression. The mapping is then used for signal evaluation.

#### ■ disable map

Choose this option in order to deactivate the interference echo suppression. The mapping is then no longer used for signal evaluation but it can be reactivated if required.

#### ■ delete map

Choose this option in order to delete the mapping. It can not be reactivated again and the instrument uses the preprogrammed default mapping.

## 6.5 Calibration of backwater and dirt detection

### 6.5.1 Basics

The flow measurement can be impaired by backwater on the downstream side or by dirt within the flume. The backwater and dirt detection function can detect these errors and ensure that the Prosonic S reacts appropriately.

Two sensors are required for backwater and dirt detection. The first sensor is mounted above the upstream water, the second above the downstream water. The Prosonic S evaluates the ratio of the downstream level  $h_2$  and the upstream level  $h_1$ .

#### Backwater detection

Backwater is detected if the ratio  $h_2/h_1$  exceeds a critical value (typically 0,8 for Venturi flumes). In this case, the flow is continuously reduced to 0. An alarm relay can be configured which indicates the backwater alarm.

#### Dirt detection

Dirt within the flume is detected if the ratio  $h_2/h_1$  falls below a critical value (typically 0,1). An alarm relay can be configured which indicates the dirt alarm.

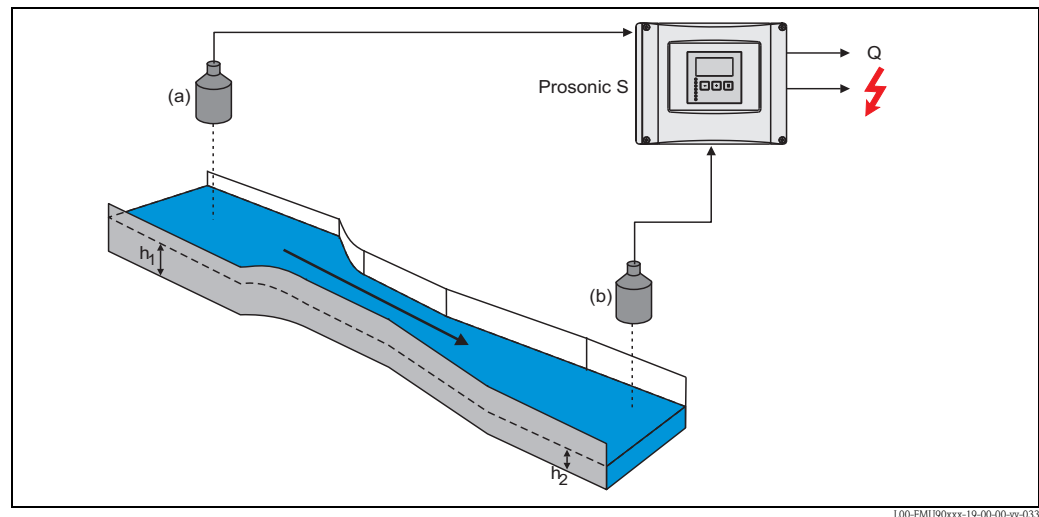

100-FMI190cxxx-19-00-00-yy-035

(a): Upstream sensor; (b): Downstream sensor



#### Note!

The ultrasonic sensor for the measurement of the downstream water level should be installed at a sufficient distance from the discharge of the flume. The measuring point must be selected in such a way that the surface of the water is calmed down and the level is not influenced by the flume anymore.



## 6.5.2 Overview

The following table gives an overview of the calibration for backwater and dirt detection. Detailed information on the parameters can be found in the sections 6.5.3 – 6.5.5.

Step	Parameter set	Parameter	Remarks	Section
<b>Calibration of the upstream sensor</b>				
1			Open the submenu "flow/flow1+backwater/flow". Calibrate the flow measurement for the upstream sensor.	→ Chap. 6.4
<b>Calibration of the downstream sensor</b>				
2			Open the submenu "flow/flow1+backwater/backwater/basic setup".	
3	backw. sensor selection	input	Select the downstream sensor.	similar to → Chap. 6.4.2
		sensor selection	Select the type of sensor ("automatic" for FDU9x)	
		detected	only available for "sensor selection" = "automatic"; Displays the detected type of sensor.	
4	backw. empty calibration	empty E	Specify the distance E between the reference point of the sensor and the bottom of the flume.	similar to → Chap. 6.4.4
		blocking distance	displays the blocking distance of the respective sensor; the maximum level may not project into the blocking distance.	
<b>Calibration of the backwater and dirt detection</b>				
5	backwater detection	ratio B	Specify upper limit B for the ratio $h_2/h_1$ . Backwater alarm is active if $h_2/h_1 > B$ .	→ Chap. 6.5.3
6	dirt detection	ratio D	Specify lower limit D for the ratio $h_2/h_1$ . Dirt alarm is active if $h_2/h_1 < D$ .	→ Chap. 6.5.4
7	backwater	act. backwater level	Displays the currently measured downstream level $h_2$ for checking purposes.	→ Chap. 6.5.5
		act flow level	Displays the currently measured upstream level $h_1$ for checking purposes.	
		act. ratio	Displays the currently measured ratio $h_2/h_1$ for checking purposes.	
		flow 1	Displays the current flow Q for checking purposes.	
<b>Interference echo suppression for the downstream sensor</b>				
7	backwater check value	distance	displays the currently measured distance between the membrane of the downstream sensor and the liquid surface.	similar to → Chap. 6.4.7
		check distance	Compare the displayed distance with the real value: <ul style="list-style-type: none"> <li>■ "distance = ok" → "backwater mapping" (see below)</li> <li>■ "distance too small" → "backwater mapping" (see below)</li> <li>■ "distance too big" → basic setup completed</li> <li>■ "distance unknown" → basic setup completed</li> <li>■ "manual" → "backwater mapping" (see below)</li> </ul>	
8	backwater mapping	distance	displays the currently measured distance between the membrane of the downstream sensor and the liquid surface	similar to → Chap. 6.4.8
		range of mapping	Determines the range over which the mapping is recorded; confirm the predefined value or enter your own value.	
		start mapping	Select: <ul style="list-style-type: none"> <li>■ no: the mapping is not recorded</li> <li>■ yes: the mapping is recorded; after completion, the "backwater detection" parameter set appears</li> </ul>	
9	backwater status	act backwater level	displays the currently measured downstream level.	similar to → Chap. 6.4.9
		distance	displays the currently measured distance between the membrane of the downstream sensor and the liquid surface. Check the value: <ul style="list-style-type: none"> <li>■ Value correct: → basic setup completed. Return to the measured value display by pressing  several times</li> <li>■ Value not correct: go back to step 7 ("backwater check value")</li> </ul>	
		flow 1	displays the currently measured flow	
		status	Used to enable, disable or delete a mapping	
10	Configuration of the backwater and dirt alarm relay, → Chap. 8.2			

### 6.5.3 "backwater detection"

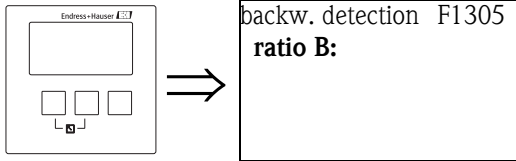

#### "ratio B"

Use this parameter to specify the upper limit for the ratio  $h_2/h_1$ .

If during the measurement the ratio exceeds this limit, the backwater alarm becomes active, i.e.:

- the warning W 00 692 appears
- the backwater alarm relay is de-energized<sup>8)</sup>
- if the backwater level continues to rise, the flow (indicated on the display and registered by the counters) is continuously reduced to 0.

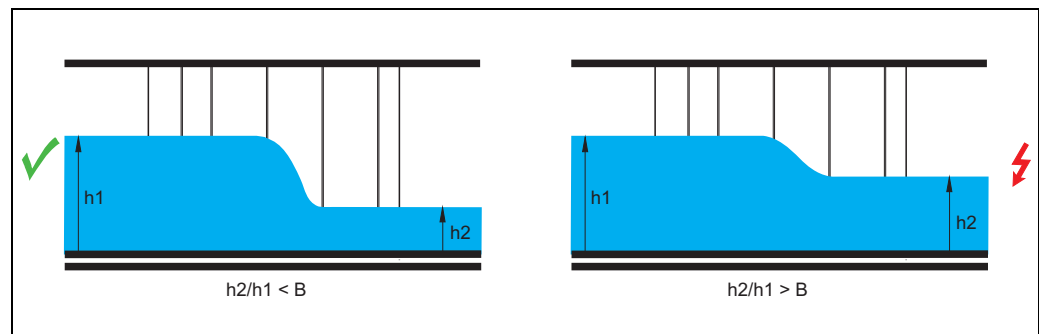

L00-FM190xxx-19-00-00-yy-035



Note!

The default setting is  $B = 0,8$ .

This is the optimum value for Venturi flumes. To ensure reliable measurement it should not be exceeded.

8) In the "relay/controls" menu, one of the relays can be defined to be the backwater alarm relay.

### 6.5.4 "dirt detection"

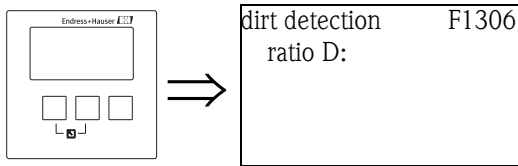

#### "ratio D"

Use this parameter to specify the lower limit for the ratio  $h_2/h_1$ .

If during the measurement the ratio falls below this level, the dirt alarm becomes active, i.e.

- the warning W 00 693 appears
- the dirt alarm relay is de-energized<sup>9)</sup>.

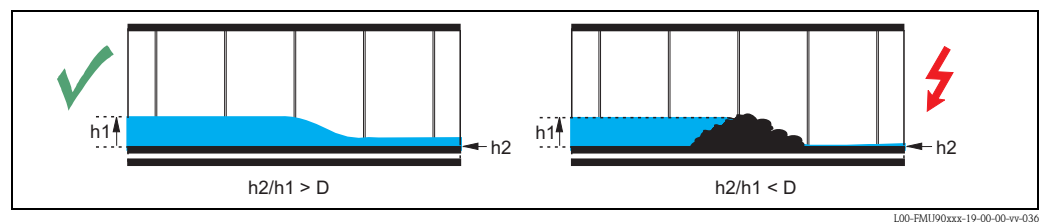

### 6.5.5 "backwater"

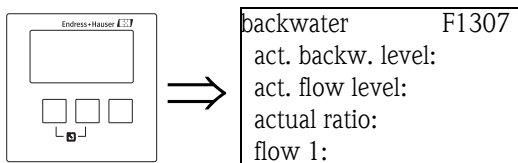

The following is displayed in this parameter set:

- the current backwater level  $h_2$  (downstream level)
- the current flow level  $h_1$  (upstream level)
- the current ratio  $h_2/h_1$
- the current flow  $Q$

Use these values to check the flow calibration as well as the calibration of the backwater and dirt detection.

9) In the "relay/controls" menu, one of the relays can be defined to be the dirt alarm relay

## 6.6 Calibration for simultaneous level and flow measurement with one sensor

It is possible to measure level and flow simultaneously with one sensor. This is especially useful for stormwater overflow basins. For this type of measurement the sensor must be mounted above the basin and the appropriate distance to the weir crest must be observed (for details refer to the description of weirs in the appendix).

The measured values can be communicated by the current outputs or the HART signal.

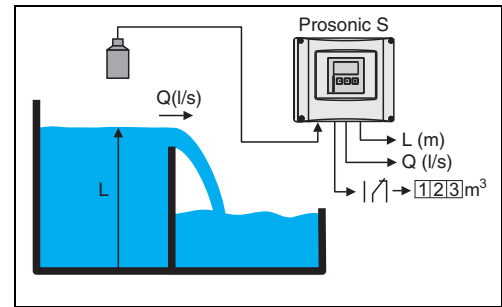

100-FM190xxx-15-00-00-xx-000

### Calibration

1. Go to the "device properties/operating param./operating mode" parameter and select the option "level+flow".
2. Go to the "level" menu and calibrate the level measurement as described in the Operating Instructions BA00288F/00.
3. Go to the "flow" menu and calibrate the flow measurement as described in → Chap. 6.4 of this manual. Select the same sensor as for the level measurement.



### Note!

It is recommended to perform the interference echo suppression when calibrating the level measurement. This suppression is automatically valid for the flow measurement as well. Therefore, the interference echo suppression can be skipped when calibrating the flow measurement.

## 6.7 Parametrization of the counters

### 6.7.1 Overview

The following table gives an overview of the parametrization of the counters. Detailed information on the parameters can be found in sections 6.7.2. – 6.7.4.

Step	Parameter set	Parameter	Remarks	Section
1			Open the "flow/flow counter" submenu.	
2			Select the type of counter: <ul style="list-style-type: none"> <li>■ totalizer (not resettable)</li> <li>■ daily counter (resettable)</li> </ul>	
3			Select the number of the totalizer or daily counter you are going to calibrate.	
4	totalizer N daily counter N (N = 1 - 3)	allocation	Select the flow to which the counter refers.	→ Chap. 6.7.2
		counting unit	Select the counting unit.	
5	totalizer N daily counter N (N = 1 - 3)	value	Indicates the current value of the counter.	→ Chap. 6.7.3
		overflow	Indicates the number of times the counter has passed the overflow. The total flow volume is : overflow x 10 <sup>7</sup> + value	
		reset	Select "yes" to reset the counter (not available for totalizers).	
6	totalizer N daily counter N (N = 1 - 3)	error handling	Define the reaction of the counter in the case of an error: <ul style="list-style-type: none"> <li>■ actual value: the current flow value is used (although its reliability is not ensured)</li> <li>■ hold: the counter uses the flow value which was present when the error occurred.</li> <li>■ stop: Counting is interrupted.</li> </ul>	→ Chap. 6.7.4
7	daily counter N (only for instruments with external switch inputs: FMU90-*****B***)	external reset	allocate external input (digin) for reset	→ Chap. 6.7.5
		external start	allocate external input (digin) for start and stop of the counter	

### 6.7.2 "totalizer N/daily counter N" (N = 1 -3)

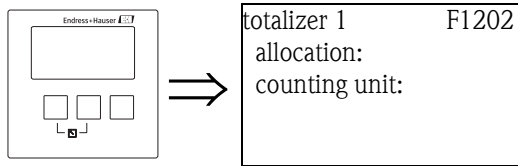

#### "allocation"

Use this parameter to allocate a flow to the counter.

##### Selection:

- none (default)
- flow 1, Q1
- flow 2, Q2 (for 2-channel instruments only)
- average flow,  $(Q1 + Q2)/2$ , (for 2-channel instruments only)
- flow 1-2,  $Q1 - Q2$ , (for 2-channel instruments only)
- flow 2-1,  $Q2 - Q1$ , (for 2-channel instruments only)
- flow 1+2,  $Q1 + Q2$ , (for 2-channel instruments only)

#### "counting unit"

Use this parameter to select the unit for the flow volume.

##### Selection:

- m<sup>3</sup>
- l
- hl
- igal
- usgal
- barrels
- inch<sup>3</sup>
- ft<sup>3</sup>
- USmgal
- Ml

### 6.7.3 "totalizer N/daily counter N" (N = 1 - 3)

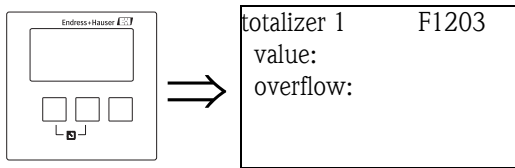

#### "value"

Displays the current flow volume.

#### "overflow"

Whenever the counter passes the overflow, this parameter is incremented by 1. The total flow volume thus is:

$$V_{\text{total}} = \text{overflow} \times 10^7 + \text{value}$$



#### Note!

The totalizer value can also be displayed on the measured value screen (menu: "display", parameters: "value 1" ... "value 6", → 76)

In order to display the total value of the totalizer (value and overflow), select the "1 value + bargraph" or "value max. size" option in the "type" parameter (→ 75).

#### "reset" (only for the daily counters)

Use this parameter to reset the counter to "0".

#### Selection:

##### ■ no (default)

"value" and "overflow" retain their values.

##### ■ yes

"value" und "overflow" are reset to "0".

### 6.7.4 "totalizer N/daily counter N" (N = 1 - 3)

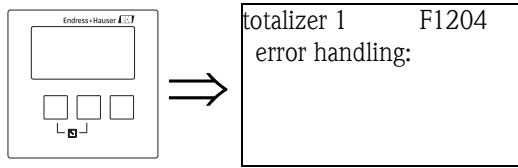

#### "error handling"

Use this parameter to define the reaction of the Prosonic S in the case of an error.

#### Selection:

- **stop**

The Prosonic S stops counting.

- **hold**

The Prosonic S continues counting. It uses the flow value which was present at the moment the error occurred.

- **actual value**

The Prosonic S continues counting. It uses the current flow value (although its reliability is no longer ensured).



### 6.7.5 "daily counter N" (N = 1 - 3)

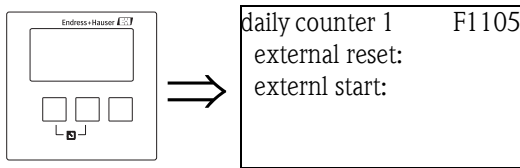

#### Note!

This parameter set is only available in instruments with external limit switches (FMU90-\*\*\*\*\*B\*\*\*).

#### "external reset"

This parameter allocates one of the external switch inputs to the counter by which it can be reset.

##### Selection:

- disabled
- ext. digin 1
- ...
- ext. digin 4

#### "external start"

This parameter allocates one of the external switch inputs to the counter by which it can be started.

##### Selection:

- disabled
- ext. digin 1
- ...
- ext. digin 4

## 6.8 Envelope curve display

After the basic setup it is recommended to assess the measurement by the envelope curve (→ Chap. 10.3).

## 6.9 After the calibration

After the calibration the Prosonic S transmits the measured value via

- the display module
- the current output  
(by default the complete measuring range (0 ...  $Q_{max}$ ) is mapped to the current range (4 ... 20 mA))
- the HART signal



Note!

### Sensor management

For instruments with multiple sensor inputs it is possible to deactivate inputs (or sensors) which are not used. To do so, go to the function "sensor management/FDU sensor N/sensor operation" and select the desired option:

- **on**  
The sensor is switched on.
- **hold**  
The sensor is switched off. The last measured value is held.
- **off**  
The sensor is switched off. No measured value is transmitted.

Additional parameters are available for optimization of the measuring point. They can be parametrized as required. A detailed description of all instrument parameters is given in the operating manual BA00290F/00, "Prosonic S FMU90 - Description of Instrument Functions". A PDF file of this document is available from

- the supplied CD-ROM
- the internet at "[www.endress.com](http://www.endress.com)"

The following chapters describe the "calibration display", "relays/controls" and "output/calculations" submenus.

## 7 The "display" menu

### 7.1 "display"

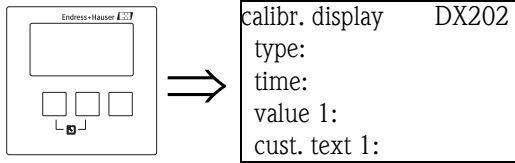

#### "type"

Use this parameter to select the format of the measured value display.

#### Selection:

- 1x value+bargraph (default for instruments with 1 current output)



- 2x value+bargraph (default for instruments with 2 current outputs)

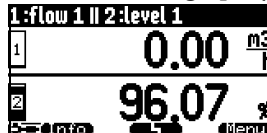

- value max. size

Up to two values are displayed alternately using the entire display:

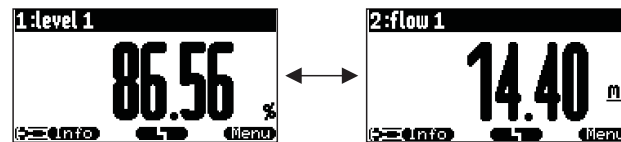

- alter 3x2 values

Up to 6 values can be displayed on three alternating pages. Each pages contains two values.

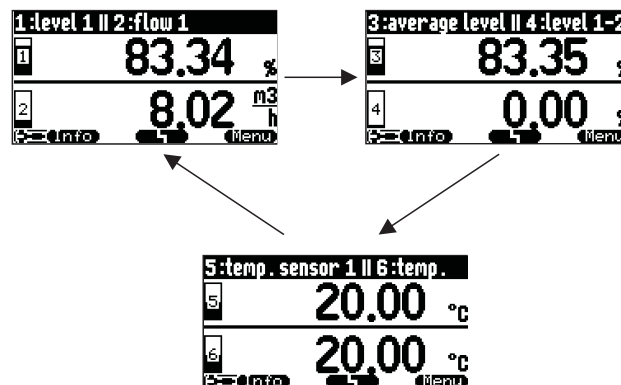

#### "time"

This parameter is used for the options "value max. size" and "alter 3x2 values". It specifies the time after which the next page appears.



Note!

To change to the next page immediately, press .

**"value 1" ... "value 6"**

Use these parameters to allocate a measured or calculated value to each of the display values. The selection depends on the instrument version and installation environment.



Note!

If "temp. sensor 1/2" is selected, depending on the setting in "sensor management/FDU sensor N" one of the following is displayed:

- the sensor temperature
- the average of the sensor temperature and the temperature of the external temperature probe
- the temperature of the external temperature probe

**"cust. text 1" ... "cust. text 6"**

These parameters can be used to allocate a text string to each of the display values. This text is displayed together with the value if "**customized text**" (in the "display format" parameter set) has been set to "**yes**".

## 7.2 "display format"

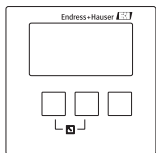

```
display format   DX201
format:
no. of decimals:
sep. character:
customized text:
```

**"format"**

Use this parameter to select the display format for numbers.

**Selection:**

- decimal (Default)
- ft-in-1/16"

**"no. of decimals"**

Use this parameter to select the number of decimals for the representation of numbers.

**Selection:**

- x
- x.x
- x.xx (Default)
- x.xxx

**"sep. character"**

Use this parameter to select the separation character for the representation of decimal numbers.

**Selection:**

- point (.) (Default)
- comma (,)

**"customized text"**

Determines if "text 1" to "text 6" from the "calibration display" parameter set are displayed.

**Selection:**

- no (Default)
- yes

### 7.3 "back to home"

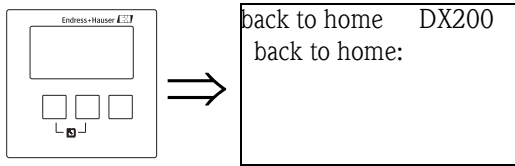

#### "back to home"

Use this parameter to specify the return time. If no entry is made during the specified time, the display returns to the measured value display.

- Range of values: 3 ... 9999 s
- Default: 900 s

## 8 The "Relay/Controls" menu

The "relay/controls" menu is used to configure the relays and control functions of the Prosonic S. The following relay functions are available for flow measurements:

- Limit relay
- Alarm and diagnostics relay
- Counting pulses and time pulses

The configuration of these functions is described in the following sections.

### 8.1 Configuration of a limit relay

#### 8.1.1 Overview

Step	Parameter set or submenu	Parameter	Remarks	Section
1	"relay/controls" menu		Select "relay configuration".	
2	relay allocation		Select a relay.	→ Chap. 8.1.2
3	relay N (N= 1 -6)	function	1. Select "limit" 2. Select the measured or calculated value to which the limit refers.	→ Chap. 8.1.3
4	relay N (N = 1 - 6)	limit type	Select a limit type.	→ Chap. 8.1.4
		switch on point	Define the switch on point. (only available for "limit type" = "standard" or "tendency/speed")	
		switch off point	Define the switch off point. (only available for "limit type" = "standard" or "tendency/speed")	
		upper switch point	Define the upper switch point. (only available for "limit type" = "inband" or "out of band")	
		lower switch point	Define the lower switch point. (only available for "limit type" = "inband" or "out of band")	
		hysteresis	Define the hysteresis. (only available for "limit type" = "inband" or "out of band")	
5	relay N (N = 1 - 6)	switch delay	Define the switch delay (Default: 0s).	→ Chap. 8.1.5
		invert	Select if the relay signal is to be inverted (default: no)	
		error handling	Define the reaction of the relay in the case of an error.	

### 8.1.2 "relay allocation"

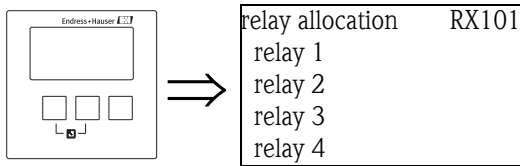

Use this parameter to select the relay you are going to configure.

#### Selection:

- All relays of the instrument version at hand



Note!

If a function has already been allocated to one of the relays, the name of this function is displayed next to the relay number.

### 8.1.3 "relay N" (N = 1 - 6) (Part 1: relay function)

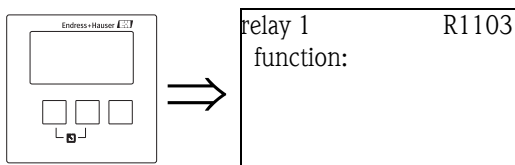

After selecting a relay, the parameter set "**relay N**" (N = 1 - 6) appears, which is used to configure the relay. Initially, it contains the "function" parameter only. To configure a limit relay, proceed according to the following steps:

1. Select the "**function**" parameter. The "**select function**" screen appears.
2. Select "**limit**". The "**function**" selection list appears.
3. Select the measured or calculated value to which the limit relay refers. The selection depends on the instrument version and the parametrization.



Note!

If temperature measurement of sensor N is selected as the function, it always refers to the temperature which has been assigned to the respective sensor in "sensor management/FDU sensor N". Possible temperatures are:

- sensor temperature
- average of sensor temperature and temperature of an external temperature sensor
- temperature of an external temperature sensor

### 8.1.4 "relay N" (N = 1 - 6) (Part 2: Limit type and switching points)

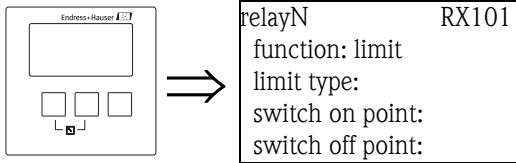

#### "Limit type"

Use this parameter to define the type of limit.

#### Selection:

##### ■ standard

For this limit type, a switch on point and a switch off point have to be defined. The switching behaviour depends on the relative position of these switching points.

##### a. switch on point > switch off point

The relay is energized if the measured value rises above the switch on point.

The relay is de-energized if the measured value falls below the switch off point.

##### b. switch on point < switch off point

The relay is energized if the measured value falls below the switch on point.

The relay is de-energized if the measured value rises above the switch off point.

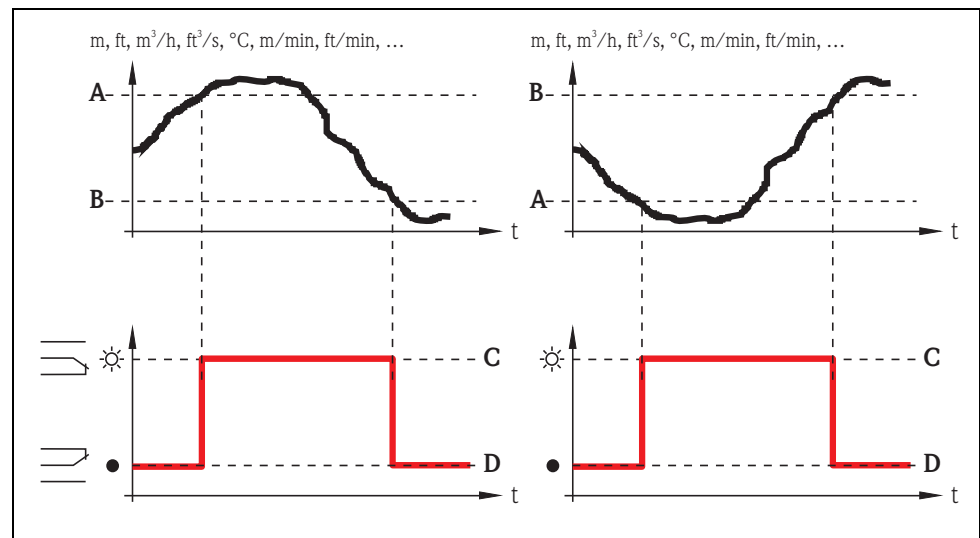

A: switch on point; B: switch off point; C: relay energized; D: relay de-energized

##### ■ tendency/speed

This limit type is similar to the "standard" type. The only difference is that variations with time of the measured value are examined instead of the measured value itself. Therefore, the unit for the switching points is "measuring value unit per minute".

##### ■ inband

For this limit type, an upper and a lower switching point have to be defined.

The relay is energized if the measured value is between the two switching points.

The relay is de-energized if the measured value is above the upper or below the lower switching point.

Additionally, a hysteresis can be defined, which affects both switching points.

##### ■ out of band

For this limit type, an upper and a lower switching point have to be defined.



The relay is energized if the measured value is above the upper or below the lower switching point.  
 The relay is de-energized if the measured value is between the two switching points.  
 Additionally, a hysteresis can be defined, which affects both switching points.

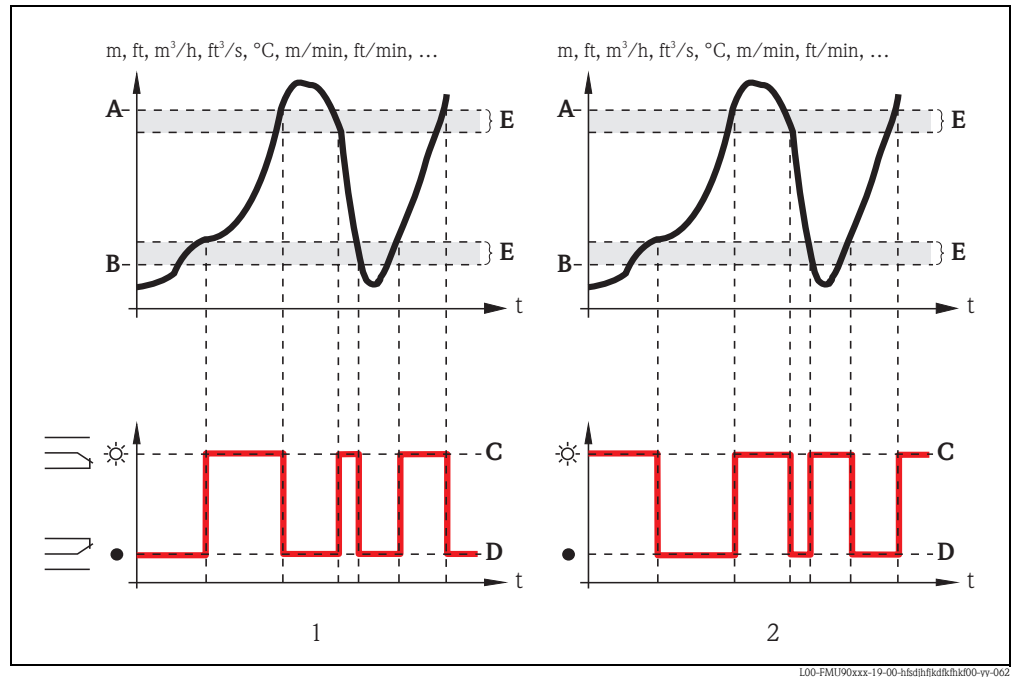

1: "inband" limit relay; 2: "out of band" limit relay  
 A: upper switching point; B: lower switching point; C: relay energized; D: relay de-energized; E: hysteresis

**"switch on point" and "switch off point"**  
 (for the "standard" limit type)

Define the switching points in these parameters.  
 They have the same unit as the measured value.



Caution!

After a change of the "unit level" or "flow unit" the switching points have to be checked and adjusted if required.

**"switch on /min" and "switch off /min"**  
 (for the "tendency/speed" limit type)

Define the switching points in these parameters.  
 Their unit is the measured value unit per minute.



Caution!

After a change of the "unit level" or "flow unit" the switching points have to be checked and adjusted if required.

**"upper switching point" and "lower switching point"**  
 (for the "inband" and "out of band" limit types)

Define the switching points in these parameters.  
 They have the same unit as the measured value.



Caution!

After a change of the "unit level" or "flow unit" the switching points have to be checked and adjusted if required.

**"hysteresis"**  
**(for the "inband" and "out of band" limit types)**

Define the hysteresis in this parameter. It has the same unit as the measured value. The hysteresis affects the upper and the lower switching point.

**8.1.5 "relay N (N = 1 - 6)"**  
**(Part 3: Relay behavior)**

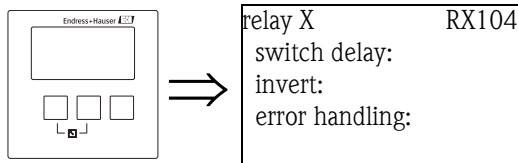

**"switch delay"**

Use this parameter to specify the switch delay (in seconds).

The relay does not switch immediately after the switch on point has been exceeded but only after the specified delay.

The measured value must exceed the switch-on point during the entire delay time.

**"invert"**

Use this parameter to specify if the switching direction of the relay is to be inverted.

**Selection:**

■ **no (default)**

The switching direction of the relay is **not** inverted. The relay switches as described in the above sections.

■ **yes**

The switching direction of the relay **is** inverted. The states "energized" and "de-energized" are interchanged as compared to the above description.

**"error handling"**

Use this parameter to specify the reaction of the relay in the case of an error.

**Selection:**

■ **actual value**

The relay switches according to the currently measured value (although its reliability is not ensured).

■ **hold (default)**

The current switching state of the relay is maintained.

■ **switch on**

The relay is energized.

■ **switch off**

The relay is de-energized.

## 8.2 Configuration of an alarm or diagnostic relay

### 8.2.1 Overview

Step	Parameter set or submenu	Parameter	Remark	Section
1	"relay controls" menu		Select "relay configuration"	
2	relay allocation		Select a relay	→ Chap. 8.2.2
3	relay N (N= 1 -6)	function	1. Select "alarm/diagnostics" 2. Select <ul style="list-style-type: none"> <li>- "alarm relay", if the relay is to indicate an alarm state of the Prosonic S.<sup>1)</sup></li> <li>- "diagnostics", if the relay is to indicate one or two user selectable states of the instrument.</li> <li>- "backwater alarm" if the relay is to indicate detected backwater<sup>2)</sup></li> <li>- "dirt alarm" if the relay is to indicate detected dirt within the flume<sup>3)</sup></li> </ul>	→ Chap. 8.2.3
4	relay N (N = 1 - 6)	allocation 1	Select the first instrument state which is to be indicated by the relay. (only available if "diagnostics" has been selected in the previous function)	→ Chap. 8.2.4
		allocation 2	Select the second instrument state which is to be indicated by the relay. (only available if "diagnostics" has been selected in the previous function)	
5	relay N (N = 1 - 6)	invert	Select if the relay signal is to be inverted (default: no)	→ Chap. 8.2.5

- 1) This is the default setting for relay 1.
- 2) Condition: a backwater detection must have been configured (→ Chap. 6.5)
- 3) Condition: a dirt detection must have been configured (→ Chap. 6.5)

### 8.2.2 "relay allocation"

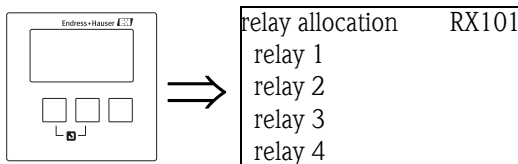

Use this parameter to select the relay you are going to configure.

**Selection:**

- All relays of the instrument version at hand



**Note!**

If a function has already been allocated to one of the relays, the name of this function is displayed next to the relay number.

### 8.2.3 "relay N" (N = 1 - 6) (Part 1: relay function)

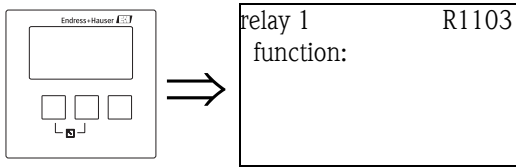

After selecting a relay, the parameter set **"relay N"** (N = 1 - 6) appears, which is used to configure the relay. Initially, it contains only the "function" parameter. To configure an alarm relay or diagnostic relay, proceed according to the following steps:

1. Select the **"function"** parameter. The **"select function"** screen appears.
2. Select **"alarm/diagnostics"**. The **"function"** selection list appears.
3. Select
  - "alarm relay", if the relay is to indicate an alarm state of the Prosonic S<sup>10</sup>.
  - "diagnostics" if the relay is to indicate one or two user selectable states of the instrument.
  - "backwater detection" if the relay is to indicate detected backwater. This option is only available if a backwater detection has been configured (see "flow" menu)
  - "dirt detection" if the relay is to indicate detected dirt within the flume. This option is only available if a dirt detection has been configured (see "flow" menu).

### 8.2.4 "relay N" (N = 1 - 6) (Part 2: Allocation of the switching condition)

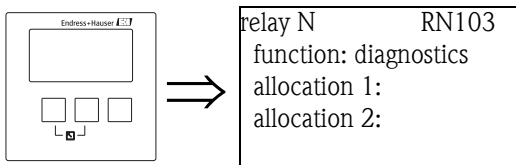

#### "allocation 1/2"

A specific instrument state or event can be allocated to each of these parameters. The relay is de-energized as soon as one of these states or events occurs.

#### Selection:

- echoloss sensor 1/2/1+2
- defective temperature sensor1/2
- defective external temperature sensor
- Accumulated alarm: defective temperature sensor
- overtemp. sensor 1/2
- Accumulated Alarm: overtemp.
- safety distance channel 1/2
- Accumulated Alarm: safety distance
- pump alarm
- pump operation

10) This is the default setting for relay 1.

### 8.2.5 "relay N" (N = 1 - 6) (Part 3: Relay behavior)

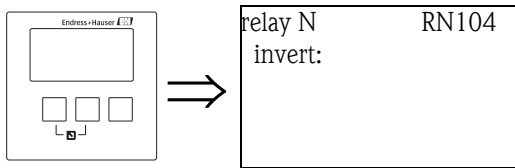

#### "invert" subfunction

Use this parameter to specify if the switching direction of the relay is to be inverted.

#### Selection:

- **no (default)**

The switching direction of the relay is **not** inverted. The relay switches as described in the above sections.

- **yes**

The switching direction of the relay **is** inverted. The states "energized" and "de-energized" are interchanged as compared to the above description.

## 8.3 Configuration of a time pulse relay

### 8.3.1 Overview

A time pulse relay generates a short pulse in regular time intervals. To configure the time pulse relay, perform the following steps:

Step	Parameter set	Parameter	Remarks	Section
1	"relay/controls" submenu		Select "relay configuration"	
2	relay allocation		Select a relay	→ Chap. 8.3.2
3	relay N (N= 1 - 6)	function	Select "time pulse".	→ Chap. 8.3.3
4	relay N (N = 1 - 6)	pulse width	Define pulse width (default: 200 ms)	→ Chap. 8.3.4
		pulse time	Define the time interval between the individual pulses.	
5	relay N (N = 1 - 6)	invert	Determine if the relay signal is to be inverted (default: no)	→ Chap. 8.3.5
		error handling	Determine the relay behaviour in the case of an error (default: actual value)	

### 8.3.2 "relay allocation"

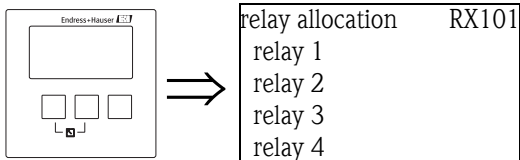

Use this parameter to select the relay you are going to configure.

#### Selection:

- All relays of the instrument version at hand



Note!

If a function has already been allocated to one of the relays, the name of this function is displayed next to the relay number.

### 8.3.3 "relay N" (N = 1 - 6) (Part 1: relay function)

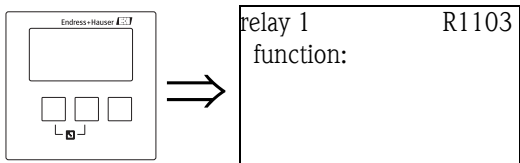

After selecting a relay, the parameter set "relay N" (N=1 - 6) appears, which is used to configure the relay. Initially, it contains the "function" parameter only. To configure a time pulse relay, proceed according to the following steps:

1. Select the "function" parameter. The "select function" screen appears.
2. Select "time pulse". The "function" selection list appears.
3. Confirm your choice by selecting "time pulse" again.

### 8.3.4 relay N (N = 1 - 6) (Part 2: Definition of the pulses)

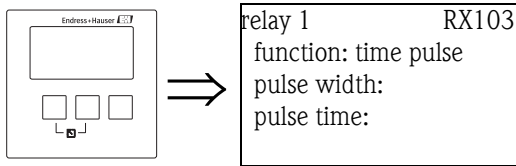

#### "pulse width" and "pulse time"

Use these parameters to specify the time interval between two pulses (pulse time) and the duration of each pulse (pulse width).

- unit of pulse time: min
- default pulse time: 1 min
- unit of pulse width: ms
- default pulse width: 200 ms

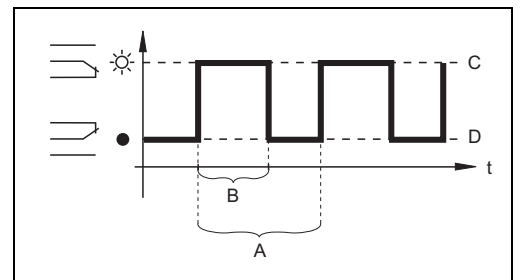

*A: pulse time; B: pulse width;  
C: relay energized; D: relay de-energized*

### 8.3.5 "relay N" (N = 1 - 6) (Part 3: Relay behavior)

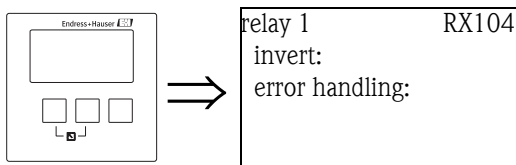

#### "invert"

Use this parameter to specify if the switching direction of the relay is to be inverted.

##### Selection:

- **no (default)**

The switching direction of the relay is **not** inverted. The relay switches as described in the above sections.

- **yes**

The switching direction of the relay **is** inverted. The states "energized" and "de-energized" are interchanged as compared to the above description.

#### "error handling"

Use this parameter to specify the reaction of the relay in the case of an error.

##### Selection:

- **actual value**

The Prosonic S continues generating pulses.

- **stop**

No pulses are generated in the case of an error.

## 8.4 Configuration of a counting pulse relay

### 8.4.1 Overview

A counting pulse relay generates a short pulse each time a certain amount of the fluid has passed the flume or weir. To configure a counting pulse relay proceed according to the following steps:

Step	Parameter set	Parameter	Remarks	Section
1	"relay/controls" menu		Select "relay configuration"	
2	relay allocation		Select a relay	→ Chap. 8.4.2
3	relay N (N = 1 - 6)	function	1. Select "counting pulse" 2. Select the flow to which the pulses refer.	→ Chap. 8.4.3
4	relay N (N = 1 - 6)	counter unit	Select the unit for the flow volume.	→ Chap. 8.4.4
		pulse value	Select the flow volume after which a pulse is to be generated.	
		pulse width	Specify the width of each pulse.	
5	relay N (N = 1 - 6)	pulse counter	Indicates, how many pulses have already been generated.	→ Chap. 8.4.5
		overflow	Indicates, how often the counter has passed the overflow ( $10^7$ ). The total number of pulses is: overflow x $10^7$ + pulse counter	
		reset counter	Is used to reset the pulse counter and overflow. <ul style="list-style-type: none"> <li>■ yes: the counter is reset</li> <li>■ no: the counter is not reset.</li> </ul>	
		start counter	Define the minimum flow for pulse counting.	
		stop counter	Define the maximum flow for pulse counting.	
6	relay N (N = 1 - 6)	invert	Determine if the relay signal is to be inverted (default: no)	→ Chap. 8.4.6
		error handling	Determine the relay behaviour in the case of an error (default: actual value).	

### 8.4.2 "relay allocation"

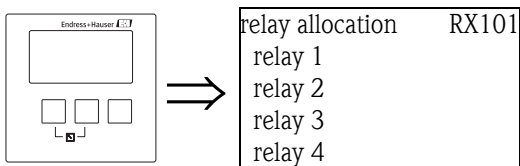

Use this parameter to select the relay you are going to configure.

#### Selection:

- All relays of the instrument version at hand



#### Note!

If a function has already been allocated to one of the relays, the name of this function is displayed next to the relay number.



### 8.4.3 "relay N" (N = 1 - 6) (Part 1: relay function)

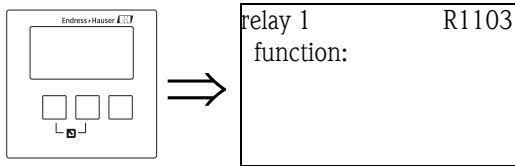

After selecting a relay, the parameter set **"relay N"** (N = 1 - 6) appears, which is used to configure the relay. Initially, it contains the "function" parameter only. To configure a counting pulse relay, proceed according to the following steps:

1. Select the **"function"** parameter. The **"select function"** screen appears.
2. Select **"counting pulse"**. The **"function"** selection list appears.
3. Select the flow to which the counting pulses are to refer.

### 8.4.4 "relay N" (N = 1 - 6) (Part 2: definition of the pulses)

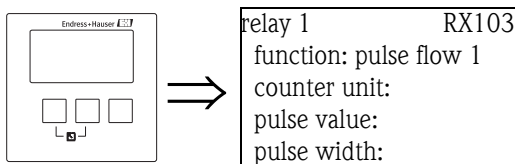

#### "counter unit"

Use this parameter to select the unit for the flow volume.

#### Selection:

- l (default)
- hl
- Ml
- m<sup>3</sup>
- dm<sup>3</sup>
- cm<sup>3</sup>
- ft<sup>3</sup>
- inch<sup>3</sup>
- us gal
- us mgal
- i gal
- barrels

#### "pulse value"

Use this parameter to specify the flow volume after which a pulse is generated.  
Default: 100 m<sup>3</sup>

#### "pulse width"

Use this parameter to specify the width of each pulse.  
Default: 200 ms

### 8.4.5 "relay N " (N = 1 - 6) (Part 3: counting value)

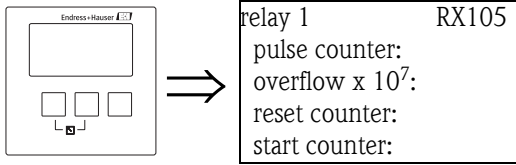

#### "pulse counter"

Displays the number of pulses which have been generated since the last overflow.

#### "overflow"

Displays, how many times the pulse counter has already passed the overflow.



Note!

The total flow volume is:

$$V_{\text{total}} = (\text{overflow} \times 10^7 + \text{pulse counter}) \times \text{pulse value}$$

#### "reset counter"

Use this parameter to reset the counter.

#### Selection:

- no (default)

"pulse counter" and "overflow" retain their values.

- yes

"pulse counter" and "overflow" are reset to "0".

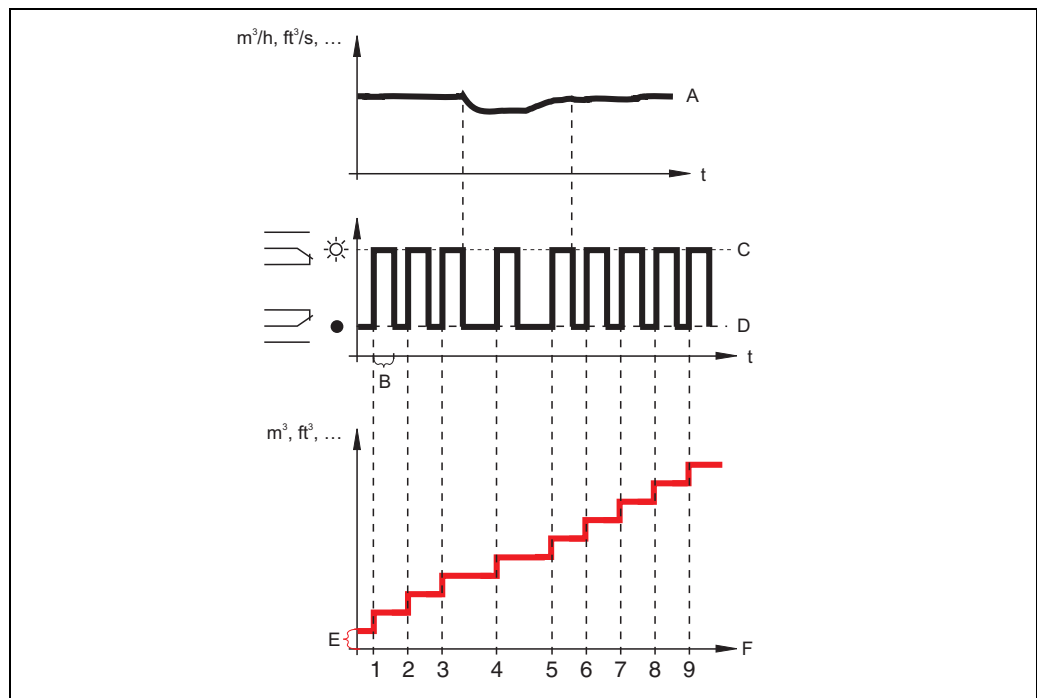

L00-FMU90xxx-19-00-00-yy-004

A: flow; B: pulse width; C: relay energized; D: relay de-energized; E: pulse value; F: pulse counter

**"start counter" and "stop counter"**

You can use these parameters to exclude very small and very large flows from being counted. If the flow is below "start counter" or above "stop counter" no pulses are generated. Both values are to be specified as a percentage of the maximum flow ( $Q_{\max}$ ).

- Default of "start counter": 0%
- Default of "stop counter": 100%

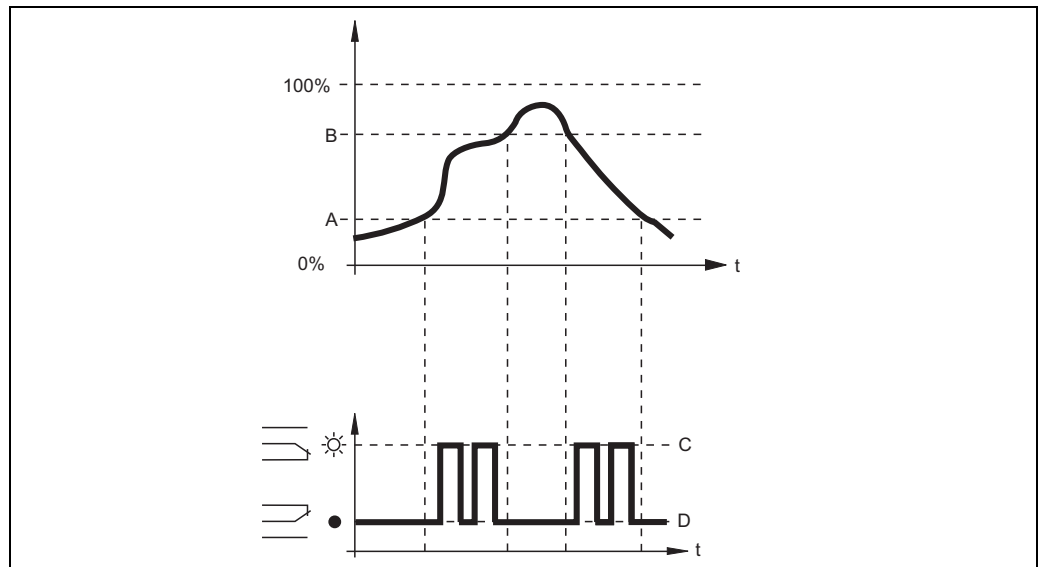

**A:** start counter; **B:** stop counter; **C:** relay energized; **D:** relay de-energized

**Note!**

These parameters can be used for dual range (nested) flumes in order to limit the pulses to the lower or upper part of the flume. For details refer to the manual "Prosonic S - Description of the instrument functions", BA00290F/00.

### 8.4.6 "relay N" (N = 1 - 6) (Part 4: relay behavior)

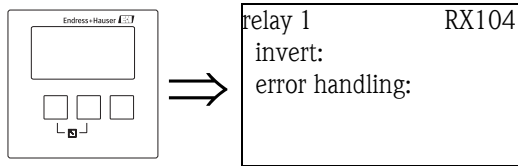

#### "invert"

Use this parameter to specify if the switching direction of the relay is to be inverted.

#### Selection:

- **no (default)**

The switching direction of the relay is **not** inverted. The relay switches as described in the above sections.

- **yes**

The switching direction of the relay **is** inverted. The states "energized" and "de-energized" are interchanged as compared to the above description.

#### "error handling"

Use this parameter to specify the reaction of the relay in the case of an error.

#### Selection:

- **actual value**

The currently measured flow value is used (although its reliability is not ensured).

- **hold**

The counter uses the flow value which was present when the error occurred.

- **stop**

No pulses are generated in the case of an error.

## 9 The "output/calculations" menu

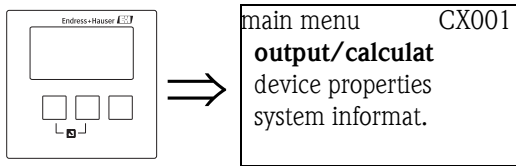

The "output/calculations" menu can be used to

- configure calculations such as averaging and subtraction
- configure the current outputs and the HART interface.

After entering the "output/calculations" menu, a selection screen appears in which you must choose the output you are going to configure.

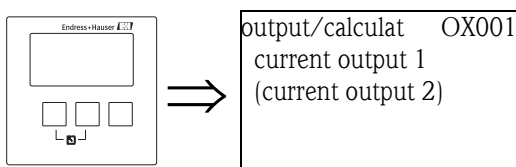

After this selection, additional submenus appear, which can be used to configure the output:

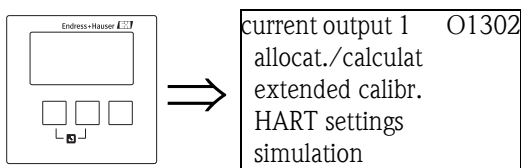

## 9.1 The "allocation/calculations" submenu

### 9.1.1 "allocation current N " (N = 1 or 2)

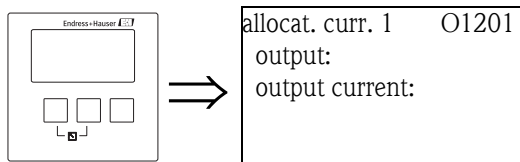

#### "output"

Allocates a measured or calculated value to the current output.

#### Selection:

The available options depend on the instrument version, the connected sensors and the instrument configuration. The following measured and calculated values may occur:

- level 1
- level 2
- flow 1
- flow 2
- average level:  $(\text{level1} + \text{level2})/2$
- level 1-2
- level 2-1
- level 1+2
- average flow
- flow 1-2
- flow 2-1
- flow 1+2
- backwater ratio  
downstream/upstream
- rake control ratio  
downstream/upstream

#### "output current"

Displays the output current (mA).

## 9.2 The "extended calibration" submenu

### 9.2.1 "mode current N" (N = 1 or 2)

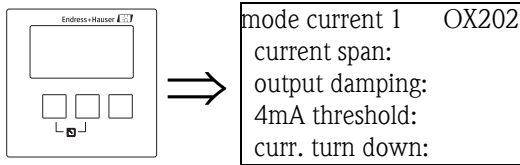

#### "current span"

Used to select the current span to which the measuring range is mapped.

##### Selection:

- **4-20 mA (default)**

The measuring range (0%-100%) is mapped to the current range 4-20 mA.

- **0-20 mA**

The measuring range (0%-100%) is mapped to the current range 0-20 mA.

- **fixed current HART**

A fixed current is output. The value can be defined in the "mA value" parameter. The measured value is transmitted by the HART signal.

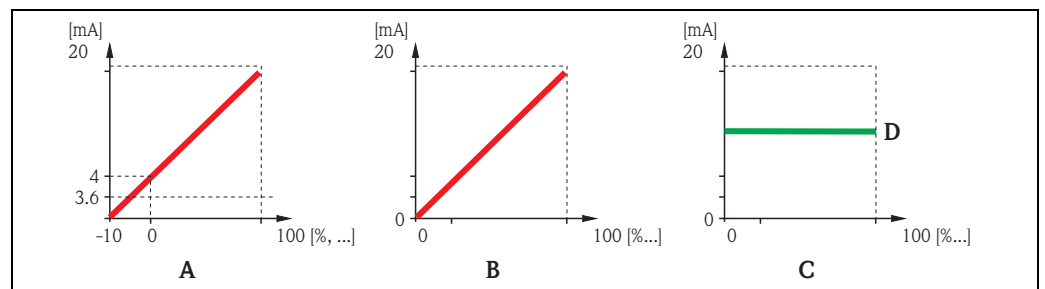

**A:** current span = 4-20 mA; **B:** current span = 0-20 mA; **C:** current span = fixed current HART;  
**D:** mA value

#### "mA value" (only available for "current span" = "fixed current HART")

Specifies the value of the fixed current.

- range of values: 3,6 - 22 mA
- default: 4 mA

**"output damping"**

Specifies the output damping  $\tau$  by which changes of the measured value are attenuated. After a surge in the level it takes  $5 \times \tau$  until the new measured value is reached.

- range of values: in preparation
- default: 1 s

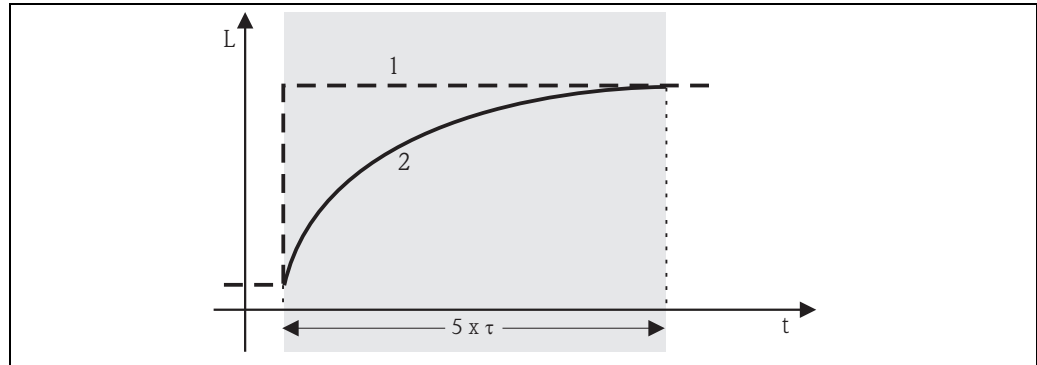

100-FMG60xxx-05-00-00-xx-012

**1:** measured value; **2:** output current

**"4 mA threshold" (only available for "current span" = "4-20mA")**

Used to switch on the 4mA threshold. The 4-mA threshold makes sure that the current never falls below 4 mA, even if the measured value is negative.

**Selection:**

- **off (default)**  
The threshold is switched off. Currents less than 4 mA may occur.
- **on**  
The threshold is switched on. The current never falls below 4 mA.

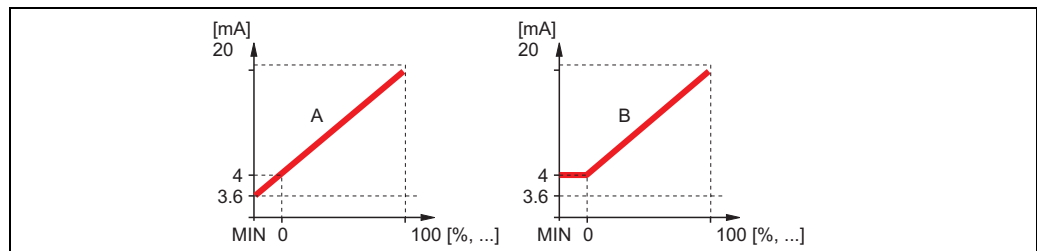

100-FMU90xxx-19-00-00-yy-067

**A:** 4mA threshold off; **B:** 4mA threshold on



**"current turn down" (not present for "current span" = "fixed current HART")**

Used to map only a part of the measuring range to the current output. The selected part is enlarged by this mapping.

**"turn down 0/4 mA" (only for "current turn down" = "on")**

Specifies the measured value for which the current is 0 or 4 mA (depending on the selected current span).

**"turn down 20 mA" (only for "current turn down" = "on")**

Specifies the measured value for which the current is 20 mA.

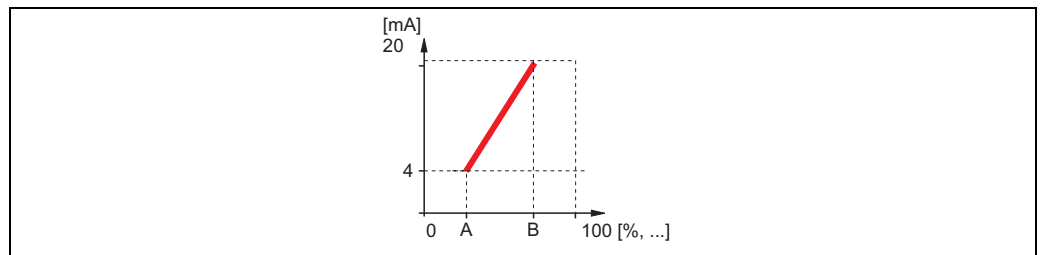

100-FMU190xxx-19-00-00-yy-068

**A:** turn down 4mA ; **B:** turn down 20 mA

## 9.3 "HART settings" submenu (only for current output 1)

### 9.3.1 "HART settings"

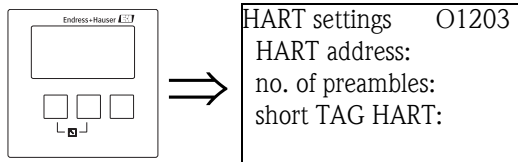

#### "HART address"

Defines the communication address for the instrument.

#### Range of values:

- for standard operation: **0 (default)**
- for multidrop operation: **1 - 15**



Note!

In multidrop operation, the output current is 4 mA by default. However, it can be adjusted in the "mA value" parameter of the "mode current" parameter set (see above).

#### "no. of preambles"

Specifies the number of preambles for the HART protocol. For lines with communication problems a slight increase of this value is recommended.

#### "short TAG HART"

in preparation

### 9.3.2 "additional HART value 2/3/4"

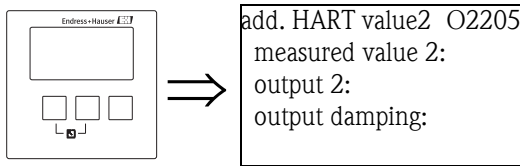

Use these parameter sets to configure the additional values transmitted by the HART protocol:

- measured value 2
- measured value 3
- measured value 4

The parameters are the same for all three measured values.



Note!

"measured value 1" is identical to the main value, which is linked to current output 1.

#### "measured value 2/3/4"

Specifies which measured value is transmitted.

##### Selection:

The selection depends on the instrument version, the connected sensors and the configuration. The following options may occur:

- none (default)
- level 1/2
- flow 1/2
- average level
- level 1-2 / 2-1 / 1+2
- rake control ratio
- backwater ratio
- temperature external sensor
- temperature sensor 1/2
- counter 1/2/3
- totalizer 1/2/3
- average flow
- flow 1-2 / 2-1 / 1+2
- distance sensor 1/2



Note!

If "temperature sensor 1/2" is selected, it always refers to the temperature which has been assigned to the respective sensor in "sensor management/FDU sensor N". Possible temperatures are:

- sensor temperature
- average of sensor temperature and temperature of an external temperature sensor
- temperature of an external temperature sensor

#### "output damping 2/3/4"

Specifies the output damping  $\tau$  by which a change of the measured value is attenuated.

After a surge of the measured value it takes  $5 \times \tau$  till the HART value has adopted the new value.

- range of values: in preparation
- default: 1 s

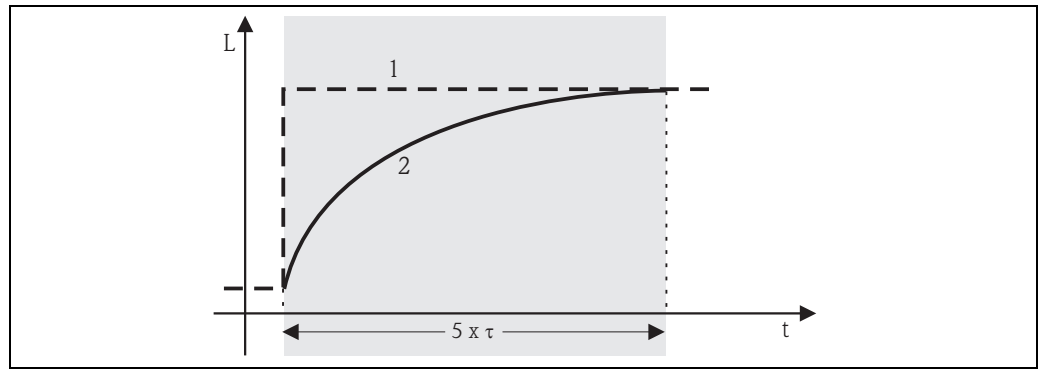

L00-FMG60xxx-05-00-00-xx-012

1: measured value; 2: HART output value

## 9.4 "Simulation" submenu

### 9.4.1 "simulation"

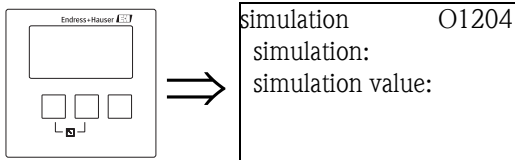

#### "simulation"

Used to switch on the simulation of the current.

##### Selection:

##### ■ off (default)

No simulation is performed. The instrument is in the measuring mode.

##### ■ on

The instrument is in the simulation mode. No measured value is transmitted to the output. Instead, the current output assumes the value specified in the "simulation value" subfunction.

#### "simulation value" (only for "simulation" = "on")

Specifies the value of the simulated output current (in mA).

## 10 Troubleshooting

### 10.1 System error messages

#### 10.1.1 Error signal



Errors occurring during commissioning or operation are signalled in the following way:

- Error symbol, error code and error description on the display and operating module
- Current output, configurable ("output on alarm" function).
  - MAX, 110%, 22 mA
  - MIN, -10%, 3,6 mA
  - HOLD (the last value is held)
  - user-specific value
- In the menu: "system information/error list/actual error"

#### 10.1.2 Last error

To access a list of the last errors which have been cleared, go to "system information/error list/last error".

#### 10.1.3 Types of errors

Type of error	Display symbol	Meaning
Alarm (A)	 continuous	The output signal assumes a value which can be defined by the "output on alarm" function: <ul style="list-style-type: none"> <li>■ MAX: 110%, 22 mA</li> <li>■ MIN: -10%, 3,6 mA</li> <li>■ Hold: last value is held</li> <li>■ user-specific value</li> </ul> Additionally, an error message appears on the display.
Warning (W)	 flashing	The instrument continues to measure. An error message is displayed.

### 10.1.4 Error codes

The error code consists of 6 digits with the following meaning:

- Digit 1: Type of error
  - A: alarm
  - W: warning
  - E: error (the user can define if the error behaves like an alarm or a warning.)
- Digits 2 and 3:
  - indicate the input channel, output channel or the relay to which the error refers. "00" means that the error does not refer to a specific channel or relay.
- Digits 4-6:
  - indicate the error according to the following table.

**Example:**

W 01 641	<ul style="list-style-type: none"> <li>■ W: Warning</li> <li>■ 01: sensor input 1</li> <li>■ 641: loss of echo</li> </ul>
----------	---

Code	Description of error	Remedy
A 00 100	software version does not fit to hardware version	
A 00 101	checksum error	full reset and recalibration required
A 00 102	checksum error	full reset and recalibration required
W 00 103	initializing - please wait	if the message does not disappear after a couple of seconds: replace electronics
A 00 106	downloading - please wait	wait for completion of the download
A 00 110	checksum error	full reset and recalibration required
A 00 111 A 00 112 A 00 114 A 00 115	electronics defective	switch instrument off/on; if the error persists: call Endress+Hauser service
A 00 116	download error	repeat download
A 00 117	hardware not recognised after exchange	
A 01 121 A 02 121	current output 01 or 02 not calibrated	call Endress+Hauser service
A 00 125	electronics defective	replace electronics
A 00 152	checksum error	full reset and recalibration required
W 00 153	initializing	if the message does not disappear after a couple of seconds: replace electronics
A 00 155	electronics defective	replace electronics
A 00 164	electronics defective	replace electronics
A 00 171	electronics defective	replace electronics
A 00 180	synchronization faulty	check synchronization wiring (s. chapter "Wiring")
A 00 183	hardware not supported	check if the installed board complies with the order code of the instrument; call Endress+Hauser service
A 01 231 A 02 231	sensor 01 or 02 defective - check connection	check for correct connection of the sensor (s. chapter "Wiring")
A 00 250	failure in external temperature sensor	check external temperature sensor and connection
A 01 281 A 02 281	temperature measurement 01 or 02 defective - check connection	check for correct connection of the sensor (s. chapter "Wiring")

Code	Description of error	Remedy
W 01 501 W 02 501	no sensor selected for channel 01 or 02	allocate sensor (s. "level" or "flow" menu)
A 01 502 A 02 502	Sensor 01 or 02 not recognized	Enter type of sensor manually ("level" or "flow" menu, submenu "basic calibration").
A 00 511	no factory calibration present	
A 01 512 A 02 512	mapping in process	wait for completion of mapping
W01 521 W02 521	new sensor 01 or 02 detected	
W01 601 W02 601	non-monotonic linearisation curve for level 01 or 02	re-enter linearisation (s. "level" menu")
W 01 602 W 02 602 W 01 603 W 02 603	non-monotonic linearisation for flow 01 or 02	re-enter linearisation (s. "flow" menu)
A 01 604 A 02 604	faulty calibration for level 01 or 02	adjust calibration (s. "level" menu)
A 01 605 A 02 605 A 01 606 A 02 606	faulty calibration flow 01 or 02	adjust calibration (s. "flow" menu)
W01 611 W02 611	linearisation points level 01 or 02: number < 2	enter further linearisation points (s. "level" menu)
W01 612 W02 612 W01 613 W02 613	linearisation points flow 01 or 02: number < 2	enter further linearisation points (s. "flow" menu)
W 01 620 ... W 06 620	pulse value too low for relay 01 - 06	check counting unit (see "flow" menu, "flow counter" submenu)
E 01 641 E 02 641	no usable echo sensor 01 or 02	check basic calibration for the respective sensor (s. "level" or "flow" menu)
A 01 651 A 02 651	Safety distance reached for sensor 01 or 02 - danger of overflowing	Error disappears if the level is out of the safety distance again. Possibly, the function "acknowledge alarm" must be used (s. "safety settings" menu)
E 01 661 E 02 661	temperature sensor 01 or 02 too high	
W 01 682 W 02 682	Current 01 or 02 out of measuring range	Perform basic calibration; check linearisation
W01 691 W02 691	filling noise detected sensor 01 or 02	
W00 692	backwater detected (if backwater detection is active)	
W00 693	dirt detected (if dirt detection is active)	
W 01 701	Operating hours alarm pump 1 ctrl 1	Reset operating hours
W 02 701	Operating hours alarm pump 1 ctrl 2	Reset operating hours
W 01 702	Operating hours alarm pump 2 ctrl 1	Reset operating hours
W 02 702	Operating hours alarm pump 2 ctrl 2	Reset operating hours
W 01 703	Operating hours alarm pump 3 ctrl 1	Reset operating hours
W 02 703	Operating hours alarm pump 3 ctrl 2	Reset operating hours
W 01 704	Operating hours alarm pump 4 ctrl 1	Reset operating hours
W 02 704	Operating hours alarm pump 4 ctrl 2	Reset operating hours

Code	Description of error	Remedy
W 01 705	Operating hours alarm pump 5 ctrl 1	Reset operating hours
W 02 705	Operating hours alarm pump 5 ctrl 2	Reset operating hours
W 01 706	Operating hours alarm pump 6 ctrl 1	Reset operating hours
W 02 706	Operating hours alarm pump 6 ctrl 2	Reset operating hours
W 01 711	Failure of pump 1 ctrl 1	check pump <sup>1)</sup>
W 02 711	Failure of pump 1 ctrl 2	check pump <sup>1)</sup>
W 01 712	Failure of pump 2 ctrl 1	check pump <sup>1)</sup>
W 02 712	Failure of pump 2 ctrl 2	check pump <sup>1)</sup>
W 01 713	Failure of pump 3 ctrl 1	check pump <sup>1)</sup>
W 02 713	Failure of pump 3 ctrl 2	check pump <sup>1)</sup>
W 01 714	Failure of pump 4 ctrl 1	check pump <sup>1)</sup>
W 02 714	Failure of pump 4 ctrl 2	check pump <sup>1)</sup>
W 01 715	Failure of pump 5 ctrl 1	check pump <sup>1)</sup>
W 02 715	Failure of pump 5 ctrl 2	check pump <sup>1)</sup>
W 01 716	Failure of pump 6 ctrl 1	check pump <sup>1)</sup>
W 02 716	Failure of pump 6 ctrl 2	check pump <sup>1)</sup>
W00 801	simulation level switched on	switch off level simulation (s. "level" menu)
W01 802 W02 802	simulation sensor 01 or 02 switched on	switch off simulation
W01 803 W02 803 W01 804 W02 804	simulation flow switched on	switch off simulation (see "flow" menu)
W01 805	simulation current 01 switched on	switch off simulation (s. "output/calculations" menu)
W02 806	simulation current 02 switched on	switch off simulation (see "output/calculations" menu)
W01 807 ... W06 807	simulation relay 01 - 06 switched on	switch off simulation
W01 808 W02 808	sensor 01 or 02 switched off	switch on sensor (see "device properties/sensor management" menu)
W01 809 W02 809	current calibration D/A active	
A 00 820 ... A 00 832	Different units for calculation of average value, sum, difference or rake control	Check the units of the respective basic calibrations (s. "level" or "flow" menu)

1) After a repair of the pump the pump control must be reset (BA00290F/00) or the FMU90 must be switched off and on.



## 10.2 Possible calibration errors

Error	Remedy
<b>Incorrect measured value</b>	Check "actual distance" <ol style="list-style-type: none"> <li>a. <b>"Actual distance" is incorrect</b> <ul style="list-style-type: none"> <li>– For measurements in bypasses or ultrasound guide pipes: Select the appropriate option in the "application parameters" parameter set.</li> <li>– Perform tank map ("distance mapping")</li> </ul> </li> <li>b. <b>"Actual distance" is correct</b> <ul style="list-style-type: none"> <li>– Check "empty calibration" and "full calibration"</li> <li>– Check the linearization</li> </ul> </li> </ol>
<b>Measured value does not change when filling or emptying a vessel</b>	<ol style="list-style-type: none"> <li>a. Perform tank map (interference echo suppression)</li> <li>b. clean sensor if necessary</li> <li>c. choose better mounting position of the sensor (to avoid interference echos)</li> </ol>
<b>With an uneven surface the measured value jumps sporadically to higher levels</b>	<ol style="list-style-type: none"> <li>a. Perform tank map (interference echo suppression)</li> <li>b. Select "turbulent surface" or "additional agitator" in the "process conditions" parameter</li> <li>c. Increase "output damping"</li> <li>d. if possible: choose better mounting position and/or larger sensor</li> </ol>
<b>When filling the vessel, the measured value sporadically drops to lower levels</b>	<ol style="list-style-type: none"> <li>a. Change the "tank geometry" to "dome ceiling" or "horizontal cylinder" ("application parameters" parameter set)</li> <li>b. If possible: avoid central mounting position of the sensor.</li> <li>c. if possible: install sensor in bypass or ultrasound guide pipe.</li> </ol>
<b>Echo loss (Error E@@641)</b>	<ol style="list-style-type: none"> <li>a. Check all settings in the "application parameters" parameter set.</li> <li>b. if possible: choose better mounting position and/or larger sensor.</li> <li>c. Align the sensor membrane parallelly to the product surface (especially for solid applications).</li> </ol>

## 10.3 Envelope curve display

The measuring signal can be checked by the envelope curve display. From the envelope curve it is possible to see if there are interference echos and if they are completely suppressed by the interference echo suppression.

The envelope curve can be displayed on the display and operating module of the Prosonic S or in the FieldCare operating program.

### 10.3.1 Envelope curve on the display module

1. Go to the "system information" submenu.
2. Select the "envelope curve" submenu.
3. (only relevant for instruments with two sensor inputs): Select the sensor whose envelope curve you want to check.
4. Select the curves to be displayed:
  - **Envelope curve:** Only the envelope curve is displayed.
  - **Env. curve + FAC:** The envelope curve and the Floating Average Curve (FAC) are displayed.
  - **Env. curve + cust. map:** The envelope curve and the customer mapping curve (for interference echo suppression) are displayed.
5. Select the plot setting:
  - **single curve**
  - **cyclic**
6. Now, the envelope curve display appears:

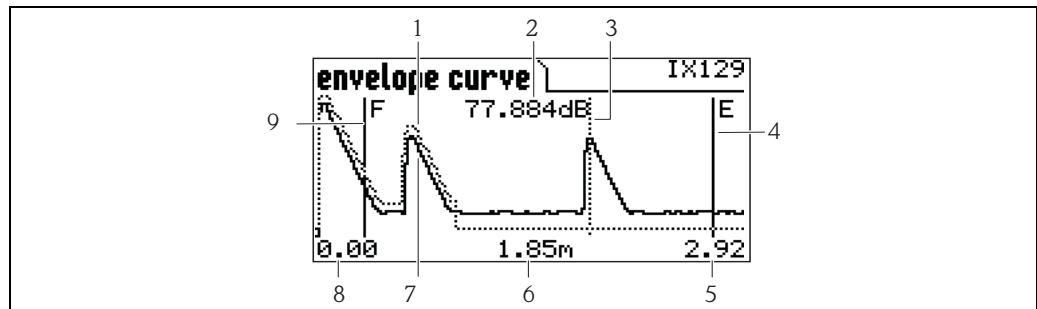

- 1 Customer mapping curve (dotted line<sup>11)</sup>)
- 2 Echo quality of the evaluated echo<sup>12)</sup>
- 3 Marking of the evaluated echo
- 4 Marking of the empty calibration E
- 5 Upper limit of the display range
- 6 Distance of the evaluated echo (measured from the reference point of the sensor)
- 7 Envelope curve (solid line)
- 8 Lower limit of the display range
- 9 Marking of the full calibration F

#### 7. Scaling of the envelope curve display

To display a part of the envelope curve in more detail, the curve can be scaled horizontally. To do so, press the left or middle key. The ◀ or ▶ symbol appears in the upper right corner of the display. You have got the following options:

- Press the **middle key** to **zoom in** the envelope curve.
- Press the **left key** to **zoom out** the envelope curve.

11) The Floating Average Curve (FAC) is represented by a dotted line as well.

12) The echo quality is the distance (in dB) between the peak of the echo and the Floating Average Curve (FAC).

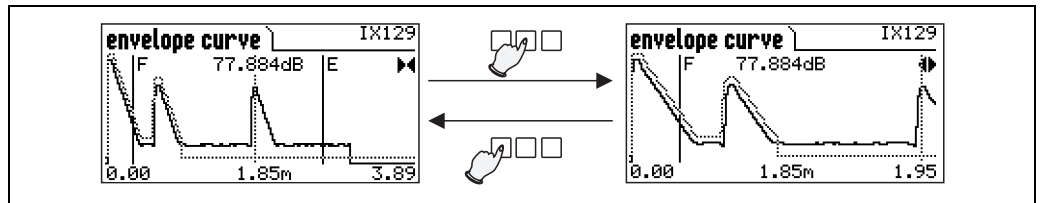

L00-FM190xxx-19-00-00-en-084

8. **Moving the envelope curve display**

To move the envelope curve display, press the right key a second time. The ◀◀ or ▶▶ symbol appears in the upper right corner of the display. You have got the following options:

- Press the **middle key** to move the envelope curve **to the right**.
- Press the **left key** to move the envelope curve **to the left**.

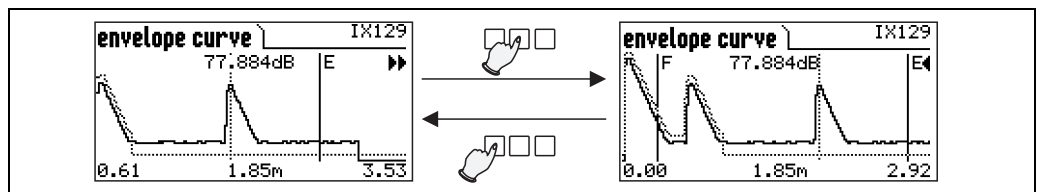

L00-FM190xxx-19-00-00-en-085

9. **Quitting the envelope curve display**

Press  to quit the envelope curve display.

### 10.3.2 Envelope curve display in the FieldCare

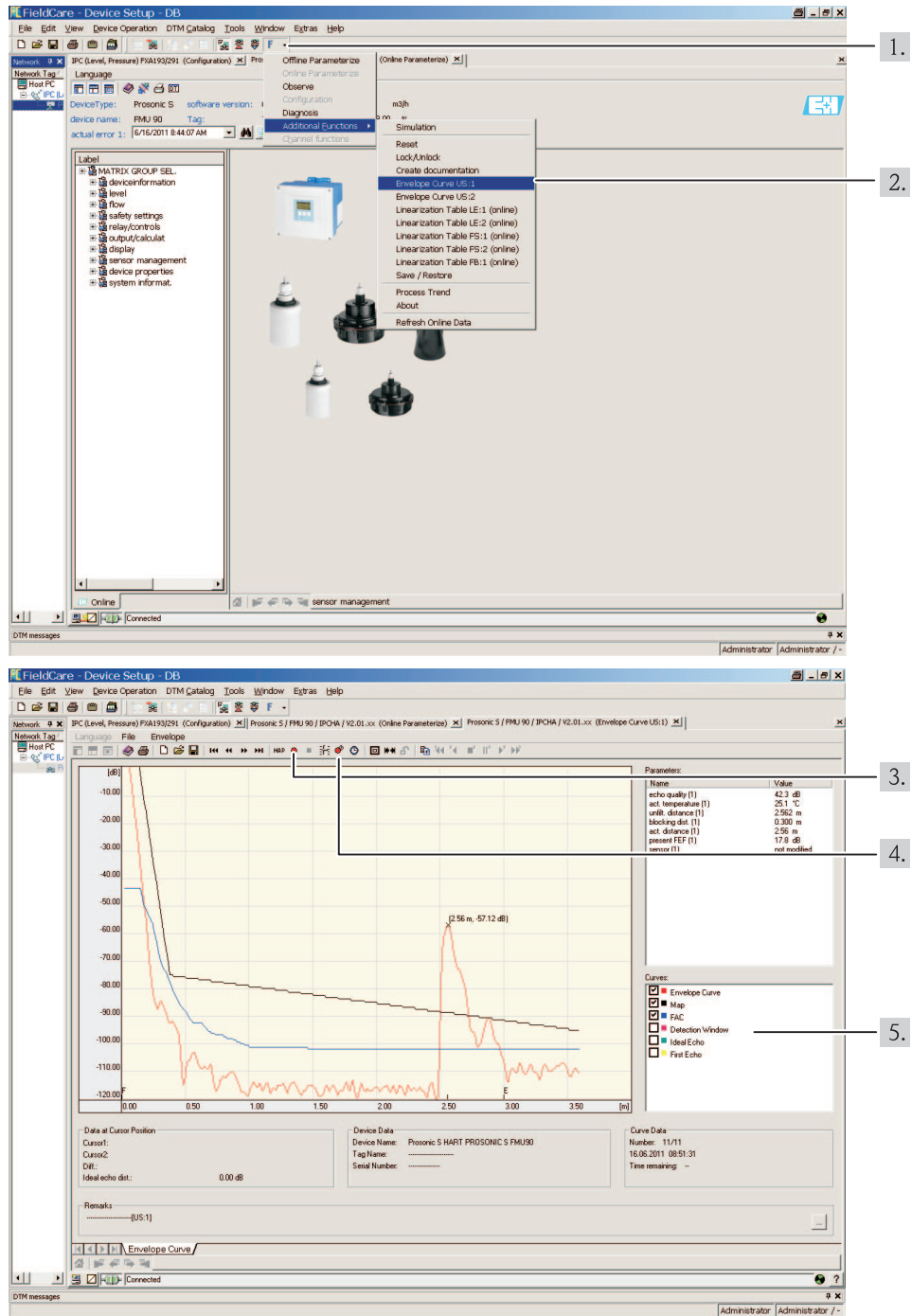

100-FMU90xxxx-19-00-00-xx-208

1. Click on "F" → "Additional Function" → "Envelope Curve".
2. Select the **sensor** whose envelope curve you want to check.
3. Click on "read curve" to display a **single curve**.
4. Click on "cyclic read" to display the curves **cyclically**.
5. Select the curves you want to check in the "Curves" window:
  - Envelope Curve
  - Map (= mapping of the interference echo suppression)
  - FAC (= Floating Average Curve)

## 10.4 Software history

Date	Software version	Changes to software	Documentation
12.2005	V 01.00.00	original software	<ul style="list-style-type: none"> <li>■ for level measurements: BA288F/00/en/12.05 52024316</li> <li>■ for flow measurements: BA289F/00/en/12.05 52024318</li> </ul>
06.2006	V 01.00.02	Relay functions for limit detection revised. No updates of "ToF Tool - Fieldtool Package" or "Fieldcare" required	
04.2007	V 02.00.00	Introduction of new options: binary inputs, e.g. for acquisition of limits or pump/motor switch positions	<ul style="list-style-type: none"> <li>■ for level measurements: BA288F/00/en/10.07 52024316</li> <li>■ for flow measurements: BA289F/00/en/10.07 52024318</li> </ul>
07.2009	V 02.01.00	Integration of the FDU90 sensor	<ul style="list-style-type: none"> <li>■ for level measurements: BA288F/00/en/07.09 71098292</li> <li>■ BA00288F/00/EN/13.12 71164411</li> <li>■ for flow measurements: BA289F/00/en/07.09 71098296</li> <li>■ BA00289F/00/EN/13.12 71164415</li> </ul>
02.2010	V02.01.01	Integration Temperaturplausibilisierung	
05.2011	V02.01.03	Improvement temperature plausibility; flow counter limitation; bugfix	

## 11 Maintenance

### 11.1 Exterior cleaning

When cleaning the exterior, always use cleaning agents that do not attack the surface of the housing and the seals.

### 11.2 Repairs

The Endress+Hauser repair concept assumes that the measuring devices have a modular design and that customers are able to undertake repairs themselves →  111, "Spare Parts". For more information on service and spare parts, if you have any questions, please contact your Endress+Hauser sales representative.

### 11.3 Repairs to Ex-approved devices

When carrying out repairs to Ex-approved devices, please note the following:

- Repairs to Ex-approved devices may only be carried out by trained personnel or by the Endress+Hauser Service.
- Comply with the prevailing standards, national Ex-area regulations, safety instructions (XA) and certificates.
- Only use original spare parts from Endress+Hauser.
- When ordering a spare part, please note the device designation on the nameplate. Only replace parts with identical parts.
- Carry out repairs according to the instructions. On completion of repairs, carry out the specified routine test on the device.
- Only Endress+Hauser Service may convert a certified device into a different certified variant.
- Document all repair work and conversions.

### 11.4 Replacement

After a complete instrument or electronic module has been replaced, the parameters can be downloaded into the instrument again via the communication interface. Prerequisite to this is that the data were uploaded to the PC beforehand using FieldCare. Measurement can continue without having to carry out a new setup. Only a linearisation and a tank map (interference echo suppression) have to be recorded again.

### 11.5 Replacing a sensor

Sensors can be replaced if required.

After replacing a sensor, the following parameters of the "basic setup" submenu must be checked:

- for sensors FDU8x: sensor type  
(sensors of the type FDU9x are automatically detected by the Prosonic S)
- the empty calibration
- for level measurements: the full calibration
- the interference echo suppression

After that, the measurement can be continued without further restrictions.

## 11.6 Spare Parts

An overview of the spare parts for your device is available in the internet at [www.endress.com](http://www.endress.com). To obtain information on the spare parts, proceed as follows:

1. Go to "[www.endress.com](http://www.endress.com)" and select your country.
2. Click "Instruments".

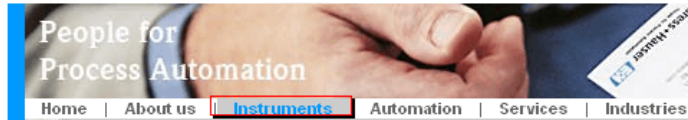

3. Enter the product name into the "product name" field.

### Endress+Hauser product search

**Via product name**

Enter the product name

4. Select the device.
5. Click the "Accessories/Spare parts" tab.

General information	Technical information	Documents/Software	Service	Accessories/Spare parts
---------------------	-----------------------	--------------------	---------	-------------------------

- ▶ Accessories
- ▼ All Spare parts
  - ▶ Housing/housing accessories
  - ▶ Sealing
  - ▶ Cover
  - ▶ Terminal module
  - ▶ HF module
  - ▶ Electronic
  - ▶ Power supply
  - ▶ Antenna module

**Advice**

Here you'll find a list of all available accessories and spare parts. To only view accessories and spare parts specific to your product(s), please contact us and ask about our Life Cycle Management Service.

◀ | 1 / 2 | ▶ | 🔍

6. Select the required spare parts (You may also use the overview drawing on the right side of the screen.)

When ordering spare parts, always quote the serial number indicated on the nameplate. As far as necessary, the spare parts also include replacement instructions.

## 11.7 Return

### Returning devices

The measuring device must be returned if repairs or a factory calibration are required, or if the wrong measuring device has been ordered or delivered. According to legal regulations, Endress+Hauser, as an ISO-certified company, is required to follow certain procedures when handling returned products that are in contact with medium.

To ensure swift, safe and professional device returns, please read the return procedures and conditions on the Endress+Hauser website at [www.services.endress.com/return-material](http://www.services.endress.com/return-material)

## 11.8 Disposal

In case of disposal please separate the different components according to their material consistence.

## 11.9 Contact addresses of Endress+Hauser

Contact addresses can be found on our homepage: [www.endress.com/worldwide](http://www.endress.com/worldwide). If you have any questions, please contact your Endress+Hauser sales representative.



## 12 Accessories

### 12.1 Commubox FXA195 HART

For intrinsically safe communication with FieldCare via the USB interface. For details refer to TI00404F/00/EN.

### 12.2 Commubox FXA291

For intrinsically safe communication with FieldCare via the service interface (IPC) of the instrument and the USB interface of a PC/Notebook.

Ordering Code: 51516983

### 12.3 Protection cover for the field housing

- Material: 316Ti (1.4571)
- is mounted by the mounting help of the Prosonic S
- Order-Code: 52024477

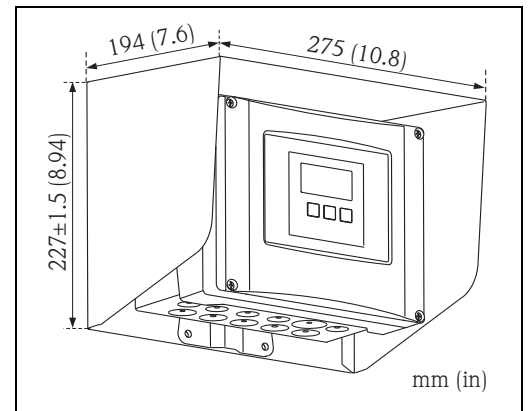

### 12.4 Mounting plate for the field housing

- suited for the mounting help of the Prosonic S
- for 1" - 2" tubes
- Dimensions: 210 x 110 mm (8.27 x 4.33 in)
- Material: 316Ti (1.4571)
- fixing clips, screws and nuts are supplied
- Order code: 52024478

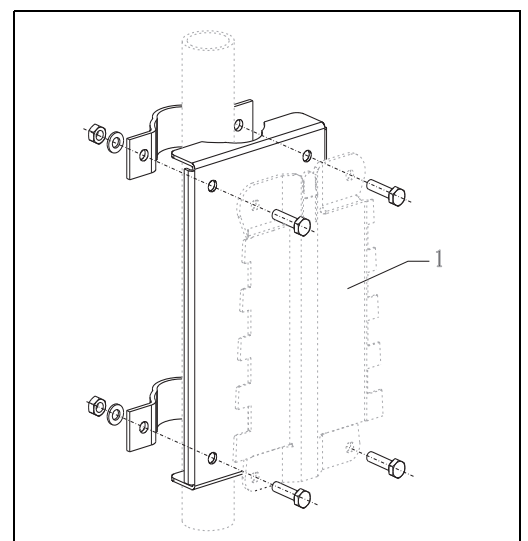

1 Mounting help of the field housing

### 12.5 Mounting bracket

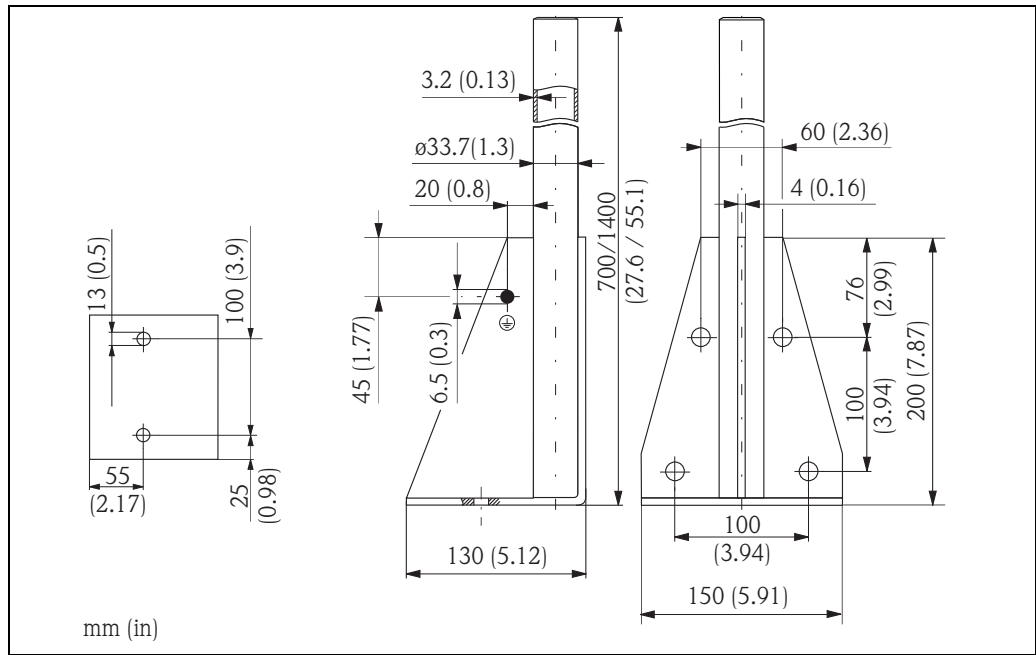

100-FM1xx-00-00-00-xx-005

Height	Material	Order Code
700 (27.6)	galv. steel	919791-0000
700 (27.6)	316Ti (1.4571)	919791-0001
1400 (55.16)	galv. steel	919791-0002
1400 (55.16)	316Ti (1.4571)	919791-0003

mm (in)

## 12.6 Adaption plate for remote display

Used to mount the remote display into the opening (138 x 138 mm (5.43 x 5.43 in)) of the remote display module of the Prosonic FMU860/861/862 (Display size: 144 x 144 mm (5.67 x 5.67 in)).

Order-Code: 52027441



### Note!

The adapter plate will be mounted directly in the old remote display of the FMU86x series. The housing of the remote display of FMU860/861/862 is the holder for the adapter plate and the new remote display of the FMU90/95 in the format 96 x 96 mm (3.78 x 3.78 in).

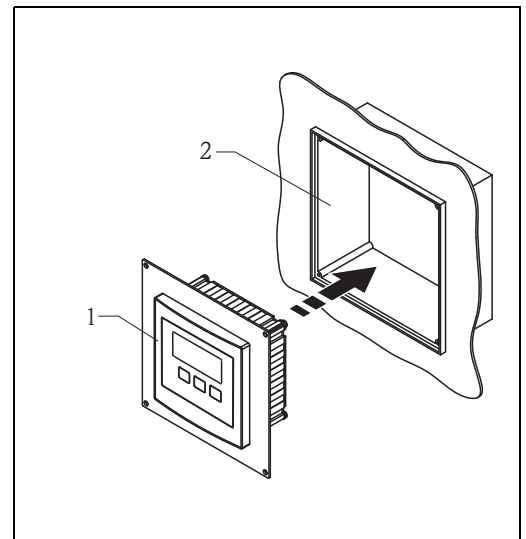

L00-FMU90xxx-00-00-00-xx-001

- 1 Remote display of the Prosonic S with adaption plate
- 2 Opening of the remote display FMU860/861/862

### Option:

Adaption plate 160 x 160 mm (6.3 x 6.3 in), thickness 3mm (0.12 in), aluminum, opening 92 x 92 mm (3.62 x 3.62 in) for remote display of the FMU90 (size of the display: 96 x 96 mm (3.78 x 3.78 in)).

Can be used to replace the FMU86x remote display or DMU2160/2260.

Order Code: TSPFU 0390

Please contact your Endress+Hauser sales representative.

## 12.7 Overvoltage protection (in IP66 housing)

- Overvoltage protection for the mains voltage and up to 3 signal outputs
- Dimensions of housing: 292 x 253 x 106 mm (11.5 x 9.96 x 4.17 in)
- Order Code: 215095-0001

## 12.8 Overvoltage protection HAW562

### 12.8.1 System principle

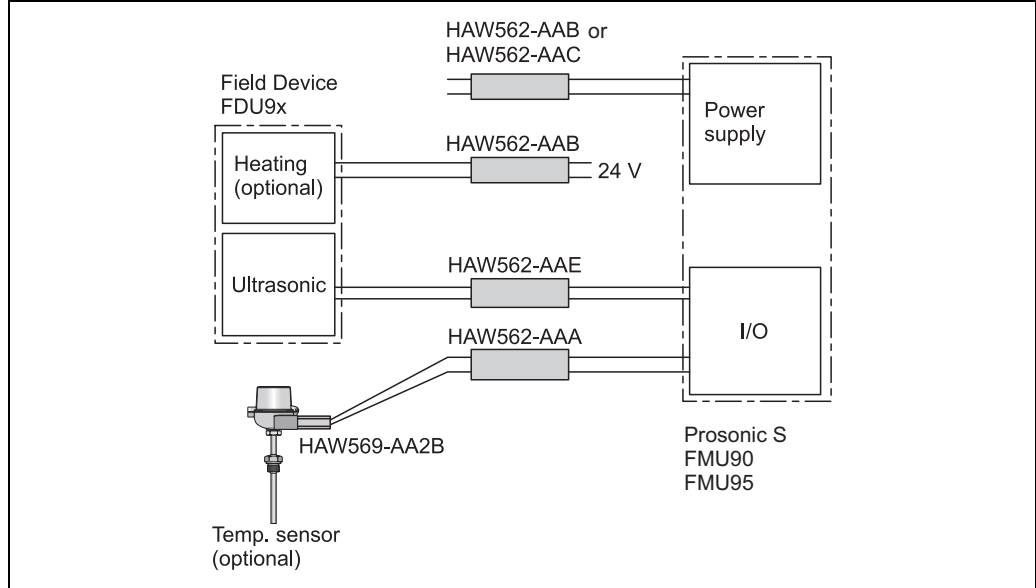

### 12.8.2 Application examples

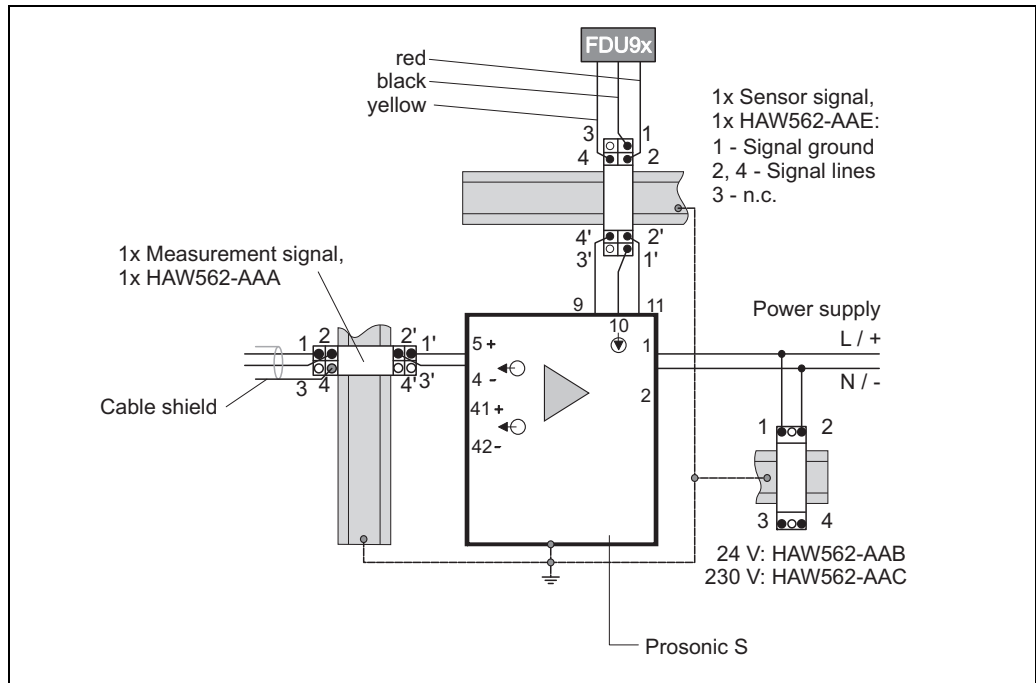

Level measurement with 1 Prosonic FDU9x level sensor, version 4 to 20 mA HART

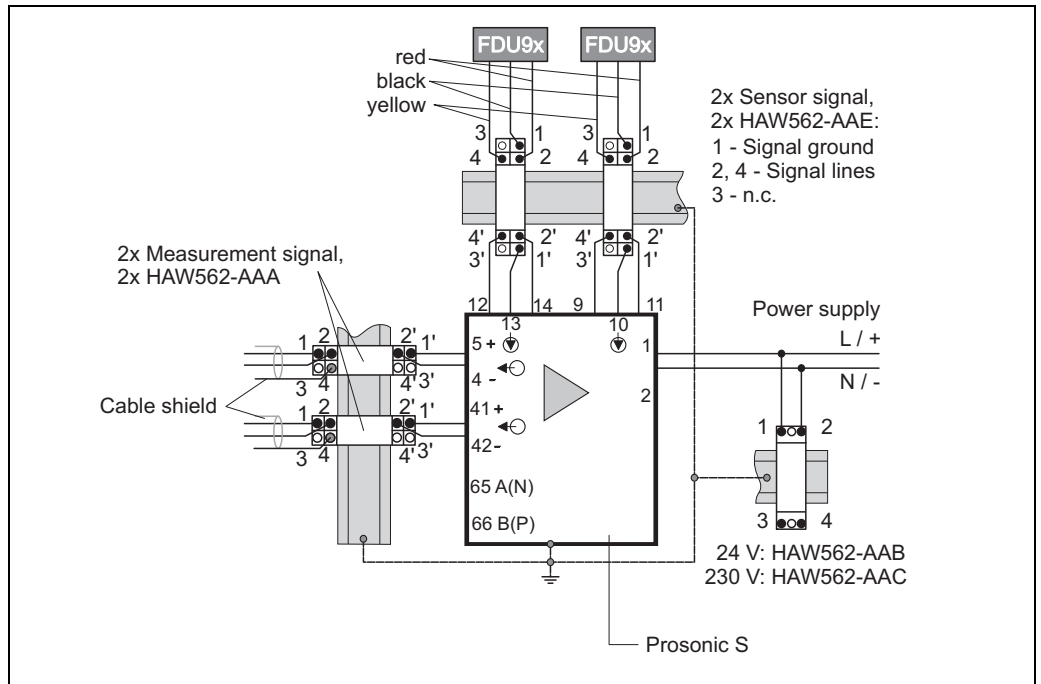

G09-HAW562zx-04-10-01-en-001

Level measurement with 2 Prosonic FDU9x level sensors, version 4 to 20 mA HART

### 12.8.3 Ordering information

Surge Arrester HAW562, compact device for DINrail installation in signal and power supply lines and communication lines protecting field devices and systems against overvoltage and magnetic induction.

Approval				
AA	Non-hazardous area			
8D	ATEX II 2 (1)G Ex ia IIC T6			
Application				
A	Measuring signal 0/4-20 mA, PFM, PA, FF			
B	Supply voltage 10-55 V (+/-20%)			
C	Supply voltage 90-230 V (+/-10%)			
D	Communication RS485/MOD-Bus/PROFIBUS DP			
E	Protection module Prosonic FMU90			
+ Additional selection (option)				
Additional approvals				
LA	SIL			
Accessory enclosed				
PA	Screen grounding terminal			
PB	Field housing			
PC	Mounting bracket, wall/pipe			
Marking				
Z1	Tagging (TAG), metal			
Z3	Commissioning label, paper			
Z6	Tagging (TAG), by customer			
HAW562 -			+	
				complete product designation

For details see Technical Informations TI01012K und TI01013K and the Operating Instruction BA00306K.

### 12.9 Extension cable for sensors

for Sensor	Material	Cable type	Order code
<ul style="list-style-type: none"> <li>■ FDU90</li> <li>■ FDU91</li> <li>■ FDU92</li> </ul>	PVC	LiYCY 2x(0.75)	71027742
<ul style="list-style-type: none"> <li>■ FDU91F</li> <li>■ FDU93</li> <li>■ FDU95</li> </ul>	PVC (-40 to +105 °C) (-40 to +221 °F)	LiYY 2x(0.75)D+1x0.75	71027743
<ul style="list-style-type: none"> <li>■ FDU95</li> <li>■ FDU96</li> </ul>	Silicone (-40 to +150 °C) (-40 to +302 °F)	Li2G2G 2x(0.75)D+1x0.75	71027745
<ul style="list-style-type: none"> <li>■ FDU90/FDU91 with heater</li> </ul>	PVC	LiYY 2x(0.75)D+2x0.75	71027746

Total length (sensor cable + extension cable): up to 300 m (984 ft)

### 12.10 Temperature sensor FMT131

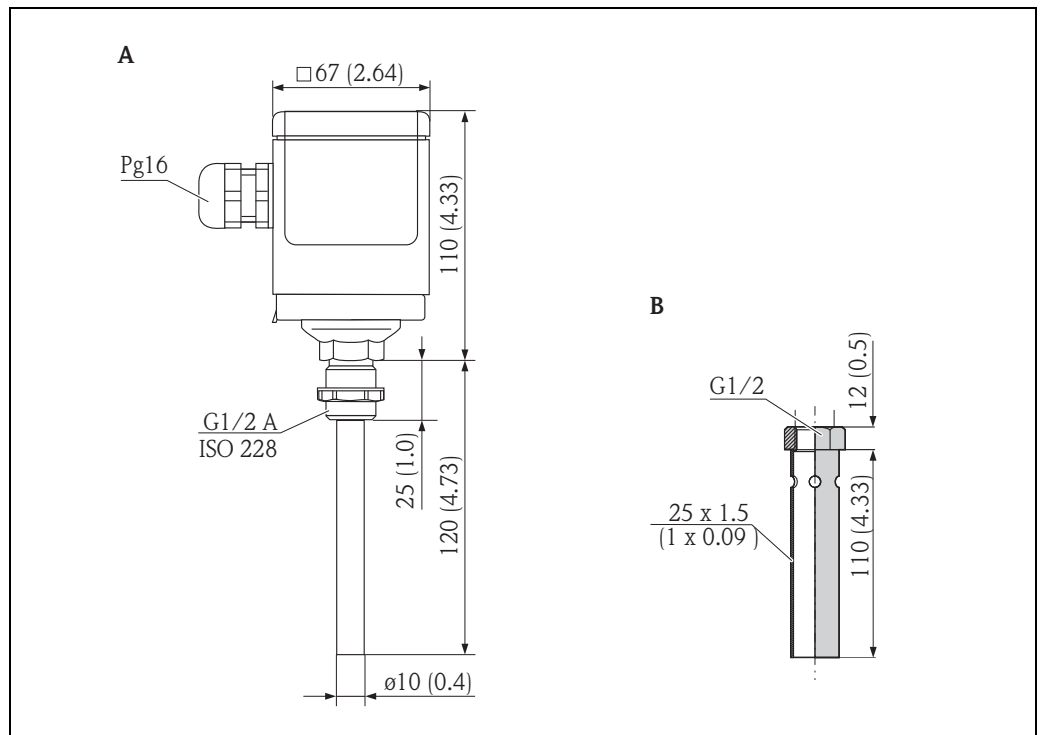

L00-FMU/90xxxx-00-00-00-xx-002a

**A** Temperature sensor FMT131  
**B** Weather protector

#### Product structure

<b>010</b>	<b>Approval</b>
	R Non-hazardous area J ATEX II 2G EEx m II T6/T5 Q FM Cl.I Div. 1 Gr. A-D, zone 1, 2 U CSA General Purpose (in preparation) S CSA Class I Div. 1
<b>020</b>	<b>Cable length</b>
	1 5 m/16 ft 2 10 m/ 32 ft 3 15 m/49 ft 4 20 m/65 ft 5 25 m/82 ft 6 30 m/98 ft 7 w/o cable, gland Pg16, IP66 8 ... m A ... ft
<b>995</b>	<b>Marking</b>
	1 Tagging (TAG)
FMT131 -	complete product designation

**Weather protection cover for FMT131**  
 Order code: 942046-0000

## 13 Technical Data

### 13.1 Technical data at a glance

#### 13.1.1 Input

Sensor inputs

Depending on the instrument version, 1 or 2 of the sensors FDU90, FDU91, FDU91F, FDU92, FDU93, FDU95 and FDU96 can be connected. The Prosonic S identifies these sensors automatically.

Sensor	FDU90	FDU91 FDU91F	FDU92	FDU93	FDU95	FDU96
max. range <sup>1)</sup> in liquids	3 (9.8)	10 (33)	20 (66)	25 (82)	-	-
max. range <sup>1)</sup> in solids	1.2 (3.9)	5 (16)	10 (33)	15 (49)	45 (148)	70 (230)

m (ft)

- 1) This table gives the maximum range. The range depends on the measuring conditions. For an estimation see Technical Information TI00396F/00, chapter "Input".

In order to support existing installations, the sensors of the series FDU8x can be connected as well. The type of sensor must be entered manually.

Sensor	FDU80 FDU80F	FDU81 FDU81F	FDU82	FDU83	FDU84	FDU85	FDU86
max. range <sup>1)</sup> in liquids	5 (16)	10 (33)	20 (66)	25 (82)	-	-	-
max. range <sup>1)</sup> in solids	2 (6.6)	5 (16)	10 (33)	15 (49)	25 (82)	45 (148)	70 (230)

m (ft)

- 1) This table gives the maximum range. The range depends on the measuring conditions. For an estimation see Technical Information TI00189F/00, chapter "Planning Recommendations".



Warning!

The sensors FDU83, FDU84, FDU85 and FDU86 with an ATEX, FM or CSA certificate are not certified for connection to the transmitter FMU90.

External limit switches (option)

Optionally, the Prosonic S FMU90 has four inputs for external limit switches (FMU90-\*\*\*\*\*B\*\*\*).

#### Switching options

- external passive limit switch (NC/NO switch)
- 0: < 8 V; 1: > 16 V

#### Usage (examples)

- pump feedback (for FMU90-\*3\*\*\*\*\*B\*\*\*) and FMU90-\*4\*\*\*\*\*B\*\*\*)
- pump tariff control (for FMU90-\*3\*\*\*\*\*B\*\*\*) and FMU90-\*4\*\*\*\*\*B\*\*\*)
- start/stop/reset of daily counters (for flow measurements) (for FMU90-\*2\*\*\*\*\*B\*\*\* and FMU90-\*4\*\*\*\*\*B\*\*\*)
- min/max level detection, e.g. by Liquiphant



External temperature sensor      Optionally, the Prosonic S FMU90 has an input for an external temperature sensor (FMU90-\*\*\*\*\*B\*\*\*).

#### Connectable sensors

- Pt100 (3-wire or 4-wire connection)  
A Pt100 with 2-wire connection may not be used due to its insufficient accuracy.
- FMT131 (from Endress+Hauser, →  113, "Accessories")

#### Usage (example)

- Time-of-flight correction for a heated sensor (FDU90-\*\*\*B\*, FDU91-\*\*\*B\*).

### 13.1.2 Output

#### Analogue outputs

Number	1 or 2, depending on instrument version
Output signal	configurable at the instrument: <ul style="list-style-type: none"> <li>■ 4 ... 20 mA with HART<sup>1)</sup></li> <li>■ 0 ... 20 mA without HART</li> </ul>
Signal on alarm	<ul style="list-style-type: none"> <li>■ for setting 4 ... 20 mA, selectable: <ul style="list-style-type: none"> <li>– -10% (3,6 mA)</li> <li>– 110% (22 mA)</li> <li>– HOLD (last current value is held)</li> <li>– user specific</li> </ul> </li> <li>■ for setting 0 ... 20 mA: <ul style="list-style-type: none"> <li>– 110% (21,6 mA)</li> <li>– HOLD (last current value is held)</li> <li>– user specific</li> </ul> </li> </ul>
Output damping	freely selectable, 0 ... 1000 s
Load	max. 600 Ω, influence negligible
max. ripple	$U_{SS} = 200 \text{ mV}$ at 47 ... 125 Hz (measured at 500Ω)
max. noise	$U_{eff} = 2,2 \text{ mV}$ at 500 Hz... 10 kHz (measured at 500Ω)

1) The HART signal is assigned to the first analogue output. The second analogue output does not carry a HART signal.

#### Relay outputs

Number	1, 3 or 6; depending on the instrument version
Type	potential-free relay, SPDT, can be inverted
Assignable functions	<ul style="list-style-type: none"> <li>■ limit (inband, out-of-band, trend, level limit)</li> <li>■ counting pulse<sup>1</sup> for flow counting (max. frequency 2 Hz; pulse width adjustable)</li> <li>■ time pulse<sup>1</sup> (max. frequency 2 Hz; pulse width adjustable)</li> <li>■ alarm/diagnosis (e.g. indication of backwater<sup>1</sup>, sludge<sup>1</sup>, echo loss etc.)</li> <li>■ pump control (alternating/fixed limit/pump rate)</li> <li>■ for FMU90-*3***** and FMU90-*4*****): additional pump control (standby pump, storm function to avoid unnecessary run times of the pumps, pump function test, flush control to clean pump shafts, operating hours alarm, pump alarm)</li> <li>■ rake control (difference or relative measurement)</li> <li>■ fieldbus relay (to be switched directly from the Profibus DP-bus)</li> </ul>
Switching power	<ul style="list-style-type: none"> <li>■ DC voltage: 35 V<sub>DC</sub>, 100 W</li> <li>■ AC voltage: 4 A, 250 V, 100 VA at cosφ = 0,7</li> </ul>
State on error	selectable: <ul style="list-style-type: none"> <li>■ HOLD (last value is held)</li> <li>■ energized</li> <li>■ de-energized</li> <li>■ present value is used</li> </ul>
Behaviour after power failure	switch-on delay selectable

LEDs <sup>2)</sup>	A yellow LED on the front panel is allocated to each relay, which lights if the relay is energized. The LED of an alarm relay lights during normal operation. The LED for a pulse relay briefly flashes at every pulse.
--------------------	---

- 1) for instrument versions with flow software (FMU90 - \*2\*\*\*\*\*)
- 2) for instrument versions with display and operating module

### 13.1.3 Power supply

Supply voltage/ Power consumption/ Current consumption	Instrument version	Supply voltage	Power consumption	Current consumption
	AC voltage (FMU90 - ****A****)	90 ... 253 V <sub>AC</sub> (50/60 Hz)	max. 23 VA	max. 100 mA at 230 V <sub>AC</sub>
	DC voltage (FMU90 - ****B****)	10,5 ... 32 V <sub>DC</sub>	max. 14 W (typically 8 W)	max. 580 mA at 24 V <sub>DC</sub>

Galvanic isolation

The following terminals are galvanically isolated from each other:

- auxiliary energy
- sensor inputs
- analogue output 1
- analogue output 2
- relay outputs
- bus connection (PROFIBUS DP)

Fuse

- 2 A T /DC
- 400 mA T /AC

accessible in the terminal compartment

### 13.1.4 Performance characteristics

Reference operating conditions

- Temperature = 24±5 °C (75±9 °F)
- Pressure = 960±100 mbar (14±1.45 psi)
- Relative humidity = 60±15 %
- Ideally reflecting surface, sensor vertically aligned (e.g. calm, plane liquid surface of 1 m<sup>2</sup> (10.76 ft<sup>2</sup>))
- No interference echoes within the signal beam
- Settings of the application parameters:
  - tank shape = flat ceiling
  - medium property = liquid
  - process condition = calm surface

Measuring uncertainty<sup>13)</sup> ±0,2 % of the maximum span of the sensor

Typical accuracy<sup>14)</sup> ±2 mm (0.08 in) + 0.17 % of the measured distance

Measured value resolution 1 mm (0.04 in) with FDU90/FDU91

13) according to NAMUR EN 61298-2  
14) after calibration

Measuring frequency	max. 3 Hz The exact value depends on the settings of the application parameters and the instrument version.
	Note! The maximum measuring frequency is obtained for "empty E" $\leq 2$ m ( $\leq 6.6$ ft) and "process condition" = "test: no filter".

Influence of the vapor pressure	The vapor pressure at 20 °C (68 °F) gives a hint on the accuracy of the ultrasonic level measurement. If the vapor pressure at 20 °C (68 °F) is below 50 mbar (1 psi), ultrasonic level measurement is possible with a very high accuracy. This is valid for water, aqueous solutions, water-solid-solutions, dilute acids (hydrochloric acid, sulfuric acid, ...), dilute bases (caustic soda, ...), oils, greases, slurries, pastes, ... High vapor pressures or outgassing media (ethanol, acetone, ammonia, ...) can influence the accuracy. If conditions like these are present, please contact your Endress+Hauser sales representative.
---------------------------------	--

### 13.1.5 Environment

Ambient temperature	-40 to 60 °C (-40 to 140 °F) The functionality of the LC display becomes restricted at $T_U < -20$ °C ( $T_U < -4$ °F). If the device is operated outdoors in strong sunlight, a protective cover should be used (→  113, "Accessories").
Storage temperature	-40 to 60 °C (-40 to 140 °F)
Climate class	<ul style="list-style-type: none"> <li>■ <b>Field housing:</b> according to DIN EN 60721-3 4K2/4K5/4K6/4Z2/4Z5/4C3/4S4/4M2 (DIN 60721-3 4K2 corresponds to DIN 60654-1 D1)</li> <li>■ <b>Housing for DIN rail mounting:</b> according to DIN EN 60721-3 3K3/3Z2/3Z5/3B1/3C2/3S3/3M1 (DIN 60721-3 3K3 corresponds to DIN 60654-1 B2)</li> </ul>
Vibration resistance	<ul style="list-style-type: none"> <li>■ Housing for DIN rail: DIN EN 60068-2-64 / IEC 68-2-64; 20 ... 2000 Hz; 0,5 (m/s<sup>2</sup>)<sup>2</sup>/Hz</li> <li>■ Field housing: DIN EN 60068-2-64 / IEC 68-2-64; 20 ... 2000 Hz; 1,0 (m/s<sup>2</sup>)<sup>2</sup>/Hz</li> </ul>
Ingress protection	<ul style="list-style-type: none"> <li>■ Field housing: IP66 / NEMA 4x</li> <li>■ Housing for DIN rail: IP20</li> <li>■ separate display: <ul style="list-style-type: none"> <li>– IP65 / NEMA 4 (front panel , if mounted in cabinet door)</li> <li>– IP20 (rear panel, if mounted in cabinet door)</li> </ul> </li> </ul>
Electromagnetic compatibility (EMC)	<ul style="list-style-type: none"> <li>■ Electromagnetic compatibility according to all relevant requirements of the EN 61326- series and NAMUR recommendation EMC (NE21). For details see declaration of conformity.</li> <li>■ With respect to interference emission the devices meet the requirements of class A and are only provided for use in an "industrial environment"!</li> </ul>

### 13.1.6 Mechanical construction

Dimensions →  11 "Installation"

Weight	Housing version	Weight
	Field housing	approx. 1.6 to 1.8 kg (3.53 to 3.97 lbs); depending on instrument version
	Housing for DIN rail	approx. 0.5 to 0.7 kg (1.10 to 1.54 lbs); depending on instrument version (→  13 "Dimensions of the DIN-rail housing")
	separate display and operating module	approx. 0.5 kg (1.10 lbs)

Materials	Part	Material
	Housing bracket	PC-FR
	Field housing	PC-FR
	Housing for DIN rail	PBT-GF

For details see Technical Information TI00397F/00.



# 14 Operating menu

## 14.1 "flow"

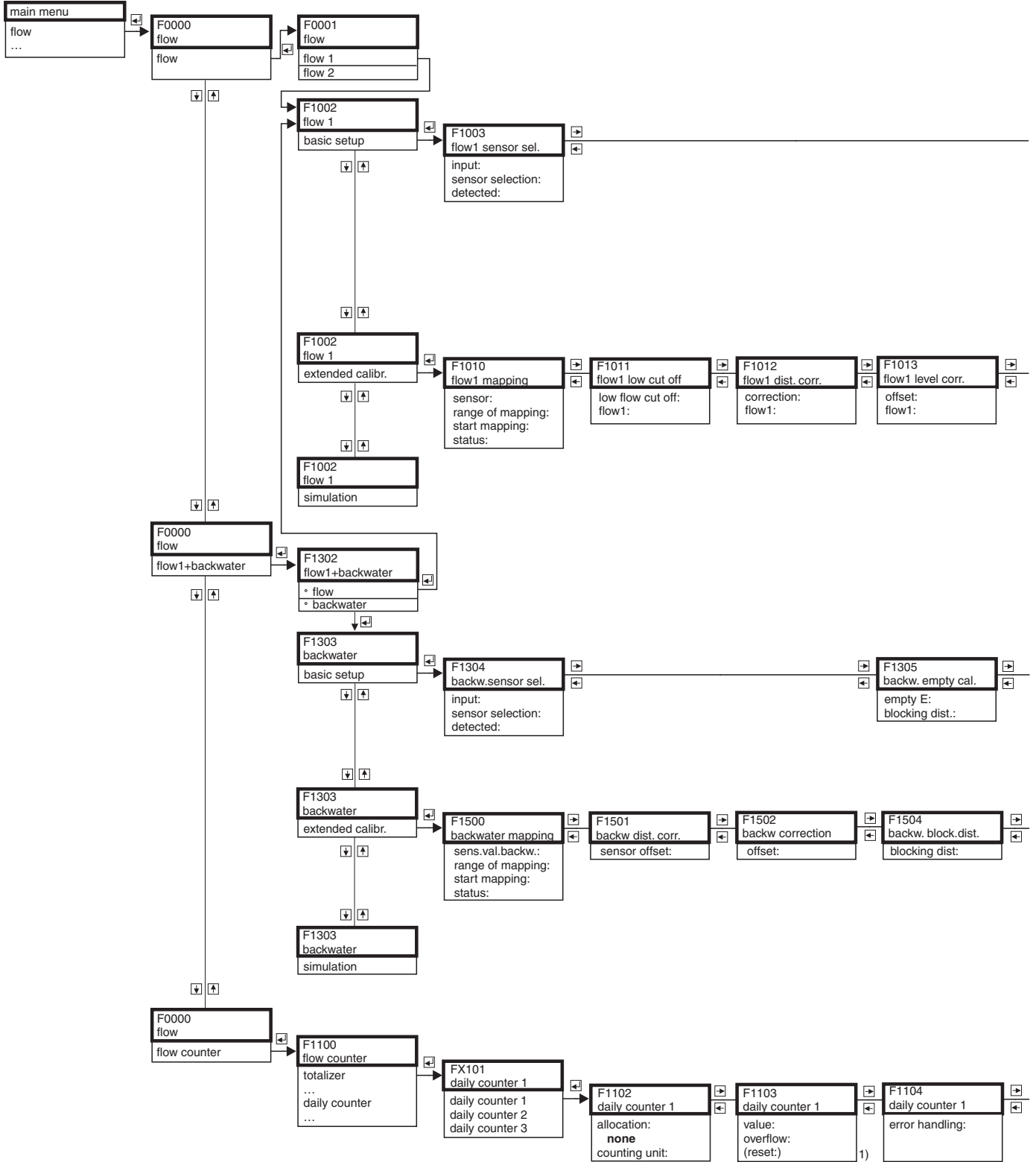

1) not available for totalizers

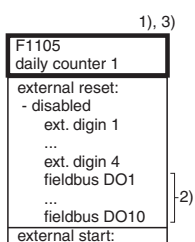
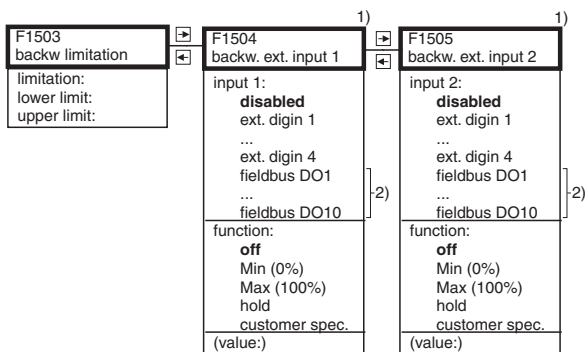
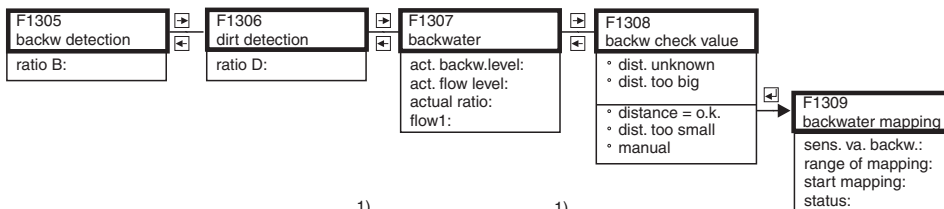
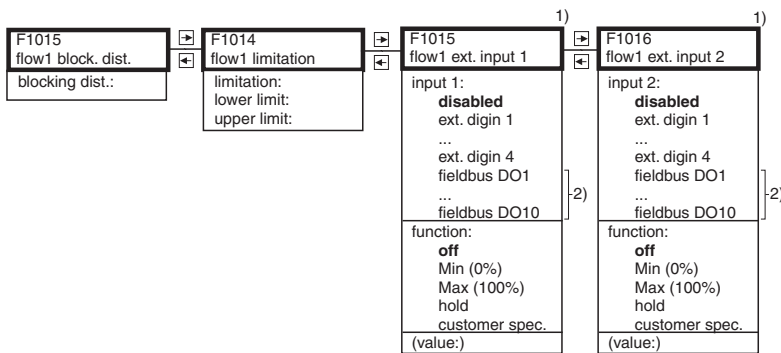
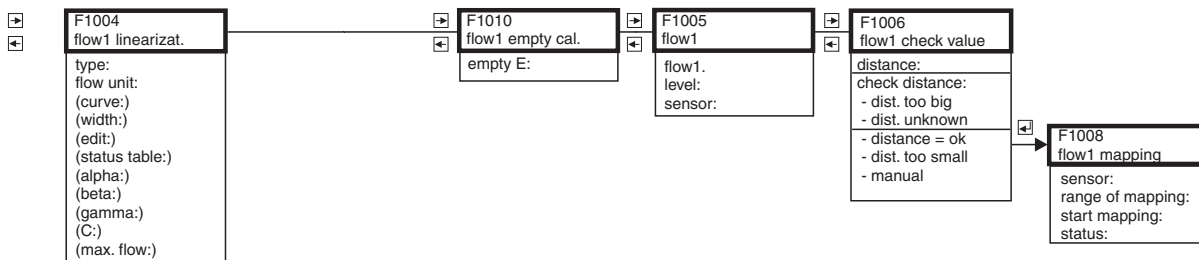

- 1) only for device version with additional switch inputs (FMU90.\*\*\*\*\*B\*\*\*)
- 2) only for PROFIBUS devices
- 3) not available for totalizers

## 14.2 "safety settings"

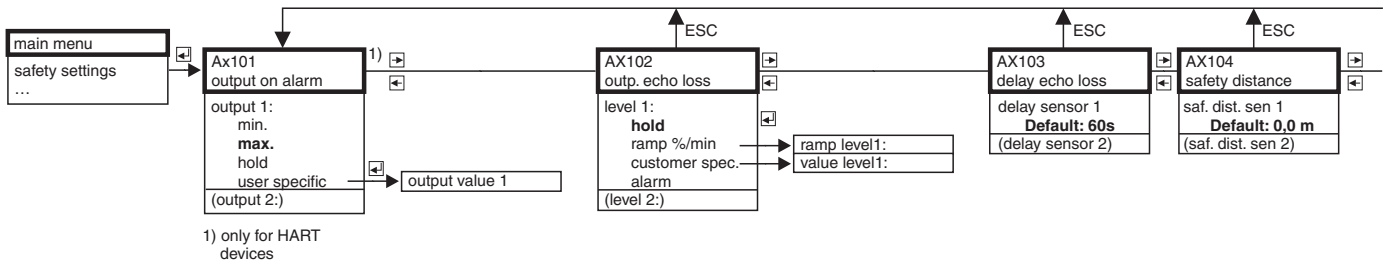



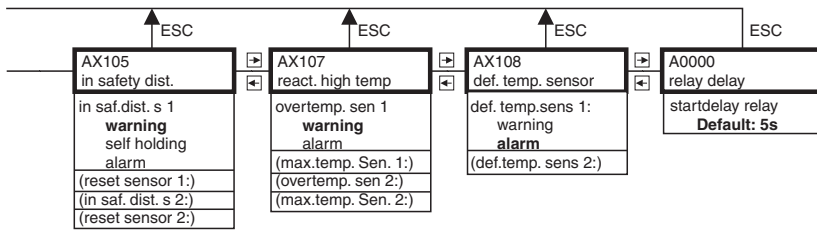

### 14.3 "relay/controls"

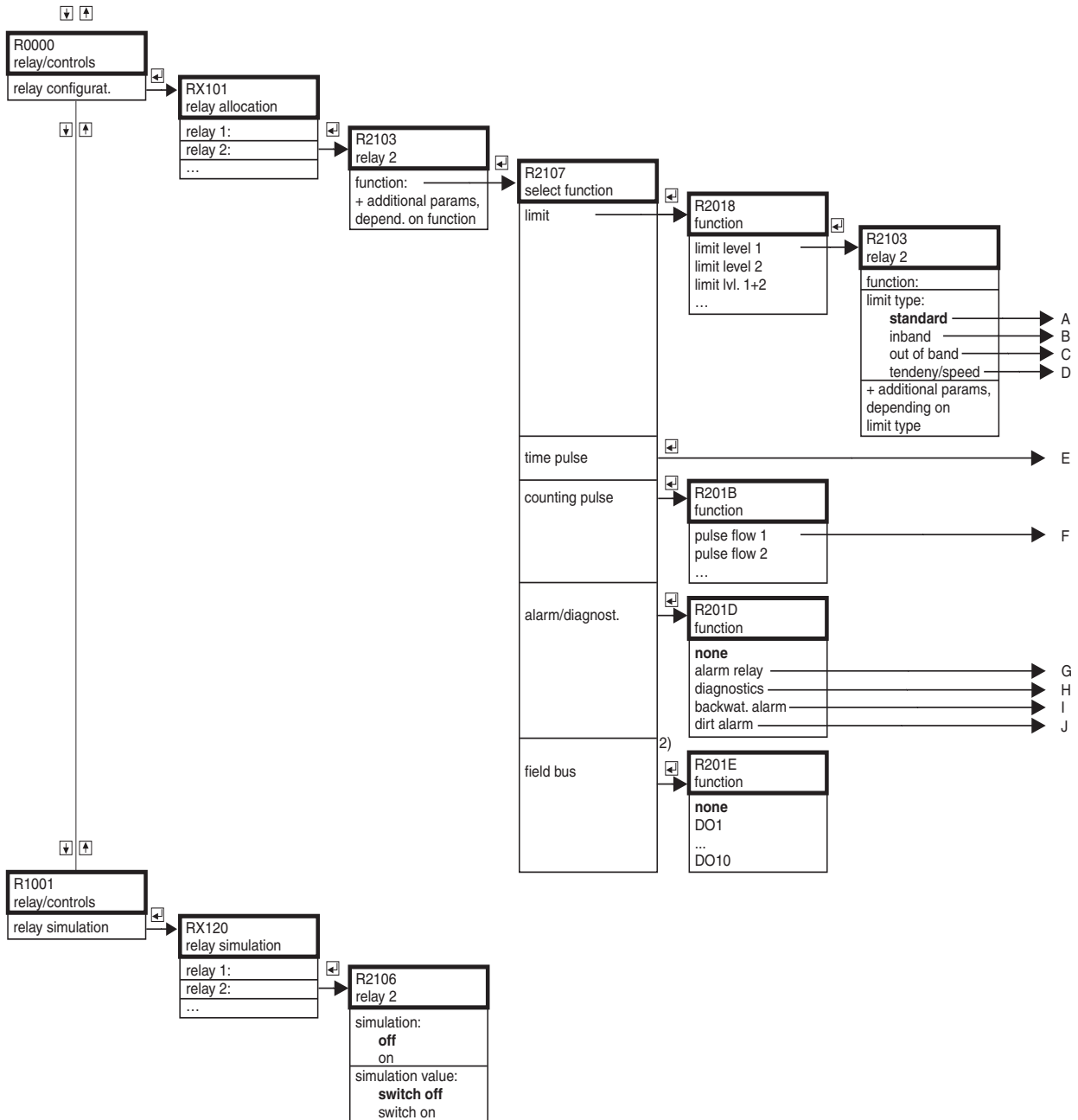

L00-FMU90xxxx-19-08-01-es-106

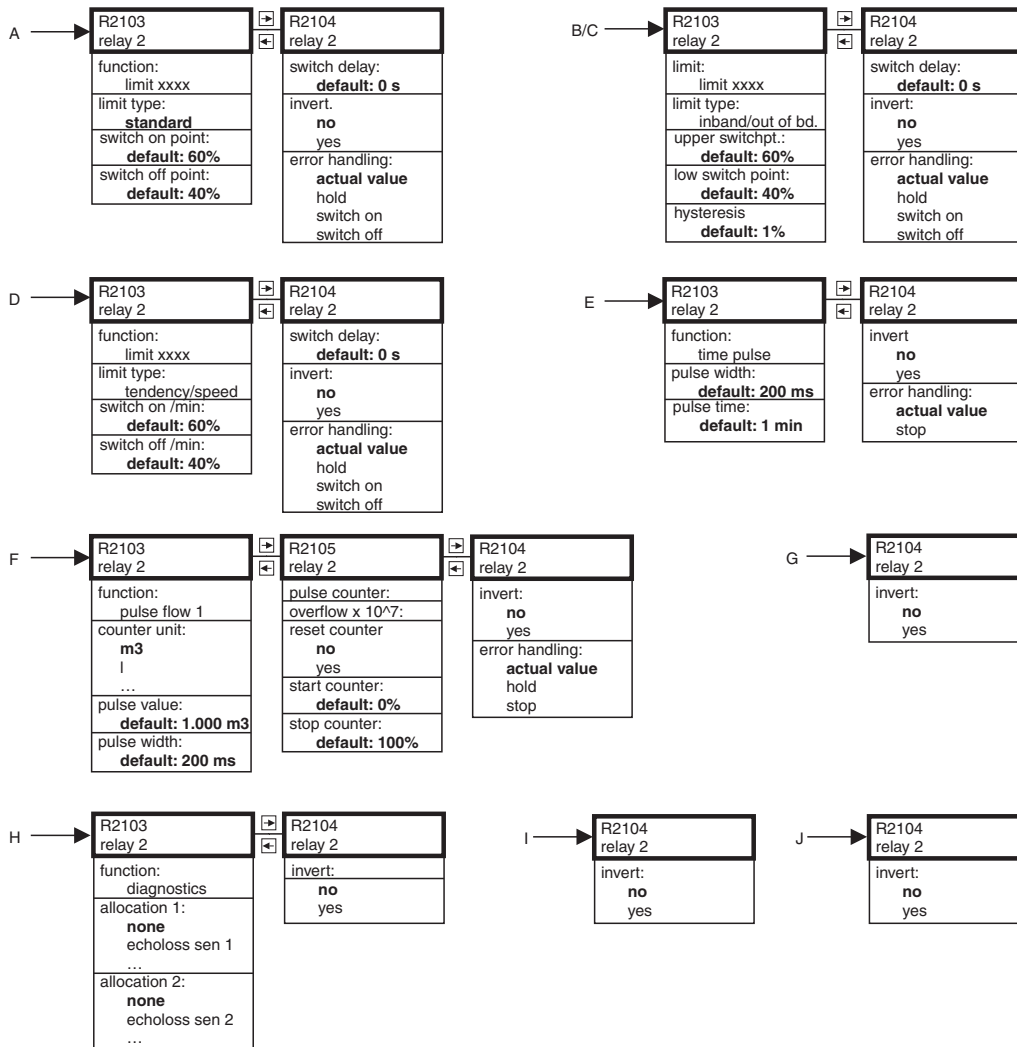

## 14.4 "output/calculations"

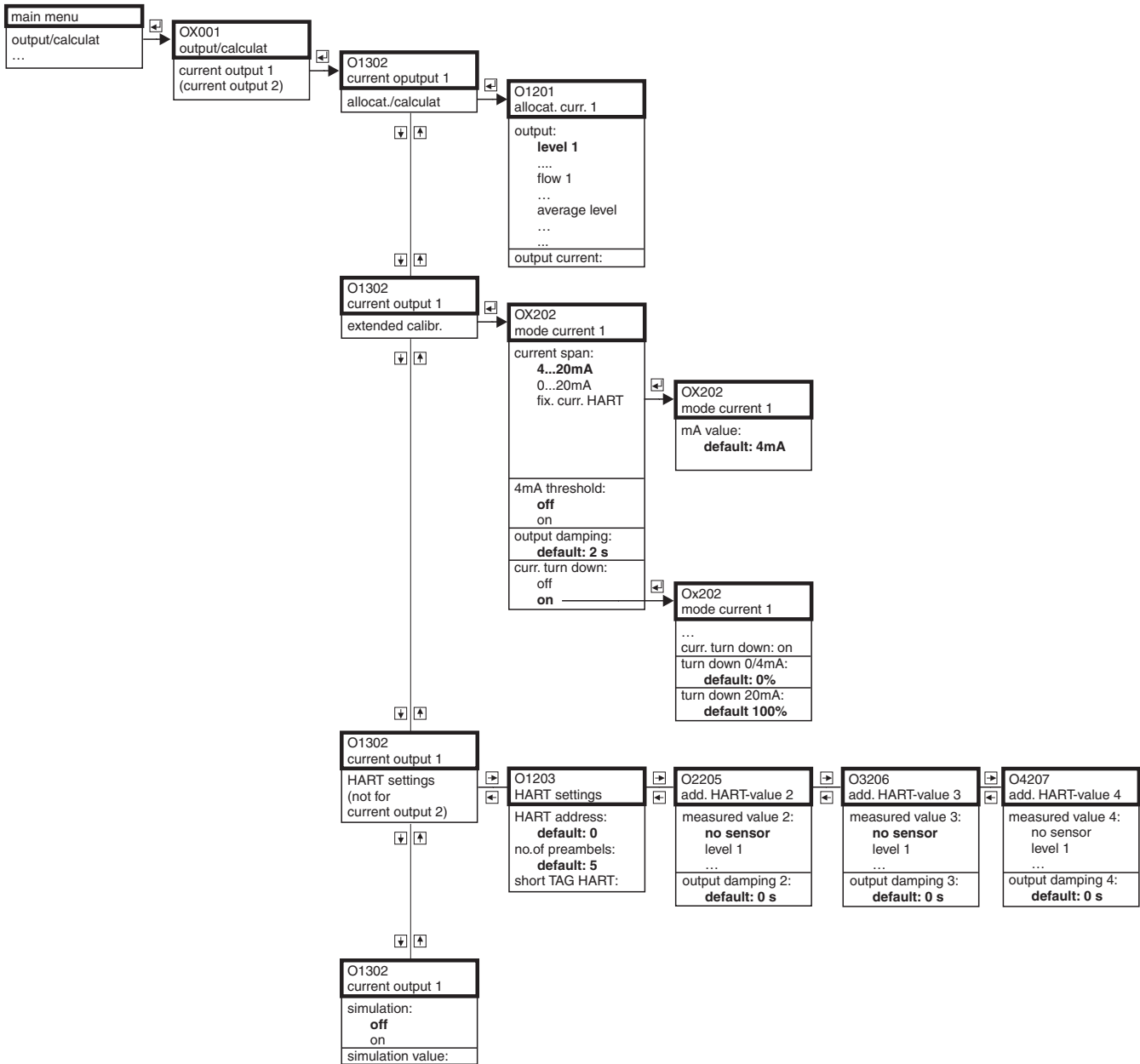

## 14.5 "device properties"

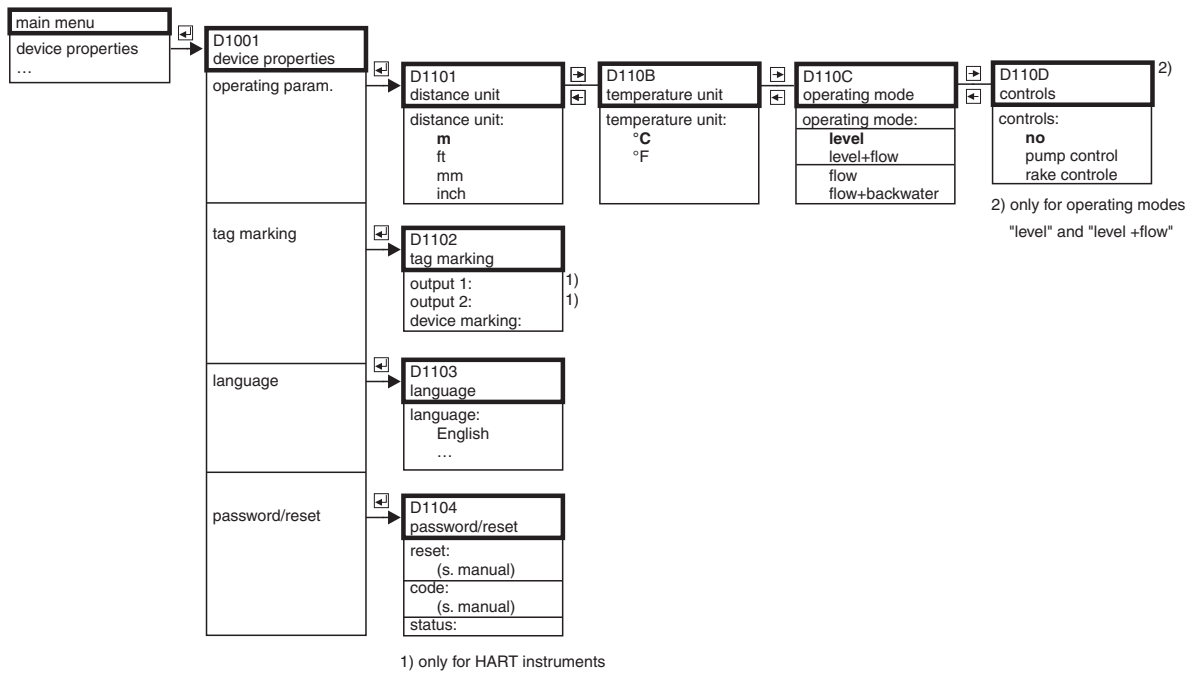

## 14.6 "system information"

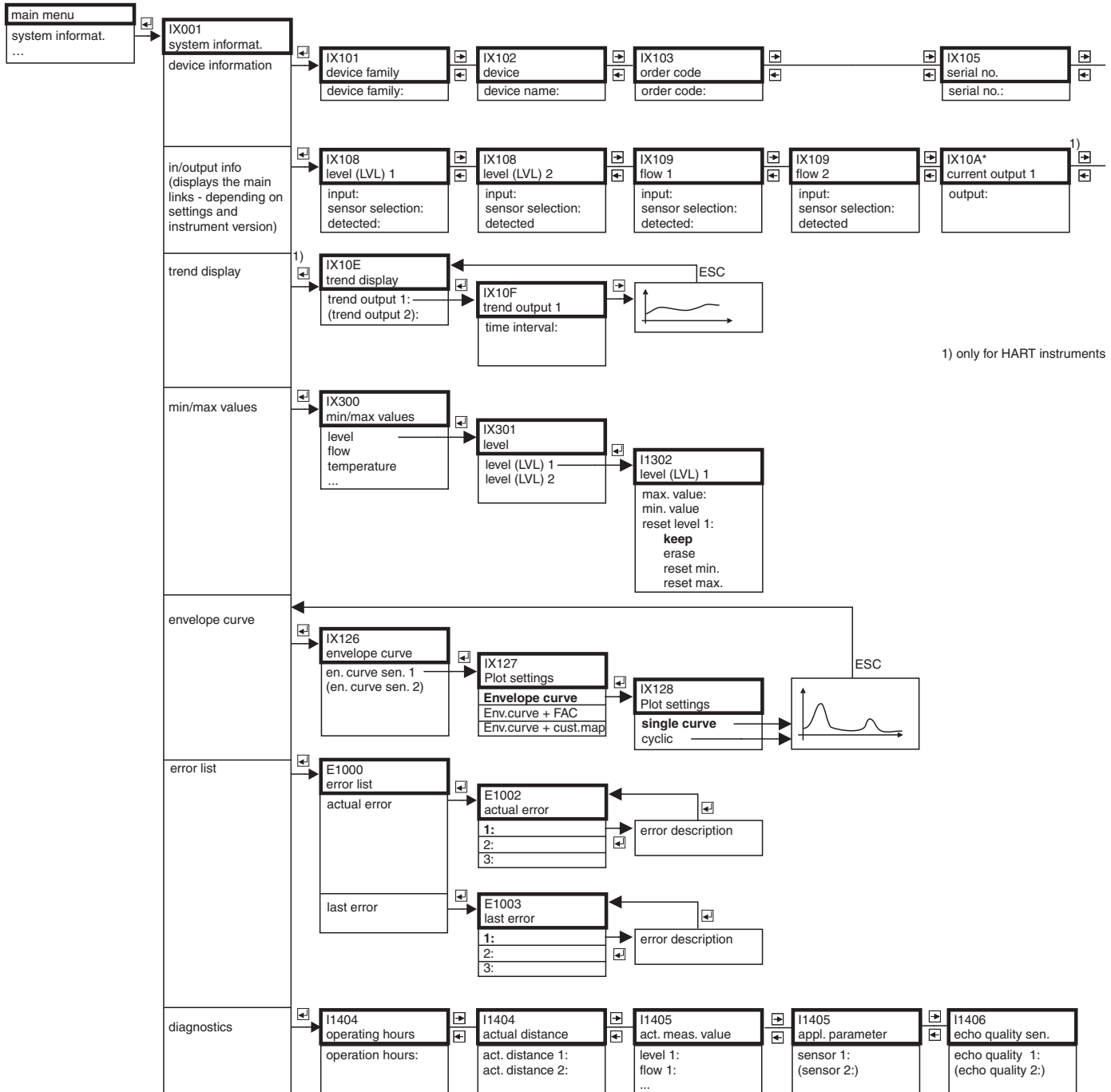

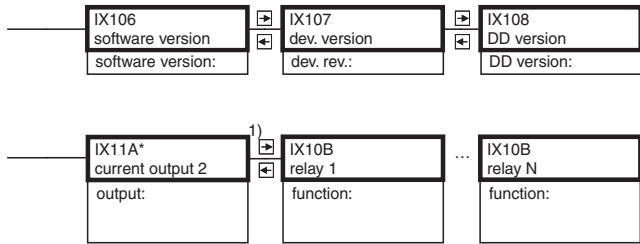

1) only for HART instruments

## 14.7 "display"

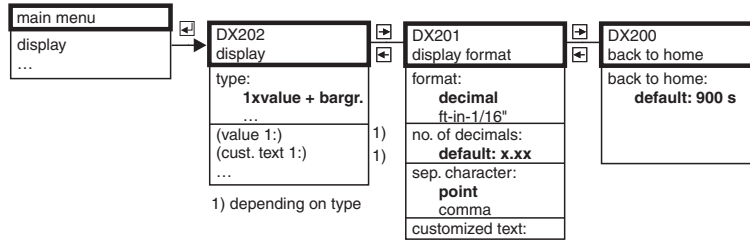

L00-FMU90xxxx-19-09-01-en-106

## 14.8 "sensor management"

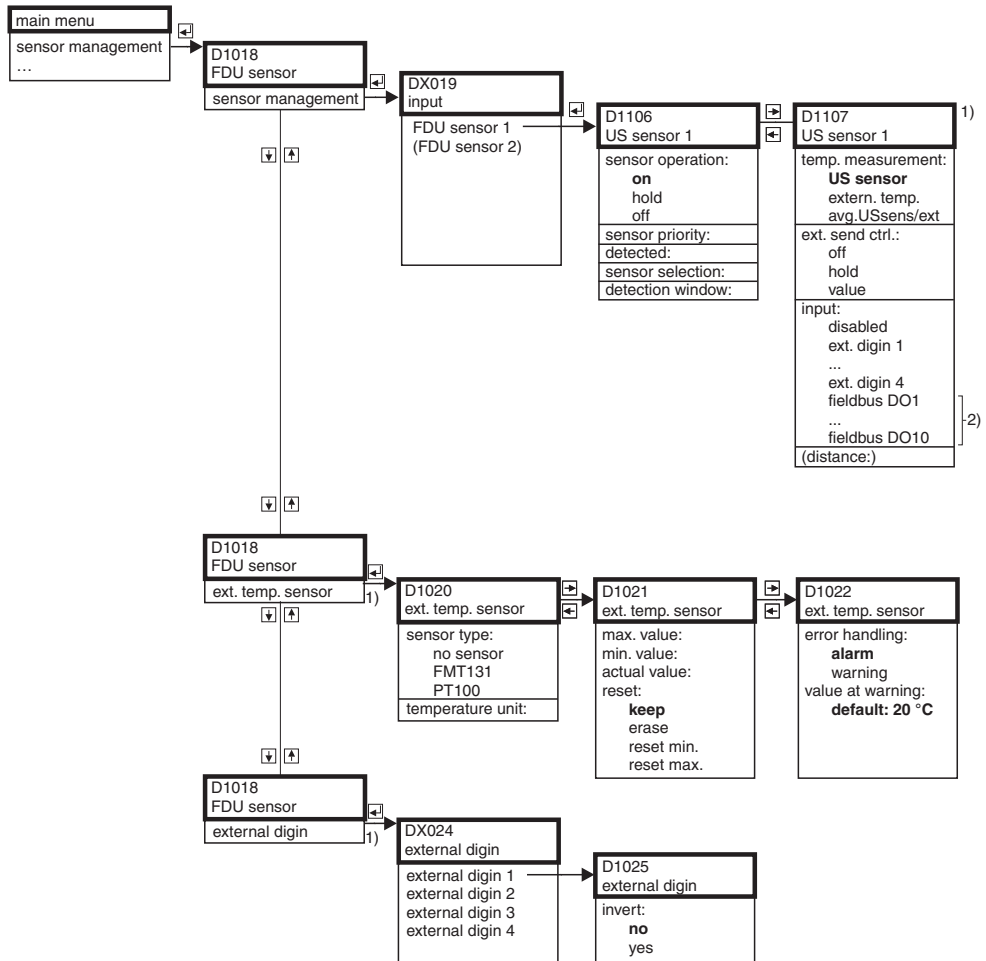

- 1) only for device version with additional switch inputs and connected external temperature sensor (FMU90-\*\*\*\*\*B\*\*\*)
- 2) only for PROFIBUS devices

L00-FMU90xxxx-19-10-01-en-106



## 15 Appendix

### 15.1 Pre-programmed flow curves

#### 15.1.1 Khafagi-Venturi flumes

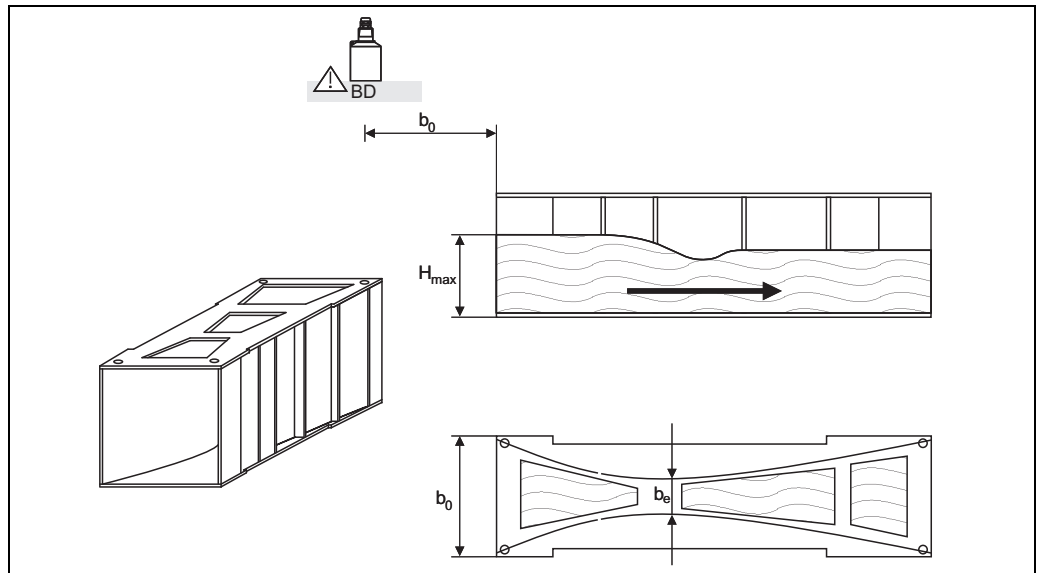

**BD:** blocking distance of the sensor

Type of flume	$b_0$	$b_e$	$H_{max}$	$Q_{max}$ [m <sup>3</sup> /h]
Khafagi-Venturi QV 302	120 (4.72)	48 (1.89)	220 (8.66)	40,09
Khafagi-Venturi QV 303	300 (11.8)	120 (4.72)	250 (9.84)	104,3
Khafagi-Venturi QV 304	400 (15.7)	160 (6.30)	350 (13.8)	231,5
Khafagi-Venturi QV 305	500 (19.7)	200 (7.87)	380 (15.0)	323,0
Khafagi-Venturi QV306	600 (23.6)	240 (9.45)	400 (15.7)	414,0
Khafagi-Venturi QV 308	800 (31.5)	320 (12.6)	600 (23.6)	1024
Khafagi-Venturi QV 310	1000 (39.4)	400 (15.7)	800 (31.5)	1982
Khafagi-Venturi QV 313	1300 (51.2)	520 (20.5)	950 (37.4)	3308
Khafagi-Venturi QV 316	1600 (63.0)	640 (25.2)	1250 (49.2)	6181

mm (in)

The pre-programmed curves can also be used for Khafagi-Venturi flumes with elevated walls. To do so,  $Q_{\max}$  has to be adjusted ("**linearization**" function, "**max. flow**" subfunction):

Type of flume	$H_{\max}$ [mm (in)]	$Q_{\max}$ [m <sup>3</sup> /h]
Khafagi-Venturi QV 302	330 (13.0)	81,90
Khafagi-Venturi QV 303	360 (14.2)	187,9
Khafagi-Venturi QV 304	460 (18.1)	359,9
Khafagi-Venturi QV 305	580 (22.8)	637,7
Khafagi-Venturi QV 306	580 (22.8)	748,6
Khafagi-Venturi QV 308	850 (33.5)	1790
Khafagi-Venturi QV 310	1200 (47.2)	3812
Khafagi-Venturi QV313	1350 (53.1)	5807
Khafagi-Venturi QV 316	1800 (70.9)	11110



Note!

After selecting the type of flume,  $Q_{\max}$  can be adjusted to the flow conditions.  $Q_{\max}$  defines the flow at which the output current is 20 mA.

### 15.1.2 ISO-Venturi flumes

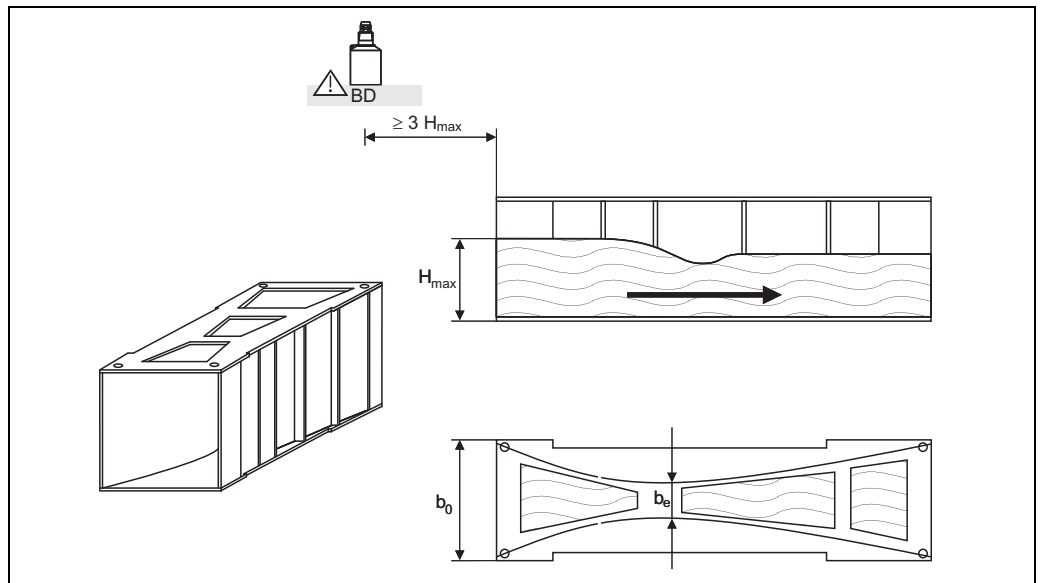

**BD:** blocking distance of the sensor

Type of flume	$b_0$	$b_e$	$H_{max}$	$Q_{max}$ [m <sup>3</sup> /h]
ISO-Venturi 415	150 (5.91)	75 (2.95)	200 (7.87)	42.5
ISO-Venturi 425	250 (9.84)	125 (4.92)	300 (11.8)	130.3
ISO-Venturi 430	400 (15.7)	200 (7.87)	400 (15.7)	322.2
ISO-Venturi 440	400 (15.7)	267 (10.5)	625 (24.6)	893.6
ISO-Venturi 450	500 (19.7)	333 (13.1)	700 (27.6)	1318.9
ISO-Venturi 480	800 (31.5)	480 (18.9)	800 (31.5)	1862.5

mm (in)



**Note!**

After selecting the type of flume,  $Q_{max}$  can be adjusted to the flow conditions.  $Q_{max}$  defines the flow at which the output current is 20 mA.

### 15.1.3 British standard Venturi flumes (BS 3680)

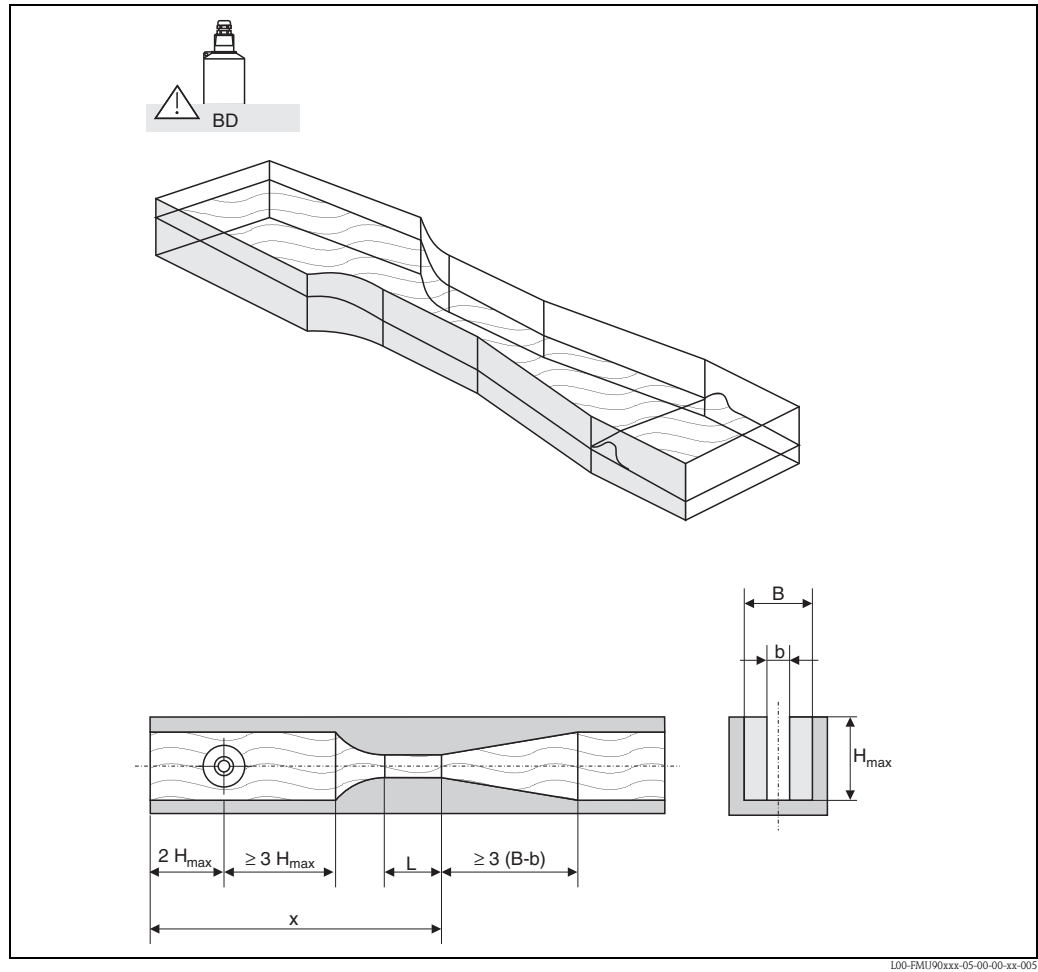

**BD:** blocking distance of the sensor

The bottom of the flume may not have any slope throughout the length  $x$ . (no measuring flume with data threshold)

Type of flume	b	H <sub>max</sub> [mm (in)]	Q <sub>max</sub> [m <sup>3</sup> /h]
BST Venturi 4"	4"	150 (5.91)	36.25
BST Venturi 7"	7"	190 (7.48)	90.44
BST Venturi 12"	12"	340 (13.4)	371.1
BST Venturi 18"	18"	480 (18.9)	925.7
BST Venturi 30"	30"	840 (33.1)	3603



Note!

After selecting the type of flume, Q<sub>max</sub> can be adjusted to the flow conditions. Q<sub>max</sub> defines the flow at which the output current is 20 mA.

### 15.1.4 Parshall flumes

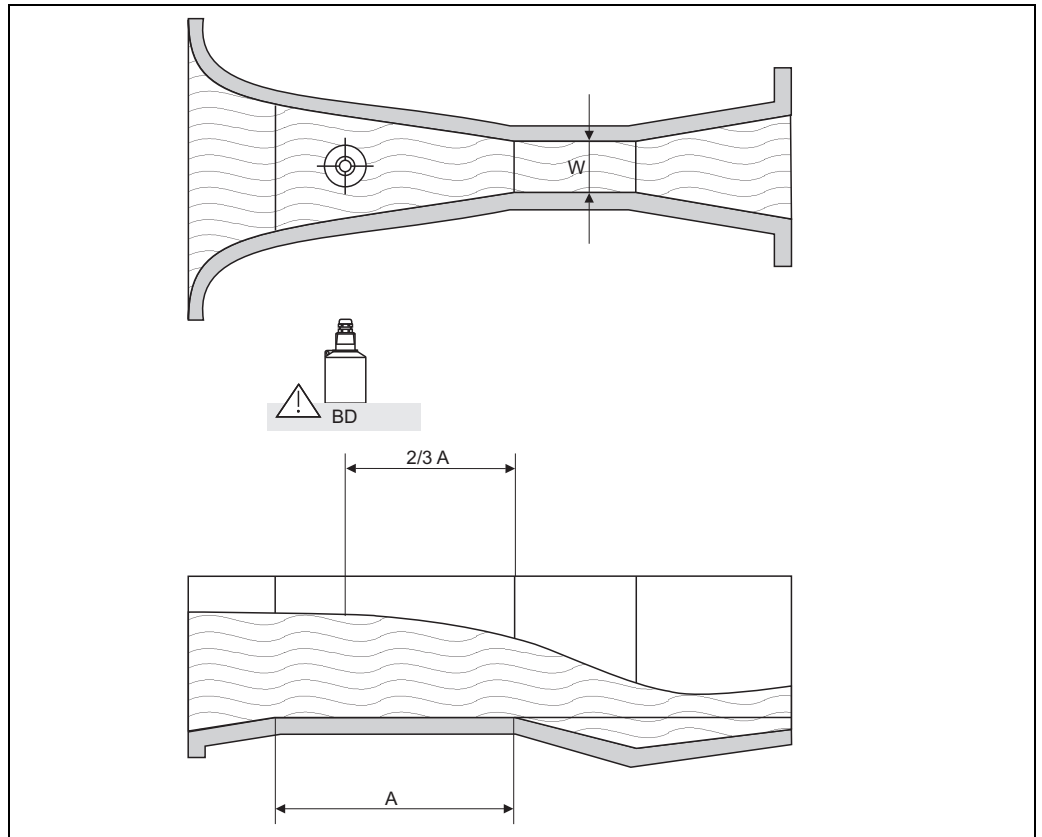

100-FMU90xxx-05-00-00-xx-000

**BD:** blocking distance of the sensor  
**A:** horizontal bottom of the channel

Type of flume	W	H <sub>max</sub> [mm (in)]	Q <sub>max</sub> [m <sup>3</sup> /h]
Parshall 1"	1"	180 (7.09)	15.23
Parshall 2"	2"	180 (7.09)	30.46
Parshall 3"	3"	480 (18.9)	203.8
Parshall 6"	6"	480 (18.9)	430.5
Parshall 9"	9"	630 (24.8)	950.5
Parshall 1 ft	1.0 ft	780 (30.7)	1704
Parshall 1.5 ft	1.5 ft	780 (30.7)	2595
Parshall 2 ft	2.0 ft	780 (30.7)	3498
Parshall 3 ft	3.0 ft	780 (30.7)	5328
Parshall 4 t	4.0 ft	780 (30.7)	7185
Parshall 5 ft	5.0 ft	780 (30.7)	9058
Parshall 6 ft	6.0 ft	780 (30.7)	10951
Parshall 8 ft	8.0 ft	780 (30.7)	14767



Note!

After selecting the type of flume, Q<sub>max</sub> can be adjusted to the flow conditions. Q<sub>max</sub> defines the flow at which the output current is 20 mA.

### 15.1.5 Palmer-Bowlus flumes

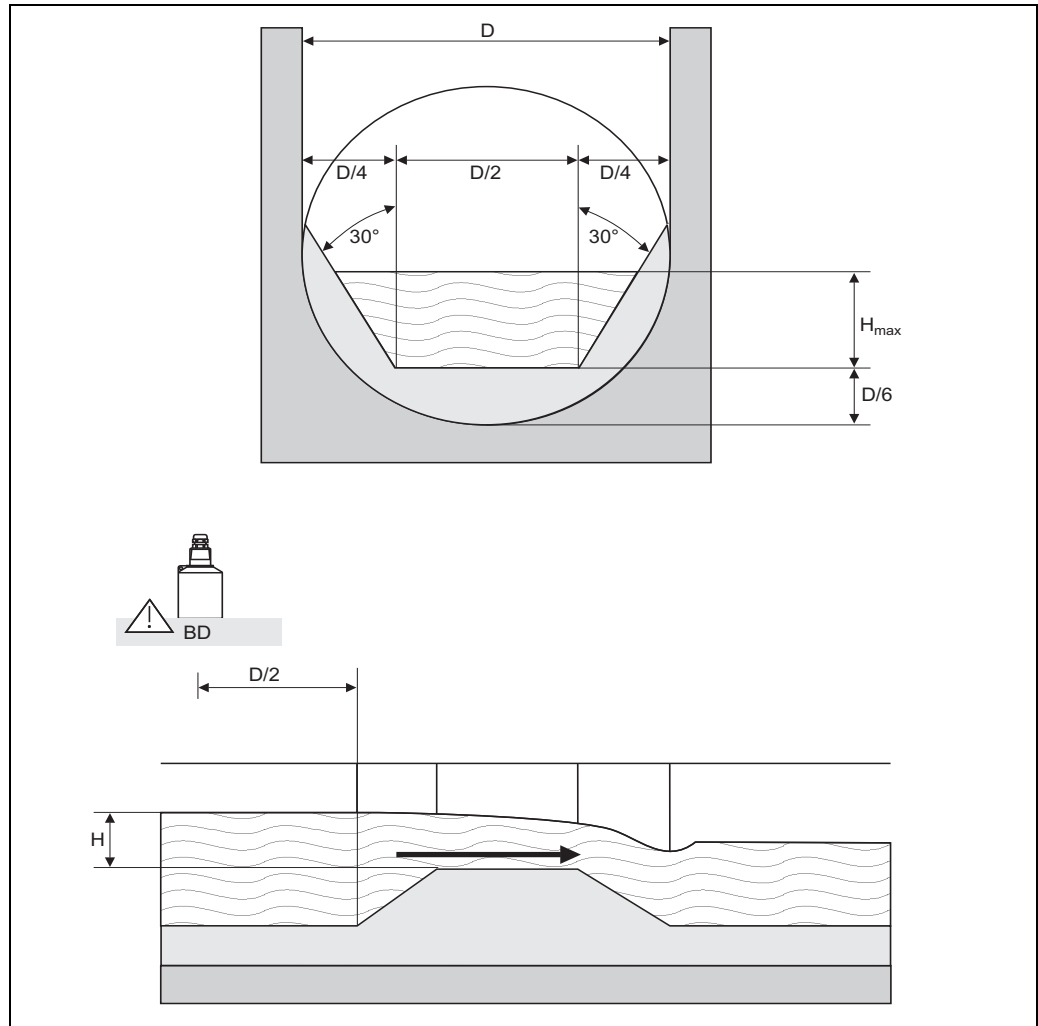

100-FMU90xxx-05-00-00-xx-007

Type of flume	D	H <sub>max</sub> [mm (in)]	Q <sub>max</sub> [m <sup>3</sup> /h]
Palmer-Bowlus 6"	6"	120 (4.72)	37.94
Palmer-Bowlus 8"	8"	150 (5.91)	68.62
Palmer-Bowlus 10"	10"	210 (8.27)	150.55
Palmer-Bowlus 12"	12"	240 (9.45)	215.83
Palmer-Bowlus 15"	15"	300 (11.8)	376.97
Palmer-Bowlus 18"	18"	330 (13.0)	499.86
Palmer-Bowlus 21"	21"	420 (16.5)	871.05
Palmer-Bowlus 24"	24"	450 (17.7)	1075.94
Palmer-Bowlus 27"	27"	540 (21.3)	1625.58
Palmer-Bowlus 30"	30"	600 (23.6)	2136.47



Note!

After selecting the type of flume, Q<sub>max</sub> can be adjusted to the flow conditions. Q<sub>max</sub> defines the flow at which the output current is 20 mA.

### 15.1.6 Rectangular weirs

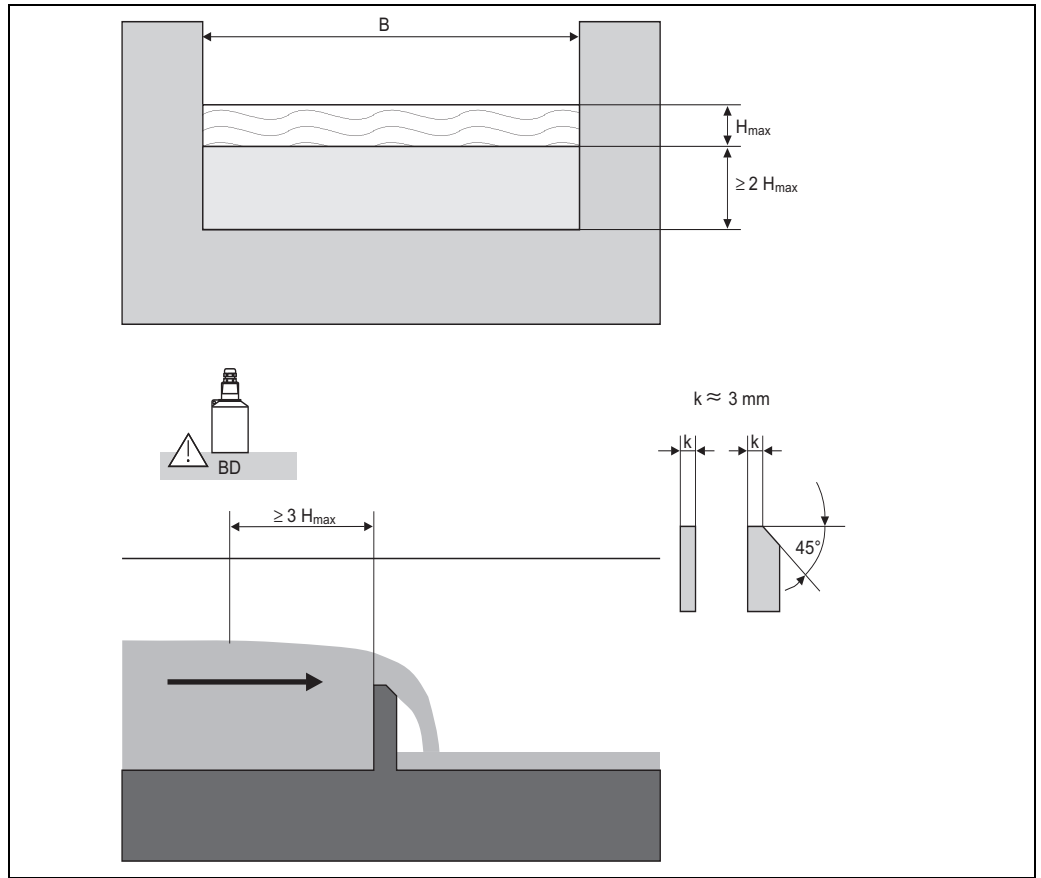

L00-FMU/90xxx-05-00-00-xx-008

Type of weir	B	H <sub>max</sub>	Q <sub>max</sub> [m <sup>3</sup> /h]
RectWT0/5H	1000 (39.4)	500 (19.7)	2418
RectWT0/T5	1000 (39.4)	1500 (59.1)	12567

mm (ft)



Note!

- In the "width" parameter, the width of the weir can be adjusted. The corresponding change of the flow curve is automatically performed by the Prosonic S.
- After selecting the type of weir, Q<sub>max</sub> can be adjusted to the flow conditions. Q<sub>max</sub> defines the flow at which the output current is 20 mA.

### 15.1.7 Constricted rectangular weirs

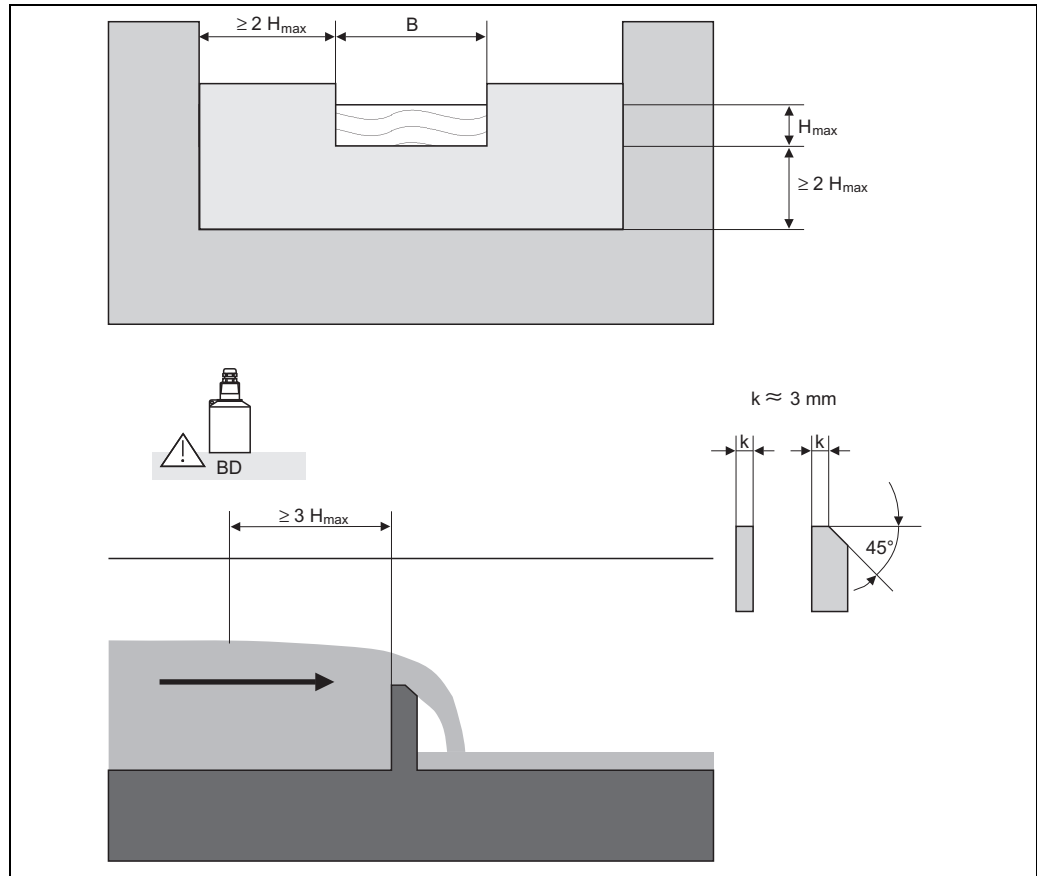

100-FMU90xxx-05-00-00-xx-009

Type of weir	B	H <sub>max</sub>	Q <sub>max</sub> [m <sup>3</sup> /h]
RectWThr 2H	200 (7.87)	120 (4.72)	51.18
RectWThr 3H	300 (11.8)	150 (5.91)	108.4
RectWThr 4H	400 (15.7)	240 (9.45)	289.5
RectWThr 5H	500 (19.7)	270 (10.6)	434.6
RectWThr 6H	600 (23.6)	300 (11.8)	613.3
RectWThr 8H	800 (31.5)	450 (17.7)	1493
RectWThr T0	1000 (39.4)	600 (23.6)	2861
RectWThr T5	1500 (59.1)	725 (28.5)	6061
RectWThr 2T	2000 (78.7)	1013 (39.9)	13352

mm (in)



Note!

- In the "width" parameter, the width of the weir can be adjusted. The corresponding change of the flow curve is automatically performed by the Prosonic S.
- After selecting the type of weir, Q<sub>max</sub> can be adjusted to the flow conditions. Q<sub>max</sub> defines the flow at which the output current is 20 mA.



### 15.1.8 Rectangular weirs according to French standard NFX

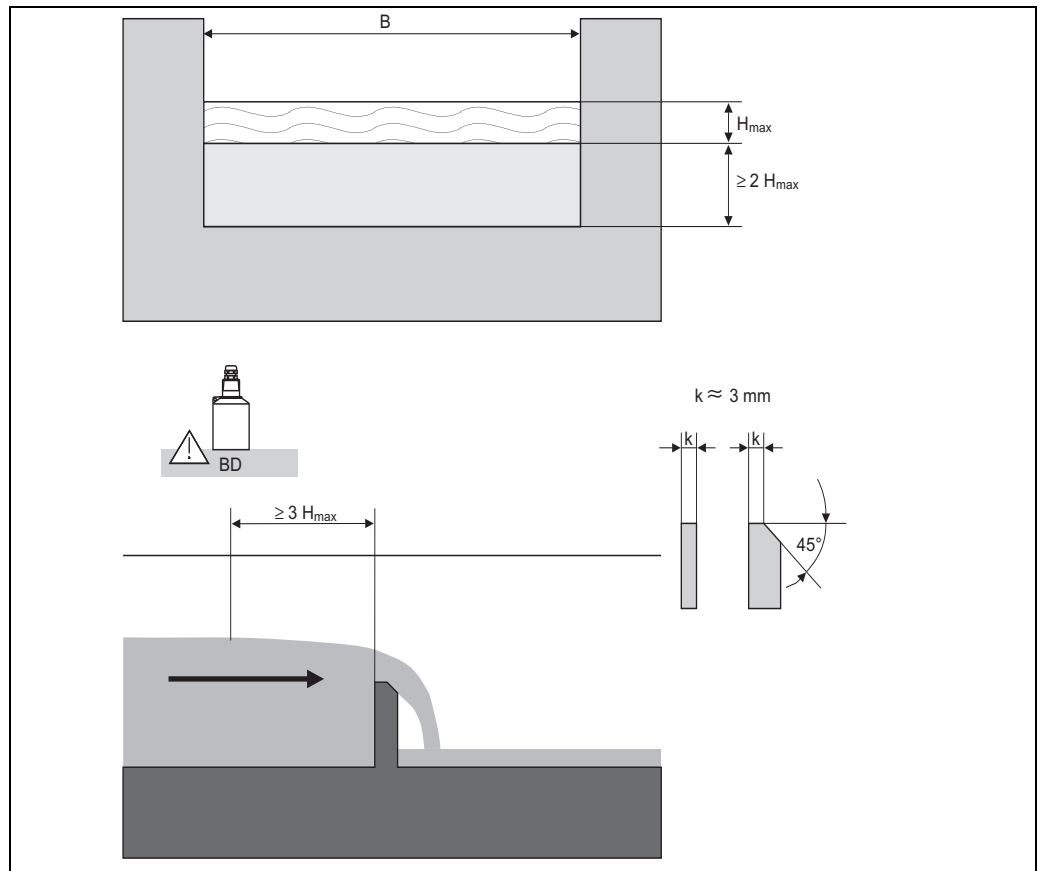

Type of weir	B	H <sub>max</sub>	Q <sub>max</sub> [m <sup>3</sup> /h]
NFX Rect T0/5H	1000 (39.4)	500 (19.7)	2427.3
NFX Rect T0/T5	1000 (39.4)	1500 (59.1)	12582.5

mm (in)



Note!

- In the "width" parameter, the width of the weir can be adjusted. The corresponding change of the flow curve is automatically performed by the Prosonic S.
- After selecting the type of weir, Q<sub>max</sub> can be adjusted to the flow conditions. Q<sub>max</sub> defines the flow at which the output current is 20 mA.

### 15.1.9 Constricted rectangular weirs according to French standard NFX

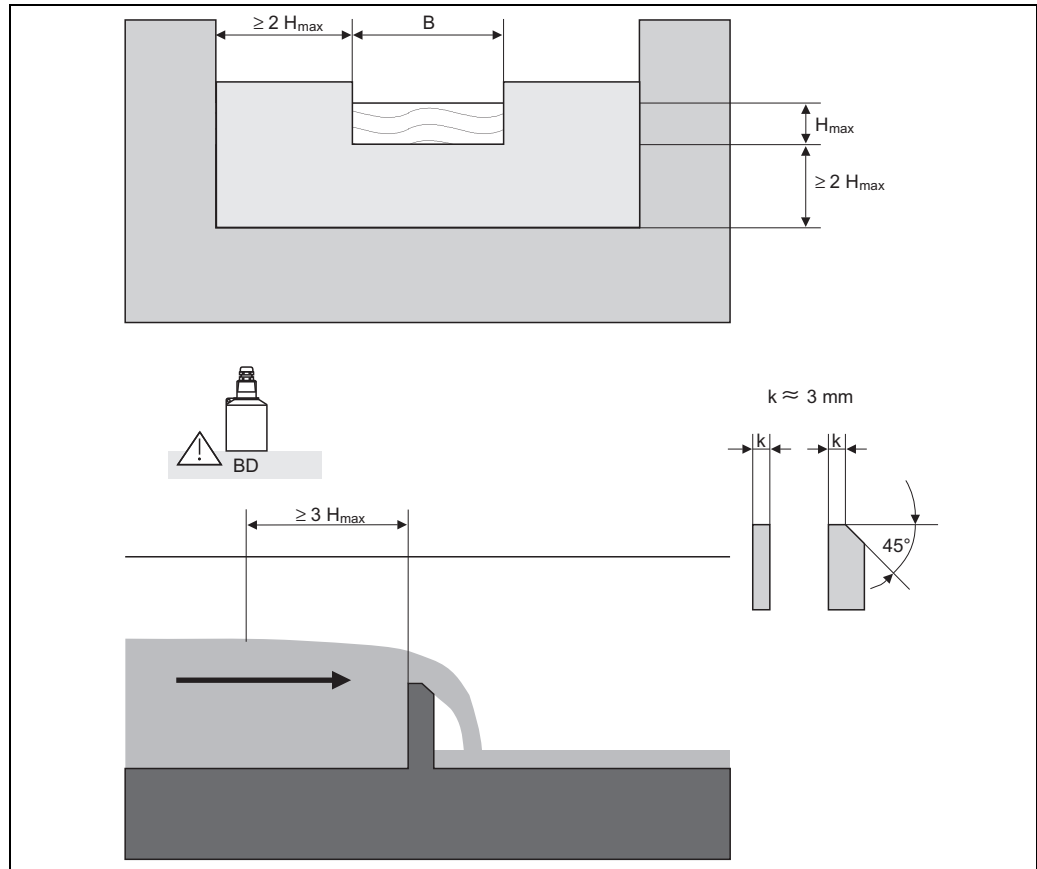

Type of weir	B	H <sub>max</sub>	Q <sub>max</sub> [m <sup>3</sup> /h]
NFX Rect WThr 2H	200 (7.87)	120 (4.72)	53.5
NFX Rect WThr 3H	300 (11.8)	150 (5.91)	111.7
NFX Rect WThr 4H	400 (15.7)	240 (9.45)	299.1
NFX Rect WThr 5H	500 (19.7)	270 (10.6)	445.8
NFX Rect WThr 6H	600 (23.6)	300 (11.8)	626.2
NFX Rect WThr 8H	800 (31.5)	450 (17.7)	1527.8
NFX Rect WThr T0	1000 (39.4)	600 (23.6)	2933.8

mm (in)



Note!

After selecting the type of weir, Q<sub>max</sub> can be adjusted to the flow conditions. Q<sub>max</sub> defines the flow at which the output current is 20 mA.

### 15.1.10 Trapezoidal weirs

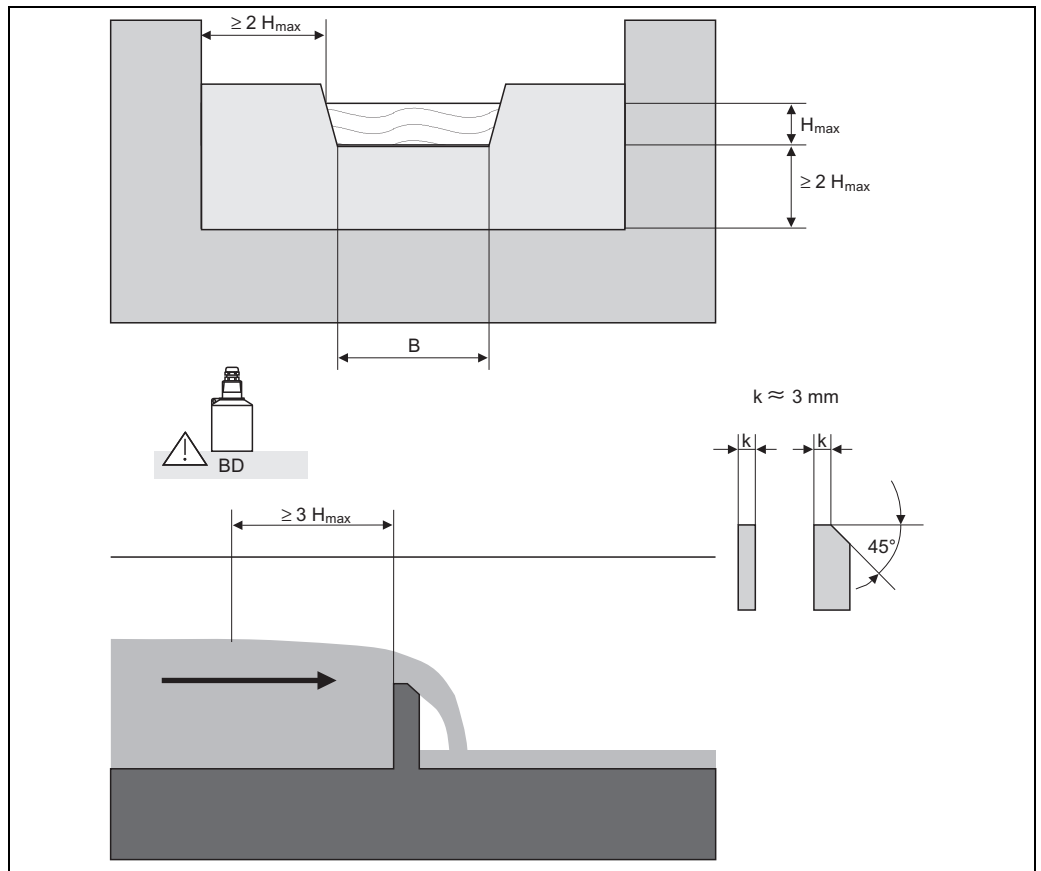

L00-FMU90xxxx-05-00-00-xx-010

Type of weir	B	H <sub>max</sub>	Q <sub>max</sub> [m <sup>3</sup> /h]
Trap.W T0/3H	1000 (39.4)	300 (11.8)	1049
Trap.W T0/T5	1000 (39.4)	1500 (59.1)	11733

mm (in)



Note!

- In the "width" parameter, the width of the weir can be adjusted. The corresponding change of the flow curve is automatically performed by the Prosonic S.
- After selecting the type of weir, Q<sub>max</sub> can be adjusted to the flow conditions. Q<sub>max</sub> defines the flow at which the output current is 20 mA.

## 15.1.11 Triangular weirs

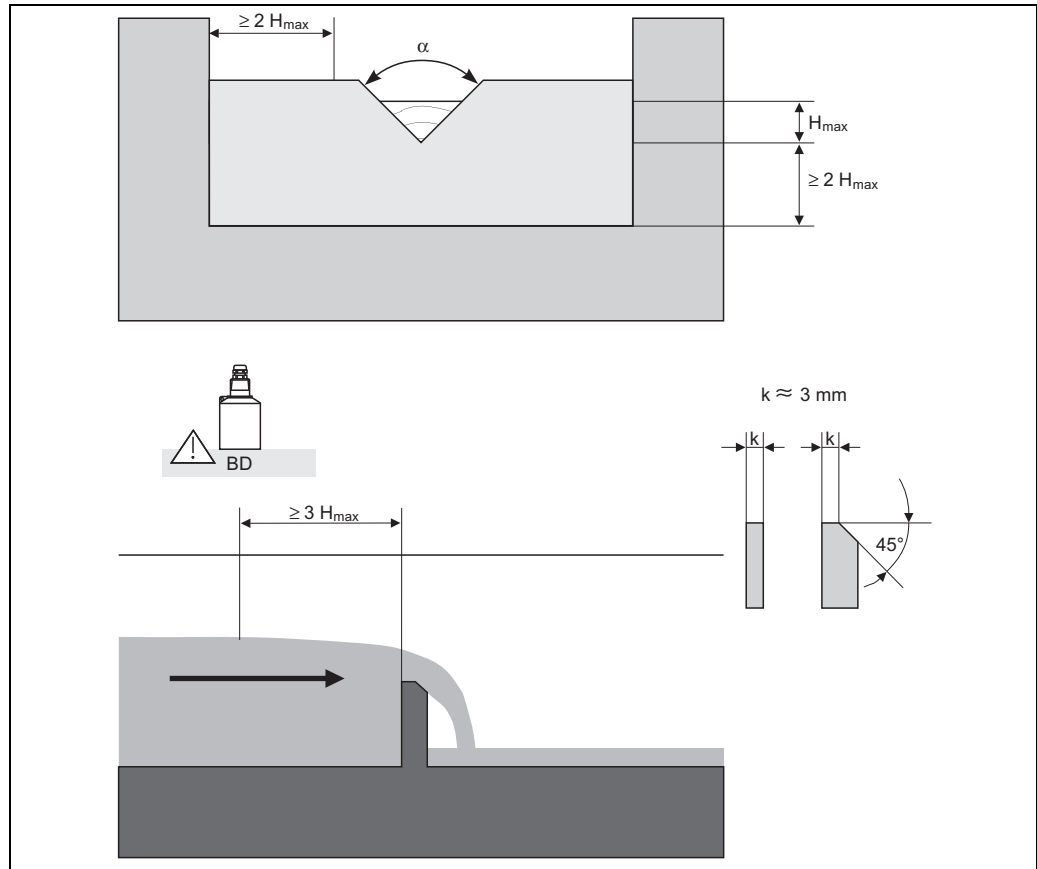

100-FMU90xxx-05-00-00-xx-011

Type of weir	$\alpha$	$H_{\max}$	$Q_{\max}$ [m <sup>3</sup> /h]
V-Weir 22.5	22.5°	600 (23.6)	276.0
V-Weir 30	30°	600 (23.6)	371.2
V-Weir 45	45°	600 (23.6)	574.1
V-Weir 60	60°	600 (23.6)	799.8
V-Weir 90	90°	600 (23.6)	1385

mm (in)



Note!

After selecting the type of weir,  $Q_{\max}$  can be adjusted to the flow conditions.  $Q_{\max}$  defines the flow at which the output current is 20 mA.

### 15.1.12 British standard triangular weirs (BS 3680)

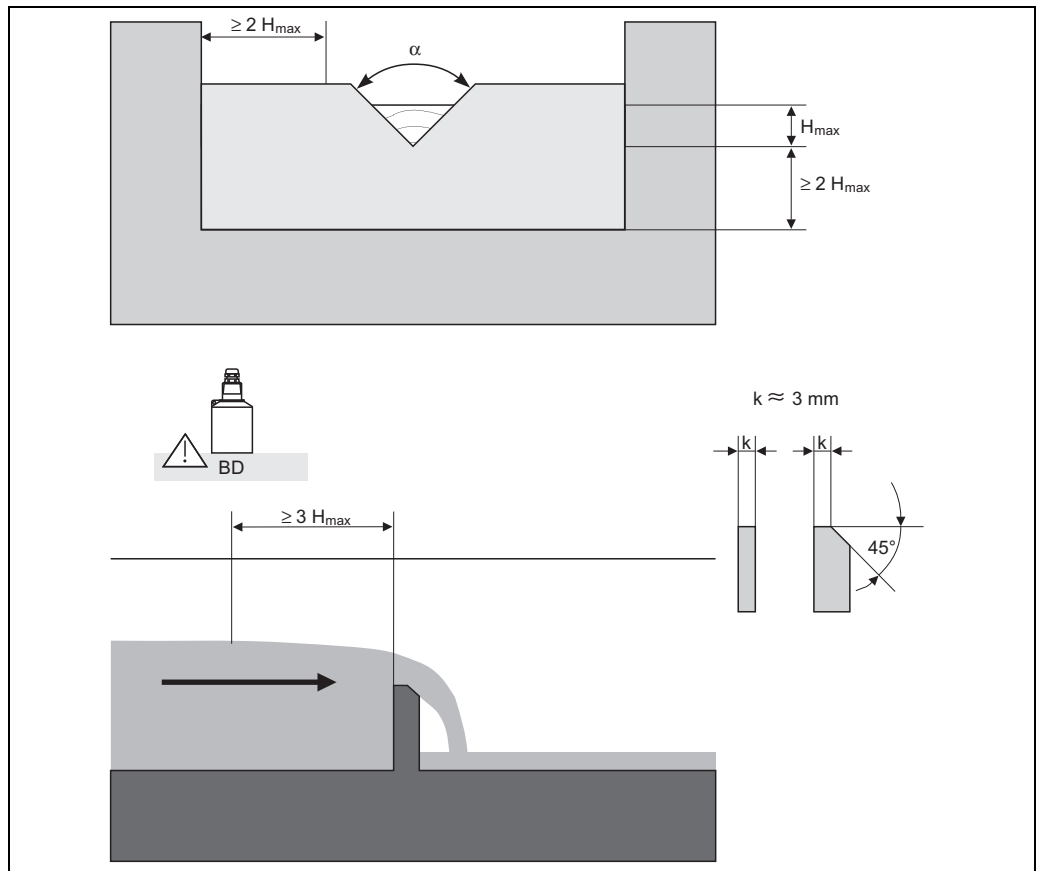

L00-FMU90xxxx-05-00-00-xx-011

Type of weir	$\alpha$	$H_{max}$	$Q_{max}$ [m <sup>3</sup> /h]
BST V-Weir 22.5 (1/4 90°)	1/4 90°	390 (15.4)	120.1
BST V-Weir 45 (1/2 90°)	1/2 90°	390 (15.4)	237.0
BST V-Weir 90	90°	390 (15.4)	473.2

mm (in)



Note!

After selecting the type of weir,  $Q_{max}$  can be adjusted to the flow conditions.  $Q_{max}$  defines the flow at which the output current is 20 mA.

### 15.1.13 Triangular weirs according to the French standard NFX

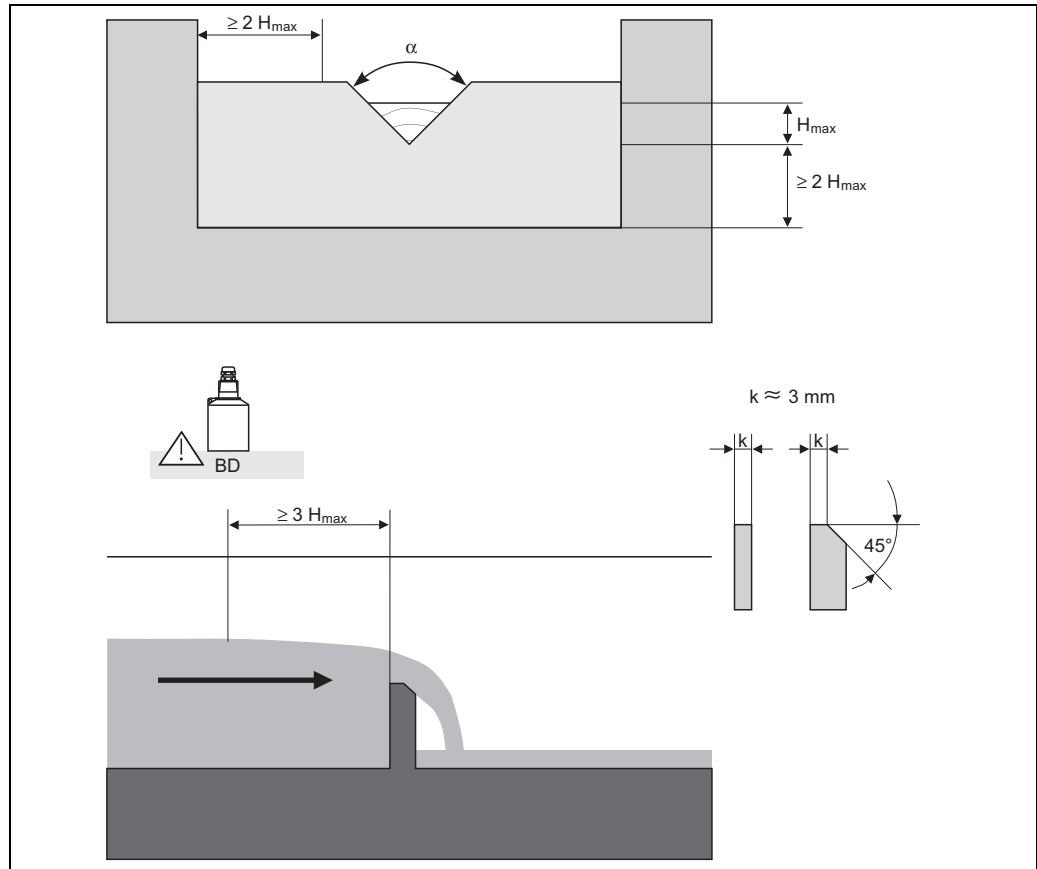

100-FMU90xxx-05-00-00-xx-011

Type of weir	$\alpha$	$H_{\max}$	$Q_{\max}$ [m <sup>3</sup> /h]
NFX V-Weir 30	30°	600 (23.6)	375.9
NFX V-Weir 45	45°	600 (23.6)	573.1
NFX V-Weir 60	60°	600 (23.6)	793.1
NFX V-Weir 90	90°	600 (23.6)	1376.7

mm (in)



Note!

After selecting the type of weir,  $Q_{\max}$  can be adjusted to the flow conditions.  $Q_{\max}$  defines the flow at which the output current is 20 mA.

## 15.2 The formula for flow calculation

If you have selected the "formula" linearization type, the flow calculation is performed according to:

$$Q = C (h^\alpha + \gamma h^\beta)$$

where:

- Q: the flow in m<sup>3</sup>/h
- C: a scaling parameter
- h: the upstream level
- $\alpha, \beta$ : the flow exponents
- $\gamma$ : a weighting constant

Appropriate values of  $\alpha$ ,  $\beta$ ,  $\gamma$  and C for the different types of flumes and weirs can be taken from the following tables.

Khafagi-Venturi flumes					
Type	Q <sub>max</sub> [m <sup>3</sup> /h]	$\alpha$	$\beta$	$\gamma$	C
QV 302	40,09	1,500	2,500	0,0013140	0,0095299
QV 303	104,3	1,500	2,500	0,0004301	0,0238249
QV 304	231,5	1,500	2,500	0,0003225	0,0317665
QV 305	323,0	1,500	2,500	0,0002580	0,0397081
QV 306	414,0	1,500	2,500	0,0002150	0,0476497
QV 308	1024	1,500	2,500	0,0001613	0,0635329
QV 310	1982	1,500	2,500	0,0001290	0,0794162
QV 313	3308	1,500	2,500	0,0000992	0,1032410
QV 316	6181	1,500	2,500	0,0000806	0,1270659

ISO-Venturi flumes					
Type	Q <sub>max</sub> [m <sup>3</sup> /h]	$\alpha$	$\beta$	$\gamma$	C
ISO 415	42,5	1,500	2,100	0,0009336	0,0146865
ISO 425	130,3	1,500	1,600	0,0959719	0,0214406
ISO 430	322,2	1,500	2,000	0,0032155	0,0379104
ISO 440	893,6	1,600	1,700	-0,2582633	0,0590888
ISO 450	1318,9	1,600	1,800	-0,0895791	0,0553654
ISO 480	1862,5	1,600	1,800	-0,0928186	0,0795737

British standard Venturi flumes (BS 3680)					
Type	Q <sub>max</sub> [m <sup>3</sup> /h]	$\alpha$	$\beta$	$\gamma$	C
BST Venturi 4"	36,25	1,500	1,000	0,0000000	0,019732
BST Venturi 7"	90,44	1,500	1,000	0,0000000	0,034532
BST Venturi 12"	371,2	1,500	1,000	0,0000000	0,059201
BST Venturi 18"	925,7	1,500	1,000	0,0000000	0,088021
BST Venturi 30"	3603	1,500	1,000	0,0000000	0,148003

Parshall flumes					
Type	$Q_{\max}$ [m <sup>3</sup> /h]	$\alpha$	$\beta$	$\gamma$	C
Parshall 1"	15,23	1,550	1,000	0,0000000	0,0048651
Parshall 2"	30,46	1,550	1,000	0,0000000	0,0097302
Parshall 3"	203,8	1,547	1,000	0,0000000	0,0144964
Parshall 6"	430,5	1,580	1,000	0,0000000	0,0249795
Parshall 9"	950,5	1,530	1,000	0,0000000	0,0495407
Parshall 1 ft	1704	1,522	1,000	0,0000000	0,0675749
Parshall 1,5 ft	2595	1,538	1,000	0,0000000	0,0924837
Parshall 2 ft	3498	1,550	1,000	0,0000000	0,1151107
Parshall 3 ft	5328	1,566	1,000	0,0000000	0,1575984
Parshall 4 ft	7185	1,578	1,000	0,0000000	0,1962034
Parshall 5 ft	9058	1,587	1,000	0,0000000	0,2329573
Parshall 6 ft	10951	1,595	1,000	0,0000000	0,2670383
Parshall 8 ft	14767	1,607	1,000	0,0000000	0,3324357

Palmer-Bowlus flumes					
Type	$Q_{\max}$ [m <sup>3</sup> /h]	$\alpha$	$\beta$	$\gamma$	C
Palmer-Bowlus 6"	37,94	0,200	2,000	0,01176	0,22063
Palmer-Bowlus 8"	68,62	0,200	2,000	0,00661	0,45306
Palmer-Bowlus 10"	150,55	0,200	2,000	0,00512	0,65826
Palmer-Bowlus 12"	215,83	0,200	2,000	0,0033	1,11787
Palmer-Bowlus 15"	376,97	0,200	2,000	0,00213	1,93489
Palmer-Bowlus 18"	499,86	0,200	2,000	0,00152	2,96269
Palmer-Bowlus 21"	871,05	0,200	2,000	0,00113	4,29769
Palmer-Bowlus 24"	1075,94	0,200	2,000	0,00091	5,73322
Palmer-Bowlus 27"	1625,58	0,200	2,000	0,00073	7,51238
Palmer-Bowlus 30"	2136,47	0,200	2,000	0,00061	9,57225

Rectangular weirs					
Type	$Q_{\max}$ [m <sup>3</sup> /h]	$\alpha$	$\beta$	$\gamma$	C
RectWT0/5H	2418	1,500	1,000	0,0000000	0,21632686
RectWT0/T5	12567	1,500	1,000	0,0000000	0,21632686



Constricted rectangular weirs					
Type	$Q_{max}$ [m <sup>3</sup> /h]	$\alpha$	$\beta$	$\gamma$	C
RectWThr 2H	51,18	1,500	1	0,0000000	0,038931336
RectWThr 3H	108,4	1,500	1	0,0000000	0,059018248
RectWThr 4H	289,5	1,500	1	0,0000000	0,077862671
RectWThr 5H	434,6	1,500	1	0,0000000	0,097949584
RectWThr 6H	613,3	1,500	1	0,0000000	0,118036497
RectWThr 8H	1493	1,500	1	0,0000000	0,156346588
RectWThr T0	2861	1,500	1	0,0000000	0,194656679
RectWThr T5	6061	1,500	1	0,0000000	0,3106200
RectWThr 2T	13352	1,500	1	0,0000000	0,4141600

Rectangular weirs according to French standard NFX					
Type	$Q_{max}$ [m <sup>3</sup> /h]	$\alpha$	$\beta$	$\gamma$	C
NFX Rect T0/5H	2427,3	1,400	2,000	0,0107097	0,2801013
NFX Rect T0/T5	12582,5	1,500	0,000	0,0000000	0,1951248

Constricted rectangular weirs according to French standard NFX					
Type	$Q_{max}$ [m <sup>3</sup> /h]	$\alpha$	$\beta$	$\gamma$	C
NFX RectWThr 2H	53,5	1,500	1,600	-0,1428487	0,0528094
NFX RectWThr 3H	111,7	1,500	1,600	-0,1115842	0,0744722
NFX RectWThr 4H	299,1	1,500	1,600	-0,0975777	0,0966477
NFX RectWThr 5H	445,8	1,500	1,600	-0,0884398	0,1187524
NFX RectWThr 6H	626,2	1,500	1,600	-0,0816976	0,1407481
NFX RectWThr 8H	1527,8	1,500	1,600	-0,0634245	0,1810272
NFX RectWThr T0	2933,8	1,500	1,600	-0,0671398	0,2285268

Trapezoidal weirs					
Type	$Q_{max}$ [m <sup>3</sup> /h]	$\alpha$	$\beta$	$\gamma$	C
Trap.W T0/3H	1049	1,500	1,000	0,0000000	0,2067454
Trap.W T0/T5	11733	1,500	1,000	0,0000000	0,2067454

Triangular weirs					
Type	$Q_{max}$ [m <sup>3</sup> /h]	$\alpha$	$\beta$	$\gamma$	C
V-Weir 22,5	276,0	2,500	1,000	0,0000000	0,0000313
V-Weir 30	371,2	2,500	1,000	0,0000000	0,0000421
V-Weir 45	574,1	2,500	1,000	0,0000000	0,0000651
V-Weir 60	799,8	2,500	1,000	0,0000000	0,0000907
V-Weir 90	1385	2,500	1,000	0,0000000	0,0001571

British standard triangular weirs (BS 3680)					
Type	$Q_{\max}$ [m <sup>3</sup> /h]	$\alpha$	$\beta$	$\gamma$	C
BST V-Weir 22,5	120,1	2,314	2,649,000	0,1430720	0,0000590
BST -Weir 45	237,3	2,340	2,610	0,2659230	0,0000880
BST V-Weir 90	473,2	2,314	2,650	0,1904230	0,0001980

Triangular weirs according to French standard NFX					
Type	$Q_{\max}$ [m <sup>3</sup> /h]	$\alpha$	$\beta$	$\gamma$	C
NFX V-Weir 30	375,9	2,400	2,800	0,0241095	0,0000616
NFX V-Weir 45	573,1	2,476	0,000	0,0000000	0,0000757
NFX V-Weir 60	793,1	2,486	0,000	0,0000000	0,0000983
NFX V-Weir 90	1376,7	2,491	0,000	0,0000000	0,0001653

### 15.3 Default block configuration

The default block configuration depends on the instrument version and the selected operating mode:

#### 15.3.1 Operating mode = "level"

**1 sensor input / 1 current output**  
(FMU90 - \*\*\*\*\*1\*1\*\*\*\*)

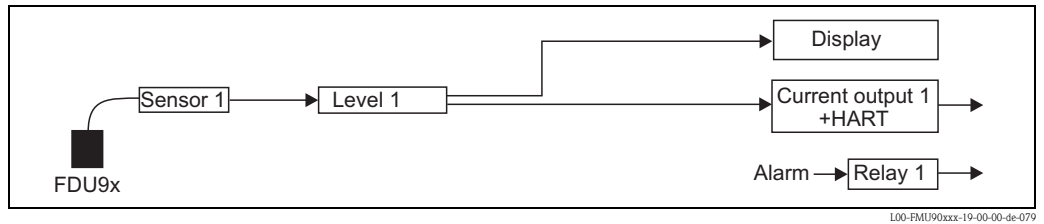

**1 sensor input / 2 current outputs**  
(FMU90 - \*\*\*\*\*1\*2\*\*\*\*)

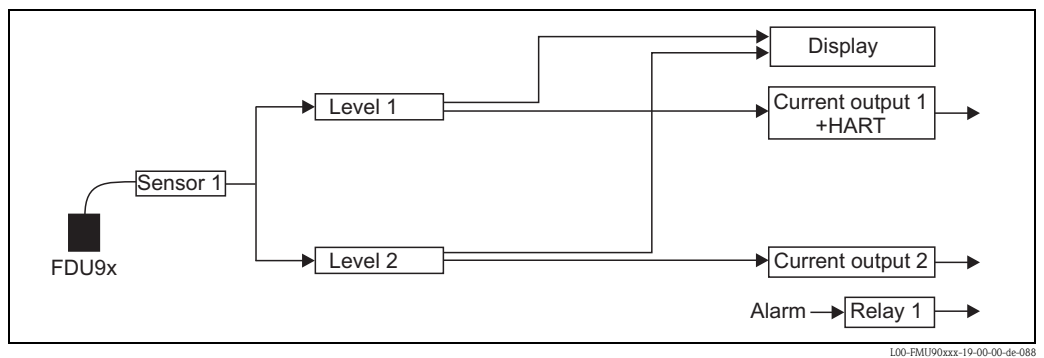

**2 sensor inputs / 2 current outputs**  
(FMU90 - \*\*\*\*\*2\*2\*\*\*\*)

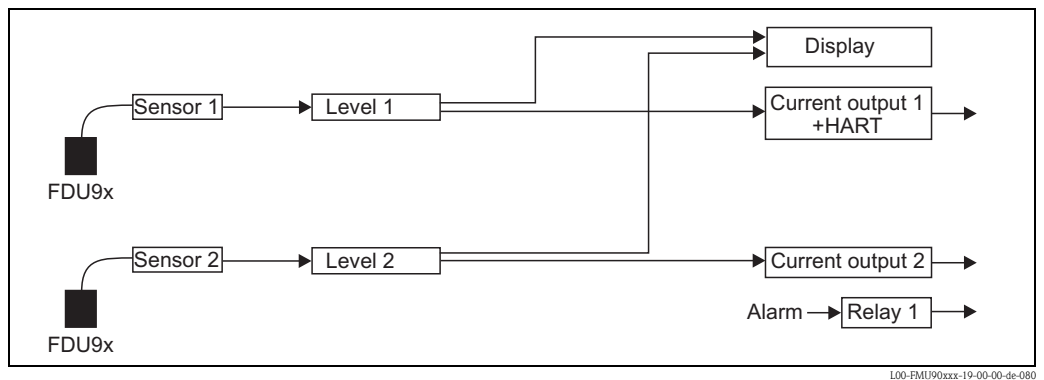

### 15.3.2 Operating mode = "level + flow"

1 sensor input / 2 current outputs  
(FMU90 - \*\*\*\*\*1\*2\*\*\*\*\*)

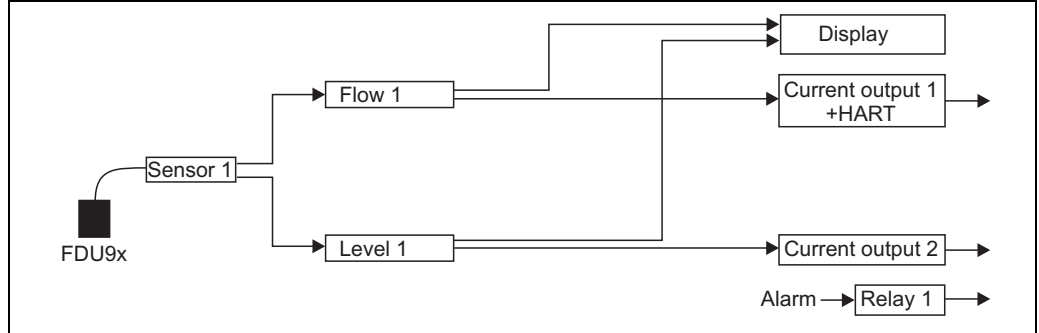

2 sensor inputs / 2 current outputs  
(FMU90 - \*\*\*\*\*2\*2\*\*\*\*\*)

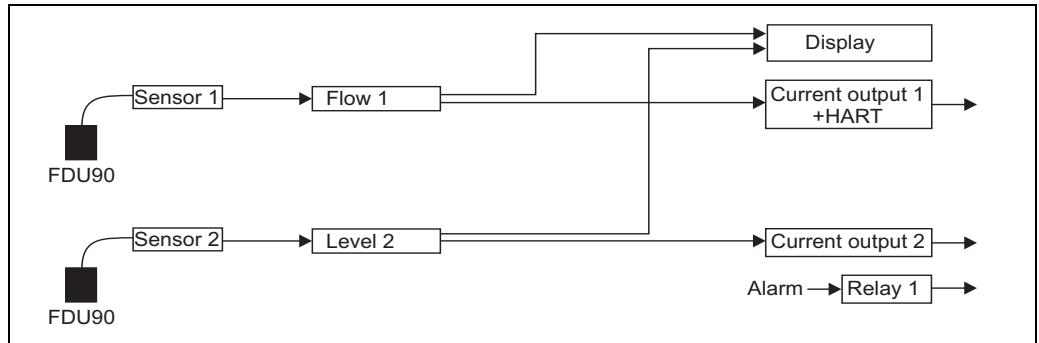

### 15.3.3 Operating mode = "flow"

1 sensor input / 1 current output  
(FMU90 - \*\*\*\*\*1\*1\*\*\*\*\*)

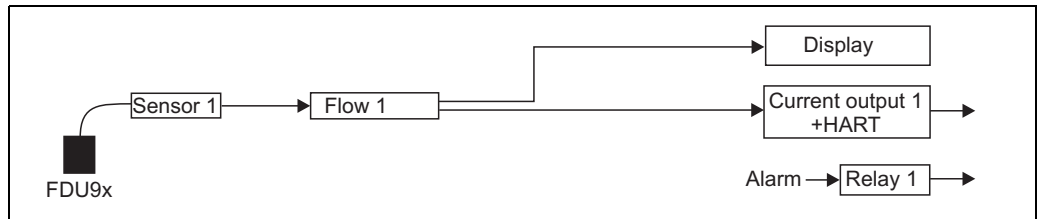

**1 sensor input / 2 current outputs**  
**(FMU90 - \*\*\*\*\*1\*2\*\*\*\*\*)**

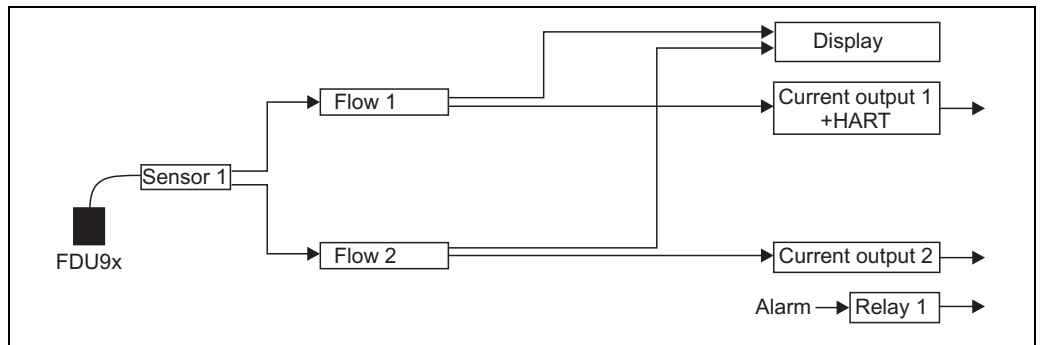

**2 sensor inputs / 2 current outputs**  
**(FMU90 - \*\*\*\*\*2\*2\*\*\*\*\*)**

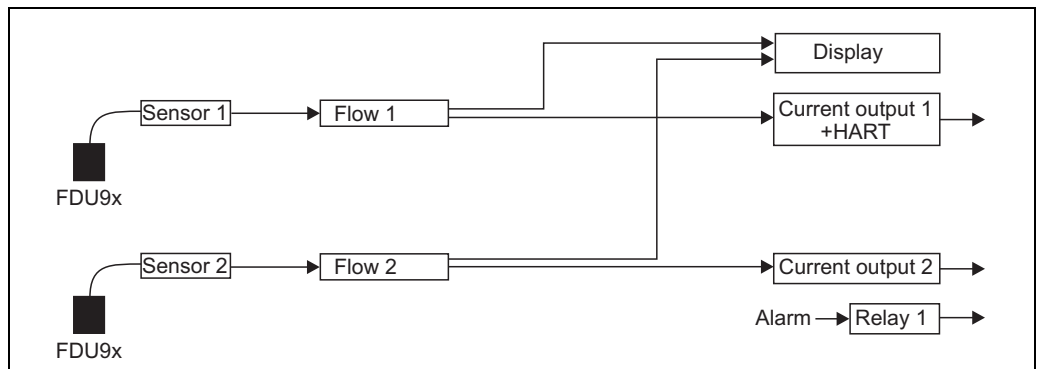

**15.3.4 Operating mode = "flow + backwater"**

**2 sensor inputs / 2 current outputs**

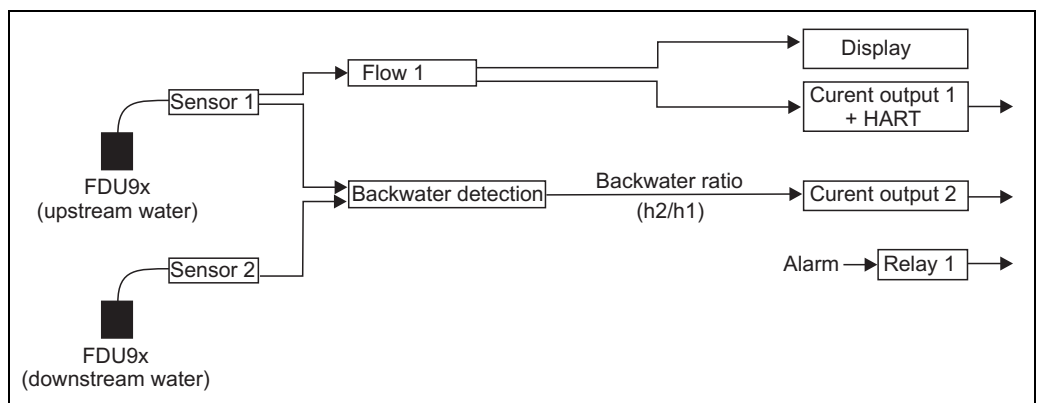

# Index

## Symbols

"additional HART value 2/3/4"	99
"allocation current N" (N = 1 or 2)	94
"back to home"	77
"backwater detection"	66
"backwater"	67
"daily counter N" (N = 1 - 3)	70-73
"dirt detection"	67
"display format"	76
"display"	75
"flow N check value" (N = 1 or 2)	61
"flow N empty calibration" (N = 1 or 2)	59
"flow N linearization" (N = 1 or 2)	57
"flow N mapping" (N = 1 or 2)	62
"flow N sensor selection" (N = 1 or 2)	56
"flow N state" (N = 1 or 2)	63
"flow N" (N = 1 or 2)	60
"HART settings"	98
"mode current M" (N = 1 or 2)	95
"relay allocation"	79, 83, 86, 88
"relay N" (N = 1 - 6) (alarm/diagnostics)	84-85
"relay N" (N = 1 - 6) (counting pulse)	89-90, 92
"relay N" (N = 1 - 6) (limit)	79-80, 82
"relay N" (N = 1 - 6) (time pulse)	86-87
"simulation"	100
"totalizer N" (N = 1 - 3)	70-72
"type"	75
"value 1" ... "value 6"	76

## A

Adaption plate for remote display	115
Adaption plate for remote display module	17
Ambient conditions	123
Auxiliary energy	122

## B

Backwater detection	64
Basic setup (flow)	54
Block configuration (Default)	155

## C

Cable entries	18
Calibration errors	105
CE mark	10
cleaning	110
Commubox	113
Commubox FXA291	113

## D

declaration of conformity	10
DIN-rail housing	7, 13
Dirt detection	64
Display and operating module	34

## E

Envelope curve	106
Error codes	102

Error signal	101
Extension cable for sensors	118

## F

field housing	7, 11
Field Xpert SFX100	47
FieldCare	47
First setup	52
Flow curves	137
Formula for flow calculation	151
Function blocks	50
FXA291	113

## H

HART settings	98
---------------	----

## I

Incoming acceptance	11
Input	120
Interference echo suppression (flow)	61
ISO-Venturi flumes	139

## K

Khafagt-Venturi flumes	137
------------------------	-----

## L

Locking	47
---------	----

## M

Mechanical construction	124
Mounting bracket	114
Mounting plate for the field housing	113

## N

Nameplate	8
-----------	---

## O

Operating menu (navigation)	39
Operational safety	5
Output	121
Overvoltage protection	115

## P

Palmer-Bowlus flumes	142
Parshall flumes	141
Performance characteristics	122
Potential equalization	32
process safety	5
Product structure	9
Produktstruktur	118
Protection cover for field housing	113

## R

Rectangular weirs	143
Rectangular weirs (constricted)	144
Rectangular weirs (NFX, constricted)	146
Rectangular weirs (NFX)	145
Relay (alarm/diagnostic)	83

Relay (counting pulse) . . . . .	88
Relay (limit) . . . . .	78
Relay (time pulse) . . . . .	86
remote display and operating module . . . . .	8, 16
repairs to Ex-approved devices . . . . .	110
Reset to default configuration . . . . .	49

## S

Safety conventions and symbols . . . . .	6
Safety Instructions . . . . .	5
Scope of delivery . . . . .	10
Sensor cable extension . . . . .	24
Sensor cable shortening . . . . .	29
Sensor connection . . . . .	23
Sensor heater . . . . .	25
Sensor mounting . . . . .	17
separate display and operating module . . . . .	31
Simulation . . . . .	100
Software history . . . . .	109
Spare Parts . . . . .	111
Storage . . . . .	11
Synchronization line . . . . .	30

## T

Terminal assignment . . . . .	20
Trademarks . . . . .	10
Transport . . . . .	11
Trapezoidal weirs . . . . .	147
Triangular weirs . . . . .	148
Triangular weirs (British Standard) . . . . .	149
Triangular weirs (NFX) . . . . .	150

## V

Venturi flumes (British Standard) . . . . .	140
---	-----

## W

Wiring . . . . .	18
------------------	----

[www.endress.com/worldwide](http://www.endress.com/worldwide)

---

**Endress+Hauser**   
People for Process Automation

---

