



HY13-1512-006-M1/US

# Torqmotor™ Service Procedure

Effective: March 2007

---



TC, TS, TB, TE, TJ, TF,  
TG, TH and TL Series  
Low Speed, High Torque  
Hydraulic Torqmotors™

---

**WARNING**

FAILURE OR IMPROPER SELECTION OR IMPROPER USE OF THE PRODUCTS AND/OR SYSTEMS DESCRIBED HEREIN OR RELATED ITEMS CAN CAUSE DEATH, PERSONAL INJURY AND PROPERTY DAMAGE.

This document and other information from Parker Hannifin Corporation, its subsidiaries and authorized distributors provide product and/or system options for further investigation by users having technical expertise. It is important that you analyze all aspects of your application and review the information concerning the product or system in the current product catalog. Due to the variety of operating conditions and applications for these products or systems, the user, through its own analysis and testing, is solely responsible for making the final selection of the products and systems and assuring that all performance, safety and warning requirements of the application are met.

The products described herein, including without limitation, product features, specifications, designs, availability and pricing, are subject to change by Parker Hannifin Corporation and its subsidiaries at any time without notice.

**Offer of Sale**

The items described in this document are hereby offered for sale by Parker Hannifin Corporation, its subsidiaries or its authorized distributors. This offer and its acceptance are governed by the provisions stated in the "Offer of Sale".

© Copyright 2007, 2006, 2005, 2000, 1999, Parker Hannifin Corporation, All Rights Reserved

**Table of Contents**

Definitions..... 3  
 Design Features ..... 4 - 5  
 Introduction ..... 7  
 Troubleshooting Guide ..... 8  
 Troubleshooting Checklist ..... 9  
 Tools and Material Required for Servicing..... 10  
 Bolt Torque ..... 11  
 Exploded Assembly View ..... 12-14  
 TC Service Parts List Chart ..... 15-16  
 TS Service Parts List Chart ..... 17  
 TB Service Parts List Chart ..... 18-19  
 TE Service Parts List Chart ..... 20-21  
 TJ Service Parts List Chart..... 22  
 TF Service Parts List Chart..... 23-24  
 TG Service Parts List Chart ..... 25-26  
 TH Service Parts List Chart ..... 27-28  
 TL Service Parts List Chart..... 29  
 Disassembly & Inspection ..... 30-37  
 Torqmotor™ Assembly..... 38-47  
 Rotor Set Component Assembly Procedure (One Piece Stator)..... 48  
 Rotor Set Component Assembly Procedure (Two Piece Stator) ..... 49-50  
 Final Checks..... 51  
 Hydraulic Fluids, Filtration, Oil Temperature ..... 51  
 Tips for Maintaining the System..... 52  
 Offer of Sale ..... Inside Back Cover

**Definitions**

- NOTE:** A NOTE provides key information to make a procedure easier or quicker to complete.  
**CAUTION:** A CAUTION refers to procedure that must be followed to avoid damaging the Torqmotor™ or other system components.  
**WARNING:** A WARNING REFERS TO PROCEDURE THAT MUST BE FOLLOWED FOR THE SAFETY OF THE EQUIPMENT OPERATOR AND THE PERSON INSPECTING OR REPAIRING THE TORQMOTOR™.

**Disclaimer**

This Service Manual has been prepared by Parker Hannifin for reference and use by mechanics who have been trained to repair and service hydraulic motors and systems on commercial and non-commercial equipment applications. Parker Hannifin has exercised reasonable care and diligence to present accurate, clear and complete information and instructions regarding the techniques and tools required for maintaining, repairing and servicing the complete line of Parker TC, TS, TB, TE, TJ, TF, TG, TH and TL Torqmotor™ Units. However, despite the care and effort taken in preparing this general Service Manual, Parker **makes no warranties** that (a) the Service Manual or any explanations, illustrations, information, techniques or tools described herein are either accurate, complete or correct as applied to a specific Torqmotor™ unit, or (b) any repairs or service of a particular Torqmotor™ unit will result in a properly functioning Torqmotor™ unit.

If inspection or testing reveals evidence of abnormal wear or damage to the Torqmotor™ unit or if you encounter circumstances not covered in the Manual, STOP – CONSULT THE EQUIPMENT MANUFACTURER’S SERVICE MANUAL AND WARRANTY. DO NOT TRY TO REPAIR OR SERVICE A TORQMOTOR™ UNIT WHICH HAS BEEN DAMAGED OR INCLUDES ANY PART THAT SHOWS EXCESSIVE WEAR UNLESS THE DAMAGED AND WORN PARTS ARE REPLACED WITH ORIGINAL PARKER REPLACEMENT AND SERVICE PARTS AND THE UNIT IS RESTORED TO PARKER SPECIFICATIONS FOR THE TORQMOTOR™ UNIT.

It is the responsibility of the mechanic performing the maintenance, repairs or service on a particular Torqmotor™ unit to (a) inspect the unit for abnormal wear and damage, (b) choose a repair procedure which will not endanger his/her safety, the safety of others, the equipment, or the safe operation of the Torqmotor™, and (c) fully inspect and test the Torqmotor™ unit and the hydraulic system to insure that the repair or service of the Torqmotor™ unit has been properly performed and that the Torqmotor™ and hydraulic system will function properly.



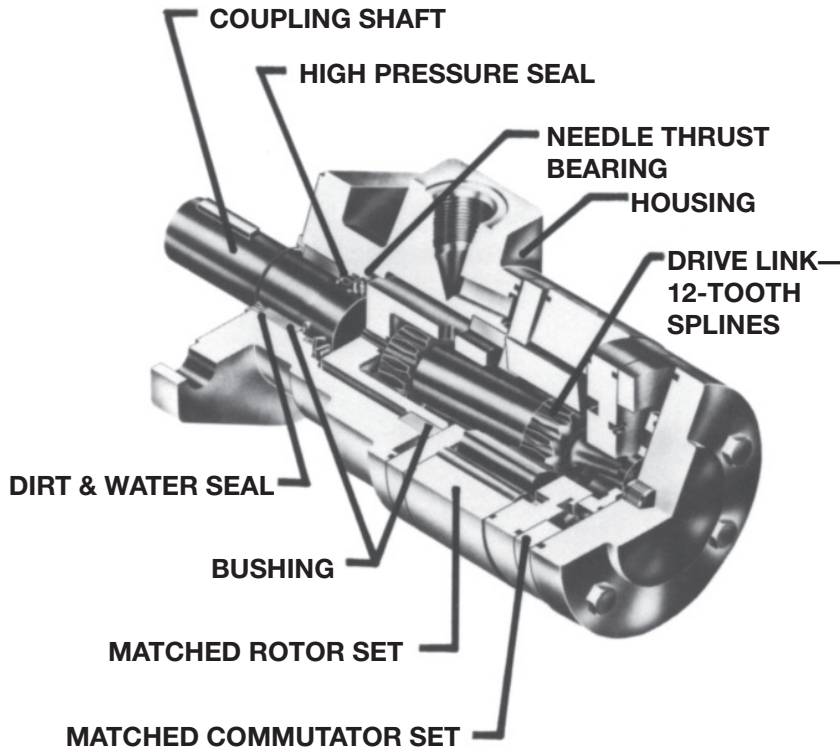

**Torqmotor™ TB/TC Series features include:**

- The roller vane rotor set design offers a low-friction, wear compensation which maximizes the useful performance life of the motor.
- Zero leak **commutation valve provides greater, more consistent volumetric efficiency.**
- Design flexibility - TB offers the widest selection of shaft options, displacements and mounting flanges in the industry.
- Patented 60-40 spline member arrangement transmits more torque with less weight.
- Full flow lubrication maximizes cooling and may provide up to 50% longer life than motors not having this feature.
- Higher pressure rating provide greater torque than competitive brands.
- Full interchangeability with other motors which are designed according to industry standards.
- Compatible with most hydraulic systems with regard to pressure, torque and speed.
- A unique high-pressure shaft seal that eliminates the need for case drains.
- Up to 13 horsepower output.

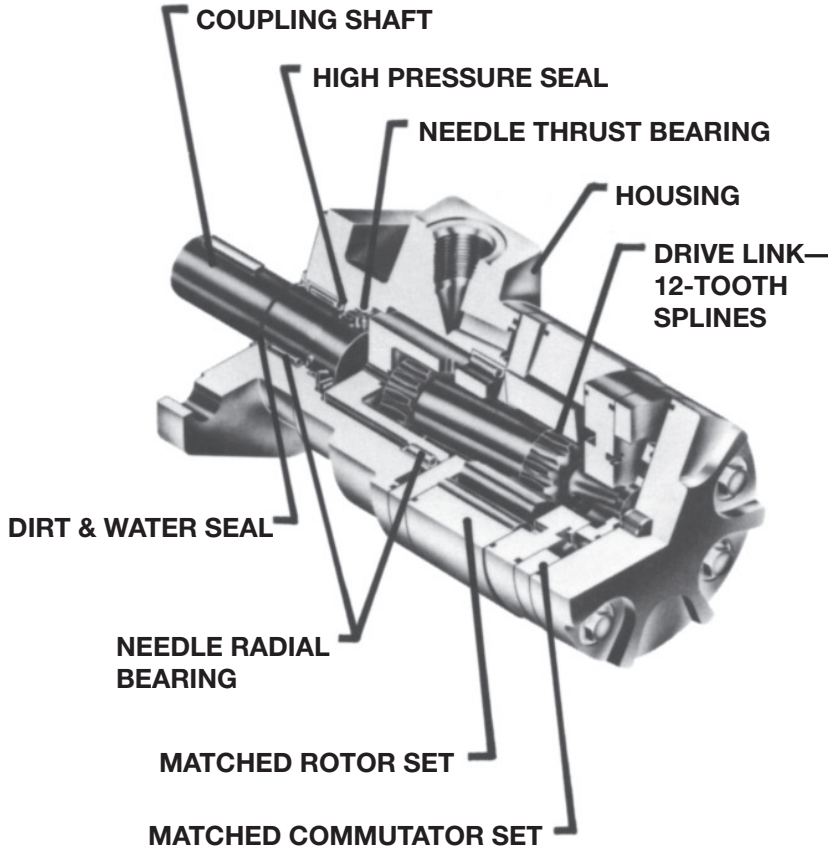

**Torqmotor™ TE Series features include:**

- Roller vanes to reduce friction and internal leakage and to maintain efficiency.
- Zero leak **commutation valve provides greater, more consistent volumetric efficiency.**
- Wheel mount version available.
- More starting torque than competitive motors in applications where the shaft is side loaded. (Competitive brands require more pressure to start the motor.)
- A needle-roller mounted coupling shaft and steel-caged thrust bearing which can withstand 1000-pound thrust loads.
- Side load capacity is 1600 lbs. (727.3 kg) maximum at center of output shaft.
- A unique high-pressure shaft seal that eliminates the need for case drains, check valves and extra plumbing.
- Up to 17 horsepower output.
- Greater durability due to superior lubrication and minimum drive spline wear.
- Patented 60-40 spline member arrangement transmits more torque with less weight.

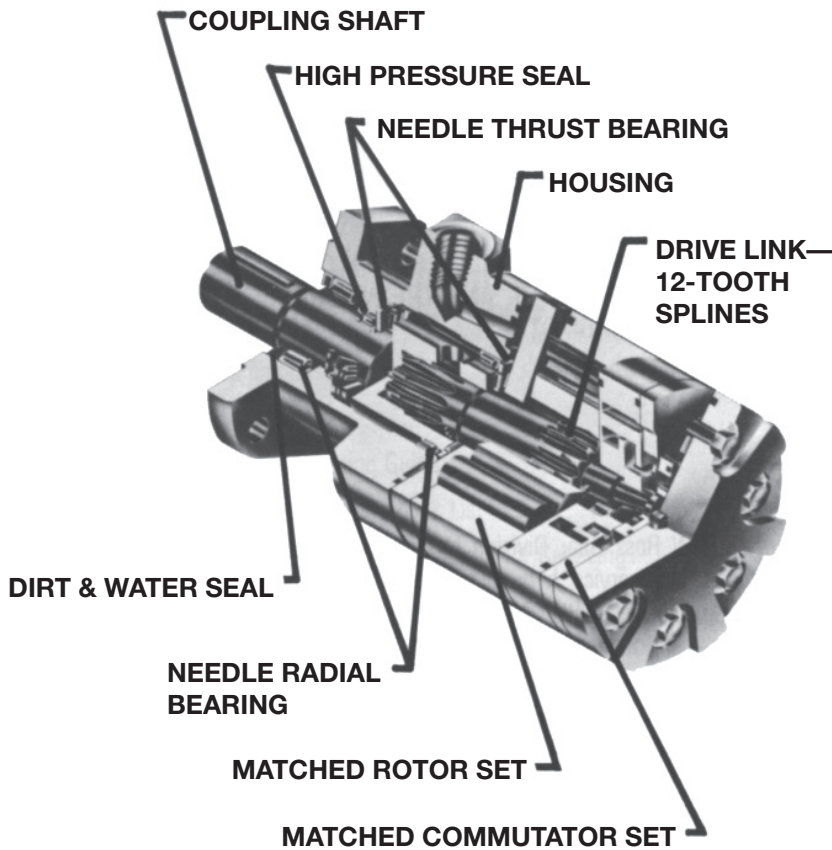

- Torqmotor™ TF Series features include:**
- Heavy-duty thrust and roller bearings for up to twice side-load capacity to the previous motor.
  - Roller vanes to reduce friction and internal leakage, and to maintain efficiency.
  - A patented orbiting commutation system for less wear and longer life.
  - A patented 60:40 arrangement of internal and external spline members to transmit more torque with less weight.
  - A unique high-pressure shaft seal that eliminates the need for case drains, check valves and extra plumbing.
  - A unique manifold designed to improve operating efficiency.
  - Up to 1000 lbs. (453.6 kg) end-thrust capacity in either direction.
  - A design that is less sensitive to contamination than competitive motors.
  - Up to 36 horsepower output.
  - Greater durability because of superior lubrication and minimum drive spline wear.
  - Superior low speed performance.
  - Zero leak **commutation valve provides greater, more consistent volumetric efficiency.**

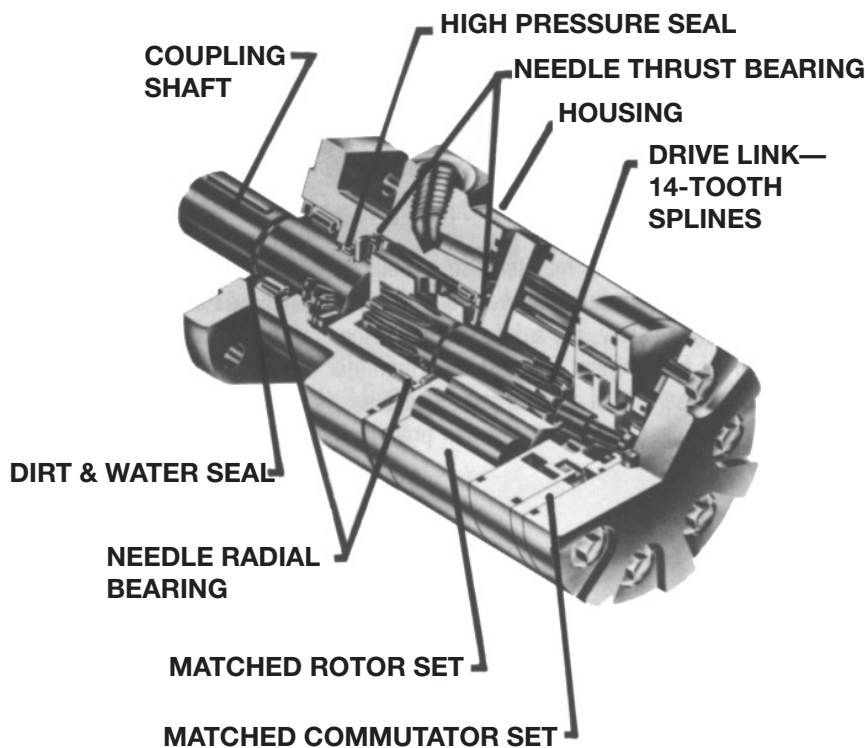

- Torqmotor™ TG/ TH/TL Series features include:**
- Roller vanes to reduce friction and internal leakage and to maintain efficiency.
  - A patented orbiting commutation system for less wear and longer life.
  - A patented 60:40 arrangement of internal and external spline members to transmit more torque with less weight.
  - A unique high-pressure shaft seal that eliminates the need for case drains, check valves and extra plumbing.
  - A manifold designed to improve operating efficiency.
  - Heavy-duty thrust and roller bearings for up to twice the side-load capacity to the previous motor.
  - Up to 1000 lbs. (453.6 kg) end-thrust capacity in either direction.
  - A design that is less sensitive to contamination than competitive motors.
  - Up to 49 horsepower output.
  - Greater durability because of superior lubrication and minimum drive spline wear.
  - Zero leak **commutation valve provides greater, more consistent volumetric efficiency.**

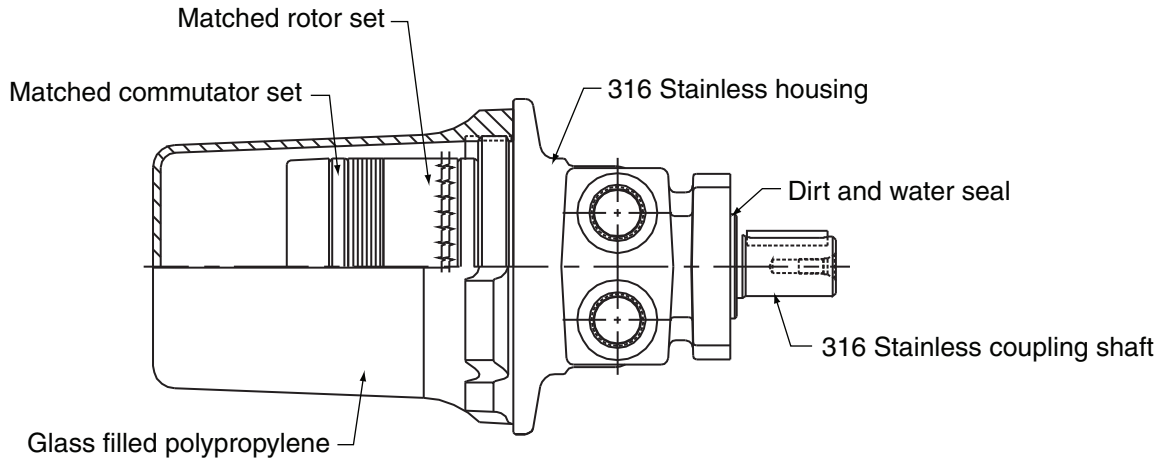

### Torqmotor™ TS Series features include:

- The roller vane rotor set design offers a low-friction, wear compensation which maximizes the useful performance life of the motor.
- Zero leak commutation valve provides greater, more consistent volumetric efficiency.
- Design flexibility—TS offers the 316 stainless steel housing and shaft with a one-size-fits-all displacements polypropylene cover.
- Patented 60-40 spline member arrangement transmits more torque with less weight.
- Full flow lubrication maximizes cooling and may provide up to 50% longer life than motors not having this feature.
- Higher pressure rating provides greater torque than competitive brands.
- Full interchangeability with other motors which are designed according to industry standards.
- Compatible with most hydraulic systems with regard to pressure, torque and speed.
- A unique high-pressure shaft weal that eliminates the need for case drains.
- Up to 13 horsepower output.

This service manual has one purpose: to guide you in maintaining, troubleshooting, and servicing the TC, TS, TB, TE, TJ, TF, TG, TH and TL Torqmotor™ (low-speed, high-torque hydraulic motor).

Material in this manual is organized so you can work on the Torqmotor™ and get results without wasting time or being confused. To get these results, you should read this entire manual before you begin any work on the Torqmotor™.

This manual also contains troubleshooting information and checklist. If you must service the Torqmotor™, the checklist will help you to determine where the problem may be.

The three-column format of the Disassembly and Inspection, and Assembly sections will make it easier for you to conduct major work on the Torqmotor™. Column 1 gives a brief key for each procedure. Column 2 explains in detail the procedure you should follow. Column 3 illustrates this procedure with photographs. Read all material carefully and pay special attention to the notes, cautions, and warnings.

A page with the Torqmotor™ exploded assembly view is provided several places in this manual. The component part names and item numbers assigned on this exploded assembly view correspond with names and item numbers (in parentheses) used in the disassembly and assembly procedures set forth in this manual. Service part list charts are also provided in this manual with the part names and exploded view item numbers cross referenced to Parker service part numbers.

Service parts are available through the Original Equipment Manufacturer or Parker approved TC, TS, TB, TE, TJ, TF, TG, TH and TL Distributors.

As you gain experience in servicing the Torqmotor™, you may find that some information in this manual could be clearer or more complete. If so, let us know about it. Do not try to second guess the manual. If you are stuck, contact us. Servicing the Torqmotor™ should be a safe and productive procedure, in order for the unit to deliver the reliable, long-life operation engineered into it.

NOTE: Before troubleshooting any system problem, check service literature published by the equipment and/or component manufacturers. Follow their instructions, if given, for checking any component other than the Torqmotor™ unit.

## Preparation

Make your troubleshooting easier by preparing as follows:

- work in a clean, well-lighted place;
- have proper tools and materials nearby;
- have an adequate supply of clean petroleum-based solvent.

WARNING: SINCE SOLVENTS ARE FLAMMABLE, BE EXTREMELY CAREFUL WHEN USING ANY SOLVENT, EVEN A SMALL EXPLOSION OR FIRE COULD CAUSE INJURY OR DEATH.

WARNING: WEAR EYE PROTECTION AND BE SURE TO COMPLY WITH OSHA AND OTHER MAXIMUM AIR PRESSURE REQUIREMENTS.

## Preliminary Checks

Hydraulic systems are often trouble-free. Hence, the problem an operator complains of could be caused by something other than the hydraulic components.

Thus, once you have determined that a problem exists, start with the easy-to-check items, such as:

- parts damaged from impact that were not properly repaired, or that should have been replaced; and
- improper replacement parts used in previous servicing
- mechanical linkage problems such as binding, broken, or loose parts or slipping belts

## Hydraulic Components

If you think the problem is caused by a hydraulic component, start by checking the easy-to-reach items.

Check all hoses and lines for cracks, hardening, or other signs of wear. Reroute any usable hoses that are kinked, severely bent, or that rest against hot engine parts. Look for leaks, especially at couplings and fittings. Replace any hoses or lines that don't meet system flow and pressure ratings.

Next, go to the reservoir and filter or filters. Check fluid level and look for air bubbles. Check the filter(s). A filter with a maximum 50 micron filtration is recommended for the Torqmotor™ system.

Visually check other components to see if they are loosely mounted, show signs of leaks, or other damage or wear.

Excessive heat in a hydraulic system can create problems that can easily be overlooked. Every system has its limitation for the maximum amount of temperature. After the temperature is attained and passed, the following can occur:

- oil seal leaks
- loss of efficiency such as speed and torque
- pump loss of efficiency
- pump failure
- hoses become hard and brittle
- hose failure

A normal temperature range means an efficient hydraulic system. Consult the manuals published by equipment and/or component manufacturers for maximum allowable temperature and hydraulic tests that may be necessary to run on the performance of the hydraulic components. The Torqmotor™ is not recommended for hydraulic systems with maximum temperatures above 200°F (93.3°C).



| Trouble   | Cause  | Remedy   |
|---|--|--|
| <b>Oil Leakage</b>  | 1. Hose fittings loose, worn or damaged.   | Check & replace damaged fittings or “O” Rings. Torque to manufacturers specifications.   |
|   | 2. Oil seal rings (4) deteriorated by excess heat.                                     | Replace oil seal rings by disassembling Torqmotor™ unit.   |
|   | 3. Special bolt (1, 1A, 1B or 1C) loose or its sealing area deteriorated by corrosion. | (a) Loosen then tighten single bolt to torque specification.<br>(b) Replace bolt.  |
|   | 4. Internal shaft seal (16) worn or damaged.   | Replace seal. Disassembly of Torqmotor™ unit necessary.  |
|   | 5. Worn coupling shaft (12) and internal seal (16).                                    | Replace coupling shaft and seal by disassembling Torqmotor™ unit.  |
| <b>Significant loss of speed under load</b>   | 1. Lack of sufficient oil supply   | (a) Check for faulty relief valve and adjust or replace as required.<br>(b) Check for and repair worn pump.<br>(c) Check for and use correct oil for temperature of operation. |
|   | 2. High internal motor leakage   | Replace worn rotor set by disassembling Torqmotor™ unit.   |
|   | 3. Severely worn or damaged internal splines.  | Replace rotor set, drive link and coupling shaft by disassembling Torqmotor™ unit.   |
|   | 4. Excessive heat.   | Locate excessive heat source (usually a restriction) in the system and correct the condition.  |
| <b>Low mechanical efficiency or undue high pressure required to operate Torqmotor™ unit</b> | 1. Line blockage   | Locate blockage source and repair or replace.  |
|   | 2. Internal interference   | Disassemble Torqmotor™ unit, identify and remedy cause and repair, replacing parts as necessary.   |
|   | 3. Lack of pumping pressure  | Check for and repair worn pump.  |
|   | 4. Excessive binding or loading in system external to Torqmotor™ unit.                 | Locate source and eliminate cause.   |

**CAUTION: If the hydraulic system fluid becomes overheated [in excess of 200°F (93.3°C)], seals in the system can shrink, harden or crack, thus losing their sealing ability.**

- Clean, petroleum-based solvent
- Emery paper
- Vise with soft jaws
- Air pressure source
- Arbor press
- Screw driver
- Masking tape
- Breaker bar
- Torque wrench-ft. lbs. (N m)
- Sockets: 1/2 or 9/16 inch thin wall, 1 inch
- Allen Sockets: 3/16, 3/8 inch
- Adjustable crescent wrench or hose fitting wrenches
- SAE 10W40 SE or SF oil
- Special bearing mandrel for TC, TB & TE Torqmotors (SEE FIGURE 1)
- Special bearing mandrel for TH Torqmotors (consult factory)
- Special bearing mandrel for TF, TG & TJ Torqmotors (SEE FIGURE 2)
- Feeler gage .005 inch (.13 mm)
- TC, TB & TE Torqmotors require blind hole bearing puller for 1.06 inch (26.9) mm) and 1.62 inch (41.1 mm) diameter bearing/bushing.
- TH Torqmotors require blind hole bearing puller for a 1.575 inch dia. (40.0 mm) and 2.130 inch dia. (54.1 mm) bearings.
- TJ, TF, TG & TL Torqmotors require blind hole bearing puller for 1.400 inch dia. (35.6 mm) and 2.130 inch dia. (54.1 mm) bearings.
- Clean corrosion resistant grease. Part #406018 is included in each seal kit. Recommended grease is Parker Specification #045236 or Mobil Mobilith SHC® 460

**NOTE: The available service seal kits include the recommended grease as a grease pack #406018**

**CAUTION: Mixing greases that have different bases can be detrimental to bearing life.**

**CONVERSIONS**

| INCHES | mm    | INCHES | mm    |
|--------|-------|--------|-------|
| .020   | .51   | 1.060  | 26.92 |
| .021   | .53   | 1.295  | 32.89 |
| .029   | .74   | 1.297  | 32.94 |
| .030   | .76   | 1.396  | 35.46 |
| .111   | 2.81  | 1.398  | 35.51 |
| .119   | 3.02  | 1.620  | 41.15 |
| .152   | 3.86  | 1.622  | 41.20 |
| .160   | 4.06  | 1.983  | 50.37 |
| .296   | 7.52  | 1.985  | 50.42 |
| .304   | 7.72  | 2.120  | 53.85 |
| .460   | 11.68 | 2.122  | 53.90 |
| .470   | 11.94 | 2.233  | 56.72 |
| .500   | 12.70 | 2.235  | 56.77 |
| .585   | 14.86 | 2.483  | 63.07 |
| .595   | 15.11 | 2.485  | 63.12 |
| .660   | 16.76 | 2.500  | 63.5  |
| .675   | 17.15 | 2.88   | 73.2  |
| 1.058  | 26.87 |        |       |

**Torque Chart**

| Part Name            | Item Number      | Torque                         |
|----------------------|------------------|--------------------------------|
| bolt 5/16 24 UNF 2A  | 1, 1A, 1B or 1C  | 25-30 ft. lbs. (33-40 N m)     |
| bolt 3/8 24 UNF 2A   | 1, 1A, 1B or 1C  | 45-55 ft. lbs. (60-76 N m)     |
| bolt 5/8 18 UNF 2A   | 12D              | 140-180 ft. lbs. (190-244 N m) |
| nut 3/4 16 UNF 2B    | 12B (TC, TB, TE) | 175-255 ft. lbs. (237-305 N m) |
| nut 1-20 UNEF 2B     | 12B (TF, TG, TL) | 300-400 ft. lbs. (407-542 N m) |
| nut 1-1/8 18 UNEF 2B | 12B (TG, TH)     | 300-400 ft. lbs. (407-542 N m) |

- TC has two steel bushing internal of housing press first steel bushing 1.223 deep from housing face the second steel bushing press .03 below face
- TL press internal bearing .576 below face
- TH press internal bearing .120 below face

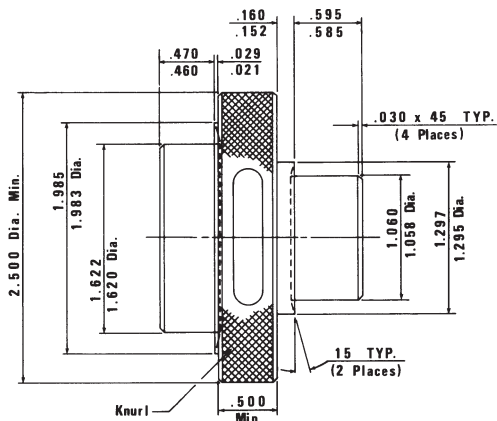

(Fabricate if considered necessary)

Figure 1 – TC, TB & TE

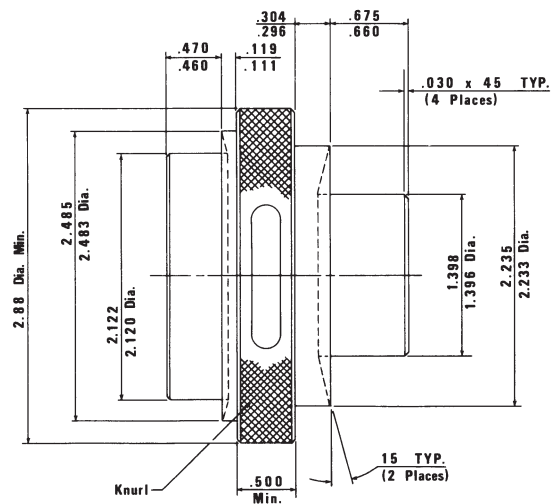

(Fabricate if considered necessary)

Figure 2 – TF & TG (see note)

**Typical Assembly**

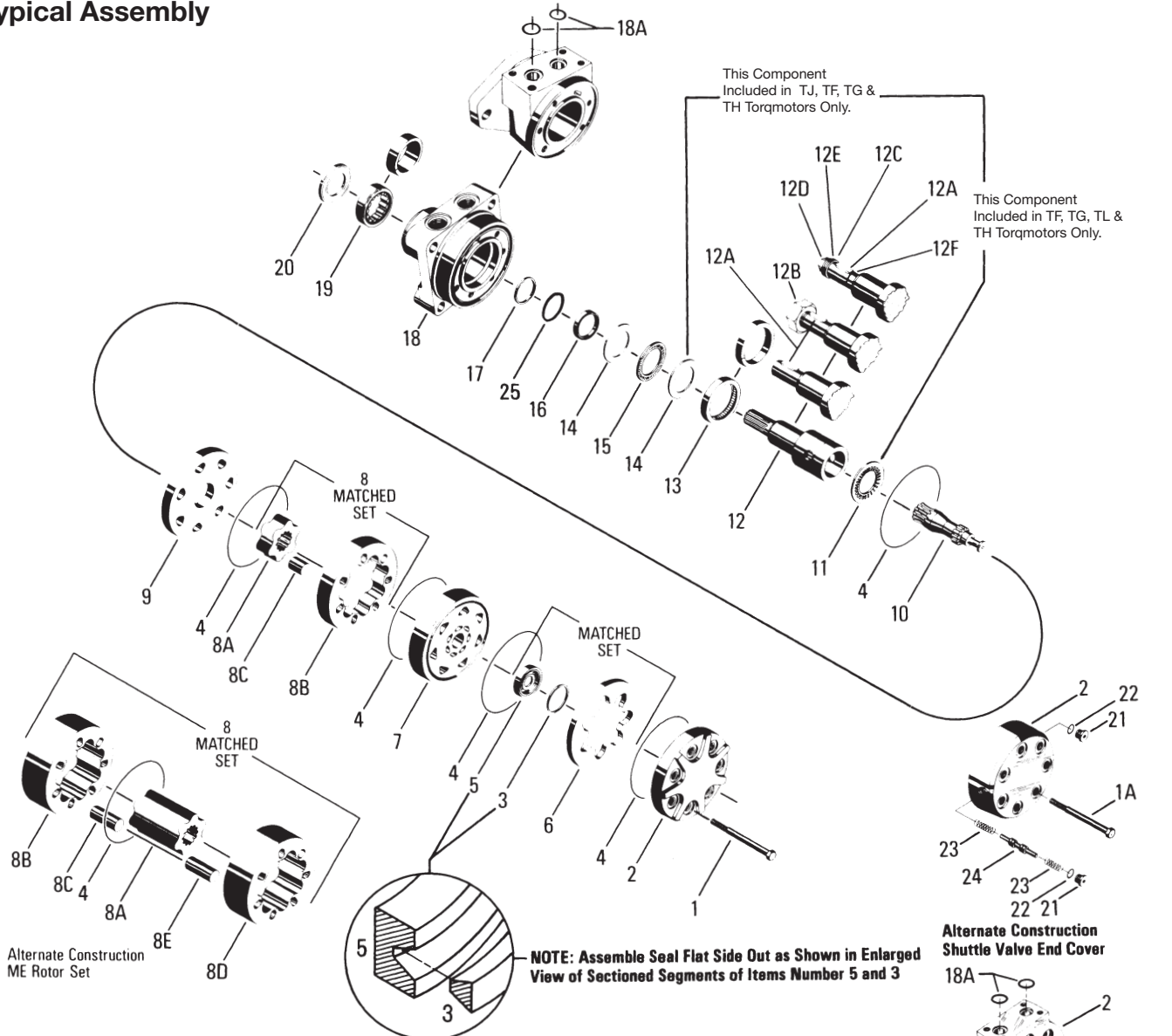

**Item**

**Description**

- |                               |                            |                               |
|-------------------------------|----------------------------|-------------------------------|
| 1. Special Bolts (5, 6, or 7) | 9. Wear Plate              | 18. Housing                   |
| 1a. Special Bolts (7)         | 10. Drive Link             | 18a. O-Ring (2)               |
| 1b. Special Bolts (7)         | 11. Thrust Bearing         | 19. Bearing/Bushing, Outer    |
| 1c. Special Bolts (7)         | 12. Coupling Shaft         | 20. Dirt & Water Seal         |
| 2. End Cover                  | 12a. Key                   | 21. Plug (2)                  |
| 3. Seal Ring-Commutator       | 12b. Nut                   | 22. O-Ring (2)                |
| 4. Seal Ring (5)              | 12c. Washer                | 23. Spring                    |
| 5. Commutator                 | 12d. Bolt                  | 24. Valve (Shuttle or Relief) |
| 6. Commutator Ring            | 12e. Lockwasher            | 25. Backup Washer             |
| 7. Manifold                   | 12f. Retaining Ring        |                               |
| 8. Rotor Set                  | 13. Bearing/Bushing, Inner |                               |
| 8a. Rotor                     | 14. Thrust Washer          |                               |
| 8b. Stator or Stator Half     | 15. Thrust Bearing         |                               |
| 8c. Vane (7)                  | 16. Seal                   |                               |
| 8d. Stator Half               | 17. Backup Ring            |                               |
| 8e. Vane (7)                  |                            |                               |

= Items not sold separately. Sold as matched sets only.

**TS Series Assembly**

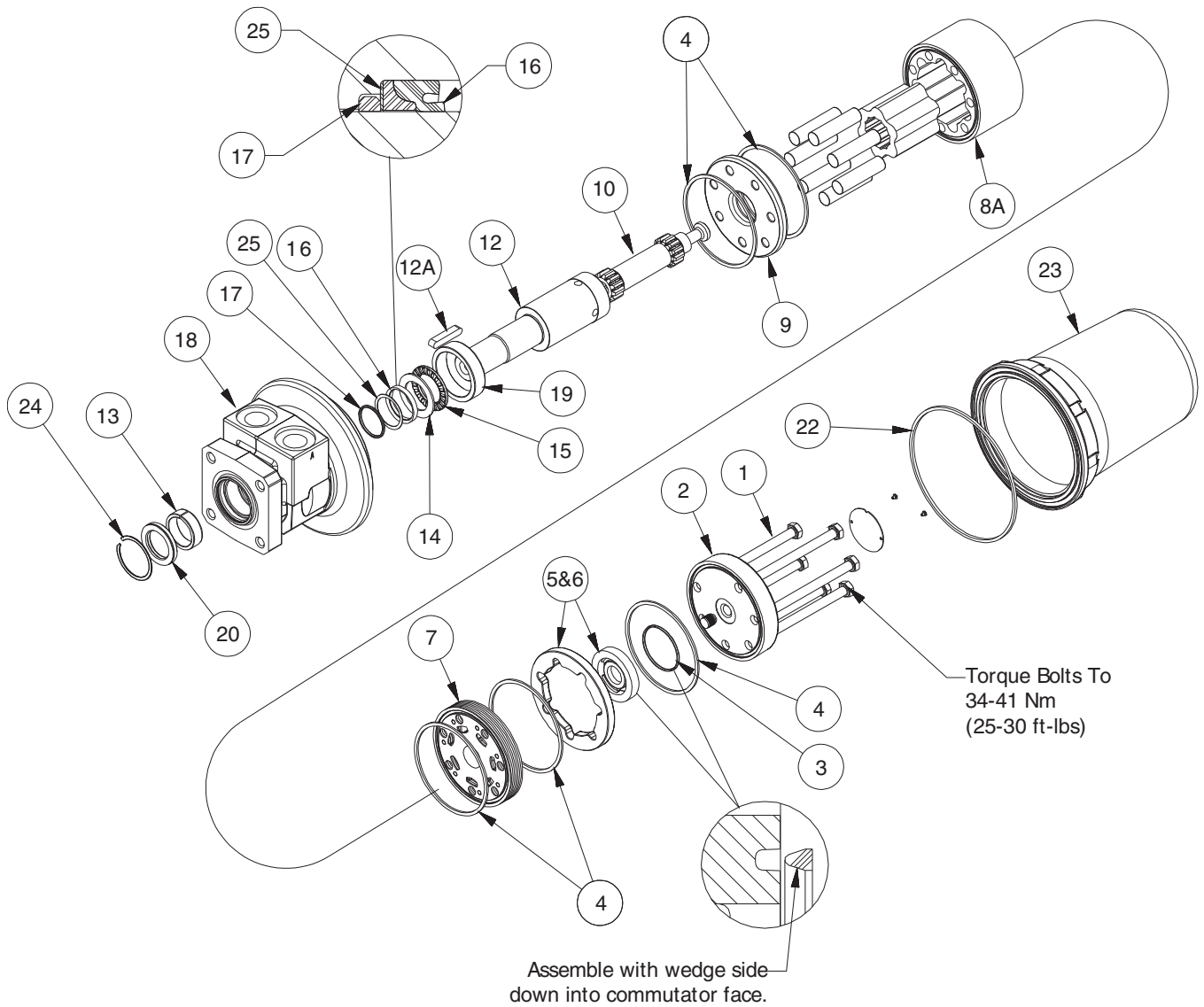

**Typical Assembly**

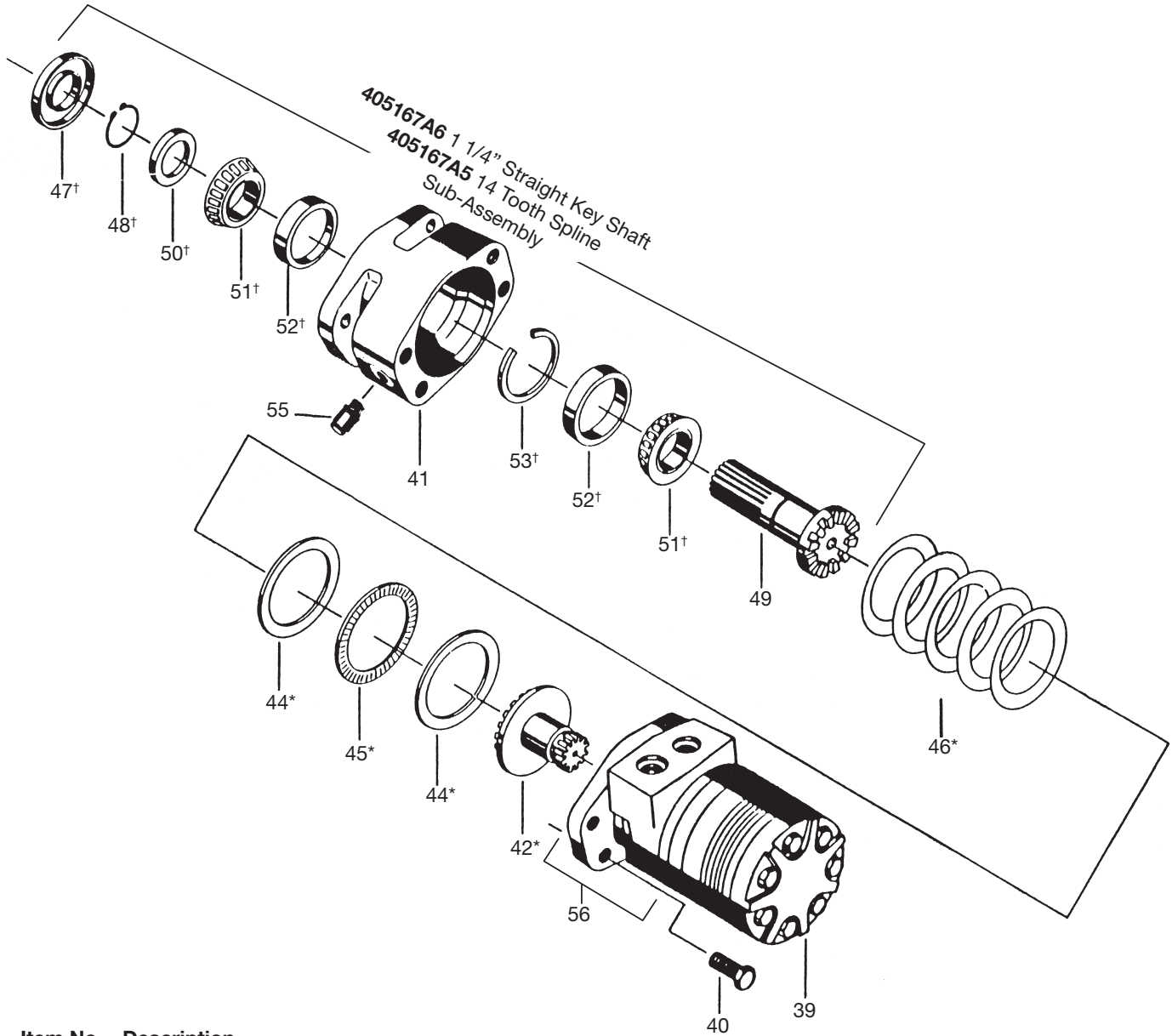

| Item No. | Description                     |            |
|----------|---------------------------------|------------|
| 39       | Torqmotor Sub-Assembly          |            |
| 40       | Bolt 1/2-13 (UNC-2A) (4 Req'd.) | 021479     |
| 41       | Clutch Housing                  | 405167     |
| 42*      | Splined Gear Drive              | 490102     |
| 44*      | Thrust Washer (2)               | 400142     |
| 45*      | Thrust Bearing                  | 073005     |
| 46*      | Disc Spring (5)                 | 028511     |
| 47†      | Seal - Dirt and Water           | 478035     |
| 48†      | Snap Ring                       | 401622     |
| 49       | Drive Shaft 14 Tooth Spline     | 093043     |
| 49       | Straight Key Shaft 1 1/4"       | 093044     |
| 50†      | Thrust Washer                   | 400141     |
| 51†      | Bearing and Cone Assembly (2)   | 067033     |
| 52†      | Bearing Cup (2)                 | 400140     |
| 53†      | Retaining Ring                  | 401623     |
| 55       | Plug                            | 036024     |
| 56       | Housing                         | ME012013A1 |

NOTE: Apply .06 in. (1.5 mm) Bead of Loctite #51514 Around Full Circumference of Pilot

\* Items sold separately: not included in Seal Kit

† SK000039 for Clutch Assembly only

SK000092 Seal Kit for Hydraulic Motor only Item #39.

Clutch Motor applies to TF Series only (Not available in 22, 25, 29 cu in.)

SHC Oil 90 WT 45± 5CC

**Chart Use Example:**

TJ0045US080AAAB Torqmotor™ includes part numbers listed to the right of TJ (SERIES), 0045 (DISP.), US (MOUNTING/PORTING), 08(SHAFT), 0 (ROTATION), and AAAB (OPTION) shown in the left hand column of the chart.

**Caution:**

The charted component service information is for the Torqmotors listed only. Refer to the original equipment manufacturer of the equipment using the Torqmotor for assembly numbers not listed below.

| SERIES | EXPLODED VIEW  |                     |                     |            |               |                  |                |               |               |                   |               |
|--------|----------------|---------------------|---------------------|------------|---------------|------------------|----------------|---------------|---------------|-------------------|---------------|
|        | ITEM #         | '5 & 6              | 7                   | 9          | '13           | '14              | '15            | 17            | '19           | 20                | 25            |
|        | DESCRIPTION    | COMMUTATOR ASSEMBLY | MANIFOLD (SEE NOTE) | WEAR PLATE | INNER BEARING | THRUST WASHER(2) | THRUST BEARING | BACKUP WASHER | OUTER BEARING | DIRT & WATER SEAL | BACKUP WASHER |
| TJ-    | Service Part # | MF018000A1          | MF015000            | 477341     | 069513        | 028348           | 069030         | 028515        | 068027        | 478035            | 029118        |

| DISPLACEMENT GROUP | EXPLODED VIEW                       |          |          |          | ROTOR                       |           |                                      |            | Overall Length |         |
|--------------------|-------------------------------------|----------|----------|----------|-----------------------------|-----------|--------------------------------------|------------|----------------|---------|
|                    | ITEM #                              | 1        | or 1A    | or 1C    | THICKNESS                   | 8A        | 8B                                   | 10         |                | "L" Dim |
|                    | DISPLACEMENT (in <sup>3</sup> /rev) | BOLT (6) | BOLT (6) | BOLT (6) | "L" DIM. OF ROTOR THICKNESS | ROTOR SET | FREE RUNNING ROTOR SET <sup>††</sup> | DRIVE LINK |                |         |
|                    |                                     |          |          |          |                             |           |                                      |            |                |         |
| 0036-              | 2.2                                 | 021311   |          |          | .2750                       | MF017003  | MF017005                             | MF013000   | 2.975          |         |
| 0045-              | 2.7                                 | 021311   | 021433   | 021308   | .3169                       | MF027003  | MF027005                             | MF023000   | 3.021          |         |
| 0050-              | 3.0                                 | 021311   | 021444   | 021308   | .3751                       | MF037003  | MF037005                             | MF033000   | 3.080          |         |
| 0065-              | 4.0                                 | 021306   | 021358   | 021435   | .5001                       | MF047003  | MF047005                             | MF043000   | 3.206          |         |
| 0080-              | 5.0                                 | 021382   | 021438   | 021359   | .6258                       | MF057003  | MF057005                             | MF053000   | 3.334          |         |
| 0100-              | 6.0                                 | 021357   | 021308   | 021445   | .7508                       | MF067003  | MF067005                             | MF063000   | 3.460          |         |
| 0130-              | 8.0                                 | 021307   | 021359   | 021439   | 1.0008                      | MF087003  | MF087005                             | MF083000   | 3.712          |         |
| 0165-              | 10.0                                | 021358   | 021310   | *        | 1.2508                      | MF107003  | MF107005                             | MF103000   | 3.969          |         |
| 0195-              | 12.0                                | 021308   | 021383   | 021465   | 1.5008                      | MF127003  | MF127005                             | MF123000   | 4.215          |         |
| 0230-              | 14.0                                | 021359   | 021384   | 021460   | 1.7508                      | MF147003  | MF147005                             | MF143000   | 4.467          |         |
| 0260-              | 16.0                                | 021310   | 021446   | 021467   | 2.0008                      | MF167003  | MF167005                             | MF163000   | 4.718          |         |
| 0295-              | 18.0                                | 021383   | 021414   | *        | 2.2508                      | MF187003  | MF187005                             | MF183000   | 4.970          |         |
| 0330-              | 20.0                                | 021384   | 021459   | 021448   | 2.5008                      | MF207003  | MF207005                             | MF203000   | 5.280          |         |
| 0365-              | 22.6                                | 021460   | 021448   | *        | 2.8406                      | MF227003  | N/A                                  | MF223000   | 5.557          |         |
| 0390-              | 24.0                                | 021414   | 021449   | 021464   | 3.0030                      | MF247003  | N/A                                  | MF243000   | 5.716          |         |

<sup>††</sup> Free running rotorset is not available in 0365 or 0390 displacements.  
\* Not released.

| HOUSING GROUP<br>Mounting Code<br>Porting Code | EXPLODED VIEW        |                       |            | COUPLING SHAFT GROUP | EXPLODED VIEW  |          |                 |        |
|--|----------------------|-----------------------|------------|----------------------|----------------|----------|-----------------|--------|
|  | ITEM #               |                       |            |                      | ITEM #         | 12       | 12A             | 12B    |
|  | DESCRIPTION          | SERVICE HOUSING ASS'Y |            |                      | DESCRIPTION    | SHAFT    | KEY             | NUT    |
| US-  | Wheel Mount (4 Bolt) | 7/8"-14 SAE O-Ring    | MP012002A1 | 08-                  | 1 1/4" Tapered | MP019000 | 038016 (5/16x1) | 025126 |

| OPTION GROUP | EXPLODED VIEW                                    |            |             |                 |               |            |
|--------------|--|------------|-------------|-----------------|---------------|------------|
|              | ITEM #   | '1, 1A, 1C |             |                 | 16            |            |
|              | DESCRIPTION                                      | BOLT       | END COVER   | COMMUTATOR SEAL | SEAL RING (5) | INNER SEAL |
| AAAB         | No Paint   | ITEM #1    | MF016007    | 032435          | 032821        | 032817     |
| AAAC         | Corrosion Resistant Paint                        | ITEM #1    | MF016007    | 032435          | 032821        | 032817     |
| AAAG         | Fluorocarbon Seals                               | ITEM #1    | MF016007    | 032435          | 032822        | 032818     |
| AABJ         | Free Running Rotor Set                           | ITEM #1    | MF016007    | 032435          | 032821        | 032817     |
| BBCK         | 1740 PSI Internal Bidirectional Relief, No Paint | ITEM #1C   | MF016006A7  |                 |               |            |
| BBCM         | 1200 PSI Internal Bidirectional Relief, No Paint | ITEM #1C   | MF016006A31 |                 |               |            |
| BBCN         | 2030 PSI Internal Bidirectional Relief, No Paint | ITEM #1C   | MF016006A5  |                 |               |            |
| BBCP         | 1450 PSI Internal Bidirectional Relief, No Paint | ITEM #1C   | MF016006A10 |                 |               |            |
| BBC T        | 1560 PSI Internal Bidirectional Relief, No Paint | ITEM #1C   | MF016006A2  |                 |               |            |
| AAJV         | Bidirectional Shuttle Valve (3:30), Black Paint  | ITEM #1A   | MF016009A1  | 032435          | 032821        | 032817     |

<sup>1</sup> Service housing ass'y ITEM #18 with part number suffix-A1 includes ITEM #13, #14, #15 and #19.

<sup>2</sup> Order (2) #032790 ITEM #18A for service housing assembly where manifold ports are used.

<sup>3</sup> Nut #025113 is required if the designated "OPTION GROUP" is AAAF, AAAN, or AAAU.

Standard seal kit #SK000146 includes five #032821 seal rings, #032435 commutator seal, #032817 shaft seal, #028515, backup ring #050016 and #029118 backup washer, #478035 dirt & water, #406018 grease pack, bulletin #050016.

Special seal kit #SK000148 for units that use fire retardant fluids or higher temperature oil includes five #032822 seal rings, #032435 commutator seal, #032818 shaft seal, #028515 backup ring, #478035 dirt & water seal, #406018 grease pack, #029118 backup washer, #050016 bulletin.

Vespel commutator seal 032751.

For reverse timed manifold, use MF015001.



**TF Service Parts List Chart**

**TC, TS, TB, TE, TJ, TF, TG, TH and TL Series**

**Chart Use Example:**

TF0080AS010AAAB Torqmotor™ includes part numbers listed to the right of TF (SERIES), 0080 (DISP.), AS (MOUNTING/PORTING), 01(SHAFT), 0 (ROTATION), and AAAA (OPTION) shown in the left hand column of the chart.

**Caution:**

The charted component service information is for the Torqmotors listed only. Refer to the original equipment manufacturer of the equipment using the Torqmotor for assembly numbers not listed below.

| EXPLODED VIEW |                |                     |                     |            |                |               |                  |                |               |               |                   |               |
|---------------|----------------|---------------------|---------------------|------------|----------------|---------------|------------------|----------------|---------------|---------------|-------------------|---------------|
| SERIES        | ITEM #         | '5 & 6              | 7                   | 9          | 11             | '13           | '14              | '15            | 17            | '19           | 20                | 25            |
|               | DESCRIPTION    | COMMUTATOR ASSEMBLY | MANIFOLD (SEE NOTE) | WEAR PLATE | THRUST BEARING | INNER BEARING | THRUST WASHER(2) | THRUST BEARING | BACKUP WASHER | OUTER BEARING | DIRT & WATER SEAL | BACKUP WASHER |
| TF-           | Service Part # | ME018000A1          | ME015000            | 477342     | 068024         | 071019        | 400136           | 069017         | 028515        | 068027        | 478035            | 029118        |

| EXPLODED VIEW <sup>2</sup> (SELECT ITEM # BOLT PER OPTION GROUP) |                                     |                     |          |          |          |           |           |            |          |          |        |
|--|-------------------------------------|---------------------|----------|----------|----------|-----------|-----------|------------|----------|----------|--------|
| DISPLACEMENT GROUP   | ITEM #                              | 1 OR 1A OR 1B OR 1C |          |          |          | 8A        | 8B        | 10         |          |          |        |
|  | DISPLACEMENT (in <sup>3</sup> /rev) | ROTOR THICKNESS     |          |          |          | ROTOR SET | ROTOR SET | DRIVE LINK | "L DIM"  |          |        |
|  |                                     | BOLT (7)            | BOLT (7) | BOLT (7) | BOLT (7) |           |           |            | 12 TOOTH | 14 TOOTH |        |
| 0080-  | 4.9                                 | 021326              | 021340   | 021273   | 021413   | .4393     | MB057003  | MB057005   | MB063000 | 4.262"   |        |
| 0100-  | 6.1                                 | 021326              | 021340   | 021273   | 021413   | .4393     | MB067003  | MB067005   | MB063000 | 4.262"   |        |
| 0130-  | 7.8                                 | 021271              | 021386   | 021273   | 021279   | .5643     | MB087003  | MB087005   | MB083000 | 4.388"   |        |
| 0140-  | 8.6                                 | 021390              | 021273   | 021273   | 021379   | .6268     | MB097003  | MB097005   | MB093000 | 4.451"   |        |
| 0170-  | 10.3                                | 021376              | 021387   | 021387   | 021392   | .7518     | MB107003  | MB107005   | MB103000 | 4.577"   |        |
| 0195-  | 12.0                                | 021352              | 021379   | 021379   | 021291   | .8768     | MB127003  | MB127005   | MB123000 | 4.703"   |        |
| 0240-  | 14.5                                | 021272              | 021291   | 021291   | 021412   | 1.0643    | MB157003  | MB157005   | MB153000 | 4.892"   |        |
| 0280-  | 17.1                                | 021340              | 021392   | 021392   | 021385   | 1.2518    | MB187003  | MB187005   | MB183000 | 5.081"   |        |
| 0360-†   | 22.2                                | 021387              | 021378   | 021378   | 021415   | 1.5018    | ME237003  | ME237007   | ME233000 |          | 5.458" |
| 0365-  | 22.2                                | 021387              | 021378   | 021378   | 021415   | 1.6268    | MB237003  | MB237005   | MB233000 | 5.458"   |        |
| 0405-†   | 24.7                                | 021379              | 021366   | 021415   | 021374   | 1.7923    | ME247003  | ME247007   | ME243000 |          | 5.604" |
| 0475-†   | 29.1                                | 021392              | 021394   | 021394   | 021393   | 2.1268    | ME297003  | ME297007   | ME293000 |          | 5.947" |

† (Not available in clutch motor)

| FRONT PORTING | Mounting Code<br>Porting Code | EXPLODED VIEW                   |                    |  |                       | SPEED SENSOR          |                   |
|---------------|-------------------------------|---------------------------------|--------------------|--|-----------------------|-----------------------|-------------------|
|               |                               | ITEM #                          | 2                  |  | '18                   |                       |                   |
|               |                               | DESCRIPTION                     | END COVER          |  | SERVICE HOUSING ASS'Y | SERVICE HOUSING ASS'Y | SENSOR            |
|               |                               | MOUNTING                        | *PORTING           |  |                       |                       |                   |
| MS-           |                               | Standard (4 Bolt)               | 7/8" O-Ring        |  | ME016000              | ME012001A1            | ME012301A1 455069 |
| US-           |                               | Wheel Mt. (4 Bolt)              | 7/8" O-Ring        |  | ME016000              | ME012002A1            | ME012301A1 455069 |
| AS-           |                               | SAE A (2 Bolt)                  | 7/8" O-Ring        |  | ME016000              | ME012006A1            | ME012306A1 455069 |
| HS-           |                               | Whl. (US) w/Machined Pilot Nose | 7/8" O-Ring        |  | ME016000              | ME012008A1            |                   |
| LS-           |                               | Whl. w/Brake Mt. (4 Bolt)       | 7/8" O-Ring        |  | ME016000              | ME012009A1            |                   |
| BS-           |                               | SAE B (2 Bolt)                  | 7/8" O-Ring        |  | ME016000              | ME012019A1            | ME012319A1 455069 |
| GS-           |                               | <b>Clutch Motor</b>             | <b>7/8" O-Ring</b> |  | <b>ME016000</b>       | <b>ME012013A1</b>     |                   |
| AM-           |                               | SAE A (2 Bolt)                  | Manifold           |  | ME016000              | ME012028A1            | ME012328A1 455069 |
| MM-           |                               | Standard (4 Bolt)               | Manifold           |  | ME016000              | ME012018A1            |                   |
| AT-           |                               | SAE A (2 Bolt)                  | 1/2" BSPF          |  | ME016000              | ME012027A1            |                   |
| MT-           |                               | Standard (4 Bolt)               | 1/2" BSPF          |  | ME016000              | ME012010A1            | ME012310A1 455069 |

| HOUSING GROUP | REAR PORTING | EXPLODED VIEW            |                                 |          |            |                       |                       | SPEED SENSOR |    |
|---------------|--------------|--------------------------|---------------------------------|----------|------------|-----------------------|-----------------------|--------------|----|
|               |              | ITEM #                   | 1, 1A, 1B, 1C                   |          |            | 2                     | '18                   | 18           | 18 |
|               |              | DESCRIPTION              | *PORTING                        | BOLT     | END COVER  | SERVICE HOUSING ASS'Y | SERVICE HOUSING ASS'Y | SENSOR       |    |
|               |              | MOUNTING                 |                                 |          |            |                       |                       |              |    |
| MA-           |              | Standard (4 Bolt)        | Rear Port (7/8" O-Ring; Axial)  | Item #1B | ME016009   | ME012004A1            |                       |              |    |
| UA-           |              | Wheel Mt. (4 Bolt)       | Rear Port (7/8" O-Ring; Axial)  | Item #1B | ME016009   | ME012005A1            |                       |              |    |
| AA-           |              | SAE A (2 Bolt)           | Rear Port (7/8" O-Ring; Axial)  | Item #1B | ME016009   | ME012007A1            | ME012307A1 455069     |              |    |
| WA-           |              | Wheel, Optional (4 Bolt) | Rear Port (7/8" O-Ring; Axial)  | Item #1B | ME016009   | ME012011A1            |                       |              |    |
| VA-           |              | SAE A (4 Bolt)           | Rear Port (7/8" O-Ring; Axial)  | Item #1B | ME016009   | ME012049A1            |                       |              |    |
| MB-           |              | Standard (4 Bolt)        | Rear Port (7/8" O-Ring; Radial) | Item #1B | ME016002   | ME012004A1            |                       |              |    |
| UB-           |              | Wheel Mt. (4 Bolt)       | Rear Port (7/8" O-Ring; Radial) | Item #1B | ME016002   | ME012005A1            |                       |              |    |
| AB-           |              | SAE A (2 Bolt)           | Rear Port (7/8" O-Ring; Radial) | Item #1B | ME016002   | ME012007A1            | ME012307A1 455069     |              |    |
| WB-           |              | Wheel, Optional (4 Bolt) | Rear Port (7/8" O-Ring; Radial) | Item #1B | ME016002   | ME012011A1            |                       |              |    |
| VB-           |              | SAE A (4 Bolt)           | Rear Port (7/8" O-Ring; Radial) | Item #1B | ME016002   | ME012049A1            |                       |              |    |
| ME-           |              | Standard (4 Bolt)        | Rear Port (Manifold; Radial)    | Item #1B | ME016001J1 | ME012004A1            |                       |              |    |
| UE-           |              | Wheel Mt. (4 Bolt)       | Rear Port (Manifold; Radial)    | Item #1B | ME016001J1 | ME012005A1            |                       |              |    |
| AE-           |              | SAE A (2 Bolt)           | Rear Port (Manifold; Radial)    | Item #1B | ME016001J1 | ME012007A1            | ME012307A1 455069     |              |    |
| WE-           |              | Wheel, Optional (4 Bolt) | Rear Port (Manifold; Radial)    | Item #1B | ME016001J1 | ME012011A1            |                       |              |    |
| VE-           |              | SAE A (4 Bolt)           | Rear Port (Manifold; Radial)    | Item #1B | ME016001J1 | ME012049A1            |                       |              |    |





| COUPLING SHAFT GROUP | EXPLODED VIEW                           |                | SPEED SENSOR   | CLUTCH MOTOR   |        |     |        |             |             |                |
|----------------------|---|----------------|----------------|----------------|--------|-----|--------|-------------|-------------|----------------|
|                      | ITEM #                                  | 12             | 12             | 12             | 12A    | 12B | 12C    | 12D         | 12E         | 12F            |
|                      | DESCRIPTION                             | COUPLING SHAFT | COUPLING SHAFT | COUPLING SHAFT | KEY    | NUT | WASHER | 5/8-18 BOLT | LOCK WASHER | RETAINING RING |
| 01-                  | Long 6B Snapwire Groove                 | MB019001       | MB019301       |                |        |     |        |             |             |                |
| 02-                  | Long Woodruff, 1/4" Tap Snapwire Groove | MB019002       | MB019302       |                | 038015 |     |        |             |             |                |
| 03-                  | 1.25" Straight Keyed 5/8-18 Int. Thd.   | MB019003       | MB019303       | 093044         | 039028 |     | 028413 | 021482      | 028992      | 401333         |
| 04-                  | 10B Spline                              | MB019004       | MB019304       |                |        |     |        |             |             |                |
| 05-                  | 14 Tooth Spline 5/8-18 Int. Thd.        | MB019005       | MB019305       | 093043         |        |     | 028413 | 021482      | 028992      |                |
| 06-                  | 19 Tooth Spline                         | MB019006       |                |                |        |     |        |             |             |                |
| 07-                  | 15 Tooth Spline                         | MB019007       | MB019307       |                |        |     |        |             |             |                |
| 08-                  | 1.25" Tapered Shaft                     | MB019000       | MB019300       |                | 038016 |     | 025126 |             |             |                |
| 17-                  | 19 Tooth Spline (16/32)                 | MB019011       |                |                |        |     |        |             |             |                |
| 22-                  | 25mm Str. w/7mm Key                     | MB019009       | MB019309       |                |        |     |        |             |             |                |
| 26-                  | 25mm Str. w/8mm Key                     | MB019017       | MB019317       |                |        |     |        |             |             |                |
| 28-                  | 13 Tooth Spline (16/32)                 | MB019023       | MB019323       |                |        |     |        |             |             |                |
| 58-                  | 1.25" Str. Nitrotec C                   | MB019040       |                |                |        |     |        |             |             |                |

| COUPLING SHAFT GROUP FOR DISP-0360, -0405, -0475 ONLY† | EXPLODED VIEW                           |                | SPEED SENSOR   |        |
|--|---|----------------|----------------|--------|
|  | ITEM #                                  | 12             | 12             | 12     |
|  | DESCRIPTION                             | COUPLING SHAFT | COUPLING SHAFT | SENSOR |
| 01-  | Long 6B Snapwire Groove                 | ME019001       | ME019301       | 455069 |
| 02-  | Long Woodruff, 1/4" Tap Snapwire Groove | ME019002       | ME019302       | 455069 |
| 03-  | 1.25" Straight Keyed 5/8-18 Int. Thd.   | ME019003       | ME019303       | 455069 |
| 04-  | 10B Spline                              | ME019004       | ME019304       |        |
| 05-  | 14 Tooth Spline 5/8-18 Int. Thd.        | ME019005       | ME019305       | 455069 |
| 06-  | 19 Tooth Spline                         | ME019006       |                |        |
| 07-  | 15 Tooth Spline                         | ME019007       |                |        |
| 08-  | 1.25" Tapered Shaft                     | ME019000       | ME019300       | 455069 |
| 19-  | 1.38" Tapered 1.125-18 Thd.             | ME019010       |                |        |
| 20-  | 1.38" Straight Key 5/8 Tap              | ME019011       | ME019311       |        |

† (Not available in clutch motor)

| OPTION GROUP | EXPLODED VIEW  |                             |             |                 |               |                         |                      |                   |                 |                 |               |        |
|--------------|--|-----------------------------|-------------|-----------------|---------------|-------------------------|----------------------|-------------------|-----------------|-----------------|---------------|--------|
|              | ITEM #   | 2 <sup>1</sup> , 1A, 1B, 1C | 2           | 3               | 4             | 16                      | 6 <sup>21</sup> & 22 | 4 <sup>6</sup> 22 | 6 <sup>23</sup> | 6 <sup>24</sup> | 12B           |        |
|              | DESCRIPTION  | BOLT (7)                    | END COVER   | COMMUTATOR SEAL | SEAL RING (5) | INNERPLUG & O-RING SEAL | ASSEMBLY             | O-RINGS           | SPRING (2)      | VALVE           | CASTLE NUT    | SENSOR |
| AAAA         | Black Paint  | Item #1                     |             | 032435          | 032819        | 032817                  |                      |                   |                 |                 |               |        |
| AAAC         | Corrosion Resistant Paint  | Item #1                     |             | 032435          | 032819        | 032817                  |                      |                   |                 |                 |               |        |
| AAAF         | Castle Nut Replacing Patch Lock Nut                              | Item #1                     |             | 032435          | 032819        | 032817                  |                      |                   |                 |                 | 025113        |        |
| AAAG         | Fluorocarbon Seals, Black Paint                                  | Item #1                     |             | 032435          | 032820        | 032818                  |                      |                   |                 |                 |               |        |
| AAAH         | Fluorocarbon Seals, No Paint                                     | Item #1                     |             | 032435          | 032820        | 032818                  |                      |                   |                 |                 |               |        |
| AAAT         | Bidirectional Shuttle Valve 11:00                                | Item #1A                    | 6ME016003A1 | 032435          | 032819        | 032817                  | 036297               | 032791            | 401642          | 415569          |               |        |
| AAAU         | Bidirectional Shuttle Valve 11:00 & Castle Nut                   | Item #1A                    | 6ME016003A1 | 032435          | 032819        | 032817                  | 036297               | 032791            | 401642          | 415569          | 025113        |        |
| BBBA         | 1000 PSI Cross Port Relief Endcover, Black Paint                 | Item #1C                    | 6ME016004A1 | 032435          | 032819        | 032817                  | 411063A1             | 032424            |                 | 41001210        | (2), 1000 PSI |        |
| BBBG         | 1500 PSI Cross Port Relief Endcover, Black Paint                 | Item #1C                    | ME016004A5  | 032435          | 032819        | 032817                  | 411063A1             | 032424            |                 | 41000976        | (2), 1500 PSI |        |
| BBBB         | 2000 PSI Cross Port Relief Endcover, Black Paint                 | Item #1C                    | 6ME016004A2 | 032435          | 032819        | 032817                  | 411063A1             | 032424            |                 | 41001220        | (2), 2000 PSI |        |
| BBCG         | 2500 PSI Int. Bidirectional Relief Endcover, No Paint            | Item # 1C                   | ME016004A6  | 032435          | 032819        | 032817                  | 411063A1             | 032424            |                 | 41001225        | (2), 2500 PSI |        |
| BBCX         | 2500 PSI Int. Bidirectional Relief Endcover, No Nut, Black Paint | Item # 1C                   | ME016004A6  | 032435          | 032819        | 032817                  | 411063A1             | 032424            |                 | 41001225        | (2), 2500 PSI |        |
| BBCW         | 3000 PSI Int. Bidirectional Relief Endcover, No Nut, No Paint    | Item # 1C                   | ME016004A3  | 032435          | 032819        | 032817                  | 411063A1             | 032424            |                 | 41001230        | (2), 3000 PSI |        |
| BBBC         | 3000 PSI Cross Port Relief Endcover, Black Paint                 | Item #1C                    | 6ME016004A3 | 032435          | 032819        | 032817                  | 411063A1             | 032424            |                 | 41001230        | (2), 3000 PSI |        |
| BBBD         | 4000 PSI Cross Port Relief Endcover, Black Paint                 | Item #1C                    | 6ME016004A4 | 032435          | 032819        | 032817                  | 411063A1             | 032424            |                 | 41001240        | (2), 4000 PSI |        |
| DDDA         | Clutch Motor   | Item #1                     | ME016000    | 032435          | 032819        | 032817                  |                      |                   |                 |                 |               |        |
| FSAA         | Speed Sensor Option  | Item #1                     | ME016000    | 032435          | 032819        | 032817                  |                      |                   |                 |                 |               | 455069 |

For reverse timed manifold, use ME015001.

<sup>1</sup> Service housing ass'y ITEM #18 with part number suffix-A1 includes ITEM #13, #14 two req'd, #15 and #19.

<sup>2</sup> Select the required bolt number in designated "DISPLACEMENT GROUP" under bolt ITEM #1, 1A, 1B or 1C shown in designated "OPTION GROUP."

<sup>3</sup> 1-20 UNEF slotted nut #025113 is required on 1-1/4" tapered shaft if the designated "OPTION GROUP" is AAAF, AAAN, or AAUU.

<sup>4</sup> ITEM #22 is part of plug & o-ring ass'y's but can be serviced separately.

<sup>5</sup> Service endcover ME016001J1 includes two #032790 o-rings, ITEM 18A on the exploded ass'y view that can also be serviced separately.

<sup>6</sup> End cover assembly item #2 also includes item #21, #22, #24 and if required item #23. All but item #21 can be serviced separately.

<sup>7</sup> ME018001A1 commutator ass'y. is required if the designated "OPTION GROUP" is AAAM, AAAN, or AAAP.

<sup>8</sup> Order (2) #032790 seals for parts when ordering manifold-style porting.

Standard seal kit #SK000092 includes six #032819 seal rings, #032435 commutator seal, #032817 inner seal, #028515 and #029118 back washers, #478035 dirt & water, #406018 grease pack, bulletin #050016.

Special seal kit #SK000093 for units that use fire retardant fluids includes six #032820 seal rings, #032435 commutator seal, #032818 inner seal, #028515 and #029118 back up washers, #478035 dirt & water seal, #406018 grease pack, bulletin #050016.

Vespel commutator seal AADJ #032439. High temperature seal black in color.

\* Standard seal kit #SK000092 for motor only. If repairing clutch, need #SK000039. Kit includes two #067033 bearing and cone assemblies, two #400140 bearing cups, one #400141 thrust washer, one #401622 snap ring, one #401632 retaining ring, and one #478030 dirt and water seal.

#SK000099 Vespel commutator seal kit, #032439 Vespel seal, #032817 inner seal, #028515 and #029118 back up washers, #478035 dirt & water seal, #032819 six seal rings, #406018 grease pack, bulletin #050016.



## Preparation Before Disassembly

- Before you disassemble the Torqmotor™ unit or any of its components read this entire manual. It provides important information on parts and procedures you will need to know to service the Torqmotor™.
- Determine whether the Torqmotor™ you are about to disassemble is the Small Frame Series TC, TS, TB, TE or TJ or the Large Frame Series TF, TG, TL or TH so you can follow those procedures that pertain to that Series Torqmotor™. The first two letters of the “spec” number on the Torqmotor™ identification tag is the Series designation. Also determine the type of end construction from the alternate views shown on the exploded view.
- The Small Frame Series TC, TS, TB & TE Torqmotors™ will have a 3.66 inch (92.9 mm) main body outside diameter and five or six 5/16-24 UNF 2A cover bolts. The Medium Frame Series TJ Torqmotors™ will have a 3.66 inch (92.9 mm) main body outside diameter and six 5/16-24 UNF 2A cover bolts. The Large Frame Series TF, TG, TL & TH Torqmotors™ will have a 5 inch (127.9 mm) main body outside diameter and seven 3/8 24 UNF 2A cover bolts.
- Refer to “Tools and Materials Required for Services” section for tools and other items required to service the Torqmotor™ and have them available.
- Thoroughly clean off all outside dirt, especially from around fittings and hose connections, before disconnecting and removing the Torqmotor™. Remove rust or corrosion from coupling shaft.
- Remove coupling shaft connections and hose fittings and immediately plug port holes and fluid lines.
- Remove the Torqmotor™ from system, drain it of fluid and take it to a clean work surface.
- Clean and dry the Torqmotor™ before you start to disassemble the unit.
- As you disassemble the Torqmotor™ clean all parts, except seals, in clean petroleum-based solvent, and blow them dry.

**WARNING:** petroleum-base solvents are flammable. Be extremely careful when using any solvent. Even a small explosion or fire could cause injury or death.

**WARNING:** WEAR EYE PROTECTION AND BE SURE TO COMPLY WITH OSHA OR OTHER MAXIMUM AIR PRESSURE REQUIREMENTS.

**CAUTION:** Never steam or high pressure wash hydraulic components. Do not force or abuse closely fitted parts.

- Keep parts separate to avoid nicks and burrs.
- Discard all seals and seal rings as they are removed from the Torqmotor™. Replace all seals, seal rings and any damaged or worn parts with genuine Parker or OEM approved service parts.

## Reference Exploded Assembly View

**Place Torqmotor in a vise**

1. Place the Torqmotor™ in a soft jawed vice, with coupling shaft (12) pointed down and the vise jaws clamping firmly on the sides of the housing (18) mounting flange or port bosses. Remove manifold port O-Rings (18A) if applicable.

**WARNING**

**WARNING:** IF THE TORQMOTOR™ IS NOT FIRMLY HELD IN THE VISE, IT COULD BE DISLODGED DURING THE SERVICE PROCEDURES, CAUSING INJURY.

**Scribe alignment mark & loose valve plugs**

2. Scribe an alignment mark down and across the Torqmotor™ components from end cover (2) to housing (18) to facilitate reassembly orientation where required. Loosen two shuttle or relief valve plugs (21) for disassembly later if included in end cover. 3/16 or 3/8 inch Allen wrench or 1 inch hex socket required. SEE FIGURES 3 & 4.

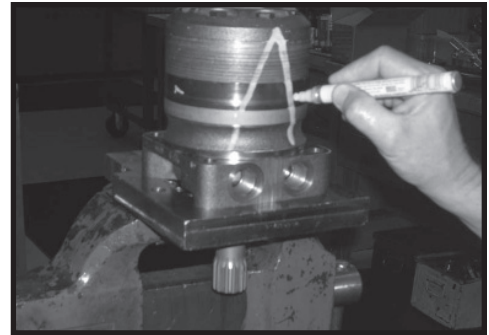

Figure 3

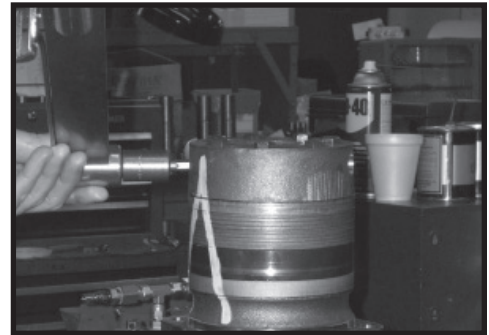

Figure 4

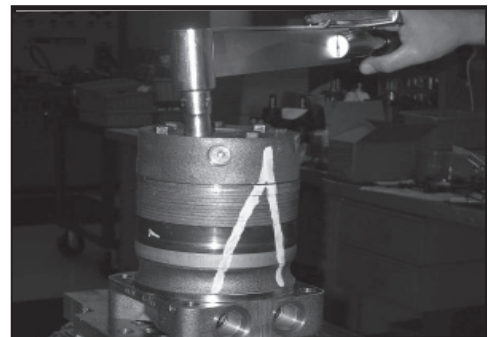

Figure 5

**Remove special bolts & inspect bolts**

3. Remove the five, six, or seven special ring head bolts (1, 1A, 1B, or 1C) using an appropriate 1/2 or 9/16 inch size socket. SEE FIGURE 5. Inspect bolts for damaged threads, or sealing rings, under the bolt head. Replace damaged bolts. SEE FIGURE 6.



Figure 6

**Remove end cover & inspect bolts**

4. Remove end cover assembly (2) and seal ring (4). Discard seal ring. SEE FIGURE 7.

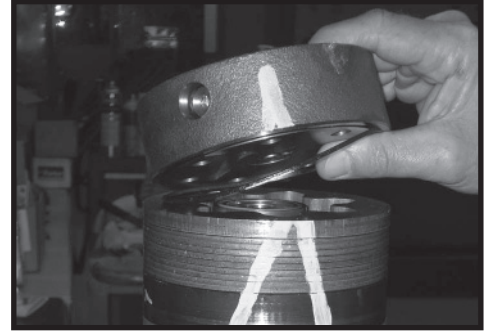

Figure 7

**NOTE**

**NOTE: Refer to the appropriate “alternate cover construction” on the exploded view to determine the end cover construction being serviced.**

**Remove plugs and valves**

5. If the end cover (2) is equipped with shuttle valve or relief valve (24) components, remove the two previously loosened plugs (21) and o-rings (22). SEE FIGURE 8.

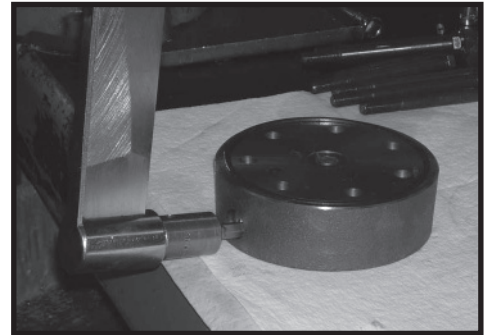

Figure 8

**CAUTION**

**CAUTION: Be ready to catch the shuttle valve or relief valve components that will fall out of the end cover valve cavity when the plugs are removed.**

**NOTE**

**NOTE: O-ring (22) is not included in seal kits but serviced separately if required.**

**NOTE**

**NOTE: The insert and if included the orifice plug in the end cover (2) must not be removed as they are serviced as an integral part of the end cover.**

**Wash & inspect end cover**

6. Thoroughly wash end cover (2) in proper solvent and blow dry. Be sure the end cover valve apertures, including the internal orifice plug, are free of contamination. Inspect end cover for cracks and the bolt head recesses for good bolt head sealing surfaces. Replace end cover as necessary. SEE FIGURE 9.

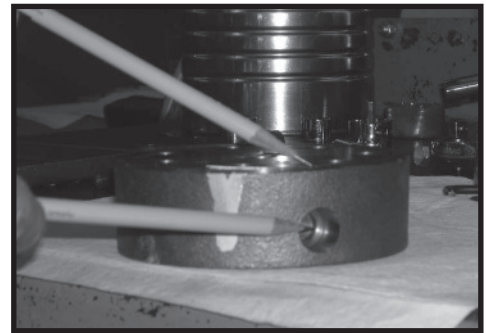

Figure 9

**NOTE**

**NOTE: A polished pattern (not scratches) on the cover from rotation of the commutator (5) is normal. Discoloration would indicate excess fluid temperature, thermal shock, or excess speed and require system investigation for cause and close inspection of end cover, commutator, manifold, and rotor set.**

**Remove & inspect commutator ring**

7. Remove commutator ring (6). SEE FIGURE 10. Inspect commutator ring for cracks, or burrs.



Figure 10

**Remove & inspect commutator**

8. Remove commutator (5) and seal ring (3) Remove seal ring from commutator, using an air hose to blow air into ring groove until seal ring is lifted out and discard seal ring. Inspect commutator for cracks or burrs, wear, scoring, spalling or brinelling. If any of these conditions exist, replace commutator and commutator ring as a matched set. SEE FIGURE 11 & 12.

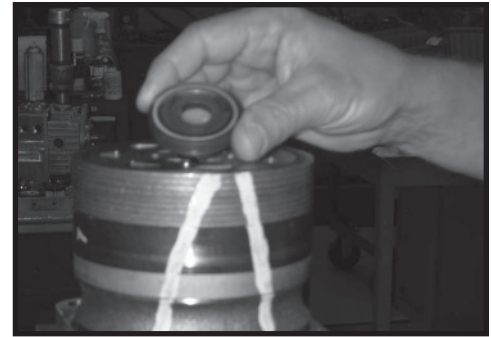

Figure 11

**Remove manifold**

9. Remove manifold (7) and inspect for cracks surface scoring, brinelling or spalling. Replace manifold if any of these conditions exist. SEE FIGURE 13. A polished pattern on the ground surface from commutator or rotor rotation is normal. Remove and discard the seal rings (4) that are on both sides of the manifold.



Figure 12

**NOTE**

**NOTE: The manifold is constructed of plates bonded together to form an integral component not subject to further disassembly for service. Compare configuration of both sides of the manifold to ensure that same surface is reassembled against the rotor set.**

**Remove & inspect rotor set & wearplate**

10. Remove rotor set (8) and wearplate (9), together to retain the rotor set in its assembled form, maintaining the same rotor vane (8C) to stator (8B) contact surfaces. SEE FIGURE 14. The drive link (10) may come away from the coupling shaft (12) with the rotor set, and wearplate. You may have to shift the rotor set on the wearplate to work the drive link out of the rotor (8A) and wearplate. SEE FIGURE 15. Inspect the rotor set in its assembled form for nicks, scoring, or spalling on any surface and for broken or worn splines. If the rotor set component requires replacement, the complete rotor set must be replaced as it is a matched set. Inspect the wearplate for cracks, brinelling, or scoring. Discard seal ring (4) that is between the rotor set and wearplate.

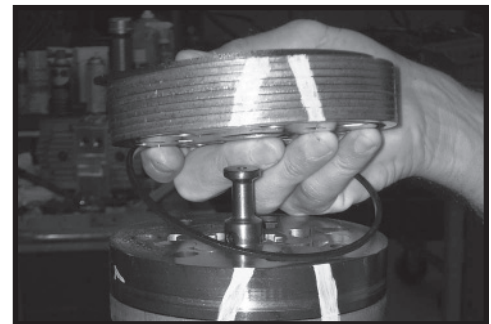

Figure 13

**NOTE**

**NOTE: The rotor set (8) components may become disassembled during service procedures. Marking the surface of the rotor and stator that is facing UP, with etching ink or grease pencil before removal from Torqmotor™ will ensure correct reassembly of rotor into stator and rotor set into Torqmotor™. Marking all rotor components and mating spline components for exact repositioning at assembly will ensure maximum wear life and performance of rotor set and Torqmotor™.**



Figure 14

**NOTE**

**NOTE:** Series TG or TH may have a rotor set with two stator halves (8B & 8D) with a seal ring (4) between them and two sets of seven vanes (8C & 8E). Discard seal ring only if stator halves become disassembled during the service procedures.



Figure 15

**NOTE**

**NOTE:** A polished pattern on the wear plate from rotor rotation is normal.

**Check rotor, vane clearance**

- 11. Place rotor set (8) and wear plate (9) on a flat surface and center rotor (8A) in stator (8B) such that two rotor lobes (180 degrees apart) and a roller vane (8C) centerline are on the same stator centerline. Check the rotor lobe to roller vane clearance with a feeler gage at this common centerline. If there is more than .005 inches (0.13 mm) of clearance, replace rotor set. SEE FIGURE 16.

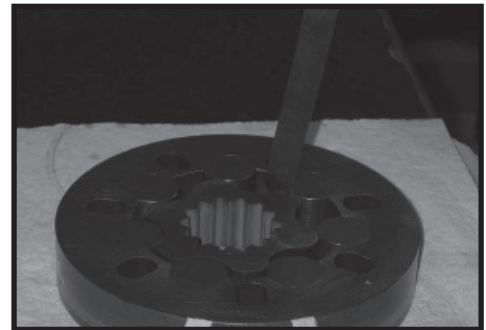

Figure 16

**NOTE**

**NOTE:** If rotor set (8) has two stator halves (8B & 8D) and two sets of seven vanes (8C & 8E) as shown in the alternate construction TG rotor set assembly view, check the rotor lobe to roller vane clearance at both ends of rotor.

**Remove & inspect drive link**

- 12. Remove drive link (10) from coupling shaft (12) if it was not removed with rotor set and wear plate. Inspect drive link for cracks and worn or damaged splines. No perceptible lash (play) should be noted between mating spline parts. SEE FIGURE 17. Remove and discard seal ring (4) from housing (18).

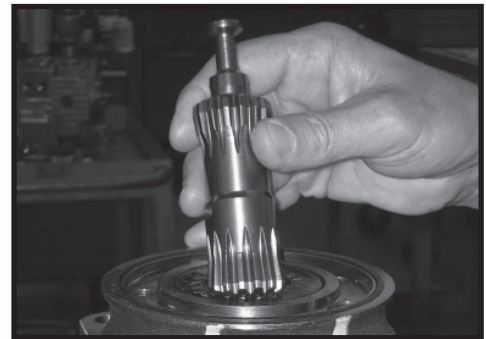

Figure 17

**Remove thrust bearing**

- 13. Remove thrust bearing (11) from top of coupling shaft (12) if Torqmotor is a Series TF, TG, TH or TL. Inspect for wear, brinelling, corrosion and a full complement of retained rollers. SEE FIGURE 18.

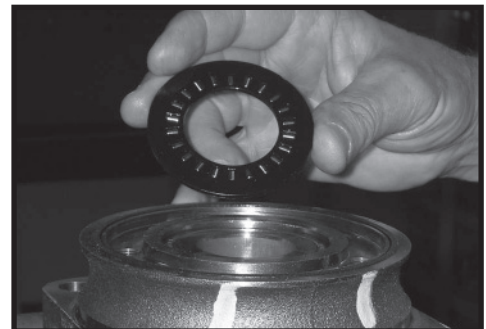

Figure 18

**Check coupling shaft for rust or corrosion**

14. Check exposed portion of coupling shaft (12) to be sure you have removed all signs of rust and corrosion which might prevent its withdrawal through the seal and bearing. Crocus cloth or fine emery paper may be used. SEE FIGURE 19. Remove any key (12A), nut (12B), washer (12C), bolt (12D), lock washer (12E), or retaining ring (12F).

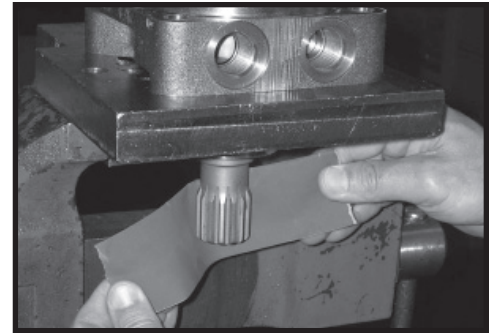

Figure 19

**Remove & inspect coupling shaft**

15. Remove coupling shaft (12), by pushing on the output end of shaft. SEE FIGURE 20. Inspect coupling shaft bearing and seal surfaces for spalling, nicks, grooves, severe wear or corrosion and discoloration. Inspect for damaged or worn internal and external splines or keyway. SEE FIGURE 21. Replace coupling shaft if any of these conditions exist.



Figure 20

**NOTE**

**NOTE: Minor shaft wear in seal area is permissible. If wear exceeds .020 inches (0.51 mm) diametrically, replace coupling shaft.**

**NOTE**

**NOTE: A slight “polish” is permissible in the shaft bearing areas. Anything more would require coupling shaft replacement.**

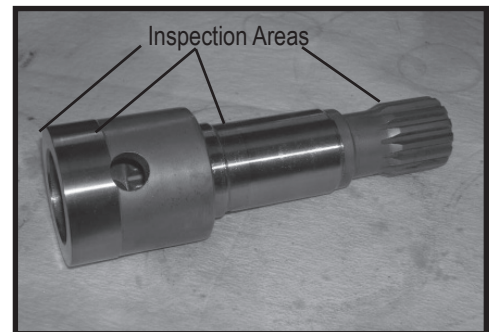

Figure 21

**Remove seal ring from housing**

16. Remove and discard seal ring (4) from housing (18).

**Remove & inspect thrust washer & thrust bearing**

17. Remove thrust bearing (15) and thrust washer (14) if the unit is a Series TC, TS, TB or TE. Inspect for wear, brinelling, corrosion and a full complement of retained rollers. SEE FIGURE 22. **Note: The TL motor has only one thrust bearing and washer.**



Figure 22

**NOTE**

**NOTE: Large Frame Series TF, TG & TJ Torqmotors have a thrust bearing (15) sandwiched between two thrust washers (14) that cannot be removed from housing (18) unless bearing (13) is removed for replacement.**

**Remove seal & washer or washers**

18. Remove seal (16) and back up ring (17) from Small Frame, TC, TB & TE housing (18) and backup washer (25). Discard both. SEE FIGURE 23.

Remove seal (16), backup ring (17), and backup washer (25) from Large Frame, Series TF, TG, TJ and TH housing by working them around unseated thrust washers (14) and thrust bearing (15) and out of the housing. Discard seal and washers. SEE FIGURE 24.



Figure 23

**NOTE**

**NOTE: The original design units of Large & Small Frame Torqmotors™ did not include backup washer (25), but must include backup washer (25) when reassembled for service.**



Figure 24

**Remove seal**

19. Remove housing (18) from vise, invert it and remove and discard seal (20). A blind hole bearing or seal puller is required. SEE FIGURE 25.



Figure 25

**Inspect housing assembly**

20. Inspect housing (18) assembly for cracks, the machined surfaces for nicks, burrs, brinelling or corrosion. Remove burrs that can be removed without changing dimensional characteristics. Inspect tapped holes for thread damage. SEE FIGURE 26. If the housing is defective in these areas, discard the housing assembly.

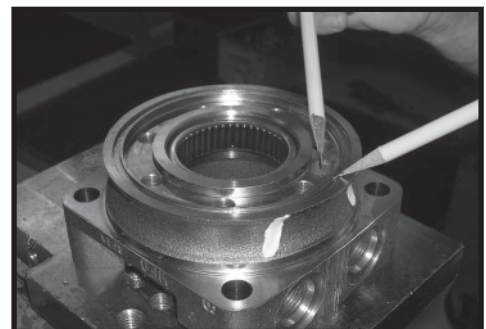

Figure 26



**Inspect housing bearing/bushing**

21. If the housing (18) assembly has passed inspection to this point, inspect the housing bearings/bushings (19) and (13) and if they are captured in the housing cavity the two thrust washers (14) and thrust bearing (15). The bearing rollers must be firmly retained in the bearing cages, but must rotate and orbit freely. All rollers and thrust washers must be free of brinelling and corrosion. SEE FIGURE 27. The TB Series bushing (19) or (13) to coupling shaft diameter clearance must not exceed .010 inch (.025 mm). A bearing, bushing, or thrust washer that does not pass inspection must be replaced. SEE FIGURE 28. If the housing has passed this inspection the disassembly of the Torqmotor™ is completed.

**NOTE**

**NOTE: The depth or location of bearing/bushing (13) in relation to the housing wear plate surface and the depth or location of bearing/bushing (19) in relation to the beginning of bearing/bushing counter bore should be measured and noted before removing the bearings/bushings. This will facilitate the correct reassembly of new bearings/bushings. SEE FIGURE 29.**

**Remove bearings or bushings & thrust washers**

22. If the bearings, bushing or thrust washers must be replaced use a suitable size bearing puller to remove bearing/bushings (19) and (13) from housing (18) without damaging the housing. Remove thrust washers (14) and thrust bearing (15) if they were previously retained in the housing by bearing (13). SEE FIGURES 30 & 31.

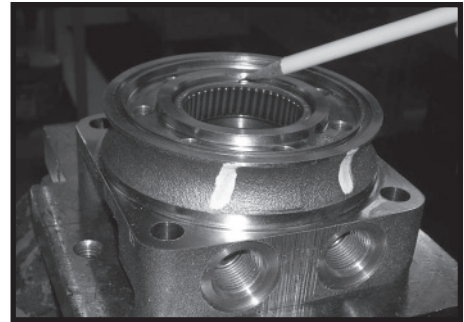

**Figure 27**

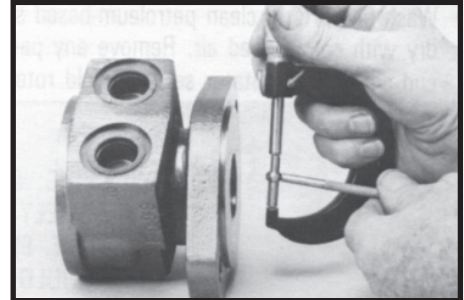

**Figure 28**

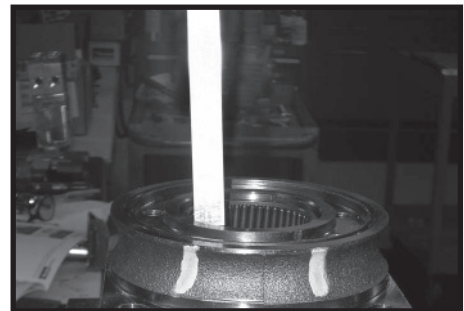

**Figure 29**



**Figure 30**



**Figure 31**

THE DISASSEMBLY OF TORQMOTOR™ IS COMPLETED.

- Replace all seals and seal rings with new ones each time you reassemble the Torqmotor™ unit. Lubricate all seals and seal rings with SAE 10W40 oil or clean grease before assembly.
- **NOTE: Individual seals and seal rings as well as a complete seal kit are available. SEE FIGURE 32. The parts should be available through most OEM parts distributors or Parker approved Torqmotor™ distributors. (Contact your local dealer for availability).**
- **NOTE: Unless otherwise indicated, do not oil or grease parts before assembly.**
- Wash all parts in clean petroleum-based solvents before assembly. Blow them dry with compressed air. Remove any paint chips from mating surfaces of the end cover, commutator set, manifold rotor set, wear plate and housing and from port and sealing areas.

**WARNING**

**WARNING: SINCE THEY ARE FLAMMABLE, BE EXTREMELY CAREFUL WHEN USING ANY SOLVENT. EVEN A SMALL EXPLOSION OR FIRE COULD CAUSE INJURY OR DEATH.**

**WARNING**

**WARNING: WEAR EYE PROTECTION AND BE SURE TO COMPLY WITH OSHA OR OTHER MAXIMUM AIR PRESSURE REQUIREMENTS.**

**Press in outer bearing/bushing**

1. If the housing (18) bearing components were removed for replacement, thoroughly coat and pack a **new** outer bearing/bushing (19) with clean corrosion resistant grease recommended in the material section. Press the new bearing/bushing into the counterbore at the mounting flange end of the housing, using the appropriate sized bearing mandrel such as described in figure 1 or figure 2 which will control the bearing/ bushing depth.

Small Frame Series TC, TS, TB and TE Torqmotor™ housings require the use of bearing mandrel shown in figure 1 to press bearing/ bushing (19) into the housing to a required depth of .151/.161 inches (3.84/4.09 mm) from the end of the bearing counterbore. SEE FIGURE 33. (TC reference page 10).

Large Frame Series TF, TL, TG & TJ Torqmotor™ housings require the use of the bearing mandrel shown in figure 2 to press bearing (19) into the housing to a required depth of .290/.310 inches (7.37/7.87 mm) from the outside end of the bearing counterbore. SEE FIGURE 34.

Large Frame Series TH Torqmotor housings require the use of a bearing mandrel. Consult factory for specifications.

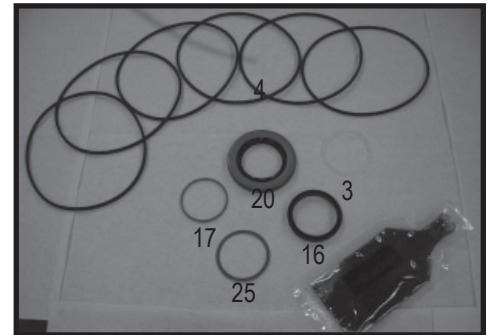

Figure 32, TF, TG seal kit

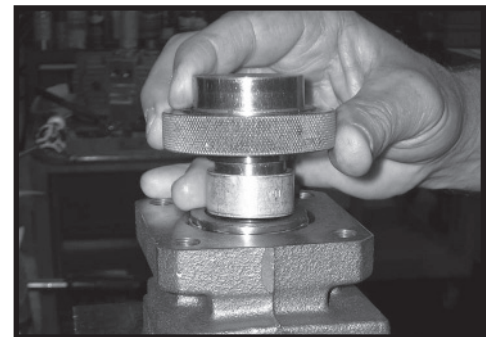

Figure 33

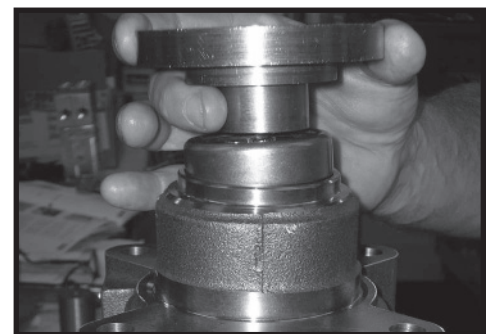

Figure 34

**NOTE** **NOTE:** Bearing mandrel must be pressed against the lettered end of bearing shell. Take care that the housing bore is square with the press base and the bearing/bushing is not cocked when pressing a bearing/bushing into the housing.

**CAUTION** **CAUTION:** If the bearing mandrel specified in the “Tools and Materials Required for Servicing” section is not available and alternate methods are used to press in bearing/bushing (13) and (19) the bearing/bushing depths specified must be achieved to insure adequate bearing support and correct relationship to adjacent components when assembled. SEE FIGURE 35.

**CAUTION** **CAUTION:** Because the bearing/bushings (13) and (19) have a press fit into the housing they must be discarded when removed. They must not be reused.

**Press in inner bearing/bushing**

2. The Small Frame Series TC, TB, TS and TE Torqmotor™ inner housing bearing/bushing (13) can now be pressed into its counterbore in housing (18) flush to .03 inch (.76 mm) below the housing wear plate contact face. Use the opposite end of the bearing mandrel that was used to press in the outer bearing/bushing (19). Reference figure 1, “Tools and Materials Required for Servicing” section. SEE FIGURE 36.

The Large Frame Series TF, TL, TG & TJ Torqmotor™ housing (18) requires that you assemble a **new** backup washer (25) & backup ring (17), **new** seal (16), with the lip facing to the inside of Torqmotor (see figure 69A), **new** thrust washer (14), **new** thrust bearing (15) and a **new** second thrust washer (14) in that order before pressing in the inner housing bearing (13). SEE FIGURE 37 & 38. When these components are in place, press **new** bearing (13) into the housing (18) to a depth of .105/.125 inches (2.67/3.18), .03 inches max for TJ (.76) below the housing wear plate contact face. Use the opposite end of the bearing mandrel used to press in outer bearing (19). Reference figure 2, in the “Tools and Materials Required for Servicing” section. SEE FIGURE 39.

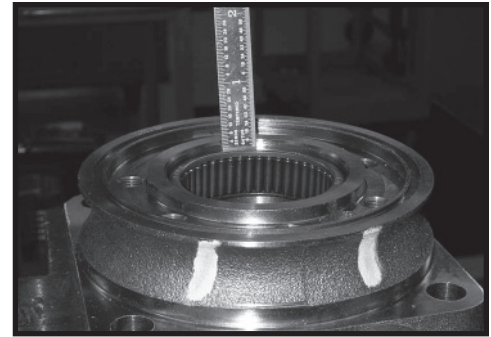

Figure 35

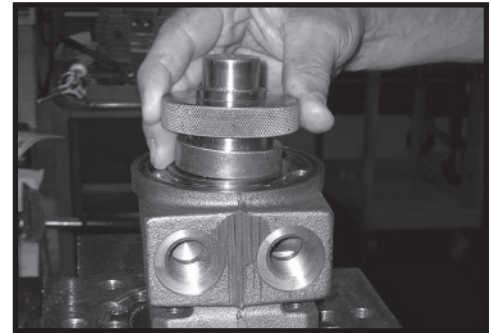

Figure 36



Figure 37



Figure 38

**Press in dirt & water seal**

3. Press a **new** dirt and water seal (20) into the housing (18) outer bearing counterbore.



Figure 39

The Small Frame Series TC, TS, TB and TE Torqmotor™ dirt and water seal (20) must be pressed in until its' flange is flush against the housing. SEE FIGURE 40.

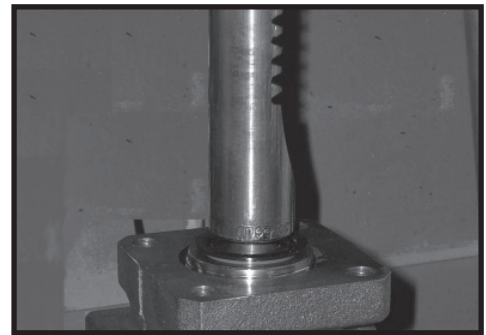

Figure 40

The Large Frame Series TF, TL, TG, TJ & TH Torqmotor™ dirt and water seal (20) must be pressed in with the lip facing out and until the seal is flush to .020 inches (.51 mm) below the end of housing. SEE FIGURE 41.

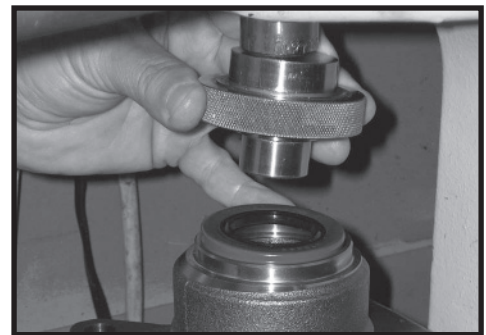

Figure 41

**Place housing assembly into vice**

4. Place housing (18) assembly into a soft jawed vise with the coupling shaft bore down, clamping against the mounting flange. SEE FIGURE 42.

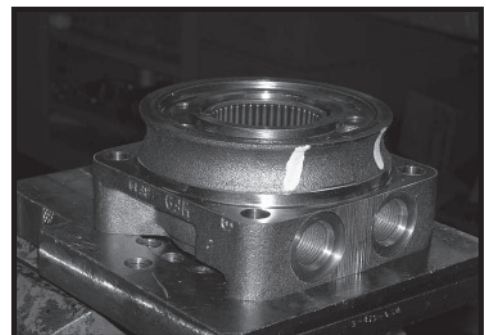

Figure 42

**Assemble backup washer & seal** 5. On Small Frame, Series TC, TS, TB & TE Torqmotors™ assemble a **new** backup ring (17), new backup washer (25) and **new** seal (16) with the seal lip facing toward the inside of Torqmotor™ (see Figure 69B), into their respective counterbores in housing (18) if they were not assembled in procedure 2.

Large Frame, Series TF, TG, TJ & TH Torqmotor™ housing (18) that did not require replacement of the bearing package will require that the two “captured” thrust washers (14) and thrust bearing (15) be unseated and vertical to the counterbore and the **new** backup ring (17), **new** backup washer (25), and **new** seal (16) be worked around the thrust bearing package and placed into their respective counterbores. The seal lip must face out of the seal counterbore and toward the inside of Torqmotor™ (see figure 69A). Be sure the thrust bearing package is resealed correctly after assembly of the seal and backup washer. SEE FIGURES 43 & 44.



Figure 43

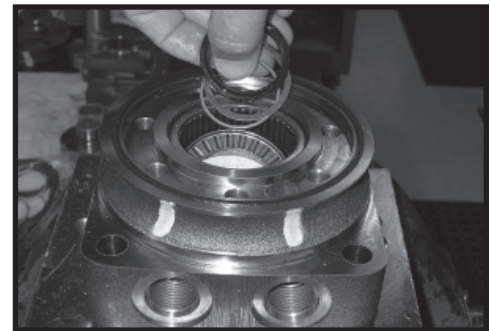

Figure 44

**CAUTION**

**CAUTION: Original design Large Frame, TF & TG Torqmotors™ that do not have backup washer (25) when disassembled must be assembled with a new backup ring (17), new backup washer (25), and new seal (16).**

**Assemble thrust washer & bearing** 6. Assemble thrust washer (14) then thrust bearing (15) that was removed from the Series TC, TB, TS or TE Torqmotor™. SEE FIGURE 45.

**NOTE**

**NOTE: Small Frame Series TC, TS, TB and TE Torqmotors™ require one thrust washer (14) with thrust bearing (15). The coupling shaft will be seated directly against the thrust bearing.**



Figure 45

**Apply masking tape to shaft** 7. Apply masking tape around splines or keyway on shaft (12) to prevent damage to seal. SEE FIGURE 46.

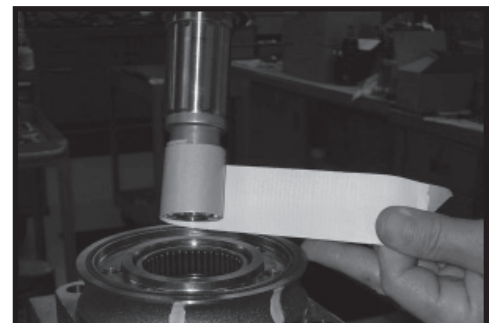

Figure 46

**Install coupling shaft**

8. Be sure that a generous amount of clean corrosion resistant grease has been applied to the lower (outer) housing bearing/bushing (19). Install the coupling shaft (12) into housing (18), seating it against the thrust bearing (15) in TC, TS, TB and TE Series housings and against the second thrust washer (14) in TF, TL, TG and TH Series housings. SEE FIGURE 47.

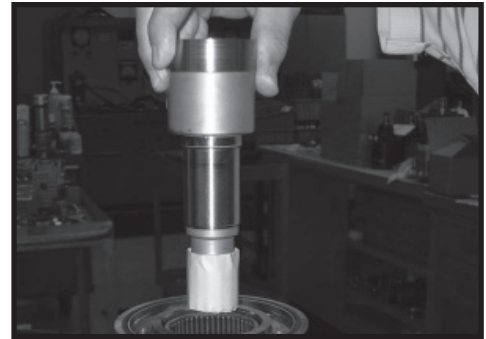

Figure 47

**CAUTION**

**CAUTION: The outer bearing (19) is not lubricated by the system's hydraulic fluid. Be sure it is thoroughly packed with the recommended grease, Parker Gear grease specification #045236, E/M Lubricant #K-70M.**

**NOTE**

**NOTE: Mobil Mobilith SHC ® 460**  
**NOTE: A 102 Tube (P/N 406010) is included in each seal kit.**

**NOTE**

**NOTE: The coupling shaft (12) will be flush or just below the housing wear surface on Small Frame, Series TC, TS, TB, TE & TJ Torqmotors™ when properly seated while the coupling shaft (12) on Large Frame, Series TF, TL, TG, or TH Torqmotors™ will be approximately .10 inch (2.54 mm) below the housing wear plate surface to allow the assembly of thrust bearing (11). The coupling shaft must rotate smoothly on the thrust bearing package. SEE FIGURE 48.**

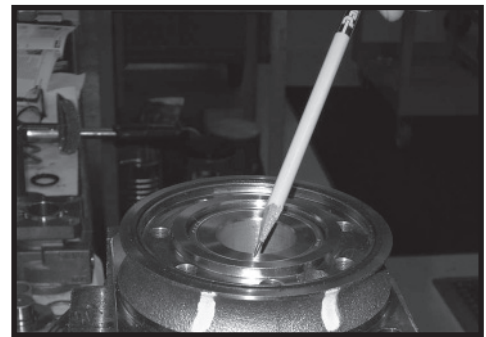

Figure 48

**Install thrust bearing**

9. Install thrust bearing (11) onto the end of coupling shaft (12) only if you are servicing an TF, TL, TG, TH or TL Series Torqmotor™. SEE FIGURE 49.



Figure 49

**Insert seal ring**

10. Apply a small amount of clean grease to a new seal ring (4) and insert it into the housing (18) seal ring groove. SEE FIGURE 50.

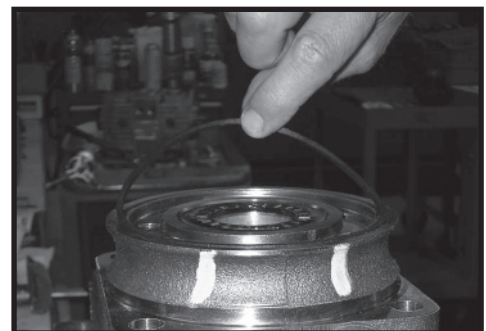

Figure 50

**NOTE**

**NOTE: One or two alignment studs screwed finger tight into housing (18) bolt holes, approximately 180 degrees apart, will facilitate the assembly and alignment of components as required in the following procedures. The studs can be made by cutting off the heads of either 3/8-24 UNF 2A or 5/16-24 UNF 2A bolts as required that are over .5 inch (12.7 mm) longer than the bolts (1, 1A, 1B, or 1C) used in the Torqmotor™.**

**Install drive link**

11. Install drive link (10) the long splined end down into the coupling shaft (12) and engage the drive link splines into mesh with the coupling shaft splines. SEE FIGURE 51.

**NOTE**

**NOTE: Use any alignment marks put on the coupling shaft and drive link before disassembly to assemble the drive link splines in their original position in the mating coupling shaft splines.**

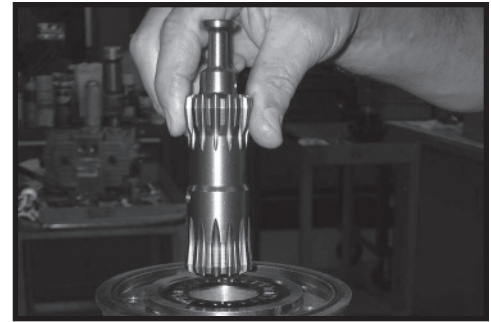

Figure 51

**Assemble wear plate**

12. Assemble wear plate (9) over the drive link (10) and alignment studs onto the housing (18). SEE FIGURE 52.

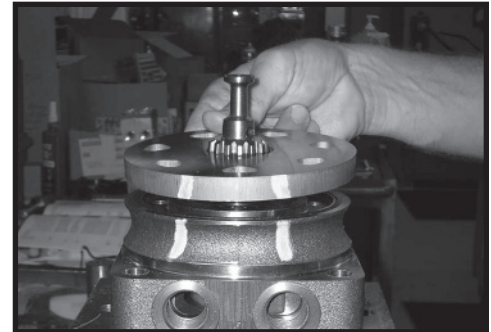

Figure 52

**Assemble seal ring**

13. Apply a small amount of clean grease to a new seal ring (4) and assemble it into the seal ring groove on the wear plate side of the rotor set stator (8B). SEE FIGURE 53.

**Install the assembled rotor set**

14. Install the assembled rotor set (8) onto wear plate (9) with rotor (8A) counterbore and seal ring side down and the splines into mesh with the drive link splines. SEE FIGURE 54.

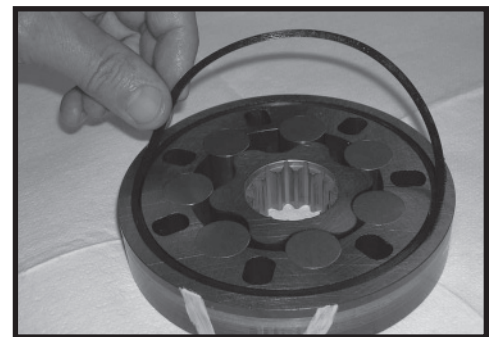

Figure 53

**NOTE**

**NOTE: It may be necessary to turn one alignment stud out of the housing (18) temporarily to assemble rotor set (8) or manifold (7) over the drive link.**

**NOTE**

**NOTE: If necessary, go to the appropriate, "Rotor Set Component Assembly Procedure."**

**NOTE**

**NOTE: The rotor set rotor counterbore side must be down against wear plate for drive link clearance and to maintain the original rotor-drive link spline contact. A rotor set without a counterbore and that was not etched before disassembly can be reinstalled using the drive link spline pattern on the rotor splines if apparent, to determine which side was down. The rotor set seal ring groove faces toward the wear plate (9).**



Figure 54

**Assemble seal ring in manifold**

15. Apply clean grease to a **new** seal ring (4) and assemble it in the seal ring groove in the rotor set contact side of manifold (7). SEE FIGURE 55.

**NOTE**

**NOTE: The manifold (7) is made up of several plates bonded together permanently to form an integral component. The manifold surface that must contact the rotor set has it's series of irregular shaped cavities on the largest circumference or circle around the inside diameter. The polished impression left on the manifold by the rotor set is another indication of which surface must contact the rotor set.**

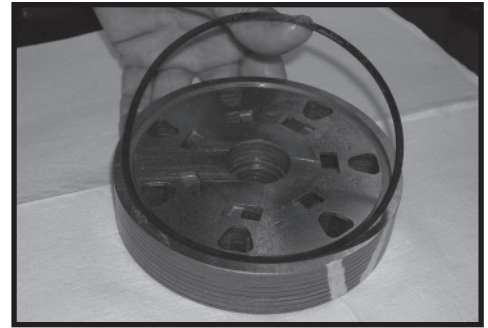

Figure 55

**Assemble manifold**

16. Assemble the manifold (7) over the alignment studs and drive link (10) and onto the rotor set. Be sure the correct manifold surface is against the rotor set. SEE FIGURE 56.

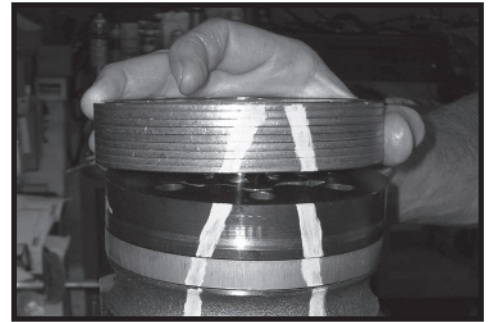

Figure 56

**Insert a seal in manifold**

17. Apply grease to a **new** seal ring (4) and insert it in the seal ring groove exposed on the manifold. SEE FIGURE 57.

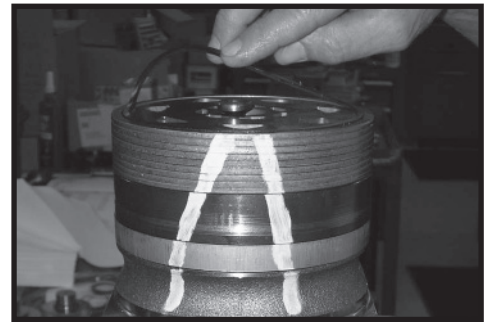

Figure 57

**Assemble commutator ring**

18. Assemble the commutator ring (6) over alignment studs onto the manifold. SEE FIGURE 58.



Figure 58



**Assemble seal & commutator**

19. Assemble a **new** seal ring (3) flat side up, into commutator (5) and assemble commutator over the end of drive link (10) onto manifold (7) with seal ring side up. SEE FIGURE 59, 60.



Figure 59

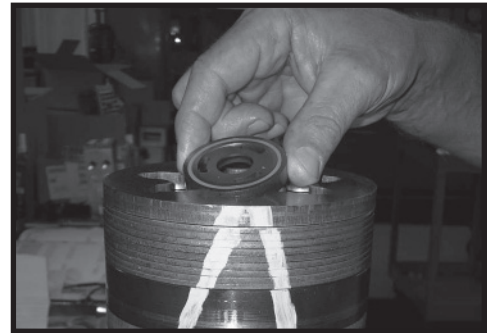

Figure 60

**Assemble shuttle valve parts into end cover**

20. If shuttle valve components items #21, #22, #23, #24 were removed from the end cover (2) turn a plug (21) with a **new** o-ring (22), loosely into one end of the valve cavity in the end cover. Insert a spring (23) the valve (24) and the second spring (23) into the other end of the valve cavity. Turn the second plug (21) with a **new** o-ring (22) loosely into the end cover valve cavity. 3/16 inch Allen wrench required. SEE FIGURE 61.

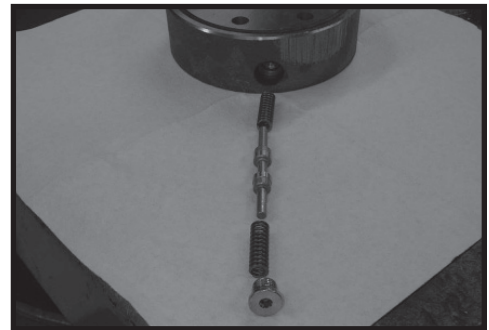

Figure 61

**Assemble relief valve parts in end cover**

21. If relief valve components items #21, #22, #24 were removed from the end cover (2) assemble a **new** o-ring (22) on the two plugs (21). Assemble a two piece relief valve (24) in each of the plugs, with the large end of the conical spring into the plug first and the small nut of the other valve piece in the small end of the conical spring. Turn each of the plug and relief valve assemblies into the end cover loosely to be torqued later. 3/8 inch Allen or 1 inch Hex socket required. SEE FIGURE 62.

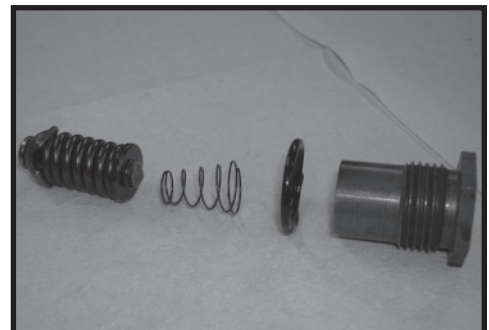

Figure 62

**Assemble seal ring & end cover**

22. Assemble a **new** seal ring (4) into end cover (2) and assemble end cover over the alignment studs and onto the commutator set. SEE FIGURE 63, 64. If the end cover has only 5 bolt holes be sure the cover holes are aligned with the 5 threaded holes in housing (18). The correct 5 bolt end cover bolt hole relationship to housing port bosses is shown in FIGURE 65.

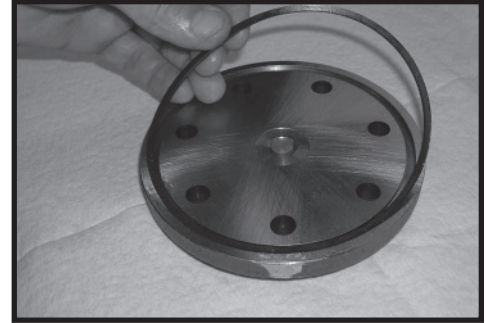

Figure 63

**NOTE**

**NOTE: If the end cover has a valve (24) or has five bolt holes, use the line you previously scribed on the cover to radially align the end cover into its original position.**

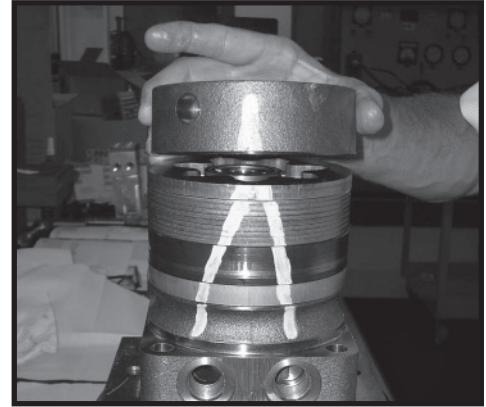

Figure 64

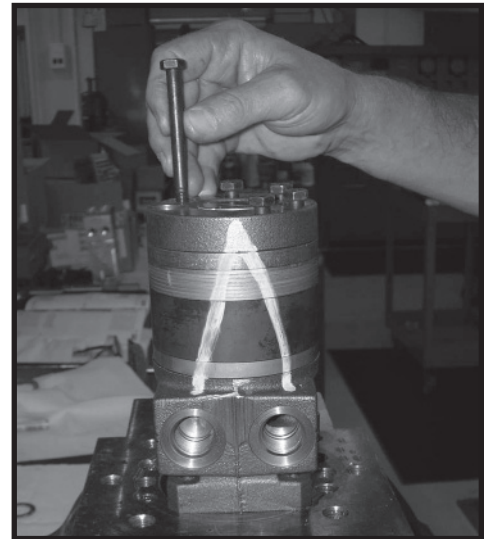

Figure 65

**Assemble cover bolts**

23. Assemble the 5, 6 or 7 special bolts (1, 1A, 1B or 1C) and screw in finger tight. Remove and replace the two alignment studs with bolts after the other bolts are in place. Alternately and progressively tighten the bolts to pull the end cover and other components into place with a final torque of 25-30 ft. lbs. (34-41 N m) for the five TC, TS, TB or six TE Series 5/16 24 threaded bolts or six TJ bolts or 50-55 ft. lbs. (68-75 N m) for the seven TF, TL, TG & TH Series 3/8-24 threaded bolts. SEE FIGURE 66, 67, 68.

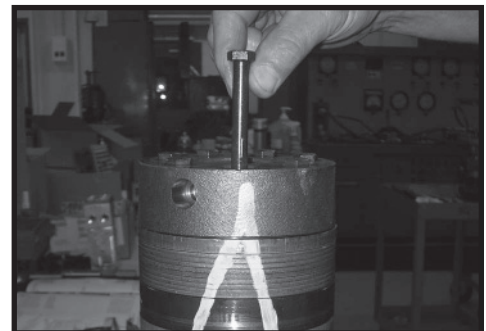

Figure 66

**NOTE**

**NOTE:** The special bolts required for use with the relief or shuttle valve (24) end cover assembly (2) are longer than the bolts required with standard and cover assembly. Refer to the individual service parts lists or parts list charts for correct service part number if replacement is required.

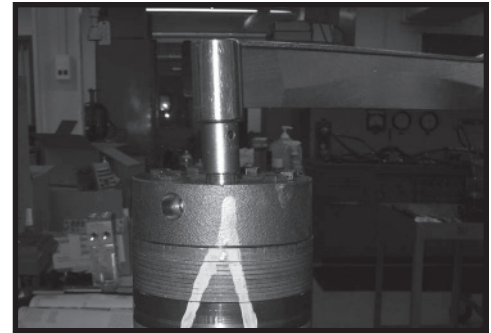

Figure 67

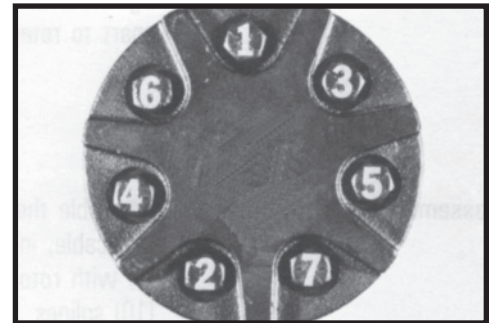

Figure 68

**Torque the valve plugs**

- 24. Torque the two shuttle valve plug assemblies (21) in end cover assembly to 9-12 ft. lbs. (12-16 N m) if cover is so equipped. SEE FIGURE 69.

Torque the two relief valve plug assemblies (21) in end cover assembly to 45-55 ft. lbs. (61-75 N m) if cover is so equipped.

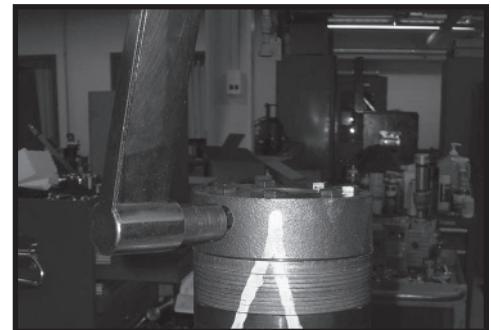

Figure 69

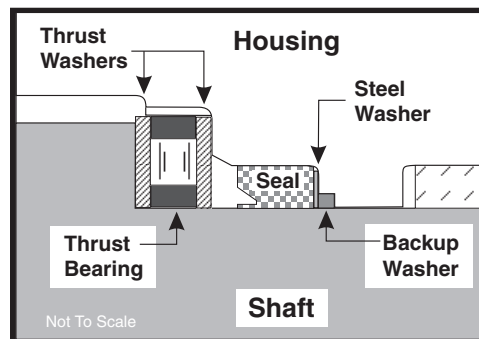

Figure 69A

Large Frame

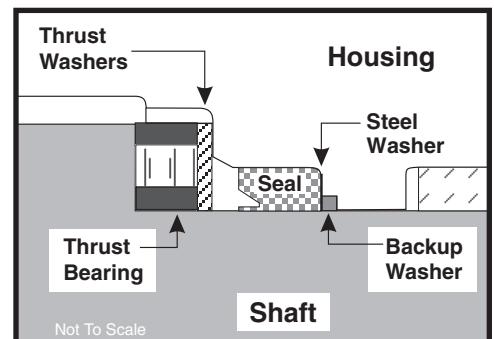

Figure 69B

Small Frame

THE ASSEMBLY OF THE TORQMOTOR™ IS NOW COMPLETE EXCEPT FOR WOODRUFF KEY (12A), NUT (12B), WASHER (12C), BOLT (12D), LOCKWASHER (12E), RETAINER RING (12F) or PORT O-RINGS (18A) AT INSTALLATION IF APPLICABLE. PROCEED TO FINAL CHECKS SECTION.

## One Piece Stator Construction

A disassembled rotor (8A) stator (8B) and vanes (8C) that cannot be readily assembled by hand can be assembled by the following procedures.

**Assemble stator** 1. Place stator (8B) onto wear plate (9) with seal ring (4) side down, after following Torqmotor™ assembly procedures 1 through 13. Be sure the seal ring is in place. SEE FIGURE 70.

**Insert two bolts** 2. If assembly alignment studs are not being utilized, align stator bolt holes with wear plate and housing bolt holes and turn two bolts (1) finger tight into bolt holes approximately 180 degrees apart to retain stator and wear plate stationary.

**Assemble rotor** 3. Assemble the rotor (8A), counterbore down if applicable, into stator (8B), and onto wear plate (9) with rotor splines into mesh with drive link (10) splines. SEE FIGURE 71.

### NOTE

**NOTE: If the manifold side of the rotor was etched during Torqmotor disassembly, this side should be up. If the rotor is not etched and does not have a counterbore, use the drive link spline contact pattern apparent on the rotor splines to determine the rotor side that must be against the wear plate.**

**Assemble vanes** 4. Assemble six vanes (8C), or as many vanes that will readily assemble into the stator vane pockets. SEE FIGURE 72.

### CAUTION

**CAUTION: Excessive force used to push the rotor vanes into place could shear off the coating applied to the stator vane pockets.**

**Assemble full complement of vanes**

5. Grasp the output end of coupling shaft (12) with locking pliers or other appropriate turning device and rotate coupling shaft, drive link and rotor to seat the rotor and the assembled vanes (8C) into stator (8B), creating the necessary clearance to assemble the seventh or full complement of seven vanes. Assemble the seven vanes using minimum force. SEE FIGURE 73.

**Remove two**

**assembled bolts** 6. Remove the two assembled bolts (1) if used to retain stator and wear plate.

Go to Torqmotor™ assembly procedure #15, to continue Torqmotor™ assembly.



Figure 70

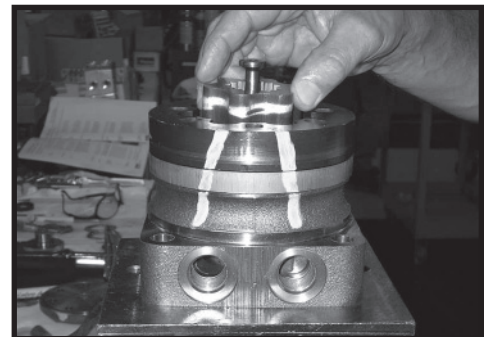

Figure 71

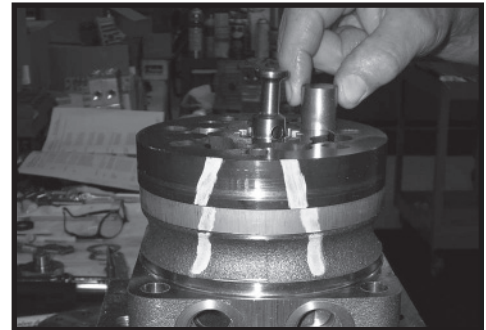

Figure 72

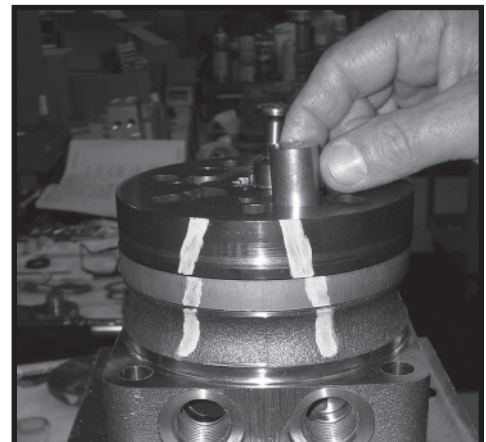

Figure 73

## Two Piece Stator Construction

A disassembled rotor set (8) that cannot be readily assembled by hand and has a two piece stator can be assembled by the following procedures.

**Assemble stator halves** 1. Place stator half (8B) onto wear plate (9) with seal ring (4) side down, after following Torqmotor™ assembly procedures 1 through 13. Be sure the seal ring is in place.

**Insert two alignment studs** 2. Align stator bolt holes with wear plate and housing bolts and turn two alignment studs finger tight into bolt holes approximately 180 degrees apart to retain stator half and wear plate stationary.

**Assemble rotor** 3. Assemble rotor (8A), counterbore down if applicable, into stator half (8B), and onto wear plate (9) with rotor splines into mesh with drive link (10) splines.

**NOTE** **NOTE: Use any marking you applied to rotor set components to reassemble the components in their original relationship to ensure ultimate wear life and performance.**

**Assemble vanes** 4. Assemble six vanes (8C), or as many vanes that will readily assemble into the stator vane pockets.

**CAUTION** **CAUTION: Excessive force used to push the rotor vanes into place could shear off the coating applied to the stator vane pockets.**

**Assemble full complement of vanes** 5. Grasp the output end of coupling shaft (12) with locking pliers or other appropriate turning device and rotate coupling shaft, drive link and rotor to seat the rotor and the assembled vanes (8C) into stator half (8B), creating the necessary clearance to assemble the seventh or full complement of seven vanes. Assemble the seven vanes using minimum force.

**Assemble seal ring in stator half** 6. Place second stator half (8D) on a flat surface with seal ring groove up. Apply a small amount of grease to a **new** seal ring (4) and assemble it into stator half ring groove.

- Assemble second stator half**
7. Assemble the second stator half (8D) over the two alignment studs and rotor (8A) with seal ring side down onto the first stator half (8B) aligning any timing marks applied for this purpose.

**CAUTION**

**CAUTION: If the stator half (8B) is a different height (thickness) than stator half (8D) the stator vanes (8C) or (8E) of the same length (height) as the stator half must be reassembled in their respective stator half for the rotor set to function properly.**

- Assemble vanes**
8. Assemble six vanes (8E), or as many vanes that will readily assemble into the stator vane pockets.

- Assemble full complement of vanes**
9. Grasp the output end of coupling shaft (12) with locking pliers or other appropriate turning device and rotate coupling shaft, drive link and rotor to seat the rotor and the assembled vanes (8E) into stator (8D), creating the necessary clearance to assemble the seventh or full complement of seven vanes. Assemble the seven vanes using minimum force.

Go to Torqmotor™ assembly procedure #15, to continue Torqmotor™ assembly.

## Final Checks

- Pressurize the Torqmotor™ with 100 p.s.i. dry air or nitrogen and submerge in solvent to check for external leaks.
- Check Torqmotor™ for rotation. Torque required to rotate coupling shaft should not be more than 50 ft. lbs. (68 N m)
- On TC, TS, TB, TE & TJ Series Torqmotors, pressure port with “A” cast under it on housing (18) is for clockwise coupling shaft rotation as viewed from the output end of coupling shaft. Pressure port with “B” cast under it is for counter clockwise coupling shaft rotation.
- On TF, TL, TG, & TH Series Torqmotors, pressure port with “B” cast under it on housing (18) is for clockwise coupling shaft rotation as viewed from the output end of coupling shaft. Pressure port with “A” cast under it is for counter clockwise coupling shaft rotation.
- Use test stand if available, to check operation of the Torqmotor™.

## Hydraulic Fluid

Keep the hydraulic system filled with one of the following:

- 10W40 SE or SF manufacturers suggested oil.
- Hydraulic fluid as recommended by equipment manufacturer, but the viscosity should not drop below 50 SSU or contain less than .125% zinc anti-wear additives.

**CAUTION: Do not mix oil types. Any mixture, or an unapproved oil, could deteriorate the seals. Maintain the proper fluid level in the reservoir. When changing fluid, completely drain old oil from the system. It is suggested also that you flush the system with clean oil.**

## Filtration

Recommended filtration 20-50 micron.

## Oil Temperature

Maximum operating temperature 200°F (93.3° C).

**Tips****Tips for Maintaining the Torqmotor™ Hydraulic System**

- Adjust fluid level in reservoir as necessary.
- Encourage all operators to report any malfunction or accident that may have damaged the hydraulic system or component.
- Do not attempt to weld any broken Torqmotor™ component. Replace the component with original equipment only.
- Do not cold straighten, hot straighten, or bend any Torqmotor™ part.
- Prevent dirt or other foreign matter from entering the hydraulic system. Clean the area around and the filler caps before checking oil level.
- Investigate and correct any external leak in the hydraulic system, no matter how minor the leak.
- Comply with manufacturer's specifications for cleaning or replacing the filter.

**CAUTION: Do not weld, braze, solder or any way alter any Torqmotor™ component.**

**CAUTION: Maximum operating pressure must not exceed recommended Torqmotor™ pressure capacity.**

**CAUTION: Always carefully inspect any system component that may have been struck or damaged during operation or in an accident. Replace any component that is damaged or that is questionable.**

**CAUTION: Do not force any coupling onto the Torqmotor™ coupling shaft as this could damage the unit internally.**

Parker extends close technical cooperation and assistance. If problems occur which you cannot solve, please contact your local Parker approved Distributor or Parker Technical Support. Our phone number and fax number and address are on the back cover of this manual.





**Parker Hannifin Corporation**  
2745 Snapps Ferry Road  
Greeneville, TN 37745 USA  
Tel: (423) 639-8151  
FAX: (423) 787-2418  
[www.parker.com/pumpmotor](http://www.parker.com/pumpmotor)