

Single sideband modulation technique can relax the bandwidth restriction

September 26 2023

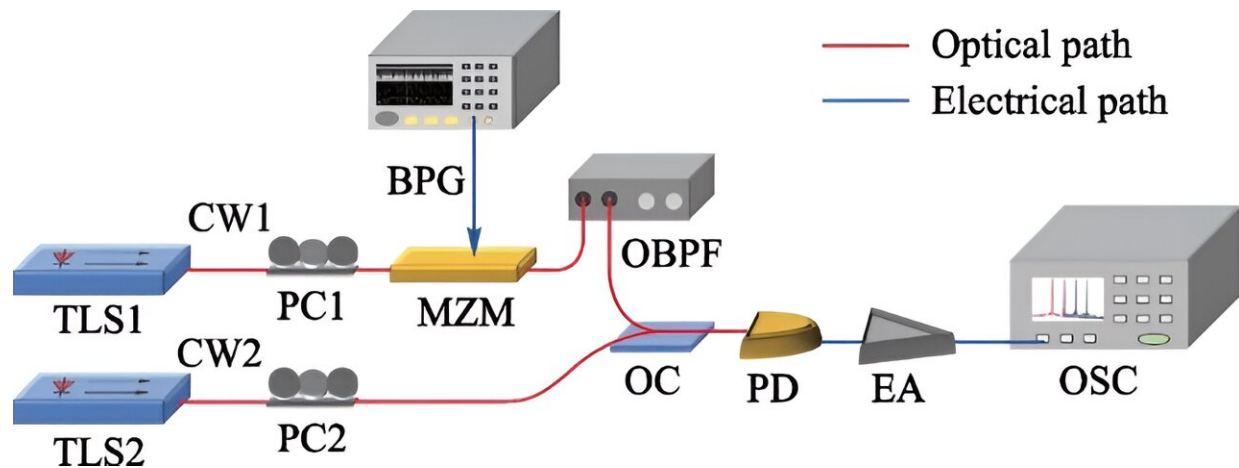

Schematic diagram of the proposed photonic generation of ASK microwave signals based on SSB modulation. Credit: *Frontiers of Optoelectronics* (2023). DOI: 10.1007/s12200-023-00075-2

As an ultra-wideband microwave signal, amplitude shift keying (ASK) can be used in many applications, such as electronic warfare, wireless communications and modern radar systems. Initially, ASK microwave signals are generated based on radio frequency analog mixing and direct digital synthesis, which limit the carrier frequency and coding bit rate of generated signals. Compared with the traditional microwave technology, microwave photonics technique can generate ASK microwave signals with high frequency and large bandwidth.

Researchers led by Prof. Xinliang Zhang and Assoc. Prof. Yuan Yu at Huazhong University of Science and Technology (HUST), Wuhan, China, are interested in microwave photonics technique, which can overcome the bottlenecks in traditional microwave electrical [technology](#).

Usually, the highest frequency of the microwave signal generated by optical beating is limited by the bandwidths of photodetectors. To maximize the microwave frequency with a limited bandwidth of photodetector, they propose to use [microwave signals](#) with single sideband format in microwave communication systems. By doing so, the bandwidth restriction set by optoelectronic devices is significantly relaxed and even higher communication speed can be obtained.

Additionally, this approach can obtain a higher microwave frequency and thus can be transmitted via higher frequency bands. The work entitled "[Photonic generation of ASK microwave signals with SSB format](#)" was published in *Frontiers of Optoelectronics* (published on July 24, 2023).

More information: Weilei Gou et al, Photonic generation of ASK microwave signals with SSB format, *Frontiers of Optoelectronics* (2023). [DOI: 10.1007/s12200-023-00075-2](https://doi.org/10.1007/s12200-023-00075-2)

Provided by Frontiers Journals

Citation: Single sideband modulation technique can relax the bandwidth restriction (2023, September 26) retrieved 26 April 2024 from <https://phys.org/news/2023-09-sideband-modulation-technique-bandwidth-restriction.html>

This document is subject to copyright. Apart from any fair dealing for the purpose of private study or research, no part may be reproduced without the written permission. The content is provided for information purposes only.