



Web: <https://pearl-hifi.com>
e-Mail: sales@pearl-hifi.com

1 - 84 Broadway St. West; Nakusp, BC; V0G 1R0
Land: + 250.888.8888 Mobile: + 587.578.4434

Perkins Electro-Acoustic Research Lab, Inc.



Engineering and Intuition Lovingly Serving the Soul of Music

Please note that the links in the PEARL logotype above are live and can be used to direct your web browser to our site or to open an e-mail addressed to ourselves.

To view our item listings on eBay, [click here](#).

To see our eBay feedback, [click here](#).

This document has been prepared as a public service . Any and all trademarks and logos used herein are the property of their owners.

It is our intent to provide this document in accordance with the stipulations with respect to “fair use” as delineated in Copyrights - Chapter 1: Subject Matter and Scope of Copyright; Sec. 107. Limitations on exclusive rights: Fair Use.

Copy of this document is seen on the [Cornell Law School](#) website and is reproduced in part below:

Sec. 107. - Limitations on exclusive rights: Fair Use

Notwithstanding the provisions of sections 106 and 106A, the fair use of a copyrighted work, including such use by reproduction in copies or phonorecords or by any other means specified by that section, for purposes such as criticism, comment, news reporting, teaching (including multiple copies for classroom use), scholarship, or research, is not an infringement of copyright. In determining whether the use made of a work in any particular case is a fair use the factors to be considered shall include:

- 1 - the purpose and character of the use, including whether such use is of a commercial nature or is for nonprofit educational purposes;
- 2 - the nature of the copyrighted work;
- 3 - the amount and substantiality of the portion used in relation to the copyrighted work as a whole; and
- 4 - the effect of the use upon the potential market for or value of the copyrighted work.

The fact that a work is unpublished shall not itself bar a finding of fair use if such finding is made upon consideration of all the above factors

TAFT-PEIRCE

PRICE LIST



Ward Sales Co.
Machine Tools
1472 Broadway
Wisconsin 7-1208 - Newark 9-0611

THE TAFT-PEIRCE MFG. COMPANY
WOONSOCKET, RHODE ISLAND

Manufacturers of

Small Tools, Gages, Magnetic Chucks, Reamers, Surface Grinders, etc., and
Contract Manufacturers of Tools and Special Machinery

L. S. LIEBERT

Jan. 1, 1945

11-1-46

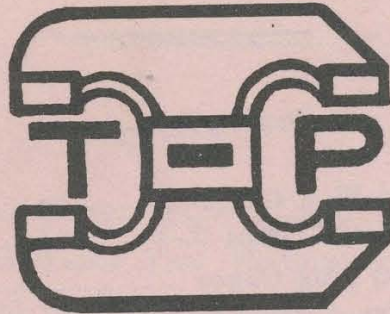

DISCOUNT SHEET

GAGES

MAGNETIC CHUCKS

TOOL ROOM SPECIALTIES

MACHINE TOOLS

ALL PRICES LISTED HEREIN

F. O. B. WOONSOCKET, R. I.

TERMS NET — 30 DAYS

THE TAFT-PEIRCE MFG. CO.

Woonsocket, Rhode Island

T. P. DISCOUNT SHEET

Pages	Description	Discount
5-21	Cylindrical Plug Gages All Styles, Classes X-Y	25%
	Cylindrical Plug Gages All Styles, Class XX	Prices on Application
23	Micrometer Plug Gages	Prices on Application
24	Master Setting Discs	Net
	Quantity Discounts on Application	
25-28	Cylindrical Ring Gages All Styles, Classes X, Y, & Z	25%
	Worn Cylindrical Plug and Ring Gages may be salvaged by chromium plating and refinishing. Prices on Application	
29	Limit Snap Gages	Net
29	Snap Gage Stands	Net
30-33	Adjustable Limit Snap Gages AGD Style Set, Sealed, and Marked (more than 25 Characters) Net Set, Sealed, and Marked (less than 25 Characters) 15% Unset and Unmarked	25%
34-37	Thread Plug Gages	15%
38-39	Thread Ring Gages	10%
40-41	Taper Pipe Thread Plug Gages	15%
40-41	Taper Pipe Thread Ring Gages	10%
42	Thread Snap Gages	Net
43	Roll Thread Snap Gages	5%
44	Thread Setting Blocks	Net
45	Thread Measuring Wires	Net
47	Taper Testing Fixtures	25%
49	Tool Room Specialties	
50	Sine Bars	25%
50	Sine Blocks	25%

Ward Sales Co.

Machine Tools

1472 Broadway

Wisconsin 7-1208 BRYant 9-9642



T. P. DISCOUNT SHEET

Pages	Description	Discount
51	Sine Bar Fixture	25%
51	Sine Bar Taper Test. Fixture	25%
52	Universal Angle Gages	25%
52	Universal Angle Blocks	25%
53	V Blocks Hardened	25%
53	V Blocks Universal	25%
54	V Blocks Cast	25%
54	Cylindrical Squares	25%
55	Hardened and Ground Parallels	25%
56	Box Parallels	25%
56	Planer and Boring Mill Parallel	25%
57	Leveling Straight Edges Cast Iron	25%
57	Steel Straight Edges	25%
58	Toolmakers Adjustable Knee	25%
58	Adjustable Angle Plate	25%
59	Toolmakers Knee	25%
59	Slotted Angle Irons	25%
60	Universal Rt. Angle Irons	25%
60	Measuring Irons	25%
61	Surface Plates	20%
62-63	Bench Centers	25%
64	Duplex Bench Blocks	25%
64	Universal Squares	25%
65	Boring Equipment	25%
67-71	Adjustable Reamers	Net
73-82	Magnetic Chucks	Net
85-86	No. 1 Precision Surface Grinder and Accessories	Net
87-88	6" Rotary Surface Grinder and Accessories.....	Net
89	Back Spot Facing Machine.....	Net

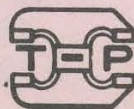

THE TAFT-PEIRCE MANUFACTURING COMPANY

Main Office and Factory

WOONSOCKET, RHODE ISLAND, U.S.A.

DISTRICT SALES OFFICES

NEW YORK CITY
Woolworth Building

DETROIT, MICHIGAN
2921 East Grand Blvd.

CHICAGO, ILLINOIS
564 West Randolph Street

BRANCH OFFICES

ATLANTA	C. W. Moore, 1545 Westwood Ave. S. W.
BOSTON	A. R. Shevlin, Park Square Bldg.
BUFFALO	R. C. Neal Co., Inc., 76 Pearl Street
CALGARY, Alberta	A. R. Williams Machinery Co., Ltd.
CINCINNATI	Walter F. Greene
CLEVELAND	Hal W. Reynolds, 3346 Superior Avenue
DALLAS	Hamilton-Huster Machinery Co.
ELMIRA, N. Y.	R. C. Neal Co., Inc., 358 No. Main St.
GRAND RAPIDS	Joseph Monahan, 351 Indiana Ave. N. W.
HOUSTON	Sam H. Penny, P. O. Box 1271
INDIANAPOLIS	Walter F. Greene, 658 Fairfield Avenue
LOS ANGELES	Frey Industrial Supply Co., 3828 Santa Fe Ave
MINNEAPOLIS	E. L. Sandberg, 724 Metropolitan Bank Bldg.
MONTREAL	A. R. Williams Mchy. Co., Ltd.
OTTAWA, Ontario	A. R. Williams Machinery Co., Ltd.
PHILADELPHIA	Wright & Gade Equipment Co., 3701 No. Broad St.
PITTSBURGH	Gus L. Kronfeld, 1609 Investment Bldg.
ROCHESTER	R. C. Neal Co., Inc., 46 Andrews Street
ST. LOUIS	Clarke Equipment Co., 320 No. Grand Blvd.
SAN FRANCISCO	Jos. C. Fletcher, 1415 Folsom Street
SEATTLE	C. & H. Supply Co., 2721 1st Ave. South
SYRACUSE	R. C. Neal Co., Inc., 569 So. Clinton Street
TOLEDO, OHIO	A. J. Kiehne, 2773 Inwood Drive
TORONTO	A. R. Williams Mchy. Co., Ltd.
VANCOUVER, B. C.	A. R. Williams, Mchy. Co., Ltd.
VICTORIA, B. C.	A. R. Williams Machinery Co., Ltd.
WASHINGTON	H. E. Czerwonky, Arlington, Va.
SOUTH AMERICA }	{ Sabin St. Germain & Associates
WEST INDIES }	{ 285 Madison Ave., New York

Ward Sales Co.
Machine Tools
1472 Broadway
Wisconsin 7-1208 BRyant 9-9642

GENERAL INDEX

<i>Page</i>	1	<i>Gage Section</i>
<i>Page</i>	49	<i>Tool Room Specialties</i>
<i>Page</i>	67	<i>Reamer Section</i>
<i>Page</i>	73	<i>Magnetic Chuck Section</i>
<i>Page</i>	83	<i>Machine Tool Section</i>
<i>Page</i>	85	<i>No. 1 Precision Surface Grinders</i>
<i>Page</i>	87	<i>6" Rotary Surface Grinder</i>
<i>Page</i>	89	<i>Back Spot Facing Machine</i>

Ward Sales Co.
Machine Tools
1472 Broadway
Wisconsin 7-1208 BRyant 9-9642

GAGE SECTION

Cylindrical Plug Gages

Micrometer Plug Gages

Master Discs

Plain Ring Gages

External Limit Gages

Taper Gages

Thread Plug Gages

Thread Ring Gages

Taper Pipe Thread Gages

Thread Snap Gages

Thread Measuring Wires

Page

1

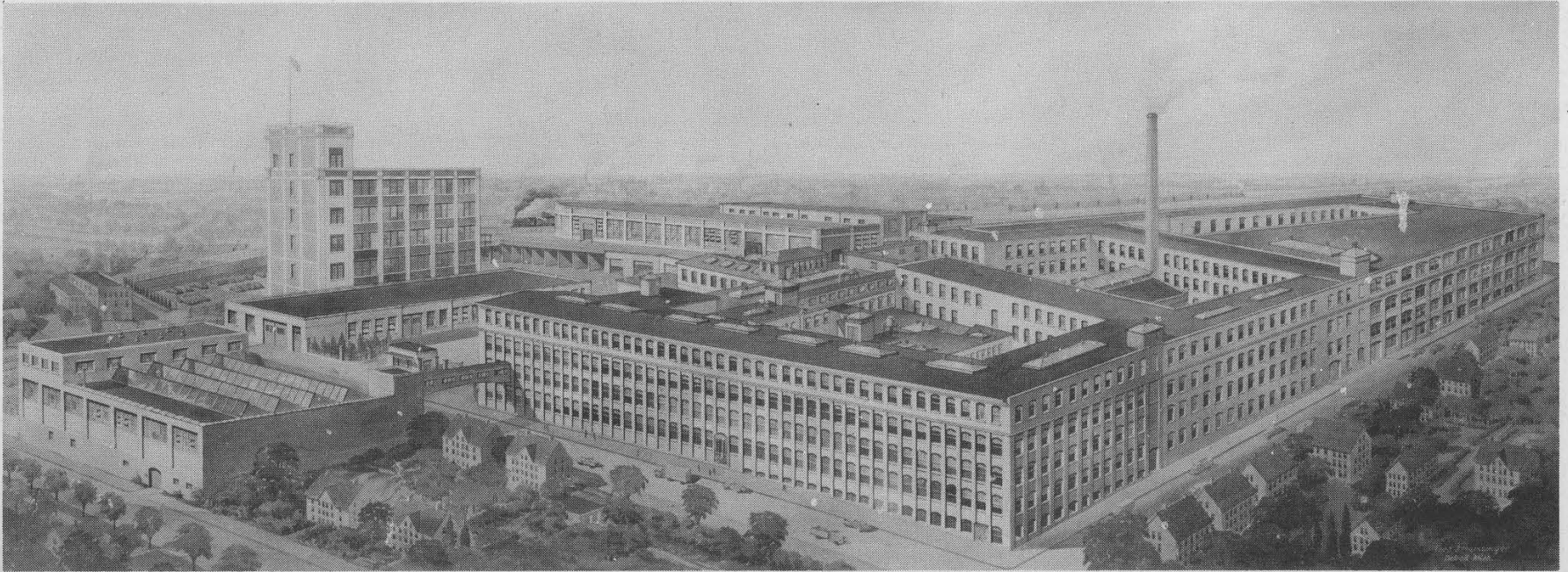

*The Taft-Peirce Manufacturing Company
Woonsocket, Rhode Island, U. S. A.*

IMPORTANT

To enable us to enter your order promptly, please supply the following information:

PLAIN PLUG GAGES

- 1 — Size of Go and No. Go Members.
- 2 — Gage makers' class of tolerance.
- 3 — Members required — Go, Not Go, Handle.
- 4 — Length of member, unless AGD standard.
- 5 — Complete instructions for marking.

ADJUSTABLE SNAP GAGES

- 1 — Model.
- 2 — Frame number.
- 3 — Range.
- 4 — Type of buttons.
- 5 — Furnish size if gage is to be set and sealed.
- 6 — Complete instructions for marking.

Page
3

THREAD GAGES

- 1 — Size.
- 2 — Threads per inch.
- 3 — Form of thread.
- 4 — Pitch diameter — Go, Not Go.
- 5 — Members required — Go, Not Go, Handle.
- 6 — Class of Gage makers' tolerance: X-Y-W.
- 7 — Class of fit: 1-2-3-4 or 5.
- 8 — Complete instructions for marking.

THREAD SNAP GAGES

- 1 — Size.
- 2 — Threads per Inch.
- 3 — Form of Thread.
- 4 — Pitch Diameter — Go, Not Go.
- 5 — Style of Frame.
- 6 — Class of Fit 1-2-3-4 or 5.
- 7 — Complete Instructions for Marking.

MAGNETIC CHUCKS

- 1 — D.C. voltage on which chuck will operate.

T-P CYLINDRICAL PLUG GAGES

Taft-Peirce plug and ring gages are manufactured in accordance with the standards recommended by the American Gage Design Committee. Illustrated on this page are the parts comprising the plain cylindrical plug gage line, showing the adaptability of the designs to various gage combinations.

TAPER LOCK PARTS



T-P Style 9311
A. G. D. Go Member



T-P Style 9313
A. G. D. Handle



T-P- Style 9312
A. G. D. Not Go Member

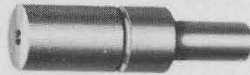

T-P-Style 9314
A. G. D. Progressive Member

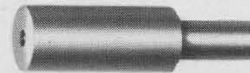

T-P Style 9322
A. G. D. Extra Long Member

REVERSIBLE OR TRILOCK PARTS



T-P Style 9311
A. G. D. Go Member



T-P Style 9313
A. G. D. Handle



T-P Style 9312
A. G. D. Not Go Member

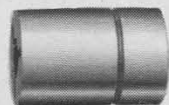

T-P Style 9314
A. G. D. Progressive Member

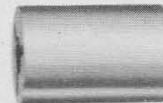

T-P Style 9322
A. G. D. Extra Long Member

GAGE MAKERS' TOLERANCES

SIZE RANGE	Class XX	Class X	Class Y	Class Z	Class ZZ
From To					
.029-.825	.00002	.00004	.00007	.00010	.00020
.825-1.510	.00003	.00006	.00009	.00012	.00024
1.510-2.510	.00004	.00008	.00012	.00016	.00032
2.510-4.510	.00005	.00010	.00015	.00020	.00040
4.510-6.010	.000065	.00013	.00019	.00025	.00050

CYLINDRICAL PLUG GAGES

HARDENED ALLOY STEEL

CLASS X Tolerances

.029- .825	.00004	1.510-2.510	.00008
.825-1.510	.00006	2.510-4.510	.00010
	4.510-6.010	.00013	



TAFT-PEIRCE STYLE 9316 A. G. D. GO Members and Handles

Size Range	Length Gaging Section	Price Each Complete				Handles any Quan.
		1	2	3-5	6-11	

Page
6

To and Above Incl..

TAPER LOCK TYPE

Size Range	Length Gaging Section	1	2	3-5	6-11	Handles any Quan.
.029- .040	3/8"	\$12.00	\$10.90	\$10.40	\$10.00	\$1.50
.040- .059	3/8	11.00	10.00	9.50	9.20	1.50
.059- .105	3/8	10.10	9.30	8.80	8.50	1.50
.105- .150	7/16	9.60	8.80	8.40	8.10	1.50
.150- .185	19/32	9.30	8.50	8.10	7.80	1.50
.185- .240	19/32	9.10	8.00	7.30	6.80	1.50
.240- .365	3/4	8.80	7.70	7.00	6.50	1.20
.365- .510	1	9.30	8.10	7.40	6.90	1.20
.510- .825	1 1/4	10.20	8.90	8.30	7.70	1.20
.825-1.135	1 3/8	11.70	10.30	9.70	9.20	1.50
1.135-1.510	1 1/2	13.50	12.00	11.30	10.70	1.80

TRILOCK REVERSIBLE TYPE

1.510-1.760	1 7/8	18.40	16.60	15.80	15.20	3.00
1.760-2.010	1 7/8	20.30	18.20	17.30	16.60	3.00
2.010-2.260	2	22.20	19.90	18.90	18.10	3.00
2.260-2.510	2	24.00	21.50	20.40	19.60	3.00
2.510-2.760	2 1/8	26.50	24.00	23.10	22.40	3.60
2.760-3.010	2 1/8	28.40	25.60	24.60	23.90	3.60
3.010-3.260	2 1/4	30.40	27.50	26.40	25.60	3.60
3.260-3.510	2 1/4	32.60	29.40	28.30	27.40	3.60
3.510-3.760	2 1/4	34.80	31.40	30.10	29.20	3.60
3.760-4.010	2 1/4	37.00	33.40	32.00	31.00	3.60
4.010-4.260	2 1/4	39.40	35.50	34.00	33.00	3.60
4.260-4.510	2 1/4	41.80	37.60	36.10	34.90	3.60

Quantity index is total number of members of identical size ordered at one time.
To price gaging members only deduct price of handle from price of complete gage.
Prices of larger sizes and quantities on application.

Above prices subject to Discount. See Discount Sheet.

CYLINDRICAL PLUG GAGES

CHROMIUM PLATED

CLASS X Tolerances

.029-.040	.00004	1.510-2.510	.00008
.040-.059	.00006	2.510-4.510	.00010
.059-.105		4.510-6.010	.00013



TAFT-PEIRCE STYLE 9316
A. G. D. GO Members and Handles

Size Range	Length Gaging Section	Price Each Complete				Handles any Quan.
		1	2	3-5	6-11	

To and Above Incl.

TAPER LOCK TYPE

.029-.040	3/8"	\$19.40	\$17.60	\$16.70	\$16.00	\$1.50
.040-.059	3/8	17.70	16.10	15.30	14.60	1.50
.059-.105	3/8	16.20	14.80	14.00	13.40	1.50
.105-.150	7/16	15.40	14.00	13.30	12.70	1.50
.150-.185	19/32	14.80	13.50	12.80	12.30	1.50
.185-.240	19/32	14.50	12.50	11.50	10.60	1.50
.240-.365	3/4	14.20	12.20	11.20	10.30	1.20
.365-.510	1	15.10	13.00	11.90	10.90	1.20
.510-.825	1 1/4	16.50	14.40	13.30	12.40	1.20
.825-1.135	1 3/8	18.90	16.60	15.50	14.70	1.50
1.135-1.510	1 1/2	21.80	19.20	18.00	17.00	1.80

TRILOCK REVERSIBLE TYPE

1.510-1.760	1 7/8	29.30	26.20	24.90	23.80	3.00
1.760-2.010	1 7/8	32.50	29.00	27.50	26.30	3.00
2.010-2.260	2	35.70	31.80	30.10	28.80	3.00
2.260-2.510	2	38.90	34.60	32.80	31.40	3.00
2.510-2.760	2 1/8	42.70	38.40	36.80	35.70	3.60
2.760-3.010	2 1/8	45.90	41.20	39.50	38.30	3.60
3.010-3.260	2 1/4	49.40	44.30	42.70	41.10	3.60
3.260-3.510	2 1/4	53.10	47.70	45.70	44.20	3.60
3.510-3.760	2 1/4	56.90	51.00	48.90	47.30	3.60
3.760-4.010	2 1/4	60.70	54.40	52.10	50.40	3.60
4.010-4.260	2 1/4	64.70	58.00	55.60	53.70	3.60
4.260-4.510	2 1/4	68.80	61.60	59.00	57.10	3.60

Quantity index is total number of members of identical size ordered at one time.
To price gaging members only deduct price of handle from price of complete gage.
Prices of larger sizes and quantities on application.

Above prices subject to Discount. See Discount Sheet.

738

Ward Sales Co.
Machine Tools
1472 Broadway
Wisconsin 7-1208 BRYANT 9-9642

CYLINDRICAL PLUG GAGES HARDENED ALLOY STEEL

CLASS X Tolerances

.029-.040	.00004	1.510-2.510	.00008
.040-.059	.00006	2.510-4.510	.00010
.059-.105	.00010	4.510-6.010	.00013



TAFT-PEIRCE STYLE 9318 A. G. D. NOT GO—Members and Handles

Size Range	Length Gaging Section	Price Each Complete				Handles any Quan.
		1	2	3-5	6-11	

Page

8

To and
Above Incl.

TAPER LOCK TYPE

.029-.040	.040	$\frac{3}{16}$ "	\$10.80	\$ 9.80	\$ 9.40	\$ 9.00	\$1.50
.040-.059	.059	$\frac{3}{16}$	9.90	9.00	8.60	8.30	1.50
.059-.105	.105	$\frac{3}{16}$	9.10	8.30	8.00	7.70	1.50
.105-.150	.150	$\frac{7}{32}$	8.70	7.90	7.60	7.30	1.50
.150-.185	.185	$\frac{9}{32}$	8.40	7.70	7.30	7.00	1.50
.185-.240	.240	$\frac{9}{32}$	8.20	7.20	6.70	6.20	1.50
.240-.365	.365	$\frac{5}{16}$	7.90	6.90	6.40	5.90	1.20
.365-.510	.510	$\frac{3}{8}$	8.40	7.30	6.70	6.20	1.20
.510-.825	.825	$\frac{1}{2}$	9.10	8.00	7.40	7.00	1.20
.825-1.135	1.135	$\frac{5}{8}$	10.50	9.30	8.70	8.30	1.50
1.135-1.510	1.510	$\frac{3}{4}$	12.10	10.80	10.10	9.60	1.80

TRILOCK REVERSIBLE TYPE

1.510-1.760	1.760	$\frac{7}{8}$	16.60	15.00	14.30	13.70	3.00
1.760-2.010	2.010	$\frac{7}{8}$	18.30	16.40	15.70	15.00	3.00
2.010-2.260	2.260	$\frac{7}{8}$	19.90	17.90	17.00	16.30	3.00
2.260-2.510	2.510	$\frac{7}{8}$	21.60	19.30	18.40	17.60	3.00
2.510-2.760	2.760	1	23.80	21.60	20.80	20.20	3.60
2.760-3.010	3.010	1	25.50	23.00	22.20	21.50	3.60
3.010-3.260	3.260	1	27.30	24.60	23.70	23.00	3.60
3.260-3.510	3.510	1	29.20	26.40	25.40	24.60	3.60
3.510-3.760	3.760	1	31.20	28.10	27.00	26.20	3.60
3.760-4.010	4.010	1	33.10	29.90	28.70	27.80	3.60
4.010-4.260	4.260	1	35.20	31.70	30.50	29.50	3.60
4.260-4.510	4.510	1	37.30	33.60	32.20	31.20	3.60

Quantity index is total number of members of identical size ordered at one time.
To price gaging members only deduct price of handle from price of complete gage.
Prices of larger sizes and quantities on application.

Above prices subject to Discount. See Discount Sheet.

CYLINDRICAL PLUG GAGES

CHROMIUM PLATED

CLASS X

Tolerances

.029-.825	.00004	1.510-2.510	.00008
.825-1.510	.00006	2.510-4.510	.00010
	4.510-6.010		.00013



TAFT-PEIRCE STYLE 9318

A. G. D. NOT GO—Members and Handles

Size Range	Length Gaging Section	Price Each Complete				Handles any Quan.
		1	2	3-5	6-11	

To and
Above Incl.

TAPER LOCK TYPE

.029-.040	$\frac{3}{16}$ "	\$17.60	\$16.00	\$15.20	\$14.50	\$1.50
.040-.059	$\frac{3}{16}$	16.00	14.60	13.80	13.20	1.50
.059-.105	$\frac{3}{16}$	14.70	13.40	12.70	12.20	1.50
.105-.150	$\frac{7}{32}$	13.90	12.70	12.10	11.60	1.50
.150-.185	$\frac{9}{32}$	13.40	12.20	11.60	11.10	1.50
.185-.240	$\frac{9}{32}$	13.20	11.40	10.50	9.60	1.50
.240-.365	$\frac{5}{16}$	12.90	11.10	10.20	9.30	1.20
.365-.510	$\frac{3}{8}$	13.60	11.80	10.80	9.90	1.20
.510-.825	$\frac{1}{2}$	14.90	13.00	12.00	11.20	1.20
.825-1.135	$\frac{5}{8}$	17.10	15.00	14.10	13.30	1.50
1.135-1.510	$\frac{3}{4}$	19.70	17.40	16.30	15.40	1.80

TRILOCK REVERSIBLE TYPE

1.510-1.760	$\frac{7}{8}$	26.60	22.80	22.60	21.60	3.00
1.760-2.010	$\frac{7}{8}$	29.50	26.30	25.10	23.90	3.00
2.010-2.260	$\frac{7}{8}$	32.30	28.80	27.30	26.20	3.00
2.260-2.510	$\frac{7}{8}$	35.20	31.30	29.70	28.40	3.00
2.510-2.760	1	38.70	34.80	33.40	32.30	3.60
2.760-3.010	1	41.50	37.30	35.80	34.70	3.60
3.010-3.260	1	44.60	40.10	38.50	37.20	3.60
3.260-3.510	1	48.00	44.20	41.30	40.00	3.60
3.510-3.760	1	51.40	46.10	44.20	42.80	3.60
3.760-4.010	1	54.80	49.10	47.10	45.60	3.60
4.010-4.260	1	58.40	52.40	50.20	48.50	3.60
4.260-4.510	1	62.10	55.60	53.30	51.50	3.60

Quantity index is total number of members of identical size ordered at one time.
To price gaging members only deduct price of handle from price of complete gage.
Prices of larger sizes and quantities on application.

Above prices subject to Discount. See Discount Sheet.

**CYLINDRICAL PLUG GAGES
HARDENED ALLOY STEEL**

**CLASS X
TAFT-PEIRCE STYLE 9322
A. G. D. EXTRA LONG—Members and Handles**

Size Range	Length Gaging Section	Price Each Complete				Handles any Quan.
		1	2	3-5	6-11	
TAPER LOCK TYPE						
To and Above Incl.						
.029-.040	11/16"	\$15.10	\$13.70	\$13.00	\$12.50	1.50
.040-.059	11/16"	13.80	12.50	11.90	11.40	1.50
.059-.105	11/16"	12.70	11.60	11.00	10.50	1.50
.105-.150	25/32	12.00	11.00	10.40	10.00	1.50
.150-.185	1	11.60	10.60	10.10	9.70	1.50
.185-.240	1	11.40	9.90	9.10	8.40	1.50
.240-.365	1 3/16	11.10	9.60	8.80	8.10	1.20
.365-.510	1 1/2	11.70	10.10	9.30	8.50	1.20
.510-.825	1 7/8	12.80	11.20	10.40	9.70	1.20
.825-1.135	2 1/8	14.70	12.90	12.10	11.50	1.50
1.135-1.510	2 3/8	16.90	15.00	14.10	13.30	1.80
TRILOCK REVERSIBLE TYPE						
1.510-1.760	2 7/8	23.00	20.60	19.60	18.80	3.00
1.760-2.010	2 7/8	25.40	22.70	21.60	20.70	3.00
2.010-2.260	3	27.80	24.80	23.60	22.60	3.00
2.260-2.510	3	30.20	27.00	25.60	24.50	3.00
2.510-2.760	3 1/4	33.30	30.00	28.80	27.90	3.60
2.760-3.010	3 1/4	35.70	32.10	30.90	29.90	3.60
3.010-3.260	3 3/8	38.30	34.50	33.10	32.10	3.60
3.260-3.510	3 3/8	41.20	37.00	35.50	34.40	3.60

Page
10

**TAFT-PEIRCE STYLE 9314
A. G. D. PROGRESSIVE—Members and Handles**

Size Range	Lgth. Gaging Sect.		Price Each Complete				Handles any Quan.
	GO	NOT GO	1	2	3-5	6-11	
TAPER LOCK TYPE							
To and Above Incl.							
.029-.040	3/4"	5/16"	\$19.40	\$17.60	\$16.70	\$16.00	1.50
.040-.059	3/4"	5/16"	17.70	16.10	15.30	14.60	1.50
.059-.105	3/4"	5/16"	16.20	14.80	14.00	13.40	1.50
.105-.150	3/4"	5/16"	15.40	14.00	13.30	12.70	1.50
.150-.185	3/4"	5/16"	14.80	13.50	12.80	12.30	1.50
.185-.240	3/4"	5/16"	14.50	12.50	11.50	10.60	1.50
.240-.365	3/4"	5/16"	14.20	12.20	11.20	10.30	1.20
.365-.510	1	3/8	15.10	13.00	11.90	10.90	1.20
.510-.825	1 1/4	1/2	16.50	14.40	13.30	12.40	1.20
.825-1.135	1 3/8	5/8	18.90	16.60	15.50	14.70	1.50
1.135-1.510	1 1/2	3/4	21.80	19.20	18.00	17.00	1.80
TRILOCK REVERSIBLE TYPE							
1.510-1.760	1 7/8	7/8	29.30	26.20	24.90	23.80	3.00
1.760-2.010	1 7/8	7/8	32.50	29.00	27.50	26.30	3.00
2.010-2.260	2	7/8	35.70	31.80	30.20	28.80	3.00
2.260-2.510	2	7/8	38.90	34.60	32.80	31.40	3.00
2.510-2.760	2 1/8	1	42.70	38.40	36.80	35.70	3.60
2.760-3.010	2 1/8	1	45.90	41.20	39.50	38.30	3.60
3.010-3.260	2 1/4	1	49.40	44.30	42.50	41.20	3.60
3.260-3.510	2 1/4	1	53.10	47.70	45.70	44.20	3.60

Quantity index is total number of members of identical size ordered at one time.
To price gaging members only deduct price of handle from price of complete gage.
Prices of larger sizes and quantities on application.

Above prices subject to Discount. See Discount Sheet.

**CYLINDRICAL PLUG GAGES
CHROMIUM PLATED**

CLASS X

TAFT-PEIRCE STYLE 9322

A. G. D. EXTRA LONG—Members and Handles

Size Range	Length Gaging Section	Price Each Complete				Handles any Quan.
		1	2	3-5	6-11	
TAPER LOCK TYPE						
To and Above	Incl.					
.029-.040	11/16"	\$25.00	\$22.70	\$21.50	\$20.50	1.50
.040-.059	11/16"	22.70	20.60	19.50	18.70	1.50
.059-.105	11/16"	20.80	18.90	17.90	17.20	1.50
.105-.150	25/32"	19.70	17.90	17.00	16.20	1.50
.150-.185	1"	18.90	17.20	16.30	15.60	1.50
.185-.240	1"	18.60	16.00	14.60	13.40	1.50
.240-.365	1 3/16"	18.30	15.70	14.30	13.10	1.20
.365-.510	1 1/2"	19.40	16.70	15.20	13.90	1.20
.510-.825	1 7/8"	21.30	18.50	17.10	15.90	1.20
.825-1.135	2 1/8"	24.30	21.30	19.90	18.80	1.50
1.135-1.510	2 3/8"	28.00	24.60	23.00	21.70	1.80
TRILOCK REVERSIBLE TYPE						
1.510-1.760	2 7/8"	37.50	33.40	31.70	30.30	3.00
1.760-2.010	2 7/8"	41.70	37.10	35.10	33.60	3.00
2.010-2.260	3"	45.90	40.70	38.60	36.90	3.00
2.260-2.510	3"	50.10	44.40	42.10	40.20	3.00
2.510-2.760	3 1/4"	54.90	49.20	47.20	45.60	3.60
2.760-3.010	3 1/4"	59.00	52.90	50.70	49.00	3.60
3.010-3.260	3 3/8"	63.60	57.00	54.60	52.80	3.60
3.260-3.510	3 3/8"	68.50	61.40	58.80	56.80	3.60

Page
11

TAFT-PEIRCE STYLE 9314

A. G. D. PROGRESSIVE—Members and Handles

Size Range	Lgth. Gaging Sect.		Price Each Complete				Handles any Quan.
	GO	NOT GO	1	2	3-5	6-11	
TAPER LOCK TYPE							
To and Above	Incl.						
.029-.040	3/4"	5/16"	\$32.50	\$29.40	\$27.80	\$26.60	1.50
.040-.059	3/4"	5/16"	29.50	26.70	25.30	24.10	1.50
.059-.105	3/4"	5/16"	27.00	24.40	23.10	22.10	1.50
.105-.150	3/4"	5/16"	25.50	23.10	21.90	20.90	1.50
.150-.185	3/4"	5/16"	24.50	22.20	21.00	20.10	1.50
.185-.240	3/4"	5/16"	24.00	20.60	18.80	17.20	1.50
.240-.365	3/4"	5/16"	23.70	20.30	18.50	16.90	1.20
.365-.510	1"	3/8"	25.20	21.60	19.60	18.00	1.20
.510-.825	1 1/4"	1/2"	27.70	23.90	22.10	20.50	1.20
.825-1.135	1 3/8"	5/8"	31.50	27.60	25.80	24.30	1.50
1.135-1.510	1 1/2"	3/4"	36.30	31.80	29.70	28.00	1.80
TRILOCK REVERSIBLE TYPE							
1.510-1.760	1 7/8"	7/8"	48.50	43.00	40.70	38.90	3.00
1.760-2.010	1 7/8"	7/8"	54.00	47.80	45.30	43.20	3.00
2.010-2.260	2"	7/8"	59.50	52.70	49.90	47.60	3.00
2.260-2.510	2"	7/8"	65.00	57.50	54.40	51.90	3.00
2.510-2.760	2 1/8"	1"	71.10	63.60	60.90	58.90	3.60
2.760-3.010	2 1/8"	1"	76.60	68.50	65.60	63.40	3.60
3.010-3.260	2 1/4"	1"	82.60	73.90	70.70	68.30	3.60
3.260-3.510	2 1/4"	1"	89.10	79.70	76.20	73.70	3.60

Quantity index is total number of members of identical size ordered at one time.
To price gaging members only deduct price of handle from price of complete gage.
Prices of larger sizes and quantities on application.

Above prices subject to Discount. See Discount Sheet.

CYLINDRICAL LIMIT PLUG GAGES HARDENED ALLOY STEEL

CLASS X Tolerances

.029- .040	.00004	1.510-2.510	.00008
.040- .059	.00006	2.510-4.510	.00010
.059- .105		4.510-6.010	.00013



TAFT-PEIRCE STYLE 9310

Size Range	Length of Gaging Section		Price Each Complete			
	GO	NOT GO	1	2	3-5	6-11

Page
12

To and Above Incl.	TAPER LOCK TYPE					
.029- .040	3/8'	3/16"	\$21.30	\$19.20	\$18.30	\$17.50
.040- .059	3/8	3/16	19.40	17.50	16.60	16.00
.059- .105	3/8	3/16	17.70	16.10	15.30	14.70
.105- .150	7/16	7/32	16.80	15.20	14.50	13.90
.150- .185	9/32	9/32	16.20	14.70	13.90	13.30
.185- .240	9/32	9/32	15.80	13.70	12.50	11.50
.240- .365	3/4	5/16	15.50	13.40	12.20	11.20
.365- .510	1	3/8	16.50	14.20	12.90	11.90
.510- .825	1 1/4	1/2	18.10	15.70	14.50	13.50
.825-1.135	1 3/8	5/8	20.70	18.10	16.90	16.00
1.135-1.510	1 1/2	3/4	23.80	21.00	19.60	18.50

TRILOCK REVERSIBLE TYPE						
1.510-1.760	1 7/8	7/8	32.00	28.60	27.10	25.90
1.760-2.010	1 7/8	7/8	35.60	31.60	30.00	28.60
2.010-2.260	2	7/8	39.10	34.80	32.90	31.40
2.260-2.510	2	7/8	42.60	37.80	35.80	34.20
2.510-2.760	2 1/8	1	42.70	42.00	40.30	39.00
2.760-3.010	2 1/8	1	50.30	45.00	43.20	41.80
3.010-3.260	2 1/4	1	54.10	48.50	46.50	45.00
3.260-3.510	2 1/4	1	58.20	52.20	50.10	48.40
3.510-3.760	2 1/4	1	62.40	55.90	53.50	51.80
3.760-4.010	2 1/4	1	66.50	59.70	57.10	55.20
4.010-4.260	2 1/4	1	71.00	63.60	60.90	58.90
4.260-4.510	2 1/4	1	75.50	67.60	64.70	62.50

Prices above are for Double End Cylindrical Limit Plug Gages complete, A. G. D. Standard, and include GO and NOT GO Members, and Handle.

Above prices subject to Discount. See Discount Sheet.

CYLINDRICAL LIMIT PLUG GAGES CHROMIUM PLATED

CLASS X Tolerances

.029- .825	.00004	1.510-2.510	.00008
.825-1.510	.00006	2.510-4.510	.00010
	4.510-6.010		.00013



TAFT-PEIRCE STYLE 9310

Size Range	Length of Gaging Section		Price Each Complete			
	GO	NOT GO	1	2	3-5	6-11
TAPER LOCK TYPE						
To and Above	Incl.					
.029- .040	$\frac{3}{8}$ "	$\frac{3}{16}$ "	\$35.50	\$32.10	\$30.40	\$29.00
.040- .059	$\frac{3}{8}$ "	$\frac{3}{16}$ "	32.20	29.20	27.60	26.30
.059- .105	$\frac{3}{8}$ "	$\frac{3}{16}$ "	29.40	26.70	25.20	24.10
.105- .150	$\frac{7}{16}$ "	$\frac{7}{32}$ "	27.80	25.20	23.90	22.80
.150- .185	$\frac{19}{32}$ "	$\frac{9}{32}$ "	26.70	24.20	22.90	21.90
.185- .240	$\frac{19}{32}$ "	$\frac{9}{32}$ "	26.20	22.40	20.50	18.70
.240- .365	$\frac{3}{4}$ "	$\frac{5}{16}$ "	25.90	22.10	20.20	18.40
.365- .510	1"	$\frac{3}{8}$ "	27.50	23.60	21.50	19.60
.510- .825	$1\frac{1}{4}$ "	$\frac{1}{2}$ "	30.20	26.20	24.10	22.40
.825-1.135	$1\frac{3}{8}$ "	$\frac{5}{8}$ "	34.50	30.10	28.10	26.50
1.135-1.510	$1\frac{1}{2}$ "	$\frac{3}{4}$ "	39.70	34.80	32.50	30.60
TRILOCK REVERSIBLE TYPE						
1.510-1.760	$1\frac{7}{8}$ "	$\frac{7}{8}$ "	52.90	46.00	44.50	42.40
1.760-2.010	$1\frac{7}{8}$ "	$\frac{7}{8}$ "	59.00	52.30	49.60	47.20
2.010-2.260	2"	$\frac{7}{8}$ "	65.00	57.60	54.40	52.00
2.260-2.510	2"	$\frac{7}{8}$ "	71.10	62.90	59.50	56.80
2.510-2.760	$2\frac{1}{8}$ "	1"	77.80	69.60	66.60	64.40
2.760-3.010	$2\frac{1}{8}$ "	1"	83.80	74.90	71.70	69.40
3.010-3.260	$2\frac{1}{4}$ "	1"	90.40	80.80	77.60	74.70
3.260-3.510	$2\frac{1}{4}$ "	1"	97.50	88.30	83.40	80.60
3.510-3.760	$2\frac{1}{4}$ "	1"	104.70	93.50	89.50	86.50
3.760-4.010	$2\frac{1}{4}$ "	1"	111.90	99.90	95.60	92.40
4.010-4.260	$2\frac{1}{4}$ "	1"	119.50	106.80	102.20	98.60
4.260-4.510	$2\frac{1}{4}$ "	1"	127.30	113.60	108.70	105.00

Prices above are for Double End Cylindrical Limit Plug Gages complete, A. G. D. Standard, and include GO and NOT GO Members, and Handle.

Above prices subject to Discount. See Discount Sheet.

CYLINDRICAL PLUG GAGES

HARDENED ALLOY STEEL

CLASS Y

Tolerances

.029- .82500007	1.510-2.51000012
.825-1.51000009	2.510-4.51000015
		4.510-6.01000019



TAFT-PEIRCE STYLE 9316

A. G. D. GO Members and Handles

Size Range	Length Gaging Section	Price Each Complete				Handles any Quan.
		1	2	3-5	6-11	

Page

14

To and
Above Incl.

TAPER LOCK TYPE

.029- .040	$\frac{3}{8}$ "	\$10.00	\$ 9.10	\$ 8.70	\$ 8.30	\$1.50
.040- .059	$\frac{3}{8}$	9.10	8.30	8.00	7.70	1.50
.059- .105	$\frac{3}{8}$	8.40	7.70	7.40	7.10	1.50
.105- .150	$\frac{7}{16}$	8.10	7.40	7.10	6.80	1.50
.150- .185	$\frac{19}{32}$	7.90	7.30	6.90	6.70	1.50
.185- .240	$\frac{19}{32}$	7.70	6.80	6.30	5.90	1.50
.240- .365	$\frac{3}{4}$	7.40	6.50	6.00	5.60	1.20
.365- .510	1	7.80	6.80	6.30	5.80	1.20
.510- .825	$1\frac{1}{4}$	8.50	7.40	6.90	6.50	1.20
.825-1.135	$1\frac{3}{8}$	9.60	8.60	8.10	7.70	1.50
1.135-1.510	$1\frac{1}{2}$	10.90	9.70	9.20	8.70	1.80

TRILOCK REVERSIBLE TYPE

1.510-1.760	$1\frac{7}{8}$	15.50	14.00	13.40	12.90	3.00
1.760-2.010	$1\frac{7}{8}$	17.10	15.40	14.70	14.10	3.00
2.010-2.260	2	18.60	16.70	15.90	15.30	3.00
2.260-2.510	2	20.10	18.10	17.20	16.50	3.00
2.510-2.760	$2\frac{1}{8}$	22.30	20.20	19.50	18.90	3.60
2.760-3.010	$2\frac{1}{8}$	24.00	21.70	20.90	20.30	3.60
3.010-3.260	$2\frac{1}{4}$	25.70	23.20	22.30	21.70	3.60
3.260-3.510	$2\frac{1}{4}$	27.40	24.70	23.80	23.10	3.60
3.510-3.760	$2\frac{1}{4}$	29.10	26.30	25.20	24.50	3.60
3.760-4.010	$2\frac{1}{4}$	30.80	27.80	26.70	25.90	3.60
4.010-4.250	$2\frac{1}{4}$	32.60	29.40	28.30	27.40	3.60
4.250-4.510	$2\frac{1}{4}$	34.70	31.20	30.00	29.10	3.60

Quantity index is total number of members of identical size ordered at one time.
To price gaging members only deduct price of handle from price of complete gage.
Prices of larger sizes and quantities on application.

Above prices subject to Discount. See Discount Sheet.

**CYLINDRICAL PLUG GAGES
CHROMIUM PLATED**

CLASS Y

Tolerances

.029- .82500007	1.510-2.51000012
.825-1.51000009	2.510-4.51000015
		4.510-6.01000019



**TAFT-PEIRCE STYLE 9316
A. G. D. GO Members and Handles**

Size Range	Length Gaging Section	Price Each Complete				Handles any Quan.
		1	2	3-5	6-11	

To and
Above Incl.

TAPER LOCK TYPE

.029- .040	3/8"	\$16.00	\$14.50	\$13.80	\$13.20	\$1.50
.040- .059	3/8	14.50	13.20	12.50	12.00	1.50
.059- .105	3/8	13.30	12.20	11.60	11.10	1.50
.105- .150	7/16	12.80	11.60	11.10	10.60	1.50
.150- .185	19/32	12.50	11.40	10.80	10.40	1.50
.185- .240	19/32	12.20	10.60	9.70	9.00	1.50
.240- .365	3/4	11.90	10.30	9.40	8.70	1.20
.365- .510	1	12.50	10.80	9.90	9.10	1.20
.510- .825	1 1/4	13.60	11.90	11.00	10.30	1.20
.825-1.135	1 3/8	15.40	13.60	12.70	12.00	1.50
1.135-1.510	1 1/2	17.40	15.40	14.40	13.70	1.80

TRILOCK REVERSIBLE TYPE

1.510-1.760	1 7/8	24.40	21.80	20.80	19.90	3.00
1.760-2.010	1 7/8	27.00	24.10	22.90	22.00	3.00
2.010-2.260	2	29.60	26.40	25.10	24.00	3.00
2.260-2.510	2	32.20	28.70	27.30	26.10	3.00
2.510-2.760	2 1/8	35.50	31.90	30.70	29.70	3.60
2.760-3.010	2 1/8	38.40	34.50	33.10	32.10	3.60
3.010-3.260	2 1/4	41.30	37.10	35.60	34.50	3.60
3.260-3.510	2 1/4	44.20	39.70	38.10	36.80	3.60
3.510-3.760	2 1/4	47.10	42.30	40.50	39.20	3.60
3.760-4.010	2 1/4	50.00	44.90	43.00	41.60	3.60
4.010-4.250	2 1/4	53.10	47.60	45.70	44.20	3.60
4.250-4.510	2 1/4	56.60	50.80	48.70	47.10	3.60

Quantity index is total number of members of identical size ordered at one time.
To price gaging members only deduct price of handle from price of complete gage.
Prices of larger sizes and quantities on application.

Above prices subject to Discount. See Discount Sheet.

CYLINDRICAL PLUG GAGES

HARDENED ALLOY STEEL

CLASS Y

Tolerances

.029— .825	.00007	1.510—2.510	.00012
.825—1.510	.00009	2.510—4.510	.00015
	4.510—6.010		.00019



TAFT-PEIRCE STYLE 9318

A. G. D. NOT GO—Members and Handles

Page
16

Size Range	Length Gaging Section	Price Each Complete				Handles any Quan.
		1	2	3-5	6-11	

To and
Above Incl.

TAPER LOCK TYPE

.029— .040	$\frac{3}{16}$ "	\$ 9.00	\$ 8.20	\$ 7.80	\$ 7.50	\$1.50
.040— .059	$\frac{3}{16}$	8.20	7.50	7.20	6.90	1.50
.059— .105	$\frac{3}{16}$	7.60	7.00	6.70	6.40	1.50
.105— .150	$\frac{7}{32}$	7.30	6.70	6.40	6.20	1.50
.150— .185	$\frac{9}{32}$	7.20	6.60	6.30	6.10	1.50
.185— .240	$\frac{9}{32}$	7.00	6.20	5.70	5.30	1.50
.240— .365	$\frac{5}{16}$	6.70	5.90	5.40	5.00	1.20
.365— .510	$\frac{3}{8}$	7.00	6.10	5.70	5.30	1.20
.510— .825	$\frac{1}{2}$	7.60	6.70	6.30	5.90	1.20
.825—1.135	$\frac{5}{8}$	8.70	7.70	7.30	6.90	1.50
1.135—1.510	$\frac{3}{4}$	9.90	8.80	8.30	7.90	1.80

TRILOCK REVERSIBLE TYPE

1.510—1.760	$\frac{7}{8}$	14.10	12.70	12.20	11.70	3.00
1.760—2.010	$\frac{7}{8}$	15.40	13.90	13.30	12.80	3.00
2.010—2.260	$\frac{7}{8}$	16.80	15.10	14.40	13.90	3.00
2.260—2.510	$\frac{7}{8}$	18.10	16.30	15.50	14.90	3.00
2.510—2.760	1	20.10	18.20	17.60	17.10	3.60
2.760—3.010	1	21.60	19.60	18.90	18.30	3.60
3.010—3.260	1	23.10	20.90	20.10	19.50	3.60
3.260—3.510	1	24.60	22.20	21.40	20.80	3.60
3.510—3.760	1	26.10	23.60	22.70	22.00	3.60
3.760—4.010	1	27.60	24.90	24.00	23.20	3.60
4.010—4.260	1	29.20	26.40	25.40	24.60	3.60
4.260—4.510	1	31.00	28.00	26.90	26.10	3.60

Quantity index is total number of members of identical size ordered at one time.
To price gaging members only deduct price of handle from price of complete gage.
Prices of larger sizes and quantities on application.

Above prices subject to Discount. See Discount Sheet.

**CYLINDRICAL PLUG GAGES
CHROMIUM PLATED**

**CLASS Y
Tolerances**

.029-.825	.00007	1.510-2.510	.00012
.825-1.510	.00009	2.510-4.510	.00015
	4.510-6.010	.00019	



**TAFT-PEIRCE STYLE 9318
A. G. D. NOT GO—Members and Handles**

Size Range	Length Gaging Section	Price Each Complete				Handles any Quan.
		1	2	3-5	6-11	

Above To and Incl.

TAPER LOCK TYPE

.029-.040	$\frac{3}{16}$ "	\$14.50	\$13.20	\$12.50	\$12.00	\$1.50
.040-.059	$\frac{3}{16}$	13.20	12.00	11.40	10.90	1.50
.059-.105	$\frac{3}{16}$	12.10	11.00	10.50	10.10	1.50
.105-.150	$\frac{7}{32}$	11.60	10.60	10.10	9.70	1.50
.150-.185	$\frac{9}{32}$	11.30	10.30	9.90	9.50	1.50
.185-.240	$\frac{9}{32}$	11.10	9.60	8.90	8.20	1.50
.240-.365	$\frac{5}{16}$	10.80	9.30	8.60	7.90	1.20
.365-.510	$\frac{3}{8}$	11.30	9.80	9.00	8.30	1.20
.510-.825	$\frac{1}{2}$	12.30	10.80	10.00	9.30	1.20
.825-1.135	$\frac{5}{8}$	13.90	12.30	11.60	10.90	1.50
1.135-1.510	$\frac{3}{4}$	15.80	14.00	13.10	12.40	1.80

TRILOCK REVERSIBLE TYPE

1.510-1.760	$\frac{7}{8}$	22.20	19.90	18.90	18.20	3.00
1.760-2.010	$\frac{7}{8}$	24.50	21.90	20.90	20.00	3.00
2.010-2.260	$\frac{7}{8}$	26.90	24.00	22.80	21.90	3.00
2.260-2.510	$\frac{7}{8}$	29.20	26.10	24.80	23.70	3.00
2.510-2.760	1	32.20	29.00	27.90	27.00	3.60
2.760-3.010	1	34.80	31.30	30.10	29.10	3.60
3.010-3.260	1	37.40	33.60	32.30	31.30	3.60
3.260-3.510	1	40.00	36.00	34.50	33.40	3.60
3.510-3.760	1	42.60	38.30	36.70	35.50	3.60
3.760-4.010	1	45.20	40.60	38.90	37.70	3.60
4.010-4.260	1	48.00	43.10	41.30	40.00	3.60
4.260-4.510	1	51.10	45.90	44.00	42.60	3.60

Quantity index is total number of members of identical size ordered at one time.
To price gaging members only deduct price of handle from price of complete gage.
Prices of larger sizes and quantities on application.

Above prices subject to Discount. See Discount Sheet.

738

Ward Sales Co.
Machine Tools
1472 Broadway
Wisconsin 7-1208 BRYant 9-9642

CYLINDRICAL PLUG GAGES HARDENED ALLOY STEEL

CLASS Y

TAFT-PEIRCE STYLE 9322

A. G. D. EXTRA LONG—Members and Handles

Size Range	Length Gaging Section	Price Each Complete				Handles any Quan.
		1	2	3-5	6-11	
TAPER LOCK TYPE						
To and Above Incl.						
.029-.040	11/16"	\$12.50	\$11.40	\$10.80	\$10.40	1.50
.040-.059	11/16"	11.40	10.40	9.90	9.50	1.50
.059-.105	11/16"	10.50	9.60	9.10	8.80	1.50
.105-.150	23/32"	10.00	9.20	8.70	8.40	1.50
.150-.185	1"	9.80	9.00	8.60	8.20	1.50
.185-.240	1"	9.60	8.40	7.70	7.20	1.50
.240-.365	1 3/16"	9.30	8.10	7.40	6.90	1.20
.365-.510	1 1/2"	9.70	8.40	7.80	7.20	1.20
.510-.825	1 7/8"	10.60	9.30	8.60	8.10	1.20
.825-1.135	2 1/8"	12.00	10.60	10.00	9.50	1.50
1.135-1.510	2 3/8"	13.60	12.10	11.40	10.80	1.80
TRILOCK REVERSIBLE TYPE						
1.510-1.760	2 7/8"	19.20	17.30	16.50	15.80	3.00
1.760-2.010	2 7/8"	21.20	19.00	18.10	17.40	3.00
2.010-2.260	3"	23.20	20.80	19.80	18.90	3.00
2.260-2.510	3"	25.20	22.50	21.40	20.50	3.00
2.510-2.760	3 1/4"	27.80	25.10	24.10	23.40	3.60
2.760-3.010	3 1/4"	30.00	27.10	26.00	25.20	3.60
3.010-3.260	3 3/8"	32.20	29.00	27.90	27.00	3.60
3.260-3.510	3 3/8"	34.40	31.00	29.70	28.80	3.60

Page
18

TAFT-PEIRCE STYLE 9314

A. G. D. PROGRESSIVE—Members and Handles

Size Range	Lgth. Gaging Sect.		Price Each Complete				Handles any Quan.
	GO	NOT GO	1	2	3-5	6-11	
TAPER LOCK TYPE							
To and Above Incl.							
.029-.040	3/4"	5/16"	\$16.00	\$14.50	\$13.80	\$13.20	1.50
.040-.059	3/4"	5/16"	14.50	13.20	12.50	12.00	1.50
.059-.105	3/4"	3/16"	13.30	12.20	11.60	11.10	1.50
.105-.150	3/4"	3/16"	12.80	11.60	11.10	10.60	1.50
.150-.185	3/4"	5/16"	12.50	11.40	10.80	10.40	1.50
.185-.240	3/4"	5/16"	12.20	10.60	9.70	9.00	1.50
.240-.365	3/4"	5/16"	11.90	10.30	9.40	8.70	1.20
.365-.510	1"	3/8"	12.50	10.80	9.90	9.10	1.20
.510-.825	1 1/4"	1/2"	13.60	11.90	11.00	10.30	1.20
.825-1.135	1 3/8"	5/8"	15.40	13.60	12.70	12.00	1.50
1.135-1.510	1 1/2"	3/4"	17.40	15.40	14.40	13.70	1.80
TRILOCK REVERSIBLE TYPE							
1.510-1.760	1 7/8"	7/8"	24.40	21.80	20.80	19.90	3.00
1.760-2.010	1 7/8"	7/8"	27.00	24.10	22.90	22.00	3.00
2.010-2.260	2"	1 1/8"	29.60	26.40	25.10	24.00	3.00
2.260-2.510	2"	1 1/8"	32.20	28.70	27.30	26.10	3.00
2.510-2.760	2 1/8"	1"	35.50	31.90	30.70	29.70	3.60
2.760-3.010	2 1/8"	1"	38.40	34.50	33.10	32.10	3.60
3.010-3.260	2 1/4"	1"	41.30	37.10	35.60	34.50	3.60
3.260-3.510	2 1/4"	1"	44.20	39.70	38.10	36.80	3.60

Quantity index is total number of members of identical size ordered at one time.
To price gaging members only deduct price of handle from price of complete gage.
Prices of larger sizes and quantities on application.

Above prices subject to Discount. See Discount Sheet.

**CYLINDRICAL PLUG GAGES
CHROMIUM PLATED**

CLASS Y

TAFT-PEIRCE STYLE 9322

A. G. D. EXTRA LONG—Members and Handles

Size Range	Length Gaging Section	Price Each Complete				Handles any Quan.
		1	2	3-5	6-11	
TAPER LOCK TYPE						
To and Above Incl.						
.029-.040	1 ¹ / ₁₆ "	\$20.50	\$18.60	\$17.60	\$16.80	1.50
.040-.059	1 ¹ / ₁₆ "	18.60	16.80	16.00	15.30	1.50
.059-.105	1 ¹ / ₁₆ "	17.00	15.50	14.70	14.10	1.50
.105-.150	2 ⁵ / ₃₂ "	16.30	14.80	14.10	13.50	1.50
.150-.185	1	15.90	14.50	13.70	13.20	1.50
.185-.240	1	15.50	13.40	12.30	11.30	1.50
.240-.365	1 ³ / ₁₆ "	14.80	12.80	11.70	10.70	1.20
.365-.510	1 ¹ / ₂ "	16.00	13.80	12.60	11.50	1.20
.510-.825	1 ⁷ / ₈ "	17.50	15.20	14.10	13.10	1.20
.825-1.135	2 ¹ / ₈ "	19.70	17.30	16.20	15.30	1.50
1.135-1.510	2 ³ / ₈ "	22.30	19.60	18.40	17.40	1.80
TRILOCK REVERSIBLE TYPE						
1.510-1.760	2 ⁷ / ₈ "	31.10	27.70	26.30	25.20	3.00
1.760-2.010	2 ⁷ / ₈ "	34.50	30.70	29.10	27.90	3.00
2.010-2.260	3	37.90	33.70	32.00	30.60	3.00
2.260-2.510	3	41.30	36.70	34.80	33.30	3.00
2.510-2.760	3 ¹ / ₄ "	45.40	40.80	39.10	37.80	3.60
2.760-3.010	3 ¹ / ₄ "	49.20	44.10	42.30	40.90	3.60
3.010-3.260	3 ³ / ₈ "	53.00	47.50	45.50	44.10	3.60
3.260-3.510	3 ³ / ₈ "	56.80	50.90	48.80	47.20	3.60

Page
19

TAFT-PEIRCE STYLE 9314

A. G. D. PROGRESSIVE—Members and Handles

Size Range	Lgth. Gaging Sect.		Price Each Complete				Handles any Quan.
	GO	NOT GO	1	2	3-5	6-11	
TAPER LOCK TYPE							
To and Above Incl.							
.029-.040	3 ³ / ₄ "	5 ⁵ / ₁₆ "	\$26.50	\$24.00	\$22.70	\$21.70	1.50
.040-.059	3 ³ / ₄ "	5 ⁵ / ₁₆ "	24.00	21.70	20.60	19.70	1.50
.059-.105	3 ³ / ₄ "	5 ⁵ / ₁₆ "	22.00	19.90	18.90	18.10	1.50
.105-.150	3 ³ / ₄ "	5 ⁵ / ₁₆ "	21.00	19.00	18.00	17.30	1.50
.150-.185	3 ³ / ₄ "	5 ⁵ / ₁₆ "	20.50	18.60	17.60	16.80	1.50
.185-.240	3 ³ / ₄ "	5 ⁵ / ₁₆ "	20.00	17.20	15.70	14.40	1.50
.240-.365	3 ³ / ₄ "	5 ⁵ / ₁₆ "	19.70	16.90	15.40	14.10	1.20
.365-.510	1	7 ⁵ / ₈ "	20.70	17.70	16.20	14.80	1.20
.510-.825	1 ¹ / ₄ "	1 ¹ / ₂ "	22.70	19.60	18.10	16.90	1.20
.825-1.135	1 ³ / ₈ "	1 ⁵ / ₈ "	25.50	22.30	20.90	19.70	1.50
1.135-1.510	1 ¹ / ₂ "	1 ³ / ₄ "	28.80	25.20	23.60	22.30	1.80
TRILOCK REVERSIBLE TYPE							
1.510-1.760	1 ⁷ / ₈ "	1 ⁷ / ₈ "	40.00	35.50	33.70	32.20	3.00
1.760-2.010	1 ⁷ / ₈ "	1 ⁷ / ₈ "	44.50	39.50	37.40	35.70	3.00
2.010-2.260	2	1 ⁷ / ₈ "	49.00	43.40	41.10	39.30	3.00
2.260-2.510	2	1 ⁷ / ₈ "	53.50	47.40	44.90	42.90	3.00
2.510-2.760	2 ¹ / ₈ "	1	58.60	52.50	50.30	48.70	3.60
2.760-3.010	2 ¹ / ₈ "	1	63.60	57.00	54.60	52.80	3.60
3.010-3.260	2 ¹ / ₄ "	1	68.60	61.40	58.80	56.90	3.60
3.260-3.510	2 ¹ / ₄ "	1	73.60	65.90	63.10	61.00	3.60

Quantity index is total number of members of identical size ordered at one time.
To price gaging members only deduct price of handle from price of complete gage.
Prices of larger sizes and quantities on application.

Above prices subject to Discount. See Discount Sheet.

CYLINDRICAL PLUG GAGES

HARDENED ALLOY STEEL

CLASS Y

Tolerances

.029-.040	.00007	1.510-2.510	.00012
.040-.059	.00009	2.510-4.510	.00015
.059-.105		4.510-6.010	.00019



TAFT-PEIRCE STYLE 9310

Size Range	Length of Gaging Section		Price Each Complete			
	GO	NOT GO	1	2	3-5	6-11

Page
20

To and Above	Incl.	TAPER LOCK TYPE					
.029-.040	$\frac{3}{8}$ "	$\frac{3}{16}$ "	\$17.50	\$15.80	\$15.00	\$14.30	
.040-.059	$\frac{3}{8}$	$\frac{3}{16}$	15.80	14.30	13.70	13.10	
.059-.105	$\frac{3}{8}$	$\frac{3}{16}$	14.50	13.20	12.60	12.00	
.105-.150	$\frac{7}{16}$	$\frac{7}{32}$	13.90	12.60	12.00	11.50	
.150-.185	$\frac{19}{32}$	$\frac{9}{32}$	13.60	12.40	11.70	11.30	
.185-.240	$\frac{19}{32}$	$\frac{9}{32}$	13.20	11.50	10.50	9.70	
.240-.365	$\frac{3}{4}$	$\frac{5}{16}$	12.90	11.20	10.20	9.40	
.365-.510	1	$\frac{3}{8}$	13.60	11.70	10.80	9.90	
.510-.825	$1\frac{1}{4}$	$\frac{1}{2}$	14.90	12.90	12.00	11.20	
.825-1.135	$1\frac{3}{8}$	$\frac{5}{8}$	16.80	14.80	13.90	13.10	
1.135-1.510	$1\frac{1}{2}$	$\frac{3}{4}$	19.00	16.70	15.70	14.80	

TRILOCK REVERSIBLE TYPE						
1.510-1.760	$1\frac{7}{8}$	$\frac{7}{8}$	26.60	23.70	22.60	21.60
1.760-2.010	$1\frac{7}{8}$	$\frac{7}{8}$	29.50	26.30	25.00	23.90
2.010-2.260	2	$\frac{7}{8}$	32.40	28.80	27.30	26.20
2.260-2.510	2	$\frac{7}{8}$	35.20	31.40	29.70	28.40
2.510-2.760	$2\frac{1}{8}$	1	38.80	34.80	33.50	32.40
2.760-3.010	$2\frac{1}{8}$	1	42.00	37.70	36.20	35.00
3.010-3.260	$2\frac{1}{4}$	1	45.20	40.50	38.80	37.60
3.260-3.510	$2\frac{1}{4}$	1	48.40	43.30	41.60	40.30
3.510-3.760	$2\frac{1}{4}$	1	51.60	46.30	44.30	42.90
3.760-4.010	$2\frac{1}{4}$	1	54.80	49.10	46.10	45.50
4.010-4.260	$2\frac{1}{4}$	1	58.20	52.20	50.10	48.40
4.260-4.510	$2\frac{1}{4}$	1	62.10	55.60	53.30	51.60

Prices above are for Double End Cylindrical Limit Plug Gages complete, A. G. D. Standard, and include GO and NOT GO Members, and Handle.

Above prices subject to Discount. See Discount Sheet.

CYLINDRICAL PLUG GAGES CHROMIUM PLATED

**CLASS Y
Tolerances**

.029-.825	.00007	1.510-2.510	.00012
.825-1.510	.00009	2.510-4.510	.00015
	4.510-6.010		.00019



TAFT-PEIRCE STYLE 9310

Size Range	Length of Gaging Section		Price Each Complete			
	GO	NOT GO	1	2	3-5	6-11
TAPER LOCK TYPE						
To and Above	Incl.					
.029-.040	$\frac{3}{8}$ "	$\frac{3}{16}$ "	\$29.00	\$26.20	\$24.80	\$23.70
.040-.059	$\frac{3}{8}$	$\frac{3}{16}$	26.20	23.70	22.40	21.40
.059-.105	$\frac{3}{8}$	$\frac{3}{16}$	23.90	21.70	20.60	19.70
.105-.150	$\frac{7}{16}$	$\frac{7}{32}$	22.90	20.70	19.70	18.80
.150-.185	$\frac{19}{32}$	$\frac{9}{32}$	22.30	20.20	19.20	18.40
.185-.240	$\frac{19}{32}$	$\frac{9}{32}$	21.80	18.70	17.10	15.70
.240-.365	$\frac{3}{4}$	$\frac{5}{16}$	21.50	18.40	16.80	15.40
.365-.510	1	$\frac{3}{8}$	22.60	19.40	17.70	16.20
.510-.825	$1\frac{1}{4}$	$1\frac{1}{2}$	24.70	21.50	19.80	18.40
.825-1.135	$1\frac{3}{8}$	$\frac{5}{8}$	27.80	24.40	22.80	21.40
1.135-1.510	$1\frac{1}{2}$	$\frac{3}{4}$	31.40	27.60	25.70	24.30
TRILOCK REVERSIBLE TYPE						
1.510-1.760	$1\frac{7}{8}$	$\frac{7}{8}$	43.60	38.70	36.70	35.10
1.760-2.010	$1\frac{7}{8}$	$\frac{7}{8}$	48.50	43.00	40.80	39.00
2.010-2.260	2	$\frac{7}{8}$	53.50	47.40	44.90	42.90
2.260-2.510	2	$\frac{7}{8}$	58.40	51.80	49.10	46.80
2.510-2.760	$2\frac{1}{8}$	1	64.10	57.30	55.00	53.10
2.760-3.010	$2\frac{1}{8}$	1	69.60	62.20	59.60	57.60
3.010-3.260	$2\frac{1}{4}$	1	75.10	67.10	64.30	62.20
3.260-3.510	$2\frac{1}{4}$	1	80.60	72.10	69.00	66.60
3.510-3.760	$2\frac{1}{4}$	1	86.10	77.00	73.60	71.10
3.760-4.010	$2\frac{1}{4}$	1	91.60	81.90	78.30	75.70
4.010-4.260	$2\frac{1}{4}$	1	97.50	87.10	83.40	80.60
4.260-4.510	$2\frac{1}{4}$	1	104.10	92.10	89.10	86.10

Prices above are for Double End Cylindrical Limit Plug Gages complete, A. G. D. Standard, and include GO and NOT GO Members, and Handle.

Above prices subject to Discount. See Discount Sheet.

CEMENTED CARBIDE GAGES



Page
22

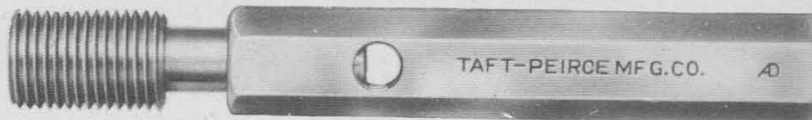
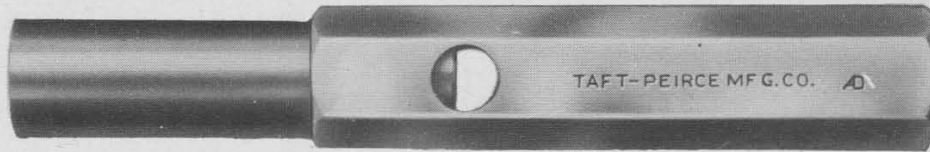

All types of plain cylindrical plug and ring gages, snap gages, and plug thread gages, as well as special designs, can be furnished from Tungsten carbide or similar materials. Prices on application.

MICROMETER PLUG GAGES

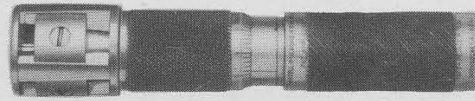

TAFT-PEIRCE STYLE 9724

This extremely accurate internal micrometer is adapted for tool room use, machine production or inspection work, and is particularly useful for salvage inspection purposes.

It is furnished in all sizes from $\frac{3}{4}$ " to 4". The range of expansion on each size is over $\frac{1}{16}$ ", so that adjoining sizes will overlap.

Some of its major advantages are as follows:

Accuracy: Checks roundness, straightness, and size of hole exactly. Direct reading to .0002", vernier reading to .0001".

Range: Each gage has a range of measurable adjustment of over $\frac{1}{16}$ ", in sizes up to $1\frac{1}{2}$ ", and of $\frac{1}{8}$ " in sizes over $1\frac{1}{2}$ ", adjoining sizes overlapping.

Economy: Gaging members can easily be relapped and reset to size. Experience indicates that thousands of holes can be gaged with the original set of blades.

Speed: Easily operated with one hand, it can be readily entered in the hole without the difficulty often experienced with solid plugs.

Adaptability: Changes in work limits can be accommodated without the expense of new gages.

Construction: The expanding members, or blades, are seated directly on a hardened cone, ground to an exact angle. Thus uniform expansion of all blades is assured. Blocks that form the sides of the ways in which the blades travel are carefully hardened, ground, lapped, and fitted.

The gage can be instantly disassembled for cleaning purposes without the use of special tools, and as readily reassembled.

Taft-Peirce Style 9324 External Ring Gages are recommended for setting or checking the Micrometer Plug Gage.

Prices on Application

MASTER SETTING DISCS

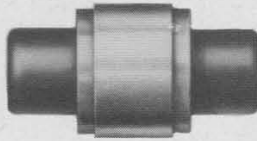

**Taft-Peirce
No. 9301**

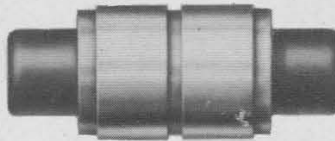

**Taft-Peirce
No. 9302**

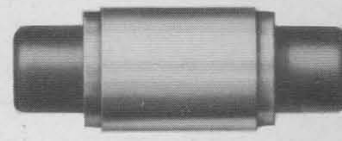

**Taft-Peirce
No. 9303**

Page
24

Size Range From To	Style 9301		Style 9302		Style 9303	
	Accuracy		Accuracy		Accuracy	
	X	Y	X	Y	X	Y
.150- .240	\$12.50	\$11.00	\$21.50	\$18.50	\$13.50	\$11.50
.240- .365	12.00	10.50	21.00	18.00	13.00	11.00
.365- .510	11.50	10.00	20.50	17.50	12.50	10.50
.510- .825	11.00	9.50	20.00	17.00	12.00	10.00
.825-1.135	11.50	10.00	20.50	17.50	12.50	10.50
1.135-1.510	12.50	11.00	24.60	21.00	13.50	11.50
1.510-1.760	14.00	12.50	27.50	23.50	15.00	13.00
1.760-2.010	16.00	14.00	31.00	27.00	17.00	14.50
2.010-2.260	18.00	15.50	34.50	30.50	19.00	16.00
2.260-2.510	20.00	17.00	38.00	34.00	21.00	18.00
2.510-2.760	22.00	18.50	41.50	37.50	23.00	20.00
2.760-3.010	24.00	20.00	45.00	41.00	26.00	22.00
3.010-3.260	26.00	22.00	48.50	44.50	28.00	24.00
3.260-3.510	28.00	24.00	52.00	48.00	30.00	26.00
3.510-3.760	30.00	26.00	56.00	51.50	32.00	28.00
3.760-4.010	32.00	28.00	60.00	55.00	34.00	30.00
4.010-4.260	34.00	30.00	64.00	58.50	36.00	32.00
4.260-4.510	36.00	32.00	68.00	62.00	38.00	34.00

Class XX Tolerance Gages Furnished.
Prices on Application.
Larger Sizes on Application.

CYLINDRICAL RING GAGES TOLERANCES

Size	Class X	Class Y	Class Z	Class ZZ
.059-.825	.00004	.00007	.00010	.00020
.825-1.510	.00006	.00009	.00012	.00024
1.510-2.510	.00008	.00012	.00016	.00032
2.510-4.760	.00010	.00015	.00020	.00040
4.760-6.260	.00013	.00019	.00025	.00050

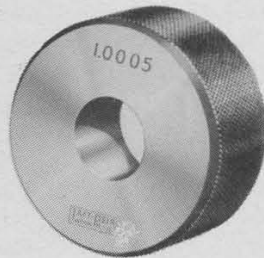

Go

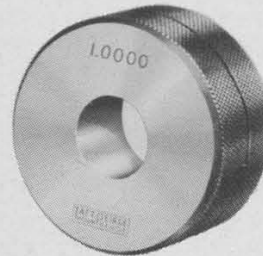

Not Go

HARDENED ALLOY STEEL CLASS X

TAFT-PEIRCE STYLE 9324 A. G. D. STANDARD

Page
25

Size Range Above To and Incl.	Thick- ness	In Quantities of					
		1	2	3-4	5-7	8-12	13 or more
.059-.090	$\frac{3}{16}$	\$ 31.00	\$ 24.80	\$ 23.20	\$ 21.70	\$ 20.10	\$ 18.60
.090-.130	$\frac{3}{16}$	29.00	23.20	21.70	20.30	18.80	17.40
.130-.240	$\frac{3}{8}$	28.00	22.40	21.00	19.60	18.20	16.80
.240-.365	$\frac{9}{16}$	29.00	23.20	21.70	20.30	18.80	17.40
.365-.510	$\frac{3}{4}$	31.00	24.80	23.20	21.70	20.30	18.80
.510-.825	$\frac{1}{2}$	34.00	27.20	25.50	23.80	22.10	20.40
.825-1.135	$1\frac{1}{8}$	38.00	30.40	28.50	26.60	24.70	22.80
1.135-1.510	$1\frac{5}{8}$	43.00	34.40	32.20	30.10	27.90	25.80
1.510-2.010	$1\frac{1}{2}$	52.00	41.60	39.00	36.40	33.80	31.20
2.010-2.510	$1\frac{1}{2}$	62.00	49.60	46.50	43.40	40.30	37.20
2.510-3.010	$1\frac{1}{2}$	72.00	57.60	54.00	50.40	46.80	43.20
3.010-3.510	$1\frac{1}{2}$	84.00	67.20	63.00	58.80	54.60	50.40
3.510-4.010	$1\frac{1}{2}$	96.00	76.80	72.00	67.20	62.40	57.60
4.010-4.760	$1\frac{1}{2}$	108.00	86.40	81.00	75.60	70.20	64.80
4.760-5.510	$1\frac{1}{2}$	140.00	112.00	105.00	98.00	91.00	84.00
5.510-6.260	$1\frac{1}{2}$	160.00	128.00	120.00	112.00	104.00	96.00

Above prices subject to Discount. See Discount Sheet.

CYLINDRICAL RING GAGES

HARDENED ALLOY STEEL CLASS Y

TAFT-PEIRCE STYLE 9324 A. G. D. STANDARD

Size Range Above To and Incl.	Length Gaging Section	In Quantities of					
		1	2	3-4	5-7	8-12	13 or more
.059-.090	$\frac{3}{16}$	\$ 26.30	\$ 21.00	\$ 19.70	\$ 18.40	\$ 17.00	\$ 15.80
.090-.130	$\frac{3}{16}$	24.60	19.70	18.40	17.20	15.90	14.70
.130-.240	$\frac{3}{8}$	23.80	19.00	17.80	16.60	15.40	14.20
.240-.365	$\frac{9}{16}$	24.60	19.70	18.40	17.20	15.90	14.70
.365-.510	$\frac{3}{4}$	26.30	21.00	19.70	18.40	17.00	15.80
.510-.825	$\frac{15}{16}$	28.90	23.10	21.60	20.20	18.70	17.30
.825-1.135	$1\frac{1}{8}$	32.30	25.80	24.20	22.60	20.90	19.30
1.135-1.510	$1\frac{5}{8}$	36.50	29.20	27.30	25.50	23.70	21.90
1.510-2.010	$1\frac{1}{2}$	44.20	35.30	33.10	30.90	28.70	26.50
2.010-2.510	$1\frac{1}{2}$	52.70	42.10	39.50	36.80	34.20	31.60
2.510-3.010	$1\frac{1}{2}$	61.20	48.90	45.90	42.80	39.70	36.70
3.010-3.510	$1\frac{1}{2}$	71.40	57.10	53.50	49.90	46.40	42.80
3.510-4.010	$1\frac{1}{2}$	81.60	65.20	61.20	57.10	53.00	48.90
4.010-4.760	$1\frac{1}{2}$	91.80	73.40	68.80	64.20	59.60	55.00
4.760-5.510	$1\frac{1}{2}$	119.00	95.20	89.20	83.30	77.30	71.40
5.510-6.260	$1\frac{1}{2}$	136.00	108.80	102.00	95.20	88.40	81.60

Page
26

CLASS Z

Size Range Above To and Incl.	Length Gaging Section	In Quantities of					
		1	2	3-4	5-7	8-12	13 or more
.059-.090	$\frac{3}{16}$	\$ 21.70	\$ 17.30	\$ 16.20	\$ 15.10	\$ 14.00	\$ 13.00
.090-.130	$\frac{3}{16}$	20.30	16.20	15.10	14.20	13.10	12.10
.130-.240	$\frac{3}{8}$	19.60	15.60	14.70	13.70	12.70	11.70
.240-.365	$\frac{9}{16}$	20.30	16.20	15.10	14.20	13.10	12.10
.365-.510	$\frac{3}{4}$	21.70	17.30	16.20	15.10	14.00	13.00
.510-.825	$\frac{15}{16}$	23.80	19.00	17.80	16.60	15.40	14.20
.825-1.135	$1\frac{1}{8}$	26.60	21.20	19.90	18.60	17.20	15.90
1.135-1.510	$1\frac{5}{8}$	30.10	24.00	22.50	21.00	19.50	18.00
1.510-2.010	$1\frac{1}{2}$	36.40	29.10	27.30	25.40	23.60	21.80
2.010-2.510	$1\frac{1}{2}$	43.40	34.70	32.50	30.30	28.20	26.00
2.510-3.010	$1\frac{1}{2}$	50.40	40.30	37.80	35.20	32.70	30.20
3.010-3.510	$1\frac{1}{2}$	58.80	47.00	44.10	41.10	38.20	35.20
3.510-4.010	$1\frac{1}{2}$	67.20	53.70	50.40	47.00	43.60	38.30
4.010-4.760	$1\frac{1}{2}$	75.60	60.40	56.70	52.90	49.10	45.30
4.760-5.510	$1\frac{1}{2}$	98.00	78.40	73.50	68.60	63.70	58.80
5.510-6.260	$1\frac{1}{2}$	112.00	89.60	84.00	78.40	72.80	67.20

Above prices subject to Discount. See Discount Sheet.

CYLINDRICAL RING GAGES

CHROMIUM PLATED CLASS X

TAFT-PEIRCE STYLE 9324 A. G. D. STANDARD

Size Range Above To and Incl.	Length Gaging Section	In Quantities of					
		1	2	3-4	5-7	8-12	13 or more
.240- .365	$\frac{9}{16}$	\$ 46.40	\$ 37.10	\$ 34.70	\$ 32.40	\$ 30.00	\$ 27.80
.365- .510	$\frac{3}{4}$	49.60	39.60	37.10	34.70	32.10	29.70
.510- .825	$\frac{5}{8}$	54.40	43.50	40.80	38.00	35.30	32.60
.825-1.135	$1\frac{1}{8}$	60.80	48.60	45.60	42.50	39.50	36.40
1.135-1.510	$1\frac{5}{16}$	68.80	55.00	51.50	48.10	44.60	41.20
1.510-2.010	$1\frac{1}{2}$	83.20	66.50	62.40	58.20	54.00	49.90
2.010-2.510	$1\frac{1}{2}$	99.20	79.30	74.40	69.40	64.40	59.50
2.510-3.010	$1\frac{1}{2}$	115.20	92.10	86.40	80.60	74.80	69.10
3.010-3.510	$1\frac{1}{2}$	134.40	107.50	100.80	94.00	87.30	80.60
3.510-4.010	$1\frac{1}{2}$	153.60	122.80	115.20	107.50	99.80	92.10
4.010-4.760	$1\frac{1}{2}$	172.80	138.20	129.60	120.90	112.30	103.60
4.760-5.510	$1\frac{1}{2}$	224.00	179.20	168.00	156.80	145.60	134.40
5.510-6.260	$1\frac{1}{2}$	256.00	204.80	192.00	179.20	166.40	153.60

Page
27

CLASS Y

Size Range Above To and Incl.	Length Gaging Section	In Quantities of					
		1	2	3-4	5-7	8-12	13 or more
.240- .365	$\frac{9}{16}$	\$ 39.30	\$ 31.50	\$ 29.40	\$ 27.54	\$ 25.50	\$ 23.60
.365- .510	$\frac{3}{4}$	42.00	33.60	31.50	29.40	27.20	25.20
.510- .825	$\frac{5}{8}$	46.20	36.90	34.50	32.30	30.00	27.70
.825-1.135	$1\frac{1}{8}$	51.60	41.20	38.70	36.10	33.50	30.90
1.135-1.510	$1\frac{5}{16}$	58.40	46.70	43.60	40.80	37.90	35.00
1.510-2.010	$1\frac{1}{2}$	70.70	56.40	52.90	49.40	45.90	42.40
2.010-2.510	$1\frac{1}{2}$	84.30	67.30	63.20	58.90	54.70	50.50
2.510-3.010	$1\frac{1}{2}$	97.90	78.20	73.40	68.50	63.50	58.70
3.010-3.510	$1\frac{1}{2}$	114.20	91.30	85.60	79.90	74.20	68.50
3.510-4.010	$1\frac{1}{2}$	130.50	104.30	97.90	91.30	84.80	78.20
4.010-4.760	$1\frac{1}{2}$	146.80	117.40	110.00	102.70	95.40	88.00
4.760-5.510	$1\frac{1}{2}$	190.40	152.30	142.80	133.20	123.70	114.20
5.510-6.260	$1\frac{1}{2}$	217.60	174.00	163.20	152.30	141.40	130.50

Above prices subject to Discount. See Discount Sheet.

CYLINDRICAL RING GAGES

CHROMIUM PLATED

CLASS Z

TAFT-PEIRCE STYLE 9324

A. G. D. STANDARD

Size Range Above To and Incl.	Length Gaging Section	In Quantities of					
		1	2	3-4	5-7	8-12	13 or more
.240- .365	$\frac{9}{16}$	\$ 32.40	\$ 25.90	\$ 24.10	\$ 22.60	\$ 21.00	\$ 19.40
.365- .510	$\frac{3}{4}$	34.70	27.60	25.90	24.20	22.40	20.70
.510- .825	$\frac{5}{8}$	38.00	30.40	28.40	26.60	24.70	22.80
.825-1.135	$1\frac{1}{8}$	42.50	33.90	31.80	29.70	27.60	25.40
1.135-1.510	$1\frac{5}{8}$	48.10	38.40	36.00	33.60	31.20	28.80
1.510-2.010	$1\frac{1}{2}$	58.20	46.50	43.60	40.70	37.80	34.90
2.010-2.510	$1\frac{1}{2}$	69.40	55.50	52.00	48.50	45.00	41.60
2.510-3.010	$1\frac{1}{2}$	80.60	64.40	60.40	56.40	52.30	48.30
3.010-3.510	$1\frac{1}{2}$	94.00	75.20	70.50	65.80	61.10	56.40
3.510-4.010	$1\frac{1}{2}$	107.50	85.90	80.60	75.20	69.80	64.40
4.010-4.760	$1\frac{1}{2}$	120.90	96.60	90.70	84.60	78.60	72.50
4.760-5.510	$1\frac{1}{2}$	156.80	125.40	117.60	109.70	101.90	94.00
5.510-6.260	$1\frac{1}{2}$	179.20	143.30	134.40	125.40	116.40	107.50

Page

28

Above prices subject to Discount. See Discount Sheet.

SALVAGING WORN PLUG GAGES

Worn Cylindrical Plug Gages can be salvaged by chromium plating, and refinished to size. Prices on application.

SALVAGING WORN RING GAGES

Worn Cylindrical Ring Gages in sizes above .240" can be salvaged by chromium plating and refinished to size. Prices on application.

LIMIT SNAP GAGES

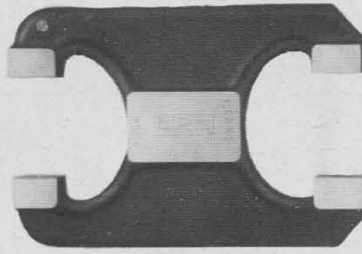

Double End
Taft-Peirce Style 9030

Size Range From To	Price Each 9030	Size Range From To	Price Each 9030
.059- .150	\$16.00	1.260-1.510	\$15.50
.150- .240	14.50	1.510-1.760	17.00
.240- .510	13.00	1.760-2.010	19.00
.510- .760	12.50	2.010-2.510
.760-1.010	13.30	2.510-3.010
1.010-1.260	14.30		

Page
29

Prices for Class Z Tolerance
Class Y and Class X on application

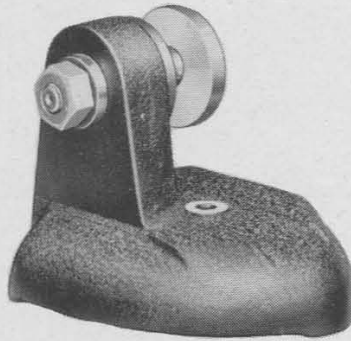

TAFT-PEIRCE SNAP GAGE STAND..... 6.50

For AGD Snap Gages, Roll Thread Snap Gages
and T.P. Adjustable Thread Snap Gages.

1144

Ward Sales Co.
Machine Tools
1472 Broadway
Wisconsin 7-1208 BRyant 9-9642

ADJUSTABLE LIMIT SNAP GAGES

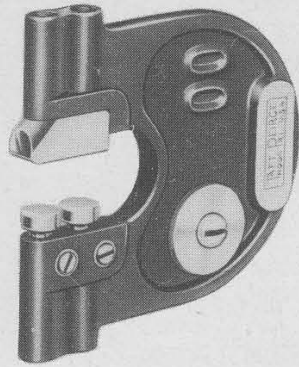

Model MC

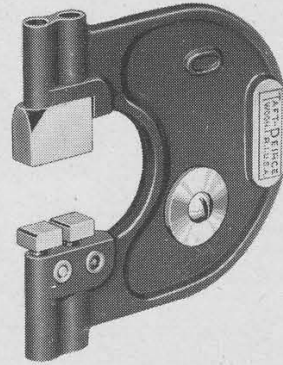

Model MSC

TAFT-PEIRCE STYLE 9033

A.G.D. Model MC and MSC

Page
30

Frame No.	Range	Price Each
00 L	.000-.195	\$10.40
00 H	.195-.385	10.40
0 L	.385-.570	10.80
0 H	.570-.760	10.80

Above prices subject to Discount. See Discount Sheet.

Anvils of worn Snap Gages ground and relapped at the following schedule:

Sizes to and including 6"	\$4.00
Sizes above 6", to and including 12"	5.00
Replacement parts—extra.	

ADJUSTABLE LIMIT SNAP GAGES



**TAFT-PEIRCE STYLE 9033
A. G. D. Model "A"**

Frame No.	Range	Price	Frame No.	Range	Price
1	0 - 1/2	\$9.50	9	4 1/2 - 5 1/4	\$15.00
2	1/2 - 1	10.00	10	5 1/4 - 6	16.00
3	1 - 1 1/2	10.50	11	6 - 7	17.00
4	1 1/2 - 2	11.00	12	7 - 8	18.00
5	2 - 2 1/2	11.50	13	8 - 9	19.00
6	2 1/2 - 3	12.00	14	9 - 10	20.00
7	3 - 3 3/4	13.00	15	10 - 11	21.00
8	3 3/4 - 4 1/2	14.00	16	11 - 12	22.00

Above prices subject to Discount. See Discount Sheet.

Anvils of worn Snap Gages ground and relapped at the following schedule:

Sizes to and including 6"	\$4.00
Sizes above 6", to and including 12"	5.00
Replacement parts extra.	

Larger Sizes Available — Prices on Application.

ADJUSTABLE LIMIT SNAP GAGES

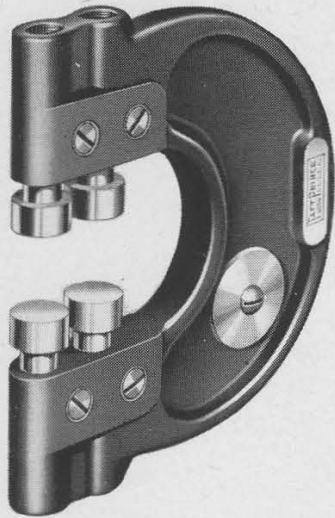

Model B

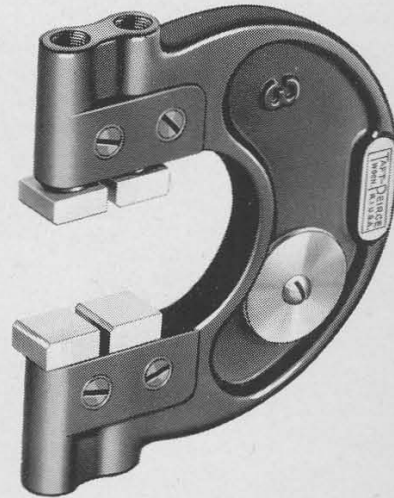

Model SB

**TAFT-PEIRCE STYLE 9033
A.G.D. Model B and SB**

Page
32

Frame No.	Range	Price	Frame No.	Range	Price
3	$\frac{1}{2}$ -1	\$11.00	10	$4\frac{5}{8}$ - $5\frac{3}{8}$	\$17.50
4	1 - $1\frac{1}{2}$	11.50	11	$5\frac{3}{8}$ - $6\frac{1}{4}$	19.00
5	$1\frac{1}{2}$ -2	12.00	12	$6\frac{1}{4}$ - $7\frac{1}{4}$	20.50
6	2 - $2\frac{1}{2}$	12.50	13	$7\frac{1}{4}$ - $8\frac{1}{4}$	21.50
7	$2\frac{1}{2}$ - $3\frac{1}{8}$	13.50	14	$8\frac{1}{4}$ - $9\frac{1}{4}$	22.50
8	$3\frac{1}{8}$ - $3\frac{7}{8}$	14.50	15	$9\frac{1}{4}$ - $10\frac{1}{4}$	23.50
9	$3\frac{7}{8}$ - $4\frac{5}{8}$	16.00	16	$10\frac{1}{4}$ - $11\frac{1}{4}$	24.50

Above prices subject to Discount. See Discount Sheet.

Anvils of worn Snap Gages ground and relapped at the following schedule:

Sizes to and including 6"	\$4.00
Sizes above 6", to and including 12"	5.00
Replacement parts—extra.	

Larger Sizes Available — Prices on Application.

ADJUSTABLE LIMIT SNAP GAGES



Model C

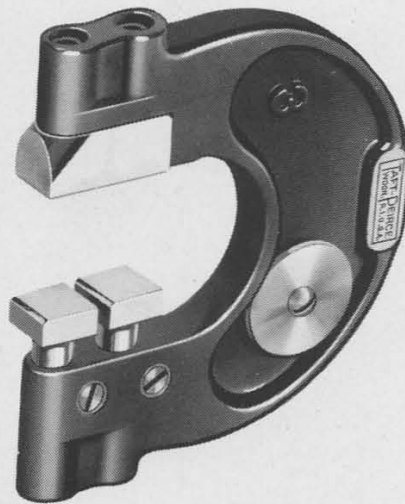

Model SC

TAFT-PEIRCE STYLE 9033

A.G.D. Model C and SC

Frame No.	Range	Price	Frame No.	Range	Price
1 H	0 - 1/4	\$10.80	9 L	4 3/16 - 4 9/16	\$17.00
2 L	1/4 - 1/2	11.50	9 H	4 9/16 - 4 15/16	17.00
2 H	1/2 - 3/4	11.50	10 L	4 15/16 - 5 5/16	19.00
3 L	3/4 - 1	12.00	10 H	5 5/16 - 5 11/16	19.00
3 H	1 - 1 1/4	12.00	11 L	5 11/16 - 6 1/8	21.00
4 L	1 1/4 - 1 1/2	12.50	11 H	6 1/8 - 6 5/8	21.00
4 H	1 1/2 - 1 3/4	12.50	12 L	6 5/8 - 7 1/8	23.00
5 L	1 3/4 - 2	13.50	12 H	7 1/8 - 7 5/8	23.00
5 H	2 - 2 1/4	13.50	13 L	7 5/8 - 8 1/8	24.00
6 L	2 1/4 - 2 1/2	14.00	13 H	8 1/8 - 8 5/8	24.00
6 H	2 1/2 - 2 3/4	14.00	14 L	8 5/8 - 9 1/8	25.00
7 L	2 3/4 - 3 1/16	15.00	14 H	9 1/8 - 9 5/8	25.00
7 H	3 1/16 - 3 7/16	15.00	15 L	9 5/8 - 10 1/8	26.00
8 L	3 7/16 - 3 13/16	16.00	15 H	10 1/8 - 10 5/8	26.00
8 H	3 13/16 - 4 3/16	16.00	16 L	10 5/8 - 11 1/8	27.00
			16 H	11 1/8 - 11 5/8	27.00

Above prices subject to Discount. See Discount Sheet.

Anvils of worn Snap Gages ground and relapped at the following schedule:

Sizes to and including 6"	\$4.00
Sizes above 6", to and including 12"	5.00
Replacement parts—extra.	

Larger Sizes Available — Prices on Application.

1144

Ward Sales Co.
Machine Tools
1472 Broadway
Wisconsin 7-1208 BRYant 9-9642

THREAD LIMIT PLUG GAGES
National Coarse, National Fine, and National Special Series
STOCK SIZES

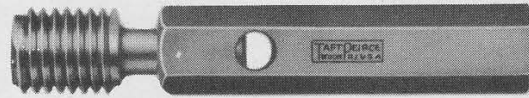

TAFT-PEIRCE STYLE 9416
A. G. D. THREAD PLUG GAGE Members and Handles

Threads per Inch				Price Each			
				Go Members Basic Size	Not Go Members Class 2 or 3	Go or Not Go Members of other Pitch Dia.	Handles
Size	NC	NF	NS	A	B	* C	D
No. 0		80		\$11.10	\$14.50	\$14.50	\$1.50
1	64	72		11.10	14.50	14.50	1.50
2	56	64		11.10	14.50	14.50	1.50
3	48	56		10.20	13.30	13.30	1.50
4	40	48		10.20	10.20	13.30	1.50
4			36	10.20	13.30	13.30	1.50
5	40	44		9.30	9.30	12.10	1.50
6	32	40		9.30	9.30	12.10	1.50
8	32	36		9.30	9.30	12.10	1.50
10	24	32		9.30	9.30	12.10	1.50
10			30	9.30	12.10	12.10	1.50
12	24	28		9.30	9.30	12.10	1.50
14			20-24	9.30	12.10	12.10	1.20
1/4"	20	28		7.80	7.80	10.00	1.20
5/16	18	24		7.80	7.80	10.00	1.20
3/8	16	24		8.40	8.40	10.90	1.20
7/16	14	20		8.40	8.40	10.90	1.20
1/2	13	20		9.00	9.00	11.80	1.20
9/16	12	18		10.00	10.00	13.00	1.20
5/8	11	18		10.00	10.00	13.00	1.20
11/16			11-16	11.20	14.50	14.50	1.20
3/4	10	16		11.20	11.20	14.50	1.20
7/8	9	14		12.10	12.10	16.00	1.50
7/8			18	12.10	16.00	16.00	1.50
1	8	14		13.50	13.50	17.50	1.50
1 1/8	7	12		15.50	20.00	20.00	1.50
1 1/4	7	12		17.20	22.50	22.50	1.80
1 3/8	6	12		19.20	25.00	25.00	1.80
1 1/2	6	12		21.20	27.50	27.50	1.80

Page
34

See next page for pricing instructions.

Above prices subject to Discount. See Discount Sheet.

Quantity Discounts on Application

* If PITCH diameters VARY from basic by more than Class One limits, Special Prices will be quoted.

THREAD PLUG GAGES

The list on the opposite page is used for all Class X thread plug gage members and handles from A. G. D. standard blanks in the National Coarse and National Fine Series from No. 0 to and including $1\frac{1}{2}$ ". A few sizes other than standard are also included, as shown. Gages should be priced as follows:

Column A — Used for pricing all basic size Go members whether used as Work Plug Members or Setting Plug Members.

Column B — Used for pricing only those Class 2 and Class 3 Not Go Working Members which are listed.

Column C — Used for pricing Not Go Work Plug Members in Classes 1 and 4; all Go Setting Plug Members in Classes 1, and some in Class 4; Not Go Setting Plug Members in Classes 1, 2, 3, and 4, etc. It is also used for those Class 2 and Class 3 Not Go Members which are not listed in Column B.

Page
35

Thread Plug Gages for Class 4 Fits.

The N. S. T. C. recommends Thread Gages to Class W tolerances where the product limits are Class 4. Prices are figured as follows:

Class 4 Go Thread Working Plug Members, and Class 4 Go Setting Plug Members, in the N. C. and N. F. series, to Class W tolerances, are priced from Column A, with an addition of $33\frac{1}{3}\%$.

Class 4 Not Go Thread Working and Setting Plug Members in the N. C. and N. F. series to Class W tolerances, are priced from Column C, with an addition of $33\frac{1}{3}\%$.

Class 5 Fits Priced on Application.

Price of assembled gage is obtained by adding price of handle to price of gaging member.

THREAD SETTING PLUG GAGES

National Coarse, National Fine, and National Special Series

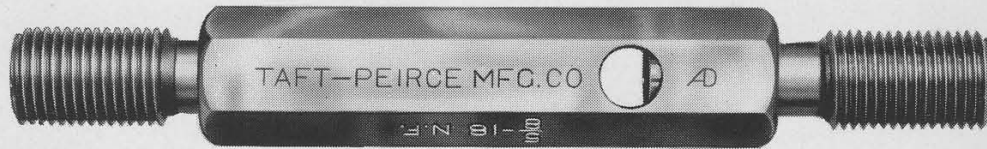

TAFT-PEIRCE STYLE 9420

A. G. D. THREAD PLUG GAGE Members and Handles

Page
36

Size	Threads per Inch			Price Each			Handles
	NC	NF	NS	Double End Class 2 & 3	Go Member Class 2 or 3	No Go Member Class 2 or 3	
				A	B	C	
No.0		80		\$27.10	\$11.10	\$14.50	\$1.50
1	64	72		27.10	11.10	14.50	1.50
2	56	64		27.10	11.10	14.50	1.50
3	48	56		25.00	10.20	13.30	1.50
4	40	48		25.00	10.20	13.30	1.50
4			36	25.00	10.20	13.30	1.50
5	40	44		22.90	9.30	12.10	1.50
6	32	40		22.90	9.30	12.10	1.50
8	32	36		22.90	9.30	12.10	1.50
10	24	32		22.90	9.30	12.10	1.50
10			30	22.90	9.30	12.10	1.50
12	24	28		22.90	9.30	12.10	1.50
14			20-24	22.60	9.30	12.10	1.20
1/4"	20	28		19.00	7.80	10.00	1.20
5/16	18	24		19.00	7.80	10.00	1.20
3/8	16	24		20.50	8.40	10.90	1.20
7/16	14	20		20.50	8.40	10.90	1.20
1/2	13	20		22.00	9.00	11.80	1.20
9/16	12	18		24.20	10.00	13.00	1.20
5/8	11	18		24.20	10.00	13.00	1.20
11/16			11-16	26.90	11.20	14.50	1.20
3/4	10	16		26.90	11.20	14.50	1.20
7/8	9	14		29.60	12.10	16.00	1.50
7/8			18	29.60	12.10	16.00	1.50
1	8	14		32.50	13.50	17.50	1.50
1 1/8	7	12		37.00	15.50	20.00	1.50
1 1/4	7	12		41.50	17.20	22.50	1.80
1 3/8	6	12		46.00	19.20	25.00	1.80
1 1/2	6	12		50.50	21.20	27.50	1.80

See next page for pricing instructions.

Above prices subject to Discount. See Discount Sheet.

THREAD SETTING PLUG GAGES

The list on the opposite page is used for all Class X thread plug gage members and handles from A. G. D. standard blanks in the National Coarse and National Fine Series from No. 0 to and including 1½". A few sizes other than standard are also included, as shown.

Class 4 and 5 Fits Class W—The N.S.T.C. recommends class W tolerance where the product limits are class 4 or class 5 Fits—Prices are figured as follows:

Class 4 Go members are priced from column B, No Go members from column C, both with the addition of 33⅓%.

Class 1 and 5 priced on application.

SET PLUGS WITH MINOR DIAMETER CHECK PLUGS



TAFT-PEIRCE STYLE 9423

Thread Setting Plugs with minor diameter check plugs are priced by adding the NET price of a NOT GO Plain Cylindrical member to the NET price of a Thread Setting Plug and Handle.

TRUNCATED SETTING PLUGS



STYLE 9421

Truncated Set Plugs — Prices on Application

THREAD RING GAGES
National Coarse, National Fine, and National Special Series
STOCK SIZES

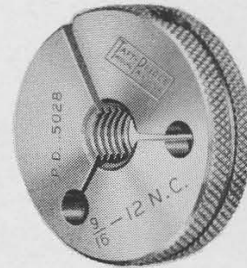
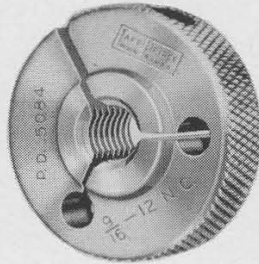

Go **TAFT-PEIRCE STYLE 9424** Not Go
A. G. D. THREAD RING Gages

Page
38

Size	Threads per Inch			Price Each	
	NC	NF	NS	Go Rings Basic Size A	Not Go Rings Class 2 or 3 B
No. 0		80		\$12.60	
1	64	72		12.60	
2	56	64		12.60	
3	48	56		11.70	
4	40	48		11.70	\$15.60
4			36	11.70	
5	40	44		10.80	14.40
6	32	40		10.80	14.40
8	32	36		10.80	14.40
10	24	32		10.80	14.40
10			30	10.80	
12	24	28		10.80	14.40
14			20-24	10.80	
$\frac{1}{4}$ "	20	28		9.00	12.00
$\frac{5}{16}$	18	24		9.00	12.00
$\frac{3}{8}$	16	24		9.60	12.80
$\frac{7}{16}$	14	20		9.60	12.80
$\frac{1}{2}$	13	20		10.20	13.60
$\frac{9}{16}$	12	18		11.20	15.00
$\frac{5}{8}$	11	18		11.20	15.00
$\frac{11}{16}$			11-16	12.40	
$\frac{3}{4}$	10	16		12.40	16.50
$\frac{7}{8}$	9	14		13.60	18.00
$\frac{7}{8}$			18	13.60	
1	8	14		15.00	20.00
$1\frac{1}{8}$	7	12		17.00	22.50
$1\frac{1}{4}$	7	12		19.00	25.00
$1\frac{3}{8}$	6	12		21.00	28.00
$1\frac{1}{2}$	6	12		23.00	31.00

See next page for pricing instructions.

Above prices subject to Discount. See Discount Sheet.

Quantity Discounts on Application

THREAD RING GAGES

The list on the opposite page is used for all basic size Go Thread Ring Gages from standard blanks in the National Coarse and National Fine Series, sizes No. 0 to and including $1\frac{1}{2}$ ". Not Go Rings for Class 2 and Class 3 in the National Coarse and National Fine Series, sizes No. 4 to and including 1"; and a few basic Go Rings other than standard.

All Go Thread Ring Gages other than listed above and all Not Go Thread Ring Gages other than listed above are made to order and will be priced promptly on application.

Thread Ring Gages for Class 4 and Class 5 Fits.

The N. S. T. C. recommends Thread Gages to Class W tolerances where the product limits are Class 4 or Class 5. Prices are figured as follows:

Class 4 Go Thread Ring Gages in the N. C. and N. F. series, to Class W tolerances, are priced from Column A, with an addition of $33\frac{1}{3}\%$.

Class 5—Prices on application.

**ARMY AND NAVY AERONAUTICAL
TAPER THREAD AND PLAIN TAPER GAGES**

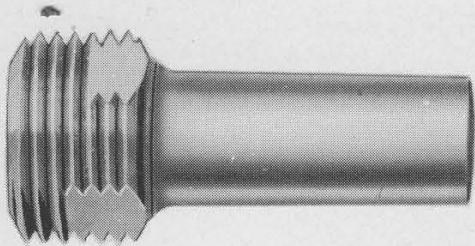

L1 MEMBER

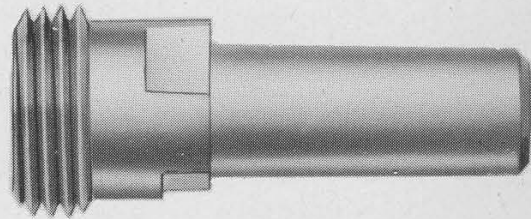

L3 MEMBER

Page
40

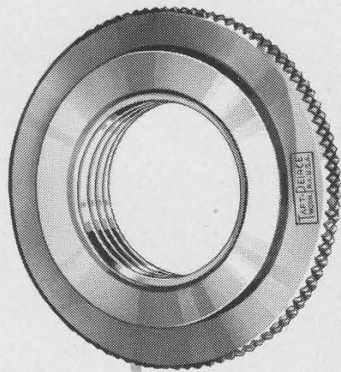

L1 RING

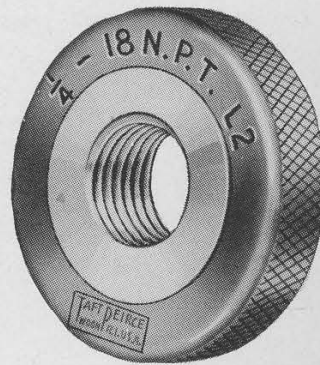

**L2 Taper Thread
Ring Gage**

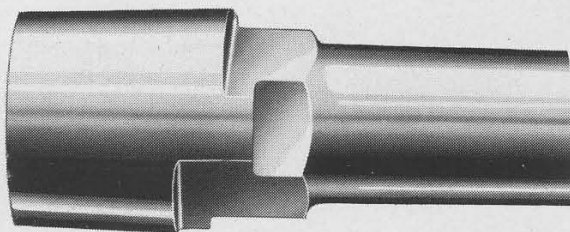

**6 Step Minor Diameter
Check Plug**

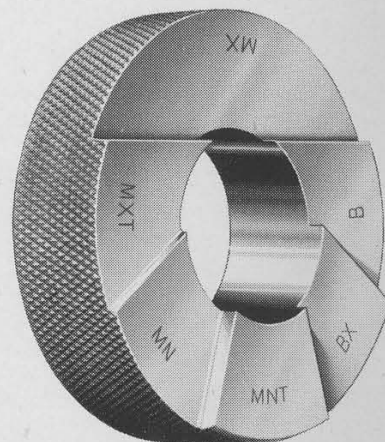

**6 Step Major Diameter
Ring Gage**

Prices on Application

All above gages made to AN-GGG-P363 specifications. When ordering specify Size and Type.

AMERICAN NATIONAL TAPER PIPE THREAD GAGES

N. S. T. C. and A. S. A. Standard Tolerances



A. G. D. Standard Plugs and Rings

Size and Pitch	Price Each		
	Plug Gage		Ring Gage
	Member	Handle	
1/8-27	\$11.40	\$1.20	\$12.60
1/4-18	13.50	1.20	14.70
3/8-18	15.90	1.20	17.10
1/2-14	18.00	1.50	19.50
3/4-14	20.50	1.50	22.00
1 -11 1/2	22.50	1.80	24.30
1 1/4-11 1/2	25.20	1.80	27.00
1 1/2-11 1/2	28.80	1.80	30.60
2 -11 1/2	34.20	1.80	36.00
2 1/2- 8	40.00	3.00	43.00
3 - 8	48.00	3.00	51.00
3 1/2- 8	66.40	3.60	70.00
4 - 8	76.40	3.60	80.00
4 1/2- 8	86.40	3.60	90.00
5 - 8	96.40	3.60	100.00
6 - 8	116.40	3.60	120.00

Page
41

Prices listed above are for Right Hand Threads to Working Gage Tolerances.

Prices for Reference and Master Gages, and Left Hand Pipe Gages, quoted on application.

Above prices subject to Discount. See Discount Sheet.

1144

Quantity Discounts on Application.

Ward Sales Co.
Machine Tools
1472 Broadway
Wisconsin 7-1208 BRYant 9-9642

THREAD LIMIT SNAP GAGES
(U.S. Patent No. 1,817,637)

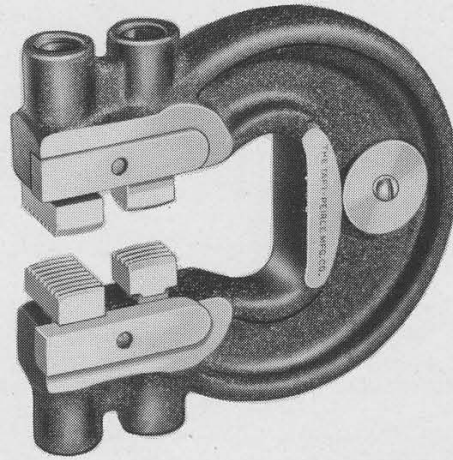

Page
42

TAFT-PEIRCE STYLE 9432

Frame No.	Size Range Inches		Price Net	Frame No.	Size Range Inches		Price Net
	From	To			From	To	
2	.060	— ¼	\$22.00	12	4½	— 5	\$ 45.00
3	¼	— ⅝	21.00	13	5 ⅛	— 5½	47.50
4	⅞	— 1	22.00	14	5 ⅞	— 6	50.00
5	1 ⅛	— 1½	24.00	15	6 ⅛	— 6½	70.00
6	1 ⅞	— 2	26.00	16	6 ⅞	— 7	75.00
7	2 ⅛	— 2½	28.00	17	7 ⅛	— 7½	80.00
8	2 ⅞	— 3	30.00	18	7 ⅞	— 8	85.00
9	3 ⅛	— 3½	32.50	19	8 ⅛	— 8½	90.00
10	3 ⅞	— 4	35.00	20	8 ⅞	— 9	95.00
11	4 ⅛	— 4½	42.50	21	9 ⅛	— 9½	100.00
				22	9 ⅞	— 10	105.00

Gaging Anvils interchangeable in Size Ranges 3 to 10. Above, are available in sets of four from stock for the following pitches: 28, 24, 20, 18, 16, 14, 13, 12, 11, 10, 9, 8, 7 Threads Per Inch American National for Threads\$11.00 per set
Standard Length of Gaging Anvils Go—¾ Inch, No Go—⅝ Inch
Special Lengths, Thread forms and Pitches available.

Prices on Application.

All NC and NF gages, class 2 and 3, will be set and sealed. Unless setting plugs or setting blocks are purchased or supplied by the customer all special gages will be shipped unset.

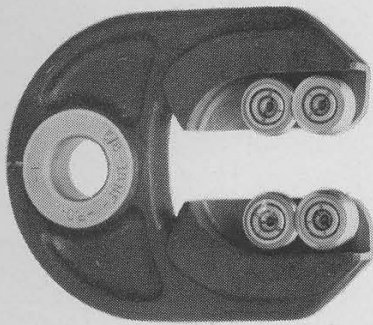

TAFT-PEIRCE

John-Sons Roll Thread Snap Gages

TAFT-PEIRCE STYLE 9435

PRICES

Major Diameter	Style A	Style B	Style C	Style D	Style E	Style F
#0 — #14			\$22.50			
1/4 — 7/16	\$24.00	\$34.00		\$28.50	\$28.50	\$31.25
1/2 — 1/8	26.00	37.00		31.00	31.00	34.00
3/4 — 1 1/8	28.00	40.00		33.50	33.50	36.75
1 — 1 3/16	30.00	43.00		36.00	36.00	39.50
1 1/4 — 1 7/16	31.00	44.50		37.25	37.25	41.00
1 1/2 — 1 11/16	32.00	46.00		38.50	38.50	42.25
1 3/4 — 1 15/16	33.00	47.50		39.75	39.75	43.75
2 — 2 3/16	34.00	49.00		41.00	41.00	45.00
2 1/4 — 2 7/16	35.00	50.50		42.25	42.25	46.25
2 1/2 — 2 11/16	36.00	52.00		43.50	43.50	47.75
2 3/4 — 2 15/16	37.00	53.50		44.75	44.75	49.10
3 — 3 5/16	38.00	55.00		46.00	46.00	50.50
3 3/8 — 3 11/16	39.00	56.50		47.25	47.25	51.85
3 1/2 — 4 1/16	40.00	58.00		48.50	48.50	53.25
4 1/8 —	41.50	60.25		50.40	50.40	55.35

Page
43

STYLES



A

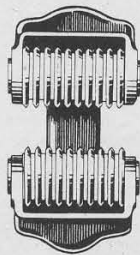

B



C

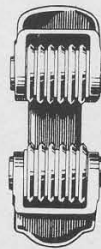

D

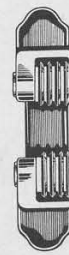

E

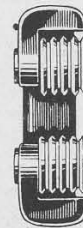

F

Prices are for "Standard Modified Style" gages to 28 Pitch. Pitches in Range No. 0 to No. 12 finer than NF are net from Col "C" Gages with Full Ribbed Not Go Rolls—Gages with Extra Length Rolls—Gages finer than 28 pitch (except style C) and special gages All priced on application.

Prices on Application.

Specify Style When Ordering.

Prices Subject to Discount — See Discount Sheet.

THREAD SETTING BLOCKS
(For Use With T.P. Thread Snap Gages)
OVER ONE INCH

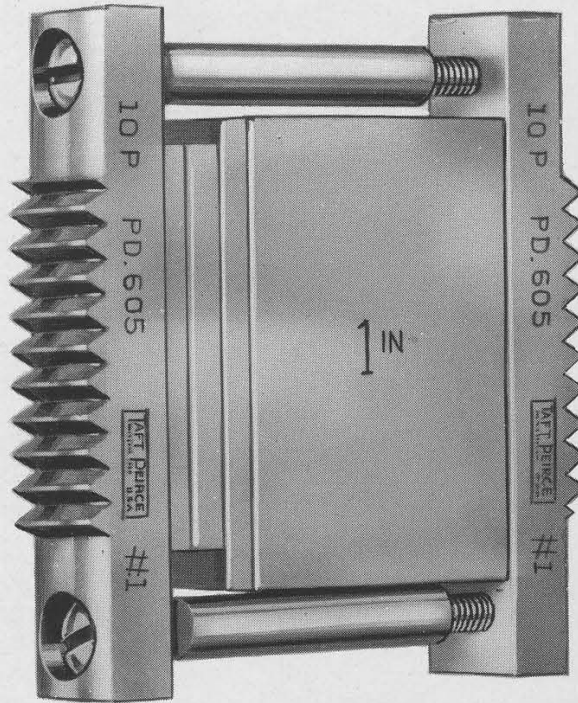

TAFT-PEIRCE STYLE 9431

Available in the following threads per inch — 28, 24, 20, 18, 16, 14, 13, 12, 11, 10, 9, 8, 7.

Price — \$42.00 Per Pair

Above price does not include Gage Block.
Specify Threads per inch when ordering.

THREAD SETTING PLUGS
(For Setting T.P. Thread Snaps)

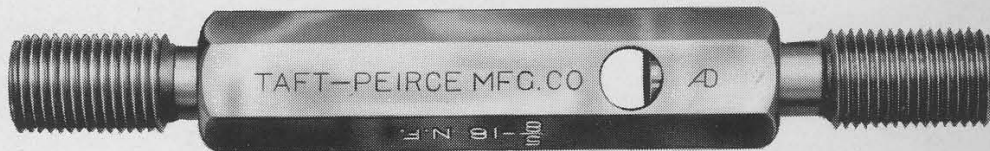

TAFT-PEIRCE STYLE 9420

For Standard Sizes see Page 36
Larger Sizes Priced on Application.

THREAD MEASURING WIRES

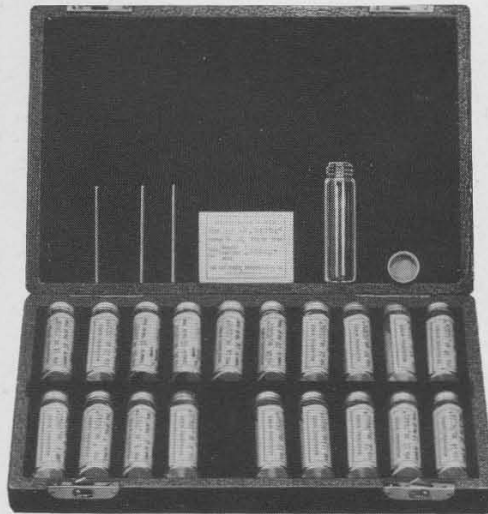

Set No. 20

Set No. 20, 6 to 36 pitch, with case, including 3 wires each for pitches 6, 7, 8, 9, 10, 11, 11½, 12, 13, 14, 16, 18, 20, 24, 26, 27, 28, 30, 32, and 36 pitch, High Speed Steel wires\$95.00

Set No. 30, 5 to 80 pitch, with case, including 3 wires each for pitches 5, 5½, 6, 7, 8, 9, 10, 11, 11½, 12, 13, 14, 16, 18, 20, 24, 26, 27, 28, 30, 32, 36, 40, 44, 48, 50, 56, 64, 72, and 80 pitch, High Speed Steel wires\$180.00

SINGLE SETS STANDARD SIZES, 3 WIRES

PITCH	PRICE PER SET	HIGH SPEED
5, 5½	\$9.00
6 to 36	5.50
40, 44, 48	7.50
50, 56, 64	9.00
72, 80	10.00

SINGLE SETS SPECIAL SIZES, 3 WIRES

SIZE	CARBON	H.S.S.	SIZE	CARBON	H.S.S.
.002-.005	\$16.50		.016-.100	\$9.00	\$11.00
.005-.007	13.50	\$17.00	.100-.180	10.50	13.00
.007-.010	12.00	15.00	.180-.250	12.00	15.00
.010-.016	10.50	13.00			

SPECIAL THREAD GAGES

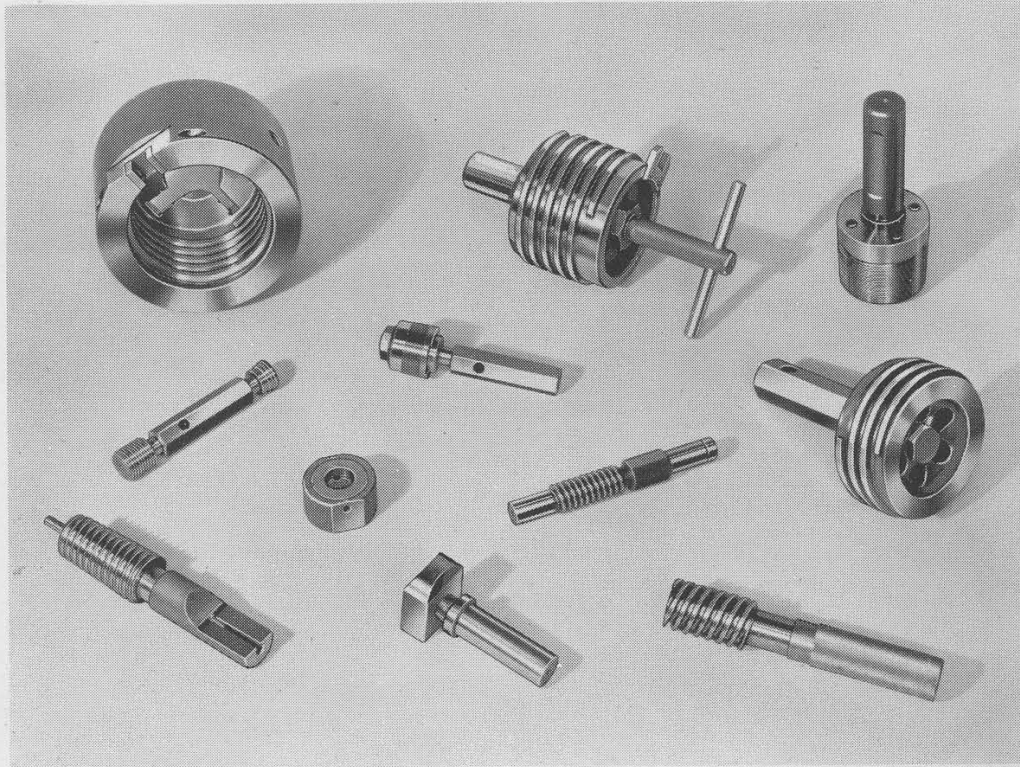

Page
46

SPECIAL THREAD GAGES

All thread gages of pitch diameters, dimensions or design not listed herein, all threads other than American National Form and all left-hand pitches are furnished on order.

Prices quoted upon application to Taft-Peirce branch offices in New York, Chicago, Detroit, or to the factory at Woonsocket, R. I.

A. P. I. GAGES

Thread Gages to specifications of American Petroleum Institute, bearing the official A. P. I. monogram, furnished on order. Prices upon application.

T-P TAPER TEST GAGES

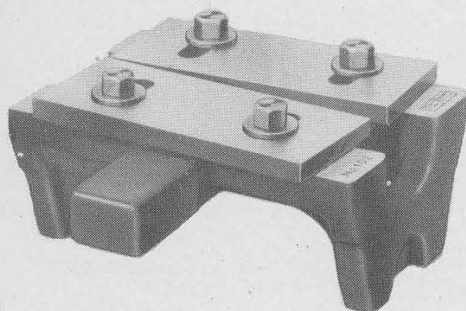

Taft-Peirce Style	Length of Blade	Largest Diameter	Price Each
9101	$3\frac{3}{8}$ "	1 "	\$35.00
9102	$5\frac{7}{16}$ "	$1\frac{5}{8}$ "	42.50
9103	8 "	$2\frac{7}{8}$ "	50.00

Above prices subject to Discount. See Discount Sheet.

Page

47

TAPER GAGES

Male and Female Taper Gages, to Brown & Sharpe, Jarno, Morse and S. A. E. Standards, or to special specifications, furnished on order. Prices on application.

Special Gages

Male and Female Gages for checking splines, keyways, profiles, contours, and other special shapes designed and built to order. Send print or sketch of part to be gaged, with tolerance required, for recommendations and quotation.

TOOL ROOM SPECIALTIES

Sine Bars

Sine Blocks

Angle Gages

Angle Blocks

V-Blocks

Cylindrical Squares

Parallels

Straight Edges

Toolmaker's Knees

Adjustable Angle Plate

Angle Irons

Bench Centers

Surface Plates

Boring Equipment

Page

49

Ward Sales Co.
Machine Tools
1472 Broadway
Wisconsin 7-1208 BRyant 9-9642

T-P SINE BARS

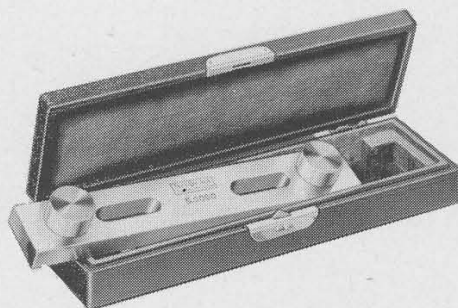

Taft-Peirce Style	Center Distance	Weight	Price Each	
			Ground Only	Edges Lapped
9114	3"	1 lb.	\$26.50	\$32.50
9115	5"	1 lb.	30.00	37.50
9116	10"	2 lbs.	60.00	75.00
9117	20"	7 lbs.	135.00	160.00

Price includes case. Specify finish required.

TAFT-PEIRCE SINE BLOCK

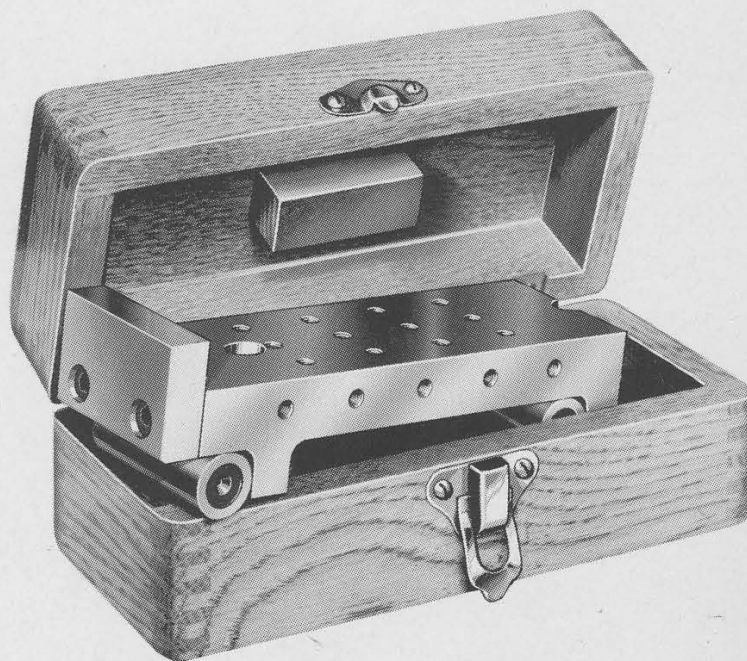

TAFT-PEIRCE STYLE 9118

Length	Center Distance	Width	Height	Weight	Price
6"	5"	2 1/8"	1 3/4"	3 1/2 lbs.	\$60.00
11 1/2"	10"	4"	1 19/32"	10 lbs.	330.00

Above prices subject to Discount. See Discount Sheet.

T-P SINE BAR FIXTURE

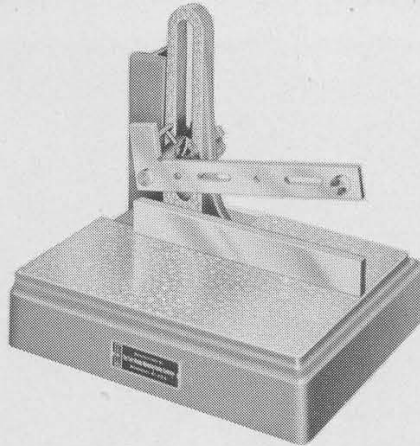

TAFT-PEIRCE STYLE 9121

Furnished complete with Sine Bar, edges lapped

Taft-Peirce Style	Center Distance of Sine Bar	Weight	Price Each
9120	5"	23 lbs.	\$190.00
9121	10"	70 lbs.	335.00

Page

51

T-P SINE BLOCK TAPER TESTING FIXTURE

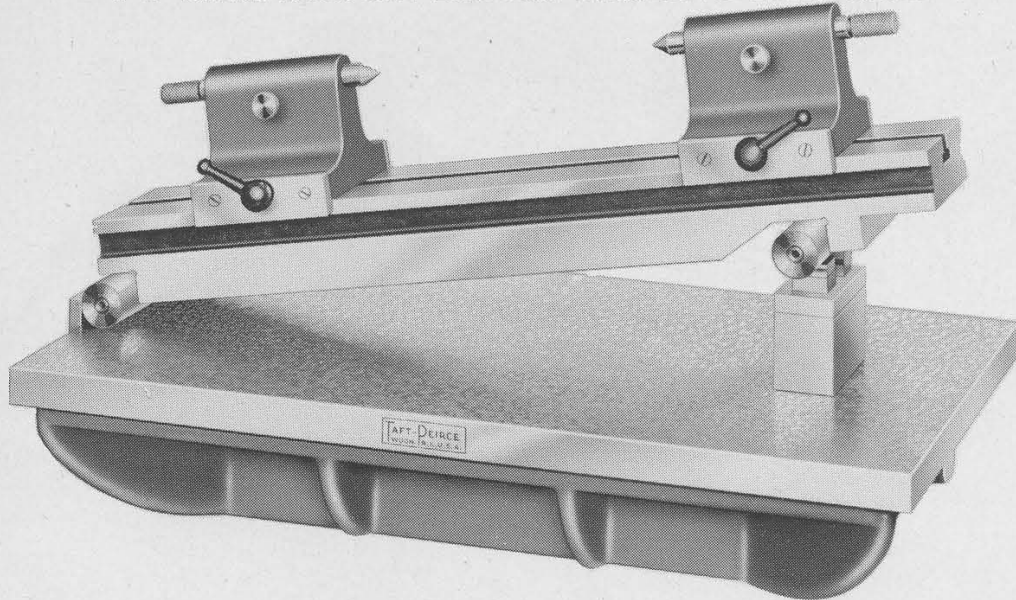

TAFT-PEIRCE STYLE 9122

T-P Style	Length	Cap. of Centers		Weight	Price
		Length	Swing		
9122	20"	15"	6"	175 lbs.	\$600.00

Price includes Taft-Peirce Surface Plate 14" x 24", Style 9211

Above prices subject to Discount. See Discount Sheet.

TAFT-PEIRCE UNIVERSAL ANGLE GAGES

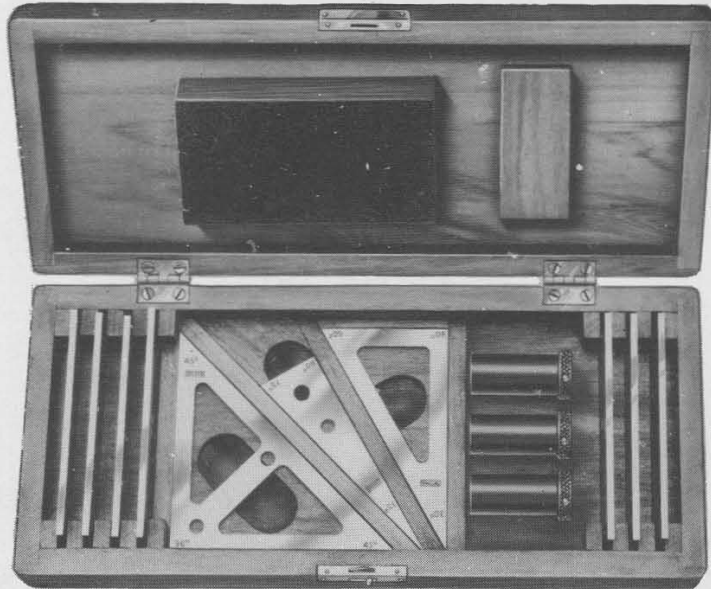

Page
52

TAFT-PEIRCE STYLE 9125

Set of ten gages and three clamps, complete with instructions, in hard wood case, as illustrated, price\$100.00

TAFT-PEIRCE UNIVERSAL ANGLE BLOCKS



TAFT-PEIRCE STYLE 9126

Set of thirteen pairs of 4" angle blocks and 3" Sine Bar complete in hardwood case as illustrated, price\$220.00

Above prices subject to Discount. See Discount Sheet.

T-P V-BLOCKS — HARDENED STEEL

(Sold in Pairs Only)

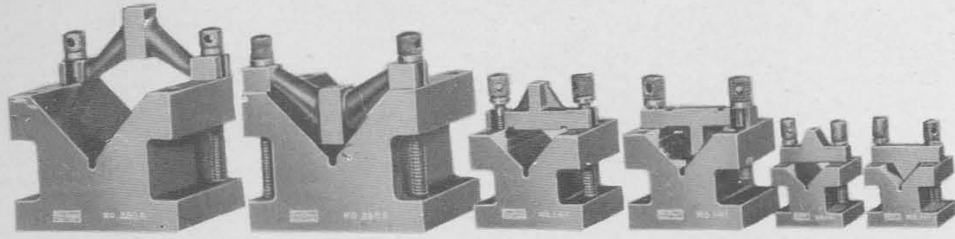

T-P Style	Length	Width	Height	Capacity	Weight Per Pair	Price Per Pair
9128	1 3/8"	1 3/8"	1 1/8"	3/4"	1 lb.	\$20.00
9129	2 1/8"	2 3/8"	1 7/8"	1 1/2"	4 lbs.	35.00
9130	2 7/8"	4"	2 7/8"	3"	14 lbs.	55.00

Page

53

T-P V-BLOCKS — UNIVERSAL

(Sold Singly)

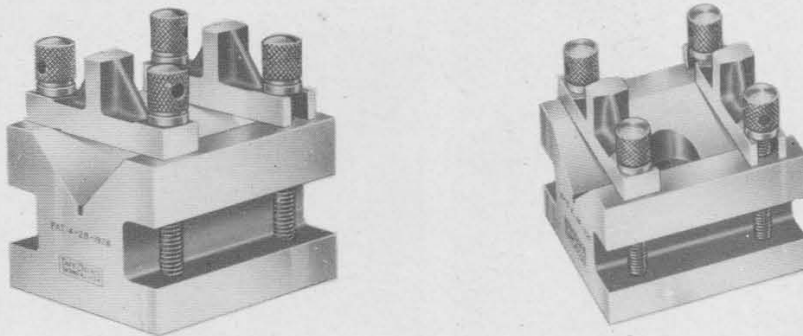

T-P Style	Length	Width	Height	Capacity	Weight Each	Price Each
9131	2 3/4"	2 3/8"	1 7/8"	1 1/2"	3 lbs.	\$35.00

Finished in pairs on order — \$85.00 per pair

Above prices subject to Discount. See Discount Sheet.

T-P V-BLOCKS — CAST IRON
(Sold in Pairs Only)

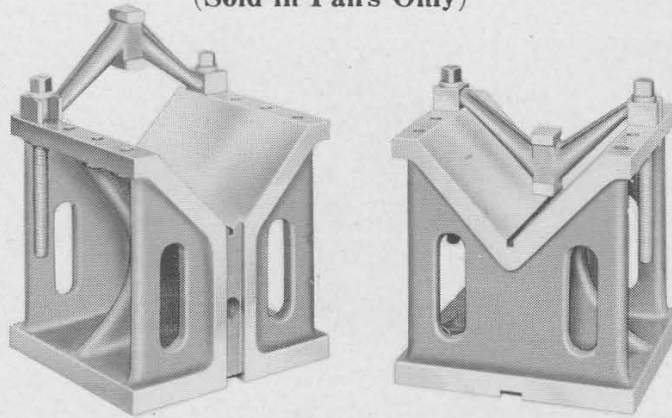

T-P Style	Length	Width	Height	Capacity	Weight Per Pair	Price Per Pair
9133	6"	6"	6"	4 1/2"	42 lbs.	\$100.00
9134	8"	8"	8"	6 3/8"	77 lbs	170.00

Page
54

T-P CYLINDRICAL SQUARES

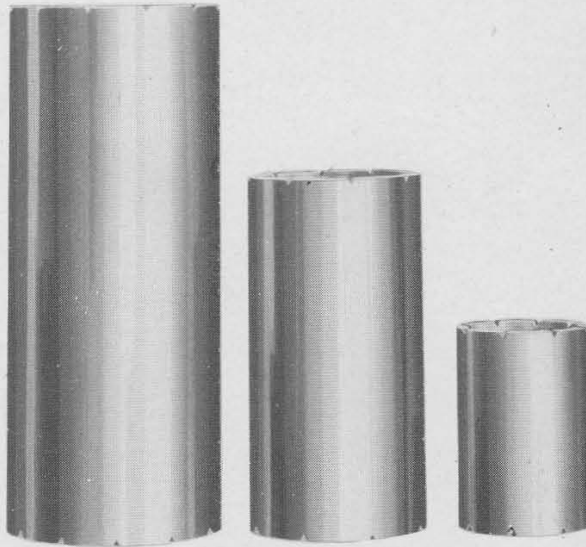

T-P Style	Diameter	Height	Weight	Price Each
9141	3"	4 1/2"	8 lbs.	\$52.50
9142	4"	8 "	27 lbs.	80.00
9143	5"	12 "	64 lbs.	110.00

Price per set, three sizes listed above — \$237.50
Prices include wooden case

Above prices subject to Discount. See Discount Sheet.

T-P HARDENED AND GROUND STEEL PARALLELS

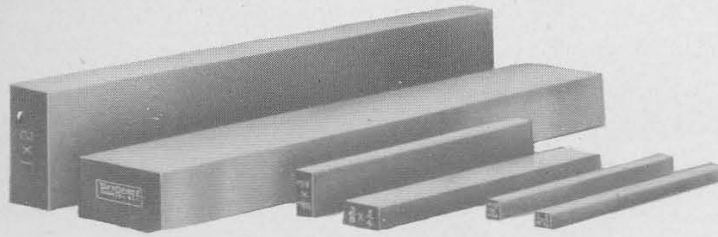

TAFT-PEIRCE STYLE 9150

Size — Inches	Price Each	Size—Inches	Price Each
$\frac{5}{16}$ x $\frac{1}{4}$ x 5 B	\$4.00	1 x $\frac{5}{16}$ x 6	\$6.75
$\frac{3}{8}$ x $\frac{1}{4}$ x 5	4.00	1 x $\frac{1}{2}$ x 6 B	6.75
$\frac{3}{8}$ x $\frac{5}{16}$ x 5 B	4.00	$1\frac{1}{8}$ x $\frac{5}{16}$ x 6	6.75
$\frac{7}{16}$ x $\frac{1}{4}$ x 5	4.00	$1\frac{1}{8}$ x $\frac{1}{2}$ x 6	7.50
$\frac{7}{16}$ x $\frac{3}{8}$ x 5	4.00	$1\frac{1}{8}$ x $\frac{5}{8}$ x 6 B	7.50
$\frac{1}{2}$ x $\frac{1}{4}$ x 5 B	4.00	$1\frac{1}{8}$ x $\frac{3}{4}$ x 6	7.50
$\frac{1}{2}$ x $\frac{5}{16}$ x 5	4.00	$1\frac{1}{4}$ x $\frac{3}{8}$ x 8	8.00
$\frac{1}{2}$ x $\frac{3}{8}$ x 5	4.00	$1\frac{1}{4}$ x $\frac{1}{2}$ x 8	8.00
$\frac{5}{8}$ x $\frac{1}{4}$ x 6	4.75	$1\frac{1}{4}$ x $\frac{5}{8}$ x 8 B	8.00
$\frac{5}{8}$ x $\frac{5}{16}$ x 6 B	4.75	$1\frac{1}{2}$ x $\frac{5}{8}$ x 8	8.75
$\frac{11}{16}$ x $\frac{9}{16}$ x 6	4.75	$1\frac{1}{2}$ x $\frac{3}{4}$ x 8 B	8.75
$\frac{3}{4}$ x $\frac{3}{8}$ x 6 B	4.75	$1\frac{1}{2}$ x $1\frac{1}{4}$ x 12	12.00
$\frac{3}{4}$ x $\frac{7}{16}$ x 6	5.50	$1\frac{3}{4}$ x $\frac{7}{8}$ x 12 B	12.00
$\frac{3}{4}$ x $\frac{1}{2}$ x 6	5.50	2 x 1 x 12 B	12.75
$\frac{13}{16}$ x $\frac{1}{4}$ x 6	5.50	$2\frac{1}{4}$ x $1\frac{1}{8}$ x 12 C	14.50
$\frac{13}{16}$ x $\frac{5}{16}$ x 6	5.50	$2\frac{1}{2}$ x $1\frac{1}{4}$ x 12 C	16.00
$\frac{13}{16}$ x $\frac{3}{8}$ x 6	5.50	$2\frac{3}{4}$ x $1\frac{3}{8}$ x 12 C	18.00
$\frac{7}{8}$ x $\frac{1}{4}$ x 6	5.50	3 x $1\frac{1}{2}$ x 12 C	20.00
$\frac{7}{8}$ x $\frac{7}{16}$ x 6 B	6.75		
$\frac{7}{8}$ x $\frac{5}{8}$ x 6	6.75		
1 x $\frac{1}{4}$ x 6	6.75		

Page
55

Set A — 2 each of 39 sizes listed, weight 147 lbs. \$595.00
 Set B — 2 each of 12 sizes listed B, weight 45 lbs. 180.00
 Set C — 2 each of 16 sizes listed B and listed C, weight 98 lbs. 320.00

Set prices include wooden case

Above prices subject to Discount. See Discount Sheet.

T-P BOX PARALLELS — CAST IRON



Page
56

T-P Style	Length	Width	Height	Weight	Price Each
9160	6"	4"	4"	14 lbs.	\$21.50
9161	6"	4"	6"	22 lbs.	32.00
9162	12"	5"	8"	55 lbs.	55.00
9163	16"	6"	14"	92 lbs.	110.00
*9164-A	10"	10"	10"		167.50
*9164-B	12"	12"	12"		200.00

*Made to order only. Special sizes prices on application.

Above may be furnished in Identical Pairs — Prices on Application.

T-P PLANER AND BORING MILL PARALLELS

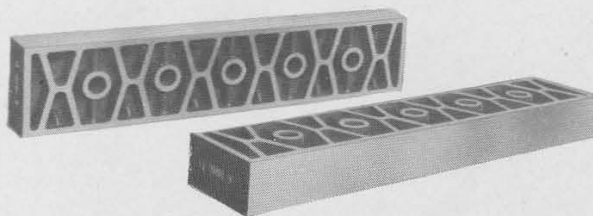

TAFT-PEIRCE STYLE 9165

No.	Length	Width	Height	Weight	Price Each
24	24"	1½"	3"	17 lbs.	\$47.50
32	24"	2"	4"	31 lbs.	60.00
†40	24"	2½"	5"	42 lbs.	70.00
†48	36"	3"	6"	82 lbs.	95.00
†64	36"	4"	8"	120 lbs.	125.00

†Finished to order promptly from seasoned castings in stock.

Above prices subject to Discount. See Discount Sheet.

**T-P LEVELLING STRAIGHT EDGES
(CAST IRON)**

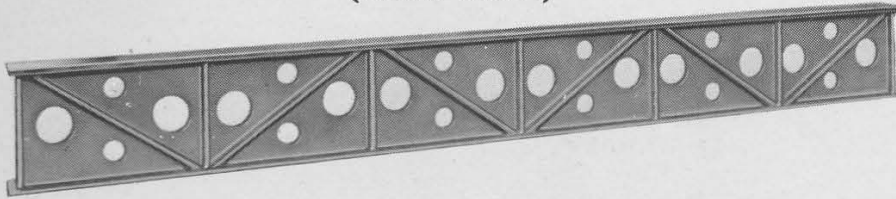

TAFT-PEIRCE STYLE 9168

Top and Bottom Surfaces Scraped

Length	Width	Height	Weight—Approx.	Price Each
36"	2 1/2"	8"	60 lbs.	\$80.00
48"	2 1/2"	8"	70 lbs.	105.00
60"	2 1/2"	8"	100 lbs.	130.00
72"	2 1/2"	8"	125 lbs.	155.00
* 96"	3 1/2"	12"	410 lbs.	300.00
*120"	3 1/2"	12"	510 lbs.	400.00
*144"	3 1/2"	12"	620 lbs.	550.00

*Made to order only.

T-P STEEL STRAIGHT EDGES



TAFT-PEIRCE STYLE 9169

Length	Height	Thickness	Weight (lbs.)	Price
12"	1"	1/4"	1	\$20.00
24"	2"	5/16"	4	40.00
36"	2 1/2"	3/8"	8	60.00
48"	3"	7/16"	16	80.00
60"	3 1/2"	1/2"	26	100.00
72"	4"	1/2"	36	120.00

Above prices subject to Discount. See Discount Sheet.

T-P TOOLMAKER'S ADJUSTABLE KNEE

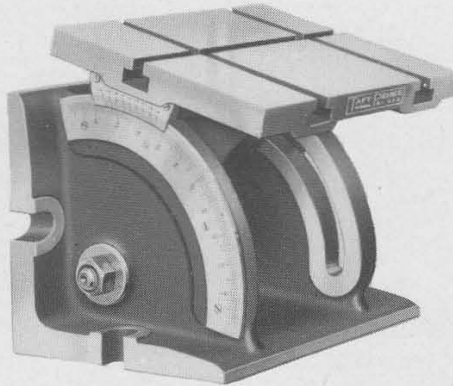

TAFT-PEIRCE STYLE 9170

Length	Width	Height	Weight	Price Each
10"	7"	9"	68	\$400.00

Angular faces scraped.

Page
58

T-P ADJUSTABLE ANGLE PLATE

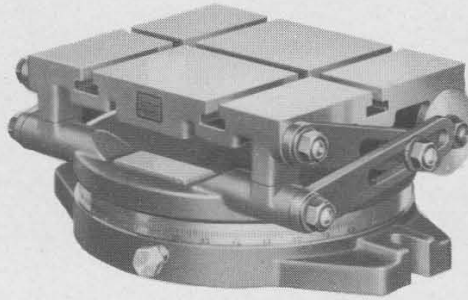

TAFT-PEIRCE STYLE 9175

Table Size	Height Horizontal	Weight	Price
8" x 10"	5"	75 lbs.	\$200.00
12" x 18"	6 1/4"	275 lbs.	750.00

Above prices subject to Discount. See Discount Sheet.

T-P TOOLMAKER'S KNEE

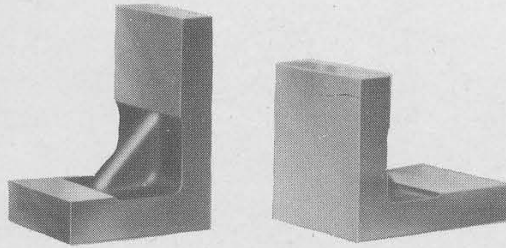

TAFT-PEIRCE STYLE 9180

Length	Width	Height	Weight	Price Each Ground	Price Each *Scraped
2½"	4"	3"	4	\$8.00	16.00

*Working surfaces only
Specify finish required when ordering.
May be furnished in Identical Pairs.
Prices on Application.

Page
59

T-P SLOTTED ANGLE IRONS

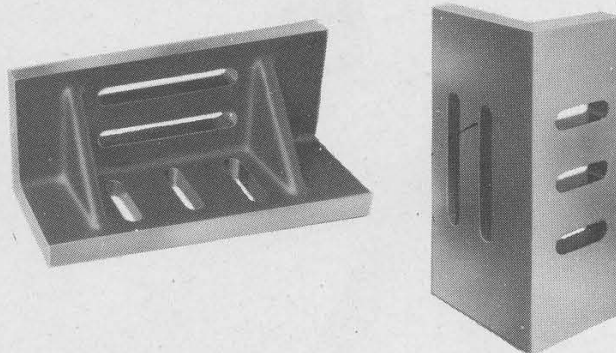

TAFT-PEIRCE STYLE 9185

First Angle	Width	Second Angle	Weight	Ground No.	Price Each	Scraped *No.	Price Each
4"	5"	5½"	8 lbs.	10	\$14.00	11	\$22.00
6"	6"	8"	20 lbs.	12	28.00	13	37.50
4"	9"	5"	16 lbs.	14	28.00	15	37.50
8"	10"	12"	54 lbs.	16	57.50	17	75.00
5"	12"	6"	30 lbs.	18	40.00	19	55.00
9"	12"	10"	67 lbs.	20	65.00	21	85.00
12"	16"	14"	150 lbs.	22	95.00	23	130.00
16"	20"	18"	220 lbs.	26	135.00	27	200.00

Special sizes to order — Prices on Application.

*Working surfaces only

Above prices subject to Discount. See Discount Sheet.

T-P UNIVERSAL RIGHT ANGLE IRONS

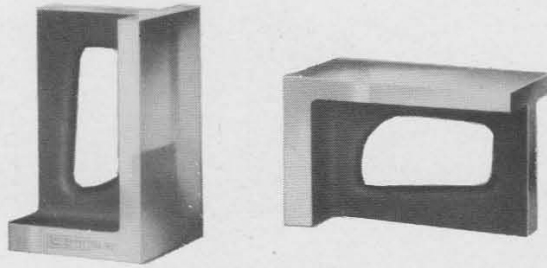

T-P Style	First Angle	Width	Second Angle	Weight	Price Each Ground	Price Each *Scraped
9191	4"	3 3/4"	5"	7 lbs.	\$20.00	\$27.00
9192	5"	4 1/2"	8"	16 lbs.	27.50	39.00
9193	7"	5 1/2"	10"	32 lbs.	40.00	57.50
9194	9"	8"	16"	80 lbs.	67.50	105.00

Page
60

*Workings or faces only

Specify finish required when ordering.

May be furnished in Identical Pairs.

Prices on Application.

T-P MEASURING IRONS

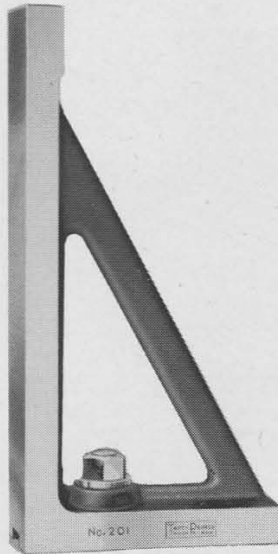

T-P Style	First Angle	Width	Second Angle	Weight	Price Each
9201	6"	2 1/2"	12 1/2"	13	\$40.00
9202	8"	4"	21 1/2"	45	67.50

Special Sizes Available — Prices on Application.

Standard Sizes Subject to Discount. See Discount Sheet.

T-P SURFACE PLATES

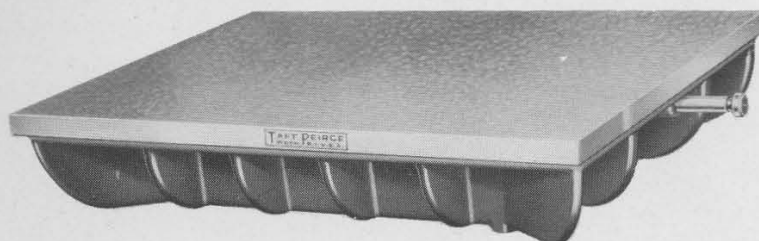

TAFT-PEIRCE STYLE No. 9210

No. 9211

Size—Inches	Approximate Weight—Pounds	Planed Only	Planed and Scraped
8 x 10	22	\$25.00	\$30.00
10 x 12	35	30.00	35.00
12 x 12	40	37.00	43.00
12 x 18	70	55.00	68.00
13 x 15	50	47.00	59.00
14 x 14	58	47.00	59.00
14 x 18	85	62.50	75.00
14 x 24	105	80.00	100.00
18 x 18	100	80.00	98.00
18 x 24	145	108.00	133.00
18 x 36	235	137.50	175.00
24 x 24	285	142.50	180.00
24 x 36	370	220.00	275.00
24 x 48	525	295.00	370.00
30 x 36	560	270.00	345.00
30 x 48	725	370.00	470.00
30 x 60	1020	470.00	595.00
30 x 72	1200	562.50	725.00
30 x 84	1400	673.00	860.00
36 x 36	700	300.00	425.00
36 x 48	1000	465.00	565.00
36 x 60	1250	537.50	700.00
36 x 72	1500	645.00	850.00
*48 x 72	2000		
*48 x 96	3000		
*48 x 144	6000		

Page
61

*Furnished on order from patterns in stock. Prices on application.

T-P Style 9212, ground only and grooved for lapping, sizes to and including 24" x 36", prices same as 9211 above.

Wooden cover furnished with scraped plates.

Cabinet type tables. Prices on application.

Above prices subject to Discount. See Discount Sheet.

Surface Plates Reconditioned — Prices on Application

TAFT-PEIRCE DUPLEX BENCH BLOCK

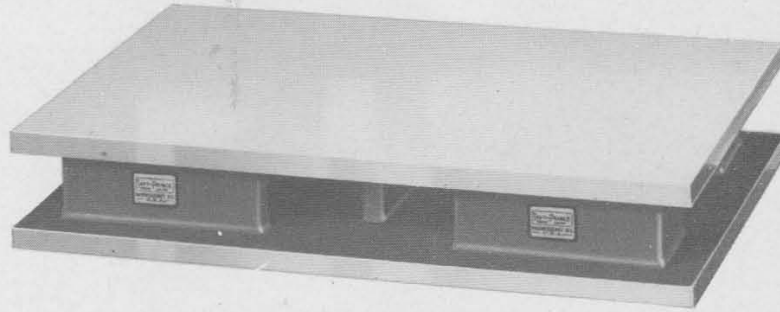

TAFT-PEIRCE STYLE 9215

Width	Length	Height	Weight	Price Each
10"	14"	2 ³ / ₈ "	37 lbs.	\$20.00

Grooved for lapping, 1/2" mesh — one side only — \$10.00 additional.
 Grooved for lapping, 1/2" mesh — both sides — \$17.50 additional.

Hand scraped—\$12.00 per side additional.

May be ordered with Special Size Mesh.

Prices on Application.

Page

62

T-P UNIVERSAL SQUARE

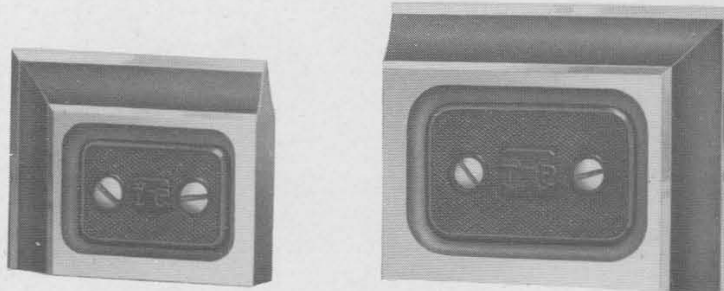

TAFT-PEIRCE STYLE 9330

T-P Style	Length	Width	Thick.	Price Each
9330	2"	2 ¹ / ₂ "	1/2"	\$27.50
9331	2 ¹ / ₂ "	3 ¹ / ₄ "	9/16"	35.00

Price includes wooden case.

Above prices subject to Discount. See Discount Sheet.

T-P PRECISION BORING EQUIPMENT

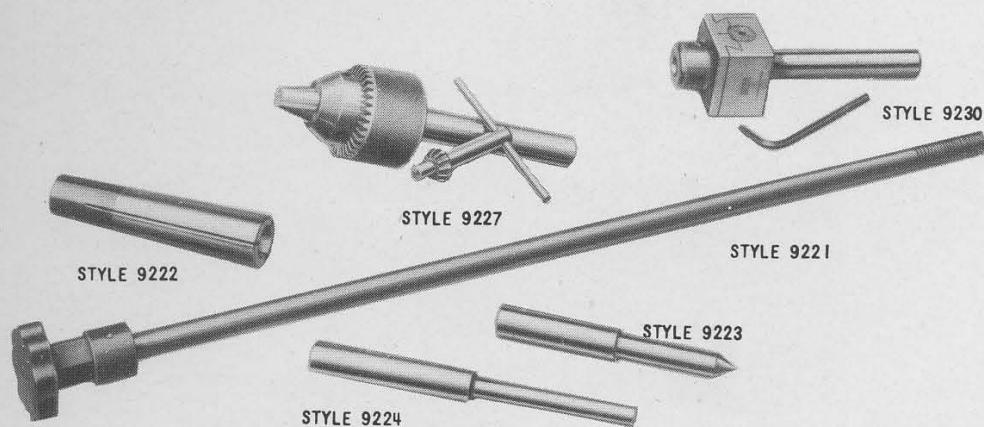

T-P Style	Part	Price Each
9221	Draw-in Rod	\$5.00
9222	Collet — No. 10 B & S Taper	30.00
9222	Collet — No. 11 B & S Taper	35.00
9223	Work Center	9.00
9224	Test Plug	9.00
9227	Drill Chuck	13.50
9230	Adjustable Boring Tool Holder	42.50 ✓

Above prices subject to Discount. See Discount Sheet.

Page
63

Ward Sales Co.
Machine Tools
1472 Broadway
Wisconsin 7-1208 BRYant 9-9642

T-P BENCH CENTERS

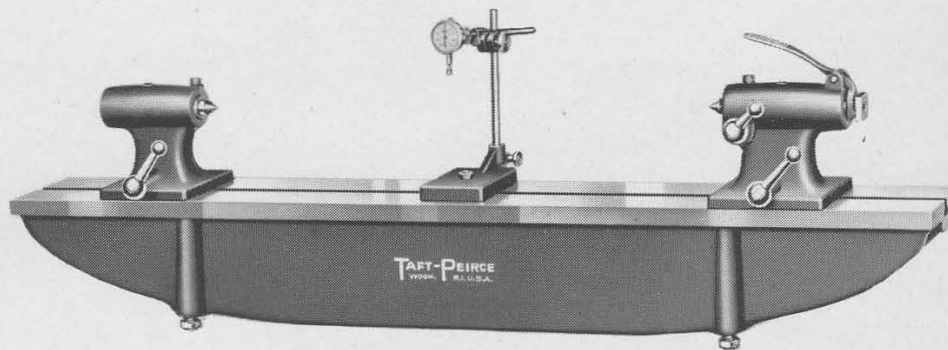

TAFT-PEIRCE STYLE 9205

Maximum Between Centers	Maximum Swing	Price	Indicator Mounting	Indicator Bracket
18"	8"	\$155.00	\$13.50	\$20.00
36"	8"	170.00	13.50	20.00
54"	12"	775.00	26.50	40.00
48"	16"	800.00	33.25	50.00
60"	10"	775.00	26.50	40.00

Page
64

Prices in Column 3 include Head and Tail Stocks with Centers, also Bed with Working Surfaces Ground. Hand Scraped Beds also furnished — Prices on Application.

Special Size Bench Centers Made to Order—Prices on Application.

Dial Indicators Priced on Application.

Above Prices Subject to Discount — See Discount Sheet.

TAFT-PEIRCE PRECISION BENCH CENTER SINE BAR INDEXING

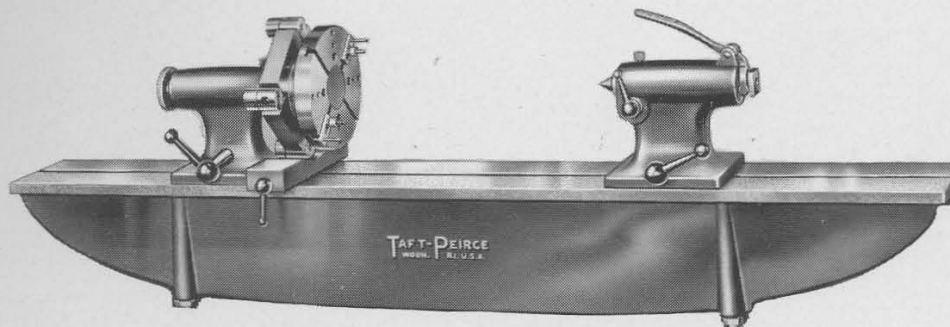

STYLE 9205-SB

Maximum Between Centers	Maximum Swing	Complete as Shown
15"	8"	\$895.00
33"	8"	960.00

Page
65

Above prices include precision head and tailstocks with centers, hand scraped bed, removable sine indexing head, hardened steel face plate and clamps.

Above Prices Subject to Discount — See Discount Sheet.

See Preceding Page for Indicator Bracket and Mounting.

GEAR ROLLING ATTACHMENTS

For Use With

TAFT-PEIRCE BENCH CENTERS

SPUR GEARS

2 Plain Heads

BEVEL GEARS

1 Adj. Head, Max. Capacity 6" Diam.

1 Plain Head

WORM GEARS AND WORMS

1 Adj. Head with Centers

Max. Capacity 3" Diam., 4" Long.

1 Plain Head

LOCATING STUDS — (Interchangeable in All Heads)

2 ea. $\frac{1}{4}$ " to 1" x $\frac{1}{8}$ "th increments with
uniform tapered shanks

Prices on Application.

REAMER SECTION

Adjustable Reamers, Service Type

Universal Connecting Rod Reaming Fixture

Universal Line Reaming Equipment

Adjustable Hand Reamers

Page

67

TAFT-PEIRCE SERVICE REAMING EQUIPMENT

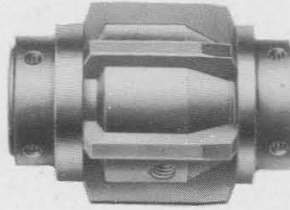

**T-P Adjustable Reamer.
Service Type**

TAFT-PEIRCE ADJUSTABLE REAMERS SERVICE TYPE

Page
68

Bar Diameter 1.000"			Bar Diameter 1.375"		
T-P No.	Nominal Diameter	Net Price Each	T-P No.	Nominal Diameter	Net Price Each
23-A	1 ³ / ₄ "	Prices on Application	28-A	2 ¹ / ₄ "	Prices on application
23-B	1 ⁷ / ₈ "		28-B	2 ³ / ₈ "	
23-C	2"		28-C	2 ¹ / ₂ "	
24-A	2 ¹ / ₈ "		29-A	2 ⁵ / ₈ "	
24-B	2 ¹ / ₄ "		29-B	2 ³ / ₄ "	
24-C	2 ³ / ₈ "		29-C	2 ⁷ / ₈ "	
25-A	2 ¹ / ₂ "		29-D	3"	
25-B	2 ⁵ / ₈ "		30-A	3 ¹ / ₈ "	
25-C	2 ³ / ₄ "		30-B	3 ¹ / ₄ "	
25-D	2 ⁷ / ₈ "		30-C	3 ⁷ / ₈ "	
25-E	3"		30-D	3 ¹ / ₂ "	
			30-E	3 ⁵ / ₈ "	
			30-F	3 ³ / ₄ "	

BLADES

Interchangeable blades for intermediate sizes listed above can be furnished as follows:

Set of 6 blades for reamers numbers 23, 24, 25, 28, fitted and ground.

Set of 8 blades for reamers numbers 29 and 30, fitted and ground.

Prices on application.

TAFT-PEIRCE SERVICE REAMING EQUIPMENT

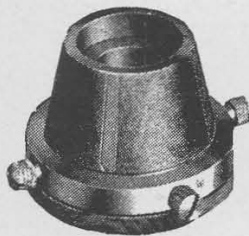

**T-P Adjustable Centering
Bushing Assembly**

T-P No.	T-P INNER SLEEVES, Hardened and Ground	Price Each Net
13	For bar diameter 1.000"	Prices on Application
19	For bar diameter 1.375"	
T-P THREADED CONES		
14	For bearing diameters 1 $\frac{3}{4}$ " — 2 $\frac{1}{8}$ "	
15	For bearing diameters 2 $\frac{1}{8}$ " — 2 $\frac{5}{8}$ "	
16	For bearing diameters 2 $\frac{1}{2}$ " — 3"	
20	For bearing diameters 3 $\frac{1}{8}$ " — 3 $\frac{3}{4}$ "	

Page
69

NOTE: One inner sleeve used with any of threaded cones, sizes listed above, to make up one adjustable centering bushing assembly.

T-P SERVICE REAMER ALIGNING BARS Hardened and Ground

T-P No.	Length	Diameter	Price Each, Net
1	54"	1.000"	Prices on Application
2	44"	1.000"	
3	52"	1.375"	
T-P REAMER ADJUSTING ARBORS			
27		Diameter 1.000"	Prices on Application
5		Diameter 1.375"	

TAFT-PEIRCE SERVICE REAMING EQUIPMENT

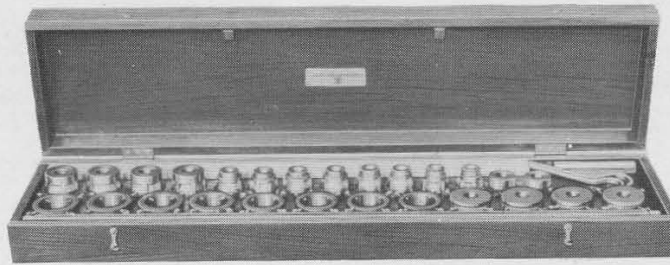

UNIVERSAL SERVICE REAMING OUTFIT

Standard Universal Service Reaming Outfits available from stock. These assemblies include the following equipment, in the sizes and quantities necessary to ream main bearings of all motors in the size ranges indicated:

- T-P Reamer Aligning Bar,
- T-P Adjustable Centering Bushing Assemblies, comprising
T-P Inner Sleeves and T-P Threaded Cones,
- T-P Adjustable Reamer for roughing cuts,
- T-P Adjustable Reamer for finish cuts,
- Additional Blades for Intermediate Reamer Sizes,
- T-P Reamer Adjusting Arbor,
- T-P Reamer Adjusting Spanners,
- Timing Gear Bushing Blanks,
- Storage Chest.

If it is desired to ream all bearings simultaneously, additional reamers and blade sets can be readily furnished. Special prices quoted upon application.

T-P Universal Service Reaming Outfits (comprising equipment listed above)

Set A, 1 3/4" to 2 3/8" (Bar diameter 1")	Prices
Set B, 2 1/2" to 3" (Bar diameter 1")	on
Set C, 2 1/4" to 2 1/2" (Bar diameter 1 3/8")	Application
Set D, 2 5/8" to 3" (Bar diameter 1 3/8")	
Set E, 3 1/8" to 3 3/4" (Bar diameter 1 5/8")	

SPECIAL ASSEMBLIES

Recommendations and quotations on Service or Manufacturing Type Reaming Equipment for individual models of automotive, marine or aviation motors will be furnished promptly upon receipt of bearing specifications.

T-P ADJUSTABLE HAND REAMERS

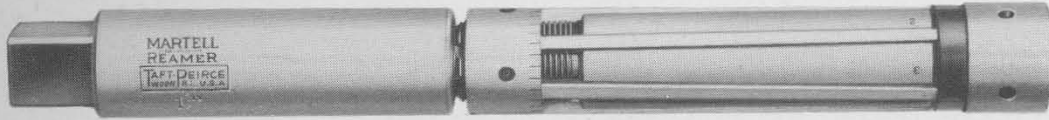

TAFT-PEIRCE STYLE 9720

Diameter — Inches	Length — Inches	
	Blades	Overall
0.750	2.750	8.125
0.812	2.750	8.125
0.875	2.750	8.375
0.937	2.750	8.375
1.000	3.375	9.000
1.062	3.375	9.000
1.125	3.375	9.500
1.187	3.375	9.500
1.250	3.375	9.875
1.312	3.375	9.875
1.375	3.375	10.500
1.437	3.375	10.500
1.500	3.375	10.875
1.562	3.375	10.875
1.625	3.375	11.312
1.687	3.375	11.312
1.750	3.375	11.812
1.812	3.375	11.812
1.875	3.375	12.312
1.937	3.375	12.312
2.000	3.375	12.812

PRICES ON APPLICATION

Reamers to be repaired or reground should be securely packed, plainly marked, and sent directly to the factory at Woonsocket, Rhode Island.

MAGNETIC CHUCK SECTION

(Manufactured under Simmons Patents)

Rectangular Magnetic Chucks

Page

73

Rotary Magnetic Chucks

Demagnetizing Switches

Demagnetizers

Magnetic Parallels

Magnetic V-Blocks

TAFT-PEIRCE *SUPERPOWER* MAGNETIC CHUCKS

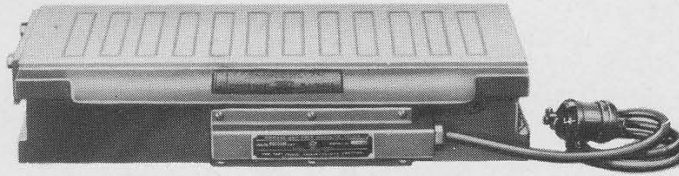

SUPERPOWER SIZE NO. 618

SUPERPOWER RECTANGULAR MODELS — ALL-STEEL CONSTRUCTION

Page
74

Size No.	Work Surface Ins.	Base Dimensions Ins.	Hght. Ins.	D. C. Watts	Approx. Shpng. Weight	Net Price Each
408-P	4 x 8	4 x 9 $\frac{1}{2}$	3	28	55	\$70.00
510-P	5 x 10	5 x 10 $\frac{1}{4}$	3 $\frac{1}{2}$	33	65	80.00
512-P	5 x 12	4 $\frac{7}{8}$ x 12	3 $\frac{5}{16}$	40	62	100.00
613-P	6 x 13	6 x 13	3 $\frac{3}{4}$	66	90	100.00
618-P	6 x 18	6 $\frac{1}{2}$ x 18	3 $\frac{3}{4}$	132	135	115.00
624-P	6 x 24	6 $\frac{1}{2}$ x 24	3 $\frac{3}{4}$	132	218	150.00
648-P	7 $\frac{1}{8}$ x 49 $\frac{1}{2}$	6 $\frac{3}{4}$ x 50 $\frac{1}{8}$	3 $\frac{3}{4}$	264	355	300.00
722-T	7 $\frac{3}{4}$ x 22	6 $\frac{1}{2}$ x 22	3 $\frac{3}{4}$	176	150	150.00
824-P	7 $\frac{3}{4}$ x 24	7 $\frac{1}{2}$ x 26	4	176	200	160.00
940-P	9 x 40	8 x 40 $\frac{3}{4}$	4 $\frac{1}{4}$	286	415	325.00
948-P	9 x 48	8 x 48 $\frac{1}{4}$	4 $\frac{1}{4}$	220	480	375.00
960-P	9 x 62 $\frac{1}{2}$	8 x 61	4 $\frac{1}{4}$	286	525	500.00
1015-P	10 $\frac{1}{4}$ x 15	10 x 18 $\frac{1}{2}$	4 $\frac{1}{4}$	110	190	150.00
1024-P	10 $\frac{1}{4}$ x 24	10 x 27 $\frac{3}{4}$	4 $\frac{1}{4}$	176	310	225.00
1031-T	10 x 31	8 $\frac{3}{4}$ x 35 $\frac{3}{8}$	4 $\frac{1}{2}$	220	394	275.00
1036-P	10 $\frac{1}{4}$ x 36	10 x 39 $\frac{3}{4}$	4 $\frac{1}{4}$	220	475	325.00
1048-P	10 $\frac{1}{4}$ x 48	10 x 51 $\frac{3}{4}$	4 $\frac{1}{4}$	330	560	425.00
1060-P	10 $\frac{1}{4}$ x 60	10 x 63 $\frac{3}{4}$	4 $\frac{1}{4}$	418	680	550.00
1134-T	11 x 34	10 x 33 $\frac{7}{8}$	4 $\frac{1}{4}$	220	385	325.00
1160-T	11 x 60	10 x 60 $\frac{1}{4}$	4 $\frac{1}{4}$	418	698	600.00
1224-P	12 $\frac{1}{4}$ x 24	12 x 24	4 $\frac{1}{4}$	264	330	275.00
1230-P	12 $\frac{1}{4}$ x 30	12 x 30	4 $\frac{1}{4}$	286	450	325.00
1236-P	12 $\frac{1}{4}$ x 36 $\frac{1}{2}$	12 x 36 $\frac{3}{8}$	4 $\frac{1}{4}$	176	570	400.00
1240-P	12 $\frac{1}{4}$ x 41 $\frac{1}{4}$	12 x 39 $\frac{1}{8}$	4 $\frac{1}{4}$	308	620	425.00
1248-P	12 $\frac{1}{4}$ x 48	12 x 48	4 $\frac{1}{4}$	220	730	525.00
1260-P	12 $\frac{1}{4}$ x 60	12 x 60 $\frac{1}{4}$	4 $\frac{1}{4}$	308	915	650.00
1272-P	12 $\frac{1}{4}$ x 72 $\frac{1}{2}$	12 x 72	4 $\frac{1}{4}$	352	1160	775.00
1284-P	12 $\frac{1}{4}$ x 84	12 x 84	4 $\frac{1}{4}$	396	1285	950.00
1296-P	12 $\frac{1}{4}$ x 96	12 x 96	4 $\frac{1}{4}$	440	1395	1200.00

**Magnetic Chucks can be operated on Direct Current only.
Voltage should be specified.**

Price includes hold down clamps and switch.

TAFT-PEIRCE SUPER POWER MAGNETIC CHUCKS

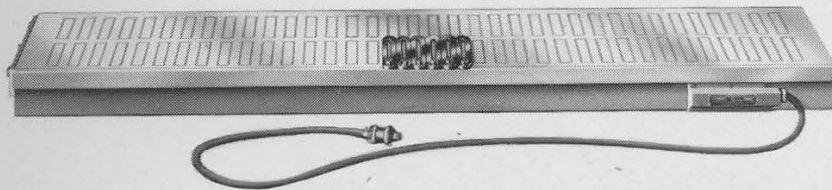

SUPERPOWER SIZE NO. 1460

T-SLOT FACE PLATE STYLE MODEL T

SUPERPOWER RECTANGULAR MODELS — ALL STEEL

CONSTRUCTION

DOUBLE ROW POLES

Size No.	Work Surface Ins.	Base Dimensions Ins.	Hght. Ins.	D. C. Watts	Approx. Shpng. Weight	Net Price Each
1424-P	14 1/4 x 24	14 x 25	4 1/4	176	450	\$325.00
1436-P	14 1/4 x 36	14 x 36 1/4	4 1/4	242	690	450.00
1448-P	14 1/4 x 48	14 x 48	4 1/4	330	770	600.00
1460-P	14 1/4 x 60	14 x 60 3/8	4 1/4	418	920	750.00
1472-P	14 1/4 x 72	14 x 72	4 1/4	484	1230	900.00
1484-P	14 1/4 x 84	14 x 84	4 1/4	836	1300	1100.00
1496-P	14 1/4 x 96	14 x 96	4 1/4	660	1600	1350.00
1518-P	15 1/4 x 18 1/4	15 x 18 1/2	4	220	360	260.00
1618-P	16 x 18 1/2	15 x 18 1/2	4 1/4	154	385	300.00
1636-P	16 x 36 1/2	15 x 36 1/4	4 1/4	330	755	525.00
1640-P	16 x 40	15 x 40	4 1/4	254	800	600.00
1648-P	16 x 48	15 x 47 7/8	4 1/4	440	865	675.00
1660-P	16 x 60	15 x 59 7/8	4 1/4	572	1050	825.00
1672-P	16 x 72	15 x 71 7/8	4 1/4	682	1305	1000.00
1684-P	16 x 84	15 x 84	4 1/4	770	1525	1200.00
1696-P	16 x 96	15 x 96	4 1/4	880	1820	1400.00
1836-P	18 1/2 x 36 1/2	18 x 36 3/8	4 1/4	396	800	600.00
1848-P	18 1/2 x 48	18 x 48	4 1/4	528	1000	825.00
1860-P	18 1/2 x 60	18 x 60	4 1/4	660	1305	950.00
1872-P	18 1/2 x 72	18 x 72	4 1/4	792	1500	1200.00
1884-P	18 1/2 x 84	18 x 84	4 1/4	924	1755	1425.00
1896-P	18 1/2 x 96	18 x 96	4 1/4	1076	2065	1650.00
2036-P	20 1/2 x 36	20 x 36 3/8	4 3/4	352	905	700.00
2048-P	20 1/2 x 48	20 x 48	4 3/4	462	1218	925.00
2060-P	20 1/2 x 60	20 x 60 1/4	4 3/4	594	1530	1125.00
2072-P	20 1/2 x 72	20 x 72	4 3/4	704	1725	1400.00
2084-P	20 1/2 x 84	20 x 84 1/2	4 3/4	721	2150	1625.00
2096-P	20 1/2 x 96	20 x 96	4 3/4	825	2500	1850.00
2436-P	24 x 36 1/2	24 x 36 3/8	5 1/4	352	1170	\$ 850.00
2440-P	24 1/2 x 40	24 x 40 1/2	5 1/4	396	1240	925.00
2448-P	24 1/2 x 48	24 x 48	5 1/4	484	1450	1125.00
2460-P	24 1/2 x 60	24 x 60	5 1/4	616	1750	1350.00
2472-P	24 1/2 x 72	24 x 72	5 1/4	704	2100	1700.00
2484-P	24 1/2 x 84	24 x 84	5 1/4	836	2450	1975.00
2496-P	24 1/2 x 96	24 x 96	5 1/4	968	2930	2250.00

Page
75

1144

Magnetic Chucks can be operated on D.C. only.

Voltage Should be Specified.

Price includes hold down clamps and switch.

TAFT-PEIRCE SUPER POWER MAGNETIC CHUCKS



Page
76

SUPERPOWER SIZE 3048P

SUPERPOWER RECTANGULAR MODELS ALL STEEL CONSTRUCTION TRIPLE ROW POLES

Size No.	Work Surface Inches	Base Dimensions Ins.	Hght. Ins.	D.C. Watts	Approx. Shpng. Wght.	Price
3036	30½ x 37½	30½ x 37½	5¼	594	1365	1200.00
3042	30½ x 42	30 x 42	5¼	660	1820	1375.00
3048	30½ x 48	30 x 48	5¼	792	2090	1550.00
3060	30½ x 60	30 x 60	5¼	990	2185	1800.00
3072	30½ x 72	30 x 72	5¼	1188	2585	2400.00
3084	30½ x 84	30 x 84	5¼	1320	3000	2750.00
3096	30½ x 96	30 x 96	5¼	1584	3450	3100.00
36 x 36	36½ x 36	36 x 36	5½	528	1575	1500.00
36 x 48	36½ x 49½	36 x 49½	5½	1188	2098	1800.00
36 x 60	36½ x 60	36 x 60	5½	940	2475	2200.00
30 x 120 30 x 144 30 x 168 30 x 192	It is recommended that magnetic chucks in these sizes or larger be assembled from standard SUPERPOWER units. Specifications and prices on application.					

For Vertical Face Grinding any rectangular models listed can be mounted on detachable fixture base. Prices on application.
Price includes hold down clamps and switch.

TAFT-PEIRCE SUPERPOWER MAGNETIC CHUCKS ADJUSTABLE MODELS

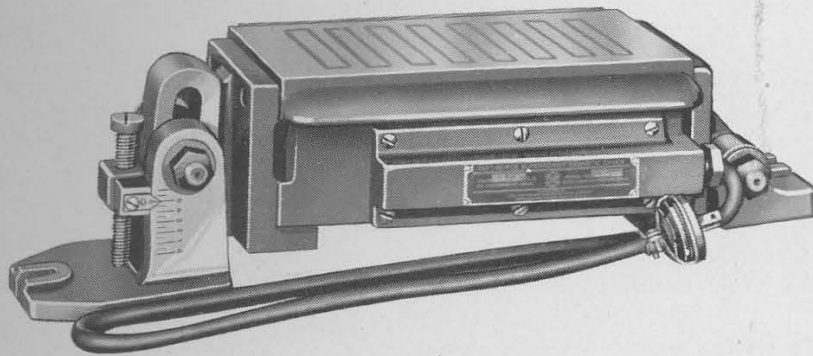

TAPER BASE MODEL

**SWIVEL
BASE
MODEL**



Page
77

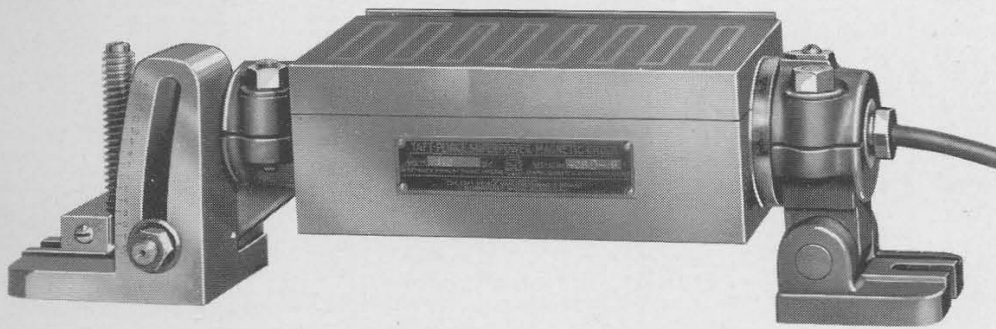

PRECISION DUPLEX BASE MODEL

Size No.	Work Surface Ins.	Base Dimensions Ins.	Hght. Ins.	D. C. Watts	Approx. Shpng. Weight	Net Price Each
408-DB	4 x 8	3 1/2 x 16 3/4	4 1/2	27	60	\$165.00
510-SB	5 x 10	4 1/2 x 14	5 1/2	25	90	150.00
510-TB	5 x 10	4 x 18	4	25	90	150.00
618-SB	6 x 18	6 x 26	7 3/4	121	175	250.00

DB Models—Duplex Base SB Models—Swivel Base TB Models—Taper Base

Note: 510-SB and 618-SB can be furnished with sine bar attachment for precision setting. Prices on application.

Magnetic Chucks operate on DIRECT CURRENT only. Orders for Taft-Peirce SUPERPOWER Chucks should state whether they are to be used with 110 or 220 volts D. C. Price includes switch.

Special sizes made to order — prices on application

**TAFT-PEIRCE SUPERPOWER MAGNETIC CHUCKS
FINE MESH MODELS**

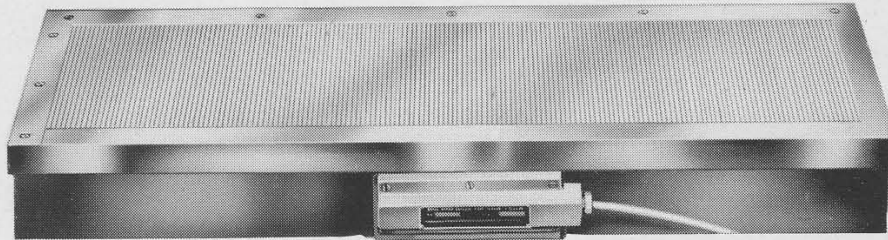

**SUPERPOWER SIZE NO. FM618
SUPER POWER RECTANGULAR MODELS
ALL STEEL CONSTRUCTION**

Page
78

**Fine Mesh Face Plate Style
Fine Mesh Models — All-Steel Construction**

Size No.	Work Surface Ins.	Base Dimensions Ins.	Hght. Ins.	D. C. Watts	Approx. Shpng. Weight	Net Price Each
FM 408	4 x 8	4 x 9½	3	28	60	\$145.00
FM 510	5 x 10	5 x 10¼	3½	33	76	165.00
FM 512	5 x 12	5 x 12	3½	70	70	100.00
FM 613	6 x 13	6 x 13	3¾	70	120	180.00
FM 618	6 x 18	6½ x 18	3¾	132	142	225.00
FM 722	7¾ x 22	6½ x 22	3¾	176	163	275.00
FM 824	7¾ x 24	7½ x 26	4	176	215	300.00
FM1036	10¼ x 36	10 x 39¾	4¼	220	400	500.00
FM1134	11 x 34	10 x 34	4¼	220	418	500.00
FM1236	12¼ x 36½	12 x 36	4¼	176	585	600.00

**Magnetic Chucks can be operated on Direct Current only.
Voltage should be specified.
Price includes hold down clamps and switch.**

Special sizes made to order — prices on application

TAFT-PEIRCE *SUPERPOWER* MAGNETIC CHUCKS FACE PLATE STYLES

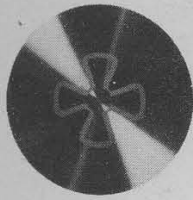

1

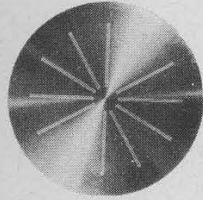

2

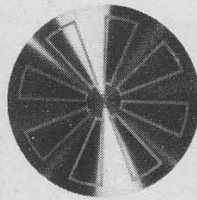

3

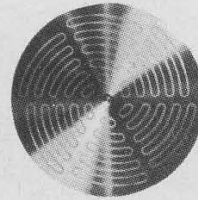

4

ROTARY MODELS

Size No.	Face Plate Dia.	Magnetic Surface		Back Plate Seat Dia.	Face to Back Plate Seat	App. Shpg. Wt.	D.C. Watts	Face Plate Style	Net Price Each
		I. D.	O. D.						
905	5 ³ / ₈	1/2	4 ⁵ / ₈	5 ¹ / ₈	3 ¹ / ₂	40	17	1	\$120.00
906	6 ¹ / ₄	7/8	5	3 ³ / ₈	4	50	35	1	135.00
908	8 ³ / ₈	1	6 ⁵ / ₈	3 ³ / ₈	4	65	38	2	150.00
910X	10 ³ / ₈	1 ¹ / ₄	8 ⁵ / ₈	5	5	110	55	2	175.00
910	10 ³ / ₈	1 ¹ / ₄	9	5	5	115	88	3 or 4	175.00
912	12 ³ / ₈	1 ¹ / ₂	10 ³ / ₄	6	5	142	88	3 or 4	250.00
916	16 ¹ / ₂	3 ¹ / ₈	15 ¹ / ₄	6	4 ³ / ₄	257	220	3 or 4	350.00
920	20 ¹ / ₂	3 ⁷ / ₈	18 ³ / ₄	12	5	390	290	4	600.00
924	24 ¹ / ₂	4 ¹ / ₂	22 ¹ / ₂	13 ¹ / ₂	5 ³ / ₈	643	275	4	800.00
930	30 ¹ / ₂	4 ¹ / ₂	28 ¹ / ₂	13 ¹ / ₂	5 ³ / ₄	825	475	4	1050.00

Style 1 Face Plate is standard for Chucks 905 and 906.

Style 2 Face Plate is standard for Chucks 908 and 910X.

Style 3 Face Plate is standard for Chucks 912 to 930 inclusive.

Style 4 Face Plate is interchangeable with Style 3 Face Plate on Chucks 912 to 930 inclusive.

Unless otherwise ordered, Superpower rotary magnetic chucks will be furnished with standard face plates listed.

Special face plates or auxiliary face plates can be furnished on order.

It is recommended that collector rings be mounted at rear of machine spindle where possible. No extra charge.

Prices quoted do not include back plates nor spindle adapters, due to variations in requirements. All prices include standard releasing switch, lead wires and contact brushes.

**MAGNETIC CHUCKS CAN BE OPERATED ON DIRECT CURRENT ONLY.
VOLTAGE SHOULD BE SPECIFIED.**

SUPERPOWER CONTROL SWITCHES

Patent applied for

For use on all types of Magnetic Chucks

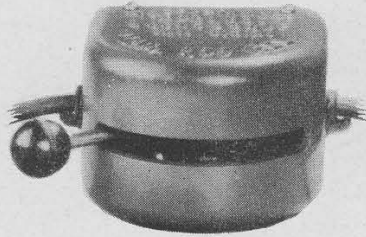

STYLE NO. 9802-1

Standard equipment for all SUPERPOWER Magnetic Chucks of power rating under 200 watts.

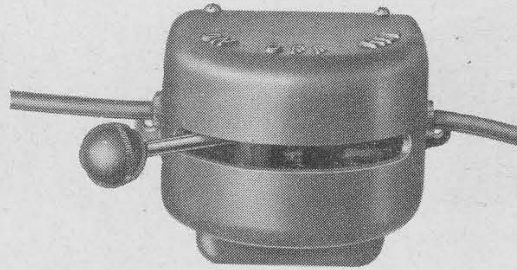

STYLE NO. 9802-2

Positive releasing type, for SUPERPOWER Magnetic Chucks under 200 watts rating. Furnished at slight extra charge.



STYLE NO. 9803-1

Drum type, Surge Control, Oil immersed. For heavy duty SUPERPOWER applications

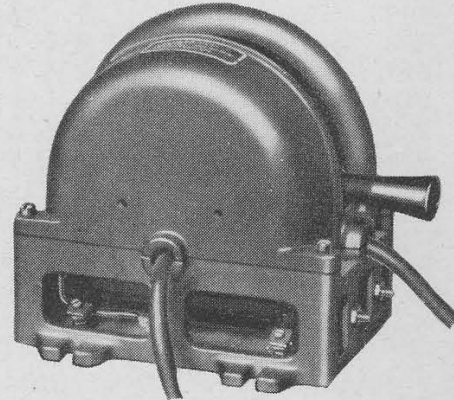

STYLE NO. 9802-3

Surge Control type, standard equipment with all SUPERPOWER Magnetic Chucks with power rating of 200 watts or more.

Page
80

Style No.	Length Inches	Width Inches	Height Inches	Weight Pounds	Price Each
9802-1	5 1/4	4 5/8	3 3/4	3 1/2	\$10.00
9802-2	5 1/4	4 5/8	5	4	15.00
9802-3	8	6 1/4	8	15	15.00
9803-1	7 1/4	7	10	30	75.00

NOTE: When ordering SUPERPOWER Control Switches give size and type of chuck with which they are to be used—ALSO D.C. VOLTAGE.

TAFT-PEIRCE DEMAGNETIZER

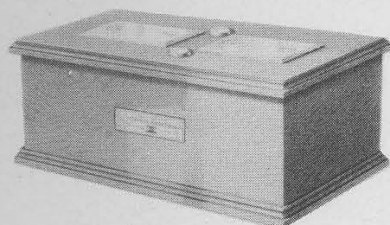

STYLE 9801-1



STYLE 9801-2

Style	Length Inches	Width Inches	Height Inches	Weight Pounds	Price	
					110-220 Volt	440-550 Volt
9801-1	13 1/4"	7 3/4"	6 1/2"	30	\$ 65.00	\$125.00
9801-2	13 1/4"	13"	6 1/2"	60	125.00	185.00

Page
81

Operates on *Alternating Current* only.
 Alternator for operation on direct current, \$38.00 extra.
 Specify voltage in ordering.

TAFT-PEIRCE MAGNETIC PARALLELS AND V-BLOCKS

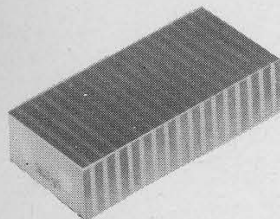

Style 9805-1

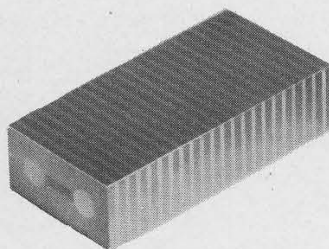

Style 9805-2

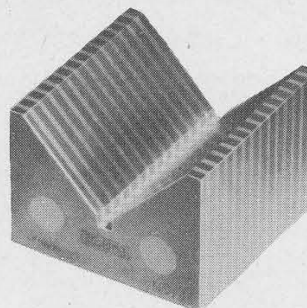

Style 9806-1

Style	Length	Width	Height	Price Each	Price Pair
9805-1	3"	1 1/2"	3/4"	\$12.50	\$22.50
9805-2	4"	2"	1"	17.50	30.00
9806-1	2 1/2"	2 1/2"	1 3/4"	25.00	45.00

Special sizes to order — Prices on application.
 Prices are net.

TAFT-PEIRCE SUPERPOWER MAGNETIC CHUCKS

Taft-Peirce Superpower Magnetic Chucks are carefully designed and constructed for operation at a voltage which is stated on the name plate. Users should not attempt to disassemble them nor make repairs locally. In case of trouble, the chuck should be returned to the factory for examination and repairs if necessary.

NEVER OPERATE A CHUCK WITHOUT THE MANUFACTURER'S APPROVED SWITCH

Alternating Current cannot be used for operating magnetic chucks. State Direct Current voltage on your order. *Do not ever, even once, operate a magnetic chuck of 200 watts rating or more without its own switching apparatus. To do so risks destruction of the windings.*

Page
82

SPECIAL SUPERPOWER MAGNETIC CHUCKS

Through its long list of basic magnetic chuck patents, special Taft-Peirce magnetic chuck installations can be designed and furnished, incorporating characteristics which are exclusive and therefore not available in other types of chucks, of either a standard or special nature.

By reason of the company's long experience in the magnetic chuck field, a very extensive line of special patterns is available, making it possible to furnish chucks for almost any type of machine not covered by stock sizes. It is noteworthy, however, that special magnetic chuck installations are not confined to applications in machine tool practice. The magnetic principle has wide application in other fields, and magnetic units can be designed and furnished for all sorts of industrial application.

MACHINE TOOL SECTION

Surface Grinders

Rotary Grinders

Back Spot Facing Machines

Backspot Facing Machines

Page
83

**TAFT-PEIRCE
NO. 1 PRECISION SURFACE GRINDER
TILTING SPINDLE**

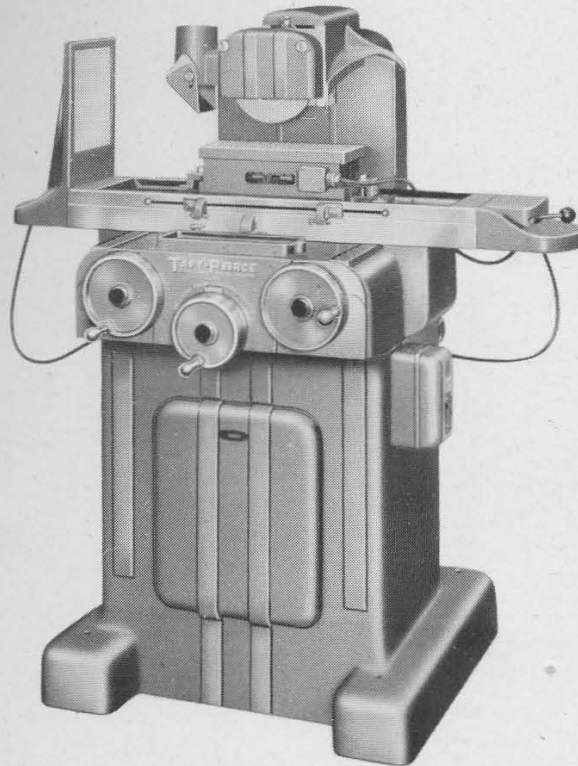

Page
85

SPECIFICATIONS

Capacity 5" x 12" x 12".

Size of wheel 7" x 1/2" x 1 1/4".

Floor space and height—60" wide—36" deep—60" high.

Shipping Data—1500# net. Domestic shipping weight—1900#—Export shipping weight 2150#.

Regular equipment:

Machine equipped with motor driven ball bearing spindle, 3600 RPM, with 30° angular adjustment. Built-in magnetic chuck switch (without chuck), ground safety glass lighting panel, wheel dressing block without diamond, one grinding wheel, one hardened and ground precision wheel thimble, nut and necessary wrenches.

Wheel spindle motor wound for either 220, 440 or 550 volts, 2 or 3 phase, 60 cycle A. C.

PRICE\$1800.00

For special accessories, see next page.

TAFT-PEIRCE ACCESSORIES
FOR
NO. 1 PRECISION SURFACE GRINDER

SUPERPOWER MAGNETIC CHUCK, SIZE NO. 512

Close mesh faceplate. See page 74 for full specifications—110 or 220 Volt, D. C.\$100.00

STYLE 9801 DEMAGNETIZERS

Style	Length Inches	Width Inches	Height Inches	Weight Pounds	Price	
					110-220 Volt	440-550 Volt
9801-1	13 1/4"	7 3/4"	6 1/2"	30	\$ 65.00	\$125.00
9801-2	13 1/4"	13"	6 1/2"	60	125.00	185.00

Page
86

SINE SETTING SLEEVE

2 1/2" Sine Bar in Cylindrical form for setting angle of grinder spindle\$25.00

UNIVERSAL ANGLE BLOCK SET

Including 3" Sine Bar\$140.25

WHEEL THIMBLE AND NUT

Hardened and Ground Precision Wheel Thimble and Nut \$16.50

WHEEL DRESSING DIAMOND

1/2 carat best quality, mounted in 3/8 x 2 holder to fit block which is furnished with machine\$16.50

HIGH SPEED ATTACHMENT

For grinding angles or recesses in a slot where larger wheel cannot be used\$275.00

WET GRINDING ATTACHMENT

Including coolant tank, pump and drain trough\$350.00

SPINDLE TILTING ATTACHMENT

For adjusting Taft-Peirce Tilting Wheel Head\$90.00

RISER BLOCK

Permits grinding work up to 24" high\$75.00

RADIUS WHEEL DRESSER

For forming radii on grinding wheel\$350.00

ANGLE WHEEL DRESSER

For forming angles on grinding wheel.....\$350.00

WHEEL BALANCING STAND

Checks balance of wheels, mounted on Standard Wheel Thimbles\$75.00

Extra Grinding Wheels\$2.50

DUST COLLECTOR

Prices on Application

TAFT-PEIRCE 6" ROTARY SURFACE GRINDER

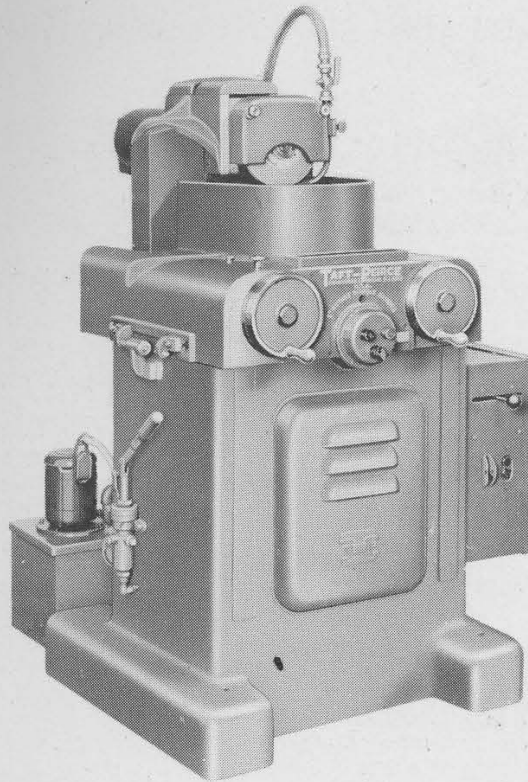

Page
87

SPECIFICATIONS

Capacity—6"

Size of Wheel—7" x 1/2" x 1 1/4"

Floor Space and Height—36" wide, 36" deep, 60" high

Shipping Data—1500# net. Domestic Shipping Weight, 1950#
Export Shipping Weight 2060#

Regular Equipment

Machine equipped with motor driven spindle, 3600 RPM, with 30° angular adjustment. Motor driven work spindle having 7 1/2° angular adjustment, magnetic chuck, and releasing switch, coolant tank and pump, wheel dressing block without diamond, one grinding wheel, one hardened and ground precision wheel thimble and nut, and necessary wrenches.

Wheel spindle motor, work spindle motor, and pump motor wound for either 220, 440, 550 volts, 2 or 3 phase, 60 cycle A.C. Magnetic chuck to operate on 110 or 220 volt D.C.

PRICE\$2800.00

1144

For Special Accessories, See Next Page

TAFT-PEIRCE ACCESSORIES
FOR
6" ROTARY SURFACE GRINDER

WHEEL DRESSING DIAMOND

½ carat best quality, mounted in ⅜" x 2" holder, to fit block which is furnished with machine\$16.50

EXTRA HARDENED AND GROUND PRECISION WHEEL THIMBLE AND NUT

\$16.50

SINE SETTING SLEEVE

In wooden case, for setting and leveling tilting spindle\$25.00

3" SINE BAR

For setting work spindle at desired angle\$20.00

GRINDING WHEELS

Extra grinding wheels\$2.50

Page
88

STYLE 9801 DEMAGNETIZERS

Style	Length Inches	Width Inches	Height Inches	Weight Pounds	Price	
					110-220 Volt	440-550 Volt
9801-1	13¼"	7¾"	6½"	30	\$ 65.00	\$125.00
9801-2	13¼"	13"	6½"	60	125.00	185.00

WHEEL BALANCING STAND

Checks balance of wheels, mounted on Standard Wheel Thimbles\$75.00

SPINDLE TILTING ATTACHMENT

For adjusting Taft-Peirce Tilting Wheel Head\$90.00

ADAPTERS FOR SHARPENING FELLOWS GEAR SHAPERCUTTERS

For threaded hole type cutter\$72.50

For large taper shank cutter, 1 1/16" dia.\$67.50

For small taper shank type cutter, .700 dia.\$67.50

For straight shank type cutter, 11/16" dia.\$60.00

For 1¼" diameter hole flat type cutter\$20.00

For 1¾" diameter hole flat type cutter\$22.50

Complete Set on Stand\$310.00

THE TAFT-PEIRCE BACK SPOT FACING MACHINE

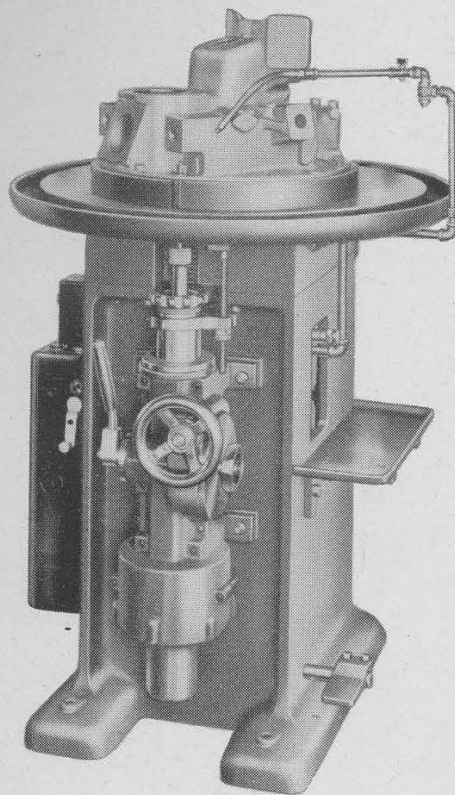

Page
89

SPECIFICATIONS

Table—Overall, 31½" diameter
Working surface, 28" diameter

Height—Floor to table top, 37"

Floor Space—34" x 32"

Motor—½ h.p.

Drive—Single V-belt

Speeds—Two speeds — 170 r.p.m. for ferrous materials; 300
r.p.m. for aluminum alloys

Feeds—Fast and slow hand feed, by lever or handwheel

Spindle—No. 2 Morse Taper

Pump—No. 11 Brown and Sharpe

Clutch—Optional equipment

Shipping Weight—Approximately 1200 lbs.

Price with Standard Electrical Equipment \$1900.00

3M-11-44

PLANOGRAPH PRINTED BY
SPAULDING-MOSS COMPANY
BOSTON, MASSACHUSETTS, U.S.A.

Spiral Binding—U.S. Patent Nos. 1516932, 1942026, 1985776. Other patents pending.

In this price list catalog the following pages are blank:

4.

48

66

72

84

