

An Energy-Efficient MAC Scheduler based on a Switched-Beam Antenna for Wireless Sensor Networks

Luca Catarinucci, Sergio Guglielmi, Luca Mainetti, Vincenzo Mighali, Luigi Patrono, Maria Laura Stefanizzi, and Luciano Tarricone

Abstract— Wireless Sensor Networks (WSNs) are receiving an ever increasing attention because they are one of the most important technologies enabling the Internet of Things vision. Since nodes of these networks are battery-powered, energy efficiency represents one of the main design objectives. This goal can be primarily achieved through an optimization of the communication phase, which is the most power consuming operation for a WSN node. However, the limited computational and storage resources of physical devices make the design of complex communication protocols particularly hard, suggesting, on the contrary, to integrate more simple communication protocols with hardware solutions aimed at energy saving. In this work, a new MAC protocol, compatible with the IEEE 802.15.4 standard, and a reconfigurable beam-steering antenna are presented and validated. They significantly reduce the nodes' power consumption by exploiting scheduling techniques and directional communications. Specifically, both during transmission and receiving phases, the node activates exclusively the antenna sector needed to communicate with the intended neighbour. The designed antenna and the proposed protocol have been thoroughly evaluated by means of simulations and test-beds, which have highlighted their good performance. In particular, the MAC protocol has been implemented on the Contiki Operating System and it was compared with the IEEE 802.15.4 standard solution.

Index Terms—Contiki, MAC protocol, Performance evaluation, Switched-beam antenna, Test bed, Wireless Sensor Networks.

I. INTRODUCTION

THE FUTURE Internet is strongly oriented to the affirmation of the concept of the Internet of Things (IoT) [1], according to which the everyday objects that surround us will become proactive actors of the global Internet, with the capability of generating and consuming information for advanced applications. Wireless technology can facilitate this evolution process also leading to a growth of the Internet itself

which is no longer seen only as a tool for linking people to services, but as a means to allow the implementation of the new Machine-to-Machine (M2M) paradigm. Among all wireless technologies, Wireless Sensor Network (WSN) is the ideal choice because sensor nodes are able to self-configure and self-organize. Basically, they have the capability to capture information from the surrounding environment (e.g., humidity, pressure, temperature) and transmit them, exploiting multihop communications, for a proper processing and utilization. This simple yet fundamental functionality is of great interest for a plethora of applications, such as building automation, surveillance, military operations, healthcare, logistics, just to mention a few of them. The other key aspect of such a type of networks is that each node is very small, low-cost, low power, and communicates through a wireless channel. However, the realization of WSN-based applications requires the use of efficient power management techniques. Indeed, sensor nodes are usually battery powered and deployed in large areas in which changing or replacing batteries is impractical or completely unfeasible. Therefore, energy consumption is a primary issue to be considered, and the use of effective solutions for increasing the nodes lifetime is fundamental in real applications.

The main procedures of a WSN node are data sensing, data processing, and data communication. This last one is certainly the most stressful operation from the point of view of power consumption, because it is associated with phenomena such as collision, overhearing (i.e. listening of messages addressed to another node), over-emitting (i.e. transmission of data to a node that cannot receive them), and idle listening (i.e. listening to the channel in absence of communications). For these reasons, many works in literature are focused on energy saving [2, 3], with particular emphasis on the MAC layer [4, 5], since it is responsible for managing channel access control mechanisms. In particular, many MAC-based energy saving solutions exploit the possibility to tune the duty cycle, so enabling nodes to switch their radio between ON and OFF state according to a predefined scheduling [6]. Unfortunately, solutions proposed in the literature are sometimes particularly expensive both from the computational and from the memory resources point of view, so it is hard to implement them on real embedded devices. These issues often suggest to combine the new MAC protocols with hardware solutions that

Manuscript received May 7, 2013; revised June 5, 2013.

L. Catarinucci, S. Guglielmi, L. Mainetti, V. Mighali, L. Patrono, M.L. Stefanizzi, and L. Tarricone are with the Department of Innovation Engineering at University of Salento, Lecce, Italy (email: {luca.catarinucci, sergio.guglielmi, luca.mainetti, vincenzo.mighali, luigi.patrono, laura.stefanizzi, luciano.tarricone}@unisalento.it).

contribute to the reduction of power consumption. Among these solutions, the use of directional or switched-beam antennas is one of the most explored. Traditionally, WSN nodes are equipped with an omnidirectional antenna; in such a case, most of the transmitted power is wasted, just because the power is not focused towards the proper direction, but is equally radiated in all directions. The rapid development of radio communications and fabrication techniques together with the use of higher and higher frequencies has favoured the antennas miniaturization. This has led to an increasing number of studies on the beam-steering antennas and their applications in different fields of radio technologies. Nevertheless, the integration of beam-steering antennas with energy-efficient MAC protocols for WSNs to reduce energy consumption and to extend sensor nodes lifetime, has not been exhaustively explored yet.

In this work, an energy-efficient MAC protocol, based on a scheduling schema and integrated with a switched-beam antenna is presented and validated. This proposed solution is able to reduce power consumption by avoiding transmissions towards unnecessary directions. More in detail, the designed antenna can be connected to the wireless module of a sensor node and work in place of the common omnidirectional antenna. It consists of a vertical half-wavelength dipole antenna and eight microstrip antennas with a directional radiation pattern in the azimuth plane. By using a control circuit consisting of a transmission line, RF-switches and a multiplexer, it is possible to dynamically switch among the nine radiation patterns (i.e., eight directional and one omnidirectional). Based on this solution, during the setup phase, each node communicates to its neighbours the time interval during which it will transmit and, in addition, it detects all antenna sectors through which it can communicate with its neighbours. Through this mechanism, at the end of the setup phase, all nodes have a *neighbourhood table* whose single entry stores the transmission time of a neighbour and the antenna sector for reaching it. The proposed solution is also able to face topology changes: every node updates its neighbour list as soon as it is not able to listen a transmission of a neighbour or it detects the presence of a new node.

In order to evaluate the effectiveness of the proposed system, the switched-beam antenna was firstly analysed through both simulative and test bed approach from an electromagnetic point of view, and then a performance comparison between the proposed MAC solution and the current IEEE 802.15.4 standard solution was carried out by using physical devices. As regards this last comparison, it is important to make an observation. Although the scheduling approach is often closely linked to the concept of duty cycle, in this work this concept was deliberately overlooked. Since the main objective was to evaluate the benefits arising from the use of directional antennas, it was considered appropriate to maintain always ON the radio component of the embedded devices.

The rest of the paper is organized as follows. Section II summarizes the state-of-the-art of energy-efficient solutions at MAC and physical layers for WSNs. The design of both the

MAC scheduler and switched-beam antenna is described in Section III. The test bed environment is presented in Section IV, while in Section V numerical results are discussed. Conclusions are drawn in Section VI.

II. RELATED WORKS

This section summarizes the most important research studies related to both multi-sector antenna system and MAC protocols based on them.

With regard to the design and realization of multi-sector antennas, an interesting switched-beam directional antenna is proposed in [7]. It is composed of four planar patch antennas arranged in a box-like structure. Such an antenna system ensures a uniform coverage of the whole horizon plane when switching among the antennas. Nevertheless, a single almost uniform radiation pattern, crucial in the addressed context, cannot be obtained. The pattern reconfigurable antenna for WSN sink nodes, presented in [8], is rather interesting as well. It can switch between conical to front-directional pattern and vice versa. Even though it shows a remarkable peak gain in front directional beam patterns, it is rather cumbersome and, moreover, does not allow an omnidirectional pattern. On the contrary, a rather compact switched-beam antenna is presented in [9]. It is composed of a four-element antenna array and shows eight directional patterns and an omnidirectional one, ensuring a uniform coverage of the 360 degree horizon. It has a compact size and low manufacture cost, but exhibits a Half-Power Beam Width (HPBW) of nearly 120 degrees which causes a large overlapping area of beams, thus not ensuring an optimized energy saving. Afterward, a reconfigurable angular diversity antenna, constructed with quad corner reflector arrays and a switching control is proposed in [10]. It shows a high radiation gain, but occupies a large volume. On the contrary, a pattern reconfigurable antenna was proposed in [11]. It is a microstrip parasitic array antenna with a small size and a simple structure but it does not ensure a coverage of 360 degrees in the azimuth plane.

Moving now at analysing the state-of-the-art related to energy-efficient MAC protocols, in [12], a protocol that uses a directional antenna and a *busy tone* to ensure the energy saving is proposed. It exploits the mechanism of RTS/CTS to discover the location of its neighbours and it stores this information in a cache table. Messages that need to be sent in broadcast force the antenna to work in omnidirectional mode, whereas unicast messages are sent in one direction using the information stored in the cache table. Nodes, actually involved in a communication, send a busy tone, i.e., a single-frequency signal produced by a simple interface for the duration of the communication. The Direction Antenna at Sink (DAaS) protocol [13], instead, extends the lifetime of the network by increasing the transmission range of the sink and by scheduling wakeup and sleep times for nodes according with the SMAC protocol [14], which is a MAC schema that manages duty cycling through a scheduling approach. In [13], “relay areas” are the portion of network in which nodes, called “one-hop relay nodes”, communicate by one-hop with the sink. To reduce the duty cycle of the one-hop relay nodes, the

sink sends a *sink beam pattern schedule* (SBPS) packet in each area, forcing the relay node to schedule communications only with the sink. In [15], the authors propose the Mobile Synchronous Transmission Asynchronous Reception Directive (MD-STAR) protocol, which is inspired to the WiseMAC [16] and SMAC protocols, with the addition of some enhancements that enable the use of directional antennas. In particular, the protocol achieves a time-space synchronization in presence of mobile nodes and allows the management of the smart antenna adapting the Radio Frequency parameters in accordance to the characteristics of the communication link. Finally, [17] presents a MAC protocol, called DU-MAC (Directional Ultra-wideband MAC), which involves the use of directional antennas to improve the energy consumption in WSNs and to reduce the problem of deafness and neighbours localization. The main idea is to reduce the power consumption by creating “omni-directional” links between network nodes, meaning that each directional link has a transmission range confined within the coverage area of an omnidirectional antenna. This solution results in a decrease of radiated power of about N times compared to a transmission in omnidirectional mode, where N is the number of antenna sectors.

III. SYSTEM DESIGN

The basic idea of the proposed solution is to integrate a prototypical multi-sectorial antenna with a MAC protocol based on scheduling. On the one hand, the scheduling should reduce the number of collisions in the network and face such phenomena as the hidden node problem, the idle listening and the over-hearing, which degrade significantly the energy resource. On the other hand, the switched-beam antenna should lower the power consumption, directing each communication only towards the proper sector.

Before describing the proposed solution, the definitions of the main parameters are introduced:

- T_0 is the time interval between two subsequent transmissions. It is the same for every node and it is preconfigured.
- *WakeTime* is the time interval in which a node can transmit the local buffered data or receive data from its neighbours.
- *Announce Packet* (Pkt_{ANN}) is a signalling packet used by each node to communicate its transmission.
- *Alert Packet* (Pkt_{ALERT}) is a signalling packet used by a node to alert a neighbour about a possible transmission overlapping.
- *Full Packet* (Pkt_{FULL}) is a signalling packet used by a node to inform its neighbours that it is out of the network.
- *Neighbourhood Table* (NBR_{TBL}) is a table used by each node to store information about the transmission times of its neighbours and the corresponding antenna sector.

A. Switched-beam antenna

This section focuses on the design and working principle of the proposed radiating structure. The basic idea is to allow the

selection of a specific radiation pattern through the use of nine antenna elements; one of them radiates in omnidirectional manner, the other eight ones radiate in a specific direction that is $n * \pi / 4$ in the azimuth plane, where $n = 0, \dots, 7$, with a HPBW of nearly 60 degrees. This configuration ensures a coverage of 360 degrees in the azimuth plane with adjacent patterns spaced 45 degrees and an overlapping of almost 15 degrees. Moreover the radiation pattern selection is controlled through a specific digital interface that is compatible with the evaluation boards used for test beds.

As described in [18], the proposed switched-beam antenna consists of eight identical directional microstrip array antennas each one providing a radiation pattern with a HPBW of nearly 60 degrees and a gain of nearly 7 dBi in the main lobe direction, a vertical half-wavelength dipole antenna with an omnidirectional pattern, and a specific control circuit used to dynamically select the radiating antenna. This radiating structure can be connected to the evaluation boards through an U.FL connector (i.e., an ultra-small surface mount coaxial connector for high-frequency signals) for the RF signal and an output interface with 4 digital pins for the control signals of the switching circuit.

Fig. 1 shows the structure of the directive and omnidirectional radiating elements. As for the dipole, a simple copper-made wire was used; vice versa, as for the directive antenna elements, in order to obtain a radiation pattern in the azimuth plane with a HPBW of nearly 60 degrees without strongly impacting upon the antenna dimension, each element was designed as an array of two rectangular patch antennas bent at a 45 degrees angle on the middle of the structure. This 3D configuration allows a positioning of eight identical antennas in a circular compact structure that significantly reduces the size of entire antenna, as shown in Fig. 2. This structure ensures a uniform coverage of the 360 degrees through the eight directive radiating patterns in the azimuth plane with a HPBW of nearly 60 degrees.

As previously mentioned, the RF signal of the evaluation board is directed to one of the nine radiating elements by setting specific combinations of bits on the 4-pin interface of the switching circuit. More specifically, nine combinations of bits have been set, each corresponding to a specific radiating element. As shown in Fig. 3, the switching circuit is composed of nine RF-switches placed on the terminations of a microstrip transmission line in star configuration, fed through a 50 Ω U.FL connector at its centre point. Moreover, a multiplexer with four digital inputs has been used in order to control the

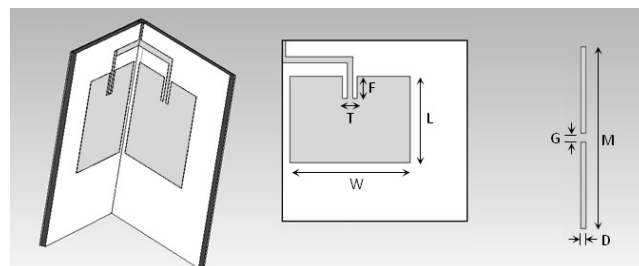

Figure 1. Geometry of the directive antenna element and half-wavelength dipole. $W=3.55\text{mm}$, $L=28.3$, $F=7.4$ mm, $T=5\text{mm}$, $D=0.244\text{mm}$, $M=59.225$, $G=0.306\text{mm}$.

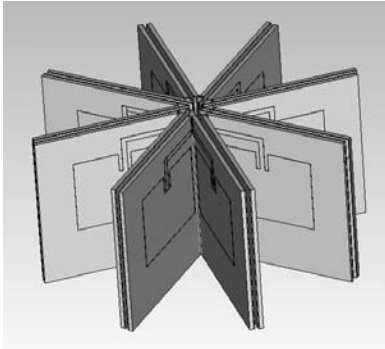

Figure 2. Geometry of the proposed antenna

entire circuit.

The RF transmission line in Block A of Fig. 3 is composed of nine quarter-wavelength-long branches. Actually, due to the presence of the switches at the branches terminations, it has been necessary to reduce the physical length L of each line. After simulation and optimization phases, in which the switches have been modelled with an equivalent circuit composed of a capacitance and a resistance in series, the length L has been reduced up to 0.18λ . Moreover, as described in [19], a width W of 3.3 mm has been obtained, using a FR4 substrate with dielectric constant $\epsilon = 3.7 @ 2.45$ GHz and thickness $h = 1.6$ mm.

The switching circuit basic operation is to dynamically connect a branch of the line to an antenna element and terminate remaining branches in a short-circuit, through nine RF switches. According to transmission line theory [20], a short-circuited branch exhibits at its input a theoretically infinite impedance likewise an open circuit. For this reason, the RF input port sees always eight open lines and $\Omega 50$ terminated line, because the designed structure presents, at any time, one of the branches connected to an antenna element and all the remaining branches short-circuited.

Block B of Fig. 3 shows the 4-16 analogy multiplexer used for the control circuit. Only nine outputs have been used to control the PIN_IN control input of the switches, through nine combinations of the four input bits ($PIN 1, \dots, 4$). It is powered

with a 3.3V supply through the input pins VCC and GND . The multiplexer used is a Philips 74HC/HCT4514 4-to-16 line decoder/demultiplexer with four binary weighted address inputs, with latches, a latch enable input, an active low enable input and 16 outputs that are mutually exclusive.

Block C of Fig. 3 shows the SPDT RF-switches used to select the different antenna elements. According to the control signal input, these devices dynamically connect the transmission line with the Ant_Out or GND_Out outputs. As for the multiplexer, the switches are powered by 3.3V supply through the lines VCC and GND . The switches used are Peregrin PE4283 RF UltraCMOS switches with a single-pin CMOS logic control input.

The entire RF structure has been modelled with the full-wave simulator CST-MS (Computer Simulation Technology-Microwave Studio). Return loss and radiation properties have been calculated by modelling the RF switches by means of proper equivalent circuits according to the datasheet. In order to verify proper operation and performance of the proposed switched-beam antenna, a prototype has been realized on a FR4 substrate ($\epsilon = 3.7 @ 1$ GHz, $h = 1.6$ mm). A picture of both the switching circuit and one of the realized switched-beam antenna are given in Fig. 4. The overall size of the antenna is 15 cm in diameter and 7 in height, instead that of the circuit is 4 x 6 cm. The cost of the entire radiating structure is estimated to be less than 40 € it includes the average cost of components, which is equal to 0.80 € and the total cost of directional antennas, realized on FR4 substrate, which is equal to €30.

B. The proposed MAC scheduler: AntDirMAC

During the network initialization phase, all nodes exchange information about their transmission time by sending a Pkt_{ANN} . On the reception of such a message from an unknown neighbour, a node updates its NBR_{TBL} by adding a new entry. However, before being stored, the information on the transmission time of the neighbour must be validated: the node verifies that the time chosen by the new neighbour does not overlap with the transmission intervals of the other

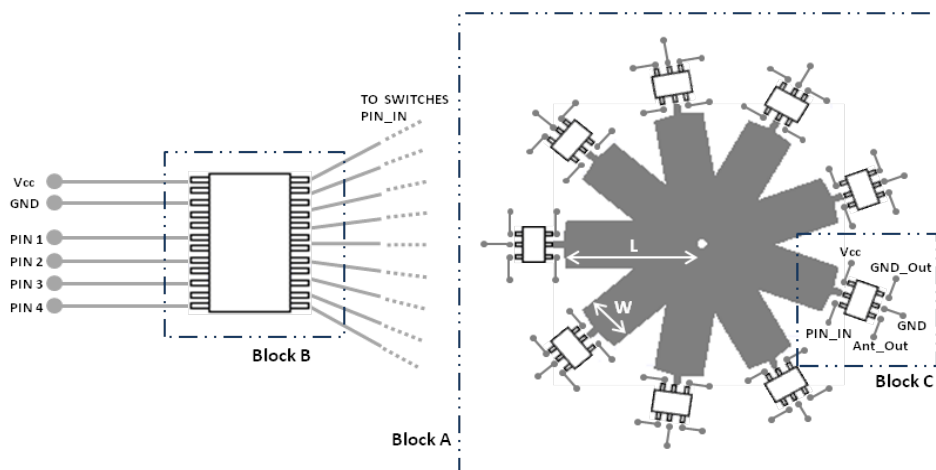

Figure 3. Structure of the proposed switching circuit

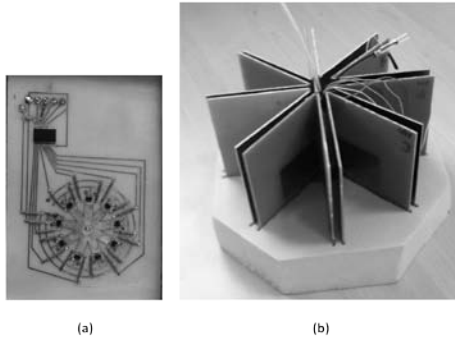

Figure 4. (a) Realized switching circuit and (b) switched-beam antenna

neighbouring nodes already stored into its NBR_{TBL} . Let us observe that the offset stored into the new entry is obtained by subtracting an appropriate time interval. It takes into account the processing, transmission and propagation time of the packet. The entries are stored in the table in an ascending order based on the offset. Otherwise, if the transmission interval chosen by the new node overlaps with any of the transmission intervals already in NBR_{TBL} , the node sends a Pkt_{ALERT} to the new node, specifying the overlapping interval. In such a case, the new neighbour stores the received information into its NBR_{TBL} and chooses a new transmission time. The Pkt_{ALERT} has been introduced to greatly reduce the hidden node problem that is one of the main problems that afflict ad hoc networks. By this way, in fact, collisions among nodes two hops away are avoided. If the new node cannot find a valid transmission time, i.e., the network is full, it communicates the information by broadcasting a Pkt_{FULL} and does not join the network. On the reception of such a message, nodes delete the corresponding entry from their NBR_{TBL} s.

Let now describe how a node chooses its own transmission time. Note that the time is divided into fixed slot time with duration T_0 . Therefore, a node must choose its transmission time within this period. In particular, it chooses a random value in a proper interval, also taking into account the choices done by its neighbours already stored in NBR_{TBL} . This time differentiation permits to reduce the channel access contention. More in detail, if the NBR_{TBL} is empty, then the transmission time is randomly selected in the interval

$$[0, T_0 - (WakeTime + 2 * TurnAroundTime)] \quad (1)$$

where $WakeTime$ is the time interval dedicated to the transmission phase and $TurnAroundTime$ is the time required by the radio for changing its state. If the NBR_{TBL} is not empty, then the node tries to set its transmission time to a value different from those of its neighbours in order to avoid collisions due to simultaneous transmissions. This value is chosen so that the time interval reserved for the transmission ($WakeTime$) does not overlap with the transmission time of any neighbour. The node chooses the two consecutive entries in the table, namely i -th and $(i+1)$ -th, whose offsets difference is maximum and checks if this difference is greater than:

$$2 * WakeTime + 4 * TurnAroundTime \quad (2)$$

Note that the node also checks the time intervals:

$$[0, offset[0]] \text{ and } [offset[n], T_0 - D] \quad (3)$$

where $offset[0]$ and $offset[n]$ are the offsets associated to the first and last entry respectively, while $D = WakeTime + 2 * TurnAroundTime$. If these conditions are satisfied, then the transmission time is chosen within the interval:

$$[offset[i] + D, offset[i + 1] - D] \quad (4)$$

where $offset[i]$ and $offset[i+1]$ are the offsets associated to entry i and $i+1$ respectively.

In order to maximize the probability that all its neighbours receive the message, a node sends the Pkt_{ANN} three times. After this announcement phase, if it has not received any Pkt_{ALERT} , the node inserts a new entry in the NBR_{TBL} containing its own address and the scheduled transmission time.

The second phase of the network initialization process is characterized by the discovery of the sectors in which the neighbours, stored in NBR_{TBL} , are located. This mechanism allows to obtain a reduction of power consumption during both transmission and reception phase. Indeed, in both cases, the node enables only the antenna sector necessary to communicate with the specific neighbour. More in detail, a node performs the localization phase during its transmission time. Indeed, before sending its data, it scans the NBR_{TBL} to check if there are unknown sectors for some neighbours. If so, the node immediately starts with the localization procedure, after which, the missing sectors are stored in the table. The localization process consists in sending a unicast $Hello_{PKT}$ on each sector antenna and awaiting a response $Hello_{PKT}$ for a short time period. The node that receives a location request via a $Hello_{PKT}$ responds with the same packet, also indicating the Received Signal Strength Indicator ($RSSI$) value of the received request. In fact, it may happen that a node receives more responses (relating to different sectors) from the same neighbour; in this case, it stores the sector corresponding to the response with the highest $RSSI$. To better clarify the node behavior in this phase, a simplified flow chart is shown in Fig. 5.

After the announcement and the localization phases, the network is in steady state. In this stage, each node knows both transmission times and sectors of its neighbours. In the steady state, two kinds of periodic events, namely the transmission and the reception of a packet, and one aperiodic event, i.e., the arrival of a new node in the network, may happen. With regard to the periodic events, the node sets a timer for the next scheduled event in its NBR_{TBL} . When the timer expires, if the scheduled event is a data transmission, the node checks the presence of packets to be transmitted in its queue, and eventually activates the proper antenna sector and starts the transmission. When the transmission ends, the node waits for an ACK from the intended receiver. If no ACK is received, the message must be sent again. At the end of its transmission interval, the node schedules the next event of the NBR_{TBL} . When the scheduled event is a data reception, the node starts listening to the channel activating the antenna sector consistent

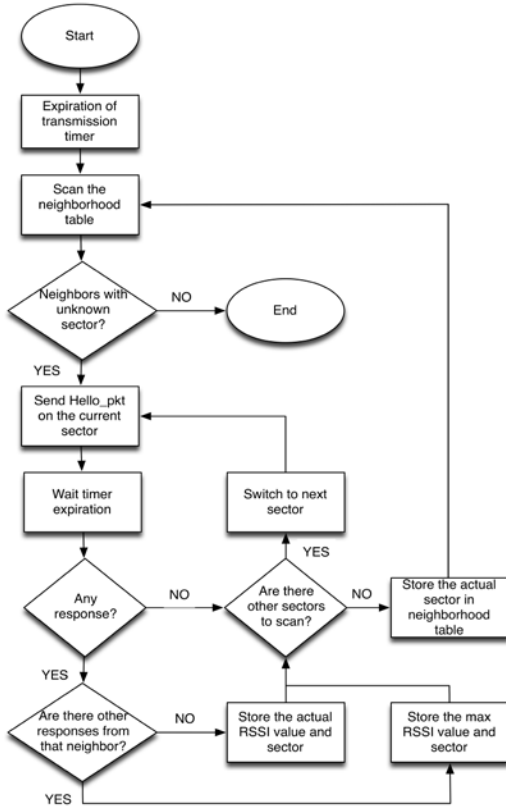

Figure 5. Flow diagram of the discovery phase

with the transmitting neighbour. If a packet is received, it sends an ACK. On the contrary, if nothing is received the node updates the packet-missed counter for the corresponding NBR_{TBL} entry. After a fixed number m , of consecutive missed receptions, the entry is removed to avoid useless awakenings (i.e., the neighbour corresponding to that entry is supposed to have left the network). A simplified flow chart of the node behaviour in this phase is shown in Fig. 6.

When a new node joins the network, it first listens to the channel for a time interval equal to $2 * T_0$, with the aim of detecting the transmissions of its current neighbours. For each packet received from an unknown node it adds an entry in its NBR_{TBL} . Afterward, it announces its presence by sending a Pkt_{ANN} to each neighbour. To provide a new node with enough time to send its Pkt_{ANN} s, nodes already members of the network always delay the transmission of their data packets of a period of time δ . This time interval is exploited by the new node to transmit its Pkt_{ANN} s.

IV. TEST BED ENVIRONMENT

The performances of the proposed solution were evaluated by using a test bed approach. This choice allowed us to analyze the real effectiveness of the presented MAC scheduler as function of the hardware characteristics of both the board (e.g., clock speed, memory) and the antenna used.

In the following, the selected hardware platform is presented, and, afterward, details about AntDirMAC implementation and the test bed settings are given.

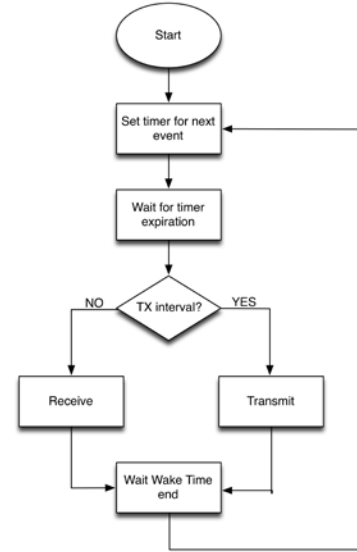

Figure 6. Flow diagram of the steady state

A. Hardware platform

The WSN node used to validate the proposed solution was realized by interconnecting the switched-beam antenna, presented in the previous section, with an MB954 (Fig. 7) board, developed by ST Microelectronics. This board is equipped with a 32-bit ARM® Cortex™-M3 microcontroller operating at a clock frequency up to 24 MHz and embedding 16 Kbytes of RAM and 256 Kbytes of eFlash as ROM. It integrates a 2.4 GHz wireless transceiver compliant with the IEEE 802.15.4 standard and a power amplifier. The mounted microcontroller is highly optimized to guarantee high performance at very low power consumption.

The selected board is also equipped with an external antenna connector and contains 24 highly configurable GPIOs with Schmitt trigger inputs. The connector and 4 different GPIOs were used to integrate the switched-beam antenna with the board.

B. AntDirMAC implementation

To develop the proposed MAC scheduler the Contiki OS [21] was used. It is a popular open-source operating system targeted to small microcontroller architectures and developed by the Swedish Institute of Computer Science. The Contiki communication stack is organized in several layers in which both protocol solutions and radio transceiver features can be easily configured.

The lowest layer of the stack is the $NETSTACK_CONF_FRAMER$. It is in charge of the data packet format conversion before the transmission over the physical channel. The upper layer is the $NETSTACK_CONF_RADIO$. It directly manages the wireless transceivers features through the appropriate device driver. These two first levels can be considered the PHY layer of the ISO/OSI model. The third layer of the Contiki stack is the $NETSTACK_CONF_RDC$, which cannot be directly mapped

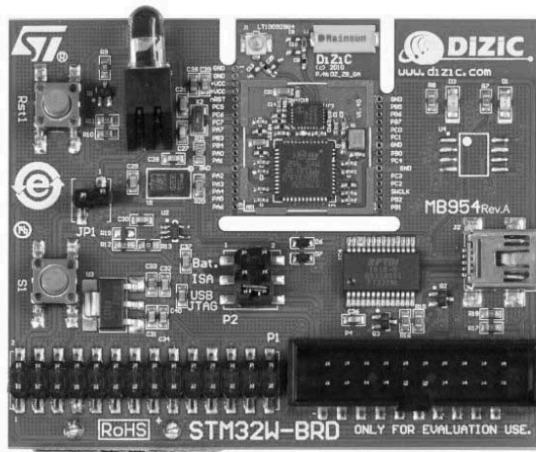

Figure 7. The MB954 evaluation board used for test beds.

to the ISO/OSI model. It is just below the MAC layer, identified as *NETSTACK_CONF_MAC*, and it is in charge of managing the radio duty cycling to provide energy saving capabilities. The last layer of the stack is the *NETSTACK_CONF_NETWORK* providing the functionality of the network layer of the ISO/OSI model.

In order to realize the connection between the switched-beam antenna and the board, a system driver has been developed. In particular, several functions to set hardware parameters have been implemented, as well as functions for managing the antenna sectors' setting. The proposed schema has been introduced into the MAC layer as a manager for the IEEE 802.15.4 MAC protocol. Considering the above described communication stack architecture, it has been developed as additional module of the *NETSTACK_CONF_MAC* layer. From an implementation point of view, the new MAC module exposes Contiki-based Application Programming Interfaces (APIs) to the upper layer while using the ones provided by the Radio Duty Cycling (RDC) drivers. Let us observe that in order to develop a software solution to be used on different architectures, the scheduler timing has been implemented as completely independent from the system clock.

C. Test bed settings and data collection scenario

An accurate characterization of the electromagnetic properties of the proposed switched-beam antenna has been performed through a careful testing phase in both laboratory and real environment; for this purpose, an Agilent 3444/7 VNA (Vector Network Analyzer) and several MB954 WSN evaluation board have been used. In particular, during the experimental campaign, one device has been connected to the proposed antenna and statically positioned in the middle of a 40 square meters area, and the other, with a standard omnidirectional configuration, used to measure the number of packets received in different points of the same area. For each radiator, the diagram individuating the portion of the area where more than 95% of the sent packets are correctly

received corresponds to the related actually covered area.

Further test campaigns have been conducted in order to better evaluate the effectiveness of the proposed integrated system.

Let us observe that, in order to reduce the nodes' power consumption, the proposed solution sends the unicast packets setting the switched-beam antenna in directive mode, and using a transmission power lower than that used to send the broadcast ones, setting the antenna in omnidirectional mode. However, to guarantee the proper operation of the protocol, the coverage ranges of the antenna in both operating modes must be almost equal. Therefore, to identify the right values of transmission power to be used in the following test bed, a preliminary experimental campaign was necessary. In such experiment (called *POWER_TEST* in the rest of the paper), a simple scenario, consisting of one sender and one receiver, was considered. As shown in Fig. 8, all test beds were carried out in an outdoor environment inside the campus of the University of Salento. In particular, a soccer field, without buildings in the surrounding area was used. The devices were positioned at a height of 1.5 m, so as to limit the multipath problem due to the ground, and placed about 15 meters apart. Moreover, the transmission power of the antenna was initially set to the value of -1 dBm for both operating modes. In order to evaluate the link quality between the nodes, the sender sends 1000 test packets with an Inter-Packet Interval (IPI) of 500 ms to the receiver, which logged the received packets, along with their *RSSI* as indicated by the radio chip. This makes each packet independent of each other [22], avoiding the bias due to bursts of packet losses. The experiment was repeated several times decreasing at each run the transmission power used in directive mode. This test was completed when the difference, in absolute value, of the *RSSI* values related to unicast and broadcast transmissions became lower than a pre-defined threshold.

The same environment settings used in the first test bed were also considered to evaluate the performances of AntDirMAC. In such an experiment (called *PERFORMANCE_TEST* in the rest of the paper), a 16-nodes grid network topology where each node can have at most 4



Figure 8. Test bed settings: distance between nodes 15 m.

neighbours was used. In this network topology, node 1 was the sink and each node sent 100 packets towards the sink at a Constant Packet Rate (CPR). To analyse the protocol behaviour with different levels of network load, three different data rates were considered: 1 packet every 10 seconds (high load), 1 packet every 30 seconds (medium load), and 1 packet per minute (a typical data rate used in sensor networks [23]). For each of selected packet rate, a value of T_0 equal to the data rate was set, thus assuming that a node wakes up for transmission only when a data packet is generated. A static routing protocol was used in order to evaluate the performance of the proposed solution avoiding routing traffic problems. To better appreciate the benefits derived by the use of the presented switched beam antenna, the proposed AntDirMAC was compared with the MAC solution implemented by the IEEE 802.15.4 standard. In particular, the always-on MAC protocol in Contiki, based on the CSMA driver, was considered. In this analysis, the energy estimation features implemented in Contiki were used to experimentally quantify the energy-efficiency of the proposed scheduler. The main simulation parameters are reported in Table I, while the results of the performed analysis are discussed in the next section. Finally, in order to collect significant information during the data collection campaigns, a custom data logging application was developed. The application, installed on the sink node, was able to send all received packets to a laptop working as a storage device. The data exchange between sink node and laptop was performed by a serial communication. By embedding in the transmitted packets the amount of time in which a node uses the radio for unicast and broadcast transmissions, a measure of the power used to send data was performed.

V. RESULTS

A. Switched-beam antenna validation

The measured return loss compared with the simulated results for the single directive antenna element is reported in Fig. 9. The directive antenna element shows good impedance matching with an observed return loss better than 25 dB.

Fig. 10 shows the S_{21} scattering parameter measured between the RF signal input port and *Ant_Out* pin of the switch (see block C of Fig. 3). Results, related to the two possible switch configurations, show a signal attenuation less than 4 dB when the switch connects a branch of the transmission line with the antenna element output, and a signal attenuation greater than 20 dB when the switch connects a branch of the transmission line with the ground plane. These results have demonstrated the proper operation of the switching circuit. Indeed, the very high measured attenuation in the case of switch OFF ensures that one and only one antenna element will transmit, at any time.

The simulated radiation patterns for the vertically polarized directive antenna element have also been computed and are reported in Fig. 11.a for the azimuth plane ($\varphi=0^\circ$) and in Fig. 11.b for the elevation plane ($\varphi=90^\circ$). The computed main lobe magnitude is 7.2 dBi, and the HPBW is nearly 60 degrees for

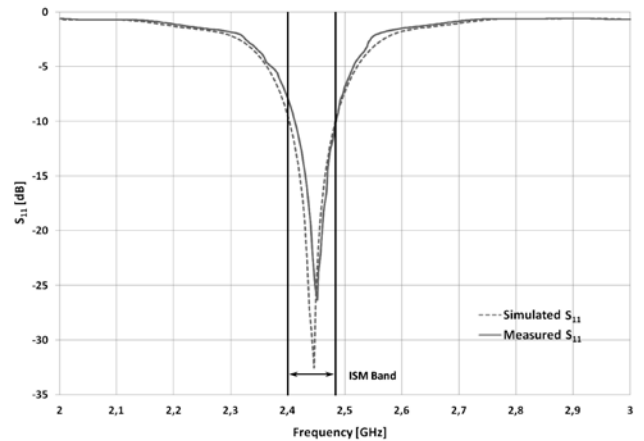

Figure 9. Measured and simulated return loss of the single directive antenna element.

the azimuth plane according to the proposed design specifications.

As previously mentioned, in order to accurately characterize the radiation properties of the proposed antenna, several tests with two MB954 evaluation boards have been performed. Fig. 12 shows the obtained diagrams for two adjacent directive radiators (dashed and solid curves) as well as for the half-wavelength dipole one (dash-dotted curve); black dots represent measurements points. In each case, the same emitted power has been considered. As expected, it can be observed the proper functioning of the proposed switched-beam antenna. Coverage areas associated to adjacent directive antennas guarantee a suitable overlapping area and a beam width compatible with the simulated one. In fact, despite conceptually different, the behaviour of the radiation patterns of Fig. 11 can be compared with those of the diagrams of Fig. 12. A substantial agreement can be observed for both directive radiators and half-wavelength dipole.

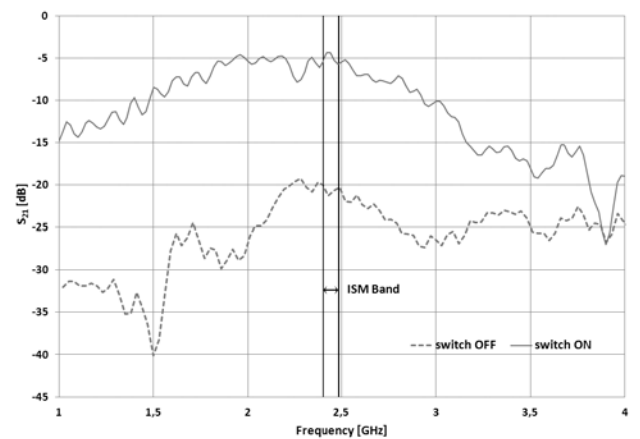

Figure 10. Measured S_{21} scattering parameter of the RF switching circuit in the case of direct connection between RF input port and *Ant_Out* pin (switch ON), and between RF input port and *GND_Out* pin (switch OFF).

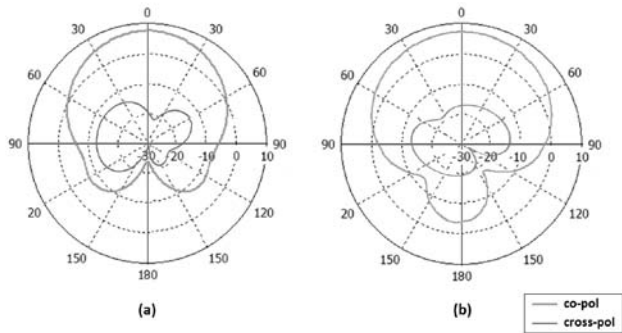

Figure 11. (a) Simulated radiation patterns for the vertically polarized directive antenna element for the azimuth plane (b) and for the elevation plane.

B. AntDirMAC Validation

The performance results, in terms of energy consumption, of the MAC scheduler in a real environment are reported and discussed in this sub-section.

Fig. 13 shows the main results obtained in the first test (POWER_TEST). They allowed us to exactly identify the most suitable values of the transmission power to use in the following experimental campaign, according with the considered environment settings. Furthermore, the analysis showed that the proposed switched-beam antenna is able to perform directional transmissions, using one of the eight sectors, at a transmission power 6.4 times lower compared to that used to transmit packets in omnidirectional manner, while keeping unchanged the coverage range.

The results of the PERFORMANCE_TEST are reported in Fig. 14. It shows the power consumption versus the hop distance between sender and receiver. Let us observe that only the power consumption related to packets transmission was considered. The measured energy consumption values are expressed in mW, while the three used data rates are labelled as DR with the indication of the elapsed time between two

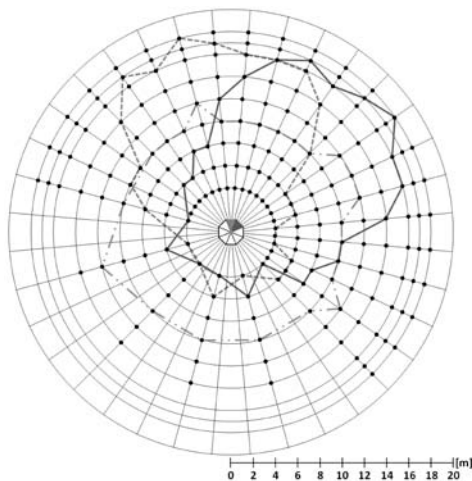

Figure 12. Diagrams representing the regions where a real WSN node correctly receive more than 95% of packets for three different radiators: 2 adjacent directive radiators and the half-wavelength.

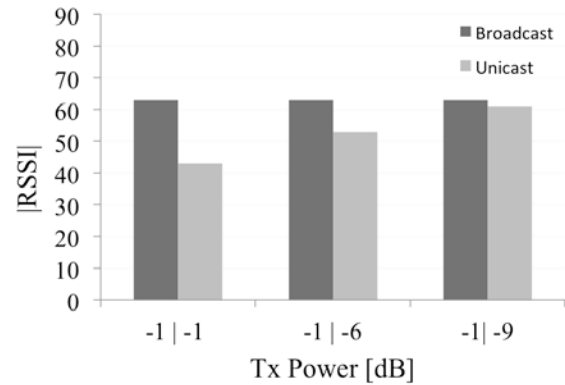

Figure 13. RSSI values varying the transmission powers used for sending broadcast and unicast packets.

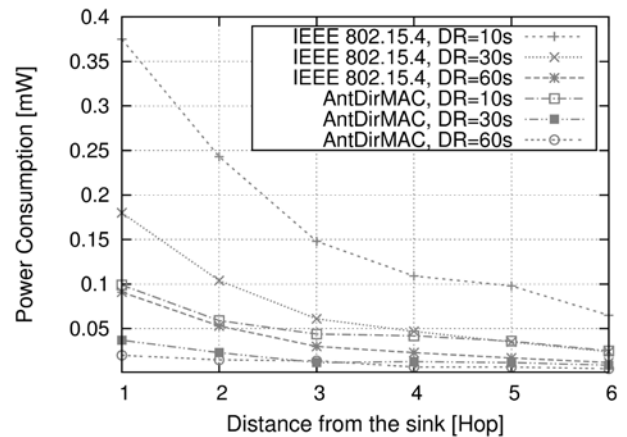

Figure 14. Performance comparison in terms of power consumption between AntDirMAC and the IEEE 802.15.4 MAC standard.

consecutive packets. It is important to observe that all reported energy consumption values are evaluated by considering only the transmission periods of the radio transceiver.

As general trend, we can observe that the nodes' power consumption slightly increases for nodes closer to the sink. In the considered network topology, in fact, each node sends data packets towards the sink by forwarding them to nodes closer to the sink. In terms of energy consumption this means that such nodes consume more energy because they are in charge of forwarding packets from farther nodes. Moreover, the curves show that the energy consumption of each node decreases when the network load decreases. Finally, the results clearly show that AntDirMAC reaches a substantial energy consumption reduction with respect to the IEEE 802.15.4 protocol. This main overall result is true for each node and configuration. In particular, the energy saved by the proposed scheduler is about the 37% for nodes closer to the sink, when considering a communication with the highest used data rate.

VI. CONCLUSIONS

In this paper an energy-efficient MAC protocol based on a switched-beam antenna is presented and validated. In particular, the presented antenna consists of a vertical half-wavelength dipole antenna and eight microstrip antennas with

a directional radiation pattern in the azimuth plane. It is connected to the wireless module of a sensor node and works in place of the common omnidirectional antenna. The proposed protocol is based on a scheduling mechanism able to reduce power consumption by avoiding transmissions towards unnecessary directions. The resulting solution has been implemented in the Contiki OS and validated through test beds.

Furthermore, a characterization of the electromagnetic properties of the switched-beam antenna is detailed, before to present energy consumption performance of the proposed scheduler by means of test beds. Overall performance results show the effectiveness of AntDirMAC, as well as its benefits in saving nodes energy and extending network lifetime with respect to the standard IEEE 802.15.4 protocol. The good results that we have obtained lead us to consider the possibility of using lower quality materials for the realization of the switched-beam antenna in the future, in order to hold costs down. It is also important to notice that although the radiating structure size does not allow integration with WSN nodes, it is only a first prototype, realized to demonstrate the appropriateness of the proposed approach. We are already working on designing a new prototype that will have much lower size and cost than those proposed so far. Furthermore, the evaluation of the proposed protocol considering a greater number of devices and different performance metrics will characterize future works.

REFERENCES

- [1] L. Mainetti, L. Patrono and A. Vilei, "Evolution of wireless sensor networks towards the Internet of Things: A survey," in *Proc. SoftCOM*, Split, Croatia, 2011, pp. 1 – 6.
- [2] S. Ehsan and B. Hamdaoui. (2011, March). A Survey on Energy-Efficient Routing Techniques with QoS Assurances for Wireless Multimedia Sensor Networks. *IEEE Communications Surveys and Tutorials*. 14(2), 265 – 278.
- [3] Q. Tang, C. Sun, H. Wen and Y. Liang, "Cross-Layer Energy Efficiency Analysis and Optimization in WSN," in *Proc. ICNSC*, Chicago, IL, 2010, pp. 138 – 142.
- [4] D. Alessandrelli, L. Patrono, G. Pellerano, M. Petracca and M.L. Stefanizzi, "Implementation and validation of an energy-efficient MAC scheduler for WSNs by a test bed approach," in *Proc. SoftCOM*, Split, Croatia, 2012, 1 – 6.
- [5] D. Alessandrelli, L. Mainetti, L. Patrono, G. Pellerano, M. Petracca and M.L. Stefanizzi. (2013). Performance Evaluation of an Energy-Efficient MAC Scheduler by using a Test Bed Approach. *Journal of Communication Software and Systems*. 9(1), pp. 84 – 96.
- [6] G. Anastasi, M. Conti, M. Di Francesco and A. Passarella. (2009, May). Energy conservation in wireless sensor networks: A survey. *Journal Ad Hoc Networks, Elsevier*. 7(3), pp. 537 – 568.
- [7] G. Giorgetti, A. Cidonali, S. K. S. Gupta and G. Manes, "Exploiting low-cost directional antennas in 2.4GHz IEEE 802.15.4 wireless sensor networks," in *Proc. of the 10th European Conference on Wireless Technology*, Munich, 2007, pp. 217 – 220.
- [8] S.H. Kyoung, A. Jihwan, K. Ki-Joon, K.Y. Hyung and J.Y. Young, "Pattern reconfigurable antenna for a wireless sensor network sink node," in *Proc. APMC*, Yokohama, 2010, pp. 2021 – 2024.
- [9] M.I. Lai, T.Y. Wu, J.C. Hsieh, C.H. Wang and S.K. Jeng. (2008, Sept.). Compact switched-beam antenna employing a four-element slot antenna array for digital home applications. *IEEE Transactions on Antennas and Propagation*. 56(9), pp. 2929 – 2936.
- [10] D.-C. Chang, B.-H. Zeng and J.-C. Liu. (2009, April). Reconfigurable angular diversity antenna with quad corner reflector arrays for 2.4GHz applications. *IET Microwaves, Antennas & Propagation*. 3(3), pp. 522 – 528.
- [11] S. Zhang, G. H. Huff, J. Feng and J. T. Bernhard. (2004, Oct.). A pattern reconfigurable microstrip parasitic array. *IEEE Transactions on Antennas and Propagation*. 52(10), pp. 2773 – 2776.
- [12] E. A. Omar and K. M. F. Elsayed, "Directional Antenna with BusyTone for Capacity Boosting and Energy Savings in Wireless Ad-hoc Networks," in *Proc. HONET*, Cairo, 2010, pp. 91 – 95.
- [13] J. Cho, J. Lee, T. Kwon and Y. Choi, "Directional Antenna at Sink (DAAs) to prolong network lifetime in Wireless Sensor Network," in *12th European Wireless Conference 2006 - Enabling Technologies for Wireless Multimedia Communications (European Wireless)*, Athens, Greece, pp. 1 – 5.
- [14] W. Ye, J. Heidemann and D. Estrin, "An energy efficient MAC protocol for wireless sensor networks", in *Proc. INFOCOM*, 2002, pp. 1567 – 1576.
- [15] L. Bencini, G. Collodi and D. Di Palma, "Energy Efficient Cross Layer Solution based on Smart Antennas for Wireless Sensor Network Applications," in *Proc. SENSORCOMM*, Venice, 2010, pp. 232 – 237.
- [16] C.C. Enz, A. El-Hoiydi, J.-D. Decotignie and V. Peiris. (2004, Aug.). WiseNET: An Ultralow-Power Wireless Sensor Network Solution. *Computer*. 37(8), pp. 62 – 70.
- [17] E. Karapistoli, I. Gragopoulos, I. Tsetsinas and F.-N. Pavlidou, "A Directional MAC Protocol with Deafness Avoidance for UWB Wireless Sensor Networks," in *Proc. ICC*, Dresden, 2009, pp. 1 – 5.
- [18] L. Catarinucci, S. Guglielmi, L. Patrono, and L. Tarricone. (2013). Switched-beam antenna for wireless sensor network nodes. *Progress in Electromagnetics Research C*. 39, pp. 193-207.
- [19] E. Collin, "Fundation of microwave engineering", McGraw Hill, New York, 2007.
- [20] Brian C. Wadell "Transmission Line Design Handbook (Artech House Antennas and Propagation Library)," Artech House Microwave Library, 1991.
- [21] A. Dunkels, B. Gronvall, and T. Voigt, "Contiki – a lightweight and flexible operating system for tiny networked sensors," in *Proc. LCN*, 2004, pp. 455 – 462.
- [22] K. Srinivasan, P. Dutta, A. Tavakoli and P. Levis. (Feb. 2010). An empirical study of low power wireless. *ACM Transactions on Sensor Networks*, 6(2).
- [23] O. Gnawali, R. Fonseca, K. Jamieson, D. Moss and P. Levis, "Collection tree protocol," in *Proc. ACM SenSys*, Berkeley, CA, USA, 2009.



Luca Catarinucci is an Assistant Professor in Electromagnetic Fields at the Department of Innovation Engineering, University of Salento, Italy. His research activity is mostly focused on the implementation of electromagnetic simulation tools, in the FDTD analysis of human-antenna interaction and in the electromagnetic characterisation of materials. Further contributions deal with the time domain reflectometry (TDR) for the

characterisation of fluids and in the radiofrequency identification (RFID) antenna and system design. He authored more than 50 papers on international and national journals and in international and national conferences and a chapter of a book with international diffusion.



Sergio Guglielmi graduated in Telecommunications Engineering at the Politecnico of Milan (Italy) in March 2010. Since February 2011 he collaborates with EML2 lab - Electromagnetic Fields Laboratory at the Innovation Engineering Department, University of Salento. His research activities are mainly focused on modelling and design of smart wireless systems for Wireless Sensor Networks, particularly oriented towards

electromagnetic aspects.



Luca Mainetti is an associate professor of software engineering and computer graphics at the University of Salento. His research interests include web design methodologies, notations and tools, services oriented architectures and IoT applications, and collaborative computer graphics. He is a scientific coordinator of the GSA Lab - Graphics and Software Architectures Lab and IDA Lab - IDentification Automation Lab at the Department of Innovation Engineering, University of Salento. He is the Rector's delegate at the ICT.



Vincenzo Mighali received the "Laurea" Degree in Computer Engineering with honors at the University of Salento, Lecce, Italy, in 2012. His thesis concerned the definition and validation of an energy-efficient and traffic-aware MAC schema based on directional antennas for Wireless Sensor Networks. Since January 2009 he collaborates with IDA Lab — IDentification Automation Laboratory at the Department of Innovation Engineering, University of Salento. His activity is focused on the definition and implementation of new tracking system based on RFID technology and on the design and validation of innovative communication protocol aimed to reduce power consumption in Wireless Sensor Networks. He is also involved in the study of new solutions for building automation. He authored several papers on international journals and conferences.



Luigi Patrono received his MS in Computer Engineering from University of Lecce, Lecce, Italy, in 1999 and PhD in Innovative Materials and Technologies for Satellite Networks from ISUFI-University of Lecce, Lecce, Italy, in 2003. He is an Assistant Professor of Network Design at the University of Salento, Lecce, Italy. His research interests include RFID, EPCglobal, Internet of Things, Wireless Sensor Networks, and design and performance evaluation of protocols. He is Organizer Chair of the international Symposium on RFID Technologies and Internet of Things within the IEEE SoftCOM conference. He is author of about 70 scientific papers published on international journals and conferences and four chapters of books with international diffusion.



Maria Laura Stefanizzi graduated cum laude in Computer Engineering at University of Salento (Italy) in April 2012. Since January 2009 she collaborates with IDA Lab - IDentification Automation Laboratory at the Department of Innovation Engineering, University of Salento. Her activity is focused on the design and validation through test beds on real devices of innovative applications and protocols aimed to reduce power consumption in Wireless Sensor Networks. She is also involved in the study of new solutions for the integration of RFID and WSN technologies.



Luciano Tarricone is full professor at the University of Lecce (Italy). He has authored about 170 scientific papers and 5 books. His main contributions are in the area of the modelling of microscopic interactions of EM fields and biosystems, and in numerical methods for efficient CAD of MW circuits and antennas. He is currently involved in the finite-difference time-domain (FDTD) analysis of human-antenna interaction, graph-theory methods for the enhancement of numerical EM techniques, novel CAD tools and procedures for MW circuits, EM parallel computing and metamaterials.