

# 2017

## POWERTRAIN COMPONENTS & REMANUFACTURED ASSEMBLIES

### Contents

#### PRODUCT INFORMATION

Ford Authorized Distributors .....	P-2 – P-3
“No-Risk” Core Return Policy .....	P-4
<b>Warranty Information</b>	
Limited Warranty Statement – New & Remanufactured Transmissions & Gas Engines .....	P-5
Limited Warranty Statement – Diesel Engines .....	P-6
Warranty Reimbursement for Diesel Engines Sold Over-the-Counter .....	P-7
Service Parts Warranty – Ford & Motorcraft Parts .....	P-8
Warranty Guides for Engine & Transmission Assemblies .....	P-9 – P-10

#### Product Information

##### GAS ENGINES

Remanufactured Gas Engine Assemblies .....	P-11
Gas Engine Buying Guide .....	P-12 – 14
Gas Engine Build Levels .....	P-15 – P-16
Intake Manifolds .....	P-17
Motorcraft Water Pumps .....	P-18

##### DIESEL ENGINES

Remanufactured Diesel Engines .....	P-19
Power Stroke Diesel Engine Buying Guide .....	P-20 – 22
Diesel Fuel System Components Buying Guide .....	P-23 – P-24

##### TRANSMISSIONS

Remanufactured Transmission Assemblies .....	P-25
Transmission Buying Guide .....	P-26 – P-28
Automatic Transmission Tips & Checklist .....	P-29
Transmission Cooler Service .....	P-33 – P-35
Remanufactured Torque Converter .....	P-36
Motorcraft Transmission Overhaul Kits .....	P-37 – P-38
Clutch Kits .....	P-39

2017 VIN Guide .....	P-40 – P-43
----------------------	-------------

Cataloging & Product Line Inquiry/Comment Form .....	P-44
--	------

#### APPLICATION BY VEHICLE

##### GAS ENGINES

###### LONGBLOCKS

Passenger Cars .....	1 – 7
Light Trucks .....	7 – 20
Medium Trucks .....	20 – 23

###### CYLINDER HEADS

Passenger Cars .....	24
Light / Medium Trucks .....	25

##### DIESEL ENGINES

Light / Medium Trucks .....	26 – 48
-----------------------------	---------

##### TRANSMISSIONS

Passenger Cars .....	49 – 55
Light Trucks .....	55 – 75
Medium Trucks .....	75 – 79

##### TORQUE CONVERTERS

Passenger Cars .....	80 – 83
Light Trucks .....	83 – 88
Medium Trucks .....	89 – 90

##### MANUAL TRANSMISSION CLUTCH KITS

Passenger Cars .....	91 – 92
Light Trucks .....	93 – 94

##### TRANSMISSION REPAIR KITS

Passenger Cars .....	95 – 96
Light Trucks .....	97 – 100

CROSS REFERENCE .....	101 – 106
-----------------------	-----------

#### BUYER'S GUIDES

Gas Engine Assemblies .....	107 – 120
Gas Engine Cylinder Heads .....	121
Diesel Engine Assemblies .....	122 – 126
Transmission Assemblies .....	127 – 152
Torque Converters .....	153 – 157
Manual Transmission Clutch Kits .....	158
Transmission Repair Kits .....	159 – 161

CATALOG LOCATION OF PART NAME AND PREFIX .....	162 – 173
--	-----------

PRODUCT  
INFORMATION

GAS ENGINES

LONGBLOCKS

CYLINDER HEADS

DIESEL ENGINES

TRANSMISSIONS

TORQUE CONVERTERS

MANUAL  
TRANSMISSION  
CLUTCH KITS

TRANSMISSION  
REPAIR KITS

CROSS REFERENCE

BUYER'S GUIDES

CATALOG LOCATION  
OF PART NAME  
AND PREFIX

## FORD AUTHORIZED DISTRIBUTORS

### **AER Sales LP**

2999 Miller St.  
San Leandro, CA 94577  
Telephone: (510) 483-5092

7103 E. 47th Ave.  
Denver, CO 80216  
Telephone: (303) 399-3673  
FAX: (303) 355-8800

144 Makaala St.  
Hilo, HI 96720  
Telephone: (808) 966-5444  
FAX: (808) 966-6566

1049 Kikowaena Place  
Honolulu, HI 96819  
Telephone: (808) 833-9999  
FAX: (808) 833-2833

231 Papa St.  
Kahului, HI 96732  
Telephone: (808) 870-3487  
FAX: (808) 877-1443

4161 Dixon Ave.  
Des Moines, IA 50313  
Telephone: (515) 262-8553  
FAX: (515) 262-0883

3301 Corporate Dr.  
Joliet, IL 60431  
Telephone: (815) 773-9435  
FAX: (815) 773-9463

4300 Round Lake Road W  
Unit 200  
Arden Hills, MN 55112  
Telephone: (651) 209-6042  
FAX: (651) 209-6044

### **AER Sales LP (Cont'd)**

8250 N.E. Underground Dr.  
Pillar 153  
Kansas City, MO 64161  
Telephone: (816) 471-4182  
FAX: (816) 452-4180

600 S. Theresa Ave.  
St. Louis, MO 63103  
Telephone: (800) 999-1315  
FAX: (314) 535-0812

5503 F Street  
Omaha, NE 68117  
Telephone: (402) 341-9742  
FAX: (402) 341-9743

11 Chapin Rd., Unit A  
Pine Brook, NJ 07058  
Telephone: (973) 575-0251  
FAX: (973) 575-7646

8333 Washington Place N.E., Ste. E  
Albuquerque, NM 87113  
Telephone: (505) 342-1606  
FAX: (505) 342-1669

5220 N.E. 152<sup>nd</sup> Place  
Portland, OR 97230  
Telephone: (888) 577-5237  
FAX: (508) 258-8422

1605 Surveyor Blvd.  
Carrollton, TX 75006  
Telephone: (972) 418-6499  
FAX: (972) 417-3150

3700 Claymoore Pk Dr., Ste. 160  
Houston, TX 77043  
Telephone: (713) 895-0475  
FAX: (713) 895-9644

### **AER Sales LP (Cont'd)**

5915 Corridor Parkway  
Schertz, TX 78154  
Telephone: (210) 651-8280  
FAX: (210) 651-6207

2233 S. 1800 West  
West Valley City, UT 84119  
Telephone: (801) 972-3332  
FAX: (801) 975-1005

18637 72nd Ave. S.  
Kent, WA 98032  
Telephone: (888) 570-6237  
FAX: (253) 437-1575

### **Factory Motor Parts**

300 Calais Dr.  
Anchorage, AK 99503  
Telephone: (907) 279-4099  
FAX: (907) 279-2015

### **Fred Jones Enterprises**

1002 South 56 Ave.  
Phoenix, AZ 85043  
Telephone: (602) 269-3232  
FAX: (602) 272-8457

1040 S. Rockefeller Drive  
Ontario, CA 91761  
Telephone: (562) 692-9034  
FAX: (562) 699-6931

550 Gills Drive  
Orlando, FL 32824  
Telephone: (407) 251-6505  
FAX: (407) 251-6508

Visit [www.fordparts.com](http://www.fordparts.com)  
for your nearest dealer.

## FORD AUTHORIZED DISTRIBUTORS

---

### **Fred Jones Enterprises (Cont'd)**

5286 Highway 85, Suite 200  
Forest Park, GA 30297  
Telephone: (404) 209-8556  
FAX: (404) 209-8559

545 Ford Ave.  
Jackson, MS 39209-2740  
Telephone: (601) 352-7750  
FAX: (601) 352-8713

4444 South Blvd.  
Charlotte, NC 28209-2673  
Telephone: (704) 525-9900  
FAX: (704) 523-2215

4050 W Sunset Rd., Ste. H  
Las Vegas, NV 89118  
Telephone: (562) 692-9034  
FAX: (702) 914-0453

6200 Southwest 29th St.  
Suite A  
Oklahoma City, OK 73179  
Telephone: (800) 927-7845  
FAX: (405) 350-4881

7145 Industrial  
El Paso, TX 79915-1224  
Telephone: (915) 860-8201  
FAX: (915) 860-8273

### **Holman**

3645 Developers Rd.  
Indianapolis, IN 46227  
Telephone: (317) 781-9373  
FAX: (317) 781-3501

444 Whitney St.  
Northborough, MA 01532  
Telephone: (508) 351-8650  
FAX: (800) 800-5984

### **Holman (Cont'd)**

8242 Sandy Ct.  
Jessup, MD 20794  
Telephone: (301) 499-0988  
FAX: (800) 767-4985

20501 Pennsylvania Rd., Ste. 140  
Brownstown Township, MI 48192  
Telephone: (734) 284-1625  
FAX: (734) 284-0901

9040 Burrough Dover Ln.  
Pennsauken, NJ 08110  
Telephone: (856) 662-3811  
FAX: (856) 663-1745

1901 Lemoyne Ave.  
Syracuse, NY 13208  
Telephone: (315) 455-7414  
FAX: (315) 454-9534

Tri County Commerce Park  
Building 3/3A  
2511 Lovi Road  
Freedom, PA 15042  
Telephone: (412) 749-7960  
FAX: (412) 749-7964

Visit [www.fordparts.com](http://www.fordparts.com)  
for your nearest dealer.



## **"No-Risk" Core Return Policy**

Our "No-Risk" Core Return policy provides 100% core credit regardless of damage or quality of returned core. This policy provides our customers confidence when quoting repairs with Ford parts.

When returning core, these guidelines must be followed:

- Returned core is the same part as the assembly purchased
- Core is 100% complete with all parts attached and all fluids drained and is returned in original package



FORD PARTS

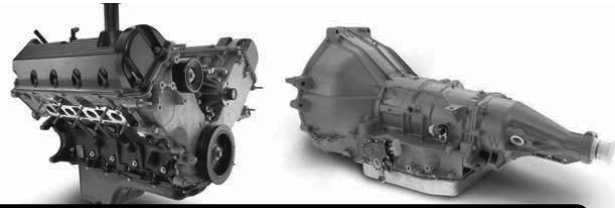

## LIMITED WARRANTY STATEMENT (FOR RETAIL SALES ON OR AFTER 9/1/2010) Ford New and Remanufactured Transmissions and Gas Engines

Ford Motor Company, The American Road, Dearborn, MI 48121 ("Ford") provides the following Limited Warranty on Ford New and Remanufactured Transmissions and Gas Engines to Ford and Lincoln Dealers (each being a "Dealer") or general Installers (each being an "Installer"). This Limited Warranty provides Ford will credit the Dealer or Installer for repairing or replacing, at Ford's option, any Ford Transmission or Gas Engine sold by Ford in the United States, for installation in the United States, in a Ford or Lincoln vehicle that was sold, registered/licensed, and operated in the United States, that is found to be defective in factory-supplied material or workmanship subject to the following terms, conditions and limitations:

Vehicle Owner: To obtain warranty service, please return your vehicle to any Ford or Lincoln Dealership or return to the Installer who originally installed the Ford Gas Engine or Transmission Assembly in your vehicle. You must have one of the following items:

- Vehicle Owner assembly installation repair order which includes Vehicle Identification Number (VIN), date of installation, assembly part number, and odometer reading
- Dealer Over-the-counter Invoice documenting date of purchase, assembly part number, & VIN
- Your powertrain was registered by a Ford or Lincoln Dealer.

### Gas Engine Long Block Assemblies (6006/6007/6V006/6V012) and Transmission Assemblies (7000/7V000/7002/7003)

- For 36 months from warranty start date (unlimited miles), Ford will cover 100% of all parts and labor at approved warranty reimbursement rates
- If installed by a Dealer, reasonable towing charges (up to 35 miles or to the nearest Dealer) are covered only if the vehicle is not covered under another towing insurance coverage
- Excludes gas engine short blocks (6009)

### Warranty Start Date for Ford New or Remanufactured Transmissions and Gas Engines

- If Dealer-installed, the Warranty Start Date is the date of installation.
- If sold Over-the-counter to a vehicle owner, the Warranty Start Date is the date of sale.
- If sold Over-the-counter to a fleet, general installer or wholesaler, the Warranty Start Date is the date the assembly is installed (could be later than the date of sale).

### Limitations to the Warranty

The following limitation applies to the products covered by this Limited Warranty:

- Towing charges are not reimbursable for Ford Transmissions and Gas Engines sold over-the-counter by a Dealer or Installer

### How to obtain Limited Warranty coverage for Ford Transmissions and Gas Engines sold over-the-counter by a Dealer or Installer:

This statement applies to over-the-counter customers of a Dealer, such as a vehicle owner, independent repair facility, wholesaler, or fleet customer.

The Dealer or Installer can claim both parts and labor under the Limited Warranty if the vehicle owner, at his/her option,

- Returns the vehicle to the Installer (from which the assembly was purchased) or to any Dealer for repairs, or
- Returns the Ford New or Remanufactured Transmission or Gas Engine to the Installer (from which the assembly was purchased) or to any Dealer for repairs

### NOTES on obtaining Limited Warranty coverage for Ford Transmissions and Gas Engines:

- This Limited Warranty may be honored by the original Installer or any Dealer (even though that particular Dealer was not the original purchaser/seller of the product)
- In order for the Dealer or Installer to claim under the Limited Warranty, the Installer or vehicle owner (whether original vehicle owner or subsequent transferee) must provide the Dealer the following information when repairs are requested:
  - Authorization code from the Powertrain Assistance Center (PAC) @ 800-392-7946
  - A copy of the original vehicle owner's assembly installation repair order
- Only new Ford Original Equipment, Ford Authorized Remanufactured, or other parts or assemblies authorized by Ford may be used to complete covered warranty repairs
- Installer labor reimbursement is calculated using Ford Labor Times Standard hours multiplied by the selling Dealership's warranty labor rate or the Installer's actual labor total, whichever is less
- Diagnostic steps taken to determine cause of warrantied concern with diagnostic results must be clearly documented on Installer repair order. (Warranty parts and labor reimbursement requests must be supported by diagnostic labor steps and test results)
- All parts replaced under warranty must be returned to your selling Dealer

THIS LIMITED WARRANTY DOES NOT COVER FORD REMANUFACTURED TRANSMISSIONS AND GAS ENGINES THAT FAIL DUE TO ABUSE, MISUSE, NEGLIGENCE, ALTERATION, ACCIDENT, RACING, OR PARTS AND ACCESSORIES INSTALLED IN VEHICLES OTHER THAN THOSE LISTED IN FORD AUTHORIZED CATALOGS INCLUDING OTHER FORD MOTOR COMPANY BRANDS, OR THE USE OF NON-FORD PARTS, OR LACK OF PROPER MAINTENANCE. THIS LIMITED WARRANTY DOES NOT COVER PARTS WHICH ARE REPLACED AS PART OF NORMAL MAINTENANCE. THIS LIMITED WARRANTY DOES NOT COVER REPEAT REPAIRS PERFORMED AS A RESULT OF A MISDIAGNOSIS OR IMPROPER PRIOR REPAIR. TO THE EXTENT ALLOWED BY LAW, LOSS OF TIME, INCONVENIENCE, LOSS OF THE USE OF THE VEHICLE, COMMERCIAL LOSS, AND INCIDENTAL AND CONSEQUENTIAL DAMAGES ARE NOT COVERED. **THERE IS NO OTHER EXPRESS OR IMPLIED WARRANTY ON THESE FORD NEW AND REMANUFACTURED TRANSMISSIONS AND GAS ENGINES INCLUDING, BUT NOT LIMITED TO, ANY IMPLIED WARRANTY OF MERCHANTABILITY OR FITNESS FOR A PARTICULAR PURPOSE.** TO THE EXTENT ALLOWED BY LAW, ANY IMPLIED WARRANTY OF MERCHANTABILITY OR FITNESS IS LIMITED TO THE DURATION OF THIS WRITTEN LIMITED WARRANTY.

To retain the safety and dependability built into this product, it is essential that your Ford Remanufactured Transmission or Gas Engine receives the scheduled maintenance at the recommended intervals contained in your vehicle Owner's Manual/Maintenance Schedule.



FORD PARTS

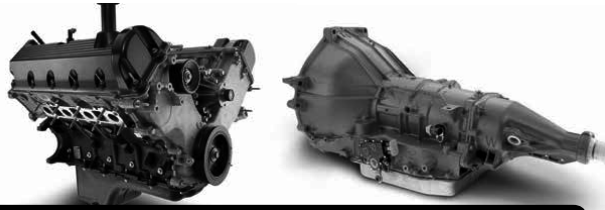

## LIMITED WARRANTY STATEMENT

### Ford and Motorcraft® Remanufactured Diesel Engines

Ford Motor Company, The American Road, Dearborn, MI 48121 ("Ford") provides the following Limited Warranty on Ford and Motorcraft Remanufactured Diesel Engines to Ford and Lincoln Dealers (each being a "Dealer") or general Installers (each being an "Installer"). This Limited Warranty provides that Ford will credit the Dealer or Installer for repairing or replacing, at Ford's option, any Ford or Motorcraft Remanufactured Diesel Engine sold by Ford that is found to be defective in factory-supplied material or workmanship subject to the following terms, conditions and limitations:

**Retail Customers: To obtain warranty service, please return your vehicle to any Ford and Lincoln Dealership or return to the Installer who originally installed the Ford or Motorcraft Diesel Engine Assembly in your vehicle. Please have your original dated receipt for installation date verification.**

#### Complete Diesel Engine (6007/6V007) and Long Block (6006/6V006) Assemblies

- 24 months from warranty start date (unlimited miles). Ford will cover 100% of all parts and labor at approved warranty reimbursement rates
- If installed by a Dealer, reasonable towing charges (up to 35 miles or to the nearest Dealer) are covered only if the vehicle is not covered under another towing insurance coverage

#### Diesel Engine Stripped Long Blocks (6V012) and Short Blocks (6009/6V009)

- 12 months from warranty start date (unlimited miles). Ford will cover 100% of all parts and labor at approved warranty reimbursement rates
- If installed by a Dealer, reasonable towing charges (up to 35 miles or to the nearest Dealer) are covered only if the vehicle is not covered under another towing insurance coverage

#### Warranty Start Date

- Ford and Motorcraft Remanufactured Diesel Engines and Components installed by the Dealer or Installer—Warranty begins on the date of installation
- Ford and Motorcraft Remanufactured Diesel Engines and Components sold by Dealer or Installer over-the-counter or to a retail purchaser—on the date of sale

#### Limitations to the Warranty

- The following limitation applies to the products covered by this Limited Warranty:
- Towing charges are not reimbursable for Ford and Motorcraft Remanufactured Diesel Engines sold over-the-counter by a Dealer or Installer.

#### How to obtain Limited Warranty coverage for Ford and Motorcraft Remanufactured Diesel Engines sold over-the-counter by a Dealer or Installer:

This statement applies to over-the-counter customers of a Dealer or Installer, such as a retail customer or fleet customer.

The Dealer or Installer can claim both parts and labor under the Limited Warranty if the retail customer, at his/her option:

- Returns the vehicle to the Installer (from which the assembly or component was purchased) or to any Dealer for repairs, or
- Returns the Ford or Motorcraft Remanufactured Diesel Engine to the Installer (from which the assembly or component was purchased) or to any Dealer for repairs

#### NOTES:

- The original Installer or any Dealer (even though that particular Dealer was not the original purchaser/seller of the product) may claim under this Limited Warranty
- In order for the Dealer or Installer to claim under the Limited Warranty, the Dealer, Installer or customer (whether original customer or subsequent transferee) must provide the original owner's repair order or sales slip when repairs are requested
- Only new Ford Original Equipment or Ford authorized remanufactured parts or assemblies may be used to complete covered warranty repairs
- Installer labor reimbursement is calculated using Ford Labor Times Standard hours multiplied by the selling dealership's warranty labor rate, or the Installer's actual labor total, whichever is less
- Diagnostic steps taken to determine cause of warrantied concern with diagnostic results must be clearly documented on Installer repair order. (Warranty parts and labor reimbursement requests must be supported by diagnostic labor steps and test results)
- All parts replaced under warranty must be returned to your selling Dealer

THIS LIMITED WARRANTY DOES NOT COVER FORD OR MOTORCRAFT REMANUFACTURED DIESEL ENGINES THAT FAIL DUE TO ABUSE, MISUSE, NEGLIGENCE, ALTERATION, ACCIDENT, RACING, OR THE USE OF NON-FORD PARTS, LACK OF PROPER MAINTENANCE OR THAT ARE INSTALLED IN VEHICLES OTHER THAN THOSE LISTED IN FORD AUTHORIZED CATALOGS.

THIS LIMITED WARRANTY DOES NOT COVER PARTS WHICH ARE REPLACED AS PART OF NORMAL MAINTENANCE.

THIS LIMITED WARRANTY DOES NOT COVER REPEAT REPAIRS PERFORMED AS A RESULT OF A MISDIAGNOSIS OR IMPROPER PRIOR REPAIR.

TO THE EXTENT ALLOWED BY LAW, LOSS OF TIME, INCONVENIENCE, LOSS OF THE USE OF THE VEHICLE, COMMERCIAL LOSS, AND INCIDENTAL AND CONSEQUENTIAL DAMAGES ARE NOT COVERED.

**THERE IS NO OTHER EXPRESS OR IMPLIED WARRANTY ON THESE FORD AND MOTORCRAFT REMANUFACTURED DIESEL ENGINES INCLUDING, BUT NOT LIMITED TO, ANY IMPLIED WARRANTY OF MERCHANTABILITY OR FITNESS FOR A PARTICULAR PURPOSE.**

TO THE EXTENT ALLOWED BY LAW, ANY IMPLIED WARRANTY OF MERCHANTABILITY OR FITNESS IS LIMITED TO THE DURATION OF THIS WRITTEN LIMITED WARRANTY

#### Warranty Reimbursement for Ford and Motorcraft Remanufactured Diesel Engines Sold Over-the-Counter

##### Dealership actions required for assemblies that were sold Over-The-Counter and replaced/installed at a dealership

- Effective with repairs dated August 1, 2005, and later when an assembly that was sold OTC is brought to a Ford or Lincoln dealership for assembly replacement, dealers not on Reduced Warranty Requirements must obtain prior approval before replacing Ford and Motorcraft Remanufactured Diesel Engines under OTC Service Part Warranty.
- Dealers can obtain prior approval by completing the Powertrain Approval form via the Professional Technician Society (PTS) website OR by contacting the Technical Hotline at (800) 826-4694 and selecting option #2 "Engine and Transmission Exchange Prior Approval".
- Reduced Warranty Requirement dealers are exempt from this requirement for REPLACEMENTS DONE IN THE DEALERSHIP for one year, but will be subject to review for inclusion in the Prior Approval process at the end of one year.

##### Dealer Reimbursement

- In order for a Dealer or Installer to claim under the Limited Warranty, the Dealer, Installer or customer (whether original customer or subsequent transferee) must provide the original owners repair order or sales slip that includes the VIN of the service vehicle, the current mileage of the service vehicle, the serial number of the part being replaced, and the labor amount charged for the replacement.
- Engine assemblies and components found defective before installation on the vehicle or before sale over-the-counter are to be returned for credit to your selling Ford Authorized Distributor for Powertrain Products.
- Dealers will be reimbursed for parts and labor (if applicable) at warranty rates.
- Reasonable removal and reinstallation labor is reimbursed when prior authorization is obtained.
- Vehicle towing required as a result of the failure of an assembly or part sold over-the-counter is not covered.

##### Dealership actions required for replacement of assemblies sold Over-The-Counter but NOT repaired/installed at a dealership.

- Ensure the OTC customer completes the Assembly Replacement Worksheet and calls the Powertrain Assistance Center (800-3927946) for an authorization number when requesting replacement of an assembly.
- DO NOT GIVE REPLACEMENT ASSEMBLIES WITHOUT THE POWERTRAIN ASSISTANCE CENTER AUTHORIZATION NUMBER.
- For over-the-counter sales, the selling dealer is responsible for submitting a warranty claim on behalf of the over-the-counter customer, and reimbursing the customer for the repair.

##### Customer (retail and/or independent installer) actions required for Warranty Reimbursement for assemblies sold Over-The-Counter

- The over-the-counter customer (retail customer, fleet customer, or general installer) can, at their option:
  - 1) Return the vehicle to the Dealer from which the assembly was purchased for repairs during regular business hours for repair by the Dealer, or
  - 2) Return the defective Ford or Motorcraft remanufactured diesel engine to the Dealer (from which the assembly was purchased) during regular business hours for repair by the Dealer, or
  - 3) Obtain replacement parts or assembly from the Dealer that sold the Ford or Motorcraft remanufactured engine to complete repairs using labor supplied by the over-the-counter customer.

#### NOTE:

It is recommended that the over-the-counter customer call the dealer to discuss possible diagnostic procedures that should be taken before removal of the assembly.

#### IMPORTANT:

Effective with repairs dated August 1, 2005 and later, all independent repair facilities (IRF) and customers installing OTC diesel engines must call the Powertrain Assistance Center at 800-392-7946 for prior authorization before removing or replacing Ford and Motorcraft Remanufactured Diesel Engine assemblies under OTC Service Part Warranty.

- The over-the-counter customer (whether original customer or subsequent transferee) must present a copy of the original sales receipt for the Ford or Motorcraft remanufactured diesel engine.
- Labor reimbursed to the over-the-counter customer will be calculated based on the standard hours listed in the Ford Service Labor Time Standards Manual multiplied by the Dealer's (from which the engine assembly or component was purchased) approved warranty labor rate in effect on the date of repair, or the over-the-counter customer's actual labor amount, whichever is less.
- Vehicle towing required as a result of the failure of an assembly or part sold over-the-counter is not covered.
- Except as noted in the prior statements, all provisions and procedures outlined in the Warranty and Policy Manual apply to Ford and Motorcraft remanufactured diesel engines installed or sold over-the-counter by Dealers.



FORD PARTS

## WARRANTY REIMBURSEMENT FOR ENGINES SOLD OVER-THE-COUNTER

### WARRANTY REIMBURSEMENT FOR FORD AND MOTORCRAFT REMANUFACTURED DIESEL ENGINES SOLD OVER-THE-COUNTER

#### Dealership actions required for assemblies that were sold Over-The-Counter and replaced/installed at a dealership

- Effective with repairs dated August 1, 2005, and later when an assembly that was sold OTC is brought to a Ford or Lincoln Mercury dealership for assembly replacement, dealers not on Reduced Warranty Requirements must obtain prior approval before replacing Ford and Motorcraft Remanufactured Diesel Engines under OTC Service Part Warranty.
- Dealers can obtain prior approval by completing the Powertrain Approval form via the Professional Technician Society (PTS) website OR by contacting the Technical Hotline at (800) 826-4694 and selecting option #2 "Engine and Transmission Exchange Prior Approval".
- Reduced Warranty Requirement dealers are exempt from this requirement for REPLACEMENTS DONE IN THE DEALERSHIP for one year, but will be subject to review for inclusion in the Prior Approval process at the end of one year.

#### Dealer Reimbursement

- In order for a Dealer or Installer to claim under the Limited Warranty, the Dealer, Installer or customer (whether original customer or subsequent transferee) must provide the original owners repair order or sales slip that includes the VIN of the service vehicle, the current mileage of the service vehicle, the serial number of the part being replaced, and the labor amount charged for the replacement.
- Engine assemblies and components found defective before installation on the vehicle or before sale over-the-counter are to be returned for credit to your selling Ford Authorized Distributor for Powertrain Products.
- Dealers will be reimbursed for parts and labor (if applicable) at warranty rates.
- Reasonable removal and reinstallation labor is reimbursed when prior authorization is obtained.
- Vehicle towing required as a result of the failure of an assembly or part sold over-the-counter is not covered.

#### Dealership actions required for replacement of assemblies sold Over-The-Counter but NOT repaired/installed at a dealership.

- Ensure the OTC customer completes the Assembly Replacement Worksheet and calls the Powertrain Assistance Center (800-392-7946) for an authorization number when requesting replacement of an assembly.

DO NOT GIVE REPLACEMENT ASSEMBLIES WITHOUT THE POWERTRAIN ASSISTANCE CENTER AUTHORIZATION NUMBER.

For over-the-counter sales, the selling dealer is responsible for submitting a warranty claim on behalf of the over-the-counter customer, and reimbursing the customer for the repair.

#### Customer (retail and/or independent installer) actions required for Warranty Reimbursement for assemblies sold Over-The-Counter

- The over-the-counter customer (retail customer, fleet customer, or general installer) can, at their option:
  - 1) Return the vehicle to the Dealer from which the assembly was purchased for repairs during regular business hours for repair by the Dealer, or
  - 2) Return the defective Ford or Motorcraft remanufactured diesel engine to the Dealer (from which the assembly was purchased) during regular business hours for repair by the Dealer, or
  - 3) Obtain replacement parts or assembly from the Dealer that sold the Ford or Motorcraft remanufactured engine to complete repairs using labor supplied by the over-the-counter customer.

#### NOTE:

It is recommended that the over-the-counter customer call the dealer to discuss possible diagnostic procedures that should be taken before removal of the assembly.

#### IMPORTANT :

Effective with repairs dated August 1, 2005 and later, all independent repair facilities (IRF) and customers installing OTC diesel engines must call the Powertrain Assistance Center at 800-392-7946 for prior authorization before removing or replacing Ford and Motorcraft Remanufactured Diesel Engine assemblies under OTC Service Part Warranty.

- The over-the-counter customer (whether original customer or subsequent transferee) must present a copy of the original sales receipt for the Ford or Motorcraft remanufactured diesel engine.
- Labor reimbursed to the over-the-counter customer will be calculated based on the standard hours listed in the Ford Service Labor Time Standards Manual multiplied by the Dealer's (from which the engine assembly or component was purchased) approved warranty labor rate in effect on the date of repair, or the over-the-counter customer's actual labor amount, whichever is less.
- Vehicle towing required as a result of the failure of an assembly or part sold over-the-counter is not covered.
- Except as noted in the prior statements, all provisions and procedures outlined in the Warranty and Policy Manual apply to Ford and Motorcraft remanufactured diesel engines installed or sold over-the-counter by Dealers.

## **Limited Service Parts Warranty – Ford and Motorcraft Parts**

### **SPW Coverage on Ford & Motorcraft Parts not replaced at Company Expense**

Parts not replaced under Company Expense, and installed or sold by dealerships or authorized distributors to retail and wholesale customers qualify for the following warranty coverage:

#### **Dealer Installed**

- Parts & labor to replace defective part within 24 months/unlimited miles
- Towing is covered, if required, but only if the vehicle is not covered under the Roadside Assistance Program
- Warranty begins from date of installation, as noted on the repair order

#### **Sold Over-the-Counter to a Retail Purchaser**

- Part Warranty is 24 months/unlimited miles
- For a retail purchaser, warranty begins on the date of sale

#### **Sold Over-the-Counter to a Fleet, Installer or Wholesaler**

- For a fleet, general installer or wholesaler, warranty begins on the date of installation or resale
- Parts & labor to replace defective part within 24 months/unlimited miles
- Fleets and Installer labor is reimbursable up to \$150/claim. Labor amount is calculated using the installer or fleet cost of labor multiplied by published labor time standard. Total cost is not to exceed the Ford Labor Times standard hours multiplied by the processing dealership's warranty labor rate.
- Diagnostic steps taken to determine cause of warranted concern with diagnostic results must be clearly documented on the installer repair order along with the Vehicle Identification Number (VIN). Warranty parts and labor reimbursement requests must be supported by diagnostic labor steps and test results.
- All parts replaced under warranty by an installer or fleet must be returned to the selling dealer.

### **SPW Coverage on Parts Replaced at Company Expense**

Parts replaced at Company expense (e.g., Customer Satisfaction Programs, Special Service Instructions, Field Service Actions (FSA), or Customer Loyalty Plan) are covered under the applicable Service Parts Warranty stated below or the remaining portion of the New Vehicle Limited Warranty (if any), whichever is greater.

- Ford/ Lincoln Cars & Light Trucks: The parts and accessories warranty is: 12 months / 12,000 miles, whichever occurs first
- 650 and higher series trucks: The parts and accessories warranty is: 12 months / unlimited miles, whichever occurs first

#### **Notes:**

- The Limited Warranty may be honored by the original installer or any Ford/Lincoln Dealer, even though that particular dealer was not the original purchaser/seller of the part.
- In order for the Dealer, Fleet or Installer to claim the Limited Warranty, the dealer, fleet, installer or customer must provide the original owner's repair order or sales slip with VIN when repairs are requested.



## WARRANTY REGISTRATION GUIDE Ford Powertrain Assembly Service Part



### Warranty Terms

Gas Engine	3 Years/Unlimited Miles on 6007/6006/6V012
Transmission Assemblies	3 Years/Unlimited Miles on automatic transmissions (7000/7V000) and manual transmissions (7002/7003)
Diesel Engine Assemblies	2 Years/Unlimited Miles on complete engines (6007/6V007) and long block (6006/6V006) 1 Year/Unlimited Miles for stripped long blocks (6012/6V012) and short blocks (6009/6V009)

### Registration Process:

#### Fleet- or Independent-Installed

- 1 Purchase assembly from Dealer/Distributor
- 2 Install assembly in vehicle
- 3 Record VIN, Installation Date, Mileage, Serial Number and Part Number on the Vehicle Owner Repair Order
- 4 Send Vehicle Owner Repair Order copy to Dealer/Distributor for registration in OASIS\*
- 5 Dealer/Distributor registers assembly in OASIS\* and generates warranty registration
- 6 Installer provides vehicle owner:
  - Warranty Policy Statement
  - OASIS\* Warranty Registration
  - Vehicle Owner Repair Order

#### Dealer-Installed

- 1 Purchase assembly from Ford Distribution Network
- 2 Install assembly in vehicle
- 3 Record VIN, Date of Installation, Mileage, Serial Number and Part Number on Vehicle Owner Repair Order
- 4 Dealer registers assembly in OASIS\* and generates Warranty Registration
- 5 Dealer provides vehicle owner:
  - Warranty Policy Statement
  - OASIS\* Warranty Registration
  - Vehicle Owner Repair Order

### FAQs:

#### \*Are vehicles for Model Years 1999 and older eligible for the Powertrain Warranty?

Yes – but they cannot be registered in OASIS. Instead, the vehicle owner must retain the Vehicle Owner Repair Order with VIN, Installation Date, Mileage, Ford Serial Number and Part Number documented.

#### Which serial number do I use for a new powertrain assembly?

New assemblies carry a tag similar to the illustration on this page. Copy the number from the label for proper registration.

#### If a powertrain is replaced under the New Vehicle Powertrain Warranty, does it receive the 3-Year/Unlimited Mileage Warranty?

No – those assemblies are covered either by the remainder of New Vehicle Warranty or 12-months/12,000 Miles, whichever is longer.

#### How do I register a powertrain if I do not install it right after purchasing the assembly?

Immediately after the installation, provide the Dealer/Distributor with a Repair Order showing the VIN, Installation Date, Mileage, Serial Number and Part Number documented.

### Where is the Serial Number?



NEW

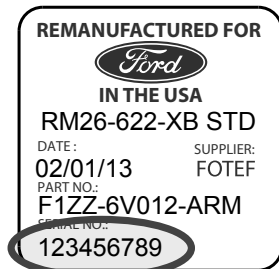

REMAN

### What does the customer need?

Warranty Policy Statement

OASIS Warranty Registration

Vehicle Owner Repair Order  
**Must include:**

- VIN
- Date of Installation
- Mileage
- Serial Number
- Part Number



FORD PARTS

# Product Information

## FORD WARRANTY COVERAGE AND REGISTRATION

for Retail and Over-the-Counter (OTC) Powertrain Assembly Sales



### Warranty Terms

- New/Remanufactured Ford Gas or Propane Engines/Transmissions
- New/Remanufactured Ford Diesel Engines

	<b>Gas/Transmission</b> (All vehicles, SSP/ Retail and OTC)	<b>Diesel</b> (All trucks, retail and OTC, incl. F650/F750 & LCF)	<b>Diesel</b> (All trucks, retail and OTC, incl. F650/F750 & LCF)
<b>Warranty Start Date:</b>	9/1/2010 – Present	6/1/2005 – Present	6/1/2005 - Present
<b>Engine Base Part Numbers:</b>	6006, 6007, 6V006, 6V012	6009, 6012, 6V009, 6V012	6006, 6007, 6V006, 6V007
<b>Transmission Base Part Numbers:</b>	7000, 7002, 7003, 7V000		
<b>Warranty Claim Program Code:</b>	SSP – Installed by Dealer OTC – Installed by Customer	SSP – Installed by Dealer OTC – Installed by Customer	SSP – Installed by Dealer OTC – Installed by Customer
<b>Time/Mileage:</b>	3 Years/Unlimited Miles	1 Year/Unlimited Miles	2 Years/Unlimited Miles

Note: No towing coverage is offered on OTC assemblies.

### OTC Warranty Repair Options

Over-the-counter customers of a Dealer (such as a vehicle owner, independent repair facility, wholesaler or fleet customer) can, at their option:

1. Return the vehicle to the installer from which the assembly was purchased.
2. Return the vehicle to the selling dealership for repairs.
3. Return the vehicle to any dealership for repairs.

### Warranty Claim Steps when OTC Customer Repairs

#### OTC Customer Responsibilities

1. Call the **Powertrain Assistance Center (PAC) at 800-392-7946** for prior authorization before removing or replacing a Ford Remanufactured Assembly under OTC Service Part Warranty.
2. Provide the selling Dealer/Distributor a copy of the assembly's OTC Customer Repair Order (whether the original purchasing customer or subsequent transferee) and the PAC authorization number. Arrange for delivery of the replacement assembly.
3. Communicate with the selling Dealer/Distributor regarding your labor amount. Labor reimbursement is based on standard hours listed in the Ford Service Labor Time Standards Manual, multiplied by the dealership's approved warranty labor rate in effect on the date of repair, or the OTC customer's actual labor amount, whichever is less.
4. Return all parts replaced under warranty to the selling Dealer/Distributor.

#### Selling Dealer/Distributor Responsibilities

1. Ensure that the OTC customer calls the **Powertrain Assistance Center at 800-392-7946** for prior authorization.
2. **DO NOT RELEASE REPLACEMENT ASSEMBLIES WITHOUT THE POWERTRAIN ASSISTANCE CENTER AUTHORIZATION NUMBER.**
3. Repairs made by the OTC customer are not included in the dealership's measured warranty expense. These repairs fall "below" the measured total line and will not have an impact on a dealership's entry or progression in the Warranty Counseling Process.
  - Note that the claim must be submitted with a miscellaneous expense code of "SVCLBR" with the corresponding labor reimbursement amount. Failure to use the miscellaneous expense code of "SVCLBR" will cause the repair to be included in your measured expense.
4. Submit a warranty claim, including the serial number of the assembly, on behalf of the OTC customer, and reimburse the OTC customer for the repair.

Dealers are required to adhere to all provisions and procedures detailed in the Warranty and Policy Manual



FORD PARTS

## REMANUFACTURED GAS ENGINE ASSEMBLIES



FORD PARTS

*Make Ford Genuine Parts your first choice for Ford and Lincoln replacement parts!*

### Genuine Ford Remanufactured Gas Engine Assemblies – the Right Fit!

- Each assembly covered by a **36 month/unlimited miles warranty on parts and service\***, with no commercial use exceptions
- Designed to deliver quality and value – include the latest engineering enhancements
- No “reverse engineering”
- Same or next day delivery
- No-risk core return policy – 100% core credit

### Gasoline Engine Features

- Sealed long blocks (6006 base) include all highly desired components including: oil filter and adapters, thermostats and correct oil pan
- Stepped cylinder bore honing helps optimize oil consumption and minimum break-in time
- Head gaskets, main and rod bearings designed specifically for remanufactured blocks, heads and crankshafts
- O.E. manufacturing processes used in assembling each engine
- Each assembly is checked on a computer-controlled test stand to verify performance criteria



\* See dealer for limited-warranty details.

# Product Information



## GENUINE FORD Gas Engine

### HOW A GAS ENGINE WORKS:

- Gasoline is supplied to the engine under high pressure through a fuel injector nozzle that atomizes fuel in a fine mist in each cylinder
- Air is mixed with fuel in the cylinder
- The mixture is compressed and ignited by a spark plug, resulting in fuel combustion and rotary engine motion

### Possible Symptoms:

- The engine uses excessive oil
- The engine does not start or runs erratically
- Excessive bearing clearances result in low oil pressure
- Contamination of oil, coolant or fuel cause performance issues or a no-start condition
- Mechanical pounding, knocking or rattling noises may indicate internal structural problems
- Clicking noises associated with the valvetrain indicate need for component adjustment or replacement

### GAS ENGINE ASSEMBLY

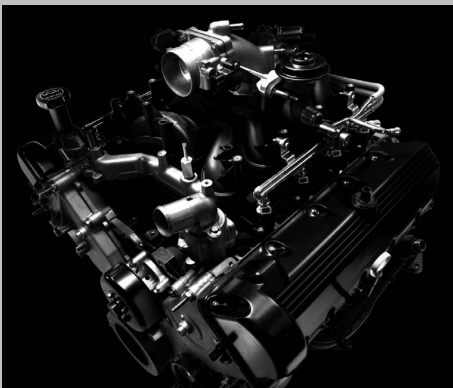

#### 3-Year Unlimited Mileage Warranty

- Only Ford-approved parts
- Latest part updates and revisions from Ford engineering
- Built to original specifications
- Commercial-use approved with full warranty
- Make, model-year and calibration-specific replacements mean the right gas engine for your vehicle

	How they work:	What can happen:
AIR	<ul style="list-style-type: none"> <li>• Air is supplied to the engine to enable combustion within each cylinder</li> <li>• Supplied air is filtered to prevent accelerated cylinder wear due to dust and abrasive contaminants</li> </ul>	<ul style="list-style-type: none"> <li>• A dirty air filter can choke off airflow to the engine, resulting in sluggish performance and poor fuel economy</li> <li>• A missing, leaking or clogged air filter can permit dirt and abrasives to enter the engine</li> </ul>
FUEL	<ul style="list-style-type: none"> <li>• Gasoline engines use a variety of fuel delivery methods, but all modern ones inject fuel either into an intake manifold, cylinder head port or directly to the cylinder</li> </ul>	<ul style="list-style-type: none"> <li>• Water in the fuel can cause fuel system corrosion and driveability issues</li> <li>• Dirty fuel can clog filters, ruin fuel injectors and accelerate cylinder wear</li> </ul>
OIL	<ul style="list-style-type: none"> <li>• Oil is the "lifblood" of the engine, providing a cooling film on internal engine components to prevent direct metal-to-metal contact, wear and damage</li> <li>• A plentiful supply of clean oil is necessary for long engine life</li> <li>• Motorcraft oil and oil filters are recommended for best protection and performance</li> </ul>	<ul style="list-style-type: none"> <li>• Oil can be drawn past worn piston rings and valve stem seals/guides and burned in the cylinder</li> <li>• Worn gaskets and oil seals can allow oil to drip out of the engine</li> <li>• A clogged oil filter can allow unfiltered oil to circulate and damage components</li> <li>• Excessive bearing clearances can allow oil to escape from critical areas, resulting in low oil pressure</li> <li>• Dirty/low oil can result in engine and camshaft bearing damage</li> </ul>
IGNITION	<ul style="list-style-type: none"> <li>• Gas engines use spark plugs to ignite the air/fuel mixture inside the cylinder</li> <li>• The mixture is ignited at a precise moment during the engine's revolution cycle</li> </ul>	<ul style="list-style-type: none"> <li>• The spark plugs can fail or wear and require replacement</li> <li>• Ignition coil(s) or spark plug wires can fail or wear, resulting in misfires or no-start conditions</li> </ul>
COOLING	<ul style="list-style-type: none"> <li>• Coolant is pumped through passages inside the engine block and cylinder heads to cool hot components</li> <li>• Coolant is pumped to an external pressurized radiator, where onrushing air flows through a finned core to remove heat</li> <li>• Coolant is returned to the engine and recirculated</li> </ul>	<ul style="list-style-type: none"> <li>• The water pump can fail and coolant cannot reach the radiator – engine overheats</li> <li>• The radiator can corrode or suffer physical damage that allows pressure to escape/coolant to leak, causing boil-over/loss and engine overheating</li> <li>• Coolant can "wear out," resulting in inadequate concentrations of important additives that prevent coolant freezing, boil-out and cooling system corrosion and clogging</li> <li>• Neglected maintenance can result in coolant freezing, system corrosion or component damage</li> </ul>
SENSORS	<ul style="list-style-type: none"> <li>• Sensors keep tabs on atmospheric conditions as well as a long list of vital engine functions</li> <li>• The sensors send data to the Engine Control Module, which in turn makes adjustments to various engine components to optimize driveability, fuel economy, performance and emissions</li> </ul>	<ul style="list-style-type: none"> <li>• Sensors can fail for a variety of reasons, from water intrusion into the component, fuel contaminants or electrical issues</li> </ul>

# GET EVERYTHING YOU'RE PAYING FOR AT A COMPETITIVE PRICE

with a **GENUINE Ford** Remanufactured Gas Engine

## We remanufacture only Ford Gas Engines – to our own original engineering specifications

Here's what adds up to a Ford engine that's closer to "new" than many competitors' engines:

- Ford proprietary blueprint specifications
- Only Ford-approved parts
- High standards in precision machining

Peace of Mind Warranty Coverage

- For 36 months from warranty start date, Ford will cover 100% of all parts and labor\*
- Unlimited mileage coverage
- If the engine is installed by a Dealer, standard towing charges are covered†
- More than 3,000 servicing Ford and Lincoln Dealers nationwide

\*At approved warranty reimbursement rates.

†If the vehicle is not covered under other towing insurance coverage; reasonable rates up to 35 miles or to the nearest Dealer.

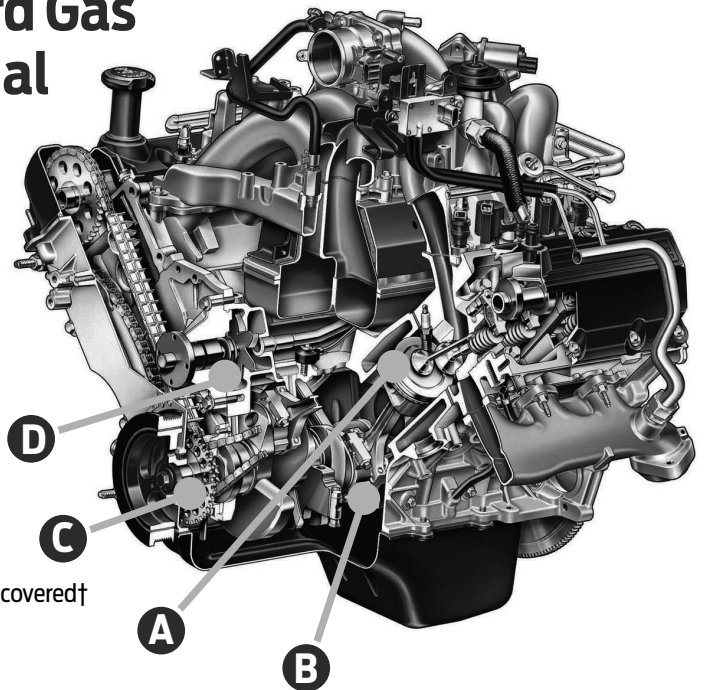

- A** **Pistons and Piston Rings – Ford Engineering-Approved**
- Pistons facilitate ignition by compressing/sealing the air/fuel mixture
  - Over time, can become worn or heavily carbon-coated

- B** **Main, Rod and Camshaft Bearings – Ford Engineering-Approved**
- Provide a soft-metal surface for the oil film to buffer against metal-to-metal contact of the crankshaft journals, connecting rods and camshaft journals
  - Oil film can break down, resulting in damaged or "spun" bearings and severe engine knock
  - Bearings can be damaged by oil contaminants, also causing damage to the components that ride on them

- C** **Oil Pump – Ford Engineering-Approved**
- Delivers oil to internal bearings
  - Can be damaged by wear by-products, water and debris
  - Pump failure can cause catastrophic engine failure

- D** **Water Pump – Ford Engineering-Approved**
- Circulates coolant through passages in the engine block and cylinder heads
  - Bearing or impeller can wear out with use

- E** **Variable Cam Timing Solenoid – Ford Engineering-Approved (not shown)**
- Adjusts camshaft timing to ensure optimum power, economy and emissions at all engine speeds
  - Can wear out over time or become obsolete due to part revisions

**All Replaced Components – Ford Engineering-Approved**

- Competitors may use any brand or quality – Ford uses only new OE replacements

# GENUINE QUALITY MAKES THE DIFFERENCE.

# 3-YEAR Unlimited Mileage Warranty

## Compare Your Gas Engine Repair Options:

Other repair options are available to you, but none offer the quality and peace of mind that Genuine Ford Remanufactured Gas Engines do. Our remanufacturing process uses genuine original equipment Ford and Motorcraft parts that are designed, manufactured and recommended by Ford Motor Company specifically for these engines. Extensive laboratory and road testing, as well as exact fit and function ensures maximum performance and efficiency. It's all backed by Ford's three-year, unlimited-mileage warranty— even for demanding commercial use. Check out what makes us your best choice:



**Ask about no-interest financing with approved credit on the Ford Service Credit Card**

	MAJOR COMPETITOR	GENUINE FORD REMANUFACTURED
<b>Warranty</b>		
Terms	<b>Only 1-Year coverage on:</b> <ul style="list-style-type: none"> <li>• Electronic fuel injectors</li> <li>• Fuel pumps</li> <li>• Water pumps</li> <li>• Sensors</li> <li>• Sending units</li> </ul>	<b>3-Year/ Unlimited Mileage</b>
Commercial Use	YES	YES
Nationwide Coverage	<b>LIMITED LOCATIONS</b> <ul style="list-style-type: none"> <li>• If approved, "the work will be performed either at (their) factory or by another selected vendor"</li> <li>• "It is the sole responsibility of the buyer to pay for such (warranty) work."</li> </ul>	<b>YES</b> At any of the more than 3,000 Ford and Lincoln Dealers nationwide or at the originating place of service, with no out-of-pocket expenses for warranty repairs.
<b>Parts Replaced</b>		
Meet OE Specifications?	Any brand or quality they specify	YES
Pistons	YES	YES
High Build Levels that Include Key Components	NO	<b>YES – Sealed long blocks include:</b> <ul style="list-style-type: none"> <li>• Spark Plugs</li> <li>• Vibration Damper/ Harmonic Balancer</li> <li>• Water pump</li> <li>• Valve cover &amp; PCV</li> <li>• New VCT Solenoid (3V modulars)</li> <li>• Oil Pan</li> <li>• Oil</li> </ul>
<b>Specifications</b>		
Original Equipment	NO Solution: Reverse-engineer a Ford engine.	YES
<b>Final Testing</b>		
OE Requirements	NO	YES
Computer Diagnostics	NO	YES



**OEM Parts & Specs at competitive prices**

<b>Gas Engine Build Levels</b>			
<b>Engine Build Levels</b>	Base part number	6006	6V012
	Part number description	Reman Sealed Long Block	Reman Unsealed Long Block
<b>Shipping Info</b>	Shipping container	Plastic crate	Plastic crate
	Engine cover	Sealed plastic bag	Sealed plastic bag
<b>Base Engine</b>	Cylinder block	●	●
	Main / rod bearings	●	●
	Crankshaft	●	●
	Rear seal	●	●
	Connecting rods	●	●
	Pistons / rings	●	●
	Timing components	●	●
	Cam bearings	●	●
	Camshaft	●	●
<b>Long Block Unsealed</b>	Cylinder head assembly	●	●
	Valves, springs, keepers & seals	●	●
	Lifters / buckets	●	●
	Pushrods	●	●
	Rocker arms / followers	●	●
	Oil pump	●	●
	Gasket installation kit	●	1990 and later
<b>Long Block Sealed</b>	Front seal	●	
	Front cover	●	
	Oil pan	●	
	Oil pickup	●	
	Vibration damper	●	
	Valve covers and gaskets	●	
	Water pump assembly	●	
	Thermostat	●	
	Spark plugs	●	
	Engine oil	●	
	Oil filter	●	
	Oil filter adapter		If applicable
	Oil cooler assembly		If originally equipped
	Intake manifold		2.0L SPI only
● = Included in build level			

## A higher level

Our product lineup has been simplified to provide the best value based on the vehicle's age. Each engine and transmission is built using parts that keep it specific to make, model, year and emissions calibration, which means each assembly is engineered to perform like the one it's replacing when it was new.

# Product Information

## Gas Engine Build Level Configuration – Family Specific

	2.0L-2V SPI	2.0L-4V ZETEC	2.0L-4V I4	2.3L-4V I4	2.5L-4V I4	2.5L 4V V-6	3.0L-2V	3.0L-4V RFF	3.0L-4V DAMB	3.5L 4V	3.8L	3.9L-2V	3.9L-4V	4.0L OHV	4.0L SOHC	4.2L	4.6L-2V & 4V	4.6L-3V	4.9L (300 cid)	5.0L OHV	5.4L-2V, 3V & 4V	5.8L OHV	6.8L 2V & 3V	7.0L (429 cid)	7.5L (460 cid)
<b>Base Part #s: Sealed Long Block S = 6006 Unsealed Long Block U = 6V012</b>																									
Cylinder Block, Head(s), Crankshaft, Camshaft(s), Pistons, Rings, Bearings, Timing Gear(s) – Chain(s) or Belt, Oil Pump.	S	US	S	S	S	US	US	US	S	S	S	S	S	US	S	S	US	S	U	U	S	U	S	U	U
Oil and Filter, Spark Plugs	S	S	S	S	S	S	S	S	S	S	S	S	S	S	S	S	S	S			S		S		
Oil Filter Adapter	S	S	S	S	S	S	S	S	S	S			S	S	S		S	S			S		S		
Oil Cooler <sup>1</sup>		S	S	S	S	S		S	S	S	S	S	S		S	S	S	S			S		S		
Oil Pan	S	S	S	S	S	S	S	S	S	S	S	S	S	S	S	S	S	S			S		S		
Installation Gaskets/Seals	S	US	S	S	S	US	US	S	S	S	S	S	S	US	S	S	US	S	U <sup>3</sup>	U <sup>3</sup>	S	U <sup>3</sup>	S	U	U <sup>3</sup>
Water Pump	S	S	S	S	S		S	S <sup>6</sup>		S	S	S	S	S	S	S	S	S			S		S		
Valve Covers	S	S	S	S	S	S		S	S	S	S	S	S	S	S	S	S	S			S		S		
Thermostat	S	S	S	S	S	S	S	S	S	S	S	S	S	S	S	S	S	S			S		S		
Lower Intake Manifold	S													S											
Front Cover	S	S	S	S	S	S	S	S	S	S	S	S	S	S	S	S	S	S			S		S		
Front Seal(s)	S	US	S	S	S	US	US	US	S	S	S	S	S	US	S	S	US	S	U <sup>3</sup>	U <sup>3</sup>	S	U <sup>3</sup>	S	U	U <sup>3</sup>
Crank Damper	S	S	S	S	S	S	S	S	S	S	S	S	S	S	S	S	S	S			S		S		
Exhaust Manifold Gasket(s)	S	US	S	S	S	US	U <sup>1</sup> S	US	S	S	S	S	S	S	S	S	US	S		U <sup>3</sup>	S		S		
Exhaust Manifold Fasteners	S	US	S	S	S	US	S	US	S	S	S	S	S	S	S	S	US	S			S		S		
PCV Valve			S	S	S	S				S				S <sup>4</sup>			S				S <sup>2</sup>		S <sup>2</sup>		
<b>Cylinder Head Kits Base Part #s: F = 6049 M = 6V049</b>																									
Cylinder Head											M			FM		M	F <sup>5</sup>				F <sup>5</sup>		F <sup>5</sup>		
Camshaft																	F <sup>5</sup>				F <sup>5</sup>		F <sup>5</sup>		
Rocker Arms																	F <sup>5</sup>				F <sup>5</sup>		F <sup>5</sup>		
Valves											M			FM		M	F <sup>5</sup>				F <sup>5</sup>		F <sup>5</sup>		
ValveStemSeal/Retainer Keys											M			FM		M	F <sup>5</sup>				F <sup>5</sup>		F <sup>5</sup>		
Head Gasket																	F <sup>5</sup>				F <sup>5</sup>		F <sup>5</sup>		
Head Bolts																	F <sup>5</sup>				F <sup>5</sup>		F <sup>5</sup>		
<b>Footnotes:</b>												Ford and Lincoln dealers can view the latest version of this chart at:													
1. If originally equipped		3. 1990/up		5. 2 Valve applications only		<a href="http://FMCDealer.com">FMCDealer.com</a> >> Parts Dept >> Parts Product Line Information >> Gas Engine																			
2. 3 Valve only		4. 1997/up		6. Some 2005-06 applications																					
Disclaimer: This chart was produced using the latest information available at the time of printing. While utmost care was used, Ford assumes no responsibility for errors, omissions, or misapplication and may change build levels without notice or obligation.																									



## INTAKE MANIFOLD KITS



FORD PARTS

*Make Ford Genuine Parts your first choice for Ford and Lincoln replacement parts!*

### High Quality Designs

- Original equipment manifolds vehicle crash tested to ensure fuel rail integrity
- Runner length and shape designed to minimize NVH and deliver strong performance at all engine speeds
- Injection-molded cases made of virgin nylon resins
- Designed to withstand coolant temperature and pressure spikes at wide-open-throttle
- Key Life durability tested to the equivalent of 10 years/150,000 miles lifetime



### Attention To Detail

- Designed to provide an optimal combination of torque, horsepower and fuel mileage
- PCV port location and size is engineered to ensure compliance with emissions specifications
- Hose spigot designs are vehicle-specific and feature retention barb for a firm hose fit
- Structural ribs add rigidity to the case
- The noise shield helps minimize NVH (not available on all models)

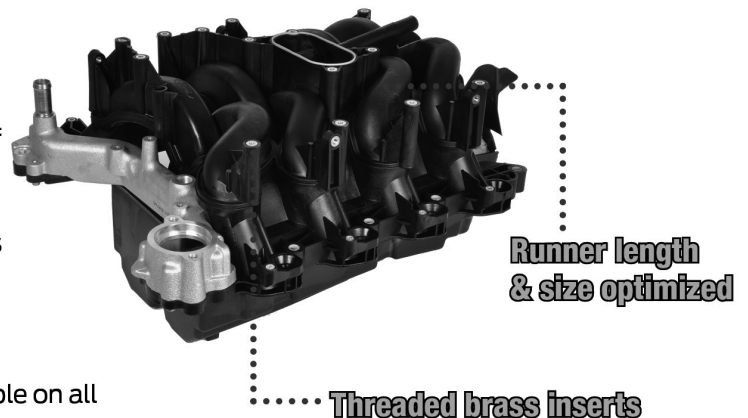

### 24-months/Unlimited Mileage Service Part Warranty

- 24-months / Unlimited Mileage Limited Warranty, which includes parts and labor costs, and is supported nationwide by Ford and Lincoln dealers and Ford Authorized Distributors (See seller for limited warranty details)
- Designed to meet stringent Ford engineering standards for performance and durability
- Recommended for all Ford, Lincoln and Mercury vehicles

### High Burst Pressure

- Ford manifolds are engineered to ensure burst pressures high enough to withstand engine backfire
- A non-OEM plenum with a low burst pressure can contribute to backfires and damaged valves and pistons

**FORD PARTS  
WARRANTY**

**UNLIMITED  
MILEAGE**  
INCLUDES LABOR

**2 YEARS**

## WATER PUMPS

*Right Part. Right Fit. Right Price Every Time!*



**Motorcraft.**

### Motorcraft® Water Pumps

#### Robust Design

- Coolant reservoir keeps normal cold-start weepage out of sight and extends bearing life
- Press tubes coated with nickel zinc for better housing connection and corrosion resistance
- Powdered-metallic hub mating surfaces provide superior alignment for smooth operation and don't need machining
- Robust impeller design engineered to optimize performance for specific vehicle applications
- Key Life durability tested to the equivalent of 10 years/150,000 miles lifetime

#### High Quality Bearings and Seals

- All pumps contain precision ground bearings to help deliver long life and efficient performance
- Bearing housing meets original equipment load requirements
- Bearings are locked into place to minimize fan-load vibration, and help ensure long-term alignment and reliability
- Latest advances in seal and bearing technology employed

#### Easy Installation

- Original equipment-designed metal gaskets include an additional sealing bead to help optimize alignment and provide long-term sealing
- Always a new product - no core charges

#### 24-months/Unlimited Mileage Service Part Warranty

- 24-months / Unlimited Mileage Limited Warranty, which includes parts and labor costs, and is supported nationwide by Ford and Lincoln dealers and Ford Authorized Distributors (See seller for limited warranty details)
  - Designed to meet stringent Ford engineering standards for performance and durability
  - Recommended for all Ford, Lincoln and Mercury vehicles

**MOTORCRAFT®  
WARRANTY**

**UNLIMITED  
MILEAGE**  
INCLUDES LABOR

**2 YEARS**

**Bearings locked  
in place**

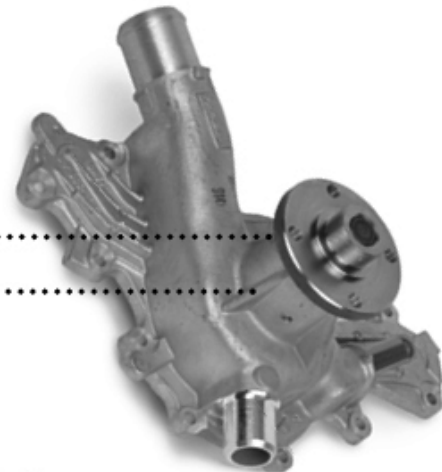

**Full-length ribs  
add stability**

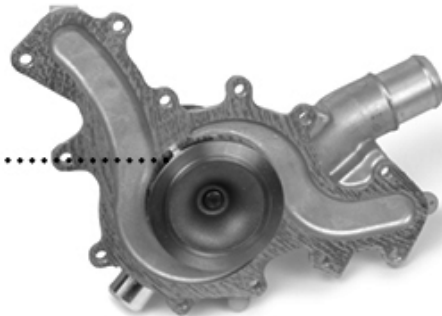

**High quality impellers**

## FORD REMANUFACTURED DIESEL ENGINES



FORD PARTS

*Make Ford Genuine Parts your first choice for Ford and Lincoln replacement parts!*

### Remanufactured to OEM Specifications:

- The only high volume V8 remanufactured diesel engines (6.0L & 6.4L) with state of the art bore spray welding procedure which are subject to bore spray manufacturing capacity
- Cylinder bores are diamond plateau honed
- Cylinder heads are new or remanufactured
- Remanufactured crankcase: Inspected for cavitation
- Crankshaft remanufacturing includes Magnifluxing
- Remanufactured injectors tested with OEM equipment
- Camshaft remanufacturing assures lift, contour, finish and size
- Remanufactured turbocharger and high pressure oil pump

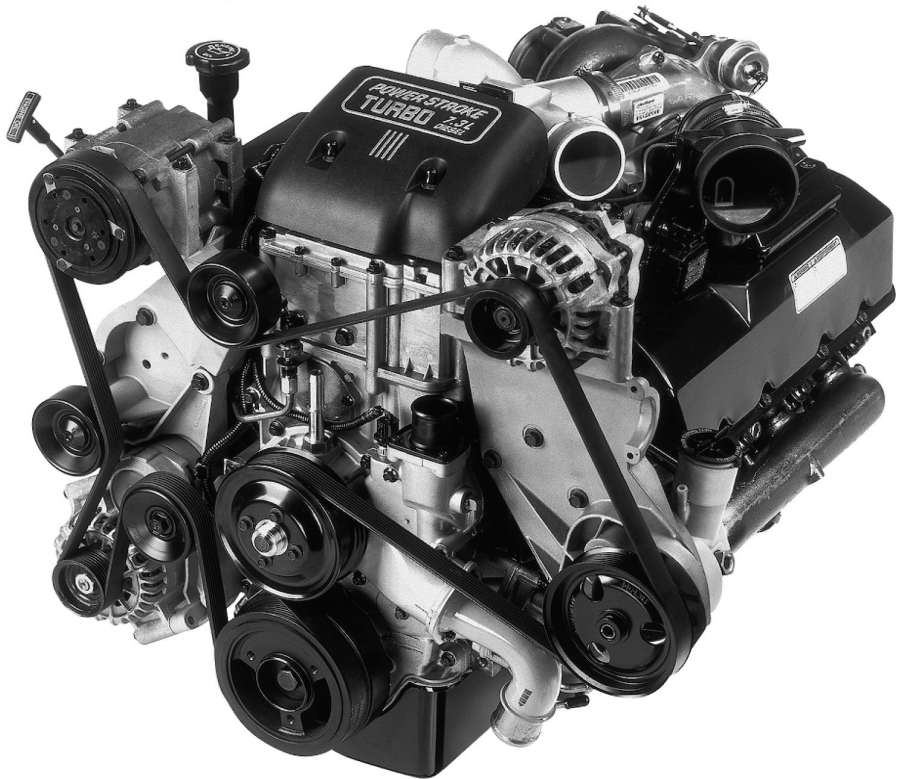

### All New:

- Bearings
- Coolant Heaters
- Core Plugs
- Gaskets
- Lube Oil Coolers: Not Cleaned or Re-Cored
- Pistons
- Piston Rings
- Premium Glow Plugs
- Seals
- Sensors
- Thermostats
- Valve Cover Gaskets
- Valve Guide Inserts
- Water Pumps

### 24-months/Unlimited Mileage Service Part Warranty

24-months / unlimited mileage limited warranty, which includes parts and labor costs, and is supported by Ford and Lincoln dealers and Ford Authorized Distributors (See seller for limited warranty details)

**FORD PARTS WARRANTY**

**UNLIMITED MILEAGE INCLUDES LABOR**

**2 YEARS**

# Product Information

## GENUINE FORD Power Stroke® Diesel Engine



### HOW A DIESEL ENGINE WORKS:

- Diesel fuel is supplied to the engine under high pressure through a fuel injector nozzle that atomizes fuel in a fine mist in each cylinder
- Air is mixed with fuel in the cylinder
- The mixture is compressed under extreme pressure (as much as 22 times atmospheric pressure), resulting in fuel combustion and rotary engine motion
- Glow plugs are used to promote the combustion process for cold starts

### Possible Symptoms:

- The engine uses excessive oil
- The engine does not start or runs erratically
- Excessive bearing clearances result in low oil pressure
- Contamination of oil, coolant or fuel cause performance issues or a no-start condition
- Mechanical pounding, knocking or rattling noises not associated with fuel knock indicate internal structural problems
- Clicking noises associated with the valvetrain indicate need for component adjustment or replacement

### DIESEL ENGINE ASSEMBLY



### 2-Year Unlimited Mileage Warranty

- All OE parts
- Latest part updates and revisions from Ford engineering
- Built to original equipment specifications
- Commercial-use approved with full warranty
- Make, model-year and calibration-specific replacements mean the right diesel engine for your vehicle

	How they work:	What can happen:
AIR	<ul style="list-style-type: none"> <li>• Air is supplied to the engine to enable combustion</li> <li>• Supplied air is filtered to prevent accelerated cylinder and turbocharger wear due to dust and abrasive contaminants</li> </ul>	<ul style="list-style-type: none"> <li>• A dirty air filter can choke off airflow to the engine, resulting in sluggish performance and poor fuel economy</li> <li>• A missing, leaking or clogged air filter can permit dirt and abrasives to enter the engine</li> </ul>
FUEL	<ul style="list-style-type: none"> <li>• Diesels use a variety of fuel delivery methods, but all inject fuel either into an intake manifold, cylinder head port or directly to the cylinder</li> <li>• Older Power Stroke® engines used high-pressure oil to drive fuel injectors</li> <li>• Ford 6.4L and 6.7L Power Stroke common rail systems deliver fuel from a main pump to a high-pressure pump, then force it through a common line ("rail") to each fuel injector, and into each cylinder</li> </ul>	<ul style="list-style-type: none"> <li>• Diesel fuel can contain water, which must be prevented from freezing and removed from the fuel system by draining the water separator</li> <li>• Water in the fuel can cause high pressure fuel pump corrosion and failure</li> <li>• High pressure fuel pump problems can result in hard hot starts, a miss at idle or oil supply aeration to the pump due to a leaking o-ring</li> <li>• Cold diesel fuel is subject to "gelling," preventing free flow from the fuel tank to the engine</li> <li>• Dirty fuel can clog filters, ruin fuel injectors and accelerate fuel pump and cylinder wear</li> </ul>
OIL	<ul style="list-style-type: none"> <li>• Oil is the "lifblood" of the engine, providing a cooling film on internal engine components to prevent direct metal-to-metal contact, wear and damage</li> <li>• A plentiful supply of clean oil is necessary for long engine life</li> <li>• Special oil formulated for diesel engines is required – Motorcraft diesel oils are recommended for best protection and performance</li> </ul>	<ul style="list-style-type: none"> <li>• Oil can be drawn past worn piston rings and valve stem seals/guides and burned in the cylinder</li> <li>• Worn oil seals can allow oil to drip out of the engine</li> <li>• A clogged oil filter can allow unfiltered oil to circulate and damage components</li> <li>• Excessive bearing clearances can allow oil to escape from critical areas, resulting in low oil pressure</li> <li>• Dirty/low oil can result in turbocharger or injector damage</li> </ul>
IGNITION	<ul style="list-style-type: none"> <li>• Diesel engines use no spark plugs – fuel is ignited through extreme compression of the air-fuel mixture</li> <li>• Cold-engine starts are aided by glow plugs</li> </ul>	<ul style="list-style-type: none"> <li>• Glow plugs can fail and require replacement</li> <li>• Diesel fuel can gel in cold weather, becoming difficult to pump and ignite</li> </ul>
COOLING	<ul style="list-style-type: none"> <li>• Coolant is pumped through passages inside the engine block and cylinder heads to cool hot components</li> <li>• Coolant is pumped to an external pressurized radiator, where onrushing air flows through a finned core to remove heat</li> <li>• Coolant is returned to the engine and recirculated</li> </ul>	<ul style="list-style-type: none"> <li>• Water pump failure results in engine overheating</li> <li>• The radiator can corrode/suffer physical damage, allowing pressure to escape/coolant to leak, causing boil-over and overheating</li> <li>• Each type of Power Stroke engine has unique coolant and testing requirements. Failure to test may lead to coolant with improper strength/concentration levels – damaging EGR coolers on newer models</li> <li>• Neglected maintenance can result in coolant freezing, corrosion or component damage</li> </ul>
EGR	<ul style="list-style-type: none"> <li>• Exhaust gases are reintroduced into the engine to reduce Oxides of Nitrogen (NOx) emissions</li> </ul>	<ul style="list-style-type: none"> <li>• Performing oil/filter and engine coolant scheduled maintenance is required to prevent EGR Cooler/Oil Cooler corrosion/plugging – Failure to perform this maintenance on time can result in overheated/failed components, increased emissions and poor performance</li> </ul>

# GET EVERYTHING YOU'RE PAYING FOR AT A COMPETITIVE PRICE

with a **GENUINE Ford** Remanufactured Diesel Engine

## **A** **Pistons and Piston Rings – NEW OE**

- State-of-the-art bore-spray technology on remanufactured Power Stroke® 6.0L and 6.4L engines results in standard-size bores in brand-new condition that allow use of standard-size pistons
- Pistons facilitate ignition by compressing/sealing the air/fuel mixture
- Over time, can become worn or heavily carbon-coated

## **B** **Main, Rod and Camshaft Bearings – NEW OE**

- Provide a soft-metal surface for the oil film to buffer against metal-to-metal contact of the crankshaft journals, connecting rods and camshaft journals
- Oil film can break down, resulting in damaged or “spun” bearings and severe engine knock
- Bearings can be damaged by oil contaminants, also causing damage to the components that ride on them

## **C** **Oil and Fuel Pumps – NEW OE**

- Deliver oil to internal bearings and fuel to the engine
- Can be damaged by wear by-products, water and debris
- Pump failure can immobilize the vehicle (fuel) or cause catastrophic engine failure (oil)

## **D** **EGR and Oil Coolers – NEW OE**

- The EGR cooler reduces exhaust gas temperatures before reintroducing gases into the engine for lower emissions
- Oil coolers reduce oil temps to prolong turbo life (when equipped) and to cool pistons/bearings more effectively
- Competitors may clean and reuse old components that can fail and cause other components to fail as well – we don't take chances

### **All Replaced Components – NEW OE**

- Competitors may use any brand or quality – Ford uses only new OE replacements

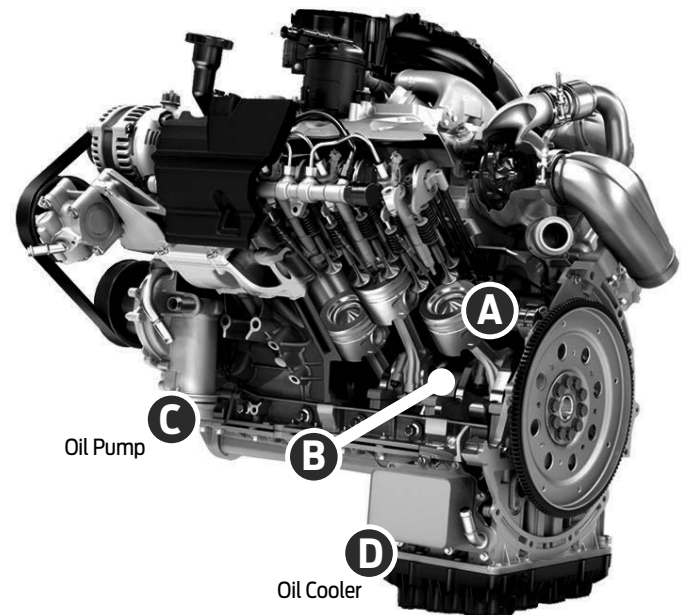

**We remanufacture only Ford Power Stroke Diesel Engines – to our own original engineering specifications**

**Ford offers twice the warranty coverage of a major competitor on:**

- **Electronic fuel injectors**
- **Hydraulic high-pressure pumps**
- **Turbochargers**
- **Water pumps and more**

A major competitor also excludes warranty coverage on oil, antifreeze, fluids and towing charges – but Ford covers them all. And more than 3,000 servicing Ford and Lincoln Dealers nationwide offer peace of mind for over-the-road travel.

# GENUINE QUALITY MAKES THE DIFFERENCE.

# 2-YEAR Unlimited Mileage Warranty

## Compare Your Diesel Engine Repair Options:

Other repair options are available to you, but none offer the quality and peace of mind that Genuine Ford Remanufactured Power Stroke® Diesels do. Our remanufacturing process uses genuine original equipment Ford and Motorcraft parts that are designed, manufactured and recommended by Ford Motor Company specifically for these engines. Extensive laboratory and road testing, as well as exact fit and function ensures maximum performance and efficiency. It's all backed by Ford's two-year, unlimited-mileage warranty— even for demanding commercial use. Check out what makes us your best choice:

	MAJOR COMPETITOR	GENUINE FORD REMANUFACTURED POWER STROKE® DIESEL
<b>Warranty</b>		
Terms	<b>Only 1-Year coverage on:</b> <ul style="list-style-type: none"> <li>• Electronic fuel injectors</li> <li>• Hydraulic high pressure pumps</li> <li>• Turbochargers</li> <li>• Water pumps</li> <li>• Sensors</li> <li>• Sending units</li> <li>• Belts and hoses</li> </ul> <b>Excludes coverage on:</b> <ul style="list-style-type: none"> <li>• Oil, antifreeze, fluids or other substances</li> <li>• Towing charges</li> </ul>	2-Year/ Unlimited Mileage
Commercial Use	YES	YES
Nationwide Coverage	<b>LIMITED LOCATIONS</b> If approved, "the work will be performed either at (their) factory or by another selected vendor," and "it is the sole responsibility of the buyer to pay for such (warranty) work."	<b>YES</b> , at any of the more than 3,000 Ford and Lincoln Dealers nationwide or at the originating place of service, with no out-of-pocket expenses for warranty repairs.
<b>Parts Replaced</b>		
Meet OE Specifications?	Any brand or quality they specify	YES
Pistons	YES	YES
EGR Cooler	NO	YES
Oil/EGR Coolers Replaced with new OE parts	NO	YES
<b>Specifications</b>		
Original Equipment	NO Solution: Reverse-engineer a Power Stroke® engine.	YES
<b>Final Testing</b>		
OE Requirements	NO	YES
Computer Diagnostics	NO	YES

**OEM Parts & Specs at Competitive Prices**



Ask about no-interest financing with approved credit on the Ford Service Credit Card



## GENUINE FORD Diesel Fuel System Components



### HOW THEY WORK TOGETHER:

- Water separators and fuel filters are your Power Stroke® Diesel engine's first line of defense against unnecessary repairs – keep the water separator drained and the filters changed on schedule
- On Power Stroke Diesels, fuel is supplied to the engine through a fuel conditioning module that combines a water separator and fuel filter
- A fuel pump transports fuel from the tank through the water separator and filter to a secondary filter at the engine (6.0L, 6.4L, 6.7L engines)
- On common rail fuel injection systems, the high pressure fuel pump further pressurizes the fuel and supplies it to a fuel injector nozzle at each cylinder
- The fuel injector atomizes fuel in a fine mist in each cylinder

### POSSIBLE SYMPTOMS:

#### Fuel Filters



- Dirty filters are the “silent killers” – damage occurs when they are neglected
- By the time symptoms such as erratic idling, lack of power or hard starts begin, engine damage is already underway

#### High Pressure Fuel Pump

- The engine does not start or runs erratically
- Hard hot starts
- A miss at idle

#### Injectors

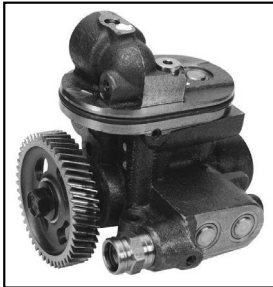
- The engine does not start or runs erratically
- Excessive black smoke from the exhaust
- Lack of power/poor economy

	How they work:	What can happen:
FILTERS	<ul style="list-style-type: none"> <li>• The Diesel Fuel Conditioning Module separates water and filters impurities from the fuel</li> <li>• The primary and secondary fuel filters remove dirt, sediment and metal particles from the fuel system, to prevent accelerated wear and damage to the fuel pumps, fuel injectors and internal engine parts</li> </ul> 	<ul style="list-style-type: none"> <li>• The water separator can pass water through the fuel system if it is not drained monthly                             <ul style="list-style-type: none"> <li>– Always drain the system <b>immediately</b> if the “Water in Fuel” light on the instrument panel illuminates</li> </ul> </li> <li>• Over time, fuel filters can become waterlogged and collapse if they are not changed on schedule and/or the water separator is not drained</li> <li>• Fuel filters can become clogged with contaminants, impede fuel flow and pass impurities to the engine if they are not changed on schedule</li> </ul>
PUMPS	<ul style="list-style-type: none"> <li>• Older Power Stroke engines deliver fuel to the engine at lower pressures than modern versions</li> <li>• Common rail systems like the Ford 6.4L and 6.7L Power Stroke engines deliver fuel from the fuel tank through a main pump                             <ul style="list-style-type: none"> <li>– From the main pump, fuel is delivered to a high-pressure pump at the engine</li> <li>– The high pressure pump further pressurizes the fuel and forces it through a common line (“rail”) that supplies the fuel injector nozzles</li> </ul> </li> </ul> 	<ul style="list-style-type: none"> <li>• Diesel fuel can contain water, which must be prevented from entering the pumps and causing corrosion that can result in pump failure                             <ul style="list-style-type: none"> <li>– In addition, contaminated diesel fuel may introduce metal debris into the high pressure system, requiring the replacement of all parts in the system</li> </ul> </li> <li>• High pressure fuel pump problems can result in hard hot starts, a miss at idle, or difficulty building proper fuel pressure</li> </ul>
INJECTORS	<ul style="list-style-type: none"> <li>• Injectors atomize pressurized fuel and spray it into the engine cylinders</li> <li>• Older Power Stroke® engines used high-pressure oil to drive fuel injectors</li> <li>• Common rail systems like the Ford 6.4L and 6.7L Power Stroke engines force fuel through a common line (“rail”) to each fuel injector nozzle, and into each cylinder</li> <li>• Clean fuel is critical to long component life and proper operation</li> </ul> 	<ul style="list-style-type: none"> <li>• The combination of dirty fuel and neglected fuel filters can damage injectors, resulting in costly repairs</li> <li>• Water in the fuel can attack internal components and cause the injectors to malfunction</li> </ul>

# MAINTAIN THE SYSTEMS

...and the components will follow

Fuel system maintenance is just the start, when it comes to preventive maintenance. The health of your fuel pumps and fuel injectors depend on it. In addition, regularly-scheduled oil/filter and fuel filter changes – along with coolant testing and maintenance – are key to ensuring long lives for your Power Stroke® Diesel's Exhaust Gas Recirculation (EGR) cooler and engine oil cooler, too.

## WHY FILTER CHANGES ARE VITAL

### 1. Keep water out of your fuel.

- This is the first line of defense against fuel pump corrosion and damage to the fuel filter. Make draining the water separator part of your routine – don't wait for the "Water in Fuel" (WIF) light to illuminate on your instrument panel. If it does illuminate, drain the separator immediately

### 2. Keep your fuel filters changed on schedule.

- Stop damage to your fuel system before it starts, by ensuring that contaminants and debris never reach your fuel pumps and injectors
- New fuel filters are inexpensive insurance and cost much less than injectors or pumps to replace

### 3. Use Genuine Ford and Motorcraft Parts

- On 6.0L and 6.4L Power Stroke engines, Motorcraft diesel fuel filters feature Aqua Block® technology to assist in keeping water upstream in the fuel system and away from pumps and injectors
  - The Aqua Block material repels water and drops it into the separator for draining
- Genuine Ford and Motorcraft replacement filters are designed (and in several applications, patented) specifically for your engine – competitive filters aren't

### 4. Maintain ALL of your Power Stroke Diesel Engine Systems

- Stay on top of all of your Power Stroke Diesel engine's maintenance items to ensure that your EGR cooler and oil cooler operate in peak condition and to avoid preventable repairs. This includes:
  - Regular oil/filter changes
  - Air filter changes
  - Coolant testing and maintenance specified by your Owner Guide

## Get More Power and Better Fuel Economy with Motorcraft Diesel Fuel Additives

**3 Sizes Available**  
Improve your diesel engine's performance with fuel system additives you can rely on:



### Motorcraft Cetane Booster & Performance Improver

- Boosts power
- Improves fuel economy
- Improves starting ability
- Smooths engine operation
- Adds lubricity to fuel to reduce engine wear
- Reduces EGR valve soot contamination
- Single shot, medium size and gallon size



### Motorcraft Anti-Gel & Performance Improver

- Helps prevent gelling of diesel fuel in lines, filters, and tanks
- Improves fuel economy
- Improves starting ability during cold weather
- Smooths engine operation
- Adds lubricity to fuel to reduce engine wear
- Single shot, medium size and gallon size



Motorcraft®



FORD PARTS



## REMANUFACTURED TRANSMISSION ASSEMBLIES



FORD PARTS

*Make Ford Genuine Parts your first choice for Ford and Lincoln replacement parts!*

### Genuine Ford Remanufactured Transmission Assemblies – the Right Fit!

- Exceptional quality and value
- Incorporate the latest engineering enhancements
- No “reverse engineering”
- Same or next day delivery
- No-risk core return policy – 100% core credit
- Each assembly covered by a **36-month/Unlimited Miles Limited Warranty** on parts and service (see dealer for details) - no commercial exceptions
- Nationwide warranty coverage
- All critical parts replaced – contributes to excellent performance and durability

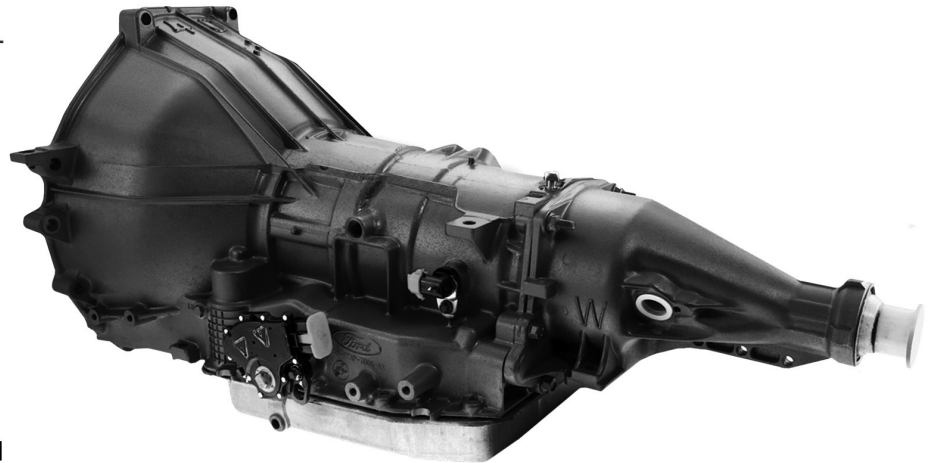

### Transmission Assembly Features

- Assemblies feature all-new gaskets and seals
- Ford-approved transmission fluid – filled before the assembly leaves the factory to ensure proper fluid is used
- Make, model, year and emission calibration specific
- Include sensors (when applicable)
- Same extensive O.E. production end of line testing for:
  - Hydraulic pressure
  - Proper shift times and points
  - Torque converter stall speed
  - Torque converter lock-up points

## GENUINE FORD Transmission



How they work:	What can happen:
<b>A TORQUE CONVERTER</b>	
<ul style="list-style-type: none"> <li>• A hydraulic coupling that transfers engine power to the transmission</li> <li>• Allows the engine to run with the vehicle stopped, by permitting a controlled amount of slip. Provides the engage/disengage function from the drive wheels at red lights</li> <li>• A lockup clutch physically locks the engine output to the transmission at steady cruising speeds to eliminate slip and increase efficiency</li> </ul>	<ul style="list-style-type: none"> <li>• A seal between the torque converter and the transmission can leak fluid</li> <li>• The torque converter can fill with debris from component wear and contaminate fresh fluid or a replacement transmission</li> <li>• Internal components can break or bend</li> <li>• The lockup clutches can slip or stop working entirely</li> <li>• The seam weld can leak</li> </ul>
<b>B FLUID AND FILTER</b>	
<ul style="list-style-type: none"> <li>• Fluid is the “lifeblood” of the transmission</li> <li>• Keeps components cool</li> <li>• Lubricates the bearings, bushings and gears</li> <li>• Prevents rust</li> <li>• Optimizes driving “feel” (clutch friction)</li> <li>• An internal filter cleans the fluid</li> <li>• Fluid/filter require periodic changes – see Owner Guide maintenance schedule</li> </ul>	<ul style="list-style-type: none"> <li>• Fluid can overheat (burn) and reduce the life of the transmission</li> <li>• Unchanged, burned fluid eventually results in transmission failure</li> <li>• Filter can eventually clog with debris (metal shavings/friction material) caused by wear</li> <li>• A clogged filter can prevent fluid flow, resulting in failure</li> </ul>
<b>C GEARS</b>	
<ul style="list-style-type: none"> <li>• Planetary gearsets offer multiple speed ratios in a compact package</li> <li>• Clutches hold specific gearset components for various gear ranges</li> </ul>	<ul style="list-style-type: none"> <li>• Bushings or bearings can fail</li> <li>• Debris can damage gear teeth</li> </ul>
<b>D OIL PUMP</b>	
<ul style="list-style-type: none"> <li>• The oil pump pressurizes fluid to:                             <ul style="list-style-type: none"> <li>– Activate clutches</li> <li>– Provide lubrication</li> <li>– Move it through the transmission cooler</li> </ul> </li> </ul>	<ul style="list-style-type: none"> <li>• The pump can fail due to wear or leakage                             <ul style="list-style-type: none"> <li>– Causes low or no fluid pressure</li> <li>– Clutches can slip and fail</li> </ul> </li> <li>• Bushings, bearings and gears lose lubrication, causing wear or failure</li> <li>• Low pressure reduces or stops fluid flow through the transmission cooler                             <ul style="list-style-type: none"> <li>– Transmission overheats as a result</li> </ul> </li> </ul>
<b>E CLUTCHES</b>	
<ul style="list-style-type: none"> <li>• Clutch pistons are actuated by fluid pressure                             <ul style="list-style-type: none"> <li>– This applies the clutch to engage the friction material</li> </ul> </li> </ul>	<ul style="list-style-type: none"> <li>• The friction materials can wear out and lose their grip, resulting in transmission slip</li> <li>• Clutch piston seals can wear or fail, resulting in friction material slip and wear</li> </ul>
<b>F MAIN CONTROL / TRANSMISSION CONTROL UNIT</b>	
<ul style="list-style-type: none"> <li>• The Main Control and Transmission Control Unit are the combined brains of the transmission</li> <li>• They direct fluid at the proper time and pressure to the clutch pistons/clutches to provide:                             <ul style="list-style-type: none"> <li>– Smooth shifts</li> <li>– The optimum gear selection for performance and fuel economy</li> </ul> </li> </ul>	<ul style="list-style-type: none"> <li>• Main control valves and solenoids contaminated by debris can stick, causing erratic shifting and clutch failure</li> </ul>

### HOW AN AUTOMATIC TRANSMISSION WORKS:

- A torque converter harnesses and transmits the engine’s rotary motion
- A hydraulic pump moves transmission fluid to the clutches and main control
- Rotary power is transferred to internal shafts and gearing
- Gearing and clutch application determines the correct combination of speed and power output to the wheels
- Rotary motion is transmitted through the differential to the drive wheels

### Possible Symptoms:

- One or more gear ranges do not work (A, B, C, D, E, F)
- The engine must be revved higher than normal to make the vehicle move (A, B, C, D, E, F)
- Vehicle driveability is jerky or erratic (A, B, D, E, F)
- A burnt odor is detected (B, E)
- Excessive noise (A, C, D)

### TRANSMISSION ASSEMBLY

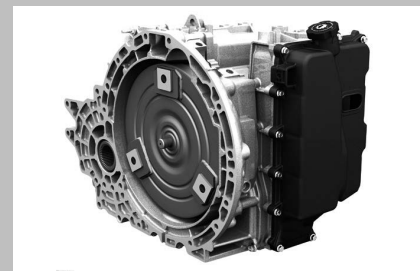

#### 3-Year Unlimited Mileage Warranty

- All Ford-designed and approved parts
- Assembled using precision assembly fixtures
- Latest parts updates and revisions from Ford engineering
- Commercial use-approved with full warranty
- The correct replacement for your vehicle
- Final testing and standards identical to new Ford production transmissions

# GET EVERYTHING YOU'RE PAYING FOR AT A COMPETITIVE PRICE

with a **GENUINE Ford Remanufactured Transmission**

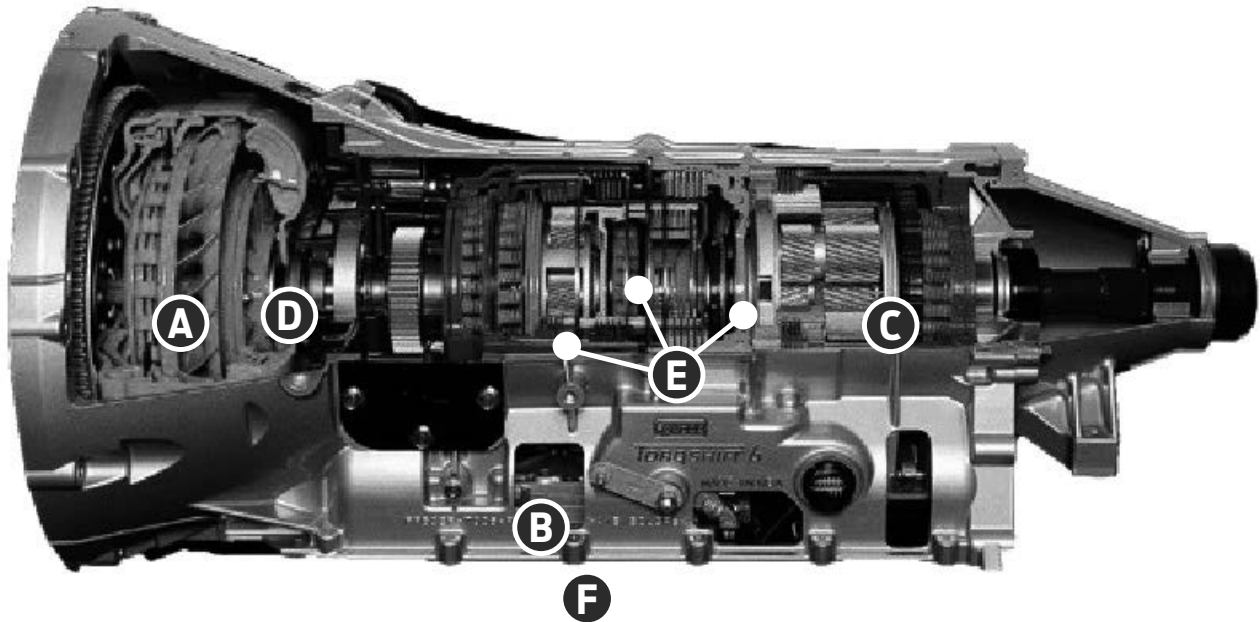

- A Torque Converter**  
A hydraulic coupling that transmits engine power to the transmission.
- Remanufactured using premium components
    - Disassembled and all parts cleaned and inspected
    - Assembled using only Ford-designed and approved parts and processes
    - Balanced using the same methods as new production units

- B Fluid and Filter**  
Provides clean lubrication, cools components, inhibits rust and optimizes “shift feel” across the normal operating temperature range
- Ford-specified, Ford-designed fluid and filter used on every unit

- C Planetary Gearsets**  
Transfer power from the torque converter to the wheels at different speeds to provide a full range of gear options
- Cleaned and inspected for wear, damage or noise and replaced when necessary

- D Pump**  
Pressurizes fluid to actuate clutches, lubricate parts and move fluid through the cooler
- Cleaned, inspected and reassembled using Ford-designed, Ford-approved parts and processes

- E Clutches and Friction Material**  
Activated by fluid pressure to transmit power to the gearset elements and to provide smooth transitions between gear ranges
- Disassembled and parts cleaned and inspected
  - Friction material and seals inspected for wear and replaced as needed with Ford-designed and approved parts
  - Assembled using state of the art equipment to ensure proper clutch clearance

- F Main Control and Transmission Control Unit (“Brains”; not pictured)**  
Interacts with vehicle computer to determine correct transmission shift speeds and timing
- Disassembled and parts cleaned and inspected
  - Solenoid valves electronically tested to ensure full-range function
  - Assembled using only Ford-designed, Ford-approved parts and processes

# GENUINE QUALITY MAKES THE DIFFERENCE.

# 3-YEAR Unlimited Mileage Warranty

## Compare Your Transmission Repair Options:

There are a number of transmission repair options available to you, but none offer the quality and peace of mind that Ford Remanufactured transmissions do. For starters, we use only the most up-to-date Original Equipment parts and offer an unsurpassed three-year, unlimited-mileage warranty. You can be certain that they're engineered and built tough enough for demanding commercial use. Check out what makes us your best choice.

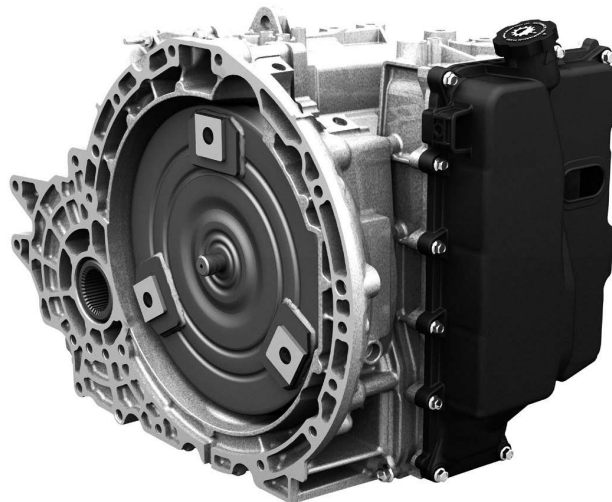

	USED TRANSMISSION	GENUINE FORD REMANUFACTURED TRANSMISSION
<b>Warranty</b>		
Terms	Varies	3-Year/ Unlimited Mileage
Nationwide Coverage	NO	YES
<b>Parts Replaced</b>		
Meet OE Specifications?	?	YES
Torque Converter	?	YES
Frictions, Steels and Bands	?	YES
Gaskets, Seals & Solenoids	?	YES
<b>Specifications</b>		
Original Equipment	?	YES
Final Testing	NO	YES
OE Requirements	?	YES
Computer Diagnostics	NO	YES



Ask about no-interest financing with approved credit on the Ford Service Credit Card



**OEM Parts & Specs at Competitive Prices**



FORD PARTS

## AUTOMATIC TRANSMISSION TIPS & CHECKLIST

To perform the task of removing and installing an automatic transmission, you should be certified in automotive transmission replacement.

### REMOVAL AND INSTALLATION

- Review all prior warranty history of the vehicle.
- Review all Technical Service Bulletins and Special Service Messages pertaining to the vehicle and transmission being serviced.
- Verify that the replacement unit is the correct unit for the vehicle.
- Use appropriate Workshop Manual for exact procedures and specifications required to remove and replace the transmission assembly.

### INSTALLATION TIPS

- Prior to installation, lightly lubricate the torque converter pilot that fits into the engine crankcase bore with multipurpose grease specification ESB-MIC93-B or equivalent.
- Ensure engine to transmission dowel pins are in place.
- Properly flush cooler and cooler lines. Refer to appropriate workshop manual for complete flushing procedures. See page P-10 to identify cooler return line. Flush system using Rotunda tool 222-00007 (or equivalent) with a Ford approved transmission fluid as the flush agent. The Rotunda flushing unit is highly recommended as it has a flow meter, maintains fluid at 140 degrees F, pulsates during cleaning, and air purges before and after flushing, which is crucial for maximum effectiveness. Any substitute flushing tool must have these features to ensure success.  
**NOTE:** Some coolers and/or bypass valves cannot be flushed. These units must be replaced.
- The replacement transmission has some fluid in it. (Rear wheel drive transmissions are full filled. Front wheel drive transmissions are partially filled). For complete fluid checking procedures, refer to the appropriate workshop manual.

**NOTE: If required, use fluid type identified on the tag attached to the remanufactured transmission. Do not overfill transmission.**

**NOTE:** Some transmissions require use of a scan tool to verify fluid temperature is in proper range when checking fluid level.

### INSTALLATION TIPS (CONT'D)

- Check and adjust transmission shift linkage as outlined in the appropriate Workshop Manual. Adjustment must be done in drive position.
- Inspect transmission wiring harness and connectors for any damaged areas and correct routing. Ensure that the harness connector has no damaged pins or seal also check for cracks or corrosion.
- Most transmissions require that the solenoid strategy be updated in the Powertrain Control Module (PCM). Verify that the PCM is programmed to the latest level. Use appropriate Workshop Manual for proper procedure.
- Follow the workshop manual "Transmission Adaptive Learn and Drive" procedure after installation.
- Correct any drivability concerns and/or codes during course of repair. Engine performance issues can adversely affect transmission operation.

### CORE SHIPPING GUIDELINES

- Use the shipping container that the replacement transmission was shipped in to return the failed transmission.
- Fully drain the fluid from the transmission pan and torque converter.
- Ensure that all components to be transferred have been removed from the failed transmission and installed on the replacement transmission.
- Verify that no dowel pins are on the failed transmission.
- Transfer all shipping caps and plugs from the replacement transmission to the failed transmission.
- Ensure the retuned failed transmission is completely reassembled.
- Install the torque converter shipping strap.

# Product Information

## TRANSMISSION OIL COOLERS & TUBES



FORD PARTS

*Make Ford Genuine Parts your first choice for Ford and Lincoln replacement parts!*

### Attention To Detail

- Sized to meet Cold Flow requirements - helps prevent overheating in cold conditions
- Aluminum fins meet rigorous Ford corrosion specifications
- Long-life aluminum alloys
- Lightweight aluminum construction

### Robust Design

- Optimum cooling capacity and performance for uphill towing
- Tough tested through a wide range of pressure and thermal cycles
- Designed for optimal heat dissipation

### Easy Installation

- Vehicle-specific designs
- Robust brackets for secure mounting
- No fabrication required

### Oil Cooler Tubes

- Vehicle specific designs
- Correct fittings minimize connections and leaks
- Routed correctly to eliminate NVH

### 24-months/Unlimited Mileage Service Part Warranty

- 24-months / unlimited mileage limited warranty, which includes parts and labor costs, and is supported nationwide by Ford and Lincoln dealers and Ford Authorized Distributors (See seller for limited warranty details)
- Designed to meet stringent Ford engineering standards for performance and durability
- Recommended for all Ford, Lincoln and Mercury vehicles

**Lightweight aluminum  
construction**

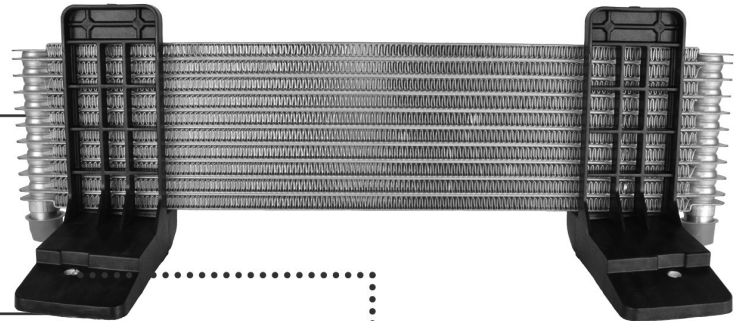
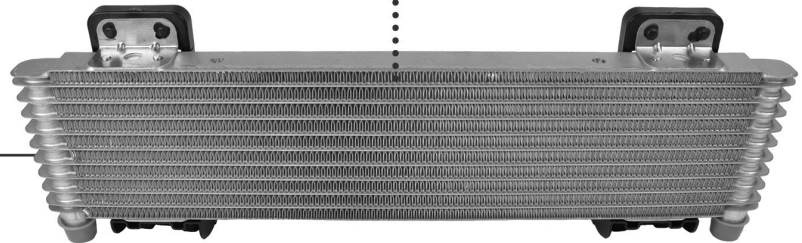

**Brackets designed for  
easy installation and  
secure mounting**

FORD PARTS  
WARRANTY

UNLIMITED  
MILEAGE  
INCLUDES LABOR

2 YEARS

## Transmission Cooler Service Guide

Front Wheel Drive Transaxles																		
Transmission Cooler Service Guide																		
Transmission Family/ Vehicle Line	Vehicle Model Year																	
	2000	2001	2002	2003	2004	2005	2006	2007	2008	2009	2010	2011	2012	2013	2014	2015	2016	
4F27E	Focus	F	F	F	F	F	F	F	F	F	F	F						
	Transit Connect										F	F	F	F				
4F50N (AX4N)	Freestar					F	F	F	F	F								
	Sable	F	F	F	F	F	F											
	Taurus	F	F	F	F	F	F	F										
	Windstar		F	F	F													
6F35	Edge/MKX												F	F	F	F	F	
	Escape									F	F	F	F	F	F	F	F	
	Explorer												F	F	F	F	F	
	Fusion/MKZ										F	F	F	F	F	F	F	
	Mariner									F	F	F						
	Milan										F	F						
	MKC															F	F	
	MKT														F	F	F	
	Police Interceptor-Sedan														F	F	F	F
	Police Interceptor-Utility														F	F	F	F
	Taurus														F	F	F	F
	Transit Connect															F	F	F
	6F50/55	Edge/MKX							F	F	F	F	F	F	F	F	F	F
		Explorer											F	F	F	F	F	F
Flex										F	F	F	F	F	F	F	F	
MKS										F	F	F	F	F	F	F	F	
MKT											F	F	F	F	F	F	F	
MKZ															F	F	F	
Police Interceptor-Sedan															F	F	F	
Police Interceptor-Utility															F	F	F	
Sable									F	F								
Taurus									F	F	F	F	F	F	F	F	F	
Taurus X									F	F								
AX4S		Sable/Taurus	F	F	F	F												
		Windstar	F															
CD4E		Cougar	F	F	F	F												
	Escape		F*	F*	F*	F*	F*	F*	F*									
	Mariner						F*	F*	F*	F*								
CVT	Five Hundred/Freestyle/Montego						R	R	R									
	Five Hundred/Freestyle/Montego						R	R	R									
Aisin AW21/ F21	Fusion							F	F	F	F	F	F					
	Milan							F	F	F	F	F	F					
	MKZ							F	F	F	F	F	F					
	Zephyr							F										
	Fusion							F	F	F	F							
FNRS	Milan							F	F	F	F							
	MKZ							F	F	F	F							
	Zephyr							F										
HF35	C-MAX Hybrid/Energi														F	F	F	
	Fusion Hybrid														F	F	F	
	MKZ Hybrid														F	F	F	
	MKZ Hybrid														F	F	F	

### Legend:

<b>F</b>	Flush cooler using Transmission Heated Cooler Line Flusher 222-00007, 222-00004 or equivalent during transmission overhaul or replacement. If the Transmission Heated Cooler Line Flusher or equivalent is not available, install a new transmission fluid cooler and/or an auxiliary transmission fluid cooler
<b>F*</b>	The Cold Weather Bypass Valve (if equipped) cannot be flushed and should be replaced during cooler system service. If the valve is not currently installed, it should be retroactively added after cooler system service. Flush the cooling system using the Transmission Heated Cooler Line Flusher 222-00007, 222-00004 or equivalent during transmission overhaul or replacement. If the Transmission Heated Cooler Line Flusher or equivalent is not available, install a new transmission fluid cooler and/or an auxiliary transmission fluid cooler
<b>R</b>	Replace cooler during transmission overhaul or replacement

**NOTE:** Some vehicles may be equipped with an optional Towing Package transmission cooler. This optional cooler (if equipped) should be replaced during transmission overhaul or replacement

## Transmission Cooler Service Guide

Rear Wheel Drive Transmissions Transmission Cooler Service Guide																	
Transmission Family/ Vehicle Line	Vehicle Model Year																
	2000	2001	2002	2003	2004	2005	2006	2007	2008	2009	2010	2011	2012	2013	2014	2015	2016
4R100	Blackwood			R (OTA)	R (OTA)												
	E-150	F	F	F	F	F											
	E-250/350/450	F	F	F	F	F											
	Excursion	R (OTA)	R (OTA)	R (OTA)	R (OTA)	R (OTA)	R (OTA)										
	Expedition/ Navigator	F	F	F	F	F											
	F-150	F	F	F	F	F											
F-250/350/450	R (OTA)	R (OTA)	R (OTA)	R (OTA)	R (OTA)												
4R44/5R44/ 5R55	Explorer/ Mountaineer	R	R														
	Explorer Sport		R	R	R												
	Explorer Sport-Trac		R	R	R	R	R										
	Ranger	R	R	R	R	R	R	R	F	F	F	F	F				
4R70/75	Crown Victoria/ Grand Marquis	R	R	R	R	R	R	R	R	R	R	R	R				
	E-150	F	F	F	F	F	F	F	F	F	F	F	F	F	F	F	F
	E-250/350/450	F	F	F	F	F	F	F	F	F	F	F	F	F	F	F	F
	Expedition	F	F	F	F	F	F	F									
	Explorer	F	F														
	F-150	F	F	F	F	F	F	F	F	F							
	Marauder				R	R											
	Mountaineer	F	F														
	Mustang	F	F	F	F	F											
	Navigator	F	F	F	F	F	F	F									
	Town Car	R	R	R	R	R	R	R	R	R	R	R	R				
5R110	E-150				R (OTA)*	R (OTA)*	R (OTA)*	R (OTA)*	R (OTA)*	R (OTA)*	R (OTA)*	R (OTA)*	R (OTA)*	R (OTA)*	R (OTA)*	R (OTA)*	R (OTA)*
	E-250/350/450				R (OTA)*	R (OTA)*	R (OTA)*	R (OTA)*	R (OTA)*	R (OTA)*	R (OTA)*	R (OTA)*	R (OTA)*	R (OTA)*	R (OTA)*	R (OTA)*	R (OTA)*
	Excursion				R (OTA)*	R (OTA)*											
	F Series SuperDuty Low Cab Forward				R (OTA)*	R (OTA)*	R (OTA)*	R (OTA)*	R (OTA)*	R (OTA)*	R (OTA)*	R (OTA)*	R (OTA)*	R (OTA)*	R (OTA)*	R (OTA)*	R (OTA)*
5R55N/M/S	Aviator				R	R	R										
	Explorer/ Mountaineer			R	R	R	R	F	F	F	F						
	Explorer Sport-Trac							F	F	F	F						
	Mustang					R	R	R	R	R							
	Lincoln LS	F	F	F	R	R	R	R									
	Thunderbird			F	R	R	R										
6HP26	Expedition/ Navigator					R	R	R	R								
6R140	F-250/350/450											R (OTAG)	R (OTAG)	R (OTAG)	R (OTAG)	R (OTAG)	R (OTAG)
	E-350/450																F
6R60/75/80	Expedition/ Navigator							R	R	F	F	F	F	F	F	F	F
	Explorer/ Mountaineer							R	R	F	F						
	Explorer Sport-Trac							R	R	F	F						
	F-150									F	F	F	F	F	F	F	F
	Mustang											F	F	F	F	F	F
Transit															F	F	

### Legend:

<b>F</b>	Flush cooler using Transmission Heated Cooler Line Flusher 222-00007, 222-00004 or equivalent during transmission overhaul or replacement. If the Transmission Heated Cooler Line Flusher or equivalent is not available, install a new transmission fluid cooler and/or an auxiliary transmission fluid cooler.
<b>R</b>	Replace cooler during transmission overhaul or replacement
<b>R (OTA)</b>	Replace Oil-To-Air cooler (if equipped) during transmission overhaul or replacement
<b>R (OTA)*</b>	Flush cooling system during transmission overhaul or new unit install. Replace OTA when flushing does not adequately clean
<b>R (OTAG)</b>	Replace Oil-To-Air cooler (if equipped) during transmission overhaul or replacement- Gasoline engine vehicles only

**NOTE:** Some vehicles may be equipped with an optional Towing Package transmission cooler. This optional cooler (if equipped) should be replaced during transmission overhaul or replacement





## TRANSMISSION COOLER SERVICE

- Most F-Super Duty vehicles have radiator in-tank fluid coolers. This type of cooler will require flushing. If flushing does not adequately clean the cooler, replacement is required. Always refer to the vehicle service publications.
- TorqShift transmission cooling system flushing procedure is unique. Refer to the vehicle workshop manual before performing this procedure.
- Replacement procedures for Oil-To-Air (OTA) and Auxiliary coolers vary based on year and model of the vehicle.

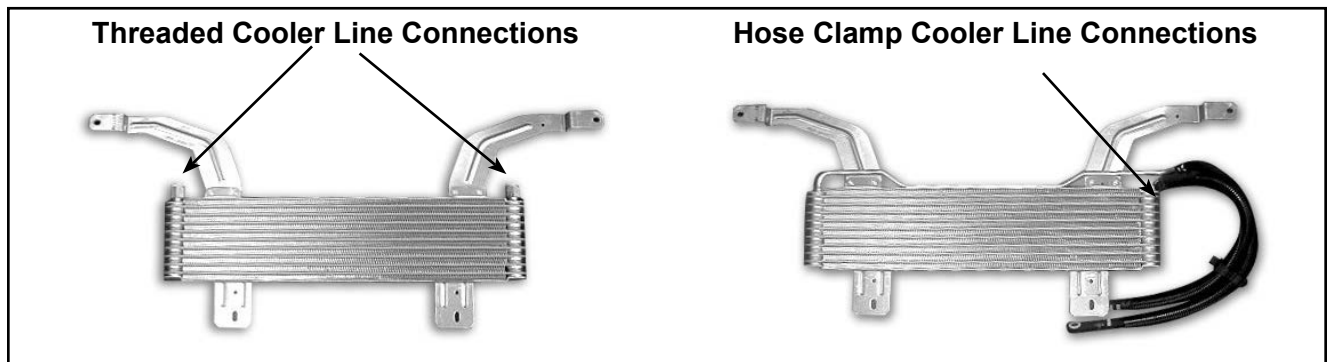

- Different types of OTA coolers are required for gasoline and diesel applications.
  - OTA Cooler with threaded cooler line connections
  - OTA Cooler with crossover tube and hose clamp connections

**Note:** Cooler application may change due to a mid-year production changeover. Always replace the OTA cooler with a cooler of the same size and cooler line connection type (threaded or hose clamp).

When any of the following vehicles with OTA transmission coolers require major transmission service the OTA cooler must be replaced.

**Note:** Always verify the correct part numbers before ordering replacement parts.

### 1999 - 2014 F-Series F-150

- 2009 - 2014 **Part # DL3Z-7A095-A** (4 ch - 1/2" line hose clamp connection)
- 2004 - 2008 **Part # 6L3Z-7A095-A** (4 ch - 1/2" line quick connection)
- 2004 - 2008 **Part # 6L3Z-7A095-B** (9 ch - 1/2" line quick connection)
- 2000 - 2003 **Part # 4L1Z-7A095-BB** (11 ch (trailer tow) - 3/8" line quick connection)
- 2000 - 2003 **Part # 5L3Z-7A095-G** (4R100 7 ch - 3/8" line quick connection)
- 2000 - 2003 **Part # 5L3Z-7A095-H** (4R70W 7 ch - 3/8" line quick connection)
- 1999 **Part # XL3Z-7A095-EA** (4R100 7 ch - inverted nut fittings)

### 1999 - 2016 F-Series Super Duty 250 - 550

- 2008 - 2010 6.4L Diesel Engine, 5R Transmission **Part # 7C3Z-7A095-B** (hose clamp 1/2" line connection)
- 2003 - 2007 6.0L Diesel Engine, 5R Transmission **Part # 5C3Z-7A095-CA** (hose clamp 1/2" line connection)
- 2001 - 2003 7.3L Diesel Engine, 4R Transmission **Part # 3C3Z-7A095-AA** (hose clamp 3/8" line connection)
- 1999 - 2001 7.3L Diesel Engine, 4R Transmission **Part # XC3Z-7A095-BA** (threaded line connector)
- 2011 - 2016 6.2L Gas Engine, 6R Transmission **Part # 9C3Z-7A095-A** (hose clamp 1/2" line connection)
- 2008 - 2016 6.8L Gas Engine, 5R Transmission **Part # 9C37-7A095-A** (hose clamp 1/2" line connection)
- 2005 - 2007 6.8L Gas Engine, 5R Transmission **Part # 5C3Z-7A095-CA** (hose clamp 1/2" line connection)
- 2017 6.2L Gas Engine, 6R Transmission **Part # HC3Z-7A095-A** (hose clamp 1/2" line connection)



## TRANSMISSION COOLER SERVICE — Cont'd

### 1999 - 2016 F-Series Super Duty 250 - 550 — Cont'd

- 2017 6.8L Gas Engine, 6R Transmission **Part # HC3Z-7A095-A** (hose clamp 1/2" line connection)
- 2017 6.7L Diesel Engine, 6R Transmission **Part # HC3Z-7A095-B** (hose clamp 1/2" line connection)
- 2001 - 2004 6.8L Gas Engine, 4R Transmission **Part # 3C3Z-7A095-AA** (hose clamp 3/8" line connection)
- 1999 - 2001 6.8L Gas Engine, 4R Transmission **Part # XC3Z-7A095-CA** (threaded line connector)
- 2008 - 2010 5.4L Gas Engine, 5R Transmission **Part # 9C3Z-7A095-A** (hose clamp 1/2" line connection)
- 2005 - 2007 5.4L Gas Engine, 5R Transmission **Part # 5C3Z-7A095-AC** (hose clamp 1/2" line connection)
- 2001 - 2004 5.4L Gas Engine, 4R Transmission **Part # 3C3Z-7A095-AA** (hose clamp 3/8" line connection)
- 1999 - 2001 5.4L Gas Engine, 4R Transmission **Part # XC3Z-7A095-CA** (threaded line connector)

### 1999 - 2017 F-53 Stripped Chassis

- 2011 - 2017 6.8L Commercial Stripped Chassis **Part # BU9Z-7A095-A** (1/2" line quick connection)
- 2005 - 2017 6.8L Recreational Stripped Chassis **Part # 5U9Z-7A095-AA** (1/2" line quick connection)
- 2014 - 2017 6.8L Commercial Stripped Chassis with BT Delivery Van Pack **Part # EU9Z-7A095-A** (1/2" line quick connection)

### 2004 - 2016 E-Series

- 2008 - 2010 6.0L Diesel Engine, 5R Transmission **Part # 8C2Z-7A095-C** (hose clamp 1/2" line connection)
- 2004 - 2007 6.0L Diesel Engine, 5R Transmission **Part # 5C2Z-7A095-DA** (hose clamp 1/2" line connection)
- 2008 - 2016 6.8L Gas Engine, 5R Transmission **Part # 8C2Z-7A095-B** (hose clamp 1/2" line connection)
- 2005 - 2007 6.8L Gas Engine, 5R Transmission **Part # 5C2Z-7A095-CA** (hose clamp 1/2" line connection)
- 2008 - 2016 5.4L Gas Engine, 5R Transmission **Part # 8C2Z-7A095-B** (hose clamp 1/2" line connection)
- 2005 - 2007 5.4L Gas Engine, 5R Transmission **Part # 5C2Z-7A095-CA** (hose clamp 1/2" line connection)
- 2008 - 2016 5.4L Gas Engine, 4R Transmission **Part # 8C2Z-7A095-A** (hose clamp 1/2" line connection)
- 2005 - 2007 5.4L Gas Engine, 4R Transmission **Part # 5C2Z-7A095-AA** (hose clamp 1/2" line connection)
- 2008 - 2016 4.6L Gas Engine, 4R Transmission **Part # 9C2Z-7A095-A** (hose clamp 3/8" line connection)
- 2005 - 2007 4.6L Gas Engine, 4R Transmission **Part # 4C2Z-7A095-EA** (hose clamp 3/8" line connection)
- 2017 6.8L Gas Engine, 6R Transmission **Part # 8C2Z-7A095-C** (hose clamp 1/2" line connection)
- 2017 6.2L Gas Engine, 6R Transmission **Part # 8C2Z-7A095-C** (hose clamp 1/2" line connection)

### 2000 - 2005 Excursion

- 2003 - 2005 6.0L Diesel Engine, 5R Transmission **Part # 5C3Z-7A095-B** (hose clamp 1/2" line connection)
- 2001 - 2003 7.3L Diesel Engine, 4R Transmission **Part # 3C3Z-7A095-AA** (hose clamp 3/8" line connection)
- 2000 - 2001 7.3L Diesel Engine, 4R Transmission **Part # XC3Z-7A095-BA** (threaded line connection)
- 2001 - 2005 6.8L Gas Engine, 4R Transmission **Part # 3C3Z-7A095-AA** (hose clamp 3/8" line connection)
- 2000 - 2001 6.8L Gas Engine, 4R Transmission **Part # XC3Z-7A095-CA** (threaded line connection)
- 2001 - 2005 5.4L Gas Engine, 4R Transmission **Part # 3C3Z-7A095-AA** (hose clamp 3/8" line connection)
- 2000 - 2001 5.4L Gas Engine, 4R Transmission **Part # XC3Z-7A095-CA** (threaded line connection)

### Other Vehicles

- 2003 - 2005 Crown Victoria / Grand Marquis / Town Car **Part # 5W1Z-3F749-A**
- 2005 Five Hundred / Montego / Freestyle with CVT **Part # 5F9Z-7A095-AC**
- 2005 - 2007 500 / Montego, AWF21, **Part # 5F9Z-7A095-AC** (1/2" line hose clamp connection)



## IDENTIFICATION OF THE RETURN TRANSMISSION COOLER LINE

The best way to identify the return cooler line (fluid coming out of the cooler and returning to the transmission) is to locate the return cooler fitting or case inlet. The return cooler fitting can be found in the following locations on the products listed below:

### Rear Wheel Drive

- 5R110 TorqShift – The REAR transmission case fitting receives the return line
- 4R100/E4OD – The REAR transmission case fitting receives the return line
- 4R70/75W-E – The TOP transmission case fitting receives the return line
- 4R44/55E, 5R44/55E, 5R55N, 5R55W, 5R55S – The TOP transmission case fitting receives the return line
- 6R60/6R75 – The TOP transmission case fitting receives the return line
- AOD – The BOTTOM transmission case fitting receives the return line
- AODE – The TOP transmission case fitting receives the return line
- C6 – The REAR transmission case fitting receives the return line
- A4LD – The TOP transmission case fitting receives the return line
- 6R140 TorqShift – The TOP transmission case fitting receives the return line
- 6R80 – The TOP transmission case fitting receives the return line
- 6HP26 – The TOP transmission case fitting receives the return line

### Front Wheel Drive

- 6F50 – The REAR transaxle case fitting receives the return line
- 6F55 – The REAR transaxle case fitting receives the return line
- CD4E (4F44E) – The REAR or pump end transaxle case fitting receives the return line
- 4F27E – The REAR or cover end transaxle case fitting receives the return line
- AX4S/AX4N (4F50N) – The BOTTOM transaxle cooler line fitting receives the return line
- AWF21 – The BOTTOM transaxle case receives the return line
- 6F35 – The REAR or lowest transaxle case fitting receives the return line
- AXOD – The BOTTOM transaxle case fitting receives the return line
- AXODE – The BOTTOM transaxle case fitting receives the return line
- FNR5 – The REAR or cover end transaxle case fitting receives the return line

**Note:** Always verify the correct part numbers before ordering replacement parts.

# Product Information

## REMANUFACTURED TORQUE CONVERTER



FORD PARTS

*Make Ford Genuine Parts your first choice for Ford and Lincoln replacement parts!*

Upgraded impeller with stronger SAE 1020 brazed blade in 6.0L diesel applications

Dynamic vector-balanced O.E. design and tolerances, consolidated to the latest design level

Upgraded stator with preloaded thrust washer and two-piece bearing for 5R110 applications

O.E. replacement parts

Hysteresis-tested damper assemblies for assured damping performance

Adherence to the tightest O.E. specs on friction surface and splines

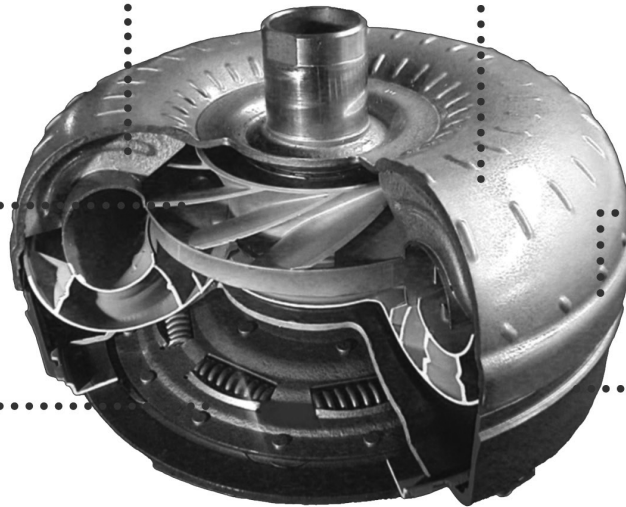

- A wide selection is available to cover most popular Ford Motor Company applications
- Designed to help get the job done right the first time, every time
- **24-months / Unlimited Mileage Limited Warranty**, which includes parts and labor costs, and is supported nationwide by Ford and Lincoln dealers and Ford Authorized Distributors (See seller for limited warranty details)
- O.E. improvements are integrated into the remanufacturing process to meet the highest Ford standards of quality and durability

- All components cleaned and re-qualified in a TS16949 certified factory
- Each Assembly feature:
  - Upgrade stator in 5R110
  - Triple plate damper assemblies
  - Upgraded impeller
  - Diesel applications get stronger impeller blades
  - Original equipment ATF
  - O.E. Replacement Parts
  - Unpainted bodies

FORD PARTS  
WARRANTY

UNLIMITED  
MILEAGE  
INCLUDES LABOR

2 YEARS

## TRANSMISSION OVERHAUL KITS

*Right Part. Right Fit. Right Price Every Time!*



### Three Levels of Overhaul Kits are Available for Flexibility

Each kit contains quality parts that meet stringent Ford Motor Company standards

- Customized for your Ford, Lincoln or Mercury vehicle
- O.E. friction surface is designed for vehicle specific fluid and calibration
- Seals are designed for leak prevention and less corrosion



### Motorcraft® Master Overhaul Kit includes everything in the Motorcraft® Overhaul Gasket & Seal Kit plus:

- Steel plates
- Bands (where applicable)
- O.E. friction plates
- Available for the full line of Ford Motor Company vehicles

### Motorcraft® Overhaul Gasket & Seal Kit includes:

- Bonded pistons and Valve body gaskets (where applicable)
- Soft and Metal-clad seals
- Ring kit (where applicable)
- Available for the full line of Ford Motor Company vehicles

### Motorcraft® Master Overhaul Less Steel Kit contains O.E. friction plates but excludes steel plates

- Not available for all applications

### 24-months/Unlimited Mileage Service Part Warranty

- 24-months / unlimited mileage limited warranty, which includes parts and labor costs, and is supported nationwide by Ford and Lincoln dealers and Ford Authorized Distributors (See seller for limited warranty details)
- Designed to meet stringent Ford engineering standards for performance and durability
- Recommended for all Ford, Lincoln and Mercury vehicles

**MOTORCRAFT®  
WARRANTY**

**UNLIMITED  
MILEAGE  
INCLUDES LABOR**

**2 YEARS**

# Product Information

## Motorcraft® Transmission Overhaul Kits



Motorcraft® Master Overhaul and Master Overhaul Less Steel kits contain 100% original equipment friction material for added strength and durability.

### Overhaul Kit

### Master Overhaul Less Steel Kit

### Master Overhaul Kit

Transmission	Bonded Pistons	Valve Body Gaskets	Soft Seals	Metal Clad Seals	Ring Kit	Friction Plates	Steel Plates	Bands
C6		X	X	X	X	X	X	
AOD		X	X	X	X	X	X	
ATX		X	X	X	X	X	X	
A4LD		X	X	X	X	X	X	
AXOD		X	X	X	X	X	X	
E40D		X	X	X	X	X	X	
4R100		X	X	X	X	X	X	
AXODE		X	X	X	X	X	X	
AX4S		X	X	X	X	X	X	
4R70E/4R70W			X	X	X	X	X	
4R75E/4R75W			X	X	X	X	X	
CD4E	X	X	X	X	X	X	X	
5R55N			X	X	X	X	X	
5R55W			X	X	X	X	X	X
AX4N	X	X	X	X	X	X	X	
4R44E/4R55E		X	X	X	X	X	X	
5R44E/5R55E		X	X	X	X	X	X	
4F27E	X	X	X	X	X	X	X	
5R110W	X		X	X	X	X	X	
5R55S			X	X	X	X	X	X
4F50N <sup>1</sup>	X	X	X	X	X	X	X	
6R60/6R75/6R80 <sup>2</sup>			X	X	X	X	X	
CVT30 <sup>3</sup>			X	X	X			
6F35/6F50/6F55 <sup>2</sup>	X	X	X	X		X	X	
6R140 <sup>2</sup>	X	X	X	X	X	X	X	

**Soft Seals:** O-Rings, lip and lathe cut seals, D-Rings, plus all paper gaskets except valve body gasket.  
**Metal Clad Seals:** Converter, pump, axle (FWD) and extension housing seals.  
**Ring Kit:** Metal and PTFE rings.

<sup>1</sup> Less Steel Kit also available

<sup>2</sup> No Less Steel Kit available

<sup>3</sup> No Less Steel Kit or Master Overhaul Kit available

## CLUTCH KITS



FORD PARTS

*Make Ford Genuine Parts your first choice for Ford and Lincoln replacement parts!*

### High Quality Designs

- Designed specifically for each vehicle

### Attention To Detail

- Clutch springs tuned to minimize gear rattle
- Friction surface uses deep-set rivets for long life
- Friction material have optimum copper content for better durability
- Pressure plates have optimum mass to operate cooler and are more durable
- Beefy pressure plate “ears” designed to better transmit engine torque
- Pilot bearings use large needle roller bearings to better transmit radial loads
- High temperature grease used in critical pilot bearings for optimal durability

### Less Down Time

- All components designed for long life and improved durability
- Better durability means less down time
- Less down time means less lost revenue for fleets and commercial owners

### 24-months/Unlimited Mileage Service Part Warranty

- 24-months / unlimited mileage limited warranty, which includes parts and labor costs, and is supported nationwide by Ford and Lincoln dealers and Ford Authorized Distributors (See seller for limited warranty details)
- Designed to meet stringent Ford engineering standards for performance and durability
- Key life durability tested to the equivalent of 10 years/150,000 miles lifetime
- Recommended for all Ford, Lincoln and Mercury vehicles

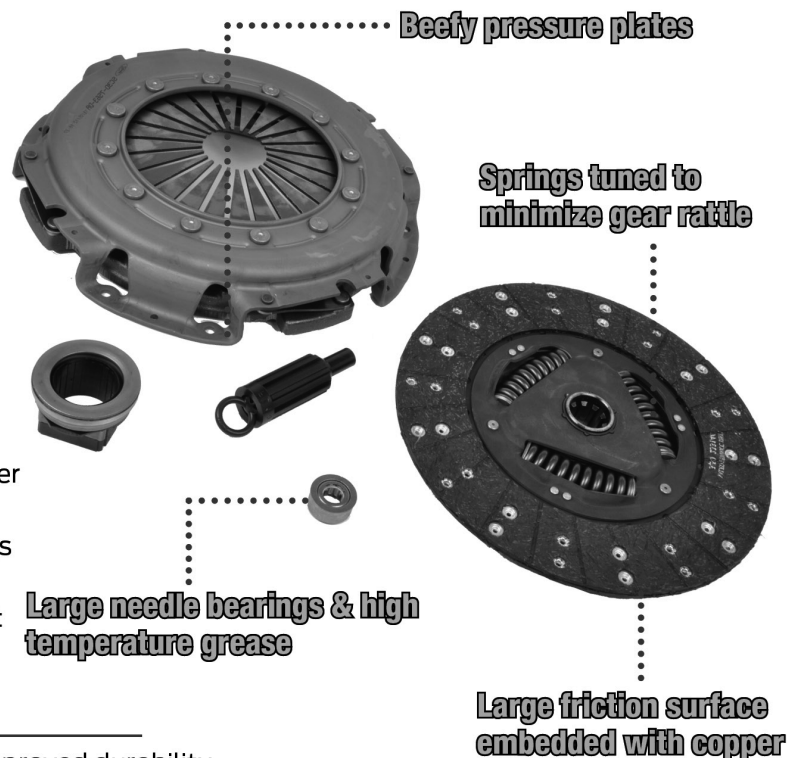

**FORD PARTS  
WARRANTY**

**UNLIMITED  
MILEAGE  
INCLUDES LABOR**

**2 YEARS**

2017

## VIN GUIDE

Your Guide to 2017 Vehicle Identification

### How To Use:

Here is your 2017 guide to interpreting universal Vehicle Identification Numbers (VIN). This vehicle information applies to 2017 models only. For previous model VIN information, check sources at your local dealerships or log onto

[www.remarketing.dealerconnection.com](http://www.remarketing.dealerconnection.com)

The VIN data provided is preliminary and prepared for the exclusive use of Ford and Lincoln dealers.

### Example:

Universal Vehicle Identification Numbers (VIN) have 17 “positions.” There is a number or a letter in each position.

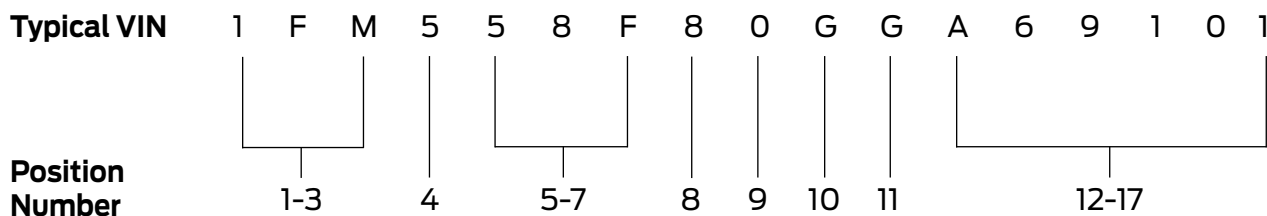

Positions	1-3	World Manufacturer Identifier
Position	4	Restraint System Type Brake Type and GVWR Class (Trucks and Vans Only)
Positions	5-7	Line, Series, Body Type
Position	8	Engine Type
Position	9	Check Digit
Position	10	Model Year
Position	11	Assembly Plant
Positions	12-17	Production Sequence Number



## 2017 VIN CODES

VIN POSITIONS 1, 2, 3			
VIN CODE	Vehicle Manufacturer	Make	Type
<b>PASSENGER CARS</b>			
1FA	Ford Motor Company, USA	Ford	Passenger Car
1LN	Ford Motor Company, USA	Lincoln	Passenger Car
3FA	Ford Motor Company, Mexico	Ford	Passenger Car
3LN	Ford Motor Company, Mexico	Lincoln	Passenger Car
WFO	Ford Motor Company, Germany	Ford	Passenger Car
<b>GENERIC TRUCK, BUS, MPV FORMAT</b>			
1FB	Ford Motor Company, USA	Ford	Bus
1FM	Ford Motor Company, USA	Ford	Multipurpose Passenger Vehicle
1FT	Ford Motor Company, USA	Ford	Truck - Completed Vehicle
2FM	Ford Motor Company of Canada, Ltd.	Ford	Multipurpose Passenger Vehicle
2LM	Ford Motor Company of Canada, Ltd.	Lincoln	Multipurpose Passenger Vehicle
5LM	Ford Motor Company, USA	Lincoln	Multipurpose Passenger Vehicle
NMD	Ford Motor Company, Europe	Ford	Truck - Completed Vehicle
<b>INCOMPLETE VEHICLES</b>			
1FC	Ford Motor Company, USA	Ford	Basic (Stripped) Chassis
1F6	Detroit Chassis LLC, USA*	Ford	Basic (Stripped) Chassis
2L1	Ford Motor Company of Canada, Ltd.	Lincoln	Incomplete Vehicle - Limousine
2LJ	Ford Motor Company of Canada, Ltd.	Lincoln	Incomplete Vehicle - Hearse
1FD	Ford Motor Company, USA	Ford	Incomplete Vehicle
3FR	Blue Diamond Truck S. De R.L. De C.V.	Ford	Incomplete Vehicle
5LD	Ford Motor Company, USA	Lincoln	Incomplete Vehicle - Limousine

\*Detroit Chassis LLC and MSX International

Vehicle Type	Brake System	GVWR Class*	GVWR Range	Restraint Category															
				1	2	3	4	5	6	7	8	9	10	11	12	13	14	15	
Passenger Car	-	-	-	K	F	B	H			6	D	U	5		T		G		
MPV, Truck	Hyd.	Class A:	Less than 3,000 lbs.																
MPV, Truck	Hyd.	Class B:	3,001-4,000 lbs.																
MPV, Truck	Hyd.	Class C:	4,001-5,000 lbs.			Y	K	A							7				
MPV, Truck	Hyd.	Class D:	5,001-6,000 lbs.			Z	L	D	G	P	T	U		8					
MPV, Truck	Hyd.	Class E:	6,001-7,000 lbs.	R	6	M	E	H					5						
MPV, Truck	Hyd.	Class F:	7,001-8,000 lbs.	B	V	R	N	F	J										
MPV, Truck	Hyd.	Class G:	8,001-9,000 lbs.				P	V											
Truck, Bus	Hyd.	Class G:	8,501-9,000 lbs.	H	C	N	Y	Z								K	1		
Truck, Bus	Hyd.	Class H:	9,001-10,000 lbs.	J	D	S	B	7	A							L	2		
Truck, Bus	Hyd.	Class 3:	10,001-14,000 lbs.	K	E	W	R	8	V							M	3		
Truck, Bus	Hyd.	Class 4:	14,001-16,000 lbs.	L	F	X	T	9									4		
Truck, Bus	Hyd.	Class 5:	16,001-19,500 lbs.	M	G	A	U	0									5		
Truck, Bus	Hyd.	Class 6:	19,501-26,000 lbs.	N													6		
Truck, Bus	Hyd.	Class 7:	26,001-33,000 lbs.	P															
Truck, Bus	Air	Class 6:	19,501-26,000 lbs.	W															
Truck, Bus	Air	Class 7:	26,001-33,000 lbs.	X															
Truck, Bus	Air	Class 8:	33,001-55,000 lbs.	Y															

\* Brake System (only) for buses and incomplete vehicles - GVWR = Class as shown are not applicable  
\*Hyd." = Hydraulic

Restraint Category	
Code	Restraint Devices and Location
1	Manual belts WITHOUT air bags
2	Manual belts with driver frontal air bag ONLY
3	Manual belts with driver and passenger frontal air bags
4	Manual belts with driver and passenger frontal air bags and side inflatable restraint (1st row)
5	Manual belts with driver and passenger frontal air bags and side inflatable restraint (1st & 2nd row)
6	Manual belts with driver and passenger frontal air bags and side inflatable restraint (1st, 2nd, 3rd rows & add'l rows)
7	Manual belts with driver and passenger frontal air bags and side inflatable restraint (1st & 2nd row) and driver/passenger knee air bag
8	Manual belts with driver and passenger frontal air bags and side inflatable restraint (1st & 2nd row) and driver knee air bag
9	Manual belts with driver and passenger frontal air bags and side inflatable restraint (1st, 2nd, & 3rd row) and driver knee air bag
10	Manual belts with driver and passenger frontal air bags and side inflatable restraint (1st, 2nd, & 3rd row) and passenger knee air bag
11	Manual belts with driver only frontal air bags and side inflatable restraint (1st row)
12	Manual belts with driver and passenger frontal air bags and driver/passenger knee restraint
13	Manual belts with driver only frontal air bags and driver/passenger side inflatable restraint (1st row)
14	Manual belts with driver only frontal air bags and driver/passenger side inflatable restraint (1st row) and driver & passenger knee air bag
15	No restraints

VIN POSITIONS 5, 6, 7 VIN Code Line, Series, Body Type for Passenger Cars			
VIN CODE	Car Line	Series	Body Type
<b>FORD</b>			
P5A	C-MAX	SE FHEV	5-Dr. Hatch
P5D	C-MAX	Titanium FHEV	5-Dr. Hatch
P5E	C-MAX	SE PHEV	5-Dr. Hatch
P5F	C-MAX	Titanium PHEV	5-Dr. Hatch
POG	Fusion	S	4-Dr. Sedan
POH	Fusion	SE FWD	4-Dr. Sedan
POK	Fusion	Titanium FWD	4-Dr. Sedan
POD	Fusion	Titanium AWD	4-Dr. Sedan
POU	Fusion	S Hybrid	4-Dr. Sedan
POL	Fusion	SE Hybrid	4-Dr. Sedan
POT	Fusion	SE AWD	4-Dr. Sedan
POP	Fusion	SE PHEV	4-Dr. Sedan
POR	Fusion	Titanium HEV	4-Dr. Sedan
POS	Fusion	Titanium PHEV	4-Dr. Sedan
POV	Fusion	Sport AWD	4-Dr. Sedan
P2D	Taurus	SE FWD	4-Dr. Sedan
P2E	Taurus	SEL FWD	4-Dr. Sedan
P2F	Taurus	Limited FWD	4-Dr. Sedan
P2H	Taurus	SEL AWD	4-Dr. Sedan
P2J	Taurus	Limited AWD	4-Dr. Sedan
P2K	Taurus	SHO AWD	4-Dr. Sedan
P2L	Taurus	Police FWD	4-Dr. Sedan
P2M	Taurus	Police AWD	4-Dr. Sedan
P4A	Fiesta	S	4-Dr. Sedan
P4B	Fiesta	SE	4-Dr. Sedan
P4E	Fiesta	SE	5-Dr. Hatch
P4C	Fiesta	Titanium	4-Dr. Sedan
P4F	Fiesta	Titanium	5-Dr. Hatch
P4T	Fiesta	S	5-Dr. Hatch
P4G	Fiesta	ST	5-Dr. Hatch
P3E	Focus	S	4-Dr. Sedan
P3F	Focus	SE	4-Dr. Sedan
P3H	Focus	SEL	4-Dr. Sedan
P3J	Focus	Titanium	4-Dr. Sedan
P3K	Focus	SE	5-Dr. Hatch
P3M	Focus	SEL	5-Dr. Hatch
P3N	Focus	Titanium	5-Dr. Hatch
P3L	Focus	ST	5-Dr. Hatch
P3R	Focus	BEV	5-Dr. Hatch
P3T	Focus	RS	5-Dr. Hatch
P9C	GT	RWD	2-Dr. Sedan
P8A	Mustang	V6 Coupe	2-Dr. Sedan
P8C	Mustang	GT Coupe	2-Dr. Sedan
P8E	Mustang	V6 Convertible	2-Dr. Sedan
P8F	Mustang	GT Convertible	2-Dr. Sedan
P8T	Mustang	I4 Coupe	2-Dr. Sedan
P8U	Mustang	I4 Convertible	2-Dr. Sedan
P8J	Mustang	Shelby Coupe	2-Dr. Sedan
<b>LINCOLN</b>			
L5A	MKZ	FWD Premier	4-Dr. Sedan
L5B	MKZ	AWD Premier	4-Dr. Sedan
L5C	MKZ	FWD Select	4-Dr. Sedan
L5D	MKZ	AWD Select	4-Dr. Sedan
L5E	MKZ	FWD Reserve	4-Dr. Sedan
L5F	MKZ	AWD Reserve	4-Dr. Sedan
L5G	MKZ	FWD Black Label	4-Dr. Sedan
L5H	MKZ	AWD Black Label	4-Dr. Sedan
L5K	MKZ	Premier HEV	4-Dr. Sedan
L5L	MKZ	Select HEV	4-Dr. Sedan
L5M	MKZ	Reserve HEV	4-Dr. Sedan
L5N	MKZ	Black Label HEV	4-Dr. Sedan
L5R	MKZ	China Gas Preferred	4-Dr. Sedan
L5S	MKZ	China HEV	4-Dr. Sedan
L9P	Continental	Premier FWD	4-Dr. Sedan
L9V	Continental	Premier AWD	4-Dr. Sedan
L9S	Continental	Select FWD	4-Dr. Sedan
L9T	Continental	Select AWD	4-Dr. Sedan
L9R	Continental	Reserve FWD	4-Dr. Sedan
L9N	Continental	Reserve AWD	4-Dr. Sedan
L9A	Continental	Black Label FWD	4-Dr. Sedan
L9B	Continental	Black Label AWD	4-Dr. Sedan
L9U	Continental	Livery FWD	4-Dr. Sedan
L9H	Continental	Livery AWD	4-Dr. Sedan

\*FWD" = Front Wheel Drive "AWD" = All Wheel Drive "BEV" = Electric "PHEV" = Plug-In Hybrid Electric Vehicle  
\*FHEV" = Full Hybrid Electric Vehicle "HEV" = Hybrid Electric Vehicle

VIN POSITIONS 5, 6, 7 VIN Code Line, Series, Body Type for Passenger Cars Multipurpose Passenger Vehicles (MPVs), Buses, and Incomplete Vehicles (IVs) with GVW Ratings of 11,000 Pounds (4990 Kilograms) or less:					
VIN CODE	Line	Series	Chassis Type	Cab/Body	Vehicle Type
<b>FORD</b>					
U1F	Expedition	XL	4X2	4-Door	MPV
U1G	Expedition	XL	4X4	4-Door	MPV
U1H	Expedition	XLT / King Ranch	4X2	4-Door	MPV
U1J	Expedition	XLT / King Ranch	4X4	4-Door	MPV
U1K	Expedition	Limited	4X2	4-Door	MPV
U2A	Expedition	Limited	4X4	4-Door	MPV
U1L	Expedition	Platinum	4X2	4-Door	MPV
U1M	Expedition	Platinum	4X4	4-Door	MPV
K1F	Expedition EL	XL	4X2	4-Door	MPV
K1G	Expedition EL	XL	4X4	4-Door	MPV
K1H	Expedition EL	XLT / King Ranch	4X2	4-Door	MPV
K1J	Expedition EL	XLT / King Ranch	4X4	4-Door	MPV
K1K	Expedition EL	Limited	4X2	4-Door	MPV
K1L	Expedition EL	Limited	4X4	4-Door	MPV
K1M	Expedition EL	Platinum	4X2	4-Door	MPV
K1N	Expedition EL	Platinum	4X4	4-Door	MPV
K3A	Edge	Sport	FWD	4-Door	MPV
K3G	Edge	SE	FWD	4-Door	MPV
K3J	Edge	SEL	FWD	4-Door	MPV
K3K	Edge	Titanium	FWD	4-Door	MPV
K4A	Edge	Sport	AWD	4-Door	MPV
K4G	Edge	SE	AWD	4-Door	MPV
K4J	Edge	SEL	AWD	4-Door	MPV
K4K	Edge	Titanium	AWD	4-Door	MPV
K5B	Flex	SE	FWD	4-Door	MPV
K5C	Flex	SEL	FWD	4-Door	MPV

# Product Information

## 2017 VIN CODES – CONT'D

**VIN POSITIONS 5, 6, 7** VIN Code Line Series Body Type for Passenger Cars, Multipurpose Passenger Vehicles (MPVs), Buses, and Incomplete Vehicles (IVs) with GVW Ratings of 11,000 Pounds (4990 Kilograms) or less:

VIN CODE	Line	Series	Chassis Type	Cab/Body	Vehicle Type
K5D	Flex	Limited	FWD	4-Door	MPV
K6C	Flex	SEL	AWD	4-Door	MPV
K6D	Flex	Limited	AWD	4-Door	MPV
K7B	Explorer	Base	FWD	4-Door	MPV
K7D	Explorer	XL	FWD	4-Door	MPV
K7F	Explorer	Limited	FWD	4-Door	MPV
K8A	Explorer	Police	4WD	4-Door	MPV
K8B	Explorer	Base	4WD	4-Door	MPV
K8D	Explorer	XL	4WD	4-Door	MPV
K8F	Explorer	Limited	4WD	4-Door	MPV
K8G	Explorer	Sport	4WD	4-Door	MPV
K8H	Explorer	Platinum	4WD	4-Door	MPV
U0F	Escape	S	4X2	4-Door	MPV
U0G	Escape	SE	4X2	4-Door	MPV
U0J	Escape	Titanium	4X2	4-Door	MPV
U9G	Escape	SE	4X4	4-Door	MPV
U9J	Escape	Titanium	4X4	4-Door	MPV
U9F	Escape-CAN	S	4X4	4-Door	MPV
<b>LINCOLN</b>					
J5F	MKT		FWD	4-Door	MPV
J5A	MKT		AWD	4-Door	MPV
J5L	MKT	Limo	AWD	4-Door	MPV / IV
J5M	MKT	Livery	FWD	4-Door	MPV
J5N	MKT	Livery	AWD	4-Door	MPV
J2H	Navigator	Select	4X2	4-Door	MPV
J2J	Navigator	Select	4X4	4-Door	MPV
J3H	Navigator L	Select	4X2	4-Door	MPV
J3J	Navigator L	Select	4X4	4-Door	MPV
J2K	Navigator	Reserve	4X2	4-Door	MPV
J2L	Navigator	Reserve	4X4	4-Door	MPV
J3K	Navigator L	Reserve	4X2	4-Door	MPV
J3L	Navigator L	Reserve	4X4	4-Door	MPV
J6J	MKX	Premier	FWD	4-Door	MPV
J6J	MKX	Premier	AWD	4-Door	MPV
J6K	MKX	Select	FWD	4-Door	MPV
J6K	MKX	Select	AWD	4-Door	MPV
J6L	MKX	Reserve	FWD	4-Door	MPV
J8L	MKX	Reserve	AWD	4-Door	MPV
J7J	MKX	Black Label	FWD	4-Door	MPV
J9J	MKX	Black Label	AWD	4-Door	MPV
J1C	MKC	Premier	4X2	4-Door	MPV
J1D	MKC	Premier	4X4	4-Door	MPV
J2C	MKC	Select	4X2	4-Door	MPV
J2D	MKC	Select	4X4	4-Door	MPV
J3C	MKC	Reserve	4X2	4-Door	MPV
J3D	MKC	Reserve	4X4	4-Door	MPV
J4C	MKC	Black Label	4X2	4-Door	MPV
J4D	MKC	Black Label	4X4	4-Door	MPV

\*MPV = Multipurpose Passenger Vehicle \*IV = Incomplete Vehicle

**VIN POSITIONS 5, 6, 7** Line Series Chassis, Cab Type or Body Type for Trucks, Multipurpose Passenger Vehicles (MPVs), Buses, Light, Medium & Heavy Trucks and Incomplete Vehicles (IVs):

VIN CODE	Line	Series	Chassis Type	Cab/Body	Vehicle Type
W7D	F-Super Duty Diesel	F-750	DRW 4X2	Crew Cab Straight Frame	IV
W7T	F-Super Duty Diesel	F-750	DRW 4X2	Crew Cab Tractor	IV
X1C	F-Series	F-150	4X2	Super Cab*	Truck
X1E	F-Series	F-150	4X4	Super Cab	Truck
X1R	F-Series	F-150	4X4	Super Cab - Raptor	Truck
W1R	F-Series	F-150	4X4	Super Cab - Raptor	Truck / IV
X2A	F-Series	F-250	4X2	Super Cab - SRW	Truck / IV
X2B	F-Series	F-250	4X4	Super Cab - SRW	Truck / IV
X2B	F-Series	F-350	4X2	Super Cab - SRW	Truck / IV
X3B	F-Series	F-350	4X4	Super Cab - SRW	Truck / IV
X3C	F-Series	F-350	4X2	Super Cab - DRW	Truck / IV
X3D	F-Series	F-350	4X4	Super Cab - DRW	Truck / IV
X3E	F-Series	F-350	4X2	Super Cab - SRW	IV
X3F	F-Series	F-350	4X4	Super Cab - SRW	IV
X3G	F-Series	F-350	4X2	Super Cab - DRW	IV
X3H	F-Series	F-350	4X4	Super Cab - DRW	IV
X4G	F-Series	F-450	4X2	Super Cab - DRW	IV
X4H	F-Series	F-450	4X4	Super Cab - DRW	IV
X5G	F-Series	F-550	4X2	Super Cab - DRW	IV
X5H	F-Series	F-550	4X4	Super Cab - DRW	IV
X6A	F-Super Duty Gas	F-650	DRW 4X2	Super Cab Straight Frame	IV
X6B	F-Super Duty Gas	F-650	DRW 4X2	Super Cab Kick-up Frame	IV
X6D	F-Super Duty Diesel	F-650	DRW 4X2	Super Cab Straight Frame	IV
X6E	F-Super Duty Diesel	F-650	DRW 4X2	Super Cab Kick-up Frame	IV
X6T	F-Super Duty Diesel	F-650	DRW 4X2	Super Cab Tractor	IV
X7A	F-Super Duty Gas	F-750	DRW 4X2	Super Cab Straight Frame	IV
X7D	F-Super Duty Diesel	F-750	DRW 4X2	Super Cab Straight Frame	IV
X7T	F-Super Duty Diesel	F-750	DRW 4X2	Super Cab Tractor	IV

\*SRW = Single Rear Wheels \*DRW = Dual Rear Wheels \*IV = Incomplete Vehicle

**VIN POSITIONS 5, 6, 7** Line Series Chassis, Cab Type or Body Type for Trucks, Multipurpose Passenger Vehicles (MPVs), Buses, Light, Medium & Heavy Trucks and Incomplete Vehicles (IVs):

VIN CODE	Line	Series	Chassis Type	Cab/Body	Vehicle Type
<b>FORD</b>					
E3F	Econoline	E-350	SRW / DRW	Cutaway	IV
E3K	Econoline	E-350	SRW / DRW	Striped Chassis	IV
E4F	Econoline	E-450	SRW / DRW	Cutaway	IV
E4K	Econoline	E-450	SRW / DRW	Striped Chassis	IV
F5D	Motorhome Chassis		4X2	Striped Chassis	IV
F5K	Commercial Chassis		4X2	Striped Chassis	IV

\*SRW = Single Rear Wheels \*DRW = Dual Rear Wheels \*IV = Incomplete Vehicle

**VIN POSITIONS 5, 6, 7** Line Series Chassis, Cab Type or Body Type for Trucks, Multipurpose Passenger Vehicles (MPVs), Buses, Light, Medium & Heavy Trucks and Incomplete Vehicles (IVs):

VIN CODE	Line	Series	Chassis Type	Cab/Body	Vehicle Type
<b>FORD</b>					
F1C	F-Series	F-150	4X2	Regular Cab	Truck
F1E	F-Series	F-150	4X4	Regular Cab	Truck
F2A	F-Series	F-250	4X2	Regular Cab - SRW	Truck / IV
F2B	F-Series	F-250	4X4	Regular Cab - SRW	Truck / IV
F3A	F-Series	F-350	4X2	Regular Cab - SRW	Truck / IV
F3B	F-Series	F-350	4X4	Regular Cab - SRW	Truck / IV
F3C	F-Series	F-350	4X2	Regular Cab - DRW	Truck / IV
F3D	F-Series	F-350	4X4	Regular Cab - DRW	Truck / IV
F3E	F-Series	F-350	4X2	Regular Cab - SRW	IV
F3F	F-Series	F-350	4X4	Regular Cab - SRW	IV
F3G	F-Series	F-350	4X2	Regular Cab - DRW	IV
F3H	F-Series	F-350	4X4	Regular Cab - DRW	IV
F4G	F-Series	F-450	4X2	Regular Cab - DRW	IV
F4H	F-Series	F-450	4X4	Regular Cab - DRW	IV
F5G	F-Series	F-550	4X2	Regular Cab - DRW	IV
F5H	F-Series	F-550	4X4	Regular Cab - DRW	IV
F6A	F-Super Duty* Gas	F-650	DRW 4X2	Regular Cab Straight Frame	IV
F6B	F-Super Duty Gas	F-650	DRW 4X2	Regular Cab Kick-up Frame	IV
F6C	F-Super Duty Gas	F-650	DRW 4X2	Regular Cab Straight Frame	IV
F6D	F-Super Duty Diesel	F-650	DRW 4X2	Regular Cab Straight Frame	IV
F6E	F-Super Duty Diesel	F-650	DRW 4X2	Regular Cab Kick-up Frame	IV
F6T	F-Super Duty Diesel	F-650	DRW 4X2	Regular Cab Tractor	IV
F7A	F-Super Duty Gas	F-750	DRW 4X2	Regular Cab Straight Frame	IV
F7D	F-Super Duty Diesel	F-750	DRW 4X2	Regular Cab Straight Frame	IV
F7T	F-Super Duty Diesel	F-750	DRW 4X2	Regular Cab Tractor	IV
W1C	F-Series	F-150	4X2	SuperCrew*	Truck
W1E	F-Series	F-150	4X4	SuperCrew	Truck
W2A	F-Series	F-250	4X2	Crew Cab - SRW	Truck / IV
W2B	F-Series	F-250	4X4	Crew Cab - SRW	Truck / IV
W3A	F-Series	F-350	4X2	Crew Cab - SRW	Truck / IV
W3B	F-Series	F-350	4X4	Crew Cab - SRW	Truck / IV
W3C	F-Series	F-350	4X2	Crew Cab - DRW	Truck / IV
W3D	F-Series	F-350	4X4	Crew Cab - DRW	Truck / IV
W3E	F-Series	F-350	4X2	Crew Cab - SRW	IV
W3F	F-Series	F-350	4X4	Crew Cab - SRW	IV
W3G	F-Series	F-350	4X2	Crew Cab - DRW	IV
W3H	F-Series	F-350	4X4	Crew Cab - DRW	IV
W4D	F-Series	F-450	4X4	Crew Cab - DRW	Truck / IV
W4G	F-Series	F-450	4X2	Crew Cab - DRW	IV
W4H	F-Series	F-450	4X4	Crew Cab - DRW	IV
W5G	F-Series	F-550	4X2	Crew Cab - DRW	IV
W5H	F-Series	F-550	4X4	Crew Cab - DRW	IV
W6A	F-Super Duty Gas	F-650	DRW 4X2	Crew Cab Straight Frame	IV
W6B	F-Super Duty Gas	F-650	DRW 4X2	Crew Cab Kick-up Frame	IV
W6D	F-Super Duty Diesel	F-650	DRW 4X2	Crew Cab Straight Frame	IV
W6E	F-Super Duty Diesel	F-650	DRW 4X2	Crew Cab Kick-up Frame	IV
W6T	F-Super Duty Diesel	F-650	DRW 4X2	Crew Cab Tractor	IV
W7A	F-Super Duty Gas	F-750	DRW 4X2	Crew Cab Straight Frame	IV

**VIN POSITIONS 5, 6, 7** VIN Code Line Series Body Type for Passenger Cars, Multipurpose Vehicles (MPVs), Buses and Incomplete Vehicles (IVs) with GVW Ratings of 11,000 lbs (4990 kg) or less:

VIN CODE	Line	Series	Chassis Type	Cab/Body	Vehicle Type	GVWR	Roof	Door	Wheel base
<b>FORD</b>									
S6E	Transit Connect	XL	Short Wheelbase	Van					
S7E	Transit Connect	XL	Long Wheelbase	Van					
S6F	Transit Connect	XL	Short Wheelbase	Van					
S7F	Transit Connect	XL	Long Wheelbase	Van					
E6E	Transit Connect	XL	Short Wheelbase	Van					
E7E	Transit Connect	XL	Long Wheelbase	Van					
E6F	Transit Connect	XL	Short Wheelbase	Van					
E7F	Transit Connect	XL	Long Wheelbase	Van					
S9E	Transit Connect	XL	Long Wheelbase	Wagon					
S8F	Transit Connect	XL	Short Wheelbase	Wagon					
S9F	Transit Connect	XL	Long Wheelbase	Wagon					
E9E	Transit Connect	XL	Long Wheelbase	Wagon					
E8F	Transit Connect	XL	Short Wheelbase	Wagon					
E9F	Transit Connect	XL	Long Wheelbase	Wagon					
E8G	Transit Connect	Titanium	Short Wheelbase	Wagon					
E9G	Transit Connect	Titanium	Long Wheelbase	Wagon					
S7P	Transit Connect	XL	Long Wheelbase	Van	Canadian Postal				
S6H	Transit Connect	XL	Short Wheelbase	Van					
S7H	Transit Connect	XL	Long Wheelbase	Van					
S6J	Transit Connect	XL	Short Wheelbase	Van					
S7J	Transit Connect	XL	Long Wheelbase	Van					
E6H	Transit Connect	XL	Short Wheelbase	Van					
E7H	Transit Connect	XL	Long Wheelbase	Van					
E6J	Transit Connect	XL	Short Wheelbase	Van					
E7J	Transit Connect	XL	Long Wheelbase	Van					
E1Z	Transit	150	SRW	Van	Truck/IV	8600#	Low	60/40	130
E1Y	Transit	150	SRW	Van	Truck/IV	8600#	Low	Slide	130
E9Z	Transit	150	SRW	Van	Truck/IV	8600#	Low	60/40	148
E2Y	Transit	150	SRW	Van	Truck/IV	8600#	Low	Slide	148
R1Z	Transit	250	SRW	Van	Truck/IV	9000#	Low	60/40	130
R1Y	Transit	250	SRW	Van	Truck/IV	9000#	Low	Slide	130
R2Z	Transit	250	SRW	Van	Truck/IV	9000#	Low	60/40	148
R2Y	Transit	250	SRW	Van	Truck/IV	9000#	Low	Slide	148
W1Z	Transit	350	SRW	Van	Truck/IV	9500#	Low	60/40	130
W1Y	Transit	350	SRW	Van	Truck/IV	9500#	Low	Slide	130
W2Z	Transit	350	SRW	Van	Truck/IV	9500#	Low	60/40	148
W2Y	Transit	350	SRW	Van	Truck/IV	9500#	Low	Slide	148
K1Z	Transit	150	SRW	Wagon	MPV/IV	8550#	Low	60/40	130
K1Y	Transit	150	SRW	Wagon	MPV/IV	8550#	Low	Slide	130
X2Z	Transit	350	SRW	Wagon	Bus/IV	9000#/9250 Di	Low	60/40	148
X2Y	Transit	350	SRW	Wagon	Bus/IV	9000#/9250 Di	Low	Slide	148
E1C	Transit	150	SRW	Van	Truck/IV	8600#	Med	Slide	130
E1D	Transit	150	SRW	Van	Truck/IV	8600#	Med	Dual	130
E2C	Transit	150	SRW	Van	Truck/IV	8600#	Med	Slide	148
E2D	Transit	150	SRW	Van	Truck/IV	8600#	Med	Dual	148

## 2017 VIN CODES – CONT'D

VIN POSITIONS 5, 6, 7 VIN Code Line Series Body Type for Passenger Cars, Multipurpose Vehicles (MPVs), Buses and Incomplete Vehicles (IVs) with GVW Ratings of 11,000 lbs (4990 kg) or less:									
VIN CODE	Line	Series	Chassis Type	Cab/Body	Vehicle Type	GVWR	Roof	Door	Wheel Base
<b>FORD</b>									
R1C	Transit	250	SRW	Van	Truck/IV	9000#	Med	Slide	130
R1D	Transit	250	SRW	Van	Truck/IV	9000#	Med	Dual	130
R2C	Transit	250	SRW	Van	Truck/IV	9000#	Med	Slide	148
R2D	Transit	250	SRW	Van	Truck/IV	9000#	Med	Dual	148
W9C	Transit	350	SRW	Van	Truck/IV	9500#	Low	Slide	130
W1D	Transit	350	SRW	Van	Truck/IV	9500#	Low	Dual	130
W2C	Transit	350	SRW	Van	Truck/IV	9500#	Med	Slide	148
W2D	Transit	350	SRW	Van	Truck/IV	9500#	Med	Dual	148
K1C	Transit	150	SRW	Wagon	MPV/IV	8550#	Med	Slide	130
X2C	Transit	350	SRW	Wagon	Bus/IV	9000/9150 Gas	Med	Slide	148
R2X	Transit	250	SRW	Van	Truck/IV	9250/9400 Di	High	Slide	148
R2U	Transit	250	SRW	Van	Truck/IV	9000#	High	Dual	148
R3X	Transit	250	SRW	Van EL	Truck/IV	9000#	High	Dual	148
R3U	Transit	250	SRW	Van EL	Truck/IV	9000#	High	Dual	148
W2X	Transit	350	SRW	Van	Truck/IV	9500#	High	Dual	148
W2U	Transit	350	SRW	Van	Truck/IV	9500#	High	Dual	148
W3X	Transit	350	SRW	Van EL	Truck/IV	9500# Gas	High	Slide	148
W3U	Transit	350	SRW	Van EL	Truck/IV	9250# Di	High	Dual	148
X2X	Transit	350	SRW	Wagon	Bus/IV	9000/9150 Gas	High	Slide	148
U4X	Transit	350 HD	DRW	Wagon EL	Bus/IV	9250/9400 Di	High	Slide	148
F4X	Transit	350 HD	DRW	Van EL	Truck/IV	10,360#	High	Slide	148
F4U	Transit	350 HD	DRW	Van EL	Truck/IV	9950#	High	Dual	148
S4X	Transit	350 HD	DRW	Van EL	Truck/IV	9950#	High	Dual	148
S4U	Transit	350 HD	DRW	Van EL	Truck/IV	10,360#	High	Dual	148
R5P	Transit	250	SRW	Cutaway	IV	9000#	N/A	N/A	138
R7P	Transit	250	SRW	Cutaway	IV	9000#	N/A	N/A	156
W5P	Transit	350	SRW	Cutaway	IV	9500#	N/A	N/A	138
W7P	Transit	350	SRW	Cutaway	IV	9500#	N/A	N/A	156
R5Z	Transit	250	SRW	Chassis Cab	IV	9000#	N/A	N/A	138
R7Z	Transit	250	SRW	Chassis Cab	IV	9000#	N/A	N/A	156
W5Z	Transit	350	SRW	Chassis Cab	IV	9500#	N/A	N/A	138
W7Z	Transit	350	SRW	Chassis Cab	IV	9500#	N/A	N/A	156
F6P	Transit	350 HD	DRW	Cutaway	IV	9950#	N/A	N/A	138
F6U	Transit	350 HD	DRW	Cutaway	IV	9950#	N/A	N/A	156
F9P	Transit	350 HD	DRW	Cutaway	IV	9950#	N/A	N/A	178
F6Z	Transit	350 HD	DRW	Chassis Cab	IV	9950#	N/A	N/A	138
F8Z	Transit	350 HD	DRW	Chassis Cab	IV	9950#	N/A	N/A	156
F9Z	Transit	350 HD	DRW	Chassis Cab	IV	9950#	N/A	N/A	178
S6P	Transit	350 HD	DRW	Cutaway	IV	10,360#	N/A	N/A	138
S8P	Transit	350 HD	DRW	Cutaway	IV	10,360#	N/A	N/A	156
S9P	Transit	350 HD	DRW	Cutaway	IV	10,360#	N/A	N/A	178
S6Z	Transit	350 HD	DRW	Chassis Cab	IV	10,360#	N/A	N/A	138
S8Z	Transit	350 HD	DRW	Chassis Cab	IV	10,360#	N/A	N/A	156
S9Z	Transit	350 HD	DRW	Chassis Cab	IV	10,360#	N/A	N/A	178

\*SRW\* = Single Rear Wheels      \*DRW\* = Dual Rear Wheels      \*MPV\* = Multipurpose Passenger Vehicle  
 \*IV\* = Incomplete Vehicle      \*Di\* = Diesel

VIN POSITION 8 Engine Type-Displacement, Cylinders, Fuel Type, Manufacturer and Horsepower (H.P.) Ratings					
CONT'D					
TABLE 2: LIGHT TRUCK/MPV					
VIN CODE	Displacement/Litre	Cylinders	Fuel	Manufacturer	Net Brake H.P.
T	3.5L GTDI	V-6	FFV/Gasoline	Ford	365/320/310
V	3.2L I5 Diesel	I5	Diesel	Ford	185

\*GDI\* = Gasoline Direct Injection      \*DOHC\* = Double Overhead Camshaft  
 \*GTDI\* = Gas Turbocharged Direct Injection      \*PFI\* = Port Fuel Injection  
 \*I-VCT\* = Independent-Variable Cam Timing      \*AIK\* = Atkinson (Electric Motor)  
 \*TI-VCT\* = Twin Independent-Variable Cam Timing

VIN POSITION 8 Engine Type-Displacement, Cylinders, Fuel Type, Manufacturer and Horsepower (H.P.) Ratings					
CONT'D					
TABLE 3: LIGHT/MEDIUM/HEAVY TRUCK (WITH GVW RATINGS OVER 11,000 POUNDS [4990 KG])					
VIN CODE	Displacement/Litre	Cylinders	Fuel	Manufacturer	Net HP / Torque
C	6.7L	V-8	Diesel	Ford	270/675
E	6.7L	V-8	Diesel	Ford	300/700
T	6.8L	V-10	Gasoline	Ford	305
X	6.7L	V-8	Diesel	Ford	440
Y	6.8L	V-10	Gas/Gaseous Prep	Ford	330/725
Y	6.8L 3V	V-10	Gasoline	Ford	330/440
					362@4750rpm/362

VIN POSITION 9 Check Digit	
The check digit must have a value of 0, 1, 2, 3, 4, 5, 6, 7, 8, 9, or X.	

VIN POSITION 10 Vehicle Model Year			
VIN Code	Year		
B	2011	F	2015
C	2012	G	2016
D	2013	H	2017
E	2014	J	2018

VIN POSITION 11 Vehicle Assembly Plant	
VIN Code	Vehicle Assembly Plant Name: Location
B	Oakville: Oakville, Ontario
D	Ohio Assembly: Avon Lake, Ohio
E	Kentucky Truck: Louisville, Kentucky
F	Dearborn: Dearborn, Michigan
G	Chicago: Chicago, Illinois
H	Multimatic: Ontario, Canada
K	Kansas City: Claycomo, Missouri
L	Michigan Assembly: Wayne, Michigan
M	Cuautilán: Cuautilán, Mexico
R	Hermosillo: Hermosillo, Mexico
V	Blue Diamond Truck: Escobedo, Mexico
0	Detroit Empowerment Zone: Detroit, Michigan
5	Flat Rock Assembly Plant (AAI): Flat Rock, Michigan
1	Valencia Assembly Plant: Valencia, Spain
U	Louisville Assembly Plant: Louisville, Kentucky
4	Saarlouis Assembly Plant: Saarlouis, Germany

VIN POSITION 12-17 Sequential Vehicle Identifiers	
<b>Passenger Cars:</b> A unique six digit numeric sequence code is assigned to each passenger car by the vehicle assembly plant of manufacture.	
100001 thru 599999 - Ford Division Vehicles	
600001 thru 999999 - Lincoln Division Vehicles	
<b>Trucks, MPVs, Buses and Incomplete Vehicles:</b> A unique six digit alphanumeric sequence code is assigned for trucks, MPVs, buses and related incomplete vehicles.	
A00001 thru F99999 - Ford Division Vehicles (except Transit Connect)	
J00001 thru L99999 - Lincoln Division Vehicles	
000001 thru 999999 - Ford Built By Blue Diamond	
000001 thru 999999 - Ford Transit Connect	

VIN POSITION 8 Engine Type-Displacement, Cylinders, Fuel Type, Manufacturer and Horsepower (H.P.) Ratings					
CONT'D					
TABLE 1: PASSENGER CAR					
VIN CODE	Displacement/Litre	Cylinders	Fuel	Manufacturer	Net Brake H.P.
2	2.0L GDI	I-4	Gasoline	Ford	160
4	Electric	Lithium-Ion	Electric	Ford	107 kW
7	2.5L	I-4	Gasoline	Ford	TBD
8	3.5L Ti-VCT	V-6	Gasoline	Ford	288
9	2.0L GTDI	I-4	Gasoline	Ford	240/252 Prem fuel
9	2.0L GTDI High Output	I-4	Gasoline	Ford	240 Prem fuel
C	2.0L GTDI	I-4	Gasoline	Ford	TBD/240
9	3.0L	V-6	Gasoline	Ford	350
C	3.0L GTDI	V-6	Gasoline	Ford	400
D	1.5L	I-4	Gasoline	Ford	181
E	1.0L Fox GTDI	I-3	Gasoline	Ford	123
E	1.0L GTDI	I-3	Gasoline	Ford	123
F	5.0L 8*84V	V-8	Gasoline	Ford	435 Prem
H	2.3L GTDI	I-4	Gasoline	Ford	350
H	2.3L 4V	I-4	Gasoline	Ford	310 Prem
F9	3.7L Ti-VCT	V-6	Gasoline	Ford	TBD/305
J	1.6L Ti-VCT	I-4	Flex	Ford	197 Prem Fuel
M	3.7L 4V	V-6	Gasoline	Ford	300
N	2.0L GTDI Low output	I-4	Gasoline	Ford	TBD
P	2.7L	V-6	Gasoline	Ford	325
P	2.7L GTDI	V-6	Gasoline	Ford	335
T	2.5L	I-4	Gasoline	Ford	141
T	3.5L GTDI	V-6	Gasoline	Ford	365
U	2.0L ATK iVCT	I-4	Hybrid/Electric	Ford	188
W	3.5L GTDI	V-6	Gasoline	Ford	TBD
X	1.6L GTDI	I-4	Gasoline	Ford	120
Z	5.2L TiVCT	V-8	Gasoline	Ford	526

VIN POSITION 8 Engine Type-Displacement, Cylinders, Fuel Type, Manufacturer and Horsepower (H.P.) Ratings					
CONT'D					
TABLE 2: LIGHT TRUCK/MPV					
VIN CODE	Displacement/Litre	Cylinders	Fuel	Manufacturer	Net Brake H.P.
6	6.2L	V-8	Gasoline	Ford	383
7	2.5L iVCT	I-4	Gasoline	Ford	168
7	2.5L DOHC PFI	I-4	Gasoline	Ford	169
8	3.5L	V-6	Gasoline	Ford	TBD/287
8	3.5L Ti-VCT	V-6	Gasoline	Ford	290/282
9	2.0L GTDI	I-4	Gasoline	Ford	TBD
9	2.0L	I-4	Gasoline	Ford	240 w/ Prem. Fuel
9	2.0L EcoBoost	I-4	Gasoline	Lincoln	237 HP
D	1.5L GTDI Sigma	I-4	Gasoline	Ford	170 w/ Prem. Fuel
F	5.0L 4V	V-8	Gasoline	Ford	386
G	3.5L EcoBoost	V-6	Gasoline	Ford	310
G	3.5L GTDI	V-6	Gasoline	Ford	365
H	2.3L EcoBoost	I-4	Gasoline	Ford	280
H	2.3L EcoBoost	I-4	Gasoline	Lincoln	275 HP
K	3.7L	V-6	Gasoline	Ford	303
M	3.7	V-6	Gasoline	Ford	275
P	2.7L GTDI	V-6	Gasoline	Ford	TBD
P	2.7L 4V	V-6	Gasoline	Ford	325
P	2.7L GTDI	V-6	Gasoline	Ford	335
R	3.7 Ti-VCT	V-6	Gasoline	Ford	304/303



# Cataloging & Product Line Inquiry/Comment Form

If you would like to state any concerns or make recommendations about the following:

- Product application omissions
- Cataloging part number recommendations
- Application recommendations

Please fill out the attached Cataloging & Product Line Inquiry/Comment Form.

Send completed form to:

**Motorcraft® Publications**  
 16800 Executive Plaza Drive - Cube 3N222  
 Dearborn, MI 48126



CATALOGING & PRODUCT LINE INQUIRY/COMMENT FORM  
 PLEASE DO NOT USE THIS CARD TO ORDER ADDITIONAL CATALOGS

Part or Catalog Description & Number: \_\_\_\_\_

Inquiry/Comment: \_\_\_\_\_  
 \_\_\_\_\_  
 \_\_\_\_\_

Submitted by:      NAME: \_\_\_\_\_

                         ADDRESS: \_\_\_\_\_

PHONE NUMBER: \_\_\_\_\_     Information Only     Response Requested

**Thank you for your interest in Motorcraft® products and your time in submitting this form.**



**Ford Contour**

Part Type	Years	Engine	Qualifier	Ford #
Reman	1998	2.0L	8G-776-**, 8G-775-**, 7G-775-**, 7G-776-**	F8RZ-6V012-ARM

**Country Squire**

Part Type	Years	Engine	Qualifier	Ford #
Reman	1991-1987	5.0L		F1AZ-6V012-BRM

**Crown Victoria**

Part Type	Years	Engine	Qualifier	Ford #
Reman	2011-2009	4.6L	9S-808-AA/AB	9W7Z-6006-ARM
	2011-2010	4.6L FLEX	Police Interceptor; 9S-864-AC	BW7Z-6006-BRM
	2010	4.6L	Police Interceptor; 9S-112-AC	BW7Z-6006-ARM
	2009	4.6L	Police Interceptor; 9S-112-AA/AB/AC	7W7Z-6006-BARM
			Police Interceptor; 9S-864-AA/AB/AC	8W7Z-6006-AARM
		4.6L FLEX	9S-802-AA/AB	7W7Z-6006-CARM
	2008	4.6L	7S-808-AA; 8S-112-AA/AB	7W7Z-6006-BARM
			8S-808-AA	9W7Z-6006-ARM
		4.6L FLEX	8S-864-AA/AB	8W7Z-6006-AARM
			8S-802-AA	7W7Z-6006-CARM
	2007	4.6L	7S-112-AA, 7S-808-AA	7W7Z-6006-BARM
			7S-804-AA	7W7Z-6006-AARM
		4.6L FLEX	7S-802-AA/AB	7W7Z-6006-CARM
	2006	4.6L	w/o Oil Cooler; 6S-804-AA/AB	5W7Z-6006-AARM
			6S-112-AA/AB; w/ Oil Cooler; 6S-808-AA/AB	5W7Z-6006-BARM
			6S-802-AA/AB	6W7Z-6006-AARM
	2005	4.6L	5S-804-AA; 5S-800-AA	5W7Z-6006-AARM
			5S-112-AA; 5S-808-AA	5W7Z-6006-BARM
	2004	4.6L GAS	w/Oil Cooler 4S-112-AA, 4S-808-AA	3W7Z-6006-BARM
			w/o Oil Cooler 4S-800-AA, 4S-804-AA/AB	3W7Z-6006-AARM
	2003	4.6L GAS	w/Oil Cooler 3G-116-**, 3G-808-**	3W7Z-6006-BARM
			3G-112-AA/AB/AC	3W7Z-6006-BARM
			w/o Oil Cooler 3G-804-AA/AB/AC	3W7Z-6006-AARM
	2002	4.6L GAS	w/o Oil Cooler 2G-804-AB/AC	2W7Z-6006-BARM
			w/ Cooler; 2G-808-AC, 2G-808-AB, 2G-116-AC, 2G-116-AB, 2G-112-AC	2W7Z-6006-CARM
			w/ Oil Cooler 2G-808-AB/AC, 2G-112-AB/AC	2W7Z-6006-CARM
	2001	4.6L	1G-112-AA, 1G-116-AA, 1G-808-AA	1W7Z-6006-GRM
			1G-804-AA	1W7Z-6006-FRM
	2000	4.6L	0G-112-AA, 0G-116-AA, 0G-808-AA	YW7Z-6006-ERM
			0G-804-AA	YW7Z-6006-DRM
	1999-1997	4.6L	7G-804-AA, 7G-808-AA, 7G-812-AA, 7G-816-AA, 8G-804-AA, 8G-808-AA, 9G-112-AA, 9G-112-AB, 9G-804-AA/AB, 9G-808-AA/AB	F8AZ-6V012-ARM
	1996	4.6L	6G-808-AA/AB	F8AZ-6V012-ARM

**Escort**

Part Type	Years	Engine	Qualifier	Ford #
Reman	1997	2.0L SOHC	w/ Automatic Trans.	F7CZ-6006-ARM

**Fiesta**

Part Type	Years	Engine	Qualifier	Ford #
New	2016-2015	1.0L EcoBoost		C1BZ-6006-C
	2016-2011	1.6L	Naturally Aspirated	D2BZ-6006-A
	2016-2014	1.6L EcoBoost		C1BZ-6006-B
	2014	1.0L EcoBoost		C1BZ-6006-A

**Five Hundred**

Part Type	Years	Engine	Qualifier	Ford #
Reman	2007	3.0L	7G-352-AA, 7G-354-AA, 7G-358-AA, 7G-360AA	5G1Z-6006-AARM
	2006	3.0L	5G-352-AB/AC, 5G-354-AB/AC, 5G-358-AB/AC, 5G-360-AB/AC, 6G-352-AA/BA/BB, 6G-354-AA/BA/BB, 6G-358-AA/BA/BB, 6G-360-AA/BA/BB	5G1Z-6006-AARM
	2005	3.0L	5G-352-AB, 5G-354-AB, 5G-358-AB, 5G-360-AB	5G1Z-6006-AARM

**Focus**

Part Type	Years	Engine	Qualifier	Ford #
Reman	2017	2.0L EcoBoost	FS-183-AC	HM5Z-6006-ARM
New	2016-2015	1.0L EcoBoost	w/ Standard Trans.	F1FZ-6006-C
	2016	1.0L EcoBoost	w/ Automatic Dual Clutch Trans.; 6F15	G1FZ-6006-A



**Focus**

**-Cont'd**

Part Type	Years	Engine	Qualifier	Ford #
New	2016-2013	2.0L EcoBoost	Exc. 4 or 6 Groove Crankshaft Pulley; DS-328-CA	DM5Z-6006-A
	2016	2.3L EcoBoost		G1FZ-6006-B
Reman	2016-2012	ELECTRIC	1 Spd.; FM58-14B280-DA	FM5Z-14B280-A
	2015	2.0L	May Have 4 Or 6 Groove Crankshaft Pulley; Before 12/08/14	FM5Z-6006-A
	2014-2013	2.0L	May Have 4 Or 6 Groove Crankshaft Pulley	FM5Z-6006-A
	2013	2.0L EcoBoost		DV6Z-6006-AARM
	2012	2.0L	Tag Number: CS170AA,CS171AA	CS4Z-6006-ARM
			Tag Number: CS-170-AB/CS-171-AB, ES-170-AA	CS4Z-6006-BRM
	2011-2010	2.0L	w/ Standard Trans.; w/ PZEV Evaporation; WG-173-AA	8S4Z-6006-AARM
	2010	2.0L	w/ Automatic Trans.; JG-170-AA	8S4Z-6006-AARM
			w/ Automatic Trans.; w/ PZEV Evaporation; WG-172-AA	8S4Z-6006-AARM
			w/ Standard Trans.; JG-171-AA; Exc. PZEV	8S4Z-6006-AARM
	2009-2008	2.0L	JG-170-AA, JG-171-AA, WG-172-AA, WG-173-AA	8S4Z-6006-AARM
	2007	2.0L	HG-170-AA/AB, HG-171-AA/AB, UG-172-AA/AB, UG-173-AA/AB	7S4Z-6006-AARM
		2.3L	7G-299-AA/AB	7L8Z-6006-FARM
		2.0L	6G-170-AA/BA, 6G-171-AA/BA, 6G-172-AA/BA, 6G-173-AA/BA	6S4Z-6006-AARM
	2006-2005	2.3L	4G-299-AA	5S4Z-6006-BARM
	2006	2.3L	6G-299-BA	6S4Z-6006-BARM
	2005	2.0L	w/ Automatic Trans.; 4G-172-AA; 4G-170-AA	5S4Z-6006-AARM
			w/ Standard Trans.; 4G-173-AA; 4G-171-AA	5S4Z-6006-AARM
	2004	2.0L DOHC	SVT; 2G-787-AB,2G-789-AB	2M5Z-6006-BARM
			3G-780-CA, 3G-784-CA	3M5Z-6006-BARM
2004-2003	2.0L SOHC	3G-452-AA, 3G-453-AA, 3G-454-AA, 3G-455-AA	2M5Z-6006-BRM	
2004	2.3L	3G-282-AB, 3G-283-AB	3M5Z-6006-CARM	
2003	2.0L DOHC	SVT; 2G-787-AA/AB, 2G-789-AA/AB	2M5Z-6006-BARM	
		3G-780-AA, 3G-784-AA	3M5Z-6006-BARM	
	2.3L	3G-282-AA, 3G-283-AA	3M5Z-6006-CARM	
2002	2.0L DOHC	SVT; 2G-787-AA, 2G-789-AA	2M5Z-6006-BARM	
		2G-779-AA, 2G-780-AA,AB,BA,DA, 2G-784-AA,AB,BA,DA, 2G-785-AA	2S4Z-6006-AARM	
	2.0L SOHC	2G-452-AA, 2G-453-AA, 2G-454-AA, 2G-455-AA	2M5Z-6006-BRM	
2001	2.0L DOHC	1G-779-**, 1G-780-**, 1G-784-**, 1G-785-**	2S4Z-6006-AARM	
	2.0L SOHC	1G-452-BA, 1G-453-BA, 1G-454-BA, 1G-455-BA	2M5Z-6006-BRM	
2000	2.0L DOHC	0G-779-AA/BA/CA, 0G-780-AA/BA/CA, 0G-784-AA/BA, 0G-785-AA/BA	YM5Z-6V012-ARM	
	2.0L SOHC	0G-452-BA, 0G-453-BA, 0G-454-BA, 0G-455-BA	2M5Z-6006-ARM	

**Freestyle**

Part Type	Years	Engine	Qualifier	Ford #
Reman	2007	3.0L	7G-352-AA,7G-354-AA,7G-358-AA,7G-360AA	5G1Z-6006-AARM
	2006	3.0L	5G-352-AB/AC,5G-354-AB/AC,5G-358-AB/AC,5G-360-AB/AC,6G-352-AA/BA/BB,6G-354-AA/BA/BB,6G-358-AA/BA/BB,6G-360-AA/BA/BB	5G1Z-6006-AARM
	2005	3.0L	5G-354-AB, 5G-360-AB	5G1Z-6006-AARM

**Fusion**

Part Type	Years	Engine	Qualifier	Ford #
New	2017	2.0L EcoBoost		HS7Z-6006-B
		2.5L		GV6Z-6006-AA
	2016-2014	1.5L EcoBoost		DS7Z-6006-E
	2016-2013	2.0L ELECTRIC/GAS		DS7Z-6006-C
		2.5L GAS		CV6Z-6006-A
Reman	2014-2013	1.6L EcoBoost		CJ5Z-6006-G
	2012	2.5L GAS	From 12/05/11	CE5Z-6006-A
		3.0L	1G-758-BA	9L8Z-6006-BRM
	2012-2011	3.0L	1G-758-AA	9L8Z-6006-BRM
		3.5L	Naturally Aspirated; w/o Trailer Tow	9H6Z-6006-ARM
	2012-2010	3.5L	BS-228BA/CA	BP5Z-6006-BARM
	2012-2011	3.5L	BS-228-AA	BP5Z-6006-AARM
	2011-2010	2.5L	9G-315-AA/BA; 0G-316-AA; 9G-316-AA/BA	9L8Z-6006-BARM
			Hybrid; 9G-314-AA/AC	9E5Z-6006-FRM
	2010	3.0L	0G-758-BA	9L8Z-6006-BRM
	2009-2007	2.3L	7G-287-AA, HG-286-AA, UG-298-AA	7E5Z-6006-AARM
	2009-2006	3.0L	6A-852-AA,7A-852-AA	6E5Z-6006-AARM
2006	2.3L	6G-287-AA/AB/AC, TG-298-AA/AB/AC, ZG-286-AA/AB/AC	6E5Z-6006-BARM	

**GT**

Part Type	Years	Engine	Qualifier	Ford #
New	2017	3.5L EcoBoost	Engine Assembly (Complete)	HG7Z-6007-A

**LTD**

Part Type	Years	Engine	Qualifier	Ford #
Reman	1986	5.0L	FI	E6AZ-6V012-ARM



LTD

-Cont'd

Part Type	Years	Engine	Qualifier	Ford #
Reman	1985-1984 1983	5.0L 5.0L	CARB; w/ 1 Piece Crankshaft Seal w/1 Piece Crankshaft Seal-From12/1/82	E5AZ-6V012-ARM E5AZ-6V012-ARM

LTD Crown Victoria

Part Type	Years	Engine	Qualifier	Ford #
Reman	1991-1987	5.0L		F1AZ-6V012-BRM

Mustang

Part Type	Years	Engine	Qualifier	Ford #
New	2016	2.3L EcoBoost	w/o Instrument Guages w/ Instrument Guages	GR3Z-6006-D GR3Z-6006-E BR3Z-6006-M
	2016-2011	3.7L		FR3Z-6006-B
	2016-2015	5.0L	w/ High Performance LS Package w/o Performance Package w/ 6R80 Transmission; LHD	FR3Z-6006-G FR3Z-6006-H GR3Z-6006-C
	2016	5.0L	RHD	GR3Z-6006-B
	2016-2015	5.2L	w/ Powertrain Coolers	GR3Z-6006-BRM
Reman	2016	3.7L	GM-210-BA/CA, GM-211BA/CA/DA	GR3Z-6006-HRM
New	2014-2011	5.0L	w/o Premium Brakes	ER3Z-6006-A
	2014-2012	5.0L	w/ Standard Trans.; w/ Premium Brakes	ER3Z-6006-B
		5.0L 32 Valves	May Require 4 WPT-1214 Pigtails For VCT	CR3Z-6006-D
	2014-2013	5.8L	w/o Super Engine Cooling System w/ Super Engine Cooling System	DR3Z-6006-A DR3Z-6006-B
Reman	2014-2011	5.0L 32 Valves	w/ Premium Turbo Brakes	DR3Z-6006-DARM
	2013-2011	3.7L	w/o Engine Oil Cooler; 1G-372-AA/BA/CA; 1G-373-AA/BA/CA/DA	BR3Z-6006-CARM
		5.0L	BG-397-AA/AB, BG-398-AA/AB	BR3Z-6006-BRM
New	2012	5.0L	3 Bolt Waterpump Pulley	EL3Z-6006-C
	2010-2008	5.4L	Shelby GT500	AR3Z-6006-A
Reman	2010	4.0L	w/ Standard Trans.; 0S-975-AA	9R3Z-6006-BRM
		4.6L	w/ Automatic Trans.; AS-836-AA	AR3Z-6006-BRM
			w/ Standard Trans.; AS-837-AA	AR3Z-6006-BRM
	2009	4.0L	w/ Automatic Trans.; 9S-974-AA	7R3Z-6006-CARM
			w/ Standard Trans.; 9S-975-AA	9R3Z-6006-BRM
		4.6L	9S-836-AA, 9S-837-AA	8R3Z-6006-AARM
	2008	4.0L	w/ Automatic Trans.; 8G-974-AA	7R3Z-6006-CARM
			w/ Standard Trans.; 8G-975-AA	7R3Z-6006-DARM
		4.6L	8S-836-AB, 8S-837-AB	8R3Z-6006-AARM
			8S-836-AA, 8S-837-AA	7R3Z-6006-AARM
			8S-303-AA	8R3Z-6006-BARM
	2007	4.0L	w/ Automatic Trans.; 7G-974-AA	6R3Z-6006-AARM
			w/ Standard Trans.; 7G-975-AA	6R3Z-6006-BARM
			w/ Automatic Trans.; 7G-974-AB	7R3Z-6006-CARM
			w/ Standard Trans.; 7G-975-AB	7R3Z-6006-DARM
		4.6L	w/ Automatic Trans.; 7S-836-AA, 7S-836-BA, 7S-836-BB	7R3Z-6006-AARM
			w/ Standard Trans.; 7S-837-BA, 7S-837-AA, 7S-837-BB	7R3Z-6006-AARM
	2006	4.0L	w/ Automatic Trans.; 6G-974-AA/AB	6R3Z-6006-AARM
			w/ Standard Trans.; 6G-975-AA/AB	6R3Z-6006-BARM
		4.6L	6S-836-AA/AB; 6S-837-AA/AB	5R3Z-6006-BARM
	2005	4.0L	w/ Standard Trans.; 5G-975-BA	5R3Z-6006-CARM
			w/ Automatic Trans.; 5G-974-AA	5R3Z-6006-AARM
		4.6L	5S-690-AA, 5S-691-AA; 5S-836-AA, 5S-837-AA	5R3Z-6006-BARM
	2004	3.9L	3G-530-CA, 3G-531-CA	4R3Z-6006-AARM
		4.6L	3G-836-AA, 3G-837-AA	3R3Z-6006-DARM
		4.6L DOHC	Mach I; w/ Automatic Trans.; 4S-300-AA	3R3Z-6006-BBRM
	2004-2003	4.6L SOHC	3G-386-AA; 3G-387-AA	3R3Z-6006-DARM
	2003	3.8L	3G-530-BA, 3G-531-BA	3R3Z-6006-ABRM
			2G-530-AA, 2G-531-AA	2R3Z-6006-DBRM
		4.6L	w/ Automatic Trans.; 3G-300-BB	3R3Z-6006-BBRM
		4.6L DOHC	Mach I; w/ Automatic Trans.; 3G-300-AA; 3G-300-BB	3R3Z-6006-BBRM
	2003-2002	4.6L SOHC	2G-836-AA/AB, 2G-837-AA/AB	2R3Z-6006-BARM
	2002	3.8L	1G-530-BA, 1G-531-BA, 2G-530-AA, 2G-531-AA	2R3Z-6006-DBRM
	2001	3.8L	1G-530AA/BA, 1G-531-AA/BA	2R3Z-6006-DBRM
		4.6L	1G-837-AA/AB/AC	1R3Z-6006-FRM
			w/ Standard Trans.; 1G-801-AA	1R3Z-6006-BARM
		4.6L SOHC	1G-836-AA	1R3Z-6006-FRM
	2000-1999	3.8L	KK-530-AA, KK-531-AA, XK-530-AA, XK-531-AA, AK-530-AA, AK-531-AA, SK-530-AA, SK-531-AA; w/ Dampener #XR3Z-6B321-AA	XR3Z-6006-CRM
	2000	3.8L	w/ Dampener #1R3Z-6B321-BA; AK-530/531-BA, SK-530/531-BA	2R3Z-6006-DBRM
		4.6L	w/ Standard Trans.; 0A-103-AA	YR3Z-6006-KRM
		4.6L SOHC	w/ Automatic Trans.; 0A-100-AA	YR3Z-6006-JRM
	1999	4.6L	w/ Standard Trans.; 9A-103-AA	XR3Z-6006-HRM
		4.6L DOHC	9G-839-AA	XR3Z-6006-YARM
	1998-1997	3.8L		F7ZZ-6V012-AARM
	1998-1996	4.6L SOHC	6A-836-AA, 6A-837-AA, 6B-836-AA, 6B-837-AA, 6D-837-AA, 7A-836-AB, 7A-837-AA/AB/AC, 7B-837-AA/AB/AC, 7D-837-AB, 8A-100-AA, 8A-101-AA, 8A-836-AA, 8A-837-AA, 8B-836-AA, 8B-837-AA	F8AZ-6V012-ARM



**Mustang**

-Cont'd

Part Type	Years	Engine	Qualifier	Ford #
Reman	1996	3.8L		F6ZZ-6V012-AARM
		4.6L DOHC	6G-839-AA	F6ZZ-6006-BRM
	1995-1994	3.8L		F4SZ-6V012-ARM
		5.0L	GT	F4ZZ-6V012-ARM
	1993	5.0L	GT	F1ZZ-6V012-BRM
	1992-1989	5.0L		F1ZZ-6V012-BRM
	1988-1987	5.0L	FI	F1ZZ-6V012-BRM

**Police Interceptor Sedan**

Part Type	Years	Engine	Qualifier	Ford #
New	2016-2015	3.5L EcoBoost		FG1Z-6006-B
	2016-2013	3.7L	Exc. Banjo Style	BA5Z-6006-D
	2014-2013	3.5L EcoBoost		DG1Z-6006-A

**Taurus**

Part Type	Years	Engine	Qualifier	Ford #
New	2016-2013	2.0L EcoBoost		DA8Z-6006-B
	2016-2012	3.5L	Naturally Aspirated; w/ Engine Oil Cooler; Remove Cooler If Not Needed	DL2Z-6006-D
	2016-2015	3.5L EcoBoost		FG1Z-6006-A
Reman	2013	2.0L EcoBoost	DV-202-AA, DX-184-CA	DA8Z-6006-ARM
	2013-2012	3.5L	Naturally Aspirated; w/ Engine Oil Cooler; 1S-342-DA, DS-342-AA, FS-342-AA/BA, FS-906-AA, GS-906-AA	DL2Z-6006-ARM
			Naturally Aspirated; w/o Engine Oil Cooler; 1S-344-DA, DS-344-AA, FS-344-AA/BA, DS/FS/GS-908-AA	DL2Z-6006-BRM
New	2012-2011	3.5L EcoBoost		AA5Z-6006-D
Reman	2012-2010	3.5L	BS-228BA/CA	BP5Z-6006-BARM
	2012-2011	3.5L	BS-228-AA	BP5Z-6006-AARM
		3.5L EcoBoost	w/ Engine Oil Cooler	BA8Z-6006-BARM
			w/o Engine Oil Cooler; BG-234-BA; BG-234-CA	BG1Z-6006-BARM
			w/o Engine Oil Cooler; BG-234-AA	BG1Z-6006-AARM
	2012	3.5L EcoBoost	1S-490-DA, DS-490-AA/BA, FS/GS-490-AA	DF1Z-6006-DRM
	2011-2009	3.5L	Naturally Aspirated; w/o Trailer Tow	9H6Z-6006-ARM
	2011	3.5L EcoBoost	1S-490-BA, CA	BA5Z-6006-AARM
	2010	3.5L	Turbocharged; w/o Oil Cooler; OS-490-AA	AU7Z-6006-ARM
	2009-2008	3.5L	9G-224-AA	7H6Z-6006-AARM
	2008	3.5L	WG-368-AA/AB/AC	7H6Z-6006-AARM
	2007-2006	3.0L 12 Valves	6A-550-AA, 6A-558-AA	4F1Z-6006-CARM
	2005	3.0L 12 Valves	4G-558-AB, 5A-550-AA, 5A-558-AA	4F1Z-6006-CARM
	2005-2004	3.0L 24 Valves	4G-850-AA, 5S-850-AA	4F1Z-6006-BARM
	2004	3.0L 12 Valves	4S-550-AA/AB, 4G-558-AA/AB	4F1Z-6006-CARM
	2003-2002	3.0L 12 Valves	2G-550-AA, 2G-258-AA, 3S-550-AA, 3S-560-AA	3F1Z-6006-DARM
	2003	3.0L 24 Valves	3S-850-AA	3F1Z-6006-CBRM
	2002-2001	3.0L 24 Valves	1G-850-AA, 2G-850-AA/BA	1F1Z-6006-ABRM
	2001	3.0L 12 Valves	1G-550-AA, 1G-558-AA	YF1Z-6006-CRM
	2000	3.0L 12 Valves	0G-558-AA, AG-550-BA, SK-550-BA	YF1Z-6006-CRM
	1999	3.0L 12 Valves	9G-558-AA, KG-550-AA/AB, XK-550-AA	XF1Z-6006-CRM
	1993-1988	3.8L		F1DZ-6V012-BRM

**Taurus X**

Part Type	Years	Engine	Qualifier	Ford #
Reman	2009-2008	3.5L	9G-224-AA	7H6Z-6006-AARM
	2009	3.5L	Naturally Aspirated; w/o Trailer Tow	9H6Z-6006-ARM
	2008	3.5L	WG-368-AA/AB/AC	7H6Z-6006-AARM

**Thunderbird**

Part Type	Years	Engine	Qualifier	Ford #
Reman	2004	3.9L	w/ Engine Oil Cooler; 4G-208-AA	4W4Z-6006-BARM
	2003	3.9L	w/o Oil Cooler; 3G-204-AA, AB	3W4Z-6006-CARM
			3G-208-AA, AB; w/ Oil Cooler	3W4Z-6006-DARM
	2002	3.9L	w/o Oil Cooler; 1G-204-CA, 2G-204-AA	2W4Z-6006-AARM
	1997	3.8L		F7ZZ-6V012-AARM
	1996	3.8L		F6ZZ-6V012-AARM
	1995-1994	3.8L	VIN 4; Exc. SC	F4SZ-6V012-ARM
	1993-1991	3.8L	Supercharged; VIN R	F3SZ-6V012-ARM
	1993-1989	3.8L	VIN 4	F1SZ-6V012-ARM
	1992-1991	5.0L		F1ZZ-6V012-BRM
	1990-1989	3.8L	Supercharged; w/ Standard Trans.	F3SZ-6V012-ARM
			Supercharged; w/ Automatic Trans.	E9SZ-6V012-BBRM
	1988-1987	5.0L		F1AZ-6V012-BRM
	1986	5.0L	FI	E6AZ-6V012-ARM





**Continental**

Part Type	Years	Engine	Qualifier	Ford #
Reman	2002-2001	4.6L	1G-822-AA	2F3Z-6006-ABRM
	1993-1991	3.8L		F15Z-6V012-ABRM
	1990-1989	3.8L		F1DZ-6V012-BRM
	1987	5.0L		F1AZ-6V012-BRM
	1986	5.0L	FI	E6AZ-6V012-ARM

**LS**

Part Type	Years	Engine	Qualifier	Ford #
Reman	2006	3.9L	w/ Engine Oil Cooler; 6G-208-AA/BA	4W4Z-6006-BARM
	2005-2003	3.0L	3G-230-AA/AB, 4G-230-AA,5G-230-AA	3W4Z-6006-ABRM
	2005	3.9L	w/ Engine Oil Cooler; 5G-208-AA	4W4Z-6006-BARM
	2004	3.9L	w/ Engine Oil Cooler; 4G-208-AA	4W4Z-6006-BARM
	2003	3.9L	w/o Engine Oil Cooler; 3G-204-AA, AB	3W4Z-6006-CARM
			3G-208-AA, AB; w/ Oil Cooler	3W4Z-6006-DARM
	2002-2001	3.0L	1G-230-AA/AB/AC/AD, 2G-230-AA	1W4Z-6006-YBRM
			1G-231-AA/AB/AC/AD, 1G-232-AA/AB/AC/AD,2G-231-AA, 2G-232-AA	2W4Z-6006-ABRM
	2002	3.9L	w/o Engine Oil Cooler; 1G-204-CA,2G-204-AA	2W4Z-6006-AARM
			1G-204-AA/BA/BB	2W4Z-6006-EARM
	2001	3.9L	w/o Engine Oil Cooler; 1G-204-CA	2W4Z-6006-AARM
			1D-206-AA/BA/BB, 1G-208-AA/BA/BB	2W4Z-6006-FARM
			9G-237-AA, 9G-238-AA/AB, XG-231-AA/AB, XG-232-AA/AB; w/ Oil Cooler	XW4Z-6006-BRM
			9G-231-AA, KG-230-AA/AB, XG-230-AA/AB	XW4Z-6006-ARM
			9G-204-BA	2W4Z-6006-EARM
2000	3.0L	9D-206-AA, 9G-208-AA	2W4Z-6006-FARM	
		3.9L		

**MKS**

Part Type	Years	Engine	Qualifier	Ford #
New	2016-2015	3.5L EcoBoost		FG1Z-6006-A
	2016-2009	3.7L	1 Bolt Banjo Style	9A5Z-6006-A
	2016-2013	3.7L	Exc. Banjo Style	BA5Z-6006-D
	2014-2011	3.5L EcoBoost		AA5Z-6006-D
Reman	2012	3.5L EcoBoost	1S-490-DA, DS-490-AA/BA, FS/GS-490-AA	DF1Z-6006-DRM
			w/o Engine Oil Cooler; BG-496-BA/CA	BA5Z-6006-DDRM
	2012-2010	3.7L	w/ Engine Oil Cooler; BG-498-BA/CA	BE9Z-6006-BARM
			1S-490-BA,CA	BA5Z-6006-AARM
2011	3.5L EcoBoost	w/o Engine Oil Cooler; BG-496-AA	BA5Z-6006-CCRM	
		w/ Engine Oil Cooler	BE9Z-6006-AARM	
New Reman	2010-2009	3.7L	3 Bolt Non-Banjo Style	9A5Z-6006-J
	2010	3.5L	Turbocharged; w/o Oil Cooler; 0S-490-AA	AU7Z-6006-ARM
	2010-2009	3.7L	w/o Engine Oil Cooler; 9G-496-BA; 3 Bolt Non-Banjo Style	9G1Z-6006-CRM
	2010	3.7L	w/ Engine Oil Cooler; 0G-498-AA	AG1Z-6006-ARM
	2009	3.7L	w/o Engine Oil Cooler; 9G-496-AA; 1 Bolt Banjo Style	9G1Z-6006-ARM

**MKZ**

Part Type	Years	Engine	Qualifier	Ford #
New	2017	2.0L EcoBoost		HS7Z-6006-B
	2016-2013	2.0L ELECTRIC/GAS		DS7Z-6006-C
	2016	2.0L EcoBoost		CJ5Z-6006-H
	2016-2013	3.7L	Exc. Banjo Style	BA5Z-6006-D
	2015	2.0L EcoBoost	Before 1/26/15	CJ5Z-6006-C
			From 1/26/15	CJ5Z-6006-H
Reman	2014-2013	2.0L EcoBoost		CJ5Z-6006-C
	2012-2009	3.5L	Naturally Aspirated; w/o Trailer Tow	9H6Z-6006-ARM
	2012-2010	3.5L	BS-228BA/CA	BP5Z-6006-BARM
	2012-2011	3.5L	BS-228-AA	BP5Z-6006-AARM
	2009	3.5L	9G-228-AA	7H6Z-6006-AARM
	2008-2007	3.5L	7G-228-AA, 9G-224-AA, 9G-228-AA	7H6Z-6006-AARM

**Mark VII**

Part Type	Years	Engine	Qualifier	Ford #
Reman	1992-1988	5.0L	LSC	F1ZZ-6V012-BRM
	1987	5.0L	Base	F1AZ-6V012-BRM
	1986	5.0L	FI; Exc. HO	E6AZ-6V012-ARM

**Town Car**

Part Type	Years	Engine	Qualifier	Ford #
Reman	2011	4.6L FLEX	9S-802-AB	7W7Z-6006-CARM



**Town Car**

**-Cont'd**

Part Type	Years	Engine	Qualifier	Ford #
Reman	2010-2009	4.6L	9S-808-AA/AB	9W7Z-6006-ARM
		4.6L FLEX	9S-802-AA/AB	7W7Z-6006-CARM
	2008	4.6L	7S-808-AA	7W7Z-6006-BARM
			8S-808-AA	9W7Z-6006-ARM
		4.6L FLEX	8S-802-AA	7W7Z-6006-CARM
	2007	4.6L	7S-112-AA, 7S-808-AA	7W7Z-6006-BARM
			7S-804-AA	7W7Z-6006-AARM
		4.6L FLEX	7S-802-AA	7W7Z-6006-CARM
	2006	4.6L	6S-808-AA/AB	5W7Z-6006-BARM
		4.6L FLEX	6S-802-AA/AB	6W7Z-6006-AARM
	2005	4.6L	5S-804-AA	5W7Z-6006-AARM
	2004	4.6L	w/Oil Cooler 4S-116-AA	3W7Z-6006-BARM
	2004-2003	4.6L	3G-114-AA/AB/AC, 3G-804-AA/AB/AC, 4S-114-AA, 4S-800-AA, 4S-804-AA/AB	3W7Z-6006-AARM
	2003	4.6L	w/Oil Cooler 3G-116-**	3W7Z-6006-BARM
	2002	4.6L	w/o Oil Cooler; 2G-114-AB/AC	2W7Z-6006-BARM
			w/ Oil Cooler 2G-116-AB,AC	2W7Z-6006-CARM
	2001	4.6L	1G-116-AA	1W7Z-6006-GRM
		1G-114-AA	1W7Z-6006-FRM	
2000	4.6L	0G-116-AA	YW7Z-6006-ERM	
		0G-114-AA	YW7Z-6006-DRM	
1990-1987	5.0L		F1AZ-6V012-BRM	
1986	5.0L	FI	E6AZ-6V012-ARM	
1983	5.0L	w/ 1 Piece Crankshaft Seal From 12/1/82	E5AZ-6V012-ARM	

**Zephyr**

Part Type	Years	Engine	Qualifier	Ford #
Reman	2006	3.0L	6A-852-AA,7A-852-AA	6E5Z-6006-AARM

**Mazda**

**6**

Part Type	Years	Engine	Qualifier	Ford #
New	2016-2014, 2010-2009	2.5L	6 Spd.; w/ Standard Trans.; USA	9B4Z-6006-F
			6 Spd.; w/ Standard Trans.; Mexico	9B4Z-6006-H
	2013-2009	2.5L	5 Spd.; w/ Automatic Trans.; Mexico	9M8Z-6006-BRM

**Mercury**

**Colony Park**

Part Type	Years	Engine	Qualifier	Ford #
Reman	1991-1987	5.0L		F1AZ-6V012-BRM

**Cougar**

Part Type	Years	Engine	Qualifier	Ford #
Reman	1997	3.8L		F7ZZ-6V012-AARM
	1996	3.8L		F6ZZ-6V012-AARM
	1995-1994	3.8L		F4SZ-6V012-ARM
	1993-1991	3.8L		F1SZ-6V012-ARM
	1992-1991	5.0L		F1ZZ-6V012-BRM
	1990-1989	3.8L	Supercharged; VIN R; w/ Standard Trans.	F3SZ-6V012-ARM
			Supercharged; VIN R; w/ Automatic Trans.	E9SZ-6V012-BBRM
			VIN 4	F1SZ-6V012-ARM
	1988-1987	5.0L		F1AZ-6V012-BRM
	1986	5.0L	FI	E6AZ-6V012-ARM
	1984	5.0L	w/ 1 Piece Crankshaft Seal	E5AZ-6V012-ARM
	1983	5.0L	w/ 1 Piece Crankshaft Seal-From 12/1/82	E5AZ-6V012-ARM

**Grand Marquis**

Part Type	Years	Engine	Qualifier	Ford #
Reman	2011-2009	4.6L	9S-808-AA/AB	9W7Z-6006-ARM
	2009	4.6L FLEX	9S-802-AA/AB	7W7Z-6006-CARM
	2008-2007	4.6L	7S-808-AA	7W7Z-6006-BARM
	2008	4.6L	8S-808-AA	9W7Z-6006-ARM
		4.6L FLEX	8S-802-AA	7W7Z-6006-CARM
	2007	4.6L	7S-804-AA	7W7Z-6006-AARM
		4.6L FLEX	7S-802-AA/AB	7W7Z-6006-CARM
	2006	4.6L	w/o Oil Cooler; 6S-804-AA/AB	5W7Z-6006-AARM
			w/ Oil Cooler; 6S-808-AA/AB	5W7Z-6006-BARM
			6S-802-AA/AB	6W7Z-6006-AARM
	2005	4.6L	w/o Oil Cooler; 5S-804-AA	5W7Z-6006-AARM
		w/ Oil Cooler; 5S-808-AA	5W7Z-6006-BARM	



**Grand Marquis**

-Cont'd

Part Type	Years	Engine	Qualifier	Ford #
Reman	2004-2003	4.6L	3G-112-AA/AB/AC, 4S-112-AA, 4S-116-AA, 4S-808-AA	3W7Z-6006-BARM
	2004	4.6L	w/Oil Cooler 4S-112-AA, 4S-808-AA	3W7Z-6006-BARM
			w/o Oil Cooler 4S-800-AA, 4S-804-AA/AB	3W7Z-6006-AARM
	2003	4.6L	w/Oil Cooler 3G-116-**	3W7Z-6006-BARM
			w/o Oil Cooler 3G-804-AA,AB,AC	3W7Z-6006-AARM
	2002	4.6L	w/o Oil Cooler 2G-804-AB/AC	2W7Z-6006-BARM
			w/ Oil Cooler 2G-808-AB/AC, 2G-112-AB/AC	2W7Z-6006-CARM
	2001	4.6L	1G-808-AA	1W7Z-6006-GRM
			1G-804-AA	1W7Z-6006-FRM
2000	4.6L	0G-808-AA	YW7Z-6006-ERM	
		0G-804-AA	YW7Z-6006-DRM	
1991-1987	5.0L		F1AZ-6V012-BRM	
1986	5.0L	FI	E6AZ-6V012-ARM	
1983	5.0L	w/ 1 Piece Crankshaft Seal From 12/1/82	E5AZ-6V012-ARM	

**Milan**

Part Type	Years	Engine	Qualifier	Ford #
Reman	2011-2010	2.5L	0G-316-AA	9L8Z-6006-BARM
			Hybrid; 9G-314-AA	9E5Z-6006-FRM
	2009-2006	3.0L	6A-852-AA,7A-852-AA	6E5Z-6006-AARM

**Montego**

Part Type	Years	Engine	Qualifier	Ford #
Reman	2007	3.0L	7G-352-AA,7G-354-AA,7G-358-AA,7G-360AA	5G1Z-6006-AARM
	2006	3.0L	5G-352-AB/AC,5G-354-AB/AC,5G-358-AB/AC,5G-360-AB/AC,6G-352-AA/BA/BB,6G-354-AA/BA/BB,6G-358-AA/BA/BB,6G-360-AA/BA/BB	5G1Z-6006-AARM
	2005	3.0L	5G-352-AB, 5G-354-AB, 5G-358-AB, 5G-360-AB	5G1Z-6006-AARM

**Mystique**

Part Type	Years	Engine	Qualifier	Ford #
Reman	1998	2.0L	8G-776-**, 8G-775-**, 7G-775-**, 7G-776-**	F8RZ-6V012-ARM

**Sable**

Part Type	Years	Engine	Qualifier	Ford #
Reman	2009-2008	3.5L	9G-224-AA	7H6Z-6006-AARM
	2009	3.5L	Naturally Aspirated; w/o Trailer Tow	9H6Z-6006-ARM
	2008	3.5L	WG-368-AA/AB/AC	7H6Z-6006-AARM
	2005	3.0L 12 Valves	4G-558-AB, 5A-550-AA, 5A-558-AA	4F1Z-6006-CARM
	2005-2004	3.0L 24 Valves	4G-850-AA, 5S-850-AA	4F1Z-6006-BARM
	2004	3.0L 12 Valves	4S-550-AA/AB, 4G-558-AA/AB	4F1Z-6006-CARM
	2003	3.0L 12 Valves	3S-550-AA; 3S-560-AA	3F1Z-6006-DARM
		3.0L 24 Valves	3S-850-AA	3F1Z-6006-CBRM
	2002	3.0L 12 Valves	2G-550-AA; 2G-258-AA	3F1Z-6006-DARM
	2002-2001	3.0L 24 Valves	1G-850-AA, 2G-850-AA/BA	1F1Z-6006-ABRM
	2001	3.0L 12 Valves	1G-550-AA, 1G-558-AA	YF1Z-6006-CRM
	2000	3.0L 12 Valves	0G-558-AA, AG-550-BA, SK-550-BA	YF1Z-6006-CRM
	1999	3.0L 12 Valves	9G-558-AA, KG-550-AA/AB, XK-550-AA	XF1Z-6006-CRM
	1993-1988	3.8L		F1DZ-6V012-BRM

**Tracer**

Part Type	Years	Engine	Qualifier	Ford #
Reman	1997	2.0L SOHC	w/ Automatic Trans.	F7CZ-6006-ARM

**Villager**

Part Type	Years	Engine	Qualifier	Ford #
Reman	1996-1993	3.0L		F6XZ-6006-BBRM

**Ford**

**Aerostar**

Part Type	Years	Engine	Qualifier	Ford #
Reman	1997-1996	3.0L		F57Z-6V012-DRM
	1997	4.0L OHV		F77Z-6V012-DARM
	1996-1995	4.0L OHV		F57Z-6V012-AARM



**Aerostar**

**-Cont'd**

Part Type	Years	Engine	Qualifier	Ford #
Reman	1994-1991 1990	4.0L OHV 4.0L OHV	w/ Automatic Trans. From 5/10/90	FOTZ-6V012-ABRM FOTZ-6V012-ABRM

**Bronco**

Part Type	Years	Engine	Qualifier	Ford #
Reman	1996	5.0L 5.8L	TK-366-AA, ZK-360-AA, ZK-361-AA, ZK-366-AA	F6TZ-6V012-CBRM F4TZ-6V012-BARM
	1995-1994	5.0L 5.8L		F4TZ-6V012-CRM F4TZ-6V012-BRM
	1993-1992	5.0L		F2TZ-6V012-ARM
	1993-1988	5.8L	w/ Dipstick In Block	F1TZ-6V012-BRM
	1992-1987	4.9L GAS	Fl; w/o T/E Holes in Head Fl; w/ TE Holes In Head	F2TZ-6V012-CRM F2UZ-6V012-DRM
	1991-1989	5.0L	w/ Knock Sensor	F1TZ-6V012-ARM
	1988	5.0L	w/ Knock Sensor From 9/1/87	F1TZ-6V012-ARM
	1987-1984	5.8L	4BBL; w/o Dipstick in Block	E4TZ-6V012-ARM
	1983	5.0L	w/ 1 Piece Crankshaft Seal From 12/1/82	E5AZ-6V012-ARM

**Econoline**

Part Type	Years	Engine	Qualifier	Ford #
New	2016-2008	5.4L	w/o Gaseous Prep Pack	9C2Z-6006-A
	2016-2010	5.4L	w/ Gaseous Fuel Prep Pack	AC2Z-6006-B
	2016-2003	6.8L	w/o Gaseous Prep Pack	9C2Z-6006-AA
	2016-2010	6.8L	w/ Gaseous Fuel Prep Pack	AC2Z-6006-A
Reman	2013-2010	5.4L	9E-640-AA	9C2Z-6006-BARM
	2013-2009	6.8L	9Q-636-AA	9C2Z-6006-CARM
	2013-2010	6.8L	AQ-638-AA	AC2Z-6006-BRM
	2011-2009	4.6L FLEX	9S-816-AA/AB	9C2Z-6006-AARM
	2010	5.4L CNG	AE-616-AA/AE-618-AA	AC2Z-6006-ARM
		5.4L FLEX	AE-616-AA/AE-618-AA	AC2Z-6006-ARM
	2009	5.4L	9E-640-AA; 9E-642-AA	9C2Z-6006-BARM
	2008	4.6L	7S-820-AA	7C2Z-6006-AARM
			8S-816-AA; FFV	8C2Z-6006-AARM
	2008-2007	5.4L	7E-872-AA, 7E-886-AA, 7E-898-AA	7C2Z-6006-BARM
	2008	6.8L	7Q-636-AA	7C2Z-6006-CARM
	2008-2007	6.8L	8E-662-AA, 8E-663-AA	7C3Z-6006-CARM
	2007	4.6L	w/ Oil Cooler; 7S-820-AA	7C2Z-6006-AARM
	2006-2005	4.6L	w/ Oil Cooler	5C2Z-6006-CRM
			w/o Oil Cooler	5C2Z-6006-BRM
	2006	5.4L	6G-872-AA, 6G-890-AA, 6G-898-AA	5C2Z-6006-ARM
		6.8L	5Q-636-CA, 6Q-636-AA	5C2Z-6006-DRM
	2005	5.4L	5G-872-AA, 5G-890-AA, 5G-892-AA, 5G-898-AA	5C2Z-6006-ARM
		6.8L	5Q-636-BA/CA	5C2Z-6006-DRM
	2004	4.6L	w/ Cooler 4S-820-AA	4C2Z-6006-BARM
			w/o Cooler 4S-818-AA	4C2Z-6006-AARM
		5.4L	4S-890-AA	4C2Z-6006-CARM
			4Q-872-AA, XE-892-AA	4C2Z-6006-FRM
		5.4L CNG	4S-616-AA	4C2Z-6006-DARM
		6.8L	4Q-636-AA/BA	4C2Z-6006-ARM
	2003-2002	4.2L	w/o Oil Cooler; 2K-706-AA/BA	1L3Z-6006-QARM
	2003	4.2L	w/o Oil Cooler; 3K-706-BA	3L3Z-6006-GARM
			w/ Oil Cooler 3K-704-BA	3C2Z-6006-JARM
		4.6L	3G-818-AC	3C2Z-6006-DARM
			3G-820-AA/AB	3C2Z-6006-EARM
			3G-818-AA/AB	3C2Z-6006-CARM
			3G-386-AA	3C2Z-6006-BBRM
		5.4L CNG	3G-890-AA	3C2Z-6006-GBRM
		5.4L GAS	3E-872-AA, WE-892-AA	3C2Z-6006-ERM
		6.8L	3E-636-AA, 3E-638-AA	3C2Z-6006-HBRM
	2002	4.2L	w/ Oil Cooler; 2K-704-AA/BA	1L3Z-6006-RARM
		4.6L	2G-818-AA/AB	2C2Z-6006-DARM
		5.4L CNG	2G-616-BA	2C2Z-6006-CBRM
		5.4L GAS	2G-890-BA	2C2Z-6006-ABRM
			2E-872-BA, UE-892-BA	2C2Z-6006-DRM
		6.8L	2E-636-BA/BB, 2E-638-BA/BB	2C2Z-6006-BBRM
	2001	4.2L	w/o Oil Cooler; 1K-706-AA/BA/CA	1L3Z-6006-QARM
			w/ Oil Cooler; 1K-704-AA/BA/CA	1L3Z-6006-RARM
		5.4L	1G-890-AA/AB	YC2Z-6006-NARM
		5.4L CNG	1G-616-AA/AB	1C2Z-6006-EARM
		5.4L GAS	1E-872-AA/AB, TE-892-AA/AB	YC2Z-6006-PARM
		6.8L	TE-634-AA, 1E-636-AA/AB	YC2Z-6006-SARM
	2000-1999	4.2L	9K-704BA, 0K-704-AA/BA/CA	XC2Z-6006-FARM
			9K-706BA, 0K-706-AA/BA/CA	XL3Z-6006-GARM
	2000	4.6L	0G-818-AA	YC2Z-6006-HARM
		5.4L CNG	0G-616-AA/AB	1C2Z-6006-EARM



Econoline

-Cont'd

Part Type	Years	Engine	Qualifier	Ford #
Reman	2000	5.4L GAS	OG-890-AB	YC2Z-6006-NARM
		6.8L	0E-872-AB, SE-892-AB	YC2Z-6006-PARM
	1999	4.6L	SE-634-AB, 0E-636-AB	YC2Z-6006-SARM
		5.4L	9G-818-BA	XC2Z-6006-GARM
	1998	5.4L	9E-892-AA	F7UZ-6006-MARM
		5.4L GAS	9G-890-AA	F7UZ-6006-LARM
		6.8L	9E-634-AA	XC2Z-6006-RARM
		4.2L	8K-704-AA, 8K-704-CA	F7UZ-6006-DRM
			8K-706-AA, 8K-706-CA	F7TZ-6006-EARM
	1998-1997	4.6L	8K-706-DA	F8TZ-6006-FARM
		5.4L	8K-704-DA	F8UZ-6006-BRM
	1998	4.6L	7G-900-AA/AB	F7TZ-6V012-BARM
		5.4L	U/8500 GVW; 7E-890-AA/AB	F7UZ-6006-LARM
	1997	6.8L	O/8500 GVW; 7E-892-AA, 7E-892-AB	F7UZ-6006-MARM
		4.2L	8E-634-AA	XC2Z-6006-RARM
	1996-1987	4.2L	7K-704-AA, 7K-704-BA, 7K-704-CA	F7UZ-6006-DRM
		5.4L	7K-706-AA, 7K-706-BA, 7K-706-CA	F7TZ-6006-EARM
	1996	6.8L	7E-890-AA/AB	F7UZ-6006-LARM
		4.9L GAS	7E-634-AA	XC2Z-6006-RARM
	1996	5.0L	FI; w/o T/E Holes In Head	F2TZ-6V012-CRM
		5.8L	FI; w/ T/E Holes In Head	F2UZ-6V012-DRM
	1996-1993	5.8L		F6TZ-6V012-CBRM
		7.5L		F4TZ-6V012-BARM
	1995-1994	5.0L		F3TZ-6V012-FRM
		5.8L		F4TZ-6V012-CRM
	1993-1992	5.0L		F4TZ-6V012-BRM
		5.8L		F2TZ-6V012-ARM
	1993-1988	5.8L	FI; w/ Dipstick Tube In Block	F1TZ-6V012-BRM
		7.5L		F2TZ-6V012-FRM
	1992-1989	5.0L		F1TZ-6V012-ARM
5.0L		w/ Knock Sensor	F1TZ-6V012-ARM	
1991-1989	5.0L	w/ Knock Sensor From 9/1/87	F1TZ-6V012-ARM	
	5.0L	FI	F2TZ-6V012-FRM	
1988	7.5L		F4TZ-6V012-ARM	
	5.8L	4BBL; w/o Dipstick Tube In Block	E4TZ-6V012-ARM	
1987	7.5L	CARB	E5TZ-6V012-HRM	
	7.5L		E5TZ-6V012-HRM	
1986	7.5L		E5AZ-6V012-ARM	
	5.0L	CARB; w/ 1 Piece Crankshaft Seal	D9UZ-6V012-DRM	
1985	5.0L	Before 4/1/85	E5TZ-6V012-HRM	
	7.5L	From 4/1/85	E5AZ-6V012-ARM	
1984	5.0L	w/ 1 Piece Crankshaft Seal	D9UZ-6V012-DRM	
	7.5L		E5AZ-6V012-ARM	
1984-1979	7.5L		D9UZ-6V012-DRM	
	5.0L	w/ 1 Piece Crankshaft Seal From 12/1/82	E5AZ-6V012-ARM	

Edge

Part Type	Years	Engine	Qualifier	Ford #
New	2016	2.0L EcoBoost		F2GZ-6006-A
	2016-2011	3.5L	w/o Engine Oil Cooler	AT4Z-6006-D
2016-2012	3.5L		Naturally Aspirated; w/ Engine Oil Cooler; Remove Cooler If Not Needed	DL2Z-6006-D
	2015	2.0L EcoBoost	CT4E-6006-AC; Thru 12/24/14	CT4Z-6006-B
2015-2008	3.5L		From 01/19/15	F2GZ-6006-A
	3.5L		w/ Class II or III Trailer Towing	9T4Z-6006-FC
Reman	2015-2012	2.0L EcoBoost	DS-328-CA	DT4Z-6006-BRM
	2014-2012	2.0L EcoBoost	CT4E-6006-AC	CT4Z-6006-B
New	2014-2011	3.7L	Exc. Banjo Style	BA5Z-6006-D
	2013-2012	3.5L	Naturally Aspirated; w/ Engine Oil Cooler; 1S-342-DA, DS-342-AA, FS-342-AA/BA, FS-906-AA, GS-906-AA	DL2Z-6006-ARM
Reman	2013-2012	3.5L	Naturally Aspirated; w/o Engine Oil Cooler; 1S-344-DA, DS-344-AA, FS-344-AA/BA, DS/FS/GS-908-AA	DL2Z-6006-BRM
	2012	2.0L EcoBoost	Exc. 4 or 6 Groove Crankshaft Pulley; DS-328-CA	DM5Z-6006-A
New	2012	2.0L EcoBoost	OD-786-AB	AT1Z-6006-ARM
	2012-2011	3.7L	CX-184-AA/BA	DB5Z-6006-ARM
Reman	2011	3.5L	w/o Engine Oil Cooler	BT4Z-6006-AARM
	2010-2007	3.5L	Naturally Aspirated; w/o Trailer Tow	BB5Z-6006-BARM
2009-2008	3.5L		9H6Z-6006-ARM	7H6Z-6006-AARM
	3.5L		9G-224-AA	9T4Z-6006-AARM
2009	3.5L		9G-222-AB	9T4Z-6006-BARM
	3.5L		9G-222-BA	7T4Z-6006-AARM
2008	3.5L		w/ Cooler; 8G-222-AA/AB	7H6Z-6006-AARM
	3.5L		w/o Cooler; 7G-224-AA	7T4Z-6006-AARM
2007	3.5L		w/ Cooler; 7G-222-AA	

Escape

Part Type	Years	Engine	Qualifier	Ford #
New	2017	2.5L		GV6Z-6006-AA
	2016	1.6L EcoBoost		CJ5Z-6006-K
	2016-2015	2.0L EcoBoost		CJ5Z-6006-C



**Escape**

**-Cont'd**

Part Type	Years	Engine	Qualifier	Ford #
New	2016-2013	2.5L GAS		CV6Z-6006-A
	2015-2013	1.6L EcoBoost		CJ5Z-6006-G
	2014	2.0L EcoBoost	Before 12/02/13 From 12/02/13	CJ5Z-6006-B CJ5Z-6006-C
	2013	2.0L EcoBoost	CS-186-AA	CJ5Z-6006-B CL8Z-6006-ARM
Reman				9E5Z-6006-C
New	2012-2010	2.5L ELECTRIC/GAS		CE5Z-6006-A
	2012	2.5L GAS		9L8Z-6006-BRM
Reman		3.0L	1G-758-BA	9L8Z-6006-BRM
		3.0L	1G-758-AA	9E5Z-6006-FRM
	2012-2011	2.5L	Hybrid; 9G-314-BA/DA	9E5Z-6006-FRM
	2011-2010	2.5L	Hybrid; 9G-314-BA/DA	9L8Z-6006-BARM
		2.5L GAS	9G-316-BA; 0G-316-AA	9L8Z-6006-BARM
	2010	3.0L	0G-758-BA	9L8Z-6006-BRM
	2009	2.5L ELECTRIC/GAS	9G-320-AA; 9G-320-BA	9L8Z-6006-CARM
		2.5L GAS	9G-313-AA; 9G-313-BA; 9G-313-CA; 9G-316-AA; 9G-316-BA	9L8Z-6006-BARM
		3.0L	9G-758-AA	9L8Z-6006-BRM
	2008	2.3L	8G-274-AA, 8G-275-AA	8L8Z-6006-BARM
	2008-2007	2.3L ELECTRIC/GAS	Hybrid; 7G-278-AA, 8G-278-AA	7L8Z-6006-GARM
	2008	3.0L	8G-758-AA	8L8Z-6006-AARM
	2007	2.3L	7G-274-BA, 7G-275-BA	7L8Z-6006-FARM
	2007-2006	3.0L	6G-758-AA	6L8Z-6006-AARM
	2006	2.3L	w/ Automatic Trans.; 6S-274-AA w/ Standard Trans.; 6S-275-AA w/ Standard Trans.; 6S-275-BA w/ Automatic Trans.; 6S-274-BA	5L8Z-6006-DRM 5L8Z-6006-DRM 7L8Z-6006-EARM 7L8Z-6006-EARM
	2006-2005	3.0L	5G-758-AC Export 5D-752-AA/AB Export 5D-756-AA/AB	5L8Z-6006-BRM 5L8Z-6006-DARM 5L8Z-6006-CRM
	2006	ELECTRIC/GAS	Hybrid; 6G-278-AA/BA	6L8Z-6006-EARM
	2005	2.3L	5G-274-AA, 5G-275-AA 5G-274-BA, 5G-275-BA	4L8Z-6006-BRM 5L8Z-6006-DRM
		3.0L	w/ Oil Cooler 5G-758-AB	5L8Z-6006-ARM
		ELECTRIC/GAS	Hybrid; 5G-278-AA/BA/CA/DA/EA/FA	5L8Z-6006-EARM
	2004	2.0L	3G-121-BA	YL8Z-6006-AARM
	2004-2001	3.0L	1G-752-AA/AB 1G-754-AA/AB Export 1D-756-AA/AB	1L8Z-6006-ABRM 1L8Z-6006-BBRM 1L8Z-6006-CBRM
	2003	2.0L	3G-121-AA	YL8Z-6006-AARM
	2002-2001	2.0L	0G-121-AA	YL8Z-6006-AARM

**Excursion**

Part Type	Years	Engine	Qualifier	Ford #
Reman	2005	5.4L	XE-880-AA	4C3Z-6006-EARM
		6.8L	5Q-666-AA	5C7Z-6006-ARM
	2004	5.4L	EE-874-AA, EE-883-AA, XE-880-AA	4C3Z-6006-EARM
		6.8L	4Q-662-AA/BA; 4Q-663-AA	4C3Z-6006-ARM
	2003	5.4L	CE-874-AA, UE-880-AA	2L3Z-6006-DBRM
	2003-2002	6.8L	2E-666-AA/AB, 2D-670-AB	2L3Z-6006-EBRM
	2002	5.4L	CD-899-AA, CE-874-AA, UE-880-AA	2L3Z-6006-DBRM
	2001	5.4L	BE-874-AA, TE-880-AA	YC3Z-6006-EARM
		6.8L	TE-664-AA, 1E-666-AA	YC3Z-6006-GARM
	2000	5.4L	AE-874-AB, SE-880-AB	YC3Z-6006-EARM
		6.8L	SE-664-AB, 0E-666-AB	YC3Z-6006-GARM

**Expedition**

Part Type	Years	Engine	Qualifier	Ford #
New	2016-2015	3.5L EcoBoost		DL3Z-6006-F
	2014-2009	5.4L		9L3Z-6006-A
Reman	2012-2009	5.4L	9S-600-AA/BA; 9S-696-AA	9L1Z-6006-AARM
	2010-2009	5.4L	w/ Automatic Trans.; 9E-874-AA	9C3Z-6006-AARM
	2008-2007	5.4L	7G-696-AA	7L3Z-6006-DARM
		5.4L	7G-696-AB	8L3Z-6006-BARM
	2006	5.4L	5G-696-BA; 5G-698-BA; 6G-694-BA, 6G-694-AA, 6G-692-BA, 6G-692-AA	5L3Z-6006-BRM
	2005	5.4L	5G-696-AA; 5G-698-BA	5L3Z-6006-BRM
	2004	4.6L	4S-308-AA	4L1Z-6006-AARM
		5.4L	3G-610-AB	3L1Z-6006-CBRM
	2003	4.6L	3G-308-BA/BB	3L1Z-6006-BARM
		5.4L	3G-308-AA/AB/AC	3L1Z-6006-AARM
	2002	4.6L	3G-610-AA/A1A/A2A, AB/A1B/A2B	3L1Z-6006-CBRM
		5.4L	2G-846-AA	2L3Z-6006-GARM
	2001	5.4L	2D-896-BA, 2G-626-BA	2L3Z-6006-CBRM
		4.6L	w/ Triton (Romeo) Engine; 1G-846-BA/BB	1L3Z-6006-PRM
	2000	5.4L	1D-896-AA, 1G-626-AA/AB	YL3Z-6006-AFRM
		4.6L	0G-846-AA	XL3Z-6006-NARM
		5.4L	0G-622-AA, 0G-626-AA, 0G-876-AA	YL3Z-6006-AFRM



Expedition

-Cont'd

Part Type	Years	Engine	Qualifier	Ford #
Reman	1999	4.6L	9G-938-AA/BA 9G-936-AA	XL1Z-6006-CARM XL1Z-6006-BARM
		5.4L	RWD; 9G-624-AA 9G-626-AA 9G-626-BA	XL3Z-6006-HRM XL3Z-6006-ADRM XL3Z-6006-AERM
		4.6L	w/ Triton (Windsor) Engine; 7G-936-**	F7TZ-6V012-BARM
		4.6L	w/ Triton (Romeo) Engine; 7G-930-** RWD; 7G-932-AA	F8TZ-6006-JARM F8TZ-6006-KARM F7TZ-6006-FARM
	1998 1998-1997	5.4L	RWD; 8G-894-AA, 7G-894-AA/AB 7G-624-AA/AB, 8G-624-AA 7G-896-AA/AB 7G-626-AA/AB, 8G-626-AA	F7TZ-6006-YARM F7TZ-6006-GARM F7TZ-6006-ZRM
		4.6L	w/ Triton (Windsor) Engine; 7G-912-**, 7G-936-**	F7TZ-6V012-BARM
	1997	4.6L		

Explorer

Part Type	Years	Engine	Qualifier	Ford #
New	2016	2.3L EcoBoost		GB5Z-6006-A
	2016-2013	3.5L	Naturally Aspirated; w/ Engine Oil Cooler; Remove Cooler If Not Needed	DL2Z-6006-D
	2016	3.5L EcoBoost	Before 08/01/15 From 08/01/15	FG1Z-6006-A FG1Z-6006-E DA8Z-6006-B FG1Z-6006-A
Reman	2015-2014	2.0L EcoBoost		DT4Z-6006-BRM
	2015	3.5L EcoBoost		AA5Z-6006-D BB5Z-6006-A DA8Z-6006-B DA8Z-6006-ARM
New	2015-2013	2.0L EcoBoost	DS-328-CA	
	2014-2013	3.5L EcoBoost		DL2Z-6006-BRM
Reman	2013	2.0L EcoBoost	Before 09/04/12 From 09/04/12	DA8Z-6006-B DA8Z-6006-ARM
	2013-2012	3.5L	DV-202-AA, DX-184-CA Naturally Aspirated; w/o Engine Oil Cooler; 1S-344-DA, DS-344-AA, FS-344-AA/BA, DS/FS/GS-908-AA	DL2Z-6006-BRM
New	2012	2.0L EcoBoost		BB5Z-6006-A
	2012-2011	3.5L	w/o Engine Oil Cooler	AT4Z-6006-D AT4Z-6006-B
Reman	2012	3.5L	Naturally Aspirated; w/ Engine Oil Cooler	AT1Z-6006-ARM DB5Z-6006-ARM
		2.0L EcoBoost	0D-786-AB CX-184-AA/BA	BB5Z-6006-AARM BB5Z-6006-BARM DL2Z-6006-ARM
New	2012-2011	3.5L	w/ Engine Oil Cooler	
	2012	3.5L	w/o Engine Oil Cooler Naturally Aspirated; w/ Engine Oil Cooler; 1S-342-DA, DS-342-AA, FS-342-AA/BA, FS-906-AA, GS-906-AA	AT4Z-6006-B 9L2Z-6006-BARM 9L2Z-6006-CARM 9L2Z-6006-AARM 7L2Z-6006-CRM 7L2Z-6006-BRM 7L2Z-6006-AARM 7L2Z-6006-BARM 6L2Z-6006-BARM 7L2Z-6006-CRM 7L2Z-6006-BRM 7L2Z-6006-AARM 6L2Z-6006-BARM 6L2Z-6006-DARM 6L2Z-6006-AARM 4L2Z-6006-EARM 4L2Z-6006-DARM 5L2Z-6006-ARM 4L2Z-6006-EARM 4L2Z-6006-DARM 4L2Z-6006-GARM 4L2Z-6006-GARM 4L2Z-6006-FARM 4L2Z-6006-FARM 4L2Z-6006-AARM 2L2Z-6006-CBRM 1L2Z-6006-BBRM 1L2Z-6006-BBRM 1L2Z-6006-BBRM 1L2Z-6006-ABRM 1L2Z-6006-ABRM 2L2Z-6006-BBRM 2L2Z-6006-FARM 3L2Z-6006-BARM 2L2Z-6006-CBRM 1L2Z-6006-BBRM 1L2Z-6006-ABRM 2L2Z-6006-BBRM 2L2Z-6006-BBRM 2L2Z-6006-AARM
New	2011	3.5L	w/ Engine Oil Cooler	AT4Z-6006-B
	Reman	2010-2009	4.0L	w/o Cooler; 9S-960-AA w/ Cooler; 9S-962-AA
2009		4.6L	9S-302-AA	
2008	4.0L	w/ Cooler; 8S-962-AA/AB w/o Cooler; 8S-960-AA/AB		
	4.6L	7S-302-AB 7S-302-AC		
2007	4.0L	w/o Cooler; 7S-960-AA w/ Cooler; 7S-962-AB w/o Cooler; 7S-960-AB		
	4.6L	7S-302-AA		
2006	4.0L	w/o Cooler; 6G-960-AA/AB w/ Cooler; 6G-962-AA/AB		
	4.6L	6S-302-AA/AB/AC		
2005	4.0L	w/ Oil Cooler 5G-962-AB w/o Oil Cooler 5G-960-AB		
	4.6L	4S-306-BA; 4S-302-BA		
2004	4.0L	w/ Oil Cooler 4G-966-AA/AB/AC w/o Oil Cooler 4G-962-AA/AB/AC		
	4.6L	XLT Sport; w/o Balance Shaft; 4G-982-AA/AB XLS Sport; w/o Balance Shaft; 4G-982-AA/AB		
2003	4.6L	XLT Sport; 4G-980-AA/AB; w/ Balance Shaft XLS Sport; 4G-980-AA/AB; w/ Balance Shaft		
	4.0L	4S-302-AA, 4S-306-AA 2G-967-BB/BC; 2G-968-BB RWD; Sport XLT; w/o Balance Shaft 1G-982-CA, 1G-989-CB RWD; Sport; w/o Balance Shaft 1G-982-CA, 1G-989-CB RWD; Sport XLS; w/o Balance Shaft 1G-982-CA, 1G-989-CB 4WD; Sport XLT; w/ Balance Shaft 1G-983-CB, 1G-984-CB 4WD; Sport XLS; w/ Balance Shaft 1G-983-CB, 1G-984-CB 2G-962-BB; 2G-966-BB/BC 2G-302-AA, 2G-306-AA 2G-302-BA, 2G-306-BA 2G-967-AA/BB, 2G-968-AA/BB RWD; Sport; w/o Balance Shaft 1G-982-BA/CA, 1G-986-BA, 1G-989-BA/CA/CB 4WD; Sport; w/ Balance Shaft 1G-980-BA, 1G-983-BA/CA/CB, 1G-984-BA/CA w/ Balance Shaft 2G-962-AA/BB, 2G-966-AA/BB, 2G-969-AA/BB 2G-962-AA/BB, 2G-966-AA/BB, 2G-969-AA/BB 1G-302-**, 1G-306-**		



**Explorer**

**-Cont'd**

Part Type	Years	Engine	Qualifier	Ford #
Reman	2001	4.0L	RWD; 0G-960-AB, 0G-961-AB RWD; Sport; 0G-960-AA/AB RWD; Sport; w/o Balance Shaft 1G-982-AA/BA, 1G-986-AA/BA, 1G-989-AA/BA 4WD; Sport; w/ Balance Shaft 1G-980-AA/BA, 1G-983-AA/BA, 1G-984-AA/BA AWD; 0G-962-AB, 0G-963-AB, 0G-964-AB 4WD; Sport; 0G-962-AA/AB 4WD; 0G-962-AB, 0G-963-AB, 0G-964-AB Postal; w/ Balance Shaft 1G-992-AA 9G-352-AA, 9G-354-AA	F77Z-6006-CRM F77Z-6006-CRM 1L2Z-6006-BBRM 1L2Z-6006-ABRM F77Z-6006-DRM F77Z-6006-DRM F77Z-6006-DRM 4L2Z-6006-CBRM F87Z-6V012-ARM 4L2Z-6006-BBRM F87Z-6006-ARM F77Z-6006-CRM F77Z-6006-DRM F77Z-6006-DRM F87Z-6006-ARM F77Z-6006-CRM F77Z-6006-DRM F77Z-6006-DRM F87Z-6006-ARM F77Z-6006-CRM F77Z-6006-DRM F77Z-6006-DRM F77Z-6V012-CARM F87Z-6V012-ARM F77Z-6V012-AARM F77Z-6006-CRM F77Z-6006-DRM F77Z-6006-DRM F77Z-6V012-CARM F5TZ-6V012-ACRM F3TZ-6V012-BRM F3TZ-6V012-CRM F1TZ-6V012-CBRM FOTZ-6V012-ABRM F1TZ-6V012-CBRM FOTZ-6V012-ABRM
	2001-1999	5.0L	Postal; 0G-966-AA/AB 9G-352-AA, 9G-354-AA	F87Z-6V012-ARM 4L2Z-6006-BBRM F87Z-6006-ARM F77Z-6006-CRM F77Z-6006-DRM F77Z-6006-DRM F87Z-6006-ARM F77Z-6006-CRM F77Z-6006-DRM F77Z-6006-DRM F87Z-6006-ARM F77Z-6006-CRM F77Z-6006-DRM F77Z-6006-DRM F87Z-6006-ARM F77Z-6006-CRM F77Z-6006-DRM F77Z-6006-DRM F87Z-6006-ARM F77Z-6006-CRM F77Z-6006-DRM F77Z-6006-DRM F87Z-6V012-CARM F87Z-6V012-ARM F77Z-6V012-AARM F77Z-6006-CRM F77Z-6006-DRM F77Z-6006-DRM F77Z-6V012-CARM F5TZ-6V012-ACRM F3TZ-6V012-BRM F3TZ-6V012-CRM F1TZ-6V012-CBRM FOTZ-6V012-ABRM F1TZ-6V012-CBRM FOTZ-6V012-ABRM
	2000	4.0L 4.0L OHV 4.0L SOHC	0G-948-AA, 0G-949-AA RWD; 0G-960-AB; 0G-961-AA/AB 4WD; 0G-962-AB; 0G-964-AA/AB; 0G-963-AA/AB AWD; 0G-962-AB; 0G-963-AA/AB	F77Z-6006-CRM F77Z-6006-DRM F77Z-6006-DRM 4L2Z-6006-CBRM F87Z-6V012-ARM 4L2Z-6006-BBRM F87Z-6006-ARM F77Z-6006-CRM F77Z-6006-DRM F77Z-6006-DRM F87Z-6006-ARM F77Z-6006-CRM F77Z-6006-DRM F77Z-6006-DRM F87Z-6006-ARM F77Z-6006-CRM F77Z-6006-DRM F77Z-6006-DRM F87Z-6006-ARM F77Z-6006-CRM F77Z-6006-DRM F77Z-6006-DRM F87Z-6006-ARM F77Z-6006-CRM F77Z-6006-DRM F77Z-6006-DRM F87Z-6V012-CARM F87Z-6V012-ARM F77Z-6V012-AARM F77Z-6006-CRM F77Z-6006-DRM F77Z-6006-DRM F77Z-6V012-CARM F5TZ-6V012-ACRM F3TZ-6V012-BRM F3TZ-6V012-CRM F1TZ-6V012-CBRM FOTZ-6V012-ABRM F1TZ-6V012-CBRM FOTZ-6V012-ABRM
	1999	4.0L OHV 4.0L SOHC	9G-948-CA, 9G-949-CA RWD; 9G-960-AA, 9G-961-AA AWD; 9G-962-AA, 9G-963-AA 4WD; 9G-962-AA, 9G-963-AA	F87Z-6006-ARM F77Z-6006-CRM F77Z-6006-DRM F77Z-6006-DRM F87Z-6006-ARM F77Z-6006-CRM F77Z-6006-DRM F77Z-6006-DRM F87Z-6006-ARM F77Z-6006-CRM F77Z-6006-DRM F77Z-6006-DRM F87Z-6006-ARM F77Z-6006-CRM F77Z-6006-DRM F77Z-6006-DRM F87Z-6006-ARM F77Z-6006-CRM F77Z-6006-DRM F77Z-6006-DRM F87Z-6006-ARM F77Z-6006-CRM F77Z-6006-DRM F77Z-6006-DRM F87Z-6V012-CARM F87Z-6V012-ARM F77Z-6V012-AARM F77Z-6006-CRM F77Z-6006-DRM F77Z-6006-DRM F77Z-6V012-CARM F5TZ-6V012-ACRM F3TZ-6V012-BRM F3TZ-6V012-CRM F1TZ-6V012-CBRM FOTZ-6V012-ABRM F1TZ-6V012-CBRM FOTZ-6V012-ABRM
	1998	4.0L OHV 4.0L SOHC	8G-948-AA, 8G-949-AA RWD; w/ Automatic Trans.; 8G-960-AA, 8G-961-AA AWD; w/ Automatic Trans.; 8G-962-AA, 8G-963-AA 4WD; w/ Automatic Trans.; 8G-962-AA, 8G-963-AA	F87Z-6006-ARM F77Z-6006-CRM F77Z-6006-DRM F77Z-6006-DRM F87Z-6006-ARM F77Z-6006-CRM F77Z-6006-DRM F77Z-6006-DRM F87Z-6006-ARM F77Z-6006-CRM F77Z-6006-DRM F77Z-6006-DRM F87Z-6006-ARM F77Z-6006-CRM F77Z-6006-DRM F77Z-6006-DRM F87Z-6006-ARM F77Z-6006-CRM F77Z-6006-DRM F77Z-6006-DRM F87Z-6006-ARM F77Z-6006-CRM F77Z-6006-DRM F77Z-6006-DRM F87Z-6V012-CARM F87Z-6V012-ARM F77Z-6V012-AARM F77Z-6006-CRM F77Z-6006-DRM F77Z-6006-DRM F77Z-6V012-CARM F5TZ-6V012-ACRM F3TZ-6V012-BRM F3TZ-6V012-CRM F1TZ-6V012-CBRM FOTZ-6V012-ABRM F1TZ-6V012-CBRM FOTZ-6V012-ABRM
	1997	4.0L OHV 4.0L SOHC	8G-352-AA/CA, 8G-354-AA/CA 8G-352-DA, 8G-354-DA RWD; w/ Automatic Trans.; 7G-960-AA, 7G-961-AA 4WD; w/ Automatic Trans.; 7G-962-AA, 7G-963-AA AWD; w/ Automatic Trans.; 7G-962-AA, 7G-963-AA	F77Z-6V012-CARM F87Z-6V012-ARM F77Z-6V012-AARM F77Z-6006-CRM F77Z-6006-DRM F77Z-6006-DRM F77Z-6006-DRM F77Z-6V012-CARM F5TZ-6V012-ACRM F3TZ-6V012-BRM F3TZ-6V012-CRM F1TZ-6V012-CBRM FOTZ-6V012-ABRM F1TZ-6V012-CBRM FOTZ-6V012-ABRM
	1996-1995	5.0L	From 10/25/96	F77Z-6V012-CARM F5TZ-6V012-ACRM F3TZ-6V012-BRM F3TZ-6V012-CRM F1TZ-6V012-CBRM FOTZ-6V012-ABRM F1TZ-6V012-CBRM FOTZ-6V012-ABRM
	1994-1993	4.0L	Exc. California California	F5TZ-6V012-ACRM F3TZ-6V012-BRM F3TZ-6V012-CRM F1TZ-6V012-CBRM FOTZ-6V012-ABRM F1TZ-6V012-CBRM FOTZ-6V012-ABRM
	1992	4.0L	w/ Standard Trans. w/ Automatic Trans.	F1TZ-6V012-CBRM FOTZ-6V012-ABRM F1TZ-6V012-CBRM FOTZ-6V012-ABRM
	1991	4.0L	w/ Standard Trans.; From 5/10/90 w/ Automatic Trans.; From 5/10/90	F1TZ-6V012-CBRM FOTZ-6V012-ABRM F1TZ-6V012-CBRM FOTZ-6V012-ABRM

**Explorer Sport Trac**

Part Type	Years	Engine	Qualifier	Ford #
Reman	2010-2009	4.0L 4.6L	w/ Cooler; 9S-962-AA 9A-868-AA	9L2Z-6006-CARM 9L2Z-6006-AARM
	2009	4.0L	w/o Cooler; 9S-960-AA	9L2Z-6006-BARM
	2008	4.6L	7S-302-AB 7S-302-AC	7L2Z-6006-AARM 7L2Z-6006-BARM
	2007	4.6L	7S-302-AA	7L2Z-6006-AARM
	2005	4.0L	5G-982-AA 5G-980-AA	4L2Z-6006-GARM 4L2Z-6006-FARM
	2004	4.0L	w/o Balance Shaft 4G-982-AA/AB w/ Balance Shaft 4G-980-AA/AB	4L2Z-6006-GARM 4L2Z-6006-FARM
	2003	4.0L	RWD; w/o Balance Shaft 1G-982-CA, 1G-989-CB 4WD; w/ Balance Shaft 1G-983-CB, 1G-984-CB	1L2Z-6006-BBRM 1L2Z-6006-ABRM
	2002	4.0L	RWD; w/o Balance Shaft 1G-982-BA/CA, 1G-986-BA, 1G-989-BA/CA 4WD; w/ Balance Shaft 1G-980-BA, 1G-983-BA/CA/CB, 1G-984-BA/CA	1L2Z-6006-BBRM 1L2Z-6006-ABRM
	2001	4.0L	RWD; 0G-960-AA/AB RWD; w/o Balance Shaft 1G-982-AA/BA, 1G-986-AA/BA, 1G-989-AA/BA 4WD; w/ Balance Shaft 1G-980-AA/BA, 1G-983-AA/BA, 1G-984-AA/BA 4WD; 0G-962-AA/AB	F77Z-6006-CRM 1L2Z-6006-BBRM 1L2Z-6006-ABRM F77Z-6006-DRM

**F-Series**

Part Type	Years	Engine	Qualifier	Ford #
New	2017	2.7L EcoBoost 3.5L EcoBoost	XLT; HL7E-6006-AA XL; HL7E-6006-AA Platinum; HL7E-6006-AA Limited; HL7E-6006-AA Lariat; HL7E-6006-AA King Ranch; HL7E-6006-AA RWD; XLT; Engine Assembly (Complete) RWD; XL; Engine Assembly (Complete) Platinum; RWD; Engine Assembly (Complete) Limited; RWD; Engine Assembly (Complete) Lariat; RWD; Engine Assembly (Complete) King Ranch; RWD; Engine Assembly (Complete) 4WD; Raptor; HS-382-AA	JT4Z-6006-A HL3Z-6006-A HL3Z-6006-A HL3Z-6006-A HL3Z-6006-A HL3Z-6006-A HL3Z-6006-A HL3Z-6007-A HL3Z-6007-A HL3Z-6007-A HL3Z-6007-A HL3Z-6007-A HL3Z-6007-A HL3Z-6007-A HL3Z-6007-B HL3Z-6006-ARM
Reman		2.7L EcoBoost	HS-602-AA	HL3Z-6006-ARM





F-Series

-Cont'd

Part Type	Years	Engine	Qualifier	Ford #
Reman	2017	3.5L	Naturally Aspirated; w/o Trailer Tow Package; GG-372-BA	HL3Z-6006-BRM
		3.5L EcoBoost	HS-364-AA	HL3Z-6006-CRM
New	2016-2015	2.7L EcoBoost		FL3Z-6006-B
	2016-2013	3.5L EcoBoost		DL3Z-6006-F
	2016-2015	5.0L	w/o Gaseous Fuel Prep Pack	FL3Z-6006-E
	2016	5.0L	w/ 6R80 Transmission; w/ Gaseous Fuel Prep Pack	GL3Z-6006-C
			w/o Gaseous Prep Pack	GL3Z-6006-B
			w/ 6R80 Transmission; w/ Gaseous Fuel Prep Pack; Includes Updated Front Cover and Idler Pulley	GL3Z-6006-D
		6.2L	w/ Gaseous Fuel Prep Pack 2	GC3Z-6006-B
Reman		5.0L	w/o Gaseous Fuel Prep Pack	FL3Z-6006-FARM
			w/ Gaseous Fuel Prep Pack	FL3Z-6006-GARM
		6.2L	w/o Gaseous Fuel Prep Pack	FC3Z-6006-CARM
			w/ Gaseous Fuel Prep Pack	FC3Z-6006-DARM
New	2015	3.5L	Naturally Aspirated	FL3Z-6006-G
	2015-2012	6.2L	w/ Gaseous Fuel Prep Pack	GC3Z-6006-B
	2014-2011	3.7L	w/ Heavy Duty Trailer Tow	BR3Z-6006-M
	2014	3.7L	w/ Gaseous Fuel Prep Pack	EL3Z-6006-D
	2014-2011	5.0L 32 Valves	3 Bolt Waterpump Pulley	EL3Z-6006-C
	2014-2012	6.2L		CL3Z-6006-A
Reman	2013	3.5L EcoBoost	DS-364-AA	DL3Z-6006-ARM
	2013-2011	3.7L	w/o Engine Oil Cooler; 1G-372-AA/BA/CA; 1G-373-AA/BA/CA/DA	BR3Z-6006-CARM
	2013	5.0L	DA-340-AA	DL3Z-6006-FRM
	2013-2010	6.2L	SVT Raptor; 1G-474-AA	AL3Z-6006-DRM
	2013-2011	6.2L	1G-472-AA/AB, 1G-473-AA/AB	BC3Z-6006-ERM
	2013-2012	6.2L	w/ Gaseous Fuel Prep Pack; CG-478-AA, CG-478-BA, DG-478-AA	DC3Z-6006-BRM
	2012-2011	3.5L EcoBoost	1S-364-AA	BL3Z-6006-CARM
		3.7L	w/ Engine Oil Cooler	BL3Z-6006-DARM
		5.0L 32 Valves		BL3Z-6006-BARM
		5.0L DOHC		DL3Z-6006-ERM
New	2012	5.4L		9L3Z-6006-A
	2010-2009	6.8L	O/8500 GVW; w/o Gaseous Prep Pack	8C3Z-6006-D
Reman	2010	4.6L	0A-860-AA	BL3Z-6006-CRM
	2010-2009	5.4L	9S-600-AA/BA; 9S-696-AA	9L1Z-6006-AARM
			w/ Automatic Trans.; 9E-874-AA	9C3Z-6006-AARM
			w/ Standard Trans.; 9E-883-AA	9C3Z-6006-BARM
	2010-2008	6.8L	8E-662-AB, 8E-663-AB	8C3Z-6006-BARM
	2009-2008	4.6L	8S-862-AA, 8S-863-AA	5L3Z-6006-ERM
	2009	4.6L	9S-840-AA/BA	9L3Z-6006-CARM
			9S-844-AA/BA	9L3Z-6006-AARM
	2008-2005	4.2L	5G-702-AA/AB, 5G-703-AA, 6G-702-AA/AB, 6G-703-AA/AB, 7G-702-AA/AB, 7G-703-AA/AB	5L3Z-6006-CRM
	2008	4.2L	7G-702-AB, 7G-703-AB	5L3Z-6006-CRM
	2008-2007	4.6L	7S-842-AA	7L3Z-6006-AARM
	2008	5.4L	8E-874-AA	7C3Z-6006-BARM
			8E-874-AB	8C3Z-6006-AARM
			8E-883-AA	8C3Z-6006-CARM
			8E-883-AB	8C3Z-6006-DARM
		5.4L FLEX	7G-600-BA	7L3Z-6006-DARM
	2008-2007	5.4L FLEX	7G-600-BB	8L3Z-6006-BARM
	2008	5.4L GAS	7G-692-BA	7L3Z-6006-DARM
	2008-2007	5.4L GAS	7G-692-BB	8L3Z-6006-BARM
	2008	6.8L	8E-662-AA, 8E-663-AA	7C3Z-6006-CARM
	2007	4.2L	6G-702-AA/AB, 6G-703-AA/AB; 7G-702-AB, 7G-703-AB	5L3Z-6006-CRM
		5.4L	7G-600-AA/BA, 7G-692-AA/BA	7L3Z-6006-DARM
		6.8L	6E-662-AA, 6E-663-AA	5C3Z-6006-BRM
	2006	4.2L	6G-702-AA/AB, 6G-703-AA/AB	5L3Z-6006-CRM
		4.6L	6S-842-AA/AB	5L3Z-6006-DRM
	2006-2005	4.6L	5S-863-AA; 5S-862-AA	5L3Z-6006-ERM
	2006	5.4L	6E-874-AA, 6E-883-AA	5C3Z-6006-ARM
			5G-698-BA; 6G-694-BA, 6G-694-AA, 6G-692-BA, 6G-692-AA	5L3Z-6006-BRM
		5.4L FLEX	6G-600-AA	6L3Z-6006-AARM
		5.4L GAS	6G-692-AA/BA, 6G-694-AA/BA	5L3Z-6006-BRM
	2006-2005	6.8L	5E-663-AA; 5E-662-AA, 6E-662-AA, 6E-663-AA	5C3Z-6006-BRM
	2005	4.2L	5G-702-AA, 5G-703-AA	5L3Z-6006-CRM
		4.6L	5S-842-AA	5L3Z-6006-DRM
		5.4L	w/ Standard Trans.; 5E-883-AA; 5E-874-AA	5C3Z-6006-ARM
			5G-692-AA, 5G-694-AA	5L3Z-6006-BRM
			XE-880-AA	4C3Z-6006-EARM
	2005-2004	6.8L	Motorhome 4Q-674-AA/BA	4U9Z-6006-ARM
	2005	6.8L	Motorhome 5E-674-AA	5U9Z-6006-ARM
	2004	4.2L	USA Built 3G-702-BA, 3G-703-BA	3L3Z-6006-GARM
			Mexico Built 3D-710-BA, 3D-711-BA	3L3Z-6006-GARM
		4.6L	4S-910-AA	5L3Z-6006-ARM
			4S-862-AA, 4S-863-AA	2L3Z-6006-KARM
			4S-842-AA	4L3Z-6006-AARM
		5.4L	EE-874-AA, EE-883-AA, XE-880-AA	4C3Z-6006-EARM
			4G-692-AA	4L3Z-6006-ARM
		5.4L CNG	4G-618-AA	4L3Z-6006-FARM
		6.8L	4D-683-AA; LPG	4C3Z-6006-BRM
		6.8L GAS	4Q-662-BA, 4Q-663-AA/BA	4C3Z-6006-ARM
	2003	4.2L	US Built 2K-702-BA, 2K-703-BA	1L3Z-6006-QARM



**F-Series**

**-Cont'd**

Part Type	Years	Engine	Qualifier	Ford #	
Reman	2003-2002	4.2L	Mexico Built 2D-710-AA/BA, 2D-711-AA/BA	1L3Z-6006-QARM	
	2003	4.2L	US Built 3G-702BA, 3G-703-BA	3L3Z-6006-GARM	
			Mexico Built 3D-710-BA, 3D-711-BA	3L3Z-6006-GARM	
	2003-2002	4.2L	South America 2D-721-BA	1L3Z-6006-RARM	
	2003	4.2L	South America 3D-721-BA	3C2Z-6006-JARM	
		4.6L	w/ Triton (Romeo) Engine; 2G-842-AB/AC, 2G-843-AB/AC	2L3Z-6006-KARM	
			w/ Triton (Windsor) Engine; 2G-912-BA/BB	2L3Z-6006-HARM	
		5.4L	Harley-Davidson Edition; 3G-392-AA	3L3Z-6006-EBRM	
			Lightning; 3G-396-AA	3L3Z-6006-EBRM	
			4WD; Export 3D-390-AA	3L3Z-6006-FARM	
			RWD; Export; 3D-388-XB	3L3Z-6006-DBRM	
		5.4L CNG	3G-384-AA	3L3Z-6006-CBRM	
		5.4L GAS	CE-874-AA, UE-880-AA; CE-883-AA	2L3Z-6006-DBRM	
			2G-622-AA, 2G-876-AA	2L3Z-6006-CBRM	
		6.8L	2D-683-AA/AB; LPG	2C3Z-6006-ABRM	
			2E-662-AB, 2E-663-AB	2L3Z-6006-EBRM	
			Motorhome; 2E-674-AA/AB	2C2Z-6006-BBRM	
	2003-2002	6.8L	USA Built 2K-702-AA/BA, 2K-703-AA/BA	1L3Z-6006-QARM	
	2002	4.2L	2G-842-AA, 2G-843-AA	2L3Z-6006-GARM	
		4.6L	w/ Triton (Romeo) Engine; 2G-842-AB, 2G-843-AB	2L3Z-6006-KARM	
			w/ Triton (Windsor) Engine; 2G-912-AA	2L3Z-6006-BARM	
			w/ Triton (Windsor) Engine; 2G-912-AB, 2G-912-BA/BB	2L3Z-6006-HARM	
		5.4L	Lightning; 2G-250-AA/AB, 2G-252-AA/AB	2L3Z-6006-ABRM	
			Harley-Davidson Edition; 2G-250-AA/AB, 2G-252-AA/AB	2L3Z-6006-ABRM	
		5.4L CNG	2G-618-AA	2C3Z-6006-BBRM	
		5.4L GAS	CD-899-AA, CE-874-AA, UE-880-AA, CE-883-AA	2L3Z-6006-DBRM	
			2D-896-BA, 2G-622-AA, 2G-876-AA	2L3Z-6006-CBRM	
		6.8L	2D-683-AA; LPG	2C3Z-6006-ABRM	
			2E-662-AA/AB, 2E-663-AA/AB	2L3Z-6006-EBRM	
		2001	4.2L	US Built 1K-702-AA/BA, 1K-703-AA/BA	1L3Z-6006-QARM
			Mexico Built 1D-710-AA/BA, 1D-711-AA/BA	1L3Z-6006-QARM	
			South America 1D-718-AA, 1D-719-AA, 1D-721-AA/BA	1L3Z-6006-RARM	
		4.6L	1G-912-AA	1L3Z-6006-DRM	
			1G-842-AA, 1G-843-AA	1L3Z-6006-PRM	
		5.4L	BE-874-AA, BE-883-AA, TE-880-AA	YC3Z-6006-EARM	
			Lightning; 1G-250-AA	1L3Z-6006-HARM	
		5.4L BI-FUEL	1G-628-AA	1L3Z-6006-MARM	
		5.4L GAS	1G-622-AA, 1G-876-AA	YL3Z-6006-AFRM	
		6.8L	TE-660-AA, TE-661-AA, 1E-662-AA, 1E-663-AA	YC3Z-6006-GARM	
	2000-1999	4.2L	0K-702-AA/BA/CA, 0K-703-AA/BA/CA, 9K-702-BA, 9K-703-BA	XL3Z-6006-GARM	
	2000	4.6L	0G-842-AA, 0G-843-AA	XL3Z-6006-NARM	
		5.4L	AE-874-AB, AE-883-AB/AC, SE-880-AB	YC3Z-6006-EARM	
	2000-1999	5.4L	Lightning; 9G-250-AA	1L3Z-6006-GARM	
	2000	5.4L BI-FUEL	0G-628-AA	1L3Z-6006-MARM	
		5.4L GAS	0G-622-AA, 0G-626-AA, 0G-876-AA	YL3Z-6006-AFRM	
		6.8L	SE-660-AB, SE-661-AB, OE-662-AB, OE-663-AB	YC3Z-6006-GARM	
	1999	4.6L	9G-840-AA, 9G-841-AA	XL3Z-6006-LARM	
			9G-842-AA, 9G-843-AA	XL3Z-6006-MARM	
			9G-842-BA, 9G-843-BA	XL3Z-6006-NARM	
		5.4L	9E-880-AA, KE-881-AA	XC3Z-6006-DARM	
		9G-876-AA, 9G-622-AA	XL3Z-6006-ADRM		
		9G-622-BA, 9G-876-BA	XL3Z-6006-AERM		
	5.4L BI-FUEL	9G-628-AA/BA	1L3Z-6006-MARM		
	5.4L GAS	RWD; 9G-620-AA, 9G-632-AA	XL3Z-6006-HRM		
		9G-876-AA, 9G-622-AA	XL3Z-6006-ADRM		
	6.8L	9E-672-CA	XC2Z-6006-RARM		
1998-1997	4.2L	RWD; 6K-702-AA/BA, 6K-703-AA/BA, 7K-702-AA/BA/CA, 7K-703-AA/BA/CA, 8K-702-AA, CA, 8K-703-AA, CA	F7TZ-6006-DARM		
1998	4.2L	8K-702-DA, 8K-703-DA	F8TZ-6006-FARM		
	4.6L	w/ Automatic Trans.; w/ Triton (Windsor) Engine; 7G-912-**	F7TZ-6V012-BARM		
		w/ Standard Trans.; w/ Triton (Windsor) Engine; 7G-913-AA, 7G-915-AA	F7TZ-6V012-ARM		
1998-1997	4.6L	w/ Triton (Romeo) Engine; 7G-840-AA, 7G-841-AA	F8TZ-6006-JARM		
		RWD; 7G-842-AA	F8TZ-6006-KARM		
	5.4L	7G-884-AA/AB, 8G-884-AA	F7TZ-6006-GARM		
		7G-622-AA/AB, 8G-822-AA	F7TZ-6006-ZRM		
	5.4L GAS	RWD; 7G-882-AA/AB, 8G-882-AA	F7TZ-6006-FARM		
		RWD; 7G-620-AA/AB, 8G-620-AA	F7TZ-6006-YARM		
1997	4.2L	4WD; 6K-714-AA/BA, 6K-715-AA/BA, 7K-714-AA/BA/CA, 7K-715-AA/BA/CA	F7TZ-6006-EARM		
	4.6L	w/ Automatic Trans.; w/ Triton (Windsor) Engine; 6G-870-AA, 7G-912-**, 7G-936-**	F7TZ-6V012-BARM		
		w/ Standard Trans.; w/ Triton (Windsor) Engine; 6G-871-AA, 7G-913-AA, 7G-915-AA	F7TZ-6V012-ARM		
		w/ Triton (Romeo) Engine; 6G-840-**	F8TZ-6006-HARM		
1997-1996	5.8L		F4TZ-6V012-BARM		
1997-1993	7.5L	Exc. Stripped Chassis	F3TZ-6V012-FRM		
1996	4.9L GAS	Fl; w/o TE Holes In Head	F2TZ-6V012-CRM		
		Fl; w/ TE Holes In Head	F2UZ-6V012-DRM		
	5.0L		F6TZ-6V012-CBRM		
1995-1987	4.9L GAS	Fl; w/o T/E Holes In Head	F2TZ-6V012-CRM		
		Fl; w/ T/E Holes In Head	F2UZ-6V012-DRM		
1995-1994	5.0L		F4TZ-6V012-CRM		
	5.8L	Lightning	F4TZ-6V012-ARM		
		Non-Lightning	F4TZ-6V012-BRM		



**F-Series**

-Cont'd

Part Type	Years	Engine	Qualifier	Ford #
Reman	1995	5.8L	XL; Non-Lightning	F4TZ-6V012-BRM
	1994	5.8L	XL	F4TZ-6V012-BRM
	1993-1992	5.0L		F2TZ-6V012-ARM
	1993-1988	5.8L	FI; w/ Dipstick Tube In Block	F1TZ-6V012-BRM
	1992-1989	7.5L		F2TZ-6V012-FRM
	1991-1989, 1987	5.0L	w/ Knock Sensor	F1TZ-6V012-ARM
	1988-1987	5.0L	w/ Knock Sensor From 9/1/87	F1TZ-6V012-ARM
	1988	5.8L	w/o Dipstick Tube In Block	E4TZ-6V012-ARM
		7.5L	FI	F2TZ-6V012-FRM
	1987-1984	5.8L	4BBL; w/o Dipstick Tube In Block	E4TZ-6V012-ARM
	1987	7.5L	CARB	E5TZ-6V012-HRM
	1986	7.5L		E5TZ-6V012-HRM
	1985	5.0L	CARB; w/ 1 Piece Crankshaft Seal	E5AZ-6V012-ARM
		7.5L	Before 4/1/85	D9UZ-6V012-DRM
		7.5L	From 4/1/85	E5TZ-6V012-HRM
	1984	5.0L	w/ 1 Piece Crankshaft Seal	E5AZ-6V012-ARM
	1984-1983, 1979	7.5L		D9UZ-6V012-DRM
1983	5.0L	w/ 1 Piece Crankshaft Seal From 12/1/82	E5AZ-6V012-ARM	

**Flex**

Part Type	Years	Engine	Qualifier	Ford #
New	2016-2012	3.5L	Naturally Aspirated; w/ Engine Oil Cooler; Remove Cooler If Not Needed	DL2Z-6006-D
	2016-2014	3.5L EcoBoost		FG1Z-6006-A
	2015-2009	3.5L	Naturally Aspirated; w/ Class II or III Trailer Towing	9T4Z-6006-FC
Reman	2013-2012	3.5L	Naturally Aspirated; w/ Engine Oil Cooler; 1S-342-DA, DS-342-AA, FS-342-AA/BA, FS-906-AA, GS-906-AA	DL2Z-6006-ARM
			Naturally Aspirated; w/o Engine Oil Cooler; 1S-344-DA, DS-344-AA, FS-344-AA/BA, DS/FS/GS-908-AA	DL2Z-6006-BRM
New	2012-2011	3.5L	Naturally Aspirated; w/o Trailer Tow	9T4Z-6006-GB
	2012-2010	3.5L EcoBoost		AA5Z-6006-D
Reman	2012-2011	3.5L EcoBoost	w/ Engine Oil Cooler	BA8Z-6006-BARM
			w/o Engine Oil Cooler; BG-234-BA; BG-234-CA	BG1Z-6006-BARM
			w/o Engine Oil Cooler; BG-234-AA	BG1Z-6006-AARM
	2012	3.5L EcoBoost	1S-490-DA, DS-490-AA/BA, FS/GS-490-AA	DF1Z-6006-DRM
	2011	3.5L EcoBoost	1S-490-BA, CA	BA5Z-6006-AARM
	2010	3.5L	Naturally Aspirated; w/ Oil Cooler; XG-368-BA; PZEV	9T4Z-6006-BARM
			Turbocharged; w/o Oil Cooler; OS-490-AA	AU7Z-6006-ARM
	2010-2009	3.5L	Naturally Aspirated; w/o Trailer Tow	9H6Z-6006-ARM
	2009	3.5L	WG-366-AD	7H6Z-6006-AARM
			XG-368-AA	9T4Z-6006-AARM
		XG-368-BA; XG-368-AB	9T4Z-6006-BARM	

**Freestar**

Part Type	Years	Engine	Qualifier	Ford #
Reman	2007-2006	3.9L	6G-542-AA/AB	6F2Z-6006-AARM
		4.2L	w/ Oil Cooler; 6G-726-AA-AB	6F2Z-6006-CARM
			w/o Oil Cooler; 6G-724-AA/AB	6F2Z-6006-BARM
	2005	3.9L	5G-542-AA	5F2Z-6006-ARM
		4.2L	w/o Oil Cooler; 5G-724-AA	5F2Z-6006-BRM
	2004	3.9L	w/ Oil Cooler; 5G-726-AA	5F2Z-6006-CRM
			4G-542-BA	4F2Z-6006-BARM
		4.2L	w/ Oil Cooler; 4G-726-AA	4F2Z-6006-DARM
			w/o Oil Cooler; 4G-724-AA	4F2Z-6006-CARM

**Police Interceptor Utility**

Part Type	Years	Engine	Qualifier	Ford #
New	2017-2015	3.5L EcoBoost		FG1Z-6006-F
	2017-2013	3.7L	Exc. Banjo Style	BA5Z-6006-D

**Ranger**

Part Type	Years	Engine	Qualifier	Ford #
Reman	2011	2.3L	7G-292-CA; 7G-293-CA	7L2Z-6006-DARM
		4.0L	0G-973-AA	8L5Z-6006-AARM
	2010	2.3L	7G-292-BA; 7G-293-BA	7L2Z-6006-DARM
		4.0L	0G-972-AA	8L5Z-6006-AARM
	2009-2007	2.3L	7G-292-AA/AB, 7G-293-AA/AB	7L2Z-6006-DARM
	2009	4.0L	9G-972-AA, 9G-973-AA	8L5Z-6006-AARM
	2008-2007	3.0L	7G-590-AA, 7G-591-AA	4L5Z-6006-DARM
	2008	4.0L	8G-972-AA, 8G-973-AA	8L5Z-6006-AARM
	2007	4.0L	w/ Automatic Trans.; 7G-972-AA	7L5Z-6006-AARM



**Ranger**

**-Cont'd**

Part Type	Years	Engine	Qualifier	Ford #
Reman	2007	4.0L	w/ Standard Trans.; 7G-973-AA w/ Automatic Trans.; 7G-972-AB	7L5Z-6006-AARM 8L5Z-6006-AARM
	2006	2.3L	w/ Standard Trans.; 7G-973-AB 6G-292-AA/AB/AC, 6G-293-AA/AB 6G-295-AA	8L5Z-6006-AARM 5L5Z-6006-ARM 4L5Z-6006-BARM 4L5Z-6006-DARM
		3.0L	6G-590-AA/AB, 6G-591-AA/AB	6L5Z-6006-AARM
		4.0L	6G-972-AA/AB, 6G-973-AA/AB	5L5Z-6006-ARM
	2005	2.3L	5G-292-AA, 5G-293-AB; 5G-292-AB; 5G-293-AA	4L5Z-6006-DARM
		3.0L	5G-590-AA/AB, 5G-591-AA/AB	4L2Z-6006-GARM
		4.0L	w/ Standard Trans.; 5G-973-AA/BA w/ Automatic Trans.; 5G-972-AA/BA	4L2Z-6006-GARM
	2004	2.3L	4G-292-BA, 4G-293-BA 4G-292-AA, 4G-293-AA 4G-295-BA	5L5Z-6006-ARM 4L5Z-6006-AARM 4L5Z-6006-BARM
		3.0L	4G-590-AA, 4G-591-AA	4L5Z-6006-DARM
		4.0L	4G-972-AA/AB, 4G-973-AA/AB	4L2Z-6006-GARM
	2003	2.3L	3G-290-AA, 3G-291-AA 3G-273-AA	2L5Z-6006-AARM 3L5Z-6006-AARM
		3.0L	2G-578-AA, 3G-590-AA, 3G-591-AA	2L5Z-6006-FARM
		4.0L	1G-972-BA, 1G-973-BA	1L2Z-6006-BBRM
	2002	2.3L	1G-270-AB, 1G-271-AB	2L5Z-6006-AARM
	2002-2001	2.3L	1G-270-AA, 1G-271-AA	2L5Z-6006-BARM
	2002	3.0L	2G-578-AA, 2G-580-AA, 2G-581-AA	2L5Z-6006-FARM
		4.0L	1G-972-AA/BA, 1G-973-AA/BA	1L2Z-6006-BBRM
	2001-2000	2.5L	0G-194-AA, 0G-195-AA	F87Z-6006-CARM
	2001	3.0L	1G-578-AA, 1G-580-AA, 1G-581-AA	YL5Z-6006-CRM
		4.0L	1G-972-AA, 1G-973-AA	1L2Z-6006-BBRM
	2000	3.0L	0G-578-AA, 0G-579-AA, 0D-580-AA, 0D-581-AA	YL5Z-6006-CRM
		4.0L OHV	0G-944-AA, 0G-945-AA	F87Z-6006-ARM
	1999	2.5L	9G-194-AA, 9G-195-AA	F87Z-6006-CARM
		3.0L	9G-578-AA, 9G-579-AA, RG-580-BA, RG-581-BA	YL5Z-6006-CRM
		4.0L OHV	9G-944-CA, 9G-945-CA	F87Z-6006-ARM
	1998	2.5L	8K-194-A*, 8K-195-A*	F87Z-6006-CARM
		3.0L	Before 7/13/98	F57Z-6V012-DRM
		4.0L OHV	8G-944-BA 8G-945-BA	F87Z-6006-ARM
	1997-1995	3.0L		F57Z-6V012-DRM
	1997	4.0L OHV		F77Z-6V012-AARM
	1996-1995	4.0L OHV	Exc. California	F5TZ-6V012-ACRM
	1994-1993	4.0L OHV	Exc. California California	F3TZ-6V012-BRM
			w/ Standard Trans.	F3TZ-6V012-CRM
			w/ Automatic Trans.	F1TZ-6V012-CBRM
	1992-1991	4.0L OHV		FOTZ-6V012-ABRM
	1990	4.0L OHV	w/ Automatic Trans.; From 5/10/90	FOTZ-6V012-ABRM

**Transit Connect**

Part Type	Years	Engine	Qualifier	Ford #
New	2016-2014	1.6L EcoBoost		CJ5Z-6006-G
		2.5L	w/o Gaseous Fuel Prep Pack	DB3Z-6006-A
Reman			w/o Gaseous Fuel Prep Pack	DC1Z-6006-ARM
New	2013-2010	2.0L	w/o Gaseous Fuel Prep Pack	AT1Z-6006-A
	2013-2011	2.0L	w/ Gaseous Fuel Prep Pack	AT1Z-6006-B

**Transit-150**

Part Type	Years	Engine	Qualifier	Ford #
New	2016-2015	3.5L EcoBoost		DK4Z-6006-G
		3.7L CNG		DK4Z-6006-C
		3.7L FLEX		DK4Z-6006-H
		3.7L LPG		DK4Z-6006-H
Reman		3.5L EcoBoost		FK4Z-6006-BRM

**Transit-250**

Part Type	Years	Engine	Qualifier	Ford #
New	2016-2015	3.5L EcoBoost		DK4Z-6006-G
		3.7L CNG		DK4Z-6006-C
		3.7L FLEX		DK4Z-6006-H
		3.7L LPG		DK4Z-6006-H
Reman		3.5L EcoBoost		FK4Z-6006-BRM

**Transit-350**

Part Type	Years	Engine	Qualifier	Ford #
New	2016-2015	3.5L EcoBoost		DK4Z-6006-G



**Transit-350**

-Cont'd

Part Type	Years	Engine	Qualifier	Ford #
New	2016-2015	3.7L CNG 3.7L FLEX 3.7L LPG		DK4Z-6006-C DK4Z-6006-H DK4Z-6006-H FK4Z-6006-BRM
Reman		3.5L EcoBoost		

**Transit-350 HD**

Part Type	Years	Engine	Qualifier	Ford #
New	2016-2015	3.5L EcoBoost 3.7L CNG 3.7L FLEX 3.7L LPG		DK4Z-6006-G DK4Z-6006-C DK4Z-6006-H DK4Z-6006-H FK4Z-6006-BRM
Reman		3.5L EcoBoost		

**Windstar**

Part Type	Years	Engine	Qualifier	Ford #
Reman	2003	3.8L	2K-542-AA 3G-542-BA	1F2Z-6006-CARM 3F2Z-6006-BARM 1F2Z-6006-CARM
	2002	3.8L	1K-542-BA, 2K-542-AA	1F2Z-6006-CARM
	2001	3.8L	1K-542-AA/BA	1F2Z-6006-CARM
	2000-1999	3.8L	9K-542-CA, 0K-542-AA	XF2Z-6006-BRM
	1999	3.0L	9G-582-AA	XF1Z-6006-CRM
	1998-1997	3.8L		F78Z-6V012-AARM
	1996	3.8L		F68Z-6V012-ABRM

**Lincoln**

**Aviator**

Part Type	Years	Engine	Qualifier	Ford #
Reman	2004 2003	4.6L 4.6L	4S-934-AA 2G-934-AA,AB,BA	2C5Z-6006-BARM 2C5Z-6006-BARM

**Blackwood**

Part Type	Years	Engine	Qualifier	Ford #
Reman	2002	5.4L	2G-260-AA	2L7Z-6006-BARM

**MKC**

Part Type	Years	Engine	Qualifier	Ford #
New	2017 2016 2016-2015 2016 2015	2.3L EcoBoost 2.0L EcoBoost 2.3L EcoBoost 2.3L EcoBoost 2.0L EcoBoost	Exc. New Style Oil Separator Includes New Style Oil Separator Before 08/31/14 From 08/31/14	HJ7Z-6006-A CJ5Z-6006-C EJ7Z-6006-A EJ7Z-6006-B CJ5Z-6006-B CJ5Z-6006-C

**MKT**

Part Type	Years	Engine	Qualifier	Ford #
New	2017-2015	3.5L EcoBoost	Exc. Transfer Cam And Crank Sensors If OEM Engine Has 2 Wire Sensors Transfer Cam And Crank Sensors If OEM Engine Has 2 Wire Sensors w/ Gaseous Fuel Prep Pack; GG-482-BA	FG1Z-6006-A AA5Z-6006-F HE9Z-6006-ARM
Reman	2017	3.7L		DA8Z-6006-A
New	2016-2013 2016-2010	2.0L EcoBoost 3.7L	w/ Class III Trailer Towing w/o Trailer Tow; 3 Bolt Non-Banjo Style	9A5Z-6006-GC 9A5Z-6006-J
	2016-2014 2014	3.7L 3.5L EcoBoost	w/ Engine Oil Cooler; w/ Gaseous Fuel Prep Pack	EA8Z-6006-A FG1Z-6006-A
	2012-2010	3.5L EcoBoost 3.7L		AA5Z-6006-D BA5Z-6006-DDRM
Reman		3.7L	w/o Engine Oil Cooler; BG-496-BA/CA w/ Engine Oil Cooler; BG-498-BA/CA	BE9Z-6006-BARM 9A5Z-6006-G
New	2011	3.7L	w/ Trailer Tow	BA5Z-6006-AARM
Reman		3.5L EcoBoost	1S-490-BA, CA	BA5Z-6006-CCRM
	2011-2010	3.7L	w/o Engine Oil Cooler; BG-496-AA w/ Engine Oil Cooler	BE9Z-6006-AARM 9A5Z-6006-C
New	2010	3.7L	w/ Trailer Tow	AU7Z-6006-ARM
Reman		3.5L 3.7L	Turbocharged; w/o Oil Cooler; 0S-490-AA w/o Engine Oil Cooler; 9G-496-BA; 3 Bolt Non-Banjo Style w/ Engine Oil Cooler; 0G-498-AA	9G1Z-6006-CRM AG1Z-6006-ARM



**MKX**

Part Type	Years	Engine	Qualifier	Ford #
New	2016-2011	3.7L	Exc. Banjo Style	BA5Z-6006-D
	2016	3.7L	Engine Assembly (Complete)	G2GZ-6007-A
Reman	2012-2011	3.7L		BT4Z-6006-AARM
New	2010-2008	3.5L	w/ Class II or III Trailer Towing	9T4Z-6006-FC
Reman	2010-2007	3.5L	Naturally Aspirated; w/o Trailer Tow	9H6Z-6006-ARM
	2009-2008	3.5L	9G-224-AA	7H6Z-6006-AARM
	2009	3.5L	9G-222-AB	9T4Z-6006-AARM
			9G-222-BA	9T4Z-6006-BARM
	2008	3.5L	w/ Cooler; 8G-222-AA/AB	7T4Z-6006-AARM
	2007	3.5L	7G-228-AA	7H6Z-6006-AARM

**Navigator**

Part Type	Years	Engine	Qualifier	Ford #
New	2016-2015	3.5L EcoBoost		DL3Z-6006-F
	2014-2009	5.4L		9L3Z-6006-A
Reman	2012-2009	5.4L	9S-600-AA/BA; 9S-696-AA	9L1Z-6006-AARM
	2010-2009	5.4L	w/ Automatic Trans.; 9E-874-AA	9C3Z-6006-AARM
	2008-2007	5.4L	7G-696-AA	7L3Z-6006-DARM
	2006	5.4L	5G-698-BA; 6G-694-BA, 6G-694-AA, 6G-692-BA, 6G-692-AA	5L3Z-6006-BRM
	2005	5.4L	5G-698-AA	5L3Z-6006-BRM
	2004	5.4L	4G-262-AA	4L7Z-6006-AARM
	2003	5.4L	3G-262-AA	3L7Z-6006-BARM
	2002	5.4L DOHC	2G-260-AA	2L7Z-6006-BARM
	2000	5.4L DOHC	0G-888-AA/AB	1L7Z-6006-DARM
	1999	5.4L DOHC	RWD; 9G-886-AA	XL7Z-6006-AARM
		5.4L SOHC	4WD; 9G-626-BA; 9G-626-AA	XL3Z-6006-ADRM
	1998	5.4L	4WD; 8G-896-AA, 7G-896-AA/AB	F77Z-6006-GARM

**Mazda**

**B2300**

Part Type	Years	Engine	Qualifier	Ford #
Reman	2009-2007	2.3L	7G-292-AA/AB, 7G-293-AA/AB	7L2Z-6006-DARM
	2006	2.3L	6G-292-AA/AB/AC, 6G-293-AA/AB	5L5Z-6006-ARM
			6G-295-AA	4L5Z-6006-BARM
	2005	2.3L	5G-292-AA, 5G-293-AB	5L5Z-6006-ARM
	2004	2.3L	4G-292-BA, 4G-293-BA	5L5Z-6006-ARM
			4G-292-AA, 4G-293-AA	4L5Z-6006-AARM
			4G-295-BA	4L5Z-6006-BARM
	2003	2.3L	3G-290-AA, 3G-291-AA	2L5Z-6006-AARM
			3G-273-AA	3L5Z-6006-AARM
	2002	2.3L	1G-270-AB, 1G-271-AB	2L5Z-6006-AARM
	2002-2001	2.3L	1G-270-AA, 1G-271-AA	2L5Z-6006-BARM

**B2500**

Part Type	Years	Engine	Qualifier	Ford #
Reman	2001-2000	2.5L	0G-194-AA, 0G-195-AA	F87Z-6006-CARM
	1999	2.5L	9G-194-AA, 9G-195-AA	F87Z-6006-CARM
	1998	2.5L	8K-194-A*, 8K-195-A*	F87Z-6006-CARM

**B4000**

Part Type	Years	Engine	Qualifier	Ford #
Reman	2005	4.0L	w/ Standard Trans.; 5G-973-AA/BA	4L2Z-6006-GARM
	2004	4.0L	4G-972-AA/AB, 4G-973-AA/AB	4L2Z-6006-GARM
	2003	4.0L	1G-972-BA, 1G-973-BA	1L2Z-6006-BBRM
	2002	4.0L	1G-972-AA/BA, 1G-973-AA/BA	1L2Z-6006-BBRM
	2001	4.0L	1G-972-AA, 1G-973-AA	1L2Z-6006-BBRM
	2000	4.0L OHV	0G-944-AA, 0G-945-AA	F87Z-6006-ARM
	1999	4.0L OHV	9G-944-CA, 9G-945-CA	F87Z-6006-ARM
	1998	4.0L OHV	8G-944-BA 8G-945-BA	F87Z-6006-ARM

**CX-9**

Part Type	Years	Engine	Qualifier	Ford #
Reman	2007	3.5L	w/ Cooler; 7D-226-AA	7T4Z-6006-AARM



**MPV**

Part Type	Years	Engine	Qualifier	Ford #
Reman	2006-2004 2003-2002	3.0L 3.0L	4G-748-AA/AB, 6G-748-AA 2G-748-AA/AB	4L8Z-6006-ARM 2L8Z-6006-ABRM

**Tribute**

Part Type	Years	Engine	Qualifier	Ford #
Reman	2011-2010	2.5L GAS	0G-316-AA	9L8Z-6006-BARM
New	2010	2.5L ELECTRIC/GAS		9E5Z-6006-C
Reman		2.5L	Hybrid; 9G-314-BA/DA	9E5Z-6006-FRM
	2009	3.0L	9G-758-AA	9L8Z-6006-BRM
	2008	3.0L	8G-758-AA	8L8Z-6006-AARM
	2006-2005	3.0L	5D-752-AA/AB	5L8Z-6006-DARM
	2006	3.0L	6G-758-AA	6L8Z-6006-AARM
	2006-2005	3.0L	Export 5D-756-AA/AB	5L8Z-6006-CRM
	2006	3.0L	w/o Oil Cooler; 6D-752-AA/BA; Japan	6L8Z-6006-BARM
			w/ Cooler; Japan; 6D-756-BA	6L8Z-6006-CARM
	2005	2.3L	5G-274-AA,5G-275-AA	4L8Z-6006-BRM
			5G-274-BA,5G-275-BA	5L8Z-6006-DRM
	2004	2.0L	3G-121-BA	YL8Z-6006-AARM
	2004-2001	3.0L	1G-752-AA/AB	1L8Z-6006-ABRM
			Export 1D-756-AA/AB	1L8Z-6006-CBRM
	2003	2.0L	3G-121-AA	YL8Z-6006-AARM
	2003-2001	3.0L	1G-754-AA/AB	1L8Z-6006-BBRM
	2002-2001	2.0L	0G-121-AA	YL8Z-6006-AARM

**Mercury**

**Mariner**

Part Type	Years	Engine	Qualifier	Ford #
New	2011-2010	2.5L ELECTRIC/GAS		9E5Z-6006-C
Reman		2.5L	Hybrid; 9G-314-BA/DA	9E5Z-6006-FRM
		2.5L GAS	0G-316-AA	9L8Z-6006-BARM
	2009	2.5L ELECTRIC/GAS	9G-320-AA; 9G-320-BA	9L8Z-6006-CARM
		2.5L GAS	9G-313-AA; 9G-313-BA; 9G-313-CA; 9G-316-AA; 9G-316-BA	9L8Z-6006-BARM
		3.0L	9G-758-AA	9L8Z-6006-BRM
	2008	2.3L	8G-274-AA, 8G-275-AA	8L8Z-6006-BARM
		3.0L	8G-758-AA	8L8Z-6006-AARM
	2007-2006	3.0L	6G-758-AA	6L8Z-6006-AARM
	2006-2005	3.0L	5G-758-AC	5L8Z-6006-BRM
	2005	2.3L	5G-274-AA,5G-275-AA	4L8Z-6006-BRM
			5G-274-BA,5G-275-BA	5L8Z-6006-DRM
		3.0L	w/ Oil Cooler 5G-758-AB	5L8Z-6006-ARM

**Monterey**

Part Type	Years	Engine	Qualifier	Ford #
Reman	2007-2006	4.2L	w/ Oil Cooler; 6G-726-AA-AB	6F2Z-6006-CARM
			w/o Oil Cooler; 6G-724-AA/AB	6F2Z-6006-BARM
	2005	4.2L	w/o Oil Cooler; 5G-724-AA	5F2Z-6006-BRM
			w/ Oil Cooler; 5G-726-AA	5F2Z-6006-CRM
	2004	4.2L	w/ Oil Cooler; 4G-726-AA	4F2Z-6006-DARM
			w/o Oil Cooler; 4G-724-AA	4F2Z-6006-CARM

**Mountaineer**

Part Type	Years	Engine	Qualifier	Ford #
Reman	2010-2009	4.0L	w/ Cooler; 9S-962-AA	9L2Z-6006-CARM
	2009	4.0L	w/o Cooler; 9S-960-AA	9L2Z-6006-BARM
		4.6L	9S-302-AA	9L2Z-6006-AARM
	2008	4.0L	w/ Cooler; 8S-962-AA/AB	7L2Z-6006-CRM
			w/o Cooler; 8S-960-AA/AB	7L2Z-6006-BRM
		4.6L	7S-302-AB	7L2Z-6006-AARM
			7S-302-AC	7L2Z-6006-BARM
	2007	4.0L	w/o Cooler; 7S-960-AA	6L2Z-6006-BARM
			w/ Cooler; 7S-962-AA	6L2Z-6006-DARM
			w/ Cooler; 7S-962-AB	7L2Z-6006-CRM
			w/o Cooler; 7S-960-AB	7L2Z-6006-BRM
		4.6L	7S-302-AA	7L2Z-6006-AARM
	2006	4.0L	w/o Cooler; 6G-960-AA/AB	6L2Z-6006-BARM
			w/ Cooler; 6G-962-AA/AB	6L2Z-6006-DARM
		4.6L	6S-302-AA/AB/AC	6L2Z-6006-AARM
	2005	4.0L	w/ Oil Cooler 5G-962-AB	4L2Z-6006-EARM
			w/o Oil Cooler 5G-960-AB	4L2Z-6006-DARM
		4.6L	4S-306-BA	5L2Z-6006-ARM
	2004	4.0L	w/ Oil Cooler 4G-966-AA/AB/AC	4L2Z-6006-EARM



**Mountaineer**

**-Cont'd**

Part Type	Years	Engine	Qualifier	Ford #
Reman	2004	4.0L	w/o Oil Cooler 4G-962-AA/AB/AC	4L2Z-6006-DARM
		4.6L	4S-302-AA, 4S-306-AA	4L2Z-6006-AARM
	2003	4.0L	2G-967-BB/BC; 2G-968-BB	2L2Z-6006-CBRM
		4.6L	2G-962-BB; 2G-966-BB/BC	2L2Z-6006-BBRM
	2002	4.0L	2G-302-AA, 2G-306-AA	2L2Z-6006-FARM
		4.6L	2G-302-BA, 2G-306-BA	3L2Z-6006-BARM
		4.0L	2G-967-AA/BB, 2G-968-AA/BB	2L2Z-6006-CBRM
		4.6L	2G-962-AA/BB, 2G-966-AA/BB, 2G-969-AA/BB	2L2Z-6006-BBRM
	2001	4.0L	2G-302-AA, 2G-306-AA	2L2Z-6006-FARM
		4.0L	1G-302**, 1G-306**	2L2Z-6006-AARM
	2001-1999	5.0L	RWD; 0G-960-AB, 0G-961-AB	F77Z-6006-CRM
		4.0L	4WD; 0G-962-AB, 0G-963-AB, 0G-964-AB	F77Z-6006-DRM
	2000	5.0L	AWD; 0G-962-AB, 0G-963-AB, 0G-964-AB	F77Z-6006-DRM
		4.0L	9G-352-AA, 9G-354-AA	F87Z-6V012-ARM
	1999	4.0L SOHC	RWD; 0G-960-AB; 0G-961-AA/AB	F77Z-6006-CRM
4.0L SOHC		4WD; 0G-962-AB; 0G-964-AA/AB; 0G-963-AA/AB	F77Z-6006-DRM	
1998	4.0L SOHC	RWD; 9G-960-AA, 9G-961-AA	F77Z-6006-CRM	
	4.0L SOHC	AWD; 9G-962-AA, 9G-963-AA	F77Z-6006-DRM	
1997	5.0L	4WD; 9G-962-AA, 9G-963-AA	F77Z-6006-DRM	
	5.0L	RWD; w/ Automatic Trans.; 8G-960-AA, 8G-961-AA	F77Z-6006-CRM	
		AWD; w/ Automatic Trans.; 8G-962-AA, 8G-963-AA	F77Z-6006-DRM	
		4WD; w/ Automatic Trans.; 8G-962-AA, 8G-963-AA	F77Z-6006-DRM	
		8G-352-AA/CA, 8G-354-AA/CA	F77Z-6V012-CARM	
		8G-352-DA, 8G-354-DA	F87Z-6V012-ARM	
		From 10/25/96	F77Z-6V012-CARM	

**Ford**

**Econoline**

Part Type	Years	Engine	Qualifier	Ford #
New	2016-2008	5.4L	w/o Gaseous Prep Pack	9C2Z-6006-A
	2016-2010	5.4L	w/ Gaseous Fuel Prep Pack	AC2Z-6006-B
Reman	2016-2003	6.8L	w/o Gaseous Prep Pack	9C2Z-6006-AA
	2016-2010	6.8L	w/ Gaseous Fuel Prep Pack	AC2Z-6006-A
	2013-2010	5.4L	9E-640-AA	9C2Z-6006-BARM
	2013-2009	6.8L	9Q-636-AA	9C2Z-6006-CARM
	2013-2010	6.8L	AQ-638-AA	AC2Z-6006-BRM
	2011-2009	4.6L FLEX	9S-816-AA/AB	9C2Z-6006-AARM
	2010	5.4L CNG	AE-616-AA/AE-618-AA	AC2Z-6006-ARM
		5.4L FLEX	AE-616-AA/AE-618-AA	AC2Z-6006-ARM
	2009	5.4L	9E-640-AA; 9E-642-AA	9C2Z-6006-BARM
	2008	4.6L	7S-820-AA	7C2Z-6006-AARM
		5.4L	8S-816-AA; FFV	8C2Z-6006-AARM
	2008-2007	5.4L	7E-872-AA, 7E-886-AA, 7E-898-AA	7C2Z-6006-BARM
	2008	6.8L	7Q-636-AA	7C2Z-6006-CARM
	2008-2007	6.8L	8E-662-AA, 8E-663-AA	7C3Z-6006-CARM
	2007	4.6L	w/ Oil Cooler; 7S-820-AA	7C2Z-6006-AARM
	2006-2005	4.6L	w/ Oil Cooler	5C2Z-6006-CRM
	2006	5.4L	w/o Oil Cooler	5C2Z-6006-BRM
		6.8L	6G-872-AA, 6G-890-AA, 6G-898-AA	5C2Z-6006-ARM
	2005	5.4L	5Q-636-CA, 6Q-636-AA	5C2Z-6006-DRM
		6.8L	5G-872-AA, 5G-890-AA, 5G-892-AA, 5G-898-AA	5C2Z-6006-ARM
	2004	6.8L	5Q-636-BA/CA	5C2Z-6006-DRM
		4.6L	w/ Cooler 4S-820-AA	4C2Z-6006-BARM
	2003	5.4L	w/o Cooler 4S-818-AA	4C2Z-6006-AARM
		5.4L	4S-890-AA	4C2Z-6006-CARM
	2002	5.4L CNG	4Q-872-AA, XE-892-AA	4C2Z-6006-FRM
		6.8L	4S-616-AA	4C2Z-6006-DARM
	2001	4.2L	4Q-636-AA/BA	4C2Z-6006-ARM
		4.6L	w/o Oil Cooler; 2K-706-AA/BA	1L3Z-6006-QARM
	2000	5.4L	w/o Oil Cooler; 3K-706-BA	3L3Z-6006-GARM
		5.4L	w/ Oil Cooler 3K-704-BA	3C2Z-6006-JARM
	2000	5.4L	3G-818-AC	3C2Z-6006-DARM
		5.4L	3G-820-AA/AB	3C2Z-6006-EARM
	2000	5.4L	3G-818-AA/AB	3C2Z-6006-CARM
		5.4L	3G-386-AA	3C2Z-6006-BBRM
	2000	5.4L	3G-890-AA	3C2Z-6006-GBRM
5.4L		3E-872-AA, WE-892-AA	3C2Z-6006-ERM	
2000	6.8L	3E-636-AA, 3E-638-AA	3C2Z-6006-HBRM	
	5.4L	2G-616-BA	2C2Z-6006-CBRM	
2000	5.4L	2G-890-BA	2C2Z-6006-ABRM	
	5.4L	2E-872-BA, UE-892-BA	2C2Z-6006-DRM	
2000	6.8L	2E-636-BA/BB, 2E-638-BA/BB	2C2Z-6006-BBRM	
	5.4L	1G-890-AA/AB	YC2Z-6006-NARM	
2000	5.4L	1G-616-AA/AB	1C2Z-6006-EARM	
	5.4L	1E-872-AA/AB, TE-892-AA/AB	YC2Z-6006-PARM	
2000	6.8L	TE-634-AA, 1E-636-AA/AB	YC2Z-6006-SARM	
	5.4L	0G-616-AA/AB	1C2Z-6006-EARM	
2000	5.4L	0G-890-AB	YC2Z-6006-NARM	





**Econoline**

-Cont'd

Part Type	Years	Engine	Qualifier	Ford #
Reman	2000	5.4L GAS	0E-872-AB, SE-892-AB	YC2Z-6006-PARM
		6.8L	SE-634-AB, 0E-636-AB	YC2Z-6006-SARM
	1999	5.4L	9E-892-AA	F7UZ-6006-MARM
	1996	5.8L		F4TZ-6V012-BARM

**F-Series**

Part Type	Years	Engine	Qualifier	Ford #
New	2016-2008	6.8L	0/8500 GVW; w/o Gaseous Prep Pack	8C3Z-6006-D
	2016-2011	6.8L	w/ Gaseous Fuel Prep Pack	BC3Z-6006-C
	2016	6.8L	Engine Assembly (Complete); w/o Gaseous Fuel Prep Pack	GC3Z-6007-E
	2016-2011	6.8L	w/o Gaseous Fuel Prep Pack	GU9Z-6006-A
Reman	2011-2008	6.8L	7E-874-AB	8U9Z-6006-AARM
			8E-662-AB, 8E-663-AB	8C3Z-6006-BARM
	2011	6.8L	BQ-660-AA	DC3Z-6006-ARM
	2008-2007	6.8L	7Q-636-AA	7C2Z-6006-CARM
	2008	6.8L	8E-662-AA, 8E-663-AA	7C3Z-6006-CARM
	2006	6.8L	Motorhome 6E-674-AA, 7E-674-AA	5U9Z-6006-ARM
	2005-2004	6.8L	Motorhome 4Q-674-AA/BA	4U9Z-6006-ARM
	2005	6.8L	Motorhome 5E-674-AA	5U9Z-6006-ARM
	2004	6.8L	4D-683-AA; LPG	4C3Z-6006-BRM
		6.8L GAS	4Q-662-BA, 4Q-663-AA/BA	4C3Z-6006-ARM
			4Q-662-AA/BA, 4Q-663-AA/BA	4C3Z-6006-ARM
	2003	6.8L	2D-683-AA/AB; LPG	2C3Z-6006-ABRM
			2E-662-AB, 2E-663-AB	2L3Z-6006-EBRM
	2003-2002	6.8L	Motorhome; 2E-674-AA/AB	2C2Z-6006-EBRM
	2002	6.8L	2D-683-AA; LPG	2C3Z-6006-ABRM
			2E-662-AA/AB, 2E-663-AA/AB	2L3Z-6006-EBRM
	2001-2000	6.8L	OE-674-AB, 1E-674-AA	YC2Z-6006-SARM
	2001	6.8L	TE-660-AA, TE-661-AA, 1E-662-AA, 1E-663-AA	YC3Z-6006-GARM
	2000	6.8L	SE-660-AB, SE-661-AB, OE-662-AB, OE-663-AB	YC3Z-6006-GARM
	1999	6.8L	9E-672-CA	XC2Z-6006-RARM
			9E-660-AA, 9E-661-AA	XC3Z-6006-FARM

**F53**

Part Type	Years	Engine	Qualifier	Ford #
New	2017	6.8L	w/o Gaseous Fuel Prep Pack	HU9Z-6007-B
	2016-2011, 2009-2008	6.8L	w/o Gaseous Fuel Prep Pack	8C3Z-6006-D
	2016-2011	6.8L	w/ Gaseous Fuel Prep Pack	BC3Z-6006-C
			w/o Gaseous Fuel Prep Pack	GU9Z-6006-A
Reman	2011	6.8L CNG	w/ Gaseous Fuel Prep Pack	BC3Z-6006-BARM
	2004	6.8L	Motor Home - Stripped Chassis; 4Q-674-AA/BA	4U9Z-6006-ARM
	2003-2002	6.8L	Motor Home - Stripped Chassis; Motorhome; 2E-674-AA/AB	2C2Z-6006-EBRM
	2001-2000	6.8L	Motor Home - Stripped Chassis; Motorhome; OE-674-AB, 1E-674-AA	YC2Z-6006-SARM
	1999	6.8L	Motor Home - Stripped Chassis; 9E-672-CA; Motorhome	XC2Z-6006-RARM
	1997-1993	7.5L	Motor Home - Stripped Chassis	F3TZ-6V012-FRM

**F59**

Part Type	Years	Engine	Qualifier	Ford #
New	2016-2011	6.8L	w/ Gaseous Fuel Prep Pack	BC3Z-6006-C
	2016	6.8L	w/o Gaseous Fuel Prep Pack	GU9Z-6006-A
	2015-2011	6.8L	w/o Gaseous Fuel Prep Pack	8C3Z-6006-D

**F600**

Part Type	Years	Engine	Qualifier	Ford #
Reman	1994-1993	7.0L GAS	w/ Forged Crankshaft	F3HZ-6V012-CRM

**F650**

Part Type	Years	Engine	Qualifier	Ford #
New	2017	6.8L	w/o Gaseous Fuel Prep Pack	HC4Z-6006-C
	2016	6.8L	w/o Gaseous Fuel Prep Pack	FC4Z-6006-A
			w/ Gaseous Fuel Prep Pack	FC4Z-6006-B

**F700**

Part Type	Years	Engine	Qualifier	Ford #
Reman	1998-1997	7.0L GAS	w/ Forged Crankshaft	F7HZ-6V012-BARM

**LONGBLOCKS**  
**Medium Trucks**  
**Ford**



**FORD PARTS**

**F700**

**-Cont'd**

Part Type	Years	Engine	Qualifier	Ford #
Reman	1996-1993	7.0L GAS	w/ Forged Crankshaft	F3HZ-6V012-CRM

**F750**

Part Type	Years	Engine	Qualifier	Ford #
New	2017	6.8L	w/o Gaseous Fuel Prep Pack	HC4Z-6006-C

**F800**

Part Type	Years	Engine	Qualifier	Ford #
Reman	1998-1997	7.0L GAS	w/ Forged Crankshaft	F7HZ-6V012-BARM



YEAR	ENGINE SIZE	QUALIFIER	FORD #
<b>FORD TRUCK</b>			
<b>F Series</b>			
1998-97	7.0L	429 CID w/ Forged Crankshaft.....	F7HZ-6V012-BARM
1996-92	7.0L	429 CID Gas w/ Forged Crankshaft .....	F3HZ-6V012-CRM

**CYLINDER HEADS**  
**Passenger Cars**  
**Ford / Lincoln / Mercury**



**FORD PARTS**

**Ford** **Crown Victoria**

<b>Years</b>	<b>Qualifier</b>	<b>Ford #</b>
2000-1997	4.6L GAS; Left	2W7Z-6049-JARM
1996	4.6L GAS; Left; Romeo	2W7Z-6049-JARM

**Mustang**

<b>Years</b>	<b>Qualifier</b>	<b>Ford #</b>
2000	4.6L Right	XL3Z-6049-CBRM
1999	4.6L Right; w/o Oil Cooler	XL3Z-6049-CBRM
1998-1996	4.6L Left	2W7Z-6049-JARM

**Lincoln** **Town Car**

<b>Years</b>	<b>Qualifier</b>	<b>Ford #</b>
2000-1996	4.6L GAS; Left	2W7Z-6049-JARM

**Mercury** **Grand Marquis**

<b>Years</b>	<b>Qualifier</b>	<b>Ford #</b>
2000-1996	4.6L GAS; Left	2W7Z-6049-JARM



**Ford**

**Econoline**

Years	Qualifier	Ford #
2001-2000	5.4L GAS; Left	XL3Z-6049-DBRM
	GAS; Right	XL3Z-6049-CBRM
2000-1999	4.6L Left	2W7Z-6049-JARM

**Excursion**

Years	Qualifier	Ford #
2001-2000	5.4L GAS; Left	XL3Z-6049-DBRM
	GAS; Right	XL3Z-6049-CBRM

**Expedition**

Years	Qualifier	Ford #
2001, 1999	5.4L GAS; Right	XL3Z-6049-CBRM
	Left	XL3Z-6049-DBRM
2000, 1998-1997	4.6L w/ Triton (Romeo) Engine; Left	2W7Z-6049-JARM
1999	4.6L Right	XL3Z-6049-CBRM

**Explorer**

Years	Qualifier	Ford #
2000-1998	4.0L OHV	F87Z-6049-BARM

**F-Series**

Years	Qualifier	Ford #
2001-1999	5.4L GAS; Left	XL3Z-6049-DBRM
	GAS; Left; XL	XL3Z-6049-DBRM
	GAS; Right	XL3Z-6049-CBRM
	GAS; Right; XL	XL3Z-6049-CBRM
	Left; Lightning	XL3Z-6049-DBRM
	Right; Lightning	XL3Z-6049-CBRM
2001	4.6L Crew Cab Pickup; Right	XL3Z-6049-CBRM
2000-1997	4.6L Left	2W7Z-6049-JARM

**Ranger**

Years	Qualifier	Ford #
2000-1998	4.0L OHV	F87Z-6049-BARM

**Lincoln**

**Navigator**

Years	Qualifier	Ford #
2000-1999	5.4L GAS; Right	XL3Z-6049-CBRM
	Left	XL3Z-6049-DBRM

# DIESEL ENGINES

## Light / Medium Trucks

### Ford



FORD PARTS

## Ford Econoline

Part Type	Years	Engine	Qualifier	Ford #
Reman	2010	6.0L DIESEL OHV	Diesel Fuel Injector Driver Module; FI; V8 363 CID (P)	4C3Z-12B599-ABRM
			Engine Short Block; V8 363 CID (P); Assembly	6C3Z-6009-ARM
			Turbocharger; V8 363 CID (P)	5C3Z-6K682-CCRM
			Turbocharger; V8 363 CID (P)	TC-17RM
			Engine Assembly (Complete); V8 363 CID (P); From Engine Serial # 299,093 and Up	6C2Z-6007-AARM
Reman	2009	6.0L DIESEL OHV	Engine Assembly (Less Accessories); V8 363 CID (P); From Engine Serial # 299,093 and Up	6C2Z-6006-AARM
			Engine Assembly (Less Accessories); V8 363 CID (P); From Engine Serial # 299,093 and Up; w/ Head Studs	5C3Z-6006-DARM
			Diesel Fuel Injector Driver Module; FI; V8 363 CID (P)	4C3Z-12B599-ABRM
			Engine Short Block; V8 363 CID (P); Assembly	6C3Z-6009-ARM
			Turbocharger; V8 363 CID (P)	5C3Z-6K682-CCRM
Reman	2008	6.0L DIESEL OHV	Turbocharger; V8 363 CID (P)	TC-17RM
			Engine Assembly (Complete); V8 363 CID (P); From Engine Serial # 299,093 and Up	6C2Z-6007-AARM
			Engine Assembly (Less Accessories); V8 363 CID (P); From Engine Serial # 299,093 and Up	6C2Z-6006-AARM
			Engine Assembly (Less Accessories); V8 363 CID (P); From Engine Serial # 299,093 and Up; w/ Head Studs	5C3Z-6006-DARM
			Diesel Fuel Injector Driver Module; FI; V8 363 CID (P)	4C3Z-12B599-ABRM
Reman	2007	6.0L DIESEL OHV	Diesel Fuel Injector Nozzle; V8 363 CID (P)	4C3Z-9E527-BRM
			Engine Short Block; V8 363 CID (P); Assembly	6C3Z-6009-ARM
			Turbocharger; V8 363 CID (P)	5C3Z-6K682-CCRM
			Turbocharger; V8 363 CID (P)	TC-17RM
			Engine Assembly (Complete); V8 363 CID (P); From Engine Serial # 299,093 and Up	6C2Z-6007-AARM
Reman	2006	6.0L DIESEL OHV	Engine Assembly (Less Accessories); V8 363 CID (P); From Engine Serial # 299,093 and Up	6C2Z-6006-AARM
			Engine Assembly (Less Accessories); V8 363 CID (P); From Engine Serial # 299,093 and Up; w/ Head Studs	5C3Z-6006-DARM
			Diesel Fuel Injector Driver Module; FI; V8 363 CID	4C3Z-12B599-ABRM
			Diesel Fuel Injector Driver Module; FI; V8 363 CID (P)	4C3Z-12B599-ABRM
			Diesel Fuel Injector Nozzle; V8 363 CID	4C3Z-9E527-BRM
			Diesel Fuel Injector Nozzle; V8 363 CID (P)	4C3Z-9E527-BRM
			Diesel High Pressure Oil Pump; V8 363 CID (P); 5C4O-9A543-AA	5C3Z-9A543-ARM
			Diesel High Pressure Oil Pump; V8 363 CID (P); 5C4O-9A543-AA	HPP-12RM
			Diesel High Pressure Oil Pump; V8 363 CID; 5C4O-9A543-AA	5C3Z-9A543-ARM
			Diesel High Pressure Oil Pump; V8 363 CID; 5C4O-9A543-AA	HPP-12RM
			Engine Short Block; V8 363 CID (P); Assembly	6C3Z-6009-ARM
			Engine Short Block; V8 363 CID; Assembly	6C3Z-6009-ARM
			Turbocharger; V8 363 CID	5C3Z-6K682-CCRM
			Turbocharger; V8 363 CID (P)	TC-17RM
			Turbocharger; V8 363 CID (P)	TC-17RM
Reman	2005	6.0L DIESEL OHV	Engine Assembly (Complete); V8 363 CID (P); From Engine Serial # 299,093 and Up	6C2Z-6007-AARM
			Engine Assembly (Complete); V8 363 CID (P); S/N 213,261 to 299,095	5C2Z-6007-BARM
			Engine Assembly (Complete); V8 363 CID; From Engine Serial # 299,093 and Up	6C2Z-6007-AARM
			Engine Assembly (Complete); V8 363 CID; S/N 213,261 to 299,095	5C2Z-6007-BARM
			Engine Assembly (Less Accessories) S/N 149,761 to 299,092; V8 363 CID	5C2Z-6006-AARM
			Engine Assembly (Less Accessories) S/N 149,761 to 299,092; V8 363 CID (P)	5C2Z-6006-AARM
			Engine Assembly (Less Accessories); V8 363 CID (P); From Engine Serial # 299,093 and Up	6C2Z-6006-AARM
			Engine Assembly (Less Accessories); V8 363 CID (P); From Engine Serial # 299,093 and Up; w/ Head Studs	5C3Z-6006-DARM
			Engine Assembly (Less Accessories); V8 363 CID; From Engine Serial # 299,093 and Up	6C2Z-6006-AARM
			Engine Assembly (Less Accessories); V8 363 CID; From Engine Serial # 299,093 and Up; w/ Head Studs	5C3Z-6006-DARM
			Diesel Fuel Injector Driver Module; FI; V8 363 CID	4C3Z-12B599-ABRM
			Diesel Fuel Injector Driver Module; FI; V8 363 CID (P)	4C3Z-12B599-ABRM
			Diesel Fuel Injector Nozzle; V8 363 CID	4C3Z-9E527-BRM
			Diesel Fuel Injector Nozzle; V8 363 CID (P)	4C3Z-9E527-BRM
			Diesel High Pressure Oil Pump; V8 363 CID (P); 5C4O-9A543-AA	5C3Z-9A543-ARM
Diesel High Pressure Oil Pump; V8 363 CID (P); 5C4O-9A543-AA	HPP-12RM			
Engine Short Block; V8 363 CID (P); Assembly	5C3Z-6009-AARM			
Engine Short Block; V8 363 CID (P); From 4/18/05; Assembly	6C3Z-6009-ARM			



Econoline

-Cont'd

Part Type	Years	Engine	Qualifier	Ford #	
Reman	2005	6.0L DIESEL OHV	Engine Short Block; V8 363 CID; Assembly	5C3Z-6009-AARM	
			Engine Short Block; V8 363 CID; From 4/18/05; Assembly	6C3Z-6009-ARM	
			Turbocharger; V8 363 CID	5C3Z-6K682-CCRM	
			Turbocharger; V8 363 CID	TC-17RM	
			Turbocharger; V8 363 CID (P)	5C3Z-6K682-CCRM	
			Turbocharger; V8 363 CID (P)	TC-17RM	
	2004	6.0L DIESEL OHV	Engine Assembly (Complete); V8 363 CID (P); Before 11/29/04 S/N 149,761 to 178,947	5C2Z-6007-AARM	
			Engine Assembly (Complete); V8 363 CID (P); From 11/29/04 S/N 178,948 to 213,261	5C2Z-6007-BARM	
			Engine Assembly (Complete); V8 363 CID; Before 11/29/04 S/N 149,761 to 178,947	5C2Z-6007-AARM	
			Engine Assembly (Complete); V8 363 CID; From 11/29/04 S/N 178,948 to 213,261	5C2Z-6007-BARM	
			Engine Assembly (Less Accessories) S/N 149,761 to 299,092; V8 363 CID	5C2Z-6006-AARM	
			Engine Assembly (Less Accessories) S/N 149,761 to 299,092; V8 363 CID (P)	5C2Z-6006-AARM	
Reman	2003	7.3L DIESEL OHV	Diesel Fuel Injector Driver Module; FI; V8 363 CID (P); From S/N 6155637 (Indy Built) or 94581 (Huntsville Built)	4C3Z-12B599-ABRM	
			Diesel Fuel Injector Nozzle; V8 363 CID (P)	4C3Z-9E527-BRM	
			Diesel High Pressure Oil Pump; V8 363 CID (P); 5C4O-9A543-AA	5C3Z-9A543-ARM	
			Diesel High Pressure Oil Pump; V8 363 CID (P); 5C4O-9A543-AA	HPP-12RM	
			Diesel High Pressure Oil Pump; V8 363 CID (P); Before S/N 151,888	4C3Z-9A543-AARM	
			Diesel High Pressure Oil Pump; V8 363 CID (P); Before S/N 151,888	HPP-8RM	
	2002	7.3L DIESEL OHV	Engine Short Block; V8 363 CID (P); Assembly; From 9/29/03	5C3Z-6009-AARM	
			Turbocharger; V8 363 CID (P)	4C3Z-6K682-CCRM	
			Engine Assembly (Complete); V8 363 CID (P)	4C2Z-6007-AARM	
			Engine Assembly (Complete); V8 363 CID (P); Before 11/29/04 S/N 149,761 to 178,947	5C2Z-6007-AARM	
			Engine Assembly (Complete); V8 363 CID (P); From 11/29/04 S/N 178,948 to 213,261	5C2Z-6007-BARM	
			Engine Assembly (Less Accessories); V8 363 CID (P)	4C2Z-6006-EARM	
Reman	2001	7.3L DIESEL OHV	Diesel High Pressure Oil Pump; V8 445 CID	F81Z-9A543-CRM	
			Diesel High Pressure Oil Pump; V8 445 CID	HPP-9RM	
			Diesel High Pressure Oil Pump; V8 445 CID (F)	F81Z-9A543-CRM	
			Diesel High Pressure Oil Pump; V8 445 CID (F)	HPP-9RM	
			Engine Connecting Rod; V8 445 CID (F); w/ Engine Serial # 1425747 And Up	1C3Z-6200-AARM	
			Engine Crankshaft; Turbocharged; V8 445 CID	1C3Z-6200-AARM	
	2000	7.3L DIESEL OHV	Engine Crankshaft; Turbocharged; V8 445 CID (F)	3C3Z-6V303-AARM	
			Engine Crankshaft; Turbocharged; V8 445 CID (F)	3C3Z-6V303-AARM	
			Fuel Injector Kit; V8 445 CID (F); #1 Thru #7	5C3Z-9VE527-BRM	
			Fuel Injector Kit; V8 445 CID (F); #8	5C3Z-9VE527-ARM	
			Fuel Injector Kit; V8 445 CID; #1 Thru #7	5C3Z-9VE527-BRM	
			Fuel Injector Kit; V8 445 CID; #8	5C3Z-9VE527-ARM	
Reman	2001	7.3L DIESEL OHV	Turbocharger Mounting Kit; Turbocharged; V8 445 CID (F); w/ EBP Valve	F81Z-6N639-CARM	
			Turbocharger Mounting Kit; Turbocharged; V8 445 CID (F); w/ EBP Valve	PTC-6RM	
			Turbocharger Mounting Kit; Turbocharged; V8 445 CID; w/ EBP Valve	F81Z-6N639-CARM	
			Turbocharger Mounting Kit; Turbocharged; V8 445 CID; w/ EBP Valve	PTC-6RM	
			Turbocharger; V8 445 CID	XC2Z-6K682-AARM	
			Turbocharger; V8 445 CID	TC-10RM	
	2000	7.3L DIESEL OHV	Turbocharger; V8 445 CID (F)	XC2Z-6K682-AARM	
			Turbocharger; V8 445 CID (F)	TC-10RM	
			Engine Assembly (Complete); V8 445 CID	XC2Z-6007-AARM	
			Engine Assembly (Less Accessories); V8 445 CID (F)	XC2Z-6006-AARM	
			Engine Assembly (Less Accessories); V8 445 CID (F)	XC2Z-6006-AARM	
			Diesel High Pressure Oil Pump; Turbocharged; V8 445 CID (F)	F81Z-9A543-CRM	
Reman	2001	7.3L DIESEL OHV	Diesel High Pressure Oil Pump; Turbocharged; V8 445 CID (F)	HPP-9RM	
			Engine Connecting Rod; Turbocharged; V8 445 CID (F); w/ Engine Serial # 1425747 And Up	1C3Z-6200-AARM	
			Engine Crankshaft; Turbocharged; V8 445 CID (F)	3C3Z-6V303-AARM	
			Fuel Injector Kit; Turbocharged; V8 445 CID (F); #1 Thru #7	5C3Z-9VE527-BRM	
			Fuel Injector Kit; Turbocharged; V8 445 CID (F); #2	5C3Z-9VE527-ARM	
			Turbocharger Mounting Kit; Turbocharged; V8 445 CID (F); w/ EBP Valve	F81Z-6N639-CARM	
	2000	7.3L DIESEL OHV	7.3L DIESEL OHV	Turbocharger Mounting Kit; Turbocharged; V8 445 CID (F); w/ EBP Valve	PTC-6RM
				Turbocharger; V8 445 CID (F)	XC2Z-6K682-AARM
				Turbocharger; V8 445 CID (F)	TC-10RM
				Engine Assembly (Complete); Turbocharged; V8 445 CID (F)	XC2Z-6007-AARM
				Engine Assembly (Less Accessories); Turbocharged; V8 445 CID (F)	XC2Z-6006-AARM
				Diesel High Pressure Oil Pump; Turbocharged; V8 445 CID (F); S/N 896812-Current	F81Z-9A543-CRM
Reman	2000	7.3L DIESEL OHV	Diesel High Pressure Oil Pump; Turbocharged; V8 445 CID (F); S/N 896812-Current	HPP-9RM	
			Engine Crankshaft; Turbocharged; V8 445 CID (F); w/ Engine Serial Number 896812 - Current	3C3Z-6V303-AARM	
			Fuel Injector Kit; Turbocharged; V8 445 CID (F); #1 Thru #7	5C3Z-9VE527-BRM	
			Fuel Injector Kit; Turbocharged; V8 445 CID (F); #8	5C3Z-9VE527-ARM	
			Turbocharger Mounting Kit; Turbocharged; V8 445 CID (F); w/ EBP Valve w/ Engine Serial # 896812-Current	F81Z-6N639-CARM	

**DIESEL ENGINES**  
**Light / Medium Trucks**  
**Ford**



**FORD PARTS**

**Econoline**

**-Cont'd**

Part Type	Years	Engine	Qualifier	Ford #
Reman	2000	7.3L DIESEL OHV	Turbocharger Mounting Kit; Turbocharged; V8 445 CID (F); w/ EBP Valve w/ Engine Serial # 896812-Current Turbocharger; V8 445 CID (F); w/ Engine Serial # 896812-Current Turbocharger; V8 445 CID (F); w/ Engine Serial # 896812-Current Engine Assembly (Complete); Turbocharged; V8 445 CID (F) Engine Assembly (Less Accessories); Turbocharged; V8 445 CID (F); For Engine S/N 896812 to current	PTC-6RM XC2Z-6K682-AARM TC-10RM XC2Z-6007-AARM XC2Z-6006-AARM
	1999	7.3L DIESEL OHV	Diesel High Pressure Oil Pump; Turbocharged; V8 445 CID (F); Kit; S/N 896811 And Below Diesel High Pressure Oil Pump; Turbocharged; V8 445 CID (F); S/N 896812-Current Diesel High Pressure Oil Pump; Turbocharged; V8 445 CID (F); S/N 896812-Current Engine Crankshaft; Turbocharged; V8 445 CID (F); w/ Engine Serial # 576010-Current Fuel Injector Kit; Turbocharged; V8 445 CID (F); #1 Thru #7 Fuel Injector Kit; Turbocharged; V8 445 CID (F); Injector Before Engine Serial # 896812 Turbocharger Mounting Kit; Turbocharged; V8 445 CID (F); w/ EBP Valve w/ Engine Serial # 896812-Current Turbocharger Mounting Kit; Turbocharged; V8 445 CID (F); w/ EBP Valve w/ Engine Serial # 896812-Current Turbocharger Mounting Kit; Turbocharged; V8 445 CID (F); w/o EBP Valve Before 12/7/98 w/ Engine Serial # 661974-896811 Turbocharger Mounting Kit; Turbocharged; V8 445 CID (F); w/o EBP Valve From 12/7/98 Turbocharger Mounting Kit; Turbocharged; V8 445 CID (F); w/o EBP Valve From 12/7/98 Turbocharger; V8 445 CID (F); w/ Engine Serial # 661974-896811 Turbocharger; V8 445 CID (F); w/ Engine Serial # 896812-Current Turbocharger; V8 445 CID (F); w/ Engine Serial # 896812-Current Engine Assembly (Complete); Turbocharged; V8 445 CID (F); For Engine S/N 661974 to 896811 Engine Assembly (Complete); Turbocharged; V8 445 CID (F); For Engine S/N 896812 to current Engine Assembly (Less Accessories) For Engine S/N 661974 to 896811; Turbocharged; V8 445 CID (F) Engine Assembly (Less Accessories); Turbocharged; V8 445 CID (F); For Engine S/N 896812 to current	5C3Z-9VA543-BRM F81Z-9A543-CRM HPP-9RM 3C3Z-6V303-AARM 5C3Z-9VE527-BRM F61Z-9VE527-BRM F81Z-6N639-CARM PTC-6RM 5C3Z-6V639-BRM F81Z-6N639-DARM PTC-7RM 5C3Z-6V682-BRM XC2Z-6K682-AARM TC-10RM 5C3Z-6V007-ARM XC2Z-6007-AARM 5C3Z-6V006-DRM XC2Z-6006-AARM
Reman	1998	7.3L DIESEL OHV	Diesel High Pressure Oil Pump; Turbocharged; V8 445 CID (F); Kit; S/N 187100-201679 Diesel High Pressure Oil Pump; Turbocharged; V8 445 CID (F); Kit; S/N 201680-896811 Engine Crankshaft; Turbocharged; V8 445 CID (F); w/ Bearings and Seal; w/ Engine Serial # 576010-Current Fuel Injector Kit; Turbocharged; V8 445 CID (F); Injector w/ Engine Serial # 661496-896811 Turbocharger Mounting Kit; Turbocharged; V8 445 CID (F); w/ EBP Valve Before 12/7/98 w/ Engine Serial # 661974-896811 Turbocharger Mounting Kit; Turbocharged; V8 445 CID (F); w/ EBP Valve w/ Engine Serial # 501-661973 Turbocharger Mounting Kit; Turbocharged; V8 445 CID (F); w/ EBP Valve w/ Engine Serial # 661974-896811 Turbocharger Mounting Kit; Turbocharged; V8 445 CID (F); w/o EBP Valve Before 12/7/98 w/ Engine Serial # 661974-896811 Turbocharger Mounting Kit; Turbocharged; V8 445 CID (F); w/o EBP Valve From 12/7/98 Turbocharger Mounting Kit; Turbocharged; V8 445 CID (F); w/o EBP Valve From 12/7/98 Turbocharger; V8 445 CID (F); w/ Engine Serial # 501-661973 Turbocharger; V8 445 CID (F); w/ Engine Serial # 661974-896811 Engine Assembly (Complete); Turbocharged; V8 445 CID (F); S/N 375549-661973 Engine Assembly (Complete); Turbocharged; V8 445 CID (F); S/N 661974-896811 Engine Assembly (Less Accessories) w/ Engine Serial # 375548-661973; Turbocharged; V8 445 CID (F) Engine Assembly (Less Accessories) w/ Engine Serial No. 661974-896811; Turbocharged; V8 4455C3Z-6V006-DRM CID (F)	F6TZ-9VA543-ARM 5C3Z-9VA543-BRM 3C3Z-6V303-AARM F61Z-9VE527-BRM 5C3Z-6V639-ARM F4TZ-6VN639-AARM 5C3Z-6V639-ARM 5C3Z-6V639-BRM F81Z-6N639-DARM PTC-7RM F4TZ-6VK682-CARM 5C3Z-6V682-BRM F7UZ-6V007-AARM 5C3Z-6V007-ARM F7UZ-6V006-AARM
	1997	7.3L DIESEL OHV	Diesel High Pressure Oil Pump; Turbocharged; V8 445 CID (F); Kit; S/N 187100-201679 Fuel Injector Kit; Turbocharged; V8 445 CID (F); Injector w/ Engine Serial # 661496-896811 Turbocharger Mounting Kit; Turbocharged; V8 445 CID (F) Turbocharger; V8 445 CID (F); w/o Pedestal w/ Engine Serial # 501-661973 Engine Assembly (Complete); Turbocharged; V8 445 CID (F); S/N 375549-661973 Engine Assembly (Less Accessories) w/ Engine Serial # 375548-661973; Turbocharged; V8 445 CID (F)	F6TZ-9VA543-ARM F61Z-9VE527-BRM F4TZ-6VN639-AARM F4TZ-6VK682-CARM F7UZ-6V007-AARM F7UZ-6V006-AARM
Reman	1996	7.3L DIESEL OHV	Diesel High Pressure Oil Pump; Turbocharged; V8 445 CID (F); Kit; S/N 187100-201679 Fuel Injector Kit; Turbocharged; V8 445 CID (F); Injector Calif Only w/ Engine Serial # 661496-89681 Cyl.1-7 Fuel Injector Kit; Turbocharged; V8 445 CID (F); Injector Calif Only w/ Engine Serial # 661496-89681 Cyl.8 Fuel Injector Kit; Turbocharged; V8 445 CID (F); Injector Exc. California w/ Engine Serial # 501-661495 Turbocharger Mounting Kit; Turbocharged; V8 445 CID (F) Turbocharger; V8 445 CID (F); w/o Pedestal w/ Engine Serial # 501-661973 Engine Assembly (Complete); Turbocharged; V8 445 CID (F); California w/ Engine Serial #201681-375548 Engine Assembly (Complete); Turbocharged; V8 445 CID (F); Exc. California w/ Engine Serial # 201681-375548 Engine Assembly (Less Accessories) California Only w/ Engine Serial # 201681-375548; Turbocharged; V8 445 CID (F) Engine Assembly (Less Accessories) Exc. California w/ Engine Serial # 201681-375548; Turbocharged; V8 445 CID (F)	F6TZ-9VA543-ARM F61Z-9VE527-BRM F61Z-9VE527-ERM F4TZ-9VE527-AARM F4TZ-6VN639-AARM F4TZ-6VK682-CARM F6UZ-6V007-AARM F6UZ-6V007-BARM F6UZ-6V006-AARM F6UZ-6V006-BARM
	1995	7.3L DIESEL OHV	Diesel High Pressure Oil Pump; Turbocharged; V8 445 CID (F); Kit; S/N 501-187099 Engine Crankshaft; V8 445 CID (F) Fuel Injector Kit; Turbocharged; V8 445 CID (F); Injector w/ Engine Serial # 501-201679 Turbocharger Mounting Kit; Turbocharged; V8 445 CID (F) Turbocharger; V8 445 CID (F); w/o Pedestal w/ Engine Serial # 501-661973 Engine Assembly (Complete); Turbocharged; V8 445 CID (F); S/N 501-201680	F4TZ-9VA543-ARM F4TZ-6V303-BARM F4TZ-9VE527-AARM F4TZ-6VN639-AARM F4TZ-6VK682-CARM F5UZ-6V007-AARM





Econoline

-Cont'd

Part Type	Years	Engine	Qualifier	Ford #
Reman	1995	7.3L DIESEL OHV	Engine Assembly (Less Accessories) w/ Engine Serial # 501-201680; Turbocharged; V8 445 CID (F)	F5TZ-6V006-AARM
	1994	7.3L DIESEL OHV	Engine Assembly (Longblock); Turbocharged; V8 445 CID (F) Engine Connecting Rod; V8 445 CID (M) Engine Crankshaft; V8 445 CID (M) Engine Oil Cooler; V8 445 CID (M); Assembly Fuel Injector Kit; V8 445 CID (M)	F5UZ-6V012-AARM XU2Z-6V200-BARM F4TZ-6V303-BARM XU2Z-6VA642-AARM 2C3Z-9VE527-DRM XU2Z-6V007-EARM XU2Z-6V012-DARM
Reman	1993	7.3L DIESEL OHV	Engine Connecting Rod; V8 445 CID (M) Engine Oil Cooler; V8 445 CID (M); Assembly Fuel Injector Kit; V8 445 CID (M)	XU2Z-6V200-BARM XU2Z-6VA642-AARM 2C3Z-9VE527-DRM
Reman	1992	7.3L DIESEL OHV	Engine Assembly (Complete); V8 445 CID (M); S/N 500079-1116330 Engine Assembly (Longblock); V8 445 CID (M); S/N 500079-1116330 Engine Connecting Rod; V8 445 CID (M) Engine Oil Cooler; V8 445 CID (M); Assembly Fuel Injector Kit; V8 445 CID (M); Injector Before 3/92 Fuel Injector Kit; V8 445 CID (M); Injector From 3/92	XU2Z-6V007-EARM XU2Z-6V012-DARM XU2Z-6V200-BARM XU2Z-6VA642-AARM 2C3Z-9VE527-DRM 2C3Z-9VE527-ERM
Reman	1991	7.3L DIESEL OHV	Engine Assembly (Complete); V8 445 CID (M); S/N 500079-1116330 Engine Assembly (Longblock); V8 445 CID (M); S/N 500079-1116330 Engine Connecting Rod; V8 445 CID (M) Engine Oil Cooler; V8 445 CID (M); Assembly Fuel Injector Kit; V8 445 CID (M)	XU2Z-6V007-EARM XU2Z-6V012-DARM XU2Z-6V200-BARM XU2Z-6VA642-AARM 2C3Z-9VE527-ERM
Reman	1990	7.3L DIESEL OHV	Engine Assembly (Complete); V8 445 CID (M); S/N 500079-1116330 Engine Assembly (Longblock); V8 445 CID (M); S/N 500079-1116330 Engine Connecting Rod; V8 445 CID (M) Engine Oil Cooler; V8 445 CID (M); Assembly Fuel Injector Kit; V8 445 CID (M)	XU2Z-6V007-EARM XU2Z-6V012-DARM XU2Z-6V200-BARM XU2Z-6VA642-AARM 2C3Z-9VE527-ERM
Reman	1989	7.3L DIESEL OHV	Engine Assembly (Complete); V8 445 CID (M); S/N 500079-1116330 Engine Assembly (Longblock); V8 445 CID (M); S/N 500079-1116330 Engine Connecting Rod; V8 445 CID (M) Engine Oil Cooler; V8 445 CID (M); Assembly Fuel Injector Kit; V8 445 CID (M)	XU2Z-6V007-EARM XU2Z-6V012-DARM XU2Z-6V200-BARM XU2Z-6VA642-AARM 2C3Z-9VE527-ERM
Reman	1988	7.3L DIESEL OHV	Engine Assembly (Complete); V8 445 CID (M); S/N 500079-1116330 Engine Assembly (Longblock); V8 445 CID (M); S/N 500079-1116330 Engine Connecting Rod; V8 445 CID (M) Engine Oil Cooler; V8 445 CID (M); Assembly Fuel Injector Kit; V8 445 CID (M)	XU2Z-6V007-EARM XU2Z-6V012-DARM XU2Z-6V200-BARM XU2Z-6VA642-AARM 2C3Z-9VE527-ERM
Reman	1987	6.9L DIESEL OHV	Engine Assembly (Complete); V8 445 CID (M); S/N 500079-1116330 Engine Assembly (Longblock); V8 445 CID (M); S/N 500079-1116330 Engine Connecting Rod; V8 420 CID (1) Engine Oil Cooler; V8 420 CID (1); Assembly Fuel Injector Kit; V8 420 CID (1)	XU2Z-6V007-EARM XU2Z-6V012-DARM XU2Z-6V200-BARM XU2Z-6VA642-AARM 2C3Z-9VE527-FRM
Reman	1986	6.9L DIESEL OHV	Engine Assembly (Complete); V8 420 CID (1) Engine Assembly (Longblock); V8 420 CID (1) Engine Connecting Rod; V8 420 CID (1) Engine Oil Cooler; V8 420 CID (1); Assembly Fuel Injector Kit; V8 420 CID (1)	XU2Z-6V007-BARM XU2Z-6V012-BARM XU2Z-6V200-BARM XU2Z-6VA642-AARM 2C3Z-9VE527-FRM
Reman	1985	6.9L DIESEL OHV	Engine Assembly (Complete); V8 420 CID (1) Engine Assembly (Longblock); V8 420 CID (1) Engine Connecting Rod; V8 420 CID (1) Engine Oil Cooler; V8 420 CID (1); Assembly Fuel Injector Kit; V8 420 CID (1)	XU2Z-6V007-BARM XU2Z-6V012-BARM XU2Z-6V200-BARM XU2Z-6VA642-AARM 2C3Z-9VE527-FRM
Reman	1984	6.9L DIESEL OHV	Engine Assembly (Complete); V8 420 CID (1) Engine Assembly (Longblock); V8 420 CID (1) Engine Connecting Rod; V8 420 CID (1) Engine Oil Cooler; V8 420 CID (1); Assembly Fuel Injector Kit; V8 420 CID (1)	XU2Z-6V007-BARM XU2Z-6V012-BARM XU2Z-6V200-BARM XU2Z-6VA642-AARM 2C3Z-9VE527-FRM
Reman	1983	6.9L DIESEL OHV	Engine Assembly (Complete); V8 420 CID (1) Engine Assembly (Longblock); V8 420 CID (1) Engine Connecting Rod; V8 420 CID (1); Assembly w/ Engine Serial # 1116330 Engine Oil Cooler; V8 420 CID (1); Assembly Engine Assembly (Complete); V8 420 CID (1)	XU2Z-6V007-BARM XU2Z-6V012-BARM XU2Z-6V200-BARM XU2Z-6VA642-AARM XU2Z-6V007-BARM

Excursion

Part Type	Years	Engine	Qualifier	Ford #
Reman	2005	6.0L DIESEL OHV	Diesel Fuel Injector Driver Module; FI; V8 363 CID (P) Diesel Fuel Injector Nozzle; V8 363 CID (P) Diesel High Pressure Oil Pump; V8 363 CID (P); 5C40-9A543-AA Diesel High Pressure Oil Pump; V8 363 CID (P); 5C40-9A543-AA Engine Short Block; V8 363 CID (P); S/N 6,155,637 to 6,344,942 or 137,745 to 299,092; Assembly Turbocharger; V8 363 CID (P); Before 1/1/05 and S/N 6439200 or 0174729	4C3Z-12B599-ABRM 4C3Z-9E527-BRM 5C3Z-9A543-ARM HPP-12RM 5C3Z-6009-AARM 4C3Z-6K682-CCRM
			Engine Assembly (Complete); V8 363 CID (P); S/N 6,244,943 to 6,429,301 or 131,587 to 181,447 Engine Assembly (Complete); V8 363 CID (P); S/N 6,429,302 to 6,560,520 or 181,448 to 213,260 Engine Assembly (Less Accessories) S/N 6,344,943 to 6,429,301 or 131,587 to 181,447; V8 363 CID (P)	5C3Z-6007-EARM 5C3Z-6007-FARM 5C3Z-6006-EARM
	2004	6.0L DIESEL OHV	Diesel Fuel Injector Driver Module; FI; V8 363 CID (P)	4C3Z-12B599-ABRM



**Excursion**

**-Cont'd**

Part Type	Years	Engine	Qualifier	Ford #
Reman	2004	6.0L DIESEL OHV	Diesel Fuel Injector Nozzle; V8 363 CID (P); Injector Before S/N 6155636 (Indy Built) or 94580 (Huntsville Built)	3C3Z-9E527-ECRM
			Diesel Fuel Injector Nozzle; V8 363 CID (P); Injector From S/N 6155637 (Indy Built) or 94581 (Huntsville Built)	4C3Z-9E527-BRM
			Diesel High Pressure Oil Pump; V8 363 CID (P); 5C4O-9A543-AA	5C3Z-9A543-ARM
			Diesel High Pressure Oil Pump; V8 363 CID (P); 5C4O-9A543-AA	HPP-12RM
			Diesel High Pressure Oil Pump; V8 363 CID (P); S/N 6000000 to 6155637	3C3Z-9A543-AARM
			Diesel High Pressure Oil Pump; V8 363 CID (P); S/N 6000000 to 6155637	HPP-10RM
			Diesel High Pressure Oil Pump; V8 363 CID (P); S/N 6155638 to 6344942	4C3Z-9A543-AARM
			Diesel High Pressure Oil Pump; V8 363 CID (P); S/N 6155638 to 6344942	HPP-8RM
			Engine Short Block; V8 363 CID (P); Assembly; Before 11/29/03 and S/N 6,155,636 or 137,744	3C3Z-6009-AARM
			Engine Short Block; V8 363 CID (P); Assembly; From 11/29/03 and S/N 6,155,137 or 137,745	5C3Z-6009-AARM
			Turbocharger; V8 363 CID (P); From S/N 6155637 or 94580	4C3Z-6K682-CCRM
			Turbocharger; V8 363 CID (P); w/ EBP Valve	3C3Z-6K682-CCRM
			Turbocharger; V8 363 CID (P); w/ EBP Valve	TC-13RM
			Turbocharger; V8 363 CID (P); w/ EBP Valve; Before S/N 6155636 or 94580	3C3Z-6K682-CCRM
			Turbocharger; V8 363 CID (P); w/ EBP Valve; Before S/N 6155636 or 94580	TC-13RM
			Turbocharger; V8 363 CID (P); w/ EBP w/ Engine Serial # 896812-Current	TC-12RM
			Engine Assembly (Complete); V8 363 CID (P); Before S/N 6,155,636	3C3Z-6007-AARM
			Engine Assembly (Complete); V8 363 CID (P); From S/N 6,155,637	4C3Z-6007-BARM
			Engine Assembly (Complete); V8 363 CID (P); From S/N 6,155,637; w/ Head Studs	4C3Z-6007-CARM
			Engine Assembly (Less Accessories) w/ Eng Tags DG-042-AE/AG, WG-042-EJ, DG-044-AE Before S/N 6,155,136 or 94,580; w/ Automatic Trans.; V8 363 CID (P)	3C3Z-6006-AARM
Engine Assembly (Less Accessories) w/ Eng Tags DG-042-AE/AG, WG-042-EJ, DG-044-AE From S/N 6,155,137 or 94,581; w/ Automatic Trans.; V8 363 CID (P)	4C3Z-6006-BARM			
Reman	2003	6.0L DIESEL OHV	Diesel Fuel Injector Driver Module; FI; V8 363 CID (P)	4C3Z-12B599-ABRM
			Diesel Fuel Injector Nozzle; V8 363 CID (P)	3C3Z-9E527-ECRM
			Diesel High Pressure Oil Pump; V8 363 CID (P)	3C3Z-9A543-AARM
			Diesel High Pressure Oil Pump; V8 363 CID (P)	HPP-10RM
			Engine Short Block; V8 363 CID (P); Assembly; Before 11/29/03 and S/N 6,155,636 or 137,744	3C3Z-6009-AARM
			Engine Short Block; V8 363 CID (P); Assembly; From 11/29/03 and S/N 6,155,137 or 137,745	5C3Z-6009-AARM
			Turbocharger; V8 363 CID (P); w/ EBP Valve	3C3Z-6K682-CCRM
			Turbocharger; V8 363 CID (P); w/ EBP Valve	TC-13RM
			Turbocharger; V8 363 CID (P); w/ EBP w/ Engine Serial # 896812-Current	TC-12RM
			Diesel High Pressure Oil Pump; V8 445 CID (F)	F81Z-9A543-CRM
		7.3L DIESEL OHV	Diesel High Pressure Oil Pump; V8 445 CID (F)	HPP-9RM
			Engine Connecting Rod; V8 445 CID (F); (Late Style) w/ Engine Serial # 1425747-Current	1C3Z-6200-AARM
			Fuel Injector Kit; V8 445 CID (F); #1 Thru #7	5C3Z-9VE527-BRM
			Fuel Injector Kit; V8 445 CID (F); #8	5C3Z-9VE527-ARM
			Turbocharger Mounting Kit; Turbocharged; V8 445 CID (F); w/ EBP Valve	F81Z-6N639-CARM
			Turbocharger Mounting Kit; Turbocharged; V8 445 CID (F); w/ EBP Valve	PTC-6RM
			Turbocharger; V8 445 CID (F); w/ EBP Valve	3C3Z-6K682-CCRM
			Turbocharger; V8 445 CID (F); w/ EBP Valve	TC-13RM
			Turbocharger; V8 445 CID (F); w/ EBP w/ Engine Serial # 896812-Current	TC-12RM
			Turbocharger; V8 445 CID (F); w/o EBP Valve	F81Z-6K682-CARM
Reman	2002	6.0L DIESEL OHV	Engine Assembly (Complete); V8 363 CID (P)	3C3Z-6007-AARM
			w/ Automatic Trans.; V8 363 CID (P); w/ Eng Tags DG-042-AG, WG-042-EJ, DG-044-AE	3C3Z-6006-AARM
			Engine Assembly (Complete); Turbocharged; V8 445 CID (F)	XC3Z-6007-CARM
			Engine Assembly (Less Accessories); Turbocharged; V8 445 CID (F)	XC3Z-6006-AARM
			Engine Assembly (Complete); Turbocharged; V8 445 CID (F)	F81Z-9A543-CRM
		7.3L DIESEL OHV	Diesel High Pressure Oil Pump; V8 445 CID (F)	HPP-9RM
			Diesel High Pressure Oil Pump; V8 445 CID (F)	1C3Z-6200-AARM
			Engine Connecting Rod; V8 445 CID (F); (Late Style) w/ Engine Serial # 1425747-Current	5C3Z-9VE527-BRM
			Fuel Injector Kit; V8 445 CID (F); #1 Thru #7	5C3Z-9VE527-ARM
			Fuel Injector Kit; V8 445 CID (F); #8	F81Z-6N639-CARM
Reman	2001	7.3L DIESEL OHV	Turbocharger Mounting Kit; Turbocharged; V8 445 CID (F); w/ EBP Valve	PTC-6RM
			Turbocharger Mounting Kit; Turbocharged; V8 445 CID (F); w/ EBP Valve	F81Z-6K682-BARM
			Turbocharger; V8 445 CID (F); w/ EBP Valve	TC-12RM
			Turbocharger; V8 445 CID (F); w/ EBP w/ Engine Serial # 896812-Current	F81Z-6K682-CARM
			Turbocharger; V8 445 CID (F); w/o EBP Valve	TC-5RM
			Turbocharger; V8 445 CID (F); w/o EBP Valve	XC3Z-6007-CARM
			Engine Assembly (Complete); Turbocharged; V8 445 CID (F)	XC3Z-6006-AARM
			Engine Assembly (Less Accessories); Turbocharged; V8 445 CID (F)	F81Z-9A543-CRM
			Diesel High Pressure Oil Pump; Turbocharged; V8 445 CID (F)	HPP-9RM
			Diesel High Pressure Oil Pump; Turbocharged; V8 445 CID (F); (Late Style) w/ Engine Serial # 1425747-Current	1C3Z-6200-AARM
Reman	2000	7.3L DIESEL OHV	Fuel Injector Kit; Turbocharged; V8 445 CID (F); #1 Thru #7	5C3Z-9VE527-BRM
			Fuel Injector Kit; Turbocharged; V8 445 CID (F); #8	5C3Z-9VE527-ARM
			Turbocharger Mounting Kit; Turbocharged; V8 445 CID (F); w/ EBP Valve	F81Z-6N639-CARM
			Turbocharger Mounting Kit; Turbocharged; V8 445 CID (F); w/ EBP Valve	PTC-6RM
			Turbocharger; V8 445 CID (F); w/ EBP Valve	F81Z-6K682-BARM
			Turbocharger; V8 445 CID (F); w/ EBP w/ Engine Serial # 896812-Current	TC-12RM
			Turbocharger; V8 445 CID (F); w/o EBP Valve	F81Z-6K682-CARM
			Turbocharger; V8 445 CID (F); w/o EBP Valve	TC-5RM
			Engine Assembly (Complete); Turbocharged; V8 445 CID (F)	XC3Z-6007-CARM
			Engine Assembly (Less Accessories); Turbocharged; V8 445 CID (F)	XC3Z-6006-AARM
Reman	2000	7.3L DIESEL OHV	Diesel High Pressure Oil Pump; Turbocharged; V8 445 CID (F); w/o IPR	F81Z-9A543-CRM
			Diesel High Pressure Oil Pump; Turbocharged; V8 445 CID (F); w/o IPR	HPP-9RM
			Engine Connecting Rod; Turbocharged; V8 445 CID (F); (Early Style) w/ Engine Serial # 896812-1425746	F4TZ-6V200-CARM
			Fuel Injector Kit; Turbocharged; V8 445 CID (F); #1 Thru #7	5C3Z-9VE527-BRM



Excursion

-Cont'd

Part Type	Years	Engine	Qualifier	Ford #
Reman	2000	7.3L DIESEL OHV	Fuel Injector Kit; Turbocharged; V8 445 CID (F); #8 Turbocharger Mounting Kit; Turbocharged; V8 445 CID (F); w/ EBP Valve Turbocharger Mounting Kit; Turbocharged; V8 445 CID (F); w/ EBP Valve Turbocharger; V8 445 CID (F); w/ EBP Valve Turbocharger; V8 445 CID (F); w/ EBP w/ Engine Serial # 896812-Current Turbocharger; V8 445 CID (F); w/o EBP Valve Turbocharger; V8 445 CID (F); w/o EBP Valve Engine Assembly (Complete); Turbocharged; V8 445 CID (F) Engine Assembly (Less Accessories); Turbocharged; V8 445 CID (F)	5C3Z-9VE527-ARM F81Z-6N639-CARM PTC-6RM F81Z-6K682-BARM TC-12RM F81Z-6K682-CARM TC-5RM XC3Z-6007-CARM XC3Z-6006-AARM

F-Series

Part Type	Years	Engine	Qualifier	Ford #
New	2017	6.7L DIESEL OHV	V8 6651cc 406 CID (T); w/ Dual Wheels; w/ Wide Frame; w/ Low Sulfur Diesel Fuel Content V8 6651cc 406 CID (T); w/ High Sulfur Diesel Fuel Content V8 6651cc 406 CID (T); w/ Low Sulfur Diesel Fuel Content; Narrow Frame; w/ Mid Sulfur Diesel Fuel Content V8 6651cc 406 CID (T); w/ Single Wheel; w/ Wide Frame; w/ Low Sulfur Diesel Fuel Content V8 6651cc 406 CID; w/ Dual Wheels; w/ Wide Frame; w/ Low Sulfur Diesel Fuel Content V8 6651cc 406 CID; w/ High Sulfur Diesel Fuel Content V8 6651cc 406 CID; w/ Low Sulfur Diesel Fuel Content; Narrow Frame; w/ Mid Sulfur Diesel Fuel Content	HC3Z-6007-M HC3Z-6007-K HC3Z-6007-J HC3Z-6007-H HC3Z-6007-M HC3Z-6007-K HC3Z-6007-J
New	2016	6.7L DIESEL OHV	V8 6651cc 406 CID; w/ Single Wheel; w/ Wide Frame; w/ Low Sulfur Diesel Fuel Content Turbocharger; V8 6651cc 406 CID (T); w/ Wide Frame Engine Assembly (Complete); V8 6651cc 406 CID (T); Narrow Frame; w/ Low or Mid Sulfur Engine Assembly (Complete); w/ 6R140 Transmission; V8 6651cc 406 CID (T); w/ Wide Frame Wheelbase; w/ Low Sulfur Diesel Fuel Content V8 6651cc 406 CID (T); High Sulfur w/ 6R140 Transmission; V8 6651cc 406 CID (T); w/ Wide Frame; Low Sulfur	HC3Z-6K682-A GC3Z-6007-G FC3Z-6007-BA GC3Z-6007-H GC3Z-6007-F HC3Z-6K682-A
New	2015	6.7L DIESEL OHV	Turbocharger; V8 6651cc 406 CID (T); w/ Wide Frame Engine Assembly (Complete); Cab & Chassis; V8 6651cc 406 CID (T); Narrow Frame Engine Assembly (Complete); Crew Cab Pickup; V8 6651cc 406 CID (T); w/ Wide Frame; Low Sulfur Engine Assembly (Complete); Extended Cab Pickup; V8 6651cc 406 CID (T); w/ Wide Frame; Low Sulfur Engine Assembly (Complete); Standard Cab Pickup; V8 6651cc 406 CID (T); w/ Wide Frame; Low Sulfur	FC3Z-6007-B FC3Z-6007-A FC3Z-6007-A FC3Z-6007-A
New	2014	6.7L DIESEL OHV	Engine Assembly (Less Accessories); V8 6651cc 406 CID (T) Turbocharger; V8 6651cc 406 CID (T); w/ Wide Frame Engine Assembly (Complete); Cab & Chassis; V8 6651cc 406 CID (T) Engine Assembly (Complete); Crew Cab Pickup; V8 6651cc 406 CID (T); w/ Wide Frame Engine Assembly (Complete); Extended Cab Pickup; V8 6651cc 406 CID (T); w/ Wide Frame Engine Assembly (Complete); Standard Cab Pickup; V8 6651cc 406 CID (T); w/ Wide Frame Engine Assembly (Less Accessories); V8 6651cc 406 CID (T)	FC3Z-6006-C BC3Z-6K682-C DC3Z-6007-BA DC3Z-6007-E DC3Z-6007-E DC3Z-6006-C
Reman			Engine Assembly (Complete); Turbocharged; V8 6651cc 406 CID (T); Narrow Frame Engine Assembly (Complete); Turbocharged; V8 6651cc 406 CID (T); w/ Wide Frame	DC3Z-6007-BRM DC3Z-6007-ARM
New	2013	6.7L DIESEL OHV	Turbocharger; V8 6651cc 406 CID (T); w/ Wide Frame Engine Assembly (Complete); Cab & Chassis; V8 6651cc 406 CID (T); Narrow Frame Engine Assembly (Complete); Crew Cab Pickup; V8 6651cc 406 CID (T); w/ Wide Frame Engine Assembly (Complete); Extended Cab Pickup; V8 6651cc 406 CID (T); w/ Wide Frame Engine Assembly (Complete); Standard Cab Pickup; V8 6651cc 406 CID (T); w/ Wide Frame Engine Assembly (Less Accessories); V8 6651cc 406 CID (T)	BC3Z-6K682-C DC3Z-6007-BA DC3Z-6007-E DC3Z-6007-E DC3Z-6007-E FC3Z-6006-C
Reman			Engine Assembly (Complete); Turbocharged; V8 6651cc 406 CID (T); Narrow Frame Engine Assembly (Complete); Turbocharged; V8 6651cc 406 CID (T); w/ Wide Frame	DC3Z-6007-BRM DC3Z-6007-ARM
New	2012	6.7L DIESEL OHV	Turbocharger; V8 6651cc 406 CID (T); w/ Wide Frame Engine Assembly (Complete); Cab & Chassis; V8 6651cc 406 CID (T); Narrow Frame Engine Assembly (Complete); Crew Cab Pickup; V8 6651cc 406 CID (T); w/ Wide Frame Engine Assembly (Complete); Extended Cab Pickup; V8 6651cc 406 CID (T); w/ Wide Frame Engine Assembly (Complete); Standard Cab Pickup; V8 6651cc 406 CID (T); w/ Wide Frame Engine Assembly (Less Accessories); V8 6651cc 406 CID (T)	BC3Z-6K682-C DC3Z-6007-BA DC3Z-6007-E DC3Z-6007-E DC3Z-6007-E FC3Z-6006-C
Reman			Engine Assembly (Complete); Turbocharged; V8 6651cc 406 CID (T); Narrow Frame Engine Assembly (Complete); Turbocharged; V8 6651cc 406 CID (T); w/ Wide Frame	DC3Z-6007-BRM DC3Z-6007-ARM
New	2011	6.7L DIESEL OHV	Turbocharger; V8 6651cc 406 CID (T); w/ Wide Frame Engine Assembly (Complete); Cab & Chassis; V8 6651cc 406 CID (T); Narrow Frame Engine Assembly (Complete); Crew Cab Pickup; V8 6651cc 406 CID (T); w/ Wide Frame Engine Assembly (Complete); Extended Cab Pickup; V8 6651cc 406 CID (T); w/ Wide Frame Engine Assembly (Complete); Standard Cab Pickup; V8 6651cc 406 CID (T); w/ Wide Frame Engine Assembly (Less Accessories); V8 6651cc 406 CID (T)	BC3Z-6K682-C DC3Z-6007-BA DC3Z-6007-E DC3Z-6007-E DC3Z-6007-E FC3Z-6006-C
Reman			Engine Assembly (Complete); Turbocharged; V8 6651cc 406 CID (T); Narrow Frame Engine Assembly (Complete); Turbocharged; V8 6651cc 406 CID (T); w/ Wide Frame	DC3Z-6007-BRM DC3Z-6007-ARM
	2010	6.4L DIESEL OHV	Clutch Kit; w/ S6-650 Transmission; V8 391 CID (R) Diesel High Pressure Oil Pump; V8 391 CID (R); 6E70-9G803-AE Diesel High Pressure Oil Pump; V8 391 CID (R); 6E70-9G803-AE Engine Short Block; w/ Automatic Trans.; V8 391 CID (R); Assembly Engine Short Block; w/ Standard Trans.; V8 391 CID (R); Assembly Turbocharger; V8 391 CID (R); High Pressure Turbocharger; V8 391 CID (R); High Pressure Turbocharger; V8 391 CID (R); High and Low Pressure Turbocharger; V8 391 CID (R); High and Low Pressure Turbocharger; V8 391 CID (R); Low Pressure	7C3Z-7L596-A 8C3Z-9A543-DRM HPP-11RM 8C3Z-6009-AARM 8C3Z-6009-BARM 8C3Z-6K682-BARM TC-14RM 8C3Z-6K682-CRM TC-16RM 8C3Z-6K682-AARM

# DIESEL ENGINES

## Light / Medium Trucks

### Ford



FORD PARTS

### F-Series

-Cont'd

Part Type	Years	Engine	Qualifier	Ford #
Reman	2010	6.4L DIESEL OHV	Turbocharger; V8 391 CID (R); Low Pressure Engine Assembly (Complete); w/ Automatic Trans.; V8 391 CID (R); Excludes Vertical EGR Cooler w/ Standard Trans.; V8 391 CID (R); Excludes Vertical EGR Cooler	TC-11RM 8C3Z-6007-AARM 8C3Z-6007-BARM
	2009	6.4L DIESEL OHV	Clutch Kit; w/ S6-650 Transmission; V8 391 CID (R) Diesel High Pressure Oil Pump; V8 391 CID (R); 6E7O-9G803-AE Diesel High Pressure Oil Pump; V8 391 CID (R); 6E7O-9G803-AE Engine Short Block; w/ Automatic Trans.; V8 391 CID (R); Assembly Engine Short Block; w/ Standard Trans.; V8 391 CID (R); Assembly Turbocharger; V8 391 CID (R); High Pressure Turbocharger; V8 391 CID (R); High Pressure Turbocharger; V8 391 CID (R); High and Low Pressure Turbocharger; V8 391 CID (R); High and Low Pressure Turbocharger; V8 391 CID (R); Low Pressure Turbocharger; V8 391 CID (R); Low Pressure	8C3Z-9A543-DRM 7C3Z-7L596-A 8C3Z-9A543-DRM HPP-11RM 8C3Z-6009-AARM 8C3Z-6009-BARM 8C3Z-6K682-BARM TC-14RM 8C3Z-6K682-CRM TC-16RM 8C3Z-6K682-AARM TC-11RM
Reman	2008	6.4L DIESEL OHV	Engine Assembly (Complete); w/ Automatic Trans.; V8 391 CID (R); Excludes Vertical EGR Cooler w/ Standard Trans.; V8 391 CID (R); Excludes Vertical EGR Cooler	8C3Z-6007-AARM 8C3Z-6007-BARM
			Clutch Kit; w/ S6-650 Transmission; V8 391 CID (R) Diesel High Pressure Oil Pump; V8 391 CID (R); 6E7O-9G803-AE Diesel High Pressure Oil Pump; V8 391 CID (R); 6E7O-9G803-AE Engine Short Block; w/ Automatic Trans.; V8 391 CID (R); Assembly Engine Short Block; w/ Standard Trans.; V8 391 CID (R); Assembly Turbocharger; V8 391 CID (R); High Pressure Turbocharger; V8 391 CID (R); High Pressure Turbocharger; V8 391 CID (R); High and Low Pressure Turbocharger; V8 391 CID (R); High and Low Pressure Turbocharger; V8 391 CID (R); Low Pressure Turbocharger; V8 391 CID (R); Low Pressure	7C3Z-7L596-A 8C3Z-9A543-DRM HPP-11RM 8C3Z-6009-AARM 8C3Z-6009-BARM 8C3Z-6K682-BARM TC-14RM 8C3Z-6K682-CRM TC-16RM 8C3Z-6K682-AARM TC-11RM
Reman	2007	6.0L DIESEL OHV	Engine Assembly (Complete); w/ Automatic Trans.; V8 391 CID (R); Excludes Vertical EGR Cooler w/ Standard Trans.; V8 391 CID (R); Excludes Vertical EGR Cooler	8C3Z-6007-AARM 8C3Z-6007-BARM
			Clutch Kit; w/ S6-650 Transmission; w/ Standard Trans.; V8 363 CID (P); Use with Single Mass Flywheel Assy Only Diesel Fuel Injector Driver Module; FI; V8 363 CID (P) Diesel Fuel Injector Nozzle; V8 363 CID (P) Diesel High Pressure Oil Pump; V8 363 CID (P); 5C4O-9A543-AA Diesel High Pressure Oil Pump; V8 363 CID (P); 5C4O-9A543-AA Engine Short Block; V8 363 CID (P); Assembly Turbocharger; V8 363 CID (P) Turbocharger; V8 363 CID (P)	3C3Z-7L596-EA 4C3Z-12B599-ABRM 4C3Z-9E527-BRM 5C3Z-9A543-ARM HPP-12RM 6C3Z-6009-ARM 5C3Z-6K682-CCRM TC-17RM
Reman	2006	6.0L DIESEL OHV	Engine Assembly (Complete); w/ Automatic Trans.; V8 363 CID (P); S/N 6,723,722 to 6,908,443 or 299,093 to 414,752 Engine Assembly (Complete); w/ Standard Trans.; V8 363 CID (P); S/N 6,723,722 to 6,908,443 or 299,093 to 414,752 Engine Assembly (Less Accessories) S/N 6,723,722 to 6,908,443 or 299,093 to 414,752; w/ Automatic Trans.; V8 363 CID (P) Engine Assembly (Less Accessories) S/N 6,723,722 to 6,908,443 or 299,093 to 414,752; w/ Standard Trans.; V8 363 CID (P)	6C3Z-6007-BARM 6C3Z-6007-AARM 6C3Z-6006-BARM 6C3Z-6006-AARM
			Clutch Kit; w/ S6-650 Transmission; w/ Standard Trans.; V8 363 CID (P); Use with Single Mass Flywheel Assy Only Diesel Fuel Injector Driver Module; FI; V8 363 CID (P) Diesel Fuel Injector Nozzle; V8 363 CID (P) Diesel High Pressure Oil Pump; V8 363 CID (P); 5C4O-9A543-AA Diesel High Pressure Oil Pump; V8 363 CID (P); 5C4O-9A543-AA Engine Short Block; V8 363 CID (P); Assembly Turbocharger; V8 363 CID (P) Turbocharger; V8 363 CID (P) Turbocharger; V8 363 CID (P); Engine Serial Number 6,155,637 To 6,344,942 Or 1 To 299,092 Turbocharger; V8 363 CID (P); Engine Serial Number 6,155,637 To 6,344,942 Or 1 To 299,092 Engine Assembly (Complete); w/ Automatic Trans.; V8 363 CID (P); S/N 6,723,722 to 6,908,443 or 299,093 to 414,752 Engine Assembly (Complete); w/ Standard Trans.; V8 363 CID (P); S/N 6,723,722 to 6,908,443 or 299,093 to 414,752 Engine Assembly (Less Accessories) S/N 6,723,722 to 6,908,443 or 299,093 to 414,752; w/ Automatic Trans.; V8 363 CID (P) Engine Assembly (Less Accessories) S/N 6,723,722 to 6,908,443 or 299,093 to 414,752; w/ Standard Trans.; V8 363 CID (P)	3C3Z-7L596-EA 4C3Z-12B599-ABRM 4C3Z-9E527-BRM 5C3Z-9A543-ARM HPP-12RM 6C3Z-6009-ARM 5C3Z-6K682-CCRM TC-17RM 4C3Z-6K682-CDRM TC-15RM 6C3Z-6007-BARM 6C3Z-6007-AARM 6C3Z-6006-BARM 6C3Z-6006-AARM
Reman	2005	6.0L DIESEL OHV	Clutch Kit; w/ S6-650 Transmission; w/ Standard Trans.; V8 363 CID (P); Use with Single Mass Flywheel Assy Only Diesel Fuel Injector Driver Module; FI; V8 363 CID (P) Diesel Fuel Injector Nozzle; V8 363 CID (P) Diesel High Pressure Oil Pump; V8 363 CID (P); 5C4O-9A543-AA Diesel High Pressure Oil Pump; V8 363 CID (P); 5C4O-9A543-AA Engine Short Block; V8 363 CID (P); Assembly Turbocharger; V8 363 CID (P); Before 11/04/04 Turbocharger; V8 363 CID (P); Engine Serial Number 6,155,637 To 6,344,942 Or 1 To 299,092 Turbocharger; V8 363 CID (P); Engine Serial Number 6,155,637 To 6,344,942 Or 1 To 299,092 Turbocharger; V8 363 CID (P); From 11/04/04 Turbocharger; V8 363 CID (P); From 11/04/04	3C3Z-7L596-EA 4C3Z-12B599-ABRM 4C3Z-9E527-BRM 5C3Z-9A543-ARM HPP-12RM 5C3Z-6009-AARM 4C3Z-6K682-CCRM 4C3Z-6K682-CDRM TC-15RM 5C3Z-6K682-CCRM TC-17RM
			Engine Assembly (Complete); w/ Automatic Trans.; V8 363 CID (P); Before 11/04/04 and S/N 6,429,301 or 181,447 Engine Assembly (Complete); w/ Automatic Trans.; V8 363 CID (P); From 11/04/04 and S/N 6,429,302 or 181,448	5C3Z-6007-BARM 5C3Z-6007-DARM



F-Series

-Cont'd

Part Type	Years	Engine	Qualifier	Ford #		
Reman	2005	6.0L DIESEL OHV	Engine Assembly (Complete); w/ Standard Trans.; V8 363 CID (P); Before 11/04/04 and S/N 6,429,301 or 181,447	5C3Z-6007-AARM		
			Engine Assembly (Complete); w/ Standard Trans.; V8 363 CID (P); From 11/04/04 and S/N 6,429,302 or 181,448	5C3Z-6007-CARM		
			Engine Assembly (Less Accessories) w/ S/N 6,344,943 to 6,560,520 or 131,587 to 213,260; w/ Automatic Trans.; V8 363 CID (P)	5C3Z-6006-BARM		
			Engine Assembly (Less Accessories); V8 363 CID (P); S/N 6,344,943 to 6,429,301 or 131,587 to 181,447	5C3Z-6006-AARM		
	2004	6.0L DIESEL OHV	Clutch Kit; w/ S6-650 Transmission; w/ Standard Trans.; V8 363 CID (P); Use with Single Mass Flywheel Assy Only	3C3Z-7L596-EA		
			Diesel Fuel Injector Driver Module; FI; V8 363 CID (P)	4C3Z-12B599-ABRM		
			Diesel Fuel Injector Nozzle; V8 363 CID (P); Injector Before S/N 6155636 (Indy Built) or 94580 (Huntsville Built)	3C3Z-9E527-ECRM		
			Diesel Fuel Injector Nozzle; V8 363 CID (P); Injector From S/N 6155637 (Indy Built) or 94581 (Huntsville Built)	4C3Z-9E527-BRM		
			Diesel High Pressure Oil Pump; V8 363 CID (P); 5C40-9A543-AA	5C3Z-9A543-ARM		
			Diesel High Pressure Oil Pump; V8 363 CID (P); 5C40-9A543-AA	HPP-12RM		
			Diesel High Pressure Oil Pump; V8 363 CID (P); Before S/N 6155636 or 94580; OE# 5010106-R91	3C3Z-9A543-AARM		
			Diesel High Pressure Oil Pump; V8 363 CID (P); Before S/N 6155636 or 94580; OE# 5010106-R91	HPP-10RM		
			Diesel High Pressure Oil Pump; V8 363 CID (P); From S/N 6155637 or 94581; OE# 5010119-R91	4C3Z-9A543-AARM		
			Diesel High Pressure Oil Pump; V8 363 CID (P); From S/N 6155637 or 94581; OE# 5010119-R91	HPP-8RM		
			Engine Short Block; V8 363 CID (P); Assembly; Before 9/29/03 and S/N 6,155,636 or 137,744	3C3Z-6009-AARM		
			Engine Short Block; V8 363 CID (P); Assembly; From 9/29/03 and S/N 6,155,637 or 137,745	5C3Z-6009-AARM		
			Turbocharger; V8 363 CID (P); From 9/29/03 and S/N 6155637 or 94580	4C3Z-6K682-CCRM		
			Turbocharger; V8 363 CID (P); w/ EBP Valve; Before 9/29/03 and S/N 6155636 or 94580	3C3Z-6K682-CCRM		
			Turbocharger; V8 363 CID (P); w/ EBP Valve; Before 9/29/03 and S/N 6155636 or 94580	TC-13RM		
			Reman		6.0L DIESEL OHV	Engine Assembly (Complete); w/ Automatic Trans.; V8 363 CID (P); Before 11/04/04 and S/N 6,429,301 or 181,447
Engine Assembly (Complete); w/ Automatic Trans.; V8 363 CID (P); Before S/N 6,155,636	3C3Z-6007-AARM					
Engine Assembly (Complete); w/ Automatic Trans.; V8 363 CID (P); From 11/04/04 and S/N 6,429,302 or 181,448	5C3Z-6007-DARM					
Engine Assembly (Complete); w/ Automatic Trans.; V8 363 CID (P); From S/N 6,155,637	4C3Z-6007-BARM					
Engine Assembly (Complete); w/ Automatic Trans.; V8 363 CID (P); From S/N 6,155,637; w/ Head	4C3Z-6007-CARM					
Studs						
Engine Assembly (Complete); w/ Standard Trans.; V8 363 CID (P); Before 11/04/04 and S/N 6,429,301 or 181,447	5C3Z-6007-AARM					
Engine Assembly (Complete); w/ Standard Trans.; V8 363 CID (P); From 11/04/04 and S/N 6,429,302 or 181,448	5C3Z-6007-CARM					
Engine Assembly (Complete); w/ Standard Trans.; V8 363 CID (P); w/ Eng Tags 3G-041-CE,DG-041-BE,WG-041-DD Before S/N 6,155,636	3C3Z-6007-BARM					
Engine Assembly (Complete); w/ Standard Trans.; V8 363 CID (P); w/ Eng Tags 3G-041-CE,DG-041-BE,WG-041-DD From S/N 6,155,637	4C3Z-6007-AARM					
Engine Assembly (Less Accessories) From S/N 6,155,637 or 94,581; w/ Automatic Trans.; V8 363 CID (P)	4C3Z-6006-BARM					
Engine Assembly (Less Accessories) From S/N 6,155,637 or 94,581; w/ Standard Trans.; V8 363 CID (P)	4C3Z-6006-AARM					
Engine Assembly (Less Accessories) before S/N 6,155,636 or 94,580; w/ Automatic Trans.; V8 363 CID (P)	3C3Z-6006-AARM					
Engine Assembly (Less Accessories) before S/N 6,155,636 or 94,580; w/ Standard Trans.; V8 363 CID (P)	3C3Z-6006-BARM					
2003	6.0L DIESEL OHV	Diesel Fuel Injector Driver Module; FI; V8 363 CID (P)				4C3Z-12B599-ABRM
		Diesel Fuel Injector Nozzle; V8 363 CID (P)				3C3Z-9E527-ECRM
		Engine Short Block; V8 363 CID (P); Assembly; Before 9/29/03 and S/N 6,155,636 or 137,744		3C3Z-6009-AARM		
		Engine Short Block; V8 363 CID (P); Assembly; From 9/29/03 and S/N 6,155,637 or 137,745		5C3Z-6009-AARM		
	7.3L DIESEL OHV	Turbocharger; V8 363 CID (P); From 9/29/03 and S/N 6155637 or 94580		4C3Z-6K682-CCRM		
		Turbocharger; V8 363 CID (P); w/ EBP Valve		3C3Z-6K682-CCRM		
		Turbocharger; V8 363 CID (P); w/ EBP Valve	TC-13RM			
		Clutch Kit; w/ Standard Trans.; V8 445 CID (F); M6HD	YC3Z-7L596-AA			
		Diesel High Pressure Oil Pump; V8 445 CID (F)	F81Z-9A543-CRM			
		Diesel High Pressure Oil Pump; V8 445 CID (F)	HPP-9RM			
		Engine Connecting Rod; V8 445 CID (F)	1C3Z-6200-AARM			
		Fuel Injector Kit; V8 445 CID (F); #1 Thru #7	5C3Z-9VE527-BRM			
	2002	7.3L DIESEL OHV	Fuel Injector Kit; V8 445 CID (F); #8	5C3Z-9VE527-ARM		
			Turbocharger Mounting Kit; Turbocharged; V8 445 CID (F)	F81Z-6N639-CARM		
			Turbocharger Mounting Kit; Turbocharged; V8 445 CID (F)	PTC-6RM		
			Turbocharger; V8 445 CID (F); w/ EBP Valve	F81Z-6K682-BARM		
			Turbocharger; V8 445 CID (F); w/ EBP w/ Engine Serial # 896812-Current	TC-12RM		
			Turbocharger; V8 445 CID (F); w/o EBP Valve	F81Z-6K682-CARM		
			Turbocharger; V8 445 CID (F); w/o EBP Valve	TC-5RM		
			Engine Assembly (Complete); w/ Automatic Trans.; V8 363 CID (P)	3C3Z-6007-AARM		
Reman	6.0L DIESEL OHV	Engine Assembly (Complete); w/ Standard Trans.; V8 363 CID (P)	3C3Z-6007-BARM			
		Engine Assembly (Less Accessories); w/ Automatic Trans.; V8 363 CID (P)	3C3Z-6006-AARM			
		Engine Assembly (Less Accessories); w/ Standard Trans.; V8 363 CID (P)	3C3Z-6006-BARM			
		Engine Assembly (Complete); w/ Automatic Trans.; V8 445 CID (F); Exc. California; w/ Eng Tags BE-002-A*	XC3Z-6007-CARM			
2002	7.3L DIESEL OHV	Engine Assembly (Complete); w/ Standard Trans.; V8 445 CID (F); w/ Eng Tags BE-001-AB/AC	XC3Z-6007-CARM			
		Engine Assembly (Longblock); V8 445 CID (F)	XC3Z-6V012-BARM			
		Clutch Kit; w/ Standard Trans.; V8 445 CID (F); M6HD	YC3Z-7L596-AA			
		Diesel High Pressure Oil Pump; V8 445 CID (F)	F81Z-9A543-CRM			
			Diesel High Pressure Oil Pump; V8 445 CID (F)	HPP-9RM		
			Engine Connecting Rod; V8 445 CID (F)	1C3Z-6200-AARM		

**DIESEL ENGINES**  
**Light / Medium Trucks**  
**Ford**



**FORD PARTS**

**F-Series**

**-Cont'd**

Part Type	Years	Engine	Qualifier	Ford #
Reman	2002	7.3L DIESEL OHV	Fuel Injector Kit; V8 445 CID (F); #1 Thru #7	5C3Z-9VE527-BRM
			Turbocharger Mounting Kit; Turbocharged; V8 445 CID (F)	F81Z-6N639-CARM
			Turbocharger Mounting Kit; Turbocharged; V8 445 CID (F)	PTC-6RM
			Turbocharger; V8 445 CID (F); w/ EBP Valve	F81Z-6K682-BARM
			Turbocharger; V8 445 CID (F); w/ EBP w/ Engine Serial # 896812-Current	TC-12RM
			Turbocharger; V8 445 CID (F); w/o EBP Valve	F81Z-6K682-CARM
	2001	7.3L DIESEL OHV	Turbocharger; V8 445 CID (F); w/o EBP Valve	TC-5RM
			Engine Assembly (Complete); w/ Automatic Trans.; V8 445 CID (F); Exc. California; w/ Eng Tags BE-002-A*, CE-002-AA/AB	XC3Z-6007-CARM
			Engine Assembly (Complete); w/ Standard Trans.; V8 445 CID (F); w/ Eng Tags BE-001-AB/AC	XC3Z-6007-CARM
			Engine Assembly (Longblock); V8 445 CID (F)	XC3Z-6V012-BARM
			Clutch Kit; w/ Standard Trans.; V8 445 CID (F); M6HD	YC3Z-7L596-AA
			Diesel High Pressure Oil Pump; V8 445 CID (F)	F81Z-9A543-CRM
Reman	2000	7.3L DIESEL OHV	Diesel High Pressure Oil Pump; V8 445 CID (F)	HPP-9RM
			Engine Connecting Rod; V8 445 CID (F)	1C3Z-6200-AARM
			Fuel Injector Kit; V8 445 CID (F); #1 Thru #7	5C3Z-9VE527-BRM
			Fuel Injector Kit; V8 445 CID (F); #8	5C3Z-9VE527-ARM
			Turbocharger Mounting Kit; Turbocharged; V8 445 CID (F)	F81Z-6N639-CARM
			Turbocharger Mounting Kit; Turbocharged; V8 445 CID (F)	PTC-6RM
	2001	7.3L DIESEL OHV	Turbocharger; V8 445 CID (F); w/ EBP Valve	F81Z-6K682-BARM
			Turbocharger; V8 445 CID (F); w/ EBP w/ Engine Serial # 896812-Current	TC-12RM
			Turbocharger; V8 445 CID (F); w/o EBP Valve	F81Z-6K682-CARM
			Turbocharger; V8 445 CID (F); w/o EBP Valve	TC-5RM
			Engine Assembly (Complete); V8 445 CID (F)	XC3Z-6007-CARM
			Engine Assembly (Less Accessories); V8 445 CID (F)	XC3Z-6006-AARM
Reman	1999	7.3L DIESEL OHV	Engine Assembly (Longblock); V8 445 CID (F)	XC3Z-6V012-BARM
			Clutch Kit; w/ Standard Trans.; V8 445 CID (F); M6HD	YC3Z-7L596-AA
			Diesel High Pressure Oil Pump; V8 445 CID (F); From 12/7/98 S/N 896812-Current	F81Z-9A543-CRM
			Diesel High Pressure Oil Pump; V8 445 CID (F); From 12/7/98 S/N 896812-Current	HPP-9RM
			Diesel High Pressure Oil Pump; V8 445 CID (F); Kit; S/N 201680-896811	5C3Z-9VA543-BRM
			Engine Connecting Rod; V8 445 CID (F); w/ Engine Serial # 501-1425746	F4TZ-6V200-CARM
	1997	7.3L DIESEL OHV	Fuel Injector Kit; V8 445 CID (F); #1 Thru #7; w/ Engine S/N 896812-Current	5C3Z-9VE527-BRM
			Fuel Injector Kit; V8 445 CID (F); Injector w/ Engine Serial # 661496-896811	F81Z-9VE527-BRM
			Turbocharger Mounting Kit; Turbocharged; V8 445 CID (F); w/ EBP Valve	F81Z-6N639-CARM
			Turbocharger Mounting Kit; Turbocharged; V8 445 CID (F); w/ EBP Valve	PTC-6RM
			Turbocharger Mounting Kit; Turbocharged; V8 445 CID (F); w/o EBP Valve w/ Engine Serial # 661974-896811	5C3Z-6V639-BRM
			Turbocharger Mounting Kit; Turbocharged; V8 445 CID (F); w/o EBP Valve w/ Engine Serial # 896812-Current	F81Z-6N639-DARM
Reman	1999	7.3L DIESEL OHV	Turbocharger Mounting Kit; Turbocharged; V8 445 CID (F); w/o EBP Valve w/ Engine Serial # 896812-Current	PTC-7RM
			Turbocharger; V8 445 CID (F); Engine Build Before 12/6/98	5C3Z-6V682-ARM
			Turbocharger; V8 445 CID (F); w/ EBP w/ Engine Serial # 896812-Current	F81Z-6K682-BARM
			Turbocharger; V8 445 CID (F); w/ EBP w/ Engine Serial # 896812-Current	TC-12RM
			Turbocharger; V8 445 CID (F); w/o EBP w/ Engine Serial # 896812-Current	F81Z-6K682-CARM
			Turbocharger; V8 445 CID (F); w/o EBP w/ Engine Serial # 896812-Current	TC-5RM
	1997	7.3L DIESEL OHV	Engine Assembly (Complete); V8 445 CID (F); Before 12/7/98; w/ EBP Valve; w/ Engine Serial # 661974-896811	5C3Z-6V007-BRM
			Engine Assembly (Complete); V8 445 CID (F); Before 12/7/98; w/ Engine Serial # 661974-896811; w/o EBP Valve	5C3Z-6V007-CRM
			Engine Assembly (Complete); V8 445 CID (F); w/o EBP Valve	XC3Z-6007-BARM
			Engine Assembly (Less Accessories) Before 12/07/98; V8 445 CID (F); w/ Engine Serial No. 661974-896811	5C3Z-6V006-CRM
			Engine Assembly (Less Accessories); V8 445 CID (F)	XC3Z-6006-AARM
			Engine Assembly (Longblock); V8 445 CID (F); Before 12/07/98	F81Z-6V012-CARM
Reman	1997	7.3L DIESEL OHV	Engine Assembly (Longblock); V8 445 CID (F); From 12/07/98	XC3Z-6V012-BARM
			Clutch Kit; Turbocharged; w/ S5-47 Transmission; w/ Standard Trans.; V8 445 CID (F)	F4TZ-7L596-AA
			Diesel High Pressure Oil Pump; V8 445 CID (F); Kit; S/N 187100-201679	F6TZ-9VA543-ARM
			Engine Connecting Rod; V8 445 CID (F)	F4TZ-6V200-CARM
			Fuel Injector Kit; V8 445 CID (F); California; Injector w/ Engine Serial # 661496-896811	F81Z-9VE527-BRM
			Fuel Injector Kit; V8 445 CID (F); Injector w/ Engine Serial # 501-661495; Exc. California	F4TZ-9VE527-AARM
Reman	1997	7.3L DIESEL OHV	Turbocharger; V8 445 CID (F); w/o Pedestal w/ Engine Serial # 501-661973	F4TZ-6VK682-CARM
			Engine Assembly (Complete); V8 445 CID (F); S/N 375549-661973; California	F7TZ-6V007-AARM
			Engine Assembly (Complete); V8 445 CID (F); S/N 375549-661973; Exc. California	F7TZ-6V007-BARM
			Engine Assembly (Less Accessories) w/ Engine Serial # 375548-661973; V8 445 CID (F); Exc. California	F7TZ-6V006-BARM



F-Series

-Cont'd

Part Type	Years	Engine	Qualifier	Ford #
Reman	1997	7.3L DIESEL OHV	Engine Assembly (Less Accessories) w/ Engine Serial # 375548-66197; V8 445 CID (F); California	F7TZ-6V006-CARM
	1996	7.3L DIESEL OHV	Engine Assembly (Longblock); V8 445 CID (F) Clutch Kit; Turbocharged; w/ S5-47 Transmission; w/ Standard Trans.; V8 445 CID (F) Diesel High Pressure Oil Pump; V8 445 CID (F); Kit; S/N 187100-201679 Engine Connecting Rod; V8 445 CID (F) Fuel Injector Kit; V8 445 CID (F); California; Injector w/ Engine Serial # 661496-896811 For Cyl.# 8 Fuel Injector Kit; V8 445 CID (F); California; Injector w/ Engine Serial # 661496-896811 For Cyls. 1-7 Fuel Injector Kit; V8 445 CID (F); Exc. California; Injector w/ Engine Serial # 501-661495 Turbocharger; V8 445 CID (F); w/o Pedestal w/ Engine Serial # 501-661973	F7TZ-6V012-ABRM F4TZ-7L596-A F6TZ-9VA543-ARM F4TZ-6V200-CARM F61Z-9VE527-ERM F61Z-9VE527-BRM F4TZ-9VE527-AARM F4TZ-6VK682-CARM
Reman			Engine Assembly (Complete); V8 445 CID (F); California; w/ Engine Serial # 201681-375548 Engine Assembly (Complete); V8 445 CID (F); Exc. California; w/ Engine Serial # 201681-375548 Engine Assembly (Less Accessories) w/ Engine Serial # 201681-375548; V8 445 CID (F); California Engine Assembly (Less Accessories) w/ Engine Serial # 201681-375548; V8 445 CID (F); Exc. California	F6TZ-6V007-BARM F6TZ-6V006-AARM F6TZ-6V006-BARM
	1995	7.3L DIESEL OHV	Clutch Kit; Turbocharged; w/ S5-42 Transmission; w/ Standard Trans.; V8 445 CID (F) Diesel High Pressure Oil Pump; Turbocharged; V8 445 CID (F); Kit Engine Connecting Rod; Turbocharged; V8 445 CID (F) Fuel Injector Kit; Turbocharged; V8 445 CID (F); Injector w/ Engine Serial # 501-661495 Turbocharger; V8 445 CID (F); w/o Pedestal w/ Engine Serial # 501-661973	F4TZ-7L596-A F4TZ-9VA543-AARM F4TZ-6V200-CARM F4TZ-9VE527-AARM F4TZ-6VK682-CARM
Reman			Engine Assembly (Complete); Turbocharged; V8 445 CID (F); S/N 35652-201680 Engine Assembly (Less Accessories) w/ Engine Serial # 501-201680; Turbocharged; V8 445 CID (F)	F5TZ-6V007-AARM F4TZ-6V006-BARM
	1994	7.3L DIESEL OHV	Engine Assembly (Longblock); Turbocharged; V8 445 CID (F) Clutch Kit; FI; Turbocharged; w/ S5-42 Transmission; w/ Standard Trans.; V8 445 CID (F); DFI Clutch Kit; FI; Turbocharged; w/ S5-42 Transmission; w/ Standard Trans.; V8 445 CID (K); DFI Diesel High Pressure Oil Pump; FI; Turbocharged; V8 445 CID (F); Kit; DFI Diesel High Pressure Oil Pump; FI; Turbocharged; V8 445 CID (K); Kit; DFI Engine Connecting Rod; FI; Naturally Aspirated; V8 445 CID (M); w/ Engine Serial # 500079-1116330; IFI Engine Connecting Rod; FI; Turbocharged; V8 445 CID (F); DFI Engine Connecting Rod; FI; Turbocharged; V8 445 CID (K); DFI Engine Oil Cooler; FI; Naturally Aspirated; V8 445 CID (M); IFI; Assembly Engine Oil Cooler; FI; Turbocharged; V8 445 CID (F); IFI; Assembly Engine Oil Cooler; FI; Turbocharged; V8 445 CID (K); IFI; Assembly Fuel Injector Kit; FI; Naturally Aspirated; V8 445 CID (M); IFI Fuel Injector Kit; FI; Turbocharged; V8 445 CID (F); DFI; Injector w/ Engine Serial # 501-661495 Fuel Injector Kit; FI; Turbocharged; V8 445 CID (F); IFI Fuel Injector Kit; FI; Turbocharged; V8 445 CID (K); DFI; Injector w/ Engine Serial # 501-661495 Fuel Injector Kit; FI; Turbocharged; V8 445 CID (K); IFI Turbocharger Mounting Kit; FI; Turbocharged; V8 445 CID (F); DFI Turbocharger Mounting Kit; FI; Turbocharged; V8 445 CID (K); DFI Turbocharger; FI; V8 445 CID (F); DFI; w/o Pedestal w/ Engine Serial # 501-661973 Turbocharger; FI; V8 445 CID (F); IFI Turbocharger; FI; V8 445 CID (K); DFI; w/o Pedestal w/ Engine Serial # 501-661973 Turbocharger; FI; V8 445 CID (K); IFI	F4TZ-6V012-AARM F4TZ-7L596-A F4TZ-7L596-A F4TZ-9VA543-AARM F4TZ-9VA543-AARM XU2Z-6V200-BARM F4TZ-6V200-CARM F4TZ-6V200-CARM XU2Z-6VA642-AARM XU2Z-6VA642-AARM XU2Z-6VA642-AARM 2C3Z-9VE527-DRM F4TZ-9VE527-AARM 2C3Z-9VE527-ARM F4TZ-9VE527-AARM 2C3Z-9VE527-ARM F4TZ-6VN639-AARM F4TZ-6VN639-AARM F4TZ-6VK682-CARM F4TZ-6VK682-BARM F4TZ-6VK682-CARM F4TZ-6VK682-BARM
Reman			Engine Assembly (Complete); FI; Naturally Aspirated; V8 445 CID (M); IFI; High Altitude w/ Engine Serial # 500079-1116330 Engine Assembly (Complete); FI; Naturally Aspirated; V8 445 CID (M); IFI; S/N 500079-1116330 Engine Assembly (Complete); FI; Turbocharged; V8 445 CID (F); DFI; S/N 501-35651 Engine Assembly (Complete); FI; Turbocharged; V8 445 CID (K); DFI; S/N 501-35651 Engine Assembly (Less Accessories) w/ Engine Serial # 1116331-End; FI; Turbocharged; V8 445 CID (F); IFI Engine Assembly (Less Accessories) w/ Engine Serial # 1116331-End; FI; Turbocharged; V8 445 CID (K); IFI Engine Assembly (Less Accessories) w/ Engine Serial # 501-201680; FI; Turbocharged; V8 445 CID (F); DFI Engine Assembly (Less Accessories) w/ Engine Serial # 501-201680; FI; Turbocharged; V8 445 CID (K); DFI Engine Assembly (Longblock); FI; Naturally Aspirated; V8 445 CID (M); IFI; S/N 500079-1116330 Engine Assembly (Longblock); FI; Turbocharged; V8 445 CID (F); DFI Engine Assembly (Longblock); FI; Turbocharged; V8 445 CID (F); IFI; S/N 1116331-End Engine Assembly (Longblock); FI; Turbocharged; V8 445 CID (K); DFI Engine Assembly (Longblock); FI; Turbocharged; V8 445 CID (K); IFI; S/N 1116331-End	XU2Z-6V007-DARM XU2Z-6V007-CARM F4TZ-6V007-FARM F4TZ-6V007-FARM F4TZ-6V006-AARM F4TZ-6V006-AARM F4TZ-6V006-BARM F4TZ-6V006-BARM XU2Z-6V012-CARM F4TZ-6V012-AARM F3TZ-6V012-AARM F4TZ-6V012-AARM F3TZ-6V012-AARM XU2Z-6V200-BARM
	1993	7.3L DIESEL OHV	Engine Connecting Rod; Naturally Aspirated; V8 445 CID (M); Assembly w/ Engine Serial # 1116330 Engine Connecting Rod; Turbocharged; V8 445 CID (C) Engine Connecting Rod; V8 445 CID (C); Assembly w/ Engine Serial # 1116330 Engine Connecting Rod; V8 445 CID (M); Assembly w/ Engine Serial # 1116330 Engine Oil Cooler; Naturally Aspirated; V8 445 CID (M); Assembly Fuel Injector Kit; Naturally Aspirated; V8 445 CID (M) Fuel Injector Kit; Turbocharged; V8 445 CID (C)	F4TZ-6V200-CARM XU2Z-6V200-BARM XU2Z-6V200-BARM XU2Z-6VA642-AARM 2C3Z-9VE527-DRM 2C3Z-9VE527-ARM
Reman			Engine Assembly (Complete); Naturally Aspirated; V8 445 CID (M); High Altitude w/ Engine Serial # 500079-1116330 Engine Assembly (Complete); Naturally Aspirated; V8 445 CID (M); S/N 500079-1116330 Engine Assembly (Less Accessories) w/ Engine Serial # 1116331-End; Turbocharged; V8 445 CID (C); IFI Engine Assembly (Longblock); Naturally Aspirated; V8 445 CID (M); S/N 500079-1116330 Engine Assembly (Longblock); Turbocharged; V8 445 CID (C)	XU2Z-6V007-CARM F4TZ-6V006-AARM XU2Z-6V012-CARM F3TZ-6V012-AARM

# DIESEL ENGINES

## Light / Medium Trucks

### Ford



FORD PARTS

## F-Series

-Cont'd

Part Type	Years	Engine	Qualifier	Ford #
Reman	1992	7.3L DIESEL OHV	Engine Connecting Rod; V8 445 CID (M) Engine Oil Cooler; V8 445 CID (M); Assembly Fuel Injector Kit; V8 445 CID (M); Injector Before 3/92 Fuel Injector Kit; V8 445 CID (M); Injector From 3/92 Engine Assembly (Complete); V8 445 CID (M) Engine Assembly (Complete); V8 445 CID (M); High Altitude w/ Engine Serial # 500079-1116330 Engine Assembly (Longblock); V8 445 CID (M)	XU2Z-6V200-BARM XU2Z-6VA642-AARM 2C3Z-9VE527-ERM 2C3Z-9VE527-DRM XU2Z-6V007-CARM XU2Z-6V007-DARM XU2Z-6V012-CARM
	1991	7.3L DIESEL OHV	Engine Connecting Rod; V8 445 CID (M) Engine Oil Cooler; V8 445 CID (M); Assembly Fuel Injector Kit; V8 445 CID (M) Engine Assembly (Complete); V8 445 CID (M) Engine Assembly (Complete); V8 445 CID (M); High Altitude w/ Engine Serial # 500079-1116330 Engine Assembly (Longblock); V8 445 CID (M)	XU2Z-6V200-BARM XU2Z-6VA642-AARM 2C3Z-9VE527-ERM XU2Z-6V007-CARM XU2Z-6V007-DARM XU2Z-6V012-CARM
Reman	1990	7.3L DIESEL OHV	Engine Connecting Rod; V8 445 CID (M) Engine Oil Cooler; V8 445 CID (M); Assembly Fuel Injector Kit; V8 445 CID (M) Engine Assembly (Complete); V8 445 CID (M) Engine Assembly (Complete); V8 445 CID (M); High Altitude	XU2Z-6V200-BARM XU2Z-6VA642-AARM 2C3Z-9VE527-ERM XU2Z-6V007-CARM XU2Z-6V007-DARM
	1989	7.3L DIESEL OHV	Engine Assembly (Longblock); V8 445 CID (M) Engine Connecting Rod; V8 445 CID (M) Engine Oil Cooler; V8 445 CID (M); Assembly Fuel Injector Kit; V8 445 CID (M) Engine Assembly (Complete); V8 445 CID (M) Engine Assembly (Complete); V8 445 CID (M); High Altitude w/ Engine Serial # 500079-1116330 Engine Assembly (Longblock); V8 445 CID (M)	XU2Z-6V012-CARM XU2Z-6V200-BARM XU2Z-6VA642-AARM 2C3Z-9VE527-ERM XU2Z-6V007-CARM XU2Z-6V007-DARM XU2Z-6V012-CARM
Reman	1988	7.3L DIESEL OHV	Engine Connecting Rod; V8 445 CID (M) Engine Oil Cooler; V8 445 CID (M); Assembly Fuel Injector Kit; V8 445 CID (M) Engine Assembly (Complete); V8 445 CID (M) Engine Assembly (Complete); V8 445 CID (M); High Altitude w/ Engine Serial # 500079-1116330 Engine Assembly (Longblock); V8 445 CID (M)	XU2Z-6V200-BARM XU2Z-6VA642-AARM 2C3Z-9VE527-ERM XU2Z-6V007-CARM XU2Z-6V007-DARM XU2Z-6V012-CARM
	1987	6.9L DIESEL OHV	Engine Connecting Rod; V8 420 CID (1) Engine Oil Cooler; V8 420 CID (1); Assembly Fuel Injector Kit; V8 420 CID (1) Engine Assembly (Complete); V8 420 CID (1) Engine Assembly (Longblock); V8 420 CID (1)	XU2Z-6V200-BARM XU2Z-6VA642-AARM 2C3Z-9VE527-FRM XU2Z-6V007-AARM XU2Z-6V012-AARM
Reman	1986	6.9L DIESEL OHV	Engine Connecting Rod; V8 420 CID (1) Engine Oil Cooler; V8 420 CID (1); Assembly Fuel Injector Kit; V8 420 CID (1) Engine Assembly (Complete); V8 420 CID (1) Engine Assembly (Longblock); V8 420 CID (1)	XU2Z-6V200-BARM XU2Z-6VA642-AARM 2C3Z-9VE527-FRM XU2Z-6V007-AARM XU2Z-6V012-AARM
	1985	6.9L DIESEL OHV	Engine Connecting Rod; V8 420 CID (1) Engine Oil Cooler; V8 420 CID (1); Assembly Fuel Injector Kit; V8 420 CID (1) Engine Assembly (Complete); V8 420 CID (1) Engine Assembly (Longblock); V8 420 CID (1)	XU2Z-6V200-BARM XU2Z-6VA642-AARM 2C3Z-9VE527-FRM XU2Z-6V007-AARM XU2Z-6V012-AARM
Reman	1984	6.9L DIESEL OHV	Engine Connecting Rod; V8 420 CID (1); Assembly w/ Engine Serial # 1116330 Engine Oil Cooler; V8 420 CID (1); Assembly Fuel Injector Kit; V8 420 CID (1) Engine Assembly (Complete); V8 420 CID (1); S/N 500078 Engine Assembly (Longblock); V8 420 CID (1); S/N 500078	XU2Z-6V200-BARM XU2Z-6VA642-AARM 2C3Z-9VE527-FRM XU2Z-6V007-AARM XU2Z-6V012-AARM
	1983	6.9L DIESEL OHV	Engine Connecting Rod; V8 420 CID (1); w/ Engine Serial # 1116330 Engine Oil Cooler; V8 420 CID (1); Assembly Engine Assembly (Complete); V8 420 CID (1); S/N 500078 Engine Assembly (Longblock); V8 420 CID (1); S/N 500078	XU2Z-6V200-BARM XU2Z-6VA642-AARM XU2Z-6V007-AARM XU2Z-6V012-AARM

## Transit-150

Part Type	Years	Engine	Qualifier	Ford #
New	2017	3.2L DIESEL DOHC	Diesel High Pressure Oil Pump; L5 195 CID (V)	FB3Z-9A543-A
	2016	3.2L DIESEL DOHC	Diesel High Pressure Oil Pump; L5 195 CID (V)	FB3Z-9A543-A
	2015	3.2L DIESEL DOHC	Diesel High Pressure Oil Pump; L5 195 CID (V) Engine Assembly (Less Accessories); L5 195 CID (V)	FB3Z-9A543-A CK4Z-6006-A

## Transit-250

Part Type	Years	Engine	Qualifier	Ford #
New	2017	3.2L DIESEL DOHC	Diesel High Pressure Oil Pump; L5 195 CID (V)	FB3Z-9A543-A
	2016	3.2L DIESEL DOHC	Diesel High Pressure Oil Pump; L5 195 CID (V)	FB3Z-9A543-A
	2015	3.2L DIESEL DOHC	Diesel High Pressure Oil Pump; L5 195 CID (V) Engine Assembly (Less Accessories); L5 195 CID (V)	FB3Z-9A543-A CK4Z-6006-A

## Transit-350

Part Type	Years	Engine	Qualifier	Ford #
	2017	3.2L DIESEL DOHC	Diesel High Pressure Oil Pump; L5 195 CID (V)	FB3Z-9A543-A





**Transit-350**

-Cont'd

Part Type	Years	Engine	Qualifier	Ford #
New	2016	3.2L DIESEL DOHC	Diesel High Pressure Oil Pump; L5 195 CID (V)	FB3Z-9A543-A
	2015	3.2L DIESEL DOHC	Diesel High Pressure Oil Pump; L5 195 CID (V)	FB3Z-9A543-A
			Engine Assembly (Less Accessories); L5 195 CID (V)	CK4Z-6006-A

**Transit-350 HD**

Part Type	Years	Engine	Qualifier	Ford #
New	2017	3.2L DIESEL DOHC	Diesel High Pressure Oil Pump; L5 195 CID (V)	FB3Z-9A543-A
	2016	3.2L DIESEL DOHC	Diesel High Pressure Oil Pump; L5 195 CID (V)	FB3Z-9A543-A
	2015	3.2L DIESEL DOHC	Diesel High Pressure Oil Pump; L5 195 CID (V)	FB3Z-9A543-A
			Engine Assembly (Less Accessories); L5 195 CID (V)	CK4Z-6006-A

**Econoline**

Part Type	Years	Engine	Qualifier	Ford #
Reman	2010	6.0L DIESEL OHV	Engine Assembly (Complete); V8 363 CID (P); From Engine Serial # 299,093 and Up	6C2Z-6007-AARM
			Engine Assembly (Less Accessories); V8 363 CID (P); From Engine Serial # 299,093 and Up	6C2Z-6006-AARM
			Engine Assembly (Less Accessories); V8 363 CID (P); From Engine Serial # 299,093 and Up; w/ Head Studs	5C3Z-6006-DARM
Reman	2009	6.0L DIESEL OHV	Diesel Fuel Injector Driver Module; FI; V8 363 CID (P)	4C3Z-12B599-ABRM
			Engine Short Block; V8 363 CID (P); Assembly	6C3Z-6009-ARM
			Turbocharger; V8 363 CID (P)	5C3Z-6K682-CCRM
Reman	2008	6.0L DIESEL OHV	Turbocharger; V8 363 CID (P)	TC-17RM
			Engine Assembly (Complete); V8 363 CID (P); From Engine Serial # 299,093 and Up	6C2Z-6007-AARM
			Engine Assembly (Less Accessories); V8 363 CID (P); From Engine Serial # 299,093 and Up	6C2Z-6006-AARM
Reman	2007	6.0L DIESEL OHV	Engine Assembly (Less Accessories); V8 363 CID (P); From Engine Serial # 299,093 and Up; w/ Head Studs	5C3Z-6006-DARM
			Diesel Fuel Injector Driver Module; FI; V8 363 CID (P)	4C3Z-12B599-ABRM
			Diesel Fuel Injector Nozzle; V8 363 CID (P)	4C3Z-9E527-BRM
Reman	2006	6.0L DIESEL OHV	Engine Short Block; V8 363 CID (P); Assembly	5C3Z-9A543-ARM
			Diesel High Pressure Oil Pump; V8 363 CID (P); 5C40-9A543-AA	HPP-12RM
			Diesel High Pressure Oil Pump; V8 363 CID (P); 5C40-9A543-AA	6C3Z-6009-ARM
Reman	2005	6.0L DIESEL OHV	Turbocharger; V8 363 CID (P)	5C3Z-6K682-CCRM
			Turbocharger; V8 363 CID (P)	TC-17RM
			Engine Assembly (Complete); V8 363 CID (P); From Engine Serial # 299,093 and Up	6C2Z-6007-AARM
Reman	2004	6.0L DIESEL OHV	Engine Assembly (Less Accessories); V8 363 CID (P); From Engine Serial # 299,093 and Up	6C2Z-6006-AARM
			Engine Assembly (Less Accessories); V8 363 CID (P); From Engine Serial # 299,093 and Up; w/ Head Studs	5C3Z-6006-DARM
			Diesel Fuel Injector Driver Module; FI; V8 363 CID (P)	4C3Z-12B599-ABRM
Reman	2004	6.0L DIESEL OHV	Diesel Fuel Injector Nozzle; V8 363 CID (P)	4C3Z-9E527-BRM
			Diesel High Pressure Oil Pump; V8 363 CID (P); 5C40-9A543-AA	5C3Z-9A543-ARM
			Diesel High Pressure Oil Pump; V8 363 CID (P); 5C40-9A543-AA	HPP-12RM
Reman	2004	6.0L DIESEL OHV	Engine Short Block; V8 363 CID (P); Assembly	6C3Z-6009-ARM
			Engine Short Block; V8 363 CID (P); From 4/18/05; Assembly	6C3Z-6009-ARM
			Turbocharger; V8 363 CID (P)	5C3Z-6K682-CCRM
Reman	2004	6.0L DIESEL OHV	Turbocharger; V8 363 CID (P)	TC-17RM
			Engine Assembly (Complete); V8 363 CID (P); Before 11/29/04 S/N 149,761 to 178,947	5C2Z-6007-AARM
			Engine Assembly (Complete); V8 363 CID (P); From 11/29/04 S/N 178,948 to 213,261	5C2Z-6007-BARM
Reman	2004	6.0L DIESEL OHV	Engine Assembly (Less Accessories) S/N 149,761 to 299,092; V8 363 CID (P)	5C2Z-6006-AARM
			Diesel Fuel Injector Driver Module; FI; V8 363 CID (P); From S/N 6155637 (Indy Built) or 94581 (Huntsville Built)	4C3Z-12B599-ABRM
			Diesel Fuel Injector Nozzle; V8 363 CID (P)	4C3Z-9E527-BRM
Reman	2004	6.0L DIESEL OHV	Diesel High Pressure Oil Pump; V8 363 CID (P); 5C40-9A543-AA	5C3Z-9A543-ARM
			Diesel High Pressure Oil Pump; V8 363 CID (P); 5C40-9A543-AA	HPP-12RM
			Diesel High Pressure Oil Pump; V8 363 CID (P); Before S/N 151,888	4C3Z-9A543-ARM
Reman	2004	6.0L DIESEL OHV	Diesel High Pressure Oil Pump; V8 363 CID (P); Before S/N 151,888	HPP-8RM



**Econoline**

-Cont'd

Part Type	Years	Engine	Qualifier	Ford #
Reman	2004	6.0L DIESEL OHV	Engine Short Block; V8 363 CID (P); Assembly; From 9/29/03 Turbocharger; V8 363 CID (P) Engine Assembly (Complete); V8 363 CID (P) Engine Assembly (Complete); V8 363 CID (P); Before 11/29/04 S/N 149,761 to 178,947 Engine Assembly (Complete); V8 363 CID (P); From 11/29/04 S/N 178,948 to 213,261 Engine Assembly (Less Accessories); V8 363 CID (P)	5C3Z-6009-AARM 4C2Z-6K682-CCRM 4C2Z-6007-AARM 5C2Z-6007-AARM 5C2Z-6007-BARM 4C2Z-6006-EARM
	2003	7.3L DIESEL OHV	Diesel High Pressure Oil Pump; V8 445 CID (F) Diesel High Pressure Oil Pump; V8 445 CID (F) Engine Connecting Rod; V8 445 CID (F); w/ Engine Serial # 1425747 And Up Engine Crankshaft; Turbocharged; V8 445 CID (F) Fuel Injector Kit; V8 445 CID (F); #1 Thru #7 Fuel Injector Kit; V8 445 CID (F); #8 Turbocharger Mounting Kit; Turbocharged; V8 445 CID (F); w/ EBP Valve Turbocharger Mounting Kit; Turbocharged; V8 445 CID (F); w/ EBP Valve Turbocharger; V8 445 CID (F) Turbocharger; V8 445 CID (F) Engine Assembly (Complete); V8 445 CID (F) Engine Assembly (Less Accessories); V8 445 CID (F)	F81Z-9A543-CRM HPP-9RM 1C3Z-6200-AARM 3C3Z-6V303-AARM 5C3Z-9VE527-BRM 5C3Z-9VE527-AARM F81Z-6N639-CARM PTC-6RM XC2Z-6K682-AARM TC-10RM XC2Z-6007-AARM XC2Z-6006-AARM
Reman	2002	7.3L DIESEL OHV	Diesel High Pressure Oil Pump; V8 445 CID (F) Diesel High Pressure Oil Pump; V8 445 CID (F) Engine Connecting Rod; V8 445 CID (F); w/ Engine Serial # 1425747 And Up Engine Crankshaft; Turbocharged; V8 445 CID (F) Fuel Injector Kit; V8 445 CID (F); #1 Thru #7 Fuel Injector Kit; V8 445 CID (F); #8 Turbocharger Mounting Kit; Turbocharged; V8 445 CID (F); w/ EBP Valve Turbocharger Mounting Kit; Turbocharged; V8 445 CID (F); w/ EBP Valve Turbocharger; V8 445 CID (F) Turbocharger; V8 445 CID (F) Engine Assembly (Complete); V8 445 CID (F) Engine Assembly (Less Accessories); V8 445 CID (F)	F81Z-9A543-CRM HPP-9RM 1C3Z-6200-AARM 3C3Z-6V303-AARM 5C3Z-9VE527-BRM 5C3Z-9VE527-AARM F81Z-6N639-CARM PTC-6RM XC2Z-6K682-AARM TC-10RM XC2Z-6007-AARM XC2Z-6006-AARM
	2001	7.3L DIESEL OHV	Diesel High Pressure Oil Pump; Turbocharged; V8 445 CID (F) Diesel High Pressure Oil Pump; Turbocharged; V8 445 CID (F) Engine Connecting Rod; Turbocharged; V8 445 CID (F); w/ Engine Serial # 1425747 And Up Engine Crankshaft; Turbocharged; V8 445 CID (F) Fuel Injector Kit; Turbocharged; V8 445 CID (F); #1 Thru #7 Fuel Injector Kit; Turbocharged; V8 445 CID (F); #2 Turbocharger Mounting Kit; Turbocharged; V8 445 CID (F); w/ EBP Valve Turbocharger Mounting Kit; Turbocharged; V8 445 CID (F); w/ EBP Valve Turbocharger; V8 445 CID (F) Turbocharger; V8 445 CID (F) Engine Assembly (Complete); Turbocharged; V8 445 CID (F) Engine Assembly (Less Accessories); Turbocharged; V8 445 CID (F)	F81Z-9A543-CRM HPP-9RM 1C3Z-6200-AARM 3C3Z-6V303-AARM 5C3Z-9VE527-BRM 5C3Z-9VE527-AARM F81Z-6N639-CARM PTC-6RM XC2Z-6K682-AARM TC-10RM XC2Z-6007-AARM XC2Z-6006-AARM
Reman	2000	7.3L DIESEL OHV	Diesel High Pressure Oil Pump; Turbocharged; V8 445 CID (F); S/N 896812-Current Diesel High Pressure Oil Pump; Turbocharged; V8 445 CID (F); S/N 896812-Current Engine Crankshaft; Turbocharged; V8 445 CID (F); w/ Engine Serial Number 896812 - Current Fuel Injector Kit; Turbocharged; V8 445 CID (F); #1 Thru #7 Fuel Injector Kit; Turbocharged; V8 445 CID (F); #8 Turbocharger Mounting Kit; Turbocharged; V8 445 CID (F); w/ EBP Valve w/ Engine Serial # 896812-Current Turbocharger Mounting Kit; Turbocharged; V8 445 CID (F); w/ EBP Valve w/ Engine Serial # 896812-Current Turbocharger; V8 445 CID (F); w/ Engine Serial # 896812-Current Turbocharger; V8 445 CID (F); w/ Engine Serial # 896812-Current Engine Assembly (Complete); Turbocharged; V8 445 CID (F) Engine Assembly (Less Accessories); Turbocharged; V8 445 CID (F); For Engine S/N 896812 to current	F81Z-9A543-CRM HPP-9RM 3C3Z-6V303-AARM 5C3Z-9VE527-BRM 5C3Z-9VE527-AARM F81Z-6N639-CARM PTC-6RM XC2Z-6K682-AARM TC-10RM XC2Z-6007-AARM XC2Z-6006-AARM
	1999 1998	7.3L DIESEL OHV 7.3L DIESEL OHV	Engine Crankshaft; Turbocharged; V8 445 CID (F); w/ Engine Serial # 576010-Current Engine Crankshaft; Turbocharged; V8 445 CID (F); w/ Bearings and Seal; w/ Engine Serial # 576010-Current	3C3Z-6V303-AARM 3C3Z-6V303-AARM

**F-Series**

Part Type	Years	Engine	Qualifier	Ford #
New	2017	6.7L DIESEL OHV	V8 6651cc 406 CID (T); w/ Dual Wheels; w/ Wide Frame; w/ Low Sulfur Diesel Fuel Content	HC3Z-6007-M
			V8 6651cc 406 CID (T); w/ High Sulfur Diesel Fuel Content	HC3Z-6007-K
			V8 6651cc 406 CID (T); w/ Low Sulfur Diesel Fuel Content; Narrow Frame; w/ Mid Sulfur Diesel Fuel Content	HC3Z-6007-J
			V8 6651cc 406 CID (T); w/ Single Wheel; w/ Wide Frame; w/ Low Sulfur Diesel Fuel Content	HC3Z-6007-H
			V8 6651cc 406 CID; w/ Dual Wheels; w/ Wide Frame; w/ Low Sulfur Diesel Fuel Content	HC3Z-6007-M
			V8 6651cc 406 CID; w/ High Sulfur Diesel Fuel Content	HC3Z-6007-K
	2016	6.7L DIESEL OHV	V8 6651cc 406 CID; w/ Low Sulfur Diesel Fuel Content; Narrow Frame; w/ Mid Sulfur Diesel Fuel Content	HC3Z-6007-J
			V8 6651cc 406 CID; w/ Single Wheel; w/ Wide Frame; w/ Low Sulfur Diesel Fuel Content	HC3Z-6007-H
			Engine Assembly (Complete); V8 6651cc 406 CID (T); Narrow Frame; w/ Low or Mid Sulfur	GC3Z-6007-G
			Engine Assembly (Complete); V8 6651cc 406 CID; Narrow Frame; w/ Low or Mid Sulfur	GC3Z-6007-G
		Engine Assembly (Complete); w/ 6R140 Transmission; V8 6651cc 406 CID (T); w/ Wide Frame Wheelbase; w/ Low Sulfur Diesel Fuel Content	FC3Z-6007-BA	
		Engine Assembly (Complete); w/ 6R140 Transmission; V8 6651cc 406 CID; w/ Wide Frame Wheelbase; w/ Low Sulfur Diesel Fuel Content	FC3Z-6007-BA	
		V8 6651cc 406 CID (T); High Sulfur	GC3Z-6007-H	



F-Series

-Cont'd

Part Type	Years	Engine	Qualifier	Ford #
New	2016	6.7L DIESEL OHV	V8 6651cc 406 CID; High Sulfur w/ 6R140 Transmission; V8 6651cc 406 CID (T); w/ Wide Frame; Low Sulfur	GC3Z-6007-H GC3Z-6007-F
New	2015	6.7L DIESEL OHV	w/ 6R140 Transmission; V8 6651cc 406 CID; w/ Wide Frame; Low Sulfur Turbocharger; V8 6651cc 406 CID (T); w/ Wide Frame	GC3Z-6007-F BC3Z-6K682-C
New			Engine Assembly (Complete); Cab & Chassis - Crew Cab; V8 6651cc 406 CID (T); Narrow Frame Engine Assembly (Complete); Cab & Chassis - Long Conventional; V8 6651cc 406 CID (T); Narrow Frame	FC3Z-6007-B FC3Z-6007-B
New	2014	6.7L DIESEL OHV	Engine Assembly (Less Accessories); V8 6651cc 406 CID (T) Turbocharger; V8 6651cc 406 CID (T); w/ Wide Frame	FC3Z-6006-C BC3Z-6K682-C
New			Engine Assembly (Complete); Cab & Chassis - Crew Cab; V8 6651cc 406 CID (T) Engine Assembly (Complete); Cab & Chassis - Long Conventional; V8 6651cc 406 CID (T) Engine Assembly (Complete); Crew Cab Pickup; V8 6651cc 406 CID (T); w/ Wide Frame Engine Assembly (Less Accessories); V8 6651cc 406 CID (T)	DC3Z-6007-BA DC3Z-6007-BA DC3Z-6007-E FC3Z-6006-C
Reman			Engine Assembly (Complete); Turbocharged; V8 6651cc 406 CID (T); Narrow Frame Engine Assembly (Complete); Turbocharged; V8 6651cc 406 CID (T); w/ Wide Frame	DC3Z-6007-BRM DC3Z-6007-ARM
New	2013	6.7L DIESEL OHV	Turbocharger; V8 6651cc 406 CID (T); w/ Wide Frame Engine Assembly (Complete); Cab & Chassis - Crew Cab; V8 6651cc 406 CID (T) Engine Assembly (Complete); Cab & Chassis - Long Conventional; V8 6651cc 406 CID (T) Engine Assembly (Complete); Crew Cab Pickup; V8 6651cc 406 CID (T); w/ Wide Frame Engine Assembly (Less Accessories); V8 6651cc 406 CID (T)	BC3Z-6K682-C DC3Z-6007-BA DC3Z-6007-BA DC3Z-6007-E FC3Z-6006-C
Reman			Engine Assembly (Complete); Turbocharged; V8 6651cc 406 CID (T); Narrow Frame Engine Assembly (Complete); Turbocharged; V8 6651cc 406 CID (T); w/ Wide Frame	DC3Z-6007-BRM DC3Z-6007-ARM
New	2012	6.7L DIESEL OHV	Turbocharger; V8 6651cc 406 CID (T); w/ Wide Frame Engine Assembly (Complete); Cab & Chassis - Crew Cab; V8 6651cc 406 CID (T); Narrow Frame Engine Assembly (Complete); Cab & Chassis - Long Conventional; V8 6651cc 406 CID (T); Narrow Frame	BC3Z-6K682-C DC3Z-6007-BA DC3Z-6007-BA
Reman			Engine Assembly (Complete); Crew Cab Pickup; V8 6651cc 406 CID (T); w/ Wide Frame Engine Assembly (Less Accessories); V8 6651cc 406 CID (T)	DC3Z-6007-E FC3Z-6006-C
New	2011	6.7L DIESEL OHV	Engine Assembly (Complete); Turbocharged; V8 6651cc 406 CID (T); Narrow Frame Engine Assembly (Complete); Turbocharged; V8 6651cc 406 CID (T); w/ Wide Frame Turbocharger; V8 6651cc 406 CID (T); w/ Wide Frame Engine Assembly (Complete); Cab & Chassis - Crew Cab; V8 6651cc 406 CID (T); Narrow Frame Engine Assembly (Complete); Cab & Chassis - Long Conventional; V8 6651cc 406 CID (T) Engine Assembly (Complete); Cab & Chassis - Long Conventional; V8 6651cc 406 CID (T); Narrow Frame	DC3Z-6007-BRM DC3Z-6007-ARM BC3Z-6K682-C DC3Z-6007-BA DC3Z-6007-BA DC3Z-6007-BA
Reman			Engine Assembly (Complete); Crew Cab Pickup; V8 6651cc 406 CID (T); w/ Wide Frame Engine Assembly (Less Accessories); V8 6651cc 406 CID (T)	DC3Z-6007-E FC3Z-6006-C
New	2010	6.4L DIESEL OHV	Engine Assembly (Complete); Turbocharged; V8 6651cc 406 CID (T); Narrow Frame Engine Assembly (Complete); Turbocharged; V8 6651cc 406 CID (T); w/ Wide Frame Clutch Kit; w/ S6-650 Transmission; V8 391 CID (R) Diesel High Pressure Oil Pump; V8 391 CID (R); 6E7O-9G803-AE Diesel High Pressure Oil Pump; V8 391 CID (R); 6E7O-9G803-AE Diesel High Pressure Oil Pump; V8 391 CID; 6E7O-9G803-AE Diesel High Pressure Oil Pump; V8 391 CID; 6E7O-9G803-AE Engine Short Block; w/ Automatic Trans.; V8 391 CID (R); Assembly Engine Short Block; w/ Standard Trans.; V8 391 CID (R); Assembly Engine Short Block; w/ Standard Trans.; V8 391 CID; Assembly Turbocharger; V8 391 CID (R); High Pressure Turbocharger; V8 391 CID (R); High Pressure Turbocharger; V8 391 CID (R); High and Low Pressure Turbocharger; V8 391 CID (R); High and Low Pressure Turbocharger; V8 391 CID (R); Low Pressure Turbocharger; V8 391 CID (R); Low Pressure Turbocharger; V8 391 CID; High Pressure Turbocharger; V8 391 CID; High Pressure Turbocharger; V8 391 CID; High and Low Pressure Turbocharger; V8 391 CID; High and Low Pressure Turbocharger; V8 391 CID; Low Pressure Turbocharger; V8 391 CID; Low Pressure	DC3Z-6007-BRM DC3Z-6007-ARM 7C3Z-7L596-A 8C3Z-9A543-DRM HPP-11RM 8C3Z-9A543-DRM HPP-11RM 8C3Z-6009-AARM 8C3Z-6009-BARM 8C3Z-6009-BARM 8C3Z-6K682-BARM TC-14RM 8C3Z-6K682-CRM TC-16RM 8C3Z-6K682-AARM TC-11RM 8C3Z-6K682-BARM TC-14RM 8C3Z-6K682-CRM TC-16RM 8C3Z-6K682-AARM TC-11RM
Reman			Engine Assembly (Complete); w/ Automatic Trans.; V8 391 CID (R); Excludes Vertical EGR Cooler w/ Standard Trans.; V8 391 CID (R); Excludes Vertical EGR Cooler	8C3Z-6007-AARM 8C3Z-6007-BARM
New	2009	6.4L DIESEL OHV	w/ Standard Trans.; V8 391 CID; Excludes Vertical EGR Cooler Clutch Kit; w/ S6-650 Transmission; V8 391 CID (R) Diesel High Pressure Oil Pump; V8 391 CID (R); 6E7O-9G803-AE Diesel High Pressure Oil Pump; V8 391 CID (R); 6E7O-9G803-AE Engine Short Block; w/ Automatic Trans.; V8 391 CID (R); Assembly Engine Short Block; w/ Standard Trans.; V8 391 CID (R); Assembly Turbocharger; V8 391 CID (R); High Pressure Turbocharger; V8 391 CID (R); High Pressure Turbocharger; V8 391 CID (R); High and Low Pressure Turbocharger; V8 391 CID (R); High and Low Pressure Turbocharger; V8 391 CID (R); Low Pressure Turbocharger; V8 391 CID (R); Low Pressure	8C3Z-6007-AARM 8C3Z-6007-BARM 7C3Z-7L596-A 8C3Z-9A543-DRM HPP-11RM 8C3Z-6009-AARM 8C3Z-6009-BARM 8C3Z-6009-BARM 8C3Z-6K682-BARM TC-14RM 8C3Z-6K682-CRM TC-16RM 8C3Z-6K682-AARM TC-11RM
Reman			Engine Assembly (Complete); w/ Automatic Trans.; V8 391 CID (R); Excludes Vertical EGR Cooler w/ Standard Trans.; V8 391 CID (R); Excludes Vertical EGR Cooler Clutch Kit; w/ S6-650 Transmission; V8 391 CID (R) Diesel High Pressure Oil Pump; V8 391 CID (R); 6E7O-9G803-AE Diesel High Pressure Oil Pump; V8 391 CID (R); 6E7O-9G803-AE Engine Short Block; w/ Automatic Trans.; V8 391 CID (R); Assembly Engine Short Block; w/ Standard Trans.; V8 391 CID (R); Assembly Turbocharger; V8 391 CID (R); High Pressure Turbocharger; V8 391 CID (R); High Pressure Turbocharger; V8 391 CID (R); High and Low Pressure Turbocharger; V8 391 CID (R); High and Low Pressure Turbocharger; V8 391 CID (R); Low Pressure Turbocharger; V8 391 CID (R); Low Pressure	8C3Z-6007-AARM 8C3Z-6007-BARM 7C3Z-7L596-A 8C3Z-9A543-DRM HPP-11RM 8C3Z-6009-AARM 8C3Z-6009-BARM 8C3Z-6009-BARM 8C3Z-6K682-BARM TC-14RM 8C3Z-6K682-CRM TC-16RM 8C3Z-6K682-AARM TC-11RM
New	2008	6.4L DIESEL OHV	Engine Assembly (Complete); w/ Automatic Trans.; V8 391 CID (R); Excludes Vertical EGR Cooler w/ Standard Trans.; V8 391 CID (R); Excludes Vertical EGR Cooler Clutch Kit; w/ S6-650 Transmission; V8 391 CID (R) Diesel High Pressure Oil Pump; V8 391 CID (R); 6E7O-9G803-AE Diesel High Pressure Oil Pump; V8 391 CID (R); 6E7O-9G803-AE Engine Short Block; w/ Automatic Trans.; V8 391 CID (R); Assembly Engine Short Block; w/ Standard Trans.; V8 391 CID (R); Assembly Turbocharger; V8 391 CID (R); High Pressure Turbocharger; V8 391 CID (R); High Pressure	8C3Z-6007-AARM 8C3Z-6007-BARM 7C3Z-7L596-A 8C3Z-9A543-DRM HPP-11RM 8C3Z-6009-AARM 8C3Z-6009-BARM 8C3Z-6009-BARM 8C3Z-6K682-BARM TC-14RM 8C3Z-6K682-CRM TC-16RM 8C3Z-6K682-AARM TC-11RM

**DIESEL ENGINES**  
**Light / Medium Trucks**  
**Ford**



**FORD PARTS**

**F-Series**

**-Cont'd**

Part Type	Years	Engine	Qualifier	Ford #	
Reman	2008	6.4L DIESEL OHV	Turbocharger; V8 391 CID (R); High Pressure	TC-14RM	
			Turbocharger; V8 391 CID (R); High and Low Pressure	8C3Z-6K682-CRM	
			Turbocharger; V8 391 CID (R); High and Low Pressure	TC-16RM	
			Turbocharger; V8 391 CID (R); Low Pressure	8C3Z-6K682-AARM	
			Turbocharger; V8 391 CID (R); Low Pressure	TC-11RM	
	Engine Assembly (Complete); w/ Automatic Trans.; V8 391 CID (R); Excludes Vertical EGR Cooler	8C3Z-6007-AARM			
	w/ Standard Trans.; V8 391 CID (R); Excludes Vertical EGR Cooler	8C3Z-6007-BARM			
	Reman	2007	6.0L DIESEL OHV	Clutch Kit; w/ S6-650 Transmission; w/ Standard Trans.; V8 363 CID (P); Use with Single Mass Flywheel Assy Only	3C3Z-7L596-EA
				Diesel Fuel Injector Driver Module; FI; V8 363 CID (P)	4C3Z-12B599-ABRM
				Diesel Fuel Injector Nozzle; V8 363 CID (P)	4C3Z-9E527-BRM
Diesel High Pressure Oil Pump; V8 363 CID (P); 5C4O-9A543-AA				5C3Z-9A543-ARM	
Diesel High Pressure Oil Pump; V8 363 CID (P); 5C4O-9A543-AA				HPP-12RM	
Engine Short Block; V8 363 CID (P); Assembly				6C3Z-6009-ARM	
Turbocharger; V8 363 CID (P)				5C3Z-6K682-CCRM	
Turbocharger; V8 363 CID (P)				TC-17RM	
Engine Assembly (Complete); w/ Automatic Trans.; V8 363 CID (P); S/N 6,723,722 to 6,908,443 or 299,093 to 414,752				6C3Z-6007-BARM	
Engine Assembly (Complete); w/ Standard Trans.; V8 363 CID (P); S/N 6,723,722 to 6,908,443 or 299,093 to 414,752				6C3Z-6007-AARM	
Reman	2006	6.0L DIESEL OHV	Engine Assembly (Less Accessories) S/N 6,723,722 to 6,908,443 or 299,093 to 414,752; w/ Automatic Trans.; V8 363 CID (P)	6C3Z-6006-BARM	
			Engine Assembly (Less Accessories) S/N 6,723,722 to 6,908,443 or 299,093 to 414,752; w/ Standard Trans.; V8 363 CID (P)	6C3Z-6006-AARM	
			Clutch Kit; w/ S6-650 Transmission; w/ Standard Trans.; V8 363 CID (P); Use with Single Mass Flywheel Assy Only	3C3Z-7L596-EA	
			Diesel Fuel Injector Driver Module; FI; V8 363 CID (P)	4C3Z-12B599-ABRM	
			Diesel Fuel Injector Nozzle; V8 363 CID (P)	4C3Z-9E527-BRM	
			Diesel High Pressure Oil Pump; V8 363 CID (P); 5C4O-9A543-AA	5C3Z-9A543-ARM	
			Diesel High Pressure Oil Pump; V8 363 CID (P); 5C4O-9A543-AA	HPP-12RM	
			Engine Short Block; V8 363 CID (P); Assembly	6C3Z-6009-ARM	
			Turbocharger; V8 363 CID (P)	5C3Z-6K682-CCRM	
			Turbocharger; V8 363 CID (P)	TC-17RM	
Reman	2005	6.0L DIESEL OHV	Turbocharger; V8 363 CID (P); Engine Serial Number 6,155,637 To 6,344,942 Or 1 To 299,092	4C3Z-6K682-CDRM	
			Turbocharger; V8 363 CID (P); Engine Serial Number 6,155,637 To 6,344,942 Or 1 To 299,092	TC-15RM	
			Engine Assembly (Complete); w/ Automatic Trans.; V8 363 CID (P); S/N 6,723,722 to 6,908,443 or 299,093 to 414,752	6C3Z-6007-BARM	
			Engine Assembly (Complete); w/ Standard Trans.; V8 363 CID (P); S/N 6,723,722 to 6,908,443 or 299,093 to 414,752	6C3Z-6007-AARM	
			Engine Assembly (Less Accessories) S/N 6,723,722 to 6,908,443 or 299,093 to 414,752; w/ Automatic Trans.; V8 363 CID (P)	6C3Z-6006-BARM	
			Engine Assembly (Less Accessories) S/N 6,723,722 to 6,908,443 or 299,093 to 414,752; w/ Standard Trans.; V8 363 CID (P)	6C3Z-6006-AARM	
			Clutch Kit; w/ S6-650 Transmission; w/ Standard Trans.; V8 363 CID (P); Use with Single Mass Flywheel Assy Only	3C3Z-7L596-EA	
			Diesel Fuel Injector Driver Module; FI; V8 363 CID (P)	4C3Z-12B599-ABRM	
			Diesel Fuel Injector Nozzle; V8 363 CID (P)	4C3Z-9E527-BRM	
			Diesel High Pressure Oil Pump; V8 363 CID (P); 5C4O-9A543-AA	5C3Z-9A543-ARM	
Reman	2004	6.0L DIESEL OHV	Diesel High Pressure Oil Pump; V8 363 CID (P); 5C4O-9A543-AA	HPP-12RM	
			Engine Short Block; V8 363 CID (P); Assembly	5C3Z-6009-AARM	
			Turbocharger; V8 363 CID (P); Before 11/04/04	4C3Z-6K682-CCRM	
			Turbocharger; V8 363 CID (P); Engine Serial Number 6,155,637 To 6,344,942 Or 1 To 299,092	4C3Z-6K682-CDRM	
			Turbocharger; V8 363 CID (P); Engine Serial Number 6,155,637 To 6,344,942 Or 1 To 299,092	TC-15RM	
			Turbocharger; V8 363 CID (P); From 11/04/04	5C3Z-6K682-CCRM	
			Turbocharger; V8 363 CID (P); From 11/04/04	TC-17RM	
			Engine Assembly (Complete); w/ Automatic Trans.; V8 363 CID (P); Before 11/04/04 and S/N 6,429,301 or 181,447	5C3Z-6007-BARM	
			Engine Assembly (Complete); w/ Automatic Trans.; V8 363 CID (P); From 11/04/04 and S/N 6,429,302 or 181,448	5C3Z-6007-DARM	
			Engine Assembly (Complete); w/ Standard Trans.; V8 363 CID (P); Before 11/04/04 and S/N 6,429,301 or 181,447	5C3Z-6007-AARM	
Reman	2004	6.0L DIESEL OHV	Engine Assembly (Complete); w/ Standard Trans.; V8 363 CID (P); From 11/04/04 and S/N 6,429,302 or 181,448	5C3Z-6007-CARM	
			Engine Assembly (Complete); w/ Automatic Trans.; V8 363 CID (P); Before 11/04/04 and S/N 6,429,301 or 181,447	5C3Z-6006-BARM	
			Engine Assembly (Less Accessories) w/ S/N 6,344,943 to 6,560,520 or 131,587 to 213,260; w/ Automatic Trans.; V8 363 CID (P)	5C3Z-6006-AARM	
			Engine Assembly (Less Accessories); V8 363 CID (P); S/N 6,344,943 to 6,429,301 or 131,587 to 181,447	5C3Z-6006-AARM	
			Clutch Kit; w/ S6-650 Transmission; w/ Standard Trans.; V8 363 CID (P); Use with Single Mass Flywheel Assy Only	3C3Z-7L596-EA	
			Diesel Fuel Injector Driver Module; FI; V8 363 CID	4C3Z-12B599-ABRM	
			Diesel Fuel Injector Driver Module; FI; V8 363 CID (P)	4C3Z-12B599-ABRM	
			Diesel Fuel Injector Nozzle; V8 363 CID (P); Injector Before S/N 6155636 (Indy Built) or 94580 (Huntsville Built)	3C3Z-9E527-ECRM	
			Diesel Fuel Injector Nozzle; V8 363 CID (P); Injector From S/N 6155637 (Indy Built) or 94581 (Huntsville Built)	4C3Z-9E527-BRM	
			Diesel Fuel Injector Nozzle; V8 363 CID; Injector Before S/N 6155636 (Indy Built) or 94580 (Huntsville Built)	3C3Z-9E527-ECRM	
Reman	2004	6.0L DIESEL OHV	Diesel Fuel Injector Nozzle; V8 363 CID; Injector From S/N 6155637 (Indy Built) or 94581 (Huntsville Built)	4C3Z-9E527-BRM	
			Diesel High Pressure Oil Pump; V8 363 CID (P); 5C4O-9A543-AA	5C3Z-9A543-ARM	
			Diesel High Pressure Oil Pump; V8 363 CID (P); 5C4O-9A543-AA	HPP-12RM	
			Diesel High Pressure Oil Pump; V8 363 CID (P); Before S/N 6155636 or 94580; OE# 5010106-R91	3C3Z-9A543-AARM	



F-Series

-Cont'd

Part Type	Years	Engine	Qualifier	Ford #
Reman	2004	6.0L DIESEL OHV	Diesel High Pressure Oil Pump; V8 363 CID (P); Before S/N 6155636 or 94580; OE# 5010106-R91	HPP-10RM
			Diesel High Pressure Oil Pump; V8 363 CID (P); From S/N 6155637 or 94581; OE# 5010119-R91	4C3Z-9A543-AARM
			Diesel High Pressure Oil Pump; V8 363 CID (P); From S/N 6155637 or 94581; OE# 5010119-R91	HPP-8RM
			Diesel High Pressure Oil Pump; V8 363 CID; 5C4O-9A543-AA	5C3Z-9A543-AARM
			Diesel High Pressure Oil Pump; V8 363 CID; 5C4O-9A543-AA	HPP-12RM
			Diesel High Pressure Oil Pump; V8 363 CID; Before S/N 6155636 or 94580; OE# 5010106-R91	3C3Z-9A543-AARM
			Diesel High Pressure Oil Pump; V8 363 CID; Before S/N 6155636 or 94580; OE# 5010106-R91	HPP-10RM
			Diesel High Pressure Oil Pump; V8 363 CID; From S/N 6155637 or 94581; OE# 5010119-R91	4C3Z-9A543-AARM
			Diesel High Pressure Oil Pump; V8 363 CID; From S/N 6155637 or 94581; OE# 5010119-R91	HPP-8RM
			Engine Short Block; V8 363 CID (P); Assembly; Before 9/29/03 and S/N 6,155,636 or 137,744	3C3Z-6009-AARM
			Engine Short Block; V8 363 CID (P); Assembly; From 9/29/03 and S/N 6,155,637 or 137,745	5C3Z-6009-AARM
			Engine Short Block; V8 363 CID; Assembly; Before 9/29/03 and S/N 6,155,636 or 137,744	3C3Z-6009-AARM
			Engine Short Block; V8 363 CID; Assembly; From 9/29/03 and S/N 6,155,637 or 137,745	5C3Z-6009-AARM
			Turbocharger; V8 363 CID (P); From 9/29/03 and S/N 6155637 or 94580	4C3Z-6K682-CCRM
			Turbocharger; V8 363 CID (P); w/ EBP Valve; Before 9/29/03 and S/N 6155636 or 94580	3C3Z-6K682-CCRM
			Turbocharger; V8 363 CID (P); w/ EBP Valve; Before 9/29/03 and S/N 6155636 or 94580	TC-13RM
			Turbocharger; V8 363 CID; From 9/29/03 and S/N 6155637 or 94580	4C3Z-6K682-CCRM
			Turbocharger; V8 363 CID; w/ EBP Valve; Before 9/29/03 and S/N 6155636 or 94580	3C3Z-6K682-CCRM
			Turbocharger; V8 363 CID; w/ EBP Valve; Before 9/29/03 and S/N 6155636 or 94580	TC-13RM
			Engine Assembly (Complete); w/ Automatic Trans.; V8 363 CID (P); Before 11/04/04 and S/N 6,429,301 or 181,447	5C3Z-6007-BARM
			Engine Assembly (Complete); w/ Automatic Trans.; V8 363 CID (P); Before S/N 6,155,636	3C3Z-6007-AARM
			Engine Assembly (Complete); w/ Automatic Trans.; V8 363 CID (P); From 11/04/04 and S/N 6,429,302 or 181,448	5C3Z-6007-DARM
			Engine Assembly (Complete); w/ Automatic Trans.; V8 363 CID (P); From S/N 6,155,637	4C3Z-6007-BARM
			Engine Assembly (Complete); w/ Automatic Trans.; V8 363 CID (P); From S/N 6,155,637; w/ Head	4C3Z-6007-CARM
			Engine Assembly (Complete); w/ Standard Trans.; V8 363 CID (P); Before 11/04/04 and S/N 6,429,301 or 181,447	5C3Z-6007-AARM
			Engine Assembly (Complete); w/ Standard Trans.; V8 363 CID (P); From 11/04/04 and S/N 6,429,302 or 181,448	5C3Z-6007-CARM
			Engine Assembly (Complete); w/ Standard Trans.; V8 363 CID (P); w/ Eng Tags 3G-041-CE,DG-041-BE,WG-041-DD Before S/N 6,155,636	3C3Z-6007-BARM
			Engine Assembly (Complete); w/ Standard Trans.; V8 363 CID (P); w/ Eng Tags 3G-041-CE,DG-041-BE,WG-041-DD From S/N 6,155,637	4C3Z-6007-AARM
			Engine Assembly (Complete); w/ Standard Trans.; V8 363 CID; Before 11/04/04 and S/N 6,429,301 or 181,447	5C3Z-6007-AARM
			Engine Assembly (Complete); w/ Standard Trans.; V8 363 CID; From 11/04/04 and S/N 6,429,302	5C3Z-6007-CARM
			Engine Assembly (Complete); w/ Standard Trans.; V8 363 CID; w/ Eng Tags 3G-041-CE,DG-041-BE,WG-041-DD Before S/N 6,155,636	3C3Z-6007-BARM
			Engine Assembly (Complete); w/ Standard Trans.; V8 363 CID; w/ Eng Tags 3G-041-CE,DG-041-BE,WG-041-DD From S/N 6,155,637	4C3Z-6007-AARM
			Engine Assembly (Less Accessories) From S/N 6,155,637 or 94,581; w/ Automatic Trans.; V8 363 CID (P)	4C3Z-6006-BARM
			Engine Assembly (Less Accessories) From S/N 6,155,637 or 94,581; w/ Standard Trans.; V8 363 CID (P)	4C3Z-6006-AARM
			Engine Assembly (Less Accessories) From S/N 6,155,637 or 94,581; w/ Standard Trans.; V8 363 CID (P)	4C3Z-6006-AARM
			Engine Assembly (Less Accessories) before S/N 6,155,636 or 94,580; w/ Automatic Trans.; V8 363 CID (P)	3C3Z-6006-AARM
			Engine Assembly (Less Accessories) before S/N 6,155,636 or 94,580; w/ Standard Trans.; V8 363 CID (P)	3C3Z-6006-BARM
			Engine Assembly (Less Accessories) before S/N 6,155,636 or 94,580; w/ Standard Trans.; V8 363 CID (P)	3C3Z-6006-BARM
			Diesel Fuel Injector Driver Module; FI; V8 363 CID	4C3Z-12B599-ABRM
			Diesel Fuel Injector Nozzle; V8 363 CID	3C3Z-9E527-ECRM
			Engine Short Block; V8 363 CID; Assembly; Before 9/29/03 and S/N 6,155,636 or 137,744	3C3Z-6009-AARM
			Engine Short Block; V8 363 CID; Assembly; From 9/29/03 and S/N 6,155,637 or 137,745	5C3Z-6009-AARM
			Turbocharger; V8 363 CID; From 9/29/03 and S/N 6155637 or 94580	4C3Z-6K682-CCRM
			Turbocharger; V8 363 CID; w/ EBP Valve	3C3Z-6K682-CCRM
			Turbocharger; V8 363 CID; w/ EBP Valve	TC-13RM
Clutch Kit; w/ Standard Trans.; V8 445 CID (F); M6HD	YC3Z-7L596-AA			
Clutch Kit; w/ Standard Trans.; V8 445 CID; M6HD	YC3Z-7L596-AA			
Diesel High Pressure Oil Pump; V8 445 CID	F81Z-9A543-CRM			
Diesel High Pressure Oil Pump; V8 445 CID	HPP-9RM			
Diesel High Pressure Oil Pump; V8 445 CID (F)	F81Z-9A543-CRM			
Diesel High Pressure Oil Pump; V8 445 CID (F)	HPP-9RM			
Engine Connecting Rod; V8 445 CID	1C3Z-6200-AARM			
Engine Connecting Rod; V8 445 CID (F)	1C3Z-6200-AARM			
Fuel Injector Kit; V8 445 CID (F); #1 Thru #7	5C3Z-9VE527-BRM			
Fuel Injector Kit; V8 445 CID (F); #8	5C3Z-9VE527-AARM			
Fuel Injector Kit; V8 445 CID; #1 Thru #7	5C3Z-9VE527-BRM			
Fuel Injector Kit; V8 445 CID; #8	5C3Z-9VE527-AARM			
Turbocharger Mounting Kit; Turbocharged; V8 445 CID	F81Z-6N639-CARM			
Turbocharger Mounting Kit; Turbocharged; V8 445 CID	PTC-6RM			
Turbocharger Mounting Kit; Turbocharged; V8 445 CID (F)	F81Z-6N639-CARM			
Turbocharger Mounting Kit; Turbocharged; V8 445 CID (F)	PTC-6RM			
Turbocharger; V8 445 CID (F); w/ EBP Valve	F81Z-6K682-BARM			
Turbocharger; V8 445 CID (F); w/ EBP w/ Engine Serial # 896812-Current	TC-12RM			
Turbocharger; V8 445 CID (F); w/o EBP Valve	F81Z-6K682-CARM			
Turbocharger; V8 445 CID (F); w/o EBP Valve	TC-5RM			

**DIESEL ENGINES**  
**Light / Medium Trucks**  
**Ford**



**FORD PARTS**

**F-Series**

**-Cont'd**

Part Type	Years	Engine	Qualifier	Ford #
Reman	2003	7.3L DIESEL OHV	Turbocharger; V8 445 CID; w/ EBP Valve	F81Z-6K682-BARM
			Turbocharger; V8 445 CID; w/ EBP w/ Engine Serial # 896812-Current	TC-12RM
			Turbocharger; V8 445 CID; w/o EBP Valve	F81Z-6K682-CARM
		6.0L DIESEL OHV	Turbocharger; V8 445 CID; w/o EBP Valve	TC-5RM
			Engine Assembly (Complete); w/ Automatic Trans.; V8 363 CID	3C3Z-6007-AARM
			Engine Assembly (Complete); w/ Standard Trans.; V8 363 CID	3C3Z-6007-BARM
	2002	7.3L DIESEL OHV	Engine Assembly (Less Accessories); w/ Automatic Trans.; V8 363 CID	3C3Z-6006-AARM
			Engine Assembly (Less Accessories); w/ Standard Trans.; V8 363 CID	3C3Z-6006-BARM
			Engine Assembly (Complete); w/ Automatic Trans.; V8 445 CID (F); Exc. California; w/ Eng Tags BE-002-A*	XC3Z-6007-CARM
		7.3L DIESEL OHV	Engine Assembly (Complete); w/ Standard Trans.; V8 445 CID (F); w/ Eng Tags BE-001-AB/AC	XC3Z-6007-CARM
			Engine Assembly (Complete); w/ Standard Trans.; V8 445 CID; w/ Eng Tags BE-001-AB/AC	XC3Z-6V012-BARM
			Engine Assembly (Longblock); V8 445 CID (F)	XC3Z-6V012-BARM
Reman	2001	7.3L DIESEL OHV	Clutch Kit; w/ Standard Trans.; V8 445 CID (F); M6HD	YC3Z-7L596-AA
			Clutch Kit; w/ Standard Trans.; V8 445 CID; M6HD	YC3Z-7L596-AA
			Diesel High Pressure Oil Pump; V8 445 CID	F81Z-9A543-CRM
			Diesel High Pressure Oil Pump; V8 445 CID	HPP-9RM
			Diesel High Pressure Oil Pump; V8 445 CID (F)	F81Z-9A543-CRM
			Diesel High Pressure Oil Pump; V8 445 CID (F)	HPP-9RM
			Engine Connecting Rod; V8 445 CID	1C3Z-6200-AARM
			Engine Connecting Rod; V8 445 CID (F)	1C3Z-6200-AARM
			Fuel Injector Kit; V8 445 CID (F); #1 Thru #7	5C3Z-9VE527-BRM
			Fuel Injector Kit; V8 445 CID; #1 Thru #7	5C3Z-9VE527-BRM
			Turbocharger Mounting Kit; Turbocharged; V8 445 CID	F81Z-6N639-CARM
			Turbocharger Mounting Kit; Turbocharged; V8 445 CID	PTC-6RM
Turbocharger Mounting Kit; Turbocharged; V8 445 CID (F)	F81Z-6N639-CARM			
Turbocharger Mounting Kit; Turbocharged; V8 445 CID (F)	PTC-6RM			
Turbocharger; V8 445 CID (F); w/ EBP Valve	F81Z-6K682-BARM			
Turbocharger; V8 445 CID (F); w/ EBP w/ Engine Serial # 896812-Current	TC-12RM			
Turbocharger; V8 445 CID (F); w/o EBP Valve	F81Z-6K682-CARM			
Turbocharger; V8 445 CID (F); w/o EBP Valve	TC-5RM			
Turbocharger; V8 445 CID; w/ EBP Valve	F81Z-6K682-BARM			
Turbocharger; V8 445 CID; w/ EBP w/ Engine Serial # 896812-Current	TC-12RM			
Turbocharger; V8 445 CID; w/o EBP Valve	F81Z-6K682-CARM			
Turbocharger; V8 445 CID; w/o EBP Valve	TC-5RM			
Engine Assembly (Complete); w/ Automatic Trans.; V8 445 CID (F); Exc. California; w/ Eng Tags BE-002-A*, CE-002-AA/AB	XC3Z-6007-CARM			
Engine Assembly (Complete); w/ Standard Trans.; V8 445 CID (F); w/ Eng Tags BE-001-AB/AC	XC3Z-6007-CARM			
Engine Assembly (Complete); w/ Standard Trans.; V8 445 CID; w/ Eng Tags BE-001-AB/AC	XC3Z-6V012-BARM			
Engine Assembly (Longblock); V8 445 CID	XC3Z-6V012-BARM			
Engine Assembly (Longblock); V8 445 CID (F)	YC3Z-7L596-AA			
Clutch Kit; w/ Standard Trans.; V8 445 CID (F); M6HD	YC3Z-7L596-AA			
Clutch Kit; w/ Standard Trans.; V8 445 CID; M6HD	F81Z-9A543-CRM			
Diesel High Pressure Oil Pump; V8 445 CID	HPP-9RM			
Diesel High Pressure Oil Pump; V8 445 CID (F)	F81Z-9A543-CRM			
Diesel High Pressure Oil Pump; V8 445 CID (F)	HPP-9RM			
Engine Connecting Rod; V8 445 CID	1C3Z-6200-AARM			
Engine Connecting Rod; V8 445 CID (F)	1C3Z-6200-AARM			
Fuel Injector Kit; V8 445 CID (F); #1 Thru #7	5C3Z-9VE527-BRM			
Fuel Injector Kit; V8 445 CID (F); #8	5C3Z-9VE527-BRM			
Fuel Injector Kit; V8 445 CID; #1 Thru #7	5C3Z-9VE527-BRM			
Fuel Injector Kit; V8 445 CID; #8	5C3Z-9VE527-BRM			
Turbocharger Mounting Kit; Turbocharged; V8 445 CID	F81Z-6N639-CARM			
Turbocharger Mounting Kit; Turbocharged; V8 445 CID	PTC-6RM			
Turbocharger Mounting Kit; Turbocharged; V8 445 CID (F)	F81Z-6N639-CARM			
Turbocharger Mounting Kit; Turbocharged; V8 445 CID (F)	PTC-6RM			
Turbocharger; V8 445 CID (F); w/ EBP Valve	F81Z-6K682-BARM			
Turbocharger; V8 445 CID (F); w/ EBP w/ Engine Serial # 896812-Current	TC-12RM			
Turbocharger; V8 445 CID (F); w/o EBP Valve	F81Z-6K682-CARM			
Turbocharger; V8 445 CID (F); w/o EBP Valve	TC-5RM			
Turbocharger; V8 445 CID; w/ EBP Valve	F81Z-6K682-BARM			
Turbocharger; V8 445 CID; w/ EBP w/ Engine Serial # 896812-Current	TC-12RM			
Turbocharger; V8 445 CID; w/o EBP Valve	F81Z-6K682-CARM			
Turbocharger; V8 445 CID; w/o EBP Valve	TC-5RM			
Engine Assembly (Complete); V8 445 CID	XC3Z-6007-CARM			
Engine Assembly (Complete); V8 445 CID (F)	XC3Z-6007-CARM			
Engine Assembly (Less Accessories); V8 445 CID	XC3Z-6006-AARM			
Engine Assembly (Less Accessories); V8 445 CID (F)	XC3Z-6006-AARM			
Engine Assembly (Longblock); V8 445 CID	XC3Z-6V012-BARM			
Engine Assembly (Longblock); V8 445 CID (F)	XC3Z-6V012-BARM			
Clutch Kit; w/ Standard Trans.; V8 445 CID (F); M6HD	YC3Z-7L596-AA			
Clutch Kit; w/ Standard Trans.; V8 445 CID; M6HD	YC3Z-7L596-AA			
Diesel High Pressure Oil Pump; V8 445 CID	F81Z-9A543-CRM			
Diesel High Pressure Oil Pump; V8 445 CID	HPP-9RM			
Diesel High Pressure Oil Pump; V8 445 CID (F)	F81Z-9A543-CRM			
Diesel High Pressure Oil Pump; V8 445 CID (F)	HPP-9RM			
Fuel Injector Kit; V8 445 CID (F); #1 Thru #7	5C3Z-9VE527-BRM			
Fuel Injector Kit; V8 445 CID (F); #8	5C3Z-9VE527-BRM			
Fuel Injector Kit; V8 445 CID; #1 Thru #7	5C3Z-9VE527-BRM			
Fuel Injector Kit; V8 445 CID; #8	5C3Z-9VE527-BRM			



F-Series

-Cont'd

Part Type	Years	Engine	Qualifier	Ford #	
Reman	2000	7.3L DIESEL OHV	Fuel Injector Kit; V8 445 CID; #8	5C3Z-9VE527-ARM	
			Turbocharger Mounting Kit; Turbocharged; V8 445 CID (F); w/ EBP Valve w/ Engine Serial # 896812-Current	F81Z-6N639-CARM	
			Turbocharger Mounting Kit; Turbocharged; V8 445 CID (F); w/ EBP Valve w/ Engine Serial # 896812-Current	PTC-6RM	
			Turbocharger Mounting Kit; Turbocharged; V8 445 CID; w/ EBP Valve w/ Engine Serial # 896812-Current	F81Z-6N639-CARM	
			Turbocharger Mounting Kit; Turbocharged; V8 445 CID; w/ EBP Valve w/ Engine Serial # 896812-Current	PTC-6RM	
			Turbocharger; V8 445 CID (F); w/ EBP w/ Engine Serial # 896812-Current	F81Z-6K682-BARM	
			Turbocharger; V8 445 CID (F); w/ EBP w/ Engine Serial # 896812-Current	TC-12RM	
			Turbocharger; V8 445 CID (F); w/o EBP w/ Engine Serial # 896812-Current	F81Z-6K682-CARM	
			Turbocharger; V8 445 CID (F); w/o EBP w/ Engine Serial # 896812-Current	TC-5RM	
			Turbocharger; V8 445 CID; w/ EBP w/ Engine Serial # 896812-Current	F81Z-6K682-BARM	
	1999	7.3L DIESEL OHV	Turbocharger; V8 445 CID; w/ EBP w/ Engine Serial # 896812-Current	TC-12RM	
			Turbocharger; V8 445 CID; w/o EBP w/ Engine Serial # 896812-Current	F81Z-6K682-CARM	
			Turbocharger; V8 445 CID; w/o EBP w/ Engine Serial # 896812-Current	TC-5RM	
			Engine Assembly (Complete); V8 445 CID	XC3Z-6007-CARM	
			Engine Assembly (Complete); V8 445 CID (F)	XC3Z-6007-CARM	
			Engine Assembly (Less Accessories); V8 445 CID	XC3Z-6006-AARM	
			Engine Assembly (Less Accessories); V8 445 CID (F)	XC3Z-6006-AARM	
			Engine Assembly (Longblock); V8 445 CID	XC3Z-6V012-BARM	
			Engine Assembly (Longblock); V8 445 CID (F)	XC3Z-6V012-BARM	
			Clutch Kit; w/ Standard Trans.; V8 445 CID (F); M6HD	YC3Z-7L596-AA	
Reman	1999	7.3L DIESEL OHV	Diesel High Pressure Oil Pump; V8 445 CID (F); From 12/7/98 S/N 896812-Current	F81Z-9A543-CRM	
			Diesel High Pressure Oil Pump; V8 445 CID (F); From 12/7/98 S/N 896812-Current	HPP-9RM	
			Diesel High Pressure Oil Pump; V8 445 CID (F); Kit; S/N 201680-896811	F4TZ-9VA543-BRM	
			Engine Connecting Rod; V8 445 CID (F); w/ Engine Serial # 501-1425746	5C3Z-6V200-CARM	
			Fuel Injector Kit; V8 445 CID (F); #1 Thru #7; w/ Engine S/N 896812-Current	5C3Z-9VE527-BRM	
			Fuel Injector Kit; V8 445 CID (F); Injector w/ Engine Serial # 661496-896811	F61Z-9VE527-BRM	
			Turbocharger Mounting Kit; Turbocharged; V8 445 CID (F); w/ EBP Valve	F81Z-6N639-CARM	
			Turbocharger Mounting Kit; Turbocharged; V8 445 CID (F); w/ EBP Valve	PTC-6RM	
			Turbocharger Mounting Kit; Turbocharged; V8 445 CID (F); w/o EBP Valve w/ Engine Serial # 661974-896811	5C3Z-6V639-BRM	
			Turbocharger Mounting Kit; Turbocharged; V8 445 CID (F); w/o EBP Valve w/ Engine Serial # 896812-Current	F81Z-6N639-DARM	
	Reman	1999	7.3L DIESEL OHV	Turbocharger Mounting Kit; Turbocharged; V8 445 CID (F); w/o EBP Valve w/ Engine Serial # 896812-Current	PTC-7RM
				Turbocharger; V8 445 CID (F); Engine Build Before 12/6/98	5C3Z-6V682-ARM
				Turbocharger; V8 445 CID (F); w/ EBP w/ Engine Serial # 896812-Current	F81Z-6K682-BARM
				Turbocharger; V8 445 CID (F); w/ EBP w/ Engine Serial # 896812-Current	TC-12RM
				Turbocharger; V8 445 CID (F); w/o EBP w/ Engine Serial # 896812-Current	F81Z-6K682-CARM
				Turbocharger; V8 445 CID (F); w/o EBP w/ Engine Serial # 896812-Current	TC-5RM
				Engine Assembly (Complete); V8 445 CID (F); Before 12/7/98; w/ EBP Valve; w/ Engine Serial # 661974-896811	5C3Z-6V007-BRM
				Engine Assembly (Complete); V8 445 CID (F); Before 12/7/98; w/ Engine Serial # 661974-896811; 5C3Z-6V007-CRM	
				Engine Assembly (Complete); V8 445 CID (F); w/o EBP Valve	XC3Z-6007-BARM
				Engine Assembly (Less Accessories) Before 12/07/98; V8 445 CID (F); w/ Engine Serial No. 661974-896811	5C3Z-6V006-CRM
Reman	1999	7.3L DIESEL OHV	Engine Assembly (Less Accessories); V8 445 CID (F)	XC3Z-6006-AARM	
			Engine Assembly (Longblock); V8 445 CID (F); Before 12/07/98	F81Z-6V012-CARM	
			Engine Assembly (Longblock); V8 445 CID (F); From 12/07/98	XC3Z-6V012-BARM	

F650

Part Type	Years	Engine	Qualifier	Ford #	
Reman	2015	6.7L DIESEL OHV	Diesel High Pressure Oil Pump; L6 408 CID (C) ISB 200; 5C40-9A543-BA	5C4Z-9A543-ERM	
			Diesel High Pressure Oil Pump; L6 408 CID (C) ISB 200; 5C40-9A543-BA	HPP-5RM	
			Turbocharger; 4 X 2; L6 408 CID (C) ISB 200; 5C40-9T428-AC	5C4Z-6K682-BRM	
			Turbocharger; 4 X 2; L6 408 CID (C) ISB 200; 5C40-9T428-AC	TC-9RM	
	2013	6.7L DIESEL OHV	6.7L DIESEL OHV	Turbocharger; L6 408 CID (C) ISB 200; 4C40-9T428-DC	4C4Z-6K682-ARM
				Turbocharger; L6 408 CID (C) ISB 200; 4C40-9T428-DC	TC-6RM
				Diesel High Pressure Oil Pump; L6 408 CID (C) ISB 200; 5C40-9A543-BA	5C4Z-9A543-ERM
				Diesel High Pressure Oil Pump; L6 408 CID (C) ISB 200; 5C40-9A543-BA	HPP-5RM
	2012	6.7L DIESEL OHV	6.7L DIESEL OHV	Turbocharger; 4 X 2; L6 408 CID (C) ISB 200; 5C40-9T428-AC	5C4Z-6K682-BRM
				Turbocharger; 4 X 2; L6 408 CID (C) ISB 200; 5C40-9T428-AC	TC-9RM
				Turbocharger; L6 408 CID (C) ISB 200; 4C40-9T428-DC	4C4Z-6K682-ARM
				Turbocharger; L6 408 CID (C) ISB 200; 4C40-9T428-DC	TC-6RM
2011	6.7L DIESEL OHV	6.7L DIESEL OHV	Diesel High Pressure Oil Pump; L6 408 CID (C) ISB 200; 5C40-9A543-BA	5C4Z-9A543-ERM	
			Diesel High Pressure Oil Pump; L6 408 CID (C) ISB 200; 5C40-9A543-BA	HPP-5RM	
			Turbocharger; 4 X 2; L6 408 CID (C) ISB 200; 5C40-9T428-AC	5C4Z-6K682-BRM	
			Turbocharger; 4 X 2; L6 408 CID (C) ISB 200; 5C40-9T428-AC	TC-9RM	
Reman	2011	6.7L DIESEL OHV	Turbocharger; L6 408 CID (C) ISB 200; 4C40-9T428-DC	4C4Z-6K682-ARM	
			Turbocharger; L6 408 CID (C) ISB 200; 4C40-9T428-DC	TC-6RM	
			Diesel High Pressure Oil Pump; L6 408 CID (C) ISB 200; 5C40-9A543-BA	5C4Z-9A543-ERM	
			Diesel High Pressure Oil Pump; L6 408 CID (C) ISB 200; 5C40-9A543-BA	HPP-5RM	

**DIESEL ENGINES**  
**Light / Medium Trucks**  
**Ford**



**FORD PARTS**

**F650**

**-Cont'd**

Part Type	Years	Engine	Qualifier	Ford #
	2011	6.7L DIESEL OHV	Turbocharger; L6 408 CID (C) ISB 200; 4C40-9T428-DC	TC-6RM
	2010	6.7L DIESEL OHV	Diesel High Pressure Oil Pump; L6 408 CID (C) ISB 200; 5C40-9A543-BA Diesel High Pressure Oil Pump; L6 408 CID (C) ISB 200; 5C40-9A543-BA Turbocharger; 4 X 2; L6 408 CID (C) ISB 200; 5C40-9T428-AC Turbocharger; 4 X 2; L6 408 CID (C) ISB 200; 5C40-9T428-AC Turbocharger; L6 408 CID (C) ISB 200; 4C40-9T428-DC Turbocharger; L6 408 CID (C) ISB 200; 4C40-9T428-DC	TC-6RM 5C4Z-9A543-ERM HPP-5RM 5C4Z-6K682-BRM TC-9RM 4C4Z-6K682-ARM TC-6RM
		7.2L DIESEL	Turbocharger; 4 X 2; L6 441 CID; 5C40-9T428-AC Turbocharger; 4 X 2; L6 441 CID; 5C40-9T428-AC	5C4Z-6K682-BRM TC-9RM
	2009	6.7L DIESEL OHV	Diesel High Pressure Oil Pump; L6 408 CID (C) ISB 200; 5C40-9A543-BA Diesel High Pressure Oil Pump; L6 408 CID (C) ISB 200; 5C40-9A543-BA Turbocharger; 4 X 2; L6 408 CID (C) ISB 200; 5C40-9T428-AC Turbocharger; 4 X 2; L6 408 CID (C) ISB 200; 5C40-9T428-AC Turbocharger; L6 408 CID (C) ISB 200; 4C40-9T428-DC Turbocharger; L6 408 CID (C) ISB 200; 4C40-9T428-DC Turbocharger; L6 408 CID (C) ISB 200; Dual Stage Turbocharger; L6 408 CID (C) ISB 200; Dual Stage	5C4Z-9A543-ERM HPP-5RM 5C4Z-6K682-BRM TC-9RM 4C4Z-6K682-ARM TC-6RM 8E7Z-6K682-A TC-7RM
		7.2L DIESEL	Turbocharger; 4 X 2; L6 441 CID; 5C40-9T428-AC Turbocharger; 4 X 2; L6 441 CID; 5C40-9T428-AC Turbocharger; L6 441 CID; Dual Stage Turbocharger; L6 441 CID; Dual Stage	5C4Z-6K682-BRM TC-9RM 8E7Z-6K682-A TC-7RM
	2008	5.9L DIESEL	Turbocharger; 4 X 2; L6 359 CID; 5C40-9T428-AC Turbocharger; 4 X 2; L6 359 CID; 5C40-9T428-AC Turbocharger; L6 359 CID; Dual Stage Turbocharger; L6 359 CID; Dual Stage	5C4Z-6K682-BRM TC-9RM 8E7Z-6K682-A TC-7RM
		6.0L DIESEL	Diesel High Pressure Oil Pump; V8 365 CID; 5C40-9A543-BA Diesel High Pressure Oil Pump; V8 365 CID; 5C40-9A543-BA Turbocharger; 4 X 2; V8 365 CID; 5C40-9T428-AC Turbocharger; 4 X 2; V8 365 CID; 5C40-9T428-AC Turbocharger; V8 365 CID; 4C40-9T428-DC Turbocharger; V8 365 CID; 4C40-9T428-DC Turbocharger; V8 365 CID; Dual Stage Turbocharger; V8 365 CID; Dual Stage	5C4Z-9A543-ERM HPP-5RM 5C4Z-6K682-BRM TC-9RM 4C4Z-6K682-ARM TC-6RM 8E7Z-6K682-A TC-7RM
		6.7L DIESEL OHV	Diesel High Pressure Oil Pump; L6 408 CID (C) ISB 200; 5C40-9A543-BA Diesel High Pressure Oil Pump; L6 408 CID (C) ISB 200; 5C40-9A543-BA Turbocharger; 4 X 2; L6 408 CID (C) ISB 200; 5C40-9T428-AC Turbocharger; 4 X 2; L6 408 CID (C) ISB 200; 5C40-9T428-AC Turbocharger; L6 408 CID (C) ISB 200; 4C40-9T428-DC Turbocharger; L6 408 CID (C) ISB 200; 4C40-9T428-DC Turbocharger; L6 408 CID (C) ISB 200; Dual Stage Turbocharger; L6 408 CID (C) ISB 200; Dual Stage	5C4Z-9A543-ERM HPP-5RM 5C4Z-6K682-BRM TC-9RM 4C4Z-6K682-ARM TC-6RM 8E7Z-6K682-A TC-7RM
		7.2L DIESEL	Turbocharger; 4 X 2; L6 441 CID; 5C40-9T428-AC Turbocharger; 4 X 2; L6 441 CID; 5C40-9T428-AC Turbocharger; L6 441 CID; Dual Stage Turbocharger; L6 441 CID; Dual Stage	5C4Z-6K682-BRM TC-9RM 8E7Z-6K682-A TC-7RM
	2007	5.9L DIESEL	Turbocharger; 4 X 2; L6 359 CID; 5C40-9T428-AC Turbocharger; 4 X 2; L6 359 CID; 5C40-9T428-AC	5C4Z-6K682-BRM TC-9RM
		6.0L DIESEL	Diesel Fuel Injector Nozzle; V8 365 CID Diesel High Pressure Oil Pump; V8 365 CID; 5C40-9A543-BA Diesel High Pressure Oil Pump; V8 365 CID; 5C40-9A543-BA Engine Short Block; V8 365 CID; Assembly; From Engine Serial # 299,093 and Up Turbocharger; 4 X 2; V8 365 CID; 5C40-9T428-AC Turbocharger; 4 X 2; V8 365 CID; 5C40-9T428-AC Turbocharger; V8 365 CID; 4C40-9T428-DC Turbocharger; V8 365 CID; 4C40-9T428-DC	4C3Z-9E527-BRM 5C4Z-9A543-ERM HPP-5RM 7C4Z-6009-AARM 5C4Z-6K682-BRM TC-9RM 4C4Z-6K682-ARM TC-6RM
		7.2L DIESEL	Turbocharger; 4 X 2; L6 441 CID; 5C40-9T428-AC Turbocharger; 4 X 2; L6 441 CID; 5C40-9T428-AC	5C4Z-6K682-BRM TC-9RM
Reman		5.9L DIESEL	Engine Assembly (Complete); L6 359 CID; 5C40-6007-GB Engine Assembly (Less Accessories); L6 359 CID; w/ Air Brakes	5C4Z-6007-JRM 5C4Z-6006-ERM
		6.0L DIESEL	Engine Assembly (Complete); V8 365 CID; w/ Hydraulic Brakes; S/N 299,093 to 414,752 Engine Assembly (Complete); V8 365 CID; 5C40-6007-GB Engine Assembly (Complete); V8 365 CID; w/ Air Brakes; S/N 299, 093 to 414, 752 Engine Assembly (Complete); V8 365 CID; w/ Hydraulic Brakes; Before Engine Assembly 299,0935C4Z-6007-JRM	5C4Z-6006-ERM 5C4Z-6007-JRM 5C4Z-6006-ERM
		7.2L DIESEL	Engine Assembly (Complete); L6 441 CID; 5C40-6007-GB Engine Assembly (Less Accessories); L6 441 CID; w/ Air Brakes	5C4Z-6007-JRM 5C4Z-6006-ERM
		5.9L DIESEL	Engine Assembly (Less Accessories); L6 441 CID; w/ Hydraulic Brakes; S/N 299,093 to 414,752 Turbocharger; 4 X 2; L6 359 CID; 5C40-9T428-AC	5C4Z-6006-ERM 5C4Z-6K682-BRM
	2006	6.0L DIESEL	Turbocharger; 4 X 2; L6 359 CID; 5C40-9T428-AC Diesel Fuel Injector Nozzle; V8 365 CID Diesel High Pressure Oil Pump; V8 365 CID; 5C40-9A543-BA Diesel High Pressure Oil Pump; V8 365 CID; 5C40-9A543-BA Engine Short Block; V8 365 CID; Assembly; From Engine Serial # 299,093 and Up Engine Short Block; V8 365 CID; w/ Engine Serial # 1 to 137,744 Turbocharger; 4 X 2; V8 365 CID; 5C40-9T428-AC Turbocharger; 4 X 2; V8 365 CID; 5C40-9T428-AC Turbocharger; V8 365 CID; 4C40-9T428-DC Turbocharger; V8 365 CID; 4C40-9T428-DC	TC-9RM 4C3Z-9E527-BRM 5C4Z-9A543-ERM HPP-5RM 7C4Z-6009-AARM 4C4Z-6009-AARM 5C4Z-6K682-BRM TC-9RM 4C4Z-6K682-ARM TC-6RM
		7.2L DIESEL	Turbocharger; 4 X 2; L6 441 CID; 5C40-9T428-AC	5C4Z-6K682-BRM





F650

-Cont'd

Part Type	Years	Engine	Qualifier	Ford #		
Reman	2006	7.2L DIESEL	Turbocharger; 4 X 2; L6 441 CID; 5C4O-9T428-AC	TC-9RM		
		5.9L DIESEL	Engine Assembly (Complete); L6 359 CID; 5C4O-6007-GB	5C4Z-6007-JRM		
			Engine Assembly (Less Accessories); L6 359 CID; w/ Air Brakes	5C4Z-6006-ERM		
		6.0L DIESEL	Engine Assembly (Less Accessories); L6 359 CID; w/ Hydraulic Brakes; S/N 299,093 to 414,752	5C4Z-6006-ERM		
			Engine Assembly (Complete); FI; V8 365 CID; w/ Hydraulic Brakes; w/ Engine Serial # 187,025 To 299,092	5C4Z-6007-JRM		
			Engine Assembly (Complete); V8 365 CID; 5C4O-6007-GB	5C4Z-6007-JRM		
			Engine Assembly (Complete); V8 365 CID; w/ Air Brakes; S/N 299, 093 to 414, 752	5C4Z-6007-JRM		
			Engine Assembly (Complete); V8 365 CID; w/ Hydraulic Brakes; Before Engine Assembly 299,093	5C4Z-6007-JRM		
			Engine Assembly (Less Accessories); V8 365 CID; w/ Air Brakes	5C4Z-6006-ERM		
			Engine Assembly (Less Accessories); V8 365 CID; w/ Hydraulic Brakes; S/N 299,093 to 414,752	5C4Z-6006-ERM		
	2005	5.9L DIESEL	Turbocharger; 4 X 2; L6 359 CID; 5C4O-9T428-AC	5C4Z-6K682-BRM		
6.0L DIESEL		Turbocharger; 4 X 2; L6 359 CID; 5C4O-9T428-AC	TC-9RM			
		Diesel Fuel Injector Nozzle; V8 365 CID	4C3Z-9E527-BRM			
		Diesel High Pressure Oil Pump; V8 365 CID; 5C4O-9A543-BA	5C4Z-9A543-ERM			
		Diesel High Pressure Oil Pump; V8 365 CID; 5C4O-9A543-BA	HPP-5RM			
		Engine Short Block; V8 365 CID; w/ Engine Serial # 1 to 137,744	4C4Z-6009-AARM			
		Turbocharger; 4 X 2; V8 365 CID; 5C4O-9T428-AC	5C4Z-6K682-BRM			
		Turbocharger; 4 X 2; V8 365 CID; 5C4O-9T428-AC	TC-9RM			
		Turbocharger; V8 365 CID; 4C4O-9T428-DC	4C4Z-6K682-ARM			
		Turbocharger; V8 365 CID; 4C4O-9T428-DC	TC-6RM			
	7.2L DIESEL	Turbocharger; 4 X 2; L6 441 CID; 5C4O-9T428-AC	5C4Z-6K682-BRM			
		Turbocharger; 4 X 2; L6 441 CID; 5C4O-9T428-AC	TC-9RM			
Reman		5.9L DIESEL	Engine Assembly (Complete); L6 359 CID; 5C4O-6007-GB	5C4Z-6007-JRM		
		6.0L DIESEL	Engine Assembly (Complete); FI; V8 365 CID; w/ Hydraulic Brakes; w/ Engine Serial # 187,025 To 299,092	5C4Z-6007-JRM		
			Engine Assembly (Complete); V8 365 CID; 5C4O-6007-GB	5C4Z-6007-JRM		
			Engine Assembly (Complete); L6 441 CID; 5C4O-6007-GB	5C4Z-6007-JRM		
		7.2L DIESEL	Engine Short Block; V8 365 CID; w/ Engine Serial # 1 to 137,744	4C4Z-6009-AARM		
		6.0L DIESEL	Turbocharger; V8 365 CID; 4C4O-9T428-DC	4C4Z-6K682-ARM		
			Turbocharger; V8 365 CID; 4C4O-9T428-DC	TC-6RM		
			Turbocharger; V8 365 CID; w/ EBP Valve	3C3Z-6K682-CCRM		
			Turbocharger; V8 365 CID; w/ EBP Valve	TC-13RM		
			Turbocharger; V8 365 CID; w/ EBP w/ Engine Serial # 896812-Current	TC-12RM		
Reman			Engine Assembly (Complete); FI; V8 365 CID; w/ Hydraulic Brakes; w/ Engine Serial # 137,745 To 187,024	5C4Z-6007-JRM		
			Engine Assembly (Complete); V8 365 CID; w/ Engine Serial # 1 to 137,744	4C4Z-6007-BRM		
			Engine Assembly (Less Accessories); V8 365 CID; w/ Engine Serial # 1 to 137,744	4C4Z-6006-DRM		
		2003	7.3L DIESEL	Turbocharger; V8 444 CID T444E; w/ EBP Valve	3C3Z-6K682-CCRM	
			Turbocharger; V8 444 CID T444E; w/ EBP Valve	TC-13RM		
			Turbocharger; V8 444 CID T444E; w/ EBP w/ Engine Serial # 896812-Current	TC-12RM		
	Reman			Engine Assembly (Complete); FI; V8 444 CID T444E; w/ Engine Serial # 1,026,248 To End	1C3Z-6007-HARM	
				V8 444 CID T444E; w/ Engine Serial # 1,026,248 To End	1C3Z-6006-DARM	
			2002	7.3L DIESEL	Engine Assembly (Complete); FI; V8 444 CID T444E; w/ Engine Serial # 1,026,248 To End	1C3Z-6007-HARM
				V8 444 CID T444E; w/ Engine Serial # 1,026,248 To End	1C3Z-6006-DARM	
		2001	7.3L DIESEL	Engine Assembly (Complete); FI; V8 444 CID T444E; w/ Engine Serial # 1,026,248 To End	1C3Z-6007-HARM	
			V8 444 CID T444E; w/ Engine Serial # 1,026,248 To End	1C3Z-6006-DARM		
		2000	7.3L DIESEL	Engine Assembly (Complete); FI; V8 444 CID T444E; w/ Engine Serial # 1,026,248 To End	1C3Z-6007-HARM	
			V8 444 CID T444E; w/ Engine Serial # 1,026,248 To End	1C3Z-6006-DARM		

F750

Part Type	Years	Engine	Qualifier	Ford #	
	2015	6.7L DIESEL OHV	Diesel High Pressure Oil Pump; L6 408 CID (C) ISB 200; 5C4O-9A543-BA	5C4Z-9A543-ERM	
			Diesel High Pressure Oil Pump; L6 408 CID (C) ISB 200; 5C4O-9A543-BA	HPP-5RM	
			Turbocharger; 4 X 2; L6 408 CID (C) ISB 200; 5C4O-9T428-AC	5C4Z-6K682-BRM	
			Turbocharger; 4 X 2; L6 408 CID (C) ISB 200; 5C4O-9T428-AC	TC-9RM	
			Turbocharger; L6 408 CID (C) ISB 200; 4C4O-9T428-DC	4C4Z-6K682-ARM	
				Turbocharger; L6 408 CID (C) ISB 200; 4C4O-9T428-DC	TC-6RM
		2013	6.7L DIESEL OHV	Diesel High Pressure Oil Pump; L6 408 CID (C) ISB 200; 5C4O-9A543-BA	5C4Z-9A543-ERM
	Diesel High Pressure Oil Pump; L6 408 CID (C) ISB 200; 5C4O-9A543-BA			HPP-5RM	
	Turbocharger; 4 X 2; L6 408 CID (C) ISB 200; 5C4O-9T428-AC			5C4Z-6K682-BRM	
	Turbocharger; 4 X 2; L6 408 CID (C) ISB 200; 5C4O-9T428-AC			TC-9RM	
Turbocharger; L6 408 CID (C) ISB 200; 4C4O-9T428-DC	4C4Z-6K682-ARM				
			Turbocharger; L6 408 CID (C) ISB 200; 4C4O-9T428-DC	TC-6RM	
	2012	6.7L DIESEL OHV	Diesel High Pressure Oil Pump; L6 408 CID (C) ISB 200; 5C4O-9A543-BA	5C4Z-9A543-ERM	
Diesel High Pressure Oil Pump; L6 408 CID (C) ISB 200; 5C4O-9A543-BA			HPP-5RM		
Turbocharger; 4 X 2; L6 408 CID (C) ISB 200; 5C4O-9T428-AC			5C4Z-6K682-BRM		
Turbocharger; 4 X 2; L6 408 CID (C) ISB 200; 5C4O-9T428-AC			TC-9RM		
Turbocharger; L6 408 CID (C) ISB 200; 4C4O-9T428-DC			4C4Z-6K682-ARM		
			Turbocharger; L6 408 CID (C) ISB 200; 4C4O-9T428-DC	TC-6RM	
	2011	6.7L DIESEL OHV	Diesel High Pressure Oil Pump; L6 408 CID (C) ISB 200; 5C4O-9A543-BA	5C4Z-9A543-ERM	
Diesel High Pressure Oil Pump; L6 408 CID (C) ISB 200; 5C4O-9A543-BA			HPP-5RM		
Turbocharger; 4 X 2; L6 408 CID (C) ISB 200; 5C4O-9T428-AC			5C4Z-6K682-BRM		
Turbocharger; 4 X 2; L6 408 CID (C) ISB 200; 5C4O-9T428-AC			TC-9RM		
Turbocharger; L6 408 CID (C) ISB 200; 4C4O-9T428-DC			4C4Z-6K682-ARM		

**DIESEL ENGINES**  
**Light / Medium Trucks**  
**Ford**



**FORD PARTS**

**F750**

**-Cont'd**

Part Type	Years	Engine	Qualifier	Ford #
	2011	6.7L DIESEL OHV	Turbocharger; L6 408 CID (C) ISB 200; 4C40-9T428-DC	TC-6RM
	2010	6.7L DIESEL OHV	Diesel High Pressure Oil Pump; L6 408 CID (C) ISB 200; 5C40-9A543-BA Diesel High Pressure Oil Pump; L6 408 CID (C) ISB 200; 5C40-9A543-BA Turbocharger; 4 X 2; L6 408 CID (C) ISB 200; 5C40-9T428-AC Turbocharger; 4 X 2; L6 408 CID (C) ISB 200; 5C40-9T428-AC Turbocharger; L6 408 CID (C) ISB 200; 4C40-9T428-DC Turbocharger; L6 408 CID (C) ISB 200; 4C40-9T428-DC	5C4Z-9A543-ERM HPP-5RM 5C4Z-6K682-BRM TC-9RM 4C4Z-6K682-ARM TC-6RM
		7.2L DIESEL	Turbocharger; 4 X 2; L6 441 CID; 5C40-9T428-AC Turbocharger; 4 X 2; L6 441 CID; 5C40-9T428-AC	5C4Z-6K682-BRM TC-9RM
	2009	6.7L DIESEL OHV	Diesel High Pressure Oil Pump; L6 408 CID (C) ISB 200; 5C40-9A543-BA Diesel High Pressure Oil Pump; L6 408 CID (C) ISB 200; 5C40-9A543-BA Turbocharger; 4 X 2; L6 408 CID (C) ISB 200; 5C40-9T428-AC Turbocharger; 4 X 2; L6 408 CID (C) ISB 200; 5C40-9T428-AC Turbocharger; L6 408 CID (C) ISB 200; 4C40-9T428-DC Turbocharger; L6 408 CID (C) ISB 200; 4C40-9T428-DC Turbocharger; L6 408 CID (C) ISB 200; Dual Stage Turbocharger; L6 408 CID (C) ISB 200; Dual Stage	5C4Z-9A543-ERM HPP-5RM 5C4Z-6K682-BRM TC-9RM 4C4Z-6K682-ARM TC-6RM 8E7Z-6K682-A TC-7RM
		7.2L DIESEL	Turbocharger; 4 X 2; L6 441 CID; 5C40-9T428-AC Turbocharger; 4 X 2; L6 441 CID; 5C40-9T428-AC Turbocharger; L6 441 CID; Dual Stage Turbocharger; L6 441 CID; Dual Stage	5C4Z-6K682-BRM TC-9RM 8E7Z-6K682-A TC-7RM
	2008	5.9L DIESEL	Turbocharger; 4 X 2; L6 359 CID; 5C40-9T428-AC Turbocharger; 4 X 2; L6 359 CID; 5C40-9T428-AC Turbocharger; L6 359 CID; Dual Stage Turbocharger; L6 359 CID; Dual Stage	5C4Z-6K682-BRM TC-9RM 8E7Z-6K682-A TC-7RM
		6.0L DIESEL	Diesel High Pressure Oil Pump; V8 365 CID; 5C40-9A543-BA Diesel High Pressure Oil Pump; V8 365 CID; 5C40-9A543-BA Turbocharger; 4 X 2; V8 365 CID; 5C40-9T428-AC Turbocharger; 4 X 2; V8 365 CID; 5C40-9T428-AC Turbocharger; V8 365 CID; 4C40-9T428-DC Turbocharger; V8 365 CID; 4C40-9T428-DC Turbocharger; V8 365 CID; Dual Stage Turbocharger; V8 365 CID; Dual Stage	5C4Z-9A543-ERM HPP-5RM 5C4Z-6K682-BRM TC-9RM 4C4Z-6K682-ARM TC-6RM 8E7Z-6K682-A TC-7RM
		6.7L DIESEL OHV	Diesel High Pressure Oil Pump; L6 408 CID (C) ISB 200; 5C40-9A543-BA Diesel High Pressure Oil Pump; L6 408 CID (C) ISB 200; 5C40-9A543-BA Turbocharger; 4 X 2; L6 408 CID (C) ISB 200; 5C40-9T428-AC Turbocharger; 4 X 2; L6 408 CID (C) ISB 200; 5C40-9T428-AC Turbocharger; L6 408 CID (C) ISB 200; 4C40-9T428-DC Turbocharger; L6 408 CID (C) ISB 200; 4C40-9T428-DC Turbocharger; L6 408 CID (C) ISB 200; Dual Stage Turbocharger; L6 408 CID (C) ISB 200; Dual Stage	5C4Z-9A543-ERM HPP-5RM 5C4Z-6K682-BRM TC-9RM 4C4Z-6K682-ARM TC-6RM 8E7Z-6K682-A TC-7RM
		7.2L DIESEL	Turbocharger; 4 X 2; L6 441 CID; 5C40-9T428-AC Turbocharger; 4 X 2; L6 441 CID; 5C40-9T428-AC Turbocharger; L6 441 CID; Dual Stage Turbocharger; L6 441 CID; Dual Stage	5C4Z-6K682-BRM TC-9RM 8E7Z-6K682-A TC-7RM
	2007	5.9L DIESEL	Turbocharger; 4 X 2; L6 359 CID; 5C40-9T428-AC Turbocharger; 4 X 2; L6 359 CID; 5C40-9T428-AC	5C4Z-6K682-BRM TC-9RM
		6.0L DIESEL	Diesel Fuel Injector Nozzle; V8 365 CID Diesel High Pressure Oil Pump; V8 365 CID; 5C40-9A543-BA Diesel High Pressure Oil Pump; V8 365 CID; 5C40-9A543-BA Engine Short Block; V8 365 CID; Assembly; From Engine Serial # 299,093 and Up Turbocharger; 4 X 2; V8 365 CID; 5C40-9T428-AC Turbocharger; 4 X 2; V8 365 CID; 5C40-9T428-AC Turbocharger; V8 365 CID; 4C40-9T428-DC Turbocharger; V8 365 CID; 4C40-9T428-DC	4C3Z-9E527-BRM 5C4Z-9A543-ERM HPP-5RM 7C4Z-6009-AARM 5C4Z-6K682-BRM TC-9RM 4C4Z-6K682-ARM TC-6RM
		7.2L DIESEL	Turbocharger; 4 X 2; L6 441 CID; 5C40-9T428-AC Turbocharger; 4 X 2; L6 441 CID; 5C40-9T428-AC	5C4Z-6K682-BRM TC-9RM
Reman		5.9L DIESEL	Engine Assembly (Complete); L6 359 CID; 5C40-6007-GB Engine Assembly (Less Accessories); L6 359 CID; w/ Air Brakes	5C4Z-6007-JRM 5C4Z-6006-ERM
		6.0L DIESEL	Engine Assembly (Complete); V8 365 CID; w/ Hydraulic Brakes; S/N 299,093 to 414,752 Engine Assembly (Complete); V8 365 CID; 5C40-6007-GB Engine Assembly (Complete); V8 365 CID; w/ Air Brakes; S/N 299, 093 to 414, 752 Engine Assembly (Complete); V8 365 CID; w/ Hydraulic Brakes; Before Engine Assembly 299,0935C4Z-6007-JRM	5C4Z-6006-ERM 5C4Z-6007-JRM 5C4Z-6006-ERM
		7.2L DIESEL	Engine Assembly (Complete); L6 441 CID; 5C40-6007-GB Engine Assembly (Less Accessories); L6 441 CID; w/ Air Brakes	5C4Z-6007-JRM 5C4Z-6006-ERM
		5.9L DIESEL	Engine Assembly (Less Accessories); L6 441 CID; w/ Hydraulic Brakes; S/N 299,093 to 414,752 Turbocharger; 4 X 2; L6 359 CID; 5C40-9T428-AC	5C4Z-6006-ERM 5C4Z-6K682-BRM TC-9RM
		6.0L DIESEL	Diesel Fuel Injector Nozzle; V8 365 CID Diesel High Pressure Oil Pump; V8 365 CID; 5C40-9A543-BA Diesel High Pressure Oil Pump; V8 365 CID; 5C40-9A543-BA Engine Short Block; V8 365 CID; Assembly; From Engine Serial # 299,093 and Up Engine Short Block; V8 365 CID; w/ Engine Serial # 1 to 137,744 Turbocharger; 4 X 2; V8 365 CID; 5C40-9T428-AC Turbocharger; 4 X 2; V8 365 CID; 5C40-9T428-AC Turbocharger; V8 365 CID; 4C40-9T428-DC Turbocharger; V8 365 CID; 4C40-9T428-DC	4C3Z-9E527-BRM 5C4Z-9A543-ERM HPP-5RM 7C4Z-6009-AARM 4C4Z-6009-AARM 5C4Z-6K682-BRM TC-9RM 4C4Z-6K682-ARM TC-6RM
		7.2L DIESEL	Turbocharger; 4 X 2; L6 441 CID; 5C40-9T428-AC	5C4Z-6K682-BRM



F750

-Cont'd

Part Type	Years	Engine	Qualifier	Ford #
Reman	2006	7.2L DIESEL	Turbocharger; 4 X 2; L6 441 CID; 5C4O-9T428-AC	TC-9RM
		5.9L DIESEL	Engine Assembly (Complete); L6 359 CID; 5C4O-6007-GB	5C4Z-6007-JRM
			Engine Assembly (Less Accessories); L6 359 CID; w/ Air Brakes	5C4Z-6006-ERM
			Engine Assembly (Less Accessories); L6 359 CID; w/ Hydraulic Brakes; S/N 299,093 to 414,752	5C4Z-6006-ERM
		6.0L DIESEL	Engine Assembly (Complete); FI; V8 365 CID; w/ Hydraulic Brakes; w/ Engine Serial # 187,025 To 299,092	5C4Z-6007-JRM
			Engine Assembly (Complete); V8 365 CID; 5C4O-6007-GB	5C4Z-6007-JRM
		Engine Assembly (Complete); V8 365 CID; w/ Air Brakes; S/N 299, 093 to 414, 752	5C4Z-6007-JRM	
		Engine Assembly (Complete); V8 365 CID; w/ Hydraulic Brakes; Before Engine Assembly 299,093	5C4Z-6007-JRM	
		Engine Assembly (Less Accessories); V8 365 CID; w/ Air Brakes	5C4Z-6006-ERM	
		Engine Assembly (Less Accessories); V8 365 CID; w/ Hydraulic Brakes; S/N 299,093 to 414,752	5C4Z-6006-ERM	
		7.2L DIESEL	Engine Assembly (Complete); L6 441 CID; 5C4O-6007-GB	5C4Z-6007-JRM
			Engine Assembly (Less Accessories); L6 441 CID; w/ Air Brakes	5C4Z-6006-ERM
		Engine Assembly (Less Accessories); L6 441 CID; w/ Hydraulic Brakes; S/N 299,093 to 414,752	5C4Z-6006-ERM	
Reman	2005	5.9L DIESEL	Turbocharger; 4 X 2; L6 359 CID; 5C4O-9T428-AC	5C4Z-6K682-BRM
		6.0L DIESEL	Turbocharger; 4 X 2; L6 359 CID; 5C4O-9T428-AC	TC-9RM
			Diesel Fuel Injector Nozzle; V8 365 CID	4C3Z-9E527-BRM
			Diesel High Pressure Oil Pump; V8 365 CID; 5C4O-9A543-BA	5C4Z-9A543-ERM
			Diesel High Pressure Oil Pump; V8 365 CID; 5C4O-9A543-BA	HPP-5RM
			Engine Short Block; V8 365 CID; w/ Engine Serial # 1 to 137,744	4C4Z-6009-AARM
		Turbocharger; 4 X 2; V8 365 CID; 5C4O-9T428-AC	5C4Z-6K682-BRM	
		Turbocharger; 4 X 2; V8 365 CID; 5C4O-9T428-AC	TC-9RM	
		Turbocharger; V8 365 CID; 4C4O-9T428-DC	4C4Z-6K682-ARM	
		7.2L DIESEL	Turbocharger; V8 365 CID; 4C4O-9T428-DC	TC-6RM
			Turbocharger; 4 X 2; L6 441 CID; 5C4O-9T428-AC	5C4Z-6K682-BRM
			Turbocharger; 4 X 2; L6 441 CID; 5C4O-9T428-AC	TC-9RM
Reman	2004	5.9L DIESEL	Engine Assembly (Complete); L6 359 CID; 5C4O-6007-GB	5C4Z-6007-JRM
		6.0L DIESEL	Engine Assembly (Complete); FI; V8 365 CID; w/ Hydraulic Brakes; w/ Engine Serial # 187,025 To 299,092	5C4Z-6007-JRM
			Engine Assembly (Complete); V8 365 CID; 5C4O-6007-GB	5C4Z-6007-JRM
			Engine Assembly (Complete); L6 441 CID; 5C4O-6007-GB	5C4Z-6007-JRM
			Engine Short Block; V8 365 CID; w/ Engine Serial # 1 to 137,744	4C4Z-6009-AARM
			Turbocharger; V8 365 CID; 4C4O-9T428-DC	4C4Z-6K682-ARM
		Turbocharger; V8 365 CID; 4C4O-9T428-DC	TC-6RM	
		Turbocharger; V8 365 CID; w/ EBP Valve	3C3Z-6K682-CCRM	
		Turbocharger; V8 365 CID; w/ EBP Valve	TC-13RM	
		Turbocharger; V8 365 CID; w/ EBP w/ Engine Serial # 896812-Current	TC-12RM	
		Engine Assembly (Complete); FI; V8 365 CID; w/ Hydraulic Brakes; w/ Engine Serial # 137,745 To 187,024	5C4Z-6007-JRM	
	Reman	2003	7.3L DIESEL	Engine Assembly (Complete); V8 365 CID; w/ Engine Serial # 1 to 137,744
			Engine Assembly (Less Accessories); V8 365 CID; w/ Engine Serial # 1 to 137,744	4C4Z-6006-DRM
			Turbocharger; V8 444 CID T444E; w/ EBP Valve	3C3Z-6K682-CCRM
			Turbocharger; V8 444 CID T444E; w/ EBP Valve	TC-13RM
			Turbocharger; V8 444 CID T444E; w/ EBP w/ Engine Serial # 896812-Current	TC-12RM
			Engine Assembly (Complete); FI; V8 444 CID T444E; w/ Engine Serial # 1,026,248 To End	1C3Z-6007-HARM
2002		7.3L DIESEL	V8 444 CID T444E; w/ Engine Serial # 1,026,248 To End	1C3Z-6006-DARM
			Engine Assembly (Complete); FI; V8 444 CID T444E; w/ Engine Serial # 1,026,248 To End	1C3Z-6007-HARM
			V8 444 CID T444E; w/ Engine Serial # 1,026,248 To End	1C3Z-6006-DARM
			Engine Assembly (Complete); FI; V8 444 CID T444E; w/ Engine Serial # 1,026,248 To End	1C3Z-6007-HARM
			V8 444 CID T444E; w/ Engine Serial # 1,026,248 To End	1C3Z-6006-DARM
			Engine Assembly (Complete); FI; V8 444 CID T444E; w/ Engine Serial # 1,026,248 To End	1C3Z-6007-HARM
2001	7.3L DIESEL	V8 444 CID T444E; w/ Engine Serial # 1,026,248 To End	1C3Z-6006-DARM	
		Engine Assembly (Complete); FI; V8 444 CID T444E; w/ Engine Serial # 1,026,248 To End	1C3Z-6007-HARM	
	2000	7.3L DIESEL	V8 444 CID T444E; w/ Engine Serial # 1,026,248 To End	1C3Z-6006-DARM
			Engine Assembly (Complete); FI; V8 444 CID T444E; w/ Engine Serial # 1,026,248 To End	1C3Z-6007-HARM
			V8 444 CID T444E; w/ Engine Serial # 1,026,248 To End	1C3Z-6006-DARM
			Engine Assembly (Complete); FI; V8 444 CID T444E; w/ Engine Serial # 1,026,248 To End	1C3Z-6007-HARM
		V8 444 CID T444E; w/ Engine Serial # 1,026,248 To End	1C3Z-6006-DARM	
		Engine Assembly (Complete); FI; V8 444 CID T444E; w/ Engine Serial # 1,026,248 To End	1C3Z-6007-HARM	

LCF

Part Type	Years	Engine	Qualifier	Ford #
Reman	2010	4.5L DIESEL	Turbocharger; V6 275 CID (Z)	6E7Z-6K682-A
			Turbocharger; V6 275 CID (Z)	TC-8RM
	2009	4.5L DIESEL	Diesel High Pressure Oil Pump; V6 275 CID (Z); 6E7O-9G803-AE	6E7Z-9A543-BRM
			Diesel High Pressure Oil Pump; V6 275 CID (Z); 6E7O-9G803-AE	HPP-7RM
			Diesel High Pressure Oil Pump; V6 275 CID (Z); RM8E7O-9G803-AA	8E7Z-9A543-CRM
			Diesel High Pressure Oil Pump; V6 275 CID (Z); RM8E7O-9G803-AA	HPP-6RM
			Turbocharger; V6 275 CID (Z)	6E7Z-6K682-A
			Turbocharger; V6 275 CID (Z)	TC-8RM
	2008	4.5L DIESEL	Engine Assembly (Complete); V6 275 CID (Z); RM8E7O-6007-AA	8E7Z-6007-ARM
			Diesel High Pressure Oil Pump; V6 275 CID (Z); 6E7O-9G803-AE	6E7Z-9A543-BRM
			Diesel High Pressure Oil Pump; V6 275 CID (Z); 6E7O-9G803-AE	HPP-7RM
			Diesel High Pressure Oil Pump; V6 275 CID (Z); RM8E7O-9G803-AA	8E7Z-9A543-CRM
		Diesel High Pressure Oil Pump; V6 275 CID (Z); RM8E7O-9G803-AA	HPP-6RM	
		Turbocharger; V6 275 CID (Z)	6E7Z-6K682-A	
2007	4.5L DIESEL	Turbocharger; V6 275 CID (Z)	TC-8RM	
		Engine Assembly (Complete); V6 275 CID (Z); RM8E7O-6007-AA	8E7Z-6007-ARM	
		Diesel High Pressure Oil Pump; V6 275 CID (Z); 6E7O-9G803-AE	6E7Z-9A543-BRM	
		Diesel High Pressure Oil Pump; V6 275 CID (Z); 6E7O-9G803-AE	HPP-7RM	
		Turbocharger; V6 275 CID (Z)	6E7Z-6K682-A	
		Turbocharger; V6 275 CID (Z)	TC-8RM	
2006	4.5L DIESEL	Engine Assembly (Complete); V6 275 CID (Z); RM6E7O-6007-AA	6E7Z-6007-FRM	
		Diesel High Pressure Oil Pump; V6 275 CID (Z); 6E7O-9G803-AE	6E7Z-9A543-BRM	
		Diesel High Pressure Oil Pump; V6 275 CID (Z); 6E7O-9G803-AE	HPP-7RM	

**DIESEL ENGINES**  
**Light / Medium Trucks**  
**Ford**



**FORD PARTS**

LCF

-Cont'd

Part Type	Years	Engine	Qualifier	Ford #
Reman	2006	4.5L DIESEL	Turbocharger; V6 275 CID (Z) Turbocharger; V6 275 CID (Z) Engine Assembly (Complete); V6 275 CID (Z); RM6E70-6007-AA	6E7Z-6K682-A TC-8RM 6E7Z-6007-FRM





**Freestyle**

Part Type	Years	Engine	Trans	Qualifier	Ford #
Automatic - Reman	2007-2005 2007-2005	3.0L	CVT (CFT30) CVT (CFT30)	AWD; 5F93-7000-DX,DY,FB,FC; 6F93-7000-BA,BB,GB,GC FWD; 5F93-7000-CU,CV,GB,GC; 6F93-7000-AA,AB,FB,FC	6F9Z-7000-BRM 6F9Z-7000-ARM

**Fusion**

Part Type	Years	Engine	Trans	Qualifier	Ford #
Automatic - New	2017	2.0L EcoBoost	6F35	w/ Stop/Start System	HS7Z-7000-A
	2017	2.5L	6F35	FWD; w/ Standard Electric Starter Motor	HS7Z-7000-F
	2016	1.5L EcoBoost	6F35	EG9P-7000-AD; w/ Stop/Start System	EG9Z-7000-AD
	2016		6F35	EG9P-7000-BC; w/ Standard Electric Starter Motor	EG9Z-7000-BC
	2016-2015	2.0L	HF35	Hybrid; 6 Bolt Converter	FG9Z-7000-C
	2016	2.0L EcoBoost	6F35	FWD; DG9P-7000-KB	DG9Z-7000-KB
	2016	2.5L	6F35	DG9P-7000-MC	DG9Z-7000-MC
	2015-2014	1.5L EcoBoost	6F35	EG9P-7000-AB; w/ Stop/Start System	EG9Z-7000-A
	2015		6F35	FWD; EG9P-7000-BB; w/ Standard Electric Starter Motor	EG9Z-7000-C
	2015-2014		6F35	RMFG9J-7000-AA; w/ Stop/Start System	EG9Z-7000-HRM
	2015	2.0L EcoBoost	6F35	FWD; DG9P-7000-KA	DG9Z-7000-K
	2015		6F35	AWD; DG9P-7000-LA	DG9Z-7000-L
	2015-2013	2.5L	6F35	DG9P-7000-MA	DG9Z-7000-M
	2014	1.5L EcoBoost	6F35	EG9P-7000-BA; w/ Standard Electric Starter Motor	EG9Z-7000-B
	2014	1.6L	6F35	DG9P-7000-AB; w/ Stop/Start System	DG9Z-7000-C
	2014-2013	2.0L EcoBoost	6F35	FWD; DG9P-7000-JA	DG9Z-7000-J
	2014-2013		6F35	AWD; DG9P-7000-SA	DG9Z-7000-S
	2012-2011	2.5L	HF35	Hybrid; CE58-7000-CA	BE5Z-7000-B
	2012-2011		6F35	FWD; BE5P-7000-MB	BE5Z-7000-D
	2012-2011	3.0L	6F35	AWD; BE5P-7000-KB	BE5Z-7000-C
	2012-2011		6F35	FWD; BE5P-7000-JB	BE5Z-7000-A
	2012-2011	3.5L	AWF21	FWD; AE5P-7000-CA	AE5Z-7000-C
	2012-2011		AWF21	AWD; AE5P-7000-DA	AE5Z-7000-D
	2010	2.5L	HF35	Hybrid; 9E58-7000-DB	9E5Z-7000-N
	2010	3.0L	6F35	AWD; 9E5P-7000-KA	9E5Z-7000-C
	2010	3.5L	F21	FWD; 9E5P-7000-CB; Before 8/3/09	9E5Z-7000-D
	2010		AWF21	AWD; 9E5P-7000-DB; Before 8/3/09	9E5Z-7000-E
	2010		AWF21	FWD; AE5P-7000-CA; From 8/03/09	AE5Z-7000-C
	2010		AWF21	AWD; AE5P-7000-DA; From 8/03/09	AE5Z-7000-D
Automatic - Reman	2015	1.5L EcoBoost	6F35	FWD; RMFG9J-7000-CA; w/ Standard Electric Starter Motor	EG9Z-7000-KRM
	2014		6F35	w/ Standard Electric Starter Motor	EG9Z-7000-JRM
	2014-2013	2.0L EcoBoost	6F35	FWD; RMEG9J-7000-CA	EG9Z-7000-CRM
	2014-2013		6F35	AWD; RMEG9J-7000-EA	EG9Z-7000-ERM
	2014-2013	2.5L	6F35	FWD; RMEG9J-7000-DA	EG9Z-7000-DRM
	2013	1.6L EcoBoost	6F35	FWD; RMEG9J-7000-FA	EG9Z-7000-FRM
	2013		6F35	RMEG9J-7000-GA; w/ Stop/Start System	EG9Z-7000-GRM
	2012-2010	3.5L	F21	FWD; Sport; AE5P-7000-CA	AE5Z-7000-FRM
	2012-2010		F21	AWD; Sport; AE5P-7000-DA	AE5Z-7000-GRM
	2011	2.5L	6F35	FWD; BE5P-7000-MB	BE5Z-7000-DRM
	2011	2.5L DOHC	6F35	FWD; BL8P-7000-GB	BL8Z-7000-GRM
	2011		6F35	AWD; BL8P-7000-HB	BL8Z-7000-HRM
	2011	3.0L	6F35	AWD; BL8P-7000-FB	BL8Z-7000-FRM
	2011		6F35	AWD; BE5P-7000-KB	BE5Z-7000-CRM
	2011	3.0L 24 Valves	6F35	FWD; BL8P-7000-EB	BL8Z-7000-ERM
	2010	2.5L	6F35	FWD; 9E5P-7000-MA	AE5Z-7000-CRM
	2010	3.0L	6F35	9E5P-7000-JA	AE5Z-7000-ARM
	2010		6F35	AWD; 9E5P-7000-KA	AE5Z-7000-BRM
	2009-2008		F21	FWD; 8E5P-7000-AA,AB,AC	8E5Z-7000-ARM
	2009-2008		F21	AWD; 8E5P-7000-BA, BB, BC	8E5Z-7000-BRM
	2008-2006	2.3L	FNR5	FWD; 8E51-7000-AA,AB,AC,AD,AE,AF; 7E51-7000-AA,AB,AC,AF; 6E51-7000-AA,AC	7E5Z-7000-BRM
	2007-2006	3.0L	F21	FWD; 6E53-7000-AA,AB,AC,AD,AE	6E5Z-7000-AERM
	2007		F21	FWD; 7E5P-7000-AE; 7E5P-7000-AD	7E5Z-7000-AERM
	2007		F21	AWD; 7E5P-7000-BE,BF	7E5Z-7000-BFRM

**Mustang**

Part Type	Years	Engine	Trans	Qualifier	Ford #
Automatic - New	2016-2015	2.3L	6R80	FR3P-7000-CB	FR3Z-7000-C
	2016-2015	3.7L	6R80	FR3P-7000-AB	FR3Z-7000-A
	2016-2015	5.0L	6R80	FR3P-7000-BB	FR3Z-7000-B
	2014	3.7L	6R80	BR3P-7000-AB; Before 6/27/14	BR3Z-7000-A
	2014		6R80	BR3P-7000-CC; From 6/27/14	BR3Z-7000-C
	2014-2013	5.0L	6R80	BR3P-7000-BB	BR3Z-7000-B
	2013-2011	3.7L	6R80	BR3P-7000-AB	BR3Z-7000-A
Automatic - Reman	2014-2011		6R80	BR3P-7000-AA	BR3Z-7000-ARM
	2014-2011	5.0L	6R80	BR3P-7000-BA	BR3Z-7000-BRM
	2010-2009	4.0L	5R55S	9R3P-7000-BA; RJL-U	9R3Z-7000-BRM
	2010-2009	4.6L	5R55S	9R3P-7000-AA; RJL-T	9R3Z-7000-ARM
	2008	4.0L	5R55S	8R3P-7000-BA; RJL-U	8R3Z-7000-BRM
	2008	4.6L	5R55S	8R3P-7000-AA; RJL-T	8R3Z-7000-ARM



Mustang

-Cont'd

Part Type	Years	Engine	Trans	Qualifier	Ford #
Automatic - Reman	2007	4.0L	5R55S	7R3P-7000-BC; RJL-U	7R3Z-7000-BRM
	2007	4.6L	5R55S	7R3P-7000-AC; RJL-T	7R3Z-7000-ARM
	2006-2005		5R55S	4R3P-7000-AC; 6R3P-7000-AB,AC; RJL-T	4R3Z-7000-ARM
	2005	4.0L	5R55S	4R3P-7000-BC; RJL-U	4R3Z-7000-BRM
	2004	3.8L	4R70W	3R3P-7000-CA; PKE-CT	3R3Z-7000-CARM
	2004	4.6L 32 Valves	4R70W	GT; 3R3P-7000-BA; PKE-CS	3R3Z-7000-BARM
	2004		4R70W	Mach I; 3R3P-7000-BA; PKE-CS	3R3Z-7000-BARM
	2003	3.8L	4R70W	1R3P-7000-AA; PKE-BC	1R3Z-7000-AARM
	2003	4.6L	4R70W	1R3P-7000-BA; PKE-BD	1R3Z-7000-BARM
	2003	4.6L 32 Valves	4R70W	Mach I; 3R3P-7000-AA; PKE-CC	3R3Z-7V000-ARM
	2002-2001	3.8L	4R70W	1R3P-7000-AA; PKE-BC	1R3Z-7V000-ARM
	2002-2001	4.6L	4R70W	1R3P-7000-BA; PKE-BD	1R3Z-7V000-BRM
	2000-1999	3.8L	4R70W	XR3P-7000-AA; PKE-AJ	XR3Z-7V000-AARM
	1990	2.3L	A4LD	90GT-7000-TAA, TBA	90GZ-7V000-TAARM
	1989		A4LD	89GT-7000-RAA, SAA	90GZ-7V000-TAARM
	1987		A4LD	87GT-7000-ABA	90GZ-7V000-TAARM

Police Interceptor Sedan

Part Type	Years	Engine	Trans	Qualifier	Ford #
Automatic - Reman	2013	3.5L EcoBoost	6F55	AWD; DA8P-7000-MB; w/ 3.16 Ratio	DA8Z-7000-FRM
	2013	3.7L	6F55	DA8P-7000-AB; w/ 3.16 Ratio	DA8Z-7000-CRM
	2013		6F55	DA8P-7000-LB; w/ 3.39 Ratio	DA8Z-7000-ERM
	2013		6F55	AWD; DA5P-7000-EB	DA5Z-7000-ARM

Taurus

Part Type	Years	Engine	Trans	Qualifier	Ford #	
Automatic - New	2016-2014		6F50	DA8P-7000-MB; 3.16 Final Drive Ratio	DA8Z-7000-M	
	2016-2013		6F35	DG1P-7000-YA	DG1Z-7000-Y	
	2016-2014		6F50	DA8P-7000-LB; 3.39 Final Drive Ratio	DA8Z-7000-L	
	2016-2013		6F50	DA8P-7000-UA	DA8Z-7000-U	
	2016-2013	3.5L	6F55	DA5P-7000-DB; 3.16 Final Drive Ratio	DA5Z-7000-M	
	2014		6F50	DA8P-7000-UB; w/ 2.77 Axle Ratio	DA8Z-7000-X	
	2014	3.5L	6F55	DA5P-7000-BB; w/ 2.77 Axle Ratio	DA5Z-7000-L	
	2013		6F55	DA5P-7000-BA; w/ 2.77 Axle Ratio	DA5Z-7000-B	
	2013		6F50	DA8P-7000-MA; 3.16 Final Drive Ratio	DA8Z-7000-F	
	2013		6F50	DA8P-7000-LA; 3.39 Final Drive Ratio	DA8Z-7000-E	
	2012-2011		6F55	RMAA5J-7000-CA; w/ 2.77 Axle Ratio; Before 7/28/11	AA5Z-7000-G	
	2012		6F50	AA8P-7000-KB; 3.39 Final Drive Ratio; Before 7/20/11	AA8Z-7000-N	
	2012-2010	3.5L	6F55	Naturally Aspirated; AA8P-7000-FC; 3.16 Final Drive Ratio	AA8Z-7000-S	
	2012-2010		6F55	FWD; AA8P-7000-HC; w/ 2.77 Axle Ratio	AA8Z-7000-T	
	2012-2010		6F55	AWD; AA8P-7000-JC; w/ 2.77 Axle Ratio	AA8Z-7000-U	
	2012-2010		6F55	AA8P-7000-KC; 3.39 Final Drive Ratio	AA8Z-7000-V	
	2012	3.5L EcoBoost	6F55	AA5P-7000-BD; w/ 2.77 Axle Ratio	AA5Z-7000-J	
	2012-2010		6F55	AA5P-7000-DD; 3.16 Final Drive Ratio	AA5Z-7000-K	
	2010		6F50	AWD; RMAA8J-7000-DA; Before 5/3/10; w/ 2.77 Axle Ratio	AA8Z-7000-J	
	Automatic - Reman	2014-2013	2.0L EcoBoost	6F35	FWD; RMEG1J-7000-AA	EG1Z-7000-ARM
		2013	3.5L	6F50	w/ Duratec Engine; DA8P-7000-LB; w/ 3.39 Ratio	DA8Z-7000-ERM
		2013			SEL; w/ Duratec Engine; DA8P-7000-UB; w/ 2.77 Ratio	DA8Z-7000-URM
		2013			SE; w/ Duratec Engine; DA8P-7000-UB; w/ 2.77 Ratio	DA8Z-7000-URM
		2013	3.5L EcoBoost SHO	6F55	AWD; DA5P-7000-BB; w/ 2.77 Ratio	DA5Z-7000-BRM
		2013		6F55	AWD; DA5P-7000-DB; w/ 3.16 Ratio	DA5Z-7000-DRM
		2012-2010	3.5L	6F50	AWD; AA8P-7000-KA,KB,KC	AA8Z-7000-KRM
		2012-2010		6F50	FWD; AA8P-7000-HA,HB,HC	AA8Z-7000-HRM
		2012-2010		6F50	AWD; AA8P-7000-JA,JB,JC	AA8Z-7000-JRM
		2012-2010		6F50	FWD; AA8P-7000-FA,FB,FC	AA8Z-7000-FRM
		2012-2010	3.5L SHO	6F55	AWD; AA5P-7000-BC,BD	AA5Z-7000-GRM
		2012-2010		6F55	AWD; AA5P-7000-DC,DD	AA5Z-7000-HRM
		2010		6F55	AWD; AA5P-7000-BA,BB	AA5Z-7000-BRM
		2010		6F55	AWD; AA5P-7000-DA,DB	AA5Z-7000-DRM
2009-2008		3.5L	6F50	FWD; 7T4P-7000-CC; 2.77 Final Drive Ratio	7T4Z-7000-BRM	
2009-2008			6F50	AWD; 7T4P-7000-DA, DB, DC; 2.77 Final Drive Ratio	8T4Z-7000-BRM	
2004		3.0L 12 Valves	4F50N	5F1B-7000-FA; 4F1P-7000-FA/FB; PNB-KA; Floor Shift	4F1Z-7000-FBRM	
2004		3.0L 24 Valves	4F50N	4F1P-7000-DA/DB; Column Shift; PNB-DA	4F1Z-7000-DBRM	
2004			4F50N	4F1P-7000-EA/EB; PNB-HA; Floor Shift	4F1Z-7000-EBRM	
2003-2001		3.0L 12 Valves	AX4S	1F1P-7000-GA; Floor Shift; PNA-FA	1F1Z-7V000-GRM	
2003-2001		AX4S	1F1P-7000-AA; Column Shift; PNA-EZ	1F1Z-7V000-ARM		
2003-2001		4F50N	1F1P-7000-CB; Column Shift; PNB-FA	1F1Z-7V000-CRM		
2003-2001		4F50N	1F1P-7000-FB; PNB-KA; Floor Shift	1F1Z-7V000-FRM		
2003-2001	3.0L 24 Valves	4F50N	1F1P-7000-DB; Column Shift; PNA-DA	1F1Z-7V000-DRM		
2003-2001		4F50N	1F1P-7000-EB; PNB-HA; Floor Shift	1F1Z-7V000-ERM		
2000	3.0L 12 Valves	AX4N	YF1P-7000-FC, FD; PNB-KA; Floor Shift	YF1Z-7V000-FRM		
2000		AX4S	YF1P-7000-HA; PNA-GA; Floor Shift	YF1Z-7V000-HRM		
2000		AX4S	YF1P-7000-AB; Column Shift; PNA-EY	YF1Z-7V000-ARM		
2000	3.0L 24 Valves	AX4N	YF1P-7000-EC, EE; PNB-HA; Floor Shift	YF1Z-7V000-ERM		
1999	3.0L 12 Valves	AX4S	XF1P-7000-AA; PNA-EW	XF1Z-7V000-AARM		

**TRANSMISSIONS**  
**Passenger Cars**  
**Ford / Lincoln**



**FORD PARTS**

**Taurus**

**-Cont'd**

Part Type	Years	Engine	Trans	Qualifier	Ford #
Automatic - Reman	1999	3.0L 24 Valves	AX4N	XF1P-7000-EB; PNB-HA; Floor Shift; w/o OD Cancel Button	XF1Z-7V000-EBRM
	1999	3.4L SHO	AX4N	XF1P-7000-BA; PNB-EA; w/ OD Cancel Button	XF1Z-7V000-BARM
	1998	3.0L 12 Valves	AX4S	F8DP-7000-AA; PNA-EV	F8DZ-7V000-AARM
	1998	3.0L 24 Valves	AX4N	F8DP-7000-DA; Column Shift; PNB-DA	F8DZ-7V000-DARM
	1997	3.0L 12 Valves	AX4N	F7DP-7000-CA; PNB-FA	F7DZ-7V000-CRM
	1997		AX4S	F7DP-7000-AA; PNA-EU	F7DZ-7V000-ARM
	1997	3.0L 24 Valves	AX4N	F7DP-7000-EA; PNB-HA; Floor Shift	F7DZ-7V000-ERM
	1997		AX4N	F7DP-7000-DA; Column Shift; PNB-DA	F7DZ-7V000-DRM
	1996		AX4N	F6DP-7000-EA; PNB-HA; Floor Shift	F6DZ-7V000-EARM
	1995-1994	3.0L	AX4S	F4DP-7000-BA, BB; PNA-EP	F4DZ-7V000-BRM

**Taurus X**

Part Type	Years	Engine	Trans	Qualifier	Ford #
Automatic - Reman	2009	3.5L	6F50	AWD; 7T4P-7000-BA, BB, BC; 3.16 Final Drive Ratio	7T4Z-7000-ARM
	2009-2008		6F50	FWD; 7T4P-7000-AA, AB, AC; 3.16 Final Drive Ratio	8T4Z-7000-ARM

**Thunderbird**

Part Type	Years	Engine	Trans	Qualifier	Ford #
Automatic - Reman	2005-2004	3.9L	5R55S	4W4P-7000-AB; R/JL-U	4W4Z-7000-ABRM
	2003		5R55S	3W4P-7000-AC; R/JL-X	3W4Z-7V000-ACRM
	2002		5R55N	2W4P-7000-AA	2W4Z-7V000-AARM
	1991-1989	3.8L	AOD	F1SP-7000-DA; E9SP-7000-FC, FD, GC; 3.08 Final Drive Ratio; PKA-FK1, EL2, EL41, DP	F1SZ-7V000-DARM
	1991	5.0L	AOD	F1SP-7000-DA; 3.08 Final Drive Ratio; PKA-FK1, EL2, EL41, DP	F1SZ-7V000-DARM

**Lincoln**

**Continental**

Part Type	Years	Engine	Trans	Qualifier	Ford #
Automatic - New	2017	2.7L	6F55	6 Bolt Converter	FG9Z-7000-C
	2017	3.0L	6F55	6 Bolt Converter	FG9Z-7000-C
	2017	3.7L	6F55	6 Bolt Converter	FG9Z-7000-C
Automatic - Reman	2002-2001	4.6L	4F50N	1F3P-7000-BC; Column Shift; PNB-GA	1F3Z-7V000-DRM
	2002-2001		4F50N	1F3P-7000-AC; PNB-CA; Floor Shift	1F3Z-7V000-CRM
	2001		4F50N	1F3P-7000-AB; PNB-CA; Floor Shift	1F3Z-7V000-ARM
	2001		4F50N	1F3P-7000-BB; Column Shift; PNB-GA	1F3Z-7V000-BRM
	2000		AX4N	XF3P-7000-AB, AC; PNB-CA; Floor Shift	XF3Z-7V000-ARM
	2000		AX4N	XF3P-7000-BB, BC; Column Shift; PNB-GA	XF3Z-7V000-BRM
	1999		AX4N	XF3P-7000-BA; Column Shift; PNB-GA	XF3Z-7V000-BARM
	1995		AX4N	F5OP-7000-BA; PNB-CA; Floor Shift	F5OZ-7V000-BRM
	1994	3.8L	AX4S	F4OP-7000-BA, BB; PNA-ES	F4OZ-7V000-BRM

**LS**

Part Type	Years	Engine	Trans	Qualifier	Ford #
Automatic - Reman	2006-2004	3.9L	5R55S	6W4P-7000-AB, AC; 4W4P-7000-AB; R/JL-U	4W4Z-7000-ABRM
	2005-2004	3.0L	5R55S	4W4P-7000-BB; R/JL-T	4W4Z-7000-BBRM
	2003		5R55S	3W4P-7000-BC; R/JL-R	3W4Z-7V000-BCRM
	2003	3.9L	5R55S	3W4P-7000-AC; R/JL-X	3W4Z-7V000-ACRM
	2002	3.0L	5R55N	2W4P-7000-BA	2W4Z-7V000-BARM
	2002	3.9L	5R55N	2W4P-7000-AA	2W4Z-7V000-AARM
	2000	3.0L	5R55N	YW4P-7000-BA; XW4P-7000-BA, BC	YW4Z-7V000-BRM
	2000	3.9L	5R55N	XW4P-7000-AA, AC; YW4P-7000-AA	YW4Z-7V000-ARM

**MKS**

Part Type	Years	Engine	Trans	Qualifier	Ford #	
Automatic - New	2016-2013	3.7L	6F50	DA8P-7000-AB; 3.16 Final Drive Ratio	DA8Z-7000-J	
	2016-2013		6F50	DA8P-7000-LB; 3.39 Final Drive Ratio	DA8Z-7000-L	
	2012-2011	3.5L	6F55	AA5P-7000-BD; w/ 2.77 Axle Ratio	AA5Z-7000-J	
	2012-2010		6F55	AA8P-7000-KC; 3.39 Final Drive Ratio	AA8Z-7000-V	
	2012-2009	3.7L	6F55	Naturally Aspirated; AA8P-7000-FC; 3.16 Final Drive Ratio	AA8Z-7000-S	
	2012-2009		6F50	AA8P-7000-KC; 3.39 Final Drive Ratio	AA8Z-7000-V	
	Automatic - Reman	2013	3.5L EcoBoost	6F55	AWD; DA5P-7000-BB; w/ 2.77 Ratio	DA5Z-7000-BRM
		2013	3.7L	6F50	DA8P-7000-AB; w/ 3.16 Ratio	DA8Z-7000-CRM
		2013		6F50	DA8P-7000-LB; w/ 3.39 Ratio	DA8Z-7000-ERM
		2012-2010	3.5L	6F50	AWD; AA8P-7000-KA, KB, KC	AA8Z-7000-KRM
2012-2010		3.5L EcoBoost	6F55	AA5P-7000-BC, BD	AA5Z-7000-GRM	
2012-2010		3.7L	6F50	AWD; AA8P-7000-KA, KB, KC	AA8Z-7000-KRM	
2012-2010			6F50	FWD; AA8P-7000-FA, FB, FC	AA8Z-7000-FRM	
2010		3.5L EcoBoost	6F55	AA5P-7000-BA, BB	AA5Z-7000-BRM	





**MKZ**

Part Type	Years	Engine	Trans	Qualifier	Ford #
Automatic - New	2016-2014	2.0L	6F50	6 Spd.; AWD; DA8P-7000-TC; w/ 2.77 Axle Ratio	DA8Z-7000-TC
	2016-2014		6F50	FWD; DA8P-7000-PC	DA8Z-7000-R
	2016	2.0L ELECTRIC/GAS	6F35	FWD; DG9P-7000-ED; w/ Standard Electric Starter Motor	DG9Z-7000-ED
	2016		6F35	AWD; DG9P-7000-FD	DG9Z-7000-FD
	2016		6F35	FWD; FG9P-7000-AC; w/ Stop/Start System	FG9Z-7000-AC
	2016-2013		6F35	FG98-7000-GA; w/ 2.91 Axle Ratio	FG9Z-7000-G
	2016-2015		6F35	FWD; DG9P-7000-KA	DG9Z-7000-K
	2016-2014		6F50	FWD; DA8P-7000-PC	DA8Z-7000-R
	2015-2013		6F35	FWD; DG9P-7000-EB	DG9Z-7000-E
	2015-2013		6F35	AWD; DG9P-7000-FB	DG9Z-7000-F
	2015		6F35	FWD; FG9P-7000-AA; w/ Stop/Start System	FG9Z-7000-A
	2015-2013		6F35	FWD; DG9P-7000-EB	DG9Z-7000-E
	2014-2013	2.0L EcoBoost	CFT30	DG98-7000-EC; w/ 2.56 Axle Ratio	FG9Z-7000-E
	2014-2013		6F35	DG9P-7000-JA	DG9Z-7000-J
	2014-2013	3.7L	CFT30	AWD; DG9P-7000-SA	DG9Z-7000-S
	2013			DA8P-7000-PB; w/ Power Split; From 2/4/13; w/ 2.91 Axle Ratio	DG9Z-7000-G
	2013		6F50	FWD; DA8P-7000-PB	DA8Z-7000-P
	2013		6F50	AWD; DA8P-7000-TA	DA8Z-7000-T
	2013		6F35	FWD; RMEG9J-7000-AA	EG9Z-7000-ARM
	2014-2013		6F35	AWD; RMEG9J-7000-BA	EG9Z-7000-BRM
2013	6F50		FWD; DA8P-7000-PC; w/ 3.39 Ratio	DA8Z-7000-PRM	
2013	6F50		AWD; DA8P-7000-TB; w/ 3.65 Ratio	DA8Z-7000-TRM	
2012-2010	3.5L		F21	FWD; AE5P-7000-CA	AE5Z-7000-FRM
2012-2010			F21	AWD; AE5P-7000-DA	AE5Z-7000-GRM
2011	2.5L	6F35	FWD; BE5P-7000-MB	BE5Z-7000-DRM	
2009-2008	3.5L	F21	FWD; 8E5P-7000-CB,CC,CD	8E5Z-7000-CRM	
2009-2008		F21	AWD; 8E5P-7000-DB,DC,DD	8E5Z-7000-DRM	
2007		F21	FWD; 7E5P-7000-CE,CF	7E5Z-7000-CFRM	
2007		F21	AWD; 7E5P-7000-DF,DG	7E5Z-7000-DGRM	
Automatic - Reman	2015-2013	2.0L EcoBoost	6F35	FWD; RMEG9J-7000-AA	EG9Z-7000-ARM
	2014-2013	2.0L	6F35	AWD; RMEG9J-7000-BA	EG9Z-7000-BRM
	2013	3.7L	6F50	FWD; DA8P-7000-PC; w/ 3.39 Ratio	DA8Z-7000-PRM
	2013	3.7L	6F50	AWD; DA8P-7000-TB; w/ 3.65 Ratio	DA8Z-7000-TRM
	2012-2010	3.5L	F21	FWD; AE5P-7000-CA	AE5Z-7000-FRM
	2012-2010		F21	AWD; AE5P-7000-DA	AE5Z-7000-GRM
	2011	2.5L	6F35	FWD; BE5P-7000-MB	BE5Z-7000-DRM
	2009-2008	3.5L	F21	FWD; 8E5P-7000-CB,CC,CD	8E5Z-7000-CRM
	2009-2008		F21	AWD; 8E5P-7000-DB,DC,DD	8E5Z-7000-DRM
	2007		F21	FWD; 7E5P-7000-CE,CF	7E5Z-7000-CFRM
2007	F21		AWD; 7E5P-7000-DF,DG	7E5Z-7000-DGRM	

**Mark VIII**

Part Type	Years	Engine	Trans	Qualifier	Ford #
Automatic - Reman	1997	4.6L	4R70W	F7LP-7000-AA; PKE-N	F7LZ-7000-ARM

**Town Car**

Part Type	Years	Engine	Trans	Qualifier	Ford #
Automatic - Reman	2011-2010	4.6L	4R75E	AW7P-7000-CA; Limo; PKE-FC	AW7Z-7000-CRM
	2011-2010		4R75E	AW1P-7000-DA; PKE-GA	AW1Z-7000-DRM
	2009		4R75E	Limousine; 9W7P-7000-CA; PKE-DY	9W7Z-7000-CRM
	2009	4.6L	4R75E	RWD; 9W1P-7000-AA; PKE-DZ	9W1Z-7000-ARM
	2009		4R75E	9W1P-7000-DA; w/ Long Wheelbase; PKE-EA	9W1Z-7000-DRM
	2008-2007		4R70W	7W1P-7000-AA; PKE-DL	7W1Z-7000-AARM
	2008-2007		4R75E	Limousine; 7W7P-7000-CA; PKE-DP	7W7Z-7000-CARM
	2008-2007		4R75E	7W1P-7000-DA; w/ Long Wheelbase; PKE-DM	7W1Z-7000-DARM
	2006		4R75E	6W1P-7000-AA,AB,CA,CB; PKG-BN; PKE-CV	6W1Z-7000-ARM
	2006		4R75E	6W1P-7000-DA,DB; w/ Long Wheelbase; PKE-CW	6W1Z-7000-DRM
	2005		4R70E	5W1P-7000-AA,CA,GA,JA; PKE-DF; PKG-BZ	5W1Z-7000-GRM
	2005		4R70E	5W1P-7000-DA,HA; w/ Long Wheelbase; PKE-CK,DG	5W1Z-7000-HRM
	2004		4.6L	4R70W	4W1P-7000-DA,FA; w/ Long Wheelbase; PKE-BG, BU
	2004	4R70W		4W1P-7000-AA; PKE-BS, PKG-AT	4W1Z-7000-AARM
	2003	4R70W		3W1P-7000-AA, CA; PKE-AX, BZ	3W1Z-7V000-ARM
	2003	4R70W		3W1P-7000-DA; PKE-CB	3W1Z-7V000-DRM
	2003	4R70W		3W1P-7000-BA; PKE-CA	3W1Z-7V000-BRM
	2000	4R70W		XW1P-7000-CA; PKE-AX	XW1Z-7V000-CARM
	2000	4R70W		YW1P-7000-AA; PKE-BN; w/ Long Wheelbase	YW1Z-7V000-ARM
	2000-1999	4R70W		XW1P-7000-BA; XW1P-7000-DA; PKG-AV; PKE-AV	XW1Z-7V000-BARM
	1999	4R70W		Base; XW1P-7000-CA; PKE-AX	XW1Z-7V000-CARM
	1999	4R70W		Cartier; XW1P-7000-CA; PKE-AX	XW1Z-7V000-CARM
	1999	4R70W	Executive; XW1P-7000-CA; PKE-AX	XW1Z-7V000-CARM	
	1999	4R70W	Signature; XW1P-7000-CA; PKE-AX	XW1Z-7V000-CARM	
	1997	4R70W	F7AP-7000-BA,GA; PKE-AF	F7AZ-7V000-BRM	
	1997	4R70W	4R70W	F7AP-7000-GA; PKG-AF	F7AZ-7V000-BRM

**Zephyr**

Part Type	Years	Engine	Trans	Qualifier	Ford #
Automatic - Reman	2006	3.0L	F21	FWD; 6E53-7000-AD,AE	6E5Z-7000-AERM
	2006		F21	FWD; 6E53-7000-AA,AB,AC,AD,AE	6E5Z-7000-AERM

**Mercury**

**Cougar**

Part Type	Years	Engine	Trans	Qualifier	Ford #
Automatic - Reman	2002-2001	2.5L	CD4E	1S8P-7000-AA	1S8Z-7V000-ARM

**TRANSMISSIONS**  
**Passenger Cars**  
**Mercury**



**FORD PARTS**

**Cougar**

**-Cont'd**

Part Type	Years	Engine	Trans	Qualifier	Ford #
Automatic - Reman	2002	2.5L	CD4E	2S8P-7000-AA; PTA-Y	2S8Z-7V000-ABRM
	2000-1999		CD4E	F83P-7000-CB; PTA-J	F83Z-7V000-CBRM
	1991	5.0L	AOD	F1SP-7000-DA; 3.08 Final Drive Ratio; PKA-FK1,EL2,EL41,DP	F1SZ-7V000-DARM
	1989	3.8L	AOD	E9SP-7000-HC,HD; w/ Floor Shift; PKA-DV2,DV31	F1SZ-7V000-DARM
	1989		AOD	E9SP-7000-HD; w/ Floor Shift; PKA-DV31	F1SZ-7V000-DARM
	1989		AOD	E9SP-7000-FD; w/ Floor Shift; PKA-EL41	F1SZ-7V000-DARM
	1989		AOD	E9SP-7000-FC,FD,GC; PKA-EL2; w/ Floor Shift	F1SZ-7V000-DARM
	1989		AOD	E9SP-7000-GC; w/ Floor Shift; PKA-DP	F1SZ-7V000-DARM
	1988		AOD	E8SP-7000-CA; PKA-DK2	F1SZ-7V000-DARM
	1988	5.0L	AOD	E8SP-7000-AB; w/ Column Shift; PKA-DR2	F1SZ-7V000-DARM
	1988		AOD	E8SP-7000-BB; w/ Floor Shift; PKA-DS2	F1SZ-7V000-DARM
	1987		AOD	E7SP-7000-CA; PKA-CZ5	F1SZ-7V000-DARM

**Grand Marquis**

Part Type	Years	Engine	Trans	Qualifier	Ford #
Automatic - Reman	2009	4.6L	4R75E	RWD; 9W7P-7000-AA; PKE-DX	9W7Z-7000-ARM
	2008-2007		4R75E	7W7P-7000-DA; w/ Handling Package; PKE-DR	7W7Z-7000-DARM
	2008-2007		4R75E	7W7P-7000-AA; PKE-DN	7W7Z-7000-AARM
	2006		4R75E	6W7P-7000-AA,AB,BA,BB; PKE-CX	6W7Z-7000-ARM
	2006		4R75E	6W7P-7000-BB; PKG-BR	6W7Z-7000-ARM
	2006		4R75E	6W7P-7000-AB; PKE-DU	6W7Z-7000-ARM
	2006		4R75E	6W7P-7000-DA, DB; w/ Handling Pkg.; PKE-CZ,DU,DW	6W7Z-7000-DRM
	2005		4R70E	5W7P-7000-AA,BA,GA,KA; PKE-CN,DH	5W7Z-7000-KRM
	2005		4R70E	5W7P-7000-BA; PKG-BA,CB	5W7Z-7000-KRM
	2005		4R70E	5W7P-7000-KA; PKE-DH	5W7Z-7000-KRM
	2005		4R70E	5W7P-7000-GA; PKG-CB	5W7Z-7000-KRM
	2005		4R70E	5W7P-7000-DA, MA; w/ Handling Pkg.; PKE-CR, DK	5W7Z-7000-MRM
	2004		4R70W	4W7P-7000-AA,BA; PKE-CE; PKG-AY	4W7Z-7000-AARM
	2003		4R70W	3W7P-7000-BA; PKG-AW	3W7Z-7V000-ARM
	2003		4R70W	3W7P-7000-AA,BA; PKE-BW	3W7Z-7V000-ARM
	2003		4R70W	3W7P-7000-DA; w/ Handling Pkg.; PKE-BY	3W7Z-7V000-DRM
	2000-1999		4R70W	XW7P-7000-AA,DA; PKE-AN	XW7Z-7V000-AARM
	2000		4R70W	YW7P-7000-AA; w/ Handling Pkg.; PKE-AN	YW7Z-7V000-ARM
	1998		4R70W	F8AP-7000-AA, CA; PKE-X, PKG-X	F8AZ-7V000-AARM

**Marauder**

Part Type	Years	Engine	Trans	Qualifier	Ford #
Automatic - Reman	2004	4.6L	4R70W	4W7P-7000-CA, EA; PKE-CF, PKG-BH	4W7Z-7000-CARM
	2003		4R70W	2W3P-7000-AA; PKE-BR	2W3Z-7V000-ARM

**Milan**

Part Type	Years	Engine	Trans	Qualifier	Ford #
Automatic - New	2011	2.5L	6F35	FWD; BE5P-7000-MB	BE5Z-7000-D
	2011-2010	2.5L ELECTRIC/GAS	HF35	CE58-7000-CA	BE5Z-7000-B
Automatic - Reman	2011	3.0L	6F35	AWD; BE5P-7000-KB	BE5Z-7000-C
	2010		6F35	AWD; 9E5P-7000-KA	9E5Z-7000-C
	2011	2.5L	6F35	BE5P-7000-MB	BE5Z-7000-DRM
	2011	2.5L DOHC	6F35	FWD; BL8P-7000-GB	BL8Z-7000-GRM
	2011		6F35	AWD; BL8P-7000-HB	BL8Z-7000-HRM
	2011	3.0L	6F35	AWD; BL8P-7000-FB	BL8Z-7000-FRM
	2011		6F35	AWD; BE5P-7000-KB	BE5Z-7000-CRM
	2011	3.0L 24 Valves	6F35	FWD; BL8P-7000-EB	BL8Z-7000-ERM
	2010	2.5L	6F35	FWD; 9E5P-7000-MA	AE5Z-7000-CRM
	2010	3.0L	6F35	9E5P-7000-JA	AE5Z-7000-ARM
	2010		6F35	AWD; 9E5P-7000-KA	AE5Z-7000-BRM
	2009-2008	2.3L	FNR5	FWD; 8E51-7000-AA,AB,AC,AD,AE,AF	7E5Z-7000-BRM
	2009	3.0L	F21	FWD; 8E5P-7000-AC; 8E5P-7000-AA,AB,AC	8E5Z-7000-ARM
	2009		F21	AWD; 8E5P-7000-BC	8E5Z-7000-BRM
	2008		F21	FWD; 8E5P-7000-AA	8E5Z-7000-ARM
	2008		F21	FWD; 8E5P-7000-AA,AB,AC	8E5Z-7000-ARM
	2008		F21	AWD; 8E5P-7000-BB; 8E5P-7000-BA, BB, BC	8E5Z-7000-BRM
	2007	2.3L	FNR5	FWD; 7E51-7000-AA,AB,AC,AF	7E5Z-7000-BRM
	2007-2006	3.0L	F21	FWD; 6E53-7000-AD,AE	6E5Z-7000-AERM
	2007		F21	FWD; 7E5P-7000-AE; 7E5P-7000-AD	7E5Z-7000-AERM
2007		F21	AWD; 7E5P-7000-BE,BF	7E5Z-7000-BFRM	
2006		F21	FWD; 6E53-7000-AA,AB,AC,AD,AE	6E5Z-7000-AERM	
2006		FNR5	FWD; RM6E5J-7000-AC	7E5Z-7000-BRM	

**Montego**

Part Type	Years	Engine	Trans	Qualifier	Ford #
Automatic - Reman	2007-2005	3.0L	CFT30	AWD; 7G13-7000-EA; 6G13-7000-EA,EB,JB,JC; 5G13-7000-BX,BY,EB,EC6G1Z-7000-BRM	





**Econoline**

**-Cont'd**

Part Type	Years	Engine	Trans	Qualifier	Ford #
Automatic - Reman	2012-2010	6.8L	5R110W	AC3P-7000-GA; PRB-NU; TorqShift	9C2Z-7000-JRM
	2012-2009		5R110W	9C3P-7000-HB; PRB-NV; TorqShift	9C2Z-7000-KRM
	2012-2010		5R110W	AC3P-7000-HA; PRB-NV; TorqShift	9C2Z-7000-KRM
	2010-2009	6.0L DIESEL	5R110W	9C2P-7000-AB; PRB-NH; TorqShift	9C2Z-7000-ARM
	2010		5R110W	AC2P-7000-AA; PRB-NH; TorqShift	9C2Z-7000-ARM
	2010-2009		5R110W	9C2P-7000-BB; PRB-NJ; TorqShift	9C2Z-7000-BRM
	2010		5R110W	AC2P-7000-BA; PRB-NJ; TorqShift	9C2Z-7000-BRM
	2010-2009		5R110W	9C2P-7000-FB; PRB-NL; TorqShift	9C2Z-7000-FRM
	2010		5R110W	AC2P-7000-FA; PRB-NL; TorqShift	9C2Z-7000-FRM
	2010-2009		5R110W	9C2P-7000-EB; PRB-NK; TorqShift	9C2Z-7000-ERM
	2010		5R110W	AC2P-7000-EA; PRB-NK; TorqShift	9C2Z-7000-ERM
	2009	5.4L	5R110W	9C2P-7000-EB; PRB-NS; TorqShift	9C2Z-7000-GRM
	2009		4R75E	RWD; 9C2P-7000-DA,DB; PKF-GB, GM	9C2Z-7000-DRM
	2008		5R110W	8C3P-7000-FD; PRB-NT; TorqShift	8C2Z-7000-FRM
	2008-2006		5R110W	6C3P-7000-AB; PRB-LK; w/ Slip Yoke; TorqShift	5C2Z-7000-TRM
	2008-2006		5R110W	6C3P-7000-AA; w/ Slip Yoke; PRB-KC; TorqShift	5C2Z-7000-TRM
	2008-2006		5R110W	6C3P-7000-BB; w/ Fixed Yoke; PRB-LL; TorqShift	5C2Z-7000-URM
	2008-2006		5R110W	6C3P-7000-BA; w/ Fixed Yoke; PRB-KD; TorqShift	5C2Z-7000-URM
	2008-2007		4R75E	7C2P-7000-DA; PKF-FM	7C2Z-7000-DARM
	2008	5.4L GAS	5R110W	8C3P-7000-ED; PRB-NS; TorqShift	8C3Z-7000-ERM
	2008-2007	6.0L	5R110W	6C3P-7000-KC; w/ Fixed Yoke; PRB-MN; TorqShift	5C2Z-7000-SRM
	2008	6.0L DIESEL	5R110W	8C2P-7000-DB; PRB-NL; TorqShift	8C2Z-7000-DRM
	2008		5R110W	8C2P-7000-CB; PRB-NK; TorqShift	8C2Z-7000-CRM
	2008		5R110W	8C2P-7000-AD; PRB-NH; TorqShift	8C2Z-7000-ARM
	2008		5R110W	8C2P-7000-BD; PRB-NJ; TorqShift	8C2Z-7000-BRM
	2008-2007	6.8L	5R110W	6C3P-7000-DC; PRB-MK; w/ Fixed Yoke; TorqShift	5C2Z-7000-VRM
	2008		5R110W	8C3P-7000-GD; PRB-NU; TorqShift	8C3Z-7000-GRM
	2008		5R110W	8C3P-7000-HD; PRB-NV; TorqShift	8C2Z-7000-HRM
	2007	4.6L	4R75E	7C2P-7000-CA; PKF-FL	7C2Z-7000-CARM
	2007	6.0L DIESEL	5R110W	7C2P-7000-AB; PRB-ME; TorqShift	7C2Z-7000-ARM
	2007		5R110W	7C2P-7000-BB; PRB-MF; TorqShift	7C2Z-7000-BRM
	2007	6.8L	5R110W	7C3P-7000-GC; PRB-MB; TorqShift	7C3Z-7000-GRM
	2007		5R110W	7C3P-7000-HC; PRB-MC; TorqShift	7C3Z-7000-HRM
	2006	4.6L	4R75E	6C2P-7000-AA; PKF-FA; 150	6C2Z-7000-ARM
	2006	5.4L	4R75E	6C2P-7000-DA; PKF-FD; 350	6C2Z-7000-DRM
	2006		4R75E	6C2P-7000-BA; PKF-FB; 150	6C2Z-7000-BRM
	2006	6.0L	5R110W	6C3P-7000-JB; w/ Slip Yoke; PRB-LR; TorqShift	5C2Z-7000-RRM
	2006		5R110W	6C3P-7000-JA; w/ Slip Yoke; PRB-KJ; TorqShift	5C2Z-7000-RRM
	2006		5R110W	6C3P-7000-KB; w/ Fixed Yoke; PRB-LS; TorqShift	5C2Z-7000-SRM
	2006		5R110W	6C3P-7000-KA; w/ Fixed Yoke; PRB-KK; TorqShift	5C2Z-7000-SRM
	2006	6.8L	5R110W	6C3P-7000-DB; w/ Fixed Yoke; PRB-LN; TorqShift	5C2Z-7000-VRM
	2006		5R110W	6C3P-7000-DA; w/ Fixed Yoke; PRB-KF; TorqShift	5C2Z-7000-VRM
	2005	4.6L	4R70E	5C2P-7000-AA; PKF-ED	5C2Z-7000-ARM
	2005	5.4L	5R110W	5C3P-7000-AB; w/ Slip Yoke; PRB-JN; TorqShift	5C2Z-7000-TRM
	2005		4R75E	5C2P-7000-EA; PKF-FE	5C2Z-7000-ERM
	2005		5R110W	5C3P-7000-BB; w/ Fixed Yoke; PRB-JP; TorqShift	5C2Z-7000-URM
	2005		4R75E	5C2P-7000-BA; PKF-EE	5C2Z-7000-BRM
	2005	6.0L	5R110W	5C3P-7000-JB; w/ Slip Yoke; PRB-JX; TorqShift	5C2Z-7000-RRM
	2005		5R110W	5C3P-7000-KB; w/ Fixed Yoke; PRB-JY; TorqShift	5C2Z-7000-SRM
	2005	6.8L	5R110W	5C32P-7000-DB; PRB-JS; TorqShift	5C2Z-7000-VRM
	2005		5R110W	RWD; 5C3P-7000-CB; TorqShift	5C3Z-7000-CRM
	2004	4.6L	4R70W	4C2P-7000-AA; PKF-DK	4C2Z-7000-AARM
	2004	5.4L	4R70W	4C2P-7000-BA; PKF-DL	4C2Z-7000-BARM
	2004		4R100	Cutaway Van; 4C2P-7000-EA; PRB-JG1	4C2Z-7000-HARM
	2004	6.0L	5R110W	w/ 158.0 In. Wheelbase; 4C3P-7000-KB; PRB-JF; TorqShift	4C2Z-7000-SARM
	2004		5R110W	w/ 176.0 In. Wheelbase; 4C3P-7000-KB; PRB-JF; TorqShift	4C2Z-7000-SARM
	2004		5R110W	w/ 138.0 In. Wheelbase; 4C3P-7000-JB; PRB-JE; TorqShift	4C2Z-7000-RARM
	2004	6.0L DIESEL	5R110W	w/ 138.0 In. Wheelbase; RM8U2J-7G497-ABA; w/o PTO; TorqShift	4C2Z-7000-JBRM
	2004	6.8L	4R100	4C2P-7000-FA; PRB-JH1	4C2Z-7000-FARM
	2003-2001	4.2L	4R70W	1C2P-7000-FA; PKF-CE	1C2Z-7V000-FRM
	2003-2001	4.6L	4R70W	1C2P-7000-JA; PKF-CG	1C2Z-7V000-JRM
	2003-2001	5.4L	4R100	Stripped Chassis; 1C2P-7000-AC; PRB-FX, FX1	1C2Z-7V000-ARM
	2003		4R100	Cutaway Van; 1C2P-7000-AC; PRB-FX, FX1	1C2Z-7V000-ARM
	2003-2001		4R70W	1C2P-7000-MA; PKF-CJ	1C2Z-7V000-MRM
	2003-2001		4R70W	1C2P-7000-LA; PKF-CH	1C2Z-7V000-LRM
	2003-2001	6.8L	4R100	1C2P-7000-BA,BB,BC; PRB-FY, FY1; 350; w/o Speedo Gear	1C2Z-7V000-BRM
	2003		4R100	1C2P-7000-BA; PRB-DB; 350; w/o Speedo Gear	1C2Z-7V000-BRM
	2003-2001	7.3L	4R100	Normal Service; 1C2P-7000-DB; PRB-GA, GA1	1C2Z-7V000-DRM
	2002-2001	4.2L	4R70W	1C2P-7000-HA; PKF-CF	1C2Z-7V000-HRM
	2002-2001	5.4L	4R100	1C2P-7000-AB; PRB-FB	1C2Z-7V000-ARM
	2002-2001		4R100	DSO Models; 1C2P-7000-TA; PRB-GZ, GZ1	1C2Z-7V000-ARM
	2001		4R100	PRB-AA; 1C2P-7000-AA	1C2Z-7V000-ARM
	2000	4.2L	4R70W	YC2P-7000-SA; DSO; PKF-BV	YC2Z-7V000-SRM
	2000		4R70W	YC2P-7000-BA; PKF-BR	YC2Z-7V000-BRM
	2000	4.6L	4R70W	YC2P-7000-CA; PKF-BS	YC2Z-7V000-CRM
	2000	5.4L	4R70W	YC2P-7000-YA; DSO; PKF-DH	YC2Z-7V000-YRM
	2000		4R100	YC2P-7000-WA; PRB-CZ	YC2Z-7V000-WRM
	2000		4R70W	YC2P-7000-NA; PKF-BU	YC2Z-7V000-NRM
	2000		4R100	YC2P-7000-EA; PRB-BH	YC2Z-7V000-TRM
	2000		4R100	YC2P-7000-TA; DSO; PRB-CW	YC2Z-7V000-TRM



Econoline

-Cont'd

Part Type	Years	Engine	Trans	Qualifier	Ford #
Automatic - Reman	2000	6.8L	4R100	YC2P-7000-UA; DSO; PRB-CX	YC2Z-7V000-URM
	2000		4R100	YC2P-7000-GA; PRB-BJ	YC2Z-7V000-URM
	2000	7.3L	4R100	YC2P-7000-JA; PRB-BK	YC2Z-7V000-JRM
	2000		4R100	YC2P-7000-KA, KB; Normal Service; PRB-BL, CM	YC2Z-7V000-KRM
	2000	5.4L	4R100	YC2P-7000-KA, KB; Heavy Duty Service; PRB-BL, CM	7U2Z-7V000-CRM
	1999		4R70W	XC2P-7000-NA; PKF-BJ	XC2Z-7V000-NARM
	1999	5.4L CNG	4R100	XC2P-7000-RA; 7TSG, 4.10 Axle Ratio; PRB-AM	F8UZ-7V000-PARM
	1999	5.4L GAS	4R100	XC2P-7000-UA; 7TSG, 4.10 Axle Ratio; PRB-CG	F8UZ-7V000-RARM
	1999	6.8L	4R100	XC2P-7000-FB; 7TSG, 4.10 Axle Ratio; PRB-AF	F8UZ-7V000-CARM
	1999	7.3L	4R100	XC2P-7000-JB; Normal Service; 7TSG, 4.10/TSS Axle Ratio; PRB-AJ	YC2Z-7V000-KRM
	1998	4.2L	4R70W	F8UP-7000-FA; PKF-AT	F8UZ-7V000-FARM
	1998	4.6L	4R70W	F8UP-7000-HA; PKF-AV	F8UZ-7V000-HARM
	1998	5.4L	E4OD	F7UP-7000-UA; 3.31- 3.73 Axle Ratio	F7UZ-7V000-UARM
	1998		4R100	F8UP-7000-NA; F8UP-7000-LA, NA; 8TSG, 3.55/3.73 Axle Ratio; PRB-U,W	F8UZ-7V000-LARM
	1998		4R100	F8UP-7000-NA; F8UP-7000-LA, NA; 8TSG, 3.55/3.73 Axle Ratio; PRB-U,W; PRB-W	F8UZ-7V000-LARM
	1998		4R100	F8UP-7000-RA; DSO,7TSG, 4.10 Axle Ratio; PRB-Z	F8UZ-7V000-RARM
	1998-1997		E4OD	F7UP-7000-PB; DSO, 7TSG, 4.10 and up Axle Ratio; PRA-XBA	F7UZ-7V000-PBRM
	1998		E4OD	F7UP-7000-PA; DSO, 7TSG, 4.10 Axle Ratio; PRA-RAA	F7UZ-7V000-PBRM
	1998	5.4L CNG	4R100	F8UP-7000-PA; 7TSG, 4.10 Axle Ratio; PRB-X	F8UZ-7V000-PARM
	1998		4R100	F8UP-7000-AA; 7TSG, 4.10 Axle Ratio; PRB-L	F8UZ-7V000-PARM
	1998	6.8L	4R100	F8UP-7000-CA; 7TSG, 4.10 Axle Ratio; PRB-N	F8UZ-7V000-CARM
	1998		4R100	F8UP-7000-SA; 7TSG, 4.10 Axle Ratio; PRB-AA	F8UZ-7V000-CARM
	1998		4R100	XC2P-7000-VA; 7TSG, 4.10 Axle Ratio; PRB-AA	F8UZ-7V000-CARM
	1998		E4OD	F7UP-7000-MA	F7UZ-7V000-MRM
	1998-1997		E4OD	F7UP-7000-FA; 8TSG	F7UZ-7V000-FRM
	1998-1997		E4OD	F7UP-7000-GA; 7TSG	F7UZ-7V000-GRM
	1998	7.3L	E4OD	F7UP-7000-JA; PRA-LCA; 7TSG, 4.10 Axle Ratio	F7UZ-7V000-JRM
	1998		E4OD	F7UP-7000-NA; PRA-WAA; 4.63 Axle Ratio	F7UZ-7V000-NRM
	1998		4R100	F8UP-7000-EA; 7TSG, 4.10/TSS Axle Ratio; PRB-R	YC2Z-7V000-KRM
	1997	5.4L	E4OD	F7UP-7000-EA,EB; 7TSG, 4.10 Axle Ratio; PRA-RAA	F7UZ-7V000-EARM
	1997		E4OD	F7TP-7000-UA; DSO	F7TZ-7V000-NARM
	1997		E4OD	F7UP-7000-PA; DSO, 7TSG, 4.10 and up Axle Ratio; PRA-XBA	F7UZ-7V000-PBRM
	1997	6.8L	E4OD	F7UP-7000-RA; DSO, 7TSG, 4.10 and up Axle Ratio	F7UZ-7V000-GRM
	1997	7.3L	E4OD	F7UP-7000-JA; 7TSG, 4.10 Axle Ratio; PRA-LCA	F7UZ-7V000-JRM
	1997		E4OD	F7UP-7000-TA; DSO; PRA-XHA	F7UZ-7V000-JRM
	1997		E4OD	F7UP-7000-NA; PRA-WAA	F7UZ-7V000-NRM
	1996	5.8L	E4OD	F6UP-7000-DA; PRA-FB10; 3.54/3.55/3.73/4.09/4.10 Final Drive Ratio	F6UZ-7V000-DARM
	1996	7.3L	E4OD	F6UP-7000-GA; 4.10 Final Drive Ratio; PRA-RC10	F6UZ-7V000-GARM
	1996	7.5L	E4OD	F6UP-7000-HA; 3.54/4.09/4.10 Final Drive Ratio; PRA-GC10	F6UZ-7V000-HARM
	1995	4.9L	E4OD	F5UP-7000-BB; PRA-DB; 3.08/3.31/3.55/3.73 Axle Ratio	F5UZ-7V000-BRM
	1995	5.8L	E4OD	F5UP-7000-DB; PRA-FB; 3.54/3.55/3.73/4.09/4.10 Final Drive Ratio	F5UZ-7V000-DRM
	1995	7.3L	E4OD	F5UP-7000-HB; 4.10 Final Drive Ratio; PRA-RC1	F5UZ-7V000-HRM
	1995	7.5L	E4OD	F5UP-7000-FB; 4.10/4.56 Final Drive Ratio; PRA-PC	F5UZ-7V000-FRM
	1995		E4OD	F5UP-7000-EB; 3.54/4.09/4.10 Final Drive Ratio; PRA-GC	F5UZ-7V000-ERM
	1994	4.9L	E4OD	F2UP-7000-DC; PRA-DA15; 3.08/3.31/3.55/3.73 Axle Ratio	F2TZ-7V000-BRM
	1994	5.8L	E4OD	F2UP-7000-EC; PRA-FA15; 3.54/3.55/3.73/4.09/4.10 Final Drive Ratio	F2TZ-7V000-FRM
	1994		E4OD	F2UP-7000-EC; 3.55 Axle Ratio; 3.54/3.55/3.73/4.09/4.10 Final Drive Ratio	F2TZ-7V000-FRM
	1994	7.3L	E4OD	F4UP-7000-BA, CA; 4.56 Axle Ratio; PRA-EAA2, FAA2	F4UZ-7V000-CRM
	1994		E4OD	F3UP-7000-FA; 4.10 Final Drive Ratio; PRA-RB5	F2UZ-7V000-NRM
	1994	7.5L	E4OD	F3UP-7000-CA; 4.10/4.56 Final Drive Ratio; PRA-PB4	F3UZ-7V000-CRM
	1994		E4OD	F3UP-7000-BA; 3.54/4.09/4.10 Final Drive Ratio; PRA-GB4	F2TZ-7V000-JRM
	1993-1992	4.9L	E4OD	F2UP-7000-DC; PRA-DA	F2TZ-7V000-BRM
	1993-1992	5.8L	E4OD	F2UP-7000-EC; PRA-FA	F2TZ-7V000-FRM
	1993-1992	7.3L	E4OD	F2UP-7000-HC; PRA-JA	F2TZ-7V000-NRM
	1993		E4OD	F3UP-7000-EA; PRA-JB	F2TZ-7V000-NRM
	1993		E4OD	F2UP-7000-NA; PRA-RA	F2UZ-7V000-NRM
	1993-1992	7.5L	E4OD	F2UP-7000-MA; PRA-PA	F3UZ-7V000-CRM
	1993-1992		E4OD	F2UP-7000-GA; PRA-GA	F2TZ-7V000-JRM
	1993		E4OD	F3UP-7000-BA; PRA-GB	F2TZ-7V000-JRM
	1992	4.9L	E4OD	F2TP-7000-BA; PRA-Y	F2TZ-7V000-BRM
	1992		E4OD	F2UP-7000-DA; PRA-DA	F2TZ-7V000-BRM
	1992	5.8L	E4OD	F2UP-7000-EA; PRA-FA	F2TZ-7V000-FRM
	1992		E4OD	F2TP-7000-FA; PRA-P	F2TZ-7V000-FRM
	1992	7.3L	E4OD	F2UP-7000-HA; PRA-JA	F2TZ-7V000-NRM
	1992		E4OD	F2TP-7000-NA; PRA-L	F2TZ-7V000-NRM
	1992		E4OD	F2TP-7000-JA; PRA-J	F2TZ-7V000-JRM
	1991-1990	5.8L	E4OD	F0TP-7000-AA; 3.54/3.73 Final Drive Ratio; PRA-P	F0TZ-7V000-ARM
	1991-1990		E4OD	F0UP-7000-HA; 3.54/3.73 Final Drive Ratio; PRA-FA	F0TZ-7V000-ARM
	1991-1990		E4OD	F0TP-7000-EA; 3.54 Final Drive Ratio; PRA-V	F0TZ-7V000-ERM
	1991-1990		E4OD	F0TP-7000-EA; PRA-V; E250 3.54 Final Drive Ratio	F0TZ-7V000-ERM
	1991-1990		E4OD	F0UP-7000-EA; 3.54 Final Drive Ratio; PRA-CA	F0TZ-7V000-ERM
	1991-1990		E4OD	F0UP-7000-EA; PRA-CA; E250 3.54 Final Drive Ratio	F0TZ-7V000-ERM
	1991-1990	7.3L	E4OD	F0UP-7000-LA; 4.10 Final Drive Ratio; PRA-JA	F0TZ-7V000-LRM
	1991		E4OD	F0TP-7000-ACA; 4.10 Final Drive Ratio; PRA-L	F0TZ-7V000-LRM
	1990	5.8L	E4OD	F0UP-7000-HA; PRA-FA; 3.54/3.73/4.10 Final Drive Ratio	F0TZ-7V000-ARM
	1990	7.3L	E4OD	F0TP-7000-WA; 4.10 Final Drive Ratio; PRA-L	F0TZ-7V000-LRM



**Edge**

Part Type	Years	Engine	Trans	Qualifier	Ford #	
Automatic - New	2016		6F35	FWD; DG9P-7000-YA; Standard Electric Starter	DG9Z-7000-Y	
	2016		6F35	FWD; F2GP-7000-BA; w/ Stop/Start System	F2GZ-7000-B	
	2016		6F55	6 Spd.; FWD; F2GP-7000-TC	F2GZ-7000-T	
	2016		6F55	6 Spd.; AWD; F2GP-7000-YC	F2GZ-7000-Y	
	2016	2.0L	6F35	AWD; DG9P-7000-ZA	DG9Z-7000-Z	
	2016-2014	3.5L	6F50	FWD; DA8P-7000-MB; 3.16 Final Drive Ratio	DA8Z-7000-M	
	2016		6F50	6 Spd.; AWD; DA8P-7000-NC	DA8Z-7000-NC	
	2015-2014	2.0L	6F35	FWD; DT4P-7000-NA; 3.21 Final Drive Ratio	DT4Z-7000-N	
	2015-2014		6F35	FWD; DE9P-7000-LA; 3.36 Final Drive Ratio	DE9Z-7000-L	
	2014	3.7L	6F50	FWD; DA8P-7000-AB; 3.16 Final Drive Ratio	DA8Z-7000-J	
	2013	2.0L	6F35	FWD; DT4P-7000-NA; From 7/30/12; 3.21 Final Drive Ratio	DT4Z-7000-N	
	2013		6F35	FWD; DE9P-7000-LA; From 7/30/12; 3.36 Final Drive Ratio	DE9Z-7000-L	
	2013		6F35	BB5P-7000-LC; 3.36 Final Drive Ratio	BB5Z-7000-L	
	2013-2011	3.5L	6F35	CT4P-7000-NC; 3.21 Final Drive Ratio	CT4Z-7000-N	
	2013		6F50	FWD; DA8P-7000-MB; 3.16 Final Drive Ratio; From 5/6/13	DA8Z-7000-M	
	2013		6F50	AWD; DA8P-7000-RB; 3.16 Final Drive Ratio; From 4/18/13	DA8Z-7000-Y	
	2013		6F50	AWD; DA8P-7000-RA; 3.16 Final Drive Ratio; Before 4/18/13	DA8Z-7000-H	
	2013-2011	3.7L	6F35	CT4P-7000-NC; 3.21 Final Drive Ratio	CT4Z-7000-N	
	2013		6F50	FWD; DA8P-7000-AA; 3.16 Final Drive Ratio; Before 5/06/13	DA8Z-7000-C	
	2013		6F50	FWD; DA8P-7000-AB; 3.16 Final Drive Ratio; From 5/6/13	DA8Z-7000-J	
	2012	2.0L	6F35	BB5P-7000-LC; Before 7/30/12; 3.36 Final Drive Ratio	BB5Z-7000-L	
	2012-2011	3.5L	6F50	AWD; BA8P-7000-GC; 3.16 Final Drive Ratio	BA8Z-7000-N	
	2012-2011		6F50	FWD; BA8P-7000-MC	BA8Z-7000-P	
	2012-2011		6F50	AWD; 3.39 Final Drive Ratio	BA8Z-7000-R	
	2012-2011	3.7L	6F50	FWD; BA8P-7000-AC	BA8Z-7000-L	
	2010		6F50	FWD; AA8P-7000-FC	AA8Z-7000-S	
	Automatic - Reman	2015-2013	2.0L EcoBoost	6F35	FWD; RMET4J-7000-AA; w/ 3.21 Ratio	ET4Z-7000-ARM
		2014-2013		6F35	FWD; DE9P-7000-LA	EE9Z-7000-ARM
		2013-2012	2.0L	6F35	FWD; CT4P-7000-NC; 3.21 Final Drive Ratio	CT4Z-7000-NRM
		2013	3.5L	6F50	FWD; DA8P-7000-MB; w/ 3.16 Ratio	DA8Z-7000-FRM
		2013		6F50	AWD; DA8P-7000-RB; w/ 3.16 Ratio	DA8Z-7000-HRM
		2013		6F50	DA8P-7000-NB; w/ 3.39 Ratio	DA8Z-7000-NRM
		2013	3.7L	6F55	DA8P-7000-AB; w/ 3.16 Ratio	DA8Z-7000-CRM
2013			6F50	DA8P-7000-LB; w/ 3.39 Ratio	DA8Z-7000-ERM	
2012-2011			6F50	AWD; BA8P-7000-GB,GC; 3.16 Final Drive Ratio	BA8Z-7000-GRM	
2012		2.0L EcoBoost	6F35	FWD; BB5P-7000-LC	BB5Z-7000-LRM	
2012-2011		3.5L	6F50	AWD; BA8P-7000-NB,NC; 3.39 Final Drive Ratio	BA8Z-7000-KRM	
2012-2011			6F50	FWD; 8A8P-7000-MB,MC	BA8Z-7000-FRM	
2012-2011		3.7L	6F50	AWD; BA8P-7000-EB,EC	BA8Z-7000-ERM	
2012-2011			6F50	FWD; BA8P-7000-AB,AC	BA8Z-7000-ARM	
2011		3.5L	6F35	FWD; BE5P-7000-JB	BE5Z-7000-ARM	
2011			6F35	FWD; BL8P-7000-EB	BL8Z-7000-ERM	
2011		3.7L	6F35	AWD; BL8P-7000-FB	BL8Z-7000-FRM	
2011			6F35	FWD; BE5P-7000-JB	BE5Z-7000-ARM	
2011			6F35	FWD; BL8P-7000-EB	BL8Z-7000-ERM	
2011			6F35	AWD; BL8P-7000-FB	BL8Z-7000-FRM	
2010-2009		3.5L	6F50	AWD; AA8P-7000-GA; 3.16 Final Drive Ratio	AA8Z-7000-GRM	
2009-2007			6F50	AWD; 7T4P-7000-BA,BB,BC; 3.16 Final Drive Ratio	7T4Z-7000-ARM	
2009			6F50	AWD; 7A1P-7000-BC; 3.39 Final Drive Ratio	7A1Z-7000-ARM	
2009-2008			6F50	FWD; 7T4P-7000-AA, AB, AC; 3.16 Final Drive Ratio	8T4Z-7000-ARM	
2009			6F50	AWD; AA8P-7000-KA,KB,KC; 3.39 Final Drive Ratio	AA8Z-7000-KRM	
2009			6F50	FWD; AA8P-7000-FA,FB,FC	AA8Z-7000-FRM	
2007			6F50	FWD; 7T4P-7000-CA,CB,CC; 2.77 Final Drive Ratio	7T4Z-7000-BRM	

**Escape**

Part Type	Years	Engine	Trans	Qualifier	Ford #
Automatic - New	2017	1.5L EcoBoost	6F35	FWD; GV6P-7000-AA	GV6Z-7000-A
	2017		6F35	4WD; GV6P-7000-RA	GV6Z-7000-B
	2017	2.0L EcoBoost	6F35	FWD; GV6P-7000-DA	GV6Z-7000-C
	2017		6F35	4WD; GV6P-7000-EA	GV6Z-7000-D
	2017	2.5L	6F35	FWD	CV6Z-7000-VD
	2016-2015	1.6L EcoBoost	6F35	FWD; CV6P-7000-FA	CV6Z-7000-FA
	2016-2014		6F35	4WD; CV6P-7000-EA	CV6Z-7000-X
	2016-2014	2.0L EcoBoost	6F35	4WD; CV6P-7000-HA	CV6Z-7000-HA
	2016	2.5L	6F35	CV6P-7000-VC	CV6Z-7000-Y
	2015	1.6L EcoBoost	6F35	FWD; CV6P-7000-CC; Before 10/22/14	CV6Z-7000-E
	2015-2013		6F35	4WD; CV6P-7000-DB	CV6Z-7000-X
	2014-2013		6F35	FWD; CV6P-7000-CC	CV6Z-7000-E
	2014	2.0L EcoBoost	6F35	FWD; CV6P-7000-AA; Before 4/25/14	CV6Z-7000-A
	2014		6F35	4WD; CV6P-7000-BA; Before 4/20/14	CV6Z-7000-B
	2014		6F35	FWD; CV6P-7000-AB; From 4/25/14	CV6Z-7000-W
	2014-2013	2.5L	6F35	FWD; CV6P-7000-VA	CV6Z-7000-V
	2013	2.0L EcoBoost	6F35	FWD; CV6P-7000-AA	CV6Z-7000-A
	2013		6F35	4WD; CV6P-7000-BA	CV6Z-7000-B
	2012-2011	2.5L	6F35	4WD; BL8P-7000-GB	BL8Z-7000-H
	2012-2011		6F35	FWD; BL8P-7000-GB	BL8Z-7000-G
	2012-2009	2.5L ELECTRIC/GAS	CVT (CFT30)	CM68-7000-AA; w/ Power Split	AM6Z-7000-A
	2012-2011	3.0L	6F35	4WD; BL8P-7000-FB	BL8Z-7000-F



**Escape**

-Cont'd

Part Type	Years	Engine	Trans	Qualifier	Ford #
Automatic - New	2012-2011	3.0L	6F35	FWD; BL8P-7000-EB	BL8Z-7000-E
	2008	2.3L ELECTRIC/GAS	CVT (CFT30)	8M64-7000-AH; w/ Power Split	8M6Z-7000-D
Automatic - Reman	2007-2006		CVT (CFT30)	7M64-7000-AD; w/ Power Split	7M6Z-7000-A
	2005			5M64-7000-DF	5M6Z-7000-B
	2015	1.6L EcoBoost		AWD; RMEV6J-7000-DA	CV6Z-7000-XRM
	2014-2013			AWD; RMEV6J-7000-DA	EV6Z-7000-DRM
	2014	2.0L EcoBoost	6F35	FWD; RMEV6J-7000-AA; Before 4/25/14	EV6Z-7000-ARM
	2014		6F35	4WD; RMEV6J-7000-BA; Before 4/20/14	EV6Z-7000-BRM
	2014-2013	2.5L	6F35	FWD; RMEV6J-7000-EA	EV6Z-7000-ERM
	2013	1.6L EcoBoost		FWD; RMEV6J-7000-CA	EV6Z-7000-CRM
	2013	2.0L EcoBoost	6F35	FWD; RMEV6J-7000-AA	EV6Z-7000-ARM
	2013		6F35	4WD; RMEV6J-7000-BA	EV6Z-7000-BRM
	2011	2.5L DOHC	6F35	FWD; BL8P-7000-GB	BL8Z-7000-GRM
	2011		6F35	AWD; BL8P-7000-HB	BL8Z-7000-HRM
	2011	3.0L	6F35	FWD; BE5P-7000-JB	BE5Z-7000-ARM
	2011		6F35	FWD; BL8P-7000-EB	BL8Z-7000-ERM
	2011		6F35	AWD; BL8P-7000-FB	BL8Z-7000-FRM
	2010-2009	2.5L	6F35	FWD; 9L8P-7000-GA	9L8Z-7000-CRM
	2010-2009	3.0L	6F35	4WD; 9L8P-7000-FA	9L8Z-7000-BRM
	2009	2.5L	6F35	4WD; 9L8P-7000-HA	9L8Z-7000-DRM
	2009	3.0L	6F35	FWD; 9L8P-7000-EA	9L8Z-7000-ARM
	2008	2.3L	CD4E	FWD; 8L8P-7000-AA	8L8Z-7000-ARM
	2008		CD4E	4WD; 8L8P-7000-BA	8L8Z-7000-BRM
	2008	3.0L	CD4E	FWD; 8L8P-7000-CA	8L8Z-7000-CRM
	2008		CD4E	4WD; 8L8P-7000-DA	8L8Z-7000-DRM
	2007-2006	2.3L	CD4E	FWD; 7L8P-7000-AA; 6L8P-7000-AA	5L8Z-7000-ERM
	2007-2006		CD4E	4WD; 7L8P-7000-BA; 6L8P-7000-BA	5L8Z-7000-FRM
	2007-2006	3.0L	CD4E	4WD; 7L8P-7000-DA; 6L8P-7000-DA	5L8Z-7000-HRM
	2007-2006		CD4E	FWD; 6L8P-7000-CA; 7L8P-7000-CA	5L8Z-7000-GRM
	2005	2.3L	CD4E	FWD; 5L8P-7000-AC,AD,AE; PTA-P	5L8Z-7000-ACRM
	2005		CD4E	FWD; 5L8P-7000-EA,EB; PTA-P	5L8Z-7000-ERM
	2005		CD4E	4WD; 5L8P-7000-FA,FB; PTA-P	5L8Z-7000-FRM
2005		CD4E	4WD; 5L8P-7000-BC,BD,BE; PTA-P	5L8Z-7000-BCRM	
2005	3.0L	CD4E	4WD; 5L8P-7000-HA,HB; PTA-V	5L8Z-7000-HRM	
2005		CD4E	FWD; 5L8P-7000-GA,GB; PTA-V	5L8Z-7000-GRM	
2005		CD4E	4WD; 5L8P-7000-DB,DC,DD; PTA-V	5L8Z-7000-DBRM	
2005		CD4E	FWD; 5L8P-7000-CB,CC,CD; PTA-V	5L8Z-7000-CBRM	
2004		CD4E	4WD; 3L8P-7000-HD; 5L8P-7000-KA; PTA-V	3L8Z-7000-HDRM	
2004		CD4E	FWD; 5L8P-7000-JA; 3L8P-7000-GD; PTA-V	3L8Z-7000-GDRM	
2003	2.0L	CD4E	4WD; RM8U2J-7G497-AKA	3L8Z-7V000-HCRM	
2003	3.0L	CD4E	4WD; 3L8P-7000-HA; PTA-V	3L8Z-7000-HARM	
2003		CD4E	FWD; 3L8P-7000-GA; PTA-V	3L8Z-7000-GARM	
2003		CD4E	4WD; 3L8P-7000-HB,HC; PTA	3L8Z-7V000-HCRM	
2002		CD4E	4WD; 2L8P-7000-FA, FB; PTA-V	2L8Z-7V000-FBRM	
2002		CD4E	FWD; 2L8P-7000-EA, EB; PTA-V	2L8Z-7V000-EBRM	
2001		CD4E	FWD; YL8P-7000-EA	YL8Z-7V000-ERM	
2001		CD4E	4WD; YL8P-7000-FB	YL8Z-7V000-FRM	

**Excursion**

Part Type	Years	Engine	Trans	Qualifier	Ford #
Automatic - Reman	2005-2001	5.4L	4R100	4WD; 1C3P-7000-BA,BB,BC; PRB-GE, GE1	1C3Z-7V000-BRM
	2005-2001		4R100	RWD; 1C3P-7000-NA,NB,NC; PRB-GR, GR1	1C3Z-7V000-NRM
	2005	6.0L DIESEL	5R110W	RWD; 5C3P-7000-NC; PRB; TorqShift	5C3Z-7000-NRM
	2005-2001	6.8L	4R100	4WD; 1C3P-7000-DA,DB,DC; PRB-GG, GG1	1C3Z-7V000-DRM
	2005-2001		4R100	RWD; 1C3P-7000-PA,PB,PC; PRB-GS, GS1	1C3Z-7V000-PRM
	2004-2003	6.0L DIESEL	5R110W	RWD; RM8U2J-7G497-AFA; Slip Yoke; TorqShift	3C3Z-7V000-KDRM
	2003	6.0L	5R110W	4WD; 3C3P-7000-GB, GH, GK; PRB-JF; PRB-JA; PRB-HV; TorqShift	4C3Z-7000-KBRM
	2003-2001	7.3L	4R100	4WD; 1C3P-7000-FA, FB; Normal Service; PRB-GJ, GJ1	1C3Z-7V000-FRM
	2003-2001		4R100	4WD; 1C3P-7000-FA, FB; Heavy Duty Service; PRB-GJ, GJ1	6U2Z-7V000-FRM
	2003-2001		4R100	RWD; 1C3P-7000-EA, EB; Normal Service; PRB-GH, GH1	1C3Z-7V000-ERM
	2003-2001		4R100	RWD; 1C3P-7000-EA, EB; Heavy Duty Service; PRB-GH, GH1	6U2Z-7V000-ERM
	2000	5.4L	4R100	RWD; YC3P-7000-NA; PRB-CK	YC3Z-7V000-ARM
	2000		4R100	4WD; YC3P-7000-BA, RA; PRB-BP, CU	YC3Z-7V000-BRM
	2000	6.8L	4R100	4WD; YC3P-7000-DA, SA; PRB-BS, CV	YC3Z-7V000-DRM
	2000		4R100	RWD; YC3P-7000-PA; PRB-CL	YC3Z-7V000-CRM
	2000	7.3L	4R100	4WD; YC3P-7000-FA, FB; PRB-CR; PRB-BU	1C3Z-7V000-FRM
	2000		4R100	RWD; YC3P-7000-EA, EB; PRB-BT; PRB-CP	1C3Z-7V000-ERM

**Expedition**

Part Type	Years	Engine	Trans	Qualifier	Ford #
Automatic - New	2016-2015	3.5L EcoBoost	6R80	RWD; FL3P-7000-CA	FL3Z-7000-C
	2014-2012	5.4L	6R80	RWD; CL1P-7000-AC	CL1Z-7000-A
	2014-2012		6R80	4WD; CL1P-7000-BC	CL1Z-7000-B
	2011-2009		6R80	RWD; BL1P-7000-AB	BL1Z-7000-A
	2011		6R80	4WD; BL1P-7000-BB	BL1Z-7000-B

**TRANSMISSIONS**  
**Light Trucks**  
**Ford**



**FORD PARTS**

**Expedition**

**-Cont'd**

Part Type	Years	Engine	Trans	Qualifier	Ford #
Automatic - Reman	2012	5.4L	6R80	4WD; CL1P-7000-BA	CL1Z-7000-BRM
	2012		6R80	RWD; CL1P-7000-AA	CL1Z-7000-ARM
	2011		6R80	4WD; BL1P-7000-BA,BB	BL1Z-7000-BRM
	2011	5.4L SOHC	6R80	RWD; BL1P-7000-AA,AB	BL1Z-7000-ARM
	2010		6R80	RWD; AL3P-7000-AA,AB,AC,AD	AL3Z-7000-ARM
	2010		6R80	4WD; AL1P-7000-BA,BB,BC,BD	AL1Z-7000-ARM
	2009	5.4L	6R80	RWD; 9L3P-7000-AF,AG,AH, NA,NB	9L3Z-7000-EARM
	2009		6R80	4WD; 9L3P-7000-BF,BG; 9L1P-7000-DC/DD, EA/EB	9L1Z-7000-BRM
	2008-2007		6R75	RWD; 7L1P-7000-AD,AE,AF,CA,CB	7L1Z-7000-ARM
	2008	5.4L	6R80	RWD; 8L1P-7000-CB, CC	8L1Z-7000-CRM
	2008		6R80	4WD; 8L1P-7000-DB, DC	8L1Z-7000-DRM
	2007		6R80	4WD; 7L1P-7000-BD,BE,BF,DA,DB	7L1Z-7000-BRM
	2006	5.4L	4R75W	4WD; 6L1P-7000-BA,BB; PKF-EZ,FZ	6L1Z-7000-BRM
	2006		4R75W	RWD; 6L1P-7000-AA,AB; PKF-EY,FY	6L1Z-7000-ARM
	2005		4R75E	RWD; 5L1P-7000-EA; PKF-DX	5L1Z-7000-ERM
	2005	4.6L	4R75E	4WD; 5L1P-7000-FA; PKY-DZ	5L1Z-7000-FRM
	2004		4R70W	4WD; 4L1P-7000-BA; PKF-DT	4L1Z-7000-BARM
	2004		4R70W	RWD; 4L1P-7000-AA; PKF-DS	4L1Z-7000-AARM
	2004	5.4L	4R70W	RWD; 4L1P-7000-CA; PKF-DU	4L1Z-7000-CARM
	2004		4R70W	4WD; 4L1P-7000-DA; PKF-DV	4L1Z-7000-DARM
	2003		4R70W	4WD; 2L1P-7000-DA; PKF-CW	2L1Z-7V000-DRM
	2003	4.6L	4R70W	RWD; 2L1P-7000-CA; PKF-CV	2L1Z-7V000-CRM
	2003		4R70W	RWD; 2L1P-7000-EA; PKF-CX	2L1Z-7V000-ERM
	2003		4R70W	4WD; 2L1P-7000-FA; PKF-CY	2L1Z-7V000-FRM
	2002-2001	4.6L	4R70W	4WD; 1L3P-7000-HA; PKF-CP	1L3Z-7V000-HRM
	2002-2001		4R70W	RWD; 1L3P-7000-FA; PKF-CN	1L3Z-7V000-FRM
	2002-2001		4R100	4WD; 1L3P-7000-BA,BB,BC; PRB-DY,FT	1C3Z-7V000-BRM
	2002-2001	4.6L	4R100	RWD; 1L1P-7000-AA,AB,AC; PRB-DW,FR,GT	1C3Z-7V000-NRM
	2000		4R70W	4WD; YL3P-7000-JA; PKF-CB	YL3Z-7V000-JRM
	2000		4R70W	RWD; YL3P-7000-HA; PKF-CA	YL3Z-7V000-HRM
	2000-1999	5.4L	4R100	RWD; XL7P-7000-AA,GB; PRB-BC,BF,CF	XL3Z-7V000-GBRM
	2000-1999		4R100	4WD; YL3P-7000-BA,HB; PRB-BD,CD	YC3Z-7V000-BRM
	1999		4R70W	RWD; XL1P-7000-AA; PKF-AL	XL3Z-7V000-EARM
1999	4.6L	4R70W	RWD; XL3P-7000-EA; PKF-AR	XL3Z-7V000-EARM	
1998		4R70W	RWD; F85P-7000-EA; PKF-BA	F85Z-7V000-EARM	
1998		5.4L	4R100	RWD; F8UP-7000-LA, NA; PRB-U,W; 3.31/3.73 Axle Ratio	F8UZ-7V000-LARM
1998	4R100		4WD; F8UP-7000-MB; 3.08/3.31/3.55/3.73 Axle Ratio; PRB-V	F8UZ-7V000-MBRM	
1998	4R100		RWD; F8UP-7000-LC; 8TSG; PRB-AC	F8UZ-7V000-LCRM	
1997	4.6L	4R70W	RWD; F75P-7000-LC, LD; 3.31/3.73 Axle Ratio	F75Z-7V000-LCRM	

**Explorer**

Part Type	Years	Engine	Trans	Qualifier	Ford #
Automatic - New	2016-2013	2.3L	6F50	4WD; DA8P-7000-KA	DA8Z-7000-G
	2016		6F35	FB5P-7000-AA; 3.36 Final Drive Ratio	FB5Z-7000-A
	2016		6F35	FB5P-7000-BA; 3.51 Final Drive Ratio	FB5Z-7000-B
	2016	3.5L	6F35	4WD; FB5P-7000-DA	FB5Z-7000-D
	2016-2014		6F55	4WD; Naturally Aspirated; DA5P-7000-EB; w/ 3.65 Final Drive Ratio	DA5Z-7000-N
	2016-2014		6F55	FWD; DA5P-7000-JB	DA5Z-7000-P
	2016-2014	3.5L EcoBoost	6F55	4WD; DA8P-7000-KB	DA8Z-7000-D
	2015-2013		6F35	FWD; DE9P-7000-LA; 3.36 Final Drive Ratio	DE9Z-7000-L
	2015-2013		6F35	FWD; DB5P-7000-SA; 3.51 Final Drive Ratio	DB5Z-7000-S
	2013	2.0L	6F50	FWD; DA8P-7000-CA; 3.39 Final Drive Ratio	DA8Z-7000-A
	2013		6F35	BL1P-7000-AB	BL1Z-7000-A
	2013-2012		6F35	BB5P-7000-SB; 3.51 Final Drive Ratio	BB5Z-7000-S
	2013	2.0L EcoBoost	6F35	BB5P-7000-LC; 3.36 Final Drive Ratio	BB5Z-7000-L
	2013		6F55	4WD; DA5P-7000-EB	DA5Z-7000-N
	2013		6F55	FWD	DA5Z-7000-E
	2012	2.0L EcoBoost	6F35	BB5P-7000-LC; Before 9/4/12; 3.36 Final Drive Ratio	BB5Z-7000-L
	2012-2011		6F55	FWD	BA5Z-7000-D
	2012-2011		6F55	AWD	BA5Z-7000-E
	2012	2.0L	6F50	FWD; BA8P-7000-MC	BA8Z-7000-P
	2012		6F50	4WD; 3.39 Final Drive Ratio	BA8Z-7000-R
	2010		5R55S	RWD	AL2Z-7000-C
	2010-2009	4.6L	6R80	4WD	AL2Z-7000-B
	2016		2.3L	6 Spd.; FWD; RMGA8J-7000-BA	DA8Z-7000-KRM
	2016		2.3L EcoBoost	6F35	FWD
	2016-2015	3.5L	6F35	6 Spd.; FWD; RMGA8J-7000-BA	DA8Z-7000-KRM
	2015		2.0L	6 Spd.; FWD; RMGA8J-7000-BA	DA8Z-7000-KRM
	2014-2013		2.0L EcoBoost	6F35	FWD; DE9P-7000-LA
	2014-2013	3.5L	6F35	FWD; DB5P-7000-SA	EB5Z-7000-ARM
	2013		6F50	AWD; Limited; DA8P-7000-KB	DA8Z-7000-GRM
	2013		6F55	4WD; w/ Duratec Engine; DA5P-7000-EB	DA5Z-7000-ARM
	2013	3.5L EcoBoost	6F50	FWD; w/ Duratec Engine; DA5P-7000-JB	DA5Z-7000-ERM
	2013		6F50	DA8P-7000-CB; w/ 3.39 Ratio	DA8Z-7000-ARM
	2013		6F55	4WD; DA5P-7000-DB; w/ 3.16 Ratio	DA5Z-7000-DRM
2012	2.0L EcoBoost	6F35	FWD; BB5P-7000-LC	BB5Z-7000-LRM	
2012-2011		6F50	AWD; BA8P-7000-NB,NC; 3.39 Final Drive Ratio	BA8Z-7000-KRM	
2012-2011		6F50	FWD; 8A8P-7000-MB,MC; 3.16 Final Drive Ratio	BA8Z-7000-FRM	





**Explorer**

-Cont'd

Part Type	Years	Engine	Trans	Qualifier	Ford #
Automatic - Reman	2012-2011	3.5L	6F55	FWD; BA5P-7000-PC,PD; 3.16 Final Drive Ratio	BA5Z-7000-BRM
	2012-2011		6F55	4WD; BA5P-7000-RC,RD; 3.39 Final Drive Ratio	BA5Z-7000-CRM
	2011		6F35	FWD; BE5P-7000-JB	BE5Z-7000-ARM
	2011		6F35	FWD; BL8P-7000-EB	BL8Z-7000-ERM
	2011	4.0L	6F35	AWD; BL8P-7000-FB	BL8Z-7000-FRM
	2010-2009		5R55S	RWD; 9L2P-7000-CA	9L2Z-7000-CRM
	2010		6R80	RWD; AL2P-7000-AA	AL2Z-7000-ARM
	2010		6R80	4WD; AL2P-7000-BA	AL2Z-7000-BRM
	2009	4.0L	6R80	RWD; 9L2P-7000-EB	9L2Z-7000-CARM
	2009		6R80	RWD; 9L2P-7000-AB,AE,AG, EA,EB	9L2Z-7000-CARM
	2009	4.6L	6R80	4WD; 9L2P-7000-BB,BE,BG, FA,FB	9L2Z-7000-DARM
	2009		6R80	AWD; 9L2P-7000-BB,BE,BG, FA,FB	9L2Z-7000-DARM
	2008-2007	4.0L	6R60	4WD; 8L2P-7000-BA; 7L2P-7000-BC,BD,BE, FB	7L2Z-7000-BRM
	2008		6R60	4WD; 8L2P-7000-HB/HC	8L2Z-7000-FRM
	2008		6R60	RWD; 8L2P-7000-GB/GC	8L2Z-7000-ERM
	2007		6R60	RWD; 8L2P-7000-AA; 7L2P-7000-AC,AD,AE,EB	7L2Z-7000-ARM
	2006	4.0L	5R55S	RWD; 6L2P-7000-EB,EC	4L2Z-7000-ABRM
	2006-2005		5R55E	RWD; 5L5P-7000-DB,DC	5L5Z-7000-DRM
	2006	4.6L	5R55S	4WD; 6L2P-7000-FB, FC	6L2Z-7000-FRM
	2006		5R55S	RWD; RM6L2J-7000-ED	6L2Z-7000-ERM
	2006		6R60	RWD; 6L2P-7000-AD,AG,AH,AK,AL,AM,AN,AP	6L2Z-7000-ARM
	2006		6R60	4WD; 6L2P-7000-BG,BH,BK,BL,BM,BN,BP	6L2Z-7000-BRM
	2005	4.0L	5R55S	4WD; 4L2P-7000-BB	4L2Z-7000-BBRM
	2005-2004		5R55S	RWD; 4L2P-7000-AB; R/JL	4L2Z-7000-ABRM
	2005-2004	4.6L	5R55S	RWD; 4L2P-7000-CC; R/JL	4L2Z-7000-CCRM
	2005-2004		5R55S	AWD; 4L2P-7000-DC; R/JL	4L2Z-7000-DCRM
	2005-2004	4.0L	5R55S	4WD; 4L2P-7000-DC; R/JL	4L2Z-7000-DCRM
	2004		5R55E	RWD; 4L5P-7000-DA; R/JL	4L5Z-7000-DARM
	2004		5R55S	AWD; 4L2P-7000-BB; R/JL	4L2Z-7000-BBRM
	2004		5R55S	4WD; 4L2P-7000-BB; R/JL	4L2Z-7000-BBRM
	2003-2002	4.0L	5R55W	RWD; 2L2P-7000-AA	2L2Z-7V000-AARM
	2003-2001		5R55E	RWD; Sport; 1L5P-7000-DA,FA	1L5Z-7V000-DRM
	2003-2001		5R55E	AWD; Sport; 1L5P-7000-EA	1L5Z-7V000-ERM
	2003-2002		5R55E	4WD; Sport; 1L5P-7000-EA	1L5Z-7V000-ERM
	2003-2002	4.6L	5R55W	4WD; 2L2P-7000-BA	2L2Z-7V000-BARM
	2003-2002		5R55S	RWD; 2L2P-7000-CA	2L2Z-7V000-CARM
	2003-2002		5R55S	4WD; 2L2P-7000-DA	2L2Z-7V000-DARM
	2002		5R55E	RWD; 2L2P-7000-AA	2L2Z-7V000-AARM
	2002	4.0L	5R55W	RWD; 1L2P-7000-AE	1L2Z-7V000-ARM
	2002		5R55W	4WD; 1L2P-7000-BE	1L2Z-7V000-BRM
	2002		5R55W	4WD; 1L2P-7000-DE	1L2Z-7V000-DRM
	2002		5R55W	RWD; 1L2P-7000-CE	1L2Z-7V000-CRM
	2001	4.0L SOHC	5R55E	4WD; 1L5P-7000-EA	1L5Z-7V000-ERM
	2001-1999	5.0L	4R70W	4WD; XL2P-7000-BA; PKF-BL	XL2Z-7V000-BARM
	2001-1999		4R70W	AWD; XL2P-7000-BA; PKF-BL	XL2Z-7V000-BARM
	2001-1999	4.0L OHV	4R70W	RWD; XL2P-7000-AA; PKF-BK	XL2Z-7V000-AARM
	2000-1999		5R55E	4WD; XL2P-7000-FA	XL2Z-7V000-FARM
2000-1999	4.0L SOHC	5R55E	AWD; XL2P-7000-FA	XL2Z-7V000-FARM	
2000-1999		5R55E	RWD; XL2P-7000-CA	XL2Z-7V000-CARM	
2000-1999		5R55E	AWD; XL2P-7000-DA	XL2Z-7V000-DARM	
2000-1999		5R55E	4WD; XL2P-7000-DA	XL2Z-7V000-DARM	
1998	4.0L	5R55E	4WD; 98GT-7000-AAA	F87Z-7V000-CARM	
1998		5R55E	AWD; 98GT-7000-AAA	F87Z-7V000-CARM	
1998		5R55E	RWD; 98GT-7000-BAA	F87Z-7V000-DARM	
1997		5R55E	AWD; 97GT-7000-ACA,AEA	F77Z-7V000-AARM	
1996-1995	4.0L	5R55E	4WD; 97GT-7000-ACA,AEA	F77Z-7V000-AARM	
1996-1995		4R55E	4WD; 96GT-7000-EBA,GAA	F68Z-7V000-EBRM	
1996-1995		4R55E	AWD; 96GT-7000-EBA,GAA	F68Z-7V000-EBRM	

**Explorer Sport Trac**

Part Type	Years	Engine	Trans	Qualifier	Ford #
Automatic - New	2010-2009	4.6L	6R80	4WD	AL2Z-7000-B
Automatic - Reman	2010-2009	4.0L	5R55S	RWD; 9L2P-7000-CA	9L2Z-7000-CRM
	2010-2009		5R55S	4WD; 9L2P-7000-DA	9L2Z-7000-DRM
2010	4.6L	6R80	RWD; AL2P-7000-AA	AL2Z-7000-ARM	
2010		6R80	4WD; AL2P-7000-BA	AL2Z-7000-BRM	
2009		6R80	RWD; 9L2P-7000-AB,AE,AG, EA,EB	9L2Z-7000-CARM	
2009		6R80	AWD; 9L2P-7000-BB,BE,BG, FA,FB	9L2Z-7000-DARM	
2008	4.0L	5R55S	RWD; 8L2P-7000-JA	8L2Z-7000-ARM	
2008		5R55S	4WD; 8L2P-7000-KA	8L2Z-7000-BRM	
2008-2007	4.6L	6R60	4WD; 7L2P-7000-BC,BD,BE, FB	7L2Z-7000-BRM	
2007	4.0L	5R55S	RWD; 7L2P-7000-CA,CB	7L2Z-7000-CRM	
2007		5R55S	4WD; 7L2P-7000-DA,DB	7L2Z-7000-DRM	
2007	4.6L	5R55S	4WD; 6L2P-7000-FB, FC	6L2Z-7000-FRM	
2007		6R60	RWD; 6L2P-7000-AL, AP	7L2Z-7000-ARM	
2007		6R60	RWD; 7L2P-7000-AB,AC,AD,AE,EB	7L2Z-7000-ARM	
2005-2004		4.0L	5R55E	4WD; 4L5P-7000-EA; R/JL	4L5Z-7000-EARM
2005		5R55E	RWD; 5L5P-7000-DB	5L5Z-7000-DRM	



**Explorer Sport Trac**

**-Cont'd**

Part Type	Years	Engine	Trans	Qualifier	Ford #
Automatic - Reman	2003-2001 2003-2001	4.0L	5R55E 5R55E	RWD; 1L5P-7000-DA,FA 4WD; 1L5P-7000-EA	1L5Z-7V000-DRM 1L5Z-7V000-ERM

**F-Series**

Part Type	Years	Engine	Trans	Qualifier	Ford #
Automatic - New	2018	2.7L EcoBoost	10R80	4WD; JL3P-7000-PA	JL3Z-7000-D
	2018	3.5L EcoBoost	10R80	4WD; JL3P-7000-PA	JL3Z-7000-D
	2017	2.7L EcoBoost	10R80	4WD; HL3P-7000-PF	HL3Z-7000-H
	2017	3.5L EcoBoost	10R80	RWD; JL3P-7000-NA	JL3Z-7000-C
	2017		10R80	4WD; HL3P-7000-PB	HL3Z-7000-B
	2017		10R80	RWD; HL3P-7000-NE	HL3Z-7000-E
	2017		10R80	4WD; Before 7-17-17; HL3P-7000-PE	HL3Z-7000-F
	2017		10R80	RWD; HL3P-7000-NF	HL3Z-7000-G
	2017		10R80	4WD; HL3P-7000-PF	HL3Z-7000-H
	2016		6R140	w/ Manual Temperature Control	AC3Z-7000-E
	2016-2011		5R110W	AC3P-7000-KA; w/ PTO; TorqShift	AC3Z-7000-K
	2016-2015	2.7L EcoBoost	6R80	RWD; FL3P-7000-GA	FL3Z-7000-G
	2016-2015		6R80	4WD; FL3P-7000-HA	FL3Z-7000-H
	2016-2015	3.5L	6R80	Naturally Aspirated; RWD; FL3P-7000-EA	FL3Z-7000-E
	2016-2015		6R80	4WD; Naturally Aspirated; w/ Ti-VCT Engine; FL3P-7000-FA; w/o Water Wading Equipment	FL3Z-7000-F
	2016-2015		HF35	4WD; Naturally Aspirated; FL3P-7000-KA; w/ Water Wading Equipment	FL3Z-7000-K
	2016-2015	3.5L EcoBoost	6R80	RWD; FL3P-7000-CA	FL3Z-7000-C
	2016		6R80	4WD; FL3P-7000-DA; w/o Water Wading Equipment; Before 9/10/15	FL3Z-7000-D
	2016-2015	5.0L	6R80	RWD; FL3P-7000-AA	FL3Z-7000-A
	2016-2015		6R80	4WD; FL3P-7000-BA; w/o Water Wading Equipment	FL3Z-7000-B
	2016-2015		6R80	4WD; FL3P-7000-JA; w/ Water Wading Equipment	FL3Z-7000-J
	2016-2015	6.2L	6R140	FC3P-7000-CA; Exc. 137 In. Wheelbase; TorqShift6	FC3Z-7000-C
	2016-2015		6R140	RWD; w/ 137.0 In. Wheelbase; FC3P-7000-FA; TorqShift6	FC3Z-7000-F
	2016-2011	6.7L	5R110W	AC3P-7000-HA; TorqShift	AC3Z-7000-H
	2016-2015	6.7L DIESEL	6R140	Cab & Chassis; FC3P-7000-DA; w/o PTO; w/ Narrow Frame; TorqShift6	FC3Z-7000-D
	2016-2015		6R140	Cab & Chassis; FC3P-7000-EA; w/ PTO; w/ Narrow Frame; TorqShift6	FC3Z-7000-E
	2016-2015		6R140	Cab & Chassis; RWD; w/ 137.0 In. Wheelbase; FC3P-7000-GA; w/o PTO; w/ Narrow Frame; TorqShift6	FC3Z-7000-G
	2016-2015		6R140	w/ 141.8 In. Wheelbase; FC3P-7000-PA; w/o PTO; TorqShift6	FC3Z-7000-P
	2016-2015		6R140	w/ 158.0 In. Wheelbase; FC3P-7000-PA; w/o PTO; TorqShift6	FC3Z-7000-P
	2016-2015		6R140	w/ 172.4 In. Wheelbase; FC3P-7000-PA; w/o PTO; TorqShift6	FC3Z-7000-P
	2016-2015		6R140	w/ 156.2 In. Wheelbase; FC3P-7000-PA; w/o PTO; TorqShift6	FC3Z-7000-P
	2016-2015		6R140	w/ 141.8 In. Wheelbase; FC3P-7000-SA; w/ PTO; TorqShift6	FC3Z-7000-S
	2016-2015		6R140	w/ 158.0 In. Wheelbase; FC3P-7000-SA; w/ PTO; TorqShift6	FC3Z-7000-S
	2016-2015		6R140	w/ 172.4 In. Wheelbase; FC3P-7000-SA; w/ PTO; TorqShift6	FC3Z-7000-S
	2016-2015		6R140	w/ 156.2 In. Wheelbase; FC3P-7000-SA; w/ PTO; TorqShift6	FC3Z-7000-S
	2016-2015		6R140	RWD; w/ 141.8 In. Wheelbase; FC3P-7000-ZA; w/ PTO; TorqShift6	FC3Z-7000-Z
	2016-2015		6R140	RWD; w/ 158.0 In. Wheelbase; FC3P-7000-ZA; w/ PTO; TorqShift6	FC3Z-7000-Z
	2016-2015		6R140	RWD; w/ 172.4 In. Wheelbase; FC3P-7000-ZA; w/ PTO; TorqShift6	FC3Z-7000-Z
	2016-2015		6R140	RWD; w/ 156.2 In. Wheelbase; FC3P-7000-ZA; w/ PTO; TorqShift6	FC3Z-7000-Z
	2015	3.5L EcoBoost	6R80	4WD; FL3P-7000-DA; w/o Water Wading Equipment	FL3Z-7000-D
	2014-2011	3.5L	6R80	RWD; RMBL3J-7000-CA	BL3Z-7000-C
	2014-2011	3.5L EcoBoost	6R80	4WD; BL3P-7000-DD	BL3Z-7000-D
	2014-2011	3.7L	6R80	RWD; BL3P-7000-EC	BL3Z-7000-E
	2014-2011		6R80	4WD; BL3P-7000-FC	BL3Z-7000-F
	2014-2011	5.0L	6R80	RWD; BL3P-7000-AC	BL3Z-7000-A
	2014-2011	5.0L FLEX	6R80	4WD; BL3P-7000-BC	BL3Z-7000-B
	2014-2011	6.2L	6R80	RWD; BL3P-7000-BC	BL3Z-7000-G
	2014-2011		6R80	4WD; BL3P-7000-HD	BL3Z-7000-H
	2014-2011		6R140	RWD; CC3P-7000-CC; Exc. 137 In. Wheelbase; TorqShift6	CC3Z-7000-R
	2014-2011		6R140	4WD; CC3P-7000-CC; TorqShift6	CC3Z-7000-R
	2014-2011		6R140	RWD; w/ 137.0 In. Wheelbase; CC3P-7000-FC; TorqShift6	CC3Z-7000-U
	2014-2012	6.7L DIESEL	6R140	4WD; w/ 137.0 In. Wheelbase; CC3P-7000-DC; w/o PTO; TorqShift6	CC3Z-7000-S
	2014-2012		6R140	RWD; CC3P-7000-DC; w/o PTO; Exc. 137 In. Wheelbase; TorqShift6	CC3Z-7000-S
	2014-2012		6R140	RWD; CC3P-7000-EC; w/ PTO; Exc. 137 In. Wheelbase; TorqShift6	CC3Z-7000-T
	2014-2012		6R140	4WD; w/ 137.0 In. Wheelbase; CC3P-7000-EC; w/ PTO; TorqShift6	CC3Z-7000-T
	2014-2013		6R140	RWD; w/ 137.0 In. Wheelbase; CC3P-7000-GC; w/o PTO; TorqShift6	CC3Z-7000-V
	2014-2013		6R140	RWD; w/ 137.0 In. Wheelbase; CC3P-7000-JC; w/ PTO; TorqShift6	CC3Z-7000-W
	2012		6R140	RWD; w/ 137.0 In. Wheelbase; CC3P-7000-GA; w/o PTO; Thru 01/09/12; TorqShift6	CC3Z-7000-G
	2012		6R140	RWD; w/ 137.0 In. Wheelbase; CC3P-7000-JA; w/ PTO; Thru 01/09/12; TorqShift6	CC3Z-7000-J
	2012		6R140	RWD; w/ 137.0 In. Wheelbase; CC3P-7000-GC; w/o PTO; From 06/15/12; TorqShift6	CC3Z-7000-V
	2012		6R140	RWD; w/ 137.0 In. Wheelbase; CC3P-7000-JC; w/ PTO; From 08/06/12; TorqShift6	CC3Z-7000-W
	2011		6R140	RWD; w/ 137.0 In. Wheelbase; BC3P-7000-GA; w/o PTO; TorqShift6	BC3Z-7000-G
	2011		6R140	RWD; w/ 137.0 In. Wheelbase; BC3P-7000-UF; w/ PTO; Before 11/01/10; TorqShift6	BC3Z-7000-U
	2011		6R140	RWD; w/ 137.0 In. Wheelbase; RMBCC3J-7000-JA; w/ PTO; From 11/01/10; TorqShift6	BC3Z-7000-J
	2011		6R140	4WD; w/ 137.0 In. Wheelbase; RMCC3J-7000-BA; w/o PTO; TorqShift6	CC3Z-7000-D
	2011		6R140	4WD; w/ 137.0 In. Wheelbase; RMCC3J-7000-CA; w/ PTO; TorqShift6	CC3Z-7000-E



F-Series

-Cont'd

Part Type	Years	Engine	Trans	Qualifier	Ford #	
Automatic - New	2010	5.4L	5R110W	RWD; w/ 137.0 In. Wheelbase; AC3P-7000-EA; TorqShift	AC3Z-7000-E	
	2010		5R110W	RWD; w/ 141.8 In. Wheelbase; AC3P-7000-EA; TorqShift	AC3Z-7000-E	
	2010		5R110W	w/ 158.0 In. Wheelbase; AC3P-7000-FA; TorqShift	AC3Z-7000-F	
	2010		5R110W	w/ 156.2 In. Wheelbase; AC3P-7000-FA; TorqShift	AC3Z-7000-F	
	2010		5R110W	w/ 172.4 In. Wheelbase; AC3P-7000-FA; TorqShift	AC3Z-7000-F	
	2010	6.2L	6R80		AL3Z-7000-H	
	2010	6.8L	5R110W	RWD; w/ 137.0 In. Wheelbase; AC3P-7000-GA; TorqShift	AC3Z-7000-G	
	2010		5R110W	RWD; w/ 141.8 In. Wheelbase; AC3P-7000-GA; TorqShift	AC3Z-7000-G	
	2010		5R110W	w/ 165.0 In. Wheelbase; AC3P-7000-HA; w/o PTO; TorqShift	AC3Z-7000-H	
	2010		5R110W	w/ 158.0 In. Wheelbase; AC3P-7000-HA; w/o PTO; TorqShift	AC3Z-7000-H	
	2010		5R110W	w/ 156.2 In. Wheelbase; AC3P-7000-HA; w/o PTO; TorqShift	AC3Z-7000-H	
	2010		5R110W	w/ 172.4 In. Wheelbase; AC3P-7000-HA; w/o PTO; TorqShift	AC3Z-7000-H	
	2010		5R110W	w/ 158.0 In. Wheelbase; AC3P-7000-KA; w/ PTO; TorqShift	AC3Z-7000-K	
	2010		5R110W	w/ 156.2 In. Wheelbase; AC3P-7000-KA; w/ PTO; TorqShift	AC3Z-7000-K	
	2010		5R110W	w/ 172.4 In. Wheelbase; AC3P-7000-KA; w/ PTO; TorqShift	AC3Z-7000-K	
	Automatic - Reman	2014-2011	3.5L	6R80	4WD; BL3P-7000-DA,DB	BL3Z-7000-HRM
		2014-2011		6R80	4WD; BL3P-7000-FA, FB	BL3Z-7000-DRM
		2014-2011	5.0L	6R80	4WD; BL3P-7000-BA, BB	BL3Z-7000-BRM
		2014-2013	6.7L DIESEL	6R140	RWD; w/ 137.0 In. Wheelbase; RMFC3J-7000-FA; w/ PTO; TorqShift6	FC3Z-7000-WRM
		2013-2011		6R80	RWD; BL3P-7000-EA, EB	BL3Z-7000-CRM
2013-2011		5.0L		RWD; BL3P-7000-AA, AB	BL3Z-7000-ARM	
2013-2011		6.2L	6R80	4WD; BL3P-7000-HA,HB	BL3Z-7000-FRM	
2013			6R140	RMFC3J-7000-AA; w/o PTO	FC3Z-7000-RRM	
2013-2012			6R140	RWD; w/ 137.0 In. Wheelbase; RMFC3J-7000-DA; w/o PTO	FC3Z-7000-URM	
2013		6.7L DIESEL	6R140	RWD; w/ 137.0 In. Wheelbase; RMFC3J-7000EA; w/o PTO	FC3Z-7000-VRM	
2013			6R140	RMFC3J-7000-BA; w/o PTO	FC3Z-7000-SRM	
2012-2010		5.4L	5R110W	4WD; AC3P-7000-FA; PRB-NT; TorqShift	9C3Z-7000-FRM	
2012-2010			5R110W	RWD; AC3P-7000-FA; w/ Fixed Yoke; PRB-NT; TorqShift	9C3Z-7000-FRM	
2012-2010			5R110W	RWD; AC3P-7000-EA; PRB-NS; TorqShift	9C3Z-7000-ERM	
2012-2011		6.2L	6R80	RWD; BL3P-7000-GA,GB	BL3Z-7000-ERM	
2012			6R140	RWD; RMCC3J-7000-AA; w/o PTO; Exc. 137 In. Wheelbase	CC3Z-7000-CRM	
2012			6R140	4WD; RMCC3J-7000-AA	CC3Z-7000-CRM	
2012			6R140	RWD; RMCC3J-7000-DA; w/o PTO	CC3Z-7000-FRM	
2012			6R140	RMFC3J-7000-AA; w/o PTO; From 6/13/12	FC3Z-7000-RRM	
2012		6.7L DIESEL	6R140	CC3Z-7000-DRM; w/o PTO	CC3Z-7000-DRM	
2012			6R140	RWD; RMCC3J-7000-CA; w/ PTO; Exc. 137 In. Wheelbase	CC3Z-7000-ERM	
2012			6R140	4WD; w/ 137.0 In. Wheelbase; RMCC3J-7000-CA; w/ PTO	CC3Z-7000-ERM	
2012			6R140	RMFC3J-7000-CA; w/ PTO	FC3Z-7000-TRM	
2012			6R140	RWD; w/ 137.0 In. Wheelbase; RMFC3J-7000EA; w/o PTO; From 06/15/2012	FC3Z-7000-VRM	
2012			6R140	RMFC3J-7000-BA; w/o PTO; Before 6/13/12	FC3Z-7000-SRM	
2012			6R140	RWD; w/ 137.0 In. Wheelbase; RMFC3J-7000-FA; w/ PTO; From 08/06/12; TorqShift6	FC3Z-7000-WRM	
2012-2010		6.8L	5R110W	RWD; AC3P-7000-GA; PRB-NU; TorqShift	9C3Z-7000-HRM	
2012-2010			5R110W	AC3P-7000-HA; PRB-NV; TorqShift	9C3Z-7000-GRM	
2012-2010			5R110W	RWD; AC3P-7000-KA; w/ Fixed Yoke; PRB-NW; TorqShift	9C3Z-7000-JRM	
2011		3.5L	6R80	RWD; BL3P-7000-CA,CB	BL3Z-7000-GRM	
2011			6.2L	6R140	RWD; RMBC3J-7000-GA; w/o PTO; Exc. 137 In. Wheelbase; TorqShift6; Shipped With 7034 Vent Attached	BC3Z-7000-GRM
2011				6R140	4WD; RMBC3J-7000-GA; TorqShift6	BC3Z-7000-GRM
2011			6R140	RWD; w/ 137.0 In. Wheelbase; RMBC3J-7000-KA; TorqShift6; Shipped With 7034 Vent Attached	BC3Z-7000-KRM	
2011			6R140	RWD; w/ 137.0 In. Wheelbase; RMBC3J-7000-KA; Shipped With 7034 Vent Attached	BC3Z-7000-KRM	
2011		6.7L DIESEL	6R140	4WD; w/ 137.0 In. Wheelbase; RMBC3J-7000-HA; w/ PTO; TorqShift6; Shipped With 7034 Vent Attached; Requires Engine Flywheel CC3Z-6375-A Which Must Be Ordered Separately	BC3Z-7000-HRM	
2011			6R140	RWD; RMBC3J-7000-HA; w/ PTO; Exc. 137 In. Wheelbase; TorqShift6; Shipped With 7034 Vent Attached; Requires Engine Flywheel CC3Z-6375-A Which Must Be Ordered Separately	BC3Z-7000-HRM	
2011			6R140	4WD; BC3Z-7000-JRM; TorqShift6; Shipped With 7034 Vent Attached; Requires Engine Flywheel CC3Z-6375-A Which Must Be Ordered Separately	BC3Z-7000-JRM	
2011			6R140	RWD; BC3Z-7000-JRM; w/ PTO; Exc. 137 In. Wheelbase; TorqShift6; Shipped With 7034 Vent Attached; Requires Engine Flywheel CC3Z-6375-A Which Must Be Ordered Separately	BC3Z-7000-JRM	
2011			6R140	RWD; w/ 137.0 In. Wheelbase; RMBC3J-7000-LA; w/o PTO; TorqShift6; Shipped With 7034 Vent Attached; Requires Engine Flywheel CC3Z-6375-A Which Must Be Ordered Separately	BC3Z-7000-LRM	
2011			6R140	RWD; w/ 137.0 In. Wheelbase; RMBC3J-7000-MA; w/ PTO; TorqShift6; Shipped With 7034 Vent Attached; Requires Engine Flywheel CC3Z-6375-A Which Must Be Ordered Separately	BC3Z-7000-MRM	
2010	4.6L		4R75E	4WD; AL3P-7000-CA; PKF-JT	AL3Z-7000-CRM	
2010			4R75E	RWD; AL3P-7000-DA	AL3Z-7000-DRM	
2010		6R80	RWD; AL3P-7000-LA,LB,LC	AL3Z-7000-NRM		
2010		6R80	4WD; AL3P-7000-MA,MB,MC	AL3Z-7000-MRM		
2010	5.4L SOHC	6R80	RWD; SVT Raptor; AL3P-7000-AA,AB,AC,AD	AL3Z-7000-ARM		
2010		6R80	4WD; AL3P-7000-BA,BB,BC,BD	AL3Z-7000-BRM		
2010	6.2L	6R80	4WD; SVT Raptor; AL3P-7000-HA	AL3Z-7000-HRM		
2010	6.4L DIESEL	5R110W	RWD; AC3P-7000-AA; PRB-NM; TorqShift	9C3Z-7000-ARM		
2010		5R110W	RWD; AC3P-7000-AA; TorqShift	9C3Z-7000-ARM		
2010		5R110W	4WD; AC3P-7000-DA; PRB-NR; TorqShift	9C3Z-7000-DRM		
2010		5R110W	RWD; AC3P-7000-DA; w/ Fixed Yoke; PRB-NR; TorqShift	9C3Z-7000-DRM		

**TRANSMISSIONS**  
**Light Trucks**  
**Ford**



**FORD PARTS**

**F-Series**

**-Cont'd**

Part Type	Years	Engine	Trans	Qualifier	Ford #
Automatic - Reman	2010	6.4L DIESEL	5R110W	4WD; AC3P-7000-BA; PRB-NN; TorqShift	9C3Z-7000-BRM
	2010		5R110W	RWD; AC3P-7000-BA; w/ Fixed Yoke; PRB-NN; TorqShift	9C3Z-7000-BRM
	2010	6.8L	5R110W	RWD; AC3P-7000-CA; w/ Fixed Yoke; PRB-NP; TorqShift	9C3Z-7000-CRM
	2010		5R110W	4WD; RM9C3J-7000-CA; PRB-NP; TorqShift	9C3Z-7000-CRM
	2010	4.6L	5R110W	4WD; AC3P-7000-KA; PRB-NW; TorqShift	9C3Z-7000-JRM
	2009		4R75E	RWD; 9L3P-7000-DB; 9L3P-7000-DA; PKF-FP; PKF-FT	9L3Z-7000-DRM
	2009	5.4L	4R75E	4WD; 9L3P-7000-CA/CB; PKF-FN/FU	9L3Z-7000-CRM
	2009		6R80	RWD; 9L3P-7000-LB/LD/LE/LF/LG/RB	9L3Z-7000-CARM
	2009	6.4L DIESEL	6R80	4WD; 9L3P-7000-MD/ME/MF/MG/SB	9L3Z-7000-DARM
	2009		5R110W	RWD; 9C3P-7000-FB; w/ Fixed Yoke; PRB-NT; TorqShift	9C3Z-7000-FRM
	2009	6.8L	5R110W	4WD; 9C3P-7000-FB; PRB-NT; TorqShift	9C3Z-7000-FRM
	2009		6R80	RWD; 9L3P-7000-AD/AE/AF/AG/AH/NA/NB	9L3Z-7000-EARM
	2009	6.4L DIESEL	6R80	4WD; 9L3P-7000-BD/BE/BF/BG/BH/BJ/PA/PB	9L3Z-7000-FARM
	2009		5R110W	RWD; 9C3P-7000-AC; TorqShift	9C3Z-7000-ARM
	2009	6.8L	5R110W	4WD; 9C3P-7000-DC; PRB-NR; TorqShift	9C3Z-7000-DRM
	2009		5R110W	RWD; 9C3P-7000-DC; PRB-NR; TorqShift	9C3Z-7000-DRM
	2009	6.8L	5R110W	4WD; 9C3P-7000-BC; PRB-NN; TorqShift	9C3Z-7000-BRM
	2009		5R110W	RWD; 9C3P-7000-BC; PRB-NN; TorqShift	9C3Z-7000-BRM
	2009	6.8L	5R110W	RWD; 9C3P-7000-CC; PRB-NP; TorqShift	9C3Z-7000-CRM
	2009		5R110W	RWD; 9C2P-7000-EB; PRB-NU; TorqShift	9C3Z-7000-HRM
	2009	6.8L	5R110W	RWD; 9C3P-7000-HB; PRB-NV; TorqShift	9C3Z-7000-GRM
	2009		5R110W	4WD; 9C3P-7000-HB; PRB-NV; TorqShift	9C3Z-7000-GRM
	2009	6.8L	5R110W	4WD; 9C3P-7000-KB; PRB-NW; TorqShift	9C3Z-7000-JRM
	2009		5R110W	RWD; 9C3P-7000-KB; PRB-NW; TorqShift	9C3Z-7000-JRM
	2008-2007	4.2L	4R75E	RWD; 7L3P-7000-AA,AB; PKF-GF, GF1	7L3Z-7000-ABRM
	2008-2007		4R75E	4WD; 7L3P-7000-CA, CB; PKF-FH, GH	7L3Z-7000-CBRM
	2008-2007	4.6L	4R75E	RWD; 7L3P-7000-BA, BB; PKF-FG, GG	7L3Z-7000-BBRM
	2008		5R110W	7C3P-7000-FC; PRB-MA; TorqShift	7C3Z-7000-FRM
	2008	5.4L	5R110W	RWD; 7C3P-7000-EC; PRB-LZ; TorqShift	7C3Z-7000-ERM
	2008-2007		4R75E	4WD; 7L3P-7000-EA, EB; PKF-FK, GK	7L3Z-7000-EBRM
	2008	5.4L GAS	5R110W	RWD; 8C3P-7000-FD; PRB-NT; TorqShift	8C3Z-7000-FRM
	2008		5R110W	4WD; 8C3P-7000-FD; PRB-NT; TorqShift	8C3Z-7000-FRM
	2008	6.4L DIESEL	4R75E	RWD; 7L3P-7000-DA, DB; PKF-FJ, GJ	7L3Z-7000-DBRM
	2008		5R110W	RWD; 8C3P-7000-ED; PRB-NS; TorqShift	8C3Z-7000-ERM
	2008	6.4L DIESEL	5R110W	RWD; 7C3P-7000-DC; PRB-LY; TorqShift	7C3Z-7000-DRM
	2008		5R110W	4WD; 7C3P-7000-DC; PRB-LY; TorqShift	7C3Z-7000-DRM
	2008	6.8L	5R110W	8C3P-7000-DD; PRB-NR; TorqShift	8C3Z-7000-DRM
	2008		5R110W	8C3P-7000-BD; PRB-NN; TorqShift	8C3Z-7000-BRM
	2008	6.8L	5R110W	RWD; 7C3P-7000-AC; PRB-LV; TorqShift	7C3Z-7000-ARM
	2008		5R110W	RWD; 8C3P-7000-CD; PRB-NP; TorqShift	8C3Z-7000-CRM
	2008	6.8L	5R110W	4WD; 7C3P-7000-BC; PRB-LW; TorqShift	7C3Z-7000-BRM
	2008		5R110W	RWD; 7C3P-7000-BC; PRB-LW; TorqShift	7C3Z-7000-BRM
	2008	6.8L	5R110W	RWD; 7C3P-7000-CC; PRB-LX; TorqShift	7C3Z-7000-CRM
	2008		5R110W	RWD; 8C3P-7000-AD; PRB-NM; TorqShift	8C3Z-7000-ARM
	2008	6.8L	5R110W	RWD; 8C3P-7000-KD; PRB-NW; TorqShift	8C3Z-7000-JRM
	2008		5R110W	4WD; 8C3P-7000-KD; PRB-NW; TorqShift	8C3Z-7000-JRM
	2008	6.8L	5R110W	RWD; 7C3P-7000-GC; PRB-MB; TorqShift	7C3Z-7000-GRM
	2008		5R110W	4WD; 7C3P-7000-KC; PRB-MD; TorqShift	7C3Z-7000-JRM
	2008	6.8L	5R110W	RWD; 8C3P-7000-HD; PRB-NV; TorqShift	8C3Z-7000-HRM
	2008		5R110W	4WD; 8C3P-7000-HD; PRB-NV; TorqShift	8C3Z-7000-HRM
	2008	6.8L	5R110W	RWD; 8C3P-7000-GD; PRB-NU; TorqShift	8C3Z-7000-GRM
	2008		5R110W	6C3P-7000-AB; PRB-LK; w/ Slip Yoke; TorqShift	5C3Z-7000-ARM
	2007-2006	5.4L	5R110W	6C3P-7000-AA; w/ Slip Yoke; PRB-KC; TorqShift	5C3Z-7000-ARM
	2007-2006		5R110W	6C3P-7000-MC; w/ Fixed Yoke; PRB-MR; TorqShift	5C3Z-7000-MRM
	2007	6.0L	5R110W	6C3P-7000-KC; w/ Fixed Yoke; PRB-MN; TorqShift	5C3Z-7000-KRM
	2007		5R110W	6C3P-7000-DC; PRB-MK; w/ Fixed Yoke; TorqShift	5C3Z-7000-DRM
	2007	6.8L	5R110W	4WD; 7C3P-7000-HC; TorqShift	7C3Z-7000-HRM
	2007		5R110W	RWD; 6L3P-7000-AA, AB; PKF-ET, FT	6L3Z-7000-FRM
	2006	4.2L	4R70E	4WD; 6L3P-7000-CA, CB; PKF-EV, FV	6L3Z-7000-HRM
	2006		4R75W	RWD; 6L3P-7000-BA, BB; PKF-EU, FU	6L3Z-7000-GRM
	2006	5.4L	5R110W	6C3P-7000-BA; w/ Fixed Yoke; PRB-KD; TorqShift	5C3Z-7000-BRM
	2006		5R110W	6C3P-7000-BB; w/ Fixed Yoke; PRB-LL; TorqShift	5C3Z-7000-BRM
	2006	5.4L	4R75W	4WD; 6L3P-7000-EA, EB; PKF-EX, FX	6L3Z-7000-KRM
	2006		4R75W	RWD; 6L3P-7000-DA, DB; PKF-EW, FW	6L3Z-7000-JRM
	2006	6.0L	5R110W	6C3P-7000-MB; w/ Fixed Yoke; PRB-LU; TorqShift	5C3Z-7000-MRM
	2006		5R110W	6C3P-7000-MA; w/ Fixed Yoke; PRB-KM; TorqShift	5C3Z-7000-MRM
	2006	6.0L	5R110W	6C3P-7000-JB; w/ Slip Yoke; PRB-LR; TorqShift	5C3Z-7000-JRM
	2006		5R110W	6C3P-7000-JA; w/ Slip Yoke; PRB-KJ; TorqShift	5C3Z-7000-JRM
	2006	6.0L	5R110W	6C3P-7000-KA; w/ Fixed Yoke; PRB-KK; TorqShift	5C3Z-7000-KRM
	2006		5R110W	6C3P-7000-KB; w/ Fixed Yoke; PRB-LS; TorqShift	5C3Z-7000-KRM
	2006	6.0L	5R110W	6C3P-7000-LB; w/ Slip Yoke; PRB-LT; TorqShift	5C3Z-7000-LRM
	2006		5R110W	6C3P-7000-LA; w/ Slip Yoke; PRB-KL; TorqShift	5C3Z-7000-LRM
	2006	6.8L	5R110W	RWD; 6C3P-7000-DB; w/ Fixed Yoke; PRB-LN; TorqShift	5C3Z-7000-DRM
	2006		5R110W	4WD; 6C3P-7000-DB; w/ Fixed Yoke; PRB-LN; TorqShift	5C3Z-7000-DRM
	2006	6.8L	5R110W	RWD; 6C3P-7000-DA; w/ Fixed Yoke; PRB-KF; TorqShift	5C3Z-7000-DRM
	2006		5R110W	4WD; 6C3P-7000-DA; w/ Fixed Yoke; PRB-KF; TorqShift	5C3Z-7000-DRM
	2006	6.8L	5R110W	4WD; 6C3P-7000-FB; w/ Fixed Yoke; PRB-LP; TorqShift	5C3Z-7000-FRM
	2006		5R110W	4WD; 6C3P-7000-FA; w/ Fixed Yoke; PRB-KH; TorqShift	5C3Z-7000-FRM
	2005	4.2L	4R70W	RWD; 5L3P-7000-AA; PKF-EC	5L3Z-7000-ARM
	2005		4.6L	4R70W	RWD; 5L3P-7000-BA; PKF-EN



F-Series

-Cont'd

Part Type	Years	Engine	Trans	Qualifier	Ford #
Automatic - Reman	2005	4.6L	4R70W	4WD; 5L3P-7000-CA; PKF-EP	5L3Z-7000-CRM
	2005	5.4L	5R110W	4WD; 5C3P-7000-BB; w/ Fixed Yoke; PRB-JP; TorqShift	5C3Z-7000-BRM
	2005		5R110W	RWD; 5C3P-7000-BB; w/ Fixed Yoke; PRB-JP; TorqShift	5C3Z-7000-BRM
	2005		4R75W	4WD; 5L3P-7000-EA; PKF-ES	5L3Z-7000-ERM
	2005		5R110W	RWD; 5C3P-7000-AB; w/ Slip Yoke; PRB-JN; TorqShift	5C3Z-7000-ARM
	2005		4R70W	RWD; 5L3P-7000-DA; PKF-ER	5L3Z-7000-DRM
	2005	6.0L	5R110W	5C3P-7000-MB; w/ Fixed Yoke; PRB-KA; TorqShift	5C3Z-7000-MRM
	2005		5R110W	5C3P-7000-JB; w/ Slip Yoke; PRB-JX; TorqShift	5C3Z-7000-JRM
	2005		5R110W	5C3P-7000-KB; w/ Fixed Yoke; PRB-JY; TorqShift	5C3Z-7000-KRM
	2005		5R110W	RWD; 5C3P-7000-LB; w/ PTO; PRB-JZ; TorqShift	5C3Z-7000-LRM
	2005	6.8L	5R110W	RWD; 5C3P-7000-DB; w/ Fixed Yoke; PRB-JS; TorqShift	5C3Z-7000-DRM
	2005		5R110W	4WD; 5C3P-7000-DB; w/ Fixed Yoke; PRB-JS; TorqShift	5C3Z-7000-DRM
	2005		5R110W	4WD; 5C3P-7000-FB; w/ Fixed Yoke; PRB-JU; TorqShift	5C3Z-7000-FRM
	2005		5R110W	RWD; 5C3P-7000-CB; TorqShift	5C3Z-7000-CRM
	2004	4.2L	4R70W	4WD; 4L3P-7000-BA; PKF-EB	4L3Z-7000-BARM
	2004		4R70W	RWD; 4L3P-7000-AA; PKF-EA	4L3Z-7000-AARM
	2004	4.6L	4R75W	4WD; 3L3P-7000-JA; PKF-DE	3L3Z-7000-JARM
	2004		4R70W	4WD; 4L3P-7000-DA; PKF-EM	4L3Z-7000-DARM
	2004		4R70W	RWD; 4L3P-7000-CA; PKF-EL	4L3Z-7000-CARM
	2004		4R75W	RWD; 3L3P-7000-HA; PKF-DC	3L3Z-7000-HARM
	2004-2001	5.4L	4R100	4WD; 1C3P-7000-BA,BB,BC; PRB-GE, GE1	1C3Z-7V000-BRM
	2004		4R100	4WD; 1L3P-7000-BC; Heavy Duty Payload California Emissions; PRB-GV1	1C3Z-7V000-BRM
	2004		4R100	RWD; 1C3P-7000-AC; PRB-GD1	1C3Z-7V000-ARM
	2004		4R100	RWD; 1L3P-7000-AC; Heavy Duty Payload California Emissions; PRB-GU1	1C3Z-7V000-ARM
	2004		4R100	SVT Lightning; 1L3P-7000-CC; PRB-GW1	1L3Z-7V000-CRM
	2004		4R75W	RWD; 3L3P-7000-MA; PKF-DG	3L3Z-7000-MARM
	2004		4R75W	4WD; 3L3P-7000-LA; PKF-DF	3L3Z-7000-LARM
	2004-2003	6.0L	5R110W	RWD; 3C3P-7000-JG; w/ PTO; PRB-JC; TorqShift	3C3Z-7V000-JGRM
	2004-2003		5R110W	4WD; 3C3P-7000-JG; w/ PTO; PRB-JC; TorqShift	3C3Z-7V000-JGRM
	2004		5R110W	4WD; 4C3P-7000-KB; w/o PTO; PRB-JF; TorqShift	4C3Z-7000-KBRM
	2004		5R110W	RWD; 4C3P-7000-KB; w/o PTO; PRB-JF; TorqShift	4C3Z-7000-KBRM
	2004-2003		5R110W	RWD; 3C3P-7000-HG; w/ PTO; PRB-JB; TorqShift	3C3Z-7V000-HGRM
	2004	6.0L DIESEL	5R110W	RWD; 4C3P-7000-JB; w/o PTO; PRB-JE; TorqShift	4C3Z-7000-JBRM
	2004	6.8L	4R100	4WD; 1C3P-7000-DA,DB,DC; PRB-GG1; w/o PTO	1C3Z-7V000-DRM
	2004		4R100	4WD; 1C3P-7000-JC; w/ PTO; PRB-GL1	1C3Z-7V000-JRM
	2004		4R100	RWD; 1C3P-7000-CC; w/o PTO; PRB-GF1	1C3Z-7V000-CRM
	2004		4R100	RWD; 1C3P-7000-HC; w/ PTO; PRB-GK1	1C3Z-7V000-HRM
	2003-2001	4.2L	4R70W	RWD; 1L3P-7000-DA; PKF-CL	1L3Z-7V000-DRM
	2003-2001	4.6L	4R70W	4WD; 1L3P-7000-HA; PKF-CP	1L3Z-7V000-HRM
	2003-2002		4R70W	RWD; 1L3P-7000-FA; PKF-CN	1L3Z-7V000-FRM
	2003	5.4L	4R100	4WD; 1L3P-7000-BC; Heavy Payload, California Emissions; PRB-GV, PRB-GV1	1C3Z-7V000-BRM
	2003		4R100	RWD; 1L3P-7000-AC; Heavy Payload, California Emissions; PRB-GU, PRB-GU1	1C3Z-7V000-ARM
	2003		4R100	RWD; 1C3P-7000-AC; PRB-GD, PRB-GD1	1C3Z-7V000-ARM
	2003		4R100	Harley-Davidson Edition; 1L3P-7000-AC; PRB-GU, PRB-GU1	1C3Z-7V000-ARM
	2003		4R100	Harley-Davidson Edition; 1L3P-7000-CC; PRB-GW, PRB-GW1	1L3Z-7V000-CRM
	2003		4R100	Lightning; 1L3P-7000-CC; PRB-GW, PRB-GW1	1L3Z-7V000-CRM
	2003-2001		4R70W	4WD; 1L3P-7000-JA; PKF-CR	1L3Z-7V000-JRM
	2003-2001		4R70W	RWD; 1L3P-7000-LA; PKF-CS	1L3Z-7V000-LRM
	2003	6.0L	5R110W	RWD; w/ 137.0 In. Wheelbase; 3C3P-7000-JF; Must Add Companion Flange 3C3P-4K177-BA and Bolt 3C3Z-7N134-CA on 4x2 applications; PRB-HX; Fixed Flange-w/ PTO; TorqShift	3C3Z-7V000-JGRM
	2003		TorqShift	RWD; w/ 137.0 In. Wheelbase; 3C3P-7000-JF; Must Add Companion Flange 3C3P-4K177-BA and Bolt 3C3Z-7N134-CA on 4x2 applications; PRB-HX; Fixed Flange-w/ PTO; TorqShift	3C3Z-7V000-JGRM
	2003		TorqShift	RWD; w/ 137.0 In. Wheelbase; 3C3P-7000-JG; Must Add Companion Flange 3C3P-4K177-BA and Bolt 3C3Z-7N134-CA on 4x2 applications; Fixed Flange-w/ PTO; PRB-JC; TorqShift	3C3Z-7V000-JGRM
	2003		5R110W	RWD; w/ 172.0 In. Wheelbase; 3C3P-7000-JF; Must Add Companion Flange 3C3P-4K177-BA and Bolt 3C3Z-7N134-CA on 4x2 applications; PRB-HX; Fixed Flange-w/ PTO; TorqShift	3C3Z-7V000-JGRM
	2003		5R110W	4WD; 3C3P-7000-JF; w/ PTO; PRB-HX; TorqShift	3C3Z-7V000-JGRM
	2003		5R110W	RWD; w/ 172.0 In. Wheelbase; 3C3P-7000-JG; Must Add Companion Flange 3C3P-4K177-BA and Bolt 3C3Z-7N134-CA on 4x2 applications; Fixed Flange-w/ PTO; PRB-JC; TorqShift	3C3Z-7V000-JGRM
	2003		5R110W	RWD; w/ 137.0 In. Wheelbase; 3C3P-7000-JG; Must Add Companion Flange 3C3P-4K177-BA and Bolt 3C3Z-7N134-CA on 4x2 applications; Fixed Flange-w/ PTO; PRB-JC; TorqShift	3C3Z-7V000-JGRM
	2003		5R110W	RWD; w/ 158.0 In. Wheelbase; 3C3P-7000-JG; Must Add Companion Flange 3C3P-4K177-BA and Bolt 3C3Z-7N134-CA on 4x2 applications; Fixed Flange-w/ PTO; PRB-JC; TorqShift	3C3Z-7V000-JGRM
	2003		5R110W	RWD; w/ 156.0 In. Wheelbase; 3C3P-7000-JG; Must Add Companion Flange 3C3P-4K177-BA and Bolt 3C3Z-7N134-CA on 4x2 applications; Fixed Flange-w/ PTO; PRB-JC; TorqShift	3C3Z-7V000-JGRM
2003		5R110W	RWD; w/ 142.0 In. Wheelbase; 3C3P-7000-JG; Must Add Companion Flange 3C3P-4K177-BA and Bolt 3C3Z-7N134-CA on 4x2 applications; Fixed Flange-w/ PTO; PRB-JC; TorqShift	3C3Z-7V000-JGRM	
2003		TorqShift	RWD; w/ 158.0 In. Wheelbase; 3C3P-7000-JG; Must Add Companion Flange 3C3P-4K177-BA and Bolt 3C3Z-7N134-CA on 4x2 applications; Fixed Flange-w/ PTO; PRB-JC; TorqShift	3C3Z-7V000-JGRM	
2003		TorqShift	RWD; w/ 172.0 In. Wheelbase; 3C3P-7000-JG; Must Add Companion Flange 3C3P-4K177-BA and Bolt 3C3Z-7N134-CA on 4x2 applications; Fixed Flange-w/ PTO; PRB-JC; TorqShift	3C3Z-7V000-JGRM	

# TRANSMISSIONS

## Light Trucks

### Ford



FORD PARTS

## F-Series

-Cont'd

Part Type	Years	Engine	Trans	Qualifier	Ford #
Automatic - Reman	2003	6.0L	TorqShift	RWD; w/ 158.0 In. Wheelbase; 3C3P-7000-JF; Must Add Companion Flange 3C3P-4K177-BA and Bolt 3C3Z-7N134-CA on 4x2 applications; PRB-HX; Fixed Flange-w/ PTO; TorqShift	3C3Z-7V000-JGRM
	2003		5R110W	RWD; w/ 156.0 In. Wheelbase; 3C3P-7000-JF; Must Add Companion Flange 3C3P-4K177-BA and Bolt 3C3Z-7N134-CA on 4x2 applications; PRB-HX; Fixed Flange-w/ PTO; TorqShift	3C3Z-7V000-JGRM
	2003		5R110W	RWD; w/ 142.0 In. Wheelbase; 3C3P-7000-JF; Must Add Companion Flange 3C3P-4K177-BA and Bolt 3C3Z-7N134-CA on 4x2 applications; PRB-HX; Fixed Flange-w/ PTO; TorqShift	3C3Z-7V000-JGRM
	2003		TorqShift	RWD; w/ 172.0 In. Wheelbase; 3C3P-7000-JF; Must Add Companion Flange 3C3P-4K177-BA and Bolt 3C3Z-7N134-CA on 4x2 applications; PRB-HX; Fixed Flange-w/ PTO; TorqShift	3C3Z-7V000-JGRM
	2003		TorqShift	RWD; w/ 158.0 In. Wheelbase; 3C3P-7000-EJ; w/o PTO; w/ Slip Yoke; PRB-HZ; TorqShift	3C3Z-7000-EJRM
	2003		5R110W	RWD; w/ 142.0 In. Wheelbase; 3C3P-7000-EH; w/o PTO; w/ Slip Yoke; PRB-HU; TorqShift	3C3Z-7000-EJRM
	2003		TorqShift	RWD; w/ 158.0 In. Wheelbase; 3C3P-7000-EH; w/o PTO; w/ Slip Yoke; PRB-HU; TorqShift	3C3Z-7000-EJRM
	2003		5R110W	RWD; w/ 142.0 In. Wheelbase; 3C3P-7000-EJ; w/o PTO; w/ Slip Yoke; PRB-HZ; TorqShift	3C3Z-7000-EJRM
	2003		TorqShift	RWD; w/ 137.0 In. Wheelbase; 3C3P-7000-EH; w/o PTO; w/ Slip Yoke; PRB-HU; TorqShift	3C3Z-7000-EJRM
	2003		TorqShift	RWD; w/ 137.0 In. Wheelbase; 3C3P-7000-EJ; w/o PTO; w/ Slip Yoke; PRB-HZ; TorqShift	3C3Z-7000-EJRM
	2003		5R110W	RWD; w/ 137.0 In. Wheelbase; 3C3P-7000-EJ; w/o PTO; w/ Slip Yoke; PRB-HZ; TorqShift	3C3Z-7000-EJRM
	2003	6.0L DIESEL	5R110W	4WD; RM8U2J-7G497-ACA; w/o PTO; TorqShift	4C3Z-7000-KBRM
	2003		5R110W	RWD; RM8U2J-7G497-ABA; w/o PTO; TorqShift	4C3Z-7000-JBRM
	2003-2001	6.8L	4R100	4WD; 1C3P-7000-DA,DB,DC; w/o PTO; PRB-GG, GG1	1C3Z-7V000-DRM
	2003		4R100	4WD; 1C3P-7000-JC; w/ PTO Provision; PRB-GL, PRB-GL1	1C3Z-7V000-JRM
	2003-2001		4R100	RWD; 1C3P-7000-CC; w/o PTO; PRB-GF, PRB-GF1	1C3Z-7V000-CRM
	2003		4R100	RWD; 1C3P-7000-HC; w/ PTO Provision; PRB-GK, PRB-GK1	1C3Z-7V000-HRM
	2003	7.3L	4R100	RWD; 1C3P-7000-LB; Heavy Duty Service; w/ PTO; PRB-GN, PRB-GN1	7U2Z-7V000-ARM
	2003		4R100	4WD; 1C3P-7000-MB; Normal Service; w/ PTO; PRB-GP, PRB-GP1	1C3Z-7V000-MRM
	2003		4R100	RWD; 1C3P-7000-LB; Normal Service; w/ PTO; PRB-GN, PRB-GN1	1C3Z-7V000-LRM
	2003-2001		4R100	4WD; 1C3P-7000-FA, FB; Normal Service; w/o PTO; PRB-GJ, GJ1	1C3Z-7V000-FRM
	2003-2001		4R100	4WD; 1C3P-7000-FA, FB; Heavy Duty Service; w/o PTO; PRB-GJ, GJ1	6U2Z-7V000-FRM
	2003-2001		4R100	RWD; 1C3P-7000-EA, EB; Normal Service; w/o PTO; PRB-GH, GH1	1C3Z-7V000-ERM
	2003-2001		4R100	RWD; 1C3P-7000-EA, EB; Heavy Duty Service; w/o PTO; PRB-GH, GH1	6U2Z-7V000-ERM
	2003		4R100	4WD; 1C3P-7000-MB; Heavy Duty Service; w/ PTO; PRB-GP, PRB-GP1	7U2Z-7V000-BRM
	2002	5.4L	4R100	4WD; 1L3P-7000-BC; Heavy Payload, California Emissions; PRB-GV	1C3Z-7V000-BRM
	2002-2001		4R100	RWD; 1C3P-7000-AC; PRB-GD	1C3Z-7V000-ARM
	2002-2001		4R100	Harley-Davidson Edition; RWD; 1L3P-7000-AC; PRB-GU	1C3Z-7V000-ARM
	2002-2001		4R100	RWD; 1L3P-7000-AC; PRB-GU; Heavy Payload, California Emissions	1C3Z-7V000-ARM
	2002-2001		4R100	Harley-Davidson Edition; RWD; 1L3P-7000-CC; PRB-GW	1L3Z-7V000-CRM
	2002		4R100	Lightning; RWD; 1L3P-7000-CC; PRB-GW	1L3Z-7V000-CRM
	2002-2001	6.8L	4R100	4WD; 1C3P-7000-JC; w/ PTO Provision; PRB-GL	1C3Z-7V000-JRM
	2002-2001		4R100	RWD; 1C3P-7000-HC; PRB-GK; w/ PTO Provision	1C3Z-7V000-HRM
	2002-2001	7.3L	4R100	RWD; 1C3P-7000-LA/LB; Heavy Duty Service; PRB-GN; w/ PTO	7U2Z-7V000-ARM
	2002-2001		4R100	4WD; 1C3P-7000-MB; Normal Service; w/ PTO; PRB-GP	1C3Z-7V000-MRM
	2002-2001		4R100	RWD; 1C3P-7000-LB; Normal Service; PRB-GN; w/ PTO	1C3Z-7V000-LRM
	2002-2001		4R100	4WD; 1C3P-7000-MA/MB; Heavy Duty Service; w/ PTO; PRB-GP	7U2Z-7V000-BRM
	2001-2000	4.6L	4R70W	RWD; YL3P-7000-DA; PKF-BY; Before 8/17/00	YL3Z-7V000-DRM
	2001	5.4L	4R100	4WD; 1C3P-7000-BA; PRB-DH	1C3Z-7V000-BRM
	2001		4R100	4WD; 1L3P-7000-BA,BB,BC; Heavy Payload, California Emissions; PRB-DY,FT	1C3Z-7V000-BRM
	2001		4R100	4WD; 1L3P-7000-BC; Heavy Payload, California Emissions; PRB-FT	1C3Z-7V000-BRM
	2001		4R100	4WD; 1L3P-7000-BB; Heavy Payload, California Emissions; PRB-FT	1C3Z-7V000-BRM
	2001		4R100	4WD; 1C3P-7000-BB; PRB-FG	1C3Z-7V000-BRM
	2001		4R100	RWD; 1C3P-7000-AA; PRB-DG	1C3Z-7V000-ARM
	2001		4R100	RWD; 1C3P-7000-AB; PRB-FF	1C3Z-7V000-ARM
	2001		4R100	RWD; 1L3P-7000-AA; Heavy Payload, California Emissions; PRB-DW,FR,GT	1C3Z-7V000-ARM
	2001		4R100	Harley-Davidson Edition; 1L3P-7000-AB; PRB-FS	1C3Z-7V000-ARM
	2001		4R100	RWD; 1L3P-7000-AB; Heavy Payload, California Emissions; PRB-FS	1C3Z-7V000-ARM
	2001		4R100	Lightning; RWD; 1L3P-7000-CA, CB; PRB-DZ, FU	1L3Z-7V000-CRM
	2001	6.8L	4R100	4WD; 1C3P-7000-DB; w/o PTO; PRB-FJ	1C3Z-7V000-DRM
	2001		4R100	4WD; 1C3P-7000-DA; w/o PTO; PRB-DK	1C3Z-7V000-DRM
	2001		4R100	4WD; 1C3P-7000-JB; w/ PTO Provision; PRB-FL	1C3Z-7V000-JRM
	2001		4R100	4WD; 1C3P-7000-JA; w/ PTO Provision; PRB-DP	1C3Z-7V000-JRM
	2001		4R100	RWD; 1C3P-7000-CA; w/o PTO; PRB-DJ	1C3Z-7V000-CRM
	2001		4R100	RWD; 1C3P-7000-CB; w/o PTO; PRB-FH	1C3Z-7V000-CRM
	2001		4R100	RWD; 1C3P-7000-HA; w/ PTO Provision; PRB-DN	1C3Z-7V000-HRM
	2001		4R100	RWD; 1C3P-7000-HB; w/ PTO Provision; PRB-FK	1C3Z-7V000-HRM
	2001	7.3L	4R100	RWD; 1C3P-7000-LA; Heavy Duty Service; w/ PTO; PRB-DS	7U2Z-7V000-ARM
	2001		4R100	4WD; 1C3P-7000-MA; Normal Service; w/ PTO; PRB-DT	1C3Z-7V000-MRM
	2001		4R100	RWD; 1C3P-7000-LA; Normal Service; w/ PTO; PRB-DS	1C3Z-7V000-LRM
	2001		4R100	4WD; 1C3P-7000-FA; Normal Service; w/o PTO; PRB-DM	1C3Z-7V000-FRM
	2001		4R100	RWD; 1C3P-7000-EA, EB; Heavy Duty Service; w/o PTO; PRB-GH, GH1	6U2Z-7V000-FRM
	2001		4R100	4WD; 1C3P-7000-FA; Heavy Duty Service; w/o PTO; PRB-DM	6U2Z-7V000-FRM
	2001		4R100	RWD; 1C3P-7000-EA; Normal Service; w/o PTO; PRB-DL	1C3Z-7V000-ERM
	2001		4R100	RWD; 1C3P-7000-EA; Heavy Duty Service; w/o PTO; PRB-DL	6U2Z-7V000-ERM
	2001		4R100	4WD; 1C3P-7000-MA; Heavy Duty Service; w/ PTO; PRB-DT	7U2Z-7V000-BRM



F-Series

-Cont'd

Part Type	Years	Engine	Trans	Qualifier	Ford #
Automatic - Reman	2000	4.2L	4R70W	RWD; YL3P-7000-EA; PKF-CC	YL3Z-7V000-ERM
	2000	4.6L	4R70W	4WD; YL3P-7000-FA; PKF-BZ	YL3Z-7V000-FRM
	2000		4R70W	RWD; YL3P-7000-DA; PKF-BY	YL3Z-7V000-DRM
	2000-1999	5.4L	4R100	RWD; XL3P-7000-GB; PRB-BC; TSS/OSS Axle Ratio	XL3Z-7V000-GBRM
	2000		4R100	RWD; YL3P-7000-AA; LD; PRB-CC	XL3Z-7V000-GBRM
	2000		4R100	Lightning; YL3P-7000-CA; PRB-CE	1L3Z-7V000-CRM
	2000		4R100	Lightning; XL3P-7000-KA; TSS/OSS Axle Ratio; PRB-BE	1L3Z-7V000-CRM
	2000		4R70W	RWD; YL3P-7000-MA; LD; PKF-BX	YL3Z-7V000-MRM
	2000		4R70W	RWD; YL3P-7000-MA; PKF-BX; Before 8/17/00	YL3Z-7V000-MRM
	2000		4R100	RWD; YC3P-7000-AA; PRB-BN	YC3Z-7V000-ARM
	2000-1999		4R100	4WD; XL3P-7000-HB; TSS/OSS Axle Ratio; PRB-BD,CD	YC3Z-7V000-BRM
	2000		4R100	4WD; YL3P-7000-BA,HB; LD; PRB-CD	YC3Z-7V000-BRM
	2000		4R100	4WD; YC3P-7000-BA, RA; PRB-BP, CU	YC3Z-7V000-BRM
	2000		4R70W	4WD; YL3P-7000-LA; Before 8/17/00; PKF-BW	YL3Z-7V000-LRM
	2000	6.8L	4R100	4WD; YC3P-7000-DA, SA; w/o PTO; PRB-BS, CV	YC3Z-7V000-DRM
	2000		4R100	RWD; YC3P-7000-CA; w/o PTO; PRB-BR	YC3Z-7V000-CRM
	2000		4R100	4WD; YC3P-7000-JA; w/ PTO; PRB-BW	YC3Z-7V000-JRM
	2000	7.3L	4R100	4WD; YC3P-7000-MA; Normal Service; PTO; PRB-BZ	1C3Z-7V000-MRM
	2000		4R100	4WD; YC3P-7000-FB; Normal Service; PRB-CR	1C3Z-7V000-FRM
	2000		4R100	4WD; YC3P-7000-FA, FB; Normal Service; PRB-BU	1C3Z-7V000-FRM
	2000		4R100	RWD; YC3P-7000-LB; Normal Service; PTO; PRB-CS	F81Z-7V000-KBRM
	2000		4R100	4WD; YC3P-7000-MB; Normal Service; PTO; PRB-CT	F81Z-7V000-KBRM
	2000		4R100	RWD; YC3P-7000-LA; Normal Service; PTO; PRB-BY	F81Z-7V000-KBRM
	2000		4R100	4WD; YC3P-7000-FB; Heavy Duty Service; PRB-CR	6U2Z-7V000-LRM
	2000		4R100	4WD; YC3P-7000-FA, FB; Heavy Duty Service; PRB-BU	6U2Z-7V000-LRM
	2000		4R100	4WD; YC3P-7000-MA; PTO; Heavy Duty Service; PRB-BZ	7U2Z-7V000-DRM
	2000		4R100	4WD; YC3P-7000-MB; PTO; Heavy Duty Service; PRB-CT	7U2Z-7V000-DRM
	2000		4R100	RWD; YC3P-7000-EA, EB; Normal Service; PRB-BT	1C3Z-7V000-ERM
	2000		4R100	RWD; YC3P-7000-EB; Normal Service; PRB-CP	1C3Z-7V000-ERM
	2000		4R100	RWD; YC3P-7000-EA, EB; Heavy Duty Service; PRB-BT	6U2Z-7V000-HRM
	2000		4R100	RWD; YC3P-7000-EB; Heavy Duty Service; PRB-CP	6U2Z-7V000-HRM
	2000		4R100	RWD; YC3P-7000-LB; PTO; Heavy Duty Service; PRB-CS	7U2Z-7V000-CRM
	2000		4R100	RWD; YC3P-7000-LA; PTO; Heavy Duty Service; PRB-BY	7U2Z-7V000-CRM
	1999		4R100	RWD; Standard Cab Pickup; F81P-7000-TA; PRB-AD	F81Z-7V000-TARM
	1999	4.2L	4R70W	RWD; XL3P-7000-BA; PKF-AP	XL3Z-7V000-BARM
	1999		4R70W	4WD; XL3P-7000-DA; PKF-AQ	XL3Z-7V000-DARM
	1999	4.6L	4R70W	RWD; XL3P-7000-EA; PKF-AR	XL3Z-7V000-EARM
	1999		4R70W	4WD; XL3P-7000-CA; PKF-AO	XL3Z-7V000-CARM
	1999		4R70W	RWD; XL3P-7000-AA; PKF-AN	XL3Z-7V000-AARM
	1999	5.4L	4R100	4WD; XC3P-7000-CA; PRB-AP	F81Z-7V000-BBRM
	1999		4R100	4WD; F81P-7000-BB; PRB-B	F81Z-7V000-BBRM
	1999		4R100	RWD; F81P-7000-AB; PRB-A	F81Z-7V000-ABRM
	1999		4R100	RWD; XC3P-7000-BA; PRB-AN	F81Z-7V000-ABRM
	1999		4R100	Lightning; RWD; XL3P-7000-KA; TSS/OSS Axle Ratio; PRB-BE	1L3Z-7V000-CRM
	1999		4R70W	4WD; XL3P-7000-JA; PKF-BG	XL3Z-7V000-JARM
	1999		4R70W	RWD; XL3P-7000-LA; PKF-BF	XL3Z-7V000-LARM
	1999	6.8L	4R100	4WD; F81P-7000-EB; PRB-D	F81Z-7V000-EBRM
	1999		4R100	4WD; XC3P-7000-EA; PRB-AS	F81Z-7V000-EBRM
	1999		4R100	RWD; F81P-7000-FB; PTO; PRB-E	F81Z-7V000-FBRM
	1999		4R100	RWD; XC3P-7000-FA; PTO; PRB-AT	F81Z-7V000-FBRM
	1999		4R100	RWD; XC3P-7000-DA; PRB-AR	F81Z-7V000-DBRM
	1999		4R100	RWD; F81P-7000-DB; PRB-C	F81Z-7V000-DBRM
	1999		4R100	4WD; XC3P-7000-GA; PTO; PRB-AU	F81Z-7V000-GBRM
	1999		4R100	4WD; F81P-7000-GB; PTO; PRB-F	F81Z-7V000-GBRM
	1999	7.3L	4R100	4WD; XC3P-7000-JA; Normal Service; PTO; PRB-AW	1C3Z-7V000-MRM
	1999		4R100	4WD; XC3P-7000-LA; Normal Service; PRB-AY	1C3Z-7V000-FRM
	1999		4R100	RWD; F81P-7000-KB; Normal Service; PTO; PRB-H	F81Z-7V000-KBRM
	1999		4R100	RWD; XC3P-7000-KA; Normal Service; PTO; PRB-AX	F81Z-7V000-KBRM
	1999		4R100	4WD; F81P-7000-LB; Heavy Duty Service; PRB-J	6U2Z-7V000-LRM
	1999		4R100	4WD; XC3P-7000-LA; Heavy Duty Service; PRB-AY	6U2Z-7V000-LRM
	1999		4R100	4WD; F81P-7000-PB; PTO; PRB-K; Heavy Duty Service	7U2Z-7V000-DRM
	1999		4R100	RWD; F81P-7000-HB; Normal Service; PRB-G	1C3Z-7V000-ERM
	1999		4R100	RWD; XC3P-7000-HA; Normal Service; PRB-AV	1C3Z-7V000-ERM
	1999		4R100	RWD; F81P-7000-HB; Heavy Duty Service; PRB-G	6U2Z-7V000-HRM
	1999		4R100	RWD; XC3P-7000-HA; Heavy Duty Service; PRB-AV	6U2Z-7V000-HRM
	1999		4R100	RWD; F81P-7000-KB; PTO; Heavy Duty Service; PRB-H	7U2Z-7V000-CRM
	1998	4.2L	4R70W	RWD; F85P-7000-GA; PKF-BC	F85Z-7V000-GARM
	1998	4.6L	4R70W	RWD; F85P-7000-BA; PKF-AX	F85Z-7V000-BARM
	1998		4R70W	4WD; F85P-7000-HA; PKF-BD	F85Z-7V000-HARM
	1998		4R70W	RWD; F85P-7000-FA; PKF-BB	F85Z-7V000-FARM
	1998	5.4L	4R100	4WD; F75P-7000-MA, MB; 3.31/3.73 Axle Ratio; PRA-PAB	F75Z-7V000-MRM
	1998		4R100	F8UP-7000-NA; 3.08/3.55 Axle Ratio; PRB-W; 3.31/3.73 Axle Ratio	F8UZ-7V000-LARM
	1998		4R100	F8UP-7000-LA, NA; PRB-U,W; 3.08/3.55 Axle Ratio; 3.31/3.73 Axle Ratio	F8UZ-7V000-LARM
	1998		4R100	4WD; F8UP-7000-MB; 3.08/3.31/3.55/3.73 Axle Ratio; PRB-V	F8UZ-7V000-MBRM
	1998		4R100	RWD; F75P-7000-LA, LB; 8 TSG; 3.08/3.55 Axle Ratio; PRA-NAB	F75Z-7V000-LCRM
	1998		4R100	RWD; F8UP-7000-LC; PRB-AC; 8 TSG	F8UZ-7V000-LCRM
	1997	4.2L	4R70W	RWD; F75P-7000-JA; PKF-X	F75Z-7V000-JRM
	1997		4R70W	4WD; F65P-7000-DA; PKF-K	F65Z-7V000-DARM
	1997	4.6L	4R70W	4WD; F75P-7000-KA; PKF-Y	F75Z-7V000-KRM
	1997		4R70W	4WD; F65P-7000-CA; PKF-J	F65Z-7V000-CARM

# TRANSMISSIONS

## Light Trucks

### Ford



FORD PARTS

### F-Series

-Cont'd

Part Type	Years	Engine	Trans	Qualifier	Ford #
Automatic - Reman	1997	4.6L	4R70W	4WD; F75P-7000-EA; PKF-T	F75Z-7V000-ERM
	1997		4R70W	RWD; F75P-7000-HA; PKF-W	F75Z-7V000-HRM
	1997	5.4L	E40D	4WD; F75P-7000-MA; 3.08/3.55 Axle Ratio; PRA-PAA	F75Z-7V000-MRM
	1997		E40D	4WD; F75P-7000-MA; PRA-PAA; LD, 3.31/3.73 Axle Ratio	F75Z-7V000-MRM
	1997		E40D	RWD; F75P-7000-LB; 8TSG, 3.31/3.73 Axle Ratio; PRA-NAB	F75Z-7V000-LCRM
	1997		E40D	RWD; F75P-7000-LC, LD; 8TSG, 3.08/3.31/3.55/3.73 Axle Ratio	F75Z-7V000-LCRM
	1997		E40D	RWD; F75P-7000-LB; 8TSG, 3.08/3.55 Axle Ratio; PRA-NAB	F75Z-7V000-LCRM
	1997		E40D	RWD; F75P-7000-LA; PRA-NAA; 8TSG, 3.08/3.55 Axle Ratio	F75Z-7V000-LRM
	1997		E40D	RWD; F75P-7000-LA; PRA-NAA; 8TSG, 3.31/3.73 Axle Ratio	F75Z-7V000-LRM
	1997	5.8L	E40D	RWD; F7TP-7000-MA; HD, 3.55/4.10 Axle Ratio; PRA-FC	F7TZ-7V000-MRM
	1997	7.3L	E40D	4WD; F7TP-7000-JA; HD, 3.55/4.10 Axle Ratio; PRA-BCA	F7TZ-7V000-JRM
	1997		E40D	RWD; F7TP-7000-NA; HD, 3.55/4.10 Axle Ratio; PRA-JD	F7TZ-7V000-NARM
	1997	7.5L	E40D	4WD; F7TP-7000-KA; HD, 3.55/4.10 Axle Ratio; PRA-YD	F7TZ-7V000-KRM
	1997		E40D	RWD; F7TP-7000-RA; Motor Home, 4.63/5.13 Axle Ratio; PRA-CCA	F7TZ-7V000-LRM
	1997		E40D	RWD; F7TP-7000-PA; HD, 3.55/4.10 Axle Ratio; PRA-GD	F7TZ-7V000-PRM
	1996	4.9L	E40D	4WD; F6TP-7000-CA; 3.55/4.10 Final Drive Ratio; PRA-HAA10	F6UZ-7V000-CARM
	1996	5.0L	E40D	RWD; F6TP-7000-DA; 3.55 Axle Ratio; PRA-AC10	F6UZ-7V000-DARM
	1996		E40D	RWD; F6TP-7000-DA; 4.10 Final Drive Ratio; PRA-AC10	F6UZ-7V000-DARM
	1996	5.8L	E40D	4WD; F6TP-7000-FA; 3.55/4.10 Final Drive Ratio; PRA-JAA10	F6TZ-7V000-FARM
	1996		E40D	4WD; F6TP-7000-FA; 3.08/3.55 Axle Ratio; PRA-JAA10	F6TZ-7V000-FARM
	1996		E40D	RWD; F6UP-7000-DA; 3.08/3.55 Axle Ratio; PRA-FB10	F6UZ-7V000-DARM
	1996		E40D	RWD; F6UP-7000-DA; 3.55/4.10 Final Drive Ratio; PRA-FB10	F6UZ-7V000-DARM
	1996	7.3L	E40D	RWD; F6UP-7000-FA; 3.55/4.10 Final Drive Ratio; PRA-JC10	F6UZ-7V000-FARM
	1996		E40D	RWD; F6UP-7000-FA; HD, 3.55/4.10 Axle Ratio; PRA-JC10	F6UZ-7V000-FARM
	1996		E40D	4WD; F6TP-7000-GA; HD, 3.55/4.10 Axle Ratio; PRA-BBA10	F6TZ-7V000-GARM
	1996		E40D	4WD; F6TP-7000-GA; 3.55/4.10 Final Drive Ratio; PRA-BBA10	F6TZ-7V000-GARM
	1996	7.5L	E40D	4WD; F6TP-7000-HA; HD, 3.55/4.10 Axle Ratio; PRA-YC10	F7TZ-7V000-KRM
	1996		E40D	4WD; F6TP-7000-HA; 3.55/4.10 Final Drive Ratio; PRA-YC10	F7TZ-7V000-KRM
	1996		E40D	RWD; F6UP-7000-HA; 3.55/4.10 Final Drive Ratio; PRA-GC10	F6UZ-7V000-HARM
	1996		E40D	RWD; F6UP-7000-HA; PRA-GC10; HD, 3.55/4.10 Axle Ratio	F6UZ-7V000-HARM
	1995	4.9L	E40D	RWD; F5UP-7000-BB; 3.08/3.31 Axle Ratio; PRA-DB	F5UZ-7V000-BRM
	1995		E40D	4WD; F5TP-7000-BB; 3.55/4.10 Final Drive Ratio; PRA-HAA	F5TZ-7V000-BRM
	1995-1994	5.0L	4R70W	RWD; F4TP-7000-AA; PKF-B	F4TZ-7V000-ARM
	1995		E40D	RWD; F5TP-7000-GB; 4.10 Final Drive Ratio; PRA-AC	F5TZ-7V000-GRM
	1995		E40D	RWD; F5TP-7000-GB; 3.55 Axle Ratio; PRA-AC	F5TZ-7V000-GRM
	1995-1994		4R70W	4WD; F4TP-7000-BA; PKF-C	F4TZ-7V000-BRM
	1995	5.8L	E40D	Lightning; RWD; F5TP-7000-AB; 4.10 Final Drive Ratio; PRA-SB	F5UZ-7V000-DRM
	1995		E40D	RWD; F5UP-7000-DB; PRA-FB; 3.08/3.55/4.10 Axle Ratio	F5UZ-7V000-DRM
	1995		E40D	4WD; F5TP-7000-CB; 3.55/4.10 Final Drive Ratio; PRA-JAA	F5TZ-7V000-CRM
	1995		E40D	4WD; F5TP-7000-CB; 3.08/3.55 Axle Ratio; PRA-JAA	F5TZ-7V000-CRM
	1995		E40D	4WD; F5TP-7000-CB; HD, 3.55/4.10 Axle Ratio; PRA-JAA	F5TZ-7V000-CRM
	1995	7.3L	E40D	RWD; F5UP-7000-GB; HD, 3.55/4.10 Axle Ratio; PRA-JC1	F5UZ-7V000-GRM
	1995		E40D	4WD; F5TP-7000-EB; HD, 3.55/4.10 Axle Ratio; PRA-BBA1	F5TZ-7V000-ERM
	1995	7.5L	E40D	RWD; F5UP-7000-FB; 4.56 Axle Ratio; PRA-PC	F5UZ-7V000-FRM
	1995		E40D	RWD; F5UP-7000-EB; PRA-GC; HD, 3.55/4.10 Axle Ratio	F5UZ-7V000-ERM
	1995		E40D	4WD; F5TP-7000-DB; HD, 3.55/4.10 Axle Ratio; PRA-YC	F5TZ-7V000-DRM
	1994	4.9L	E40D	RWD; F2UP-7000-DC; 3.08/3.31 Axle Ratio; PRA-DA15	F2TZ-7V000-BRM
	1994	5.0L	E40D	4WD; F4TP-7000-FA; 3.55 Axle Ratio; PRA-BB4	F2TZ-7V000-HRM
	1994		E40D	RWD; F4TP-7000-EA; 3.55/4.10 Final Drive Ratio; PRA-AB4	F4TZ-7V000-ERM
	1994	5.8L	E40D	RWD; F2UP-7000-EC; 3.55/4.10 Final Drive Ratio; PRA-FA15	F2TZ-7V000-FRM
	1994		E40D	Lightning; RWD; F2TP-7000-AGA; 4.10 Final Drive Ratio; PRA-SA10	F2TZ-7V000-FRM
	1994		E40D	RWD; F2UP-7000-EC; 3.08/3.55 Axle Ratio; PRA-FA15	F2TZ-7V000-FRM
	1994		E40D	4WD; F2TP-7000-HA; PRA-R14, R; HD, 3.08/3.55/4.10 Axle Ratio	F2TZ-7V000-HRM
	1994	7.3L	E40D	4WD; F3TP-7000-LA; PRA-BAA6; 3.55/4.10/5.13 Axle Ratio	F3TZ-7V000-LRM
	1994		E40D	RWD; F3UP-7000-EA; 3.55/4.10 Final Drive Ratio; PRA-JB6	F2TZ-7V000-NRM
	1994		E40D	RWD; F3UP-7000-EA; HD, 3.55/4.10 Axle Ratio; PRA-JB6	F2TZ-7V000-NRM
	1994		E40D	RWD; F4UP-7000-CA; 4.56 Ratio; PRA-FAA2	F4UZ-7V000-CRM
	1994		E40D	RWD; F4UP-7000-BA; 4.56 Ratio; PRA-EAA2	F4UZ-7V000-CRM
	1994	7.5L	E40D	4WD; F3TP-7000-EB; HD, 3.55/4.10 Axle Ratio; PRA-YB3	F2TZ-7V000-MRM
	1994		E40D	4WD; F3TP-7000-EB; HD, 3.55/4.10 Axle Ratio; PRA-YB3	F2TZ-7V000-MRM
	1994		E40D	RWD; F4TP-7000-MA; F3UP-7000-CA; 4.56 Axle Ratio; PRA-PB4; PRA-KAA2; w/ 7 Tooth Speedo Gear; w/ Electronic Speed Sensor	F3UZ-7V000-CRM
	1994		E40D	RWD; F3UP-7000-BA; PRA-GB4; HD, 3.55/4.10 Axle Ratio	F2TZ-7V000-JRM
	1994		E40D	RWD; F3UP-7000-BA; 3.55/4.10 Final Drive Ratio; PRA-GB4	F2TZ-7V000-JRM
	1993-1992	4.9L	E40D	RWD; F2UP-7000-DC; PRA-DA	F2TZ-7V000-BRM
	1993-1992	5.0L	E40D	RWD; F2TP-7000-DA; PRA-AA	F2TZ-7V000-FRM
	1993-1992		E40D	4WD; F2TP-7000-EA; PRA-BA	F2TZ-7V000-HRM
	1993-1992	5.8L	E40D	RWD; F2UP-7000-EC; PRA-FA	F2TZ-7V000-FRM
	1993-1992		E40D	RWD; F2TP-7000-AGA; PRA-SA	F2TZ-7V000-FRM
	1993-1992		E40D	4WD; F2TP-7000-HA; PRA-R	F2TZ-7V000-HRM
	1993-1992	7.3L	E40D	4WD; F2TP-7000-PA; HD; PRA-G	F3TZ-7V000-LRM
	1993-1992		E40D	4WD; F2TP-7000-PA; PRA-G	F3TZ-7V000-LRM
	1993-1992		E40D	RWD; F2UP-7000-HC; PRA-JA	F2TZ-7V000-NRM
	1993	7.5L	E40D	RWD; F3TP-7000-GA; PRA-AAA	F2TZ-7V000-MRM
	1993-1992		E40D	4WD; F2TP-7000-LA; HD; PRA-F	F2TZ-7V000-LRM
	1993-1992		E40D	4WD; F2TP-7000-LA; PRA-F	F2TZ-7V000-LRM
	1992	4.9L	E40D	RWD; F2TP-7000-BA; PRA-Y	F2TZ-7V000-BRM
	1992		E40D	RWD; F2UP-7000-DA; PRA-DA	F2TZ-7V000-BRM
	1992	5.8L	E40D	RWD; F2UP-7000-EA; PRA-FA	F2TZ-7V000-FRM
	1992		E40D	RWD; F2TP-7000-FA; PRA-P	F2TZ-7V000-FRM
	1992	7.3L	E40D	RWD; F2TP-7000-NA; PRA-L	F2UZ-7V000-NRM





**F-Series**

-Cont'd

Part Type	Years	Engine	Trans	Qualifier	Ford #
Automatic - Reman	1992	7.3L	E4OD	RWD; F2UP-7000-HA; PRA-JA	F2UZ-7V000-NRM
	1992	7.5L	E4OD	RWD; F2TP-7000-JA; PRA-J	F2TZ-7V000-JRM
	1991-1990	5.0L	E4OD	RWD; F0TP-7000-YA; PRA-AA	FOTZ-7V000-ARM
	1991	5.8L	E4OD	4WD; F1TP-7000-MA; PRA-R	FOTZ-7V000-BRM
	1991		E4OD	4WD; F1TP-7000-LA, MA; PRA-BA	FOTZ-7V000-BRM
	1991-1990		E4OD	RWD; F0TP-7000-AA; 3.54/3.73 Final Drive Ratio; PRA-P	FOTZ-7V000-ARM
	1991-1990		E4OD	RWD; F0UP-7000-HA; 3.54/3.73 Final Drive Ratio; PRA-FA	FOTZ-7V000-ARM
	1991-1990		E4OD	RWD; F0TP-7000-EA; 3.54 Final Drive Ratio; PRA-V	FOTZ-7V000-ERM
	1991-1990		E4OD	RWD; F0UP-7000-EA; 3.54 Final Drive Ratio; PRA-CA	FOTZ-7V000-ERM
	1991	7.3L	E4OD	RWD; F0TP-7000-ACA; 4.10 Final Drive Ratio; PRA-L	FOTZ-7V000-LRM
	1991-1990		E4OD	RWD; F0UP-7000-LA; 4.10 Final Drive Ratio; PRA-JA	FOTZ-7V000-LRM
	1991-1990		E4OD	4WD; F0TP-7000-UA; PRA-G	FOTZ-7V000-URM
	1990	5.8L	E4OD	4WD; F0TP-7000-BB; PRA-R	FOTZ-7V000-BRM
	1990		E4OD	4WD; F0TP-7000-BA, BB, ZA; PRA-R	FOTZ-7V000-BRM
	1990		E4OD	4WD; F0TP-7000-ZA; PRA-BA	FOTZ-7V000-BRM
	1990	7.3L	E4OD	RWD; F0TP-7000-WA; 4.10 Final Drive Ratio; PRA-L	FOTZ-7V000-LRM
	1989		E4OD	4WD; E9TP-7000-GA, GB; PRA-G	E9TZ-7V000-CRM

**Flex**

Part Type	Years	Engine	Trans	Qualifier	Ford #	
Automatic - New	2016-2014		6F50	AWD; DA8P-7000-SB; 3.65 Final Drive Ratio	DA8Z-7000-S	
	2016-2014		6F50	FWD; DA8P-7000-CB; 3.39 Final Drive Ratio	DA8Z-7000-K	
	2013		6F50	FWD; DA8P-7000-CA; 3.39 Final Drive Ratio	DA8Z-7000-A	
	2013		6F50	AWD; DA8P-7000-SA; 3.65 Final Drive Ratio	DA8Z-7000-B	
	2012-2009	3.5L	6F55	Naturally Aspirated; AA8P-7000-FC; 3.16 Final Drive Ratio	AA8Z-7000-S	
	2012-2009		6F50	AA8P-7000-KC; 3.39 Final Drive Ratio	AA8Z-7000-V	
	2012-2010	3.5L EcoBoost	6F55	AA5P-7000-DD; 3.16 Final Drive Ratio	AA5Z-7000-K	
	2011		6F50	AA8P-7000-KB; 3.39 Final Drive Ratio; Before 3/28/11	AA8Z-7000-N	
	Automatic - Reman	2013	3.5L EcoBoost	6F50	FWD; DA8P-7000-CB; w/ 3.39 Ratio	DA8Z-7000-ARM
		2013		6F50	AWD; DA8P-7000-SB; w/ 3.65 Ratio	DA8Z-7000-BRM
2013			6F50	DA5P-7000-DB; w/ 3.16 Ratio	DA5Z-7000-DRM	
2012-2009		3.5L	6F50	AWD; AA8P-7000-KA, KB, KC	AA8Z-7000-KRM	
2012-2009			6F50	FWD; AA8P-7000-FA, FB, FC	AA8Z-7000-FRM	
2012-2011			6F55	AWD; AA5P-7000-DC, DD	AA5Z-7000-HRM	
2011-2009			6F50	AWD; 9E9P-7000-KA	9E9Z-7000-BRM	
2010		3.5L EcoBoost	6F55	AWD; AA5P-7000-DA, DB	AA5Z-7000-DRM	
2009		3.5L	6F50	FWD; 9E9P-7000-FA	9E9Z-7000-ARM	

**Freestar**

Part Type	Years	Engine	Trans	Qualifier	Ford #
Automatic - Reman	2007-2005	3.9L	AX4N	5F2P-7000-BA, BB, BC; PNB-LA	5F2Z-7000-BRM
	2007-2005	4.2L	AX4N	5F2P-7000-AA, AB, AC; PNB-MA	5F2Z-7000-ARM
	2004	3.9L	AX4N	4F2P-7000-BA; PNB-LA	4F2Z-7000-BARM
	2004	4.2L	AX4N	RM4F2J-7000-AC; 4F2P-7000-AA, AB; PNB-MA	4F2Z-7000-ABRM

**Police Interceptor Utility**

Part Type	Years	Engine	Trans	Qualifier	Ford #
Automatic - New	2013	3.7L	6F55	DA5P-7000-GA	DA5Z-7000-K
Automatic - Reman	2013		6F55	AWD; DA5P-7000-GA	DA5Z-7000-KRM

**Ranger**

Part Type	Years	Engine	Trans	Qualifier	Ford #
Automatic - Reman	2011	2.3L	5R44E	RWD; BL5P-7000-CA	7L5Z-7000-CRM
	2011	4.0L	5R55E	4WD; BL5P-7000-EA	7L5Z-7000-ERM
	2011		5R55E	RWD; BL5P-7000-DA	7L5Z-7000-DRM
	2010-2009	2.3L	5R44E	RWD; 9L5P-7000-CA	7L5Z-7000-CRM
	2010-2009	4.0L	5R55E	4WD; 9L5P-7000-EA	7L5Z-7000-ERM
	2010-2009		5R55E	RWD; 9L5P-7000-DA	7L5Z-7000-DRM
	2008	2.3L	5R44E	RWD; 8L5P-7000-CA	7L5Z-7000-CRM
	2008-2007		5R44E	RWD; 7L5P-7000-CA, CB	7L5Z-7000-CRM
	2008	3.0L	5R44E	RWD; 8L5P-7000-AA	7L5Z-7000-ARM
	2008		5R55E	4WD; 8L5P-7000-BA	7L5Z-7000-BRM
	2008	4.0L	5R55E	4WD; 8L5P-7000-EA	7L5Z-7000-ERM
	2008		5R55E	RWD; 8L5P-7000-DA	7L5Z-7000-DRM
	2007-2006	2.3L	5R44E	RWD; 5L5P-7000-CB; RJL	5L5Z-7000-CRM
	2007	3.0L	5R44E	RWD; 7L5P-7000-AA, AB, BA, BB	7L5Z-7000-ARM
	2007		5R44E	4WD; 7L5P-7000-AA, AB, BA, BB	7L5Z-7000-BRM
	2007	4.0L	5R55E	4WD; 7L5P-7000-EA, EB	7L5Z-7000-ERM
	2007		5R55E	RWD; 7L5P-7000-DA, DB	7L5Z-7000-DRM
	2006-2005	3.0L	5R44E	RWD; 5L5P-7000-AB; RJL	5L5Z-7000-ARM



**Ranger**

-Cont'd

Part Type	Years	Engine	Trans	Qualifier	Ford #
Automatic - Reman	2006-2004	4.0L	5R55E	4WD; 4L5P-7000-EA; R/JL	4L5Z-7000-EARM
	2006-2005		5R55E	RWD; RM5L5J-7000-DC	5L5Z-7000-DRM
	2005	2.3L	5R55E	RWD; 5L5P-7000-CB; R/JL	5L5Z-7000-CRM
	2005-2004	3.0L	5R55E	4WD; 4L5P-7000-BA; R/JL	4L5Z-7000-BARM
	2004	2.3L	5R55E	RWD; 4L5P-7000-CA; R/JL	4L5Z-7000-CARM
	2004	3.0L	5R55E	RWD; 4L5P-7000-AA; R/JL	4L5Z-7000-AARM
	2004	4.0L	5R55E	RWD; 4L5P-7000-DA; R/JL	4L5Z-7000-DARM
	2003-2002	2.3L	5R44E	RWD; 2L5P-7000-CB	2L5Z-7V000-CBRM
	2003-2002	3.0L	5R44E	RWD; 2L5P-7000-AB	2L5Z-7V000-ABRM
	2003-2001	4.0L	5R55E	RWD; 1L5P-7000-DA,FA	1L5Z-7V000-DRM
	2003-2002		5R55E	4WD; 1L5P-7000-EA	1L5Z-7V000-ERM
	2001-1999	2.5L	4R44E	RWD; XL5P-7000-CA	XL5Z-7V000-CARM
	2001	3.0L	5R44E	RWD; 1L5P-7000-AA	1L5Z-7V000-ARM
	2001	4.0L SOHC	5R55E	4WD; 1L5P-7000-EA	1L5Z-7V000-ERM
	2000-1999	3.0L	5R55E	RWD; XL5P-7000-AA	XL5Z-7V000-AARM
	2000-1999		4R44E	4WD; XL5P-7000-BA	XL5Z-7V000-BARM
	2000-1999	4.0L	5R55E	4WD; XL5P-7000-EA	XL5Z-7V000-EARM
	2000-1999		5R55E	RWD; XL5P-7000-DA	XL5Z-7V000-DARM
	1998		5R55E	4WD; 98GT-7000-LAA,LBA	F87Z-7V000-LARM
	1997		5R55E	4WD; 97GT-7000-ACA,AEA	F77Z-7V000-AARM
1996-1995	3.0L	4R44E	RWD; 95GT-7000-BAA,KAA	F57Z-7V000-KARM	

**Transit Connect**

Part Type	Years	Engine	Trans	Qualifier	Ford #
Automatic - New	2017	2.5L	6F35		DV6Z-7000-P
	2016	1.6L	6F35	DV6P-7000-UB	DV6Z-7000-E
	2016-2015	2.5L	6F35	FWD; DV6P-7000-ZA; 3.21 Final Drive Ratio; Before 9/24/15	DV6Z-7000-D
	2016		6F35	DV6P-7000-ZB	DV6Z-7000-F
	2015	1.6L	6F35	DV6P-7000-UA; 3.06 Ratio; Before 9/24/15	DV6Z-7000-B
	2015-2014		6F35	FWD; DV6P-7000-VA; 3.51 Final Drive Ratio	DV6Z-7000-C
	2015		6F35	DV6P-7000-UB; From 9/24/15	DV6Z-7000-E
	2015		6F35	RMGV6J-7000-LA; 3.06 Ratio; Before 9/24/15	DV6Z-7000-BRM
	2015-2014		6F35	FWD; RMGV6J-7000-LA; 3.51 Final Drive Ratio	DV6Z-7000-CRM
	2015	2.5L	6F35	DV6P-7000-ZB; From 9/24/15	DV6Z-7000-F
	2015		6F35	RMGV6J-7000-DA; 3.21 Final Drive Ratio; Before 9/24/15	DV6Z-7000-DRM
	2014	1.6L	6F35	DV6P-7000-UA; 3.06 Ratio	DV6Z-7000-B
	2014		6F35	RMGV6J-7000-LA; 3.06 Ratio	DV6Z-7000-BRM
	2014	2.5L	6F35	FWD; DV6P-7000-ZA; 3.21 Final Drive Ratio	DV6Z-7000-D
	2014		6F35	RMGV6J-7000-DA; 3.21 Final Drive Ratio	DV6Z-7000-DRM
	2013-2012	2.0L	4F27E	BT1P-7000-DA	BT1Z-7000-A
	2011		4F27E	8M5P-7000-AA; Before 1/17/11	8M5Z-7000-A
	2011		4F27E	BT1P-7000-DA; From 1/17/11	BT1Z-7000-A
	2010		4F27E	8M5P-7000-AA	8M5Z-7000-A
	Automatic - Reman	2013-2011		4F27E	BT1P-7000-DA; 3.9 Axle
2011-2010			4F27E	8M5P-7000-AA; 4.2 Axle	8M5Z-7000-ARM

**Transit-150**

Part Type	Years	Engine	Trans	Qualifier	Ford #
Automatic - New	2016	3.2L	6R80	w/ 148.0 In. Wheelbase; GK4P-7000-DA	GK4Z-7000-C
	2016		6R80	w/ 130.0 In. Wheelbase; GK4P-7000-DA	GK4Z-7000-C
	2016	3.5L	6R80	GK4P-7000-EA	GK4Z-7000-D
	2016	3.7L	6R80	w/ 148.0 In. Wheelbase; GK4P-7000-FA	GK4Z-7000-E
	2016		6R80	w/ 130.0 In. Wheelbase; GK4P-7000-FA	GK4Z-7000-E
	2015	3.2L	6R80	w/ 148.0 In. Wheelbase; CK4P-7000-DC	CK4Z-7000-F
	2015	3.5L	6R80	CK4P-7000-EB	CK4Z-7000-D
	2015	3.7L	6R80	w/ 148.0 In. Wheelbase; CK4P-7000-FB	CK4Z-7000-E

**Transit-250**

Part Type	Years	Engine	Trans	Qualifier	Ford #
Automatic - New	2016	3.2L	6R80	w/ 156.0 In. Wheelbase; GK4P-7000-AA	GK4Z-7000-A
	2016		6R80	w/ 138.0 In. Wheelbase; GK4P-7000-DA	GK4Z-7000-C
	2016		6R80	w/ 130.0 In. Wheelbase; GK4P-7000-DA	GK4Z-7000-C
	2016		6R80	w/ 148.0 In. Wheelbase; GK4P-7000-DA	GK4Z-7000-C
	2016	3.5L	6R80	GK4P-7000-EA	GK4Z-7000-D
	2016	3.7L	6R80	w/ 156.0 In. Wheelbase; GK4P-7000-CA	GK4Z-7000-B
	2016		6R80	w/ 138.0 In. Wheelbase; GK4P-7000-FA	GK4Z-7000-E
	2016		6R80	w/ 148.0 In. Wheelbase; GK4P-7000-FA	GK4Z-7000-E
	2016		6R80	w/ 130.0 In. Wheelbase; GK4P-7000-FA	GK4Z-7000-E
	2015	3.2L	6R80	w/ 156.0 In. Wheelbase; CK4P-7000-AC	CK4Z-7000-A
	2015		6R80	w/ 138.0 In. Wheelbase; CK4P-7000-DC	CK4Z-7000-F
	2015		6R80	w/ 148.0 In. Wheelbase; CK4P-7000-DC	CK4Z-7000-F
	2015	3.5L	6R80	CK4P-7000-EB	CK4Z-7000-D
	2015	3.7L	6R80	w/ 156.0 In. Wheelbase; CK4P-7000-CB	CK4Z-7000-C



**Transit-250**

-Cont'd

Part Type	Years	Engine	Trans	Qualifier	Ford #
Automatic - New	2015	3.7L	6R80	w/ 138.0 In. Wheelbase; CK4P-7000-FB	CK4Z-7000-E
	2015		6R80	w/ 148.0 In. Wheelbase; CK4P-7000-FB	CK4Z-7000-E

**Transit-350**

Part Type	Years	Engine	Trans	Qualifier	Ford #
Automatic - New	2016	3.2L	6R80	w/ 178.0 In. Wheelbase; GK4P-7000-AA	GK4Z-7000-A
	2016		6R80	w/ 156.0 In. Wheelbase; GK4P-7000-AA	GK4Z-7000-A
	2016		6R80	w/ 148.0 In. Wheelbase; GK4P-7000-DA	GK4Z-7000-C
	2016	3.5L	6R80	GK4P-7000-EA	GK4Z-7000-D
	2016		6R80	w/ 178.0 In. Wheelbase; GK4P-7000-CA	GK4Z-7000-B
	2016	3.7L	6R80	w/ 156.0 In. Wheelbase; GK4P-7000-CA	GK4Z-7000-B
	2016		6R80	w/ 148.0 In. Wheelbase; GK4P-7000-FA	GK4Z-7000-E
	2015	3.2L	6R80	w/ 156.0 In. Wheelbase; CK4P-7000-AC	CK4Z-7000-A
	2015		6R80	w/ 178.0 In. Wheelbase; CK4P-7000-AC	CK4Z-7000-A
	2015	3.5L	6R80	w/ 148.0 In. Wheelbase; CK4P-7000-DC	CK4Z-7000-F
	2015		6R80	CK4P-7000-EB	CK4Z-7000-D
	2015	3.7L	6R80	w/ 156.0 In. Wheelbase; CK4P-7000-CB	CK4Z-7000-C
	2015		6R80	w/ 178.0 In. Wheelbase; CK4P-7000-CB	CK4Z-7000-C
	2015	6R80	w/ 148.0 In. Wheelbase; CK4P-7000-FB	CK4Z-7000-E	

**Transit-350 HD**

Part Type	Years	Engine	Trans	Qualifier	Ford #
Automatic - New	2016	3.2L	6R80	w/ 178.0 In. Wheelbase; GK4P-7000-AA	GK4Z-7000-A
	2016		6R80	w/ 156.0 In. Wheelbase; GK4P-7000-AA	GK4Z-7000-A
	2016		6R80	w/ 138.0 In. Wheelbase; GK4P-7000-DA	GK4Z-7000-C
	2016	3.5L	6R80	w/ 148.0 In. Wheelbase; GK4P-7000-DA	GK4Z-7000-C
	2016		6R80	GK4P-7000-EA	GK4Z-7000-D
	2016	3.7L	6R80	w/ 156.0 In. Wheelbase; GK4P-7000-CA	GK4Z-7000-B
	2016		6R80	w/ 178.0 In. Wheelbase; GK4P-7000-CA	GK4Z-7000-B
	2016	3.2L	6R80	w/ 138.0 In. Wheelbase; GK4P-7000-FA	GK4Z-7000-E
	2016		6R80	w/ 148.0 In. Wheelbase; GK4P-7000-FA	GK4Z-7000-E
	2015	3.5L	6R80	w/ 156.0 In. Wheelbase; CK4P-7000-AC	CK4Z-7000-A
	2015		6R80	w/ 178.0 In. Wheelbase; CK4P-7000-AC	CK4Z-7000-A
	2015	3.7L	6R80	w/ 148.0 In. Wheelbase; CK4P-7000-DC	CK4Z-7000-F
	2015		6R80	w/ 138.0 In. Wheelbase; CK4P-7000-DC	CK4Z-7000-F
	2015	3.5L	6R80	CK4P-7000-EB	CK4Z-7000-D
	2015		6R80	w/ 156.0 In. Wheelbase; CK4P-7000-CB	CK4Z-7000-C
	2015	3.7L	6R80	w/ 178.0 In. Wheelbase; CK4P-7000-CB	CK4Z-7000-C
2015	6R80		w/ 148.0 In. Wheelbase; CK4P-7000-FB	CK4Z-7000-E	
2015	6R80	w/ 138.0 In. Wheelbase; CK4P-7000-FB	CK4Z-7000-E		

**Windstar**

Part Type	Years	Engine	Trans	Qualifier	Ford #
Automatic - Reman	2003-2001	3.8L	4F50N	1F2P-7000-CC; PNB-LA	1F2Z-7V000-CRM
	2000		AX4S	YF2P-7000-BA; PNA-WK	YF2Z-7V000-BRM
	1999	3.0L	AX4S	XF2P-7000-BA; PNA-WC	XF2Z-7V000-BARM
	1998-1997		AX4S	F88P-7000-AA; From 9/9/97; PNA-WE1	F88Z-7V000-AARM
	1998-1997		AX4S	F78P-7000-AA; Before 9/9/97; PNA-WA	F78Z-7V000-ARM
	1998-1997	3.8L	AX4S	F78P-7000-BA; Before 9/9/97; PNA-WC	F78Z-7V000-BRM
	1998-1997		AX4S	F88P-7000-BA; From 9/9/97; PNA-WF1	F88Z-7V000-BARM
	1997-1996	AX4S	F68P-7000-AA; PNA-WC	F68Z-7V000-AARM	
	1995	AX4S	F48P-7000-BA; PNA-WB	F48Z-7V000-BRM	

**Lincoln**

**Aviator**

Part Type	Years	Engine	Trans	Qualifier	Ford #
Automatic - Reman	2005-2004	4.6L	5R55S	AWD; 4L2P-7000-FC; RJL	4L2Z-7000-FCRM
	2005-2004		5R55S	RWD; 4L2P-7000-EC; RJL	4L2Z-7000-ECRM
	2003		5R55S	AWD; 3L2P-7000-FB,FE	3L2Z-7V000-FERM
	2003		5R55S	3L2P-7000-EB,EE	3L2Z-7V000-EERM

**Blackwood**

Part Type	Years	Engine	Trans	Qualifier	Ford #
Automatic - Reman	2002	5.4L	4R100	1L7P-7000-AA,AB,AC,AD; PRB-GX; PRB-FV	3L7Z-7V000-ARM

# TRANSMISSIONS

## Light Trucks

### Lincoln



FORD PARTS

### MKC

Part Type	Years	Engine	Trans	Qualifier	Ford #
Automatic - New	2017	2.0L EcoBoost	6F35	4WD; GJ7P-7000-BA; w/ Stop/Start System	GJ7Z-7000-A
	2016		6F35	EJ7P-7000-LA; w/ Standard Electric Starter Motor	EJ7Z-7000-M
	2016	2.3L EcoBoost	6F35	FWD; EJ7P-7000-KB	EJ7Z-7000-N
	2016		6F35	EJ7P-7000-JC	EJ7Z-7000-L
	2015		6F35	AWD; EJ7P-7000-HA	EJ7Z-7000-H
	2015	2.0L EcoBoost	6F35	FWD; EJ7P-7000-KA	EJ7Z-7000-K
	2015		6F35	AWD; EJ7P-7000-JA	EJ7Z-7000-J
		2.3L	6F35		

### MKT

Part Type	Years	Engine	Trans	Qualifier	Ford #	
Automatic - New	2016-2014		6F50	DA8P-7000-AB; 3.16 Final Drive Ratio	DA8Z-7000-J	
	2016		6F35	EJ7P-7000-JA	DE9Z-7000-M	
	2016-2014	3.5L	6F55	DA5P-7000-EB; w/ 3.65 Final Drive Ratio	DA5Z-7000-N	
	2015-2013		6F35	FWD; DE9P-7000-LA	DE9Z-7000-L	
	2013	2.0L	6F55	DA5P-7000-EB; 3.65 Final Drive Ratio	DA5Z-7000-N	
	2013		6F50	DA8P-7000-AA; 3.16 Final Drive Ratio	DA8Z-7000-C	
	2012-2010		6F55	AA8P-7000-KC; 3.39 Final Drive Ratio	AA8Z-7000-V	
	2012-2010	3.5L EcoBoost	6F55	AA5P-7000-DD; 3.16 Final Drive Ratio	AA5Z-7000-K	
	2012-2010		6F50	Naturally Aspirated; AA8P-7000-FC; 3.16 Final Drive Ratio	AA8Z-7000-S	
	2012-2010	3.7L	6F50	AA8P-7000-KC; 3.39 Final Drive Ratio	AA8Z-7000-V	
	2011		6F50	AA8P-7000-KB; 3.39 Final Drive Ratio; Before 3/28/11	AA8Z-7000-N	
	Automatic - Reman	2014-2013	2.0L EcoBoost	6F35	FWD; DE9P-7000-LA	EE9Z-7000-ARM
		2013		6F55	AWD; DA5P-7000-DB; w/ 3.16 Ratio	DA5Z-7000-DRM
		2013	3.7L	6F50	DA8P-7000-AB; w/ 3.16 Ratio	DA8Z-7000-CRM
2012-2011		6F55		AWD; AA5P-7000-DC,DD	AA5Z-7000-HRM	
2012-2010		3.7L	6F50	AWD; AA8P-7000-KA,KB,KC	AA8Z-7000-KRM	
2012-2010			6F50	FWD; AA8P-7000-FA,FB,FC	AA8Z-7000-FRM	
2010		3.5L EcoBoost	6F55	AWD; AA5P-7000-DA,DB	AA5Z-7000-DRM	

### MKX

Part Type	Years	Engine	Trans	Qualifier	Ford #	
Automatic - New	2016		6F35	FWD; DG9P-7000-YA; Standard Electric Starter	DG9Z-7000-Y	
	2016		6F55	FWD; F2GP-7000-VC	F2GZ-7000-VC	
	2016		6F55	AWD; F2GP-7000-XC	F2GZ-7000-XC	
	2016		6F35	FWD; G2GP-7000-AA	G2GZ-7000-AA	
	2016		6F35	AWD; G2GP-7000-BA	G2GZ-7000-BA	
	2016		2.7L	6F50	AWD; DA8P-7000-TC; w/ 2.77 Axle Ratio	DA8Z-7000-TC
	2016-2014			3.7L	FWD; DA8P-7000-AB; 3.16 Final Drive Ratio	DA8Z-7000-J
	2013-2012		6F35	6F35	CT4P-7000-NC; 3.21 Final Drive Ratio	CT4Z-7000-N
	2013			6F50	FWD; DA8P-7000-AA; 3.16 Final Drive Ratio; Before 5/06/13	DA8Z-7000-C
	2013		6F50	6F50	FWD; DA8P-7000-AB; 3.16 Final Drive Ratio; From 5/6/13	DA8Z-7000-J
	2012-2011			6F50	FWD; BA8P-7000-AC	BA8Z-7000-L
	2010		6F50	6F50	FWD; AA8P-7000-FC	AA8Z-7000-S
	2013			3.7L	6F50	DA8P-7000-LB; w/ 3.39 Ratio
	2012-2011		6F50		AWD; BA8P-7000-EB,EC	BA8Z-7000-ERM
2012-2011	6F50	6F50	FWD; BA8P-7000-AB,AC	BA8Z-7000-ARM		
2009-2007		3.5L	6F50	AWD; 7A1P-7000-BA,BB,BC; 3.39 Final Drive Ratio	7A1Z-7000-ARM	
2009-2008	6F50		FWD; 7T4P-7000-AA, AB, AC; 3.16 Final Drive Ratio	8T4Z-7000-ARM		
2009	6F50	6F50	AA8P-7000-KA,KB,KC	AA8Z-7000-KRM		
2009		6F50	AA8P-7000-FA,FB,FC	AA8Z-7000-FRM		
2007	6F50	6F50	FWD; 7T4P-7000-CA,CB,CC; 2.77 Final Drive Ratio	7T4Z-7000-BRM		

### Mark LT

Part Type	Years	Engine	Trans	Qualifier	Ford #
Automatic - Reman	2008-2007	5.4L	4R75E	4WD; 7L3P-7000-EA,EB; PKF-FK,GK	7L3Z-7000-EBRM
	2008-2007		4R75E	RWD; 7L3P-7000-DA,DB; PKF-FJ,GJ	7L3Z-7000-DBRM
	2006		4R75W	4WD; 6L3P-7000-EA, EB; PKF-FX	6L3Z-7000-KRM
	2006		4R75W	4WD; 6L3P-7000-EA; PKF-EX, FX	6L3Z-7000-ERM
	2006		4R75W	RWD; 6L3P-7000-DA; PKF-EW, FW	6L3Z-7000-DRM
	2006		4R75W	RWD; 6L3P-7000-DA, DB; PKF-FW	6L3Z-7000-JRM
	2006		4R75W		

### Navigator

Part Type	Years	Engine	Trans	Qualifier	Ford #	
Automatic - New	2016	3.5L EcoBoost	6R80	4WD; FL1P-7000-DA; From 9/10/15	FL1Z-7000-B	
	2016-2015		6R80	RWD; FL3P-7000-CA	FL3Z-7000-C	
	2014-2012		5.4L	6R80	RWD; CL1P-7000-AC	CL1Z-7000-A
	2014-2012		6R80	4WD; CL1P-7000-BC	CL1Z-7000-B	
	2011		6R80	4WD; BL1P-7000-BB	BL1Z-7000-B	
Automatic - Reman	2012		6R80	4WD; CL1P-7000-BA	CL1Z-7000-BRM	
	2012		6R80	RWD; CL1P-7000-AA	CL1Z-7000-ARM	



**Navigator**

-Cont'd

Part Type	Years	Engine	Trans	Qualifier	Ford #
Automatic - Reman	2011	5.4L	6R80	4WD; BL1P-7000-BA,BB	BL1Z-7000-BRM
	2011		6R80	RWD; BL1P-7000-AA,AB	BL1Z-7000-ARM
	2010	5.4L SOHC	6R80	RWD; AL3P-7000-AA,AB,AC,AD	AL3Z-7000-ARM
	2010		6R80	4WD; AL1P-7000-BA,BB,BC,BD	AL1Z-7000-ARM
	2009	5.4L	6R80	RWD; 9L3P-7000-AF,AG,AH, NA,NB	9L3Z-7000-EARM
	2009		6R80	4WD; 9L3P-7000-BF,BG; 9L1P-7000-DC/DD, EA/EB	9L1Z-7000-BRM
	2007		6HP26	RWD; 7L7Z-7000-AC	DL7Z-7000-ERM
	2007		6HP26	4WD; 7L7Z-7000-BD	DL7Z-7000-FRM
	2006-2005		6HP26	RWD; 5L74-7000-AE	DL7Z-7000-ARM
	2006-2005		6HP26	4WD; 5L74-7000-BE	DL7Z-7000-BRM
	2004-2003		4R100	RWD; 3L7P-7000-AA; PRB-HE, PRB-HE1	3L7Z-7V000-ARM
	2004-2003		4R100	4WD; 3L7P-7000-BA; PRB-HF, PRB-HF1	3L7Z-7V000-BRM
	2002-2001		4R100	RWD; 1L7P-7000-AA,AB,AC,AD; PRB-EA	3L7Z-7V000-ARM
	2002-2001		4R100	4WD; 1L7P-7000-BA,BB,BC; PRB-EB,FW,GY	3L7Z-7V000-BRM
	2000			RWD; XL3P-7000-GB; PRB-BC	XL3Z-7V000-GBRM
	2000		4R100	4WD; YL1P-7000-BA; PRB-CB	XL1Z-7V000-DBRM
	2000	5.4L DOHC	4R100	RWD; YL1P-7000-AA; PRB-CA	XL1Z-7V000-CBRM
	2000	5.4L SOHC	4R100	RWD; YL7P-7000-AA; PRB-CF	XL3Z-7V000-GBRM
	2000		4R100	4WD; YL3P-7000-BA; PRB-BD	YC3Z-7V000-BRM
	1999	5.4L DOHC	4R100	RWD; XL1P-7000-CB; PRB-BA	XL1Z-7V000-CBRM
	1999		4R100	4WD; XL1P-7000-DB; PRB-BB	XL1Z-7V000-DBRM
	1999	5.4L SOHC	4R100	RWD; XL7P-7000-AA,GB; PRB-BC,BF,CF	XL3Z-7V000-GBRM
	1999		4R100	4WD; XL3P-7000-HB; PRB-BD,CD	YC3Z-7V000-BRM
	1998	5.4L	E4OD	4WD; F75P-7000-MB; 3.31/3.73 Axle Ratio; PRA-PAB	F75Z-7V000-MRM
	1998		4R100	RWD; F8UP-7000-LA, NA; PRB-U,W; 3.31/3.73 Axle Ratio	F8UZ-7V000-LARM
	1998		4R100	4WD; F8UP-7000-MB; 3.08/3.31/3.55/3.73 Axle Ratio; PRB-V	F8UZ-7V000-MBRM
	1998		4R100	RWD; F8UP-7000-LC; 8TSG; PRB-AC	F8UZ-7V000-LCRM

**Mazda**

**B2300**

Part Type	Years	Engine	Trans	Qualifier	Ford #
Automatic - Reman	2006-2005	2.3L	5R44E	RWD; 5L5P-7000-CB; R/JL	5L5Z-7000-CRM
	2004		5R44E	RWD; 4L5P-7000-CA; R/JL	4L5Z-7000-CARM

**B2500**

Part Type	Years	Engine	Trans	Qualifier	Ford #
Automatic - Reman	2001-1999	2.5L	4R44E	RWD; XL5P-7000-CA	XL5Z-7V000-CARM

**B3000**

Part Type	Years	Engine	Trans	Qualifier	Ford #
Automatic - Reman	2006-2005	3.0L	5R55E	RWD; 5L5P-7000-AB; R/JL	5L5Z-7000-ARM
	2004		5R55E	RWD; 4L5P-7000-AA; R/JL	4L5Z-7000-AARM
	2003-2002		5R55E	RWD; 2L5P-7000-AB	2L5Z-7V000-ABRM
	2003		5R55E	4WD; 2L5P-7000-BB	2L5Z-7000-BBRM
	2001		5R55E	RWD; 1L5P-7000-AA	1L5Z-7V000-ARM
	2000-1999		M5R1	RWD; XL5P-7000-AA	XL5Z-7V000-AARM
	2000-1999		4R44E	4WD; XL5P-7000-BA	XL5Z-7V000-BARM
	1996-1995		4R44E	RWD; 95GT-7000-BAA,KAA	F57Z-7V000-KARM

**B4000**

Part Type	Years	Engine	Trans	Qualifier	Ford #
Automatic - Reman	2005-2004	4.0L	5R55E	4WD; 4L5P-7000-EA; R/JL	4L5Z-7000-EARM
	2004		5R55E	RWD; 4L5P-7000-DA; R/JL	4L5Z-7000-DARM
	2003		5R55E	4WD; 1L5P-7000-EA	1L5Z-7000-EARM
	2003		5R55E	RWD; 1L5P-7000-DA,FA	1L5Z-7000-DARM
	2002-2001		5R55E	RWD; 1L5P-7000-DA,FA	1L5Z-7V000-DRM
	2002-2001		5R55E	4WD; 1L5P-7000-EA	1L5Z-7V000-ERM
	2000-1999		5R55E	4WD; XL5P-7000-EA	XL5Z-7V000-EARM
	2000-1999		5R55E	RWD; XL5P-7000-DA	XL5Z-7V000-DARM
	1998		5R55E	4WD; 98GT-7000-LAA,LBA	F87Z-7V000-LARM
	1997		5R55E	4WD; 97GT-7000-ACA,AEA	F77Z-7V000-AARM

**Tribute**

Part Type	Years	Engine	Trans	Qualifier	Ford #
Automatic - New	2011	2.5L	6F35	4WD; BL8P-7000-GB	BL8Z-7000-H
	2011		6F35	FWD; BL8P-7000-GB	BL8Z-7000-G
	2011	3.0L	6F35	4WD; BL8P-7000-FB	BL8Z-7000-F
	2011		6F35	FWD; BL8P-7000-EB	BL8Z-7000-E

**TRANSMISSIONS**  
**Light Trucks**  
**Mazda / Mercury**



**FORD PARTS**

**Tribute**

**-Cont'd**

Part Type	Years	Engine	Trans	Qualifier	Ford #
Automatic - Reman	2010-2009	2.5L	6F35	FWD; 9L8P-7000-GA	9L8Z-7000-CRM
	2010-2009	3.0L	6F35	4WD; 9L8P-7000-FA	9L8Z-7000-BRM
	2009	2.5L	6F35	4WD; 9L8P-7000-HA	9L8Z-7000-DRM
	2009	3.0L	6F35	FWD; 9L8P-7000-EA	9L8Z-7000-ARM
	2008	2.3L	CD4E	FWD; 8L8P-7000-AA	8L8Z-7000-ARM
	2008		CD4E	4WD; 8L8P-7000-BA	8L8Z-7000-BRM
	2008	3.0L	CD4E	FWD; 8L8P-7000-CA	8L8Z-7000-CRM
	2008		CD4E	4WD; 8L8P-7000-DA	8L8Z-7000-DRM
	2007	2.3L	CD4E	FWD; 7L8P-7000-AA	5L8Z-7000-ERM
	2007		CD4E	AWD; 7L8P-7000-BA	5L8Z-7000-FRM
	2007	3.0L	CD4E	AWD; 7L8P-7000-DA	5L8Z-7000-HRM
	2007		CD4E	FWD; 7L8P-7000-CA	5L8Z-7000-GRM
	2006	2.3L	CD4E	FWD; 6L8P-7000-AA	5L8Z-7000-ERM
	2006		CD4E	AWD; 6L8P-7000-BA	5L8Z-7000-FRM
	2006	3.0L	CD4E	AWD; 6L8P-7000-DA	5L8Z-7000-HRM
	2006		CD4E	FWD; 6L8P-7000-CA	5L8Z-7000-GRM
	2005	2.3L	CD4E	FWD; 5L8P-7000-AC,AD,AE; PTA-P	5L8Z-7000-ACRM
	2005		CD4E	FWD; 5L8P-7000-EA,EB; PTA-P	5L8Z-7000-ERM
	2005		CD4E	AWD; 5L8P-7000-FA,FB; PTA-P	5L8Z-7000-FRM
	2005		CD4E	AWD; 5L8P-7000-BC,BD,BE; PTA-P	5L8Z-7000-BCRM
	2005	3.0L	CD4E	AWD; 5L8P-7000-HA,HB; PTA-V	5L8Z-7000-HRM
	2005		CD4E	FWD; 5L8P-7000-GA,GB; PTA-V	5L8Z-7000-GRM
	2005		CD4E	AWD; 5L8P-7000-DB,DC,DD; PTA-V	5L8Z-7000-DBRM
	2005		CD4E	FWD; 5L8P-7000-CB,CC,CD; PTA-V	5L8Z-7000-CBRM
	2004		CD4E	4WD; 3L8P-7000-HD; PTA-V	3L8Z-7000-HDRM
	2004		CD4E	4WD; 5L8P-7000-KA; PTA-V	3L8Z-7000-HDRM
	2004		CD4E	FWD; 5L8P-7000-JA; PTA-V	3L8Z-7000-GDRM
	2004		CD4E	FWD; 3L8P-7000-GD; PTA-V	3L8Z-7000-GDRM
	2003		CD4E	4WD; 3L8P-7000-HA; PTA-V	3L8Z-7000-HARM
	2003		CD4E	FWD; 3L8P-7000-GA; PTA-V	3L8Z-7000-GARM
	2003		CD4E	4WD; 3L8P-7000-HB,HC; PTA	3L8Z-7V000-HCRM
	2002		CD4E	4WD; 2L8P-7000-FA,FB; PTA-V	2L8Z-7V000-FBRM
	2002		CD4E	FWD; 2L8P-7000-EA,EB; PTA-V	2L8Z-7V000-EBRM
	2001		CD4E	FWD; YL8P-7000-EA	YL8Z-7V000-ERM
2001		CD4E	4WD; YL8P-7000-FB	YL8Z-7V000-FRM	

**Mercury**

**Mariner**

Part Type	Years	Engine	Trans	Qualifier	Ford #
Automatic - New	2011	2.5L	6F35	4WD; BL8P-7000-GB	BL8Z-7000-H
	2011		6F35	FWD; BL8P-7000-GB	BL8Z-7000-G
	2011	3.0L	6F35	4WD; BL8P-7000-FB	BL8Z-7000-F
	2011		6F35	FWD; BL8P-7000-EB	BL8Z-7000-E
Automatic - Reman	2007-2006	2.3L ELECTRIC/GAS	CVT (CFT30)	8M64-7000-AH; w/ Power Split	8M6Z-7000-D
	2007-2006		CVT (CFT30)	7M64-7000-AD; w/ Power Split	7M6Z-7000-A
Automatic - Reman	2010-2009	2.5L	6F35	FWD; 9L8P-7000-GA	9L8Z-7000-CRM
	2010-2009	3.0L	6F35	4WD; 9L8P-7000-FA	9L8Z-7000-BRM
	2009	2.5L	6F35	4WD; 9L8P-7000-HA	9L8Z-7000-DRM
	2009	3.0L	6F35	FWD; 9L8P-7000-EA	9L8Z-7000-ARM
	2008	2.3L	CD4E	FWD; 8L8P-7000-AA	8L8Z-7000-ARM
	2008		CD4E	4WD; 8L8P-7000-BA	8L8Z-7000-BRM
	2008	3.0L	CD4E	FWD; 8L8P-7000-CA	8L8Z-7000-CRM
	2008		CD4E	4WD; 8L8P-7000-DA	8L8Z-7000-DRM
	2007	2.3L	CD4E	FWD; 7L8P-7000-AA	5L8Z-7000-ERM
	2007-2006		CD4E	4WD; 7L8P-7000-BA; 6L8P-7000-BA	5L8Z-7000-FRM
	2007	3.0L	CD4E	4WD; 7L8P-7000-DA	5L8Z-7000-HRM
	2007		CD4E	FWD; 7L8P-7000-CA	5L8Z-7000-GRM
	2006	2.3L	CD4E	FWD; 6L8P-7000-AA	5L8Z-7000-ERM
	2006	3.0L	CD4E	4WD; 6L8P-7000-DA	5L8Z-7000-HRM
	2006		CD4E	FWD; 6L8P-7000-CA	5L8Z-7000-GRM
	2005	2.3L	CD4E	FWD; 5L8P-7000-AC,AD,AE; PTA-P	5L8Z-7000-ACRM
	2005		CD4E	FWD; 5L8P-7000-EA,EB; PTA-P	5L8Z-7000-ERM
	2005		CD4E	FWD; 5L8P-7000-FA,FB; PTA-P	5L8Z-7000-FRM
	2005		CD4E	FWD; 5L8P-7000-CB,CC,CD; PTA-V	5L8Z-7000-CBRM
	2005	3.0L	CD4E	4WD; 5L8P-7000-HA,HB; PTA-V	5L8Z-7000-HRM
2005		CD4E	4WD; 5L8P-7000-GA,GB; PTA-V	5L8Z-7000-GRM	
2005		CD4E	4WD; 5L8P-7000-DB,DC,DD; PTA-V	5L8Z-7000-DBRM	

**Monterey**

Part Type	Years	Engine	Trans	Qualifier	Ford #
Automatic - Reman	2007-2005	4.2L	4F50N	5F2P-7000-AA,AB,AC; PNB-MA	5F2Z-7000-ARM
	2007-2005		AX4N	5F2P-7000-AA,AB,AC; PNB-MA	5F2Z-7000-ARM
	2004		AX4N	4F2P-7000-AA,AB; PNB-MA	4F2Z-7000-ABRM
	2004		AX4N	RM4F2J-7000-AC	4F2Z-7000-ABRM



**Mountaineer**

Part Type	Years	Engine	Trans	Qualifier	Ford #
Automatic - Reman	2010-2009	4.0L	5R55S	RWD; 9L2P-7000-CA	9L2Z-7000-CRM
	2010	4.6L	6R80	RWD; AL2P-7000-AA	AL2Z-7000-ARM
	2010		6R80	4WD; AL2P-7000-BA	AL2Z-7000-BRM
	2009		6R80	RWD; 9L2P-7000-AB,AE,AG, EA,EB	9L2Z-7000-CARM
	2009		6R80	AWD; 9L2P-7000-BB,BE,BG, FA,FB	9L2Z-7000-DARM
	2008-2007		6R60	AWD; 8L2P-7000-BA; 7L2P-7000-BC,BD,BE, FB	7L2Z-7000-BRM
	2008		6R60	4WD; 8L2P-7000-HB/HC	8L2Z-7000-FRM
	2008-2007		6R60	RWD; 8L2P-7000-GB/GC	8L2Z-7000-ERM
	2007		6R60	RWD; 8L2P-7000-AA; 7L2P-7000-AC, AD, AE, EB	7L2Z-7000-ARM
	2006	4.0L	5R55S	RWD; 6L2P-7000-EB,EC	4L2Z-7000-ABRM
	2006		5R55S	AWD; 6L2P-7000-FB, FC	6L2Z-7000-FRM
	2006		5R55S	RWD; RM6L2J-7000-ED	6L2Z-7000-ERM
	2006	4.6L	6R60	RWD; 6L2P-7000-AD,AG,AH,AK,AL,AM,AN,AP	6L2Z-7000-ARM
	2006		6R60	AWD; 6L2P-7000-BM,BN,BP	6L2Z-7000-BRM
	2006		6R60	AWD; 6L2P-7000-BG,BH,BK,BL	6L2Z-7000-BRM
	2005-2004	4.0L	5R55S	AWD; 4L2P-7000-BB; R/JL	4L2Z-7000-BBRM
	2005-2004		5R55S	RWD; 4L2P-7000-AB; R/JL	4L2Z-7000-ABRM
	2005-2004	4.6L	5R55S	RWD; 4L2P-7000-CC; R/JL	4L2Z-7000-CCRM
	2005-2004		5R55S	AWD; 4L2P-7000-DC; R/JL	4L2Z-7000-DCRM
	2004	4.0L	5R55E	RWD; 4L5P-7000-DA; R/JL	4L5Z-7000-DARM
	2003-2002		5R55W	RWD; 2L2P-7000-AA	2L2Z-7V000-AARM
	2003-2002		5R55W	AWD; 2L2P-7000-BA	2L2Z-7V000-BARM
	2003-2002		5R55W	4WD; 2L2P-7000-BA	2L2Z-7V000-BARM
	2003-2002	4.6L	5R55S	RWD; 2L2P-7000-CA	2L2Z-7V000-CARM
	2003-2002		5R55S	4WD; 2L2P-7000-DA	2L2Z-7V000-DARM
	2002	4.0L	5R55W	RWD; 1L2P-7000-AE	1L2Z-7V000-ARM
	2002		5R55W	4WD; 1L2P-7000-BE	1L2Z-7V000-BRM
	2002		5R55W	AWD; 1L2P-7000-BE	1L2Z-7V000-BRM
	2002	4.6L	5R55W	AWD; 1L2P-7000-DE	1L2Z-7V000-DRM
	2002		5R55W	4WD; 1L2P-7000-DE	1L2Z-7V000-DRM
	2002		5R55W	RWD; 1L2P-7000-CE	1L2Z-7V000-CRM
	2001	4.0L SOHC	5R55E	RWD; 1L5P-7000-DA,FA	1L5Z-7V000-DRM
	2001		5R55E	AWD; 1L5P-7000-EA	1L5Z-7V000-ERM
	2001		5R55E	4WD; 1L5P-7000-EA	1L5Z-7V000-ERM
	2000-1999	4.0L	5R55E	RWD; XL2P-7000-CA	XL2Z-7V000-CARM
	2000-1999		5R55E	AWD; XL2P-7000-DA	XL2Z-7V000-DARM
	2000-1999		5R55E	4WD; XL2P-7000-DA	XL2Z-7V000-DARM
	2000-1999	5.0L	4R70W	4WD; XL2P-7000-BA; PKF-BL	XL2Z-7V000-BARM
	2000-1999		4R70W	AWD; XL2P-7000-BA; PKF-BL	XL2Z-7V000-BARM
	2000-1999		4R70W	RWD; XL2P-7000-AA; PKF-BK	XL2Z-7V000-AARM
	1998	4.0L	5R55E	AWD; 98GT-7000-AAA	F87Z-7V000-CARM
	1998		5R55E	4WD; 98GT-7000-AAA	F87Z-7V000-CARM
	1998		5R55E	RWD; 98GT-7000-BAA	F87Z-7V000-DARM

**Ford**

**Econoline**

Part Type	Years	Engine	Trans	Qualifier	Ford #
Automatic - New	2016-2010	5.4L	4R75E	AC2P-7000-DA	AC2Z-7000-D
	2016-2010		5R110W	w/ 176.0 in. Wheelbase; AC3P-7000-FA; TorqShift	AC3Z-7000-F
Automatic - Reman	2016-2009	6.8L	5R110W	w/ 176.0 in. Wheelbase; AC3P-7000-HA; w/o PTO; TorqShift	AC3Z-7000-H
	2014-2010	4.6L	4R75E	AC2P-7000-CA	AC2Z-7000-C
	2016-2009	5.4L	5R110W	9C3P-7000-FB; w/ Fixed Yoke; PRB-NT; TorqShift	9C2Z-7000-HRM
	2016-2010		5R110W	AC3P-7000-FA; w/ Fixed Yoke; PRB-NT; TorqShift	9C2Z-7000-HRM
	2014-2010	4.6L	4R75E	RWD; AC2P-7000-CA; PKF-IL	AC2Z-7000-CRM
	2014-2010	5.4L	4R75E	RWD; AC2P-7000-DA; PKF-IM	AC2Z-7000-DRM
	2014-2010		4R75E	4 X 2; AC2P-7000-DA; PKF-IM	AC2Z-7000-DRM
	2012-2009		5R110W	AC3P-7000-EA; PRB-NS; TorqShift	9C2Z-7000-GRM
	2012-2009	6.8L	5R110W	9C2P-7000-EB; PRB-NU; TorqShift	9C2Z-7000-JRM
	2012-2010		5R110W	AC3P-7000-GA; PRB-NU; TorqShift	9C2Z-7000-JRM
	2012-2009		5R110W	9C3P-7000-HB; PRB-NV; TorqShift	9C2Z-7000-KRM
	2012-2010		5R110W	AC3P-7000-HA; PRB-NV; TorqShift	9C2Z-7000-KRM
	2009	4.6L	4R75E	RWD; 9C2P-7000-CA,CB; PKF-GA, GL	9C2Z-7000-CRM
	2009	5.4L	5R110W	9C2P-7000-EB; PRB-NS; TorqShift	9C2Z-7000-GRM
	2009		4R75E	RWD; 9C2P-7000-DA,DB; PKF-GB, GM	9C2Z-7000-DRM
	2008-2007	4.6L	4R75E	7C2P-7000-CA; PKF-FL	7C2Z-7000-CARM
	2008	5.4L	5R110W	8C3P-7000-FD; PRB-NT; TorqShift	8C2Z-7000-FRM
	2008-2007		4R75E	7C2P-7000-DA; PKF-FM	7C2Z-7000-DARM
	2008	5.4L GAS	5R110W	8C3P-7000-ED; PRB-NS; TorqShift	8C3Z-7000-ERM
	2008-2007	6.8L	5R110W	6C3P-7000-DC; PRB-MK; w/ Fixed Yoke; TorqShift	5C2Z-7000-VRM
	2008		5R110W	8C3P-7000-GD; PRB-NU; TorqShift	8C3Z-7000-GRM
	2008		5R110W	8C3P-7000-HD; PRB-NV; TorqShift	8C2Z-7000-HRM
	2007	5.4L	5R110W	7C3P-7000-FC; PRB-MA; TorqShift	7C3Z-7000-FRM
	2007		5R110W	7C3P-7000-EC; PRB-LZ; TorqShift	7C3Z-7000-ERM
	2007	6.0L	5R110W	6C3P-7000-KC; w/ Fixed Yoke; PRB-MN; TorqShift	5C2Z-7000-SRM
	2007	6.0L DIESEL	5R110W	7C2P-7000-AB; PRB-ME; TorqShift	7C2Z-7000-ARM
	2007		5R110W	7C2P-7000-BB; PRB-MF; TorqShift	7C2Z-7000-BRM
	2007	6.8L	5R110W	7C3P-7000-GC; PRB-MB; TorqShift	7C3Z-7000-GRM
	2007		5R110W	7C3P-7000-HC; PRB-MC; TorqShift	7C3Z-7000-HRM
	2006	4.6L	4R75E	6C2P-7000-CA; PKF-FC; 250	6C2Z-7000-CRM



**Econoline**

**-Cont'd**

Part Type	Years	Engine	Trans	Qualifier	Ford #
Automatic - Reman	2006	5.4L	5R110W	6C3P-7000-BB; w/ Fixed Yoke; PRB-LL; TorqShift	5C2Z-7000-URM
	2006		5R110W	6C3P-7000-BA; w/ Fixed Yoke; PRB-KD; TorqShift	5C2Z-7000-URM
	2006	6.0L	4R75E	6C2P-7000-DA; PKF-FD; 250	6C2Z-7000-DRM
	2006		5R110W	6C3P-7000-JB; w/ Slip Yoke; PRB-LR; TorqShift	5C2Z-7000-RRM
	2006		5R110W	6C3P-7000-JA; w/ Slip Yoke; PRB-KJ; TorqShift	5C2Z-7000-RRM
	2006		5R110W	6C3P-7000-KB; w/ Fixed Yoke; PRB-LS; TorqShift	5C2Z-7000-SRM
	2006	6.8L	5R110W	6C3P-7000-KA; w/ Fixed Yoke; PRB-KK; TorqShift	5C2Z-7000-SRM
	2006		5R110W	6C3P-7000-DA; w/ Fixed Yoke; PRB-KF; TorqShift	5C2Z-7000-VRM
	2006	4.6L	5R110W	6C3P-7000-DB; w/ Fixed Yoke; PRB-LN; TorqShift	5C2Z-7000-VRM
	2005		4R70E	5C2P-7000-CA; PKF-EF	5C2Z-7000-CRM
	2005	5.4L	4R75E	5C2P-7000-DA; PKF-EH	5C2Z-7000-DRM
	2004	4.6L	4R70W	4C2P-7000-CA; PKF-DM	4C2Z-7000-CARM
	2004	5.4L	4R100	4C2P-7000-EA; PRB-JG1; w/ 158.0 or 176 In. Wheelbase	4C2Z-7000-EARM
	2004	4R70W	4R100	4C2P-7000-DA; PKF-EG	4C2Z-7000-DARM
	2004		4R100	Stripped Chassis - Incomplete; 4C2P-7000-HA; PRB-JK1	4C2Z-7000-HARM
	2004	4R100	4R100	Cutaway; 4C2P-7000-PA	4C2Z-7000-PARM
	2004	4R100	4R100	4C2P-7000-JA; DSO Models; PRB-JL1	4C2Z-7000-JARM
	2004	6.0L	5R110W	4C3P-7000-KB; PRB-JF; TorqShift	4C2Z-7000-SARM
	2004	6.8L	4R100	4C2P-7000-GA; PRB-JJ1	4C2Z-7000-GARM
	2004	4R100	4R100	4C2P-7000-LA; DSO Models; PRB-JM1	4C2Z-7000-LARM
	2003	4.2L	4R70W	1C2P-7000-HA; PKF-CF	1C2Z-7V000-HRM
	2003	4.6L	4R70W	3C2P-7000-AA; PKF-DR	3C2Z-7V000-ARM
	2003, 2001	5.4L	4R100	DSO Models; 1C2P-7000-TA; PRB-GZ, GZ1	1C2Z-7V000-ARM
	2003-2001		4R100	1C2P-7000-NA,NB,NC; PRB-DF,FE,GC	1C2Z-7V000-NRM
	2003-2001	6.8L	4R100	1C2P-7000-CA,CB,CC; PRB-FZ, FZ1, FD, DC	1C2Z-7V000-CRM
	2003-2001	7.3L	4R100	DSO Models; 1C2P-7000-VB; PRB-HC	1C2Z-7V000-DRM
	2003-2001	4R100	4R100	Normal Service; 1C2P-7000-EA, EB; PRB-GB, PRB-GB1	1C2Z-7V000-ERM
	2003-2001		4R100	Heavy Duty Service; 1C2P-7000-EA, EB; PRB-GB, PRB-GB1; 450	7U2Z-7V000-FRM
	2001	5.4L	4R100	Stripped Chassis; 1C2P-7000-AC; PRB-FX, FX1	1C2Z-7V000-ARM
	2000	6.8L	4R100	YC2P-7000-JA; PRB-BK	YC2Z-7V000-JRM
	2000	7.3L	4R100	YC2P-7000-MA, MB; Normal Service; PRB-BM, CN	YC2Z-7V000-MRM
	2000	4R100	4R100	YC2P-7000-MA, MB; Heavy Duty Service; PRB-CN	7U2Z-7V000-BRM
	1999	6.8L	4R100	XC2P-7000-HB; PRB-AH	F8UZ-7V000-JARM
	1999	7.3L	4R100	XC2P-7000-LB; Normal Service; TSS Axle Ratio; PRB-AL	F8UZ-7V000-KARM
	1999	4R100	4R100	XC2P-7000-LB; Heavy Duty Service; TSS Axle Ratio; PRB-AL	7U2Z-7V000-KRM
	1998	4R100	4R100	F8UP-7000-KA; DSO,TSS Axle Ratio; PRB-T	F8UZ-7V000-KARM
	1997	6.8L	E4OD	F7UP-7000-MA	F7UZ-7V000-MRM
	1997	7.3L	E4OD	4 X 2; F7UP-7000-VA	F7UZ-7V000-VARM
	1997		E4OD	4 X 2; F7UP-7000-NA; PRA-WAA; 4.63 Axle Ratio	F7UZ-7V000-NRM
	1997		E4OD	4 X 2; F7UP-7000-XA; PRA-XLA	F7UZ-7V000-NRM

**F-Series**

Part Type	Years	Engine	Trans	Qualifier	Ford #
Automatic - New	2016-2011	6.7L	5R110W	AC3P-7000-KA; w/ PTO; TorqShift	AC3Z-7000-K
	2016-2011		5R110W	AC3P-7000-HA; TorqShift	AC3Z-7000-H
	2016-2015	6.7L DIESEL	6R140	Cab & Chassis - Crew Cab; FC3P-7000-DA; w/o PTO; w/ Narrow Frame; TorqShift6	FC3Z-7000-D
	2016-2015		6R140	Cab & Chassis - Long Conventional; FC3P-7000-DA; w/o PTO; w/ Narrow Frame; TorqShift6	FC3Z-7000-D
	2016-2015	6R140	6R140	Cab & Chassis - Crew Cab; FC3P-7000-EA; w/ PTO; w/ Narrow Frame; TorqShift6	FC3Z-7000-E
	2016-2015		6R140	Cab & Chassis - Long Conventional; FC3P-7000-EA; w/ PTO; w/ Narrow Frame; TorqShift6	FC3Z-7000-E
	2016-2015	6R140	6R140	w/ 172.4 In. Wheelbase; FC3P-7000-PA; w/o PTO; TorqShift6	FC3Z-7000-P
	2016-2015		6R140	w/ 156.2 In. Wheelbase; FC3P-7000-PA; w/o PTO; TorqShift6	FC3Z-7000-P
	2016-2015	6R140	6R140	w/ 172.4 In. Wheelbase; FC3P-7000-SA; w/ PTO; TorqShift6	FC3Z-7000-S
	2016-2015		6R140	w/ 156.2 In. Wheelbase; FC3P-7000-SA; w/ PTO; TorqShift6	FC3Z-7000-S
	2016-2015	6R140	6R140	4 X 2; w/ 172.4 In. Wheelbase; FC3P-7000-ZA; w/ PTO; TorqShift6	FC3Z-7000-Z
	2016-2015		6R140	4 X 2; w/ 156.2 In. Wheelbase; FC3P-7000-ZA; w/ PTO; TorqShift6	FC3Z-7000-Z
	2016-2015	6R140	6R140	4 X 4; w/ 172.4 In. Wheelbase; FC3P-7000-ZA; w/ PTO; w/ Wide Frame; TorqShift6	FC3Z-7000-Z
	2016-2011		6.8L	5R110W	AC3P-7000-HA; TorqShift
	2014-2012	6.7L DIESEL		6R140	4 X 2; CC3P-7000-DC; w/o PTO; Exc. 137 In. Wheelbase; TorqShift6
	2014-2012	6.8L	6R140	4 X 2; CC3P-7000-EC; w/ PTO; Exc. 137 In. Wheelbase; TorqShift6	CC3Z-7000-T
	2010		5R110W	w/ 165.0 In. Wheelbase; AC3P-7000-HA; w/o PTO; TorqShift	AC3Z-7000-H
	2010	5R110W	5R110W	w/ 172.4 In. Wheelbase; AC3P-7000-HA; w/o PTO; TorqShift	AC3Z-7000-H
	2010		5R110W	w/ 172.4 In. Wheelbase; AC3P-7000-KA; w/ PTO; TorqShift	AC3Z-7000-K
	Automatic - Reman	2013	6.7L DIESEL	6R140	4 X 2; w/ 137.0 In. Wheelbase; RMFC3J-7000EA; w/o PTO
2013		6R140		RMFC3J-7000-BA; w/o PTO	FC3Z-7000-SRM
2012		6R140	6R140	CC3Z-7000-DRM; w/o PTO	CC3Z-7000-DRM
2012			6R140	4 X 2; RMCC3J-7000-CA; w/ PTO; Exc. 137 In. Wheelbase	CC3Z-7000-ERM
2012		6R140	6R140	RMFC3J-7000-CA; w/ PTO	FC3Z-7000-TRM
2012			6R140	4 X 2; w/ 137.0 In. Wheelbase; RMFC3J-7000EA; w/o PTO; From 06/15/2012	FC3Z-7000-VRM
2012		6R140	6R140	4 X 2; w/ 137.0 In. Wheelbase; RMCC3J-7000-FA; w/ PTO	CC3Z-7000-JRM
2012			6R140	4 X 2; RMCC3J-7000-EA; w/o PTO; Thru 01/09/2012	CC3Z-7000-GRM
2012		6.8L	6R140	RMFC3J-7000-BA; w/o PTO; Before 6/13/12	FC3Z-7000-SRM
2012-2010			5R110W	4 X 2; AC3P-7000-GA; PRB-NU; TorqShift	9C3Z-7000-HRM
2012-2010	5R110W	5R110W	AC3P-7000-HA; PRB-NV; TorqShift	9C3Z-7000-GRM	





F-Series

-Cont'd

Part Type	Years	Engine	Trans	Qualifier	Ford #
Automatic - Reman	2012-2010	6.8L	5R110W	4 X 2; AC3P-7000-KA; w/ Fixed Yoke; PRB-NW; TorqShift	9C3Z-7000-JRM
	2012-2011		5R110W	Motor Home - Stripped Chassis; RMBU9J-7000-AA; TorqShift	BU9Z-7000-ARM
	2011	6.7L DIESEL	6R140	4 X 2; RMBC3J-7000-HA; w/ PTO; Exc. 137 In. Wheelbase; TorqShift6; Shipped With 7034 Vent Attached; Requires Engine Flywheel CC3Z-6375-A Which Must Be Ordered Separately	BC3Z-7000-HRM
	2011		6R140	4 X 2; BC3Z-7000-JRM; w/ PTO; Exc. 137 In. Wheelbase; TorqShift6; Shipped With 7034 Vent Attached; Requires Engine Flywheel CC3Z-6375-A Which Must Be Ordered Separately	BC3Z-7000-JRM
	2011		6R140	4 X 4; BC3Z-7000-JRM; TorqShift6; Shipped With 7034 Vent Attached; Requires Engine Flywheel CC3Z-6375-A Which Must Be Ordered Separately	BC3Z-7000-JRM
	2010	6.4L DIESEL	5R110W	4 X 2; AC3P-7000-AA; PRB-NM; TorqShift	9C3Z-7000-ARM
	2010		5R110W	4 X 2; AC3P-7000-DA; w/ Fixed Yoke; PRB-NR; TorqShift	9C3Z-7000-DRM
	2010		5R110W	4 X 4; AC3P-7000-DA; PRB-NR; TorqShift	9C3Z-7000-DRM
	2010		5R110W	4 X 4; AC3P-7000-BA; PRB-NN; TorqShift	9C3Z-7000-BRM
	2010		5R110W	4 X 2; AC3P-7000-BA; w/ Fixed Yoke; PRB-NN; TorqShift	9C3Z-7000-BRM
	2010		5R110W	4 X 2; AC3P-7000-CA; w/ Fixed Yoke; PRB-NP; TorqShift	9C3Z-7000-CRM
	2010		5R110W	4 X 4; RM9C3J-7000-CA; PRB-NP; TorqShift	9C3Z-7000-CRM
	2010		5R110W	4 X 4; AC3P-7000-KA; PRB-NW; TorqShift	9C3Z-7000-JRM
	2009	6.4L DIESEL	5R110W	4 X 2; 9C3P-7000-AC; TorqShift	9C3Z-7000-ARM
	2009		5R110W	4 X 2; 9C3P-7000-DC; PRB-NR; TorqShift	9C3Z-7000-DRM
	2009		5R110W	4 X 2; 9C3P-7000-BC; PRB-NN; TorqShift	9C3Z-7000-BRM
	2009		5R110W	4 X 2; 9C3P-7000-CC; PRB-NP; TorqShift	9C3Z-7000-CRM
	2008		5R110W	4 X 4; 7C3P-7000-DC; PRB-LY; TorqShift	7C3Z-7000-DRM
	2008		5R110W	4 X 2; 7C3P-7000-DC; PRB-LY; TorqShift	7C3Z-7000-DRM
	2008		5R110W	8C3P-7000-DD; PRB-NR; TorqShift	8C3Z-7000-DRM
	2008		5R110W	8C3P-7000-BD; PRB-NN; TorqShift	8C3Z-7000-BRM
	2008		5R110W	4 X 2; 7C3P-7000-AC; PRB-LV; TorqShift	7C3Z-7000-ARM
	2008		5R110W	4 X 2; 8C3P-7000-CD; PRB-NP; TorqShift	8C3Z-7000-CRM
	2008		5R110W	4 X 4; 7C3P-7000-BC; PRB-LW; TorqShift	7C3Z-7000-BRM
	2008		5R110W	4 X 2; 7C3P-7000-BC; PRB-LW; TorqShift	7C3Z-7000-BRM
	2008		5R110W	4 X 2; 7C3P-7000-CC; PRB-LX; TorqShift	7C3Z-7000-CRM
	2008		5R110W	4 X 2; 8C3P-7000-AD; PRB-NM; TorqShift	8C3Z-7000-ARM
	2007	6.0L	5R110W	6C3P-7000-MC; w/ Fixed Yoke; PRB-MR; TorqShift	5C3Z-7000-MRM
	2007		5R110W	6C3P-7000-KC; w/ Fixed Yoke; PRB-MN; TorqShift	5C3Z-7000-KRM
	2007	6.8L	5R110W	6C3P-7000-DC; PRB-MK; w/ Fixed Yoke; TorqShift	5C3Z-7000-DRM
	2007		5R110W	4 X 4; 7C3P-7000-HC; TorqShift	7C3Z-7000-HRM
	2006	6.0L	5R110W	6C3P-7000-MA; w/ Fixed Yoke; PRB-KM; TorqShift	5C3Z-7000-MRM
	2006		5R110W	6C3P-7000-MB; w/ Fixed Yoke; PRB-LU; TorqShift	5C3Z-7000-MRM
	2006		5R110W	6C3P-7000-JA; w/ Slip Yoke; PRB-KJ; TorqShift	5C3Z-7000-JRM
	2006		5R110W	6C3P-7000-JB; w/ Slip Yoke; PRB-LR; TorqShift	5C3Z-7000-JRM
	2006		5R110W	6C3P-7000-KA; w/ Fixed Yoke; PRB-KK; TorqShift	5C3Z-7000-KRM
	2006		5R110W	6C3P-7000-KB; w/ Fixed Yoke; PRB-LS; TorqShift	5C3Z-7000-KRM
	2006		5R110W	6C3P-7000-LB; w/ Slip Yoke; PRB-LT; TorqShift	5C3Z-7000-LRM
	2006		5R110W	6C3P-7000-LA; w/ Slip Yoke; PRB-KL; TorqShift	5C3Z-7000-LRM
	2006	6.8L	5R110W	4 X 2; 6C3P-7000-DA; w/ Fixed Yoke; PRB-KF; TorqShift	5C3Z-7000-DRM
	2006		5R110W	4 X 2; 6C3P-7000-DB; w/ Fixed Yoke; PRB-LN; TorqShift	5C3Z-7000-DRM
	2006		5R110W	4 X 4; 6C3P-7000-DA; w/ Fixed Yoke; PRB-KF; TorqShift	5C3Z-7000-DRM
	2006		5R110W	4 X 4; 6C3P-7000-DB; w/ Fixed Yoke; PRB-LN; TorqShift	5C3Z-7000-DRM
	2006		5R110W	4 X 4; 6C3P-7000-FB; w/ Fixed Yoke; PRB-LP; TorqShift	5C3Z-7000-FRM
	2006		5R110W	4 X 4; 6C3P-7000-FA; w/ Fixed Yoke; PRB-KH; TorqShift	5C3Z-7000-FRM
	2005	6.0L	5R110W	5C3P-7000-MB; w/ Fixed Yoke; PRB-KA; TorqShift	5C3Z-7000-MRM
	2005		5R110W	5C3P-7000-JB; w/ Slip Yoke; PRB-JX; TorqShift	5C3Z-7000-JRM
	2005		5R110W	5C3P-7000-KB; w/ Fixed Yoke; PRB-JY; TorqShift	5C3Z-7000-KRM
	2005		5R110W	4 X 2; 5C3P-7000-LB; w/ PTO; PRB-JZ; TorqShift	5C3Z-7000-LRM
	2005	6.8L	5R110W	4 X 2; 5C3P-7000-DB; w/ Fixed Yoke; PRB-JS; TorqShift	5C3Z-7000-DRM
	2005		5R110W	4 X 2; 5C3P-7000-CB; TorqShift	5C3Z-7000-CRM
	2004-2003	6.0L	5R110W	4 X 2; 3C3P-7000-JG; w/ PTO; PRB-JC; TorqShift	3C3Z-7V000-JGRM
	2004		5R110W	4 X 4; 3C3P-7000-JG; w/ PTO; PRB-JC; TorqShift	3C3Z-7V000-JGRM
	2004		5R110W	4 X 4; 4C3P-7000-KB; w/o PTO; PRB-JF; TorqShift	4C3Z-7000-KBRM
	2004		5R110W	4 X 2; 4C3P-7000-KB; w/o PTO; PRB-JF; TorqShift	4C3Z-7000-KBRM
	2004	6.0L DIESEL	5R110W	4 X 2; 4C3P-7000-JB; w/o PTO; PRB-JE; TorqShift	4C3Z-7000-JBRM
	2004	6.8L	4R100	4 X 4; 1C3P-7000-DA,DB,DC; PRB-GG1; w/o PTO	1C3Z-7V000-DRM
	2004		4R100	4 X 4; 1C3P-7000-JC; w/ PTO; PRB-GL1	1C3Z-7V000-JRM
	2004		4R100	4 X 2; 1C3P-7000-CC; w/o PTO; PRB-GF1	1C3Z-7V000-CRM
	2004		4R100	4 X 2; 1C3P-7000-HC; w/ PTO; PRB-GK1	1C3Z-7V000-HRM
	2003	6.0L	TorqShift	4 X 2; w/ 200.0 In. Wheelbase; 3C3P-7000-JG; Must Add Companion Flange 3C3P-4K177-BA and Bolt 3C3Z-7N134-CA on 4x2 applications; Fixed Flange-w/ PTO; PRB-JC; TorqShift	3C3Z-7V000-JGRM
	2003		TorqShift	4 X 2; w/ 200.0 In. Wheelbase; 3C3P-7000-JF; Must Add Companion Flange 3C3P-4K177-BA and Bolt 3C3Z-7N134-CA on 4x2 applications; PRB-HX; Fixed Flange-w/ PTO; TorqShift	3C3Z-7V000-JGRM
	2003		TorqShift	4 X 2; w/ 176.0 In. Wheelbase; 3C3P-7000-JF; Must Add Companion Flange 3C3P-4K177-BA and Bolt 3C3Z-7N134-CA on 4x2 applications; PRB-HX; Fixed Flange-w/ PTO; TorqShift	3C3Z-7V000-JGRM
	2003		TorqShift	4 X 2; w/ 176.0 In. Wheelbase; 3C3P-7000-JG; Must Add Companion Flange 3C3P-4K177-BA and Bolt 3C3Z-7N134-CA on 4x2 applications; Fixed Flange-w/ PTO; PRB-JC; TorqShift	3C3Z-7V000-JGRM
	2003	6.0L DIESEL	5R110W	4 X 4; RM8U2J-7G497-ACA; w/o PTO; TorqShift	4C3Z-7000-KBRM
	2003		5R110W	4 X 2; RM8U2J-7G497-ABA; w/o PTO; TorqShift	4C3Z-7000-JBRM
	2003-2001	6.8L	4R100	4 X 4; 1C3P-7000-DA,DB,DC; w/o PTO; PRB-GG, GG1	1C3Z-7V000-DRM
	2003		4R100	4 X 4; 1C3P-7000-JC; w/ PTO Provision; PRB-GL, PRB-GL1	1C3Z-7V000-JRM

# TRANSMISSIONS

## Medium Trucks

### Ford



FORD PARTS

### F-Series

-Cont'd

Part Type	Years	Engine	Trans	Qualifier	Ford #	
Automatic - Reman	2003	6.8L	4R100	Motor Home - Stripped Chassis; 1C3P-7000-KC; PRB-GM, PRB-GM1	1C3Z-7V000-KRM	
	2003-2001		4R100	4 X 2; 1C3P-7000-CC; w/o PTO; PRB-GF, PRB-GF1	1C3Z-7V000-CRM	
	2003	7.3L	4R100	4 X 2; 1C3P-7000-HC; w/ PTO Provision; PRB-GK, PRB-GK1	1C3Z-7V000-HRM	
	2003		4R100	4 X 2; 1C3P-7000-LB; Heavy Duty Service; w/ PTO; PRB-GN, PRB-GN1	7U2Z-7V000-ARM	
	2003		4R100	4 X 4; 1C3P-7000-MB; Normal Service; w/ PTO; PRB-GP, PRB-GP1	1C3Z-7V000-MRM	
	2003		4R100	4 X 2; 1C3P-7000-LB; Normal Service; w/ PTO; PRB-GN, PRB-GN1	1C3Z-7V000-LRM	
	2003-2001		4R100	4 X 4; 1C3P-7000-FA, FB; Normal Service; w/o PTO; PRB-GJ, GJ1	1C3Z-7V000-FRM	
	2003-2001		4R100	4 X 4; 1C3P-7000-FA, FB; Heavy Duty Service; w/o PTO; PRB-GJ, GJ1	6U2Z-7V000-FRM	
	2003-2001		4R100	4 X 2; 1C3P-7000-EA, EB; Normal Service; w/o PTO; PRB-GH, GH1	1C3Z-7V000-ERM	
	2003-2001		4R100	4 X 2; 1C3P-7000-EA, EB; Heavy Duty Service; w/o PTO; PRB-GH, GH1	6U2Z-7V000-ERM	
	2003		6.8L	4R100	4 X 4; 1C3P-7000-MB; Heavy Duty Service; w/ PTO; PRB-GP, PRB-GP1	7U2Z-7V000-BRM
	2002-2001			4R100	4 X 4; 1C3P-7000-JC; w/ PTO Provision; PRB-GL	1C3Z-7V000-JRM
	2002-2001	4R100		Motor Home - Stripped Chassis; 1C3P-7000-KC; PRB-GM	1C3Z-7V000-KRM	
	2002-2001	4R100		4 X 2; 1C3P-7000-HC; PRB-GK; w/ PTO Provision	1C3Z-7V000-HRM	
	2002-2001	7.3L		4R100	4 X 2; 1C3P-7000-LA/LB; Heavy Duty Service; PRB-GN; w/ PTO	7U2Z-7V000-ARM
	2002-2001			4R100	4 X 4; 1C3P-7000-MB; Normal Service; w/ PTO; PRB-GP	1C3Z-7V000-MRM
	2002-2001	4R100		4 X 2; 1C3P-7000-LB; Normal Service; PRB-GN; w/ PTO	1C3Z-7V000-LRM	
	2002-2001	6.8L		4R100	4 X 4; 1C3P-7000-MA/MB; Heavy Duty Service; w/ PTO; PRB-GP	7U2Z-7V000-BRM
	2001			4R100	4 X 4; 1C3P-7000-DB; w/o PTO; PRB-FJ	1C3Z-7V000-DRM
	2001			4R100	4 X 4; 1C3P-7000-DA; w/o PTO; PRB-DK	1C3Z-7V000-DRM
	2001		4R100	4 X 4; 1C3P-7000-JA; w/ PTO Provision; PRB-DP	1C3Z-7V000-JRM	
	2001		4R100	4 X 4; 1C3P-7000-JB; w/ PTO Provision; PRB-FL	1C3Z-7V000-JRM	
	2001		4R100	Motor Home - Stripped Chassis; 1C3P-7000-KA; PRB-DR	1C3Z-7V000-KRM	
	2001		4R100	Motor Home - Stripped Chassis; 1C3P-7000-KB; PRB-FM	1C3Z-7V000-KRM	
	2001		4R100	4 X 2; 1C3P-7000-CA; w/o PTO; PRB-DJ	1C3Z-7V000-CRM	
	2001		4R100	4 X 2; 1C3P-7000-CB; w/o PTO; PRB-FH	1C3Z-7V000-CRM	
	2001		4R100	4 X 2; 1C3P-7000-HB; w/ PTO Provision; PRB-FK	1C3Z-7V000-HRM	
	2001	7.3L	4R100	4 X 2; 1C3P-7000-HA; w/ PTO Provision; PRB-DN	1C3Z-7V000-HRM	
	2001		4R100	4 X 2; 1C3P-7000-LA; Heavy Duty Service; w/ PTO; PRB-DS	7U2Z-7V000-ARM	
	2001		4R100	4 X 4; 1C3P-7000-MA; Normal Service; w/ PTO; PRB-DT	1C3Z-7V000-MRM	
	2001		4R100	4 X 2; 1C3P-7000-LA; Normal Service; w/ PTO; PRB-DS	1C3Z-7V000-LRM	
	2001		4R100	4 X 4; 1C3P-7000-FA; Normal Service; w/o PTO; PRB-DM	1C3Z-7V000-FRM	
	2001		4R100	4 X 4; 1C3P-7000-FA; Heavy Duty Service; w/o PTO; PRB-DM	6U2Z-7V000-FRM	
	2001		4R100	4 X 2; 1C3P-7000-EA; Normal Service; w/o PTO; PRB-DL	1C3Z-7V000-ERM	
	2001		4R100	4 X 2; 1C3P-7000-EA; Heavy Duty Service; w/o PTO; PRB-DL	6U2Z-7V000-ERM	
	2001		4R100	4 X 4; 1C3P-7000-MA; Heavy Duty Service; w/ PTO; PRB-DT	7U2Z-7V000-BRM	
	2000		6.8L	4R100	4 X 4; YC3P-7000-DA, SA; w/o PTO; PRB-BS, CV	YC3Z-7V000-DRM
	2000	4R100		4 X 2; YC3P-7000-CA; w/o PTO; PRB-BR	YC3Z-7V000-CRM	
	2000	4R100		4 X 4; YC3P-7000-JA; w/ PTO; PRB-BW	YC3Z-7V000-JRM	
	2000	4R100		4 X 2; Motor Home - Stripped Chassis; YC3P-7000-KA; PRB-BX	YC3Z-7V000-KRM	
	2000	7.3L		4R100	4 X 4; YC3P-7000-MA; Normal Service; PTO; PRB-BZ	1C3Z-7V000-MRM
	2000			4R100	4 X 4; YC3P-7000-FB; Normal Service; PRB-CR	1C3Z-7V000-FRM
	2000			4R100	4 X 4; YC3P-7000-FA, FB; Normal Service; PRB-BU	1C3Z-7V000-FRM
	2000			4R100	4 X 2; YC3P-7000-LA; Normal Service; PTO; PRB-BY	F81Z-7V000-KBRM
	2000			4R100	4 X 4; YC3P-7000-MB; Normal Service; PTO; PRB-CT	F81Z-7V000-KBRM
	2000			4R100	4 X 2; YC3P-7000-LB; Normal Service; PTO; PRB-CS	F81Z-7V000-KBRM
	2000		4R100	4 X 4; YC3P-7000-FB; Heavy Duty Service; PRB-CR	6U2Z-7V000-LRM	
	2000		4R100	4 X 4; YC3P-7000-FA, FB; Heavy Duty Service; PRB-BU	6U2Z-7V000-LRM	
	2000		4R100	4 X 4; YC3P-7000-MB; PTO; Heavy Duty Service; PRB-CT	7U2Z-7V000-DRM	
	2000		4R100	4 X 4; YC3P-7000-MA; PTO; Heavy Duty Service; PRB-BZ	7U2Z-7V000-DRM	
	2000	4R100	4 X 2; YC3P-7000-EB; Normal Service; PRB-CP	1C3Z-7V000-ERM		
	2000	4R100	4 X 2; YC3P-7000-EA, EB; Normal Service; PRB-BT	1C3Z-7V000-ERM		
	2000	4R100	4 X 2; YC3P-7000-EB; Heavy Duty Service; PRB-CP	6U2Z-7V000-HRM		
	2000	4R100	4 X 2; YC3P-7000-EA, EB; Heavy Duty Service; PRB-BT	6U2Z-7V000-HRM		
	2000	4R100	4 X 2; YC3P-7000-LA; PTO; Heavy Duty Service; PRB-BY	7U2Z-7V000-CRM		
	2000	4R100	4 X 2; YC3P-7000-LB; PTO; Heavy Duty Service; PRB-CS	7U2Z-7V000-CRM		
	1999	4R100	4 X 2; Motor Home - Stripped Chassis; XC3P-7000-MA; F81P-7000-TA; PRB-AD; PRB-AZ	F81Z-7V000-TARM		
	1999	6.8L	4R100	4 X 2; Standard Cab Pickup; F81P-7000-TA; PRB-AD	F81Z-7V000-TARM	
	1999		4R100	4 X 4; F81P-7000-EB; PRB-D	F81Z-7V000-EBRM	
	1999		4R100	4 X 4; XC3P-7000-EA; PRB-AS	F81Z-7V000-EBRM	
	1999		4R100	4 X 2; F81P-7000-FB; PTO; PRB-E	F81Z-7V000-FBRM	
	1999		4R100	4 X 2; XC3P-7000-FA; PTO; PRB-AT	F81Z-7V000-FBRM	
	1999		4R100	4 X 2; XC3P-7000-DA; PRB-AR	F81Z-7V000-DBRM	
	1999		4R100	4 X 2; F81P-7000-DB; PRB-C	F81Z-7V000-DBRM	
	1999		4R100	4 X 4; XC3P-7000-GA; PTO; PRB-AU	F81Z-7V000-GBRM	
	1999		4R100	4 X 4; F81P-7000-GB; PTO; PRB-F	F81Z-7V000-GBRM	
	1999		7.3L	4R100	4 X 4; XC3P-7000-JA; Normal Service; PTO; PRB-AW	1C3Z-7V000-MRM
	1999	4R100		4 X 4; XC3P-7000-LA; Normal Service; PRB-AY	1C3Z-7V000-FRM	
	1999	4R100		4 X 2; F81P-7000-KB; Normal Service; PTO; PRB-H	F81Z-7V000-KBRM	
	1999	4R100		4 X 2; XC3P-7000-KA; Normal Service; PTO; PRB-AX	F81Z-7V000-KBRM	
	1999	4R100		4 X 4; XC3P-7000-LA; Heavy Duty Service; PRB-AY	6U2Z-7V000-LRM	
	1999	4R100		4 X 4; F81P-7000-LB; Heavy Duty Service; PRB-J	6U2Z-7V000-LRM	
	1999	4R100		4 X 4; F81P-7000-PB; PTO; PRB-K; Heavy Duty Service	7U2Z-7V000-DRM	
	1999	4R100		4 X 2; XC3P-7000-HA; Normal Service; PRB-AV	1C3Z-7V000-ERM	
	1999	4R100		4 X 2; F81P-7000-HB; Normal Service; PRB-G	1C3Z-7V000-ERM	
	1999	4R100		4 X 2; F81P-7000-HB; Heavy Duty Service; PRB-G	6U2Z-7V000-HRM	
	1999	4R100	4 X 2; XC3P-7000-HA; Heavy Duty Service; PRB-AV	6U2Z-7V000-HRM		
	1999	4R100	4 X 2; F81P-7000-KB; PTO; Heavy Duty Service; PRB-H	7U2Z-7V000-CRM		
	1997	7.5L	E4OD	F7TP-7000-JA; 4.63/5.13 Axle Ratio; PRA-BCA	F7TZ-7V000-JRM	
	1997		E4OD	4WD; F7TP-7000-LA; 4.63/5.13 Axle Ratio; PRA-GCA	F7TZ-7V000-LRM	



F-Series

-Cont'd

Part Type	Years	Engine	Trans	Qualifier	Ford #
Automatic - Reman	1996	7.3L	E4OD	4 X 2; F6TP-7000-GA; PRA-BBA10; 5.13 Axle Ratio	F6TZ-7V000-GARM
	1996	7.5L	E4OD	4 X 2; F6TP-7000-JA; 4.63/5.13 Axle Ratio; PRA-GBA10	F6TZ-7V000-JARM
	1995	7.3L	E4OD	4 X 2; F5TP-7000-EB; PRA-BBA1; 5.13 Axle Ratio	F5TZ-7V000-ERM
	1995	7.5L	E4OD	4 X 2; F5TP-7000-LB; 4.63/5.13 Axle Ratio; PRA-GBA	F5TZ-7V000-JRM
	1994	7.3L	E4OD	4 X 2; F3TP-7000-LA; PRA-BAA6; 5.13 Axle Ratio	F3TZ-7V000-LRM
	1994	7.5L	E4OD	4 X 2; F3TP-7000-EB; 4.63/5.13 Axle Ratio; PRA-YB3	F2TZ-7V000-MRM
	1993-1992	7.3L	E4OD	4 X 2; F2TP-7000-SA; PRA-C	F3TZ-7V000-LRM
	1993		E4OD	4 X 2; F3TP-7000-LA; PRA-BAA	F3TZ-7V000-LRM
	1993-1992	7.5L	E4OD	4 X 2; F2TP-7000-MA; PRA-A	F2TZ-7V000-MRM
	1993		E4OD	4 X 2; F3TP-7000-GA; PRA-AAA	F2TZ-7V000-MRM
	1993		E4OD	4 X 2; F3TP-7000-EB; PRA-YB	F2TZ-7V000-MRM
	1993		E4OD	4 X 2; F3TP-7000-EA; PRA-YA	F2TZ-7V000-MRM
	1991-1990	7.3L	E4OD	4 X 2; F0TP-7000-SA; PRA-C	F0TZ-7V000-URM
	1991-1990	7.5L	E4OD	4 X 2; F0TP-7000-NA; PRA-A	F0TZ-7V000-NRM

F53

Part Type	Years	Engine	Trans	Qualifier	Ford #
Automatic - New	2016-2015	6.8L	6R140	GC4P-7000-AA	GC4Z-7000-AA
	2015-2011		5R110W	BU9P-7000-AA; TorqShift; Fixed Flange	BU9Z-7000-A
Automatic - Reman	2008-2007	7.5L	5R110W	7C3P-7000-HC; PRB-MC; TorqShift	7C3Z-7000-HRM
	2007		5R110W	6C3P-7000-DD; PRB-MC; TorqShift	7C3Z-7000-HRM
	1996		E4OD	Motor Home - Stripped Chassis; F6TP-7000-KA; PRA-CBA10	F6TZ-7V000-JARM
	1995		E4OD	Motor Home - Stripped Chassis; F5TP-7000-JB; PRA-CBA	F5TZ-7V000-JRM
	1993		E4OD	4 X 2; Motor Home - Stripped Chassis; F3TP-7000-DB; PRA-WB	F2TZ-7V000-MRM
	1993-1992		E4OD	F2TP-7000-ACA; Motor Home; PRA-N	F0TZ-7V000-NRM
	1991		E4OD	F1TP-7000-NA; Motor Home, RV E30/33; PRA-N	F0TZ-7V000-NRM
	1990		E4OD	F0FP-7000-AA; Motor Home, RV E30/33; PRA-N	F0TZ-7V000-NRM

F650

Part Type	Years	Engine	Trans	Qualifier	Ford #	
Automatic - New	2016	6.7L DIESEL	6R140	GC4P-7000-BB; w/ PTO	GC4Z-7000-Z	
	2016		6R140	GC4P-7000-BA; w/ Trans PTO	GC4Z-7000-BA	
	2016	DIESEL	6R140	GC4P-7000-HA; w/o Trans PTO	GC4Z-7000-HA	
	2016		6R140	GC4P-7000-VA; w/o Trans PTO	GC4Z-7000-V	
	2016	GAS	6R140	GC4P-7000-XA; w/ Trans PTO	GC4Z-7000-XA	
	2015		6R140	FC4P-7000-VA; w/o PTO; TorqShift6	FC4Z-7000-V	
	2015	6.8L	6R140	FC4P-7000-XA; w/ PTO; TorqShift6	FC4Z-7000-X	
	2014-2012		6R140	CC4P-7000-VB; w/o PTO; TorqShift6	CC4Z-7000-A	
	2014-2012		6R140	CC4P-7000-XB; w/ PTO; TorqShift6	CC4Z-7000-B	
	Automatic - Reman	2015-2012		6R140	RMFC4J-7000-AA; w/o PTO	CC4Z-7000-ARM
		2015-2012		6R140	RMFC4J-7000-BA; w/ PTO	CC4Z-7000-BRM

F750

Part Type	Years	Engine	Trans	Qualifier	Ford #
Automatic - New	2016	6.7L DIESEL	6R140	GC4P-7000-BB; w/ PTO	GC4Z-7000-Z
	2016		6R140	GC4P-7000-BA; w/ Trans PTO	GC4Z-7000-BA
	2016	DIESEL	6R140	GC4P-7000-HA; w/o Trans PTO	GC4Z-7000-HA
	2016		6R140	GC4P-7000-VA; w/o Trans PTO	GC4Z-7000-V
	2016	GAS	6R140	GC4P-7000-XA; w/ Trans PTO	GC4Z-7000-XA
	2015		6R140	FC4P-7000-VA; w/o PTO; TorqShift6	FC4Z-7000-V
	2015	6.7L DIESEL	6R140	FC4P-7000-XA; w/ PTO; TorqShift6	FC4Z-7000-X

LCF

Part Type	Years	Engine	Trans	Qualifier	Ford #	
Automatic - Reman	2009	4.5L DIESEL	5R110W	w/ PTO; PRB-NX; 9E7P-7000-AA; AE7P-7000-AA; TorqShift	9E7Z-7000-ARM	
	2009		5R110W	w/o PTO; PRB-NY; 9E7P-7000-BA; AE7P-7000-BA; TorqShift	9E7Z-7000-BRM	
	2009		5R110W	4WD; RM6E7J-7000-BB; w/o PTO; TorqShift	6E7Z-7000-BBRM	
	2008			8E7P-7000-BB; w/o PTO; PRB-NY	8E7Z-7000-BARM	
	2008			8E7P-7000-AB; w/ PTO; PRB-NX	8E7Z-7000-AARM	
	2007			7E7P-7000-AA; w/ PTO; PRB-LH; TorqShift	7E7Z-7000-AARM	
	2007			7E7P-7000-BA; w/o PTO; PRB-LJ	7E7Z-7000-BARM	
	2006			5R110W	4WD; RM6E7J-7000-AB; w/ PTO; TorqShift	6E7Z-7000-ABRM

# TORQUE CONVERTERS

## Passenger Cars

### Ford



FORD PARTS

#### Ford Crown Victoria

Part Type	Years	Engine	Trans	Qualifier	Ford #
Automatic - New	2011	4.6L	4R70W	11.25 In.; Dark Green; Aluminum Drive Shaft	9W7Z-7902-A
	2011		4R75W	11.25 In.; Dark Green; Aluminum Drive Shaft	9W7Z-7902-A
Automatic - Reman	2010-2009		4R75E	11.25 In.; Dark Green; Aluminum Drive Shaft	9W7Z-7902-A
	2011		4R70W	w/ Steel Drive Shaft	7L3Z-7902-HRM
	2011, 2007		4R75W	w/ Steel Drive Shaft	7L3Z-7902-HRM
	2011, 2007		4R70W	w/ Aluminum Drive Shaft	7W7Z-7902-BRM
	2011, 2007		4R75W	w/ Aluminum Drive Shaft	7W7Z-7902-BRM
	2010		4R75E	w/ Steel Drive Shaft	7L3Z-7902-HRM
	2010		4R75E	w/ Aluminum Drive Shaft	7W7Z-7902-BRM
	2009-2007		4R75E	Base; w/ Steel Drive Shaft	7L3Z-7902-HRM
	2009		4R75E	Police Interceptor; w/ Aluminum Drive Shaft	7W7Z-7902-BRM
	2008-2007		4R75E	Police Interceptor	7W7Z-7902-BRM
	2008		4R75E	Base; w/ Aluminum Drive Shaft	7W7Z-7902-BRM
	2007		4R75W		7L3Z-7902-HRM
	2007		4R70W		7L3Z-7902-HRM
	2007		4R70W	Police Interceptor	7W7Z-7902-BRM
	2003		4R70W	XW7P-7902-A,D; 1W7P-7902-A,B; 3W7P-7902-A,B	F8AZ-7902-AARM
	2002-2000		4R70W	Base; XW7P-7902-A,D; 1W7P-7902-A,B; 3W7P-7902-A,B	F8AZ-7902-AARM
	2002-1999		4R70W	Police Interceptor	F8LZ-7902-BARM
	2001		4R70W	Base; 1W7P-7902-A,B	F8AZ-7902-AARM
	1999		4R70W	LX	F8AZ-7902-AARM
1999		4R70W	Base	F8AZ-7902-AARM	
1998-1996		4R70W		F8AZ-7902-AARM	
1995-1994		AOD-E		F8AZ-7902-AARM	

#### Five Hundred

Part Type	Years	Engine	Trans	Qualifier	Ford #
Automatic - Reman	2007-2005	3.0L	CFT30		5F9Z-7902-BRM

#### Focus

Part Type	Years	Engine	Trans	Qualifier	Ford #
Automatic - New	2017-2016	2.0L	4F27E	6F15	FM5Z-7902-C
	2011-2008				8S4Z-7902-A
Automatic - Reman	2011-2008		4F27E		8S4Z-7902-ARM
	2007-2000		4F27E	XS4P-7902-BB,BC,BD; YS4P-7902-BA; 3S4P-7902-BA, XS4P-7902-C2E, D2E,CF,DF; 1S4P-7902-CA, DA;3S4P-7902-CA,DA; 5S4P-7902-BA	XS4Z-7902-BBRM
	2004-2003	2.3L	4F27E	3S4P-7902-A,CA; 3S4P-7902-CB	3S4Z-7902-CARM

#### Freestyle

Part Type	Years	Engine	Trans	Qualifier	Ford #
Automatic - Reman	2007-2005	3.0L	CFT30		5F9Z-7902-BRM

#### Fusion

Part Type	Years	Engine	Trans	Qualifier	Ford #
Automatic - New	2017-2014	1.5L EcoBoost	6F35		EG9Z-7902-D
	2017-2013	2.0L EcoBoost	6F35		DG9Z-7902-F
	2017-2011	2.5L	6F35		9L8Z-7902-H
	2014-2013	1.6L	6F35	GTDI	CV6Z-7902-F
	2012-2010	3.5L	F21		7E5Z-7902-A
	2009-2006		FNR5		6E5Z-7902-A
	2009-2006	3.0L	F21		6E5Z-7902-B
Automatic - Reman	2012-2010	2.5L	6F35		9L8Z-7902-BRM
	2012-2010	3.0L	6F35		9L8Z-7902-ARM

#### Mustang

Part Type	Years	Engine	Trans	Qualifier	Ford #
Automatic - New	2017-2015	2.3L EcoBoost	6R80		FR3Z-7902-A
	2017-2015	3.7L DOHC	6R80		FL3Z-7902-A
	2017-2015	5.0L	6R80		FL3Z-7902-B
	2014	3.7L	6R80		CK4Z-7902-B
	2014	5.0L DOHC	6R80	From 04/15/14	BR3Z-7902-CF
	2014		6R80	Before 04/15/14	BR3Z-7902-GA
	2013-2011	3.7L	6R80		BR3Z-7902-EA
	2013-2011	5.0L DOHC	6R80		BR3Z-7902-GA
	2010-2007	4.0L	5R55S		7L2Z-7902-A
	Automatic - Reman	2010-2007			5 Spd.; w/ Automatic Trans.
2010-2005		4.6L SOHC	5R55S	4L2P-7902-E,F	7R3Z-7902-ARM



**Mustang**

-Cont'd

Part Type	Years	Engine	Trans	Qualifier	Ford #
Automatic - Reman	2006-2005	4.0L SOHC	5R55S	XR3P-7902-A; 1R3P-7902-A	4R3Z-7902-AARM
	2004-2001	3.8L	4R70W		3R3Z-7902-ABRM
	2004	3.9L	4R70W		3R3Z-7902-ABRM
	2000-1998	3.8L	4R70W		F85Z-7902-AARM
	2000-1998	4.6L	4R70W		F8LZ-7902-BARM
	1997-1996	3.8L	4R70W		F8AZ-7902-AARM
	1995-1994		AOD-E		F8AZ-7902-AARM
	1994	5.0L	AOD-E		F8AZ-7902-AARM

**Police Interceptor Sedan**

Part Type	Years	Engine	Trans	Qualifier	Ford #
Automatic - New	2017-2013	3.7L	6F50	3 Bolt Converter	DA8Z-7902-E

**Probe**

Part Type	Years	Engine	Trans	Qualifier	Ford #
Automatic - Reman	1992-1990	3.0L	4EAT-G		FO2Z-7902-ARM

**Taurus**

Part Type	Years	Engine	Trans	Qualifier	Ford #
Automatic - New	2017-2013	2.0L	6F35	3 Bolt Converter	BB5Z-7902-F
	2017-2013	3.5L	6F55		DA5Z-7902-D
	2017-2013		6F50		DA8Z-7902-A
	2012-2011		6F55		AA5Z-7902-B
	2012-2010		6F50		9E9Z-7902-B
Automatic - Reman	2010		6F55	4 Bolt Converter	AA5Z-7902-A
	2012-2011	3.5L EcoBoost	6F55	3 Bolt Converter	AA5Z-7902-BRM
	2010		6F55	4 Bolt Converter	AA5Z-7902-ARM
	2009-2008	3.5L	6F50		7T4Z-7902-ARM
	2007-2004	3.0L	4F50N		3F1Z-7902-ADRM
	2003-2001	3.0L DOHC	4F50N	1F1P-7902-D,E	1F1Z-7902-AARM
	2003-2001	3.0L OHV	AX4S	1F1P-7902-A,G	1F1Z-7902-BARM
	2003-2001		AX4S	1F1P-7902-C,F	1F2Z-7902-AARM
	2000	3.0L DOHC	AX4N	YF1P-7902-D,E	F88Z-7902-AARM
	2000	3.0L OHV	AX4N		F8DZ-7902-CARM
	1999-1997	3.0L DOHC	AX4N		F8DZ-7902-AARM
	1999-1996	3.0L OHV	AX4N		F68Z-7902-ARM

**Taurus X**

Part Type	Years	Engine	Trans	Qualifier	Ford #
Automatic - Reman	2009-2008	3.5L	6F50		7T4Z-7902-ARM

**Thunderbird**

Part Type	Years	Engine	Trans	Qualifier	Ford #
Automatic - Reman	2005-2003	3.9L	5R55S	4W4P-7902-A	7R3Z-7902-ARM
	1997	3.8L	4R70W		F8AZ-7902-AARM
	1997-1994	4.6L	4R70W		F8AZ-7902-AARM

**Lincoln**

**Continental**

Part Type	Years	Engine	Trans	Qualifier	Ford #
Automatic - New	2018-2017		6F55	6 Bolt	FG9Z-7902-C
	2018-2017	2.7L	6F50	3 Bolt Converter	DA8Z-7902-F
	2018-2017	3.0L	6F50	3 Bolt Converter	DA8Z-7902-F
	2018-2017	3.7L	6F50	3 Bolt Converter	DA8Z-7902-F

**LS**

Part Type	Years	Engine	Trans	Qualifier	Ford #
Automatic - Reman	2006-2004	3.9L	5R55S	4W4P-7902-A	7R3Z-7902-ARM
	4W4P-7902-B			4W4Z-7902-BARM	
	2005-2004	3.0L	5R55S	4W4P-7902-A	7R3Z-7902-ARM
	2005-2004			4W4P-7902-B	4W4Z-7902-BARM

**TORQUE CONVERTERS**  
**Passenger Cars**  
**Lincoln / Mercury**



**FORD PARTS**

**MKS**

Part Type	Years	Engine	Trans	Qualifier	Ford #
Automatic - New	2016-2013	3.5L	6F55	3 Bolt Converter	DA5Z-7902-D
	2016-2013	3.7L	6F50	3 Bolt Converter	DA8Z-7902-E
	2012-2011	3.5L	6F55	3 Bolt Converter	AA5Z-7902-B
	2012-2009	3.7L	6F50		9E9Z-7902-B
	2010	3.5L	6F55	4 Bolt Converter	AA5Z-7902-A
Automatic - Reman	2012-2011	3.5L EcoBoost	6F55	3 Bolt Converter	AA5Z-7902-BRM
	2010		6F55	4 Bolt Converter	AA5Z-7902-ARM
	2009	3.7L	6F50	3.16 Final Drive Ratio	9E9Z-7902-BRM

**MKZ**

Part Type	Years	Engine	Trans	Qualifier	Ford #
Automatic - New	2017-2014		6F50	3 Bolt Converter	DA8Z-7902-F
	2017-2014	2.0L	6F35		DG9Z-7902-F
	2013	2.5L DOHC	6F35		DG9Z-7902-F
	2013	3.7L	6F50	3 Bolt Converter	DA8Z-7902-E
	2012-2007	3.5L	F21		7E5Z-7902-A

**Mark VIII**

Part Type	Years	Engine	Trans	Qualifier	Ford #
Automatic - Reman	1998-1996	4.6L	4R70W		F8LZ-7902-BARM
	1995-1994		AOD-E		F8LZ-7902-BARM

**Town Car**

Part Type	Years	Engine	Trans	Qualifier	Ford #
Automatic - Reman	2011-2007	4.6L	4R70W	Exc. Limo	7L3Z-7902-HRM
	2011-2007		4R70W	Limo Conversion Package	7W7Z-7902-BRM
	2006-2004		4R70W	w/ Executive Long Wheelbase Pack	8L3Z-7902-BRM
	2006-2004		4R70W	Limo	8W7Z-7902-ARM
	2003-2000		4R70W	Sedan; XW1P-7902-B,D; YW1P-7902-A; 1W1P-7902-A,C; 3W1P-7902-A,C,D,E,F	F8AZ-7902-AARM
	2003-1998		4R70W	Limousine	F8LZ-7902-BARM
	2001		4R70W	Sedan; 1W1P-7902-A,C,D	F8AZ-7902-AARM
	1999-1998		4R70W	Sedan	F8AZ-7902-AARM
	1997-1993		4R70W		F8AZ-7902-AARM
	1992		AOD-E		F8AZ-7902-AARM
	1992		AOD		F8AZ-7902-AARM

**Zephyr**

Part Type	Years	Engine	Trans	Qualifier	Ford #
Automatic - New	2006	3.0L	F21		6E5Z-7902-B

**Mercury**

**Cougar**

Part Type	Years	Engine	Trans	Qualifier	Ford #
Automatic - Reman	2002-2001	2.5L	CD4E	1S8P-7902-A,B; 2S8P-7902-A	YL8Z-7902-BCRM
	1997	3.8L	4R70W		F8AZ-7902-AARM
	1997-1996	4.6L	4R70W		F8AZ-7902-AARM
	1995-1994		AOD-E		F8AZ-7902-AARM

**Grand Marquis**

Part Type	Years	Engine	Trans	Qualifier	Ford #
Automatic - Reman	2011, 2008-2007	4.6L	4R70W	w/o Handling Package	7L3Z-7902-HRM
	2011, 2008-2007		4R70W	w/ Sport Equipment Package	7W7Z-7902-BRM
	2010-2009		4R75E	w/o Handling Package	7L3Z-7902-HRM
	2010-2009		4R75E	w/ Sport Equipment Package	7W7Z-7902-BRM
	2006-2004		4R70W	w/o Special Equipment Package	8L3Z-7902-BRM
	2006-2004		4R70W	w/ Sport Equipment Package	8W7Z-7902-ARM
	2003-2000		4R70W	XW7P-7902-A,D; 1W7P-7902-A,B; 3W7P-7902-A,B	F8AZ-7902-AARM
	2002-2000		4R70W	w/ Sport Equipment Package	F8LZ-7902-BARM
	1999-1996		4R70W		F8AZ-7902-AARM
	1995-1992		AOD-E		F8AZ-7902-AARM
	1992		AOD		F8AZ-7902-AARM



**Milan**

Part Type	Years	Engine	Trans	Qualifier	Ford #
Automatic - New	2009-2006	3.0L	FNR5		6E5Z-7902-A
	2009-2006		F21		6E5Z-7902-B
Automatic - Reman	2011-2010	2.5L	6F35		9L8Z-7902-BRM
	2011-2010	3.0L	6F35		9L8Z-7902-ARM

**Montego**

Part Type	Years	Engine	Trans	Qualifier	Ford #
Automatic - Reman	2007-2005	3.0L	CFT30		5F9Z-7902-BRM

**Sable**

Part Type	Years	Engine	Trans	Qualifier	Ford #
Automatic - Reman	2009-2008	3.5L	6F50		7T4Z-7902-ARM
	2005-2004	3.0L	4F50N		3F1Z-7902-ADRM
	2003-2001	3.0L DOHC	4F50N	1F1P-7902-D,E	1F1Z-7902-AARM
	2003-2001	3.0L OHV	AX4S	1F1P-7902-A,G	1F1Z-7902-BARM
	2003-2001		AX4S	1F1P-7902-C,F	1F2Z-7902-AARM
	2000	3.0L DOHC	AX4N	YF1P-7902-D,E	F88Z-7902-AARM
	2000	3.0L OHV	AX4N		F8DZ-7902-CARM
	1999-1997	3.0L DOHC	AX4N		F8DZ-7902-AARM
	1999-1996	3.0L OHV	AX4N		F68Z-7902-ARM

**Ford**

**Bronco**

Part Type	Years	Engine	Trans	Qualifier	Ford #
Automatic - Reman	1996-1991	5.0L	E4OD		F7TZ-7902-FARM
	1996-1991	5.8L	E4OD		F7TZ-7902-FARM
	1992-1990	4.9L	E4OD		F7TZ-7902-EARM

**Econoline**

Part Type	Years	Engine	Trans	Qualifier	Ford #	
Automatic - New	2017	6.2L	6R140	4 Bolt Converter	CC4Z-7902-A	
	2017-2016	6.8L	6R140	4 Bolt Converter; TorqShift6	CC4Z-7902-A	
	2017-2009		5R110W	TorqShift	9C3Z-7902-B	
	2016-2009	5.4L	5R110W	TorqShift	9C3Z-7902-C	
	2016-2015		4R70W		9C2Z-7902-A	
	2014-2009	4.6L	4R75W		9C2Z-7902-B	
	2014-2004	5.4L SOHC	4R75W		9C2Z-7902-A	
	2010-2009	6.0L DIESEL	5R110W	TorqShift	9C2Z-7902-C	
	2007	5.4L SOHC	4R75E		9C2Z-7902-A	
	Automatic - Reman	2011-2008	4.6L	4R75W		7L3Z-7902-HRM
		2011-2008	5.4L	4R75W		7L3Z-7902-GRM
		2011-2007	6.8L	5R110W	TorqShift	7C3Z-7902-JRM
		2010-2007	5.4L	5R110W	TorqShift	7C3Z-7902-KRM
		2010-2007	6.0L DIESEL	5R110W	TorqShift	7C2Z-7902-BRM
		2007	4.6L	4R75E	RWD; w/ Triton (Romeo) Engine	8L3Z-7902-BRM
2007		5.4L	4R75E	From 12/04/06	7L3Z-7902-GRM	
2007			4R75W	From 12/04/06	7L3Z-7902-GRM	
2007			4R75W	Before 12/04/06	8L3Z-7902-ARM	
2007			4R75E	Before 12/04/06	8L3Z-7902-ARM	
2007-2004		6.8L	5R110W	5C3P-7902-BB; TorqShift	6C3Z-7902-ERM	
2006-2004		4.6L	4R75W	RWD; w/ Triton (Romeo) Engine	8L3Z-7902-BRM	
2006-2004			4R70W	RWD; w/ Triton (Romeo) Engine	8L3Z-7902-BRM	
2006-2005		5.4L	5R110W	TorqShift	6C3Z-7902-FRM	
2006-2004			4R75W		8L3Z-7902-ARM	
2006-2004		6.0L DIESEL	5R110W	TorqShift	6C3Z-7902-DRM	
2003-2000			4R70W	YC2P-7902-A,B,C,S; 1C2P-7902-F,H,J,S; 3C2P-7902-AA	F8AZ-7902-AARM	
2003-2000		5.4L	4R70W	YC2P-7902-D,N; 1C2P-7902-L,MA,YA; XL3P-7902-AA	XL3Z-7902-AARM	
2003-2001			4R100	4C2P-7902-E,H,J; 1C2P-7902-AC,NC,TA; 1C3P-7902-DB,AC,BC	1C3Z-7902-DBRM	
2003-2000		6.8L	4R100	4C2P-7902-F,L; 4C2P-7902-G,L	1C3Z-7902-BARM	
2003-1998		7.3L DIESEL	4R100		1C3Z-7902-CARM	
1999-1997		4.2L	4R70W		F8AZ-7902-AARM	
1999-1997		4.6L	4R70W		F8AZ-7902-AARM	
1999		6.8L	4R100	XC2P-7902-F,G; XC2P-7902-H; w/ 4 Mounting Studs	XC3Z-7902-AARM	
1998-1997			E4OD	w/ 4 Mounting Studs	XC3Z-7902-AARM	
1996-1991	4.9L	E4OD		F7TZ-7902-EARM		
1996-1991	5.0L	E4OD		F7TZ-7902-EARM		
1996-1994		4R75W		F8AZ-7902-AARM		
1996-1994		4R70W		F8AZ-7902-AARM		
1996-1991	7.5L	E4OD		F7TZ-7902-EARM		

# TORQUE CONVERTERS

## Light Trucks

### Ford



FORD PARTS

### Edge

Part Type	Years	Engine	Trans	Qualifier	Ford #
Automatic - New	2017-2016		6F35		DG9Z-7902-F
	2017-2015		6F55	6 Bolt	FG9Z-7902-C
	2017-2016		6F50	3 Bolt Converter	DA8Z-7902-F
	2017-2013	3.5L	6F50	3 Bolt Converter	DA8Z-7902-A
	2015		6F35	From 1-19-15	DG9Z-7902-F
	2015	2.0L	6F35	Thru 12-24-14	BB5Z-7902-F
	2014-2012		6F35		BB5Z-7902-F
	2014-2013	3.7L	6F50	3 Bolt Converter	DA8Z-7902-E
	2012-2011	3.5L	6F50	3 Bolt Converter	BT4Z-7902-C
	2012-2011	3.7L	6F50	w/ Automatic Trans.; 3 Bolt Converter	BT4Z-7902-B
Automatic - Reman	2010	3.5L	6F50		9E9Z-7902-B
	2012-2011				BT4Z-7902-CRM
	2012-2011	3.7L	6F55		BT4Z-7902-BRM
	2008-2007	3.5L	6F50		7T4Z-7902-ARM

### Escape

Part Type	Years	Engine	Trans	Qualifier	Ford #
Automatic - New	2017-2013	2.0L EcoBoost	6F35		BB5Z-7902-F
	2017-2011	2.5L	6F35		9L8Z-7902-H
	2016-2013	1.6L EcoBoost	6F35		CV6Z-7902-F
Automatic - Reman	2012-2009	2.5L	6F35		9L8Z-7902-BRM
	2012-2009	3.0L	6F35		9L8Z-7902-ARM
	2008-2005	2.3L	CD4E		5L8Z-7902-DBRM
	2006-2001	3.0L DOHC	CD4E	2L8P-7902-E, 2L8P-7902-F, 3L8P-7902-GA,GB,GC,HA,HB,HC; YL8P-7902-E,F	YL8Z-7902-BCRM
	2006-2001		CD4E	3L8P-7902-GD,HD	3L8Z-7902-BARM

### Excursion

Part Type	Years	Engine	Trans	Qualifier	Ford #
Automatic - Reman	2005-2000	5.4L	4R100	1C3P-7902-BC,NC	1C3Z-7902-DBRM
	2005-2000	6.8L	4R100	1C3P-7902-C,D,P	1C3Z-7902-BARM
	2003-2001	7.3L DIESEL	4R100	Turbocharged	1C3Z-7902-CARM
	2000	5.4L	4R100	YC3P-7902-B,N,R	XL3Z-7902-BARM

### Expedition

Part Type	Years	Engine	Trans	Qualifier	Ford #
Automatic - New	2017-2015	3.5L EcoBoost	6R80		FL3Z-7902-D
	2014-2009	5.4L	6R80		BR3Z-7902-FA
Automatic - Reman	2008-2007		6R75		7L1Z-7902-C
	2006-2005		4R75W		8L3Z-7902-CRM
	2005		4R70W		8L3Z-7902-CRM
	2004-2003	4.6L	4R70W		F8AZ-7902-AARM
	2004-2003	5.4L	4R70W		XL3Z-7902-AARM
	2002-2001		4R70W	1L3P-7902-F,H	F8AZ-7902-AARM
	2002-1997	5.4L	4R100		XL3Z-7902-BARM
	2000-1997	4.6L	4R70W		F85Z-7902-AARM

### Explorer

Part Type	Years	Engine	Trans	Qualifier	Ford #
Automatic - New	2017-2015	2.0L EcoBoost	6F35		BB5Z-7902-F
	2017-2013	3.5L	6F55	Turbocharged; 3 Bolt Converter; 3.16 Final Drive Ratio	DA5Z-7902-D
	2017-2016			4WD; 3 Bolt Converter	DA8Z-7902-F
	2017-2013	3.5L EcoBoost	6F55	3 Bolt Converter	DA8Z-7902-A
	2017-2013		6F50	3 Bolt Converter	DA8Z-7902-A
	2015	3.5L	6F55	Naturally Aspirated; 3 Bolt Converter; Before 3-20-15	DA8Z-7902-E
	2015			4WD; 3 Bolt Converter; From 3-20-15	DA8Z-7902-F
	2014-2013		6F55	Naturally Aspirated; 3 Bolt Converter	DA8Z-7902-E
	2012	2.0L	6F55	3 Bolt Converter; BT4P-7902-CA	BT4Z-7902-C
	2012		6F50	3 Bolt Converter; BT4P-7902-CA	BT4Z-7902-C
	2012-2011	3.5L	6F50	3 Bolt Converter; BT4P-7902-CA	BT4Z-7902-C
	2012-2011		6F55	3 Bolt Converter; BT4P-7902-CA	BT4Z-7902-C
	2010-2007	4.0L SOHC	5R55S		7L2Z-7902-A
	2009-2006	4.6L	6R60		9L3Z-7902-B
	Automatic - Reman	2012-2011			
2010-2004		4.0L	5R55S		4L2Z-7902-AARM
2010-2002		4.0L SOHC	5R55E	5 Spd.	7L2Z-7902-ARM
2010-2006		4.6L	6R60		8L2Z-7902-ARM
2009-2004			5R55S		4L2Z-7902-BARM
2001-1998		5.0L	4R70W	XL2P-7902-A,B	F85Z-7902-AARM
1996-1995		4.0L	4R55E		F5TZ-7902-DARM





**TORQUE CONVERTERS**  
**Light Trucks**  
**Ford**



FORD PARTS

**F-Series**

-Cont'd

Part Type	Years	Engine	Trans	Qualifier	Ford #
Automatic - Reman	1996-1994	5.0L	4R70W		F8AZ-7902-AARM
	1996-1991	5.8L	E4OD		F7TZ-7902-FARM
	1990	7.5L	E4OD		F7TZ-7902-EARM

**Flex**

Part Type	Years	Engine	Trans	Qualifier	Ford #
Automatic - New	2017-2014	3.5L	6F50	6 Spd.; FWD; 3 Bolt Converter	DA8Z-7902-A
	2017-2013		6F55	3 Bolt Converter	DA5Z-7902-D
	2017-2013		6F50	3 Bolt Converter; 3.65 Final Drive Ratio	DA8Z-7902-E
	2017-2014	3.5L	6F50	AWD; 3 Bolt Converter	DA8Z-7902-F
	2013		6F50	6 Spd.; 3 Bolt Converter	DA8Z-7902-A
	2012-2011		6F55	3 Bolt Converter	AA5Z-7902-B
Automatic - Reman	2012-2009	3.5L EcoBoost	6F50		9E9Z-7902-B
	2010		6F55	4 Bolt Converter	AA5Z-7902-A
	2012-2011		6F50	3 Bolt Converter	AA5Z-7902-BRM
	2010-2009	3.5L	6F50	3.16 Final Drive Ratio	9E9Z-7902-BRM
	2010	3.5L EcoBoost	6F50	4 Bolt Converter	AA5Z-7902-ARM

**Freestar**

Part Type	Years	Engine	Trans	Qualifier	Ford #
Automatic - Reman	2007-2004	3.9L	AX4N		5F2Z-7902-BCRM
	2007-2004	4.2L	AX4N		5F2Z-7902-ACRM

**Police Interceptor Utility**

Part Type	Years	Engine	Trans	Qualifier	Ford #
Automatic - New	2017-2014	3.5L EcoBoost	6F55	3.16 Final Drive Ratio; 3 Bolt Converter	DA5Z-7902-D
	2017-2013	3.7L	6F50	3 Bolt Converter	DA8Z-7902-A

**Ranger**

Part Type	Years	Engine	Trans	Qualifier	Ford #
Automatic - New	2011-2007	4.0L	5R55E		7L2Z-7902-A
	2007		5R44E		7L2Z-7902-A
Automatic - Reman	2011-2004	2.3L	5R55E	5 Spd.; w/ Automatic Trans.; EAO	4L5Z-7902-AARM
	2011-2004	4.0L SOHC			7L2Z-7902-ARM
	2008-2004	3.0L OHV	5R55E		4L5Z-7902-BARM
	2007-2005	2.3L	5R44E		4L5Z-7902-AARM
	2007-2005	3.0L OHV	5R44E		4L5Z-7902-BARM
	2006-2005	4.0L	5R44E		4L2Z-7902-AARM
	2006-2004		5R55E	NAAO	4L2Z-7902-AARM
	2003-2001	2.3L		NAAO	2L5Z-7902-AARM
	2003-2001	3.0L		5 Spd.; EAO; 2L5P-7902-AB, BB, CB	2L5Z-7902-AARM
	1996-1995	4.0L	4R55E	5 Spd.; EAO; 2L5P-7902-AB, BB, CB	F5TZ-7902-DARM
	1996-1995		4R44E		F5TZ-7902-DARM
	1995		A4LD		F5TZ-7902-DARM

**Transit Connect**

Part Type	Years	Engine	Trans	Qualifier	Ford #
Automatic - New	2017-2014	2.5L	4F27E		8S4Z-7902-A
	2017		6F35	Before 02/08/17	9L8Z-7902-H
	2017		6F35	From 02/08/17	9L8Z-7902-L
	2016-2014	1.6L	6F35		CV6Z-7902-F
	2016-2014	2.5L	6F35		9L8Z-7902-H
	2013-2010	2.0L	4F27E		8S4Z-7902-A
Automatic - Reman	2012-2010		4F27E		8S4Z-7902-ARM

**Transit-150**

Part Type	Years	Engine	Trans	Qualifier	Ford #
Automatic - New	2017-2015	3.2L DIESEL	6R80		CK4Z-7902-A
	2017-2016	3.5L	6R80		FL3Z-7902-D
	2017-2016	3.7L	6R80		FL3Z-7902-A
	2015	3.5L EcoBoost	6R80		FL3Z-7902-C
	2015	3.7L	6R80		CK4Z-7902-B



**Transit-250**

Part Type	Years	Engine	Trans	Qualifier	Ford #
Automatic - New	2017-2015	3.2L DIESEL	6R80		CK4Z-7902-A
	2017-2016	3.5L	6R80		FL3Z-7902-D
	2017-2016	3.7L	6R80		FL3Z-7902-A
	2015	3.5L EcoBoost	6R80		FL3Z-7902-C
	2015	3.7L	6R80		CK4Z-7902-B

**Transit-350**

Part Type	Years	Engine	Trans	Qualifier	Ford #
Automatic - New	2017-2015	3.2L DIESEL	6R80		CK4Z-7902-A
	2017-2016	3.5L	6R80		FL3Z-7902-D
	2017-2016	3.7L	6R80		FL3Z-7902-A
	2015	3.5L EcoBoost	6R80		FL3Z-7902-C
	2015	3.7L	6R80		CK4Z-7902-B

**Transit-350 HD**

Part Type	Years	Engine	Trans	Qualifier	Ford #
Automatic - New	2017-2015	3.2L DIESEL	6R80		CK4Z-7902-A
	2017-2016	3.5L	6R80		FL3Z-7902-D
	2017-2016	3.7L	6R80		FL3Z-7902-A
	2015	3.5L EcoBoost	6R80		FL3Z-7902-C
	2015	3.7L	6R80		CK4Z-7902-B

**Windstar**

Part Type	Years	Engine	Trans	Qualifier	Ford #
Automatic - Reman	2003-2001	3.8L	4F50N	1F2P-7902-C	1F2Z-7902-AARM
	2000	3.0L	AX4S	YF2P-7902-A	F88Z-7902-AARM
	2000	3.8L	AX4S	YF2P-7902-B	F88Z-7902-BARM
	1999	3.0L	AX4S		F88Z-7902-AARM
	1999-1998	3.8L	AX4S		F88Z-7902-BARM
	1998-1996	3.0L	AX4S		F68Z-7902-ARM
	1997-1996	3.8L	AX4S		F68Z-7902-ARM

**Lincoln**

**Aviator**

Part Type	Years	Engine	Trans	Qualifier	Ford #
Automatic - Reman	2005-2003	4.6L	5R55S	4L2P-7902-E,F	7R3Z-7902-ARM

**Blackwood**

Part Type	Years	Engine	Trans	Qualifier	Ford #
Automatic - Reman	2002	5.4L	4R100		1L7Z-7902-BBRM

**MKC**

Part Type	Years	Engine	Trans	Qualifier	Ford #
Automatic - New	2017-2015		6F35	FWD	BB5Z-7902-F
	2017-2015	2.0L EcoBoost		AWD	BB5Z-7902-F
	2017-2015	2.3L EcoBoost	6F35	AWD	EJ7Z-7902-J

**MKT**

Part Type	Years	Engine	Trans	Qualifier	Ford #
Automatic - New	2017-2013	2.0L EcoBoost	6F35		BB5Z-7902-F
	2017-2013	3.5L	6F55	3 Bolt Converter; 3.16 Final Drive Ratio	DA5Z-7902-D
	2017-2013	3.7L	6F55	3 Bolt Converter; 3.65 Final Drive Ratio	DA8Z-7902-E
	2017-2016		6F50	3 Bolt Converter	DA8Z-7902-F
	2013-2011	3.5L	6F55	3 Bolt Converter	AA5Z-7902-B
	2012-2010	3.7L	6F50		9E9Z-7902-B
	2010	3.5L	6F55		AA5Z-7902-A
Automatic - Reman	2012-2011	3.5L EcoBoost	6F55	3 Bolt Converter	AA5Z-7902-BRM
	2010		6F55	4 Bolt Converter	AA5Z-7902-ARM

# TORQUE CONVERTERS

## Light Trucks

### Lincoln / Mazda / Mercury



FORD PARTS

#### MKX

Part Type	Years	Engine	Trans	Qualifier	Ford #
Automatic - New	2017-2015	3.7L	6F35	6 Bolt 3 Bolt Converter 3 Bolt Converter w/ Automatic Trans.; 3 Bolt Converter	DG9Z-7902-F
	2017-2015		6F55		FG9Z-7902-C
	2017-2016		6F50		DA8Z-7902-F
	2017-2013		6F50		DA8Z-7902-E
	2012-2011		6F50		BT4Z-7902-B
Automatic - Reman	2010	3.5L	6F50		9E9Z-7902-B
	2012-2011		6F55		BT4Z-7902-BRM
	2012-2011		6F50		BT4Z-7902-CRM
	2009-2007	3.5L	6F50		7T4Z-7902-ARM

#### Navigator

Part Type	Years	Engine	Trans	Qualifier	Ford #
Automatic - New	2017-2015	3.5L EcoBoost	6R80	6 Spd.; w/ Automatic Trans.	FL3Z-7902-D
	2014-2010	5.4L	6R80		BR3Z-7902-FA
	2006-2005		6HP26		5L7Z-7902-AA
Automatic - Reman	2004-2003		4R100		1L7Z-7902-BBRM
	2002-1999	5.4L DOHC	4R100	YL1P-7902-A,B,C,D	XL7Z-7902-AARM
	2000-1998	5.4L	4R100	F8UP-7902-L; XL3P-7902-G,H; XL7P-7902-A	XL3Z-7902-BARM

#### Mazda

#### B2300

Part Type	Years	Engine	Trans	Qualifier	Ford #
Automatic - Reman	2003-2001	2.3L		5 Spd.; EAO; 2L5P-7902-AB,BB,CB	2L5Z-7902-AARM

#### B3000

Part Type	Years	Engine	Trans	Qualifier	Ford #
Automatic - Reman	2003-2001	3.0L		5 Spd.; EAO; 2L5P-7902-AB,BB,CB	2L5Z-7902-AARM

#### Tribute

Part Type	Years	Engine	Trans	Qualifier	Ford #
Automatic - Reman	2008-2005	2.3L		CD4E	5L8Z-7902-DBRM

#### Mercury

#### Mariner

Part Type	Years	Engine	Trans	Qualifier	Ford #
Automatic - New	2011	2.5L	6F35		9L8Z-7902-H
Automatic - Reman	2011-2009		6F35		9L8Z-7902-BRM
	2011-2009	3.0L	6F35		9L8Z-7902-ARM
	2008-2005	2.3L	CD4E		5L8Z-7902-DBRM
	2006-2005	3.0L	CD4E		5L8Z-7902-DBRM

#### Monterey

Part Type	Years	Engine	Trans	Qualifier	Ford #
Automatic - Reman	2007-2004	4.2L	AX4N		5F2Z-7902-ACRM
	2005		4F50N		5F2Z-7902-ACRM

#### Mountaineer

Part Type	Years	Engine	Trans	Qualifier	Ford #
Automatic - New	2010-2007	4.0L SOHC	5R55S		7L2Z-7902-A
	2010-2006	4.6L	6R60		9L3Z-7902-B
Automatic - Reman	2010-2004	4.0L	5R55S	RWD	4L2Z-7902-AARM
	2010-2001	4.0L SOHC		4WD; 5 Spd.; w/ Automatic Trans.	7L2Z-7902-ARM
	2010-2004	4.6L	5R55S		4L2Z-7902-BARM
	2009-2006		6R60		8L2Z-7902-ARM
	2001-1998	5.0L	4R70W	XL2P-7902-A,B	F85Z-7902-AARM

#### Ford

#### Econoline

Part Type	Years	Engine	Trans	Qualifier	Ford #
Automatic - New	2017-2016	6.8L	6R140	4 Bolt Converter; TorqShift6	CC4Z-7902-A
	2017-2009		5R110W	TorqShift	9C3Z-7902-B
	2016-2009	5.4L	5R110W	TorqShift	9C3Z-7902-C



Econoline

-Cont'd

Part Type	Years	Engine	Trans	Qualifier	Ford #	
Automatic - New	2016-2015	5.4L	4R70W		9C2Z-7902-A	
	2014-2009	4.6L	4R75E		9C2Z-7902-B	
	2014-2009	5.4L	4R75W		9C2Z-7902-A	
	2014-2008, 2006-2005	5.4L SOHC	4R75E		9C2Z-7902-A	
	2010-2009	6.0L DIESEL	5R110W	TorqShift	9C2Z-7902-C	
	2007	4.6L SOHC	4R75E		9C2Z-7902-A	
	Automatic - Reman	2011-2007	4.6L	4R75E		7L3Z-7902-HRM
		2011-2008	5.4L	4R75E		7L3Z-7902-GRM
		2011-2009		4R75W		7L3Z-7902-GRM
		2011-2007	6.8L	5R110W	TorqShift	6C3Z-7902-JRM
2010-2007		5.4L	5R110W	TorqShift	7C3Z-7902-KRM	
2010-2007		6.0L DIESEL	5R110W	TorqShift	7C2Z-7902-BRM	
2007		5.4L	4R75E	From 12/04/06	7L3Z-7902-GRM	
2007			4R75E	Before 12/04/06	8L3Z-7902-ARM	
2007-2006, 2004		6.8L	5R110W	5C3P-7902-BB; TorqShift	6C3Z-7902-ERM	
2006, 2004		4.6L	4R70W	RWD; w/ Triton (Romeo) Engine	8L3Z-7902-BRM	
2006		4R75E	RWD; w/ Triton (Romeo) Engine	8L3Z-7902-BRM		
2006	5.4L	5R110W	TorqShift	6C3Z-7902-FRM		
2006-2005		4R75E		8L3Z-7902-ARM		
2006, 2004	6.0L DIESEL	5R110W	TorqShift	6C3Z-7902-DRM		
2005-2004		4R100		1C3Z-7902-CARM		
2004	4.6L	4R75W	RWD; w/ Triton (Romeo) Engine	8L3Z-7902-BRM		
2004-2001	5.4L	4R100	4C2P-7902-E,H,J; 1C2P-7902-AC,NC,TA; 1C3P-7902-DB,AC,BC	1C3Z-7902-DBRM		
2004-2000	6.8L	4R100	4C2P-7902-F,L; 4C2P-7902-G,L	1C3Z-7902-BARM		
2003		4R70W	YC2P-7902-A,B,C,S; 1C2P-7902-F,H,J,S; 3C2P-7902-AA	F8AZ-7902-AARM		
2003	5.4L	4R70W	YC2P-7902-D,N; 1C2P-7902-L,MA,YA; XL3P-7902-AA	XL3Z-7902-AARM		
2003-1998	7.3L DIESEL	4R100		1C3Z-7902-CARM		
1999	6.8L	4R100	XC2P-7902-F,G; XC2P-7902-H; w/ 4 Mounting Studs	XC3Z-7902-AARM		
1997		E4OD	w/ 4 Mounting Studs	XC3Z-7902-AARM		
1996	7.5L	E4OD		F7TZ-7902-EARM		

F-Series

Part Type	Years	Engine	Trans	Qualifier	Ford #
Automatic - New	2017-2015	6.7L DIESEL	6R140	TorqShift6	HC3Z-7902-A
	2017	6.8L	6R140	4 Bolt Converter; TorqShift6	CC4Z-7902-A
	2017-2009		5R110W	TorqShift	9C3Z-7902-B
	2014-2013	6.7L DIESEL	6R140	Turbocharged; 6 Bolt; TorqShift6	CC3Z-7902-D
	2013-2011		6R140	6 Spd.; w/ Automatic Trans.; 4 Bolt Converter; Requires flywheel # CC3Z-6375-A.; TorqShift6	CC4Z-7902-A
Automatic - Reman	2010-2009	6.4L DIESEL	5R110W	TorqShift	9C3Z-7902-DRM
	2008	6.4L	5R110W	TorqShift	7C3Z-7902-HRM
	2008	6.8L	5R110W	TorqShift	7C3Z-7902-JRM
	2007-2003	6.0L	5R110W	TorqShift	6C3Z-7902-DRM
	2007-2004	6.8L	5R110W	5C3P-7902-BB; TorqShift	6C3Z-7902-ERM
	2004-2000		4R100	1C3P-7902-C,D,H,J	1C3Z-7902-BARM
	2003-1999	7.3L DIESEL	4R100	Turbocharged	1C3Z-7902-CARM
	1999	6.8L	4R100	F81P-7902-D,E,F,G; XC3P-7902-D,E,F,G; w/ 4 Mounting Studs	XC3Z-7902-AARM
	1997-1990	7.5L	E4OD		F7TZ-7902-EARM

F53

Part Type	Years	Engine	Trans	Qualifier	Ford #
Automatic - New	2017-2011, 2009-2008	6.8L	5R110W	TorqShift	9C3Z-7902-B
Automatic - Reman	2015-2011, 2009-2006, 2004		4R100		1C3Z-7902-BARM
	2007-2006, 2004		5R110W	5C3P-7902-BB; TorqShift	6C3Z-7902-ERM
	1999		4R100	F81P-7902-T; XC3P-7902-M; w/ 4 Mounting Studs	XC3Z-7902-AARM

F59

Part Type	Years	Engine	Trans	Qualifier	Ford #
Automatic - New	2017-2011	6.8L	5R110W	TorqShift	9C3Z-7902-B
Automatic - Reman	2017-2011		5R110W		1C3Z-7902-BARM
	1994-1990	7.3L DIESEL	4R100		F1TZ-7902-CRM

F650

Part Type	Years	Engine	Trans	Qualifier	Ford #
Automatic - New	2017-2016	6.7L DIESEL	6R140	TorqShift6	HC3Z-7902-A
	2016-2012	6.8L	6R140	RWD; 4 Bolt Converter; TorqShift6	CC4Z-7902-A

**TORQUE CONVERTERS**  
**Medium Trucks**  
**Ford**



**FORD PARTS**

**F750**

Part Type	Years	Engine	Trans	Qualifier	Ford #
Automatic - New	2017-2016	6.7L DIESEL	6R140	TorqShift6	HC3Z-7902-A

**LCF**

Part Type	Years	Engine	Trans	Qualifier	Ford #
Automatic - New	2010-2006	4.5L DIESEL	5R110W	TorqShift	9E7Z-7902-AA
Automatic - Reman	2009-2006		5R110W	TorqShift	7E7Z-7902-ARM



**Ford**

**Contour**

Part Type	Years	Eng	Qualifier	Ford #
Clutch Kit	2000-1997	2.0L	Clutch Kit; w/ MTX75 Transmission; Outer Diameter: 9-7/16" Splines: 1" Teeth: 23	F7RZ-7L596-AA
	1996-1995	2.0L	Clutch Kit; w/ MTX75 Transmission; Outer Diameter: 9-7/16" Splines: 1" Teeth: 23	F5RZ-7L596-CA

**Escort**

Part Type	Years	Eng	Qualifier	Ford #
Clutch Kit	2003	2.0L	Clutch Kit; w/ G5M Transmission; DOHC	6S4Z-7L596-A
	2002-2001	2.0L	Clutch Kit; w/ MTX Transmission; SOHC	6S4Z-7L596-A
	2000-1997	2.0L	Clutch Kit; w/ G5M Transmission; SOHC	6S4Z-7L596-A

**Focus**

Part Type	Years	Eng	Qualifier	Ford #
Clutch Kit	2011-2005	2.0L	Clutch Kit; w/ MTX75 Transmission; Outer Diameter: 9" Splines: 15/16" Teeth: 23	7S4Z-7L596-AA
	2007-2004	2.3L	Clutch Kit; w/ MTX75 Transmission; Outer Diameter: 9" Splines: 15/16" Teeth: 23	7S4Z-7L596-AA
	2004	2.0L	Clutch Kit; w/ MTX75 Transmission; DOHC; Outer Diameter: 9" Splines: 15/16" Teeth: 23	YS4Z-7L596-DA
	2004		Clutch Kit; w/ IB5 Transmission; SOHC; Outer Diameter: 8-11/16" Splines: 3/4" Teeth: 17	YS4Z-7L596-EA
	2003-2002	2.0L	Clutch Kit; w/ MTX75 Transmission; DOHC; SE; Outer Diameter: 9" Splines: 15/16" Teeth: 23	YS4Z-7L596-DA
	2003-2002		Clutch Kit; w/ MTX75 Transmission; DOHC; ZTS; Outer Diameter: 9" Splines: 15/16" Teeth: 23	YS4Z-7L596-DA
	2003-2002		Clutch Kit; w/ MTX75 Transmission; DOHC; ZTW; Outer Diameter: 9" Splines: 15/16" Teeth: 23	YS4Z-7L596-DA
	2003-2002		Clutch Kit; w/ MTX75 Transmission; DOHC; ZX3; Outer Diameter: 9" Splines: 15/16" Teeth: 23	YS4Z-7L596-DA
	2003-2002		Clutch Kit; w/ MTX75 Transmission; DOHC; ZX5; Outer Diameter: 9" Splines: 15/16" Teeth: 23	YS4Z-7L596-DA
	2003-2000	2.0L	Clutch Kit; w/ IB5 Transmission; SOHC; Outer Diameter: 8-11/16" Splines: 3/4" Teeth: 17	YS4Z-7L596-EA
	2003	2.0L	Clutch Kit; w/ MTX75 Transmission; DOHC; SE; Outer Diameter: 9" Splines: 15/16" Teeth: 23	YS4Z-7L596-DA
	2003		Clutch Kit; w/ MTX75 Transmission; DOHC; ZTS; Outer Diameter: 9" Splines: 15/16" Teeth: 23	YS4Z-7L596-DA
	2003		Clutch Kit; w/ MTX75 Transmission; DOHC; ZTW; Outer Diameter: 9" Splines: 15/16" Teeth: 23	YS4Z-7L596-DA
	2003		Clutch Kit; w/ MTX75 Transmission; DOHC; ZX3; Outer Diameter: 9" Splines: 15/16" Teeth: 23	YS4Z-7L596-DA
	2003		Clutch Kit; w/ MTX75 Transmission; DOHC; ZX5; Outer Diameter: 9" Splines: 15/16" Teeth: 23	YS4Z-7L596-DA
	2001-2000	2.0L	Clutch Kit; w/ MTX75 Transmission; DOHC; Outer Diameter: 9" Splines: 15/16" Teeth: 23	YS4Z-7L596-DA

**Fusion**

Part Type	Years	Eng	Qualifier	Ford #
Clutch Kit	2012-2010	2.5L	Clutch Kit; w/ G6M Transmission	AE5Z-7L596-A
	2009-2006	2.3L	Clutch Kit; w/ G5M Transmission	6E5Z-7L596-A

**Mustang**

Part Type	Years	Eng	Qualifier	Ford #
Clutch Kit	2010-2007	4.0L	Clutch Kit; w/ T5OD Transmission; From 12/04/06; 254mm OD; 10 Teeth; 1-1/16" Splines	8R3Z-7L596-A
	2010-2005	4.6L	Clutch Kit; w/ TR3650 Transmission; 24 Valve; Outer Diameter: 280mm	5R3Z-7L596-A
	2007	4.0L	Clutch Kit; w/ T5OD Transmission; Before 12/04/06; Outer Diameter: 254mm; Splines: 1-1/16" Teeth: 10	5R3Z-7L596-B
	2006-2005	4.0L	Clutch Kit; w/ T5OD Transmission; Outer Diameter: 254mm; Splines: 1-1/16" Teeth: 10	5R3Z-7L596-B
	2004-2002	4.6L	Clutch Kit; w/ T56 Transmission; DOHC; Outer Diameter: 280mm	3R3Z-7L596-AA
	2004-2002		Clutch Kit; w/ TR3650 Transmission; SOHC; Outer Diameter: 280mm	1R3Z-7L596-AA

**MANUAL TRANSMISSION CLUTCH KITS**  
**Passenger Cars**  
**Ford / Mercury**



**FORD PARTS**

**Mustang**

— Cont'd

Part Type	Years	Eng	Qualifier	Ford #
Clutch Kit	2004-2001	3.8L	Clutch Kit; w/ T5OD Transmission; Outer Diameter: 11" Splines: 1-1/16" Teeth: 10	F7ZZ-7L596-BA
	2004	3.9L	Clutch Kit; w/ T5OD Transmission; Outer Diameter: 11" Splines: 1-1/16" Teeth: 10	F7ZZ-7L596-BA
	2001	4.6L	Clutch Kit; w/ T45OD Transmission; DOHC; Outer Diameter: 280mm	YR3Z-7L596-HA
	2001		Clutch Kit; w/ T-45 Transmission; SOHC; Before 2/05/01; w/ Engine Tag # 1G-837-AA; Outer Diameter: 10-1/2	F6ZZ-7L596-DA
	2001		Clutch Kit; w/ TR3650 Transmission; SOHC; From 2/05/01; w/ Engine Tag # 1G-837-AB/AC; Outer Diameter: 280mm	1R3Z-7L596-AA
	2000-1997	3.8L	Clutch Kit; w/ T5 Transmission; Outer Diameter: 11" Splines: 1-1/16" Teeth: 10	F7ZZ-7L596-BA
	2000-1996	4.6L	Clutch Kit; w/ T-45 Transmission; SOHC; Outer Diameter: 10-1/2	F6ZZ-7L596-DA
	2000-1996		Clutch Kit; w/ T5 Transmission; SOHC; Outer Diameter: 10-1/2	F6ZZ-7L596-DA
	2000	4.6L	Clutch Kit; w/ T-45 Transmission; SOHC; Outer Diameter: 280mm	YR3Z-7L596-HA
	2000		Clutch Kit; w/ T5 Transmission; SOHC; Outer Diameter: 280mm	YR3Z-7L596-HA
	1999	4.6L	Clutch Kit; w/ T-45 Transmission; DOHC; Outer Diameter: 280mm	YR3Z-7L596-HA
	1999		Clutch Kit; w/ T5 Transmission; DOHC; Outer Diameter: 280mm	YR3Z-7L596-HA
	1998-1996	4.6L	Clutch Kit; w/ T-45 Transmission; DOHC; Outer Diameter: 10-1/2	F6ZZ-7L596-GA
	1998-1996		Clutch Kit; w/ T5 Transmission; DOHC; Outer Diameter: 10-1/2	F6ZZ-7L596-GA
	1996	3.8L	Clutch Kit; w/ T5 Transmission; Outer Diameter: 11" Splines: 1-1/16" Teeth: 10	F4ZZ-7L596-AB
	1995-1994	3.8L	Clutch Kit; w/ T5 Transmission	F4ZZ-7L596-CA
	1995	5.0L	Clutch Kit; w/ T5 Transmission; GTS; Outer Diameter: 10-1/2" Splines: 1-1/16" Teeth: 10	F5ZZ-7L596-FA
	1995		Clutch Kit; w/ T5 Transmission; SVT Cobra; Outer Diameter: 280mm	F5ZZ-7L596-JA
	1994	5.0L	Clutch Kit; w/ T5 Transmission; Outer Diameter: 10-1/2" Splines: 1-1/16" Teeth: 10	F5ZZ-7L596-FA
	1993	5.0L	Clutch Kit; w/ T5 Transmission; Exc. High Performance; Outer Diameter: 10-1/2" Splines: 1-1/16" Teeth: 10	F3ZZ-7L596-EA
	1993		Clutch Kit; w/ T5 Transmission; High Performance; Outer Diameter: 10-1/2" Splines: 1-1/16" Teeth: 10	F5ZZ-7L596-FA
	1992-1989	5.0L	Clutch Kit; w/ T5 Transmission; Outer Diameter: 10-1/2" Splines: 1-1/16" Teeth: 10	F3ZZ-7L596-EA
	1988-1987	5.0L	Clutch Kit; 1 Transmission; Outer Diameter: 10-1/2" Splines: 1-1/16" Teeth: 10	F3ZZ-7L596-EA

**Mercury**

**Cougar**

Part Type	Years	Eng	Qualifier	Ford #
Clutch Kit	2002-1999	2.0L	Clutch Kit; w/ MTX75 Transmission; Outer Diameter: 9-7/16" Splines: 1" Teeth: 23	F7RZ-7L596-AA

**Mystique**

Part Type	Years	Eng	Qualifier	Ford #
Clutch Kit	2000-1997	2.0L	Clutch Kit; w/ MTX75 Transmission; Outer Diameter: 9-7/16" Splines: 1" Teeth: 23	F7RZ-7L596-AA
	1996-1995	2.0L	Clutch Kit; w/ MTX75 Transmission; Outer Diameter: 9-7/16" Splines: 1" Teeth: 23	F5RZ-7L596-CA





**Ford**

**Aerostar**

Part Type	Years	Eng	Qualifier	Ford #
Clutch Kit	1994-1993	3.0L	Clutch Kit; M50DR1; Outer Diameter: 8-7/8" Splines: 1" Teeth: 23	F37Z-7L596-LA
	1992-1990	3.0L	Clutch Kit	F17Z-7L596-KA

**Escape**

Part Type	Years	Eng	Qualifier	Ford #
Clutch Kit	2012-2009	2.5L	Clutch Kit; w/ AK Transmission; GAS	5L8Z-7L596-A
	2008-2005	2.3L	Clutch Kit; w/ AK Transmission; GAS	5L8Z-7L596-A
	2004-2001	2.0L	Clutch Kit; w/ G5M Transmission; Outer Diameter: 225mm	3L8Z-7L596-AA

**Explorer**

Part Type	Years	Eng	Qualifier	Ford #
Clutch Kit	2003-2002	4.0L	Clutch Kit; Sport XLS; M50DR1; Outer Diameter: 10" Splines: 1" Teeth: 23	1L2Z-7L596-EB
	2001-1998	4.0L	Clutch Kit; M50DR1; Outer Diameter: 10" Splines: 1" Teeth: 23	F87Z-7L596-CA
	2001	4.0L	Clutch Kit; Sport; M50DR1; Outer Diameter: 10" Splines: 1" Teeth: 23	1L2Z-7L596-EB
	1992-1991	4.0L	Clutch Kit; M50DR1; Outer Diameter: 10" Splines: 1" Teeth: 23	F27Z-7L596-GA

**Explorer Sport Trac**

Part Type	Years	Eng	Qualifier	Ford #
Clutch Kit	2003-2001	4.0L	Clutch Kit; M50DR1; Outer Diameter: 10" Splines: 1" Teeth: 23	1L2Z-7L596-EB

**F-Series**

Part Type	Years	Eng	Qualifier	Ford #
Clutch Kit	2010-2008	6.4L	Clutch Kit; w/ S6-650 Transmission	7C3Z-7L596-A
	2010-2004	5.4L	Clutch Kit; w/ S6-650 Transmission; Outer Diameter: 11-15/16" Splines: 1-1/4" Teeth: 10	8C3Z-7L596-GA
	2010-2004	6.8L	Clutch Kit; w/ S6-650 Transmission; Outer Diameter: 11-15/16" Splines: 1-1/4" Teeth: 10	8C3Z-7L596-DA
	2008-1997	4.2L	Clutch Kit; M50DR2; Outer Diameter: 11-7/16" Splines: 1-1/16" Teeth: 10	6L3Z-7L596-K
	2007-2004	6.0L	Clutch Kit; w/ S6-650 Transmission; Use with Single Mass Flywheel Assy Only	3C3Z-7L596-EA
	2004-1997	4.6L	Clutch Kit; M50DR2; Outer Diameter: 11-7/16" Splines: 1-1/16" Teeth: 10	6L3Z-7L596-J
	2003-2002	5.4L	Clutch Kit; M6HD; Outer Diameter: 11-15/16" Splines: 1-1/4" Teeth: 10	8C3Z-7L596-GA
	2003-1999	6.8L	Clutch Kit; w/ S5-47 Transmission; Outer Diameter: 11-15/16" Splines: 1-1/4" Teeth: 10	8C3Z-7L596-DA
	2003-1999	7.3L	Clutch Kit; M6HD; Outer Diameter: 13" Splines: 1-3/8" Teeth: 10	YC3Z-7L596-AA
	2001-1999	5.4L	Clutch Kit; w/ S5-47 Transmission; Outer Diameter: 11-15/16" Splines: 1-1/4" Teeth: 10	8C3Z-7L596-GA
	1997-1996	7.3L	Clutch Kit; w/ S5-47 Transmission; Turbocharged; Outer Diameter: 12-3/16" Splines: 1-1/4" Teeth: 10	F4TZ-7L596-A
	1995	7.3L	Clutch Kit; w/ S5-42 Transmission; Turbocharged; Outer Diameter: 12-3/16" Splines: 1-1/4" Teeth: 10	F4TZ-7L596-A
	1994	7.3L	Clutch Kit; w/ S5-42 Transmission; Turbocharged; FI; DFI; Outer Diameter: 12-3/16" Splines: 1-1/4" Teeth: 10	F4TZ-7L596-A

**Ranger**

Part Type	Years	Eng	Qualifier	Ford #
Clutch Kit	2011-2009	3.0L	Clutch Kit; w/ M5R1HD Transmission; Outer Diameter: 9-1/4" Splines: 1" Teeth: 23	7L5Z-7L596-JA
	2011-2006	2.3L	Clutch Kit; w/ M5R1HD Transmission; Outer Diameter: 8-7/8" Splines: 1" Teeth: 23	7L5Z-7L596-GA
	2011-2006	4.0L	Clutch Kit; w/ M5R1HD Transmission; Outer Diameter: 10" Splines: 1" Teeth: 23	7L5Z-7L596-CA
	2008-2006	3.0L	Clutch Kit; w/ M5R1HD Transmission; Outer Diameter: 9-1/4" Splines: 1" Teeth: 23	7L5Z-7L596-JA
	2005-2004	2.3L	Clutch Kit; w/ R1 Transmission; Outer Diameter: 8-7/8" Splines: 1" Teeth: 23	7L5Z-7L596-GA

# MANUAL TRANSMISSION CLUTCH KITS

## Light Trucks

### Ford / Mazda



FORD PARTS

### Ranger

— Cont'd

Part Type	Years	Eng	Qualifier	Ford #
Clutch Kit	2005-2004	2.3L	Clutch Kit; w/ R1HD Transmission; Outer Diameter: 8-7/8" Splines: 1" Teeth: 23	7L5Z-7L596-GA
	2005-2004	3.0L	Clutch Kit; w/ R1HD Transmission; Outer Diameter: 9-1/4" Splines: 1" Teeth: 23	7L5Z-7L596-JA
	2005-2004	4.0L	Clutch Kit; w/ R1HD Transmission; Outer Diameter: 10" Splines: 1" Teeth: 23	7L5Z-7L596-CA
	2003-2001	4.0L	Clutch Kit; M50DR1; Outer Diameter: 10" Splines: 1" Teeth: 23	7L5Z-7L596-CA
	2003-1998	3.0L	Clutch Kit; M50DR1; Outer Diameter: 9-1/4" Splines: 1" Teeth: 23	7L5Z-7L596-JA
	2003-1995	2.3L	Clutch Kit; M50DR1; Outer Diameter: 8-7/8" Splines: 1" Teeth: 23	7L5Z-7L596-GA
	2001-1998	2.5L	Clutch Kit; M50DR1; Outer Diameter: 8-7/8" Splines: 1" Teeth: 23	7L5Z-7L596-GA
	2000-1998	4.0L	Clutch Kit; M50DR1; Outer Diameter: 10" Splines: 1" Teeth: 23	F87Z-7L596-CA
	1994-1993	2.3L	Clutch Kit; M50DR1; Outer Diameter: 8-7/8" Splines: 1" Teeth: 23	F37Z-7L596-FA
	1994-1993	3.0L	Clutch Kit; M50DR1; Outer Diameter: 8-7/8" Splines: 1" Teeth: 23	F37Z-7L596-LA
	1992-1991	3.0L	Clutch Kit	F17Z-7L596-KA
	1992-1988	2.3L	Clutch Kit; M50DR1; Outer Diameter: 8-7/8" Splines: 1" Teeth: 23	F27Z-7L596-DA
	1988	2.0L	Clutch Kit; M50DR1; Outer Diameter: 8-7/8" Splines: 1" Teeth: 23	F27Z-7L596-DA

### Mazda

### B2300

Part Type	Years	Eng	Qualifier	Ford #
Clutch Kit	2008-2006	2.3L	Clutch Kit; w/ M5R1HD Transmission; Outer Diameter: 8-7/8" Splines: 1" Teeth: 23	7L5Z-7L596-GA
	2005-2004	2.3L	Clutch Kit; Outer Diameter: 8-7/8" Splines: 1" Teeth: 23	7L5Z-7L596-GA
	2003-2002	2.3L	Clutch Kit; w/ M5R1 Transmission; Outer Diameter: 8-7/8" Splines: 1" Teeth: 23	7L5Z-7L596-GA
	2001	2.3L	Clutch Kit; w/ M5R1 Transmission; Outer Diameter: 8-7/8" Splines: 1" Teeth: 23	7L5Z-7L596-GA
	1994	2.3L	Clutch Kit; M50DR1; Outer Diameter: 8-7/8" Splines: 1" Teeth: 23	F37Z-7L596-FA

### B2500

Part Type	Years	Eng	Qualifier	Ford #
Clutch Kit	2000-1998	2.5L	Clutch Kit; M50DR1; Outer Diameter: 8-7/8" Splines: 1" Teeth: 23	7L5Z-7L596-GA

### B3000

Part Type	Years	Eng	Qualifier	Ford #
Clutch Kit	2007-2006	3.0L	Clutch Kit; w/ M5R1HD Transmission; Outer Diameter: 9-1/4" Splines: 1" Teeth: 23	7L5Z-7L596-JA
	2005-2004	3.0L	Clutch Kit; Outer Diameter: 9-1/4" Splines: 1" Teeth: 23	7L5Z-7L596-JA
	2003-2001	3.0L	Clutch Kit; w/ M5R1 Transmission; Outer Diameter: 9-1/4" Splines: 1" Teeth: 23	7L5Z-7L596-JA
	2000-1998	3.0L	Clutch Kit; M50DR1; Outer Diameter: 9-1/4" Splines: 1" Teeth: 23	7L5Z-7L596-JA
	1994	3.0L	Clutch Kit; M50DR1; Outer Diameter: 8-7/8" Splines: 1" Teeth: 23	F37Z-7L596-LA

### B4000

Part Type	Years	Eng	Qualifier	Ford #
Clutch Kit	2008-2003	4.0L	Clutch Kit; w/ M5R1HD Transmission; Outer Diameter: 10" Splines: 1" Teeth: 23	7L5Z-7L596-CA
	2002-2001	4.0L	Clutch Kit; w/ M5R1 Transmission; Outer Diameter: 10" Splines: 1" Teeth: 23	7L5Z-7L596-CA
	2000-1998	4.0L	Clutch Kit; M50DR1; Outer Diameter: 10" Splines: 1" Teeth: 23	F87Z-7L596-CA

### Tribute

Part Type	Years	Eng	Qualifier	Ford #
Clutch Kit	2004	2.0L	Clutch Kit; Outer Diameter: 225mm	3L8Z-7L596-AA
	2003-2001	2.0L	Clutch Kit; w/ G5M Transmission; Outer Diameter: 225mm	3L8Z-7L596-AA



Year	Eng. Size	Qualifer	Master Overhaul Kit With Steel	Overhaul Gasket & Seal Kit
<b>Ford</b>				
<b>Contour</b>				
2000-1995		w/ CD4E Transmission		MTK-132932
<b>Crown Victoria</b>				
2010-1998	4.6L V8	w/ 4R70W Transmission	MTKV-K5300K	MTK-132940
1997-1996	4.6L V8	w/ 4R70W Transmission		MTK-132940
1995-1992	4.6L V8	w/ AOD-E Transmission		MTK-132940
<b>Fiesta</b>				
2017-2014		KTEV6P-7153-AA,BA; DPS6		MTK-132936
2013-2011	1.6L L4	DPS6		MTK-132918
<b>Five Hundred</b>				
2007-2005		w/ CVT Transmission		MTK-122900
<b>Focus</b>				
2017-2014		KTEV6P-7153-AA,BA; DPS6		MTK-132936
2017-2016		MMT6		MTK-132934
2014-2012	2.0L L4	DPS6		MTK-132918
2011-2008	2.0L L4	w/ 4F27E Transmission; w/o Clutch Pistons	MTKV-K4600D	MTK-132907
2008-2000	2.0L L4	w/ 4F27E Transmission; w/ Clutch Pistons		MTK-46900C
2007-2004	2.0L L4	w/ 4F27E Transmission; w/o Clutch Pistons		MTK-132907
<b>Freestyle</b>				
2007-2005		w/ CVT Transmission		MTK-122900
<b>Fusion</b>				
2017-2013		w/ 6F35 Transmission		MTK-132935
2012-2009		w/ 6F35 Transmission		MTK-132924
<b>Mustang</b>				
2017-2011		w/ 6R80 Transmission		MTK-132922
2013-2011	3.7L V6	w/ 6R80 Transmission	MTKV-1C	
2013-2011	5.0L V8	w/ 6R80 Transmission	MTKV-1D	
2010-2005		w/ 5R55S Transmission	MTKV-K2701G	MTK-27900H
2004-2001		w/ 4R70W Transmission	MTKV-K5300K	MTK-132940
2000-1999	3.8L V6	w/ 4R70W Transmission	MTKV-K5300K	MTK-132940
2000-1998	4.6L V8	w/ 4R70W Transmission	MTKV-K5300K	MTK-132940
1998-1996	3.8L V6	w/ 4R70W Transmission		MTK-132940
1997-1996	4.6L V8	w/ 4R70W Transmission		MTK-132940
1995-1994	5.0L V8	w/ AOD-E Transmission		MTK-132940
<b>Police Interceptor Sedan</b>				
2017-2013		w/ 6F55 Transmission		MTK-132914
2013		w/ 6F35 Transmission		MTK-132935
<b>Taurus</b>				
2017-2014		w/ 6F35 Transmission		MTK-132924
2017-2013	3.5L V6	w/ 6F55 Transmission		MTK-132914
2012-2010	3.5L V6	w/ 6F50 Transmission	MTKV-K5601A	MTK-132914
2009-2008	3.5L V6	w/ 6F50 Transmission	MTKV-K11701A	MTK-132908
2007-2004	3.0L V6	w/ 4F50N Transmission	MTKV-K6700T	MTK-67900F
2003-2001	3.0L V6	w/ 4F50N Transmission		MTK-132929
<b>Taurus X</b>				
2009-2008	3.5L V6	w/ 6F50 Transmission	MTKV-K11701A	MTK-132908
<b>Thunderbird</b>				
2005-2003		w/ 5R55S Transmission	MTKV-K2701G	MTK-27900H
1997-1994		w/ 4R70W Transmission		MTK-132940
<b>Lincoln</b>				
<b>Continental</b>				
2002-2001	4.6L V8	w/ 4F50N Transmission		MTK-132929

# TRANSMISSION REPAIR KITS

## Passenger Cars

### Lincoln / Mercury



FORD PARTS

Year	Eng. Size	Qualifer	Master Overhaul Kit With Steel	Overhaul Gasket & Seal Kit
<b>Lincoln -Cont'd</b>				
<b>LS</b>				
2006-2003	3.9L V8	w/ 5R55S Transmission	MTKV-K2701G	MTK-27900H
2005-2003	3.0L V6	w/ 5R55S Transmission	MTKV-K2701G	MTK-27900H
<b>MKS</b>				
2016-2013	3.5L V6	w/ 6F55 Transmission		MTK-132914
2016-2013	3.7L V6	w/ 6F50 Transmission		MTK-132914
2012-2010		w/ 6F50 Transmission	MTKV-K5601A	MTK-132914
2009		w/ 6F50 Transmission	MTKV-K11701A	MTK-132908
<b>MKZ</b>				
2017-2013		w/ 6F50 Transmission		MTK-132914
2017-2015		w/ 6F35 Transmission		MTK-132935
2014-2009		w/ 6F35 Transmission		MTK-132924
<b>Mark VIII</b>				
1998-1997	4.6L V8	w/ 4R70W Transmission	MTKV-K5300K	MTK-132940
1996	4.6L V8	w/ 4R70W Transmission		MTK-132940
1995-1993	4.6L V8	w/ AOD-E Transmission		MTK-132940
<b>Town Car</b>				
2010-1998	4.6L V8	w/ 4R70W Transmission	MTKV-K5300K	MTK-132940
1997-1993	4.6L V8	w/ 4R70W Transmission		MTK-132940
1992	4.6L V8	w/ AOD-E Transmission		MTK-132940
<b>Mercury</b>				
<b>Cougar</b>				
2002-1999		w/ CD4E Transmission		MTK-132932
1997-1994		w/ 4R70W Transmission		MTK-132940
<b>Grand Marquis</b>				
2010-1998	4.6L V8	w/ 4R70W Transmission	MTKV-K5300K	MTK-132940
1997-1996	4.6L V8	w/ 4R70W Transmission		MTK-132940
1995-1992	4.6L V8	w/ AOD-E Transmission		MTK-132940
<b>Marauder</b>				
2004-2003	4.6L V8	w/ 4R70W Transmission	MTKV-K5300K	MTK-132940
<b>Milan</b>				
2011-2010		w/ 6F35 Transmission		MTK-132924
2009		w/ 6F35 Transmission		MTK-132938
<b>Montego</b>				
2007-2005		w/ CVT Transmission		MTK-122900
<b>Mystique</b>				
2000-1995		w/ CD4E Transmission		MTK-132932
<b>Sable</b>				
2009-2008	3.5L V6	w/ 6F50 Transmission	MTKV-K11701A	MTK-132908
2005-2004	3.0L V6	w/ 4F50N Transmission	MTKV-K6700T	MTK-67900F
2003-2001	3.0L V6	w/ 4F50N Transmission		MTK-132929
1999-1998	3.0L V6	w/ AX4N Transmission		MTK-132929



Year	Eng. Size	Qualifier	Master Overhaul Kit With Steel	Overhaul Gasket & Seal Kit
<b>Ford</b>				
<b>Aerostar</b>				
1997		w/ 5R55E Transmission	MTKV-K2801C	MTK-28900D
1997		w/ 4R44E Transmission	MTKV-K2801C	MTK-28900D
1997-1990		w/ A4LD Transmission		MTK-132931
<b>Bronco</b>				
1996		w/ 4R100 Transmission		MTK-73900B
1996-1990		w/ E4OD Transmission		MTK-132933
<b>Econoline</b>				
2017-2005		w/ 4R75W Transmission	MTKV-K5300K	MTK-132940
2017-2005		w/ 5R110W Transmission	MTKV-K3602C	MTK-36900B
2017-2016		w/ 6R140 Transmission		MTK-132939
2010-2007		w/ 4R75E Transmission	MTKV-K5300K	MTK-132940
2005-1999		w/ 4R70W Transmission	MTKV-K5300K	MTK-132940
2005-1999		w/ 4R100 Transmission		MTK-73900B
2004		w/ 5R110W Transmission	MTKV-K3601D	MTK-36900B
2000-1999	5.4L V8	w/ 4R100 Transmission	MTKV-K7300D	
2000-1999	7.3L V8	w/ 4R100 Transmission	MTKV-K7300D	
1998	5.4L V8	w/ E4OD Transmission	MTKV-K7300D	MTK-73900B
1998	5.4L V8	w/ 4R100 Transmission; w/ 4.10 Axle	MTKV-K7300D	MTK-73900B
1998	5.4L V8	w/ 4R100 Transmission; w/ 3.55 or 3.73 axle	MTKV-K7300D	MTK-73900B
1998	5.4L V8	w/ 4R100 Transmission; w/ 3.55 Axle	MTKV-K7300D	
1998	6.8L V10	w/ E4OD Transmission	MTKV-K7300D	MTK-73900B
1998	6.8L V10	w/ 4R100 Transmission; w/ 4.10 Axle	MTKV-K7300D	MTK-73900B
1998	6.8L V10	w/ 4R100 Transmission; w/ 3.73 Axle	MTKV-K7300D	MTK-73900B
1998	7.3L V8	w/ 4R100 Transmission; w/ 4.10 Axle	MTKV-K7300D	MTK-73900B
1998	7.3L V8	w/ E4OD Transmission	MTKV-K7300D	MTK-73900B
1998	7.3L V8	w/ 4R100 Transmission; w/ 3.55 Axle	MTKV-K7300D	MTK-73900B
1998	7.3L V8	w/ 4R100 Transmission; w/ 3.55 Axle; ESD	MTKV-K7300D	MTK-73900B
1997-1994		w/ 4R70W Transmission	MTKV-K5300K	MTK-132940
1997-1996		w/ E4OD Transmission		MTK-73900B
1996-1994		w/ 4R75W Transmission	MTKV-K5300K	MTK-132940
<b>Edge</b>				
2017-2013		w/ 6F50 Transmission		MTK-132914
2017-2013		w/ 6F35 Transmission		MTK-132935
2012-2010	3.5L V6	w/ 6F50 Transmission	MTKV-K5601A	MTK-132914
2009-2007		w/ 6F50 Transmission	MTKV-K11701A	MTK-132908
<b>Escape</b>				
2017-2013		w/ 6F35 Transmission		MTK-132935
2012-2009		w/ 6F35 Transmission		MTK-132924
2008-2001		w/ CD4E Transmission	MTKV-K5800H	
2008-2001		w/ CD4E Transmission; 3U2J-7153-AC		MTK-85900D
2008-2001		w/ CD4E Transmission; F7RZ-7153-AA		MTK-132932
<b>Excursion</b>				
2005		w/ 5R110W Transmission	MTKV-K3602C	MTK-36900B
2005-2000		w/ 4R100 Transmission; FOTZ-7153-A		MTK-132933
2005-2000	5.4L V8	RWD; w/ 4R100 Transmission; 1U2J-7153-HE		MTK-73900B
2004-2003		w/ 5R110W Transmission	MTKV-K3601D	MTK-36900B
2000	6.8L V10	w/ 4R100 Transmission	MTKV-K7300D	
<b>Expedition</b>				
2017-2015	3.5L V6	w/ 6R80 Transmission		MTK-132922
2014	5.4L V8	w/ 6R80 Transmission		MTK-132922
2013-2009	5.4L V8	w/ 6R80 Transmission	MTKV-K13201D	MTK-132922
2008-2007	5.4L V8	w/ 6R75 Transmission	MTKV-K13200D	MTK-132922
2006-1999		w/ 4R70W Transmission	MTKV-K5300K	MTK-132940

# TRANSMISSION REPAIR KITS

## Light Trucks

### Ford



FORD PARTS

Year	Eng. Size	Qualifer	Master Overhaul Kit With Steel	Overhaul Gasket & Seal Kit
<b>Ford -Cont'd</b>				
<b>Expedition -Cont'd</b>				
2006-1999		w/ 4R75W Transmission	MTKV-K5300K	MTK-132940
2003-1998		w/ 4R100 Transmission		MTK-73900B
1998-1997		w/ 4R70W Transmission		MTK-132940
<b>Explorer</b>				
2017-2012		w/ 6F35 Transmission		MTK-132935
2015-2012	2.0L L4	w/ 6F50 Transmission		MTK-132914
2013-2011	3.5L V6	w/ 6F55 Transmission		MTK-132914
2010-2009		w/ 5R55S Transmission		MTK-27900H
2010-2009	4.6L V8	w/ 6R80 Transmission	MTKV-K13201D	MTK-132922
2008-2004		w/ 5R55S Transmission	MTK-K2701F	MTK-27900H
2008-2006	4.6L V8	w/ 6R60 Transmission	MTKV-K13200D	MTK-132922
2005-2001	4.0L V6	RWD; w/ 5R55E Transmission		MTK-132931
2003-2002		w/ 5R55W Transmission	MTK-K2701F	MTK-27900H
2003-2001	4.0L V6	4WD; w/ 5R55E Transmission		MTK-28900D
2003-2001	4.0L V6	w/ 5R55E Transmission	MTKV-K2801C	
2001-1999	5.0L V8	w/ 4R70W Transmission	MTKV-K5300K	MTK-132940
2000-1997	4.0L V6	w/ 5R55E Transmission	MTKV-K2801C	MTK-28900D
1998-1996	5.0L V8	w/ 4R70W Transmission		MTK-132940
<b>Explorer Sport Trac</b>				
2010-2009		w/ 5R55S Transmission		MTK-27900H
2010-2007		w/ 6R80 Transmission	MTKV-K13201D	MTK-132922
2008-2007		w/ 5R55S Transmission	MTK-K2701F	MTK-27900H
2008-2007		w/ 6R60 Transmission	MTKV-K13200D	MTK-132922
2005-2001		w/ 5R55E Transmission	MTKV-K2801C	MTK-28900D
<b>F-Series</b>				
2017-2014		w/ 6R80 Transmission		MTK-132922
2017		w/ 10R80 Transmission		MTK-132941
2017-2014	6.2L V8	FLEX; w/ 6R140 Transmission		MTK-132939
2017-2014	6.7L V8	DIESEL; w/ 6R140 Transmission		MTK-132939
2016-2005		w/ 5R110W Transmission	MTKV-K3602C	MTK-36900B
2013-2009		w/ 6R80 Transmission	MTKV-K13201D	MTK-132922
2013-2011	6.2L V8	FLEX; w/ 6R140 Transmission	MTKV-K5900C	MTK-132939
2013-2011	6.7L V8	DIESEL; w/ 6R140 Transmission	MTKV-K5900A	MTK-132939
2010-2005		w/ 4R75W Transmission	MTKV-K5300K	MTK-132940
2010-1999		w/ 4R70W Transmission	MTKV-K5300K	MTK-132940
2004		w/ 4R100 Transmission; 1U2J-7153-HF		MTK-73900B
2004-2003		GAS; w/ 5R110W Transmission	MTKV-K3601D	MTK-36900B
2004-1999		w/ 4R100 Transmission; FOTZ-7153-A		MTK-132933
2004-2000	5.4L V8	w/ 4R100 Transmission; 1U2J-7153-HE		MTK-73900B
2004-2003	6.0L V8	DIESEL; w/ 5R110W Transmission	MTKV-K3601D	MTK-36900B
2003-2001	5.4L V8	w/ 4R100 Transmission		MTK-73900B
2000	5.4L V8	w/ 4R100 Transmission	MTKV-K7300D	MTK-73900B
1999	5.4L V8	w/ 4R100 Transmission; 1U2J-7153-HF		MTK-73900B
1999	5.4L V8	RWD; w/ 4R100 Transmission	MTKV-K7300D	MTK-73900B
1999	7.3L V8	w/ 4R100 Transmission; 1U2J-7153-HF		MTK-73900B
1999	7.3L V8	w/ 4R100 Transmission; 1U2J-7153-HE		MTK-73900B
1998-1997		w/ 4R70W Transmission		MTK-132940
1998	5.4L V8	4WD; w/ 4R100 Transmission		MTK-73900B
1998	5.4L V8	RWD; w/ 4R100 Transmission		MTK-73900B
1997	5.4L V8	RWD; w/ E4OD Transmission		MTK-73900B
1997	5.4L V8	4WD; w/ E4OD Transmission		MTK-73900B
1997-1996	5.8L V8	w/ E4OD Transmission		MTK-73900B
1997-1996	7.3L V8	w/ E4OD Transmission		MTK-73900B
1997-1996	7.5L V8	w/ E4OD Transmission		MTK-73900B
1996	4.9L L6	w/ E4OD Transmission		MTK-73900B



Year	Eng. Size	Qualifer	Master Overhaul Kit With Steel	Overhaul Gasket & Seal Kit
<b>Ford -Cont'd</b>				
<b>F-Series -Cont'd</b>				
1996	4.9L L6	Sold in United States; w/ E4OD Transmission		MTK-73900B
1996-1994	5.0L V8	w/ 4R70W Transmission		MTK-132940
1996	5.0L V8	w/ E4OD Transmission		MTK-73900B
<b>Flex</b>				
2017-2013	3.5L V6	w/ 6F50 Transmission		MTK-132914
2012-2010	3.5L V6	w/ 6F50 Transmission	MTKV-K5601A	MTK-132914
2009	3.5L V6	w/ 6F50 Transmission	MTKV-K11701A	MTK-132908
<b>Freestar</b>				
2007-2004		w/ AX4N Transmission	MTKV-K6700T	MTK-67900F
<b>Police Interceptor Utility</b>				
2017-2013		w/ 6F50 Transmission		MTK-132914
2013		w/ 6F35 Transmission		MTK-132935
<b>Ranger</b>				
2011-1997		5R44E	MTKV-K2801C	MTK-28900D
1995-1990		w/ A4LD Transmission		MTK-132931
<b>Transit Connect</b>				
2017-2014	2.5L L4	w/ 6F35 Transmission		MTK-132924
2016-2014	1.6L L4	w/ EcoBoost Engine		MTK-132935
2013-2010	2.0L L4	w/ 4F27E Transmission; w/ Clutch Pistons		MTK-46900C
2013-2010	2.0L L4	w/ 4F27E Transmission; w/o Clutch Pistons	MTKV-K4600D	MTK-132907
<b>Transit-150</b>				
2017-2015		w/ 6R80 Transmission		MTK-132922
<b>Transit-250</b>				
2017-2015		w/ 6R80 Transmission		MTK-132922
<b>Transit-350</b>				
2017-2015		w/ 6R80 Transmission		MTK-132922
<b>Transit-350 HD</b>				
2017-2015		w/ 6R80 Transmission		MTK-132922
<b>Lincoln</b>				
<b>Aviator</b>				
2005-2003		w/ 5R55S Transmission	MTK-K2701F	MTK-27900H
<b>Blackwood</b>				
2003-2002		w/ 4R100 Transmission; FOTZ-7153-A		MTK-132933
2003-2002	5.4L V8	w/ 4R100 Transmission; 1U2J-7153-HE		MTK-73900B
<b>MKC</b>				
2017-2015		w/ 6F35 Transmission		MTK-132935
<b>MKT</b>				
2017-2014		w/ 6F35 Transmission		MTK-132924
2017-2013		w/ 6F55 Transmission		MTK-132914
2013		w/ 6F35 Transmission		MTK-132935
2012-2010		w/ 6F50 Transmission	MTKV-K5601A	MTK-132914
<b>MKX</b>				
2017-2016		w/ 6F35 Transmission		MTK-132935
2017-2013	3.7L V6	w/ 6F50 Transmission		MTK-132914
2015-2014		w/ 6F35 Transmission		MTK-132924
2013-2012		w/ 6F35 Transmission		MTK-132935
2012-2010		w/ 6F50 Transmission	MTKV-K5601A	MTK-132914
2009-2007		w/ 6F50 Transmission	MTKV-K11701A	MTK-132908
<b>Mark LT</b>				
2008-2006		w/ 4R75W Transmission	MTKV-K5300K	MTK-132940
<b>Navigator</b>				
2017-2015	3.5L V6	w/ 6R80 Transmission		MTK-132922

# TRANSMISSION REPAIR KITS

## Light Trucks

### Lincoln / Mazda / Mercury



FORD PARTS

Year	Eng. Size	Qualifer	Master Overhaul Kit With Steel	Overhaul Gasket & Seal Kit
<b>Lincoln -Cont'd</b>				
<b>Navigator -Cont'd</b>				
2014	5.4L V8	w/ 6R80 Transmission		MTK-132922
2013-2009	5.4L V8	w/ 6R80 Transmission	MTKV-K13201D	MTK-132922
2004-1998		w/ 4R100 Transmission; 1U2J-7153-HE		MTK-73900B
2004-2003		w/ 4R100 Transmission; FOTZ-7153-A		MTK-132933
1998		w/ E4OD Transmission; 1U2J-7153-HE		MTK-73900B
<b>Mazda</b>				
<b>B2300</b>				
2008-2004		w/ 5R55E Transmission	MTKV-K2801C	MTK-28900D
2003-2001		w/ 5R44E Transmission	MTKV-K2801C	MTK-28900D
1997		w/ 4R44E Transmission	MTKV-K2801C	MTK-28900D
<b>B2500</b>				
2000-1998		w/ 4R44E Transmission	MTKV-K2801C	MTK-28900D
<b>B3000</b>				
2007-2001		w/ 5R55E Transmission	MTKV-K2801C	MTK-28900D
2000-1997		w/ 4R44E Transmission	MTKV-K2801C	MTK-28900D
<b>B4000</b>				
2008-1997		w/ 5R55E Transmission	MTKV-K2801C	MTK-28900D
<b>Tribute</b>				
2008-2001		w/ CD4E Transmission	MTKV-K5800H	MTK-85900D
<b>Mercury</b>				
<b>Mariner</b>				
2011-2009		w/ 6F35 Transmission		MTK-132924
2008-2005		w/ CD4E Transmission	MTKV-K5800H	
2008-2005		w/ CD4E Transmission; 3U2J-7153-AC		MTK-85900D
2008-2005		w/ CD4E Transmission; F7RZ-7153-AA		MTK-132932
<b>Monterey</b>				
2007-2004		w/ AX4N Transmission	MTKV-K6700T	MTK-67900F
<b>Mountaineer</b>				
2010-2008		w/ 5R55S Transmission		MTK-27900H
2010-2009		w/ 6R80 Transmission	MTKV-K13201D	MTK-132922
2008-2006	4.6L V8	w/ 6R60 Transmission	MTKV-K13200D	MTK-132922
2007-2005		w/ 5R55S Transmission	MTK-K2701F	MTK-27900H
2004	4.0L V6	w/ 5R55S Transmission	MTK-K2701F	MTK-27900H
2004	4.6L V8	w/ 5R55S Transmission	MTK-K2701F	MTK-27900H
2003-2002		w/ 5R55W Transmission	MTK-K2701F	MTK-27900H
2001-1998	4.0L V6	w/ 5R55E Transmission	MTKV-K2801C	MTK-28900D
2001-1999	5.0L V8	w/ 4R70W Transmission	MTKV-K5300K	MTK-132940
1998-1997	5.0L V8	w/ 4R70W Transmission		MTK-132940





Year	Eng. Size	Qualifer	Master Overhaul Kit With Steel	Overhaul Gasket & Seal Kit
<b>Ford</b>				
<b>Econoline</b>				
2017-2005		w/ 5R110W Transmission	MTKV-K3602C	MTK-36900B
2016		w/ 4R75W Transmission	MTKV-K5300K	
2015-2005		w/ 4R70W Transmission	MTKV-K5300K	
2014		w/ 4R75W Transmission		MTK-132940
2006		w/ 4R75E Transmission		MTK-132940
2005-2000		w/ 4R100 Transmission		MTK-73900B
2004-2003		w/ 4R70W Transmission	MTKV-K5300K	MTK-132940
2004		w/ 5R110W Transmission	MTKV-K3601D	MTK-36900B
1998	5.4L V8	w/ 4R100 Transmission; w/ 4.10 Axle; ESD	MTKV-K7300D	
1998	6.8L V10	w/ 4R100 Transmission; w/o 4.10 Axle		MTK-73900B
1998	6.8L V10	w/ 4R100 Transmission; w/o 4.10 Axle; ESD	MTKV-K7300D	
1998	7.3L V8	w/ 4R100 Transmission; w/ 4.10 Axle		MTK-73900B
1998	7.3L V8	w/ 4R100 Transmission; w/ 3.55 Axle		MTK-73900B
1997		w/ 4R70W Transmission	MTKV-K5300K	
<b>F-Series</b>				
2017-2014	6.7L V8	DIESEL; w/ 6R140 Transmission		MTK-132939
2016-2005		w/ 5R110W Transmission	MTKV-K3602C	MTK-36900B
2013-2011	6.7L V8	DIESEL; w/ 6R140 Transmission	MTKV-K5900A	MTK-132939
2004		w/ 4R100 Transmission; 1U2J-7153-HF		MTK-73900B
2004-2003		GAS; w/ 5R110W Transmission	MTKV-K3601D	MTK-36900B
2004-1999		w/ 4R100 Transmission; FOTZ-7153-A		MTK-132933
2004-2003	6.0L V8	DIESEL; w/ 5R110W Transmission	MTKV-K3601D	MTK-36900B
1999	7.3L V8	w/ 4R100 Transmission; 1U2J-7153-HF		MTK-73900B
<b>F53</b>				
2017-2011	6.8L V10	w/ 5R110W Transmission		MTK-36900B
2017-2016	6.8L V10	w/ 6R140 Transmission		MTK-132939
2009-2006	6.8L V10	w/ 5R110W Transmission		MTK-36900B
2004-2000		Motor Home - Stripped Chassis; w/ 4R100 Transmission		MTK-132933
<b>F59</b>				
2017-2011	6.8L V10	w/ 5R110W Transmission		MTK-36900B
<b>F650</b>				
2017-2016	6.8L V10	w/ 6R140 Transmission		MTK-132939
2012-2004		4C4O-7153-FA		MTK-132903
2012-2004		4C4O-7153-CA		MTK-85903
<b>F750</b>				
2017-2004		4 X 2		MTK-85901
2017-2002		0HQ5X; 0HQ26		MTK-85902
2012-2004		4C4O-7153-FA		MTK-132903
2012-2004		4C4O-7153-CA		MTK-85903

# CROSS REFERENCE Transmissions



FORD PARTS

Engineering Number	Service Number	Engineering Number	Service Number	Engineering Number	Service Number	Engineering Number	Service Number
1C3P-7000-BA, BB, BC	1C3Z-7V000-BRIM	1L3P-7000-CC	1L3Z-7V000-CRIM	3S4P-7000-AA	3S4Z-7000-AARM	5C2P-7000-BA	5C2Z-7000-BRIM
1C3P-7000-BB	1C3Z-7V000-BRIM	1L3P-7000-DA	1L3Z-7V000-DRM	3W1P-7000-AA, CA	3W1Z-7V000-ARM	5C2P-7000-CA	5C2Z-7000-CRIM
1C3P-7000-CA	1C3Z-7V000-CRIM	1L3P-7000-FA	1L3Z-7V000-FRIM	3W1P-7000-BA	3W1Z-7V000-BRIM	5C2P-7000-DA	5C2Z-7000-DRIM
1C3P-7000-CB	1C3Z-7V000-CRIM	1L3P-7000-HA	1L3Z-7V000-HRIM	3W1P-7000-DA	3W1Z-7V000-DRIM	5C2P-7000-EA	5C2Z-7000-ERIM
1C3P-7000-CC	1C3Z-7V000-CRIM	1L3P-7000-JA	1L3Z-7V000-JRIM	3W4P-7000-AC	3W4Z-7V000-ACRIM	5C32P-7000-DB	5C3Z-7000-VRIM
1C3P-7000-DA	1C3Z-7V000-DRIM	1L3P-7000-LA	1L3Z-7V000-LRIM	3W4P-7000-BC	3W4Z-7V000-BCRIM	5C3P-7000-AB	5C2Z-7000-TRIM
1C3P-7000-DA, DB, DC	1C3Z-7V000-DRIM	1L5P-7000-AA	1L5Z-7V000-ARM	3W7P-7000-AA, BA	3W7Z-7V000-ARM	5C3P-7000-AB	5C3Z-7000-ARM
1C3P-7000-DB	1C3Z-7V000-DRIM	1L5P-7000-DA, FA	1L5Z-7000-DARM	3W7P-7000-BA	3W7Z-7V000-ARM	5C3P-7000-BB	5C2Z-7000-URIM
1C3P-7000-EA	1C3Z-7V000-ERM	1L5P-7000-DA, FA	1L5Z-7V000-DRM	3W7P-7000-CA, EA	3W7Z-7V000-CRIM	5C3P-7000-BB	5C3Z-7000-BRIM
1C3P-7000-EA	6U2Z-7V000-ERM	1L5P-7000-EA	1L5Z-7000-EARM	3W7P-7000-DA	3W7Z-7V000-DRIM	5C3P-7000-CB	5C3Z-7000-CRIM
1C3P-7000-EA, EB	1C3Z-7V000-ERM	1L5P-7000-EA	1L5Z-7V000-ERM	4C2P-7000-AA	4C2Z-7000-AARM	5C3P-7000-DB	5C3Z-7000-DRIM
1C3P-7000-EA, EB	6U2Z-7V000-ERM	1L7P-7000-AA, AB, AC, AD	3L7Z-7V000-ARM	4C2P-7000-BA	4C2Z-7000-BARM	5C3P-7000-FB	5C3Z-7000-FRIM
1C3P-7000-EA, EB	6U2Z-7V000-FRIM	1L7P-7000-BA, BB, BC	3L7Z-7V000-BRIM	4C2P-7000-CA	4C2Z-7000-CARM	5C3P-7000-JB	5C2Z-7000-RRIM
1C3P-7000-FA	1C3Z-7V000-FRIM	1R3P-7000-AA	1R3Z-7V000-AARM	4C2P-7000-DA	4C2Z-7000-DARM	5C3P-7000-JB	5C3Z-7000-JRIM
1C3P-7000-FA	6U2Z-7V000-FRIM	1R3P-7000-AA	1R3Z-7V000-ARM	4C2P-7000-EA	4C2Z-7000-EARM	5C3P-7000-KB	5C2Z-7000-SRIM
1C3P-7000-FA, FB	1C3Z-7V000-FRIM	1R3P-7000-BA	1R3Z-7000-BARM	4C2P-7000-EA	4C2Z-7000-HARM	5C3P-7000-KB	5C3Z-7000-KRIM
1C3P-7000-FA, FB	6U2Z-7V000-FRIM	1R3P-7000-BA	1R3Z-7V000-BRIM	4C2P-7000-FA	4C2Z-7000-FARM	5C3P-7000-LB	5C3Z-7000-LRIM
1C3P-7000-HA	1C3Z-7V000-CRIM	1S4P-7000-CA	1S4Z-7V000-CRIM	4C2P-7000-GA	4C2Z-7000-GARM	5C3P-7000-MB	5C3Z-7000-MRIM
1C3P-7000-HB	1C3Z-7V000-HRIM	1S4P-7000-DA	1S4Z-7V000-DRIM	4C2P-7000-HA	4C2Z-7000-HARM	5C3P-7000-NC	5C3Z-7000-NRIM
1C3P-7000-HC	1C3Z-7V000-HRIM	1S8P-7000-AA	1S8Z-7V000-ARM	4C2P-7000-JA	4C2Z-7000-JARM	5F1B-7000-FA	4F1Z-7000-FBRIM
1C3P-7000-JA	1C3Z-7V000-JRIM	1W7P-7000-AA, BA	1W7Z-7V000-ARM	4C2P-7000-PA	4C2Z-7000-PARM	5F2P-7000-AA, AB, AC	5F2Z-7000-ARM
1C3P-7000-JB	1C3Z-7V000-CRIM	1W7P-7000-AA	1W7Z-7V000-CRIM	4C3P-7000-BA	4C3Z-7000-RARM	5F2P-7000-BA, BB, BC	5F2Z-7000-BRIM
1C3P-7000-JC	1C3Z-7V000-JRIM	2L1P-7000-CA	2L1Z-7V000-CRIM	4C3P-7000-JB	4C3Z-7000-JBRIM	5F93-7000- CU, CV, GB, GC	6F9Z-7000-ARM
1C3P-7000-KA	1C3Z-7V000-KRIM	2L1P-7000-DA	2L1Z-7V000-DRIM	4C3P-7000-KB	4C2Z-7000-SARM	5F93-7000-DX, DY, FB, FC	6F9Z-7000-BRIM
1C3P-7000-KB	1C3Z-7V000-KRIM	2L1P-7000-EA	2L1Z-7V000-ERM	4C3P-7000-KB	4C3Z-7000-KBRIM	5G13-7000-	6G1Z-7000-ARM
1C3P-7000-KC	1C3Z-7V000-FRIM	2L1P-7000-FA	2L1Z-7V000-FRIM	4F1P-7000-CA/CB	4F1Z-7000-CBRIM	5G13-7000-BX, BY, EB, EC	6G1Z-7000-BRIM
1C3P-7000-LA	1C3Z-7V000-LRIM	2L2P-7000-AA	2L2Z-7V000-AARM	4F1P-7000-DA/DB	4F1Z-7000-DBRIM	5G13-7000-CT, CU, CV	6G1Z-7000-CDRIM
1C3P-7000-LA	7U2Z-7V000-ARM	2L2P-7000-BA	2L2Z-7V000-BARM	4F1P-7000-EA/EB	4F1Z-7000-EBRIM	5L1P-7000-EA	5L1Z-7000-ERM
1C3P-7000-LA/LB	7U2Z-7V000-ARM	2L2P-7000-CA	2L2Z-7V000-CARM	4F1P-7000-FA/FB	4F1Z-7000-FBRIM	5L1P-7000-FA	5L1Z-7000-FRIM
1C3P-7000-LB	1C3Z-7V000-LRIM	2L2P-7000-DA	2L2Z-7V000-DARM	4F2P-7000-AA, AB	4F2Z-7000-ABRIM	5L3P-7000-AA	5L3Z-7000-ARM
1C3P-7000-LB	7U2Z-7V000-ARM	2L5P-7000-AB	2L5Z-7V000-ABRIM	4F2P-7000-BA	4F2Z-7000-BARM	4F2Z-7000-BARM	5L3Z-7000-ARM
1C3P-7000-MA	1C3Z-7V000-MRIM	2L5P-7000-BB	2L5Z-7000-BBRIM	4L1P-7000-AA	4L1Z-7000-AARM	4L1Z-7000-AARM	5L3Z-7000-BRIM
1C3P-7000-MA	7U2Z-7V000-BRIM	2L8P-7000-EA, EB	2L8Z-7V000-EBRIM	4L1P-7000-BA	4L1Z-7000-BARM	4L1Z-7000-BARM	5L3Z-7000-CRIM
1C3P-7000-MA/MB	7U2Z-7V000-BRIM	2L8P-7000-FA, FB	2L8Z-7V000-FBRIM	4L1P-7000-CA	4L1Z-7000-CARM	4L1Z-7000-CARM	5L3Z-7000-DRIM
1C3P-7000-MB	1C3Z-7V000-MRIM	2S8P-7000-AA	2S8Z-7V000-ABRIM	4L1P-7000-DA	4L1Z-7000-DARM	4L1Z-7000-DARM	5L3Z-7000-ERM
1C3P-7000-MB	7U2Z-7V000-BRIM	2W3P-7000-AA	2W3Z-7V000-ARM	4L2P-7000-AB	4L2Z-7000-ABRIM	4L2Z-7000-ABRIM	5L5Z-7000-ARM
1C3P-7000-NA, NB, NC	1C3Z-7V000-NRIM	2W4P-7000-AA	2W4Z-7V000-AARM	4L2P-7000-BB	4L2Z-7000-BBRIM	4L2Z-7000-BBRIM	5L5Z-7000-CRIM
1C3P-7000-PA, PB, PC	1C3Z-7V000-PRIM	2W4P-7000-BA	2W4Z-7V000-BARM	4L2P-7000-CC	4L2Z-7000-CCRIM	4L2Z-7000-CCRIM	5L5Z-7000-DRIM
1F1P-7000-AA	1F1Z-7V000-ARM	3C2P-7000-AA	3C2Z-7V000-ARM	4L2P-7000-DC	4L2Z-7000-DCRIM	4L2Z-7000-DCRIM	5L5P-7000-DB, DC
1F1P-7000-AB	1F1Z-7V000-CRIM	3C3P-7000-EH	3C3Z-7000-EJRM	4L2P-7000-EC	4L2Z-7000-ECRIM	4L2Z-7000-ECRIM	5L74-7000-AE
1F1P-7000-DB	1F1Z-7V000-DRIM	3C3P-7000-EJ	3C3Z-7000-EJRM	4L2P-7000-FC	4L2Z-7000-FCRM	4L2Z-7000-FCRM	5L74-7000-BE
1F1P-7000-EB	1F1Z-7V000-ERM	3C3P-7000-GB, GH, GK	4C3Z-7000-KBRIM	4L3P-7000-AA	4L3Z-7000-AARM	4L3Z-7000-AARM	5L8P-7000-AC, AD, AE
1F1P-7000-FB	1F1Z-7V000-FRIM	3C3P-7000-HG	3C3Z-7V000-HGRIM	4L3P-7000-BA	4L3Z-7000-BARM	4L3Z-7000-BARM	5L8P-7000-BC, BD, BE
1F1P-7000-GA	1F1Z-7V000-GRIM	3C3P-7000-JF	3C3Z-7V000-JGRIM	4L3P-7000-CA	4L3Z-7000-CARM	4L3Z-7000-CARM	5L8P-7000-BC, CC, CD
1F2P-7000-CC	1F2Z-7V000-CRIM	3C3P-7000-JG	3C3Z-7V000-JGRIM	4L3P-7000-DA	4L3Z-7000-DARM	4L3Z-7000-DARM	5L8P-7000-DB, DC, DD
1F3P-7000-AB	1F3Z-7V000-ARM	3L2P-7000-EB, EE	3L2Z-7V000-EERM	4L5P-7000-AA	4L5Z-7000-AARM	4L5Z-7000-AARM	5L8P-7000-DB, DC, DD
1F3P-7000-AC	1F3Z-7V000-CRIM	3L2P-7000-FB, FE	3L2Z-7V000-FERM	4L5P-7000-BA	4L5Z-7000-BARM	4L5Z-7000-BARM	5L8P-7000-EA, EB
1F3P-7000-BB	1F3Z-7V000-BRIM	3L3P-7000-HA	3L3Z-7000-HARM	4L5P-7000-CA	4L5Z-7000-CARM	4L5Z-7000-CARM	5L8P-7000-FA, FB
1F3P-7000-BC	1F3Z-7V000-DRIM	3L3P-7000-JA	3L3Z-7000-JARM	4L5P-7000-DA	4L5Z-7000-DARM	4L5Z-7000-DARM	5L8P-7000-GA, GB
1L1P-7000-AA, AB, AC	1C3Z-7V000-NRIM	3L3P-7000-LA	3L3Z-7000-LARM	4L5P-7000-EA	4L5Z-7000-EARM	4L5Z-7000-EARM	5L8P-7000-HA, HB
1L2P-7000-AE	1L2Z-7V000-ARM	3L3P-7000-MA	3L3Z-7000-MARM	4R3P-7000-AC	4R3Z-7000-ARM	4R3Z-7000-ARM	5L8P-7000-JA
1L2P-7000-BE	1L2Z-7V000-BRIM	3L7P-7000-AA	3L7Z-7V000-ARM	4R3P-7000-BC	4R3Z-7000-BRIM	4R3Z-7000-BRIM	5L8P-7000-KA
1L2P-7000-CE	1L2Z-7V000-CRIM	3L7P-7000-BA	3L7Z-7V000-BRIM	4S4P-7000-FA	4S4Z-7000-FARM	4S4Z-7000-FARM	5M64-7000-DF
1L2P-7000-DE	1L2Z-7V000-DRIM	3L8P-7000-GA	3L8Z-7000-GARM	4W1P-7000-AA	4W1Z-7000-AARM	4W1Z-7000-AARM	5S4P-7000-FA
1L3P-7000-AA	1C3Z-7V000-ARM	3L8P-7000-GD	3L8Z-7000-GDRM	4W1P-7000-DA, FA	4W1Z-7000-DARM	4W1Z-7000-DARM	5W1P-7000- AA, CA, GA, JA
1L3P-7000-AB	1C3Z-7V000-ARM	3L8P-7000-HA	3L8Z-7000-HARM	4W4P-7000-AB	4W4Z-7000-ABRIM	4W4Z-7000-ABRIM	5W1P-7000-DA, HA
1L3P-7000-AC	1C3Z-7V000-ARM	3L8P-7000-HB, HC	3L8Z-7V000-HCRIM	4W4P-7000-BB	4W4Z-7000-BBRIM	4W4Z-7000-BBRIM	5W7P-7000- AA, BA, GA, KA
1L3P-7000-BA, BB, BC	1C3Z-7V000-BRIM	3L8P-7000-HD	3L8Z-7000-HDRM	4W7P-7000-AA, BA	4W7Z-7000-AARM	4W7Z-7000-AARM	5W7P-7000- AA, BA, GA, KA
1L3P-7000-BB	1C3Z-7V000-BRIM	3R3P-7000-AA	3R3Z-7V000-ARM	4W7P-7000-CA, EA	4W7Z-7000-CARM	4W7Z-7000-CARM	5W7P-7000- CA, EA, HA, LA
1L3P-7000-BC	1C3Z-7V000-BRIM	3R3P-7000-BA	3R3Z-7000-BARM	4W7P-7000-DA, FA	4W7Z-7000-DARM	4W7Z-7000-DARM	5W7P-7000-DA, MA
1L3P-7000-CA, CB	1L3Z-7V000-CRIM	3R3P-7000-CA	3R3Z-7000-CARM	5C2P-7000-AA	5C2Z-7000-ARM	5C2Z-7000-ARM	5W7P-7000-GA
							5W7P-7000-KA



Engineering Number	Service Number	Engineering Number	Service Number	Engineering Number	Service Number	Engineering Number	Service Number
6C2P-7000-AA	6C2Z-7000-ARM	6L8P-7000-AA	5L8Z-7000-ERM	7L8P-7000-BA	5L8Z-7000-FRM	8M5P-7000-AA	8M5Z-7000-A
6C2P-7000-BA	6C2Z-7000-BRM	6L8P-7000-BA	5L8Z-7000-FRM	7L8P-7000-CA	5L8Z-7000-GRM	8M5P-7000-AA	8M5Z-7000-ARM
6C2P-7000-CA	6C2Z-7000-CRM	6L8P-7000-CA	5L8Z-7000-GRM	7L8P-7000-DA	5L8Z-7000-HRM	8M64-7000-AH	8M6Z-7000-D
6C2P-7000-DA	6C2Z-7000-DRM	6L8P-7000-DA	5L8Z-7000-HRM	7M64-7000-AD	7M6Z-7000-A	8R3P-7000-AA	8R3Z-7000-ARM
6C3P-7000-AA	5C2Z-7000-TRM	6R3P-7000-AB,AC	4R3Z-7000-ARM	7R3P-7000-BC	7R3Z-7000-BRM	8S4P-7000-FA	8S4Z-7000-ARM
6C3P-7000-AA	5C3Z-7000-ARM	6S4P-7000-FA	6S4Z-7000-FRM	7T4P-7000-AA, AB, AC	8T4Z-7000-ARM	90GT-7000-TAA, TBA	90GZ-7V000-TAARM
6C3P-7000-AB	5C2Z-7000-TRM	6W1P-7000-AA,AB,CA,CB	6W1Z-7000-ARM	7T4P-7000-BA,BB,BC	7T4Z-7000-ARM	95GT-7000-BAA,KAA	F57Z-7V000-KARM
6C3P-7000-AB	5C3Z-7000-ARM	6W1P-7000-DA,DB	6W1Z-7000-DRM	7T4P-7000-CA,CB,CC	7T4Z-7000-BRM	96GT-7000-EBA,GAA	F68Z-7V000-EBRM
6C3P-7000-BA	5C2Z-7000-URM	6W4P-7000-AB, AC	4W4Z-7000-ABRM	7T4P-7000-CC	7T4Z-7000-BRM	97GT-7000-ACA,AEA	F77Z-7V000-AARM
6C3P-7000-BA	5C3Z-7000-BRM	6W7P-7000-AA,AB,BA,BB	6W7Z-7000-ARM	7T4P-7000-DA, DB, DC	8T4Z-7000-BRM	98GT-7000-AAA	F87Z-7V000-CARM
6C3P-7000-BB	5C2Z-7000-URM	6W7P-7000-AB	6W7Z-7000-ARM	7W1P-7000-AA	7W1Z-7000-AARM	98GT-7000-BAA	F87Z-7V000-DARM
6C3P-7000-BB	5C3Z-7000-BRM	6W7P-7000-BB	6W7Z-7000-ARM	7W1P-7000-DA	7W1Z-7000-DARM	98GT-7000-LAA,LBA	F87Z-7V000-LARM
6C3P-7000-DA	5C2Z-7000-VRM	6W7P-7000-CA,CB,EA,EB	6W7Z-7000-ARM	7W7P-7000-AA	7W7Z-7000-AARM	9C2P-7000-AB	9C2Z-7000-ARM
6C3P-7000-DA	5C3Z-7000-DRM	6W7P-7000-DA, DB	6W7Z-7000-DRM	7W7P-7000-CA	7W7Z-7000-CARM	9C2P-7000-BB	9C2Z-7000-BRM
6C3P-7000-DB	5C2Z-7000-VRM	7A1P-7000-BA,BB,BC	7A1Z-7000-ARM	7W7P-7000-DA	7W7Z-7000-DARM	9C2P-7000-CA,CB	9C2Z-7000-CRM
6C3P-7000-DB	5C3Z-7000-DRM	7A1P-7000-BC	7A1Z-7000-ARM	87GT-7000-ABA	90GZ-7V000-TAARM	9C2P-7000-DA,DB	9C2Z-7000-DRM
6C3P-7000-DC	5C2Z-7000-VRM	7C2P-7000-AB	7C2Z-7000-ARM	89GT-7000-RAA, SAA	90GZ-7V000-TAARM	9C2P-7000-EB	9C2Z-7000-ERM
6C3P-7000-DC	5C3Z-7000-URM	7C2P-7000-BB	7C2Z-7000-BRM	8A8P-7000-MB,MC	8A8Z-7000-FRM	9C2P-7000-EB	9C2Z-7000-GRM
6C3P-7000-DD	7C3Z-7000-HRM	7C2P-7000-CA	7C2Z-7000-CRM	8C2P-7000-AD	8C2Z-7000-ARM	9C2P-7000-EB	9C2Z-7000-JRM
6C3P-7000-FA	5C3Z-7000-FRM	7C2P-7000-DA	7C2Z-7000-DARM	8C2P-7000-BD	8C2Z-7000-BRM	9C2P-7000-EB	9C3Z-7000-HRM
6C3P-7000-FB	5C3Z-7000-FRM	7C3P-7000-AC	7C3Z-7000-ARM	8C2P-7000-CB	8C2Z-7000-CRM	9C2P-7000-FB	9C2Z-7000-FRM
6C3P-7000-JA	5C2Z-7000-RRM	7C3P-7000-BC	7C3Z-7000-BRM	8C2P-7000-DB	8C2Z-7000-DRM	9C3P-7000-BC	9C3Z-7000-BRM
6C3P-7000-JA	5C3Z-7000-JRM	7C3P-7000-CC	7C3Z-7000-CRM	8C3P-7000-AD	8C3Z-7000-ARM	9C3P-7000-CC	9C3Z-7000-CRM
6C3P-7000-JB	5C2Z-7000-RRM	7C3P-7000-DC	7C3Z-7000-DRM	8C3P-7000-BD	8C3Z-7000-BRM	9C3P-7000-DC	9C3Z-7000-DRM
6C3P-7000-JB	5C3Z-7000-JRM	7C3P-7000-EC	7C3Z-7000-ERM	8C3P-7000-CD	8C3Z-7000-CRM	9C3P-7000-FB	9C2Z-7000-HRM
6C3P-7000-KA	5C2Z-7000-SRM	7C3P-7000-FC	7C3Z-7000-FRM	8C3P-7000-DD	8C3Z-7000-DRM	9C3P-7000-FB	9C3Z-7000-FRM
6C3P-7000-KA	5C3Z-7000-KRM	7C3P-7000-GC	7C3Z-7000-GRM	8C3P-7000-ED	8C3Z-7000-ERM	9C3P-7000-HB	9C2Z-7000-KRM
6C3P-7000-KB	5C2Z-7000-SRM	7C3P-7000-HC	7C3Z-7000-HRM	8C3P-7000-FD	8C2Z-7000-FRM	9C3P-7000-HB	9C3Z-7000-GRM
6C3P-7000-KB	5C3Z-7000-KRM	7C3P-7000-KC	7C3Z-7000-KRM	8C3P-7000-FD	8C3Z-7000-FRM	9C3P-7000-KB	9C3Z-7000-JRM
6C3P-7000-KC	5C2Z-7000-SRM	7E51-7000-AA,AB,AC,AF	7E5Z-7000-BRM	8C3P-7000-GD	8C3Z-7000-GRM	9E58-7000-DB	9E5Z-7000-N
6C3P-7000-KC	5C3Z-7000-KRM	7E5P-7000-AD	7E5Z-7000-AERM	8C3P-7000-HD	8C2Z-7000-HRM	9E5P-7000-CB	9E5Z-7000-D
6C3P-7000-LA	5C3Z-7000-LRM	7E5P-7000-AE	7E5Z-7000-AERM	8C3P-7000-HD	8C3Z-7000-HRM	9E5P-7000-DB	9E5Z-7000-E
6C3P-7000-LB	5C3Z-7000-LRM	7E5P-7000-AE	7E5Z-7000-BFRM	8C3P-7000-KD	8C3Z-7000-JRM	9E5P-7000-JA	AE5Z-7000-ARM
6C3P-7000-MA	5C3Z-7000-MRM	7E5P-7000-BE,BF	7E5Z-7000-CFRM	8E51-7000-AA,AB,AC,AD,AE,AF	7E5Z-7000-BRM	9E5P-7000-KA	9E5Z-7000-C
6C3P-7000-MB	5C3Z-7000-MRM	7E5P-7000-CE,CF	7E5Z-7000-DGRM	8E5P-7000-AA	8E5Z-7000-ARM	9E5P-7000-KA	AE5Z-7000-BRM
6C3P-7000-MC	5C3Z-7000-MRM	7E5P-7000-DF,DG	7E5Z-7000-AARM	8E5P-7000-AB,AB,AC	8E5Z-7000-ARM	9E5P-7000-MA	AE5Z-7000-CRM
6E51-7000-AA,AC	7E5Z-7000-BRM	7E7P-7000-AA	7E7Z-7000-AARM	8E5P-7000-AC	8E5Z-7000-ARM	9E9P-7000-FA	9E9Z-7000-ARM
6E53-7000-AA,AB,AC,AD,AE	6E5Z-7000-AERM	7E7P-7000-BA	7E7Z-7000-BARM	8E5P-7000-BA, BB, BC	8E5Z-7000-BRM	9E9P-7000-KA	9E9Z-7000-BRM
6E53-7000-AD,AE	6E5Z-7000-AERM	7G13-7000-EA	6G1Z-7000-BRM	8E5P-7000-BB	8E5Z-7000-BRM	9L2P-7000-AB,AE,AG,EA,EB	9L2Z-7000-CARM
6F93-7000-AA,AB,FB,FC	6F9Z-7000-ARM	7L1P-7000-AD,AE,AF,CA,CB	7L1Z-7000-ARM	8E5P-7000-BC	8E5Z-7000-BRM	9L2P-7000-BB,BE,BG,FA,FB	9L2Z-7000-DARM
6F93-7000-BA,BB,GB,GC	6F9Z-7000-BRM	7L1P-7000-BD,BE,BF,DA,DB	7L1Z-7000-BRM	8E5P-7000-CB,CC,CD	8E5Z-7000-CRM	9L2P-7000-CA	9L2Z-7000-CRM
6G13-7000-CB,CD	6G1Z-7000-CDRM	7L2P-7000-AC,AD,AE,EB	7L2Z-7000-ARM	8E5P-7000-DB,DC,DD	8E5Z-7000-DRM	9L2P-7000-DA	9L2Z-7000-DRM
6G13-7000-DA,DB,HB,HC	6G1Z-7000-ARM	7L2P-7000-AC, AD, AE, EB	7L2Z-7000-ARM	8E7P-7000-AB	8E7Z-7000-AARM	9L2P-7000-EB	9L2Z-7000-CARM
6G13-7000-EA,EB,JB,JC	6G1Z-7000-BRM	7L2P-7000-AC,AD,AE,EB	7L2Z-7000-ARM	8E7P-7000-BB	8E7Z-7000-BARM	9L3P-7000-DB	9L3Z-7000-DRM
6L1P-7000-AA,AB	6L1Z-7000-ARM	7L2P-7000-BC,BD,BE,	7L2Z-7000-BRM	8L1P-7000-CB, CC	8L1Z-7000-CRM	9L3P-7000-AD/AE/AF/AG/AH/NA/NB	9L3Z-7000-EARM
6L1P-7000-BA,BB	6L1Z-7000-BRM	7L2P-7000-CA,CB	7L2Z-7000-CRM	8L1P-7000-DB, DC	8L1Z-7000-DRM	9L3P-7000-AF,AG,AH,NA,NB	9L3Z-7000-EARM
6L2P-7000-AD,AG,AH,AK,AL,AM,AN,AP	6L2Z-7000-ARM	7L2P-7000-DA,DB	7L2Z-7000-DRM	8L2P-7000-AA	7L2Z-7000-ARM	9L3P-7000-AG/AH/NA/NB	9L3Z-7000-FARM
6L2P-7000-BG,BH,BK,BL	6L2Z-7000-BRM	7L3P-7000-AA,AB	7L3Z-7000-ABRM	8L2P-7000-BA	7L2Z-7000-BRM	9L3P-7000-BA,BD/BE/BF/BG/BH/BJ/PA/PB	9L3Z-7000-FARM
6L2P-7000-BG,BH,BK,BL,BM,BN,BP	6L2Z-7000-BRM	7L3P-7000-BA,BB	7L3Z-7000-BBRM	8L2P-7000-HB/HC	8L2Z-7000-FRM	9L3P-7000-BF,BG	9L1Z-7000-BRM
6L2P-7000-BM,BN,BP	6L2Z-7000-BRM	7L3P-7000-CA,CB	7L3Z-7000-CBRM	8L2P-7000-JA	8L2Z-7000-ARM	9L3P-7000-CA/CB	9L3Z-7000-CRM
6L2P-7000-EB,EC	4L2Z-7000-ABRM	7L3P-7000-DA,DB	7L3Z-7000-DBRM	8L2P-7000-KA	8L2Z-7000-ARM	9L3P-7000-DA	9L3Z-7000-DRM
6L2P-7000-FB, FC	6L2Z-7000-FRM	7L3P-7000-EA,EB	7L3Z-7000-EBRM	8L5P-7000-AA	7L5Z-7000-ARM	9L3P-7000-DA	9L3Z-7000-CARM
6L3P-7000-AA,AB	6L3Z-7000-FRM	7L5P-7000-AA,AB,BA,BB	7L5Z-7000-ARM	8L5P-7000-BA	7L5Z-7000-BRM	9L3P-7000-LB/LD/LE/LF/LG/RB	9L3Z-7000-DARM
6L3P-7000-BA, BB	6L3Z-7000-GRM	7L5P-7000-CA,CB	7L5Z-7000-CRM	8L5P-7000-CA	7L5Z-7000-CRM	9L3P-7000-MD/ME/MF/MG/SB	7L5Z-7000-CRM
6L3P-7000-CA, CB	6L3Z-7000-HRM	7L5P-7000-DA,DB	7L5Z-7000-DRM	8L5P-7000-DA	7L5Z-7000-DRM	9L3P-7000-7000-CA	7L5Z-7000-CRM
6L3P-7000-DA	6L3Z-7000-DRM	7L5P-7000-EA,EB	7L5Z-7000-ERM	8L5P-7000-EA	7L5Z-7000-ERM	9L5P-7000-DA	7L5Z-7000-DRM
6L3P-7000-DA, DB	6L3Z-7000-JRM	7L7Z-7000-AC	DL7Z-7000-ERM	8L8P-7000-AA	8L8Z-7000-ARM	9L5P-7000-EA	7L5Z-7000-ERM
6L3P-7000-EA	6L3Z-7000-ERM	7L7Z-7000-BD	DL7Z-7000-FRM	8L8P-7000-BA	8L8Z-7000-BRM	9L8P-7000-EA	9L8Z-7000-ARM
6L3P-7000-EA, EB	6L3Z-7000-KRM	7L8P-7000-AA	5L8Z-7000-ERM	8L8P-7000-CA	8L8Z-7000-CRM	9L8P-7000-FA	9L8Z-7000-BRM
				8L8P-7000-DA	8L8Z-7000-DRM	9L8P-7000-GA	9L8Z-7000-CRM
						9L8P-7000-HA	9L8Z-7000-DRM

# CROSS REFERENCE Transmissions



FORD PARTS

Engineering Number	Service Number	Engineering Number	Service Number	Engineering Number	Service Number	Engineering Number	Service Number
9R3P-7000-AA	9R3Z-7000-ARM	AW1P-7000-DA	AW1Z-7000-DRM	BU9P-7000-AA	BU9Z-7000-A	DA8P-7000-LA	DA8Z-7000-E
9R3P-7000-BA	9R3Z-7000-BRM	AW7P-7000-AA	AW7Z-7000-ARM	BV6P-7000-DG	BV6Z-7000-L	DA8P-7000-LB	DA8Z-7000-ERM
9W1P-7000-DA	9W1Z-7000-DRM	AW7P-7000-CA	AW7Z-7000-CRM	BV6P-7000-FF	BV6Z-7000-M	DA8P-7000-LB	DA8Z-7000-L
9W7P-7000-AA	9W7Z-7000-ARM	BA5P-7000-PC,PD	BA5Z-7000-BRM	CA6P-7000-FB	CA6Z-7000-L	DA8P-7000-MA	DA8Z-7000-F
9W7P-7000-CA	9W7Z-7000-CRM	BA5P-7000-RC,RD	BA5Z-7000-CRM	CA6P-7000-FC	CA6Z-7000-L	DA8P-7000-MB	DA8Z-7000-FRM
AA5P-7000-BA,BB	AA5Z-7000-BRM	BA8P-7000-AB,AC	BA8Z-7000-ARM	CA6P-7000-HG	CA6Z-7000-H	DA8P-7000-MB	DA8Z-7000-M
AA5P-7000-BC,BD	AA5Z-7000-GRM	BA8P-7000-AC	BA8Z-7000-L	CA6P-7000-HK	CA6Z-7000-M	DA8P-7000-NB	DA8Z-7000-NRM
AA5P-7000-BD	AA5Z-7000-J	BA8P-7000-EB,EC	BA8Z-7000-ERM	CC3P-7000-CC	CC3Z-7000-R	DA8P-7000-NC	DA8Z-7000-NC
AA5P-7000-DA,DB	AA5Z-7000-DRM	BA8P-7000-GB,GC	BA8Z-7000-GRM	CC3P-7000-DC	CC3Z-7000-S	DA8P-7000-PB	DA8Z-7000-PC
AA5P-7000-DC,DD	AA5Z-7000-HRM	BA8P-7000-GC	BA8Z-7000-N	CC3P-7000-EC	CC3Z-7000-T	DA8P-7000-PB	DG9Z-7000-G
AA5P-7000-DD	AA5Z-7000-K	BA8P-7000-MC	BA8Z-7000-P	CC3P-7000-FC	CC3Z-7000-U	DA8P-7000-PC	DA8Z-7000-PRM
AA8P-7000-FA,FB,FC	AA8Z-7000-FRM	BA8P-7000-NB,NC	BA8Z-7000-KRM	CC3P-7000-GA	CC3Z-7000-G	DA8P-7000-PC	DA8Z-7000-R
AA8P-7000-FC	AA8Z-7000-S	BB5P-7000-LC	BB5Z-7000-L	CC3P-7000-GC	CC3Z-7000-V	DA8P-7000-RA	DA8Z-7000-H
AA8P-7000-GA	AA8Z-7000-GRM	BB5P-7000-LC	BB5Z-7000-LRM	CC3P-7000-JA	CC3Z-7000-J	DA8P-7000-RB	DA8Z-7000-HRM
AA8P-7000-HA,HB,HC	AA8Z-7000-HRM	BB5P-7000-SB	BB5Z-7000-S	CC3P-7000-JC	CC3Z-7000-W	DA8P-7000-RB	DA8Z-7000-Y
AA8P-7000-HC	AA8Z-7000-T	BC3P-7000-GA	BC3Z-7000-G	CC3Z-7000-DRM	CC3Z-7000-DRM	DA8P-7000-SA	DA8Z-7000-B
AA8P-7000-JA,JB,JC	AA8Z-7000-JRM	BC3P-7000-UF	BC3Z-7000-U	CC4P-7000-VB	CC4Z-7000-A	DA8P-7000-SB	DA8Z-7000-BRM
AA8P-7000-JC	AA8Z-7000-U	BC3Z-7000-JRM	BC3Z-7000-U	CC4P-7000-XB	CC4Z-7000-B	DA8P-7000-SB	DA8Z-7000-S
AA8P-7000-KA,KB,KC	AA8Z-7000-KRM	BE5P-7000-JB	BE5Z-7000-A	CE58-7000-CA	BE5Z-7000-B	DA8P-7000-TA	DA8Z-7000-T
AA8P-7000-KB	AA8Z-7000-N	BE5P-7000-JB	BE5Z-7000-ARM	CK4P-7000-AC	CK4Z-7000-A	DA8P-7000-TB	DA8Z-7000-TRM
AA8P-7000-KC	AA8Z-7000-V	BE5P-7000-KB	BE5Z-7000-C	CK4P-7000-BC	CK4Z-7000-C	DA8P-7000-TB	DA8Z-7000-TC
AC2P-7000-AA	9C2Z-7000-ARM	BE5P-7000-KE	BE5Z-7000-ARM	CK4P-7000-CB	CK4Z-7000-F	DA8P-7000-UA	DA8Z-7000-U
AC2P-7000-BA	9C2Z-7000-BRM	BE5P-7000-MB	BE5Z-7000-D	CK4P-7000-EB	CK4Z-7000-D	DA8P-7000-UB	DA8Z-7000-URM
AC2P-7000-CA	AC2Z-7000-C	BE5P-7000-MB	BE5Z-7000-DRM	CK4P-7000-FB	CK4Z-7000-E	DA8P-7000-UB	DA8Z-7000-X
AC2P-7000-CA	AC2Z-7000-CRM	BL1P-7000-AA,AB	BL1Z-7000-ARM	CL1P-7000-AA	CL1Z-7000-ARM	DB5P-7000-SA	DB5Z-7000-S
AC2P-7000-DA	AC2Z-7000-D	BL1P-7000-AB	BL1Z-7000-A	CL1P-7000-AC	CL1Z-7000-A	DE9P-7000-LA	DE9Z-7000-L
AC2P-7000-DA	AC2Z-7000-DRM	BL1P-7000-BA,BB	BL1Z-7000-A	CL1P-7000-BA	CL1Z-7000-BRM	DG1P-7000-YA	DG1Z-7000-Y
AC2P-7000-EA	9C2Z-7000-ERM	BL1P-7000-BB	BL1Z-7000-B	CL1P-7000-BC	CL1Z-7000-B	DG98-7000-EC	FG9Z-7000-E
AC2P-7000-FA	9C2Z-7000-FRM	BL3P-7000-AA, AB	BL3Z-7000-ARM	CM68-7000-AA	AM6Z-7000-A	DG9P-7000-AB	DG9Z-7000-C
AC3P-7000-AA	9C3Z-7000-ARM	BL3P-7000-AC	BL3Z-7000-A	CT4P-7000-NC	CT4Z-7000-N	DG9P-7000-EB	DG9Z-7000-E
AC3P-7000-BA	9C3Z-7000-BRM	BL3P-7000-BA, BB	BL3Z-7000-BRM	CT4P-7000-NC	CT4Z-7000-NRM	DG9P-7000-ED	DG9Z-7000-ED
AC3P-7000-CA	9C3Z-7000-CRM	BL3P-7000-BC	BL3Z-7000-B	CV6P-7000-AA	CV6Z-7000-A	DG9P-7000-FB	DG9Z-7000-F
AC3P-7000-DA	9C3Z-7000-DRM	BL3P-7000-BC	BL3Z-7000-G	CV6P-7000-AB	CV6Z-7000-W	DG9P-7000-FD	DG9Z-7000-FD
AC3P-7000-EA	9C2Z-7000-GRM	BL3P-7000-CA,CB	BL3Z-7000-GRM	CV6P-7000-BA	CV6Z-7000-B	DG9P-7000-JA	DG9Z-7000-J
AC3P-7000-EA	9C3Z-7000-ERM	BL3P-7000-DA,DB	BL3Z-7000-HRM	CV6P-7000-CC	CV6Z-7000-E	DG9P-7000-KA	DG9Z-7000-K
AC3P-7000-EA	AC3Z-7000-E	BL3P-7000-DD	BL3Z-7000-D	CV6P-7000-DB	CV6Z-7000-X	DG9P-7000-KB	DG9Z-7000-KB
AC3P-7000-FA	9C2Z-7000-HRM	BL3P-7000-EA, EB	BL3Z-7000-CRM	CV6P-7000-EA	CV6Z-7000-X	DG9P-7000-LA	DG9Z-7000-L
AC3P-7000-FA	9C3Z-7000-FRM	BL3P-7000-EC	BL3Z-7000-E	CV6P-7000-FA	CV6Z-7000-FA	DG9P-7000-MA	DG9Z-7000-M
AC3P-7000-FA	AC3Z-7000-F	BL3P-7000-FA, FB	BL3Z-7000-DRM	CV6P-7000-HA	CV6Z-7000-HA	DG9P-7000-MC	DG9Z-7000-MC
AC3P-7000-GA	9C2Z-7000-JRM	BL3P-7000-FC	BL3Z-7000-F	CV6P-7000-VA	CV6Z-7000-V	DG9P-7000-SA	DG9Z-7000-S
AC3P-7000-GA	9C3Z-7000-HRM	BL3P-7000-GA,GB	BL3Z-7000-ERM	CV6P-7000-VC	CV6Z-7000-Y	DG9P-7000-YA	DG9Z-7000-Y
AC3P-7000-GA	AC3Z-7000-G	BL3P-7000-HA,HB	BL3Z-7000-FRM	DA5P-7000-BA	DA5Z-7000-B	DG9P-7000-ZA	DG9Z-7000-Z
AC3P-7000-HA	9C2Z-7000-KRM	BL3P-7000-HD	BL3Z-7000-H	DA5P-7000-BA	DA5Z-7000-BRM	DM58-7000-CD	DM5Z-7000-L
AC3P-7000-HA	9C3Z-7000-GRM	BL5P-7000-CA	7L5Z-7000-CRM	DA5P-7000-BB	DA5Z-7000-L	DT4P-7000-NA	DT4Z-7000-N
AC3P-7000-HA	AC3Z-7000-H	BL5P-7000-DA	7L5Z-7000-DRM	DA5P-7000-DB	DA5Z-7000-DRM	DV6P-7000-UA	DV6Z-7000-B
AC3P-7000-KA	9C3Z-7000-JRM	BL5P-7000-EA	7L5Z-7000-ERM	DA5P-7000-DB	DA5Z-7000-M	DV6P-7000-UB	DV6Z-7000-E
AC3P-7000-KA	AC3Z-7000-K	BL8P-7000-EB	BL8Z-7000-E	DA5P-7000-EB	DA5Z-7000-ARM	DV6P-7000-VA	DV6Z-7000-C
AE5P-7000-CA	AE5Z-7000-C	BL8P-7000-EB	BL8Z-7000-ERM	DA5P-7000-EB	DA5Z-7000-N	DV6P-7000-ZA	DV6Z-7000-D
AE5P-7000-CA	AE5Z-7000-FRM	BL8P-7000-FB	BL8Z-7000-F	DA5P-7000-GA	DA5Z-7000-K	DV6P-7000-ZB	DV6Z-7000-F
AE5P-7000-DA	AE5Z-7000-D	BL8P-7000-FB	BL8Z-7000-FRM	DA5P-7000-GA	DA5Z-7000-KRM	E7SP-7000-CA	F1SZ-7V000-DARM
AE5P-7000-DA	AE5Z-7000-GRM	BL8P-7000-GB	BL8Z-7000-G	DA5P-7000-JB	DA5Z-7000-ERM	E8SP-7000-AB	F1SZ-7V000-DARM
AL1P-7000-BA,BB,BC,BD	AL1Z-7000-ARM	BL8P-7000-GB	BL8Z-7000-GRM	DA5P-7000-JB	DA5Z-7000-P	E8SP-7000-BB	F1SZ-7V000-DARM
AL2P-7000-AA	AL2Z-7000-ARM	BL8P-7000-GB	BL8Z-7000-H	DA8P-7000-AA	DA8Z-7000-C	E8SP-7000-CA	F1SZ-7V000-DARM
AL2P-7000-BA	AL2Z-7000-BRM	BL8P-7000-HB	BL8Z-7000-HRM	DA8P-7000-AB	DA8Z-7000-CRM	E9SP-7000-FC,FD,GC	F1SZ-7V000-DARM
AL3P-7000-AA,AB,AC,AD	AL3Z-7000-ARM	BR3P-7000-AA	BR3Z-7000-ARM	DA8P-7000-AB	DA8Z-7000-J	E9SP-7000-FD	F1SZ-7V000-DARM
AL3P-7000-BA,BB,BC,BD	AL3Z-7000-BRM	BR3P-7000-AB	BR3Z-7000-A	DA8P-7000-CA	DA8Z-7000-A	E9SP-7000-GC	F1SZ-7V000-DARM
AL3P-7000-CA	AL3Z-7000-CRM	BR3P-7000-BA	BR3Z-7000-BRM	DA8P-7000-CB	DA8Z-7000-ARM	E9SP-7000-HC,HD	F1SZ-7V000-DARM
AL3P-7000-DA	AL3Z-7000-DRM	BR3P-7000-BB	BR3Z-7000-B	DA8P-7000-CB	DA8Z-7000-K	E9SP-7000-HD	F1SZ-7V000-DARM
AL3P-7000-HA	AL3Z-7000-HRM	BR3P-7000-CC	BR3Z-7000-C	DA8P-7000-KA	DA8Z-7000-G	E9TP-7000-GA, GB	E9TZ-7V000-CRM
AL3P-7000-LA,LB,LC	AL3Z-7000-NRM	BT1P-7000-DA	BT1Z-7000-A	DA8P-7000-KB	DA8Z-7000-D	EG9P-7000-AB	EG9Z-7000-A
AL3P-7000-MA,MB,MC	AL3Z-7000-MRM	BT1P-7000-DA	BT1Z-7000-BRM	DA8P-7000-KB	DA8Z-7000-GRM	EG9P-7000-AD	EG9Z-7000-AD



Engineering Number	Service Number	Engineering Number	Service Number	Engineering Number	Service Number	Engineering Number	Service Number
EG9P-7000-BA	EG9Z-7000-B	F3TP-7000-EB	F2TZ-7V000-MRMM	F75P-7000-MB	F75Z-7V000-MRMM	F8UP-7000-KA	F8UZ-7V000-KARM
EG9P-7000-BB	EG9Z-7000-C	F3TP-7000-GA	F2TZ-7V000-MRMM	F78P-7000-AA	F78Z-7V000-ARM	F8UP-7000-LA, NA	F8UZ-7V000-LARM
EG9P-7000-BC	EG9Z-7000-BC	F3TP-7000-LA	F3TZ-7V000-LRMM	F78P-7000-BA	F78Z-7V000-BRMM	F8UP-7000-LC	F8UZ-7V000-LCRM
EJ7P-7000-HA	EJ7Z-7000-H	F3UP-7000-BA	F2TZ-7V000-JRMM	F7AP-7000-BA, GA	F7AZ-7V000-BRMM	F8UP-7000-MB	F8UZ-7V000-MBRMM
EJ7P-7000-JA	DEJZ-7000-M	F3UP-7000-CA	F3UZ-7V000-CRMM	F7AP-7000-GA	F7AZ-7V000-BRMM	F8UP-7000-NA	F8UZ-7V000-LARM
EJ7P-7000-JA	EJ7Z-7000-J	F3UP-7000-EA	F2TZ-7V000-NRMM	F7DP-7000-AA	F7DZ-7V000-ARM	F8UP-7000-PA	F8UZ-7V000-PARM
EJ7P-7000-JC	EJ7Z-7000-L	F3UP-7000-FA	F2UZ-7V000-NRMM	F7DP-7000-CA	F7DZ-7V000-CRMM	F8UP-7000-RA	F8UZ-7V000-RARM
EJ7P-7000-KA	EJ7Z-7000-K	F48P-7000-BA	F48Z-7V000-BRMM	F7DP-7000-DA	F7DZ-7V000-DRMM	F8UP-7000-SA	F8UZ-7V000-CARM
EJ7P-7000-KB	EJ7Z-7000-N	F4DP-7000-BA, BB	F4DZ-7V000-BRMM	F7DP-7000-EA	F7DZ-7V000-ERM	FA6P-7000-FA, KB, BB	FA6Z-7000-H
EJ7P-7000-LA	EJ7Z-7000-M	F4OP-7000-BA, BB	F4OZ-7V000-BRMM	F7LP-7000-AA	F7LZ-7000-ARM	FB5P-7000-AA	FB5Z-7000-A
F0FP-7000-AA	FOTZ-7V000-NRMM	F4TP-7000-AA	F4TZ-7V000-ARM	F7TP-7000-JA	F7TZ-7V000-JRMM	FB5P-7000-BA	FB5Z-7000-B
F0TP-7000-AA	FOTZ-7V000-ARM	F4TP-7000-BA	F4TZ-7V000-BRMM	F7TP-7000-KA	F7TZ-7V000-KRMM	FB5P-7000-DA	FB5Z-7000-D
F0TP-7000-ACA	FOTZ-7V000-LRMM	F4TP-7000-EA	F4TZ-7V000-ERM	F7TP-7000-LA	F7TZ-7V000-LRMM	FC3P-7000-CA	FC3Z-7000-C
F0TP-7000-BA, BB, ZA	FOTZ-7V000-BRMM	F4TP-7000-FA	F4TZ-7V000-ERM	F7TP-7000-MA	F7TZ-7V000-MRMM	FC3P-7000-DA	FC3Z-7000-D
F0TP-7000-BB	FOTZ-7V000-BRMM	F4TP-7000-MA	F3UZ-7V000-CRMM	F7TP-7000-NA	F7TZ-7V000-NARM	FC3P-7000-EA	FC3Z-7000-E
F0TP-7000-EA	FOTZ-7V000-ERM	F4UP-7000-BA	F4UZ-7V000-CRMM	F7TP-7000-PA	F7TZ-7V000-PRMM	FC3P-7000-FA	FC3Z-7000-F
F0TP-7000-NA	FOTZ-7V000-NRMM	F4UP-7000-BA, CA	F4UZ-7V000-CRMM	F7TP-7000-RA	F7TZ-7V000-LRMM	FC3P-7000-GA	FC3Z-7000-G
F0TP-7000-SA	FOTZ-7V000-CRMM	F4UP-7000-CA	F4UZ-7V000-CRMM	F7TP-7000-UA	F7TZ-7V000-NARM	FC3P-7000-PA	FC3Z-7000-P
F0TP-7000-UA	FOTZ-7V000-URMM	F5OP-7000-BA	F5OZ-7V000-BRMM	F7UP-7000-EA, EB	F7UZ-7V000-EARM	FC3P-7000-SA	FC3Z-7000-S
F0TP-7000-WA	FOTZ-7V000-LRMM	F5TP-7000-AB	F5UZ-7V000-DRMM	F7UP-7000-FA	F7UZ-7V000-FRMM	FC3P-7000-ZA	FC3Z-7000-Z
F0TP-7000-YA	FOTZ-7V000-ARM	F5TP-7000-BB	F5TZ-7V000-BRMM	F7UP-7000-GA	F7UZ-7V000-GRMM	FC4P-7000-VA	FC4Z-7000-V
F0TP-7000-ZA	FOTZ-7V000-BRMM	F5TP-7000-CB	F5TZ-7V000-CRMM	F7UP-7000-JA	F7UZ-7V000-JRMM	FC4P-7000-XA	FC4Z-7000-X
F0UP-7000-EA	FOTZ-7V000-ERM	F5TP-7000-DB	F5TZ-7V000-DRMM	F7UP-7000-MA	F7UZ-7V000-MRMM	FG9P-7000-GA	FG9Z-7000-G
F0UP-7000-HA	FOTZ-7V000-ARM	F5TP-7000-EB	F5TZ-7V000-ERM	F7UP-7000-NA	F7UZ-7V000-NRMM	FG9P-7000-AA	FG9Z-7000-A
F0UP-7000-LA	FOTZ-7V000-LRMM	F5TP-7000-GB	F5TZ-7V000-GRMM	F7UP-7000-PA	F7UZ-7V000-PBRMM	FG9P-7000-AC	FG9Z-7000-AC
F1FP-7000-VA	F1FZ-7000-VA	F5TP-7000-JB	F5TZ-7V000-JRMM	F7UP-7000-PB	F7UZ-7V000-PBRMM	FL1P-7000-DA	FL1Z-7000-B
F1SP-7000-DA	F1SZ-7000-DA	F5TP-7000-LB	F5TZ-7V000-LRMM	F7UP-7000-RA	F7UZ-7V000-GRMM	FL3P-7000-AA	FL3Z-7000-A
F1TP-7000-LA, MA	FOTZ-7V000-BRMM	F5UP-7000-BB	F5UZ-7V000-BRMM	F7UP-7000-TA	F7UZ-7V000-JRMM	FL3P-7000-BA	FL3Z-7000-B
F1TP-7000-MA	FOTZ-7V000-BRMM	F5UP-7000-DB	F5UZ-7V000-DRMM	F7UP-7000-UA	F7UZ-7V000-UARM	FL3P-7000-CA	FL3Z-7000-C
F1TP-7000-NA	FOTZ-7V000-NRMM	F5UP-7000-EB	F5UZ-7V000-ERM	F7UP-7000-VA	F7UZ-7V000-VARM	FL3P-7000-DA	FL3Z-7000-D
F2GP-7000-BA	F2GZ-7000-B	F5UP-7000-FB	F5UZ-7V000-FRMM	F7UP-7000-XA	F7UZ-7V000-NRMM	FL3P-7000-EA	FL3Z-7000-E
F2GP-7000-TC	F2GZ-7000-T	F5UP-7000-GB	F5UZ-7V000-GRMM	F81P-7000-AB	F81Z-7V000-ABRMM	FL3P-7000-FA	FL3Z-7000-F
F2GP-7000-VC	F2GZ-7000-VC	F5UP-7000-HB	F5UZ-7V000-HRMM	F81P-7000-BB	F81Z-7V000-BBRMM	FL3P-7000-GA	FL3Z-7000-G
F2GP-7000-XC	F2GZ-7000-XC	F65P-7000-CA	F65Z-7V000-CARM	F81P-7000-DB	F81Z-7V000-DBRMM	FL3P-7000-HA	FL3Z-7000-H
F2GP-7000-YC	F2GZ-7000-Y	F65P-7000-DA	F65Z-7V000-DARM	F81P-7000-EB	F81Z-7V000-EBRMM	FL3P-7000-JA	FL3Z-7000-J
F2TP-7000-ACA	FOTZ-7V000-NRMM	F68P-7000-AA	F68Z-7V000-AARM	F81P-7000-FB	F81Z-7V000-FBRMM	FL3P-7000-KA	FL3Z-7000-K
F2TP-7000-AGA	F2TZ-7V000-FRMM	F6DP-7000-EA	F6DZ-7V000-EARM	F81P-7000-GB	F81Z-7V000-GBRMM	FM5P-7000-DA	FM5Z-7000-D
F2TP-7000-BA	F2TZ-7V000-BRMM	F6TP-7000-CA	F6TZ-7V000-CARM	F81P-7000-HB	1C3Z-7V000-ERM	F0UP-7000-HA	FOTZ-7V000-ARM
F2TP-7000-DA	F2TZ-7V000-DARM	F6TP-7000-DA	F6TZ-7V000-DARM	F81P-7000-HB	6U2Z-7V000-HRMM	FR3P-7000-AB	FR3Z-7000-A
F2TP-7000-EA	F2TZ-7V000-HRMM	F6TP-7000-FA	F6TZ-7V000-FARM	F81P-7000-KB	7U2Z-7V000-CRMM	FR3P-7000-BB	FR3Z-7000-B
F2TP-7000-FA	F2TZ-7V000-FRMM	F6TP-7000-GA	F6TZ-7V000-GARM	F81P-7000-KB	F81Z-7V000-KBRMM	FR3P-7000-CB	FR3Z-7000-C
F2TP-7000-HA	F2TZ-7V000-HRMM	F6TP-7000-HA	F7TZ-7V000-KRMM	F81P-7000-LB	6U2Z-7V000-LRMM	FU6J-19090-W	F0CZ-7V000-BRMM
F2TP-7000-JA	F2TZ-7V000-JRMM	F6TP-7000-JA	F6TZ-7V000-JARM	F81P-7000-PB	7U2Z-7V000-DRMM	FU6V-19090-N	F0CZ-7V000-ARM
F2TP-7000-LA	F2TZ-7V000-LRMM	F6TP-7000-JA	F6TZ-7V000-KARM	F81P-7000-TA	F81Z-7V000-TARM	FU6V-19090-R	F0CZ-7V000-ARM
F2TP-7000-MA	F2TZ-7V000-MRMM	F6TP-7000-KA	F6TZ-7V000-JARM	F83P-7000-CA, CB, CC	F83Z-7V000-CBRMM	G2GP-7000-AA	G2GZ-7000-AA
F2TP-7000-NA	F2TZ-7V000-NRMM	F6TP-7000-KA	F6TZ-7V000-KARM	F83P-7000-CB	F83Z-7V000-CBRMM	G2GP-7000-BA	G2GZ-7000-BA
F2TP-7000-NA	F2UZ-7V000-NRMM	F6UP-7000-DA	F6UZ-7V000-DARM	F85P-7000-BA	F85Z-7V000-BARM	GC4P-7000-AA	GC4Z-7000-AA
F2TP-7000-PA	F3TZ-7V000-LRMM	F6UP-7000-FA	F6UZ-7V000-FARM	F85P-7000-EA	F85Z-7V000-EARM	GC4P-7000-BA	GC4Z-7000-BA
F2TP-7000-SA	F3TZ-7V000-LRMM	F6UP-7000-GA	F6UZ-7V000-GARM	F85P-7000-FA	F85Z-7V000-FARM	GC4P-7000-BB	GC4Z-7000-Z
F2UP-7000-DA	F2TZ-7V000-BRMM	F6UP-7000-HA	F6UZ-7V000-HARM	F85P-7000-GA	F85Z-7V000-GARM	GC4P-7000-VA	GC4Z-7000-V
F2UP-7000-DC	F2TZ-7V000-BRMM	F73P-7000-AB	F83Z-7V000-CBRMM	F85P-7000-HA	F85Z-7V000-HARM	GC4P-7000-XA	GC4Z-7000-XA
F2UP-7000-EA	F2TZ-7V000-FRMM	F75P-7000-EA	F75Z-7V000-ERM	F88P-7000-AA	F88Z-7V000-AARM	GJ7P-7000-BA	GJ7Z-7000-A
F2UP-7000-EC	F2TZ-7V000-FRMM	F75P-7000-HA	F75Z-7V000-HRMM	F88P-7000-BA	F88Z-7V000-BARM	GK4P-7000-AA	GK4Z-7000-A
F2UP-7000-GA	F2TZ-7V000-JRMM	F75P-7000-JA	F75Z-7V000-JRMM	F8AP-7000-AA, CA	F8AZ-7V000-AARM	GK4P-7000-CA	GK4Z-7000-B
F2UP-7000-HA	F2TZ-7V000-NRMM	F75P-7000-KA	F75Z-7V000-KRMM	F8DP-7000-AA	F8DZ-7V000-AARM	GK4P-7000-DA	GK4Z-7000-C
F2UP-7000-HA	F2UZ-7V000-NRMM	F75P-7000-LA	F75Z-7V000-LRMM	F8DP-7000-DA	F8DZ-7V000-DARM	GK4P-7000-EA	GK4Z-7000-D
F2UP-7000-HC	F2TZ-7V000-NRMM	F75P-7000-LA, LB	F75Z-7V000-LCRM	F8UP-7000-AA	F8UZ-7V000-PARM	GK4P-7000-FA	GK4Z-7000-E
F2UP-7000-MA	F3UZ-7V000-CRMM	F75P-7000-LB	F75Z-7V000-LCRM	F8UP-7000-CA	F8UZ-7V000-CARM	GV6P-7000-AA	GV6Z-7000-A
F2UP-7000-NA	F2UZ-7V000-NRMM	F75P-7000-LC, LD	F75Z-7V000-LCRM	F8UP-7000-EA	YC2Z-7V000-KRMM	GV6P-7000-DA	GV6Z-7000-C
F3TP-7000-DB	F2TZ-7V000-MRMM	F75P-7000-MA	F75Z-7V000-MRMM	F8UP-7000-FA	F8UZ-7V000-FARM	GV6P-7000-EA	GV6Z-7000-D
F3TP-7000-EA	F2TZ-7V000-MRMM	F75P-7000-MA, MB	F75Z-7V000-MRMM	F8UP-7000-HA	F8UZ-7V000-HARM	GV6P-7000-FA	GV6Z-7000-B

# CROSS REFERENCE Transmissions



FORD PARTS

Engineering Number	Service Number	Engineering Number	Service Number	Engineering Number	Service Number	Engineering Number	Service Number
RM4F2J-7000-AC	4F2Z-7000-ABRM	XC2P-7000-LB	F8UZ-7V000-KARM	YC2P-7000-JA	YC2Z-7V000-JRM		
RM5L5J-7000-DC	5L5Z-7000-DRM	XC2P-7000-NA	XC2Z-7V000-NARM	YC2P-7000-KA, KB	7U2Z-7V000-CRM		
RM6E5J-7000-AC	7E5Z-7000-BRM	XC2P-7000-RA	F8UZ-7V000-PARM	YC2P-7000-KA, KB	YC2Z-7V000-KRM		
RM6E7J-7000-AB	6E7Z-7000-ABRM	XC2P-7000-UA	F8UZ-7V000-RARM	YC2P-7000-MA, MB	7U2Z-7V000-BRM		
RM6E7J-7000-BB	6E7Z-7000-BBRM	XC2P-7000-VA	F8UZ-7V000-CARM	YC2P-7000-MA, MB	YC2Z-7V000-MRM		
RM6L2J-7000-ED	6L2Z-7000-ERM	XC3P-7000-BA	F81Z-7V000-ABRM	YC2P-7000-NA	YC2Z-7V000-NRM		
RM8U2J-7G497-ABA	4C3Z-7000-JBRM	XC3P-7000-CA	F81Z-7V000-BBRM	YC2P-7000-SA	YC2Z-7V000-SRM		
RM8U2J-7G497-ACA	4C3Z-7000-KBRM	XC3P-7000-DA	F81Z-7V000-DBRM	YC2P-7000-TA	YC2Z-7V000-TRM		
RM8U2J-7G497-AFA	3C3Z-7V000-KDRM	XC3P-7000-EA	F81Z-7V000-EBRM	YC2P-7000-UA	YC2Z-7V000-URM		
RM8U2J-7G497-AKA	3L8Z-7V000-HCRM	XC3P-7000-FA	F81Z-7V000-FBRM	YC2P-7000-WA	YC2Z-7V000-WRM		
RM9C3J-7000-CA	9C3Z-7000-CRM	XC3P-7000-GA	F81Z-7V000-GBRM	YC2P-7000-YA	YC2Z-7V000-YRM		
RMAA5J-7000-CA	AA5Z-7000-G	XC3P-7000-HA	1C3Z-7V000-ERM	YC3P-7000-AA	YC3Z-7V000-ARM		
RMAA8J-7000-DA	AA8Z-7000-J	XC3P-7000-HA	6U2Z-7V000-HRM	YC3P-7000-BA, RA	YC3Z-7V000-BRM		
RMBC3J-7000-GA	BC3Z-7000-BRM	XC3P-7000-JA	1C3Z-7V000-MRM	YC3P-7000-CA	YC3Z-7V000-CRM		
RMBC3J-7000-HA	BC3Z-7000-HRM	XC3P-7000-KA	F81Z-7V000-KBRM	YC3P-7000-DA, SA	YC3Z-7V000-DRM		
RMBC3J-7000-JA	BC3Z-7000-J	XC3P-7000-LA	1C3Z-7V000-FRM	YC3P-7000-EA, EB	1C3Z-7V000-ERM		
RMBC3J-7000-KA	BC3Z-7000-KRM	XC3P-7000-LA	6U2Z-7V000-LRM	YC3P-7000-EA, EB	6U2Z-7V000-HRM		
RMBC3J-7000-LA	BC3Z-7000-LRM	XC3P-7000-MA	F81Z-7V000-TARM	YC3P-7000-EB	1C3Z-7V000-ERM		
RMBC3J-7000-MA	BC3Z-7000-MRM	XF1P-7000-AA	XF1Z-7V000-AARM	YC3P-7000-EB	6U2Z-7V000-HRM		
RMBL3J-7000-CA	BL3Z-7000-C	XF1P-7000-BA	XF1Z-7V000-BARM	YC3P-7000-FA, FB	1C3Z-7V000-FRM		
RMBU9J-7000-AA	BU9Z-7000-ARM	XF1P-7000-EB	XF1Z-7V000-EBRM	YC3P-7000-FA, FB	6U2Z-7V000-LRM		
RMCC3J-7000-AA	CC3Z-7000-CRM	XF2P-7000-BA	XF2Z-7V000-BARM	YC3P-7000-FB	1C3Z-7V000-FRM		
RMCC3J-7000-BA	CC3Z-7000-D	XF3P-7000-AB, AC	XF3Z-7V000-ARM	YC3P-7000-FB	6U2Z-7V000-LRM		
RMCC3J-7000-CA	CC3Z-7000-E	XF3P-7000-BA	XF3Z-7V000-BARM	YC3P-7000-JA	YC3Z-7V000-JRM		
RMCC3J-7000-DA	CC3Z-7000-ERM	XF3P-7000-BB, BC	XF3Z-7V000-BRM	YC3P-7000-KA	YC3Z-7V000-KRM		
RMCC3J-7000-EA	CC3Z-7000-FRM	XL1P-7000-AA	XL1Z-7V000-EARM	YC3P-7000-LA	7U2Z-7V000-CRM		
RMCC3J-7000-FA	CC3Z-7000-GRM	XL1P-7000-CB	XL1Z-7V000-CBRM	YC3P-7000-LA	F81Z-7V000-KBRM		
RMCC3J-7000-GA	CC3Z-7000-JRM	XL1P-7000-DB	XL1Z-7V000-DBRM	YC3P-7000-LB	7U2Z-7V000-CRM		
RMEG1J-7000-AA	EG1Z-7000-ARM	XL2P-7000-AA	XL2Z-7V000-AARM	YC3P-7000-LB	F81Z-7V000-KBRM		
RMEG9J-7000-AA	EG9Z-7000-ARM	XL2P-7000-BA	XL2Z-7V000-BARM	YC3P-7000-MA	1C3Z-7V000-MRM		
RMEG9J-7000-BA	EG9Z-7000-ARM	XL2P-7000-CA	XL2Z-7V000-CARM	YC3P-7000-MA	7U2Z-7V000-DRM		
RMEG9J-7000-CA	EG9Z-7000-CRM	XL2P-7000-DA	XL2Z-7V000-DARM	YC3P-7000-MB	7U2Z-7V000-DRM		
RMEG9J-7000-DA	EG9Z-7000-DRM	XL2P-7000-FA	XL2Z-7V000-FARM	YC3P-7000-MB	F81Z-7V000-KBRM		
RMEG9J-7000-EA	EG9Z-7000-ERM	XL3P-7000-AA	XL3Z-7V000-AARM	YC3P-7000-NA	YC3Z-7V000-ARM		
RMEG9J-7000-FA	EG9Z-7000-FRM	XL3P-7000-BA	XL3Z-7V000-BARM	YC3P-7000-PA	YC3Z-7V000-CRM		
RMEG9J-7000-GA	EG9Z-7000-GRM	XL3P-7000-CA	XL3Z-7V000-CARM	YF1P-7000-AB	YF1Z-7V000-ARM		
RMET4J-7000-AA	ET4Z-7000-ARM	XL3P-7000-DA	XL3Z-7V000-DARM	YF1P-7000-EC, EE	YF1Z-7V000-ERM		
RMEV6J-7000-AA	EV6Z-7000-ARM	XL3P-7000-EA	XL3Z-7V000-EARM	YF1P-7000-FC, FD	YF1Z-7V000-FRM		
RMEV6J-7000-BA	EV6Z-7000-BRM	XL3P-7000-GB	XL3Z-7V000-GBRM	YF1P-7000-HA	YF1Z-7V000-HRM		
RMEV6J-7000-CA	EV6Z-7000-CRM	XL3P-7000-HB	YC3Z-7V000-BRM	YF2P-7000-BA	YF2Z-7V000-BRM		
RMEV6J-7000-DA	CV6Z-7000-XRM	XL3P-7000-JA	XL3Z-7V000-JARM	YL1P-7000-AA	XL1Z-7V000-CBRM		
RMEV6J-7000-DA	EV6Z-7000-DRM	XL3P-7000-KA	1L3Z-7V000-CRM	YL1P-7000-BA	XL1Z-7V000-DBRM		
RMEV6J-7000-EA	EV6Z-7000-ERM	XL3P-7000-LA	XL3Z-7V000-LARM	YL3P-7000-AA	XL3Z-7V000-GBRM		
RMFC3J-7000-AA	FC3Z-7000-RRM	XL5P-7000-AA	XL5Z-7V000-AARM	YL3P-7000-BA	YC3Z-7V000-BRM		
RMFC3J-7000-BA	FC3Z-7000-SRM	XL5P-7000-BA	XL5Z-7V000-BARM	YL3P-7000-BA, HB	YC3Z-7V000-BRM		
RMFC3J-7000-CA	FC3Z-7000-TRM	XL5P-7000-CA	XL5Z-7V000-CARM	YL3P-7000-CA	1L3Z-7V000-CRM		
RMFC3J-7000-DA	FC3Z-7000-URM	XL5P-7000-DA	XL5Z-7V000-DARM	YL3P-7000-DA	YL3Z-7V000-DRM		
RMFC3J-7000-FA	FC3Z-7000-WRM	XL5P-7000-EA	XL5Z-7V000-EARM	YL3P-7000-EA	YL3Z-7V000-ERM		
RMFC3J-7000EA	FC3Z-7000-VRM	XL7P-7000-AA, GB	XL3Z-7V000-GBRM	YL3P-7000-FA	YL3Z-7V000-FRM		
RMFC4J-7000-AA	CC4Z-7000-ARM	XR3P-7000-AA	XR3Z-7V000-AARM	YL3P-7000-HA	YL3Z-7V000-HRM		
RMFC4J-7000-BA	CC4Z-7000-BRM	XW1P-7000-BA	XW1Z-7V000-BARM	YL3P-7000-JA	YL3Z-7V000-JRM		
RMFG9J-7000-AA	EG9Z-7000-HRM	XW1P-7000-CA	XW1Z-7V000-CARM	YL3P-7000-LA	YL3Z-7V000-LRM		
RMFG9J-7000-CA	EG9Z-7000-KRM	XW1P-7000-DA	XW1Z-7V000-BARM	YL3P-7000-MA	YL3Z-7V000-MRM		
RMGA8J-7000-BA	DA8Z-7000-KRM	XW4P-7000-AA, AC	YW4Z-7V000-ARM	YL7P-7000-AA	XL3Z-7V000-GBRM		
RMGV6J-7000-DA	DV6Z-7000-DRM	XW4P-7000-BA, BC	YW4Z-7V000-BRM	YL8P-7000-EA	YL8Z-7V000-ERM		
RMGV6J-7000-LA	DV6Z-7000-BRM	XW7P-7000-AA, DA	XW7Z-7V000-AARM	YL8P-7000-FB	YL8Z-7V000-FRM		
RMGV6J-7000-LA	DV6Z-7000-CRM	XW7P-7000-CA	XW7Z-7V000-CARM	YW1P-7000-AA	YW1Z-7V000-ARM		
XC2P-7000-FB	F8UZ-7V000-CARM	YC2P-7000-BA	YC2Z-7V000-BRM	YW4P-7000-AA	YW4Z-7V000-ARM		
XC2P-7000-HB	F8UZ-7V000-JARM	YC2P-7000-CA	YC2Z-7V000-CRM	YW4P-7000-BA	YW4Z-7V000-BRM		
XC2P-7000-JB	YC2Z-7V000-KRM	YC2P-7000-EA	YC2Z-7V000-TRM	YW7P-7000-AA	YW7Z-7V000-ARM		
XC2P-7000-LB	7U2Z-7V000-KRM	YC2P-7000-GA	YC2Z-7V000-URM				



Make	Year	Make	Year	Make	Year	Make	Year
<b>1C2Z-6006-EARM</b>		<b>1L3Z-6006-QARM</b>		<b>1W7Z-6006-FRM cont'd</b>		<b>2F3Z-6006-ABRM</b>	
<b>ENGINE LONG BLOCK</b>		<b>ENGINE LONG BLOCK</b>		Lincoln		<b>ENGINE LONG BLOCK</b>	
Ford		Ford		Town Car 2001		Lincoln	
Econoline	2001-2000	Econoline	2003-2001	Mercury		Continental 2002-2001	
<b>1F1Z-6006-ABRM</b>		F-Series 2003-2001		Grand Marquis 2001		<b>2L2Z-6006-AARM</b>	
<b>ENGINE LONG BLOCK</b>		<b>1L3Z-6006-RARM</b>		<b>1W7Z-6006-GRM</b>		<b>ENGINE LONG BLOCK</b>	
Ford		<b>ENGINE LONG BLOCK</b>		Ford		Ford	
Taurus	2002-2001	Ford		Crown Victoria 2001		Explorer 2002	
Mercury		Econoline 2002-2001		Lincoln		Mercury	
Sable	2002-2001	F-Series 2003-2001		Town Car 2001		Mountaineer 2002	
<b>1F2Z-6006-CARM</b>		<b>1L7Z-6006-DARM</b>		Mercury		<b>2L2Z-6006-BBRM</b>	
<b>ENGINE LONG BLOCK</b>		<b>ENGINE LONG BLOCK</b>		Grand Marquis 2001		<b>ENGINE LONG BLOCK</b>	
Ford		Lincoln		<b>2C2Z-6006-ABRM</b>		Ford	
Windstar	2003-2001	Navigator 2000		<b>ENGINE LONG BLOCK</b>		Explorer 2003-2002	
<b>1L2Z-6006-ABRM</b>		<b>1L8Z-6006-ABRM</b>		Ford		Mercury	
<b>ENGINE LONG BLOCK</b>		<b>ENGINE LONG BLOCK</b>		Econoline 2002		Mountaineer 2003-2002	
Ford		Ford		<b>2C2Z-6006-BBRM</b>		<b>ENGINE LONG BLOCK</b>	
Explorer	2003-2001	Escape 2004-2001		<b>ENGINE LONG BLOCK</b>		Ford	
Explorer Sport Trac 2003-2001		Mazda		Ford		Explorer 2003-2002	
<b>1L2Z-6006-BBRM</b>		Tribute 2004-2001		Econoline 2002		Mercury	
<b>ENGINE LONG BLOCK</b>		<b>1L8Z-6006-BBRM</b>		F-Series 2003-2002		Mountaineer 2003-2002	
Ford		<b>ENGINE LONG BLOCK</b>		F53 2003-2002		<b>2L2Z-6006-FARM</b>	
Explorer	2003-2001	Ford		<b>2C2Z-6006-CBRM</b>		<b>ENGINE LONG BLOCK</b>	
Explorer Sport Trac	2003-2001	Escape 2004-2001		<b>ENGINE LONG BLOCK</b>		Ford	
Ranger 2003-2001		Mazda		Ford		Explorer 2003-2002	
<b>Mazda</b>		Tribute 2003-2001		Econoline 2002		Mercury	
B4000	2003-2001	<b>1L8Z-6006-CBRM</b>		<b>2C2Z-6006-DARM</b>		Mountaineer 2003-2002	
<b>1L3Z-6006-DRM</b>		<b>ENGINE LONG BLOCK</b>		<b>ENGINE LONG BLOCK</b>		<b>2L3Z-6006-ABRM</b>	
<b>ENGINE LONG BLOCK</b>		Ford		Ford		<b>ENGINE LONG BLOCK</b>	
Ford		Escape 2004-2001		Econoline 2002		Ford	
F-Series 2001		Mazda		<b>2C2Z-6006-DRM</b>		F-Series 2002	
<b>1L3Z-6006-GARM</b>		Tribute 2004-2001		<b>ENGINE LONG BLOCK</b>		<b>2L3Z-6006-BARM</b>	
<b>ENGINE LONG BLOCK</b>		<b>1R3Z-6006-BARM</b>		Ford		<b>ENGINE LONG BLOCK</b>	
Ford		<b>ENGINE LONG BLOCK</b>		Econoline 2002		Ford	
F-Series 2000-1999		Mustang 2001		<b>2C3Z-6006-ABRM</b>		F-Series 2002	
<b>1L3Z-6006-HARM</b>		<b>1R3Z-6006-FRM</b>		<b>ENGINE LONG BLOCK</b>		<b>2L3Z-6006-CBRM</b>	
<b>ENGINE LONG BLOCK</b>		<b>ENGINE LONG BLOCK</b>		Ford		<b>ENGINE LONG BLOCK</b>	
Ford		Ford		F-Series 2003-2002		Ford	
F-Series 2001		Mustang 2001		<b>2C3Z-6006-BBRM</b>		Expedition 2002	
<b>1L3Z-6006-MARM</b>		<b>1W4Z-6006-YBRM</b>		<b>ENGINE LONG BLOCK</b>		F-Series 2003-2002	
<b>ENGINE LONG BLOCK</b>		<b>ENGINE LONG BLOCK</b>		Ford		<b>2L3Z-6006-DBRM</b>	
Ford		Lincoln		F-Series 2002		<b>ENGINE LONG BLOCK</b>	
F-Series 2001-1999		LS 2002-2001		<b>2C5Z-6006-BARM</b>		Ford	
<b>1L3Z-6006-PRM</b>		<b>1W7Z-6006-FRM</b>		<b>ENGINE LONG BLOCK</b>		Excursion 2003-2002	
<b>ENGINE LONG BLOCK</b>		<b>ENGINE LONG BLOCK</b>		Lincoln		F-Series 2003-2002	
Ford		Ford		Aviator 2004-2003			
Expedition	2001	Crown Victoria 2001					
F-Series 2001							

# BUYER'S GUIDE

## Gas Engine Assemblies



FORD PARTS

Make	Year	Make	Year	Make	Year	Make	Year
<b>2L3Z-6006-EBRM</b>		<b>2M5Z-6006-BARM</b>		<b>2W7Z-6006-CARM</b>		<b>3F1Z-6006-DARM</b>	
<b>ENGINE LONG BLOCK</b>		<b>ENGINE LONG BLOCK</b>		<b>ENGINE LONG BLOCK</b>		<b>ENGINE LONG BLOCK</b>	
Ford		Ford		Ford		Ford	
Excursion	2003-2002	Focus	2004-2002	Crown Victoria	2002	Taurus	2003-2002
F-Series	2003-2002	<b>2M5Z-6006-BRM</b>		Lincoln		Mercury	
<b>2L3Z-6006-GARM</b>		<b>ENGINE LONG BLOCK</b>		Town Car		Sable	
<b>ENGINE LONG BLOCK</b>		Ford		2002		2003-2002	
Ford		Focus		2004-2001		<b>3F2Z-6006-BARM</b>	
Expedition	2002	<b>2R3Z-6006-BARM</b>		<b>3C2Z-6006-BBRM</b>		<b>ENGINE LONG BLOCK</b>	
F-Series	2002	<b>ENGINE LONG BLOCK</b>		<b>ENGINE LONG BLOCK</b>		Ford	
<b>2L3Z-6006-HARM</b>		Ford		Econoline		Windstar	
<b>ENGINE LONG BLOCK</b>		Mustang		2003		2003	
Ford		2003-2002		<b>3C2Z-6006-CARM</b>		<b>3L1Z-6006-AARM</b>	
F-Series	2003-2002	<b>2R3Z-6006-DBRM</b>		<b>ENGINE LONG BLOCK</b>		<b>ENGINE LONG BLOCK</b>	
<b>2L3Z-6006-KARM</b>		<b>ENGINE LONG BLOCK</b>		Econoline		2003	
<b>ENGINE LONG BLOCK</b>		Ford		2003		Ford	
Ford		Mustang		2003-2000		Expedition	
F-Series	2004-2002	<b>2S4Z-6006-AARM</b>		<b>3C2Z-6006-DARM</b>		<b>3L1Z-6006-CBRM</b>	
<b>2L5Z-6006-AARM</b>		<b>ENGINE LONG BLOCK</b>		<b>ENGINE LONG BLOCK</b>		<b>ENGINE LONG BLOCK</b>	
<b>ENGINE LONG BLOCK</b>		Ford		Econoline		2003	
Ford		Focus		2002-2001		Ford	
Ranger	2003-2002	<b>2W4Z-6006-AARM</b>		<b>3C2Z-6006-EARM</b>		Expedition	
Mazda		<b>ENGINE LONG BLOCK</b>		<b>ENGINE LONG BLOCK</b>		2004-2003	
B2300	2003-2002	Ford		Econoline		<b>3L2Z-6006-BARM</b>	
<b>2L5Z-6006-BARM</b>		Lincoln		2003		<b>ENGINE LONG BLOCK</b>	
<b>ENGINE LONG BLOCK</b>		LS		2002-2001		Ford	
Ford		<b>2W4Z-6006-ABRM</b>		<b>3C2Z-6006-ERM</b>		Explorer	
Ranger	2002-2001	<b>ENGINE LONG BLOCK</b>		<b>ENGINE LONG BLOCK</b>		2003	
Mazda		Lincoln		Econoline		2003	
B2300	2002-2001	LS		2002-2001		Mountaineer	
<b>2L5Z-6006-FARM</b>		<b>2W4Z-6006-EARM</b>		<b>3C2Z-6006-GBRM</b>		<b>3L3Z-6006-CBRM</b>	
<b>ENGINE LONG BLOCK</b>		<b>ENGINE LONG BLOCK</b>		<b>ENGINE LONG BLOCK</b>		<b>ENGINE LONG BLOCK</b>	
Ford		Lincoln		Ford		Ford	
Ranger	2003-2002	LS		Econoline		F-Series	
<b>2L7Z-6006-BARM</b>		<b>2W4Z-6006-FARM</b>		2003		2003	
<b>ENGINE LONG BLOCK</b>		<b>ENGINE LONG BLOCK</b>		<b>3C2Z-6006-HBRM</b>		<b>3L3Z-6006-DBRM</b>	
Lincoln		Lincoln		<b>ENGINE LONG BLOCK</b>		<b>ENGINE LONG BLOCK</b>	
Blackwood	2002	LS		2003		Ford	
Navigator	2002	2001-2000		Econoline		F-Series	
<b>2L8Z-6006-ABRM</b>		<b>2W7Z-6006-BARM</b>		2003		2003	
<b>ENGINE LONG BLOCK</b>		<b>ENGINE LONG BLOCK</b>		F-Series		2003	
Mazda		Ford		<b>3F1Z-6006-CBRM</b>		<b>3L3Z-6006-FARM</b>	
MPV	2003-2002	Crown Victoria		<b>ENGINE LONG BLOCK</b>		<b>ENGINE LONG BLOCK</b>	
<b>2M5Z-6006-ARM</b>		2002		Ford		Ford	
<b>ENGINE LONG BLOCK</b>		Lincoln		Taurus		F-Series	
Ford		Town Car		2003		2003	
Focus	2000	2002		Mercury		<b>3L3Z-6006-GARM</b>	
<b>ENGINE LONG BLOCK</b>		Mercury		Sable		<b>ENGINE LONG BLOCK</b>	
Ford		Grand Marquis		2002		Ford	
Econoline		2003		2003		Econoline	
2003		2003		2003		2003	





Make	Year	Make	Year	Make	Year	Make	Year
<b>3L3Z-6006-GARM cont'd</b>		<b>3W7Z-6006-AARM</b>		<b>4C3Z-6006-EARM</b>		<b>4L2Z-6006-CBRM</b>	
F-Series	2004-2003	<b>ENGINE LONG BLOCK</b>		<b>ENGINE LONG BLOCK</b>		<b>ENGINE LONG BLOCK</b>	
<b>3L5Z-6006-AARM</b>		Ford		Ford		Ford	
<b>ENGINE LONG BLOCK</b>		Crown Victoria	2004-2003	Excursion	2005-2004	Explorer	2001
Ford		Lincoln		F-Series		<b>4L2Z-6006-DARM</b>	
Ranger	2003	Town Car		2005-2004		<b>ENGINE LONG BLOCK</b>	
Mazda		Mercury		<b>ENGINE LONG BLOCK</b>		Ford	
B2300	2003	Grand Marquis		2005-2004		Explorer	
<b>3L7Z-6006-BARM</b>		<b>3W7Z-6006-BARM</b>		Taurus		2005-2004	
<b>ENGINE LONG BLOCK</b>		<b>ENGINE LONG BLOCK</b>		Mercury		2005-2004	
Lincoln		Ford		Sable		2005-2004	
Navigator		Crown Victoria		<b>4F1Z-6006-CARM</b>		<b>ENGINE LONG BLOCK</b>	
2003		2004-2003		<b>ENGINE LONG BLOCK</b>		Ford	
<b>3M5Z-6006-BARM</b>		Lincoln		Ford		Explorer	
<b>ENGINE LONG BLOCK</b>		Town Car		Taurus		2005-2004	
Ford		2004-2003		2007-2004		Mercury	
Focus		Grand Marquis		2005-2004		Mountaineer	
2004-2003		2004-2003		Sable		2005-2004	
<b>3M5Z-6006-CARM</b>		<b>4C2Z-6006-AARM</b>		<b>4F2Z-6006-BARM</b>		<b>4L2Z-6006-FARM</b>	
<b>ENGINE LONG BLOCK</b>		<b>ENGINE LONG BLOCK</b>		<b>ENGINE LONG BLOCK</b>		<b>ENGINE LONG BLOCK</b>	
Ford		Ford		Ford		Ford	
Focus		Econoline		Freestar		Explorer	
2004-2003		2004		2004		2004	
<b>3R3Z-6006-ABRM</b>		<b>4C2Z-6006-ARM</b>		<b>4F2Z-6006-CARM</b>		<b>4L2Z-6006-GARM</b>	
<b>ENGINE LONG BLOCK</b>		<b>ENGINE LONG BLOCK</b>		<b>ENGINE LONG BLOCK</b>		<b>ENGINE LONG BLOCK</b>	
Ford		Ford		Ford		Ford	
Mustang		Econoline		Freestar		Explorer	
2003		2004		2004		2004	
<b>3R3Z-6006-BBRM</b>		<b>4C2Z-6006-BARM</b>		Mercury		Explorer Sport Trac	
<b>ENGINE LONG BLOCK</b>		<b>ENGINE LONG BLOCK</b>		Monterey		2005-2004	
Ford		Ford		2004		Ranger	
Mustang		Econoline		<b>4F2Z-6006-DARM</b>		2005-2004	
2004-2003		2004		<b>ENGINE LONG BLOCK</b>		Mazda	
<b>3R3Z-6006-DARM</b>		<b>4C2Z-6006-CARM</b>		Ford		B4000	
<b>ENGINE LONG BLOCK</b>		<b>ENGINE LONG BLOCK</b>		Freestar		2005-2004	
Ford		Ford		2004		<b>4L3Z-6006-AARM</b>	
Mustang		Econoline		Mercury		<b>ENGINE LONG BLOCK</b>	
2004-2003		2004		Monterey		Ford	
<b>3W4Z-6006-ABRM</b>		<b>4C2Z-6006-DARM</b>		2004		F-Series	
<b>ENGINE LONG BLOCK</b>		<b>ENGINE LONG BLOCK</b>		<b>4L1Z-6006-AARM</b>		2004	
Lincoln		Ford		<b>ENGINE LONG BLOCK</b>		<b>4L3Z-6006-ARM</b>	
LS		Econoline		Ford		<b>ENGINE LONG BLOCK</b>	
2005-2003		2004		Expedition		Ford	
<b>3W4Z-6006-CARM</b>		<b>4C2Z-6006-FRM</b>		2004		F-Series	
<b>ENGINE LONG BLOCK</b>		<b>ENGINE LONG BLOCK</b>		<b>4L2Z-6006-AARM</b>		2004	
Ford		Ford		<b>ENGINE LONG BLOCK</b>		<b>4L3Z-6006-FARM</b>	
Thunderbird		Econoline		Ford		<b>ENGINE LONG BLOCK</b>	
2003		2004		Explorer		Ford	
Lincoln		<b>4C3Z-6006-ARM</b>		2004		F-Series	
LS		<b>ENGINE LONG BLOCK</b>		Mercury		2004	
2003		Ford		Mountaineer		<b>4L5Z-6006-AARM</b>	
<b>3W4Z-6006-DARM</b>		Excursion		2004		<b>ENGINE LONG BLOCK</b>	
<b>ENGINE LONG BLOCK</b>		F-Series		2004		Ford	
Ford		<b>4C3Z-6006-BRM</b>		<b>ENGINE LONG BLOCK</b>		Ranger	
Thunderbird		<b>ENGINE LONG BLOCK</b>		Ford		2004	
2003		Ford		Explorer		Mazda	
Lincoln		F-Series		2000		B2300	
LS		2004				2004	

# BUYER'S GUIDE

## Gas Engine Assemblies



FORD PARTS

Make	Year	Make	Year	Make	Year	Make	Year
<b>4L5Z-6006-BARM</b>		<b>5C2Z-6006-CRM</b>		<b>5L3Z-6006-ARM</b>		<b>5L8Z-6006-DARM</b>	
<b>ENGINE LONG BLOCK</b>		<b>ENGINE LONG BLOCK</b>		<b>ENGINE LONG BLOCK</b>		<b>ENGINE LONG BLOCK</b>	
Ford		Ford		Ford		Ford	
Ranger	2006, 2004	Econoline	2006-2005	F-Series	2004	Escape	2006-2005
<b>Mazda</b>		<b>5C2Z-6006-DRM</b>		<b>5L3Z-6006-BRM</b>		<b>Mazda</b>	
B2300	2006, 2004	<b>ENGINE LONG BLOCK</b>		<b>ENGINE LONG BLOCK</b>		Tribute	2006-2005
<b>4L5Z-6006-DARM</b>		Ford		Ford		<b>5L8Z-6006-DRM</b>	
<b>ENGINE LONG BLOCK</b>		Econoline	2006-2005	Expedition	2006-2005	<b>ENGINE LONG BLOCK</b>	
Ford		<b>5C3Z-6006-ARM</b>		F-Series	2006-2005	Ford	
Ranger	2008-2004	<b>ENGINE LONG BLOCK</b>		Lincoln		Escape	2006-2005
<b>4L7Z-6006-AARM</b>		Ford		Navigator	2006-2005	<b>Mazda</b>	
<b>ENGINE LONG BLOCK</b>		F-Series	2006-2005	<b>5L3Z-6006-CRM</b>		Tribute	2005
Lincoln		<b>5C3Z-6006-BRM</b>		<b>ENGINE LONG BLOCK</b>		Mercury	
Navigator	2004	<b>ENGINE LONG BLOCK</b>		Ford		Mariner	2005
<b>4L8Z-6006-ARM</b>		Ford		F-Series	2008-2005	<b>5L8Z-6006-EARM</b>	
<b>ENGINE LONG BLOCK</b>		F-Series	2007-2005	<b>5L3Z-6006-DRM</b>		<b>ENGINE LONG BLOCK</b>	
Mazda		<b>5C7Z-6006-ARM</b>		<b>ENGINE LONG BLOCK</b>		Ford	
MPV	2006-2004	<b>ENGINE LONG BLOCK</b>		Ford		Escape	2005
<b>4L8Z-6006-BRM</b>		Ford		F-Series	2006-2005	<b>5R3Z-6006-AARM</b>	
<b>ENGINE LONG BLOCK</b>		Excursion	2005	<b>5L3Z-6006-ERM</b>		<b>ENGINE LONG BLOCK</b>	
Ford		<b>5F2Z-6006-ARM</b>		<b>ENGINE LONG BLOCK</b>		Ford	
Escape	2005	<b>ENGINE LONG BLOCK</b>		Ford		Mustang	2005
<b>Mazda</b>		Ford		F-Series	2009-2008, 2006-2005	<b>5R3Z-6006-BARM</b>	
Tribute	2005	Freestar	2005	<b>5L5Z-6006-ARM</b>		<b>ENGINE LONG BLOCK</b>	
<b>Mercury</b>		<b>5F2Z-6006-BRM</b>		<b>ENGINE LONG BLOCK</b>		Ford	
Mariner	2005	<b>ENGINE LONG BLOCK</b>		Ford		Mustang	2006-2005
<b>4R3Z-6006-AARM</b>		Ford		Ranger	2006-2004	<b>5R3Z-6006-CARM</b>	
<b>ENGINE LONG BLOCK</b>		Freestar	2005	<b>Mazda</b>		<b>ENGINE LONG BLOCK</b>	
Ford		<b>Mercury</b>		B2300	2006-2004	Ford	
Mustang	2004	Monterey	2005	<b>5L8Z-6006-ARM</b>		Mustang	2005
<b>4U9Z-6006-ARM</b>		<b>5F2Z-6006-CRM</b>		<b>ENGINE LONG BLOCK</b>		<b>5S4Z-6006-AARM</b>	
<b>ENGINE LONG BLOCK</b>		<b>ENGINE LONG BLOCK</b>		Ford		<b>ENGINE LONG BLOCK</b>	
Ford		Ford		Escape	2005	Ford	
F-Series	2005-2004	Freestar	2005	<b>Mercury</b>		Focus	2005
F53	2004	<b>Mercury</b>		Mariner	2005	<b>5S4Z-6006-BARM</b>	
<b>4W4Z-6006-BARM</b>		Monterey	2005	<b>5L8Z-6006-BRM</b>		<b>ENGINE LONG BLOCK</b>	
<b>ENGINE LONG BLOCK</b>		<b>5G1Z-6006-AARM</b>		<b>ENGINE LONG BLOCK</b>		Ford	
Ford		<b>ENGINE LONG BLOCK</b>		Ford		Focus	2006-2005
Thunderbird	2004	Ford		Escape	2006-2005	<b>5U9Z-6006-ARM</b>	
<b>Lincoln</b>		Five Hundred	2007-2005	<b>Mercury</b>		<b>ENGINE LONG BLOCK</b>	
LS	2006-2004	Freestyle	2007-2005	Mariner	2006-2005	Ford	
<b>5C2Z-6006-ARM</b>		<b>Mercury</b>		<b>5L8Z-6006-CRM</b>		F-Series	2006-2005
<b>ENGINE LONG BLOCK</b>		Montego	2007-2005	<b>ENGINE LONG BLOCK</b>		<b>5W7Z-6006-AARM</b>	
Ford		<b>5L2Z-6006-ARM</b>		Ford		<b>ENGINE LONG BLOCK</b>	
Econoline	2006-2005	<b>ENGINE LONG BLOCK</b>		Escape	2006-2005	Ford	
<b>5C2Z-6006-BRM</b>		Ford		<b>Mazda</b>		Crown Victoria	2006-2005
<b>ENGINE LONG BLOCK</b>		Explorer	2005	Tribute	2006-2005	<b>Lincoln</b>	
Ford		<b>Mercury</b>				Town Car	2005
Econoline	2006-2005	Mountaineer	2005				



Make	Year	Make	Year	Make	Year	Make	Year
<b>5W7Z-6006-AARM cont'd</b>		<b>6L2Z-6006-BARM cont'd</b>		<b>6S4Z-6006-BARM</b>		<b>7H6Z-6006-AARM cont'd</b>	
<b>Mercury</b>		<b>Mercury</b>		<b>ENGINE LONG BLOCK</b>		<b>Mercury</b>	
Grand Marquis	2006-2005	Mountaineer	2007-2006	<b>Ford</b>		Sable	2009-2008
<b>5W7Z-6006-BARM</b>		<b>6L2Z-6006-DARM</b>		Focus	2006	<b>7L2Z-6006-AARM</b>	
<b>ENGINE LONG BLOCK</b>		<b>ENGINE LONG BLOCK</b>		<b>6W7Z-6006-AARM</b>		<b>ENGINE LONG BLOCK</b>	
<b>Ford</b>		<b>Ford</b>		<b>ENGINE LONG BLOCK</b>		<b>Ford</b>	
Crown Victoria	2006-2005	Explorer	2006	<b>Ford</b>		Explorer	2008-2007
<b>Lincoln</b>		<b>Mercury</b>		Crown Victoria	2006	Explorer Sport Trac	2008-2007
Town Car	2006	Mountaineer	2007-2006	<b>Lincoln</b>		<b>Mercury</b>	
<b>Mercury</b>		<b>6L3Z-6006-AARM</b>		Town Car	2006	Mountaineer	2008-2007
Grand Marquis	2006-2005	<b>ENGINE LONG BLOCK</b>		<b>Mercury</b>		<b>7L2Z-6006-BARM</b>	
<b>6E5Z-6006-AARM</b>		<b>Ford</b>		Grand Marquis	2006	<b>ENGINE LONG BLOCK</b>	
<b>ENGINE LONG BLOCK</b>		F-Series	2006	<b>7C2Z-6006-AARM</b>		<b>ENGINE LONG BLOCK</b>	
<b>Ford</b>		<b>6L5Z-6006-AARM</b>		<b>ENGINE LONG BLOCK</b>		<b>Ford</b>	
Fusion	2009-2006	<b>ENGINE LONG BLOCK</b>		<b>Ford</b>		Explorer	2008
<b>Lincoln</b>		<b>Ford</b>		Econoline	2008-2007	Explorer Sport Trac	2008
Zephyr	2006	Ranger	2006	<b>7C2Z-6006-BARM</b>		<b>Mercury</b>	
<b>Mercury</b>		<b>6L8Z-6006-AARM</b>		<b>ENGINE LONG BLOCK</b>		Mountaineer	2008
Milan	2009-2006	<b>ENGINE LONG BLOCK</b>		<b>Ford</b>		<b>7L2Z-6006-BRM</b>	
<b>6E5Z-6006-BARM</b>		<b>Ford</b>		Econoline	2008-2007	<b>ENGINE LONG BLOCK</b>	
<b>ENGINE LONG BLOCK</b>		Escape	2007-2006	<b>7C2Z-6006-CARM</b>		<b>ENGINE LONG BLOCK</b>	
<b>Ford</b>		<b>Mazda</b>		<b>ENGINE LONG BLOCK</b>		<b>Ford</b>	
Fusion	2006	Tribute	2006	<b>Ford</b>		Explorer	2008-2007
<b>6F2Z-6006-AARM</b>		<b>Mercury</b>		Econoline	2008	<b>Mercury</b>	
<b>ENGINE LONG BLOCK</b>		Mariner	2007-2006	F-Series	2008-2007	Mountaineer	2008-2007
<b>Ford</b>		<b>6L8Z-6006-BARM</b>		<b>7C3Z-6006-BARM</b>		<b>7L2Z-6006-CRM</b>	
Freestar	2007-2006	<b>ENGINE LONG BLOCK</b>		<b>ENGINE LONG BLOCK</b>		<b>ENGINE LONG BLOCK</b>	
<b>6F2Z-6006-BARM</b>		<b>Mazda</b>		<b>Ford</b>		<b>Ford</b>	
<b>ENGINE LONG BLOCK</b>		Tribute	2006	F-Series	2008	Explorer	2008-2007
<b>Ford</b>		<b>6L8Z-6006-CARM</b>		<b>7C3Z-6006-CARM</b>		<b>Mercury</b>	
Freestar	2007-2006	<b>ENGINE LONG BLOCK</b>		<b>ENGINE LONG BLOCK</b>		Mountaineer	2008-2007
<b>Mercury</b>		<b>Mazda</b>		<b>Ford</b>		<b>7L2Z-6006-DARM</b>	
Monterey	2007-2006	Tribute	2006	Econoline	2008-2007	<b>ENGINE LONG BLOCK</b>	
<b>6F2Z-6006-CARM</b>		<b>6L8Z-6006-EARM</b>		F-Series	2008	<b>ENGINE LONG BLOCK</b>	
<b>ENGINE LONG BLOCK</b>		<b>ENGINE LONG BLOCK</b>		<b>7E5Z-6006-AARM</b>		<b>7L3Z-6006-AARM</b>	
<b>Ford</b>		<b>Ford</b>		<b>ENGINE LONG BLOCK</b>		<b>ENGINE LONG BLOCK</b>	
Freestar	2007-2006	Escape	2006	<b>Ford</b>		<b>Ford</b>	
<b>Mercury</b>		<b>6R3Z-6006-AARM</b>		Fusion	2009-2007	F-Series	2008-2007
Monterey	2007-2006	<b>ENGINE LONG BLOCK</b>		<b>7H6Z-6006-AARM</b>		<b>7L3Z-6006-DARM</b>	
<b>6L2Z-6006-AARM</b>		<b>Ford</b>		<b>ENGINE LONG BLOCK</b>		<b>ENGINE LONG BLOCK</b>	
<b>ENGINE LONG BLOCK</b>		Mustang	2007-2006	<b>Ford</b>		<b>ENGINE LONG BLOCK</b>	
<b>Ford</b>		<b>6R3Z-6006-BARM</b>		Edge	2009-2007	<b>Ford</b>	
Explorer	2006	<b>ENGINE LONG BLOCK</b>		Flex	2009	Expedition	2008-2007
<b>Mercury</b>		<b>Ford</b>		Taurus	2009-2008	F-Series	2008-2007
Mountaineer	2006	Mustang	2007-2006	Taurus X	2009-2008	<b>Lincoln</b>	
<b>6L2Z-6006-BARM</b>		<b>6S4Z-6006-AARM</b>		<b>Lincoln</b>		Navigator	2008-2007
<b>ENGINE LONG BLOCK</b>		<b>ENGINE LONG BLOCK</b>		MKX	2009-2007		
<b>Ford</b>		<b>Ford</b>		MKZ	2009-2007		
Explorer	2007-2006	Focus	2006				

# BUYER'S GUIDE

## Gas Engine Assemblies



FORD PARTS

Make	Year	Make	Year	Make	Year	Make	Year
<b>7L5Z-6006-AARM</b>		<b>7W7Z-6006-BARM</b>		<b>8L5Z-6006-AARM</b>		<b>9A5Z-6006-G</b>	
<b>ENGINE LONG BLOCK</b>		<b>ENGINE LONG BLOCK</b>		<b>ENGINE LONG BLOCK</b>		<b>ENGINE LONG BLOCK</b>	
Ford		Ford		Ford		Lincoln	
Ranger	2007	Crown Victoria	2009-2007	Ranger	2011-2007	MKT	2011
<b>7L8Z-6006-EARM</b>		Lincoln		<b>8L8Z-6006-AARM</b>		<b>9A5Z-6006-GC</b>	
<b>ENGINE LONG BLOCK</b>		Town Car	2008-2007	<b>ENGINE LONG BLOCK</b>		<b>ENGINE LONG BLOCK</b>	
Ford		Mercury		Ford		Lincoln	
Escape	2006	Grand Marquis	2008-2007	Escape	2008	MKT	2016-2010
<b>7L8Z-6006-FARM</b>		<b>7W7Z-6006-CARM</b>		Mazda		<b>9A5Z-6006-J</b>	
<b>ENGINE LONG BLOCK</b>		<b>ENGINE LONG BLOCK</b>		Tribute	2008	<b>ENGINE LONG BLOCK</b>	
Ford		Ford		Mercury		Lincoln	
Escape	2007	Crown Victoria	2009-2007	Mariner	2008	MKS	2010-2009
Focus	2007	Lincoln		<b>8L8Z-6006-BARM</b>		MKT	2016-2010
<b>7L8Z-6006-GARM</b>		Town Car	2011-2007	<b>ENGINE LONG BLOCK</b>		<b>9B4Z-6006-F</b>	
<b>ENGINE LONG BLOCK</b>		Mercury		Ford		<b>ENGINE LONG BLOCK</b>	
Ford		Grand Marquis	2009-2007	Escape	2008	Mazda	
Escape	2008-2007	<b>8C2Z-6006-AARM</b>		Mercury		6	2016-2014, 2010-2009
<b>7R3Z-6006-AARM</b>		<b>ENGINE LONG BLOCK</b>		Mariner	2008	<b>9B4Z-6006-H</b>	
<b>ENGINE LONG BLOCK</b>		Ford		<b>8R3Z-6006-AARM</b>		<b>ENGINE LONG BLOCK</b>	
Ford		Econoline	2008	<b>ENGINE LONG BLOCK</b>		Mazda	
Mustang	2008-2007	<b>8C3Z-6006-AARM</b>		Ford		6	2016-2014, 2010-2009
<b>7R3Z-6006-CARM</b>		<b>ENGINE LONG BLOCK</b>		Mustang	2009-2008	<b>9C2Z-6006-A</b>	
<b>ENGINE LONG BLOCK</b>		Ford		<b>8R3Z-6006-BARM</b>		<b>ENGINE LONG BLOCK</b>	
Ford		F-Series	2008	<b>ENGINE LONG BLOCK</b>		Ford	
Mustang	2009-2007	<b>8C3Z-6006-BARM</b>		Ford		Econoline	2016-2008
<b>7R3Z-6006-DARM</b>		<b>ENGINE LONG BLOCK</b>		Mustang	2008	<b>9C2Z-6006-AA</b>	
<b>ENGINE LONG BLOCK</b>		Ford		<b>8S4Z-6006-AARM</b>		<b>ENGINE LONG BLOCK</b>	
Ford		F-Series	2011-2008	<b>ENGINE LONG BLOCK</b>		Ford	
Mustang	2008-2007	<b>8C3Z-6006-CARM</b>		Ford		Econoline	2016-2003
<b>7S4Z-6006-AARM</b>		<b>ENGINE LONG BLOCK</b>		Focus	2011-2008	<b>9C2Z-6006-AARM</b>	
<b>ENGINE LONG BLOCK</b>		Ford		<b>8U9Z-6006-AARM</b>		<b>ENGINE LONG BLOCK</b>	
Ford		F-Series	2008	<b>ENGINE LONG BLOCK</b>		Ford	
Focus	2007	<b>8C3Z-6006-D</b>		Ford		Econoline	2011-2009
<b>7T4Z-6006-AARM</b>		<b>ENGINE LONG BLOCK</b>		F-Series	2011-2008	<b>9C2Z-6006-BARM</b>	
<b>ENGINE LONG BLOCK</b>		Ford		<b>8W7Z-6006-AARM</b>		<b>ENGINE LONG BLOCK</b>	
Ford		F-Series	2016-2008	<b>ENGINE LONG BLOCK</b>		Ford	
Edge	2008-2007	F53	2016-2011, 2009-2008	Crown Victoria	2009-2008	Econoline	2013-2009
Lincoln		F59	2015-2011	<b>9A5Z-6006-A</b>		<b>9C2Z-6006-CARM</b>	
MKX	2008	<b>8C3Z-6006-DARM</b>		<b>ENGINE LONG BLOCK</b>		<b>ENGINE LONG BLOCK</b>	
Mazda		<b>ENGINE LONG BLOCK</b>		Lincoln		Ford	
CX-9	2007	Ford		MKS	2016-2009	Econoline	2013-2009
<b>7W7Z-6006-AARM</b>		F-Series	2008	<b>9A5Z-6006-C</b>		<b>9C3Z-6006-AARM</b>	
<b>ENGINE LONG BLOCK</b>		<b>8L3Z-6006-BARM</b>		<b>ENGINE LONG BLOCK</b>		<b>ENGINE LONG BLOCK</b>	
Ford		<b>ENGINE LONG BLOCK</b>		Lincoln		Ford	
Crown Victoria	2007	Ford		MKT	2010	Expedition	2010-2009
Lincoln		Expedition	2008-2007			F-Series	2010-2009
Town Car	2007	F-Series	2008-2007			Lincoln	
Mercury						Navigator	2010-2009
Grand Marquis	2007						



Make	Year	Make	Year	Make	Year	Make	Year
<b>9C3Z-6006-BARM</b>		<b>9L1Z-6006-AARM cont'd</b>		<b>9L8Z-6006-BARM cont'd</b>		<b>9T4Z-6006-GB</b>	
<b>ENGINE LONG BLOCK</b>		F-Series	2010-2009	Milan	2011-2010	<b>ENGINE LONG BLOCK</b>	
Ford		Lincoln		<b>9L8Z-6006-BRM</b>		Ford	
F-Series	2010-2009	Navigator	2012-2009	<b>ENGINE LONG BLOCK</b>		Flex	
<b>9E5Z-6006-C</b>		<b>9L2Z-6006-AARM</b>		Ford		<b>9W7Z-6006-ARM</b>	
<b>ENGINE LONG BLOCK</b>		<b>ENGINE LONG BLOCK</b>		Escape	2012-2009	<b>ENGINE LONG BLOCK</b>	
Ford		Ford		Fusion	2012-2010	Ford	
Escape	2012-2010	Explorer	2009	<b>Mazda</b>		Crown Victoria	
<b>Mazda</b>		Explorer Sport Trac	2010-2009	Tribute		2011-2008	
Tribute	2010	<b>Mercury</b>		Mercury		Lincoln	
<b>Mercury</b>		Mountaineer	2009	Mariner		Town Car	
Mariner	2011-2010	<b>9L2Z-6006-BARM</b>		<b>9L8Z-6006-CARM</b>		Mercury	
<b>9E5Z-6006-FRM</b>		<b>ENGINE LONG BLOCK</b>		<b>ENGINE LONG BLOCK</b>		Grand Marquis	
<b>ENGINE LONG BLOCK</b>		Ford		Ford		<b>AA5Z-6006-D</b>	
Ford		Explorer	2010-2009	Escape		<b>ENGINE LONG BLOCK</b>	
Escape	2011-2010	Explorer Sport Trac	2009	Mercury		Ford	
Fusion	2011-2010	<b>Mercury</b>		Mariner		Explorer	
<b>Mazda</b>		Mountaineer	2009	<b>9M8Z-6006-BRM</b>		Flex	
Tribute	2010	<b>9L2Z-6006-CARM</b>		<b>ENGINE LONG BLOCK</b>		Taurus	
<b>Mercury</b>		<b>ENGINE LONG BLOCK</b>		Mazda		Lincoln	
Mariner	2011-2010	Ford		6		MKS	
Milan	2011-2010	Explorer		2013-2009		MKT	
<b>9G1Z-6006-ARM</b>		Explorer Sport Trac		<b>9R3Z-6006-BRM</b>		<b>AA5Z-6006-F</b>	
<b>ENGINE LONG BLOCK</b>		Mercury		<b>ENGINE LONG BLOCK</b>		<b>ENGINE LONG BLOCK</b>	
Lincoln		Mountaineer		Ford		Lincoln	
MKS	2009	<b>9L3Z-6006-A</b>		Mustang		MKT	
<b>9G1Z-6006-CRM</b>		<b>ENGINE LONG BLOCK</b>		2010-2009		2017-2015	
<b>ENGINE LONG BLOCK</b>		Ford		<b>9T4Z-6006-AARM</b>		<b>AC2Z-6006-A</b>	
Lincoln		Expedition		<b>ENGINE LONG BLOCK</b>		<b>ENGINE LONG BLOCK</b>	
MKS	2010-2009	F-Series		Ford		Ford	
MKT	2010	Lincoln		Edge		Econoline	
<b>9H6Z-6006-ARM</b>		Navigator		Flex		2016-2010	
<b>ENGINE LONG BLOCK</b>		2014-2009		Lincoln		<b>AC2Z-6006-ARM</b>	
Ford		<b>9L3Z-6006-AARM</b>		MKX		<b>ENGINE LONG BLOCK</b>	
Edge		<b>ENGINE LONG BLOCK</b>		2009		Ford	
Flex	2010-2009	Ford		<b>9T4Z-6006-BARM</b>		Econoline	
Fusion	2012-2011	F-Series		<b>ENGINE LONG BLOCK</b>		2010	
Taurus	2011-2009	2009		Ford		<b>AC2Z-6006-B</b>	
Taurus X	2009	<b>9L3Z-6006-CARM</b>		Edge		<b>ENGINE LONG BLOCK</b>	
Lincoln		<b>ENGINE LONG BLOCK</b>		Flex		Ford	
MKX	2010-2007	Ford		2010-2009		Econoline	
MKZ	2012-2009	F-Series		Lincoln		2016-2010	
<b>Mercury</b>		2009		MKX		<b>AC2Z-6006-BRM</b>	
Sable	2009	<b>9L8Z-6006-BARM</b>		2009		<b>ENGINE LONG BLOCK</b>	
<b>9L1Z-6006-AARM</b>		<b>ENGINE LONG BLOCK</b>		<b>9T4Z-6006-FC</b>		Ford	
<b>ENGINE LONG BLOCK</b>		Ford		<b>ENGINE LONG BLOCK</b>		Econoline	
Ford		Escape		Ford		2013-2010	
Expedition	2012-2009	Fusion		Edge		<b>AG1Z-6006-ARM</b>	
<b>9L1Z-6006-AARM</b>		Mazda		Flex		<b>ENGINE LONG BLOCK</b>	
<b>ENGINE LONG BLOCK</b>		Tribute		2015-2009		Lincoln	
Ford		2011-2010		Lincoln		MKS	
Expedition		<b>Mercury</b>		MKX		2010	
2012-2009		Mariner		2010-2008		MKT	
		2011-2009				2010	

# BUYER'S GUIDE

## Gas Engine Assemblies



FORD PARTS

Make	Year	Make	Year	Make	Year	Make	Year
<b>AL3Z-6006-DRM</b>		<b>BA5Z-6006-AARM cont'd</b>		<b>BC3Z-6006-C cont'd</b>		<b>BP5Z-6006-AARM cont'd</b>	
<b>ENGINE LONG BLOCK</b>		MKT 2011		F53 2016-2011		Lincoln	
Ford		<b>BA5Z-6006-CCRM</b>		F59 2016-2011		MKZ 2012-2011	
F-Series 2013-2010		<b>ENGINE LONG BLOCK</b>		<b>BC3Z-6006-ERM</b>		<b>BP5Z-6006-BARM</b>	
<b>AR3Z-6006-A</b>		Lincoln		<b>ENGINE LONG BLOCK</b>		<b>ENGINE LONG BLOCK</b>	
<b>ENGINE LONG BLOCK</b>		MKS 2011-2010		Ford		Ford	
Ford		MKT 2011-2010		F-Series 2013-2011		Fusion 2012-2010	
Mustang 2010-2008		<b>BA5Z-6006-D</b>		<b>BE9Z-6006-AARM</b>		Taurus 2012-2010	
<b>AR3Z-6006-BRM</b>		<b>ENGINE LONG BLOCK</b>		<b>ENGINE LONG BLOCK</b>		Lincoln	
<b>ENGINE LONG BLOCK</b>		Ford		Lincoln		MKZ 2012-2010	
Ford		Edge 2014-2011		MKS 2011-2010		<b>BR3Z-6006-BRM</b>	
Mustang 2010		Police Interceptor Sedan 2016-2013		MKT 2011-2010		<b>ENGINE LONG BLOCK</b>	
<b>AT1Z-6006-A</b>		Police Interceptor Utility 2017-2013		<b>BE9Z-6006-BARM</b>		Ford	
<b>ENGINE LONG BLOCK</b>		Lincoln		<b>ENGINE LONG BLOCK</b>		Mustang 2013-2011	
Ford		MKS 2016-2013		Lincoln		<b>BR3Z-6006-CARM</b>	
Transit Connect 2013-2010		MKX 2016-2011		MKS 2012-2010		<b>ENGINE LONG BLOCK</b>	
<b>AT1Z-6006-ARM</b>		MKZ 2016-2013		MKT 2012-2010		Ford	
<b>ENGINE LONG BLOCK</b>		<b>BA5Z-6006-DDRM</b>		<b>BG1Z-6006-AARM</b>		F-Series 2013-2011	
Ford		<b>ENGINE LONG BLOCK</b>		<b>ENGINE LONG BLOCK</b>		Mustang 2013-2011	
Edge 2012		Lincoln		Ford		<b>BR3Z-6006-M</b>	
Explorer 2012		MKS 2012-2010		Flex 2012-2011		<b>ENGINE LONG BLOCK</b>	
<b>AT1Z-6006-B</b>		MKT 2012-2010		Taurus 2012-2011		Ford	
<b>ENGINE LONG BLOCK</b>		<b>BA8Z-6006-BARM</b>		<b>BG1Z-6006-BARM</b>		F-Series 2014-2011	
Ford		<b>ENGINE LONG BLOCK</b>		<b>ENGINE LONG BLOCK</b>		Mustang 2016-2011	
Transit Connect 2013-2011		Ford		Ford		<b>BT4Z-6006-AARM</b>	
<b>AT4Z-6006-B</b>		Flex 2012-2011		Flex 2012-2011		<b>ENGINE LONG BLOCK</b>	
<b>ENGINE LONG BLOCK</b>		Taurus 2012-2011		Taurus 2012-2011		Ford	
Ford		<b>BB5Z-6006-A</b>		<b>BL3Z-6006-BARM</b>		Edge 2012-2011	
Explorer 2012-2011		<b>ENGINE LONG BLOCK</b>		<b>ENGINE LONG BLOCK</b>		Lincoln	
<b>AT4Z-6006-D</b>		Ford		Ford		MKX 2012-2011	
<b>ENGINE LONG BLOCK</b>		Explorer 2013-2012		F-Series 2012-2011		<b>BW7Z-6006-ARM</b>	
Ford		<b>BB5Z-6006-AARM</b>		<b>BL3Z-6006-CARM</b>		<b>ENGINE LONG BLOCK</b>	
Edge 2016-2011		<b>ENGINE LONG BLOCK</b>		Ford		Ford	
Explorer 2012-2011		Ford		F-Series 2012-2011		Crown Victoria 2010	
<b>AU7Z-6006-ARM</b>		<b>BB5Z-6006-BARM</b>		<b>BL3Z-6006-CRM</b>		<b>BW7Z-6006-BRM</b>	
<b>ENGINE LONG BLOCK</b>		<b>ENGINE LONG BLOCK</b>		<b>ENGINE LONG BLOCK</b>		<b>ENGINE LONG BLOCK</b>	
Ford		Ford		Ford		Ford	
Flex 2010		Edge 2011		F-Series 2010		Crown Victoria 2011-2010	
Taurus 2010		Explorer 2012-2011		<b>BL3Z-6006-DARM</b>		<b>C1BZ-6006-A</b>	
Lincoln		<b>BC3Z-6006-BARM</b>		<b>ENGINE LONG BLOCK</b>		<b>ENGINE LONG BLOCK</b>	
MKS 2010		<b>ENGINE LONG BLOCK</b>		Ford		Ford	
MKT 2010		Ford		F-Series 2012-2011		Fiesta 2014	
<b>BA5Z-6006-AARM</b>		<b>ENGINE LONG BLOCK</b>		<b>BP5Z-6006-AARM</b>		<b>C1BZ-6006-B</b>	
<b>ENGINE LONG BLOCK</b>		Ford		<b>ENGINE LONG BLOCK</b>		<b>ENGINE LONG BLOCK</b>	
Ford		F53 2011		Ford		Ford	
Flex 2011		<b>BC3Z-6006-C</b>		Fusion 2012-2011		Fiesta 2016-2014	
Taurus 2011		<b>ENGINE LONG BLOCK</b>		Taurus 2012-2011			
Lincoln		Ford					
MKS 2011		F-Series 2016-2011					



Make	Year	Make	Year	Make	Year	Make	Year
<b>C1BZ-6006-C</b>		<b>CS4Z-6006-ARM</b>		<b>DB5Z-6006-ARM cont'd</b>		<b>DL2Z-6006-ARM</b>	
<b>ENGINE LONG BLOCK</b>		<b>ENGINE LONG BLOCK</b>		Explorer	2012	<b>ENGINE LONG BLOCK</b>	
Ford		Ford		<b>DC1Z-6006-ARM</b>		Ford	
Fiesta	2016-2015	Focus	2012	<b>ENGINE LONG BLOCK</b>		Edge	2013-2012
<b>CE5Z-6006-A</b>		<b>CS4Z-6006-BRM</b>		Ford		Explorer	2012
<b>ENGINE LONG BLOCK</b>		<b>ENGINE LONG BLOCK</b>		Transit Connect	2016-2014	Flex	2013-2012
Ford		Ford		<b>DC3Z-6006-ARM</b>		Taurus	2013-2012
Escape	2012	Focus	2012	<b>ENGINE LONG BLOCK</b>		<b>DL2Z-6006-BRM</b>	
Fusion	2012	<b>CT4Z-6006-B</b>		Ford		<b>ENGINE LONG BLOCK</b>	
<b>CJ5Z-6006-B</b>		<b>ENGINE LONG BLOCK</b>		F-Series	2011	Ford	
<b>ENGINE LONG BLOCK</b>		Ford		<b>DC3Z-6006-BRM</b>		Edge	2013-2012
Ford		Edge	2015-2012	<b>ENGINE LONG BLOCK</b>		Explorer	2013-2012
Escape	2014-2013	<b>CV6Z-6006-A</b>		Ford		Flex	2013-2012
Lincoln		<b>ENGINE LONG BLOCK</b>		F-Series	2013-2012	Taurus	2013-2012
MKC	2015	Ford		<b>DF1Z-6006-DRM</b>		<b>DL2Z-6006-D</b>	
<b>CJ5Z-6006-C</b>		Escape	2016-2013	<b>ENGINE LONG BLOCK</b>		<b>ENGINE LONG BLOCK</b>	
<b>ENGINE LONG BLOCK</b>		Fusion	2016-2013	Ford		Ford	
Ford		<b>D2BZ-6006-A</b>		Flex	2012	Edge	2016-2012
Escape	2016-2014	<b>ENGINE LONG BLOCK</b>		Taurus	2012	Explorer	2016-2013
Lincoln		Ford		Lincoln		Flex	2016-2012
MKC	2016-2015	Fiesta	2016-2011	MKS	2012	Taurus	2016-2012
MKZ	2015-2013	<b>D9UZ-6V012-DRM</b>		<b>DG1Z-6006-A</b>		<b>DL3Z-6006-ARM</b>	
<b>CJ5Z-6006-G</b>		<b>ENGINE LONG BLOCK</b>		<b>ENGINE LONG BLOCK</b>		<b>ENGINE LONG BLOCK</b>	
<b>ENGINE LONG BLOCK</b>		Ford		Ford		Ford	
Ford		Econoline	1985-1979	Police Interceptor	2014-2013	F-Series	2013
Escape	2015-2013	F-Series	1985-1983, 1979	Sedan		<b>DL3Z-6006-ERM</b>	
Fusion	2014-2013	<b>DA8Z-6006-A</b>		<b>DK4Z-6006-C</b>		<b>ENGINE LONG BLOCK</b>	
Transit Connect	2016-2014	<b>ENGINE LONG BLOCK</b>		<b>ENGINE LONG BLOCK</b>		Ford	
<b>CJ5Z-6006-H</b>		Lincoln		Ford		F-Series	2012
<b>ENGINE LONG BLOCK</b>		MKT	2016-2013	Transit-150	2016-2015	<b>DL3Z-6006-F</b>	
Lincoln		<b>DA8Z-6006-ARM</b>		Transit-250	2016-2015	<b>ENGINE LONG BLOCK</b>	
MKZ	2016-2015	<b>ENGINE LONG BLOCK</b>		Transit-350	2016-2015	Ford	
<b>CJ5Z-6006-K</b>		Ford		Transit-350 HD	2016-2015	Expedition	2016-2015
<b>ENGINE LONG BLOCK</b>		Explorer	2013	<b>DK4Z-6006-G</b>		F-Series	2016-2013
Ford		Taurus	2013	<b>ENGINE LONG BLOCK</b>		Lincoln	
Escape	2016	<b>DA8Z-6006-B</b>		Transit-150	2016-2015	Navigator	2016-2015
<b>CL3Z-6006-A</b>		<b>ENGINE LONG BLOCK</b>		Transit-250	2016-2015	<b>DL3Z-6006-FRM</b>	
<b>ENGINE LONG BLOCK</b>		Ford		Transit-350	2016-2015	<b>ENGINE LONG BLOCK</b>	
Ford		Explorer	2015-2013	Transit-350 HD	2016-2015	Ford	
F-Series	2014-2012	Taurus	2016-2013	<b>DK4Z-6006-H</b>		F-Series	2013
<b>CL8Z-6006-ARM</b>		<b>DB3Z-6006-A</b>		<b>ENGINE LONG BLOCK</b>		<b>DM5Z-6006-A</b>	
<b>ENGINE LONG BLOCK</b>		<b>ENGINE LONG BLOCK</b>		Ford		<b>ENGINE LONG BLOCK</b>	
Ford		Ford		Transit-150	2016-2015	Ford	
Escape	2013	Transit Connect	2016-2014	Transit-250	2016-2015	Edge	2012
<b>CR3Z-6006-D</b>		<b>DB5Z-6006-ARM</b>		Transit-350	2016-2015	Focus	2016-2013
<b>ENGINE LONG BLOCK</b>		<b>ENGINE LONG BLOCK</b>		Transit-350 HD	2016-2015	<b>DR3Z-6006-A</b>	
Ford		Ford		<b>ENGINE LONG BLOCK</b>		<b>ENGINE LONG BLOCK</b>	
Mustang	2014-2012	Edge	2012	Ford		Ford	
				Transit-150	2016-2015	Mustang	2014-2013
				Transit-250	2016-2015		
				Transit-350	2016-2015		
				Transit-350 HD	2016-2015		

# BUYER'S GUIDE

## Gas Engine Assemblies



FORD PARTS

Make	Year	Make	Year	Make	Year	Make	Year
<b>DR3Z-6006-B</b>		<b>E5TZ-6V012-HRM cont'd</b>		<b>F15Z-6V012-ABRM</b>		<b>F1TZ-6V012-CBRM</b>	
<b>ENGINE LONG BLOCK</b>		F-Series	1987-1985	<b>ENGINE LONG BLOCK</b>		<b>ENGINE LONG BLOCK</b>	
Ford		<b>E6AZ-6V012-ARM</b>		Lincoln		Ford	
Mustang	2014-2013	<b>ENGINE LONG BLOCK</b>		Continental	1993-1991	Explorer	1992-1991
<b>DR3Z-6006-DARM</b>		Ford		<b>F1AZ-6V012-BRM</b>		Ranger	
<b>ENGINE LONG BLOCK</b>		LTD	1986	<b>ENGINE LONG BLOCK</b>		<b>F1ZZ-6V012-BRM</b>	
Ford		Thunderbird	1986	Ford		<b>ENGINE LONG BLOCK</b>	
Mustang	2014-2011	Lincoln		Country Squire	1991-1987	Ford	
<b>DS7Z-6006-C</b>		Continental	1986	LTD Crown Victoria	1991-1987	Mustang	1993-1987
<b>ENGINE LONG BLOCK</b>		Mark VII	1986	Thunderbird	1988-1987	Thunderbird	1992-1991
Ford		Town Car	1986	Lincoln		Lincoln	
Fusion	2016-2013	<b>Mercury</b>		Continental	1987	Mark VII	1992-1988
Lincoln		Cougar	1986	Mark VII	1987	<b>Mercury</b>	
MKZ	2016-2013	Grand Marquis	1986	Town Car	1990-1987	Cougar	1992-1991
<b>DS7Z-6006-E</b>		<b>E9SZ-6V012-BBRM</b>		<b>Mercury</b>		<b>F2GZ-6006-A</b>	
<b>ENGINE LONG BLOCK</b>		<b>ENGINE LONG BLOCK</b>		Colony Park	1991-1987	<b>ENGINE LONG BLOCK</b>	
Ford		Ford		Cougar	1988-1987	Ford	
Fusion	2016-2014	Thunderbird	1990-1989	Grand Marquis	1991-1987	Edge	2016-2015
<b>DT4Z-6006-BRM</b>		<b>Mercury</b>		<b>F1DZ-6V012-BRM</b>		<b>F2TZ-6V012-ARM</b>	
<b>ENGINE LONG BLOCK</b>		Cougar		<b>ENGINE LONG BLOCK</b>		<b>ENGINE LONG BLOCK</b>	
Ford		EA8Z-6006-A		Ford		Ford	
Edge	2015-2012	<b>ENGINE LONG BLOCK</b>		Taurus	1993-1988	Bronco	1993-1992
Explorer	2015-2013	Lincoln		Lincoln		Econoline	1993-1992
<b>DV6Z-6006-AARM</b>		MKT	2016-2014	Continental	1990-1989	F-Series	1993-1992
<b>ENGINE LONG BLOCK</b>		<b>EJ7Z-6006-A</b>		<b>Mercury</b>		<b>F2TZ-6V012-CRM</b>	
Ford		<b>ENGINE LONG BLOCK</b>		Sable	1993-1988	<b>ENGINE LONG BLOCK</b>	
Focus	2013	Lincoln		<b>F1FZ-6006-C</b>		Ford	
<b>E4TZ-6V012-ARM</b>		MKC	2016-2015	<b>ENGINE LONG BLOCK</b>		Bronco	1992-1987
<b>ENGINE LONG BLOCK</b>		<b>EJ7Z-6006-B</b>		Ford		Econoline	1996-1987
Ford		<b>ENGINE LONG BLOCK</b>		Focus	2016-2015	F-Series	1996-1987
Bronco	1987-1984	Lincoln		<b>F1SZ-6V012-ARM</b>		<b>F2TZ-6V012-FRM</b>	
Econoline	1987-1984	MKC	2016	<b>ENGINE LONG BLOCK</b>		<b>ENGINE LONG BLOCK</b>	
F-Series	1988-1984	<b>EL3Z-6006-C</b>		Ford		Ford	
<b>E5AZ-6V012-ARM</b>		<b>ENGINE LONG BLOCK</b>		Thunderbird	1993-1989	Econoline	1992-1988
<b>ENGINE LONG BLOCK</b>		Ford		<b>Mercury</b>		F-Series	1992-1988
Ford		F-Series	2014-2011	Cougar	1993-1989	<b>F2UZ-6V012-DRM</b>	
Bronco	1983	Mustang	2012	<b>F1TZ-6V012-ARM</b>		<b>ENGINE LONG BLOCK</b>	
Econoline	1985-1983	<b>EL3Z-6006-D</b>		<b>ENGINE LONG BLOCK</b>		Ford	
F-Series	1985-1983	<b>ENGINE LONG BLOCK</b>		Ford		Bronco	1992-1987
LTD	1985-1983	Ford		Bronco	1991-1988	Econoline	1996-1987
Lincoln		F-Series	2014	Econoline	1991-1988	F-Series	1996-1987
Town Car	1983	<b>ER3Z-6006-A</b>		F-Series	1991-1987	<b>F3HZ-6V012-CRM</b>	
<b>Mercury</b>		<b>ENGINE LONG BLOCK</b>		<b>F1TZ-6V012-BRM</b>		<b>ENGINE LONG BLOCK</b>	
Cougar	1984-1983	Ford		<b>ENGINE LONG BLOCK</b>		Ford	
Grand Marquis	1983	Mustang	2014-2011	Ford		F600	1994-1993
<b>E5TZ-6V012-HRM</b>		<b>ER3Z-6006-B</b>		Bronco		F700	1996-1993
<b>ENGINE LONG BLOCK</b>		<b>ENGINE LONG BLOCK</b>		Econoline			
Ford		Ford		F-Series			
Econoline	1987-1985	Mustang	2014-2012	F-Series			





Make	Year	Make	Year	Make	Year	Make	Year
<b>F3SZ-6V012-ARM</b>		<b>F4TZ-6V012-CRM cont'd</b>		<b>F77Z-6006-CRM</b>		<b>F7TZ-6006-EARM</b>	
<b>ENGINE LONG BLOCK</b>		Econoline	1995-1994	<b>ENGINE LONG BLOCK</b>		<b>ENGINE LONG BLOCK</b>	
Ford		F-Series	1995-1994	Ford		Ford	
Thunderbird	1993-1989	<b>F4ZZ-6V012-ARM</b>		Explorer	2001-1997	Econoline	1998-1997
<b>Mercury</b>		<b>ENGINE LONG BLOCK</b>		Explorer Sport Trac	2001	F-Series	1997
Cougar	1990-1989	Ford		<b>Mercury</b>		<b>F7TZ-6006-FARM</b>	
<b>F3TZ-6V012-BRM</b>		Mustang	1995-1994	Mountaineer	2001-1998	<b>ENGINE LONG BLOCK</b>	
<b>ENGINE LONG BLOCK</b>		<b>F57Z-6V012-DRM</b>		<b>F77Z-6006-DRM</b>		Ford	
Ford		<b>ENGINE LONG BLOCK</b>		<b>ENGINE LONG BLOCK</b>		Expedition	
Explorer	1994-1993	Ford		Explorer	2001-1997	1998-1997	
Ranger	1994-1993	Aerostar	1997-1996	Explorer Sport Trac	2001	F-Series	
<b>F3TZ-6V012-CRM</b>		Ranger	1998-1995	<b>F77Z-6006-GARM</b>		<b>ENGINE LONG BLOCK</b>	
<b>ENGINE LONG BLOCK</b>		<b>F5TZ-6V012-AARM</b>		<b>ENGINE LONG BLOCK</b>		Ford	
Ford		<b>ENGINE LONG BLOCK</b>		Mercury		Expedition	
Explorer	1994-1993	Ford		Mountaineer	2001-1998	1998-1997	
Ranger	1994-1993	Aerostar	1996-1995	<b>F77Z-6V012-AARM</b>		F-Series	
<b>F3TZ-6V012-FRM</b>		<b>F5TZ-6V012-ACRM</b>		<b>ENGINE LONG BLOCK</b>		Lincoln	
<b>ENGINE LONG BLOCK</b>		<b>ENGINE LONG BLOCK</b>		Ford		Navigator	
Ford		Ford		Explorer	1997	1998	
Econoline	1996-1993	Explorer	1996-1995	Ranger	1997	<b>F7TZ-6006-YARM</b>	
F-Series	1997-1993	Ranger	1996-1995	<b>F77Z-6V012-CARM</b>		<b>ENGINE LONG BLOCK</b>	
F53	1997-1993	<b>F68Z-6V012-ABRM</b>		<b>ENGINE LONG BLOCK</b>		Ford	
<b>F4SZ-6V012-ARM</b>		<b>ENGINE LONG BLOCK</b>		Ford		Expedition	
<b>ENGINE LONG BLOCK</b>		Ford		Explorer	1998-1997	1998-1997	
Ford		Windstar	1996	<b>Mercury</b>		F-Series	
Mustang	1995-1994	<b>F6TZ-6V012-CBRM</b>		Mountaineer	1998-1997	1998-1997	
Thunderbird	1995-1994	<b>ENGINE LONG BLOCK</b>		<b>F77Z-6V012-DARM</b>		<b>ENGINE LONG BLOCK</b>	
<b>Mercury</b>		Ford		<b>ENGINE LONG BLOCK</b>		Ford	
Cougar	1995-1994	Bronco	1996	Ford		Expedition	
<b>F4TZ-6V012-ARM</b>		Econoline	1996	Aerostar	1997	1998-1997	
<b>ENGINE LONG BLOCK</b>		F-Series	1996	<b>F78Z-6V012-AARM</b>		<b>ENGINE LONG BLOCK</b>	
Ford		<b>F6XZ-6006-BBRM</b>		<b>ENGINE LONG BLOCK</b>		Ford	
F-Series	1995-1994	<b>ENGINE LONG BLOCK</b>		Ford		F-Series	
<b>F4TZ-6V012-BARM</b>		Mercury		Windstar	1998-1997	1998-1997	
<b>ENGINE LONG BLOCK</b>		Villager	1996-1993	<b>F7CZ-6006-ARM</b>		<b>ENGINE LONG BLOCK</b>	
Ford		<b>F6ZZ-6006-BRM</b>		<b>ENGINE LONG BLOCK</b>		Ford	
Bronco	1996	<b>ENGINE LONG BLOCK</b>		Ford		Econoline	
Econoline	1996	Ford		Escort	1997	1998-1997	
F-Series	1997-1996	Mustang	1996	<b>Mercury</b>		Expedition	
<b>F4TZ-6V012-BRM</b>		<b>F6ZZ-6V012-AARM</b>		Tracer	1997	1998-1997	
<b>ENGINE LONG BLOCK</b>		<b>ENGINE LONG BLOCK</b>		<b>F7HZ-6V012-BARM</b>		<b>ENGINE LONG BLOCK</b>	
Ford		Ford		<b>ENGINE LONG BLOCK</b>		Ford	
Bronco	1995-1994	Mustang	1996	Ford		Econoline	
Econoline	1995-1994	Thunderbird	1996	F700	1998-1997	1998-1997	
F-Series	1995-1994	<b>Mercury</b>		F800	1998-1997	F-Series	
<b>F4TZ-6V012-CRM</b>		Cougar	1996	<b>F7TZ-6006-DARM</b>		<b>ENGINE LONG BLOCK</b>	
<b>ENGINE LONG BLOCK</b>		<b>ENGINE LONG BLOCK</b>		<b>ENGINE LONG BLOCK</b>		Ford	
Ford		Ford		Ford		Econoline	
Bronco	1995-1994	Mustang		F-Series		1999-1997	
		Thunderbird		1998-1997		<b>F7UZ-6006-MARM</b>	
		Cougar		1998-1997		<b>ENGINE LONG BLOCK</b>	
						Ford	
						Econoline	
						1999-1998	

# BUYER'S GUIDE

## Gas Engine Assemblies



FORD PARTS

Make	Year	Make	Year	Make	Year	Make	Year
<b>F7ZZ-6V012-AARM</b>		<b>F8TZ-6006-JARM</b>		<b>FG1Z-6006-F</b>		<b>FR3Z-6006-G</b>	
<b>ENGINE LONG BLOCK</b>		<b>ENGINE LONG BLOCK</b>		<b>ENGINE LONG BLOCK</b>		<b>ENGINE LONG BLOCK</b>	
Ford		Ford		Ford		Ford	
Mustang	1998-1997	Expedition	1998-1997	Police Interceptor Utility	2017-2015	Mustang	2016-2015
Thunderbird	1997	F-Series	1998-1997	<b>FK4Z-6006-BRM</b>		<b>FR3Z-6006-H</b>	
Mercury		<b>F8TZ-6006-KARM</b>		<b>ENGINE LONG BLOCK</b>		<b>ENGINE LONG BLOCK</b>	
Cougar	1997	<b>ENGINE LONG BLOCK</b>		Ford		Ford	
<b>F87Z-6006-ARM</b>		Ford		Transit-150		Mustang	
<b>ENGINE LONG BLOCK</b>		Expedition		2016-2015		2016-2015	
Ford		F-Series		2016-2015		<b>G1FZ-6006-A</b>	
Explorer	2000-1998	F8UZ-6006-BRM		Transit-250		<b>ENGINE LONG BLOCK</b>	
Ranger	2000-1998	<b>ENGINE LONG BLOCK</b>		Transit-350		Ford	
Mazda		Ford		Transit-350 HD		Focus	
B4000	2000-1998	Econoline		2016-2015		2016	
<b>F87Z-6006-CARM</b>		<b>FC3Z-6006-CARM</b>		<b>FL3Z-6006-B</b>		<b>G1FZ-6006-B</b>	
<b>ENGINE LONG BLOCK</b>		<b>ENGINE LONG BLOCK</b>		<b>ENGINE LONG BLOCK</b>		<b>ENGINE LONG BLOCK</b>	
Ford		Ford		Ford		Ford	
Ranger	2001-1998	F-Series		F-Series		Focus	
Mazda		2016		2016-2015		2016	
B2500	2001-1998	<b>FC3Z-6006-DARM</b>		<b>FL3Z-6006-E</b>		<b>G2GZ-6007-A</b>	
<b>F87Z-6V012-ARM</b>		<b>ENGINE LONG BLOCK</b>		<b>ENGINE LONG BLOCK</b>		<b>ENGINE LONG BLOCK</b>	
<b>ENGINE LONG BLOCK</b>		Ford		Ford		Lincoln	
Ford		F-Series		F-Series		MKX	
Explorer	2001-1998	2016		2016-2015		2016	
Mercury		<b>FC4Z-6006-A</b>		<b>FL3Z-6006-FARM</b>		<b>GB5Z-6006-A</b>	
Mountaineer	2001-1998	<b>ENGINE LONG BLOCK</b>		<b>ENGINE LONG BLOCK</b>		<b>ENGINE LONG BLOCK</b>	
<b>F8AZ-6V012-ARM</b>		Ford		Ford		Ford	
<b>ENGINE LONG BLOCK</b>		F-Series		F-Series		Explorer	
Ford		2016		2016		2016	
Explorer	2001-1998	<b>FC4Z-6006-B</b>		<b>FL3Z-6006-G</b>		<b>GC3Z-6006-B</b>	
Mercury		<b>ENGINE LONG BLOCK</b>		<b>ENGINE LONG BLOCK</b>		<b>ENGINE LONG BLOCK</b>	
Mountaineer	2001-1998	Ford		Ford		Ford	
<b>F8AZ-6V012-ARM</b>		F650		F-Series		F-Series	
<b>ENGINE LONG BLOCK</b>		2016		2015		2016-2012	
Ford		<b>FC4Z-6006-B</b>		<b>FL3Z-6006-GARM</b>		<b>GC3Z-6007-E</b>	
Crown Victoria	1999-1996	<b>ENGINE LONG BLOCK</b>		<b>ENGINE LONG BLOCK</b>		<b>ENGINE LONG BLOCK</b>	
Mustang	1998-1996	Ford		Ford		Ford	
<b>F8RZ-6V012-ARM</b>		F650		F-Series		F-Series	
<b>ENGINE LONG BLOCK</b>		2016		2016		2016	
Ford		<b>FG1Z-6006-A</b>		<b>FM5Z-14B280-A</b>		<b>GL3Z-6006-B</b>	
Ford		<b>ENGINE LONG BLOCK</b>		<b>DRIVE MOTOR</b>		<b>ENGINE LONG BLOCK</b>	
Contour	1998	Ford		Focus		Ford	
Mercury		Explorer		2016-2012		F-Series	
Mystique	1998	Flex		2016-2012		2016	
<b>F8TZ-6006-FARM</b>		Taurus		<b>FM5Z-6006-A</b>		<b>GL3Z-6006-C</b>	
<b>ENGINE LONG BLOCK</b>		Lincoln		<b>ENGINE LONG BLOCK</b>		<b>ENGINE LONG BLOCK</b>	
Ford		MKS		Ford		Ford	
Econoline	1998	2016-2015		Focus		F-Series	
F-Series	1998	MKT		2015-2013		2016	
<b>F8TZ-6006-HARM</b>		<b>FG1Z-6006-B</b>		<b>FOTZ-6V012-ABRM</b>		<b>GL3Z-6006-D</b>	
<b>ENGINE LONG BLOCK</b>		<b>ENGINE LONG BLOCK</b>		<b>ENGINE LONG BLOCK</b>		<b>ENGINE LONG BLOCK</b>	
Ford		Ford		Ford		Ford	
F-Series	1997	Police Interceptor Sedan		Aerostar		F-Series	
<b>F8TZ-6006-HARM</b>		2016-2015		1994-1990		2016	
<b>ENGINE LONG BLOCK</b>		<b>FG1Z-6006-E</b>		Explorer		<b>GR3Z-6006-B</b>	
Ford		<b>ENGINE LONG BLOCK</b>		Ranger		<b>ENGINE LONG BLOCK</b>	
Ford		Ford		1992-1991		Ford	
Explorer	2016	Explorer		1992-1990		Mustang	
<b>F8TZ-6006-HARM</b>		2016		<b>FR3Z-6006-B</b>		2016-2015	
<b>ENGINE LONG BLOCK</b>		<b>ENGINE LONG BLOCK</b>		<b>ENGINE LONG BLOCK</b>		2016-2015	
Ford		Ford		Ford		2016-2015	
Explorer	2016	Mustang		Mustang		2016-2015	
<b>F8TZ-6006-HARM</b>		2016		2016-2015		2016-2015	
<b>ENGINE LONG BLOCK</b>		<b>ENGINE LONG BLOCK</b>		<b>ENGINE LONG BLOCK</b>		<b>ENGINE LONG BLOCK</b>	
Ford		Ford		Ford		Ford	
Mustang	2016-2015	Mustang		Mustang		Mustang	
<b>F8TZ-6006-HARM</b>		2016-2015		2016-2015		2016-2015	
<b>ENGINE LONG BLOCK</b>		<b>ENGINE LONG BLOCK</b>		<b>ENGINE LONG BLOCK</b>		<b>ENGINE LONG BLOCK</b>	
Ford		Ford		Ford		Ford	
Mustang	2016-2015	Mustang		Mustang		Mustang	
<b>F8TZ-6006-HARM</b>		2016-2015		2016-2015		2016-2015	
<b>ENGINE LONG BLOCK</b>		<b>ENGINE LONG BLOCK</b>		<b>ENGINE LONG BLOCK</b>		<b>ENGINE LONG BLOCK</b>	
Ford		Ford		Ford		Ford	
Mustang	2016-2015	Mustang		Mustang		Mustang	
<b>F8TZ-6006-HARM</b>		2016-2015		2016-2015		2016-2015	
<b>ENGINE LONG BLOCK</b>		<b>ENGINE LONG BLOCK</b>		<b>ENGINE LONG BLOCK</b>		<b>ENGINE LONG BLOCK</b>	
Ford		Ford		Ford		Ford	
Mustang	2016-2015	Mustang		Mustang		Mustang	
<b>F8TZ-6006-HARM</b>		2016-2015		2016-2015		2016-2015	
<b>ENGINE LONG BLOCK</b>		<b>ENGINE LONG BLOCK</b>		<b>ENGINE LONG BLOCK</b>		<b>ENGINE LONG BLOCK</b>	
Ford		Ford		Ford		Ford	
Mustang	2016-2015	Mustang		Mustang		Mustang	
<b>F8TZ-6006-HARM</b>		2016-2015		2016-2015		2016-2015	
<b>ENGINE LONG BLOCK</b>		<b>ENGINE LONG BLOCK</b>		<b>ENGINE LONG BLOCK</b>		<b>ENGINE LONG BLOCK</b>	
Ford		Ford		Ford		Ford	
Mustang	2016-2015	Mustang		Mustang		Mustang	



Make	Year	Make	Year	Make	Year	Make	Year
<b>GR3Z-6006-C</b>		<b>HG7Z-6007-A</b>		<b>JT4Z-6006-A</b>		<b>XL3Z-6006-ADRM cont'd</b>	
<b>ENGINE LONG BLOCK</b>		<b>ENGINE LONG BLOCK</b>		<b>ENGINE LONG BLOCK</b>		F-Series	1999
Ford		Ford		Ford		Lincoln	
Mustang	2016	GT	2017	F-Series	2017	Navigator	1999
<b>GR3Z-6006-D</b>		<b>HJ7Z-6006-A</b>		<b>XC2Z-6006-FARM</b>		<b>XL3Z-6006-AERM</b>	
<b>ENGINE LONG BLOCK</b>		<b>ENGINE LONG BLOCK</b>		<b>ENGINE LONG BLOCK</b>		<b>ENGINE LONG BLOCK</b>	
Ford		Lincoln		Ford		Ford	
Mustang	2016	MKC	2017	Econoline	2000-1999	Expedition	1999
<b>GR3Z-6006-E</b>		<b>HL3Z-6006-A</b>		<b>XC2Z-6006-GARM</b>		F-Series	1999
<b>ENGINE LONG BLOCK</b>		<b>ENGINE LONG BLOCK</b>		<b>ENGINE LONG BLOCK</b>		<b>XL3Z-6006-GARM</b>	
Ford		Ford		Ford		<b>ENGINE LONG BLOCK</b>	
Mustang	2016	F-Series	2017	Econoline	1999	Ford	
<b>GR3Z-6006-HRM</b>		<b>HL3Z-6006-ARM</b>		<b>XC2Z-6006-RARM</b>		Econoline	2000-1999
<b>ENGINE LONG BLOCK</b>		<b>ENGINE LONG BLOCK</b>		<b>ENGINE LONG BLOCK</b>		F-Series	2000-1999
Ford		Ford		Ford		<b>XL3Z-6006-HRM</b>	
Mustang	2016	F-Series	2017	Econoline	1999-1997	<b>ENGINE LONG BLOCK</b>	
<b>GU9Z-6006-A</b>		<b>HL3Z-6006-BRM</b>		F-Series	1999	Ford	
<b>ENGINE LONG BLOCK</b>		<b>ENGINE LONG BLOCK</b>		F53	1999	Expedition	1999
Ford		Ford		<b>XC3Z-6006-DARM</b>		F-Series	1999
F-Series	2016-2011	F-Series	2017	<b>ENGINE LONG BLOCK</b>		<b>XL3Z-6006-LARM</b>	
F53	2016-2011	<b>HL3Z-6006-CRM</b>		Ford		<b>ENGINE LONG BLOCK</b>	
F59	2016	<b>ENGINE LONG BLOCK</b>		F-Series	1999	Ford	
<b>GV6Z-6006-AA</b>		Ford		<b>XC3Z-6006-FARM</b>		F-Series	1999
<b>ENGINE LONG BLOCK</b>		F-Series	2017	<b>ENGINE LONG BLOCK</b>		<b>XL3Z-6006-MARM</b>	
Ford		<b>HL3Z-6007-A</b>		Ford		<b>ENGINE LONG BLOCK</b>	
Escape	2017	<b>ENGINE LONG BLOCK</b>		F-Series	1999	Ford	
Fusion	2017	Ford		<b>XF1Z-6006-CRM</b>		F-Series	1999
<b>HC2Z-6006-A</b>		F-Series	2017	<b>ENGINE LONG BLOCK</b>		<b>XL3Z-6006-NARM</b>	
<b>ENGINE SHORT BLOCK</b>		<b>HL3Z-6007-B</b>		Ford		<b>ENGINE LONG BLOCK</b>	
Ford		<b>ENGINE LONG BLOCK</b>		Taurus	1999	Ford	
F-Series	2016-2012	Ford		Windstar	1999	Expedition	2000
<b>HC2Z-6006-B</b>		F-Series	2017	<b>Mercury</b>		F-Series	2000-1999
<b>ENGINE SHORT BLOCK</b>		<b>HM5Z-6006-ARM</b>		Sable	1999	<b>XL7Z-6006-AARM</b>	
Ford		<b>ENGINE LONG BLOCK</b>		<b>XF2Z-6006-BRM</b>		<b>ENGINE LONG BLOCK</b>	
Econoline	2017	Ford		<b>ENGINE LONG BLOCK</b>		Lincoln	
<b>HC2Z-6006-C</b>		Focus	2017	Ford		Navigator	1999
<b>ENGINE SHORT BLOCK</b>		<b>HS7Z-6006-B</b>		Windstar	2000-1999	<b>XR3Z-6006-CRM</b>	
Ford		<b>ENGINE LONG BLOCK</b>		<b>XL1Z-6006-BARM</b>		<b>ENGINE LONG BLOCK</b>	
Econoline	2017	Ford		<b>ENGINE LONG BLOCK</b>		Ford	
<b>HC4Z-6006-C</b>		Fusion	2017	Ford		Mustang	2000-1999
<b>ENGINE LONG BLOCK</b>		Lincoln		Expedition	1999	<b>XR3Z-6006-HRM</b>	
Ford		MKZ	2017	<b>XL1Z-6006-CARM</b>		<b>ENGINE LONG BLOCK</b>	
F650	2017	<b>HU9Z-6007-B</b>		<b>ENGINE LONG BLOCK</b>		Ford	
F750	2017	<b>ENGINE LONG BLOCK</b>		Ford		Mustang	1999
<b>HE9Z-6006-ARM</b>		Ford		Expedition	1999	<b>XR3Z-6006-YARM</b>	
<b>ENGINE LONG BLOCK</b>		F53	2017	<b>XL3Z-6006-ADRM</b>		<b>ENGINE LONG BLOCK</b>	
Lincoln				<b>ENGINE LONG BLOCK</b>		Ford	
MKT	2017			Ford		Mustang	1999
				Expedition	1999		

# BUYER'S GUIDE

## Gas Engine Assemblies



FORD PARTS

Make	Year	Make	Year
<b>XW4Z-6006-ARM</b>		<b>YL5Z-6006-CRM</b>	
<b>ENGINE LONG BLOCK</b>		<b>ENGINE LONG BLOCK</b>	
Lincoln		Ford	
LS	2000	Ranger	2001-1999
<b>XW4Z-6006-BRM</b>		<b>YL8Z-6006-AARM</b>	
<b>ENGINE LONG BLOCK</b>		<b>ENGINE LONG BLOCK</b>	
Lincoln		Ford	
LS	2000	Escape	2004-2001
<b>YC2Z-6006-HARM</b>		<b>Mazda</b>	
<b>ENGINE LONG BLOCK</b>		Tribute	
Ford			2004-2001
Econoline	2000	<b>YM5Z-6V012-ARM</b>	
<b>YC2Z-6006-NARM</b>		<b>ENGINE LONG BLOCK</b>	
<b>ENGINE LONG BLOCK</b>		Ford	
Ford		Focus	2000
Econoline	2001-2000	<b>YR3Z-6006-JRM</b>	
<b>YC2Z-6006-PARM</b>		<b>ENGINE LONG BLOCK</b>	
<b>ENGINE LONG BLOCK</b>		Ford	
Ford		Mustang	2000
Econoline	2001-2000	<b>YR3Z-6006-KRM</b>	
<b>YC2Z-6006-SARM</b>		<b>ENGINE LONG BLOCK</b>	
<b>ENGINE LONG BLOCK</b>		Ford	
Ford		Mustang	2000
Econoline	2001-2000	<b>YW7Z-6006-DRM</b>	
F-Series	2001-2000	<b>ENGINE LONG BLOCK</b>	
F53	2001-2000	Ford	
<b>YC3Z-6006-EARM</b>		Crown Victoria	
<b>ENGINE LONG BLOCK</b>		2000	
Ford		<b>Lincoln</b>	
Excursion	2001-2000	Town Car	
F-Series	2001-2000	2000	
<b>YC3Z-6006-GARM</b>		<b>Mercury</b>	
<b>ENGINE LONG BLOCK</b>		Grand Marquis	
Ford		2000	
Excursion	2001-2000	<b>YW7Z-6006-ERM</b>	
F-Series	2001-2000	<b>ENGINE LONG BLOCK</b>	
<b>YF1Z-6006-CRM</b>		Ford	
<b>ENGINE LONG BLOCK</b>		Crown Victoria	
Ford		2000	
Taurus	2001-2000	<b>Lincoln</b>	
<b>Mercury</b>		Town Car	
Sable	2001-2000	2000	
<b>YL3Z-6006-AFRM</b>		<b>Mercury</b>	
<b>ENGINE LONG BLOCK</b>		Grand Marquis	
Ford		2000	
Expedition	2001-2000		
F-Series	2001-2000		



Make	Year	Make	Year
<b>2W7Z-6049-JARM</b>		<b>XL3Z-6049-DBRM cont'd</b>	
<b>ENGINE CYLINDER HEAD</b>		Expedition	2001, 1999
<b>Ford</b>		F-Series	2001-1999
Crown Victoria	2000-1996	<b>Lincoln</b>	
Econoline	2000-1999	Navigator	2000-1999
Expedition	2000, 1998-1997	<b>XU2Z-6V049-AARM</b>	
F-Series	2000-1997	<b>ENGINE CYLINDER HEAD</b>	
Mustang	1998-1996	<b>Ford</b>	
<b>Lincoln</b>		Econoline	1983
Town Car	2000-1996	<b>XU2Z-6V049-CARM</b>	
<b>Mercury</b>		<b>ENGINE CYLINDER HEAD</b>	
Grand Marquis	2000-1996	<b>Ford</b>	
<b>F4TZ-6V049-AARM</b>		Econoline	1987-1984
<b>ENGINE CYLINDER HEAD</b>		F-Series	1987-1984
<b>Ford</b>		<b>XU2Z-6V049-DARM</b>	
F-Series	1994-1993	<b>ENGINE CYLINDER HEAD</b>	
<b>F4TZ-6V049-BARM</b>		<b>Ford</b>	
<b>ENGINE CYLINDER HEAD</b>		Econoline	1994-1988
<b>Ford</b>		F-Series	1994-1988
Econoline	1995		
F-Series	1995-1994		
<b>F5TZ-6V049-AARM</b>			
<b>ENGINE CYLINDER HEAD</b>			
<b>Ford</b>			
Econoline	2003-1995		
Excursion	2003-2000		
F-250 HD	1997		
F-Series	2003-1999, 1997-1995		
<b>F87Z-6049-BARM</b>			
<b>ENGINE CYLINDER HEAD</b>			
<b>Ford</b>			
Explorer	2000-1998		
Ranger	2000-1998		
<b>XL3Z-6049-CBRM</b>			
<b>ENGINE CYLINDER HEAD</b>			
<b>Ford</b>			
Econoline	2001-2000		
Excursion	2001-2000		
Expedition	2001, 1999		
F-Series	2001-1999		
Mustang	2000-1999		
<b>Lincoln</b>			
Navigator	2000-1999		
<b>XL3Z-6049-DBRM</b>			
<b>ENGINE CYLINDER HEAD</b>			
<b>Ford</b>			
Econoline	2001-2000		
Excursion	2001-2000		

# BUYER'S GUIDE

## Diesel Engine Assemblies



FORD PARTS

Make	Year	Make	Year	Make	Year	Make	Year
<b>1C3Z-6006-DARM</b>		<b>3C3Z-6007-AARM cont'd</b>		<b>4C3Z-6006-AARM</b>		<b>4C4Z-6006-DRM</b>	
<b>ENGINE LONG BLOCK</b>		F-Series	2004-2003	<b>ENGINE LONG BLOCK</b>		<b>ENGINE LONG BLOCK</b>	
Ford		<b>3C3Z-6007-BARM</b>		Ford		Ford	
F650	2003-2000	<b>ENGINE LONG BLOCK</b>		F-Series	2004	F650	2004
F750	2003-2000	Ford		<b>4C3Z-6006-BARM</b>		F750	2004
<b>1C3Z-6007-HARM</b>		F-Series	2004-2003	<b>ENGINE LONG BLOCK</b>		<b>4C4Z-6007-BRM</b>	
<b>ENGINE LONG BLOCK</b>		<b>3C3Z-6009-AARM</b>		Ford		<b>ENGINE LONG BLOCK</b>	
Ford		<b>ENGINE SHORT BLOCK</b>		Excursion	2004	Ford	
F650	2003-2000	Ford		F-Series	2004	F650	2004
F750	2003-2000	Excursion	2004-2003	<b>4C3Z-6007-AARM</b>		F750	2004
<b>1C3Z-6200-AARM</b>		F-Series	2004-2003	<b>ENGINE LONG BLOCK</b>		<b>4C4Z-6009-AARM</b>	
<b>ENGINE CONNECTING ROD</b>		<b>3C3Z-6K682-CCRM</b>		Ford		<b>ENGINE SHORT BLOCK</b>	
Ford		<b>TURBOCHARGER</b>		F-Series	2004	Ford	
Econoline	2003-2001	Ford		<b>4C3Z-6007-BARM</b>		F650	2006-2004
Excursion	2003-2001	Excursion	2004-2003	<b>ENGINE LONG BLOCK</b>		F750	2006-2004
F-Series	2003-2001	F-Series	2004-2003	Ford		<b>4C4Z-6K682-ARM</b>	
<b>2C3Z-9VE527-ARM</b>		F650	2004-2003	Excursion	2004	<b>TURBOCHARGER</b>	
<b>FUEL INJECTOR KIT</b>		F750	2004-2003	F-Series	2004	Ford	
Ford		<b>3C3Z-6V303-AARM</b>		<b>4C3Z-6007-CARM</b>		F650	2015, 2013-2004
F-Series	1994-1993	<b>ENGINE CRANKSHAFT</b>		<b>ENGINE LONG BLOCK</b>		F750	2015, 2013-2004
<b>2C3Z-9VE527-DRM</b>		Ford		Ford		<b>5C2Z-6006-AARM</b>	
<b>FUEL INJECTOR KIT</b>		Econoline	2003-1998	Excursion	2004	<b>ENGINE LONG BLOCK</b>	
Ford		<b>3C3Z-9A543-AARM</b>		F-Series	2004	Ford	
Econoline	1994-1992	<b>DIESEL HIGH PRESSURE OIL PUMP</b>		<b>4C3Z-6K682-CCRM</b>		Econoline	2006-2005
F-Series	1994-1992	Ford		<b>TURBOCHARGER</b>		<b>5C2Z-6007-AARM</b>	
<b>2C3Z-9VE527-ERM</b>		Excursion	2004-2003	Ford		<b>ENGINE LONG BLOCK</b>	
<b>FUEL INJECTOR KIT</b>		F-Series	2004	Econoline	2004	Ford	
Ford		<b>3C3Z-9E527-ECRM</b>		Excursion	2005-2004	Econoline	2005-2004
Econoline	1992-1988	<b>DIESEL FUEL INJECTOR NOZZLE</b>		F-Series	2005-2003	<b>5C2Z-6007-BARM</b>	
F-Series	1992-1988	Ford		<b>4C3Z-6K682-CDRM</b>		<b>ENGINE LONG BLOCK</b>	
<b>2C3Z-9VE527-FRM</b>		Excursion	2004-2003	<b>TURBOCHARGER</b>		Ford	
<b>FUEL INJECTOR KIT</b>		F-Series	2004-2003	Ford		Econoline	2006-2004
Ford		<b>4C2Z-6006-EARM</b>		F-Series	2006-2005	<b>5C3Z-6006-AARM</b>	
Econoline	1987-1984	<b>ENGINE LONG BLOCK</b>		<b>4C3Z-9A543-AARM</b>		<b>ENGINE LONG BLOCK</b>	
F-Series	1987-1984	Ford		<b>DIESEL HIGH PRESSURE OIL PUMP</b>		Ford	
<b>3C3Z-6006-AARM</b>		Econoline	2004	Ford		F-Series	2005
<b>ENGINE LONG BLOCK</b>		<b>4C2Z-6007-AARM</b>		Econoline	2004	<b>5C3Z-6006-BARM</b>	
Ford		<b>ENGINE LONG BLOCK</b>		Excursion	2004	<b>ENGINE LONG BLOCK</b>	
Excursion	2004-2003	Ford		F-Series	2004	Ford	
F-Series	2004-2003	Econoline	2004	<b>4C3Z-9E527-BRM</b>		F-Series	2005
<b>3C3Z-6006-BARM</b>		<b>4C3Z-12B599-ABRM</b>		<b>DIESEL FUEL INJECTOR NOZZLE</b>		<b>5C3Z-6006-DARM</b>	
<b>ENGINE LONG BLOCK</b>		<b>DIESEL FUEL INJECTOR DRIVER MODULE</b>		Ford		<b>ENGINE LONG BLOCK</b>	
Ford		Ford		Econoline	2008-2004	Ford	
F-Series	2004-2003	Econoline	2010-2004	Excursion	2005-2004	Econoline	2010-2006
<b>3C3Z-6007-AARM</b>		Excursion	2005-2003	F-Series	2007-2004	<b>5C3Z-6006-EARM</b>	
<b>ENGINE LONG BLOCK</b>		F-Series	2007-2003	F650	2007-2005	<b>ENGINE LONG BLOCK</b>	
Ford		<b>3C3Z-6007-AARM</b>		F750	2007-2005	Ford	
Excursion	2004-2003	<b>ENGINE LONG BLOCK</b>		<b>4C3Z-9E527-BRM</b>		Excursion	2005



Make	Year	Make	Year	Make	Year	Make	Year
<b>5C3Z-6007-AARM</b>		<b>5C3Z-6V007-BRM</b>		<b>5C3Z-9VE527-BRM cont'd</b>		<b>6C3Z-6009-ARM</b>	
<b>ENGINE LONG BLOCK</b>		<b>ENGINE LONG BLOCK</b>		Excursion	2003-2000	<b>ENGINE SHORT BLOCK</b>	
Ford		Ford		F-Series	2003-1999	Ford	
F-Series	2005-2004	F-Series	1999	<b>5C4Z-6006-ERM</b>		Econoline	2010-2005
<b>5C3Z-6007-BARM</b>		<b>5C3Z-6V007-CRM</b>		<b>ENGINE LONG BLOCK</b>		F-Series	2007-2006
<b>ENGINE LONG BLOCK</b>		<b>ENGINE LONG BLOCK</b>		Ford		<b>6E7Z-6007-FRM</b>	
Ford		Ford		F650	2007-2006	<b>ENGINE LONG BLOCK</b>	
F-Series	2005-2004	F-Series	1999	F750	2007-2006	Ford	
<b>5C3Z-6007-CARM</b>		<b>5C3Z-6V639-ARM</b>		<b>5C4Z-6007-JRM</b>		LCF	2007-2006
<b>ENGINE LONG BLOCK</b>		<b>TURBOCHARGER MOUNTING KIT</b>		<b>ENGINE LONG BLOCK</b>		<b>6E7Z-6K682-A</b>	
Ford		Ford		Ford		<b>TURBOCHARGER</b>	
F-Series	2005-2004	Econoline	1998	F650	2007-2004	Ford	
<b>5C3Z-6007-DARM</b>		<b>5C3Z-6V639-BRM</b>		F750	2007-2004	LCF	2010-2006
<b>ENGINE LONG BLOCK</b>		<b>TURBOCHARGER MOUNTING KIT</b>		<b>5C4Z-6K682-BRM</b>		<b>6E7Z-9A543-BRM</b>	
Ford		Ford		<b>TURBOCHARGER</b>		<b>DIESEL HIGH PRESSURE OIL PUMP</b>	
F-Series	2005-2004	Econoline	1999-1998	F650	2015, 2013-2005	Ford	
<b>5C3Z-6007-EARM</b>		F-Series	1999	F750	2015, 2013-2005	LCF	2009-2006
<b>ENGINE LONG BLOCK</b>		<b>5C3Z-6V682-ARM</b>		<b>5C4Z-9A543-ERM</b>		<b>7C4Z-6009-AARM</b>	
Ford		<b>TURBOCHARGER</b>		<b>DIESEL HIGH PRESSURE OIL PUMP</b>		<b>ENGINE SHORT BLOCK</b>	
Excursion	2005	Ford		Ford		Ford	
<b>5C3Z-6007-FARM</b>		F-Series	1999	F650	2015, 2013-2005	F650	2007-2006
<b>ENGINE LONG BLOCK</b>		<b>5C3Z-6V682-BRM</b>		F750	2015, 2013-2005	F750	2007-2006
Ford		<b>TURBOCHARGER</b>		<b>6C2Z-6006-AARM</b>		<b>8C3Z-6007-AARM</b>	
Excursion	2005	Ford		<b>ENGINE LONG BLOCK</b>		<b>ENGINE LONG BLOCK</b>	
<b>5C3Z-6009-AARM</b>		Econoline	1999-1998	Ford		Ford	
<b>ENGINE SHORT BLOCK</b>		<b>5C3Z-9A543-ARM</b>		Econoline	2010-2006	F-Series	2010-2008
Ford		<b>DIESEL HIGH PRESSURE OIL PUMP</b>		<b>6C2Z-6007-AARM</b>		<b>8C3Z-6007-BARM</b>	
Econoline	2005-2004	Ford		<b>ENGINE LONG BLOCK</b>		<b>ENGINE LONG BLOCK</b>	
Excursion	2005-2003	Econoline	2007-2004	Ford		Ford	
F-Series	2005-2003	Excursion	2005-2004	Econoline	2010-2006	F-Series	2010-2008
<b>5C3Z-6K682-CCRM</b>		F-Series	2007-2004	<b>6C3Z-6006-AARM</b>		<b>8C3Z-6009-AARM</b>	
<b>TURBOCHARGER</b>		<b>5C3Z-9VA543-BRM</b>		<b>ENGINE LONG BLOCK</b>		<b>ENGINE SHORT BLOCK</b>	
Ford		<b>DIESEL HIGH PRESSURE OIL PUMP</b>		Ford		Ford	
Econoline	2010-2005	Ford		F-Series	2007-2006	F-Series	2010-2008
F-Series	2007-2005	Econoline	1999-1998	<b>6C3Z-6006-BARM</b>		<b>8C3Z-6009-BARM</b>	
<b>5C3Z-6V006-CRM</b>		F-Series	1999	<b>ENGINE LONG BLOCK</b>		<b>ENGINE SHORT BLOCK</b>	
<b>ENGINE LONG BLOCK</b>		<b>5C3Z-9VE527-ARM</b>		Ford		Ford	
Ford		<b>FUEL INJECTOR KIT</b>		F-Series	2007-2006	F-Series	2010-2008
F-Series	1999	Ford		<b>6C3Z-6007-AARM</b>		<b>8C3Z-6K682-AARM</b>	
<b>5C3Z-6V006-DRM</b>		Econoline	2003-2000	<b>ENGINE LONG BLOCK</b>		<b>TURBOCHARGER</b>	
<b>ENGINE LONG BLOCK</b>		Excursion	2003-2000	Ford		Ford	
Ford		F-Series	2003, 2001-2000	F-Series	2007-2006	F-Series	2010-2008
Econoline	1999-1998	<b>5C3Z-9VE527-BRM</b>		<b>6C3Z-6007-BARM</b>		<b>8C3Z-6K682-BARM</b>	
<b>5C3Z-6V007-ARM</b>		<b>FUEL INJECTOR KIT</b>		<b>ENGINE LONG BLOCK</b>		<b>TURBOCHARGER</b>	
<b>ENGINE LONG BLOCK</b>		Ford		Ford		Ford	
Ford		Econoline	2003-1999	F-Series	2007-2006	F-Series	2010-2008
Econoline	1999-1998						

# BUYER'S GUIDE

## Diesel Engine Assemblies



FORD PARTS

Make	Year	Make	Year	Make	Year	Make	Year
<b>8C3Z-6K682-CRM</b>		<b>DC3Z-6007-BRM</b>		<b>F4TZ-6VN639-AARM</b>		<b>F6TZ-6V006-BARM</b>	
<b>TURBOCHARGER</b>		<b>ENGINE LONG BLOCK</b>		<b>TURBOCHARGER MOUNTING KIT</b>		<b>ENGINE LONG BLOCK</b>	
Ford		Ford		Ford		Ford	
F-Series	2008	F-Series	2014-2011	Econoline	1998-1995	F-Series	1996
F-Series	2010-2008	<b>DC3Z-6007-E</b>		F-Series	1994	<b>F6TZ-6V007-AARM</b>	
<b>8C3Z-6K682-CRM</b>		<b>ENGINE LONG BLOCK</b>		<b>F4TZ-9VA543-AARM</b>		<b>ENGINE LONG BLOCK</b>	
<b>TURBOCHARGER</b>		Ford		<b>DIESEL HIGH PRESSURE OIL PUMP</b>		Ford	
Ford		F-Series	2014-2011	Ford		F-Series	1996
F-Series	2008	<b>F3TZ-6V012-AARM</b>		<b>F4TZ-9VE527-AARM</b>		<b>F6TZ-6V007-BARM</b>	
F-Series	2010-2008	<b>ENGINE LONG BLOCK</b>		Econoline	1995	<b>ENGINE LONG BLOCK</b>	
<b>8C3Z-9A543-DRM</b>		Ford		F-Series	1995-1994	Ford	
<b>DIESEL HIGH PRESSURE OIL PUMP</b>		F-Series	1994-1993	<b>F4TZ-9VE527-AARM</b>		F-Series	1996
Ford		<b>F4TZ-6V006-AARM</b>		<b>FUEL INJECTOR KIT</b>		<b>F6TZ-9VA543-ARM</b>	
F-Series	2010-2008	<b>ENGINE LONG BLOCK</b>		Ford		<b>DIESEL HIGH PRESSURE OIL PUMP</b>	
<b>8E7Z-6007-ARM</b>		Ford		Econoline	1996-1995	Ford	
<b>ENGINE LONG BLOCK</b>		F-Series	1994-1993	F-Series	1997-1994	Econoline	1998-1996
Ford		<b>F4TZ-6V006-BARM</b>		<b>F5TZ-6V006-AARM</b>		F-Series	1997-1996
LCF	2009-2008	<b>ENGINE LONG BLOCK</b>		<b>ENGINE LONG BLOCK</b>		<b>F6UZ-6V006-AARM</b>	
<b>8E7Z-6K682-A</b>		Ford		Ford		<b>ENGINE LONG BLOCK</b>	
<b>TURBOCHARGER</b>		F-Series	1995-1994	Econoline	1995	Ford	
Ford		<b>F4TZ-6V007-FARM</b>		<b>F5TZ-6V007-AARM</b>		Econoline	1996
F650	2009-2008	<b>ENGINE LONG BLOCK</b>		<b>ENGINE LONG BLOCK</b>		<b>F6UZ-6V006-BARM</b>	
F750	2009-2008	Ford		Ford		<b>ENGINE LONG BLOCK</b>	
<b>8E7Z-9A543-CRM</b>		F-Series	1994	F-Series	1995	Ford	
<b>DIESEL HIGH PRESSURE OIL PUMP</b>		<b>F4TZ-6V012-AARM</b>		<b>F5UZ-6V007-AARM</b>		Econoline	1996
Ford		<b>ENGINE LONG BLOCK</b>		<b>ENGINE LONG BLOCK</b>		<b>F6UZ-6V007-AARM</b>	
LCF	2009-2008	Ford		Ford		<b>ENGINE LONG BLOCK</b>	
<b>BC3Z-6K682-C</b>		F-Series	1995-1994	Econoline	1995	Ford	
<b>TURBOCHARGER</b>		<b>F4TZ-6V200-CARM</b>		<b>F5UZ-6V012-AARM</b>		Econoline	1996
Ford		<b>ENGINE CONNECTING ROD</b>		<b>ENGINE LONG BLOCK</b>		<b>F6UZ-6V006-BARM</b>	
F-Series	2015-2011	Ford		Ford		<b>ENGINE LONG BLOCK</b>	
<b>CK4Z-6006-A</b>		Excursion	2000	Econoline	1995	Ford	
<b>ENGINE LONG BLOCK</b>		F-Series	1999, 1997-1993	<b>F61Z-9VE527-BRM</b>		Econoline	1996
Ford		<b>F4TZ-6V303-BARM</b>		<b>FUEL INJECTOR KIT</b>		<b>F7TZ-6V006-BARM</b>	
Transit-150	2015	<b>ENGINE CRANKSHAFT</b>		Ford		<b>ENGINE LONG BLOCK</b>	
Transit-250	2015	Ford		Econoline	1999-1996	Ford	
Transit-350	2015	Econoline	1995-1994	F-Series	1999, 1997-1996	F-Series	1997
Transit-350 HD	2015	<b>F4TZ-6VK682-BARM</b>		<b>F61Z-9VE527-ERM</b>		<b>F7TZ-6V006-CARM</b>	
<b>DC3Z-6007-ARM</b>		<b>TURBOCHARGER</b>		<b>FUEL INJECTOR KIT</b>		<b>ENGINE LONG BLOCK</b>	
<b>ENGINE LONG BLOCK</b>		Ford		Ford		Ford	
Ford		F-Series	1994	Econoline	1996	F-Series	1997
F-Series	2014-2011	<b>F4TZ-6VK682-CARM</b>		F-Series	1996	<b>F7TZ-6V007-AARM</b>	
<b>DC3Z-6007-BA</b>		<b>TURBOCHARGER</b>		<b>F6TZ-6V006-AARM</b>		<b>ENGINE LONG BLOCK</b>	
<b>ENGINE LONG BLOCK</b>		Ford		<b>ENGINE LONG BLOCK</b>		Ford	
Ford		Econoline	1998-1995	Ford		F-Series	1997
F-Series	2014-2011	F-Series	1997-1994	F-Series	1996	<b>F7TZ-6V007-BARM</b>	
						<b>ENGINE LONG BLOCK</b>	
						Ford	
						F-Series	1997





Make	Year	Make	Year	Make	Year	Make	Year
<b>F7TZ-6V012-ABRM</b>		<b>FB3Z-9A543-A cont'd</b>		<b>HC3Z-6K682-A</b>		<b>PTC-6RM</b>	
<b>ENGINE LONG BLOCK</b>		Transit-250	2017-2015	<b>TURBOCHARGER</b>		<b>TURBOCHARGER MOUNTING KIT</b>	
Ford		Transit-350	2017-2015	Ford		Ford	
F-Series	1997	Transit-350 HD	2017-2015	F-Series	2016-2015	Econoline	2003-1999
<b>F7UZ-6V006-AARM</b>		<b>FC3Z-6006-C</b>		<b>HPP-10RM</b>		Excursion	2003-2000
<b>ENGINE LONG BLOCK</b>		<b>ENGINE LONG BLOCK</b>		<b>DIESEL HIGH PRESSURE OIL PUMP</b>		F-Series	2003-1999
Ford		Ford		Ford		<b>PTC-7RM</b>	
Econoline	1998-1997	F-Series	2015-2011	Excursion	2004-2003	<b>TURBOCHARGER MOUNTING KIT</b>	
<b>F7UZ-6V007-AARM</b>		<b>FC3Z-6007-A</b>		F-Series	2004	Ford	
<b>ENGINE LONG BLOCK</b>		<b>ENGINE LONG BLOCK</b>		<b>HPP-11RM</b>		Econoline	1999-1998
Ford		Ford		<b>DIESEL HIGH PRESSURE OIL PUMP</b>		F-Series	1999
Econoline	1998-1997	F-Series	2015	Ford		<b>TC-10RM</b>	
<b>F81Z-6K682-BARM</b>		<b>FC3Z-6007-B</b>		F-Series	2010-2008	<b>TURBOCHARGER</b>	
<b>TURBOCHARGER</b>		<b>ENGINE LONG BLOCK</b>		<b>HPP-12RM</b>		Ford	
Ford		Ford		<b>DIESEL HIGH PRESSURE OIL PUMP</b>		Econoline	2003-1999
Excursion	2002-2000	F-Series	2015	Ford		<b>TC-11RM</b>	
F-Series	2003-1999	<b>FC3Z-6007-BA</b>		Econoline	2007-2004	<b>TURBOCHARGER</b>	
<b>F81Z-6K682-CARM</b>		<b>ENGINE LONG BLOCK</b>		Excursion	2005-2004	Ford	
<b>TURBOCHARGER</b>		Ford		F-Series	2007-2004	F-Series	2010-2008
Ford		F-Series	2016	<b>HPP-5RM</b>		<b>TC-12RM</b>	
Excursion	2003-2000	<b>GC3Z-6007-F</b>		<b>ENGINE LONG BLOCK</b>		<b>TURBOCHARGER</b>	
F-Series	2003-1999	<b>ENGINE LONG BLOCK</b>		Ford		Ford	
<b>F81Z-6N639-CARM</b>		Ford		F-Series	2016	Excursion	2004-2000
<b>TURBOCHARGER MOUNTING KIT</b>		<b>GC3Z-6007-G</b>		<b>GC3Z-6007-G</b>		F-Series	2003-1999
Ford		<b>ENGINE LONG BLOCK</b>		<b>ENGINE LONG BLOCK</b>		F650	2004-2003
Econoline	2003-1999	Ford		F-Series	2016	F750	2004-2003
Excursion	2003-2000	F-Series	2016	<b>GC3Z-6007-H</b>		<b>TC-13RM</b>	
F-Series	2003-1999	<b>GC3Z-6007-H</b>		<b>ENGINE LONG BLOCK</b>		<b>TURBOCHARGER</b>	
<b>F81Z-6N639-DARM</b>		<b>ENGINE LONG BLOCK</b>		Ford		Ford	
<b>TURBOCHARGER MOUNTING KIT</b>		Ford		F-Series	2016	Excursion	2004-2003
Ford		<b>HC3Z-6007-H</b>		<b>HC3Z-6007-H</b>		F-Series	2004-2003
Econoline	1999-1998	<b>ENGINE LONG BLOCK</b>		<b>ENGINE LONG BLOCK</b>		F650	2004-2003
F-Series	1999	Ford		F-Series	2017	F750	2004-2003
<b>F81Z-6V012-CARM</b>		<b>HC3Z-6007-J</b>		<b>HC3Z-6007-J</b>		<b>TC-14RM</b>	
<b>ENGINE LONG BLOCK</b>		<b>ENGINE LONG BLOCK</b>		<b>ENGINE LONG BLOCK</b>		<b>TURBOCHARGER</b>	
Ford		Ford		F-Series	2017	Ford	
F-Series	1999	F-Series	2017	<b>HC3Z-6007-K</b>		F-Series	2010-2008
<b>F81Z-9A543-CRM</b>		<b>HC3Z-6007-K</b>		<b>ENGINE LONG BLOCK</b>		<b>TC-15RM</b>	
<b>DIESEL HIGH PRESSURE OIL PUMP</b>		<b>ENGINE LONG BLOCK</b>		Ford		<b>TURBOCHARGER</b>	
Ford		Ford		F-Series	2017	Ford	
Econoline	2003-1999	F-Series	2017	<b>HC3Z-6007-M</b>		F-Series	2006-2005
Excursion	2003-2000	<b>HC3Z-6007-M</b>		<b>ENGINE LONG BLOCK</b>		<b>TC-16RM</b>	
F-Series	2003-1999	<b>ENGINE LONG BLOCK</b>		Ford		<b>TURBOCHARGER</b>	
<b>FB3Z-9A543-A</b>		<b>ENGINE LONG BLOCK</b>		F-Series	2017	Ford	
<b>DIESEL HIGH PRESSURE OIL PUMP</b>		Ford		<b>HC3Z-6007-M</b>		F-Series	2010-2008
Ford		F-Series	2017	<b>ENGINE LONG BLOCK</b>			
Transit-150	2017-2015			Ford			
				Econoline	2003-1999		
				Excursion	2003-2000		
				F-Series	2003-1999		

# BUYER'S GUIDE

## Diesel Engine Assemblies



FORD PARTS

Make	Year	Make	Year	Make	Year
<b>TC-17RM</b>		<b>XC3Z-6007-BARM</b>		<b>XU2Z-6V200-BARM</b>	
<b>TURBOCHARGER</b>		<b>ENGINE LONG BLOCK</b>		<b>ENGINE CONNECTING ROD</b>	
Ford		Ford		Ford	
Econoline	2010-2005	F-Series	1999	Econoline	1994-1983
F-Series	2007-2005	<b>XC3Z-6007-CARM</b>		F-Series	1994-1983
<b>TC-5RM</b>		<b>ENGINE LONG BLOCK</b>		<b>XU2Z-6VA642-AARM</b>	
<b>TURBOCHARGER</b>		Ford		<b>ENGINE OIL COOLER</b>	
Ford		Excursion		Ford	
Excursion	2002-2000	F-Series		Econoline	
F-Series	2003-1999	2003-2000		1994-1983	
<b>TC-6RM</b>		<b>XC3Z-6V012-BARM</b>		F-Series	
<b>TURBOCHARGER</b>		<b>ENGINE LONG BLOCK</b>		1994-1983	
Ford		Ford			
F650	2015, 2013-2004	F-Series		2003-1999	
F750	2015, 2013-2004	<b>XU2Z-6V007-AARM</b>			
<b>TC-7RM</b>		<b>ENGINE LONG BLOCK</b>			
<b>TURBOCHARGER</b>		Ford			
Ford		F-Series		1987-1983	
F650	2009-2008	<b>XU2Z-6V007-BARM</b>			
F750	2009-2008	<b>ENGINE LONG BLOCK</b>			
<b>TC-8RM</b>		Ford			
<b>TURBOCHARGER</b>		Econoline		1987-1983	
Ford		<b>XU2Z-6V007-CARM</b>			
F650	2010-2006	<b>ENGINE LONG BLOCK</b>			
F750	2010-2006	Ford			
<b>TC-9RM</b>		F-Series		1994-1988	
<b>TURBOCHARGER</b>		<b>XU2Z-6V007-DARM</b>			
Ford		<b>ENGINE LONG BLOCK</b>			
F650	2015, 2013-2005	Ford			
F750	2015, 2013-2005	F-Series		1994-1988	
<b>XC2Z-6006-AARM</b>		<b>XU2Z-6V007-EARM</b>			
<b>ENGINE LONG BLOCK</b>		<b>ENGINE LONG BLOCK</b>			
Ford		Ford			
Econoline	2003-1999	Econoline		1994-1988	
<b>XC2Z-6007-AARM</b>		<b>XU2Z-6V012-AARM</b>			
<b>ENGINE LONG BLOCK</b>		<b>ENGINE LONG BLOCK</b>			
Ford		Ford			
Econoline	2003-1999	F-Series		1987-1983	
<b>XC2Z-6K682-AARM</b>		<b>XU2Z-6V012-BARM</b>			
<b>TURBOCHARGER</b>		<b>ENGINE LONG BLOCK</b>			
Ford		Ford			
Econoline	2003-1999	Econoline		1987-1984	
<b>XC3Z-6006-AARM</b>		<b>XU2Z-6V012-CARM</b>			
<b>ENGINE LONG BLOCK</b>		<b>ENGINE LONG BLOCK</b>			
Ford		Ford			
Excursion	2003-2000	F-Series		1994-1988	
F-Series	2001-1999	<b>XU2Z-6V012-DARM</b>			
		<b>ENGINE LONG BLOCK</b>			
		Ford			
		Econoline		1994-1988	



Make	Year	Make	Year	Make	Year	Make	Year
<b>1C2Z-7V000-ARM</b>		<b>1C2Z-7V000-NRM</b>		<b>1C3Z-7V000-KRM</b>		<b>1F1Z-7V000-ERM cont'd</b>	
<b>AUTOMATIC TRANSMISSION ASSEMBLY</b> Ford		<b>AUTOMATIC TRANSMISSION ASSEMBLY</b> Ford		<b>AUTOMATIC TRANSMISSION ASSEMBLY</b> Ford		Mercury	
Econoline	2003-2001	Econoline	2003-2001	F-Series	2003-2001	Sable	2003-2001
<b>1C2Z-7V000-BRM</b>		<b>1C3Z-7V000-ARM</b>		<b>1C3Z-7V000-LRM</b>		<b>1F1Z-7V000-FRM</b>	
<b>AUTOMATIC TRANSMISSION ASSEMBLY</b> Ford		<b>AUTOMATIC TRANSMISSION ASSEMBLY</b> Ford		<b>AUTOMATIC TRANSMISSION ASSEMBLY</b> Ford		<b>AUTOMATIC TRANSMISSION ASSEMBLY</b> Ford	
Econoline	2003-2001	F-Series	2004-2001	F-Series	2003-2001	Taurus	2003-2001
<b>1C2Z-7V000-CRM</b>		<b>1C3Z-7V000-BRM</b>		<b>1C3Z-7V000-MRM</b>		Mercury	
<b>AUTOMATIC TRANSMISSION ASSEMBLY</b> Ford		<b>AUTOMATIC TRANSMISSION ASSEMBLY</b> Ford		<b>AUTOMATIC TRANSMISSION ASSEMBLY</b> Ford		Sable	2003-2001
Econoline	2003-2001	Excursion	2005-2001	F-Series	2003-1999	<b>1F1Z-7V000-GRM</b>	
<b>1C2Z-7V000-DRM</b>		Expedition	2002-2001	<b>1C3Z-7V000-NRM</b>		<b>AUTOMATIC TRANSMISSION ASSEMBLY</b> Ford	
<b>AUTOMATIC TRANSMISSION ASSEMBLY</b> Ford		F-Series	2004-2001	<b>AUTOMATIC TRANSMISSION ASSEMBLY</b> Ford		Taurus	2003-2001
Econoline	2003-2001	<b>1C3Z-7V000-CRM</b>		Excursion	2005-2001	Mercury	
<b>1C2Z-7V000-ERM</b>		<b>AUTOMATIC TRANSMISSION ASSEMBLY</b> Ford		Expedition	2002-2001	Sable	2003-2001
<b>AUTOMATIC TRANSMISSION ASSEMBLY</b> Ford		F-Series	2004-2001	<b>1C3Z-7V000-PRM</b>		<b>1F2Z-7V000-CRM</b>	
Econoline	2003-2001	<b>1C3Z-7V000-DRM</b>		<b>AUTOMATIC TRANSMISSION ASSEMBLY</b> Ford		<b>AUTOMATIC TRANSMISSION ASSEMBLY</b> Ford	
<b>1C2Z-7V000-FRM</b>		<b>AUTOMATIC TRANSMISSION ASSEMBLY</b> Ford		Excursion	2005-2001	Windstar	2003-2001
<b>AUTOMATIC TRANSMISSION ASSEMBLY</b> Ford		Excursion	2005-2001	<b>1F1Z-7V000-ARM</b>		<b>1F3Z-7V000-ARM</b>	
Econoline	2003-2001	F-Series	2004-2001	<b>AUTOMATIC TRANSMISSION ASSEMBLY</b> Ford		<b>AUTOMATIC TRANSMISSION ASSEMBLY</b> Lincoln	
<b>1C2Z-7V000-HRM</b>		<b>1C3Z-7V000-ERM</b>		Taurus	2003-2001	Continental	2001
<b>AUTOMATIC TRANSMISSION ASSEMBLY</b> Ford		<b>AUTOMATIC TRANSMISSION ASSEMBLY</b> Ford		Mercury		<b>1F3Z-7V000-BRM</b>	
Econoline	2003-2001	Excursion	2003-2000	Sable	2003-2001	<b>AUTOMATIC TRANSMISSION ASSEMBLY</b> Lincoln	
<b>1C2Z-7V000-JRM</b>		F-Series	2003-1999	<b>1F1Z-7V000-CRM</b>		Continental	2001
<b>AUTOMATIC TRANSMISSION ASSEMBLY</b> Ford		<b>1C3Z-7V000-FRM</b>		<b>AUTOMATIC TRANSMISSION ASSEMBLY</b> Ford		<b>1F3Z-7V000-CRM</b>	
Econoline	2003-2001	<b>AUTOMATIC TRANSMISSION ASSEMBLY</b> Ford		Taurus	2003-2001	<b>AUTOMATIC TRANSMISSION ASSEMBLY</b> Lincoln	
<b>1C2Z-7V000-LRM</b>		Excursion	2003-2000	Mercury		Continental	2002-2001
<b>AUTOMATIC TRANSMISSION ASSEMBLY</b> Ford		F-Series	2003-1999	Sable	2003-2001	<b>1F3Z-7V000-DRM</b>	
Econoline	2003-2001	<b>1C3Z-7V000-HRM</b>		<b>1F1Z-7V000-DRM</b>		<b>AUTOMATIC TRANSMISSION ASSEMBLY</b> Lincoln	
<b>1C2Z-7V000-MRM</b>		<b>AUTOMATIC TRANSMISSION ASSEMBLY</b> Ford		Taurus	2003-2001	Continental	2002-2001
<b>AUTOMATIC TRANSMISSION ASSEMBLY</b> Ford		F-Series	2004-2001	Mercury		<b>1L2Z-7V000-ARM</b>	
Econoline	2003-2001	<b>1C3Z-7V000-JRM</b>		Sable	2003-2001	<b>AUTOMATIC TRANSMISSION ASSEMBLY</b> Ford	
<b>1C2Z-7V000-NRM</b>		<b>AUTOMATIC TRANSMISSION ASSEMBLY</b> Ford		<b>1F1Z-7V000-ERM</b>		Explorer	2002
<b>AUTOMATIC TRANSMISSION ASSEMBLY</b> Ford		F-Series	2004-2001	<b>AUTOMATIC TRANSMISSION ASSEMBLY</b> Ford		Mercury	
Econoline	2003-2001	<b>1C3Z-7V000-LRM</b>		Taurus	2003-2001	Mountaineer	2002
<b>1C2Z-7V000-ORM</b>		<b>AUTOMATIC TRANSMISSION ASSEMBLY</b> Ford					

# BUYER'S GUIDE

## Transmission Assemblies



FORD PARTS

Make	Year	Make	Year	Make	Year	Make	Year
<b>1L2Z-7V000-BRM</b>		<b>1L5Z-7000-DARM</b>		<b>1R3Z-7V000-ARM</b>		<b>2L1Z-7V000-FRM</b>	
<b>AUTOMATIC TRANSMISSION ASSEMBLY</b>		<b>AUTOMATIC TRANSMISSION ASSEMBLY</b>		<b>AUTOMATIC TRANSMISSION ASSEMBLY</b>		<b>AUTOMATIC TRANSMISSION ASSEMBLY</b>	
Ford		Mazda		Ford		Ford	
Explorer	2002	B4000	2003	Mustang	2002-2001	Expedition	2003
<b>Mercury</b>		<b>1L5Z-7000-EARM</b>		<b>1R3Z-7V000-BRM</b>		<b>2L2Z-7V000-AARM</b>	
Mountaineer	2002	<b>AUTOMATIC TRANSMISSION ASSEMBLY</b>		<b>AUTOMATIC TRANSMISSION ASSEMBLY</b>		<b>AUTOMATIC TRANSMISSION ASSEMBLY</b>	
		Mazda		Ford		Ford	
<b>1L2Z-7V000-CRM</b>		B4000	2003	Mustang	2002-2001	Explorer	2003-2002
<b>AUTOMATIC TRANSMISSION ASSEMBLY</b>		<b>1L5Z-7V000-ARM</b>		<b>1S4Z-7V000-CRM</b>		<b>Mercury</b>	
Ford		<b>AUTOMATIC TRANSMISSION ASSEMBLY</b>		<b>AUTOMATIC TRANSMISSION ASSEMBLY</b>		Mountaineer	2003-2002
Explorer	2002	Ford		Ford		<b>2L2Z-7V000-BARM</b>	
<b>Mercury</b>		Ranger	2001	Focus	2002-2000	<b>AUTOMATIC TRANSMISSION ASSEMBLY</b>	
Mountaineer	2002	Mazda		<b>1S4Z-7V000-DRM</b>		Ford	
		B3000	2001	<b>AUTOMATIC TRANSMISSION ASSEMBLY</b>		Explorer	2003-2002
<b>1L2Z-7V000-DRM</b>		<b>1L5Z-7V000-DRM</b>		Ford		<b>Mercury</b>	
<b>AUTOMATIC TRANSMISSION ASSEMBLY</b>		<b>AUTOMATIC TRANSMISSION ASSEMBLY</b>		Focus	2002-2000	Mountaineer	2003-2002
Ford		Ford		<b>1S8Z-7V000-ARM</b>		<b>2L2Z-7V000-CARM</b>	
Explorer	2002	Explorer	2003-2001	<b>AUTOMATIC TRANSMISSION ASSEMBLY</b>		<b>AUTOMATIC TRANSMISSION ASSEMBLY</b>	
<b>Mercury</b>		Explorer Sport Trac	2003-2001	<b>Mercury</b>		Ford	
Mountaineer	2002	Ranger	2003-2001	Cougar	2002-2001	Explorer	2003-2002
		Mazda		<b>1W7Z-7V000-ARM</b>		<b>Mercury</b>	
<b>1L3Z-7V000-CRM</b>		B4000	2002-2001	<b>AUTOMATIC TRANSMISSION ASSEMBLY</b>		Mountaineer	2003-2002
<b>AUTOMATIC TRANSMISSION ASSEMBLY</b>		<b>Mercury</b>		Ford		<b>2L2Z-7V000-DARM</b>	
F-Series	2004-1999	Mountaineer	2001	Crown Victoria	2002-2001	<b>AUTOMATIC TRANSMISSION ASSEMBLY</b>	
<b>1L3Z-7V000-DRM</b>		<b>1L5Z-7V000-ERM</b>		<b>1W7Z-7V000-CRM</b>		Ford	
<b>AUTOMATIC TRANSMISSION ASSEMBLY</b>		<b>AUTOMATIC TRANSMISSION ASSEMBLY</b>		<b>AUTOMATIC TRANSMISSION ASSEMBLY</b>		Explorer	2003-2002
Ford		Ford		Ford		<b>Mercury</b>	
F-Series	2003-2001	Explorer	2003-2001	Crown Victoria	2002-2001	Mountaineer	2003-2002
<b>1L3Z-7V000-FRM</b>		Explorer Sport Trac	2003-2001	<b>2L1Z-7V000-CRM</b>		<b>2L5Z-7000-BBRM</b>	
<b>AUTOMATIC TRANSMISSION ASSEMBLY</b>		Ranger	2003-2001	<b>AUTOMATIC TRANSMISSION ASSEMBLY</b>		<b>AUTOMATIC TRANSMISSION ASSEMBLY</b>	
Ford		Mazda		Ford		Mazda	
Expedition	2002-2001	B4000	2002-2001	Expedition	2003	B3000	2003
F-Series	2003-2002	<b>Mercury</b>		<b>2L1Z-7V000-DRM</b>		<b>2L5Z-7V000-ABRM</b>	
<b>1L3Z-7V000-HRM</b>		Mountaineer	2001	<b>AUTOMATIC TRANSMISSION ASSEMBLY</b>		<b>AUTOMATIC TRANSMISSION ASSEMBLY</b>	
<b>AUTOMATIC TRANSMISSION ASSEMBLY</b>		<b>1R3Z-7000-AARM</b>		Ford		Ford	
Ford		<b>AUTOMATIC TRANSMISSION ASSEMBLY</b>		Expedition	2003	Ranger	2003-2002
Expedition	2002-2001	Ford		<b>2L1Z-7V000-ERM</b>		<b>Mazda</b>	
F-Series	2003-2001	Mustang	2003	<b>AUTOMATIC TRANSMISSION ASSEMBLY</b>		B3000	2003-2002
<b>1L3Z-7V000-JRM</b>		<b>1R3Z-7000-BARM</b>		Ford		<b>2L5Z-7V000-CBRM</b>	
<b>AUTOMATIC TRANSMISSION ASSEMBLY</b>		<b>AUTOMATIC TRANSMISSION ASSEMBLY</b>		Expedition	2003	<b>AUTOMATIC TRANSMISSION ASSEMBLY</b>	
Ford		Ford				Ford	
F-Series	2003-2001	Mustang	2003			Ranger	2003-2002
<b>1L3Z-7V000-LRM</b>							
<b>AUTOMATIC TRANSMISSION ASSEMBLY</b>							
Ford							
F-Series	2003-2001						



Make	Year	Make	Year	Make	Year	Make	Year
<b>2L8Z-7V000-EBRM</b>		<b>3C3Z-7V000-JGRM</b>		<b>3L8Z-7000-GARM</b>		<b>3S4Z-7000-AARM</b>	
<b>AUTOMATIC TRANSMISSION ASSEMBLY</b>		<b>AUTOMATIC TRANSMISSION ASSEMBLY</b>		<b>AUTOMATIC TRANSMISSION ASSEMBLY</b>		<b>AUTOMATIC TRANSMISSION ASSEMBLY</b>	
Ford		Ford		Ford		Ford	
Escape	2002	F-Series	2004-2003	Escape	2003	Focus	2004
<b>Mazda</b>		<b>3C3Z-7V000-KDRM</b>		<b>Mazda</b>		<b>3W1Z-7V000-ARM</b>	
Tribute	2002	<b>AUTOMATIC TRANSMISSION ASSEMBLY</b>		Tribute	2003	<b>AUTOMATIC TRANSMISSION ASSEMBLY</b>	
<b>2L8Z-7V000-FBRM</b>		Ford		<b>3L8Z-7000-GDRM</b>		Lincoln	
<b>AUTOMATIC TRANSMISSION ASSEMBLY</b>		Excursion	2004-2003	<b>AUTOMATIC TRANSMISSION ASSEMBLY</b>		Town Car	2003
Ford		<b>3L2Z-7V000-EERM</b>		Ford		<b>3W1Z-7V000-BRM</b>	
Escape	2002	<b>AUTOMATIC TRANSMISSION ASSEMBLY</b>		Escape	2004	<b>AUTOMATIC TRANSMISSION ASSEMBLY</b>	
<b>Mazda</b>		Lincoln		<b>Mazda</b>		Lincoln	
Tribute	2002	Aviator	2003	Tribute	2004	Town Car	2003
<b>2S8Z-7V000-ABRM</b>		<b>3L2Z-7V000-FERM</b>		<b>3L8Z-7000-HARM</b>		<b>3W1Z-7V000-DRM</b>	
<b>AUTOMATIC TRANSMISSION ASSEMBLY</b>		<b>AUTOMATIC TRANSMISSION ASSEMBLY</b>		<b>AUTOMATIC TRANSMISSION ASSEMBLY</b>		<b>AUTOMATIC TRANSMISSION ASSEMBLY</b>	
Mercury		Lincoln		Ford		Lincoln	
Cougar	2002	Aviator	2003	Escape	2003	Town Car	2003
<b>2W3Z-7V000-ARM</b>		<b>3L3Z-7000-HARM</b>		<b>Mazda</b>		<b>3W4Z-7V000-ACRM</b>	
<b>AUTOMATIC TRANSMISSION ASSEMBLY</b>		<b>AUTOMATIC TRANSMISSION ASSEMBLY</b>		Tribute	2003	<b>AUTOMATIC TRANSMISSION ASSEMBLY</b>	
Mercury		Ford		<b>3L8Z-7000-HDRM</b>		Ford	
Marauder	2003	F-Series	2004	<b>AUTOMATIC TRANSMISSION ASSEMBLY</b>		Thunderbird	2003
<b>2W4Z-7V000-AARM</b>		<b>3L3Z-7000-JARM</b>		Ford		Lincoln	
<b>AUTOMATIC TRANSMISSION ASSEMBLY</b>		<b>AUTOMATIC TRANSMISSION ASSEMBLY</b>		Escape	2004	LS	2003
Ford		Ford		<b>Mazda</b>		<b>3W4Z-7V000-BCRM</b>	
Thunderbird	2002	F-Series	2004	Tribute	2004	<b>AUTOMATIC TRANSMISSION ASSEMBLY</b>	
Lincoln		<b>3L3Z-7000-LARM</b>		<b>3L8Z-7V000-HCRM</b>		Lincoln	
LS	2002	<b>AUTOMATIC TRANSMISSION ASSEMBLY</b>		Ford		LS	2003
<b>2W4Z-7V000-BARM</b>		Ford		Escape	2003	<b>3W7Z-7V000-ARM</b>	
<b>AUTOMATIC TRANSMISSION ASSEMBLY</b>		F-Series	2004	<b>Mazda</b>		<b>AUTOMATIC TRANSMISSION ASSEMBLY</b>	
Lincoln		<b>3L3Z-7000-MARM</b>		Tribute	2003	Ford	
LS	2002	<b>AUTOMATIC TRANSMISSION ASSEMBLY</b>		<b>3R3Z-7000-BARM</b>		Crown Victoria	2003
<b>3C2Z-7V000-ARM</b>		Ford		<b>AUTOMATIC TRANSMISSION ASSEMBLY</b>		Mercury	
<b>AUTOMATIC TRANSMISSION ASSEMBLY</b>		F-Series	2004	Ford		Grand Marquis	2003
Ford		<b>3L7Z-7V000-ARM</b>		Mustang	2004	<b>3W7Z-7V000-CRM</b>	
Econoline	2003	<b>AUTOMATIC TRANSMISSION ASSEMBLY</b>		<b>3R3Z-7000-CARM</b>		<b>AUTOMATIC TRANSMISSION ASSEMBLY</b>	
<b>3C3Z-7000-EJRM</b>		Lincoln		<b>AUTOMATIC TRANSMISSION ASSEMBLY</b>		Ford	
<b>AUTOMATIC TRANSMISSION ASSEMBLY</b>		Blackwood	2002	Ford		Crown Victoria	2003
Ford		Navigator	2004-2001	Mustang	2004	<b>3W7Z-7V000-DRM</b>	
F-Series	2003	<b>3L7Z-7V000-BRM</b>		<b>3R3Z-7V000-ARM</b>		<b>AUTOMATIC TRANSMISSION ASSEMBLY</b>	
<b>3C3Z-7V000-HGRM</b>		<b>AUTOMATIC TRANSMISSION ASSEMBLY</b>		Ford		Ford	
<b>AUTOMATIC TRANSMISSION ASSEMBLY</b>		Lincoln		Crown Victoria	2003	Crown Victoria	2003
Ford		Navigator	2004-2001	<b>Mercury</b>		Grand Marquis	2003
F-Series	2004-2003						

# BUYER'S GUIDE

## Transmission Assemblies



FORD PARTS

Make	Year	Make	Year	Make	Year	Make	Year
<b>4C2Z-7000-AARM</b>		<b>4C2Z-7000-PARM</b>		<b>4F2Z-7000-ABRM</b>		<b>4L2Z-7000-DCRM</b>	
<b>AUTOMATIC TRANSMISSION ASSEMBLY</b> Ford		<b>AUTOMATIC TRANSMISSION ASSEMBLY</b> Ford		<b>AUTOMATIC TRANSMISSION ASSEMBLY</b> Ford		<b>AUTOMATIC TRANSMISSION ASSEMBLY</b> Ford	
Econoline	2004	Econoline	2004	Freestar	2004	Explorer	2005-2004
<b>4C2Z-7000-BARM</b>		<b>4C2Z-7000-RARM</b>		<b>Mercury</b>		<b>Mercury</b>	
<b>AUTOMATIC TRANSMISSION ASSEMBLY</b> Ford		<b>AUTOMATIC TRANSMISSION ASSEMBLY</b> Ford		Monterey	2004	Mountaineer	2005-2004
Econoline	2004	Econoline	2004				
<b>4C2Z-7000-CARM</b>		<b>4C2Z-7000-SARM</b>		<b>4F2Z-7000-BARM</b>		<b>4L2Z-7000-ECRM</b>	
<b>AUTOMATIC TRANSMISSION ASSEMBLY</b> Ford		<b>AUTOMATIC TRANSMISSION ASSEMBLY</b> Ford		<b>AUTOMATIC TRANSMISSION ASSEMBLY</b> Ford		<b>AUTOMATIC TRANSMISSION ASSEMBLY</b> Lincoln	
Econoline	2004	Econoline	2004	Freestar	2004	Aviator	2005-2004
<b>4C2Z-7000-DARM</b>		<b>4C3Z-7000-JBRM</b>		<b>4L1Z-7000-AARM</b>		<b>4L2Z-7000-FCRM</b>	
<b>AUTOMATIC TRANSMISSION ASSEMBLY</b> Ford		<b>AUTOMATIC TRANSMISSION ASSEMBLY</b> Ford		<b>AUTOMATIC TRANSMISSION ASSEMBLY</b> Ford		<b>AUTOMATIC TRANSMISSION ASSEMBLY</b> Lincoln	
Econoline	2004	Econoline	2004	Expedition	2004	Aviator	2005-2004
<b>4C2Z-7000-EARM</b>		<b>4C3Z-7000-KBRM</b>		<b>4L1Z-7000-BARM</b>		<b>4L3Z-7000-AARM</b>	
<b>AUTOMATIC TRANSMISSION ASSEMBLY</b> Ford		<b>AUTOMATIC TRANSMISSION ASSEMBLY</b> Ford		<b>AUTOMATIC TRANSMISSION ASSEMBLY</b> Ford		<b>AUTOMATIC TRANSMISSION ASSEMBLY</b> Ford	
Econoline	2004	F-Series	2004-2003	Expedition	2004	F-Series	2004
<b>4C2Z-7000-FARM</b>		<b>4C3Z-7000-LBRM</b>		<b>4L1Z-7000-CARM</b>		<b>4L3Z-7000-BARM</b>	
<b>AUTOMATIC TRANSMISSION ASSEMBLY</b> Ford		<b>AUTOMATIC TRANSMISSION ASSEMBLY</b> Ford		<b>AUTOMATIC TRANSMISSION ASSEMBLY</b> Ford		<b>AUTOMATIC TRANSMISSION ASSEMBLY</b> Ford	
Econoline	2004	Excursion	2003	Expedition	2004	F-Series	2004
<b>4C2Z-7000-GARM</b>		<b>4F1Z-7000-CBRM</b>		<b>4L1Z-7000-DARM</b>		<b>4L3Z-7000-CARM</b>	
<b>AUTOMATIC TRANSMISSION ASSEMBLY</b> Ford		<b>AUTOMATIC TRANSMISSION ASSEMBLY</b> Mercury		<b>AUTOMATIC TRANSMISSION ASSEMBLY</b> Ford		<b>AUTOMATIC TRANSMISSION ASSEMBLY</b> Ford	
Econoline	2004	F-Series	2004-2003	Expedition	2004	F-Series	2004
<b>4C2Z-7000-HARM</b>		<b>4F1Z-7000-DBRM</b>		<b>4L2Z-7000-ABRM</b>		<b>4L3Z-7000-DARM</b>	
<b>AUTOMATIC TRANSMISSION ASSEMBLY</b> Ford		<b>AUTOMATIC TRANSMISSION ASSEMBLY</b> Ford		<b>AUTOMATIC TRANSMISSION ASSEMBLY</b> Ford		<b>AUTOMATIC TRANSMISSION ASSEMBLY</b> Ford	
Econoline	2004	Taurus	2004	Explorer	2006-2004	F-Series	2004
<b>4C2Z-7000-IARM</b>		<b>4F1Z-7000-EBRM</b>		<b>4L2Z-7000-BBRM</b>		<b>4L5Z-7000-AARM</b>	
<b>AUTOMATIC TRANSMISSION ASSEMBLY</b> Ford		<b>AUTOMATIC TRANSMISSION ASSEMBLY</b> Ford		<b>AUTOMATIC TRANSMISSION ASSEMBLY</b> Ford		<b>AUTOMATIC TRANSMISSION ASSEMBLY</b> Ford	
Econoline	2004	Mercury		Explorer	2005-2004	Ranger	2004
<b>4C2Z-7000-LARM</b>		<b>4F1Z-7000-FBRM</b>		<b>4L2Z-7000-CCRM</b>		<b>Mazda</b>	
<b>AUTOMATIC TRANSMISSION ASSEMBLY</b> Ford		<b>AUTOMATIC TRANSMISSION ASSEMBLY</b> Ford		<b>AUTOMATIC TRANSMISSION ASSEMBLY</b> Ford		B3000	2004
Econoline	2004	Sable	2004	Mountaineer	2005-2004		
<b>4C2Z-7000-MARM</b>		<b>4F1Z-7000-GBRM</b>		<b>4L2Z-7000-DCRM</b>		<b>4L5Z-7000-BARM</b>	
<b>AUTOMATIC TRANSMISSION ASSEMBLY</b> Ford		<b>AUTOMATIC TRANSMISSION ASSEMBLY</b> Ford		<b>AUTOMATIC TRANSMISSION ASSEMBLY</b> Ford		<b>AUTOMATIC TRANSMISSION ASSEMBLY</b> Ford	
Econoline	2004	Taurus	2004	Explorer	2005-2004	Ranger	2005-2004
<b>4C2Z-7000-NARM</b>		<b>4F1Z-7000-HBRM</b>		<b>4L2Z-7000-ECRM</b>		<b>4L5Z-7000-CARM</b>	
<b>AUTOMATIC TRANSMISSION ASSEMBLY</b> Ford		<b>AUTOMATIC TRANSMISSION ASSEMBLY</b> Ford		<b>AUTOMATIC TRANSMISSION ASSEMBLY</b> Ford		<b>AUTOMATIC TRANSMISSION ASSEMBLY</b> Ford	
Econoline	2004	Mercury		Mountaineer	2005-2004	Ranger	2004
<b>4C2Z-7000-OARM</b>		<b>4F1Z-7000-IBRM</b>		<b>4L2Z-7000-FCRM</b>			
<b>AUTOMATIC TRANSMISSION ASSEMBLY</b> Ford		<b>AUTOMATIC TRANSMISSION ASSEMBLY</b> Ford		<b>AUTOMATIC TRANSMISSION ASSEMBLY</b> Ford			
Econoline	2004	Sable	2005-2004	Explorer	2005-2004		
<b>4C2Z-7000-PARM</b>		<b>4F1Z-7000-JBRM</b>		<b>4L2Z-7000-GCRM</b>			
<b>AUTOMATIC TRANSMISSION ASSEMBLY</b> Ford		<b>AUTOMATIC TRANSMISSION ASSEMBLY</b> Ford		<b>AUTOMATIC TRANSMISSION ASSEMBLY</b> Ford			
Econoline	2004	Mercury		Mountaineer	2005-2004		
<b>4C2Z-7000-QARM</b>		<b>4F1Z-7000-KBRM</b>		<b>4L2Z-7000-HCRM</b>			
<b>AUTOMATIC TRANSMISSION ASSEMBLY</b> Ford		<b>AUTOMATIC TRANSMISSION ASSEMBLY</b> Ford		<b>AUTOMATIC TRANSMISSION ASSEMBLY</b> Ford			
Econoline	2004	Sable	2005-2004	Explorer	2005-2004		
<b>4C2Z-7000-RARM</b>		<b>4F1Z-7000-LBRM</b>		<b>4L2Z-7000-ICRM</b>			
<b>AUTOMATIC TRANSMISSION ASSEMBLY</b> Ford		<b>AUTOMATIC TRANSMISSION ASSEMBLY</b> Ford		<b>AUTOMATIC TRANSMISSION ASSEMBLY</b> Ford			
Econoline	2004	Mercury		Mountaineer	2005-2004		
<b>4C2Z-7000-SARM</b>		<b>4F1Z-7000-MBRM</b>		<b>4L2Z-7000-JCRM</b>			
<b>AUTOMATIC TRANSMISSION ASSEMBLY</b> Ford		<b>AUTOMATIC TRANSMISSION ASSEMBLY</b> Ford		<b>AUTOMATIC TRANSMISSION ASSEMBLY</b> Ford			
Econoline	2004	Sable	2005-2004	Explorer	2005-2004		
<b>4C2Z-7000-TARM</b>		<b>4F1Z-7000-NBRM</b>		<b>4L2Z-7000-KCRM</b>			
<b>AUTOMATIC TRANSMISSION ASSEMBLY</b> Ford		<b>AUTOMATIC TRANSMISSION ASSEMBLY</b> Ford		<b>AUTOMATIC TRANSMISSION ASSEMBLY</b> Ford			
Econoline	2004	Mercury		Mountaineer	2005-2004		
<b>4C2Z-7000-UARM</b>		<b>4F1Z-7000-OBRM</b>		<b>4L2Z-7000-LCRM</b>			
<b>AUTOMATIC TRANSMISSION ASSEMBLY</b> Ford		<b>AUTOMATIC TRANSMISSION ASSEMBLY</b> Ford		<b>AUTOMATIC TRANSMISSION ASSEMBLY</b> Ford			
Econoline	2004	Sable	2005-2004	Explorer	2005-2004		
<b>4C2Z-7000-VARM</b>		<b>4F1Z-7000-PBRM</b>		<b>4L2Z-7000-MCRM</b>			
<b>AUTOMATIC TRANSMISSION ASSEMBLY</b> Ford		<b>AUTOMATIC TRANSMISSION ASSEMBLY</b> Ford		<b>AUTOMATIC TRANSMISSION ASSEMBLY</b> Ford			
Econoline	2004	Mercury		Mountaineer	2005-2004		
<b>4C2Z-7000-WARM</b>		<b>4F1Z-7000-QBRM</b>		<b>4L2Z-7000-NCRM</b>			
<b>AUTOMATIC TRANSMISSION ASSEMBLY</b> Ford		<b>AUTOMATIC TRANSMISSION ASSEMBLY</b> Ford		<b>AUTOMATIC TRANSMISSION ASSEMBLY</b> Ford			
Econoline	2004	Sable	2005-2004	Explorer	2005-2004		
<b>4C2Z-7000-XARM</b>		<b>4F1Z-7000-RBRM</b>		<b>4L2Z-7000-OCRM</b>			
<b>AUTOMATIC TRANSMISSION ASSEMBLY</b> Ford		<b>AUTOMATIC TRANSMISSION ASSEMBLY</b> Ford		<b>AUTOMATIC TRANSMISSION ASSEMBLY</b> Ford			
Econoline	2004	Mercury		Mountaineer	2005-2004		
<b>4C2Z-7000-YARM</b>		<b>4F1Z-7000-SBRM</b>		<b>4L2Z-7000-PCRM</b>			
<b>AUTOMATIC TRANSMISSION ASSEMBLY</b> Ford		<b>AUTOMATIC TRANSMISSION ASSEMBLY</b> Ford		<b>AUTOMATIC TRANSMISSION ASSEMBLY</b> Ford			
Econoline	2004	Sable	2005-2004	Explorer	2005-2004		
<b>4C2Z-7000-ZARM</b>		<b>4F1Z-7000-TBRM</b>		<b>4L2Z-7000-QCRM</b>			
<b>AUTOMATIC TRANSMISSION ASSEMBLY</b> Ford		<b>AUTOMATIC TRANSMISSION ASSEMBLY</b> Ford		<b>AUTOMATIC TRANSMISSION ASSEMBLY</b> Ford			
Econoline	2004	Mercury		Mountaineer	2005-2004		



Make	Year	Make	Year	Make	Year	Make	Year
<b>4L5Z-7000-CARM cont'd</b>		<b>4W4Z-7000-BBRM</b>		<b>5C2Z-7000-SRM</b>		<b>5C3Z-7000-KRM</b>	
Mazda		AUTOMATIC TRANSMISSION ASSEMBLY		AUTOMATIC TRANSMISSION ASSEMBLY		AUTOMATIC TRANSMISSION ASSEMBLY	
B2300	2004	Lincoln		Ford		Ford	
<b>4L5Z-7000-DARM</b>		LS	2005-2004	Econoline	2008-2005	F-Series	2007-2005
<b>AUTOMATIC TRANSMISSION ASSEMBLY</b>		<b>4W7Z-7000-AARM</b>		<b>5C2Z-7000-TRM</b>		<b>5C3Z-7000-LRM</b>	
Ford		AUTOMATIC TRANSMISSION ASSEMBLY		AUTOMATIC TRANSMISSION ASSEMBLY		AUTOMATIC TRANSMISSION ASSEMBLY	
Explorer	2004	Ford		Ford		Ford	
Ranger	2004	Crown Victoria		Econoline		F-Series	
Mazda		2004		2008-2005		2006-2005	
B4000	2004	<b>Mercury</b>		<b>5C2Z-7000-URM</b>		<b>5C3Z-7000-MRM</b>	
<b>Mercury</b>		Grand Marquis		AUTOMATIC TRANSMISSION ASSEMBLY		AUTOMATIC TRANSMISSION ASSEMBLY	
Mountaineer	2004	2004		Ford		Ford	
<b>4L5Z-7000-EARM</b>		<b>4W7Z-7000-CARM</b>		Econoline		F-Series	
<b>AUTOMATIC TRANSMISSION ASSEMBLY</b>		AUTOMATIC TRANSMISSION ASSEMBLY		2008-2005		2007-2005	
Ford		Ford		<b>5C2Z-7000-VRM</b>		<b>5C3Z-7000-NRM</b>	
Explorer Sport Trac	2005-2004	Crown Victoria		AUTOMATIC TRANSMISSION ASSEMBLY		AUTOMATIC TRANSMISSION ASSEMBLY	
Ranger	2006-2004	2004		Ford		Ford	
Mazda		<b>Mercury</b>		Econoline		Excursion	
B4000	2005-2004	Marauder		2008-2005		2005	
<b>4R3Z-7000-ARM</b>		<b>4W7Z-7000-DARM</b>		<b>5C3Z-7000-ARM</b>		<b>5F2Z-7000-ARM</b>	
<b>AUTOMATIC TRANSMISSION ASSEMBLY</b>		AUTOMATIC TRANSMISSION ASSEMBLY		AUTOMATIC TRANSMISSION ASSEMBLY		AUTOMATIC TRANSMISSION ASSEMBLY	
Ford		Ford		Ford		Ford	
Mustang	2006-2005	Crown Victoria		F-Series		Freestar	
<b>4R3Z-7000-BRM</b>		2004		2007-2005		2007-2005	
<b>AUTOMATIC TRANSMISSION ASSEMBLY</b>		<b>5C2Z-7000-ARM</b>		<b>5C3Z-7000-BRM</b>		<b>Mercury</b>	
Ford		AUTOMATIC TRANSMISSION ASSEMBLY		AUTOMATIC TRANSMISSION ASSEMBLY		Monterey	
Mustang	2006-2005	Ford		Ford		2007-2005	
<b>4R3Z-7000-BRM</b>		Econoline		F-Series		<b>5F2Z-7000-BRM</b>	
<b>AUTOMATIC TRANSMISSION ASSEMBLY</b>		2005		2006-2005		AUTOMATIC TRANSMISSION ASSEMBLY	
Ford		<b>5C2Z-7000-BRM</b>		<b>5C3Z-7000-CRM</b>		Ford	
Mustang	2005	AUTOMATIC TRANSMISSION ASSEMBLY		AUTOMATIC TRANSMISSION ASSEMBLY		Freestar	
<b>4S4Z-7000-FARM</b>		Ford		Ford		2007-2005	
<b>AUTOMATIC TRANSMISSION ASSEMBLY</b>		Econoline		Econoline		<b>5L1Z-7000-ERM</b>	
Ford		2005		2005		AUTOMATIC TRANSMISSION ASSEMBLY	
Focus	2005	<b>5C2Z-7000-CRM</b>		F-Series		Ford	
<b>4W1Z-7000-AARM</b>		AUTOMATIC TRANSMISSION ASSEMBLY		2005		Expedition	
<b>AUTOMATIC TRANSMISSION ASSEMBLY</b>		Ford		<b>5C3Z-7000-DRM</b>		2005	
Lincoln		Econoline		AUTOMATIC TRANSMISSION ASSEMBLY		<b>5L1Z-7000-FRM</b>	
Town Car	2004	2005		Ford		AUTOMATIC TRANSMISSION ASSEMBLY	
<b>4W1Z-7000-DARM</b>		<b>5C2Z-7000-DRM</b>		F-Series		Ford	
<b>AUTOMATIC TRANSMISSION ASSEMBLY</b>		AUTOMATIC TRANSMISSION ASSEMBLY		2007-2005		Expedition	
Lincoln		Ford		<b>5C3Z-7000-FRM</b>		2005	
Town Car	2004	Econoline		AUTOMATIC TRANSMISSION ASSEMBLY		<b>5L3Z-7000-ARM</b>	
<b>4W4Z-7000-ABRM</b>		2005		Ford		AUTOMATIC TRANSMISSION ASSEMBLY	
<b>AUTOMATIC TRANSMISSION ASSEMBLY</b>		<b>5C2Z-7000-ERM</b>		F-Series		Ford	
Ford		AUTOMATIC TRANSMISSION ASSEMBLY		2006-2005		F-Series	
Thunderbird	2005-2004	Ford		<b>5C3Z-7000-JRM</b>		2005	
Lincoln		Econoline		AUTOMATIC TRANSMISSION ASSEMBLY		<b>5L3Z-7000-BRM</b>	
LS	2006-2004	2005		Ford		AUTOMATIC TRANSMISSION ASSEMBLY	
<b>5C2Z-7000-RRM</b>		AUTOMATIC TRANSMISSION ASSEMBLY		F-Series		Ford	
Ford		Ford		2006-2005		F-Series	
Thunderbird	2005-2004	Econoline				2005	
Lincoln		2006-2005					
LS	2006-2004						

# BUYER'S GUIDE

## Transmission Assemblies



FORD PARTS

Make	Year	Make	Year	Make	Year	Make	Year
<b>5L3Z-7000-CRM</b>		<b>5L8Z-7000-CBRM</b>		<b>5L8Z-7000-HRM cont'd</b>		<b>6C2Z-7000-DRM</b>	
<b>AUTOMATIC TRANSMISSION ASSEMBLY</b> Ford		<b>AUTOMATIC TRANSMISSION ASSEMBLY</b> Ford		Mercury Mariner	2007-2005	<b>AUTOMATIC TRANSMISSION ASSEMBLY</b> Ford	
F-Series	2005	Escape	2005	<b>5M6Z-7000-B</b>		Econoline	2006
<b>5L3Z-7000-DRM</b>		<b>Mazda</b>		<b>AUTOMATIC TRANSMISSION ASSEMBLY</b> Ford		<b>6E5Z-7000-AERM</b>	
<b>AUTOMATIC TRANSMISSION ASSEMBLY</b> Ford		Tribute	2005	Escape	2005	<b>AUTOMATIC TRANSMISSION ASSEMBLY</b> Ford	
F-Series	2005	Mercury Mariner	2005	<b>5W1Z-7000-GRM</b>		Fusion	2007-2006
<b>5L3Z-7000-ERM</b>		<b>5L8Z-7000-DBRM</b>		<b>AUTOMATIC TRANSMISSION ASSEMBLY</b> Lincoln		Lincoln Zephyr	2006
<b>AUTOMATIC TRANSMISSION ASSEMBLY</b> Ford		<b>AUTOMATIC TRANSMISSION ASSEMBLY</b> Ford		Town Car	2005	Mercury Milan	2007-2006
F-Series	2005	Escape	2005	<b>5W1Z-7000-HRM</b>		<b>6E7Z-7000-ABRM</b>	
<b>5L5Z-7000-ARM</b>		<b>Mazda</b>		<b>AUTOMATIC TRANSMISSION ASSEMBLY</b> Lincoln		<b>AUTOMATIC TRANSMISSION ASSEMBLY</b> Ford	
<b>AUTOMATIC TRANSMISSION ASSEMBLY</b> Ford		Tribute	2005	Town Car	2005	LCF	2006
Ranger	2006-2005	Mercury Mariner	2005	<b>5W7Z-7000-KRM</b>		<b>6E7Z-7000-BBRM</b>	
<b>Mazda</b>		<b>5L8Z-7000-ERM</b>		<b>AUTOMATIC TRANSMISSION ASSEMBLY</b> Ford		<b>AUTOMATIC TRANSMISSION ASSEMBLY</b> Ford	
B3000	2006-2005	<b>AUTOMATIC TRANSMISSION ASSEMBLY</b> Ford		Crown Victoria	2005	LCF	2009
<b>5L5Z-7000-CRM</b>		Escape	2007-2005	Mercury Grand Marquis	2005	<b>6F9Z-7000-ARM</b>	
<b>AUTOMATIC TRANSMISSION ASSEMBLY</b> Ford		<b>Mazda</b>		<b>5W7Z-7000-LRM</b>		<b>AUTOMATIC TRANSMISSION ASSEMBLY</b> Ford	
Ranger	2007-2005	Tribute	2007-2005	<b>AUTOMATIC TRANSMISSION ASSEMBLY</b> Ford		Freestyle	2007-2005
<b>Mazda</b>		Mercury Mariner	2007-2005	Crown Victoria	2005	<b>6F9Z-7000-BRM</b>	
B2300	2006-2005	<b>5L8Z-7000-FRM</b>		Mercury Grand Marquis	2005	<b>AUTOMATIC TRANSMISSION ASSEMBLY</b> Ford	
<b>5L5Z-7000-DRM</b>		<b>AUTOMATIC TRANSMISSION ASSEMBLY</b> Ford		<b>5W7Z-7000-MRM</b>		<b>AUTOMATIC TRANSMISSION ASSEMBLY</b> Ford	
<b>AUTOMATIC TRANSMISSION ASSEMBLY</b> Ford		Escape	2007-2005	<b>AUTOMATIC TRANSMISSION ASSEMBLY</b> Ford		Freestyle	2007-2005
Explorer	2006-2005	<b>Mazda</b>		Crown Victoria	2005	<b>6G1Z-7000-ARM</b>	
Explorer Sport Trac	2005	Tribute	2007-2005	Mercury Grand Marquis	2005	<b>AUTOMATIC TRANSMISSION ASSEMBLY</b> Ford	
Ranger	2006-2005	Mercury Mariner	2007-2005	<b>6C2Z-7000-ARM</b>		Five Hundred	2006-2005
<b>5L8Z-7000-ACRM</b>		<b>5L8Z-7000-GRM</b>		<b>AUTOMATIC TRANSMISSION ASSEMBLY</b> Ford		Mercury Montego	2006-2005
<b>AUTOMATIC TRANSMISSION ASSEMBLY</b> Ford		<b>AUTOMATIC TRANSMISSION ASSEMBLY</b> Ford		Econoline	2006	<b>6G1Z-7000-BRM</b>	
Escape	2005	Escape	2007-2005	<b>6C2Z-7000-BRM</b>		<b>AUTOMATIC TRANSMISSION ASSEMBLY</b> Ford	
<b>Mazda</b>		<b>Mazda</b>		<b>AUTOMATIC TRANSMISSION ASSEMBLY</b> Ford		Five Hundred	2007-2005
Tribute	2005	Tribute	2007-2005	Econoline	2006	Mercury Montego	2007-2005
Mercury Mariner	2005	Mercury Mariner	2007-2005	<b>6C2Z-7000-CRM</b>		<b>6G1Z-7000-CDRM</b>	
<b>5L8Z-7000-BCRM</b>		<b>5L8Z-7000-HRM</b>		<b>AUTOMATIC TRANSMISSION ASSEMBLY</b> Ford		<b>AUTOMATIC TRANSMISSION ASSEMBLY</b> Ford	
<b>AUTOMATIC TRANSMISSION ASSEMBLY</b> Ford		<b>AUTOMATIC TRANSMISSION ASSEMBLY</b> Ford		Econoline	2006	Five Hundred	2006-2005
Escape	2005	Escape	2007-2005	<b>6G1Z-7000-CDRM</b>			
<b>Mazda</b>		<b>Mazda</b>					
Tribute	2005	Tribute	2007-2005				





Make	Year	Make	Year	Make	Year	Make	Year
<b>6G1Z-7000-CDRM cont'd</b>		<b>6L3Z-7000-FRM</b>		<b>6U2Z-7V000-LRM</b>		<b>7C2Z-7000-CARM</b>	
Mercury		AUTOMATIC TRANSMISSION ASSEMBLY		AUTOMATIC TRANSMISSION ASSEMBLY		AUTOMATIC TRANSMISSION ASSEMBLY	
Montego	2006-2005	Ford		Ford		Ford	
<b>6L1Z-7000-ARM</b>		F-Series	2006	F-Series	2000-1999	Econoline	2008-2007
AUTOMATIC TRANSMISSION ASSEMBLY		<b>6L3Z-7000-GRM</b>		<b>6W1Z-7000-ARM</b>		<b>7C2Z-7000-DARM</b>	
Ford		AUTOMATIC TRANSMISSION ASSEMBLY		AUTOMATIC TRANSMISSION ASSEMBLY		AUTOMATIC TRANSMISSION ASSEMBLY	
Expedition	2006	Ford		Lincoln		Ford	
<b>6L1Z-7000-BRM</b>		F-Series	2006	Town Car	2006	Econoline	2008-2007
AUTOMATIC TRANSMISSION ASSEMBLY		<b>6L3Z-7000-HRM</b>		<b>6W1Z-7000-DRM</b>		<b>7C3Z-7000-ARM</b>	
Ford		AUTOMATIC TRANSMISSION ASSEMBLY		AUTOMATIC TRANSMISSION ASSEMBLY		AUTOMATIC TRANSMISSION ASSEMBLY	
Expedition	2006	Ford		Lincoln		Ford	
<b>6L2Z-7000-ARM</b>		F-Series	2006	Town Car	2006	F-Series	2008
AUTOMATIC TRANSMISSION ASSEMBLY		<b>6L3Z-7000-JRM</b>		<b>6W7Z-7000-ARM</b>		<b>7C3Z-7000-BRM</b>	
Ford		AUTOMATIC TRANSMISSION ASSEMBLY		AUTOMATIC TRANSMISSION ASSEMBLY		AUTOMATIC TRANSMISSION ASSEMBLY	
Explorer	2006	Ford		Ford		Ford	
Mercury		F-Series	2006	Crown Victoria	2006	F-Series	2008
Mountaineer	2006	Lincoln		Mercury		<b>7C3Z-7000-CRM</b>	
<b>6L2Z-7000-BRM</b>		Mark LT	2006	Grand Marquis	2006	AUTOMATIC TRANSMISSION ASSEMBLY	
AUTOMATIC TRANSMISSION ASSEMBLY		<b>6L3Z-7000-KRM</b>		<b>6W7Z-7000-CRM</b>		Ford	
Ford		AUTOMATIC TRANSMISSION ASSEMBLY		AUTOMATIC TRANSMISSION ASSEMBLY		F-Series	2008
Explorer	2006	Ford		Ford		<b>7C3Z-7000-DRM</b>	
Mercury		F-Series	2006	Crown Victoria	2006	AUTOMATIC TRANSMISSION ASSEMBLY	
Mountaineer	2006	Lincoln		Mercury		Ford	
<b>6L2Z-7000-ERM</b>		Mark LT	2006	Grand Marquis	2006	F-Series	2008
AUTOMATIC TRANSMISSION ASSEMBLY		<b>6S4Z-7000-FRM</b>		<b>7A1Z-7000-ARM</b>		<b>7C3Z-7000-ERM</b>	
Ford		AUTOMATIC TRANSMISSION ASSEMBLY		AUTOMATIC TRANSMISSION ASSEMBLY		AUTOMATIC TRANSMISSION ASSEMBLY	
Explorer	2006	Ford		Ford		Ford	
Mercury		F-Series	2006	Crown Victoria	2006	Econoline	2007
Mountaineer	2006	Lincoln		Mercury		F-Series	2008
<b>6L2Z-7000-FRM</b>		Mark LT	2006	Grand Marquis	2006	<b>7C3Z-7000-FRM</b>	
AUTOMATIC TRANSMISSION ASSEMBLY		<b>6U2Z-7V000-ERM</b>		<b>7A1Z-7000-ARM</b>		AUTOMATIC TRANSMISSION ASSEMBLY	
Ford		AUTOMATIC TRANSMISSION ASSEMBLY		AUTOMATIC TRANSMISSION ASSEMBLY		Ford	
Explorer	2006	Ford		Ford		Econoline	2007
Explorer Sport Trac	2007	Excursion	2003-2001	Edge	2009	F-Series	2008
Mercury		F-Series	2003-2001	Lincoln		<b>7C3Z-7000-GRM</b>	
Mountaineer	2006	<b>6U2Z-7V000-FRM</b>		MKX	2009-2007	AUTOMATIC TRANSMISSION ASSEMBLY	
<b>6L3Z-7000-DRM</b>		AUTOMATIC TRANSMISSION ASSEMBLY		<b>7C2Z-7000-ARM</b>		Ford	
AUTOMATIC TRANSMISSION ASSEMBLY		Ford		AUTOMATIC TRANSMISSION ASSEMBLY		Econoline	2007
Lincoln		Excursion	2003-2001	Ford		F-Series	2008
Mark LT	2006	F-Series	2003-2001	Econoline	2007	<b>7C3Z-7000-HRM</b>	
<b>6L3Z-7000-ERM</b>		<b>6U2Z-7V000-HRM</b>		<b>7C2Z-7000-BRM</b>		AUTOMATIC TRANSMISSION ASSEMBLY	
AUTOMATIC TRANSMISSION ASSEMBLY		AUTOMATIC TRANSMISSION ASSEMBLY		AUTOMATIC TRANSMISSION ASSEMBLY		Ford	
Lincoln		Ford		Ford		Econoline	2007
Mark LT	2006	Excursion	2003-2001	Econoline	2007	F-Series	2008
<b>6L3Z-7000-ERM</b>		F-Series	2003-2001	<b>7C2Z-7000-BRM</b>		<b>7C3Z-7000-HRM</b>	
AUTOMATIC TRANSMISSION ASSEMBLY		<b>6U2Z-7V000-LRM</b>		AUTOMATIC TRANSMISSION ASSEMBLY		AUTOMATIC TRANSMISSION ASSEMBLY	
Lincoln		AUTOMATIC TRANSMISSION ASSEMBLY		Ford		Ford	
Mark LT	2006	Ford		Econoline	2007	Econoline	2007
<b>6L3Z-7000-ERM</b>		F-Series	2000-1999	<b>7C2Z-7000-BRM</b>		F-Series	2008
AUTOMATIC TRANSMISSION ASSEMBLY		<b>6U2Z-7V000-LRM</b>		AUTOMATIC TRANSMISSION ASSEMBLY		<b>7C3Z-7000-HRM</b>	
Lincoln		AUTOMATIC TRANSMISSION ASSEMBLY		Ford		AUTOMATIC TRANSMISSION ASSEMBLY	
Mark LT	2006	Ford		Econoline	2007	Ford	
<b>6L3Z-7000-ERM</b>		F-Series	2000-1999	<b>7C2Z-7000-BRM</b>		AUTOMATIC TRANSMISSION ASSEMBLY	
AUTOMATIC TRANSMISSION ASSEMBLY		<b>6U2Z-7V000-LRM</b>		AUTOMATIC TRANSMISSION ASSEMBLY		Ford	
Lincoln		AUTOMATIC TRANSMISSION ASSEMBLY		Ford		Econoline	2007
Mark LT	2006	Ford		Econoline	2007	F-Series	2008
<b>6L3Z-7000-ERM</b>		F-Series	2000-1999	<b>7C2Z-7000-BRM</b>		<b>7C3Z-7000-HRM</b>	
AUTOMATIC TRANSMISSION ASSEMBLY		<b>6U2Z-7V000-LRM</b>		AUTOMATIC TRANSMISSION ASSEMBLY		AUTOMATIC TRANSMISSION ASSEMBLY	
Lincoln		AUTOMATIC TRANSMISSION ASSEMBLY		Ford		Ford	
Mark LT	2006	Ford		Econoline	2007	Econoline	2007

# BUYER'S GUIDE

## Transmission Assemblies



FORD PARTS

Make	Year	Make	Year	Make	Year	Make	Year
<b>7C3Z-7000-HRM cont'd</b>		<b>7L1Z-7000-ARM</b>		<b>7L3Z-7000-DBRM</b>		<b>7R3Z-7000-BRM</b>	
F-Series 2007		<b>AUTOMATIC TRANSMISSION ASSEMBLY</b>		<b>AUTOMATIC TRANSMISSION ASSEMBLY</b>		<b>AUTOMATIC TRANSMISSION ASSEMBLY</b>	
F53 2008-2007		Ford		Ford		Ford	
<b>7C3Z-7000-JRM</b>		Expedition 2008-2007		F-Series 2008-2007		Mustang 2007	
<b>AUTOMATIC TRANSMISSION ASSEMBLY</b>		<b>7L1Z-7000-BRM</b>		Lincoln		<b>7T4Z-7000-ARM</b>	
Ford		<b>AUTOMATIC TRANSMISSION ASSEMBLY</b>		Mark LT 2008-2007		<b>AUTOMATIC TRANSMISSION ASSEMBLY</b>	
F-Series 2008		Ford		<b>7L3Z-7000-EBRM</b>		Ford	
<b>7E5Z-7000-AERM</b>		Expedition 2007		<b>AUTOMATIC TRANSMISSION ASSEMBLY</b>		Edge 2009-2007	
<b>AUTOMATIC TRANSMISSION ASSEMBLY</b>		<b>7L2Z-7000-ARM</b>		Ford		Taurus X 2009	
Ford		<b>AUTOMATIC TRANSMISSION ASSEMBLY</b>		F-Series 2008-2007		<b>7T4Z-7000-BRM</b>	
Fusion 2007		Ford		Lincoln		<b>AUTOMATIC TRANSMISSION ASSEMBLY</b>	
Mercury		Explorer 2007		Mark LT 2008-2007		Ford	
Milan 2007		Explorer Sport Trac 2007		<b>7L5Z-7000-ARM</b>		Edge 2007	
<b>7E5Z-7000-BFRM</b>		Mercury		<b>AUTOMATIC TRANSMISSION ASSEMBLY</b>		Taurus 2009-2008	
<b>AUTOMATIC TRANSMISSION ASSEMBLY</b>		Mountaineer 2007		Ford		Lincoln	
Ford		<b>7L2Z-7000-BRM</b>		Ranger 2008-2007		MKX 2007	
Fusion 2007		<b>AUTOMATIC TRANSMISSION ASSEMBLY</b>		<b>7L5Z-7000-BRM</b>		Mercury	
Mercury		Ford		<b>AUTOMATIC TRANSMISSION ASSEMBLY</b>		Sable 2009-2008	
Milan 2007		Explorer 2008-2007		Ford		<b>7U2Z-7V000-ARM</b>	
<b>7E5Z-7000-BRM</b>		Explorer Sport Trac 2008-2007		Ranger 2008-2007		<b>AUTOMATIC TRANSMISSION ASSEMBLY</b>	
<b>AUTOMATIC TRANSMISSION ASSEMBLY</b>		Mercury		<b>7L5Z-7000-CRM</b>		Ford	
Ford		Mountaineer 2008-2007		<b>AUTOMATIC TRANSMISSION ASSEMBLY</b>		F-Series 2003-2001	
Fusion 2008-2006		<b>7L2Z-7000-CRM</b>		Ford		<b>7U2Z-7V000-BRM</b>	
Mercury		<b>AUTOMATIC TRANSMISSION ASSEMBLY</b>		Ranger 2011-2007		<b>AUTOMATIC TRANSMISSION ASSEMBLY</b>	
Milan 2009-2006		Ford		<b>7L5Z-7000-DRM</b>		Ford	
<b>7E5Z-7000-CFRM</b>		Explorer Sport Trac 2007		<b>AUTOMATIC TRANSMISSION ASSEMBLY</b>		Econoline 2000	
<b>AUTOMATIC TRANSMISSION ASSEMBLY</b>		<b>7L2Z-7000-DRM</b>		Ford		F-Series 2003-2001	
Lincoln		<b>AUTOMATIC TRANSMISSION ASSEMBLY</b>		Ranger 2011-2007		<b>7U2Z-7V000-CRM</b>	
MKZ 2007		Ford		<b>7L5Z-7000-ERM</b>		<b>AUTOMATIC TRANSMISSION ASSEMBLY</b>	
<b>7E5Z-7000-DGRM</b>		Explorer Sport Trac 2007		<b>AUTOMATIC TRANSMISSION ASSEMBLY</b>		Ford	
<b>AUTOMATIC TRANSMISSION ASSEMBLY</b>		<b>7L3Z-7000-ABRM</b>		Ford		Econoline 2000	
Lincoln		<b>AUTOMATIC TRANSMISSION ASSEMBLY</b>		Ranger 2011-2007		F-Series 2000-1999	
MKZ 2007		Ford		<b>7M6Z-7000-A</b>		<b>7U2Z-7V000-DRM</b>	
<b>7E7Z-7000-AARM</b>		F-Series 2008-2007		<b>AUTOMATIC TRANSMISSION ASSEMBLY</b>		<b>AUTOMATIC TRANSMISSION ASSEMBLY</b>	
<b>AUTOMATIC TRANSMISSION ASSEMBLY</b>		<b>7L3Z-7000-BBRM</b>		Ford		Ford	
Ford		<b>AUTOMATIC TRANSMISSION ASSEMBLY</b>		Escape 2007-2006		F-Series 2000-1999	
LCF 2007		Ford		Mercury		<b>7U2Z-7V000-FRM</b>	
<b>7E7Z-7000-BARM</b>		F-Series 2008-2007		Mariner 2007-2006		<b>AUTOMATIC TRANSMISSION ASSEMBLY</b>	
<b>AUTOMATIC TRANSMISSION ASSEMBLY</b>		<b>7L3Z-7000-CBRM</b>		<b>7R3Z-7000-ARM</b>		Ford	
Ford		<b>AUTOMATIC TRANSMISSION ASSEMBLY</b>		<b>AUTOMATIC TRANSMISSION ASSEMBLY</b>		Econoline 2003-2001	
LCF 2007		Ford		Ford		<b>7U2Z-7V000-KRM</b>	
		F-Series 2008-2007		Mustang 2007		<b>AUTOMATIC TRANSMISSION ASSEMBLY</b>	
						Ford	
						Econoline 1999	



Make	Year	Make	Year	Make	Year	Make	Year
<b>7W1Z-7000-AARM</b>		<b>8C2Z-7000-FRM</b>		<b>8C3Z-7000-JRM</b>		<b>8L2Z-7000-BRM</b>	
<b>AUTOMATIC TRANSMISSION ASSEMBLY</b> Lincoln		<b>AUTOMATIC TRANSMISSION ASSEMBLY</b> Ford		<b>AUTOMATIC TRANSMISSION ASSEMBLY</b> Ford		<b>AUTOMATIC TRANSMISSION ASSEMBLY</b> Ford	
Town Car	2008-2007	Econoline	2008	F-Series	2008	Explorer Sport Trac	2008
<b>7W1Z-7000-DARM</b>		<b>8C2Z-7000-HRM</b>		<b>8E5Z-7000-ARM</b>		<b>8L2Z-7000-ERM</b>	
<b>AUTOMATIC TRANSMISSION ASSEMBLY</b> Lincoln		<b>AUTOMATIC TRANSMISSION ASSEMBLY</b> Ford		<b>AUTOMATIC TRANSMISSION ASSEMBLY</b> Ford		<b>AUTOMATIC TRANSMISSION ASSEMBLY</b> Ford	
Town Car	2008-2007	Econoline	2008	Fusion	2009-2008	Explorer	2008
<b>7W7Z-7000-AARM</b>		<b>8C3Z-7000-ARM</b>		<b>Mercury</b>		<b>Mercury</b>	
<b>AUTOMATIC TRANSMISSION ASSEMBLY</b> Ford		<b>AUTOMATIC TRANSMISSION ASSEMBLY</b> Ford		Milan	2009-2008	Mountaineer	2008-2007
Crown Victoria	2008-2007	F-Series	2008	<b>8E5Z-7000-BRM</b>		<b>8L2Z-7000-FRM</b>	
<b>Mercury</b>		<b>8C3Z-7000-BRM</b>		<b>AUTOMATIC TRANSMISSION ASSEMBLY</b> Ford		<b>AUTOMATIC TRANSMISSION ASSEMBLY</b> Ford	
Grand Marquis	2008-2007	<b>AUTOMATIC TRANSMISSION ASSEMBLY</b> Ford		Fusion	2009-2008	Explorer	2008
<b>7W7Z-7000-CARM</b>		<b>8C3Z-7000-CRM</b>		<b>Mercury</b>		<b>Mercury</b>	
<b>AUTOMATIC TRANSMISSION ASSEMBLY</b> Ford		<b>AUTOMATIC TRANSMISSION ASSEMBLY</b> Ford		Milan	2009-2008	Mountaineer	2008
Crown Victoria	2008-2007	F-Series	2008	<b>8E5Z-7000-CRM</b>		<b>8L8Z-7000-ARM</b>	
<b>Lincoln</b>		<b>8C3Z-7000-DRM</b>		<b>AUTOMATIC TRANSMISSION ASSEMBLY</b> Lincoln		<b>AUTOMATIC TRANSMISSION ASSEMBLY</b> Ford	
Town Car	2008-2007	<b>AUTOMATIC TRANSMISSION ASSEMBLY</b> Ford		MKZ	2009-2008	Escape	2008
<b>7W7Z-7000-DARM</b>		<b>8C3Z-7000-ERM</b>		<b>8E5Z-7000-DRM</b>		<b>Mazda</b>	
<b>AUTOMATIC TRANSMISSION ASSEMBLY</b> Ford		<b>AUTOMATIC TRANSMISSION ASSEMBLY</b> Ford		<b>AUTOMATIC TRANSMISSION ASSEMBLY</b> Lincoln		Tribute	2008
Crown Victoria	2007	F-Series	2008	MKZ	2009-2008	<b>Mercury</b>	
<b>Mercury</b>		<b>8C3Z-7000-FRM</b>		<b>8E7Z-7000-AARM</b>		Mariner	2008
Grand Marquis	2008-2007	<b>AUTOMATIC TRANSMISSION ASSEMBLY</b> Ford		<b>AUTOMATIC TRANSMISSION ASSEMBLY</b> Ford		<b>8L8Z-7000-BRM</b>	
<b>8C2Z-7000-ARM</b>		<b>8C3Z-7000-GRM</b>		<b>AUTOMATIC TRANSMISSION ASSEMBLY</b> Ford		<b>AUTOMATIC TRANSMISSION ASSEMBLY</b> Ford	
<b>AUTOMATIC TRANSMISSION ASSEMBLY</b> Ford		<b>AUTOMATIC TRANSMISSION ASSEMBLY</b> Ford		LCF	2008	Escape	2008
Econoline	2008	Econoline	2008	<b>8E7Z-7000-BARM</b>		<b>Mazda</b>	
<b>8C2Z-7000-BRM</b>		<b>8C3Z-7000-HRM</b>		<b>AUTOMATIC TRANSMISSION ASSEMBLY</b> Ford		Tribute	2008
<b>AUTOMATIC TRANSMISSION ASSEMBLY</b> Ford		<b>AUTOMATIC TRANSMISSION ASSEMBLY</b> Ford		LCF	2008	<b>Mercury</b>	
Econoline	2008	F-Series	2008	<b>8L1Z-7000-CRM</b>		Mariner	2008
<b>8C2Z-7000-CRM</b>		<b>8C3Z-7000-IRM</b>		<b>AUTOMATIC TRANSMISSION ASSEMBLY</b> Ford		<b>8L8Z-7000-CRM</b>	
<b>AUTOMATIC TRANSMISSION ASSEMBLY</b> Ford		<b>AUTOMATIC TRANSMISSION ASSEMBLY</b> Ford		Expedition	2008	<b>AUTOMATIC TRANSMISSION ASSEMBLY</b> Ford	
Econoline	2008	Econoline	2008	<b>8L1Z-7000-DRM</b>		Escape	2008
<b>8C2Z-7000-DRM</b>		<b>8C3Z-7000-JRM</b>		<b>AUTOMATIC TRANSMISSION ASSEMBLY</b> Ford		<b>Mazda</b>	
<b>AUTOMATIC TRANSMISSION ASSEMBLY</b> Ford		<b>AUTOMATIC TRANSMISSION ASSEMBLY</b> Ford		Expedition	2008	Tribute	2008
Econoline	2008	F-Series	2008	<b>8L2Z-7000-ARM</b>		<b>Mercury</b>	
<b>8C2Z-7000-ERM</b>		<b>8C3Z-7000-KRM</b>		<b>AUTOMATIC TRANSMISSION ASSEMBLY</b> Ford		Mariner	2008
<b>AUTOMATIC TRANSMISSION ASSEMBLY</b> Ford		<b>AUTOMATIC TRANSMISSION ASSEMBLY</b> Ford		Explorer Sport Trac	2008	<b>8L8Z-7000-DRM</b>	
Econoline	2008	F-Series	2008	<b>8L2Z-7000-BRM</b>		<b>AUTOMATIC TRANSMISSION ASSEMBLY</b> Ford	
				<b>AUTOMATIC TRANSMISSION ASSEMBLY</b> Ford		Escape	2008
				Explorer Sport Trac	2008		

# BUYER'S GUIDE

## Transmission Assemblies



FORD PARTS

Make	Year	Make	Year	Make	Year	Make	Year
<b>8L8Z-7000-DRM cont'd</b>		<b>8T4Z-7000-BRM cont'd</b>		<b>9C2Z-7000-KRM</b>		<b>9E5Z-7000-C</b>	
Mazda		Mercury		AUTOMATIC TRANSMISSION ASSEMBLY		AUTOMATIC TRANSMISSION ASSEMBLY	
Tribute	2008	Sable	2009-2008	Ford		Ford	
Mercury		<b>90GZ-7V000-TAARM</b>		Econoline	2012-2009	Fusion	2010
Mariner	2008	AUTOMATIC TRANSMISSION ASSEMBLY		<b>9C3Z-7000-ARM</b>		Mercury	
<b>8M5Z-7000-A</b>		Ford		AUTOMATIC TRANSMISSION ASSEMBLY		Milan	2010
AUTOMATIC TRANSMISSION ASSEMBLY		Mustang		Ford		<b>9E5Z-7000-D</b>	
Ford		1990-1989, 1987		F-Series		AUTOMATIC TRANSMISSION ASSEMBLY	
Focus	2011-2009	<b>9C2Z-7000-ARM</b>		2010-2009		Ford	
Transit Connect	2011-2010	AUTOMATIC TRANSMISSION ASSEMBLY		<b>9C3Z-7000-BRM</b>		Fusion	
<b>8M5Z-7000-ARM</b>		Ford		AUTOMATIC TRANSMISSION ASSEMBLY		2010	
AUTOMATIC TRANSMISSION ASSEMBLY		Econoline		Ford		<b>9E5Z-7000-E</b>	
Ford		2010-2009		F-Series		AUTOMATIC TRANSMISSION ASSEMBLY	
Focus	2011-2009	<b>9C2Z-7000-BRM</b>		2010-2009		Ford	
Transit Connect	2011-2010	AUTOMATIC TRANSMISSION ASSEMBLY		<b>9C3Z-7000-CRM</b>		Fusion	
<b>8M6Z-7000-D</b>		Ford		AUTOMATIC TRANSMISSION ASSEMBLY		2010	
AUTOMATIC TRANSMISSION ASSEMBLY		Econoline		Ford		<b>9E5Z-7000-N</b>	
Ford		2010-2009		F-Series		AUTOMATIC TRANSMISSION ASSEMBLY	
Escape	2008	<b>9C2Z-7000-CRM</b>		2010-2009		Ford	
Mercury		AUTOMATIC TRANSMISSION ASSEMBLY		<b>9C3Z-7000-DRM</b>		Fusion	
Mariner	2008	Ford		AUTOMATIC TRANSMISSION ASSEMBLY		2010	
<b>8R3Z-7000-ARM</b>		Econoline		Ford		<b>9E7Z-7000-ARM</b>	
AUTOMATIC TRANSMISSION ASSEMBLY		2009		F-Series		AUTOMATIC TRANSMISSION ASSEMBLY	
Ford		<b>9C2Z-7000-DRM</b>		2010-2009		Ford	
Mustang	2008	AUTOMATIC TRANSMISSION ASSEMBLY		<b>9C3Z-7000-ERM</b>		LCF	
AUTOMATIC TRANSMISSION ASSEMBLY		Ford		AUTOMATIC TRANSMISSION ASSEMBLY		2009	
Ford		Econoline		Ford		<b>9E7Z-7000-BRM</b>	
		2009		F-Series		AUTOMATIC TRANSMISSION ASSEMBLY	
		<b>9C2Z-7000-ERM</b>		2012-2010		Ford	
		AUTOMATIC TRANSMISSION ASSEMBLY		<b>9C3Z-7000-FRM</b>		LCF	
		Ford		AUTOMATIC TRANSMISSION ASSEMBLY		2009	
		Econoline		Ford		<b>9E9Z-7000-ARM</b>	
		2010-2009		F-Series		AUTOMATIC TRANSMISSION ASSEMBLY	
		<b>9C2Z-7000-FRM</b>		2012-2009		Ford	
		AUTOMATIC TRANSMISSION ASSEMBLY		<b>9C3Z-7000-GRM</b>		Flex	
		Ford		AUTOMATIC TRANSMISSION ASSEMBLY		2009	
		Econoline		Ford		<b>9E9Z-7000-BRM</b>	
		2010-2009		F-Series		AUTOMATIC TRANSMISSION ASSEMBLY	
		<b>9C2Z-7000-GRM</b>		2012-2009		Ford	
		AUTOMATIC TRANSMISSION ASSEMBLY		<b>9C3Z-7000-HRM</b>		Flex	
		Ford		AUTOMATIC TRANSMISSION ASSEMBLY		2011-2009	
		Econoline		Ford		<b>9L1Z-7000-BRM</b>	
		2012-2009		F-Series		AUTOMATIC TRANSMISSION ASSEMBLY	
		<b>9C2Z-7000-HRM</b>		2012-2009		Ford	
		AUTOMATIC TRANSMISSION ASSEMBLY		<b>9C3Z-7000-JRM</b>		Expedition	
		Ford		AUTOMATIC TRANSMISSION ASSEMBLY		2009	
		Econoline		Ford		Lincoln	
		2016-2009		F-Series		Navigator	
		<b>9C2Z-7000-JRM</b>		2012-2009		2009	
		AUTOMATIC TRANSMISSION ASSEMBLY				<b>9L2Z-7000-CARM</b>	
		Ford				AUTOMATIC TRANSMISSION ASSEMBLY	
		Econoline				Ford	
		2012-2009				Explorer	
						2009	



Make	Year	Make	Year	Make	Year	Make	Year
<b>9L2Z-7000-CARM cont'd</b>		<b>9L3Z-7000-FARM</b>		<b>9W1Z-7000-ARM</b>		<b>AA5Z-7000-HRM</b>	
Explorer Sport Trac	2009	<b>AUTOMATIC TRANSMISSION ASSEMBLY</b>		<b>AUTOMATIC TRANSMISSION ASSEMBLY</b>		<b>AUTOMATIC TRANSMISSION ASSEMBLY</b>	
<b>Mercury</b>		Ford		Lincoln		Ford	
Mountaineer	2009	F-Series	2009	Town Car	2009	Flex	2012-2011
<b>9L2Z-7000-CRM</b>		<b>9L8Z-7000-ARM</b>		<b>9W1Z-7000-DRM</b>		Taurus	
<b>AUTOMATIC TRANSMISSION ASSEMBLY</b>		<b>AUTOMATIC TRANSMISSION ASSEMBLY</b>		<b>AUTOMATIC TRANSMISSION ASSEMBLY</b>		Lincoln	
Ford		Ford		Lincoln		MKT	
Explorer	2010-2009	Escape	2009	Town Car	2009	<b>AA5Z-7000-J</b>	
Explorer Sport Trac	2010-2009	<b>Mazda</b>		<b>9W7Z-7000-ARM</b>		<b>AUTOMATIC TRANSMISSION ASSEMBLY</b>	
<b>Mercury</b>		Tribute	2009	<b>AUTOMATIC TRANSMISSION ASSEMBLY</b>		Ford	
Mountaineer	2010-2009	<b>Mercury</b>		Ford		Taurus	
<b>9L2Z-7000-DARM</b>		Mariner	2009	Crown Victoria		2009	
<b>AUTOMATIC TRANSMISSION ASSEMBLY</b>		<b>9L8Z-7000-BRM</b>		Mercury		Lincoln	
Ford		<b>AUTOMATIC TRANSMISSION ASSEMBLY</b>		Grand Marquis		MKS	
Explorer	2009	Ford		2009		<b>AA5Z-7000-K</b>	
Explorer Sport Trac	2009	Escape	2010-2009	<b>9W7Z-7000-CRM</b>		<b>AUTOMATIC TRANSMISSION ASSEMBLY</b>	
<b>Mercury</b>		<b>Mazda</b>		<b>AUTOMATIC TRANSMISSION ASSEMBLY</b>		Ford	
Mountaineer	2009	Tribute	2010-2009	Ford		Flex	
<b>9L2Z-7000-DRM</b>		<b>Mercury</b>		Crown Victoria		2009	
<b>AUTOMATIC TRANSMISSION ASSEMBLY</b>		Mariner	2010-2009	Lincoln		Taurus	
Ford		<b>9L8Z-7000-CRM</b>		Town Car		2009	
Explorer Sport Trac	2010-2009	<b>AUTOMATIC TRANSMISSION ASSEMBLY</b>		<b>AA5Z-7000-BRM</b>		<b>AUTOMATIC TRANSMISSION ASSEMBLY</b>	
<b>9L3Z-7000-CARM</b>		Ford		<b>AUTOMATIC TRANSMISSION ASSEMBLY</b>		Ford	
<b>AUTOMATIC TRANSMISSION ASSEMBLY</b>		Escape	2010-2009	Ford		Edge	
Ford		<b>Mazda</b>		Taurus		2009	
F-Series	2009	Tribute	2010-2009	Lincoln		Flex	
<b>9L3Z-7000-CRM</b>		<b>Mercury</b>		MKS		2012-2009	
<b>AUTOMATIC TRANSMISSION ASSEMBLY</b>		Mariner	2010-2009	<b>AA5Z-7000-DRM</b>		Taurus	
Ford		<b>9L8Z-7000-DRM</b>		<b>AUTOMATIC TRANSMISSION ASSEMBLY</b>		Lincoln	
F-Series	2009	<b>AUTOMATIC TRANSMISSION ASSEMBLY</b>		Ford		MKS	
<b>9L3Z-7000-DARM</b>		Ford		Flex		2012-2010	
<b>AUTOMATIC TRANSMISSION ASSEMBLY</b>		Escape	2009	Taurus		2010	
Ford		<b>Mazda</b>		Lincoln		2010	
F-Series	2009	Tribute	2009	MKT		2010	
<b>9L3Z-7000-DRM</b>		<b>Mercury</b>		<b>AA5Z-7000-G</b>		<b>AA8Z-7000-GRM</b>	
<b>AUTOMATIC TRANSMISSION ASSEMBLY</b>		Mariner	2009	<b>AUTOMATIC TRANSMISSION ASSEMBLY</b>		<b>AUTOMATIC TRANSMISSION ASSEMBLY</b>	
Ford		<b>9R3Z-7000-ARM</b>		Ford		Ford	
F-Series	2009	<b>AUTOMATIC TRANSMISSION ASSEMBLY</b>		Taurus		2012-2011	
<b>9L3Z-7000-EARM</b>		Ford		<b>AA5Z-7000-GRM</b>		<b>AA8Z-7000-J</b>	
<b>AUTOMATIC TRANSMISSION ASSEMBLY</b>		Mustang	2010-2009	<b>AUTOMATIC TRANSMISSION ASSEMBLY</b>		<b>AUTOMATIC TRANSMISSION ASSEMBLY</b>	
Ford		<b>9R3Z-7000-BRM</b>		Ford		Ford	
Expedition	2009	<b>AUTOMATIC TRANSMISSION ASSEMBLY</b>		Taurus		2012-2010	
F-Series	2009	Ford		Lincoln		2010	
<b>Lincoln</b>		Mustang	2010-2009	MKS		2012-2010	
Navigator	2009	Ford					

# BUYER'S GUIDE

## Transmission Assemblies



FORD PARTS

Make	Year	Make	Year	Make	Year	Make	Year
<b>AA8Z-7000-JRM</b>		<b>AA8Z-7000-V cont'd</b>		<b>AE5Z-7000-ARM</b>		<b>AL2Z-7000-ARM</b>	
<b>AUTOMATIC TRANSMISSION ASSEMBLY</b>		Lincoln		<b>AUTOMATIC TRANSMISSION ASSEMBLY</b>		<b>AUTOMATIC TRANSMISSION ASSEMBLY</b>	
Ford		MKS	2012-2009	Ford		Ford	
Taurus	2012-2010	MKT	2012-2010	Fusion	2010	Explorer	2010
<b>AA8Z-7000-KRM</b>		<b>AC2Z-7000-C</b>		Mercury		Explorer Sport Trac	2010
<b>AUTOMATIC TRANSMISSION ASSEMBLY</b>		<b>AUTOMATIC TRANSMISSION ASSEMBLY</b>		Milan	2010	Mercury	
Ford		Ford		AE5Z-7000-BRM		Mountaineer	2010
Edge	2009	Econoline	2014-2010	<b>AUTOMATIC TRANSMISSION ASSEMBLY</b>		<b>AL2Z-7000-B</b>	
Flex	2012-2009	<b>AC2Z-7000-CRM</b>		Ford		<b>AUTOMATIC TRANSMISSION ASSEMBLY</b>	
Taurus	2012-2010	<b>AUTOMATIC TRANSMISSION ASSEMBLY</b>		Fusion	2010	Ford	
Lincoln		Ford		Mercury		Explorer	2010-2009
MKS	2012-2010	Econoline	2014-2010	Milan	2010	Explorer Sport Trac	2010-2009
MKT	2012-2010	<b>AC2Z-7000-D</b>		<b>AE5Z-7000-C</b>		<b>AL2Z-7000-BRM</b>	
MKX	2009	<b>AUTOMATIC TRANSMISSION ASSEMBLY</b>		<b>AUTOMATIC TRANSMISSION ASSEMBLY</b>		<b>AUTOMATIC TRANSMISSION ASSEMBLY</b>	
<b>AA8Z-7000-N</b>		Ford		Ford		Ford	
<b>AUTOMATIC TRANSMISSION ASSEMBLY</b>		Econoline	2016-2010	Fusion	2012-2010	Explorer	2010
Ford		<b>AC2Z-7000-DRM</b>		<b>AE5Z-7000-CRM</b>		Explorer Sport Trac	2010
Flex	2011	<b>AUTOMATIC TRANSMISSION ASSEMBLY</b>		<b>AUTOMATIC TRANSMISSION ASSEMBLY</b>		Mercury	
Taurus	2012	Ford		Ford		Mountaineer	2010
Lincoln		Econoline	2014-2010	Fusion	2010	<b>AL2Z-7000-C</b>	
MKT	2011	<b>AC3Z-7000-E</b>		Mercury		<b>AUTOMATIC TRANSMISSION ASSEMBLY</b>	
<b>AA8Z-7000-S</b>		<b>AUTOMATIC TRANSMISSION ASSEMBLY</b>		Milan	2010	Ford	
<b>AUTOMATIC TRANSMISSION ASSEMBLY</b>		Ford		<b>AE5Z-7000-D</b>		Explorer	2010
Ford		Econoline	2016-2009	<b>AUTOMATIC TRANSMISSION ASSEMBLY</b>		<b>AL3Z-7000-ARM</b>	
Edge	2010	F-Series	2016, 2010	Ford		<b>AUTOMATIC TRANSMISSION ASSEMBLY</b>	
Flex	2012-2009	<b>AC3Z-7000-F</b>		Fusion	2012-2010	Ford	
Taurus	2012-2010	<b>AUTOMATIC TRANSMISSION ASSEMBLY</b>		<b>AE5Z-7000-FRM</b>		Expedition	2010
Lincoln		Ford		<b>AUTOMATIC TRANSMISSION ASSEMBLY</b>		F-Series	2010
MKS	2012-2009	Econoline	2016-2010	Ford		Lincoln	
MKT	2012-2010	F-Series	2010	Fusion	2012-2010	Navigator	2010
MKX	2010	<b>AC3Z-7000-G</b>		Lincoln		<b>AL3Z-7000-BRM</b>	
<b>AA8Z-7000-T</b>		<b>AUTOMATIC TRANSMISSION ASSEMBLY</b>		MKZ	2012-2010	<b>AUTOMATIC TRANSMISSION ASSEMBLY</b>	
<b>AUTOMATIC TRANSMISSION ASSEMBLY</b>		Ford		<b>AE5Z-7000-GRM</b>		Ford	
Ford		Econoline	2016-2009	<b>AUTOMATIC TRANSMISSION ASSEMBLY</b>		F-Series	2010
Taurus	2012-2010	F-Series	2010	Ford		<b>AL3Z-7000-CRM</b>	
<b>AA8Z-7000-U</b>		<b>AC3Z-7000-H</b>		Fusion	2012-2010	<b>AUTOMATIC TRANSMISSION ASSEMBLY</b>	
<b>AUTOMATIC TRANSMISSION ASSEMBLY</b>		<b>AUTOMATIC TRANSMISSION ASSEMBLY</b>		Lincoln		Ford	
Ford		Ford		MKZ	2012-2010	F-Series	2010
Taurus	2012-2010	Econoline	2016-2009	<b>AL1Z-7000-ARM</b>		<b>AL3Z-7000-DRM</b>	
<b>AA8Z-7000-V</b>		<b>AC3Z-7000-I</b>		<b>AUTOMATIC TRANSMISSION ASSEMBLY</b>		<b>AUTOMATIC TRANSMISSION ASSEMBLY</b>	
<b>AUTOMATIC TRANSMISSION ASSEMBLY</b>		<b>AUTOMATIC TRANSMISSION ASSEMBLY</b>		Ford		Ford	
Ford		Ford		Expedition	2010	F-Series	2010
Flex	2012-2009	F-Series	2016-2010	Lincoln			
Taurus	2012-2010	<b>AC3Z-7000-K</b>		Navigator	2010		
<b>AUTOMATIC TRANSMISSION ASSEMBLY</b>		<b>AUTOMATIC TRANSMISSION ASSEMBLY</b>					
Ford		Ford					
Flex	2012-2009	F-Series	2016-2010				
Taurus	2012-2010						



Make	Year	Make	Year	Make	Year	Make	Year
<b>AL3Z-7000-H</b>		<b>BA5Z-7000-D</b>		<b>BA8Z-7000-P</b>		<b>BC3Z-7000-KRM</b>	
<b>AUTOMATIC TRANSMISSION ASSEMBLY</b> Ford		<b>AUTOMATIC TRANSMISSION ASSEMBLY</b> Ford		<b>AUTOMATIC TRANSMISSION ASSEMBLY</b> Ford		<b>AUTOMATIC TRANSMISSION ASSEMBLY</b> Ford	
F-Series	2010	Explorer	2012-2011	Edge	2012-2011	F-Series	2011
<b>AL3Z-7000-HRM</b>		<b>BA5Z-7000-E</b>		Explorer	2012	<b>BC3Z-7000-LRM</b>	
<b>AUTOMATIC TRANSMISSION ASSEMBLY</b> Ford		<b>AUTOMATIC TRANSMISSION ASSEMBLY</b> Ford		<b>BA8Z-7000-R</b>		<b>AUTOMATIC TRANSMISSION ASSEMBLY</b> Ford	
F-Series	2010	Explorer	2012-2011	<b>AUTOMATIC TRANSMISSION ASSEMBLY</b> Ford		F-Series	2011
<b>AL3Z-7000-MRM</b>		<b>BA8Z-7000-ARM</b>		Edge	2012-2011	<b>BC3Z-7000-MRM</b>	
<b>AUTOMATIC TRANSMISSION ASSEMBLY</b> Ford		<b>AUTOMATIC TRANSMISSION ASSEMBLY</b> Ford		Explorer	2012	<b>AUTOMATIC TRANSMISSION ASSEMBLY</b> Ford	
F-Series	2010	Edge	2012-2011	<b>BB5Z-7000-L</b>		F-Series	2011
<b>AL3Z-7000-NRM</b>		Lincoln		<b>AUTOMATIC TRANSMISSION ASSEMBLY</b> Ford		<b>BC3Z-7000-U</b>	
<b>AUTOMATIC TRANSMISSION ASSEMBLY</b> Ford		MKX	2012-2011	Edge	2013-2012	<b>AUTOMATIC TRANSMISSION ASSEMBLY</b> Ford	
F-Series	2010	<b>BA8Z-7000-ERM</b>		Explorer	2013-2012	F-Series	2011
<b>AM6Z-7000-A</b>		<b>AUTOMATIC TRANSMISSION ASSEMBLY</b> Ford		<b>BB5Z-7000-LRM</b>		<b>BE5Z-7000-A</b>	
<b>AUTOMATIC TRANSMISSION ASSEMBLY</b> Ford		Edge	2012-2011	<b>AUTOMATIC TRANSMISSION ASSEMBLY</b> Ford		<b>AUTOMATIC TRANSMISSION ASSEMBLY</b> Ford	
Escape	2012-2009	Lincoln		Edge	2012	Fusion	2012-2011
<b>AW1Z-7000-DRM</b>		MKX	2012-2011	Explorer	2012	<b>BE5Z-7000-ARM</b>	
<b>AUTOMATIC TRANSMISSION ASSEMBLY</b> Lincoln		<b>BA8Z-7000-FRM</b>		<b>BB5Z-7000-S</b>		<b>AUTOMATIC TRANSMISSION ASSEMBLY</b> Ford	
Town Car	2011-2010	<b>AUTOMATIC TRANSMISSION ASSEMBLY</b> Ford		<b>AUTOMATIC TRANSMISSION ASSEMBLY</b> Ford		Edge	2011
<b>AW7Z-7000-ARM</b>		Edge	2012-2011	Explorer	2013-2012	Escape	2011
<b>AUTOMATIC TRANSMISSION ASSEMBLY</b> Ford		<b>BA8Z-7000-GRM</b>		<b>BC3Z-7000-G</b>		Explorer	2011
Crown Victoria	2011-2010	<b>AUTOMATIC TRANSMISSION ASSEMBLY</b> Ford		<b>AUTOMATIC TRANSMISSION ASSEMBLY</b> Ford		<b>BE5Z-7000-B</b>	
<b>AW7Z-7000-CRM</b>		Edge	2012-2011	F-Series	2011	<b>AUTOMATIC TRANSMISSION ASSEMBLY</b> Ford	
<b>AUTOMATIC TRANSMISSION ASSEMBLY</b> Ford		<b>BA8Z-7000-KRM</b>		<b>BC3Z-7000-GRM</b>		Fusion	2012-2011
Crown Victoria	2011-2010	<b>AUTOMATIC TRANSMISSION ASSEMBLY</b> Ford		<b>AUTOMATIC TRANSMISSION ASSEMBLY</b> Ford		Mercury	
Lincoln		Edge	2012-2011	F-Series	2011	Milan	2011-2010
Town Car	2011-2010	Explorer	2012-2011	<b>BC3Z-7000-HRM</b>		<b>BE5Z-7000-C</b>	
<b>BA5Z-7000-BRM</b>		<b>BA8Z-7000-L</b>		<b>AUTOMATIC TRANSMISSION ASSEMBLY</b> Ford		<b>AUTOMATIC TRANSMISSION ASSEMBLY</b> Ford	
<b>AUTOMATIC TRANSMISSION ASSEMBLY</b> Ford		<b>AUTOMATIC TRANSMISSION ASSEMBLY</b> Ford		F-Series	2011	Fusion	2012-2011
Explorer	2012-2011	Edge	2012-2011	<b>BC3Z-7000-J</b>		Mercury	
<b>BA5Z-7000-CRM</b>		Lincoln		<b>AUTOMATIC TRANSMISSION ASSEMBLY</b> Ford		Milan	2011
<b>AUTOMATIC TRANSMISSION ASSEMBLY</b> Ford		MKX	2012-2011	F-Series	2011	<b>BE5Z-7000-CRM</b>	
Explorer	2012-2011	<b>BA8Z-7000-N</b>		<b>BC3Z-7000-JRM</b>		<b>AUTOMATIC TRANSMISSION ASSEMBLY</b> Ford	
		<b>AUTOMATIC TRANSMISSION ASSEMBLY</b> Ford		<b>AUTOMATIC TRANSMISSION ASSEMBLY</b> Ford		Fusion	2011
		Edge	2012-2011	F-Series	2011	Mercury	
						Milan	2011

# BUYER'S GUIDE

## Transmission Assemblies



FORD PARTS

Make	Year	Make	Year	Make	Year	Make	Year
<b>BE5Z-7000-D</b>		<b>BL3Z-7000-B</b>		<b>BL3Z-7000-G</b>		<b>BL8Z-7000-FRM cont'd</b>	
<b>AUTOMATIC TRANSMISSION ASSEMBLY</b>		<b>AUTOMATIC TRANSMISSION ASSEMBLY</b>		<b>AUTOMATIC TRANSMISSION ASSEMBLY</b>		Escape	2011
Ford		Ford		Ford		Explorer	2011
Fusion	2012-2011	F-Series	2014-2011	F-Series	2014-2011	Fusion	2011
<b>Mercury</b>		<b>BL3Z-7000-BRM</b>		<b>BL3Z-7000-GRM</b>		<b>Mercury</b>	
Milan	2011	<b>AUTOMATIC TRANSMISSION ASSEMBLY</b>		<b>AUTOMATIC TRANSMISSION ASSEMBLY</b>		Milan	2011
<b>BE5Z-7000-DRM</b>		Ford		Ford		<b>BL8Z-7000-G</b>	
<b>AUTOMATIC TRANSMISSION ASSEMBLY</b>		F-Series	2014-2011	F-Series	2011	<b>AUTOMATIC TRANSMISSION ASSEMBLY</b>	
Ford		<b>BL3Z-7000-C</b>		<b>BL3Z-7000-H</b>		Escape	2012-2011
Fusion	2011	<b>AUTOMATIC TRANSMISSION ASSEMBLY</b>		<b>AUTOMATIC TRANSMISSION ASSEMBLY</b>		Mazda	
Lincoln		Ford		Ford		Tribute	2011
MKZ	2011	F-Series	2014-2011	F-Series	2014-2011	<b>Mercury</b>	
<b>Mercury</b>		<b>BL3Z-7000-CRM</b>		<b>BL3Z-7000-HRM</b>		Mariner	2011
Milan	2011	<b>AUTOMATIC TRANSMISSION ASSEMBLY</b>		<b>AUTOMATIC TRANSMISSION ASSEMBLY</b>		<b>BL8Z-7000-GRM</b>	
<b>BL1Z-7000-A</b>		Ford		Ford		<b>AUTOMATIC TRANSMISSION ASSEMBLY</b>	
<b>AUTOMATIC TRANSMISSION ASSEMBLY</b>		F-Series	2013-2011	F-Series	2014-2011	Escape	2011
Ford		<b>BL3Z-7000-D</b>		<b>BL8Z-7000-E</b>		Fusion	2011
Expedition	2011-2009	<b>AUTOMATIC TRANSMISSION ASSEMBLY</b>		<b>AUTOMATIC TRANSMISSION ASSEMBLY</b>		<b>Mercury</b>	
Explorer	2013	Ford		Ford		Milan	2011
<b>BL1Z-7000-ARM</b>		F-Series	2014-2011	Escape	2012-2011	<b>BL8Z-7000-H</b>	
<b>AUTOMATIC TRANSMISSION ASSEMBLY</b>		<b>BL3Z-7000-DRM</b>		Mazda		<b>AUTOMATIC TRANSMISSION ASSEMBLY</b>	
Ford		<b>AUTOMATIC TRANSMISSION ASSEMBLY</b>		Tribute	2011	Escape	2012-2011
Expedition	2011	Ford		Mercury		Mazda	
Lincoln		F-Series	2014-2011	Mariner	2011	Tribute	2011
Navigator	2011	<b>BL3Z-7000-E</b>		<b>BL8Z-7000-ERM</b>		Mercury	
<b>BL1Z-7000-B</b>		<b>AUTOMATIC TRANSMISSION ASSEMBLY</b>		<b>AUTOMATIC TRANSMISSION ASSEMBLY</b>		Mariner	2011
<b>AUTOMATIC TRANSMISSION ASSEMBLY</b>		Ford		Ford		<b>BL8Z-7000-HRM</b>	
Expedition	2011	F-Series	2014-2011	Edge	2011	<b>AUTOMATIC TRANSMISSION ASSEMBLY</b>	
Lincoln		<b>BL3Z-7000-ERM</b>		Escape	2011	Ford	
Navigator	2011	<b>AUTOMATIC TRANSMISSION ASSEMBLY</b>		Explorer	2011	Escape	2011
<b>BL1Z-7000-BRM</b>		Ford		Fusion	2011	Fusion	2011
<b>AUTOMATIC TRANSMISSION ASSEMBLY</b>		F-Series	2012-2011	<b>Mercury</b>		<b>Mercury</b>	
Ford		<b>BL3Z-7000-F</b>		Milan	2011	Milan	2011
Expedition	2011	<b>AUTOMATIC TRANSMISSION ASSEMBLY</b>		<b>BL8Z-7000-F</b>		<b>BL8Z-7000-HRM</b>	
Lincoln		Ford		Ford		<b>AUTOMATIC TRANSMISSION ASSEMBLY</b>	
Navigator	2011	F-Series	2014-2011	Escape	2012-2011	Ford	
<b>BL3Z-7000-A</b>		<b>BL3Z-7000-FRM</b>		Mazda		Escape	2011
<b>AUTOMATIC TRANSMISSION ASSEMBLY</b>		<b>AUTOMATIC TRANSMISSION ASSEMBLY</b>		Tribute	2011	Fusion	2011
Ford		Ford		Mercury		<b>Mercury</b>	
F-Series	2014-2011	F-Series	2013-2011	Mariner	2011	Milan	2011
<b>BL3Z-7000-ARM</b>		<b>BL8Z-7000-FRM</b>		<b>BL8Z-7000-FRM</b>		<b>BR3Z-7000-A</b>	
<b>AUTOMATIC TRANSMISSION ASSEMBLY</b>		<b>AUTOMATIC TRANSMISSION ASSEMBLY</b>		<b>AUTOMATIC TRANSMISSION ASSEMBLY</b>		<b>AUTOMATIC TRANSMISSION ASSEMBLY</b>	
Ford		Ford		Ford		Ford	
F-Series	2013-2011	Edge	2011	Edge	2011	Mustang	2014-2011





Make	Year	Make	Year	Make	Year	Make	Year
<b>BR3Z-7000-B</b>		<b>CA6Z-7000-L</b>		<b>CC3Z-7000-J</b>		<b>CC4Z-7000-B</b>	
<b>AUTOMATIC TRANSMISSION ASSEMBLY</b> Ford		<b>AUTOMATIC TRANSMISSION ASSEMBLY</b> Ford		<b>AUTOMATIC TRANSMISSION ASSEMBLY</b> Ford		<b>AUTOMATIC TRANSMISSION ASSEMBLY</b> Ford	
Mustang	2014-2013	Fiesta	2015-2011	F-Series	2012	F650	2014-2012
<b>BR3Z-7000-BRM</b>		<b>CA6Z-7000-M</b>		<b>CC3Z-7000-JRM</b>		<b>CC4Z-7000-BRM</b>	
<b>AUTOMATIC TRANSMISSION ASSEMBLY</b> Ford		<b>AUTOMATIC TRANSMISSION ASSEMBLY</b> Ford		<b>AUTOMATIC TRANSMISSION ASSEMBLY</b> Ford		<b>AUTOMATIC TRANSMISSION ASSEMBLY</b> Ford	
Mustang	2014-2011	Fiesta	2014	F-Series	2012	F650	2015-2012
<b>BR3Z-7000-C</b>		<b>CC3Z-7000-CRM</b>		<b>CC3Z-7000-R</b>		<b>CK4Z-7000-A</b>	
<b>AUTOMATIC TRANSMISSION ASSEMBLY</b> Ford		<b>AUTOMATIC TRANSMISSION ASSEMBLY</b> Ford		<b>AUTOMATIC TRANSMISSION ASSEMBLY</b> Ford		<b>AUTOMATIC TRANSMISSION ASSEMBLY</b> Ford	
Mustang	2014	F-Series	2012	F-Series	2014-2011	Transit-250	2015
<b>BT1Z-7000-A</b>		<b>CC3Z-7000-D</b>		<b>CC3Z-7000-S</b>		Transit-350	2015
<b>AUTOMATIC TRANSMISSION ASSEMBLY</b> Ford		<b>AUTOMATIC TRANSMISSION ASSEMBLY</b> Ford		<b>AUTOMATIC TRANSMISSION ASSEMBLY</b> Ford		Transit-350 HD	2015
Transit Connect	2013-2011	F-Series	2011	F-Series	2014-2012	<b>CK4Z-7000-C</b>	
<b>BT1Z-7000-BRM</b>		<b>CC3Z-7000-DRM</b>		<b>CC3Z-7000-T</b>		<b>AUTOMATIC TRANSMISSION ASSEMBLY</b> Ford	
<b>AUTOMATIC TRANSMISSION ASSEMBLY</b> Ford		<b>AUTOMATIC TRANSMISSION ASSEMBLY</b> Ford		<b>AUTOMATIC TRANSMISSION ASSEMBLY</b> Ford		Transit-250	2015
Transit Connect	2013-2011	F-Series	2012	F-Series	2014-2012	Transit-350	2015
<b>BU9Z-7000-A</b>		<b>CC3Z-7000-E</b>		<b>CC3Z-7000-U</b>		Transit-350 HD	2015
<b>AUTOMATIC TRANSMISSION ASSEMBLY</b> Ford		<b>AUTOMATIC TRANSMISSION ASSEMBLY</b> Ford		<b>AUTOMATIC TRANSMISSION ASSEMBLY</b> Ford		<b>CK4Z-7000-D</b>	
F53	2015-2011	F-Series	2011	F-Series	2014-2011	<b>AUTOMATIC TRANSMISSION ASSEMBLY</b> Ford	
<b>BU9Z-7000-ARM</b>		<b>CC3Z-7000-ERM</b>		<b>CC3Z-7000-V</b>		Transit-150	2015
<b>AUTOMATIC TRANSMISSION ASSEMBLY</b> Ford		<b>AUTOMATIC TRANSMISSION ASSEMBLY</b> Ford		<b>AUTOMATIC TRANSMISSION ASSEMBLY</b> Ford		Transit-250	2015
F-Series	2012-2011	F-Series	2012	F-Series	2014-2012	Transit-350	2015
<b>BV6Z-7000-L</b>		<b>CC3Z-7000-FRM</b>		<b>CC3Z-7000-W</b>		Transit-350 HD	2015
<b>AUTOMATIC TRANSMISSION ASSEMBLY</b> Ford		<b>AUTOMATIC TRANSMISSION ASSEMBLY</b> Ford		<b>AUTOMATIC TRANSMISSION ASSEMBLY</b> Ford		<b>CK4Z-7000-E</b>	
Focus	2013-2012	F-Series	2012	F-Series	2014-2012	<b>AUTOMATIC TRANSMISSION ASSEMBLY</b> Ford	
<b>BV6Z-7000-M</b>		<b>CC3Z-7000-G</b>		<b>CC4Z-7000-A</b>		Transit-150	2015
<b>AUTOMATIC TRANSMISSION ASSEMBLY</b> Ford		<b>AUTOMATIC TRANSMISSION ASSEMBLY</b> Ford		<b>AUTOMATIC TRANSMISSION ASSEMBLY</b> Ford		Transit-250	2015
Focus	2014	F-Series	2012	F650	2014-2012	Transit-350	2015
<b>CA6Z-7000-H</b>		<b>CC3Z-7000-GRM</b>		<b>CC4Z-7000-ARM</b>		Transit-350 HD	2015
<b>AUTOMATIC TRANSMISSION ASSEMBLY</b> Ford		<b>AUTOMATIC TRANSMISSION ASSEMBLY</b> Ford		<b>AUTOMATIC TRANSMISSION ASSEMBLY</b> Ford		<b>CK4Z-7000-F</b>	
Fiesta	2014	F-Series	2012	F650	2015-2012	<b>AUTOMATIC TRANSMISSION ASSEMBLY</b> Ford	
						Transit-150	2015
						Transit-250	2015
						Transit-350	2015
						Transit-350 HD	2015
						<b>CL1Z-7000-A</b>	
						<b>AUTOMATIC TRANSMISSION ASSEMBLY</b> Ford	
						Expedition	2014-2012

# BUYER'S GUIDE

## Transmission Assemblies



FORD PARTS

Make	Year	Make	Year	Make	Year	Make	Year
<b>CL1Z-7000-A cont'd</b>		<b>CV6Z-7000-FA</b>		<b>DA5Z-7000-B</b>		<b>DA5Z-7000-N</b>	
Lincoln		AUTOMATIC TRANSMISSION ASSEMBLY		AUTOMATIC TRANSMISSION ASSEMBLY		AUTOMATIC TRANSMISSION ASSEMBLY	
Navigator	2014-2012	Ford		Ford		Ford	
<b>CL1Z-7000-ARM</b>		Escape	2016-2015	Taurus	2013	Explorer	2016-2013
<b>AUTOMATIC TRANSMISSION ASSEMBLY</b>		<b>CV6Z-7000-HA</b>		<b>DA5Z-7000-BRM</b>		<b>DA5Z-7000-P</b>	
Ford		AUTOMATIC TRANSMISSION ASSEMBLY		AUTOMATIC TRANSMISSION ASSEMBLY		AUTOMATIC TRANSMISSION ASSEMBLY	
Expedition	2012	Ford		Ford		Ford	
Lincoln		Escape	2016-2014	Taurus	2013	MKT	2016-2013
Navigator	2012	<b>CV6Z-7000-V</b>		<b>DA5Z-7000-DRM</b>		<b>DA8Z-7000-A</b>	
<b>CL1Z-7000-B</b>		AUTOMATIC TRANSMISSION ASSEMBLY		AUTOMATIC TRANSMISSION ASSEMBLY		AUTOMATIC TRANSMISSION ASSEMBLY	
Ford		Ford		Ford		Ford	
Expedition	2014-2012	Escape	2014-2013	Explorer	2013	Explorer	2013
Lincoln		<b>CV6Z-7000-VD</b>		Flex	2013	Flex	2013
Navigator	2014-2012	AUTOMATIC TRANSMISSION ASSEMBLY		Taurus	2013	<b>DA8Z-7000-ARM</b>	
<b>CL1Z-7000-BRM</b>		Ford		<b>DA5Z-7000-E</b>		AUTOMATIC TRANSMISSION ASSEMBLY	
AUTOMATIC TRANSMISSION ASSEMBLY		Ford		AUTOMATIC TRANSMISSION ASSEMBLY		Ford	
Expedition	2012	Escape	2017	Explorer	2013	Explorer	2013
Lincoln		<b>CV6Z-7000-W</b>		Flex	2013	Flex	2013
Navigator	2012	AUTOMATIC TRANSMISSION ASSEMBLY		Taurus	2013	<b>DA8Z-7000-B</b>	
<b>CT4Z-7000-N</b>		Ford		<b>DA5Z-7000-ERM</b>		AUTOMATIC TRANSMISSION ASSEMBLY	
AUTOMATIC TRANSMISSION ASSEMBLY		Ford		AUTOMATIC TRANSMISSION ASSEMBLY		Ford	
Edge	2013-2011	Escape	2015-2013	Explorer	2013	Flex	2013
Lincoln		Escape	2016-2014	<b>DA5Z-7000-K</b>		<b>DA8Z-7000-BRM</b>	
MKX	2013-2012	<b>CV6Z-7000-X</b>		AUTOMATIC TRANSMISSION ASSEMBLY		AUTOMATIC TRANSMISSION ASSEMBLY	
<b>CT4Z-7000-NRM</b>		AUTOMATIC TRANSMISSION ASSEMBLY		Ford		Ford	
AUTOMATIC TRANSMISSION ASSEMBLY		Ford		Ford		Ford	
Edge	2013-2012	Escape	2015-2013	Police Interceptor Utility	2013	Flex	2013
<b>CV6Z-7000-A</b>		<b>CV6Z-7000-XRM</b>		<b>DA5Z-7000-KRM</b>		<b>DA8Z-7000-C</b>	
AUTOMATIC TRANSMISSION ASSEMBLY		AUTOMATIC TRANSMISSION ASSEMBLY		AUTOMATIC TRANSMISSION ASSEMBLY		AUTOMATIC TRANSMISSION ASSEMBLY	
Ford		Ford		Ford		Ford	
Escape	2014-2013	Escape	2015	Police Interceptor Utility	2013	Edge	2013
<b>CV6Z-7000-B</b>		<b>CV6Z-7000-Y</b>		<b>DA5Z-7000-L</b>		<b>DA8Z-7000-CRM</b>	
AUTOMATIC TRANSMISSION ASSEMBLY		AUTOMATIC TRANSMISSION ASSEMBLY		AUTOMATIC TRANSMISSION ASSEMBLY		AUTOMATIC TRANSMISSION ASSEMBLY	
Ford		Ford		Ford		Ford	
Escape	2014-2013	Escape	2016	Taurus	2014	Edge	2013
<b>CV6Z-7000-E</b>		<b>DA5Z-7000-ARM</b>		<b>DA5Z-7000-M</b>		Police Interceptor Sedan	
AUTOMATIC TRANSMISSION ASSEMBLY		AUTOMATIC TRANSMISSION ASSEMBLY		AUTOMATIC TRANSMISSION ASSEMBLY		Lincoln	
Ford		Ford		Ford		MKS	
Escape	2015-2013	Explorer	2013	Taurus	2016-2013	MKT	2013
		Police Interceptor Sedan	2013				



Make	Year	Make	Year	Make	Year	Make	Year
<b>DA8Z-7000-D</b>		<b>DA8Z-7000-J</b>		<b>DA8Z-7000-R</b>		<b>DE9Z-7000-L</b>	
<b>AUTOMATIC TRANSMISSION ASSEMBLY</b> Ford		<b>AUTOMATIC TRANSMISSION ASSEMBLY</b> Ford		<b>AUTOMATIC TRANSMISSION ASSEMBLY</b> Lincoln		<b>AUTOMATIC TRANSMISSION ASSEMBLY</b> Ford	
Explorer	2016-2014	Edge	2014-2013	MKZ	2016-2014	Edge	2015-2013
<b>DA8Z-7000-E</b>		Lincoln		<b>DA8Z-7000-S</b>		Explorer	2015-2013
<b>AUTOMATIC TRANSMISSION ASSEMBLY</b> Ford		MKS	2016-2013	<b>AUTOMATIC TRANSMISSION ASSEMBLY</b> Ford		Lincoln	
Taurus	2013	MKT	2016-2014	Flex	2016-2014	MKT	2015-2013
<b>DA8Z-7000-ERM</b>		<b>DA8Z-7000-K</b>		<b>DA8Z-7000-T</b>		<b>DE9Z-7000-M</b>	
<b>AUTOMATIC TRANSMISSION ASSEMBLY</b> Ford		<b>AUTOMATIC TRANSMISSION ASSEMBLY</b> Ford		<b>AUTOMATIC TRANSMISSION ASSEMBLY</b> Lincoln		<b>AUTOMATIC TRANSMISSION ASSEMBLY</b> Lincoln	
Edge	2013	Flex	2016-2014	MKZ	2013	MKT	2016
Police Interceptor Sedan	2013	<b>DA8Z-7000-KRM</b>		<b>DA8Z-7000-TC</b>		<b>DG1Z-7000-Y</b>	
Taurus	2013	<b>AUTOMATIC TRANSMISSION ASSEMBLY</b> Ford		<b>AUTOMATIC TRANSMISSION ASSEMBLY</b> Lincoln		<b>AUTOMATIC TRANSMISSION ASSEMBLY</b> Ford	
Lincoln		Explorer	2016-2015	MKX	2016	Taurus	2016-2013
MKS	2013	<b>DA8Z-7000-L</b>		MKZ	2016-2014	<b>DG9Z-7000-C</b>	
MKX	2013	<b>AUTOMATIC TRANSMISSION ASSEMBLY</b> Ford		<b>DA8Z-7000-TRM</b>		<b>AUTOMATIC TRANSMISSION ASSEMBLY</b> Ford	
<b>DA8Z-7000-F</b>		<b>AUTOMATIC TRANSMISSION ASSEMBLY</b> Ford		<b>AUTOMATIC TRANSMISSION ASSEMBLY</b> Lincoln		Fusion	2014
<b>AUTOMATIC TRANSMISSION ASSEMBLY</b> Ford		Taurus	2016-2014	MKZ	2013	<b>DG9Z-7000-E</b>	
Taurus	2013	Lincoln		<b>DA8Z-7000-U</b>		<b>AUTOMATIC TRANSMISSION ASSEMBLY</b> Lincoln	
<b>DA8Z-7000-FRM</b>		MKS	2016-2013	<b>AUTOMATIC TRANSMISSION ASSEMBLY</b> Ford		MKZ	2015-2013
<b>AUTOMATIC TRANSMISSION ASSEMBLY</b> Ford		<b>DA8Z-7000-M</b>		Taurus	2016-2013	<b>DG9Z-7000-ED</b>	
Edge	2013	<b>AUTOMATIC TRANSMISSION ASSEMBLY</b> Ford		<b>DA8Z-7000-URM</b>		<b>AUTOMATIC TRANSMISSION ASSEMBLY</b> Lincoln	
Police Interceptor Sedan	2013	Edge	2016-2013	<b>AUTOMATIC TRANSMISSION ASSEMBLY</b> Ford		MKZ	2016
<b>DA8Z-7000-G</b>		Taurus	2016-2014	Taurus	2013	<b>DG9Z-7000-F</b>	
<b>AUTOMATIC TRANSMISSION ASSEMBLY</b> Ford		<b>DA8Z-7000-NC</b>		<b>DA8Z-7000-X</b>		<b>AUTOMATIC TRANSMISSION ASSEMBLY</b> Lincoln	
Explorer	2016-2013	<b>AUTOMATIC TRANSMISSION ASSEMBLY</b> Ford		<b>AUTOMATIC TRANSMISSION ASSEMBLY</b> Ford		MKZ	2015-2013
<b>DA8Z-7000-GRM</b>		Edge	2016	Taurus	2014	<b>DG9Z-7000-FD</b>	
<b>AUTOMATIC TRANSMISSION ASSEMBLY</b> Ford		<b>DA8Z-7000-NRM</b>		<b>DA8Z-7000-Y</b>		<b>AUTOMATIC TRANSMISSION ASSEMBLY</b> Lincoln	
Explorer	2013	<b>AUTOMATIC TRANSMISSION ASSEMBLY</b> Ford		<b>AUTOMATIC TRANSMISSION ASSEMBLY</b> Ford		MKZ	2016
<b>DA8Z-7000-H</b>		Edge	2013	Edge	2013	<b>DG9Z-7000-G</b>	
<b>AUTOMATIC TRANSMISSION ASSEMBLY</b> Ford		<b>DA8Z-7000-P</b>		<b>DB5Z-7000-S</b>		<b>AUTOMATIC TRANSMISSION ASSEMBLY</b> Lincoln	
Edge	2013	<b>AUTOMATIC TRANSMISSION ASSEMBLY</b> Lincoln		<b>AUTOMATIC TRANSMISSION ASSEMBLY</b> Ford		MKZ	2013
<b>DA8Z-7000-HRM</b>		MKZ	2013	Explorer	2015-2013	<b>DG9Z-7000-J</b>	
<b>AUTOMATIC TRANSMISSION ASSEMBLY</b> Ford		<b>DA8Z-7000-PRM</b>				<b>AUTOMATIC TRANSMISSION ASSEMBLY</b> Ford	
Edge	2013	<b>AUTOMATIC TRANSMISSION ASSEMBLY</b> Lincoln				Fusion	2014-2013
		MKZ	2013				

# BUYER'S GUIDE

## Transmission Assemblies



FORD PARTS

Make	Year	Make	Year	Make	Year	Make	Year
<b>DG9Z-7000-J cont'd</b>		<b>DL7Z-7000-ARM</b>		<b>DV6Z-7000-D</b>		<b>EG9Z-7000-AD</b>	
Lincoln MKZ	2014-2013	AUTOMATIC TRANSMISSION ASSEMBLY Lincoln Navigator	2006-2005	AUTOMATIC TRANSMISSION ASSEMBLY Ford Transit Connect	2016-2014	AUTOMATIC TRANSMISSION ASSEMBLY Ford Fusion	2016
<b>DG9Z-7000-K</b>		<b>DL7Z-7000-BRM</b>		<b>DV6Z-7000-DRM</b>		<b>EG9Z-7000-ARM</b>	
AUTOMATIC TRANSMISSION ASSEMBLY Ford Fusion		AUTOMATIC TRANSMISSION ASSEMBLY Lincoln Navigator		AUTOMATIC TRANSMISSION ASSEMBLY Ford Transit Connect		AUTOMATIC TRANSMISSION ASSEMBLY Lincoln MKZ	
	2015		2006-2005		2015-2014		2015-2013
Lincoln MKZ	2016-2015	<b>DL7Z-7000-ERM</b>		<b>DV6Z-7000-E</b>		<b>EG9Z-7000-B</b>	
AUTOMATIC TRANSMISSION ASSEMBLY Ford Fusion		AUTOMATIC TRANSMISSION ASSEMBLY Lincoln Navigator		AUTOMATIC TRANSMISSION ASSEMBLY Ford Transit Connect		AUTOMATIC TRANSMISSION ASSEMBLY Ford Fusion	
	2016		2007		2016-2015		2014
<b>DG9Z-7000-L</b>		<b>DL7Z-7000-FRM</b>		<b>DV6Z-7000-F</b>		<b>EG9Z-7000-BC</b>	
AUTOMATIC TRANSMISSION ASSEMBLY Ford Fusion		AUTOMATIC TRANSMISSION ASSEMBLY Lincoln Navigator		AUTOMATIC TRANSMISSION ASSEMBLY Ford Transit Connect		AUTOMATIC TRANSMISSION ASSEMBLY Ford Fusion	
	2015		2007		2016-2015		2016
<b>DG9Z-7000-M</b>		<b>DM5Z-7000-L</b>		<b>DV6Z-7000-P</b>		<b>EG9Z-7000-BRM</b>	
AUTOMATIC TRANSMISSION ASSEMBLY Ford Fusion		AUTOMATIC TRANSMISSION ASSEMBLY Ford C-Max		AUTOMATIC TRANSMISSION ASSEMBLY Ford Transit Connect		AUTOMATIC TRANSMISSION ASSEMBLY Lincoln MKZ	
	2015-2013		2016-2013		2017		2014-2013
<b>DG9Z-7000-MC</b>		<b>DT4Z-7000-N</b>		<b>E9TZ-7V000-CRM</b>		<b>EG9Z-7000-C</b>	
AUTOMATIC TRANSMISSION ASSEMBLY Ford Fusion		AUTOMATIC TRANSMISSION ASSEMBLY Ford Edge		AUTOMATIC TRANSMISSION ASSEMBLY Ford F-Series		AUTOMATIC TRANSMISSION ASSEMBLY Ford Fusion	
	2016		2015-2013		1989		2015
<b>DG9Z-7000-S</b>		<b>DV6Z-7000-B</b>		<b>EB5Z-7000-ARM</b>		<b>EG9Z-7000-CRM</b>	
AUTOMATIC TRANSMISSION ASSEMBLY Ford Fusion		AUTOMATIC TRANSMISSION ASSEMBLY Ford Transit Connect		AUTOMATIC TRANSMISSION ASSEMBLY Ford Explorer		AUTOMATIC TRANSMISSION ASSEMBLY Ford Fusion	
	2014-2013		2015-2014		2014-2013		2014-2013
Lincoln MKZ	2014-2013	<b>DV6Z-7000-BRM</b>		<b>EE9Z-7000-ARM</b>		<b>EG9Z-7000-DRM</b>	
AUTOMATIC TRANSMISSION ASSEMBLY Ford Transit Connect		AUTOMATIC TRANSMISSION ASSEMBLY Ford Edge		AUTOMATIC TRANSMISSION ASSEMBLY Ford Explorer		AUTOMATIC TRANSMISSION ASSEMBLY Ford Fusion	
	2015-2014		2014-2013		2014-2013		2014-2013
Edge	2016	<b>DV6Z-7000-C</b>		<b>EG1Z-7000-ARM</b>		<b>EG9Z-7000-ERM</b>	
AUTOMATIC TRANSMISSION ASSEMBLY Ford Edge		AUTOMATIC TRANSMISSION ASSEMBLY Ford Transit Connect		AUTOMATIC TRANSMISSION ASSEMBLY Ford Edge		AUTOMATIC TRANSMISSION ASSEMBLY Ford Fusion	
	2016		2015-2014		2014-2013		2014-2013
Lincoln MKX	2016	<b>DV6Z-7000-CRM</b>		<b>EG9Z-7000-A</b>		<b>EG9Z-7000-FRM</b>	
AUTOMATIC TRANSMISSION ASSEMBLY Ford Edge		AUTOMATIC TRANSMISSION ASSEMBLY Ford Transit Connect		AUTOMATIC TRANSMISSION ASSEMBLY Ford Taurus		AUTOMATIC TRANSMISSION ASSEMBLY Ford Fusion	
	2016		2015-2014		2014-2013		2013
				<b>EG9Z-7000-A</b>			
				AUTOMATIC TRANSMISSION ASSEMBLY Ford Fusion			
					2015-2014		



Make	Year	Make	Year	Make	Year	Make	Year
<b>EG9Z-7000-GRM</b>		<b>ET4Z-7000-ARM</b>		<b>F2GZ-7000-B</b>		<b>F2TZ-7V000-MRM</b>	
AUTOMATIC TRANSMISSION ASSEMBLY Ford		AUTOMATIC TRANSMISSION ASSEMBLY Ford		AUTOMATIC TRANSMISSION ASSEMBLY Ford		AUTOMATIC TRANSMISSION ASSEMBLY Ford	
Fusion	2013	Edge	2015-2013	Edge	2016	F-Series	1994-1992
<b>EG9Z-7000-HRM</b>		<b>EV6Z-7000-ARM</b>		<b>F2GZ-7000-T</b>		F53	1993
AUTOMATIC TRANSMISSION ASSEMBLY Ford		AUTOMATIC TRANSMISSION ASSEMBLY Ford		AUTOMATIC TRANSMISSION ASSEMBLY Ford		<b>F2TZ-7V000-NRM</b>	
Fusion	2015-2014	Escape	2014-2013	Edge	2016	AUTOMATIC TRANSMISSION ASSEMBLY Ford	
<b>EG9Z-7000-JRM</b>		<b>EV6Z-7000-BRM</b>		<b>F2GZ-7000-VC</b>		Econoline	1993-1992
AUTOMATIC TRANSMISSION ASSEMBLY Ford		AUTOMATIC TRANSMISSION ASSEMBLY Ford		AUTOMATIC TRANSMISSION ASSEMBLY Lincoln		F-Series	1994-1992
Fusion	2014	Escape	2014-2013	MKX	2016	<b>F2UZ-7V000-NRM</b>	
<b>EG9Z-7000-KRM</b>		<b>EV6Z-7000-CRM</b>		<b>F2GZ-7000-XC</b>		AUTOMATIC TRANSMISSION ASSEMBLY Ford	
AUTOMATIC TRANSMISSION ASSEMBLY Ford		AUTOMATIC TRANSMISSION ASSEMBLY Ford		AUTOMATIC TRANSMISSION ASSEMBLY Lincoln		Econoline	1994-1993
Fusion	2015	Escape	2013	MKX	2016	F-Series	1992
<b>EJ7Z-7000-H</b>		<b>EV6Z-7000-DRM</b>		<b>F2GZ-7000-Y</b>		<b>F3TZ-7V000-LRM</b>	
AUTOMATIC TRANSMISSION ASSEMBLY Lincoln		AUTOMATIC TRANSMISSION ASSEMBLY Ford		AUTOMATIC TRANSMISSION ASSEMBLY Ford		AUTOMATIC TRANSMISSION ASSEMBLY Ford	
MKC	2015	Escape	2014-2013	Edge	2016	F-Series	1994-1992
<b>EJ7Z-7000-J</b>		<b>EV6Z-7000-ERM</b>		<b>F2TZ-7V000-BRM</b>		<b>F3UZ-7V000-CRM</b>	
AUTOMATIC TRANSMISSION ASSEMBLY Lincoln		AUTOMATIC TRANSMISSION ASSEMBLY Ford		AUTOMATIC TRANSMISSION ASSEMBLY Ford		AUTOMATIC TRANSMISSION ASSEMBLY Ford	
MKC	2015	Escape	2014-2013	Econoline	1994-1992	Econoline	1994-1992
<b>EJ7Z-7000-K</b>		<b>F0CZ-7V000-ARM</b>		F-Series	1994-1992	F-Series	1994
AUTOMATIC TRANSMISSION ASSEMBLY Lincoln		AUTOMATIC TRANSMISSION ASSEMBLY Mercury		<b>F2TZ-7V000-FRM</b>		<b>F48Z-7V000-BRM</b>	
MKC	2015	Tracer	1996-1993	AUTOMATIC TRANSMISSION ASSEMBLY Ford		AUTOMATIC TRANSMISSION ASSEMBLY Ford	
<b>EJ7Z-7000-L</b>		<b>F0CZ-7V000-BRM</b>		Econoline	1994-1992	Windstar	1995
AUTOMATIC TRANSMISSION ASSEMBLY Lincoln		AUTOMATIC TRANSMISSION ASSEMBLY Mercury		F-Series	1994-1992	<b>F4DZ-7V000-BRM</b>	
MKC	2016	Tracer	1995-1993	<b>F2TZ-7V000-HRM</b>		AUTOMATIC TRANSMISSION ASSEMBLY Ford	
<b>EJ7Z-7000-M</b>		<b>F1FZ-7000-VA</b>		AUTOMATIC TRANSMISSION ASSEMBLY Ford		Taurus	1995-1994
AUTOMATIC TRANSMISSION ASSEMBLY Lincoln		AUTOMATIC TRANSMISSION ASSEMBLY Ford		Bronco	1994-1992	Mercury	
MKC	2016	Focus	2016-2015	F-Series	1994-1992	Sable	1995-1994
<b>EJ7Z-7000-N</b>		<b>F1SZ-7V000-DARM</b>		<b>F2TZ-7V000-JRM</b>		<b>F4OZ-7V000-BRM</b>	
AUTOMATIC TRANSMISSION ASSEMBLY Lincoln		AUTOMATIC TRANSMISSION ASSEMBLY Ford		AUTOMATIC TRANSMISSION ASSEMBLY Ford		AUTOMATIC TRANSMISSION ASSEMBLY Lincoln	
MKC	2016	Thunderbird	1991-1989	Econoline	1994-1992	Continental	1994
<b>F1SZ-7V000-DARM</b>		Mercury		F-Series	1994, 1992	<b>F4TZ-7V000-ARM</b>	
Thunderbird	1991-1989	Cougar	1991, 1989-1987	<b>F2TZ-7V000-LRM</b>		AUTOMATIC TRANSMISSION ASSEMBLY Ford	
<b>F1SZ-7V000-DARM</b>		<b>F1SZ-7V000-DARM</b>		AUTOMATIC TRANSMISSION ASSEMBLY Ford		F-Series	1995-1994
Cougar	1991, 1989-1987	<b>F1SZ-7V000-DARM</b>		F-Series	1993-1992		

# BUYER'S GUIDE

## Transmission Assemblies



FORD PARTS

Make	Year	Make	Year	Make	Year	Make	Year
<b>F4TZ-7V000-BRM</b>		<b>F5TZ-7V000-JRM</b>		<b>F68Z-7V000-AARM</b>		<b>F6UZ-7V000-GARM</b>	
<b>AUTOMATIC TRANSMISSION ASSEMBLY</b> Ford		<b>AUTOMATIC TRANSMISSION ASSEMBLY</b> Ford		<b>AUTOMATIC TRANSMISSION ASSEMBLY</b> Ford		<b>AUTOMATIC TRANSMISSION ASSEMBLY</b> Ford	
F-Series	1995-1994	F-Series	1995	Windstar	1997-1996	Econoline	1996
<b>F4TZ-7V000-ERM</b>		F53	1995	<b>F68Z-7V000-EBRM</b>		<b>F6UZ-7V000-HARM</b>	
<b>AUTOMATIC TRANSMISSION ASSEMBLY</b> Ford		<b>F5UZ-7V000-BRM</b>		<b>AUTOMATIC TRANSMISSION ASSEMBLY</b> Ford		<b>AUTOMATIC TRANSMISSION ASSEMBLY</b> Ford	
F-Series	1994	<b>AUTOMATIC TRANSMISSION ASSEMBLY</b> Ford		Explorer	1996-1995	Econoline	1996
<b>F4UZ-7V000-CRM</b>		Econoline	1995	<b>F6DZ-7V000-EARM</b>		F-Series	1996
<b>AUTOMATIC TRANSMISSION ASSEMBLY</b> Ford		F-Series	1995	<b>AUTOMATIC TRANSMISSION ASSEMBLY</b> Ford		<b>F75Z-7V000-ERM</b>	
Econoline	1994	<b>F5UZ-7V000-DRM</b>		Taurus	1996	<b>AUTOMATIC TRANSMISSION ASSEMBLY</b> Ford	
F-Series	1994	<b>AUTOMATIC TRANSMISSION ASSEMBLY</b> Ford		Mercury		F-Series	1997
<b>F50Z-7V000-BRM</b>		Econoline	1995	Sable	1996	<b>F75Z-7V000-HRM</b>	
<b>AUTOMATIC TRANSMISSION ASSEMBLY</b> Lincoln		F-Series	1995	<b>F6TZ-7V000-CARM</b>		<b>AUTOMATIC TRANSMISSION ASSEMBLY</b> Ford	
Continental	1995	<b>F5UZ-7V000-ERM</b>		<b>AUTOMATIC TRANSMISSION ASSEMBLY</b> Ford		F-Series	1997
<b>F57Z-7V000-KARM</b>		<b>AUTOMATIC TRANSMISSION ASSEMBLY</b> Ford		F-Series	1996	<b>F75Z-7V000-JRM</b>	
<b>AUTOMATIC TRANSMISSION ASSEMBLY</b> Ford		Econoline	1995	<b>F6TZ-7V000-FARM</b>		<b>AUTOMATIC TRANSMISSION ASSEMBLY</b> Ford	
Ranger	1996-1995	F-Series	1995	<b>AUTOMATIC TRANSMISSION ASSEMBLY</b> Ford		F-Series	1997
<b>Mazda</b>		<b>F5UZ-7V000-FRM</b>		Bronco	1996	<b>F75Z-7V000-KRM</b>	
B3000	1996-1995	<b>AUTOMATIC TRANSMISSION ASSEMBLY</b> Ford		F-Series	1996	<b>AUTOMATIC TRANSMISSION ASSEMBLY</b> Ford	
<b>F5TZ-7V000-BRM</b>		Econoline	1995	<b>F6TZ-7V000-GARM</b>		F-Series	1997
<b>AUTOMATIC TRANSMISSION ASSEMBLY</b> Ford		F-Series	1995	<b>AUTOMATIC TRANSMISSION ASSEMBLY</b> Ford		<b>F75Z-7V000-LCRM</b>	
F-Series	1995	<b>F5UZ-7V000-GRM</b>		F-Series	1996	<b>AUTOMATIC TRANSMISSION ASSEMBLY</b> Ford	
<b>F5TZ-7V000-CRM</b>		<b>AUTOMATIC TRANSMISSION ASSEMBLY</b> Ford		<b>F6TZ-7V000-JARM</b>		Expedition	1997
<b>AUTOMATIC TRANSMISSION ASSEMBLY</b> Ford		F-Series	1995	<b>AUTOMATIC TRANSMISSION ASSEMBLY</b> Ford		F-Series	1998-1997
Bronco	1995	<b>F5UZ-7V000-HRM</b>		F-Series	1996	<b>F75Z-7V000-LRM</b>	
F-Series	1995	<b>AUTOMATIC TRANSMISSION ASSEMBLY</b> Ford		F53	1996	<b>AUTOMATIC TRANSMISSION ASSEMBLY</b> Ford	
<b>F5TZ-7V000-DRM</b>		Econoline	1995	<b>F6UZ-7V000-DARM</b>		F-Series	1997
<b>AUTOMATIC TRANSMISSION ASSEMBLY</b> Ford		<b>F65Z-7V000-CARM</b>		<b>AUTOMATIC TRANSMISSION ASSEMBLY</b> Ford		<b>F75Z-7V000-MRM</b>	
F-Series	1995	<b>AUTOMATIC TRANSMISSION ASSEMBLY</b> Ford		Econoline	1996	<b>AUTOMATIC TRANSMISSION ASSEMBLY</b> Ford	
<b>F5TZ-7V000-ERM</b>		F-Series	1997	F-Series	1996	F-Series	1998-1997
<b>AUTOMATIC TRANSMISSION ASSEMBLY</b> Ford		<b>F65Z-7V000-DARM</b>		<b>F6UZ-7V000-FARM</b>		Lincoln	
F-Series	1995	<b>AUTOMATIC TRANSMISSION ASSEMBLY</b> Ford		<b>AUTOMATIC TRANSMISSION ASSEMBLY</b> Ford		Navigator	1998
<b>F5TZ-7V000-GRM</b>		F-Series	1997	F-Series	1996	<b>F77Z-7V000-AARM</b>	
<b>AUTOMATIC TRANSMISSION ASSEMBLY</b> Ford						<b>AUTOMATIC TRANSMISSION ASSEMBLY</b> Ford	
F-Series	1995					Explorer	1997



Make	Year	Make	Year	Make	Year	Make	Year
<b>F77Z-7V000-AARM cont'd</b>		<b>F7LZ-7000-ARM</b>		<b>F7UZ-7V000-JRM</b>		<b>F81Z-7V000-FBRM</b>	
Ranger	1997	<b>AUTOMATIC TRANSMISSION ASSEMBLY</b>		<b>AUTOMATIC TRANSMISSION ASSEMBLY</b>		<b>AUTOMATIC TRANSMISSION ASSEMBLY</b>	
Mazda		Lincoln		Ford		Ford	
B4000	1997	Mark VIII	1997	Econoline	1998-1997	F-Series	1999
<b>F78Z-7V000-ARM</b>		<b>F7TZ-7V000-JRM</b>		<b>F7UZ-7V000-MRM</b>		<b>F81Z-7V000-GBRM</b>	
<b>AUTOMATIC TRANSMISSION ASSEMBLY</b>		<b>AUTOMATIC TRANSMISSION ASSEMBLY</b>		<b>AUTOMATIC TRANSMISSION ASSEMBLY</b>		<b>AUTOMATIC TRANSMISSION ASSEMBLY</b>	
Ford		Ford		Ford		Ford	
Windstar	1998-1997	F-Series	1997	Econoline	1998-1997	F-Series	1999
<b>F78Z-7V000-BRM</b>		<b>F7TZ-7V000-KRM</b>		<b>F7UZ-7V000-NRM</b>		<b>F81Z-7V000-KBRM</b>	
<b>AUTOMATIC TRANSMISSION ASSEMBLY</b>		<b>AUTOMATIC TRANSMISSION ASSEMBLY</b>		<b>AUTOMATIC TRANSMISSION ASSEMBLY</b>		<b>AUTOMATIC TRANSMISSION ASSEMBLY</b>	
Ford		Ford		Ford		Ford	
Windstar	1998-1997	F-Series	1997-1996	Econoline	1998-1997	F-Series	2000-1999
<b>F7AZ-7V000-BRM</b>		<b>F7TZ-7V000-LRM</b>		<b>F7UZ-7V000-PBRM</b>		<b>F81Z-7V000-TARM</b>	
<b>AUTOMATIC TRANSMISSION ASSEMBLY</b>		<b>AUTOMATIC TRANSMISSION ASSEMBLY</b>		<b>AUTOMATIC TRANSMISSION ASSEMBLY</b>		<b>AUTOMATIC TRANSMISSION ASSEMBLY</b>	
Ford		Ford		Ford		Ford	
Crown Victoria	1997	F-Series	1997	Econoline	1998-1997	F-Series	1999
Lincoln		<b>F7TZ-7V000-MRM</b>		<b>F7UZ-7V000-UARM</b>		<b>F83Z-7V000-CBRM</b>	
Town Car	1997	<b>AUTOMATIC TRANSMISSION ASSEMBLY</b>		<b>AUTOMATIC TRANSMISSION ASSEMBLY</b>		<b>AUTOMATIC TRANSMISSION ASSEMBLY</b>	
<b>F7DZ-7V000-ARM</b>		<b>AUTOMATIC TRANSMISSION ASSEMBLY</b>		<b>AUTOMATIC TRANSMISSION ASSEMBLY</b>		<b>AUTOMATIC TRANSMISSION ASSEMBLY</b>	
<b>AUTOMATIC TRANSMISSION ASSEMBLY</b>		<b>AUTOMATIC TRANSMISSION ASSEMBLY</b>		<b>AUTOMATIC TRANSMISSION ASSEMBLY</b>		<b>AUTOMATIC TRANSMISSION ASSEMBLY</b>	
Ford		Ford		Ford		Ford	
Taurus	1997	F-Series	1997	Econoline	1998	Contour	1998
Mercury		<b>F7TZ-7V000-NARM</b>		<b>F7UZ-7V000-VARM</b>		Mercury	
Sable	1997	<b>AUTOMATIC TRANSMISSION ASSEMBLY</b>		<b>AUTOMATIC TRANSMISSION ASSEMBLY</b>		Cougar	2000-1999
<b>F7DZ-7V000-CRM</b>		<b>AUTOMATIC TRANSMISSION ASSEMBLY</b>		<b>AUTOMATIC TRANSMISSION ASSEMBLY</b>		Mystique	1998
<b>AUTOMATIC TRANSMISSION ASSEMBLY</b>		<b>AUTOMATIC TRANSMISSION ASSEMBLY</b>		<b>AUTOMATIC TRANSMISSION ASSEMBLY</b>		<b>F85Z-7V000-BARM</b>	
Ford		Econoline	1997	Econoline	1997	<b>AUTOMATIC TRANSMISSION ASSEMBLY</b>	
Taurus	1997	F-Series	1997	<b>F81Z-7V000-ABRM</b>		<b>AUTOMATIC TRANSMISSION ASSEMBLY</b>	
Mercury		<b>F7TZ-7V000-PRM</b>		<b>AUTOMATIC TRANSMISSION ASSEMBLY</b>		<b>AUTOMATIC TRANSMISSION ASSEMBLY</b>	
Sable	1997	<b>AUTOMATIC TRANSMISSION ASSEMBLY</b>		<b>AUTOMATIC TRANSMISSION ASSEMBLY</b>		<b>AUTOMATIC TRANSMISSION ASSEMBLY</b>	
<b>F7DZ-7V000-DRM</b>		<b>AUTOMATIC TRANSMISSION ASSEMBLY</b>		<b>AUTOMATIC TRANSMISSION ASSEMBLY</b>		<b>AUTOMATIC TRANSMISSION ASSEMBLY</b>	
<b>AUTOMATIC TRANSMISSION ASSEMBLY</b>		<b>AUTOMATIC TRANSMISSION ASSEMBLY</b>		<b>AUTOMATIC TRANSMISSION ASSEMBLY</b>		<b>AUTOMATIC TRANSMISSION ASSEMBLY</b>	
Ford		Ford		Ford		Ford	
Taurus	1997	Econoline	1997	F-Series	1999	F-Series	1998
Mercury		<b>F7UZ-7V000-FRM</b>		<b>F81Z-7V000-DBRM</b>		<b>F85Z-7V000-EARM</b>	
Sable	1997	<b>AUTOMATIC TRANSMISSION ASSEMBLY</b>		<b>AUTOMATIC TRANSMISSION ASSEMBLY</b>		<b>AUTOMATIC TRANSMISSION ASSEMBLY</b>	
<b>F7DZ-7V000-ERM</b>		<b>AUTOMATIC TRANSMISSION ASSEMBLY</b>		<b>AUTOMATIC TRANSMISSION ASSEMBLY</b>		<b>AUTOMATIC TRANSMISSION ASSEMBLY</b>	
<b>AUTOMATIC TRANSMISSION ASSEMBLY</b>		<b>AUTOMATIC TRANSMISSION ASSEMBLY</b>		<b>AUTOMATIC TRANSMISSION ASSEMBLY</b>		<b>AUTOMATIC TRANSMISSION ASSEMBLY</b>	
Ford		Ford		Ford		Ford	
Taurus	1997	Econoline	1998-1997	F-Series	1999	Expedition	1998
Mercury		<b>F7UZ-7V000-GRM</b>		<b>F81Z-7V000-EBRM</b>		<b>F85Z-7V000-FARM</b>	
Sable	1997	<b>AUTOMATIC TRANSMISSION ASSEMBLY</b>		<b>AUTOMATIC TRANSMISSION ASSEMBLY</b>		<b>AUTOMATIC TRANSMISSION ASSEMBLY</b>	
<b>AUTOMATIC TRANSMISSION ASSEMBLY</b>		<b>AUTOMATIC TRANSMISSION ASSEMBLY</b>		<b>AUTOMATIC TRANSMISSION ASSEMBLY</b>		<b>AUTOMATIC TRANSMISSION ASSEMBLY</b>	
Ford		Ford		Ford		Ford	
Taurus	1997	Econoline	1998-1997	F-Series	1999	F-Series	1998
Mercury		<b>F7UZ-7V000-HARM</b>		<b>F81Z-7V000-HBRM</b>		<b>F85Z-7V000-HARM</b>	
Sable	1997	<b>AUTOMATIC TRANSMISSION ASSEMBLY</b>		<b>AUTOMATIC TRANSMISSION ASSEMBLY</b>		<b>AUTOMATIC TRANSMISSION ASSEMBLY</b>	
<b>AUTOMATIC TRANSMISSION ASSEMBLY</b>		<b>AUTOMATIC TRANSMISSION ASSEMBLY</b>		<b>AUTOMATIC TRANSMISSION ASSEMBLY</b>		<b>AUTOMATIC TRANSMISSION ASSEMBLY</b>	
Ford		Ford		Ford		Ford	
F-Series	1998	F-Series	1998	F-Series	1998	F-Series	1998

# BUYER'S GUIDE

## Transmission Assemblies



FORD PARTS

Make	Year	Make	Year	Make	Year	Make	Year
<b>F87Z-7V000-CARM</b>		<b>F8UZ-7V000-CARM</b>		<b>F8UZ-7V000-PARM</b>		<b>FC3Z-7000-G</b>	
<b>AUTOMATIC TRANSMISSION ASSEMBLY</b>		<b>AUTOMATIC TRANSMISSION ASSEMBLY</b>		<b>AUTOMATIC TRANSMISSION ASSEMBLY</b>		<b>AUTOMATIC TRANSMISSION ASSEMBLY</b>	
Ford		Ford		Ford		Ford	
Explorer	1998	Econoline	1999-1998	Econoline	1999-1998	F-Series	2016-2015
<b>Mercury</b>		<b>F8UZ-7V000-FARM</b>		<b>F8UZ-7V000-RARM</b>		<b>FC3Z-7000-P</b>	
Mountaineer	1998	<b>AUTOMATIC TRANSMISSION ASSEMBLY</b>		<b>AUTOMATIC TRANSMISSION ASSEMBLY</b>		<b>AUTOMATIC TRANSMISSION ASSEMBLY</b>	
		Ford		Ford		Ford	
		Econoline	1998	Econoline	1999-1998	F-Series	2016-2015
<b>F87Z-7V000-DARM</b>		<b>F8UZ-7V000-HARM</b>		<b>FA6Z-7000-H</b>		<b>FC3Z-7000-RRM</b>	
<b>AUTOMATIC TRANSMISSION ASSEMBLY</b>		<b>AUTOMATIC TRANSMISSION ASSEMBLY</b>		<b>AUTOMATIC TRANSMISSION ASSEMBLY</b>		<b>AUTOMATIC TRANSMISSION ASSEMBLY</b>	
Ford		Ford		Ford		Ford	
Explorer	1998	Econoline	1998	Fiesta	2016-2015	F-Series	2013-2012
<b>Mercury</b>		<b>F8UZ-7V000-JARM</b>		<b>FB5Z-7000-A</b>		<b>FC3Z-7000-S</b>	
Mountaineer	1998	<b>AUTOMATIC TRANSMISSION ASSEMBLY</b>		<b>AUTOMATIC TRANSMISSION ASSEMBLY</b>		<b>AUTOMATIC TRANSMISSION ASSEMBLY</b>	
		Ford		Ford		Ford	
		Econoline	1999	Explorer	2016	F-Series	2016-2015
<b>F87Z-7V000-LARM</b>		<b>F8UZ-7V000-KARM</b>		<b>FB5Z-7000-B</b>		<b>FC3Z-7000-SRM</b>	
<b>AUTOMATIC TRANSMISSION ASSEMBLY</b>		<b>AUTOMATIC TRANSMISSION ASSEMBLY</b>		<b>AUTOMATIC TRANSMISSION ASSEMBLY</b>		<b>AUTOMATIC TRANSMISSION ASSEMBLY</b>	
Ford		Ford		Ford		Ford	
Ranger	1998	Econoline	1999	Explorer	2016	F-Series	2013-2012
<b>Mazda</b>		<b>F88Z-7V000-AARM</b>		<b>FB5Z-7000-D</b>		<b>FC3Z-7000-TRM</b>	
B4000	1998	<b>AUTOMATIC TRANSMISSION ASSEMBLY</b>		<b>AUTOMATIC TRANSMISSION ASSEMBLY</b>		<b>AUTOMATIC TRANSMISSION ASSEMBLY</b>	
		Ford		Ford		Ford	
		Econoline	1999-1998	Explorer	2016	F-Series	2012
<b>F88Z-7V000-BARM</b>		<b>F8UZ-7V000-LARM</b>		<b>FC3Z-7000-C</b>		<b>FC3Z-7000-URM</b>	
<b>AUTOMATIC TRANSMISSION ASSEMBLY</b>		<b>AUTOMATIC TRANSMISSION ASSEMBLY</b>		<b>AUTOMATIC TRANSMISSION ASSEMBLY</b>		<b>AUTOMATIC TRANSMISSION ASSEMBLY</b>	
Ford		Ford		Ford		Ford	
Windstar	1998-1997	Econoline	1998	Explorer	2016	F-Series	2013-2012
		Expedition	1998				
		F-Series	1998				
<b>F8AZ-7V000-AARM</b>		<b>F8UZ-7V000-LCRM</b>		<b>FC3Z-7000-D</b>		<b>FC3Z-7000-VRM</b>	
<b>AUTOMATIC TRANSMISSION ASSEMBLY</b>		<b>AUTOMATIC TRANSMISSION ASSEMBLY</b>		<b>AUTOMATIC TRANSMISSION ASSEMBLY</b>		<b>AUTOMATIC TRANSMISSION ASSEMBLY</b>	
Ford		Ford		Ford		Ford	
Lincoln		Expedition	1998	F-Series	2016-2015	F-Series	2013-2012
Navigator	1998	F-Series	1998				
<b>F8UZ-7V000-LCRM</b>		<b>F8DZ-7V000-AARM</b>		<b>FC3Z-7000-E</b>		<b>FC3Z-7000-WRM</b>	
<b>AUTOMATIC TRANSMISSION ASSEMBLY</b>		<b>AUTOMATIC TRANSMISSION ASSEMBLY</b>		<b>AUTOMATIC TRANSMISSION ASSEMBLY</b>		<b>AUTOMATIC TRANSMISSION ASSEMBLY</b>	
Ford		Ford		Ford		Ford	
Expedition	1998	Lincoln		F-Series	2016-2015	F-Series	2014-2012
F-Series	1998	Navigator	1998				
<b>F8DZ-7V000-AARM</b>		<b>F8UZ-7V000-MBRM</b>		<b>FC3Z-7000-F</b>		<b>FC3Z-7000-Z</b>	
<b>AUTOMATIC TRANSMISSION ASSEMBLY</b>		<b>AUTOMATIC TRANSMISSION ASSEMBLY</b>		<b>AUTOMATIC TRANSMISSION ASSEMBLY</b>		<b>AUTOMATIC TRANSMISSION ASSEMBLY</b>	
Ford		Ford		Ford		Ford	
Taurus	1998	Expedition	1998	F-Series	2016-2015	F-Series	2016-2015
<b>Mercury</b>		F-Series	1998				
Grand Marquis	1998	Lincoln					
		Navigator	1998				
<b>F8DZ-7V000-DARM</b>		<b>F8UZ-7V000-MBRM</b>		<b>AUTOMATIC TRANSMISSION ASSEMBLY</b>		<b>AUTOMATIC TRANSMISSION ASSEMBLY</b>	
<b>AUTOMATIC TRANSMISSION ASSEMBLY</b>		<b>AUTOMATIC TRANSMISSION ASSEMBLY</b>		Ford		Ford	
Ford		Ford		F-Series	2016-2015	F-Series	2016-2015
Taurus	1998	Expedition	1998				
<b>Mercury</b>		F-Series	1998				
Sable	1998	Lincoln					
		Navigator	1998				





Make	Year	Make	Year	Make	Year	Make	Year
<b>FC4Z-7000-V</b>		<b>FL3Z-7000-B</b>		<b>FOTZ-7V000-ARM</b>		<b>G2GZ-7000-AA</b>	
<b>AUTOMATIC TRANSMISSION ASSEMBLY</b>		<b>AUTOMATIC TRANSMISSION ASSEMBLY</b>		<b>AUTOMATIC TRANSMISSION ASSEMBLY</b>		<b>AUTOMATIC TRANSMISSION ASSEMBLY</b>	
Ford		Ford		Ford		Lincoln	
F650	2015	F-Series	2016-2015	Econoline	1991-1990	MKX	2016
F750	2015	<b>FL3Z-7000-C</b>		F-Series	1991-1990	<b>G2GZ-7000-BA</b>	
<b>FC4Z-7000-X</b>		<b>AUTOMATIC TRANSMISSION ASSEMBLY</b>		<b>FOTZ-7V000-BRM</b>		<b>AUTOMATIC TRANSMISSION ASSEMBLY</b>	
<b>AUTOMATIC TRANSMISSION ASSEMBLY</b>		Ford		<b>AUTOMATIC TRANSMISSION ASSEMBLY</b>		Lincoln	
Ford		Expedition	2016-2015	Ford		MKX	2016
F650	2015	F-Series	2016-2015	Bronco	1991-1990	<b>GB5Z-7000-YRM</b>	
F750	2015	Lincoln		F-Series	1991-1990	<b>AUTOMATIC TRANSMISSION ASSEMBLY</b>	
<b>FG9Z-7000-A</b>		Navigator	2016-2015	<b>FOTZ-7V000-ERM</b>		Ford	
<b>AUTOMATIC TRANSMISSION ASSEMBLY</b>		<b>FL3Z-7000-D</b>		<b>AUTOMATIC TRANSMISSION ASSEMBLY</b>		Explorer	2016
Lincoln		<b>AUTOMATIC TRANSMISSION ASSEMBLY</b>		Ford		<b>GC4Z-7000-AA</b>	
MKZ	2015	Ford		Econoline	1991-1990	<b>AUTOMATIC TRANSMISSION ASSEMBLY</b>	
<b>FG9Z-7000-AC</b>		F-Series	2016-2015	F-Series	1991-1990	Ford	
<b>AUTOMATIC TRANSMISSION ASSEMBLY</b>		<b>FL3Z-7000-E</b>		<b>FOTZ-7V000-LRM</b>		F53	2016-2015
Lincoln		<b>AUTOMATIC TRANSMISSION ASSEMBLY</b>		<b>AUTOMATIC TRANSMISSION ASSEMBLY</b>		<b>GC4Z-7000-BA</b>	
MKZ	2016	Ford		Ford		<b>AUTOMATIC TRANSMISSION ASSEMBLY</b>	
<b>FG9Z-7000-C</b>		F-Series	2016-2015	Econoline	1991-1990	Ford	
<b>AUTOMATIC TRANSMISSION ASSEMBLY</b>		<b>FL3Z-7000-F</b>		F-Series	1991-1990	F650	2016
Ford		<b>AUTOMATIC TRANSMISSION ASSEMBLY</b>		<b>FOTZ-7V000-NRM</b>		F750	2016
C-Max	2016-2015	Ford		<b>AUTOMATIC TRANSMISSION ASSEMBLY</b>		<b>GC4Z-7000-HA</b>	
Fusion	2016-2015	F-Series	2016-2015	Ford		<b>AUTOMATIC TRANSMISSION ASSEMBLY</b>	
Lincoln		<b>FL3Z-7000-G</b>		F-Series	1991-1990	Ford	
Continental	2017	<b>AUTOMATIC TRANSMISSION ASSEMBLY</b>		F53	1993-1990	F650	2016
<b>FG9Z-7000-E</b>		Ford		<b>FOTZ-7V000-URM</b>		F750	2016
<b>AUTOMATIC TRANSMISSION ASSEMBLY</b>		F-Series	2016-2015	<b>AUTOMATIC TRANSMISSION ASSEMBLY</b>		<b>GC4Z-7000-V</b>	
Lincoln		<b>FL3Z-7000-H</b>		Ford		<b>AUTOMATIC TRANSMISSION ASSEMBLY</b>	
MKZ	2014-2013	<b>AUTOMATIC TRANSMISSION ASSEMBLY</b>		F-Series	1991-1990	Ford	
<b>FG9Z-7000-G</b>		Ford		<b>FR3Z-7000-A</b>		F650	2016
<b>AUTOMATIC TRANSMISSION ASSEMBLY</b>		F-Series	2016-2015	<b>AUTOMATIC TRANSMISSION ASSEMBLY</b>		F750	2016
Lincoln		<b>FL3Z-7000-J</b>		Ford		<b>GC4Z-7000-XA</b>	
MKZ	2016-2013	<b>AUTOMATIC TRANSMISSION ASSEMBLY</b>		Mustang	2016-2015	<b>AUTOMATIC TRANSMISSION ASSEMBLY</b>	
<b>FL1Z-7000-B</b>		Ford		<b>FR3Z-7000-B</b>		Ford	
<b>AUTOMATIC TRANSMISSION ASSEMBLY</b>		F-Series	2016-2015	<b>AUTOMATIC TRANSMISSION ASSEMBLY</b>		F650	2016
Lincoln		<b>FL3Z-7000-K</b>		Ford		F750	2016
Navigator	2016	<b>AUTOMATIC TRANSMISSION ASSEMBLY</b>		Mustang	2016-2015	<b>GC4Z-7000-Z</b>	
<b>FL3Z-7000-A</b>		Ford		<b>FR3Z-7000-C</b>		<b>AUTOMATIC TRANSMISSION ASSEMBLY</b>	
<b>AUTOMATIC TRANSMISSION ASSEMBLY</b>		F-Series	2016-2015	<b>AUTOMATIC TRANSMISSION ASSEMBLY</b>		Ford	
Ford		<b>FM5Z-7000-D</b>		Ford		F650	2016
F-Series	2016-2015	<b>AUTOMATIC TRANSMISSION ASSEMBLY</b>		Mustang	2016-2015	F750	2016
		Ford					
		C-Max	2016-2015				

# BUYER'S GUIDE

## Transmission Assemblies



FORD PARTS

Make	Year	Make	Year	Make	Year	Make	Year
<b>GJ7Z-7000-A</b>		<b>GV6Z-7000-C</b>		<b>JL3Z-7000-D</b>		<b>XL1Z-7V000-DBRM</b>	
<b>AUTOMATIC TRANSMISSION ASSEMBLY</b> Lincoln		<b>AUTOMATIC TRANSMISSION ASSEMBLY</b> Ford		<b>AUTOMATIC TRANSMISSION ASSEMBLY</b> Ford		<b>AUTOMATIC TRANSMISSION ASSEMBLY</b> Lincoln	
MKC	2017	Escape	2017	F-Series	2018	Navigator	2000-1999
<b>GK4Z-7000-A</b>		<b>GV6Z-7000-D</b>		<b>XC2Z-7V000-NARM</b>		<b>XL2Z-7V000-AARM</b>	
<b>AUTOMATIC TRANSMISSION ASSEMBLY</b> Ford		<b>AUTOMATIC TRANSMISSION ASSEMBLY</b> Ford		<b>AUTOMATIC TRANSMISSION ASSEMBLY</b> Ford		<b>AUTOMATIC TRANSMISSION ASSEMBLY</b> Ford	
Transit-250	2016	Escape	2017	Econoline	1999	Explorer	2001-1999
Transit-350	2016					<b>Mercury</b>	
Transit-350 HD	2016	<b>HL3Z-7000-B</b>		<b>XF1Z-7V000-AARM</b>		Mountaineer	2000-1999
		<b>AUTOMATIC TRANSMISSION ASSEMBLY</b> Ford		<b>AUTOMATIC TRANSMISSION ASSEMBLY</b> Ford		<b>XL2Z-7V000-BARM</b>	
<b>GK4Z-7000-B</b>		F-Series	2017	Taurus	1999	<b>AUTOMATIC TRANSMISSION ASSEMBLY</b> Ford	
<b>AUTOMATIC TRANSMISSION ASSEMBLY</b> Ford		<b>HL3Z-7000-E</b>		<b>Mercury</b>		Explorer	2001-1999
Transit-250	2016	<b>AUTOMATIC TRANSMISSION ASSEMBLY</b> Ford		Sable	1999	<b>Mercury</b>	
Transit-350	2016	F-Series	2017	<b>XF1Z-7V000-BARM</b>		Mountaineer	2000-1999
Transit-350 HD	2016	<b>HL3Z-7000-F</b>		<b>AUTOMATIC TRANSMISSION ASSEMBLY</b> Ford		<b>XL2Z-7V000-CARM</b>	
		<b>AUTOMATIC TRANSMISSION ASSEMBLY</b> Ford		Taurus	1999	<b>AUTOMATIC TRANSMISSION ASSEMBLY</b> Ford	
<b>GK4Z-7000-C</b>		F-Series	2017	<b>XF1Z-7V000-EBRM</b>		Explorer	2000-1999
<b>AUTOMATIC TRANSMISSION ASSEMBLY</b> Ford		<b>HL3Z-7000-G</b>		<b>AUTOMATIC TRANSMISSION ASSEMBLY</b> Ford		<b>Mercury</b>	
Transit-150	2016	<b>AUTOMATIC TRANSMISSION ASSEMBLY</b> Ford		Taurus	1999	Mountaineer	2000-1999
Transit-250	2016	F-Series	2017	<b>Mercury</b>		<b>XL2Z-7V000-DARM</b>	
Transit-350	2016	<b>HL3Z-7000-H</b>		Sable	1999	<b>AUTOMATIC TRANSMISSION ASSEMBLY</b> Ford	
Transit-350 HD	2016	<b>AUTOMATIC TRANSMISSION ASSEMBLY</b> Ford		<b>XF2Z-7V000-BARM</b>		Explorer	2000-1999
		F-Series	2017	<b>AUTOMATIC TRANSMISSION ASSEMBLY</b> Ford		<b>Mercury</b>	
<b>GK4Z-7000-D</b>		<b>HS7Z-7000-A</b>		Windstar	1999	Mountaineer	2000-1999
<b>AUTOMATIC TRANSMISSION ASSEMBLY</b> Ford		<b>AUTOMATIC TRANSMISSION ASSEMBLY</b> Lincoln		<b>XF3Z-7V000-ARM</b>		<b>XL2Z-7V000-FARM</b>	
Transit-150	2016	Fusion	2017	<b>AUTOMATIC TRANSMISSION ASSEMBLY</b> Lincoln		<b>AUTOMATIC TRANSMISSION ASSEMBLY</b> Ford	
Transit-250	2016	<b>HS7Z-7000-F</b>		Continental	2000	Explorer	2000-1999
Transit-350	2016	<b>AUTOMATIC TRANSMISSION ASSEMBLY</b> Ford		<b>XF3Z-7V000-BARM</b>		<b>XL3Z-7V000-AARM</b>	
Transit-350 HD	2016	Fusion	2017	<b>AUTOMATIC TRANSMISSION ASSEMBLY</b> Lincoln		<b>AUTOMATIC TRANSMISSION ASSEMBLY</b> Ford	
		<b>JL3Z-7000-C</b>		Continental	1999	F-Series	1999
<b>GK4Z-7000-E</b>		<b>AUTOMATIC TRANSMISSION ASSEMBLY</b> Ford		<b>XF3Z-7V000-BRM</b>		<b>XL3Z-7V000-BARM</b>	
<b>AUTOMATIC TRANSMISSION ASSEMBLY</b> Ford		<b>AUTOMATIC TRANSMISSION ASSEMBLY</b> Ford		<b>AUTOMATIC TRANSMISSION ASSEMBLY</b> Lincoln		<b>AUTOMATIC TRANSMISSION ASSEMBLY</b> Ford	
Transit-150	2016	F-Series	2017	Continental	2000	F-Series	1999
Transit-250	2016			<b>XL1Z-7V000-CBRM</b>		<b>XL3Z-7V000-CARM</b>	
Transit-350	2016			<b>AUTOMATIC TRANSMISSION ASSEMBLY</b> Lincoln		<b>AUTOMATIC TRANSMISSION ASSEMBLY</b> Ford	
Transit-350 HD	2016			Navigator	2000-1999	F-Series	1999



Make	Year	Make	Year	Make	Year	Make	Year
<b>XL3Z-7V000-DARM</b>		<b>XL5Z-7V000-DARM</b>		<b>YC2Z-7V000-JRM</b>		<b>YC3Z-7V000-BRM</b>	
<b>AUTOMATIC TRANSMISSION ASSEMBLY</b>		<b>AUTOMATIC TRANSMISSION ASSEMBLY</b>		<b>AUTOMATIC TRANSMISSION ASSEMBLY</b>		<b>AUTOMATIC TRANSMISSION ASSEMBLY</b>	
Ford		Ford		Ford		Ford	
F-Series	1999	Ranger	2000-1999	Econoline	2000	Excursion	2000
<b>XL3Z-7V000-EARM</b>		<b>Mazda</b>		<b>YC2Z-7V000-KRM</b>		<b>YC3Z-7V000-CRM</b>	
<b>AUTOMATIC TRANSMISSION ASSEMBLY</b>		B4000	2000-1999	<b>AUTOMATIC TRANSMISSION ASSEMBLY</b>		<b>AUTOMATIC TRANSMISSION ASSEMBLY</b>	
Ford		<b>XL5Z-7V000-EARM</b>		Ford		Ford	
Expedition	1999	<b>AUTOMATIC TRANSMISSION ASSEMBLY</b>		Econoline	2000-1998	Expedition	2000-1999
F-Series	1999	Ford		<b>YC2Z-7V000-MRM</b>		F-Series	2000-1999
<b>XL3Z-7V000-GBRM</b>		Ranger	2000-1999	<b>AUTOMATIC TRANSMISSION ASSEMBLY</b>		Lincoln	
<b>AUTOMATIC TRANSMISSION ASSEMBLY</b>		<b>Mazda</b>		Ford		Navigator	2000-1999
Ford		B4000	2000-1999	Econoline	2000	<b>YC3Z-7V000-DRM</b>	
Expedition	2000-1999	<b>XR3Z-7V000-AARM</b>		<b>YC2Z-7V000-NRM</b>		<b>AUTOMATIC TRANSMISSION ASSEMBLY</b>	
F-Series	2000-1999	<b>AUTOMATIC TRANSMISSION ASSEMBLY</b>		<b>AUTOMATIC TRANSMISSION ASSEMBLY</b>		Ford	
Lincoln		Ford		Econoline	2000	Excursion	2000
Navigator	2000-1999	Mustang	2000-1999	<b>YC2Z-7V000-SRM</b>		F-Series	2000
<b>XL3Z-7V000-JARM</b>		<b>XW1Z-7V000-BARM</b>		<b>AUTOMATIC TRANSMISSION ASSEMBLY</b>		<b>YC3Z-7V000-JRM</b>	
<b>AUTOMATIC TRANSMISSION ASSEMBLY</b>		<b>AUTOMATIC TRANSMISSION ASSEMBLY</b>		Ford		<b>AUTOMATIC TRANSMISSION ASSEMBLY</b>	
Ford		Lincoln		Econoline	2000	Ford	
F-Series	1999	Town Car	2000-1999	<b>YC2Z-7V000-TRM</b>		F-Series	2000
<b>XL3Z-7V000-LARM</b>		<b>XW1Z-7V000-CARM</b>		<b>AUTOMATIC TRANSMISSION ASSEMBLY</b>		<b>YC3Z-7V000-KRM</b>	
<b>AUTOMATIC TRANSMISSION ASSEMBLY</b>		<b>AUTOMATIC TRANSMISSION ASSEMBLY</b>		Ford		<b>AUTOMATIC TRANSMISSION ASSEMBLY</b>	
Ford		Lincoln		Econoline	2000	Ford	
F-Series	1999	Town Car	2000-1999	<b>YC2Z-7V000-URM</b>		F-Series	2000
<b>XL5Z-7V000-AARM</b>		<b>XW7Z-7V000-AARM</b>		<b>AUTOMATIC TRANSMISSION ASSEMBLY</b>		<b>YF1Z-7V000-ARM</b>	
<b>AUTOMATIC TRANSMISSION ASSEMBLY</b>		<b>AUTOMATIC TRANSMISSION ASSEMBLY</b>		Ford		<b>AUTOMATIC TRANSMISSION ASSEMBLY</b>	
Ford		Ford		Econoline	2000	Ford	
Ranger	2000-1999	Crown Victoria	2000-1999	<b>YC2Z-7V000-WRM</b>		Taurus	2000
<b>Mazda</b>		<b>Mercury</b>		<b>AUTOMATIC TRANSMISSION ASSEMBLY</b>		<b>Mercury</b>	
B3000	2000-1999	Grand Marquis	2000-1999	Ford		Sable	2000
<b>XL5Z-7V000-BARM</b>		<b>XW7Z-7V000-CARM</b>		Econoline	2000	<b>YF1Z-7V000-ERM</b>	
<b>AUTOMATIC TRANSMISSION ASSEMBLY</b>		<b>AUTOMATIC TRANSMISSION ASSEMBLY</b>		<b>YC2Z-7V000-YRM</b>		<b>AUTOMATIC TRANSMISSION ASSEMBLY</b>	
Ford		Ford		<b>AUTOMATIC TRANSMISSION ASSEMBLY</b>		Ford	
Ranger	2000-1999	Crown Victoria	2000-1999	Ford		Taurus	2000
<b>Mazda</b>		<b>YC2Z-7V000-BRM</b>		Econoline	2000	<b>Mercury</b>	
B3000	2000-1999	<b>AUTOMATIC TRANSMISSION ASSEMBLY</b>		<b>YC3Z-7V000-ARM</b>		Sable	2000
<b>XL5Z-7V000-CARM</b>		Ford		<b>AUTOMATIC TRANSMISSION ASSEMBLY</b>		<b>YF1Z-7V000-FRM</b>	
<b>AUTOMATIC TRANSMISSION ASSEMBLY</b>		Econoline	2000	Ford		<b>AUTOMATIC TRANSMISSION ASSEMBLY</b>	
Ford		<b>YC2Z-7V000-CRM</b>		Excursion	2000	Ford	
Ranger	2001-1999	<b>AUTOMATIC TRANSMISSION ASSEMBLY</b>		F-Series	2000	Taurus	2000
<b>Mazda</b>		Ford				<b>Mercury</b>	
B2500	2001-1999	Econoline	2000			Sable	2000

# BUYER'S GUIDE

## Transmission Assemblies



FORD PARTS

Make	Year	Make	Year
<b>YF1Z-7V000-HRM</b>		<b>YL8Z-7V000-FRM</b>	
<b>AUTOMATIC TRANSMISSION ASSEMBLY</b>		<b>AUTOMATIC TRANSMISSION ASSEMBLY</b>	
Ford		Ford	
Taurus	2000	Escape	2001
<b>Mercury</b>		<b>Mazda</b>	
Sable	2000	Tribute	2001
<b>YF2Z-7V000-BRM</b>		<b>YW1Z-7V000-ARM</b>	
<b>AUTOMATIC TRANSMISSION ASSEMBLY</b>		<b>AUTOMATIC TRANSMISSION ASSEMBLY</b>	
Ford		Lincoln	
Windstar	2000	Town Car	2000
<b>YL3Z-7V000-DRM</b>		<b>YW4Z-7V000-ARM</b>	
<b>AUTOMATIC TRANSMISSION ASSEMBLY</b>		<b>AUTOMATIC TRANSMISSION ASSEMBLY</b>	
Ford		Lincoln	
F-Series	2001-2000	LS	2000
<b>YL3Z-7V000-ERM</b>		<b>YW4Z-7V000-BRM</b>	
<b>AUTOMATIC TRANSMISSION ASSEMBLY</b>		<b>AUTOMATIC TRANSMISSION ASSEMBLY</b>	
Ford		Lincoln	
F-Series	2000	LS	2000
<b>YL3Z-7V000-FRM</b>		<b>YW7Z-7V000-ARM</b>	
<b>AUTOMATIC TRANSMISSION ASSEMBLY</b>		<b>AUTOMATIC TRANSMISSION ASSEMBLY</b>	
Ford		Ford	
F-Series	2000	Crown Victoria	2000
<b>YL3Z-7V000-HRM</b>		<b>Mercury</b>	
<b>AUTOMATIC TRANSMISSION ASSEMBLY</b>		Grand Marquis	
Expedition	2000		2000
<b>YL3Z-7V000-JRM</b>			
<b>AUTOMATIC TRANSMISSION ASSEMBLY</b>			
Ford			
Expedition	2000		
<b>YL3Z-7V000-LRM</b>			
<b>AUTOMATIC TRANSMISSION ASSEMBLY</b>			
Ford			
F-Series	2000		
<b>YL3Z-7V000-MRM</b>			
<b>AUTOMATIC TRANSMISSION ASSEMBLY</b>			
Ford			
F-Series	2000		
<b>YL8Z-7V000-ERM</b>			
<b>AUTOMATIC TRANSMISSION ASSEMBLY</b>			
Ford			
Escape	2001		
<b>Mazda</b>			
Tribute	2001		



Make	Year	Make	Year	Make	Year	Make	Year
<b>1C3Z-7902-BARM</b>		<b>2L5Z-7902-AARM</b>		<b>4L5Z-7902-BARM</b>		<b>6C3Z-7902-DRM</b>	
<b>AUTOMATIC TRANSMISSION TORQUE CONVERTER</b>		<b>AUTOMATIC TRANSMISSION TORQUE CONVERTER</b>		<b>AUTOMATIC TRANSMISSION TORQUE CONVERTER</b>		<b>AUTOMATIC TRANSMISSION TORQUE CONVERTER</b>	
Ford		Ford		Ford		Ford	
Econoline	2004-2000	Ranger	2003-2001	Ranger	2008-2004	Econoline	2006-2004
Excursion	2005-2000	<b>Mazda</b>				F-Series	2007-2003
F-Series	2004-1999	B2300	2003-2001	<b>4R3Z-7902-AARM</b>		<b>6C3Z-7902-ERM</b>	
F53	2015-2011, 2009-2006, 2004	B3000	2003-2001	<b>AUTOMATIC TRANSMISSION TORQUE CONVERTER</b>		<b>AUTOMATIC TRANSMISSION TORQUE CONVERTER</b>	
F59	2017-2011	<b>3F1Z-7902-ADRM</b>		Ford		Ford	
<b>1C3Z-7902-CARM</b>		<b>AUTOMATIC TRANSMISSION TORQUE CONVERTER</b>		Mustang		2006-2005	
<b>AUTOMATIC TRANSMISSION TORQUE CONVERTER</b>		Ford		<b>4W4Z-7902-BARM</b>		<b>AUTOMATIC TRANSMISSION TORQUE CONVERTER</b>	
Ford		Taurus		<b>AUTOMATIC TRANSMISSION TORQUE CONVERTER</b>		Ford	
Econoline	2005-1998	2007-2004		Lincoln		Econoline	
Excursion	2003-2001	<b>Mercury</b>		LS		2007-2004	
F-Series	2003-1999	Sable		2006-2004		F53	
<b>1C3Z-7902-DBRM</b>		<b>3L8Z-7902-BARM</b>		<b>5F2Z-7902-ACRM</b>		2007-2006, 2004	
<b>AUTOMATIC TRANSMISSION TORQUE CONVERTER</b>		<b>AUTOMATIC TRANSMISSION TORQUE CONVERTER</b>		<b>AUTOMATIC TRANSMISSION TORQUE CONVERTER</b>		<b>6C3Z-7902-FRM</b>	
Ford		Ford		Ford		<b>AUTOMATIC TRANSMISSION TORQUE CONVERTER</b>	
Econoline	2004-2001	Escape		Freestar		Ford	
Excursion	2005-2000	2006-2001		2007-2004		Econoline	
F-Series	2004-2001	<b>3R3Z-7902-ABRM</b>		<b>Mercury</b>		2006-2005	
<b>1F1Z-7902-AARM</b>		<b>AUTOMATIC TRANSMISSION TORQUE CONVERTER</b>		Monterey		2007-2004	
<b>AUTOMATIC TRANSMISSION TORQUE CONVERTER</b>		Ford		<b>5F2Z-7902-BCRM</b>		<b>AUTOMATIC TRANSMISSION TORQUE CONVERTER</b>	
Econoline	2004-2001	Mustang		<b>AUTOMATIC TRANSMISSION TORQUE CONVERTER</b>		Ford	
Excursion	2005-2000	2004-2001		Ford		Econoline	
F-Series	2004-2001	<b>3S4Z-7902-CARM</b>		Freestar		2006-2005	
<b>1F1Z-7902-BARM</b>		<b>AUTOMATIC TRANSMISSION TORQUE CONVERTER</b>		2007-2004		F-Series	
<b>AUTOMATIC TRANSMISSION TORQUE CONVERTER</b>		Ford		<b>5F9Z-7902-BRM</b>		2007-2005	
Econoline	2004-2001	Focus		<b>AUTOMATIC TRANSMISSION TORQUE CONVERTER</b>		2007-2004	
Excursion	2005-2000	2004-2003		Ford		Five Hundred	
F-Series	2004-2001	<b>4L2Z-7902-AARM</b>		Five Hundred		2007-2005	
<b>1F1Z-7902-BARM</b>		<b>AUTOMATIC TRANSMISSION TORQUE CONVERTER</b>		Freestyle		2007-2005	
<b>AUTOMATIC TRANSMISSION TORQUE CONVERTER</b>		Ford		<b>Mercury</b>		2007-2005	
Econoline	2004-2001	Explorer		Montego		2007-2005	
Excursion	2005-2000	2010-2004		<b>5L7Z-7902-AA</b>		<b>AUTOMATIC TRANSMISSION TORQUE CONVERTER</b>	
F-Series	2004-2001	Explorer Sport Trac		<b>AUTOMATIC TRANSMISSION TORQUE CONVERTER</b>		Ford	
<b>1F1Z-7902-BARM</b>		2005-2001		Lincoln		Fusion	
<b>AUTOMATIC TRANSMISSION TORQUE CONVERTER</b>		Ranger		Navigator		2009-2006	
Econoline	2004-2001	2006-2004		2006-2005		<b>Mercury</b>	
Excursion	2005-2000	<b>Mercury</b>		<b>5L8Z-7902-DBRM</b>		Milan	
F-Series	2004-2001	Mountaineer		<b>AUTOMATIC TRANSMISSION TORQUE CONVERTER</b>		2009-2006	
<b>1F1Z-7902-BARM</b>		2010-2004		Ford		2009-2006	
<b>AUTOMATIC TRANSMISSION TORQUE CONVERTER</b>		<b>4L2Z-7902-BARM</b>		Ford		Lincoln	
<b>AUTOMATIC TRANSMISSION TORQUE CONVERTER</b>		<b>AUTOMATIC TRANSMISSION TORQUE CONVERTER</b>		Ford		Zephyr	
Econoline	2004-2001	Ford		Explorer		2006	
Excursion	2005-2000	Explorer		2010-2004		<b>Mercury</b>	
F-Series	2004-2001	2009-2004		Mountaineer		Milan	
<b>1F1Z-7902-BARM</b>		<b>Mercury</b>		2010-2004		2009-2006	
<b>AUTOMATIC TRANSMISSION TORQUE CONVERTER</b>		Mountaineer		<b>4L5Z-7902-AARM</b>		<b>7C2Z-7902-BRM</b>	
Econoline	2004-2001	2010-2004		<b>AUTOMATIC TRANSMISSION TORQUE CONVERTER</b>		<b>AUTOMATIC TRANSMISSION TORQUE CONVERTER</b>	
Excursion	2005-2000	<b>4L2Z-7902-BARM</b>		Ford		Ford	
F-Series	2004-2001	<b>AUTOMATIC TRANSMISSION TORQUE CONVERTER</b>		Econoline		2010-2007	
<b>1F1Z-7902-BARM</b>		Ford		2009-2004		<b>7C3Z-7902-HRM</b>	
<b>AUTOMATIC TRANSMISSION TORQUE CONVERTER</b>		Explorer		2008-2005		<b>AUTOMATIC TRANSMISSION TORQUE CONVERTER</b>	
Econoline	2004-2001	2009-2004		<b>Mazda</b>		<b>AUTOMATIC TRANSMISSION TORQUE CONVERTER</b>	
Excursion	2005-2000	<b>Mercury</b>		Tribute		Ford	
F-Series	2004-2001	Mountaineer		2008-2005		F-Series	
<b>1F1Z-7902-BARM</b>		2010-2004		<b>Mercury</b>		2008	
<b>AUTOMATIC TRANSMISSION TORQUE CONVERTER</b>		<b>4L5Z-7902-AARM</b>		Mariner		2008	
Econoline	2004-2001	<b>AUTOMATIC TRANSMISSION TORQUE CONVERTER</b>		2008-2005		<b>7C3Z-7902-JRM</b>	
Excursion	2005-2000	Ford		2008-2005		<b>AUTOMATIC TRANSMISSION TORQUE CONVERTER</b>	
F-Series	2004-2001	Ranger		2008-2005		Ford	
<b>1F1Z-7902-BARM</b>		2011-2004		2008-2005		Econoline	
<b>AUTOMATIC TRANSMISSION TORQUE CONVERTER</b>		<b>AUTOMATIC TRANSMISSION TORQUE CONVERTER</b>		2008-2005		2011-2007	
Econoline	2004-2001	Ford		2008-2005		F-Series	
Excursion	2005-2000	Ranger		2008-2005		2008	
F-Series	2004-2001	2011-2004		2008-2005		<b>7C3Z-7902-JRM</b>	
<b>1F1Z-7902-BARM</b>		<b>AUTOMATIC TRANSMISSION TORQUE CONVERTER</b>		2008-2005		<b>AUTOMATIC TRANSMISSION TORQUE CONVERTER</b>	
<b>AUTOMATIC TRANSMISSION TORQUE CONVERTER</b>		Ford		2008-2005		Ford	
Econoline	2004-2001	Ranger		2008-2005		Econoline	
Excursion	2005-2000	2011-2004		2008-2005		2011-2007	
F-Series	2004-2001	2011-2004		2008-2005		F-Series	
<b>1F1Z-7902-BARM</b>		<b>AUTOMATIC TRANSMISSION TORQUE CONVERTER</b>		2008-2005		2008	
<b>AUTOMATIC TRANSMISSION TORQUE CONVERTER</b>		Ford		2008-2005		2008	
Econoline	2004-2001	Ranger		2008-2005		2008	
Excursion	2005-2000	2011-2004		2008-2005		2008	
F-Series	2004-2001	2011-2004		2008-2005		2008	

# BUYER'S GUIDE

## Torque Converters



FORD PARTS

Make	Year	Make	Year	Make	Year	Make	Year
<b>7C3Z-7902-KRM</b>		<b>7L3Z-7902-HRM</b>		<b>8L2Z-7902-ARM cont'd</b>		<b>9C2Z-7902-B</b>	
<b>AUTOMATIC TRANSMISSION TORQUE CONVERTER</b>		<b>AUTOMATIC TRANSMISSION TORQUE CONVERTER</b>		Mercury		<b>AUTOMATIC TRANSMISSION TORQUE CONVERTER</b>	
Ford		Ford		Mountaineer 2009-2006		Ford	
Econoline	2010-2007	Crown Victoria	2011-2007	<b>8L3Z-7902-ARM</b>		Econoline	2014-2009
F-Series	2008	Econoline	2011-2007	<b>AUTOMATIC TRANSMISSION TORQUE CONVERTER</b>		<b>9C2Z-7902-C</b>	
<b>7E5Z-7902-A</b>		F-Series		Ford		<b>AUTOMATIC TRANSMISSION TORQUE CONVERTER</b>	
<b>AUTOMATIC TRANSMISSION TORQUE CONVERTER</b>		Lincoln		Econoline 2007-2004		Ford	
Ford		Town Car 2011-2007		F-Series 2006-2004		Econoline 2010-2009	
Fusion	2012-2010	Mercury		<b>8L3Z-7902-BRM</b>		<b>9C3Z-7902-B</b>	
Lincoln		Grand Marquis 2011-2007		<b>AUTOMATIC TRANSMISSION TORQUE CONVERTER</b>		<b>AUTOMATIC TRANSMISSION TORQUE CONVERTER</b>	
MKZ	2012-2007	<b>7L3Z-7902-JRM</b>		Ford		Ford	
<b>7E7Z-7902-ARM</b>		<b>AUTOMATIC TRANSMISSION TORQUE CONVERTER</b>		Econoline 2007-2004		Econoline 2017-2009	
<b>AUTOMATIC TRANSMISSION TORQUE CONVERTER</b>		Ford		F-Series 2006-2004		F-Series 2017-2009	
Ford		F-Series 2008-2007		Lincoln		F53 2017-2011, 2009-2008	
LCF	2009-2006	<b>7R3Z-7902-ARM</b>		Town Car 2006-2004		F59 2017-2011	
<b>7L1Z-7902-C</b>		<b>AUTOMATIC TRANSMISSION TORQUE CONVERTER</b>		Mercury		<b>9C3Z-7902-C</b>	
<b>AUTOMATIC TRANSMISSION TORQUE CONVERTER</b>		Ford		Grand Marquis 2006-2004		<b>AUTOMATIC TRANSMISSION TORQUE CONVERTER</b>	
Ford		Mustang 2010-2005		<b>8L3Z-7902-CRM</b>		<b>AUTOMATIC TRANSMISSION TORQUE CONVERTER</b>	
Expedition	2008-2007	Thunderbird 2005-2003		<b>AUTOMATIC TRANSMISSION TORQUE CONVERTER</b>		Ford	
<b>7L2Z-7902-A</b>		Lincoln		Ford		Econoline 2016-2009	
<b>AUTOMATIC TRANSMISSION TORQUE CONVERTER</b>		Aviator 2005-2003		Expedition 2006-2005		F-Series 2010-2009	
Ford		LS 2006-2004		F-Series 2007-2004		<b>9C3Z-7902-DRM</b>	
Explorer	2010-2007	<b>7T4Z-7902-ARM</b>		<b>8S4Z-7902-A</b>		<b>AUTOMATIC TRANSMISSION TORQUE CONVERTER</b>	
Explorer Sport Trac	2010-2007	<b>AUTOMATIC TRANSMISSION TORQUE CONVERTER</b>		<b>AUTOMATIC TRANSMISSION TORQUE CONVERTER</b>		Ford	
Mustang	2010-2007	Ford		Focus 2011-2008		F-Series 2010-2009	
Ranger	2011-2007	Edge 2008-2007		Transit Connect 2017-2010		<b>9E7Z-7902-AA</b>	
Mercury		Taurus 2009-2008		<b>8S4Z-7902-ARM</b>		<b>AUTOMATIC TRANSMISSION TORQUE CONVERTER</b>	
Mountaineer	2010-2007	Taurus X 2009-2008		<b>AUTOMATIC TRANSMISSION TORQUE CONVERTER</b>		Ford	
<b>7L2Z-7902-ARM</b>		Lincoln		Ford		LCF 2010-2006	
<b>AUTOMATIC TRANSMISSION TORQUE CONVERTER</b>		MKX 2009-2007		Focus 2011-2008		<b>9E9Z-7902-B</b>	
Ford		Mercury		Transit Connect 2012-2010		<b>AUTOMATIC TRANSMISSION TORQUE CONVERTER</b>	
Explorer	2010-2002	Sable 2009-2008		<b>8W7Z-7902-ARM</b>		Ford	
Explorer Sport Trac	2010-2007	<b>7W7Z-7902-BRM</b>		<b>AUTOMATIC TRANSMISSION TORQUE CONVERTER</b>		Edge 2010	
Mustang	2010-2007	<b>AUTOMATIC TRANSMISSION TORQUE CONVERTER</b>		Lincoln		Flex 2012-2009	
Ranger	2011-2004	Ford		Town Car 2006-2004		Taurus 2012-2010	
Mercury		Crown Victoria 2011-2007		Mercury		Lincoln	
Mountaineer	2010-2001	Lincoln		Grand Marquis 2006-2004		MKS 2012-2009	
<b>7L3Z-7902-GRM</b>		Town Car 2011-2007		<b>9C2Z-7902-A</b>		MKT 2012-2010	
<b>AUTOMATIC TRANSMISSION TORQUE CONVERTER</b>		Mercury		<b>AUTOMATIC TRANSMISSION TORQUE CONVERTER</b>		MKX 2010	
Ford		Grand Marquis 2011-2007		Ford		<b>9E9Z-7902-BRM</b>	
Econoline	2011-2007	<b>8L2Z-7902-ARM</b>		<b>AUTOMATIC TRANSMISSION TORQUE CONVERTER</b>		<b>AUTOMATIC TRANSMISSION TORQUE CONVERTER</b>	
F-Series	2010-2007	<b>AUTOMATIC TRANSMISSION TORQUE CONVERTER</b>		Econoline 2016-2004		Ford	
		Ford				Flex 2010-2009	
		Explorer 2010-2006				Lincoln	
		Explorer Sport Trac 2010-2007				MKS 2009	



Make	Year	Make	Year	Make	Year	Make	Year
<b>9L3Z-7902-B</b>		<b>AA5Z-7902-A cont'd</b>		<b>BR3Z-7902-EA</b>		<b>CC4Z-7902-A</b>	
<b>AUTOMATIC TRANSMISSION TORQUE CONVERTER</b>		Lincoln		<b>AUTOMATIC TRANSMISSION TORQUE CONVERTER</b>		<b>AUTOMATIC TRANSMISSION TORQUE CONVERTER</b>	
Ford		MKS 2010		Ford		Ford	
Explorer 2009-2006		MKT 2010		F-Series 2013-2011		Econoline 2017-2016	
Explorer Sport Trac 2010-2007		<b>AA5Z-7902-ARM</b>		Mustang 2013-2011		F-Series 2017-2011	
F-Series 2010-2009		<b>AUTOMATIC TRANSMISSION TORQUE CONVERTER</b>		<b>BR3Z-7902-FA</b>		F650 2016-2012	
Mercury		Ford		<b>AUTOMATIC TRANSMISSION TORQUE CONVERTER</b>		<b>CK4Z-7902-A</b>	
Mountaineer 2010-2006		Flex 2010		Ford		<b>AUTOMATIC TRANSMISSION TORQUE CONVERTER</b>	
<b>9L8Z-7902-ARM</b>		Taurus 2010		Expedition 2014-2009		Ford	
<b>AUTOMATIC TRANSMISSION TORQUE CONVERTER</b>		Lincoln		F-Series 2014-2009		Transit-150 2017-2015	
Ford		MKS 2010		Lincoln		Transit-250 2017-2015	
Escape 2012-2009		MKT 2010		Navigator 2014-2010		Transit-350 2017-2015	
Fusion 2012-2010		<b>AA5Z-7902-B</b>		<b>BR3Z-7902-GA</b>		Transit-350 HD 2017-2015	
Mercury		<b>AUTOMATIC TRANSMISSION TORQUE CONVERTER</b>		<b>AUTOMATIC TRANSMISSION TORQUE CONVERTER</b>		<b>CK4Z-7902-B</b>	
Mariner 2011-2009		Ford		Ford		<b>AUTOMATIC TRANSMISSION TORQUE CONVERTER</b>	
Milan 2011-2010		Flex 2012-2011		Mustang 2014-2011		Ford	
<b>9L8Z-7902-BRM</b>		Taurus 2012-2011		<b>BT4Z-7902-B</b>		F-Series 2014	
<b>AUTOMATIC TRANSMISSION TORQUE CONVERTER</b>		Lincoln		<b>AUTOMATIC TRANSMISSION TORQUE CONVERTER</b>		Mustang 2014	
Ford		MKS 2012-2011		Ford		Transit-150 2015	
Escape 2012-2009		MKT 2013-2011		Edge 2012-2011		Transit-250 2015	
Fusion 2012-2010		<b>AA5Z-7902-BRM</b>		Lincoln		Transit-350 2015	
Mercury		<b>AUTOMATIC TRANSMISSION TORQUE CONVERTER</b>		MKX 2012-2011		Transit-350 HD 2015	
Mariner 2011-2009		Ford		<b>BT4Z-7902-BRM</b>		<b>CV6Z-7902-F</b>	
Milan 2011-2010		Flex 2012-2011		<b>AUTOMATIC TRANSMISSION TORQUE CONVERTER</b>		Ford	
<b>9L8Z-7902-H</b>		Taurus 2012-2011		Ford		Escape 2016-2013	
<b>AUTOMATIC TRANSMISSION TORQUE CONVERTER</b>		Lincoln		Edge 2012-2011		Fusion 2014-2013	
Ford		MKS 2012-2011		Lincoln		Transit Connect 2016-2014	
Escape 2017-2011		MKT 2012-2011		MKX 2012-2011		<b>CV6Z-7902-F</b>	
Fusion 2017-2011		<b>BB5Z-7902-F</b>		<b>BT4Z-7902-C</b>		<b>AUTOMATIC TRANSMISSION TORQUE CONVERTER</b>	
Transit Connect 2017-2014		<b>AUTOMATIC TRANSMISSION TORQUE CONVERTER</b>		<b>AUTOMATIC TRANSMISSION TORQUE CONVERTER</b>		Ford	
Mercury		Ford		Ford		Escape 2016-2013	
Mariner 2011		Edge 2015-2012		Edge 2012-2011		Fusion 2014-2013	
<b>9L8Z-7902-L</b>		Escape 2017-2013		Explorer 2012-2011		Transit Connect 2016-2014	
<b>AUTOMATIC TRANSMISSION TORQUE CONVERTER</b>		Explorer 2017-2015		<b>BT4Z-7902-CRM</b>		<b>DA5Z-7902-D</b>	
Ford		Taurus 2017-2013		<b>AUTOMATIC TRANSMISSION TORQUE CONVERTER</b>		<b>AUTOMATIC TRANSMISSION TORQUE CONVERTER</b>	
Transit Connect 2017		Lincoln		Ford		Ford	
<b>9W7Z-7902-A</b>		MKC 2017-2015		Edge 2012-2011		Escape 2016-2013	
<b>AUTOMATIC TRANSMISSION TORQUE CONVERTER</b>		MKT 2017-2013		Explorer 2012-2011		Fusion 2014-2013	
Ford		<b>BL3Z-7902-BA</b>		Lincoln		Transit Connect 2016-2014	
Crown Victoria 2011-2009		<b>AUTOMATIC TRANSMISSION TORQUE CONVERTER</b>		MKX 2012-2011		<b>DA5Z-7902-D</b>	
<b>AA5Z-7902-A</b>		Ford		<b>CC3Z-7902-D</b>		<b>AUTOMATIC TRANSMISSION TORQUE CONVERTER</b>	
<b>AUTOMATIC TRANSMISSION TORQUE CONVERTER</b>		F-Series 2013-2011		<b>AUTOMATIC TRANSMISSION TORQUE CONVERTER</b>		Ford	
Ford		<b>BR3Z-7902-CF</b>		Ford		Explorer 2017-2013	
Flex 2010		<b>AUTOMATIC TRANSMISSION TORQUE CONVERTER</b>		F-Series 2014-2013		Flex 2017-2013	
Taurus 2010		Ford		Mustang 2014		Police Interceptor 2017-2014	
		Mustang 2014				Utility 2017-2013	
						Taurus 2017-2013	
						Lincoln	
						MKS 2016-2013	
						MKT 2017-2013	

# BUYER'S GUIDE

## Torque Converters



FORD PARTS

Make	Year	Make	Year	Make	Year	Make	Year
<b>DA8Z-7902-A</b>		<b>EJ7Z-7902-J</b>		<b>F88Z-7902-AARM cont'd</b>		<b>FG9Z-7902-C</b>	
<b>AUTOMATIC TRANSMISSION TORQUE CONVERTER</b>		<b>AUTOMATIC TRANSMISSION TORQUE CONVERTER</b>		Windstar	2000-1999	<b>AUTOMATIC TRANSMISSION TORQUE CONVERTER</b>	
Ford		Lincoln		Mercury		Ford	
Edge	2017-2013	MKC	2017-2015	Sable	2000	Edge	2017-2015
Explorer	2017-2013	<b>F1TZ-7902-CRM</b>		<b>F88Z-7902-BARM</b>		Lincoln	
Flex	2017-2013	<b>AUTOMATIC TRANSMISSION TORQUE CONVERTER</b>		<b>AUTOMATIC TRANSMISSION TORQUE CONVERTER</b>		Continental	2018-2017
Police Interceptor Utility	2017-2013	Ford		Ford		MKX	2017-2015
Taurus	2017-2013	F-Series	1997-1990	Windstar	2000-1998	<b>FL3Z-7902-A</b>	
<b>DA8Z-7902-E</b>		F59	1994-1990	<b>F8AZ-7902-AARM</b>		<b>AUTOMATIC TRANSMISSION TORQUE CONVERTER</b>	
<b>AUTOMATIC TRANSMISSION TORQUE CONVERTER</b>		<b>F5TZ-7902-DARM</b>		<b>AUTOMATIC TRANSMISSION TORQUE CONVERTER</b>		Ford	
Ford		<b>AUTOMATIC TRANSMISSION TORQUE CONVERTER</b>		Ford		F-Series	2017-2015
Edge	2014-2013	Explorer	1996-1995	Crown Victoria	2003-1994	Mustang	2017-2015
Explorer	2015-2013	Ranger	1996-1995	Econoline	2003-1994	Transit-150	2017-2016
Flex	2017-2013	<b>F68Z-7902-ARM</b>		Expedition	2004-2001	Transit-250	2017-2016
Police Interceptor Sedan	2017-2013	<b>AUTOMATIC TRANSMISSION TORQUE CONVERTER</b>		F-Series	2003-1994	Transit-350	2017-2016
Lincoln		Ford		Mustang	1997-1994	Transit-350 HD	2017-2016
MKS	2016-2013	<b>AUTOMATIC TRANSMISSION TORQUE CONVERTER</b>		Thunderbird	1997-1994	<b>FL3Z-7902-B</b>	
MKT	2017-2013	Ford		Lincoln		<b>AUTOMATIC TRANSMISSION TORQUE CONVERTER</b>	
MKX	2017-2013	Taurus	1999-1996	Town Car		Ford	
MKZ	2013	Windstar	1998-1996	Mercury		Mustang	
<b>DA8Z-7902-F</b>		Mercury		Cougar	1997-1994	<b>FL3Z-7902-C</b>	
<b>AUTOMATIC TRANSMISSION TORQUE CONVERTER</b>		Sable	1999-1996	Grand Marquis	2003-1992	<b>AUTOMATIC TRANSMISSION TORQUE CONVERTER</b>	
Ford		<b>F7TZ-7902-EARM</b>		<b>F8DZ-7902-AARM</b>		Ford	
Edge	2017-2016	<b>AUTOMATIC TRANSMISSION TORQUE CONVERTER</b>		<b>AUTOMATIC TRANSMISSION TORQUE CONVERTER</b>		F-Series	2017-2014
Explorer	2017-2015	Ford		Ford		Transit-150	2015
Flex	2017-2014	Bronco	1992-1990	Taurus	1999-1997	Transit-250	2015
Lincoln		Econoline	1996-1991	Mercury		Transit-350	2015
Continental	2018-2017	F-Series	1997-1990	Sable	1999-1997	Transit-350 HD	2015
MKT	2017-2016	<b>F7TZ-7902-FARM</b>		<b>F8DZ-7902-CARM</b>		<b>FL3Z-7902-D</b>	
MKX	2017-2016	<b>AUTOMATIC TRANSMISSION TORQUE CONVERTER</b>		<b>AUTOMATIC TRANSMISSION TORQUE CONVERTER</b>		<b>AUTOMATIC TRANSMISSION TORQUE CONVERTER</b>	
MKZ	2017-2014	Ford		Ford		Ford	
<b>DG9Z-7902-F</b>		Bronco	1996-1991	Taurus	2000	Expedition	2017-2015
<b>AUTOMATIC TRANSMISSION TORQUE CONVERTER</b>		F-Series	1997-1991	Mercury		F-Series	2017-2015
Ford		<b>F85Z-7902-AARM</b>		Sable	2000	Transit-150	2017-2016
Edge	2017-2015	<b>AUTOMATIC TRANSMISSION TORQUE CONVERTER</b>		<b>F8LZ-7902-BARM</b>		Transit-250	2017-2016
Fusion	2017-2013	Ford		<b>AUTOMATIC TRANSMISSION TORQUE CONVERTER</b>		Transit-350	2017-2016
Lincoln		Expedition	2000-1997	Ford		Transit-350 HD	2017-2016
MKX	2017-2015	Explorer	2001-1998	Crown Victoria	2002-1999	Lincoln	
MKZ	2017-2013	F-Series	1999-1998	Mustang	2000-1998	Navigator	
<b>EG9Z-7902-D</b>		Mustang	2000-1998	Lincoln		<b>FM5Z-7902-C</b>	
<b>AUTOMATIC TRANSMISSION TORQUE CONVERTER</b>		Mercury		Mark VIII	1998-1994	<b>AUTOMATIC TRANSMISSION TORQUE CONVERTER</b>	
Ford		Mountaineer	2001-1998	Town Car	2003-1998	Ford	
Fusion	2017-2014	<b>F88Z-7902-AARM</b>		Mercury		Focus	
<b>AUTOMATIC TRANSMISSION TORQUE CONVERTER</b>		Ford		Grand Marquis		2017-2016	
Ford		Ford					
		Taurus	2000				





Make	Year	Make	Year
<b>FO2Z-7902-ARM</b>		<b>XS4Z-7902-BBRM</b>	
<b>AUTOMATIC TRANSMISSION TORQUE CONVERTER</b>		<b>AUTOMATIC TRANSMISSION TORQUE CONVERTER</b>	
Ford		Ford	
Probe	1992-1990	Focus	2007-2000
<b>FR3Z-7902-A</b>		<b>YL8Z-7902-BCRM</b>	
<b>AUTOMATIC TRANSMISSION TORQUE CONVERTER</b>		<b>AUTOMATIC TRANSMISSION TORQUE CONVERTER</b>	
Ford		Ford	
Mustang	2017-2015	Escape	2006-2001
<b>HC3Z-7902-A</b>		<b>Mercury</b>	
<b>AUTOMATIC TRANSMISSION TORQUE CONVERTER</b>		Cougar	
Ford		2002-2001	
F-Series	2017-2015		
F650	2017-2016		
F750	2017-2016		
<b>HC3Z-7902-B</b>			
<b>AUTOMATIC TRANSMISSION TORQUE CONVERTER</b>			
Ford			
F-Series	2017		
<b>XC3Z-7902-AARM</b>			
<b>AUTOMATIC TRANSMISSION TORQUE CONVERTER</b>			
Ford			
Econoline	1999-1997		
F-Series	1999		
F53	1999		
<b>XL3Z-7902-AARM</b>			
<b>AUTOMATIC TRANSMISSION TORQUE CONVERTER</b>			
Ford			
Econoline	2003-2000		
Expedition	2004-2003		
F-Series	2003-1999		
<b>XL3Z-7902-BARM</b>			
<b>AUTOMATIC TRANSMISSION TORQUE CONVERTER</b>			
Ford			
Excursion	2000		
Expedition	2002-1997		
F-Series	2000-1999		
<b>Lincoln</b>			
Navigator	2000-1998		
<b>XL7Z-7902-AARM</b>			
<b>AUTOMATIC TRANSMISSION TORQUE CONVERTER</b>			
Lincoln			
Navigator	2002-1999		

# BUYER'S GUIDE

## Manual Transmission Clutch Kits



FORD PARTS

Make	Year	Make	Year	Make	Year	Make	Year
<b>1L2Z-7L596-EB</b>		<b>6S4Z-7L596-A</b>		<b>F27Z-7L596-DA</b>		<b>F5ZZ-7L596-JA</b>	
<b>CLUTCH KIT</b>		<b>CLUTCH KIT</b>		<b>CLUTCH KIT</b>		<b>CLUTCH KIT</b>	
<b>Ford</b>		<b>Ford</b>		<b>Ford</b>		<b>Ford</b>	
Explorer	2003-2001	Escort	2003-1997	Ranger	1992-1988	Mustang	1995
Explorer Sport Trac	2003-2001						
		<b>7C3Z-7L596-A</b>		<b>F27Z-7L596-GA</b>		<b>F6ZZ-7L596-DA</b>	
		<b>CLUTCH KIT</b>		<b>CLUTCH KIT</b>		<b>CLUTCH KIT</b>	
		<b>Ford</b>		<b>Ford</b>		<b>Ford</b>	
		F-Series	2010-2008	Explorer	1992-1991	Mustang	2001-1996
		<b>1R3Z-7L596-AA</b>		<b>7L5Z-7L596-CA</b>		<b>F37Z-7L596-FA</b>	
		<b>CLUTCH KIT</b>		<b>CLUTCH KIT</b>		<b>CLUTCH KIT</b>	
		<b>Ford</b>		<b>Ford</b>		<b>Ford</b>	
		Mustang	2004-2001	Ranger	1994-1993	Mustang	1998-1996
		<b>3C3Z-7L596-EA</b>		<b>F37Z-7L596-LA</b>		<b>F6ZZ-7L596-GA</b>	
		<b>CLUTCH KIT</b>		<b>CLUTCH KIT</b>		<b>CLUTCH KIT</b>	
		<b>Ford</b>		<b>Ford</b>		<b>Ford</b>	
		Ranger	2011-2001	Ranger	1994-1993	Mustang	1998-1996
		<b>Mazda</b>		<b>Mazda</b>		<b>F7RZ-7L596-AA</b>	
		B4000	2008-2001	B2300	1994	<b>CLUTCH KIT</b>	
						<b>Ford</b>	
						Contour	2000-1997
						<b>Mercury</b>	
						Cougar	2002-1999
						Mystique	2000-1997
						<b>F7ZZ-7L596-BA</b>	
						<b>CLUTCH KIT</b>	
						<b>Ford</b>	
						Mustang	2004-1997
						<b>F87Z-7L596-CA</b>	
						<b>CLUTCH KIT</b>	
						<b>Ford</b>	
						Explorer	2001-1998
						Ranger	2000-1998
						<b>Mazda</b>	
						B4000	2000-1998
						<b>YC3Z-7L596-AA</b>	
						<b>CLUTCH KIT</b>	
						<b>Ford</b>	
						F-Series	2003-1999
						<b>YR3Z-7L596-HA</b>	
						<b>CLUTCH KIT</b>	
						<b>Ford</b>	
						Mustang	2001-1999
						<b>YS4Z-7L596-DA</b>	
						<b>CLUTCH KIT</b>	
						<b>Ford</b>	
						Focus	2004-2000
						<b>YS4Z-7L596-EA</b>	
						<b>CLUTCH KIT</b>	
						<b>Ford</b>	
						Focus	2004-2000



Make	Year	Make	Year	Make	Year	Make	Year
<b>MTK-122900</b>		<b>MTK-132922</b>		<b>MTK-132932 cont'd</b>		<b>MTK-132939 cont'd</b>	
<b>OVERHAUL KIT</b>		<b>OVERHAUL KIT</b>		Escape	2008-2001	F-Series	2017-2011
<b>Ford</b>		<b>Ford</b>		<b>Mercury</b>		F53	2017-2016
Five Hundred	2007-2005	Expedition	2017-2007	Cougar	2002-1999	F650	2017-2016
Freestyle	2007-2005	Explorer	2010-2006	Mariner	2008-2005	<b>MTK-132940</b>	
<b>Mercury</b>		Explorer Sport Trac	2010-2007	Mystique	2000-1995	<b>OVERHAUL KIT</b>	
Montego	2007-2005	F-Series	2017-2009	<b>MTK-132933</b>		<b>Ford</b>	
<b>MTK-132903</b>		Mustang	2017-2011	<b>OVERHAUL KIT</b>		Crown Victoria	2010-1992
<b>OVERHAUL KIT</b>		Transit-150	2017-2015	<b>Ford</b>		Econoline	2017-1999, 1997-1994 2006-1997
<b>Ford</b>		Transit-250	2017-2015	Bronco	1996-1990	Expedition	2001-1996
F650	2012-2004	Transit-350	2017-2015	Excursion	2005-2000	Explorer	2010-1994
F750	2012-2004	Transit-350 HD	2017-2015	F-Series	2004-1999	F-Series	2004-1994
<b>MTK-132907</b>		<b>Lincoln</b>		F53	2004-2000	Mustang	1997-1994
<b>OVERHAUL KIT</b>		Navigator	2017-2009	<b>Lincoln</b>		Thunderbird	
<b>Ford</b>		<b>Mercury</b>		Blackwood	2003-2002	<b>Lincoln</b>	
Focus	2011-2004	Mountaineer	2010-2006	Navigator	2004-2003	Mark LT	2008-2006
Transit Connect	2013-2010	<b>MTK-132924</b>		<b>MTK-132934</b>		Mark VIII	1998-1993
<b>MTK-132908</b>		<b>OVERHAUL KIT</b>		<b>OVERHAUL KIT</b>		Town Car	2010-1992
<b>OVERHAUL KIT</b>		<b>Ford</b>		<b>Ford</b>		<b>Mercury</b>	
<b>Ford</b>		Escape	2012-2009	Focus	2017-2016	Cougar	1997-1994
Edge	2009-2007	Fusion	2012-2009	<b>MTK-132935</b>		Grand Marquis	2010-1992
Flex	2009	Taurus	2017-2014	<b>OVERHAUL KIT</b>		Marauder	2004-2003
Taurus	2009-2008	Transit Connect	2017-2014	<b>Ford</b>		Mountaineer	2001-1997
Taurus X	2009-2008	<b>Lincoln</b>		Edge	2017-2013	<b>MTK-132941</b>	
<b>Lincoln</b>		MKT	2017-2014	Escape	2017-2013	<b>OVERHAUL KIT</b>	
MKS	2009	MKX	2015-2014	Explorer	2017-2012	<b>Ford</b>	
MKX	2009-2007	MKZ	2014-2009	Fusion	2017-2013	F-Series 2017	
<b>Mercury</b>		<b>Mercury</b>		Police Interceptor Sedan	2013	<b>MTK-27900H</b>	
Sable	2009-2008	Mariner	2011-2009	Police Interceptor Utility	2013	<b>OVERHAUL KIT</b>	
<b>MTK-132914</b>		Milan	2011-2010	Transit Connect	2016-2014	<b>Ford</b>	
<b>OVERHAUL KIT</b>		<b>MTK-132929</b>		<b>Lincoln</b>		Explorer	2010-2002
<b>Ford</b>		<b>OVERHAUL KIT</b>		MKC	2017-2015	Explorer Sport Trac	2010-2007
Edge	2017-2010	<b>Ford</b>		MKT	2013	Mustang	2010-2005
Explorer	2015-2011	Taurus	2003-2001	MKX	2017-2016, 2013-2012	Thunderbird	2005-2003
Flex	2017-2010	<b>Lincoln</b>		MKZ	2017-2015	<b>Lincoln</b>	
Police Interceptor Sedan	2017-2013	Continental	2002-2001	<b>MTK-132936</b>		Aviator	2005-2003
Police Interceptor Utility	2017-2013	<b>Mercury</b>		<b>OVERHAUL KIT</b>		LS	2006-2003
Taurus	2017-2010	Sable	2003-2001, 1999-1998	<b>Ford</b>		<b>Mercury</b>	
<b>Lincoln</b>		<b>MTK-132931</b>		Fiesta	2017-2014	Mountaineer	2010-2002
MKS	2016-2010	<b>OVERHAUL KIT</b>		Focus	2017-2014	<b>MTK-28900D</b>	
MKT	2017-2010	<b>Ford</b>		<b>MTK-132938</b>		<b>OVERHAUL KIT</b>	
MKX	2017-2010	Aerostar	1997-1990	<b>OVERHAUL KIT</b>		<b>Ford</b>	
MKZ	2017-2013	Explorer	2005-2001	<b>Mercury</b>		Aerostar	1997
<b>MTK-132918</b>		Ranger	1995-1990	Milan	2009	Explorer	2003-1997
<b>OVERHAUL KIT</b>		<b>MTK-132932</b>		<b>MTK-132939</b>		Explorer Sport Trac	2005-2001
<b>Ford</b>		<b>OVERHAUL KIT</b>		<b>OVERHAUL KIT</b>		Ranger	2011-1997
Fiesta	2013-2011	<b>Ford</b>		<b>Ford</b>		<b>Mazda</b>	
Focus	2014-2012	Contour	2000-1995	Econoline		B2300	2008-2001, 1997

# BUYER'S GUIDE

## Transmission Repair Kits



FORD PARTS

Make	Year	Make	Year	Make	Year	Make	Year
<b>MTK-28900D cont'd</b>		<b>MTK-85901</b>		<b>MTKV-K13200D cont'd</b>		<b>MTKV-K4600D</b>	
B2500	2000-1998	<b>OVERHAUL KIT</b>		<b>Mercury</b>		<b>MASTER OVERHAUL KIT</b>	
B3000	2007-1997	<b>Ford</b>		Mountaineer 2008-2006		<b>Ford</b>	
B4000	2008-1997	F750	2017-2004	<b>MTKV-K13201D</b>		Focus	2011-2008
<b>Mercury</b>		<b>MTK-85902</b>		<b>MASTER OVERHAUL KIT</b>		Transit Connect	2013-2010
Mountaineer 2001-1998		<b>OVERHAUL KIT</b>		<b>Ford</b>		<b>MTKV-K5300K</b>	
<b>MTK-36900B</b>		<b>Ford</b>		Expedition 2013-2009		<b>MASTER OVERHAUL KIT</b>	
<b>OVERHAUL KIT</b>		F750 2017-2002		Explorer 2010-2009		<b>Ford</b>	
<b>Ford</b>		<b>MTK-85903</b>		Explorer Sport Trac 2010-2007		Crown Victoria 2010-1998	
Econoline	2017-2004	<b>OVERHAUL KIT</b>		F-Series 2013-2009		Econoline 2017-1999, 1997-1994 2006-1999	
Excursion	2005-2003	<b>Ford</b>		<b>Lincoln</b>		Expedition 2006-1999	
F-Series	2016-2003	F650	2012-2004	Navigator 2013-2009		Explorer 2001-1999	
F53	2017-2011, 2009-2006	F750	2012-2004	<b>Mercury</b>		F-Series 2010-1999	
F59	2017-2011	<b>MTK-K2701F</b>		Mountaineer 2010-2009		Mustang 2004-1998	
<b>MTK-46900C</b>		<b>MASTER OVERHAUL KIT</b>		<b>MTKV-K2701G</b>		<b>Lincoln</b>	
<b>OVERHAUL KIT</b>		<b>Ford</b>		<b>MASTER OVERHAUL KIT</b>		Mark LT 2008-2006	
<b>Ford</b>		Explorer 2008-2002		<b>Ford</b>		Mark VIII 1998-1997	
Focus	2008-2000	Explorer Sport Trac 2008-2007		Mustang 2010-2005		Town Car 2010-1998	
Transit Connect	2013-2010	<b>Lincoln</b>		Thunderbird 2005-2003		<b>Mercury</b>	
<b>MTK-67900F</b>		Aviator 2005-2003		<b>Lincoln</b>		Grand Marquis 2010-1998	
<b>OVERHAUL KIT</b>		<b>Mercury</b>		LS 2006-2003		Marauder 2004-2003	
<b>Ford</b>		Mountaineer 2007-2002		<b>MTKV-K2801C</b>		Mountaineer 2001-1999	
Freestar	2007-2004	<b>MTKV-1C</b>		<b>MASTER OVERHAUL KIT</b>		<b>MTKV-K5601A</b>	
Taurus	2007-2004	<b>MASTER OVERHAUL KIT</b>		<b>Ford</b>		<b>MASTER OVERHAUL KIT</b>	
<b>Mercury</b>		<b>Ford</b>		Aerostar 1997		<b>Ford</b>	
Monterey	2007-2004	Mustang 2013-2011		Explorer 2003-1997		Edge 2012-2010	
Sable	2005-2004	<b>MTKV-1D</b>		Explorer Sport Trac 2005-2001		Flex 2012-2010	
<b>MTK-73900B</b>		<b>MASTER OVERHAUL KIT</b>		Ranger 2011-1997		Taurus 2012-2010	
<b>OVERHAUL KIT</b>		<b>Ford</b>		<b>Mazda</b>		<b>Lincoln</b>	
<b>Ford</b>		Mustang 2013-2011		B2300 2008-2001, 1997		MKS 2012-2010	
Bronco	1996	<b>MTKV-K11701A</b>		B2500 2000-1998		MKT 2012-2010	
Econoline	2005-1996	<b>MASTER OVERHAUL KIT</b>		B3000 2007-1997		MKX 2012-2010	
Excursion	2005-2000	<b>Ford</b>		B4000 2008-1997		<b>MTKV-K5800H</b>	
Expedition	2003-1998	Edge 2009-2007		<b>Mercury</b>		<b>MASTER OVERHAUL KIT</b>	
F-Series	2004-1996	Flex 2009		Mountaineer 2001-1998		<b>Ford</b>	
<b>Lincoln</b>		Taurus 2009-2008		<b>MTKV-K3601D</b>		Escape 2008-2001	
Blackwood	2003-2002	Taurus X 2009-2008		<b>MASTER OVERHAUL KIT</b>		<b>Mazda</b>	
Navigator	2004-1998	<b>Lincoln</b>		<b>Ford</b>		Tribute 2008-2001	
<b>MTK-85900D</b>		MKS 2009		Econoline 2004		<b>Mercury</b>	
<b>OVERHAUL KIT</b>		MKX 2009-2007		Excursion 2004-2003		Mariner 2008-2005	
<b>Ford</b>		<b>Mercury</b>		F-Series 2004-2003		<b>MTKV-K5900A</b>	
Escape	2008-2001	Sable 2009-2008		<b>MTKV-K3602C</b>		<b>MASTER OVERHAUL KIT</b>	
<b>Mazda</b>		<b>MTKV-K13200D</b>		<b>MASTER OVERHAUL KIT</b>		<b>Ford</b>	
Tribute 2008-2001		<b>MASTER OVERHAUL KIT</b>		<b>Ford</b>		F-Series 2013-2011	
<b>Mercury</b>		<b>Ford</b>		Econoline 2017-2005		<b>MTKV-K5900C</b>	
Mariner	2008-2005	Expedition 2008-2007		Excursion 2005		<b>MASTER OVERHAUL KIT</b>	
		Explorer 2008-2006		F-Series 2016-2005		<b>Ford</b>	
		Explorer Sport Trac 2008-2007				F-Series 2013-2011	



Make	Year
<b>MTKV-K6700T</b>	
<b>MASTER OVERHAUL KIT</b>	
<b>Ford</b>	
Freestar	2007-2004
Taurus	2007-2004
<b>Mercury</b>	
Monterey	2007-2004
Sable	2005-2004
<b>MTKV-K7300D</b>	
<b>MASTER OVERHAUL KIT</b>	
<b>Ford</b>	
Econoline	2000-1998
Excursion	2000
F-Series	2000-1999



## CATALOG LOCATION OF PART NAME AND PREFIX

*Arranged by Catalog*

PART NAME	PREFIX
<b>Air Conditioner Parts</b>	
A/C Accumulator.....	YF, YL
A/C Accumulator with Hose Assembly.....	YF, YL
A/C Clutch Cycle Switch.....	YH
A/C Compressor – New.....	YC
A/C Compressor and Clutch Assy.....	YCC
A/C Compressor Clutch.....	YB
A/C Compressor Clutch Coil.....	YB
A/C Compressor Clutch Coil Lead Wiring Harness....	YH
A/C Compressor Clutch Hub.....	YB
A/C Compressor Clutch Pulley.....	YB
A/C Compressor Relief Valve.....	YF
A/C Compressor Shaft Seal Kit.....	YE
A/C Condenser.....	YJ
A/C Condenser Seal Kit.....	YJ
A/C Control Switch.....	YH
A/C Evaporator Core.....	YK
A/C Evaporator Core Case.....	MM
A/C Evaporator Core Kit.....	YK
A/C Evaporator Inlet and Outlet Tube Assembly.....	YF
A/C Evaporator Temperature Sensor.....	YH
A/C Expansion Valve.....	YG
A/C In-Line Filter.....	YF
A/C Line O-Ring/Kit.....	YF
A/C Manifold Hose Assembly.....	YF
A/C Orifice Tube.....	YG
A/C Receiver Drier.....	YL
A/C Receiver Drier / Dessicant Element Filter.....	YL
A/C Refrigerant Hose Fitting.....	YF
A/C Refrigerant Discharge Hose.....	YF
A/C Refrigerant Discharge/Suction Hose Assembly...	YF
A/C Refrigerant Hose.....	YF
A/C Refrigerant Liquid Hose.....	YF
A/C Refrigerant Suction Hose.....	YF
A/C Service Valve.....	YF
A/C System O-Ring and Gasket Set.....	YF
A/C Temperature Control Sensor and Bracket Assembly.....	YH
A/C Vacuum Control Valve.....	YG
A/C Vacuum Hose.....	YF
Alternator Pulley.....	GP
Auto Transmission Oil Cooler.....	YO
Cabin Air Temperature Sensor.....	YH
Drive Belt Idler Pulley.....	YS
Engine Cooling Fan Blade.....	YA
Engine Cooling Fan Clutch.....	YB

PART NAME	PREFIX
<b>Air Conditioner Parts – cont'd</b>	
Engine Cooling Fan Controller.....	RR
Heater Coolant Heater Control.....	YG
Hose Clamp.....	YF
HVAC Blower Control Module.....	YH
HVAC Blower Control Motor Resistor.....	YH
HVAC Blower Control Switch.....	YH
HVAC Blower Motor.....	MM
HVAC Blower Motor Housing.....	MM
HVAC Blower Motor Resistor.....	MM
HVAC Blower Wheel.....	MM
HVAC Control Panel Resistor.....	YH
HVAC Cut-Off Switch.....	YH
HVAC Defrost Mode Door Actuator.....	YH
HVAC Floor Mode Door Actuator.....	YH
HVAC Heater Blend Door Actuator.....	YH
HVAC Heater Control Switch.....	YH
HVAC Heater Control Valve.....	YG
HVAC Heater Core.....	HC
HVAC Heater Plenum Chamber Assembly.....	YH
HVAC Mode Door Motor.....	YH
HVAC Recirculation Door Actuator.....	YH
HVAC Temperature Sensor.....	YH
Instrument Panel Air Duct Air Temp Sensor.....	YH
Motor and Fan Assy. – Engine Cooling.....	RF
Remanufactured A/C Compressor Clutch.....	YBR
Voltage Regulator.....	GR
<b>Alternator, Distributor, Starter, Major Components</b>	
Armature.....	GM, SM
Bearing C.E. Head.....	GE, SH
Bearing D.E. ....	MC
Bearing D.E. Head.....	GE
Brush.....	SB
Drive.....	SD
Field Coil.....	SC
Housing D.E. ....	SE
Rectifier Assembly.....	GY
Rotor.....	GM
Starters.....	SA, SZ
<b>Batteries</b>	
Batteries.....	BH, BXL, BXT

**Arranged by Catalog**

<b>PART NAME</b>	<b>PREFIX</b>
<b>Belts, Hoses and Tensioners</b>	
Accessory Drive Belt.....	JC
Auto Trans Oil Cooler Hose.....	KM
Belt Tensioner.....	BT
Brake Hydraulic Bulkline.....	KK
EGR Vacuum Hose.....	KX
Engine Auxiliary Water Pump Hose.....	KM
Engine Coolant By-Pass Hose.....	KM
Engine Coolant Hose.....	KM
Engine Coolant Overflow Hose.....	KM
Engine Coolant Recovery Tank Hose.....	KM
Engine Coolant Water Outlet.....	KM
Fuel Hose.....	KFL
HVAC Heater Hose.....	KH, KHM, KM
HVAC Heater Hose Assy.....	KH
HVAC Heater Pipe.....	KT
PCV Valve Hose.....	KCV
Radiator.....	RAD
Radiator Assembly.....	RAD
Radiator Coolant By-Pass Hose.....	KM
Radiator Coolant Hose.....	KB, KM, KMS, KS
Serpentine Belt.....	JK
Transfer Case Vent Hose.....	KK
Vacuum Hose.....	KDV
V-Belt.....	JC
Windshield Washer Hose.....	KW
<b>Brake and Wheel Hub Products</b>	
ABS Wheel Speed Sensor.....	BRAB
Axle Output Shaft Seal.....	BRS
Battery.....	BXL, BXT
Battery Spacer.....	BS
Brake Bleed Screw – OE.....	BKBOE
Brake Bleeder Screw.....	BKBF
Brake Caliper – Loaded w/Super Duty Pads.....	BRCLS
Brake Drums.....	BRD
Brake Drums – OE.....	BRDF
Brake Hydraulic Hose.....	BRHF, BRHR
Brake Hydraulic Line. BRT, BRTA, BRTAF, BRTAR, BRTF, BRTH, BRTR	
Brake Master Cylinder.....	BRMC
Brake Master Cylinder Cap.....	BRFC
Brake Rotors – OE.....	BRRF
Brake Spring Kit.....	BRSK
Brake Wheel Cylinder.....	BRWC
Brake Wheel Seal.....	BRS
Disc Brake Caliper.....	BRC
Disc Brake Caliper – Loaded.....	BRCL
Disc Brake Caliper – Unloaded – OE.....	BRCF
Disc Brake Caliper Bracket.....	BRBC, BRBCF, BRBCR, BRBF, BRBPB, BRBR
Disc Brake Caliper Repair Kit.....	BKCF, BKCOE

<b>PART NAME</b>	<b>PREFIX</b>
<b>Brake and Wheel Hub Products – cont'd</b>	
Disc Brake Caliper Repair Kit.....	BRCK
Disc Brake Hardware Kit.....	BRPK
Disc Brake Hub – OE.....	HUB
Disc Brake Loaded Caliper – OE.....	BRCLF
Disc Brake Pad.....	BR
Disc Brake Pads – OE.....	BRF
Disc Brake Rotor.....	BRR
Drum Brake Adjusting Spring Kit.....	BKSOE
Drum Brake Self Adjuster Repair Kit.....	BRAK
Drum Brake Shoe.....	BR, BRF
Drum Brake Shoe Hold Down Kit.....	BRVP
Hardware Spring Kit.....	BKSF
Hub and Rotor Assy.....	BRRF
Pads – Super Duty.....	BRSD
Parking Brake Adjuster.....	BKAF, BKAOE
Parking Brake Cable.....	BRCA
Parking Brake Hardware Kit.....	BKSF, BKSOE
Parking Brake Shoe.....	BRP
Parking Brake Shoe – OE.....	BRPF
Power Brake Booster.....	BRB
Power Brake Booster Vacuum Pump.....	BRPV
Wheel Bearing – Cone and Roller.....	BRG
Wheel Bearing and Hub Assembly.....	HUB
Wheel Bearing Assy Kit.....	HUB
Wheel Bearing Retainer.....	BRS
<b>Caps, Thermostats and Water Pumps</b>	
Auto Trans – Seals and O-Rings Kit.....	MTK
Engine Coolant Outlet Gasket.....	RG
Engine Coolant Outlet Gasket.....	RTS
Engine Coolant Outlet O-Ring.....	RG
Engine Coolant Pipe O-Ring.....	RG
Engine Coolant Recovery Tank Cap.....	RL, RS
Engine Coolant Recovery Tank Seal.....	RTS
Engine Coolant Thermostat Gasket.....	RG
Engine Coolant Thermostat Gasket.....	RTS
Engine Coolant Thermostat Housing.....	RH
Engine Coolant Thermostat Housing and Gasket.....	RG
Engine Coolant Thermostat Housing Cover.....	RH
Engine Coolant Thermostat/Water Outlet Assy.....	RT
Engine Coolant Water Inlet Gasket.....	RG
Engine Coolant Water Outlet.....	RH
Engine Oil Filler Cap.....	EC
Engine Oil Filter Cover.....	EC
Engine Water Pump.....	PWR
Fuel Cap.....	FC
Pulley Bolt Cover.....	PWR
Radiator Cap.....	RL, RS
Water Pump.....	PW

**CATALOG LOCATION OF  
PART NAME AND PREFIX**

**Arranged by Catalog**

<b>PART NAME</b>	<b>PREFIX</b>
<b>Electrical Switches</b>	
Airbag Deactivation Indicator – Passenger.....	SW
Auxiliary Light.....	SW
Axle Shift Control Switch.....	SW
Back Up Light Switch.....	SW
Bearing C.E. Head – Generator.....	SH
Brake Light Switch.....	SW
Brake Pressure Relay.....	SW
Buzzer – Low Air Pressure.....	SW
Circuit Breaker Switch.....	SW
Clamp–On Bracket Switch.....	SW
Courtesy Lamp Switch.....	SW
Cruise Control Circuit Switch.....	SW
Cruise Control Switch.....	SW
Diesel Glow Plug Switch.....	SW
Dimmer Switch.....	SW
Distributor Modulator Ambient Switch.....	SW
Distributor Modulator Valve.....	SW
Distributor Modulator Valve Switch.....	SW
Door Jamb Switch.....	SW
Door Lock Actuator Switch.....	SW
Door Open Warning Switch.....	SW
Door Window Switch.....	SW
Drive – Starter.....	SD
Emergency Warning Switch.....	SW
Engine Air, Oil Pressure Switch.....	SW
Engine Coolant Temperature Switch.....	SW
Engine Start Switch.....	SW
Flasher – Emergency Warning.....	SW
Flasher – Turn Indicator.....	SW
Fog Lamp Switch.....	SW
Fuse Holder Switch.....	SW
Glow Plug Control Module.....	SW
Hazard Warning Flasher.....	SF
Hazard Warning Flasher.....	SW
Headlight/Headlamp Switch.....	SW
Heater Switch.....	SW
Horn Button Switch.....	SW
HVAC Climate Control Module.....	CCM
Ignition Key Warning Switch.....	SW
Ignition Lock Cylinder Switch.....	SW
Ignition Starter Switch.....	SW
Ignition Switch.....	SW
Instrument Cluster – Voltage Regulator Switch.....	SW
Jack Plug Cover.....	SW
Lighting Control Module.....	LCM
Multi Function Module.....	MFM
Multi Purpose Switch.....	SW
Neutral Safety Switch.....	SW
Overhead Console Switch.....	SW
Push Pull Switch.....	SW

<b>PART NAME</b>	<b>PREFIX</b>
<b>Electrical Switches – cont'd</b>	
Regulator – Instrument Cluster.....	SW
Relay – Glow Plug.....	SW
Remote Tire Pressure Monitor Sensor Valve Assembly.....	TPMS
Resistor.....	DY
Seat Belt Switch.....	SW
Seat Switch.....	SW
Solenoid Switch.....	SW
Spare Accessory Switch.....	SW
Spark Control Switch.....	SW
Speed Control Actuator Switch.....	SW
Speed Control Deactivator Switch.....	SW
Speed Control Wiring Assy.....	SW
Starter.....	SA
Starter Button Switch.....	SW
Starter Relay Switch.....	SW
Starter Solenoid Relay.....	SW
Starter Solenoid Switch.....	SW
Starter/Clutch Switch.....	SW
Stoplight Switch.....	SW
Sunroof Switch.....	SW
Temperature Control Relay.....	SW
Temperature Lamp Switch.....	SW
Temperature Sending Switch.....	SW
Tire Pressure Monitoring System Control Unit.....	TPMS
Tire Pressure Monitoring System Sensor.....	TPMS
Tire Pressure Monitoring System Sensor Grommet.....	TPMS
Tire Pressure Monitoring System Sensor Mounting Band.....	TPMS
Tire Pressure Monitoring System Sensor Nut.....	TPMS
Tire Pressure Monitoring System Valve Stem Cap.....	TPMS
Toggle Switch.....	SW
Transfer Case Manual Lever Position Sensor.....	SW
Transmission Oil Pressure Switch.....	SW
Transmission Ranger Sensor Switch.....	SW
Truck Lock Switch.....	SW
Turn Indicator Switch.....	SW
Turn Signal Flasher.....	SF
Turn Signal Flasher.....	SW
Turn Signal/Windshield Wiper Assy.....	SW
Two–Speed Axle Shift.....	SW
Voltage Regulator.....	GR
Windshield Washer Switch.....	SW
Windshield Wiper Switch.....	SW
Windshield Wiper/Washer.....	SW



Arranged by Catalog

CATALOG LOCATION OF  
PART NAME AND PREFIX

PART NAME	PREFIX
<b>Filters and PCV Valves</b>	
Air Filter .....	FA
Auto Trans Filter Kit .....	FT
Cabin Air Filter .....	FP
Engine Crankcase Breather Element.....	FA
Fuel (Diesel) Filter .....	FD
Fuel (Gas) Filter.....	FG
Fuel Water Separator Filter .....	FW
HVAC Seat Filter .....	FS
Hydraulic Fuel Filter.....	FH
Oil Filter .....	FL
PCV Valve .....	EV
Pollen Filter .....	FP
<b>Fuel and Emission Systems</b>	
4WD Actuator Valve .....	CX
Absolute Pressure (MAP) Sensor .....	CX
Absolute Pressure Sensor .....	DY
Air Charge Temperature Sensor .....	DY
Air Check Valve .....	CX
Ambient Air Temp Sensor .....	DY
Auto Trans Oil Temperature Sensor .....	DY
Auto Trans Output Shaft Speed Sensor .....	DY
Barometric Pressure Sensor .....	DY
Carburetor Bowl Vent Solenoid .....	CX
Carburetor Repair Kit .....	CT
Choke Pull-Off.....	CK
Choke Thermostat.....	CM
Coolant Temperature Sensor .....	DY
Diesel Glow Plug Switch .....	DY
Distributor Modulator Ambient Switch.....	SW
Distributor Modulator Valve.....	SW
Distributor Modulator Valve Switch .....	SW
Distributor Vacuum and Vent Control Valve.....	DY
Distributor Vacuum Control Check Valve .....	DY
EGR Pressure Sensor .....	DPFE
EGR Valve .....	CX
EGR Valve Gasket.....	CG
EGR Valve Sensor.....	CX
Emission System Vacuum Reservoir.....	CX
Engine Coolant Temp Sensor .....	DY
Engine Coolant Temperature Sensor.....	DY
Engine Crankshaft Position Sensor .....	DY
Feedback (DPFE) Sensor .....	DPFE
Fuel Charging Wiring System .....	CM
Fuel Inj. Idle Air Control Valve Gasket .....	CG
Fuel Injection Nozzle .....	CN
Fuel Injector .....	CN
Fuel Injector Kit.....	CN
Fuel Injector O-Ring.....	CM
Fuel Injectors .....	CM

PART NAME	PREFIX
<b>Fuel and Emission Systems – cont'd</b>	
Fuel Pressure Regulator .....	CM
Fuel Pressure Relief Valve Cap.....	CM
Fuel Pump .....	PF
Fuel Pump and Bracket Assy.....	PFB
Fuel Pump and Sender .....	PFS
Fuel Pump and Sender Assembly.....	PS
Fuel Pump Gasket.....	CG
Fuel Pump Tank Seal .....	CG
Fuel Sender and Hanger Assembly .....	PS
Fuel Tank Pressure Sensor .....	CX
Fuel Tank Sender.....	PS
Fuel Tank Sending Unit Lock Ring.....	FPR
Fuel Vapor Storage Canister Valve .....	CX
Fuse Block .....	DY
Fuse Connector.....	DY
Heated Oxygen Sensor.....	DY
Idle Air Control Valve.....	CX
Ignition Barometric Pressure Switch.....	DY
Ignition Coil .....	DG
Ignition Control Module.....	DY
Ignition Timing Vacuum Switch.....	DY
Intake Air Temperature Sensor .....	DY
Intake Manifold Runner Control Valve.....	CM
Intake Manifold Temp Sensor .....	CX
Intake Manifold Temperature Sensor .....	DY
Manifold Absolute Pressure Sensor .....	DY
Manifold Secondary Air Injection Bypass Valve .....	CX
Mass Air Flow Sensor.....	AFLS
Multi Purpose Relay.....	DY
Oxygen Sensor .....	DY
PCV Valve .....	EV
Secondary Air Injection Control Valve .....	CX
Secondary Air Injection Pump.....	CX
Secondary Air Injection Supply Valve .....	CX
Sensor-Fuel Injector Pressure .....	CM
Speed Control Sensor.....	DY
Throttle Body Spacer.....	CM
Throttle Position Sensor .....	CX
Throttle Position Sensor .....	DY
Transfer Case Fluid Temperature Sensor .....	DY
Universal Relay .....	DY
Vacuum Breaker Control and Bracket Assy .....	CK
Vacuum Breaker Control and Bracket.....	CX
Vacuum Control Valve .....	DY
Vacuum Regulator Valve.....	CX
Vapor Canister Purge Valve.....	CX
Vapor Canister Purge Valve Hose.....	CX
Vehicle Speed Sensor .....	DY

**CATALOG LOCATION OF  
PART NAME AND PREFIX**

**Arranged by Catalog**

PART NAME	PREFIX
<b>Popular Parts</b>	
Air Filter .....	FA
Batteries.....	BH, BXL, BXT
Diesel Glow Plug.....	ZD
Distributor Adapter Ring .....	DJ
Distributor Armature .....	DT
Distributor Cap.....	DH
Distributor Rotor .....	DR
Engine Coolant Recovery Tank Cap.....	RL, RS
Engine Coolant Thermostat.....	RT
Engine Crankcase Breather Element.....	FA
Engine Oil Filler Cap .....	EC
Fuel (Diesel) Filter .....	FD
Fuel (Gas) Filter.....	FG
Fuel Cap .....	FC
Ignition Capacitor.....	DC
Ignition Coil .....	DG
Ignition Contact Set.....	DP
Oil Filter .....	FL
PCV Valve .....	EV
Radiator Cap.....	RL, RS
Single Lead Spark Plug Wire.....	WR
Spark Plug .....	SP
Spark Plug Wire Set.....	WR
Starter Solenoid Switch .....	SW
Voltage Regulator.....	GR
Windshield Wiper Blade.....	WW
<b>Powertrain Components and Remanufactured Assemblies</b>	
Auto Trans Master Repair Kit.....	MTKV
<b>Rotating Electrical, Ignition Components, Wire and Cable</b>	
Alternator.....	GL, GLV
Auto Trans Modulator Valve .....	TM
Ballast Resistor .....	DY
Battery Ground Strap.....	WC
Camshaft Position Sensor.....	DU
Distributor.....	DA
Distributor Adapter Ring .....	DJ
Distributor Armature .....	DT
Distributor Cap.....	DH
Distributor Ignition Pickup.....	DU
Distributor Rotor .....	DR
Distributor Vacuum Advance.....	DD
Drive – Starter .....	SD
Engine Crankshaft Synchronizer.....	DA
Fuel Pump Jumper Harness Kit.....	WT
HVAC Blower Motor.....	MM
HVAC Blower Motor Resistor .....	MM

PART NAME	PREFIX
<b>Rotating Electrical, Ignition Components, Wire and Cable – cont'd</b>	
Ignition Capacitor.....	DC
Ignition Coil .....	DG
Ignition Contact .....	DP
Junction Block Assy .....	DY
Modulators .....	TM
Resistor.....	DY
Seat Regulator Motor .....	MM
Single Lead Spark Plug Wire.....	WR
Solenoid Switch.....	SW
Spark Plug Boot.....	WR
Spark Plug Wire Set.....	WR
Starter.....	SA
Starter Cable.....	WC
Starter Solenoid Switch .....	SW
Sunroof Motor .....	MM
Tailgate Window Motor .....	MM
Window Lift Regulator .....	WLR
Window Lift Regulator and Motor Assy.....	WLRA
Windshield Washer Pump.....	WG
Windshield Wiper Motor .....	WM
Windshield Wiper Switch.....	SW
Wiring Pigtails .....	WPT
<b>Spark Plugs</b>	
Diesel Glow Plug.....	ZD
Spark Plug .....	SP
<b>Steering, Suspension and CV Products</b>	
Axle Shaft Assy .....	TX
Ball Joint.....	MCS
CV Joint Boot.....	TS
CV Joint Boot Kit.....	TS
Drive Shaft CV Joint Kit.....	TX
Power Steering Gear – Reman.....	STRV
Power Steering Hose.....	PSH
Power Steering Pump.....	STP, STPV
Power Steering Pump and Gear Assy .....	STE
Remanufactured Steering Gears.....	STG
Shock Absorber .....	AA
Shock Absorber .....	AD
Shock Absorber .....	AM
Shock Absorber .....	AS
Shock Absorber .....	ASH, AST
Shock Absorber .....	ASHV
Shock Absorber Bushing.....	AD
Shock Mount.....	AD
Shock Mount Insulator .....	AD
Shock Mounting Kit .....	AD
Shocks and Struts.....	AS, AT, ASH, AST

**Arranged by Catalog**

PART NAME	PREFIX
<b>Steering, Suspension and CV Products – cont'd</b>	
Starter Solenoid Switch .....	SW
Steering Damper .....	ASH
Steering Damper Kit .....	ASHV
Steering Drag Link .....	MDF, MDOE
Steering Drag Link .....	MDS
Steering Drag Link .....	MEOE, MEF, MES
Steering Gear .....	STE
Steering Idler Arm .....	MCS, MCSOE, MCF, HEF
Steering Idler Arm .....	MEOE, MEF, MES
Steering Knuckle.....	MEOE, MEF, MES
Steering Pitman Arm.....	MCS, MCSOE, MCF, HEF
Steering Pumps .....	STP, STPV
Steering Swivel Pin Kit.....	MEOE, MEF, MES
Steering Tie Rod End.....	MEF, MDF, MDS
Steering Tie Rod End.....	MEOE, MEF, MES
Steering Tie Rod End Adjusting Sleeve .....	MEOE, MEF,
	MES
Steering Tie Rod End Adjusting Sleeve .....	MES, MEF
Steering Tie Rod End Assembly.....	MEF
Steering Tie Rod End Kit .....	MEF
Suspension Ball Joint.....	MCF
Suspension Ball Joint.....	MCS, MCSOE, MCF, HEF
Suspension Ball Joint Kit .....	MCF
Suspension Bearing Bracket.....	AD
Suspension Control Arm.....	MCS, MCSOE, MCF, HEF
Suspension Control Arm	
and Ball Joint Assy .....	MCS, MCSOE, MCF, HEF
Suspension Control Arm Bumper .....	AD
Suspension Shock Mount Bracket.....	AD
Suspension Shock Mounting Kit .....	AD
Suspension Stabilizer Bar Link Kit .....	MCS, MCSOE, MCF,
	HEF
Suspension Stabilizer Bar Link Nut .....	AD
Suspension Strut Assembly .....	AM
Suspension Strut Assy.....	ASH, AST
Suspension Strut Bearing.....	AD
Suspension Strut Mount .....	AD
Suspension Strut Mount Bushing .....	AD
Suspension Strut Rod Bushing .....	AD
Suspension Strut Rod Lock Nut.....	AD
Suspension Track Bar .....	MCF
<b>Windshield Wiper Blades</b>	
Windshield Wiper Blade.....	WW
Remanufactured Power .....	STP, STPV
<b>Wiper and Window Lift Motors</b>	
Power Window Lift Motor .....	WLM
Remanufactured Wiper Motor .....	WMV



## CATALOG LOCATION OF PART NAME AND PREFIX

*Arranged by Prefix*

PART PREFIX	PART TYPE	CATALOG REFERENCE NUMBER
AA	Shock Absorber	SSD 200
AD	Shock Absorber	SSD 200
	Shock Absorber Bushing	SSD 200
	Shock Mount	SSD 200
	Shock Mount Insulator	SSD 200
	Shock Mounting Kit	SSD 200
	Suspension Bearing Bracket	SSD 200
	Suspension Control Arm Bumper	SSD 200
	Suspension Shock Mount Bracket	SSD 200
	Suspension Shock Mounting Kit	SSD 200
	Suspension Stabilizer Bar Link Nut	SSD 200
	Suspension Strut Bearing	SSD 200
	Suspension Strut Mount	SSD 200
	Suspension Strut Mount Bushing	SSD 200
	Suspension Strut Rod Bushing	SSD 200
	Suspension Strut Rod Lock Nut	SSD 200
AFLS	Mass Air Flow Sensor	FES 200
AM	Shock Absorber	SSD 200
	Suspension Strut Assembly	SSD 200
AS	Shock Absorber	SSD 200
AS, AT, ASH, AST	Shocks and Struts	SSD 200
ASH	Steering Damper	SSD 200
ASH, AST	Suspension Strut Assy	SSD 200
	Shock Absorber	SSD 200
ASHV	Shock Absorber	SSD 200
	Steering Damper Kit	SSD 200
BH, BXL, BXT	Batteries	BD 200 APF 200
BKAF, BKAOE	Parking Brake Adjuster	PV 200
BKBF	Brake Bleeder Screw	PV 200
BKBOE	Brake Bleed Screw – OE	PV 200
BKCF, BKCOE	Disc Brake Caliper Repair Kit	PV 200
BKSF	Hardware Spring Kit	PV 200
	Parking Brake Hardware Kit	PV 200
BKSOE	Drum Brake Adjusting Spring Kit	PV 200
	Parking Brake Hardware Kit	PV 200
BR	Disc Brake Pad	PV 200
	Drum Brake Shoe	PV 200
BRAB	ABS Wheel Speed Sensor	PV 200

PART PREFIX	PART TYPE	CATALOG REFERENCE NUMBER
BRAB	Drum Brake Self Adjuster Repair Kit	PV 200
BRB	Power Brake Booster	PV 200
BRBC, BRBCF, BRBCR, BRBF, BRBPB, BRBR	Disc Brake Caliper Bracket	PV 200
BRC	Disc Brake Caliper	PV 200
BRCA	Parking Brake Cable	PV 200
BRCF	Disc Brake Caliper – Unloaded – OE	PV 200
BRCK	Disc Brake Caliper Repair Kit	PV 200
BRCL	Disc Brake Caliper – Loaded	PV 200
BRCLF	Disc Brake Loaded Caliper – OE	PV 200
BRCLS	Brake Caliper – Loaded w/Super Duty Pads	PV 200
BRD	Brake Drums	PV 200
BRDF	Brake Drums – OE	PV 200
BRF	Drum Brake Shoe	PV 200
	Disc Brake Pads – OE	PV 200
BRFC	Brake Master Cylinder Cap	PV 200
BRG	Wheel Bearing – Cone and Roller	PV 200
BRHF, BRHR	Brake Hydraulic Hose	PV 200
BRMC	Brake Master Cylinder	PV 200
BRP	Parking Brake Shoe	PV 200
BRPF	Parking Brake Shoe – OE	PV 200
BRPK	Disc Brake Hardware Kit	PV 200
BRPV	Power Brake Booster Vacuum Pump	PV 200
BRR	Disc Brake Rotor	PV 200
BRRF	Brake Rotors – OE	PV 200
	Hub and Rotor Assy	PV 200
BRS	Axle Output Shaft Seal	PV 200
	Brake Wheel Seal	PV 200
	Wheel Bearing Retainer	PV 200
BRSD	Pads – Super Duty	PV 200
BRSK	Brake Spring Kit	PV 200
BRT, BRTA, BRTAF, BRTAR, BRTF, BRTR	Brake Hydraulic Line	PV 200
BRVP	Drum Brake Shoe Hold Down Kit	PV 200
BRWC	Brake Wheel Cylinder	PV 200

### CATALOG NAME AND REFERENCE NUMBER

<b>AC 200</b>	Air Conditioner Parts	<b>FES 200</b>	Fuel and Emission Systems	<b>PV 200</b>	Brake and Wheel Hub Products
<b>APF 200</b>	Popular Parts	<b>FI 200</b>	Filters and PCV Valves	<b>SP 251</b>	Electrical Switches
<b>BD 200</b>	Batteries	<b>GSR 200</b>	Belts, Hoses and Tensioners	<b>SSD 200</b>	Steering, Suspension and CV Products
<b>CW 200</b>	Caps, Thermostats and Water Pumps	<b>M 200</b>	Spark Plugs	<b>WW 200</b>	Windshield Wiper Blades
<b>EWC 200</b>	Rotating Electrical, Ignition Components, Wire and Cable	<b>PTF 200</b>	Powertrain Components and Remanufactured Assemblies		

**CATALOG LOCATION OF  
PART NAME AND PREFIX**

**Arranged by Prefix**

PART PREFIX	PART TYPE	CATALOG REFERENCE NUMBER
BS	Battery Spacer	PV 200
BT	Belt Tensioner	GSR 200
BXL, BXT	Battery	PV 200
CG	EGR Valve Gasket	FES 200
CG	Fuel Inj. Idle Air Control Valve Gasket	FES 200
	Fuel Pump Gasket	FES 200
	Fuel Pump Tank Seal	FES 200
CK	Choke Pull-Off	FES 200
	Vacuum Breaker Control and Bracket Assy	FES 200
CCM	HVAC Climate Control Module	SP 251
CM	Choke Thermostat	FES 200
	Fuel Charging Wiring System	FES 200
	Fuel Injector O-Ring	FES 200
	Fuel Injectors	FES 200
	Fuel Pressure Regulator	FES 200
	Fuel Pressure Relief Valve Cap	FES 200
	Intake Manifold Runner Control Valve	FES 200
	Sensor-Fuel Injector Pressure	FES 200
	Throttle Body Spacer	FES 200
CN	Fuel Injector	FES 200
	Fuel Injector Kit	FES 200
	Fuel Injection Nozzle	FES 200
CT	Carburetor Repair Kit	FES 200
CX	4WD Actuator Valve	FES 200
	Absolute Pressure (MAP) Sensor	FES 200
	Air Check Valve	FES 200
	Carburetor Bowl Vent Solenoid	FES 200
	EGR Valve	FES 200
	EGR Valve Sensor	FES 200
	Emission System Vacuum Reservoir	FES 200
	Fuel Tank Pressure Sensor	FES 200
	Fuel Vapor Storage Canister Valve	FES 200
	Idle Air Control Valve	FES 200
	Intake Manifold Temp Sensor	FES 200
	Manifold Secondary Air Injection Bypass Valve	FES 200
	Secondary Air Injection Control Valve	FES 200
	Secondary Air Injection Pump	FES 200
	Secondary Air Injection Supply Valve	FES 200
	Throttle Position Sensor	FES 200
	Vacuum Breaker Control and Bracket	FES 200
	Vacuum Regulator Valve	FES 200
	Vapor Canister Purge Valve	FES 200
	Vapor Canister Purge Valve Hose	FES 200
DA	Engine Crankshaft Synchronizer	EWC 200
DA	Distributor	EWC 200
DC	Ignition Capacitor	EWC 200 APF 200

PART PREFIX	PART TYPE	CATALOG REFERENCE NUMBER
DD	Distributor Vacuum Advance	EWC 200
DG	Ignition Coil	EWC 200 APF 200
DH	Distributor Cap	EWC 200 APF 200
DJ	Distributor Adapter Ring	EWC 200 APF 200
DP	Ignition Contact Set	EWC 200 APF 200
DPFE	EGR Pressure Sensor	FES 200
	Feedback (DPFE) Sensor	FES 200
DR	Distributor Rotor	EWC 200 APF 200
DT	Distributor Armature	EWC 200 APF 200
DU	Camshaft Position Sensor	EWC 200
	Distributor Ignition Pickup	EWC 200
DY	Absolute Pressure Sensor	FES 200
	Air Charge Temperature Sensor	FES 200
	Ambient Air Temp Sensor	FES 200
	Auto Trans Oil Temperature Sensor	FES 200
	Auto Trans Output Shaft Speed Sensor	FES 200
	Ballast Resistor	EWC 200
	Barometric Pressure Sensor	FES 200
	Coolant Temperature Sensor	FES 200
	Engine Coolant Temp Sensor	FES 200
	Engine Crankshaft Position Sensor	FES 200
	Diesel Glow Plug Switch	FES 200
	Distributor Vacuum and Vent Control Valve	FES 200
	Distributor Vacuum Control Check Valve	FES 200
	Engine Coolant Temperature Sensor	FES 200
	Fuse Block	FES 200
	Fuse Connector	FES 200
	Heated Oxygen Sensor	FES 200
	Ignition Barometric Pressure Switch	FES 200
	Ignition Control Module	FES 200
	Ignition Timing Vacuum Switch	FES 200
	Intake Air Temperature Sensor	FES 200
	Intake Manifold Temperature Sensor	FES 200
	Junction Block Assy	EWC 200
	Manifold Absolute Pressure Sensor	FES 200
	Multi Purpose Relay	FES 200
	Oxygen Sensor	FES 200
	Resistor	EWC 200 SP 251
	Speed Control Sensor	FES 200
	Throttle Position Sensor	FES 200

**CATALOG NAME AND REFERENCE NUMBER**

<b>AC 200</b>	Air Conditioner Parts	<b>FES 200</b>	Fuel and Emission Systems	<b>PV 200</b>	Brake and Wheel Hub Products
<b>APF 200</b>	Popular Parts	<b>FI 200</b>	Filters and PCV Valves	<b>SP 251</b>	Electrical Switches
<b>BD 200</b>	Batteries	<b>GSR 200</b>	Belts, Hoses and Tensioners	<b>SSD 200</b>	Steering, Suspension and CV Products
<b>CW 200</b>	Caps, Thermostats and Water Pumps	<b>M 200</b>	Spark Plugs	<b>WW 200</b>	Windshield Wiper Blades
<b>EWC 200</b>	Rotating Electrical, Ignition Components, Wire and Cable	<b>PTF 200</b>	Powertrain Components and Remanufactured Assemblies		

# CATALOG LOCATION OF PART NAME AND PREFIX

Arranged by Prefix

PART PREFIX	PART TYPE	CATALOG REFERENCE NUMBER
DY – cont'd	Transfer Case Fluid Temperature Sensor	FES 200
	Universal Relay	FES 200
	Vacuum Control Valve	FES 200
	Vehicle Speed Sensor	FES 200
EC	Engine Oil Filler Cap	APF 200 CW 200
	Engine Oil Filter Cover	CW 200
EV	PCV Valve	FI 200 FES 200 APF 200
FA	Air Filter	FI 200 APF 200
	Engine Crankcase Breather Element	FI 200 APF 200
FC	Fuel Cap	APF 200 CW 200
FD	Fuel (Diesel) Filter	FI 200 APF 200
FG	Fuel (Gas) Filter	FI 200 APF 200
FH	Hydraulic Fuel Filter	FI 200
FL	Oil Filter	FI 200 APF 200
FP	Cabin Air Filter	FI 200
	Pollen Filter	FI 200
FPR	Fuel Tank Sending Unit Lock Ring	FES 200
FS	HVAC Seat Filter	FI 200
FT	Auto Trans Filter Kit	FI 200
FW	Fuel Water Separator Filter	FI 200
GL, GLV	Alternator	EWC 200
GP	Alternator Pulley	AC 200
GR	Voltage Regulator	AC 200 SP 251 APF 200
HC	HVAC Heater Core	AC 200
HUB	Disc Brake Hub – OE	PV 200
	Wheel Bearing and Hub Assembly	PV 200
	Wheel Bearing Assy Kit	PV 200
JC	Accessory Drive Belt	GSR 200
	V-Belt	GSR 200
JK	Serpentine Belt	GSR 200
KB	Radiator Coolant Hose	GSR 200
KCV	PCV Valve Hose	GSR 200

PART PREFIX	PART TYPE	CATALOG REFERENCE NUMBER
KDV	Vacuum Hose	GSR 200
KFL	Fuel Hose	GSR 200
KH	HVAC Heater Hose	GSR 200
	HVAC Heater Hose Assy	GSR 200
KHM	HVAC Heater Hose	GSR 200
KK	Brake Hydraulic Bulkline	GSR 200
	Transfer Case Vent Hose	GSR 200
KM	Auto Trans Oil Cooler Hose	GSR 200
	Engine Auxiliary Water Pump Hose	GSR 200
	Engine Coolant By-Pass Hose	GSR 200
	Engine Coolant Hose	GSR 200
	Engine Coolant Overflow Hose	GSR 200
	Engine Coolant Recovery Tank Hose	GSR 200
	Engine Coolant Water Outlet	GSR 200
	HVAC Heater Hose	GSR 200
	Radiator Coolant By-Pass Hose	GSR 200
KM, KMS, KS	Radiator Coolant Hose	GSR 200
KT	HVAC Heater Pipe	GSR 200
KW	Windshield Washer Hose	GSR 200
KX	EGR Vacuum Hose	GSR 200
LCM	Lighting Control Module	SP 251
MCF	Suspension Ball Joint	SSD 200
	Suspension Ball Joint Kit	SSD 200
	Suspension Control Arm and Ball Joint Assembly	SSD 200
	Suspension Track Bar	SSD 200
MCS	Ball Joint	SSD200
MCS, MCSOE, MCF, HEF	Steering Idler Arm	SSD 200
	Steering Pitman Arm	SSD 200
	Suspension Ball Joint	SSD 200
	Suspension Control Arm	SSD 200
	Suspension Control Arm and Ball Joint Assy	SSD 200
	Suspension Stabilizer Bar Link Kit	SSD 200
MDF, MDOE	Steering Drag Link	SSD 200
MDS	Steering Drag Link	SSD 200
MEF	Steering Tie Rod End Assembly	SSD 200
	Steering Tie Rod End Kit	SSD 200
MEF, MDF, MDS	Steering Tie Rod End	SSD 200
MEOE, MEF, MES	Steering Drag Link	SSD 200
	Steering Idler Arm	SSD 200
	Steering Knuckle	SSD 200
	Steering Swivel Pin Kit	SSD 200
	Steering Tie Rod End	SSD 200
	Steering Tie Rod End Adjusting Sleeve	SSD 200
MES, MEF	Steering Tie Rod End	SSD 200
	Adjusting Sleeve	SSD 200
MFM	Multi Function Module	SP 251

## CATALOG NAME AND REFERENCE NUMBER

<b>AC 200</b>	Air Conditioner Parts	<b>FES 200</b>	Fuel and Emission Systems	<b>PV 200</b>	Brake and Wheel Hub Products
<b>APF 200</b>	Popular Parts	<b>FI 200</b>	Filters and PCV Valves	<b>SP 251</b>	Electrical Switches
<b>BD 200</b>	Batteries	<b>GSR 200</b>	Belts, Hoses and Tensioners	<b>SSD 200</b>	Steering, Suspension and CV Products
<b>CW 200</b>	Caps, Thermostats and Water Pumps	<b>M 200</b>	Spark Plugs	<b>WW 200</b>	Windshield Wiper Blades
<b>EWC 200</b>	Rotating Electrical, Ignition Components, Wire and Cable	<b>PTF 200</b>	Powertrain Components and Remanufactured Assemblies		

## Arranged by Prefix

PART PREFIX	PART TYPE	CATALOG REFERENCE NUMBER
MM	A/C Evaporator Core Case	AC 200
	HVAC Blower Motor	AC 200
		EWC 200
	HVAC Blower Motor Housing	AC 200
	HVAC Blower Motor Resistor	AC 200
		EWC 200
	HVAC Blower Wheel	AC 200
	Seat Regulator Motor	EWC 200
	Sunroof Motor	EWC 200
	Tailgate Window Motor	EWC 200
MTK	Auto Trans – Seals and O-Rings Kit	CW 200
MTKV	Auto Trans Master Repair Kit	PTF 200
PF	Fuel Pump	FES 200
PFB	Fuel Pump and Bracket Assy	FES 200
PFS	Fuel Pump and Sender	FES 200
PS	Fuel Pump and Sender Assembly	FES 200
	Fuel Sender and Hanger Assembly	FES 200
	Fuel Tank Sender	FES 200
PSH	Power Steering Hose	ST 200
PW	Water Pump	CW 200
PWR	Engine Water Pump	CW 200
	Pulley Bolt Cover	CW 200
RAD	Radiator	GSR 200
RAD	Radiator Assembly	GSR 200
RF	Motor and Fan Assy. – Engine Cooling	AC 200
RG	Engine Coolant Outlet Gasket	CW 200
	Engine Coolant Outlet O-Ring	CW 200
	Engine Coolant Pipe O-Ring	CW 200
	Engine Coolant Thermostat Gasket	CW 200
	Engine Coolant Thermostat Housing and Gasket	CW 200
	Engine Coolant Water Inlet Gasket	CW 200
RH	Engine Coolant Thermostat Housing	CW 200
	Engine Coolant Thermostat Housing Cover	CW 200
	Engine Coolant Water Outlet	CW 200
RL, RS	Radiator Cap	APF 200
		CW 200
	Engine Coolant Recovery Tank Cap	APF 200
		CW 200
RR	Engine Cooling Fan Controller	AC 200
RT	Engine Coolant Thermostat	APF 200
	Engine Coolant Thermostat/Water Outlet Assy	CW 200
RTS	Engine Coolant Outlet Gasket	CW 200
	Engine Coolant Thermostat Gasket	CW 200
	Engine Coolant Recovery Tank Seal	CW 200
SA	Starter	EWC 200
		SP 200
SD	Drive – Starter	SP 200
		EWC 200

## CATALOG LOCATION OF PART NAME AND PREFIX

PART PREFIX	PART TYPE	CATALOG REFERENCE NUMBER
SF	Turn Signal Flasher	SP 251
	Hazard Warning Flasher	SP 251
SH	Bearing C.E. Head – Generator	SP 200
SP	Spark Plug	M 200
		APF 200
STE	Power Steering Pump and Gear Assy	SSD 200
	Steering Gear	SSD 200
STG	Remanufactured Steering Gears	SSD 200
STP, STPV	Remanufactured Power Steering Pumps	SSD 200
	Power Steering Pump	SSD 200
STRV	Power Steering Gear – Reman	SSD 200
SW	Airbag Deactivation Indicator – Passenger	SP 251
	Axle Shift Control Switch	SP 251
	Brake Light Switch	SP 251
	Brake Pressure Relay	SP 251
	Buzzer – Low Air Pressure	SP 251
	Clamp–On Bracket Switch	SP 251
	Courtesy Lamp Switch	SP 251
	Diesel Glow Plug Switch	SP 251
	Distributor Modulator Ambient Switch	SP 251
		FES 200
	Distributor Modulator Valve	SP 251
		FES 200
	Distributor Modulator Valve Switch	SP 251
		FES 200
	Door Lock Actuator Switch	SP 251
	Door Open Warning Switch	SP 251
	Emergency Warning Switch	SP 251
	Engine Start Switch	SP 251
	Flasher – Emergency Warning	SP 251
	Flasher – Turn Indicator	SP 251
	Fog Lamp Switch	SP 251
	Glow Plug Control Module	SP 251
	Ignition Key Warning Switch	SP 251
	Ignition Starter Switch	SP 251
	Ignition Switch	SP 251
	Instrument Cluster – Voltage Regulator Switch	SP 251
	Jack Plug Cover	SP 251
	Overhead Console Switch	SP 251
	Regulator – Instrument Cluster	SP 251
	Relay – Glow Plug	SP 251
Seat Belt Switch	SP 251	
Spare Accessory Switch	SP 251	
Spark Control Switch	SP 251	
Speed Control Actuator Switch	SP 251	
Speed Control Deactivator Switch	SP 251	
Speed Control Wiring Assy	SP 251	
Starter Solenoid Relay	SP 251	
Starter/Clutch Switch	SP 251	
Sunroof Switch	SP 251	

## CATALOG NAME AND REFERENCE NUMBER

<b>AC 200</b>	Air Conditioner Parts	<b>FES 200</b>	Fuel and Emission Systems	<b>PV 200</b>	Brake and Wheel Hub Products
<b>APF 200</b>	Popular Parts	<b>FI 200</b>	Filters and PCV Valves	<b>SP 251</b>	Electrical Switches
<b>BD 200</b>	Batteries	<b>GSR 200</b>	Belts, Hoses and Tensioners	<b>SSD 200</b>	Steering, Suspension and CV Products
<b>CW 200</b>	Caps, Thermostats and Water Pumps	<b>M 200</b>	Spark Plugs	<b>WW 200</b>	Windshield Wiper Blades
<b>EWC 200</b>	Rotating Electrical, Ignition Components, Wire and Cable	<b>PTF 200</b>	Powertrain Components and Remanufactured Assemblies		

# CATALOG LOCATION OF PART NAME AND PREFIX

Arranged by Prefix

PART PREFIX	PART TYPE	CATALOG REFERENCE NUMBER	
SW – cont'd	Temperature Lamp Switch	SP 251	
	Transmission Oil Pressure Switch	SP 251	
	Transmission Ranger Sensor Switch	SP 251	
	Turn Signal/Windshield Wiper Assy	SP 251	
	Two-Speed Axle Shift	SP 251	
	Windshield Wiper/Washer	SP 251	
SW	Auxiliary Light	SP 251	
	Back Up Light Switch	SP 251	
	Circuit Breaker Switch	SP 251	
	Cruise Control Switch	SP 251	
	Cruise Control Circuit Switch	SP 251	
	Dimmer Switch	SP 251	
	Door Jamb Switch	SP 251	
	Door Window Switch	SP 251	
	Engine Air, Oil Pressure Switch	SP 251	
	Engine Coolant Temperature Switch	SP 251	
	Fuse Holder Switch	SP 251	
	Hazard Warning Flasher	SP 251	
	Headlight/Headlamp Switch	SP 251	
	Heater Switch	SP 251	
	Horn Button Switch	SP 251	
	Ignition Lock Cylinder Switch	SP 251	
	Multi Purpose Switch	SP 251	
	Neutral Safety Switch	SP 251	
	Push Pull Switch	SP 251	
	Seat Switch	SP 251	
	Starter Solenoid Switch	EWC 200	
		SP 251	
		APF 200	
		SSD 200	
		Starter Button Switch	SP 251
		Starter Relay Switch	SP 251
		Stoplight Switch	SP 251
		Solenoid Switch	EWC 200
			SP 251
		Temperature Control Relay	SP 251
		Temperature Sending Switch	SP 251
		Toggle Switch	SP 251
		Transfer Case Manual Lever Position Sensor	SP 251
		Truck Lock Switch	SP 251
		Turn Indicator Switch	SP 251
		Turn Signal Flasher	SP 251
		Windshield Washer Switch	SP 251
		Windshield Wiper Switch	EWC 200
			SP 251
	TM	Auto Trans Modulator Valve	EWC 200
Modulators		EWC 200	
TPMS	Remote Tire Pressure Monitor		
	Sensor Valve Assembly	SP 251	
	Tire Pressure Monitoring System Control Unit	SP 251	
	Tire Pressure Monitoring System Sensor	SP 251	

PART PREFIX	PART TYPE	CATALOG REFERENCE NUMBER
TPMS – cont'd	Tire Pressure Monitoring System Sensor Grommet	SP 251
	Tire Pressure Monitoring System Sensor Mounting Band	SP 251
	Tire Pressure Monitoring System Sensor Nut	SP 251
	Tire Pressure Monitoring System Valve Stem Cap	SP 251
TS	CV Joint Boot	SSD 200
	CV Joint Boot Kit	SSD 200
TX	Axle Shaft Assy	SSD 200
	Drive Shaft CV Joint Kit	SSD 200
WC	Battery Ground Strap	EWC 200
	Starter Cable	EWC 200
WG	Windshield Washer Pump	EWC 200
WLM	Power Window Lift Motor	WL 200
WLR	Window Lift Regulator	EWC 200
WLRA	Window Lift Regulator and Motor Assy	EWC 200
WM	Windshield Wiper Motor	EWC 200
WMV	Remanufactured Wiper Motor	WL 200
WPT	Wiring Pigtails	EWC 200
WR	Spark Plug Boot	EWC 200
WR	Single Lead Spark Plug Wire	EWC 200
		APF 200
	Spark Plug Wire Set	EWC 200
		APF 200
WT	Fuel Pump Jumper Harness Kit	EWC 200
WW	Windshield Wiper Blade	APF 200
		WW 200
YA	Engine Cooling Fan Blade	AC 200
YB	A/C Compressor Clutch	AC 200
	A/C Compressor Clutch Coil	AC 200
	A/C Compressor Clutch Hub	AC 200
	A/C Compressor Clutch Pulley	AC 200
	Engine Cooling Fan Clutch	AC 200
YBR	Remanufactured A/C Compressor Clutch	AC 200
YC	A/C Compressor – New	AC 200
YCC	A/C Compressor and Clutch Assy	AC 200
YE	A/C Compressor Shaft Seal Kit	AC 200
YF	A/C Accumulator	AC 200
	A/C Accumulator with Hose Assembly	AC 200
	A/C Compressor Relief Valve	AC 200
	A/C Evaporator Inlet and Outlet Tube Assembly	AC 200
	A/C In-Line Filter	AC 200
	A/C Line O-Ring/Kit	AC 200
	A/C Manifold Hose Assembly	AC 200
	A/C Refrigerant Discharge Hose	AC 200
	A/C Refrigerant Discharge/Suction Hose Assembly	AC 200

## CATALOG NAME AND REFERENCE NUMBER

<b>AC 200</b>	Air Conditioner Parts	<b>FES 200</b>	Fuel and Emission Systems	<b>PV 200</b>	Brake and Wheel Hub Products
<b>APF 200</b>	Popular Parts	<b>FI 200</b>	Filters and PCV Valves	<b>SP 251</b>	Electrical Switches
<b>BD 200</b>	Batteries	<b>GSR 200</b>	Belts, Hoses and Tensioners	<b>SSD 200</b>	Steering, Suspension and CV Products
<b>CW 200</b>	Caps, Thermostats and Water Pumps	<b>M 200</b>	Spark Plugs	<b>WW 200</b>	Windshield Wiper Blades
<b>EWC 200</b>	Rotating Electrical, Ignition Components, Wire and Cable	<b>PTF 200</b>	Powertrain Components and Remanufactured Assemblies		



## CATALOG LOCATION OF PART NAME AND PREFIX

### Arranged by Prefix

PART PREFIX	PART TYPE	CATALOG REFERENCE NUMBER
YF – cont'd	A/C Refrigerant Hose	AC 200
	A/C Refrigerant Hose Fitting	AC 200
	A/C Refrigerant Liquid Hose	AC 200
	A/C Refrigerant Suction Hose	AC 200
	A/C Service Valve	AC 200
	A/C System O-Ring and Gasket Set	AC 200
	A/C Vacuum Hose	AC 200
	Hose Clamp	AC 200
YG	A/C Expansion Valve	AC 200
	A/C Orifice Tube	AC 200
	A/C Vacuum Control Valve	AC 200
	Heater Coolant Heater Control	AC 200
	HVAC Heater Control Valve	AC 200
YH	A/C Clutch Cycle Switch	AC 200
	A/C Compressor Clutch Coil Lead	
	Wiring Harness	AC 200
	A/C Control Switch	AC 200
	A/C Evaporator Temperature Sensor	AC 200
	A/C Temperature Control Sensor and Bracket Assembly	AC 200
	Cabin Air Temperature Sensor	AC 200
	HVAC Blower Control Module	AC 200
	HVAC Blower Control Switch	AC 200
	HVAC Blower Control Motor Resistor	AC 200
	HVAC Control Panel Resistor	AC 200
	HVAC Cut-Off Switch	AC 200
	HVAC Defrost Mode Door Actuator	AC 200
	HVAC Floor Mode Door Actuator	AC 200
	HVAC Heater Blend Door Actuator	AC 200
	HVAC Heater Control Switch	AC 200
	HVAC Heater Plenum Chamber Assembly	AC 200
	HVAC Mode Door Motor	AC 200
	HVAC Recirculation Door Actuator	AC 200
	HVAC Temperature Sensor	AC 200
Instrument Panel Air Duct Air Temp Sensor	AC 200	
YJ	A/C Condenser	AC 200
	A/C Condenser Seal Kit	AC 200
YK	A/C Evaporator Core	AC 200
	A/C Evaporator Core Kit	AC 200
YL	A/C Accumulator	AC 200
	A/C Accumulator with Hose Assembly	AC 200
	A/C Receiver Drier	AC 200
	A/C Receiver Drier / Dessiccant Element Filter	AC 200
YO	Auto Transmission Oil Cooler	AC 200
YS	Drive Belt Idler Pulley	AC 200
ZD	Diesel Glow Plug	M 200
		APF 200

### CATALOG NAME AND REFERENCE NUMBER

<b>AC 200</b>	Air Conditioner Parts	<b>FES 200</b>	Fuel and Emission Systems	<b>PV 200</b>	Brake and Wheel Hub Products
<b>APF 200</b>	Popular Parts	<b>FI 200</b>	Filters and PCV Valves	<b>SP 251</b>	Electrical Switches
<b>BD 200</b>	Batteries	<b>GSR 200</b>	Belts, Hoses and Tensioners	<b>SSD 200</b>	Steering, Suspension and CV Products
<b>CW 200</b>	Caps, Thermostats and Water Pumps	<b>M 200</b>	Spark Plugs	<b>WW 200</b>	Windshield Wiper Blades
<b>EWC 200</b>	Rotating Electrical, Ignition Components, Wire and Cable	<b>PTF 200</b>	Powertrain Components and Remanufactured Assemblies		

