

1935-1960



**B
U
I
C
K

P
A
R
T
S**

BUICK PARTS: GROUP NUMBERS

Engine • Clutch • Decals.....	Group 0
Cooling • Oiling • Grills	Group 1
Electrical • Lamps	Group 2
Fuel • Carburetion • Exhaust	Group 3
Transmission • Brakes	Group 4
Wheels • Propeller Shaft • Rear Axle	Group 5
Front Suspension • Steering	Group 6
Frame • Springs • Shocks • Bumpers	Group 7
Hood • Front Fenders • Running Boards	Group 8
Heater • Air Conditioner • Firewall • Radio • Antenna	Group 9
Glass • Doors • Cowl • Weatherstrip • Wiper • Dash	Group 10
Rear 1/4 Glass • Seats • Door Sills • Dome Lenses	Group 11
Rocker Panels • Rear Sheet Metal • Deck Lid.....	Group 12
Convertible Tops and Parts	Group 13
Door Panels • Misc. Interior • Headlinings	Group 14
Carpet • Floor Mats • Trunk Linings	Group 15
Literature.....	Group 16

-ATTENTION-

This catalog pertains to
1930's and Up All models ONLY

We also have catalogues and stock Buick parts for:

1961 and Up Special, Skylark, Sportwagon and Gran Sport

1961 and Up LeSabre, Invicta, Wildcat, Electra 225,
Centurion, Century and Apollo

1973 and Up Regal, Grand National, T-Type and GNX

Please inquire about separate catalogs for the above Buicks

www.oldbuickparts.com

All rights reserved. No part of this publication may be reproduced without prior written permission from CARS, Inc. Illustrations in this catalog are representations only and may not exactly depict any particular part or part number. Prices subject to change without notice.



We Rebuild:

Alternators

Brake Boosters

Brake Shoes

Carburetors

Convertible Top Pumps

Drive Shaft Supports

Generators

Motor Mounts

Pressure Plate Assembly

Rocker Assembly

Starter Motors

Voltage Regulators

Wheel Cylinders

Ball Joints

Brake Cables

Camshafts

Clutch Discs

Distributors

Fuel Pumps

Master Cylinders

Oil Pumps

Transmission Mounts

Shocks

Vacuum Advances

Water Pumps

Vacuum Wiper Motors

Please Inquire.

We are a full service company.



CARS, LLC

205 Pearl St. • Neshanic Station, NJ 08853

(908) 369-3666 • (908) 369-7595 Fax

www.oldbuickparts.com

Motor Mounts Sold Outright



1933-1938 Front Motor Support Pads.
1933-1936 All (2 pair needed)
1937-1938 All (1 pair needed)
 MM368.....\$12.75 pr.

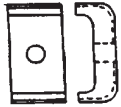

1934-1938 Front Motor Mounts.
1934-1935 Specials;
1936 All Except Convertibles,
1937-1938 All.
 MM367.....\$89.50 pr.

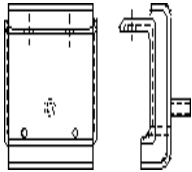

1940-1947 Front, Except Series 90.
 (Sold Outright - no core charge)
 MM407.....sold outright.....\$125.00 pr.

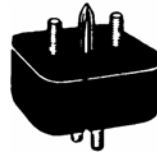

1948-1953
1948-1952 All;
1953 Specials.
 MM483.....\$79.50 pr.

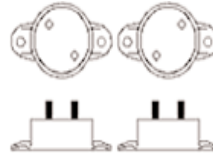

1953 All V-8 Engines.
 MM53.....\$99.50 pr.



1953-1956 All V-8 Engines.
 MM536.....\$105.00 pr.



1957-1958 All Front.
 Sold outright, No core charge.
 MM578.....\$129.50 pr.



1959-1960 All Front.
 Sold outright, No core charge.
 MM590.....\$72.50 pr.

Motor Mount Rebuilding Service (0.027)

We now offer you complete revulcanization of your motor mounts. Fresh, new rubber will insure safe and smooth running. The mounts listed below are sold on an exchange basis only. If we have your needed mount ready to ship we will charge you an additional core deposit of \$50.00 per item. This charge is fully refundable upon receiving your rebuildable cores. We prefer you send your mounts for rebuilding. Please allow at least 2 weeks for this process.

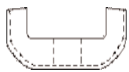

1934-1935 Series 50 and 60. Front.
 Series 50 - 2nd type after frame #2727014;
 Series 60 - used after frame #2728021.
 MM345FRS.....\$180.59 pr.

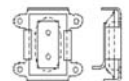

1934-1935 Series 40. Rear.
 1934 All series 40.
 1935 All Series 40 up to frame #2789239.
 MM345RS.....\$490.19 pr.

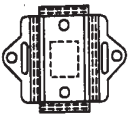

1935 Series 50. Rear.
 MM35RS.....\$148.89 pr.

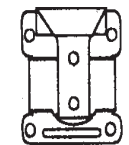

1935 Series 60 (Century) Rear.
 MM35CRS.....\$169.17 pr.

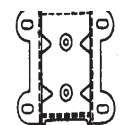

1935-1936. Rear.
 1935 Series 40 after frame #2789239.
 1936 series 40 all exc. model 46C.
 MM356RS.....\$194.79 pr.

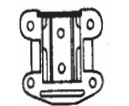

1936 Series 80-90 exc. 80C. Rear.
 MM36BRS.....\$312.59 pr.

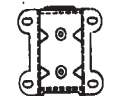

1936 Series 60. Closed Body Styles.
 MM36RS.....\$284.99 pr.



1937-1938 Special. Rear Motor Mounts.
 MM378RS.....\$275.19 pr.

1937-1938 Century and Roadmaster.
 Rear Motor Mounts.
 MM378BRS.....\$261.79 pr.

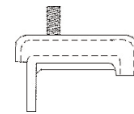

1939 Special and Century. Front motor mounts.
 MM39FRS.....\$187.49 pr.

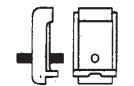

1939 Series 80-90. Front Motor Mounts.
 MM39BRS.....\$184.99 pr.

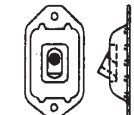

1939 All Rear Motor Mounts.
 MM39RS.....\$175.89 pr.

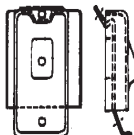

1940 Special and Century, Rear.
 MM40SRS.....\$254.79 pr.

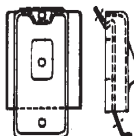

1940 Super and Roadmaster. Rear Motor Mounts.
 MM40BRS.....\$263.79 pr.

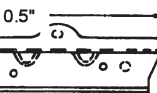

1940 Series 80-90. Rear Motor Mounts.
 MM40LRS.....\$270.69 pr.

1941-1942 Series 90. Front Motor Mounts.
 MM412RS.....\$164.49 pr.

1941-1947 Rear Motor Mount.
 MM417RS.....\$153.39 ea.

Engine Parts (Group 0)

Exhaust Valves (.0297)

1931-1935 Series 60; 1936-1952 Roadmaster, Century and Limited.		EV362.....	\$17.00 ea.
1936-1953 Special and Super.		EV363.....	\$17.00 ea.
1953 All V-8.		EV53.....	\$17.00 ea.
1954 All.		EV54.....	\$19.00 ea.
1955 Exhaust Valve.		EV55.....	\$17.00 ea.
1956 Exhaust Valve.		EV56.....	\$17.00 ea.
1957-1958 Exhaust Valve.		EV578.....	\$17.00 ea.
1959-1960 With 401 Engine.		EV596.....	\$17.00 ea.

(.303) Valve Springs (.306)

1937-1947 All; 1948-1949 Special and Super; 1950 thru 1953 Special with Standard Trans.		VS473I.....Inner.....	\$4.85 ea.
		VS473IS.....Inner...(Set of 16).....	\$69.50 set
		VS473.....Outer.....	\$4.85 ea.
		VS473S.....Outer...(Set of 16).....	\$69.50 set

1948-1952 All; 1953 Special. (Dynaflow)		VS483I.....Inner.....	\$4.85 ea.
		VS483IS.....Inner...(Set of 16).....	\$69.50 set
		VS483.....Outer.....	\$4.85 ea.
		VS483S.....Outer...(Set of 16).....	\$69.50 set

1953-1960 All V-8. (inner).		VS536.....	\$5.00 ea.
		VS536S.....(Set of 16).....	\$58.00 set

1953-1960 All V-8. (outer).		VS596.....	\$4.75 ea.
		VS596S.....(Set of 16).....	\$52.25 set

Valve Spring Retainers (keepers) (.310)

	1936-1965 All.	VR365.....	\$3.75 pr.
	Valve Spring Retainer Set	VR365S.....(Set of 32).....	\$49.50 set

Intake Valves (.296)

1936-1952 Roadmaster, Century and Limited.		IV362.....	\$17.00 ea.
1936-1953 Special and Super.		IV363.....	\$17.00 ea.
1953 All V-8.		IV53.....	\$17.00 ea.
1954-1956 All.		IV546.....	\$17.00 ea.
1957-1958 All.		IV578.....	\$17.00 ea.
1959-1960 With 401 Engine.		IV596.....	\$17.00 ea.

Valve Guides and Seals (.283)

1934-1952 Series 40, 50; 1953 Series 40 Exhaust and Intake Valve Guides.		VG384.....	\$4.85 ea.
		VG384S.....(Set of 16).....	\$69.50 set

1936-1952 320 Engines Exhaust and Intake Valve Guides.		VG407.....	\$4.75 ea.
--	--	------------	------------

 1953-1960 Intake and Exhaust Valve Guides.		VG733.....	\$4.00 ea.
---	--	------------	------------

1953-1960 All V-8 Valve Stem Seals.		VSS536.....	\$3.00 ea.
--	--	-------------	------------

Valve Seat Inserts

1955-1956 All (Exhaust).		VSI557.....	\$4.50 ea.
1957-1958 All (Exhaust).		VSI572.....	\$4.50 ea.
1959-1960 All 364 and 401 Engines (Intake).		VSI592.....	\$4.75 ea.
1959-1960 All 364 and 401 engines (Exhaust).		VSI590.....	\$4.75 ea.

Hydraulic Valve Lifters

1936-1953 All Mechanical Lifters. (Outright).		VL360.....	\$22.50 ea.
1948-1953 All Straight-8 Engines. Hydraulic Valve Lifter. New, not rebuilt.		VL483.....	\$22.50 ea.
		VL483S.....Full Set of 16.....	\$339.00 set
1953-1955 Hydraulic Valve Lifters (Outright).		VL535.....	\$11.25 ea.
1956-1960 Hydraulic Valve Lifters (Outright).		VL567.....	\$9.50 ea.
		VL567S.....Full Set of 16.....	\$139.50 set

Main Bearing Sets (.096)



Sets are available in standard 010, .020, .030, and .040 undersized.

Please specify when ordering.

- 1937-1938 Special.**
MBS378.....\$279.50 set
- 1937-1952 Series 60, 70, 80, 90.**
MBS372.....\$259.00 set
- 1939-1950**
 1939-1949: Special and Super;
 1950: Special.
MBS390.....\$249.50 set
- 1950-1953**
 1950-1952: Super;
 1951-1953: Special.
MBS503.....\$217.00 set
- 1953-1956 All V-8.**
MBS536.....\$159.00 set
- 1957-1960 All with 364 Engine.**
MBS571.....\$139.00 set
- 1959-1960 All with 401 Engine.**
MBS596.....\$179.50 set

Camshafts Regrinding Service

- 1935-1953 All Straight 8 Engines.**
CS353R.....\$296.50 ea.
- 1957-1960 All Engines.**
CS576R.....\$296.50 ea.



New Camshafts - Sold Outright (.519)

- 1953-1956 All V-8.**
CS536.....\$324.00 ea.
- 1957-1960 All Engines.**
CS576.....\$169.50 ea.
- All Years. All Engines. Cam break-in lube.**
CL300.....\$6.75 ea.

Connecting Rods (.603)



- 1959-1960 All with 401 Engine.**
CR596.....\$59.50 ea.

Connecting Rod Bearings (.604)

- 1936-1950 248 Engines**
 1936-1949: Special and Super;
 1950: Special.
RBS360.....\$149.50 set
- 1937-1952 Series 60, 70, 80, 90, 320 Engines**
RBS372.....\$137.50 set
- 1950-1953 263 Engines**
 1950-1952: Super;
 1951-1953: Special.
RBS503.....\$129.50 set
- 1953-1956 All V-8.**
RBS536.....\$115.75 set
- 1957-1960 All.**
RBS576.....\$89.50 set



Camshaft Bearings (.546)



- 1936-1953 All. Straight-8 Engines.**
CBS363.....\$89.00 set
- 1953-1956 All. V-8 Camshaft Bearing Set.**
CBS536.....\$78.50 set
- 1957-1960 All.**
CBS576.....\$47.50 ea.

ZDDP Oil Supplement - 4 oz. Bottle



ZDDPlus is a oil additive that contains high concentraions of Zinc Diakyl Dithiophosphate, which has been the primary extreme pressure ingredient now missing from modern day motor oils. This is a must in all flat-tappet engines!

ZDDP\$14.00 ea.

- ZDDP5.....(5 Bottles).....\$39.95



Engine Parts (Group 0)

Pistons (0.629)

We also have oversize pistons - same price

1938-1950 All 248 Engines.	
P380S.....(Set of 8).....	\$295.00 set
1938-1952 All 320 Engines.	
P382S..... (Set of 8).....	\$329.50 set
1950-1953 All 263 Engines.	
P503S.....(Set of 8).....	\$295.00 set
1953 All 322 V-8 Engines.	
P53.....	\$49.50 ea.
P53S.....(Set of 8).....	\$295.00 set
1954-1955 Special with 264 Engine.	
P545S.....(Set of 8).....	\$499.50 set
1954-1956 Super, Century, Skylark and Roadmaster with 322 Engine.	
P546S.....(Set of 8).....	\$365.00 set
1957-1958 All;	
1959-1961 LeSabre. 364 Engines	
P571S.....(Set of 8).....	\$315.00 set

All others PLEASE INQUIRE

Harmonic Balancer Rebuilding Service



Balancers are completely disassembled, shot peened and inspected. Threaded holes are repaired and new seal saver is installed. (non-rope seal apps.) New silicone rubber is injected, then vulcanized for proper bonding. Please remove any bolted pulleys before sending. For those not listed, please inquire.

1953-1956 All 322 V-8 Engines.	
HB322RS.....	\$199.50 ea.
1954-1955 All Special, 264 Engine. No Rubber Type.	
HB264RS.....	\$89.50 ea.
1954-1955 All Special, 264 Engine. Riveted Type.	
HB264RRS.....	\$199.50 ea.
1957-1960 All 364 Engine. Riveted. 75% of weight removed from ring. External Balanced.	
HB364RS.....	\$199.50 ea.
1959-1960 All 401 Engine. Riveted type.	
HB401RS.....	\$199.50 ea.

Piston Ring Sets (0.643)

We also have oversize rings

1937-1950 All 248 Engines.	
PRS380.....	\$115.00 set
1938-1952 All 320 Engines.	
PRS382.....	\$125.00 set
1951-1953 Special and Super with Straight-8 Engine.	
PRS513.....	\$115.00 set
1953-1956 All with 322 Engine, Cast Iron.	
PRS322.....	\$89.50 set
1953-1956 All with 322 Engine, Moly Set.	
PRS322M.....	\$129.50 set
1954-1955 All Special with 264 Engine.	
PRS264.....	\$95.00 set
1957-1960	
1957-1958: All;	
1959-1960: with 364. Cast Iron.	
PRS364.....	\$95.00 set
1957-1960	
1957-1958: All;	
1959-1960: with 364. Moly Set.	
PRS364M.....	\$129.50 set
1959-1960 All with 401 Engine, Cast Iron.	
PRS401C.....	\$94.50 set
1959-1960 All with 401 Engine, Moly Set.	
PRS401M.....	\$139.00 set

Push Rods (0.426)

1937-1940 Special;	
1940 Super. 13".	
PR370.....	\$15.50 ea.
1941-1949 Special with Solid Lifters. 12 13/16"	
PR419.....	\$16.50 ea.
1949 Super:	
1950 Special. For Cars with Hydraulic Lifters. 11"	
PR490.....	\$16.50 ea.
1950-1953 For Dynaflo Cars.	
1950-1952 Super;	
1951-1953 Special .	
PR503.....	\$16.50 ea.
1950-1953 Special. All with Standard Transmission 12-1/8" length.	
PR503S.....	\$16.50 ea.
1953-1955 All V-8.	
PR535.....	\$7.50 ea.
1956 All.	
PR56.....	\$7.50 ea.
1957-1961 364 Engine.	
PR573.....	\$7.50 ea.
PR573S.....(Set of 16).....	\$115.00 set
1959-1960 All with 401 Engine.	
PR597.....	\$7.00 ea.
PR597S.....(Set of 16).....	\$109.00 set

Timing Chains (0.724)



- 1934-1949** Special;
1940-1949 Super.
TC349.....\$92.00 ea.
- 1936-1949** Series 60, 70, 80, 90
TC369.....\$84.75 ea.
- 1950-1952** Special and Super;
1953 Special. 49 Links.
TC503.....\$78.50 ea.
- 1950-1952** Roadmaster.
TC502.....\$78.50 ea.
- 1953-1960** All V-8.
TC536.....\$34.50 ea.

Aluminum Valve Covers



- 1953-1960** All V-8 Engines. Grooved with "BUICK" as original. Nice reproduction!
AVC536\$239.00 pr.



- 1963-1966** All with Aluminum Valve Covers. Chrome Plated.
WRS636\$39.00 pr.



- "AC OIL" Chrome twist on cap.
OC647\$34.50 ea.



Timing Chain Sets with Iron Cam Gear (Includes chain and 2 gears)

- 1934-1949**
1934-1938: Special;
1939-1949: All Special and Super.
TS349\$216.00 set
- 1936-1949** Series 60, 70, 80 and 90.
TS369\$225.00 set
- 1950-1952** Roadmaster.
TS502\$195.00 set
- 1950-1953** Specials and Super with Straight-8 Engine
TS503\$249.50 set
- 1953-1956** All V-8.
TS536\$104.50 set
- 1957-1960** All.
TS576\$149.50 set

Timing Chain Cover



- 1957-1960** All 364, 401,425.
New and Improved
A beautiful high quality reproduction with improved oil passages, a modern front mounted neoprene seal already installed.
Made In USA
TC576.....\$379.50 ea.



ORDER BY PHONE !

908-369-3666

Engine Parts (Group 0)

Rocker Arm Assembly Rebuilding Service

1937-1953 All Straight 8 Engines with mechanical or hydraulic lifters.

RAA373\$549.00 ea.

1953-1958 All. V-8.

RAA538\$399.00 pr.

1959-1960 All.

RAA596\$379.50 pr.

Rocker Arm Shafts (.353)

1953-1960 All. V-8, rocker arm shaft.

RS536\$48.50 ea.

RS536PPair.....\$95.00 pr.

Rocker Arms (0.333)

1953-1960 All V8 Reproduced in steel.

Set includes 16 rocker arms.

RAS536\$225.00 set



1953-1958 V8 Rocker Arm (Exhaust).

Reproduced in **steel**.

RA536E\$17.00 ea.



1953-1955 V8 Rocker Arm (Intake).

Reproduced in **steel**.

RA536I\$17.00 ea.



1959-1960 All 364, 401 engines.

Fits LH 4 Rear and RH 4 Front.

Reproduced in **steel**.

RA596A\$16.00 ea.



1959-1960 All 364, 401 engines.

Fits RH 4 Rear and LH 4 Front.

Reproduced in **steel**.

RA596B\$16.00 ea.

Rocker Arm Adjusting Ball (0.276)

1924 thru 1952 All;

1953 Special. NOT for Hydraulic Lifter Applications.

AB243\$4.25 ea.

1959-1960 All V8 Reproduced in **steel**.

Set includes 16 rocker arms.

RAS536\$208.50 set



Valve Cover and Spark Plug Cover Hardware (.416)



1934-1938 series 40;

1936-1953 All. Straight 8 Engines. Rocker Cover Studs.

RS343\$4.25 ea.



1934-1935 series 40;

1936-1940 All. Straight 8 Engines.

Spark Plug Cover Studs.

CS340\$2.75 ea.



1936-1949 Rocker Cover and Spark Plug Cover Nut.

RN369\$3.00 ea.

W6\$.50 ea.

(Fiber washer for use under RN395)



1950-1955 Rocker Cover Nuts.

(Also fits 1939-1953 Spark Plug Covers).

RN395\$3.00 ea.

W6\$.50 ea.

(Fiber washer for use under RN395)



1953-1956 Spark Plug Cover Nuts.

Also fits Rocker Covers. (.416)

SN536\$3.00 ea.

W6\$.50 ea.

(Fiber washer for use under SN536)



1957-1960 Valve Rocker Cover Bolt Grommet. (4 per car).

VCG572\$3.75 ea.

Freeze Plug Kits (.553) (enough for complete overhaul)



1927-1953 All. Straight 8.

FPK273\$17.50 kit

1953-1960 All V-8.

FPK536\$18.50 kit

Cars, Inc. World Leader in



Parts & Service

Clutch Pressure Plate Replacement Kit

1939-1955

- 1939 -1955:** Series 40;
- 1939 -1953:** Series 50.

Includes NEW Clutch, Pressure Plate, throw out bearing (old collar must be used) Pilot bearing and alignment tool. Features improved 10 1/2" clutch disc.

CPA395\$285.00 kit

Clutch Disc Rebuilding Service

1931-1937

- 1931-1935:** Series 50;
- 1934-1937:** Series 40.

CD317.....10" - 1 1/4.....\$98.50 ea.

1931-1935 Century. 9 7/8" - 1 1/2".

CD315\$98.50 ea.

1936-1937 Series 60, 70, 90.

CD367.....11" - 1 1/4.....\$98.50 ea.

1938 Special.

CD38.....10" - 1 1/8"\$97.50 ea.

1938-1948 10 1/2" - 1 1/8" discs. Series 60, 70, 80 and 90.

CD388\$97.50 ea.

1939-1955 All. 10" x 1 1/8".

- 1939-1952:** Special and Super;
- 1953-1955:** Special.

CD395\$97.50 ea.

CD395R.....New Replacement\$75.00 ea.

1953-1960

- 1953-1955:** Super and Century;
- 1956-1960:** All.

CD530\$97.50 ea.

Clutch Pressure Plate Assembly Rebuilding Service

1934-1956 All.

PP366.....\$167.75 ea.

1957-1963 All.

PP573.....\$197.50 ea.

1940 Series 50,70;



1941 Center;

1942-1953 Outer.

EB403.....\$39.50 ea.

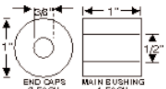

1941-1953 All Standard trans. Kit, clutch equalizer. Kit includes metal sleeved rubber bushing & 2 end seals. (0.806)

EB413\$60.79 kit



1941-1949 All models. Bumper, clutch pedal stop at toe board. (. 832)

PS419.....\$20.29 ea.

Clutch Parts

1939-1955 Special & Super Modern Replacement Pressure

Plate assembly sold with no core charge.

PP395R.....\$125.00 ea.

Matching clutch disc for above.

CD395R\$75.00 ea.



Clutch Parts (0.886)



Clutch Release Equalizer Seal

1941-1960 All.

ES410.....\$6.50 ea.



Clutch Arm Boot

1940-1955 All.

CB405.....\$12.50 ea.

Clutch Throw Out Bearings (.799)

1932 thru 1935 series 50;

1936 series 60-80-90;

1937 All.

TB327\$79.50 ea.

1938 All.

TB38\$51.00 ea.

1939-1955

1939-1952: All Special and Super;

1953-1955: All Specials.

TB395.....(Bearing only)\$37.50 ea.

TB395A.....(Assembly)\$37.50 ea.

1939-1960 Bearing

1939-1952: Series 60, 70, 80 and 90;

1953-1955: Super and Century;

1956-1960: All.

TB416\$59.50 ea.



Clutch Bearing Clip

1938-1960 All.

BC386\$45.00 ea.



Clutch Release Support

1938-1960 All standard transmissions.

CRS380\$46.50 ea.

Clutch Pilot Bearings (.649)

1932-1956

1932-1933 series 50;

1934-1935 series 40,50;

1936-1956 All. Except 1938 Specials & 1939.

PB366.....\$19.50 ea.

1938 Special; 1939 all.

PB389.....\$19.50 ea.

1957-1960 Clutch pilot bearing.

PB570.....\$8.00 ea.



Buick Decals • Tags • Etc. (Group 0)



Decal and Detail Kits

This kit includes 15-23 decals but is not limited to Valve Covers, Glove Box, Jack Instruction, Oil Filter and Air Cleaner decals. Priced to **SAVE!**

Sets include decals that originally came with car. Standard equipment only.

DK36	1936	\$90.00
DK37	1937	\$100.00
DK38	1938	\$100.00
DK39	1939Series 50, 60, 70.....	\$110.00
DK39S	1939Series 40.....	\$100.00
DK40	1940Series 50, 60, 70.....	\$110.00
DK40S	1940Series 40.....	\$110.00
DK41	1941Black value cover decal.....	\$110.00
DK42	1942	\$110.00
DK46	1946	\$110.00
DK47	1947	\$110.00
DK48S	1948Special & Super	\$110.00
DK48	1948Roadmaster.....	\$110.00
DK49	1949	\$110.00
DK50	1950	\$100.00
DK51	1951	\$100.00
DK52	1952	\$100.00
DK53	1953Series 70 & Skylark.....	\$104.50
DK53U	1953Super.....	\$93.50
DK53S	1953Series 40.....	\$100.00
DK54T	1954All 2BBL Models.....	\$100.00
DK54F	1954All 4BBL Models.....	\$100.00
DK55T	1955All 2BBL Models.....	\$90.00
DK55F	1955All 4BBL Models.....	\$100.00
DK56T	1956All 2BBL Models.....	\$86.50
DK56F	1956All 4BBL Models.....	\$92.00
DK57T	1957All 2BBL Models.....	\$87.00
DK57F	1957All 4BBL Models.....	\$94.00
DK58T	1958All 2BBL Models.....	\$87.00
DK58F	1958All 4BBL Models.....	\$99.00
DK59T	1959All 2BBL Models.....	\$105.00
DK59F	1959All 4BBL Models.....	\$87.00
DK60T	1960All 2BBL Models.....	\$89.50
DK60F	1960All 4BBL Models.....	\$88.50

Individual kit decals are not returnable.



D37



D40



D41

Owners Manual Envelopes

D37	1936-1940	\$8.25
D38	1941	\$3.25
D39	1942-1950	\$8.50
D40	1951-1954	\$3.25
D41	1955-1957	\$3.25
D145	1958 All.....	(Beautifully Embossed).....	\$5.75

Engine Compartment Decals/Tags

D1	1931-1960	Generator Warning Tag	\$8.00
D86	1936-1960	Antifreeze Tag.....	\$2.50
D19	1937-1953	Oil Filler Cap Decal.....	\$8.00
D31	1941-1958	Trico Washer Pump Decal	\$4.50
D202	1941-1958	GM Windshield Washer Bracket Decal	\$8.00
* D22	1952-1956	Power Steering Pump Decal	\$5.00
D230	1941-1958	GM Auto. Windshield Washer Decal (yellow).....	\$4.50
D375	1954-1960	Electric Antenna.....	\$8.00
D172	1954-1960	Air Conditioning Compressor Warning Decal.....	\$8.50
D72	1955-1960	Harrison A.C. Tag Metal	\$9.00
D296	1959-1960	Optikleen Bottle Label.....	\$7.50
D178	1959-1960	Cooling System Decal.....	\$8.50
D370	1960	New Car Price Booklet	\$8.00

* Laser cut, looks silk screened.



D1



D5



D71

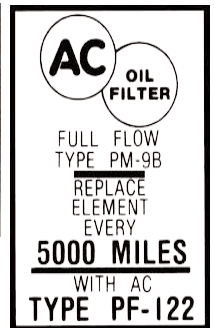

D74

Oil Filter Decals

D3	1930-36	A.C. (W6).....	\$8.00
D4	1937-47	A.C. (L1)	\$8.50
D5	1949-53	A.C. (P127).....	\$8.00
D73	1946-48	"A.C."	\$8.50
D74	1953-58	A.C. (PF122).....	\$8.00



D 108



D 112



D 111



D310



D 117



D 118

Garage Wall, Tool Box Decals

D108	Old Style Buick Logo (blue and white).....	\$8.50
D111	"Genuine Buick Parts" 2" x 2 1/2" Water Transfer.....	\$1.50
D112	"Buick 8" 2" x 2 1/2" Water Transfer.....	\$1.50
D117	"Authorized Service" (10" diameter red, white and blue decal).....	\$8.50
D118	"Authorized Service" (5" diameter red, white and blue decal).....	\$6.50
D310	Tri-Shield 12" (red, white and blue).....	\$9.75
D379	1953-1960 "Air Conditioned" window decal.....	\$8.50
9 D75	"Authorized Buick" Lube Sticker.....	\$2.25



D10

D12



D21



D16



D17

Valve Cover Decals

- D6 **1936-37 "Valve/Head Silent Oil Cushion"**\$11.00
- D19 **1937-1953 Oil Filler Cap decal (silver).....**\$8.00
- D7 **1938 "Buick 8 Dynafash Oil Cushion"**\$9.50
- D8 **1939-1940 Ser. 40 "Dynafash Oil"**\$9.50
- D9 **1939-1940 Ser. 60-70 " Dynafash Oil"**\$9.50
- D10 **1941-1953 "Valve in Head Fireball".**
- D10B **1941-1947 All: Black**
- D10U **1948 Special & Super. Blue**
- D10R **1948 Roadmaster;**
- 1949-1952 All; 1953 Special Red**\$7.25
- *D10RV - SAA, Laser cut, looks silk screened..\$12.50
- D21 **1948-1953 "Hydraulic Lifter" decal.....**\$8.00
- D13 **1950-1953 263 Cubic Inch decal**\$4.50
- D12 **1953-1955 V8 w/ raised covers. (set of two).....**\$8.00
- D184 **1953-60 V-8 Oil Filler Cap decal (orange)**\$3.00



D85

Air Cleaner Decals

- D14 **1935-1936 (Dry Element).....**\$8.00
- D20 **1936-1946 Oil type or Dry style warning (Oval) ..**\$4.00
- D15 **1936-1946(Oil Bath Type).....**\$8.50
- D419 **1931-1934 Dry style air cleaner**\$8.50
- D16 **1946-1953 (All straight 8); 1953 Super**\$6.00
- D17 **1953-1957 4bbl. Carb. (orange. Oil Bath Type) ..**\$4.00
- D16 **1954-1956 2bbl. Carb. (orange).....**\$6.00
- D18 **1957 2BBL Oil Bath Type (white).....**\$4.00
- D173 **1958 2bbl. Air Cleaner (white).....**\$8.50
- D162 **1958 4 bbl. Air Cleaner decal (red)**\$8.75
- D174 **1958 4 bbl. Air Poise Suspension decal (red).....**\$8.50
- D85 **1959-1960 Wildcat 445 (2 piece set on lid).....**\$12.25
- D368 **1959-1960 4bbl Service Inst. on side. A63C**\$8.50
- D182 **1959-1960 2bbl Service Inst. on side. A86C.....**\$8.50



D30



D44



D165

Interior Decals/Tags

- D24 **1936 Glove Box Tire Pressure**\$8.00
- D23 **1936-1960 Owners I.D. Card**\$3.25
- D76 **1936-1937 Battery Warrantee**\$3.50
- D208 **1936-1954 Buick Service Policy.....**\$7.75
- D30 **1934-1958 Glove Box Key Sticker**\$6.00
- D25 **1937 Glove Box Tire Pressure**\$8.00
- D81 **1937-1953 Tire and Wheel Balance Tag**\$8.00
- D82 **1937-1953 Oil and Tire Instruction Tag.....**\$8.00
- D79 **1937-1960 Compass Directions**\$8.50
- D367 **1937-1960 New Car Break-in Tag**\$8.00
- D26 **1938 Glove Box Sticker.....**\$8.00
- D27 **1939-1947 Glove Box Sticker**\$3.75
- D209 **1939-54 Buick Battery Warranty Cert.**\$7.50
- D206 **1940 Electric Clock Instructions**\$8.00
- D207 **1940 Buick New Car**
- Inspection/Adjustment Sheet
- D211 **1940-1954 Chrome Care Instructions**\$7.00
- D71 **1940-1963 Casco Auto. Lighter Tag**
- Interior Decal.....\$7.50
- D28 **1948-1950 Glove Box Sticker**\$2.75
- D29 **1951-1954 Glove Box Sticker**\$2.75
- D385 **1955-1960 Battery Certificate**\$7.50
- D44 **1956-1960 Glove Box Door Sticker.....**\$4.75
- D124 **1957-1958 2-Speed Windshield Wiper Tag.**\$8.00
- D165 **1957-1960 Glove Box "Lacquer Paint".....**\$8.00
- D36 **1958-1959 Autronic Eye Instructions**\$7.00



D33

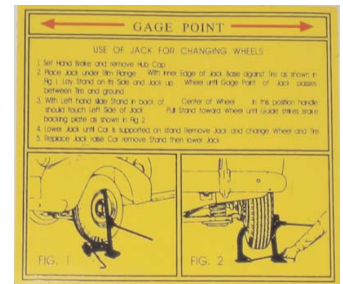

D93

Trunk Decals/Tags

- D93 **1938-1941 Jack Instructions**\$3.50
- D110 **1942-1948 Jack Instructions**\$8.00
- D245 **1949 Jack Instructions**\$8.50
- D32 **1955 Jack Instructions**\$4.00
- D33 **1956 Jack Instructions**\$4.50
- D34 **1957 Jack Instructions**\$8.00
- D113 **1958 Jack Instructions**\$8.00
- D35 **1958-1960 Air Suspension.....**\$7.50
- D356 **1959 Jack Instructions**\$8.25
- D170 **1959-1960 Jack Decal (on Jack).....**\$8.00
- D360 **1960 Jack Instructions**\$8.50

Engine Gaskets (Group 0)

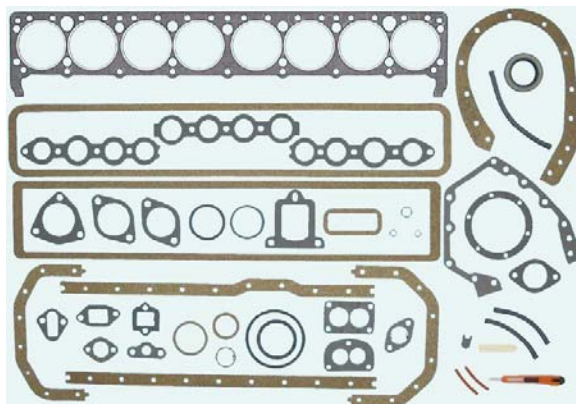

Full Engine Gasket Sets, Head Rebuilding Sets and Head Gaskets

1931-1935 Series 50, 60, 80, 90. Inc composition head gasket.
 FGS315.....Full Rebuilding Set.....\$395.00 ea.
 HG315.....Head Gasket, Series 50.....\$170.00 ea.
 HG315B.....Head Gasket Series 60, 80, 90.....\$190.00 ea.

1934-1949 All Special and Super;
1950 Special. for 233 and 248 engines. prg-346 not included.
 FGS340.....Full Rebuilding Set.....\$150.00 ea.
 HGS349.....Head Rebuilding Set.....\$112.00 ea.
 HG349.....Head Gasket Only.....\$59.50 ea.

1950-1953 All Special and Super. 263 engines.
 FGS503.....Full Rebuilding Set.....\$149.00 ea.
 HGS503.....Head Rebuilding Set.....\$99.50 ea.
 HG503S.....Head Gasket Only. .015.....\$63.50 ea.

1936-1952 Series 60, 70, 80, 90. 320 engines.
 FGS362.....Full Rebuilding Set.....\$215.00 ea.
 HGS362.....Head Rebuilding Set.....\$112.00 ea.
 HG362.....Head Gasket Only. .045.....\$68.50 ea.

1953-1956 All V-8 engines. Includes .015 head gaskets.
 *FGS536S.....Full Rebuilding Set.....\$149.00 ea.
 HGS536.....Head Rebuilding Set.....\$112.00 ea.
 HG536.....Head Gaskets Only.....\$89.50 pr.

1953-1953 All V-8 engines. Includes .015 head gaskets.
 *FGS536S.....Full Rebuilding Set.....\$149.00 ea.

1957-1960 All V-8 engines. Includes .045 head gaskets.
 *FGS576.....Full Rebuilding Set.....\$139.50 ea.
 HGS576.....Head Rebuilding Set.....\$112.00 ea.
 HG576.....Head Gaskets Only.....\$77.50 pr.

* Contains new "rubber lip" timing cover seal!



Timing Cover Gasket Sets

1934-1941 All 248 and 263 straight-8 engines.
 TCS341.....(includes rope seal).....\$27.50 ea.
1942-1953 All 248 and 263 straight-8 engines.
 TCS423.....(includes rubber lip seal).....\$31.50 ea.
1942-1949 All 320 Roadmaster straight-8 engines.
 TCS429.....(includes rubber lip seal).....\$29.50 ea.
1950-1952 All 320 Roadmaster straight-8 engines.
 TCS502.....(includes rubber lip seal).....\$31.50 ea.
1953-1960 All V-8.
 TCS536.....(includes rubber lip seal).....\$20.00 ea.

Timing Cover Gaskets and Seals

1934-1953 All 248 and 263 straight-8 engines. Cover gasket.
 BG13022.....(cork/rubber gasket).....\$10.50 ea.
1934-1953 All 248 and 263 straight-8 engines. Back plate.
 BG10038.....(paper gasket).....\$7.75 ea.
1936-1952 All 60, 70, 80, 90, 320 Engines. Cover gasket.
 BG13023.....(cork/rubber gasket).....\$10.50 ea.
1936-1952 All 60, 70, 80, 90, 320 Engines. Back plate.
 BG10037.....(paper gasket).....\$7.50 ea.
1937-1953 All straight-8 engines. Front rope seal.
 BG7056.....\$9.50 ea.
1942-1953 All 248 and 263 straight-8 engines;
1942-1949 All 60, 70, 80, 90, 320 Engines. Modern lip seal.
 BG3494.....\$19.50 ea.
1950-1952 Roadmaster, 320 Engines. Modern lip seal.
 BG3495.....\$14.50 ea.
1953-1960 All V-8. Cover gasket.
 BG12060.....\$11.75 ea.
1953-1960 All V-8. Front seal. Modern lip seal.
 TCS536L.....\$12.75 ea.

Rear Main Seals

1934-1953 All straight-8 engines;
1957-1960 All. Rear main rope seal.
 RMS346.....\$17.50 ea.
1939-1953 All. Special and Super; **1953** Special.
 Lip seal.
 RMS343M.....\$43.50 ea.
1953-1956 All. V-8 engines. Rope seal set.
 RMS536.....\$17.00 ea.
1957-1960 All. V-8 engines. Rubber lip type seal.
 RMS576.....\$24.50 ea.

Distributor Base Gaskets

1934-1952 All; **1953** Special. Crankcase vent gasket.
 BG4225.....\$4.75 ea.
1934-1952 All; **1953** Special. Distributor base gasket.
 BG1272.....\$3.75 ea.
1953-1960 All V-8. Distributor base gasket.
 BG1634.....\$3.75 ea.



Valve Cover Gaskets

- 1934-1953;**
1934-1952 All Special and Super;
1953 Special.
VCG343.....\$20.50 ea.
- 1936-1952** All Series 60, 70, 80, 90. 320 engines.
VCG362.....\$20.50 ea.
- 1953-1960** All V-8 engines.
VCG536.....\$16.50 pr.
- VCG572.....(Bolt grommets, 4 needed).....\$3.75 ea.

Push Rod Cover Gaskets

- 1934-1936** All Series 40.
PRG346.....\$18.00 ea.
- 1937-1949** All Special and Super;
1950 Special.
PRG370.....\$16.00 ea.
- 1951-1953** All Special.
1950-1952 Super.
PRG503.....\$16.00 ea.
- 1936-1952** All Series 60, 70, 80, 90. 320 engines.
PRG362.....\$16.00 ea.
- 1936-1953** All straight-8 engines. Push rod nut gasket.
PRG363.....(8 req. per car).....\$1.00 ea.









- 1953-1956** All V-8 engines.
PRG536.....\$9.75 ea.
- 1957-1960** All V-8 engines.
PRG576.....\$9.75 ea.

Misc. Oil Gaskets

- 1934-1952** Special & Super; **1953** Special. Oil pump cover.
BG3381.....\$4.50 ea.
- 1934-1952** Special & Super; **1953** Special. Oil pump/block.
BG3292.....\$4.50 ea.
- 1936-1952** Ser. 60, 70, 80, 90. 320 engines. Oil pump mtg.
BG3871.....\$4.75 ea.
- 1953-1956** All V-8 engines. Oil pump inlet. Tri-angular.
BG3484.....\$4.75 ea.
- 1953-1960** All V-8 engines. Oil pump body.
BG2380.....\$4.75 ea.
- 1953-1960** All V-8 engines. Oil filter housing to block.
BG3486.....(except 1957-1958).....\$4.75 ea.
- BG3595.....(1957-1958 only).....\$4.75 ea.
- 1953-1960** All except 1959. Oil pump inlet.
BG2324.....(All except 1959).....\$4.75 ea.
- BG1479.....(1959 only).....\$4.75 ea.
- 1957-1958** All engines. Oil pump body.
BG2469.....\$4.75 ea.

Thermostat Related Gaskets

-  **1933-1953** All straight 8 engines. Water outlet.
WOG330.....\$2.50 ea.
-  **1934-1940** All Special and Super. Thermostat housing.
BG2172.....\$2.75 ea.
-  **1936-1940** All 60, 70, 80, 90 320 engines;
1941-1949 All engines. Thermostat housing.
BG2173.....\$2.75 ea.
-  **1950-1953** All straight 8 engine. Thermostat housing/head.
BG3386.....\$2.75 ea.
-  **1934-1953** All straight 8 engines. Therm. Hsg. bolt seals.
BG134.....(2 needed per car).....\$1.00 ea.
-  **1953-1960** All V-8 Engines. Water outlet.
WOG536.....\$2.25 ea.

Water Pump and Manifold Gaskets

- 1934-1940** All Special and Super. Water pump backing plate.
WPG340.....\$6.50 ea.
- 1941-1953** All straight-8 eng. Water pump backing plate.
WPG413.....\$6.50 ea.
- 1934-1940** All Special and Super. Water pump to block.
BG2204.....\$2.50 ea.
- 1936-1940** All 60, 70, 80, 90 320 engines w/ pump to block;
1941-1949 All engines water pump to block;
1950-1953 All straight-8. Water pump to elbow.
BG2140.....\$2.50 ea.
- 1950-1953** All straight-8 eng. Water pump elbow to block.
BG3015.....\$3.00 ea.
- 1953-1955** All V-8 engines. Water pump mounting gasket.
WPG535.....\$4.50 ea.



- 1953-1960** All V-8 engines. Water manifold seal kit. Contains two end gaskets and center "o" ring.
WMK536.....\$9.50 ea.

- 1956-1960** All V-8 engines. Water pump mounting gasket.
WPG561.....\$5.50 ea.

Oil Pan Gaskets

- 1934-1952** All Special and Super; **1953** Special.
OPG343.....\$17.50 ea.
- 1936-1952** All series 60, 70, 80, 90. 320 engines.
OPG362.....\$17.50 ea.
- 1953-1956** All V-8 engines.
OPG536.....\$15.00 ea.
- 1957-1960** All V-8 engines.
OPG576.....\$15.00 ea.
- 1934-1958** All engines. Fiber oil pan drain plug gasket.
ODG348.....\$2.75 ea.
- ODG348C.....Crushable copper as original.....\$3.00 ea.
- 1959-1960** All. Oil pan drain plug gasket.
ODG595C.....Crushable copper as original.....\$3.00 ea.



Buick Engine Enamel (Group 0)

Original Colors to Authenticate your Engine.
 Our Enamels are the Finest available. Heat
 Resistant to 700° F. Can be Easily Brushed or
 Sprayed to Obtain a Rich Deep Gloss.
 Sold in Quart or Spray Cans.

* Note: Spray cans can NOT be shipped by Air.

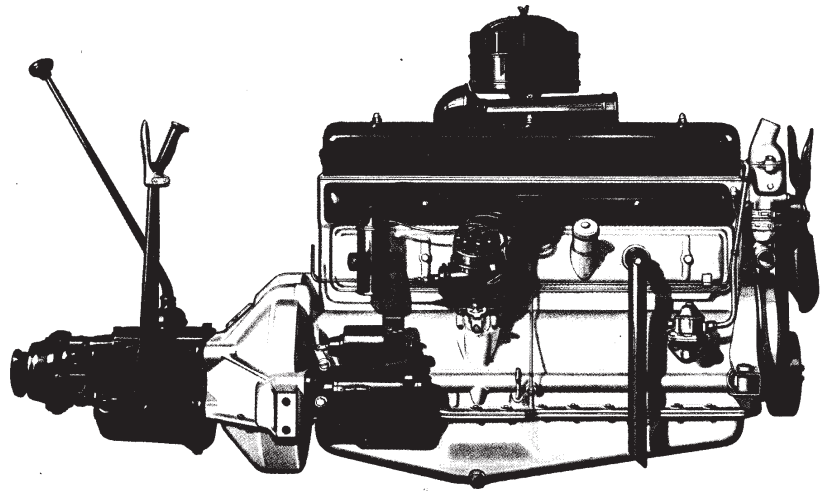

Please Note:
 Spray Cans cannot be shipped by Air.



YEARS
 1932
 1933-1938
 1939-1940
 1941
 1942-1952
 Also 1953
 1953-1960

APPLICATION

Black
 Forest green engine paint
 Gray engine paint
 Dante red engine paint
 Turquoise engine paint
 Series 40 buick turquoise
 All V8 buick green

Quart Cans

EP1.....\$24.50
 EP298.....\$27.50
 EP390.....\$27.50
 EP41.....\$27.50
 EP423.....\$27.50
 EP536.....\$27.50

12 oz. Spray Can

EP1S\$14.00
 EP298S\$14.00
 EP390S.....\$14.00
 EP41S\$14.00
 EP423S\$14.00
 EP536S.....\$14.00



Spray Gun for Engine Enamels

Self-propelled unit enables you to spray up to 16 oz. of paint. Great for use on engine enamels listed above that are not available in spray cans.

SG220.....\$12.50 ea.
 Refill cartridge.
 SGR220\$8.00 ea.

Engine Compartment and Chassis Paint

All years satin black paint. This is correct enamel for frame and engine compartments. Authentic for all years. Excellent for use on fan, radiator, air cleaner, side pans, shroud, etc.

EP2.....(Quart).....\$24.50 ea.
 EP2S.....(12 oz. spray can)\$14.00 ea.

All years universal gloss black. Excellent for engine dress-up, chassis and general use.

EP1.....(Quart).....\$24.50 ea.
 EP1S.....(12 oz. spray can)\$14.00 ea.

Cast Iron Paint

Extremely High Temperature - 1800 degrees. Excellent for manifolds and exhaust systems. **Will not burn OFF.**
 EP3.....(pint).....\$32.00 ea.
 EP3S.....(spray can).....\$19.50 ea.



Optional Dante Red Wheel Paint

Our EP41 and EP41S is also used as a correct replacement for the optional wheel color - Dante red used from 1938 thru 1960.

(Group 1) Grille Emblems • Mouldings



1937
Grille Emblem
GO37....\$68.00 ea.

1939
Vertical Grille Moulding. All Models.
GM39.....\$149.50 ea.



1940
GE40.....\$115.00 ea.



1941
Grille Emblem
GE41...\$149.75 ea.

Cooling • Oiling (Group 1)

Water Pumps (New!) Sold Outright



Years	Part No.	Price
1936-1939 Special; 1940 Special & Super.....	WP340.....	Soon
1936-1940 Series 60-70-80-90; 1941-1949 All.....	WP369.....	\$147.95 ea.
1950-1952 All; 1953 Specials.....	WP503.....	\$147.95 ea.
1953-1955 All V-8 engines - New Water Pump Sold Outright.....	WP535.....	\$137.95 ea.
1956 All.....	WP56.....	\$137.95 ea.
1957 All.....	WP578.....	\$137.95 ea.
1958 All w/o AC	WP578.....	\$137.95 ea.
1958 All with AC Except 5 Bladed Fan.....	WP578.....	\$137.95 ea.
1959-1960 All.....	WP591.....	\$147.95 ea.

Water Pump Exchange or Rebuilding Services (1.069)

Water pumps are freshly re-built to assure long lasting performance. If in stock, they are sold on an exchange basis with a core charge, or send in your pump for fresh rebuild. Core charge will be refunded after your OEM rebuildable pump is returned. **1934-1949** ball bearing type pumps can also be rebuilt on a case by case basis. Allow about 2-4 weeks.



Years	Part No.	Core Charge	Price
1934-1939 Series 40; 1940 Series 40-50.....	WP340EI.....	\$100.00.....	\$118.50 ea.

Water Pump Covers (1.113)

"Backing Plates"

1934 thru 1940 All straight 8. WPC340.....	\$ 28.00 ea.
1936-1940 Series 60, 70, 80, 90; 1941 thru 1953 All straight 8. WPC363.....	\$ 19.50 ea.

Water Pump & Engine Nipple

1934-1960 all. For 5/8" heater hose as required. WPN341.....	\$ 6.95 ea.
1948-1953 Dynaflo water pump nipple. WPN483.....	\$ 9.50 ea.



Water Pump Hardware Kits











You never have to worry about breaking another bolt. High strength stainless steel bolts will never rust.

1934-1939 Special; 1940 Special & Super. WPH340.....	\$ 4.25 kit
1950-1953 All Straight-8 engines. WPH503.....	\$4.25 kit
1953-1958 all V-8. WPH538.....	\$ 11.75 kit



Radiator Hoses

Our radiator hoses are pre-formed as the originals, (no flex type), to fit and look authentic. Some may come longer and need minor trimming.

	Year	(1.159)	Upper Hose Part No.	Lower Hose Part No.		
	1934-1938	Specials	UH360	LH360	\$13.50	\$19.50
UH 360	1936-1938	Series 60-70-90	UH360	LH360	\$13.50	\$19.50
	1936-1953	By-pass hose	BP363			\$ 4.00
	1939-1940	Specials and Supers.	UH393	LH393	\$15.75	\$18.50
	1939-1940	Series 60-70	UH393	LH393	\$15.75	\$18.50
	1939-1940	Series 80-90	UH360	LH360	\$13.50	\$19.50
	1941	Specials and Supers	UH413	LH41	\$15.75	\$18.50
LH 41	1941	All 320 engines	UH413	LH393	\$15.75	\$18.50
	1942-1947	Series 40-50 to frame #14717304	LH429	LH429	\$18.50	\$18.50
LH 429	1942-1947	Series 60-70-90	UH478	LH393	\$18.50	\$18.50
	1947	Series 40-50 after frame #14717304	UH478	LH429	\$18.50	\$18.50
UH 478	1948-1949	Special and Super.	UH478	LH429	\$18.50	\$18.50
	1948	Roadmaster before frame #14710654	UH478	LH393	\$18.50	\$18.50
UH 428	1948	Ser. 70 after #14710654	UH478	LH393	\$18.50	\$18.50
	1949-1952	Roadmaster.	UH428	LH393	\$20.00	\$18.50
UH 54	1950-1952	Series 40-50; 1953 Series 40	UH413	LH393	\$13.50	\$18.50
	1953	Super, Roadmaster and Skylark	UH428	LH536	\$20.00	\$18.50
UH 57	1954-1956	All	UH54	LH536	\$18.50	\$18.50
	1957	All	UH57	LH570	\$17.50	\$19.50
UH 58	1958	All	UH58	LH570	\$18.75	\$19.50
	1959	All	UH590	LH570	\$18.75	\$19.50
UH 590	1960	All	UH590		\$18.75	
	1934-1960	Radiator drain cock. Brass.	DV344			\$6.75 ea.

Radiator Hose Clamps

These are the correct "Wittek Tower Top" hose clamps. They are correct for all 1941-1960 models.

2 1/16" Diameter fits most upper hose. This is a stock size.
HC216.....\$2.75 ea.



2" Diameter fits most upper hose. Smaller than stock.
HC200.....\$2.75 ea.

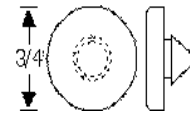

1956-1959 Bumper, radiator fan shroud as required.
HB429.....\$2.25 ea.

Cooling System Seal Tabs

Developed by GM for sealing and stabilization of your cooling system. Highly recommended by Buick engineers for all older cars. Pack of 6 non-toxic tabs.



CT300.....\$6.00 pack

Wire Hose Clamps



For 9/16" diameter hose.
HC916W.....\$ 1.00 ea.
HC916WP.....(5 Pack).....\$ 3.25 ea.

For 3/4" diameter hose.
HC340W.....\$ 0.75 ea.
HC340WP.....(5 Pack).....\$ 3.25 ea.

For 13/16" diameter hose.
HC1316W.....\$ 1.00 ea.
HC1316WP.....(5 Pack).....\$ 4.25 ea.

For 15/16" diameter hose.
HC1516W.....\$ 0.75 ea.
HC1516WP.....(5 Pack).....\$ 4.25 ea.

For 1" diameter hose.
HC100W.....\$ 1.00 ea.
HC100WP.....(5 Pack).....\$ 4.25 ea.

For 1-1/4" diameter hose.
HC114W.....\$ 1.00 ea.
HC114WP.....(5 Pack).....\$ 5.00 ea.

For 2" diameter hose.
HC200W.....\$ 2.75 ea.
HC200WP.....(5 Pack).....\$12.25 ea.

Buick Fan Belts, Power Steering,

AC Belts (1.416)



Please note that 1953-1960 belts are also offered as 100% authentically correct. They feature a flat un-cogged surface for a smooth and quiet ride, comes with the original GM numbers, stamped right into the belt.

		Cars	Part #	
1934-1939	*Specials.....		FB340.....	\$22.50 ea.
1936-1939	Series 60-80-90.....		FB369.....	\$32.00 ea.
1940	All Special & Super.....		FB40S.....	\$27.50 ea.
1940	Series 60-70-80-90.....		FB40B.....	\$29.50 ea.
1941-1949	Special & Super.....		FB419S.....	\$21.00 ea.
1941-1949	*Series 60-70-90.....		FB419B.....	\$37.50 ea.
1950	All Special & Super.....		FB340.....	\$22.50 ea.
1950	Roadmasters.....		FB50B.....	\$25.50 ea.
1951-1952	Roadmaster.....		FB512.....	\$17.50 ea.
1951-1952	Special & Super; 1953 Specials.....		FB513.....	\$15.00 ea.
1953	All V-8 Fan/Gen Belt		FB530.....	\$19.75 ea.
	Exact Reproduction.....		FB1343438.....	\$34.50 ea.
1953	All V-8 Power Steering Belt		FB530.....	\$19.75 ea.
	Exact Reproduction.....		FB1343438.....	\$34.50 ea.
1953	All V-8 Matched Pair Belt Set		FB53S.....	\$35.00 pr.
	Exact Reproduction.....		FB1343438S.....	\$65.00 pr.
1954-1957	All Fan/Gen Belt w/o AC ;			
1957	Fan/Gen Belt w/ AC Early ..		FB548.....	\$19.75 ea.
1954	Power Steering Belt		FB548.....	\$19.75 ea.
	Exact Reproduction.....		FB1163447.....	\$34.50 ea.
1954 & 1956	All Fan/Gen Belts . Matched Pair.....		FB548S.....	\$37.50 pr.
	Exact Reproduction.....		FB1163447S.....	\$65.00 pr.
1955-1956	Power Steering Belt		FB556.....	\$23.50 ea.
1957	All Late Fan/Gen Belt w/ AC		FB578A	\$22.50 ea.
1957	All w/o AC and 1" type w/ AC2 Power Steering Belt		FB578.....	\$22.50 ea.
	Exact Reproduction.....		FB1163447.....	\$34.50 ea.
1957	All Early. AC Belt		FB57E.....	\$22.50 ea.
1957	All Late. AC Belt		FB57E.....	\$22.50 ea.
1958	All Fan/Gen Belt w/ AC		FB578A	\$22.50 ea.
1958	All Fan/Gen Belt w/o AC ...		FB548.....	\$21.00 ea.
	Exact Reproduction.....		FB1180978.....	\$34.50 ea.
1958	All w/o AC or Air Ride Power Steering Belt		FB578.....	\$22.50 ea.
1958	All AC Belts (uses 2 belts)		FB58S.....	\$43.50 pr.
1959-1960	All Fan/Gen Belt w/o AC ...		FB530.....	\$19.75 ea.
	Exact Reproduction.....		FB1188358.....	\$34.50 ea.
1959-1960	All Fan/Gen/AC Belts 364 eng. Uses 2 belts.....		FB590S.....	\$43.50 pr.
	Exact Reproduction.....		FB1180978S.....	\$65.00 pr.
1959-1960	All Fan/Gen/AC Belts 401 eng. Uses 2 belts.....		FB590S.....	\$43.50 pr.
1959-1960	All Power Steering Belt		FB591.....	\$22.50 ea.

* Not as wide as original

Water Outlets (1.153)



1954-1957 Thermo. Housing water outlet and gasket.
WO547\$19.75 ea.

WOB536.....Bolts & Washers for Above.....\$3.75 ea.

1958-1960 Thermo. Housing water outlet and gasket.
WO581.....\$29.50 kit
WOB536.....Bolts & Washers for Above.....\$3.75 ea.



Temperature Sending Unit

1960 All.
TSU608\$19.75 ea.

Thermostats (1.246)

All thermostats include gaskets



1933-1953 All except 1953 V-8.
T330180°\$9.75 ea.
T330L160°\$9.75 ea.
T330H.....195°\$9.75 ea.
WOG330.....Gasket for Above\$2.25 ea.

1953-1960 All V-8 Engines.
T536180°\$9.75 ea.
T536L.....160°\$9.75 ea.
T536H195°\$9.75 ea.
WOG536.....Gasket for Above.....\$2.25 ea.





RC2

Radiator Caps



RC10

Take a good look at these caps. They are identical to the originals. Correct in every detail, they feature the cap number, instructions and of course genuine "AC" identification stamped right into the cadmium plated surface. Show quality, approved and licensed by Buick.

1934-1936 All	
RC2	\$39.50 ea.
1937-1939 All. Non-pressure. No detail.	
RC10	\$36.50 ea.
1940-1946 All;	
1947 up to frame 14717305 on Special and Super; up to frame 14710656 on Roadmaster. 7 lb.	
RC13	\$33.50 ea.
1947 after frame 14717305 on Special and Super; after frame 14710656 on Roadmaster; 4lb.	
1948 All	
RC509	\$33.50 ea.
1949 Roadmaster Early. 13lb. cap.	
RC559	\$33.50 ea.
1949 all Special and Super. Roadmaster Late;	
1950 thru 1956 All. 7 lb.	
RC549	\$33.50 ea.
1957-1960 All. 15 lb.	
RC15D	\$33.50 ea.

Replacement Radiator Caps



1937-1939 All. Non-pressure.	
RC379	\$10.50 ea.



1940-1947 All. 7 lb.	
RC407	\$10.50 ea.



1948-1949 All. 4 lb.	
RC489	\$13.50 ea.



1950-1956 All. 7 lb.	
RC506	\$10.50 ea.



1957-1960 All. 15 lb.	
RC579	\$16.50 ea.

Heater Hose



HH58.....5/8".....	\$1.10 per foot
HH5850.....5/8".....	\$43.50 per 50 feet
HH34.....3/4".....	\$1.10 per foot
HH3450.....3/4".....	\$43.50 per 50 feet

Heater Hose Clamps (1.066)



Buick used "**Tower Top**" Heater hose clamps on all cars from **1942-1960**. We supply a reproduction identical to the clamp made by the Wittek Company. They are authentic and correct. Measure your OD.

1942-1960 "Tower Top" Heater hose clamps. All GM.	
HC340.....(for 3/4" hose with 1 1/4" OD).....	\$2.75 ea.
HC340S.....(for 3/4" hose with 1 3/16" OD).....	\$2.75 ea.
HC580.....(for 5/8" hose with 1 1/16" OD).....	\$2.75 ea.
HC580S.....(for 5/8" hose with 1" OD).....	\$2.75 ea.



www.oldbuickparts.com

908-369-3666

Oil Pump Rebuilding Service

- 1936-1937** Specials.
 OP367RS\$129.50 ea.
- 1938-1952**
 1938-1940: Series 60, 70, 80, 90;
 1946-1952: Roadmaster.
 OP382RS\$129.50 ea.
- 1938-1953**
 1938-1939: Special;
 1940-1952: Special and Super;
 1953: Special.
 OP383RS\$129.50 ea.
- 1953** V-8 Oil pump.
 OP53RS\$129.50 ea.
- 1954-1956** Oil pump.
 OP546RS\$129.50 ea.
- 1957-1958** Oil pump rebuilt.
 OP578RS.....Oil pump only\$299.00 ea.
- 1959-1960** With engine 401 engine oil pump.
 OP591RS.....\$107.00 ea.

Oil Pump Kits (1.652)



- 1934-1939** Special and Super.
 OPK349\$96.50 ea.
- 1936-1952** Century, Roadmaster w/ 320 eng, oil pump kit.
 OPK362\$96.50 ea.
- 1940-1952** Special and Super; **1953** Special. Oil pump kit.
 OPK403\$96.50 ea.
- 1953-1956** All V-8 engines. Oil pump kit.
 OPK536\$96.50 ea.
- 1957-1958** Oil pump kit.
 OPK578\$87.80 ea.
- 1959-1960** All. Oil pump kit.
 OPK591\$96.50 ea.

ZDDP Oil Supplement - 4 oz. Bottle



ZDDPlus is a oil additive that contains high concentraions of Zinc Diakyl Dithiophosphate, which has been the primary extreme pressure ingredient now missing from modern day motor oils.

This is a must in all flat-tappet engines!

ZDDP.....\$14.00 ea.

ZDDP5.....(5 bottles).....\$39.95



Oil Filter Elements (1.836)



1939-1947 All. (Replaces AC-P112)
 OF397\$18.50 ea.



1948 All except Roadmaster with hydraulic lifters. (Replaces AC-P115)
 OF48\$16.00 ea.



1948-1953 (Replaces AC-P127)
 1948: Roadmaster with hydraulic lifters;
 1949-1952: All;
 1953: Specials.
 OF493\$15.00 ea.



1953-1958 All V-8. (Replaces AC-P122)
 OF538\$15.50 ea.



1959-1960 All. (Replaces AC-PF24)
 OF596\$11.00 ea.

Oil Pan Drain Plugs & Gaskets (1.453)

1929-1937 All. Self treading 11/16" oversize. Plug w/ gasket.
 OP297\$4.00 set

1938-1958 All. Self threading 5/8" oversize. Plug w/ gasket.
 OP388\$5.75 set

1934-1958 All engines. Drain plug gasket.
 ODG348.....Nylon\$2.75 ea.
 ODG348C.....Crushable copper\$3.00 ea.



1959-1960 1/2", x 20 thread. Plug w/ gasket.
 OP595.....\$5.50 set



1959-1960 All. Drain plug gasket.
 ODG595.....Nylon.....\$2.50 ea.
 ODG595C.....Crushable copper.....\$3.00 ea.



Oil Pressure Switch



1960 All.
 OPS606.....\$11.75 set

Oil Filter/Breather Caps (1.758)

1936-1960 All. Twist on type. Genuine "AC" reproduction with embossed letters. Show quality.





OC397.....Black.....\$34.50 ea.
 OC647.....Chrome.....\$39.50 ea.

1939-1960 All. Twist on type. Aftermarket replacement.
 OC397A\$9.75 ea.

1953-1955 V-8 All. Push in type. Aftermarket replacement.
 OC535.....\$7.50 ea.











Cooling • Oiling Gaskets (Group 1)

Thermostat Related Gaskets

-  **1933-1953** All straight 8 engines. Water outlet.
WOG330\$2.50 ea.
-  **1934-1940** All Special & Super. Thermostat housing.
BG2172\$2.75 ea.
-  **1936-1940** All 60, 70, 80, 90 320 engines;
1941-1949 All engines. Thermostat housing.
BG2173\$3.00 ea.
-  **1950-1953** All straight 8 engine. Thermostat
housing/head.
BG3386\$2.75 ea.
-  **1934-1953** All straight 8 engines. Therm. Hsg.
bolt seals.
BG134.....(2 needed per car)\$1.00 ea.

-  **1953-1960** All V-8 engines. Water outlet.
WOG536\$2.25 ea.

Water Pump & Manifold Gaskets









-  **1934-1940** All Special and Super. Water pump
backing plate.
WPG340\$4.95 ea.
-  **1936-1940** Series 60, 70, 80, 90 engines w/
water pump backing plate;
1941-1953 All straight-8 eng. Water pump
backing plate.
WPG413\$4.95 ea.
-  **1934-1940** All Special and Super. Water pump
to block.
BG2204\$2.75 ea.
-  **1936-1940** All 60, 70, 80, 90 320 engines w/
pump to block;
-  **1941-1949** All engines water pump to block;
-  **1950-1953** All straight-8 engines. Water pump
to elbow.
BG2140\$3.00 ea.
-  **1950-1953** All straight-8 eng. Water pump
elbow to block.
BG3015\$3.00 ea.
-  **1953-1955** All V-8 engines. Water pump
mounting gasket.
WPG535\$4.75 ea.
-  **1953-1960** All V-8 engines. Water manifold
seal kit. Contains two end gaskets and center
"o" ring.
WMK536\$9.00 ea.
-  **1956-1960** All V-8 engines. Water pump
mounting gasket.
WPG561\$4.75 ea.



Oil Pan Gaskets

- 1934-1952** All Special and Super; **1953** Special.
OPG343\$17.50 ea.
- 1936-1952** All series 60, 70, 80, 90. 320 engines.
OPG362\$17.50 ea.
- 1953-1956** All V-8 engines.
OPG536\$15.00 ea.
- 1957-1960** All V-8 engines.
OPG576\$14.50 ea.

Misc. Oil Gaskets

-  **1934-1958** All engines. Oil pan drain plug
gasket.
ODG348.....\$2.75 ea.
-  **1934-1952** Special and Super; **1953** Special.
Oil pump cover.
BG3381.....\$4.50 ea.
-  **1934-1952** Special and Super;
1953 Special. Oil pump/block.
BG3292.....\$4.50 ea.
-  **1936-1952** Ser. 60, 70, 80, 90. 320 engines.
Oil pump mtg.
BG3871.....\$4.50 ea.
-  **1953-1956** All V-8 engines. Oil pump inlet.
triangular.
BG3484.....\$4.50 ea.
-  **1953-1960** All V-8 engines.
Oil pump body.
BG2380.....\$4.50 ea.
-  **1953-1960** All V-8 engines. Oil filter housing
to block.
BG3486.....(except 1957-1958)\$4.50 ea.
BG3595.....(1957-1958 only)\$4.50 ea.
-  **1953-1960** All except 1959. Oil pump inlet.
BG2324.....(All except 1959).....\$4.50 ea.
BG1479.....(1959 only).....\$4.50 ea.
-  **1957-1958** All engines. Oil pump body.
BG2469.....\$4.50 ea.

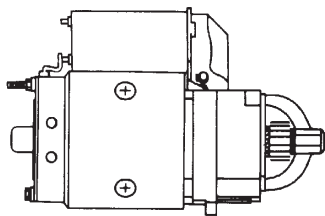

Starter Rebuilding Service

*Does Not Include Solenoid
Ask About Outright Sales*

- 1934-1938** Special.
S348.....Solenoid not included.....\$194.50 ea.
1936-1938 Series 60-80-90.
S368.....Solenoid not included.....\$194.50 ea.
1939-1950
 1939: Special;
 1940-1950: Special and Super.
S390.....Solenoid not included.....\$199.50 ea.
1939-1950 Roadmaster.
S390B.....Solenoid not included.....\$194.50 ea.
1951-1953
 1951-1952: Special and Super;
 1953: Special.
S513.....\$194.50 ea.
1951-1952 Roadmaster.
S512.....\$194.50 ea.
1953 Super and Roadmaster.
S53.....\$194.50 ea.
1954-1956 All.
S546.....\$194.50 ea.
1957-1958 All.
S578.....\$189.50 ea.
1959-1960 All.
S590.....\$189.50 ea.

Starter Band

- 1928-1953:** All.
SB283.....\$9.50 ea.



Starter ID Tag



- 1931-1960** Delco, starter, gen., and distributor ID tag.
ET6....(ALL 6 VOLT)....\$7.00 ea.
ET12...(ALL 12 VOLT)...\$7.00 ea.

Starter Brush Sets

- 1935-1952;**
1953 Series 40.
SBS353.....\$5.50 set
1953-1960 All V-8.
SBS539.....\$6.50 set



Starter Solenoid Boots



- 1934-1950** All. Solenoid boot. Cover on starter motor solenoid. (2.140)
SB420.....\$8.50 ea.



- 1951-1956** Starter solenoid boot.
SB516.....\$11.50 ea.

Starter Solenoids (2.100)



- 1934-1941** All. (Rebuilding Service).
SS341.....\$189.50 ea.
1942-1950 All Engines. (Sold Outright).
SS420.....\$129.50 ea.
1951-1953
 1951-1952: Special and Super;
 1953: Special. (Sold Outright).
SS513.....\$129.50 ea.
1953 All V-8 Engines. (Rebuilding Service).
SS53.....\$249.50 ea.
1954-1956 All. (Sold Outright).
SS546.....\$64.50 ea.
1957-1960 All. (Sold Outright).
SS575.....\$38.50 ea.

Starter Solenoid Repair Kit



- 1957-1960** All.
SRK570.....\$24.50 kit

Starter Drives

- 1932-1953**
 1932-1952: All;
 1953: Specials.
SD393.....\$51.00 ea.
1953 All V-8.
SD53.....\$49.50 ea.
1954-1956 All.
SD546.....\$41.00 ea.
1957-1960 Starter drive.
SD571.....\$57.00 ea.



Starter Relay (2.127)

- 1953-1960** All 12V.
SR530.....\$59.50 ea.



Horn Contact Separator



- 1938-1949** Special;
1940 Super.
HS389.....\$47.69 ea.

Starter Motor End Bushings



- 1931-1952** Series 60, 70, 80, 90 - drive end.
SB282D.....\$3.75 ea.
1931-1952 Series 60, 70, 80, 90 - center.
SB282C.....\$3.00 ea.
1931-1952 Series 40, 50;
1953 Series 40 - drive end.
SB313D.....\$3.75 ea.

Ignition Parts (Group 2)

Years	POINT SET (2.384) 	CONDENSER (2.393) 	DIST. CAP (2.367) 	ROTOR (2.382) 	IGNITION COIL (2.170) 	COMPLETE TUNE UP KITS 8 Spark Plugs, Points, Rotor, Condenser, Cap, Wire Set. Complete \$94.50
1937	D103.....\$11.50	D203...\$6.00	D302..\$16.50	D401...\$8.00	IC373...\$26.50	TK37
1938-1952;	D103.....\$11.50	D203...\$6.00	D302..\$16.50	D401...\$8.00	IC373...\$26.50	TK383
1953 Special	D103.....\$11.50	D203...\$6.00	D302..\$16.50	D401...\$8.00	IC373...\$26.50	TK383
1953-1956 V-8	D104.....\$13.50	D203...\$6.00	D305..\$16.50	D403...\$16.50	IC539...\$26.50	TK536
1957-1958	D106.....\$16.50	D204...\$6.00	D308..\$13.50	D409...\$7.50	IC539...\$26.50	TK576
1958-1959	D106.....\$16.50	D204...\$6.00	D308..\$13.50	D409...\$7.50	IC539...\$26.50	TK590



Ignition Switch

1949: Super & Roadmaster;
1950-1953: All;
1956-1958: All.
 IS498\$44.95 ea.

Delco Ignition Points

1937-1953 Original Delco Ignition Points.
 IP373N\$27.50 ea.
1953-1956 All V-8 Original Delco Ignitions Points.
 IP536N\$26.50 ea.

Original Ignition Lock Cylinder With 2 Keys

1935-1939 All
 IL359.....\$19.50 ea. 
1941-1953:
1941-1950: All;
1951-1953: Super, Roadmaster & Skylark.
 IL413.....\$52.50 ea.
1951-1953 Specials;
1954-1956 Same
 IL513\$28.00 ea.
1957-1960 All
 IL359\$19.50 ea.
1941-1960 All, replacement type. (non original).
 IL414.....\$19.50 kit

Key Blanks-Genuine GM

1933-1960 Octagon.
 KB10.....\$4.50 ea.
1933-1960 Rounded.
 KB11.....\$4.50 ea.

Spark Plugs (2.270)

 SP86 **1929-1937** All\$3.25 ea.
 SP45R **1938-1942** All\$2.95 ea.
 SP45R **1946-1949** All\$2.95 ea.
 SP45R **1950-1952;** All **1953** Ser 40\$2.95 ea.
 SP45R **1953-1957** All V-8 (use #45)...\$2.95 ea.
 SP45R **1958** All\$2.95 ea.
 SPR43S **1959-1960** All\$2.95 ea.







Spark Plug Boots

1953-1956 All V-8.
 SB536\$3.00 ea.
1957-1960 Spark plug boots (8 per car).
 Use with original type copper core ignition wires.
 SB577\$3.00 ea.

Spark Plug Wire Sets

1936-1952 All; **1953** Series 40.
1953-1956 All V-8.
 IW366S\$45.00 set
1957-1960 All.
 IW576.....\$29.50 set

Spark Plug Wire Grommets, etc.

1936-1953 All Straight-8 spark plug wire retainers. 4 piece set.
 WR363\$27.50 set

1953 Oblong for spark plug wire clip at right rear head. Uses two per car. Series 50 and 70.
 WG53C\$29.29 pr

1953 Trapezoidal style under spark plug cover flange at right end of both sides. One pair per car. Series 50 and 70.
 WG53\$15.45 ea.

1954-1956 (4 per car).
 WG546\$7.50 ea.

1957-1958 (4 per car).
 WG578\$4.95 ea.

1959-1960 Ignition wire retainer.
 WR596\$4.25 ea.



www.oldbuickparts.com

Never Change Points Again!

Upgrade to an electronic ignition. Fits entirely inside the distributor.

Installs as quickly as changing a set of points. No black boxes, complicated wiring or special brackets. Only two wires to connect.

IGNITOR ELECTRONIC IGNITION KITS

NO.

PRICE

8 CYLINDER

1937-1953 All Straight 8, 6 volt, negative ground	PI1183N6	\$125.00
1937-1953 All Straight 8, 12 volt, negative ground (original distributor)	PI1183	\$122.00
1953-1956 All V-8 Mechanical advance under baseplate	PI1185LS	\$99.50
1957-1974 All V-8 Except 215, 300, 340 Engines	PI1181LS	\$95.00
1957-1974 All V-8	PI1181	\$95.00
1957-1974 All V-8 (Ignitor II)	PI91181	\$122.00

6 CYLINDER

1968-1974 All	PI1162A	\$99.00
1962-1967 V-6 Engine	PI1164	\$99.00
1962-1967 V-6 Engine (Odd Fire)	PI1165	\$99.00

HIGH PERFORMANCE COIL

1937-1953 All Straight 8, 6 volt, negative ground (Black)	PC45011	\$39.50
1937-1953 All Straight 8, 6 volt, negative ground (Chrome)	PC45001	\$49.50
1953-1974 All (Black)	PC40011	\$39.50
1953-1974 All (Chrome) 12 v	PC40001	\$46.50
1953-1974 All (For Ignitor II applications only - Chrome) 12 v	PC45001	\$49.50
1953-1974 All (For Ignitor II applications only - Black) 12 v	PC45011	\$39.50
Coil Bracket	CB350	\$6.50
Coil Bracket (Chrome)	CB350C	\$11.50

HIGH PERFORMANCE SPARK PLUG WIRES

Low 500 ohm/ft. resistance with spiral wound alloy to suppress electromagnetic radiation plus redundant current paths.

V-8 7.0mm Stock-Look Custom Set

1953-1960 All	PW708103	\$46.50
1960-1967 Special, Skylark, GS (Ex 1967 GS 400)	PW708103	\$46.50
1967-1966 LeSabre, Wildcat, Invicta, Electra, Riviera All 364, 401, 425 Engines	PW708105	\$44.50
1967 GS-400	PW708102	\$44.50
1968-1974 All 350, 400, 430, 455 w/o HEI	PW708102	\$44.50

6 CYLINDER 7.0mm STOCK-LOOK Custom Set

1968-1974 ALL	PW706101	\$44.50
---------------------	----------	---------

Ignition Parts (Group 2)

Battery Cable Covers (2.343)

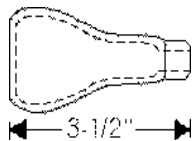

1931-1960 Battery cable cover. Two per car.
CC315\$6.25 ea.

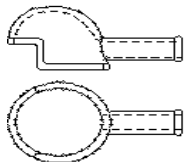

1932-1960 All. Battery cable cover. Located on switch side and junction block. (Two per car).
CC325.....\$6.25 ea.

Battery Cables

Ground Cables (-) (2.341)

- BC9 **1931-1932** All; **1933** series 60,80,90;
1934-1935 Series 40, 60, 90;
1936-1937 All;
1950-1951 Special and Super;
1953 Special.....\$15.00 ea.
- BC13 **1933-1935** Series 50;
1938-1949 All;
1950-1952 Roadmaster.....\$16.00 ea.
- BC19 **1953** Ser. 50-70; **1954-56**;
1958-60\$18.50 ea.
- BC24 **1957**\$19.50 ea.



Switch Cables (+) (2.342)

- BC48 **1933-1937** All\$39.50 ea.
- BC17 **1938-1953** All Straight 8;
1958-1960 All\$16.50 ea.
- BC14 **1953** All V-8 engines;
1957 All\$17.00 ea.
- BC19 **1954-1956** All.\$17.50 ea.



See Wire Loom, page 25 cover some battery cables.

Switch to Starter Cable



1953-1960
1953-1956: All;
1959-1960: All.
SC32\$30.00 ea.



1953-1958 Battery Cable Terminal Block. Fits All V-8 Engines.
TB538.....\$59.50 ea.

Battery Hold Down Clamps (2.335)

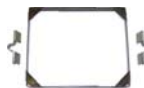

1932-1937 All series 40 and 50.
BC327\$34.50 ea.



1939-1949 All with shield.
BC399\$67.50 ea.



1939-1953 All straight 8 w/o shield.
BC393\$49.50 ea.



1955-1957 All.
BC557\$61.00 ea.



1960 All. Rubber coated as original.
BC602\$42.00 ea.

Battery Parts (9.775) 2 per car



1939-1953
1939-1952: All;
1953: Series 40 Battery hold down. Grommet.
BG393.....\$3.00 ea.



1953-1958 Battery cushion. Attaches to battery hold. (4 per car).
BC548\$2.75 ea.

Battery Top Louvre



1953 Super, Roadmaster and Skylark.
BL53\$49.50 ea.

Battery Hold Down Bolts (2.334)



1939-1953 All. Battery hold down kits. Kit contains 2 bolts, 2 grommets, 2 wing nuts, and 2 washers.
BK393\$12.25 set

1954-1958 All. Battery hold down kits. Kit contains 2 bolts, 2 washers, 2 wing nuts, 4 (BC548) cushions.
BK548\$17.25 ea.



1960 All, two needed per car. Includes washer and wing nut.
BB602\$6.50 ea.

Generator Rebuilding Service

Ask About Outright Sales

G356	1935-1936 Special and Super	\$289.50
G36	1936 Series 60, 80, and 90.....	\$289.50
G37	1937 Special.....	\$289.50
G3B	1937 Series 60, 80, and 90.....	\$289.50
G389	1938-1939 All.....	\$289.50
G409	1940-1948 All; 1949 Special.....	\$215.00
G491	1949 Super and Roadmaster; 1950-1951 All.....	\$215.00
G523	1952 All; 1953 Special.....	\$215.00
G536	1953-1956 All V-8.....	\$215.00
G57	1957 Without air conditioning	\$215.00
G57A	1957 All with air conditioning	\$215.00
G58	1958 Without air conditioning	\$215.00
G58A	1958 All with air conditioning	\$215.00
G59	1959 Without air conditioning	\$215.00
G59A	1959 All with air conditioning	\$215.00
G602	1960 Without air conditioning	\$215.00
G60A	1960 All with air conditioning	\$215.00

Generator Brush Sets (2.285)



Part No.	Years	
GBS359	1935-1939 All.....	\$9.95 set
GBS401	1940-1951 All.....	\$5.75 set
GBS527	1952-1957 All.....	\$6.50 set
GBS401	1958-1960 All.....	\$5.75 set

Generator Bearings (2.306)



1941-1960 Generator front bearing.	
GEB412	\$8.75 ea.
1934-1952 Generator com. end bushing.	
GEB302	\$9.75 ea.
1954-1957 Generator rear bearing. (2.298)	
GEB547	\$17.75 ea.
1958-1960 Generator rear bearing.	
GEB581	\$15.75 ea.

Generator Pulley (2.274)

1957-1960 All without air conditioning. Single Pulley.	
AP575	\$33.25 ea.

Generator I.D. Tag

1931-1960 Delco, starter, generator and distributor ID tag.	
ET6.....(ALL 6 VOLT)....	\$7.00 ea.
ET12...(ALL 12 VOLT)....	\$7.00 ea.



Generator Band



1929-1952 All.	
GB292	\$10.50 ea.

Generator Oiler



1929-1960 As Required.	
GO292.....	\$9.50 ea.

Voltage Regulators (2.500)



1940-1953 All 6 volt replacement.	
VR403	\$89.50 ea.
1953-1956 All, 12 volt replacement.	
VR536	\$79.50 ea.
1957-1960 1957 All ;1958-1960 All with out A.C.	
VR572	\$69.50 ea.
1958-1960 All with A.C. - replacement.	
VR582A.....	\$99.50 ea.

Coil Resistor



1953-1960 Coil resistor on firewall.	
CR533.....	\$11.50 ea.

Horn Relay (2.815)



1937-1953 All six volt replacement horn relay.	
HR373	\$19.50 ea.
1953-1956 All V-8.	
HR536	\$18.00 ea.
1957-1958 All.	
HR578	\$13.25 ea.
1959-1960 All.	

Ignition Switch



1949 Super And Roadmaster.	
1950-1953 All.	
1956-1958 All.	
IS498	\$44.95 ea.
HR590	\$79.75 ea.

Electrical (Group 2)

Distributor Adjusting Tool

1957-1960 All.
DT575\$10.00 ea.

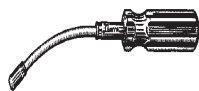

Universal Coil Bracket

With mount for Radio Capacitor.

CB350\$6.50 ea.
CB350C.....Chrome.....\$11.75 ea.



CB303.....gold iradite as pictured.....\$6.50 ea.

Distributor Rebuilding Service (2.361)

1934-1953
1934-1952: All;
1953: Special.
D343\$325.50 ea.
1954-1958 All. Does not include vacuum.
D548\$167.50 ea.
1959-1960 All.
D596\$167.50 ea.

Distributor Vacuum Control Rebuilding Service (2.410)

1937-1952 All.
VC372RS\$66.00 ea.
1953 Special.
VC53RS\$66.00 ea.
1953 Super, Roadmaster, Skylark; 1954-1956 All.
VC536RS\$66.00 ea.
1957-1959 All.
VC579RS\$66.00 ea.



1960 All. Sold outright.
VC600\$17.50 ea.



Electronic Distributor

Now available for the Vintage Buick Straight 8 is the high performance DUI Distributor! This high powered ignition will light the fire in the straight 8 like never before. Built with our popular Street Strip DUI Coil, you can open the plug gaps to a massive .055"! Also included is the high dwell Dyna-Module which allows the coil to produce a longer duration spark over stock ignitions. The advance curve is custom tuned to provide the most power throughout the RPM range with no pre-detonation. Additional benefits are quicker starting, smoother idle and it is all electronic - NO POINTS! Installation is easy with only one wire required for hookup Bring your straight 8 up to date by adding some serious firepower with the DUI! Comes with easy to follow instructions and is backed by a one year warranty.

- Simple One Wire Hookup
- Allows for Wider Plug Gaps
- All Electronic Ignition - No Points
- 50,000 Volt Coil and Dyna Module
- Performance Tuned Advance Curve
- Increased Horsepower and Fuel Mileage



1936-1953 (12 volt only) 248, 263, 320 engines.
DUI383\$395.00 ea.
State cap color: Black, Red, Blue, Yellow or Clear.

1957-1966 Nailhead high performance distributor.
Buick 264, 322, 364, 401, 425 V-8 engines.
DUI536\$395.00 ea.
State cap color: Black, Red, Blue, Yellow or Clear.

Live Wires® are a high quality, low resistance set of spark plug wires designed to deliver all of the spark energy from the coil to the plugs. Built with a high temperature sleeve that protects the plug wire from the extreme under hood temperatures. Inside this high temperature sleeve is an 8mm stainless steel spiral wire wrapped around a magnetic core with a durable and lasting silicone jacket. Creating an extremely low resistance for optimum spark travel.

Live Wires



IW383B.....(Black).....\$119.50 ea.*
IW383R.....(Red).....\$119.50 ea.*
IW383U.....(Blue).....\$119.50 ea.*
IW383P.....(Purple).....\$119.50 ea.*
IW383Y.....(Yellow).....\$119.50 ea.*
IW383S.....(Sliver).....\$121.00 ea.*

*** For use with DUI383 ONLY.**

IW576B.....(Black).....\$109.00 ea.*
IW576R.....(Red).....\$109.00 ea.*
IW576U.....(Blue).....\$109.00 ea.*
IW576P.....(Purple).....\$109.00 ea.*
IW576Y.....(Yellow).....\$109.00 ea.*
IW576S.....(Sliver).....\$121.00 ea.*

*** For use with DUI536 Electronic Distributor**

Headlamp Doors (Rims) (2.728)

1940 All. stainless steel. Perfect reproduction.
 HD40\$50.00 ea.
1940 All. Completely assembled with our HR407 rubber seal and HC402 clips.
 HD40A\$59.75 ea.
 HDS408.....Retaining Screw\$3.25 ea.
1941 All. Headlamp door.
 HD41\$23.25 ea.
 HDS408.....Retaining Screw\$3.25 ea.
1942-1948 All. Headlamp door.
 HD428\$26.50 ea.
 HDS408.....Retaining Screw\$3.25 ea.
1942-1948; 1949 Special Headlamp spear.
 HS429\$12.50 ea.
1949-1952 Headlight door. Stainless steel.
 HD492\$55.00 ea.
 HDS492.....Retaining Screw\$2.25 ea.

Headlamp Mounting Ring

1940-1954 All; **1955** First Type.
 HMR405.....\$27.50 ea.

Headlamp Bucket Assembly

1949-1952 All. Less Bulb.
 HB492.....\$94.50 ea.

Headlamp Retainers

1940-1954 All;
1955 First type.
 Chrome plated. Beautiful!
 HR405.....\$27.50 ea.
1956-1957 All.
 HR567.....\$27.50 ea.
1940-1960 Retainer screw.
 HS400.....\$1.25 ea.

Headlamp Seals

1940-1957
1940 All;
1949 Super & Roadmaster;
1950-1957 all except 1955.
 HB407.....\$12.75 pr.
1941-1949. (For 9" dia. seals)
1941-1948 All;
1949 Specials.
 HB419.....\$14.50 pr.
1955 All.
 HB55.....\$38.59 pr.

Headlamp Bucket Grommet



1940 thru 1957 All.
 BG407.....\$7.50 ea.

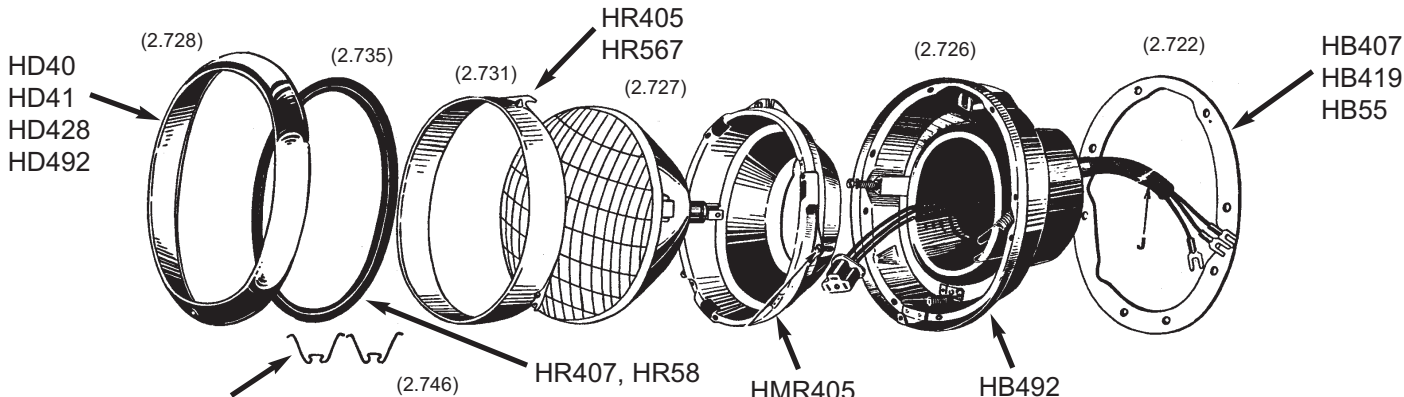

1936-1939 All. Headlamp retaining clips. 3 clips per set. Stainless steel. 2 sets per car.
 HC369.....\$5.50 set
1940-1952 All. Headlamp rim seal retaining clips. 4 clips per set. Stainless steel. Two sets per car.
 HC402.....\$6.25 set

1940-1957 Headlamp door seals.
 HR407.....\$18.50 pr.
1958 All.
 HR58.....\$52.29 pr.

1958 All. Headlamp to fender seals.
 HB58.....\$59.69 pr.
1958-1960 All;
 Headlamp adjusting screw assembly.
 HA582.....\$3.50 ea.

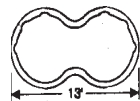

"Guide" Genuine T-3 Headlamps (2.727)

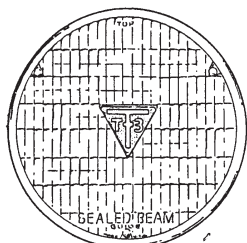

1956-1957
 Two Hi/Low Beams.
 SB567S.....TOS

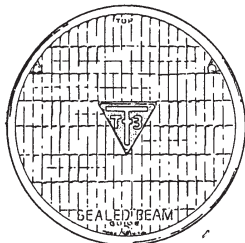

1958-1959
 Two Hi/Low Beams
 Two Hi Beams.
 SB589S.....TOS

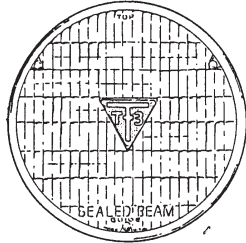

1960
 Two Hi/Low Beams
 Two Hi Beams.
 SB607S.....\$149.00 set

Replacement Sealed Beams (2.727)

1940-1953 Headlamp sealed beam, 6 volt. (Halogen)
 SB6.....\$12.50 ea.

1953-1957 12 volt.
 SB12.....\$11.00 ea.

1958-1960 All. Headlamp sealed beam. #1, high beam. Two terminals.
 SB1.....\$11.00 ea.

1958-1960 All. Headlamp sealed beam. #2, low beam. Three terminals.
 SB2.....\$11.00 ea.

Headlamps and Parts (Group 2)

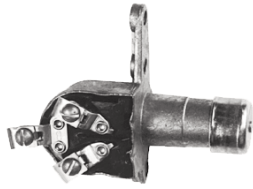

Headlamp Dimmer Switches

1934-1958

1934-1956 All;
1957-1958 All, except with Autronic Eye.

HDS348.....\$19.50 ea.

1959-1960 All, except with Autronic Eye.

HDS590.....\$24.50 ea.

Headlamp Terminal Junction Blocks



1936-1939 (6 prongs).

JB369.....\$21.50 ea.

1940-1951 (8 prongs).

JB401.....\$19.50 ea.



1952-1955

JB525.....\$21.00 ea.

Headlamp Mounting Pads



1934-1935 For 3 1/4" x 6 1/4" base,
non-symmetrical. Series 50, 60 and 90.

HLP345B.....\$73.99 pr.

1934-1935 Headlight bracket to fender.
Right and left. Series 40.

HLP345.....\$52.99 pr.

1936 All series.

HLP36.....\$33.50 pr.

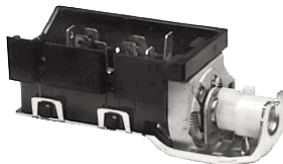

Headlamp Switches

1949-1953 All 6 volt aftermarket replacement type.

HS493.....\$49.50 ea.

1959-1960 All. OEM replacement type.

HS593.....\$49.50 ea.

Wire Loom

Asphalt coated fabric. Wire loom for battery
cables, headlamps, wire etc.



WL180	1/8" ID	\$1.85 ft.
WL316	3/16" ID	\$1.85 ft.
WL140	1/4" ID	\$2.10 ft.
WL516	5/16" ID	\$2.10 ft.
WL380	3/8" ID	\$2.10 ft.
WL716	7/16" ID	\$2.10 ft.
WL120	1/2" ID	\$2.10 ft.
WL916	9/16" ID	\$2.40 ft.
WL580	5/8" ID	\$2.40 ft.
WL340	3/4" ID	\$2.40 ft.

Woven Wire Mesh Split Loom



WWL316	3/16" ID	\$1.75 ft.
WWL380	3/8" ID	\$2.00 ft.
WWL120	1/2" ID	\$2.50 ft.
WWL340	3/4" ID	\$3.00 ft.
WWL100	1" ID	\$3.50 ft.

Headlamp Wiring Grommets



1936 Grommet, headlight wiring from
headlight bulb through mounting brace.
Series 40.

WG36.....\$40.99 pr.



1936-1941 Electric wire through body for
head and tail lights. 3/8" I.D. for 11/16" hole.
WG361.....\$2.25 ea.

New Halogen Headlamp Technology for Your Old Buick

One of the weakest systems in older cars is the quality of
lighting. Night driving is particularly unsafe due to low
levels of candlepower. Modern technology has developed
state of the art **Halogen Head-lamps** now available for
your Buick.

1940-1953

Two Hi/Low 6V
Halogen Beams.

SB6H.....\$86.50 set

1953-1957

Two Hi/Low
Halogen 12V Beams.













SB12X.....\$49.50 set



Park Lamp Pads

-  **1936** All. Parking lamp mounting pads.
PLP36.....\$57.79 pr.
-  **1937** All. Parking lamp mounting pads.
PLP37.....\$34.50 pr.
-  **1938** All. Parking lamp mounting pads.
PLP38.....\$33.00 pr.
-  **1939** All. Parking lamp mounting pads.
PLP39.....\$52.39 pr.
-  **1940** All. Parking lamp mounting pads.
PLP40.....\$47.00 pr.
-  **1941** All. Parking lamp mounting pads.
PLP41.....\$72.50 pr.
-  **1942-1948** Super and Roadmaster parking lamp mounting pads.
PLP428.....\$16.25 pr.
-  **1953-1954** All (Lamp to body gasket).
PLP534.....\$9.75 pr.

Front Parking Lens Gaskets

-  **1936-1938** All.
PLG368.....\$5.50 pr.
-  **1939** All.
PLG39.....\$5.50 pr.
-  **1941** All.
PLG41.....\$9.75 pr.
-  **1946-1949**
1946-1948: All; 1949: Specials.
PLG469.....\$4.50 pr.
-  **1949** Super and Roadmaster.
Four gaskets for two lamps.
PLG49.....\$8.00 pr.
-  **1950-1952** All.
PLG502.....\$8.50 pr.
-  **1953-1954** All.
PLG534.....\$7.00 pr.
-  **1955** All Special and Century.
PLG55.....\$5.75 pr.
-  **1955** Super and Roadmaster.
PLG55B.....\$11.00 pr.
-  **1956-1957** All.
PLG567.....\$6.00 pr.
-  **1958** All.
PLG58.....\$6.50 pr.
-  **1959** All.
PLG59.....\$22.50 pr.

Parking Lens Door Gaskets

-  **1953-1954** Replaces #5944066. Made from soft durable rubber.
PLDG534.....\$46.39 pr.



Front Parking Lamp Lenses

-  **1936** All.
PL36.....\$24.50 ea.
-  **1937-1938** All. Includes gaskets
PL378.....\$39.50 ea
-  **1939** All.
PL39.....TOS
-  **1941** All.
PL41.....\$39.50 ea.
-  **1946-1949**
1946-1948 All;
1949 Specials.
PL469.....TOS
-  **1949** All Super and Roadmaster.
PL49.....\$35.00 ea.
-  **1950-1952** All. "Guide".
PL502.....\$20.00 ea.
-  **1953-1954** All. "Guide".
PL534.....\$20.00 ea.
-  **1955** Special and Century. "Guide".
PL55.....\$20.00 ea.
-  **1955** Super and Roadmaster.
PL55B.....\$28.50 ea.
-  **1956-1957** All. "Guide".
PL567.....\$25.00 ea.
-  **1958** All. "Guide".
PL58.....\$28.50 ea.

Fender Lights

-  **1936-1938** Replacement. These lamps are quality made but not exact reproductions.
PL300.....\$185.50 pr.

Parking Lamp Doors

-  **1946-1949**
1946-1948 All; 1949 Special.
LD469.....\$39.50 ea.
-  **1950-1952**
1950 All; 1951-1952 Super & Roadmaster.
LD503.....\$20.00 ea.
-  Highly Polished Stainless Steel Screws
LDS503.....\$2.95 ea.

Tail Lamps (Group 2)

Tail Lamp Lenses (2.682)



All Cars; Blue dot glass lenses with chrome ring.
BD360.....\$12.75 pr.

1939-1940 Special & Centruy
Plastic Replacement
TL390.....\$32.00 ea.



1940 Super and Roadmaster. Glass
as original.
TL40R.....(R.H. Side).....\$21.50 ea.
TL40L.....(L.H. Side).....\$21.50 ea.



1942-1948 Super and Roadmaster.
Both sides.



TL428P.....\$69.50 pr.



1949 Super and Roadmaster.
TL49.....\$30.00 ea.

1950-1952 "Guide".

1950: All;
1951-1952: Super and Roadmaster.

TL502.....\$36.50 ea.

1951-1952 Specials.

TL512.....\$37.50 ea.



TL53 TL54

1953 All. Four per car. "Guide" imprint.
Brass ferrules and deep red color as
original. Licensed by GM. Beware of
cheap imitations!

TL53.....\$17.50 ea.



TL55 TL56

1954 All except Skylark. "Guide" imprint.
Brass ferrules and deep red color as
originals. Four per car. Licensed by GM.

TL54.....\$24.50 ea.

1955 All. "Guide".

TL55.....\$39.50 ea.
S26.....Correct Stainless Screws.....\$1.15 ea.

1956 All. "Guide".

TL56.....\$43.50 ea.

1957 All. Stop lamp lens.

SL57.....\$37.50 ea.

1957 Special and Century.

TL57.....\$40.00 ea.

1957 Special & Rdmstr. No marking on lens.

TL57B.....\$54.50 ea.

1958 Special & Century. No marking on lens.

TL58S.....\$89.50 ea.

1958 Special & Century. No marking on lens.

TL58B.....\$89.50 ea.

1958 Special & Century. No marking on lens.

TL58L.....\$99.50 ea.

1959 All. Tail lamp lens. No marking on lens.

TL59.....\$47.50 ea.

1960 All. Tail lamp lens.

TL60.....\$47.50 ea.

Tail Lamp Lens Gaskets (2.684)

1936 Tail lamp lens gasket.

TLG36.....\$5.00 pr.



1937 All.

TLG37.....\$6.50 pr.

1938-1940

1938: All;

1939-1940: Series 80-90.

TLG380.....\$7.75 pr.



1939-1940 Special and Century, Tail lamp lens
gasket.

TLG390.....\$7.50 pr.

1942-1948 All.

TLG428.....\$12.50 pr.



1949 Super and Roadmaster, 4 piece tail lamp
gasket set.

TLG49.....(For Two Lamps).....\$11.50 pr.

1950-1952

1950: All;

1951-1952: Super and Roadmaster.

TLG502.....\$9.75 pr.



1951-1952 Special.

TLG512.....\$8.00 pr.

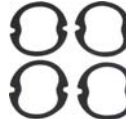

1953 All.

TLG53S.....(Set of 4).....\$9.75 set

1954 All except Skylark.

TLG54S.....(Set of 4).....\$9.75 set



1955 Tail lamp lens gaskets.

TLG55.....\$9.50 pr.

1956 Tail lamp lens gaskets.

TLG56.....\$9.50 pr.



1957 Special and Century.

TLG57.....\$9.50 pr.

1957 Super and Roadmaster.

TLG57B.....\$9.00 pr.



1957 All. (for oval stop lamp lens).

SLG57.....\$7.25 pr.

1958 all Special and Century.

TLG58S.....\$44.50 pr.



1958 Super and Roadmaster.

TLG58B.....\$50.19 pr.

1960 All.

TLG60.....\$50.19 pr.



Tail Lamp Mounting Pads (2.660)



1933-1935 All Series.
TLP335.....\$57.89 pr.



1936 All Series.
TLP36.....\$36.00 pr.



1937 Special and Century.
TLP37.....\$36.00 pr.

1937 Series 80 and 90.
TLP37B.....\$73.99 pr.



1938 Special and Century.
TLP38.....\$34.50 pr.

1938-1940 Series 80 and 90.
TLP380.....\$75.99 pr.



1939-1940 Special and Century.
TLP390.....\$26.50 pr.



1939-1940 Super and Roadmaster.
TLP40.....\$47.50 pr.

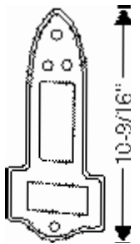

1941 Four door touring Sedan and four door convertible. Phaeton. Models 51, 51C, 71, 71C.
TLP41A.....\$103.79 pr.

1941 Series 50 ,70 coupes and convertible coupes. Models 56, 56C, 56S, 76C, 76S.
TLP41B.....\$105.79 pr.

1941-1942 Series 90 only.
TLP41C.....\$129.89 pr.



1937-1959 Horn Contact Wire
1937-1959 All.
HCW379.....\$21.75 ea.



Horn Button Lens
1939-1940 Clear horn button lens.
HBL390.....\$20.00 ea.



Directional Signal Return Spring
1955-1960 All.
CS550.....\$12.75 ea.

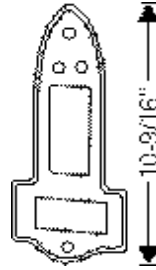

1941-1949
1941-1942: Model 41, 41 SE, 61;
1946-1949: Model 41.
TLP41D.....\$103.79 pr.

1941-1949
1941-1942: Series 40 and 60 coupes;
1946-1949: Model 46S.
TLP41E.....\$103.79 pr.



1942-1948 Super and Roadmaster.
TLP428.....\$33.50 pr.

1950-1952
1950: All Series;
1951-1952: Super and Roadmaster.
TLP502.....\$8.50 pr.



1951-1952 Specials.
TLP512.....\$25.75 pr.



1953 All. Seal, tail lamp bodies to fender.
Four required per car. Four in set. (2.685)
TLP53.....\$121.19 set



1954 All. Tail lamp rubber mounting pad.
Four required per car. (Except Skylark)
TLP54.....\$88.50 set



1954 Skylark. Seal, tail lamp to fender. (8.204)
TLP54S.....\$91.00 pr.

1955-1957 All. 2 55" pieces enough for both sides.
TLP557.....\$21.00 pr.

TLP557



Tail Lamp Parts (Group 2)



1949 Gasket junction block for taillight wiring. One pair per car. Series 50 & 70.
 TWG49.....\$9.69 pr.

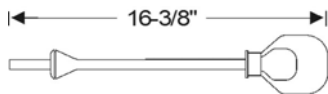

1950-1951 Boot and hose, tail lamp wiring. Four piece set includes end covers.

1950: all models;
1951: Series 50 and 70.

TWB501.....\$151.99 set

1942-1948 Tail Lamp Bezels

Die cast chrome. Fits either side.



1942-1948 Super & Roadmaster. These parts are sold as "seconds". They may have small pitting or imperfections in the chrome. Great for the "driver". For Super and Roadmaster series.

TB428BS.....\$29.75 ea.

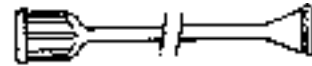

1953 Boot, tail lamp and turn signal wiring. Excellent quality tubing with correct molded ends. Order two pair per car.

TWB53.....(All except Skylark).....\$102.99 pr.
 TWB53X.....(Skylark - 4 piece set).....\$291.69 set

1954 All except Skylark. Seal, reflector signal, between taillights. A smaller replacement for 1953.

RS534.....\$30.99 pr.

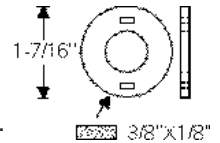

1950-1952 Tail Lamp Bezel



Die cast chrome. Fits either side.

Beautiful reproduction.

1950: All;
1951-1952: Super and Roadmaster.

TB502.....\$41.00 ea.

Screws for Above.

LDS502.....\$3.25 ea.



Tail Lamp Reflex



1956: All;
1958: Limited.

TR508.....\$15.00 ea.

NOTICE CAR SHOW ATTENDEES FREE DELIVERIES

We will be happy to bring any parts you need.

Please call in advance of the show to place your order.

Look For Us!

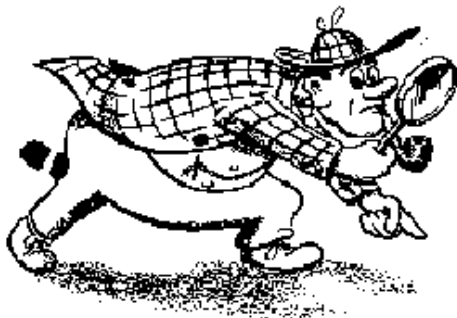

If your thinking of attending any of the shows listed below, be sure to stop by and say "Hello". We will be glad to discuss some of our newest items or simply talk about your **BUICK**.

Plan ahead by calling-in your order weeks ahead of time. We will be able to bring your entire order and save you shipping too.

GS Nationals
Buick Nationals
 *Hershey GDB 31-34
 (Near Lamp Post 86)

Back-up Lenses (2.697)



1950-1953 "Guide".
1950: All;
1951-1953: Super, Roadmaster, Skylark.
 BL503\$19.50 ea.



1951-1953 Special.
 BL513\$18.50 ea.



1955 All. "Guide"
 BL55\$22.50 ea.
 S26.....Correct Stainless Screws ...\$1.15 ea.



1956 All. "Guide".
 BL56\$34.50 ea.



1957 all. "Guide".
 BL57\$39.50 ea.



1958 Special & Century. No marking on lens.
 BL58\$49.50 ea.

Back-up Lens Gaskets



1949 All Super and Roadmaster. Gaskets.
 BLG49\$8.59 pr.



1950-1953
1950 all:
1951-1953: Super, Roadmaster, Skylark.
 BLG503\$5.00 pr.



1951-1953 All Specials.
 BLG513\$4.50 pr.



1955 Back-up lamp lens gaskets.
 BLG55\$6.00 pr.



1956 Back-up lamp lens gaskets.
 BLG56\$6.50 pr.



1957 All.
 BLG57\$7.50 pr.



1958 Super, Roadmaster, Limited
 BLG58...lens to housing gaskets...\$12.50 pr.
 BBG58.....bezel to lens gasket\$16.50 pr.

Turn Signal Bulb Housing Gasket

1939-1940 1/8" Die cut sponge rubber.
 DHG390.....\$34.19 ea.

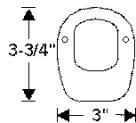

License Lamp Gasket Set

1946-1960 Gasket set, rear license lamp assembly. One rubber ring and one cork rubber gasket comprise set.

1946-1947: Series 50 and 70;

1950-1953: All series;

1958: Roadmaster;

1959: Station Wagons.



LG462\$12.29 set

Back-up Lamp Parts

1949 Gasket, back up light housing.
 One pair per car. All Super and Roadmasters (except station wagons).
 BLP49.....\$46.99 pr.



1949 Series 50 and 70. Seal, backup lamp housing to inside of body. One pair per car.
 BLS49.....\$8.59 pr.



1950-1963 Back-up lamp door chrome plated steel.

1950: All;

1951-1953: Super, Roadmaster and Skylark.
 LD503.....\$19.50 ea.



Screws for the above. Correct highly polished stainless steel.

LDS503\$2.95 ea.



1951-1953 Special deluxe back-up light chrome ring.
 BR513\$34.50 ea.

License Lenses

1938-1949;
1938-1941 All;
1942 Series 40, 60, 90;
1946-1949 Special.



LL389



LLG389



LLC389

LL389.....\$13.50 ea.
 LLG389.....Gasket for Above.....\$4.00 ea.
 LLC389....Chrome Cover for Above-not Exact...\$17.50 ea.

1954-1955 All.



LL545L.....LH Side.....\$17.50 ea.

LL545R.....RH Side.....\$17.50 ea.

LLG545.....(Gaskets).....\$6.50 pr.



1956 License Lamp Lens.

LL56.....\$23.00 ea.

LLG56.....(Gasket).....\$3.50 ea.



1959 License Lamp Lens.

LL59.....\$51.00 ea.

License Light Wire Grommet

1941-1948 Buick Most Models. Through decklid inner panel. 1 1/4" O.D. x 3/8" I.D. 1/4" thick for 1" hole in sheet metal.

LG418.....\$2.39 ea.

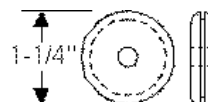

Bulbs and Fuses (Group 2)



Bulbs (8.991)



Year & Model	Head-light	Parking	Direction Front	Signal Rear	Tail	Stop	License Plate	Instru-ment	Indicator	Dome	Back-up
'35-'36	B2330/B2331	B55	----	----	B63	B87	B63	B55	B51	B81	----
'37, '38, '39	B2330/B2331	B55	-----	-----	B1154	B1154	B63	B55	B51	B81	----
'40	SB6	B1154	B1154	-----	B1154	B1154	B63	B55	B51	B81	-----
'41	SB6	B1154	B1154	-----	B1154	B1154	B63	B55	B51	B82	-----
'42	SB6	B1154	B1154	B1129	B1154	B1154	B63	B55	B51	B88	-----
'46-'49 (series 40)	SB6	B1154	B1154	B1129	B1154	B1154	B63	B55	B51	B81	B82
'46-'48 (ser. 50, 70)	SB6	B1154	B1154	B1154	B1154	B1154	B63	B55	B51	B81	B82
'49 (series 50 & 70)	SB6	B1154	B1154	B1154	B1154	B1154	B63	B55	B51	B88	B1129
'50	SB6	B1154	B1154	B1129	B1154	B1154	B63	B55	B51	B88	B1129
'51-'52	SB6	B63 B1154	B1154	B1129	B1154	B1154	B63	B55	----	B88	B1129 B1133
'53 (series 40)	SB6	B1154	B1154	B1129	B1154	B1154	B63	B55	B51	B210	B1133
'53 (ser. 50-70 12V)	SB12	B1034	B1034	B1073	B1034	B1034	B67	B57	B53	B1004	B1073
'54	SB12	B1034	B1034	B1073	B1034	B1034	B67	B57	B53	B90 B1004	B1073
'55	SB12	B1034	B1034	B1034	B1034	B1034	B67	B57	B53	B90 B1004	B1073
'56	SB12	B1034	B1034	B1034	B1034	B1034	B67	B57	B57	B90 B1004	B1073
'57	SB12	B1034	B1034	B1073	B67	B1073	B67	B57	B53	B90 B1004	B1073
'58	SB1, SB2	B1034	B1034	B1034	B1034	B1034	B67	B57	B57	B90 B1004	B1073
59	SB1, SB2	B1034	B1034	B1034	B1034	B1034	B67	B57	B57	B90 B1004	B1073
'60	SB1, SB2	B1034	B1034	B1034	B1034	B1034	B67	B5357	B57	B90 B1004	B1073

Prices: **B51**-\$1.50, **B53**-\$1.50, **B55**-\$1.50, **B57**-\$1.25, **B63**-\$1.25, **B67**-\$1.50, **B81**-\$1.75, **B82**-\$1.50, **B87**-\$2.00, **B88**-\$2.50, **B89**-\$2.00, **B90**-\$2., **B210**-\$5.25, **B1000**-\$5.75, **B1004**-\$2.75, **B1034**-\$2.75, **B1073**-\$2.75, **B1129**-\$2.75, **B1133**-\$4.00, **B1154**-\$2.00, **B1157**-\$2.00, **B2330**-\$8.75, **B2331** (High Intensity Bulb)-\$18.50, **SB1**-\$11.25, **SB2**-\$12.50, **SB6**-\$12.50, **SB12**-\$12.25.



Fog Lamp Kit

All years as required. Two 5 " 12 volt amber lamps in chrome housings. Easy mounting stud with wire.
 FL300.....\$69.50 pr.

Signal Flashers



1941-1953 All. Six volt directional signal flasher.
 SF413.....\$12.75 ea.
1953-1960 All 12 volt.
 SF530.....\$10.75 ea.



www.oldbuickparts.com

908-369-3666

Headlamp Sockets



For 3 prong beam numbers SB6, 6006, SB12, 6012, SB2, 4000 and 4002.
PT6\$4.75 ea.



For 2 prong beam numbers SB1, 4001.
PT7\$4.25 ea.

Lamp Sockets and Pigtails



Single contact with lead. Fits bulb numbers 51, 53, 55 and 57.
PT1\$2.25 ea.

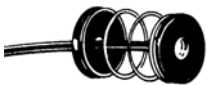

Single contact with lead. Fits bulb numbers 63, 67, 81, 87, 89, 1073, 1129, 1133, 1141 and 1156.
PT2\$2.25 ea.

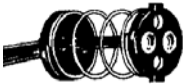

Double contact with lead. For ears reversed. Bulbs numbers 82, 88, 90, 210, 1004, 1034, 1154 and 1157.
PT3\$2.75 ea.



Double contact with lead. For ears aligned bulbs.
PT4\$2.50 ea.

Parking and Tail Lamp Sockets

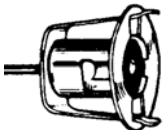

Single contact with lead. For 3/4" to 1 1/8" hole.
LS1\$4.25 ea.

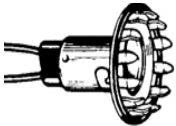

Double contact with lead. For bulb numbers 1034 and 1154. Fits 1 1/8" hole.
LS5\$5.75 ea.

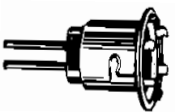

Double contact with leads. Fits 3/4" hole. For bulb numbers 1034, 1154 and 1157.
LS9\$5.75 ea.



Double contact with leads. Fits 3/4" to 1 1/8" hole. For bulb numbers 1034, 1154 and 1157.
LS2\$5.75 ea.



Double contact with leads. Fits 3/4" to 1 1/8" hole. For bulb numbers 82, 88, 90, 210 and 1004.
LS3\$7.90 ea.



Double contact with leads. Fits 1 1/8" hole. For bulb numbers 1034, 1154 and 1157.
LS4\$5.75 ea.

Interior/Dash Sockets



Single contact with lead for dome etc. For bulb numbers 63, 67, 81 89, 1073, 1129 and 1133.
PT8\$8.75 ea.



Double contact with lead. For dome and map lamps. Reversed ears. Bulb numbers 82, 88, 90, 210 and 1004.
PT9\$7.00 ea.



Double contact with lead for ears aligned bulbs.
PT10\$2.50 ea.

Back-Up and License Lamp Sockets

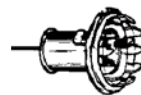

Single contact with lead. Fits 3/4" hole. Bulb numbers 63, 67, 81, 89 1129 and 1133.
LS6\$5.75 ea.



Single contact with lead. Fits 1 1/8" hole with ground wire. For bulb numbers 63, 67, 81, 89, 1129 and 1133.
LS7TOS



Single contact with lead. Fits 1 1/8" hole. For bulb numbers 63, 67, 81, 89, 1129 and 1133.
LS8\$6.00 ea.

Wiring Harnesses (Group 2)

Each harness is manufactured with factory color code specifications and made from patterns developed from original Buick harnesses. Each wire is tagged or identified individually for easy installation. We offer the largest selection of Buick harnesses found anywhere. Don't see your particular harness listed here? We can develop a new harness from your old one. Please call for more information.

[Early] 1936 BUICK Special / Series 40

[Headlight Switch had 8 Terminals]

WH3640EM.....Main Lighting Harness.....	\$779.75
WH3640EHG.....Horn Button Ground Wire	\$8.00
WH3640EDE..... Dash and Engine Harness	\$273.50
WH3640EI..... Instrument Light Wiring	\$10.75
WH3640ECL.....Cigar Lighter Wire	\$5.50
WH3640EC.....Clock Harness	\$59.75
WH3640EFT..... Fuel Tank Connector Wire	\$6.75
WH3640EGS..... Engine Ground Strap	\$41.00

[Late] 1936 BUICK Special / Series 40

[Headlight Switch had 10 Terminals]

WH3640LHB..... Headlight Bucket Wires [pair]	\$54.25
WH3640LFL..... Fender Light Bucket Wires [pair]	\$46.75
WH3640LM..... Main Lighting Harness	\$773.75
WH3640LHG.....Horn Button Ground Wire	\$8.00
WH3640LDE.....Dash and Engine Harness	\$273.50
WH3640LI..... Instrument Light Wiring	\$12.00
WH3640LCL.....Cigar Lighter Wire	\$6.75
WH3640LC.....Clock Harness	\$59.75
WH3640LFT.....Fuel Tank Connector Wire	\$6.75
WH3640LGS.....Engine Ground Strap	\$41.00

[Late] 1936 BUICK Century / Series 60

[Headlight Switch had 10 Terminals]

WH3660LHB..... Headlight Bucket Wires [pair]	\$54.25
WH3660LFL..... Fender Light Bucket Wires [pair]	\$46.75
WH3660LM.....Main Lighting Harness	\$743.00
WH3660LHG.....Horn Button Ground Wire	\$8.00
WH3660LDE..... Dash and Engine Harness	\$276.00
WH3660LI..... Instrument Light Wiring	\$12.00
WH3660LCL.....Cigar Lighter Wire	\$6.75
WH3660LC.....Clock Harness	\$59.75
WH3660LDL4.....Dome Light Wiring [4dr.sedan]	\$14.50
WH3660LDL2.....Dome Light Wiring [2dr.sedan]	\$14.50
WH3660LFT.....Fuel Tank Connector Wire	\$6.75

[Early] 1936 BUICK Roadmaster / Series 80

WH3680M..... Main Lighting Harness	\$814.00
WH3680DE..... Dash and Engine Harness	\$277.00

Wiring Harness Tape

Non-adhesive vinyl Harness wrap is same as used by GM.
1" wide, 100 foot roll.

WT100.....1" wide.	\$12.50 roll
-------------------------	--------------

1937 BUICK Special / Series 40

WH3740DEH..... Dash, Engine and Headlight Harness ..	\$812.75
WH3740I..... Instrument Light Wiring	\$37.50
WH3740C.....Clock and Glove Box Harness	\$80.25
WH3740BT.....Body and Taillights Harness [2dr.coupe] ..	\$338.25
WH3740BT4.....Body and Taillights Harness [4dr.sedan] ..	\$344.50
WH3740DLS..... Dome Light Wiring [4dr.sedan]	\$18.25
WH3740FT.....Fuel Tank Connector Wire	\$13.75
WH3740GS..... Engine Ground Strap	\$43.50

1937 BUICK Century / Series 60

WH3760DEH..... Dash, Engine and Headlight Harness ...	\$738.00
WH3760I.....Instrument Light Wiring	\$38.75
WH3760C..... Clock and Glove Box Harness	\$80.25
WH3760FT.....Fuel Tank Connector Wire	\$12.00
WH3760GS..... Engine Ground Strap	\$41.00

1937 BUICK Roadmaster / Series 80

WH3780DEH.....Dash, Engine and Headlight Harness	\$759.00
WH3780I..... Instrument Light Wiring	\$38.75
WH3780BT4.... Body and Taillights Harness [4dr.sedan] ..	\$373.25
WH3780FT.....Fuel Tank Connector Wire	\$12.00
WH3780GS..... Engine Ground Strap	\$41.00

1937 BUICK Limited / Series 90

WH3790DEH..... Dash, Engine and Headlight Harness ...	\$759.00
WH3790I..... Instrument Light Wiring	\$38.75
WH3790BT..... Body and Taillights Harness	\$244.75
WH3790IL..... Interior Light and Door Switch Wiring	\$154.00
WH3790FT.....Fuel Tank Connector Wire	\$12.00
WH3790GS.....Engine Ground Strap	\$41.00

1938 BUICK Special / Series 40

WH3840DEH..... Dash, Engine and Headlight Harness ...	\$871.50
WH3840BT.....Body and Taillights Harness [2dr.coupe] ..	\$379.50
WH3840BT4....Body and Taillights Harness [4dr.sedan] ..	\$392.00
WH3840BTC....Body and Taillights Harness [2dr.conv.] ..	\$360.75
WH3840FL.....Fender Light Bucket Wires [pair]	\$46.25
WH3840C..... Clock and Glove Box Harness	\$80.25
WH3840HB..... Headlight Bucket Wires [pair]	\$47.50
WH3840FT.....Fuel Tank Connector Wire	\$12.25
WH3840HS..... Heater Switch Wiring	\$35.25
WH3840TB.....Taillight Bucket Wires [pair]	\$60.00

1938 BUICK Century / Series 60

WH3860HB..... Headlight Bucket Wires [pair]	\$47.50
WH3860FL.....Fender Light Bucket Wires [pair]	\$46.25
WH3860DEH....Dash, Engine and Headlight Harn. [lhd]..	\$871.50
WH3860DEHR..Dash, Engine and Headlight Harn. [rhd]..	\$892.25
WH3860C..... Clock and Glove Box Harness	\$80.25
WH3860HS..... Heater Switch Wiring	\$35.25
WH3860BT4.....Body and Taillights Harness [4dr.sedan] ..	\$392.00
WH3860FT.....Fuel Tank Connector Wire	\$13.50
WH3860TB.....Taillight Bucket Wires [pair]	\$60.00

(Group 2) Wiring Harnesses

1938 BUICK Roadmaster / Series 80

WH3880HB.....	Headlight Bucket Wires [pair]\$47.50
WH3880FL.....	Fender Light Bucket Wires [pair]\$46.25
WH3880DEH.....	Dash, Engine and Headlight Harness	\$945.00
WH3880BTL.....	Body Harness.....	\$513.00
WH3880HS.....	Heater Switch Wiring\$35.25
WH3880C.....	Clock and Glove Box Harness\$80.25
WH3880TB.....	Taillight Bucket Wires [pair]\$59.75
WH3880FT.....	Fuel Tank Connector Wire\$13.50

1938 BUICK Limited / Series 90

WH3890HB.....	Headlight Bucket Wires [pair]\$47.50
WH3890FL.....	Fender Light Bucket Wires [pair]\$46.25
WH3890DEH.....	Dash, Engine and Headlight Harness	..\$945.00
WH3890BTL.....	Body and Taillights Harness [4dr.limo]	..\$592.50
WH3890C.....	Clock and Glove Box Harness\$80.25
WH3890HS.....	Heater Switch Wiring\$35.25
WH3890TB.....	Taillight Bucket Wires [pair]\$59.75
WH3890FT.....	Fuel Tank Connector Wire\$13.50

1939 BUICK Special / Series 40

WH3940HB.....	Headlight Bucket Wires [pair]\$91.75
WH3940FL.....	Park and Turn Signal Bucket Wires [pair]\$91.50
WH3940DEH....	Dash, Engine and Headlight Harness	...\$738.00
WH3940BT2....	Body and Taillights Harness [2dr.coupe]	\$437.00
WH3940BT4S...	Body and Taillights Harness [4dr.sedan]	\$444.50
WH3940BTH...	Body and Taillights Harness [hearse]\$467.75
WH3940TS.....	Turn Signal Switch Harness\$121.00
WH3940C.....	Clock and Glove Box Harness\$82.75
WH3940FT.....	Fuel Tank Connector Wire\$13.50

1939 BUICK Century / Series 60

WH3960HB.....	Headlight Bucket Wires [pair]\$91.75
WH3960FL.....	Park and Turn Signal Bucket Wires [pair]\$73.50
WH3960TS.....	Turn Signal Switch Harness\$121.00
WH3960FT.....	Fuel Tank Connector Wire\$13.50
WH3960DEH....	Dash, Engine and Headlight Harness	...\$833.50
WH3960C.....	Clock and Glove Box Harness\$82.75
WH3960BT2C..	Body and Taillights Harness [2dr.conv.]	..\$444.50
WH3960BT2P..	Body and Taillights Harness [2dr.coupe]	..\$430.00
WH3960BTS...	Body and Taillights Harness [4dr.sedan]	..\$444.50
WH3960LL.....	License Light Wires\$11.00

1939 BUICK Roadmaster / Series 80

WH3980HB.....	Headlight Bucket Wires [pair]\$91.75
WH3980FL.....	Park and Turn Signal Bucket Wires [pair]\$73.50
WH3980DEH....	Dash, Engine and Headlight Harness	...\$859.25
WH3980TS.....	Turn Signal Switch Harness\$119.00
WH3980C.....	Clock and Glove Box Harness\$85.50
WH3980BT.....	Body/Taillights Harness w/o turns\$512.50
WH3980BTS.....	Body/Taillights Harness w/ turns\$611.50
WH3980FT.....	Fuel Tank Connector Wire\$13.50

1939 BUICK Limited / Series 90

WH3990HB.....	Headlight Bucket Wires [pair]\$91.75
WH3990FL.....	Park and Turn Signal Bucket Wires [pair]\$73.50
WH3990DEH....	Dash, Engine and Headlight Harness	...\$859.25
WH3990TS.....	Turn Signal Switch Harness\$119.00
WH3990C.....	Clock and Glove Box Harness\$85.50
WH3990BT.....	Body/Taillights Harness w/o turns\$498.75
WH3990BTS.....	Body/Taillights Harness w/ turns\$541.00
WH3990FT.....	Fuel Tank Connector Wire\$13.50

1940 BUICK Special / Series 40

WH4040HB.....	Headlight Bucket Wires [pair]\$84.00
WH4040FL.....	Park and Turn Signal Bucket Wires [pair]	...\$75.00
WH4040DEH....	Dash, Engine and Headlight Harness	..\$925.50
WH4040BT.....	Body and Taillights Harness [2dr.coupe]	\$437.00
WH4040BT4....	Body and Taillights Harness [4dr.sedan]	\$444.50
WH4040TS.....	Turn Signal Switch Harness\$94.25
WH4040C.....	Clock and Glove Box Harness\$84.00
WH4040I.....	Instrument Light Cluster\$65.00
WH4040CL.....	Cigar Lighter Feed Wire\$13.50
WH4040FT.....	Fuel Tank Connector Wire\$13.50
WH4040LL.....	License Light Wires\$12.00

1940 BUICK Super / Series 50

WH4050HB.....	Headlight Bucket Wires [pair]\$84.00
WH4050FL.....	Park and Turn Signal Bucket Wires [pair]\$75.25
WH4050DEH....	Dash, Engine and Headlight Harness	...\$887.50
WH4050I.....	Instrument Light Cluster\$65.00
WH4040IA.....	Instrument Light Cluster w/ Ashtray Lite\$72.50
WH4050TS.....	Turn Signal Switch Harness\$94.25
WH4050C.....	Clock and Glove Box Harness\$84.00
WH4050HD.....	Heater and Defroster Wiring\$41.00
WH4050CL.....	Cigar Lighter Feed Wire\$13.50
WH4050BTC.....	Body and Taillights Harness [conv.]\$444.50
WH4050BT.....	Body and Taillights Harness [2dr.coupe]	\$437.00
WH4050BT4....	Body and Taillights Harness [4dr.sedan]	\$444.50
WH4050FT.....	Fuel Tank Connector Wire\$13.50
WH4050LL.....	License Light Wires\$12.00

1940 BUICK Century / Series 60

WH4060HB.....	Headlight Bucket Wires [pair]\$84.00
WH4060FL.....	Park and Turn Signal Bucket Wires [pair]	..\$75.25
WH4060DEH....	Dash, Engine and Headlight Harness	..\$914.50
WH4060TS.....	Turn Signal Switch Harness\$94.25
WH4060C.....	Clock and Glove Box Harness\$84.00
WH4060I.....	Instrument Light Cluster\$65.00
WH4060CL.....	Cigar Lighter Feed Wire\$13.50
WH4060BT4...	Body and Taillights Harness [4dr.sedan]	..\$472.50
WH4060FT.....	Fuel Tank Connector Wire\$13.50
WH4060LL.....	License Light Wires\$12.00

Wiring Harnesses (Group 2)

1940 BUICK Roadmaster / Series 70

WH4070HB.....	Headlight Bucket Wires [pair]\$84.00
WH4070FL.....	Park and Turn Signal Bucket Wires [pair]	..\$75.00
WH4070DEH....	Dash, Engine and Headlight Harness\$887.50
WH4070BT4...	Body and Taillights Harn. [4dr.sedan]\$410.25
WH4070TS.....	Turn Signal Switch Harness\$94.25
WH4070C.....	Clock and Glove Box Harness\$84.00
WH4070CL.....	Cigar Lighter Feed Wire\$12.25
WH4070I.....	Instrument Light Cluster\$72.50
WH4070TB.....	Taillight Bucket Wires [pair]\$61.75
WH4070FT.....	Fuel Tank Connector Wire\$12.25
WH4070LL.....	License Light Wires\$9.25

1940 BUICK Limited / Series 80

WH4080HB.....	Headlight Bucket Wires [pair]\$84.00
WH4080FL.....	Park and Turn Signal Bucket Wires [pair]	..\$75.00
WH4080DEH....	Dash, Engine and Headlight Harness	..\$968.25
WH4080BT4	Body and Taillights Harn. [4dr.sedan/4819]	\$444.50
WH4080TS.....	Turn Signal Switch Harness\$94.25
WH4080C.....	Clock and Glove Box Harness\$84.00
WH4080I.....	Instrument Light Cluster\$65.00
WH4080TB.....	Taillight Bucket Wires [pair]\$59.75
WH4080CL.....	Cigar Lighter Feed Wire\$12.25
WH4080FT.....	Fuel Tank Connector Wire\$12.25
WH4080LL.....	License Light Wires\$9.25

1940 BUICK Limited / Series 90

WH4090HB.....	Headlight Bucket Wires [pair]\$84.00
WH4090FL.....	Park and Turn Signal Bucket Wires [pair]\$75.00
WH4090DEH....	Dash, Engine and Headlight Harness\$968.25
WH4090BT4..	Body & Taillights Harn. [4dr.sedan/4923]\$586.25
WH4090TS.....	Turn Signal Switch Harness\$94.25
WH4090C.....	Clock and Glove Box Harness\$84.00
WH4090I.....	Instrument Light Cluster\$65.00
WH4090TB.....	Taillight Bucket Wires [pair]\$59.75
WH4090CL.....	Cigar Lighter Feed Wire\$12.25
WH4090FT.....	Fuel Tank Connector Wire\$12.25
WH4090LL.....	License Light Wires\$9.25

1941 BUICK Special / Series 40

WH4140HB.....	Headlight Bucket Wires [pair]\$104.25
WH4140FL.....	Park and Turn Signal Bucket Wires [pair]	...\$94.25
WH4140DEH.Dash, Eng. and Headlight Harness [41SE].		\$987.75
WH4140DEHS..Dash, Eng. & Headlight Harn. [ex.41SE].		\$987.75
WH4140C.....	Clock Harness\$103.00
WH4140I.....	Instrument Light Cluster\$65.00
WH4140HD.....	Heater and Defroster Wiring\$56.00
WH4140BT..	Body and Taillights Harness [2dr.sedanet]	..\$579.00
WH4140BTC... Body and Taillights Harness [2dr.conv.]		..\$558.25
WH4140FT.....	Fuel Tank Connector Wire\$12.25
WH4140LL.....	License Light Bucket Wire\$9.25

1941 BUICK Super / Series 50

WH4150HB.....	Headlight Bucket Wires [pair]\$104.25
WH4150FL.....	Park and Turn Signal Bucket Wires [pair]	...\$94.25
WH4150DEH....	Dash, Eng. and Headlight Harness\$987.75
WH4150I.....	Instrument Light Cluster\$65.00
WH4150HD.....	Heater and Defroster Wiring\$56.00
WH4150BTC... Body and Taillights Harness [2dr.conv.]		..\$558.25
WH4150BT... Body and Taillights Harness [4dr.sedan]		...\$612.00
WH4150FT.....	Fuel Tank Connector Wire\$12.25
WH4150LL.....	License Light Bucket Wire\$9.25

1941 BUICK Century / Series 60

WH4160HB.....	Headlight Bucket Wires [pair]\$104.25
WH4160FL.....	Park and Turn Signal Bucket Wires [pair]	...\$94.25
WH4160DEH....	Dash, Eng. and Headlight Harness\$974.25
WH4160I.....	Instrument Light Cluster\$65.00
WH4160HD.....	Heater and Defroster Wiring\$56.00
WH4160BT... Body and Taillights Harness [4dr.sedan]		...\$500.00
WH4160BTC... Body and Taillights Harness [2dr.conv.]		..\$558.25
WH4160FT.....	Fuel Tank Connector Wire\$12.25
WH4160LL.....	License Light Bucket Wire\$9.25

1941 BUICK Roadmaster / Series 70

WH4170HB.....	Headlight Bucket Wires [pair]\$104.25
WH4170FL.....	Park and Turn Signal Bucket Wires [pair]	...\$94.25
WH4170DEH....	Dash, Eng. and Headlight Harness\$974.25
WH4170I.....	Instrument Light Cluster\$65.00
WH4170HD.....	Heater and Defroster Wiring\$56.00
WH4170BTC... Body and Taillights Harness [2dr.conv.]		..\$558.25
WH4170BT... Body and Taillights Harness [4dr.sedan]		...\$612.00
WH4170BTP..Body and Taillights Harness [4dr.phaeton].		\$801.75
WH4170FT.....	Fuel Tank Connector Wire\$12.25
WH4170LL.....	License Light Bucket Wire\$9.25

1941 BUICK Limited / Series 90

WH4190HB.....	Headlight Bucket Wires [pair]\$104.25
WH4190FL.....	Park and Turn Signal Bucket Wires [pair]	...\$94.25
WH4190DEH....	Dash, Eng. and Headlight Harness\$974.25
WH4190I.....	Instrument Light Cluster\$65.00
WH4190HD.....	Heater and Defroster Wiring\$56.00
WH4190FT.....	Fuel Tank Connector Wire\$12.25

(Group 2) Wiring Harnesses

1942 BUICK Roadmaster / Series 70

WH4270HB.....	Headlight Bucket Wires [pair]\$104.25
WH4270FL.....	Park and Turn Signal Bucket Wires [pair]	...\$91.75
WH4270DEH.....	Dash, Eng. and Headlight Harness\$810.25
WH4270I.....	Instrument Light Cluster\$65.00
WH4270C.....	Clock Harness\$103.00
WH4270GB.....	Glove box Harness\$9.50
WH4270HD.....	Heater and Defroster Wiring\$33.00
WH4270PT.....	Power Top Control Harness\$409.00
WH4270BT..	Body and Taillights Harness [2dr.sedanet]	..\$483.50
WH4270BTC...	Body and Taillights Harness [2dr.conv.]	..\$719.75
WH4270FT.....	Fuel Tank Connector Wire\$12.25

1947 BUICK Super / Series 50

WH4750HB.....	Headlight Bucket Wires [pair]\$107.00
WH4750DEH.....	Dash, Eng. and Headlight Harness\$907.00
WH4750I.....	Instrument Light Cluster\$65.00
WH4750FT.....	Fuel Tank Connector Wire\$12.25

1948 BUICK Special / Series 40

WH4840HB.....	Headlight Bucket Wires [pair]\$107.00
WH4840FL.....	Park and Turn Signal Bucket Wires [pair]	...\$91.75
WH4840DEH.....	Dash, Eng. and Headlight Harness\$1025.75
WH4840C.....	Clock Harness\$103.00
WH4840I.....	Instrument Light Cluster\$65.00
WH4840BT..	Body and Taillights Harness [2dr.sedanet]	..\$611.25
WH4840FT.....	Fuel Tank Connector Wire\$12.25

1948 BUICK Super / Series 50

WH4850HB.....	Headlight Bucket Wires [pair]\$107.00
WH4850FL.....	Park and Turn Signal Bucket Wires [pair]	...\$91.75
WH4850DEH.....	Dash, Eng. and Headlight Harness\$1029.50
WH4850I.....	Instrument Light Cluster\$65.00
WH4850BT..	Body and Taillights Harness [2dr.sedan]	...\$493.50
WH4850FT.....	Fuel Tank Connector Wire\$12.25
WH4850HD.....	Heater and Defroster Wiring\$33.00
WH4850TS.....	Turn Signal Switch Harness\$109.50
WH4850BTS...	Body and Taillights Harness [4dr.sedan]	..\$903.50
WH4850BTC.....	Body and Taillights Harness [conv.]\$738.00
WH4850PT....	Power Window & Top Control Harness\$401.00
WH4850PS.....	Power Seat Control Harness (conv.)\$98.00
WH4850FT.....	Fuel Tank Connector Wire\$12.25
WH4850LL.....	License Light Bucket Wire\$13.50

1948 BUICK Roadmaster / Series 70

WH4870HB.....	Headlight Bucket Wires [pair]\$107.00
WH4870FL.....	Park and Turn Signal Bucket Wires [pair]	...\$91.75
WH4870DEHS.Dash, Eng. & Headlight Harn.(std.trans).		\$1029.50
WH4870DEH.Dash, Eng. & Headlight Harn.(auto.trans).		\$1041.75
WH4870I.....	Instrument Light Cluster\$65.00
WH4870C.....	Clock Harness\$108.25
WH4870BT.....	Body and Taillights Harness [conv.]\$737.75
WH4870PT..	Power Window & Top Control Harn. (conv)	\$443.00
WH4870PS.....	Power Seat Control Harness (conv.)\$98.00
WH4870FT.....	Fuel Tank Connector Wire\$12.25
WH4870BL.....	Back-up Light Bucket Wires\$46.25

1949 BUICK Super / Series 50

WH4950HB.....	Headlight Bucket Wires [pair]\$87.50
WH4950FL.....	Park and Turn Signal Bucket Wires [pair]	...\$82.75
WH4950SH.....	Starter to Ignition Harness. (auto trans)\$212.25
WH4950SHS....	Starter to Ignition Harness. (std. trans)\$212.25
WH4950HR.....	Horn Realy to Horn Wiring.....	\$13.50
WH4950DEH.Dash, Eng. & Headlight Harn. (auto trans)		\$885.00
WH4950DEHS.Dash, Eng. & Headlight Harn. (std. trans)		\$885.00
WH4950TS.....	Turn Signal Switch Harness\$109.50
WH4950BTC.....	Body and Taillights Harness [conv.]\$606.00
WH4950BTS..	Body and Taillights Harness [4dr.sedan]	..\$655.00
WH4950BTW....	Body and Taillights Harness [wagon]\$684.25
WH4950FT.....	Fuel Tank Connector Wire\$10.50
WH4950LL.....	License Light Bucket Wire\$13.50

1949 BUICK Roadmaster / Series 70

WH4970HB.....	Headlight Bucket Wires [pair]\$87.50
WH4970FL.....	Park and Turn Signal Bucket Wires [pair]	...\$82.75
WH4970SH.....	Starter to Ignition Harness. (auto trans)\$212.25
WH4970HR.....	Horn Realy to Horn Wiring.....	\$12.25
WH4970TS.....	Turn Signal Switch Harness\$109.50
WH4970DEH.Dash, Eng. & Headlight Harn. (auto trans)		\$885.00
WH4970DEHS.Dash, Eng. & Headlight Harn. (std. trans)		\$885.00
WH4970BTC.....	Body and Taillights Harness [conv.]\$568.00
WH4970BTR....	Body and Taillights Harn. [2-dr. ht]\$757.75
WH4970BTS..	Body and Taillights Harness [4dr.sedan]	..\$664.50
WH4970BTA....	Body and Taillights Harness [ambul]\$516.50
WH4970PT....	Power Window & Top Control Harness\$690.25
WH4970PS... Power Seat Control Harness (4-dr sedan)		...\$98.00
WH4970FT.....	Fuel Tank Connector Wire\$10.50
WH4970LL.....	License Light Bucket Wire\$13.50

1950 BUICK Special / Series 40

(Early Models, heater & blower switches are side by side)

WH5040HB.....	Headlight Bucket Wires [pair]\$87.50
WH5040FL.....	Park and Turn Signal Bucket Wires [pair]	...\$77.75
WH5040DEH.Dash, Eng. & Headlight Harn.(auto trans).		\$1054.00
WH5040DEHS.Dash, Eng. & Headlight Harn.(std. trans)		\$1054.25
WH5040TS.....	Turn Signal Switch Harness. (pair)\$114.50
WH5040GB.....	Glove box Light Switch Wire\$8.00
WH5040ML.....	Map Light Wiring\$14.50
WH5040BT.....	Body and Taillights Harness\$317.00
Note: Tail Lamp Wiring requires the purchase of our TWB501		
WH5040IL..Interior light & Door Switch 43,43D,46,46S	\$531.25
WH5040FT.....	Fuel Tank Connector Wire\$9.25
WH5040BL.....	Back-up Light Bucket Wires\$43.50
WH5040LL.....	License Light Bucket Wire\$43.50

Wiring Harnesses (Group 2)

1950 BUICK Special / Series 40

(Late Models, heater & blower switches are separated)

WH5040LHB.....	Headlight Bucket Wires [pair]\$87.50
WH5040LFL....	Park and Turn Signal Bucket Wires [pair]	...\$77.75
WH5040LDH.Dash, Eng. & Headlight Harn.(auto trans).		\$1065.00
WH5040LDHS.Dash, Eng. & Headlight Harn.(std. trans)		\$1065.00
WH5040LTS.....	Turn Signal Switch Harness. (pair)\$114.50
WH5040LGB.....	Glove box Light Switch Wire\$8.00
WH5040LML.....	Map Light Wiring\$15.75
WH5040LBT.....	Body and Taillights Harness\$317.00

Note: Tail Lamp Wiring requires the purchase of our TWB501

WH5040LIL..	Interior light & Door Switch 43,43D,46,46S	..\$531.25
WH5040LFT.....	Fuel Tank Connector Wire\$9.25
WH5040LBL.....	Back-up Light Bucket Wires\$43.50
WH5040LLL.....	License Light Bucket Wire\$43.50

1950 BUICK Super / Series 50

WH5050HB.....	Headlight Bucket Wires [pair]\$87.50
WH5050DEH.Dash, Eng. & Headlight Harn.(auto trans).		\$1065.00

1950 BUICK Roadmaster / Series 70

WH5070HB.....	Headlight Bucket Wires [pair]\$87.50
WH5070DEH.Dash, Eng. & Headlight Harn.(auto trans).		\$1065.00
WH5070IL.....	Interior light and Door Switch (4-dr. sedan)	..\$595.00
WH5070B.....	Body Harness [4dr.sedan]\$197.25
WH5070T.....	Tail Lamp Harness [4dr.sedan]\$197.25

Note: Tail Lamp Wiring requires the purchase of our TWB501

1951 BUICK Special / Series 40

WH5140DEH.Dash, Eng. & Headlight Harn.(auto trans).		\$1071.00
WH5140BT... Body and Taillights Harness, Model 46S	\$667.00

1951 BUICK Super / Series 50

WH5150HB.....	Headlight Bucket Wires [pair]\$87.50
WH5150DEH.Dash, Eng. & Headlight Harn.(auto trans).		\$1032.00
WH5150BTW....	Body and Tail Lamp Harness [wagon]	...\$385.75

Note: Tail Lamp Wiring requires the purchase of our TWB501

WH5150ILW.....	Interior light & Door Switch (wagon)\$563.00
WH5150T.....	Tail Lamp Harness [4dr.sedan]\$155.00

Note: Tail Lamp Wiring requires the purchase of our TWB501

1953 BUICK Special / Series 40

WH5340DEH..Dash, Eng. & Headlight Harn.(std trans).		..\$1032.00
WH5340DEHA.Dash, Eng. & Headlight Harn.(auto trans)		\$969.00
WH5340BTC.....	Body and Tail Lamp Harness [conv]\$953.50
WH5340G.....	Generator Harness\$75.00
WH5340LGB.....	Glove box Light Switch Wire\$8.00
WH5340ML.....	Map Light Wires\$8.00
WH5340PB.....	Parking Brake Warning Light Wires\$16.00
WH5340CL.....	Courtesy Light Harness (convertible)\$51.00
WH5340HM.....	Heater Motor Feed Wire\$43.50
WH5340LL.....	License Light Bucket Wire\$8.00

1953 BUICK Super / Series 50

WH5350HB.....	Headlight Bucket Wires [pair]\$98.00
WH5350FL....	Park and Turn Signal Bucket Wires [pair]\$85.25
WH5350DEH.Dash, Eng. & Headlight Harn.(auto trans).		\$1226.50
WH5350BTW....	Body and Tail Lamp Harness [wagon]	...\$392.00
WH5350ILW.....	Interior light and Door Switch (wagon)\$558.25
WH5350FT.....	Fuel Tank Connector Wire\$10.50

1953 BUICK Roadmaster / Series 70

WH5370HB.....	Headlight Bucket Wires [pair]\$98.00
WH5370FL....	Park and Turn Signal Bucket Wires [pair]\$85.25
WH5370DEH.Dash, Eng. & Headlight Harn.(auto trans).		\$1228.50
WH5370BTC....	Body & Tail Lamp Harness [conv]\$892.50
WH5370BTW....	Body and Tail Lamp Harness [wagon]	...\$392.00
WH5370P...Power Window, Seat,Top Control Harness		...\$850.75
WH5370PT.....	Power Top Feed Cable\$83.00
WH5370TS.....	Turn Signal Switch Harness.\$108.25
WH5370SR.....	Starter to Relay Harness.\$43.50
WH5370ILW.....	Interior light & Door Switch (wagon)\$558.25
WH5370FT.....	Fuel Tank Connector Wire\$10.50

1953 BUICK Skylark / Model 76X

WH53XHB.....	Headlight Bucket Wires [pair]\$98.00
WH53XFL....	Park and Turn Signal Bucket Wires [pair]\$85.25
WH53XDEH.....	Dash, Eng. and Headlight Harn\$1226.50
WH53XBT....	Body & Tail Lamp Harness [conv]\$892.50
WH53XP...Power Window,Seat,Top Control Harness	\$764.75
WH53XPT.....	Power Top Feed Cable\$83.00
WH53XTS.....	Turn Signal Switch Harness.\$108.25
WH53XSR.....	Starter to Relay Harness.\$43.50
WH53XFT.....	Fuel Tank Connector Wire\$10.50

1954 BUICK Special / Series 40

WH5440HB.....	Headlight Bucket Wires [pair]\$96.75
WH5440FL....	Park and Turn Signal Bucket Wires [pair]\$15.75
WH5440DEH.Dash, Eng. & Headlight Harn.(auto trans).		\$1211.75
WH5440BT....	Body & Tail Lamp Harness [2-dr. sedan]	..\$757.75
WH5440BTS... Body & Tail Lamp Harness [4-dr. sedan]		..\$757.75
WH5440GB.....	Glove box Light Switch Wire\$8.00
WH5440ML.....	Map Light Switch Wire\$8.00
WH5440TS.....	Turn Signal Switch Harness.\$118.50
WH5440DL....	Dome Light/Switch Wire (2-dr. sedan)\$118.50
WH5440LBL.....	Back-up Light Bucket Wires (pair)\$13.50
WH5440LL.....	License Light Bucket Wires (pair)\$70.00

1954 BUICK Roadmaster / Series 70

WH5470HB.....	Headlight Bucket Wires [pair]\$96.75
WH5470DEH.Dash,Eng. & Headlight Harn. (auto trans).		\$1333.00
WH5470SS.....	Starter Solenoid Harness\$41.00
WH5470DLC.....	Dome Light Harness (conv)\$96.75
WH5470TS.....	Turn Signal Switch Harness.\$118.50
WH5470BTC.....	Body and Tail Lamp Harness [conv]\$868.00
WH5470P.....	Power Window,Seat Control Harness\$872.75
WH5470SC.....	Verticle Seat Control Harness.\$100.50

(Group 2) Wiring Harnesses

1954 BUICK Skylark / Series 100

WH54XTS.....Turn Signal Switch Harness.\$118.50

1955 BUICK Special / Series 40

WH5540HB..... Headlight Bucket Wires [pair]\$96.75
 WH5540DEH.....Dash, Eng. and Headlight Harn.\$1307.25
 WH5540BT..... Body & Tail Lamp Harness [2-dr. ht]\$708.75
 WH5540TS.....Turn Signal Switch Harness.....\$123.50
 WH5540LL.....License Light Bucket Wires (pair)\$54.25

1955 BUICK Century / Series 60

WH5560HB..... Headlight Bucket Wires [pair]\$100.50
 WH5560DEH.Dash, Eng. & Headlight Harn.(auto trans).\$1307.25
 WH5560BTC.... Body & Tail Lamp Harness [conv]\$902.25
 WH5560BTH.... Body & Tail Lamp Harness [4-dr. ht]\$708.25
 WH5560TS.....Turn Signal Switch Harness.\$123.50
 WH5560PW.....Power Window Control Harn (conv)\$891.25
 WH5560PSW....Power Seat Control Harn w/ pwr. wind. ..\$135.00
 WH5560PS....Power Seat Control Harn w/o pwr. wind. ...\$241.00
 WH5560ILR.....Rear Interior Light (4-dr. ht).....\$206.00
 WH5560RC.....Rear Seat Cigar Lighter.....\$41.00

1955 BUICK Roadmaster / Series 70

WH5570HB..... Headlight Bucket Wires [pair]\$96.75
 WH5570DEH.Dash, Eng. & Headlight Harn.(auto trans).\$1338.00
 WH5570BTC.... Body and Tail Lamp Harness [conv]\$858.00
 WH5570PW.....Power Window Control Harn. conv).\$899.75
 WH5570SS.....Starter Solenoid Harness.....\$41.00
 WH5570DLC..... Dome Light Harness (conv).....\$65.00

1957-1960 Wiring Harness Straps



1957-1960 All as required. 2" overall length. Metal.
 WS1\$3.75 ea



1957-1960 All as required. 1/4" high. Metal.
 WS2\$3.75 ea



1957-1960 All as required. 5/8" high. Metal.
 WS3\$3.75 ea

1957 BUICK Special / Series 40

WH5740HB..... Headlight Bucket Wires [pair]\$98.00
 WH5740EH.....Engine and Headlight Harn.....\$509.25
 WH5740HH.....Horn Bucket Wires (pair)\$17.25

1957 BUICK Century / Series 60

WH5760HB..... Headlight Bucket Wires [pair]\$98.00
 WH5760EH.....Engine and Headlight Harn.....\$509.25
 WH5760DH.....Dash Harness.....\$739.50
 WH5760HH.....Horn Bucket Wires (pair)\$17.25
 WH5760SS.....Starter Solenoid Harness.....\$46.25
 WH5760DLW..... Dome Light Harness (wagon)\$72.50

1957 BUICK Roadmaster / Series 70

WH5770CLC..... Dome Light Harness (conv).....\$65.00

1959 BUICK Lesabre

WH59LEH.....Engine and Headlight Harn.....\$519.00
 WH59LSS.....Starter Solenoid Harness.....\$43.25
 WH59LDH.....Dash Harness.....\$1192.25
 WH59LCB.....Circuit Breaker Wires.....\$84.00
 WH59LGB.....Glove Box Light Harness.....\$9.25
 WH59LBHC.....Body Harness. (conv).....\$410.75
 WH59LTL.....Tail Lamp Harness\$319.50
 WH59LWM.....Windshield Wiper Motor Harness.....\$138.75
 WH59LRFW.....Window Harness. (RH Front)\$197.25
 WH59LLFW.....Window Harness. (LH Front).....\$236.00
 WH59LRRW.....Window Harness. (RH Rear).....\$194.75
 WH59LLRW.....Window Harness. (LH Rear).....\$212.25
 WH59LPW.....Power Window Connector Harness\$152.75
 WH59LML.....Map Light Wire.....\$12.25
 WH59LH.....Heater Harness\$56.00
 WH59LHBW.....Hand Brake Wiring\$54.25
 WH59LCLR.....Courtesy Lamp Harness (RH Rear)\$121.50



www.oldbuickparts.com

908-369-3666

Carburetor Rebuilding and Restoration Service (3.725)

Each carburetor is totally disassembled and cleaned in a hot tank solution. Then, each component is correctly plated, painted and colored to duplicate its original factory finish. The carburetor is reassembled using all proper gaskets, pumps, needles and seats, etc. and new correct screws. Finally, all bench adjustments are made to factory specs. This includes correct shimming of the start switch. The result, the best rebuilt and restored carburetor available in the Hobby Allow about 4 weeks.

NOTE: This is not an area to skimp on your restoration. Demand the best!

1932-1938 Marvel Carburetors.
CRS328M.....\$469.00 ea.

1935-1936 Stromberg Carburetors.
CRS356.....\$416.00 ea.

1937-1938 Stromberg Carburetors.
CRS378.....without choke.....\$349.00 ea.
CRS378C.....with choke.....\$395.00 ea.

1939-1948 All with Diaphragm type starter switch.
CRS398.....\$389.00 ea.

1939-1960 All 2bbl Carburetors w/ Bakelite switch.
CRS390.....\$379.50 ea.

1952-1960 4bbl. Carburetor rebuilding service.
CRS520.....\$399.00 ea.

Others by inspection and quotation

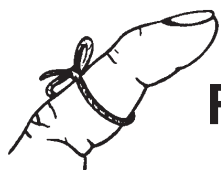

Remember!

Carter Carburetor Rebuilding Kits

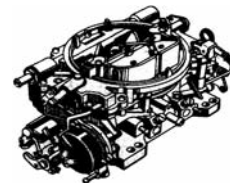

1936-1940 All models. WDO 2 BBL.
Numbers: 419, 440, 448, 474.
CKC360.....\$42.75 ea.

1941-1942 All 40-90. WCD 2BBL.
Numbers: 487, 549, 551.
CKC412.....\$42.75 ea.

1941-1942 Dual Carbs. WCD 2 BBL.
Numbers: 528, 529, 533, 534, 543, 544. For both kits.
CKC412D.....\$59.00 ea.

1946-1949 Models 40-50-70. WCD 2 BBL. Numbers: 608, 609, 663, 664.
CKC469.....\$43.00 ea.

1950-1955
1950-1951: Roadmaster. WCD 2 BBL.
Numbers: 725, 726, 882, 883, 2017, 2081, 2179.

1950-1955: Models 40-50. WCD 2 BBL.
Numbers: 725, 726, 882, 883, 2017, 2081.
CKC505.....\$45.00 ea.
CKC505A.....(#2179 only).....\$45.00 ea.

1952-1953 Roadmaster. WCFB 4 BBL.
Numbers 894, 996, 2053, 2083.
CKC523.....\$44.75 ea.

1954-1956 Super and Skylark WCFB 4 BBL.
Numbers: 2082, 2197, 2347, 2358.
CKC546.....\$47.00 ea.



CKC546

1955-1960 Special and LeSabre. WGD 2 BBL.
Numbers: 2292, 2378, 2400, 2536, 2529, 2548, 2674, 2675, 2682, 2837, 2838, 2845, 2979, 2980.
CKC550.....\$47.00 ea.

1957-1960 All AFB 4 BBL.
Numbers: 2507, 2800, 2840, 2877, 2981, 2982.
CKC570.....\$47.00 ea.

Check to see that the carburetor number matches that of the part you are ordering. Any letters after the main number are also included in our kits.

Carter numbers after 1937 are stamped on the bottom of the throttle body.

Stromberg numbers from 1939 are stamped on the top bowl cover.

Rochester Carburetor Kits

- 1955** All models. 4 GC 4 BBL.
Numbers: 7006200, 7009100.
CKR55.....\$41.50 ea.
- 1956** All models. 4 GC 4 BBL.
Numbers: 7009200.
CKR56.....\$41.50 ea.
- 1957-1958** All models. 4 GC 4 BBL.
Numbers: 7010070, 7011570, 7011600.
CKR578.....\$41.50 ea.
- 1958 Late** All models. 4 GC 4 BBL.
Numbers: 7013100.
CKR58.....\$41.50 ea.
- 1959-1960** All 4 GC 4 BBL. Numbers: 7013044, 7015040, 7019040, 7020040, 7020041.
CKR592.....\$41.50 ea.

Stromberg Carburetor Kits

- 1934-1936** Model 40. EE-1, 2 BBL.
Numbers: 7-1, 7-2, 7-4, 7-5, 7-7, 7-9.
CKS346.....\$57.50 ea.
- 1936** 60-80-90. EE-22,2 BBL.
Numbers: 7-6, 7-8, 7-10.
CKS36.....\$44.50 ea.
- 1937-1949** 40-50. AA 2 BBL.
Numbers: 7-12, 7-17, 7-19, 7-24, 7-31, 7-32, 7-66, 7-69, 7-74, 7-75, 7-79, 7-81, 7-82,
CKS379.....\$49.50 ea.
- 1937-1955**
1937-1951: 60-70-80-90. AA 2 BBL.
Numbers: 7-13, 7-15, 7-18, 7-20, 7-22, 7-23, 7-33, 7-34, 7-36.
1953-1955: Special and Super. AA 2 BBL.
Numbers: 7-57, 7-70, 7-77, 7-80, 7-89, 7-91, 7-95, 7-96, 7-102, 380150.
CKS375.....\$49.50 ea.
- 1941-1942** All with Dual Carbs. AA 2 BBL.
Numbers: 7-39, 41, 42, 43, 44, 45, 46, 47, 55, 59 and 60. Contains parts for both carbs.
CKS412D.....\$64.50 ea.
- 1950-1953**
1950-1952: Special and Super. AA 2 BBL.
Numbers: 7-88, 7-90.
1953: Special. AA 2 BBL. Numbers: 7-88, 7-90.
CKS503.....\$47.50 ea.
- 1952-1954** Roadmaster and Skylark. 4A 4 BBL.
Numbers: 7-92, 7-94, 7-98.
CKS524.....\$54.50 ea.
- 1955-1956** Special. WW 2 BBL.
Numbers: 7-103, 7-104, 7-105.
CKS556.....\$57.50 ea.
- 1957** Special with Dynaflo. WW 2 BBL.
Numbers: 7-106.
CKS57.....\$57.50 ea.
- 1958-1960** Special and LeSabre. WW 2 BBL.
Numbers: 7-109, 7-112, 7-113.
CKS580.....\$59.50 ea.

Carburetor Bowl Floats



- 1934-1936** Stromberg EE1. Brass.
CF346S.....\$39.50 ea.
- 1936-1940** Carter WDO. Brass.
CF360C.....\$37.50 ea.
- 1937-1953** Stromberg AA 2BBL. Brass.
CF373S.....\$48.00 ea.
- 1941-1955** Carter WCD. Brass.
CF415C.....\$47.50 ea.
- 1955-1956** Rochester 4GC. Brass. (2 needed per car)
CF556R.....\$42.75 ea.
- 1955-1961** Stromberg WW. Plastic.
CF551S.....\$37.50 ea.
- 1957-1960** Carter AFB 4BBL. Brass.(2 needed per car)
CF577C.....\$34.50 ea.

Fuel Bowl Gaskets



- 1936-1940** Special & Super. Fuel bowl gasket.
BG2002.....\$2.25 ea.
- 1941-1953** All straight. Fuel bowl gasket.
BG2088.....\$2.25 ea.

Carburetor to Intake Manifold Gaskets

- 1935-1939** Special;
1940-1949 Special and Super.
Use 2 on dual carb set-ups.
CMG359.....\$3.75 ea.
CI3.....(Thick Insulator).....\$14.75 ea.
- 1936-1949** All 320 engines;
1950-1952 Special and Super;
1953 Special;
1954-1955 All 2bbl carbs.
CMG395.....\$3.75 ea.
CI4.....(Thick Insulator).....\$14.25 ea.
- 1953** Roadmaster;
1954 Century, Roadmaster, Skylark;
1955-1956 Century, Super, Roadmaster
For 4bbl carbs.
CMG536.....\$4.25 ea.
- 1955** Late Carter and Rochester 2bbl;
1956-1960 All carter and Rochester 2bbl.
CMG554.....\$4.50 ea.
- 1957-1960** All 4bbl.
CMG576.....\$4.75 ea.



Fuel • Carburetion • Exhaust (Group 3)

Carter Baffle Plates



Stainless steel plate between carb. and intake manifold. This plate is essential for protection against disintegration of aluminum base of carb. It is also necessary for proper idle and smooth running.



1954-1956 All with 4bbl. carbs.
BP546\$16.50 ea.

1957-1960 All with Carter AFB 4bbl.
BP576\$17.50 ea.

Accelerator Return Springs (3.459)

1939-1947 All except dual carburetor set-up.
AS397.....(stainless steel).....\$7.50 ea.



1948-1956 Accelerator return spring.

1948-1952: All;

1953: Specials;

1955-1956 All.

AS483.....(stainless steel).....\$7.00 ea.



Linkage Rod Clips



1946-1960 Carburetor throttle rod clip.
1/4" rod diameter.

RC460.....(swing right).....\$1.00 ea.

RC460L.....(swing left).....\$1.00 ea.

Linkage Rod Bushing



Carburetor throttle rod bushing and grommet. 1/4" rod diameter.

RB460\$6.00 ea.

Carburetor Dash Pots



1954-1956 All. (3.440)

DP546\$29.50 ea.

1957-1960 All.

DP573\$29.50 ea.

Choke Stove Pipe Replacement Kits (3.545)

1935-1953 all Straight-8 engines.

All as required. Includes PI300.

CSK350\$15.50 kit

1935-1960 all V-8 engines.

All as required. Includes PI300.

CSK530\$18.25 kit



Choke Stove Pipe Insulator



This modern aramid fiber sleeve greatly resembles the original. It is heat resistant up to 650°F. Also, excellent for wrapping vapor locked fuel lines. Sold by the foot. All years.

PI300\$5.25 ft.

Gas Filters



1957-1960 Gas filter replacement element.
GF572.....\$7.50 ea.

1957-1960 AC replacement. Gas filter assembly with element.

GF572A.....\$32.50 ea.



All years replacement. Clear in-line gas filter. Great for near gas tank or frame installation. Important for insuring clean fuel to fuel pump.

GF100\$4.50 ea.



GF140



GF516



GF516C



GF380

GF140.....For 1/4" ID Hose.....\$9.25 ea.

GF516.....For 5/16" IDHose.....\$9.25 ea.

GF516C.....For 5/16" ID Hose(clear).....\$6.50 ea.

GF380.....For 3/8" ID Hose.....\$9.25 ea.

Carburetor to Air Cleaner Gaskets



1953-1960 All 2bbl carbs.

ACG535\$3.50 ea.

1952-1956 All Carter and Stromberg 4bbl;

1957-1960 All 4bbl Carburetors.

ACG526\$3.50 ea.

Air Filters (3.411)

1958-1960

1958: All;

1959-1960: with 4 bbl. carb., air filter.

AF582.....\$24.50 ea.

1959 All with 2 bbl. carburetor, air filter.

AF59.....\$15.50 ea.

1960 All with 2 bbl. carburetor, air filter.

AF607.....\$15.00 ea.



Air Cleaner Wing Nut (3 .920)

1953-1960 Replacement air cleaner wing nut.
WN530\$17.75 ea.

Intake Manifold Gaskets

1936-1953

1936-1953: Straight-8
(See Exhaust Manifold Gaskets);



1953-1956: All V-8.
IMG536\$17.50 pr.

1957-1960

IMG576\$18.50 pr.

Intake Manifold Pilots

1934-1953

1934-1939: Specials;
1940-1952: Special and Super;
1953: Special.



MP253\$2.50 ea.

1931-1952

1931-1935: Series 60;
1936-1939: Series 60, 80, 90;
1940-1952: Series 60, 70, 80, 90 (For 320 Engines).

MP312\$2.50 ea.

Intake Manifold/Carburetor Studs

1935-1949:

1935-1942 Special;
1937 Series 60, 80, 90;
1941-1942 All with dual carbs.
front carb;
1942-1949 All with single carb.
S13\$3.75 ea.

Intake Manifold Plugs

This plug is often rusted out and sometimes missing.
Leakage around this plug
causes poor carburetion.



1957-1960

1957-1958: All;
1959-1960: LeSabre with 2bbl carburetor.
MP579\$11.50 ea.



1959-1960: All with 4-bbl. carburetor.
MP596\$12.75 ea.



1955-1956: All manifold plug gasket.
BG3780\$4.75 ea.

Exhaust Manifold French Locks

The best restoration can be ruined by rust spreading from original unsightly locks to your engine block and manifolds. We made these from lifetime rust-free **stainless steel**.

1953-1956 All V-8.

FL536\$2.75 ea.



1957-1960 All.

FL576\$3.50 ea.

V-8 Exhaust Manifold Gaskets

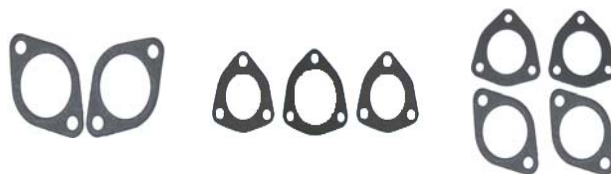

1953-1955 All V-8.

EMG536.....(To Engine block)\$13.50 set

FG535.....(3 pc. Flange set)\$11.75 set

1956 All

EMG536.....(To Engine block)\$13.50 set

FG56.....(4 pc. Flange set)\$12.50 set

1957-1960 All.

EMG576\$13.50 set

FG576.....(Flange gasket)\$8.75 set

Brass Nuts. Tall. 3/8-16. All years as required. For manifolds, pipes, trim etc.
N6P\$3.75 pr.



Cast Iron Paint



Extremely high temp. Excellent for manifolds and exhaust systems. Will not burn off.

EP3.....\$32.00 pt.

EP3S....(16 oz spray can)....\$19.50 ea.

Fuel • Carburetion • Exhaust (Group 3)

1934 to 1953 248 & 263 Engines

Exhaust Manifold (3.601)

1939-1953

1939-1952: All Special and Super;

1953: Special. Exhaust manifold.

EM393\$649.00 ea.



EM393



Exhaust Manifold Gaskets (3.270)

1934-1953 Special and Super (Straight eight).

Intake - exhaust manifold gaskets.

MG363.....(Composite material).....\$16.00 set

MG363C.....(Copper shielded material).....\$39.50 set

FG363.....(Flange gasket exc. dual carb)\$4.50 ea.

BG4516.....(Flange 1941-1942 dual carb)\$4.00 ea.

1934-1953 Manifold to engine block threaded studs. Nine per car. Not a generic STUD. 100% correct.



MS363\$2.75 ea.



1934-1953 Manifold washer stamped steel as original 7 needed per car.

MW363.....\$2.75 ea.

MW363R.....Round-1 needed\$2.50 ea.



N14.....(nuts for above).....\$.75 ea.

MW363S.....Complete set of 8 w/ nuts\$39.50 ea.

Valve Body



1939-1953 All Straight 8. Valve body.

No Butterfly. (3.645)

1939-1952 Special and Super;

1953: Special. For 248 and 263 engines.

VB393.....\$365.00 ea.

VB393B..... (With Butterfly).....\$595.00 ea.

Valve Body Parts



1934-1953 Special and Super valve body to exhaust, manifold ring.(3.657)

VBR343\$7.75 ea.

Brass Nuts. Tall. 3/8-16. All years as required. For manifolds, pipes, trim etc.

N6P.....\$3.75 pr.



Valve Body Gaskets (3.657)



1934-1953 Special and Super, valve body to exhaust manifold gasket. Triangular.

VBG343\$4.50 ea.



1937-1953 Valve body to intake manifold gasket. All except dual carburetor set-ups.

VBI373\$6.00 ea.

1936-1956 All. Exhaust manifold valve body return spring. (3.678)

Correctly colored as original.

MS366.....\$3.50 ea.



1940-1956 All. Exhaust manifold valve body thermostatic coil.

MT406\$12.50 ea.

1936-1953 Exhaust manifold valve body stud. (3.275)

MS363.....(2 per car).....\$2.75 ea.

Valve Body Bolt Kits

Our Valve Body bolts washers & nuts are correct in every way. Bolts are grade 8 and zinc plated for strength and durability. Nuts are brass as original for authentic look and easy disassembly . NOTE: Always tighten manifolds in step sequence between hot and cold intervals then assemble manifolds gradually.

Valve Body to Intake Manifold



1937-1951 All;

1952 Super;

1952-1953 Special .

VBB373I\$6.50 kit

Value Body to Exhaust Manifold



1939-1952 All;

1953 Special.

VBB393E\$11.50 kit

Valve Body Assembly Kits

Contains all necessary bolts, washers, studs, nuts, gaskets and ring for complete assembly.



1937-1952 All. Special & Super exc. dual carb. jobs;

1953 Special.

VVBK373\$29.50 kit



1934-1960 Exhaust pipe to manifold bolt kit. Stainless steel with brass nuts. FBK340\$9.95 ea.

1934 to 1952 320 Straight 8 Engines



(3.601)

Exhaust Manifold Gaskets (3.270)

- 1936-1952** Century, Roadmaster, Limited. Intake - Exhaust manifold gaskets.
- MG362.....\$16.50 set
 - MG362C.....(Copper shielded material).....\$49.50 set
 - FG360.(1936-1940 flange gasket. 2 needed)\$3.75 ea.
 - FG412.(1941-1942 flange gasket. 2 needed)\$4.75 ea.
 - FG462.....(1946-1952 flange gasket)\$4.00 ea.

1936-1952 Series 60, 70, 80 and 90. Front manifold section. EM362F\$399.00 ea.

1936-1952 Series 60, 70, 80 and 90. Rear manifold section. EM362R.....\$399.00 ea.



1937-1938 Series 60-80-90. Center section. (Can be altered for use on 1936).

MC378\$395.00 ea.

1939-1951 Series 60-70-80-90. Center section.

MC391\$399.00 ea.

1934-1953 Manifold to engine block threaded studs. Nine per car. Not a generic STUD. 100% correct.



MS363.....\$2.75 ea.

1934-1953 Manifold washer stamped steel as original 7 needed per car. MW363.....\$4.50 ea.



MW363R.....Round-1 needed\$2.50 ea.



N14.....(nuts for above).....\$.75 ea.

MW363S.....Complete set of 8 w/ nuts\$39.50 ea.

VALVE BODY

Exhaust Manifold Valve Body (3.645)

1937-1951 Series 60-70-80-90. VB371.....\$399.00 ea.



Valve Body Parts



1936-1952 Roadmaster and Limited valve body to exhaust manifold ring. (3.657) VBR361\$7.75 ea.

1936-1951 Century, Roadmaster, Limited. Valve body to exhaust manifold gasket. Triangular. (3.657) VBG361\$4.50 ea.



1937-1953 Valve body to intake manifold gasket. All except dual carb. set-ups. VBI373\$6.00 ea.

Brass Nuts. Tall. 3/8-16. All years as required. For manifolds, pipes, trim etc. N6P.....\$3.75 pr.



Manifold Parts

1936-1956 All. Exhaust manifold valve body return spring. (3.678) Correctly colored as original.



MS366\$3.50 ea.



1940-1956 All. Exhaust manifold valve body thermostatic coil.

MT406\$9.75 ea.

Valve Body Bolt Kits

Our Valve Body bolts washers & nuts are correct in every way. Bolts are grade 8 and zinc plated for strength and durability. Nuts are brass as original for authentic look and easy disassembly . NOTE: Always tighten manifolds in step sequence between hot and cold intervals then assemble manifolds gradually.

Valve Body to Intake Manifold

1937-1951 All; VBB373I.....\$6.50 kit



Value Body to Exhaust Manifold

1939-1952 All; VBB393E\$11.50 kit



Valve Body Assembly Kits

Contains all necessary bolts, washers, studs, nuts, gaskets and ring for complete assembly.

1937-1951 Series 60, 70, 80, 90. VBK371.....\$29.50 kit



1934-1960 Exhaust pipe to manifold bolt kit. Stainless steel with brass nuts. FBK340\$9.95 ea.

Fuel • Carburetion • Exhaust (Group 3)

Carburetor Mounting Insulators (3.726)



1935-1939 Special;
1940-1949 Special and Super
 (use 2 on dual carb. set-ups.)
 CI3.....Insulator\$14.25 ea.
 CMG359.....Gasket.....\$3.75 ea.



1939-1949 all 320 engines exc. dual carb set-ups;
1950-1952 Special and Super;
1953 Special; **1954-1955** all 2bbl.
 CI4.....Insulator\$14.25 ea.
 CMG395.....Gasket.....\$3.75 ea.

Accelerator Return Springs (3.459)

1939-1947 All except dual carburetor set-up.



AS397.....(stainless steel).....\$7.50 ea.

1948-1956 Accelerator return spring.

1948-1952: All;

1953: Specials;

1955-1956 All.

AS483.....(stainless steel).....\$7.00 ea.

Gas Filters



1957-1960 Gas filter replacement element.
 GF572\$7.50 ea.



1957-1960 AC replacement. Gas filter assembly with element.
 GF572A.....\$29.50 ea.

In Line Gas Filters



GF140.....For 1/4" ID Hose.....\$9.25 ea.

GF516.....For 5/16" IDHose.....\$9.25 ea.



GF516C..For 5/16" ID Hose(clear).\$6.50 ea.

GF380.....For 3/8" ID Hose.....\$9.25 ea.



Air Cleaner Wing Nut (3.920)

1953-1960 Replacement air cleaner wing nut.

WN530\$1.75 ea.

Carter Baffle Plates



Stainless steel plate between carb. and intake manifold. This plate is essential for protection against disintegration of aluminum base of carb. It is also necessary for proper idle and smooth running.



1954-1956 All with 4bbl. carbs.
 BP546.....\$16.50 ea.

1957-1960 All with Carter AFB 4bbl.
 BP576.....\$17.50 ea.



1946-1960 Carburetor throttle rod clip.

1/4" rod diameter.

RC460.....(swing right).....\$1.00 ea.

RC460L.....(swing left).....\$1.00 ea.

Linkage Rod Bushing

Carburetor throttle rod bushing and grommet. 1/4" rod diameter.



RB460.....\$6.00 ea.

Carburetor Dash Pots

1954-1956 All. (3.440)

DP546.....\$29.50 ea.

1957-1960 All.

DP573.....\$29.50 ea.



Air Filters (3.410)

1958-1960

1958: All;

1959-1960: with 4 bbl. carb., air filter.

AF582\$24.50 ea.

1959 All with 2 bbl. carburetor, air filter.

AF59\$15.50 ea.

1960 All with 2 bbl. carburetor, air filter.

AF607\$15.00 ea.



1941-1956 Gas Tanks \$249.00

1941-1956 Tanks are available in 4 models that are basically the same with the exceptions of the filler neck location. They may not be an exact replacement, requiring slight or no modification. Please measure the distance from the front of your tank (including the flange) to the center of the filler neck and match to chart.



- Overall size: 31-1/2"W x 27-1/2"L x 7-1/2"D
- 17 Gallon Capacity.
- Mounts with Original or CARS TS416 Mounting Straps.
- Filler Neck and 2-1/4" ID Connecting Hose Included.
- Accepts Original or CARS SU396 Sending Units.
- Made from Galvanneal Steel. Coated at the Steel Mill for Maximum Rust Protection.
- Primer Rust.
- Extra Shipping Required.

GT416 A, B, C, D\$259.00

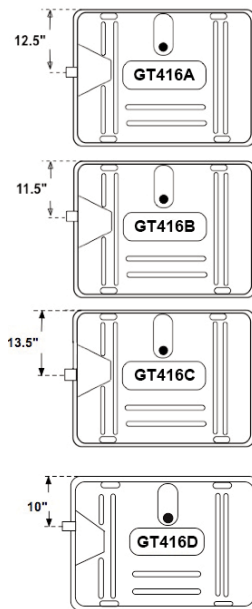

Installed on 1953 Skylark



1957 & 1958 Gas Tanks

GT58 Pictured

GT57 1957 All\$399.00
 GT58..... 1958 Fits all except Limited.....\$399.00
 GT58L..... 1958 Limited\$399.00

NOTE: Neck position for Super & Roadmaster is slightly different but functions the same.

Gas Tank Sending Units 1939-1958

1939-1958 Complete quality re-productions. Our units are tested and calibrated before shipment. Gasket, float and strainer sock are included.



1939 thru 1956 All. Complete with correct brass fittings.

NOTE: This unit can be used in 1932 to 1938 models w/ mounting hole modification.

SU396\$74.50 ea.

1957 All.
 SU57\$72.50 ea.



1958 All. Includes strainer sock.
 SU58.....\$74.50 ea.

1946-1958 Brass gas tank float.
 TF468.....\$8.50 ea.



Gas Tank Gasket and Parts



1935-1960 Gas tank fuel gauge gasket.
 GG355\$3.75 ea.

1935-1960 Fuel gauge screws & washers kit. (5)
 GGS355.....\$4.50 kit.



1935-1960 All. Gas tank strap cushions.
 SC350\$12.75 pr.

1935-1940 Gas tank T- Bolts.
 TB390.....\$14.00 pr.



1941-1958 Gas tank strap. Fit original or All CARS GT416 tanks.
 TS418.....\$29.50 pr.

Gas Tank Cleaner/Degreaser

Cleans and degreases. 1 Qt.
 TC1.....\$12.25 ea.



Gas Tank Etch

Removes light rust and will prep for sealer/liner. 16oz.
 TE1\$16.00 ea.



Gas Tank Sealer/Liner

Alcohol resistant. Quart can.
 TS1\$34.50 ea.



Gas Filler Grommets



1924-1927 Gas Filler Neck Grommet
1924 Buick Models 51, 51A, 55
1925-1926 Buick All Models
1927 Buick Models 51, 55

Fuel Filler Neck Through Rear Apron
 Replaces Factory OEM # 171872
 GF247.....\$49.59 ea.



1933-1935 Gas filler grommet.
1933: All Series 50 and 60 except
 Victoria Coupe;
1934-1935 All Models 66C, 66S, 67, 68.
 GF335.....\$66.99 ea.



1933-1935 Gas filler grommet.
1933: All Model 58, 68, 86, 90, 90L, 91;
1934-1935 All Models 61, 68C.
 GF335B\$62.99 ea.



1936-1937 Gas filler grommet.
1936: All;
1937: Series 80-90.
 GF367.....\$17.50 ea.



1937 Gas filler grommet. Special and
 Century.
 GF37.....\$17.50 ea.



1937-1938 Rubber cover, automatic choke
 cable at carburetor.
 CC378\$53.59 ea.



GC366A



GC346L



GC366R

Gas Caps

1932-1956 All. Cadmium as original. Aftermarket.
 GC366\$8.50 ea.

1930-1956 All. Stainless steel. AC accessory type.
 GC366R\$9.25 ea.

1932-1956 All. Authentic reproduction. Cadmium.
 GC366A.....\$24.50 ea.

1934-1956 All. GM logo locking gas cap.
 GC346L\$55.00 ea.

1957-1960 Gas cap.
 GC575\$9.50 ea.

Lead Additive

All Buick engines needing leaded gas.
 LA1.....\$13.50 ea.



Gas Pedals (3.451)

1931-1935 Full slip-over type. Sold outright.

1931-1932 Series 60, 80, 90;

1933 All;

1934-1935 Series 50, 60, 90,

GP315.....(Black).....\$65.99 ea.

GP315N.....(Brown).....\$70.29 ea.



1934-1935 Series 40. Send in your old core to have fresh rubber vulcanized. 3 week service.

GP345\$103.29 ea.

1936-1937 Pad, accelerator pedal. Slip-over type with heavy retainer lip to fit over original pedal after stripping old rubber off.

1936: Series 80 and 90;

1937: All.

GP367\$57.19 ea.

1938-1940 Pad, accelerator pedal.

Rubber flanges all around as original to over pedal carcass.

1938: All;

1939-1940: All Series 80 and 90.

GP380.....\$57.19 ea.



1939-1942

1939: Special & Century;

1940: Series 40, 50, 60 and 70;

1941-1942: Most Models;

GP392B.....(Black).....\$46.00 ea.

GP392N.....(Brown).....\$46.50 ea.

1940-1942 Pad, accelerator pedal.

Slip over type old carcass, perfect copy.

1940: Series 50 and 70;

1941-1942: All.

1946-1948: Series 50, 70;

1948-1949: All.

GP402\$35.00 ea.



1946-1954 Made with steel core as original. (Black).

GP464\$24.50 ea.



1948-1958 All; Accelerator pedal bellows. Fits behind gas pedal. Often missing.

AB488\$9.75 ea.



1955-1956 (Black).

GP556\$36.50 ea.

1955-1956 (Blue).

GP556U.....\$34.50 ea.

1957-1958 Gas pedal with steel core (Black).

GP578\$34.50 ea.

Universal Exhaust Hangers (3.616)

Fits 1 1/2" - 2" O.D. Twists or bends to any position. Absorbs road vibrations.

EH1\$5.75 ea.

Use with any 1 1/8" - 3" size muffler clamp. Rotates 360°. Absorbs road vibrations.

EH2\$6.50 ea.

Universal hanger.

EH3\$6.50 ea.



Authentic Hangers/Supports

1937-1952 All; **1953** Special; **1954** Special, Century, Skylark. Muffler, exhaust pipe and tail pipe clamp.

MC374\$15.00 ea.

1939 Special and Century tail pipe hangers.

TPH39F.....(Front)\$29.50 ea.

TPH39R.....(Rear Over Axle).....\$29.50 ea.

MS39R.....(Rear Muffler Support).....\$38.50 ea.

1940 Super and Roadmaster; **1941** All. Muffler support.

MS401.....(Fits Front or Rear)\$42.50 ea.

1941 All; **1942-1949** Special; **1950** All. Tail pipe hangers.

TPH410F.....(Front)\$29.50 ea.

TPH418R.....(Rear Over Axle).....\$29.00 ea.

Exhaust Deflectors

1936-1955 Original accessory. Stainless steel, complete with hardware.

ED365.....\$45.00 ea.

1954-1955 All: Tubular type. Chrome plated steel.

ED545.....\$19.50 ea.



1957 Exhaust Deflector

1957 All Models: Stamped steel. Looks identical to original. Correct for judging.

ED57\$74.50 ea.



Fuel • Carburetion • Exhaust (Group 3)

Fuel Pumps



1930-1953 All 6 volt. Universal replacement electric fuel pump.

FP6\$99.50 ea.

1953-1960 All V-8. Universal replacement electric fuel pump.

FP12\$49.50 ea.

1957-1960 Replacement fuel pump. Sold outright no exchange necessary.

FP575\$39.75 ea.



1955-1956

1955: Late;

1956: All. (Top mounts w/ 1 screw).

FP556RS.....(Rebuilding Service)\$99.50 ea.

FP556EI....(Exchange w/ \$100 core charge) ...\$125.00 ea.

1957-1958 All.

FP578RS.....(Rebuilding Service)\$89.25 ea.

FP578EI....(Exchange w/ \$100 core charge) ...\$125.00 ea.

1959-1960 All.

FP595RS.....(Rebuilding Service)\$89.25 ea.

FP595EI....(Exchange w/ \$100 core charge) ...\$125.00 ea.

Fuel Pump Rebuilding

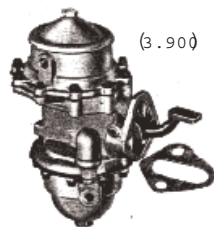

(3.900)

Send in your fuel pump for the best quality rebuilding service available. Pumps are completely disassembled, refurbished and guaranteed. Allow about 3-5 weeks. If in stock, some are sold on an exchange basis - with core charge refundable after your old OEM is deemed rebuildable.

We buy old Pumps...Please inquire.

1934-1935 Series 40.

FP345RS.....(Rebuilding Service)\$99.50 ea.

FP345EI....(Exchange w/ \$100 core charge) ...\$125.00 ea.

1936-1937 Specials; (State filtered or non-filtered type).

1938: Specials (early production).

FP368RS.....(Rebuilding Service)\$99.50 ea.

FP368EI....(Exchange w/ \$100 core charge) ...\$125.00 ea.

1938-1939

1938: Specials (late production);

1939: Specials. Inverted type.

FP389RS.....(Rebuilding Service)\$99.50 ea.

FP389EI....(Exchange w/ \$100 core charge) ...\$125.00 ea.

1936-1939 Series 60-80-90.

FP369RS.....(Rebuilding Service)\$99.50 ea.

FP369EI....(Exchange w/ \$100 core charge) ...\$125.00 ea.

1940-1951 Special and Super.

FP401RS.....(Rebuilding Service)\$99.50 ea.

FP401EI....(Exchange w/ \$100 core charge) ...\$125.00 ea.

1940-1951 Series 60-70-80-90.

FP401LRS.....(Rebuilding Service)\$99.50 ea.

FP401LEI....(Exchange w/ \$100 core charge) ...\$125.00 ea.

1952-1953

1952: Special and Super;

1953: Special.

FP523RS.....(Rebuilding Service)\$99.50 ea.

FP523EI....(Exchange w/ \$100 core charge) ...\$125.00 ea.

1952 Roadmaster.

FP52RS.....(Rebuilding Service)\$99.50 ea.

FP52EI....(Exchange w/ \$100 core charge)\$125.00 ea.

1953-1955

1953-1954: All;

1955: Early. (Top mounts with 6 screws).

FP535RS.....(Rebuilding Service)\$99.50 ea.

FP535EI....(Exchange w/ \$100 core charge) ...\$125.00 ea.

Fuel Pump Gaskets

1934-1935 series 40, 50 fuel pump mounting gasket.

BG2085.....\$2.50 ea.

1936-1960 All fuel pump mounting gasket.

BG2306.....\$2.50 ea.



Fuel Pump Rebuilding Kits (3.925)

1935-1938 Specials with single action (pump #421).

FPK358\$56.50 ea.

1936-1938 Series 60-80-90. Double action (pump #422).

FPK368\$89.50 ea.

1938-1939 Specials. For single action pumps (#518).

FPK389\$62.50 ea.

1940-1951 All double action pumps. (#519, 529, 530, 843).

FPK381\$89.50 ea.

1939 Series 60-80-90. Double action pump (#518).

FPK39\$89.50 ea.

1952-1953

1952: All; **1953:** Specials.

FPK523\$89.50 ea.

1953-1955 All V-8 engine, double action pump.

FPK535.....(Top mounts with 6 screws).....\$89.50 ea.

1955-1956 All.

FPK556.....(Top mounts with 1 screw)\$89.50 ea.

1957-1958 All.

FPK578\$69.50 ea.

1959-1960 All.

FPK575\$69.50 ea.

Cover Plate Assembly

Used for cars with electric fuel pumps.

CP300.....\$12.50 ea.



Fuel Pump Hardware Kits

1940-1960 all engines. Correct bolts/washers.

FPH406.....\$2.75 ea.

Gas Lines (3.158)

1940-1953 Gas line to pump hose.

1940-1952: All;

1953: Specials.

GL403.....\$24.50 ea.

1953-1956 All V-8, gas line to fuel pump hose.

GL536.....\$23.50 ea.



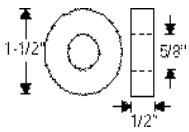

1933-1936 Transmission support pad. Lower.
1933-1935 All;
1936 Series 40. Sold outright!
 TM336\$12.75 ea.

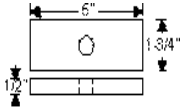

1934-1936 Series 40. Transmission support pa. Upper. Sold outright!
 TM346\$21.99 ea.



1936-1937 Pad set, transmission support. Use your original channel, plate and cap. One set (2 pad per set) per car. Series 60, 80 and 90. Sold outright!
 TM367\$128.99 set



1937 Series 40. Pad, transmission support. Two per car. Sold outright!
 TM37\$33.49 pr.



1940-1953 Shift lever rubber bearing (Ball).
 SB403\$10.50 ea.



1957-1960 Trans Lever Return Spring (Auto Trans).
 LR570\$14.50 ea.



1938-1939 Insulator blocks, transmission support, upper and lower. These blocks are not vulcanized to steel, but are installed in shells at time of assembly like the original.
1938: Series 60, 80, and 90;
1939: Series 80 and 90. Sold outright!
 TI389\$94.99 pr.



1940-1947 Transmission Mount.
 TM407\$74.00 ea.

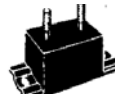

1948-1958 All Dynaflow except 1953 Super, Roadmaster, Skylark. Sold outright!
 TM488\$32.00 ea.



1948-1956 All Standard; 1953 Super, Roadmaster and Skylark. Sold outright!
 TM486S\$55.00 ea.

1948-1956 All. (Thrust Pad). Sold outright!
 Includes Nuts & Washers
 TP486\$48.50 ea.



1957-1959 All. Ex. flight pitch. (Thrust pad). Sold outright!
 TP579\$59.00 ea.



Transmission Mount Rebuilding

We now offer you complete revulcanization of your transmission mounts. Fresh, new rubber will insure safe and smooth running. If we have your needed mount ready to ship we will charge you an additional core deposit of \$50.00 per item. This charge is fully refundable upon receiving your rebuildable cores. We prefer you send your mounts for rebuilding. Please allow at least 2-3 weeks for this process.

1958-1959 All flight pitch transmissions.
 TM589FRS\$222.99 pr.

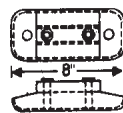
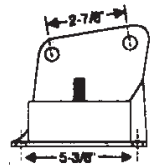

1959-1960 All with automatic transmission.
 TM590RS\$141.19 ea.

1938 Special, with standard transmission. Pad, transmission mounting upper and lower.
 TM38RS\$158.19 set

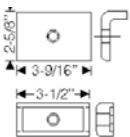
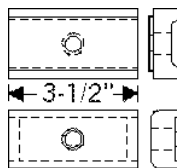

1938-1940 Special with semi-auto trans.
 TM380RS\$177.59 set

Shift Rod Insulators

1941-1954 (4.019)

1941-1948 All;
1949-1953 Series 40-50;
1954 Series 40-50-60. All standard trans. (3 per car) Shift Lever Insulator.



SLI400\$4.25 ea.

Shift Boots



1934-1938 Shift Boot

1934-1935 Series 40-60;
1936-1938 Series 40.

SB348(Black)\$17.00 ea.
 SB348N(Brown)\$52.99 ea.

Transmission (Group 4)

Automatic Transmission Kits (4.005)

Model	Year	Master Overhaul Kit	Banner Kit	Paper, Rubber, Rings & Seals	External Seal-up Kit	Torque Ball Seal Kit
Dynaflow.....	1948-1952	TOK484 \$269.00 ea.....	TKB484..... \$252.50 ea.....	TRK484..... \$209.50 ea.....	TSK484..... \$105.00 ea.....	TBK482 \$89.50 ea.
Dynaflow.....	1953-1954	TOK484 \$269.00 ea.....	TKB484..... \$252.50 ea.....	TRK484..... \$209.50 ea.....	TSK484..... \$105.00 ea.....	TBK535 \$89.50 ea.
Dynaflow	1955	TOK550 \$289.50 ea.....	TKB550..... \$252.50 ea.....	TRK550..... \$229.00 ea.....	TSK550..... \$89.50 ea.....	TBK535 \$89.50 ea.
Dynaflow	1956	TOK550 \$289.50 ea.....	TKB550..... \$252.50 ea.....	TRK550..... \$229.00 ea.....	TSK550..... \$89.50 ea.....	TBK56 \$89.50 ea.
Dynaflow.....	1957-1958	TOK550 \$289.50 ea.....	TKB550..... \$252.50 ea.....	TRK550..... \$229.00 ea.....	TSK550..... \$89.50 ea.....	TBK578 \$89.50 ea.
Dynaflow.....	1959-1960	TOK550 \$289.50 ea.....	TKB550..... \$252.50 ea.....	TRK550..... \$229.00 ea.....	TSK550..... \$89.50 ea.....	TBK590 \$89.50 ea.
Flightpitch.....	1958-1959	N/A..... N/A.....	N/A..... N/A.....	TRK589..... \$455.00 ea.....	TSK589..... \$144.50 ea.....	TBK538 \$89.50 ea.

Paper, Rubber, Rings & Seals: All Gaskets, Lipseals, O-Rings, Sealing Rings, Front Pump Seal and Ext. Hsg. Seal.

Master Overhaul Kit: All Parts in Paper, Rubber, Rings & Seals Kits plus Friction (lined) Clutches & Steel Clutches.

Banner Kit: Same as Paper, Rubber, Rings & Seals also Cyclinder Friction Clutches Kit, but w/o Steel Clutches.

External Seal-up Kit: Stops any external Leaks. Contains Front Pump Seal, Extension Housing Seal, Selector Lever Seal and External Gaskets (including Pan Gasket and Converter Gasket or O-Ring).

Torque Ball Kit: Torque Ball Retainer with vulcanized seal, rear transmission seal, shims and seal.



Dynaflow Clutches

1948-1960 All. 5 each. Molded per car.

DC483F.....Fricton.....\$13.00 ea.

DC483S.....Steel.....\$14.00 ea.



Transmission Bands Exchange or Rebuild Service

1948-1958 Front (Low).

DB488L.....Core \$60.....\$75.00 ea.

1959-1963 Front (Low).

DB593L.....Core \$100.....\$75.00 ea.

1948-1958 Exc. 49 Roadmaster Rear (Reverse).

DB488R.....Core \$60.....\$75.00 ea.



1949 Roadmaster Rear (Reverse).

DB49R.....Core \$60.....\$75.00 ea.

1959-1963 All. Rear (Reverse).

DB593R.....Core \$60.....\$75.00 ea.



Standard Transmission Gasket Kits

- 1934-1938 Special.**
TGK348.....\$15.00 ea. 
- 1936-1939 Century, Roadmaster, Limited.**
TGK379\$22.25 ea. 





- 1939-1948 Series 60, 70, 80, 90.**
1953-1960 All.
Includes: Extension Housing Gasket, Case To Clutch Housing Gasket, Case Cover Gasket.
TGK390.....\$16.00 ea. 

- 1939-1955 Special and Super.**
TGK395.....\$15.00 ea. 

Dynaflow Transmission Pan Gaskets

- 1948-1960 All.**
TPG483.....\$10.00 ea. 
- 1958-1960 All. Flight pitch.**
TPG589.....\$19.00 ea. 
- 1934-1960 All engines. Fiber oil pan drain plug gasket.**
ODG348\$2.75 ea.
ODG348C.....Crushable copper as original.....\$3.00 ea.

Transmission Seals

-  **1939-1954 All standard trans. Front main drive seal. (4.354)**
TS394.....\$11.75 ea.
- 1939-1960 All selector seal on side of case.** 
SS390\$21.75 ea.
-  **1940-1952:**
1940-1942 Series 60 and 70;
1946-1952 All. Rear. (serves as propeller shaft seal also).
TS482.....\$15.25 ea.
- 1951-1960 All. converter pump seal. "O" Ring".**
PS513.....\$10.75 ea.
-  **1948-1960 Dynaflow front pump seal. Exc. 3T.**
TS483F\$14.00 ea.
- 1953-1958 All. Rear.**
(serves as propeller shaft seal also).
TS538\$11.50 ea.
- 1959-1960 All. Rear.**
(serves as propeller shaft seal also). 
TS590.....\$11.50 ea.

Transmission Bands

- 1948-1960 All. Rebuilding service only.**
TB483.....\$75.75 ea.

Transmission Bearings

Front (Main Drive)

- 1935 Series 40;**
1936-1960 All.
TBF350.....\$59.50 ea. 

Rear Bearing

- 1932-1935 Series 50, 60;**
1934-1952 Series 40 Standard;
1940 1952 Series 50 Standard;
1953-1955 Series 40 Standard;
1956-1960 Dynaflow rear end or output shaft.
TBR320\$59.50 ea
- 1936-1942 Series 60, 90;**
1936-1940 Series 80;
1940 1948 Series 70;
1953-1955 Series 50, 60 Standard;
1956-1958 Series 40 Standard;
1956-1960 LeSabre Standard:
TBR360\$59.50 ea

Speedometer Cables & Casings

Our speedometer cable assemblies are made exactly as original. They feature rust proof and leak proof galvanized armor casings so they function and look authentic. Lengths are matched for your car-not just an oversized "fits all" cable.

- 1937-1940 Series 40, 60;**
1938 Series 80, 90;
1940 Series 50, 70;
1941 Series 40, 50;
1942-1952 All ;
1953 Special;
1954-1955 Series 40, 60, 100;
1954-1958 All Standard Trans.
SC378\$29.50 ea. 
- 1937 Series 80, 90 ;**
1938 Series 40 w/ auto trans.
1939-1940 Series 80, 90;
1941 Series 60, 70, 90;
1953 Super, Roadmaster, Skylark;
1959-1960 All.
SC370\$32.50 ea. 
-  **1954-1955 Series 50, 70, AT;**
1956 All AT;
1957-1958 All AT.
SC378B\$30.50 ea.
- 1936-1960 All. Speedometer cable repair kit.**
SRK360.....\$16.00 ea. 
- All Years.**
Speedometer cable lubricant.
SCL300\$5.00 ea. 

See Group 5 for Torque Ball Sealing Kits.

Brakes (Group 4)

1939-1953 New Master Cylinders

Fully assembled, ready to install

1939-1940: Except Limited;
1941-1949 all.

MC399.....	\$148.50 ea.
1950-1952 All;	
1953 Special	
MC503.....	\$164.00 ea.
1960 Regular brakes.	
MC60.....	\$139.50 ea.



Master Cylinder Cap for Above

MCC393.....	\$12.00 ea.
-------------	-------------

We prefer you send **your** master cylinder for resleeving. This process takes about two weeks. Units are cleaned, honed or sleeved as necessary. They are returned with a fresh repair kit ready for assembly. Please note, we can re-sleeve any master cylinder, but, we can only supply kits as listed in the "Repair Kit" section. Please keep your filler cap, end caps, internal parts and push rod. We can also send you a master cylinder on an exchange basis. If we have your needed part ready to ship we will charge you an additional core deposit of \$100.00 refundable upon receiving your original equipment and rebuildable core. Previously sleeved units are \$25 additional.

Master Cylinder Resleeving Regular Brakes (4.650)

1936 Special.	
MC36RS.....	\$132.50 ea.
1936 Century, Roadmaster, Limited.	
MC36BRS.....	\$137.50 ea.
1937-1938 Special.	
MC378SRS.....	\$137.50 ea.
1937-1938 Century.	
MC378CRS.....	\$137.50 ea.
1937 thru 1940 Roadmaster and Limited.	
MC370RS.....	\$147.50 ea.
1939-1949	
1939-1940: Except Limited;	
1941-1949 All.	
MC399RS.....	\$137.50 ea.
1950-1953	
1950-1952 All;	
1953 Special.	
MC503RS.....	\$137.50 ea.
1953 Super, Roadmaster with dynaflow.	
MC53RS.....	\$137.50 ea.
1954-55 All.	
MC545RS.....	\$147.50 ea.
1956 All regular brakes.	
MC56RS.....	\$499.00 ea.
1957 Regular brakes.	
MC57RS.....	\$137.50 ea.
1958 Regular brakes.	
MC58RS.....	\$137.50 ea.
1959 Regular brakes.	
MC59RS.....	\$137.50 ea.

Master Cylinders Repair Kits (4.649)



1936 Special, Series 40. 1"	
MK36S.....	\$36.50 ea.
1936 Series 60, 80, 90. 1 1/8"	
MK36.....	\$32.50 ea.
1937-1940 Series 80, 90. 1 1/8" diameter	
MK370.....	\$32.50 ea.
1937-1955	
1937-1940: All except 80 and 90;	
1941-1955: All regular brakes.	
MK375.....(1" Diameter).....	\$23.50 ea.
1956 All with standard brakes	
MK56.....	\$59.50 ea.
1957 All with standard brakes	
MK57.....	\$23.50 ea.
1958-1960 All with regular brakes.	
MK596.....	\$26.25 ea.
1960 All with power brakes.	
MK602.....	\$22.25 ea.

Power Brake Master Cylinder Rebuilding Kits and Parts (4.649)



1955-1959 Moraine power brake overhaul kit.	
PBK559.....	\$98.50 ea.
1953-1960 Moraine power brake leather piston seal.	
BL530.....	33.50 ea.



Master Cylinders Power Brakes Power Brake Unit Rebuilding Service



1954-1960 All Delco Moraine and Bendix Treadlevac.	
MC530.....	\$445.00 ea.
1953-1954 All Kelsey Hayes. Note. It is our understanding that the 1953 kelsey hayes units were recalled by Buick and replaced with 1954 units. They can be identified by a 6 1/2" piston chamber as opposed to 4" on 1954 units. We cannot rebuild the early 1953 models (cast #37002).	
MC534K.....	\$548.50 ea.

Moraine Brake Shafts (Pistons)



1955 All.	
BS55.....	\$97.50 ea.
1956 All.	
BS56.....	\$97.50 ea.
1957-1959 All.	
BS579.....	\$97.50 ea.

Wheel Cylinders (4.665)

FRONT:

1937-1942:

- 1937-1939 Special and Century;
- 1940-1941 All except 80 and 90;
- 1942 All except series 90.



- FWC372R.....R.H. Side\$39.00 ea.
- FWC372L.....L.H. Side\$39.00 ea.

1942-1957 All.

- FWC427R.....R.H. Side\$39.00 ea.
- FWC427L.....L.H. Side\$39.00 ea.

1958-1960 All

- FWC580R.....R.H. Side\$48.50 ea.
- FWC580L.....L.H. Side\$48.50 ea.

REAR:

1938-1942:

- 1938-1939 Special and Century;
- 1940 Special, Super, Century, Roadmaster;
- 1941 All;
- 1942 Series 90.

- RWC380.....Fits Either Side\$39.50 ea.

1942-1949 All.

- RWC429R.....R.H. Side\$35.00 ea.
- RWC429L.....L.H. Side\$35.00 ea.

1950-1960 All.

- RWC500R.....R.H. Side\$35.00 ea.
- RWC500L.....L.H. Side\$35.00 ea.

Wheel Cylinder Repair Kits (4.667)

FRONT:

1936 Series 40, front. 1 1/16"

- FK36\$10.00 ea.

1936-1940

- 1936: Series 60, 80, and 90;
- 1937-1940: Series 80 and 90. Front. 1 1/4"



- FK360\$13.50 ea.

1937-1941 All, except 80-90, front. 1 3/32"

- FK371\$10.50 ea.

1942-1960 All. Front. 1 1/8"

- FK426\$10.25 ea.

REAR:

1936 Series 60-80-90;

1937-1940 Series 80 and 90, rear. 1 3/16"

- RK360\$11.25 ea.

1936-1960 All Except above listed.

- RK370\$10.00 ea.

Wheel Cylinder Re-Sleeving Service

1936-1941 We re-sleeve your cylinders with brass.

- WCS361\$89.50 ea.



Silicone Brake Fluid

One Gallon Size

- SF360\$63.00 gal.

Power Brake Units

1953 All Models.

- PBU53\$595.00 ea.

1954 Special, Century, & Skylark.

- PBU54\$595.00 ea.

1954 Super & Roadmaster.

- PBU54B.....\$595.00 ea.

1955 All Models.

- PBU55\$595.00 ea.



Brake Overhaul Kits

Our complete kits include the following:

- 4 Wheel cylinder kits
- * • 1 Master cylinder kit. Standard brakes only
- 4 Brake shoe sets
- 3 Hydraulic brake hoses
- 2 Brake spring hardware kits

* Not available for 1956

1936 Special.

- BOK36S\$189.50 ea.

1937-38 Special with 1-3/4" shoes.

- BOK378\$189.50 ea.

1937-38 Century (Ser. 60) & Roadmaster (Ser. 70) w/ 2" shoes.

- BOK378B\$189.50 ea.

1939 All except 80 - 90 and Convertibles;

1940 Series 50, 70;

1941 All except convertibles.

- BOK391v\$189.50 ea.

1940 Special.

- BOK40S\$189.50 ea.

1941-1949 Roadmaster.

- BOK419\$189.50 ea.

1942-1949 Special and Super.

- BOK429\$209.50 ea.

1950-51 Special and Super.

- BOK501\$189.50 ea.

1950-51 Century and Roadmaster. All w/o power brakes.

- BOK501B\$189.50 ea.

1952 Super.

- BOK52\$189.50 ea.

1952-55 Special.

- BOK525\$189.50 ea.

1952 Roadmaster Early;

1953-1956 all Roadmaster.

- BOK526R\$189.50 ea.

1953-55 Super, Century;

1954 Skylark.

- BOK535\$189.50 ea.

1956 Special, Super, Century.

- BOK56\$239.50 ea.

1957 Special, Super, Century.

- BOK57\$189.50 ea.

1958 All.

- BOK58\$189.50 ea.

1959 All.

- BOK59\$189.50 ea.

56 1960 All.

- BOK60\$189.50 ea.

Brakes (Group 4)

Brake Shoes (5.017)

Years	Part No.	Width	Price
FRONT (set is enough for 2 wheels)			
1936-1951	1936-1951 Special and Super.....	BS29.....1 3/4"	\$69.50 set
1937-1938	1937-1938 Century, Roadmaster w/ 2" shoes.....	BS340.....2"	\$59.50 set
1940-1957	1940-51 Ser. 60-70; 1952-57 Sr 40,50,60,100.....	BS197....2 1/4"	\$49.50 set
1952-1957	52 sr. 70 late; 53-57 all Roadmaster.	BS64.....2 1/2"	\$79.50 set
1958-1960	1952 Roadmaster early; 1958-1960 all.....	BS65.....2 1/2"	\$58.00 set
REAR (set is enough for 2 wheels)			
1936-1955	1936-1955 Series 40; 1940-1952 Series 50.....	BS29.....1 3/4"	\$69.50 set
1940-1960	1940-1952 Series 60-70; 1953-1955 Series- 50-60-70-100; 1956-1960 All.....	BS197....2 1/4"	\$49.50 set



Brake Hoses (4.680)

Years	Part No.	Price
FRONT		
1936-1940	1936 All; 1937-1940 Series 80-90 Front.....	FH360.....\$19.00 ea.
1937-1938	1937-1938 Series 40-60 Front.....	FH378.....\$19.50 ea.
1939-1949	1939 Series 40-60; 1940 Series All exc. 80, 90. 1941-1949 All. Front.....	FH399.....\$18.00 ea.
	New Modern Stainless Steel Braided	FH399SS...\$29.50 ea.
1950-1956	1950-1956 All. Front.....	FH506.....\$18.50 ea.
1957-1960	1957-1960 All. Front.....	FH575.....\$18.50 ea.
REAR		
1936-1941	1936 Exc. convert.; 1937 All exc. 80C; 1938-1939 All exc.convert; 1941 All. Except convertibles. Rear.....	RH361.....\$18.00 ea.
	New Modern Stainless Steel Braided	RH361SS..\$34.00 ea.
	1936 Models 46C, 66C, 80C; 1937 80C; 1938-1939 All convertibles; 1941-1949 Models 51C, 56C, 71C, 76C.....	RH369C....\$26.50 ea.
1940-1949	1940 Series 80-90; 1940 Series 40-60 except convertibles; 1941-1949 All.Except convertibles.Rear.....	RH409.....\$19.00 ea.
1950-1955	All. Rear.....	RH505.....\$18.50 ea.
1956-1958	All. Rear.....	RH568.....\$24.50 ea.
1959-1960	All. Rear.....	RH590.....\$24.50 ea.



Brake Drums (5.809)

Brand New! Cast Iron replacements.
(When replacing aluminum front drums - purchase in pairs.)

Front 1 3/4"	
1936-1951 Super; 1936-1951 Special. BD365	\$114.50 ea.
Rear 1 3/4"	
1936-1952 Super exc. wagons; 1936-1955 Special BD365	\$114.50 ea.
Front 2 1/4"	
1942-1951 Roadmaster; 1942-1957 Century; 1952-1957 Super exc. wagons; 1952-1957 Special; BD420	\$114.50 ea.
Rear 2 1/4"	
1942-1957 Century & Roadmaster; 1953-1957 Super; 1956-1957 Special; 1958-1960 All. BD420	\$114.50 ea.
Front 2 1/2"	
1952-1957 Roadmaster; 1958-1960 All BD520	\$114.50 ea.

Brake Spring Kits (5.023) Kits are per one axle

1936-1955	1936-1951 All Front or Rear, exc. 89,90; 1952-1955 Special, Rear.....	BSK365.....\$24.50 ea.
1952-1960	1952-1957 All Roadmaster, Front; 1956-1960 All Front.....	BSK520F.....\$24.50 ea.
1952-1960	1952-1957 All exc. Roadmaster, Front; 1952-1955 Roadmaster, Rear; 1952-1955 Super, Century, Skylark, Rear; 1956-1960 All Rear.....	BSK520.....\$24.50 ea.
1936-1960	All. Brake Adjusting Screw. Fits front & rear.....	BAS362.....\$10.75 ea.



BAS362

Rear Drum & Wheel Pilot

1934-1935 Series 40; 1936 Series 40, 60, 70; 1937-1960 All; DAP340.....	\$7.50 ea.
--	------------



Brake Hose Clip



1936-1960 All.
BC360\$1.25 ea.

Brake Pedal Pads (4.630)



1932-1940 Pad, brake and clutch pedals full slip-over type as original.
1936: Series 60, 80 and 90;
1937-1940: Series 80 and 90.
PC320.....(Black).....\$71.19 pr.
PC320N.....(Brown).....\$72.69 pr.

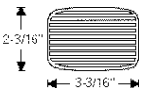

1936-1955
1936: Series 40;
1937-1939: Series 40-60;
1940-1947: All except 80-90;
1948-1952: All Park brake pedal;
1953: Early models, park brake pedal;
1948-1955: Standard transmission. Three per car.
PC345.....(Black).....\$8.50 ea.
PC345N.....(Brown).....\$8.50 ea.



1948-1952 All Brake pedal pads with dynaflo transmission. (Black).
PC482\$15.00 ea.



1953-1954 Park brake pedal pad.
1953: All. Late models;
1954: All.
PC534\$33.59 ea.



1953-1955 Brake pedal pad. All with dynaflo and regular brakes.
PC535R\$28.19 ea.



Stop on a Dime!
With Brake Parts From Cars, Inc.

Brake Pedal Pads



PC535P



PC535

1953-1955 All with power brakes.
PC535P.....("Power Brake").....\$27.50 ea.
PC535.....(no letters on pad).....\$22.25 ea.



1955-1958 Park Brake pedal pad.
PC558.....(Black).....\$12.00 ea.
PC558U.....(Blue).....\$14.50 ea.
PC558G.....(Green).....\$14.50 ea.



1956 All with power brakes.
PC56\$32.50 ea.



1956 All with regular brakes.
PC56R\$24.50 ea.



1956-1958 All with manual trans. Clutch and brake pedal.
PC568S.....(Black).....\$56.69 pr.



1957-1958 Power brake pedal cover.
PC578BW.....(Black).....\$23.25 ea.
PC578PY.....(Gray).....\$28.25 ea.



1957-1958 All with regular brakes and auto trans.
PC578S.....(Black).....\$27.50 ea.

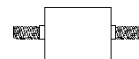

1953-1954 Vacuum pump mount.
PM534\$7.29 ea.

Stop Light Switches (2.447)



1936-1940 All.
SLS360\$19.50 ea.



1941-1955 All.
SLS415\$13.50 ea.



1956-1960 All.
SLS563\$10.75 ea.



1936-1980 Brake adjuster hole plug. (4 per car).
BC340\$1.00 ea.



1936-1958 All, brake and clutch pedal return grommets.(9.775) (2 per car)
PG365.....\$7.75 ea.

Brake Cables (Group 4)

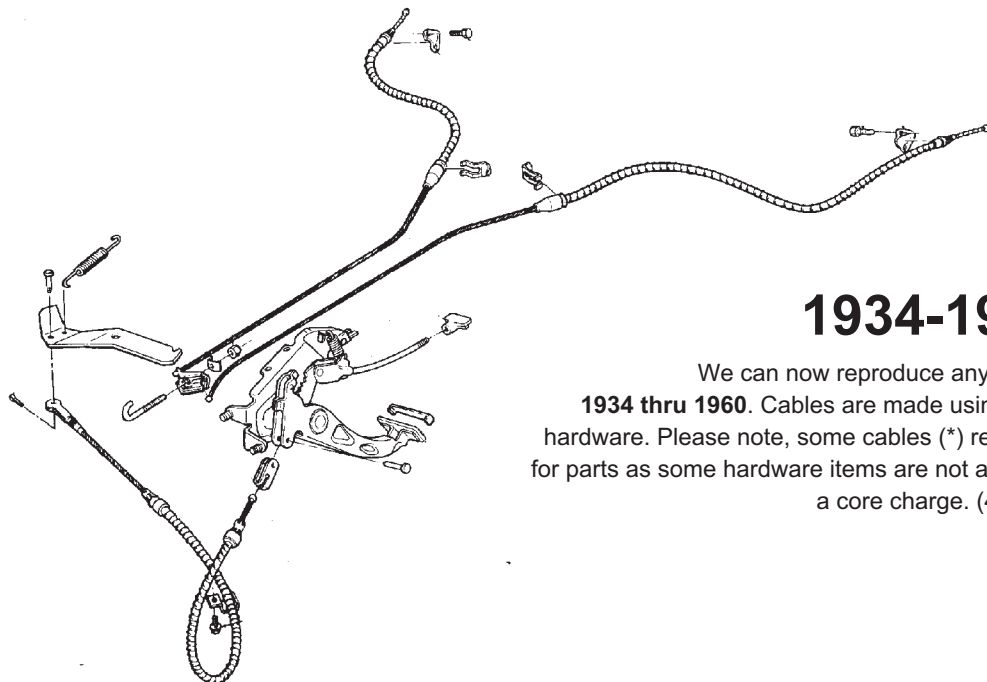

1934-1960

We can now reproduce any cable listed from **1934 thru 1960**. Cables are made using correct conduit, cable and hardware. Please note, some cables (*) require that we have your old unit for parts as some hardware items are not available. Some are available with a core charge. (4.779)

Year & Model	Front	Cost	Rear	Cost
1934-1935 (40)	R1266724 (2)	\$119.00 ea.	R1267082 (2)	\$123.50 ea.
1934-1935 (50)	R1282837 (2)	\$119.00 ea.	R1284204 (2)	\$123.50 ea.
1934-1935 (60)	R1282594 (2)	\$119.00 ea.	R1284205 (2)	\$123.50 ea.
1934-1935 (90)	R1282538 (2)	\$119.00 ea.	R1284205 (2)	\$123.50 ea.
1936 (40)	R1293175 (1)	\$119.00 ea.	R1289833 (2)	\$123.50 ea.
1936 (60)	R1294332 (1)	\$119.00 ea.	R1294331 (2)	\$123.50 ea.
1936 (80)	R1293288 (1)	\$119.00 ea.	R1290372 (2)	\$123.50 ea.
1936 (90)	R1293288 (1)	\$119.00 ea.	R1290319 (2)	\$123.50 ea.
1937 (40, 60)	R1298782 (1)	\$119.00 ea.	R1299321 (2)	\$123.50 ea.
1937 (80)	R1298783 (1)	\$119.00 ea.	R1299322 (2)	\$123.50 ea.
1937 (90)	R1298783 (1)	\$119.00 ea.	R1299323 (2)	\$123.50 ea.
1938 (40, 60)	R1304324 (1)	\$119.00 ea.	R1304326 (1)	\$123.50 ea.
1938 (80)	R1305200 (1)	\$119.00 ea.	R1305229 (1)	\$123.50 ea.
1938 (90)	R1305201 (1)	\$119.00 ea.	R1305229 (1)	\$123.50 ea.
1939 (40, 60)	R1308610 (1)	\$119.00 ea.	R1308315 (1)	\$123.50 ea.
1939 (80)	R1309111 (1)	\$119.00 ea.	R1309114 (1)	\$123.50 ea.
1939 (90)	R1309112 (1)	\$119.00 ea.	R1310348 (1)	\$123.50 ea.
1940 (40, 50, 60, 70)	R1315857 (1)	\$119.00 ea.	R1315855 (1)	\$123.50 ea.
1940 (80)	R1314860 (1)	\$119.00 ea.	R1310348 (1)	\$123.50 ea.
1940 (90)	R1314861 (1)	\$119.00 ea.	R1310348 (1)	\$123.50 ea.
1941 (44,44C,46S,47)	R1321478 (1)	\$119.00 ea.	R1316875 (1)	\$123.50 ea.
1941 (41, 41SE, 46, 46S, 46SSE, 49, 50, 60, 70)	R1315857 (1)	\$119.00 ea.	R1316815 (1)	\$123.50 ea.
1941 (90)	R1319737 (1)	\$119.00 ea.	R1310348 (1)	\$123.50 ea.
1942 (44, 44C, 47, 48, 48S)	R1325350 (1)	\$119.00 ea.	R1316875 (1)	\$123.50 ea.

Year & Model	Front	Cost	Rear	Cost
1942 (41, 41SE, 46, 46s, 46SSE, 49);				
1942 all Century;				
1946-1949 (Specials)	R1339588 (1)	\$119.00 ea.	R1316875 (1)	\$123.50 ea.
1942-1948 (50, 70)	R1323639 (1)	\$119.00 ea.	R1322613 (1)	\$123.50 ea.
1949 (50, 70)	R1339589 (1)	\$119.00 ea.	R1316875 (1)	\$123.50 ea.
1950 all except models 52 and 72;				
1951-1953 all Super, Roadmaster and Skylark, except models				
(52,72,72R)	R1338927 (1)	\$94.50 ea.	R1316875 (1)	\$87.50 ea.
1951-1953 (Specials)	R1338927 (1)	\$94.50 ea.	R1342444 (1)	\$87.50 ea.
1950-1953 (52, 72, 72R)	R1339434 (1)	\$94.50 ea.	R1316875 (1)	\$87.50 ea.
1954-1956 Special, Century,				
Skylark	R1166151 (1)	\$94.50 ea.	R1163029 (1)	\$87.50 ea.
1954-1956 Super and Rdmst. ..	R1173411 (1)	\$94.50 ea.	R1162575 (1)	\$87.50 ea.
1957-1958 Special -				
standard trans.	R1178540 (1)	\$94.50 ea.	R1174857 (1)	\$87.50 ea.
1957-1958 Special and				
Century A.T.	R1175039 (1)	\$94.50 ea.	R1174857 (1)	\$87.50 ea.
1957-1958 Super, Limited,				
Roadmaster	R1175040 (1)	\$94.50 ea.	R1174857 (1)	\$87.50 ea.
1959 LeSabre, Invicta	R1187115 (1)	\$94.50 ea.	R1187358 (1)	\$87.50 ea.
1959 Electra	R1187116 (1)	\$94.50 ea.	R1187358 (1)	\$87.50 ea.
1960 LeSabre and Invicta	R1193879 (1)	\$94.50 ea.	R1193782 (1)	\$87.50 ea.
1960 Electra	R1193880 (1)	\$94.50 ea.	R1193782 (1)	\$87.50 ea.

* Old cable needed or \$25 core charge

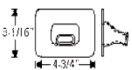

1934-1935 Boot or collar for hand brake lever.
HB345\$83.99 ea.

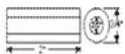

1934-1948 Brake cable anti-rub cover.
CB348.....\$6.99 ea.



1936-1960 All. Brake Cable Gaskets.
BCG360\$6.95 pr.



1938-1958 All. Parking brake cable rubber
buffer.
CB388\$7.75 ea.



1959-1960 All. Parking brake cable rubber
buffer.
CB590\$6.75 ea.



1940-1959 Parking Brake Return Spring.
BRS409\$15.00 ea.



www.oldbuickparts.com

908-369-3666

Torque Ball • Propeller Shaft (Group 5)

Torque Ball Seal (5.560)



1934-1948 Torque ball packing (cork seal).
TS348\$22.75 ea.



1936-1948 Sealing kit - includes seal, gaskets and instructions.
All models except 1939.
TBK348\$35.50 ea.

Torque Ball Retainer

Developed by Buick in 1960 to fit all Dynaflo from 1948 thru 1960. Does not have lip, so dust boot now rests against retainer.



1948-1960 (5.560)
1948-1960: All Dynaflo;
1953-1960: All Standard.
TBR480\$69.50 ea.

Dynaflo Torque Ball Sealing Kits

The common cause of transmission leakage can now be corrected with the installation of these kits.

Kit contains: Retainer with seal (TBR480) featured above, rear transmission seal, shims, spline shaft seal and instructions.



1948-1953 All Dynaflo.
1948-1952: All;
1953: Specials.
TBK482\$94.50 ea.



1953-1958 All Dynaflo.
1953 Super and Roadmaster;
1954 thru **1958** all.
TBK538\$94.50 ea.



1959-1960 All Dynaflo.
TBK590\$94.50 ea.

Torque Ball Boots (5.565)



1939 Series Special and Century.
TB39\$36.50 ea.

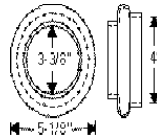

1948-1952 All;
1953 Compare with TB535.
TB482\$39.50 ea.



1953 Some - compare TB482;
1954-1955 All.
TB535\$24.00 ea.

Torque Ball Outer Seals (5.560)

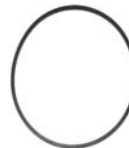

1956-1960 All. Located on outer retainer, 4 7/8" dia.
TBS560\$6.00 ea.

1957-1960 All. Seals torque ball flange. 5" dia.
TBS570\$6.00 ea.

Torque Ball Supports (5.565)

1939 Special and Century.
New rubber vulcanized to your old cores.

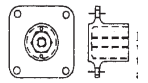

TM39\$248.75 pr.

Note: You must send in your core to be revulcanized.

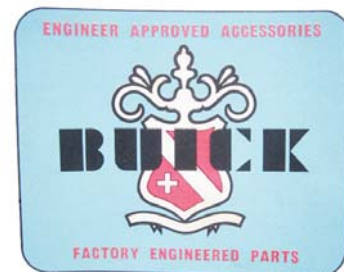

Torque Ball Bushings (5.566)



1934-1938 Series 40 & Special.
TBB348.....\$97.50 ea.



1936-1939 Series 60, 80 and 90.
TBB369.....\$97.50 ea.



1948-1955 Bronze Bushing.
(Can be used to back to 1940)
TBB485.....\$79.50 ea.



1956 All
TBB56.....\$77.50 ea.

1957-1959
TBB579.....\$77.50 ea.

Torque Tube Gaskets-Shims (5.560)



1940-1960 All. Torque tube to torque ball.
TBG400.....\$3.00 ea.



1940-1955 All. Torque tube to rear axle.
TTG405.....\$8.00 ea.

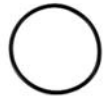

1959-1960 Torque Tube "O" Ring.
TTS590.....\$8.50 ea.

Torque Ball Shim Kits (5.560)

1934-1956 All series 40 & 50 with
standard transmission.
TBG345.....\$8.00 ea.



1936-1948 ser. 60, 70, 80, 90 with
standard transmission;
1948-1960 All Dynaflo.
TBG480.....\$8.00 ea.

Drive Shaft Front Seals

1940-1952:
1940-1942 Series 60 and 70;
1946-1952 All. Rear.
(serves as propeller shaft seal also).
TS482.....\$15.25 ea.



1953-1958 All. Rear.
(serves as propeller shaft seal also).
TS538.....\$11.50 ea.



1959-1960 All. Rear.
(serves as propeller shaft seal also).
TS590.....\$11.50 ea.



Drive Shaft Bearing (5.506)



1957-1960 All.
DSB570.....\$59.50 ea.

Propeller Shaft Seal



1946-1953 All. Spline Seal.
PS463.....\$11.00 ea.

Propeller Shaft Coupling Pins
Hardened Steel

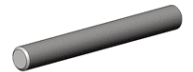

1934-1936 Series 40.
PP346.....\$4.75 ea.

1936 Series 60, 70, 80, 90;
1937-1939 All.
PP369.....\$4.75 ea.

1940-1955 All.
PP405.....\$4.75 ea.

1957-1960 All.
PP570.....\$4.75 ea.

Driveshaft Universal Joints



1957-1960 All. Rear drive shaft U-joint.
For saginaw type. 15/32" O.D. cap.
UJ574.....\$22.50 ea.



1957-1960 All. Rear drive shaft U-joint.
Spicer type. 1 1/16" O.D. cap.
UJ573.....\$22.50 ea.

Rear Axle (Group 5)

Rear Axle Rubber Parts

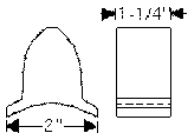

1932-1936 Bumpers, rubber, rear axle to frame.

1932-1933: Series 50;
1934-1935: Series 40 and 50;
1936: Series 40. (5.395)

AB326\$63.49 pr.

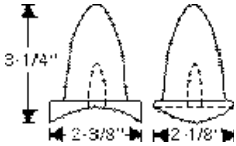

1936-1937 Bumper, rubber, rear axle to frame.

1936: Series 60, 80, and 90.
1937: Series 80, and 90.

AB367\$76.39 pr.



1936-1937 Pad, rear spring insulator for 2-1/4" wide springs. Four per car.

1936: Series 60, 80 and 90;
1937: Series 80 and 90.

SI367\$29.75 ea.



1937 Series 40 and 60. Bumper, rear axle to frame. Two per car. (5.395)

AB37\$83.99 pr.

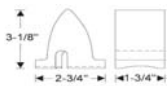

1938 All. Bumper, rear spring, rubber. Right and left.

AB38\$99.89 pr.



1954-1958 All models. Rear axle differential vent.

DV548.....\$9.50 ea.



1938-1958 All. Insulator, rear coil spring clamp bolt (upper end). Fabric reinforced rubber as original. Two per car.

SI389\$24.50 pr.



1938-1960 Insulator, rear coil spring lower. Fabric reinforced rubber as original. Two per car.

SI380\$21.50 pr.



1941-1957 Bumper, rear axle.

1941: Series 40, 50, 60 and 70;
1942: Series 40 and 60;
1946-1948: Model 40;
1949-1957: All.

AB417\$99.50 pr.



1958 Bumper, rear axle. All modes except Air Poise. New rubber on new steel cores.

AB58.....\$148.99 pr.



1951-1958 Bumper, rear axle stop. Molded left and right. Send in your old units for revulcanization.

1951-1952: Series 40 only;
1953-1958: All Series.

AB518.....\$91.59 pr.

Rear Axle Radius Rod Bushings (5.417)

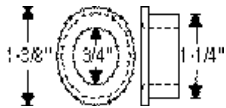

1938-1940 Series 80 and 90. Four per car.

AB380.....(Set of 4).....\$65.56 set



1938-1958 All. Four per car.

AB388.....(Set of 4).....\$19.50 set



1960 Rear All. 1 set per car.

RRB600\$49.50 set

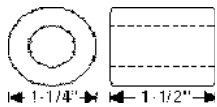

1940-1941 Series 40, 50, 60 and 70. Bushing, rear stabilizer bar mounting. Fits original bracket.

SB401.....\$64.29 pr.

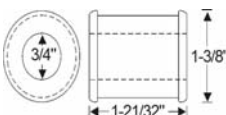

1956-1960 All models. Bushing, strut rod at drive shaft tube. Two per car.

SB560.....\$25.38 pr.



Cars LLC., recognized leader in Buick Parts and Service since 1973

Pinion Bearings



1936 Special;
1937-1939 Special and Century; (Rear)
PBR369\$90.25 ea.

1936-1954 Front.

1936: Series 60, 80, 90;
1937-1939: Series 80, 90;
1940-1955: All.

PBF414\$69.00 ea.

1936-1954 Rear.

1936: Series 60, 80;
1937-1939: Series 80, 90;
1940-1954: All.

PBR414\$98.50 ea.

1955 All. Rear.

PBR55\$49.50 ea.

1956-1962 All. Front.

PBF562\$36.00 ea.

1956-1962 All. Rear.

PBR562\$79.50 ea.

Carrier Side Differential Bearings (5.536)

1932-1937

1932-1933: Series 50;
1934-1935: Series 40-50;
1936 Special;
1937 Special and Century; 1939 Century.

DB327\$97.50 ea.

1938-1955

1938-1939: Series 40, 60;
1940-1942: 40, 50, 60, 70;
1946-1955: All.



DB385\$59.00 ea.

1958-1960 All.

DB562\$434.50 ea.

Rear Wheel Bearings (5.855)



1934-1955

1934-1936: Series 40;
1937-1955: All, except 80-90.

RWB345\$44.00 ea.

1935-1955 All, except 80-90 (inner race) . (5.855)

RAR345\$24.25 ea.

1956-1960 All.

RWB562\$74.50 ea.

Rear Axle Cover Gaskets (5.399)

1931-1955

1931-1935: Series 50;
1936-1939: Series 40 and 60;
1940-1942: Series 40, 50, 60 and 70;
1946-1955: All.

RAG305\$9.25 ea.

1936-1942

1936: Series 60 and 80;
1937-1942: Series 80 and 90.

RAG362\$9.50 ea.

Pinion Bearing Lock Nut



1934-1936: Series 40;
1937-1939: Special & Century.
PBN349\$18.50 ea.

Pinion Seals (5.455)

1940-1955 All.

PS535\$24.50 ea.

1956-1960 All. Front.

PS562\$26.50 ea.



Rear Axle Seals (5.822)



1936-1955 (Inner).

1934-1936: Series 40;
1937-1939: Series 40-60;
1940-1955: All exc. 80-90.

IOS375\$11.50 ea.

1937-1941 (Outer).

1937-1941: Series 80-90

OOS371\$15.00 ea.

1936-1955 (Outer).

1934-1936: Series 40;
1937-1939: Series 40-60;
1940-1955: All exc. 80-90.

OOS375\$13.00 ea.

1956-1960 All. Outer.

OS560\$15.00 ea.

Backing Plate Gaskets-Shims (5.8.19)

1934-1955 Axle housing to brake backing plate. Four or more per car.

1934-1936: Specials;
1941-1955: All. (5.560)

AG345\$4.00 ea.

1956-1960 All. Axle housing to brake backing plate and between wheel bearing retainer. Four or more per car (.015)

AG562\$4.50 ea.

ABG560.....(3 1/4" Diameter).....\$4.50 ea.



Rear Axle Carrier Gaskets

1931-1955

1931-1935: Series 50;
1936-1939: Series 40 and 60;
1940-1942: Series 40, 50, 60 and 70;
1946-1955: All.

RCG305\$9.50 ea.

1936-1942

1936: Series 60 and 80;
1937-1942: Series 80 and 90.

RCG362\$9.50 ea.

1956-1960 All.

RCG560\$9.50 ea.



Wire Wheels (Group 5)

1953-1955 Wire Wheels

A beautiful reproduction of the wheels that came as original equipment on 1953-1954 Skylarks and as optional equipment on all 1953-1955 Buicks. These wheels will fit many years up to and beyond 1960. Wheels measure 15" x 6". (5 on 5, 3" rear spacing.) They are produced with safety Rims so tubless can be used.



- Chrome Wheel with Chrome Spokes.**
 WW536.....\$699.00 ea.
- Chrome Wheel with Stainless Steel Spokes.**
 WW536S.....\$870.00 ea.

Wire Wheel Chrome Bolts (6.335)



- 1953-1955 All.**
- WB536.....\$8.50 ea.
 WB536S.....(Set of 20).....\$157.50 set
- 1957-1960** As required for use on aluminum front drums only where longer bolt is needed.
- WB570.....\$9.25 ea.
 WB570S.....(10 of WB536, 10 of WB570)169.50 set

Spinner Retainers

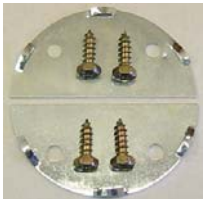

- 1953-1955** Stamped steel as original (For original spinners only). Includes screws, one set needed per wheel.
 SR535\$12.50 set

Wire Wheel Spinners and Inserts



- Die Cast & Chrome Plated as Original. Beautiful!**
 S536.....\$70.25 ea.

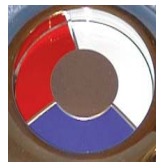

- Plain Tri-Shield.** Red, white and blue. Metal as original with mounting tabs. For use on S536 or original spinners only. 100 point show quality!
 SI536\$36.00 ea.



- "Skylark"** Red, white and blue insert. Metal as original with mounting tabs. For use on S536 or original spinners only. 100 point show quality!
 SI536S.....\$36.00 ea.

Wheel Spinner Gasket Set

- SG536.....(Set of 4).....\$15.50 set



www.oldbuickparts.com
908-369-3666

Hubcaps

We take pride in offering you these reproduction **BUICK** Hubcaps. Each hubcap is highly polished as the originals.



1936 All.
HC36\$78.00 ea.



1937 All.
HC37\$77.00 ea.



1938 All.
HC38.....\$149.00 ea.



1939-1940 All.
HC390.....\$72.00 ea.



1941-1950 All.
HC410.....\$71.50 ea.
HC410S.....(set of 4)\$279.00 set

NOTE: We have a few **1941-1950** later style caps on hand. These are the same as our HC410 but have a tri-shield in the center. Original, made by Buick. May have shop wear.
HC410T\$25.75 ea.



1955; 1956-1957 Wheel Cover Inserts

(6.871)
Red Plastic with chrome letters.
Show quality. Licensed by GM.

1955 All. Wheel cover center emblem, red plastic.
WP55.....\$23.00 ea.
WP55S(set of 4)\$85.00 set

1956-1957 All. Wheel cover emblem.
WP561.....\$20.00. ea.
WP561S(set of 4)\$78.50 set

Hubcap Clips (5.864)

1936-1940 1 1/2" Tall. Not for 3 clip style wheels.
HC360\$3.00 ea.



1935-1954 As required.
"Compare with existing clips"
HC364.....\$3.00 ea.

Curb Feelers



All Years. Accessory.
CF300\$15.00 pr.

Wheel Trim Rings

1936-1954 Stainless Steel 15".
Except 1948-1949 "Wide Style".
TR15\$32.50 ea.
TR15S.....(set of 4)\$118.50 ea.



1936-1941 Stainless Steel 16".
TR16.....\$32.50 ea.
TR16S.....(set of 4)\$118.50 ea.

1934-1960 Valve Stem Caps

Needed for BACH point judging. Use metal caps thru 1950.
Use rubber caps 1951 and up.



VC290.....(Chrome Knurled).\$5.50 set of 5



VC300.....(Chrome Octagonal).....\$4.75 set of 5



VC301.....(Stem Type).....\$5.50 set of 5



VC511.....(Rubber Type).....\$3.75 set of 5

Wheel Bolts

1935-1960
1935-1956: Front;
1957-1960 Front ext alum. drums;
1941-1958: Rear.
WB350.....\$4.00 ea.



Front Suspension (Group 6)

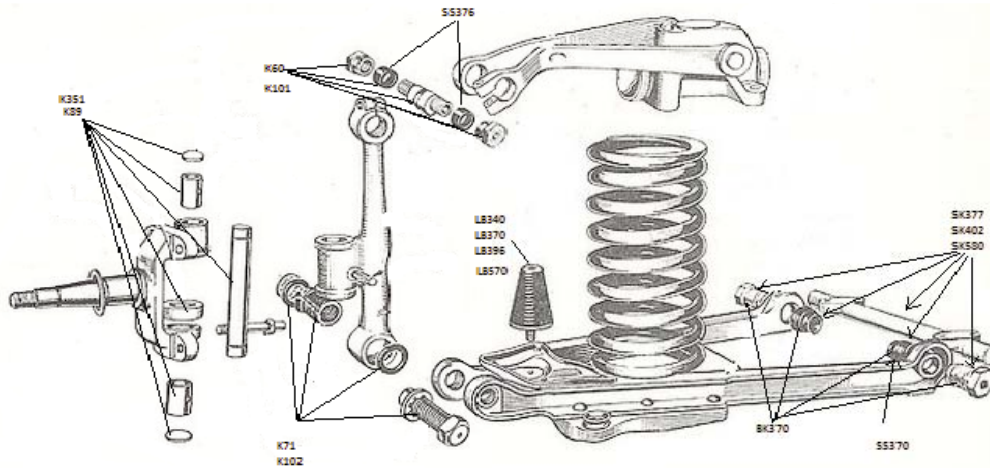

Lower Control Arm

- 1937-1952:** lower knuckle support pin series.
1937-1939: sr. 40-60;
1940: All ex. 80, 90;
1941 thru 1952: Series 60, 70, 90 (6.174)
 K102\$54.00 ea.
1941-1952: Series 40-50;
1953-1956: All. (6.174)
 K71\$55.00 ea.
1937-1938: Series 40-60;
1946-1957: All. Lower control arm shaft kit.
 SK377\$79.50 ea.
1940-1942:
1940: All ex 80-90;
1941-1942: All. Lower control arm shaft kit.
 SK402\$119.00 ea.
1958-1960: All. Lower control arm shaft kit.
 SK580\$99.50 ea.
1937-1960: All, except 1939 and 1940. Lower control arm bushing kit. 1 side.
 BK370.....(with rubber).....\$39.50 pr.
1937-1960: All. Lower control arm shaft seal. (Rubber dirt seal).
 SS370\$3.50 ea.
1939: Series 40 and 60. Rubber bushings, lower suspension arm, inner.
 AB39\$39.50 pr.
1934-1940: Front spring bumpers. Our new bumpers include lower metal clamps.
1934-1936: Series 40; 1936 All;
1937-1940: Series 80, 90.
 LB340\$39.50 pr.
1937-1940: Bumper, front lower arm. (7.422)
1937-1939: Series 40 and 60;
1940: Series 40, 50, 60, 70 (except series 50 and 70 convertibles).
 LB370\$53.00 pr.
1939-1956: Lower control arm bumper.
 LB396\$16.50 ea.
1957: All. Lower left side ball joint.
 LBJ57L.....(rebuild service)\$359.00 ea.
1957: All. Lower right side ball joint.
 LBJ57R.....(rebuild service)\$359.00 ea.
1958-1960: Lower ball joint. Fits either side.
 LBJ580\$89.50 ea.
1957-1960: Lower control arm bumper.
 LB570\$22.50 ea.



Upper Control Arm

- 1937-1939:** Upper knuckle support pin ser.40-60;
1940-1948: All.
 K101\$48.00 ea.
1949-1956: All.
 K60\$48.00 ea.
1949-1956: All. Upper Knuckle Support Pin Kits (2).
 K60P\$89.50 pr.
1937-1960: Upper and lower outer support pin seals.
 SS376\$3.25 ea.
1954-1956: Upper inner shaft kit.
 UI546\$97.50 ea.
1957-1960: All. Upper inner shaft kit.
 UI570\$98.50 ea.
1954-1960: Upper control arm bushing and rubber kit. For one side.
 BK545\$39.50 pr.
1934-1940: Rebound pad, front suspension, upper arm, on frame.
1934-1935: Series 50,60, and 90;
1936-1940: Series 80 and 90.
 UB340\$106.69 pr.
1934-1936: Series 40. Bumper, steering knuckle support upper arm (for front shock absorber arm).
 UB346\$78.99 pr.
1937-1956: All except 80. Upper a-frame bumper.
 UB376\$9.00 ea.
1957-1960: All. Upper control arm bumper.
 UB573\$9.50 ea.
1957: All. Upper left side ball joint.
 UBJ57L.....(rebuild service)\$279.50 ea.
1957: All. Upper right side ball joint.
 UBJ57R.....(rebuild service)\$279.50 ea.
1958-1960: Upper ball joint.
 UBJ580\$109.50 ea.

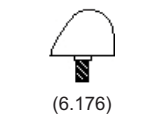
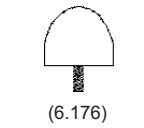



1934-1956: King pin kit. (6.203)
1934-1936: Series 40;
1937-1956: All except series 80, 90.
K89.....(Enough for entire car)\$84.00 ea.



1941-1942: King pin kit. Series 90. (6.203)
K351...(Enough for entire car) ..\$136.50 ea.



1954-1956: Idler arm frame bracket and bushing.
IA546\$89.50 ea.

1957-1960: Idler arm frame bracket and bushing.
IA570\$79.50 ea.

Tie Rod Ends

1937-1940:
1937: All;
1938-1940: 80, 90 (2 needed per car, R.H. outer and L.H. inner)
TE372R.....\$29.50 ea.



1937-1952:
1937-1941: All;
1942-1952: Series 60, 70, 90. (2 needed per car, R.H. inner and L.H. outer).
TE372L.....\$37.50 ea.



Check your car for left hand or right hand threads. Throughout the years many were changed.

1942-1948: Series 40-50. Fits either side.
TE468\$33.50 ea.



1949-1958: Tie rod end.
1949-1952: Series 40-50;
1953-1956: All. L.H. and R.H.
1957-1958 All. L.H. and R.H.



TE492\$31.00 ea.
1959-1960: Tie rod end. Either side outer.
TE591\$94.50 ea.



1937-1960: All. Dust cover, tie rod ends.
EC372.....\$3.25 ea.

Tie Rod End Adjusting Sleeve

(6.234)



1950-1958: All. Fits either side.
AS506\$14.50 ea.

1959-1960: All. Fits either side.
AS590\$30.25 ea.

Grease Fittings

All models as required. Sold in packs of 10.
GF360S.....(1/4" diameter).....\$7.75 pack



GF360B.....(3/8" diameter).....\$8.75 pack



Front End Rebuilding Kits

(1939-1940, state rubber or metal bushings, shafts n/a)

1937-1956 Kits include;

- 2 Lower inner shafts with bushings
- 1 King pin kit with bushings
- Upper and Lower outer support pin kits
- 2 Outer tie rod ends • 2 Stabilizer link kits

1957-1960 Kits include;

- 2 Lower inner shafts with bushings
- 2 Upper inner shafts with bushings
- 2 Upper ball joints • 2 Lower ball joints
- 2 Outer tie rod ends • 2 Stabilizer link kits

1937-1939: Special and Century with threaded LCA shafts and bushings.

FEK379.....\$369.00 kit

1939: Special and Century with rubber bushings on lower control arms.

FEK39R\$325.00 kit

1940: All;

1941-1942: Series 60-70-90.

FEK402.....\$472.00 kit

1941-1942: Special and Super.

FEK412.....\$472.00 kit

1946-1952: Roadmaster.

FEK462.....\$365.00 kit

1946-1948: Special and Super.

FEK468.....\$365.00 kit

1949-1952: Special and Super.

1953: All.

FEK4953.....\$365.00 kit

1954-1956: All. (Includes upper bushings)

FEK546.....\$429.00 kit

1957: All. Ball joint cores needed. Rebuild only.

FEK57.....\$1679.00 kit

1958: All.

FEK58.....\$809.75 kit

1959-1960: All.

FEK590.....\$989.00 kit



Front Suspension (Group 6)

Centerlink Repair Kits

- 1941:** Special and Super;
1941 thru 1952: series 60, 70, 80, 90.
1953: Series 50 - 70
 CRK412\$197.50 ea.
1942 thru 1952: Special and Super;
1953: Special.
 CRK423\$101.50 ea.
1954 thru 1956: All.
 CRK546\$75.00 ea.
1957-1958: All with power steering.
 CRK578P\$179.50 ea.
1957-1958: All with regular steering.
 CRK578R\$189.75 ea.
1959-1960: All.
 CRK590\$167.50 ea.



Power Steering Pump Shaft Seals

- 1953-1957:** All.
 SPS537\$16.50 ea.
1958-1960: All.
 SPS585\$14.50 ea.



Power Steering Pump (Rebuilt)

- 1959-1960:** All. \$50 core.
 SP594\$89.00 ea.

Power Steering Pump Reservoir Cap

- 1959-1960:** All.
 RC596\$59.00 ea.



Front Wheel Grease Seals

- 1934-1940:** All Series 40, 50, 60, 70.
 GS340\$14.00 ea.
1941-1956: All.
 GS416\$16.00 ea.
1957-1960: All.
 GS570\$15.00 ea.



(6.326)



- 1956-1960:** Steering column coupling disc repair kit.
 SD570\$24.50 ea.

Power Steering Hoses

Replacements for all 1952-1960 models. Some hoses may have a slightly different appearance than original.

- 1952-1953:**
1952: All;
1953: Special. Pressure hose (long).
 SH523P\$39.50 ea.
1952: Power steering return hose (short).
 SH52R\$39.50 ea.
1953: Special. Power steering return hose (short).
 SH53R\$39.50 ea.
1953-1955: V-8, pressure hose.
 SH535P\$53.00 ea.
1953-1955: V-8, return hose.
 SH535R\$53.00 ea.
1956: All, pressure hose.
 SH56P\$49.50 ea.
1956: All, return hose.
 SH56R\$13.50 ea.
1957-1958: All pressure hose (exc. air ride).
 SH578P\$52.00 ea.
1957: All, return hose.
 SH57R\$13.50 ea.
1957-1958: All pressure hose (exc. air ride).
 SH578P\$53.00 ea.
1958: All;
1959: All LeSabre 1st type, return hose.
 SH589R.....(20").....\$39.50 ea.
1959: LeSabre 2nd type;
1959: All Invicta & Electra;
1960: All, return hose.
 SH592R\$29.50 ea.



Front Wheel Alignment Pilot

- 1934-1939:** Special;
1940-1958: All except aluminum drums.
 WAP348\$8.50 ea.



Front Wheel Grease Caps (6.330)

- 1934-1960:**
1934-1940: Series 40.
1937-1940: Series 40, 50, 60, 70.
 2 3/32" D:9.
 GC340\$18.50 ea.
1941-1960: All 2 7/32"OD.
 GC410\$18.50 ea.



- 1939-1957:** Front Backing Plate Leather Seals
1939-1940: Series 40-60;
1940-1942: All Except 80-90;
1946-1957: All.
 PS397\$14.50 ea.

Power Steering Pump Seal Kits

(includes short seals)



1953-1954: All.	
SPK534.....	\$53.50 ea.
1955: All.	
SPK55.....	\$53.50 ea.
1956: All.	
SPK56.....	\$53.50 ea.
1957: All.	
SPK57.....	\$53.50 ea.
1958: All.	
SPK58.....	\$53.50 ea.
1959-1960: All.	
SPK596.....	\$34.50 ea.

1960 Steering Gear Box Rebuilding Kit

SBK606.....	\$82.75 ea.
-------------	-------------

Pitman Shaft Seal Kit

1957 thru 1960 all with power steering.

PSK577.....	\$20.00 ea.
-------------	-------------

Front Stabilizer Bar Bushings

1948-1958: All. Front stabilizer bar bushing.
Two per car.

SB488.....	\$19.50 pr.
------------	-------------



Seat Bumper

1959-1960 All 2 Door Models

SB590.....	\$12.50 pr.
------------	-------------

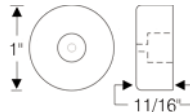

Front Wheel Bearings

Outer



1930: Series 50-60;	
1931-1942: Series 80-90;	
OWB292.....	\$119.50 ea.
1932-1960: (6.313)	
1932-1935: Series 50-60;	
1941-42: All except 80-90;	
1946-1960: All.	
OWB320.....	\$41.50 ea.
1934-1940:	
1934-1936: Series 40;	
1937-1939: Series 40-60;	
1940: All except 80-90.	
OWB340.....	\$31.50 ea.

Inner



1930: Series 50-60;	
1931-1933: Series 80-90;	
1934-1939: Series 90;	
1940-1942: Series 80-90	
IWB292.....	\$134.50 ea.
1932-1935: Series 50-60;	
1936: Series 60-80;	
1937-1939: Series 80;	
IWB329.....	\$68.50 ea.
1937-1940: (6.311)	
1937-1939: Series 40-60;	
1940: except 80-90.	
IWB370.....	\$46.50 ea.
1941-1956:	
1941-1942: except 80-90;	
1946-1956: All.	
IWB416.....	\$52.50 ea.
1957-1960: All.	
IWB570.....	\$39.50 ea.

Frame • Springs • Shocks (Group 7)

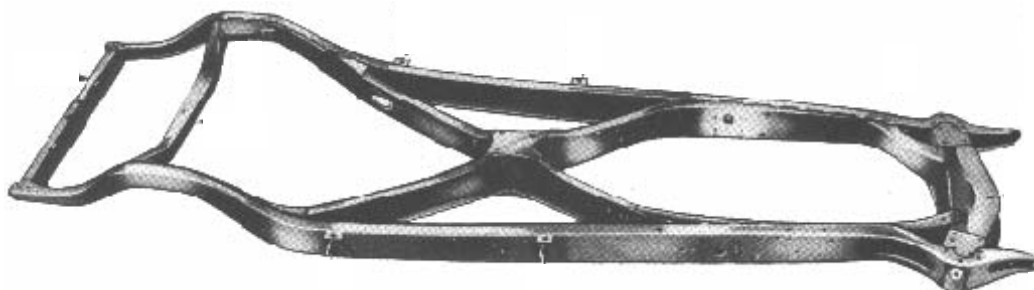

Stabilizer Repair Kits (7.240)



- 1937-1953 All Front;**
1940-1941: All Rear.
 SK373\$17.00 pr.
1954-1956 All Front.
 SK373\$17.00 pr.
1957-1960 All Front.
 SK373\$17.00 pr.



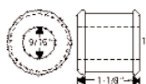

- 1937-1960 All. Stabilizer link bushing.**
 (8 needed per car).
 SB376\$1.25 ea.





- 1934-1935 All. Stabilizer link bushing.**
 SB316\$12.99 ea.

Stabilizer Bar to Frame Bushings

- 1937 Front stabilizer bar bushing. Two per car.**
 Series 40 and 60.
 SB37\$75.59 pr. 

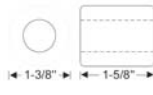
- 1937-1938 Bushing, stabilizer bracket.**
1937: Series 80 and 90 only;
1938: Series 40 and 60 only.
 SB378\$38.25 pr. 

- 1941-1947 Front stabilizer bar bushing.**
 Two per car. Series 40, 50, 60 and 70.
 SB417\$39.75 pr. 

- 1948-1958 All. Front stabilizer bar bushing.**
 Two per car.
 SB488\$19.50 pr. 

- 1959-1960 All.**
 SB593\$15.25 pr. 

Coil Springs

- 1935-1960 Front coil springs. (7.412)**
 CS350F\$195.00 pr. 
1935-1960 Rear coil springs. (7.503)
 CS350R\$185.00 pr. 



- 1938-1960 Pad, front coil spring insulator, upper. Two per car.**
 5 1/8" O.D. (7.420)
1938: All models;
1939-1941: Series 80 and 90;
1954-1960: All. (7.420)
 SI381\$25.00 pr.

- 1939-1953 Insulators, front coil spring. Fabric reinforced rubber as original. One pair required per car. (7.420)**
1939-1940: Exc. Limited;
1941-53: All.
 SI395\$10.00 pr. 

- 1938-1958 Insulators, rear coil spring clamp bolt (upper end). Two per car. Fabric reinforced rubber as original. All models. 7.545**
 SI389\$25.25 pr. 

- 1938-1960 Insulators, rear coil springs, upper. Fabric reinforced rubber. One pair per car.**
 SI380\$23.50 pr. 

Spring Insulator Pad

- 1936-1937 Series 60, 80, 90. Pad, rear spring insulator for 2 1/4" wide springs. 4 per car.**
 SI367\$31.29 ea. 

Lower Spring Clamp Bolt

-  **1938-1950 All;**
1951-1953: All V-8.
 CB383\$9.50 ea.



All Years: Satin Black paint: This is the correct enamel for frame and engine compartment, and is authentic for all years;

EP2\$24.50 qt.
 EP2S.....(12 oz. spray can)\$14.00 ea.

All Years: Universal gloss black: (Excellent for chassis, and general sse).

EP1\$19.50 qt.



"Miracle Paint" Tough stuff!

Hirsch brand, works very well as tested by our personnel. Bonds to rust, will not crack chip or peel. Impervious to gasoline, thinner, salt. Can be applied by brush or spray.

MP300B.....Black (quart)\$35.00 ea.
 MP300S.....Silver (quart)\$35.00 ea.
 MP300C.....Clear (quart)\$35.00 ea.
 MP300BG.....Black (gallon)\$101.00 ea.
 MP300SG.....Silver (gallon)\$101.00 ea.
 MP300CG.....Clear (gallon)\$101.00 ea.

Tubing and Wiring Clip

FC1.....\$2.50 ea.



License Plate Frame

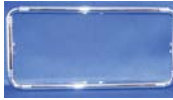

1933-1960 Front or rear. Genuine GM repro
 LF330\$36.00 ea.



1920-1960 License plate bolt kit.
 Two bolts and two nuts per kit.
 LB300\$2.50 kit

Rear Bumper Fillers (Gravel Deflectors)



1937-1938 All Special and Century.
 BF378R\$105.00 ea.

1939 All Special and Century.
 BF39R\$210.00 pr.

1940 All Special and Century.
 BF40R\$220.00 ea.



www.oldbuickparts.com

908-369-3666

Frame • Springs • Shocks (Group 7)



Send in your lever shocks for the best quality rebuilding service available. Shocks are disassembled and refurbished as necessary to guarantee correct performance. Allow only about 3 days. If in stock, they are sold on an exchange basis with core charge - refundable after receipt of your old rebuildable core. Add "EI" for exchange, "RS" for rebuilding service.

Lever Type Shocks	FRONT		Rebuild Price Each	REAR		Rebuild Price Each
	Right	Left		Right	Left	
1935 Ser. 40.....	S1932B	1932A \$169.50	1431C.....	1431D	\$159.50
1936 Ser. 40.....	S1932B	1932A \$169.50	1439E.....	1439F	\$159.50
1937 Ser. 40-60.....	S1947A	1947B \$169.50	1713A.....	1713B	\$159.50
1938 Ser. 40-60.....	S1947A	1947B \$169.50	*1754C.....	*1754D.....	\$159.50
1938 Ser. 80-90.....	S1933B	1933A \$179.50	See Tube Section..		
1939 Ser. 40-60.....	S1948A	1948A \$159.50	2103A, E.....	2103B, F	\$159.50
1939-40 Ser. 80-90.....	S1933B,D	1933A,C \$169.50	1751R.....	1751S	\$159.50
1940 Ser. 40-50-60-70..	S1948A	1948A \$159.50	2105A.....	2105B	\$159.50
1941 Ser. 40-50-60-70..	S1948AX	1948AX \$159.50	2105C.....	2105D	\$159.50
1941-42 Ser. 90.....	S1948A	1948A \$159.50	1757A.....	1758B	\$159.50
1942 Ser. 40-50-60-70..	S1948A	1948A \$159.50	2105C.....	2105D	\$159.50
1946-53 Ser. 40-50-70.....	S1948A	1948A \$159.50	2105C.....	2105D	\$159.50
1954-55 Ser. 40-50-60-70-100 (tube section)			2105X.....	2105Y	\$159.50

*1754C, D are knee action, see tube section for tube type

TUBE SHOCKS



Tube Shock numbers followed by the letter "G" are state of the art Gas shocks, developed specifically for your Buick.

We can also supply shocks in:

CS540.....COIL BOOSTER.....\$149.00 pr.
AS540.....AIR SHOCKS.....\$149.00 pr.

	FRONT	REAR
1938 All rear, tube type.....	RS38...\$109.00 pr.	
1954-55 All..FS107.....\$85.00 pr....	(see lever section)..FS107G....\$93.50 pr.	
1956 All..FS107.....\$85.00 pr....	RS94...\$89.50 pr....	FS107G....\$93.50 pr. RS945G...\$79.50 pr.
1957 All..FS132G..\$97.50 pr....	RS94...\$76.00 pr....	RS94G.....\$79.50 pr.
1958 All..FS155.....\$79.50 pr....	RS94...\$76.00 pr....	FS155G....\$93.50 pr. RS945G...\$79.50 pr.
1959-60 All..FS144G..\$103.50 pr..	RS145..\$89.50 pr..	RS145G....\$89.50 pr.



Rear Shock Links

1937 Special and Century.	
SL37.....	\$84.50 pr.
N11S2.....Locknut kit for above.....	\$1.75 kit
1939-1940	
1939 All;	
1940 Series 80 and 90.	
SL390.....	\$84.50 pr.
N11S2.....Locknut kit for above.....	\$1.75 kit
1940 Special, Super, Century, Roadmaster	
SL40.....	\$84.50 pr.
N11S2.....Locknut kit for above.....	\$1.75 kit
1941-1953 All except 1951-1953 Special;	
1954-1955 Super and Roadmaster.	
SL413.....	\$84.50 pr.
N10S4.....Locknut kit for above.....	\$3.75 kit
1951-1955	
1951-1953 Special;	
1954-1955 Special, Century, Skylark.	
SL515.....	\$84.50 pr.
N10S4.....Locknut kit for above.....	\$3.75 kit

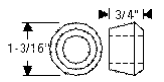
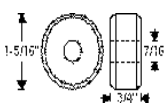
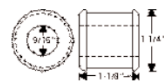

1934-1935 Rear shocks and brackets mounting kit. 18 piece hardened steel hardware kit.	
SBK568R	\$17.00 ea.
1931-1936 Shock absorber link bushing.	
1931-1933 series 60, 80, 90.	
1934-1935 series 50, 60, 90.	
1936 All.	
SB316	\$13.99 ea.
1934-1935 Shock absorber link bushing. Some models as req. 1 5/16" OD, 7/16" ID.	
SB345	\$11.99 ea.
1934-1935 Shock absorber arm bushing. Series 40. 3/8" ID, 7/8" OD, 13/16" long.	
SB345S	\$6.99 ea.
1938 All Rear. Shock absorber bushing. Eight required per car.	
SB38	\$2.25 ea.
1955-1960 Grommet/bushing, shock absorber mounting 5/8" hole, 1-3/16" O.D., 3/4" thick. Double cone style. Rear.	
SB556	\$4.29 ea.



(7.799)

1953 Front Bumper "Special" Plastic Emblem.
BE53L\$112.50 ea.



1953 Front Bumper "Super" Plastic Emblem.
BE53S.....\$112.50 ea.



(7.799)

1953 Front Bumper "Roadmaster" Plastic Emblem.
BE53R\$112.50 ea.



1946-1949 Bumper Emblems

1946-1949 All. "Special".
BE468L\$39.00 ea.

1946-1948 "Super".
BE468\$39.00 ea.

1949 All. "Super".
BE49S.....\$43.00 ea.



1949 All. "Roadmaster".
BE49R\$43.00 ea.



ORDER BY PHONE!
Call 908-369-3666

Bumper Details

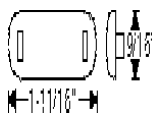

1940-1949 Anti-rattle, front or rear bumper gravel shield.
1940: Series 50, 70, Rear, 3 per car;
1941-1948: All, front, 2 or 4 per car;
1949: Series 40 front two or four per car.
HB379\$7.50 ea.

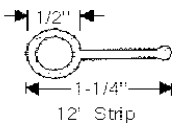

1941-1948 Anti-squeak, gravel shield-to-rear bumper, bulb type seal. 12 foot strip. Some models.
GS418.....\$59.89 ea.

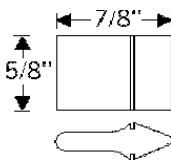

1941-1953 Bumper, rear car bumper gravel deflector (anti-rattle), rubber. Five or more used per car.
1941: All (except style 49);
1942-1953: All.
DB413\$5.39 ea.



1936-1960 All cars. License plate mounting bolts. (two bolts - 2 nuts).
LB300.....\$2.50 set

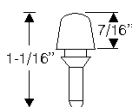

1950-1953 All. Bumper, license plate.
LB505\$7.50 pr.

1946-1960 Gasket set, rear license lamp assembly. One rubber ring and one cork rubber gasket comprise set.
1946-1947: Series 50 and 70;
1950-1953: All series;
1958: Roadmaster;
1959: Station Wagons.



LG462\$8.75 set



1951-1952 Super and Roadmaster. Bumper, front gravel deflector as required.
HB429.....\$3.50 ea.



1955-1960 All front license plate rubber bumper. (two per car).
LB552\$2.75 pr.



1957 All. Gas lid rubber bumper.
GB57\$12.50 pr.



1957 "Fuel" door. Beautiful reproduction.
GD57\$79.00 ea.



1957 All. Grill to front bumper Insulators.
GI57\$59.69 pr.

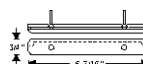

1959-1960 All except wagons. Fuel filler door bumper.
GB590\$24.69 pr

Bumper Parts (Group 7)

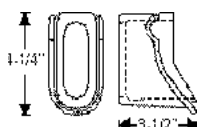

1933-1935 Most models.
BGR335 (Most models without
luggage rack)\$165.49 pr.

BGR335L (Most models with
luggage rack)\$123.29 pr.

1934-1935 Series 40.
BGR345\$103.39 pr.



1936 All. Front bumper grommets.
BGF36\$37.50 pr.

1937-1938 Series 40-60.
Front bumper grommets.
BGF378\$42.50 pr.

1937-1938 Series 80-90.
Front bumper grommets.
BGF378B\$86.29 pr.



1939-1941 All except 80-90.
Front bumper grommets.
BGF391\$40.00 pr.



1939-1941 Front Bumper.
1939-1940: Series 80, 90;
1941: Series 90.
BGF391B\$41.80 pr.

1936 All round type.
Rear bumper grommets.
BGR36\$28.00 pr.



1936-1937 Rear bumper grommets.
Series 80 and 90.
BGR367\$110.59 pr.

1937 and 1939 Special & Century
Rear bumper grommets.
BGR379\$39.50 pr.

1938 Series 40-60.
Rear bumper grommets.
BGR38\$48.50 pr.



1938-1940 Rear bumper grommets.
Excellent copy. Series 80 and 90.
BGR380\$121.79 pr.

1940 All except Series 80-90. Rear
bumper grommets.
BGR40\$38.50 pr.

1942-1946 Series 50-70.
Rear bumper grommets.
BGR426\$94.99 pr.

1951-1952 All. Seal, bumper arm.
One pair per car. (7.829)
BGF512\$52.99 pr.

Bumper Bolts (7.859)



1937-1938 All front and rear.
BB378\$9.50 ea.

1939-1941
1939-1940: Front and rear;
1941: Rear only.
BB391\$2.75 ea.



1942-1949
1942-1948: All;
1949: Special.
BB429K\$7.75 ea.

1949 Series 50-70 rear only.
BB490K\$2.75 ea.



1949-1953
1949: Series 50-70 front and rear;
1950-1953: Front;
1951-1953 Super & Roadmaster, Skylark rear.
BB493K\$7.50 ea.

1954-1960 All. (1/2-13 x 1 1/4).
BB490K\$2.75 ea.



Rear Bumper Fillers (7.834)

1954-1955 All Special, Century, Skylark.
BF545\$36.00 pr.

1956 40-60. Rear bumper to body rubber seal.
BF56\$27.50 ea.

1956 50-70. Rear bumper to body rubber seal.
BF56B\$27.50 ea.

1954
BF54B\$35.00 ea.

1959
BF59\$56.99 pr.

1960 All, except wagons.
BF60\$41.69 pr.

Retaining Clips for Above Fillers

MC12\$0.50 ea.

Make Your Own Fillers

Correct composition rubber material is excellent for
duplication using your old aprons as a pattern.

MR4812.....(48" x 12").....\$72.00 ea.
MR4824.....(48" x 24").....\$144.00 ea.
MR4836.....(48" x 36").....\$216.00 ea.
MR4848.....(48" x 48").....\$288.00 ea.

**1937, 1938,
1940 and 1955
Hood Ornaments**

These quality reproductions are in detail, highly polished and triple chrome plated for long lasting beauty. They have already enhanced many trophy winning **BUICKS**.



HO37.....(1937).....\$139.50



HO558



HOB55



HO40.....(1940).....\$90.00



HO55G

- HO55.....**1955** Chrome Complete Assembly....\$144.50 ea.
- HO558....**1955-1958** Chrome Ring.....\$59.00 ea.
- HOB55....**1955** Chrome Base.....\$79.50 ea.
- HO55G....**1955** Roadmaster Gold Assembly....\$180.00 ea.



HO38.....(1938)....\$149.50

Hood Letters

Hood letters are die cast and heavy chrome plated as the originals. Mounting pins are in correct locations for easy fit. *(We recommend silicone rubber for attaching letters) or, check page 59 for mounting clips.*



- 1939** Hood letters.
HL39.....\$51.25 set



- 1940** Hood letters.
HL40.....\$49.50 set



- 1941** Hood letters.
HL41.....\$49.50 set



- 1954** Hood letters.
HL54.....\$54.00 set



- 1955** Hood letters.
HL55.....\$54.00 set



- HL55G.....Gold.....\$67.50 set
- MC210..clip kit for above (10).\$17.50



- 1956** Hood letters.
HL56.....\$54.00 set
- MC210..clip kit for above (10).\$17.50



- 1957** Hood letters. Includes "ARROWS".
HL57.....\$57.00 set



- 1958** Hood letters.
HL58.....\$54.00 set

Hood Emblems (8.005)

- 1939** Hood emblem (Cloisonne).
HE39.....TOS



- 1948-1949** Hood plastic emblem.
1948 All;
1949 Special.
HE489\$85.00 ea.



- 1949** Hood plastic emblem.
Super and Roadmaster.
HE49\$85.00 ea.



- 1950** Hood plastic emblem.
HE50\$85.00 ea.



- 1951-1952** Hood plastic emblem.
HE512\$85.00 ea.



- 1953** Hood plastic emblem.
HE53\$85.00 ea.

Hood Hinges

- 1937-1938** Hood hinges. Polished stainless steel. \$200.00 ea.
- 1937 Special**.....41.5"HH37S
- 1937 Century**.....45"HH37C
- 1937 Series 80, 90**.....45 1/4"HH37B
- 1938 Special**.....41"HH38S
- 1938 Century**.....44.5"HH38C
- 1938 Series 80, 90**.....43"HH38B

Hood Bumpers (Group 8)



1935-1940 Fisher Body I.D. Plate (oval metal).
FP320.....\$9.00 ea.



1936-1937 All. Pads, rear hood corners.
Original style with metal core and metal
fastening tabs.
HP367R\$48.00 pr.



1937-1949 Pad, hood rest. Metal core with tab.
All models.
1937-1938 Six per car;
1939-1949 Up to 12 per car.
HB379\$8.75 ea.



1939-1940 All. Hood bumper.
Vulcanized to metal (6 per car).
HB390\$7.00 ea.

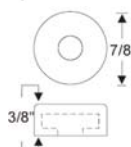

1938-1958 Bumper, hood rest, cap type for
adjustable screw, 7/8" O.D., 3/8" thick. Some
models as required.
TB415.....\$1.75 ea.



1941 All. Pad, hood side center rest.
HB41A.....\$53.89 pr.



1941 All. Bumper for bracket, radiator upper
panel to grill. One per car. Rubber only. Use
original steel bracket.
HB41B.....\$8.99 ea.

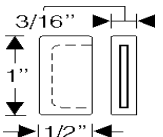

1941 All models. Bumper, hood front. Two
required per car. Slips over metal bracket as
shown.
HB41C.....\$8.99 ea.



1941 All models. Bumper, hood side pilot. Set
of four. Steel washer vulcanized in rubber.
HB41D.....\$71.99 ea.



1941 All. Bumper, hood to cowl, for 1/4" hole.
HB426\$2.75 ea.

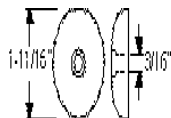

1942-1949 All models. Bumper, hood,
fastened to cowl at rear of hood. 1-11/16"
diameter. Two per car.
HFB429\$3.75 ea.



1942-1959 Bumper, hood two uses. Hood to
radiator shell at side panel, six per car. Hood
to fender and hood rail as required. 1956-1959
All on radiator shroud.
1942-1959 All;
HB429\$3.50 ea.



1948 Bumper, hood front in grille. 3/4"
diameter X 5/16" thick, self-retaining for 1/4"
hole, two per car. Series 50 and 70.
HB48\$2.75 ea.

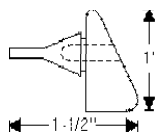

1948-1953 Many models. Hood to fender
bumper.
HFB483.....\$3.75 ea.



1949 Series 50-70. Also fits other years. Hood
to fender bumper.
HFB49R.....\$4.50 ea.



1949 Super, Roadmaster. Seal plate, hood
fastener control, cable through firewall.
Rubber with steel core.
FWG49\$48.00 ea.



1949 Super, Roadmaster. Hood to fender
bumper.
HFB49B\$3.50 ea.



1949-1953 Bumper, rubber, hood ledge corner
at shroud. Two per car. Some as required.
HB493.....\$16.59 ea.



1949-1955
1949 Super, Roadmaster;
1950-1955 All. Hood to radiator grill frame
bumper.
GB495.....\$3.50 ea.

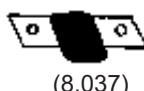

1950-1952 Bumper, hood side to fender
ledge. Metal core molded in as original.
1950 All models;
1951-1952 All Super, Roadmaster
HFB502.....\$9.50 ea.

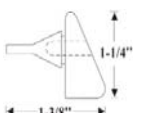

1953-1954 Bumper, hood to fender. Uses four
per car for most models.
HFB534.....\$7.00 ea.



1953-1955 Most models. Bumper, fan shroud.
SB535\$2.50 ea.



1955-1958 Bumper, hood side, self-retaining
type. Six per car.
HFB558.....\$5.50 ea.



1958 Bumper, hood side on fender ledge.
HFB58.....\$17.49 ea.



1959-1960 All. Front hood rubber bumper.
HB595.....\$2.75 ea.



1958-1960 Hood bumper stud (w/o rubber
cap) stud only, stainless steel.
HS585.....\$4.75 ea.

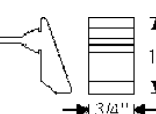

1959-1960 Bumper, hood to fender ledge. All
models as required.
HFB591R.....\$8.19 ea.

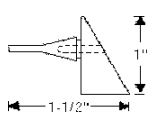

1959-1960 All full size models. Bumper hood
to fender ledge.
HFB591.....\$12.39 ea.

Hood Insulation
1941-1960 (8.021)

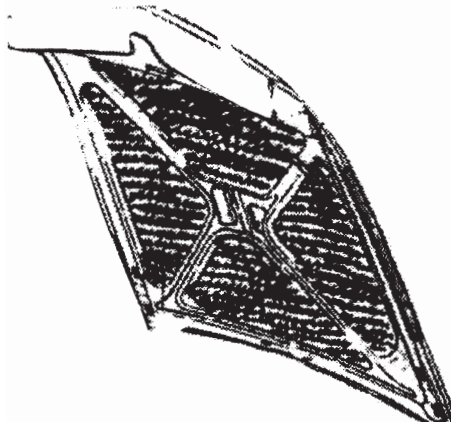

1953 Super & Roadmaster.
HI53\$39.50 ea.

Below listed insulators are pre-cut, ready to install. Should you not see your car and or model listed, please send us your old items to make new patterns. You will receive a discounted new insulator. See spray adhesive below for application. Our hood pads are in stock, ready to ship.

- 1954 All.**
HI54\$39.50 ea.
- 1955-1956 All.**
HI556\$39.50 ea.
- 1957 All.**
HI57\$39.50 ea.
- 1958 All.**
HI58\$39.50 ea.
- 1959 All**
HI59\$39.50 ea.
- 1960 All**
HI60\$39.50 ea.

For years and models not listed above

Generic hood insulation pad. Gray fiberglass. Easy to trim and apply. 48" x 55" x 1"

HI415\$39.50 ea.

Spray adhesive for application of hood Insulation

SA360.....(20 oz)\$18.00 ea.



Hood Insulation Retainers (Sombremos)

1954-1956 All
HIR546\$11.50 ea.

Hood Letters Retainer



1955 Buick.
Correct clip to keep your hood letters in place.
MC210\$17.50 set

Horseshoe Molding Clip



1955-1956

Rear 1/4 panel ornament clip for retaining chrome horse ornament.
MC2.....\$2.25 ea.

Hood Corner Pads

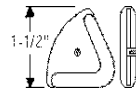

1934-1935 All. Pads, hood corners, front.
HP345F\$67.69 pr.

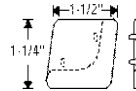

1934-1935 Series 40. Pads, hood corners, rear.
HP345R.....\$85.79 pr.

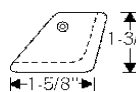

1934-1935 Series 50, 60, 90. Pads, hood corners, rear.
HP345RB\$85.79 pr.



1936-1937 All. Pads, hood corners, front. Original type with metal carcass and retaining tab.
HP367.....Front\$67.69 pr.
HP367R.....Rear\$67.69 pr.

1946-1960 Accessory Jack Cases
(8.820)



A genuine Buick accessory, part # 981521, 981161. These cases were made from excess materials left over from the upholstery shops at GM. They came in assorted colors and trim.

- JC460BT.....(Black with Tan Trim)\$37.50 ea.
- JC460BR.....(Black with Red Trim).....\$37.50 ea.
- JC460BY.....(Black with Gray Trim).....\$37.50 ea.
- JC460BW.....(Black with White Trim)\$37.50 ea.

Fender Splash Aprons



1960 All models. Fender apron set. Includes All factory holes required for installation.
FA60\$92.39 ea.

Make Your Own Fender Splash Aprons

Correct composition rubber material is excellent for duplication using your old aprons as a pattern.

- MR4812.....(48" x 12")\$40.75 ea.
- MR4824.....(48" x 24")\$81.50 ea.
- MR4836.....(48" x 36")\$122.25 ea.
- MR4848.....(48" x 48")\$163.00 ea.

Hood Parts (Group 8)

1942-1948 Hood Handle Frame



This item is often split or broken to a degree that the opening mechanism will not function. Die cast chrome. Triple plated. Fits either side. Does not include handle.

HF428\$87.50 ea.



Winged speed nut. For fastening 1/8" hood letters and other ornaments.

MC38\$1.25 ea.

MC38S.....(pack of 25).....\$19.50 ea.



Tool necessary for removing and installing MC38 clips without damaging studs or paint.

CT555\$29.25 ea.

Includes 25 clips plus tool.

MC38K.....\$49.50 ea.

Hood Cables and Springs



1949 Hood release cables. Super and Roadmaster.

HC49\$39.00 pr.



1949 Super and Roadmaster, hood cable return spring. (Stainless steel).

AS397\$8.00 ea.



1950-1952 Hood cable return spring (Stainless steel).

CS502\$7.00 ea.



1950-1952 Hood release cable.

1950: All.

1951-1952 Super and Roadmaster.

HC502\$39.00 pr.



1951-1952 Special. Hood release cable.

HC512\$39.00 pr.



1950-1952 Hood cable spring protective sleeve.

SL502\$7.75 pr.



1949-1952 Hood cable pull handle. "HOOD"

HH492\$54.00 ea.



1950-1952 Air Intake tube end seals. (2 per car; 18" each).

AS502\$14.97 pr.

(9.784)

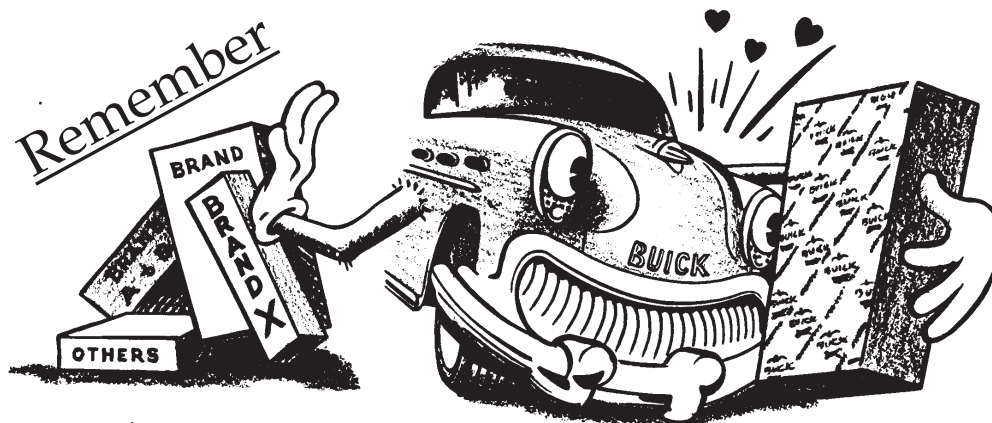

Your Buick is mighty "Choosy" about the company it keeps.....Treat it to the Best! Use only Cars Quality Original and Reproduction Parts.

Portholes

Throughout the years, one of **BUICK'S** most distinguishable trademarks has been the "Porthole" or "venti-port". We are proud to preserve this tradition in offering the following examples. Each is made identical to the original. (8.147)

- PH49 **1949** ALL Models\$37.50 ea.
- PH50 **1950** ALL Models\$19.50 ea.
- PH512 **1951-1952** Specials and Supers;
 PHL512 Left hand set.....\$44.50 ea.
 PHR512 Right hand set.....\$44.50 ea.
- PH512R **1951-1952** Roadmasters.....\$35.50 ea.

1952 Roadmaster Porthole Inserts

Replacement insert for worn or missing parts. Stainless.

- PI512R.....\$9.75 ea.
- PH53 **1953** All Models....(includes mounting bracket)..\$43.50 ea.
- PH54 **1954** All Models.....\$42.50 ea.
- PH55 **1955** All Models.....\$53.00 ea.
- PH56 **1956** All Models.....\$47.50 ea.
- PH60L **1960** All Models.....(L.H. Side).....\$37.50 ea.
- PH60R **1960** All Models.....(R.H. Side).....\$37.50 ea.

1948-1952 Scripts. The detail and workmanship on these three scripts is magnificent. The chrome plating is beautiful. Our scripts come complete with correct "speed nuts" for mounting on fenders.

- SS480 **1948-1950** Series 50.....(Super)\$30.00 ea.
- RS480 **1948-1950** Series 70.....(Roadmaster)\$59.50 ea.
- DS482 **1948-1952** All Dyna. Trans.(Dynaflow).....\$31.50 ea.

Fender Hardware

We had these pieces fabricated to be as close to the original as possible. All are finished with correct plating. These apply to All 1936-1960 Models.

-  **1936-1960** Fender bolt. Zinc plated 5/16-18 thread, 25 pack. Correct head.
 FB1.....(1").....\$9.50 pk.
 FB12.....(1/2").....\$9.50 pk.
 FB34.....(3/4").....\$9.50 pk.

-  **1936-1960** Fender washer. Zinc 25 pack. 5/16 ID, 7/8 OD. Correct reproduction
 FW78\$9.50 pk.

- 1936-1960** Fender star washer. 5/16 ID, 7/8 OD. 25 pack.
 FS78\$9.50 ea.

-  **1936-1953** Rear. Fender cage nuts. (Also other uses).
 CN363\$3.25 ea.

-  **1957-1960** All as required. Exact copy of square washer bolt. Up to 30 or more per car. 5/16"-18 x 3/4".
 FB579\$3.25 ea.



1959 Front Fender Monograms

- FM59E....."Electra"\$33.50 ea.
- FM59225....."225"\$19.00 ea.
- FM59I....."Invicta"\$33.50 ea.



Curb Feelers for All Years

- CF300.....\$15.00 pr.



1958 Front Fender Ornaments

- Beautiful cast chrome, two per car.
 HO558\$59.00 ea.

1958 Buick Limited Crown Molding

- Rear fender, fits either side. Die cast chrome.
 CM58.....\$249.00 ea.



Rear Fender • Running Boards (Group 8)

1935-1960 Rear fender inner seal.
(between deflector and fender-36" length)
AS502.....\$14.37 ea.



(9.784)

1959 and 1960 Rear Fender Fin Clips



1959 All. For peak molding on rear fender.
MC79\$2.75 ea.



1960 All. For peak molding on rear fender.
MC80\$2.75 ea.

1955-1956 Rear Fender and Rear Door Scripts



SS56.....**1955-1956** "Special"\$59.00 ea.
SS56U.....**1956** "Super".....\$59.50 ea.
CS56.....**1956** "Century"\$59.00 ea.



1954-1956 Rear fender gas door guard. Die cast chrome. All models.
DG546.....\$59.50 ea.

1958 Buick Limited Rear Fender Louvers



Rear Fender Louver Moldings

1958 Limited rear fender louvers. Beautiful die cast reproduction. Chrome plated. Complete with hardware.
L58\$10.50 ea.
L58S.....(set of 30).....\$275.00 set

1958 Rocker Panel Clips (8.309)

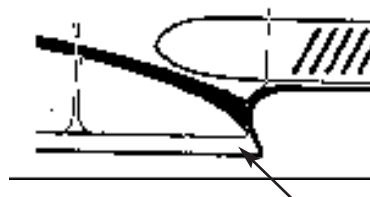

1958 All Roadmaster and Limited. 20 per car.
MC6.....\$2.75 ea.

1960 All. 18 per car.
MC81.....\$2.75 ea.

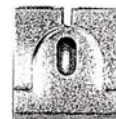

Running Board Matting (8.299)

Antenna Connection Boot

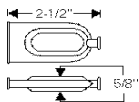

1936-1939 Buick All as Required. Antenna Connection Boot. Located on Running Board
RB369.....\$40.29 ea.

1934-1935 Running board matting, exact copy using parallel ribbed pattern. Extruded width 8 1/4", so butting is required. Give required dimensions. Series 40.
RB345.....\$499.00 set

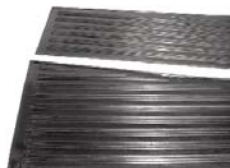

1936 Specials. Made in one piece with steel backs and bend over tabs.



RB36\$499.50 pr.

1941 All. 5" wide x 41" long.
RB41\$189.50 pr.



1937-1938 Running board matting. Special original design, molded in solid aluminum molds, right and left. Size includes stock for apron riser and outer radius. Some splicing necessary. Subject to batching so order early. Series 40.
RB378\$879.59 set

1939 Running board matting, original pattern with material to come down over ends and sides. Super workmanship, made in solid aluminum molds, each in one piece; no splicing required. Series 40.
RB39\$903.99 set

1938-1949 All. Gas door return spring.
GDS389\$9.75 pr.



(Group 9) Body to Frame Mounting Pads



1937 All Series 40 and 60 (except convertibles). Shim, body sill, for #3, #5, and #7 body bolts. Six per car.
BM37\$8.25 ea.

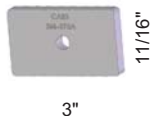

1937-1938 All Series 40 and 60 (except convertibles). Shim, body sill, for #2, #4 and #6 body bolts. Six per car.
BM378A\$9.50 ea.



1937-1940 Shim, body sill. For #1 bolt holding body.
1937-1939: Series 40 and 60 (except convertibles);
1940: Series 40, 50, 60 and 70 (except convertibles).
BM370\$9.50 ea.



1938-1939 Insulator, body bolt.
1938: All 40 and 60 closed models. For #2-3 bolts;
1939: All 40 and 60 closed models. For #2-3-4-5 bolts;
1939: All 40 and 60 convertibles. For #6 bolts.
BM389\$10.00 ea.



1940 Cushion washer, body bolt, 5/16" x 1-3/4". As required.
BM40R\$10.00 ea.



1940 Pad, body mounting, 5/16" x 1-3/4" x 2-1/4" with locating boss.
BM40\$9.50 ea.



1940 Pad, body mounting, 3/8" x 2" x 2". with locating collar. As required.
BM40A\$9.50 ea.



1940 Cushion washer, body bolt, 3/8" x 2". As required.
BM40B\$9.50 ea.



1940-1949 Insulator, cushion body mounting to frame. 1/2" thick. Up to 20 required per car. Check number needed for your particular body.
BM409\$9.50 ea.



1940-1958 Pad, body mounting. 2" square with 7/8" hole. Most convertible models as required.
BM408\$6.25 ea.



1941-1958 Rubber washer, body bolt pad. Under frame bracket for holddown nut. 3/4" thick. See also BM418B.
BM418\$9.50 ea.



1941-1958 Pads, body mounting, 2" square type, with locating boss and steel core.
BM418A\$9.00 ea.



1941-1958 Cushions, body mounting bolt, 2" round x 1/2" thick rubber. 15/16" hole. Up to 20 required, for closed cars.
BM418B\$7.00 ea.
BM418C
Same as 418B but 3/4" hole.\$7.50 ea.



1942-1956 Insulator, body mounting pad with metal insert. 1-7/8" round and 1/2" thick x 3/4" metal sleeve. Most models as required.
BM426\$11.00 ea.



1952-1956 All Series 50 and 70. Insulator, body mounting pad (#7 position). Two per car.
1953-1956: Some.
BM52\$9.50 ea.

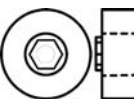

1958-1960 Insulator, body bolt. 1-7/8" O.D. x 7/8" I.D. x 3/4" high, with 7/16" nut and washer molded in. Used on some models as required.
BM580\$12.00 ea.



1958-1960 Pad, body mounting. 1-7/8" O.D. x 11/16" with 1-1/8" diameter collar, washer and 7/8" O.D. sleeve. Number used varies.
1958-1960: All (except convertibles).
BM584\$11.00 ea.



1959-1960 Insulator, body hold down bolt. 2" O.D. x 7/8" I.D. Number used as required.
1959: All Models;
1960: Some Models;
BM595\$8.50 ea.





1957-1960 Al as required. 2 1/4" square x 7/16" thick. Hole size is 3/4".
BM570\$11.50 ea.

Body to Frame Mounting Pads (Group 9)

Universal Body Mounts

These body mounts are made from original GM molds. They were used in many Buick applications, however, parts books will not identify them by number. Many can be cut, doubled-up, or shaved to fit your needs.

 Diameter - 1 11/16"
Thickness - 11/16"
Hole Size - 15/16"
BM2\$7.80 ea.

 Diameter - 1 15/16"
Thickness - 3/4"
Hole Size - 1"
BM3\$9.50 ea.

 Diameter - 2 5/8"
Thickness - 1"
Hole Size - 7/8"
Includes metal insert.
BM4\$9.50 ea.

 Diameter - 2"
Thickness - 1/2"
Hole Size - 1/2"
BM5\$9.50 ea.

 Diameter - 2 1/2"
Thickness - 3/4"
Hole Size - 9/16"
Includes metal insert.
BM6\$9.50 ea.

 Diameter - 2 1/2"
Thickness - 13/16"
Hole Size - none.
Solid rubber.
Insert diameter - 1 5/16"
BM7\$11.00 ea.

 Diameter - 1 5/8"
Thickness - 7/16"
Hole Size - 3/4"
BM9\$9.50 ea.

 Diameter - 2 1/16"
Thickness - 13/16"
Hole Size - none.
Solid rubber.
Insert diameter - 1 5/16"
BM11\$9.50 ea.

 Diameter - 2"
Thickness - 13/16"
Hole Size - 7/8"
BM12.....\$9.50 ea.

 Diameter - 2"
Thickness - 7/8"
Hole Size - 9/16"
Includes metal insert.
BM13.....\$12.00 ea.

 Diameter - 1 3/4"
Thickness - 1 11/16"
Hole Size - 7/8"
BM15.....\$9.50 ea.

Body Mount Bolts

 7/16-14 x 2". Grade 5.
B1\$0.75 ea.
B1B.....(Box of 25)....\$12.75 ea.

7/16-14 x 2 1/2". grade 5
B2\$1.00 ea.
B2B.....(Box of 25)....\$15.00 ea.

**Don't See Your
Body Mounts Listed?**
If you send your old mounts
and bolts, we will try and make
a complete kit for you at a
discounted price!

Body Mount Washers

 Diameter - 1 7/8"
Thickness - 1/8"
Hole Size - 0.45"
Extra thick.
W4.....\$1.00 ea.

Diameter - 1 3/8"
Thickness - 7/64"
Hole Size - 9/16"
Insert diameter - 1 5/16"
W5.....\$0.50 ea.
W5B...(box of 50)...\$15.00 ea.

Diameter - 1 1/16"
Thickness - 7/64"
Hole Size - 9/16"
W7\$0.50 ea.
W7B...(box of 50)...\$15.00 ea.

Diameter - 1 1/4"
Thickness - 5/64"
Hole Size - 1/2"
W9\$0.50 ea.
W9B...(box of 50)...\$15.00 ea.

Diameter - 13/16"
Thickness - 1/16"
Hole Size - 13/32"
W10.....\$0.50 ea.
W10B...(box of 50)..\$15.00 ea.

Diameter - 7/8"
Thickness - 1/16"
Hole Size - 3/8"
W2\$0.50 ea.
W2B...(box of 50)...\$15.00 ea.

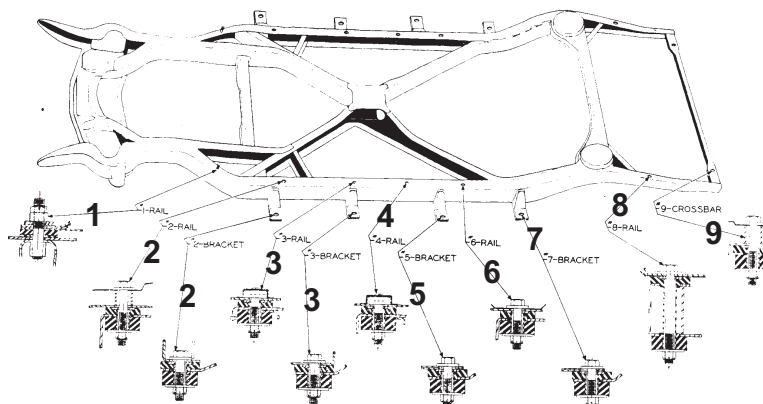

Roof Mounted Antennas (9.645)

Our antenna assembly is an exact reproduction of that used on all **BUICKS** from **1940-1953**.

1940-1953 Sedans.

AM403 Antenna Mast (4 sections).....\$25.00 ea.

AM413 Antenna Base Die cast chrome.....\$31.50 ea.

AA403 Assembly (mast and base).....\$57.00 ea.

AM423 Antenna Mast. **1942-1953** (3 sections)

1942-1949 All convertibles;

1950-1953 All 2 dr. hardtop & convert. ...\$25.00 ea.

AG403 Antenna Rubber Grommet - **1940-1953** All.....\$3.25 ea.

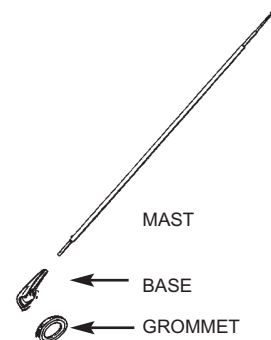

Front Fender Mounted Antenna Parts



1954-1960 Chrome antenna retaining nut.
AN544.....\$16.00 ea.



1940-1953 Antenna mounting pad. Will also fit 1954-1960 but slightly larger.
AG403.....\$3.75 ea.



1954-1956 Antenna adaptor (Spacer).
AA546.....\$14.00 ea.



1954-1958 Antenna switch.
AS548.....\$39.50 ea.

Cigar Lighter Fuse (9.712)

1953-1960 All Casco lighters.

CF532.....\$29.50 ea.



Air Duct Hose

Sturdy, wire reinforced defroster and air duct made like the original with rubber impregnated cloth covering. Specify inner diameter and length. Sold in 1 foot increments only.



AD150.....	1 1/2"	\$9.00 ft.
AD200.....	2"	\$9.50 ft.
AD250.....	2 1/2"	\$11.75 ft.
AD275.....	2 3/4"	\$12.75 ft.
AD300.....	3"	\$13.00 ft.
AD350.....	3 1/2"	\$12.25 ft.
AD375.....	3 3/4"	\$13.00 ft.
AD400.....	4" (4' max.)	\$13.00 ft.
AD500.....	5"	\$14.50 ft.
AD538.....	5 3/8"	\$15.50 ft.

A.C. Clutch Bearing (8.846)

1958-1960 All.

ACB585.....\$41.00 ea.

A.C. Refrigerant for R-12 and 134-a

5 oz. standard can. Includes red dye for leak detection. A drop-in replacement for CFC-12 and HFC-134a. **No system evacuation needed.** Up to 30% more efficient than CFC-12 and far more efficient than HFC-134a.

ACR360.....\$10.00 ea.



Antenna Insulators

1937-1938 All Factory Installations. 2 pair per running board needed, or buy set of 8.

RI378.....\$34.00 ea.

RI378S.....(Set of 8).....\$328.76 set.

Steering Column Jackets (6.518)

1937-1939 Series 40 and 60.

CJ379.....(Black).....\$55.99 ea.

CJ379N.....(Brown).....\$71.19 ea.

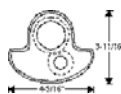

1940 All. Steering column jacket.

CJ40...(Special & Century **Black**)...\$77.99 ea.

CJ40N...(Special & Century **Brown**)..\$81.99 ea.

CJ40B.....(Series 80,90 **Black**).....\$60.59 ea.

CJ40BN....(Series 80,90 **Brown**)....\$64.59 ea.

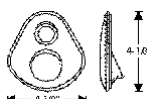

1941 All Series 60-70-90.

CJ41.....(Black).....\$198.89 ea.

CJ41N.....(Brown).....\$197.29 ea.

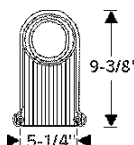

1953 Models 56C, 76C and 76R.

CJ53.....(Black).....\$176.19 ea.

CJ53N.....(Brown).....\$169.29 ea.



1954-1955 Models Super & Roadmaster.

Steering column jacket.

CJ545.....(Black).....\$152.39 ea.

CJ545N.....(Brown).....\$135.79 ea.



1954-1956

CJ546...(Series 40,60,100 Black)...\$193.69 ea.

1957-1958 All. Steering column jacket.

CJ578.....\$157.39 ea.



1956 All Super & Roadmaster.

CJ56B.....\$250.79 ea.



Firewall (Group 9)

- 

1929-1937 Grommet, water temperature indicator pipe through dash. 3-angle hole oval grommet, 15/16" x 1 7/8".
FG297\$33.49 ea.
- 

1936 Grommet, firewall for wiring harness and other usage.
FG36\$23.99 ea.
- 

1936-1938 All as required. Radio antenna end loop. Cord reinforced rubber. On runningboard.
AR368\$44.39 ea.
- 

1936-1939 All as required. Boot for antenna connection on runningboard.
RB369\$31.25 ea.
- 

1937-1941 All. Firewall grommets. Two piece set. Located on firewall.
FG371\$20.00 set
- 

1937-1948 All. Coil wire grommet. (on firewall).
CWG379\$7.25 ea.
- 

1939-1948 Grommet, firewall, parking brake cable, has 3/8" angular hole through 1 3/8" diameter grommet.
FG391\$7.50 ea.
- 

1939-1949 Grommet, speedometer cable through firewall (lower).
 - 1939:** Series 40;
 - 1940:** Series 50 (except convertible);
 - 1941-1942:** All; 1946-1949: Series 40.
 FG399\$21.99 ea.
- 

1939-1948 Speedometer cable grommet.
 - 1939-1940:** Series 60-70-80-90;
 - 1941:** Models 51-51C-56-56S;
 - 1942-1948:** All.
 SG398\$8.50 ea.
- 

1939-1949 Grommet, oil pressure, water temp, and vacuum line through firewall.
 - 1939-1940:** Super, Century, Roadmaster and Limited only;
 - 1941-1942:** All models;
 - 1946-1948:** Special;
 - 1949:** All.
 FG399T\$14.99 ea.
- 

1937-1949 Wiring harness grommet.
 - 1937-1948:** All;
 - 1949:** Specials.
 FWG379\$26.00 ea.

- 

1940 Grommet, 2 holes for oil pressure and water temperature lines through firewall. Series 40 and 50.
FG40\$15.99 ea.
- 

1940-1941 Grommet for ignition switch conduit through firewall.
FG401\$18.29 ea.
- 

1940-1949 Grommet, parking brake cable through firewall. Most models.
FG409\$7.59 ea.
- 

1940-1958 Grommet, hand brake cable through firewall. Fits all models.
FG408\$4.50 ea.
- 

1940-1960 Cowl plug, for 1" hole.
BP360\$3.00 ea.
- 

1942-1953 Grommet, parking brake release rod.
FG423\$2.75 ea.
- 

1942-1955 Grommet, parking brake release rod.
FG425\$3.99 ea.
- 

1942-1960 Grommet, wiring harness through fender skirts, or hood latch low mounting panels. All series.
FG420\$4.25 ea.
- 

1946-1957 Grommet, windshield wiper control cable or gas gauge wire through rear compartment pan.
 - 1946-49:** Models 50, 59, 70-79;
 - 1951-53:** Series 50 and 70;
 - 1954-1957:** All series.
 FG467\$2.50 ea.
- 

1949 Grommet, speedometer cable and windshield washer lines through firewall. Series 50 and 70.
FG49\$20.99 ea.
- 

1949 Super and Roadmaster. Seal plate, hood fastener control cable through firewall. Rubber with steel core.
FWG49\$62.89 ea.
- 

1950-1953 Grommet, firewall, vent control cable.
 - 1950:** All Series;
 - 1951-1952:** Series 50 and 70;
 - 1953:** All Series (except Skylark).
 FWG503\$4.79 ea.
- 

1950-1953 All. Grommet for oil pressure and water, or vacuum lines.
FWG503A\$12.59 ea.



1950-1953 Grommet, firewall, windshield washer hose.
FG503\$12.29 ea.



1950-1956 Grommet, park brake cable through frame.
1950-1953 Super, Roadmaster, Skylark;
1954-1956 All.
FG506C\$13.99 ea.



1950-1958 Most models. Firewall grommet. Houses oil and temperature gauge lines.
FWG506\$9.50 ea.



1950-1958 Most models. Firewall grommets. Separates vacuum lines.
FG506\$9.25 ea.



1950-1960 Plug, shroud or cowl upper panel gauge holes and for various holes requiring plug. For 1/2" hole. Amount as needed.
CP416\$3.00 ea.



1951-1953 Seal, heater control valve. High quality sponge rubber designed to cushion heater control valve and keep out noise and water.
HVG513\$11.00 ea.



1953 Grommet, wiring harness through firewall.
FWG53\$48.19 ea.



1954-1955 Grommet, underseat heater to ranco valve through frame. Used on convertibles with underseat heaters.
FG545\$30.99 ea.

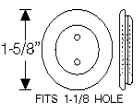

1954-1956 Grommet, oil pressure and temp lines through firewall. All as required.
FWG546T\$19.19 ea.

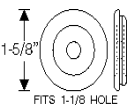

1954-1956 Grommet, speedometer cable through firewall. All as required.
FWG546S\$19.19 ea.

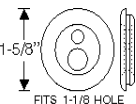

1954-1956 Grommet, vacuum lines & ignition resistor wire through firewall. All as required.
FWG546V\$19.19 ea.

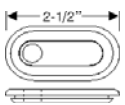

1954-1956 Grommet, parking brake cable through firewall. All as required.
FWG546B\$22.99 ea.

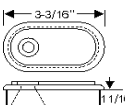

1954-1956 Grommet, main wiring harness through firewall. All as required.
FWG546W\$24.69 ea.



1954-1956 Body plug used in various locations through sheet metal. All as required 7/8" hole.
BP780\$2.25 ea.



1954-1956 Body plug used in various locations through sheet metal. All as required 1" hole.
BP100\$1.75 ea.



1954-1957 All. Firewall gasket. Sponge rubber for heater control valve.
FG547\$6.00 ea.

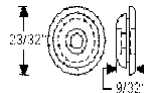

1956 Grommet, air conditioning cable.
FG56A\$2.25 ea.



1957-1958 All. Firewall grommet. Water temp. wire.
FWG577\$9.29 ea.



1959-1960 All. Grommet, antenna lead through sheet metal.
FG599\$14.99 ea.

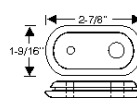

1960 Grommet, for heater control cabled wiring harness through firewall. All as required.
FWG60\$28.79 ea.

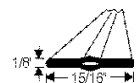

1928-1939 Cowl lacing. Hollow center for which to run electrical wires. Fastens with rivets.
CL289H\$9.49 ea.

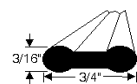

1928-1939 Cowl lacing. Solid cross-section. Fastens with rivets.
CL289\$9.49 ea.

Heater Control Valves (9.795)

1942-1960 Rebuilt and restored.
HV420\$153.50 ea.



Heater Hose at Cowl



1950-1953 "U" shaped heater hose at cowl.
HH503\$11.25 ea.



All years as required. For view of traffic lights hidden by roof. A reproduction of a genuine Buick accessory.
LF300\$39.75 ea.

Firewall Insulators (15.280)

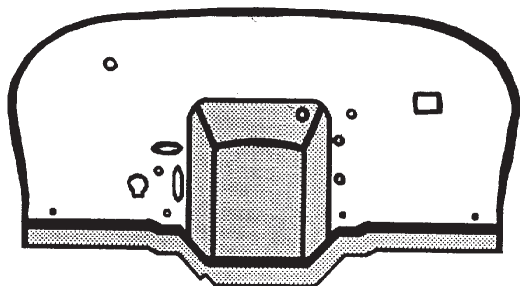

Our **Firewall Insulators** are fabricated and contour molded from strong ABS material.

Each one is formed to fit and look like the original. Holes are already cut. Insulation material is also included and fastened to the back side.

Where applicable, the rubber draft seal is installed and sewn on as original. Some minor modifications may be necessary to adapt special needs such as air conditioning, etc. If you do not see your car listed please call. We are continually

adding to the list! We can also fabricate an insulator from your old pattern.

Firewall Insulator Retainer.

1950 thru 1960 all as required.

IR500.....\$1.75 ea.



www.oldbuickparts.com

908-369-3666

<u>Item #</u>	<u>Description</u>	<u>Price</u>
FI27A	1927 Buick Series 50.....	\$199.50 ea.
FI30A	1930 Buick Series 60.....	\$224.50 ea.
KP30	1930 All. Cowl Kick Panels.....	\$89.50 ea.
FI31A	1931 Series 50	\$294.50 ea.
FI31B	1931 Elec. Grommet.....	\$29.50 ea.
FI31C	1931 Series 60	\$294.50 ea.
FI31D	1931 Series 80-90	\$294.50 ea.
CJ312	1931-32 All. Steering Column Jacket	\$51.50 ea.
FI32A	1932 Series 50	\$294.50 ea.
FI32B	1932 Series 60	\$294.50 ea.
FI32C	1932 Series 80-90	\$294.50 ea.
FI33A	1933 Series 50-60	\$217.50 ea.
FI345A	1934-1935 Series 40	\$279.50 ea.
FI345B	1934-1935 Series 60-80-90.....	\$227.50 ea.
FI36A	1936 Series 40-60	\$290.00 ea.
FI36B	1936 Series 80-90	\$267.50 ea.
FI37A	1937 Series 40-60	\$279.50 ea.
FI37B	1937 Series 80-90	\$279.50 ea.
KP37	1937 All. Side Cowl Kick Panels.....	\$74.50 ea.
FI38A	1938 Series 40-60	\$290.00 ea.
FI38B	1938 Series 80-90	\$290.00 ea.
KP38	1938 Series 40-60, Cowl Kick Panels	\$74.50 ea.
FI39A	1939 Series 40-60	\$290.00 ea.
FI39B	1939 Series 60-90	\$310.00 ea.
FI40A	1940 Series 40-60	\$290.00 ea.
FI40B	1940 Series 50-70	\$290.00 ea.
FI40C	1940 Series 80-90	\$290.00 ea.
KP40	1940 All. Side Cowl Kick Panels.....	\$74.50 ea.
FI41A	1941 Series 40-60	\$290.00 ea.
FI41B	1941 Series 50-70	\$290.00 ea.
FI41C	1941 Series 80-90	\$295.00 ea.
FI428B	1942-1948 Series 40	\$290.00 ea.
FI428A	1942-1948 Series 50-70	\$290.00 ea.
FI49A	1949 Series 50-70	\$290.00 ea.
FI502A	1950-1953 Special.....	\$290.00 ea.
FI503A	1950-53 Super, Rdmstr, Skylark	\$285.00 ea.
FI545A	1954-1955 Super and Rdmaster	\$285.00 ea.
FI545B	1954-55 Spec., Cent. and Sky.	\$285.00 ea.
KP545	1954-55 Spec. and Cn Kick Panels.....	\$74.50 ea.
FI56A	1956 Special and Century	\$285.00 ea.
FI56B	1956 Super and Roadmaster	\$285.00 ea.
FI578A	1957-1958 All	\$285.00 ea.
FI590A	1959-1960 All	\$285.00 ea.

**Hood to Cowl
Weatherstrips** (9.127)

CS492

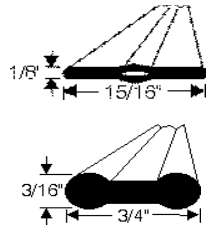

1928-1939 Hood to cowl lace webbing. Has hollow center to accept wires if needed. Fastens with rivets as original. CL289H\$12.25 ft.

1928-1939 Hood to cowl lace webbing. Does not have hollow center as above. Fastens with rivets as original.

- CL289\$12.25 ft.
- 1940** Weatherstrip, hood-to-cowl, right and left. Super and Roadmaster.
- CS40B\$163.19 ea.
- 1941** Weatherstrip, hood-to-cowl, right and left.
- CS41B.....(All Super and Roadmaster).....\$163.19 ea.
- 1941** Weatherstrip, hood-to-cowl. Series 40, 60, 90 (except models 44C, 44S, and 47).
- CS41\$170.19 ea.
- CS41S.....(Models 44, 44C, 44S, and 47).....\$154.89 ea.
- 1942-1948** Weatherstrip, hood-to-cowl, right and left. Super and Roadmaster.
- CS428\$169.59 ea.
- 1949** Super. Two piece, right and left. Held by carrot retainers. Uniform 4" retainer spacing.
- CS49.....(All Super Models).....\$171.79 pr.
- 1949-1952** Weatherstrip, hood-to-cowl, with self-retainer stems. 56-1/2" long.
- 1949** Roadmaster.
- 1950** Some. (also see CS502P)
- 1950-1952** Super and Roadmaster. (also see CS502P)
- CS492\$119.50 ea.
- 1950-1952** Weatherstrip, hood-to-cowl. Uniform 4-1/8" retainer spacing. Left and right strips 31" each. Used on some models, compare to CS492.
- CS502P\$165.49 pr.
- 1951-1952** Special. Weatherstrip, hood-to-cowl.
- CS512\$163.19 ea.
- 1953** Special All 2 and 4-door Sedans.
- CS53S\$112.79 ea.
- 1953** Super, Roadmaster, Skylark. See CP538 or CF540 for retaining plugs. 60-1/2" long.
- CS53\$71.49 ea.
- 1957** Special and Century.
- CS57S\$78.99 ea.
- 1957** Super and Roadmaster.
- CS57B\$56.75 ea.
- 1953-1958** Cowl lacing-Extrusion
- 1953:** Series 50-70;
- 1954-1958:** Most. Located top of cowl.
- See CP538 for retaining plugs. See CF540 for fasteners.
- CL538\$39.50 ea.
- 1959-1960** All models. Hood-to-cowl weatherstrip.
- CS590\$36.99 ea.

Cowl Parts

- 1934-1935** Windshield frame to cowl mounting pad. 2 parts with jointed center. Canvas base as original. For all convertible coupes and sedans exc. 1935 series 40 convertible coupe.
- WP345\$153.49 ea.
- WP35..(1935 Ser. 40 Conv't Cpe)..\$169.19 ea.
- 1934-1935** All cowl vent seal.
- CV345.....\$33.59 ea.
- 1936-1937** Cowl vent seal.
- 1936:** All;
- 1937:** Series 80 and 90.
- CV367.....\$20.00 ea.
- 1937-1941** Cowl vent seal.
- 1937:** Series 40-60;
- 1938-1940:** All;
- 1941:** Series 40, models 44, 44C, 44S, 47;
- 1941** All Super and Roadmaster.
- CV371.....\$18.00 ea.
- 1941** Cowl vent seal.
- Series 40, 60, 90 except models 44, 44C, 44S, 47.
- CV41.....\$56.19 ea.
- 1939-1941** Cowl vent drain tube.
- 1939-1940** Special and Century;
- 1941** Special exc. Estate Wagon;
- 1941** All Series 60 and 90
- CT391\$50.99 ea.
- 1941-1960** Most models. Cowl plug. Located top of cowl.
- CP416.....\$3.00 ea.
- 1953-1958** Cowl lacing rubber retaining Plug. Used on CL538.
- CP538.....\$2.25 ea.
- 1953-1954** Grommet, cowl gutter drain hose. For 3/4" hole through cowl side wall. 3/8" I.D.
- 1953:** Skylark;
- 1954:** All.
- HG534\$8.45 ea.
- 1954-1960** Fastener, hood to cowl weatherstrip (and other uses), self-retaining steel button, 11/16" head, for 5/16" hole but will fit down to 1/4" hole.
- CF540\$1.85 ea.
- 1947-1953.** Windshield wiper trans. link grommet.
- 1947-1952:** All;
- 1953:** Special.
- WLG473.....\$2.25 ea.
- 1932-1940** Fisher body I.D. plate (oval metal).
- FP320\$10.00 ea.
- 1941-1958** Fisher body I.D. plate (oval metal).
- FP418\$11.25 ea.

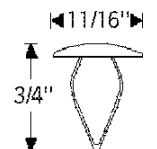
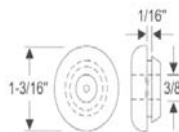
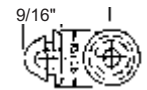
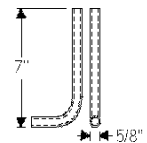
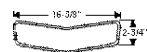
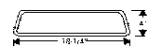

Windshield Wiper Parts (Group 10)

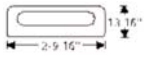

1933-1935. Some Models as required.

WW335\$27.89 pr.



1936-1937 Mounting gasket, windshield wiper transmission.

1936: All;

1937: Series 80 and 90 (except convert).

WW367\$16.89 pr.



1937-1938 Mounting gasket, windshield wiper transmission. Carefully made to proper outline with smooth radius at edge. Mounted on cowl. Series 40 and 60.

WW378\$15.99 pr.



1938-1940 Gasket, windshield wiper transmission mounting. Series 80 and 90. WW380\$15.69 pr.



1939 Gasket, wiper transmission mounting. About 7/8" x 1 1/8". Early 1939 cars only. Series 40 and 60. WW39\$14.19 pr.

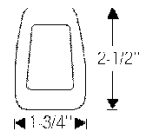

1939-1940 Mounting gasket, windshield wiper transmission.

1939: Series 40 and 60 (later type with larger transmission);

1940: Series 40 and 60.

WW390\$15.49 pr.

1940-1949 Gasket, windshield wiper transmission mounting. 1 1/4" x 1 1/2" inside dimension.

1940: All Series 50 and 70;

1941: Series 40, Style 4409, 09D, 27, 27B, 27D; All Series 50, 60, 70 & 90;

1942: Series 40, Style 4407, 07B, 09; Series 60, Style 4607, 09; Series 90;

1946-1949: Series 40, Style 4406, 09.

WW409\$9.50 pr.



1942-1948 Mounting pad, wiper transmission. Most closed models, Series 50 and 70. WW428\$14.99 pr.



1947-1953 Grommet, wiper control connection link. 11/32" ID x 19/32" OD Series 40.

WG473.....\$8.59 ea.



1951-1953 Specials, gasket, windshield wiper transmission to cowl.

WW513\$11.49 pr.

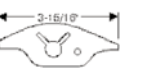

1950-1953 Super, Roadmaster and Skylark. Wiper transmission gasket.

WW503\$17.39 pr.



1959 Cap or seal, wiper motor crank. For two speed wiper motors only.

WS59\$36.49 ea.



1936-1940 Windshield wiper acorn nuts.

WN360.....\$3.00 ea.

1950-1953 Windshield Escutcheons.

WE503.....\$39.50 pr.

Wiper Transmission Nuts

1950-1954 All.

1955 Special, Super, Century.

WN503.....\$14.50 pr.

1954 Late w/ shoulder;

1955-1956 All.

WN546.....\$16.00 pr.

1954 Early w/ flat face;

1957-1958 All.

WN548.....\$16.00 pr.



1954-1958 Wiper nut removal tool.

WT548\$17.25 ea.

Wiper Transmission Escutcheons

1950-1953

1950: All;

1951-1953: Super Roadmaster, Skylark.

WE503.....\$39.50 pr.



1954 Super & Roadmaster.

WTE54B.....\$95.00 pr.



1955-1956

1955: Roadmaster;

1956: Super & Roadmaster.

WTE556.....\$95.00 pr.



1957 Super & Century .

WTE57S.....\$84.00 pr.



*****We have a limited supply of **NOS 1/4"** vacuum hose. It features correct outside diameter and "draw" lines for that authentic look.*****

VH14OEM.....\$3.50 ft.



1957-1958 Windshield wiper control handle.

WH578.....\$39.50 ea.



1959-1960 Windshield washer pump repair kit.

WRK594\$12.25 ea.





**Wiper Motor Rebuilding Service
1935 - 1958**

WR358\$135.00 ea.

1935 - 1958 Electric Wiper Motors

These replacement motors, mount in the stock location, and use existing linkage & transmissions. System comes complete with 2 speed switch (that must be used), all hardware & instructions. Available in 12 volt only.



All Kits \$238

- 1935-1936 All Buick, Olds, Pontiac.....EWM36
- 1937-1938 All Buick & Pontaic;
- 1939 CadillacEWM378
- 1939 All Buick;
- 1939 Olds Ser. 60;
- 1939 Pontaic Qual 6EWM39
- 1940 All Buick Except 80, 90;
- 1940 Pont.Closed & Convert models 26, 28.....EWM40
- 1941 All Buick, Oldsmobile & Pontaic.....EWM41
- 1942-1949 All Buick Ser. 40-60 ;
- 1942-1948 Olds Ser. 60, 70;
- 1942-1948 Pontaic Passenger CarsEWM429
- 1946-1948 Buick Super & RoadmasterEWM468
- 1949 Buick Super & Roadmaster;
- 1949-1951 Olds 98EWM49
- 1950-1953 Buick Super & RoadmasterEWM503
- 1951-1953 Buick SpecialEWM513
- 1955-1956 Buick Super & RoadmasterEWM546
- 1955-1956 Buick Special & CenturyEWM556
- 1957 BuickEWM57
- 1958 BuickEWM58

Wiper Arms

1937-1939 All;
1940 Special & Century.
WA370\$18.00 ea.



WN360.....Chrome Nuts for Above.....\$3.00 ea.



1941-1948 All;
1949 Special. (Replacement) Uses our WB360 blade.
WA419\$16.50 ea.



WN360.....Chrome Nuts for Above.....\$3.00 ea.



1949 Super & Roadmaster;
1950-1953 All.
WA493\$35.00 pr.



1954-1956 All models except Cam-o-Matic. Has flat end. Accepts our WB546 only.
WA546L.....Left Hand Side\$32.50 ea.
WA546R.....Right Hand Side.\$32.50 ea.
WA546.....\$62.50 pr.



1959-1960 LeSabre, Invicta. For non-overlap type arms.
WA592L.....(Left Hand Side)\$30.25 ea.
WA592R.....(Right Hand Side)\$30.25 ea.

Wiper Blades

1936-1948 All.
1949 Special 9" or cut to length.
WB360\$6.50 ea.



1949 Super & Roadmaster;
1950-1954 All, except Skylark. Hook end as original.
WB11.....11" blade\$16.50 ea.
WB12.....12" blade\$16.50 ea.
WB503.....(Genuine 12" Trico reproduction)\$32.50 ea.



1953 Skylark:
1954-1956 All. with flat ended wiper arm.
WB12F\$17.50 ea.



1957-1958 All.
WB13\$23.50 ea.



1959-1960 All.
WB15\$16.50 ea.



1936-1948 All.
1949 Special Link Retainer.
WL369.....\$4.00 ea.



Windshield Wiper Parts (Group 10)

Windshield Washer Nozzles

1953-1960 All. Can be used back to 1941.
WN540.....\$9.50 pr.



Windshield Wiper Switch

1959 All.
WS592\$59.50 ea.

Windshield Washer Jars and Lids

1951-1958 Glass Jar. All as required.
WJ518.....\$59.00 ea.



1951-1956 All. Lid. Does not include pump.
JL516\$65.00 ea.

1957-1958 All. Lid. Does not include pump
JL578\$75.00 ea.

Trico Lid Decal

D31\$4.75 ea.



GM Lid Decal

D230\$4.75 ea.



Wiper Hose

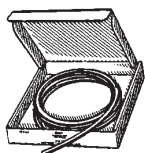

Windshield wiper hose. (7/64").
VH764\$1.50 per foot
Windshield wiper hose. (5/32").
VH532\$1.50 per foot
Windshield wiper hose. (7/32").
VH732\$1.50 per foot
Windshield wiper hose. (1/4").
VH14\$1.50 per foot

Windshield Washer Repair Kits



1951-1956 All. Matches our JL514 lid.
WRK516\$37.00 ea.
WPS516...(Pump spring)\$29.50 ea.

1957-1958 All. Matches our JL568 lid.
WRK578.....\$69.50 ea.
WPS578...(Pump spring)....\$29.50 ea.



1959-1960 Optikleen Bottles and Caps



Bottle assembly. Includes stainless steel
bracket and cap.
OB598.....\$36.50 ea.

Cap only. Includes stenciled writing.
OC598\$6.75 ea.

Optikleen bottle label.
D46.....\$3.75 ea.
Optikleen bottle cap label.
D107.....\$4.00 ea.



www.oldbuickparts.com
908-369-3666

(Group 10) Vulcanized Windshield Seals

1934-1935 Series 40 closed bodies **WITHOUT** reveal molding.
WS345\$131.99 ea.

1936 Series 40 and 60 closed bodies **WITHOUT** reveal molding. (Order DP356 division post seal separate).
WS36\$106.00 ea.

1936 Special & Century convertible coupes, models 46C, 66C. (Order DP356 division post seal separately).
WS36C\$196.99 ea.

1936-1937 Model 80C and 90. (Order DP378 division post seal separately).
WS367R.....(Model 80C 4-dr. Sport Phaeton).....\$186.99 ea.
WS367.....(Series 90 with reveal molding).....\$135.99 ea.

1937-1938 Series 40 and 60 except convertibles. For cars **WITHOUT** reveal molding. (Order DP378 division post seal separately).
WS378\$128.19 ea.

1937-1938 Series 40 and 60 convertibles **WITHOUT** reveal molding. (Order DP378 division post seal separately).
WS378C\$131.99 ea.

1938-1940
1938-1939: Series 80 and 90 convertible;
1940: Series 80 convertible.
WS380\$143.69 ea.

1939 Special and Century closed cars (Order DP39 post seal separately).
WS39.....(For cars **without** reveal molding).....\$150.39 ea.
WS39M.....(For cars **with** reveal molding).....\$120.99 ea.

1939; Special convertible **WITHOUT** reveal molding. (Order DP39C post seal separately).
WS39C\$167.99 ea.

1939-1940 Models **WITH** reveal molding.
1939: Series 40 and 60 Convertible; All Series 80 and 90 (except convertible).
1940: All Series 80 and 90 (exc. conv't.) Order division post seal DP39C for Ser. 40 and 60.
WS390\$165.79 ea.

1940 Special & Century **WITH** reveal molding. Inc. division seal
WS40C.....(Convertible Models).....\$184.49 ea.
WS40M.....(Except Convertible Models).....\$169.39 ea.

1940-1941 Series 50 and 70 convertibles **WITH** reveal molding. (Order PW419 pinchweld seal and DR418 division post retainer for 1941 models only).
WS40BC\$205.89 ea.

1940-1948
1940-1941: Series 50, 70 closed cars;
1942: Models 51, 71; 1946: Models 51, 71, 59;
1947-1948: Models 51, 71, 59, 79
(For **1941-1948**, Order PW419 pinchweld seal and DR418 division post retainer separately).
WS408\$208.99 ea.

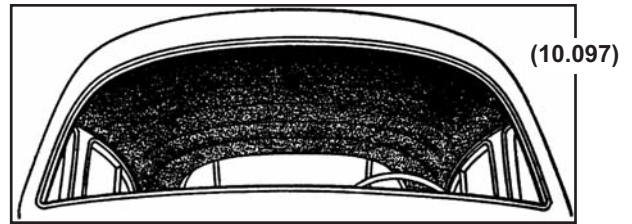

1941-1942
1941: Models 44, 44S, 44C, and 47
1942: Models 44, 44C, and 47 (Order PW419 pinchweld seal and DR418 division post retainer separately).
WS412\$110.99 ea.

1941-1949 For cars with reveal molding.
1941: Models 41, 41SE, 46, 46S, 46SSE;
ALL Series 60,90;
1942: Models 41, 46, 46S, 46SSE,
ALL Series 60, 90;
1946-1949: Models 41, 46S .
(order DR418 division post seal separately)
WS419\$170.89 ea.

1942-1948 Super and Roadmaster with reveal molding. Models 56S and 76S. Order PW419 pinchweld seal and DR418 division post retainer separately.
WS428S\$215.29 ea.

1942-1948 Model 56C and 76C convertible **WITH** reveal molding. (Order PW419 pinchweld seal and DR418 division post retainer separately).
WS428\$214.99 ea.

1949 Super and Roadmaster 2-door HT and converts.
WS49\$442.39 set

1949 Model 56S and 76S (lockstrip included).
WS49S\$351.79 set

1949 Models 51, 59, 71 and 79 (lockstrip type).
WS49B\$365.69 set

1950 Models 41, 41D, 43, 43D, 46 and 46D **WITH** reveal molding.
WS50\$353.79 ea.

1950-1953 Models **WITH** reveal molding.
1950: Models 51, 56S, 59, 71, 76S, 79;
1951: Models 51, 56S, 59, 79R;
1952-1953: Models 59, 79R.
WS503S\$279.99 ea.

1950-1953 Models **WITH** reveal molding.
1950: Models 56C, 56R, 75R, 76C,76R;
1951: Models 56C, 56R, 56RD, 76C, 76MR, 76R; 1952-1953: Models 56C, 56R, 76C, 76R.
WS503C\$281.49 ea.



1950-1953
1950: Models 52, 52X, 72, 72X;
1951-1953: Models 52, 52X, 72R, 72RX.
WS503\$288.69 ea.

Vulcanized Windshield Seals (Group 10)

Vulcanized Windshield Seals (con't)

- 1951-1953** Models 45R and 46C (Special Riviera Hardtop and Convertible).
 WS513C\$153.59 ea.
- 1951-1953** Models 41D and 48D.
 WS513S\$153.59 ea.
- 1953** Model 76X (Skylark).
 WS53X\$281.49 ea.
- 1954-1956** (For models with reveal molding).
1954: Special, Century, Skylark;
1955-1956: All Series 40, 60 Convertibles and closed models exc. mod 43 and 63. Slotted for chrome across top only, remainder chrome lays on top. 1st type.
 WS546\$196.99 ea.
- 1955-1956** (For models with reveal molding).
1955-1956 Series 40, 60 Closed models and models 43 and 63. 2nd type Slotted for chrome on top and bottom left and right. The remainder is not slotted.
 WS556\$215.69 ea.
- 1954-1956**
1954: Models 52, 72R;
1955-1956: Models 52, 72
 WS546BS\$205.59 ea.
- 1954-1956**
1954: 56C, 56R, 76CX, 76RX;
1955: Models 56C, 56R, 76C, 76R;
1956: Models 53, 56C, 56R, 73, 76C, 76R
 WS546B\$152.00 ea.
- 1957-1958**
1957: Models 53, 73, 73A, 75;
1958: Models 53, 75, 750
 WS578B\$202.69 ea.
- 1957-1958**
1957-1958: Models 41, 43, 46R, 48, 49, 49D, 56R, 61, 63, 66R, 69, 75R, 76A, 76R, 755
 WS578\$202.69 ea.
- 1957-1958** All convertibles.
 WS578C\$208.69 ea.
- 1959-1960** All models.
 WS590\$160.29 ea.



Windshield Division Post Seals

- 
- 1935-1936** Most models. Inner and outer seals. Two piece set.
 DP356\$29.69 set
- 
- 1936-1937**
1936 All series 40, 60.
1936-1937 model 80C.
 DP367\$98.39 set

Windshield Division Post Seals

- 
- 1937** Series 90. Includes steel core. Acts as retainer for outer chrome. Similar to out DP378 but shorter. 12\".
 DP37\$98.39 set.
- 
- 1938-1940** Series 80, 90 except convertibles. 2 piece set with screw holes.
 DP380\$74.89 set
- 
- 1937-1938** Most models. Inner and outer seals. Steel core, threaded as original. 13 1/2\".
 DP378\$69.99 set
- 
- 1939** Series 40 and 60. (except convertible).
 DP39\$27.25 set
- 
- 1939** Series 40 and 60 convertibles. Inner and outer seals.
 DP39C\$7.79 set
- 
- 1939-1940** Some models. Two piece set.
 DP390(17\" to 20\")\$17.50 ea.
- 
- 1941-1948** All models. Windshield center post, "H" section, requires fitting to top and bottom, not drilled. (Already molded in vulcanized seals purchased from CARS).
 DP418\$26.50 ea.
- 
- 1941-1948** Retainer, rubber, for outside windshield center post stainless molding. Use w/ original stainless molding and clips.
 DR418\$17.50 ea.

Windshield Rubber Extrusions

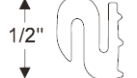
- 
- 1935-1936** Some models. For windows without chrome reveal molding. 12 ft. strip. **NOTE:** For **1935-1936** cars with two piece windshields, use division post seal DP36, ordered separately.
 WR356\$34.50 ea.
- 
- 1937-1940** Some models. For windows without chrome reveal molding. (For cars with two piece windshield, select seal for division post). 12 ft. strip.
 WR370\$48.50 ea.
- 
- 1937-1948** Most models. For windows with chrome reveal molding. Plain channel for 1/4\" glass. 12 ft. strip.
 WR378\$58.25 ea.
- 
- 1941-1948** Some models. Pinchweld seal. To seal and retain outer reveal molding. 12 ft. strip.
 PW419\$58.99 ea.

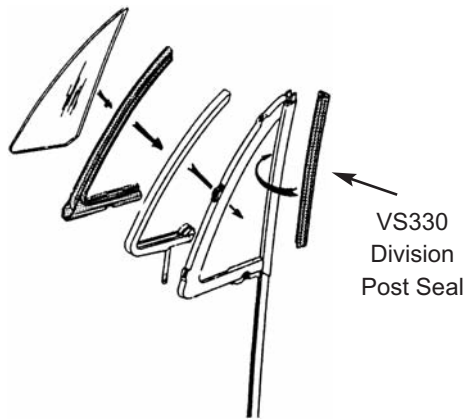

1934-1960 All models. Front vent window division post vertical seal. (see above).

VS33012.50 pr.

1934-1935 Series 40 except convertibles.
VW345\$180.99 pr.

1934-1935 All Series. (For convertibles).
VW345C\$186.89 pr.

1934-1935 Series 50, 60, 90 except convertibles
VW345B.....\$192.49 pr.

1936 Series 40 and 60 closed models.
VW36\$188.49 pr.

1936-1937
1936: 46C, 66C, 80C;
1937: 80C.
VW367C\$186.89 pr.

1936-1937
1936: 81, 91, 90, 90L, Sedans;
1937: All closed models 80 and 90.
VW367B.....\$180.99 pr.

1937-1938 Series 40 and 60 except convertibles.
VW378\$118.00 pr.

1937-1938 Series 40 and 60 convertibles.
VW378C\$175.49 pr.

1938-1940 Series 80 and 90 convertibles.
VW380C\$187.19 pr.

1938-1940 Series 80 and 90 except convertibles.
VW380\$192.49 pr.

1939-1940 Series 40 and 60 convertibles.
VW390C\$109.50 pr.

1939-1940 Series 40 and 60 except convertibles.
VW390\$95.00 pr.

1940 Series 80-90 convertibles.
VW40C\$137.50 pr.

1940 Series 80-90 Closed Cars.
VW40L\$192.49 pr.

1940-1941 Series 50 and 70 convertibles.
VW401C.....\$129.00 pr.

1940-1941 Series 50, 70 except convertibles.
VW401\$159.49 pr.

1941-1942 All Special convertibles.
VW412C.....\$175.49 pr.

1941-1942
1941: Model 44S, 46, 47;
1942: Model 44,47.
VW412\$166.39 pr.

1941-1949
1941 Models 41, 41SE, 44, 44S, 46S, 46SSE; All Series 60, 90;
1942: Models 41, 41SE, 46, 46S, 46SSE, 61, 66S, All Series 90;
1946-1949 Specials.
VW419\$129.50 pr.

1942 Model 48 and 48S.
VW42\$181.19 pr.

1942-1948 Series 50, 70 convertibles.
VW428C.....\$89.50 pr.

1942-1948 Series 50, 70 except convertibles.
VW428\$129.50 pr.

1949 Models 56C, 76R and 76C.
VW49\$147.50 pr.

1949 Model 51, 59, 71 and 79.
VW49B.....\$178.89 pr.

1950-1953;
1950: Model 52, 52X, 72, 72X;
1951-1953: Model 52, 52X, 72R, 72RX.
VW503S\$183.79 pr.

1950-1953 All Super and Roadmaster two door hardtop and convertibles except Skylark.
VW503C.....\$214.69 pr.

1949-1953;
1949: Models 56S, 76S;
1950: All Series 40's; Models 51, 56S, 71, 76S;
1950-1953: Models 59, 79, 79R;
1951: Models 51, 56S.
VW493.\$187.89 pr.

Windshield Drain Tubes



1957-1958 All.
DT578F.....\$37.50 pr.

Front Vent Window Seals (Group 10)

1951-1953;

1951-1952: Model 41, 41D, 46S, 48D;

1953: Models 41D, 48D.

VW513\$175.49 pr.

1951-1953 Models 45R and 46C.

VW513C\$272.29 pr.



1951-1958 Cushion, side window glass in vent frame at top. All hardtop and convertibles.

WC518\$57.29 pr.

1953 Skylark Model 76X.

VW53X\$275.79 pr.

1954-1956 Special, Century, Skylark, 2 door hardtop and convertibles.

VW546\$201.69 pr.

VWB546.....(Seals at bottom of vent window).....\$48.00 pr.

1954-1956 Models 52, 72, 72R.

VW546B\$171.39 pr.

1954-1956;

1954: Models 56C, 56R, 76CX, 76RX;

1955-1956: Models 56, 56C, 76C, 56R, 76R;

1956: Models 53, and 73.

VW546BC\$270.29 pr.



1954-1956

1954: Models 41D, 48D, 49, 69, 61;

1955: Models 41, 48, 49, 61, 69;

1956: Models 41, 48, 49, 69.

VW546S\$159.49 pr.

1954-1956; Special, Century, Skylard 2 door hardtop & convertibles. Includes vertical seals.

VW546M\$155.00 pr.

1955-1956; Special and Century 4 door hardtop.

VW556H\$192.49 pr.

1957-1958 1957: Models 56C, 56R, 75R, 76A, 76C,

76R;1958: Models 56R, 76C, 75R, 755, 756.

VW578C\$219.39 pr.



1957-1958 Special and Century two door hardtop and convertibles.

VW578.....\$165.00 pr.

1957-1958 1957: Models 41, 48, 49 and 61;

1958: Special Estate Wagon.

VW578S\$214.69 pr.

1957-1958 Super, Roadmaster and Limited four door hardtop.

VW578H\$214.69 pr.

1957-1958

1957 Four door hardtop and Riviera Wagons.

Models 43, 49D, 63, 69;

1958 Riviera Wagons, models 49D and 69

VW578W\$219.39 pr.

1958 Models 41, 48, and 61.

VW58\$218.99 pr.

1958 Models 43 and 63 Riviera 4-dr. H.T.

VW58A\$219.39 pr.

1959 All four door Sedans and Wagons.

VW590S\$134.49 pr.

1959-1960 All convertible and hardtop models, except 4829. Includes vehicle seals.

VW590.....\$95.00 pr.

1959-1960 Electra 225 four door hardtop, Model 4829.

VW590H\$193.69 pr.

1959-1960 Cushion, side window glass. Two and four door hardtop.

WC590H\$58.99 pr.

1960 All four door Sedans and Wagons.

VW60S\$138.29 pr.

Power Vent Window Gears

1959-1960 Power vent window gears.

VG595.....\$97.50 pr.



Vent Window Lock Repair Kit

1939-1958 All except convertibles.

VLR398\$16.50 ea.

GOING TO THE SHOWS?

Free delivery to:

Buick Nationals

GS Nationals

Hershey

CALL WELL IN ADVANCE.

We are proud to offer you the MIRRORS listed below. They represent complete coverage of all model **BUICKS** from **1939 - 1960**. Exact in detail, they are manufactured to be identical to the originals. They come to you in a kit. This kit includes, mirror(s), gaskets, and hardware. 1939-1953 mirrors can be attached to vent frame with kit provided or "clipped on" with MC393.



1939-1947

- MK397 Left and Right Hand Mirror Kits\$149.50 pr.
- MKL397 Left Hand Mirror Kit\$79.50 ea.
- MKR397 Right Hand Mirror Kit.....\$77.50 ea.
- MC393 Mirror Clip (fits all G.M. 1939-1953)\$5.75 ea.
- MG393 Mirror Gasket 1939-1953 Fits either side\$3.75 ea.
- MGK393 Mirror Mounting Kit 1939-1953 Fits either side\$5.50 ea.
- MG397 Mirror Glass Replacement.....\$9.25 ea.

Universal curved arm peep mirror features chrome arm with stainless steel mirror head. Complete with mounting hardware. Fits either side. Clips to drip rail.
 PM300 (3" Head)\$18.99 ea.
 PM400 (4" Head)\$28.50 ea.



1948-1953

- Left and Right Hand Mirror Kits.
MK483.....\$95.00 pr.
- Left Hand Mirror Kit.
MKL483.....\$53.50 ea.
- Right Hand Mirror Kit.
MKR483\$51.00 ea.
- Mirror Clip (fits all G.M. 1939-1953).
MC393.....\$5.75 ea.
- Mirror Gasket. 1948-1953 Fits either side.
MG393\$3.75 ea.



1954-1956 Special, Century and Skylark.

- MK546S Left and Right Hand Mirror Kits....\$159.00 pr.
- MKL546S Left Hand Mirror Kit.....\$85.00 ea.
- MKR546S Right Hand Mirror Kit.....\$82.50 ea.
- MG546SL Mirror gasket Left hand side.....\$3.75 ea.
- MG546SR Mirror gasket Right hand side.....\$3.75 ea.



1954-1956 Super and Roadmaster.

- MK546B Left and Right Hand Mirror Kits....\$159.00 pr.
- MKL546B Left Hand Mirror Kit.....\$85.00 ea.
- MKR546B Right Hand Mirror Kit.....\$82.50 ea.
- MG546BL Mirror gasket Left hand side.....\$3.75 ea.
- MG546BR Mirror gasket Right hand side.....\$3.75 ea.



Replacement Mirror Head

- 1954-1958 All.** Will fit our reproduction exactly, or drill and fill as necessary for original.
MH548\$19.75 ea.



1957-1958 All Models.

- MK578 Left and Right Hand Mirror Kits...\$159.00 pr.
- MKL578 Left Hand Mirror Kit.....\$85.00 ea.
- MKR578 Right Hand Mirror Kit.....\$82.50 ea.
- MG578L Mirror gasket Left hand side.....\$3.75 ea.
- MG578R Mirror gasket Right hand side.....\$3.75 ea.



1959-1960 All Models ("BUICK") engraved on back.

- MK590 Left or Right Hand Mirror Kit.....\$139.50 ea.
- MG590 Mirror gasket and hardware kit.....\$9.75 ea.



Glass Channels and Supplies (Group 10)

Complete Window Channel Kits

Each kit listed below contains enough channels and sweepers to complete one car. Clips, cushions and vertical seals are sold separately. Rivets, staples or screws can be obtained locally. See the next page for individually priced items and other necessities.

1933-1939 All Convertible Coupes.
WCK339C\$80.25 set

1933-1939 All 4-door Sedans with sliding rear 1/4 window.
WCK339S\$229.75 set

1933-1939 All 2-door Sedans and Coupes with sliding rear window.
WCK339S2\$179.50 set

1933-1939 All 2-door Sedans and Coupes with 4 roll-up windows and 4-dr. Sedans with fixed rear 1/4 window.
WCK339S4\$289.50 set

1936-1939 All 2-door Business Coupes.
WCK369B\$134.75 set

1940-1941 All 2-door Business Coupes.
WCK401B\$129.50 set

1940-1949 All Convertible Coupes;
1949 All Super and Roadmaster 2-dr. Hardtops;
1954-1956 All 2-dr. Hardtop and Convertible models.
WCK406C\$96.50 set

1940-1954 All 4-door Sedans and all Wagons.
WCK404S\$249.75 set

1940-1956 All 2-door Sedans and Coupes with sliding rear window.
WCK406S2\$179.50 set

1940-1956 All 2-door Sedans and Coupes with 4 roll-up windows.
WCK406S4\$219.75 set

1950-1953 All 2-dr. Hardtop and Convertible models.
WCK503C\$104.50 set

1955-1956 All 4-dr. Hardtops and Hardtop Wagons.
WCK556H\$114.50 set

1955-1956 All 4-door Sedans and Wagons. For 4 roll-up windows.
WCK556S\$249.50 set

1957-1960 All 2-dr. Hardtop and Convertible models.
WCK570C\$133.50 set

1957-1960 All 4-dr. Hardtops and Hardtop Wagons.
WCK570H\$190.00 set

1957-1960 All 4-door Sedans and Wagons. For 4 roll-up windows
WCK570S\$295.00 set

1957-1960 All 2-door Sedans and Coupes with sliding rear window.
WCK570S2\$219.00 set

1957-1960 All 2-door Sedans and Coupes with 4 roll-up windows.
WCK570S4\$274.50 set

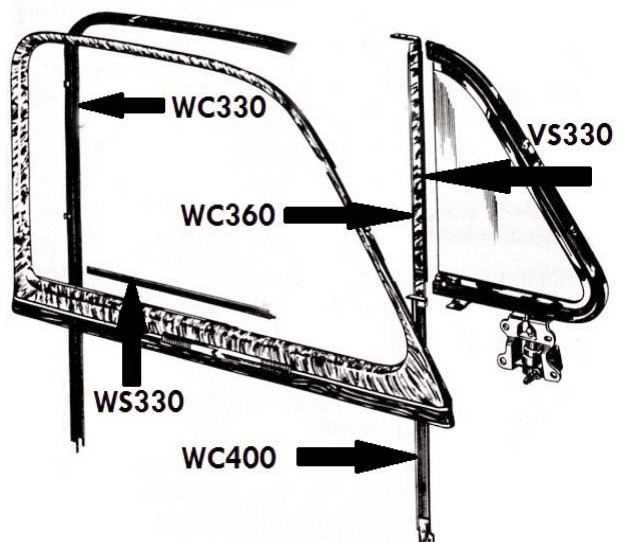

www.oldbuickparts.com
908-369-3666

(Group 10) Glass Channels and Supplies



1925-1938 (All GM) side window glass run channel. Comes in 14" lengths.
WC358.....\$11.75 ea.



1936-1960 All front and rear upper. Rigid glass channel. Two 18" lengths.
WC360.....\$16.50 pr.

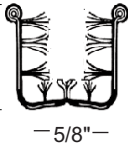

1933-1960 All side windows. Six foot lengths. Flexible glass channel. For sides and top of window. Most closed models.
WC330.....(1) 72" length.....\$37.50 ea.
WC330A.....(2) 36" lengths.....\$36.50 pr.



1940-1960 All front and rear lower. Rigid glass channel. Two 16" lengths.
WC400.....\$12.50 pr.

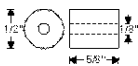

1931-1953 Most models. Anti-rattle rollers, side window.
WC313.....\$3.00 ea.

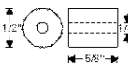

1931-1955 Most models. Anti-rattle rollers, side window.
WR315.....\$3.00 ea.



1928-1960 Channel, side window glass. U-shaped steel channel attach your own window regulator cam to underside as required. Sold in 4 foot strips. 3/8" at top. 9/16" at bottom.
WC280.....\$18.50 ea.

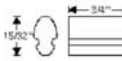

1936-1938 Anti-rattle bumpers, side window.
WC368.....\$5.99 ea.

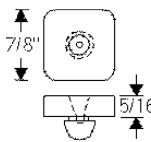

1941-1960 As required. Cushion (stem bumper), window stop, lower. Front and rear door, rear side quarter windows as required. Compare with WC414.
WC411.....\$4.75 ea.

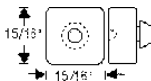

1941-1960 Cushion (stem bumper), window stop, lower. For front and rear door, rear side and quarter windows as required. 15/16" square, 1/2" thick. Compare with WC411.
WC414.....\$8.59 ea.



1933-1956 Flexible sweeper used on inner and outer frames. 64" length.
WS330.....\$22.50 ea.
WS330A.....(2) 32" lengths.....\$20.00 pr.
WS330B.....(2) 36" lengths.....\$20.00 pr.
WS330C.....(2) 24" lengths.....\$18.25 pr.



Sweeper Clip for fastening WS330. Six clips required per door.
SC330.....\$0.75 ea.



1957-1960 Flexible sweeper used on inner and outer frames. 64" length. (Wider than WS330).
WS575.....\$39.50 ea.
WS575A.....(2) 32" lengths.....\$39.50 pr.
WS575B.....(2) 36" lengths.....\$39.50 pr.



1933-1960 All. Vent window vertical seals. Fits front and rear doors. One or two pair required.
VS330.....\$9.75 pr.

1933-1960 All. Glass setting tape.
ST330.....\$0.85/ft.



1957-1958 Flexible snap-in channel. Front and rear doors.
WC578.....64" length.....\$39.50 ea.
WC578A.....(2) 32" length.....\$36.50 pr.
WC578B.....(2) 48" length.....\$36.50 pr.

Chrome Edge



1958-1972 All inner belt line window sash sweeper. Rigid rubber covered weatherstrip with flock lining. 1/4" flat chrome edge. Re-seal on front and rear doors quarter windows. As required.
WS582.....64" length.....\$29.50 ea.
WS582A.....(2) 32" length.....\$27.50 pr.
WS582B.....(2) 48" length.....\$29.50 pr.
WS582C.....(2) 24" length.....\$22.50 pr.



Glass Channels and Supplies (Group 10)

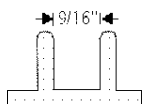

1925-1932 Side window channel. Flocked 9/16" wide. As required.
CC252.....\$11.39 ft.

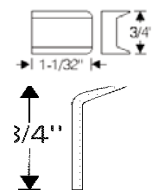

1925-1936 Lower window rest pad. 2 needed per window. For all closed cars.
WC256.....\$9.29 ea.

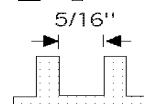

1926-1936 Lower window outer glass seal. Fastens to door. All as required. 3/4" tall.
WS266.....\$4.19 ft.

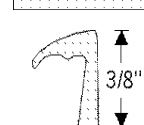

1925-1938 Side window channel. Flocked 5/16" wide for 1/4" glass. As required.
CC258.....\$11.49 ft.

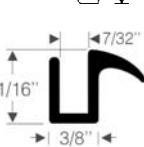

1927-1936 Lower window outer glass seal. 3/8" tall. Retained by metal strip in side of channel.
WS276.....\$4.19 ft.

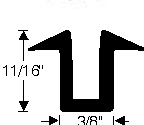

1930-1940 Channel pad, window carrier, weatherstrip. Used for some side window lower channel.
WS300.....\$3.75 ft.



1931-1940 Weatherstrip, side window, double-lip seal type, used as filler for 1/4" glass in metal carrier channel.
WS310.....\$6.39 ft.

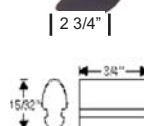

1932-1960 Mohair liner with rubber backing. Apply to division bars and channels as req.
ML325.....\$11.00 (3) ft.



1936-1938 Window anti-rattlepad. Fits into slots on inner and outer sides. As required
WP368.....\$6.49 ea.

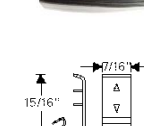

1939-1955 Some models. Filler channel weatherstrip, door window sash channel. Special type with wide weatherstrip edge. 3 ft. lengths. Trim as necessary.
WS392.....\$19.67 ea.

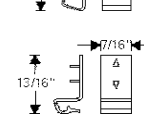

1939-1956 Side window channel clip. Standard GM. Compare to your original.
CC396A.....\$3.19 ea.



1939-1956 Side window channel clip. Standard GM. Compare to your original.
CC396B.....\$3.19 ea.

All Years. The best weatherstrip adhesive we have found. 3M Brand.
WA360.....\$13.50 ea.

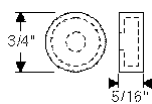

1940-1958 Window cushion. Six required per car. Snaps over pedestal as pictured.
WC408.....\$2.00 ea.

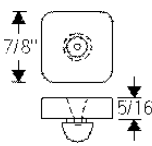

1941-1960 As required. Cushion (stem bumper), window stop, lower. Front and rear door, rear side quarter windows as required. Compare with WC414.
WC411.....\$5.50 ea.

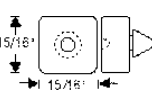

1941-1960 Cushion (stem bumper), window stop, lower. For front and rear door, rear side and quarter windows as required. 15/16" square, 1/2" thick. Compare with WC411.
WC414.....\$9.29 ea.

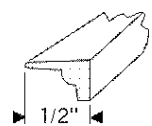

1942-1955 Weatherstrip, sash channel, outer, for side windows, 1/2" wide weatherstrip (cross section).
WS425.....\$4.19 ft.



1953 Weatherstrip, door window sash channel. Please order by foot. Known to fit Skylark (76X), may fit other models.
WS53.....\$6.89 ft.



1959-1960 Weatherstrip, upper vertical on rear body lock pillar, 11" long steel core, cloth facing. Style 4829 (Electra 225 four door Riviera Sedan) only.
WS590E.....\$132.89 pr.

Upper Window Frames

Chrome plated, pre-drilled, ready to install.

1954-1956 Special, Century, Skylark Converts.
WF546C.....\$214.75 pr.

1954-1956 Super and Roadmaster 2 dr. HT & Convertibles.
WF546.....\$214.75 pr.

1954-1956 Super and Roadmaster Convertibles.
WF546BC.....\$214.75 pr.

Adhesive Backed Bow Drill

Cloth tape used to cover roof rail weather-strip rear 1/4 window seals, etc. as req. Waterproof and sunproof. Comes in 5 foot rolls.

BD250B.....(Black 2 1/2" wide).....\$12.00 ea.
BD250T.....(Tan 2 1/2" wide).....\$9.75 ea.
BD500B.....(Black 5" wide).....\$23.75 ea.
BD500T.....(Tan 5" wide).....\$22.00 ea.

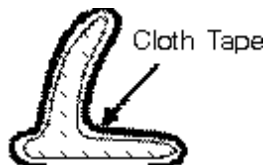

(Group 10) Door Weatherstrip Sets

1935-1936 All closed models.

DWS356A.....(Front Doors).....\$112.79 set
DWS356B.....(Rear Doors)\$78.39 set

1937-1938 Special and Century Convertibles. **Front doors.**

Set includes 14 feet of DW378S, 7 feet of DW369,
20 WC391 clips and 40 WC378 clips.

DWS378A\$199.19 set

1937-1938 Special and Century convertibles. **Rear doors.**

Set includes 10 feet of DW378, 4 feet of DW369, 20
WC369 clips and 30 WC378 clips.

DWS378B\$155.79 set

1937-1938 All Special and Century closed models. **Front doors.**

Set includes 22 feet of DW378S, 7 feet of DW369, 20
WC369 clips and 70 WC378 clips.

DWS378C\$213.19 set

1937-1938 All Special and Century closed models. **Rear**

doors. Set includes 20 feet of DW378S, 5 feet of DW369,
20 WC369 clips and 70 WC378 clips.

DWS378D\$205.99 set

1939 Special and Century convertibles. **Front doors.** Set

Includes 14 feet DW379, 7 feet DW369, 20 WC369 clips.

DWS39A\$92.00 set

1939 Special and Century convertibles. **Rear door.** Set

includes 10 feet of DW379, 6 feet of DW369 and 20 WC369
clips.

DWS39B\$70.75 set

1939 All Special and Century closed models. **Front doors.**

Set includes 22 feet of DW378S, 7 feet of DW369 and 20
WC369 clips.

DWS39C\$170.99 set

1939 All Special and Century closed models. **Rear doors.**

Set includes 20 feet of DW379, 5 feet of DW369 and
20 WC369 clips.

DWS39D\$157.49 set

1940-1941 For closed models.

1940: All. **Front or rear doors;**

1941: Series 50, 70. **Front or rear doors.**

Set includes 28' of DW379.

DWS401A\$66.50 set

1940-1941 Convertibles. **For front and rear doors.**

1940-1941: Special and Century convertibles. Front and
rear.

1940-1941: Super and Roadmaster Convertibles. Rear
Set includes 20' of DW379.

DWS401B\$56.50 set

1940-1941 Super and Roadmaster two and four door
convertibles. **Front doors.** Set includes 20' of DW379 and
one pair AW401.

DWS401C\$89.50 set

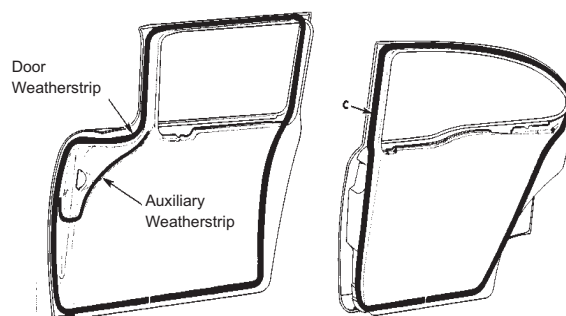

1941 Special, Century, Limited closed models. **Front**

doors. Set includes 20' of DW379, one DW418 and

moulded corners.
DWS41A\$187.19 set

1941-1949 Rear doors. Closed cars.

1941-1942: Series 40, 60, 90;

1946-1949: All Specials.

Set includes 20' of DW379, one DW418 and moulded
corners.

DWS419A\$184.19 set

1942-1949 Front doors. Closed models.

1942: Series 40, 60 and 90;

1946-1949: Specials.

Set includes one set AW429H, one DW418 and moulded
corners.

DWS429A\$314.99 set

1942-1948 Super and Roadmaster closed models.

Front doors. Set includes one set AW429H, one DW418
and moulded corners.

DWS428A\$336.69 set

1942-1948 Super and Roadmaster closed models.

Rear doors. Set includes one pair of AW429H, one strip of
DW418 and moulded corners.

DWS428B\$346.89 set

1950-1951 Super and Roadmaster sedans.

1950: All;

1951: (1st type);

Front doors. Set includes one pair AW503B, one pair
DW501, one pair AW503A, one pair AW503A and one pair
DB503.

DWS501A\$465.89 set

1950-1953 Super and Roadmaster sedans. **Rear doors.**

Set includes all components to correctly surround doors.

DWS503B\$250.29 set

1950-1953 All Series 50 and 70 hardtops and

convertibles. **Front doors.** Set includes one pair of
AW503U, one pair of DW523, one pair of DW513L, one
pair of DB503, and one pair of AW503A.

DWS503\$628.79 set

Door Weatherstrip Sets (Group 10)

1951-1953 Special, 2-door hardtop and convertibles.
Front doors. Comes ready to install with molded ends.
 DWS513\$342.99 pr.

1951-1953 Super and Roadmaster sedans.
1951: (2nd type);
1952-1953: All.
Front doors. Set includes one pair AW503B, one pair AW513, one pair AW503A, one pair DB503.
 DWS513A\$462.39 set

1953 Special two door Sedans. Sufficient footage for complete door circumference.
 DWS53A.....\$155.89 pr.

1954 Front doors. Full circumference sets. glue-on style.
1954 models 41, 48, 49, 61, 69, 52, 72
 DWS54.....\$127.19 set

1954-1955 Special, Century, and Skylark 2-door hardtop and convertibles. **Front doors.** Comes ready to install with molded ends. Glue on type.
 DWS545\$185.89 pr.

1954-1955 Full circumference set for both **rear doors**, includes molded clearance for power window lines and button fasteners. 1954: Models 52 and 72; 1955: Models 52 and 72 (early type).
 DWS545B\$191.59 set

1954-1956 Special and Century. **Front or rear doors.** Full circumference sets. Clip-on style.
1954-1956 models 41, 48, 61 front doors;
1955-1956 models 49 and 69 wagons front or rear doors;
1954 models 52, 72 front doors;
 DWS546.....\$127.19 set

1954-1955 models 41, 48, 61 rear doors;
1956 models 41, 48 rear doors.
 DWS546R\$127.19 set

1954-1956 Super and Roadmaster two door hardtops.
Front doors. Complete, with molded ends. Includes 8 fasteners.
 DWS546A\$189.29 set

1954-1956 Super and Roadmaster convertible. **Front doors.** Complete with molded ends. (8 fasteners).
 DWS546B\$189.29 set

1955-1956 Special and Century 2 door hardtops and convertibles. Molded end pieces and inserted clips as originals. Remove if not needed.
 DWS556\$117.00 pr.

1955-1956 Special and Century 4 door hardtops models.
Front Doors. Molded end pieces and inserted clips as originals.
 DWS556F\$181.99 pr.

1955-1956 Special and Century 4-door hardtop models.
Rear Doors. Molded end pieces and inserted clips as originals.
 DWS556R.....\$192.29 pr.

1955 Super and Roadmaster four door sedans. **Front doors.** Full circumference set for both front doors, includes button type fasteners.
 DWS55A\$69.75 set

1956 Super & Roadmaster 4-door hardtop. Moulded ends.
 DWS56A.....(**Front Doors**).....\$197.19 pr.
 DWS56B.....(**Rear Doors**).....\$210.99 pr.

1957 Special two door Sedan model 48.
 DWS57A.....\$174.69 pr.

1957-1958 Special and Century two door hardtop and convertible. Moulded end pieces and inserted clips.
 DWS578\$129.50 pr.

1957-1958 Special and Century four door hardtops and hardtop wagons. **Front doors**, moulded end pieces and inserted clips. Models 43, 49D, 63, 69.
 DWS578C.....\$219.69 pr.

1957 Special and Century four door hardtops and hardtop wagons. **Rear doors**, moulded end pieces and inserted clips. Models 43, 49D, 63, 69.
 DWS57B.....\$204.79 pr.

1957 Super and Roadmaster four door hardtops.
Rear doors, moulded end pieces with inserted clips.
 DWS57C.....\$234.99 pr.

1958 Super, Roadmaster, and Limited four door hardtops.
Rear doors, moulded end pieces with inserted clips.
 DWS58C.....\$224.79 pr.

1958 Special and Century four door hardtops and hardtop wagons. **Rear doors**, moulded end pieces and inserted clips. Models 43, 49D, 63, 69.
 DWS58B.....\$224.29 pr.

1957-1958 Super, Roadmaster, and Limited four door hardtops. **Front doors**, moulded end pieces with inserted clips.
 DWS58A.....\$279.29 pr.

1957-1958 Super, Roadmaster, and Limited two door hardtop. Moulded end pieces and inserted clips.
 DWS578B.....\$191.59 pr.

1957-1958 Super, Roadmaster, and Limited convertibles. Moulded end pieces and inserted clips.
 DWS578A.....\$198.19 pr.

Continued on Next Page

(Group 10) Door Weatherstrips

1958 All Special two door Sedans model 48.
DWS58S.....\$190.29 pr.

1958 All Special & Century four door Sedans. Front doors.
DWS58D.....\$227.89 pr.

1958 Special & Century four door Sedans. Rear doors.
DWS58E.....\$171.89 pr.

1959-1960 LeSabre 2-door sedan. Front doors. Moulded ends.
DWS590G.....\$162.99 pr.

1959-1960 Electra 4-door sedan. Front doors. Moulded ends.
DWS590F.....\$180.99 pr.

1959-1960 LeSabre, Invicta four door hardtop. Front doors.
Molded ends and inserted clips.
DWS590A.....\$165.19 pr.

1959-1960 All four door hardtops. Rear doors.
Moulded end pieces with inserted pins.
DWS590B.....\$171.79 pr.

1959-1960 Electra four door hardtop. Front doors.
Moulded end pieces with inserted pins.
DWS590C.....\$163.89 pr.

1959-1960 4-door sedans, models 4419, 4619, 4434, 4445, 4635, 4645. Front doors. Moulded ends.
DWS590D.....\$160.49 pr.

1959-1960 All sedans. Rear doors. Moulded ends.
DWS590E.....\$174.79 pr.



1959-1960 All two door hardtops and convertibles. Moulded ends and pins.
DWS590.....\$153.25 pr.

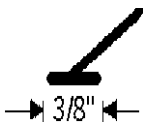

1935-1936 Seal, door top, fits in light metal track. Closed cars. Two door styles need about 5 ft. per door. Four door styles need about 7 ft. per side.
DW356.....\$4.29/ft.



1936-1938 Clip, door bottom weatherstrip retaining. As required. Doors usually require one clip every 6".
WC369.....\$1.50 ea.

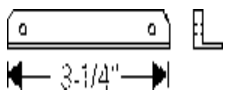

1936 All; 1937 Series 80-90 ex. convertible. Weather seals, front door upper hinge with steel core as original.
WS367H.....\$58.69 pr.

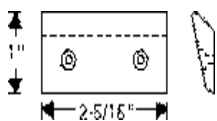

1937 Models 46C, 66C; 1938 All Special and Century Convertibles. Weather seals, hinge post at instrument panel.
WS378H.....\$79.99 pr.

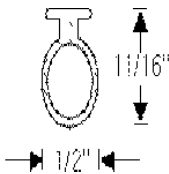

1936-1939 Door bottom seal, held by metal track or by clips. (see WC369 for clips). Two door styles need about 3 1/2' per door. Four door styles need about 5 ft. per side.
1936-1937: All;
1938: Special and Century.
DW369.....\$6.49/ft.

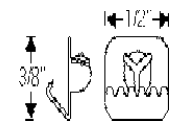

1937-1938 Metal clip for attaching door edge weatherstrips. For 1/4" holes. Doors usually require 1 clip every 6".
WC378.....\$1.00 ea

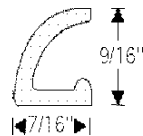

1937-1938 Weatherstrip, door opening, sides and top. Full profile of superior grade sponge, made for use of clips: WC378.
DW378.....\$6.99 ft.



1937-1949 1937-1938 Can be substituted easily for DW378 and DW369 to fit around entire door. Smooth skinned sponge rubber.
1939-1948: All;
1949: Specials.
DW379.....\$2.50/ft.

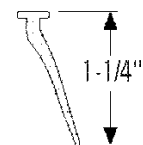

1938-1941 Weatherstrip, door opening, fits retainer under edge of body sill to form seal when door is closed. 6 foot strips. Series 80 and 90.
DW381.....\$110.89 pr.

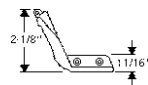

1940-1941 Auxiliary Front door hinge pillar, right and left. Metal core, located at top front of front door, under door flange. Series 50, 70 convertibles.
AW401.....\$87.19 pr.

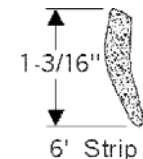

1941-1948 Weatherstrip, door bottom, sponge constant section, solid skin surface, excellent quality. 6 foot strips as required on most models.
DW418.....\$48.19 ea.



1942-1948 Weatherstrip, door at lock pillar, 40" long with molded ends. All Super and Roadmaster convertibles.
AW428C.....\$120.59 pr.

Door Weatherstrips (Group 10)



1942-1950 weatherstrip, hinge post on door or body opening. Bend and trim to fit. 4' length.
AW420\$29.96 ea.



1949-1952 All. Door bottom seal. Fits into retainer.
DW492.....4' length.....\$15.75 ea.



1949-1953
1949 Super and Roadmaster.
1950-1953 Most models. Please compare profile. * For lighter seal, DW379 can be used.
DW493\$2.25/ft.

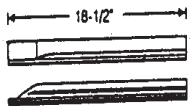

1949 Weatherstrip, windshield post to vent window frame, fits steel retainer rail, right and left. Riviera hardtops and convertibles.
AW49\$142.59 pr.

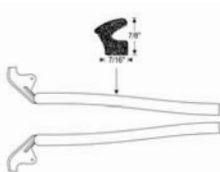

1950-1951 Weatherstrip, front door bottom. Molded right and left hand ends.
1950: Most models;
1951: 50 and 70 1st type doors (see AW513 for 2nd type).
DW501\$189.99 pr.



1950-1953 Weatherstrip, body hinge pillar to door, bellows type seal. 8" x 27" nylon reinforced rubber, 1/16" thick. All models.
DB503.....\$56.75 pr.



1950-1951 Super and Roadmaster 2-door Hardtops and Coupes. Rear side door weatherstrip.
AW501R\$187.19 pr.

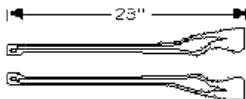

1950-1953 All Super, Roadmaster, and Skylark, two door hardtop and convertible. Weatherstrip, front door. Upper on edge of door or body opening. Special ends, right and left.
AW503U\$118.25 pr.

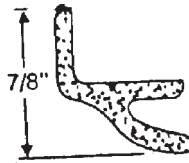

1950-1953 Weatherstrip, front door opening, front body hinge pillar, lower. Extruded sponge. Original config.
1950: Model 56C, 56R, 75R, 76C, and 76R;
1951-1953: All Series 50, 70 including **1953** Skylark 76X.
AW503A.....\$49.79 pr.

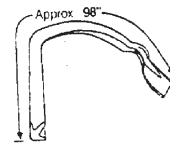

1950-1953 Weatherstrip, front door. Includes molded ends. With steel screw retainer as original.
1950: Models 41, 41D, 43D, 46, 46D, 51, 52, 52X, 56S, 59, 71, 72, 72X, 76S, 79; (43 and 46S 2nd type)
1951-1953: Models 51, 52, 52X, 56S, 59, 71, 72, 72X and 79.
AW503B.....\$184.79 pr.

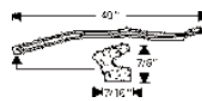

1951-1953 Door bottom weatherstrip. Molded left and right, overall length 40 inches.
1951: Models 50 and 70, 2nd type, except 56S;
1952-1953: Models 50-70.
AW513\$186.19 pr.

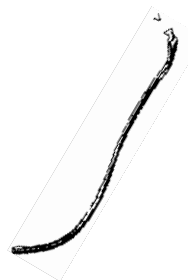

1952-1953 Weatherstrip, front door lock pillar. Ready to install with molded ends. All hardtop coupes and convertibles including '53 Skylark.
DW523.....\$181.69 pr.



1951-1954 all;
1955 Most models. Please compare profile with DW550. Can also be used from 1951-1953
DW515\$2.50/ft.



ORDER BY PHONE !
908-369-3666

(Group 10) Door Weatherstrips

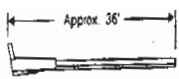

1952-1953 Front door lock pillar, with molded ends. All 2 dr. hardtops and convertibles including 1953 Skylark.
AW523\$187.19 pr.

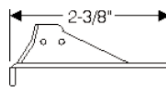

1952-1953 Super and Roadmaster 2-door hardtop models 56R and 76R. Seal, roof rail at vent.
AW523A\$55.49 pr.



1954-1958 Seal, roof rail, outer at 1/4 window.

1954-1956: Century and Special, Riviera with hardtop coupes;

1957-1958: Super and Roadmaster, Riviera with hardtop coupes;

1957: Roadmaster Riviera hardtop coupes wrap around and 3 piece window.

1958: Limited Riviera Coupe.
RR548A\$31.29 pr.

1955-1960

1955-1956: Correct configuration, most models. Compare with DW515

1957-1960: Excellent glue on replacement.

DW550\$1.75/ft.

1956 Roof rail Filler w/s. Attaches to body. Made with metal core as original.

AW56\$73.89 pr.

1955-1960 All. Correct configuration with inserted pins. Remove pins for glue apps.
DW577\$2.75 ft.

1957-1960 All as required. Door weatherstrip retainer.

WR577\$0.50 ea.

1954-1958 Front door, auxiliary on body above belt line. Two strips 15" long.

1954-1958: Compare with AW547;
1958: Models 43, 46C, 46R, 49D, and 63.
PS549\$65.29 pr.

1954-1958 Same as above. Sponge stick-on replacement.
PS548\$8.50 pr.

1959-1960 Most models. Weatherstrip, front door opening. Auxillary on door hinge pillar at belt line, right and left. Set includes four button type fasteners.

AW591\$29.50 set

1959-1960 Gutter, cowl side drain, left and right. Rubber with metal core as original. All post models.

AW590\$118.49 pr.

1959-1960 Electra 225 4-door model 4829. Upper vertical weatherstrip at rear body lock pillar. 11: long.

AW590A\$132.89 pr.



1954-1956 Special, Century and Skylark weatherstrip, front door, auxiliary on door front at belt line, right and left. Includes bottom fastener.
AW546\$58.25 set

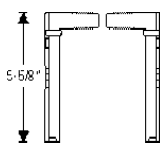

1954-1956 Weatherstrip, front door upper corner, outer (at front end of flipper). Right and left, steel core. Models 46R and 66R 2-door hardtop.
AW546A\$100.29 pr.

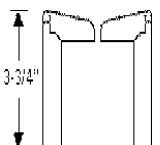

1954-1956 Weatherstrip, upper front door hinge pillar at roof rail. Molded rubber with brass core. Fits 56R, 76R and 76RX Riviera hardtop coupes.
AW546B\$91.19 pr.

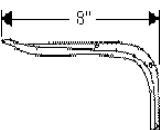

1954-1956 Super and Roadmaster, front door opening, auxiliary on cowl at belt line. Right and left steel core.
AW546C\$170.59 pr.



1954-1957 Most Models. Weatherstrip, windshield post, upper to door. Two strips approximately 15" long. Compare with PS548.
AW547\$15.00 pr.

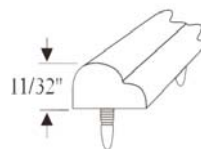

1954-1958;

1954-1956 Super and Roadmaster, may need trimming;

1957-1958 All. weatherstrip, front door, auxiliary on door front at belt line, right and left. Includes bottom fasteners.

AW548\$18.50 set



1954-1960 Fastener, door edge weatherstrip, steel. 1/2" long, 13/32" diameter head, black finish. All models as required.
WF1\$1.00 ea.

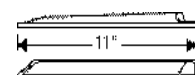

Door Bumpers (Group 10)

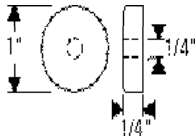

1932-1936 bumper, front and rear body hinge pillar, 1" diameter x 1/4" thick, held by screw, steel core. Auxiliary, used only where needed to prevent door rattle.
DB326.....\$9.29 ea.

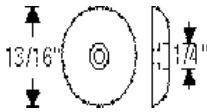

1932-1948 Bumper, front door above the upper hinge on the upper radius of the door. Stiff-backed, retained by screw, mounted on door. All closed GM models.
DB328.....\$8.59 ea.



1933-1939 Pad, door jamb (door side bumper). Heavily used all models 1933-1936, also on some convert. thru 1939.
DB339.....\$9.00 ea.



1936-1939 Bumper, door center post, upper, fits 1/4" hole, 5/16" thick, self-retaining. Most closed bodies as required.
DB360.....\$1.75 ea.

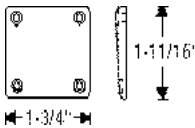

1937-1953 Bumper, door side. Square type held by 4 screws, metal core as original. Convertibles and hardtops.
DB373\$53.25 pr.

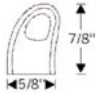

1940 Super 4-door sedan. Rear door vent grommets. Set of 4.
VG40.....\$65.99 set

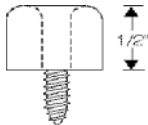

1941-1960 Door post bumper. Most models. Hollowed center. Used with screw.
DB411.....(Steel Core)\$2.25 ea.



1941-1960 Door pillar bumper. All, except convertibles.
DB410.....\$1.75 ea.

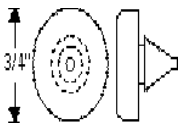

1937-1956 Bumper, door hinge pillar upper. 3/4" diameter, 3/16" thick, for 1/4" hole. Most models, as required.
DB426\$3.49 ea.

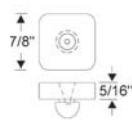

1941-1960 As required. Cushion (stem bumper), window stop, lower. Front and rear door, rear side quarter windows as required. Compare with WC414.
WC411\$5.50 ea.



1941-1960 Cushion (stem bumper), window stop, lower. For front and rear door, rear side and quarter windows as required. 15/16" square, 1/2" thick. Compare with WC411.
WC414\$7.25 ea.



Door Panel Retainers
1959-1975 All as required.
DPR598\$1.00 ea.



Door Adjustment Hole Plug

1941-1948 convertible. Fits a 5/8" wide x 1" long hole.
DAP418.....\$5.50 ea.

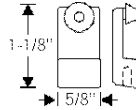

1949 Door bumper, lower, held by one screw and one carrot retainer. All Super and Roadmaster. Two door models.
DB49\$22.89 ea.

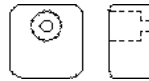

1949 Bumpers, front door, upper. Approximately 5/8" square, 3/8" I.D. Steel core, retained by screw. Super and Roadmaster including Estate Wagon.
DB49F.....\$47.89 pr.

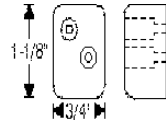

1949 Bumpers, rear door upper, right and left. 1/2" X 3/4" X 1", steel core, retained by two screws. Models 51, 71.
DB49R\$61.89 pr.



1949-1960 Door pillar bumper.
DB500A-3/8" W. x 1/2" H.\$2.75 ea.
DB500B-3/8" W. x 5/8" H.\$2.75 ea.
DB500C-1/2" W. x 7/16" H.\$2.75 ea.



1957-1960 Door bumper. Most models.
DB570\$2.75 ea.



1959-1960 Bumper, door, used upper and/or lower as required.
DB595\$2.75 ea.



1937-1960 Door panel repair clip.
PN370\$0.65 ea.

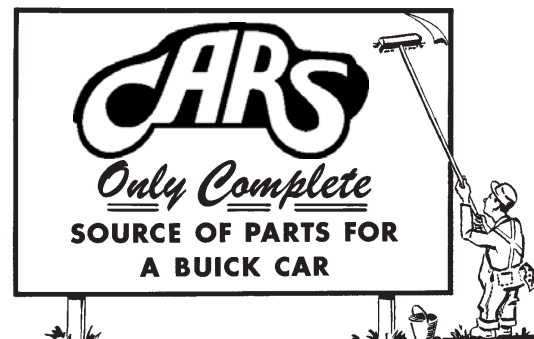

Outer Door Handle Parts



1937-1939 Special, Century.
Stainless steel outside door handle.
DH378\$176.50 ea.

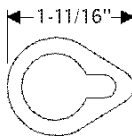

1939-1949 Mounting pad, door lock cylinder,
1939: Series 40 and 60;
1940: Series 40, 50, 60 and 70;
1941-1949: All. Fits either side.
KLG399\$2.75 ea.



1950-1953 Gasket set, door handle, Front and rear door if necessary. One set for two doors.
1950: All (exc. 59, 76C, 76R, and 79);
1951: All 40 and 50 (exc. 59);
1952-1953: All (exc. 59, 79R).
HG503\$8.75 set



1954-1956 Door handles. Special, Century, Skylark 2-door models. Pair. Includes buttons
DH546S\$145.00 pr.



1954-1956 Door handle gaskets. Special, Century, Skylark 2-door models. For 2 handles
HG5462\$9.75 per set



1954-1956 Door handle gaskets. Special, Century, Skylark 4-door models. Front and rear. One set for two doors.
HG5464\$9.00 set



1950-1958 Door handle button seals / cushions.
BS508\$1.00 ea



1954-1960 Gasket, door lock cylinder. Exact reproduction. 7/8" I.D.
1954: 40, 60, 100;
1955-1960: As required.
KLG540\$1.25 ea.



1954-1956 Gasket, door handle. Super and Roadmaster 2 door models. For 2 handles.
HG546B2\$33.59 set



1954-1956 Gasket, door handle. Models 52 & 72. One set for 2 handles.
HG546B\$33.29 set



1957-1958 Gasket set, outside door handle. Four piece set for two handles.
1957: All Front doors;
1957: All Special and Century rear doors;
1958: All Special and Century front doors.



HG578\$8.50 set

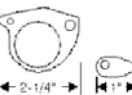

1958 Gaskets, door handle, four piece set for two handles. Some models, as required.
HG58\$9.50 set

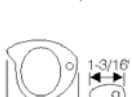

1959-1960 Outside chrome door handles. Includes buttons and springs.
1959: All front & rear.
1960: All front.
DH590S\$135.00 pr.

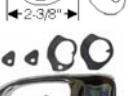

1959-1960 Gasket set, outside door handles. Four piece set for two handles.
HG590\$10.00 set



1960 Chrome outside rear door handles. Includes buttons, springs and gaskets.
DH605S\$95.00 set



Door Handle Ferrules



1926-1937 Ferrule, for 3/4" outside door handle. Chrome plated brass (includes grommet). All models.
HF307\$8.00 ea.



1938-1940 Ferrule, outside door handle. Chrome plated brass. Includes grommet.
1938-1939: All;
1940: All (exc. 50 and 70)
HF380\$8.00 ea.



1940-1948 Ferrule, outside door handle with rubber sleeve.
1940: Series 50 and 70;
1941-1948: All models.
HF408\$7.00 ea.



1929-1948 Installing tool, door and trunk handle ferrule. This tool does a quick, neat and efficient job of installing ferrules staking them internally to keep them in place.
FT358\$45.00 ea.

Door Handle Escutcheons Die Cast and Chrome Plated

1942 Models 46, 46S, 56S, 61, 66S, 76S;
1942-1947 Model 41;
1942-1948 Super & Roadmaster convertibles.
HE428\$59.00



Key Blanks



1935-1960 All. Octagon.
KB10\$4.50 ea.

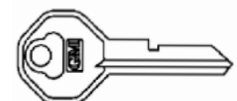

1935-1960 All. Rounded.
KB11\$4.50 ea.

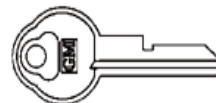

Door Lock Pairs with 2 Keys

1954 Special, Century, Skylark;
1955-1956 Special, Century and Wagons exc. 43, 63. Change forks as necessary.
DLS546\$39.50 set
1955-1956 Special and Century, models 43 and 63.
DLS556ATOS
1959 All except 2 door Sedans.
DLS596\$39.50 set
1959 All 2 door Sedans.
DLS59\$46.50 set
1960 All 2 door Sedans.
DLS608\$39.50 set
1960 All 4 door models.
DLS604\$39.50 set



Door Handles and Parts (Group 10)

1939-1958 Inner Door Handles (10.512)



1939 thru 1953 ALL;
1954 thru 1958 Super,
Roadmaster, Limited. Die cast and

beautifully chrome plated as original. (Note these will replace 1939-1940 with plastic insert type but will not look original.)

DH398\$19.50 ea.

1939-1958 Window Cranks (10.797)

Same application as above. Includes chrome knob.



WC398.....(Window Crank).....\$19.50 ea.

VC398.....(Vent Crank)\$19.50 ea.

1951-1953 Window Cranks

Includes black knob w/ stainless steel cap.



WC512.....(Window Crank).....\$26.50 ea.

VC512.....(Vent Crank)\$26.50 ea.

Door Handle & Window Crank Escutcheons



1939 All. Maroon low profile 1/4".
HE39L.....\$7.25 ea.



1940-1952 All smooth finish 1 piece.
HE461.....\$11.50 ea.



1940-1952 All smooth finish 2 pieces.
(Spring loaded)
HE461S.....\$15.25 ea.



1952-1953 All "Starburst". 1 piece.
HE523.....\$13.50 ea.



1952-1953 All "Starburst". 2 pieces.
(Spring loaded)
HE523S.....\$17.50 ea.



Door Handle & Vent Crank, Spring loaded.
1954-1956 All Super & Roadmaster Front;
1957 Models 75, 75R.
HE547S.....\$16.50 ea.



1954-1956 Models 52,53,72,73 rear door handle;
1954-1958 Super & Roadmaster Window
Handle;
1957-1958 Super & Roadmaster exc. 75,
75R. Door & Vent handle;
HE548.....\$12.50 ea.

1954-1958 Inner Door Handles (10.512)



Fits Special, Century, Skylark. Chrome plated. 5" "Drumstick" style.

DH542\$32.50 ea.

1959-1960 All
DH594\$16.50 ea.

1954-1958 Window Cranks (10.797)



Special & Century. These new items are correct in every-way including black knobs as per original. They are not generic replacements such as you might see elsewhere.

WC548.....(Window Crank).....\$27.25 ea.

VC548.....(Vent Crank)\$27.25 ea.

1959-1960 Window Cranks



1959-1960 all as required. Front and rear.

WH594.....\$16.50 ea.

Inner Door Handle Parts



1931-1953 Door handle retaining clip. All.
(10 Pack).
HRC318.....\$2.25 pack



1933-1948 All;
1949 Special. Tapered screw for securing
outer door handles to lock mechanism.
HS339.....\$3.25 ea.



1954-1960 All. Door handle retaining clip.
(10 Pack).
HRC540.....\$2.25 pack



1937-1960 Interior door handle tension spring.
HS395.....\$1.50 ea.



1935-1960 Door handle removal tool. All.
HT360.....\$7.75 ea.

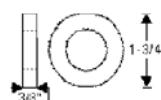

1935-1958 Sponge rubber, interior door handle
escutcheon.
2" O.D. X 3/8" thick. Some models.
EW353.....\$2.75 ea.



1954-1960 Door handle washers.
HW552.....\$3.00 ea.



1957-1960 All as required. Window regulator
roller and rivet.
WR576.....\$3.25 ea.

Rear Ash Trays



1948 Roadmaster Model 76S;
1949-1953 Super, Roadmaster & Skylark,
 2-dr hardtop & convertibles.
1954-1958 Skylark & Century convertible.
1954-1958 Super, Roadmaster & Limited,
 2-dr hardtop & convertibles.
 AT488.....\$34.50 ea.
 ATB488.....Bezel for Above.....\$21.50 ea.



1959-1960 LeSabre, Invicta, Electra 2-dr. ht.;
1959-1960 All convertibles.
 AT597.....\$24.50 ea.

1959-1960 Vent Cranks



1959-1960 all as required.
 VC594.....\$16.50 ea.

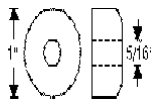

1930-1940 Cushion, door check link. 1" diameter X 3/8" thick with 5/16" hole. All models using rod type door check.
 CB300.....\$7.29 ea.

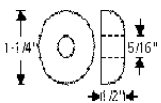

1930-1940 End stop and cushion, door check link rod. Rubber with embedded steel plate, 5/16" diameter thread. Most models with rod type door checks.
 CB301.....\$14.99 ea.

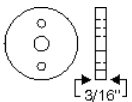

1931-1940 Rubber washer, door check link stop.
1931-1939: All;
1940: Series 40, 60, 80, and 90.
 CB310.....\$8.99 ea.



1939-1949 Check link end nut, (rubber bar with steel bar insert) .3/4" x 3/4" x 2" threaded.
1939: All Series 40, 60 rear;
1940: Series 40 and 60 rear; Series 50 and 70 front and rear;
1941-1948: All, front and rear;
1949: Series 40, front.
 LN399.....\$28.59 ea.



1931-1960 All as required. Door hinge pin correct 11/32" O.D. 4" length. Cut to shorten if necessary.
 HP310.....\$3.00 ea.



1931-1960 Door hinge bushing. Two per hinge pin. Bronze.
 HB310.....\$1.00 ea.



(10.778)

1946-1948 Conduit (double rubber hose), body to door, for hydraulic and electrical lines to power window. Convertible only.
 DC468.....\$51.29 pr.



1950-1952 Conduit, hydraulic line and power window wire. Front doors Two pieces 9 1/2".
1950: 52X, 56C, 72X, 76C, 76R;
1951: 52X, 56C, 72RX, 76C, 76R;
1952: 59, 79R.

DC502.....\$51.29 pr.

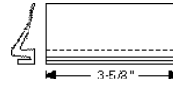

1940-1949 Seal, door lock, front and rear. Protects lock mechanism from dust & weather.

Front door: 1940: Series 50 and 70;

1941-1948: All;

1949: Models, 41, 46S.

Rear door: 1942: Series 40, 60 and 90;

1946-1947: All.

LS409.....\$40.49 pr.



1941-1948 Door bottom drain seals.

DG418.....\$5.00 ea.



1954-1956 Special, Century, Skylark. Door bottom drain hole seal.

HS546.....\$6.49 ea.

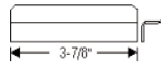

1956-1958 Weatherstrip, door bottom drain hole seal. Also used on tailgate of station wagon. (2 required for this use).

1956: Series 50 and 70;

1957-1958: All including station wagon.

HS568.....\$6.49 ea.

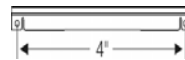

1957 Super and Roadmaster 4-door hardtop models. Weatherstrip, rear door hinge pillar.

PS57.....\$78.99 pr.

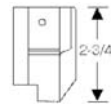

1959-1960 All Models. Weatherstrip, door bottom drain hole seal.

HS591.....\$6.29 pr.

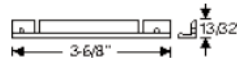

Door Lock Buttons



1936-1941 LB361.....(Brown).....\$7.49 ea.

1937-1942 LB372.....(Chrome).....\$9.75 ea.

1942-60 LB427.....(Black).....\$3.50 ea.

1942-60 LB427N.....(Brown).....\$8.29 ea.

1942-60 LB427R.....(Red).....\$4.50 ea.

1942-60 LB427G.....(Green).....\$4.50 ea.

1942-60 LB427U.....(Lt. Blue).....\$4.50 ea.

1946-1958 LB468.....(Chrome).....\$9.50 ea.

Power Window Motors

1954-1960 Power window motors.

Includes 12 tooth gear.

Left front or left rear quarter.

WM540L.....\$125.00 ea.

Right hand front or rear quarter.

WM540R.....\$125.00 ea.



Door Parts (Group 10)

Door Striker Chrome Plated



1939 Special & Century;
1940 Super Wagon
 DS390C.....\$30.00 ea.



1940 Super & Roadmaster Exc. Wagons.
1941-1948 All;
1949 Special
 DS409.....\$29.50 ea.

Door Striker Screw

1939-1940

1/4"-28 X 5/8" SS Slotted

SS398.....\$2.75 ea.



1949-1953 Door striker screws. Pack of 6.
 SS506.....\$9.75 set

1954-1960 All. Pack of 6.

SS540.....\$9.75 set



1954-1960 Door striker.
1954-1956: All Special, Cent. &
 Skylark;
1956: Super and Road. 4 dr. hardtop;
1957-1960: All.
 DS542.....\$40.75 pr.

Door Striker Casing Cap



1940 Series 50, 70, 80, 90.

1941-1948 All Front.

1940-1941 Models 51C, 71C,
 Series 80, 90 Rear.

DSC408.....\$24.00 ea.



1937-1948 All.

Door Casing Cap Screw Set for 2.
 (6 screws)

SS378.....\$6.00 set

Striker Repair Kits

1937-1939 All.

8 Piece kit repairs one door.

DRK379.....\$20.00 ea.

1940-1948 Most Models; 1949 Special.

Enough for 2 doors, either front or rear.

DRK409.....\$40.00 ea.



ORDER BY PHONE!
Call 908-369-3666

(Group 10) Power Window Switches



1949-1953 All with hydraulic windows. 4 button assembly
Includes chrome Escutcheon.
WS493A\$219.00 ea.



1949-1953 All with hydraulic windows. 4 button switch
Does not include chrome Escutcheon.
WS493\$175.00 ea.



1949-1953 All. 4-button chrome Escutcheon.
WSE493\$62.00 ea.

1949-1953 all. Fits R.H. door and either side rear. Assy. Includes chrome Escutcheon.
WS493SA.....\$109.00 ea.



1949-1953 all. Fits R.H. Door and either side rear. Switch.
Does not include chrome Escutcheon.
WS493S\$79.00 ea.



1949-1953 All. Single button chrome Escutcheon.
WSE493S.....\$42.00 ea.

1949-1953 All. Button only. Fits all hydraulic switches.
WSB493.....\$19.50 ea.



1954 Century and Skylark with hydraulic windows. 4 button assembly. Includes chrome Escutcheon.
WS54A\$259.00 ea.
WS54SA.....(Single Button Assembly)\$109.00 ea.



1954-1957 All with electric windows. 4 button assembly
Includes chrome Escutcheon.
WS547A\$209.00 ea.

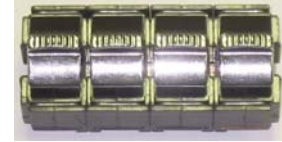

1954-1957 All with electric windows. 4 button switch.
Does not include chrome Escutcheon.
WS547\$160.00 ea.



1954-1957 All. 4-Button chrome Escutcheon.
WSE547\$60.00 ea.

1954-1957 All. Fits R.H. door and either side rear. Assy. Includes chrome Escutcheon.
WS547SA.....\$109.00 ea.



1954-1957 All. Fits R.H. door and either side rear. Switch. Does not include chrome Escutcheon.
WS547S\$79.00 ea.

1957 Buick Models 75, 75R Only. Rear Door or Quarter Window. Switch - 1 Button
WS543.....\$82.50 ea.



1954-1957 All. Button only. For Single button switches.
WSB547.....\$19.50 ea.
WSB547M..(For 4-button switches)..\$19.50 ea.

1954-1957 All. Single button chrome Escutcheon.
WSE547S.....\$42.00 ea.



1958-1960 Window with contact. All "4 in a row type"
WSC583\$105.00 ea.



1958-1960 All. Contact for all single button switches
WSC584.....\$39.50 ea.

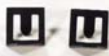

Interior Parts (Group 10)

Inside Rear View Mirror (10.185)



1939-1953 Chrome backed with stud.
IM393\$27.00 ea.



1939-1953 Chrome backed. Day-Nite with bent threaded stud mirror is 9" wide.
IM393D.....\$69.50 ea.

1939-1953 All. 7" mirror mounted with threaded stud. Day-Nite.
IM393S.....\$69.50 ea.



1948-1953 Straight threaded stud to mount. Day-Nite. Mirror is 9" wide.
IM483\$66.00 ea.



1950-1953 Day-Nite with flat end stem/screw mount.
IM503.....\$89.50 ea.



1954-1956 Day-Nite.
IM546\$88.50 ea.



1957-1960 Day-Nite.
IM572\$79.50 ea.

Mirror Screw

1953-1960 As required.

MS532.....\$2.75 ea.



Tissue Dispenser & Emblems



1950-1959 All genuine Buick accessory. Includes emblem.
TB509K.....\$79.00 ea.

All Years. Adhesive backed. Also can be used on our seat belts.

TBE550.....\$7.50 ea.



Convertible Chrome Visor Parts



1939-1948 Convertible chrome visor bracket.
VB398.....(4 needed per car).....\$49.50 ea.



1939-1948 Convertible chrome visor bracket mount.
VM398.....(4 needed per car).....\$47.50 ea.



1954-1958 All Convertibles. Chrome plated visor retainers w/ screws.
VR548..\$57.50 ea.



1942-1960 All. Odometer reset knob.
RK425.....\$3.75 ea.



1939-1960 Coat hook - chrome.
CH396\$12.00 pr.



1937-1942 Sunvisor end plug.
VP372.....(Black).....\$4.75 ea.
VP372N.....(Brown).....\$7.29 ea.



1938-1955 Many models. Bumper, rubber, glove box door, for 1/8" to 5/32" thick pad, 5/16" diameter. Compare with GDB410.
GDB385\$1.00 ea.



1938-1955 Many models. Bumper, rubber, glove box door, for 1/8" to 5/32" hole, 1/4" thick pad, 5/16" diameter. Compare with GDB385.
GDB410\$1.25 ea.



1937-1939 Many models. Grommet, glove box door check link, for 1 1/8" slot in dash.
GG379\$23.99 ea.



1940 All. Grommet, glove box door check link.
GG40\$5.99 ea.

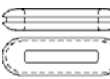

1949 Some models. Grommet, glove box door check link, for 1" slot in dash.
GG49\$25.19 ea.

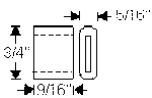

1950-1960 Bumper or grommet, glove box door check link. Fits on glove box door arm as required.
GG503\$7.50 ea.

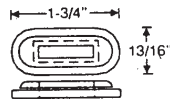

1956-1958 Grommet, glove box door cushion. Used on all models as required.
GG568\$16.39 ea.

Vanity Mirrors



1936-1949 All. A "GM" dealer installed accessory. Can be written on. Clips on visor.
VM369.....\$30.50 ea.



1954-1960 Vanity mirror is an exact reproduction. Clips to sunshade as original.
VM549.....\$49.50 ea.

Glove Boxes



1934-1935 Series 40. GB345	\$35.00 ea.
1934-1935 Series 50-60-90. GB345B	\$35.00 ea.
1936 All. Felt lined as original. GB36	\$35.00 ea.
1937 All except Limited. Felt lined as original. GB37S	\$33.00 ea.
1937 Limited. Felt lined as original. GB37B	\$35.00 ea.
1938 All. Felt lined as original. GB38	\$33.00 ea.
1939 Special and Century. Felt lined as original. GB39S	\$33.00 ea.
1940 Special, Century, Limited. Felt lined as original. GB40S	\$33.00 ea.
1940 Super and Roadmaster. Felt lined as original. GB40B	\$33.00 ea.
1941 All. Felt lined as original. GB41	\$39.50 ea.
1942-1948 Super and Roadmaster. GB428	\$33.00 ea.
1942-1949 1942: Models 41, 41SE, 46, 46S, 46SSE, 61, 66S, all series 90; 1946-1949: All Specials. GB429	\$33.00 ea.

1949 Super and Roadmaster. GB49	\$32.50 ea.
1950-1952 1950: All; 1951-1952: Super and Roadmaster. GB502	\$32.50 ea.
1951-1953 Special. GB513	\$32.50 ea.
1953 Super, Roadmaster and Skylark. GB53	\$32.50 ea.
1954-1955 Super and Roadmaster. GB545	\$32.50 ea.
1954-1955 Special, Century and Skylark. GB545S	\$32.50 ea.
1956 Special and Century. GB56S	\$32.50 ea.
1956 Super and Roadmaster. GB56	\$32.50 ea.

Glove Box Lock with Two Keys (10.266)



1941-1953 All. GBL415	\$29.25 set
1954-1956 All. GBL546	\$29.25 set
1959 All. GBL59	\$27.75 set



www.oldbuickparts.com
908-369-3666

Interior Parts (Group 10)

Gear Shift Knobs

1930-1935 All as Original;
1936-1938 All as replacement.
Screw on - Black

GK308.....\$12.75 ea.



1936-1938 Ivory, 3/8" fine thread. Brass insert.

GK368.....\$26.00 ea.

GK368P.....Push on Style.....\$26.00 ea.



1937-1940 Cowl Vent Knob. Ivory.

CVK370.....\$19.50 ea.

Antenna Knobs

1941-1947 All.

AK417.....(Ivory).....\$26.00 ea.



1949-1953 All. Except convertibles. Black.

AK493.....\$26.00 ea.

Brake Knobs

1942-1948 All Ivory.

BRK428.....\$7.50 ea.



1947-1955 All Black.

BRK475.....\$7.50 ea.



Door Handle & Window Crank

Excutecons



1939 All with low profile. Maroon. 1/4"

HE39L.....\$7.25 ea.



1939 All with high profile. Maroon. 3/8"

HE39H.....\$7.25 ea.

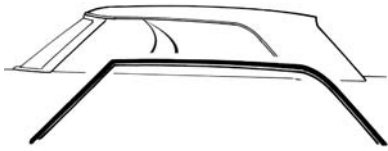

Roof Rail Weatherstrip (10.721)

- 1949** Riviera Roadmaster hardtops.
RR49\$443.59 set
- 1950** Models 56R, 75R and 76R for early models.
RR50\$264.99 set
- 1950-1951**
 1950: Models 56R, 75R, 76R (Later models);
 1951: Models 56R, 56RD, 76MR, 76R.
RR501\$210.19 pr.
- 1952-1953** Super and Roadmaster two door hardtop.
(Flipper seals). 2, 30" pieces
RR523F\$39.50 pr.
- 1954-1958** Flipper stops. Mounts at rear of door for 2 door
hardtop models.
1954-1956 Special and Century;
1957-1958 Super, Roadmaster, Limited.
FS548.....\$35.79 pr.
- 1955-1956** All four door hardtops. Two 6' lengths.
RR556\$149.00 pr.
- 1955-1956** Special and Century 4 door hardtops.
Includes metal core as original.
RR556M\$604.49 pr.
- 1955-1956** Super and Roadmaster 4 door hardtops.
Includes metal core as original.
RR556BM.....\$600.49 pr.
- 1957-1958** Special and Century. Four door hardtops and
hardtop wagons. Two 6' lengths.
RR578\$89.50 pr.
- 1957-1958** All. Two door hardtops. Two 40" pieces.
RR578A.....\$89.50 pr.
- 1957-1958** Super, Roadmaster and Limited four door hardtops.
RR578B.....\$202.69 pr.

1959-1960 Electra four door "Flat Tops". Models
4739-4839. Includes molded ends and inserted clips.
RR590F\$95.00 pr.

1959-1960 All two door hardtop. Two piece set includes
R and L molded sections for body hinge pillar and R and L
sponge weatherstrips with inserted clips.
RR590H.....\$149.50 set

1959-1960 LeSabre, Invicta four door "Flat Tops". Models
4439-4639. Includes molded ends and inserted clips.
RR590S\$199.00 pr.

1959-1960 Electra four door "Flat Tops". Model 4829.
Includes molded ends and inserted clips.
RR590SE\$202.59 pr.

1959-1960 All four door hardtops. Two 8' lengths of
extruded rubber. Does not have molded ends as original.
An inexpensive substitute.
RR590\$67.50 pr.

Spray adhesive for application of bow drill cloth.
SA360.....(20 oz.).....\$18.00 can



Adhesive Backed Bow Drill



Cloth tape used to cover roof rail
weatherstrip rear 1/4 window seals,
etc. as req. Waterproof and sun-
proof. Comes in 5 foot rolls.

- BD250B.....(Black 2 1/2" wide).....\$17.99 ea.
- BD250T.....(Tan 2 1/2" wide).....\$15.99 ea.
- BD500B.....(Black 5" wide).....\$37.99 ea.
- BD500T.....(Tan 5" wide).....\$22.00 ea.

Bow Drill Cloth

54" width and is sold by the yard. Not adhesive backed.
Please order black or tan.

- 1935-1960** All. Black.
BD360B\$22.75 yd.
- 1935-1960** All. Tan.
BD360T\$22.75 yd.

Rear Vent Window Seals (Group 10)

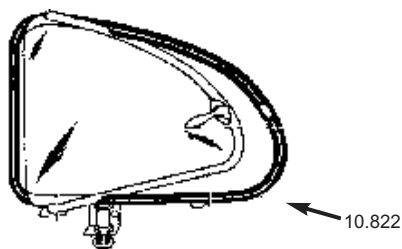

- 1934-1960** All Models. Rear vent window division post vertical seal.
VS330.....\$12.00 pr.
- 1934-1935** Model 61 and 91 four door sedans.
RVW345\$223.49 pr.
- 1934-1935** Models 47, 57, 58, 67, 68, 90, 90L, 97, 98.
RVW345A.....\$216.99 pr.
- 1934-1935** Model 41 four door sedans.
RVW345B.....\$185.99 pr.
- 1936** Special and Century four door sedans.
RVW356\$216.99 pr.
- 1936-1937** Model 81 and 81F.
RVW367F\$185.99 pr.
- 1936-1937** Models 90, 90L, and 91.
RVW367L\$215.99 pr.
- 1937-1938** Model 41 and 61 four door Sedans.
Full swing types.
RVW378\$110.50 pr.
- 1937-1938** Model 47 and 67 plain back Sedans.
(splicing required).
RVW378S.....\$216.99 pr.
- 1938-1940** Series 90. Includes division bar seals and run channel.
RVW380B.....\$281.59 set
- 1940-1942;**
 1940-1941: Model 51 and 71;
 1942: Model 47.
RVW402\$174.49 pr.
- 1942-1948** Model 51 and 71.
RVW428\$182.59 pr.
- 1949** Model 51 and 71.
RVW49\$216.99 pr.

1949-1960 Grommet, rear quarter window lift hose.

1949-1950: Models 56C, 76C, 76R;

1951: Models 46C, 56C, 76C, 76MR, 76R;

1952: Models 46C, 56C, 76C, 76R;

1953: Models 56C, 76C, 76R, 76X;

1954: Model 66C and 100.



QG490\$5.79 ea.

1950-1953;

1950: Model 52, 52X, 72, and 72X;

1951-1953: Models 52, 52X, 72R, and 72RX.

RVW503S.....\$202.99 pr.

1951-1953 Special four door Sedans.

RVW513\$120.00 pr.

1954 Super & Roadmaster 4-door Sedan models 52 & 72R

RVW54\$218.59 pr.

1954-1956 Special and Century four door Sedans with opening vent windows.

RVW546\$169.50 pr.

1955-1956 Model 52 and 72.

RVW556S.....\$223.49 pr.

1958 Vent window weatherstrip, rear door. Models 53, 75 and 750.

RVW58H.....\$216.99 pr.

**Fax Us
Your Order
Save Time!**

When sending us a long order
it is easier to just fax it.

908-369-7595

(Group 10) Rear Window Vulcanized Seals

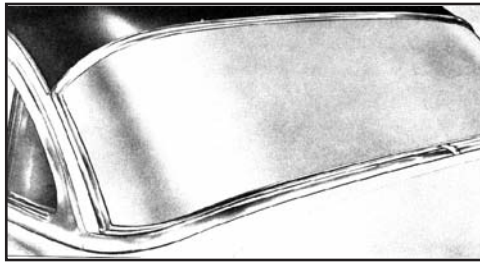

1937-1940 Channel, back window, for windows without chrome reveal molding. Eight foot strip.
WR370A\$30.25 ea.

1937-1948 Most models. Channel, back window, for windows with chrome reveal molding. Plain channel for 1/4" glass. Eight foot strip.
BS378B\$53.25 ea.

1938-1940 Series 90 All closed cars.
BS380\$173.29 ea.

1939-1940 Specials. For closed models.
BS390\$129.89 ea.

1938-1940 Models 81 and 81F.
BS380A\$178.89 ea.

1939-1949:
1939-1940: All series 40, 60 with reveal molding;
1941-1949: All Special and Century.
1946-1948 Super and Roadmaster Sedans, 56S, 76S.
 BS399.\$147.89 ea.

1940 All Closed 50 and 70 Series Models;
1941 Series 50, 70, 90 (except convertibles)
 Models **WITH** reveal molding.
 BS401.....\$131.49 ea.

1941-1948 Pinchweld seal, back window, to seal and retain outer reveal molding. Used in conjunction with BS378 and BS401. Some models. 12 foot strip.
 PW419\$41.25 ea.

1942-1948 All Super and Roadmaster. 4 door sedans.
 BS428A\$146.19 ea.

1949 Model 56S, and 76S (lock strip included).
 BS49S\$212.79 set

1949 Model 76R (Roadmaster two door hardtop).
 BS49R\$440.69 set

1949 Model 51 and 71.
 BS49B.\$222.39 ea.

1950 Model 43, 46, 46S. For cars **WITHOUT** reveal molding.
 BS50S\$156.19 ea.

1950-1951 Models **WITH** reveal molding.
1950: Models 41, 41D, 51, 71;
1951: Model 51.
 BS501.....\$368.59 ea.

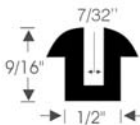
 **1926-1931** Mounting channel for fixed back window. Double weatherstrip type for 1/2" glass. 7' 3" strip. Most closed bodies.
 BS261\$42.00 ea.

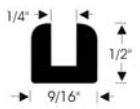
 **1928-1932** Setting channel for fixed back window. Plain style. 7' 6" strip.
 BS282\$63.29 ea.

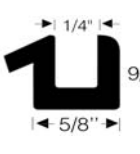
 **1933-1934** Some models. Channel, back window, for windows with or without chrome reveal molding. Most cars require 8 ft.
 BS334\$6.39 ft.

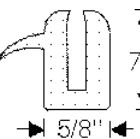
 **1935-1936** Some models. Channel, back window, for window without chrome reveal molding. Eight foot strip.
 BS356.....\$53.25 ea.

1936 Model 41, 48, 61, and 68 w/o reveal molding.
 BS36\$89.50 ea.

1936 Models 81, 90, 90L, 91. (Order DP367R divider pads, separately).
 BS36A\$89.50 ea.

1936 Special and Century Coupes without reveal molding.
 BS36H.....\$118.99 ea.

1937 All 80 and 90 Series except convertibles. (Order DP367R divider pads, separately).
 BS37\$84.25 pr.

1937-1938 Special and Century models **WITHOUT** reveal molding. Models 44, 47, 64 and 67.
 BS378\$147.89 pr

1937-1938 Special and Century models **WITHOUT** reveal molding. Models 41, 48, 46, 46s, 61, 66s, 68
 BS378A\$147.89 ea.

Rear Window Vulcanized Seals (Group 10)

1950-1951 Models WITH reveal molding. 1950: Models 46D, 46S, 43D, 56S, 76S; 1951: Model 56S. BS501S	\$190.49 ea.
1950-1952 Model 52, 72R. BS502S	\$365.59 ea.
1950-1952 Models WITH reveal molding. 1950: Model 56R, 75R, 76R; 1951: Model 56R, 76MR, 76R; 1952: Model 56R, 76R. BS502R	\$417.59 ea.
1951-1952 Model 41, 41D, 48D. Models WITH reveal molding. BS512	\$351.99 ea.
1951-1952 Model 45R (Special Riviera). Molded with divider bars for 3 piece window. BS512H	\$316.19 ea.
1951-1952 Special model 46S BS512S	\$198.99 ea.
1953 Model 48D, 45R, 41D BS53S	\$167.59 ea.
1953 Model 52, 52X, 72R, 72RX. BS53B	\$187.89 ea.
1953 Model 56R and 76R. BS53H	\$313.59 ea.
1954 Model 52, 72R. BS54B	\$193.29 ea.
1954-1956; 1954: Model 41D, 48D, 61 1955: Model 41, 48, 61; 1956: Model 48, 41. BS546S	\$214.19 ea.
1954-1956 Model 46R, 66R. BS546H	\$222.39 ea.
1954-1956; 1954-1955: 56R, 76R; 1956: 56R, 53, 76R, 73. BS546B	\$182.59 ea.
1954-1956 Models 49 and 69. (Estate Wagon). BS546W	\$91.59 ea.
1955-1956 Special and Century four door hardtops. BS556	\$177.59 ea.
1955-1956 Model 52, 72. BS556B	\$182.59 ea.
1957 Special and Century 2 and 4 door Sedans. 3 piece set. BS57	\$226.00 ea.

1957 Special and Century 2 dr and -dr. HT (3 piece set). BS57H	\$251.50 st.
1957 Model 53, 73, 73A, 75. BS57B	\$198.89 ea.
1957 Models 56R, 75R, 76A, 76R. BS57BH	\$198.89 ea.
1957-1958 Wagon. BS578W	\$305.99 ea.
1958 Special and Century. BS58	\$198.89 ea.
1958 Model 53, 75, 750. BS58B	\$180.79 ea.
1958 Super, Roadmaster, Limited models 56R, 75R, 755. BS58H	\$198.89 ea.
1959 LeSabre Sedans WITHOUT inside garnish molding. BS59LS	\$215.29 ea.
1959 LeSabre 2 door Hard Top WITHOUT inside garnish molding. BS59LH	\$206.79 ea.
1959 1960 All 2 door hardtops with garnish molding, models 44, 46, 4737. BS590H	\$173.99 ea.
1959-1960 All LeSabre and Invicta 4-dr. HT.; All Electra 4 dr. H.T. with panorama back windows. Models 4439, 4639, 4739, 4839. BS590	\$272.29 ea.
1959-1960 All 2 + 4 door Sedan models WITH inside garnish molding. BS590S	\$185.19 ea.

Rear Window Clips



1954 Models. 41D, 48, 61. Maybe others.
MC88



1954-1956 Models. 52, 72;
1957-1958 all Special, Super and Roadmaster. Maybe others.
MC89

Rear Window Drain Tubes



1957-1958 All Sedan Models. Maybe others.
DT578

Rear Quarter Seals (Group 11)

Rear Quarter Window to Front Window Seals

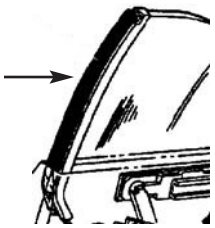

- 1942-1960** All two door hardtop and convertibles.
 QS490.....\$19.50 pr.
- 1955-1960** All four door hardtop and station wagons.
 QS550.....\$19.50 pr.

Adhesive Backed Bow Drill

Cloth tape used to cover roof rail weatherstrip rear 1/4 window seals, etc. as req. Waterproof and sunproof. Comes in 5 foot rolls.

- BD250B.....(Black 2 1/2" wide).....\$14.25 ea.
 BD250T.....(Tan 2 1/2" wide).....\$11.50 ea.
 BD500B.....(Black 5" wide).....\$27.50 ea.
 BD500T.....(Tan 5" wide).....\$23.00 ea.

Rear Quarter Window Fixed Seals

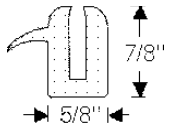

- 1935-1940** Channel, fixed quarter window (type without chrome reveal molding).
 Four ft. strip. Some models.
 RQS350.....\$25.56 ea.

- 1937-1938** Channel, fixed quarter window. One piece. No splicing required. All coupes except convertibles.
 RQS378\$121.39 pr.

- 1939-1940** Weatherstrip, fixed rear quarter window. One piece.
 1939: Model 46;
 1940: Models 46 and 66.
 RQS390\$123.29 pr.

- 1952-1960** Rear 1/4 window pivot Kit.
1952-1953 All Hardtops and Convertibles;
1954-1960 All Convertibles.
 QWK520\$29.50 ea.

Rear Quarter Window Upper Chrome Frames

- 1942-1948** Super and Roadmaster Convertibles.
 QWF428.....\$299.50 pr.
- 1951-1953** Super and Roadmaster Convertibles.
 QWF513.....\$299.50 pr.
- 1954-1956** Special, Century Hardtop models.
 QWF546H.....\$299.50 pr.
- 1954-1956** Special, Century and Skylark Convertibles.
 QWF546C.....\$299.50 pr.
- 1954-1956** 2-door hardtop. Super and Roadmaster.
 QWF546BH.....\$299.50 pr.
- 1954-1956** 2-door Convertible models. Super and Rdmstr.
 QWF546BC.....\$299.50 pr.

1939-1949 Weatherstrip, sliding quarter window. Mounted vertically in body where leading edge of sliding window fits when closed. Right and left rubber.

- 1939:** Models 41, 46S, 61, 66S. Series 80;
1940: Models 41, 46S, 61, 66S, 76S. Series 80;
1941: Models 41, 41SE, 46, 56, 56S, 76S. Ser. 80;
1942: Models 41, 41SE, Series 90;
1946-1949: Model 41.
 RQS399\$70.79 pr.



- 1939-1950** Weatherstrip, inner and outer for sliding quarter window, chrome beaded, mohair faced, flexible stock. May be formed to required outline 64" strip.
 WS330\$20.00 ea.

1954-1956 Filler channel with lip for stationary rear side windows and tailgate windows.

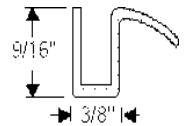

- WR546\$6.39 ft.



- 1954-1956** Models 41 and D. Weatherstrip, fixed quarter window.
 RQS546\$190.59 pr.

1957-1958 4-dr. hardtop wagons - models 49, 49D, 69. Rear side glass. Fully molded.



- RQS578W\$305.69 pr.

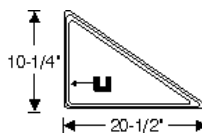

- 1959-1960** Electra 225 6-window hardtop model 4829 Weatherstrip, fixed quarter window.
 RQS590E\$189.89 pr.

1959-1960 All 4-door sedan models 4419, 4619, 4719. Weatherstrip, fixed quarter window.



- RQS590A.....\$147.39 pr.

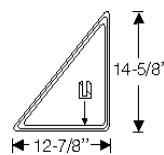

- 1959-1960** 2 door, 4 door and wagon models with fixed triangular quarter window.
 RQS590B\$139.99 pr.

Rear Quarter Window Parts

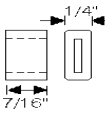
- 

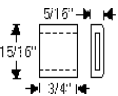
1942-1953 Bumper, rear 1/4 window lower.
Models 44C, 56C, 56R, 76C, 76R, 76X.
QB423L.....\$6.39 ea.
- 

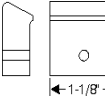
1942-1953 Bumper, rear 1/4 window upper.
Models 44C, 56C, 56R, 76C, 76R, 76X.
QB423U.....\$6.99 ea.
- 

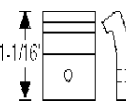
1952-1953 Bumper, 1/4 window at lock pillar.
All 2-dr. hardtop and convertibles.
QB523.....\$40.99 pr.
- 

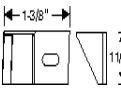
1954-1956 All Super and Roadmaster.
convertibles, Rear 1/4 window rubber bumper
w/ steel core.
QB546.....\$37.49 pr.
- 

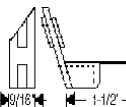
1954-1956 All Super and Roadmaster models
56r, 76r, 76rx. Rear 1/4 window/roof rail seals.
QS546.....\$50.39 pr.
- 

1957-1958 Division post upper bumper.
1957 All sedans and riviera wagon;
1958 Super, Road. Riviera HT & Lim. Riv. Sed.
WB578.....\$62.50 pr.

Lock Pillar Seals

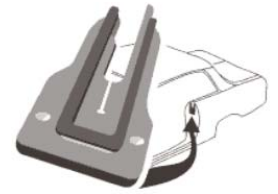

- 1954-1956** Special and Century two door hardtops.
LPS546\$85.79 pr.
- 1954-1956** Super and Roadmaster two door hardtops.
LPS546B\$77.59 pr.
- 1954-1956** All convertibles.
LPS546C.....\$29.50 pr.
- 

1954-1956 Models 46C, 66C
1954 Model 100 Lock pillar
weatherstrip under window.
LPW546C\$84.50 pr.
- 1957-1958** Super, Roadmaster, Limited 2-Door hardtop.
LPS578\$75.39 pr.
- 1957-1958** Special and Century 2-Door hardtops.
LPS578A.....\$63.29 pr.
- 1957-1958** Super, Roadmaster, and Limited convertibles.
LPS578C.....\$72.89 pr.
- 1958** All 4-dr. hardtops and hardtop wagons for front doors.
LPS58F\$56.19 pr.
- 1958** All 4-dr. hardtops and hardtop wagons for rear doors.
LPS58R.....\$65.99 pr.
- 1957-1960** Convertibles.
 1957: Special and Century;
 1959-1960: All.
LPS570\$59.29 pr.
- 

1957 Convertibles.
Lock pillar weatherstrip under window.
LPW57\$69.75 pr.
- 1959-1960** Electra 4 door hardtop model 4829.
LPS590A.....\$72.89 pr.
- 1959-1960** All 2 door hardtops.
LPS590\$55.79 pr.
- 1959-1960** All 4 door hardtop. On rear door.
hinge pillar.
LPS590S.....\$75.19 pr.
- 1959-1960** All 4 door hardtop. (For front doors).
LPS590F\$60.39 pr.
- 1959-1961** LaSabre, Electra and Invicta convertibles.
LPS591C.....\$45.50 pr.

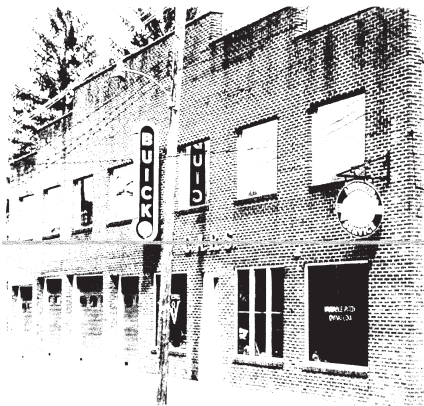

Visit us at our
Worldwide Headquarters

We're located in a small village amongst the
vast farmland in western New Jersey

Dome Lamps • Seat Parts (Group 11)

Dome Lenses - Courtesy Lenses

(11.927, 11.928)

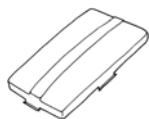

1939-1940 All closed cars, dome lamp lens.
DL390.....\$12.00 ea.

Sedan Dome Lens Rim



1939 Special & Century; 1940-1942 SER.90
DR392.....\$26.50 ea.



1940-1949 All convertibles, on top bow.
DL409.....\$12.50 ea.



1940-1949 Convertible top bow lens rim.
DR409.....\$20.00 ea.

1941-1949 Except convertibles. Dome lens.
DL419.....\$14.00 ea.



1950-1956 All except convertibles.
DL506.....\$10.50 ea.



1950-1956 Except convertibles. Chrome dome lens rim. Has square hole for switch.
DR506.....\$19.50 ea.



1950-1956 All convertibles. 1954-1956 Series 50-70 convertibles located on top bow.
DL506C.....\$10.00 ea.

Housing for above lens. Complete.
DLH506C.....\$33.00 ea.



1950-1960 All with side roof courtesy lens.
CL502.....\$9.75 ea.



1954-1960 All convertibles. Rear courtesy lamp housings.
CLH542.....\$27.75 ea.



1954-1960 All convertibles and 2 door hardtop (at rear armrest).
CL544.....\$6.00 ea.



1957-1960 All round style (3 7/8").
DL578.....\$12.00 ea.

Seat Parts

1936-1940 Pads, folding front seat rest, steel core. Also used as bumper, slat iron to compartment on convertibles.



SP360.....\$75.00 pr.

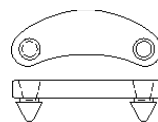

1941-1949 Rest pads, seat back, outer, on two door styles with folding seats. Specify color when ordering.

1941-1948: All as required;
1949: Style 4407 only.

SP419.....(Black).....\$52.89 pr.

SP419N.....(Brown).....\$56.89 pr.



1953-1958 Seat rest bumper. Used on all 2-door models. 4 needed per car.

SB538.....\$7.75 ea.

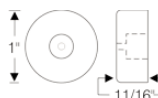

1959-1960 Seat rest bumper. Used on all 2-door models. 2 needed per car.

SB590.....\$15.99 ea.

Hog Rings

For attaching seat covers to frame.

HR360.....Bag of 100.....\$8.75 ea.



Hog Ring Pliers

For attaching hog rings to seat covers.

HRP360.....\$29.50 ea.



Door Jamb Switches

1930-1958:

1930 thru 1956 All front and rear.

1957-1958 All rear.

DJS308.....\$19.00 ea.



1959-1960 All

DJS590.....\$24.25 ea.



Power Seat Switches

1957-1958 All 6-way power seats.

Includes chrome Escutcheon.

SS578A.....\$219.00 ea.



1957-1958 All 6-way power seats.

Does not include chrome Escutcheon.

SS578.....\$199.00 ea.



1957-1958 All 6-way power seats. Chrome Escutcheon.

SSE578.....\$120.00 ea.



*Door Sills are Custom made one set at a time, delivery may take up to 7 mo. or longer.
We do stock some for immediate delivery - (*) or add "P" to the item to check availability.*

IF YOU DO NOT SEE YOUR MODEL LISTED, PLEASE ASK. WE CAN CUSTOM MAKE ANY SILL.

YEAR	MODELS	CARS #	PRICE
1909	4-Door Touring Model 17 (aluminum)	DS0917A\$239.53 set
1918-1920	4-Door Touring, 7-Passenger E-49, H-49, K-49.....	DS180\$321.20 set
1922	2-Door Sport Roadster Model 54 3 passenger.....	DS22\$239.53 set
1923	2-Door Models 39, 44.....	DS23\$239.53 set
1923	4-Door Touring Models 35, 45, 49.....	DS23A\$272.25 set
1925	2-Door Master Series Coupe Model 40.....	DS25\$239.53 set
1925	4-Door Standard and Master Models 255, 45, 47, 47A.....	DS25A\$272.25 set
1926	2-Door Master Series Models 44, 48.....	DS26\$239.53 set
1926	4-Door Master Series Touring 5-Passenger Model 45.....	DS26B\$272.25 set
1927	2-Door Master Series Sport Roadster Model 54 4-Passenger.....	DS27\$239.53 set
1927	4-Door Standard and Master Series Models 25, 50	DS27A\$272.25 set
1928	2-Door Standard and Master Series Models 24, 26S, 54.....	DS28\$266.75 set
1928	4-Door Standard Series Sedan 5-Passenger Model 20	DS28A\$266.75 set
1928	4-Door Standard Series Models 25, 27, 47	DS28B\$293.98 set
1929	2-Door Models 20, 26S, 44, 46, 48, 54CC, 58	DS29\$250.53 set
1929	4-Door Touring Series 116 Australian Body.....	DS29A\$293.98 set
1929	4-Door Sedan Models 27, 47, 51, 57 Series 121	DS29B\$293.98 set
1929	4-Door Sedan McLaughlin 7-Passenger Model 50 Series 129	DS29M\$293.98 set
1929	4-Door Closed Coupe Sedan 5-Passenger Model 41 Series 121 ..	DS29N\$293.98 set
1930	2-Door Models 40, 44, 46, 46S	DS30\$250.53 set
1930	4-Door Sedan Models 47, 57, 67	DS30A\$293.98 set
1931	2-Door Models 56C, 56S, 64, 66, 66S, 86, 94, 96S, 96C	DS31\$250.53 set
1931	4-Door Models 55, 57, 67, 95.....	DS31A\$293.98 set
1932	2-Door Convertible Models 68C, 86, 96C	DS32\$250.53 set
1932	4-Door Sedan Models 57, 67, 87, 90, 90L	DS32A\$293.98 set
1932	4-Door Sport Phaeton 7-Passenger Model 95, Series 90	DS32B\$348.43 set
1933	2-Door Models 56S, 58, 68, 96	DS33\$250.53 set
1933	4-Door Sedan Models 57, 67, 87, 88C.....	DS33A\$293.98 set
1934	2-Door Convertible Coupe Model 96C, Series 90	DS34\$250.53 set
1934	4-Door Sedan Models 47, 67, 91, 98C, 90L.....	DS34A\$293.98 set
1935	2-Door Convertible Coupe Model 66C, Series 60	DS35\$250.53 set

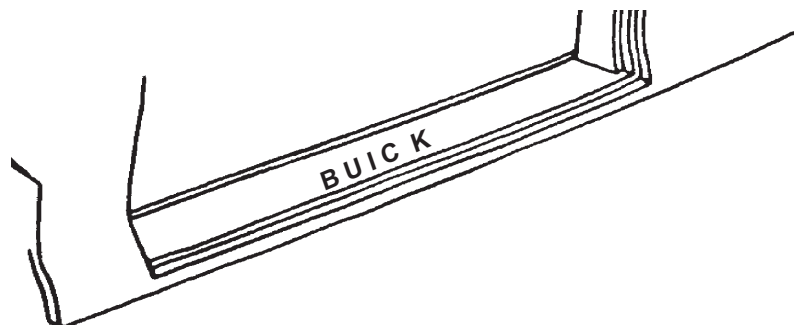

Door Sills (Group 11.175)

*Door Sills are Custom made one set at a time, delivery may take up to 7 mo. or longer.
We do stock some for immediate delivery - (*) or add "P" to the item to check availability.*

IF YOU DO NOT SEE YOUR MODEL LISTED, PLEASE ASK. WE CAN CUSTOM MAKE ANY SILL.

YEAR	MODELS	CARS #	PRICE	SCREW SET	PRICE
1936	2-Door Century Models 66S, 68	DS36	\$239.53 set	DSS555.....	\$5.78 set
1936	4-Door Special and Century Sedan Models 41, 61	DS36A	\$293.98 set		
1936	4-Door Roadmaster Sedan Models 80C, 81	DS36B	\$293.98 set		
1937	4-Door McLaughlin Special	DS36M	\$293.98 set		
1937	4-Door Roadmaster Phaeton Model 80C	DS37SC	\$294.25 set		
1937-1938	2-Door Sedans Model 44, 48, 64, 68	DS378S	\$239.53 set		
1937-1938	2-Door Coupes and Conv't. Model 46, 46C, 46S, 66C, 66S	DS378C	\$239.53 set		
1937-1938	4-Door Roadmaster Series 80 and 90.....	DS378B	\$328.90 set		
1937-1938	4-Door Sedan and Conv't. Model 40C, 41, 47, 60C, 61, 67	DS378	\$304.98 set		
1939	4-Door Touring Sedan (5 pass.) Model 41	DS39TS	\$365.00 set		
1939	4-Door Sport Phaeton Model 80C	DS39SP	\$328.90 set		
1939	4-Door Convertible Sedan Model 81C	DS39CV	\$328.90 set		
1939-1940	4-Door Special Century Phaeton Model 41C, 61C.....	DS390	\$348.43 set		
1939-1940	2-Door Convertible & Coupe Models 46,46C,46S,66,66C,66S.....	DS390CP	\$345.50 set		
1939-1940	2-Door Special Model 48.....	DS40P	\$294.25 set		
1940	4-Door Sedan Special Series 40 Model 41	DS40SS	\$317.35 set		
1940	2-Door Business Coupe Model 46	DS40SC	\$317.35 set		
1940	2-Door Convertible and Coupe Models 56C, 56S, 76C, 76S	DS40C	\$279.75 set		
1940	4-Door Super Convertible Sedan Model 51C.....	DS40E	\$321.20 set		
1940	4-Door Roadmaster Convertible Sedan Model 71C.....	DS40F	\$321.20 set		
1940	4-Door Super Woody Wagon Model 59	DS40D	\$321.20 set		
1940	4-Door Series 80	DS40B	\$328.90 set		
1940	4-Door Super Sedan Model 51 (6 pieces).....	DS40M	\$352.00 set		
1940	4-Door Century Series 60 Model 61	DS40BC	\$315.70 set		
1940	4-Door Roadmaster Sedan Model 71.....	DS40BS	\$346.23 set		
1940	4-Door Flxble Ambulance.....	DS40A	\$444.40 set		
1941-1949	4-Door Special and Century Sedans Models 41, 47, 61.....	DS419	\$328.90 set		
1941	2-Door Special Sport Coupe Model 44S	DS41SC	\$259.60 set		
1941	2-Door Convertible and Coupe 56C, 56S, 76C, 76S.....	DS41CC	\$317.35 set		
1941 & 1946	2-Door Convertible Special 44C (left and right diff.)	DS41CS	\$317.35 set		
1941	4-Door Convertible Series 51, 51C, 71, 71C (6 pieces).....	DS41BC	\$340.45 set		
1941-1942	4-Door Estate Wagon Model 49	DS41W	\$352.00 set		
1941-1948	2-Door Sedanette 46SSE, 66S, 46S	DS41W	\$300.03 set		
1942	2-Door Super Convertible Coupe 56C - no etch	DS42CC	\$352.00 set		
1942	2-Door Super and Roadmaster Conv't. Models 56C, 76C	DS42BC	\$375.10 set		

*Door Sills are Custom made one set at a time, delivery may take up to 7 mo. or longer.
We do stock some for immediate delivery - (*) or add "P" to the item to check availability.*

IF YOU DO NOT SEE YOUR MODEL LISTED, PLEASE ASK. WE CAN CUSTOM MAKE ANY SILL.

YEAR	MODELS	CARS #	PRICE	SCREW SET	PRICE
1946-1948	4-Door Estate Wagon (no etch).....	DS48W\$352.00	set	
1946-1948	2-Door Convertible 56C, 76C (left and right diff.)	DS468C\$ 352.00	set	
1947-1948	2-Door Super and Roadmaster Sedanette Models 56S, 76S.....	DS47S\$328.90	set	
1946-1948	4-Door Super and Road. Sedans & Wag. Mod 51, 59, 71, 79.....	DS468B\$340.45	set	
1949	4-Door Super and Road. Sedans & Wag. Mod 51, 59, 71, 79.....	DS49B\$325.60	set	
1949	2-Door Super and Roadmaster Sedanette Models 56S, 76S9.....	DS49S\$317.35	set	
1949	2-Door Super and Road. Conv. Models 56C,76C, 76R.....	DS49BC\$340.45	set	
1950	2-Door Special Models 46D, 46S. No Etch	DS50\$306.08	set	
1950	4-Door Special Models 41, 41D ,43, 43D.....	DS50A\$321.20	set	
1950	2-Door Super and Road. Mod 56S,56R,56C,75R,76S,76C,76R...DS50C	DS50C\$299.48	set	
1950	4-Door Super and Roadmaster Sedans Models 52, 72.....	DS50B\$317.35	set	
1950	4-Door Super and Road. Sedans & Wag. Mod 51, 59, 71, 79.....	DS50D\$325.60	set	
1950	2-Door Super and Road. 56R, 56C, 56S, 76R, 76C..5" at widest	DS51C\$299.48	set	
1951	2-Door Sup & Road. 56R, 56C, 56S, 76R, 76C 3 3/4" at widest....	DS51D\$363.83	set	
1951	4-Door Special Sedan Models 41, 41D	DS51S\$365.00	set	
1951	4-Door Super & Road. Sedan & Wag Mod 51, 59, 71, 79.....	DS51W\$340.45	set	
1951	4-Door Super Mod 52 no etch, Front sill 4 1/8" at widest part.....	DS51BX\$328.90	setDSS555.....\$5.78 set
1951	4-Door Super Model 52 no etch, Front sill 3 3/8" at widest	DS51BS\$328.90	set	
1952-1953	4-Door Special Sedan Models 41, 41D	DS523\$321.20	set	
1952-1953	4-Door Super and Road. Sedans & Wag Mod 52, 59, 72R, 79	DS52W\$363.83	set	
1952-1953	2-Door Super and Roadmaster Models 56C, 56R, 76C, 76R.....	DS523BC\$328.90	set	
1952-1953	2-Door Special Models 45R, 46C, 46S, 48D (4 piece set).....	DS513S\$325.00	set	
1953	Skylark.....	DS53X\$274.50	set	
1954	4-Door Special and Century Sedan Models 41D, 61, 69.....	DS54A\$332.20	set	
1954	4-Door Super and Roadmaster Sedan Models 52, 72R.....	DS54B\$332.20	set	
1954	2-Door Skylark.....	DS54X\$288.48	set	
1954	2-Door Special and Century Mod 46R, 46C, 48D, 66R, 66C	DS54C\$323.13	set	
1954	2-Door Super and Road Cpe & Conv. mod 56R, 56C76R, 76C...DS54BC.....	DS54BC\$345.00	set	
1955-1956*	2-Door Special and Century Mod 46R, 46C, 48, 66R, 66C	DS556\$145.00	set	
1955-1956*	4-Door Special and Century Hardtop Models 43, 63.....	DS556RS\$159.00	set	
1955-1956*	4-Door Special, Century Sedan & Wagon Models 41, 49, 61, 69	DS556S\$179.00	set	
1955-1956	2-Door Super and Roadmaster Models 56R, 56C, 76R, 76C.....	DS556R\$229.48	set	
1955-1956	4-Door Super and Roadmaster Models 52, 72R	DS556RB\$353.93	set	
1957-1958*	2-Door Special and Century Models 46R, 46C, 48, 66R, 66C	DS578\$129.00	set	
1957-1958	4-Door Special and Century Models 41, 43, 49, 49D, 63, 69	DS578D\$399.00	set	
1957-1958	2-Door All Super, Roadmaster and Limited Models	DS578B\$288.48	set	
1957-1958	4-Door Super, Roadmaster and Limited Hardtops	DS578A\$288.48	set	
1959-1960*	All 2-Door Models.....	DS590\$129.25	set	
1959-1960	4-Door LeSabre, Invicta and Wagon Models.....	DS590A\$299.48	set	
1959-1960	4-Door Electra 225 Models.....	DS590B\$299.48	set	

Floorpans • Rocker Panels • Trunk Pans (Group 12)



All floor pans, trunk pans and inner rocker panels are made of 18 gauge coated steel. Outer rocker panels are made of 20 gauge coated steel. Panels are custom made and usually take a week or so to fabricate.

1937-1940 All Special

Floor Pans (Front and Rear) (12.980)

FP370FFL.....(FRONT LEFT)	\$94.50 ea.
FP370FFR.....(FRONT RIGHT)	\$94.50 ea.
FP370RFL.....(REAR LEFT)	\$94.50 ea.
FP370RFR.....(REAR RIGHT)	\$94.50 ea.

1939-1940 All Super and Roadmaster

Floor Pans (Front and Rear) (12.980)

FP390FFL.....(FRONT LEFT)	\$94.50 ea.
FP390FFR.....(FRONT RIGHT)	\$94.50 ea.
FP390RFL.....(REAR LEFT)	\$94.50 ea.
FP390RFR.....(REAR RIGHT)	\$94.50 ea.

1940-1941 All Super and Roadmaster

Rocker Panels for 4-dr. Models. (12.934)

RP401L4..... (L.H.OUTER PANEL)	\$79.50 ea.
RP401R4..... (R.H.OUTER PANEL)	\$79.50 ea.
RP401IL..... (L.H. INNER PANEL).....	\$79.50 ea.
RP401IR.....(R.H. INNER PANEL)	\$79.50 ea.

1941-1949 All Special

Rocker Panels (12.934)

RP409L..... (L.H.OUTER PANEL)	\$79.50 ea.
RP409R..... (R.H.OUTER PANEL)	\$79.50 ea.

1941-1949 All Models

Floor Pans (Front and Rear) (12.980)

FP419FFL.....(FRONT LEFT)	\$94.50 ea.
FP419FFR.....(FRONT RIGHT)	\$94.50 ea.
FP419RFL.....(REAR LEFT)	\$94.50 ea.
FP419RFR.....(REAR RIGHT)	\$94.50 ea.

1942-1948 All Super and Roadmaster

Rocker Panels (12.934)

RP428L..... (L.H.OUTER PANEL)	\$79.50 ea.
RP428R..... (R.H.OUTER PANEL)	\$79.50 ea.

1949 All Super and Roadmaster

Rocker Panels for 4-dr. Models. (12.934)

RP49L4..... (L.H.OUTER PANEL)	\$79.50 ea.
RP49R4..... (R.H.OUTER PANEL)	\$79.50 ea.

1950 All;

1951-1953 Super, Roadmaster, Skylark.

Front Toeboards (12.980)

TB503L.....(LEFT)	\$94.50 ea.
TB503R.....(RIGHT)	\$94.50 ea.

Floor Pans (Front and Rear) (12.980)

FP503FFL.....(FRONT LEFT)	\$94.50 ea.
FP503FFR.....(FRONT RIGHT)	\$94.50 ea.
FP503RFL.....(REAR LEFT)	\$94.50 ea.
FP503RFR.....(REAR RIGHT)	\$94.50 ea.

Under Seats (Front and Rear) (12.980)

FP503FSL.....(13" FRONT LEFT).....	\$99.50 ea.
FP503FSR.....(13" FRONT RIGHT)	\$99.50 ea.
FP503RSL.....(REAR LEFT).....	\$149.00 ea.
FP503RSR.....(REAR RIGHT).....	\$149.00 ea.

Rocker Panels for 2-dr. Models. (12.934)

RP503L..... (L.H.OUTER PANEL)	\$94.50 ea.
RP503R..... (R.H.OUTER PANEL)	\$94.50 ea.
RP503IL..... (L.H. INNER PANEL).....	\$94.50 ea.
RP503IR..... (R.H. INNER PANEL)	\$94.50 ea.

Rocker Panels for 4-dr. Models. (12.934)

RP503L4..... (L.H.OUTER PANEL)	\$74.50 ea.
RP503R4..... (R.H.OUTER PANEL)	\$74.50 ea.

Sill Panels. For 2-dr. Models. (12.934)

SP503L.....(LEFT ANGLE)	\$49.50 ea.
SP503R.....(RIGHT ANGLE)	\$49.50 ea.

(Group 12) Floorpans • Rocker Panels • Trunk Pans

1951-1953 Special.

Front Toeboards (12.980)

TB513L.....(LEFT)\$117.00 ea.
TB513R.....(RIGHT)\$117.00 ea.

Floor Pans (Front & Rear) (12.980)

FP513FFL.....(FRONT LEFT)\$94.50 ea.
FP513FFR.....(FRONT RIGHT)\$94.50 ea.
FP513RFL.....(REAR LEFT)\$94.50 ea.
FP513RFR.....(REAR RIGHT)\$94.50 ea.

Rocker Panels for 2-dr. Models. (12.934)

RP513L(L.H. OUTER PANEL)\$49.50 ea.
RP513R(R.H. OUTER PANEL)\$49.50 ea.
RP513I.....(INNER PANEL)\$105.00 ea.

Rocker Panels for 4-dr. Models. (12.934)

RP513L4(L.H. OUTER PANEL)\$94.50 ea.
RP513R4(R.H. OUTER PANEL)\$94.50 ea.
RP513I.....(INNER PANEL)\$105.00 ea.

1954 - 1956 Special, Century, Skylark

Front Toeboard (12.980)

TB546L.....(LEFT)\$94.50 ea.
TB546R.....(RIGHT)\$94.50 ea.

Floor Pans (Front & Rear) (12.980)

FP546FL.....(FRONT LEFT)\$94.50 ea.
FP546FR.....(FRONT RIGHT)\$94.50 ea.
FP546RL.....(REAR LEFT)\$94.50 ea.
FP546RR.....(REAR RIGHT)\$94.50 ea.

Side Extension pc (connects front & rear floor pans. 5" x 22")

SE546L.....(LEFT)\$94.50 ea.
SE546R.....(RIGHT)\$94.50 ea.

Wiring Covers (12.934)

WC546L.....(LEFT)\$94.50 ea.
WC546R.....(RIGHT)\$94.50 ea.

Rocker Panels for 2-dr. Models. (12.934)

RP546L.....(OUTER LEFT)\$94.50 ea.
RP546R.....(OUTER RIGHT)\$94.50 ea.
RP546I.....(INNER PANEL)\$94.50 ea.

Rocker Panels for 4-dr. Models. (12.934)

RP546L4.....(OUTER LEFT)\$94.50 ea.
RP546R4.....(OUTER RIGHT)\$94.50 ea.
RP546IR4.....(INNER RIGHT)\$105.00 ea.
RP546IL4.....(INNER LEFT)\$105.00 ea.

Trunk Floor Pan. (12.980)

TP546\$335.00 ea.

1954 - 1956 Super and Roadmaster (12.980)

Front Toeboard

TB546BL.....(LEFT)\$94.50 ea.
TB546BR.....(RIGHT)\$94.50 ea.

Floor Pans (Front & Rear) (12.980)

FP546BFL.....(FRONT LEFT)\$94.50 ea.
FP546BFR.....(FRONT RIGHT)\$94.50 ea.
FP546BRL.....(REAR LEFT)\$94.50 ea.
FP546BRR.....(REAR RIGHT)\$94.50 ea.

Under Front Seat (12.980)

FP546BL.....(LEFT)\$99.50 ea.
FP546BR.....(RIGHT)\$99.50 ea.

Rocker Panels for 2-dr. models. (12.934)

RP546BL.....(OUTER LEFT)\$94.50 ea.
RP546BR.....(OUTER RIGHT)\$94.50 ea.
RP546I.....(INNER PANEL)\$94.50 ea.

Rocker Panels for 4-dr. models. (12.934)

RP546BL4.....(OUTER LEFT)\$94.50 ea.
RP546BR4.....(OUTER RIGHT)\$94.50 ea.
RP546I.....(INNER PANEL)\$94.50 ea.

Top of Rocker Panel for 2-dr. models. (12.934)

RP546BTL.....(LEFT)\$79.50 ea.
RP546BTR.....(RIGHT)\$79.50 ea.

Wiring Covers (for on top of rockers 2-dr. models).

WC546BL.....(LEFT)\$94.50 ea.
WC546BR.....(RIGHT)\$94.50 ea.

Conv. Rear Seat Channels

RSC546BL.....(LEFT)\$99.50 ea.
RSC546BR.....(RIGHT)\$99.50 ea.



www.oldbuickparts.com

908-369-3666

Floorpans • Rocker Panels • Trunk Pans (Group 12)

1957-1958 All models (12.980)

Front Toeboard

TB578L.....(LEFT).....\$110.00 ea.
TB578R.....(RIGHT).....\$110.00 ea.

Floor Pans (Front & Rear) (12.980)

FP578FL.....(FRONT LEFT).....\$94.50 ea.
FP578FR.....(FRONT RIGHT).....\$94.50 ea.
FP578RL.....(REAR LEFT).....\$94.50 ea.
FP578RR.....(REAR RIGHT).....\$94.50 ea.

Side of Front Seat (12.980)

FP578SL.....(LEFT).....\$99.50 ea.
FP578SR.....(RIGHT).....\$99.50 ea.

1957-1958 Special & Century

Rocker Panels for 2-dr. Models. (12.934)

RP578L.....(OUTER LEFT).....\$94.50 ea.
RP578R.....(OUTER RIGHT).....\$94.50 ea.
RP578IL.....(INNER LEFT).....\$94.50 ea.
RP578IR.....(INNER RIGHT).....\$94.50 ea.

Rocker Panels for 4-dr. Models. (12.934)

RP578L4.....(OUTER LEFT).....\$94.50 ea.
RP578R4.....(OUTER RIGHT).....\$94.50 ea.
RP578IL4.....(INNER LEFT).....\$94.50 ea.
RP578IR4.....(INNER RIGHT).....\$94.50 ea.

1957-1958 Super, Roadmaster & Limited

Rocker Panels for 2-dr. Models. (12.934)

RP578BL.....(OUTER LEFT).....\$94.50 ea.
RP578BR.....(OUTER RIGHT).....\$94.50 ea.
RP578BIL.....(INNER LEFT).....\$94.50 ea.
RP578BIR.....(INNER RIGHT).....\$94.50 ea.

Rocker Panels for 4-dr. Models. (12.934)

RP578BL4.....(OUTER LEFT).....\$94.50 ea.
RP578BR4.....(OUTER RIGHT).....\$94.50 ea.
RP578BIL4.....(INNER LEFT).....\$94.50 ea.
RP578BIR4.....(INNER RIGHT).....\$94.50 ea.

Rocker Panel Extensions for 4-dr. Models. (12.934)

RPE578BL4.....(LEFT).....\$159.00 ea.
RPE578BR4.....(RIGHT).....\$159.00 ea.

1959-1960

Front Toeboard

TB590L.....(LEFT).....\$97.50 ea.
TB590R.....(RIGHT).....\$97.50 ea.

Floor Pans (Front & Rear) (12.980)

FP590FL.....(FRONT LEFT).....\$94.50 ea.
FP590FR.....(FRONT RIGHT).....\$94.50 ea.
FP590RL.....(REAR LEFT).....\$94.50 ea.
FP590RR.....(REAR RIGHT).....\$94.50 ea.

Outer Rocker Panels for 2-dr. Models. (12.934)

RP590L.....(OUTER LEFT).....\$94.50 ea.
RP590R.....(OUTER RIGHT).....\$94.50 ea.

Outer Rocker Panels for 4-dr. Models. (12.934)

RP590L4.....(OUTER LEFT).....\$94.50 ea.
RP590R4.....(OUTER RIGHT).....\$94.50 ea.

Inner Rocker Panels for All Models.

RP590I.....(INNER PANEL).....\$65.00 ea.

Trunk Floor Pan. (12.980)

TP590.....\$390.00 ea.

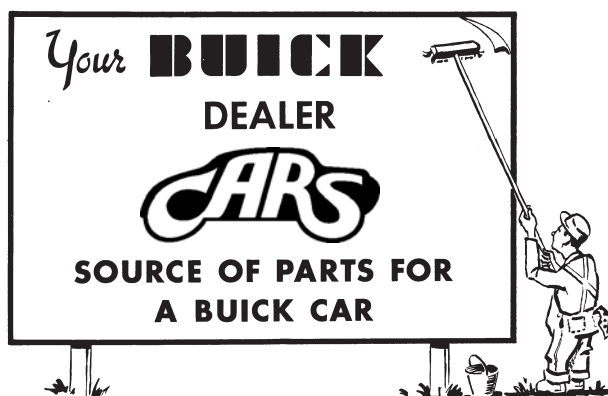

(Group 12) Rear Fender

-  **1936-1955 Fender welt.**
 FW25.....(25 ft. roll).....\$23.25 ea.
 FW50.....(50 ft. roll).....\$44.00 ea.
-  **1938-1940 Gas door bumper.**
 GDB385\$1.00 ea.
-  **1941-1961 All. Gas door bumper.**
 GDB410\$1.25 ea.
-  **1951-1956 Gas door bumper.**
1951-1953 Specials;
1954-1956 All (Two per car).
 GB516\$5.00 pr.
-  **1933-1935 Gas filler grommet.**
1933 All series 50 and 60 exc. Vic. Coupe
1934-1935 All Series 40-50-90;
1934-1935 models 66c, 66s, 67, 68
 GF335\$54.50 ea.
-  **1933-1935 Gas filler grommet.**
1933 Models 58, 68, 86, 90, 90L, 91;
1934-1935 Models 61, 68C
 GF335B\$48.75 ea.
-  **1936-1937 Gas filler grommet.**
 1936 All;
 1937 Series 80-90.
 GF367\$20.00 ea.
-  **1937 Gas filler grommet. Special and Century.**
 GF37\$29.50 ea.
-  **1935-1960 Rear fender inner seal.**
 (between deflector and fender). (36" length).
 AS502.....\$11.75 ea.
-  **1936-1941 Fender skirt seals. Some pre-war cars with removable fender skirts.**
 FS361\$77.99 pr.
-  **1941-1948 Fender skirt seals. Similar to FS361, but thicker. Known to fit Super and Roadmaster. Approx. 2- 5 foot strips.**
 FS418\$67.59 pr.
-  **1941-1950 Fender skirt seals. Exact copy. Trim notch for skirt lock at installation. Most models. Compare to picture. 2- 5 foot strips.**
 FS410\$73.59 pr.
-  **1947-1950 Fender skirt seal. Compare to picture. 1-10 foot strip.**
 FS470.....\$72.89 ea.
-  **1952 Mounting pads, rear fender crown molding Two per car. Models 41D, 45R, 46C and 48D.**
 OP52S\$105.89 pr.
-  **1942-1948 All.**
1955 Rear fender reflex.
 TR425.....\$12.50 pr.
-  **1940 Super and Roadmaster. Rubber stone shield, rear fender, right and left hand. Fully molded to original contour with attaching tabs but without steel backing plate. Will fit fender contour perfectly.**
 GG40\$536.19 pr.
-  **1940-1941 Super and Roadmaster. Rubber gravel guard between body and rear fender, right and left steel core.**
 GG401\$188.49 pr.
-  **1941 Super and Roadmaster. Gravel shield, rear fender. Molded with metal backing and holding tabs as original.**
 GS41.....\$546.99 pr.
-  **1941-1949 Gravel guard, rear fender. Fully molded with metal backing and attaching tabs as original.**
1941: All 40, 60, & 90 Series except 40 Series 118" wheelbase models 44, 44C, 44S, 47;
1942: All 121" Series 40 and All 60 Series without factory fenderskirts;
1946-1949: All Series 40 without factory fenderskirts.
 GS419.....\$546.99 pr.
-  **1957 All. Rear fender extension bumper.**
 FEB57\$7.29 ea.
-  **1959-1960 All except wagons. Fuel filler door bumper.**
 FDB590.....\$21.50 ea.

Trunk (Group 12)

Trunk Weatherstrips (12.269)

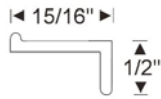

1936 Special and Century. Rumbleseat lid, lower, approximately 37" long.
RW36\$77.99 ea.

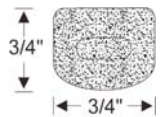

1936-1937 In gutter. 3/4" x 3/4" x 14'.
Found in some sedan models. Sponge.
TW367\$110.79 ea.

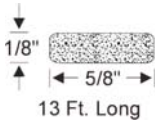

1936-1937 In gutter. 5/8" x 1/8" x 13'.
Found in gutter of some sedan models.
Sponge.
TW367A\$32.89 ea.

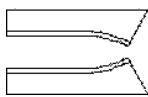

1937-1938 Convertible coupes.
Rumbleseat lid, lower corner, RH and LH.
RW378\$77.99 ea.



1936-1940 Coupes and convertibles.
Use as required.
TW360A.....3/4" x 1/2" x 16'.....\$49.00
TW360B.....1" x 1/2" x 16'.....\$51.00
TW360C.....1" x 5/8" x 16'.....\$106.99



1937-1941 All Sedans, and convertible Sedans.
TW371.....15' length\$69.50 ea.

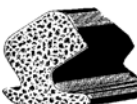

1940-1948 Special Models.
Used on body, 16' length.
TW408\$29.50 ea.



1940-1950
Used on body for 7/8" to 1" gutter.
Compare with TW413, 15' length.
TW493\$136.50 ea.



1941-1953 Used on Body for 5/8" to 3/4" gutter. Compare with TW493. Measure gutter width for correct weatherstrip. 15' length.
TW413\$126.50 ea.



1942-1948 Super and Roadmaster.
Available in 16 foot lengths.
TW428\$85.00 ea.

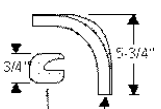

1949-1953 Molded wide corners to use with TW413 center section for across front of trunk opening. Molded corners made with each leg approximately 5-3/4" long. Some models as required.
TA493.....\$76.29 pr.



1949-1953 Roadmasters, Series 70, 16' length.
TW493R.....\$39.50

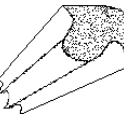

1949-1956
1949-1953 Special and Super.
1954-1956 Special, Century, Skylark
Located on trunk lid.
TW496.....\$3.25/ft.

Trunk Weatherstrips Kits Full Replacement Kits



1950 Models 41, 41D, 51, 52, 56C, 56R, 71, 72, 75C, 75R, 76R.
TWS50.....\$149.99 ea.

1950 Models 43, 46, 46S, 46D, 56S, 76S.
1951 56S.
TWS501.....\$161.69 ea.

1951 All Exc. 56S & Wagons.
1952-1953 All Exc. Wagons.
TWS513.....\$126.19 ea.

Weatherstrip Adhesive



All Years. The Best weatherstrip adhesive we have found. 3M brand. 5 oz tube.
WA360.....\$13.50 ea.

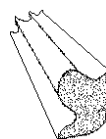

1954-1956 Super and Roadmaster. Located in gutter of body. Compare with TW542.
TW546.....\$2.75/ft.

7/16"



1954-1960
1954-1956: Series 50-70; Compare/TW546
1957-1960: All. In gutter. Compare/TW582.
TW542.....\$2.50/ft.



1958-1960 Located in gutter of body. Note "laid-over" configuration of sealing lip. Compare with TW542.
TW58218.....(18' length).....\$60.50 ea.
TW58220.....(20' length).....\$65.75 ea.

Trunk Lid Bumpers

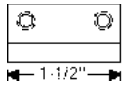

1937-1940 Bumper, decklid. Steel core, screw held. Two per car.
1937-1938: Series 40 and 60 coupes;
1939-1940: Series 40 and 60 coupe and convertibles.

TB370\$63.19 ea.

1940 Pads, decklid lower stop, right and left. Series 40 and 50.

TB40\$69.19 ea.



1941-1949 bumper, decklid opening on lid. Metal core, as original, screw held. Two per car.

1941-1948: All;
1949: Series 40.

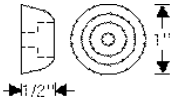

TB419\$17.98 ea.

1942-1950 Bumper, rubber, for decklid. Molded with clearance for screw.

1942: All (except Series 90, station wagon, 44C Special convertible coupe).
1946-1950: All.

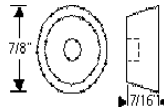

TB420\$3.19 ea.

1941-1960 All. Deck lid Bumper. Deck lid rests on pedestal type.



TB415\$1.75 ea.

1949-1960 All. Deck lid Bumper. Plug in type on lid.

TB495\$2.75 ea.

1948-1953 Bumper, rubber, for tailgate on station wagon.

HFB483\$4.00 ea.

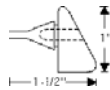

1950-1953 Bumper, tail gate. Metal core molded in as original. Series 59 and 79 wagons.

HFB502\$8.25 ea.

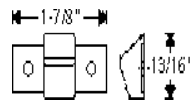

1951-1955 T-nut, rubber, decklid bumper ingutter at sides. Steel core, two required per car.

TB515\$24.99 ea.



1957-1958 Tailgate support bumper. 4 needed per car. Applies to all wagons.

TB578\$13.69 ea.



1957-1958 Tailgate anti-rattle bumper. Mounts on jamb area. Applies to all wagons.

TB578W\$12.79 ea.



1959 Tailgate bumper. Applies to all wagons.

TB59\$15.75 ea.

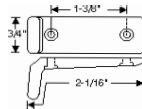

1959-1960 Tailgate weatherstrip. Applies to all wagons.

TW590\$36.89 pr.

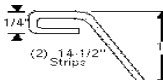

1959-1960 Tailgate bumper. All wagons.

TB598\$5.69 ea.

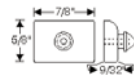

Trunk Floor Plugs

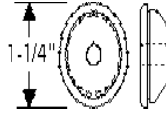

1940-1948 Plug, trunk floor pan construction holes, also rest pad for spare wheel area. 1 1/8" O.D., fits 7/8" diameter holes. 6-8 per car, as required. Series 50 and 70. FP408.....\$2.50 ea.

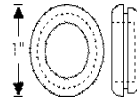

1950-1955 Plug, trunk floor pan. For 3/4" hole in sheet metal.

1950-1953 All;
1954-1955 Special, Century, Skylark
 FP505A.....\$5.69 ea.



1950-1960 Plug, trunk and floor pan drain hole. For 1/2" hole in sheet metal. Many models.

FP505.....\$2.25 ea.



1950-1957 Plug, floor pan, rear compartment and body, for 3/4" sheet metal hole. Many models.

FP507.....\$2.25 ea.



1959-1960 Plug, floor pan, rear compartment and body, for 3/4" sheet metal hole. Up to 12 per car.

FP596.....\$1.75 ea.



1936-1960 Rubber body hole plug. For 1" hole.

BP360.....\$3.00ea.

Body Plugs/Trunk Plugs

- BP120 1/2" Hole Diameter.....\$1.75 ea.
- BP580 5/8" Hole Diameter.....\$1.75 ea.
- BP340 3/4" Hole Diameter.....\$2.25 ea.
- BP780 7/8" Hole Diameter.....\$2.25 ea.
- BP100 1" Hole Diameter.....\$1.75 ea.
- BP114 1 1/4" Hole Dia.\$1.75 ea.
- BP112 1 1/2" Hole Dia.\$2.25 ea.
- BP118 1 1/8" Hole Dia.\$2.50 ea.



1935-1960 Plug, body sheet metal holes. Used in various places. For 1 1/2" hole in body. Many models.

BP355\$3.25 ea.



1959-1960 Plug, floor pan, rear compartment and body, for 3/4" sheet metal hole. 12 per car.

BP598\$2.25 ea.



1950-1960 Trunk Hinge to Lid bolt Set.

Set of 4 correct bolts and scalloped washers.
 TB500\$21.00 set

Trunk (Group 12)

Trunk Area Parts



1936 All. Rumble step plate.
RP36\$50.19 ea.



1937-1938 All. Rumble step plate.
RP378\$14.00 ea.

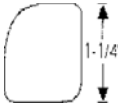

1936 Pads, rumbleseat lid corners original style, rounded triangular shape. Some models.
LC36\$38.29 pr.

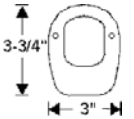

1939-1940 All. Gasket, turn signal bulb housing. 1/8" die cut sponge rubber.
DHG390\$31.89 pr.



1938-1942 Most models. Grommet, license lamp socket.
LG382.....\$8.00 ea.

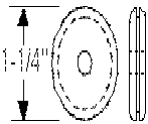

1941-1948 Most models. Grommet, license light wire through decklid inner panel. 1 1/4" O.D. x 3/8" I.D. 1/4" thick for 1" hole in sheet metal.
LG418.....\$3.00 ea.



1946-1960 Gasket set, rear license lamp assembly. One rubber ring and one cork rubber gasket set.

1946-1947: Series 50 and 70;
1950-1953: All Series;
1958: Roadmaster;
1959: Station wagons.



LG462.....\$8.75 set

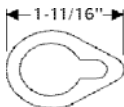

1951-1955 Trunk lock gasket as required. Tear drop shaped.
KLG399.....\$2.75 ea.

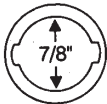

1954-1960 As required. Gasket, trunk lock cylinder. Exact reproduction. 7/8" I.D.
KLG540.....\$1.25 ea.

Trunk Locks (with 2 keys)

1955-1958 All Except Wagons + L.H. Locks.
TLS558.....\$25.50 set

1959-1960 All Except Wagons.
TLS590.....\$27.75 set

Sound Deadening Material

Used under floor matting, on inside of outer sheet metal panels, between trunk inner panels etc.

Heavy, black, tar type material.
SD300.....44" x 64".....\$47.50 ea.

Waffle pattern, Dark Brown, more paper type.
SD301.....27" x 36".....\$29.50 ea.

Closed-cell Foam. Adhesive-backed. Form-fitting.
Light and soft. Nice underpadding.
SD302.....42" x 72".....\$39.50 ea.



1946-1960 Jack Case

A genuine Buick accessory, part # 981521, 981161. These cases were made from excess materials left over from the upholstery shops at GM. They came in assorted colors and trim.

JC460BT.....(Black with Tan Trim).....\$39.50 ea.
JC460BR.....(Black with Red Trim).....\$39.50 ea.
JC460BY.....(Black with Gray Trim).....\$39.50 ea.
JC460BY.....(Black with White Trim).....\$39.50 ea.

Trunk Emblems and Hinge Pads



DLP37



DLP390



DLP428



DLP502

1937 Models 41, 48, 61, 68 and all Ser 80-90. Deck Lid Emblem Pad. DLP37	\$39.50 ea.
1937 Models 40c, 44, 47, 60c, 64, 67 Plainback. Deck Lid Emblem Pad. DLP37S	\$42.50 ea.
1938 All. Deck Lid Emblem Pad. DLP38	\$14.00 ea.
1939-1940 All. Deck Lid Emblem Pad. DLP390	\$18.00 ea.
1941 All. Deck Lid Emblem Pad. DLP41	\$19.00 ea.
1942-1948 Series 50-70. Deck Lid Emblem Pad. DLP428	\$44.50 ea.
1949 All. Deck Lid Emblem Pad. DLP49	\$25.25 ea.
1950-1952 All. Deck Lid Emblem Pad. DLP502	\$25.00 ea.
1953 All. Deck Lid Emblem Pad. DLP53	\$24.50 ea.
1954 All. Deck Lid Emblem Pad. DLP54	\$24.50 ea.
1955 All. Deck Lid Emblem Pad. DLP55	\$26.00 ea.
1956 All. Deck Lid Emblem Pad. DLP56.....Slightly Larger.....	\$42.00 ea.
DLP56S.....Exact Original Fit.....	\$105.39 ea.



DLP37S



DLP41



DLP49



DLP53

Deck Handle Mounting Pads



DH381

1938-1941 All; 1942-1949 Specials. Deck Handle Mounting Pad. DH381	\$28.50 ea.
1942-1948 All Super and Roadmaster Models. Deck Handle Mounting Pad. DH429	\$15.00 ea.
1955-1958 Deck Handle Mounting Pad . 1955-1957: Super and Roadmaster; 1958: Special, Super and Century exc. wagons. DH558	\$9.75 ea.



DH429

Trunk Hinge Pads



TH36

1936 All. Trunk Hinge Pads. (4 piece set). TH36	\$25.75 set
1937 Roadmaster and Limited. Non-beaded as original. (4 piece set). TH37	\$44.49 set
1937-1938 Models 41,41C,48,61,61C,68. Trunk Hinge Pads. (4 piece set). TH378	\$28.25 set
1939-1940 All except 1940 Series 50-70 Coupe and Convertibles. Trunk Hinge Pads. (4 piece set). TH390	\$51.79 set
1940 Series 50-70 Coupe and Convertibles. Trunk Hinge Pads. (4 piece set). TH390C	\$25.25 set
1940-1942: 1940 models, 56S, 56C, 56S, 76C Coupes; 1941 models, 44, 44C, 44S, 56, 56S, 56C, 76S, 76C Coupes; 1942 models, 44 Coupe. TH402	\$37.99 set



TH378



TH390

Trunk Lid Ornaments (Group 12)



1939

Trunk Plastics. (For letters use TPL391).
TP39.....\$68.00 pr.

1939-1941

Trunk Emblem.

TE391.....\$32.00 ea.



1940

Trunk Plastics. (For letter use TPL391).
TP40.....\$47.50 pr.



1939-1941

"BUICK EIGHT" Chrome letters.

TPL391.....\$29.50 set



1939-1940 Deck Lid Emblem, Lens Gasket.
DLG390.....(2 per car).....\$7.50 pr.



1941

Trunk Plastics (for letters, use TPL-391).
TP41.....\$42.50 pr.



1942-1948 All; 1949 Special

Trunk Base (die cast chrome)

TB428.....\$82.50 ea.



Trunk Emblem.

1942-1948 All; 1949 Special

TE429.....\$42.25 ea.



1942-1948 Trunk Plastics

TP428.....\$72.50 pr.



1948 "Dyna Flow" Trunk Plastics

TP48.....\$85.00 pr.



1949 Trunk Plastics. Series 50-70.

TP49.....\$125.00 set



1950-1952 Trunk Plastics. For auto trans. cars

TP502.....\$95.00 pr.



1950-1952 Trunk Plastics. For standard trans. cars

TP502S.....\$125.00 pr.



1953 Trunk Plastics.

TP53.....\$69.00 pr.



1955 Trunk Plastic

TP55\$69.50 ea.



1958 Limited Trunk "Whiskers"

TW58\$33.50 ea.

TW58S.....(Set of 4).....\$119.50 set

Convertible Tops (13.347)

Our convertible tops are designed and manufactured by a large company responsible for thousands of trophy winning classic cars in the past 15 years. *Each top is Custom made for perfect appearance and fit.* All seams are sewn with matching bond thread, dielectrically or latex sealed for long lasting water protection. Tops are guaranteed against defects for a full 54 months. All tops come with heavy duty clear vinyl window. A solid rear panel can also be ordered for installation of your framed glass window. Hardware also included. We recommend Haartz Cloth for 1936-1953 **BUICKS** and Vinyl for 1954-1960 **BUICKS.** When ordering, keep in mind, the second color listed is the color inside the car.

HAARTZ Stayfast Cloth Tops: The best top available, made with 4 bonded layers of waterproof fabric.
Available Colors: Black/Black, Black/Tan, Dark Blue/Black, Medium Blue/Black, Medium Blue/Tan, Dark Brown/Black, Tan/Tan, Tan/Black, Lt. Neutral/Black, Lt. Neutral/Tan, Dk. Beige/Black, True Burgundy/Black, Charcoal/Black, Medium Gray/Black, Pepper/Black, Red Berry/Black.
 1941 thru 1960 only. No patterns for 1940 back.

CT360HS.....\$589.50 kit

Stayfast by the yard. 58" wide. State color.
 SC300.....\$80.25 yd.

Bow Drill Cloth

Used to make convertible Top Wells. 66" wide.
 BD360B (Black).....\$22.75 per yd.
 BD360T (Tan).....\$22.75 per yd.

Convertible Top Frame Rebuilding Kits



Our kits contain all necessary bolts, bushings, nuts, wash-ers, and rivets to completely rebuild your frame. TFK546 has 119 pieces, TFK546B has 125 pieces. You will need a 21/64" drill bit and a cold chisel to stake rivets.

1954-1956 All Special, Century, Skylark.
 TFK546.....\$224.00 ea.

1954-1956 All Super and Roadmaster.
 TFK546B.....\$224.00 ea.

Convertible Top Header Bows

Replaces the rusted and worn-out front bow. New tacking strip and windlace included.

1959-1960 All.
 HB590.....\$459.00 ea.



Heavy Duty Vinyl: Quality Sateen Back 32 ounce durable vinyl. *Available Colors:* Black/Black, Tan/Tan, White/Black, Brown/Black, Beige/Sliver Tan, Red/Black, Maroon/Black, Green/Green, Dark Green/Black, Buckskin/Black, Pale Blue/Black, Med Blue/Black, Dark Blue/Black.

CT360V32.....\$289.50 kit

Deluxe Heavy Duty Vinyl: Superior Sateen Back 38 ounce durable vinyl. *Available Colors:* Black over Black, White over Black.

CT360V38.....\$389.50 kit

Convertible Top Pad Kit: For all convertible tops listed above. (13.349)

TP360B.....(Black).....\$95.00 kit

TP360T.....(Tan).....\$79.50 kit

TP360D.....(Durable).....\$59.75 kit

TP360S.....(Stayfast).....\$149.50 kit



Convertible Boots (13.450)

We have many patterns for boots in stock. We can also reproduce a boot from your old boot or pattern. Vinyl.
 TB400.....\$199.50 ea.

Convertible Well Liners (13.450)

We have patterns for the cars listed below at this time. We can also make a new well liner from your old one. Please inquire about this procedure.

1950-1952 Super and Roadmaster.
 WL502B.....\$104.50 ea.

1954-1958 Special, Century, Skylark.
 WL548.....\$104.50 ea.

1959-1960 All.
 WL590.....\$69.50 ea.

Convertible Top Handles

1957-1960 Chrome Convertible Top Locking Handles.

TH570.....\$95.00 pr.



Convertible Top Handle Striker

1957-1960 Convertible Top Handle Striker Plates.

THS570.....\$98.00 pr.

Convertible Top Hydro-lectric Systems (Group 14)

Firewall Pump Rebuilding Service (14.481)

1946-1954 Firewall pump rebuilding service. Our pumps are 100% remanufactured to operate better than new. Pumps are even returned with stainless steel screws. Add \$75.00 for 100 point restoration. See NOS section for pumps sold outright.
 * Five (5) year warranty.
 FPR464.....\$549.00 ea.

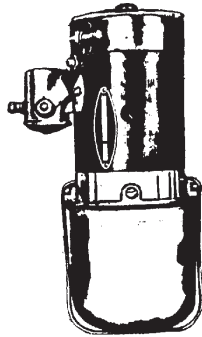

* Always use ATF. Brake fluid will reduce your warranty to one year.

Firewall Pump Solenoid (14.465)



PS464.....(6 Volt).....\$36.75 ea.



PS464H.....(12 Volt).....\$52.75 ea.

Firewall Pump Reservoir and Bails (14.486)

Duro/Hydro (Aluminum pump body): Short style reservoir. Zinc plated steel. Includes gasket.

PR464S\$129.50 ea.
 Bail clip for above.
 RB464S\$37.50 ea.

Duro/Hydro: Steel tall style reservoir. Includes gasket.

PR464S\$129.50 ea.
 Bail clip for above.
 RB464T\$37.50 ea.

GM/Moraine (Cast iron pump): Reservoir. Includes gasket.

PR464T\$139.50 ea.
 Bail clip for above.
 RB464T\$39.50 ea.

Delco/Moraine rotary vane at 90° angle aluminum pump. Reservoir. Includes gasket.

PR464D\$79.50 ea.

Convertible Top Pump / Motors

1946-1953 6 Volt pumps firewall. Sold outright. These replacement pumps will fit in the original mounting location, but do not look original.

TP463.....\$787.00 ea.

NOTE: 1954 and some 1955 Buicks had hose ports at the top of the pump. All Replacement pumps have ports at the sides. Order Top hose set CHS-546.

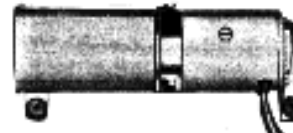

1953-1954 12 Volt firewall pump replacement.

TP534.....\$787.00 ea.

1953 Special - 6V.

TP53S\$289.00 ea.

1954-1956 Verticle Top Pump/Motor Replacement.

TP546R\$279.00 ea.

1957-1960 Top Pump/Motor.

TP572.....\$279.00 ea.



Control Valves (14.465)

Control Valve Rebuilding Service Valves are cleaned, re-sealed and tested.

1946-1950 Under dash or on firewall bakelite valve type. Rebuilding service.

CVS465\$169.50 ea.

1950-1954 Under seat twin solenoid type. Rebuilding service.

CVS504\$369.50 ea.
 New cover\$95.00 ea.

Convertible Top Frame Rebuilding Hardware Kit

1954-1956 Special, Century, Skylark.

119 piece kit.
 TFK546.....\$219.50 ea.

1954-1956 Super and Roadmaster.
 125 piece kit.

TFK546B.....\$219.50ea.



(Group 14) Convertible Top Hydro-lectric Systems

Convertible Top Cylinders (14.475)

1946-1960 Convertible top cylinders. Absolutely the Best obtainable. Five (5) year warranty. Always use ATF. TIP! Always lubricate the shafts and seals with ATF after winter storage.



1946-1953 All. Except 1953 Special.	
TC463.....	\$157.50 ea.
1953 Special.	
TC53.....	\$157.50 ea.
1954-1956 All.	
TC546.....	\$157.50 ea.
1957-1958 Special and Century.	
TC578.....	\$157.50 ea.
1957-1958 Super Roadmaster, Limited.	
TC578B.....	\$157.50 ea.
1959-1960 All..	
TC590.....	\$157.50 ea.

Convertible Top Motor/Pump mounts.



1946-1954. Three per car.	
PM464.....	\$8.75 ea.

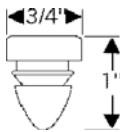

1953-1960 Grommet, folding top hydraulic pump mount. Special design to hold pump mounting bracket to floor pan. Four per car.	
PM531.....	\$3.69 ea.

Convertible Top Hose Sets

For years 1953 and earlier, please supply length and fittings information



1954-1956 All. Correct black rubber hose as original.	
CHS546.....	\$107.00 set
1957-1960 All. Correct black rubber hose as original.	
CHS571.....	\$107.00 set
Individual hoses are available for all applications. These replacement hoses do not look authentic, but they will function as original.	
CH460.....	\$42.50 ea.

1946-1961 All. Folding top hydraulic cylinder support spacers. 4 used per car.	
CS461.....	\$5.39 ea.

Convertible Sun Visor Parts

1939-1948 Convertible chrome visor bracket.	
VB398.....(4 needed per car).....	\$49.50 ea.



1939-1948 Convertible chrome visor bracket mount.	
VM398....(4 needed per car)....	\$47.50 ea.

1954-1958 All Convertibles. Chrome plated visor retainers w/ screws.	
VR548..	\$57.50 ea.



Window and Seat Cylinders

1946-1954 Includes solenoid. (Stainless steel shafts). Five (5) year warranty with ATF. One (1) year with brake fluid.	
1946-1954 Door window cylinder.	
DC464.....	\$169.50 ea.
1946-1954 Quarter window cylinder.	
QC464.....	\$169.50 ea.
1946-1954 Seat cylinder. (Back and forth).	
SC464.....	\$169.50 ea.
1946-1954 Seat cylinder. (Up and down). Rebuild.	
SC464P.....	\$199.00 ea.

Tacking Strips

1936-1960 Convertible top front tacking strip. 1/8" x 5/8".	
TSF360.....	\$3.00/ft.
1936-1960 Convertible top rear tacking strip. 3/16" x 1/2".	
TSR360.....	\$3.00/ft.



Convertible Top Handles & Striker Plates



1949-1953 Convertible top locking handle w/ hardware.	
TH493.....	\$65.00 ea.

1954-1956 Convertible top handle.	
TH546.....	\$95.00 ea.

1957-1960 Chrome convertible top locking handles.	
TH570.....	\$95.00 pr.



1957-1960 Convertible top handle striker plates.	
THS570.....	\$98.00 pr.







Top Alignment Pins

1954 Some as Required. 1/4" - 20 thread, stainless steel.	
TAP54.....	\$8.50 ea.
1954-1956 3/8" - 24 thread, stainless steel.	
TAP546.....	\$8.50 ea.

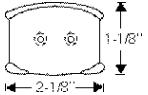

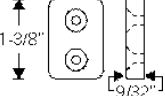
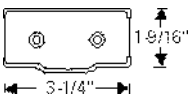
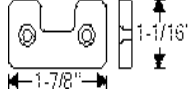
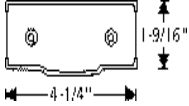
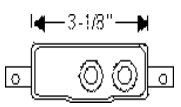
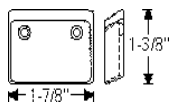
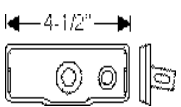
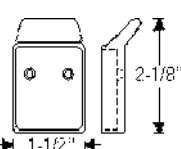
Convertible Top Parts (Group 14)

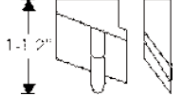
-  **1936-1937 Detachable center post pad. Top and bottom 4/set.**
PP367\$213.29 set.
-  **1936-1937 Model 80C Conv. top rest blocks.**
RB367\$52.69 pr.
-  **1936-1937 Model 80C Conv. top 3rd bow rest pads.**
RP367\$68.69 pr.
-  **1936-1940 All. Slat iron to compartment pads.**
SP360\$80.49 pr.
-  **1937-1938 Models 40C and 60C. Detachable center post pad. Top and bottom 4/set.**
PP378\$233.49 set.
-  **1937-1938 Special and Century convertibles. Folding post bottom pads.**
PP378B.....\$85.99 pr.
-  **1938-1940 Series 80 convertible sedan. Detachable center post pad. Top and bottom 4/set.**
PP380\$273.29 set.
-  **1939-1940 Models 41C and 61C. Detachable center post pad. Top and bottom 4/set.**
PP390\$397.39 set.
-  **1940 Special and Century convertibles. Folding post pads.**
PP40\$94.19 pr.
-  **1940-1941 Models 51C and 71C. Detachable center post pad. Top and bottom 4/set.**
PP401\$297.99 set.
-  **1940-1941 Convertibles. Top folding post bottom pads.**
PP401CS..(For Convertible Sedans)..\$83.99 pr.
PP401CC..(For Convertible Sedans)..\$75.59 pr.

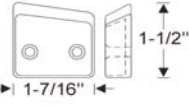
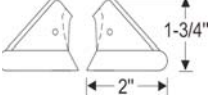
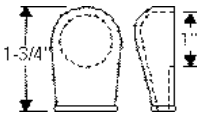
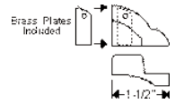
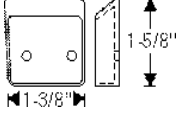
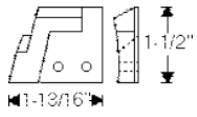
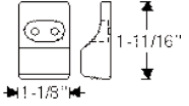
-  **1941-1942 Model 44C. Side roof rail to front roof rail corner fillers. Metal core with threaded holes for screws. Pair.**
TF412\$100.99 pr.
- 1941-1952 Top Cushions.**
1941-1948 top end of folding pillar to side of roof rail at rear.
1941-1952 folding post on female hinge for folding top.
TC412.....\$41.99 pr.
-  **1942 Convertibles. Top folding post bottom pads. Metal core. Fastens with two screws.**
PP42.....\$84.29 pr.
-  **1942-1948 All convertibles. Bumper, folding top bow folding post on bottom of post, held by 2 screws. Steel core.**
TB428C\$76.39 pr.
-  **1942-1948 56C and 76C. Fillers, folding top to side roof rail to front roof rail. Metal core as original. Right and left sides.**
TF428C\$75.59 pr.
-  **1949 Super and Roadmaster convertibles, side roof rail bumper caps. (Gray rubber, four per car). Set of 4.**
TC49\$50.50 set
-  **1949 Super and Roadmaster convertibles. Fillers, folding top front corners.**
TF49\$65.99 pr.
-  **1949 Super and Roadmaster convertibles. Bumpers at rear quarter window.**
TB49\$63.49 pr.
-  **1950-1953 Super and Roadmaster convertibles. Folding post hinge bumpers.**
TB503.....\$85.99 pr.
-  **1951-1953 Roadmaster. Top rest pads.**
RP513.....\$40.69 ea.
- 1953-1956 Side roof rail bumpers. 2-4/car**
1953 model 46R;
1954-1956 All convertibles.
TB536.....\$55.39 pr.

(Group 14) Convertible Roof Rail Weatherstrip



1933-1941 All. Fits into metal channel retainer. Sold in 12 ft. lengths. Enough for both sides.

RR341\$79.88 ea.

1942 Special. Eight (8) piece set for right and left sides, including windshield post strip.

RR42C.....\$342.19 ft.

1942-1948 Super and Roadmaster convertible sedan. Eight (8) piece set.

RR428\$479.79 set

1949 Super & Roadmaster. Six (6) piece set consists of right and left hand sections over door window quarter window, and folding top post. Does not include bow seal.

RR49C.....\$431.89 set

1950-1953 Super and Roadmaster. Eight (8) piece set for Right and Left side consists of: rubber sections for front corners, over door window, quarter window, and folding top post. Does not include windshield stanchion seals.

RR503\$483.19 set

1951-1952 Special. Six (6) piece set.

RR512\$288.99 set

1953 Specials. Nine (9) piece set includes left and right side (3 pieces per side), front corners, and front bow strip.

RR53\$379.89 set

1953 Skylark. Eight (8) piece set consists of right and left sections for front corners, door window upper quarter window upper, and folding top post.

RR53X\$761.99 set

1954-1956 Super and Roadmaster. Nine (9) piece set includes: metal cores, proper studs, and front bow weatherstrip.

RR546\$552.29 set.

1954-1956 Nine (9) piece set includes: front bow and two front corner sections.

1954-1956: Special and Century;

1954: Skylark.

RR546C.....\$601.79 set

1957-1958 Nine (9) piece set for right and left side includes: steel shank running full length with staked in studs as original, front corner pieces, and front bow seal.

1957: Super and Roadmaster;

1958: Roadmaster and Limited.

RR578BC\$549.79 set

1957-1958 Special and Century. Weatherstrip, convertible roof rail. Nine(9) piece set complete with metal core, proper studs and front bow with strip.

RR578C.....\$584.49 set

1959-1960 LeSabre and Invicta. Weatherstrip, roof rail. Set includes front bow seal, metal core and studs.

RR590B\$396.19 set

1959-1960 Electras. Seven (7) piece set includes: metal core, front bow seal and studs.

RR590C.....\$394.99 set

Adhesive Backed Bow Drill



Cloth tape used to cover roof rail weatherstrip rear 1/4 window seals, etc. as req. Waterproof and sunproof.

Comes in 5 foot rolls.

BD250B.....(Black 2 1/2" wide).....\$16.79 ea.

BD250T.....(Tan 2 1/2" wide).....\$14.99 ea.

BD500B.....(Black 5" wide).....\$35.49 ea.

BD500T.....(Tan 5" wide).....\$21.25 ea.

Convertible Top Parts (Group 14)

Pillar Seals

- 1949** All Convertibles. Weatherstrip, windshield post to vent window frame, fits steel retainer rail, right and left. PS49.....\$115.25 pr.
- 1950-1953** Super, Roadmaster and Skylark convertibles. PS503.....\$182.59 pr.
- 1959-1960** Weatherstrip, front body hinge pillar, upper. Molded right and left, with retaining clips. Convertibles only. PS590.....\$118.50 pr.



- 1942-1948** Super and Roadmaster. Weatherstrip, windshield header for folding top. 53" length. BS428\$220.89 ea.

Convertible Front Bow Seals (14.060)

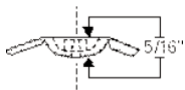

- 1932-1935** Weatherstrip, front bow-to-windshield, soft rubber with correct holes and hinged flaps. Convertibles. BS325\$180.29 ea.



- 1936-1937** Seal, convertible top front bow-to-windshield with integral end pads. Must be modified slightly. **1936:** All; **1937:** Series 80 and 90. BS367.....\$165.49 ea.



- 1937-1940** Weatherstrip, front bow-to-windshield, outer, right and left, molded with end hook, screw holes and clearances. Convertibles. BS370.....\$119.89 pr.



- 1937-1940** Weatherstrip, front bow-to-windshield, inner, right and left. Convertibles. BS370I\$114.29 pr.

- 1937-1940** Clip w/s fastener for front bow. Approx. 30 per car. Fits in 1/4" hole. Convertibles. Cadmium plated. BSC370.....\$4.29 ea.

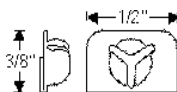

- 1939-1942** Weatherstrip and pad, front bow to windshield, inner. Approximately four (4) ft. 10" strip for one car.

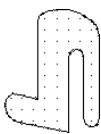

- 1939-1941:** Sport Phaeton and all convertibles; **1942:** Series 40 convertibles. BS392.....\$50.39 ea.

- 1939-1948** Weatherstrip, front bow-to-windshield, outer, four (4) ft. 10" strip. All convertibles. BS398A\$57.29 ea.

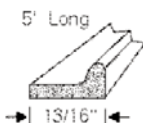

- 1951-1953** Weatherstrip, front bow of convertible. Sponge rubber extrusion with correct dimensions. 5' length. BS513E.....\$30.69 ea.

- 1949** Super and Roadmaster convertibles. Weatherstrip, windshield header to convertible front bow. Molded replacement with correct holes for locking pins. BS49\$216.99 ea.

- 1951-1953** Weatherstrip, front bow with strip. With metal core in center section as original. **1951:** 56C after body #6528; **1951:** 76C after body #2508; **1952-1953:** All 56C and 76C. BS513\$143.79 ea.

- 1954-1956** Series 40-60-100 convert. top bow seal. BS546\$16.00 ea.

Drain Tubes and Grommets



- 1957** Special and Century convertible drain tubes. DT57\$34.50 pr.



- 1957** Special and Century convertible drain tube grommets. TG57\$20.00 pr.



- 1957** All convertibles. Lock pillar weatherstrip. Located under rear 1/4 window. LPW57\$69.75 pr.

Convertible Top Molding Clips



- 1957** Special and Century convertibles. For belt molding. Up to 20 per car. MC90\$3.75 ea.



ORDER BY PHONE!

908-369-3666

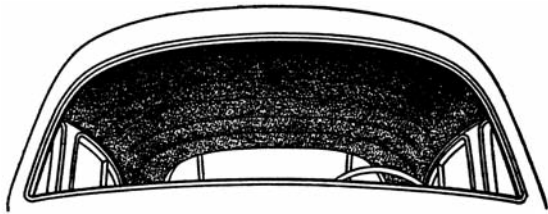

Our Headliners are the finest quality, manufactured by the same company that supplies GM. All Headliners are custom made from original patterns to guarantee perfect fit and easy installation. All kits include: detailed instructions and contain extra material to cover the sun visors. Samples of materials are available upon request..

1935-1958 Napped Cloth Headliners

Cloth Colors Available: Gray, Dark Taupe, Dark Tan, Black, Med. Blue, Lt. Green, Dk. Green, Aqua, Ivory, Red, Maroon. Other colors available upon request (please send SASE for samples) (Extra Cloth Headlining Material. 54" wide - \$22.00 yard). Add \$15 for wagons.

- HL357.....**1931-1947**.....\$237.75
- HL488.....**1948-1958**.....\$269.50
- HY358..... Extra Yardage.....\$22.00 yd.

1954-1960 Leatherette Headliners

VINYL COLORS AVAILABLE: White, Off White, Black, Brown, Beige, Tan, Dark Blue, Maroon, Green, Red, Turquoise, Yellow, Black or White Perforated. (Extra Leatherette Material. 54" wide - \$39.50 yard).

- HL540.....\$249.50
- HL540P.....(Perforated).....\$325.00

Windlace Stops

1930's thru 1960's all as required.

- WLS360.....\$11.75 pr.



Headliner Trim Kits

Our Trim Kits come complete with the proper amount of windlace, wire-on, and instructions. (extra wire-on may be needed on some 1935-1949 cars. *Please order* WO359.....\$12.75 yd.)

- HTK3582.....**1935-1948** 2-dr. Models.....\$139.50
- HTK3584.....**1935-1950** 4-dr. Models.....\$222.00
- HTK4902.....**1949-1960** 2-dr. Models.....\$111.00
- HTK4904.....**1949-1960** 4-dr. Models.....\$209.50

Original style cloth covered windlace. Available in 14 colors. Black, Cashmere, Taupe, Antique Taupe, Brown, Dark Brown, Gray, Antique Gray, Green, Dark Green, Blue, Dark Blue, Red, Maroon.

- WL360.....\$18.50 yd.

When ordering Headliner or Headliner Trim Kits, please give all information about the car, including **Model** and **Style** Number. This number is stamped on the I.D. plate on the firewall. These items are custom made. Allow two to three weeks for delivery.

Package Shelf Material

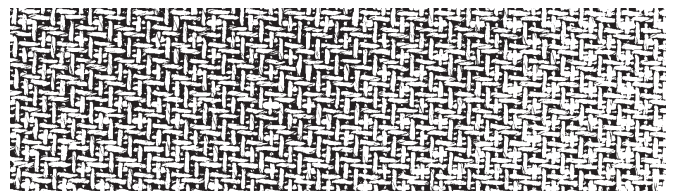

Duplicates the texture and appear-ance of the original. Comes in 18" x 70" roll. It can be applied to hardboard with spray adhesive (SA360), then trimmed to fit. Paint to match. All models as required.

- PS300.....\$39.50 ea.

Seat Belts (Group 14)

Seat Belts

Quality made aftermarket seat belts come in various colors and styles. Colored belts: add \$5 and code, are custom made and not returnable. Please see our website for colors.

77" recommended for fronts, 60" for rears. Per person.

Chrome Lift Lever Style



Lap belts come standard with authentic style chrome buckle. Black (B), tan (T), rust (R), dark brown (DB), orange (O), glove red (GR), maroon (M), charcoal (C), navy blue (NB), powder blue (PB), turquoise (TQ), ivory (I), white (W), gray (G), silver (S), dark green (DG).

- SB20074B.....(77" Black) Hardware Inc.....\$39.50 ea.
- SB20060B.....(60" Black) Hardware Inc.....\$39.50 ea.
- SBH200.....(Hardware Kit Only).....\$5.25 ea.

Plastic Push Button Style



Lap belts with push-button plastic buckle. Black (B), Taupe (T), Maroon (M), Light Gray (LG), Blue (U). Sizes available are 60" and 74" for the black, light gray and taupe. The blue and maroon are available in 74" only. Colored belts, (add \$3 and code), are custom made and not returnable.

- SB200P74B.....(74" Black).....\$39.50 ea.
- SB200P60B.....(60" Black).....\$39.50 ea.
- SBH200.....(Hardware Kit).....\$5.25 ea.

Metal Push Button Style



Lap belts with push-button metal buckle. Black (B), Taupe (T), Gray (G), Colored belts, (add \$3 and code), are custom made and not returnable.

- SB200M74B.....(74" Black).....\$39.50 ea.

Seatbelt Hardware Kit



- SBH200\$5.25 ea.

Seat Belt Buckle Emblems



Old style Buick coat of arms. Fits well on our lift lever seat belts.

- TBE550.....\$7.50 ea.



GM mark of excellence. Fits well on our lift lever seat belts.

- D55\$3.75 ea.



GM Mark of excellence. Embossed. Fits well on our lift lever seat belts.

- D55E\$6.50 ea.

Rear Ash Trays



1948 Roadmaster Model 76S;

1949-1953 Super, Roadmaster & Skylark, 2-dr hardtop & convertibles.

1954-1958 Skylark & Century convertible.

1954-1958 Super, Roadmaster & Limited, 2-dr hardtop & convertibles.

AT488.....\$31.50 ea.



ATB488.....Bezel for Above.....\$14.00 ea.



1959-1960 LeSabre, Invicta, Electra 2-dr. ht.;

1959-1960 All convertibles.

AT597.....\$22.25 ea.



www.oldbuickparts.com

908-369-3666

Front Kick Panels

Kick panels listed from 1937-1940 are made from ABS plastic. Panels from 1946-1960 up are made from hard board and fawn colored which can be painted or dyed to match any interior.

1937 Special & Century. KP37	\$89.50 pr.	1956 All models w/ 5 rivets. Fawn. KP56	\$39.50 pr.
1938 Special & Century. KP38	\$89.50 pr.	1957 All w/ hardware. KP57	\$39.50 pr.
1939 Special & Century. KP39	\$89.50 pr.	1958 All w/ 5 rivets. Fawn. KP58	\$39.50 pr.
1940 Special & Century. KP40	\$94.50 pr.	1959 All. Fawn. KP59	\$39.50 pr.
1946-1948 Roadmaster. KP468R.....	\$39.50 pr.	1960 All closed models w/o AC. Fawn. KP60	\$39.50 pr.
1953 Roadmaster. KP53R.....	\$42.50 pr.	1960 All closed models w/ AC. Fawn. KP60A	\$39.50 pr.
1954-1955 Special and Century. Fawn. KP545	\$39.50 pr.	1960 All convertibles. Fawn. KP60C	\$39.50 pr.



www.oldbuickparts.com

908-369-3666

**1949-1960
Front and Rear Carpet Sets**



Our carpets are cut and sewn from manufacturers specifications for correct fit and easy installation. All sets include matching vinyl heel pad on drivers side, bound edges, and jute underpadding. 500 Series is 80/20 Ralon. 600 and 800 Series is 100% nylon.

- Full Set (front & rear) 500 Series Nylon Loop.....\$209.50
- Full Set (front & rear) 600 Series Nylon Loop.....\$209.50
- Full Set (front & rear) 800 Series Nylon Cut Pile...\$209.50

When ordering, specify color and number, year, model and style of car. Colors listed are "names" only and do not imply any exact shade, color or trim code that may have been originally offered. **We strongly suggest that you receive a sample before you purchase any carpet.** FREE samples are available by sending S.A.S.E. Sorry, no returns on custom made items.

Carpet by the yard - 36" x 40" (for kick panels, doors, etc. (Two (2) yard minimum).

- Nylon Loop.....\$51.50 yd.
- Nylon Cut Pile\$51.50 yd.



Floor Mat Set - Universal 4 Piece Set

These are a high quality carpeted floor mat set. Made of high quality carpet. Available in Cutpile or Loop. Finished With A Seamed Binding. A complete set of 4 mats. Front Mat Measures 25-3/4" High by 16-3/4" Wide. Available in Many Colors. Quality Nibbed Backing Prevents Mat Creep. These Mats Stay In Place!

Select Carpet Type And Color Below

- FM300.....\$89.50 set

NYLON LOOP

- C501 - Black
- C601 - Black
- C622 - Light Blue
- C540 - Navy Blue
- C602 - Dark Blue
- C508 - Turquoise
- C608 - Turquoise
- C609 - Forest Green
- C565 - Bright Red
- C615 - Deep Red
- C525 - Burgundy
- C625 - Maroon
- C557 - Gunmetal Gray
- C521 - Saddle
- C621 - Saddle
- C610 - Chocolate Brown

NYLON CUT PILE

- C801 - Black
- C8170 - Lapis Blue
- C840 - Navy Blue
- C8075 - Medium Gray
- C815 - Deep Red
- C825 - Maroon/Burgundy
- C897 - Charcoal Gray
- C853 - Silver Gray
- C854 - Caramel
- C851 - Biscuit
- C810 - Chocolate Brown
- C869 - Willow Green

NYLON LOOP

- Black
- Red
- Aqua
- Ford Blue
- Dark Blue
- Dark Green
- Medium Blue
- Medium Saddle
- Maroon
- Fawn
- Gold
- Genmetal Gray

NYLON CUT PILE

- Black
- Dark Gray
- Red
- Oxblood
- Sandstone
- Graphite
- Desert Tan
- Flame Red
- Medium Gray

1937-1938 Front Floor Mats

1937-1938 40 & 60 models . Brown.
 FM378N.....\$285.00 ea.
1937-1938 40 & 60 models . Black
 FM378B.....\$280.00 ea.
1937-1938 80 & 90 models. Black. Unpunched.
 FM378BB\$280.00 ea.
1937-1938 80 & 90 models. Brown. Unpunched.
 FM378BN\$295.00 ea.
1939-1940 Special & Century.
 FM390.....Black.....\$340.00 ea.
 FM390N.....Brown.....\$340.00 ea.
1940-1948 Super Roadmaster.
 FM408.....Black.....\$395.00 ea.
 FM408N.....Brown.....\$395.00 ea.
1941-1948 Special & Century.
 FM418.....Black.....\$395.00 ea.
 FM418N.....Brown.....\$395.00 ea.

1950-1956 Front Floor Mats (15.292)

An excellent reproduction of a Genuine Buick Accessory. These mats come in colors and apply to all models. They feature the Buick logo licensed by Buick. They can also be used in the rear depending upon your size requirements. They are 18" wide and 16 1/2" tall.



1950-1956 All models. Black with Buick logo. Oem #981116
 FM506\$49.50 pr.
1950-1956 All models. Blue with Buick logo. Oem #981118
 FM506U\$49.50 pr.
1950-1956 All models. Red with Buick logo. Oem #981510
 FM506R\$49.50 pr.
1950-1956 All models. Maroon w/Buick logo. Oem #981117
 FM506M\$49.50 pr.
1950-1956 All models. Green w/ Buick logo. Oem #981119
 FM506G\$49.50 pr.

All years. Carpet Under Padding. 27 oz. (36" x 72")

JP360.....\$14.00 ea.

All Years. Sound Deadening material. Heavy rubberized material. 39" x 72".

SD300.....\$44.75 ea.

All Years. Sound Deadening material. Lighter, dark brown more paper-type material. 27" x 36".

SD301.....\$27.50 ea.

All Years. Sound Deadening material. Closed-cell foam, adhesive backed. Very light and soft. Easy cut. 42" x 72".

SD302.....\$37.50 ea.

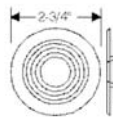

1936-1960 Grommet for dimmer Switch on carpet floor. 1" hole.

SG360\$7.75 ea.



1946-1956 Most Special, Century, Super.

TM466.....(56" Wide).....\$95.00 yard



1950-1958 Roadmaster, Skylark, Limited

some others. Cross Stich..... \$70.25 yard

TM508G - 43" wide.....green backing-green thread

TM508TV - 48" wide.....taupe backing-violet thread

TM508OO - 44" wide.....orange backing-orange thread



All years Universal. An inexpensive substitute for non-authentic trunk dress-up. High quality gold backing with darker gold thread.

TM6.....(60" Wide).....\$49.00 yard

Trunk Cardboard Panel Kits (Group 15.222)

Below listed are new trunk panel kits that we have completed. These panel kits will complement our trunk lining material seen on previous pages. Panel Kits are available in the following colors and ordered by adding the corresponding letters to the part number. Example: if you want TPK546B in metallic green, order TPK546BMG. Of course, they may also be custom sprayed the color of your choice.

We will continue to make more kits as we receive samples from our customers. Please let us know if you have patterns from your car that we can use. In turn we will supply you with a discounted new kit. Some kits are regularly stock, others are special ordered. So allow 2-3 weeks delivery.

Color	Add Letters
Black	B
Brown	N
Gray	A
Maroon	M
Pebble Beige	PB
Off White	OW
Metallic Green	MG



TPK546A



TPK590C

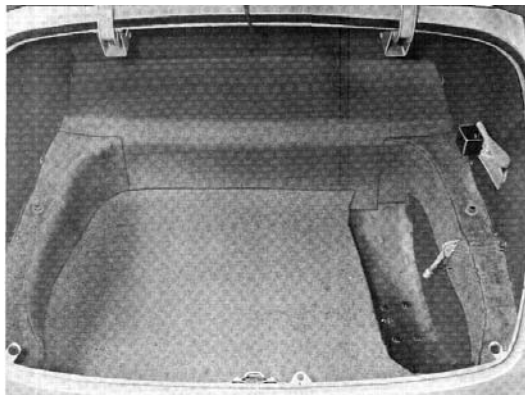

1937 All.

TPK37.....3 Piece Set.....149.50 set

1949 Super & Roadmaster Sedanette.

TPK49S.....\$79.50 set

1951-1953 Super & Roadmaster 2-dr. hardtop models

56R, 76R. 3 pc. Black.

TPK513HB.....\$89.50 set

1951-1953 Super & Roadmaster 2-dr. hardtop models 56R,

76R. 3 pc. Brown.

TPK513HN.....\$89.50 set

1951-1953 Super & Roadmaster 2-dr. hardtop models 56R,

76R. 3 pc. Gray.

TPK513HA.....\$89.50 set

1953 Super 2-dr. hardtop. 3 pc. Brown side panels.

TPK53A.....\$125.00 set

1954 Skylark.

TPK54S.....\$79.50 set

1954 Special & Century 4-dr. Sedan. 3 pc. Brown side panels.

TPK54AN.....\$65.00 set

1954 Super & Roadmaster 4-dr. Sedan. 4 pc. Brown side panels.

TPK54BN.....\$125.00 set

Sound Deadener Kit

Sound Deadeners help insulate your vehicle from road noise and engine heat. They are available in EVA, and are custom made to fit each model perfectly. ACC sound deadeners meet federal standards for flammability retardation. It's the perfect beginning when replacing your carpet and to increase its durability. 7 piece kit.

1955-1957 Century, Special and Roadmaster.

SD557.....\$100.00

1959-1960 LeSabre, Invicta and Electra.

SD590.....\$100.00

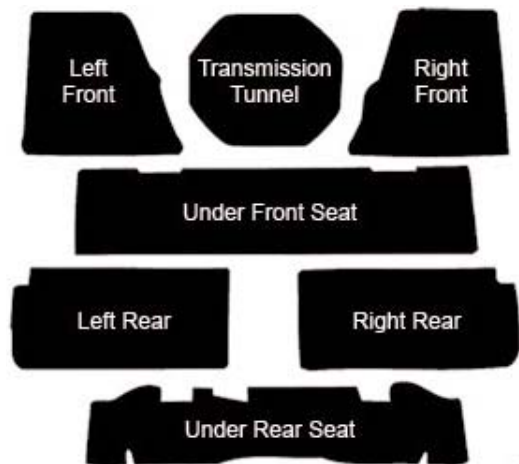

(Group 15.222) Trunk Cardboard Panel Kits

1954-1956 All Super & Roadmaster exc. convt. 3 pieces. TPK546A\$79.50 set	1957 Special & Century 2-dr hardtop. 3 pc. Gray side panels. TPK57\$125.00 set
1954-1956 Special & Century 2-dr hardtop. 3 pc. Gray side panels. TPK546A\$125.00 set	1957 Special & Century convertible. 4 pc. Gray side panels. TPK57BA.....\$125.00 set
1954-1956 All Special and Century except convertibles and wagons. 3 pieces. TPK546B\$89.50 set	1957 Special & Century 4-dr. Sedan. 3 pc. Gray side panels. TPK57S\$125.00 set
1954-1956 Special & Century convertible. 2 pc. Brown side panels. TPK546CN\$85.00 set	1957 Super 2-dr hardtop. 3 pc. Gray side panels. TPK57CA.....\$65.00 set
1954-1956C Super & Roadmaster 2-dr. hardtop models 56R, 76R. 5 pc. kit Gray. TPK546AA.....\$79.50 set	1957 Roadmaster. 3 pc Gray side panels. TPK57RA.....\$65.00 set
1954-1956C Super & Roadmaster 2-dr. hardtop models 56R, 76R. 5 pc. kit Black. TPK546AB.....\$79.50 set	1958 Special & Century 2-dr hardtop. 3 pc. Gray side panels. TPK58AA.....\$125.00 set
1954-1956C Super & Roadmaster 2-dr. hardtop models 56R, 76R. 5 pc. kit Maroon. TPK546AM\$79.50 set	1958 Super 2-dr hardtop. 2 pc. Gray side panels. TPK58BA.....\$85.00 set
1954-1956C Super & Roadmaster 2-dr. hardtop models 56R, 76R. 5 pc. kit Metallic Green. TPK546AMG\$79.50 set	1958 Roadmaster 4-dr hardtop. 3 pc. Gray side panels. TPK58R4A.....\$85.00 set
1954-1956C Super & Roadmaster 2-dr. hardtop models 56R, 76R. 5 pc. kit Brown. TPK546AN.....\$79.50 set	1958 Limited 4-dr hardtop. 2 pc. Gray side panels. TPK58L4HA.....\$65.00 set
1954-1956C Super & Roadmaster 2-dr. hardtop models 56R, 76R. 5 pc. kit Off White. TPK546OW\$79.50 set	1958 Limited convertible. 4 pc. Gray side panels. TPK58LCA.....\$85.00 set
1954-1956C Super & Roadmaster 2-dr. hardtop models 56R, 76R. 5 pc. kit Pebble Beige. TPK546APB\$79.50 set	1959-1960 Electra 225 4-dr. hardtop. TPK590A\$59.00 set
1955 Super & Roadmaster convertible. 2 pc. Black side panels. TPK55CB.....\$85.00 set	1959-1960 Electra 2-dr. hardtop. 5 pc. Gray houndstooth side panels. TPK590AGHT.....\$125.00 set
1956 Super 4-dr. Hardtop. TPK56A\$89.50 set	1959-1960 Electra 4-dr. hardtop. 5 pc. Gray houndstooth side panels. TPK590E4\$125.00 set
1956 Super 4-dr. Sedan. TPK56B\$89.50 set	1959-1960 Lesabre & Invicta 4-dr. hardtop. 4 pc. Gray houndstooth side panels. TPK590H4\$85.00 set
	1959-1960 Lesabre & Invicta convertible. 6 pc. Gray houndstooth side panels. TPK590C\$125.00 set

Literature (Group 16)

SHOP MANUALS: A Shop Manual is *essential*. This should be your very first purchase after buying your car. These fully illustrated books were originally developed by **BUICK** for trained **BUICK** mechanics. They offer in detail, description and analysis as well as maintenance and step by step overhaul procedures. All of our Shop Manuals are *Full Size* as originals with the clearest print and pictures available in a "xerox" type copy form. The covers are "in color" and protected by a heavy clear plastic to keep them clean. As an additional feature, each manual is spiral bound in plastic for long lasting use.

OWNERS MANUALS: Originally placed in the glove compartment of each car. They contain a wealth of information on awareness, instruction and maintenance of your newly purchased car.

FISHER BODY MANUALS: These books are "Shop Manuals" for the Body of the car. Topics include Doors, Panels, Weatherstripping, Glass, Glass Channels and all interior. Fisher Body Manuals through 1948 deal with all G.M. Fisher Bodied Cars. Later years deal specifically with **BUICK** only.

CHASSIS AND BODY PARTS BOOKS: These books were sent to **BUICK** dealerships for their Parts Department Staff to recognize and identify parts. The illustrations within, enable you to find the "group" and "part number" of each part - then identify.

All items listed below are quality copied from genuine Buick originals. They are provided as informative tools for restoration purposes.

Shop Manuals		Fisher Manuals		Owners Manuals		Chassis & Body Parts Books	
1933-1936 ALL.....	SM336..... \$44.50						
1936 ALL.....	SM36..... \$37.50	BM36.....	\$20.00	OM36*....	\$14.75	PB2846..(740 pg.)..	\$79.50
1937 ALL.....	SM37..... \$39.50	BM378.....	\$20.00	OM37.....	\$14.75	PB2846..(740 pg.)..	\$79.50
1937-1939 ALL.....	SM379.... \$44.50						
1938 ALL.....	SM38..... \$38.50	BM378.....	\$20.00	OM38*...	\$14.75	PB2846..(740 pg.)..	\$79.50
1939 ALL.....	SM39..... \$30.00	BM390.....	\$20.00	OM39.....	\$14.75	PB2846..(740 pg.)..	\$79.50
NOTE: 1938 Shop Manuals is needed to supplement 1939 Shop Manual							
1940 ALL.....	SM40..... \$39.50	BM390.....	\$20.00	OM40...	\$17.50	PB2846..(740 pg.)..	\$79.50
1940-1942 ALL.....	SM402..... \$49.50						
1941 ALL.....	SM41..... \$39.50	BM412.....	\$16.50	OM41...	\$14.75	PB2846..(740 pg.)..	\$79.50
1942 ALL.....	SM42..... \$37.00	BM412.....	\$16.50	OM42.....	\$14.75	PB2846..(740 pg.)..	\$79.50
1946 ALL.....	SM46..... \$19.50	BM468.....	\$20.00	OM46.....	\$17.50	PB2846..(740 pg.)..	\$79.50
1946-1947 ALL.....	SM467.... \$37.50	BM468.....	\$20.00	OM47.....	\$17.50	PB429..(1435 pg.)	\$136.75
1948 ALL.....	SM489.... \$54.50	BM468.....	\$20.00	OM48...	\$14.75	PB429..(1435 pg.)	\$136.75
1949 SPECIAL.....	SM489.... \$49.50	BM468.....	\$20.00	OM49.....	\$17.50	PB429..(1435 pg.)	\$136.75
1949 SUPER, ROADMASTER.....	SM489.... \$49.50	BM49.....	\$20.00	OM49...	\$17.50	PB429..(1435 pg.)	\$136.75
1950 SPECIAL.....	SM50..... \$49.50	INC. IN SM50		OM50S...	\$14.75	PB429..(1435 pg.)	\$136.75
1950 SUPER, ROADMASTER.....	SM50..... \$49.50	INC. IN SM50		OM50...	\$17.50	PB429..(1435 pg.)	\$136.75
1951 ALL.....	SM51..... \$49.50	INC. IN SM51		OM51...	\$14.75	PB51.....	\$33.50
1952 ALL.....	SM52..... \$54.50	INC. IN SM52		OM52...	\$14.75	PB52.....	\$33.50
1952-1953 ALL.....	SM523.... \$49.50						
1953 SPECIAL.....	SM52..... \$54.50	INC. IN SM52		OM53	\$14.75	PB53.....	\$33.50
1953 ALL V-8.....	SM53..... \$39.50	INC. IN SM53		OM53...	\$14.75	PB53.....	\$33.50
1954 ALL.....	SM54..... \$49.50	INC. IN SM54		OM54.....	\$17.50	PB54.....	\$33.50
1955 ALL.....	SM55..... \$49.50	INC. IN SM55		OM55.....	\$15.00	PB55.....	\$33.50
1956 ALL.....	SM56..... \$49.50	INC. IN SM56		OM56.....	\$15.00	PB56.....	\$33.50
1957 ALL.....	SM57..... \$54.50	BM57...\$33.50		OM57...	\$16.50	PB57.....	\$33.50
1958 ALL.....	SM58..... \$54.50	BM58...\$33.50		OM58.....	\$17.00	PB58.....	\$33.50
1959 ALL.....	SM59..... \$59.50	BM59...\$33.50		OM59.....	\$17.50	PB59.....	\$33.50
1960 ALL.....	SM60..... \$59.50	BM60...\$33.50		OM60.....	\$14.75	PB60.....	\$33.50

We also have Shop manuals available on CD ROM Disc - Ask your sales agent for details

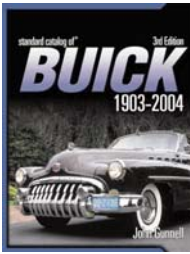

1903-2000 (Second Edition)
Standard Catalog for Buick. CD ROM. Illustrated features, articles and specifications. Includes grading system and price guide.

SG1CD.....\$20.00 ea.

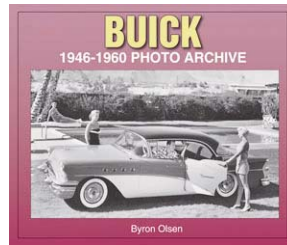

1946-1960
Buick Photo Archive. 130 pages. Cleanly reproduced photos from General Motors archives and other sources. Great gift idea.

PA1\$30.75 ea.

Shop Manuals on CDROM Disc

These computerized shop manuals will allow you to view the actual Buick publications on your computer screen or print them out for use in the shop. Most CD's also contain facts and figures for the model year(s) they cover. Our Cd's also include Chassis and Body Parts books at no extra charge.

- 1940 ALL:** 1940 Shop manual, 1928-1954 Buick Parts, 1940-1970 Buick Parts
SM40CD.....\$49.75
- 1942-1947 ALL:** 1942 Shop Manual, 1946-47 Shop Manual Supplement,
1928-1954 Buick Parts Book, 1940-1960 Buick Parts Book
SM427CD.....\$49.75
- 1948-1949 ALL:** 1948 Buick Shop Manual, 1949 Supplement, 1948-1950 Dynaflo Manual
1928-1954 Buick Parts Book, 1940-1960 Buick Parts Book
SM489CD.....\$49.75
- 1950 ALL:** 1950 Buick Shop Manual, 1948-1950 Dynaflo Manual, 1928-1954 Buick Parts Book
1940-1960 Buick Parts Book
SM50CD.....\$49.75
- 1951 ALL:** 1951 Buick Shop Manual, 1928-1954 Buick Parts Book, 1940-1960 Buick Parts Book
1948-1950 Dynaflo Manual
SM51CD.....\$49.75
- 1952-1953 ALL:** 1952 Buick Shop Manual, 1953 Supplement, 1928-1954 Buick Parts Book
1940-1960 Buick Parts Book
SM523CD.....\$51.25
- 1954 ALL:** 1954 Buick Shop Manual, 1928-1954 Buick Parts Book, 1940-1960 Master Body Parts
SM54CD.....\$51.25
- 1955 ALL:** 1955 Buick Shop Manual, 1940-1960 Buick Parts Book
SM55CD.....\$51.25
- 1956 ALL:** 1956 Buick Shop Manual, 1940-1960 Buick Master Body Parts Book
SM56CD.....\$51.25
- 1957 ALL:** 1957 Buick Shop Manual, 1957 Buick Body Manual, 1940-1960 Buick Parts Book
SM57CD.....\$51.25
- 1958 ALL:** 1958 Buick Shop Manual, 1958 Buick Body Manual, 1940-1960 Buick Parts Book
SM58CD.....\$51.25
- 1959 ALL:** 1959 Buick Shop Manual, 1959 Buick Body Manual, 1940-1960 Buick Parts Book
SM59CD.....\$51.25
- 1960 ALL:** 1960 Buick Shop Manual, 1959 Buick Body Manual, 1940-1960 Buick Parts Book
SM60CD.....\$51.25

Literature (Group 16)

Sales Brochures, Technical Books, Guides, Lists, etc. (16.700)

YEAR	DESCRIPTION	ITEM #	PRICE
1936	Dealer Service Bulletins. 70 pages of problem fixers.....	DSB36.....	\$12.75
1936-1941	"Good Housekeeping In Your Car". 11 page booklet on upholstery care	GH361	\$ 5.50
1936-1952	GM Interchange Book	IB52.....	\$18.25
1936-1953	"Users Guide". 65 page booklets containing over 80 topics and 196 suggestions, to get the most out of your BUICK. (Was put in glove box of all GM cars in this era).	UG363.....	\$ 11.75
1937	Dealer Service Bulletins. 92 pages of problem fixers.....	DSB37	\$15.25
1937	"1937 Buick Delivered Price List"	PS37.....	\$ 2.25
1937	"1937 Buick Accessories" card. A listing of accessories and retail prices.....	DC37	\$ 3.25
1938	Dealer Service Bulletins. 95 pages of "problem fixers".....	DSB38.....	\$17.00
1938	"1938 Buick Delivered Price List". Price card for all models & accessories.....	DC38	\$ 3.25
1939	"1939 Buick Delivered Price List". Price card for all models & accessories.....	DC39	\$ 3.25
1940	"1940 Buick Delivered Price List". Price card for all models & accessories.....	DC40	\$ 3.25
1941	"1941 Buick Delivered Price List". Price card for all models & accessories.....	DC41	\$ 3.25
1941	1941 Buick Restoration Facts by William C. Anderson. 204 page book - great.....	RFB41	\$ 42.25
1946	1946 Models and Accessories Price List	PS46.....	\$ 2.75
1948-1950	Dynaflow Drive Repair Manual (can be used through 1953)	DDB480.....	\$15.00
1949	"1949 Buick Delivered Price List". Price card for all models and accessories	DC49	\$ 3.25
1949	"Features" sales booklet. Illustrates outstanding features of 1949 Buicks	SB49.....	\$ 9.00
1949-1955	Ionia Body Parts book for Buick Estate Wagons.....	WPB495	\$15.00
1949-1957	GM Interchange book.....	IB57	\$18.50
1950	1950 Models and Accessories Price List.	PS50.....	\$ 2.75
1950	"Engineer Approved Accessories for 1950"	AL50	\$11.25
1951	"1951 Buick Delivered Price List"	PS51.....	\$2.25
1952	1952 Models and Accessories Price List.	PS52.....	\$ 2.25
1952	"Engineer Approved Accessories for 1952"	AL52	\$ 11.25
1953	Shop Manual. Same as previous page but bound poorly. Great for a working manual. This is the manual your not afraid to get greasy. 1/3 the price	SM53S.....	\$14.50
1953	1953 Models and Accessories Price List	PS53.....	\$ 2.50
1953	"Engineer Approved Accessories for 1953"	AL53	\$ 11.25
1953-1955	Air Conditioning Manual.	ACB534	\$11.00
1953-1960	Kelsey-Hayes Power Brake repair pamphlet	BB530.....	\$ 11.25
1954	1954 Models and Accessories Price List	PS54.....	\$ 2.50
1954	"Engineer Approved Accessories for 1954".	AL54	\$ 11.25
1955	1955 Models and Accessories Price List	PS55.....	\$ 2.50
1955	"Engineer Approved Accessories for 1955"	AL55	\$ 11.25
1956	1956 Models and Accessories Price List	PS56.....	\$ 2.75
1956	Power Steering System Repair Manual.	PSB56	\$ 10.00
1959	1959 Models and Accessories Price List	PS59.....	\$ 2.50

(Group 17) **Hardware • Push-In Wire Clips**



1/4" - 3/16" Hole size.
1/2" x 1/2".
MC3\$0.50 ea.
MC3B Box 100\$25.00 ea.



3/4" x 15/16" Head.
5/16" Hole size.
MC17\$0.50 ea.
MC17B Box 100\$25.00 ea.



1/2" Head diameter.
5/16" Hole size.
MC5\$0.50 ea.
MC5B Box 100\$25.00 ea.



A11/16" x 9/16" Head.
5/16" Hole size.
MC20\$0.50 ea.
MC20B Box 100\$25.00 ea.



1/2" Head diameter.
1/4" Hole size.
MC12\$0.50 ea.
MC12B Box 100\$25.00 ea.



1" x 7/8" Head.
5/16" - 3/8" Hole size.
MC21\$0.50 ea.
MC21B Box 50\$25.00 ea.



5/8" x 5/8" Head.
5/16" Hole size.
MC13\$0.50 ea.
MC13B Box 50\$14.00 ea.



7/8" x 7/8" Head.
5/16" - 3/8" Hole size.
MC22\$0.50 ea.
MC22B Box 50\$25.00 ea.



3/4" Head diameter.
5/16" - 3/8" Hole size.
MC16\$0.65 ea.
MC16B Box 100\$25.00 ea.



1" x 1 1/8" Head.
5/16" - 3/8" Hole size.
MC24\$0.50 ea.
MC24B Box 50\$12.50 ea.



www.oldbuickparts.com

908-369-3666

Hardware Section (Group 17)

Moulding Clips Threaded Type, (Nuts Included)

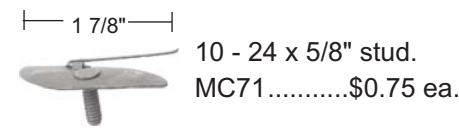
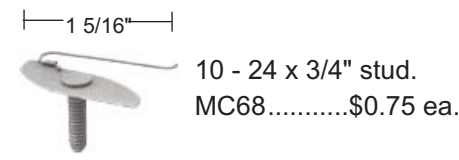
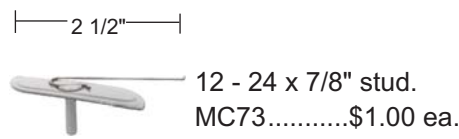
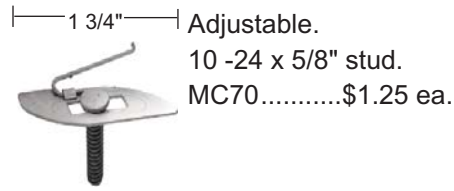
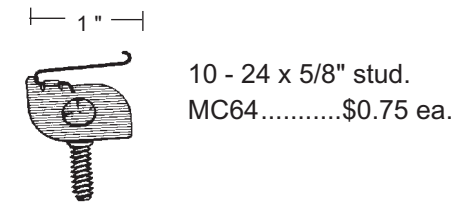
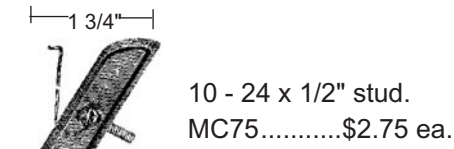
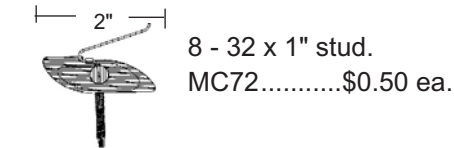
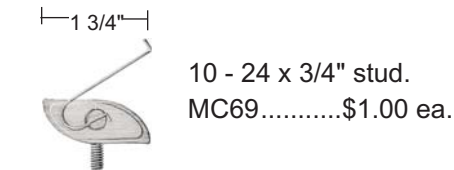
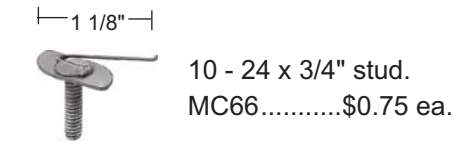
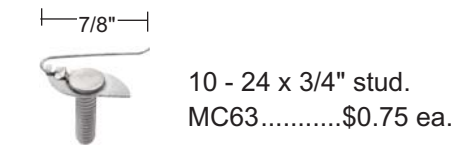

Universal Break-Off Type

10 - 24 x 3/4" stud.
MC1\$1.00 ea.



Door Panel Fasteners

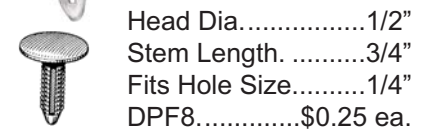
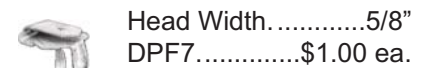
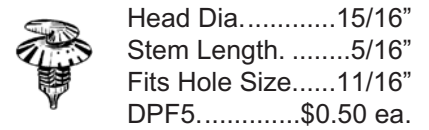
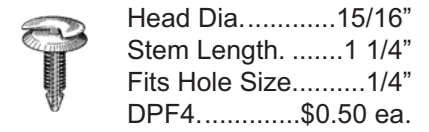
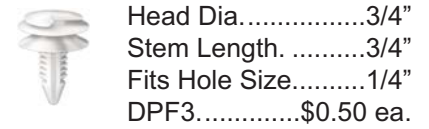
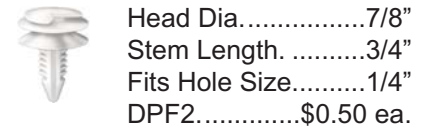
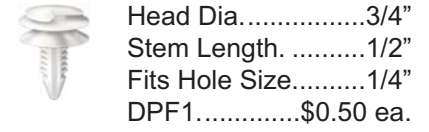

Misc. Retainers

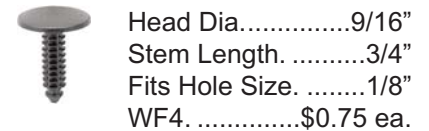
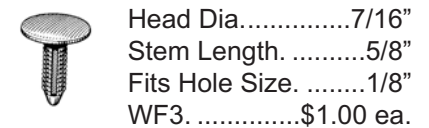
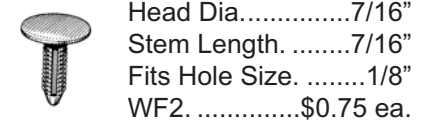

Push-In Clips

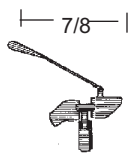

For 5/16" - 3/8" hole.
MC47\$0.75 ea.



5/16" hole.
MC49\$0.75 ea.

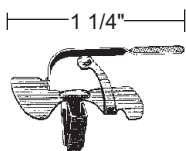

For 3/8" hole.
MC50\$0.75 ea.

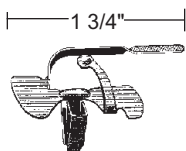

For 3/8" hole.
MC51\$2.25 ea.

Universal Wire Moulding Clips Push-in Type



5/16" - 1/2" Moulding.
3/8" Hole size.
MC29\$0.25 ea.
MC29B..Box 50..\$12.25 ea.

Nylon Clips

Push into oval holes in panels, then moulding snap over them.



MC84\$2.25 ea.



MC85\$2.25 ea.

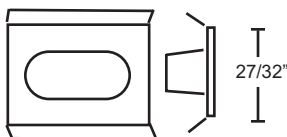

MC86\$2.25 ea.



MC86\$1.00 ea.

Chrome Trim Screws



#6 Chrome Plated Phillips Oval Head

TS612.....	6x1/2"\$0.25
TS658.....	6x5/8"\$0.25
TS634.....	6x3/4"\$0.25
TS678.....	6x7/8"\$0.25
TS6100.....	6x1"\$0.50
TS6114.....	6x1 1/4"\$0.50

#8 Chrome Plated Phillips Oval Head

TS8386.....	8x3/8" w/ #6 Head.....	\$0.25
TS812.....	8x1/2".....	\$0.25
TS8126.....	8x1/2" w/ #6 Head.....	\$0.50
TS858.....	8x5/8".....	\$0.25
TS8586.....	8x5/8" w/ #6 Head.....	\$0.25
TS834.....	8x3/4".....	\$0.50
TS8346.....	8x3/4" w/ #6 Head.....	\$0.50
TS83410.....	8x3/4" w/ #10 Head.....	\$0.50
TS878.....	8x7/8".....	\$0.50
TS8786.....	8x7/8" w/ #6 Head.....	\$0.50
TS8100.....	8x1".....	\$0.50
TS81006.....	8x1" w/ #6 Head.....	\$0.50
TS8118.....	8x1 1/8".....	\$0.50
TS81186.....	8x1 1/8" w/ #6 Head.....	\$0.50
TS8114.....	8x1 1/4".....	\$0.50
TS81146.....	8x1 1/4" w/ #6 Head.....	\$0.50
TS8112.....	8x1 1/2".....	\$0.50
TS81126.....	8x1 1/2" w/ #6 Head.....	\$0.50
TS81346.....	8x1 3/4" w/ #6 Head.....	\$0.75

#10 Chrome Plated Phillips Oval Head

TS1012.....	10x1/2".....	\$0.50
TS10128.....	10x1/2" w/ #8 Head.....	\$0.50
TS1058.....	10x5/8".....	\$0.50
TS1034.....	10x3/4".....	\$0.50
TS1000.....	10x1".....	\$0.50
TS10008.....	10x1" w/ #8 Head.....	\$0.50
TS10114.....	10x1 1/4".....	\$0.50
TS101126.....	10x1 1/2" w/ #6 Head.....	\$0.50
TS10134.....	10x1 3/4" w/ #6 Head.....	\$0.75
TS10200.....	10x2.....	\$0.50
TS10348.....	10x3/4" w/ #8 Head.....	\$0.50

Hardware Section (Group 17)

Windshield and Backglass Moulding Clips



1969-1975
1969-1970:
 LeSabre and Wildcat
 two door models.
 Backglass. 22 per car;

1971-1972: All Electra, LeSabre and
 Wildcat four door hardtops.
 Backglass. As required;

1971-1972: All Electra. Backglass. As
 required;

1973-1975: All windshield. Backglass
 and 1/4" glass. As required.

MC32.....\$0.75 ea.



1963-1965 Windshield &
 back glass. 26 needed per
 car.

1963-1966

MC91.....\$1.00 ea.



1968-1971
 1968: All with soft roof
 trim. Windshield upper
 and side. Backglass.
 As required;

1969-1971: All windshield and
 backglass. As required.

MC33.....\$0.75 ea.



1968-1973 All windshield and
 Backglass (Emergency) As required.

MC35.....\$1.00 ea.



1965-1968
 All windshield
 and Backglass.
 As required.

MC34.....\$1.00 ea.



1966-1975
 All as required.
 Windshield and
 Backglass.

(Emergency - screw-on type).

MC37.....\$1.75 ea.



1974-2015
 All as required.
 MC101....\$1.00 ea.

Other Windshield - Backglass Clips (Use as required)

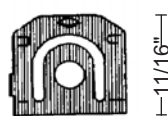

1 1/16"



1"

Windshield & backglass
 clips. Use as required.
 MC41\$0.75 ea.



3/4"

Windshield & backglass
 clips. Use as required.
 MC42.....\$0.75 ea.

Windshield & backglass
 clips. Use as required.
 MC43.....\$0.75 ea.



1 1/16"

Windshield & backglass
 clips. Use as required.
 MC44\$0.75 ea.



7/8"

Windshield & backglass
 clips. Use as required.
 MC39.....\$1.00 ea.

Window Rollers (see also window bearings on next page)



1 1/16"

1957 thru 1972
 all as required.
 WR576\$3.25



1978 thru 1995 all as
 required. 5/16" wide.
 WR785.....\$4.75 ea.



1969-1974 as
 required. 11/32" wide.
 WR694.....\$5.50 ea.



1"

1968 thru 1978 all
 as required. 7/16"
 wide.
 WR682\$6.50 ea.

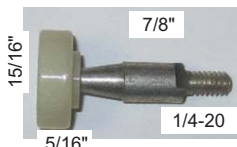

1968-1975 as required.
 5/16" wide.
 WR685.....\$3.75 ea.



1979-2004 as req.
 With metal insert.
 WR790.....\$3.75 ea.



1 1/16"

1972 thru 1999 all
 as required. 11/64"
 id.
 WR727\$2.25 ea.



1971-1980 as required.
 5/16" wide.
 WR710.....\$4.75 ea.



Tubular Nuts
(8.921)

For attaching monograms, emblems, etc. with studs. Measure your pin diameter and the size of the hole. Consider nylon tubular nuts. Although not original, they will not rust or chip paint.

Stud size 1/16" Hole size 9/64"
TN1.....Nylon\$0.50 ea.
TN1P.....Pack of 25\$7.75

Stud size 3/32" Hole size 1/8"
TN2.....Steel\$0.25 ea.
TN2P.....Pack of 25\$6.75

Stud size 1/8" Hole size 5/32"
TN3.....Steel\$0.25 ea.
TN3P.....Pack of 25\$6.75

Stud size 1/8" Hole size 11/64"
TN5.....Nylon\$0.50 ea.
TN5P.....Pack of 25\$9.75

Stud size 1/8" Hole size 3/16"
TN6.....Steel\$0.55 ea.
TN6P.....Pack of 25\$7.00

Stud size 1/8" Hole size 1/4"
TN7.....Steel\$0.50 ea.
TN7P.....Pack of 25\$8.75

Stud size 5/32" Hole size 7/32"
TN8.....Steel\$0.50 ea.
TN8P.....Pack of 25\$12.75

Stud size 5/32" Hole size 3/16"
TN9.....Nylon\$0.50 ea.
TN9P.....Pack of 25\$7.75

Stud size 3/16" Hole size 7/32"
TN10.....Steel\$0.50 ea.
TN10P.....Pack of 25\$8.75

Stud size 3/16" Hole size 13/64"
TN11.....Steel\$0.50 ea.
TN11P.....Pack of 25\$8.75

Stud size 1/4" Hole size 5/16"
TN12.....Steel\$0.65 ea.
TN12P.....Pack of 25\$7.00



Flat Nuts (8.921)

For attaching monograms, emblems, etc. with studs. Measure your stud diameter.

FN1.....1/16"\$0.25 ea.
FN1P.....Pack of 25\$4.75

FN2.....3/32"\$0.25 ea.
FN2P.....Pack of 25\$4.75

FN3.....1/8"\$0.25 ea.
FN3P.....Pack of 25\$4.75

FN4.....5/32"\$0.25 ea.
FN4P.....Pack of 25\$4.75

FN5.....3/16"\$0.25 ea.
FN5P.....Pack of 25\$4.75

FN6.....1/4"\$0.25 ea.
FN6P.....Pack of 25\$5.75

FN7.....5/16"\$0.25 ea.
FN7P.....Pack of 25\$5.75

Round Flat Nuts (8.921)



FN8.....1/8"\$0.25 ea.
FN8P.....Pack of 25\$5.75

FN9.....3/16"\$0.25 ea.
FN9P.....Pack of 25\$5.75

Cage Nuts /"U" Nuts

(8.155)



1935-1960 All as required. Cage nut.
CN363.....\$3.25 ea.



For 5/16"-18 Screw.
Range - .025" - .060"
Center of hole to edge - 9/16"

UN1\$.50 ea.
UN1B.....Box of 50\$17.00 ea.



For 3/8"-16 Screw.
Range - .050" - .200"
Center of hole to edge - 3/4"

UN2\$.75 ea.
UN2B.....Box of 25\$15.00 ea.

Thread Cutting Nuts



Sold in packs of 25 pieces (8.921)

For 1/8" stud. 5/16" Hex.
7/16" washer OD. Zinc plated.
TCN18516\$4.25 pack

For 1/8" stud. 1/4" Hex. Zinc plated.
TCN1814\$4.25 pack

For 5/16" stud. 1/2" Hex.
7/8" washer OD. Zinc plated.
TCN51612\$4.25 pack

For 5/32" stud. 11/32" Hex.
9/16" washer OD. Zinc plated.
TCN53238\$4.50 pack

For 3/16" stud. 3/8" Hex.
1/2" washer OD. Zinc plated.
TCN31638\$4.25 pack

For 1/4" stud. 7/16" Hex.
9/16" washer OD. Zinc plated.
TCN14716\$4.25 pack

Window Bearings



1968-1974 as required. low profile. 1 7/32" dia.
WB684A.....\$3.75



1968-1974 as required. 1" dia.
WB684B\$3.75



1968-1974 as required. 1" dia. high cap.
WB684C.....\$3.75

Buick License Plates

Laser Cut License Plates

These beautiful license plates are made of durable high impact acrylic and are approximately 3/16" thick. Hand inlaid design.

1913 Buick Logo



Black acrylic with bright red square. The "Buick" is shiny mirror like. LP1\$25.75

Buick Tri-Shield - Gold



Black acrylic with gold mirror lettering. Tri-Shield is red, white and blue inlay. LP9\$25.75

Buick Tri-Shield - Silver



Black acrylic with silver mirror lettering. Tri-Shield is red, white and blue inlay. LP8\$25.75

T-Type Turbo 6



Black acrylic with bright yellow/red laser cut and inlaid insignia. LP7\$25.75

Silk Screened License Plates

Heavy gauge embossed aluminum plate.

Buick Tri-Shield



Black with white shield and white "BUICK" lettering. LP2\$9.75

Buick Gold Hawk



Black with gold BUICK Hawk. Sharp! LP3\$9.75

GS by Buick



Black with red "GS" and white "Fast with Class" LP4\$9.75

Grand National



Black plate, red and yellow "6" with gold lettering. LP6\$9.75

Buick License Plates - Frames and Accessories

License Plate Frame Solid Brass



These heavy, **solid brass** frames have "BUICK" stamped in the center flanked by the buick tri-shield. Gold & Chrome (pictured) available.

- Gold - LP13\$25.75
- Chrome - LP12\$25.75

License Plate Grand National



Bad to the

- bone.
- LP19\$7.25

License Plate Cover Bubble Cover

Protect your License plate with this clear see-thru bubble cover.

- LP14\$15.50

Fender Covers

GSX Beats You in Stages



Heavy gauge with tool ridge

- FC5.....\$27.25

GS by Buick



A Quality fender cover with tool ridge

- FC3.....\$16.50

"GO BUICK"



These were found recently in the back room of an old Buick Dealership in Bayonne, NJ. Estimates are that these were from the 1970's.

- LP18\$6.25

Stainless Steel License Plates

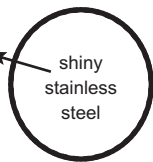

Shiny **Stainless Steel** license plate with clear lettering. Tri-Shield is red, white and blue.

- LP10 (Clear Letters)\$25.75
- LP11 (GOLD Letters)\$25.75
- LP20 (BLACK Letters)\$25.75

Index

B

Body to Frame Mounting Pads 82

Body Mount Bolts 83

Brakes 55

Drums 57

Hoses 57

Master Cylinder Resleeving Regular Brakes PB 55

Master Cylinders Power Brakes 55

Master Cylinders - Repair Kits 55

Moraine Brake Shafts (Pistons) 55

Overhaul Kits 56

Pedal Pads 58

Power Brake Master Cylinder Rebuilding Kits & Parts 55

Power Brake Unit Rebuilding Service 55

Shoes 57

Spring Kits 57

Wheel Cylinder Repair Kits 56

Wheel Cylinders 56

Bumpers 74

1946-1949 Bumper Emblems 74

Bolts 75

Details 74

Fillers 75

Make Your Own Fillers 75

Retaining Clips 75

C

Carpets • Mats 142

Carpet Sets 142

Front Floor Mats PB 142

Chrome Bolts 65

Complete Window Channel Kits 97

Convertible Roof Rail Weatherstrip 137

Adhesive Backed Bow Drill 137

Drain Tubes and Grommets 138

Front Bow Seals 138

Pillar Seals 138

Top Molding Clips 138

Convertible Top Hydro-lectric Systems 134

Control Valves 134

Firewall Pump Rebuilding Service 134

Firewall Pump Solenoid 134

Pump Reservoir and Bails 134

Tacking Strips 135

Top Cylinders 135

Top Frame Rebuilding Hardware Kit 134

Top Hose Sets 135

Window and Seat Cylinders 135

Convertible Top Parts 136

Convertible Tops 133

Boots 133

Bow Drill Cloth 133

Convertible Top Pad Kit 133

Deluxe Heavy Duty Vinyl 133

HAARTZ Stayfast Cloth Tops 133

Heavy Duty Vinyl 133

Top Frame Rebuilding Kits 133

Well Liners 133

Cooling 14

Cowl 88

Cowl Parts 88

Hood to Cowl Weatherstrips 88

D

Decals 9

Dome Lamps 120

Dome Lenses - Courtesy Lenses 120

Door Bumpers 105

Door Handles 106

1939-1958 Inner Door Handles 107

1939-1958 Window Cranks 107

Door Handle Ferrules 106

Door Lock Pairs with 2 Keys 106

Inner Door Handle Parts 107

Outer Door Handle Parts 106

Door Parts 108

Door Sills 121

Door Weatherstrip Sets 100

E

Engine 2

Aluminum Valve Covers 6

Camshaft Bearings 4

Camshafts Regrinding Service 4

Clutch Parts 8

Clutch Pilot Bearings 8

Clutch Throw Out Bearings 8

Connecting Rod Bearings 4

Freeze Plug Kits 7

Harmonic Balancer Rebuilding Service 5

Intake Valves 3

Main Bearing Sets 4

Motor Mounts 2

New Camshafts 4

Piston Ring Sets 5

Pistons 5

Push Rods 5

Rocker Arm Adjusting Ball 7

Rocker Arm Assembly Rebuilding Service 7

Rocker Arm Shafts 7

Rocker Arms 7

Timing Chain Sets with Iron Cam Gear 6

Timing Chains 6

Valve Cover & Spark Plug Cover Hardware 7

Valve Guides & Seals 3

Valve Seat Inserts 3

Engine Enamel 13

Engine Compartment and Chassis Paint 13

Spray Gun 13

Engine Gaskets 11

Misc. Oil Gaskets 12

Oil Pan Gaskets 12

Push Rod Cover Gaskets 12

Rear Main Seals 11

Timing Cover Gasket Sets 11

Timing Cover Gaskets & Seals 11

Valve Cover Gaskets 12

Water Pump & Manifold Gaskets 12

Exhaust 50

1957 Exhaust Deflecto 50

V-8 Exhaust Manifold Gaskets PB 46

Authentic Hangers/Supports 50

Index

Exhaust Deflectors 50
Exhaust Manifold French Locks PB 46
Universal Exhaust Hangers 50

F

Fenders 80

1955-1956 Rear Fender and Rear Door Scripts PB 80
1958 Front Fender Ornaments 80
1959 Front Fender Monograms 80
Fender Hardware 80
Porthole Inserts PB 80
Portholes 80

Firewall 85

Firewall Insulators 87

Floorpans • Rocker Panels • Trunk Pans 124

Frame 71

License Plate Frame 72
Miracle Paint 72
Rear Bumper Fillers (Gravel Deflectors) 72
Stabilizer Bar to Frame Bushings 71
Stabilizer Repair Kits 71
Tubing & Wiring Clip 72

Front Suspension

Front End Rebuilding Kits 68
Front Wheel Grease Seals 69
Lower Control Arm 67
Tie Rod End Adjusting Sleeve 68
Tie Rod Ends 68

Front Vent Window Seals 94

Vent Window Lock Repair Kit 95
Windshield Drain Tubes 94

Fuel • Carburetion 41

1935-1953 Carburetor Mounting Insulators 47
Accelerator Return Springs 47
Air Filters 47
Carburetor Dash Pots 47
Carburetor Rebuilding and Restoration Service 41
Carburetor to Intake Manifold Gaskets 42
Carter Baffle Plates 47
Carter Carburetor Rebuilding Kits 41
Choke Stove Pipe Replacement Kits PB 46
Choke Stove Pipe Insulator PB 46
Cover Plate Assembly 51
Fuel Bowl Gaskets 42
Fuel Pump Hardware Kits 51
Fuel Pump Rebuilding Kits 51
Gas Caps PB 48
Gas Filters 47
Gas Lines 51
Gas Pedals 50
Gas Tank Sending Units 1939-1958 48
Intake Manifold Gaskets PB 46
Intake Manifold Pilots PB 46
Intake Manifold Plugs PB 46
Intake Manifold/Carburetor Studs PB 46
Linkage Rod Clips 47
Rochester Carburetor Kits 42
Stromberg Carburetor Kits 42

G

Glass Channels and Supplies 99

Adhesive Backed Bow Drill 99

Upper Window Frames 99

Grille Emblem 14

H

Hardware • Push-In Wire Clips 149

"U" Nuts PB 153
Backglass Clips 152
Cage Nuts PB 153
Chrome Trim Screws 151
Flat Nuts 153
Nylon Clips 151
Push-In Clips 151
Push-In Wire Clips 149
Round Flat Nuts 153
Thread Cutting Nuts 153
Tubular Nuts 153
Universal Wire Moulding Clips Push-in Type 151
Window Bearings PB 153
Window Rollers 152
Windshield and Backglass Moulding Clips 152

Headlinings 139

Package Shelf Material 139
Trim Kits 139
Windlace Stops 139

Hood • Running Boards 78

Hood Corner Pads 78
Hood Insulation 1941-1960 78
Jack Case 78
Make You Own Fender Splash Aprons 78

Hood Bumpers 77

Hood Ornaments 76

Letters 76

Hood Parts 79

1942-1948 Hood Handle Frame 79
Hood Cables and Springs 79

I

Interior Parts 111

Adhesive Backed Bow Drill 114
Bow Drill Cloth 114
Glove Box Lock with Two Original Keys 112
Glove Boxes 112
Inside Rear View Mirror 111
Vanity Mirrors 111

L

Literature 146

Guides 148
Lists 148
Manuals 146
Parts Book 146
Sales Brochures 148
Technical Books 148

M

Mirrors PB 96

Replacement Mirror Head 96

Moulding 14

O

Oiling 18

Oil Filter Element 18
Oil Filter/Breather Cap 18

Index

Oil Pan Drain Plug and Gasket 18
Oil Pressure Switch 18
Oil Pump 18

Oiling Gasket 19

Oil Pan 19
Thermostat 19
Water Pump 19

P

Power Window Switches 110

R

Radio • Antenna • Under Dash 84

1937-1938 Antenna Insulators 84
1941-1953 Roof Mounted Antennas 84
1953-1960 Cigar Lighter Fuse 84
1954-1960 Front Fender Mounted Antenna Hardware 84
Air Duct Hose 84
Steering Column Jackets 84

Rear Axle 63

Backing Plate Gaskets-Shims 64
Differential Bearings 64
Pinion Bearings 64
Pinion Seals 64
Radius Rod Bushings 63
Rear Axle Carrier Gaskets 64
Rear Axle Cover Gaskets 64
Rear Axle Seals 64
Rear Wheel Bearings 64
Rubber Parts 63

Rear Fender 127

Rear Fender • Running Boards 81

1955-1956 Rear Fender and Rear Door Scripts 81
1958 Rear Fender Louvers 81
1958 Rocker Panel Clips 81
1959 & 1960 Rear Fender Fin Clips 81
Running Board Matting 81

Rear Quarter Seals 118

Adhesive Backed Bow Drill 118
Fixed Seals 118
Seals 118
Upper Chrome Frames 118
Window Parts 119

Rear Window Vulcanized Seals 116

S

Seat Belts 140

Chrome Lift Lever Style 140
Dress-up your Seat Belts 140
Hardware Kit 140
Metal Push Button Style 140
Plastic Push Button Style 140

Seat Parts 120

Door Jamb Switches 120
Hog Ring Pliers 120
Hog Rings 120
Power Seat Switches 120

Shocks 72

Lever Type Shocks 73
Rear Shock Links 73
Rebuild 73

Spinner Retainers 65

Spinners & Inserts 65

Springs 71

Coil Springs 71
Insulator Pad 71

T

Torque Ball • Propeller Shaft 61

Driveshaft Universal Joints PB 61
Dynaflow Torque Ball Sealing Kits 61
Retainer 61
Seal 61
Tube Gaskets-Shims PB 61

Transmission 52

Automatic Transmission Kits 53
Bands PB 53
Dynaflow Transmission Pan Gaskets PB 53
Seals PB 53
Speedometer Cables PB 53
Standard Transmission Gasket Kits PB 53
Transmission Mount Rebuilding 52

Trunk 128

Body Plugs 129
Floor Plugs 129
Lid Bumpers 129
Lid Parts PB 130
Sound Deadening Material 130
Trunk Locks (with 2 keys) 130
Trunk Plugs 129
Weatherstrips 128

Trunk Cardboard Panel Kits 144

Trunk Lid Ornaments 132

Trunk Lining Materials 143

Trunk Mounting Pads 131

Deck Handle Mounting Pads 131
Hinge Pads 131
Trunk Emblems 131

V

Vulcanized Windshield Seals

Division Post Seals 93
Rubber Extrusions 93

W

Wheels 66

1934-1960 Valve Stem Caps 66
1955; 1956-1957 Wheel Cover Inserts 66
1958 Wheel Cover Inserts 66
Curb Feelers 66
Hubcap Clips 66
Hubcaps 66
Trim Rings 66
Wheel Bolts 66

Windshield Wiper Parts 89

1959-1960 Optikleen Bottles & Caps PB 90
Blades 90
GM Lid Decal PB 90
Repair Kits PB 90
Trico Lid Decal PB 90
Washer Jars & Lids PB 90

Wire Wheels 65



www.oldbuickparts.com

NEVER CHANGE POINTS AGAIN!

UPGRADE TO AN ELECTRONIC IGNITION. FITS ENTIRELY INSIDE THE DISTRIBUTOR.
 INSTALLS AS QUICKLY AS CHANGING A SET OF POINTS. NO BLACK BOXES,
 COMPLICATED WIRING OR SPECIAL BRACKETS. ONLY TWO WIRES TO CONNECT.

IGNITOR ELECTRONIC IGNITION KITS	NO.	PRICE
8 CYLINDER		
1937-1953 ALL Straight 8, 6 volt, negative ground.....	PI1183N6	\$82.25
1937-1953 ALL Straight 8, 12 volt, negative ground (original distributor)	PI1183	\$74.75
1953-1956 ALL V-8 Mechanical advance under baseplate	<i>New Design - No Magnet Ring</i> PI1185LSC	\$69.50
1957-1974 ALL V-8 Except 215, 300, 340 Engines	<i>New Design - No Magnet Ring</i> PI1181LSC	\$69.50
1957-1974 ALL V-8	PI1181	\$67.50
1957-1974 ALL V-8 (IGNITOR II)	PI91181	NEW \$95.25
6 CYLINDER		
1968-1974 All	PI1162A	\$67.50
1962-1967 V-6 Engine.....	PI1164	\$67.50
1962-1967 V-6 Engine (Odd Fire)	PI1165	\$67.50
HIGH PERFORMANCE COILS (40,000 VOLT WITH STOCK APPEARANCE)		
1937-1953 ALL Straight 8, 6 volt, negative ground (BLACK).....	PC45011	\$35.75
1937-1953 ALL Straight 8, 6 volt, negative ground (CHROME)	PC45001	\$44.00
1953-1974 ALL (BLACK)	PC40011	\$29.50
1953-1974 ALL (CHROME) 12 v.....	PC40001	\$37.50
1953-1974 ALL (FOR IGNITOR II APPLICATIONS ONLY)(CHROME) 12 v.....	PC45001	NEW \$44.00
1953-1974 ALL (FOR IGNITOR II APPLICATIONS ONLY)(BLACK) 12 v.	PC45011	NEW \$35.75
Coil Bracket	CB350	\$6.75
Coil Bracket (CHROME).....	CB350C	\$9.50
HIGH PERFORMANCE SPARK PLUG WIRES		
Low 500 ohm/ft. resistance with spiral wound alloy to suppress electromagnetic radiation plus redundant current paths.		
V-8 7.0MM STOCK-LOOK CUSTOM SET		
1960-1967 Special, Skylark, GS (Ex 1967 GS 400)	PW708103	\$39.50
1953-1960 All	PW708103	\$39.50
1967-1966 Lesabre, Wildcat, Invicta, Electra, Riviera All 364,401,425 Engines.....	PW708105	\$39.50
1967 GS -400.....	PW708102	\$39.50
1968-1974 All 350, 400, 430, 455 w/o HEI	PW708102	\$39.50
6 CYLINDER 7.0MM STOCK-LOOK CUSTOM SET		
1968-1974 ALL.....	PW706101	\$39.50





www.oldbuickparts.com

CARS, LLC
205 Pearl Street
Neshanic Station, NJ 08853

Telephone Number: 908-369-3666 Fax: 908-369-7595

Catalog Order Form

YEAR CARB.
NAME SUPER, ROADMASTER
SERIES 40,50,70,4800,ETC.
BODY STYLE
ENGINE, CU. IN. AIR CONDITIONING

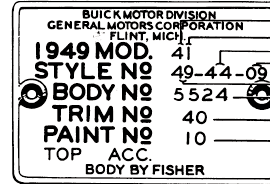

MODEL SERIES
BODY TYPE
MODEL SERIES
BODY TYPE
MODEL YEAR
FACTORY IDENTIFICATION
TRIM DESIGN AND MATERIAL
COLOR COMBINATION

MAILING OR CREDIT CARD BILLING ADDRESS

SHIPPING ADDRESS (if different)

NAME
ADDRESS
CITY STATE ZIP
DAYTIME TELEPHONE

NAME
ADDRESS
CITY STATE ZIP
EVENING TELEPHONE

NOTE: ALWAYS GIVE STREET ADDRESS: UPS AND TRUCK LINES CANNOT DELIVER TO POST OFFICE BOXES.

Table with 6 columns: QTY, GROUP NUMBER, PART NUMBER, DESCRIPTION, PRICE EACH, TOTAL PRICE OF ITEMS

Credit Card Information

Visa Mastercard Discover

IMPORTANT: COPY ACCOUNT NUMBER FROM YOUR CREDIT CARD

Expiration date boxes

EXPIRATION DATE OF CARD

MONTH YEAR

Summary table with rows: SUB TOTAL, US Shipping Add 10% (\$9.90 Min.), NJ Residents Add 6.085% Sales Tax, TOTAL AMOUNT

SIGNATURE

NOTE: ADDRESS ABOVE MUST BE EXACTLY AS IT APPEARS ON YOUR STATEMENT



www.oldbuickparts.com

CARS, LLC
205 Pearl Street
Neshanic Station, NJ 08853

Telephone Number: 908-369-3666 Fax: 908-369-7595

Catalog Order Form

YEAR CARB.
NAME SUPER, ROADMASTER
SERIES 40,50,70,4800,ETC.
BODY STYLE
ENGINE, CU. IN. AIR CONDITIONING

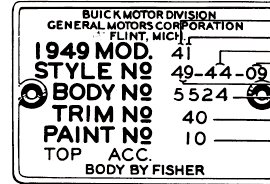

MODEL SERIES
BODY TYPE
MODEL SERIES
BODY TYPE
MODEL YEAR
FACTORY IDENTIFICATION
TRIM DESIGN AND MATERIAL
COLOR COMBINATION

MAILING OR CREDIT CARD BILLING ADDRESS

SHIPPING ADDRESS (if different)

NAME
ADDRESS
CITY STATE ZIP
DAYTIME TELEPHONE

NAME
ADDRESS
CITY STATE ZIP
EVENING TELEPHONE

NOTE: ALWAYS GIVE STREET ADDRESS: UPS AND TRUCK LINES CANNOT DELIVER TO POST OFFICE BOXES.

Table with 6 columns: QTY, GROUP NUMBER, PART NUMBER, DESCRIPTION, PRICE EACH, TOTAL PRICE OF ITEMS

Credit Card Information

Visa Mastercard Discover

IMPORTANT: COPY ACCOUNT NUMBER FROM YOUR CREDIT CARD

Expiration date boxes

EXPIRATION DATE OF CARD

MONTH YEAR

Summary table with rows: SUB TOTAL, US Shipping Add 10% (\$9.90 Min.), NJ Residents Add 6.085% Sales Tax, TOTAL AMOUNT

SIGNATURE

NOTE: ADDRESS ABOVE MUST BE EXACTLY AS IT APPEARS ON YOUR STATEMENT

Ordering Instructions

ORDER BY TELEPHONE or FAX. Monday through Friday, 8:30AM to 5:00PM. Other hours by chance.

Telephone: 908-369-3666

Fax: 908-369-7595.

ORDER BY MAIL. Please use Catalog Item Order Form, giving complete information requested. Order by Group and Part numbers where applicable. If you do not have enough space use back of the form or a plain piece of paper.

Shipping and Handling Charges

Shipping and Handling charges are estimated at 10% for most orders but not less than our \$9.90 minimum. We pay shipping on in stock orders over \$750.00 within the 48 states (Not included are custom made items, rebuilt or special orders, large items. Large items (fenders, hood, etc.) are shipped freight collect by common carrier and must be pre-paid by check. Foreign Customers please add 20% to order for shipping and handling. Additional shipping charges will apply to large or heavy items. (All Air Shipments, Blue Label, etc. are additional). We ship UPS & USPS unless specified.

Means of Payment



Personal Checks: We gladly accept your personal check. Returned checks will be subject to a \$35.00 retransmission fee.

Visa-Mastercard-Discover:

Foreign: All orders are payable in U.S. funds only. Any extra charges applied such as foreign interchange, duties, customs fees etc. are the responsibility of the customer and will be passed on accordingly.

Damages in Shipment

Damage in transit is the responsibility of the delivering carrier. Retain all packing materials and immediately contact the carrier to file your claim. Do not return damaged items to us as further shipping will result in the loss of claim settlement.

Guarantee - Returns

Your satisfaction is very important to us. If you are not satisfied with an item please phone and tell us why. We will accept any returnable item **within 30 days of the sale** (call first for authorization) provided it is in good unused condition and is returned prepaid with a copy of our receipt. We will then replace the item or refund the original cost. **Parts returned through no fault of CARS, Inc. will be subject to a restocking charge.** Not included in this policy are custom made items such as yard goods, carpets etc., electrical items, and some used parts. Custom items, if made incorrectly with be repaired, not refunded. Labor charges are not refundable. Returns will effect discount and free shipping programs. Expedited delivery charges are not returnable under any circumstances.

Back Orders

In the event an item is not in stock at the time of the order, we will back order until the item comes in or for 30 days at which time you may request a refund.

Subject to Change

All prices, part numbers, specifications, policies and terms are subject to change without notice. All parts subject to prior sale. Always double-check when ordering. Availability is not guaranteed.

Quantity Discount

We will extend a quantity discount of 10% on orders of new parts totalling over \$1,000.00 paid for by cash, check, or postal money order. Excluded are custom made items and all services. Friends and club members should find this advantageous by combining their orders to meet the quantity discount. All items, however, will be shipped to one address. Actual shipping charges will apply.

DEALER INQUIRIES WELCOME

Come visit our Showroom

Appointments recommended

CARS, LLC

205 Pearl Street

Neshanic Station, NJ 08853

Phone: 908-369-3666

Fax: 908-369-7595

Website: www.oldbuickparts.com



TM



CARS, Inc.

205 Pearl St.

Neshanic Station, NJ 08853

(908) 369-3666 Phone

(908) 369-7595 Fax



www.oldbuickparts.com

