

Galaxy VM

160–225 kVA 480 V,
160–200 kVA 400 V

Operation

10/2016



Legal Information

The Schneider Electric brand and any registered trademarks of Schneider Electric Industries SAS referred to in this guide are the sole property of Schneider Electric SA and its subsidiaries. They may not be used for any purpose without the owner's permission, given in writing. This guide and its content are protected, within the meaning of the French intellectual property code (Code de la propriété intellectuelle français, referred to hereafter as "the Code"), under the laws of copyright covering texts, drawings and models, as well as by trademark law. You agree not to reproduce, other than for your own personal, noncommercial use as defined in the Code, all or part of this guide on any medium whatsoever without Schneider Electric's permission, given in writing. You also agree not to establish any hypertext links to this guide or its content. Schneider Electric does not grant any right or license for the personal and noncommercial use of the guide or its content, except for a non-exclusive license to consult it on an "as is" basis, at your own risk. All other rights are reserved.

Electrical equipment should be installed, operated, serviced, and maintained only by qualified personnel. No responsibility is assumed by Schneider Electric for any consequences arising out of the use of this material.

As standards, specifications, and designs change from time to time, please ask for confirmation of the information given in this publication.

Table of Contents

Important Safety Instructions — SAVE THESE INSTRUCTIONS	5
Safety Precautions	6
Overview of UPS User Interface	7
Overview of Mimic Diagram	8
Overview of Status LEDs	8
Display Menu Tree	8
Display Menu Tree – UPS	9
Display Menu Tree – Frequency Converter with Batteries	10
Display Menu Tree – Frequency Converter	11
Display Symbols	11
Overview of Controller Interface	12
Configuration	13
Add a New User or Edit an Existing User	13
Delete a User	13
Configure the Display Preferences	14
Configure the Display Settings	14
Configure the UPS Output Voltage Compensation	15
Configure High Efficiency Mode	16
Configure the Redundancy Level of the Parallel System	17
Configure the Input Contacts	17
Configure the Output Relays	18
Configure Reminder Settings	19
Configure Battery Alarm Threshold	19
Configure Automatic Battery Test	20
Configure the Network	21
Configure the Modbus	22
Restore Default Configuration	23
Operation	24
Operation Modes	24
UPS Operation Modes	24
System Operation Modes	27
Operation Procedures	28
Access Password-Protected Screens	28
View the System Status Information	29
Operation Procedures for Single UPS Systems	32
Operation Procedures for Parallel UPS Systems	36
Operation Procedures for Frequency Converter Systems	41
Start a Boost Charge of the Batteries	41
Access a Configured Network Management Interface	42
Maintenance	43
Replace the Top Filter	43
Replace the Three Bottom Filters	44
Troubleshooting	45
Troubleshooting via the Mimic Diagram LEDs	45
Input LED	45
Inverter LED	45

Load LED	45
Battery LED	46
Bypass LED	46
Reboot the Display	46
Reset the Password	47
Logs	47
View the NMC Log	47
View the UPS Log	49
Export Data from Logs	49
View the Active Alarms	50
Alarm Levels	50
Alarm Messages	50
Tests	55
Perform a Battery Test	55
Perform a Runtime Calibration	55
Perform an Annunciators Test	56
Calibrate the Display	56
Determine if you need a Replacement Part	56
Find the UPS Serial Number	57
Return Parts to Schneider Electric	57

Important Safety Instructions — SAVE THESE INSTRUCTIONS

Read these instructions carefully and look at the equipment to become familiar with it before trying to install, operate, service or maintain it. The following safety messages may appear throughout this manual or on the equipment to warn of potential hazards or to call attention to information that clarifies or simplifies a procedure.



The addition of this symbol to a “Danger” or “Warning” safety message indicates that an electrical hazard exists which will result in personal injury if the instructions are not followed.



This is the safety alert symbol. It is used to alert you to potential personal injury hazards. Obey all safety messages with this symbol to avoid possible injury or death.

DANGER

DANGER indicates a hazardous situation which, if not avoided, **will result in death or serious injury**.

Failure to follow these instructions will result in death or serious injury.

WARNING

WARNING indicates a hazardous situation which, if not avoided, **could result in death or serious injury**.

Failure to follow these instructions can result in death, serious injury, or equipment damage.

CAUTION

CAUTION indicates a hazardous situation which, if not avoided, **could result in minor or moderate injury**.

Failure to follow these instructions can result in injury or equipment damage.

NOTICE

NOTICE is used to address practices not related to physical injury. The safety alert symbol shall not be used with this type of safety message.

Failure to follow these instructions can result in equipment damage.

Please Note

Electrical equipment should only be installed, operated, serviced, and maintained by qualified personnel. No responsibility is assumed by Schneider Electric for any consequences arising out of the use of this material.

A qualified person is one who has skills and knowledge related to the construction, installation, and operation of electrical equipment and has received safety training to recognize and avoid the hazards involved.

Safety Precautions

⚠ DANGER

HAZARD OF ELECTRICAL SHOCK, EXPLOSION OR ARC FLASH

All safety instructions in this document must be read, understood and followed.

Failure to follow these instructions will result in death or serious injury.

⚠ DANGER

HAZARD OF ELECTRICAL SHOCK, EXPLOSION OR ARC FLASH

After the UPS system has been electrically wired, do not start up the system. Start-up must only be performed by Schneider Electric.

Failure to follow these instructions will result in death or serious injury.

Overview of UPS User Interface

The user interface consists of:

- A. Display interface
- B. Status LEDs
- C. Mimic diagram
- D. Inverter ON button
- E. Inverter OFF button
- F. USB port for export of logs
- G. Display reset button
- H. Network connection LED:
 - Solid green: The system has valid TCP/IP settings.
See *Configure the Network, page 21*.
 - Flashing green: The system does not have valid TCP/IP settings.
 - Solid orange: The display is inoperable. Contact Schneider Electric.
 - Flashing orange: The system is making BOOTP requests.
See *Configure the Network, page 21*.
 - Alternately flashing green and orange: If the LED is alternately flashing slowly, the system is making DHCP requests.
See *Configure the Network, page 21*.
 - If the LED is alternately flashing rapidly, the system is starting up.
 - Off: The display is not receiving input power or the display is inoperable.
- I. LED for indication of network connection type:
 - Solid green: The system is connected to a network operating at 10 Megabits per second (Mbps).
 - Flashing green: The system is receiving or transmitting data packets at 10 Megabits per second (Mbps).
 - Solid orange: The system is connected to a network operating at 100 Megabits per second (Mbps).
 - Flashing orange: The system is receiving or transmitting data packets at 100 Megabits per second (Mbps).
 - Off: One or more of the following exists: The display is not receiving input power, the cable that connects the system to the network is disconnected, the device that connects the system to the network is turned off, or the display is inoperable. Check the connections and if the LED remains off, contact Schneider Electric.
- J. Slots reserved for service.

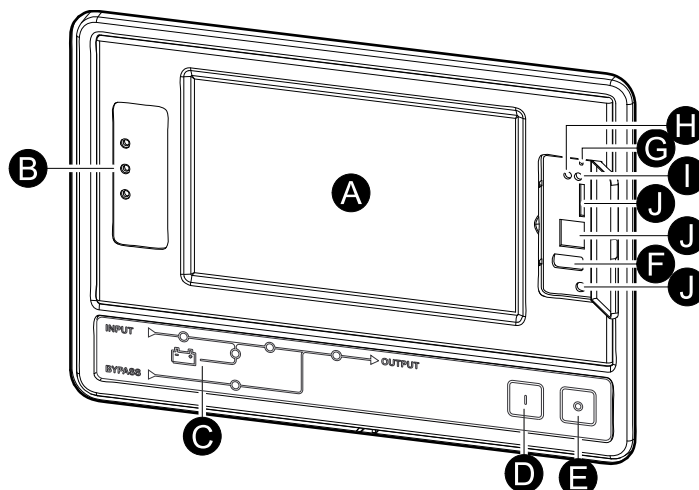

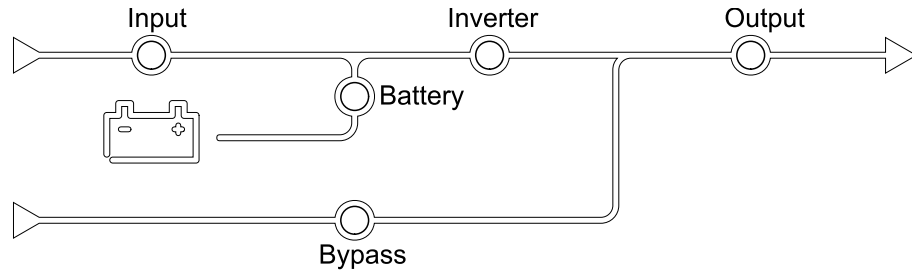

Overview of Mimic Diagram





The mimic diagram shows the power flow through the UPS system, and the status of the main functions.

Each LED can be in one of the below three states:

Green	The corresponding function is active and OK	
Red	The corresponding function is not working properly	
Off	The corresponding function is not active	

Overview of Status LEDs

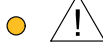
The status LEDs placed next to the display interface shows the current status of the UPS system:

  	<ul style="list-style-type: none"> • Green: The load is protected • Green + Orange: The load is protected, but the system reports an alarm at warning level • Orange + Red: The load is unprotected and the system reports an alarm at warning level and an alarm at critical level • Red: The load is unprotected and the system reports an alarm at critical level
---	--

Display Menu Tree

The menus available are dependent on how the system is configured to operate:

- As a UPS
- As a frequency converter with batteries
- As a frequency converter

Display Menu Tree – UPS

NOTE: The control and configuration screens are password-protected.

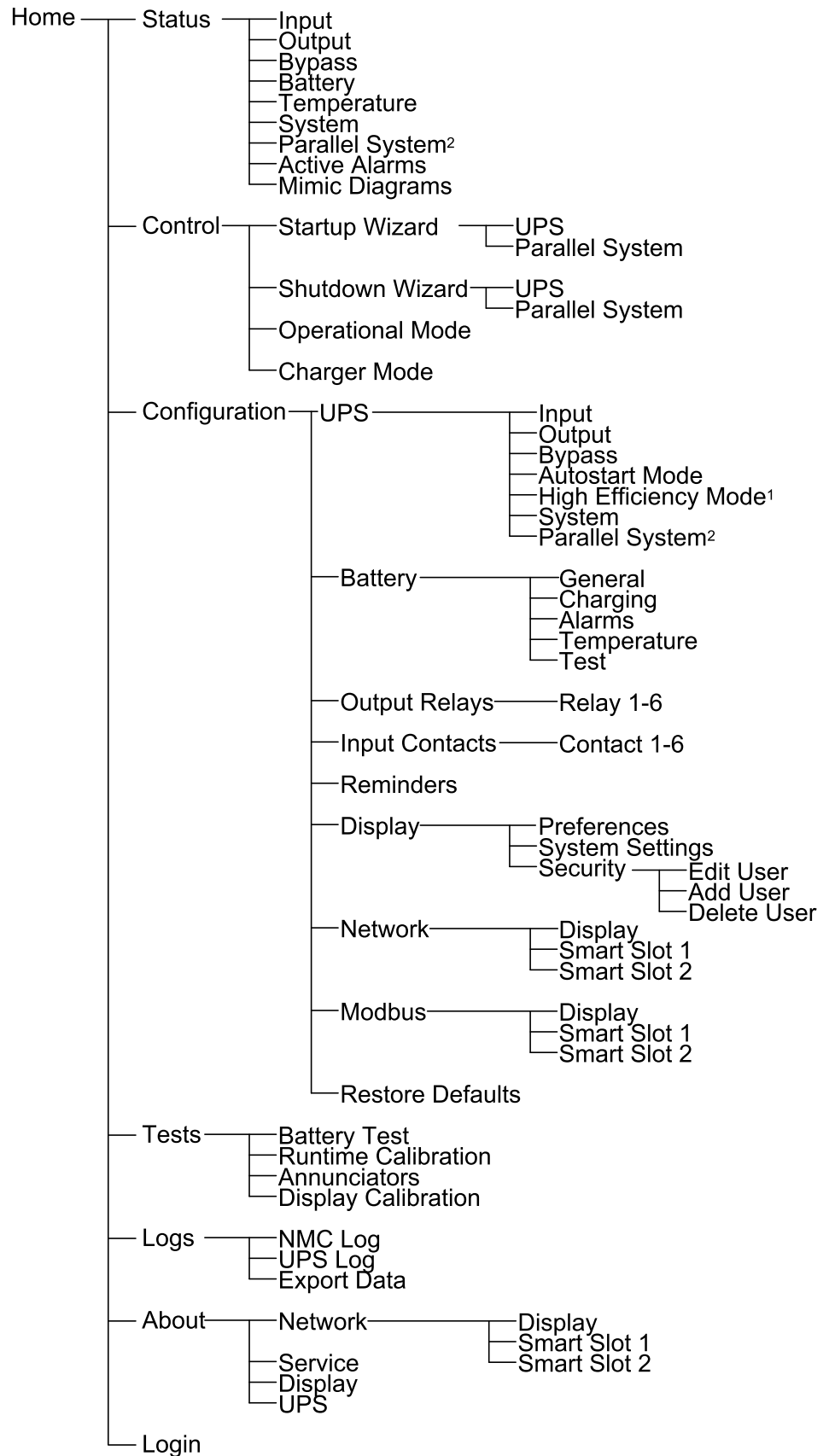

¹ Only available in single systems

² Only available in parallel systems

Display Menu Tree – Frequency Converter with Batteries

NOTE: The control and configuration screens are password-protected.

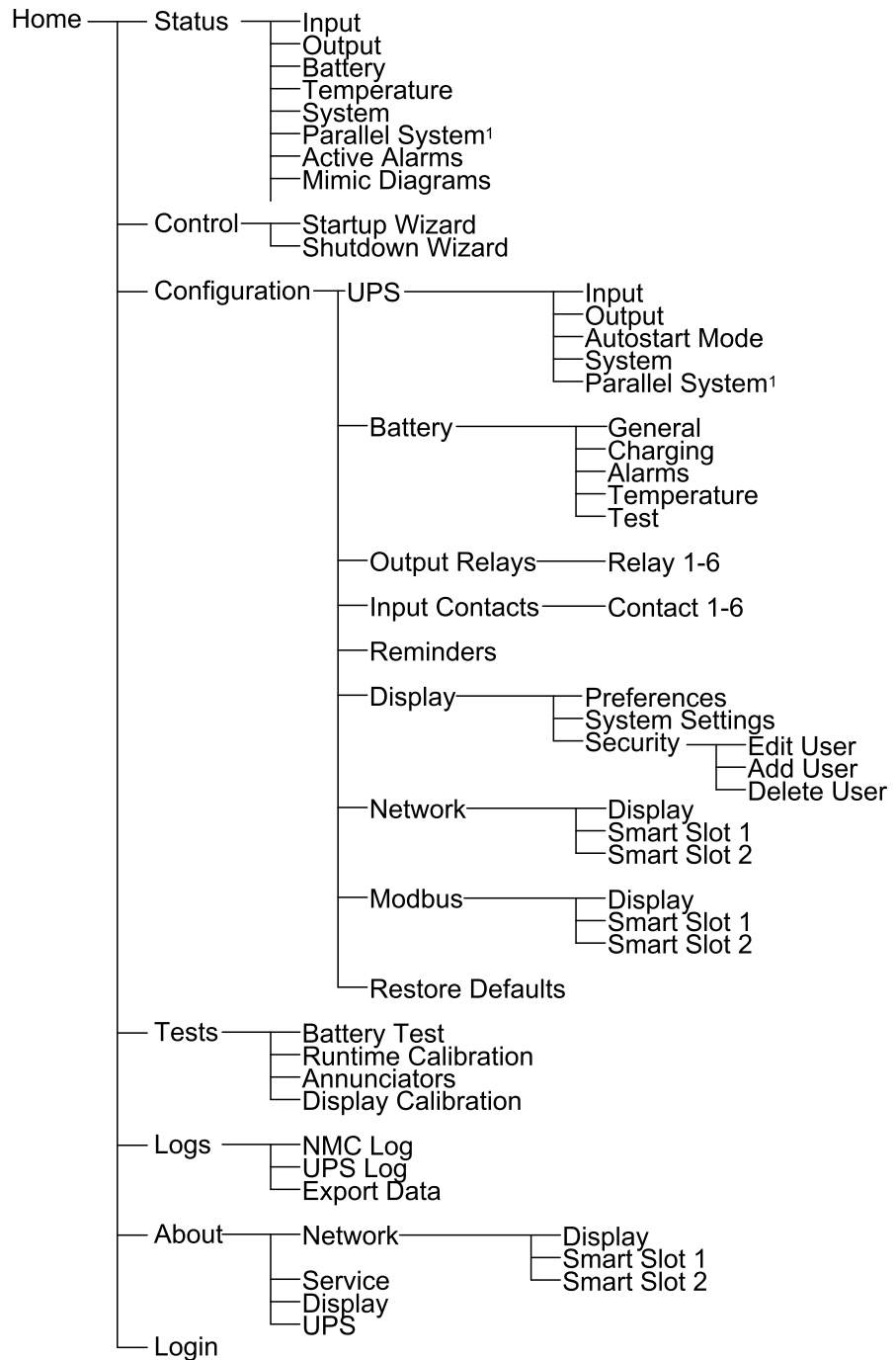



¹ Only available in parallel systems

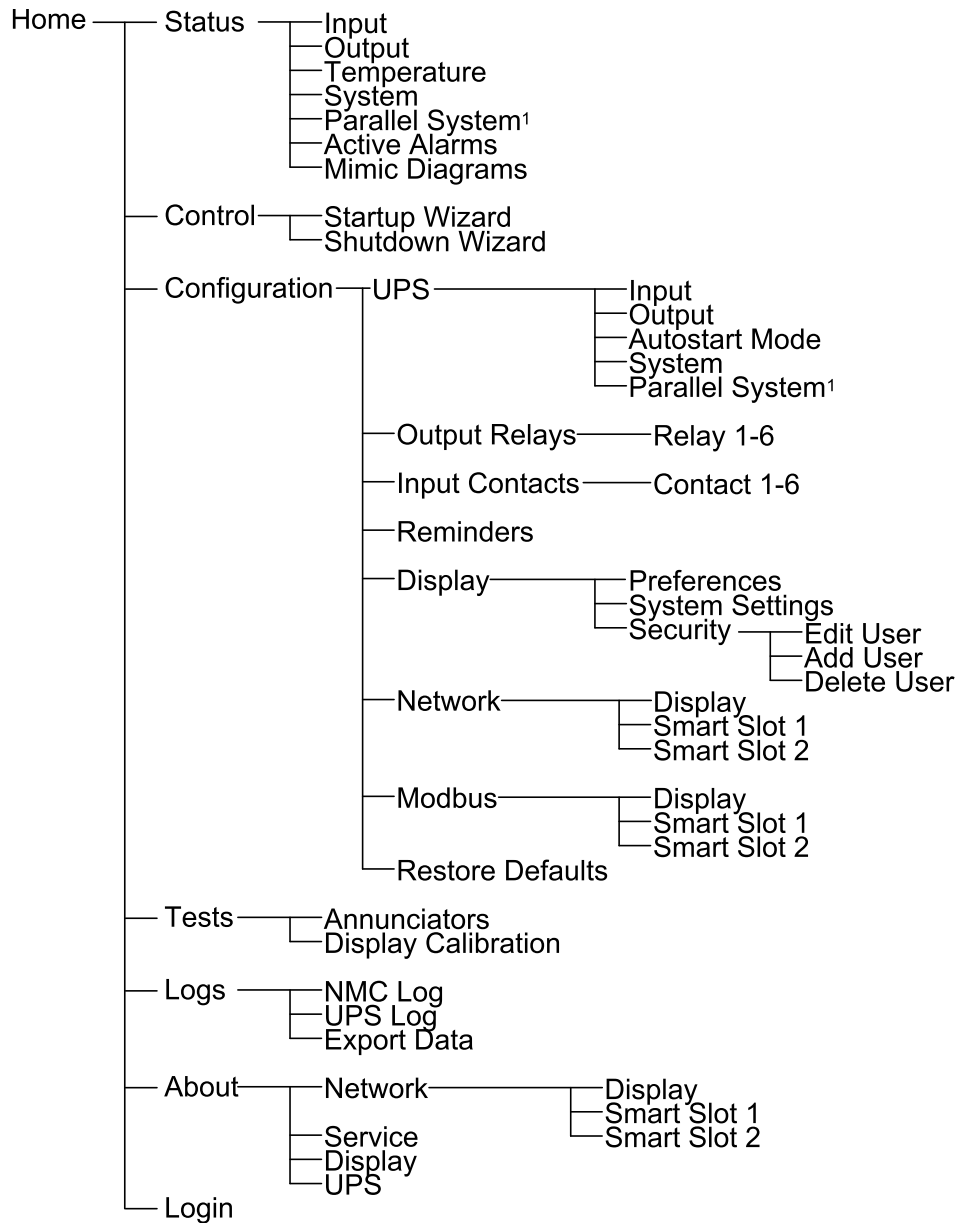

Display Menu Tree – Frequency Converter



¹ Only available in parallel systems

Display Symbols

Symbol	Description
	The locked home button appears when the system is locked by a password protection. Tap this button to go to the home screen of the display.
	The unlocked home button appears when the system has been unlocked using the password. Tap this button to go to the home screen of the display.
	Tap the OK button to confirm your selections and exit the current screen.

Symbol	Description
	Tap the ESC button to cancel your changes and exit the current screen.
	Tap the filter button to set up the filters for your logs.
	Tap the recycle bin button to clear the log.

Overview of Controller Interface

Front View of Power Cabinet

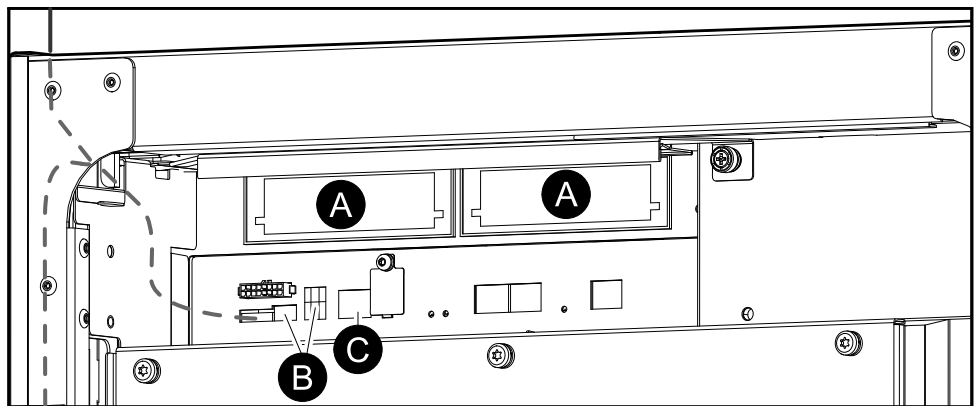

- A. Two Smart Slots for optional Network Management Cards
- B. Modbus and modbus dip switch settings
- C. Ethernet

Configuration

Add a New User or Edit an Existing User

1. From the home screen on the display select **Configuration > Display > Security**.
2. Select **Add User** to add a new user or select **Edit User** to edit an existing user of the system.



The screenshot shows a configuration screen with a top navigation bar. The navigation bar contains a home icon and four buttons: 'Configuration', 'Display', 'Security', and 'Add User'. Below the navigation bar, there are three input fields labeled 'Name:', 'Pin:', and 'Confirm Pin:'. At the bottom right of the screen, there are two buttons labeled 'ESC' and 'OK'.

3. In the **Name** field, type in the name of the user. Complete with **Enter**.
4. In the **Pin** field, type in a pin code for the user. Complete with **Enter**.
5. In the **Confirm Pin** field, retype the pin code of the user. Complete with **Enter**.
6. Tap **OK** to save your settings.

Delete a User

1. From the home screen on the display select **Configuration > Display > Security > Delete User**.
2. Browse to the user that you wish to delete using the up and down arrows and tap **OK**.
3. Tap **Yes** to confirm deletion of an existing user of the system.

Configure the Display Preferences

- From the home screen on the display select **Configuration > Display > Preferences**.

- Select the preferred language using the up and down arrows.
 - Select the preferred date format using the up and down arrows.
 - Select the preferred temperature units: US Customary (°Fahrenheit) or Metric (°Celsius).
 - Set the current date and time using one of the below two methods:
 - Set the date and time manually on the display by selecting **Manual** and typing the actual date and time and completing with **Enter**.
 - Set the date and time automatically by selecting **Synchronize with the NTP server** (Network Time Protocol server).
- NOTE:** NTP server settings can be configured in the network management interface via the Web.
- Tap **OK** to save your settings.

Configure the Display Settings

- From the home screen on the display select **Configuration > Display > System Settings**.

- Set the **Alarm Volume**. Choose between: **Off**, **Low**, **Medium**, and **High**.

3. Set the **Button Volume**. Choose between: **Off**, **Low**, **Medium**, and **High**.
4. Set the **Brightness** of the display. Choose between: **Low**, **Medium**, and **High**.
5. Enable or disable **Backlight Timeout**. If you wish to enable backlight timeout, set the time limit in minutes for enabling backlight timeout. Choose between: **60**, **30**, **10**, **5**, and **1**.
6. Set the intensity of the backlight. Choose between: **Off**, **Very Low**, **Low**, and **Medium**.
7. Set the time limit in minutes for automatic log off. Choose between: **60**, **30**, **10**, **5**, and **1**.
8. Tap **OK** to save your settings.

Configure the UPS Output Voltage Compensation

1. From the home screen on the display select **Configuration > UPS > Output**.
2. Tap arrow to the right to go to the next output configuration screen.

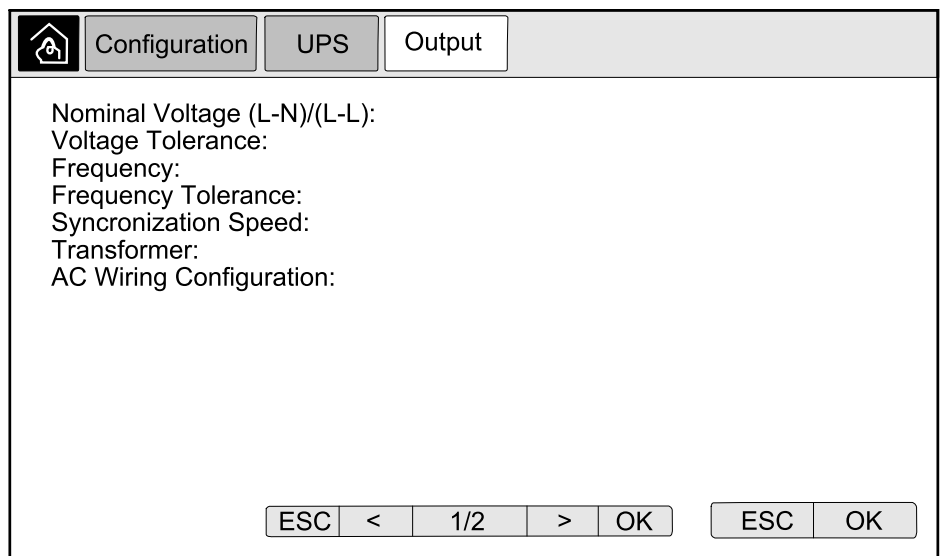

3. Under **Voltage Compensation** select the preferred voltage compensation for your system. Choose between **-3%**, **-2%**, **-1%**, **0%**, **1%**, **2%**, or **3%**.

NOTE: This setting is shared between all UPSs in a parallel system.

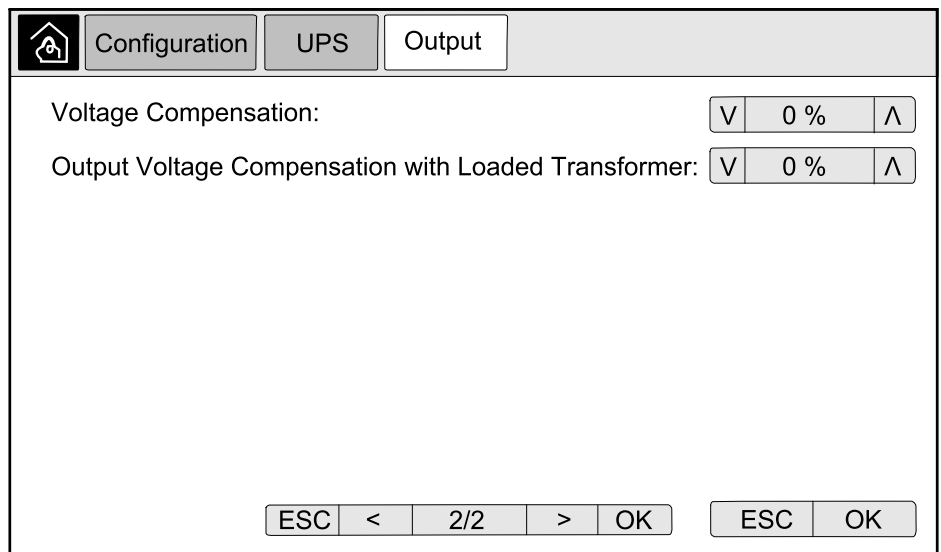

- 4. Under **Output Voltage Compensation with Loaded Transformer** select the preferred output voltage compensation to compensate for load dependent transformer voltage drop. Choose between **0%**, **1%**, **2%**, or **3%**.

NOTE: This setting must be identical for all UPSs in a parallel system.

NOTE: When this setting is set to 0%, the output transformer voltage compensation is disabled.

- 5. Tap **OK** to confirm your setting.

Configure High Efficiency Mode

NOTE: ECO Mode must be enabled by Schneider Electric during service configuration to make this selection available.

- 1. From the home screen on the display select **Configuration > UPS > High Efficiency Mode** and configure the following settings:

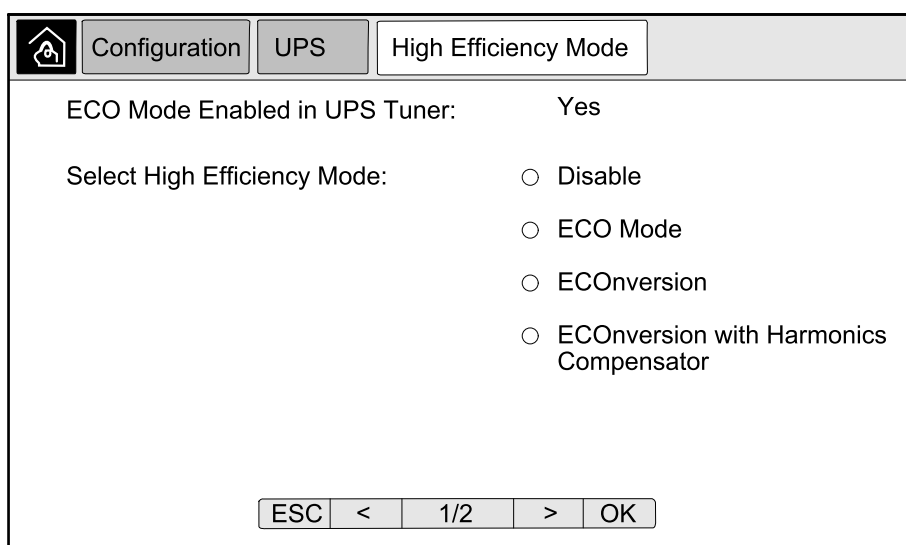

- a. **Select High Efficiency Mode:** Choose between **Disable**, **ECO Mode**, **ECONversion**, and **ECONversion with Harmonics Compensation**.

- 2. Tap > and configure the schedule settings:

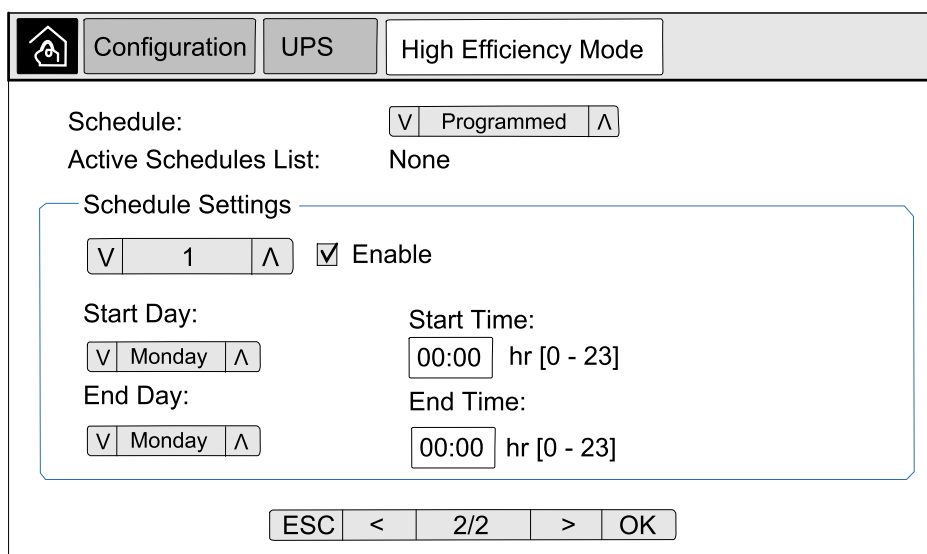

- a. **Schedule:** Select when the system should enter the selected ECONversion or ECO mode. Choose between **Always**, **Programmed** and **Never**.
- b. **Active Schedules List:** If you chose **Programmed** above, select **Enable** and set the time and date for when the system should enter the selected ECONversion or ECO mode.

3. Tap **OK** to confirm your settings.

Configure the Redundancy Level of the Parallel System

This procedure sets the redundancy level of your parallel system. The parallel system can contain up to five UPS units:

- a 4+1 system with four UPS units in capacity and one in redundancy
- a 5+0 system with five UPS units for capacity

1. From the home screen on the display select **Configuration > UPS > Parallel System**.

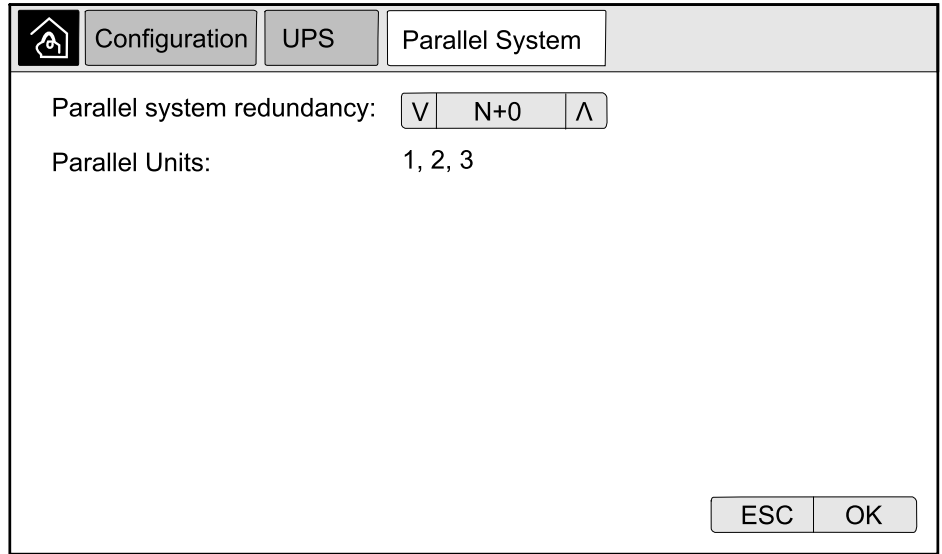

2. Under **Parallel system redundancy** select the redundancy for your UPS system. Choose between **N+0, N+1, N+2, N+3, N+4**.
3. Tap **OK** to confirm your setting.

Configure the Input Contacts

1. On the display select **Configuration > Input Contacts** and select the input contact that you wish to configure.

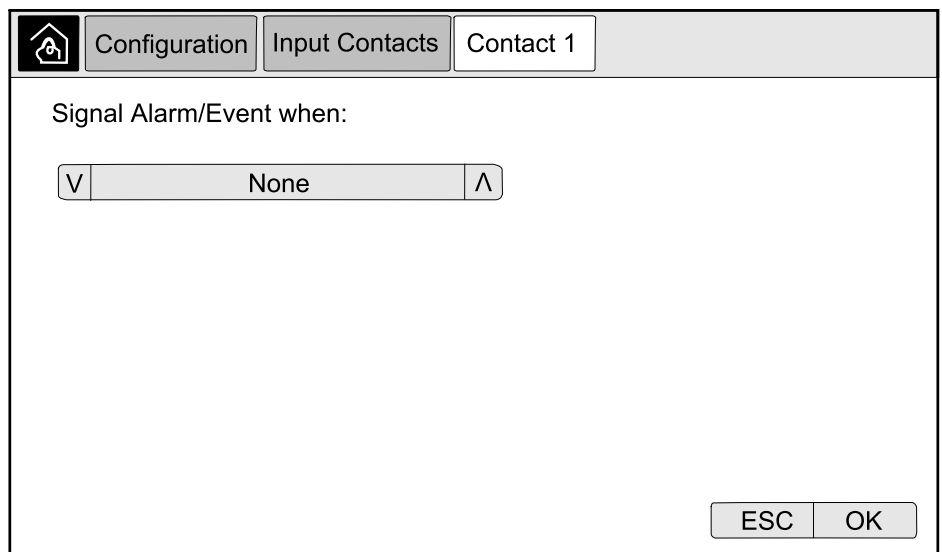

- Choose between the below six options:

Custom Input 1	External Battery Monitor Detected Fault
Custom Input 2	Battery Room Ventilation Inoperable
Ground fault	Supplied By Genset
Flywheel inoperable	Disable High Efficiency Mode

- Tap **OK** to save your settings.

Configure the Output Relays

- On the display select **Configuration > Output Relays** and select the output relay that you wish to configure.
- Select the function that you wish to use the specific output relay for from the list below:

Common Alarm	Normal Operation
Battery Operation ¹	Maintenance Bypass ²
Static Bypass ¹	High Efficiency Mode
Output Overload	Fan Inoperable
Battery is not Working Correctly ¹	Battery Disconnected ¹
Battery Voltage Low ¹	Input Out of Tolerance
Bypass Out of Tolerance ²	UPS Warning
UPS Critical	Parallel Redundancy Lost
External Fault	UPS Maintenance Mode
System Critical	System Warning
System Common Alarm	

- Set the delay in seconds for the specific output to activate. Select a value between 0 and 60 seconds.
- Tap **OK** to save your settings.

1. Not available when operating as a frequency converter without batteries
 2. Not available when operating as a frequency converter

Configure Reminder Settings

When the air filters have been replaced, the reminders settings must be updated.

1. From the home screen on the display select **Configuration > Reminders**.

Setting	Value	Range
Reminders Signalling	<input checked="" type="checkbox"/> Enable	
<u>Air Filter Check</u>		
Reminder:	<input checked="" type="checkbox"/> Enable	
Duration before 1st Reminder:	52 weeks	[1 - 500]
Elapsed Time:	0 days	[0 - 3650]
Remaining Time:	0 days	
Remaining Reminders:	3	
Reminder Status	In progress	

2. Configure the following settings:
 - a. **Reminders Signalling:** Select **Enable** to enable the display of all reminders.
 - b. **Reminder:** Select **Enable** to enable the display of reminders for air filter replacement.
 - c. **Duration before 1st Reminder:** Set the time in weeks before the first reminder is shown.
 - d. **Elapsed Time:** Manually set the number of days that the air filters have been used.
3. Tap **OK** to confirm your settings.

Configure Battery Alarm Threshold

1. From the home screen on the display select **Configuration > Battery > Alarms**.

Low Battery Shutdown Level:	1.68 V/cell
Low battery alarm threshold:	240 sec [60 - 6000]

2. Select your preferred battery alarm threshold in seconds. Select a value between 60 and 6000 seconds and complete with **Enter**.

3. Tap **OK** to confirm your setting.

Configure Automatic Battery Test

1. From the home screen on the display select **Configuration > Battery > Test**.

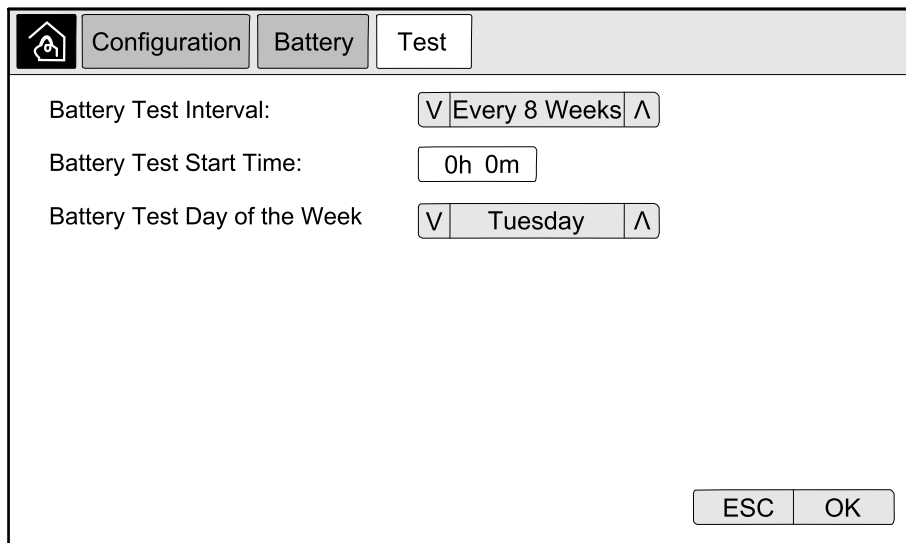

2. Set your preferred settings for the automatic battery test:
 - a. **Battery Test Interval:** Select your preferred interval for battery tests. Choose between: **Never, Every 52 Weeks, Every 26 Weeks, Every 12 Weeks, Every 8 Weeks, Every 4 weeks, Every 2 Weeks, or Once a Week.**
NOTE: If you run battery tests too frequently it can reduce the lifetime of the batteries.
 - b. **Battery Test Start Time:** Select the time of the day in 24 hour format that the test should take place and complete with **Enter**.
 - c. **Battery Test Day of the Week:** Select the day of the week that the test should take place and complete with **Enter**.
3. When all settings have been completed, tap **OK** to confirm your settings.

Configure the Network

The network can be configured for the display and for the cards in Smart Slot 1 and Smart Slot 2.

1. From the home screen on the display select **Configuration > Network** and select either **Display**, **Smart Slot 1**, or **Smart Slot 2** if present.
2. Configure the following settings:
 - a. **TCP/IPv4: Enable IPv4** (if applicable), and select the **Address Mode** (**Manual**, **DCHP**, or **BOOTP**).

- b. **TCP/IPv6: Enable IPv6** (if applicable), select **Auto Configuration** or **Manual Configuration**, and select the **DHCPv6 Mode** (**Router controlled**, **Non-Address Information Only**, **Never**, or **Address and Other Information**).

NOTE: Tap **Addresses** to see all valid IPv6 addresses.

- c. **Web Access: Enable Web** (if applicable) and select the **Access Mode** (**HTTP** or **HTTPS**).

NOTE: Not available for Smart Slots.

Configuration Network Display **Web Access**

Enable Web

Access Mode

V HTTP ^

Port 80 [80, 5000 - 32768]

Restore Port To Default

ESC OK

- d. **FTP server: Enable FTP** (if applicable).

NOTE: Not available for Smart Slots.

Configuration Network Display **FTP server**

Enable FTP

Port 21 [21, 5001 - 32768]

Restore Port To Default

ESC OK

Configure the Modbus

The modbus can be configured for the display and for the cards in Smart Slot 1 and Smart Slot 2.

NOTE: Only the display and optional Network Management Card AP9635 can be used for serial modbus.

1. From the home screen on the display select **Configuration > Modbus** and select either **Display, Smart Slot 1**, or **Smart Slot 2**.

- Configure the modbus by enabling **Serial** or **TCP** access, and adding the needed values.

- Tap **OK** to confirm your settings.

Restore Default Configuration

- From the home screen on the display select **Configuration > Restore Defaults**.

- Select one of the below options:
 - **Restart Network Interface:** Select this option to restart network interface.
 - **Reset All:** Select this option to reset all settings to default. You can select to leave out the TCP/IP settings from the reset procedure.
 - **Reset Only:** Select this option if you only wish to reset parts of the settings to default values. You can select to reset the following settings: **TCP/IP**, **Event Configuration**, and **Display Settings**.
- When you have made your selection, tap **OK** to reset the selected settings to default.

Operation

Operation Modes

The Galaxy UPS has two different levels of operation mode:

- UPS Operation Mode: The operation mode of the operated UPS
- System Operation Mode: The operation mode of the complete UPS system

UPS Operation Modes

Normal

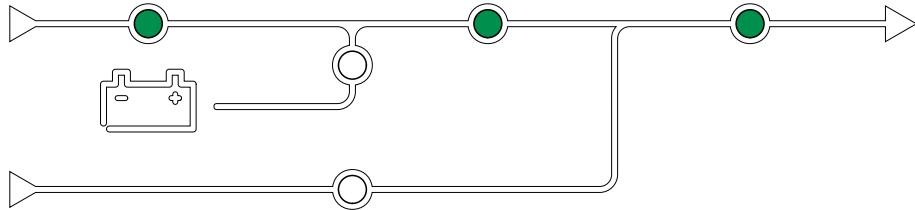

During normal operation, the UPS supports the load with conditioned power. While the UPS is in normal operation, the input, inverter, and load LEDs are green, and the battery and bypass LEDs are off.

Battery

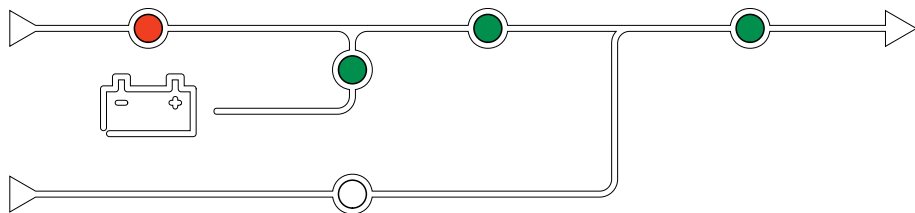

If the utility/mains supply fails, the UPS transfers to battery operation and supports the load with conditioned power from the DC source. While the UPS system is in battery operation, the battery, inverter, and load LEDs are green, the bypass LED is off and the input LED is red.

Requested Static Bypass

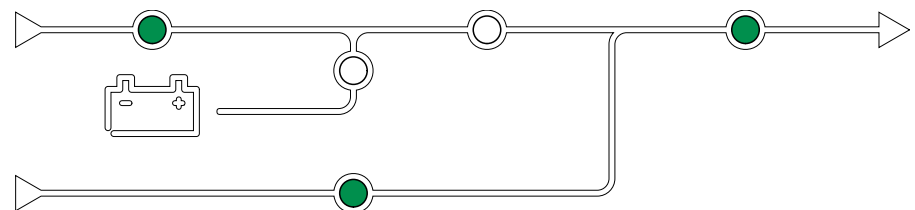

The UPS can be transferred to requested static bypass following a command from the display. During static bypass operation, the load is supplied from the bypass source. If a fault is detected, the UPS will transfer to normal operation or forced static bypass operation. If there is an interruption to the utility/mains power supply during requested static bypass operation, the system will transfer to battery operation. The load may experience a short duration interruption of power (4 to 8 ms) during the transfer from requested static bypass.

During requested static bypass, the input, bypass and output LEDs are green and the battery and inverter LEDs are off.

Forced Static Bypass

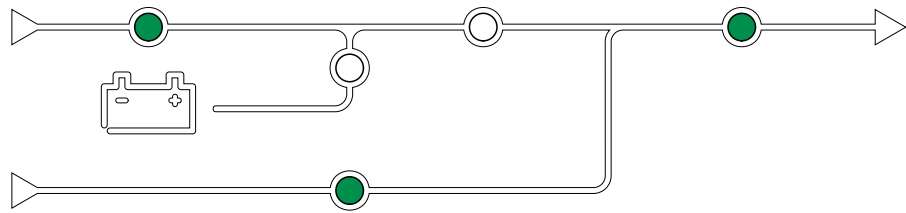

The UPS is in forced static bypass following a command from the UPS system or because the user has pressed the inverter OFF button on the UPS. During forced static bypass operation, the load is supplied directly by the bypass source.

During forced static bypass, the input, bypass and output LEDs are green and the battery and inverter LEDs are off or red if an alarm is present.

NOTE: The batteries are not available as an alternate power source while the UPS is in forced static bypass operation.

Maintenance Bypass Operation

When the Maintenance Bypass Breaker (MBB) is closed, the UPS system enters maintenance bypass operation. The load is supplied with unconditioned power from the bypass input.

NOTE: The batteries are not available as an alternate power source while the UPS is in maintenance bypass operation.

Static Bypass Standby

NOTE: Static bypass standby is only applicable to an individual UPS in a parallel system.

The UPS enters static bypass standby if the UPS is prevented from entering forced static bypass and the other UPS units of the parallel system can support the load.

In static bypass standby the output of the specific UPS is off.

The UPS automatically changes to the preferred operation mode when possible.

NOTE: If the other UPS units cannot support the load, the parallel system enters forced static bypass. The UPS in static bypass standby will then transfer to forced static bypass.

Inverter Standby

NOTE: Inverter standby is only applicable to an individual UPS in a parallel system.

The UPS enters inverter standby if there is an interruption to the utility/mains supply of one UPS and the other UPS units of the parallel system can support the load with the configured redundancy level maintained. This is to avoid that the batteries are being drained in situations where it is not necessary.

Battery Test

The UPS is in battery test mode when the UPS is performing a battery self-test or a runtime calibration.

NOTE: The battery test will be aborted if the utility/mains supply is interrupted or a critical alarm is present and will return to normal operation upon return of utility/mains.

ECO Mode

NOTE: ECO mode must be enabled by a Schneider Electric field service engineer.

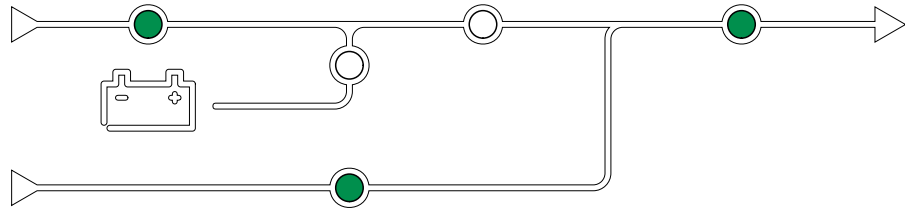

ECO mode allows the UPS to be configured to use requested static bypass, with the load supplied through the bypass, as the preferred operation mode under predefined circumstances.

If a fault is detected (bypass voltage out of tolerance, output voltage out of tolerance, etc), the UPS will immediately change to normal operation or forced static bypass.

The main advantage of ECO mode is a reduction in the consumption of electrical power.

In case of interruption to the utility/mains supply, the UPS transfers to inverter operation for a continuous supply of the load.

The load may experience a short duration interruption of power (4 to 8 ms) during this transfer.

The batteries are charged when the UPS is in ECO mode.

NOTE: When changes to ECO mode settings are made on one UPS in a parallel system, the settings are shared to all UPSs in the parallel system.

ECOConversion Mode

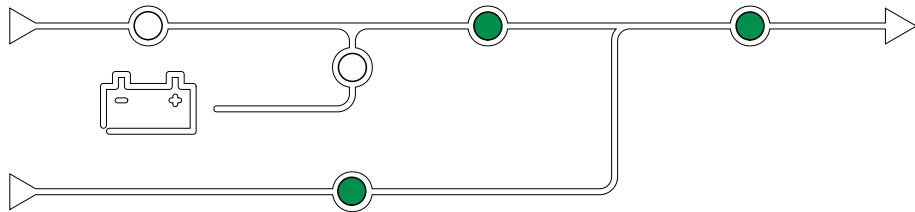

ECOConversion allows the system to supply the active part of the load through the bypass. The inverter is kept running in parallel with the bypass source and supplies the reactive part of the load.

The input power factor of the UPS is, regardless of the load power factor, maintained close to unity as the reactive part of the load is significantly reduced in the UPS input current.

In case of an interruption to the utility/mains supply, the inverter immediately maintains the output voltage so that breaks or drops during the transfer from ECOConversion mode are practically eliminated.

The batteries are charged when the UPS is in ECOConversion mode.

NOTE: When changes to ECOConversion settings are made on one UPS in a parallel system, the settings are shared to all UPSs in the parallel system.

Self-test

After start-up of the UPS system, the UPS will perform an automatic self-test. The status and progress of the self-test are indicated by the flashing LEDs on the mimic diagram.

When the self-test has been passed, the LEDs will indicate the operation mode of the UPS system.

NOTE: If an LED continues to flash after completion of the self-test, please call Schneider Electric.

For more information on self-test, see Troubleshooting via the Mimic Diagram LEDs after Self-Test.

Off

When the UPS is in off, the UPS does not supply the connected load with power.

System Operation Modes

The system operation mode indicates the current output status of the complete UPS system and which source that supplies the load.

Inverter

In inverter operation the load is supplied by the inverters. The UPS mode can be in either normal or battery operation when the system operation mode is inverter operation.

Requested Static Bypass

When the system is in requested static bypass, the load is supplied from the bypass source. If a fault is detected, the system will transfer to inverter operation or forced static bypass operation. The load may experience a short duration interruption of power (4 to 8 ms) during the transfer from requested static bypass.

Forced Static Bypass

The system is in forced static bypass following a command from the UPS system or because the user has pressed the inverter OFF button on the UPS units. During static bypass operation, the load is supplied directly by the bypass source.

NOTE: The batteries are not available as an alternate power source while the system is in forced static bypass operation.

Maintenance Bypass

In maintenance bypass operation, the load is supplied by unconditioned power from the bypass input via the maintenance bypass breaker.

NOTE: The batteries are not available as an alternate power source in maintenance bypass operation.

ECO Mode

NOTE: ECO mode must be enabled by a Schneider Electric field service engineer.

ECO Mode allows the system to be configured to use requested static bypass, with the load supplied through the bypass, as the preferred operation mode under predefined circumstances.

The main advantage of ECO mode is a reduction in the consumption of electrical power.

In case of interruption to the utility/mains supply, the UPS transfers to inverter operation for a continuous supply of the load.

The load may experience a short duration interruption of power (4 to 8 ms) during this transfer.

ECOversion Mode

ECOversion allows the system to supply the active part of the load through the bypass. The inverter is kept running in parallel with the bypass source and supplies the reactive part of the load.

The input power factor of the UPS is, regardless of the load power factor, maintained close to unity as the reactive part of the load is significantly reduced in the UPS input current.

In case of an interruption to the utility/mains supply, the inverter immediately maintains the output voltage so that breaks or drops during the transfer from ECOversion mode are practically eliminated. The behaviour is the same for all UPSs in the parallel system.

Off

When the system operation mode is off, the UPS system does not supply the connected load with power.

Operation Procedures

Access Password-Protected Screens

V				Λ
Pin				
<input type="text"/>				
1	2	3	±	
4	5	6	:	
7	8	9	.	
0	ESC	DEL	↩	

1. When prompted for the password, select your username.
2. Type in the pin code for your username.

NOTE: The default pin code is 1234.

View the System Status Information

1. From the home screen on the display select **Status**.
2. Select the area for which you wish to see the status. Choose between:

Input

Phase-to-Neutral³	
Voltage (phase-to-neutral)	The present phase-to-neutral input voltage in volts (V).
Current	The present input current from the AC utility power source per phase in amperes (A).
Maximum RMS Current	The maximum current for the latest 30 days.
Apparent Power	The present apparent power input for each phase in kVA. Apparent power is the product of RMS (root mean square) volts and RMS amperes.
Active Power	The present active power (or real power) input for each phase in kilowatts (kW). Active power is the portion of power flow that, averaged over a complete cycle of the AC waveform, results in net transfer of energy in one direction.
Power Factor	The ratio of the active power to apparent power.
Phase-to-Phase	
Voltage (phase-to-phase)	The present phase-to-phase input voltage.
Total Apparent Power	The present total apparent power input (for all three phases) in kVA.
Total Active Power	The present total active power input (for all three phases) in kW.
Frequency	The present input frequency in hertz (Hz).
Energy	The total energy consumption since the time of installation or since the number was reset.

3. Only applicable in systems with neutral connection.

Output

Phase-to-Neutral⁴	
Voltage (phase-to-neutral)	The phase-to-neutral output voltage at the inverter in volts (V).
Current	The present output current for each phase in amperes (A).
Maximum RMS Current	The maximum current for the latest 30 days.
Apparent Power	The present apparent power output for each phase in thousands of Volt-Amps (kVA). Apparent power is the product of RMS (root mean square) volts and RMS amperes.
Active Power	The present active power (or real power) output for each phase in kilowatts (kW). Active power is the portion of power flow that, averaged over a complete cycle of the AC waveform, results in net transfer of energy in one direction.
Power Factor	The present output power factor for each phase. Power factor is the ratio of active power to apparent power.
Current Crest Factor	The present output crest factor for each phase. The output crest factor is the ratio of the peak value of the output current to the RMS (root mean square) value.
Current THD	The THD (total harmonic distortion) for each phase, as a percentage, for the present output current.
Phase-to-Phase	
Voltage (phase-to-phase)	The phase-to-phase output voltage at the inverter in volts (V).
Total Apparent Power	The present apparent power output for each phase in thousands of Volt-Amps (kVA). Apparent power is the product of RMS (root mean square) volts and RMS amperes.
Total Active Power	The present total active output power (for all three phases) in kilowatts (kW).
Load	The percentage of the UPS capacity presently used across all phases. The load percentage for the highest phase load is displayed.
Neutral Current ¹	The present output neutral current in amperes (A).
Frequency	The present output frequency in hertz (Hz).
Inverter Status	The general condition of the inverter.
PFC Status	The general condition of the PFC.
Energy	The total energy supplied since the time of installation or since the value was reset.

4. Only applicable in systems with neutral connection.

Bypass

Phase-to-Neutral⁵	
Voltage (phase-to-neutral)	The present phase-to-neutral bypass voltage (V).
Current	The present bypass current for each phase, in amperes (A).
Maximum RMS Current	The maximum current for the latest 30 days.
Apparent Power	The present apparent bypass power for each phase in thousands of Volt-Amps (kVA). Apparent power is the product of RMS (root mean square) volts and RMS amperes.
Active Power	The present active bypass power for each phase in kilowatts (kW). Active power is the time average of the instantaneous product of voltage and current.
Power Factor	The present bypass power factor for each phase. Power factor is the ratio of active power to apparent power.
Phase-to-Phase	
Voltage (phase-to-phase)	The present phase-to-phase bypass voltage (V).
Total Apparent Power	The present total apparent bypass power (for all three phases) in thousands of Volt-Amps (kVA).
Total Active Power	The present total active bypass power (for all three phases) in kilowatts (kW).
Frequency	The present bypass frequency in hertz (Hz).

Battery

Voltage	The present battery voltage.
Current	The present battery current in amperes (A). A positive current indicates that the battery is charging; a negative current indicates that the battery is discharging.
Power	The present DC power being drawn from the battery, in kilowatts (kW).
Estimated Charge Level	The present battery charge, as a percentage of full charge capacity.
Estimated Charge Time	The estimated time, in minutes, until the batteries reach 100% charge.
Runtime Remaining	The amount of time in hours and minutes before the batteries reach the low-voltage shutdown level.
Charger Mode	The operation mode of the charger (Off, Float, Boost, Equalization, Cyclic, Test).
Battery Status	The general condition of the battery.
Charger Status	The general condition of the charger.
Total Battery Capacity	The total capacity available from the available batteries.

Temperature

Ambient Temperature	Ambient temperature in degrees Celsius or Fahrenheit at the air intake of the UPS.
Exhaust Air Temperature	Exhaust air temperature in degrees Celsius or Fahrenheit at the air exhaust of the UPS.

5. Only applicable in systems with neutral connection.

System

Output Voltage	The phase-to-phase output voltage at the inverter in volts (V).
Output Current	The present output current for each phase in amperes (A).
Output Frequency	The present output frequency in hertz (Hz).
Runtime Remaining	The amount of time in hours and minutes before the batteries reach the low-voltage shutdown level.
System Time	The time of the UPS system.
UPS Operation Mode	The operation mode of the operated UPS.
System Operation Mode	The operation mode of the complete UPS system.
Total Output Power	The apparent and active power (or real power) output for each phase.
Output Power	The phase-to-phase apparent and active power (or real power) output for each phase.

Parallel System

Input Current	The present phase-to-phase input current in amperes (A).
Output Current	The present phase-to-phase output current in amperes (A).
Bypass Current	The present phase-to-phase bypass current in amperes (A).
Parallel UPS Number	The parallel UPS number of the operated UPS.
Parallel system redundancy	The redundancy for the parallel system.
Number of Parallel Units	The total number of UPSs in the parallel system.
Parallel Units	The numbers of all UPSs in the parallel system.
Output Total Apparent Power	The present total apparent output power (for all three phases) in thousands of Volt-Amps (kVA).
Output Total Load	The percentage of the UPS system capacity presently used across all phases. The load percentage for the highest phase load is displayed.

Active Alarms

Active Alarms	For more information on active alarms, go to <i>View the Active Alarms, page 50</i> .
---------------	---

Mimic

Mimic	The mimic diagram shows the current status of the main parts of the UPS system: power sources, converters, bypass static switch and breakers, and it shows the power flow through the system.
-------	---

- Tap the home button to exit the screens and return to the home screen.

Operation Procedures for Single UPS Systems

Start Up Single System from Maintenance Bypass Operation

Use this procedure to start up a single system from maintenance bypass operation with the load supplied through the MBB and all other breakers open.

NOTE: Only operate a breaker when the associated breaker LED is green.

Front View of Single UPS

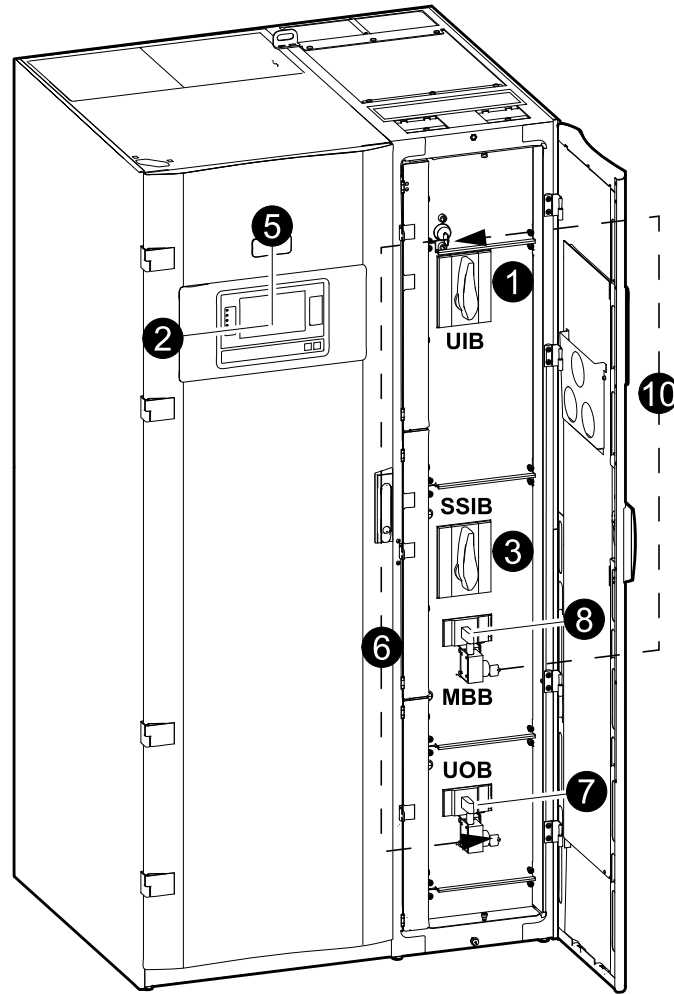

1. Close the unit input breaker UIB on the front of the I/O cabinet. This will power up the display interface after approximately 30 seconds.
2. From the home screen on the display, select **Control > Startup Wizard**. Select **Startup from Maintenance Bypass** and follow the steps which appear on the screen.

NOTE: The following is a generic startup procedure. Always follow the steps of the **Startup Wizard** which are specific to your system.

3. Close the static switch input breaker SSIB on the front of the I/O cabinet.
4. Close the battery breakers in your specific battery solution.
5. Initiate transfer to static bypass by tapping the **Transfer Load to static bypass** button on the display interface.

In systems with kirk-keys, the key is released from the solenoid key release unit.

If the UPS system does not transfer to requested static bypass, go to **Status > Active Alarms** to see if there are active alarms that prevent the UPS system from transferring to static bypass.

6. In systems with kirk-keys, insert the key in the lock on the unit output breaker UOB and turn to unlock.
7. Close the unit output breaker UOB.
8. Open the maintenance bypass breaker MBB. The system transfers to normal operation.
9. In systems with kirk-keys, turn the key in the lock of the maintenance bypass breaker MBB to lock open.

The key is released.

10. In systems with kirk-keys, insert the key in the solenoid key release unit.

Shut Down Single System from Normal to Maintenance Bypass Operation

Use this procedure to shut down a single system to maintenance bypass operation with the load supplied through the MBB.

NOTE: Only operate a breaker when the associated breaker LED is green.

Front View of Single UPS

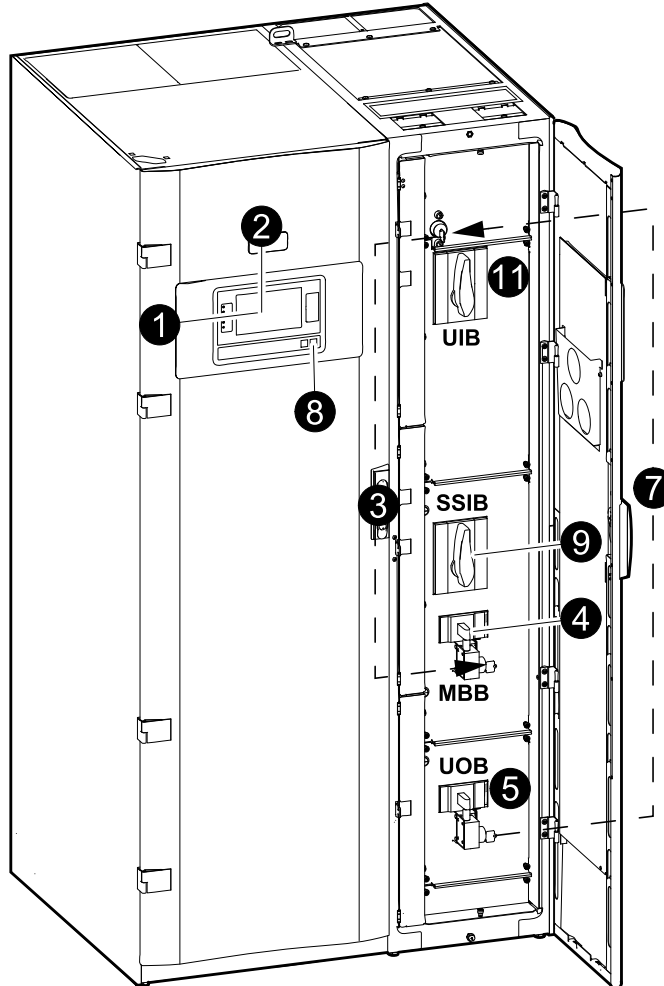

1. From the home screen on the display, select **Control > Shutdown Wizard**. Select **Shut down ending in Maintenance Bypass** and follow the steps which appear on the screen.

NOTE: The following is a generic shutdown procedure. Always follow the steps of the **Shutdown Wizard** which are specific to your system.

2. Initiate transfer to static bypass by tapping the **Transfer Load to static bypass** button on the display interface.

In systems with kirk-keys, the key is released from the solenoid key release unit.

If the UPS system does not transfer to requested static bypass, go to **Status > Active Alarms** to see if there are active alarms that prevent the UPS system from transferring to static bypass.

3. In systems with kirk-keys, insert the key in the lock on the maintenance bypass breaker MBB and turn to unlock.
4. Close the maintenance bypass breaker MBB on the front of the I/O cabinet. In systems with kirk-keys, the key is held in the lock.

5. Open the unit output breaker UOB.
6. In systems with kirk-keys, turn the key in the lock on the unit output breaker UOB to lock open.
The key is released.
7. In systems with kirk-keys, insert the key in the solenoid key release unit.
8. Initiate transfer to forced static bypass by tapping the Inverter OFF button on the front of the UPS system.
9. Open the static switch input breaker SSIB on the front of the I/O cabinet.
10. Open the battery breakers in your specific battery solution.
11. Open the unit input breaker UIB on the front of the I/O cabinet.

Transfer UPS from Normal to Requested Static Bypass Operation

1. From the home screen on the display select **Control > Operational Mode**.

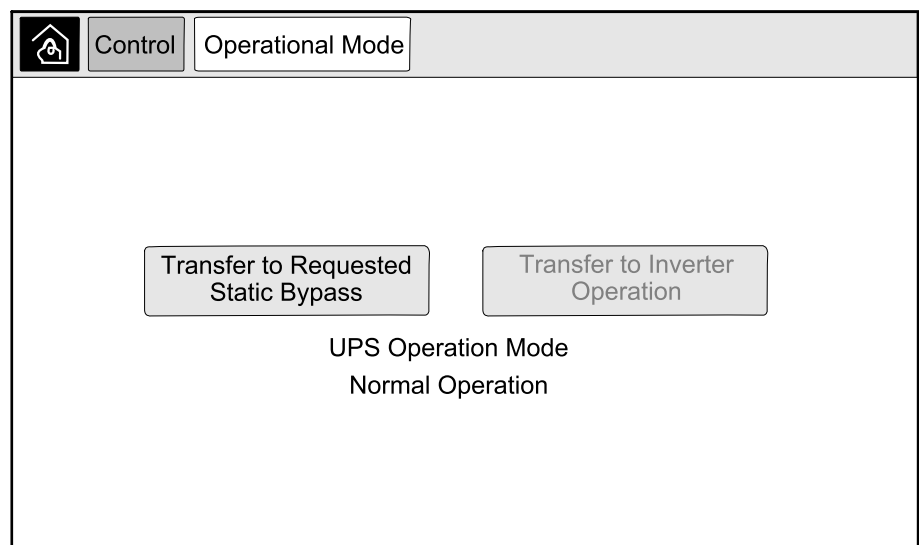

2. Tap the **Transfer to Requested Static Bypass** button.

NOTE: If the conditions for performing a transfer are not met, the button will be grayed out.

3. Verify that the **UPS Operation Mode** changes to **Requested Static Bypass**.

Transfer UPS from Requested Static Bypass Operation to Normal Operation

1. From the home screen on the display select **Control > Operational Mode**.

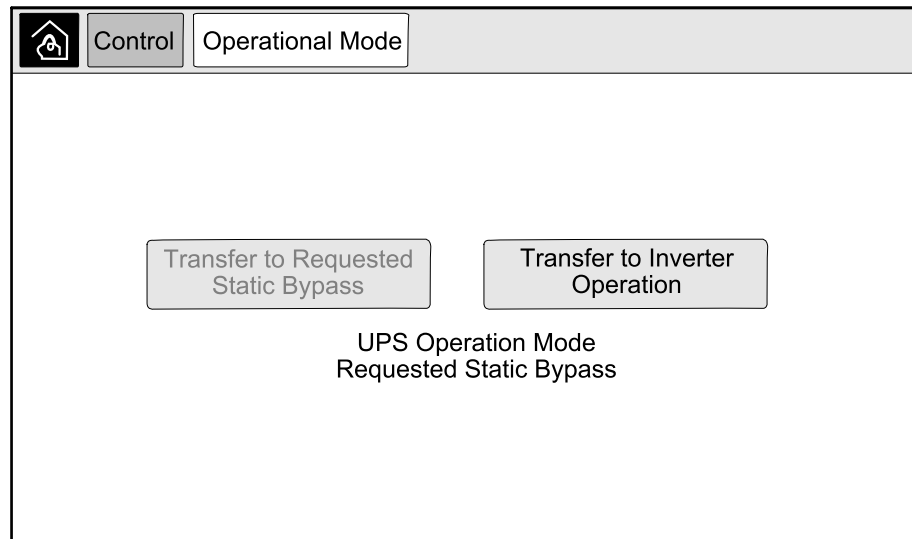

2. Tap the **Transfer to Inverter Operation** button.

NOTE: If the conditions for performing a transfer are not met, the button will be grayed out.

3. Verify that the **UPS Operation Mode** changes to **Normal Operation**.

Operation Procedures for Parallel UPS Systems

Start Up Parallel System from Maintenance Bypass Operation

Use this procedure to start up a parallel system from maintenance bypass operation with the load supplied through the MBB and all other breakers open.

NOTE: Only operate a breaker when the associated breaker LED is green.

Front View of One Parallel UPS and System Bypass Cabinet

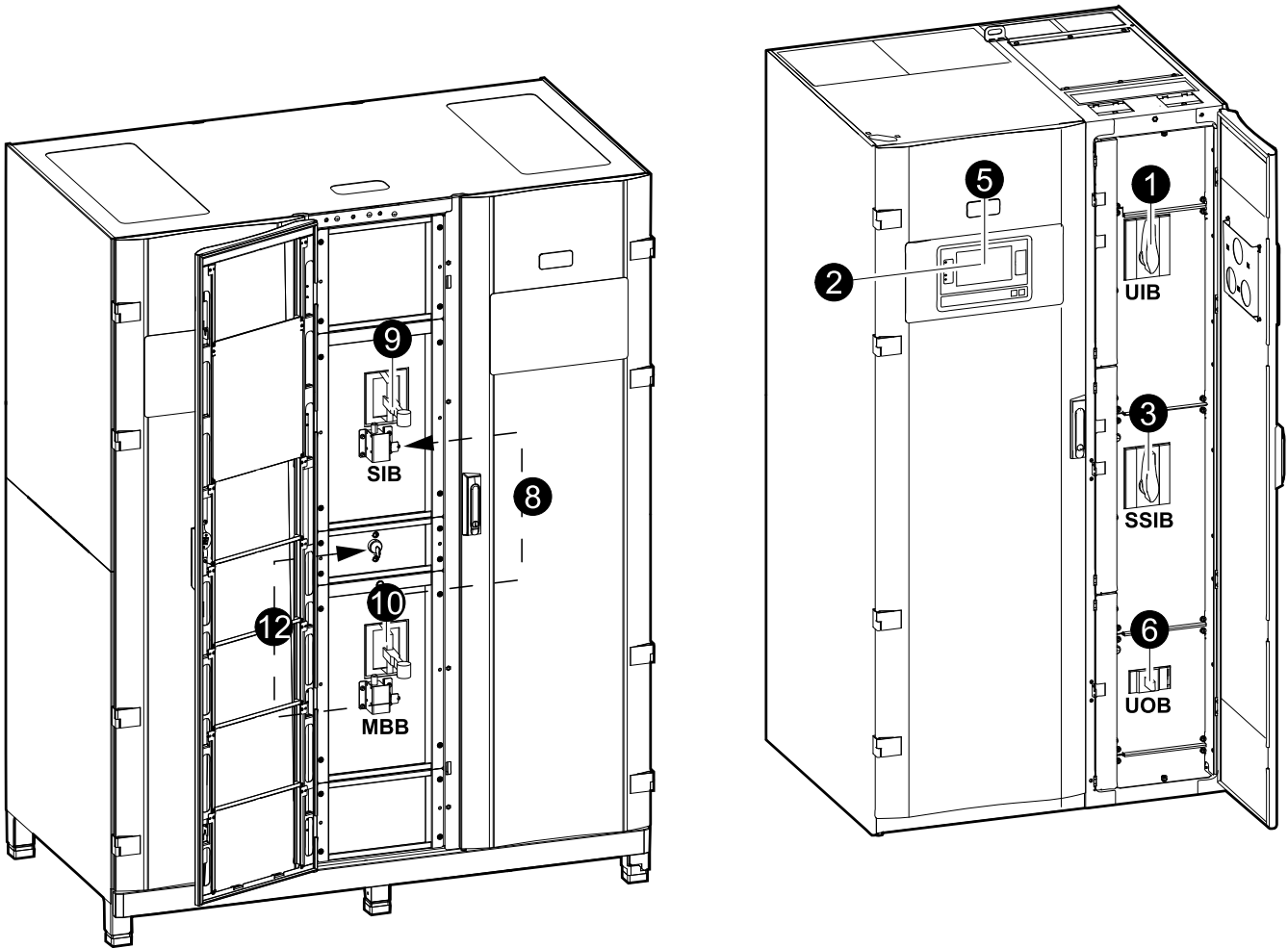

1. Close the unit input breaker UIB on the front of the I/O cabinet. This will power up the display interface after approximately 30 seconds.
2. From the home screen on the display, select **Control > Startup Wizard**. Select **Startup from Maintenance Bypass** and follow the steps which appear on the screen.

NOTE: The following is a generic startup procedure. Always follow the steps of the **Startup Wizard** which are specific to your system.

3. Close the static switch input breaker SSIB on the front of the I/O cabinet.
4. Close the battery breakers in your specific battery solution.
5. Initiate transfer to static bypass by tapping the **Transfer Load to static bypass** button on the display interface.

In systems with kirk-keys, the key is released from the solenoid key release unit.

If the UPS system does not transfer to static bypass, go to **Status > Active Alarms** to see if there are active alarms that prevent the UPS system from transferring to static bypass.

6. Close the unit output breaker UOB.
7. Repeat steps 1 to 6 for the remaining UPS units in the parallel system before continuing.
8. In systems with kirk-keys, insert the key from the solenoid key release unit in the lock on the system isolation breaker SIB and turn to unlock.
9. Close the system isolation breaker SIB.
10. Open the maintenance bypass breaker MBB. The system transfers to normal operation.

11. In systems with kirk-keys, turn the key in the lock of the maintenance bypass breaker MBB to lock open.
The key is released.
12. In systems with kirk-keys, insert the key in the solenoid key release unit.

Shut Down Parallel System from Normal to Maintenance Bypass Operation

Use this procedure to shut down a parallel system to maintenance bypass operation with the load supplied through the MBB.

NOTE: Only operate a breaker when the associated breaker LED is green.

Front View of One Parallel UPS and System Bypass Cabinet

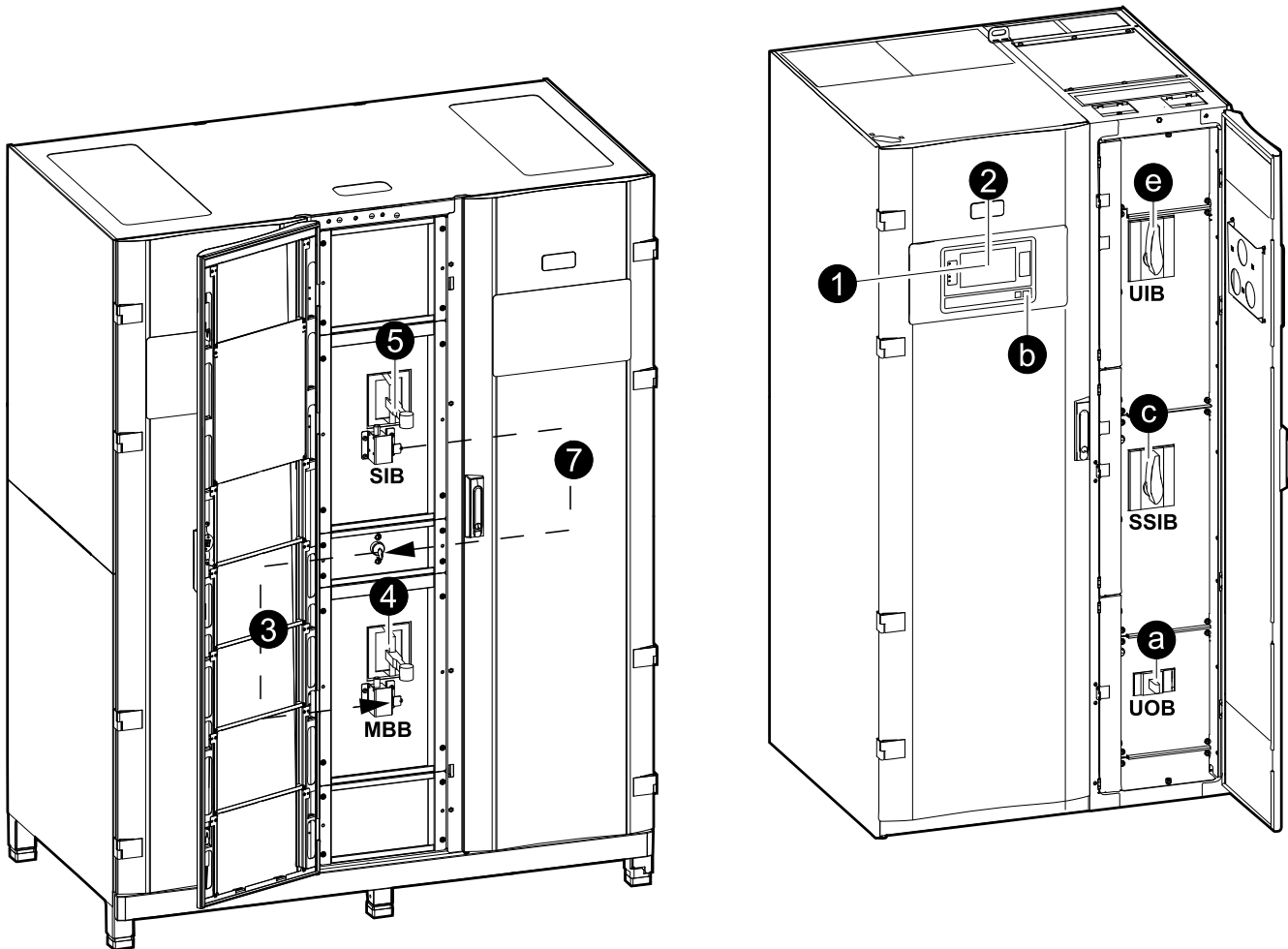

1. From the home screen on the display, select **Control > Shutdown Wizard**. Select **Shut down ending in Maintenance Bypass** and follow the steps which appear on the screen.

NOTE: The following is a generic shutdown procedure. Always follow the steps of the **Shutdown Wizard** which are specific to your system.

2. Initiate transfer to static bypass by tapping the **Transfer Load to static bypass** button on the display interface.

In systems with kirk-keys, the key is released from the solenoid key release unit in the system bypass cabinet.

If the UPS system does not transfer to requested static bypass, go to **Status > Active Alarms** to see if there are active alarms that prevent the UPS system from transferring to static bypass.

3. In systems with kirk-keys, insert the key in the lock on the maintenance bypass breaker MBB and turn to unlock.

4. Close the maintenance bypass breaker MBB in the system bypass cabinet.
In systems with kirk-keys, the key is held in the lock.
5. Open the system isolation breaker SIB.
6. In systems with kirk-keys, turn the key in the lock on the system isolation breaker SIB to lock open.
The key is released.
7. In systems with kirk-keys, insert the key in the solenoid key release unit.
8. Perform the following steps for each UPS unit in the parallel system:
 - a. Open the unit output breaker UOB.
 - b. Initiate transfer to forced static bypass by tapping the Inverter OFF button on the front of the UPS system.
 - c. Open the static switch input breaker SSIB on the front of the I/O cabinet.
 - d. Open the battery breakers in your specific battery solution.
 - e. Open the unit input breaker UIB on the front of the I/O cabinet.

Start Up and Add UPS to a Running Parallel System

Use this procedure to start up a UPS and add it to a running parallel system.

NOTE: Only operate a breaker when the associated breaker LED is green.

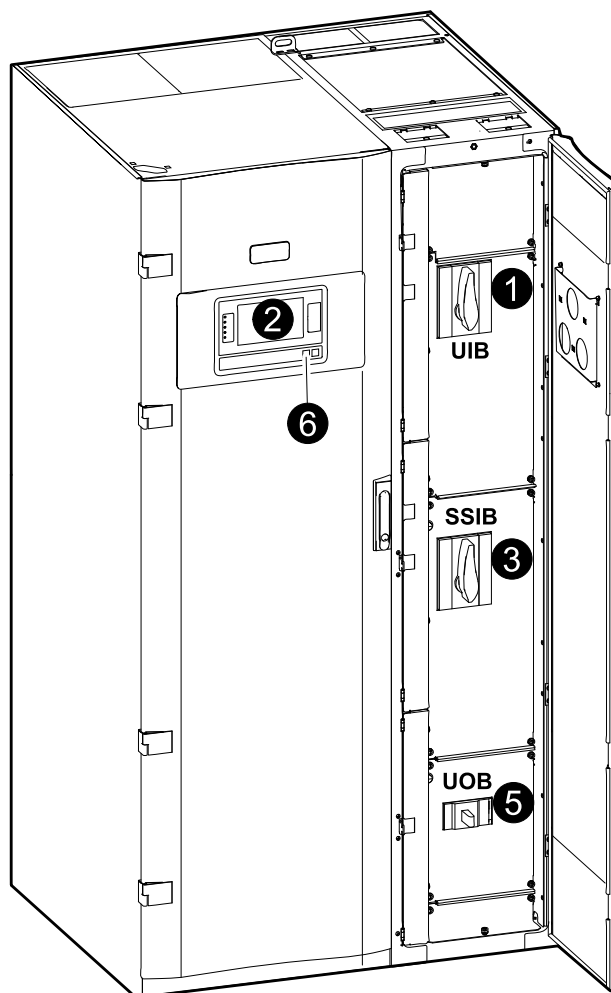

1. Close the unit input breaker UIB on the front of the I/O cabinet.
This will power up the display interface after approximately 30 seconds.

- From the home screen on the display, select **Control > Startup Wizard**. Select **Startup UPS into a parallel system** and follow the steps which appear on the screen.

NOTE: The following is a generic startup procedure. Always follow the steps of the Startup Wizard which are specific to your system.

- Close the static switch input breaker SSIB on the front of the I/O cabinet.
- Close the battery breakers in your specific battery solution.
- Close the unit output breaker UOB.

NOTE: In systems with additional individual downstream disconnection devices, the additional disconnection devices must be closed before the UOB in the added UPS.

- Turn the inverter on by tapping the Inverter ON button on the front of the UPS.

Isolate this Single UPS from the Parallel System

Use this procedure to shut down one UPS in a running parallel system.

NOTE: Before initiating this procedure, ensure that the remaining UPS units can supply the load.

NOTE: Only operate a breaker when the associated breaker LED is green.

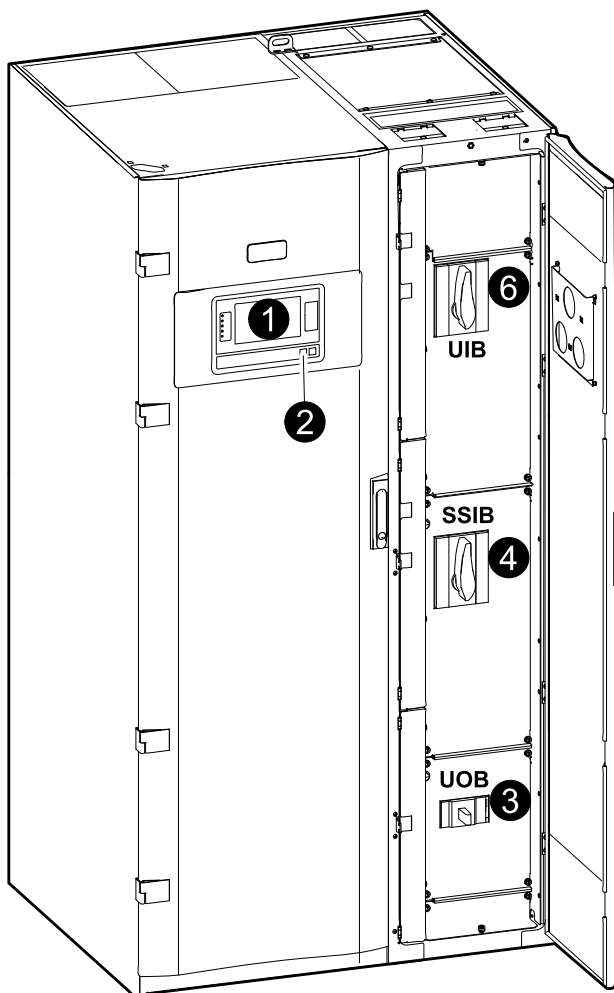

- From the home screen on the display, select **Control > Shutdown Wizard**. Select **Shut down UPS in a parallel system** and follow the steps which appear on the screen.

NOTE: The following is a generic shutdown procedure. Always follow the steps of the Shutdown Wizard which are specific to your system.

- Turn off the UPS by pressing the Inverter OFF key on the front of the UPS.

3. Open the unit output breaker UOB.
4. Open the static switch input breaker SSIB on the front of the I/O cabinet.
5. Open the battery breakers in your specific battery solution.
6. Open the unit input breaker UIB on the front of the I/O cabinet.

Operation Procedures for Frequency Converter Systems

Start-Up System Operating as Frequency Converters

Use this procedure to start up a single system, a parallel system working as frequency converters, or to start up a single frequency converter and add it into a running parallel system working as frequency converters.

NOTE: Only operate a breaker when the associated breaker LED is green.

1. Close the unit input breaker UIB on the front of the I/O cabinet.
This will power up the display interface after approximately 30 seconds.
2. From the home screen on the display, select **Control > Startup Wizard**. Select **Startup from Off Operation** and follow the steps which appear on the screen.

NOTE: The following is a generic startup procedure. Always follow the steps of the **Startup Wizard** which are specific to your system.

3. Close the battery breakers BB1 and BB2 (if present).
4. Close the unit output breaker UOB.
5. Close the system isolation breaker SIB.
6. Tap **Turn Inverter On** on the display interface.

Shut Down System Operating as Frequency Converters

Use this procedure to shut down a single system, a parallel system operating as frequency converters.

NOTE: Only operate a breaker when the associated breaker LED is green.

1. From the home screen on the display, select **Control > Shutdown Wizard**. Select **Shutdown ending in Off Operation** and follow the steps which appear on the screen.

NOTE: The following is a generic shutdown procedure. Always follow the steps of the **Shutdown Wizard** which are specific to your system.

2. Open the unit output breaker UOB.
3. Open battery breakers BB1 and BB2 (if present).
4. Open the unit input breaker UIB on the front of the I/O cabinet.
5. Repeat steps 1 to 4 on each Galaxy VM in the parallel system.
6. Open the system isolation breaker (if present).

Start a Boost Charge of the Batteries

Boost charge gives the possibility of doing a fast recharge of a discharged battery.

NOTE: Boost charge must be enabled by Schneider Electric during start-up for this option to be available.

1. From the home screen on the display select **Control > Charger Mode**.

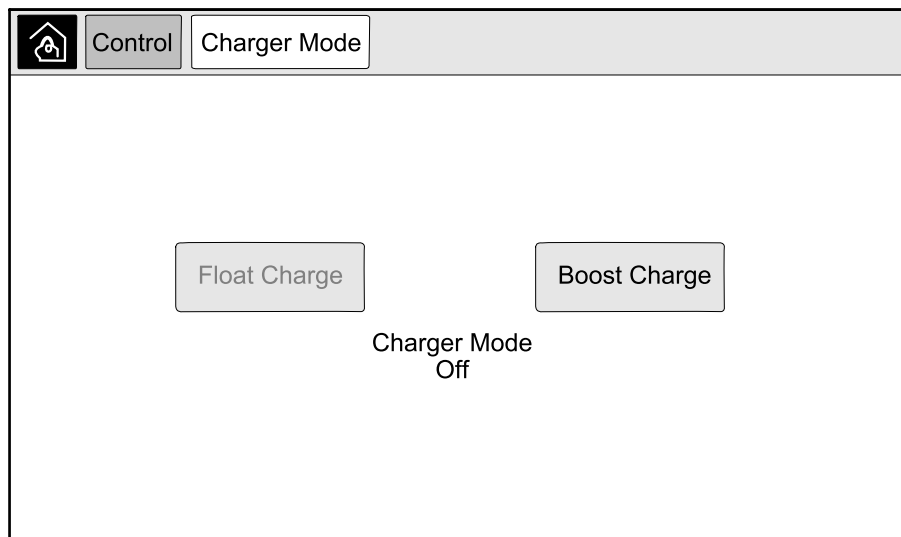

2. Select **Boost Charge** to initiate a single boost charge of the batteries.
The UPS system starts boost charging the batteries.
To stop the boost charge and go back to float charge, select **Float Charge**.

Access a Configured Network Management Interface

The below procedure describes how to access the network management interface from a web interface. It is also possible to use the following interfaces:

- Telnet and SSH
- SNMP
- FTP
- SCP

NOTE: Ensure that only one network management interface in the entire system is set to synchronize time.

Use Microsoft Internet Explorer® 7.x or higher on Windows operating systems only or Mozilla® Firefox® 3.0.6 or higher on all operating systems to access the web interface of the network management interface. Other commonly available browsers may work but have not been fully tested.

You can use either of the following protocols when you use the web interface:

- The HTTP protocol (enabled by default), which provides authentication by user name and Pin but no encryption.
- The HTTPS protocol, which provides extra security through Secure Socket Layer (SSL); encrypts user names, Pin, and data being transmitted; and authenticates Network Management Cards by means of digital certificates.

1. Access the network management interface by its IP address (or its DNS name, if a DNS name is configured).
2. Enter the user name and password.
3. To enable or disable the HTTP or HTTPS protocol, use the **Network** menu on the **Administration** tab, and select the **Access** option under the **Web** heading on the left navigation menu.

Maintenance

User-Replaceable Parts

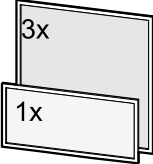
Part	Replacement Procedure	
Filter Kit (GVMDFW-KIT)	<ul style="list-style-type: none">• <i>Replace the Top Filter, page 43</i>• <i>Replace the Three Bottom Filters, page 44</i>	

Replace the Top Filter

Rear View of the Front Door

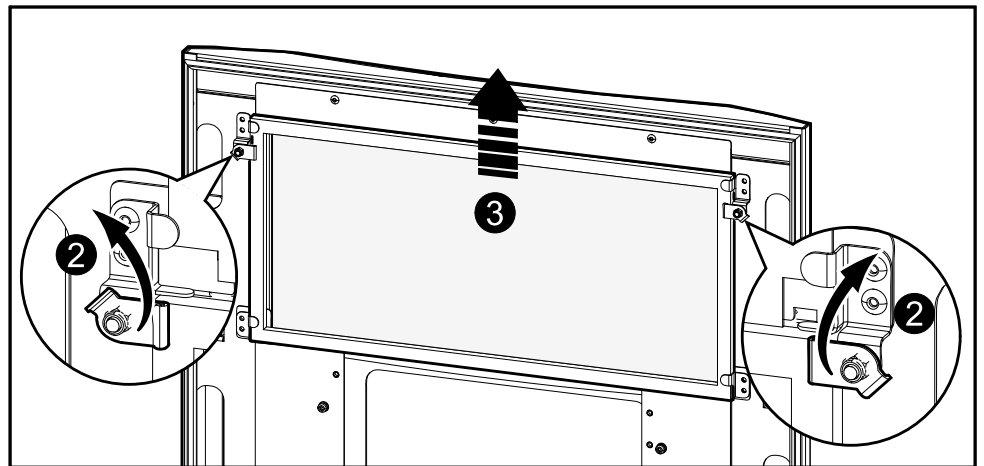

1. Open the front door of the cabinet.
2. Turn the filter locks to release the filter.
3. Lift up the filter.
4. Take the replacement filter from the installation kit and install the new filter.
5. Turn the filter locks to fasten the filter.

Replace the Three Bottom Filters

Rear View of the Front Door

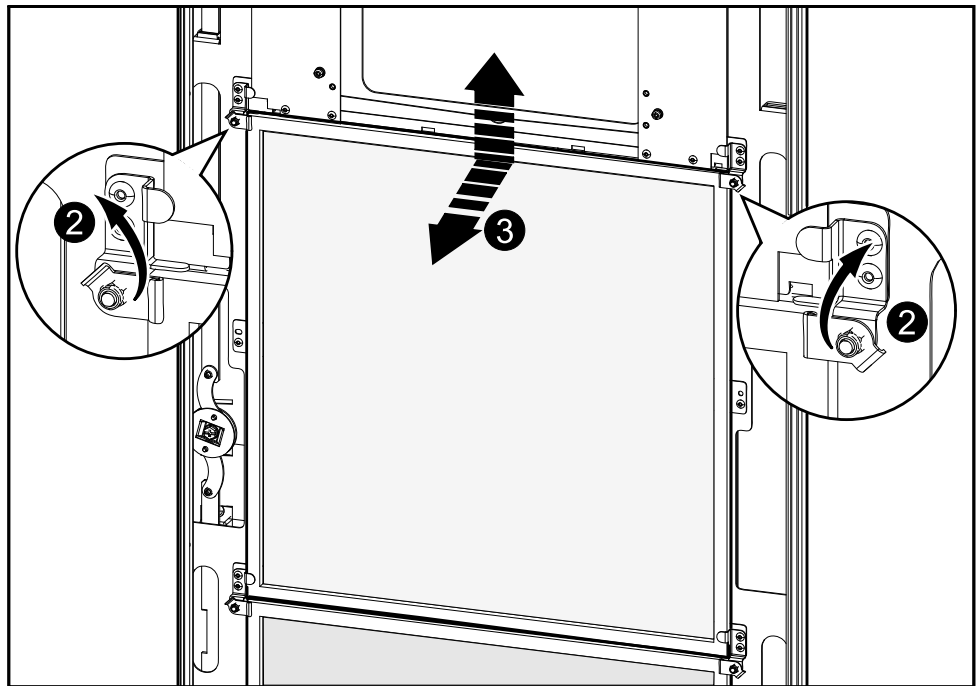

1. Open the front door of the cabinet.
2. Turn the filter locks to release the filters.
3. Tilt the filters out and lift them up.
4. Take the replacement filters from the installation kit and install the new filters.
5. Turn the filter locks to fasten the filters.

Troubleshooting

Troubleshooting via the Mimic Diagram LEDs

The mimic diagram shows the status of the main functions and the energy flow supplying the load. The different LEDs are either green, red or turned off depending on the status of the system functions. In this section it is listed what a red LED on the mimic diagram is indicating to help troubleshooting.

Input LED

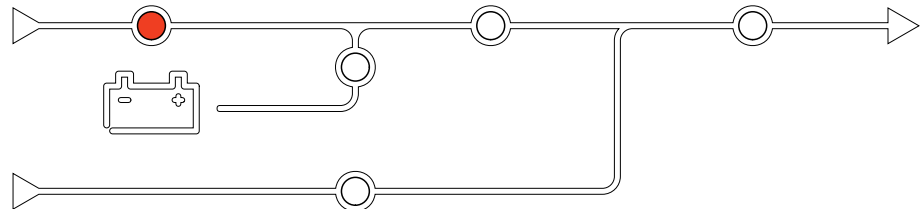

If the input LED is red, it can be caused by the following:

- UIB is open
- Input out of tolerance (waveform-, voltage-, or frequency out of tolerance)
- Power factor correction inoperable

Inverter LED

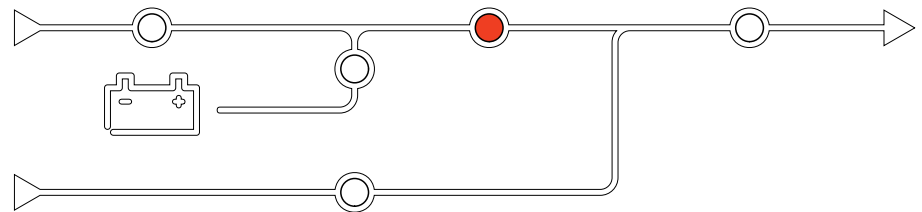

If the inverter LED is red, it can be caused by the following:

- Inverter PLL synchronization inoperable
- Inverter inoperable

Load LED

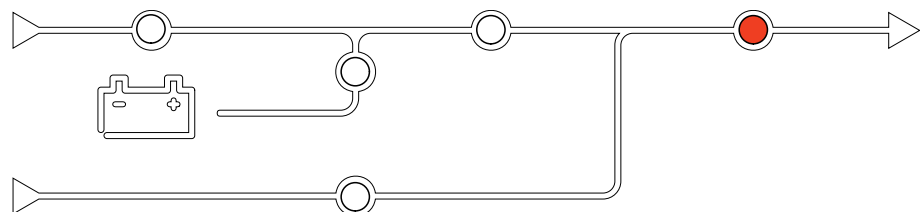

If the load LED is red, it can be caused by the following:

- UOB is open
- SIB is open
- Output voltage out of tolerance

Battery LED

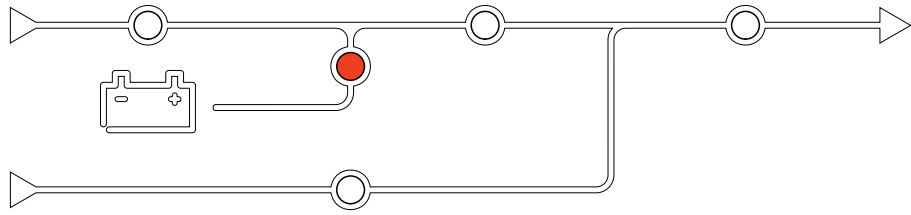

If the Battery LED is red, it can be caused by the following:

- Critical battery alarm active
- Charger inoperable
- Battery breaker disconnected

Bypass LED

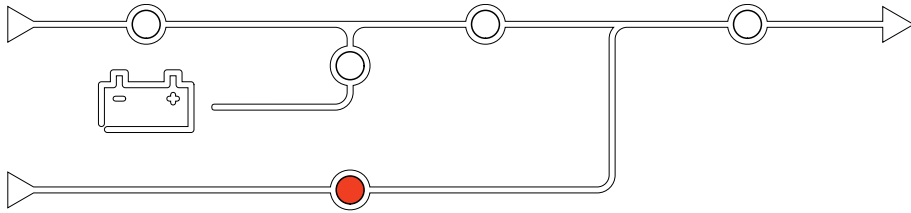

If the bypass LED is red, it can be caused by the following:

- SSIB is open
- Static bypass switch inoperable
- Bypass out of tolerance

Reboot the Display

NOTE: A reboot of the display does not impact the settings made.

1. Open the shutter door on the front right side of the display.
2. Press the reboot button with a pointed object like a pen or a paper clip.

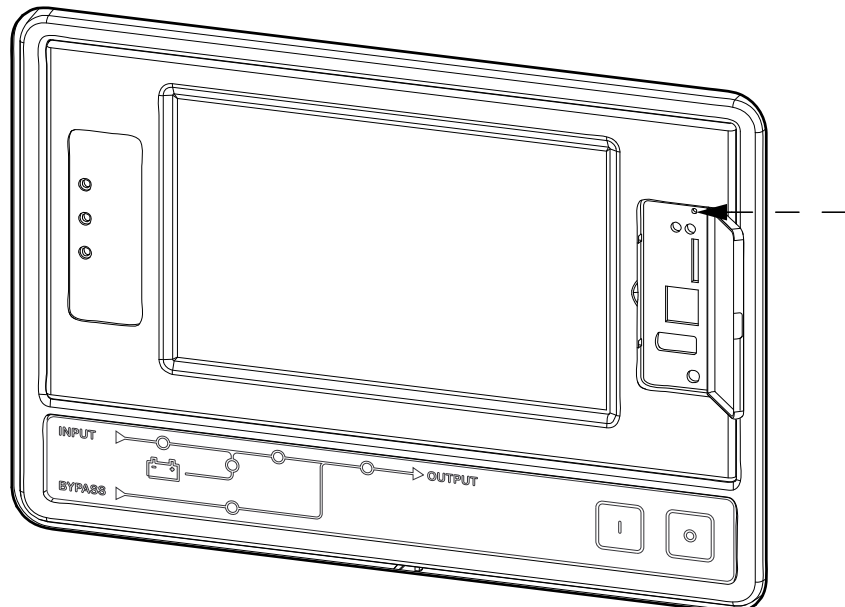

The display is rebooted.

Reset the Password

Use a local computer that connects to the display through the serial port to access the command line interface.

NOTE: The serial port is located behind the shutter door on the display front panel.

1. Select a serial port on a local computer, and disable any service that uses that port.
2. Connect the provided serial cable (part number 940-0299) to the selected port on the computer and to the console port on the UPS display.
3. On the local computer, run a terminal program (such as HyperTerminal®) and configure the selected port for 9600 bps, 8 data bits, no parity, 1 stop bit, and no flow control.
4. Press **ENTER**, repeatedly if necessary, to display the User Name prompt.

If you are unable to display the **User Name** prompt, verify the following:

- The serial port is not in use by another application.
 - The terminal settings are correct as specified in step 3.
 - The correct cable is being used as specified in step 2.
5. Press the **Reset** button behind the shutter door on the display front panel. The Status LED will flash alternately orange and green. Press the **Reset** button a second time immediately while the LED is flashing to reset the user name and password to their defaults temporarily.
 6. Press **ENTER**, repeatedly if necessary, to display the User Name prompt again, then use the default password, **apc**, for the user name and password. (If you take longer than 30 seconds to log on after the User Name prompt is redisplayed, you must repeat step 5 and log on again).
 7. In the command line interface, use the following commands to change the password setting, which is **apc** at this stage:
 - `user -n <user name> -pw <user password>`For example, to change the user password to XYZ, type:
 - `user -n apc -pw XYZ`
 8. In the command line interface, use the following commands to change the display pin setting:
 - `user -n <user name> -tp <user pin>`For example, to change the user pin to 4321, type:
 - `user -n apc -tp 4321`
 9. Type **quit** or **exit** to log off, reconnect any serial cable you disconnected, and restart any service you disabled.

Logs

There are two types of logs:

- NMC Log: Contains information about the display and network activities.
- UPS Log: Contains information about the system status and operation modes.

View the NMC Log

1. From the home screen on the display select **Logs > NMC Log**.

2. You can browse through the list of the events using the arrows.

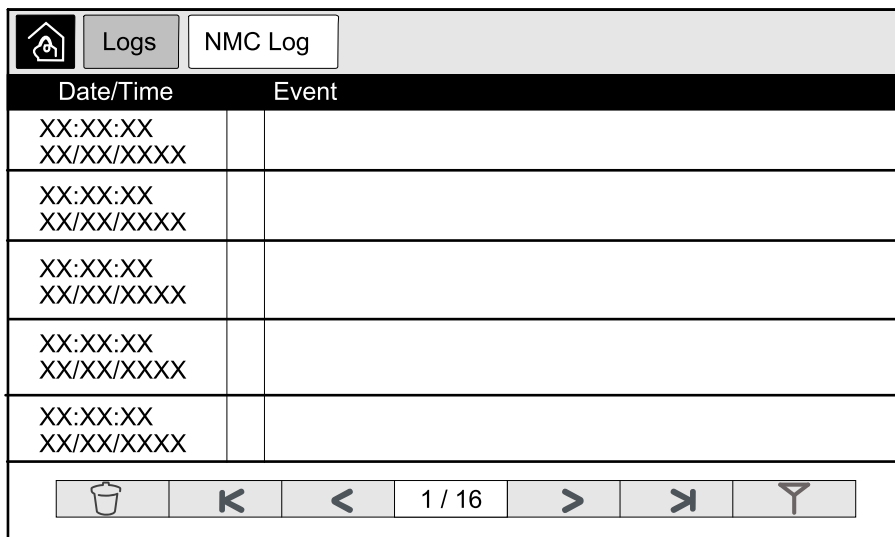

3. You can now perform the following operations in the event log:

a. Tap the filter button to filter the events. Different filter settings are available, including:

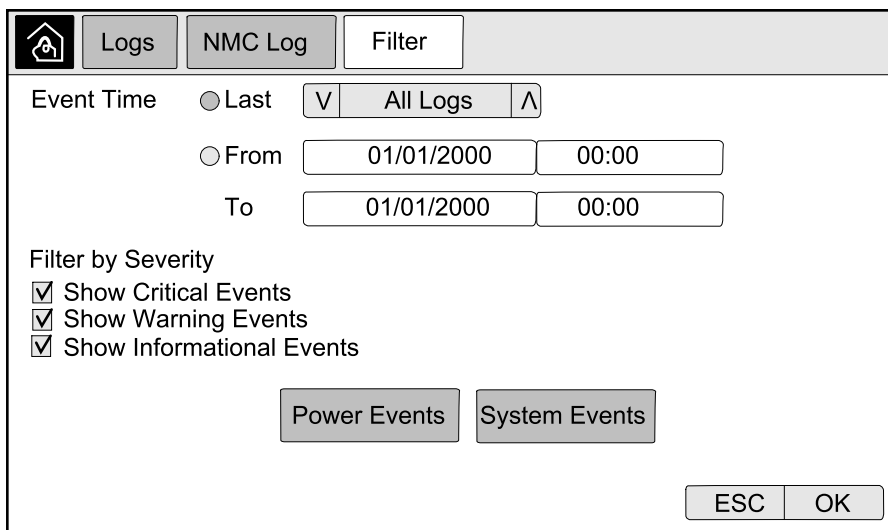

Filters for **Power Events**: **Communication, Device, Output, Input, Battery, UPS Operation Mode, Parallel System, Reminders, Switchgear, and/or RFC 1628 MIB.**

Filters for **System Events**: **Mass Configuration and/or Security.**

b. Tap the recycle bin button to clear the event log and select **Yes** to confirm.

4. Tap the home button to exit the log.

View the UPS Log

1. From the home screen on the display select **Logs > UPS Log**.

Date/Time		Event
XX:XX:XX XX/XX/XXXX		
XX:XX:XX XX/XX/XXXX		
XX:XX:XX XX/XX/XXXX		
XX:XX:XX XX/XX/XXXX		
XX:XX:XX XX/XX/XXXX		

🗑️ ⏪ ⏩ 1 / 16 ⏴ ⏵ ⏶

2. You can now browse through the list of the UPS events using the arrows.
3. You can perform the following operations in the UPS log:
 - a. Tap the filter button to filter the events. Different filter settings are available, including:

Filters for Power Events: Communication, Device, Output, Input, Battery, UPS Operation Mode, Parallel System, Reminders, Switchgear, and/or RFC 1628 MIB.

Filters for System events: Mass Configuration and/or Security.
 - b. Tap the recycle bin button to clear the UPS log and select **Yes** to confirm.
4. Tap the home button to exit the log.

Export Data from Logs

The exported log can only be used by Schneider Electric customer support for analysis.

1. From the home screen on the display select **Logs > Export Data**.
2. Insert a USB device in the USB port located on the front of the display.

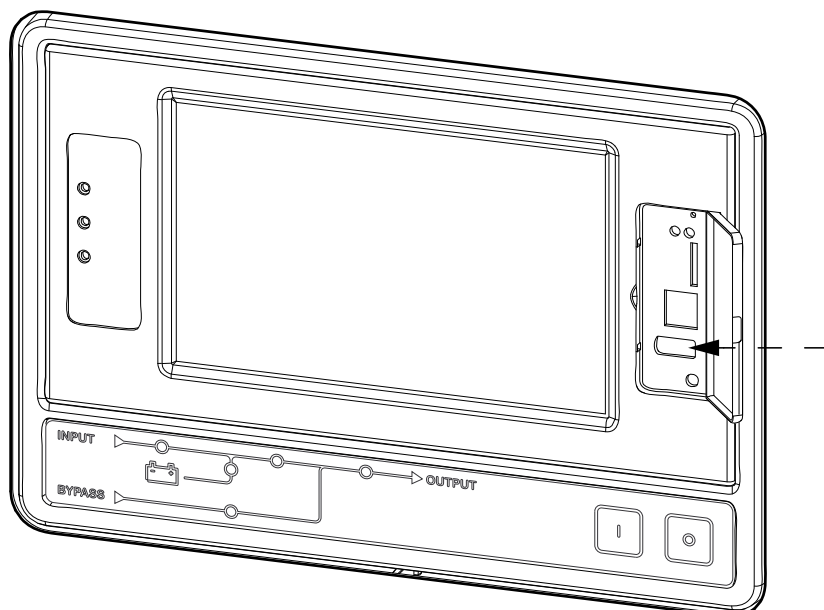

3. Tap the **Start Data Export** button.

When the download is complete, the following message will be shown on the screen: **Data Exported Successfully. Remove USB device.**

4. Remove the USB device and tap the home button to exit the screen.
5. The exported data on the USB device can now be sent to Schneider Electric support for analyzing.

View the Active Alarms

When there is an active alarm in the system, a symbol indicating the alarm level is shown in the top right corner of the screen and the buzzer is active.

1. From the home screen on the display select **Status > Active Alarms**. Tapping the display will also silence the buzzer temporarily without login. By logging in and tapping the display, the buzzer will be silenced permanently.
2. You can now browse through the list of active alarms using the left and right arrows.
3. Tap the **Refresh** button to update the list with the latest active alarms.

Alarm Levels

There are three alarm levels:

- **Critical:** Take immediate action and call Schneider Electric.
- **Warning:** The load remains supported, but action must be taken. Call Schneider Electric.
- **Informational:** No immediate action required. Check the cause of the alarm as soon as possible.

Alarm Messages

Alarm/Event	Severity	Display Text	Description	Corrective Action Text
Alarm	Warning	Abnormal state at input contact zone A	An abnormal state exists for integrated Environmental Monitor input contact zone A	Please check the environment
Alarm	Warning	Abnormal state at input contact zone B	An abnormal state exists for integrated Environmental Monitor input contact zone B	Please check the environment
Alarm	Warning	Air Filter technical check recommended	The air filters need to be checked as preventive maintenance is recommended.	The Air Filters may need to be replaced.
Alarm	Warning	Ambient temperature high	Ambient temperature is high.	
Alarm	Warning	Ambient temperature out of tolerance	The ambient temperature out of tolerance	
Alarm	Warning	Batteries are discharging	The load is drawing more power than the UPS can draw from the input, causing the UPS to draw power from the batteries.	
Alarm	Warning	Battery breaker BB1 open	Battery breaker BB1 is open	
Alarm	Warning	Battery breaker BB2 open	Battery breaker BB2 is open	
Alarm	Warning	Battery capacity is below minimum acceptable level	The battery capacity is below the minimum acceptable value according to UPS power rating. Risk of battery damage.	Change battery configuration and/or add larger capacity battery
Event	Informational	Battery breakers tripped	To prevent the batteries deep discharging, the battery breakers have been tripped by the system.	Close the battery breakers manually.

Alarm/Event	Severity	Display Text	Description	Corrective Action Text
Alarm	Warning	Battery condition is poor	Battery capacity is lower than 50%	Batteries should be replaced.
Alarm	Warning	Battery condition is weak	Battery capacity is between 50% to 75%	
Alarm	Warning	Battery is below minimum acceptable runtime	The battery runtime is below configured minimum acceptable value.	
Alarm	Critical	Battery is not working correctly	A battery is not working correctly.	Please contact Schneider Electric.
Alarm	Warning	Battery room ventilation inoperable	Input relay indicates that the battery room ventilation is not working correctly	
Alarm	Warning	Breaker MBB closed	Maintenance bypass breaker MBB is closed, feeding the load with unprotected power from bypass.	
Alarm	Warning	Breaker SIB open	System isolation breaker SIB is open, and system cannot feed the load	
Alarm	Warning	Breaker SSIB open	Bypass static switch input breaker SSIB is open, making static bypass operation unavailable.	
Alarm	Warning	Breaker UIB open	Unit input breaker UIB is open, and the UPS is prevented from running in normal operation	
Alarm	Warning	Breaker UOB open	Unit output breaker UOB is open, and UPS cannot feed the load	
Alarm	Warning	Bypass frequency out of tolerance	Bypass input frequency is out of tolerance	Check bypass input frequency and bypass input frequency setting.
Alarm	Warning	Bypass phase missing	Bypass input is missing a phase.	Check bypass input. Please contact Schneider Electric.
Alarm	Warning	Bypass phase sequence incorrect	The phase rotation on bypass input is incorrect	Check bypass input. Please contact Schneider Electric.
Alarm	Warning	Bypass voltage out of tolerance	Bypass input voltage is out of tolerance and UPS is prevented from going into requested bypass mode	
Alarm	Warning	Charge power is reduced	The battery charge power has been reduced.	The input for this functionality was activated, or the input current has reached the maximum limit. Please contact Schneider Electric.
Alarm	Warning	Communication cable termination missing or damaged	One or more communication cable terminators is/are missing or damaged	
Alarm	Warning	Confirm redundancy lost and/or transfer to Forced Static Bypass	One or more communication cable terminators is/are missing or damaged	
Alarm	Warning	Confirm Turn Load Off	Off button has been pushed while inverter is on and with no bypass available. User must confirm that the UPS turns off the power to the load.	Confirm turn off either via display or by pushing the off button again.
Alarm	Informational	Customer Input 1 activated	Customer input relay 1 is activated	
Alarm	Informational	Customer Input 2 activated	Customer input relay 2 is activated	
Alarm	Warning	Display communication is lost	Main Controller is unable to communicate with the display	Please contact Schneider Electric.
Alarm	Warning	Display communication is lost	Main Controller is unable to communicate with the display	Please contact Schneider Electric.
Alarm	Warning	Display firmware incompatibility detected	The firmware of the display is detected as incompatible with the rest of the system.	Perform a firmware update.
Alarm	Critical	EPO Switch Activated	An emergency power off (EPO) switch is activated.	Deactivate the Emergency Power Off switch.

Alarm/Event	Severity	Display Text	Description	Corrective Action Text
Alarm	Warning	External battery monitoring detected fault	Input relay indicates external battery monitoring detected fault	
Alarm	Warning	External sync frequency out of tolerance	External sync frequency is out of tolerance	Check external sync frequency.
Alarm	Warning	External sync phase missing	External sync is missing a phase.	Check External sync.
Alarm	Warning	External sync phase sequence incorrect	The phase rotation on external sync is incorrect	Please contact Schneider Electric.
Alarm	Warning	External sync temporarily disabled	External sync has been temporarily disabled because UPS cannot lock and synchronize to the external sync source	Check external sync
Alarm	Warning	External sync voltage out of tolerance	External sync voltage is out of tolerance and UPS is prevented from going into external sync mode	
Alarm	Critical	Fan inoperable	UPS has one or more inoperable fans. Fan redundancy is lost	
Alarm	Critical	Firmware update - Incorrect UPS operation mode	The UPS is no longer in the correct operation mode during firmware update. Risk of load drop.	Transfer UPS to maintenance bypass.
Alarm	Warning	Firmware versions in parallel UPS units are not identical	The firmware versions in parallel UPS units are not identical	Firmware update all UPS units in the parallel system to the same version
Alarm	Critical	Flywheel inoperable	Input relay indicates that the flywheel is not working correctly.	
Alarm	Critical	General parallel system event	The parallel system is not configured correctly or is not working correctly	Please contact Schneider Electric.
Alarm	Informational	Genset is supplying the UPS	Input relay indicates that a genset is supplying the UPS	
Alarm	Warning	Ground fault detected	Input relay indicates that a ground fault has been detected.	Please contact Schneider Electric.
Alarm	Warning	High Battery Temperature Level	The battery temperature is above the Alarm setting	Check the battery temperature. A high temperature may decrease the battery lifetime.
Alarm	Informational	High Efficiency Mode disabled	High efficiency mode is disabled from an input relay	
Alarm	Warning	High humidity threshold violation at remote sensor	A high humidity threshold violation exists for integrated Environmental Monitor sensor	Please check the environment.
Alarm	Warning	High temperature threshold violation at remote sensor	A high temperature threshold violation exists for integrated Environmental Monitor sensor	Please check the environment.
Alarm	Warning	Input frequency out of tolerance	Mains input frequency is out of tolerance	Check input frequency and input frequency setting.
Alarm	Warning	Input phase missing	Input is missing a phase.	Check input. Please contact Schneider Electric.
Alarm	Warning	Input phase sequence incorrect	The phase rotation on input is incorrect	Check input. Please contact Schneider Electric.
Alarm	Warning	Input voltage out of tolerance	Mains input voltage is out of tolerance	
Alarm	Warning	Inverter is Off due to a request by the user	The inverter is off due to a request by the user	
Alarm	Warning	Inverter output is not in phase with bypass input	The UPS inverter output is not in phase with the bypass input.	
Alarm	Warning	Lost communication to remote sensor	Lost the local network management interface-to-integrated Environmental Monitor	Please check the environment.

Alarm/Event	Severity	Display Text	Description	Corrective Action Text
Alarm	Warning	Lost parallel redundancy	The load exceeds limit for an N+x UPS in redundancy (x is the configurable parallel redundancy)	Reduce the load on the system.
Alarm	Warning	Low Battery Temperature Level	The battery temperature is below the Alarm setting	
Alarm	Warning	Low humidity threshold violation at remote sensor	A low humidity threshold violation exists for integrated Environmental Monitor sensor	Please check the environment.
Alarm	Warning	Low temperature threshold violation at remote sensor	A low temperature threshold violation exists for integrated Environmental Monitor sensor	Please check the environment.
Alarm	Warning	Maximum humidity threshold violation at remote sensor	A maximum humidity threshold violation exists for integrated Environmental Monitor sensor	Please check the environment.
Alarm	Warning	Maximum temperature threshold violation at remote sensor	A maximum temperature threshold violation exists for integrated Environmental Monitor sensor	Please check the environment.
Alarm	Warning	Minimum humidity threshold violation at remote sensor	A minimum humidity threshold violation exists for integrated Environmental Monitor sensor	Please check the environment.
Alarm	Warning	Minimum temperature threshold violation at remote sensor	A minimum temperature threshold violation exists for integrated Environmental Monitor sensor	Please check the environment.
Alarm	Warning	Modular battery breaker open	Modular battery breaker is open.	
Alarm	Warning	Modular battery cabinet is not working correctly	Modular battery cabinet is not working correctly	Check battery cabinet. Please contact Schneider Electric.
Alarm	Warning	NMC 1 firmware incompatibility detected	The firmware of the NMC in Smart Slot 1 is detected as incompatible with the rest of the system.	Perform a firmware update.
Alarm	Warning	NMC 2 firmware incompatibility detected	The firmware of the NMC in Smart Slot 2 is detected as incompatible with the rest of the system.	Perform a firmware update.
Alarm	Warning	Not enough UPS units ready to turn on inverter	One or more parallel UPS units have been requested to turn on inverter, but not enough UPS units are ready for system to enter inverter on operation.	Turn on inverter of more UPS units and/or check the setting "Minimum Number of UPS Required to Supply Load".
Alarm	Warning	Output frequency out of tolerance	Output frequency is out of tolerance	Check output frequency and output frequency setting.
Alarm	Warning	Output voltage out of tolerance	The output voltage is out of tolerance	
Alarm	Warning	Overload on UPS due to high ambient temperature	The load exceeds the rated capacity when running with high ambient temperature.	Reduce load on system or ambient temperature.
Alarm	Warning	Overload or short circuit on UPS	Reduce load on system or check for output short circuit	The load exceeds 100% of rated capacity or there is a short circuit on the output.
Alarm	Warning	Parallel communication lost on PBUS cable 1	PBUS cable 1 may be damaged	Replace parallel Cable 1.
Alarm	Warning	Parallel communication lost on PBUS cable 2	PBUS cable 2 may be damaged	Replace parallel Cable 2.
Alarm	Warning	Parallel mixed operation mode	One or more parallel UPS units are operating in battery operation, while others are operating in normal operation	
Alarm	Warning	Parallel unit not present	Main Controller is unable to communicate with parallel UPS X. The UPS might have been powered down or communication cables may be damaged	
Alarm	Critical	Restricted air flow	Restricted air flow.	This could be caused by a clogged air filter or other obstacle blocking air flow.

Alarm/Event	Severity	Display Text	Description	Corrective Action Text
Alarm	Critical	Self-test - Did not pass	Self-test did not complete correctly	Check event log and active alarms for more details.
Alarm	Warning	Startup recommended	The product has been running overtime without startup	Please contact Schneider Electric for secure startup.
Alarm	Critical	Static bypass switch inoperable	Static bypass switch is inoperable. UPS is prevented from going into static bypass operation	Please contact Schneider Electric.
Alarm	Warning	Static bypass switch warning	The static bypass switch needs a technical check but is still fully operational	Please contact Schneider Electric.
Alarm	Critical	Surveillance detected fault	Surveillance detected fault	Please contact Schneider Electric.
Alarm	Warning	Synchronization unavailable - system is freerunning	The UPS is unable to synchronize to the bypass input, external source or parallel system.	
Alarm	Critical	System locked in bypass operation	The system is locked in bypass operation	The system has toggled between inverter operation and bypass operation more than 10 times within 1 minute. Please activate on button to transfer back to normal operation.
Alarm	Critical	System operation mode - Forced Static Bypass	The system is in bypass in response to a critical event or an inverter off request	
Alarm	Warning	System operation mode - Maintenance Bypass	The system load is supplied through Maintenance Bypass Breaker (MBB).	
Alarm	Critical	System operation mode - Off	The system output power is turned off.	
Alarm	Warning	System operation mode - Requested Static Bypass	The system is in bypass in response to the UPS front-panel or a user-initiated software command, typically for maintenance	
Alarm	Critical	System operation mode - Static Bypass Standby	The system is in static bypass standby operation in response to a critical event or an inverter off request.	
Alarm	Warning	Technical Check recommended	The product and its batteries need to be checked as preventive maintenance is recommended	Please contact Schneider Electric.
Alarm	Critical	UPS configuration incorrect	UPS is configured incorrectly	Please contact Schneider Electric.
Alarm	Warning	UPS operation mode - Battery	On battery power in response to an input power problem.	
Alarm	Informational	UPS operation mode - Battery Test	On battery power in response to a test of the performance of the batteries.	
Alarm	Critical	UPS operation mode - Forced Static Bypass	The UPS is in bypass in response to a critical event or an inverter off request	
Alarm	Informational	UPS operation mode - Initialize	The UPS is initializing	
Alarm	Informational	UPS operation mode - Inverter Standby	The UPS is ready to enter battery operation but awaits permission from the system. UPS output is off	
Alarm	Warning	UPS operation mode - Maintenance Bypass	The UPS load is supplied through Maintenance Bypass Breaker (MBB).	
Alarm	Critical	UPS operation mode - Off	The output power is turned off.	
Alarm	Warning	UPS operation mode - Requested Static Bypass	The UPS is in bypass in response to the UPS front-panel or a user-initiated software command, typically for maintenance	

Alarm/Event	Severity	Display Text	Description	Corrective Action Text
Alarm	Warning	UPS operation mode - Static Bypass Standby	The UPS is ready to enter static bypass but awaits permission from the system. UPS output is off	
Alarm	Critical	UPS settings reset to default	Unit settings has been reset to default. The UPS is locked in off operation until settings are confirmed.	Please contact Schneider Electric.
Alarm	Warning	Warranty expiring soon	The product is reaching the end of warranty	Please contact Schneider Electric.

Tests

The UPS system can perform the following tests to ensure correct performance of the system:

- **Battery Test**
- **Runtime Calibration**
- **Annunciators**
- **Display Calibration**

Perform a Battery Test

Prerequisites:

- The batteries must be more than 50% charged.
- The runtime available must be more than 4 minutes.
- The operation mode must be normal operation, EConversion, or ECO mode.
- The system operation mode must be normal, EConversion, or ECO mode.

This feature performs a number of tests on the batteries, such as fuse-blown check, weak battery detection. The test will discharge the battery, and use about 10% of the total capacity. Meaning if you have 10 minutes of runtime, the test will run for 1 minute. The **Battery Test** can be set up to run automatically in different time intervals (from weekly and up to once a year).

1. From the home screen on the display select **Tests > Battery Test**.
2. Tap the **Start Battery Self-Test** button.

NOTE: If you wish to manually stop the battery self-test, tap the **Abort Battery Self-Test** button.

Perform a Runtime Calibration

This feature is used for calibrating the estimated remaining battery runtime value. In this test the UPS transfers to battery operation and the batteries are discharged to the low DC warning level. Based on the elapsed time and information about the load, the battery capacity can be calculated and the estimated runtime calibrated.

Schneider Electric recommends performing battery runtime calibration at start-up, when batteries are replaced, or when changes are made to the battery cabinets.

NOTICE

RISK OF EQUIPMENT DAMAGE

- During a runtime calibration the batteries will be at a very low level and therefore not capable of supporting your system load in case of a input power failure.
- Batteries will be discharged to 10% capacity and this will result in a low battery runtime after the calibration.
- Repeated battery testing or calibration can affect the lifetime of the battery.

Failure to follow these instructions can result in equipment damage.

Prerequisites:

- Batteries must be 100% charged.
- The load percentage must be at least 10% and must not change more than 20% during test.
- The bypass supply must be available.
- The operation mode must be normal operation, EConversion, or ECO mode.
- The system operation mode must be inverter, EConversion, or ECO mode.

1. From the home screen on the display select **Tests > Runtime Calibration**.
2. Tap the **Start Runtime Calibration** button.

NOTE: If you wish to manually stop the runtime calibration, tap the **Abort Runtime Calibration** button.

Perform an Annunciators Test

1. From the home screen on the display select **Tests > Annunciators**.
2. Tap the **Start** button to initiate the test.

During the annunciators test the LEDs on the display and the mimic diagram and the audible alarm are tested.

Calibrate the Display

From the home screen on the display select **Tests > Display Calibration** and then select the calibration you want to perform.

- **Calibrate:** Tests and adjusts the touch screen target sensitivity.
- **Calibration Check:** Checks the calibration adjustments.

Determine if you need a Replacement Part

To determine if you need a replacement part, contact Schneider Electric and follow the procedure below so that the representative can assist you promptly:

1. In the event of an alarm condition, scroll through the alarm lists, record the information, and provide it to the representative.
2. Write down the serial number of the unit so that you will have it easily accessible when you contact Schneider Electric.
3. If possible, call Schneider Electric from a telephone that is within reach of the display so that you can gather and report additional information to the representative.

4. Be prepared to provide a detailed description of the problem. A representative will help you solve the problem over the telephone, if possible, or will assign a return material authorization (RMA) number to you. If a module is returned to Schneider Electric, this RMA number must be clearly printed on the outside of the package.
5. If the unit is within the warranty period and has been started up by Schneider Electric, repairs or replacements will be performed free of charge. If it is not within the warranty period, there will be a charge.
6. If the unit is covered by a Schneider Electric service contract, have the contract available to provide information to the representative.

Find the UPS Serial Number

1. From the home screen on the display interface select **About > UPS**.
2. Note down the serial number and have it ready for customer support.

NOTE: If the display is not available, the serial number can also be found on a label in each specific cabinet.

Return Parts to Schneider Electric

Call Schneider Electric to obtain an RMA number.

To return an inoperable part to Schneider Electric, pack the module in the original shipping materials, and return it by insured, prepaid carrier. The customer support representative will provide the destination address. If you no longer have the original shipping materials, ask the representative about obtaining a new set. Pack the module properly to avoid damage in transit. Never use styrofoam beads or other loose packaging materials when shipping a module. The module may settle in transit and become damaged. Enclose a letter in the package with your name, RMA number, address, a copy of the sales receipt, description of the problem, a phone number, and a confirmation for payment (if necessary).

NOTE: Damages sustained in transit are not covered under warranty.

Schneider Electric
35 rue Joseph Monier
92500 Rueil Malmaison
France

+ 33 (0) 1 41 29 70 00

www.schneider-electric.com

As standards, specifications, and design change from time to time,
please ask for confirmation of the information given in this publication.

© 2013 – 2016 Schneider Electric. All rights reserved.

990–4758C–001