

---

# 1001 RADIO QUESTIONS & ANSWERS

---

compiled by the staff of  
**RADIO NEWS**  
1926

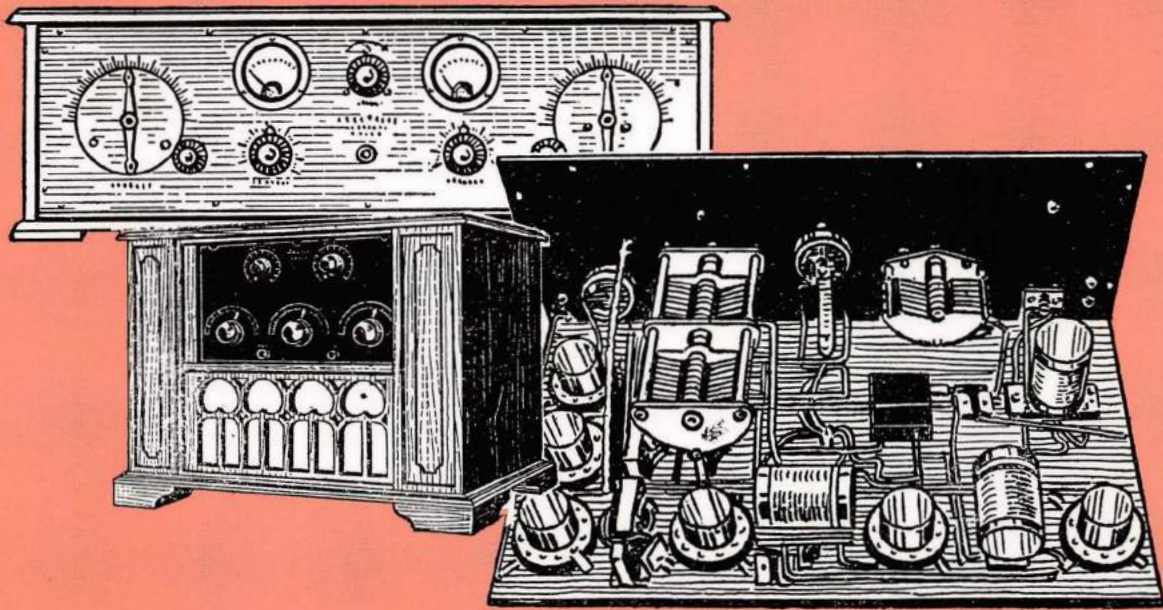

reprinted by Lindsay Publications Inc



# 1001 Radio Questions and Answers

Compiled by the Staff of



*Edited by*

**LEON L. ADELMAN**

Associate Editor Radio News

A Classified, Complete Collection of Radio Questions and  
Answers, of Incalculable and Inestimable Value to  
Everyone Interested in Radio, Covering Practi-  
cally Every Phase of the Art

**VOL. NO. 1**

Published by

**EXPERIMENTER PUBLISHING COMPANY, Inc.**

**53 PARK PLACE  
NEW YORK**

# 1001 Radio Questions and Answers

---

## CONTENTS

Subject	Page No.
Miscellaneous Circuits.....	5
Popular Circuits.....	39
Tube Data.....	64
Transmitting Circuits.....	67
Current Supply.....	69
Amplifiers.....	72
Antennae.....	75
Miscellaneous Apparatus.....	77

---

### 1001 Radio Questions and Answers

edited by Leon L. Adelman

Original copyright 1926  
by Experimenter Publishing Co., Inc.

Reprinted by Lindsay Publications Inc.,  
Bradley IL 60915

All rights reserved. 1993

ISBN 1-55918-100-1

1 2 3 4 5 6 7 8 9 0

#### WARNING

Remember that the materials and methods described here are from another era. Workers were less safety conscious then, and some methods may be downright dangerous. Be careful! Use good solid judgement in your work, and think ahead. Lindsay Publications Inc. has not tested these methods and materials and does not endorse them. Our job is merely to pass along to you information from another era. Safety is your responsibility.

Write for a complete catalog of unusual books available from:

Lindsay Publications Inc  
PO Box 12  
Bradley IL 60915-0012

# 1001 Radio Questions and Answers

## INTRODUCTION

**I**T was with Maxwell's conceptions of the electromagnetic wave theory and Hertz's pioneer experiments which confirmed those theories, that interest in what was destined to prove a most wonderful art, was first aroused. This was in the latter part of the nineteenth century at a time when little was known about electricity, and still less about its application to serve humanity.

As time progressed, history records that the young and energetic wireless experimenter, Marconi, after a series of elaborate experiments, was able to transmit telegraph messages over a few hundred yards, and in the eventful year of 1901, in the latter part of the month of December, to be sure, successfully sent the famous letter "S" across the Atlantic Ocean.

Since that time, the development of wireless, or radio as it is now called, has been meteoric. Yet this rapid development really started but a relatively few years ago, from the time radio telephony was inaugurated as a medium to convey amusement and entertainment to the public. It is, therefore, stressed, that in the period between 1921 and today, most of the remarkable work in radio has been done.

As a result of the almost miraculous advance in the radio art, many of the major as well as the minor achievements have not been fully made clear to an interested host of enthusiasts. Questions have arisen from time to time which have been answered at random in the radio publications, but no serious thought has ever been entertained to compile a classified summary of the most important questions and their corresponding answers into a volume under one cover. It is for this very reason that this book is offered to the radio enthusiast, whether he be merely a beginner or an advanced technician on the subject. It is felt that those questions which are of the greatest importance have been dealt with in the simplest and best possible manner.

To the reader, this volume is recommended as a treatise which will stand for many years to come, both as a source of undisputable information and as a reference to solve the many perplexing questions that so often arise when *radio* is the topic for discussion.

*Editor.*

---

Copyright by  
EXPERIMENTER PUBLISHING CO., INC.  
1926

All rights reserved, including that of translation into foreign languages, including the Scandinavian  
Printed in the United States of America

# STEP INTO THE LIMELIGHT!

## Surprise Your Friends With a Mastery of Mystery

Master this great book, 116 pages of Tricks, size 9 x 12 inches, compiled by the staff of *SCIENCE and INVENTION Magazine* under the direction of Prof. Dunninger, the man who mystified President Coolidge, Prince of Wales, etc.

Be the popular man in your circle of friends. You can entertain them and hold their attention with a thousand surprises and novelties.

POPULAR MAGIC is a book for you, for everybody, young or old. But especially for those who want popularity, those who want to realize how much the admiration of friends helps toward making life worth more.

POPULAR MAGIC contains thousands of simple, entertaining parlor tricks, as many puzzling magical stunts and a whole book full of mystic spirit novelties. A new set of tricks for every day of the year. Compiled from the great magazine "SCIENCE and INVENTION."

GET THIS GREAT BOOK TODAY. Chock full of Tricks, Novelties, Mystic performances, Master sleights-of-hand, Gags, Disappearing acts. All kinds of fun. Buy a copy or order direct.

**PRICE 50c—SOLD EVERYWHERE**

POPULAR MAGIC is sold on all newsstands. You can obtain a copy today from your news dealer or you can use the coupon on this page and order direct enclosing 50c money order or stamps.

**EXPERIMENTER PUBLISHING CO., Inc.**  
53 PARK PLACE NEW YORK CITY

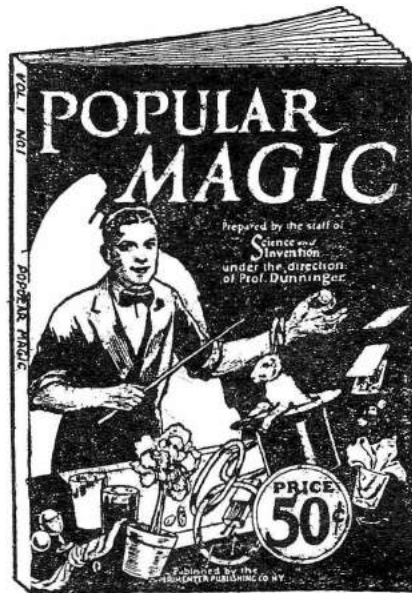

EXPERIMENTER PUBLISHING CO., Inc.  
53 Park Place, New York, N. Y.

Gentlemen:—Enclosed find 50c for which send me one copy of POPULAR MAGIC.

Name .....

Address .....

City..... State.....

## How to make your own SPEECH AMPLIFIER

**SPECIALLY PRICED**  
While they last **95c**  
per unit  
or 2 for \$1.75

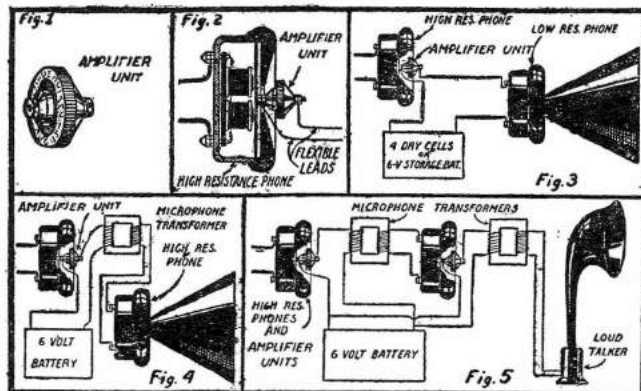

Fig. 1 shows the amplifier unit.  
Fig. 2 shows how the unit is attached to a telephone receiver. The first procedure is to mount the unit on the diaphragm of a telephone receiver, which usually is a high resistance telephone, either 1,000 or 1,500 ohms.

Next we select the loud speaking telephone. If a low resistance telephone is available, it should have for maximum efficiency an impedance equal to the resistance of the amplifier unit, or about 10 ohms; it is connected up as shown in Figure 3. A 5 ohm telephone receiver is used in this circuit with a 6-volt storage battery.

Two telephones taken from a good double headset of 2,000 to 3,000 ohms which do not rattle on strong currents, are employed in Fig. 4, one at the receiving end, the other as loud talker. In

this hook-up there is one instrument which must absolutely be used with this combination, the transformer. As stated before in connection with Fig. 3, the impedance of the telephone, if used in direct connection, should equal the resistance of the unit. But as the impedance of the telephone in Fig. 4 is much higher than the resistance of the unit, it may be 200 times as great, a transformer having a step-up ratio is used to match up the resistance of the unit with the impedance of the loud speaking telephone. In other words, the primary coil of the transformer should have an impedance (which is sometimes called "A. C. resistance") equal to the resistance of the unit, or about 10 ohms, and the secondary coil should have an impedance equal to the impedance of the high resistance

telephone. This transformer may be purchased in any Radio Store and is called a microphone transformer or modulation transformer, designed primarily to use in radio transmitting sets. A 6-volt battery gives the best results. The current passing through the unit will vary from .1 to .25 ampere.

Fig. 5 shows a circuit for further increasing the volume of sound. This is simply two of the circuits, such as shown in Fig. 4, linked together. This arrangement is highly sensitive and the telephones on which the units are mounted should be packed in a box of cotton, as the slightest vibration or sound in the room will be picked up and heard in the loud talker. Any sensitive radio loud talker may be used in this particular circuit.

**M**ICROPHONE Transmitter Buttons have been used for a number of years to make powerful sound transmitting elements. These very sensitive amplifiers offer every "Radio Fan" the means of building his own powerful speech amplifier. We offer herewith to the constructor these special *Amplifier Units*.

**PRESS GUILD,**  
66 W. Broadway, New York City, N. Y.

Enclosed find 95c—\$1.75 for which send me postpaid one—two amplifier units as advertised.

Name .....

Address .....

Town..... State.....

**T**HESE and innumerable other interesting experiments are possible with these amplifiers. Every amateur should have at least one or two in his "Lab" or workshop. A four-page instruction pamphlet is sent with every unit.

**PRESS GUILD, 66 West Broadway, New York, N. Y.**

# Miscellaneous Circuits

## (1) RADIO FREQUENCY WITH REGENERATION

Q. 1. Can radio frequency amplification be used with a three-circuit regenerative receiver of the honeycomb coil type?

A. 1. Radio frequency amplification can be used with a honeycomb coil regenerative receiver. If more than two stages of R. F. are used, difficulty might be experienced with regeneration. In this case the tickler coil can be shorted out of the circuit.

Q. 2. Please show a hook-up of this circuit with two stages of R. F. amplification.

A. 2. This hook-up will be found in these columns.

## (2) HAND CAPACITY

Q. 1. I have a home-made regenerative receiver, using a Peerless coil. A zinc shield is used. How can extreme body capacity be eliminated?

A. 1. You do not state whether the capacity effect is most noticeable from condenser or coil. If from the former, try reversing the leads; the rotor plates should connect to the point of lowest potential (usually the A-). If from the latter, try reversing the leads to the coil rotor. Try grounding the filament circuit. It may be advisable to use a grounded-frame condenser.

## (3) HONEYCOMBS AND AMPLIFIERS

Q. 1. Please publish hook-up using following material: Triple honeycomb mounting, series and shunt switch, .002 M. F. .001 M. F. and .0005 M. F. variable condensers, one .002 fixed condenser, tube socket, one rheostat, one grid leak and one stage of audio frequency amplification.

A. 1. The hook-up for the mentioned materials will be found on this page. Use

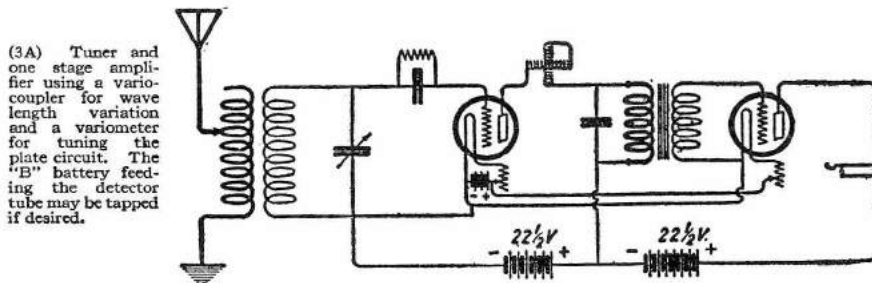

a six volt, 80-ampere storage battery for heating the tube filaments and 45 volts "B" battery for the amplifier plates with a tap off at 22 1/2 volts for the detector tube.

Q. 2. What hook-up is best to use with a variocoupler, a variometer, a variable condenser, one detector tube and one step amplifier.

A. 2. This circuit may be found on this page.

Q. 3. What size and kind of wire should be used in wiring a circuit?

A. 3. No. 14 gauge copper wire is the correct size for wiring.

Q. 4. Is radio frequency or audio frequency amplification used in the Westinghouse R. C. set?

A. 4. This is a regenerative receiver and does not employ radio frequency amplifier tubes. There is a certain amount of amplification (regeneration) at radio frequency, in the detector tube.

## (4) TWO-STAGE AMPLIFIER

Q. 1. Please publish a diagram of a single-

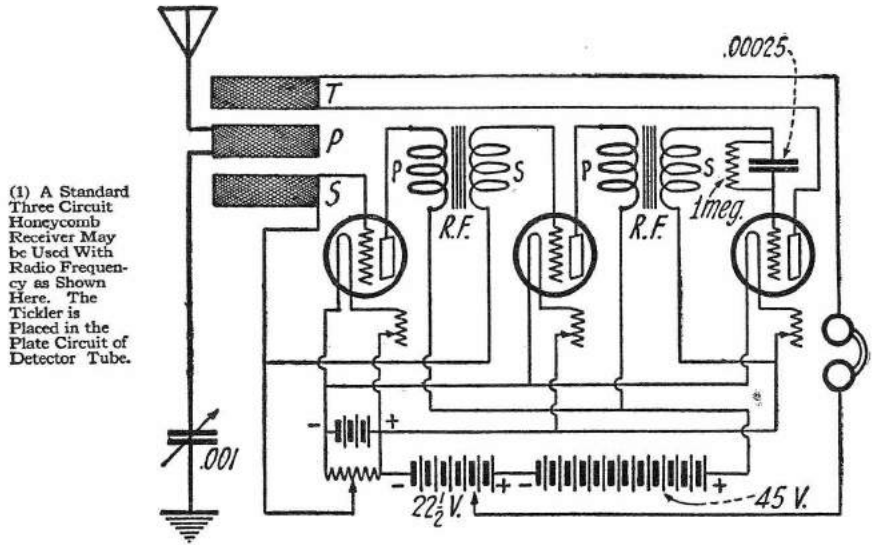

circuit tuner, using the Atwater-Kent two-stage amplifier.

A. 1. This diagram will be found on the next page.

## (5) ENGLISH REFLEX CIRCUIT

Q. 1. Can a reflex set be constructed without using the regular audio frequency and radio frequency transformers?

A. 1. We are showing on the next page, a reflex set of the type you desire. One stage of straight audio frequency amplification has been added to it. This stage of audio fre-

Q. 2. Can a loop be used with a one tube reflex set?

A. 2. Only for stations a short distance away. The two tube circuit we show here is more practical.

Q. 3. Can two or three tubes be controlled by one rheostat?

A. 3. It is quite practical to use one rheostat to control two radio frequency or two audio frequency amplifier tubes, but it is always advisable to employ a separate rheostat for the detector tube.

## (6) CHOKE COIL AMPLIFICATION

Q. 1. Please show a diagram of a set incorporating two stages of radio frequency amplification, tube detector and two stages of audio frequency amplification, using choke coil amplification throughout.

A. 1. The system of connections is shown on page 6.

Q. 2. What tuning system should be employed?

A. 2. We are showing an aperiodic antenna tuning system. A 54-turn coil is shown. This coil is tapped, four turns from one end.

Q. 3. What type of impedance should be used?

A. 3. Spark coil secondaries or audio frequency transformer secondaries may be used, or their equivalent.

## (7) R. F. AMPLIFICATION WITH REINARTZ CIRCUIT

Q. 1. Kindly show a hook-up of the Reinartz tuner with one stage of radio frequency amplification.

A. 1. This hook-up will be found in these columns. Tuned radio frequency must be used in this circuit. The primary of a vario-

quency amplification is transformer-coupled in order to get a high voltage step-up resulting in increased signal strength. The reflexed tube utilizes choke coil audio frequency amplification. Need for a radio frequency transformer has been eliminated by the use of the loop. The .00025-mfd. condenser is for regeneration control. The choke coil may be an audio frequency transformer secondary. The loop is wound on a 16-inch square frame.

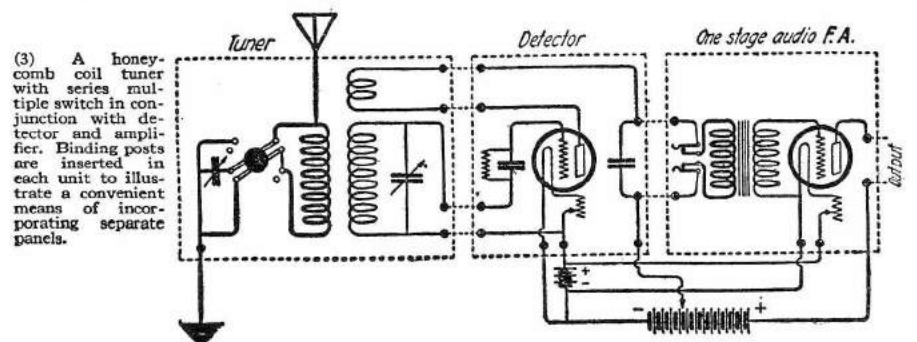

coupler may be used for this purpose. A variometer can be substituted for the coil and condenser, if more convenient. We would suggest that the tickler winding be reversed, for best results.

A. 2. It will greatly reduce, if not prevent, radiation.

Q. 3. Can the very small "B" batteries of the size called "Signal Corps" be used in a superheterodyne?

A. 3. These batteries have such a short

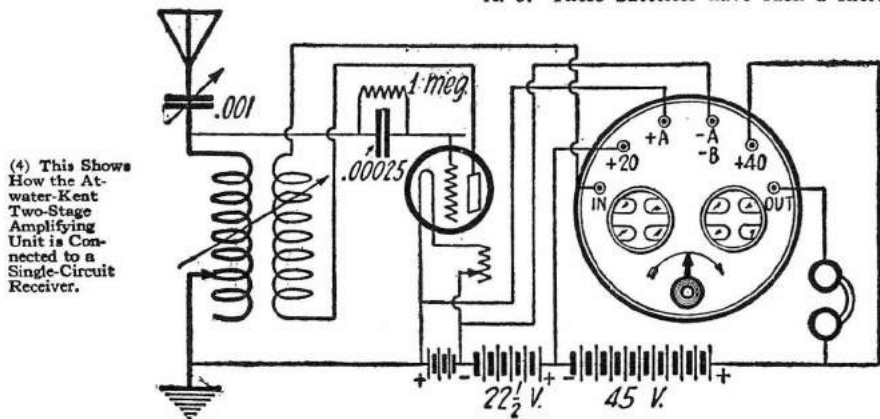

(4) This Shows How the At-water-Kent Two-Stage Amplifying Unit is Connected to a Single-Circuit Receiver.

(8) CONDENSERS WITH H. C. COILS

Q. 1. What capacity variable condensers are most suitable for the primary and secondary circuits when using honeycomb coils?

A. 1. A condenser of .001 mfd. should be used in the primary circuit, and a condenser of .0005 mfd. will be suitable for the secondary.

Q. 2. How can radio frequency amplification be added to the Autoplex?

A. 2. Radio frequency cannot be successfully added to the Autoplex.

Q. 3. Is the super-heterodyne receiver superior to other receivers for phone reception?

A. 3. This receiver is conceded to be the most efficient for both code and phone.

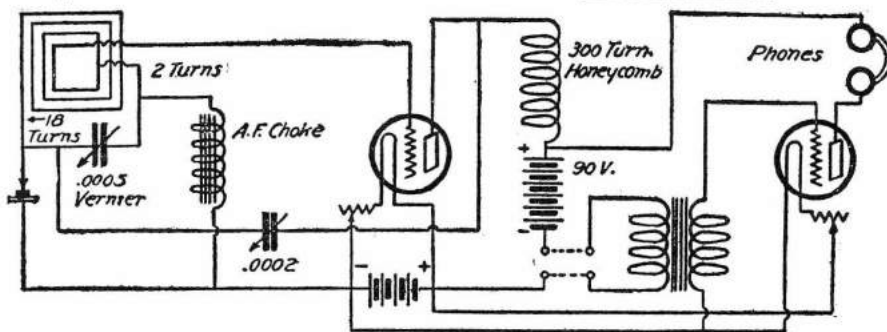

(5) This British reflex circuit is worthy of trial. It is the simplest circuit of this type yet developed.

(9) R. F. AND A. F. WITH SAME TUBES

Q. 1. Please show hook-up of two stages

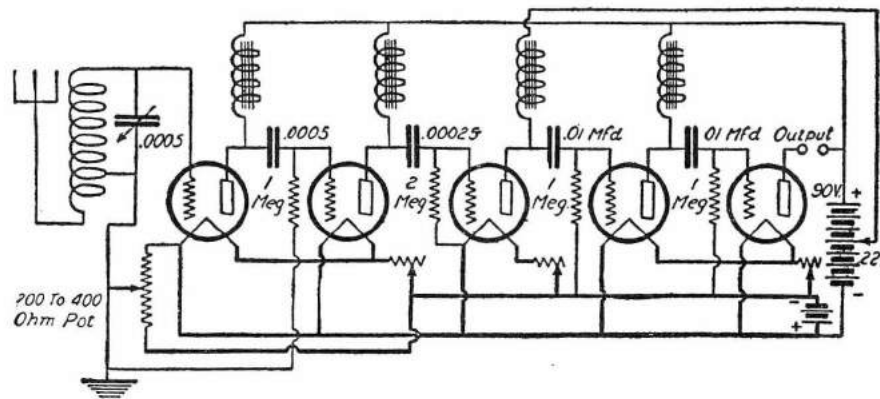

(6) Amplification at both radio and audio frequencies may be had by the use of choke coils, in the manner shown in the diagram. Note that fixed condensers of different capacity values are connected in series with the respective grid circuits.

of A. F. and two stages of R. F. using the same tubes.

A. 1. Hook-up is shown on these pages.

(10) MUSHY SIGNALS

Q. 1. Why do certain stations come in "mushy"?

A. 1. This is ordinarily caused by some station (receiving or sending) heterodyning with the wave of the station you are trying to receive. Should the trouble originate in your receiving set, try changing the grid leak.

(11) FILAMENT CONTROL JACKS

Q. 1. How can filament control jacks be added to my set?

A. 1. The diagram of a two stage amplifier using filament control jacks is shown in these columns.

Q. 2. Will radio frequency prevent radiation when placed before the detector of a regenerative set?

life that they should be used in a portable receiver only. Larger batteries should be used in permanent installations.

(13) R.F. WITH THREE-CIRCUIT RECEIVER

Q. 1. Can one stage of radio frequency and one stage of audio frequency amplification be added to a three-circuit receiver? Please publish diagram.

A. 1. This diagram appears on page 7. One stage of radio frequency is placed before the tuner. In this way regeneration may also be used. If there is a variable condenser in the antenna or ground circuit of the variocoupler it must be placed in shunt, as shown.

Q. 2. Is there any other way in which I can increase the receiving range of my set?

A. 2. This is the only way in which a greater receiving range may be had.

Q. 3. Would there be an increase of volume by using direct aerial coupling, instead of inductive coupling?

A. 3. Yes. But tuning would be more broad.

Q. 4. Is enameled wire just as good as D.C.C. wire to wind a coupler with?

A. 4. Just as good results will be had with enameled wire, when used for this purpose.

(7) The Reinartz Circuit May Be Used With R. F. Amplification, As Shown Here. Tuned R. F. Is Used Instead Of An R. F. Transformer.

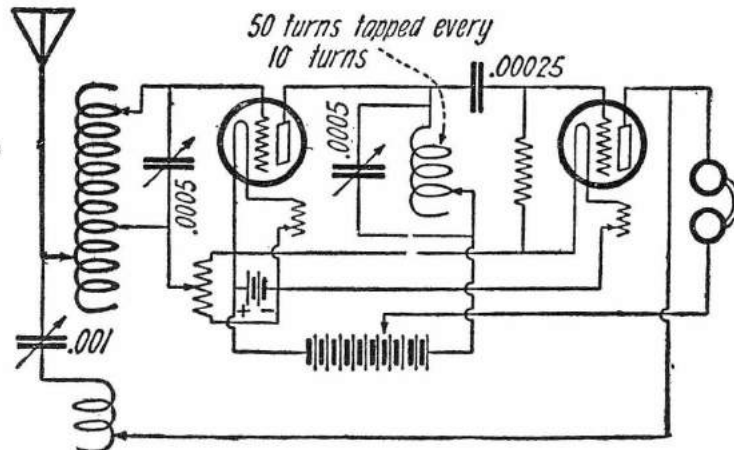



**(14) JACKS WITH REFLEX CIRCUIT**

Q. 1. Please show a hook-up, showing how jacks may be inserted in a three-tube reflex circuit, using a variocoupler as a tuner. Also show how a loop may be used in this hook-up.

A. 1. This hook-up will be found in these columns. Two double-circuit and one closed-circuit jack are used. A double-circuit jack is also used in the secondary circuit, so that the loop may be plugged in. The loop may consist of eight turns of wire, on a four-foot square frame.

Q. 2. Should the grid return be connected to the positive or negative of the "A" battery for the detector and amplifier?

A. 2. For the detector the grid return should be connected to the positive, and for the amplifiers to the negative side of the "A" battery.

Q. 3. Will an Autoplex, a three circuit regenerative set using plate variometer, or a single circuit set, interfere with nearby receiving sets by radiation?

A. 3. Yes, all three.

variometer may be used in place of this inductance and condenser if desired. If W.D.11 tubes are used, two dry cells, connected in parallel, should be substituted for the storage battery.

Q. 2. Can a three-tube neutrodyne receiver be used with the Aeriola Sr.?

Q. 5. Could a variocoupler be substituted for two honeycomb coils of 50 and 60 turns, respectively?

A. 5. A variocoupler with the same number of turns on both primary and secondary may be successfully used, instead of the honeycomb coils, as a tuner.

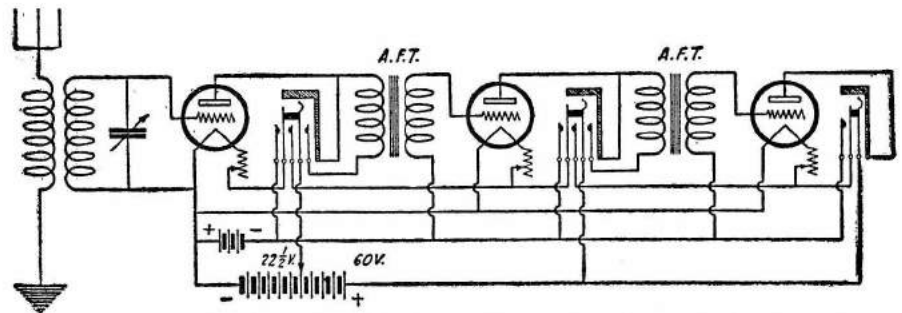

(11) Filament control jacks may be employed in any circuit in place of double circuit jacks. This diagram shows the proper connections.

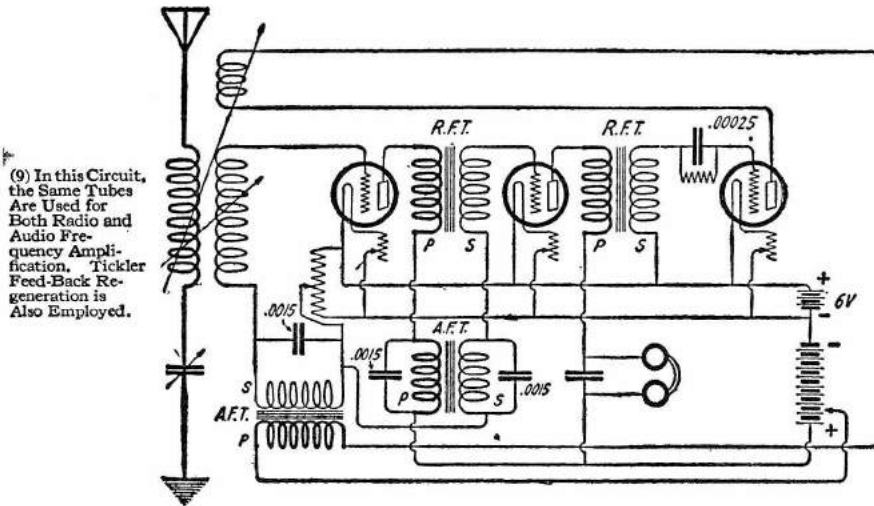

(9) In this Circuit, the Same Tubes Are Used for Both Radio and Audio Frequency Amplification. Tickler Feed-Back Regeneration is Also Employed.

**(15) R.F. AMPLIFICATION WITH AERIOLOA, SR.**

Q. 1. Can radio frequency amplification be added to the Aeriola Sr. receiver? If so, please show a diagram using two stages.

A. 1. This hook-up appears on these pages. The radio frequency in this case is put before the tuner, and a separate tuning coil is used for tuning. Two separate "B" batteries must also be used.

Q. 2. Is a single tube reflex circuit better than a single tube Reinzart?

A. 2. Distance and volume would probably be in favor of the reflex. The range of the reflex depends greatly on the adjustment of the crystal detector while the Reinzart is entirely independent of this variable factor, consequently more consistent in operation.

Q. 3. Is a 5,000-mile range guarantee of broadcast reception legitimate?

A. 3. Such a range cannot be guaranteed with any type of set, due to the uncertain atmospheric conditions that control the distance over which reception is possible.

**(16) PHANTOM CIRCUIT**

Q. 1. Please publish the hook-up of the so-called Phantom Circuit.

A. 1. This circuit will be found in these columns. You will notice that this is simply a tuned plate receiver, using an antenna and ground only.

**(17) ONE STAGE TUNED R.F.**

Q. 1. Will you please publish a circuit for a detector and one stage of radio frequency?

A. 1. This hook-up appears herewith. Tuned radio frequency is used and exceptional results should be obtained with this system. The R. F. inductance may consist of a tapped coil of 50 turns on a 3" tube. A

A. 2. We cannot advise using a delicately balanced radio frequency amplifier, such as the neutrodyne, with a regenerative receiver. Better results will be had by using the standard circuit, which has appeared in our columns.

Q. 3. What can I use as a fixed inductance to avoid the use of a coupler?

A. 3. Spiderweb or honeycomb coils may be used in place of a variocoupler with excellent results.

**(18) LOOP ANTENNA**

Q. 1. Show a hook-up of an all wave coupler with a loop and two tubes (det. and one step of audio frequency).

A. 1. A loop cannot be used in conjunction with this tuner efficiently and radio frequency must be used, as not enough energy is received with a loop for a detector alone. A loop, shunted by a .001 variable condenser is the antenna and tuner in itself.

Q. 2. Also show with detector and one stage of R. F. amplification.

A. 2. Diagram will be found on these pages.

Q. 3. Would like specifications of loop.

A. 3. Eight turns of No. 18 wire on a loop four feet square and shunted by a variable condenser of .001 capacity will be satisfactory.

Q. 4. What is the maximum wave-length range of the Autoplex circuit?

A. 4. If variometers of large size are used in this circuit, it should tune from 200 to about 540 meters.

**(19) TWO-VARIOMETER HOOK-UP**

Q. 1. Give a hook-up of two variometers and variable condenser.

A. 1. This hook-up will be found in these columns.

**(20) INCREASING WAVE-LENGTH RANGE**

Q. 1. How can 509 meters be reached with a single circuit tuner?

A. 1. Connect a fixed condenser across the

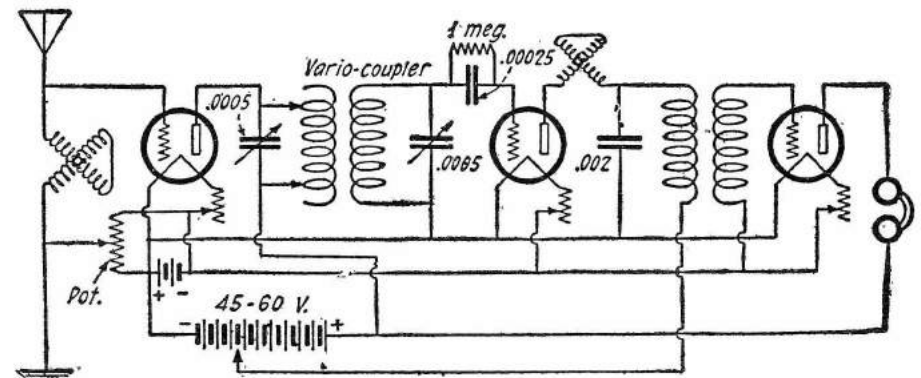

(13) Here is Shown the Best Method of Using One Stage of R.F. Amplification with a Standard Regenerative Receiver.

Q. 4. Please show the method of changing a "Signal Corps" type B-C-14-A (200-600) crystal receiving set into a single tube set.

A. 4. The method of change is shown in these columns. The buzzer need not be used when a vacuum detector is used. The variometer in the phone circuit enables regeneration to be obtained over the entire wave-length range.

grid coil of .00025 mfd., or .0005 mfd. capacity.

**(21) NEUTRODYNING THE REFLEX**

Q. 1. Is it possible to incorporate the Neutrodyne principle in a reflex set, thereby eliminating the usual potentiometer used to control tube oscillation?

A. 1. We are showing a reflex circuit in-

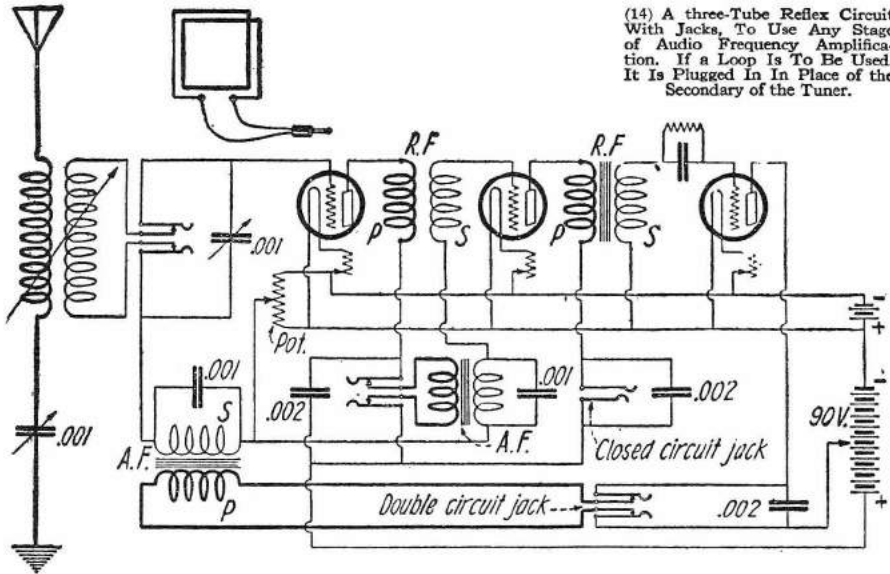

(14) A three-Tube Reflex Circuit With Jacks, To Use Any Stage of Audio Frequency Amplification. If a Loop Is To Be Used, It Is Plugged In In Place of the Secondary of the Tuner.

corporating the Neutrodyne principle.

Q. 2. What type of transformers should be used in a circuit of this type, incorporating four tubes, one as detector?

A. 2. Regular neutroformers will give excellent results. Phusiformers will also be satisfactory. It is probable that ordinary radio frequency transformers will have too great coupling and too many turns on the primary.

(22) "C" BATTERY IN R.C. SET

Q. 1. Please let me know how a "C" battery may be used in an R.C. set.

A. 1. The only way to use a "C" battery in an R.C. set would be to insert a battery of required size in the grid circuit of each amplifying tube. The negative terminal should go to the grid and the positive terminal through the secondary of the amplifying transformer to the negative of the "A" battery. Unless you are able to rearrange the wiring inside the set we would not advise that a "C" battery be used.

(23) POWER SUPPLY FROM A.C. SOURCE

Q. 1. What is the diagram of connections of a four tube set, using a crystal for detection, when a 110-volt, alternating current source supplies the necessary "A" and "B" potentials?

A. 1. We are showing the diagram of connections for a four tube set incorporating two stages of radio frequency and a crystal detector. An untuned primary circuit simplifies the tuning. The center-tapped transformers are designed for the output voltages shown.

(24) RADIO VS. AUDIO FREQUENCY

Q. 1. Is radio frequency better than audio frequency?

A. 1. This all depends on what is desired. Audio frequency will amplify anything that is

rectified by the detector so that a large volume of sound is had. Radio frequency amplifies the signals before they reach the detector, thus bringing in signals that would not otherwise be heard with the detector and A. F. amplification alone.

Q. 2. Please publish a hook-up using a loose coupler with detector and two stages of audio frequency amplification, using only two tubes.

A. 2. This cannot be done. Two tubes could be used for detector, one stage of radio and one stage of audio frequency, but not for

(15) Radio Frequency May Be Added to the Aeriola, Sr., with Good Results. Only One Transformer is Needed for Two Stages as Shown Above.

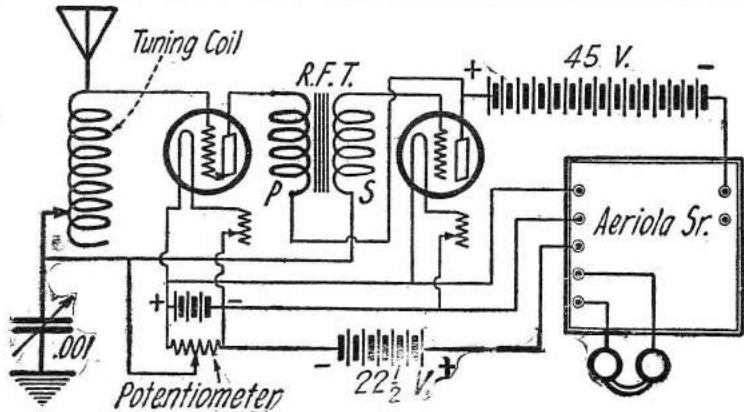

detector and two stages of audio frequency.

Q. 3. How is it possible to use a tube as a radio frequency amplifier in conjunction with a crystal detector?

A. 3. The diagram shown in answer to your inquiry makes this clear. Need for a potentiometer has been dispensed with by the use of the Superdyne method of controlling oscillations. If the aerial is not long, the primary winding may be dispensed with and the connection shown used.

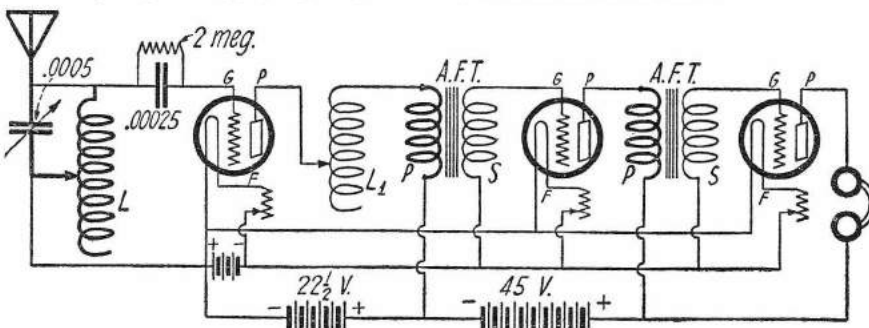

(16) The "Phantom" Circuit. Upon Examination It Will Be Seen That It Is a Single Circuit Tuned Plate Receiver.

(25) TICKLER COIL

Q. 1. My tickler coil does not make much difference in the action of my set. What could be done to cause it to function?

A. 1. A fixed condenser about .0005 mfd. connected to both sides of the tickler coil should cause your set to oscillate. A phone condenser of about .001 mfd. capacity will also improve the reception. Try reversing the lead to the tickler.

(26) COMPARISON CIRCUIT

Q. 1. Please show a diagram of connections of a switching system for making a comparison between a single circuit receiver and a three circuit receiver. One stage of audio frequency amplification may be used for either set.

A. 1. The diagram you request is shown in these columns. Note that provision has been made to apply the correct "B" battery voltage to the particular tube that is used in each set.

Q. 2. Sometimes I have to place my hand on the grid variometer to receive music. How can this be avoided?

A. 2. The placing of the hand on the grid variometer is equal to adding a capacity to this circuit. Either you are not using enough inductance or a slight addition of inductance to this circuit will be necessary.

(27) SHARPENING THE THREE-CIRCUIT TUNER

Q. 1. Can the tuning of my three-circuit tuner be sharpened without changing any of its connections?

A. 1. We are showing a system that has given very good results. It is important that the additional coil used be in non-inductive relation to the set. The two connections shown should be tried to determine the best

one. Either a variometer or a coil-and-condenser may be used to vary the wavelength.

(28) MUSIC FADES

Q. 1. Why is it that, when listening to a distant station, the music slowly fades away and after a short time grows distinct again?

A. 1. This peculiar phenomenon, known as fading, is something that is not the fault of the receiving set. It seems to be due to the changing of atmospheric conditions. No remedy for it has been worked out as yet.

Q. 2. Are UV-199 and C-399 tubes satisfactory for reflex and Super-Heterodyne receivers?

A. 2. These tubes will work very well in reflex circuits (excepting those of the neutralized type, in which the advantages of the standard storage battery tube are quite pronounced).

They are not as constant in operation as the standard storage battery tubes, under Super-Heterodyne demands. It is sometimes necessary to reactivate these tubes at short intervals.

(29) VARIOMETER-UNIT DIAGRAM

Q. 1. How may a Peerless coil be used in a radio frequency hook-up?

A. 1. A very efficient diagram, incorporating the transformer-coupled and tuned-plate systems of radio frequency amplification, with an untuned primary is shown in these columns. No variable condensers are required.

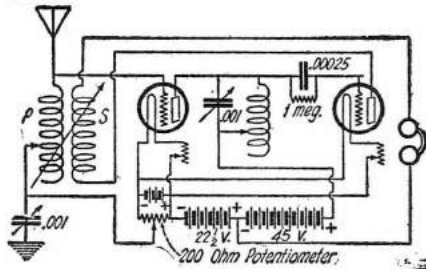

(17) Very Good Results Will be Had by Using One Stage of Tuned Radio Frequency. The Inductance May be the Primary of a Variocoupler.

**(30) VERNIER CONDENSER**

Q. 1. I would like to know if a 23-plate condenser with a vernier dial is as good as a 23-plate vernier condenser.

A. 1. A variable condenser using a vernier dial will give just as good results as a standard vernier condenser.

Q. 2. How many stages of R. F. amplification does it take to get a longer range than the Armstrong "super" circuit?

A. 2. A good regenerative circuit will, as a rule, receive longer distances than the "super," although the volume of sound will not be as great.

**(31) COMBINATION CRYSTAL AND TUBE CIRCUIT**

Q. 1. Will you kindly publish a diagram of a circuit which will enable me to use the following combinations: A vacuum tube detector, a crystal detector, or a crystal detector

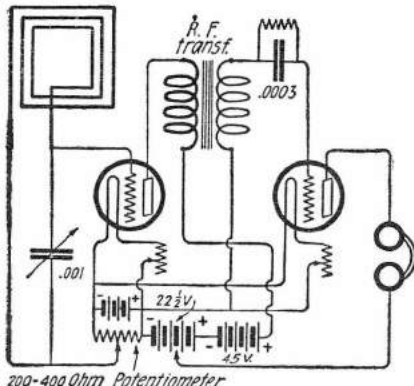

(18) A Two Tube Loop Antenna Set with one Stage of Radio Frequency Amplification. Variation of Wave-lengths is Accomplished by the Variable Condenser.

with one stage of radio frequency amplification?

A. 1. A diagram for the arrangement you desire will be found on these pages. It will be necessary in this arrangement to use four single-pole double-throw switches. One is employed to short circuit the grid condenser and leak when the vacuum tube is employed as a radio frequency amplifier. A variometer may be inserted in lead between point 1 of switch C and phones if the regenerative feature is desired.

Q. 2. Which is considered better for volume, a five-watt, or UV-201A tube?

A. 2. If connected in the proper circuit and sufficient voltage is used on the plate, a five-watt tube would give better results.

Q. 3. What is the best two-tube set to use with a condenser plug?

A. 3. Any regenerative or radio frequency set should function in favorable locations.

**(32) R.C.SET WITH RADIO FREQUENCY**

Q. 1. Kindly publish a diagram for one

stage of radio frequency amplification added to a Westinghouse R. C. set, for the purpose of preventing radiation.

A. 1. The diagram is given herewith.

**(33) SIMPLEST GRID LEAK**

Q. 1. What is the simplest form of grid leak?

A. 1. Pencil marks between two machine screws, separated 1/2 inch, work quite well. The value of the leak depends upon the amount of graphite between the posts.

**(34) REINARTZ CIRCUIT WITH RADIO FREQUENCY**

Q. 1. In what way can we add radio frequency to our Reinartz circuit?

A. 1. Connections are shown for two different types of Reinartz circuits. Dotted lines denote connections if regular tuned plate is used; in such an instance the connections marked "X" are removed.

**(35) CRYSTAL SET RANGE**

Q. 1. Please give the average range of a

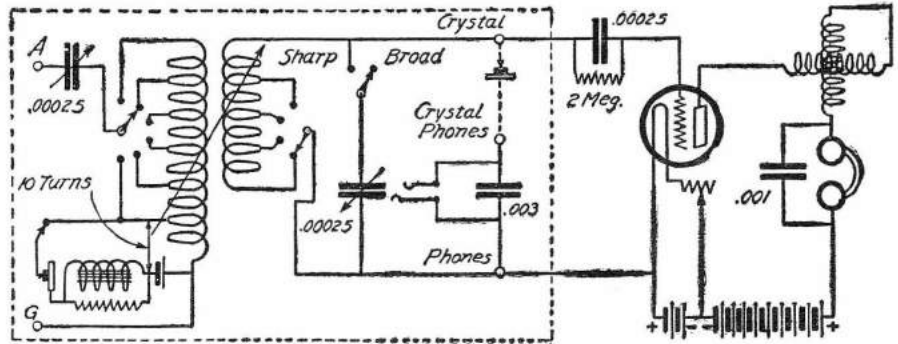

(17) A Signal Corps crystal set may be changed into an efficient tube unit, as shown here.

crystal set consisting of a loose coupler, crystal, variable condenser and loading coil.

A. 1. The range of any receiving set depends upon the power of the transmitting stations. A crystal set is usually conceded a receiving range of about 30 miles, but when receiving the high-power broadcasting stations, sending today, a distance of 100 or 200 miles can be covered under good conditions.

**(36) LONG WAVE RECEIVER**

Q. 1. Please publish a diagram for a long wave receiver enabling me to pick up European stations.

A. 1. You will find a diagram on these pages suitable for your purpose. Honeycomb coils are used in this circuit. The proper sizes may be selected by consulting the wave-length tables generally furnished by concerns manufacturing the coils.

Q. 2. What wave-length will be had when using a primary honeycomb of 1,500 turns and a secondary honeycomb coil of 1,250 turns?

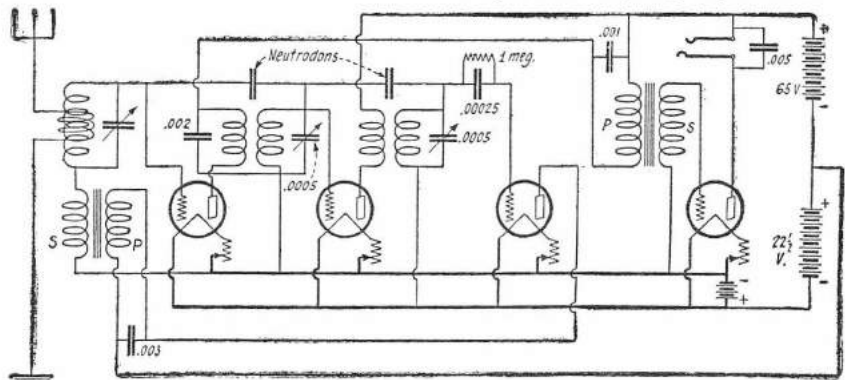

(21) Circuit diagram of a four tube reflexed Neutrodyne. Through this arrangement the utilization of a potentiometer is done away with. The four tubes in this circuit do the work of five.

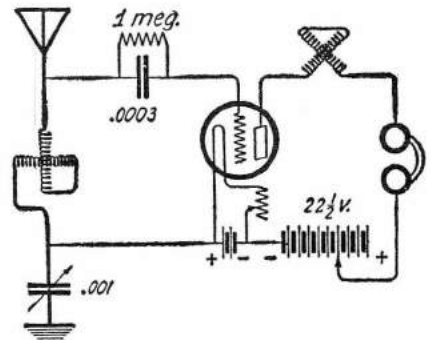

(19) A Variometer Tuned Plate Circuit Regenerative Receiver. This Type Is Easily Controlled.

A. 2. A 23-plate condenser will be required to tune the secondary. This secondary will respond to signals between 7,000 and 14,000 meters. The primary may use the same size condenser connected in series with the aerial, but .001 mfd. would be better.

**(37) COUPLED CIRCUIT TUNER**

Q. 1. Kindly publish a hook-up that can be used with an Atwater-Kent coupled circuit tuner, a W.D.-11 tube and a .001 mfd. variable condenser.

A. 1. A hook-up for this apparatus will be found in these columns. The condenser may be inserted in the ground circuit, as shown, to obtain finer tuning.

**(38) REDUCING BODY-CAPACITY**

Q. 1. How can I reduce body-capacity?

A. 1. Keep filament current as low as possible. Reverse connections to condensers from which effect is noted. If capacity effect is noticed from the variocoupler, try reversing the rotor leads. Reverse variometer leads, if effect is noticed from this instrument.

**(39) BRISTOL POWER AMPLIFIER**

Q. 1. Please publish the circuit of the Bristol power amplifier unit, as added to a standard receiving set using one stage of straight audio frequency amplification.

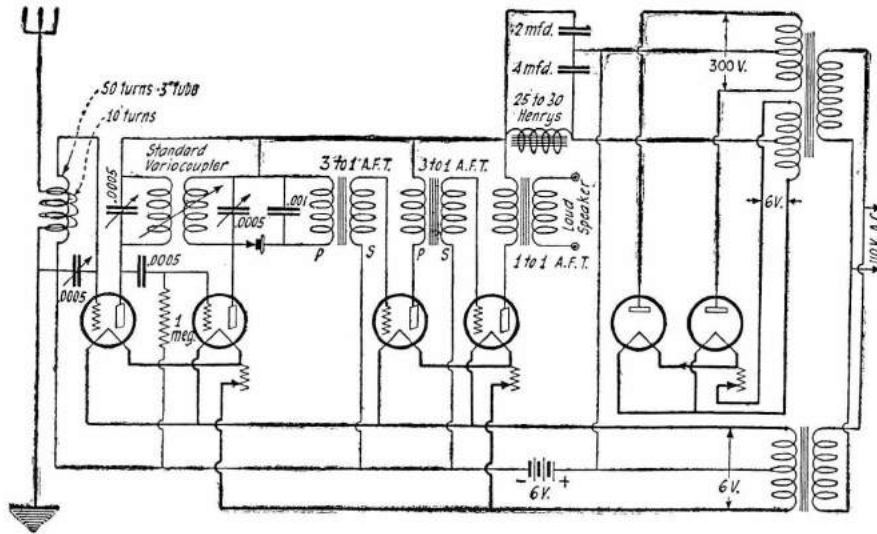

(23) A receiving circuit equipped to derive the necessary "A" and "B" potentials direct from a 110-volt alternating current source. A rectifier and filter system is utilized to eliminate the A. C. hum.

A. 1. This circuit is shown in these columns. It is seen to employ an auto-transformer having a ratio of 2:1.

Q. 2. How could the conductively coupled transformer used in this power amplifier be made?

A. 2. The primary of a push-pull output transformer, or the secondary of a push-pull input transformer, should work well in this set. The primary is left unconnected. Two standard audio frequency transformers could be tried also; their secondaries are connected in series, furnishing a center tap as required by this circuit.

(40) "SUPER" RANGE

Q. 1. What is the best tube for "Super" circuits?

A. 1. Use a UV-202, or WE-216A.

Q. 2. What is the average range of a one tube Super Regenerative set using a two foot loop, as compared to an outside aerial.

A. 2. About the same.

(41) CORRECT GRID LEAK

Q. 1. Why does the music come in clear for a few seconds and then cut off and then start again, with a continuous repetition of this effect?

A. 1. This is due to incorrect grid leak adjustment. Lowering the grid leak resistance will correct it. If this is noticed only on long distance stations it is known as fading, or swinging, and cannot be avoided.

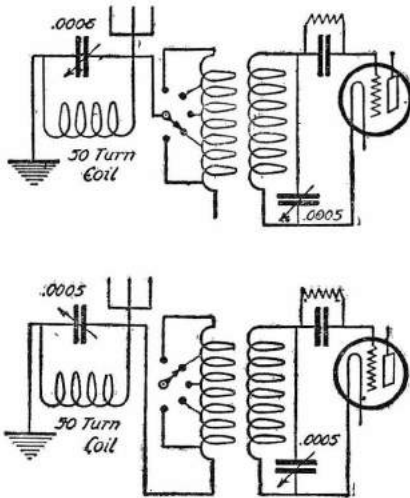

(27) A simple method of sharpening tuning. Both connections shown should be tried.

Q. 2. How may dry battery tubes be added to the Radiola III so as to increase the range and volume?

A. 2. A diagram showing a method by which this can be done is shown. It will be noticed that a separate "B" battery is re-

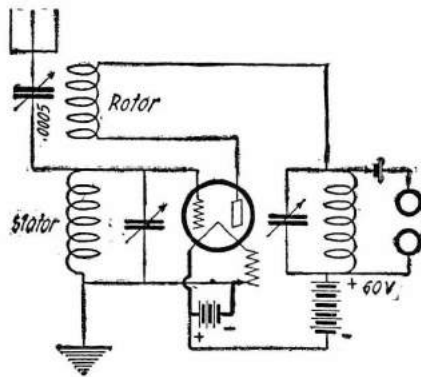

(24) A circuit employing the vacuum tube as a radio frequency amplifier and a crystal as the detector. This circuit should prove quite sensitive and selective.

quired for the second stage of R.F. amplification. This circuit uses five tubes arranged as two stages of tuned impedance radio frequency amplification, detector and two stages of audio frequency amplification. Five

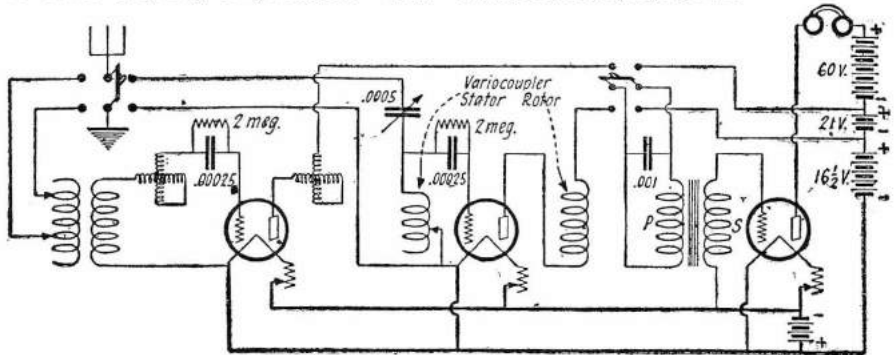

(26) By employing this arrangement the set can be switched from a single to a three circuit tuner at will. The audio frequency amplifier can also be used with one or the other circuit by throwing a second switch.

standard dry cells (one for each tube used) are shown, all being connected in parallel. The "link" may be tried in various positions for best results. An aerial series condenser may be required, depending upon the size of the aerial used.

(42) RADIO FREQUENCY AMPLIFICATION

Q. 1. Which of the following methods will give the greatest amplification per stage in radio frequency circuits, tuned impedance or the transformer coupled Neutrodyne method?

A. 1. When tuned impedance radio frequency amplification is employed, a potentiometer must usually be used in order to keep the tube from oscillating and as a potentiometer introduces losses in this circuit, it naturally follows that the Neutrodyne method of reception will prove superior. The capacities of the tubes are neutralized by special neutralizing capacities which allow these tubes to operate at full efficiency without danger of spilling over, or going into a state of oscillation on any wave-length.

Q. 2. What plate voltage is required for the oscillator of Super-Heterodynes?

A. 2. It is seldom that more than 45 volts are required. Often 20 to 25 volts are sufficient.

(43) IMPROVING THE CRYSTAL SET

Q. 1. How can I use a battery with my crystal set?

A. 1. The diagram appears in these columns.

(44) PLATE AND GRID VARIOMETERS

Q. 1. What are the advantages of a plate variometer and a grid variometer in a detector and two-stage amplifier outfit?

A. 1. The function of these variometers in a vacuum tube circuit is to tune the plate circuit with the grid circuit so that a retransfer of energy may take place between the plate and grid circuits, thereby producing the well-known regenerative effect.

(45) LINK CIRCUIT

Q. 1. Please publish the sharpest tuning circuit available?

A. 1. Circuits may often be sharp without seeming so. There are several methods of securing very sharp tuning. The "link" circuit, using one turn of very low resistance, rubber covered wire, around each of two tuning inductances will form a very sharp tuner and it can be used with almost any set. The two coils must be in non-inductive relation to each other.

Q. 2. Is there any advantage in placing the phones between the "B" battery and plate?

A. 2. This will not increase the efficiency of the set any, but will prove of advantage when audio frequency amplification is added. If placed in this position, the "B" battery can be used to supply plate voltage for both detector and amplifying tube.

Q. 3. I have made three fixed crystal detectors. Can I use them all in one set?

A. 3. Only one crystal detector is used at a time. The three can be used in conjunction with a three-point switch, so that any detector may be cut into the circuit at will.

**(46) SIMPLE TWO-TUBE SET**

Q. 1. Please publish a circuit using the following apparatus: One variometer, one variocoupler, two jacks, one 23-plate condenser and two tubes.

A. 1. A hook-up employing these instruments will be found in these columns. The circuit is one using the tuned plate method of regeneration.

Q. 2. How is it possible to make a sensitivity test of a receiver?

A. 2. This is done by placing an audio frequency modulated oscillator near the receiving set and tuning the oscillator to the wave-length for which the receiver is set. The oscillator is then moved away from the receiving set. The further the oscillator can be removed from the set, the more sensitive is the receiver.

**(47) ULTRA-AUDION CIRCUIT**

Q. 1. Please publish an Ultra-Audion

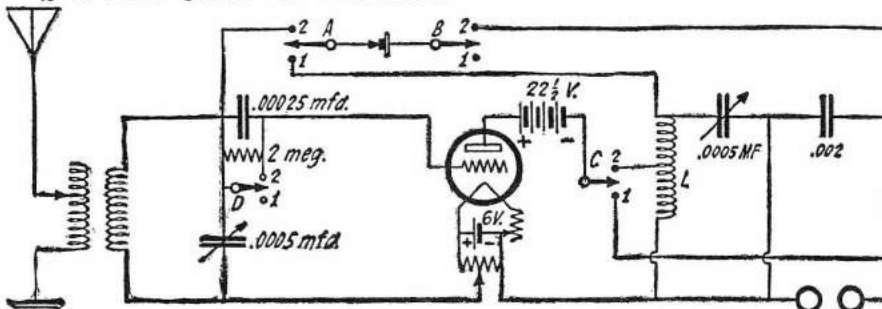

(31) Three combinations may be had with this combination. For tube detector alone place all switches on points 1. For crystal alone the tube is turned out and switches "A" and "B" are placed on point 2. For R. F. amplifier and crystal detector place "B," "C" and "D" on points 2 and "A" on 1.

hook-up with one stage of audio frequency amplification.

A. 1. This hook-up appears on these pages. A variocoupler is used as the tuner in this circuit. Regeneration is obtained and controlled by the variable condenser which is connected from the plate to the filament.

**(48) LONG-WAVE COUPLER**

Q. 1. On a long-wave coupler, is the section that is wound for short waves on the upper or lower end of the tube?

A. 1. The short-wave winding is wound on the end of the tube which contains the rotor.

Q. 2. Is it practical to use a switching system to secure any desired circuit?

A. 2. Losses, due to long leads and high resistance points of contact would be very high, and this method of connecting is not to be recommended. Coupling effects due to the long leads would prevent a correct comparison of the various circuits, at their maximum efficiency.

**(49) FIXED COUPLER**

Q. 1. Please give the details of a fixed coupler and the circuit in which it would be used.

A. 1. A diagram showing the connections for this coupler will be found in these columns. Both coils may be wound on a form 3 1/2 in. in diameter; the primary being wound directly over the secondary. The tickler rotates inside of the secondary.

**(50) TUNING**

Q. 1. What are some general instructions for tuning.

A. 1. The aerial should be adjusted to the approximate wave-length it is desired to receive. Follow up with an adjustment of the grid and plate controls.

**(51) SWITCHING SYSTEM**

Q. 1. Please show a switching system for connecting a set to either a loop, or to a regular aerial and ground. Also show a method for adding one stage of radio frequency amplification at will. It is desired to use this system with a four-tube reflex receiver.

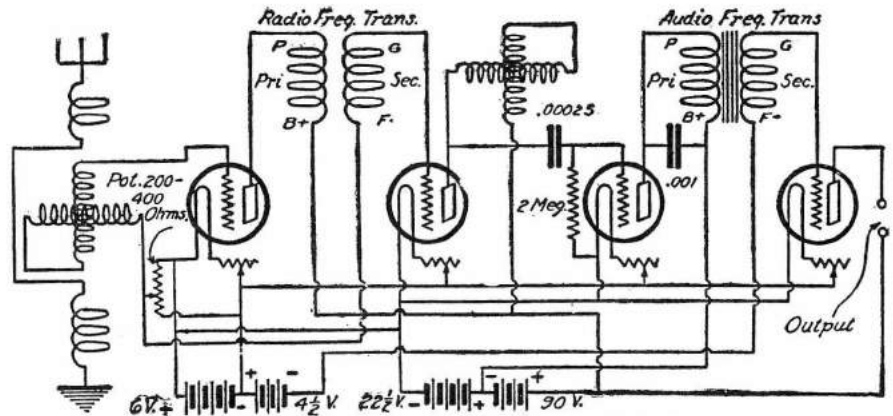

(29) Good selectivity and long range are embodied in this circuit.

system could be simplified, if double-pole, double-throw switches were used. As shown, it will work correctly, with push-pull switches. It is very necessary to have the correct number of turns on the primary coil B. A re-wound variocoupler may be used for the two A coils. Spider-web or honeycomb inductances may be used for the five loading coils and the two B coils. If spider-web coils are used, the loading coils may be placed parallel on an insulating rod, and separated about one-half inch, or a trifle less, with the exception of coil L5, which is placed in non-inductive relation to the other inductances in the set, to reduce the possibility of coupling to such an extent as to affect tuning. The primary and secondary B coils should be in very close inductive relation. Spider-web coils are preferable here. The radio frequency amplifier is designed not to oscillate

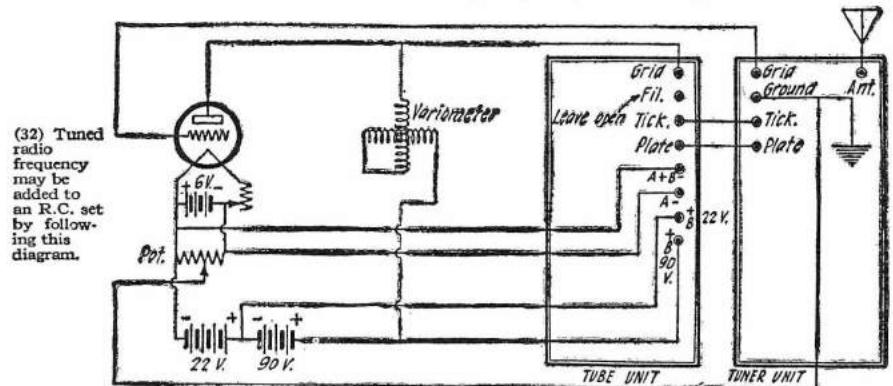

(32) Tuned radio frequency may be added to an R.C. set by following this diagram.

A. 1. This circuit is shown in these columns. The switching system is as follows: Loop and set, A1, B2, C1; aerial and set, A2, B1, C1; loop and set, plus the additional stage of tuned radio frequency amplification, A2, B1, C2; aerial and set, plus radio frequency unit, A1, B2, C2. This switching

and very low loss equipment must be employed for maximum results. Due to the lack of regeneration, it is necessary that special attention be paid to the design of the tuning inductances, and their relation to the rest of the set, in order to reduce the possibility of broad-tuning, especially when the

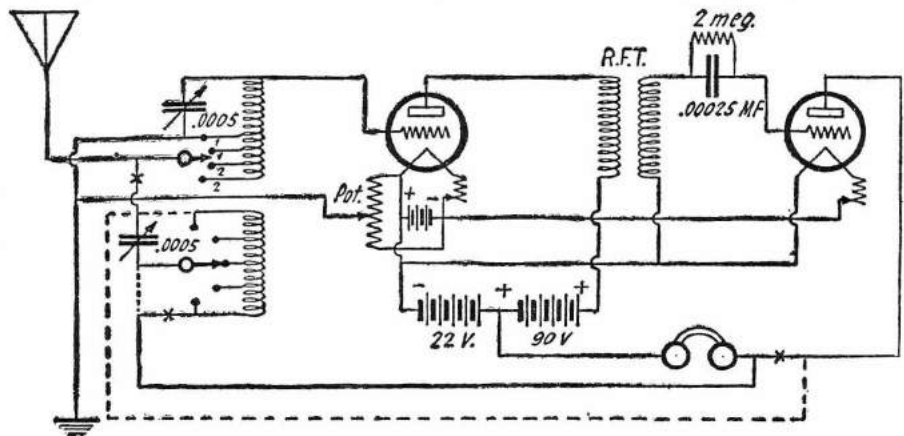

(34) Two methods of adding regeneration to the Reinartz circuit are shown here. If the dotted lines are followed, regeneration is obtained by the tickler feedback method.

aerial and ground are used. The regular batteries supplying the main set may be used for the additional amplifier as well. The UV-199 tube is admirably suited for the radio frequency amplifying tube.

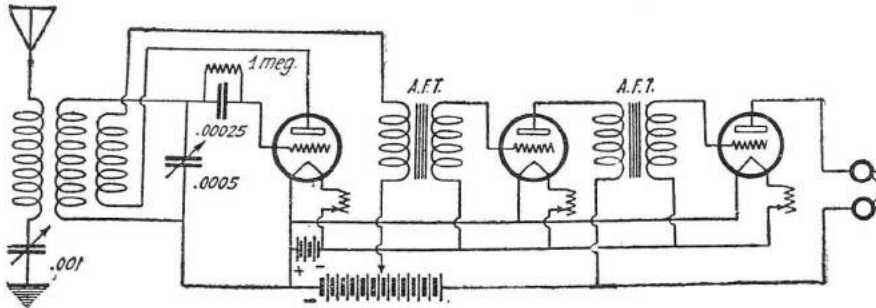

(36) A circuit for the reception of long wave European stations, together with a two-stage amplifier to permit sufficient volume. Honeycomb coils are used for tuning and regeneration.

**(52) R.F. WITH REGENERATION**

Q. 1. Please publish a hook-up using one stage of radio frequency amplification, showing how regeneration can be obtained in the detector circuit.

A. 1. This hook-up will be found here-with. An ordinary variocoupler may be used in this circuit for a tuned radio frequency transformer. Only a portion of the primary winding is used, depending upon the diameter of the tube. If the tube is 3 1/2 in. in diameter, approximately 37 turns will be employed, and these are used as the secondary of the transformer. The primary of the transformer is made by winding 12 turns of No. 20 S.C.C. wire directly over the original primary winding. These two windings may be separated by a tight-fitting cardboard tube. The secondary, or rotor, of the coupler is used in this case to obtain regeneration by connecting it in the plate circuit of the detector tube.

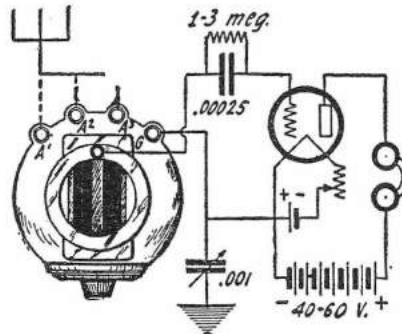

(37) This shows how an Atwater-Kent coupled circuit tuner is connected up in a vacuum tube circuit.

win type C unit is to be used on the third stage.

A. 1. This hook-up will be found in these

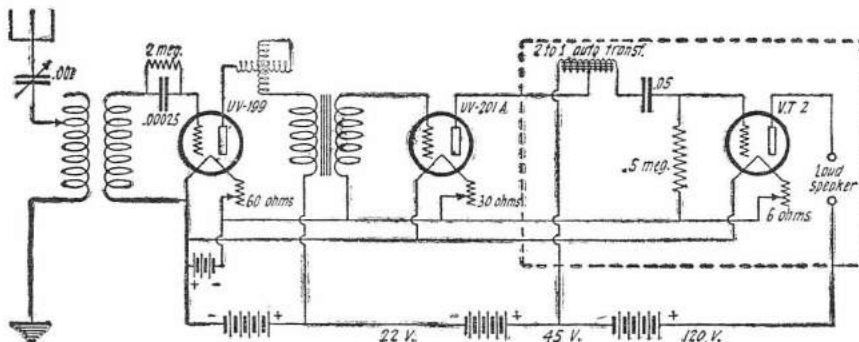

(39) A regenerative circuit with a two-stage audio frequency amplifier. The second stage is a power amplifier and employs an auto transformer. A high "B" battery voltage is essential.

**(53) SELECTIVE SINGLE CIRCUIT RECEIVER**

Q. 1. I have a single circuit receiving set employing two stages of audio frequency with a Magnavox. I would like to know if I could possibly increase the selectivity of this set.

A. 1. We are showing in these columns a hook-up of a single circuit receiver employing a method whereby great selectivity can be obtained. It consists of a wave trap placed in the secondary or grid circuit of the tuner. This wave trap has two coils, both wound on a 3-inch tube and separated from each other by 1/4 inch.

Q. 2. What is the average range of a receiving set of this kind? My longest distance has been about 1,000 miles.

A. 2. 1,000 miles is considered a good average range for a receiver of this type. If you can receive consistently stations at this distance you have nothing to complain of.

Q. 3. Is there a way to prevent the oscillations of a single circuit receiving set from being transmitted?

A. 3. A practical method is to employ radio frequency before the detector.

**(54) THREE STAGE A.F. CIRCUIT**

Q. 1. Please publish a hook-up for a detector and three stages of audio frequency amplification using WD-11 tubes. A Bald-

columns. A separate "B" battery is advisable for the third stage of audio frequency, as shown. If WD-11 tubes are used, three or four dry cells should be connected in parallel for the filaments.

Q. 2. I have three All-American transformers with ratios of 10:1, 5:1 and 3:1. In what stages should these transformers be placed?

A. 2. These transformers should be placed in first, second and third stages, as listed in this question.

**(55) R. F. WITH RA-10**

Q. 1. Please publish a hook-up of a Paragon RA-10 with two stages of radio and two stages of audio frequency amplification.

A. 1. This circuit will be found in these columns. We have shown the regular connection for the plate variometer, but regeneration will be difficult to obtain in this manner and this instrument can be eliminated and the wiring made as shown by the dotted line.

Q. 2. What is spaghetti used for, and could I use it on the set described above?

A. 2. Spaghetti is used as an insulator, and should be used on bare wires, where there is danger of their touching. Where wires are separated, this tubing is not necessary.

Q. 3. Are air-core or iron-core radio frequency transformers most susceptible to close coupling effects?

A. 3. Iron-core radio frequency transformers may be placed much closer together than air-core transformers.

**(56) COMBINATION CRYSTAL AND TUBE SET**

Q. 1. Please publish a circuit using three spider web coils showing how a crystal or a tube may be used as the detector.

A. 1. This diagram appears on these pages. A single pole, double throw switch is used to change from crystal to tube.

**(57) TRANSFORMER MARKINGS**

Q. 1. Why are radio frequency and audio frequency transformers in diagrams not marked with the numbers, to designate the connections, the same as the transformers?

A. 1. Different makes of transformers have different markings, thus making such a procedure impossible. Just remember to connect the outside secondary lead of transformers to the grid, and the primary connection will usually take care of itself. Reversing the primary leads may improve reception a little.

**(58) D.L. 1500 COILS**

Q. 1. What kind of coil is the D.E. 1500?

A. 1. The D. L. 1500 coils mentioned are duo-lateral wound coils of 1500 turns, otherwise known as honeycomb coils.

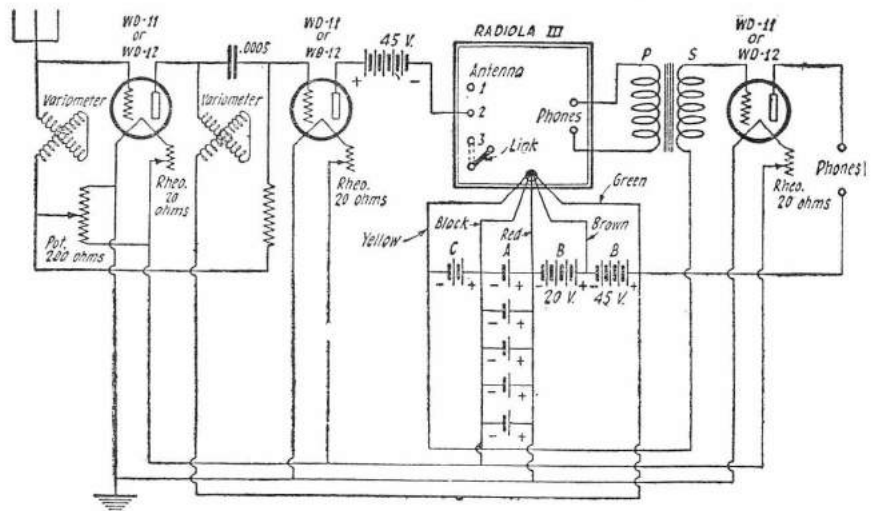

(41) The Radiola III used in conjunction with a two-stage tuned impedance radio frequency amplifier and an extra stage of audio frequency amplification. Note that there are five tubes altogether and that for every tube there's a dry cell.

Q. 2. Is it possible to make a combination three-circuit and single-circuit receiver?

A. 2. It is not advisable to make a combination receiver of this kind, as the switching arrangement would be too complicated. We are showing a diagram, however, where, by

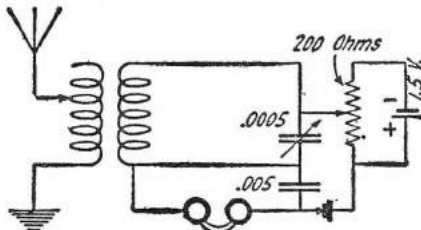

(43) The sensitivity of a crystal set can be increased by adding a battery and potentiometer.

means of two switches, a two-circuit regenerative receiver may be converted into a single circuit set.

**(59) TUBE FOR AUTOPLEX CIRCUIT**

Q. 1. Will you please tell me whether a UV-199 tube can be used as satisfactorily as the UV-201A tube in the new Autoplex circuit?

A. 1. A UV-199 tube can be used with fair success in the Autoplex circuit, but if sufficient volume for the operation of a loud speaker is desired a UV-201A tube should be employed. As the Autoplex receiver is an amplifying circuit, a tube having a high amplification factor is necessary.

**(60) NEUTROFORMER DESIGN**

Q. 1. Please publish in your columns, data giving the construction of the transformers used in the Neurodyne receiver.

A. 1. The secondary of a Neuroformer consists of 62 turns of No. 22 S.C.C. wire wound on a tube three inches in diameter. A tap is taken off at the 15th turn. The primary consists of 8 turns of the same size wire wound on a tube small enough to fit snugly inside of the secondary. This winding should be under the lower 15 turns of the secondary.

Q. 2. Kindly show a neurodyne circuit using these transformers?

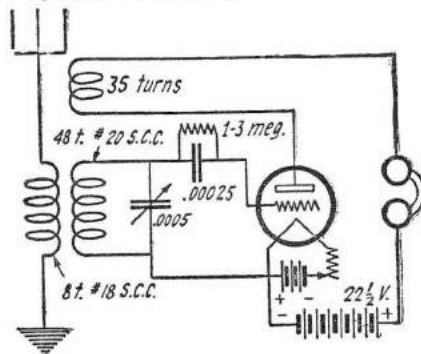

49) Very good results are secured with this circuit using a fixed coupler. A tickler coil provides regeneration.

A. 2. This circuit appears herewith. The plate of the tube should go to the lower terminal of the primary and the grid of the next tube should go to the upper end of the secondary.

**(61) CORRECT "B" BATTERY VOLTAGE**

Q. 1. With a standard regenerative set, the signals suddenly stop, but can be brought back by touching the grid post on the socket, or by turning the tube rheostat off and then turning it on again. Grid leaks do not seem to make much difference. The plate voltage was varied between 16 and 25 volts. What is the remedy for this?

A. 1. You are using an exceptionally soft tube which will require a "B" battery potential of less than 16 volts. Some tubes,

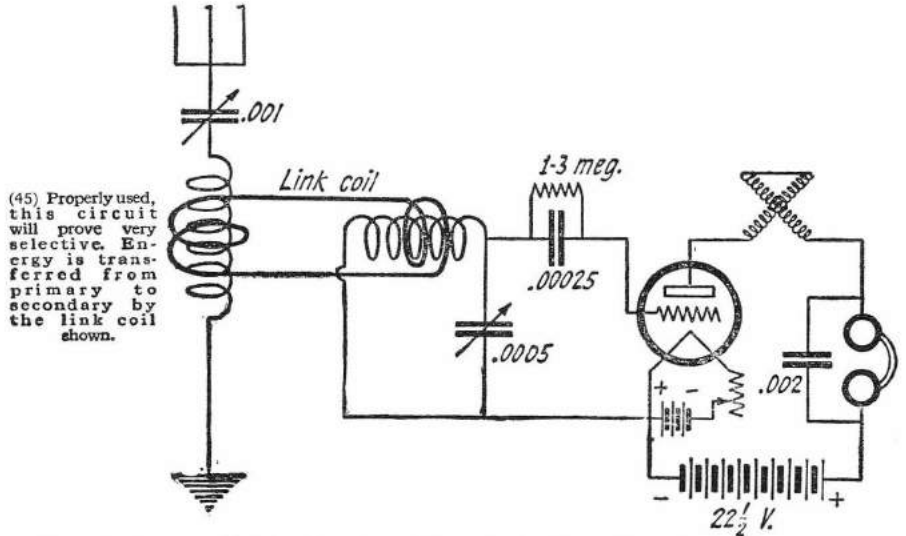

(45) Properly used, this circuit will prove very selective. Energy is transferred from primary to secondary by the link coil shown.

particularly the ones first developed, would very often operate perfectly with a plate potential of not more than 3 or 4 volts.

**(62) TUNED R.F. AMPLIFICATION**

Q. 1. Would you kindly publish how two stages of tuned radio frequency can be added to a standard three-circuit receiver?

A. 1. This circuit appears on these pages. The radio frequency is placed before the

A. 2. Yes. There is a tap for short wavelengths taken from both windings.

**(64) A.F. WITH THE AUTOPLEX**

Q. 1. Please publish the Autoplex circuit with two stages of audio frequency amplification.

A. 1. This hook-up will be found in these columns. The primary of the first audio frequency transformer should have at least 1,000 ohms resistance.

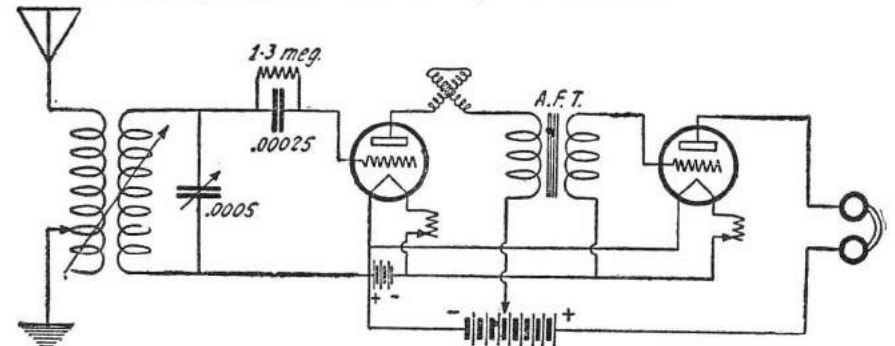

(46) A very efficient type of regenerative circuit with a one-stage audio frequency amplifier, for the reception of broadcast stations. A variocoupler and a variable condenser are employed for tuning and a variometer for regeneration.

tuner and the variocoupler is used as a tuned radio frequency transformer.

**(63) RADIO AND AUDIO FREQUENCY**

Q. 1. Does radio frequency amplification increase the sound?

A. 1. Radio frequency amplification increases the range of reception, audio frequency amplification is used to increase the volume of the received signals.

Q. 2. Does the UV-1714 transformer have a tapped primary and secondary?

Q. 2. Can WD-12 tubes work efficiently in this set?

A. 2. WD-12 tubes will give fair results, but will not give the volume of a good amplifying tube. We would suggest a UV-201A or a Western Electric 216-A tube in this circuit.

Q. 3. Can a loop be used with this set?

A. 3. A loop may be used by placing it in the circuit between the grid variometer and the 1250-turn coil. Better results might be obtained with a ground connected in the usual place when using a loop.

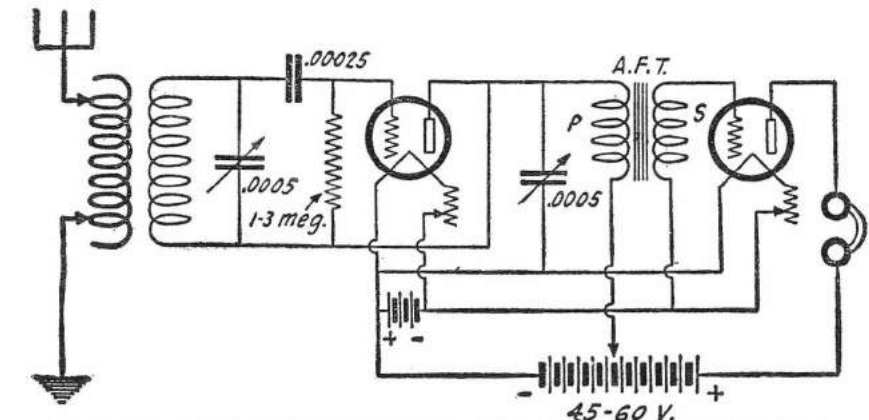

(47) Good Results Will Be Had With the Well Known Ultra Audion. The .0005 mfd. Variable Condenser Connected from the Plate to the Filament of the Detector Tube Controls the Regeneration.

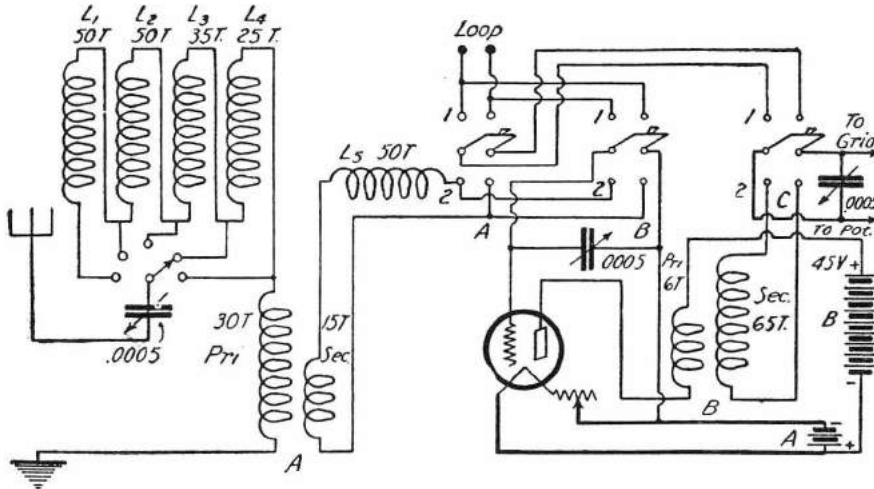

(51) This radio frequency amplifier has been designed to be adaptable to any set using a loop. Some Super-Heterodynes are exceptions. The switches must be well insulated; their bases should be tested for leakage by means of headphones and a battery of about 60 volts. Correct layout of the apparatus is another important consideration.

**(65) A.F. AMPLIFICATION WITH CRYSTAL RECEIVER**

Q. 1. I have a crystal set that works remarkably well and would like to know if audio frequency amplification can be added.

A. 1. Audio frequency amplification can be used with good results with a crystal set. The primary of the first A.F. transformer is connected in the circuit in place of the phones.

Q. 2. Please publish a two-stage amplifier to be used with a crystal set.

A. 2. This circuit appears in these columns.

Q. 3. Will two stages run a loud speaker?

A. 3. Sufficient volume on local stations will be obtained to operate a loud speaker with this circuit.

**(66) TUNED R. F. IN REFLEX**

Q. 1. Is it possible to use variometers in place of R. F. transformers in a three-tube reflex circuit? If so, please give hook-up.

A. 1. One stage of tuned R. F. can be used in conjunction with one stage of transformer-coupled R. F. in a reflex circuit. The tuned R. F. must be placed in the second stage. A diagram will be found on these pages showing the correct circuit.

Q. 2. How do results obtained with such a set compare with results obtained with detector and two stages of A. F.?

A. 2. The signals obtained with this circuit will be a little louder than with a detector and two stages of A. F., but the receiving range will be much greater with the reflex. This type of receiver usually takes a great deal of experimenting before maximum results are obtained.

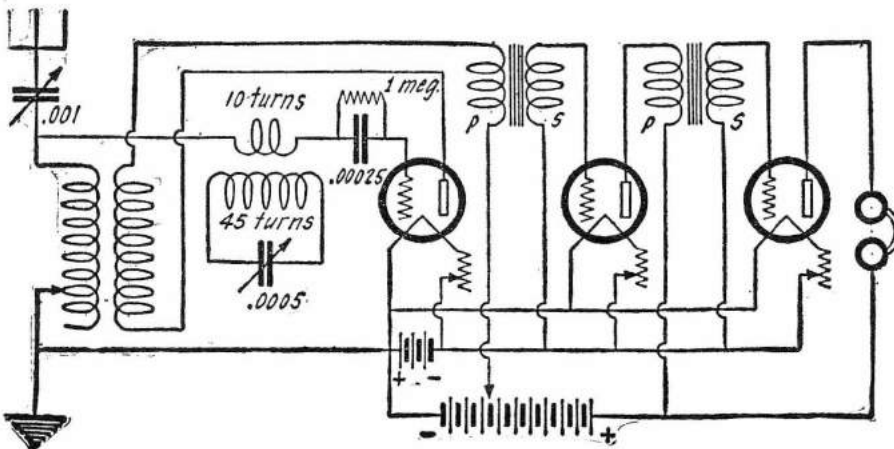

(53) Great Selectivity Can Be Obtained with a Single Circuit Receiver by Using the System Shown Here. Both Coils Are Wound on the Same Tube.

**(69) THREE-CIRCUIT TUNER**

Q. 1. Please publish a three-tube circuit which will be very selective and sensitive. I have one variocoupler and two variometers.

A. 1. This hook-up appears in these columns. A small fixed condenser can be shunted across the secondary of the coupler and grid variometer for the higher broadcast wave-lengths, by means of the switch shown. If the primary has not sufficient inductance, the variable condenser in the antenna circuit can be shunted across the primary to increase the wave-length.

Q. 2. What are the best condenser capacities to employ in the primary, secondary and tickler circuits of a honeycomb coil receiving set?

A. 2. Use a condenser having a capacity of .0005 mfd. for wave-lengths up to 3,000 meters. If you expect to go up to 20,000 meters it would be advisable to use .001 mfd. condensers.

Q. 3. Is there any advantage in using a variable condenser in shunt with the tickler coil?

A. 3. The addition of this control complicates tuning considerably and it would be

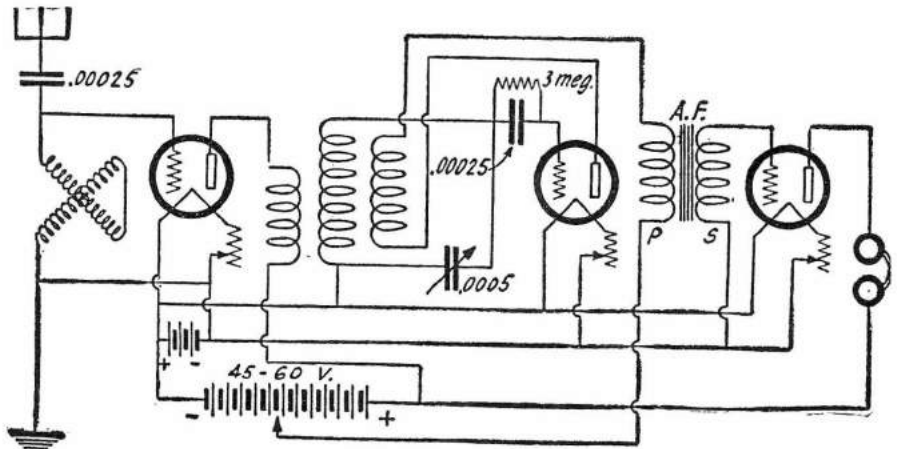

(52) Regeneration Can Be Used in Conjunction with a Radio Frequency Amplifier if This Circuit is Used. Details Are Given in the Text.

**(67) HONEYCOMB COILS**

Q. 1. How many feet of wire have the D.L.-1250 and the D.L.-1500 coils?

A. 1. The D.L.-1250 has, approximately, 800 ft. and the D.L.-1500, 950 ft.

**(68) CAPACITY OF COIL WINDINGS**

Q. 1. Does wax on the windings of variocouplers and variometers affect them?

A. 1. As wax has a higher dielectric constant than the cotton or silk covering of the wire, it will slightly increase the distributed capacity of the coil. The effect, however, should not be noticeable on the signals.

found rather difficult to use the circuit. The use of a variometer in this position, however, will result in a decrease in the selectivity of the set.

**(70) REGENERATION WITH TUNED R. F.**

Q. 1. Kindly publish a diagram of a one-stage tuned R. F. receiver, using regeneration.

A. 1. This hook-up will be found on these pages. The primary of a variocoupler is used for the tuned impedance and the secondary is connected in the plate circuit of the detector, for regeneration. If only the broadcast wave-lengths are desired, 40 turns will be sufficient on the primary.

Q. 2. During the last year, I have had five WD-11 tubes burned out in my Acriola, Sr. Is this the fault of the set or tubes?

A. 2. We do not believe that the set is at fault in this instance. It is possible that the tubes may be defective, but most likely you have been burning the filaments too brightly, thus decreasing their lives.

Q. 3. Will the insertion of a variometer between the aerial and the plate, in an ultra-audion circuit, cause the set to be regenerative?

A. 3. This is a regenerative circuit without the addition of the variometer. Should you find that the set does not oscillate, it will be necessary to locate the fault, which may be a poor tube, wrong "B" battery voltage, wrong connections, poor connections, or poor instruments.

**(71) A SIX-TUBE SUPER-HETERODYNE**

Q. 1. Please publish a diagram of a Super-Heterodyne Receiver, using radio frequency transformers instead of resistances.



A. 1. This circuit appears in these columns. Iron-core transformers, designed to operate efficiently on 3,000 meters, are used.

**(72) COCKADAY COIL DATA**

Q. 1. Please give data of the Cockaday coil unit.

A. 1. The Cockaday coil combines four windings. One is an absorption circuit consisting of an inductance across which a 17-plate condenser is connected (.00025 mfd.). The grid tuning coil also has a condenser connected across it, of the same size. There is also an aerial loading coil and an aerial coupling coil. The absorption coil consists of 34 turns of No. 18 D.C.C. wire wound on a 3 1/2-inch tube. The grid coil consists of 65 turns of the same size wire, on the same tube. The aerial loading coil consists of 43 turns of No. 18 D.C.C. wire, double bank wound on a 3 1/2-inch tube and tapped at the 7th, 13th,

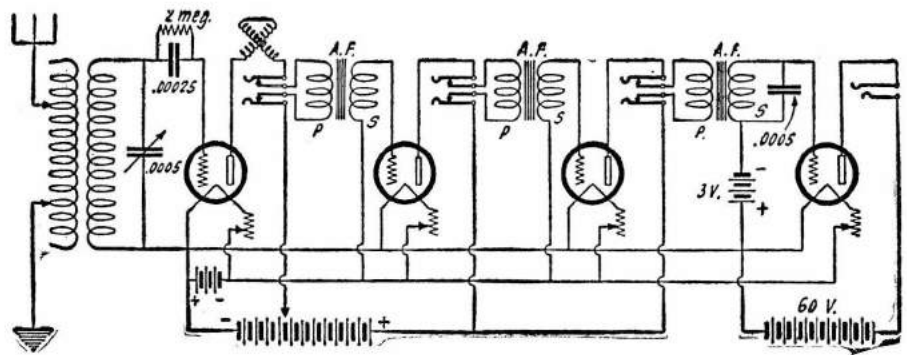

(54) Plenty of Volume Will Be Had from This Three Stage Audio Frequency Amplifier. A Separate "B" Battery is Used on the Plate of the Last Amplifier Tube.

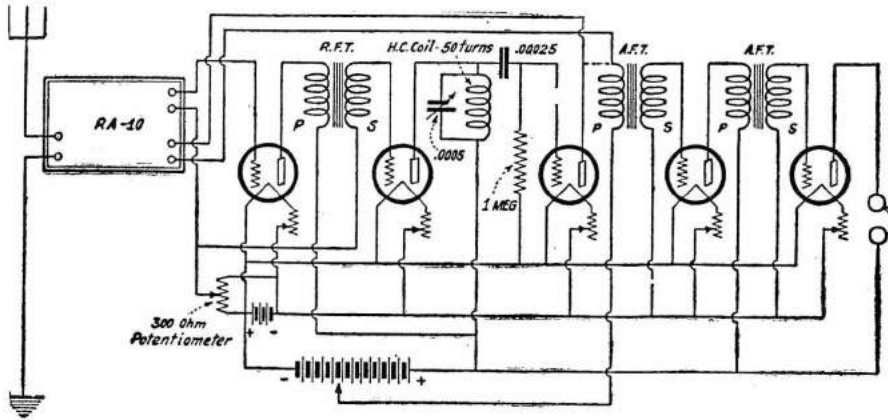

(55) Two Stages of Radio and Two of Audio Frequency Can Be Added to an RA-10 Receiver as Shown Here. Tuned R.F. is Used in the Second Stage for Selective Tuning.

21st, 31st and 43rd turns. This coil must be placed in non-inductive relation to all the other inductances. The aerial coupling coil consists of one turn of No. 14 wire, wound on the same tube as the grid and absorption coils.

**(73) R. F. RECEIVER**

Q. 1. Please publish a diagram of a re-

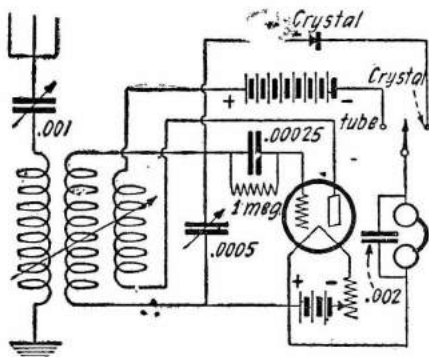

(56) A Crystal or a Tube May Be Used as the Detector in This Circuit by Means of the Single Pole, Double Throw Switch.

ceiver using two stages of radio and two stages of audio frequency amplification, with filament-control jacks. Both outside and loop aerials are to be used.

A. 1. This diagram will be found in these columns. Filament-control jacks are shown in each stage of audio frequency. The first jack controls the filaments of the detector and two radio tubes. A double-circuit jack is placed in the secondary circuit of the tuner, so that a loop can be plugged in. A variometer is used to tune the secondary circuit, but this instrument cannot be placed in the plate circuit of the detector for regeneration, when radio frequency is used.

**(74) R. F. WITH CRYSTAL**

Q. 1. Please publish a hook-up showing

how one stage of radio frequency can be added to my crystal set.

A. 1. This circuit appears on these pages.

Q. 2. May I add one step of audio frequency amplification to this set? Please publish this hook-up.

A. 2. This has also been shown on this diagram.

Q. 3. What results as to distance and volume of sound may I get from each one of them?

A. 3. With R. F. alone the range will be greatly increased although the volume will not be much greater than the crystal set. With the A.F. the volume will be about four times as great, but the distance will remain about the same as with the crystal set alone.

Q. 4. Would a wave-trap serve to tune out strong interfering stations?

A. 4. A properly designed two-coil wave trap would probably greatly reduce, if not eliminate, the signals from interfering stations.

**(75) R. F. HOOK-UP**

Q. 1. Can radio frequency be added to a standard three-circuit receiver without changing the wiring?

A. 1. This can be done by placing the radio frequency in front of the tuner, and using a separate tuning coil.

Q. 2. Please publish this diagram.

A. 2. This diagram will be found in these columns.

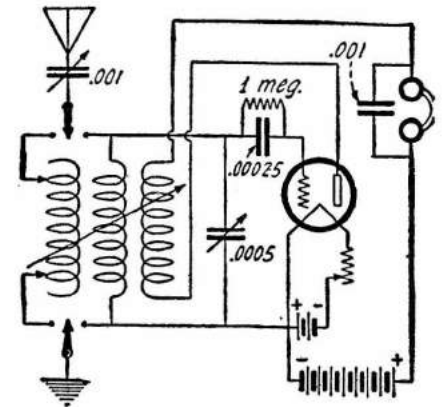

(58) When There is No Interference, a Single Circuit Receiver Might Give Louder Signals. A Two-Circuit Regenerative Set May Be Quickly Changed to a Single Circuit by Means of Switch as Shown.

**(76) RADIO AND AUDIO FREQUENCY**

Q. 1. I am about 400-600 miles from broadcasting stations. If head-phones are used, what combination of amplification would be best, using 3 tubes?

A. 1. For this distance, we would suggest one stage of tuned radio frequency and one stage of audio frequency.

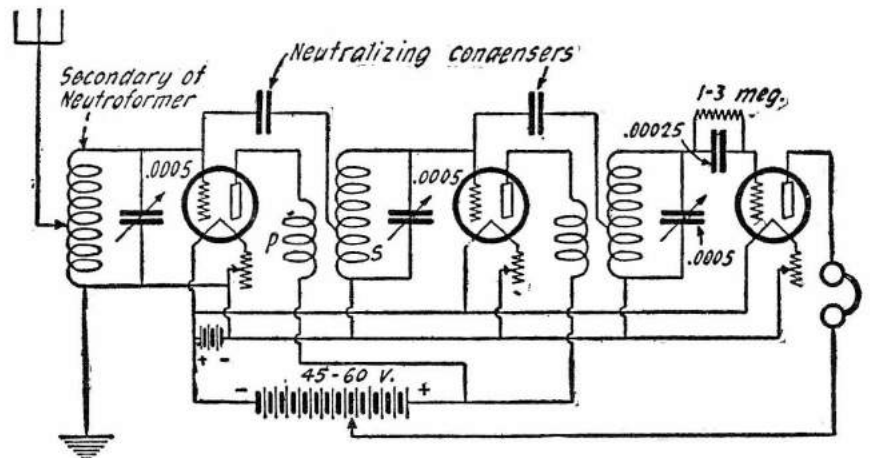

(60) The Neurodyne Circuit Using Two Stages of Radio Frequency. The Secondary of the First Neuroformer is Used as the Tuner.

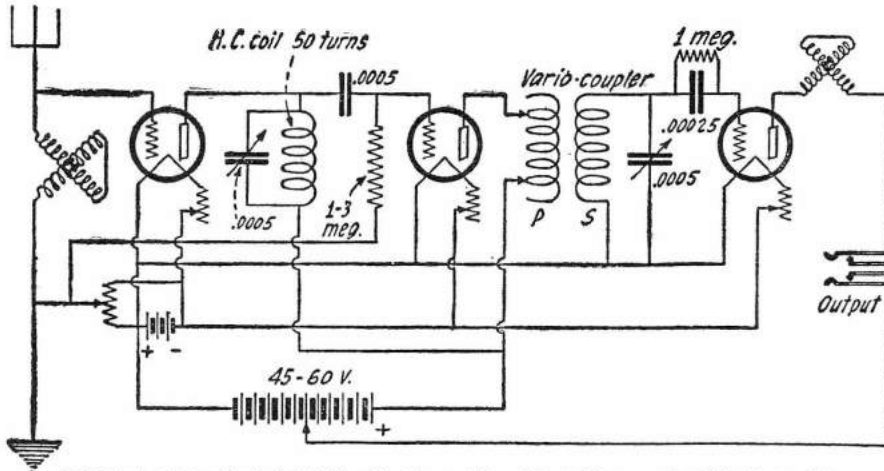

(62) Here is the Best Method of Adding Two Stages of Tuned Radio Frequency Amplification to a Three-Circuit Regenerative Receiver. The Variocoupler is Used as Tuned R.F. Transformer.

**(77) ONE TUBE SUPER-HETERODYNE**

Q. 1. Is it possible to construct a Super-Heterodyne in such a manner as to eliminate vacuum tubes?

A. 1. Diagram A shows the most practical method of doing this. The two detectors are of the usual crystal variety and may be of the fixed adjustment type.

The oscillating unit required to produce the beat note of 5,000 meters may be an oscillating crystal of the quartz, Rochelle salts, or zincite-steel type. Since these systems are either experimental or unavailable to the average experimenter, we have shown the more practical vacuum tube oscillator. A WD-11 tube will be quite satisfactory. Of course, any other tube can be used as well.

The radio frequency transformer used may be of the iron core variety, as shown, or of the air core type. The values of the primary and secondary condensers will be determined by the transformer construction. The transformer constants given are for the Tropafomer. If air core Ultraformers are used, the primary condenser would be of about .001 mfd. capacity (a 43-plate variable condenser would do for test) and a .00025-mfd. condenser will be used across the secondary (an 11-plate condenser could be used here).

Q. 2. Is it possible to combine the Tropadyne principle, with a Super-Heterodyne employing crystal detectors?

A. 2. Circuit B illustrates the method. It may be advisable to connect one side of the headphones to "A" minus, or to the ground, as shown.

This system would be satisfactory only for local reception, using a loop aerial.

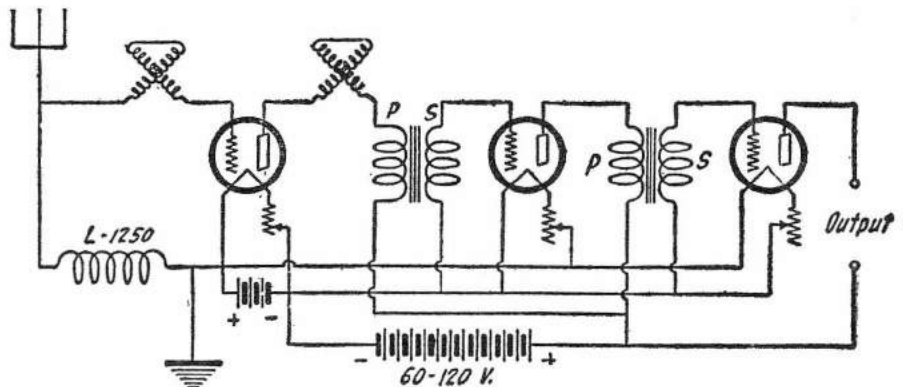

(64) Audio Frequency Can Be Added to the Autoplex Circuit in the Usual Manner. A Loud Speaker Must Be Used with Two Stages.

Since the lower potential side of the oscillator condenser is at a higher potential than "A" minus, it is necessary to use a

**(78) CONDENSER CAPACITIES**

Q. 1. Will you kindly publish the capacities of 23 and 43-plate condensers?

(65) Much Greater Volume Will Be Obtained from a Crystal Receiver by Using Two Stages of Audio Frequency Amplification.

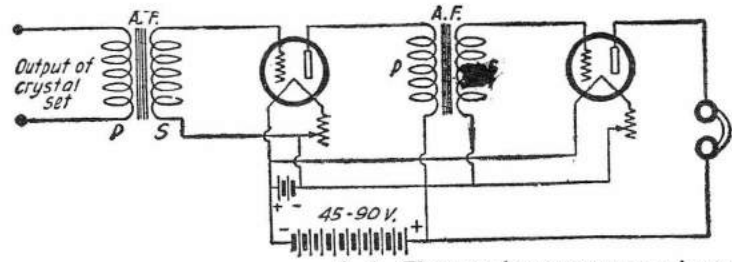

A. 1. These condensers are, approximately, .0005 and .001 mfd. capacity, respectively. This will vary a trifle one way or the other, according to the size and distance of the plates from each other.

**(79) PICTURE DIAGRAM**

Q. 1. Please publish a picture diagram of the standard three circuit tuner, using honeycombs. What variations could you suggest for increasing the range or volume?

A. 1. This circuit will be found in these columns. The size honeycomb coils required may be readily determined from the following table of wave-lengths obtainable when standard honeycomb coils are shunted by variable condensers of .001 mfd. capacity. If condensers of .0005 mfd. capacity are used, the maximum wave-length will be approximately half the value shown. The minimum value will be determined by the minimum capacity of the condenser used.

If only the detector tube is used, the aerial and ground connect to primary B. If the radio frequency unit is added, the aerial and ground connect to a honeycomb coil placed in non-inductive relation to the other three honeycomb coils. Primary B then becomes the coupling coil that couples the output of

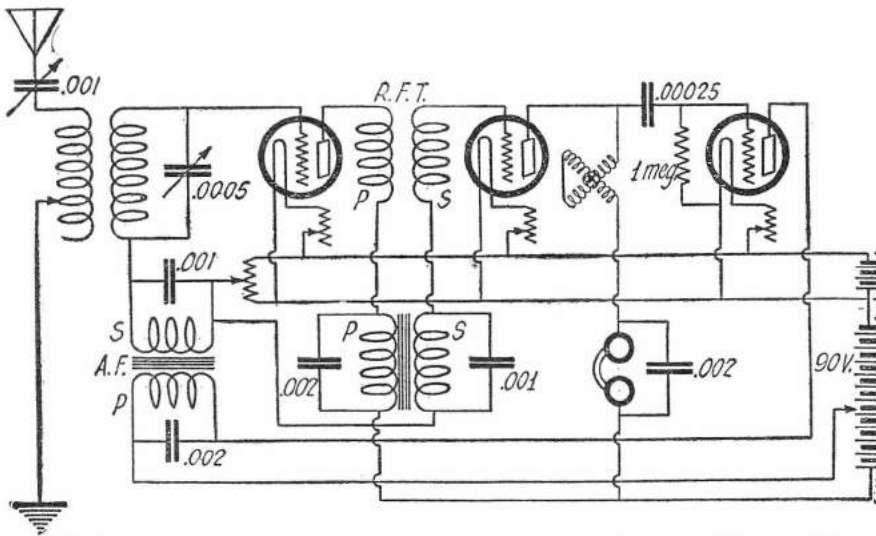

(66) Tuned R.F. Amplification May Be Used in a Reflex Circuit by Following This Diagram. Only One Stage Is Tuned and It Must Be Next to the Detector.

the radio frequency tube to the detector input. If an audio frequency amplifier is added, there should be no difficulties. This method of adding an audio frequency amplifier unit may be applied to any set having the same battery connection system.

Number of Turns	Wave-Length
25	130-375
35	180-515
50	240-730
75	330-1030
100	450-1460
150	660-2200
200	930-2850
250	1300-4000
300	1550-4800
400	2050-6300
500	3000-8500
600	4000-12000
750	5000-15000
1000	6200-19000
1250	7000-21000
1500	8200-25000

This circuit is readily adaptable to almost every radio instrument. For example: Primary "A" may be home-constructed of about 55 turns of No. 20 wire wound on a three-inch tube. Or, it may be a variometer. The tickler may be a variometer, while primary

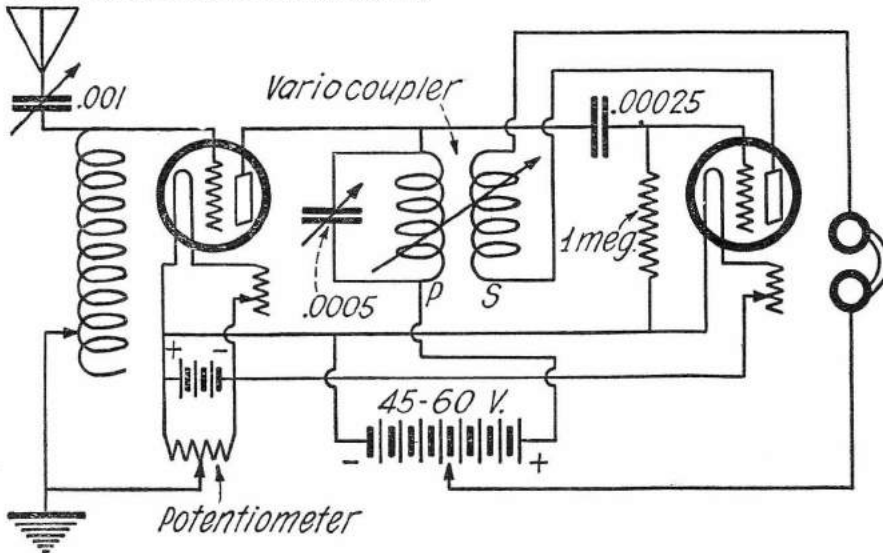

(70) One Stage of Tuned Radio Frequency Amplification Can Be Used in a Regenerative Receiver By Following This Circuit.

"B" and secondary may comprise the usual two-coil type coupler. If desired, the untuned primary, three-coil type of coupler may be used for the primary "B," secondary and tickler. In this case the primary "B" variable condenser would not be required since this condenser is only used when the "tuned aerial" tuning system is employed.

If the "aperiodic antenna" or untuned primary aerial tuning system is employed, this aerial coil may still be used as the coupling coil, should one desire to add radio frequency amplification. Again the variable condenser would not be required across the coil "B." By using this aperiodic method of coupling it is possible to eliminate one control, at the expense of reduced volume. Just how much this reduction is will depend upon local conditions (action of the particular receiving set used, and electrical characteristics of the antenna system used).

The aperiodic antenna system may be used in the three-coil honeycomb receiver. In this case it is necessary to unwind about 15 turns of wire from a 25-turn honeycomb. The remaining 10 turns will probably be sufficient for coupling. However, the coil should first be tried with 15 turns remaining; five more turns may be removed later if desired.

Any good make of audio frequency transformer may be used. If it is not expected to add more than one stage of audio frequency amplification, a high ratio-transformer should

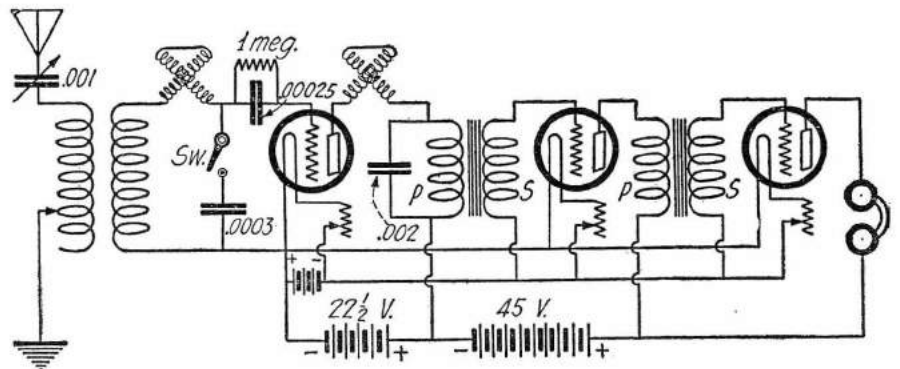

(69) Here is the Familiar Short-Wave Regenerative Receiver. This Circuit is Hard to Beat for Efficient Results. A Small Fixed Condenser is Used in the Secondary Circuit for Higher Wave-Lengths.

prove entirely satisfactory. The voltage amplification would thereby be greatest (resulting in greater signal strength) and distortion, while present, would not be objectionable.

This circuit should operate a good loud speaker when local stations are being received if only the detector and one stage of audio frequency amplification are used.

If the potentiometer should have no effect, carefully check the connections, test the radio frequency tube. This tube should oscillate strongly in a regenerative receiving circuit, as the detector tube. The detector "B" battery may be found critical in value. This voltage should be determined while receiving weak signals. For soldering connections use only a resin flux.

Q. 2. Please show the picture diagram of the correct circuit for the ultra-audion regenerative receiver, with one stage of audio added.

A. 2. This circuit is shown in these columns, in the manner you request. Any type of inductance, such as a variometer, honeycomb, spider-web, or plain tapped coil may be used for "A." A smaller variable condenser may be used, if desired, depending upon the particular inductance construction adopted.

Q. 3. Why does removing the catwhisker from the crystal of my reflex set cause a loud howl in the loud speaker? And, why is it necessary to change the catwhisker location when changing from one extreme wavelength to the other, in order to prevent a loud howl? Other reflex sets I know of do not have this trouble.

A. 3. Both these experiences are caused by the same major effect—the crystal detector has a variable resistance. This resistance is varied as the contact is changed. Your receiver is similar to thousands of others, in that a loud howl is heard when the catwhisker is lifted from the crystal. All this is understood when one considers the fact that the damping, or oscillation control of the circuit is governed largely by the amount of resistance in the circuit. By reducing the number of turns in the plate coil of the tube circuit that is oscillating, it is possible to stop the oscillation of the circuit. The effect of reducing the number of plate turns is obtained

Remember to keep all leads as short as possible; do not place variable condensers at the ends of coils; do not place too close to coils (a happy medium must be struck between too close an inductive relation of instruments, and the desired short distance connections).

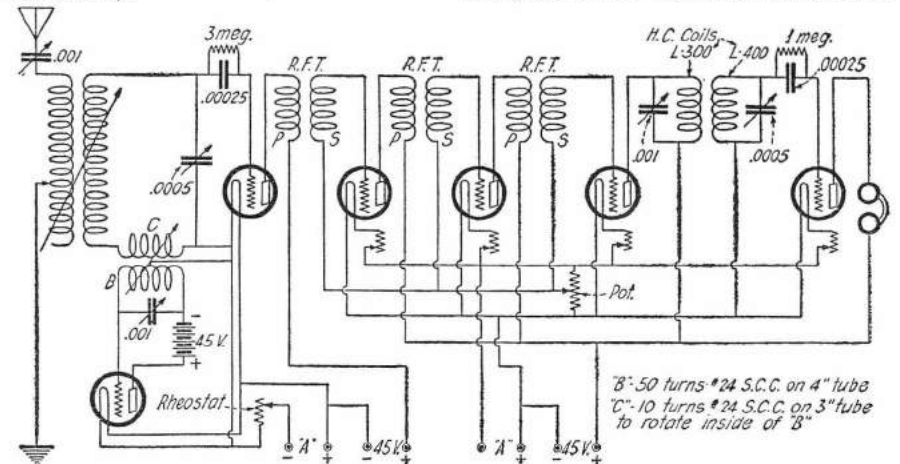

(71) If you Want to Pull in Those Long-Distance Stations, This is the Circuit You Should Use. A Six-Tube Super-Heterodyne, Using Transformer Coupled R.F. Amplification.

B'-50 turns #24 S.C.C. on 4" tube  
C'-10 turns #24 S.C.C. on 3" tube  
to rotate inside of B'

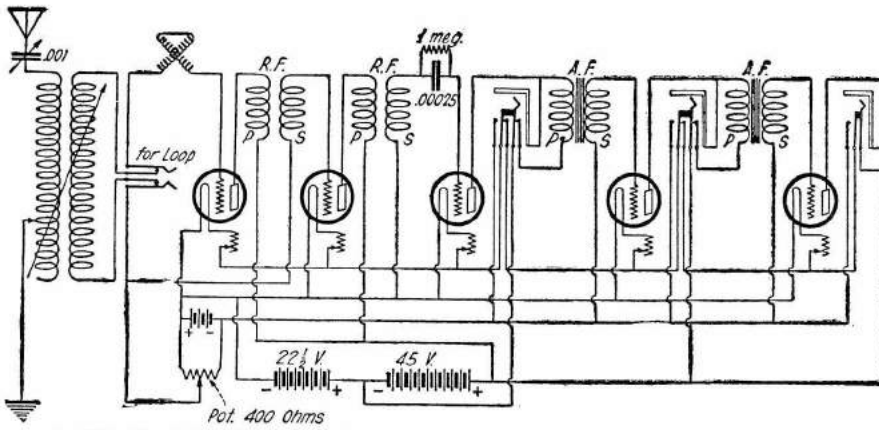

(73) This Circuit Will Give Very Good Results, if Correctly Handled. Two Stages of Radio and Two Stages of Audio Frequency Amplification Are Shown.

by connecting a resistance in the secondary circuit of the R.F. transformer, the primary of which is in the tube plate circuit. The crystal is this resistance. At the longer wave-length adjustment, less resistance is required in the circuit to stop oscillation, than at the short wave-length. This variable resistance requirement is met by varying the catwhisker location and pressure, as stated above. Some receivers use fixed crystals. In this case, where other special conditions exist, such as a reduced number of plate coil turns, it may not be necessary to make any change in the detector resistance to control circuit oscillation. In general, it may be said that receivers having such a critical adjustment of the crystal are more sensitive than those not so blessed (?).

**(80) RADIATE OR RE-RADIATE?**

Q. 1. What is the meaning of "re-radiate?"

A. 1. This term is often incorrectly used in reference to radiation of energy from a receiving set. Radio frequency current, picked up by bridges, girders, and other large metallic objects may often be re-radiated.

Q. 2. Does it make any difference how long the leads in a set are?

A. 2. All leads should be short. It is imperative that grid and plate leads (particularly the grid leads) be reduced to the shortest possible length, if best results are desired.

Q. 3. Is it not possible to use the Hartley transmitting circuit in a broadcast receiver?

A. 3. Yes, this may be done, and the diagram shows how. Wind 90 turns of No. 22 D.C.C. wire on a 3-inch tube. Tap this in the center, as shown. The aerial coil is wound over the grid half of the 90-turn coil, near the tap.

If your purse, or other equally powerful reason, motivates you to use only one tube, the headphones may be connected "on the dotted line" (as the book salesman would say).

For local reception, a 45-volt "B" battery may be used. For distant reception not over 22 1/2 volts can ordinarily be used. This necessitates an extra battery in order that the audio amplifier may have sufficient plate voltage. This extra potential, between 22 1/2

and 45 volts, may be supplied by connecting a battery of this rating at "X."

There are four oscillation controls, the "B"

(74) Greater Distances Can Be Covered If One Stage of Radio and One of Audio Frequency Are Added To a Crystal Set. This Diagram Shows How It Is Done.

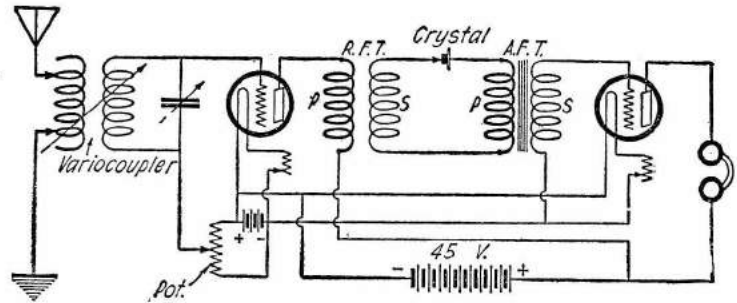

voltage, the filament heat, the grid leak value and the resistance of "R." It is necessary as in any set, to have a perfect grid leak; a

poor one will be noisy. The variable resistance range of "R" will probably have to be from about 200 ohms, to possibly 5,000 ohms.

body capacity effects which are very pronounced in this receiver?

A. 1. The regular method of eliminating

(75) One Stage of R. F. May Be Added to a Standard Three-Circuit Receiver, as Shown Here. No. R. F. Transformer Is Used, the Output of the Amplifying Tube Being Connected Directly to the Antenna and Ground Posts of the Tuner.

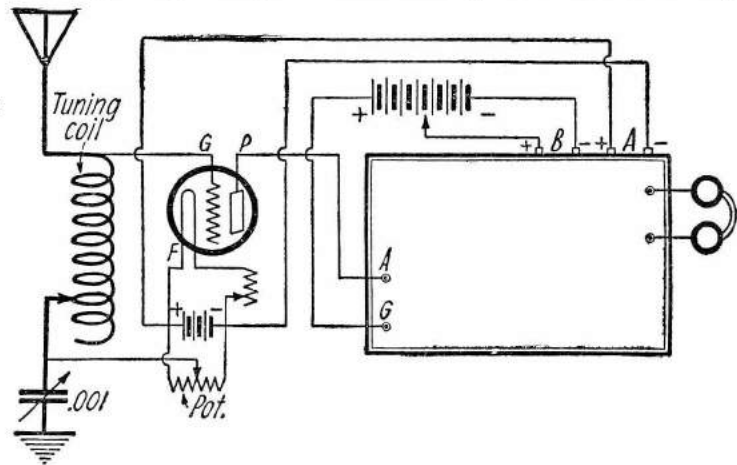

body capacity effects is to shield the back of the panel with tinfoil or copper and connect this shield to the ground. We believe, however, that if your secondary variable condenser is connected in the circuit with the movable plates connected to the filament, you will not be troubled by capacity effects.

(77) These three diagrams (A, B and C) will enable anyone to construct a one-tube Super-Heterodyne. The intermediate frequency transformer primary and secondary must be tuned to exactly the same wave-length.

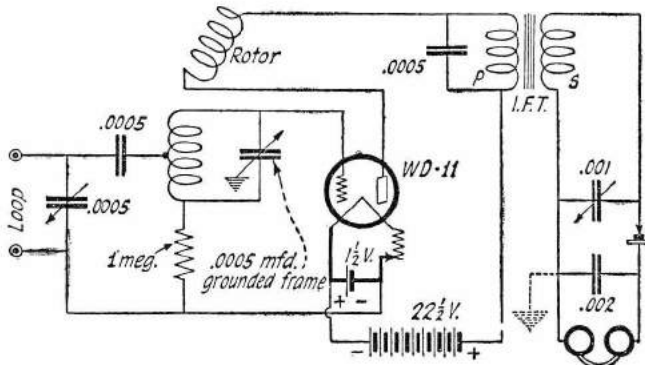

**(82) PICTURE DIAGRAM**

Q. 1. Please show the picture diagram of a reflex receiver having only one tube.

A. 1. We are showing it on page 20.

The crystal detector is shown connected to a center tap on the second radio frequency transformer secondary. The object of this is to increase selectivity. The dotted line indicates how one side of the radio frequency transformer secondary may be connected to "A" minus. This connection sometimes improves reception considerably, strong capacity effect being noted until this connection is made.

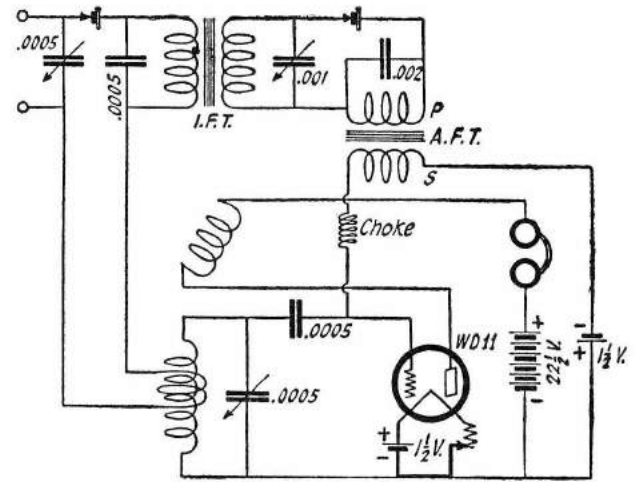
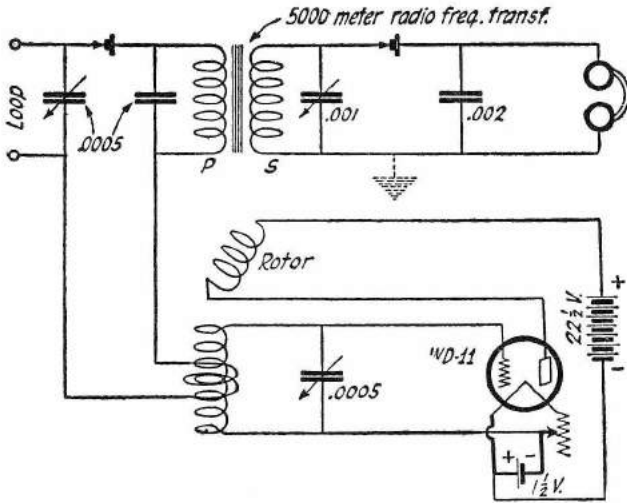

(77) Any standard oscillator coupler, or even a broadcast type coupler, may be used in circuits "A" and "C". The wave-length variation is easily controlled by increasing or decreasing the number of turns in the grid circuit of the oscillator tube. The loop condenser must be of low loss type. Do not use a phone plug for loop connecting.

All coils are wound in the same direction, with any convenient size of wire. Three-inch tubes may be used. If larger tubes are used, less turns are required; if smaller, more turns. Although the spacing between the 12 (and 15) turn primary and the 50-turn secondary looks large, the spacing of a single turn of wire will probably be found quite sufficient. A greater spacing will considerably sharpen the tuning, but also decrease the volume. This reduction is most noticeable when receiving signals from distant stations. Enamel, cotton or silk may be used as wire insulation, the latter two being preferable.

The potentiometer controls amplification (regeneration).

Any good audio frequency transformer may be used. Those of high ratio are not desirable in regular sets, but in reflex receivers high ratio transformers seem to be desirable, rather than otherwise. The UV-712 transformer (of which there are two types) was originally designed for high amplification of spark signals. (That is, one type was.) In regular broadcast receivers considerable distortion results when these are used. This circuit may be used with these audio frequency transformers with quite excellent results.

Different tubes and different audio frequency transformers (and different placing of apparatus) require different "by-pass" condenser (that is, the condensers connected to the primary and to the secondary windings of the audio frequency transformer) values. Other values than those shown should be tried and the result noted.

This is an extremely efficient circuit for the reception of local stations. Tone quality is very good. If the radio frequency coils are not crowded together, selectivity should be quite sufficient for all ordinary needs.

The size of the "A" battery used will depend upon the tube used and the tube selected is a matter of personal like and dislike. A regular "storage battery tube" will

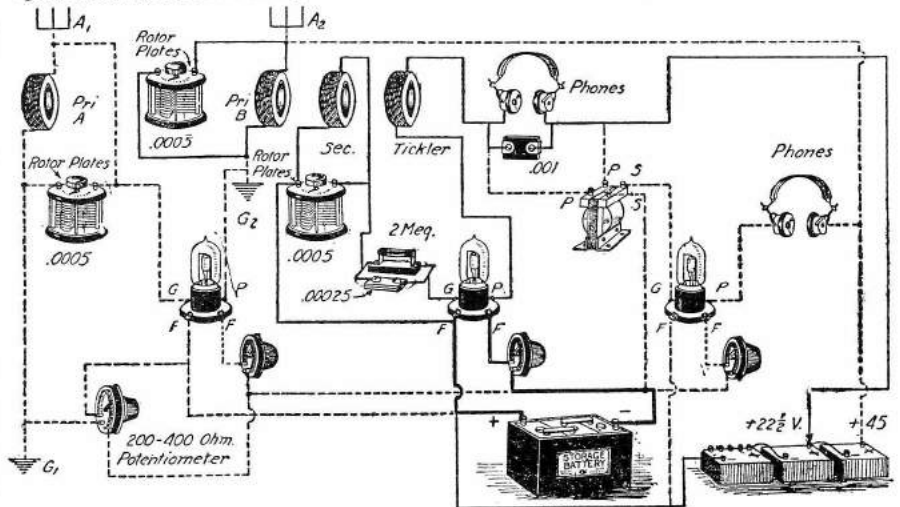

(79) One stage of tuned radio frequency amplification and one stage of transformer coupled audio frequency amplification may be easily added to the three-honeycomb type of regenerative receiver, as shown in this picture diagram.

Although an adjustable crystal detector is shown, one of the fixed variety may be used. A dozen different minerals should be tried. At least two different "detector stands" should be tried.

give best results. You are fairly safe in buying a tube that will oscillate.

(83) 5-TUBE SET

Q. 1. Please show a switching arrangement connected to the 5-tube radio frequency circuit. I wish to be able to use either an outside aerial and ground, or a loop. A variometer and a 2-coil variocoupler are available.

A. 1. This circuit will be found on page 21. The usual 2-coil coupler, having about 10 to 15 turns on the primary and about 50 turns on the 3-inch tube secondary, may be used.

The variometer should not be in inductive relation to the coupler. With the variometer short-circuited, you are using the so-called aperiodic antenna system. With the variometer in use, you are using the tuned antenna system.

The loop aerial will require between 90 and 110 feet of wire. This may be stranded or solid wire. No. 14 B. & S. gauge is a good size. It may be wound in the "flat spiral" (over-grown spiderweb coil) fashion, or on a box frame, like a direction-finding loop.

Ballantine vario-transformers may be used with excellent results. Any other make of transformers may also be used. The vario-transformers would have to be mounted in some accessible manner, as it is necessary to adjust these as different stations are tuned in.

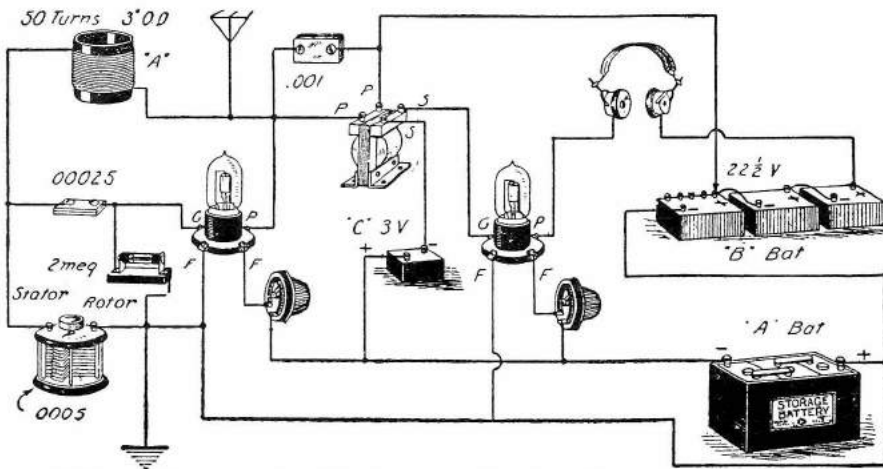

(79) By controlling regeneration with the filament rheostat, and using the correct constants, it is possible to make a sensitive receiver with only one tuning control, the variable condenser. This is the first regenerative circuit ever used. A softer detector tube will give particularly good results in this circuit. Vary the grid leak for best signal strength, from distant stations.

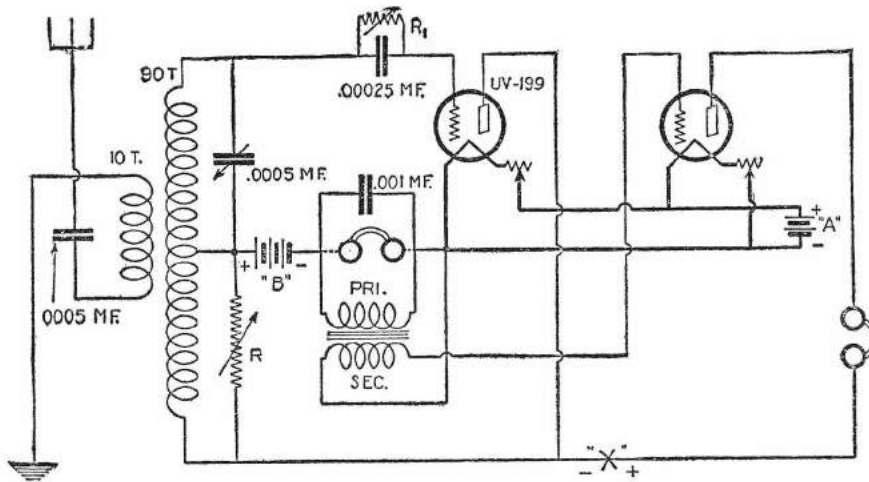

(80) Not a reflex circuit! It is a standard oscillator circuit with oscillation control by the "losser" method in the form of shunt resistance, R. An advantage of the circuit lies in the fact that there are no movable coils. There are only two main controls and only one of these, the variable condenser, has any effect on the wave-length.

The vario-transformer has a variable primary operated and connected like a variometer. The secondary is made in the same manner.

Head-phones may be connected to the detector output by just touching the phone tips to the primary posts of the first audio frequency transformer.

The make and ratio of the audio frequency transformers are optional. We would recommend audio transformers of low ratio, when the detector is preceded by one or more stages of radio frequency amplification.

Phone-plug losses are often quite high at radio frequencies. Consequently, it is not advisable to use a phone-plug to connect the loop to the set; use two binding posts. The two loop leads should be loose, not together.

**(84) WAVE LENGTH FREQUENCIES**

Q. 1. Please give the frequencies of the following wave-lengths: 100, 200, 360, 400 and 600 meters.

A. 1. These frequencies are 3,000 kilocycles (abbreviated KC.); 1,500 KC., 833.3 KC., 750 KC., and 500 KC. respectively.

**(85) RECEIVING RANGE**

Q. 1. I have a standard three-circuit regenerative receiver, and have received stations 800 miles distant with an inside antenna. Am I obtaining maximum efficiency with this equipment?

A. 1. A distance of 800 miles with an indoor antenna is very good, and you may rest assured that you are getting maximum results.

**(86) EXPERIMENTERS' CIRCUIT**

Q. 1. Would the enclosed circuit function satisfactorily with an outside aerial?

A. 1. We are showing this diagram with a few modifications that we believe will improve the operation of the circuit.

With the aerial switch on point 1, the coupling is aperiodic and inductive. With the connection to point 2, the coupling is capacitive and semi-tuned.

Resistance R1 and R2 are the usual type of variable plate resistors, variable between 10,000 and 100,000 ohms. With R1 shorted by means of the off-on switch, it will be necessary to use a lower "B" battery potential, since it is not necessary to have a 135-volt plate potential to overcome the resistance of a plate resistor. The connection is indicated by the dotted line, the previous connection being broken at "X1."

The tendency of the first radio frequency tube circuit to oscillate is considerably reduced by connecting "C" battery C1 as shown. A "lower loss" connection would be that indicated by "X."

"G. L." is two megohms. "R3," one-half to two megohms. The voltage of battery "C" may be about four and one-half volts. "C1" need be only one and one-half to three volts.

Coils L and L1 are in fixed inductive relation and may be made exactly the same as the radio frequency coil (with the 15-turn primary), shown in picture diagram 82.

Coils L2 and L3 are in variable inductive relation. Secondary stator coil L2 may consist of about 50 turns of No. 24 D.C.C. wire wound on a 3-inch tube. Rotor L3 may con-

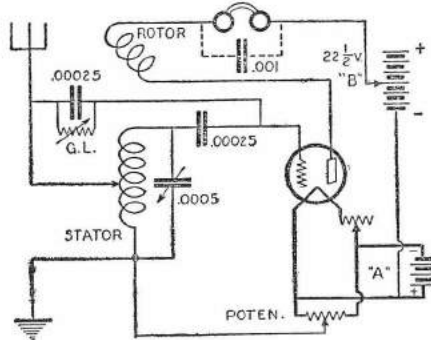

(80A) One of the variations of the single-circuit receiver. There should be no difficulty in making this operate in a satisfactory manner.

sist of about 12 turns of the same size wire, wound on a 2 1/2-inch tube. Coils L2 and L3 must not be in inductive relation to coils L1 and L2. Coils L2 and L3 may comprise a regular 2-coil variocoupler.

**(87) TUNED RADIO FREQUENCY**

Q. 1. What is the Starr system of "tuned absorption," as used to prevent oscillation of tuned radio frequency circuits? It is desired to use one stage of push-pull audio frequency amplification with a phone jack so arranged

that plugging the phones into the detector jack will automatically disconnect the push-pull amplifier tube filaments. When the head-phones are removed from the detector jack, the loud speaker should be automatically connected to the output of the amplifier.

A. 1. As has been occasionally explained in these columns, the reason manufacturers try in so many ways to prevent oscillation without the use of a potentiometer or connecting the R.F. tube grid return leads to "A" positive, is two-fold. First, if a positive potential is put on the grid, i. e., if the grid is "biased positive," "B" battery consumption is considerably increased. Second, the tuning is not then as sharp. In ordinary sets the practice is to run the grid return lead to "A" minus.

Consider the three tuned radio frequency transformers, having primaries and secondaries, as regular neutroformers designed for the Neutrodyne circuit. One make has a secondary winding of 58 turns of No. 24 D.C.C. wire wound on a 2 3/4-inch tube. The primary consists of 6 turns of No. 26 D.C.C. wire wound on a 2 1/2-inch tube, which tube just fits inside the secondary. This primary may be re-wound to 12 turns. The absorption coil "A" is tuned by means of the .00004 mfd. fixed condenser to a wave-length of about 250 meters. The "A" coils are made by winding 36 turns of No. 26 D.C.C. wire on a tube the same size as the one used for the primary winding, viz., 2 1/2 inches.

**(88) PICTURE DIAGRAMS**

Q. 1. Please show a picture diagram of an efficient receiver using only a crystal detector.

A. 1. We are showing three circuits in these columns using a crystal detector but three different methods of tuning.

Fig. 88-A uses a standard variometer, "L." C-1 denotes a variable condenser of .0005 to .001 mfd. which may be used to increase signal strength and reduce interference between stations. C-3 may be about .002 to .005 mfd. capacity.

Fig. 88-B shows an inductance "L" of about 50 turns of No. 20 D.C.C. wire wound on a three-inch tube and shunted by a variable condenser "C-2" of about .0005 mfd. capacity. The aerial variable condenser described above is shown as C-1. If desired an audio frequency amplifier may be used.

Fig. 88-C shows a standard variocoupler as the tuning coil. The aerial tuning condenser may be in series with the aerial as at "X," or may be connected in parallel to the primary "P" as indicated by the dotted lines. This primary may consist of about 40 turns of No. 20 D.C.C. wire wound on a three-inch tube. One-quarter inch away from this coil, and on the same tube, are wound 50 turns of the same size wire. This is the secondary "S." If desired, about 60 turns of No. 30 S.C.C. wire may be wound on a 2 1/2-inch rotor turning inside of the three-inch tube containing winding "S," the rotor winding constituting the primary.

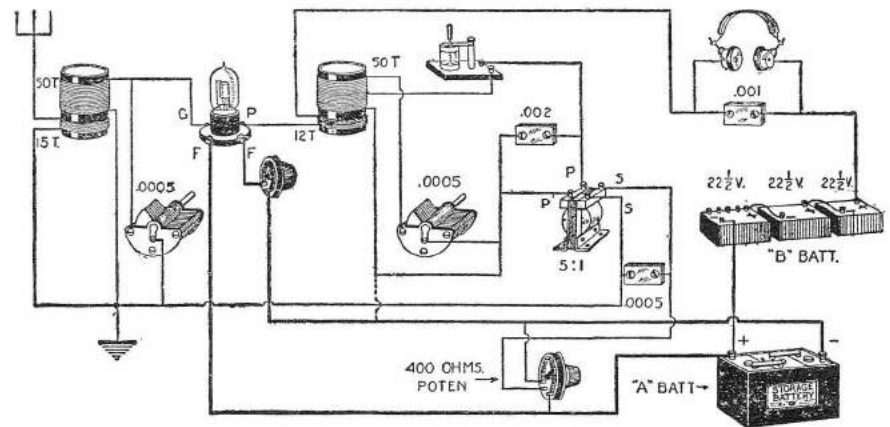

(82) Above we are showing an efficient 1-tube reflex circuit. Good quality and range are promised to constructors who build this set with care. An adjustable detector may be used, but fixed ones are now obtainable.

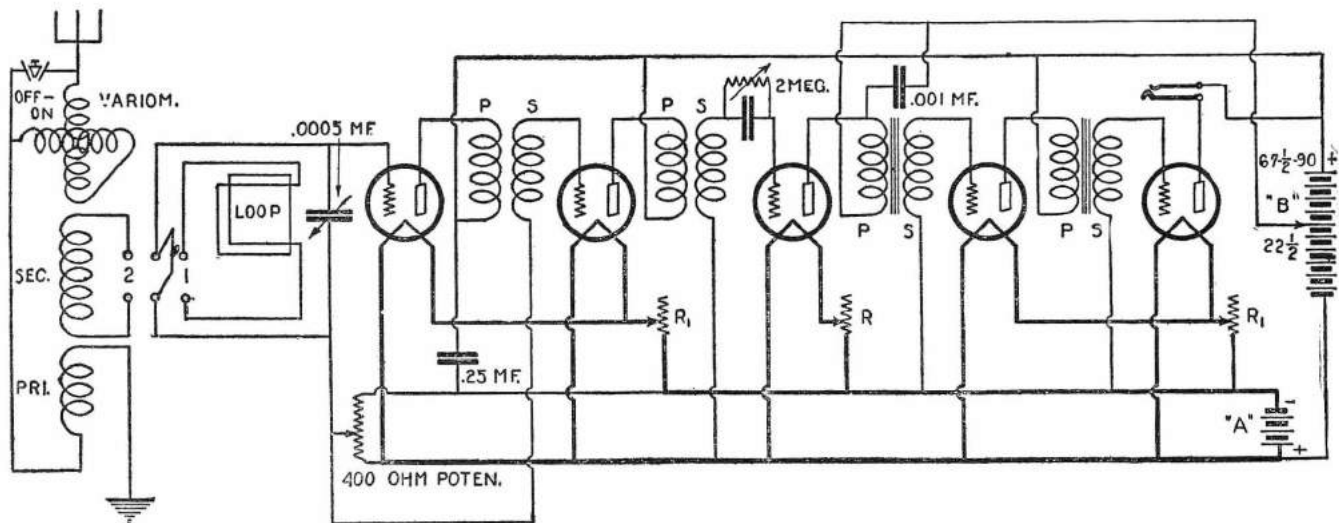

(83) A 2-dial radio frequency set. Either a loop aerial or a regular aerial and ground may be used. For good operation over the entire broadcast wave-length range it will be necessary to use a good make of radio frequency transformer. Dry cell tubes may be used.

**(89) TUNED IMPEDANCE COUPLING**

Q. 1. What is the schematic circuit of a tuned impedance receiver with a tuned aerial circuit?

A. 1. The circuit is shown on page 23. A variable detector leak is shown. Coils "L" are made by winding 50 turns of bell wire on 3-inch tubes. With these, condensers "C" will have a capacity of .0005 mfd. A smaller capacity will be required if larger coils are used, and *vice versa*. Potentiometer resistance, 400 ohms. A.F. transformer ratios and make are optional.

Q. 2. Can the Inverse-Duplex principle be used in a three tube Neutrodyne receiver?

A. 2. It is experimental and not to be advised.

**(90) A MODIFIED REINARTZ SET**

Q. 1. Is the enclosed diagram a satisfactory one? This appeared in a foreign publication and exceptional results were claimed for it.

A. 1. We have modified the schematic circuit somewhat, as you will see (90). Better operation results when the 200-turn choke coil is used. This may be wound with No. 30 S.S.C. or S.C.C. wire, on a two-inch form. This choke coil must be in non-inductive relation to the other coils in the set.

Note the absence of a phone condenser—this is characteristic of Reinartz receivers.

This modified Reinartz will be found one of the finest sets for all-round good operation. It is easy to tune (the .0005 mf. variable condenser controlling the wave-length to which the set will respond). Oscillation control is positive and easy (this is all in the setting of the .00025 mf. variable condenser). Sensitivity is assured by proper adjustment of the grid leak resistance and the detector "B" potential.

The 16-turn aerial coil serves a double purpose: it couples the aerial to the grid, and the plate to the grid.

A simple coil construction is shown in "90A." End "4" goes to the aerial and lead "1" connects to the .00025 mf. fixed grid condenser. A "lower loss" (Ye gods, this is becoming a habit. We used the same two words last month; probably will next month. Here's hoping they strike bottom sometime, on this "low loss," "lower loss," "lowest loss" business) coil would result if the wire is wound over one-eighth or one-quarter inch square strips of celluloid laid lengthwise on the coil so as to prevent the wire touching the tube. If this design is followed, cardboard, Bakelite, Radion (hard rubber), Formica or wood may be used as the form. Otherwise, it is best to use hard rubber.

Q. 2. How can a Diode be used in place of a crystal, in a reflex set?

A. 2. Circuit "90-B" shows how to use the 2-element "Fleming Valve" type of rectifier. "A" will necessarily consist of a good many turns, since a periodic, or tuned aerial circuit is being used, instead of an aperiodic, or untuned one. Winding "A" (having leads Nos. 3 and 4, with "4" being the aerial connection) will have about 45 or 50 turns and coil "B" will contain the same count, connection "1" being the grid connection. The second radio frequency unit (C and D) has a primary of about eight turns, the exact value to be determined by experiment, with "4" being the plate lead. The secondary, "D" will have about 45 or 50 turns, with "1" connecting to the plate of the 2-element tube.

**(91) REGENERATION IN THE ULTRA-SELECTIVE RECEIVER**

Q. 1. How is it possible to make regenerative the Ultra-Selective receiver?

A. 1. Circuit 91 is a modification of the arrangement.

Regeneration condenser R.C. is variably controlled from the panel front and has the same value as N.C. The detector plate circuit by-pass condenser is not required. By eliminating this unit regeneration control is made better.

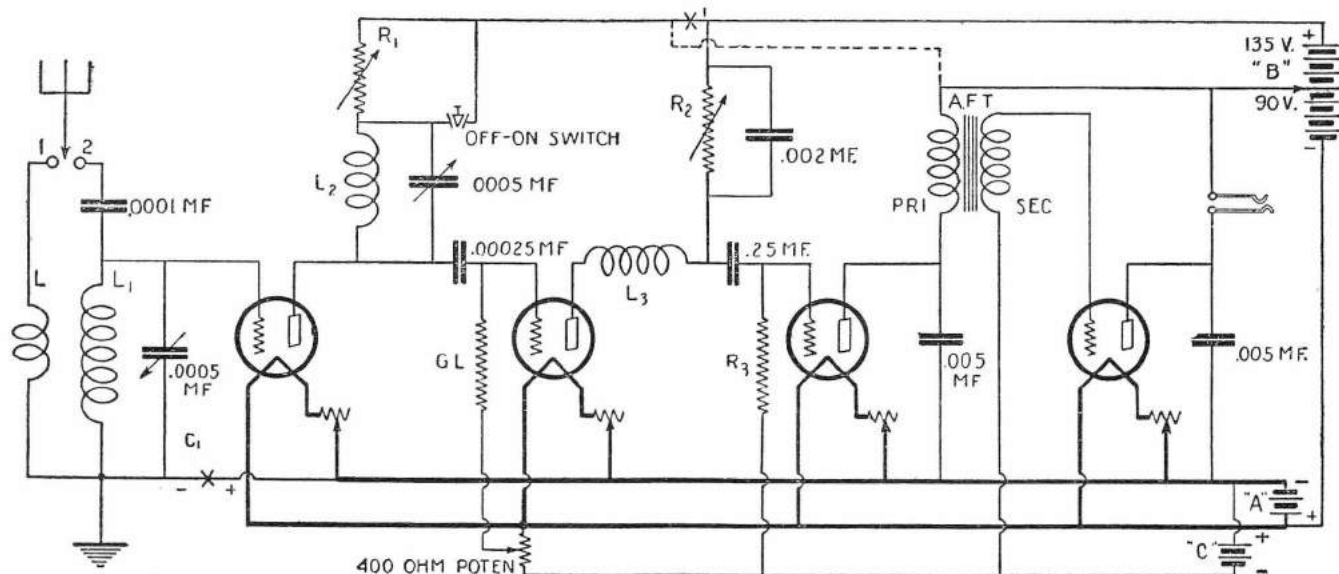

(86) How an efficient receiver may be wired, using one fixed coupler, one variocoupler, two variable condensers and two variable plate resistors, in addition to the customary equipment. Coils L2 and L3 are in inductive relation to one another.

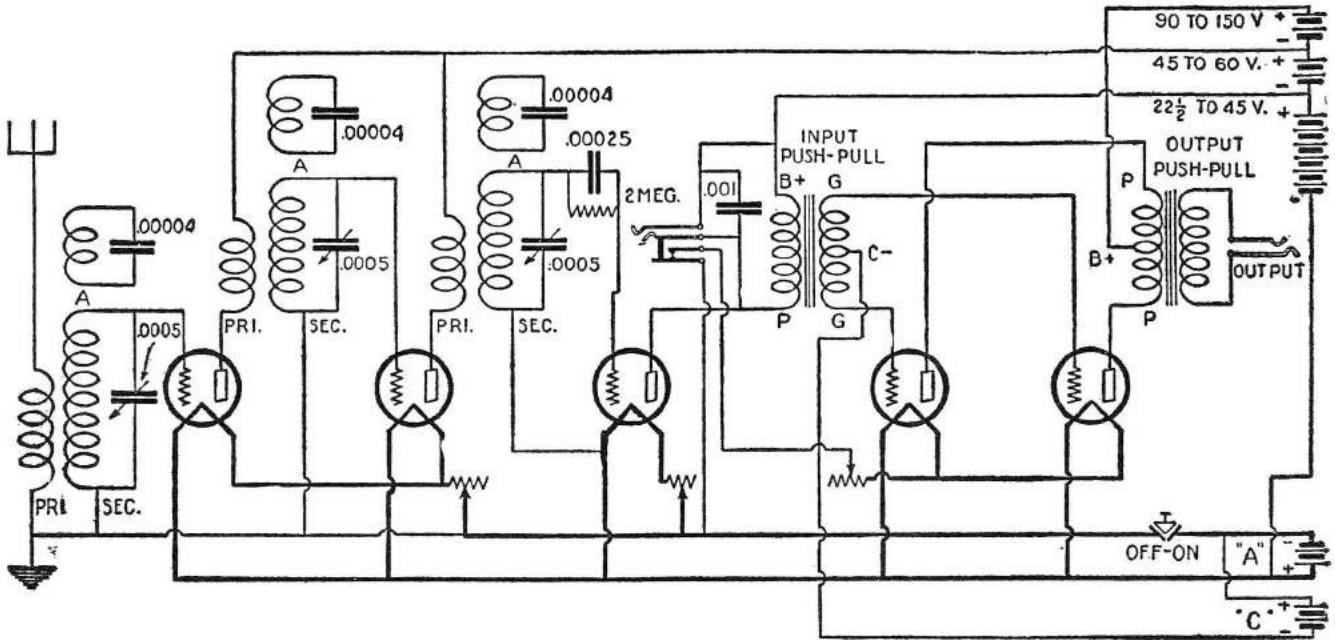

(87) The Starr "tuned absorption" system for oscillation control in tuned radio frequency receivers. If small variable condensers, such as the new Turnit (they fit in the regular grid leak mounting) or the Amplex, are used to tune the absorption coil, an extremely flexible control is secured. The tuned radio frequency coils should be in non-inductive relation to one another, so that the loss necessarily created by coil "A" may be kept at a minimum.

In the circuit of this type a semi-periodic aerial tuning feature is secured, eliminating the aerial condenser, loading coil L and the variability of L-2. The result of this is reduction in sensitivity and selectivity at the expense of greater ease in operation. However, selectivity and sensitivity remain very high under nearly all conditions.

The value of L-1 is determined by the maximum value of the particular variable

coupling units are wound on 2 1/2-inch tubes. Each six-turn coil is wound over its corresponding coil with only a single layer of Empire cloth, or similar insulating material, separating the two.

Since a General Radio audio transformer is used in the circuit you show, we recommend that you use the secondary grid leak shown.

If a pilot light is used to indicate that the "A" battery circuit is closed—that the tubes are lighted—resistance R will be required to reduce the voltage to the right amount for the particular bulb used. An ordinary flashlight bulb may be used. The value of R will vary. If a four-volt lamp is used, R will have a value of about 25 ohms. Therefore, R may be a 30-ohm rheostat, and adjusted for the pilot lamp used.

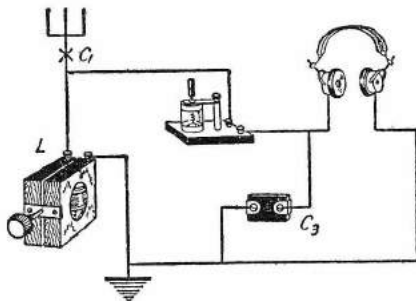

(88-A) A complete radio set is shown. Anyone can make this receiver at slight expense. The few parts may be made or purchased.

condenser used in shunt. This is true also of unit A-B-C. Values found excellent in practice are as follows:

L-1, 59 turns; L-2, 15 turns; A-B-C, 60 turns tapped at 12 turns for A, 12 turns for B, and the remainder, 36 turns, for C. It may be necessary to vary the tapping point for N.C. one turn either way, to make neutralization easier. If 201A type tubes are used, circuit balance is more easily had, with these coil sizes. L-1 and L-2 may be wound on the same tube, with about 1/4 inch space between the two coils.

We recommend a "C" battery at "X," of 1 1/2 to 3 volts. The dotted line 2mf. condenser across its two terminals is theoretically desirable.

Q. 2. Please advise me whether the enclosed four-tube diagram will work.

A. 2. We have corrected your diagram in the manner shown (91-A).

This circuit is credited to G. N. Garrison. The object of the small coupling coils is to eliminate inductive feed-back.

The 64-turn coils are wound on 3-inch tubes. The 60-turn coil is wound on the same size tube. All four coils are spaced in non-inductive relation to one another. The

**(92) REGENERATIVE REFLEX**

Q. 1. Can the enclosed reflex circuit be made regenerative?

A. 1. The changes necessary are clearly indicated in circuit 92. Condenser C-1 and C-2 may both be of 23-plate size. A standard two-coil coupler (or, a three-coil coupler with the primary remaining unused) may constitute the tuning unit. Approximately the same number of turns will be required in both stator and rotor. The stator may be wound with about 50 turns of No. 26 S.C.C. wire, on a 3-inch tube, and the rotor may be wound with about 60 turns of the same size wire. The stator is on a 3-inch tube; the rotor tube is about 2 1/2 inches in diameter. Condenser "C" has a value of

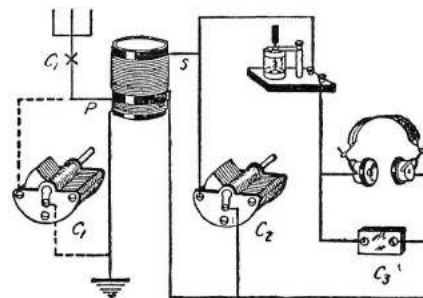

(88-C) A very simple crystal set. The inductance coil shown may be a standard two-coil variocoupler either tapped or untapped.

about .00025 mfd.; the exact value will vary with the particular aerial used. Any convenient ratio of audio frequency transformer may be used. The "B" potential will be 22 1/2 volts, as usual. Try reversing the crystal detector for best results.

Q. 2. Please show a circuit using the regular three-circuit coupler, but with provision for:

- (a) Grid leak rectification.
- (b) Grid bias rectification.

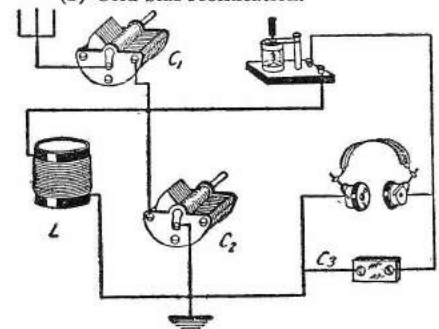

(88-B) A two-dial crystal set. Winding the single coil inductance should present no difficulties to the experimenter. Sharp tuning is not a feature.

- (c) Crystal detector rectification.

I would like to have any one of the three arranged to be had optionally.

A. 2. The circuit requested is shown as 92-A.

Switches Sw. 1 and Sw. 2 may be of the push-pull type, in which event the crystal shorted by Sw. 1 should preferably be of the fixed type.

The grid leak shorted by Sw. 2 is variable, and must be of the very finest quality, otherwise noisy operation is sure to result.

Variable condenser "C" is a Chelton Midget, or the equivalent thereof.

A 400-ohm potentiometer is to be preferred. The writer is of the opinion that this is the first time this composite diagram has ever been shown. It affords complete mastery of the major rectification means.

The "B" potential should be varied to determine the best value. It will probably be found that 22 1/2 volts is the required potential.

Try reversing tickler leads. Crystal rectification and grid-bias rectification are best for quality; grid leak rectification is best for sensitivity.



Condenser rotor plates are indicated by the arrowhead.

Q. 3. Would one stage of transformer coupled radio frequency amplification and one stage of tuned impedance radio frequency be more efficient with a loop aerial than two stages of transformer coupled radio frequency?

A. 3. Yes, with any type of aerial.

Q. 4. I would wish to be advised as to how my 2-variometer circuit can be arranged so that there is regeneration control by means of a potentiometer. I have a 400-ohm potentiometer I can use. The two variometers are in inductive relation, resulting in strong circuit oscillation at the shorter wave-lengths.

A. 4. We have modified your circuit in the manner requested. It is shown in diagram Q. 92-B.

We are inclined to believe it would be better to transpose the aerial and ground connections, although it is stated that results are exceptional with the arrangement shown.

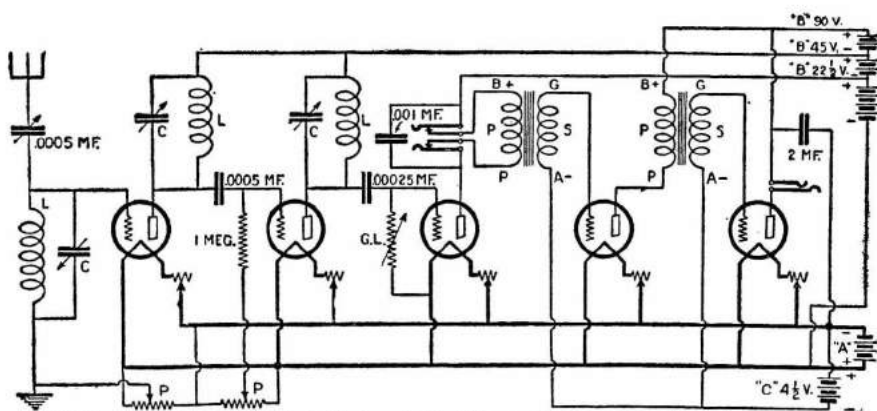

(89) Tuned Impedance. The standard schematic circuit for a receiver using "tuned impedance" coupling. Each tuned unit, when adjusted for a given signal, "rejects" that signal, causing the signal to charge the blocking condenser and, in turn, operate the grid of the amplifier tube. Undesired signals are "accepted" and do not operate the amplifier tubes. The circuit shown is very selective.

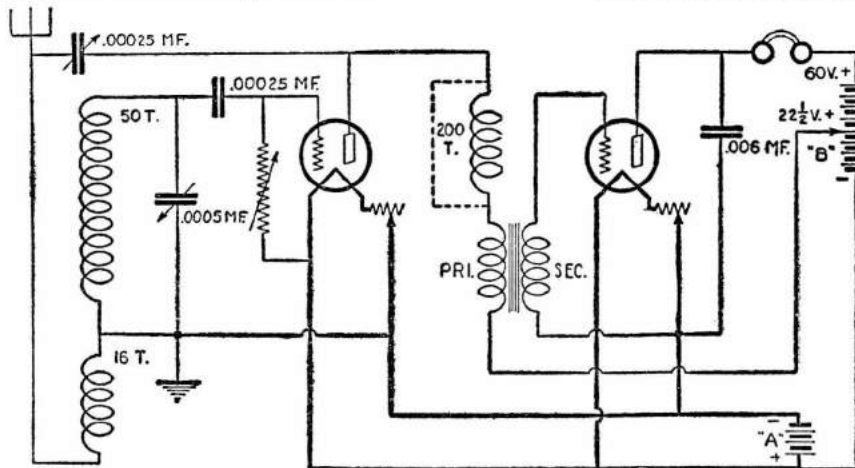

(90) An excellent two-tube diagram. In this circuit the feed-back coil and the antenna coil are combined in one winding. Any convenient form of coil winding may be used.

(93) CHANGING NEUTRODYNE

Q. 1. What is the simplest way to add a detector and oscillator to a five-tube neutrodyne set?

A. 1. The super-heterodyne system can not be employed with a five-tube neutrodyne receiver. The neutrodyne, by means of tuned transformers, amplifies efficiently on all of the low wave-lengths for which it is designed.

(94) THROTTLE CONTROL OF REGENERATION

Q. 1. What is "Throttle" control of regeneration?

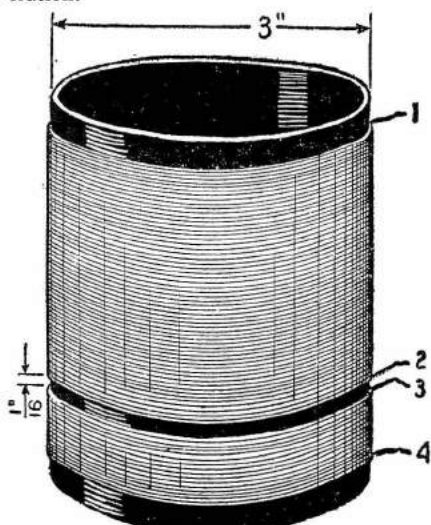

(90-A) A standard two-coil unit. This may be used in a great many different circuits and sets. This is a convenient coil for tapping or otherwise altering.

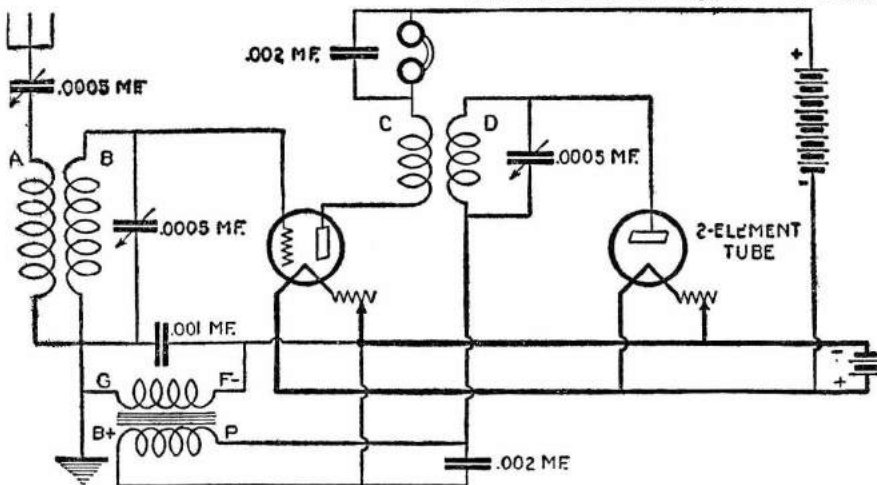

(90-B) A two-tube reflex. In this circuit a two-element tube supplants the usual crystal detector or three-element tube detector. The descriptive text is quite complete. Battery potentials and condenser values should be varied for best results.

A. 1. This is control of regeneration by means of a variable by-pass condenser connected across the primary of the audio frequency transformer connected in the plate circuit or, from the plate binding post of this winding to the "A" battery. This is made clear in the circuit diagram, 94.

Regeneration is controlled by means of variable condenser "C," which we may call the "throttle condenser." It may have a value of .0005 to .001 mf., the exact value being governed by the natural capacities of the instruments used. The distributed capacity, as it is called, of the audio frequency transformer, is represented as "C-1." If its value is large, only a small capacity variation will be necessary in "C," to start and stop circuit

oscillation; and if small, the value of the other may be made larger.

The three-coil coupler is of standard type and may, for example, have the values stated below:

Primary, 6 to 15 turns at the filament end of the secondary. Secondary, about 50 turns of No. 24 D.C.C. wire wound on a 3-inch tube, at the end of the primary winding. It is not necessary to space the primary and the secondary more than 1/8-inch. Rotor, 20 turns of the same size wire on a 2 1/2-inch tube or ball, placed at the grid end of the secondary and rotably arranged. If dry cell tubes having lower internal capacities are used, it will probably be necessary to increase the number of tickler, or rotor turns to about 35 to 40, in which case it may be more convenient to use a smaller size of wire. The exact number of turns for the tickler must be such that the rotor can be left in one position, almost full coupling, and not changed thereafter. The number of tickler turns must be so proportioned that throttle condenser "C" will fully control circuit oscillation at all wave-lengths, without recourse to an adjustment of "rotor."

It is advisable to operate this circuit with at least one stage of audio frequency amplification, as otherwise the capacity of the phone cords would become part of the "throttle" capacity and capacity effects would be very noticeable and annoying; every movement of one's head would vary the phone cord capacity and, thereby, the regenerative balance of the circuit.

(95) EXPERIMENTAL REFLEX

Q. 1. Is there any method of reflex amplification not requiring an audio frequency transformer?

A. 1. We are showing herewith an experi-



**(102) FOUR ELEMENT TUBES**

**Q. 1.** What is the diagram of connections of a set incorporating one stage of tuned radio frequency amplification, detector and one stage of transformer coupled audio frequency amplification, employing the Philips' Tetrode?

**A. 1.** The circuit for these double grid tubes is shown in these columns.

Note that the plate voltage on the amplifier tubes should never exceed 12 volts. The detector voltage will range between 2 and 4 volts. The amplifier voltage will range between 4 and 10 volts.

The inner grids connect to the positive connections of the respective plate battery taps, as shown. This inner grid connection is the small binding post on the shell of the socket.

These tubes require a special socket since the foreign method of isolating the plate prong is used.

It must be remembered that the terminal filament voltage is only 3½ volts, at ½ ampere.

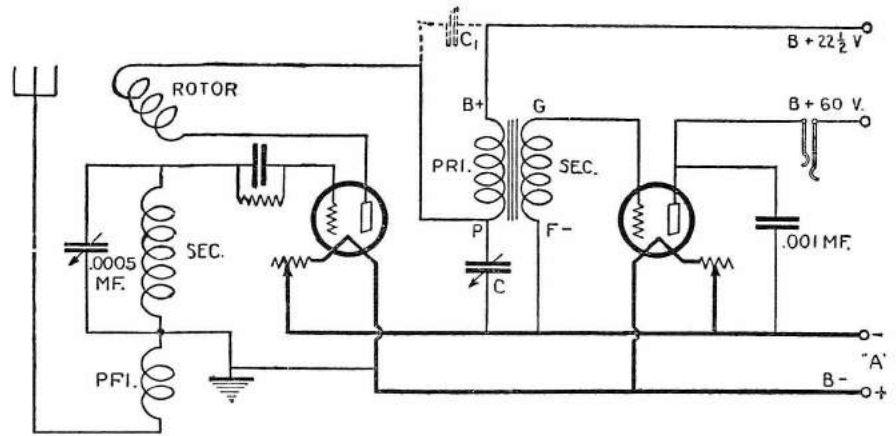

(94) A regenerative circuit employing the use of inductive and capacitive feed-back, termed "throttle control."

frame condenser is particularly desirable in the positions of C2 and C3. The variable resistor also assists in the stabilization.

The first three inductances may comprise the standard three-winding variocoupler having an untuned primary. The remaining two inductances may also be a coil of this type, with the untuned, or primary winding left unconnected.

The value of the "C" battery will be determined by individual conditions. Remember that its use reduces distortion, increases the "B" battery life and reduces the tendency to oscillate.

**Q. 2.** I have a detector tube that stops oscillating at times, but will start again by moving the primary switch. Can you inform me what is the trouble?

**A. 2.** This might be caused by a bad connection in your set. Perhaps the contacts of your tube socket are loose and do not make a firm contact. Examine all connections at the binding posts. We do not believe that this is caused by the tube itself.

**(104) SUPER-REGENERATION**

**Q. 1.** Is it possible to use Super-Regeneration on the short wave-lengths?

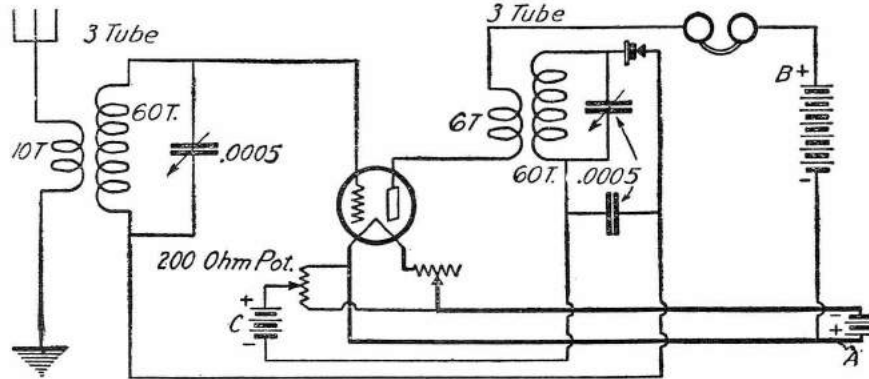

(95) The experimenter will welcome this reflex circuit wherein audio frequency current variations in the .0005 mfd. fixed condenser, due to the rectifying action of the crystal, are impressed upon the grid of the tube, resulting in dual amplification.

The standard system of connections for three element tubes is followed throughout, with the exception of the inner control grid shown.

**(103) CASCADE REGENERATION**

**Q. 1.** Is it possible to make a cascade regenerative receiver having tuned impedance coupling for the radio frequency amplifier, but regeneration in both detector and radio frequency amplifier?

**A. 1.** Cascade regeneration is difficult to handle. The circuit is shown in these columns.

To reduce the tendency of the set to generate parasitic oscillations, it is quite necessary that the aerial, grid and plate coils of the first radio frequency amplifier tube be placed in non-inductive relation to the balance of the inductances used in the set. The remaining two inductances, viz.: the tuned impedance of the detector circuit, and its relative rotor, are in inductive relation to one another.

To stabilize the control, one stage of audio frequency amplification has been added; this tends to reduce the effects of body capacity which would otherwise be objectionable to a much greater extent, unless special precautions were taken. The use of a grounded-

(96) A Two Stage Audio Frequency Amplifier Using Choke Coils. Grid Condensers are Provided to Keep the "B" Battery Voltage Off the Grids.

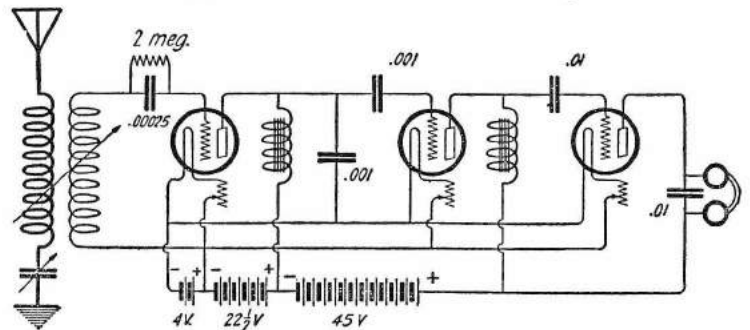

**A. 1.** It has been found that Super-Regeneration on the short wave-lengths seems to be a considerably better proposition than Super-Regeneration on the regular amateur or broadcast wave-lengths. The standard circuit will be found in these columns. The circuit used is that of the standard regenerative receiver with the addition of the coils DL-1250 and DL-1500, with their accompanying capacities. These two honeycombs are in variable inductive relation. When receiving short wave-lengths between 50 and 110 meters for the primary, six turns of No. 20 D.C.C. wire wound directly over the secondary will be satisfactory. The secondary may consist of about 15 turns of No. 24 D.C.C. wire wound on a three-inch form. It will be advisable to use some special form of low loss winding, such as the pickle bottle, spiderweb, honeycomb, lattice, or Morecroft type.

However, the method of using insulating strips should be applied to the secondary

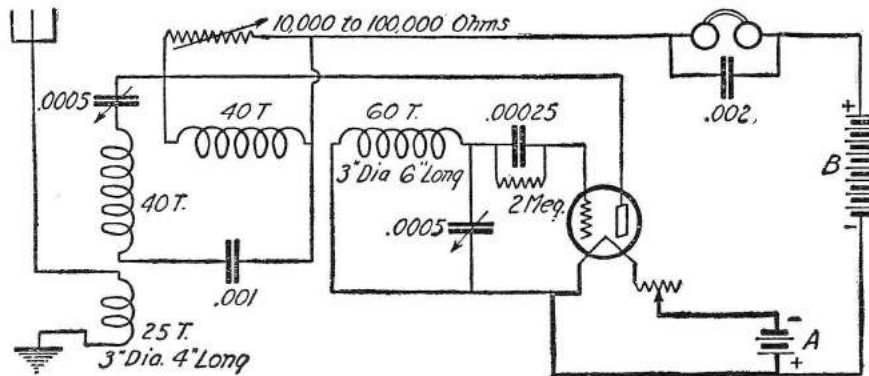

(97) The increasingly popular Filter Circuit is seen to be that of an exceptionally sharp-tuning, complete receiver. Careful instrument layout, careful construction and good apparatus will be required for best results.

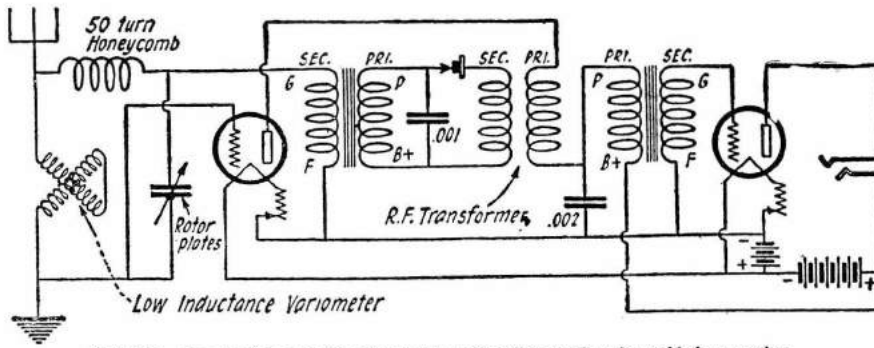

(99) This reflex circuit is exceptionally free from distortion and is quite stable in operation.

winding as well as to the primary winding. The tickler may be wound on a solid tube in a manner similar to the primary coil construction.

**(105) ONE DIAL CIRCUIT**

Q. 1. Please give the circuit for a set using one dial tuning.

A. 1. We are showing the circuit you request in these columns. The primary and secondary must be wound in the same direction. One tube is used for both windings, with a separation of 1/4 inch between each.

Q. 2. If it is possible to incorporate the new DeForest Anti-Radiation device of Roy A. Weagant with a regenerative receiver of the so-called single-circuit type, so as to prevent radiation of squeals and whistles, please show how it can be done and give all details necessary. Would the large Acme audio transformer work satisfactorily in the set? Or would the Erla code transformer work best?

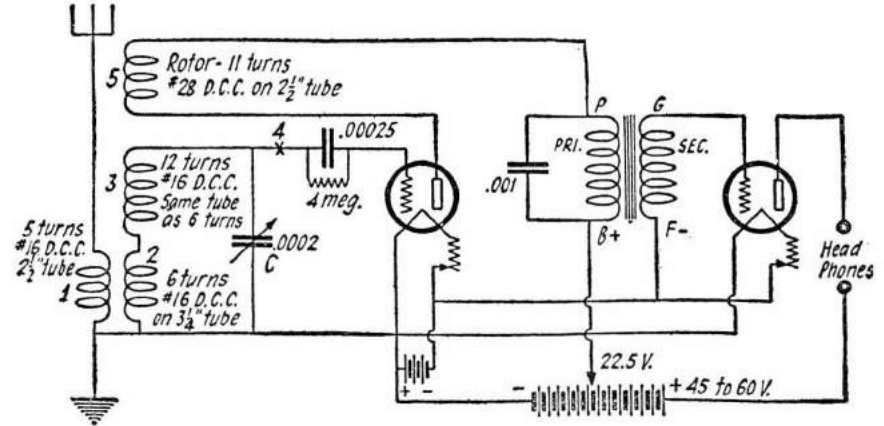

(101) Low losses and a minimum wave-length of 65 meters are the features of this set. It is primarily designed for the reception of telegraphic code signals.

The ratios of the new and old model Acme transformers, and other comparative data are:

No.	Ratio	Hght.	Dpth.	Wdth.	Wght.
A-2...	4 1/2:1	3"	2"	2 1/2"	8 oz.
MA-2...	5:1	3"	4"	4"	16 oz.

It is inadvisable to use the code transformers mentioned, unless it is desired to receive mostly code signals, in which case inductances "L" and "rotor" would be entirely different from their broadcast values; which may be, for example, "L," 50 turns of No. 20 D.C.C. wire on a 3-inch tube; "rotor," 20 to 40 turns of No. 24 D.C.C. wire wound on a 2 1/2-inch form, the exact number of plate coil turns determined by the particular tubes used.

The Erla code transformer is called the

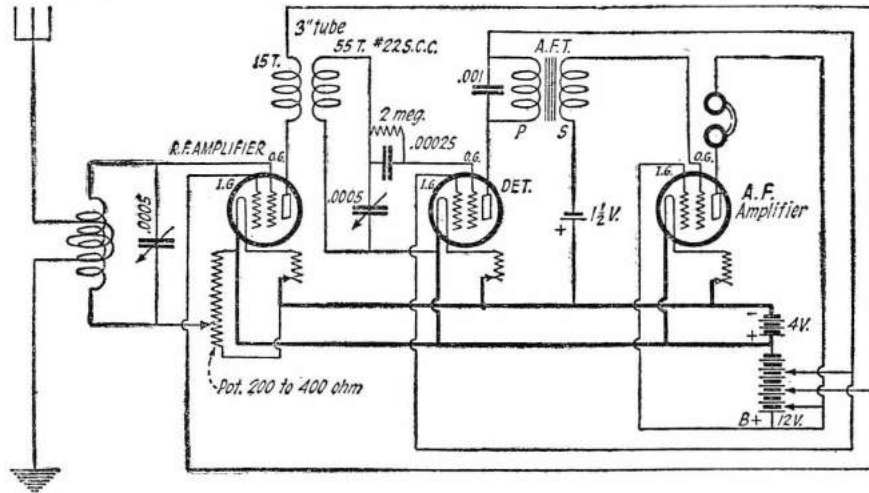

(102) The use of double grid tubes as radio frequency amplifiers, detectors and audio frequency amplifiers is clearly shown. Solodyne tubes might work in this circuit.

A. 2. Yes, it is possible to apply the principle you mention with no difficulty at all. The changes are probably made sufficiently clear in circuit diagram 105-B.

The aerial is removed from its usual position (1) and placed as shown at (2). The .00025 ufd. condenser shown in the first position of the aerial may be tried at point "X" of the aerial in the second position, but it will probably not be found at all necessary for its usual purpose—increasing selectivity.

The coil marked "Choke" may be the secondary of a good radio frequency transformer of the aperiodic type, such as the Acme R-2, the Duratran, the All-American R-201A, etc.

A Chelton Midget condenser may be used as N.C. Other condensers of the type used in neutrodyne for neutralizing purposes will probably prove satisfactory, if 50 uuuf. capacity can be obtained.

Any good make of audio frequency transformers may be used, with the lower ratio transformer in the second stage.

"1,000 cycle" transformer and at this frequency at which it peaks, the voltage amplification ratio is approximately 30:1. It is the most suitable transformer on the market for the amplification of code signals of 1,000 cycles frequency (approximately).

**(106) RANGE OF CRYSTAL DETECTOR**

Q. 1. What is the average range of a crystal detector?

A. 1. This all depends upon local conditions, size of antenna etc. However, a good crystal set should receive music at a distance of twenty to twenty-five miles and code from 300 to 500 miles.

Q. 2. I have heard that if a Gold Grain detector is used in an Erla reflex circuit it will burn out the elements of the detector. Is this correct?

A. 2. There will be no danger of the detector being burned out in this or any other reflex circuit. The crystal is in series with the secondary of the R.F. transformer and the primary of the A.F. transformer only, and there is no battery in this circuit.

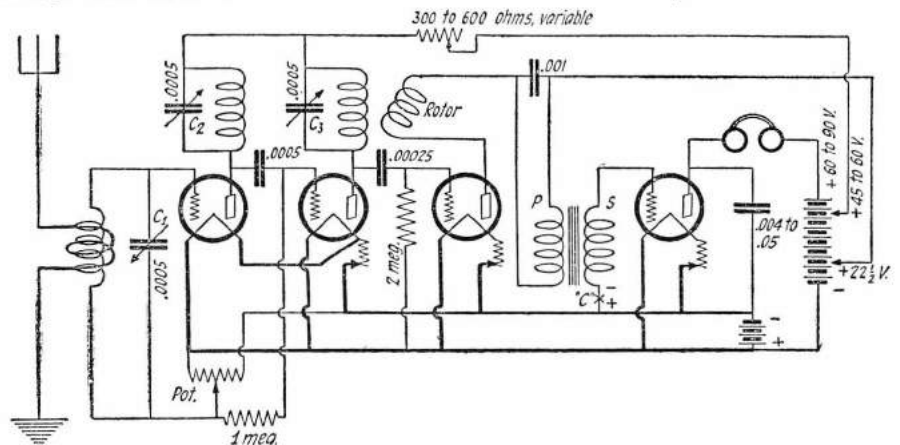

(103) The Double Regenerator shown looks very easy to build, but it may be difficult to get the correct angular relation and inductive values for best operation. Use good parts.

**(107) SUPERDYNE**

Q. 1. In what way can the Superdyne principle be applied, to use the tube unit of an RC set?

A. 1. The method is shown in these columns. The untuned primary consists of about eight turns of insulated wire wound over the secondary.

Q. 2. Are there any special points to be borne in mind when laying out the instruments?

A. 2. It is very important that the plate tuning coil be placed in non-inductive relation to the coils in the grid circuit. If the plate coupling coil (the rotor ball) is placed too close to the stator coil to which it is coupled, regeneration control will not be satisfactory.

**(108) RADIO STABILITY**

Q. 1. Am considering the construction of a set. Is there much possibility of its being useless in a short time, due to changes in the radio field?

A. 1. If a standard circuit is used the set should be useful for a long time to come. The laws governing radio communication are the same now as they were in 1898 and a set built along the standard lines is not likely to pass out of date due to any radical changes.

**(109) A. F. WITH REINARTZ CIRCUIT**

Q. 1. Please show a hook-up with one or two stages added to the Reinartz circuit.

A. 1. This hook-up appears on these pages.

**(110) NEUTRODYNE CIRCUIT**

Q. 1. Please publish the Neutrodyne Circuit, using three stages of radio and one stage of audio-frequency amplification.

A. 1. This circuit appears on these pages.

**(111) PICTURE DIAGRAMS**

Q. 1. Please show a picture diagram of a one-tube receiver that may be readily adapted to the standard radio receiving circuits now in general use.

A. 1. The picture diagram marked Q. 111 shows how to connect a single tube in the form of a unit that makes it possible to try conveniently practically all of the more important circuits used in radio reception.

Any tubes may be used. It is best to use a storage "A" battery of six volts, with UV-201A, C-301A, Magnavox, DeForest or Schicklering six-volt tubes. A 20 to 30-ohm rheostat may be used. If dry cell tubes of the UV-199 or C-399 type are used, three dry cells or two sections of a storage battery (four volts) may be used. Since these tubes require a special socket, it is necessary to use this socket, or else use an adapter that will accommodate dry cell tubes to sockets de-

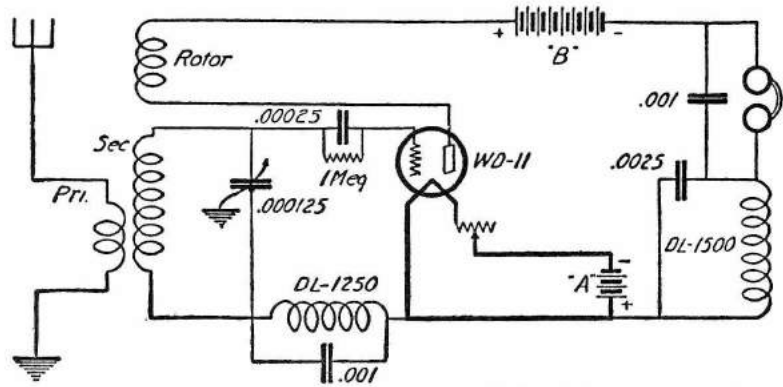

(104) Super-regeneration, or regeneration, at short wave-lengths? By a slight change, the experimenter has either available, at will. We will welcome reports, addressed to the editor, on reception conditions in various parts of the world, at short wave-lengths.

signed for storage battery tubes. Regenerative circuits may be used to make extremely efficient receivers, even with dry cell tubes of the WD-11, WD-12, C-11 and C-12 type, operating with a single dry cell or a single storage cell.

The single dry cell tube has made it possible for thousands of people to possess efficient radio sets that do not require rechargeable batteries. A single dry cell will operate a dry cell tube for a period of 90 to 100 hours. Since the dry cell costs less than 50c, the operating expense is very little. In

expense of maintenance. Heat accelerates the chemical action in "B" battery cells, so do not place the battery near a heater, or in the sun. "Keep in a cool, dry place." Never "short" the "B" battery for a fraction of a second to determine its worth for your set. Such a procedure has questionable value when the husky "A" battery is the victim.

The entire apparatus may be set up on a table, while various combinations of the instruments are tried. After it has been finally decided just what circuit and equipment will be used in the final receiver, a permanent lay-out and wiring may be planned. (See page 31.)

"Test clips" soldered to short lengths of wire are now obtainable, making a change in the circuit merely a matter of seconds.

The make of apparatus is optional. A variable grid leak is recommended. The "B" battery voltage should be kept as low as possible, if the greatest sensitivity is desired. Changing the "B" battery voltage necessitates a new value for the grid leak, hence the suggestion of a variable leak of "noiseless" type. (A poorly-made leak will constantly change in its resistance, resulting in crackling sounds and generally poor reception). The grid condenser and the phone condenser must also have the feature of "noiselessness." Poorly-made paper or mica-insulated condensers permit a partial, intermittent current leakage that also results in crackling sounds—or total inoperation. A "B" battery containing one or more "dead" or inactive cells, an "A" battery in need of recharging, and vacuum tube sockets of poor construction can also cause crackling sounds or total inoperation.

Phone cords partly broken will cause crackling sounds. Shaking the cord will quickly check this possibility.

To return to battery voltages—we wish to state that 22½ volts is the usual plate potential for all detector tubes. If the regenerative circuit will not oscillate with this potential, it may be necessary to increase the voltage to 40 or 50. Beyond this it is not advisable to go, as sensitivity is then greatly decreased. If there is thought to be sufficient inductance in the plate circuit, and the circuit refuses to "perk," even with a phone condenser and a reversal of the tickler leads, try another tube; the non-oscillation may be due to too high a vacuum or too little emission of electrons from the filament. We have not suggested a reversal of the "A" battery leads as a way of assisting oscillation, since such a connection ("B" minus to "A" minus) has the effect of reducing the "B" battery voltage, which was not what we desired to do in the instance given.

The first of four standard regenerative circuits we intend to show in picture form is the one-time "standard."

**2-Variometer, Variocoupler Diagram.**

This circuit requires five controls, two for the two variometers (V-1 and V-2), one for the variocoupler rotor and two for the

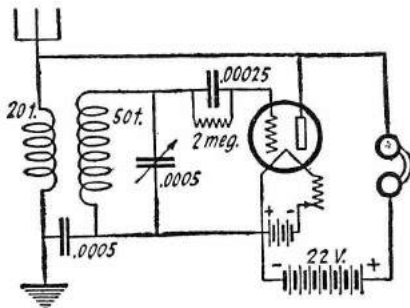

(105) A one control receiver incorporating the advantages of regeneration. It has a fair degree of selectivity.

estimating the cost, proper consideration must be given to the operating life and initial price of the vacuum tube and the "B" battery. Properly operated, the average life of the vacuum tube is about 1,500 hours, while the "B" battery is usually found to last from six months to a year, depending upon the make, size, demands and other factors.

One way of greatly lengthening the life of the tube is to use precaution in lighting the filament; remember, an increase of 10 per cent. in filament heat, beyond the rated heat, will decrease the life of the tube one-half.

The "B" battery, too, comes under consideration if one desires the least possible

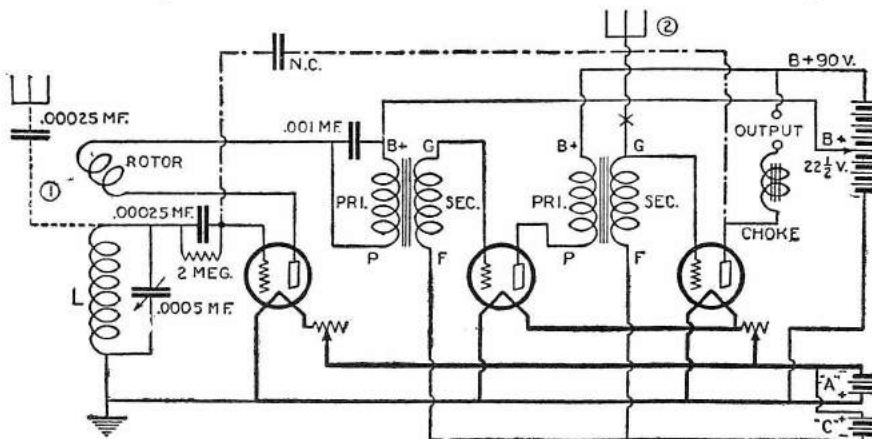

(105-B) A single circuit receiver designed so as to reduce radiation to a minimum.

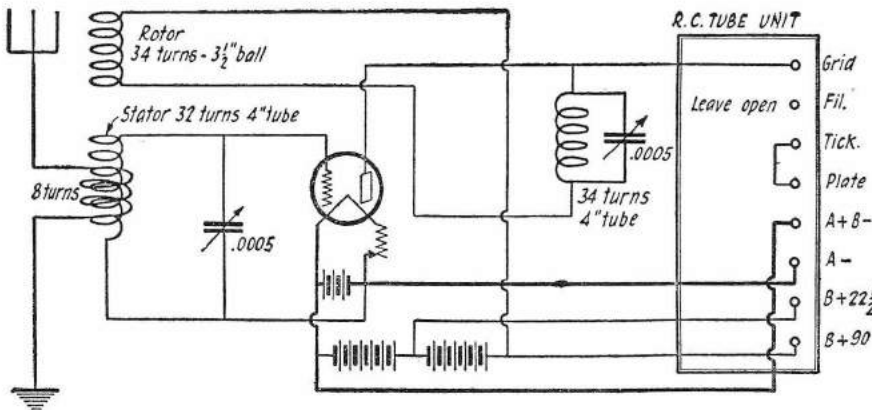

(107) Diagram of connections for changing an RC set into a Superdyne. No change of wiring within the RC unit is necessary.

switches. The grid lead of diagram 111 must be broken at X and connected to the two X leads of grid variometer V-1 (111-A).

Although the switches are marked "units" and "tens," there are only seven leads shown connecting to each switch. Some variocouplers have a total of 14 taps and others have a total of 20 taps. The "units" switch has a tap taken at every turn for the first seven (or ten) turns. The "tens" switch has a tap taken at every seven (or ten) turns, for 49 (or 100) turns. If the units-and-sevens tapping arrangement is used there will be a total of 56 turns—110 turns if the units-and-tens systems is followed. Either will be satisfactory.

With the tapped primary of the variocoupler V. C. connected to a well-insulated copper aerial in one piece, and a good ground connection made to a well-scraped cold water pipe or a five-foot iron rod driven into moist earth, and the four binding-posts of the tube unit connected to the four binding-posts of the tuning unit, one has a complete receiving set.

Plate circuit variometer V-2 controls range, selectivity and volume. (Or, in one word, regeneration.) The rotating secondary of the variocoupler also assists in sharpening the tuning, maximum selectivity being obtained when the rotor is placed at "loosest coupling," the position shown in the diagram. Reversing the connections of plate variometer V-2 sometimes improves the reception.

If it is desired to have the set operate as a plain detector, without the regenerative feature afforded by the plate variometer, this instrument may be put out of operation by short-circuiting it by means of the shorting wire marked "jumper."

Note that the .0005 mfd. variable condenser is not required if variometers are used to tune the grid and plate circuits of this set in the manner illustrated. The variometer is known as a "continuously variable inductance" and no other means of changing the wave-length is needed.

If the variocoupler rotor contains sufficient wire, the .0005 mfd. variable condenser may be used to tune the grid circuit. Grid tuning variometer V-1 is then not needed.

#### 2-Coil Variocoupler Diagram

The variocoupler described above may be used in constructing an effective receiver that does not require variometers. A lead from one end of the variocoupler tapped primary connects to binding-post "G." The other end of the primary connects to binding-post "F+." The variable condenser tunes the grid circuit so formed. The plate circuit is not tuned, as previously. "Regeneration" is controlled by means of the "tickler feed-back" supplied by the rotor. (Fig. 111-B.)

If the primary leads are not securely fastened to the switch-points and the primary coil, there can be no reception of signals when the switch lever makes contact with the poorly connected taps.

As stated previously, minimum coupling is secured when the rotor is situated as shown.

Maximum coupling is 90 degrees to either side of this position. Some variocouplers are of the "180 degree" type. With these, maximum coupling is in a position 180 degrees from the minimum coupling position of the rotor. Most of the 180-degree variocouplers have a stop that limits the amount of motion to 180 degrees. It is advisable to try reversing the rotor connections if such a coupler is used, in order to determine the best connection.

This is the most broadly-tuning circuit of the four, but if the set is situated some distance from powerful broadcasting stations, this objection is not serious.

The three circuits using variocouplers are all limited to the wave-length range to which the couplers will respond. This is usually about 200 to 575 meters. It is occasionally desirable to receive stations operating on wave-lengths as high as 30,000 meters. A few of the foreign broadcast stations operate on 2,000 and 3,000 meters. The most practical circuit for receiving all wave-lengths is the three-coil tuner.

#### 3-Honeycomb Circuit

Circuit 111-C shows a standard 3-coil honeycomb mounting containing primary coil 1, secondary coil 2, and tickler coil 3. The size of these honeycombs will be found to be very nearly the same for a given wave-length range.

In using the honeycomb reception system, it will be found necessary to employ a variable condenser connected from aerial to ground, as indicated by the dotted line and the letter "C." This condenser may have a maximum capacity of .0005 or .001 mfd.

The flexibility of wave-length change

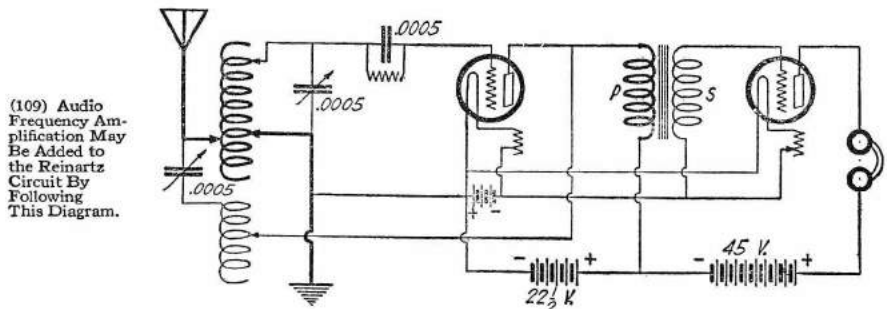

(109) Audio Frequency Amplification May Be Added to the Reinartz Circuit By Following This Diagram.

afforded by the plug-in system may be extended to include "spider-web" coils wound on flat, slotted forms. Efficient reception is possible on 25 and 50 meters with the use of suitable spider-web coils.

#### Untuned Primary Receiver

Diagram 111-D illustrates the type of regenerative receiver most commonly used at the present time; it owes its popularity to its high selectivity, high sensitivity and ease of control. Only one dial is required for the variable condenser wave-length control and one dial for the tickler feed-back amplifica-

tion control. It has been found that variable condenser losses are of less importance than inductance losses and, for that reason, one should take exceptional care to see that the coils used are of low-loss construction. The circuit using this form of coil has been heralded under a hundred aliases, its outstanding claim being its ability as a DX-er (long-distance receiver).

A satisfactory coil construction would be 10 turns of No. 18 annunciator wire for the untuned primary and 50 turns of No. 20 or 22 D.C.C. wire wound on a 3-inch tube. Wind both coils the same way and space the primary about  $\frac{1}{8}$  to  $\frac{1}{2}$  inch from the secondary. Any form of tickler coil may be used. About 20 turns of No. 26 or 28 D.C.C. wire on a  $2\frac{1}{2}$ -inch rotatable tube or ball will be satisfactory. The mechanical arrangement of the rotating element must be left to the ingenuity of the constructor.

Circuits 111-B and 111-D are extremely good for portable sets, or for sets located where conditions are not favorable for best reception. The use of substitute aerials in the form of electric light lines (a Ducon is used), fire escapes, inside-of-room aerials, wire fences, metal roofs, leader pipes, door-bell wiring, an insulated wire laid on the ground, an insulated wire buried one foot deep in the ground, and various other unusual conductors may often result in surprisingly good reception. If it is found very difficult to receive signals of readable intensity, try connecting any one of the convenient aerial systems mentioned above to the end of the secondary marked "G" of the variocoupler shown in tuning unit 111-D.

#### (112) CONDENSER TROUBLE

Q. 1. Why do I get crackling noises and sometimes a loud bang in my phones and then silence when adjusting the variable condenser of my receiving set?

A. 1. Either poor connection to the rotor plates or a short circuit between the rotor and the stator plates of the condenser at certain positions is the probable cause.

Q. 2. Does it make any difference, at amateur or broadcast wave-lengths, whether the variable condenser across an inductance is connected close to the inductance, or some distance from the inductance, granting that mechanical reasons make it necessary to place the coil at a greater-than-usual distance from its two connections to the tube?

A. 2. It would be more desirable to place the condenser at the greatest distance from the coil, so as to include as much of the coil leads in the oscillatory circuit tuned by the condenser, as possible. Otherwise, high frequency parasitic oscillations may be generated

by reason of the inductance and capacity furnished by the leads not included in the tuned circuit. The effect of these oscillations is not always noticeable. The shorter the wave-length, the more pronounced these effects become. In transmitting circuits, these oscillations are often easily detectable, where the above precautions have not been taken, sometimes causing inoperation of the set.

Q. 3. How may we add a UV-201A tube as an audio frequency amplifier to our Duo-Reflex set?

A. 3. The usual A.F. hook-up is followed.



secondary or grid circuit, and plate. A three-coil honeycomb receiver is not a three-circuit receiver, but is a regenerative two-circuit tuner. Following this same line, a so-called single-circuit tuner, using a variometer in the plate circuit, for regeneration, is really a two-circuit receiver, even though commonly called a single circuit.

Q. 2. Compare a book condenser with one of the interleaving type.

A. 2. Book condensers do not have a straight-line capacity curve unless a special mechanical design is employed; they stand a higher voltage; dielectric losses are greater; almost impossible to short-circuit; have greater mechanical strength; require less

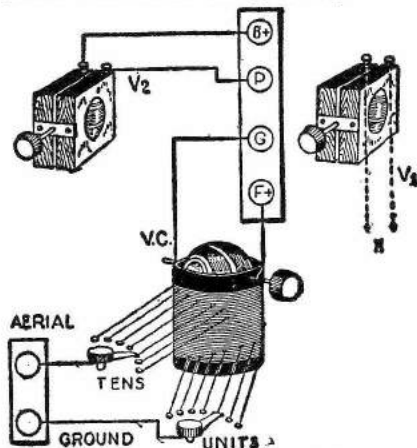

(111-A) The "2-variometer, variocoupler" regenerative arrangement. This was once the standard of reception circuits, but a demand for simplicity of control forced the "untuned primary" receiver into the lead.

space; are not sufficiently accurate for laboratory work; can be used on front or back of a panel.

#### (119) A. F. TRANSFORMER IN REFLEX

Q. 1. Can an audio frequency transformer with a ratio of  $4\frac{1}{2}:1$  be used in place of a 6:1 ratio transformer in a three-tube reflex circuit?

A. 1. It is always advisable to use a low ratio transformer whenever possible in a reflex receiver, and for this reason better results should be obtained with the transformer of a  $4\frac{1}{2}:1$  ratio.

Q. 2. Is a tuned impedance radio frequency, or a Neutrodyne, circuit better for DX reception?

A. 2. They are about the same. Theoretically, the Neutrodyne has the advantage of voltage step-up, but the tuned impedance radio frequency amplifier more closely approaches the point of maximum regeneration.

Q. 3. Would a potentiometer improve the Neutrodyne?

A. 3. If a potentiometer were used, the advantages of the Neutrodyne would be lost.

Q. 4. Which of the above mentioned circuits is the most selective?

A. 4. They are both exceptionally selective.

Q. 5. Can honey-comb coils be used to advantage in the construction of variometers for an Autoplex receiver?

A. 5. By connecting two honey-comb coils in series, each of about 30 to 50 turns and sliding one across the other, a variometer action will be had which may be satisfactory. The wave-length range of such a construction is rather limited and it is doubtful if results will compare very favorably with those secured through the use of a standard variometer of correct design. Of course, a high natural inductance and low natural capacity is thus secured, but the usual honey-comb construction does not permit a very wide variation between maximum and minimum.

#### (120) VARIABLE CONDENSERS

Q. 1. Why does the tuning sharpen considerably when a 43-plate condenser is substituted for the 23-plate condenser in my set?

A. 1. This is because a change of one degree in the position of the rotor plates moves twice the number of plates as before. Having twice the surface, it will cover twice as wide a wave-length band as previously. In other words, you will be able to tune to any station previously heard, as well as those in an additional wave-length band nearly equal to the original band. We wish to mention that there is a possibility of your not being able to receive all the stations at the very lowest setting of the 43-plate condenser. This is explained by the fact that the minimum capacity has been increased by the greater number of plates in relation to the lowest capacity setting. If desired, a very small fixed condenser may be inserted in series with the variable condenser. It will reduce both the minimum and maximum capacities obtainable from the 43-plate condenser.

Q. 2. Is it possible to use a .0005 mfd. grounded-frame condenser, to eliminate capacity effect, as the oscillator condenser of the Tropadyne, instead of the usual .001 mfd. variable condenser?

A. 2. Yes. Instead of the usual 20 to 24 turns of No. 20 S.S.C. wire, for the plate, and 29 turns for the grid (3" tube), use 20 turns of No. 24 S.S.C. wire in the plate and 51 turns in the grid. Tap in the center. A standard two-coil (or a three-coil, if the primary is left unconnected), variocoupler may be used with increased efficiency. The fixed resistance should be between  $\frac{1}{4}$  and  $\frac{1}{2}$  megohm.

Q. 3. Is it best to wind a variocoupler with "Litz" or regular wire?

A. 3. We do not believe that there would be any advantage in using Litzendraht wire in place of D.S.C. wire, D.C.C. wire, silk covered enameled wire or cotton covered enameled wire. We believe that there would be an advantage to the use of this wire in preference to plain enameled, S.C.C., or S.S.C. wire. Even at best, it is very important that every single strand be connected; a poorly connected or broken strand so increases the resistance at high frequencies that it becomes less efficient than ordinary wire, otherwise not nearly as good.

#### (121) CRYSTAL RECEPTION

Q. 1. Would a person seven miles away be able to hear phone transmission from a station using one 5-watt tube and 100 volts on the plate? The Colpitts system is used with a microphone in the ground circuit.

A. 1. It is not probable that a crystal receiver would be able to receive this station at this distance.

Q. 2. What will be the range of this set under normal conditions?

A. 2. With a sensitive receiver at the receiving end, this transmitter might cover a distance of about four or five miles.

Q. 3. Will better results be obtained in a two-circuit regenerative receiver, with spider-web or honeycomb coils?

A. 3. This circuit will work equally well with either set of coils.

Q. 4. What size coils should be used in this circuit?

A. 4. The size of the primary coil will depend upon the length of the antenna. A honeycomb coil of 50 or 75 turns with a variable condenser in series can be used in this position. The secondary coil should have at least 50 turns and the tickler should have 75 turns. The spider web coils should have about 10 turns more on each coil for the same wave-lengths.

#### (122) RADIATION PROBLEM

Q. 1. It seems that there must be some way to prevent radiation from existing radio sets, either by legislation or use of special apparatus, and there must be some sets on the market which do not radiate. What information is available on this subject?

A. 1. The matter of radiation from receiving sets is daily becoming a matter of

concern to all broadcast listeners-in. The matter of legislation has been abandoned due to the difficulties of enforcing any laws that might be enacted. Most of the sets causing interference are the low priced ones of the highly radiating type of regenerative receiver. While the sets could be reworked for a different circuit they would not be as efficient as before and would require additional tubes to restore their former efficiency.

The need of all this can be eliminated by education of the public to certain rules for tuning, which are: No. 1. Reduce the detector tube filament current as much as possible, consistent with good reception. No. 2. Reduce the tickler coupling as much as possible. Observation of these two points will result in a "Golden Rule" set. A simple test to determine whether a set is oscillating is to turn the wave-length dial slightly; if a whistle is heard on both sides of the adjustment for the program, the set is oscillating, radiating a wave that is interfering with other receiving sets. The remedy is to immediately reduce the coupling or reduce the filament current. This will result in better reception of the program.

One can be sure of having a non-radiating set by purchasing a receiver such as the Neutrodyne, Teleadyne, Ultradyne or Super-Heterodyne. Laboratory experiments indicate the possibility that an entirely new type of detector incapable of oscillation or regeneration, will shortly take its place among radio apparatus as an instrument of great sensitivity, and rival of the three element tube when used as a detector. A description is given elsewhere of an instrument which may be added to radiating sets to prevent radiation. This seems to be a very successful solution of the problem, and we may expect further advances along the line of equipment which may be used with existing sets, enabling broadcast listeners to enjoy a complete program without hearing the *Canary Islands* broadcasting.

#### (123) STRAIGHT LINE CONDENSERS

Q. 1. What is a straight line condenser?

A. 1. A condenser whose value varies directly according to the position of the plates. A condenser may be calibrated, or its curve plotted, in one of three ways, according to wave-length, capacity or frequency. A condenser having a straight line calibration for frequency will not have a straight line according to wave-length. A condenser having a straight line according to capacity cannot

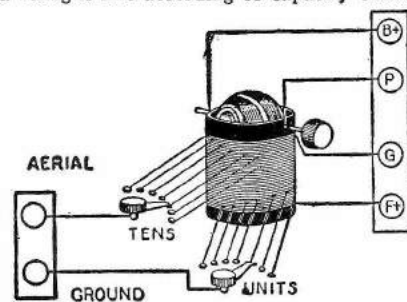

(111-B) The "2-coil variocoupler with tapped primary" unit. This is submitted for those who wish to construct the simple 2-coil variocoupler regenerative circuit.

be of the straight line type for either of the other two. No two of these curves can be the same. When a condenser is stated to be of the straight line type, no information is given until the statement is completed by the words, "for wave-length," or "for capacity," or, "for frequency."

Q. 2. What are the advantages and disadvantages of straight line condensers?

A. 2. Condensers with decremeter plates, or their equivalent, have a straight line for capacity. The value of this is mostly in work where it is desirable to know the capacity at each setting of the pointer. The capacity will be proportional to the scale readings. In tuning to stations, the stations



will be lumped at the lower end of the condenser, making tuning more difficult at the short-wave lengths than if the condenser design were changed so as to have a straight line variation for wave-length. When the latter is the case, the dial degrees will be proportional to the wave-length and there will be a certain number of meters per degree of variation. Occasionally, it is desirable to have a condenser so designed as to have straight line calibration for frequency. Knowing the frequency of the stations, the location of the correct tuning point is readily determined, since the dial variations will be proportionate for the variations in frequency. The practice of referring to a station's frequency, rather than its wave-length, is becoming more general and condensers designed for straight line frequency variation will be in greater demand.

Q. 3. Why is it that a neutrodyne with three stages of radio frequency amplification has not been put on the market? Would such a (6-tube) set be a success?

A. 3. We consider your inquiry very interesting. Sets having more than two stages of radio frequency amplification are available, but there are no neutrodynes among the lot. Some of the points are:

1. Two stages require three dials; three stages, at that rate, would necessitate four dials! Take too much time to tune. One-dial controls are easy, in the laboratory. When it comes to commercial production, we have "an equine of a differing hue." A two-dial arrangement might prove practical, after a great deal of experimentation, but there would be plenty of work before the set was ready for the public. It takes a mighty good one-dial set, where the one dial operates two controls, to equal a 2-dial set where either dial has but one control.

2. Some current supply units will work well with five tubes but poorly on six. Too, the sixth tube means added expense (the tube price) and battery consumption (if batteries are used) would be more. One more tube means one more place for trouble.

3. Tube noises would be more pronounced. Detector tube would often be overloaded, resulting in distortion. Audio amplifier would have to be a wonder to be really efficient, if the set were to include two stages of audio, for both tubes and transformers would have a terrific load when locals were operating.

4. If set is made on low-loss lines, one would have to put a "ring door-bell" sign out, and hope the signals could read, for the selectivity would be so high it would take considerable time to tune in wanted signals originating at a distance of more than, say, 150 miles. Anyone who has tuned a neutrodyne can appreciate this.

5. Every stage requires neutralization. This is (more or less) easy to do at home, given all the time, knowledge and patience necessary for success. But to do this rapidly and certainly in production is an entirely different matter. Then again, a set balanced in the factory test rooms would not necessarily be balanced (neutralized) when entirely different tubes and batteries are used by the broadcast listener.

6. There is the amount to be added to the purchase price of the set, due to several additional production costs.

Considering everything, there would probably be a sale for a set having three stages of radio frequency amplification, neutralized, if the above stated objections were overcome. The most important point, two points we should say, would be to (a) keep down the number of tuning controls and (b) have a resulting efficiency greater than could be secured by the use of a lesser number of tubes.

Q. 4. If a neutrodyne is assembled with parts made under license from the holders of the neutrodyne patent, can further royalties be claimed by anyone?

A. 4. The assembled set may be used for non-commercial reception, and all will be well, but a license and the payment of a royalty is required before the set can be sold

(technically). However, there can be little harm, I believe, in disposing of one, or perhaps two, receivers of a certain type, just so the making and selling does not become a habit.

(124) CONSTRUCTION OF CONDENSERS

Q. 1. Would there be any saving over the list price of a 1/2 mfd. condenser, if same was constructed?

A. 1. These condensers are now manufactured in such an efficient manner that production costs are very low, resulting in a low retail price. We would not advise you to construct a condenser of this size under these conditions.

Q. 2. If turning a variometer in a set produces squeals and whistles, what is the cause of inability to produce them?

A. 2. We presume you are referring to the variometer in some sort of a regenerative receiver. There are three conditions possible in such receivers. First, non-regeneration; second, regeneration; and, third, oscillation. The first is the most insensitive condition of the set. Practically every regenerative receiver is in a regenerative condition at even the least regenerative setting of its instruments. Regeneration in the receiver results in greatly increased signal strength. Pushing the regeneration too far results in the production of continuous oscillations. During this condition, signals received will be heterodyned by the oscillations generated by the receiving set. This results in the production of the whistles and squeals referred to. Distortion of the voice results also. Should the exact center of the transmitting station carrier wave be tuned to (zero beat reception), voice and music may be received with only slight distortion. This exact position, though, is very difficult to keep. Signals received from radiating receiving sets will be heterodyned by the locally generated current and will produce whistles, etc., in addition to such audible signals as are being radiated by

the plate circuit inductance to the correct value, or by arranging the plate inductance so as to be in strong inductive relation to the grid inductance, or by increasing the capacity of the tube in some manner, such as by connecting a very slight capacity from the grid to the plate of the tube. The second cause is excessive resistance in the grid or plate circuits. This resistance may take the form of poor instruments (poor construction, or poor materials), or of poor connections. Testing is about the only way to determine the exact location of undesired resistance in sets.

(125) WIRING DATA

Q. 1. Is there any disadvantage in using spaghetti on all wires? Does spaghetti tubing absorb moisture?

A. 1. This insulation should be used only when there is danger of one wire touching another. Air is the best dielectric. When replaced by something else, dielectric absorption losses are greater. Also, parallel wires carrying currents of two different potentials act as two plates of a condenser. With air as a dielectric the condenser effect is a minimum. In some sets this condenser effect may make the receiver inoperative.

Q. 2. Which is best to use, No. 14 enameled wire, No. 18 annunciator (bell) wire, or round or square bus wire?

A. 2. Either the enameled wire or the bus wire. We do not believe there is any difference worth considering, in the use of square or round bus wire, unless one is wiring a set to operate on short waves, such as 50 meters or less. The annunciator wire has the disadvantage of causing considerable condenser effect due to the paraffined cotton thread used as a covering.

Q. 3. I have completed shielding my panel with tin foil and find I am not getting the distant points as well as before. All electrical connections are free from the tin foil except the ground. Do you suppose the tin foil absorbs the energy?

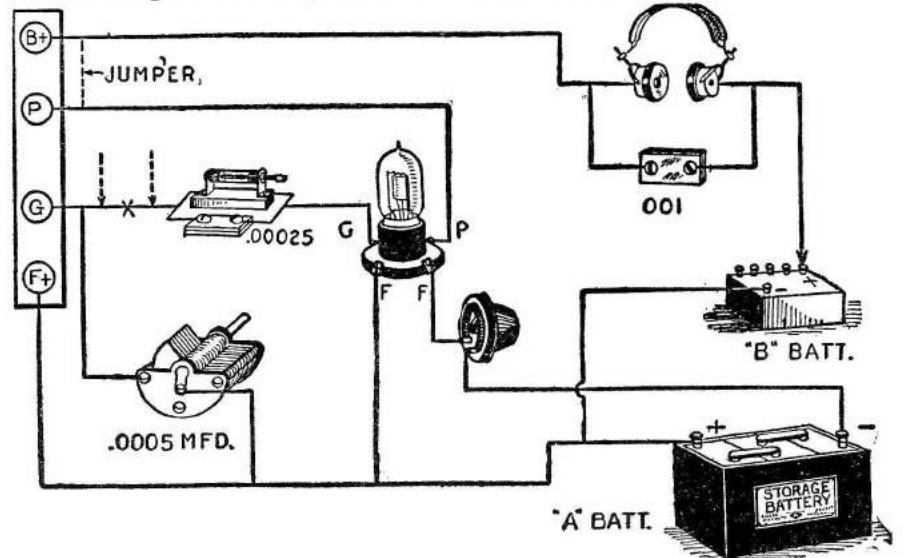

(111) This picture diagram of a tube unit and the diagram of one of the coil units shown above, should enable anyone to construct a very efficient 1-tube receiver. The completed set may be later enlarged to include audio frequency amplification if the owner desires to operate a loud speaker.

the outside receiving set. A receiving set only regenerating will still receive any audio frequency whistles or squeals that are radiated. That is why sets in congested localities will receive all sorts of peculiar sounds. These usually take the form of whistles. These whistles are not caused by the regenerative receiving set properly handled, but are the result of radiations from regenerative receivers allowed to oscillate. If the receiving set cannot be made to oscillate, it is doubtful if the point of maximum regeneration can be reached. There are two causes for this. One is lack of coupling between the grid and plate circuits and may be overcome by increasing or decreasing the inductance of

A. 3. Use one piece of tin foil for shielding each instrument, connecting all to a common ground connection. One piece covering the whole panel surface creates considerable eddy currents resulting in loss of energy. If possible, reduce your aerial to one wire and increase the length.

(126) REINARTZ WITH LOOP

Q. 1. Will you kindly publish a diagram that will enable me to use a loop antenna with my Reinartz set?

A. 1. The Reinartz circuit does not function very well when radio frequency is

employed and a loop would be of no use without radio frequency amplification. One of the features of the Reinartz is its aperiodic antenna method of input. Where a loop is used for local reception, one side would probably connect to the point at which the antenna is usually connected, the other side being left open. Tuning will be exceptionally sharp. The loop would be tuned with the usual condenser across its two terminals.

#### (127) COMPENSATING CONDENSER

Q. 1. How is a compensating condenser connected in a radio frequency amplifier?

A. 1. The moving plate connects to the grid of the first tube. One fixed plate connects to the plate of the second tube and the other fixed plate connects to the plate of the third tube. This is the connection when three stages of radio frequency amplification are employed. By this means a positive or negative current may be induced to the grid of the first tube, thus controlling regeneration and oscillation without the need for a potentiometer.

Q. 2. Several times of late I have been listening to the local broadcast station with a crystal tuner, and while they were standing by with the generator running I have been able to tune in distant broadcasting stations and C.W. signals quite distinguishable that I could not hear before. Is my crystal oscillating? If so could you kindly explain how this happens?

A. 2. The reception you mention may have been the result of several causes. The operator at the broadcast station whose duty it is to keep a constant watch by listening in with a receiving set, may have been tuning to the stations you heard. A re-radiation of these signals may have been picked up by the transmitting aerial and superimposed on the carrier wave emanating from the transmitting antenna. We do not believe your crystal was oscillating.

Receiving sets in your neighborhood sufficiently close to effect your antenna may have been tuned to signals you heard, and re-radiated to your aerial. C.W. signals radiated by local oscillating receivers may be heterodyning with the transmitting station waves you mention, producing a beat which would be audible when rectified by your crystal detector.

Is it not possible that the signals which you refer to as being those of a continuous wave transmitter, may have been the signals of a station transmitting I.C.W. (interrupted, continuous waves)?

Q. 3. Although the tubes in my set seem to operate well in other sets they do not seem to function in the present receiver. According to hydrometer test the "A" battery is fully charged. The tubes do not light up very brightly. In lieu of other wire, I have been using a two-conductor phone cord "A" battery lead. Can you offer any possible reasons for my results?

A. 3. The inoperation of your receiver is probably due to the phone cord you are using as an "A" battery connection. Use No. 18 wire, or larger, for your "A" battery leads. The phone cord is made with what is called "tinsel cord" and has a very high resistance.

#### (128) CALCULATING SPIDER WEB INDUCTANCES

Q. 1. Is there any considerable difference in the inductance value of a single layer coil and a double layer bank wound coil using the same number of turns, and the same size tube?

A. 1. The inductance of the double bank wound coil will be approximately four times that of the single layer coil.

Q. 2. What is the dielectric constant of celluloid?

A. 2. The dielectric constant of celluloid, taking air at 1.0, varies between 4.2 and 16.0.

Q. 3. How can the inductance of spider-web and honeycomb coils be calculated?

A. 3. To calculate the inductance of a spider web coil the following formula may be used.

$$L = \frac{m^2 d}{100,000}$$

Where L = Inductance in millihenries,  
m = The number of turns in coil  
d = Mean or average diameter in centimeters.

Honeycomb coils may have their inductance calculated by employing this formula

$$L = \frac{0.315 r^2 N^2}{6r + 9e + 10h}$$

Where L = Inductance in microhenries  
N = Number of turns  
r = Average or mean radius in centimeters

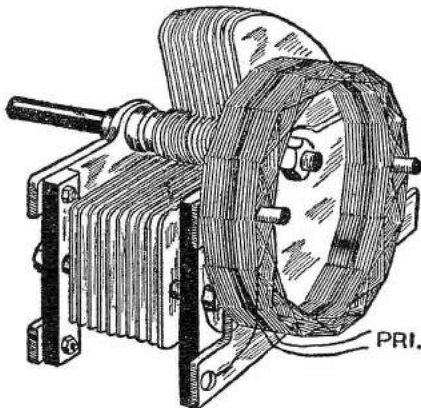

(117) The Freshman "eddy currents" method of oscillation control. The inductance is placed sufficiently close to the condenser end-plate for the lines of force of the coil to cause eddy currents (a form of loss).

e = Thickness of the coil measured from inside to outside diameter in centimeters

h = Length of coil in centimeters. One inch equals 2.54 centimeters.

#### (129) SWITCH FOR RADIO AND AUDIO FREQUENCY

Q. 1. Is it possible to wire a receiving set so that the amplifying tube can be used either as a radio or an audio frequency amplifier at will, by means of a switching arrangement?

A. 1. This is not practicable. An arrangement of this sort would require such a multiplicity of switches and wiring, that even if it could be done, it would operate considerably below average efficiency.

#### (130) LOOP AERIALS AND THE NEUTRODYNE

Q. 1. Is there more than one way to connect a loop to the Neutrodyne?

A. 1. We are showing several methods of connecting loop aerials to the Neutrodyne. If a ground is used, the directional effect of the loop will be eliminated or, at least, greatly reduced.

#### (131) TAPPED H. C. COILS

Q. 1. Can a honeycomb coil be tapped? If so, how many taps should there be on a coil of 25 turns?

A. 1. A honeycomb coil can be tapped by soldering leads at certain intervals, on the side of the coil. This can be done with advantage with a large coil, but for one of 25 turns it would not be necessary.

#### (132) NEUTRODYNE QUERIES

Q. 1. Why are all neutroformers used in Neutrodyne receivers wound with a ratio of approximately 4:1?

A. 1. The secondary of the neutroformer is wound with a certain number of turns, which when used with a condenser of a certain size will respond to all broadcast wave-lengths. As a rule, this will be approximately 60 turns of No. 22 S.C.C. wire. Use 15 turns of wire for the primary, as this has been found to give best results.

Q. 2. Is a set properly neutralized, if when the radio frequency tubes are turned on full, the set goes into a howl and oscillates?

A. 2. If the radio frequency tubes oscillate at any point, it shows that the set has been improperly neutralized. The object of the neutralizing capacities is to eliminate any chance of the tubes oscillating on any wave-length.

Q. 3. Would it be proper to use a "C" battery in the radio frequency part?

A. 3. A "C" battery may be used with advantage in a Neutrodyne receiver, if a high "B" voltage is used on the amplifier tubes.

#### (133) DATA ON WAVE TRAP

Q. 1. What size wire and tube, and how many turns should be used with a condenser of .001 mfd. capacity, for the construction of a wave-trap?

A. 1. This would depend upon the wave-length for which the wave-trap is desired. We presume that a trap for the broadcast wave-length is desired. This is constructed by winding 45 turns of No. 24 S.C.C. wire on a 3" tube. Shunted by a variable condenser of .001 mfd. it will respond to wave-lengths from 220 to 600 meters.

#### (134) CONDENSER DATA

Q. 1. What is a "grounded frame" condenser?

A. 1. A condenser having both movable and fixed plates entirely insulated from the frame. The frame may thus be grounded, without materially affecting the operating characteristics of the condenser. If the frame is connected to the point of lowest potential, no capacity effect is possible.

Q. 2. What is a "grounded rotor" condenser?

A. 2. A condenser whose movable plates are connected to the frame. The capacity effect possible is governed by the circuit, since it is not possible to place the frame at a potential lower than the potential of the movable plates.

Q. 3. What is the "square law" of variable condensers?

A. 3. That the change in capacity is proportional to the square of the change in the relation of the movable and stator plates.

#### (135) SELECTIVE CRYSTAL RECEIVER

Q. 1. Please give me the constants for the enclosed diagram of a crystal receiver said to be very selective.

A. 1. A single three-inch tube is used, and No. 20 D.C.C. wire. About nine inches of tubing will be required. Each winding is separated by the space of a single turn.

Q. 2. I understand it is possible to test the suitability of crystals for use in reflex receivers, by means of a 25-volt "B" battery and a milliammeter. Please give me further details about this.

A. 2. The crystal on test, "B" battery and milliammeter are all connected in series. A suitable crystal must pass  $1\frac{1}{2}$  to 2 milliamperes. Reverse the crystal to determine best connection for maximum readings.

#### (136) NOISY SET

Q. 1. Please explain why a WD-11 tube will not work in a set that operates when a UV-200 tube is used.

A. 1. We should say that the WD-11 tube is defective. Or, a higher "B" battery may be required for it. While the UV-200

tube may operate with only 16 or 18 volts on the plate, you may require as high as 45 volts on the plate of the WD-11 tube. It is also possible that your "A" battery was not sufficiently strong; try putting the entire output of a single dry cell on the filament of the tube. Some rheostats do not cut out quite enough wire at the minimum resistance position, resulting in a greatly reduced current supply to the filament (insufficient for operation of the tube). If an adapter is used, contacts may not be perfect. The information you furnished was only fragmentary.

Q. 2. What can you suggest for reducing the rushing sounds heard when no signals are coming through my five tube set (two stages of tuned radio frequency amplification)?

A. 2. You may have a noisy "B" battery or tube. Socket connections may not be good. You may have leaky fixed condensers. The grid leak may be noisy. The "A" battery may be in need of charging, or it may be erratic in action for other reasons. The rheostat or battery switch may not be making good connection. The phone cord may be partly broken and the test for this is to shake the phone cord without moving the phone plug. If loud crackling sounds are heard when the phone cord is moved, it is evident that the cord should be changed. Occasionally phone plugs do not make good connection in the jack. The variable condensers may be making poor contact. If turning the plates produces loud crackling sounds, this may usually be considered the trouble.

Poor connections are easily located by moving the panel and by moving the wires. Often, wires that appear to be firmly fastened may not be making good contact at all. Try a .005 mfd. condenser from the last audio tube plate, to "A" minus.

Q. 3. What are microphonic noises?  
 A. 3. The "imperfect contact" microphone consists, in addition to the battery supply, of metals imperfectly touching. This combination is susceptible to slight motions. If such a condition arises in a receiving set, the result is a "microphonic" effect and the constantly varying current causes the audible sounds usual from imperfect contact microphones.

**(137) INDUCTION**

Q. 1. I cannot understand how the current gets from the stator to the rotor of a variocoupler when there is no electrical connection. Please explain.

A. 1. This is what is known as induction. Any wire carrying current has a magnetic field, known as lines of force, surrounding it. If a wire or any conductor is drawn rapidly through these lines of force, a current is induced in the wire. As an alternating current is flowing in the primary of the variocoupler, the lines of force are expanding and collapsing in unison with the alternations of the current. When this happens it is equivalent to moving the secondary through stationary lines of force. When the magnetic field expands and collapses, it is cut by the stationary wire of the secondary, thus generating a current in the secondary winding. For a full explanation of induction we refer you to standard textbooks on radio.

**(138) WAVE TRAP**

Q. 1. Please publish instructions for constructing a wave trap.

A. 1. A wave trap usually consists of a coil of a certain size shunted by a variable condenser, and inserted in the antenna circuit of the tuner. This may consist of 50 turns of No. 24 S.C.C. wire, wound on a tube 3" in diameter. This can be shunted by a condenser of .0005 mfd.

**(139) RE-RADIATION FROM A TUBE SET**

Q. 1. Do vacuum tube sets in the vicinity

of a crystal set make the reception of music possible by the crystal set by re-radiating it?

A. 1. Crystal sets have been known to receive signals that were ordinarily outside of their receiving radius, due to some tube set in the vicinity. If a tube set is tuned to the exact wave length of the distant phone station and is set in oscillation it will naturally radiate these oscillations. This acts as if an oscillator were used in conjunction with the crystal set, reducing the resistance of the circuit to zero, thus permitting the weak signals received to produce a sufficient response in the detector circuit. Enough energy being received in this manner, it is rectified by the crystal and actuates the phones.

**(140) AUTOPLEX VARIOMETERS**

Q. 1. Can variometers having honeycomb windings be used successfully in the Autoplex receiver?

A. 1. If these variometers will tune to a wave-length of 600 meters they will probably work in the Autoplex.

Q. 2. Should the grid return of the Autoplex be to the positive or negative lead?

A. 2. Most tubes will work best with a negative connection. Try both.

**(141) HONEYCOMB SET**

Q. 1. Would it be advisable to change a three-circuit honeycomb set to a single-circuit regenerative, using one or more of the honeycomb coils?

A. 1. There would be no advantage in changing a three-circuit receiver to a single-circuit one. The signals might be a trifle louder, but this would be offset by the resultant broadness of tuning.

Q. 2. Will a two-stage amplifier using WD-11's work well with a Radiotron UV-200 as a detector?

A. 2. This combination will give fair results, but we would suggest that for loudest signals UV-201A tubes be used in the amplifying unit.

Q. 3. Is a three-circuit honeycomb set as efficient as a single-circuit for broadcast receiving?

A. 3. A three-circuit receiver is much more efficient than a single-circuit. Although a bit more difficult to tune, it is far more selective and interfering stations can be tuned out much more easily.

**(142) RADIO FREQUENCY TUNING**

Q. 1. I have been told that sets using radio frequency are very difficult to tune. Is this true?

A. 1. Radio frequency will make the set tune sharper, but if the radio frequency unit is constructed correctly, it should not prove more difficult to tune than the average regenerative set.

Q. 2. What is the difference between tuned and untuned radio frequency amplification?

A. 2. Untuned radio frequency uses transformer or choke coil coupled amplifiers. Tuned radio frequency is where the amplifying tubes are coupled by a small inductance which is shunted by a variable condenser for tuning. A variometer may also be used for this purpose.

Q. 3. What are the chief disadvantages in using radio frequency?

A. 3. If the set is constructed correctly, there are no real disadvantages except the further current consumption of the storage and "B" batteries. In view of the great range obtained, this of course can be ignored.

**(143) CHANGE OF CIRCUIT**

Q. 1. At present I am using a single-circuit regenerative receiver, with which I have received over 1,000 miles. Would I get better results if I changed to a three-circuit receiver?

A. 1. If you do not experience any bad interference with your present set, we would not advise any change. A three-circuit tuner is more selective, but the receiving range will be about the same.

Q. 2. Which hook-up would give louder and more satisfactory results with one stage of audio frequency amplification?

A. 2. Audio frequency amplification has no bearing on the tuning qualities of a receiver. It simply amplifies the results obtained from the detector.

Q. 3. Do you think that just as good results can be obtained by using 1½-volt peanut tubes instead of the five and six-volt tubes?

A. 3. Tubes using 1½ volts on the filament are good audio frequency amplifiers, but better results will be obtained with six-volt tubes.

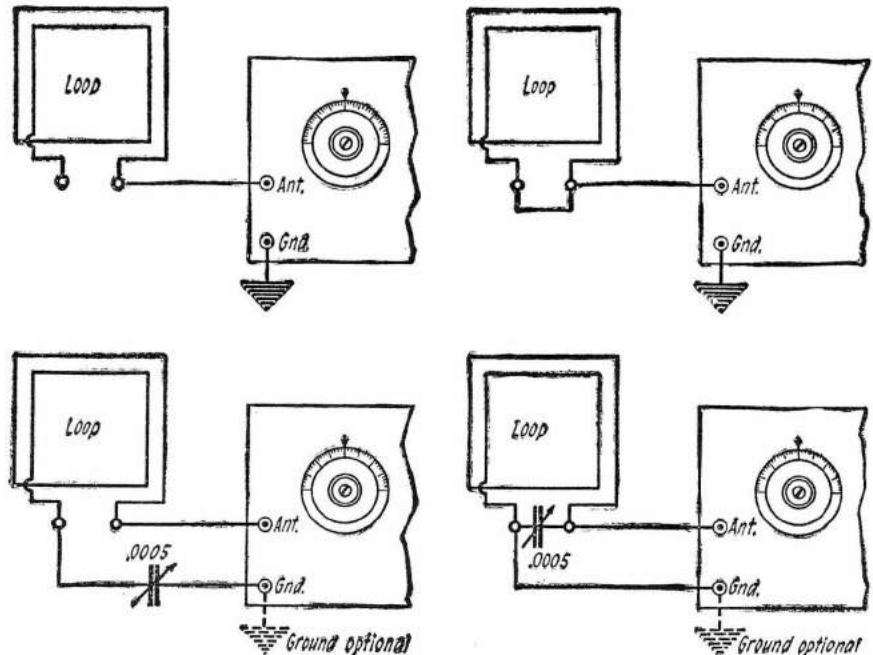

(130) Showing a number of different methods of employing a loop aerial with a Neutrodyne receiver. The use of a ground connection will reduce the directional effect of the loop aerial considerably.

**(144) NEUTRALIZING THE NEUTRODYNE**

**Q. 1.** How are the neutrodyne neutralizing condensers adjusted?

**A. 1.** The simplest way is to tune in a very strong signal of a low wave-length. The tube, in which the capacity is to be neutralized, is removed from the socket and the tube filament prongs insulated in such a way as to prevent its lighting, and then replaced in the socket. The neutralizing condenser is now adjusted until the signal becomes inaudible. Should it be found impossible to neutralize the tube to any extent, it may be necessary to reverse the primary windings of the neutroformers. If the capacity of one neutrodon is found to be insufficient, two may be used, connected in parallel. If the minimum capacity of the neutrodon is found to be too great for the particular tube used, the circuit can be balanced by connecting a neutrodon from the grid to the plate of the tube in the circuit that is being neutralized. By an adjustment of these two neutrodons it should be possible to balance the circuits very easily. After the circuits have been adjusted for short wave-lengths, the test should be repeated for the maximum wave-lengths obtainable on the set. With this latter adjustment it may be necessary to change the neutralizing condensers a little bit to prevent oscillation at the longer wave-lengths.

**Q. 2.** What causes the great difference in the balance of a neutrodyne set when the tubes are changed?

**A. 2.** This unbalancing you have noticed is due to the difference in the internal capacity of the tube.

**Q. 3.** What is the effect of increasing the capacity of the neutralizing condenser after the balancing-out point has been reached?

**A. 3.** The increased capacity acts as a short circuit of the tube and results in reduced signal strength. Occasionally, increasing the capacity may cause oscillation in the tube circuit.

**(145) PHONE CORD CAPACITY**

**Q. 1.** How can capacity effect from the phone cord be reduced?

**A. 1.** Connect the primary of a transformer in the set, in place of the headphones. The secondary connects to the headphones. It will be necessary to use an iron core transformer having the same primary impedance as the plate circuit of the vacuum tube and a secondary resistance equal to the headphones. A regular audio frequency transformer will often do. Its primary connects to the headphones and the secondary connects in the plate circuit of the set, or vice versa, depending upon the transformer. Or, a 1:1 ratio transformer may be used. It is to be noted here that phones having a very low direct current resistance, for example the standard line telephone receivers of 80 ohms, can be efficiently operated in a set by the use of a properly designed transformer having a secondary resistance equal to the resistance of the phones.

**Q. 2.** Please state some general points to be observed in the construction of what would be classed as a "good receiver."

**A. 2.** Your last question was of such importance we decided to answer it here.

Some constructors use a blow-torch for soldering connections. A blow-torch should be used only under special conditions. There are few set builders capable of using the tool properly. It should never be used for making soldered joints close to coils. Charred insulation between two turns is almost as bad as having two bare turns touching one another. Two turns with charred insulation between can undo all attempts towards a low-loss receiver design. A blow-torch is of most use where relatively large metals must be kept at a high soldering temperature.

Soldering flux should be used in the smallest quantities possible. Most jacks have highly absorbent insulating material and flux is quickly drawn into it by capillary attraction, causing a partial leakage that results in re-

duced volume, noisy operation or both. Resin flux is always safe to use, from the standpoint of leakage by absorption. However, too much resin flux will cause a poor joint. It may look perfect, but a little strain breaks the connection.

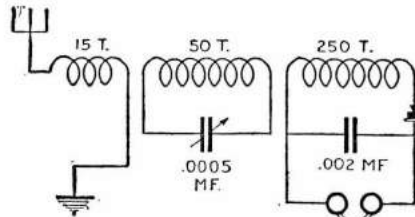

(135) A crystal receiver circuit designed for selectivity. It is also the height of simplicity.

Design the receiver in such a way that all connections will be short. This short distance proposition is controlled to a considerable extent, in the radio frequency stages, by the minimum distance permissible for the coil spacing.

All the battery leads may be bunched. High frequency leads should be kept well away from the direct current supply leads, and from one another. Spaghetti insulation should be used on high frequency leads, only where there is danger of connections touching. Bus bar bent at a right angle looks good and does not cause any appreciable loss. Bending wire sharply is to be avoided. Tighten binding post connections with pliers.

**(146) HETERODYNING INTERFERENCE**

**Q. 1.** I have had great trouble trying to stop a squealing sound when receiving broadcasting. How can I prevent this?

**A. 1.** This is, perhaps, due to the carrier wave of two or more broadcasting stations heterodyning each other. This carrier wave would not be heard if only one station was transmitting, but when two are on, the two carrier waves overlap each other and produce an audible beat note in the receivers. This could also be caused by a receiving set in the vicinity, tuned to the same wave-length as the transmitting station and receiving with the detector tube in a state of oscillation.

**(147) BODY CAPACITY**

**Q. 1.** I have a shield on the back of my set and it is properly grounded, however, if I take my hand away from my condenser dial it destroys my tuning. How can this be prevented?

**A. 1.** We note that you say your shield is on the back of your set. We presume you mean on the back of the panel where it belongs. If you are using a secondary condenser, the movable plates should be connected to the filament side of the secondary and not to the grid side. If this connection is correctly made, very little capacity effect should be noticed.

**Q. 2.** Does the UV-199 tube have anything to do with this?

**A. 2.** There should be no more capacity effect with this tube than with any other.

**(148) RADIO OR AUDIO FREQUENCY**

**Q. 1.** Should radio or audio frequency amplification be used to increase the audibility of a very faint station, when headphones are used?

**A. 1.** Radio frequency amplification will be best.

**Q. 2.** In adding to a one tube set, is audio or radio frequency amplification to be preferred?

**A. 2.** If additional range is desired, radio frequency amplification will be best. Audio

frequency amplification will increase the audibility of stations usually received.

**Q. 3.** Is it necessary to obtain permission to construct radio sets for sale?

**A. 3.** It would be necessary to make contracts with the companies holding the patents on the type of receiver you wish to make.

**(149) WD-11 IN REFLEX**

**Q. 1.** Will a WD-11 tube give good results for headphone reception in the Erla Duo-Reflex receiver?

**A. 1.** Good results will be had with this tube in this circuit. Not more than 60 volts should be used on the plate.

**Q. 2.** Would a variocoupler with a single set of taps be as effective as those with two sets of taps?

**A. 2.** This variocoupler will prove efficient, but a variable condenser should be placed in the antenna circuit for close tuning.

**Q. 3.** Would honeycomb coils be as efficient in this circuit as the variocoupler?

**A. 3.** If the proper size coils are used, they will be just as satisfactory as the coupler. Coils of 50 turns may be used for both primary and secondary.

**Q. 4.** Is a potentiometer required in a reflex receiver?

**A. 4.** This depends upon the particular receiver. Some receivers require a variable control of the grid voltage. Considering the case of two reflex receivers constructed of exactly the same parts, in seemingly the same way, one may oscillate freely, unless controlled by a potentiometer, while the other may be operated at very nearly the point of maximum regeneration, without requiring the control afforded by a potentiometer. Should the set not oscillate, it is seldom that maximum results can be secured. This is because maximum amplification results from maximum regeneration, which point is reached just before the tube starts to oscillate. The very peak of regeneration, though, usually results in considerable distortion of the signals, and the generation of objectionable tube noises. The maximum desirable amount of regeneration varies, usually, according to the wave-length to which the set is adjusted. Potentiometers afford a nicety of control for maintaining the grid voltage, at the best value for the desired amount of regeneration.

**(150) BEST SUPER-HETERODYNE**

**Q. 1.** There are so many descriptions for Super-Heterodyne construction, that it is almost impossible to decide which is the best. What is the most sensitive and selective Super-Heterodyne known at present?

**A. 1.** Theoretically, there is only one result possible from a given type of set. To compare the theoretically possible results of certain sets and reject those receivers which would seem to incorporate undesirable principles would seem to be the solution. Practically, the problem is an entirely different one. Almost every type of Super-Heterodyne described so far has had its construction description attended with long lists of distant stations received. It is not so much a question of "which is best?" as it is "how can I best construct which?" Because they practically all follow the same principles of operation, there are very few which will not give exceptionally good results if constructed and operated in the best manner possible. True, certain modifications have been developed, each having its merit, but the actual value of these modifications, to a constructor, must be determined by personal test, since two people may try identically the same idea and secure diametrically opposite results.

**Q. 2.** Using a WD-12 tube in a Cockaday circuit, the range seems to be narrow, as only KFKX can be heard; how can the range be increased?

**A. 2.** That question, too, is not definite. The 23-plate condensers you are using should result in quite sufficient wave-length range, unless one or both condensers short-circuit

at some positions of the plates. Test for this by means of the usual battery-head-phones-condenser series connection. You may have a poor tube. Try it in a standard regenerative circuit. If more than a single dry cell has been connected to the tube (the cells being in series), your tube has probably lost its property of filament electron emission. Leaving the tube lit for a few hours, with the "B" battery disconnected, may restore the tube to its former standard of performance, but we doubt it.

Due to the slight amount of data furnished, we find it most difficult to determine just why your set does not perform more satisfactorily.

Vary the plate potential. Finally, try another grid condenser and another leak. A variable one may be of benefit.

Q. 3. Would a UV-199 tube function better in the above circuit?

A. 3. Not unless your trouble is tube trouble. Tube for tube, we do not believe you would find much difference between the operation of either tube, as a detector, in the Cockaday circuit, if both vacuum tubes are good.

#### (151) LITZENDRAHT VS. SOLID WIRE

Q. 1. Would Litzendraht wire be more efficient than silk covered wire in a crystal receiver?

A. 1. According to tests that have been made by Prof. Morecroft on the comparative merits of the two wires, Litzendraht was found more efficient on wave-lengths above 300 meters. Below this wave-length, solid wire proves best. Great care must be used, when employing Litz. wire, so that no strands are broken, as the resistance increases considerably if the cable is not perfect.

Q. 2. What crystal would you advise using?

A. 2. Silicon or Galena would give very good results.

#### (152) SUPER-HETERODYNES

Q. 1. What is the advantage of heterodyning to produce a high-wave beat, or intermediate frequency, as used in super-heterodynes?

A. 1. Radio frequency currents are amplified much more efficiently at high wave-lengths than at low ones. Amplifying at long wave-lengths permits the use of tubes having a greater amplification factor, producing a stronger impulse. At short wave-lengths, capacity between the elements of the tube produces a short circuit that limits the amount of amplification. The main advantage, however, is that every station received is raised to a certain fixed wave-length where the radio frequency transformers amplify at maximum efficiency.

Q. 2. What determines the wave-length range a super-heterodyne will cover?

A. 2. The wave-length range of the input grid circuit and of the oscillator circuit are the controlling factors. Most super-heterodynes are designed to cover the broadcast wave-lengths, by having a range of 200 to 600 meters.

#### (153) BANK WINDING

Q. 1. Please publish detailed information in regard to bank winding.

A. 1. We are showing in these columns a diagram that illustrates fully the method of winding bank-wound coils. When turn No. 5 comes around, between and above turns No. 2 and No. 4, it is bent sharply across turn No. 4 and continues around above and between turns No. 3 and No. 5. When it comes around again, it is bent sharply down to the tube and continues as shown in the diagram. The winding should be kept fairly tight and a fairly large size wire should be used, such as No. 22 B. & S. gauge. If smaller wire is used, difficulty will be experienced in banking.

#### (154) SUPER-HETERODYNE

Q. 1. When using four stages of transformer coupled radio frequency in a Super-Heterodyne circuit, is it necessary to use more than one stabilizer to keep the grids at their proper potential?

A. 1. One stabilizer controlling the four tubes is sufficient, but we would advise using separate rheostats for each tube.

Q. 2. Is it necessary to completely encase each unit in a separate copper box?

A. 2. If the instruments are properly arranged and the wiring done correctly, this will not be necessary.

Q. 3. May one set of batteries be used for the entire set?

A. 3. Yes, if the correct circuit is used.

#### (155) HOME MADE VARIOMETERS

Q. 1. What type of receiver is the Autoplex?

A. 1. The Autoplex circuit is in the Super-Regenerative class.

Q. 2. Would home-made variometers be efficient enough for this circuit?

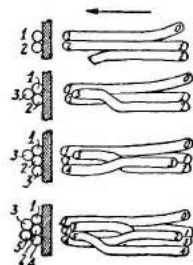

(153) Method Used in Bank Winding. This is Fully Described in Answer to Question 153.

A. 2. It is doubtful if home constructed variometers would be sufficiently accurate for this circuit. High maximum and low minimum inductance are difficult to obtain without the use of precision instruments.

Q. 3. Is it possible to make a Superdyne out of a Radiola V?

A. 3. It could be done, but would require entire re-designing of the apparatus. Even when completed, results would not be as satisfactory as from a set particularly adapted to this circuit. The metal cabinet of your Radiola V would cause undesirable coupling between circuits which should be in non-inductive relation.

Q. 4. Is an Erla Selectoformer as efficient as a variocoupler?

A. 4. A variocoupler permits selection of the optimum coupling of primary and secondary inductances, for a given wave-length. In addition, the optimum value of inductance for a given wave-length maybe had. The vacuum tube functions best when the highest voltage variation is secured. Using the maximum amount of inductance possible, for a given wave-length, produces this condition. However, changing the inductance value for the various wave-lengths changes the electrical coupling of the primary and secondary coils. On weak signals this is particularly pronounced. The correct coupling may be restored by changing the coupling.

#### (156) RECEIVING RANGE

Q. 1. How far can radio concerts be received with a honeycomb receiving set using three coils, primary, secondary and tickler? Detector tube only is used.

A. 1. Under good conditions this set should have a receiving range at night of 500 to 1,000 miles. This, however, depends a good deal upon local conditions, skill of the operator, etc.

Q. 2. If larger coils are used, will the receiving distance increase?

A. 2. No. The wave-length only will be increased.

#### (157) R.F. IN THE COLPITTS CIRCUIT

Q. 1. I am using a receiver employing

the Colpitts oscillator circuit. Will you kindly publish a diagram showing how one stage of radio frequency amplification may be added?

A. 1. Radio frequency amplification cannot be adapted to a receiver using the Colpitts oscillator circuit.

#### (158) R.F. AMPLIFICATION FOR ALL WAVES

Q. 1. Kindly publish information how to make a radio frequency amplifier to cover a range of from 200 to 5,000 meters.

A. 1. A radio frequency transformer cannot be made to cover this band of wave-lengths. A transformer of this kind would receive efficiently on wave-lengths around 2,000 meters, and all above or below this wave the results would be very poor. To receive efficiently on all waves it would be necessary to use transformers that could be plugged in and out of the circuit for different wave-lengths.

Q. 2. Can the same kind of transformers be used in each stage of amplification?

A. 2. Yes, the same kind of transformers are used in each stage.

Q. 3. Please publish hook-up of Westinghouse "RC" set with wave trap.

A. 3. The hook-up is shown herewith. Another and simpler wave trap is made by using a 23-plate condenser in shunt to a honeycomb coil of about 50 turns. To insert the wave trap, break the aerial lead-in, where it comes to the set and insert the primary winding of the trap.

Q. 4. Can a loop antenna be used with my "RC" set with success?

A. 4. Not without adding one or more stages of radio frequency amplification.

#### (159) WAVE TRAP DESIGN

Q. 1. Please give me constructional details for wave trap.

A. 1. The proper design for a two-coil wave-trap is as follows: Secondary, 50 turns of No. 22 cotton-covered enameled wire, wound on a three-inch bakelite tube. The primary consists of 10 turns of No. 18 cotton-covered enameled wire, wound over the secondary. The primary may be separated from the secondary by two or three layers of Empire cloth, or several match sticks, well shellacked, may be fastened to the secondary with shellac, and the primary wound on these sticks.

Q. 2. Can a 43-plate condenser be used?

A. 2. Use a 23-plate condenser, it will be better.

Q. 3. Will a wave-trap eliminate static and spark transmitter interference?

A. 3. A wave-trap will reduce static interference only slightly. It will considerably reduce most spark transmitter interference. If the spark transmission is exactly on the adjustment of the broadcast station, it will not be possible to eliminate the spark (code) sending station signals without doing likewise to the broadcast transmission.

Q. 4. How is the term "meter" used for receiving? Can a set with adjustments for 360 meters hear stations of that wave-length from any part of the world?

A. 4. "Meter" is the measurement unit used to determine the distance between the crests of successive waves transmitted from a station. A receiving set has in its circuit inductance and capacity which when varied can equal or become in resonance with the wave-length of various transmitting stations. The reception of signals from a distant station depends entirely upon the sensitivity of the receiver, power of the transmitter and existing atmospheric conditions.

#### (160) FADING

Q. 1. Can you tell me why signals come in loudly and then fade away? Is there something wrong with my receiver?

A. 1. This is commonly known as fading or swinging signals. Most long distance stations swing in this fashion. No satis-

factory theory has yet been given to account for this, and it cannot be prevented.

Q. 2. Will a potentiometer of 300 ohms help to keep it steady?

A. 2. A potentiometer will be of no use in this case.

Q. 3. What could be the explanation of weak signals from local stations when using a Super-Heterodyne having intermediate frequency iron core transformers marked "10,000 meters"? The filter coupler consists of two 250-turn honeycomb coils. A .002 mfd. fixed condenser is connected across each coil.

A. 3. The filter coupler must be sharply tuned (or nearly tuned) to the wave-length peak (that is, the wave-length at which the amplification is greatest) of the intermediate frequency transformers selected. For that reason it will be necessary to use larger honeycomb coils than you now have. Try two 600-turn honeycomb coils shunted by two variable condensers having maximum capacities of about .001 mfd.

#### (161) TRANSFORMER CONNECTIONS

Q. 1. What is the correct way to connect up a transformer marked P1, P2, S1 and S2?

A. 1. P1 ordinarily designates the outside end of the primary winding. S1 ordinarily designates the outside end of the secondary. The outside ends of the primary and secondary windings should usually connect to the points of highest potential (the exception is in reflex circuits). These would be, respectively, the plate and grid.

#### (162) SPIDER WEB COIL QUERIES

Q. 1. What size spider web coils are most efficient on wave-lengths of 200 to 600 meters?

A. 1. A spider web coil should contain about 45 turns of wire for these wave-lengths. A variable condenser of .001 mfd. capacity should be used in shunt with the coil.

Q. 2. Can spider web coils be built to tune up to 2,500 meters?

A. 2. Such a coil could be made which would work efficiently, but it would be very large, having an approximate diameter of 2½ ft., 1,200 turns of No. 26 S.C.C. wire would be needed for this coil.

Q. 3. Why are rheostats ordinarily placed in the negative lead?

A. 3. If a "C" battery is used, it makes little difference whether the rheostats are placed in the negative or positive leads from the battery. However, if the audio frequency amplifier grid return lead connects directly to "A" minus (no "C" battery being used), there will still be a negative bias, possibly one volt, on the grid of the tube, if a rheostat is placed in series with the tube filament and its connection to the negative side of the "A" battery. This voltage drop or potential difference would be absent, if the filament connected directly to "A" minus (no rheostat at all); and if the rheostat were connected in the positive lead, the grid voltage would be zero, instead of slightly negative. If a "C" battery is used the desired negative potential can then be secured, regardless of the rheostat location. If no "C" battery is used, "B" battery consumption will be less and amplification will be greater, if the rheostat is connected in the negative lead.

In the detector position, it makes little difference whether the rheostat is in the positive or in the negative lead. A regulation of the grid leak will ordinarily adjust the tube for best operation. The grid leak may connect from the grid to "A" plus or minus, as determined best.

Connecting the rheostat in the negative lead of the radio frequency amplifier tubes will cause the tubes to oscillate a little more readily. This will be quickly noticed if a potentiometer is used to control the grid voltage. With the rheostat in the negative lead, it will be necessary to move the potentiometer arm more nearly to the positive end of the potentiometer than if the rheostat were in the positive lead.

#### (163) INTERFERENCE

Q. 1. When using my Atwater-Kent Radiodyne I experience interference, which sometimes sounds like clapping of hands, and there is always a crackling noise in the ear phones. Can you tell me what is wrong in this receiver?

A. 1. It would seem from your description that one of your "B" batteries is defective and delivers a fluctuating current to the plates of your tubes. It would be best in this case to try a new set of batteries in this position. It is also possible that you are using a poor grid leak. This would be especially the case if you are using a variable leak, as a good many of these instruments are poorly made and cause a frying sound in the receivers.

Q. 2. I do not seem to get any more distance than I did with a three-tube set. Would UV-201A tubes get more distance than the WD-12 tubes, which I am using?

A. 2. UV-201A tubes would undoubtedly give more volume and might prove better radio frequency amplifiers than the tubes you are now using. As a detector, however, this tube is no better than the WD-12. If the large tubes are used, it will be necessary to use a storage battery for heating the filaments.

Q. 3. What determines the number of circuits of a receiver?

A. 3. A receiver using a single coil for tuning is generally known as a single circuit set, but this may or may not have regeneration by means of the feed-back method. If a variometer is used to obtain regeneration it means that the plate circuit must be tuned, giving a two-circuit receiver. A three-circuit receiver consists of one wherein there are three circuits to tune, namely: the primary, secondary and plate circuits.

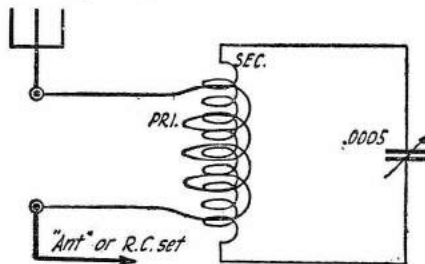

(158) This wave trap may be used with any receiver. The primary may consist of 10 turns of No. 18 S.C.C. wire.

#### (164) CRYSTAL DETECTORS

Q. 1. Is it true that the buzzer test is not always the best way of locating a sensitive spot on a detector crystal?

A. 1. Many times the test buzzer signals will be received clearly, while station signals cannot be received satisfactorily without a readjustment of the detector.

Also, a station may be heard very satisfactorily and yet the test buzzer may not be heard with maximum intensity.

Sometimes different stations will be received best at different points on the crystal.

Q. 2. What are the dimensions of a long wave transformer (10,000 meters) made with honeycomb coils?

A. 2. A DL-500 and a DL-1,000 honeycomb coil (the latter shunted by a .00025 mfd. fixed condenser) will make a very excellent long wave transformer of high efficiency. These two coils may be fastened together mechanically.

#### (165) R.F. TRANSFORMERS IN REFLEX

Q. 1. Can a stage of radio frequency amplification with a transformer be added to a single circuit regenerative receiver?

A. 1. Radio frequency can be added to practically any standard circuit, but it would be of no advantage to use one stage with a single circuit receiver, as in this case regeneration will be sacrificed and the tuning would be very much broader.

Q. 2. What size honeycomb coils are required to receive 5,000 to 8,000 meter stations?

A. 2. The wave range of the average 500-turn coil is 3,000 to 8,500 meters, when shunted by a variable condenser of .001 mfd. capacity. This coil will be about right for the primary. Use a 600-turn coil, wave range, 4,000 to 12,000 meters, for the secondary. The tickler may be between 400 and 600 turns. For those who do not mind the extra work entailed in tuning, a third variable condenser connected in parallel to the tickler coil will be found to result in the reception of more distant stations. A good procedure is to tune in the desired station, then reduce the coupling between secondary and tickler, increasing the capacity of the tickler condenser, which condenser should previously have been set at its lowest capacity. Maximum amplification from the tube will result when the coupling is least. It may be found possible to reach a nearly zero inductive coupling of the coils, inasmuch as the tube elements may furnish sufficient capacity coupling to maintain oscillation or regeneration.

#### (166) TRANSFORMER SPACING

Q. 1. What is the correct spacing distance for intermediate frequency transformers?

A. 1. This depends upon the design of the transformers. Placing them end to end, as you suggest, is even more undesirable than placing them side by side. If placed side by side, the spacing may usually be about three inches. The best procedure is to put the coils at right angles.

#### (167) METAL CABINET

Q. 1. Would a cabinet made of sheet iron and grounded, effect the efficiency of a three-circuit set?

A. 1. A cabinet of this kind would have detrimental effect on a receiver, but if made of copper or brass, it would prove very effective in eliminating induction from outside sources and body capacity effects.

#### (168) CONDENSER IN GROUND

Q. 1. Would a variable condenser in the ground circuits function as well or better than taps on a three-circuit receiver?

A. 1. A condenser gives finer tuning than taps alone. It would be best to use both.

Q. 2. What difference would it make if such a condenser were placed in the aerial instead of the ground circuit?

A. 2. It would make no difference except in single circuit sets where the condenser should be placed in the ground circuit with the rotary plates on the ground side to eliminate hand capacity effects.

#### (169) DAYTIME RECEPTION

Q. 1. I have a single tube regenerative receiver which works well at night, but I cannot hear anything during the day; why is this?

A. 1. Reception of broadcasting during the day is never as good as at night. One theory for this is that the sun absorbs a portion of the electro-magnetic waves, thereby decreasing their strength which reduces the signal at the receiver. This condition may be somewhat counterbalanced by the addition of more tubes to the receiving set although a great difference will still be noted between day and night reception.

#### (170) EFFECT OF CLOSE COUPLING

Q. 1. Why is it that with less wire, with the primary wound in the grooves of the secondary form, the wave-length range is greater than when the primary and secondary are wound in separate coils? Enameled wire was used.

A. 1. The natural wave-length of both the primary and secondary circuits is considerably increased by the close coupling, and better results will be had if a greater number of turns are used with a coupling of about  $\frac{1}{4}$ -inch. The condenser effect of two coils so closely related is very undesirable.

(171) PATENT ADVICE

Q. 1. Is an invention for transmitting and receiving printed matter, by radio, of any value?

A. 1. We have similar systems at the present time, but, of course, there is always room for improvement and your idea may have greater value than any of those now used.

Q. 2. I am not in a position to construct a working model. What should be my course of action?

A. 2. Interest someone who has the necessary capital and have a working model made. It is advisable that you write a complete description of your invention and have it witnessed by a notary public as a means of protection.

Q. 3. Why does my potentiometer smoke (two of them have burned out) when connected up?

A. 3. You may have an imperfect instrument. Usually, though, it is an entirely different cause. If the potentiometer arm and one end of the potentiometer winding are connected across the "A" battery and the switch arm placed so that only a few turns are included in the circuit, the fine wire, unable to carry the current, will fuse (burn out). Only the two outside ends of the potentiometer winding should be connected across the battery (switch arm going only to the grid return lead). The total resistance of the entire winding is so high that it cannot fuse or melt under this, the correct, connection.

Q. 4. What can I use to fill the unwanted holes in a panel used for experimental work?

A. 4. Black sealing wax may be used for black panels and the proper shade of brown sealing wax for brown panels. The proper degree of "mottling" may be obtained by the addition of a very slight amount of black sealing wax.

Q. 5. How are panels given a dull finish?

A. 5. The original polish of bakelite, formica or hard rubber panels is easily removed with No. 00 emery cloth. The graining is usually done with a left-and-right motion. If a somewhat finer finish is desired, the panel may be rubbed with very fine emery powder. For bakelite, a light machine oil lubricant may be used with the powder; on hard rubber, oil should not be used, plain water being much better.

(172) SOLDERING

Q. 1. Can the use of acid-core solder be the cause of a set not functioning properly?

A. 1. Possibly. It depends somewhat upon what is being soldered and the way in which the soldering is done. In general, it is very inadvisable to use acid flux for any kind of soldering in connection with radio apparatus.

Q. 2. What would be a satisfactory method for soldering radio instruments and wiring?

A. 2. First, have a real hot soldering copper (called a soldering "iron"). This "iron" should not be allowed to turn red, as this causes the "tin" to burn off. To make a satisfactory connection the hot iron should be applied to the work, so as to heat the work before the solder is applied. When the solder on the iron seems to be taking hold of the surface to be soldered the solder can be applied. If a resin core flux is used, no other flux is usually necessary to make the solder stick.

In order for the iron to work properly it is necessary that it be well "tinned." The simplest way to make sure of this is to have a large sheet of tin handy, also a jelly glass of

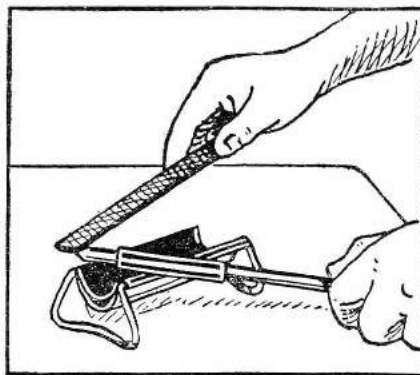

(172) Be sure your iron is clean before attempting to solder with it. A file will scrape the dirt off.

muric acid which has been "killed" by the addition of sufficient scrapings of zinc to prevent the further formation of bubbles when more zinc is added. By heating the iron to almost a red heat, then quickly dipping it into the acid, the iron will readily become coated with a film of solder, when the iron is rubbed around on the sheet of tin, on which are pieces of solder. A file sometimes assists the process. No flux is used in this operation, the acid treatment being sufficient for the purpose. When all sides of the iron have become coated with a film of bright solder, the iron is "tinned" and is ready for use; without the tinning, solder will not stick to the soldering copper and the soldering copper will not heat the work.

Beware of soldering "pastes." They sometimes cause more harm than good. There are several good soldering pastes on the market, but they must be used judiciously. An excess may form a leakage path just where it is not wanted. A little care and thought will be all that is necessary. Capillary attraction sometimes causes conducting fluxes to creep into undesirable places. Sometimes, too, it will spatter into the wrong spot.

Acid flux, even though "killed" in the manner described above, is not desirable because it often causes poor connections to develop, due to a slow corrosion. On small work, such as soldering wires, smaller than size 30 B. & S., it often eats entirely through, causing an open circuit.

Sal ammoniac strongly attacks the soldering iron, quickly rendering it unfit for use.

The best flux, resin (pronounced, "rosin"), may be used as the core of the solder, as mentioned in the first paragraph, or it may be made into a convenient solution, as desired. The solution is made by dissolving resin in alcohol until the desired density is secured. It is applied with a brush and the soldering is done immediately. In either case, excess resin should be removed with alcohol and a brush or cloth, after the soldering is completed.

If the work to be soldered is easily movable, see that no motion takes place until a few seconds after the solder has clouded. If thick metals are being soldered, the pieces should be held immovable until the solder has thoroughly hardened.

When the job is done, move the pieces to see if the union is perfect. A juncture seemingly perfect can cause much inconvenience if it is not so. (See next page.)

Keep the iron clean and have a cloth handy for this use.

(173) STUDIO DESIGN

Q. 1. Please describe the construction of a modern broadcast station studio.

A. 1. The walls may be constructed of gypsum block. Over this is placed a layer of lith. This is a sound absorbing material. It is also applied to the ceiling. A triple wall construction should be used. Between the walls a thick layer of sound deadening material is laid. The furniture should be wood-doweled, not nailed.

Q. 2. Should draperies be used to prevent echoes?

A. 2. A certain amount of reverberation is required. By use of a partial drapery, the correct balance between reverberation and a total absence of echo may be easily obtained. If the special wall construction described above is used, no drapery is required.

Q. 3. What is the difference between reverberation and echo?

A. 3. Reverberation is a type of echo so closely spaced to the original sound that the separation cannot be detected by the ear. An echo is so timed that the separation can be readily detected.

Q. 4. I have been advised that acid should not be used in soldering electrical connections, on account of corrosion. Is this true?

A. 4. If the acid is not wiped off after soldering, it will naturally corrode the wire to some degree after a while. If fairly large wires are soldered, this will make no difference. Where very fine wires are connected, such as are used in amplifying transformers, it is best to use some non-corroding paste.

Q. 5. What is the correct speed for drilling small holes in bakelite?

A. 5. A little oil on small drills rotating at about 1,200 r.p.m. will be correct.

(174) BAKELITE

Q. 1. Kindly describe the general composition of bakelite.

A. 1. The reaction of formaldehyde and carbolic acid, under certain conditions, produces a resin-like material. Alcohol or acetone will dissolve this compound. This compound,

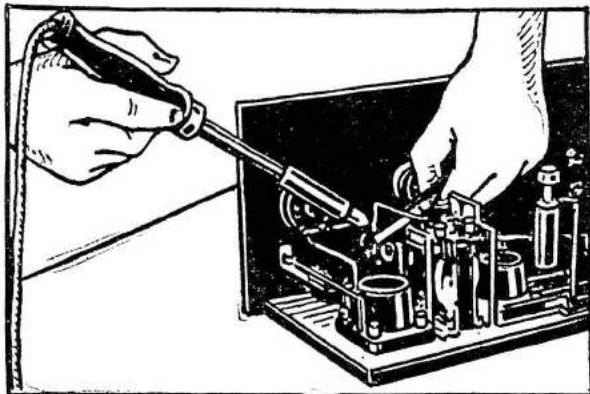

(172) Left: The correct way to solder the end of a bus bar wire to a terminal. Grip it with the pliers to hold it steady. Right: Pliers are essential when soldering a joint like this.

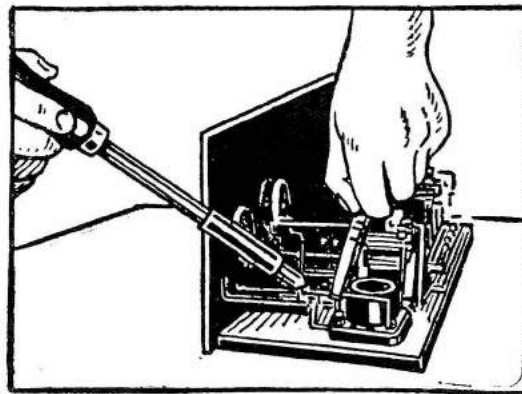

which has been termed synthetic resin, will first melt, upon the application of heat, but the heat produces a chemical change that causes the liquid to harden. Once hardened, it cannot be softened, not even by the use of the former solvents. Once permanently hardened, it becomes infusible, insoluble, and impervious to oil or water. It has become "chemically inert." There is no gradual deterioration, such as we see in the rusting of iron, the hydrolyzing of shellac compositions, or the sulphur "bloom" of rubber.

Q. 2. How is it possible to mould bakelite?

A. 2. Powdered bakelite is mixed with some filling ingredient, such as fibre, wood pulp, asbestos, or wood "flour." This powder is "plastic moulded" by being put in a heating press exerting a 2,000-pound pressure per square inch. The chemical change referred to above then takes place, the compound first melting and conforming to the mould form, and then hardening permanently.

Q. 3. What is the specific gravity of bakelite?

A. 3. Approximately 1.4.

Q. 4. Will I be able to broadcast a half hour each day without a license?

A. 4. No. A license is required for any class of transmitting.

### (175) ADDING HEADPHONES

Q. 1. Please explain the reason for the fact that two or more pairs of headphones cannot be connected to my set (a standard three-circuit regenerative receiver which works very well with one pair of receivers), using either the series or the parallel connection, without making the set inoperative.

A. 1. Providing the headphones are all right, the trouble may be remedied by increasing the "B" battery voltage. It may be necessary slightly to change the value of the grid leak. Reversing the connection of one or both pairs of receivers may help.

Q. 2. What is the main difference between a line telephone receiver and a regular loud speaker?

A. 2. The line telephone receiver is not required to respond as truly to such a wide range of frequencies as the loud speaker, also, the resistance of the line receiver is considerably lower. The usual resistance of line receivers is only 75 to 80 ohms, while loud speakers operating directly in the plate circuit of the tube are wound to resistances between 1,000 and 3,000 ohms. Where line receiver diaphragms are considered satisfactory, if made of ordinary ferrotypic iron, loud speaker diaphragms must be of exactly the right material and dimensions, or distortion of certain frequencies will result. The physical construction of the loud speaker case and parts is designed with exactness, down to the minutest detail, greatly exceeding the thought expended on the ordinary line receiver. But each unit suits its particular purpose in a quite satisfactory manner.

Q. 3. How was it possible for WEA, as recently stated by the press, to broadcast with a power of 5 K.W., when legal limitation is 1 K.W.?

A. 3. This was permitted under the special license held by that station.

### (176) RADIO BIOGRAPHY

Q. 1. What were Marconi's major steps in developing radio?

A. 1. Marconi applied for a British patent June 3, 1896. He conducted demonstrations before British Post Office Officials, first for a distance of about 300 ft. (between the Savings Bank Department in Queen Victoria St., and the General Post Office), then  $1\frac{3}{4}$  miles on Salisbury Plain. At the next trial, also on Salisbury Plain, four miles were covered. Bristol Channel was crossed in May, 1897. Ship to shore, and vice versa, experiments were conducted for a distance of about 10 miles in July, 1897. British Lighthouse radio service was instituted in December, 1898. March, 1899, the Straits of Dover were crossed. From that time on, increasing distances were covered until upon Dec. 12, 1901.

the now famous letter "S" was unmistakably received at St. John's, Newfoundland, from a Marconi station located at Poldhu, Cornwall.

Q. 2. What are the addresses of the National Radio Trade Association; National Association of Broadcasters; National Radio Chamber of Commerce; American Society of Composers, Authors and Publishers, and of the Hazeltine Corporation who, I understand,

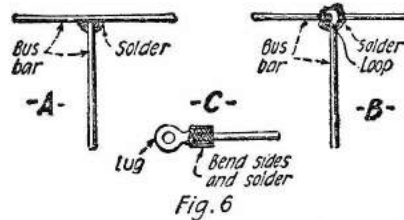

(172-A) It is bad practice to solder two wires together in the manner shown at A. The B method is the best. C shows how a lug should be soldered to a wire.

license companies to use the Neutrodyne patents?

A. 2. The Hazeltine Corporation, 15 Exchange Place, Jersey City, N. J., have turned over the right to license manufacturers under the Neutrodyne patents, to the Independent Radio Mfgs., Inc., 165 Broadway, New York City.

The other addresses you request are: National Radio Trade Association, 1133 Broadway, New York City; National Association of Broadcasters, 1265 Broadway, New York City; National Radio Chamber of Commerce, 165 Broadway, New York City; American Society of Composers, Authors and Publishers, 56 West 45th Street, New York City.

Q. 3. What are the headquarters addresses of the Esperanto Associations in England, France, Canada and the United States.

A. 3. The addresses you request are: British Esperanto Association, 17 Hart Street, London, W.C. 1, England; Central Esperantiste, 51 Rue de Clichy, Paris, France; The Toronto Esperanto Society, 113 Maitland Street, Toronto, Canada; Esperanto Association of North America, 507 Pierce Bldg., Copley Square, Boston 17, Mass.

### (177) DEFINITION

Q. 1. How may frequency, in kilocycles, be determined, given the wave-length? In cycles?

A. 1. Dividing 300,000 by the wave-length will give you the frequency in kilocycles. To convert kilocycles to cycles, multiply by 1,000.

### (178) GLASS DRILLING

Q. 1. How can small and large holes be drilled in a glass panel?

A. 1. Small holes may be drilled in glass panels by using either a high speed drill or a triangular file. It is necessary to use a drill guide to keep the drill in position. A high

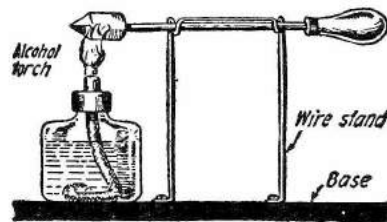

Fig. 5

(172) An alcohol torch will produce sufficient heat for heating a small soldering iron, in absence of better means.

speed need only be used with the drill. The file speed must be determined by experiment. Use a heavy solution of camphor in oil of turpentine while drilling. For holes larger

than one-fourth inch, use a copper tube. Emery and water are used with this type of drill. To increase the feed of the grinding mixture slots may be cut in the tube.

Q. 2. Should radio instruments be insulated from the glass panel?

A. 2. Radio instruments should be insulated from the glass panel. Bakelite or hard rubber may be used for this purpose. These non-hygroscopic materials must be used because glass is hygroscopic and, therefore, is a good insulator only when perfectly dry.

### (179) PATENT ADVICE

Q. 1. I have discovered a hook-up which seems to be better than any I have tried before, including most standard ones. Would it be worth while to obtain a patent on the hook-up?

A. 1. If your new hook-up has incorporated in it something new that has not been used before, a patent might be obtained. If, however, you are using regeneration, no patent could be had, as any circuit of this kind is already covered by the Armstrong patents. If regeneration is not used and you think the results obtained are worth while, we would suggest that you get in touch with some reliable patent attorney.

Q. 2. Why are the amateurs permitted to send "CQ" in code a dozen or more times, at a wave-length of 80 meters, when the Government has requested that these letters be sent only a few times?

A. 2. This regulation was intended to apply to spark transmission, not C.W. (continuous wave) transmission with inductively coupled antenna systems. Due to the extremely sharp tuning at such short wave-lengths, it is necessary that the receiving set be adjusted very slowly. For this reason the amateurs have been permitted to repeat this general call many times before signing the letters assigned to the sending station. This gives the receiver a chance to properly tune in the calling station, an operation requiring much more time on the short wave-lengths than at the longer wave-lengths or when the continuous waves are interrupted. Such interrupted or modulated signals are more readily tuned in, but this type of transmission is not permitted on the wave-length band you refer to.

### (180) PATENT LICENSES

Q. 1. Who controls the Neutrodyne patents?

A. 1. The Independent Radio Mfgs., Inc., 165 Broadway, New York City.

Q. 2. Who controls the regenerative patents?

A. 2. The Western Electric Co., New York City.

Q. 3. Who controls the crystal detector patents?

A. 3. The Wireless Specialty Apparatus Co., Boston, Mass., control the original detector patents.

### (181) NON-TECHNICAL RADIO BOOK

Q. 1. Where can one get information about how to read diagrams, how the various radio instruments are used, why they function, what the advantages and disadvantages of the various instruments are, etc.?

A. 1. "Radio For All," by H. Gernsback, which may be obtained from the Experimenter Publishing Co., 53 Park Place, New York City, gives all the information about radio that it is possible to convey in non-technical terms, and will probably be just the source of information you need.

### (182) BUS-WIRE CONDUCTIVITY

Q. 1. Why is tinned bus wire used for connections if copper is a better conductor at high frequencies?

A. 1. Copper is not a good conductor if it

(Continued on Page 81)



# Popular Circuits

## (189) SECOND HARMONIC SUPER-HETERODYNE

Q. 1. Will you please show the diagram of connections employed in the R. C. A. second harmonic Super-Heterodyne, together with construction data and an explanation of the principle of operation?

A. 1. In Fig. 189-A we are illustrating in a general way the principle involved in the second harmonic Super-Heterodyne. This picture is to be compared with Fig. 189-B.

In the circle A of the picture diagram is a representation of the weak incoming broadcast signal. Circle A-1 represents this same signal made stronger by the amplified action of the first vacuum tube. This tube does nothing but amplify signals. It is reflexed in a manner to be described later.

The amplified plate current of the first tube is transferred by induction to the grid circuit of the second tube. This grid current is shown in circle A-2.

This second tube acts as the first detector and also as the frequency changer.

If you count the number of cycles represented in A, A-1 and A-2, you will see that there are nine complete cycles.

You will note that in B-1 we have only four cycles. This is the strong fundamental oscillator frequency produced by the second tube, which must act as an oscillator as well as the second detector.

Heterodyning is the next operation to be considered. When one frequency is added to a different frequency the combination of the two produces beats which may be considered as another frequency. This "beat" frequency is the difference in frequency between the first two. For instance, if an audible note of 1,000 cycles is sounded at the same time that an audible note of 400 cycles is sounded, a listener will hear these two and still a third note having a frequency which is the difference between the two, or 600 cycles. This, the production of a third frequency by adding one frequency to another, is "heterodyning." In our example of audio sounds, the third frequency of 600 cycles is called the "beat," or "beat frequency." In a Super-Heterodyne this beat frequency is ordinarily termed the "intermediate frequency."

Our fundamental oscillator frequency B-1, of 4 cycles, heterodynes the A-2 frequency, producing a beat note or intermediate frequency of 5 cycles. However, let us suppose our intermediate frequency C-1 to be 1 cycle. Consequently, a beat frequency of 5 cycles does not affect the filter coupler in the second tube plate circuit, tuned to the frequency C-1 of 1 cycle.

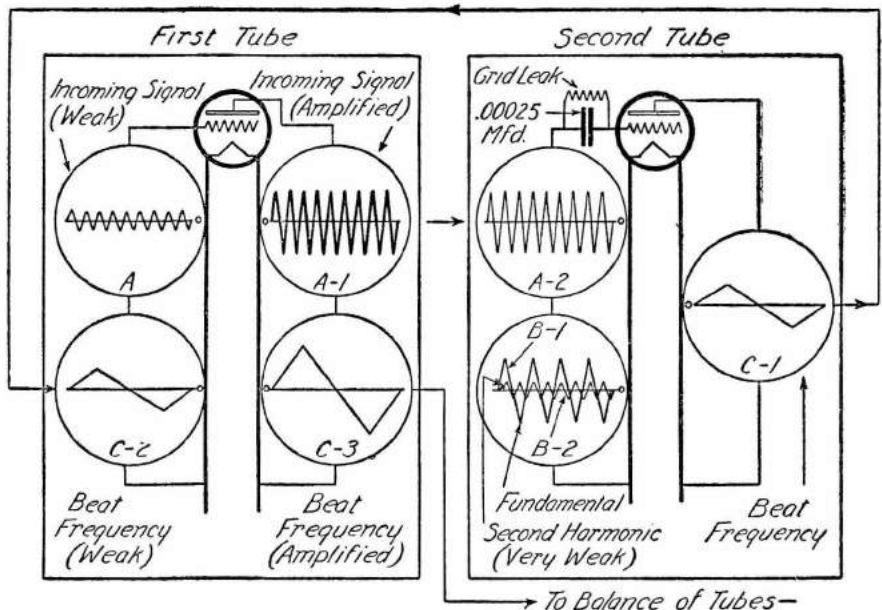

(189-A) The Second-Harmonic Super-Heterodyne principle of operation, graphically shown. The accompanying text explains the system in considerable detail.

Due to what is termed "asymmetrical action" in the tube, the oscillator tube is capable of producing a "second harmonic," or second frequency B-2, which is very much weaker than the fundamental. (The need for utilizing the 8-cycle harmonic of 4 cycles rather than producing a fundamental of 8 cycles will be stated below.)

The second harmonic of any frequency is just double that number of vibrations ( $\frac{1}{2}$  the wave-length) in a given time.

B-2, the second harmonic, consists of 8 cycles (i. e., twice  $\times$  4). When these 8 cycles are caused to heterodyne (to be added to) the A-2 frequency of 9 cycles, the difference is only 1 cycle. This beat frequency of 1 cycle is the same as the adjustment of the filter coupler which is designed for 1 cycle.

C-2 is the beat frequency or intermediate frequency which has been reflexed into the grid circuit of the first tube, which now amplifies once more. The output, C-3, of this tube is stronger than C-2 and considerably more powerful than the original incoming signal A.

The output, C-3, continues on to other tubes which act consecutively to further

amplify at the intermediate frequency, detect, then amplify at audio frequency.

### Explanatory Circuit.

189-B is a schematic circuit illustrating the system. The 50-turn coil may be the secondary of a standard aerial tuning coil wound with No. 22 or 24 D.C.C. wire on a 3-inch tube. The primary may be wound directly over the filament end.

The two honeycombs are in variable inductive relation and must not be in inductive relation to other coils in the set.

The 500-turn honeycomb coils and the two variable condensers comprise the standard filter coupler which, when Giblin-Remler coils are used, will respond to wave-lengths between approximately 1,730 and 7,900 meters. If intermediate frequency transformers are used having a higher wave-length, it will be necessary to connect two fixed condensers, each of .001 mfd. capacity, in parallel to each of the .001 mfd. variable condensers.

If we consider an actual example of an incoming signal having a frequency of 500,000 cycles (600 meters), to which the 50-turn coil and its variable condenser are tuned, and an intermediate frequency amplifier and filter coupler tuned to 50,000 cycles (6,000 meters), it becomes necessary to heterodyne some frequency with the incoming signal frequency in order to produce a difference of 50,000 cycles.

Adding 50,000 cycles to 500,000 cycles we derive a total of 550,000 cycles (554 meters), the frequency required of our oscillator.

If the oscillatory circuit now including the 125-turn honeycomb coil were to include a much smaller honeycomb coil instead, so as to cover practically the same wave-length range as the broadcast stations, in the same manner as the regular oscillator system Super-Heterodyne, a peculiar effect would be noted; it would not be possible to adjust this circuit so as to heterodyne with the incoming signal without de-tuning the input circuit. Inversely, it would not be possible to tune the input circuit without de-tuning the oscillator circuit.

It is an entirely different matter when the wave-length range of the oscillator circuit is

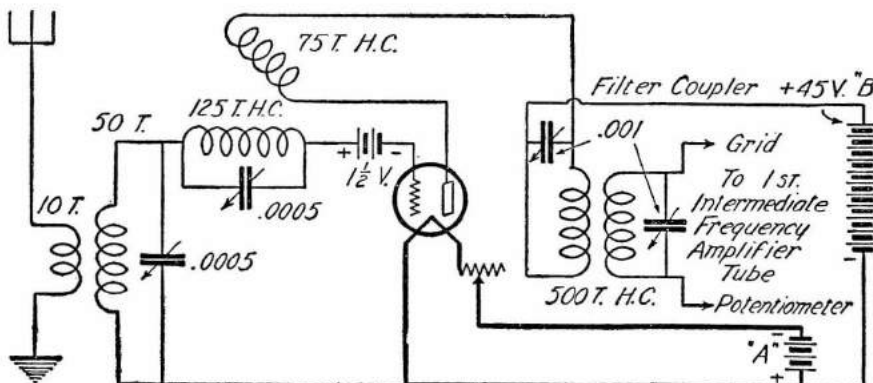

(189-B) This circuit shows how the Second Harmonic, shown above, is generated. There are many possibilities of the principle. The values given are variable. A loop is recommended in place of the 50 turn inductance.

placed considerably outside the operating range of the input tuning circuit, which is accomplished by doubling the wave-length; tuning the 125-turn honeycomb circuit designed for this new wave-length range no longer has any appreciable detuning effect on the input circuit.

Our beat frequency, we have decided, is to be about 50,000 cycles. The asymmetrical tube action mentioned above causes our oscillator to produce the desired frequency, which will result in a beat of 50,000 cycles. Granting an arbitrary incoming signal frequency of 500,000 cycles (600 meters) and the requirement of an oscillator frequency of 550,000 cycles (545 meters) the 125-turn honeycomb coil circuit is tuned to 275,000 cycles (1,090 meters). Tuning this circuit does not appreciably affect the input tuning, while the second harmonic of 1,090 meters occurs at the required 545 meters (550,000 cycles).

Remember that these figures are used only for illustrating the principle. They will be different for every wave-length received and for the different intermediate frequencies for which the set may be designed.

**Experimental Circuit.**

Circuit 189-C shows a complete set having one stage of short-wave amplification (tube No. 1), first detector (tube No. 2), oscillator (tube No. 2), first intermediate frequency amplifier (tube No. 1), second stage of intermediate frequency amplification (tube No. 3), second detector (tube No. 4), and one stage of audio frequency amplification (tube No. 5)—seven operations being performed with five tubes.

In this circuit the instrument marked R.F.T. (B.W.) can probably be a regular radio frequency transformer, air core, designed to cover the broadcast wave-lengths.

We are showing a "C" battery in the oscillator tube circuit. This tube must act as detector as well, and, therefore, it may be advisable to try connecting a grid condenser and leak, or a crystal detector, at "X."

Although iron core intermediate frequency transformers I.F.T. 1, I.F.T. 2 and I.F.T. 3 are shown (if the experimenter has a set of Tropafomers, they will readily adapt themselves to many experiments with this circuit), it is possible that air core transformers which amplify best at about 6,000 to 8,000 meters could be used.

It will be noticed that the primary I.F.T. 1 is connected into the circuit in a different manner than usual. It is a particularly efficient method of connection in this circuit.

The second harmonic Super-Heterodyne is generally conceded to be the most difficult type of receiver to construct outside of the

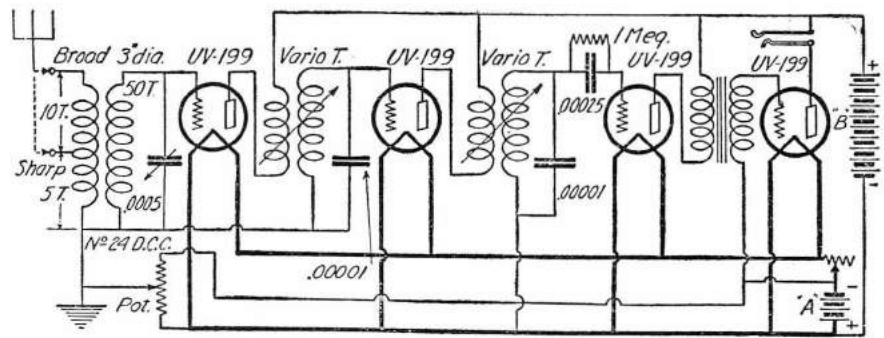

(189-D) Voltage step-up through the use of two-coil transformers, and tuned grid circuits with fixed condensers, are outstanding features of this receiver. Loud speaker reproduction of local signals, and loud headphone reproduction of very distant stations, using only dry cell tubes, is had.

laboratory. Only a skilled engineer can hope to successfully build a set incorporating this particular principle.

Q. 2. What is the diagram of connections employed in the Boonton Light Four receiving set (portable)?

A. 2. The circuit of this set will be found in Fig. 189-D, above. UV-199 tubes are used throughout. Ballantine variotransformers are used in place of the usual fixed transformers. These transformers are so constructed as to be variable in wave-length in a manner similar to the variometer. The primary is in two parts, as is the secondary. One-half of each winding is variable in inductive relation to the remaining half. This enables the determination of opposing or assisting fields, resulting in a wave-length control. These transformers are varied in conjunction with the tuning condenser. By the use of these transformers, high amplification is had at one desired wave-length, without the usual requirement of considerable space for variable condensers.

Although no condenser is shown, it might be advisable to shunt a .001 mfd. fixed condenser across the primary of the audio frequency transformer.

This circuit may be used to include any make of fixed radio frequency transformers, although results will not be as good as when the secondaries are tuned in some manner. If desired, standard air-core radio frequency transformers designed to be tuned by means of shunt variable condensers may be used in place of the two variotransformers.

The aerial tuning transformer may be of standard type. A regular variocoupler would be satisfactory. The primary may be untuned, as shown, or not, as personal wishes dictate.

The weight of the outfit, with batteries and all, is in the neighborhood of 20 pounds.

**(190) REFLEXED NEUTRODYNE**

Q. 1. Kindly show the circuit of the Ware Type T Neutrodyne that uses three UV-199 tubes.

A. 1. The circuit to which you refer will be found in these columns. Standard neutroformers may be used. A very satisfactory unit for coil "A" may be made by winding 45 turns of No. 22 D.C.C. wire on a three-inch tube. This coil may be tapped eight and 16 turns from the filament end. Unit "B" may be made by winding 50 turns of the same size wire on another tube of the same size. One or two layers of Empire cloth are wound over this secondary winding (a tap for the neutralizing condenser connection may be taken about 20 turns from the filament end of this coil), and over this, near the filament end, is wound the primary which may consist of about 16 turns of the same size wire.

The first radio frequency tube is reflexed and the out-put of this tube is tapped by the jack connected to the primary of the last audio frequency transformer. The out-put of the three tubes is secured by plugging into the jack in the plate circuit of the last tube.

This set is designed for best operation with UV-199 tubes. It is necessary that the two inductances be placed in non-inductive relation to one another and that extreme care be taken in the construction of the set, in order to keep the coupling between wires and instruments at a minimum.

Poor results will be experienced if standard sockets are used with adapters; low capacity, UV-199 sockets are required.

A reflexed Neutrodyne is a difficult receiver to construct without factory facilities.

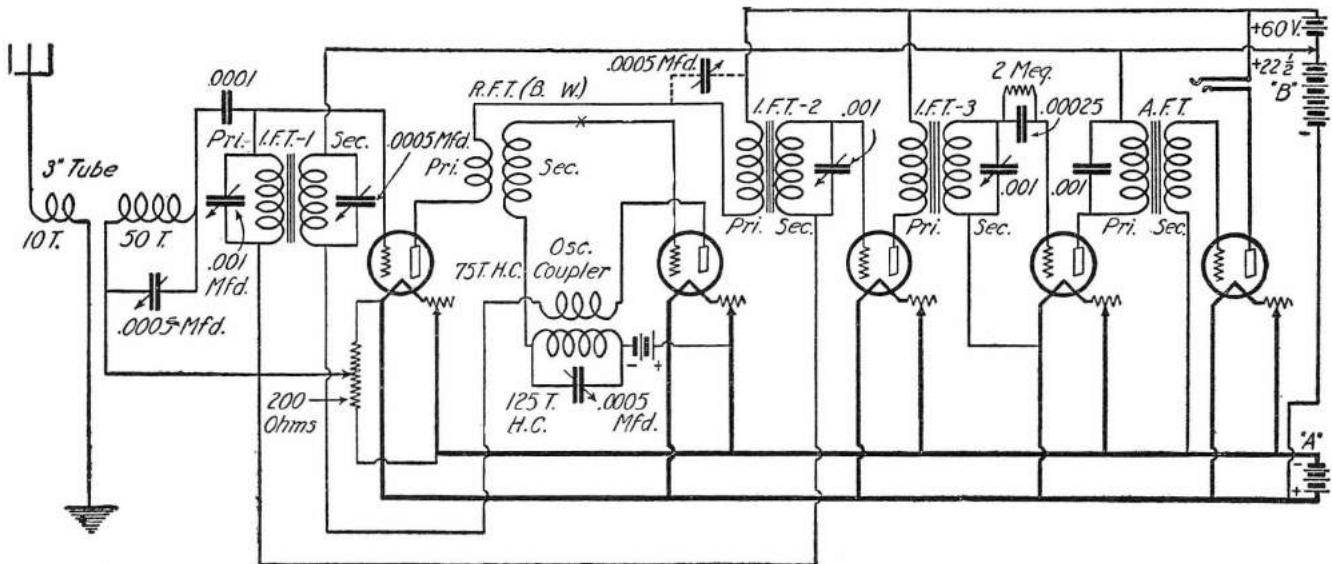

(189-C) The Second-Harmonic Super-Heterodyne. Although an aerial is shown, a loop is recommended, unless the aerial is quite short. This receiver is considered as non-radiating since the first radio frequency tube has considerable blocking effect in one direction.

**(191) INVERSE DUPLEX RECEIVER**

Q. 1. Please publish a picture diagram of the Inverse Duplex Receiver.

A. 1. The diagram is shown in these columns.

Q. 2. What suggestions can be made for correct construction of this receiver?

A. 2. A tapped loop may be used, as shown, or a standard loop may be used. High ratio audio frequency transformers introduce considerable distortion. We recommend ratios of the order of 3:1, unless, of course, a crystal detector is used. Additional stability is had by connecting grid return leads of R.F. tubes to individual potentiometers of about 200 ohms. This results in a better control of the grid voltages of the tubes being reflexed. Should the potentiometers be used, it will be unnecessary to use a by-

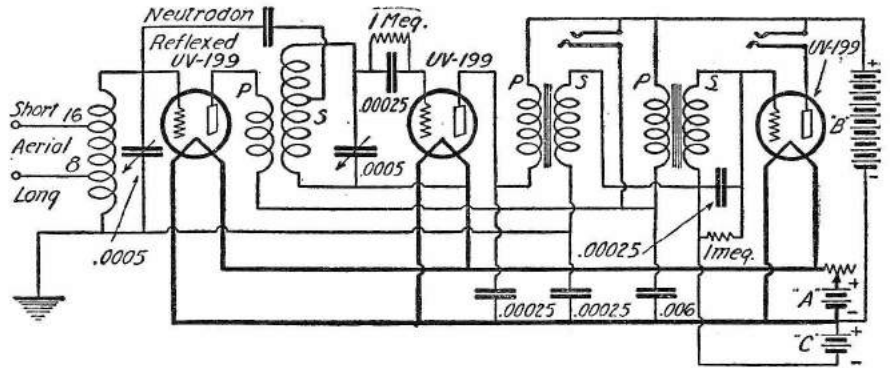

(190) The Ware Type T, reflexed, two-control Neutrodyne. Only one stage of radio frequency amplification, neutralized, instead of the usual two stages. An unusual way of employing a single circuit jack, to tap the reflexed stage output, is shown.

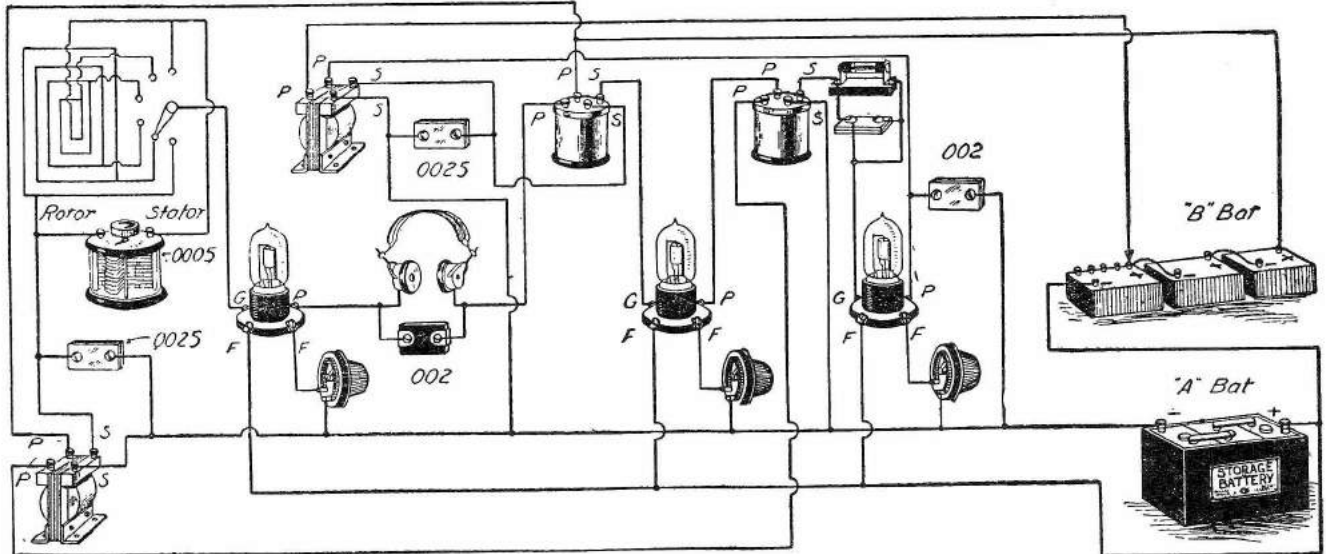

(191) The Improved Inverse Duplex circuit. As with most reflex receivers, exactly the correct apparatus must be used, in exactly the correct way. The particular feature of this circuit is the equalizing of the load imposed on the tubes.

pass condenser. If desired, the grid return may be connected to "A" plus, or to the negative connection of a small "C" battery. This results in a wide control of the grid voltage of the detector tube, resulting in maximum efficiency of this tube. Only the very best of tubes can be used in a reflex receiver, with anything like satisfactory results. It is also very important to have well-designed radio frequency transformers;

low loss condensers are also a necessity. This latter is due to the fact that regeneration is not present to reduce the effects of resistance present in poorly designed condensers. The battery voltages used must be determined by test. Reversing primary leads is often helpful in reducing or eliminating audio frequency howls that occasionally develop in such receivers. Fixed condensers, or resis-

tances, placed at proper locations determined by experiment, are also often helpful.

**(192) L-2 ULTRADYNE**

Q. 1. Please show the L-2 Ultradyne circuit.

A. 1. The circuit you request is shown in these columns.

Q. 2. Are there any improvements in this receiver over the earlier model?

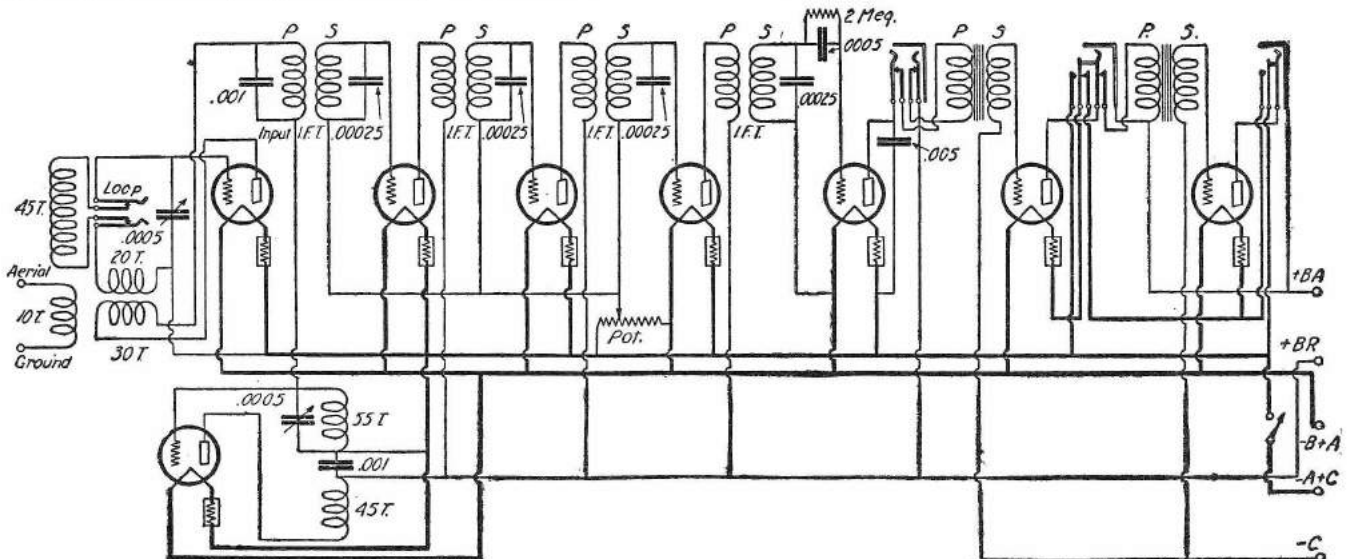

(192) The Model L-2 Ultradyne is seen to incorporate the latest developments in Super-Heterodyne construction. While the major portion of the amplification at radio frequency is dependent upon a properly designed and constructed intermediate frequency amplifier, considerable additional selectivity and sensitivity are had by the incorporation of regeneration in the first tube, as shown.

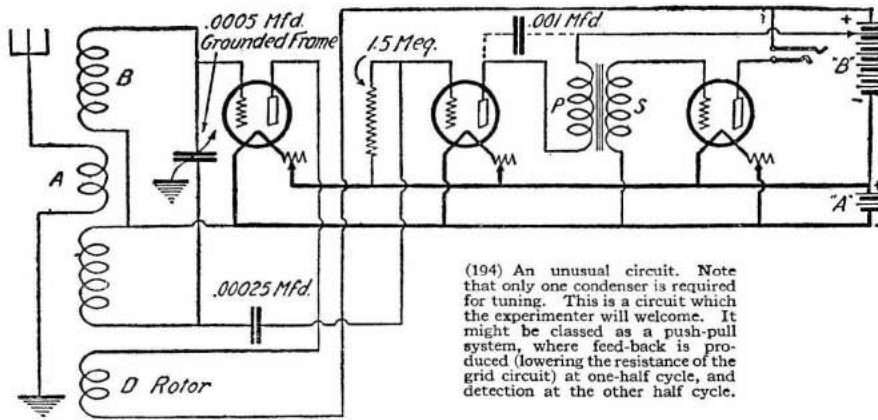

(194) An unusual circuit. Note that only one condenser is required for tuning. This is a circuit which the experimenter will welcome. It might be classed as a push-pull system, where feed-back is produced (lowering the resistance of the grid circuit) at one-half cycle, and detection at the other half cycle.

A. 2. It is a much more sensitive receiver than the earlier model, due to the addition of regeneration in the modulator tube circuit. Having ballast resistances in place of rheostats, tube controls have been eliminated. Furthermore, the latest transformers have a special low loss form of winding. The regeneration coils, tuning, and oscillator coils are of a special spider-web form. These improved windings considerably lower the resistance and other losses in the circuit. This results in sharper tuning and greater range.

A. 1. This circuit appears on these pages. A switch is used to change from "super" to plain regenerative. When used as a "super" either the antenna or ground may be connected to the antenna binding post. When used as a plain regenerative, the ground is connected at B.

(196) O'CONNOR FREQUENCY CHANGER

Q. 1. Please give full construction details for making the O'Connor Frequency Changer.

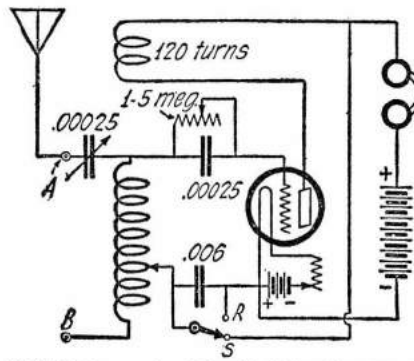

(195) The Improved and Simplified Flewelling Circuit is Shown Here. Excellent Results Should be Obtained From This Circuit.

I wish to use it in conjunction with a Neurodyne receiver.

A. 1. The important details are contained in the text below:

"Pri. 1" is the primary winding of the first neurotransformer, and it is absolutely necessary that this primary connect ONLY to the two posts indicated as "output."

The Neurodyne is adjusted for the maximum wave-length, which will be in the neighborhood of 600 meters. After once being adjusted, there is no further adjustment of this receiver required. The tuning

controls are now reduced to two, the two tuning condensers in the frequency changer.

The object of the O'Connor Frequency Changer is to transfer incoming received signals to the wave-length for which the regular receiving set has been tuned to respond.

This effect is obtained by means of the usual "Heterodyne" method.

In "Heterodyning" a signal from one wave-length (frequency) to another, a second, or "beat" frequency is used. The difference between the beat frequency and the incoming signal is called the "intermediate" frequency. In regular Super-heterodyne the "intermediate" frequency is of a wave-length between 1,000 and 10,000 meters. The intermediate frequency of this frequency changer is about 600 meters as determined by the adjustment of the standard receiver being used, in this case one of the Neurodyne type.

There is one big advantage in the use of the combination shown which will appeal to any one having had previous experience in operating a standard Super-heterodyne. It will be recalled that stations in the middle of the tuning band were heard at two different points on the oscillator dial. Those unfortunately having sets that tune in stations from three to eight times are probably wishing their sets would work in such a way as to bring in stations at not over two points on the oscillator dial; but such receiving sets have other afflictions than an intermediate frequency amplifier—signal response to wave-lengths between 1,000 and 10,000 meters, the cause for reception of stations at two points on the oscillator dial.

By using the extremely low intermediate frequency of 600 meters, it is not possible to hear twice any broadcast stations that operate on the present American wave-length band of 200 to 545 meters, so far as intermediate frequency amplifier design, the main governing factor, is concerned.

The oscillator design has a wave-length range of approximately 161 to 287 meters, in order to heterodyne stations in the regular broadcast range, so as to produce the 600-meter intermediate frequency.

The oscillator design is as follows:

"L" and "L-1," 49 turns of No. 24 D.D.C. wire, wound "double-spider-web" or "Lorenz" fashion. The coils are 1/8-inch thick, with a 3/8-inch core, and are slidably arranged on a 3- or 4-inch insulating rod, the best coupling of the two coils being determined by test.

The exact number of turns required for "L," is readily determined experimentally, by varying the number of turns in this grid coil until a 545 meter signal station is heard with the oscillator dial at about 95.

The use of .00013— $\mu$ f. condenser results in obtaining tuning over exactly the wave band desired, with a half-circle variation of the capacity of the .00025— $\mu$ f. condenser.

The "B" and "A" battery shown may be the regular current supply to the radio set. Be sure "B" minus connects to the same "A" battery terminal of both the oscillator and

(193) ULTRAFORMERS

Q. 1. Will the Sodian tube function as detector without serious modification of the Ultradyne set?

A. 1. The Sodian tube should work quite well in the Ultradyne, but we have no information about its so being used. A special R.F. transformer with comparatively loose coupling would have to be employed.

Q. 2. Will a variometer in the plate circuit of the detector tube improve the set?

A. 2. There will be no advantage gained.

Q. 3. Will the Ultradyne operate a loud speaker from coast to coast?

A. 3. It has done so.

(194) AUGMENTOR CIRCUIT

Q. 1. What system of connections is used in the "Augmentor" circuit of Francis Hoyt?

A. 1. The diagram of connections is shown in this department.

On a tube three inches in diameter wind 12 turns of No. 20 D.C.C. wire, to form coil "A." Coils "B" and "C" are about the same, viz: 25 turns of No. 22 or No. 24 D.C.C. wire wound on the same tube as primary "A." Coils "B" and "C" are placed either side of coil "A", but separated about one or two turns. Rotor "D" may consist of a spiderweb or a cylindrical winding of about 30 turns, on a tube 2 1/4 to 2 1/2 inches in diameter.

Since both the movable and stator plates of the variable condenser connect to points of high potential, it is not possible to eliminate hand capacity by grounding any part of the ordinary variable condensers. Grounded rotor condensers are no different, in this respect. Grounded frame condensers, however, will be entirely free from capacity effect.

Although not shown in the original diagram, it may be advisable to connect a variable condenser of .001 mfd. capacity across the primary of the first audio frequency transformer, as shown by the dotted lines.

This circuit resolves itself into one stage of tuned radio frequency amplification, detector, and one stage of audio frequency amplification, with variable coupling (the rotor) between the radio frequency tube and the detector.

(195) LATEST FLEWELLING CIRCUIT

Q. 1. Kindly publish a hook-up of the Flewelling circuit:

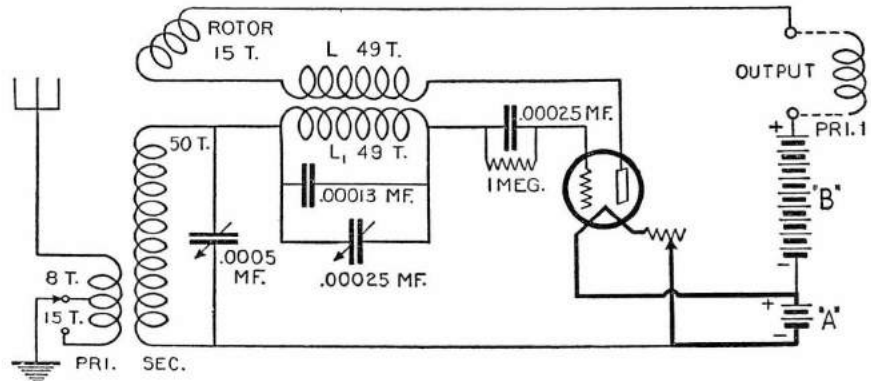

(196) The O'Connor frequency changer, which may be used in connection with any receiver.

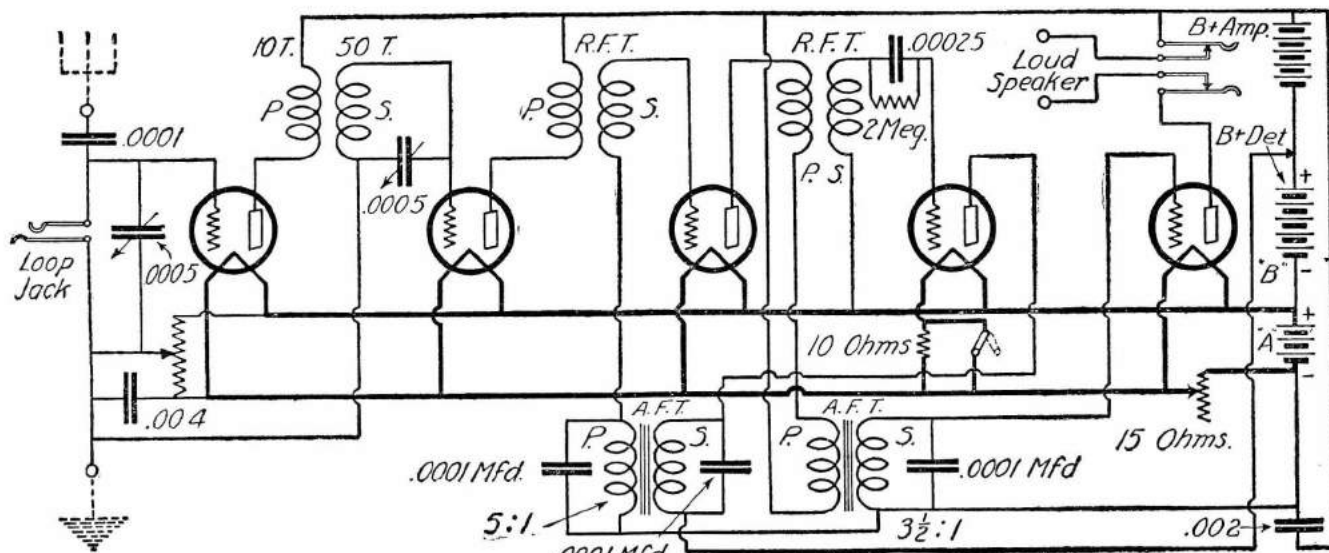

(197) The DeForest D-17 Reflex Loop Receiver. There have been a great many requests for this modern reflex circuit. The usual crystal detector has been replaced by a tube detector.

the regular set. Probably not more than 10 turns will be required in "Pri. 1," depending upon the particular tube used as the detector-oscillator.

**(197) DE FOREST D-17 SET**

Q. 1. What is the schematic circuit of the DeForest D-17 reflex receiver?

A. 1. We are showing this circuit in these columns. In the commercial receiver the tuned radio frequency transformer shown is shielded from the rest of the set. The cores of the audio frequency transformers are grounded by being connected to the ground wire, as is also the shield of the radio frequency transformer. In the manufactured set, it has been found desirable to connect a wire from the large metal throat of the loud speaker to the ground. This ground wire has a .002 mfd. fixed condenser in series with it. We have not shown this in the circuit, as the experimenter will probably use an entirely different type of loud speaker.

The 50-turn radio frequency transformer secondary may be wound on a tube three inches in diameter. One-quarter inch from this winding, and on the same tube, may be wound the eight or ten-turn primary. Wind both coils in the same direction with No. 22 or 24 D.C.C. wire. Connect the outside end of the primary winding to the plate of the first radio frequency tube and connect the

outside end of the secondary to the grid of the second radio frequency tube.

We suggest that the experimenter try several different makes of fixed radio frequency transformers in order to find two that are suitable for this set. Iron core transformers will most likely be best.

The audio frequency transformer ratios need not be exactly as shown, but the instruments must be of good design.

A loop aerial may be plugged into the loop jack. For additional range, one may try adding a ground and an aerial. Since this will broaden the tuning and greatly reduce or entirely eliminate the directional properties of the ordinary loop, it may be best to defer the use of an aerial and ground when powerful local stations are in operation.

When the head-phones are removed from the jack, the loud speaker is automatically put into operation.

A standard 200- to 400-ohm potentiometer may be used. This is shown connected across the "A" battery.

It is quite essential that low loss variable condensers be used.

Crowding apparatus closely together is to be avoided.

If storage battery tubes are used throughout, the 10-ohm resistance is shorted by means of the shorting switch (which may be of the push-pull type) shown. If a dry cell tube detector is used, this short is removed, thus

reducing the brilliancy of the dry cell tube filament. If dry cell tubes are used throughout the resistance is once more shorted and only two storage battery cells or three dry cells should be employed for filament lighting.

**(198) SUPER-ZENITH**

Q. 1. Please show the Super-Zenith circuit, with constants.

A. 1. We are showing the circuit in these columns. Note that the three, four and five turn coils rotate. They are fastened to the variable condenser rotor shafts and, therefore, turn as the variable condensers are adjusted. These rotating coils may be wound on tubes 2½ inches in diameter, with No. 24 or 26 D.C.C. wire (No. 22 or 24 D.C.C. wire being used for the remaining coils).

The seven- and ten-turn plate coils are fixed, being wound on the same three-inch tube as the 61-turn secondaries, but spaced from them about one-quarter of an inch.

The object in dividing each plate coil into two sections, with one section rotatable, is to maintain a constant plate condition at all wave-lengths, rather than have possible oscillation at certain wave-lengths.

It is quite necessary that each tuned radio frequency transformer (61-turn secondaries) be in non-inductive relation to the others. Placing at an angle to the baseboard, similar to a neutroformer layout, is satisfactory.

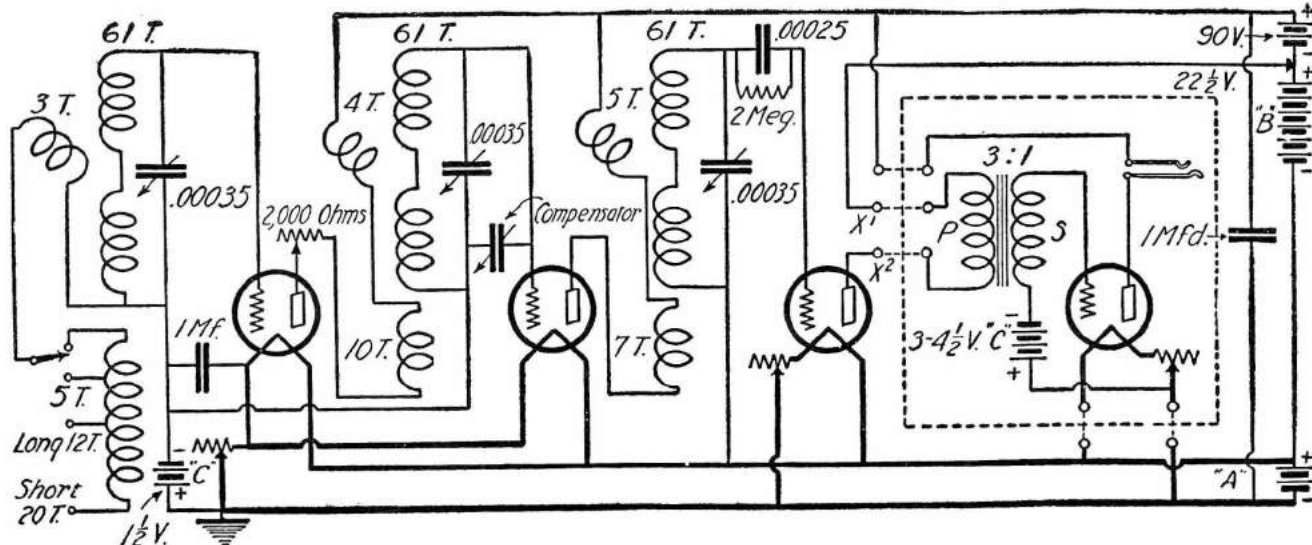

(198) The Super-Zenith circuit. This is a successful method of preventing tube oscillation, without using neutralizing condensers. The construction details are quite complete. Regeneration and oscillation in the first tube circuit are perfectly controlled by a variable plate resistance.

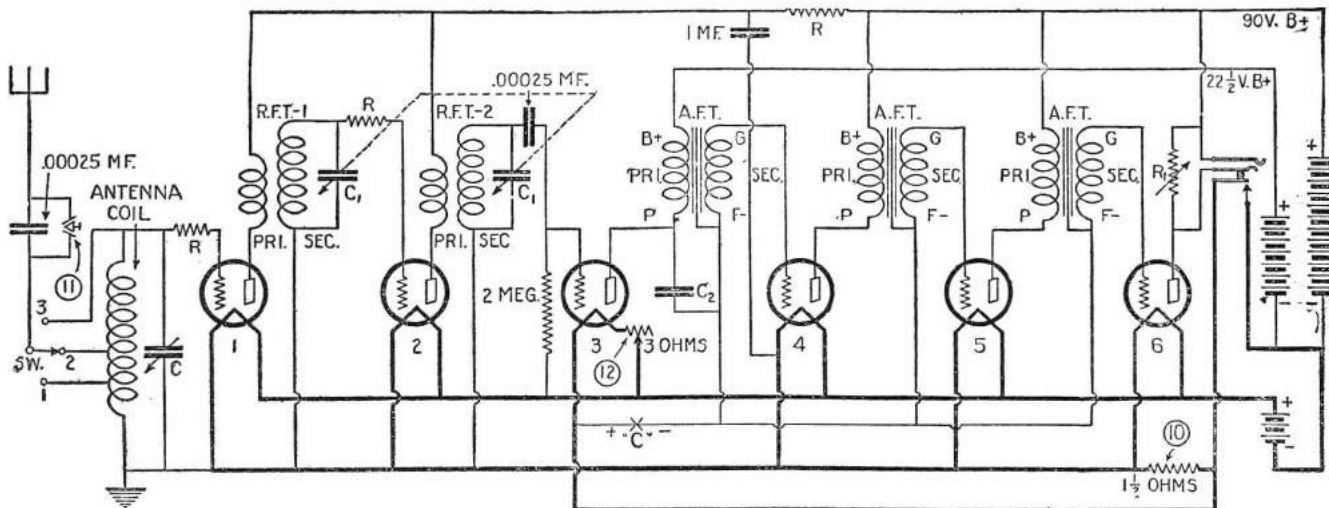

(199) Schematic diagram of connection system employed in Universal Plio-6, a receiver designed to cover a wave-length range of 35 to 3,500 meters, by use of the well-known plug-in coil principle. Plugging the loud speaker plug into its jack puts the set into operation automatically, as a "filament control" jack is used.

The 2,000-ohm variable resistance must be non-inductive. A regular carbon or graphite type of resistance will be satisfactory.

The aerial, if short, connects to the end of the 20-turn aerial coil which is wound on the same tube as the 61-turn secondary, but separated about one-quarter inch from it.

In the commercial set the variable condensers that tune the grid circuits of the second radio frequency tube and the detector tube are mechanically arranged to turn with only one knob.

Standard storage battery tubes will probably give best results.

We are showing one stage of audio frequency amplification, but the audio frequency amplification desired is optional.

Connect headphones to binding posts X1 and X2, if the audio frequency amplifier is not used.

If three variable condensers are used to tune the set, the balancing condenser will not be required. This is only used to compensate for any variations, when two variable condensers are geared together. The balancing condenser need only be of three or four plate size.

A single dry cell, or a single flashlight cell, will be satisfactory for the 1 1/2-volt "C" battery.

Note that all constants shown (coil turns, etc.) must be considered as variable, depending upon individual conditions.

The construction of this receiver should not be attempted unless one has had considerable experience in making experimental sets.

### (199) THE UNIVERSAL PLIO-6 RECEIVER

Q. 1. How can I build the Universal Plio-6 Receiver? The wave-length range of this set is said to be from 30 or 35 meters to about 3,500 meters. Can an amateur successfully build this set, after having assembled several receivers of 3- to 5-tube size and made them all work well?

A. 1. The schematic circuit of the receiver mentioned, as well as pictures and construction details, appear in these columns.

The Golden-Leutz receiver described is the first on the American market to have such a wide wave-length range, and yet be designed for high quality reproduction. As will be found stated elsewhere in these columns, receivers are in use for efficient reception of code signals in the 200- to 3,000-meter band, but there has been no occasion to take special "pains" with the audio unit. In fact, it is good engineering to design a code receiver to be highly responsive to a limited frequency scale; anyone having had experience in the reception of C.W. signals will realize that here such a design is quite la mode.

There should be no difficulty in constructing this set, if the correct kit is used and the construction blueprints carefully followed. However, one must be rather well along in the "game" to be able to build the receiver successfully from all home-constructed "components," as our English cousins would have it. For example, it may seem a very common-place matter to wind up a few radio frequency transformers to the particular

number of turns specified, wire these to the balance of the parts necessary, and consider the receptor completed. Instead, it will be found that the work has only just started, since the placement of the parts, and the constants of every home-constructed unit will vary. However, if commercial apparatus is used, the biggest variable factor is removed and satisfactory operation is assured more quickly.

Resistance units "R" are non-inductive resistances of about 750 ohms; whatever is sufficient to prevent circuit oscillation. Perhaps 600 ohms will be sufficient in some sets, depending on the constants of the instruments selected. Tubes and radio frequency transformers, and the placement of the latter, are the most important controlling factors in the values of "R." These resistances are shown in Fig. 199.

Condenser "C" is of .0005 mfd. capacity; "C-2," .00025 mfd.; the two variable condensers marked "C-1" are each of .0005 mfd. capacity, and constitute what is called a 2-gang variable condenser unit. The fact of the common shaft is indicated by the dotted line. Rotor plates, indicated by the arrow-head, are grounded to the panel.

The audio frequency transformers are all of the same ratio, 2:1. If desired, one less stage of audio frequency amplification may be used, and the first audio frequency transformer replaced with a higher-ratio instrument; even a 6:1 ratio transformer may be successfully employed, if care is taken in construction. This matter of two or three stages of audio frequency amplification has been investigated by Golden-Leutz, the co-designers of this receiver, with the result diagrammed. It seems that a two-stage unit having one high-and one low-ratio transformer amplifies to the requisite degree, but "tube noises," that is, "rushing" sounds, result. By adding an additional stage, but reducing the voltage step-up required of each stage, the input signal seems to be amplified to a greater degree than the "action sounds" incident to operation with high-ratio audio frequency transformers. Observe that all the A.F.T. cores are in a line—it is not necessary to place them at right angles. All cores are grounded to "A" minus.

A separate detector "B" battery is recommended and shown in the diagram.

Variable resistance "R-1" shunting the output (the loud speaker, of course) may be a Bradleyohm, or any other good make of variable resistance capable of carrying the heavy plate current resulting without becoming "noisy," having a range of 10,000 to 100,000 ohms. It acts as a volume and quality control. On weak signals, very little

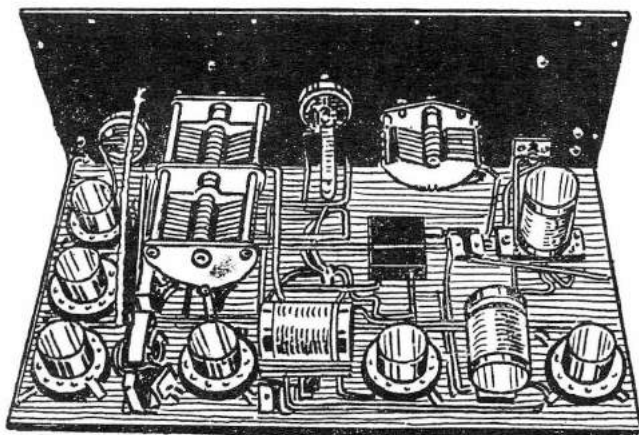

(199) Rear view of a set built in accordance with the schematic circuit shown above as 199. The inductances are arranged plug-in fashion. 35 meters to 3,500 meters is the wave-length range of Universal Plio-6.

resistance will be used; the unit will be operating at its maximum value, 100,000 ohms. By de-tuning ("throwing" the set slightly out of tune by adjusting the tuning circuits slightly off the exact adjustment for a powerful station), varying the 3-ohm detector tube filament rheostat, and resistance "R-1," the output is controlled without sacrificing quality.

The 1½-ohm resistance unit is most non-inductive. It is a 6-inch length of Nichrome wire, asbestos covered, and shows in the picture as connecting to the panel.

The value of a "C" battery may be determined by insertion in the grid return leads, as shown at "X."

In passing, mention should be made of the design of the variable condenser plates. It

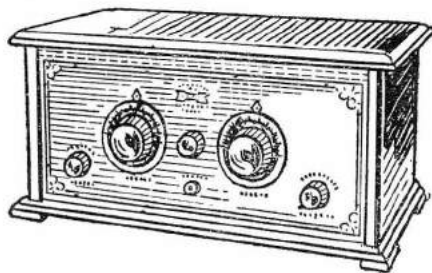

(199) Front view of receiver of set described elsewhere in these columns. A metal panel is one of the unusual features of this excellent receiver.

is such that the resultant curve is neither straight-line capacity or straight-line wavelength; it is "betwixt and between." The explanation is this: All the higher power stations, those operating with more than 500 watts, have a "Class B" rating. One of the requirements of Class B stations is that they operate on wave-lengths over 280 meters. If we divide the full broadcast wave-length range in two parts, we may say the general effect of a "straight-line wave-length" condenser is to separate the high-wave stations and crowd the low-wave stations, while a condenser designed to have a "straight-line frequency" calibration may be said to crowd the high-wave stations and separate the low-wave stations. When we consider that there are approximately three times as many stations in the high-wave, Class B, division as there are in the low, and that every one of these Class B stations is employing over 500 watts, the ever-present and vital problem of selectivity is seen, truly, to be a fit one for the most Solomon of Solomons. The variable condensers comprising that part of the kit used in the construction of the receiver shown in the illustrations, are unique in that the plate design is such that the resultant tuning curve is between a true straight-line wavelength and a true straight-line frequency curve.

There is no reason why "B" eliminators cannot be used to furnish the plate potentials, if one of the "no hum" variety, of which there are few, is chosen.

Storage battery tubes are required throughout, unless a different design is followed, and we are not prepared to furnish this experimental data.

All filaments are "out" until the loud speaker plug is inserted into the filament control jack. Instead of this scheme, a Carter jack-switch can be used to light the filaments automatically at the "on" position, in addition to connecting the set to the loud speaker. Since, with this plan, no plug is used, loud speaker connection must be provided for in some manner and you have probably guessed that this is accomplished by providing two binding posts, which posts are wired to the "jack" part of the "jack-switch."

An etched, metal panel is recommended by the designers.

In Universal Plio-6, three plug-in units are used to cover a certain frequency (wave-length) band. One, a single coil, is "antenna

coil." The remaining are "R.F.T.-1" and "R.F.T.-2." "Antenna coil" is, in general, similar to "unit L-1" also therein described. There is an exception to this statement of similarity of coils. It is that the number of turns in the various designs for "unit L-1" should be just halved. Example, the antenna coil has 55 turns. It is tapped at three places, instead of only one. Figuring from the filament end of the coil, calculate taking a tap ½, ⅓ and all the way (the grid end) across the coil. Now for R.F.T.-1 and 2. They may have the number of primary turns indicated, but halve the number of secondary turns mentioned. This reduction of turns is necessitated by the fact that the variable condensers used in Plio-6 are of double the capacity the ones in the super-heterodyne (Universal Plio-6, you know, is in the tuned radio frequency class).

The coil design described above calls for four sets of coils. By careful design of the coils, the kit-maker has been enabled to reduce the number of coil sets required to three, to reach 550 meters. Two extra sets are needed to reach the maximum wave-length of 3,600 meters. A suggested design is as follows, for the set of coils required for a wave-length range of 1200 to 3600 meters. "Antenna coil," tapped as described above, may be made by winding a 3½-inch tube with No. 36 D.S.C. wire to a width of 2½ inches. The untapped secondaries of R.F.T.-1 and R.F.T.-2 are similarly wound, while the primaries may consist of about one inch of winding of the same size wire, wound over the filament end of the secondary and separated by a single layer of Empire cloth.

The set of shorter range coils for 500 to 1500 meters may be made by double-space winding the same diameter tubing, with the same wire, for a distance of 1¼ inches with the same size wire for "antenna coil"—tapping as described above—and the secondaries of R.F.T.-1 and R.F.T.-2. (Wires may be double-spaced by winding two wires side by side and removing one, after the winding is completed.) The primaries may consist of about one inch of winding, double-spaced, over the filament ends of the coils.

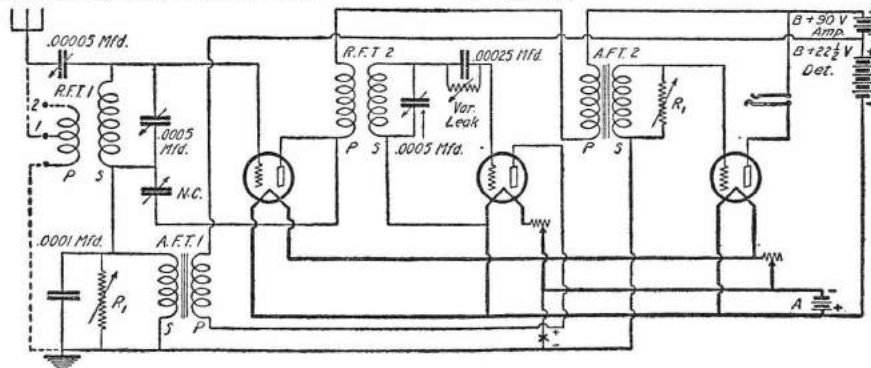

(200) The new Harkness reflex circuit, neutralized. This set will be found extremely selective if apparatus of good quality is used. Any type of tube may be used if sockets and rheostats are changed accordingly.

#### (200) LATEST HARKNESS REFLEX CIRCUIT

Q. 1. Please show the latest Harkness reflex circuit.

A. 1. The latest Harkness reflex is being shown in these columns.

Radio frequency transformers R.F.T.2 may be made by winding about 50 turns of No. 24 D.C.C. wire on a three-inch tube. One end of this secondary coil connects to the grid. The other end connects to "A" plus. About one-quarter inch from this end of the secondary is wound the primary, which may consist of about 15 turns of the same size wire.

In the earlier Harkness receivers the tuned radio frequency transformer marked R.F.T.1 consisted of two coils which we have designated "P" and "S." In the newer circuit it has been found possible to eliminate the 15 turn primary, the aerial being connected

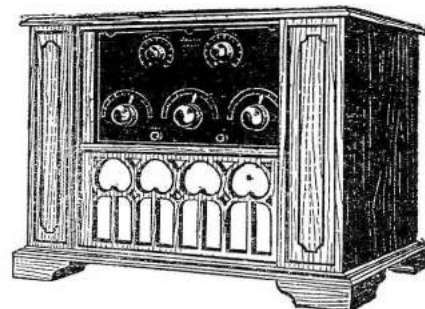

(201) DeForest F-5 receiver exterior appearance. Note built-in loud speaker (with opening, cloth and grill-work covered). A modern 5-tube set.

directly to, the grid end of the 50 turn secondary (wound with No. 24 D.C.C. wire on a three-inch tube), through a very small variable condenser instead of to the 10 turn tap or the end of the primary. The capacity of this condenser is higher than the maximum capacity of the average condenser of the "neutrodon" type. It is of such small size that changes in its capacity change the wave-length very little, but an excellent control of selectivity is afforded by its use. This method of inducing antenna current to the control grid of an amplifier tube will probably come into more general use.

The neutralizing condenser marked N.C. may be of the usual "neutrodon" type.

Resistances R-1, which may be variable grid leaks, will probably be required if the General Radio No. 285 audio frequency transformers are used. The .0001 mfd. fixed by-pass condenser may not be required with these transformers if the metal shell is connected to "A" minus.

Before the neutralizing condenser is adjusted a loud howl should be heard when both tuning condensers tune their respective circuits to the same wave-length.

The variable condenser rotor plates are indicated by the arrowheads.

If a three to six and one-half volt "C" battery is placed at "X," it will be possible to use as high as 135 volts in the amplifier "B" battery.

#### (201) DE FOREST F-5 RECEIVER

Q. 1. What information can you furnish about the DeForest F-5 receiver incorporating two stages of tuned radio frequency, detector, and two stages of transformer coupled audio frequency amplification? Desire particularly to know the method used for preventing circuit oscillation, as well as any other general information you think would be of interest.

A. 1. All the information we have available on the circuit you mention is contained in the accompanying text and in the diagram appearing in these columns.

It will be noticed that circuit oscillation is controlled by the resistances marked R-1 and R-2, which may be 400-ohm potentiometers. There is little adjustment of these units required after they have once been set for the particular tubes used in the receiver. Those desiring to pursue still further the subject of

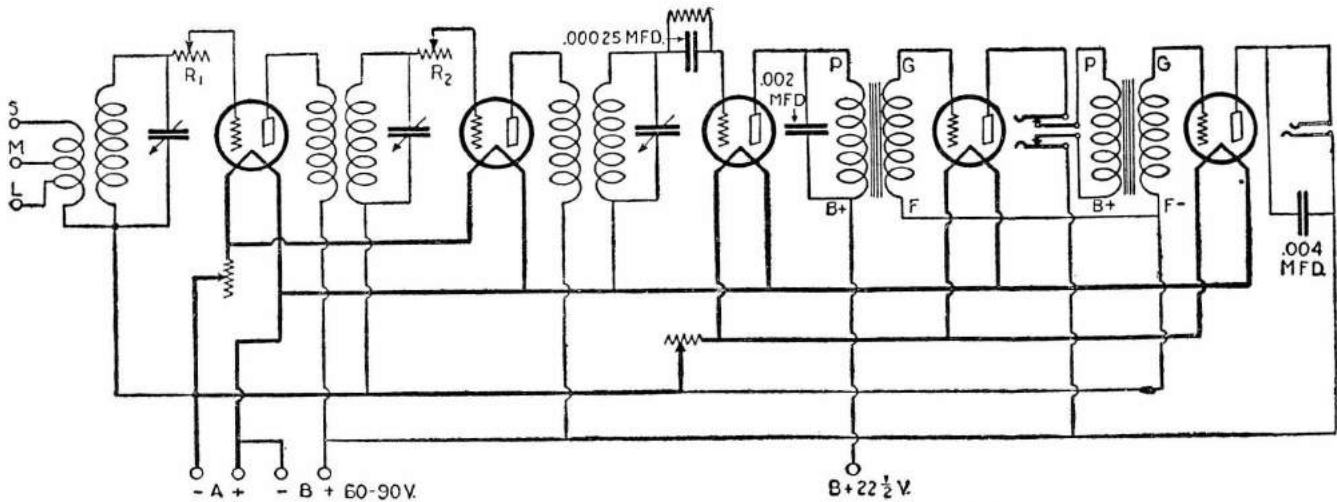

(201) Schematic circuit of "Type F-5" DeForest radio set. Units "R-1" and "R-2" are termed "anti-radiation devices." They control circuit oscillation. Ground is connected to "A" minus. Grid and plate leads must be short, while battery leads may be bunched like a telephone cable.

oscillation control are referred to the article, "Oscillations and How They Are Overcome," appearing in the May, 1925 issue of *Radio News* (pages 2083, 2084 and 2085).

The radio frequency transformers are of the "astatic" type. That is, they do not possess an appreciable field. The value of the variable condensers will depend upon the inductance value of the secondary.

The variable condensers used in the commercial receivers having the F-5 circuit are of .0005 mfd. capacity.

The first audio frequency transformer has a ratio of 5:1; the second, 3 1/2:1.

The aerial length has little effect upon the dial settings, as there is compensation by means of the three binding posts marked "S," "M" and "L," for, respectively, short, medium or long aerials. The recommended length is about 150 feet. This is the length of wire (it is wound on a built-in reel of aluminum), supplied with the "portable" model, F-5 receiver. A flexible ground lead 15 feet long is supplied. Complete with tubes and batteries, the weight is about 37 pounds.

Shock-absorber sockets are used. Grid leak value will probably be about as usual—two megohms. The "C" potential required for the audio frequency amplifier grids is secured by utilizing the voltage drop occasioned by placing the rheostats in the "A" battery negative lead. This eliminates the need for a "C" battery, the patent on the use of which is held by the American Telephone and Telegraph Company, which, in turn, has

licensed but a few companies to use the patent.

(202) GAROD NEUTRODYNE

Q. 1. Please show the Garod Neurodyne circuit, but using one stage of audio frequency amplification instead of two stages.

A. 1. We are showing this circuit in these columns.

All the neutroformers use 3-inch tubes for the secondaries. The primaries, on tubes 2 3/4 inches in diameter, fit just inside the filament end of the secondaries. Neuroformer N-1 has a primary of seven and one-half turns of No. 24 D.C.C. wire, the same wire being used throughout.

The secondary comprises 70 turns. Neuroformers N-2 and N-3 each have four one-half turn primaries and 65 turn secondaries. These two neutroformers are tapped 22 turns from the filament end of the secondary. Neuroformer N-1 is tapped in the center. They must be placed at the usual non-inductive coupling angle. All coils are wound in the same direction.

It will be noted that the connections to both the primary and secondary of neuroformer N-2 are reversed.

A variable detector grid leak may be used. Standard neutralizing condensers may be used. While the point of neutralization is quite sharply defined, it is not difficult to find.

Although Stromberg-Carlson 4.3:1 ratio audio frequency transformers are used, any

other good make of transformer may be used.

This set is extremely selective, sensitive and clear reproducing. Signals are also very strong. "B" battery consumption is unusually low. All this is explained by the high negative "C" potential, the detector grid return to "A" negative, the one-quarter megohm resistances, correctly placed and proportioned condensers, and carefully designed neutroformers. Of course, the audio frequency amplifier must be well designed in order to maintain the high quality signals of the detector circuit.

(203) ROBERTS "KNOCK-OUT" REFLEX SET

Q. 1. Please show and describe the Roberts circuit using a "C" battery and one of the forms of neutralization. Are any changes required when using the No. 285 General Radio audio frequency transformers?

A. 1. We are showing this circuit in these columns. In addition to the variable detector leak "R," which may be a Bradley-leak, one more leak of the same range will be required across each of the secondaries of the audio frequency transformers when using the No. 285 transformer mentioned above. The fixed condenser values indicated cannot be considered as exact. It may be necessary to use larger or smaller values than, the e shown. This is particularly true of the .002 mfd. fixed condenser. Also, the .0001 mfd. fixed condensers shown in shunt (parallel) to

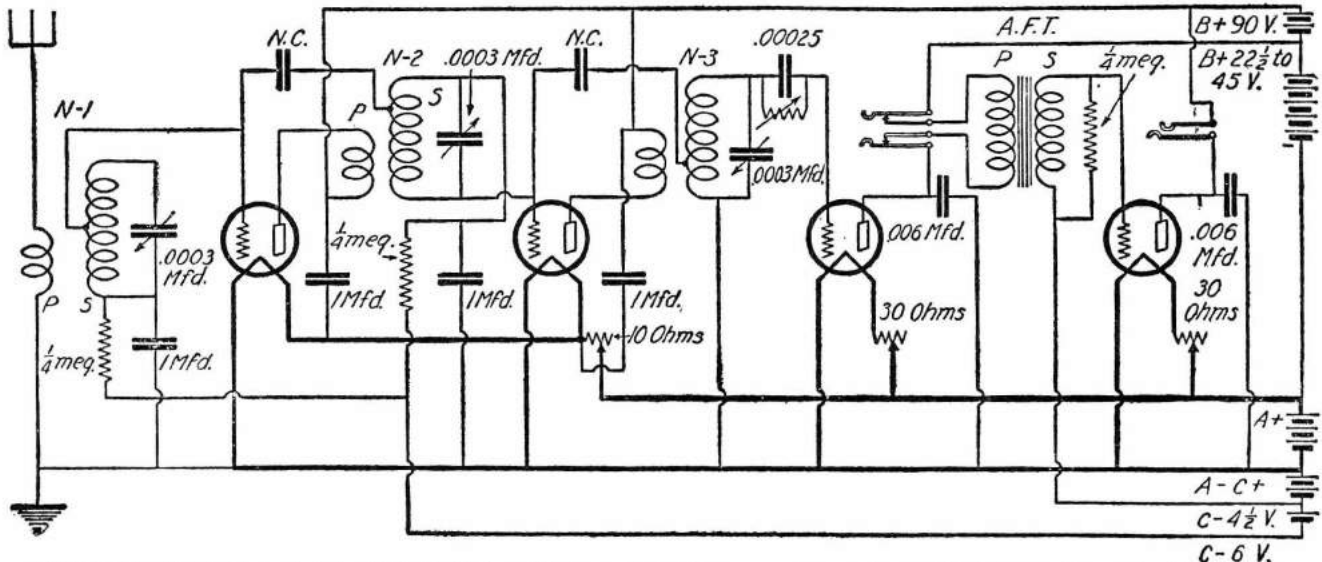

(202) The Garod Neurodyne. A study of this circuit shows it to be one difficult to surpass, where a prime requisite is tone quality, yet also, it is extremely sensitive. Although reception may be excellent at the detector, a very careful audio frequency amplifier design must be employed to retain this quality. Note resistances in the radio frequency amplifier grid return leads.



the primary and secondary of the audio frequency transformer in the grid circuit of the first tube should be varied in value to determine the best capacity.

If the small neutralizing condenser "N.C." should accidentally short circuit, it would cause the total "B" potential to be applied to the tube filaments, thus burning out all the tubes. To prevent this, we are showing a "stunt" in the form of a large fixed condenser which may be of about .001 mfd. capacity. This has practically no effect on the functioning of the neutralizing condenser and it serves as an added protection to the tubes. If this fixed condenser is not available, the circuit is indicated by the dotted line.

The aerial inductance "L" may consist of about 55 turns of No. 20 D.C.C. wire, tapped in the center and wound on a three-inch tube or on a spiderweb form.

Once adjusted, the aerial condenser need not be changed unless the aerial is changed.

The most difficult parts of the set are the windings comprising unit N-1. This unit is now being manufactured with spiderweb coils. There are two ways of making this four-part unit. One is to wind the coils in cylindrical shape and the other is to wind the wire on spiderweb forms. S and F denote the start and finish of a two-wire coil made by winding two wires, side by side, at one time. The wire used should not be larger than No. 26 D.C.C. It is advisable to have one wire colored so that there will be no mistakes when making connections. It has been found that the radio frequency tube may be neutralized much easier if these two wires are first twisted. Twenty turns of this twisted wire are wound on a spiderweb form or a three-inch tube. This leaves four connecting ends, two at the start ("S" and "S") and two at the finish ("F" and "F"). The finish of one coil ("F") and the start of the other coil ("S") are connected together. On a second spiderweb form, placed about one-half inch from the first, are wound about 45 turns of No. 22 D.C.C. wire. If the three-inch tube is being used, the same number of turns may be wound, starting one-quarter inch from the starting end of the 20-turn coil. At the finishing end of the 20-turn coil is placed the rotating tickler ("rotor"). This may be of about 22 turns. If spiderweb forms are being used, the tickler may be of about the same number of turns placed on one of these forms and variably coupled to the secondary.

The variable condenser rotor plates are indicated by the arrowheads.

Use from 90 to 125 volts "B" battery and a "C" potential of 4 to 6 volts.

This circuit is sensitive, selective and very loud. The quality of reproduction depends greatly upon the inductive relations of the

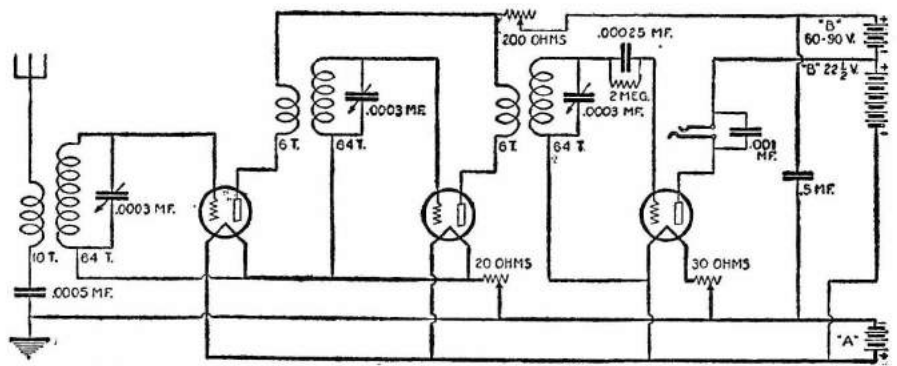

(203-A) The principle of the Kompentrol is illustrated. It is seen that a series resistance of 200 ohms, connected in the plate circuit of the radio frequency stages, controls the tendency of the circuit to oscillate. In making up such a receiver it is quite necessary that the coils be in non-inductive relation, in order to have maximum amplification from each tube.

various coils, as will be evidenced by a little experimentation with the circuit. Aerial length seems to have very little effect on this receiver, in the matter of selectivity.

The quality of reproduction will be improved somewhat by connecting the detector variable grid lead to "A" minus instead of to "A" plus, although the sensitivity is not then quite as great.

The aerial coil must not be in inductive relation to the balance of the coils in the set.

If the secondary coil can be arranged to have a variable inductive relation to the double-wire plate coil, the coupling point for best operation may be easily found.

Q. 2. I hope you will not mind furnishing the construction data and circuit diagram of the Kompentrol receiver. It seems very selective, even though a resistance is used to stop circuit oscillation.

A. 2. While the Kompentrol radio set incorporates two stages of audio frequency amplification we are showing the circuit without audio amplification, which is standard. (203-A)

Any convenient coil construction may be followed. You may wind a 3-inch coil to the number of turns shown, with No. 22 D.C.C. wire. The primary may be alongside, or over, one end.

If you wish to use variable condensers of .0005 mfd. capacity, reduce the number of grid coil turns to 45 or 50.

For best results it is necessary, as in practically all tuned radio frequency receivers, to have the lowest possible stray field coupling. This is secured by paying close attention to the coil angles and to the wiring and placement of the equipment.

The 200-ohm resistance may be a potentiometer. Greater quality and less sensitivity will result by connecting the detector grid return lead to "A" minus instead of "A" plus.

(204) MAGNAVOX ONE-DIAL SET

Q. 1. What is the circuit of the Magnavox one-dial receiver type TRF-5?

A. 1. The circuit of this and the type TRF-50 receiver is shown.

Condensers "C" are variable between .00001 and .00015 mfd. These are called "ratio" condensers. They are controlled by the three white porcelain knobs. When a distant station is being received, these three ratio condensers are varied until maximum signal strength is reached, and need not again be adjusted unless the set is moved or the tubes are changed.

When balancing the tuned circuits, it is advisable to make the adjustments while a low wave-length station is operating. If the variable ratio condensers are adjusted for a high wave-length station, there is a possibility of circuit oscillation when receiving stations at the shorter wave-lengths.

The radio frequency choke may consist of 300 turns of No. 30 D.S.C. wire, wound on a 2-inch tube.

It will be noticed that no detector grid leak is used in the manufactured set. The experimenter may wish to use the customary grid leak from the detector grid to "A" plus. A variable one will be satisfactory.

Audio frequency transformers having a ratio of about 3:1 will probably be found best.

Variometer V-2 may be tapped at about 8 to 15 turns from one end of the stator

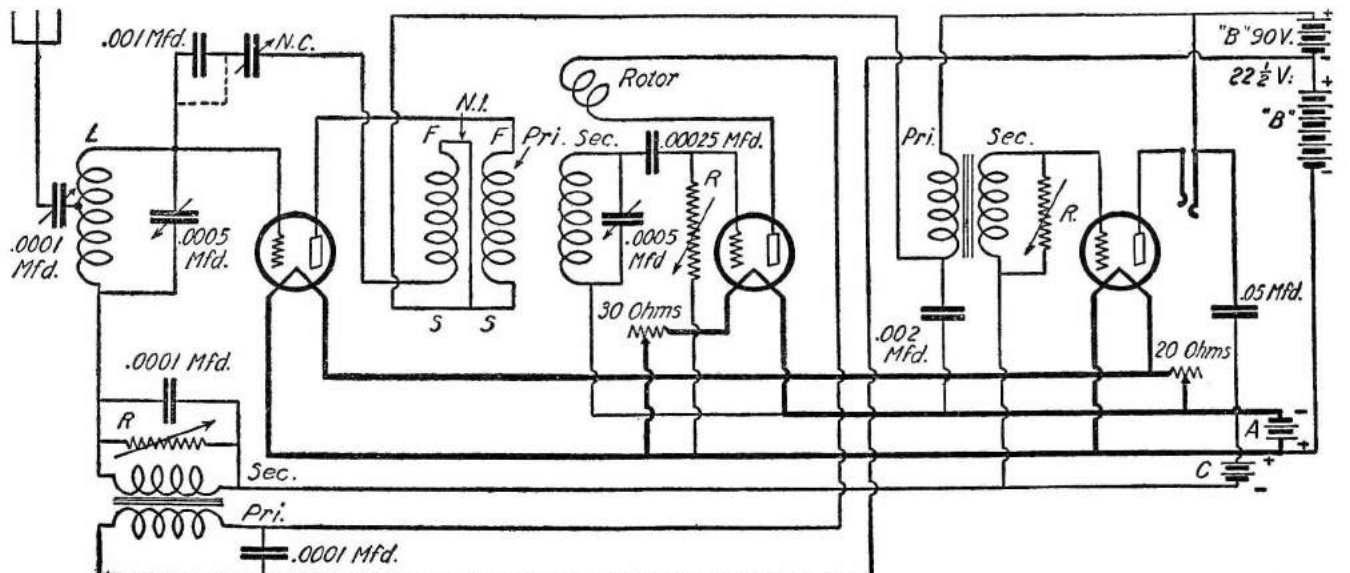

(203) Roberts' non-oscillating reflex. One of the latest reflex circuits. Careful construction will result in an excellent receiver. It is advisable to experiment somewhat with this circuit as slight changes, particularly in coil relations, effect the reproduction quality.

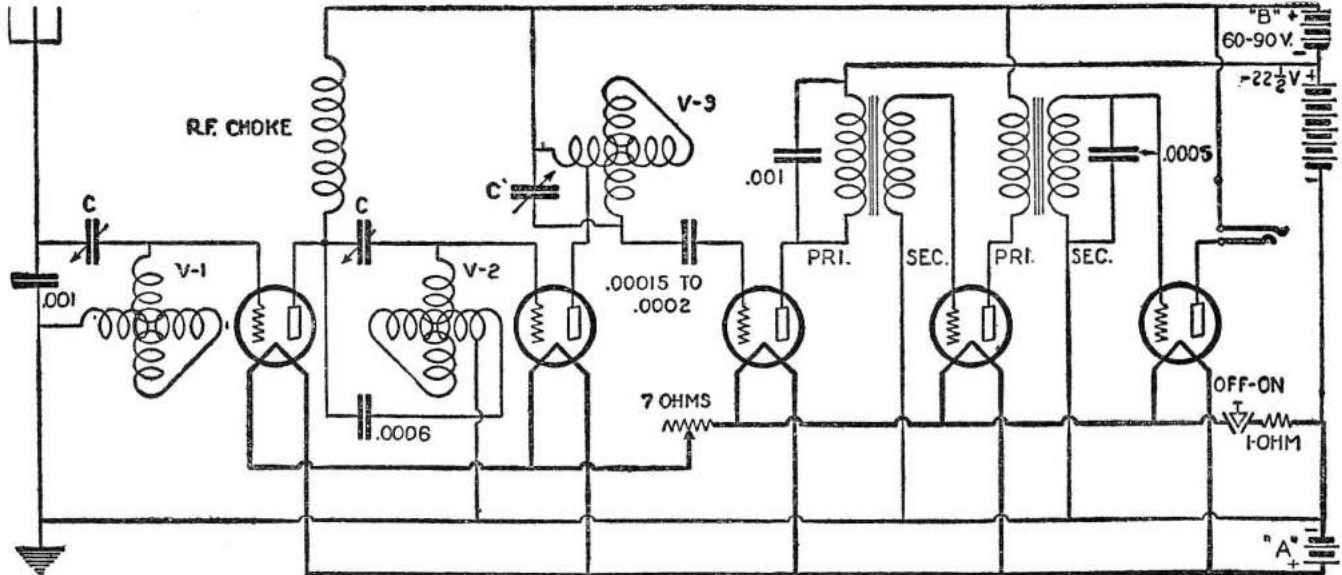

(204) The Magnavox One-dial Receiver has aroused considerable interest by reason of the excellent results that have been secured by its owners. Tiny white knobs control the "ratio condensers" used to balance the circuits to the particular tubes and local conditions encountered.

winding, as shown, the exact number of turns being determined by experiment. Variometer V-3 may be tapped 5 to 10 turns from one end of the stator winding. The three variometers are mechanically arranged to be controlled by a single dial.

The 7-ohm rheostat is marked "Volume Control," and used in the following manner: With "Volume Control" at maximum, a whistling note is heard on tuning in a station. Turning "Volume Control" towards minimum, thus reducing the filament current of the first two radio frequency amplifier tubes, will now eliminate the whistle.

These are not the most efficient form of inductance, solenoid coils (the type of coil made by winding a single layer of wire on an ordinary tube) being best from a "loss" standpoint, but this type of coil is being used by radio set manufacturers to a great extent, because they do not have as strong an external field as solenoids, a fact which makes it much

Q. 2. What is the new Flewelling circuit?  
 A. 2. This circuit will be found on the next page. It is essential that resistances be smoothly variable over a wide range. A Bradley-leak will be particularly suitable. A Turnit would also be satisfactory, in some cases. Hand-capacity is very pronounced, when adjusting the value of this leak. For that reason the unit should be so placed and mounted as to be adjustable through an insulating control rod.

Since both the movable and stator plates of the variable condenser are at higher-than-ground potential, capacity effects will be very objectionable when tuning in, unless grounded-frame condensers are used, or some form of remote control of the standard type of condensers is possible.

No aerial and ground are used with this set. The rotor and stator of the tuning unit both contain 50 turns of wire. A low-loss form of winding is very necessary. Two 50-turn spiderwebs will be satisfactory, one being in variable inductive relation to the other.

Note the large size of the detector grid condenser.

A continuous, high-pitched whistle should be heard when the set is operating properly. This is the "variation frequency" characteristic of super-regenerative receivers. Since no aerial and ground are required, radiation from this receiver is very slight.

Q. 3. Where do the color marked cords of the Atwater-Kent model 9 receiver connect?

A. 3. The cord key is: White, ground; black, -"A"; red, +"A"; green, -"B"; yellow, +20; brown, +"B." Yellow is for the detector plate battery and the brown is for the amplifier plate battery.

(205) AIRTROLA NON-OSCILLATING RECEIVER

Q. 1. Please show the schematic circuit of the Airtrola receiver. This uses an adjustment called the "Compentrol" for controlling oscillation.

A. 1. We are showing this circuit in these columns.

The "Compentrol" unit comprises the three-turn coil wound on the outside of the secondary and connected through the 200-ohm (or 400-ohm) variable resistance. A standard potentiometer may be used as these are obtainable in 200- and 400-ohm size.

The construction of the tuned radio frequency transformer containing this absorption coil is shown in the drawing marked "205." The tuned radio frequency coils must be placed in non-inductive relation to one another. The winding having terminals one and two is the stabilizing coil. This set is being shown without the second stage of audio frequency amplification since this is standard.

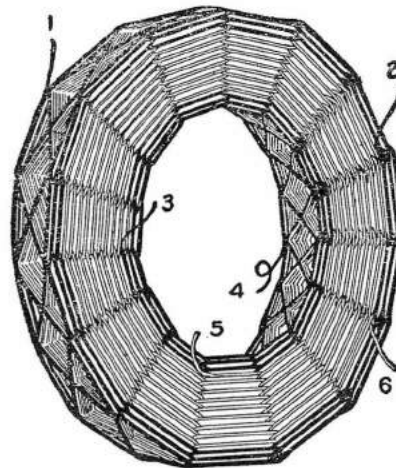

(205) The "shorted turns" method of preventing oscillation in tuned radio frequency receivers is described in the text referring to this inductance coil.

easier to prevent coupling of the fields. If the fields couple, undesirable oscillation starts.

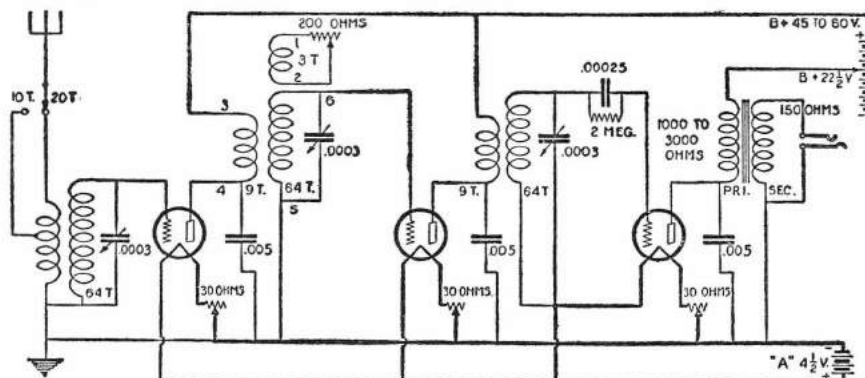

(205-A) The "Airtrola," shown above, and the "Radio Knight" tuned radio frequency receivers both use the "absorption loss" method for preventing oscillation in such receivers. Varying the amount of loss, or absorption, of the circuit by means of a variable resistance makes it possible to adapt the set to any tubes and particular set conditions for maximum results.

(206) E.I.S. NAVY MODEL C-10, 50- TO 600-METER SUPER-HET.

Q. 1. What is the schematic circuit employed in the 50- to 600-meter super-heterodyne of the Experimenters Information Service design? Any constructional details you can furnish will be greatly appreciated.

A. 1. This extremely efficient circuit is being illustrated and described in these columns. The difficulties that will be encountered in properly constructing this receiver are apparent to the experienced constructor. As is true in building all radio sets, the use of correct parts is half the battle.

The Navy Model C-10, as it is called, has the highly desirable feature of plug-in coils. Design data given below shows that it is convenient to receive signals from stations operating on as low as 50 meters. This makes it possible to listen in on the short-wave phone and code experiments of this and

many other countries. The following corrected list will be of great interest, particularly to those contemplating building the E.I.S. Model C-10 set, or even the more standard types of short-wave receivers, such as the one fully described on page 372 of the April, 1925, issue of *The Experimenter* magazine; page 596 of the July, 1925, issue of *The Experimenter*, and page 16 of the July, 1925, issue of *Radio News*.

Wave-length	Call letters	Location
20.0	POX	Nauen, Germany
25.0	2YT	Poldhu, England
25.0	POY	Nauen, Germany
26.0	POX	Nauen, Germany
30.0	8GA	Paris, France
30.0	2XI	Schenectady, N. Y.
32.0	2YT	Poldhu, England
35.0	2XI	Schenectady, N. Y.
36.0	LPZ	Buenos Aires, Argentine
38.0	2XI	Schenectady, N. Y.
40.0	1XAO	Belfast, Me.
42.0	FW	Paris, France
43.0	WIR	New Brunswick, N. J.
47.0	POZ	Nauen, Germany
50.0	NKF	Anacostia, D. C.
56.0	KFKX	Hastings, Neb.
58.79	KDKA	East Pittsburgh, Pa.
60.0	1XAO	Belfast, Me.
60.0	2YT	Poldhu, England
62.0	KDKA	East Pittsburgh, Pa.
67.0	8XS	East Pittsburgh, Pa.
70.0	POX	Nauen, Germany
74.0	WIR	New Brunswick, N. J.
75.0	8GB	Paris, France
75.0	WGN	Rocky Point, L. I.
76.0	POX	Nauen, Germany
83.0	RDW	Moscow, Russia
84.0	NKF	Anacostia, D. C.
85.0	8GB	Paris, France
86.0	NQC	San Diego, Calif.
90.0	6XO	Kahuku, T. H.
90.0	1XAO	Belfast, Me.
92.0	2YT	Poldhu, England
94.0	2YT	Poldhu, England
95.0	SFR	Paris, France
96.0	8XS	East Pittsburgh, Pa.
99.0	6XI	Bolinas, Calif.
100.0	POX	Nauen, Germany
100.0	2XI	Schenectady, N. Y.
100.0	NAM	Norfolk, Va.
103.0	WGH	Tuckerton, N. J.
105.0	WHU	S. S. "Big Bill"
107.0	2XI	Schenectady, N. Y.
112.0	1XAO	Belfast, Me.
115.0	FL	Paris, France
120.0	1XAO	Belfast, Me.
146.0	6XO	Kahuku, T. H.

In addition to, the above list, we are publishing an available record of "N" stations operating on short waves. However, these listings are only approximate and are more variable than the ones shown above:

Call	Location	Wave-length
NKF	Bellevue, D. C.	20, 41.6, 54.4, 71.5, 81.5
NPM	Honolulu, T. H.	49
NPG	San Francisco, Calif.	40, 43, 81
NPU	Tutuila, Samoa	53

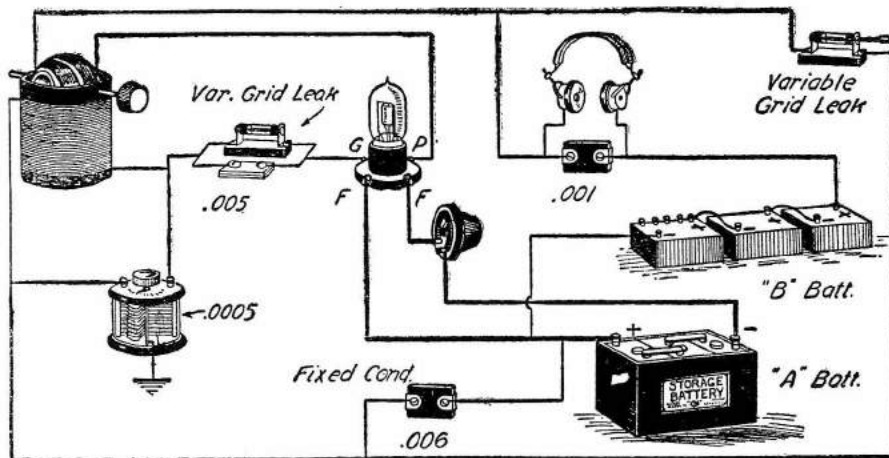

(205-B) The latest Flewelling circuit. The frame of the variable condenser, insulated from both sets of plates, is grounded. Thus hand-capacity, otherwise present, is eliminated. It is essential that very efficient variable leaks be used.

NBA	Balboa, C. Z.	54
NPO	Cavite, P. I.	70
NAJ	Great Lakes, Ill.	76
NEL	Lakehurst, N. J.	80
NFV	Quantico, Va.	77.4
NPL	San Diego, Calif.	71.7
NOG	San Diego, Calif.	70.5
NAL	Washington, D. C.	20.0, 30.6
NRRL	U.S.S. Seattle	40
NEPQ	U.S.S. Relief	20
NDF	U.S.S. California	119 to 149
NIRX	U.S.S. Canopus	75
NERM	U.S.S. Los Angeles	70 to 84.5
NOW	U.S.S. Mexico	40
NUQB	U.S.S. Pope	75
NITZ	U.S.S. Sturgeon Bay	150
NEDJ	U.S.S. West Virginia	119 to 149

M	Mexico
N	Netherlands
O	South Africa
P	Portugal
PI	Philippine Islands
Q	Cuba
R	Argentine
S	Scandinavia (Denmark, Finland, Iceland, Norway, Sweden).
U	United States
Y	Uruguay
Z	New Zealand

If the experimenter cares to design coils for the reception of wave-lengths up to about 1,000 meters, the following compendium of long-wave broadcast stations will be of interest.

For wave-lengths above 1,000 meters the experimenter is advised to use a different type of receiver from the super-heterodyne.

Wave-length	Call	Location
550	OKP	Prague, Czechoslovakia
550	YN	Lyons, France
570	PRG	Prague, Czechoslovakia
600	CD	Ocean Falls, B. C.
600	OHW	Vienna, Austria
600	SPE	Rio de Janeiro, Brazil, S. A.
650	—	Honegg, Switzerland
650	—	Zurich, Switzerland
680	SASD	Sundsvaal, Sweden
750	—	Berlin, Germany
(1) 775	—	Copenhagen, Denmark
800	2BZ	Calcutta, India
(6) 850	—	Kiev, Russia
(7) 850	HB2	Lausanne, Switzerland
900	FND	Dijon, France
900	—	Abbeville, France
940	—	Leningrad, Russia
950	MT1	Budapest, Hungary
950	HB	Budapest, Hungary
(5) 950	—	Odense, Denmark
1010	—	Moscow (Sokolniki Station), Russia
1050	PX9	Amsterdam, Holland
1050	NSF	Hilversum, Holland
1050	PCMM	Ymuiden, Holland
1060	HDO	Hilversum, Holland
1070	PCGG	The Hague, Holland
1100	HB1	Geneva, Switzerland
1100	HB2	Lausanne, Switzerland
1100	HBK	Kloten, Switzerland
1100	BAV	Haeren, Belgium
1100	2FC	Sydney, Australia
(3) 1150	—	Ryvang, Denmark
1200	EBX	Cartagena, Spain
(4) 1250	—	Hjorring, Denmark
1250	6WF	Perth, Australia
(8) 1300	LP	Berlin, Germany
1370	SASE	Boden, Sweden
1450	RDW	Moscow (Central Station), Russia
(7) 1525	NRD	Toulouse, France
1590	DS	Iroquois, Canada

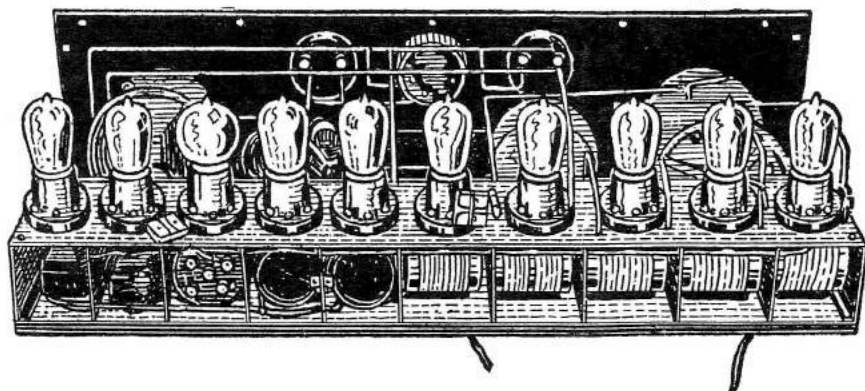

(206) How "the makin's" of the E.I.S. super-heterodyne look when put together. All the sockets are on a metal panel or a strip. General Radio No. 271 L.F. transformers and filter were used. Note vertical shields between each unit.

(206) View of a receiver built from the circuit shown below. The panel is engraved. A well-balanced appearance has been obtained without sacrifice of efficiency.

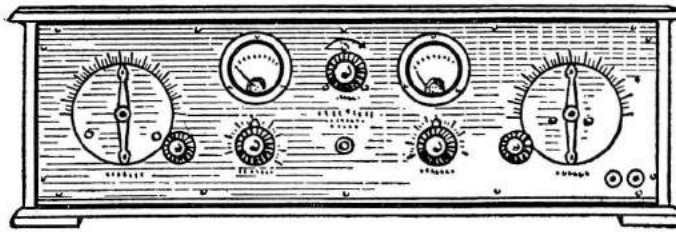

- 1590 DT Twin Falls, Ontario
- (2) 1600 5XX Daventry, England
- 1600 CD Ocean Falls, B. C.
- 1600 — Issy-sur-Molineaux, Fr.
- 1625 HFF Belgrade, Yugoslavia
- 1650 EGC Madrid, Spain
- 1650 — Rakovitzka, Yugoslavia
- 1680 GED Croyden, England
- 1780 SFR Clichy (Radio-Paris), Fr.
- 1780 8AJ Paris, France
- 1800 KAV Norddeich, Germany
- 1800 OKB Brunn, Czechoslovakia
- 1900 DV Victoriaville, Que., Can.
- 1900 DW Gouin Dam, Que., Can.
- 1900 DX Quebec, Canada
- 1900 DY Thetford Mines, Quebec, Canada
- 2200 EGC Madrid, Spain
- 2400 OXE Lyngby, Denmark
- 2500 SASE Boden, Sweden
- 2500 YG Tours, France
- 2650 FL Paris (Eiffel Tower), Fr.
- 3000 DO Glace Bay, Nova Scotia
- 3300 DQ Markham, Ontario
- 4000 LP Konigswusterhausen, Germany.

The references given are as follows:

- (1) Closed for repairs. See Ryvang.
- (2) Replaces Chelmsford; relays 2LO emissions with 25 k.w.
- (3) Substitute for Copenhagen.
- (4) Ryvang program relay.
- (5) Ryvang program relay.
- (6) All announcements in IDO.
- (7) Aerodrome.
- (8) Konigswusterhausen Station.

The 750-ohm resistances are non-inductive.

One of the most interesting features of this modern super-heterodyne is the single dial control of three variable condensers, each of .00025 mfd. capacity. These condensers must be absolutely precise in their construction, else the individual capacity curves will vary slightly at a given dial setting, resulting in greatly reduced sensitivity and selectivity. Hogan Patent No. 1,014,002 covers this single control of a multiplicity of condensers.

The three individual condensers comprising the three-condenser unit are shielded from one another and the multiple unit is shielded from the two remaining variable condensers in the set, which two are already shielded in themselves.

If other variable condenser values are used,

entirely different coil construction will be required and we are not prepared to furnish exact coil data for other coils than those herein described. This, because a certain amount of experimental verification would be required and it is not possible at this time to undertake these experiments.

The first three tubes acting as radio frequency amplifiers of the incoming signal at the regular broadcast wave-lengths are called the *direct radio frequency amplifier bank*.

Straight-line frequency condensers may be used, having the maximum capacities mentioned, if the calibration is desired to indicate frequency. Or, straight-line wave-length condensers may be used, having the maximum capacity mentioned, if indication in terms of wave-length is desired.

A vernier adjustment of the three-gang and oscillator condensers is absolutely required.

Condenser "C-1" will have a value depending upon the constants of the particular aerial system used. Any one of the new, unusually small variable condensers having a maximum capacity of about .0005 or .00025 mfd., and adjusted by means of a screwdriver, may be used, or it may be of either of these two capacities, and non-adjustable, if either of these two values is correct for the aerial system used.

When the set is first tested, it is advisable to try each unit as it is completed. When the *direct radio frequency amplifier bank* and first detector are fully wired, it is very easy to test it. With a pair of head-phones connected into the circuit in place of the primary of the first intermediate frequency transformer, as shown by the dotted lines, signals should be heard clearly, loudly and undistorted, from stations at considerable distances. It will be necessary to connect a fixed condenser, "C-2," of perhaps .00025 mfd. capacity, across the head-phones, as also indicated by dotted lines. This condenser will probably not be needed with the long-wave transformers, although this is dependent upon the design of the transformers.

If the diagram is studied a bit it will be seen that with the arrangement mentioned above, we have a standard four-tube set consisting of a tube detector preceded by three stages of short-wave amplification with each stage tuned by means of variable condensers. The wave-length at which this four-tube system will operate is dependent upon the inductance and capacity in the tuning circuit,

as usual. By arranging the inductances in four sets, and fixing them so that each set can be plugged into receptacles in nearly the same manner as the well-known honeycombs, it becomes possible to tune as low as 50 or 60 meters, or even lower, if the experimenter cares to design coils for the lower wave-lengths, and up as high as 600 meters, or higher, if, once again, the experimenter cares to design coils to go higher than this, although in this direction, 1,000 meters is about the highest practical wave-length to which designers proportion a super-heterodyne to respond. The design for four sets of plug-in units (of which there are five—four of the *direct radio frequency amplifier bank*, and one for the oscillator tube circuits) to cover the wave-lengths between 50 and 600 meters will be found on the opposite page.

After this four-tube unit is working properly, the oscillator tube is inserted in its socket and, if everything here is wired correctly, a whistle will be heard as the oscillator tuning dial is adjusted so that the oscillator output frequency heterodynes with the incoming signals. If this whistle is not heard, test the oscillator for circuit oscillation. Methods for testing the oscillator and other parts of a super-heterodyne are given in the articles listed in *Radio News* below:

- "The L-1 Ultradyne," February, 1924, page 1058.
- "The Tropadyne," August, 1924, page 170.
- "The L-2 Ultradyne," January, 1925, page 1189.
- "The Pressley," February, 1925, page 1438.
- "Second-Harmonic Super-Heterodyne," May, 1925, page 2110.
- "The Super-Unidyne," September, 1925, page 328.
- "Matching Tubes," April, 1925, page 1899.
- "Some Super-Heterodyne Notes," March, 1925, page 1666.
- "L-1 Ultradyne Notes," April, 1924, page 1419.
- "Matching Transformers," July, 1924, page 51.
- "Super-Heterodyne Notes," October, 1924, page 492.
- "Tropadyne Notes," November, 1924, page 691.
- "A New Super-Heterodyne," October, 1925, page 444.

The shielding is of 1/8" inch sheet zinc, polished, and lacquered with a light coating of white shellac. The shielding is grounded to "A" minus, as usual.

The selection of audio frequency transformers is optional. A good combination is a ratio of about 6:1 for the first audio frequency transformer and about 2:1 for the second one. In order to use successfully the high ratio of 6:1 it is essential that only the highest grade transformer be selected; a transformer of poor design may easily have a turns ratio of 6:1 (six times as many turns on the secondary as are in the primary), but

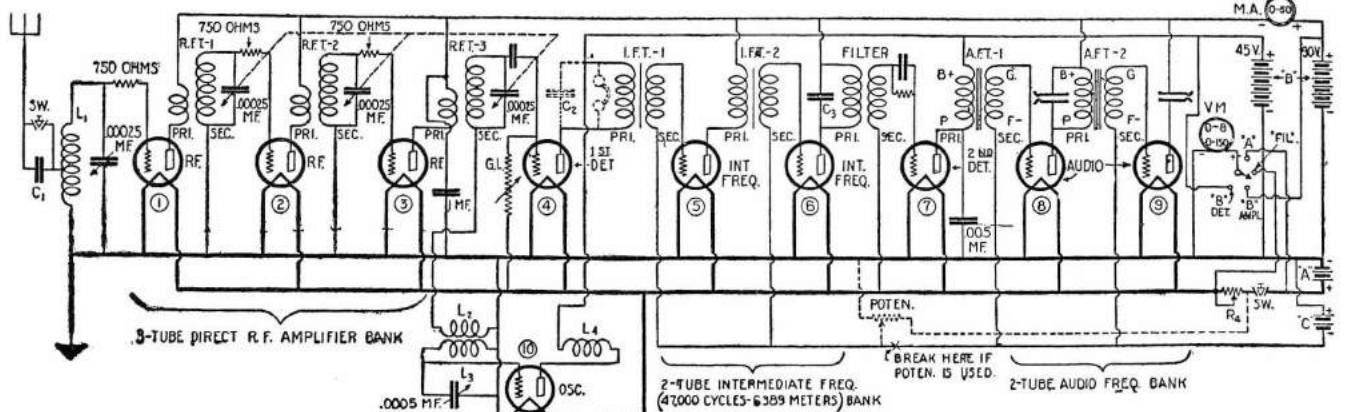

(206) The Experimenters' Information Service Navy Model C-10 super-heterodyne designed for a wave-length range from 600 meters down to 50 meters, the band being covered through the expedient of interchangeable coils. Blueprints are not available.

made on such skimpy lines as to be a total failure in this circuit, or any other circuit where considerable amounts of current are to be handled.

The writer would recommend that the experimenter use impedance coupling instead of transformer coupling for extreme audio quality, in conjunction with UX-112 tubes, 6 to 9 volts grid bias and a "B" potential of 140 to 150 volts. A particularly desirable form of impedance coil is the Thordarson "Autoformer," consisting of only one winding. Because it has a tap taken from part of the winding, the instrument becomes an "auto-transformer," having, therefore, a small voltage step-up of 1½:1.

It is suggested that a battery cable be used to connect the batteries to the set. This will modernize the receiver to the extent of eliminating the need for binding posts. The color code may be:

- Black A—B—C+
- Red A+
- Brown C—
- Green B+45V.
- Yellow B+90V.

The separate 45-volt "B" battery should be used to supply the plate potential of the first detector, second detector and oscillator. The experimenter may use the regular 90-volt "B" battery, however, and tap at 45 volts, as a matter of experiment, but reproduction will be better if two separate batteries are used. Batteries must be kept at full charge.

The volt-meter switch makes it possible to indicate at will, the potential of the "B" battery, the "A" battery, and the voltage actually applied to the terminals of the vacuum tubes, after having passed through the rheostat. This "terminal voltage" will be about 5 volts for UV-201A type tubes.

"R-4" is a ¾-ohm rheostat. It may be connected in the usual way, or it may be connected in the manner recommended in the circuit. Although separate rheostats could have been used for the various tube banks, there is no question but that construction and operation are simplified in the use of the single rheostat, "R-4." If UV-201A tubes are used, the rheostat must be capable of carrying at least 2½ amperes continuously. It is recommended that the Western Electric 216A tube be used as the second detector (7), if best quality is desired. Since this tube will consume .96 amperes at 5 volts, the potential that will be applied to, this tube with all the other tubes in operation (the rated consumption of the WE-216A is 1. amperes at 6 volts), the rheostat must be able, in this case, to carry about 3½ amperes.

The bias required to prevent oscillation of the intermediate frequency amplifier circuits is entirely a matter of experiment. It is dependent upon the construction of the transformers selected. In the original set the amount of grid bias is determined by experiment, after which there is no variation in this part of the circuit for greater sensitivity by more complete control of grid bias potential of tubes (5) and (6). The writer would prefer to connect a 400-ohm potentiometer in the standard fashion indicated in dotted lines. The value for the filter coils and condenser C-3 are dependent upon the intermediate frequency transformers selected. It will be necessary to use the filter coupler designed for these transformers.

For extreme sensitivity the grid leak of detector tube (4) may be variable. The usual .00025 mfd. fixed condenser and two megohm grid leak are used in the grid circuit of detector tube (7). Tube (4) grid condenser is .00025 mfd.

As previously stated, the wave range of 50 to 600 meters is made possible by arranging the coils in plug-in fashion. The method of doing this is pictured and described in the June, 1925, issue of *Radio News*, page 2259, and *The Experimenter* magazine of July, 1925, page 596. The actual constants for the coils are given in the table below:

APPROXIMATE COIL WAVE-LENGTH

A	Approx. 55 to 110 Meters
B	100 " 100 to 220 "

C	"	180 to 370	"
D	"	225 to 550	"

UNITS L-1

- A Coil 30 Turns, Tap At 3 Turns
- B Coil 54 Turns, Tap At 10 Turns
- C Coil 70 Turns, Tap At 7 Turns
- D Coil 110 Turns, Tap At 11 Turns

UNITS R.F.T.-1, R.F.T.-2, R.F.T.-3

- A Pri. 3 Turns—Sec. 30 Turns
- B Pri. 4 Turns—Sec. 34 Turns
- C Pri. 5 Turns—Sec. 70 Turns
- D Pri. 6 Turns—Sec. 110 Turns

No. 28 D.C.C. No. 32 D.C.C.

Both coils are wound in the same direction. Secondary is wound on tube 1¾-inches in diameter. Primary is wound over the filament end of the secondary. Primary and secondary are separated by Empire cloth or paper.

L-2, L-3, L-4 OSCILLATOR UNIT

- A L-2, 3 Turns L-3, 30 Turns L-4, 15 Turns
- B L-2, 4 Turns L-3, 54 Turns L-4, 27 Turns
- C L-2, 5 Turns L-3, 70 Turns L-4, 35 Turns
- D L-2, 6 Turns L-3, 110 Turns L-4, 50 Turns

No. 28 D.C.C. No. 32 D.C.C. No. 32 D.C.C.

All coils are wound in the same direction. Pick-up coil L-2 is wound over the filament end of grid coil L-3; Empire paper or cloth insulation. L-3 is wound on a 1¼-inch tube. One-eighth of an inch from coil L-3 is wound plate coil L-4.

It must be pointed out that the voltmeter switch will short-circuit the "B" battery if the switch-points are not arranged sufficiently far apart to prevent the switch arm's touching two points at once.

(207) THE HETEROPLEX

Q. 1. Is it possible to add a push-pull audio frequency amplifier to the Heteroplex receiver, without using the usual system employing center tapped transformers? I do not want to use resistance-coupled push-pull amplification, because the amplification is not as great. Please give construction details for the Heteroplex.

A. 1. A very clever arrangement permitting push-pull audio frequency amplification with standard audio frequency transformers of any good make is incorporated in the Heteroplex circuit shown in these columns. The values for "R" and "R-1" are somewhat experimental. For "R" we suggest two one-half or one-megohm leaks. For "R-1" we suggest two 10,000- to 100,000-ohm resistances.

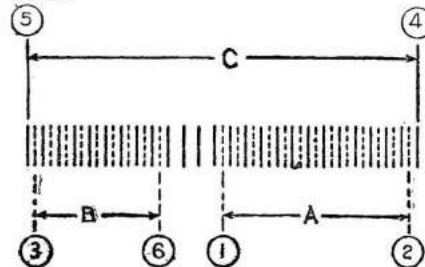

(207-A) A cross-section of the Heteroplex tuning unit. The three windings are clearly indicated.

If you have never seen a Heteroplex coil, you may find it difficult to catch on to the way this unit is made. It consists of three windings which we have lettered "A," "B" and "C." Grid tuning coil "C" consists of 40 turns of No. 26 S.S.C. wire wound on a tube three inches in diameter. Note that this coil has every turn spaced the distance of a No. 22 wire. This was accomplished by winding 40 turns with two wires, one a No. 26 and the other a No. 22. This makes a total of 80 turns (40 turns to each size wire). The last manoeuvre is to count down 11 turns from end "5" of the coil and cut the No. 22 wire. Count 24 turns of the No. 22 wire, from end "4," and again cut the No. 22 wire. Throw away the five turns of No. 22 wire remaining. Coil "B" is the 11-turn coil sep-

arated from the 24-turn coil "A" by about one-quarter of an inch. Try reversing the connections to coil "C." Sketch 207-A shows "C" as solid lines; coils "A" and "B" are represented by the dotted lines. To reach the full wave band it will probably be necessary to use a good fixed condenser connected across the variable one, as shown by the dotted lines in 207.

Q. 2 Please print general information on the present status of broadcasting, such as number of stations, minimum and maximum power used, etc.

A. 2. We have had a goodly number of our readers ask that question. The data is as follows:

Radio broadcasting is considered to have started when station KDKA, East Pittsburgh, Pa., broadcast the Harding-Cox Presidential Election Returns, November 2, 1920.

Although not done originally, new stations are given the prefix "W" if located East of the Mississippi, and "K" if located West of that river.

There is a total of 580 stations operating within the broadcast limits of 200 and 545 meters. (July 1, 1925.)

If found necessary to prevent congestion, new class "A" stations may be assigned to wave-lengths as low as 150 meters (2,000 kilocycles). Also, a few of the present class "A" or class "C" stations may be transferred to the lower region (of wave-lengths).

Station WGY, Schenectady, N. Y., is now doing experimental simultaneous transmission on four wave-lengths: 1,660 meters (2XAH), 379.5 meters (WGY), 109 meters (2XX), and 38 meters (2XAF). Reports on comparative reception are desired.

On Independence Day, July 4, 1925, 28 stations were linked for simultaneous transmission, the largest number mobilized to date. This was "some" hook-up.

Stations are listed as class A, B or C. Details appear below.

Class A

Broadcast stations in this class operate on the wave-length band between the limits of 200 and 280 meters. There are 465 of these stations. No minimum power specified; lowest listed, five watts. Maximum power permitted, 500 watts. Mechanical music (phonograph or player piano) may be broadcast. No regular studio requirements to be met. Operating hours may be easily changed. The shortest wave station, WIBD, Joliet, Ill., (200 meters; 1,500 kilocycles) is in this classification.

Class B

Wave-length range, 280 meters (1,070 kilocycles) to 545 meters (550 kilocycles). There are 115 of these stations. Minimum power permitted, 500 watts. Maximum power so far permitted, fifty kilowatts. Class B stations are the cream of all the broadcast stations. To retain their licenses, they must abide by a lofty standard of efficiency. They must continue a program, even though an accident occur to the apparatus. Insurance against interruption must be made in the form of duplicate equipment. If the origin of the program is outside the studio, even duplicate telephone lines must be maintained, in anticipation of possible telephone line trouble. (The use of a portable, short-wave transmitter eliminates the need for telephone line maintenance.) A standardized studio is required. Mechanical music is not permitted.

Class C

This was the classification given to stations that were formerly assigned to the 360-meter (833 kilocycles) wave-length only. The unexpectedly rapid growth of broadcasting quickly caused a congestion at this wave-length. They have all been transferred to the A or B classification, with new wave-length assignments. Class C is extinct.

Super-power stations are being talked of nationally and internationally. Those opposed to the idea are in the majority.

Subcommittee No. 6 (Interference Problems), of the Third National Radio Conference, called October 6, 1924, reported to the Secretary of Commerce, Herbert Hoover, as follows: "From such data as is now available it is believed this object (signal strength not exceeding that of stations local to populous centers) will be attained if the station is so located with respect to populous centers that the distance between it and the boundary of such community will not be less than the quotient obtained by dividing the product of antenna current in amperes times effective antenna height in meters by a constant tentatively set at 100. Experience may make it advisable to modify this constant, but it seems sufficiently conservative to serve for the initiation of this experimental work." It is interesting to note here that station power increase of two or three times the normal amount is noticeable to local receivers only as a slight broadening of the tuning; at a distance, however, reception is far better than with the lower power. Super-power is a successful combatant of strong static conditions.

There is talk of operation at 25 and even 50 kilowatts (25,000 and 50,000 watts) but whether this transmission will be permitted outside of experimental regulations is a question. The only installations we could consider at this time as being in the Super-power class would be the following class B stations rated at over one kilowatt power input:

- 1½ Kw.
  - WTAM..... Cleveland, Ohio
  - WCCO..... Minneapolis, Minn.
  - KYW..... Chicago, Ill.
  - WHT..... Deerfield, Ill.
- 2 Kw.
  - KGO..... Oakland, Calif.
  - KFI..... Los Angeles, Calif.
  - KFKX..... Hastings, Nebr.
  - KOA..... Denver, Colo.
  - WBZ..... Springfield, Mass.
  - WGY..... Schenectady, N. Y.
  - WORD..... Batavia, Ill.
- 2½ Kw.
  - WCBF..... Zion, Ill.
- 3 Kw.
  - WEAF..... New York, N. Y.
- 5 Kw.
  - WLW..... Cincinnati, Ohio
  - WSAI..... Cincinnati, Ohio
  - WOC..... Davenport, Iowa
- 50 Kw.
  - WJZ..... Bound Brook, N. J.

Two class B stations, KSD, St. Louis, Mo., and KFUD, St. Louis, Mo., operate on the longest wave employed for regular broadcast transmission, 545 meters.

It is estimated that there are approximately 6,000,000 receiving installations in the United States at this date.

Stations that pick "out of the air" programs transmitted on one wave-length and re-transmit them on another wave-length, are called "relay stations." The wave-lengths reserved for "relay broadcasting," as it is termed, are:

Meters range	Frequency range (Kilocycles)	Width of the Band (Kilocycles)
26.3 to 27.3	11,400 to 11,000	400
30.0 to 33.3	10,000 to 9,000	1,000
52.6 to 54.5	5,700 to 5,500	200
60.0 to 66.6	5,000 to 4,500	500
105.0 to 109.0	2,850 to 2,750	100

Radio broadcast regulation authority is vested in the United States Department of Commerce.

**(208) RADIOLA SUPER-HETERODYNES**

Q. 1. Please publish full details for the construction of the Radiola Super-Heterodyne.

- A. 1. The Radio Corporation of America does not make this information public.
- Q. 2. Can UV-201A tubes be used with the Radiola Super-Heterodyne?
- A. 2. These sets are designed to use UV-199 tubes only.

**(209) THE RORN CIRCUIT**

Q. 1. Please publish the correct hook-up of the RORN tuned radio frequency amplifier, showing also how to connect it to a CR-9 receiver.

- A. 1. This hook-up will be found in these columns. This amplifier is supplied with a number of output coils, so that it can be used efficiently up to 3000 meters. This output coil is placed in inductive relation to the tuner in the receiving set.

**(210) SECOND HARMONIC SUPER-HETERODYNE**

Q. 1. What is the general principle of the second harmonic heterodyne frequency used in the new Armstrong Super-Heterodyne?

A. 1. Instead of using the major vibrations of the oscillator, the second harmonic is used to produce the beat note that is amplified by the intermediate frequency amplifiers.

Q. 2. What is the advantage of this system?

A. 2. By using this system it is possible to incorporate the oscillator and detector in one tube, thus eliminating the need for another tube.

Q. 3. Can the oscillator and first detector of a Super-Heterodyne be combined, as in the "Second Harmonic" set, without using the second harmonic principle?

A. 3. The only way this can be done satisfactorily, so far as we know, is by the use of the "Tropadyne" principle developed by Clyde J. Fitch.

**(211) S.C.R.-59 AIRPLANE SET**

Q. 1. Please show the diagram of the Signal Corps Airplane Receiving Set, type S. C. R. 59, manufactured by the Western Electric Co.

A. 1. This diagram is being shown in these columns. This receiver was designed for W. E. type VT-1 tubes. Nevertheless, standard tubes will give excellent results in this circuit. Only one dial is necessary for tuning. This receiver will require a rather short aerial, if maximum selectivity is desired. The circuit is a standard non-regenerative one with two stages of impedance, or choke coil amplification. Considerably greater signal strength would result by the interposition of some sort of inductance such as a variometer, or a tapped coil, in the plate circuit of the detector to give regeneration. However, maximum quality of reproduction results in the system employed in this receiver. The choke coils may be made in the following manner: Wind a core about two inches long and one-half inch in diameter, to a diameter of one inch, using No. 38 enameled wire. It is best to enclose this coil with a soft iron case. When General Electric tubes are used, the dotted line connection is used, eliminating the fixed filament resistance. This resistance may be a standard rheostat, where it is desired to construct this receiver, of a type suitable for the type tube being used. The tuning inductance may be any type of coil having a value enabling tuning to the desired wave-length band. A variometer could be used.

**(212) THE SUPER-UNIDYNE**

Q. 1. What is the diagram of connections used in the Super-Unidyne receiver? This is

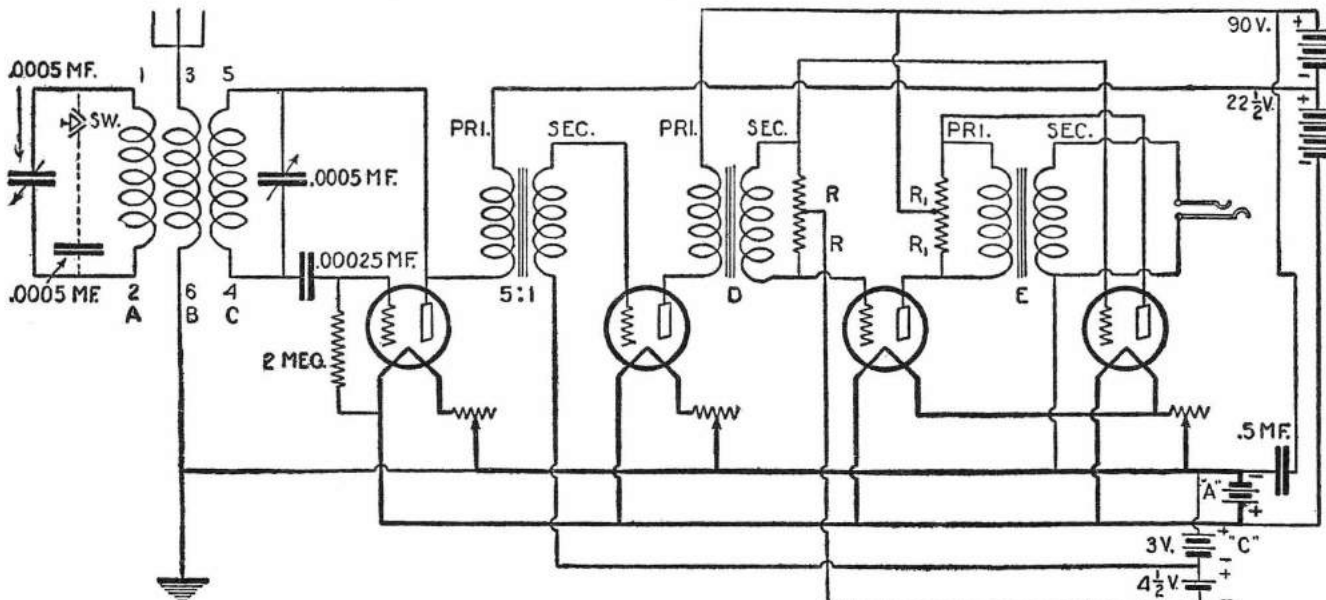

(207) The Heteroplex circuit with two stages of audio frequency amplification added. Regular push-pull transformers are not required for the stage of push-pull amplification. High selectivity, excellent sensitivity and considerable amplification with little distortion are the virtues of this system of connections.

a seven-tube set employing the super-heterodyne principle. The receiver has three stages of short-wave, high frequency amplification, a first detector, an oscillator, a second detector and two stages of audio frequency amplification. The unusual part of the set is that no intermediate frequency amplification is used.

A. 1. We are showing the circuit of this very interesting receiver in these columns.

The radio frequency transformers marked "L" may be the standard type of so-called "tuned radio frequency transformer" designed to cover the broadcast wave-length band. Freshman, Toroformer, Syckles, Erla "Balloon" Circlord, Andrews "Paddlewheel," Hammarlund, Rasco "R.F. Spiderweb," or even Neutrodyne coils may be used in the three radio frequency amplifier stages, if care is used in building this part of the set. The value of the condensers marked "C-1" will be dependent upon the constants of the particular coils selected for "L." The most important points to remember in placing these coils are: the coils *must* be in *non-inductive* relation; leads *must* be short. The latter refers most strongly to the grid leads; the plate leads are next in importance.

Both potentiometers are of the 400-ohm type. The four rheostats may all be of twenty- or thirty-ohms rating, the first-named rating being best for the usual quarter-ampere tubes.

There is only one intermediate frequency transformer in this set and even this is more properly termed a "filter coupler."

It is the coil with the .00025 mf. condensers across the primary and secondary (P and S) coils. These condensers will, in practice, necessarily vary from this value. In order to tune this filter coupler properly, these two condensers should be of the very small, variable mica type having a maximum capacity of about .0005 mf. There are at least three such instruments on the market, the Amplex "Grid-Denser," the X-L Laboratories "Variodenser," and the "Turn-It" condenser.

Both primary and secondary filter coils have the same constants, in the regular set, but other, nearly similar coils may be used; anyone having a stray Ultraformer or Tropoformer around will find it adaptable to this set.

An ambitious experimenter can make his own coil by winding 500 turns of No. 30 D.S.C. wire in a groove one-quarter inch wide and one inch in diameter. This is the primary. Duplicate this for the secondary. Both coils are wound in the same direction. The outside of the primary goes to the plate and the outside secondary lead goes to the grid. By the time you have filled the two grooves, the diameters will have grown to about three inches. This groove proposition is easily attended to by having some cigar-box wood cut to the diameters of one inch and three inches. You will need three 3-inch, and two 1-inch disks. These are placed together alternately this way: 3-1-3-1-3, with a brass

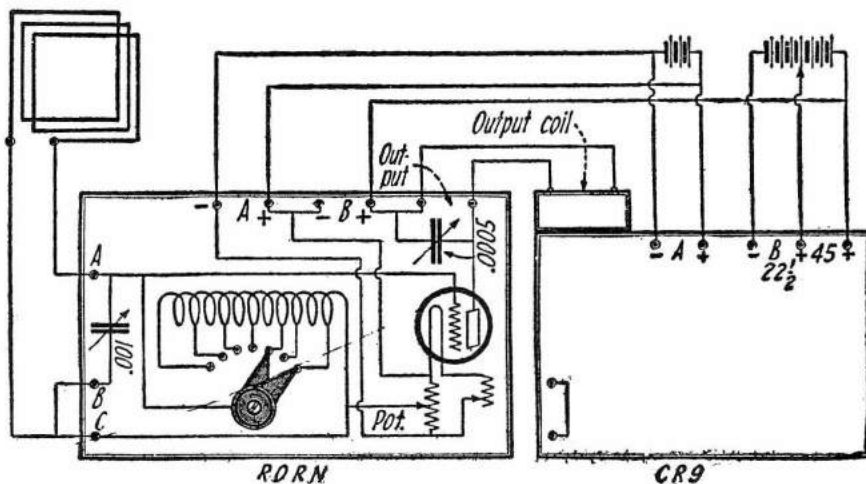

(209) The Method of Connecting the RORN Tuned R. F. Amplifier to the C. R-9 Receiver. If an Outdoor Antenna Is Used, it is Connected Directly to "B" and "C."

screw running through the center of the five pieces, to hold them together. Four sets of such coils may be used in any super-heterodyne. It is best to make the cigar-box wood impervious to moisture by painting it with collodion or thin shellac. The finest treatment is to place the wood in melted paraffin until air bubbles stop coming to the surface, then remove and allow the excess paraffin to drain off.

The three-coil oscillator L-1 is next on the construction list. All three coils are wound in the same direction, with No. 24 D.C.C. wire on a three-inch tube. Wind "A" to about 18 turns; leave one-quarter inch space and wind 45 turns for "B," and, lastly, 12 turns for "C," one-quarter inch from "B."

There is nothing new or unusual about the filament control jacks for the audio stages.

Right here we wish to voice a warning. Keep the oscillator in non-inductive relation to the other coils in the set.

As in all multi-tube sets, good tubes are a prime requisite.

Condenser rotor plates are indicated by the arrowhead. Body-capacity effects will be strong, at the oscillator condenser, unless a separately grounded frame condenser is used. Straight-line wave-length or straight-line frequency condensers should be used—not straight-line capacity.

The oscillator variable condenser dial readings may be made to closely match the remaining three variable condensers in the set, if they are of the same capacity, by changing the number of turns in grid coil "B." A little experimentation here will do the trick.

(213) ULTRADYNE

Q. 1. Can the Ultradyne equipment be used in a standard Super-Heterodyne circuit?

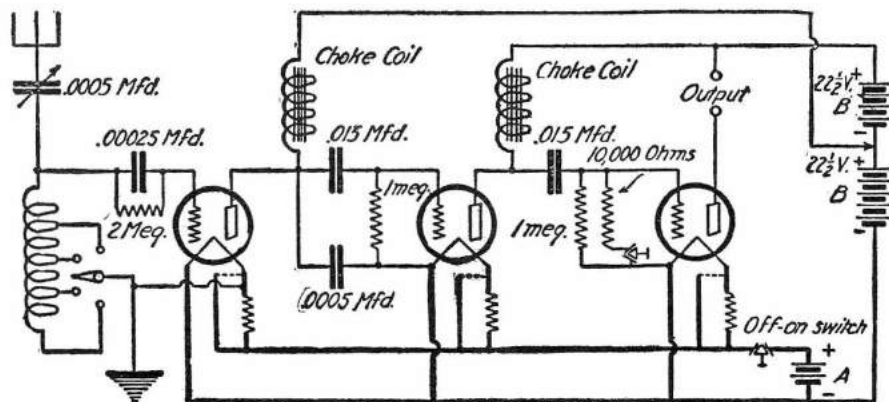

(211) A variocoupler used in place of the single tuning inductance shown will result in considerably sharper tuning. Audio-frequency transformer secondaries make excellent choke coils for such a circuit. Being non-oscillating, this receiver cannot radiate, but sensitivity is sacrificed thereby. This is a Signal Corps Airplane receiver.

A. 1. These parts may be used and with very nearly the same connections. A little study of the two circuits will show the two or three changes necessary in the wiring.

Q. 2. Will it be necessary to rewire the modulator circuit as a first detector?

A. 2. Best results will be had by operating the first tube as the detector, if the standard Super-Heterodyne circuit is desired.

(214) THE TYPE 4DL REFLEX SET

Q. 1. How is the Inverse Duplex form of reflex circuit different from any other kind of reflex circuit? I am particularly interested in the Inverse Duplex circuit as incorporated in the Grimes Type 4DL Inverse Duplex reflex receiver, a set having a tube detector, two stages of tuned radio frequency amplification and three stages of audio frequency amplification, using only four dry cell tubes.

A. 1. The schematic diagram of the connections of a Type 4DL Grimes Inverse Duplex receiver is shown in "214." This is one of the most up-to-date and efficient reflex circuits known to the radio art. By "efficient" we mean the reproduction is loud (there are three stages of audio frequency amplification), quite clear (probably due, in the main, to the use of the reflexing principle, since most sets would not be very clear reproducing with the same audio frequency transformers used in a straight audio amplifier circuit), the set is very compact (UV-199, or C-299 dry cell tubes are used and "battery compartments" in the set encase all batteries), sensitive (explained by the tube detector and two stages of radio frequency amplification) and selective (secured by extremely careful design, as it is not usual for sets using "astatic" inductances to be very sharply resonant, and a good part of the selectivity must be attributed to the two stages of tuned radio frequency amplification.) The general statement has been made, from time to time, that a set will necessarily be sensitive if it is selective. That these two conditions are not synonymous, anyone can appreciate when it is remembered that, by means of certain extremely sharp-tuning circuits, a crystal receiver can be made as selective as most tube sets. However, the crystal sensitivity will not approach the tube sensitivity. On the other hand, circuit selectivity is required if long distance reception is to be expected while powerful local stations are broadcasting, although this long distance reception cannot be secured, even though the set is selective, if the detector is not sufficiently sensitive to respond to minute current variations.

The Principle

Detail 214-A represents four radio vacuum tubes used in a standard reflex circuit, wherein a tube detector is used. The amplification sequence is as follows: three stages of radio

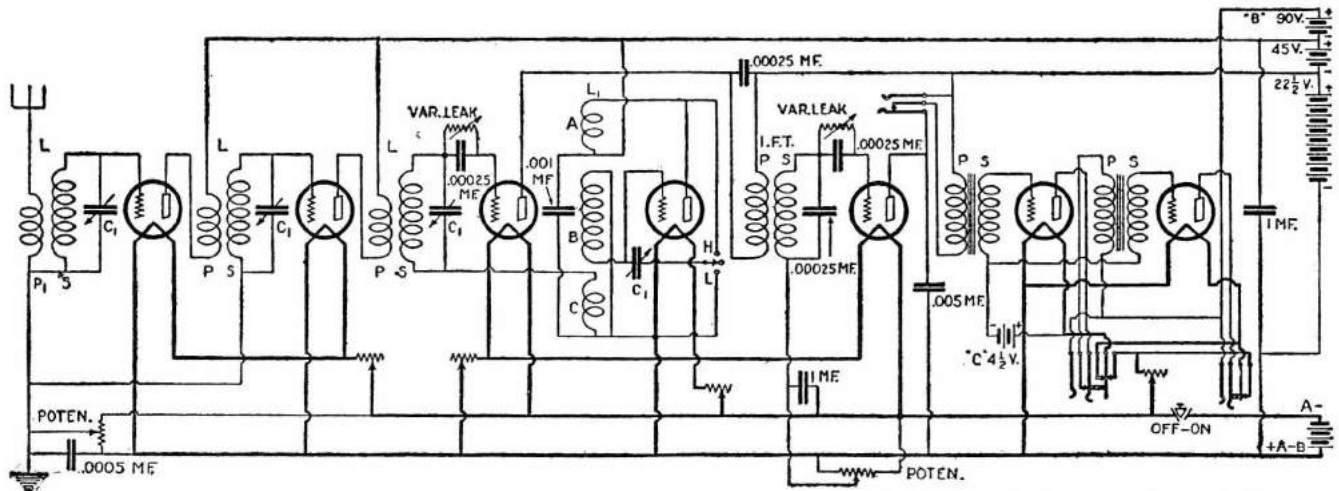

(212) The Super-Unidyne circuit. Storage battery tubes are best. Two stages of radio frequency amplification are used. The fourth tube from the left is the oscillator tube. There is no intermediate frequency amplification. The oscillator is used only to furnish selectivity and a certain amount of amplification which is the result of heterodyning.

frequency amplification (shown in dotted lines), detection, three stages of audio frequency amplification (shown in solid lines). A unit of tube amplification of two has been assigned. That is, one volt on the grid of the first tube becomes two volts on the plate, because of the "amplification constant" of the tube being (assumed) two. Two volts on the grid of the second tube becomes four volts on the plate of that tube. (The two volts grid input, amplified by the "amplification constant" of two, becomes four volts, or the amount of voltage at the plate.)

It must be understood at the start that the values shown in 214-A, B, C and D, are not actual values secured in practice, but arbitrary figures taken, to give a representation of the relative conditions existing in four types of reflex circuits. For example, we have shown that the same rate of amplification progression is being used for currents at both radio frequency and audio frequency, which is not the case in practice. To give practical figures would not convey the relative information in quite the desired manner.

From careful consideration of 214-A, it is seen that the last amplifier tube, the third from the left, is carrying the maximum radio frequency load, the load due to the successive and cumulative amplification of the first two

tubes. And that third amplifier tube is also carrying the maximum audio frequency load, due to successive and cumulative amplification by the same first two tubes, of the detector output (which output is current at audio frequency). This is a representation of

the circuit must of necessity be poor, as compared to a circuit containing an equal number of tubes operating in a more balanced manner, such as when the Inverse Duplex circuit is used. This contention we will not pass judgment upon now. At a later date we expect to state the arguments of the "ayes" and "nays."

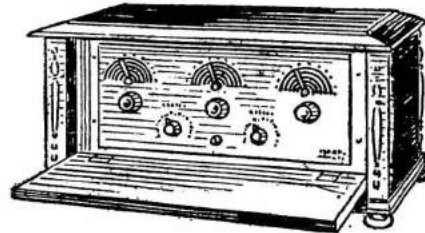

(214) Exterior view of the Renaissance Model, Grimes Inverse Duplex Receiver, incorporating the 4-DL circuit described in these columns. The circuit is shown below.

straight reflex operation, using a tube detector. If a crystal detector is used, the general operation is identical. It is claimed by the Inverse Duplex exponents that the total power handled by the third amplifier tube is so great as to cause inefficient operation; that the loads being unbalanced, the operation of

214-B shows the action in the Acme reflex, a receiver that has proved very efficient in practice. It is seen that there are only two reflexed tubes, the second and third, to carry a dual load. Although the third tube carries the maximum radio frequency current, it does not carry quite the maximum audio current. The fourth tube does nothing but amplify at audio frequency and it is this tube that carries the maximum audio frequency current. A crystal detector is used in place of a tube detector, for various practical reasons. Theoretically, a tube detector can be used, but practically it is, generally, inadvisable. The first tube amplifies only at radio frequency.

214-C illustrates the principle of the Inverse Duplex system. A tube detector is shown, but it is extremely difficult to construct a practical receiver using a tube detector, for the (unstated) reasons obtaining in the previous cases. That the commercial Grimes set does this is a feather in the manufacturer's cap

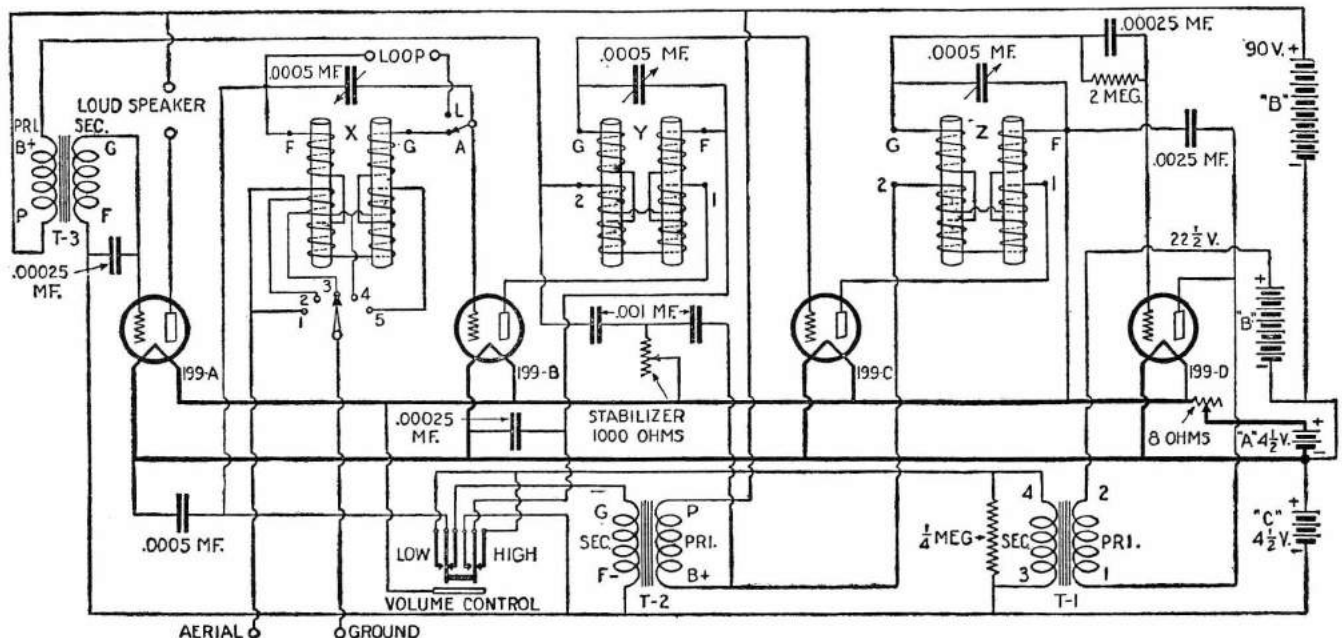

(214) This type 4-DL Grimes Inverse Duplex (reflex) circuit. This is one of the latest developments of the reflexed principle. There is wide room for experiment in this field. Note the "C" battery biasing all amplifier tube grids, resulting in low "B" battery consumption.



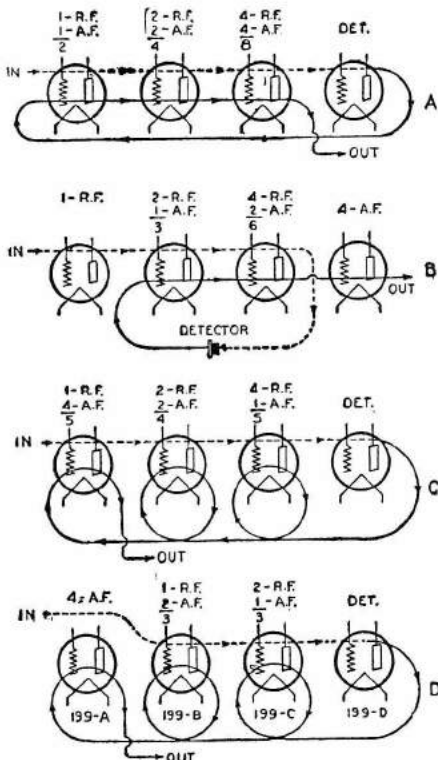

(214-A, B, C, D) The sequence of amplification in four different circuits is depicted above.

It is seen that the first of the amplifier tubes, of which there are three, carries the minimum radio frequency current and the maximum audio frequency current; the last amplifier, the third tube, carries the maximum radio frequency current and the minimum audio frequency current, thus, it is claimed, equalizing the load imposed on the tubes.

214-D illustrates the principle involved in a more practical design of the apparatus (the set to be described), still using the Inverse Duplex principle of "balanced amplification." Only two tubes are reflexed (the UV-199 or C-399 tubes marked "199-B" and "199-C"), one tube being used only for amplification at audio frequency ("199-A") and the advantages of a tube detector being secured through the use of "199-D" as such, through very careful circuit design.

**The Schematic Diagram**

This is 214. The first radio frequency amplifier tube is "199-B," reflexed as the second audio frequency amplifier tube. The second radio frequency tube, "199-C," acts also as the first audio frequency amplifier. "199-D" is the detector, while "199-A" is a third stage audio frequency amplifier, to be used only on weak signals; strong signals easily overload this tube, causing considerable distortion. Standard storage battery tubes could probably be used, but entirely different coil and (fixed and variable) condenser capacities would be required, values not known at this writing.

**The Audio Frequency Circuit**

The first audio frequency transformer, "T-1," of special make, has a voltage step-up ratio of 2:1. Any other transformer having the same ratio can be tried. Jefferson "Star" transformers, the ratio of which is 3:1, are the second and third audio frequency transformers (respectively, T-2 and T-3). The "Star" is obtainable in a 6:1 ratio, but this is not the one desired in this circuit.

The first thing most people will notice is that audio frequency transformers "T-2" and "T-3" do not have their primaries connected as indicated by the letters on the transformers. The primary connections have been reversed. This is usually called "changing the

phase." The makers of this set call it "timing the audio frequency current phase with respect to the radio frequency current phase." This proceeding seems to be essential in reflex circuits and is done in, for example, the Acme reflex mentioned above. The proper connection for the primary of transformer "T-1" is most easily determined by reversing the two primary leads and noting the result.

The one-quarter megohm leak connected across the secondary of "T-1" may need to be of a different value. Making this resistance variable results in a flexibility much to be desired (in an experimental receiver).

**The Radio Frequency Circuit**

"Astatic" coils are used in this receiver. They are probably recognized more quickly when stated to be of the "Binocular" type. Each tuned radio frequency transformer presents the appearance of a couple of misplaced steamboat smokestacks (of rather small dimensions). "Binocular" is the trade name used by a different manufacturer of coils of the same general appearance. The particular ones to be described, not to be outdone in the matter of trade name, are known as "Twin Cylinder" coils. This "automobilish" effect is further heightened by calling the volume control switch the "Gear Shift Switch"! By the way: Although a nice, expensive switch is used for "Volume Control," a regular double-pole, double-throw switch can be used in a "breadboard" receiver (a receiver built on a baseboard and sans cabinet, sans panel and sans everything else but the essentials).

Some makes of astatic coils have the secondary wound on two different tubes, and the primary wound on only one. All the Grimes coils, however, have not only 2-section secondaries, but 2-section primaries as well. The advantages of the astatic coil are mainly two: The units X, Y and Z do not pick up the radiations of local broadcast stations (an objection to large-dimensional, solenoidal transformers), and there is no inductive transfer of energy from unit X, Y or Z to unit Z, Y or X; no "radiation" from a unit. (These points hold also for toroidal windings, but these are a higher loss type of inductance than these twin-cylinder coils.) The astatic coil is a high-loss form of inductance, as judged by our present standards, but it seems from the performance of this radio receiver that proper design of the equipment can overcome, in great part, the objectionable features of the construction.

Now for the data: Primary, No. 28 S. C. C. wire. Secondary, No. 26 enameled. Winding directions are clearly indicated. All secondaries consist of 128 turns, 64 turns on each hard rubber 1½-inch tube. Of course, there are two tubes to a unit. Only the secondary turns are wound in a 40-to-the-inch thread, or

unit Y consists of 24 turns evenly divided between the two tubes. Unit Z has a 32-turn primary similarly apportioned, one-half to each tube. Each two coils may be placed in any convenient manner, just so they parallel one another, with a ½-inch separation between each two coils comprising a radio frequency transformer unit.

195 to 550 meters is the range of this coil (and .0005-mfd. variable condenser) design.

We are more accustomed to reading of four, five and six turns as comprising the primary winding of the average tuned radio frequency transformer. Thirty turns seems an astonishingly large number. Circuit oscillation due to feed-back, and consequent radiation of a shrill whistle, is prevented by normal coil loss and by the 1,000-ohm stabilizing resistance, a Central Radio Laboratories unit, non-inductive and of the lowest possible capacity. From a study of detail 214-E it is seen that the circuit is so arranged that a .001-mfd. fixed condenser is connected from the plate side of one of the audio frequency transformer primaries, to "C" minus. This by-passes the radio frequency currents around this transformer winding and around the "B" battery. However (that word comes in mighty handy), the by-passed radio frequency energy is compelled to go through the 1,000-ohm stabilizer and the loss, or energy absorption, in this instrument is made sufficient to prevent strong circuit oscillation, but not so great as to prevent a certain amount of regeneration (that mysterious genius that hides in vacuum tube circuits and, assisted by the "B" battery, makes mighty watts out of tiny micro-watts), the saving feature of 95 per cent. of the circuits of today.

**Feature Summary**

Summed up, the special points of the Renaissance Model, Grimes Inverse Duplex Receiver, incorporating the 4-DL circuit, will "stack up" about like this:

1. Designed for UV-199 or C-399 type tubes.
2. Tube detector.
3. Astatic tuned radio frequency transformers.
4. Separate detector "B" battery.
5. Aerial length compensation.
6. Three stages of audio frequency amplification.
7. Self-contained (excepting aerial, ground and loud speaker).
8. Non-radiating circuit.
9. Double duty (reflex) operation of two of the tubes, in the Inverse Duplex manner.
10. Negative grid bias (high "C" potential) on all amplifier tube grids.
11. Optional use of loop or antenna.
12. Circuit radiation control ("Stabilizer")

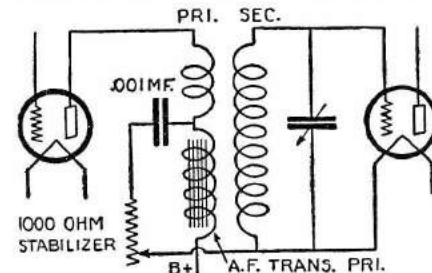

(214-E) The method of oscillation control used in the type 4-DL reflex set.

groove. The experimenter may try D. C. C. wire, closely wound, instead of enameled wire, groove-spaced. Each secondary is split evenly so as to make room for the primary winding, which is spaced from the secondary by the distance of only one turn of wire. The first transformer, X, has a primary of 32 turns (16 turns on each tube, with 32 secondary turns on one side and 32 secondary turns on the other), tapped start-4-8-16-32. This is the antenna compensator and the switch arm position for best results will depend upon individual aerial installations. The primary of

**(215) THE DOUBLE SELECTOR MULTIFLEX**

Q. 1. Some time last year Victor Greiff developed a peculiar reflex circuit using a crystal detector and a "losser" control of circuit oscillation. Please give the constants of this circuit.

A. 1. The Double Selector Multiflex circuit about which you inquire is being shown in these columns.

A potentiometer will furnish the necessary 200 ohms.

The three radio frequency transformers are called "Tunads."

An A.F. transformer secondary, or a Ford spark coil secondary will work admirably as the A.F. choke.

A variometer may be substituted for the first 2-coil radio frequency transformer.

The value of "G.L." will be about 50,000 ohms, but a "C" battery should be used, and a higher grid leak resistance.

Tunads have 64-turn secondaries to be used with variable condensers of .0003 mf. capacity (and 12 turns in the aerial coil—primary of "A"—and eight turns in the first plate coil—the primary of "B"). The data in the present

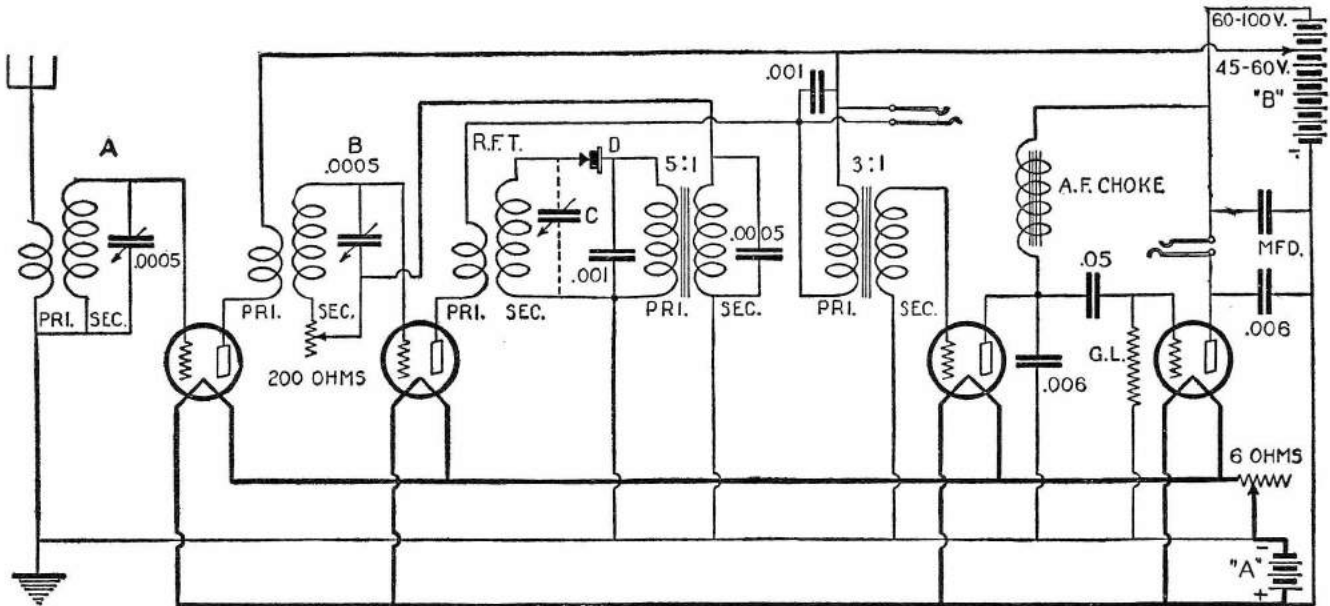

(215) The Double Selector Multiflex circuit of Victor Greiff. This diagram shows two stages of tuned radio frequency amplification and three stages of audio frequency amplification, using a crystal detector instead of the usual tube detector. The second radio frequency tube circuit is reflexed for one stage of audio frequency amplification.

instance would be: coil "A," 10-turn primary and 50-turn secondary; coil "B," 6-turn primary and 50-turn secondary. Instead, "R.F.T." may be a standard radio frequency transformer designed to work without a variable condenser. The capacity range of "C" will be determined by the particular coil construction decided upon for "R.F.T." The crystal detector "D" may be fixed or adjustable.

Be sure to maintain a non-inductive relation of the three R.F. coil units.

**(216) SIGNAL CORPS SUPER-HETERODYNE**

Q. 1. Will you kindly show the Signal Corps Super-Heterodyne circuit attributed to Jackson Pressley?

A. 1. We are showing the circuit in these columns. An oscillator, center tapped, is used having the correct values for the intermediate frequency transformers and loop used. The I. F. T. condenser values shown are correct for Ultraformers. Since the oscillator variable condenser is always at higher-than-ground potential, a grounded-frame condenser will be required to eliminate hand capacity.

The balancing condenser, BC, is adjusted in the following manner. Place the headphones in the circuit of the oscillator tube at "X" and place the oscillator dial at about the middle of the range. The loop tuning condenser and balancing condenser are then varied until the usual click is absent, or heard only faintly.

Condenser BC may comprise three large plates, total, arranged as is the usual compensating condenser used to control resistance-coupled radio frequency amplifiers.

From a study of this diagram it will be seen that the bridge principle originally described

latter circuit, the balance is obtained by means of a variable grid leak placed between the free end of the oscillator coil and the filament. Since there are no capacities in shunt with the oscillator tuning condenser, in this design, a wider tuning range may be covered.

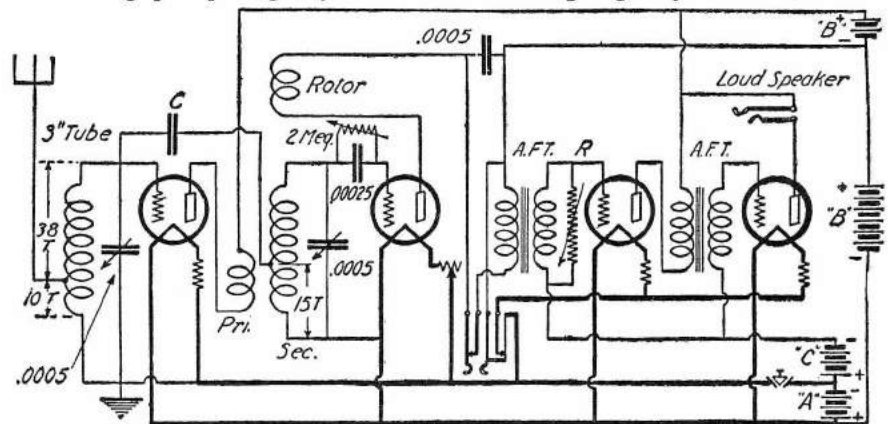

(216-A) Radio frequency amplification added to a regenerative receiver. This is possible only through extremely careful design and construction. This circuit shows how to do it. There are other features to this circuit, the Browning-Drake, as well.

in the August, 1924, issue of *Radio News*, in the article, "The Tropadyne Circuit," by Clyde J. Fitch, has been employed. In the

Q. 2. Would it be possible to apply regeneration to the oscillator-detector tube of the Tropadyne?

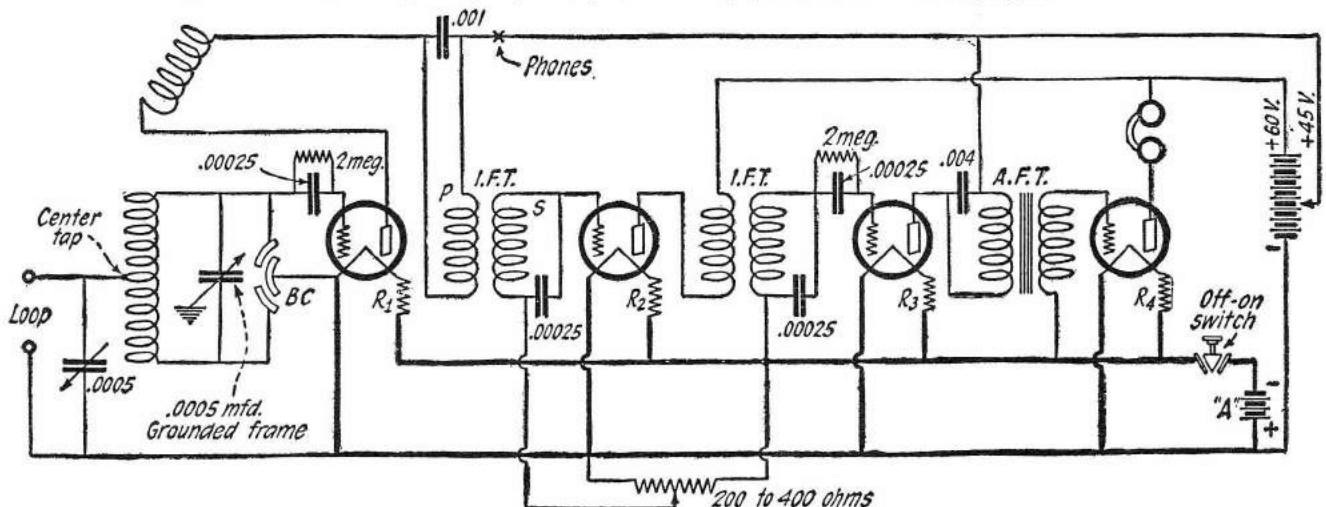

(216) A variation of the Tropadyne principle described in the August, 1924, issue of *RADIO NEWS* is here illustrated as the new Signal Corps Super-Heterodyne. Additional stages of intermediate frequency amplification may be added if desired.



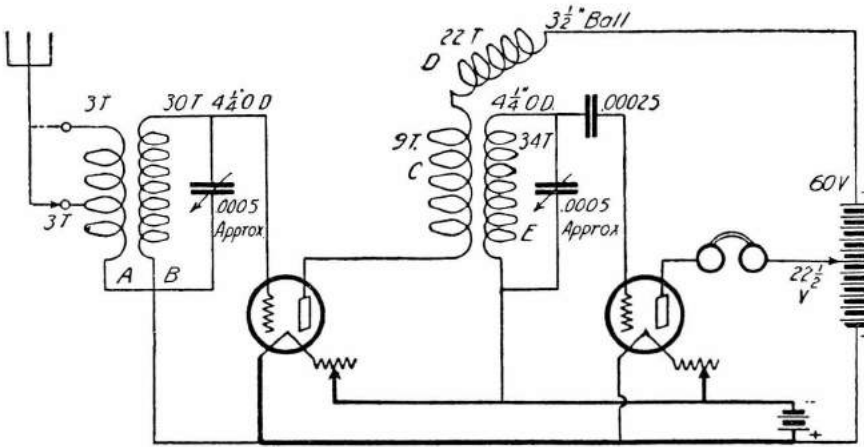

(220) The new Superdyne circuit is a distinct advance over the old one. The quality of reception will please the most critical. The amount of distortion caused by an additional audio frequency amplifier will depend upon the perfection of the amplifier design.

**(219) ACME REFLEX CIRCUIT**

Q. 1. Kindly publish the Acme four-tube reflex circuit in connection with a loop aerial.  
 A. 1. The circuit you ask for will be found on page 57.  
 Q. 2. What are the capacities of the fixed condensers connected across the audio frequency transformer secondaries and also the one across the loud speaker?  
 A. 2. The capacities of the fixed condensers from left to right are: .00025 mfd.; .00025 mfd.; .002 mfd. and the one across the loud speaker, .005 mfd. Use fixed condensers having mica insulation.  
 Q. 3. What circuit is used in the Supertone long range receiver?  
 A. 3. The circuit used in the Supertone set is that of the standard three-circuit tuner, with two stages of audio frequency amplification. Tickler feed back, tuned grid and untuned aerial circuit are used.

**(220) THE NEW SUPERDYNE**

Q. 1. Please show the wiring diagram and give constructional details for the new Superdyne receiver.  
 A. 1. The circuit is shown in these columns. Note that the new Superdyne is quite different from the old one. The two tuning condensers have been combined in one control. The remaining control is that of the negative feed-back, if such it may be called. The most important point to observe in the construction of this receiver is to keep inductances A and B in non-inductive relation to inductances C, D and E. Should the inductances couple to any extent, it will not be possible to neutralize the set. With coils A and B separated from C, D and E about 6 inches, it was not found possible to prevent oscillation until coils A and B had been turned to exactly the right angle to the other inductances, a variation of 1/4 inch being sufficient to throw the set out of balance. Also note that coil A consists of only nine turns, yet it is so wound as to take up the entire winding space of coil B, over which it is wound. This also holds true for coil C. Special condensers of 25 plate size are used. The rotor, D, should be rotatable through 180 degrees, zero coupling being at 90 degrees from either extreme. No detector grid leak is used, sufficient leakage being furnished by the condenser itself. UV-201A or C-301A tubes are used in both positions. Note the absence of a phone condenser.

**(221) THE NEUTRODYNE RECEIVER**

Q. 1. What wave-lengths is the Freed-Eisemann Neutrodyne receiver adapted to?  
 A. 1. Approximately 200 to 600 meters.  
 Q. 2. Is the receiver very selective?

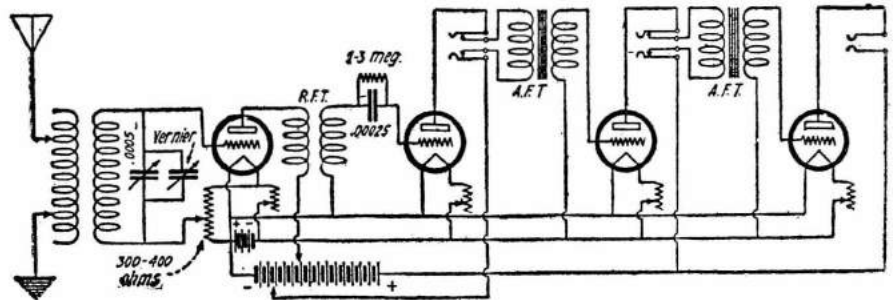

(222) Circuit diagram of the Federal Type 59 Receiver. This employs one stage of transformer coupled radio frequency amplification and two stages of audio frequency amplification.

A. 2. As this receiver employs two stages of tuned radio frequency, it should prove very selective.  
 Q. 3. What is the approximate cost of building one?  
 A. 3. If good instruments are used, the cost of building this receiver would be approximately \$75 to \$85.

**(222) FEDERAL TYPE 59 RECEIVER**

Q. 1. Will you please publish a hook-up of the Type 59 Federal receiver?  
 A. 1. You will find the hook-up of this receiver on this page. Jacks are shown after the detector, first and second steps.

**(223) ULTRADYNE QUERIES**

Q. 1. Using UV-199 or UV-201A tubes,

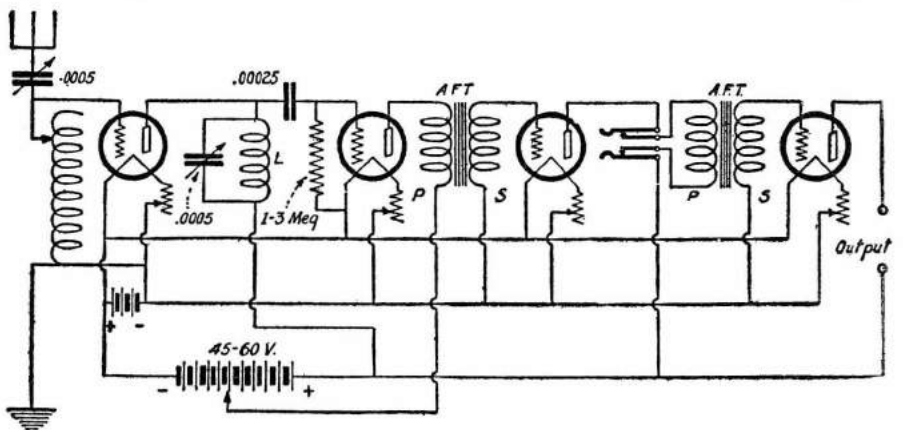

(224) The Crosley XJ Receiver is Similar to the Well-Known Model X. A Jack is Used After the First Stage of A. F. So That Phones May Be Used.

what size should the potentiometer in the Ultradyne be?

A. 1. A potentiometer of 300 or 400 ohms is recommended for any tubes.  
 Q. 2. Can the Ultradyne be used with three tubes?  
 A. 2. Not very successfully. It would work with four tubes but would not be efficient.

**(224) CROSLY XJ RECEIVER**

Q. 1. Would you please publish the hook-up of the Crosley XJ receiver?  
 A. 1. This hook-up will be found in these columns. This circuit is identical with the familiar model X receiver with a jack in the plate circuit of the first A.F. tube for phones.

**(225) "B" BATTERY CURRENT CONSUMPTION**

Q. 1. What is the approximate "B" battery current consumption of the Ultradyne? (8 tubes.)  
 A. 1. 30 to 35 milliamperes are required, at 90 volts potential, for good operation of the Ultradyne.

Q. 2. How long will "B" batteries last?  
 A. 2. It is impossible to say just how long "B" batteries would last, as it depends upon many conditions, such as location of batteries (whether hot or cold, damp or dry), materials used to make the battery, the length of time they have been out of the factory and the number of hours the set is in use.

**(226) A. & P. PHANTOM CIRCUIT**

Q. 1. Please publish the hook-up of the Atlantic and Pacific Phantom Circuit.  
 A. 1. This circuit appears on these pages and it will be seen that it is a modification of the Reinartz circuit. If a ground is used to receive instead of the antenna, it is connected directly to the aerial binding post. A ground may be used with the aerial, by connecting it as shown by the dotted lines, and better results will sometimes be had with this arrange-

ment. The ground connection is taken from the center of the variometer coil that goes to the antenna.

**(227) GREBE CR-13 RECEIVER**

Q. 1. Please publish diagram of the Grebe CR-13, short-wave receiver.

A. 1. This diagram appears herewith. It will be seen upon close examination that this is a single circuit receiver using a radio frequency transformer with a tuned secondary. The variometer used for tuning is wound with approximately 19 turns on each half of the stator and rotor coils; the entire instrument consists of 76 turns of wire. No. 14 or No. 16 D.C.C. wire should be employed in this instrument. The coil in the plate circuit of the radio frequency tube consists of 15 turns of No. 26 S.C.C. wire wound on a tube approximately  $4\frac{1}{2}$  inches in diameter. This winding is in inductive relation to the stator winding of the second variometer. This variometer is wound with No. 16 D.C.C. wire employing 23 turns for each half of the stator and rotor coils, giving a total of 92 turns for the complete variometer.

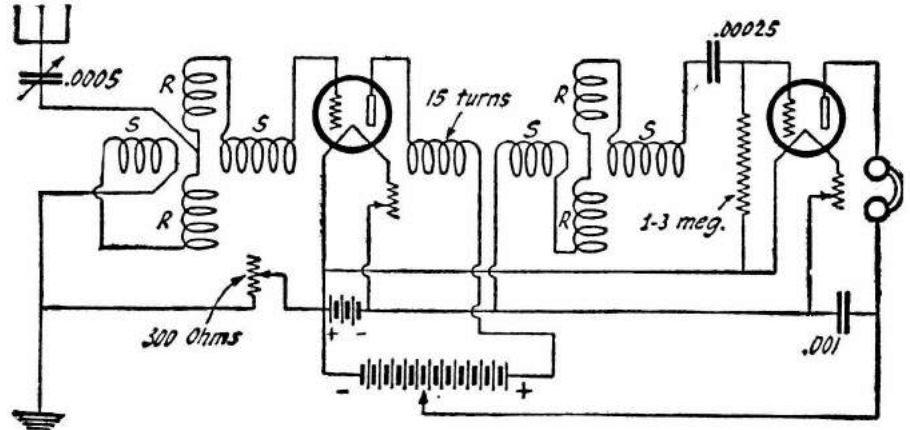

(227) The Circuit Above is That Used in the Grebe CR-13 Amateur Short Wave Receiver. This Arrangement Employs Two Split Variometers.

A. 1. We are showing this circuit in these columns.

operate the loud speaker so that signals are clearly understandable in a large room, using a loop aerial about two feet in diameter, receiving the programs broadcast by a 1 K.W. station 1,000 miles away, using only the detector output preceded by three stages of intermediate frequency amplification. No aerial or ground should be used for this test.

**(231) FINE SUPER-HETERODYNE RESULTS**

Q. 1. What would be considered good operation of a Super-Heterodyne?

A. 1. It is difficult to answer your question. Location, regardless of the set used, is a very important factor in determining the results with a set. We should say it was functioning satisfactorily if a set employing three stages of intermediate frequency amplification will operate the loud speaker on only the detector, when only a coil three inches in

**(232) KENNEDY TYPE 220 RECEIVER**

Q. 1. Please show the wiring diagram of the Kennedy Type 220 receiving set.

A. 1. The diagram you request is shown in these columns.

Q. 2. What is the wave-length range of this receiver?

A. 2. 185 to 3,350 meters.

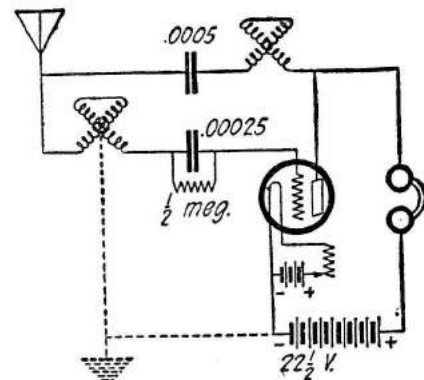

(226) Very Good Results Are Claimed For This Circuit. If a Ground Is Used With the Aerial It Is Connected As Shown By the Dotted Lines.

**(228) SUPERDYNE CIRCUIT**

Q. 1. What is the Superdyne circuit?

A. 1. The circuit you request is shown in these columns.

Q. 2. Should the reactance coil and variocoupler be in inductive relation?

A. 2. No. The reactance coil and variocoupler should be at right angles to each other.

Q. 3. How are the coils made for broadcast and amateur reception?

A. 3. Secondary inductance, RC, is on a 4-inch tube. The negative-feedback rotor, XY, is a  $3\frac{3}{8}$ -inch ball. Plate Reactor inductance, WC, is on a 4-inch tube. Correct wire turns for broadcast wave-lengths are shown. For amateur wave-lengths, use the 16-turn tap on RC and the 16-turn tap on WC. XY remains the same. The aerial and ground are coupled to RC by four turns of No. 18 lamp cord wound tightly around it.

**(229) OSCILLATOR TUBE FOR ULTRADYNE**

Q. 1. Could I use DeForest DV-2 power tubes for all but the oscillator in the Ultradyn?

A. 1. Yes.

Q. 2. What make of radio frequency transformers would you advise or would it be better to make my own?

A. 2. Any radio frequency transformer designed for use with the Super-Heterodyne circuit and made by a reputable manufacturer may be used.

Q. 3. Could I have the set separated into three tubes and tuning outfit into one unit and the remainder of the tubes in another?

A. 3. We would not advise it.

**(230) ZENITH RECEIVER**

Q. 1. Please publish the hook-up of the Zenith 3-R receiver.

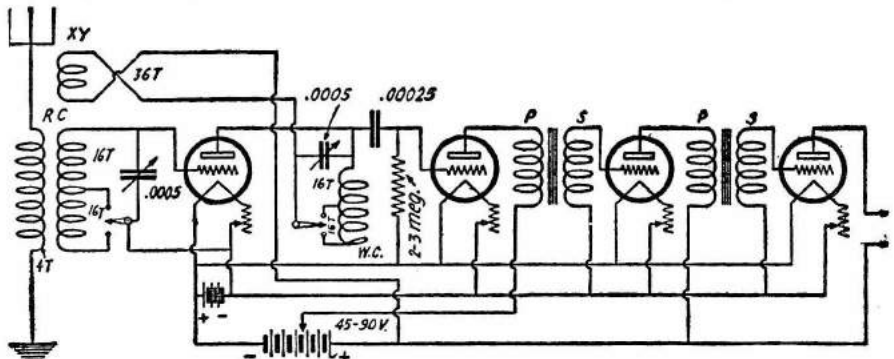

(228) The Superdyne circuit with two stages of audio frequency. Reversed feed back controls the oscillation of the R. F. tube.

diameter is used as the pickup device, receiving the signals from stations located within a radius of 100 miles and having a power of about one K.W. Also, it should be possible to

**(233) SUPER-PLIODYNE**

Q. 1. Please show the Super-Plodyne circuit.

A. 1. We are showing the circuit in these

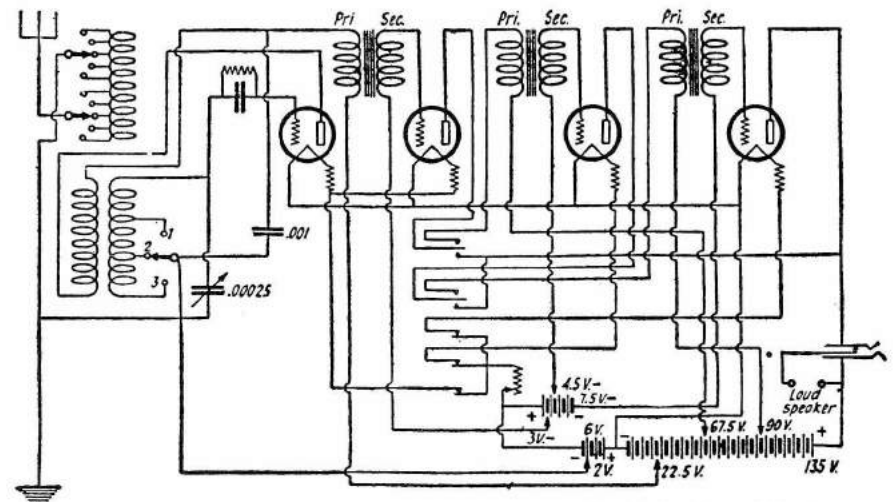

(230) This is the Zenith 3-R circuit. A special switching system for selecting the amplifier stages is used which eliminates the usual jack-and-plug method.

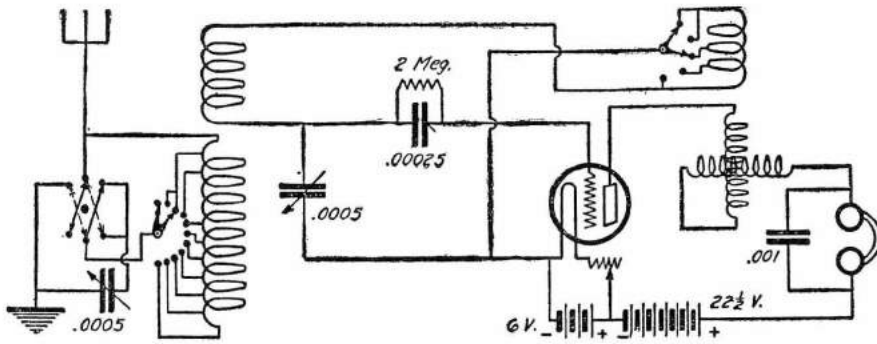

(232) This Kennedy Type-220 regenerative receiver diagram illustrates another variation in three-circuit tuners.

columns. Since this system tunes very broadly, it is much easier to extend this method of amplification to include many tubes, and control all the stages with one or two dials, than it would be with the usual neutrodyning system, which tunes very sharply at each stage.

Q. 2. How are the transformers for this circuit made?

A. 2. The secondaries of the transformers consist of 100 turns of No. 26 D.C.C. wire wound on a 2-inch tube. The primaries consist of 25 turns wound on a 1 3/4-inch tube. The primary winding has the space of three

A. 1. The reference you mention was to the use of wax or paraffin in considerable amounts. A small amount on the Ultraformers is not injurious.

(236) LONG DISTANCE RECEIVER

Q. 1. Please publish information about a four- or five-tube set which will receive signals 2,000 to 3,000 miles distant, consistently?

A. 1. There are no sets that will receive signals from such a distance, consistently. The nearest approach is the super-heterodyne.

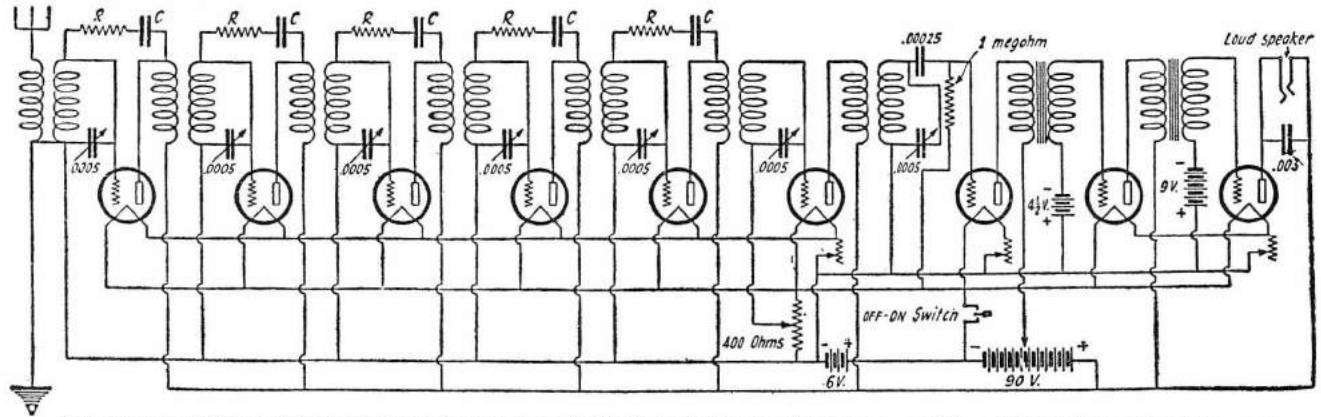

(233) This Super-Plidyne illustrates the Ferrand system for controlling the oscillations in radio frequency amplifiers, extended to include six stages of radio frequency amplification. Every stage must be carefully balanced. All the variable condensers are geared to one dial.

turns between each turn. The primary fits inside of the secondary. The primaries are wound in a reversed direction to that of the secondaries.

Q. 3. What is the correct value for the neutralizing resistances?

A. 3. All the values (R) are the same and must be determined by experiment, as the value is different for the different types of tubes. It will range between 20,000 and 120,000 ohms. The condenser value (C) is not critical.

The most advanced models are known as the "Ultradyne" and the "Armstrong second harmonic, reflexed, Super-Heterodyne."

(237) ERLA REFLEX CIRCUITS

Q. 1. Please publish the circuit of the Erla two-tube reflex receiver.

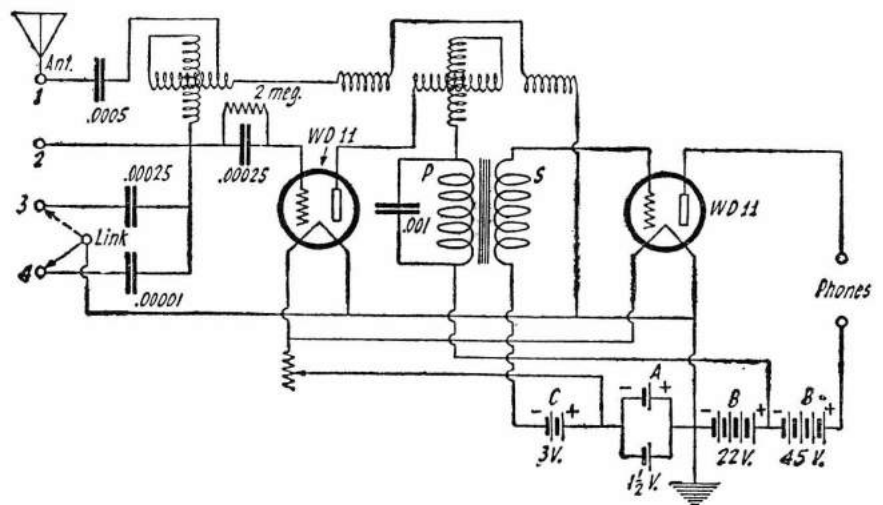

(234) The circuit diagram of the Radiola III receiving set. This is a regenerative circuit with a detector and one stage of audio frequency amplification. Employing WD-11 vacuum tubes, two dry cells will be sufficient for lighting the filaments.

(234) RADIOLA III DIAGRAM

Q. 1. What is the wiring diagram of the Radiola III receiving set?

A. 1. We are showing the wiring diagram of the Radiola III in these columns. The bar marked "link" may be placed on posts three, or four, or left unconnected to either. The link is only used when extra sharp tuning is necessary. This circuit is seen to be that of the standard single circuit regenerative receiver with a few refinements.

(235) DIELECTRIC

Q. 1. I recently noticed an article stating that the wax on annunciator (bell) wire reduces the efficiency of an inductance formed with this wire, due to a high distributed capacity. Does it mean that a small amount of paraffin accidentally put on a small portion of the Ultradyne transformers will reduce their efficiency?

A. 1. This circuit appears in these columns.

(238) TRIRDYN

Q. 1. Please show the diagram of connections of the Crosley Model 3R3 Trirdyn.

A. 1. This diagram is shown here.

Q. 2. How may the coils be constructed?

A. 2. A standard neutroformer may be used for coil "A." A suitable coil has 45 turns of No. 22 D.C.C. copper wire wound on a three-inch form. The primary winding is made by placing about 15 turns of the same size wire directly over the secondary. A few layers of paper or Empire cloth may be used to insulate the two layers. Unit "B" may be a standard variocoupler with about eight turns of wire wound over the primary, for the B1, winding.

Q. 3. What are the functions of this circuit?

A. 3. This circuit incorporates transformer-coupled radio frequency amplification, detection, regeneration, reflex audio frequency amplification and straight audio frequency amplification.

(239) FEDERAL TYPE 102 RECEIVER

Q. 1. What is the schematic diagram of the Federal Type 102 receiver?

A. 1. We are showing the diagram in these columns.

Q. 2. Please give description of the tuning inductance and set.

A. 2. A spider-web winding is employed in this receiver. An equivalent coil may be made by winding 55 turns of No. 22 D.C.C. copper wire on a three-inch tube. Taps for the aerial

are taken off at the fourth and eighth turns. Series ground condensers of various values may be tried. The rotor plates of the variable condenser connect to the side of the circuit indicated by the arrowhead. Iron core radio frequency transformers, as shown, or air core transformers, may be used. A push-pull switch is used to control the filaments of the vacuum tubes.

**(240) SINGLE-TUBE REFLEX**

Q. 1. Will you please publish the hook-up of the Erla Duo-Reflex Circuit?  
 A. 1. The diagram will be found on these pages. A special radio-frequency transformer, manufactured by the Electrical Research Laboratories, is used in this circuit.

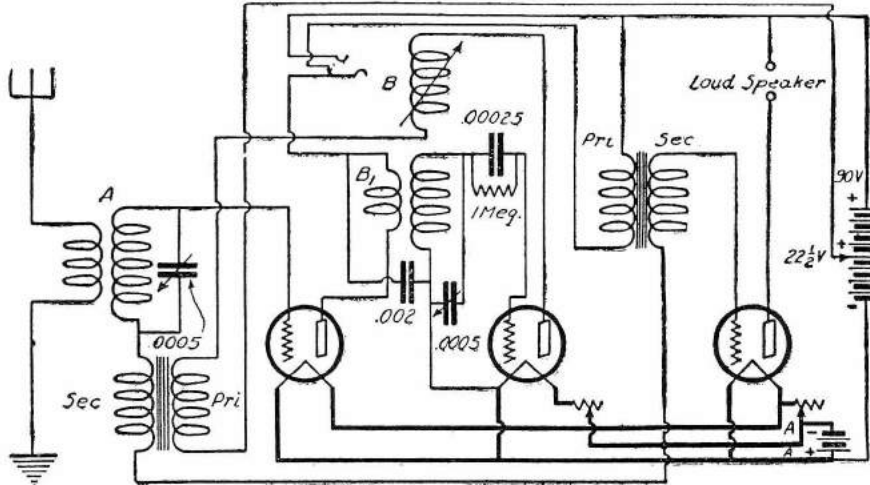

(238) The 3-control Trirdyn circuit is capable of high amplification. One tube is reflexed. It consists of one stage of tuned radio frequency amplification, a detector and two stages of audio frequency amplification.

**(241) FLEWELLING DATA**

Q. 1. Does the fact that a "Super" will not equal a regenerative set (in range) apply to the Flewelling?  
 A. 1. The Flewelling ordinarily receives over very considerable distances. It might be noted here that almost every circuit that has appeared in print has its adherents who will tell of their coast-to-coast reception. It seems that it is not so much a question of circuit as of striking the right conditions that secures the maximum results from a given set of parts.  
 Q. 2. Give data on the Flewelling variocoupler.  
 A. 2. This is a standard variocoupler re-wound so as to have about 120 turns on the rotor and 60 turns on the stator. The stator coil is tapped at 20, 30, 40, 50 and 60 turns. It will probably be necessary to bank wind the rotor inductance in order to get sufficient wire in this space.  
 Q. 3. Which circuit has greater range—the improved Flewelling, using one condenser, or the Duo Reflex using one tube and a crystal detector?

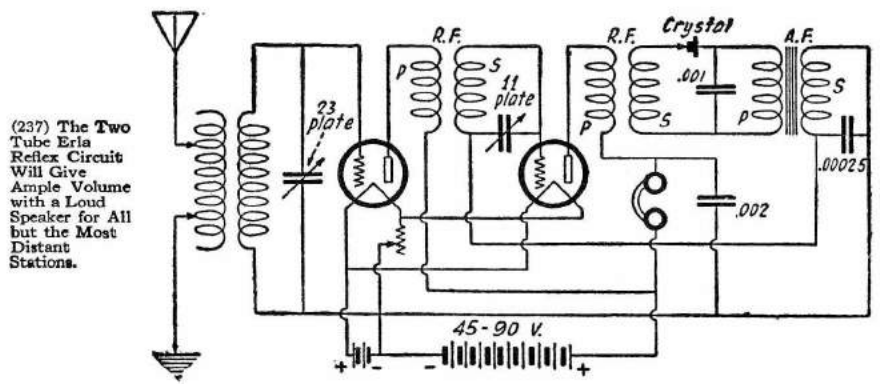

(237) The Two Tube Erla Reflex Circuit Will Give Ample Volume with a Loud Speaker for All but the Most Distant Stations.

A. 3. Due to the Flewelling set being a very sensitive one, we are quite sure you will get greater range with this set than with the Reflex, provided, however, the Flewelling is made correctly.

**(242) PARAGON R. A. 10**

Q. 1. Please publish a hook-up of the Paragon R.A. 10 receiver.  
 A. 1. This hook-up is shown herewith. Special attention is called to the switching arrangement for the long waves. Two blades are mounted on the same shaft, one on the outside of the panel and the other on the inside, and insulated from each other. When thrown to the left, both of the long wave coils are shorted out of the circuit.

**(243) GREBE REGENERATIVE CIRCUIT**

Q. 1. Please publish a hook-up of the Grebe regenerative circuit using, I believe, in the circuit a split variometer.  
 A. 1. The circuit you desire is printed on these pages.  
 Q. 2. Should not these instruments when

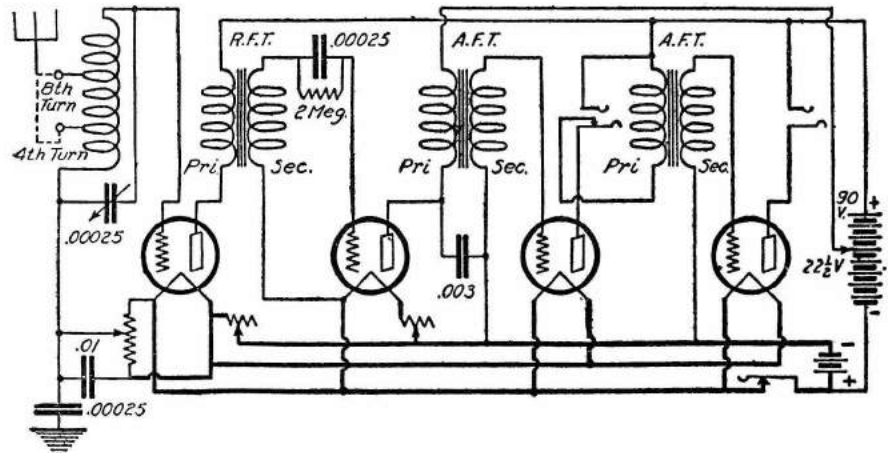

(239) Schematic diagram of the Federal Type 102 Special Receiver. Heavy lines readily identify the "A" battery circuit. A potentiometer shunted by a .01 mfd. fixed controls the radio frequency amplifier tube.

connected in accord with a set similar to the Grebe be able to receive at least faintly, and when soldered be even better?  
 A. 2. The soldering of all connections will increase the efficiency of reception, however, no difficulty in reception should be experienced with unsoldered leads.

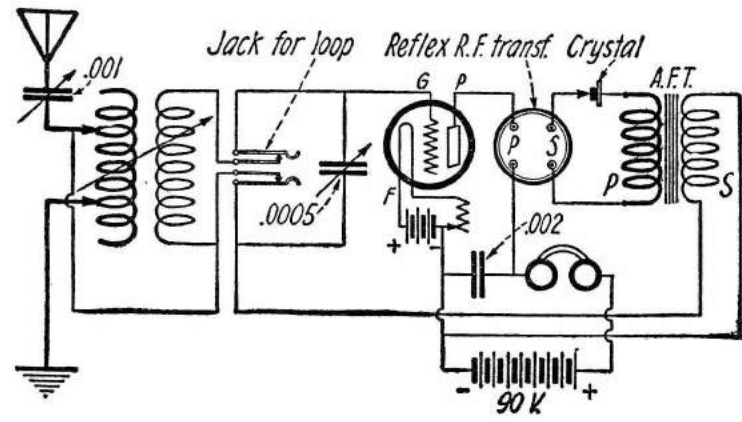

(240) Remarkable Results Are Claimed for the "Erla Duo-Reflex" Circuit, Shown Here. Only One Tube is Used for Two Stages of Amplification.

**(244) DE FOREST TYPE D REFLEX RECEIVER**

Q. 1. Will you kindly publish the circuit used in the De Forest Reflex receiver?  
 A. 1. This hook-up appears on these pages. A crystal detector is used and very clear reception is obtained.  
 Q. 2. Is this receiving outfit designed for loop reception, or can it be used with the regular aerial?

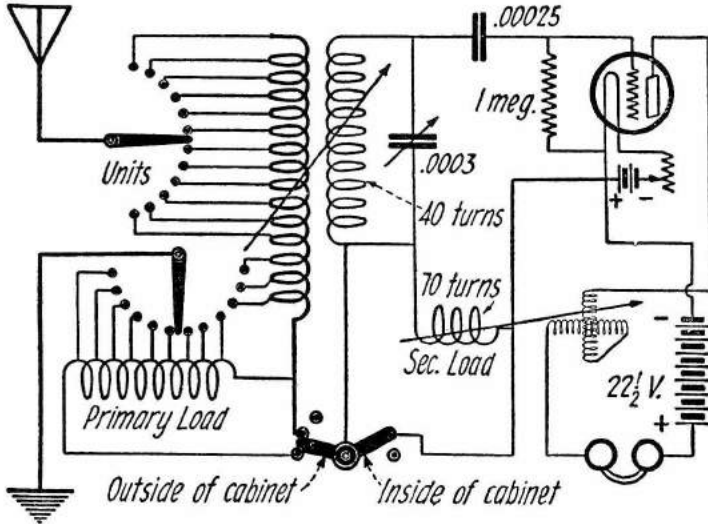

(242) The Circuit of the Well-Known Paragon R. A. 10. Special Attention is Called to the Switching Arrangement.

A. 2. This receiver is designed to be used with a loop, but it can be used with a regular antenna in conjunction with a good receiving tuner.

**(245) AERIOLA SR. HOOK-UP**

Q. 1. Please show the hook-up of the Aeriola Sr. receiver, describing the instruments used.

A. 1. This hook-up will be found in these columns. The two variometer stators are wound on the same tube. The stator of the variometer in the antenna circuit is continued for five turns on each side of the stator winding of the plate variometer. Two binding posts are used for the antenna connection. If connected to one binding post a fixed condenser will be in the antenna circuit so the set can be tuned to lower wave-lengths.

**(246) UNIDYNE**

Q. 1. What is the diagram of connections employed in the Unidyne?

A. 1. This circuit is shown in these columns.

Q. 2. How are the radio frequency transformers constructed?

A. 2. The exact construction of these transformers has not been made public. A suitable inductance for the first transformer is made by winding 50 turns of No. 22 C.C. copper wire on a three-inch tube. Over this is wound about 10 turns of the same size wire. The second transformer may have the same size secondary on the same size tube, but the primary has only eight turns of wire and is separated from the secondary by about one-quarter inch.

**(247) RADIOLA GRAND**

Q. 1. Please publish the circuit of the Radiola Grand, showing all values.

A. 1. This hook-up will be found in these columns. The push-pull method of amplification is used and special transformers are necessary. A tapped resistance is shunted across the primary of the second transformer to control the volume of sound.

**(248) FLEWELLING CIRCUIT**

Q. 1. Please publish a hook-up showing the Flewelling circuit with all apparatus named.

A. 1. This hook-up appears herewith. No ground connection is needed and very selective results are obtained. The resistance across the .006 mfd. condenser is very critical and should be variable. All instruments are named on the diagram.

**(249) SUPER-HETERODYNE RADIATION**

Q. 1. Kindly explain in detail why 8-tube Super-Heterodynes do not radiate.

A. 1. This is due to the fact that the first tube does not oscillate and therefore acts as an

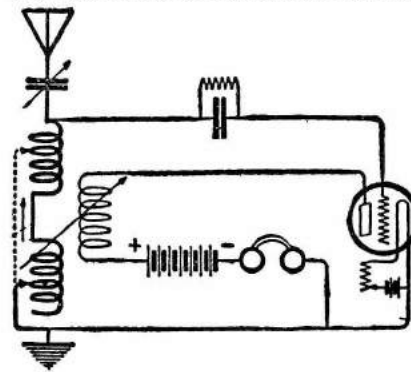

(243) Single circuit tuner with tickler feed-back. The main inductance is split at the center, the tickler thereby being in equal inductive relation to the entire coil.

effective blocking tube for currents generated by the oscillator tube, or the intermediate frequency stages. While it has been claimed that there is a radiation of the oscillator currents this radiation can be detected only a short distance from the set. Of course, there is generally conceded to be a radiation from the oscillator coils, which cannot be prevented except by shielding and it is probably this current, rather than the aerial current, which is picked up by receiving sets in the immediate vicinity. While these coils form an effective

antenna and counterpoise system, the amount of energy that can be radiated is very slight indeed. Such currents as may pass the blocking tube due to the grid-to-plate capacity, are only weakly radiated from the aerial. When a loop is used, even this possibility of interference becomes a minimum. Reviewing these facts we may consider Super-Heterodynes as non-radiating.

**(250) DATA ON FRESHMAN SET**

Q. 1. Kindly tell me at what angle and how should the radio frequency transformers be placed in the Freshman tuned radio frequency set.

A. 1. The placement of these coils is described elsewhere in these columns.

Q. 2. Where could a loop be used in this set?

A. 2. A loop may be added to the Freshman set, or any equivalent receiver of the tuned radio frequency type.

Q. 3. What are the advantages of using three rheostats instead of two?

A. 3. The use of three rheostats instead of two will result in greater selectivity, sensitivity, quality and volume, since these four points are all closely related and considerably dependent upon the heat of the tube filaments. The third rheostat makes it possible to have independent control of the radio frequency tube filaments, the detector tube filament and the audio frequency tube filaments, giving more flexibility in the control of circuit regeneration, present in such receivers to varying degrees.

**(251) TROPADYNE**

Q. 1. So far I have been unable to hear any sounds from my Tropadyne, using New York Coil Company intermediate frequency transformers.

A. 1. For best results, the equipment designed for this receiver and now available on the market should be used. Properly constructed, this set will prove to be sensitive, selective, clear and loud.

A 23-plate variable condenser is required across the secondary of each one of the transformers. The size condenser required for the primary of the input transformer would probably in the neighborhood of .001 mfd.

Test all tubes in an oscillating receiver, to determine whether they are uniform in their characteristics. Test your potentiometer for open circuit. It is also possible that you have connected it across the tube filaments instead of across the "A" battery direct. Some of the wires may be making poor contact. The condenser across your radio frequency transformer may be shorted. If you are using a phone condenser in the detector plate circuit, that also may be short circuited.

Test your transformers for open circuit. This may be done by connecting a single dry cell in series with a pair of receivers. When

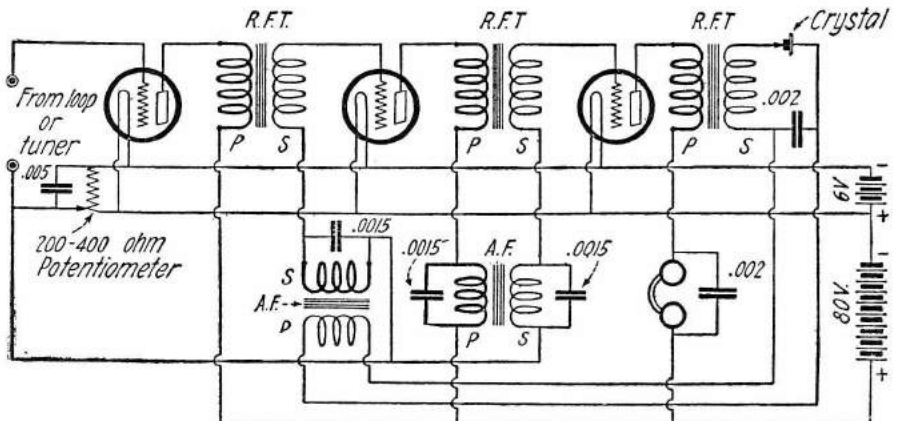

(244) Here is the DeForest Reflex Circuit. Three Tubes Are Used for Five Stages of Amplification. A Crystal is Used for the Detector.



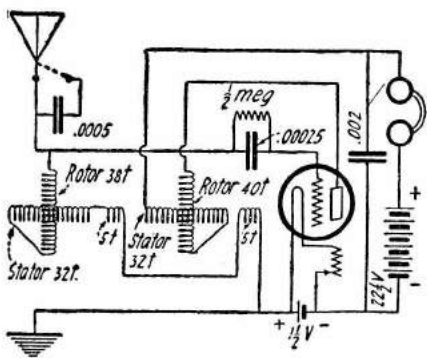

(245) Diagram of the Aeriola, Sr. Receiver. Two Variometers Are Used, One as the Tuning Unit and the Other in the Plate Circuit.

one side of the receivers is touched to the free binding post of the battery, a loud click should be heard. This click should also be heard if the free end of the battery and the free end of the headphones are touched to the primary or secondary terminals of the transformers. It will be noticed, when testing audio frequency transformers, that the click is much less pronounced at the secondary side as compared to the primary side. This is due to the greater resistance of the secondary and is not to be considered a fault.

Examine the tube sockets carefully; it is possible that the tubes are making poor connection to the socket springs.

Test all batteries to be sure they are at the rated voltage. This should be the first operation whenever testing defective sets.

Check the wiring very carefully to be sure that a primary is not connected where a secondary should be, or vice versa; also to be sure that battery polarities are correct.

most sets will. If separate rheostats are used for each radio frequency stage, the filament of the first tube may be "turned out." Distant stations are seldom heard with this arrangement.

Do not forget the by-pass condenser from the plate of the detector tube, to "A" minus; .002 mfd. is usually about right. A resistance variable between 25,000 and 250,000 ohms, in shunt to the secondary of the first or second audio frequency transformer often improves the quality of amplified signals, in addition to acting as a volume control. This is due to the imposed load being controlled and adapted better to the conditions of the particular amplifier used.

**(253) SHARPENING SUPER-HETERODYNE TUNING**

Q. 1. Can the tuning of my Ultradyne be sharpened?

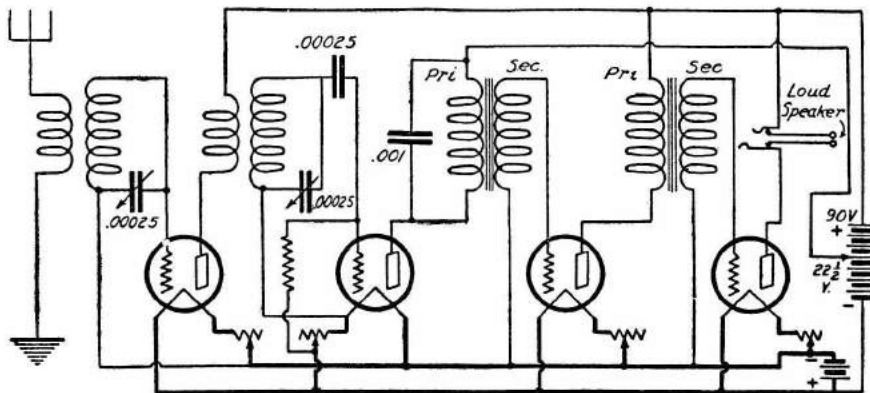

(246) The Unidyne receiver has only two tuning controls. The condenser rotor plates connection for least capacity effect is indicated by the arrowhead location, the point of the arrow designating the side upon which are the rotor plates.

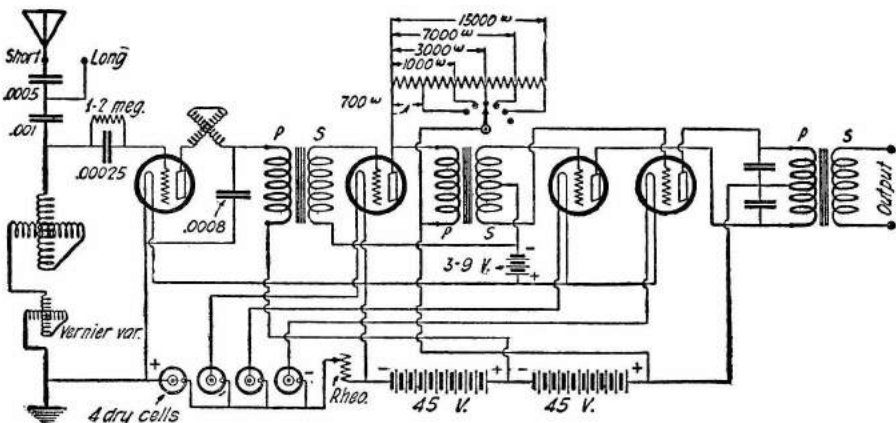

(247) The Circuit of the Radiola Grand. The Push-pull Method of Amplification Is Used, and Special Transformers Are Necessary.

**(252) NEUTRODYNE DATA**

Q. 1. Is there any way of increasing the efficiency of a Neutrodyne that is neutralized and functioning well, without adding tubes?

A. 1. Try connecting a crystal detector in the lead to the grid of the detector tube. A fixed crystal detector, known to be sensitive, would be the most convenient to use. Some experimenters find that a fixed condenser in series with the aerial will improve the quality of reception, even though the primary is untuned; the value is in the neighborhood of .006 mfd. capacity.

If the radio frequency stages are connected to the same rheostat as the detector or audio frequency stages, better results will be had, although it increases the number of controls, by using a separate rheostat for the radio frequency tubes; one rheostat will be sufficient. A 20-ohm one will be satisfactory.

Locals will be received with less distortion and less interference, if the first radio frequency tube is removed from the socket. All sets will not respond to this treatment, but

A. 1. We are illustrating a method of greatly sharpening the tuning of sets of the Super-Heterodyne class. The sharpening of the tuning is obtained by the addition of a "C" battery of 4 1/2 to 16 volts in the detector circuit. In using this system the grid leak and condenser must be removed from the circuit. (Page 82.)

Q. 2. Are condensers required across the secondaries of the intermediate frequency transformers to increase selectivity?

A. 2. Condensers may be used for this purpose, but they must be very accurately balanced to the transformers. The diagram illustrates a simpler method for securing increased selectivity.

Q. 3. Do resistance coupled amplifiers have as great a tendency towards self-oscillation as transformer-coupled or tuned-impedance coupled radio frequency amplifiers?

A. 3. Self-oscillation is not as easy to secure in resistance-coupled amplifiers, as in those of other types, hence the use of a "compensating condenser," developed by the

French Army for controlling oscillations, to permit of either phone or C. W. reception.

**(254) INTERFLEX HINTS**

Q. 1. Kindly tell me what precautions to observe in building an efficient Interflex set.

A. 1. We have listed below the points we have found of greatest importance in connection with the Interflex receivers.

1. It has been found that the All-American type R-201A and Acme type R-2 radio frequency transformers give exceptionally good results in the Interflex sets.

2. Try reversing the radio frequency frequency transformer primary connections. Also, try reversing secondary connections.

3. A carborundum crystal is particularly good. Other kinds of crystals having rectifying properties can be tried, but they are not likely to give as good results.

4. Different carborundum crystals should be tried and reversing the connections sometimes makes a difference.

5. An aerial length of 65 feet, including lead-in, is excellent.

6. In the 4-tube circuit, the radio frequency, or first tube may have a plate potential of about 45 to 60 volts; the second tube, the one having its grid connected to the crystal detector (and therefore called the post-crystal tube) may have a plate potential of 22 1/2 to 45 volts, for best results.

The voltage for this (post-crystal) tube remains the same if the stage of radio frequency preceding it is not used.

7. When adding an audio frequency amplifier, a small condenser across the primary or secondary of the first audio frequency transformer may improve the operation.

8. Changing tubes around often results in a surprising improvement in tone, volume and selectivity.

(Continued on Page 81)

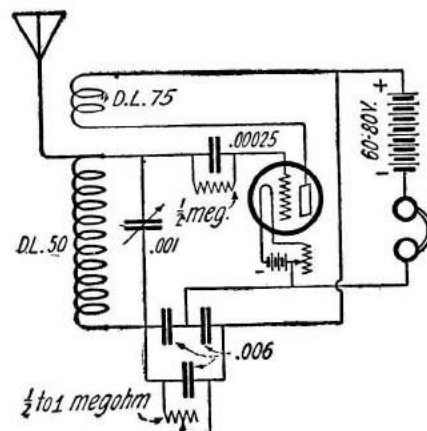

(248) The New Flewelling Circuit. The Resistance Across the .006 Mfd. Condenser is Very Critical.

# Tube Data

## (256) TUBE TESTER

Q. 1. What are the wiring diagram connections of the Jewell Radio Test Set?

A. 1. This diagram is shown in these columns. This unit has been specially designed for tube testing, and a complete set of curves may be made showing every D.C. characteristic of any vacuum tube, by the use of this instrument. In addition, the individual instruments may be arranged for innumerable other tests. See the March, 1925, issue of *Science and Invention* magazine, which contains an excellent article on modern testing sets, including one for the determination of the A.C. characteristics of vacuum tubes.

It will be noticed that the rheostat is in the positive lead. This is for the purpose of securing a zero grid potential when the potentiometer arm is placed half way between the two ends. Were the rheostat in the negative lead with the grid return to "A" minus, a negative grid bias would be placed on the grid, and this grid bias would not be indicated by the grid voltmeter, unless the grid return connected directly to the filament, when the applied plate voltage would be lowered, due to the rheostat resistance. This drop in voltage will not be shown by the plate voltmeter, in either case.

## (257) TUBE CHECKER

Q. 1. Please give circuit and general information of the Jewell pattern No. 110 "Tube Checker."

A. 1. You should have no difficulty in constructing a very satisfactory instrument from the circuit shown and the following data.

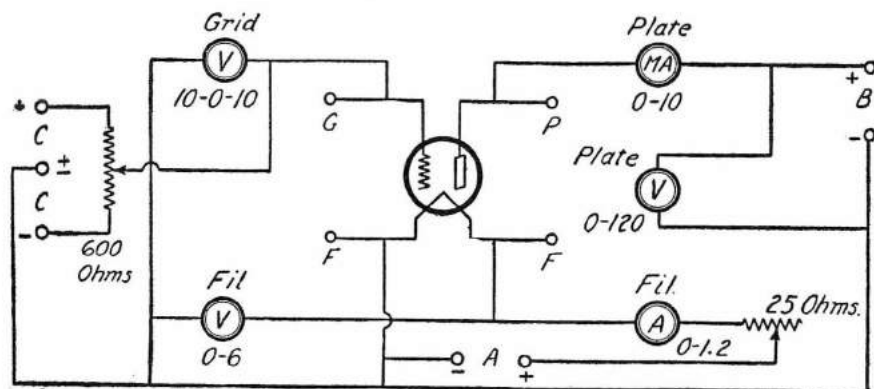

(256) Direct current tube characteristics are indicated with test sets connected as shown. A different circuit arrangement is required for determining the exact characteristics under alternating current conditions.

The latest model of this unit has a push button connected to the grid binding post of the socket and to the "A" battery in such a way that the grid connects directly to negative "A" when the button is normally out. When depressed, the grid is connected directly to the rheostat (which is connected in the positive lead of the "A" battery). The rheostat is a special one having three sections of three different resistances. When the switch arm is turned one-third of the way, the resistance is 1.5 ohms; when turned two-thirds of the way, the resistance is 5.5 ohms; when all of the resistance is in circuit, the total resistance is 60 ohms with a carrying capacity of .25 ampere.

The resistance "R" may be wound on a wood spool about  $\frac{3}{4}$  inch long and  $\frac{1}{2}$  inch in diameter. For the unit mentioned this spool is wound to a resistance of about 1,000 ohms with a wire having a zero temperature coefficient of resistance, such as manganin, constantan or advance. The model without

the grid bias polarity button has a coil wound to only 300 ohms. The value of this resistance lies in its largely preventing burning out of the plate milliammeter accidentally.

Use a single storage cell or a single dry cell for tubes having a terminal voltage of 1.1 volts, such as the C-11 and WD-11 tubes. Use two cells of a storage battery or three dry cells, in series, for tubes having a terminal voltage of three volts, such as the 399 and UV-199 tubes. Use a regular three-cell storage battery or four dry cells in series when testing tubes having a terminal voltage of five volts such as the C-301A and UV-201A tubes.

The value of a vacuum tube as an amplifier may be said to be, roughly proportional to the plate current change for a given grid voltage change.

The application of this in the instrument under consideration is given below.

With normal tubes, a definite current will flow in the plate circuit of the tube when the filament is operated at the rated terminal voltage. This direct current will be indicated by the plate milliammeter. Now, reversing the grid polarity should result in a considerable change in the milliammeter reading. The amount of this change will indicate the value of the tube; a relatively large change occurring, if the tube is a very good amplifier. The most important point to observe is the rise in plate current value when the tube grid polarity is made positive by depressing the push button. This ratio, which should be high, is of more importance than the exact values indicated.

## (258) R.C.A. TUBE DATA

Q. 1. Please state the particular usages of the new "UX" type tubes.

A. 1. The "tree" marked 258 shows the particular uses to which the complete line of R.C.A. receiving tubes and auxiliary receiving tubes are best adapted.

## (259) TUBE ACTION

Q. 1. In what way does a detector tube function differently than a radio frequency tube; and why doesn't a radio frequency tube detect?

A. 1. With a certain grid and plate voltage conditions are usually satisfactory for the radio frequency amplification, detection and audio frequency amplification of radio signals. It is understood that the grid plate and filament voltages are maintained within certain prescribed limits, each limit depending upon whether the tube is to amplify, oscillate or detect.

With a certain grid voltage and a certain plate voltage (usually about 22 1-2 plate volts and zero grid volts) the grid has been found to cause the greatest amount of change in the plate current, when a very slight voltage (the incoming signal) is applied to the grid. Under these conditions the tube is found to function particularly well as a detector. The rectification is most perfect with the above values. Incoming signals are not amplified to nearly as great an extent as they would be with different grid and plate voltages.

Since a tube is capable of functioning as an oscillator, amplifier, or detector, it is only natural to believe that there are different conditions necessary for the best operation of a tube for any one of these three actions.

The best condition for amplification depends upon whether the amplification is to be at audio frequency or radio frequency. If at audio, high plate voltages are best, plus a high negative grid voltage. Under these conditions the tube could be made to oscillate strongly, if placed in a radio frequency circuit, which would cause great distortion, however; as a detector, under the same conditions, results would be relatively unsatisfactory, as a small, incoming signal would have very little effect upon the highly negative grid.

Under the conditions for best radio frequency amplification, the radio frequency transformer secondary connects directly to the grid. The other side of the transformer connects to a potentiometer. Often, the grid voltage may be zero, but the plate voltage is preferably between 45 and 90 volts. For best results as a detector, a grid condenser is usually employed. In the radio frequency amplifier no grid condenser is used. If a very low plate voltage is used on the radio frequency amplifier, detection will be had, to a certain extent on the radio frequency tubes, but amplification will not be high. This detection is rather slight as compared to the amount of detection which will take place in the properly arranged detector tube circuit. The grid condenser, when used, is a determining factor in the best rectification of radio frequency currents.

It is thus seen that associated tube apparatus must be of a design that will work in harmony with the desired function of the tube.

The information just given must be taken as general, since a complete exposition of vacuum tube actions cannot be made in the amount of space available in these columns. The facts pointed out should explain, in only a general way, the reasons for the various grid and plate voltages used on the various tubes of receiving sets.

## (260) CURRENT CONTROL

Q. 1. I have read that when resistance is included in an electric current, instead of checking the current, it consumes it. Where a wire rheostat is used, is the current from a battery kept back by the resistance wire on said rheostat, or is it merely consumed, so that, by the time it has passed through the resistance element there is only a small portion left?

A. 1. The flow of current in a circuit is determined by the resistance in that circuit. A certain resistance will allow a certain current to pass. It does not matter whether the resistance is composed of wire or carbon. When a wire rheostat is used, the current is controlled by the length of resistance wire in series. When a carbon rheostat is used, the pressure applied to the carbon determines the current consumption.

Q. 2. Would a carbon disc rheostat aid in prolonging the life of a charge?

A. 2. As explained above, a rheostat consisting of carbon consumes as much current as a wire rheostat of the same resistance.

Q. 3. Why are radio tubes so costly?

A. 3. To bring vacuum tubes to their present state of perfection, thousands of dollars have been spent in development. Part of this development expense is compensated for by the present price of the tubes.

Q. 4. Can a UV-200 tube lose its efficiency without the filament burning out?

A. 4. Yes. Through constant use, the electron emission may considerably decrease, necessitating an increase in battery current to maintain efficiency.

**(261) REACTIVATION OF TUBES**

Q. 1. Is there any method for rehabilitating UV-199 and UV-201A tubes which light but do not function satisfactorily?

A. 1. We are showing the correct circuit for the reconditioning of the tubes you mention. This equipment is in regular use at several places where these tubes are reconditioned. Any transformer having the output indicated will be satisfactory. The catalog number shown is that of the General Electric transformer particularly adaptable to the requirements. While it is possible to recondition only one or two tubes at a time, it is better practice to operate the circuit with four tubes in the sockets at one time, using the time-voltage formula shown. (P. 82).

For UV-201A tubes, the G. E. No. 236095, 100-watt step-down transformer will be satisfactory. Two transformers, two double pole double throw switches and four UV-199 sockets and four UV-201A sockets may be mounted on one board, making a complete reconditioning unit. Note that the 100-watt transformer will have the switch arm on point three, not on point one, as is necessary for the 50-watt transformer. However, these voltages should be checked with a voltmeter, as it may be necessary to move the switch arm one way or the other, depending upon the current supply voltage. Only connections B, C and D on both transformers are used, the A connection remaining open.

The 100-watt transformer, when connected in the manner of the 50-watt transformer, with the switch arm exception mentioned above, will deliver (closely) the voltages of eight and 16 volts. Putting the double-pole double-throw switch on one side should deliver 16 volts to the filaments of the UV-201A tubes for a period of only 30 seconds. Finish off with the switch in the opposite position, delivering eight volts for 10 minutes. For the UV-199 tubes, start with 10 volts for only 30 seconds and then immediately change over to four volts for a period of 10 minutes. Many tubes thus treated test as considerably better than when first purchased.

Q. 2. What are the "boiling" and "baking" methods for tube reactivation?

A. 2. In the boiling method a voltage of approximately 10 per cent. in excess of the terminal voltage of the tube is applied to the tube filament for a period of from two to 15 hours, without the plate potential being applied. It is no longer necessary to continue the process if after a period of a few hours the tube is found to function satisfactorily when the plate potential is applied, with the tube placed in the regular receiving set. A safe and satisfactory method for speeding up the tube repair is described in answer to the question above.

In the "baking" method the tubes are placed on their sides in a granite-ware dish in an oven hot enough for baking bread. After 30 minutes they are taken out and allowed to cool off, then placed in the set and the filaments lighted for 15 minutes with the "B" battery disconnected. At the end of this time the filament current should be suddenly cut off. This heating and cooling will repair many tubes. This is the oven treatment.

**(262) STORAGE BATTERY USED WITH UV-199 TUBES**

Q. 1. Can a six-volt storage battery be used with UV-199 tubes? How?

A. 1. UV-199 tubes may be operated on a six-volt storage battery by using only two of the cells of the battery, thus obtaining four volts. If the full six volts are used, a 60-ohm rheostat must be employed.

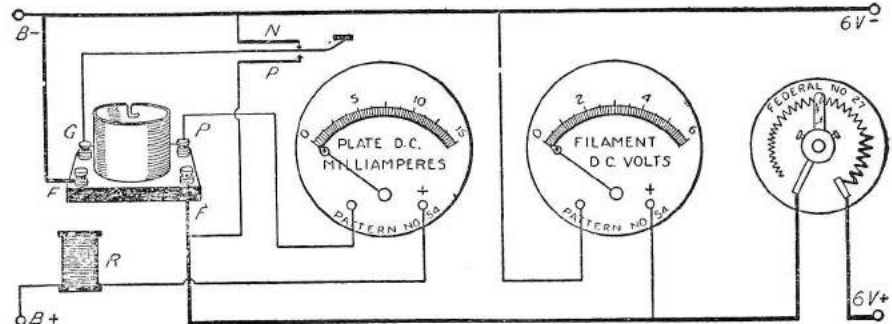

(257) Tube Checker. This is about the simplest and most inexpensive instrument one can have for rapidly determining the D. C. characteristics of vacuum tubes.

**(263) TUBE DATA**

Q. 1. What is the difference between the UV-199 tube and the C-299 tube?

A. 1. The former is manufactured for the Radio Corporation of America, by the General Electric or Westinghouse Tube Laboratories. The latter is manufactured for E. T. Cunningham, Inc., by the General Electric Company.

Q. 2. Should the inside of these tubes be plain or colored, for best results as amplifiers?

A. 2. The color of the tubes has absolutely no bearing on their use in any radio circuit.

Q. 3. If it were possible to use all the current registered by an ammeter connected to three new dry cells which are connected in series, how long could a UV-199 tube be operated?

A. 3. Taking an arbitrary figure of 30 amperes for the battery, the filament could burn for 500 hours. This efficiency cannot be developed in practice.

Q. 4. Which is the better tube, WD-12 or UV-199?

A. 4. The UV-199 seems to be the better all around tube.

**(264) MORE TUBE DATA**

Q. 1. What are the advantages and particular uses of the various tubes?

A. 1. The UV-199 tube is a very good radio frequency amplifier. It is an excellent detector and fair audio frequency amplifier. It consumes less current than any other tube, resulting in the lowest upkeep cost. The WD-11 tube operates in about the same manner as the UV-199 tube. One dry cell supplies the correct current for this tube, while a large flashlight battery is the correct supply for the UV-199. The WD-12 designation is for the WD-11, when a standard base is used. The UV-200 is the best detector tube available. It functions best when not preceded by an amplifier. This tube is a poor amplifier of either radio or audio frequency currents, due mainly to a low vacuum and gas content. The UV-200 requires a very high filament supply current, requiring a low resistance rheostat for proper control. The UV-201 consumes the same amount of current as the UV-200. Having a high vacuum, it is a particularly good audio frequency amplifier. The UV-201A tube requires only one-fourth the current of the UV-201 tube, due to a special filament being used, and functions in about the same manner. Having a high amplification factor, but a high internal capacity as compared to smaller tubes, it serves well as the intermediate radio frequency amplifier tube of Super-Heterodynes. This tube, or its equi-

valent, should be used where high amplification is desired at frequencies under 300 K.C. The Cunningham line, having the letter "C" preceding the tube number, may be considered for most purposes, as equivalent to the Radio Corporation of America line designated by UV. In the DeForest line (designated by DV), the DV-2 may be considered as equivalent to the UV-201A, while the DV-3 tube

closely resembles the WD-11, but where the latter uses a single dry cell, the DV-3 requires two dry cells for its filament supply. All tubes should oscillate easily. The best audio frequency amplifiers are the best oscillators. Myers tubes are designated only as Dry Battery, or Universal (operates with a storage battery filament supply). The former compares with the DV-3 tube, and the latter compares with the UV-201A and DV-2 tubes. Having a low internal capacity, the Myers tubes make very good radio frequency amplifiers. It is possible to use as high as 300 volts, plate potential.

Q. 2. What make is a "peanut" tube?

A. 2. This name has erroneously been applied to the UV-199 tube. It correctly refers to the Western Electric Type "N" tube.

Q. 3. What are the features of the "peanut" tubes?

A. 3. The N tube is about one-half the size of the UV-199 tube. Consuming one-quarter ampere, at 1.1 volts, it requires only one dry cell for best operation. It is an excellent radio frequency amplifier, at high frequencies, but is only a fair amplifier of audio frequencies. This tube is a very good detector.

Q. 4. What voltage is required for the plate of a UV-201A tube when used as a detector?

A. 4. It depends entirely upon the particular tube. Various voltages should be tried. Distant stations are usually received best when about 22½ volts are used. Local stations will be received with greater volume if the plate voltage is increased to 45 volts or more.

Q. 5. Will the WD-11 tube give as good results as a six-volt tube?

A. 5. The WD-11 tube will prove just as efficient as a detector as the standard six-volt tube.

**(265) TUBE DATA AGAIN**

Q. 1. Please state the temperatures at which the standard vacuum tube filaments operate.

A. 1. The heat of standard tube filaments, when operated at the normal, rated value, is shown in the following table:

UV-199	1950° absolute Centigrade
UV-201A	1950° absolute Centigrade
UV-200	2450° absolute Centigrade
UV-201	2450° absolute Centigrade
UV-202	2600° absolute Centigrade
WD-11	1098° absolute Centigrade
WD-12	1098° absolute Centigrade

To reduce the temperatures from absolute Centigrade to Centigrade, subtract 273°.

Q. 2. What are the constants of the Cunningham 250-watt tube with the "A" filament?

A. 2. The same as the 250-watt, C-304 tube, except for the filament consumption. The constants of the C-304A tube are:

rheostat will be satisfactory to use with these tubes, however. With a 6-volt storage battery care should be taken not to burn the filaments too brightly as these tubes operate on four volts.

well when adapters are used as when the correct sockets are used. This is due to the fact that the capacity between the elements of the tubes is increased. This causes a reduction in the amount of amplification. In addition to this fault, four more contacts are added to the set, at every tube, often causing tube noises.

Q. 2. What is the advantage of the UV-199 tube?

A. 2. Its outstanding feature is an extremely high electron emission at a low filament current consumption and temperature.

Q. 3. Do double grid tubes operate as well as single grid tubes?

A. 3. In the main, no. There are circuits where double grid tubes are of greater value than single grid tubes. The principle of the double grid tube is correct, but the great majority of these tubes are not made as perfectly as the three element tubes. The special construction of the better known three element tubes is not available to the present manufacturers of four element tubes.

For experimental purposes, the available four element tubes will usually be found satisfactory.

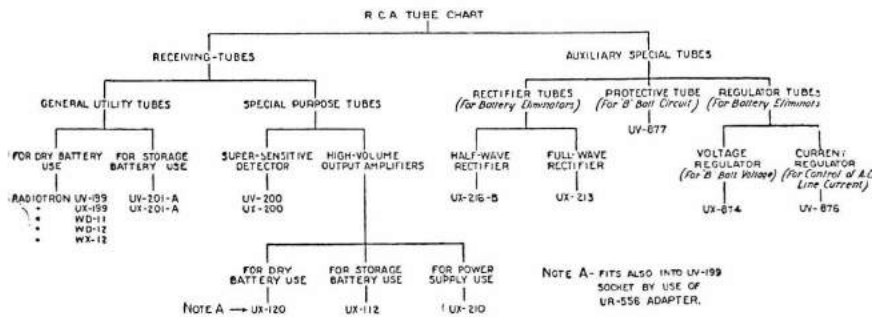

(258) This chart may be used to determine the best tube for receivers, both plain and those employing various methods of amplification, or using dry cells in place of storage batteries.

Filament Terminal Voltage . . . . . 11 volts  
 Filament Supply Voltage . . . . . 12 volts  
 Filament Current . . . . . 3.85 amperes  
 (As against 14.75 amperes for the C-304 tube.)  
 Normal Plate Voltage . . . . . 2,000 volts  
 Normal Plate Current . . . . . 200 milliamperes  
 (2,000 volts, zero grid.)  
 Amplification Constant . . . . . 25  
 Mutual Conductance . . . . . 5,000 mhos.  
 Conductance is the reciprocal of resistance.  
 Its unit is the mho, or "reciprocal ohm."

Q. 3. Can an old type Bradleystat be used with a UV-201A tube?

A. 3. This instrument can be used with a UV-201A with good results.

#### (266) THE SODION TUBE

Q. 1. Does the Sodian tube excel all other makes as a detector?

A. 1. There has been very little actual work done with this tube outside of the laboratory and we cannot say at this time whether it will excel all other makes for all around work. In a demonstration it showed great promise as a rectifier of weak signals, giving as much volume without regeneration as a good detector tube does in a regenerative receiver.

Q. 2. What A.F. and R.F. transformers operate most efficiently with it?

A. 2. Any good audio frequency transformer may be used with this tube. A special radio frequency transformer must be used, if it is employed directly ahead of the tube. This tube requires very loose coupling in a transformer or a tuner for best results, this coupling being determined by experiment. Two honeycomb coils of 25 and 50 turns for the primary and secondary may be used as a tuned radio frequency transformer when using this tube. The secondary of the transformer should be shunted by a .0005 mfd. capacity variable condenser.

Q. 3. Please give specifications for the construction of a coupler especially adapted for DX work with this tube.

A. 3. If this coupler is to be used with the Sodian tube without radio frequency it may take the form of an ordinary coupler with the exception that the secondary must be much more widely separated from the primary. As stated in answer to question No. 2, this coupling must be determined by experiment.

#### (267) MYERS TUBES

Q. 1. Will Myers tubes amplify and detect as well as standard six-volt tubes?

A. 1. These tubes will prove very good as amplifiers and detectors. They probably will not amplify at audio frequency as well as the UV-201A tube, but they will give excellent results when used for radio frequency.

Q. 2. Will Myers tubes operate on filament control devices?

A. 2. We are undecided as to just what is meant by this question. An ordinary 10-ohm

#### (268) REPAIRED TUBES

Q. 1. Is a repaired tube as good as a new one?

A. 1. Sometimes a repaired tube will give as good results as when new, but as a rule we do not believe it will equal a new tube.

Q. 2. Would a WD-11 or a UV-199 give better results?

A. 2. These tubes when used as detectors would give about equal results, but when used as amplifiers, the UV-199 would prove superior.

Q. 3. How bright should a Sodian tube filament be kept for best operation?

A. 3. Bright yellow is about the right brilliancy for the Sodian tube. Signal strength and filament life are greatly reduced when the filament is operated at too high a temperature.

#### (269) VOLTAGES ON MYERS TUBES

Q. 1. Can both types of the Myers tubes be used as detector or amplifier?

A. 1. Yes, but the 'Myers High Mu' tube will be better as an amplifier.

Q. 2. What is the filament and plate voltage of each tube?

A. 2. Both tubes take four volts for the filament. Each tube will take 60 volts on the plate but the High Mu tube can be used with 120 volts with safety.

Q. 3. What are the characteristics of the DeForest DV-2 tube?

A. 3. This tube may be used as a detector or amplifier; 150 volts is the maximum amplifier plate voltage, and 60 is the maximum detector plate voltage. A 10-ohm rheostat connected in the negative lead is satisfactory for operation on a 6-volt supply. The current consumption is one-quarter ampere. This tube functions best as a power amplifier.

#### (270) BOOTLEG TUBES

Q. 1. What is a method of distinguishing genuine tubes from the bootleg variety?

A. 1. This fact can only be determined by laboratory inspection of each tube, either as a complete tube or in its component parts. The only practical method of obtaining a standard tube is to purchase it from a reputable dealer who will make adjustments if it is found defective.

Q. 2. What vacuum pump would be advised for the home construction of experimental vacuum tubes?

A. 2. First use a Gaede mercury pump capable of producing a vacuum of .00001 millimeter, then use a piston pump of the Geryk type, or equivalent.

#### (271) TUBE ADAPTERS

Q. 1. What are the objections to using adapters with the various tubes?

A. 1. If the tubes are being used as radio frequency amplifiers, they will not function as

#### (272) MUTUAL CONDUCTANCE

Q. 1. How can the mutual conductance of a vacuum tube be determined?

A. 1. The amplification constant, multiplied by one million, when divided by the plate-to-filament impedance will give the mutual conductance in micro-mhos.

Q. 2. What maximum plate voltage is safe for Myers High-Mu tubes?

A. 2. The exceptionally high potential of 300 volts is allowable.

Q. 3. Does the filament of the UV-200 tube consume 5 watts in one second, one minute, or one hour?

A. 3. They consume 5 watt-hours in one hour.

#### (273) VACUUM TUBE CONSTRUCTION

Q. 1. Why does the filament quickly burn out, in home constructed tubes, even though highly evacuated?

A. 1. This may be due to an imperfection of the filament wire. It may also be caused by a poor juncture of the lead-in wire and the glass, due to a difference in the co-efficient of expansion of the lead-in wires and the glass. Occluded gases will also effect the filament life.

Q. 2. Where can vacuum tube construction data be obtained?

A. 2. See Scott-Taggart's book, "Thermionic Tubes in Radio Telegraphy and Telephony."

Q. 3. Can eight dry cells, connected in series-multiple so as to give six volts, be used with efficiency as an "A" battery for the UV-201A tubes?

A. 3. Dry cells may be used for lighting the filaments of the tubes in this way, if desired, but the dry cells would not last very long. We would suggest a storage battery for this purpose.

#### (274) DATA ON THE UV-199

Q. 1. Why does the UV-199 tube fail to function when a higher voltage than normal is put on the filament?

A. 1. The filament of the UV-199 is composed of tungsten, containing a certain amount of thorium oxide. When three volts are applied to the filament, a portion of this oxide comes to the surface and forms a thin coating on the outside of the filament. There is also a continuous reserve just under the surface of the filament. It is this thorium oxide which emits electrons. If a voltage of 5 to 10 volts is accidentally applied to the filament, all of the thorium is vaporized. If the high voltage is left on too long, the reserve is also consumed. When this happens the "B" battery must be disconnected, and the filament lighted to its normal temperature, until a new supply of thorium has come to the surface again. The tube will then function as well as before.

(Continued on page 82)

# Transmitting Circuits

**(279) SIMPLE PHONE TRANSMITTER**

Q. 1. Please publish a phone and C. W. circuit which uses one tube.

A. 1. This circuit appears on these pages. A D.P.D.T. switch is used so that either voice or key can be used.

Q. 2. Is the arc transmitter more likely to produce harmonics than other types of transmitters?

A. 2. The arc is a prolific producer of harmonics. It has been stated that the Eiffel Tower station has been heard on different harmonics between 650 and 162 meters. The great objection to the arc system is apparent. Fortunately there have been new developments enabling a nearly entire control of the harmonics ordinarily produced and radiated by arc transmitters.

Q. 3. What does "Hi!" mean? I often hear amateurs use this expression when radiophoning to one another.

A. 1. This means "Ha! Ha!" It is the radio laugh.

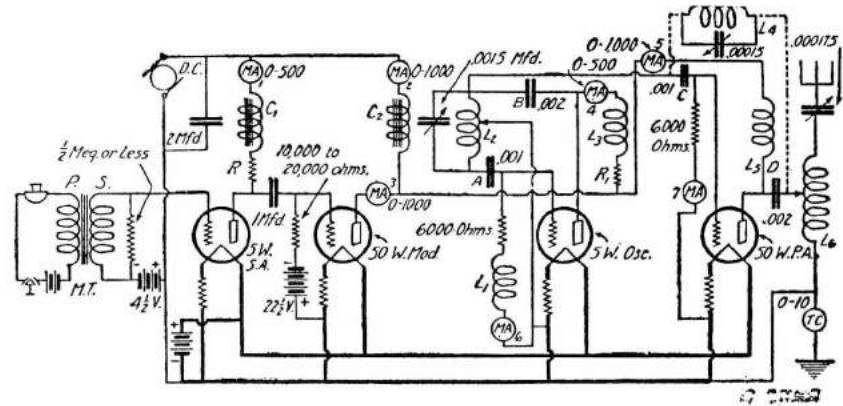

(280) This is the schematic diagram of one of the most efficient radiophone transmitters it is possible to construct. Constant wave-length and nearly complete modulation are outstanding features of this exceptionally efficient transmitter.

**(280) EXCELLENT TRANSMITTER**

Q. 1. Please show a diagram of connection for an exceptionally efficient transmitting set of about 50-watts power. It is desired to use this transmitter for phone transmission on a wave-length of about 200 meters. The current should remain constant, regardless of aerial wave-length variation.

A. 1. We are herewith showing the constant current (Heising's) master oscillator transmitter. Modulation is nearly complete, as practically 80 per cent. to 90 per cent. of the output is modulated.

The 5-henry choke coil, L-1, may comprise 15,000 turns of No. 28 single cotton silk covered, or enameled wire. A soft iron core five inches long and three-fourths inch square is used. The choke C-2 may consist of about 6,000 turns of the same wire, wound on the same size core. Inductance L-1 may be 200 turns of No. 30 D.C.C. wire wound on a three-inch tube. This design is the same for L-3,

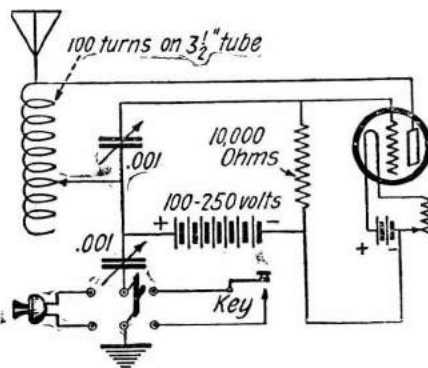

(279) This Diagram Shows a Simple C.W. and Phone Transmitter That Will Give Good Results. A D.P.D.T. Switch is Used for Voice or Key.

L-2 should consist of 40 turns of No. 22 C.C. wire, wound on a half-inch tube. L-4 is the same size as L-2. L-5 consists of 300 turns of No. 20 D.C.C. wire wound on a three-inch tube. Inductance L-6 consists of about 30-turns of No. 22 C.C. wire, wound on a three-inch tube, tapped every turn. The condensers marked A, B, C and D may function better if of slightly different capacity from that indicated in the diagram.

These constants are for transmission on a wave-length of 200 meters with an antenna of .0006 mfd. capacity and with a natural wave-length of 300 meters. Individual conditions may necessitate slight changes in the con-

stants. The resistance of a particular aerial with which this circuit was developed to maximum efficiency had a value of 15 ohms. Western Electric 5-watt tubes were used with 350 volts on the plates; 50-watt tubes, 750 volts on the plate.

Q. 3. What is the transmitting range of a 10-watt phone set?

A. 3. Ranges of sets cannot be given with any degree of accuracy.

Q. 4. Can an "S" tube rectifier be used for a 250-watt set?

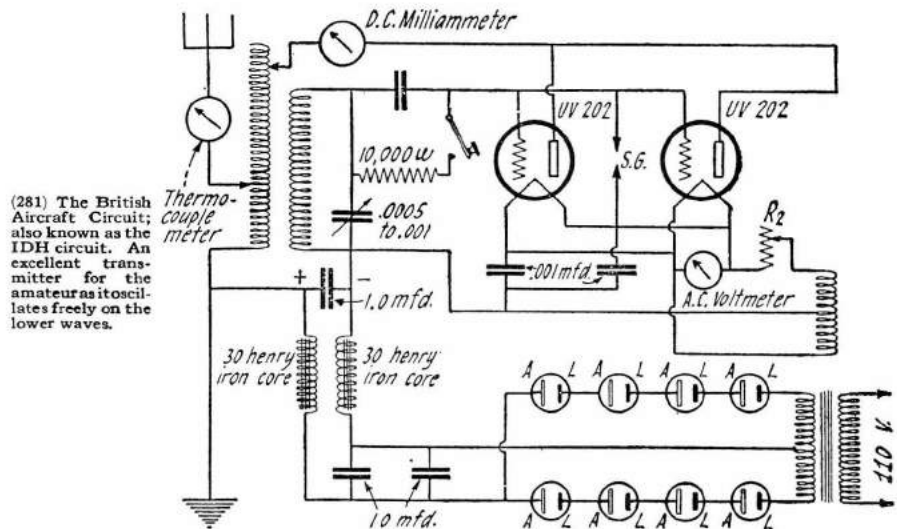

(281) The British Aircraft Circuit; also known as the IDH circuit. An excellent transmitter for the amateurs it oscillates freely on the lower waves.

**(281) BRITISH AIRCRAFT CIRCUIT**

Q. 1. Kindly publish the British Aircraft Circuit employing two 5-watt tubes.

A. 1. This circuit is shown herewith.

Q. 2. What do the initials I. C. W. mean?

A. 2. Interrupted Continuous Waves.

A. 4. Since the output of the "S" tube is somewhat limited, best results will be had by using these tubes for stations up to 50-watt size. The most economical operation of larger sets will be had by the use of a motor-generator or a chemical rectifier.

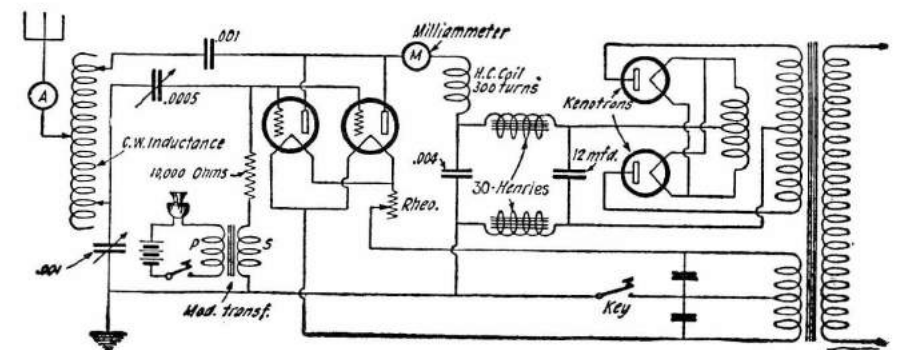

(282) Here is the Circuit for a Good 10-Watt C.W. and Phone Transmitter. Kenotron Tubes Are Used to Rectify the Plate Voltage.

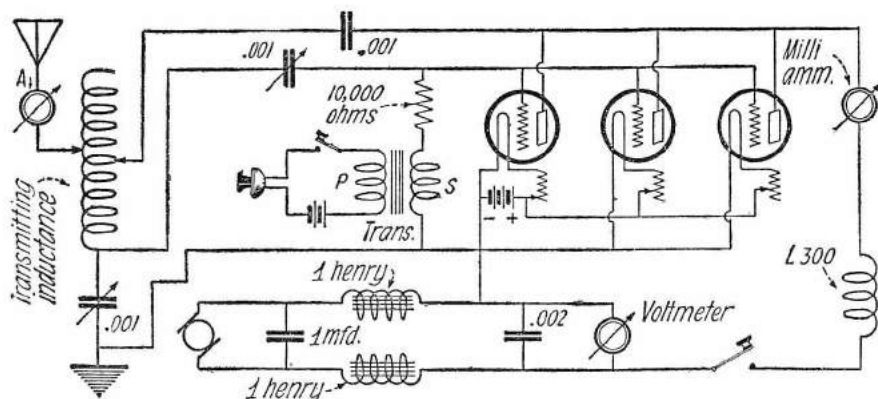

(283) Here is Shown an Efficient 15-Watt Transmitter. The Colpitts Oscillator Circuit is Used and a Very Good Range Can Be Obtained.

#### (282) C.W. TRANSMITTER

Q. 1. Please publish a hook-up using Kenotron rectifier tubes in place of a chemical rectifier.

A. 1. This hook-up will be found in these columns. Two Kenotron rectifying tubes are used in place of the chemical rectifier.

#### (283) A 15-WATT C.W. TRANSMITTER

Q. 1. Will you please publish a good hook-up for a 15-watt transmitter?

A. 1. This hook-up will be found in these columns. This set can also be used for telephone transmission.

Q. 2. What is the maximum transmitting range of an oscillating receiving set using a UV-201A tube?

A. 2. The results of several tests made independently indicate that there is no difficulty in transmitting by phone and code for a distance of 15 miles. This is a concrete example of the great interference that can be caused by a receiving set in the oscillating condition.

Q. 3. What kind of coil is it that is numbered L-300 used in this circuit?

A. 3. This coil is a Duo-Lateral or a honeycomb coil of 300 turns.

#### (284) 5-WATT TRANSMITTER

Q. 1. Kindly publish a hook-up similar to the Paragon 5-watt transmitter. This can be used as a C.W., I.C.W. or phone transmitter.

A. 1. This hook-up will be found in these columns.

#### (285) HOT-WIRE AMMETER

Q. 1. Is it advisable to short circuit the hot-wire ammeter in a transmitting set, when not required for readings?

A. 1. The ammeter constitutes a resistance in the circuit and should be short circuited when not being used.

#### (286) 5-WATT TRANSMITTER

Q. 1. Please publish a circuit for a 5-watt C.W. transmitter, showing how we can use 220-V D.C. light current for the plate.

A. 1. The diagram you request will be found on these pages. Care must be taken to get the polarity as shown, otherwise there will be a short circuit and the house fuses will be blown.

#### (287) TRANSMITTING LICENSE

Q. 1. How may I secure a license to transmit?

A. 1. To secure a license to transmit you must apply to the Radio Supervisor of your district for application blanks and then pass an examination on radio, and be able to receive code at 10 words or more per minute.

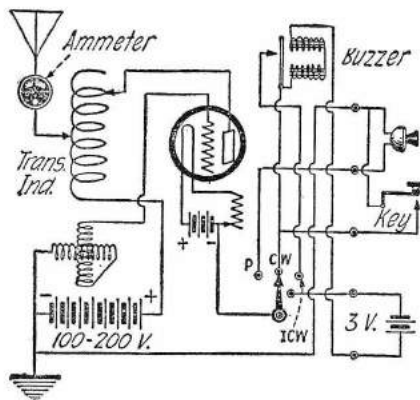

(284) Here is a Good Circuit for a Low-Power Phone, I.C.W. and C.W. Transmitter. This Is Similar to the Paragon 5-Watt Transmitter.

#### (288) COMBINATION RECEIVER AND TRANSMITTER

Q. 1. Please publish a receiving hook-up that can also be used as a C.W. and phone transmitter.

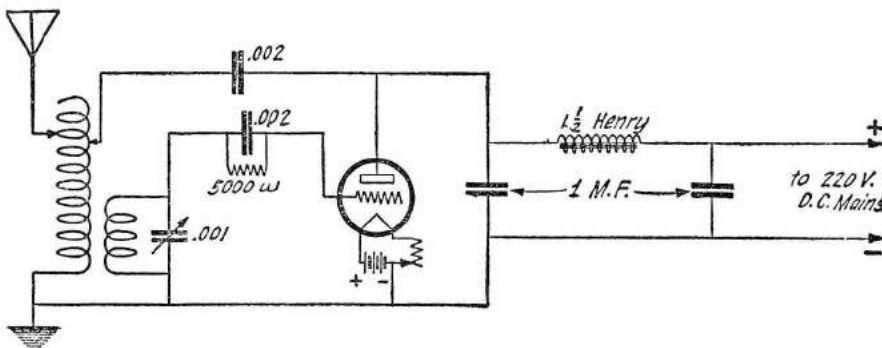

(286) A five-watt C.W. transmitter circuit of the reversed feed back type employing 220 volts D.C. for the plate supply. A choke coil and two fixed condensers serve to smooth out the commutator ripple of the generator. The key is placed in series with the negative side of the 220-volt main.

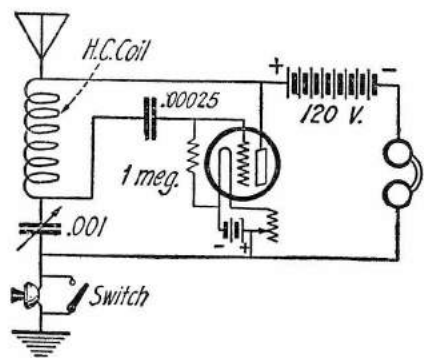

(288) The Colpitts Circuit is an Excellent Oscillator, and Will Give Good Results as a Receiver or a Transmitter.

A. 1. This hook-up will be found in these columns. A honeycomb coil may be used as the tuning inductance and a microphone or key may be inserted in the ground circuit for transmitting. A hard tube should be used so that a high "B" battery voltage can be used on the plate.

Q. 2. Can a galvanometer be used in place of the hot-wire ammeter in a one-tube transmitting set?

A. 2. A galvanometer could be used, but it would be necessary to use a comparatively low-resistance shunt in order to control the current in the galvanometer circuit. A galvanometer would probably function if connected across a short length of the lead-in or ground wire, current sufficient to operate the galvanometer being picked up due to the difference of potential existing between the two points of the lead-in or ground to which connection was made. This instrument, however, is not recommended for this purpose.

#### (289) CODE SENDING REGULATION

Q. 1. How can code broadcasting, before 8:00 p.m. and after 10:00 p.m. be prevented?

A. 1. Commercial transmitting on commercial wave-lengths may be done at any hour of the day or night. Amateur transmitting may be done, on the proper wave-length, by permission of the Government at any hour of the day or night, except the period set aside and designated as the "quiet hours." The quiet hours are from 8:00 p.m. to 10:00 p.m.

#### (290) SPARK COIL "C. W."

Q. 1. What is the voltage and amperage of the average 1/4-inch spark coil, using eight volts on the primary?

A. 1. This would depend upon the type of spark coil used and the adjustment of the vibrator. The secondary voltage would be about 7,000 volts, with an amperage of about two or three milli-amperes.

Q. 2. Give hook-up of a 5-watt C. W. transmitter, using a spark coil.

A. 2. This circuit appears on P. 82. The same storage battery is used to light the tube and operate the coil. Better results would be obtained with a separate battery of eight or ten volts on the primary of the spark coil.

#### (291) 10-WATT TRANSMITTER

Q. 1. Please publish a hook-up of a 10-watt C. W. transmitter, using rectified A. C. on the plates and using a separate filament transformer.

A. 1. This hook-up will be found in these columns. An electrolytic rectifier is used to supply D. C. for the plates of the tubes.

#### (292) MODULATION SYSTEMS

Q. 1. Which form of modulation is best: grid, plate, antenna or absorption?

A. 1. Very good results have been secured with practically all the systems named. The actual system to be used depends upon the particular transmitting circuit employed, some sets producing better results with one method than with another. Plate, or constant current and grid modulation are generally conceded to be the two best systems.

(Continued on page 82)

# Current Supply

## (295) PREPARING STORAGE BATTERY PLATES

Q. 1. How is the paste prepared for storage battery plates?

A. 1. A pasted plate is usually made by applying to a hard lead-antimony grid, a paste made of some oxide of lead, usually litharge (PbO), or red lead (Pb<sub>3</sub>O<sub>4</sub>) and some liquid and other substance such as anthracine, glycerine, graphite, potassium silicate, etc., to increase the hardness, porosity, toughness and conductivity. After the grid is filled with the paste the plate is dried. After being completely dried a number of plates are assembled in a forming bath of dilute sulphuric acid with dummy lead plates for the opposite electrode and a forming charge is given by passing the proper current through the voltaic couple thus formed. Positive plates are formed by connecting the plates to be formed as the anode; the current further oxidizing the lead oxide to lead peroxide (PbO<sub>2</sub>). Negative plates are formed by passing the current in the opposite direction, reducing the lead oxide to sponge lead.

## (296) "B" BATTERIES AND BALKITE CHARGER

Q. 1. How can radio "B" batteries be charged with a Balkite charger?

A. 1. The Balkite battery charger, while designed primarily for the purpose of charging 6-volt "A" filament batteries may be used if desired for charging radio "B" storage batteries.

For charging one of these batteries with the Balkite charger the "plus" terminal of the battery is connected to the positive terminal of the charger. (The red tip is positive.) The other lead is connected to the connector strip in the middle of the battery, that is, between the 6th and the 7th cells. By turning on charging current, this section of the battery will charge at the proper rate.

After charging the first section, the "plus" red clip is placed where the negative clip was, that is, at the midpoint of the battery, and the "minus" clip put on the negative terminal of the battery.

Q. 2. When using this charger, can the "B" batteries be charged in units of more than six cells?

A. 2. No.

## (297) "S" TUBES

Q. 1. How is the "S" tube rectifier connected at various voltages, when used to supply current to transmitting sets?

A. 1. We are showing these circuits. By using a standard filter consisting of two choke coils and two condensers, practically pure D.C. will be had. The choke coils may be of one-half henry inductance. The condensers will have to be about 25 mfd. An electrolytic condenser will fill the requirements. When connected in parallel, "S" tubes require resistances "R" of about 1,000 ohms.

Q. 2. What is the life of the "S" tube?

A. 2. Approximately 3,000 hours.

## (298) ELECTROLYTIC RECTIFIERS

Q. 1. What is the metal used in the Balkite "Fansteel" charger?

A. 1. It has lately been found commercially possible to use tantalum. That metal is now used in the Balkite charger.

Q. 2. Why are several electrolytic rectifier cells required when charging a high-voltage battery?

A. 2. At 30 to 35 volts aluminum begins to disintegrate. This is also true of tantalum. It is for this reason that storage "B" batteries

of more than 20 volts should be connected in series parallel so the battery will comprise banks of cells of 20 to 24 volts each. In this manner a charging rate, equal to the sum of the charging rate of each bank of batteries, is used.

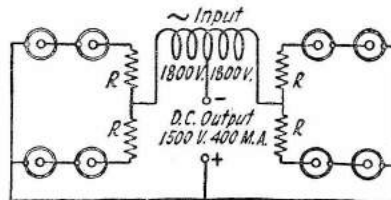
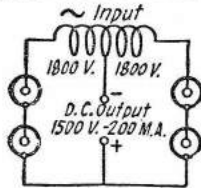
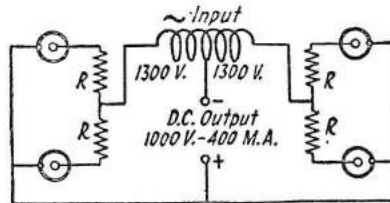
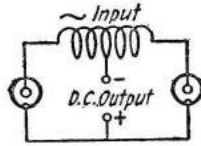

Showing the numerous ways in which the "S" tube rectifiers can be used.

## (299) AMPERAGE FOR STORAGE BATTERY CHARGING

Q. 1. Can a step-down transformer giving six volts be used in place of the electric bulbs used to charge a storage battery?

A. 1. We presume you refer to an electrolytic rectifier which uses a certain number of lamps to allow a certain current to flow. A step-down transformer could not be used even if it were designed to pass the required number of amperes. The reason for this is that an electrolytic rectifier will not function with less than 50 volts. If the transformer were designed to deliver 50 volts at 5 amperes at the secondary, it could be used for this purpose.

## (300) BUZZER AS PLATE CURRENT SUPPLY

Q. 1. Can a buzzer be used to supply the plate voltage for a 6-watt transmitter?

A. 1. A buzzer of special design would be required in order to supply a sufficiently high voltage, and current for a 5-watt tube.

## (301) BATTERY TESTING

Q. 1. Should my 28 volt "B" battery, acid electrolyte, be tested with an ammeter?

A. 1. An ammeter should not be used for testing batteries. It is sometimes desirable to test storage batteries with a special ammeter, but a voltmeter is the safest instrument to use. Do not permit the voltage to drop lower than 1.6 volts per cell. A hydrometer is usually used for testing storage batteries, but there is too little electrolyte in "B" battery cells for it to be used there.

Q. 2. Should an Edison alkali electrolyte battery be tested with a hydrometer?

A. 2. The specific gravity of this battery changes but little between charge and discharge. Use a voltmeter.

## (302) 32-VOLT "A" BATTERY

Q. 1. Is there any way to use a 32-volt storage battery as a radio "A" battery?

A. 1. The most efficient way of doing this, without changing the connection on the battery, would be to connect the battery up in the regular way, but putting resistance in one lead. The value of this resistance would be about 128 ohms. When buying resistance wire it will be necessary to use a size sufficiently large to pass the amperage required by the tube;  $\frac{1}{4}$ -ampere wire will be required if a UV-201A tube is used.

Q. 2. Would it be correct to use three cells at a time?

A. 2. This would be very injurious to the battery. One or two of the cells will probably never be charged to the full amount, if this system is used, and the battery will be useless in a short time.

Q. 3. Could the above mentioned battery be used as a "B" battery?

A. 3. It could be used very well. It would be advisable to connect a potentiometer across this battery. The resistance of this potentiometer should be 6,000 ohms. The potentiometer will be connected in the circuit between one battery terminal and the output, in the manner of a common rheostat. Voltage is thus regulated.

Q. 4. How many lamps are needed to charge a 6-volt battery at 5 amperes, using a 2-jar rectifier?

A. 4. Five 100-watt lamps in parallel, or equivalent.

## (303) STORAGE BATTERY QUERY

Q. 1. What is the voltage, when a storage battery begins emitting gas while on charge?

A. 1. Approximately 2.35 volts per cell.

Q. 2. What is the specific gravity at this point of the charge?

A. 2. Approximately 1.325.

## (304) STORAGE BATTERY SEPARATORS

Q. 1. What woods are used as storage battery separators?

A. 1. The woods used, in the order of their life under storage battery use, are: Basswood, poplar, Douglas fir, California redwood, white cedar and cypress.

Q. 2. How are separators sawed?

A. 2. Separators of quarter-sawed wood are the best.

Q. 3. Is there any satisfactory method for cleaning sulphated plates?

A. 3. The most thorough method is described below: "Tear down" the battery, so that the elements can be immersed in a solution made by dissolving  $\frac{1}{2}$  pound of ammonium acetate in 1 quart of water, in an earthenware jar; leave them so for  $\frac{1}{2}$  hour. This will free the plates from the sulphate. Wash in clear water and dry. The battery may now be re-assembled.

## (305) DRY BATTERY LIFE CURVE

Q. 1. Is the life curve for dry batteries straight?

A. 1. Dry battery life is proportional to the current consumption, as well as to the time they are used for a continuous period.

## (306) "B" SUPPLY VIA "S" TUBE

Q. 1. Can an "S" tube be used in a circuit for supplying "B" potentials for detector and amplifier?

A. 1. We are showing a circuit employing the Amrad "S" tube, and Mershon electrolytic condensers of very high capacity. Resistances "A," "B," "C" and "D" total 19,900 ohms. Unit "A" consists of six resistances, each of 1,400 ohms. Unit "B" consists of four resistances, each of 125 ohms. Unit "C" is 1,000 ohms and unit "D" is 10,000 ohms. Lavite resistances should be entirely satisfactory.

Q. 2. Does the Daniell cell use copper sulphate in powder or crystal form?

A. 2. Crystal.

### (307) STEP-UP TRANSFORMERS

Q. 1. What is the difference between an A. C. and a D. C. step-up transformer?

A. 1. There is no such thing as a D. C. step-up transformer. A transformer relies upon the principle of induction for its operation, which is caused by the magnetic field of a pulsating or alternating current, expanding and collapsing in unison with the alternations, and in so doing, cutting the turns of a secondary coil, thereby inducing a voltage in direct ratio to the number of turns in this coil. As direct current has no fluctuating magnetic field, it cannot be used to operate a transformer.

### (308) CURRENT SUPPLY UNIT

Q. 1. What is the wiring diagram of the Western Electric No. 2-A Current Supply Unit and how is it connected to the Western Electric Amplifier?

A. 1. The circuit and diagram of connections are shown in these columns.

Q. 2. How is the No. 2-A current supply unit made?

A. 2. Exact constants have not been made public and the average experimenter is not advised to attempt the building of one of these instruments as it is a very easy matter to burn out the two tubes if a wrong connection is accidentally made.

Q. 3. What is meant by the mark "G" on the Western Electric Power Amplifier?

A. 3. This marks the ground connection. It is sometimes better to leave the ground unconnected.

### (309) CHARGING STORAGE "B" BATTERIES

Q. 1. Can a Homecharger, manufactured

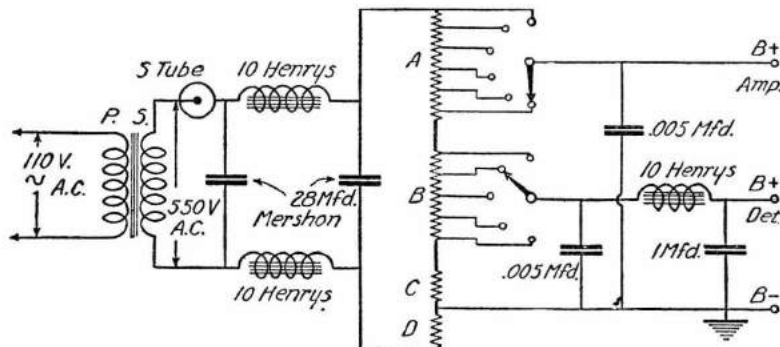

(306) A standard current supply circuit. Plate voltages up to about 100 are obtainable. The parts, being in limited demand, are not purchasable in most radio stores, but can be obtained from the larger companies.

by the Automatic Electrical Devices Co., be used to charge a storage "B" battery?

A. 1. We give herewith a diagram showing how a storage "B" battery may be charged by a Homecharger. A six-volt storage "A" battery is connected to the charger in the usual manner. The regular connection to the lamp socket is also made. The fuse must be removed from the charger before the "B" battery is connected. The negative of the "B" battery is connected to the binding post that the negative "A" is connected to. The positive terminal of the "B" is connected to one side of the A.C. line with a 50- or 75-watt

lamp in series. The other side of the A.C. line is connected directly to the vibrator screw, as shown on the diagram. If connections are properly made the lamp will burn quite dully.

### (310) RECTIFIER QUERIES

Q. 1. Please give dimensions of jars and plates of a four-jar electrolytic rectifier.

A. 1. Jars having a capacity of one quart should be used. Pure lead and aluminum plates 5" long and 1" wide should be employed. These plates should be immersed in the solution to a depth of about  $3\frac{1}{2}$ ".

Q. 2. Where may the lead and the aluminum necessary for this rectifier be obtained?

A. 2. Pure lead and aluminum sheeting may be obtained from Patterson Bros., 27 Park Row, New York City.

### (311) ELECTROLYTIC RECTIFIER SOLUTION

Q. 1. How is the borax solution for an electrolytic rectifier made?

A. 1. This solution is prepared by dissolving ordinary borax in distilled water. The borax is added to the water until no more can be dissolved. The solution should then be placed aside until all extra borax has settled in the bottom. The clear solution can now be poured off to use in the rectifier.

Q. 2. Please publish a hook-up of two-jar electrolytic rectifier for use in charging a 100-volt storage "B" battery at about two amperes and 112 volts.

A. 2. As you have 110-volt supply, you cannot charge this battery at 112 volts. Also it would be injurious to the battery to charge it at two amperes. A storage "B" battery should not be charged at a higher rate than  $\frac{1}{2}$ -ampere. The best way to charge this battery would be to divide it into two batteries of 50 volts each, place them in parallel, and connect them in series with a one-jar rectifier and the 110-volt line. A 75-watt lamp should also be placed in the circuit to allow the correct amount of current to pass.

Q. 3. Are tungsten lamps better than carbon lamps when used as a resistance in this rectifier?

A. 3. Both types of lamps will work equally well in this circuit.

A. 1. Under exceptional conditions this distance can be covered. It will be much better to use a UV-202 tube and about 250 volts on the plate.

Q. 2. Can a Ford coil be used as a source of plate current for this transmitter?

A. 2. It could be used for code transmission. It will be necessary to use some other form of current supply, if voice transmission is desired.

Q. 3. I have been advised that placing the "B" batteries on a dry wood board on a radiator is not desirable, as it makes a capacity to ground and sometimes causes considerable feed-back to the input side of the set. Is this correct?

A. 3. In addition to the above, and primarily, it will greatly reduce the life of the "B" battery due to the great acceleration of the action of the acids on the metals. "B" batteries should always be kept in a cool, dry location.

Q. 4. If it is convenient to give storage "B" batteries a booster charge every day, would there be any disadvantage in tapping off different voltages for the radio frequency amplifier, detector and audio frequency amplifier?

A. 4. Since the drain of the high voltage end of the battery would be subnormal and the drain on the low voltage end of the battery would be abnormal, the cells comprising the low voltage end of the battery would expand and contract and generate gases to a much greater degree than those at the opposite end, causing a loss of the active material due to its dropping out of the grids. This would result in much quicker depreciation of these cells.

That is an argument in favor of the expensive but more efficient arrangement of individual batteries for the three voltages you mentioned.

### (314) TRANSFORMERS

Q. 1. What is the design for a transformer to deliver a secondary plate voltage of 250 and a secondary filament voltage of 8 from a 32-volt, direct current source?

A. 1. Transformers operate only from an alternating current supply. It would be necessary to know what voltage and amperage supplied, if it was intended to operate the transformer in conjunction with a converter or generator.

### (315) ALKALINE BATTERY

Q. 1. How does the Edison Battery function and what materials are the plates made of?

A. 1. In the alkaline or Edison battery, the positive plate consists of alternate layers of nickel hydrate and pure nickel flake, packed in perforated nickel plated steel tubes. The negative plate consists of iron oxide held in a somewhat similar way. The electrolyte used is a 20-per-cent solution of caustic potash in water. The electrolyte acts only as a carrier of oxygen between the plates and does not form chemical compounds with the active materials. The voltage of this cell is about 1.4 volts. The specific gravity of the solution remains practically constant and a hydrometer cannot be used to determine if the battery is charged. A volt meter can be used for this purpose. This battery can be completely shorted without harming the plates. Any water can be used in the electrolyte, provided it is free from acids and sulphur. During charging hydrogen gas is given off freely and as this is very explosive when combined with air, all open flames must be kept away.

### (316) CONNECTING A LAMP RESISTANCE

Q. 1. Should six 60-watt lamps be connected in series when charging "A" batteries from an electrolytic rectifier?

A. 1. The lamps should be connected in parallel.

### (312) FORD COIL VOLTAGE

Q. 1. Can a Ford coil be used to supply the current to the plates of the amplifier tubes of a receiving set?

A. 1. No.

Q. 2. What is the approximate secondary voltage and amperage of a Ford coil with four to six volts on the primary?

A. 2. About 9,000 volts and one-half milliamperes.

### (313) FORD COIL "B" BATTERY

Q. 1. Will I be able to send 20 miles with a UV-201 tube using 100 volts on the plate?



Q. 2. Does the long thin line or the short thick line denote the positive binding post of a cell or battery?

A. 2. The long thin line denotes the positive connection. In some diagrams this is shown erroneously reversed, the short line denoting the positive connection.

Q. 3. Does it make any difference whether the "A" battery connects to the switch arm, or the resistance wire, of a rheostat?

A. 3. It makes no practical difference whether the rheostat is connected one way or the other. Also, polarity markings on the tube sockets may be disregarded, if it will not be confusing to you.

**(317) BATTERY CHARGES**

Q. 1. Is it possible to recharge a 6-volt 60-ampere-hour radio battery from a 24-volt automobile battery, and how?

A. 1. It is possible to charge a radio battery from a 24-volt, D.C. source, by connecting the positive leads of both batteries together and the negative leads of both batteries together. A resistance must be inserted in series with either a positive or negative lead, of the six-volt battery. The value of this resistance must be sufficient to permit not more than five amperes to pass through the circuit.

Q. 2. What would be the lowest specific gravity allowable for the radio battery?

A. 2. The specific gravity should not drop lower than 1.200.

Q. 3. Could this radio battery be connected so as to charge from the automobile charger?

A. 3. If the same charger is used, as is used with the 24-volt battery, this could not be done without special wiring.

**(318) CORRECT TUBE BATTERY**

Q. 1. Are Leclanche wet batteries suitable for WD-11 tubes?

A. 1. These batteries are quite efficient. They may be used in place of the usual dry cell or storage battery.

Q. 2. Which would be more economical, a single dry cell or a 2-volt storage-battery unit, for lighting a WD-11 tube?

A. 2. If facilities for charging a storage battery are available, it will probably be better to use that type of battery. Otherwise it would be more economical to use a single dry cell.

**(319) CADMIUM TEST**

Q. 1. What is cadmium?

A. 1. Cadmium is an element which, in the electro-chemical series, is between lead-peroxide and sponge lead.

Q. 2. How is it used in connection with storage batteries?

A. 2. When a cadmium stick is inserted in a storage battery cell, it forms a small battery, when in relation to either the positive or negative plates. The voltage of this small battery determines the condition of the positive or negative plates, depending on which plates are being tested.

Q. 3. What is the advantage of a cadmium test?

A. 3. It enables an easy check-up to be made upon the relative states of charge of the individual groups of plates, or even in the individual plates of a cell, thus quickly indicating an undercharged plate.

**(320) 32 VOLTS FOR PLATE AND FILAMENT**

Q. 1. Can the electric current from a 32-volt farm lighting plant be used to light the filament of a tube?

A. 1. A diagram will be found on these pages showing how this is done. One 40-watt lamp is placed in series with the line to cut down the voltage and supply the amperage for the tube. We assume that a tube drawing one ampere, such as a radiotron, is to be used.

Q. 2. Could same source of current be utilized for plate voltage?

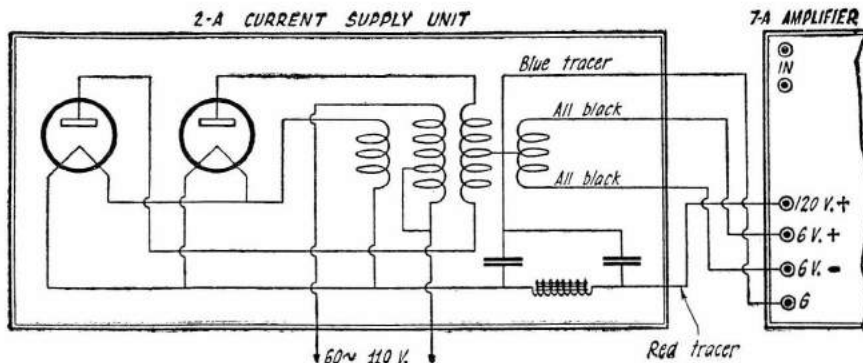

(308) The circuit diagram of the Western Electric No. 2-A current supply unit. Two 2-element vacuum tubes are employed for rectifying the alternating current from the lighting mains.

A. 2. This has also been shown on the diagram.

Q. 3. Can a "B" battery be constructed from home-made cells comprising carbon and zinc, in some manner?

A. 3. A very satisfactory battery may be built up with cells constructed in the following

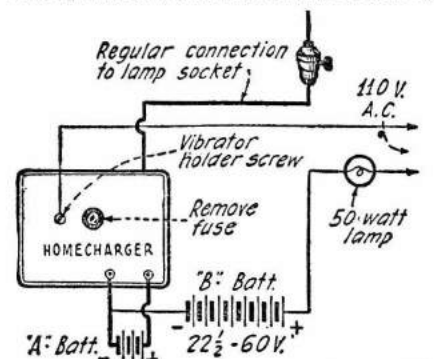

(309) If You Want to Charge Your Storage "B" Battery with a Homecharger, Follow This Diagram.

manner: Secure as many carbon rods, from old dry cells, as there are cells wanted. Heat these to a very faint red. After they have cooled to a point where they will not ignite paraffin, dip them in melted paraffin and leave them there until they are saturated. Then drill quarter-inch channels for nearly the entire lengths of the rods. A zinc wire about a 3/64-inch diameter forms one electrode, of which the carbon tubes form the other. This wire is of such a length, and is bent in such a fashion as to reach over to the next carbon tube to the outside of which it is fastened. It can be tightly bound thereto by means of wire. These carbon tubes are insulated from each other. The zinc wire is insulated from the

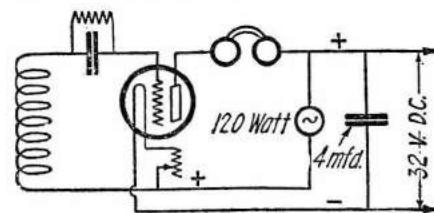

(320) A 32 Volt Lighting Circuit Can be Used to Light the Filament of a Tube. The Plate Voltage is Also Supplied From the Same Source.

carbon tube by means of a couple of pieces of soft rubber, one piece being fastened to the tip of the zinc wire, so as to prevent it touching the bottom of the carbon tube. The tubes are filled with an electrolyte consisting of water, 1 pint; salammoniac, 3 ounces; zinc chloride, 1 ounce. Paraffin oil spread over the top of the nearly filled tubes will prevent rapid evaporation of the electrolyte. As a protection against corrosion, all exposed metal parts should be well insulated by an application of the paraffin.

**(321) USE OF HYDROMETER**

Q. 1. What condition of a storage battery is determined by a hydrometer?

A. 1. A hydrometer reading shows the specific gravity, or density of the electrolyte. A reading of 1.250 or higher shows a fully charged battery and a reading less than 1,200, a discharged one.

**(322) PREVENTING CAPILLARY ACTION**

Q. 1. How can the creepage of storage battery electrolyte, due to capillary action, be prevented?

A. 1. Vaseline applied to the top of the battery will prevent it.

Q. 2. Can I use three 2-volt "B" battery units to make a 6-volt "A" battery?

A. 2. This may be done but, due to the low capacity of the cells, they will not last for any length of time, and frequent recharging would be necessary.

**(323) NOVEL PLATE SUPPLY**

Q. 1. Please show how to combine an amplifier using UX-112 tubes and the radio frequency circuit accompanying this inquiry.

A. 1. We believe you will find the circuit shown in the diagram 323 will meet your requirements.

The constants are as follows:

L 48 turns of No. 24 D.C.C. wire tapped at 2 turns from the filament end of the coil for "L." 8 turns for "M." and 15 turns for "S." L-1 50 turns of No. 24 D.C.C. wire wound on a 3-inch tube. One-eighth of an inch from the filament end of this coil is wound L-2, 25 to 40 turns (depending upon tubes used) of the same size wire, wound on the same tube with a separation between L-1 and L-2 of about 1/8-inch. For UV-201A type tubes 25 turns will probably be found about right. For dry cell tubes, more nearly 40 turns will be required. L-3, 15 to 35 turns (depending upon tubes used) of No. 24 D.C.C. wire, on a 3-inch tube. L-3 is separated from L-1 by a distance to be determined by test. It will probably be about 3 inches, and in inductive relation as shown. All coils are wound in the same direction. Condenser C-1 may have a maximum capacity of .0005. C-2 has a value of about .00025 -mf.

It may be advisable to connect a choke coil at "X" this coil to consist of about 200 turns of No. 30 D.S.C. wire on a 2-inch tube.

To insure greater quality, grid-bias rectification is used, instead of the more ordinary grid-leak rectification.

Good audio frequency transformers must be used. Chokes one and two may be Auto-formers with a voltage step-up ratio of 1:1 1/2.

To eliminate strong hand-capacity effect, the writer has shown the rotor of C-2 connecting to the "C" battery side of the instrument.

The electrolytic rectifiers are very easily made. The tubes are 1 x 6-inch test tubes filled with a solution of sodium phosphate, made by dissolving about a teaspoon full of the chemical to a cup of water (use the neutral salt, not acid sodium phosphate). The electrodes are thin aluminum and iron strips, 1/4-inch wide and 6 inches long. The positive

(Continued on Page 83)

# Amplifiers

## (326) TRANSMITTER BUTTON AS AMPLIFIER

Q. 1. Please give a diagram showing how to use a transmitter button to amplify radio signals.

A. 1. This diagram will be found on these pages.

## (327) POWER TUBES FOR AMPLIFICATION

Q. 1. Can power tubes be used in place of

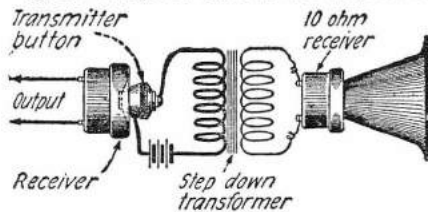

(326) Simple Loudspeaker Using a Skinderviken Button Coupled to a 10 Ohm Receiver Through a Step Down Transformer.

the regular amplifying tubes and detector in a Westinghouse R. C. set?

A. 1. Power tubes can be used to advantage in any amplifying circuit, provided enough voltage is put on the plates. This would be advantageous in the second stage, but there would be very little advantage in the first stage. Better results will be obtained by using a soft tube for the detector.

## (338) DATA ON 30 HENRY CHOKE COIL

Q. 1. Please give full directions how to make a choke coil of 30 Henrys, to use in a power amplifier.

A. 1. A diagram will be found in these columns, wherein all the necessary data will be found for this coil.

Q. 2. In an audio frequency amplifier, is it better to use a transformer having a 3 to 1 ratio in the first step and one having a 10 to 1 or 6 to 1 ratio in the second step; or both transformers of the same ratio?

A. 2. If two transformers of different ratios are used, the one having the small ratio should be placed in the second step. Good results will be had if both transformers have a ratio of 3 to 1 and there will not be so much chance for distortion.

## (329) SPECIAL PUSH-PULL CIRCUIT

Q. 1. Please show a picture diagram of an amplifier having two stages of audio frequency amplification, both of the push-pull type.

A. 1. For such a circuit it is necessary to use a special coupling transformer having a center tap on both the primary and secondary windings.

A push-pull amplifier of two stages will require four tubes. An amplifier of the usual type, consisting of two stages, would require only two tubes. However, by using the system shown in our diagram one is assured of extreme quality and high amplification. Still greater volume is obtained by using a "B" battery potential as high as 150 volts, with a "C" battery voltage of nine to twelve volts.

Q. 2. Is it necessary to use this type of amplification after one stage of the usual audio frequency amplification?

A. 2. The special push-pull amplifier connection shown in the picture diagram can be used to amplify directly the output of the detector tube of a set. However, unless this detector tube is preceded by one or more stages of radio frequency amplification, it will

be more economical to use one stage of regular transformer coupled audio frequency amplification and then one stage of the push-pull type.

## (330) AUDIO FREQUENCY AMPLIFICATION

Q. 1. What make of audio frequency transformers would give greatest amplification, and what ratio should be used for first and second stages?

A. 1. The first stage can use a transformer with a ratio of 5 to 1, and the second stage transformer should have a ratio of 3 to 1. Good results can sometimes be obtained in the first stage with a 9 to 1 ratio, but as a rule this is too high. Any standard transformer will give good results.

Q. 2. Can any standard audio frequency transformer be used with good results with the Myers Hi Mu Audion?

A. 2. Yes, any good transformer will prove satisfactory with these tubes.

Q. 3. Would it be advisable to use a push-pull amplifier instead of the regular second stage amplifier in a Neutrodyne set?

A. 3. Greater clarity and somewhat greater volume would result. While it would mean greater expense for materials and upkeep, the labor of its construction, and the use

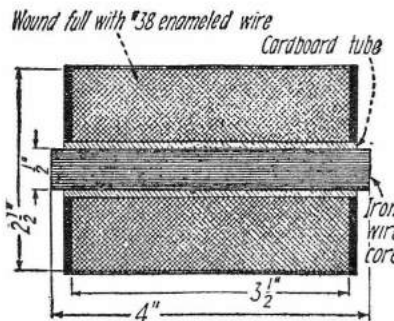

(328) Constructional Details of a 30 Henry Iron Core Choke Coil To Be Used in a Power Amplifier Circuit.

of additional space in the cabinet, we believe the results would be worth it, if the work were done carefully and the transformers and wiring not crowded.

## (331) BALANCED FEED-BACK POWER AMPLIFIER

Q. 1. What is the diagram of connections for a balanced feed-back power amplifier, in

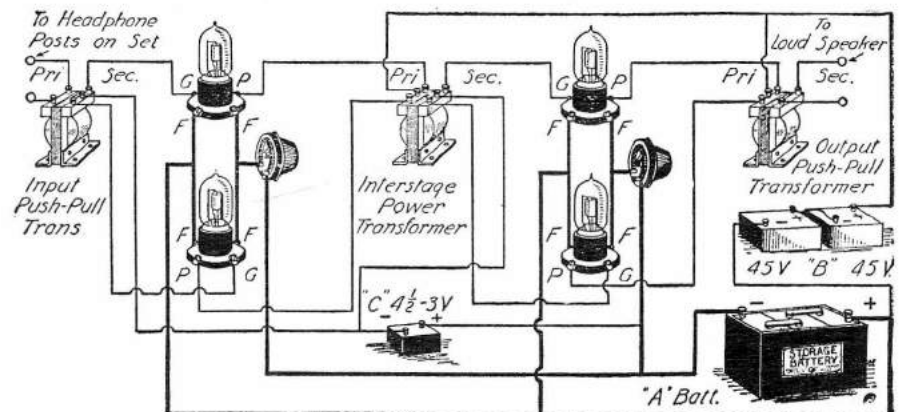

(329) This circuit shows how to connect two stages of audio frequency amplification, both of the push-pull type. A special "interstage" transformer is required.

order to use the amplifier with or without the feed-back feature, as desired?

A. 1. A diagram of connections is shown. The "C" battery may be left out if a low amplifier voltage is used. Loudest signals will be had with a high plate voltage.

Q. 2. What type of tubes will give good results in this amplifier?

A. 2. High vacuum tubes, such as the Myers, DV-2, UV-201A, C-301A, UV-202, C-302, W.E.-216A or W.E.-203B will give excellent results.

## (332) RESISTANCE PUSH-PULL AMPLIFIER

Q. 1. Having found my three-tube, untuned primary, regenerative receiver particularly satisfactory, I would like to add a stage of push-pull audio frequency amplification, using resistance coupling, to the stage of transformer amplification now used; what would be the circuit?

A. 1. The circuit you request will be found in these columns. Condensers A and B will be found helpful for increasing the quality of reproduction from some sets. The correct values must be determined by experiment, but will probably be found to be between .002 mfd. and .006 mfd.

## (333) SQUEAL IN THIRD STEP

Q. 1. How can I eliminate the continual squeal when I plug in on the third step of my amplifier?

A. 1. We would suggest that you have a separate "B" battery for your third step. This should remedy the trouble. If this does not eliminate the squeal, your transformers are probably mounted too close together. A .0005 mfd. fixed mica condenser, connected across the secondary of the third transformer, will prove of help in this case.

## (334) A. F. TRANSFORMER RATIO

Q. 1. Give the transformer ratio for the 1st, 2nd and 3rd stages of audio frequency amplification.

A. 1. As a rule a transformer with a ratio of more than five to one will not give good results in any stage, although a nine to one ratio can sometimes be used in the first stage. The best results will be obtained with a five to one transformer for the first stage and a three to one ratio for the second and third stages. This holds good for all standard tubes on the market.

Q. 2. Is there any simple rule for adding a "C" battery to any audio frequency amplifier?

A. 2. The wire (or wires) connecting to the audio frequency transformer (or transformers), and thence to the filament, should be connected to the negative post of the "C" battery, instead of to the filament. The positive post of the "C" battery connects to the point on the filament circuit to which the transformer wires were previously connected.

Q. 3. What are the advantages of push-pull amplification?

A. 3. Using this system of amplification, it is possible to handle considerably greater volumes without distortion. Where a single tube would be operated beyond the correct point on its characteristic curve, due to overloading, thus producing an over-amplification of certain frequencies (resulting in distortion); in push-pull amplification the work can be divided between the two tubes, neither tube being overloaded and each tube operating at maximum efficiency. In addition, variations of current in the push-pull circuits are balanced out and only the input variations of current are amplified.

Q. 4. How may I eliminate some of the noises from three stages of audio frequency?

A. 4. The third stage should be entirely shielded on all sides, if possible, and grounded. If the cores of all the A. F. transformers are grounded, it will help to a great extent. It is possible that the "B" battery is the cause of a good deal of trouble. Fluctuating voltage from the "B" battery, although not noticeable

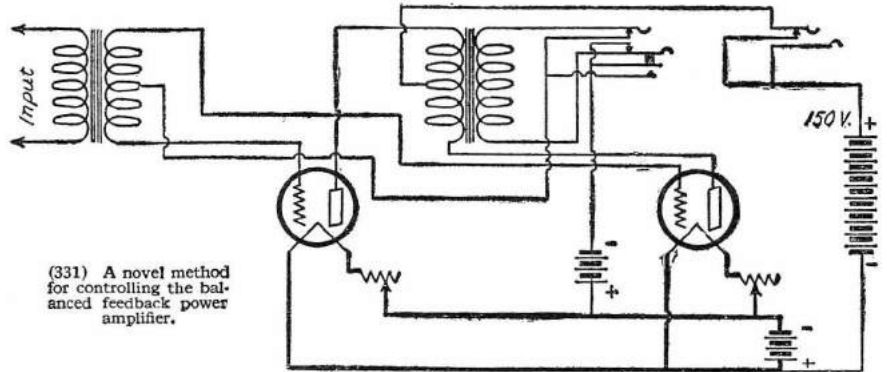

(331) A novel method for controlling the balanced feedback power amplifier.

you mention. The grid return lead should be connected to "A" minus. If a "C" battery is used the grid return lead should connect to "C" minus (negative).

Try removing the fixed condenser you now have connected across the primary of your audio frequency transformer.

If convenient, try another audio frequency transformer. The one you now have may be open-circuited, short-circuited or grounded. To test for an open circuit, connect either post of a dry cell to one cord tip of a pair of headphones. There now remains one cord tip and

the remaining end to either secondary connection. If a strong click is heard, the windings are connected, which should not be the case. If a very slight click is heard it may be regarded as the natural charge and discharge click of the condenser formed by these two windings. This does not denote a fault. Either the primary or secondary may be grounded to the metal casing of the transformer and this is readily tested by touching the casing with one free end of the test set, and first one, then the other winding, with the remaining test set end. Only an extremely slight click should be heard. Use a detector plate circuit R. F. choke.

To test for a short circuit it is necessary to connect the transformer into the set. If, now, the two primary binding posts are tightly pressed with the fingers, the signal strength should be considerably reduced. The result should be similar when testing the secondary in this manner. If there is no noticeable difference then there must be a leakage having a resistance of the value developed by the pressure of your fingers, or even less. Such a resistance usually takes the form of partly conducting binding post panels. A fibre strip for these binding posts is often the cause of trouble, although good fibre is satisfactory for the purpose mentioned above.

A jack partly shorted by soldering flux will give you the same result.

Be sure the tube prongs are making good connection to the socket springs.

The jack springs may be making poor contact.

Q. 2. Please show the audio amplifier circuit of Carl E. Gerlach. This circuit appeared in the Saturday radio section of one of the Metropolitan dailies. Also, please incorporate a filament control jack in such a way as to connect the "A" battery to the field coil of a Magnavox loud speaker.

A. 2. We are showing the circuit in these columns. Plate resistors "R-1," "R-2" and "R-3" may be variable between the limits of 25,000 and 250,000 ohms. The operating value will be about 100,000 ohms. Grid leak "R-4" should be variable for best determination.

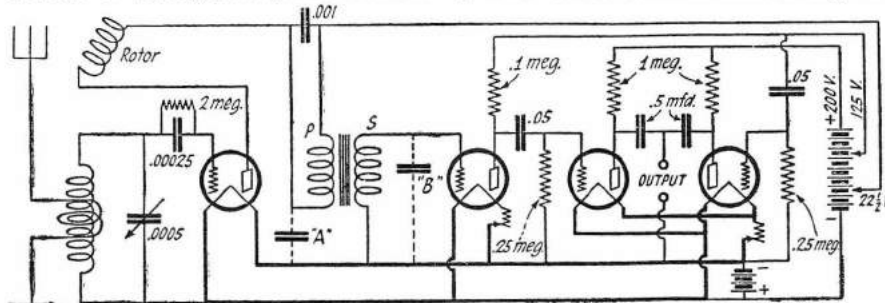

(332) Resistance Coupled Push-Pull Amplification is employed in this circuit. Tubes of 5-watt size will be better than the usual type for the power tubes. Use a plate voltage of 200.

in the detector, will be very much in evidence on three stages. A radio frequency choke coil, consisting of 75 turns of wire on a 2" tube, placed in the grid circuit of all the amplifying tubes will be beneficial. In such an amplifier the turns ratio of transformers should not exceed 3 to 1.

**(335) IMPROVING A.F. AMPLIFICATION**

Q. 1. Why do not WD-12 tubes work better as amplifiers on 45 volts than 22½ volts?

A. 1. Try using a "C" battery of 1½ volts. The negative side of this "C" battery connects to the transformer post marked "A" minus (-) and the positive side of this battery will then connect to the minus post of the filament, or "A," battery.

**(336) IMPROVING THE AUDIO UNIT**

Q. 1. I have a very efficient modified Reinartz set, but have no success with the one-stage audio frequency amplifier I have added to it. The signal strength is exactly the same as with the detector alone. Am using UV-199 tubes, 67 volts "B" potential and a 3:1 ratio audio frequency transformer. What can I do to get increased signal strength?

A. 1. Remove batteries before making any tests not requiring the "A" and "B" potentials.

You may have a poor amplifier tube; test your amplifier tube in another set. The lead from the tube grid to the audio frequency transformer secondary is called the grid lead; the remaining secondary connection post connects to the "A" battery and the connecting wire is called the grid return lead. This grid return lead may be connected, in your receiver, to "A" plus. This will give the effect

one dry cell post unconnected. It may be advisable to remove the set wires from the primary and secondary. Connecting the free phone tip to one end of the primary and the free dry cell tip to the other end should result in a click of considerable strength. This shows the primary circuit is not broken. I may be short-circuited but this requires a different test, and is not a usual fault with defective transformers. This test for open circuit may now be applied to the secondary. Occasionally some transformers will give a click, even though there is a break in the winding, but this click is so slight that it is not easily heard.

To test for a ground, remove all wires from the transformer and connect one free end of the test set to either primary connection, and

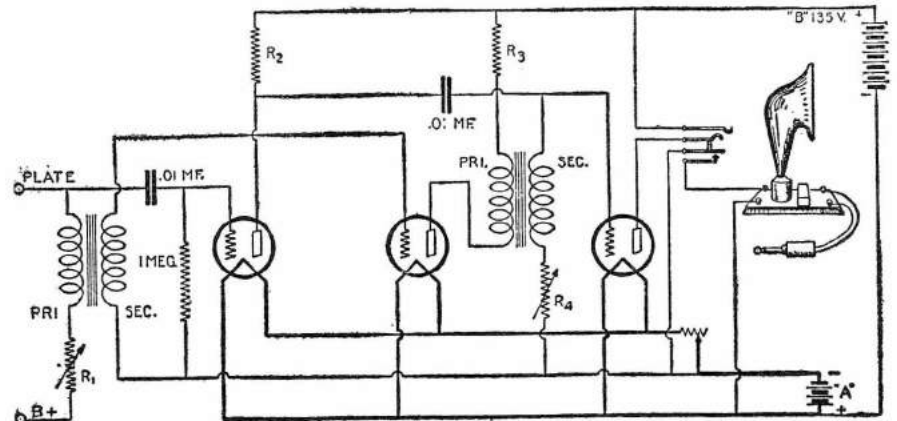

(336) This amplifier circuit is said to have the advantages of both resistance coupling and transformer coupling. If a standard loud speaker is used, the special out-put jack connection is not required. Do not place the audio transformers too close, and connect their cases or cores to "A" minus.

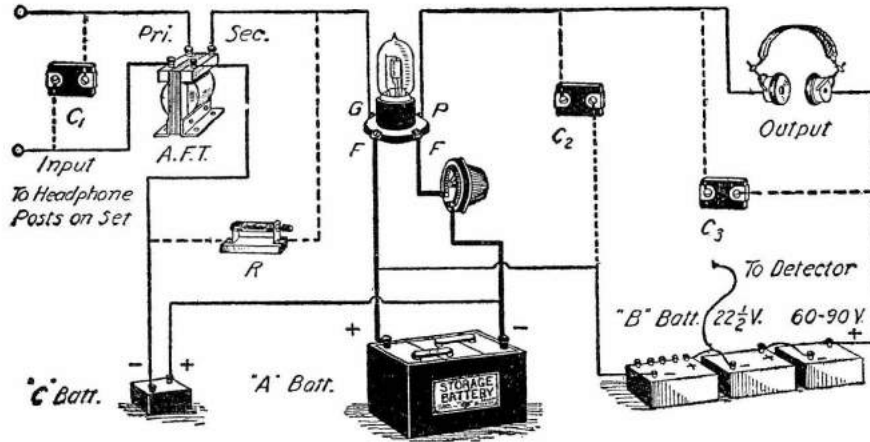

(337-A) Picture diagram of a standard audio frequency amplifier, showing tone quality controls in dotted lines. Connect "B" minus to "A" minus if the balance of set is so connected. A separate current supply may be used for this unit.

tion of the correct value. Standard good quality audio frequency transformers are used. This amplifier has given an exceptionally good account of itself in every instance of its use that has come to our attention. Notice that there are two stages of resistance coupling and two stages of transformer coupling. The object of this, as claimed by the inventor, is to build up the volume, by resistance amplification, of frequencies to which the transformer is not responsive. Whether or not this explanation satisfies the theorist, results are what count.

If the detector unit does not incorporate a phone condenser, it will be necessary to connect a fixed condenser of .001 to .002 mfd. capacity across the two input, or "plate," "B" posts of the amplifier.

The loud speaker battery posts are wired to the jack in the manner shown, while the loud speaker output is connected to the usual plug.

Q. 3. What is the approximate increase of "B" battery voltage required when resistance amplification is used?

A. 3. About 50 per cent.

nects into any set in place of the headphones. If a dry cell tube is used, dry cell "A," "B" and "C" batteries may be used, resulting in a portable unit. If a storage battery tube is used, the amplifier may be used as the first, second or even third stage of amplification, the dry cell tube not being very good where the volume handled is very great, as in the latter instance.

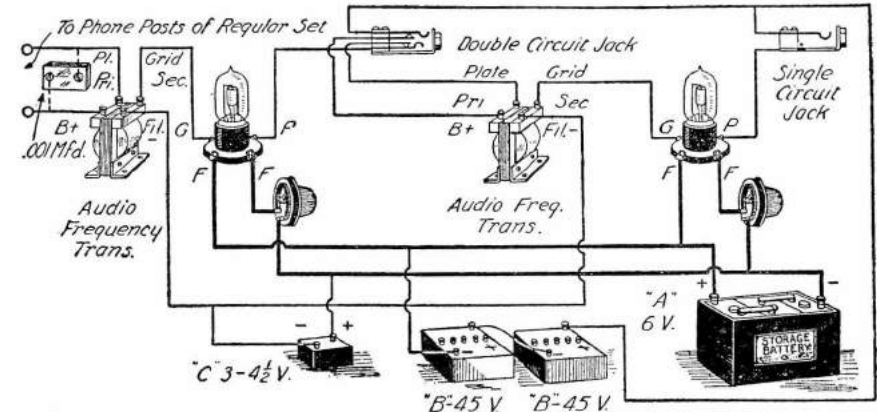

(337-B) If this picture diagram is followed correctly, no one should have any difficulty in adding audio frequency amplification to any set.

**(337) SKINDERVIKEN BUTTON CIRCUIT**

Q. 1. How can I attach a Skinderviken button to a radio set?

A. 1. By attaching this button to the diaphragm of one of the phones, amplification may be obtained provided there is sufficient vibration of the receiver diaphragm to effect the movement of the carbon grains enclosed in the button. The Skinderviken button, in turn, should be connected in series with two or three dry cells, another pair of receivers or a loud-speaker.

Q. 2. Please show a picture diagram of a one-stage audio frequency amplifier that may be added to any set. I would prefer the use of General Radio No. 285 audio frequency transformers.

A. 2. This circuit is being shown in these columns.

If desired, individual batteries may be used for this amplifier unit. The primary con-

Any good make of audio frequency transformer may be used. If it is desired to use this amplifier as the second stage in a Super-Heterodyne or the third stage in any type of receiver it will be necessary to use very good materials and exceptional care in the construction of the unit.

The values of the condensers shown will depend upon the set and the amplifier. If the number 285 audio frequency transformer is used, resistance "R," of two to five megohms will probably be needed. This often eliminates a high-pitched whistle sometimes present. When other audio frequency transformers are used it may be necessary to use as low a resistance as 50,000 ohms. Therefore, a Bradley-leak may be used across the secondary of a No. 285 transformer and a Bradley-

mentioned above, such markings are quite unnecessary in practical use.

The ratio of the audio frequency transformers should not be too high, otherwise distortion may be too great. A ratio of about 4:1 for the first transformer and about 3:1 for the second transformer is usually a good combination. However, individual transformers vary greatly in their characteristics and in consequence it is often possible to use altogether different ratios, with very satisfactory results.

It is occasionally desirable to use a variable resistance connected across the secondary of the first or second audio frequency transformer to improve the quality.

Also a fixed condenser of one or two mfd. sometimes assists greatly to reduce battery noises, when connected from "B" plus to "B" minus.

Whether a fixed condenser (usually of about .001 mfd.) is required across the primary of the first audio frequency transformer (as shown by the dotted lines) will be governed by the particular conditions of your receiving circuit and first audio frequency stage equipment.

Q. 4. In building a three-stage audio frequency amplifier for a Radiola III, what ratio transformers should be used? Should they be arranged at right angles?

A. 4. Transformers of about 4:1 ratio will probably be satisfactory. It may be advisable, however, to use a 3:1 or even a 2:1 ratio for the last audio frequency transformer. Best results will be had from a push-pull, resistance coupled, or choke coil, third-stage amplifier.

(Continued on Page 84)

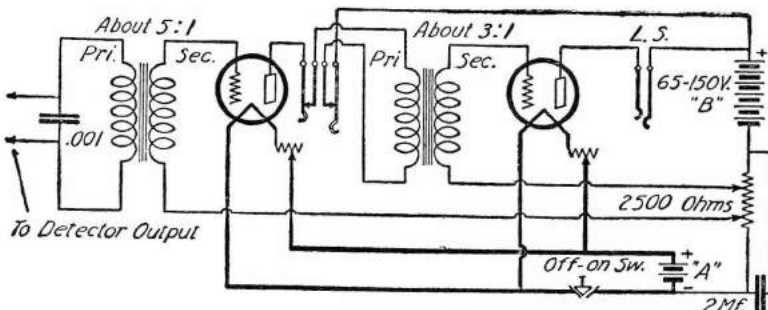

(337-C) "C" battery potential, but no "C" battery. Seemingly paradoxical, explained by the resistance in series with the "B" battery supply. The voltage drop is at negative potential.

# Antennae

## (338) EFFICIENT ANTENNA LENGTH

Q. 1. What is the most efficient length of a one-wire antenna with a series condenser for broadcast work?

A. 1. The best all round antenna is one wire, about 150' long, including the lead in and ground. This will have a natural period of 210 meters, which will leave sufficient inductance to be used in the tuner.

Q. 2. Which is more advisable, a short antenna, directly connected to the set, or a longer one with a series condenser?

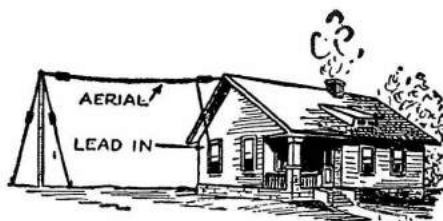

(388) For receiving purposes, a simple one-wire aerial strung between the house and a tree or mast is the best.

A. 2. A long antenna is better. The series condenser will give a finer degree of tuning than can be accomplished by means of switches on the tuner.

## (339) LIGHTING CIRCUIT AS AN ANTENNA

Q. 1. Would it be as satisfactory to use the lighting circuit for an aerial, using the Antenna in series?

A. 1. This would depend largely upon certain conditions, such as length of wire in the circuit between the transformer and instruments, etc. As a rule good results are obtained, although a regular antenna is preferable.

Q. 2. Can WD-11 tubes be used satisfactorily in this circuit?

A. 2. Yes, these tubes will work efficiently in any standard circuit.

Q. 3. How is it possible to tell the direction from which the signals are being received when using a loop aerial?

A. 3. The most satisfactory way to calibrate the directional effect of a loop is to receive given stations and mark the setting of the loop resulting in maximum signal strength.

## (340) ANTENNA DESIGN

Q. 1. Which is the best aerial, one wire, two wires or a four-wire cage, 50' high and about 130' between masts?

A. 1. For receiving purposes, the one wire would prove as efficient as the others. If a transmitting antenna were desired the four-wire cage would be best, but the length would have to be cut down to about 70' to be under the 200-meter amateur transmitting wavelength.

## (341) ANTENNA QUERIES

Q. 1. How long should the antenna be, including the lead-in, when it is about 35' from the ground?

A. 1. A single wire about 100' long will give very good results. Including the lead-in, the length will be about 125'.

Q. 2. Should the antenna wire run in one straight line, or could it be stretched in a triangular shape? My house is only 45' long and there are no trees or other houses near.

A. 2. For best results the antenna should run in a straight line, but, if the antenna is stretched from one corner of the front of the house to a pole in the center of the rear, and from there to the opposite corner on the front, very good results can be expected. The lead-in should be taken from one end of the wire at the corner of the house.

## (342) AERIALS FOR SUMMER USE

Q. 1. Is the range of receiving sets less during the summer than during the winter?

A. 1. Yes.

Q. 2. Is the "static level" greater during the summer than during the winter?

A. 2. Yes.

Q. 3. What would be the best aerial system for summer use?

A. 3. A low aerial will pick up less static, in proportion to the signals, than a high aerial. A short aerial is better than a long one, for summer use. A loop aerial is best of all.

## (343) DUCON ANTENNA PLUG

Q. 1. What are the capacities of the two fixed condensers used in the Ducon antenna plug, using the lighting circuit as aerial?

A. 1. One condenser is about .0003 mfd. capacity and the other is approximately .003 mfd. capacity.

## (344) EFFECT OF RAIN STORMS

Q. 1. Why is it that my set is much more sensitive during a rain storm?

A. 1. It is probably due to the fact that your ground connection is not a very good one and is greatly improved when damp. You may ascertain this by pouring water over it on a clear day.

## (345) THE EFFECT OF LIGHTNING RODS

Q. 1. My aerial points north and south, paralleling a high-voltage line on the west side. The separation is about 400 feet. Would that prevent reception from the west?

A. 1. It might reduce reception from the west when arranged as you mention. It is doubtful, however, if a high-tension wire at that distance would greatly affect reception.

Q. 2. How could reception from the west be improved?

A. 2. Try running a wire in an easterly direction for a length equal to that of your north-and-south aerial. The lead-in is taken off at the west end.

Q. 3. Do lightning rods on a house interfere with reception when using a large indoor loop or attic aerial?

A. 3. The lightning protection system of a house, if properly installed, might somewhat reduce the range of radio sets using indoor aerials. The effect would be more noticeable the nearer the inside aerial is to the lightning rods.

## (346) ANTENNA LOCATION

Q. 1. I have a 120-foot single-wire aerial strung on two 20-foot masts erected over a steel building 25 feet high, and, facing on the north side, a high mountain containing mineral deposits. Would it be beneficial to support the masts on insulators and also insulate the guy wires at frequent intervals?

A. 1. Insulating the guy wires every 15 or 20 feet is recommended. It is also suggested that the aerial be raised about 10 feet. It is not necessary to insulate the masts at their bases unless they are of metal.

Q. 2. Being located on a hill, should the antenna run parallel or horizontal to the ground?

A. 2. Run the aerial parallel to the ground.

Q. 3. Since my set is of the single-circuit regenerative type, will a low, short antenna improve reception?

A. 3. The use of a short aerial will increase the selectivity of the receiver and therefore should improve reception. It should be within the limits of 75 to 100 feet. Less interference from static should be noted with a low aerial.

## (347) STATIC

Q. 1. I have a regenerative set using a variocoupler and two variometers. I am troubled with a grinding noise on all wavelengths, and sometimes a whistle. Can you tell me what the trouble is?

A. 1. Probably a good deal of this interference is caused by static. This can be determined by disconnecting the antenna and ground, and if this is the cause, the noises will disappear. Such noises may also be caused by a crudely constructed grid leak or by a defective "B" battery. Try a different detector tube. The whistle is evidently caused by too much regeneration.

Q. 2. My aerial is about 40' from, and at right angles to a power line. Will this prevent reception?

A. 2. If no disturbing noises are present in your phones, you are having no trouble from this source.

## (348) STATIC ELIMINATOR

Q. 1. Is there such a thing as a "static eliminator"? If so, how can one be made or where may one be bought?

A. 1. Up to the present time, there is no apparatus which effectively eliminates static interference. However, the use of the resonance wave coil will reduce static interference considerably, but cascade amplification is necessary for its use.

## (349) ANTENNA QUERIES

Q. 1. For amateur receiving, will an aerial 40' high give as good results as one 75' high?

A. 1. Theoretically, the higher the antenna the better the reception will be. An antenna 75' high would give very good results, but, if it is desired to receive on 200 meters, the horizontal part of the antenna should not exceed 60'. An antenna 40' high and 100' long will be very efficient, although the results obtained may not equal those obtained on the higher antenna.

Q. 2. Does the height of an aerial determine the receiving range?

A. 2. Very good results have been obtained on low aerials, but, as a rule, the higher the aerial, the greater the receiving range.

## (350) AMATEUR WAVE-LENGTHS

Q. 1. What would be the procedure for tuning an amateur transmitting set to 400-meters?

A. 1. Two hundred meters is the limit for amateur wave-lengths. It is advisable to use a wave meter for properly adjusting the set. The transmitter may be put in operation and adjusted until the wave meter indicates that a wave-length not greater than 200 meters is being radiated.

**(351) TUNING TROUBLE**

Q. 1. I have a two-variometer and variocoupler receiving set and my aerial is about 250' long, including the lead-in. I get no tuning whatever on the taps or variable condenser in series with antenna. What is wrong?

A. 1. Your antenna is altogether too long for good results on the broadcast wavelengths. The natural period of this antenna is about 340 meters, and we would suggest that you shorten it to 150' or less. You should also check your ground connection.

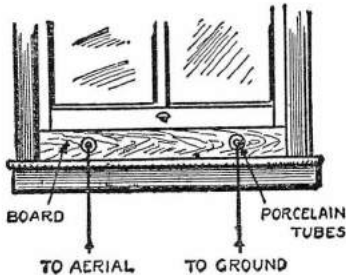

(352) One manner of leading the aerial and ground wires to the receiving set without making holes in the window sash. The window can be raised or lowered without disturbing the wires.

**(352) WAVE-LENGTH OF LIGHTING CIRCUIT AERIAL**

Q. 1. How is the natural wave-length of an aerial, consisting of a lighting circuit in conjunction with a condenser plug, determined?

A. 1. An aerial of this type is aperiodic, that is, it will vibrate over a wide band of frequencies or wave-lengths. Selection of the desired frequency is accomplished by tuning the secondary of the receiving tuner.

Q. 2. I desire to put up an aerial, but can only have a length 40 feet, also cannot be higher than 25 feet. How many wires should be used, how should they be separated?

A. 2. Two wires separated six feet will be satisfactory. The two wires are connected at the end opposite the lead-in.

Q. 3. Are the flat lead-ins placed between window sash and sill as efficient as the usual type requiring that a hole be drilled?

A. 3. During dry weather the flat lead-in is ordinarily quite satisfactory, but during damp weather the old style through-wall lead-ins of bakelite, Pyrex, hard rubber, or glazed porcelain are the best.

**(353) EFFECT OF STEEL BUILDINGS**

Q. 1. Do buildings covered with sheet metal have any effect on receiving sets operated in them, and, if so, what precaution must be taken to minimize the interference?

A. 1. A building built largely of steel will absorb, to a certain degree, some of the signal energy that would otherwise go into the receiving set. This will be particularly noticeable when a loop aerial is used and, in this case, the directional effect of the loop cannot be relied upon. There will be very little effect on a set using an outside antenna, unless it is in the midst of many steel buildings.

**(354) WAVE FRONT DISTORTION**

Q. 1. Does the metal of a ship have any effect on radio waves, when using a loop aerial?

A. 1. The ship's mass may often introduce a distortion error of as much as 20 per cent.

Q. 2. When would a distortion effect be most noticeable?

A. 2. When the sending station is on a line 45 degrees from the ship's center line.

Q. 3. When is distortion least noticeable?

A. 3. Wave distortion is zero with the wave front traveling lengthwise of the ship.

**(355) X-RAY INTERFERENCE**

Q. 1. Please publish a way to eliminate the interference caused by X-Ray machines. There are three of these machines near us and reception is impossible while they are in operation.

A. 1. There is very little that can be done to eliminate this interference. You might try erecting a single wire, about 3' from and parallel to your present antenna, and connecting it directly to the ground. It might be of help to ground your receiving antenna at the far end, through an iron core choke coil of about one henry.

**(356) IN-DOOR AERIAL LIGHTNING PROTECTION**

Q. 1. What method is required for lightning protection, when an attic aerial is used?

A. 1. There is no danger from an indoor aerial and no protective measures need be taken.

Q. 2. The other night I heard a loud buzzing in the receivers when bringing the aerial and ground close together. A short spark would jump from one to the other. This only lasted for about half an hour. What was the cause of it?

A. 2. The occurrence you mention was due to the presence of atmospheric electricity. It is called "static." The same effects will be noticed whenever an electrical storm is within a few miles of the receiving set.

Q. 3. Will a condenser, in series with the antenna, do anything to minimize static?

A. 3. A condenser in this position will have no effect on static whatsoever. It will only reduce the wave-length of the antenna and set, and will give finer tuning than could be obtained by means of switches.

**(357) COMPASS STATION LOOP AERIAL**

Q. 1. Please give design data for a direction finding loop of a size that will tune to the radio beacon wave-length of 1,000 meters; this loop to be similar to the ones used on ship-board.

A. 1. Cross two light pieces of wood seven feet long, at an angle of 90 degrees. Fasten seven-inch wooden or bakelite spreaders on the four ends. This frame is wound with 12 turns of No. 20 insulated copper wire spaced one-half inch. This will form a square of approximately five feet on each side. A condenser having a maximum capacity of at least .0007 mfd. will be required in shunt with this loop.

Q. 2. Where can this loop be tapped for reception of broadcast stations?

A. 2. A tap is taken at the sixth or seventh turn.

Q. 3. Is a loop aerial always directional?

A. 3. No.

**(358) COMPASS LOOP ACCURACY**

Q. 1. What is the most accurate way for taking compass loop bearings?

A. 1. With weak signals, a bearing is taken in the line indicated by the loop when set for maximum signal strength. When taking the bearing of a station of greater power, greatest accuracy is had when the adjustment is made for minimum signal strength.

Q. 2. Please describe a loop having a direction finding accuracy of two or three-degrees.

A. 2. The loop described in answer to question 357, above, has this efficiency, when using the minimum signal strength method just described.

Q. 3. What is the approximate range of a standard loop receiver using one tube without regeneration?

A. 3. The rated range is 50 miles.

**(359) LOOP LEADS**

Q. 1. Should loop wires to a set run parallel and close?

A. 1. This will result in broad tuning and reduced volume. Use two separate leads and do not run them close together.

**(360) SERIES CONDENSER**

Q. 1. Will a .0005 mfd. variable condenser, placed in series in the antenna circuit, greatly improve the tuning qualities of a standard three-circuit receiver?

A. 1. If a "units" and a "tens" switch are used to tune the primary, a variable condenser will not be necessary. The primary tuning is, as a rule, not so important; the fine tuning being accomplished in the secondary circuit. If the primary tunes too high a condenser may be placed in series to reduce the wave-length.

Q. 2. Should the condenser be placed between the tuner and the antenna, or the ground?

A. 2. Equal results will be had with the condenser in either position.

Q. 3. Should the movable or the stationary plates go to the ground?

A. 3. The movable plates should be connected to the ground.

**(361) LOCATION OF AERIAL**

Q. 1. My aerial is at the side of a house and under a tree; will these conditions interfere with receiving?

A. 1. Yes, but to what extent it is hard to say. We suggest that you raise your aerial or change its location.

Q. 2. Would a properly insulated lightning protection system be of benefit in case the aerial was directly struck by lightning?

A. 2. The value of the lightning protection system is in keeping the air surrounding the aerial, from becoming too highly charged.

Q. 3. I have about 100 feet of No. 12 German silver wire. Would this make as good an antenna as copper, or has it too much resistance?

A. 3. The resistance is much too high. Use copper for your aerial.

**(362) AERIAL WIRE**

Q. 1. What size and kind of wire should I use for the lead-in from the aerial to my receiving set?

A. 1. The lead-in wire should be equivalent to the aerial. If a multi-wire aerial is used, the lead-in may be composed of as many strands (each of the same size as the aerial wire) as there are in the aerial, or it may consist of one wire having a conductivity equal to the total of the number of wires in the aerial.

Q. 2. What size and kind of wire should I use for the ground wire?

A. 2. No. 4 weather-proof, rubber-covered wire, or the equivalent of the lead-in, is standard.

Q. 3. Can rubber insulated aerial wire be used to advantage?

A. 3. This wire has the disadvantage of added weight. Reception is practically the same, using either bare or insulated wire. The

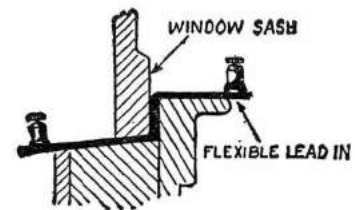

(352-A) An easy way to lead the aerial wire into the receiving set. A piece of well insulated copper ribbon is employed.

insulated wire has the advantage of not corroding. This corrosion would considerably reduce the efficiency of the aerial. The insulated wire has the disadvantage of becoming unsightly in time, due to the action of the elements.

**(363) CAGE ANTENNA LENGTH**

Q. 1. What should be the length of a cage-aerial, using four strands of wire to receive the 360 and 400 meter stations?

(Continued on Page 84)

# Miscellaneous Apparatus

## (366) FILTER FOR SUPER-HETERODYNES

Q. 1. Is there any way of reducing the loud rushing sound and other tube noises, when two stages of A. F. amplification are used, in sets of the super-heterodyne type?

A. 1. A simple way of reducing tube noises in the super-heterodyne is to connect a resistance of 5,000 ohms to 200,000 ohms across the secondary winding of the first A.F. transformer. The exact value for this must be determined by experiment. A condenser is usually required across the primary winding of this transformer. The capacity will vary between .001 mfd. and .006 mfd. We are showing in these columns the connection for a filter which may be tried. It may be advisable to vary the constants somewhat, depending upon the particular set. The primary or secondary of an audio frequency transformer could be tried as the iron core choke; the unused winding being left unconnected.

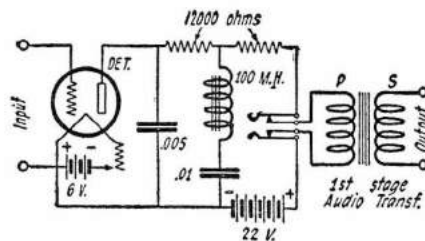

(366) A filter system consisting of two resistances, two fixed condensers and a choke coil will help materially to eliminate stray noises in any form of receiving set.

## (367) STORM DETECTOR

Q. 1. How are the "storm detectors" used in electric sub-stations to indicate the approach of storms made?

A. 1. The circuit is being shown elsewhere. Relay "R" may have a resistance of 400-ohms or higher. The bell is arranged to strike the gong when the spring pulls the hammer back, after the hammer has struck coherer "C." The coherer follows the usual construction. It may be made by arranging two nickel plugs to fit a glass tube of about 1/4-inch bore. Fill a 1/4-inch space with an iron-nickel filings (equal proportions) mixture. Separate spark gap about 1/64 of an inch. Relay coil "R" may be a "ringer" coil. With switch lever on "2," aerial is grounded and the arrangement inoperative. With switch on "1," normal signals and electric disturbances will not affect the instruments. However, as soon as the energy is sufficient to break down the resistance of spark gap "S.G.," the coherer becomes highly conductive, completing circuit through "R," which, in turn, completes circuit through bell, or de-cohering apparatus.

Q. 2. I wound a transformer primary for 60-cycle current supply. Why did it blow a fuse when put on a 25-cycle supply?

A. 2. The 25-cycle current changes polarity too slowly and, therefore, arose to too high a value before the polarity reversed.

## (368) SELENIUM CELLS

Q. 1. Can you give me the name of a manufacturer of selenium cells?

A. 1. These cells are manufactured by the Selenium Laboratories, Goodground, L. I.

Q. 2. What is a "Gimbal Loop"?

A. 2. A loop mounted on "gimbals," a form of swivel support permitting movement in any direction, allowing the loop to move in "azimuth" and "declination." This is made clear from a study of "Q. 368." Two arrows indicate the motion. For broadcast wavelengths, about 100 ft. of wire will be needed. Arrange the number of turns and their diameters in any convenient manner to assure using about this length of wire.

Q. 3. Please give directions for adjusting Baldwin Type C phones.

A. 3. These phones are adjusted correctly at the factory and should not be touched. If the phone does not give good results it should be sent back to the maker for repairs.

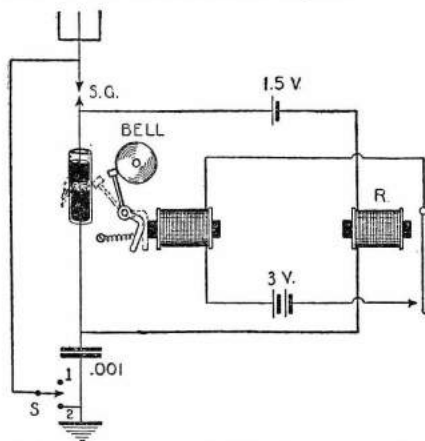

(367) A "storm detector." The coherer operates in a horizontal position. The metal plugs are preferably slanted, rather than straight-faced as shown.

## (369) BEAM TRANSMISSION

Q. 1. What are the advantages of direction finders?

A. 1. By their use, ships in a fog may safely pass one another. Small boats, if equipped with direction finders, may easily locate their mother ship. Transmitting stations unlawfully operating may be located.

Q. 2. What is meant by "beam transmission"?

A. 2. This is the new term given to radio transmission where the maximum amount of energy is focused in one direction.

Q. 3. What is "Toll Broadcasting"?

A. 3. Broadcasting by rental agreement. Some stations charge a definite sum for a definite period, for the use of the broadcasting station and its personnel.

## (370) CONDENSER SYMBOL

Q. 1. Does the head of a variable condenser arrow, as used in radio diagrams, denote the rotor or stator plates?

A. 1. Heretofore no significance has been attached to the arrowhead position. All circuits should show the rotor plates on the same side as the arrowhead.

Q. 2. Does it make any difference if variable condenser connections are reversed?

A. 2. Connection of the rotor plates to the side of lowest potential greatly reduces "hand-capacity" effect.

Q. 3. Please give circuit and necessary information for making a wave meter for cali-

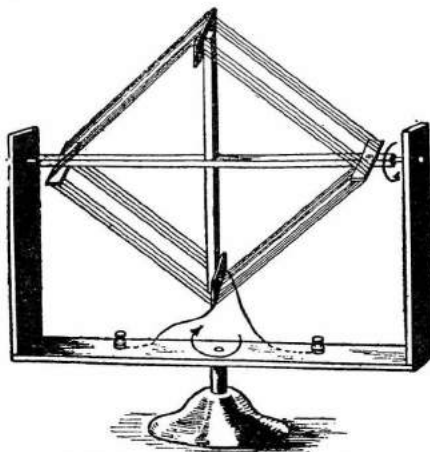

(368) The Gimbal Loop. Wave front of broadcast signal travels in vertical plane, while that of some forms of static is said to travel horizontally, enabling one to balance out either, optionally, with a gimbal-mounted loop.

brating receiving sets. Would like to have a wave meter designed for simplicity, as well as efficiency.

A. 3. We are pleased to describe to you the "Buzzerdyne," a development of an English experimenter, Percy W. Harris. You should find this instrument ideal for your requirements.

Essentially, we have a vacuum tube arranged in an oscillatory circuit (diagram 370) and modulated at an audible frequency. The result is the radiation of a signal that may be received by any type of set and detected without the need of heterodyning, as would not be the case were the emitted signal an unmodulated one of radio frequency. The received signal is a pure whistle, of pleasing tone, which tunes "as sharp as a razor." In this respect it is far better than a buzzer modulated type of wave meter, as the resonance point is much more pronounced, resulting in greater accuracy. Also, the Buzzerdyne is noiseless (as compared to a regular buzzer unit)!

By using the push-pull switch shown, the variable condenser scale is "spread out," making it easier to secure an accurate reading. Two curves will be needed—one for condenser switch in and one for switch out.

For ordinary purposes, L-1 may consist of about 50 turns of No. 20 or 22 enameled D.C.C. wire wound on a 3-inch tube. Plate coil L-2 may consist of about 15 or 20 turns of the same size wire wound on the same tube, with a separation of about 1/16 to 1/8 inch between the finish of the grid winding (the filament connection) and the start of the plate winding (the "B" battery connection; both windings in same direction). The imaginative radio bug may get the notion that a regular "air-core, tuned radio frequency transformer" could be used for the Buzzerdyne coil unit. Fine! Go ahead and use it. It is designed for the broadcast wave-lengths and will probably work "right off the bat," covering the full wave band, if the right tuning condenser is used. Warning! Do not make the mistake of using a toroid or other form of "astatic" coil. The things don't radiate, and we are depending upon the radiation from the coils to be picked up by the receiving set to be calibrated.

A storage battery tube is not needed for our Buzzerdyne. A dry cell one is O. K. The value of R-2 depends upon "A" potential and tube used. "V" is a high-resistance voltmeter reading 0-6. Correct reading is the "terminal voltage" of the tube used. "M.A." is a milliammeter reading 0-50. Neither is needed, except for completeness.

Grid leak R-1 is a Bradleyohm variable between 25,000 and 250,000 ohms. The use of such a leak value in conjunction with a .01 mfd. grid condenser results in the production of an audio frequency, which modulates the out-going radio frequency, due to what is known as "cumulative rectification," or periodical charge and discharge of the grid condenser, resulting in an audio note (if the action takes place at audio frequency). Vari-

ous writers have explained the action. Scott-Taggart has described it very clearly (page 118) in his work, "Thermionic Vacuum Tubes."

The finished instrument may be sent to a testing laboratory, or it may be calibrated at home. In the latter event, one may write to the Government Printing Office, Washington, D. C., for the current issue of the "Radio Service Bulletin" (price, five cents per copy; twenty-five cents per year, of 12 issues). This contains a list of the broadcast stations sending on almost exactly the allotted wave. Other stations may be as accurate, but there is considerable likelihood otherwise. By using curve paper, and using the base line for dial numbers and left vertical edge for wavelengths, dots can be placed on the horizontal and vertical line intersection where one of these "standard frequency" stations is heard, repeating the operation for each station in the list.

I will make the operation a little more clear. Here is the way to go about it. Listen in on a regular radio set for a "standard frequency" station. When it is heard, turn to the Buzzerdyne and adjust its dial until you hear the

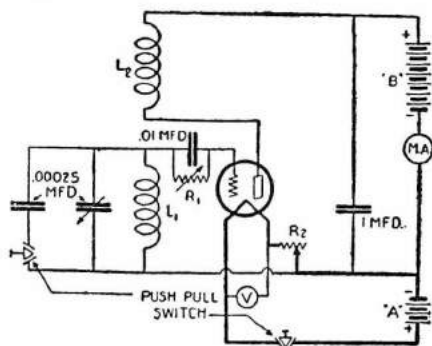

(370) The "Buzzerdyne." An improved wavemeter. By peculiar electrical action, a pure audio note modulation is obtained.

Buzzerdyne whistle in the regular radio set. Now both set and wave meter are in resonance, and you are ready to mark your curve paper. After you have secured four or more different resonance points covering the entire adjustment range of the Buzzerdyne, join the dots with a smooth curve, and your buzzer-note-autodyne wave meter is complete.

### (371) CATHODOPHONE

Q. 1. What is the cathodophone?

A. 1. It is a "glow" microphone. It is not the same as glow microphones using an arc. The invention is based upon the findings of Wehuel, that the surface of glowing wires coated with an oxide (such as baryta, calcium oxide, strontia), gives off free negative electrons in rarefied gas. This property has been discovered to hold in air at normal pressures also. The high speed of the electron is missing, however, as the free electrons collide with air molecules or atoms, thus forming ions. The glowing oxide body being made the cathode (hence the name of the transmitter), the ions will drift slowly to the anode and thus become carriers for the electric current.

This "ion current" or "emission current" is subject to various pressure modifications in much the same way (but to a higher degree) as the atmosphere. When a sort of "box" of refractory material coated with an oxide is made to glow by a resistance heating, a bluish glow is set up between it and a perforated diaphragm slightly separated from it by an air gap. The diaphragm is also the small end of a funnel which catches sound waves—the funnel being slotted to avoid vibratory distortion. Thus sound oscillations will be transmitted to the glowing portion of the air gap, causing variations in the "emission current." These are registered in the circuit of which this air gap is a part, via a resistance, and thus carried through tube amplifiers.

### (372) ACOUSTICS

Q. 1. What are the first and second series of vibrations of a sound?

A. 1. The first series is the basic tone and that is called the fundamental. The second series is called the second harmonic and has just twice the number of vibrations in the space of a second as the fundamental.

Q. 2. What is the effect of the fundamental and harmonics produced by a musical instrument?

A. 2. Harmonics produce the timbre, or characteristic sounds of the instrument. One musical instrument may radiate 50 per cent. of the sound energy on the fundamental note and the balance is divided in various proportions on higher frequencies or harmonics. Another instrument may radiate 65 per cent. of the energy on the fundamental note and the balance in various harmonics. The easily distinguished tone of the brass horn is due to strong vibrations at the seventh and ninth harmonics.

Q. 3. What substances may be used for nickel plating on copper or brass?

A. 3. A nickel anode in a solution of double sulphate of nickel and ammonium, specific gravity 1.13. This solution must be neutral or slightly alkaline, as an acid bath will cause the nickel to peel off. Approximately a pound of the double salt to each gallon of solution, is used.

Q. 4. What is the resistance range of the Turn-It variable grid leak?

A. 4. Rated approximately from  $\frac{1}{2}$  to 5 megohms.

### (373) MICROPHONES

Q. 1. How can microphone currents be amplified by a vacuum tube?

A. 1. Picture diagram numbered 373 shows how this is done. The microphone required a high current at a very low voltage. The vacuum tube requires a high voltage but a very low current. The "modulation transformer" serves to adapt the microphone circuit to the requirements of the vacuum tube circuit.

Any firm selling transmitting apparatus will have this form of transformer, which has a low resistance primary (about 25 ohms) and a high resistance secondary (about 1,000 ohms). An ordinary Ford spark-coil is often quite suitable.

A regular telephone transmitter may be used instead of the microphone, but it will not be as sensitive. Several telephone companies manufacture hand transmitters and microphones.

While the regular "A" battery used to supply the tube is shown as supplying the necessary microphone current, it may be necessary to have a different microphone current supply, depending upon the constants of the microphone used.

The regular 2-stage audio frequency amplifier of your radio set may be used. The modulation transformer may be used in place of the first audio frequency transformer; or the set may be left connected up in the regular way and then the microphone made up as a separate unit. When it is desired to use the microphone, it is only necessary to connect the secondary of the modulation transformer to the primary of the first audio-frequency transformer. Since one side of the modulation transformer and one side (the filament side) of the audio transformer may always be connected, it then becomes necessary only to have a regular push-pull switch to connect the remaining two transformer posts, in order to use the microphone. The microphone may also be connected directly across the primary of the first audio frequency transformer.

Those who are hard of hearing will find the system explained in the diagram marked 373 a great improvement over a microphone used alone, in the customary manner. The ordinary microphone connection uses only a small battery, the receiver and the microphone. It is usual for this combination to be very noisy, particularly when the battery is new. This is

due to an overloading of the microphone. This overloading is prevented by using the tube amplifier shown. The microphone is operated with much less battery current, eliminating the loud, rushing sound usually present. In addition, quality is very greatly improved and greater volume is obtainable.

If the microphone is used with the 2-stage amplifier of a regular set, as described above, the exceptionally high amplification resulting may cause the loud speaker output to feed into the microphone, resulting in a "reflexing" of the audio sounds that builds up until a loud, continuous howl is heard. This may be prevented or reduced in one or more of several ways. The howl will stop if the microphone is moved to another room. Try reducing the tube filament current. Mount the microphone in a framework in such a way that the entire "mike" is suspended by springs. Rubber bands fastened to the "mike" and to the framework will afford the necessary spring suspension. The microphone may be suspended in a metal box open at one end, the box being grounded. This is an improvement over the plain framework mounting mentioned above. The microphone should not touch the metal at any point.

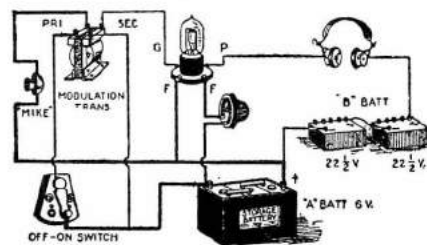

(373) Amplifying voice currents. This illustrates the principle involved in telephone "repeaters."

### (374) FUSIBLE ALLOYS

Q. 1. Please give information on the fusible alloys of Rose, Wood, Newton, Newburg.

A. 1. Rose's Metal, lead, 1; tin, 1; bismuth, 2; melting point, 93 deg. C. Wood's Metal, lead, 2; tin, 1; bismuth, 4; cadmium, 1; melting point, 60 deg. C. Newton's Metal, lead, 5; tin, 3; bismuth, 8; melting point, 94 deg. C. Newburg's Metal, lead, 3; tin, 2; bismuth, 5; melting point, 91 deg. C. The fusing temperature may be further reduced by the addition of a slight amount of mercury. Any of the above amalgams will be entirely satisfactory for mounting crystals. The proportions are by weight.

### (375) INTERFERENCE

Q. 1. What method should be followed in eliminating interference due to a telephoning machine?

A. 1. High mica usually causes excessive sparking at the commutator of the ringing machine. The result is often the radiation of a high frequency current which causes considerable interference at radio receiving stations. Turning down the commutator is the best remedy for this trouble.

We are showing a diagram of a filter. This is sometimes required. It should be connected as close as possible to the ringing machine. Condensers "C" are each of 2 mf. capacity. Inductances "L" are each the No. 5-AA Retardation Coil, obtainable from the Western Electric Company. This coil has an extremely low resistance to the ringing current, which is usually of only 16 cycles. To currents of radio frequency, however, the resistance is very high. The direct current resistance of this unit, with both coils in series (the 5-AA Retardation Coil has two windings which may be connected in series or parallel) is only about 75 ohms. The voltage of a ringing machine output is extremely high, in the neighborhood of 100 to 110 volts, but the current is very small. A 75-ohm receiver may be used in place of the Retard Coils if these are not available, two receivers being used, one in place of each of the No. 5-AA coils.



**Q. 2.** How is it possible to sustain the vibrations of a tuning fork without employing the usual system of a contact on one side of one of the tines and an electro-magnet on one side of the other?

**A. 2.** Eccles and Jordan have patented the system shown in diagram 375-A.

The note generated is determined mainly by the natural period of the tuning fork. This note is of practically constant frequency. The output is (nearly) sinusoidal.

Electro-magnets A-1 and B-1 may be ordinary 75-ohm head-phone electro-magnets, for experimental construction and test.

"B" may be about 45 to 60 volts. If the WD-12 type tube shown is used, the customary single dry cell or single storage cell is used, as "A."

Any audio frequency transformer may be used.

Movement of one tine induces current in grid coil A-1. This causes a momentary plate current change which causes plate magnet B-1 to attract (or repel) the other tine, sustaining vibration at the natural period of the tuning fork.

Radio amateurs should investigate the possibilities of this application of the vacuum tube, in connection with transmission.

Note this: At Northolt, England, such a tuning fork arrangement has been successfully used as a modulator, at radio frequency, in a "constant current" transmitter that proved more efficient than the "master oscillator" system! In this particular instance the tuning fork was adjusted for a natural period of 1,963.6 cycles per second. It was possible to use the 22nd harmonic of this frequency! This harmonic has a frequency of 43,200 cycles and is, therefore, well within the super-audible frequency range. By the use of a negative bias, instead of the positive bias shown, full advantage was taken of the asymmetrical action of the vacuum tube, resulting in the production of a relatively strong oscillation on this unusually far-removed harmonic. The antenna current at Northolt is 100 amperes.

To produce audio frequency oscillations in a vacuum tube circuit has formerly required large values of inductance and capacity. The result was a bulky unit. By selection of proper values it should be possible to produce an audio oscillator having a wide frequency range, slight bulk and a reasonably small amplitude variation.

**(376) RESISTANCE OF MAGNET WIRE**

**Q. 1.** Will you please publish a list of the various sizes of copper wire from No. 12 up, giving the number of ohms per foot.

**A. 1.** It is not practicable to give the number of ohms per foot, as the resistance would be too small for the larger sizes. Following is a list of the different sizes of wire, showing the number of ohms per 1,000 ft.

Ohms per 1,000 ft.		Ohms per 1,000 ft.	
B. & S.	No. 12	B. & S.	No. 27
13	1.580	28	51.3
14	1.995	29	64.8
15	2.504	30	81.6
16	3.172	31	103.
17	4.001	32	130.
18	5.04	33	164.
19	6.36	34	206.
20	8.25	35	260.
21	10.12	36	328.
22	12.76	37	414.
23	16.25	38	523.
24	20.30	39	660.
25	25.60	40	832.
26	32.2		1049.
	40.7		

**(377) MAGNAVOX AS MICROPHONE**

**Q. 1.** Could a Magnavox R-3 loud speaker be used as the microphone for a transmitting set?

**A. 1.** It would probably work quite well in such an arrangement. It would be advisable to remove horn, and arrange a small mouth-piece instead.

**Q. 2.** I understand the Neon tube may be made to cause circuit oscillation. If this is the case at audio frequency, I would like to know how to make an audio frequency oscillator using the Neon tube.

**A. 2.** The circuit requested is 377. Resistance "R" may be a fixed unit. The value required is most easily determined by making

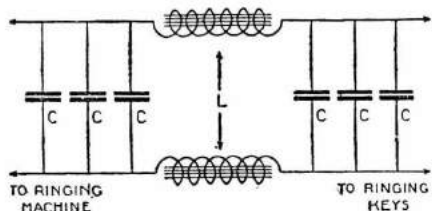

(375) Telephone ringers often cause interfering sounds similar to those caused by lightning. The purpose of this circuit is to eliminate this interference.

"R" variable with a range of 25,000 to 250,000 ohms, for testing the initial set-up.

The output may be used for testing the response for loud speakers, audio transformers and head-phones to various audio frequencies.

The Neon tube may be an "Osglim lamp" obtainable in England, or the more easily acquired Neon lamps used in the Westinghouse "Spark-C" automobile spark plug tester, or the Airco "Ignition Gauge."

Since this type of lamp only requires about 15 milliamperes at 200 to 300 volts, to "strike" the tube (The word "strike" is taken from electrical nomenclature, ordinarily used in connection with electric arcs, with reference to the starting of the arc action; and relates in this instance to the lighting of the tube), and, since the current required to maintain oscillation of the Neon tube circuit is only about two milliamperes, an ordinary "B" battery will furnish amply sufficient current. In fact, "B" battery current consumption is about one-third that of the ordinary vacuum tube. Another feature is the elimination of the "A" battery.

**(378) VERNIER DIAL RATIOS**

**Q. 1.** What are the ratios of the vernier dials and condensers now available, exclusive of those having independently controlled condenser plates?

**A. 1.** We submit the following:

Vernier Dials	Reduction Ratio
Pico.....	12:1
Velvet Vernier (National).....	6:1
Apex.....	12:1
Micro-Dial (Jewett).....	50:1
Accuratune (Mydar).....	80:1
Branton.....	10:1
Kellogg (cam action).....	25:1
Remler.....	12:1
Eztoon (Butler).....	80:1

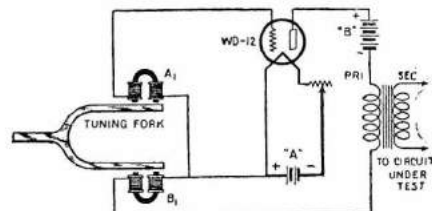

(375-A) Maintaining constant vibration of a tuning fork, by means of a vacuum tube. An application of the device is described.

Ultra-vernier (Phenix).....	20:1
Sensory.....	76:1
A. C. H. (on 3-inch dial).....	156:1
A. C. H. (on 4-inch dial).....	215:1
Uni-vernier.....	12:1
Verni-Dial (Erla).....	14:1
General Radio (on 2 3/4-inch dial)....	5:1
General Radio (on 4-inch dial).....	8:1
Stasco.....	110:1

Vernier Condensers	Reduction Ratio
Acme.....	8:1
Remler.....	165:1
Signal.....	3:1
Barrett & Paden.....	10:1
National.....	6:1
Bruno.....	10:1
Ustoolco.....	9:1
General Radio (4-inch dial).....	8:1
Mesco.....	12:1
Nelslide.....	2:1
Wade.....	32:1
Hammarlund (cam action).....	25:1

These ratios are calculated on a full circle, 360° turn of the main dial.

**(379) PHONES**

**Q. 1.** What is the difference between 5-10-1000 ohm phones?

**A. 1.** The ohmage of a phone is determined by the number of turns on the pole pieces. A five-ohm phone would have comparatively few turns as compared with a phone of 1,000 or 1,500 ohms.

**Q. 2.** Which is best for a crystal or tube set?

**A. 2.** A pair of phones with an ohmage of 1,000 for each phone is usually used for both crystal and tube sets.

**Q. 3.** What are the different kinds of transformers, and what are their uses?

**A. 3.** There are many kinds of transformers, but we presume that you refer to transformers used in receiving sets. There are radio and audio frequency amplifying transformers. The radio frequency transformer is used to amplify the signals at radio frequency before they reach the detector. The audio frequency transformer amplifies the signals at audio frequency after they are rectified by the detector.

**Q. 4.** What is the average current required for the proper operation of a button microphone?

**A. 4.** The average current required is 20 milliamperes.

**Q. 5.** What is the object of the piece of string at the end of headphone cords?

**A. 5.** This is a "tie-cord." It is fastened to the receiver in some convenient manner and serves to take the strain which would otherwise develop at the point where the phone cord is soldered to the phone tip. There is usually a knob or a loop made on the receiver for this purpose.

**(380) BEVERAGE ANTENNA**

**Q. 1.** Please publish data for a Beverage antenna for 200- to 600-meter reception.

**A. 1.** A Beverage antenna should be at least one wave-length long. Thus, for 200-meter reception, an antenna of about 660' long is required. This should point in the direction from which the desired signal is to be received. The far-end of the antenna should be grounded through a non-inductive resistance of about 550 ohms. For 600-meter reception, an antenna of at least 2,000' long would be necessary. As this type of antenna is very directional, it is not recommended for general use.

**Q. 2.** What is the need for insulators in mast guy wires?

**A. 2.** The need for guy wire insulators is greatest when the aerial is being used for transmission. The guy wires absorb a certain amount of energy radiated from the aerial, and this absorption is quite considerable when the guy wires approach resonance with the aerial circuit. Breaking the guy wires up into short lengths greatly reduces this absorption.

**Q. 3.** What is an "electro-dynamic" loud speaker?

**A. 3.** A loud speaker having a coil of fine wire suspended in a strong electromagnetic field. The fine coil of wire is fastened to the diaphragm and connects to the output of the radio set. The strong electromagnetic field is created by connecting the winding of the elec-

tromagnet to a source of direct current. The field of the fine wire coil, produced by a received signal, reacts against the field of the electromagnet very strongly, producing a mechanical motion of the coil, and hence of the diaphragm also.

### (381) MAGNET WIRE

Q. 1. Can enameled wire be used in radio winding instead of double or single cotton covered wire?

A. 1. Enameled wire can be satisfactorily used instead of cotton-covered wire. A greater number of turns can be wound in a given space when using enameled wire.

Q. 2. Can No. 30 or 32 wire be used where No. 26 wire is mentioned?

A. 2. No. 30 or 32 wire can be substituted for No. 26, but the coil will have more distributed capacity and a higher resistance. Fewer turns also will be used for a given wavelength.

Q. 3. Is there any advantage in using No. 18 wire on a variometer instead of No. 24?

A. 3. The answer to Q. 2 also applies here. Also, when large wire is used on a coil, the tuning will be sharper. Fairly large wire should always be used where possible.

Q. 4. What determines the number of ohms a pair of phones may have?

A. 4. The resistance of the coils in a pair of phones is expressed in ohms, this usually being about 1,000 ohms for each single phone. Very fine wire must be used to get the necessary number of turns on the coils which give the phone its high resistance.

### (382) CONDENSERS AND WAVE-LENGTH

Q. 1. Does increasing the capacity of a series condenser increase or decrease the wave-length?

A. 1. A condenser in series with an inductance will decrease the wave-length, but if the capacity of the condenser is increased, the wave-length will increase, but it will never equal the wave-length of the inductance alone.

Q. 2. Does increasing the capacity of a condenser shunted across an inductance increase or decrease the wave-length?

A. 2. A condenser shunted across an inductance will increase the wave-length of the inductance. Increased capacity will always increase the present wave-length of any circuit.

Q. 3. What is meant by the expression, "directing traffic"?

A. 3. The "traffic" referred to is the code messages transmitted and received by commercial and amateur operators. Anyone appointed to determine the most expeditious method of disposing of the messages received and transmitted by the various stations is spoken of as "directing traffic."

Q. 4. Kindly state the general rules for increase of inductive impedance and of capacitive impedance.

A. 4. The inductive impedance increase of a coil is directly proportional to the increase in cycles per second of the current. Capacitive impedance varies as the reciprocal of the frequency.

### (383) CONDENSERS IN SERIES

Q. 1. Will two variable condensers each having a capacity of .001 mfd., when hooked in series, equal a variable condenser with a capacity of .002 mfd.?

A. 1. The two condensers would have to be placed in parallel if it is desired to combine their capacities. When connected in series, the total capacity would be .0005 mfd.

Q. 2. What is the highest radio station in the world?

A. 1. We understand the recently opened station on the Pic-du-Midi Mountain, in the Upper Pyrenees, near the Spanish border, is the highest station in the world. It is located 9,439 feet above sea level.

Q. 3. What is meant by a ten per cent. acid solution, weight or quantity?

A. 3. This means by quantity. In other words, nine parts of water to one part of sulphuric acid.

### (384) CALCULATION OF CONDENSER CAPACITY

Q. 1. Please publish formula for calculating the capacity of a condenser.

A. 1. This formula follows herewith:

$$C = \frac{A \times K}{4 \times 3.1416 \times T \times 900,000}$$

C = Capacity in mfd.

A = Area in sq. centimeters of one set of plates or surface.

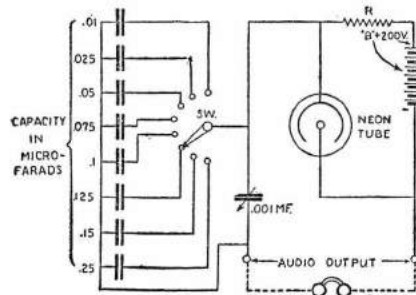

(377) An audio frequency oscillator, involving the use of a Neon tube.

K = Dielectric constant, or specific inductive capacity of the dielectric used.

T = Thickness of the dielectric between the plates' surface, measured in centimeters.

The dielectric constant may be found in any good text-book of radio.

Q. 2. How many ohms resistance has No. 22-gauge copper wire?

A. 2. This size copper wire has a resistance of 16.25 ohms per thousand feet, or 62.236 feet per ohm.

Q. 3. What is the proper connection for my headphone cords marked red and black? How should they be connected to the set for best results?

A. 3. This depends on the make of the receivers. While listening to a weak station reverse the leads and leave the headphones connected in the way that gives loudest response. Make note of the color that connects to "B" plus and always connect the headphones in that way, when trying other sets or circuits. Most usually the red cord should be connected to the "B" battery plus.

### (385) POLARITY OF PHONES

Q. 1. Will you please inform me how to determine the polarity of a telephone receiver. I have a Baldwin and a Western Electric phone.

A. 1. Unscrew the cap of the Western Electric and place a compass over the pole pieces of the magnets. The compass needle will swing around and the north pole of the needle will point to the south pole of the magnet. The same procedure is followed with the Baldwin, except that the mechanism must be taken out and the compass held over the single magnet, when it is held in a vertical position, with the poles of the magnet at the top.

Q. 2. Do loud speakers having large horns require more energy input than do those having small horns?

A. 2. No.

### (386) MISCELLANEOUS

Q. 1. Is there any advantage in reversing loud speaker and headphone connections to the set?

A. 1. It is advisable to try reversing these connections when receiving a fairly weak signal as the volume is often increased considerably.

Q. 2. Why are some loud speakers made better by reversing the connections to the set?

A. 2. Practically every loud speaker and pair of headphones has strong permanent magnets. A heavy "B" battery current in the windings tends to assist these magnets when "poled," or connected one way, and tends not only to neutralize the magnetic field of these permanent magnets but to demagnetize these magnets as well, destroying the efficiency of the instrument if reversed.

Many loud speakers and head-phones are marked to indicate which wire connects to the positive "B" battery connection. This wire is usually marked with a red thread called a "tracer."

Q. 3. How many turns of No. 30 enameled wire can be wound on a tube one inch long?

A. 3. The number of turns to the inch may be determined from the table printed below.

### URNS PER LINEAR INCH Kind of Insulation

Gauge Wire	B&S	DCC	SCC	DSC	SSC	Enam- eled	Enam- eled and SSC	Enam- eled and SSC
14	13.7	14.6	14.7	15.0	15.2	14.2	14.7	14.7
15	15.0	16.2	16.4	17.0	17.0	15.8	16.5	16.5
16	16.7	18.0	18.2	19.0	18.7	17.6	18.4	18.4
17	18.5	20.0	20.0	21.2	21.4	19.5	20.5	20.5
18	20.3	22.3	22.3	23.6	24.0	21.7	22.9	22.9
19	22.5	25.0	25.2	27.0	27.2	24.2	25.8	25.8
20	24.5	27.5	27.5	29.5	30.1	26.5	28.4	28.4
21	27.5	30.8	30.8	32.8	33.6	29.6	31.5	31.5
22	30.0	34.0	34.0	36.6	37.7	32.7	35.0	35.0
23	32.7	37.5	37.5	40.7	42.3	36.1	39.0	39.0
24	35.5	41.5	41.5	45.3	47.2	39.7	43.1	43.1
25	38.5	45.7	45.7	50.3	52.9	43.7	47.9	47.9
26	41.8	50.2	50.2	55.7	59.0	47.8	52.8	52.8
27	45.0	55.0	55.0	61.7	65.8	52.1	58.1	58.1
28	48.5	60.0	60.0	68.3	73.9	57.0	64.4	64.4
29	52.0	65.5	65.5	75.4	82.2	61.9	70.6	70.6
30	55.5	71.3	71.3	83.1	92.3	67.4	77.9	77.9
31	60.0	77.3	77.3	91.6	103.0	72.8	85.3	85.3
32	62.7	83.7	83.7	101.0	116.0	79.1	93.9	93.9
33	66.3	90.3	90.3	110.0	130.0	85.6	103.0	103.0
34	70.0	97.0	97.0	120.0	145.0	91.7	112.0	112.0
35	73.4	104.0	104.0	131.0	164.0	98.8	123.0	123.0
36	77.0	111.0	111.0	143.0	182.0	105.0	133.0	133.0
37	80.3	126.0	126.0	155.0	206.0	113.0	146.0	146.0
38	83.5	133.0	133.0	168.0	235.0	120.0	157.0	157.0
39	89.7	140.0	140.0	181.0	261.0	128.0	172.0	172.0

### (387) SLEEPER RX-1 RECEIVER

Q. 1. I have heard a good deal of the new Sleeper RX-1 Model Receiver. Can you confirm any of the reports as regards its sensitivity and over-all efficiency as a receiver? Also, can you furnish me with constructional details, providing this type of receiver is simple to build.

A. 1. The receiver you mention has aroused a great deal of discussion and interest here in New York City, especially in the radio sections of our various local newspapers. It is very simple and quiet-operating, these two characteristics making it an ideal receiver for the home. The circuit that is used in this receiver is of the conventional type, no "tricks" being incorporated; thus permitting the average builder with very little radio knowledge to build this set, without having to make any peculiar or intricate adjustment.

Another feature in its favor is that it is very inexpensive to build, the parts necessary being few, although necessarily of a high quality. The quality of reproduction obtained from this receiver is excellent, due to the stage of resistance-coupled amplification that follows the detector tube. This is a better scheme than the average system of resistance-coupled amplification, which usually follows a stage or two of transformer-coupled, because distortion from the output of the detector circuit is immediately corrected; whereas, when transformer-coupled amplification follows the detector output, the distortion is enhanced.

The parts necessary for this circuit are as follows:

- 2 .005-mf. variable condensers, preferably of low-loss straight-line frequency type;
- 2 Coils, wound on a 3-inch tube, and consisting of 45 turns of No. 22 D.S.C.; one having placed within it a primary winding of 8 turns, on a 2½-inch tube (The other coil has a tap at the 35th turn);

(Continued on Page 84)

## Miscellaneous Circuits

(Continued from Page 38)

becomes corroded, and tinning prevents corrosion. Theoretically, tinned bus wire has a higher R.F. resistance, but, practically, results are the same.

Q. 2. Why is gold plated wire not used more extensively, if gold is a better conductor than any other metal?

A. 2. The purest grades of copper have a greater conductivity than gold. Ordinarily, gold has a lower conductivity than the ordinary grades of copper.

Gold or silver-plated bus wire has the advantage of not corroding.

### (183) MULTIPLE LOUD-SPEAKERS

Q. 1. Why cannot several loud speakers be operated from the same set, thereby increasing the sound?

A. 1. We do not believe that any noticeable increase in volume would be had with an arrangement of this kind. As this would constitute a divided circuit, the energy received by each loud speaker would be only a portion of the total, and the sound produced would be reduced in each loud speaker correspondingly.

Q. 2. Is a loud speaker any good when made by clamping a pair of head-phones on the horn? Some of the loud speakers of this type require only a single unit.

A. 2. Head-phones are not designed for adequate handling of the strong currents necessary for proper loud speaker operation. There are many "units" obtainable that may be incorporated in some of the various types of horns. These units are entirely satisfactory for loud speakers.

A pair of head-phones designed to be really sensitive to weak signals will rattle greatly if forced to operate for even "moderate" loud speaker volume. Although not recommended a simple expedient that permits of loud speaker operation with most head-phones (with the exception of the Brown and the Baldwin brands) is the raising of the diaphragm from the pole-pieces. It is the touching of the diaphragm against the pole-pieces which causes the rattle. Sometimes merely reversing the diaphragm, so that the inside now becomes the outside, is sufficient to stop the rattle. A thin paper washer, one-eighth inch wide and with an outside diameter equal to the diaphragm diameter, may be used to raise the diaphragm slightly from the pole-pieces, a sufficient number of washers being used to prevent the rattling.

Another thing. Some head-phones are wound with wire much finer than that used in other makes of receivers. The wire is large enough for ordinary signal strength, but is insufficient when taxed by the output of a 2-stage audio frequency amplifier. The result is a burn-out which renders the phones useless until repaired.

### (184) RADIO MATHEMATICS BOOKS

Q. 1. What books deal with the higher mathematics of radio?

A. 1. Radio mathematics are well covered by "Principles of Radio Communication," by Morecroft; "Elementary Mathematics of Radio," by Willis; "Wireless Telegraphist's Pocketbook," by Fleming; Bureau of Standards' "Circular No. 74." These may be had by writing to the Wireless Press, 326 Broadway, New York City. An exception is "Circular No. 74," which may be obtained from the Government Printing Office, Washington, D. C.

### (185) MEANING OF D. X.

Q. 1. What is the meaning of D. X. in radio?

A. 1. D. X. means long distance transmission or reception.

### (186) RADIO COMMUNICATION DISTRICTS

Q. 1. Kindly advise me as to whom application should be made for station license information.

A. 1. We have had so many inquiries from all parts of the country for this information, that we are herewith printing the list of the nine radio communication districts, and the territory covered by each. Communications should be addressed to the Radio Supervisor at the Custom House in the principal city of the district.

(1) BOSTON, MASS.: Maine, New Hampshire, Vermont, Massachusetts, Rhode Island, Connecticut.

(2) NEW YORK, N. Y.: New York (county of New York, Staten Island, Long Island, and counties on the Hudson River to and including Schenectady, Albany and Rensselaer) and New Jersey (counties of Bergen, Passaic, Essex, Union, Middlesex, Monmouth, Hudson and Ocean).

(3) BALTIMORE, MD.: New Jersey (all counties not included in second district), Pennsylvania (counties of Philadelphia, Delaware, all counties south of the Blue Mountains, and Franklin county), Delaware, Maryland, Virginia, District of Columbia.

(4) SAVANNAH, GA.: North Carolina, South Carolina, Georgia, Florida, Porto Rico.

(5) NEW ORLEANS, LA.: Alabama, Mississippi, Louisiana, Texas, Tennessee, Arkansas, Oklahoma, New Mexico.

(6) SAN FRANCISCO, CAL.: California, Hawaii, Nevada, Utah, Arizona.

(7) SEATTLE, WASH.: Oregon, Washington, Alaska, Idaho, Montana, Wyoming.

(8) DETROIT, MICH.: New York (all counties not included in second district), Pennsylvania (all counties not included in third district), West Virginia, Ohio, Michigan (Lower Peninsula).

(9) CHICAGO, ILL.: Indiana, Illinois, Wisconsin, Michigan (Upper Peninsula), Minnesota, Kentucky, Missouri, Kansas, Colorado, Iowa, Nebraska, North Dakota, South Dakota.

### (187) LOUD SPEAKER EXTENSION CORD

Q. 1. Can a 20-foot extension cord be used on a loud speaker without decreasing the volume?

A. 1. Using an extension cord will reduce the volume slightly, but results will be entirely satisfactory.

Q. 2. Please publish the Radio Act of Congress of August 13, 1912. I understand this act contains the regulations covering radio communication.

A. 2. The act to which you refer takes up many pages in the booklet called "Radio Communication Laws of the United States," published by the Government Printing Office, Washington, D. C. This publication may be procured from the Superintendent of Documents, Government Printing Office, Washington, D. C., at the price of 15c per copy.

### (188) BEST SOLDERED JOINT

Q. 1. What is the correct per cent of solder materials?

A. 1. This depends on intended use of the solder. Average soft solder for copper is 60 per cent tin and 40 per cent lead.

Q. 2. How is a good copper joint made?

A. 2. By bringing the two surfaces as close together as possible and using a minimum of solder. This is necessary as copper has seven times the conductivity of solder.

Q. 3. What is a simple way, when direction of the current in a wire is known, to determine the direction of flow of the magnetic lines of force?

A. 3. With the wire grasped in the right hand, the thumb extended and pointing in the direction of the current flow, the curved fingers will denote the direction of the magnetic lines of force. A diagram showing this will be found below.

Q. 4. Please give signal audibility values?

A. 4.

#### Signal Audibilities

R1—Faint signals, just audible.

R2—Weak signals, barely readable.

R3—Weak signals, but readable.

R4—Fair signals, easily readable.

R5—Moderately strong signals.

R6—Strong signals.

R7—Good, strong head-phone signals. Would be readable through heavy QRN and QRM.

R8—Very strong signals. Medium loud speaker volume.

R9—Extremely strong signals, strong loud speaker volume.

#### Phone Audibility and Quality

M1—Speech garbled.

M2—"Hashed" speech.

M3—Uneven modulation.

M4—Clear voice.

M5—Very clear, modulation perfect.

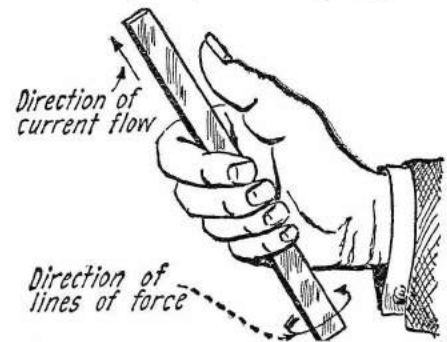

(188) When the direction of the current flow is known, the direction of the lines of force can easily be determined. The flow is from negative to positive.

## Popular Circuits

(Continued from Page 63)

9. The following Interflex articles have been published:

"The Interflex" (1 dial), *Radio News*, September, 1925.

"The Balanced Interflex" (1 dial), *Radio News*, October, 1925.

"The Interflex Receiver" (1 dial), *Radio Review*, October, 1925. *N. Y. Telegram*, August 29, 1925.

"The Regenerative Interflex" (1 dial), *Radio News*, December, 1925.

10. Note the effect of connecting a small variable condenser (about 5-plate size) from the post-crystal tube grid to "A" minus.

11. Fixed detectors are usually more rugged and are generally more satisfactory than adjustable ones.

12. Tune very slowly.

### (255) NEUTRODYNES

Q. 1. Please list the trade names of the Neutrodynes licensed under the Hazeltine patents.

A. 1. The following 14 Neutrodyne receivers are licensed under these patents:

Amrad	Howard
Carloyd	King-Hinners
Eagle	Murdock
Fada	Stromberg-Carlson
Freed-Eisemann	R. E. Thompson
Garod	Ware
Gilfillan	Workrite

Further information relating to these receivers may be obtained by writing to the Advertising Department of this company.

Q. 2. How can my Neurodyne be adjusted so as to shift the dial readings further forward? KSD is received at about 120 on the dial. Would like to receive this station at about 195 on the dial.

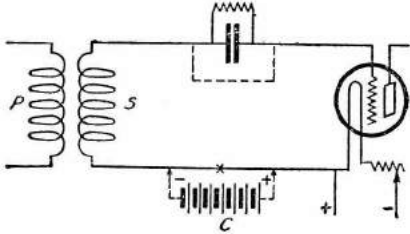

(253) Replacing grid leak and condenser with a "C" battery often increases Super-Heterodyne selectivity.

A. 2. Changing the capacity or changing the inductance will control the wave-length. If it is not convenient to change the variable condensers to others having a lower maximum capacity, you may reduce the number of turns of the secondaries of the neuroformers. If the secondary windings are changed and difficulty is experienced in neutralizing the set, it may be necessary to reduce the number of turns in the neuroformer primaries.

Since you do not state the capacities of the variable condensers used, or the constants of the neuroformers, we cannot furnish specific information.

Q. 3. Why is it that a Neurodyne constructed with standard parts does not neutralize when using UV-199 tubes? The neurodons have no effect and the circuit will not oscillate.

A. 3. The neuroformers you are using were designed to operate best when standard six-volt storage battery tubes are used. Since the circuit will not oscillate when dry cell tubes are used, on account of the low internal capacity of these tubes, it becomes necessary either to increase the number of turns in the primaries of the neuroformers or else to connect a very small condenser across the grid and plate terminals of the radio frequency tubes. Neurodons will probably be found satisfactory in this capacity. Do not forget to install the detector plate circuit by-pass condenser that connects across the headphones, or across headphones and "B" battery; it causes a big increase in signal strength and the circuit will oscillate more easily.

### Tube Data

(Continued from page 66)

Q. 2. What is the Diode tube?

A. 2. This is a vacuum tube having only two elements—filament and plate. It is technically known as the Fleming valve, in honor of the inventor.

Q. 3. Is a dry battery as efficient for use with a UV-201A as regular storage battery?

A. 3. Since a UV-201A requires six volts for the filament, it would be necessary to employ four dry cells. Their life would be short for the reason that this tube consumes 1/4 ampere filament current. It would, therefore, be advisable to use a storage battery.

### (275) C-299 TUBE

Q. 1. What capacity grid condenser and grid leak does the C-299 require?

A. 1. The grid condenser should be about .00025 mfd. The grid leak value is best found by experimentation, usually about three megohms.

Q. 2. Is a C-299 as good a detector as a C-300?

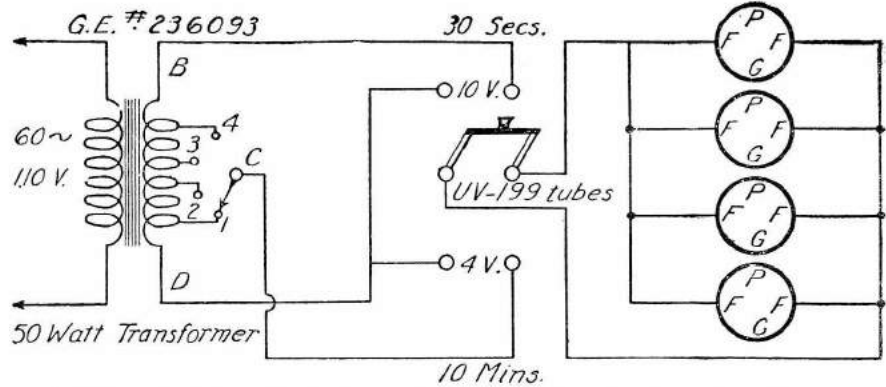

(261) By this simple expedient of applying an alternating current of higher-than-usual value, for a short time, to coated filaments, tubes using this filament construction may be made to function perfectly. This system is only for tubes that light but operate poorly.

A. 2. A C-299 will give as good results as the C-300 tube when the proper grid leak is used.

Q. 3. What are the characteristics of the Magnavox Type A tube?

A. 3. Filament voltage, 5; amperage, .20 to .25 amp. Plate volts, 60 to 120. Amplification constant, 8 to 12. Mutual conductance, 800 to 1200 micromhos. Standard base. It is a three-element tube with an unusual design of grid.

A. 2. Yes, this tube can be used in the Flewelling or any "super" circuit, but over 90 volts should not be used on the plate.

## Transmitting Circuits

(Continued from page 68)

### (276) QUESTIONS ON TUBES

Q. 1. Is the UV-199 superior to the WD-11, UV-200 or the UV-201-A as a detector?

A. 1. The UV-199, although not designed as a detector, gives very good results when used in this capacity. We believe that it will prove just as efficient as any of the aforementioned tubes when used in a detector circuit.

Q. 2. In a three-tube set, using UV-201-A tubes, how many dry batteries are used and how are they arranged?

A. 2. Four dry cells should be connected in series for the filament of the UV-201-A. It would be better, however, to use four more cells connected in parallel with the other four, to give longer life to the batteries.

### (277) TUBE QUERY

Q. 1. Can a UV-200 be made to work, if it stops working as soon as it gets hot?

A. 1. A change of "B" battery voltage would probably cause the tube to function for a time.

### (278) WD-11 AS AN AMPLIFIER

Q. 1. Will the WD-11 give the same volume on a loud-speaker as the standard six-volt tubes?

A. 1. Although fairly efficient as an amplifier, the WD-11 will not give as great a volume of sound as standard tubes, such as the UV-201-A or VT-2.

Q. 2. Can the WD-11 be used in the Flewelling circuit?

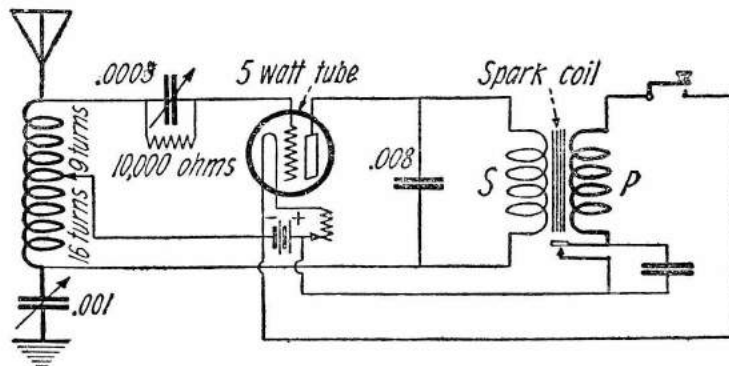

(290) Very Good Results Will Be Obtained With the I.C.W. Transmitter. A Spark Coil Is Used to Supply the Plate Potential.

### (293) C. W. TRANSFORMER DESIGN

Q. 1. Kindly publish complete details for the construction of a 200-watt transformer similar to the Acme C. W. transformer.

A. 1. A 200-watt transformer may be constructed as follows: A core 8 x 6 x 2 in. sq. is required. The primary will consist of 414-turns of No. 14 D.C.C. wire. The secondary will consist of 4,574 turns of No. 34 D.C.C. wire tapped at the 2,287 turn. The two filament windings will consist of 38 turns of No. 14 D.C.C. wire. Each of these two windings should also have center taps at the 19th turn. The transformer will give two secondary voltages of 550 and each filament winding will deliver 10 volts.

### (294) W. E. TRANSMITTING TUBES

Q. 1. What general information is available on the Western Electric transmitting tubes?

A. 1. The 50-watt "G," or 211-A tube, has the following characteristics: It fits a standard 50-watt socket; the filament is oxide coated and is kept constant at 3.4 amperes; the filament voltage varies; the correct voltage is between 9 and 9.8. It is not advisable to operate the tube with more than its optimum voltage of 750 on the plate, although the maximum permissible potential is 1,000 volts. The grid bias voltage varies between -30 volts and -60 volts. The plate current is 65 milliamperes, with a grid voltage of -30 volts and a plate voltage of 750. The voltage amplification is 11 to 13 and the impedance between plate and filament is 3,500 ohms.

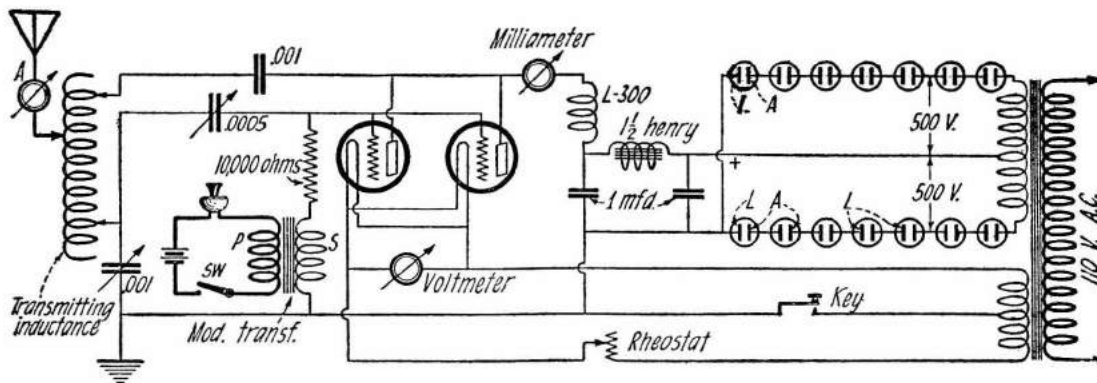

(291) This 10-watt C. W. and fone transmitter uses A. C. rectified by an electrolytic rectifier. The circuit is capable of good results.

The 250-watt 212-A, or "I" tube, has these characteristics: A special four-prong socket is required; constant filament current, 6.25 amperes; filament voltage, 9 to 9.8; grid voltage, -30 to -60 volts; plate voltage, 1,000 to 2,000, with best operation at 1,500 volts; with a grid bias voltage of -60 and a plate voltage of 1,500, the voltage amplification is 15 to 17 and the impedance is 2,000 ohms. Do not impress the supply on the plate until the tube has been heated for five minutes. The filament may be burned out if the full plate voltage is then applied; one-half the voltage should be applied at first. If desired, a high grid bias may be employed to reduce the plate voltage. As this bias voltage is reduced to normal, the plate voltage will increase. The grids and plates of these tubes are made of metallic nickel which has been coated with black nickel oxide. It is very important that the plates are not heated beyond a faint red at the center.

Switch Sw.B may be a push-pull arrangement, for selecting either the first or second stage of power amplification. The tubes recommended for the two-power stages marked 4 and 5 are UX-112-type tubes. Type UX-210 tubes can also be used in these two positions with extraordinarily good results. In the event that these tubes are used, no filament resistance is required at "R," with a 6-volt supply. When UX-112 tubes are used a resistance capable of carrying 1/2 ampere per tube must be provided for the set. The UX-210-type tube will require a negative "C" bias in the neighborhood of 15 volts.

The 8-mf. condensers must have a high insulation value.

By use of the unusually efficient and high plate voltage supply described above, one need not give the attention needed by "B" batteries of the usual type which age rapidly under such heavy duty service and eventually become noisy, or the storage "B" battery that requires frequent recharging, or the next best proposition, the motor generator with its attendant and undesirable commutator noises.

This circuit is an unusually efficient one for driving cone-type reproducers.

Readers will be interested to know that a set built with this form of plate supply reproduced the signals of a broadcast station fifty miles away so loudly and clearly as to be perfectly understandable at excellent audibility, two miles from the loud speaker.

Experimenters desiring more detailed information regarding the tuning system and circuit, selected for the qualities of selectivity and sensitivity, and the plate supply selected for the reasons enumerated above, are advised to study these references:

"The Reactodyne Circuit," page 796, December, 1925, issue of *Radio News*; "Electrostatic A. C. to D. C. Converters," page 1077, March, 1923, issue of *Science and Invention*.

Q. 2. How are "B" batteries charged from an "A" battery charging tube rectifier?

A. 2. Whether you have a 2-amp. or a 5-amp. tube charger, you should find no difficulty in following circuit 323A.

The voltage distribution in the auto-transformer is shown.

Knowing the charging rate of your "B" battery, you may determine the size lamp required to pass the correct charging current by a glance at this table:

Lamp Wattage	Charging Rate Amperes (A single 12-cell unit)	Charging Rate Amperes (2 units in series)
25	.075	.....
40	.125	.090
60	.165	.125
75	.250	.175
100	.275	.225
150	.350	.275

Q. 3. May dry "B" batteries be connected in series with storage "B" batteries?

A. 3. Yes. It is not advisable unless a high resistance voltmeter is used for checking battery voltages. The potential of a 32-volt or 110-volt D. C. lighting current may be increased by connecting a "B" battery in series, where the drain is slight, as when supplying plate current for a receiving set.

Q. 4. If the "A" battery is turned entirely off, and the "B" battery is left connected to the plates of the tubes, would there be any "B" battery consumption?

A. 4. There would be no consumption whatsoever.

Q. 5. Would there be any electrical discharge from the positive terminals of the "B" batteries, where graduated voltages are applied to the various stages of amplification, if the negative lead is opened with a switch?

A. 5. No.

## Current Supply

(Continued from Page 71)

element, the aluminum, must be of the purest grade obtainable.

The iron, or negative electrode, serves only as a connection to the electrolyte. It is the aluminum oxide film, the formation to be described, with which we are most concerned.

The transformer is a 50-watt, 110-volt, 60-cycle transformer with a 220-volt secondary winding tapped off evenly. This secondary voltage, which is very critical, is the plate potential to be determined by test.

Although 8-mf. condensers are shown, condensers of larger capacity will reduce any ripple that may remain in the output.

Before using this rectifier on the set, switch Sw.C should be set for the lowest possible voltage and the transformer connected to the 110-volt line for about 10 minutes. The oxide film will by then be formed on the aluminum electrodes.

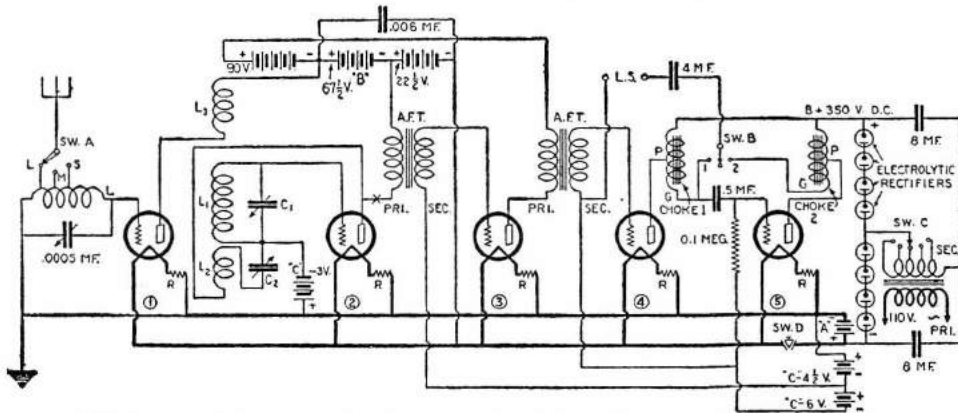

(323) An unusual circuit employing the use of electrolytic rectifiers to supply B voltage for the plates of the last two amplifier tubes. (See page 71).

### (324) RECTIFIER DATA

Q. 1. Please furnish formula giving strength of sodium bicarbonate solution in a four-jar type, lead-aluminum rectifier.

A. 1. Saturated.

Q. 2. Also the strength of ammonium phosphate solution.

A. 2. Saturated.

Q. 3. What is the aluminum area per ampere output?

A. 3. Five to ten square inches.

Q. 4. Is it possible for the "B" battery to cause a sound like that of "static"? If the answer is in the affirmative, is there any easy way of testing for the trouble?

A. 4. A run-down "B" battery may cause crackling sounds that cannot be distinguished from some forms of static due to an electrified condition of the air. You do not state whether you are using one or more tubes. If yours is a single-tube set, the first substitution method will not apply.

If you have two 45-volt "B" battery units, it is probable that only one is causing the trouble. Therefore, try one of the two batteries. In that case the set will be operating on only 45 volts plate potential, but the crackling sounds will be heard just the same, if the poor battery is connected into the circuit in place of the perfect battery.

A second, and sometimes not convenient, substitution method is to try a new "B" battery in place of the one, or ones, in the set.

If the voltage of the battery is determined by a high-resistance voltmeter, the needle will

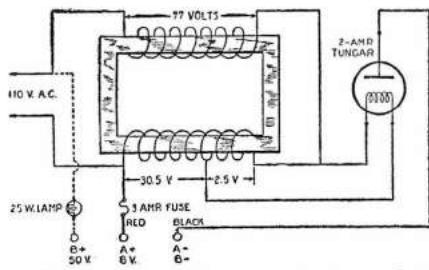

(323-A) Charging "B" batteries by means of an "A" battery-charger of the regular 2-ampere or 5-ampere type.

fluctuate if there are one or more defective cells. A poor battery will usually have an extremely low voltage reading.

If a pair of head-phones (really good phones should not be used for this test) are connected across the "B" battery, with a grid leak of high resistance in series, crackling is practically absent when the battery is good. A perfect grid leak is absolutely essential.

Q. 5. What is the advantage of a "B" battery with several taps?

A. 5. Tubes work best with a certain voltage on the plate. This value is most critical for detector tubes. A difference of  $1\frac{1}{2}$  volts will often make the difference between the set working well, or working poorly, in the case of some tubes that are used. This is particularly true of tubes designated as being "soft" (having a low vacuum), or "gassy" (having certain gases inside), either by design, or as a result of the tube having been in operation for some time. The continued use of a tube sometimes liberates a sufficient amount of gas from the glass, and from the elements of the tube, to cause a radical change in its operation. Modern tubes are considerably more stable in operation than the older ones and the critical point will be found very close to 21 volts, usually. Some of the older tubes were so variable that it was not unusual to find one that would work perfectly with only three or four volts on the plate. If controlled by a switch, the taps must be so spaced that the switch arm will not connect two working contacts at the same instant, since this would short circuit part of the battery.

### (325) OHM'S LAW

Q. 1. Can you quote Ohm's Law in simple form?

A. 1. We can, at least, try.  $C$  equals  $E$  divided by  $R$ ; likewise,  $R$  equals  $E$  divided by  $C$ ; and as well,  $E$  equals  $C$  multiplied by  $R$ ; wherein, in any of the three, the symbol  $C$  denotes the current,  $E$  the electromotive force and  $R$  the resistance. Furthermore, current is measured in amperes, electromotive force in volts and resistance in ohms.

## Amplifiers

(Continued from page 74)

Q. 5. Is it not possible to use the "B" battery to supply a "C" potential?

A. 5. The method is shown in these columns. At first glance, one is inclined to believe that the potential applied to the grids will be positive in polarity but a little study of the circuit will show that this is not true. The by-pass condenser is quite essential. A common "A" battery may be used, but it is advisable to use a separate "B" battery.

## Antennae

(Continued from Page 76)

A. 1. An antenna of this type should be about 80' long. No better results, however,

will be obtained with this antenna than with a single wire of the same length.

Q. 2. What is the best type of receiving antenna?

A. 2. The best type of receiving antenna is a single wire 125' long, above all surrounding objects, if possible.

Q. 3. Why is a one-wire aerial better than a two-, three-, or four-wire aerial?

A. 3. For transmission, the four-wire aerial is better. For reception, there is very little difference in the result and the one-wire aerial is cheaper and easier to install and maintain.

### (364) ANTENNA INTERFERENCE

Q. 1. Does an aerial installed on a roof cause non-reception from a loop used directly under the antenna?

A. 1. An antenna should affect the loop in no way under these circumstances. If the loop is in a steel building, reception might be impaired and the directional effect would most likely be nullified.

Q. 2. Will a loop function if fastened to the radiator cap of an automobile?

A. 2. Yes, very well.

Q. 3. Using a six-tube set, the sounds caused by passing trolley cars are objectionable; telephone conversation and bell ringing are also quite audible, what is the remedy?

A. 3. It is almost impossible to eliminate trolley induction if one is very near the trolley lines. It is probable that your aerial, the aerial lead-in, or ground lead, are in strong inductive relation to telephone lines. It is possible that your lead-in, after entering the house, runs parallel to telephone wires between the walls of the house. It is often found that changing the ground connection to a different ground eliminates the trouble. Placing your aerial at right angles to the trolley lines should eliminate or greatly reduce the trolley induction.

Q. 4. What size loop aerial is best for all-around receiving if I use two stages of R. F. amplification?

A. 4. The best loop antenna should consist of eight turns of wire, wound on a four-foot square frame. This is rather large for the average experimenter, and we would suggest a loop three feet square, wound with 10 turns. The last four turns should be tapped.

Q. 5. What is the best height for a counterpoise?

A. 5. Ten feet may be considered the average height.

Q. 6. Will the use of a counterpoise in place of my usual ground connection enable me to tune out local stations?

A. 6. If your present ground connection has a high resistance, due to natural or created causes, the resistance should be less with the counterpoise, thus serving to sharpen the tuning of your aerial circuit by decreasing the damping. Whether you will be thereby enabled to tune out your local stations will depend upon the design of the remainder of your set.

### (365) LIGHTNING

Q. 1. In the event of lightning hitting an antenna, would there be any danger to the inside of the house?

A. 1. There is always danger during an electrical storm, no matter if the house supports an antenna or not. If lightning should hit an antenna it might follow it to the inside of the house or it might jump from the wire at some point to some other part of the house. There are only a very few cases on record where lightning has hit an antenna as against the hundreds of times where houses without antennae have been struck. A properly grounded antenna is a protection rather than a menace.

Q. 2. Do the plugs that screw into an electric socket, to take the place of an antenna, give satisfactory results?

A. 2. Although these plugs are not as efficient as a good antenna, the results obtained are, as a rule, very good.

## Miscellaneous Apparatus

(Continued from Page 80)

- 1 .00025-mf. grid condenser;
- 1 Two-megohm grid leak;
- 1 .01-mf. condenser;
- 1 One-megohm grid leak;
- 4 Sockets;
- 1 25-ohm resistance;
- 1 4:1 transformer;
- 2 15-ohm rheostats;
- 1 10-ohm rheostat;
- 1 Single-circuit jack;
- Binding posts, etc.

The circuit diagram for this receiver is shown on the next page. (Fig. 387).

"C" batteries are used in conjunction with this receiver to obtain the proper bias on the radio frequency tube and on the first audio tube. Flexible leads should be used where the "C" battery is connected, in this particular circuit, to one end of the variable condenser in the radio frequency circuit, and to one end of the resistance in the first audio circuit. It is suggested, for best results, to use two 201A or 301A tubes; and two 199, or one 199 for the radio frequency amplifier circuit and one Sodian tube for the detector. Tubes other than the 199 in the R.F., and the Sodian in the detector stage will be found to cause undue oscillation. A special Hi-Mu tube (Daven U-20 or other similar tubes) may be used in the resistance-coupled stage. Do not attempt to use a transformer of a higher ratio than the 4:1 mentioned above, or distortion will result. A resistance is placed in series with the filament circuit of the first R.F.T. to cause a slight voltage drop, and thereby prevent the 199 tube from burning out from excessive filament voltage. The resistance should be in the neighborhood of 25 ohms. The filament adjustment of the Sodian tube is not very critical. It can be set at a certain position and left there permanently. The audio frequency rheostat can be adjusted and left in that position.

There are no extravagant claims made for this receiver. Remember, it is simply a home set, built especially for quality reproduction; and has not too many "gadgets" to adjust, although this receiver is capable of producing as good results as some of the numerous "much touted" ones.

### (388) CAPACITY LEAD-IN

Q. 1. What is a "capacity lead-in"?

A. 1. This is clearly shown in "388" to be nothing but two circles of metal foil pasted on either side of a window glass. This forms a condenser of considerable capacity and makes it unnecessary to drill a hole through the window or wall. The signals may be said to "go right through the glass."

Copper foil is best. A connection binding post is soldered in the middle of each six-inch circle before fastening to the pane. Use heavy foil or light sheeting.

### (389) RESISTANCE-COUPLED AUDIO AMPLIFIER

Q. 1. Please give me details and constants used in the construction of a resistance-coupled audio amplifier. I am using, at present, a three-tube neutrodyne set in connection with a commercial two-stage transformer-coupled audio amplifier; and would like to substitute for this type of amplifier one of the resistance-coupled type to improve the tone of quality obtained. Any information you may give me in regards to this type of amplifier will be greatly appreciated.

A. 1. A resistance-coupled audio amplifier we can recommend for use with any receiver is shown in 389.

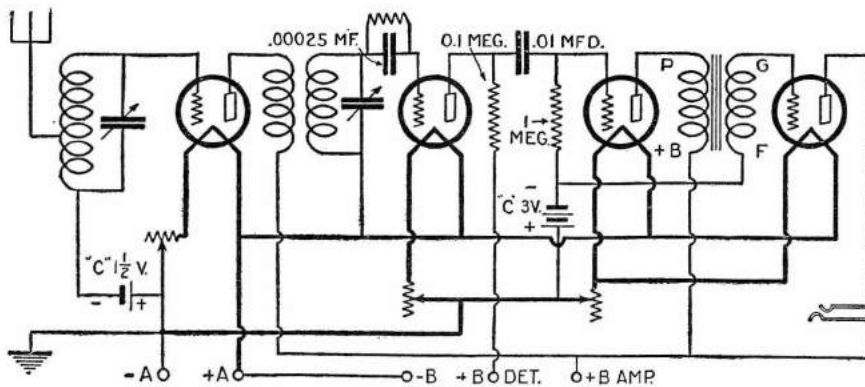

(387). The Sleeper RX-1 Receiving Circuit. Inexpensive and simple to build, one wonders at the results obtained in regard to both sensitivity and quality, for the time and money spent. The stage of resistance-coupled amplification before the ordinary transformer-coupled stage, accounts for the set's unusual quality of reproduction.

An amplifier with the constants shown and efficiently built, will be capable of giving practically true reproduction; and will satisfy the most critical in regards to tone quality obtained. It is suggested that "B" batteries of the storage or dry type be used for supplying the "B" voltage to this amplifier. Most "B" eliminators on the market have some slight A.C. ripple or hum, unless the D.C. output is of an extremely high quality. We suggest that you stick to ordinary "B" batteries for use with this resistance amplifier, unless you are positive that the "B" eliminator you may wish to use is satisfactory.

**(390) TUNED RADIO FREQUENCY SET USING VARIOMETERS**

Q. 1. It seems that none of the popular radio publications are featuring any unusual circuits that contain the "obsolete" (?) variometer. I have an old two-variometer and vario-coupler set, which I used a few years ago for the reception of broadcast and amateur stations. I would like to incorporate the variometers in some sort of unusual five-tube circuit that will be capable of producing satisfactory results in regards to selectivity and sensitivity. Can you furnish me with a diagram of such a circuit? If additional parts are required, please mention them.

A. 1. Due to the entrance of various low-loss coils on the market, variometers have become somewhat obsolete. However, we are here showing a diagram (390-A), of a 5 tube circuit which employs variometers, with remarkable results possible. The circuit is exactly similar to that of the monophase, except that we substitute for the complicated coils described in that article an ordinary, wooden, old-fashioned "contraption," without any resulting decrease in the efficiency of the receiver. The parts necessary for this circuit are as follows:

- 3 Large wooden variometers,
  - 2 10-ohm rheostats,
  - 1 Double-circuit jack,
  - 3 Dials,
  - 1 Single-circuit jack,
  - 1 Fixed-capacity condenser of .006 mf.,
  - 1 Grid condenser of .0005 mf.,
  - 2 Feet of 1/4-inch wooden rod,
  - 5 Tube sockets,
  - 1 4 1/2-volt "C" battery,
  - 1 By-pass condenser, .001 mf.,
  - 1 Battery switch,
  - 1 2-megohm grid leak,
  - 2 Audio frequency transformers,
  - 1/2 Pound of No. 20 D.C.C. wire,
  - 1 20-ohm rheostat,
  - 1 Binding post strip, with seven binding posts mounted thereon,
  - 1 Hard rubber, or bakelite panel, 7 x 24 inches,
  - 1 Wooden baseboard, 6 x 22 inches, 3/4 inch thick,
  - 2 Brass brackets for mounting the binding post rack at the rear of the sub-panel,
- Necessary bus-bar, screws, antenna equipment and other incidental parts.

Six inductances, each consisting of eight turns, and wound in the well-known "basket-weave" fashion, are necessary. These coils are then mounted on the sides of the variometers, being supported by 1/4-inch round dowel sticks. The method of mounting these coils is illustrated in Fig. 390. It should be noted that one coil is fastened permanently to the side of the variometer, whereas the other is left free to slide. The movable coil is called the "compensator" coil, and is used to adjust the receiver "to just before the point of oscillation." No condensers are necessary in this receiver, all tuning being done by the variometers. If, in any case, the variometer should be found too small to cover successfully the broadcast wave-length band, fixed condensers ranging from .00025 to .0005 mf. capacity should be shunted directly across the winding of the variometer; in other words, across the secondary or grid inductances, to cover the range satisfactorily.

If the oscillation cannot be controlled or removed by the compensator coils, the builder should try reversing the connections from these coils. In order to obtain greater selectivity the 8-turn primary windings on each variometer should be moved some little distance from the variometer, until the desired selectivity results.

**(391) BATTERY ELIMINATOR**

Q. 1. I would like to construct a battery eliminator, to be used in conjunction with my receiving set. The set requires "A," "B" and "C" batteries, and the current supply is of the alternating type. Can you furnish me with a diagram and any other necessary data to construct such an eliminator?

A. 1. It is possible to construct an eliminator, operating from an A.C. source, for lighting the filament of a radio receiving set, as well as to provide "B" battery and "C" battery voltages. A few changes in the wiring of the set will be necessary, although the high efficiency of this eliminator will more than compensate the builder for his additional pains.

The particular arrangement shown in 391 was designed for use with a five-tube receiver, although receivers employing a different number of tubes may be used by changing the values of the resistances connected in series with the filaments. You will note that

(389). A resistance coupled audio amplifier which may be added to any receiving set, in place of the ordinary audio stages, and which results in an output of unusual high degree as regards tonal quality. It is recommended that storage or dry batteries be used to furnish "B" voltage for this circuit, unless an exceptionally high type of "B" eliminator is available.

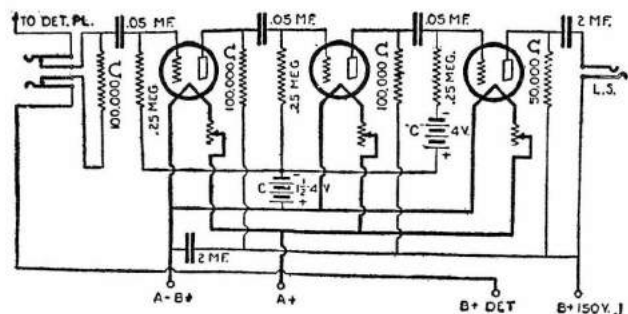

the filaments of the tubes of the receiver are placed in series instead of the conventional parallel method. Parts necessary are:

- 1 Power transformer,
- 1 Filter choke—General Radio, Amertran,
- 1 Rectifier tube socket,
- 4 1,500-ohm potentiometers,
- 5 2mf. filter condensers,
- 3 .5- to 2-mf. by-pass condensers,
- 1 Binding post strip—5 posts,
- 1 200-ohm potentiometer, or Black's polarizer,
- 1 5-watt bell-ringing transformer,
- 1 0-100 milliammeter (optional),
- 1 1 1/2-ohm filament rheostat,
- 1 UX-213 or CX-313 rectifier tube. (Raytheon helium tube may also be used),
- 1 Baseboard, 12 x 18 inches.

The new rectifier tube, mentioned above, has two filaments and two plates contained within the one glass bulb; and when connected to the transformer secondary, as shown, will deliver both halves of the A.C. wave in the form of pulsating D.C., with a voltage of 250 under normal load. If the General Radio power transformers are used, a 1 1/4-ohm

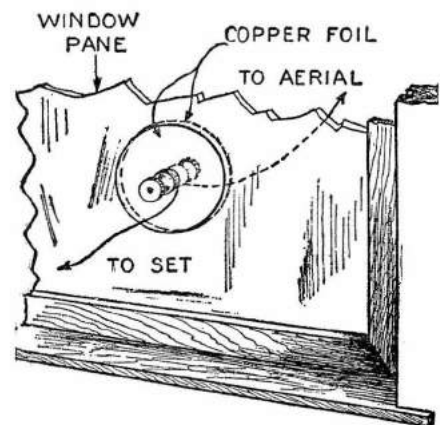

(388). An ingenious "stunt," permitting lead-in connection from an outside aerial to the receiving set, without window holes, porcelain tubes, etc.

resistance must be placed in series with the rectifier filament lead, as the CX-313 tube draws two amperes at 5 volts. The resistance may be of the filament-rheostat type. The Raytheon tube, which does not have a filament, may also be used as the rectifier.

The filtered 250 volts D.C. is used to provide plate and filament voltages for the various tubes in the receiver, by means of a set of resistances which are so designed and placed that the load across the rectifier draws exactly 70 milliamperes constantly. In series with these resistances are placed the filaments of the vacuum tubes, which are wired so that they are in series instead of in parallel, as is the usual custom. Bias voltages for the various grid circuits are obtained through wiring the series filament circuit in such a manner that the voltage drop across the filament of each tube can be used to furnish "C" voltage for some other tube in the same circuit.

**(392) A LOW-POWER RADIO PHONE TRANSMITTER**

Q. 1. I would like to build a low-power

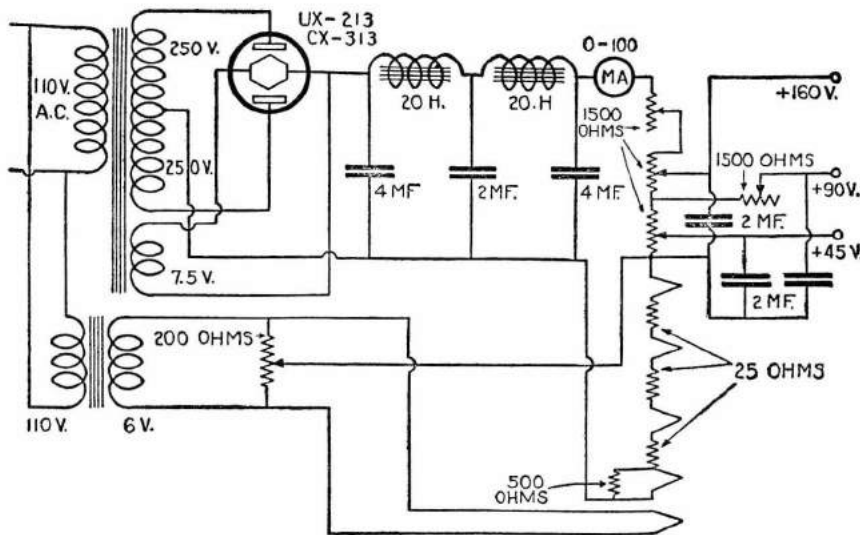

(391). "Just what you wanted." An "A," "B" and "C" battery eliminator, giving an unusually "pure" output, free from A.C. hum or distortion. Note that the filaments of the receiving tubes must be connected "in series," instead of the usual "parallel method."

phone transmitter which I could also use for code transmission. Can you furnish me with a circuit diagram for same, including the parts necessary, with values. I would rather have one that does not employ the use of any complicated apparatus, nor require a good deal of skill and experience for its adjustment, as I am a newcomer in the radio transmission phase of this wonderful science.

A. 1. A low-power radio phone transmitter which can be used for the transmission of code is shown in 392. A single 5-watt tube is employed. The parts necessary for the construction of this transmitter are as follows:

- 1 5-watt tube,
- 1 Socket for the above,
- 1 5,000-ohm transmitting resistance,
- 1 modulation transformer,
- 1 3-ohm power rheostat,
- 1 Microphone,
- 1 High-pitched buzzer,
- 1 Transmitting key,
- 1 Double-pole, double-throw switch.

The transmitting inductance can be constructed by the builder. It consists of 20-turns of No. 14 cotton-covered and enameled wire. This coil should be tapped every two turns after the tenth turn. A primary winding of five turns is wound on top of the secondary, with the same size wire.

When the switch is thrown in one position the transmitter is ready for radio phone transmission; in the other position it is used for code transmission. A motor generator or "B" batteries should be used to supply the plate voltage for the transmitting tube. About 350 volts is suggested, so that a reliable range of at least 25 miles may be covered. It

is also suggested that a radiation ammeter be used in series with the antenna, to facilitate the adjustment of the transmitter. Maximum output from the transmitter occurs when the ammeter indicates its highest reading. An ordinary 6-volt flashlight lamp may be substituted for the radiation ammeter, maximum output being indicated by its brightest glow. A switch should be placed across the lamp, and short-circuited when the transmitter is being used for communication.

(393) ELIMINATING STATION INTERFERENCE

Q. 1. I am bothered by constant interference of one particular local station which transmits with 1,500 watts of power. The transmitting station is within the immediate vicinity. Is there any selector or wave-trap circuit that you can give me, which will eliminate this interference? I am positive that the trouble is not in the receiving set, as neighbor friends with radio sets are experiencing the same difficulty.

A. 1. A filter or wave-trap which will eliminate the trouble you mention is shown on page 87. (393.). Its construction is fairly simple, having but two parts; although the adjustment of this filter is somewhat complicated. However, once adjusted, it needs no further handling or dial twisting.

The parts necessary for this wave-filter are as follows:

- 1 .001-mf. variable condenser, low-loss type,
- 1 .0005-mf. variable condenser, low-loss type,
- 1 Variable resistance, 0-25,000 ohms,
- 2 Bakelite tubes, 3-inch diameter, 4 1/2 inches long,

1/2 Pound No. 22 D.S.C. wire.

L<sub>1</sub> consists of 55 turns wound on one of the tubes. L<sub>2</sub> is 45 turns wound on the remaining tube. L<sub>3</sub> is wound on top of L<sub>2</sub>, but is separated by a sheet of empire cloth, or waxed paper, and has ten turns. C<sub>1</sub> is the .001mf. variable condenser and C<sub>2</sub> is the .0005mf. variable condenser. The theory of this wave-trap is as follows:

The incoming signal flows through cells L<sub>1</sub> and L<sub>2</sub>. The circuit comprising L<sub>1</sub> and C<sub>1</sub> is tuned to the frequency of the interfering station, and the condenser is then set at that position. The circuit enclosing C<sub>2</sub> and L<sub>3</sub> is commonly termed an absorption circuit. The condenser of this circuit is rotated until the signal of the interfering station is heard at a minimum strength. The circuit, when in resonance with the interfering station, will absorb almost all of the energy received from that station. The energy is received from coil L<sub>2</sub>, which is closely coupled to L<sub>3</sub>, which is closely coupled to L<sub>1</sub>. In this way, signals of other stations will be allowed to pass through, but that of the interfering station is dissipated in the absorption circuit. The resistance across L<sub>1</sub> and C<sub>1</sub>, serves as a static-leak, the resistance being variable to obtain the best adjustment possible.

(394) WHAT FARADS AND HENRYS ARE

Q. 1. Among the various and numerous technical terms used in radio are the expressions microfarad and microhenry. I have referred to numerous books on these two terms and cannot seem to get a clear definition or conception of these two terms. I would be very grateful if you could explain them, possibly illustrate in some way, so that these two terms may become clear to me.

A. 1. Just as the gallon, pint, or gill is a unit of measurement to compare or measure liquids, and the inch, foot or yard a unit of measurement to compare or measure size or length, so the henry and farad are the units of measurement to compare various sizes of coils and condensers, respectively.

The unit of capacity is the farad. How large this unit is may be somewhat vaguely suggested to our imagination by the fact that if everybody in the United States had 18 each of the so-called .0005-mfd. condensers (usually equal to 18 plates), the total capacity of the whole lot, connected in parallel, would be one farad. The question naturally arises in everybody's mind, why such a huge unit was ever chosen to begin with. A volt, the unit of potential, is a convenient size. An ampere, the unit of current, is convenient. An ohm is an easily-obtained quantity of resistance. These three are the basic units. Starting with these three, such a unit as a farad is a derived unit; that is, it follows as a matter of definition.

A condenser is fundamentally a dielectric with a conductive plate on each side of it. Connected to an electric source, the condenser

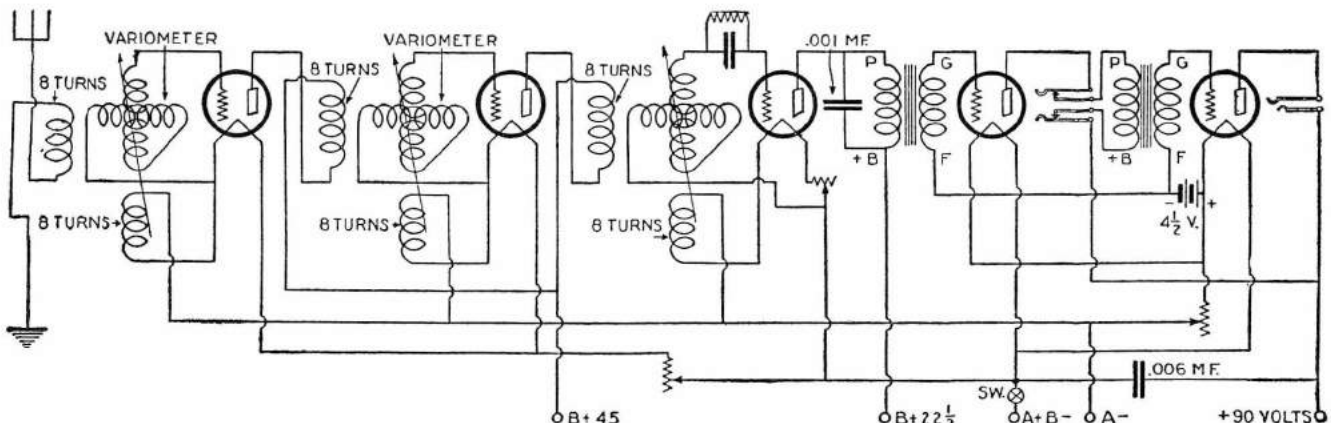

(390-A) Variometers "in fashion" again. The Monophase Circuit, recently published in RADIO NEWS, modified so that these instruments may be used efficiently. The method of mounting the coils necessary to the variometer is shown in another illustration, 390.



is charged. The larger the charge, the greater the difference of potential between the two conductive plates; and the equation is that  $Q$  equals  $E$  times  $C$ , when  $Q$  is the charge,  $E$  is the potential, and  $C$  is a constant for any particular dielectric and arrangement of parts.  $C$  is a ratio of  $Q$  to  $E$ , and we call it the capacity.

The unit of capacity is the capacity of a condenser charged to a potential of one volt by a unit quantity of electricity. The name of a unit quantity of electricity is a coulomb, which is the charge transmitted in one second by a current of one ampere. Really, therefore, the farad is the ratio of the unit of charge to the unit of potential.

Like the unit of capacity, the unit of inductance is a tremendous unit. It is the henry. While in capacity we usually deal with the millionth part of a farad, in inductance we usually deal with the thousandth part of a henry, the millihenry; although in radio work the microhenry is not uncommon, because air-cored coils are much used.

The henry is also a derived unit and its size is due, not to design, but to force of circumstances. It is the inductance in a circuit when the electro-motive force induced in the circuit is one volt, and the inducing current varies at the rate of one ampere per second. It, therefore, is derived from the unit of voltage and the unit of current.

Unfortunately, the formulas for inductances are subject to many correction factors, and are very elaborate. It is almost impossible to figure accurately the inductance of a coil without consideration of a multitude of factors, some of which cannot be known with accuracy. In general, the inductance is directly proportional to the length of the coil, the square of the mean diameter, and the square of the number of turns per unit of length; and in each case the inductance depends on the material of the core.

A core of iron gives much greater inductance than one of any other substance. Air and non-magnetic materials give minimum inductance.

Put simply, the larger the diameter the greater the inductance, and the gain is more rapid than simple proportion. A 4-inch coil diameter gives 16 times the inductance of a 1-inch coil. The number of turns per inch of length determines the inductance largely. Double the number of turns per inch, as by using finer wire, and you will get four times the inductance. The longer the coil the greater the inductance.

Various interesting and technical data and explanations may be obtained from the book Morecroft's "Principles of Radio"; and from the data sheets published in the various radio departments of the *Experimenter*, *Science and Invention*, *Radio Listeners' Guide and Call Book*, and *Radio Review*.

**(395) REMEDIES FOR INTERFERENCE**

Q. 1. In my immediate vicinity there is a constant electrical disturbance of some sort which bothers radio receiving sets in this location. Perhaps you can mention the various causes of such disturbances, and remedies, so that I may in some way familiar-

ize myself concerning same and perhaps eliminate?

A. 1. An original review of causes and remedies would be somewhat too lengthy for this department, but some helpful suggestions may be found in the article on page 1286 of the March, 1926 issue of *Radio News*, entitled "Tracing Interference to Its Lair," which tells of the methods employed by the U. S. Bureau of Standards in detecting and combating interference.

**(396) WHY "A" AND "B" BATTERIES?**

Q. 1. In connecting up radio receivers, I have often heard the expressions "A" and "B" batteries, as applied to the various batteries that are connected to the receiving set; and have often wondered why there are two batteries necessary. Why the different expressions "A" and "B" are used. What the functions of each are. Why one has only 6 volts, whereas the other has at least 90. Perhaps you can clear up some of these difficulties?

A. 1. To explain why we have "A" and "B" batteries in a receiving set, the functions of each, and why one high-voltage and one low-voltage battery is used, it is necessary to go into an explanation of the principle of the vacuum tube as used for radio purposes. We will attempt to make this explanation as clear and non-technical as possible. For a technical and lengthy explanation of the evolution

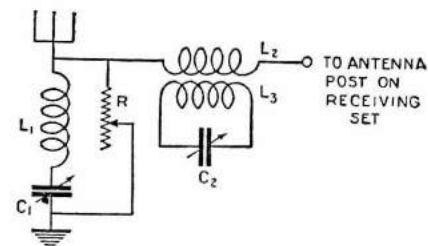

(393). An exceedingly efficient wave-trap to eliminate that "local station" interference. The circuit is similar to that employed by broadcast stations to "eliminate their own" interference, thus enabling them to listen to other stations.

and functions of a vacuum tube, the reader is referred to the December, 1925, January and February, 1926, issues of *The Experimenter* or to Morecroft's "Principles of Radio," or Van Der Bijl's "Thermionic Tubes."

Through the researches of scientists, such as Thomson, Richardson and Millikan, we know now that when certain metals are heated to incandescence, particles of matter are thrown off. These particles are called electrons and the theory explaining this phenomenon is called the "Electron Theory." Incidentally, these electrons are negative particles, and at present the smallest particles of matter known.

In 1904 Fleming (another scientist) was granted a patent on the device called a "Fleming valve," which consists of a filament-and-plate element enclosed in an evacu-

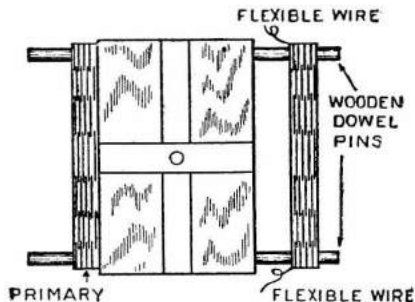

(390). The method used for mounting the coils to the variometer for the modified Monophase circuit shown on previous page.

ated glass vessel. In school, in the physics or science class, we learned that positive attracts negative, or vice versa, depending upon which has greater strength. Fleming inserted in his device a battery of high potential. The positive side of this battery was connected to the plate within the vessel, thus making the plate highly positive, thereby enabling it to attract the electrons which were thrown off by the heated filament. This device was of little practical use as far as radio (in those days called "wireless") was concerned, until 1906 when DeForest inserted the third element called the "grid," thereby making the most sensitive detector known.

Now to show how "A" and "B" batteries are concerned. The battery required to heat the filament to incandescence is called the "A" battery (probably because it is the first battery to be taken into consideration, or primary battery). The battery required to give the plate its positive potential is called the "B" battery. However, since the filament consumes an enormous amount of current compared to that used by the plate element of the tube, the battery necessary to heat the filament must have a high amperage capacity, ranging from 120 ampere-hours up, depending upon the number of tubes used in the receiving set, and the type of tubes. In the early days tubes were manufactured with filaments which required six volts and consumed about an ampere. At present, due to research and developments made by the General Electric engineers, we have radio tubes which operate from a dry cell or two, and consume only from .06 to .25 of an ampere.

The "plate" of the tube consumes very little current, as aforementioned but requires an extremely high potential, varying from 22½ volts for a "soft" or detector tube, to 90 volts for the ordinary amplifier tube, and about 135 volts for a power-amplifier. Ordinary "B" batteries are constructed (consisting of a number of very small cells) so that, although their amperage capacity is very low, ranging from 2 to 7 ampere-hours (of total output) the voltage delivered is high because of the small cells, each delivering 1½ volts, being connected in series.

**(397) OPERADIO PORTABLE RECEIVER**

Q. 1. I have an Operadio portable receiver which I carry around with me in my visits to several of the big cities throughout the country, my position being that of a traveling salesman. Some time back, however, an accident happened to the set, which necessitates complete rewiring. I wonder if you could furnish me with the diagram of this receiver. The receiver is the one which includes all batteries, and loud speaker within a folding case, the loop being of the folding type also, and also comprising the top cover of the case.

A. 1. The diagram you desire is shown in these columns, 397. The model shown is the "1925 Operadio," which we believe is the model you describe. More complete information and data concerning this receiver may be obtained from the Operadio Corporation, 8 S. Dearborn St., Chicago, Ill.

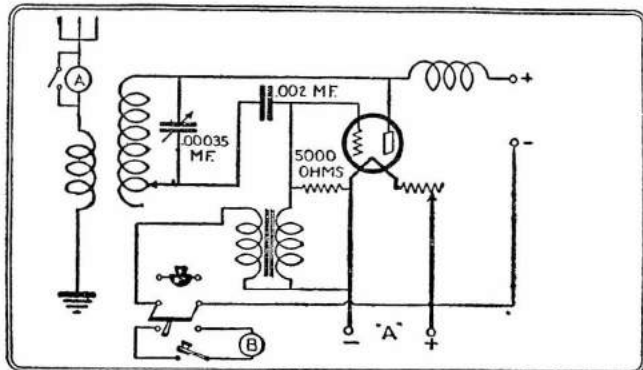

(392). A five-watt phone and I.C.W. transmitter, which may be constructed by the average experimenter. It has a consistent radiophone range of about 20 miles. I.C.W. range of about 500 miles. "B" is a high-pitched buzzer, and the transformer shown is a modulation transformer, which may be a Ford spark coil whose vibrator has been "screwed down tight."

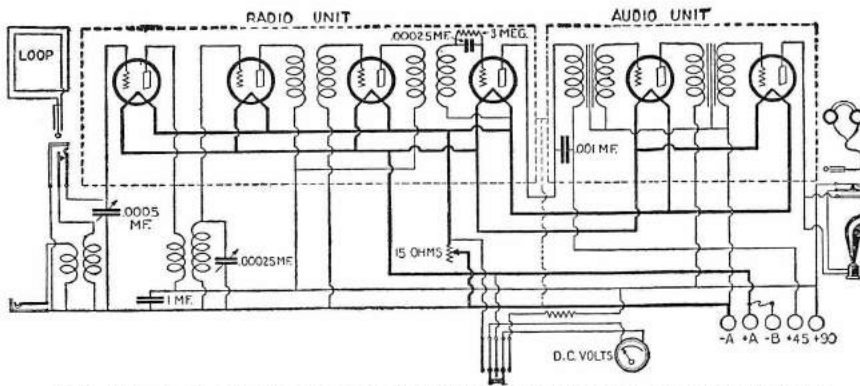

(397). The circuit of the Operadio portable receiving set, with the exact connections used in the manufactured receiver. This receiver employs three stages of radio frequency amplification, tube detector, and two stages of audio frequency amplification, using the 199 type tubes throughout.

### 25-B Amplifier Unit

Q. 2. Recently I had the pleasure of listening to a 25-B amplifier unit, constructed by the Western Electric Co., which was attached to an ordinary one-tube receiving set and operated from an alternating current lighting source. The volume and quality produced was perfect, in fact so much so that it has aroused a desire on my part to construct this unit. Any constructional data and diagram you can furnish me that will enable me to build this unit, will be sincerely appreciated.

A. 2. The following is all the data we could secure (and which we think will be necessary to build this unit) and which was obtained from a booklet which includes all the information for the care and operation of the 25-B amplifier, as published by the Western Electric Co.:

"A good loud speaking telephone requires more electrical energy for its proper functioning than most audio frequency amplifiers in common use are able to deliver without overloading the vacuum tube in the last stage. It is generally possible to secure ample volume with these amplifiers, but at the expense of the quality of reproduction, due to the distortion which results from this overloading. The No. 25-B amplifier is intended for use as an adjunct to a loud-speaking energy at audio frequencies, so that the loud-speaking telephone may function at maximum capability.

"It consists essentially of a single stage amplifier with a self-contained current supply set for both the vacuum tubes used in it. It employs two Western Electric No. 205-D vacuum tubes, one as an amplifier and the other as a rectifier.

"No batteries are required for the operation of this amplifier. The only current supply necessary is the ordinary 110-volt 60-cycle A.C. house lighting current. No other form of house lighting supply can be used with this apparatus. The house lighting supply is transformed, rectified and filtered by the self-contained current supply set so as to properly energize the amplifier without the use of batteries. The amplifier consumes about 40 watts; that is it takes about the same power as a medium sized incandescent bulb.

"When used in conjunction with a radio receiving set, this amplifier is not intended to provide all the audio frequency amplification necessary for proper loud-speaking telephone operation; but only that portion of the amplification where there is most likely to be overloading, that is, the last stage. Thus, if satisfactory volume is obtained in a headset from the detector tube of a radio receiving set, one stage of ordinary audio frequency amplification plus the No. 25-B amplifier will provide sufficient energy to operate a loud-speaking telephone so as to be audible throughout a good sized room.

"The amplifier is equipped with a cord to connect it to a radio receiving set and also has a cord with a plug to connect it to the lighting circuit. A switch in the latter cord is furnished, to turn the power on or off, and

is the only control on the amplifier. The apparatus is contained in a metal cabinet.

### Operation

"The cord attached to the terminals marked "IN" should be connected to the radio receiving set. It is immaterial to which of the terminals the conductors are connected. For the best results, the amplifier should have one stage of ordinary audio frequency amplification between it and the detector tube of the radio receiving set.

If the radio receiving set contains no audio frequency amplification, one stage should be introduced between the radio receiving set and the amplifier. If the radio receiving set contains one stage of audio frequency amplification, the amplifier should be connected directly to its output.

"If the radio receiving set contains two or more stages of audio frequency amplification, the amplifier, for ordinary reception, should be connected to the output of the first audio frequency stage. On very weak signals, more volume may be obtained by using both audio frequency stages in the radio receiver, connecting the amplifier to the output of the second audio frequency stage. The quality of reception, however, is very likely to be impaired by the introduction of this additional audio frequency stage. This is not the best method of obtaining more volume on weak signals. The fact that two audio frequency stages are needed to give sufficient volume, indicates that the energy input from the detector tube of the radio receiving set is too small. The better remedy for this condition would be to increase the energy input to the detector tube by additional amplification ahead of the detector tube; increasing the coupling or whatever means the radio receiving set affords.

"Conversely, if too much volume is ob-

tained with only one stage of audio frequency amplification between the detector tube and the amplifier, it indicates that the energy input to the detector tube is too large, and consequently the detector tube is probably overloaded and introducing distortion. The best remedy for this is to reduce the amplification ahead of the detector tube, decreasing the coupling, or whatever means the radio receiving set affords. Do not eliminate the audio frequency stage of amplification between the detector tube and the amplifier. While this will reduce the volume, the detector tube will be overloaded and consequently the quality of reproduction will be impaired.

### Other Connections

"Connect the cord of the loud-speaking telephone to the terminals marked "OUT." It is immaterial to which of the terminals the conductors are connected. Connect the terminals marked "G" to a water pipe, radiator or other effective ground.

"Connect the cord with the plug to a 110-volt 60-cycle A.C. lighting circuit. To put the amplifier in operation, press the light colored button of the cord switch. To turn the amplifier off, press the black button of the cord switch.

"This apparatus will amplify without distortion the output of the radio receiving set to which it is connected. For this reason, if the output of the radio receiver is unsatisfactory in any way (that is, if there is 'howling,' interference, etc.), the amplifier will not correct matters; on the contrary it makes such interference or other disturbances more noticeable because of the amplification it effects.

"When the amplifier is not in use turn off the cord switch. This is important as it conserves the life of the vacuum tubes."

Values of the parts to be used in the construction of this unit are indicated on the diagram.

### (398) STUDIO-TYPE SUPER-HETERODYNE

Q. 1. I am particularly interested in the Western Electric Super-Heterodyne receivers used so extensively in broadcast studios. The particular model I refer to is called Type 6004-C Radio Receiving Outfit. Any information concerning the construction of the parts, etc., circuit diagram, and any other data that will materially aid me in the construction of this receiver would be greatly appreciated. I intend building a receiver for my own private use and trust that there are no objections in furnishing this information for this purpose.

A. 1. The information you desire was obtained after a great deal of difficulty, and we are publishing as much data as is available. However, we would like to impress you with

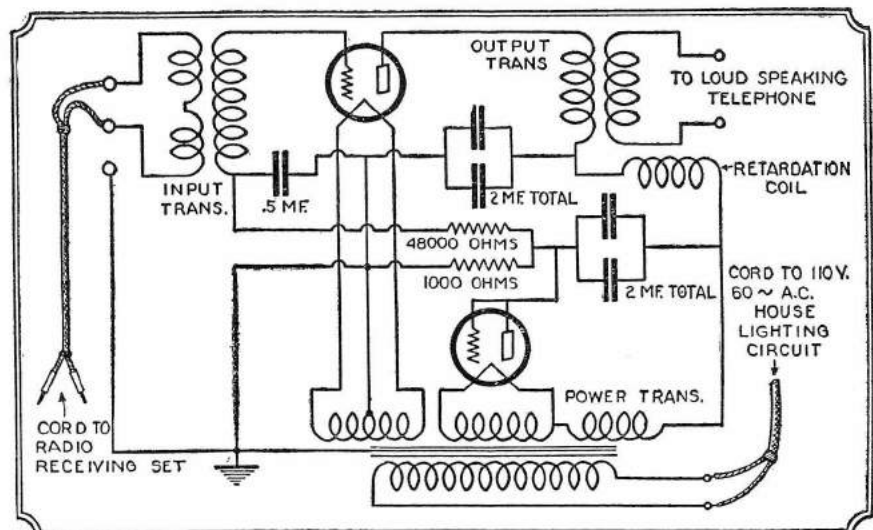

(397-A). The Western Electric Type 25B power amplifier unit which operates directly from an alternating current source, without any batteries required. The unit is very efficient.

the fact that the Western Electric Co. does not offer this receiver for sale to any person that desires one, the set being only sold to broadcasting stations. Neither can you obtain parts of this set from the Western Electric Co.; although it may be possible to substitute parts of similar value. To aid you in the construction of this receiver, we are furnishing the characteristic data of each part.

The number 6004-C Super-Heterodyne receiver, as designed by the Western Electric Co., operates over a frequency range of from 1,360 to 460 kilo-cycles, corresponding to a wave-length range of from 220 to 650 meters. The receiver uses the small peanut type "N" tube, although the 199 type may be substituted in its place.

The oscillator coil is of special design; consisting of three windings, two of which are wound on a 2-inch bakelite tube with 48 turns of No. 28 D.C.C. wire; the third is wound on a 1-inch tube with 40 turns of No. 28 D.C.C. wire.

The intermediate transformer may be of either the 50- or 60-kc. type, which use an iron core to broaden the peak of amplification of the transformer. The filter transformer is

characteristics are somewhat similar to those of the intermediate transformer, with the exception that no iron core is used.

**Construction of the Receiver**

Please note that the diagrams accompanying the answer to your question are two; Fig. 398-A being the original as used in the Western Electric Super, and Fig. 398-B, a modification to simplify wiring and eliminate some testing jacks incorporated in the original receiver to facilitate testing and repairing of the set by the maker. These we think to be unnecessary in an ordinary amateur constructed receiver, although you may use them should you so desire. Also, the original receiver uses only one stage of audio frequency amplification, as it is intended to be used in conjunction with a power amplifier. In our modification of the circuit, we show two stages of audio frequency amplification, so that loud speaker volume may be obtained without the addition of any other amplifiers.

The parts necessary are as follows:

- 1 oscillator coil, as per specifications,
- 2 50- or 60-K.C. iron core intermediate frequency transformers,

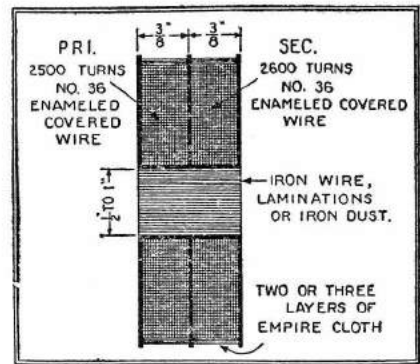

(398). Design of an intermediate transformer which operates with maximum efficiency at 50 to 60 kilocycles. The correct amount of iron core must be determined experimentally.

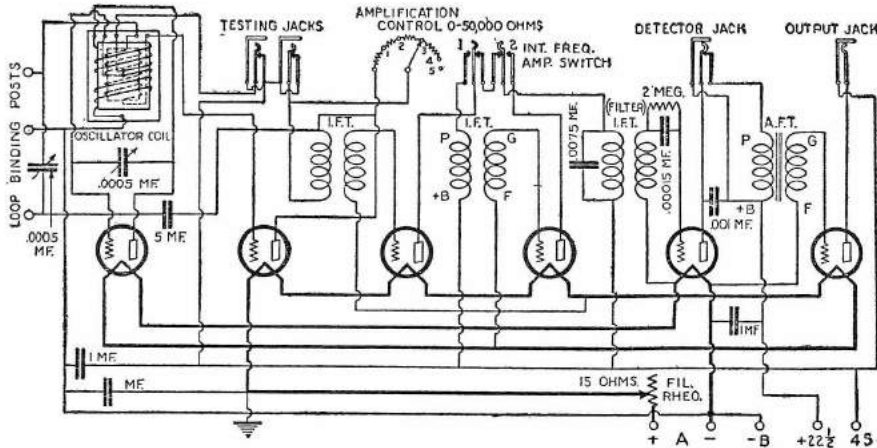

(398-A). The original circuit used by the Western Electric Company in their type 6004-C radio receiving outfit. The oscillator coil design and connections are included in the diagram; the two 48-turn windings being placed on a 2-inch tube; the 40-turn winding on a 1-inch tube mounted within the 2-inch tube coil.

used in the output stage or last radio frequency stage, connecting to the detector tube and to give the set the necessary selectivity. It would be advisable, when obtaining the intermediate R.F. transformers, to obtain the filter transformer that is designed to be used with that particular type.

Details for the construction of an intermediate transformer that has the necessary characteristics to enable it to be used in conjunction with the "N" tubes are also shown in Fig. 398. The filter transformer charac-

- 2 .0005 mf. variable condensers, preferably of the straight-line-frequency type.
- 1 filter transformer,
- 1 midget variable condenser, range from 2 to 30 mmf.
- 2 double-circuit jacks,
- 1 single-circuit jack,
- 1 filament switch,
- 1 15-ohm rheostat,
- 1 0- to 50,000-ohm variable resistance,
- 1 7 x 21 bakelite panel,
- Shielding screws, bolts, etc., including

**Filament Control**

To put the radio receiver in operation, open the panel (by pressing the buttons on the sides of the cabinet near the top) sufficiently to view the vacuum tubes and turn the filament rheostat knob from the "OFF" position in the direction indicated to increase the current. The rheostat should be turned only far enough so that the filaments of the tubes light to a yellowish red. Close the panel and proceed with the tuning.

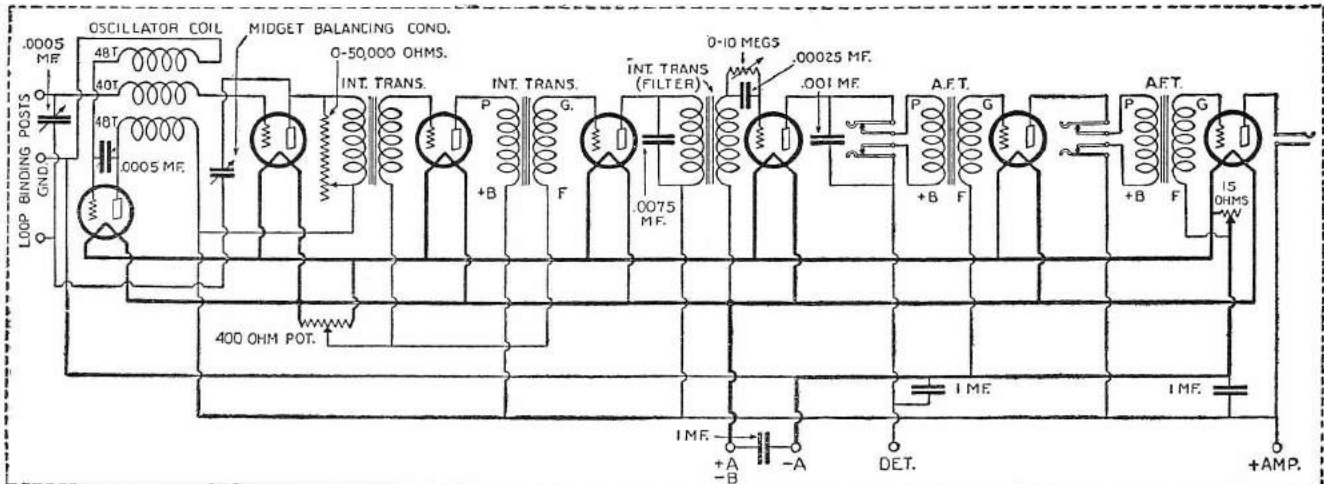

(398-B). A modification of the original circuit of Fig. 398-A, in which the potentiometer method of controlling the grid bias on the intermediate radio frequency stages is used. Two stages of audio amplification are used instead of one, as in the original. The 0 to 50,000-ohm variable resistance, which is used as a volume control, may be eliminated.

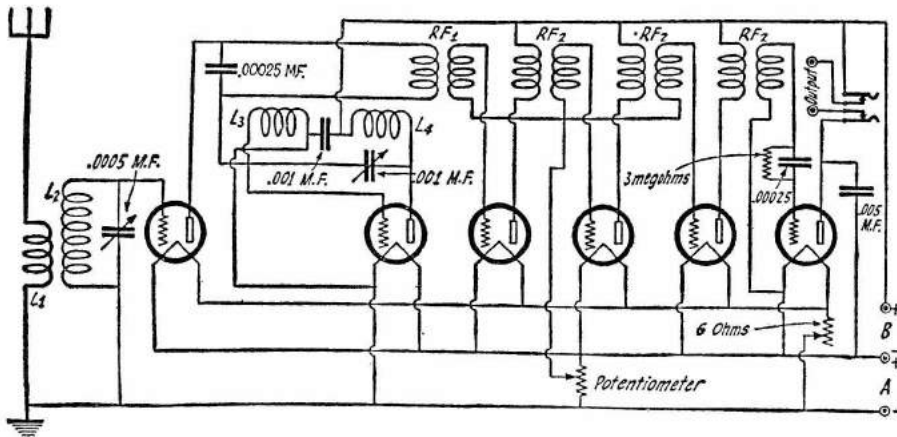

(399). This is the complete circuit diagram of the Ultradyne L-1 receiver, which incorporates the "modulation system." As explained in the text, one or two stages of audio frequency amplification should be added so that loud speaker results can be obtained on distant stations.

After the radio receiver is in operation and the reception is satisfactory, the filament rheostat should be turned counter-clockwise as far as possible without causing a material decrease in the volume of sound received; that is, it is preferable to operate the filaments at a dull red rather than a yellowish red, if sufficient volume is obtained. The vacuum tubes should never be allowed to become more brilliant than a yellowish red, or reception will not be improved and the life of the vacuum tubes will be considerably reduced.

When the outfit is not in use, turn the filament rheostat knob to the "OFF" position in order to conserve the life of the batteries and vacuum tubes.

**Tuning**

To tune the radio receiver to a particular station, set the "Intermediate Frequency Amplifier Switch" at "2" and the "Amplification Control" at "5" (see Fig. 398-A.) Turn the two-point switch on the tuning unit to the contact marked "A" for the antenna unit. This makes the primary circuit aperiodic. Then set the coupling knob at maximum and turn the tuning and oscillator condensers of the receiver slowly. The tuning condenser should be turned so that the pointer advances only a few graduations at a time. For every setting of the tuning condenser, the oscillator condenser should be turned so that the pointer passes over a considerable number of graduations, in order to find both settings of the oscillator condenser. After the signal has been obtained, turn the switch on the tuning unit to the contact marked "T," and turn the primary tuning knob on the unit until maximum signal intensity is obtained. Now reduce the coupling, as this improves the selectivity and the tuning may be refined by readjusting all three condensers. This is important if good quality is desired. Do not attempt to reduce the volume by manipulation of the condensers. This will throw the receiver out of tune and impair the quality of the reception. The radio receiver should always be tuned as accurately as possible, and the volume controlled as explained below.

The operator is advised to keep a record of the various stations received, together with the various dial settings, in order to facilitate returning to these stations.

**Volume Control**

The volume may be controlled by varying the intermediate frequency amplification, or by cutting in or out the stage of audio frequency amplification.

One or two stages of intermediate frequency amplification may be employed as desired by setting the "Intermediate Frequency Amplifier Switch" at "1" or "2" (see Fig. 398-A.) With the switch set at "2", the volume will be considerably greater than with the switch set at "1," but the quality of reception may not be as good on

strong signals. A finer regulation of volume can be obtained by adjustment of the "Amplification Control." This finer regulation operates when employing either one or two stages of intermediate frequency amplification.

The headset is provided with a cord and a plug which may be inserted either in the detector jack or the output jack. If the plug is inserted in the former, the stage of audio frequency amplification is cut out and the volume of sound will be considerably less than if the plug is inserted in the output jack.

When a loud-speaking telephone outfit is used in conjunction with the radio receiver, two general means of controlling the volume will be available; i. e., those provided in the radio receiver and those in the loud-speaking telephone outfit. To obtain a given volume of reception with this combination it will generally be preferable to utilize all of the amplification available from the loud-speaking telephone outfit and only a portion of that available from the radio receiver, rather than utilize only a portion of the amplification available in the loud-speaking telephone outfit and all the amplification available in the radio receiver. This method of operation improves the quality of reception, as it prevents needless "over-loading" of the detector and places the heavy load on that portion of the combination designed to carry it.

**Maintenance**

A gradual decrease in the volume of reception indicates that the filament "A" or plate "B" batteries are becoming exhausted. Examine the vacuum tubes. If the filaments of the vacuum tubes cannot be made to glow

at a yellowish-red color by adjustment of the rheostat, the decreased volume is caused by an exhausted filament battery, and this battery should be recharged. If the filaments can be made to glow at the above brilliancy and the volume of reception is still unsatisfactory, the "B" batteries are probably exhausted and should be replaced.

A sudden cessation of reception probably indicates that a vacuum tube has been burned out. Examine them. The filaments of the tubes are connected in series and if one is burned out all the tubes will fail to light. To determine which tube is burned out, test each in succession by replacing it with a new one and noting whether all the tubes then light.

If difficulties other than those mentioned above are experienced, examine the receiver cord, the wiring to the batteries, and the connections between the radio receiver, the tuning unit and the filter for loose or broken connections.

**(399) The ULTRADYNE L1 RECEIVER**

Q. 1. I am unable to procure blueprints or the original issue (February, 1924, issue of "Radio News") in which the Ultradyne circuit is described. Your circulation department informed me that no additional copies are available. I, and several of my friends, would like to build this receiver, as we have heard much of its efficiency; in fact, have heard several receivers that incorporate this principle, and I am now determined to build one just like them. Can you please supply me with the necessary data? Undoubtedly you have some copy from which you could obtain the original information. Also, where can I purchase the parts which are most essential?

A. 1. In view of the fact that we have received innumerable requests for Ultradyne data, due to the shortage of back copies in which this information was published, we are herewith reprinting the Ultradyne article. All data are included, for both oscillator and antenna coils and the intermediate transformers; as these parts can no longer be purchased, due to present Super-Heterodyne litigation.

*The Ultradyne Receiver, by R. E. Lacault*  
(Reprinted from the February, 1924, issue of "Radio News")

The super-heterodyne receiver is coming more into use among the amateurs and broadcast listeners, on account of its numerous advantages; and it is our intention to describe in this article the construction of a super-heterodyne functioning under a new principle. This improved receiver, which has proved superior to the usual type, is the result of a long series of experiments carried out by the author. The principle of operation of this receiving system has already been explained

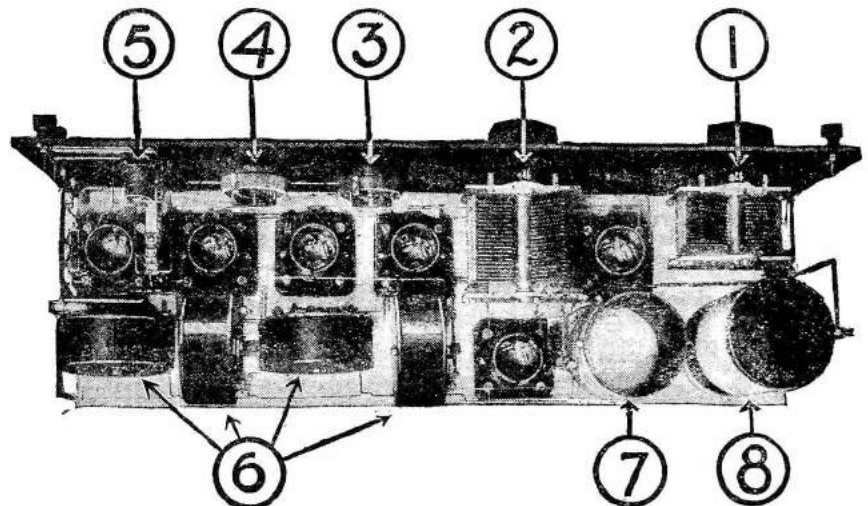

(399-A). Illustration of the Ultradyne L-1 receiver showing panel and parts layout. Note that the intermediate frequency transformers are mounted at right angles at each other to prevent interstage coupling. A slightly larger panel is required, if audio frequency amplification is to be added to the receiver.

in many text books and radio magazines; but we shall describe it again in a few words for the benefit of those who do not have such references at hand.

Everyone who has operated an ordinary regenerative receiver has noticed that, when a broadcast station is being received, a whistle is heard in the telephones when regeneration is increased beyond a certain limit. This is caused by the receiver itself, which oscillates and produces, by interference with the carrier-wave of the transmitting station, a beat note of an audible frequency. A beat note has a frequency equal to the difference between the two frequencies which produce it. For instance, if a carrier wave of 1,000 kilocycles is received, a beat note of 1,000 cycles will be heard in the receivers if an alternating current of 999 kilocycles, or 1,001 kilocycles, is made to interfere with the carrier wave.

In the super-heterodyne receiver, this principle is employed; but instead of producing beat notes at an audible frequency, beats of a super-audible frequency, such as 50 or 100 kilocycles are used. By means of a variable condenser the oscillator circuit may be tuned so that such a beat note is produced for any incoming signal. Therefore, no matter what the incoming signal frequency is, the signal which is amplified and detected is always of the same frequency. This is a great advantage, because it is easier to design a radio frequency amplifier to function on one frequency only, than one which amplifies in the same proportion a broad band of frequencies.

In most short-wave radio-frequency amplifiers using untuned transformers, the amplification varies for each frequency. It is generally found that greater amplification is obtained at two points; while comparatively smaller amplification is had over the remainder of the frequency range covered by the transformer. If tuned radio-frequency transformers are employed, the tuning becomes very complicated, owing to the numerous controls; and it is difficult to tune in a station unless the entire amplifier is calibrated. The radio-frequency amplifier is used in the super-heterodyne receiver is designed to amplify at maximum intensity at one frequency only; thus increasing the selectivity, since only signal frequencies which are interfered with by means of the oscillator can pass through the amplifier.

**The Modulation System**

In the ordinary type of super-heterodyne, the first tube employed as a frequency changer is connected as a detector with a grid-condenser and grid-leak. This detector rectifies the incoming signal after it has been heterodyned, and the variation caused in the plate circuit is amplified through a long-wave radio-frequency amplifier. In the system to be described a new principle is made use of. This, which has been called the modulation system, causes the incoming signal to modulate the oscillations produced locally, in the same way that the speech modulates the output of the oscillator tubes in a radio-telephone transmitter. This system, which is a departure from the conventional detector arrangement is not only more simple, but produces a greater signal strength, which is more noticeable on weak signals.

399C shows the principle of operation of the circuit. The first tube, which is called the modulator, is connected across the oscillating circuit of the oscillator; the plate-filament space acting as a resistance, the value of which is varied by the incoming signals impressed upon the grid. In this arrangement no "B" battery is necessary, for the plate of the modulator tube is supplied by high-frequency current from the oscillating circuit. To receive continuous waves, this arrangement is very efficient, and it has been applied very successfully to the super-heterodyne receiver described in the article.

To give an idea of the sensitiveness of this receiving arrangement we mention the results obtained with it in New York City, the set being installed on the fourth floor of an apartment house situated in a good location.

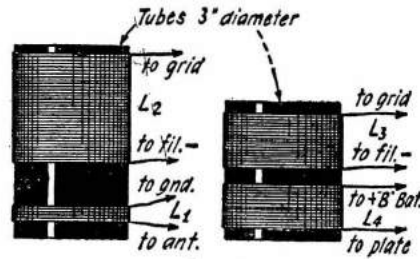

Fig. 6

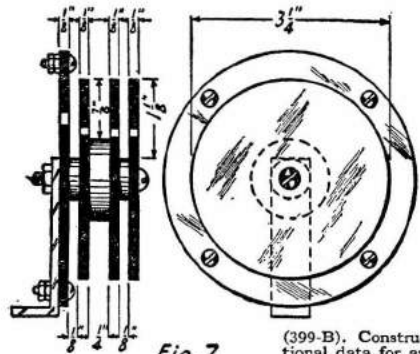

Fig. 7

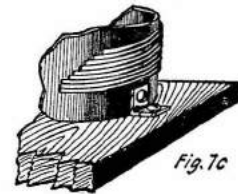

Fig. 7c

(399-B). Constructional data for antenna and oscillator coils and intermediate frequency transformers. Refer to text for numbers of turns, etc.

Using only the secondary coil, composed of 72 turns of wire wound on a tube 3 inches in diameter, stations in Cincinnati, Detroit, Atlanta, Chicago and other cities are heard practically every night and with good audibility. No audio-frequency amplification is used, and no loop, aerial or ground is connected to the receiver. With one or two stages of audio frequency the loud speaker may be operated and, of course, the music and speech are audible throughout the apartment.

**Hook-up and Parts**

Fig. 399 is a complete diagram of connections of the receiver. The entire outfit may be mounted in a cabinet 7x24 inches, and is composed of the following parts:

- 1 Panel 7x24 inches,
- 1 Cabinet 7x24x7 inches.
- 1 Variable Condenser, .001-mf., with vernier,
- 1 Variable Condenser, .0005-mf., with or without vernier,
- 1 Potentiometer,

- 1 Rheostat, 6-ohm,
- 1 Double-Circuit Jack,
- 1 Battery Switch,
- 7 Binding Posts,
- 6 Sockets,
- 4 Radio-Frequency transformers,
- 1 Grid Condenser, .00025-mf.,
- 1 Fixed Condenser, .001-mf.,
- 1 Grid-Leak with mountings,
- 1 Fixed Condenser, .00025-mf.,
- 1 Fixed Condenser, .005-mf.,
- 1 Tube of bakelite, hard rubber or formica, 3 inches in diameter and 6 inches long,
- 1 Tube of the same material, same diameter, 3 3/4 inches long,
- Bus-bar for connections, screws, baseboard, 7x23 inches, wire, etc.

The constructional details of the tuning inductance and of the oscillator coil are given in Fig. 6. L1, which is the untuned primary, consists of eight turns of No. 20 D.C.C. wire, wound half an inch from the end of the tubing. L2 which constitutes the secondary, is wound with 72 turns of the same wire, and 1 1/2 inches away from the primary on the same tubing. The oscillator coil is composed of two sections wound in the same direction, as shown in Fig. 6. The first section L3, connected between the grid and the filament of the oscillator tube, is composed of 24 turns of No. 20 D.C.C. wire; while the second section, L4, connected between the plate and "B" battery, is wound with 32 turns of the same wire. These coils should be carefully wound and given a light coat of special varnish, which may be obtained from firms manufacturing insulating materials. If no such varnish is obtainable, a light coat of varnish made of acetone, in which celluloid is dissolved, will do very nicely. No shellac should be used on the coils.

It is advisable to fasten the ends of the wire, in each coil, to small screws with nuts fixed on the tubing, as this permits a good connection to be made between the connecting wires and the inductance. The coils may be fastened to the baseboard supporting them by means of small brackets made of brass strips bent at right-angles as shown in Fig. 7C. The ends of the wire in each coil should be soldered to the screws fastened to the tubing, in order to insure perfect contact. Once the set is wired, a drop of solder should also be applied to the joint of the bus-bar wire and the screw.

**R. F. Transformers**

The radio-frequency transformers may be of any suitable type designed for long wave reception. Those used in the receiver illustrated are of a special design; and may be easily constructed of hard wood or insulating material, such as hard rubber or bakelite. Fig. 7 shows how these transformers are constructed. They may be turned out of a solid piece, or made up of discs of the proper thickness and diameter. The end disk, which is of greater diameter than the others, sup-

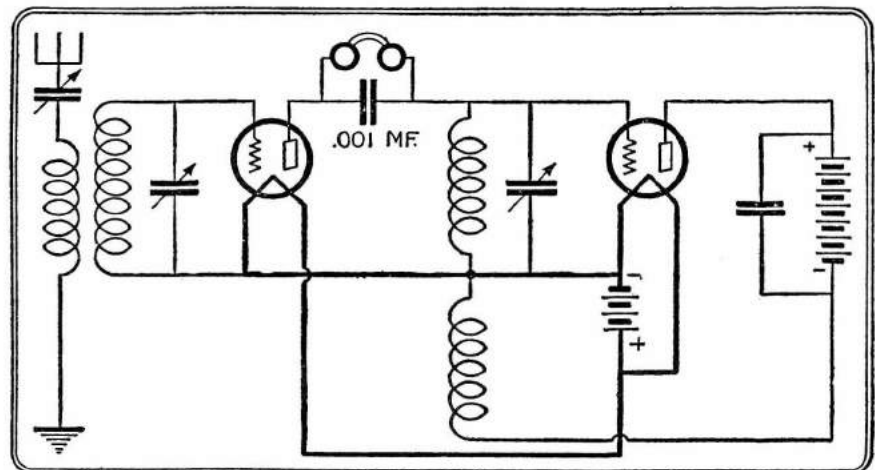

(399-C). The fundamental principle of the Ultradyne receiver, showing the first detector and oscillator circuit employing the efficient modulation system. This method is a radical departure from the conventional, and results in a receiver of remarkable efficiency.

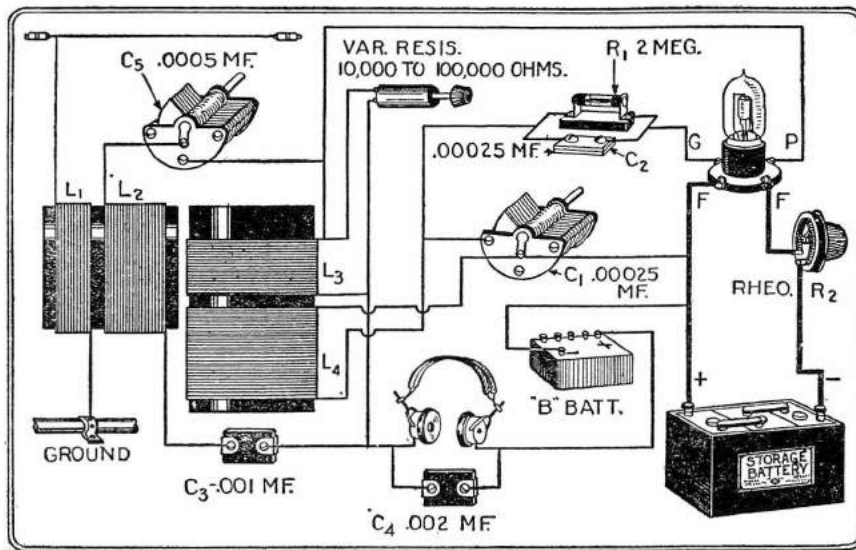

(400) The Journal One-Knob Filter Tuner, is an efficient one-tube receiver which is very popular with New York fans. A consistent DX-getter, and yet easily operated. Either the dry-cell or storage-battery type tube may be employed, with practically equal efficiency.

ports four screws or binding posts, to which are fastened the ends of the primary and secondary windings; and a bracket, made of a strip of brass fastened under the screw holding the unit, permits its mounting on the base board. The primary should be wound first and should consist of 500 turns of No. 28 double silk covered wire in the center slot, which is  $\frac{1}{4}$ -inch wide. The secondary is wound in two sections with No. 30 double silk covered wire: 550 turns should be wound in each slot on each side of the primary. The two sections may be wound without breaking the wire by passing it over the primary from one section to the other. To maintain the ends of the wires in place, a drop of sealing wax may be applied on the last turn of both windings. Once the transformers are wound, the screws used as binding posts are fixed on the large disc and the ends of the wire are soldered to them.

The beginning of the primary and secondary windings should go to the positive pole of the "B" battery and center arm of the potentiometer, respectively; while the outside ends of the windings are connected to the plates and grids of the amplifying tubes. In order to reduce the action of one transformer upon the other, they should be mounted so that their axes are at right-angles to each other. It should be noted that the primary of the first transformer is wound with only 300 turns, so that its natural frequency is brought up to that of the other transformers when the .00025uf. by-pass condenser is connected across it.

The illustration shows the arrangements of parts on the baseboard supporting the outfit. In order to simplify the wiring of the receiver, it would be advisable to proceed as follows: after the various pieces of apparatus mounted on the panel are fixed, all the wires which are against the panel may be placed and soldered. The sockets, inductances, and transformers are then wired separately and the panel fixed to the base. The only connections which remain to be made are those joining the condensers, rheostat, potentiometer and binding posts.

Before mounting the various parts on the panel and baseboard, it is a good precaution to screw tightly all the screws and bolts of the sockets, rheostats and other apparatus, which are very difficult to reach with tools, once they are fixed on the panel or board. We strongly recommend that any amateur attempting to build such a receiver, use instruments of good quality, as this is an important factor in the results obtained with a super-heterodyne receiver of this type. The connections should be made with bus-bar wire bent at right-angles, or else with No. 16 copper wire, which is cheaper and very efficient for connections.

#### Aerial and Ground

If a loop aerial is used, the tuning inductance composed of L1 and L2 is not necessary, since the loop is connected across the first condenser in place of the inductance L2. However, it is preferable to use a short antenna; as the signal strength is greatly increased with this type of collector. If no antenna can be installed outdoors, a single wire, stretched around a room at a distance of about a foot from the walls and ceiling by means of insulators, will be preferable to a loop. The ground connection may be taken on the radiator system, the water pipe, or any other grounded metal-work. If none is available, a counterpoise may be made with a length of lamp cord wound spiral-fashion under the carpet, or rug.

The tuning of the super-heterodyne receiver is extremely simple, and in a short time anyone should be able to bring in distant stations, provided the tuning and oscillator condensers are turned very slowly. As the tuning is very sharp, a vernier is necessary on the oscillator condenser, but it may be dispensed with on the tuning condenser, which is not so critical in adjustment. The receiver may be calibrated if the same loop or tuning circuit is used at all times; and if desired a silver dial may be employed on the tuning condenser, thus permitting the inscription of the station call letters to be put directly on it.

To tune the receiver, the tuning condenser should be moved two degrees at a time, and the oscillator condenser turned over the whole scale range for each setting of the tuning condenser. Some station should be heard at one place or another along the scale; if whistles are heard, the potentiometer controlling the radio frequency amplifier should be turned until the whistles stop. The station may then be brought in loudly and clearly. The potentiometer may then be adjusted at the most critical point, where amplification is maximum; and need not be readjusted unless very weak signals are tuned in. The rheostat acts as a vernier for the potentiometer, and sometimes may prove quite useful in bringing to good audibility a distant station. It will be found that signals are heard at two different adjustments of the oscillator condenser; it is best to try the setting which gives loudest signals. After a few hours spent in operating this receiver, it will be quite easy to tune in stations, for at a certain point a slight rushing noise is heard, indicating that a carrier wave is tuned in.

From 45 to 90 volts of "B" battery may be used on this receiver. If an audio frequency amplifier is added to operate the loud speaker, it is advisable to use a separate "B" battery on the audio frequency tubes, although the same filament battery may be used. It is

recommended to use 201-A or 301-A tubes for the modulator and radio frequency amplifier. A different tube may be used as a detector, although very good results may be obtained with one of the above-mentioned tubes, if the proper grid-leak resistance is used. For the oscillator we would recommend a 216-A, or E tube (VT-2), although any other tube which operates well as an oscillator may be employed. It is a good idea to try the tubes in different positions, for very often some tubes function better in some stages than in others.

#### (400) NEW YORK EVENING JOURNAL CIRCUITS

Q. 1. Can you furnish me with the circuit diagram of the Journal's new One-Knob set, and all other data necessary for the proper construction of this receiver, as I am unable to obtain the radio section of the New York Journal in which this receiver was published? Please do not give the schematic circuit diagram, as I am unable, as yet, to understand radio symbols. A diagram of the picture type, that is, showing a picture of the various instruments used and the wiring connected to the various instruments in the proper order, will be greatly appreciated. Also, may the coils be purchased? I would rather buy them than attempt to construct them (due to lack of radio experience), unless absolutely necessary.

A. 1. We are herewith showing a set diagram of the new Journal One-Knob receiver, as you request. Also, due to the enormous popularity of the Filter Tuner originated by the New York Evening Journal, and the numerous requests received for this and the other circuits, we are publishing both these circuits, including all the data necessary for the construction of each. The circuits are named as follows:

Journal One-Knob Circuit and Journal Selective Filter Tuner. The Journal One-Tube One-Knob Set is shown in June, 1926 *Radio News*.

The following is the list of parts necessary for the construction of the Journal One-Knob set (5-tubes): (Fig. 400-A.)

- 1 Panel 7 x 21 x 3-16 inches,
- 1 Baseboard 10 x 19 inches. This size is necessary because of the triple-gang condenser, room for which must be provided,
- 1 Single-Circuit Jack,
- 1 Battery Switch,
- 1 Triple or three-gang Condenser of three .00035-mf. units, all of which are rotated by a single shaft,
- 1 Grid Leak, 2-megohm,
- 1 Grid Condenser, .00025-mf.,
- 9 Binding posts, etc.

The coils are wound with a half-pound of No. 22 D.C.C. copper wire on bakelite tubes three inches in diameter. The first tube, the aerial coupler, is 3 inches long; the other two each  $3\frac{1}{2}$  inches long. Three rotor coils are  $2\frac{3}{4}$  inches in diameter and  $\frac{3}{4}$ -inch long. We know of no commercial manufacturer who is producing these coils. It is possible to obtain coils somewhat similar in construction and rewind to make them coincide.

#### Adjustments

The following is a description, taken from the New York Journal, of the proper method of adjusting the receiver.

"The process of balancing the Journal's new one-knob set is done somewhat in this manner; tune in a long wave station around 500 meters, more or less, for a preliminary test to determine if the condenser sections need to be balanced. Take a ruler without a metal edge or a wooden stick, not a pencil, and turn the rotor of one coil and then another, beginning with the aerial, one way or another to hear which position gives the loudest signal.

"When this is found turn the condenser to another station lower in the wave-scale, and make another adjustment of the coil rotors. If a gain in signal strength, is observed it indicates that the condenser sections are not

balanced; and if no gain occurs it shows that the sections need no further attention.

"If the condenser sections are balanced properly, they will show an equal reduction in capacity as the shaft is turned toward the lower wave-scale; and when this is so the coils will be tuned alike on the high and low waves. If one section of the triple condenser reduces in unequal amount, one coil will be out of tune, which will be shown when the rotor, being turned, will increase the volume at any point.

*To Change Capacity*

"Each section of the condenser is provided with a means of increasing or decreasing the capacity, to compensate for any differences that exist between one section of the condenser and another. To balance the condenser, tune in a long-wave station again, and move the compensating plate on each section, using a stick to avoid hand-capacity effects, until the best setting is obtained, indicated by the greatest volume.

"The long wave stations are best for balancing, because adjustments of the set at these points are not subject to regenerative effects that occur in the lower bands. If balancing is attempted in these low channels, the results will be false because of the increased volume produced by regeneration when the balance is upset. Here is one case where the strongest impulse is obtained when the set is unbalanced, a fact which will be recognized when one makes the test. For this reason, the preliminary balances of both coils and condenser sections should be made on waves above 450 meters. After they are obtained, further refinements may be made on the shorter wave settings.

"If you suspect that one section is badly out of tune with another, it can be tested by a simple process. Wind a ten-turn aerial coil, with leads long enough to be connected to the aerial and ground and placed in different positions in the set. Place this aerial coil about three inches from the detector secondary and, with the two radio frequency tubes turned off, observe the setting of the dial when tuning the detector alone. Note this setting, and move the coil to the second radio frequency secondary, and turn on the second tube, removing the first from the socket and observing this setting. By comparing the settings you can instantly tell which section is unbalanced, and compensate accordingly. This is never necessary if the coils and condensers are made accurately.

"It will be found that the two vertical-coil rotors will be in about the same position when balanced. The aerial coil position depends

on the length of the aerial. A change in the position of any rotor or compensator affects the entire set."

**THE FILTER TUNER**

"This is a one-tube set, and can be used with one or two tubes of audio frequency amplification. The signal from the aerial passes through an untuned primary coil and is filtered from other signals by two intermediate, or linking coils, before it reaches the secondary. Two features of the Filter Tuner giving it a unique place in radio, are the arrangements for reducing the resistance of the linking circuit and for controlling the current used for the purpose.

"Increased selectivity without loss of volume is accomplished by including one of the linking coils in the plate circuit. The wiring, as shown in Fig. 400, is simple, and the set is appreciated by the person who likes to build a receiver at home. Regardless of the theoretical complexity of the circuit, it can be made and operated by the novice.

"Standard parts are used, which may be obtained at the cost of an ordinary one-tube set. The coils are wound on two bakelite or cardboard tubes, three inches in diameter. The tube for the primary and first filter coil is four inches long; and that for the second filter coil and secondary winding is six inches long. No. 20 D.C.C. copper wire is used on the four coils.

"Both filter coils, L2 and L3, have forty turns each, while the primary L1 has twenty-five, and the secondary L4 sixty turns. As shown in the arrangement of the parts, the tubes are mounted at right-angles, to eliminate inductive transfer of energy from the primary to the secondary direct. This excludes all but the desired station.

"The variable-resistance unit controls the strength of the magnetic field produced by the second filter coil L3 which, in turn, affects the entire filter circuit. This controls regeneration and volume. The grid-leak, R1, and condenser, C2, may be 2-megohm and .00025 mf., respectively. The "B" battery should not exceed 67 volts on the detector.

The set can be built into a 7 x 12-inch panel and cabinet. The filter variable condenser C5 should be mounted on the left of the panel and the secondary condenser C1 on the right. The filament rheostat R2 and filter resistance can be mounted vertically in line between these condensers, with the latter on top. The six-inch tube should be mounted vertically, with the primary and the first filter coil in position behind the filter con-

denser. The terminals of the coils should be brought through holes bored in the tube with a 1-16-inch drill, and their position should be near their terminal connections.

By using a 7 x 10-inch hard-rubber panel for a baseboard, mounting it to the main panel with brass angles, a first-class job can be made of the wiring, which may be concealed beneath the panel. On the front of the panel are mounted the aerial and ground binding posts; and on the base-panel are mounted the "A" and "B" battery binding posts.

The operator will develop his own system of tuning the set, but in general he will find that the two variable condensers tune with about the same settings, and that stations are picked up best by advancing the filter condenser slightly more than the secondary condenser. Clearing up distant stations is done by turning the filter condenser slightly behind the position of the secondary condenser. A point of adjustment is found on the filter resistance where signals over a given wave-band may be received without further adjustment of that unit. With this set a long aerial can be used to advantage, as none of the interfering problems common to other one-tube sets are encountered.

**(401) NEUTRODYNE CONSTRUCTION**

Q. 1. In building a Neutrodyne receiver, would you advise me to purchase a set of manufactured parts or to construct the coils and pick out the other parts myself?

A. 1. The Neutrodyne sets made by well-known concerns in knock-down form are very good and we would suggest that you buy one of these rather than purchasing parts promiscuously. If you wish to build the coils, patterns may be obtained. Name of companies furnished on receipt of stamped addressed envelope.

Q. 2. Would you recommend that I build a three-tube Neutrodyne without audio frequency amplification or that I build the five-tube type with two stages of audio frequency?

A. 2. If a three-tube Neutrodyne set is built, it may readily be used with an external two-stage audio frequency amplifier as the latter has nothing whatsoever to do with the operation of the Neutrodyne set itself. In general, we believe this would be the best plan for you to follow as you could then locate any trouble in your radio frequency and detector circuits, if such should occur, without having to contend with the audio frequency amplifier also.

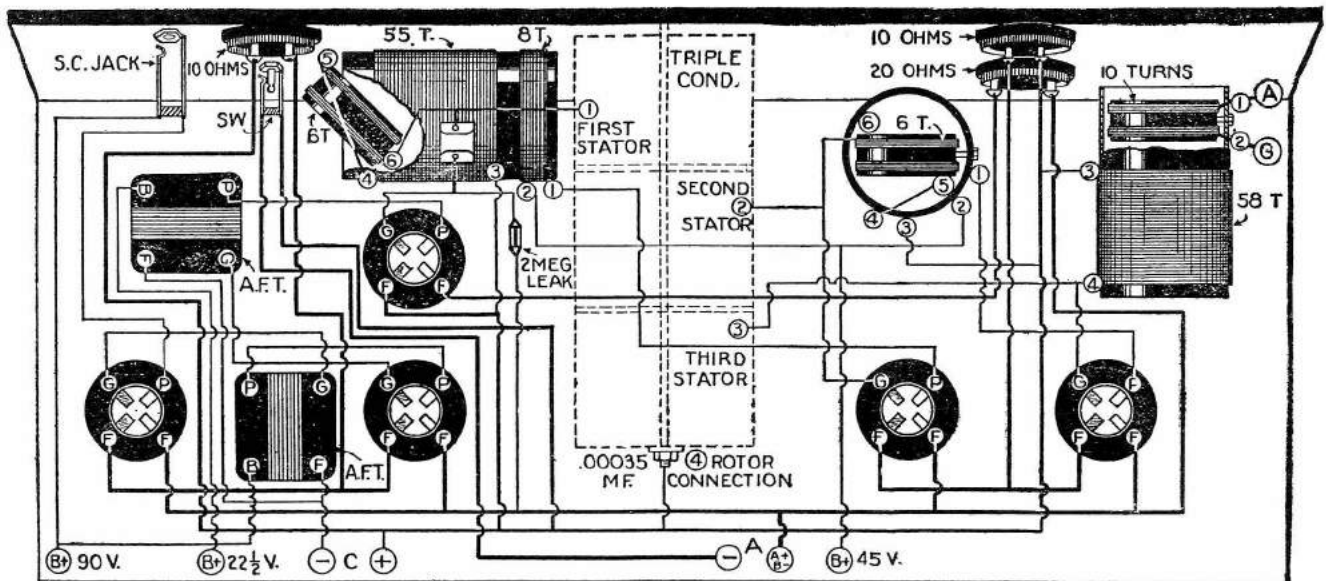

(400A). The Journal One-Knob, five tube, receiver consisting of two stages R. F. amplification, regenerative detector, and two stages A.F., extremely efficient and selective receiver, although only one dial is employed for tuning. Any type of tubes may be employed in this receiver, although for best results it is advisable that storage-battery type, 201-A or 301-A tubes be used throughout.

# To Our Readers

**T**HE publishers of "1001 RADIO QUESTIONS and ANSWERS" have spared no effort or expense to bring out a book which should prove of value to every radio fan, be he an amateur or a broadcast listener.

It was a tremendous task to compile a book of this nature. It required several months' time. We are anxious to know what you think of this book and whether or not it should be brought up to date and printed periodically, two or three times a year.

We will therefore ask you to be good enough to let us hear from you on the attached form. Whatever you may say will not obligate you in any manner.

Very truly yours,

EXPERIMENTER PUBLISHING COMPANY

---

EXPERIMENTER PUBLISHING COMPANY, INC.,  
53 PARK PLACE,  
NEW YORK, N. Y.

Gentlemen:

I have the following to say regarding your "QUESTIONS and ANSWERS" book:

---

---

---

---

---

---

---

If it should be revised and brought up-to-date two or three times each year, I would buy it from my newsdealer. Check yes  or no

NAME \_\_\_\_\_

ADDRESS \_\_\_\_\_

CITY \_\_\_\_\_ STATE \_\_\_\_\_



# Want to know more about Radio Equipment?

## READ

116 PAGES OF THE  
FINEST ARTICLES  
FROM  
"RADIO NEWS"

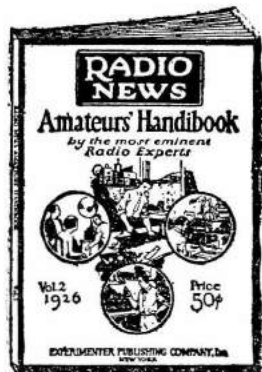

The "RADIO NEWS" Amateurs Handbook is a large 116 page magazine size book containing a wide, varied and carefully selected array of the finest and most helpful radio articles that have appeared in the pages of Radio's Greatest Magazine, "RADIO NEWS."

The cream of practical, up-to-the-minute, circuits and miscellaneous information and data is culled from "RADIO NEWS" and presented in compact form in this book.

**PRICE**  
**50¢**

116 Pages, Size 9 x 12 Inches,  
300 Illustrations.

SOLD EVERYWHERE

## READ

HUNDREDS OF  
HINTS, SHORT  
CUTS AND  
PRACTICAL RADIO  
IDEAS



The 500 "RADIO WRINKLES BOOK" is a very comprehensive compilation of the best time and money saving hints that can be effected. Under fifteen separate and distinct headings, the entire field of radio apparatus and instruments has been covered in simple, understandable language. There are no ifs nor buts to complicate directions. The Beginner as well as the more advanced radio man will soon find that this book contains a veritable storehouse of practical, inexpensive hints toward improving his radio apparatus.

**PRICE**  
**50¢**

116 Pages, Diagrams and Drawings galore, Size 9 x 12.

SOLD EVERYWHERE

Published and Distributed by  
**Experimenter Publishing Co., Inc., 53 Park Place, New York, N. Y.**

### THE RADIO TROUBLE FINDER

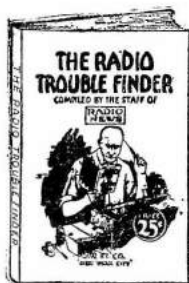

**PRICE**  
25c  
**EACH**

No matter how much or how little you know of your radio receiver, this new "Radio Trouble Finder" book is going to be a big help.

It explains the common and special faults of all the standard receivers of today; tells how to recognize instantly, by various sounds, where the trouble lies and also gives special simple tests by which you can determine what is wrong with your receiver. Then for each particular fault there is explained the proper procedure for correcting it.

All troubles and their remedies are arranged in simple charts so that even the most inexperienced radio user will have no trouble in keeping his set at all times in first class condition.

SOLD ON ALL NEWS STANDS

Distributed by

**THE CONSRAD COMPANY, Inc.**  
64 Church Street New York, N. Y.

### 150 RADIO HOOKUPS

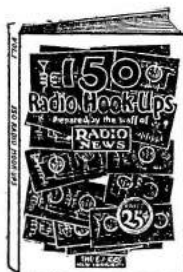

What more could you ask?—150 of the very finest, selected hookups most popular today. Each one completely explained and fully illustrated so that a complete receiver can be constructed from the information.

No out-of-date Hookups—all the finest and best in common use today. 64 pages—Size 6 x 9 inches.

Don't miss this opportunity—All Radio and News dealers have fresh copies *Now*. If there is no dealer near write us direct enclosing 25 cents.

*Save Money! Make Hundreds  
of useful and  
valuable things  
at home*

WITH  
**"HOW TO  
MAKE IT"**



Building your own home furniture, cameras, radio cabinets, sport devices, etc., is easy if you know what materials you need, and have an illustrated explanation on how to proceed. Then too, you can save a good deal of money by making these valuable things yourself.

"How to make it," a big book compiled from the great magazine "Science and Invention," is full to the brim with hundreds of up-to-date things to make at home. Things that can be made by any man with only a few simple tools.

**PRICE**  
**50¢**

116 Pages of Information.  
Everything Illustrated,  
Size 9 x 12 Inches.

SOLD EVERYWHERE

Published and Distributed by  
**EXPERIMENTER PUBLISHING CO., Inc.**  
53 Park Place New York, N. Y.

# "BUILD YOUR OWN" WITH "RASCO" PARTS!

Buy from the Oldest and Original Exclusive Radio Parts House in the United States  
We pay ALL transportation charges in U. S. ALL GOODS SENT PREPAID IN 24 HOURS

Order direct  
from this page

**SPECIAL PRICES FOR FEBRUARY**

Money refunded if  
goods do not satisfy



**Dial Marker**  
The big little thing you have been waiting for. Just drill a hole in the panel and mount the marker above the dial. Nickel plated and polished.  
F7788 Dial Marker, three for .....\$1.10

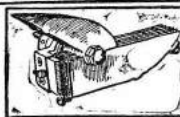

**Patent S.L.F. Condensers**  
The famous Patent S.L.F. Condenser. The latest word in condensers. Sturdy, compact, take up less room than most others. Minimum insulation used.  
F4432 .00035 mf. 4" plate .....\$2.95  
F4433 .0005 mf. 23" plate ..... 3.95

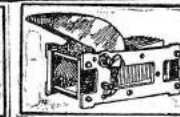

**S.L.F. Condensers**  
Lowest prices ever offered. Despite this low price, these condensers are made with precision aluminum stampings, hard rubber insulation. Money back if not satisfactory.  
F3513 .00025 13 pl. \$1.06  
F3517 .00035 17 pl. 1.20  
F3523 .0005 23 pl. 1.35



**"Guaranteed" Vacuum Tubes**  
We consider the "Guaranteed" tube one of the best on the market. Any tube replaced if defective, no return of filament. Calibrated curve goes with each tube.  
F701A 5 v. .25 amp. \$1.25  
F799 3 volt. .08 amp. 1.25



**Audio Transformer**  
This is the famous Patent Audioformer. Nickel case is grounded to base. Extra high degree of amplification. Minimum distortion and reaction. Binding posts and solder lugs. Ratio 3 1/2 to 1.  
F2811 Mounted type \$4.50  
F2812 Unmounted .. 3.15



**Audio Frequency Transformer**  
No better Transformer made. Highest class materials. Impregnated coils. Sillicon steel stampings used. Save 50 per cent by assembling it yourself.  
F1100 Ratio 4 1/2-1. \$1.40  
F1150 Ratio 6 1/2-1. 1.40



**Sponge-Rubber Cushions**  
Get rid of tube noises due to vibration. Softest sponge rubber made. Size 2 1/2"x3", 3/4" thick.  
F6989 Sponge-rubber cushions, each .... \$0.12  
Six for ..... 0.60

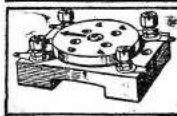

**Universal Socket**  
Takes new "X" type tubes as well as old standard "UV" and "C" types. Made entirely of Insolantite. No capacity effect between plate and grid. New phosphor bronze wiping contacts. Standard mounting type.  
F5814 .....\$0.49

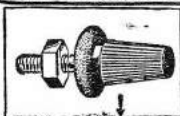

**Rasco Vernier**  
Why use a vernier dial when a vernier attachment will do anything and everything a vernier dial accomplishes? Cleverest vernier made. Can be used with any dial. Soft rubber ring engages dial. Nothing to come apart.  
F1450 Vernier.....\$0.12



**FONEKUSHIONS**  
Made of sponge rubber. Make wearing your receivers a pleasure. Positively exclude all noises and make reception a pleasure. Sponge rubber will last for years. Light as a feather. Sanitary.  
F3550 Fonekushions, set of two .....\$0.35



**Dial Button**  
Made in blue enamel and gold, to be worn in button hole. Every radio fan wants one. 3/4" diameter, best gold plate. Perfect reproduction of radio dial.  
F7799 Dial Button, Each .....\$0.25

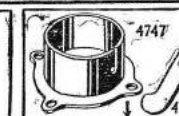

**Vacuum Tube Shell**  
Nickel plated shell for the man who builds his own. 4 holes to attach to sub-base. Each shell comes complete with 4 phosphor bronze socket contacts. See illus. 4743.  
F4747 Vacuum Tube Shell and Contacts .....\$0.16



**Cord Tip Jack**  
Takes place of binding posts. Cord tip firmly gripped by jack. Made of brass, nickel plated. Screw to attach lead wire. No soldering necessary.  
F1500 Cord tip jack, Each .....\$0.15

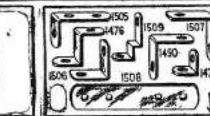

**Brass Nickel plated Brackets**  
All illustrations 1/4 size.  
F1505 Bracket, each \$0.05  
F1507 Bracket, each .05  
F1509 Bracket, each .04  
F1476 Bracket, each .05  
F1506 Bracket, each .05  
F1490 Bracket, each .04  
F1475 Bracket, each .03  
F1568 Bracket, each .05



**Microvern**  
THE vernier dial for extra sharp tuning. No backlash. Special finish permits logging of stations on dial. Beautiful appearance. Comes in gold or silver finish. State which wanted.  
F3056 Microvern, any finish .....\$1.76



**Rasco 130° Variocoupler**  
Silk wire wound on bakelite tubes. Six taps. Wave length, 150 to 600 meters. For panel mounting. 7/4" shaft. Your money refunded if it is not all we claim.  
F3100 Variocoupler prepaid .....\$1.65

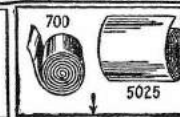

**Copper Ribbon**  
.0005" thick.  
F700 3/4" wide; F701 3/4" wide; F702 3" wide.  
All sizes per foot. ....\$0.01  
**Copper Foil**  
.001" thick. 4" wide.  
F5025 Copper Foil, per foot .....\$0.10  
10-foot length ..... 0.80

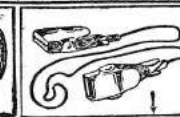

**Rasco Clip Leads**  
Invaluable for experimental work. Clip lead hooks in a JIC onto any wire, binding post or conductor. Safest experimental connection. Brass clips, 1 foot silk wire, green or red.  
F7887 Clip Leads, ea. \$0.12  
Dozen lot .....1.35



**Adapter**  
Patent Improved Adapter. Takes 199-type tubes. Fits standard 201A sockets. Phosphor bronze springs. Short circuits impossible. Bakelite molded.  
F6521 Adapter .....\$0.36

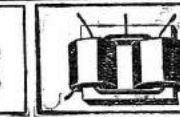

**PUSH-PULL Transformer**  
Push Pull Transformer for many new circuits. See any radio magazine. Made of best materials. Coils impregnated. Sillicon steel laminations. Save 50 per cent by assembling yourself. Simple instructions furnished.  
F1159 Push-Pull Transformer, ratio 6 1/2 to 1 \$2.35

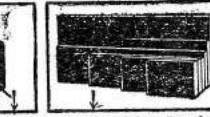

**Hard Rubber Panels**  
Highest dielectric strength as per Bureau of Standards. Beautiful high finish.  
F7100 7x10x-16" .....\$0.65  
F7120 7x12x-16" ..... 0.79  
F7140 7x14x-16" ..... 0.89  
F7180 7x18x-16" ..... 1.15  
F7210 7x21x-16" ..... 1.31  
F7240 7x24x-16" ..... 1.46

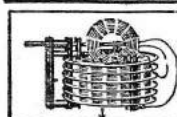

**Low Loss Tuner**  
Same type as used in our LOLOS EXPLORER. Tunes from 200 to 600 meters. Hard rubber insulation throughout. Silver plated primary. Secondary D. C. C. Ticker silk insulated wire.  
F2690 Tuner .....\$5.00



**"T" Wire Connectors**  
This big little article solves all troubles when making "T" wire connections. Made to take 1-16" square or round bus-bar wire. Can be attached with a pair of pliers.  
F2975 "T" Wire Connectors, 12 for .....\$0.10

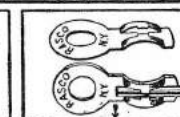

**Nosolder Lugs**  
Finally, a real solderless lug is here. Soldering positively done away with. Takes square or round bus-bar, which it holds with a vise-like grip. Perfect connection. Just slide bus-bar into slip-grip.  
F3727 Lug, 25 for .....\$0.20



**Low Loss Coil**  
Same type as used in Freshman and other Tuned Radio Frequency sets. D.C.C. wire. 200-650 wave length. 3" diameter. 1" wide. 5-16" thick & connections, 2 primary, 2 secondary.  
F2629 Low Loss Coil \$0.43



**Binding Post Strip**  
Made of hard rubber, gold engraved lettering. Two nickel brackets for mounting. 7 hard rubber binding posts. "ANT", "GND", "A-", "A+", "B-", "DET B+", "AMP B+"  
F870 Binding Posts \$0.35



**Tinned Nickel Lugs**  
All our lugs are tinned. F310 Brass Lugs for No. 8 screw, doz. ....\$0.10  
F311 Copper Lugs for No. 8 and 6 screws, doz. 0.10  
F309 Copper Lugs for Nos. 4, 6 and 8 screws, doz. 0.10  
F308 Copper Lugs for 6-32 screw, doz. ....0.10



**Battery Snap Switch**  
This Switch is produced under high standards of workmanship. Action is positive. Solderless contact screws used. One-hole mounting. Nickel-plated all over. Most serviceable switch made.  
F7985 .....\$0.36

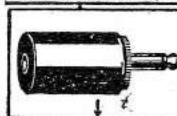

**Phone Plugs**  
Sold from 50c to 65c everywhere. Hard rubber composition shell and patented cord tip holder. Finest workmanship throughout.  
F1030 Rasco Telephone Plug, Each .....\$0.23



**Bakelite Socket**  
Octagon shape. Four nickel binding posts, phosphor bronze contact springs. Best brown bakelite.  
F6310 Bakelite socket \$0.40  
F6500 Tube Socket. Made entirely of composition. Best made. Each. ....\$0.35



**Binding Post Name Plates**  
Dia. 3/4". These styles: Phones, Ground, - Out, - In, - A, - B, - C, - D, - E, - F, - G, - H, - I, - J, - K, - L, - M, - N, - O, - P, - Q, - R, - S, - T, - U, - V, - W, - X, - Y, - Z, - 1, - 2, - 3, - 4, - 5, - 6, - 7, - 8, - 9, - 0, - +, - -, - ., - /, - %, - &, - @, - #, - \$, - %, - ^, - &, - \*.  
F6600 Name Plates, Dozen .....\$0.15

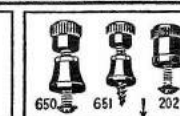

**"Rasco" Posts**  
Made of hard rubber composition.  
F650-51 Each .....\$0.06  
F202 Has nickel plated bottom, each .....\$0.06  
Dozen, each style. ....\$0.70  
F122 Initialed Binding Posts, Set of 8, Per Set .....\$0.25

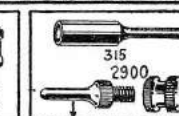

**Cord Tips**  
Standard phone cord tips, nickelled.  
F315 Each .....\$0.03  
Separable Cord Tips  
No solder required. Wire goes in ferrule. Shank holds it tight. Nickel plated.  
F2900 Each .....\$0.06

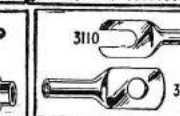

**"Perfect" Lugs**  
These new and improved lugs are brass, nickel plated, flattened on top as shown. Made of a single piece of metal. Lead wire goes into tube.  
F3110, F3080 "Perfect" Lugs, Each .....\$0.02  
Dozen lots ..... 0.20

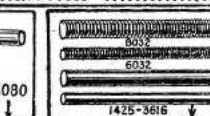

**Brass Rods**  
Sold in 6 lengths only.  
F8032 Rod 8-32" thread length .....\$0.08  
F6032 Rod, 6-32" thread length .....\$0.05  
F1425 Rod, plain, 3/4" round, length .....\$0.10  
F3616 Rod, plain 3-16" round, length .....\$0.06

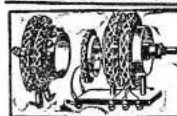

**Roberts Coils**  
Diamond weave coils, used in standard Roberts Circuit. Tunes 200 to 570 meters. Used in 2, 3, or 4 tube circuits. These are genuine Stickle Coils, not imitations. Set comprises two units, as illustrated.  
F-8112, Roberts Coils .....\$5.95



**100-Ampere Storage Batteries**  
Guaranteed for two years. Only new material used. Genuine hard rubber case. Acid-proof terminals. Hard rubber vents. Strong carrying handle. Written guarantee goes with each.  
F-8100, 6 volt 100-ampere hour battery .....\$9.50  
Shipped express collect.

**New 1926 "Rasco" Catalog No. 15**  
CONTAINS 75 VACUUM TUBE HOOK-UPS, 300 ILLUSTRATIONS, 500 ARTICLES  
All Armstrong Circuits are explained clearly, all values having been given, leaving out nothing that could puzzle you.  
Just to name a few of the circuits: The V.T. as a detector and one-step amplifier; all Armstrong circuits; one-step radio frequency amplifier and detector; three stage audio frequency amplifier; short wave regenerative circuits; 4-stage radio frequency amplifier; radio and audio frequency amplifier; inductively coupled amplifier; all Reflex Circuits.

**FREE A POSTAL CARD BRINGS IT**

**NEW BATTERY LEAD TAGS**  
Latest wrinkle made in metal, nickel-plated, polished. Clamp tag on battery wire, and it won't come off. These five styles: "B+", "B+", "DET.", "B+", "A+", and "A-".  
F8030 Tags, set of 10 \$0.15  
200 ohms ..... 0.50

**RHOESTATS AND POTENTIOMETERS**  
High heat bakelite base. Come with tapered, knurled knob, 2 1/2" dia. Complete with pointer.  
F4310 8 ohm .....\$0.38  
F4311 30 ohm ..... 0.44  
F4312 Potentiometer  
F8030 Tags, set of 10 \$0.15  
200 ohms ..... 0.50

**RADIO SPECIALTY COMPANY, 94 Park Place, New York City**  
Factories: Brooklyn, N. Y. Eldridge, Md.



ISBN 1-55918-100-1