

NATIONAL ADVISORY COMMITTEE FOR AERONAUTICS

E-146

# WARTIME REPORT

ORIGINALLY ISSUED

October 1945 as  
Advance Restricted Report E5H13

CYLINDER TEMPERATURES OF TWO LIQUID-COOLED AIRCRAFT  
CYLINDERS FOR VARIOUS ENGINE AND COOLANT CONDITIONS

By Eugene J. Manganiello and Everett Bernardo

Aircraft Engine Research Laboratory  
Cleveland, Ohio

PROPERTY OF JET PROPULSION LABORATORY LIBRARY  
CALIFORNIA INSTITUTE OF TECHNOLOGY



WASHINGTON

NACA WARTIME REPORTS are reprints of papers originally issued to provide rapid distribution of advance research results to an authorized group requiring them for the war effort. They were previously held under a security status but are now unclassified. Some of these reports were not technically edited. All have been reproduced without change in order to expedite general distribution.





NATIONAL ADVISORY COMMITTEE FOR AERONAUTICS

ADVANCE RESTRICTED REPORT

CYLINDER TEMPERATURES OF TWO LIQUID-COOLED AIRCRAFT CYLINDERS  
FOR VARIOUS ENGINE AND COOLANT CONDITIONS

By Eugene J. Manganiello and Everett Bernardo

SUMMARY

As a supplement to an investigation of the cooling characteristics of a multicylinder liquid-cooled engine, tests were conducted with two liquid-cooled cylinders in order to isolate the effects of the various engine and coolant variables on cylinder temperatures and to obtain engine-cooling data required for a fundamental study of the heat-transfer processes in liquid-cooled engines.

Cylinder temperatures were obtained for a large range of engine speeds, manifold pressures, carburetor-air temperatures, fuel-air ratios, spark advances, coolant-flow rates, average coolant temperatures, and coolant pressures with water and AN-E-2 ethylene glycol and other ethylene glycol-water mixtures as coolants.

The results indicate that the average cylinder temperatures increased nearly linearly with charge-flow rate (air plus fuel) and indicated horsepower, increased a relatively small amount for an increase in carburetor-air temperature, increased rapidly at a constant charge-flow rate as the fuel-air mixture was enriched to a fuel-air ratio of 0.067 and decreased with further enriching, increased practically linearly with an increase in spark advance from 20° to 42° B.T.C. but changed less rapidly from 12° to 20° B.T.C. The average cylinder temperatures also decreased a relatively small amount for an increase in the coolant-flow rate of most of the solutions used, increased nearly linearly with an increase in the average coolant temperature, and increased slightly with an increase in coolant pressure but only at the high cylinder temperatures. In addition, the results showed that the average cylinder temperatures were lower when using water or the more aqueous ethylene glycol solutions than when using AN-E-2 ethylene glycol.

The numerical relations obtained between the cylinder temperatures and each of the variables investigated were dependent upon the values of the other engine and coolant conditions under which the particular variable was investigated.

## INTRODUCTION

Recent and projected improvement in the power output of liquid-cooled aircraft engines has introduced the problem of reducing excessive cylinder temperatures and has restimulated research in the cooling of liquid-cooled engines.

An experimental investigation of the cylinder temperatures existing in a liquid-cooled engine is reported in reference 1, which presents results for several coolants showing the effect of coolant temperature and coolant-flow rate on cylinder-head temperature. Tests in which the effect of coolant pressure was also investigated were conducted at Wright Field (Memo. Rep. Ser. No. ENG-57-523-216) in 1943 on a Continental Hyper No. 1 cylinder. In the tests of reference 1 the cylinder-head temperature was measured at only one location, but in the tests with the Continental cylinder a more complete survey was made. In neither case, however, was the effect of such variables as engine speed, manifold pressure, carburetor-air temperature, fuel-air ratio, and spark advance investigated.

The tests reported herein were conducted as a supplement to an investigation of the cooling characteristics of a multicylinder liquid-cooled engine in order to isolate the effects of the various engine and coolant variables on cylinder temperatures and to obtain engine-cooling data required for a study of the fundamental heat-transfer processes in liquid-cooled engines.

The present investigation was conducted by the NACA at Cleveland, Ohio during the winter of 1943 and the spring of 1944 with two modified Lycoming O-1230 liquid-cooled cylinders. Cylinder temperatures were obtained for a range of engine speeds, manifold pressures, carburetor-air temperatures, fuel-air ratios, spark advances, coolant-flow rates, average coolant temperatures, and coolant pressures at atmospheric exhaust back pressure with water and AN-E-2 ethylene glycol and other ethylene glycol-water mixtures as coolants.



## APPARATUS

## Test Equipment and General Measurements

The general arrangement of the test setup is shown in figure 1. Two Lycoming O-1230 cylinders with  $5\frac{1}{4}$ -inch bores,  $5\frac{3}{4}$ -inch strokes, and 7.6 compression ratios were used in these tests. Although a  $4\frac{3}{4}$ -inch stroke is normally used with Lycoming O-1230 cylinders, the available crankshaft predicated a  $5\frac{3}{4}$ -inch stroke. In order to accommodate the longer stroke, the barrel was extended by means of an adapter. Each cylinder was tested on a single-cylinder test stand equipped with standard accessories for determining engine speed and brake horsepower and was enclosed in an asbestos-lined box in order to reduce heat loss to surroundings other than the coolant. The valve timing used with an intake-valve tappet clearance of 0.013 inch (cold) and an exhaust-valve tappet clearance of 0.016 inch (cold) was as follows:

Intake valve opens, degrees B.T.C. . . . .	30
Intake valve closes, degrees A.B.C. . . . .	84
Exhaust valve opens, degrees B.B.C. . . . .	41
Exhaust valve closes, degrees A.T.C. . . . .	67

Fuel consumption was measured with a calibrated rotameter and air was metered to the carburetor by means of a flange-tap orifice installed according to A.S.M.E. specifications. Electric heaters installed upstream of the carburetor were used to vary the carburetor-air temperature. The air temperature was measured both in front of the orifice and at the intake manifold. All temperature measurements were made with iron-constantan thermocouples in conjunction with either a portable-type potentiometer or a self-balancing indicating-type potentiometer.

## Installation Details of Cylinder A

Barrel modifications and thermocouples. - On the first cylinder tested, cylinder A, the barrel coolant jacket was modified in order to separate the head and the barrel coolant flows. Figure 2 is a diagram showing the modifications and the thermocouple installation. The original barrel coolant jacket was machined to within  $\frac{3}{8}$  inch of the top sealing band. The coolant-transfer passages between the head and the barrel coolant jackets were plugged and two rows of four thermocouples (1 to 8) were spot-welded at  $90^\circ$  intervals around the outside of the barrel. The thermocouple junctions were coated with several layers of insulating varnish and baked in order to

reduce errors arising because of conduction loss to the coolant. The thermocouple leads were insulated both from each other and from the barrel with flexible glass sleeving. The modified coolant jacket was then welded in position with the thermocouple leads traversing the jacket, as shown in figure 2.

Head thermocouples (gas side). - In the head of cylinder A, 15 thermocouples (9 to 23) were installed approximately 1/8 inch from the inner wall. Thermocouples 9 to 12 were located where the head and the barrel are joined and are referred to as "intermediate" thermocouples; thermocouples 13 to 21 were installed in the combustion chamber proper; thermocouple 22 was located on the exhaust-valve guide and thermocouple 23 in the top portion of the exhaust port.

The methods used for installing the gas-side head thermocouples are illustrated in figures 3(a) and 3(b). The thermocouple junction in the solid portion of the head (fig. 3(a)) was peened into the metal at the bottom of a 1/8-inch drilled hole. Alundum tubing having two passages, one for each lead, was then inserted to prevent the leads from contacting the sides of the drilled hole. The alundum insulators were secured by peening metal into a groove around the insulators.

Figure 3(b) shows the method used when it was necessary for the thermocouple wires to cross a coolant passage. A brass screw plug bridged the passage and screwed into the inner wall. The thermocouple junction was then peened into the metal at the bottom of a 1/8-inch drilled hole, and the leads were insulated with alundum tubing. A sealing washer and a nut were screwed on the outer end of the sleeve to prevent leakage past the threads.

Head thermocouples (liquid side). - Four thermocouples (24 to 27) were located on the liquid-side surface of the combustion-chamber wall by the method shown in figure 3(c). A brass screw plug was threaded through the coolant jacket wall and forced into a circular groove in the outer surface of the combustion-chamber wall. The thermocouple was then installed as shown in figure 3(b), except that the junction was peened into the metal within 1/8 inch of the liquid surface.

#### Installation Details of Cylinder B

The second cylinder tested, cylinder B, differed from cylinder A in that the barrel jacket and the coolant-flow paths were not altered. Cylinder B was tested because it was suspected that a crack had developed in the head of cylinder A before completion of



the tests and that exhaust gas was leaking into the coolant system. Figure 4 is a diagram of cylinder B including the thermocouple installation. The thermocouple installation was the same as that used in cylinder A except that no thermocouples were installed on the barrel and that four single thermocouples (28 to 31) were installed  $90^\circ$  apart around the head directly above the coolant-transfer holes connecting the head and the barrel coolant passages.

### Cooling Systems

Cylinder A. - Figure 5 is a diagram of the cooling system used with cylinder A showing the location of the coolant thermocouples and the pressure gages. The coolant flow was divided at the cylinder, part going through the head jacket and the rest through the barrel jacket. The coolant-flow rate was measured with rotameters that had been calibrated over a range of coolant temperatures for the various liquids used. The inlet temperature of the coolant was controlled by means of a mixing-valve-type temperature regulator. Four thermocouples were distributed across the pipe diameter of each inlet and outlet coolant line, within approximately 3 inches of the engine, for measuring the average fluid temperatures. The method used for installing these thermocouples is shown in figure 3(d). Inasmuch as each set of four thermocouples was connected in series, the reading obtained was four times that of an average temperature indication. Each set in the inlet and outlet coolant lines was also differentially connected in order to measure directly the temperature rise of the coolant in flowing through the head and the barrel jackets. The junctions of all the coolant thermocouples were coated with an insulating varnish to reduce the possibility of introducing an error, caused by electrolytic action, in the temperatures indicated.

Cylinder B. - The coolant system used with cylinder B is shown in figure 6. The system is the same as that used with cylinder A except that the flow was not divided at the cylinder and both the barrel outlet and the head inlet coolant temperatures were obtained by means of four single thermocouples (28 to 31, fig. 4). These thermocouples were also used in conjunction with the barrel inlet and the head outlet thermopiles in order to determine the temperature rise of the coolant in flowing through the barrel and the head jackets. In addition, the two thermopiles were differentially connected in order to measure directly the over-all temperature rise of the coolant.

## Coolants

The coolants used were water and AN-E-2 ethylene glycol and nominal (by volume) 70 percent-30 percent and 30 percent-70 percent ethylene glycol-water mixtures. The specification of AN-E-2 ethylene glycol on a weight basis is 94.5 percent ethylene glycol, 2.5 percent triethanolamine phosphate, and 3.0 percent water, but for convenience AN-E-2 ethylene glycol will be referred to as a "nominal" (by volume) 97 percent-3 percent glycol-water mixture.

## METHODS AND TESTS

## Tests Conducted

Tests were conducted over the following range of conditions:

Engine speed, rpm . . . . .	1050-2760
Manifold pressure, inches of mercury absolute . . . . .	21.0-39.0
Carburetor-air temperature, °F . . . . .	80-222
Fuel-air ratio . . . . .	0.048-0.121
Spark advance, degrees B.T.C. . . . .	12-42
Coolant-flow rate, pounds per minute . . . . .	10.0-128.3
Average coolant temperature, °F . . . . .	90.0-311.0
Coolant pressure, pounds per square inch absolute . . . . .	17-75

In order to isolate the effect of the engine and the coolant variables on cylinder temperatures, one item was varied in each test while all others were maintained approximately constant. More tests than were necessary to establish the effect of the variables were made in order to check the results as the tests progressed. A summary of the tests conducted is presented in table 1. Run numbers are given for convenience in using large original data tables, which are not included in this report but are available upon request from the National Advisory Committee for Aeronautics.

Atmospheric exhaust pressure was maintained throughout the investigation. A spark advance of approximately 28° B.T.C. was used in all of the tests except the variable spark-advance tests and a carburetor-air temperature of approximately 80° F was used except in the tests in which it was the variable. The carburetor-air flow was maintained approximately constant in all of the tests except those in which either the speed or the manifold pressure was varied. In most of the variable-speed tests the manifold pressure was held constant, which resulted in slight variations of indicated mean effective pressure. In a few of the variable-speed tests conducted with cylinder B, however, the manifold pressure was adjusted to maintain an approximately constant indicated mean effective pressure.



The pressure on the coolant was varied by applying compressed air to the top of the expansion tank through the vent line shown in figures 5 and 6. A bleed valve in the vent line was used when runs were made at atmospheric pressure. The coolant-pressure values presented in this report are the values recorded on the outlet side of the cylinder because that pressure was the lowest in the cylinder coolant jackets.

Friction horsepower was determined at intervals throughout the tests by motoring runs, which were conducted at the values of engine speed, manifold pressure, and oil temperature that were maintained during the power tests. The oil supplied to the engine was maintained at an approximately constant temperature of 160° F.

The ethylene-glycol concentration of the coolants was determined from the boiling point and the specific gravity of samples taken at intervals throughout the tests.

#### Calculations

Heat rejection to coolant. - The heat rejected to the coolant was obtained from the product of the coolant-flow rate, the temperature rise of the coolant in flowing through the cylinder jackets, and the specific heat of the coolant at the average coolant temperature. Values for the specific heats of the coolants were obtained from reference 2 and are plotted in figure 7 as a function of temperature.

Head, barrel, and total heat-rejection values were calculated for cylinder A. Only the total heat-rejection values, however, were calculated for cylinder B because of the inaccuracy of the temperature indications of thermocouples 28 to 31.

Temperature averages. - The average head and the average barrel coolant temperatures were taken as the arithmetic mean of the coolant temperatures measured at the inlet and the outlet coolant lines of the head and the barrel, respectively. Average cylinder temperatures were determined by averaging all the temperatures obtained from the thermocouples located in each particular portion of the cylinder. The following table lists the thermocouples used for calculating each of the average cylinder temperatures used herein. (See figs. 2 and 4.)

Average temperature	Cylinder	Thermocouples
Head (gas side)	A and B	13-21
Head (liquid side)	A and B <sup>1</sup>	24-27
Barrel (liquid side)	A <sup>2</sup>	1-8
Intermediate	B <sup>3</sup>	9-12

<sup>1</sup>Thermocouple 26 was damaged in cylinder B.

<sup>2</sup>Barrel thermocouples were not installed in cylinder B.

<sup>3</sup>Intermediate thermocouples were damaged in cylinder A.

For convenience the average head (gas-side) temperature will be referred to as the "head" temperature and the average head (liquid-side) temperature will be referred to as the "liquid-side head" temperature. For that portion of the cylinder where the head and the barrel are joined the average temperature is represented by the "intermediate" temperature.

The liquid-side head temperature may not be representative of the entire head because of the small number of thermocouples used. The barrel temperature should be considered only as roughly representative of the true average barrel temperature because of possible errors introduced by the conduction of heat from the thermocouple junctions to the coolant.

## RESULTS AND DISCUSSION

A summary of data from cylinder A and cylinder B is presented in the original data tables (available on request).

In almost every test the maximum observed cylinder temperatures occurred at thermocouple 21 located in the center of the head between the valves and at thermocouple 5 located on the top portion of the barrel on the exhaust and antithrust side. The temperatures obtained from these thermocouples are therefore listed as maximums throughout the original data tables.

### Effect of Engine Variables on Average

#### Cylinder Temperatures

Figures 8 to 15 show the effect of the various engine variables investigated on the average cylinder temperatures. (The average cylinder temperatures are the head and the barrel temperatures for cylinder A and the head and the intermediate temperatures for cylinder B.)



Indicated horsepower and charge-flow rate. - The effect of charge-flow rate (air plus fuel) and indicated horsepower on average cylinder temperatures is presented in figure 8 from tests conducted with cylinder A using AN-E-2 ethylene glycol as a coolant. The head and barrel temperatures increased approximately  $1.7^{\circ}$  F and  $0.7^{\circ}$  F, respectively, per unit increase in indicated horsepower. The linear variation in cylinder temperatures with indicated horsepower is approximately the same, irrespective of whether the change was obtained by varying the speed or the manifold pressure. The linear relation obtained between the indicated horsepower and the weight of charge-flow rate is shown in figure 9 and obviously justifies the double abscissa scale used in figure 8.

Similar results are presented in figures 10 and 11 from data obtained with cylinder B with water as a coolant. The head temperature increased approximately  $1.2^{\circ}$  F and the intermediate temperature approximately  $0.6^{\circ}$  F per unit increase in indicated horsepower.

Carburetor-air temperature. - The results of two tests conducted with cylinder A at different values of indicated horsepower to determine the effect of carburetor-air temperature on average cylinder temperatures are presented in figure 12. The change in cylinder temperatures was relatively small; an increase of  $150^{\circ}$  F in the carburetor-air temperature resulted in an increase of approximately  $11^{\circ}$  F in the head temperature and approximately  $3^{\circ}$  F in the barrel temperature.

Fuel-air ratio. - Figures 13 and 14 show the effect of fuel-air ratio on the average cylinder temperatures, as determined from tests conducted with cylinder A and cylinder B, respectively. The coolants used were AN-E-2 ethylene glycol with cylinder A and water with cylinder B. The charge-flow rate was maintained approximately constant in each test. The highest cylinder temperatures were obtained at a fuel-air ratio of approximately 0.067, which is in the region of the chemically correct mixture. The decrease in temperature with a deviation in the fuel-air ratio from the chemically correct mixture is more rapid in the lean range than in the rich range. The approximate changes in average cylinder temperatures resulting from a change in fuel-air ratio from 0.047 to 0.067 and from 0.067 to 0.117 are tabulated:

Fuel-air-ratio change	Average temperature change, $^{\circ}$ F			
	Cylinder A (fig. 13)		Cylinder B (fig. 14)	
	Head	Barrel	Head	Intermediate
0.047-0.067	48	15	44	15
.067- .117	58	26	40	15

Spark advance. - The variation of average cylinder temperatures with spark advance is shown in figure 15 as obtained from tests conducted with cylinder A. As the spark was retarded from 42° to 20° B.T.C., the cylinder temperatures decreased. Below this point the head temperatures began decreasing at a slower rate and the barrel temperatures began increasing. The rate of change of the head and barrel temperatures from 42° to 20° B.T.C. was approximately 1.7° F and 0.6° F, respectively, per degree change in spark advance.

#### Effect of Coolant Variables on Cylinder Temperatures

Figures 16 to 22 show the effect of the various coolant variables investigated on the average cylinder temperatures. Although the effects of several variables are shown in each figure, they will be discussed separately in the succeeding paragraphs.

Coolant-flow rate. - Tests were conducted with cylinder A and repeated with cylinder B at different conditions of indicated horsepower and average coolant temperature to determine the effect of the coolant-flow rate of four different coolants on average cylinder temperatures. The results of these tests are shown in figures 16 and 17. In all the tests, the cylinder temperatures decreased with an increase in the coolant-flow rate; decrease was greater at the low flow rates than at the high.

The average changes in head and intermediate temperatures resulting from an increase in head coolant-flow rate from 55 to 125 pounds per minute and the average change in barrel temperature resulting from an increase in barrel coolant-flow rate from 15 to 45 pounds per minute are tabulated as follows:

	Change in coolant-flow rate	Average temperature change, °F			
		Coolant, glycol-water, percent by volume			
		97-3	70-30	30-70	0-100
<sup>a</sup> Cylinder A (fig. 16)					
Head	55-125	37	21	<sup>b</sup> 14	13
Barrel	15-45	36	26	<sup>b</sup> 12	8
<sup>c</sup> Cylinder B (fig. 17)					
Head	55-125	30	22	19	17
Intermediate	55-125	19	11	9	7

<sup>a</sup>Test conditions: ihp, 55; average coolant temperature, 185°-201° F; coolant pressure, 19 lb/sq in. absolute.

<sup>b</sup>The coolant was actually 38 percent-62 percent glycol-water.

<sup>c</sup>Test conditions: ihp, 47; average coolant temperature, 125° F; coolant pressure, 19 lb/sq in. absolute.



The data presented in figure 16 are not directly comparable with those in figure 17 because of the differences in the operating conditions under which the data were obtained.

Average coolant temperature. - The variation of average cylinder temperatures with average coolant temperature for four different coolants is shown in figures 18 to 21. The data were obtained from tests conducted with both cylinder A and cylinder B at two different conditions of indicated horsepower, head coolant-flow rate, and head coolant pressure. The cylinder temperatures increased approximately linearly with the coolant temperature for most of the coolants tested; however, some of the head temperatures increased slightly more rapidly at the high coolant temperatures than at the low temperatures.

The average changes in average cylinder temperatures per degree Fahrenheit change in average coolant temperature as obtained from figures 18 to 21 are presented in the following table:

Coolant, glycol- water (percent by volume)	Slope							
	<sup>a</sup> Cylinder A (fig. 18)		<sup>a</sup> Cylinder B (fig. 19)		<sup>b</sup> Cylinder A (fig. 20)		<sup>b</sup> Cylinder B (fig. 21)	
	Head	Barrel	Head	Inter- mediate	Head	Barrel	Head	Inter- mediate
97-3	0.66	0.68	0.66	0.79	0.75	0.77	0.85	0.85
70-30	.68	.69	.62	.85	.73	.71	.81	.88
30-70	<sup>c</sup> .78	<sup>c</sup> .77	.80	.88	<sup>c</sup> .90	<sup>c</sup> .88	.87	.90
0-100	.87	.84	.90	.96	.92	.85	.92	.97

<sup>a</sup>Test conditions: 1hp, 55; head coolant-flow rate, 70 lb/min; coolant pressure, 19 lb/sq in. absolute.

<sup>b</sup>Test conditions: 1hp, 48; head coolant-flow rate, 126 lb/min; coolant pressure, 60 lb/sq in. absolute.

<sup>c</sup>The coolant was actually 38 percent-62 percent glycol-water.

For the same coolant, the head temperatures presented in figures 18 and 19 agree within approximately 5° F with a slightly larger deviation (approximately 11° F) obtained with water at the high average coolant temperatures. The barrel temperatures presented in figure 18, of course, are not comparable with the intermediate temperatures presented in figure 19.

In the comparison of figures 20 and 21, the head temperatures obtained with water differ by only 3° F and the data obtained with both the nominal 30 percent-70 percent and the nominal 70 percent-30 percent glycol-water mixtures agree within approximately 14° F.

The head temperatures presented in figure 21 for AN-E-2 ethylene glycol, however, are from approximately 25° F to 35° F lower than the corresponding temperatures given in figure 20.

The results shown in figures 18 and 19 are not directly comparable with the results presented in figures 20 and 21 because the tests from which the results were obtained were conducted under different operating conditions.

Coolant pressure. - The effect of coolant pressure on average cylinder temperatures is shown in figures 14, 17, 19, and 21, as obtained from tests of cylinder B where each test condition was investigated at two different coolant pressures. Data on the effect of coolant pressure on the average and the maximum head temperatures are presented in figure 22 as obtained from four tests conducted with cylinder A using water as a coolant. At the high cylinder temperatures and low coolant pressures, decreasing the coolant pressure slightly decreased the cylinder temperatures, which indicated that some boiling was taking place on the hot metal surfaces. This effect is slightly more noticeable in the maximum than in the average head temperatures. In figures 14, 17, 19, and 21, it will be seen that a maximum decrease of approximately 8° F in the average head temperature was obtained by decreasing the coolant pressure from 59 to 19 pounds per square inch absolute. In figure 22 at an average coolant temperature of 200° F, decreasing the coolant pressure from 60 to 20 pounds per square inch absolute resulted in a decrease of approximately 13° F in the average head temperature and approximately 16° F in the maximum head temperature.

The results obtained at Wright Field (Memo. Rep. Ser. No. ENG-57-523-216) with a Continental Hyper No. 1 cylinder, indicated similar effects of coolant pressure on cylinder temperatures. At relatively high cylinder and coolant temperatures, however, initial decrease in coolant pressure resulted in slightly greater decrease in cylinder temperatures than was obtained in the tests reported herein. In addition, further reduction in coolant pressure eventually resulted in increased cylinder temperatures probably owing to the transition of boiling from the nuclear to the film phase. Film-phase boiling evidently was not reached in the present investigation.

Coolant composition. - The effect of coolant composition on average cylinder temperatures is shown in figures 16 to 21. The average cylinder temperatures obtained with AN-E-2 ethylene glycol were higher than the corresponding temperatures obtained with either water or the more aqueous ethylene-glycol solutions. The following table lists the mean temperature difference between the



average cylinder temperatures obtained with AN-E-2 ethylene glycol and those obtained with each of the other aqueous solutions tested:

Coolant, glycol- water (percent by volume)	Average temperature difference, °F					
	Cylinder A (fig. 16)		Cylinder B (fig. 17)		Cylinder A (fig. 18)	
	Head	Barrel	Head	Inter- mediate	Head	Barrel
70-30	32	25	19	16	27	23
30-70	<sup>a</sup> 42	<sup>a</sup> 31	45	30	<sup>a</sup> 47	<sup>a</sup> 39
0-100	63	47	55	39	68	53

Coolant, glycol- water (percent by volume)	Average temperature difference, °F					
	Cylinder B (fig. 19)		Cylinder A (fig. 20)		Cylinder B (fig. 21)	
	Head	Inter- mediate	Head	Barrel	Head	Inter- mediate
70-30	23	14	22	10	4	8
30-70	47	30	<sup>a</sup> 36	<sup>a</sup> 27	23	18
0-100	58	38	62	42	32	25

<sup>a</sup>The coolant was actually 38 percent-62 percent glycol-water.

The discrepancy between the temperature differences from figure 21 and the other temperature differences is probably due to some error in the AN-E-2 ethylene-glycol data presented in figure 21. (It was previously pointed out that these data are from approximately 25° F to 35° F lower than comparable data presented in fig. 20.)

#### Relation between Cylinder Temperatures

Maximum and average cylinder temperatures. - Figures 23 and 24 show the linear relations between the average and the maximum cylinder temperatures of cylinder A and cylinder B, respectively, for a wide range of engine and coolant conditions. The maximum head temperature was approximately 55° F higher than the average head temperature in cylinder A (fig. 23) and approximately 60° F higher in cylinder B (fig. 24). The maximum barrel temperature of cylinder A was approximately 17° F higher than the average barrel temperature.

The relations shown in these and in figures 25 to 28 are representative of all the data presented in the original data tables although only a portion of the data are plotted in each figure.

Exhaust-valve-guide and head temperatures. - The linear relations between the exhaust-valve-guide temperature (thermocouple 24) and the head temperature of cylinders A and B are presented in figures 25 and 26, respectively. The results are from the same tests from which data are presented in figures 23 and 24. The exhaust-valve-guide temperature is approximately  $13^{\circ}$  F higher than the head temperature in cylinder A (fig. 25) and approximately  $36^{\circ}$  F higher in cylinder B (fig. 26). The relations obtained are quite consistent considering that the temperature of the exhaust-valve guide may be affected by wearing of the valve guide and by exhaust gas escaping around the valve stem.

Liquid-side head and head temperatures. - The linear variation of the liquid-side head temperature with the head temperature is shown in figure 27 for tests conducted with cylinder A over a wide range of engine and coolant conditions. The liquid-side head temperature was approximately  $55^{\circ}$  F lower than the head temperature. The relation is good considering that the liquid-side head temperature was determined from the average of only four thermocouples (24 to 27, fig. 2).

Figure 28 shows similar data from tests conducted with cylinder B. It will be recalled that with this cylinder the liquid-side head temperature was obtained from the average of only three thermocouples (24, 25, and 27, fig. 4). The liquid-side head temperature of cylinder B (fig. 28) was approximately  $44^{\circ}$  F lower than the head temperature.

#### SUMMARY OF RESULTS

For the range of conditions investigated in tests with the two cylinders cooled with various aqueous ethylene-glycol solutions, the average cylinder temperatures:

1. Increased nearly linearly with charge-flow rate (air plus fuel) and indicated horsepower.
2. Increased a relatively small amount for an increase in carburetor-air temperature.
3. Increased rapidly at a constant charge-flow rate as the fuel-air mixture was enriched to a fuel-air ratio of 0.067 and decreased with further enriching.
4. Increased practically linearly with an increase in spark advance from  $20^{\circ}$  to  $42^{\circ}$  B.T.C. but changed less rapidly from  $12^{\circ}$  to  $20^{\circ}$  B.T.C.



5. Decreased a relatively small amount for an increase in coolant-flow rate for most of the solutions tested.

6. Increased nearly linearly with an increase in the average coolant temperature for the solutions tested.

7. Increased slightly with an increase in coolant pressure but only at the high average cylinder temperatures.

8. Were lower with water or the more aqueous ethylene-glycol solutions than with AN-E-2 ethylene glycol.

The numerical relations obtained between the average cylinder temperatures and each of the variables investigated were dependent upon the values of the other engine and coolant conditions under which the particular variable was investigated.

Aircraft Engine Research Laboratory,  
National Advisory Committee for Aeronautics,  
Cleveland, Ohio.

#### REFERENCES

1. Shayeson, Maurice W.: Single-Cylinder Engine Tests of High-Temperature Coolants. A.C.T.R. No. 4700, Materiel Div., Army Air Corps, Oct. 22, 1941.
2. Cragoe, C. S.: Properties of Ethylene Glycol and Its Aqueous Solutions. Cooperative Fuel Res. Committee, CRC, July 1943.

TABLE 1. - SUMMARY OF TESTS CONDUCTED WITH CYLINDER A AND CYLINDER B

Variable	Range of variable	Coolant, glycol-water (nominal percent by volume)	Cylinder A	Cylinder B
			Runs	Runs
Engine speed, rpm	1050-2760	97-3 0-100	1-10, 51-62, 64-73	153-162 60-73, 122-137, 366-385
Manifold pressure, in. Hg absolute	21.0-39.0	97-3 0-100	12-23, 41-49, 147-153	163-178 44-59, 350-365, 386-397
Carburetor-air temperature, °F	80-222	97-3	111-117, 140-146	
Fuel-air ratio	0.048-0.121	97-3 0-100	95-110	328-349
Spark advance, degrees B.T.C.	12-42	97-3	118-127	
Coolant-flow rate, lb/min	10.0-128.3	97-3	24-40, 75-82, 368-379, 388-401	141-152, 207-220
		70-30	177-182, 189-195, 410-421	232-245, 258-271
		30-70	196-204, 211-218, 436-441, 446-451, 459-470	284-297, 308-321
Average coolant temperature, °F	90.0-311.0	0-100	160-176, 278-284, 319-336	74-87, 98-111, 398-411
		97-3	83-94, <sup>a</sup> 128-139, 380-387, 402-409	179-206
		70-30	183-188, 422-435	221-231, 246-257
Coolant pressure, lb/sq in. absolute	17-75	30-70	205-210, 442-445, 452-458	272-283, 298-307
		0-100	154-159, 273-277, 337-341	88-97, 112-121, 412-421
		0-100	342-367	

<sup>a</sup>Coolant flow also varied.



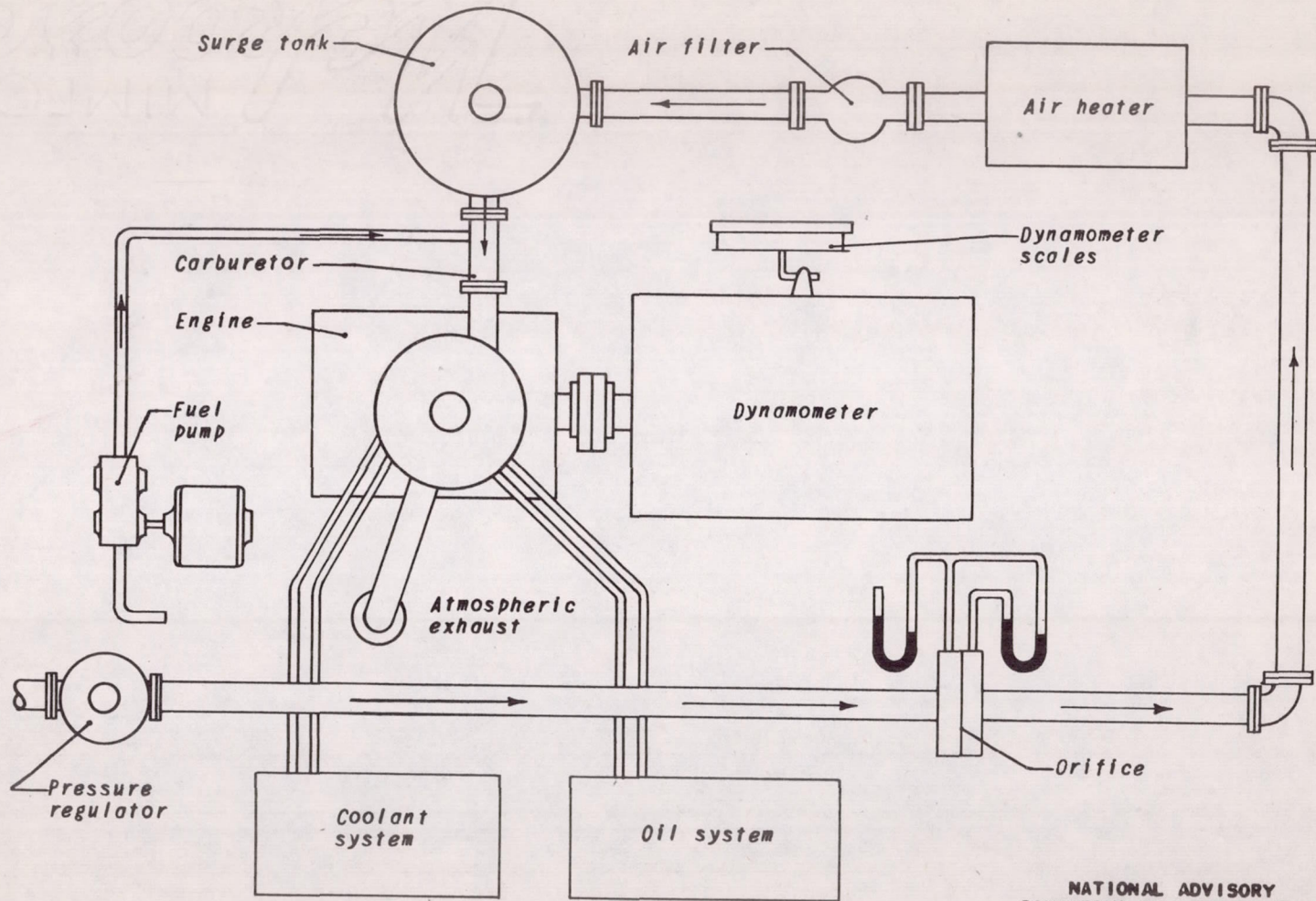

NATIONAL ADVISORY  
COMMITTEE FOR AERONAUTICS

Figure 1. - Diagrammatic layout of engine-testing setup.



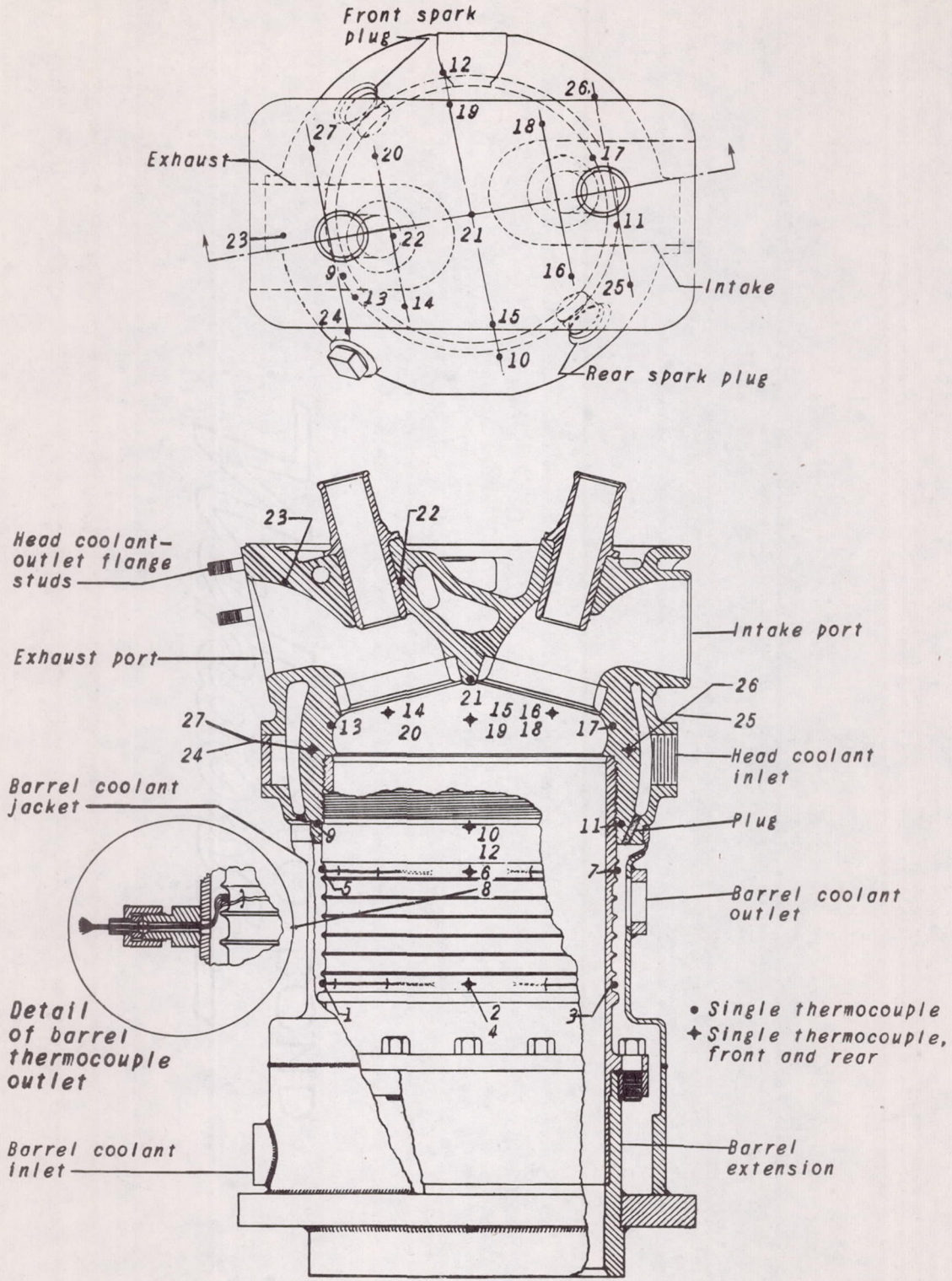

NATIONAL ADVISORY  
COMMITTEE FOR AERONAUTICS

Figure 2. - Thermocouple installation and modifications of cylinder A.



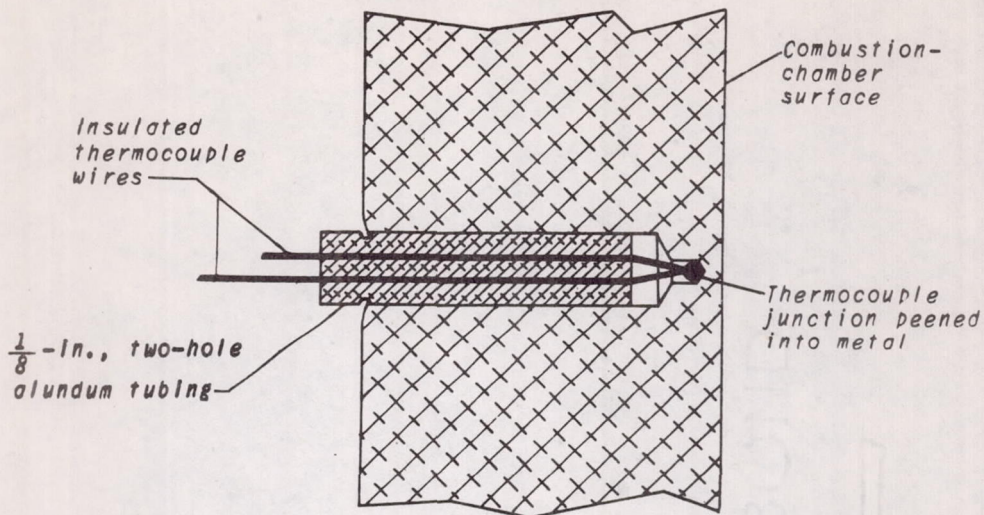

(a) Gas-side head thermocouple in solid portions of cylinder head.

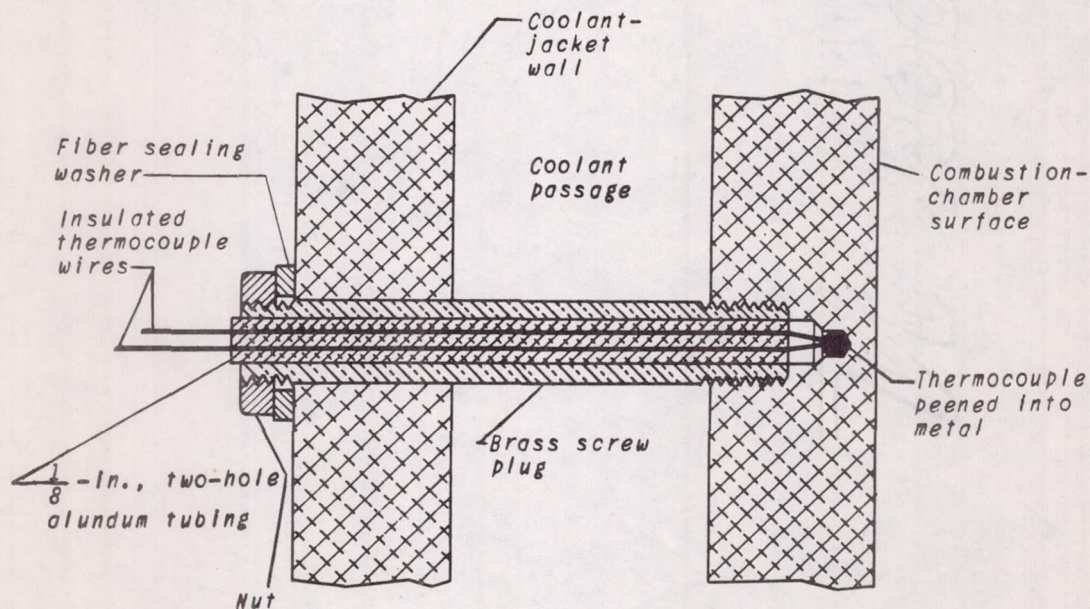

(b) Gas-side head thermocouple crossing through coolant passage of cylinder head.

NATIONAL ADVISORY  
COMMITTEE FOR AERONAUTICS

Figure 3. - Thermocouple-installation details of head and coolant thermocouples.



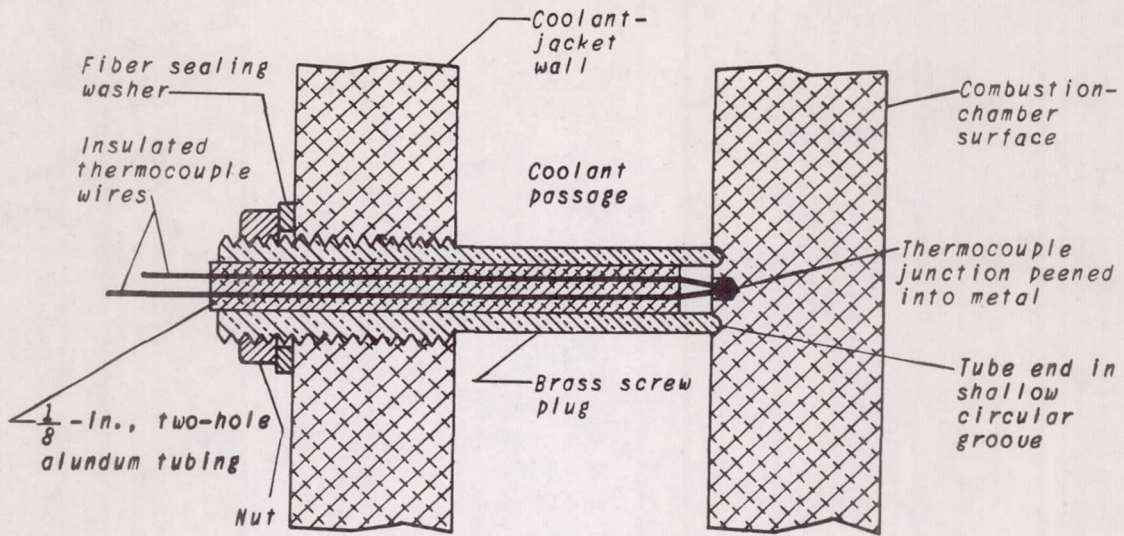

(c) Liquid-side head thermocouple.

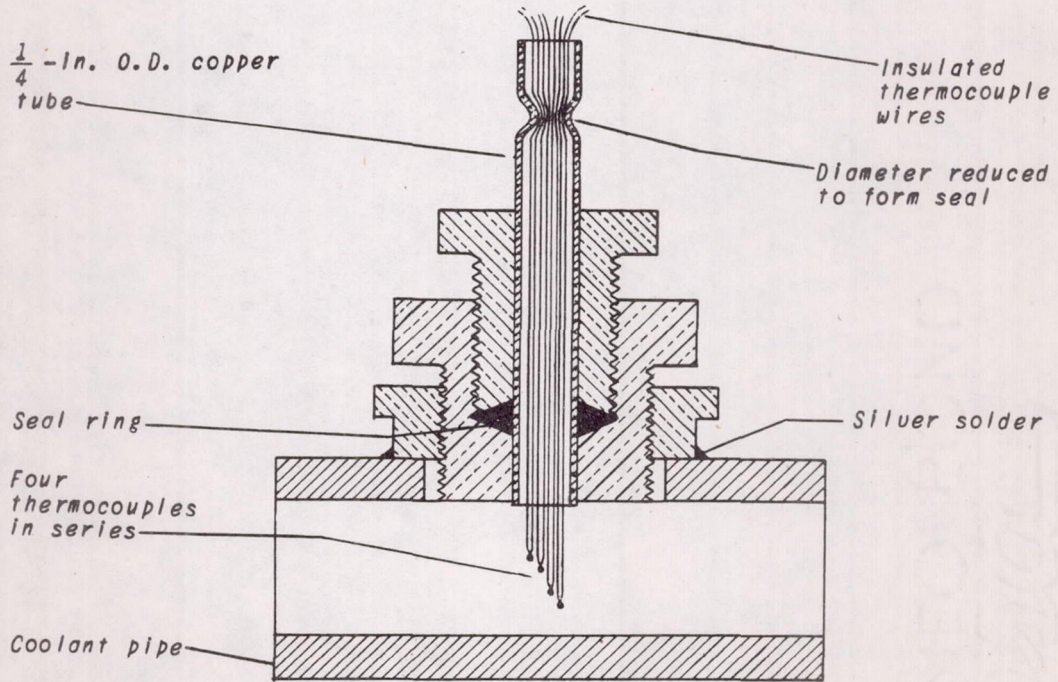

(d) Coolant thermocouples in coolant pipes.



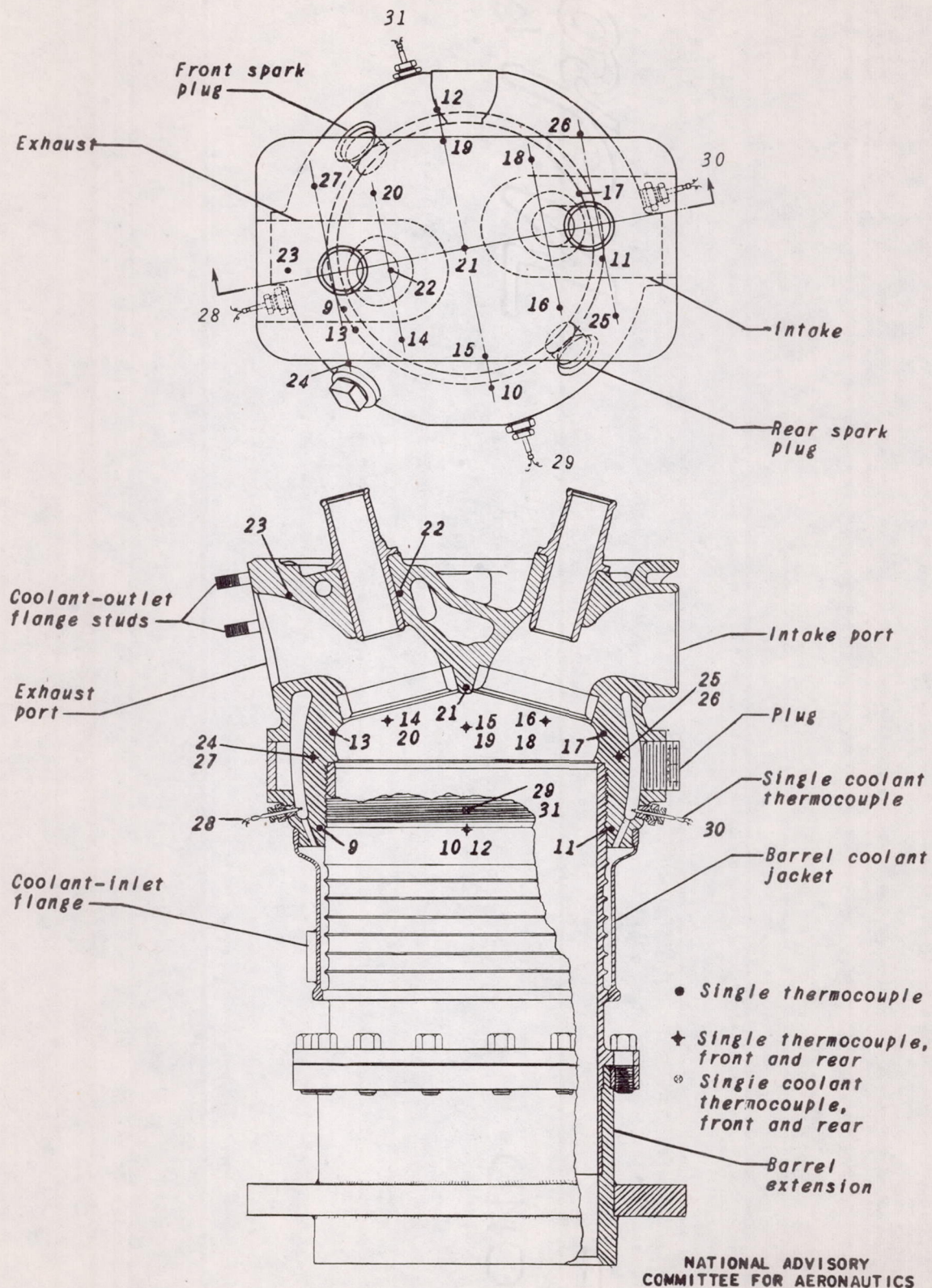

Figure 4. - Thermocouple installation of cylinder B.



Thermocouples  
in  
coolant stream

- Single thermocouple
- ⊗ Four thermocouples connected in series

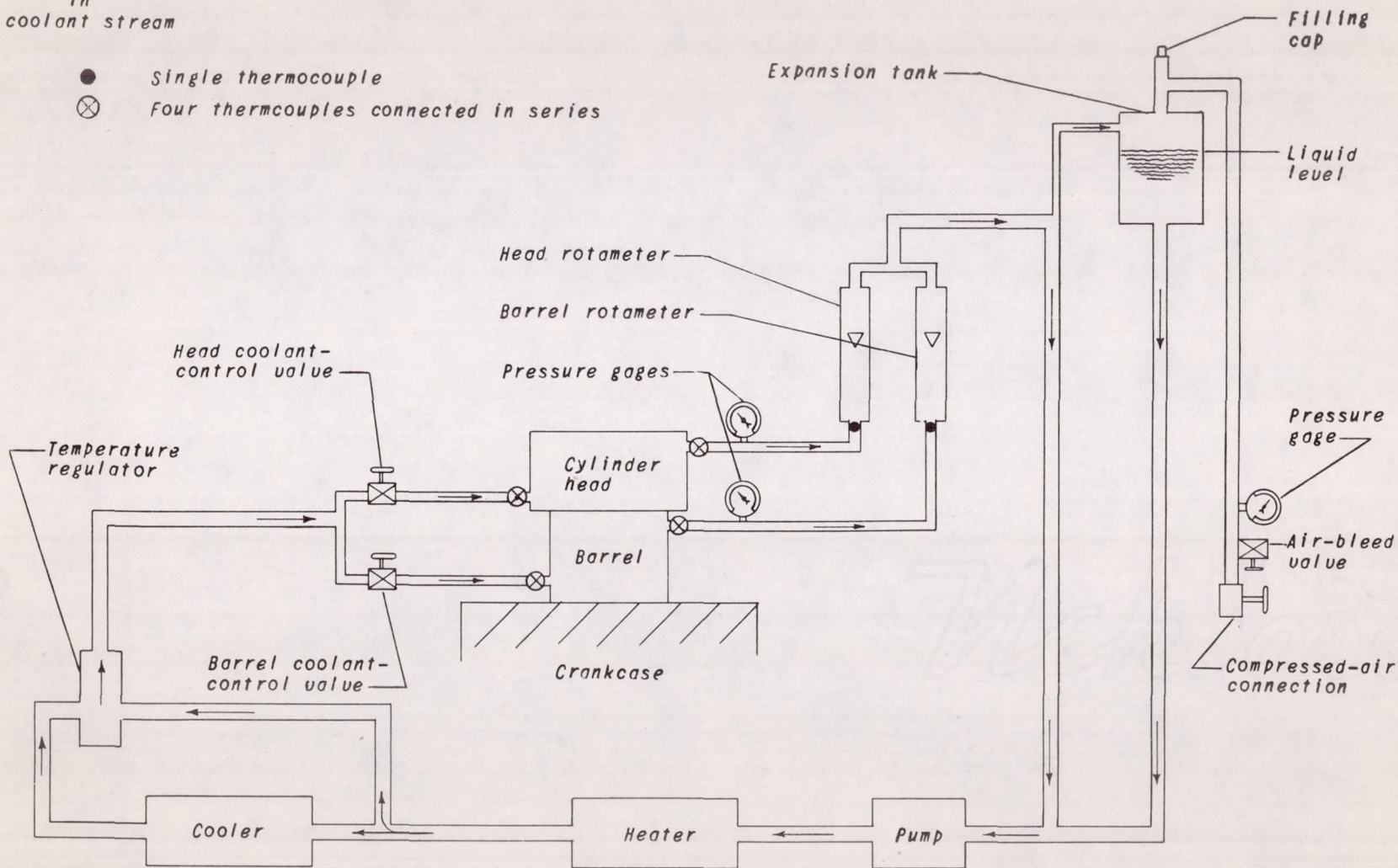

Figure 5. - Schematic diagram of cooling system, cylinder A.

NATIONAL ADVISORY  
COMMITTEE FOR AERONAUTICS



Thermocouples  
in  
coolant stream

- Single thermocouple
- ◆ Single thermocouple, front and rear
- ⊗ Four thermocouples connected in series

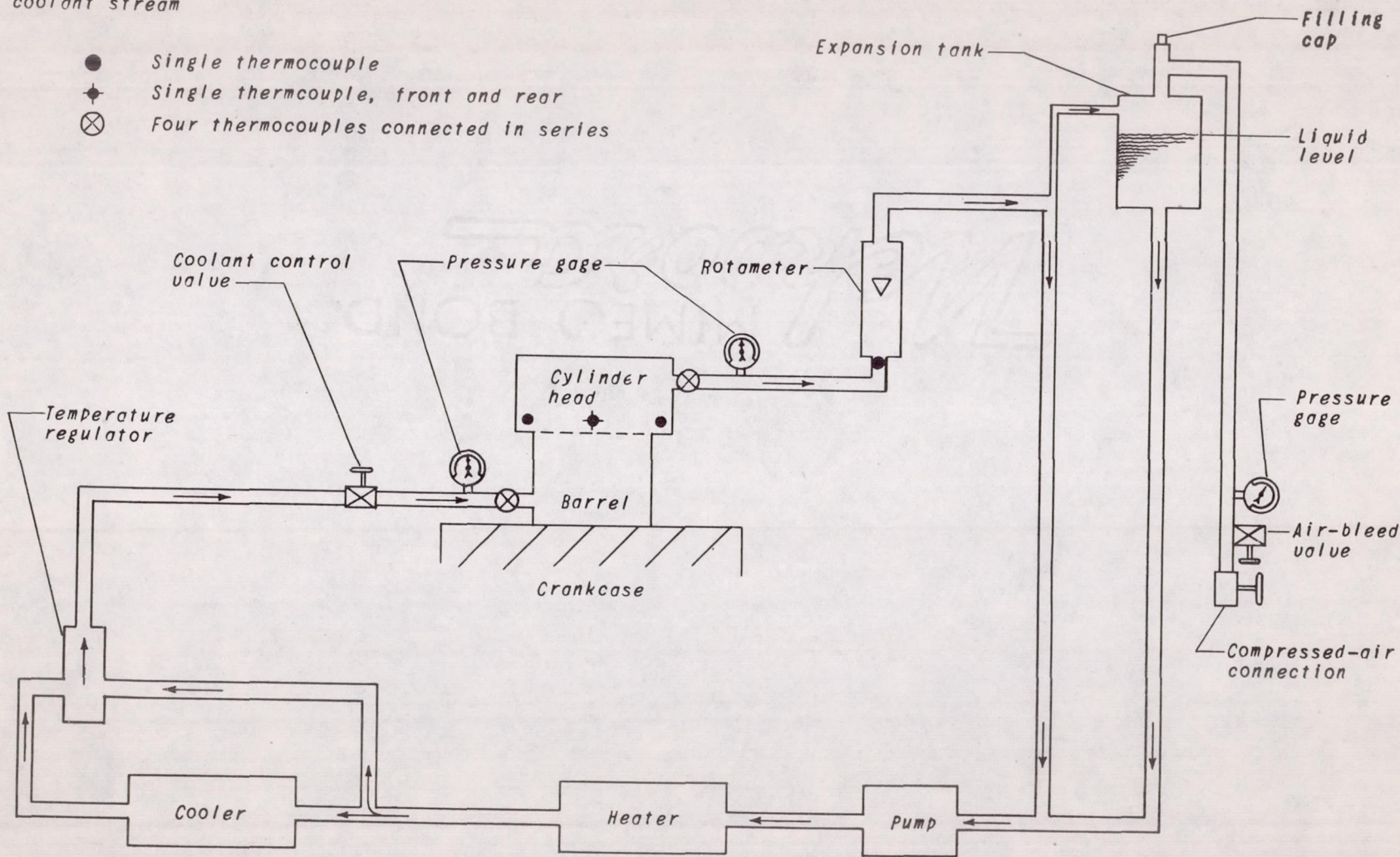

Figure 6. - Schematic diagram of cooling system, cylinder B.



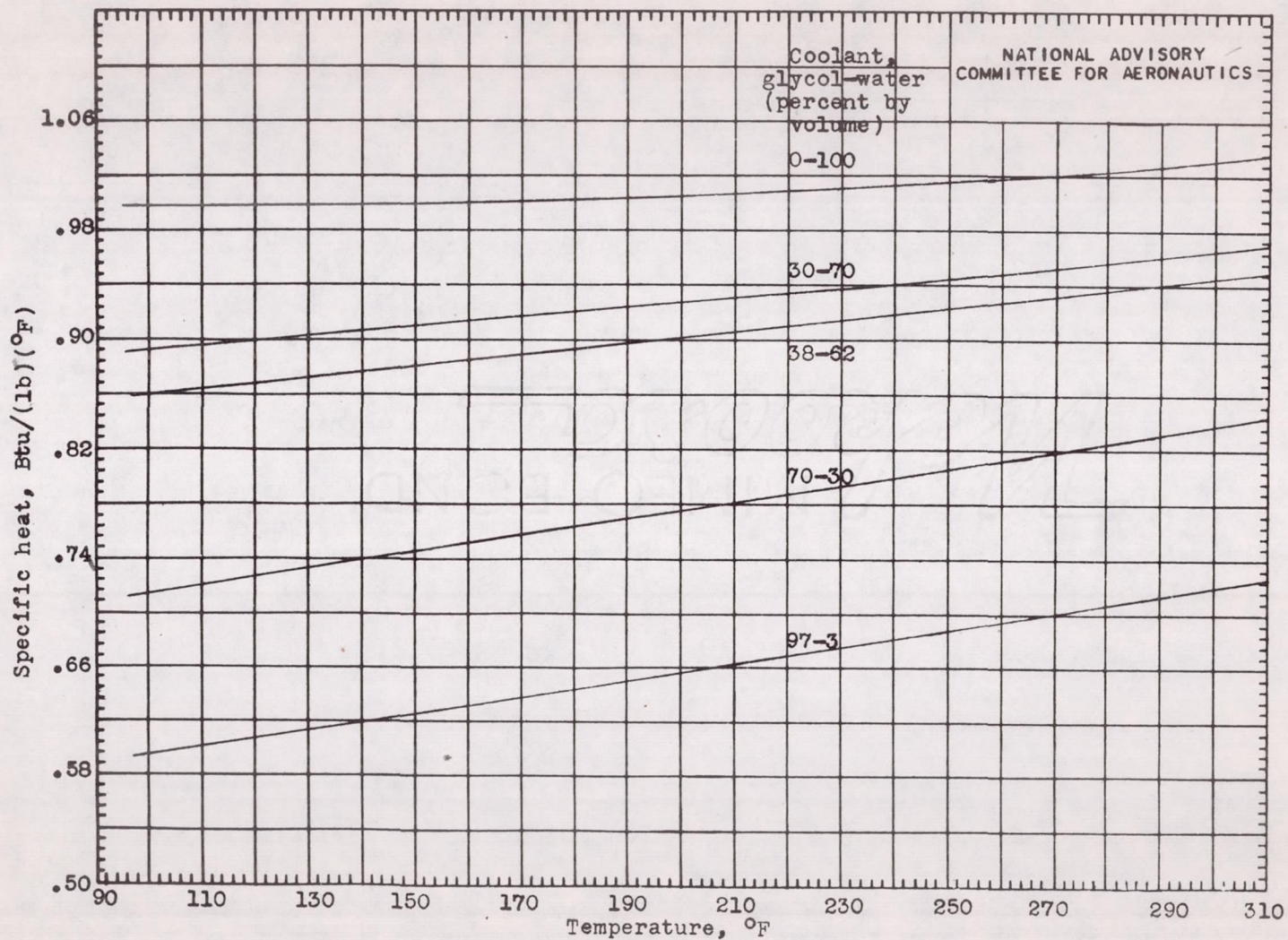

Figure 7.- Variation of specific heat with temperature for various glycol-water solutions.  
(Data from reference 2.)



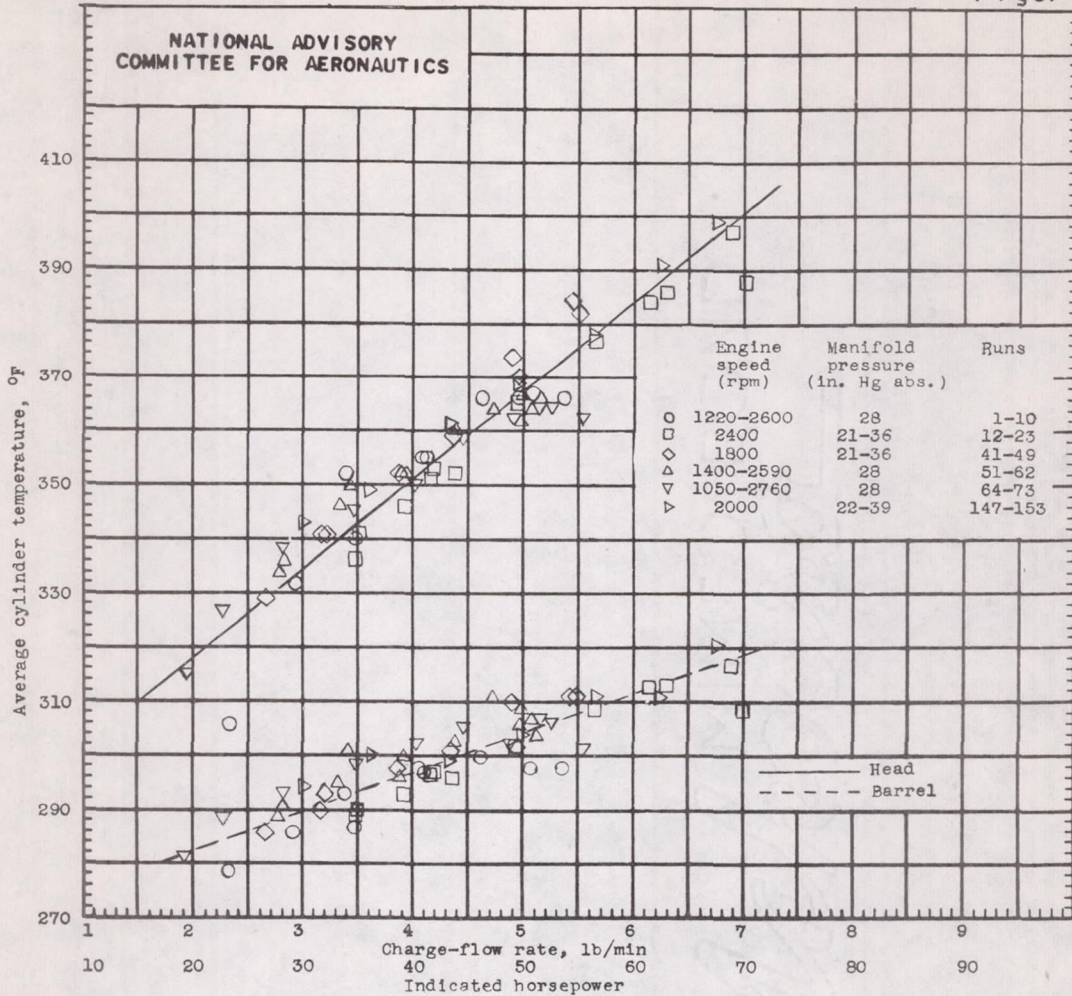

Figure 8.- Effect of charge-flow rate and indicated horsepower on average head and barrel temperatures. Cylinder A; coolant, AN-E-2 ethylene glycol; average coolant temperature, 247° F; coolant-flow rate; head, 73 pounds per minute; barrel, 30 pounds per minute; barrel pressure, 19 pounds per square inch absolute; fuel-air ratio, 0.075; spark advance, 28° B.T.C.; carburetor-air temperature, 80° F.

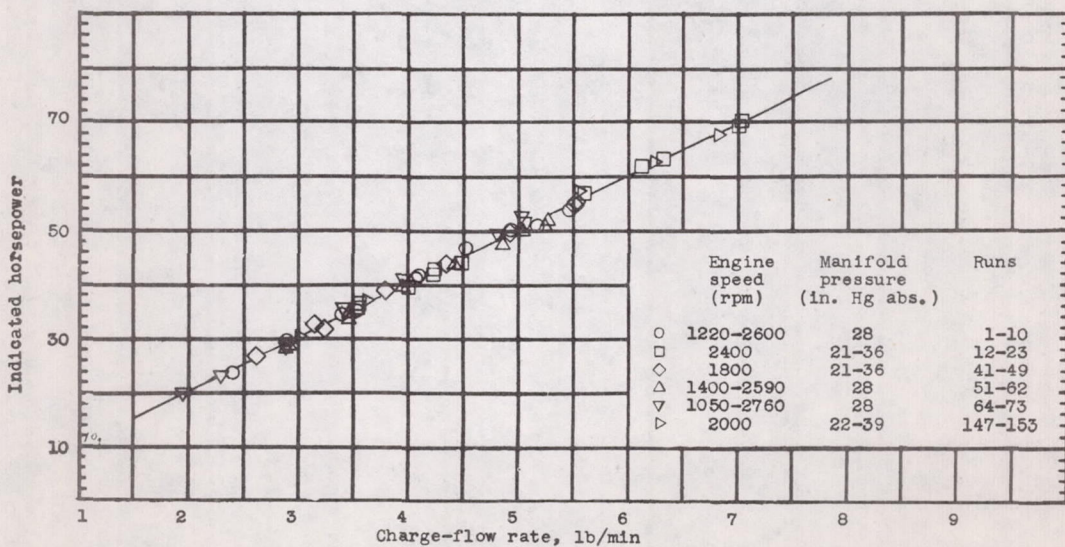

Figure 9.- Relation of indicated horsepower to charge-flow rate, cylinder A.



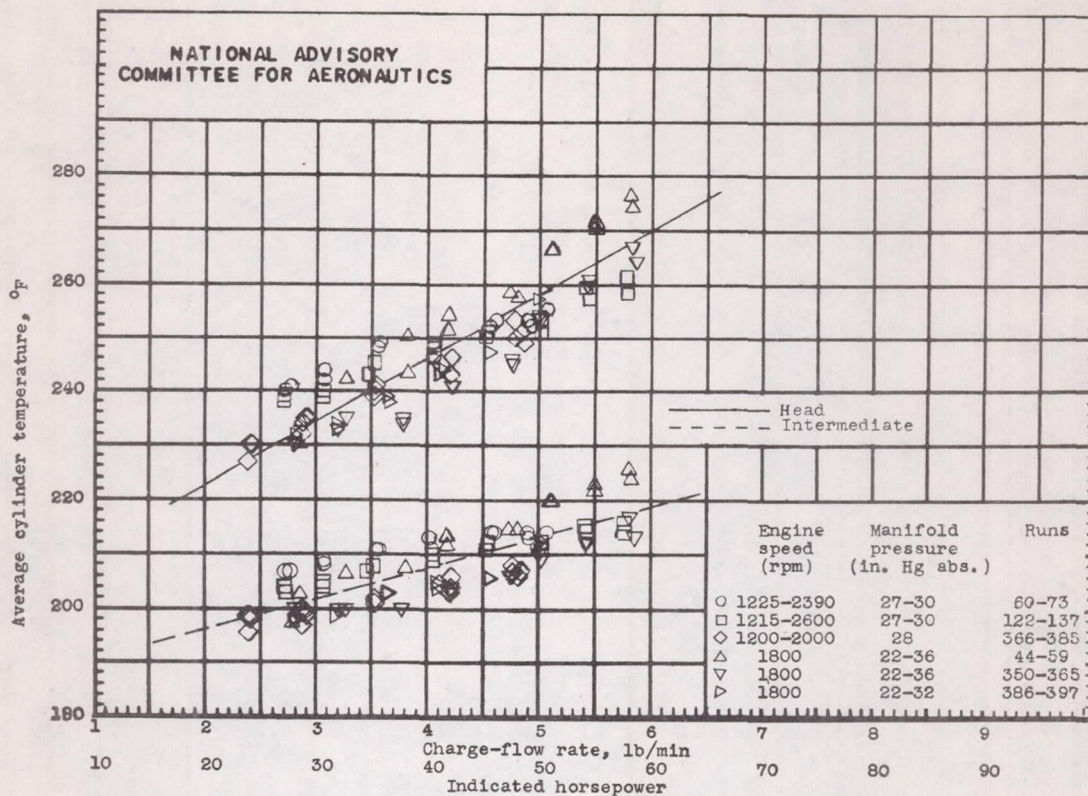

Figure 10.- Effect of charge-flow rate and indicated horsepower on average head and intermediate temperatures. Cylinder B; coolant, water; average coolant temperature, 173° F; coolant-flow rate, 70 pounds per minute; coolant pressure, 15 and 59 pounds per square inch absolute; fuel-air ratio, 0.079; spark advance, 28° B.T.C.; carburetor-air temperature, 76° F.

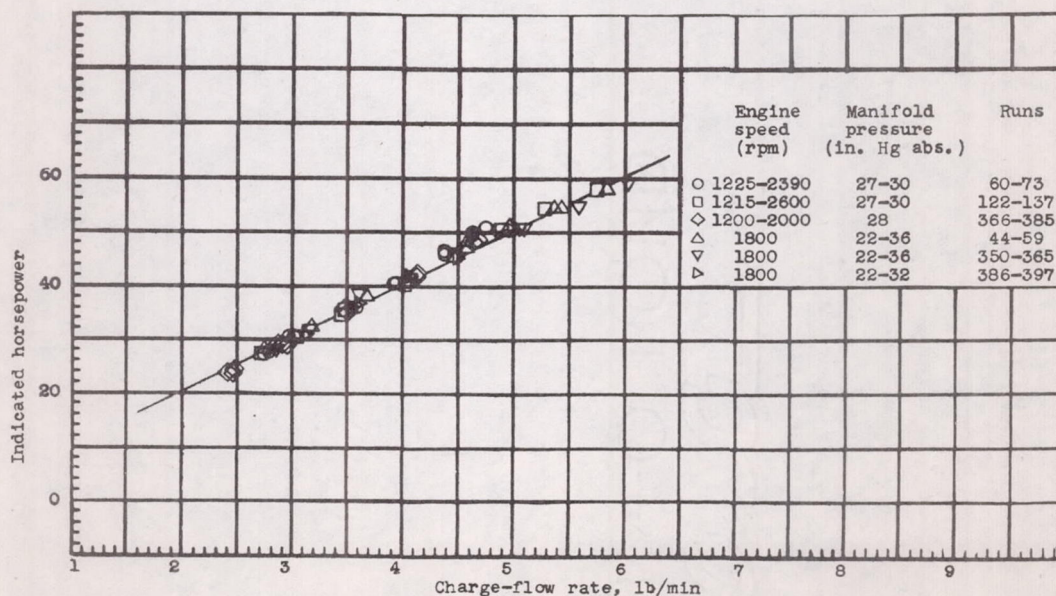

Figure 11.- Relation of indicated horsepower to charge-flow rate, cylinder B.



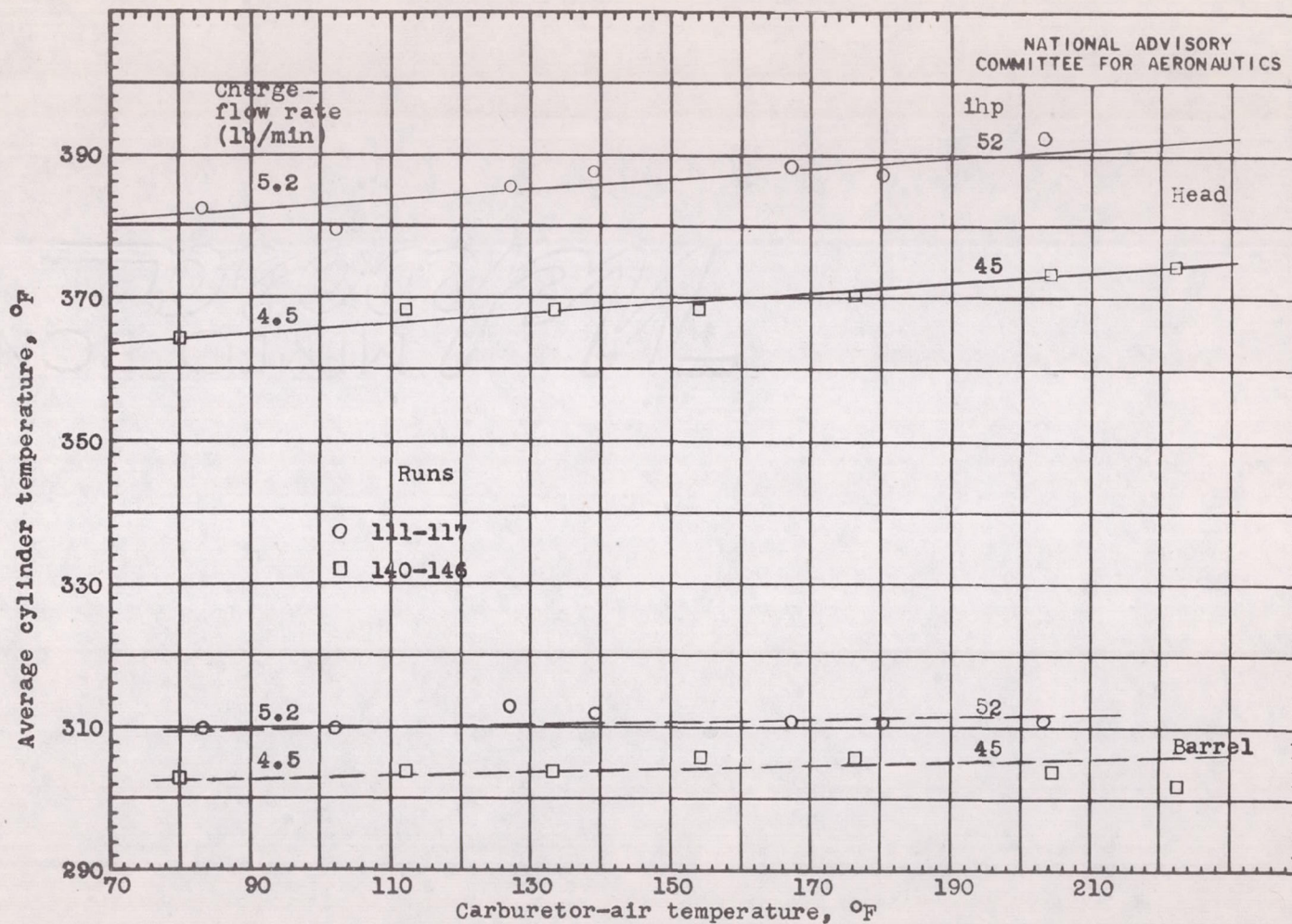

Figure 12.- Effect of carburetor-air temperature on average head and barrel temperatures. Cylinder A; coolant, AN-E-2 ethylene glycol; average coolant temperature: head, 249° F, barrel, 247° F; coolant-flow rate: head, 72 pounds per minute, barrel, 30 pounds per minute; coolant pressure, 19 pounds per square inch absolute; engine speed, 2000 rpm; fuel-air ratio, 0.077; spark advance, 28° B.T.C.



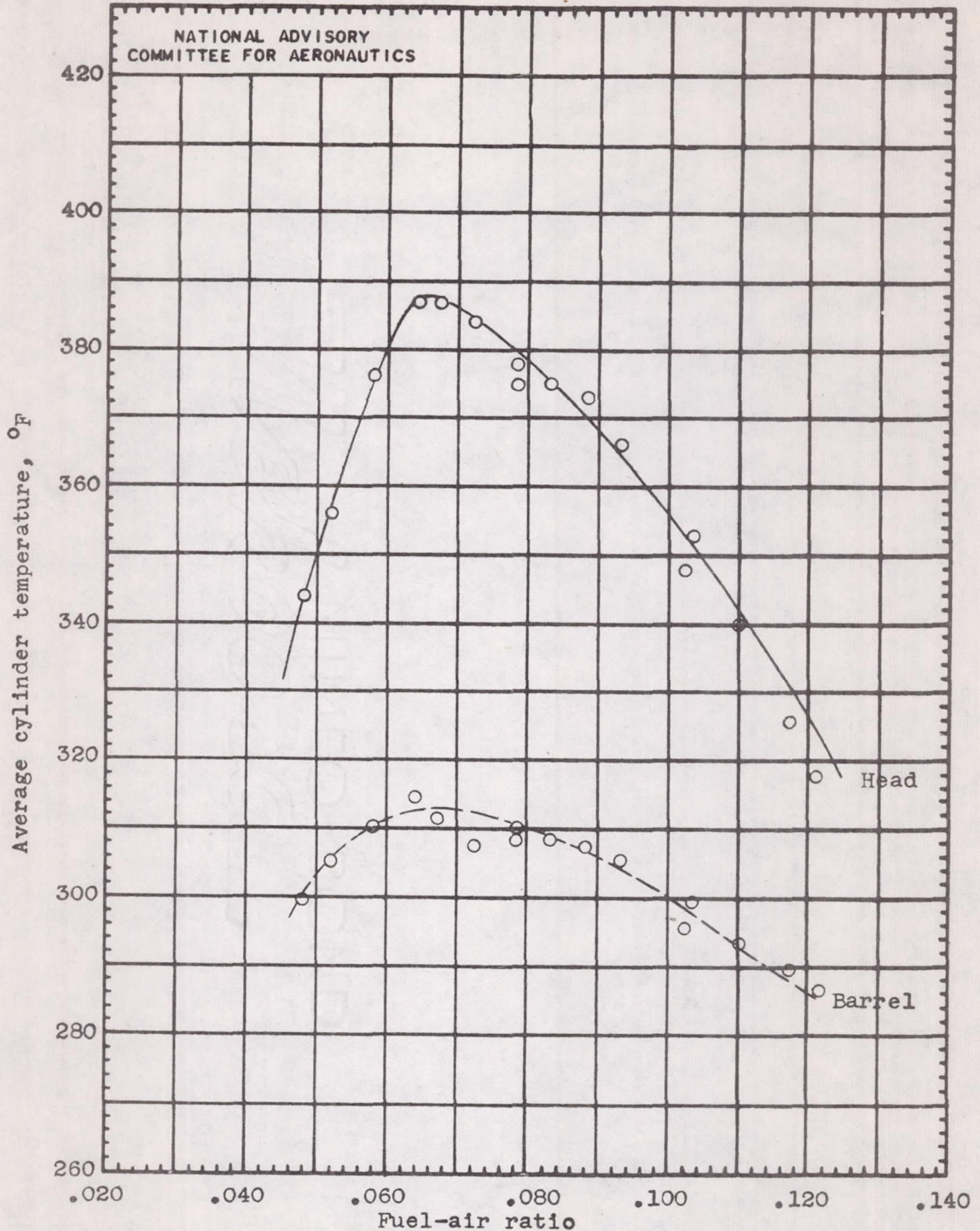

Figure 13.- Effect of fuel-air ratio on average head and barrel temperatures. Cylinder A; coolant, AN-E-2 ethylene glycol; average coolant temperature: head, 249° F, barrel, 247° F; coolant-flow rate: head, 73 pounds per minute, barrel, 30 pounds per minute; coolant pressure, 19 pounds per square inch absolute; engine speed, 2000 rpm; indicated horsepower, 43 to 54; charge-flow rate, 5.3 to 5.5 pounds per minute; spark advance, 28° B.T.C.; carburetor-air temperature, 80° F; runs, 95 to 110.



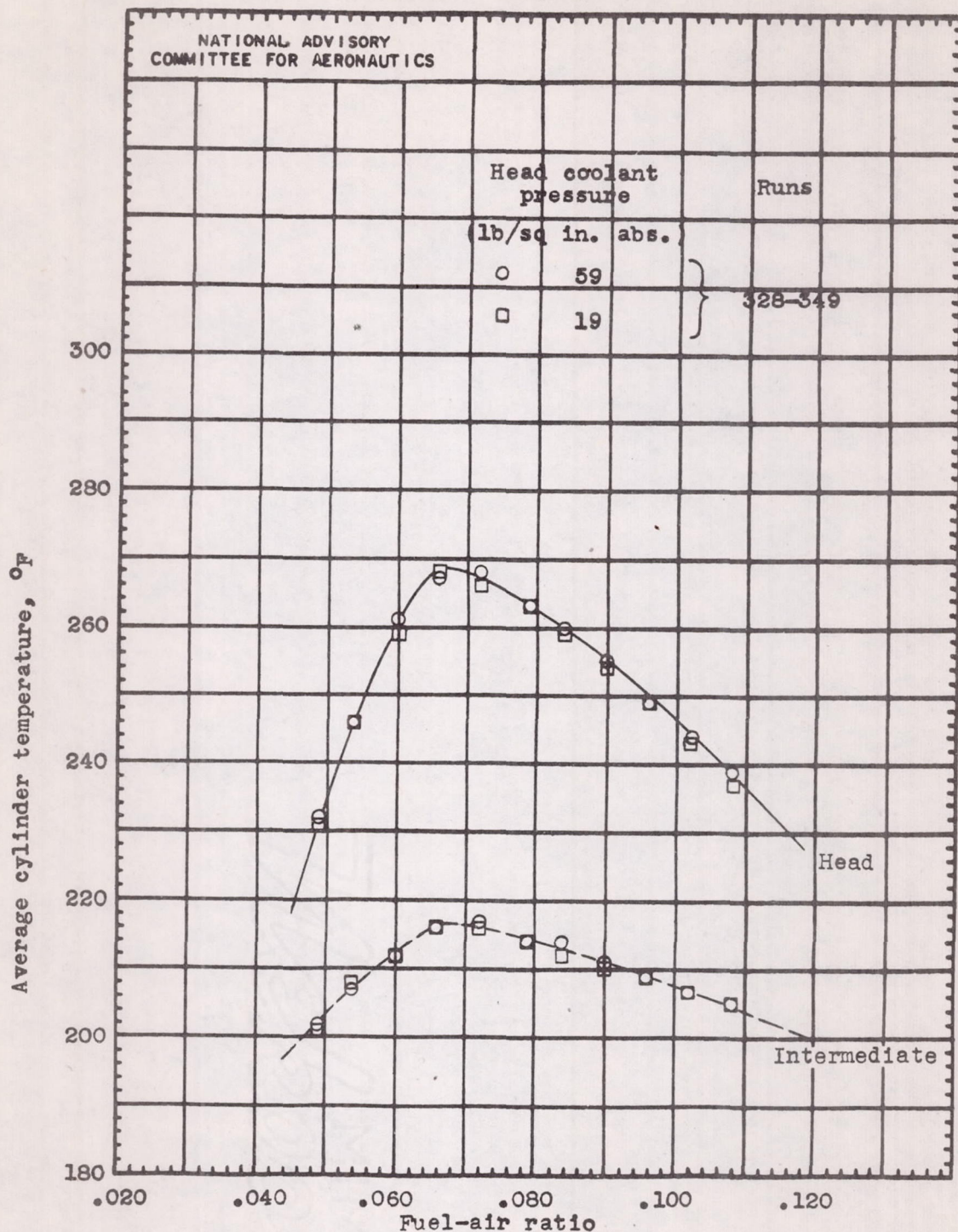

Figure 14.- Effect of fuel-air ratio on average head and intermediate temperatures. Cylinder B; coolant, water; average coolant temperature, 173° F; coolant-flow rate, 70 pounds per minute; engine speed, 2000 rpm; indicated horsepower, 40 to 62; charge-flow rate, 5.6 to 5.9 pounds per minute; spark advance, 28° B.T.C.; carburetor-air temperature, 74° F.



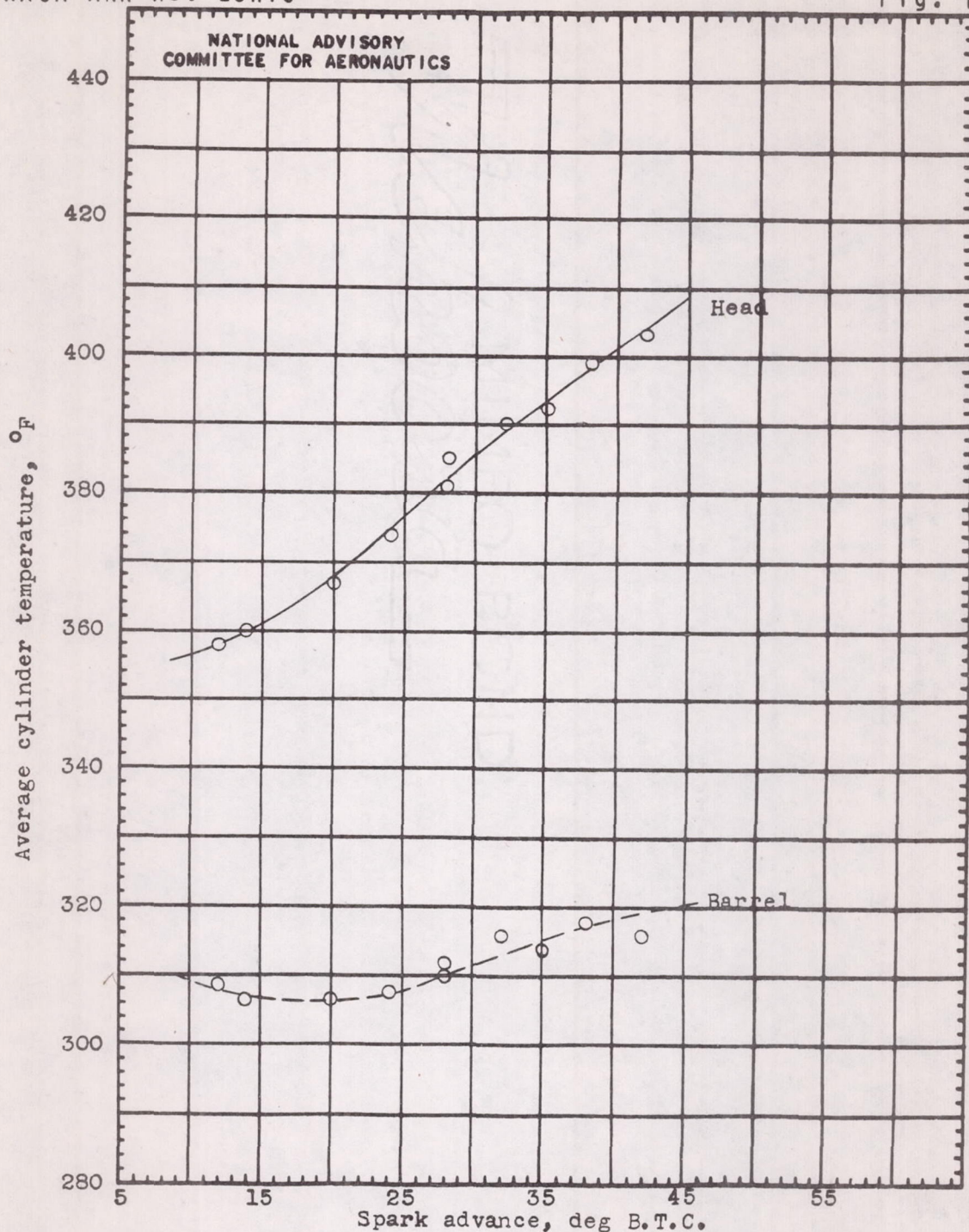

Figure 15. - Effect of spark advance on average head and barrel temperatures. Cylinder A; coolant, AN-E-2 ethylene glycol; average coolant temperature: head, 249° F, barrel, 247° F; coolant-flow rate: head, 72 pounds per minute, barrel, 30 pounds per minute; coolant pressure, 19 pounds per square inch absolute; engine speed, 2000 rpm; indicated horsepower, 48 to 55; charge-flow rate, 5.4 pounds per minute; fuel-air ratio, 0.077; carburetor-air temperature, 83° F; runs, 118 to 127.



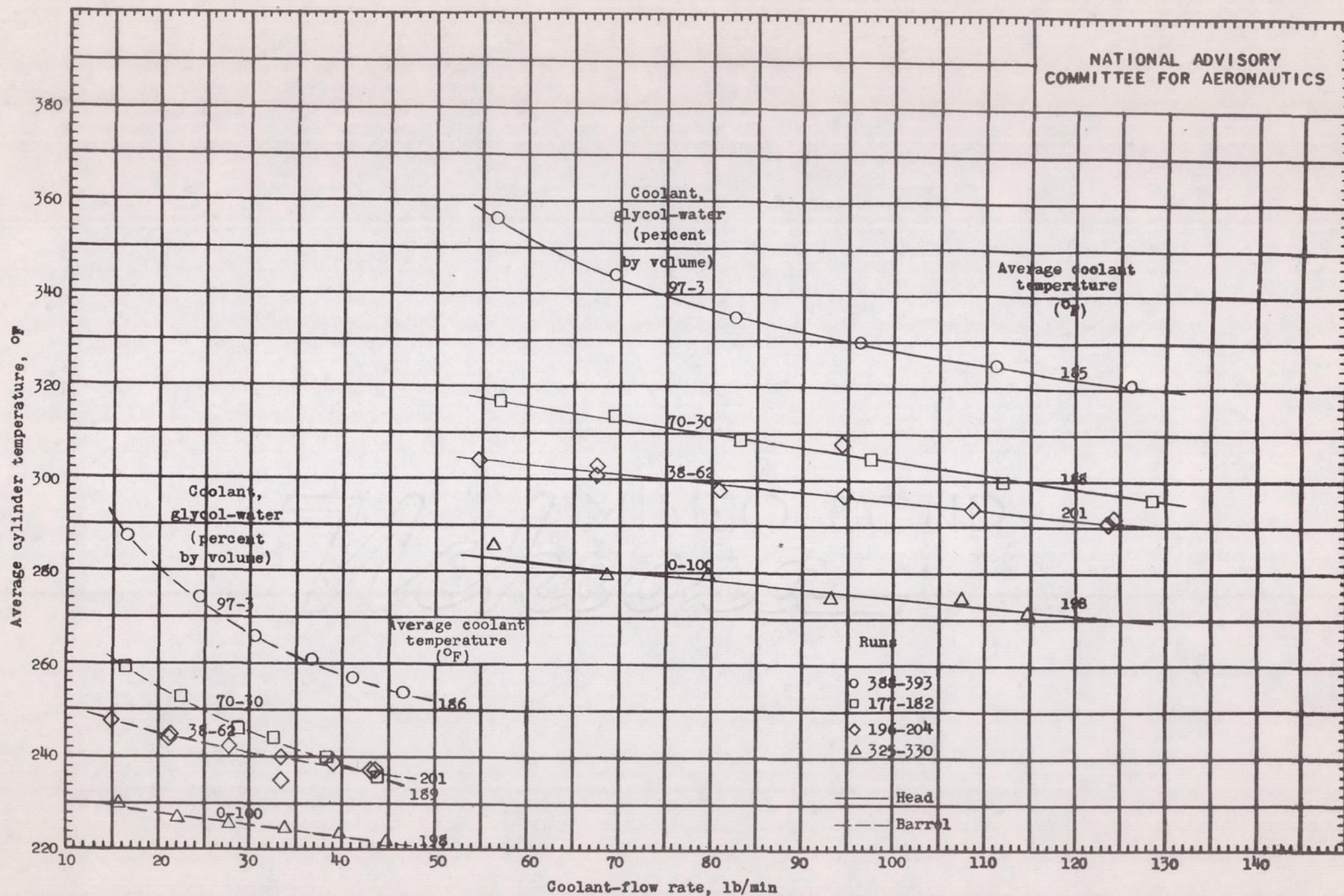

Figure 16.- Effect of coolant-flow rate on average head and barrel temperatures using various glycol-water solutions. Cylinder A; coolant pressure, 19 pounds per square inch absolute; engine speed, 2000 rpm; indicated horsepower, 55; charge-flow rate, 5.5 pounds per minute; fuel-air ratio, 0.078; spark advance, 28° B.T.C.; carburetor-air temperature, 84° F.



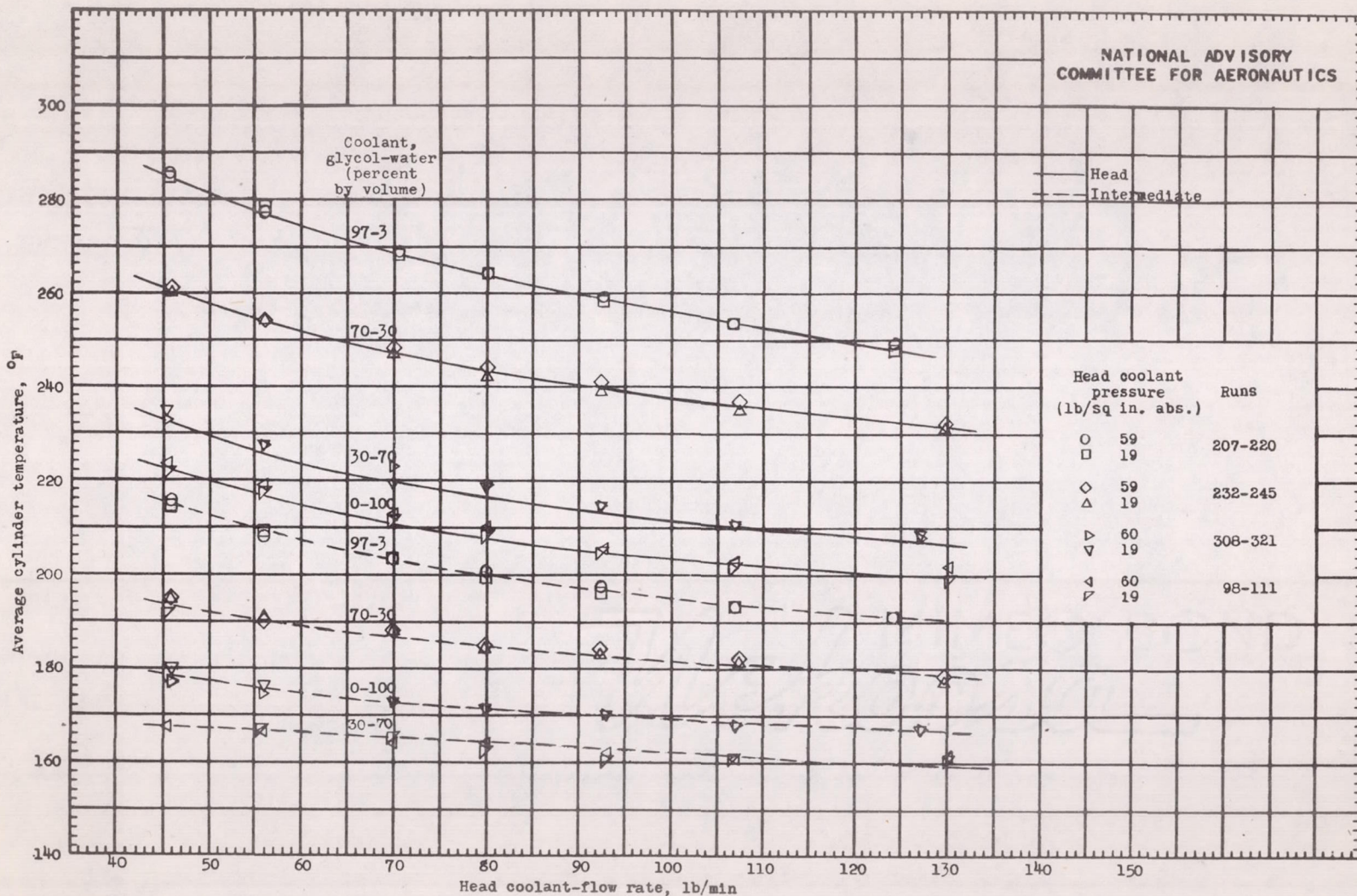

Figure 17.- Effect of coolant-flow rate on average head and intermediate temperatures using various glycol-water solutions. Cylinder B; average coolant temperature, 125° F; engine speed, 1800 rpm; indicated horsepower, 47; charge-flow rate, 4.6 pounds per minute; fuel-air ratio, 0.079; spark advance, 28° B.T.C.; carburetor-air temperature, 75° F.



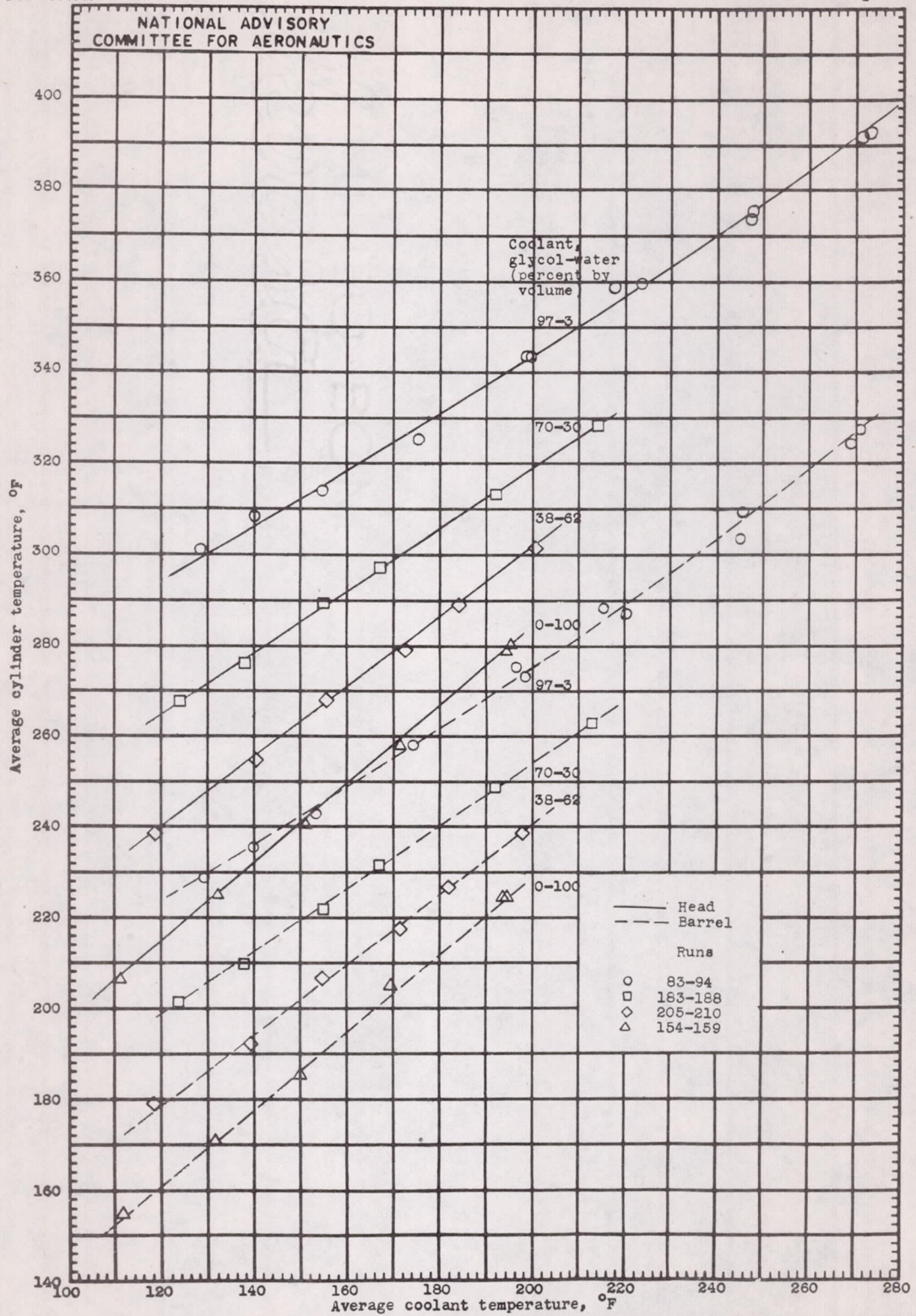

Figure 18.- Effect of average coolant temperature on average head and barrel temperatures using various glycol-water solutions at a head coolant-flow rate of approximately 70 pounds per minute and a barrel coolant-flow rate of 30 pounds per minute. Cylinder A; coolant pressure, 19 pounds per square inch absolute; engine speed, 2000 rpm; indicated horsepower, 55; charge-flow rate, 5.4 pounds per minute; fuel-air ratio, 0.078; spark advance, 28° B.T.C.; carburetor-air temperature, 81° F.



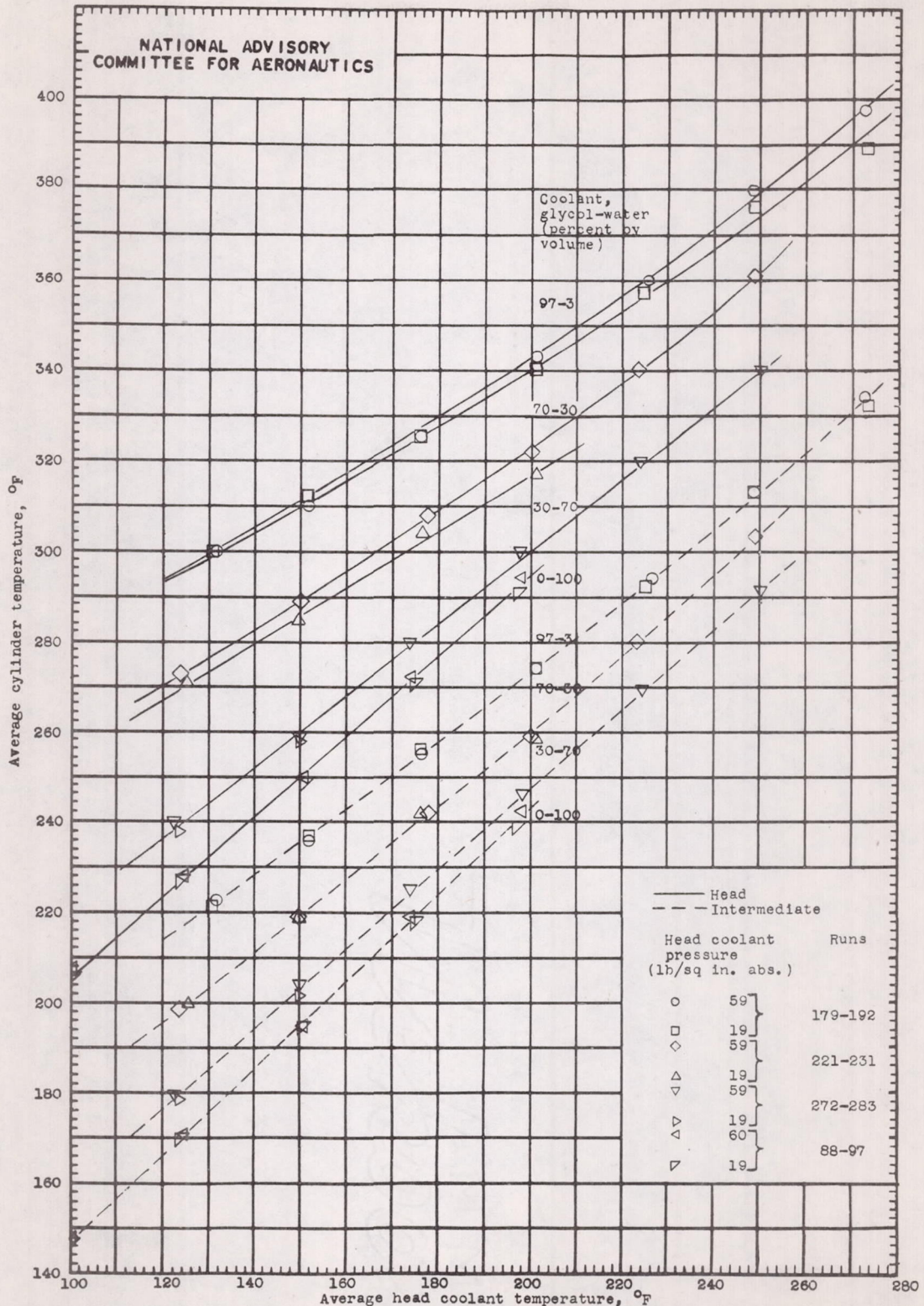

Figure 19.- Effect of average coolant temperature on average head and intermediate temperatures using various glycol-water solutions at a coolant-flow rate of approximately 70 pounds per minute. Cylinder B; engine speed, 2000 rpm; indicated horsepower, 56; charge-flow rate, 5.6 pounds per minute; fuel-air ratio, 0.079; spark advance, 28° B.T.C.; carburetor-air temperature, 75° F.



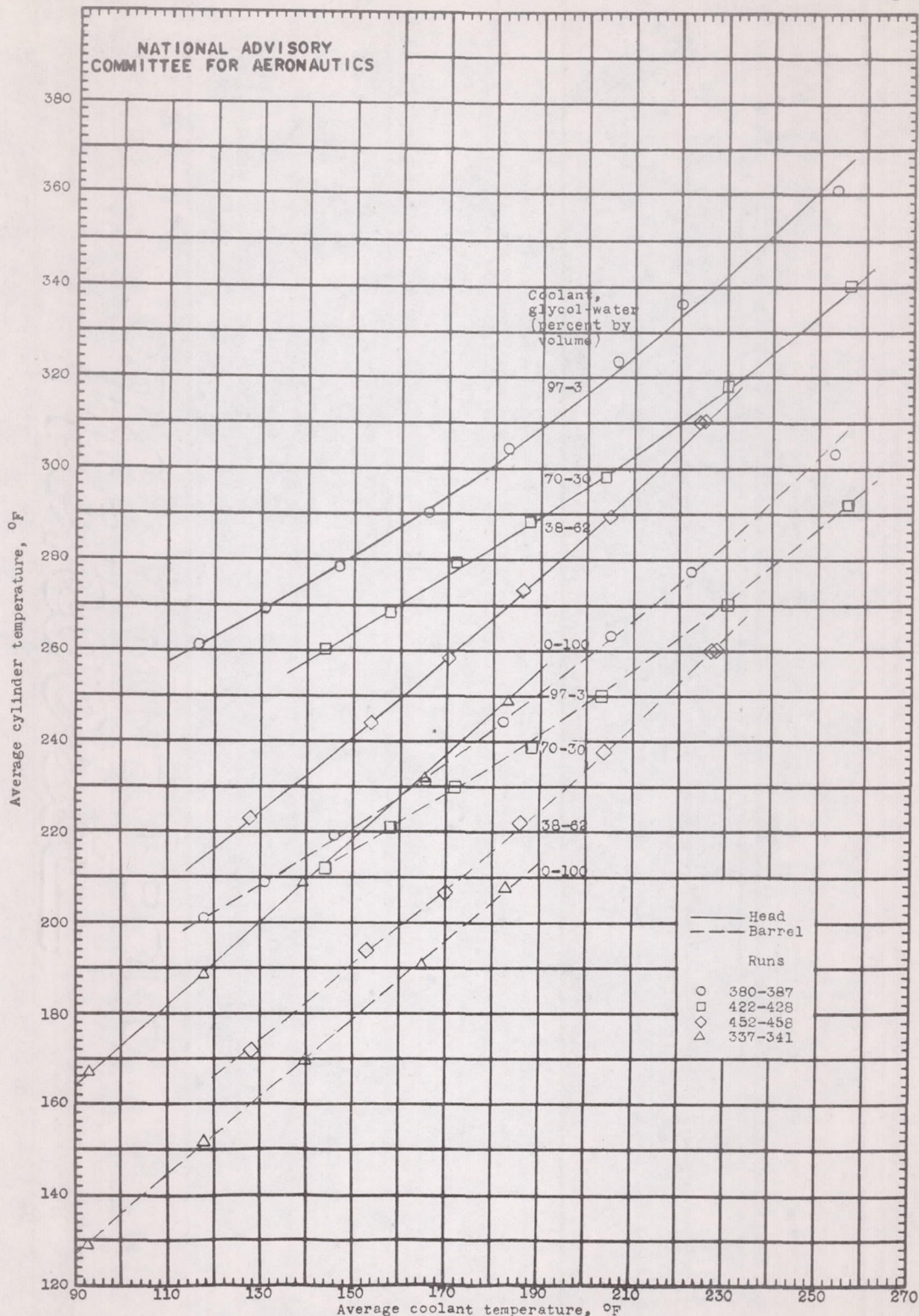

Figure 20.- Effect of average coolant temperature on average head and barrel temperatures using various glycol-water solutions at a head coolant-flow rate of approximately 125 pounds per minute and a barrel coolant-flow rate of 46 pounds per minute. Cylinder A; coolant pressure; head, 50 pounds per square inch absolute, barrel, 42 pounds per square inch absolute; engine speed, 1800 rpm; indicated horsepower, 48; charge-flow rate, 4.6 pounds per minute; fuel-air ratio, 0.078; spark advance, 28° B.T.C.; carburetor-air temperature, 86° F.



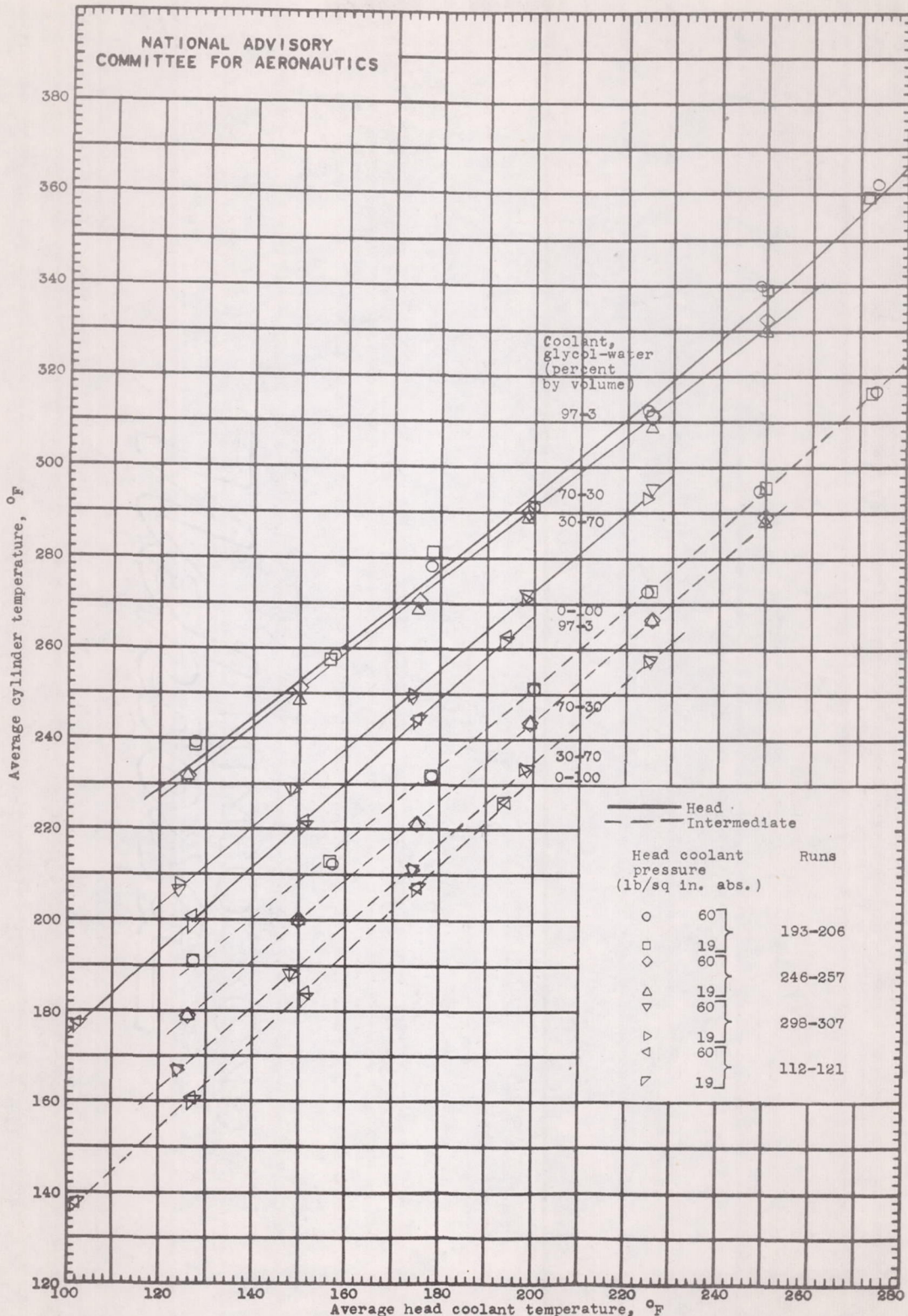

Figure 21.- Effect of average coolant temperature on average head and intermediate temperatures using various glycol-water solutions at a coolant-flow rate of approximately 127 pounds per minute. Cylinder B; engine speed, 1800 rpm; indicated horsepower, 47; charge-flow rate, 4.6 pounds per minute; fuel-air ratio, 0.079; spark advance, 28° B.T.C.; carburetor-air temperature, 77° F.



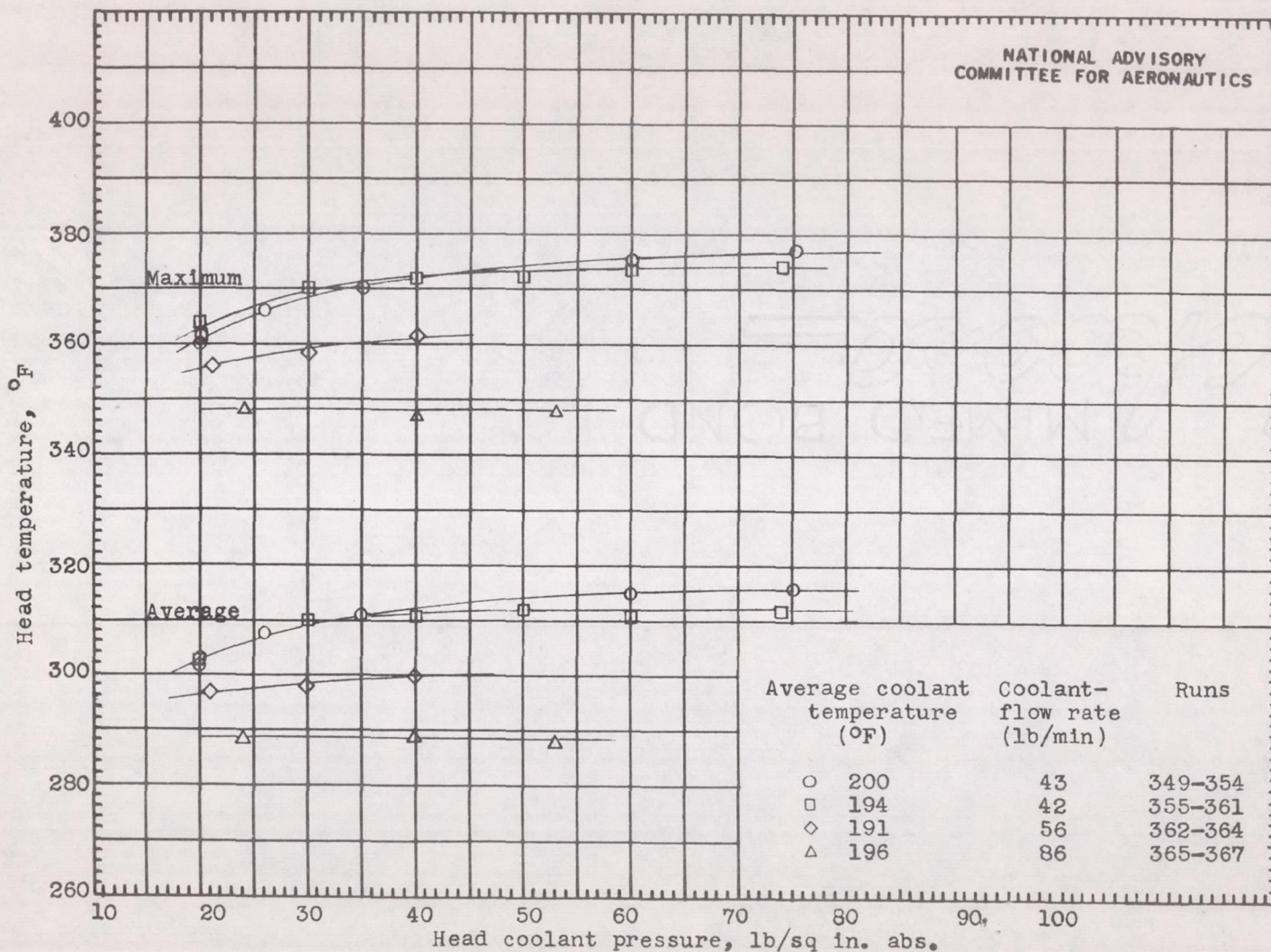

Figure 22.- Effect of coolant pressure on average and maximum head temperatures using water as a coolant under various conditions of average coolant temperature and flow rate. Cylinder A; engine speed, 2200 rpm; indicated horsepower, 68; charge-flow rate, 7.1 pounds per minute; fuel-air ratio, 0.078; spark advance, 28° B.T.C.; carburetor-air temperature, 82° F.



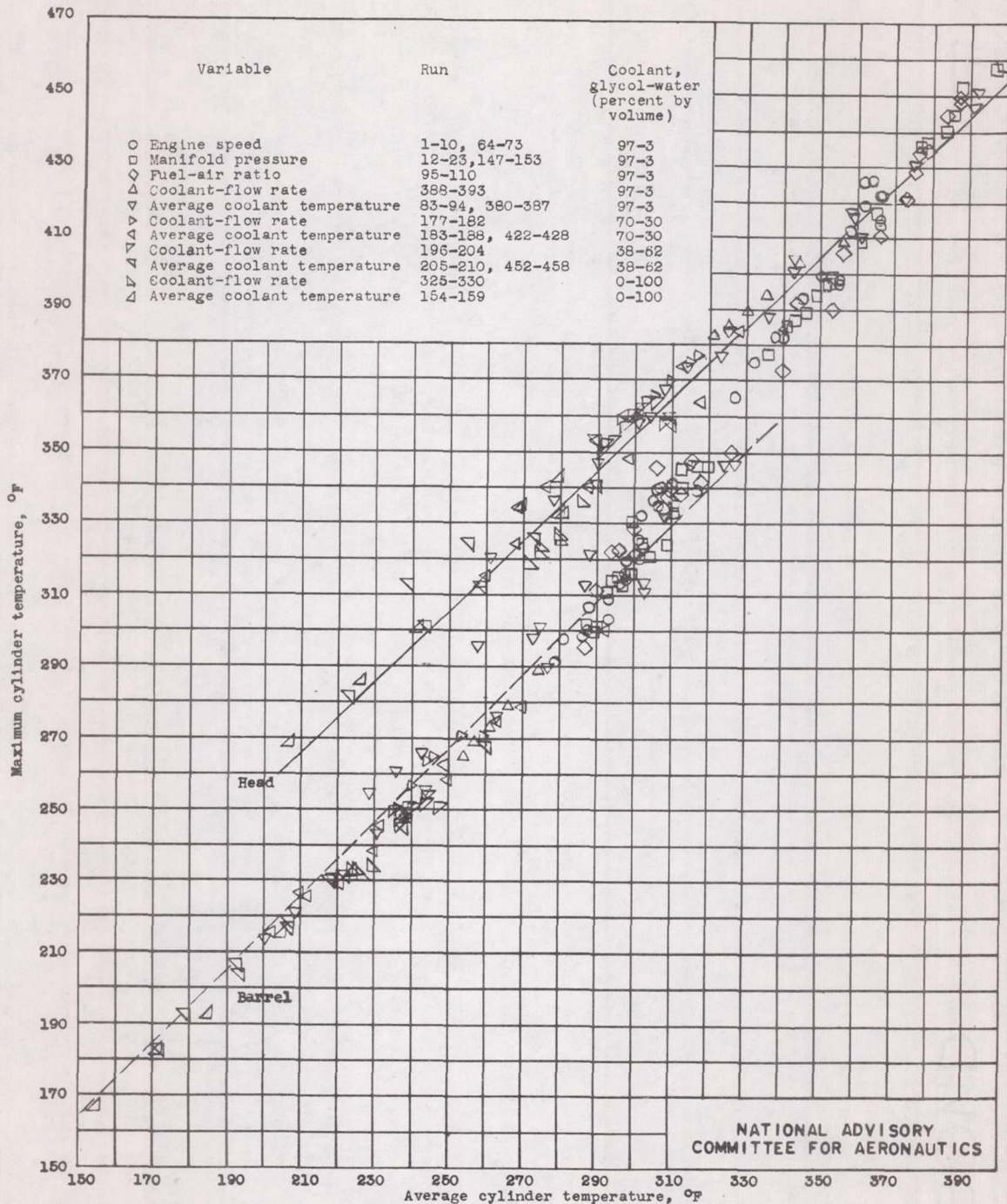

Figure 23.- Relation between maximum and average cylinder temperatures under various operating conditions, cylinder A.



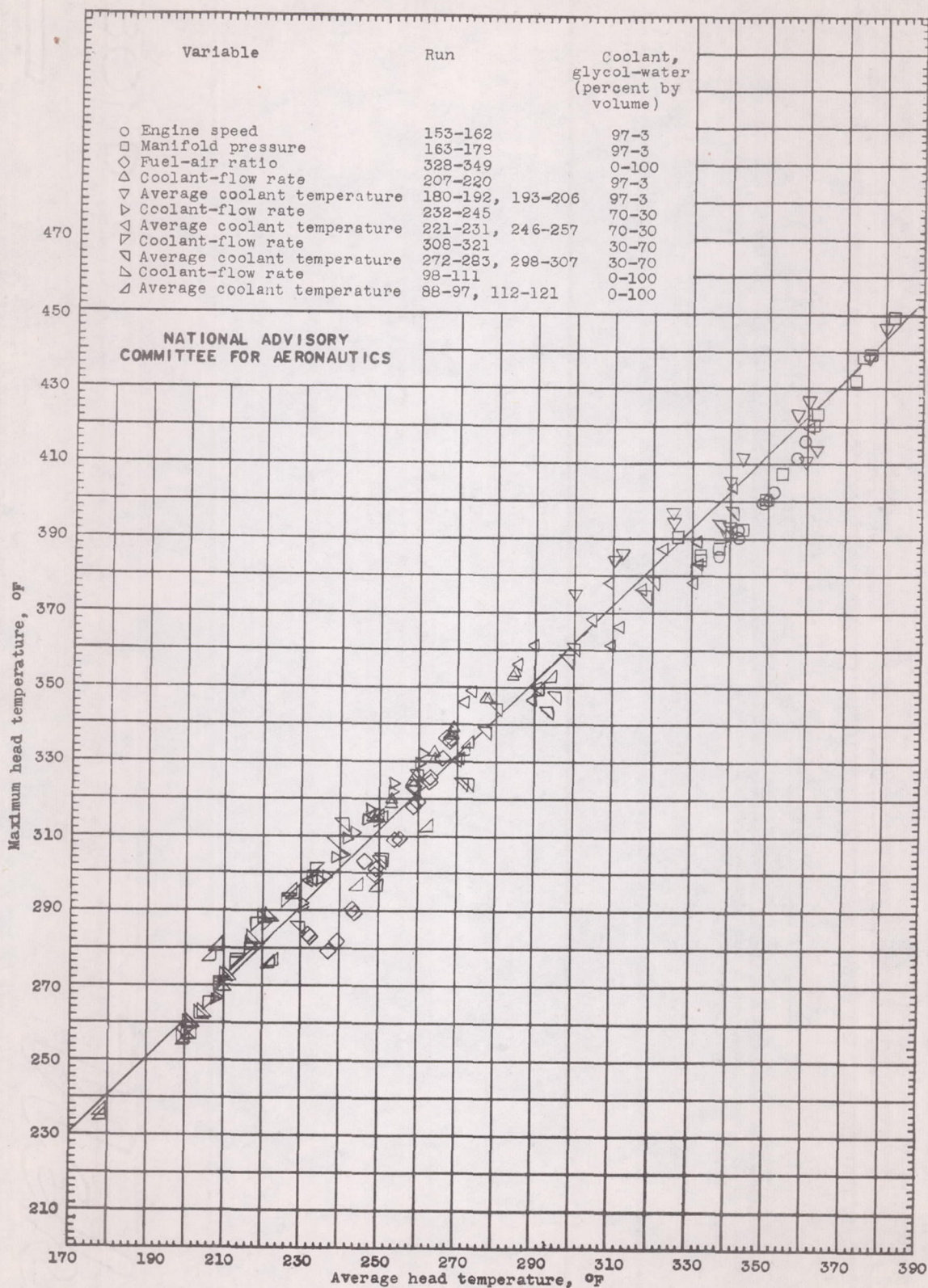

Figure 24.- Relation between maximum and average head temperatures under various operating conditions, cylinder B.



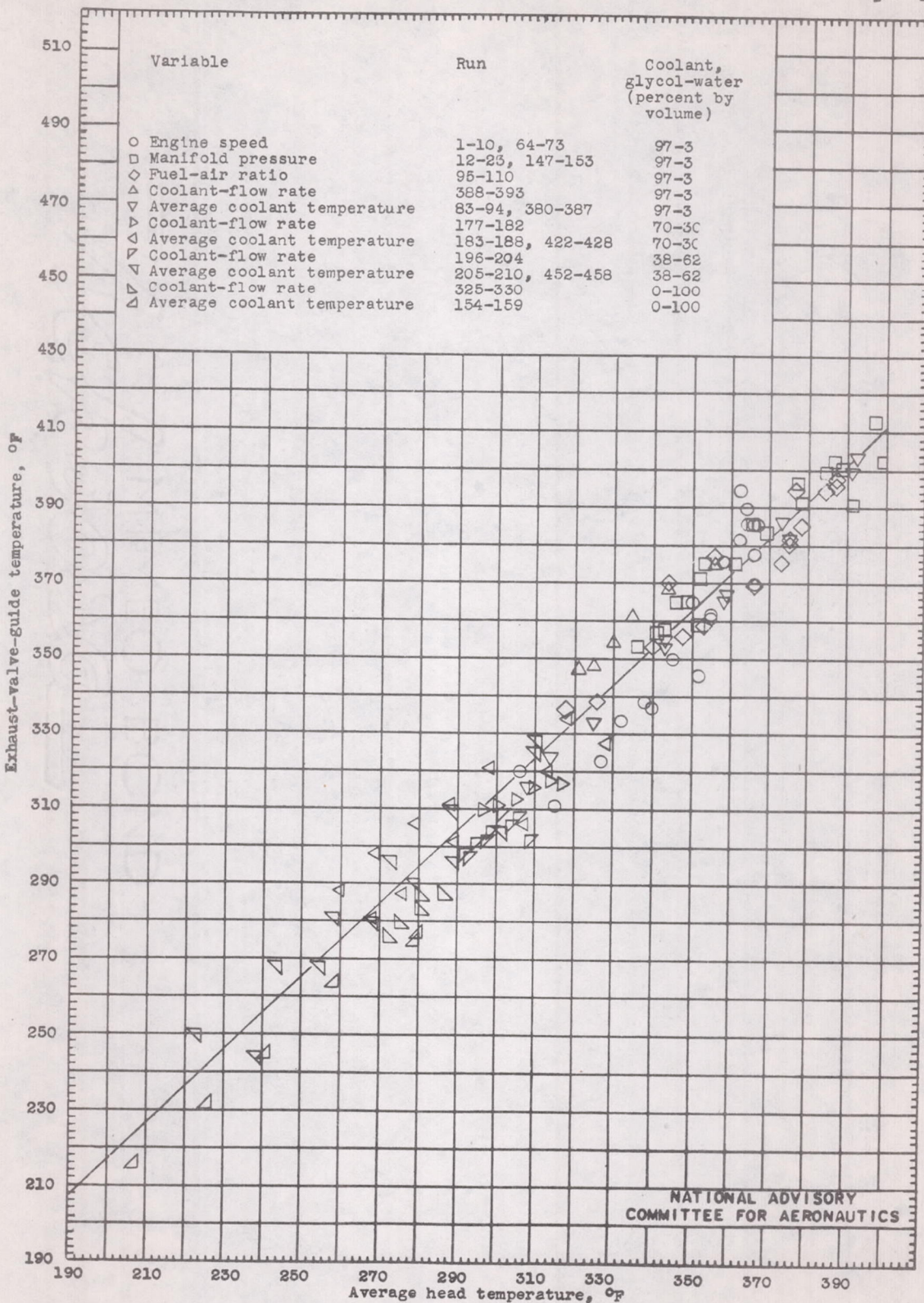

Figure 25.- Relation between exhaust-valve-guide and average head temperatures under various operating conditions, cylinder A.



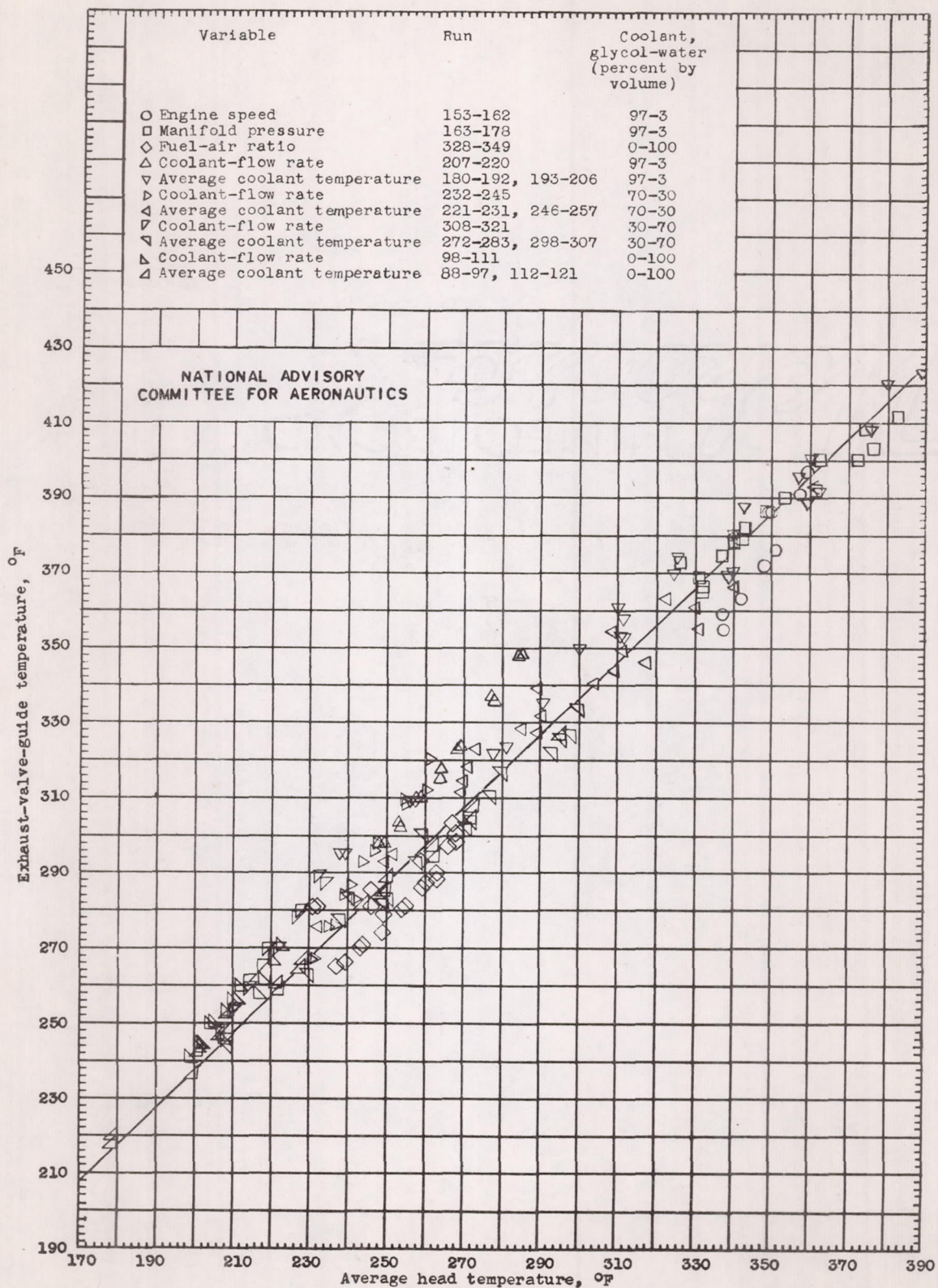

Figure 26.- Relation between exhaust-valve-guide and average head temperatures under various operating conditions, cylinder B.



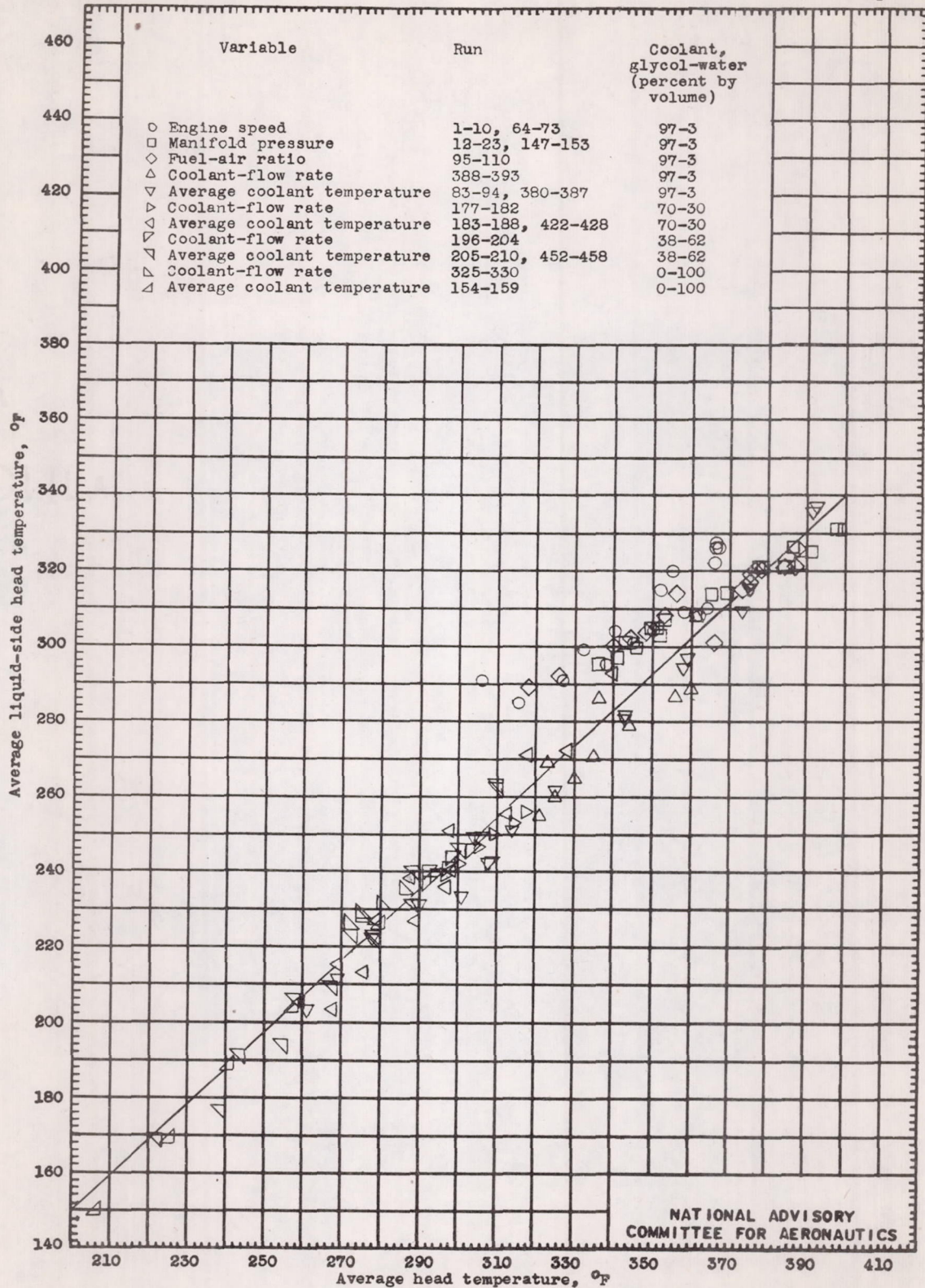

Figure 27.- Relation between average liquid-side head and average head temperatures under various operating conditions, cylinder A.



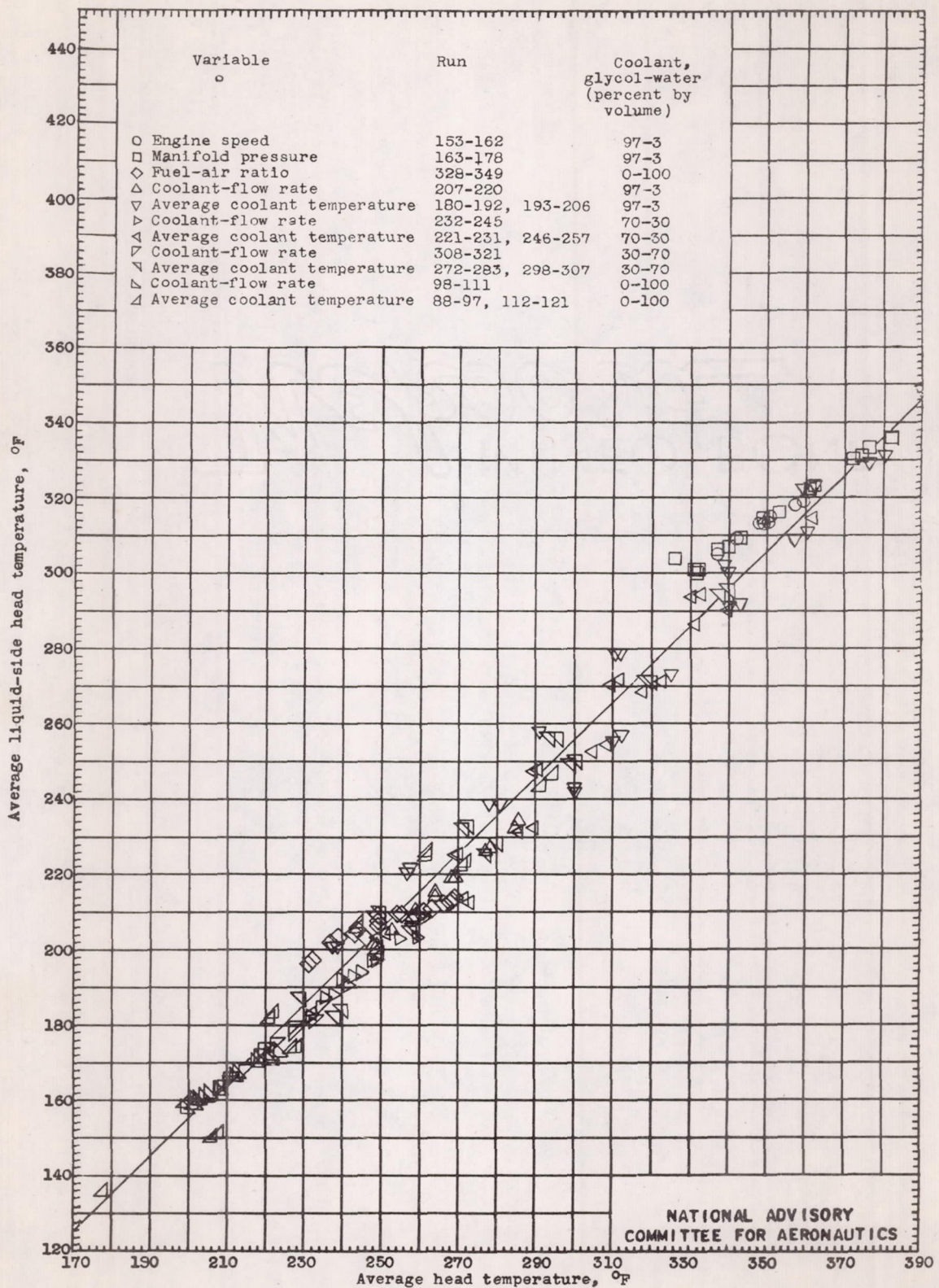

Figure 28.- Relation between average liquid-side head and average head temperatures under various operating conditions, cylinder B.