

N76-31251

(NASA-CR-147884) ASTP VIDEO TAPE RECORDER  
GROUND SUPPORT EQUIPMENT (AUDIO/CTE  
SPLITTER/INTERLEAVER). OPERATIONS MANUAL  
(Radio Corp. of America) 238 p HC \$8.00

N76-31251

Unclas

CSCI 22D G3/14 02487

OPERATIONS MANUAL

ASTP VIDEO TAPE RECORDER  
GROUND SUPPORT EQUIPMENT  
(AUDIO/CTE SPLITTER/INTERLEAVER)

NASA CONTRACT  
NAS9-13767



RECORDING SYSTEMS  
GOVERNMENT COMMUNICATIONS SYSTEMS  
CAMDEN, NEW JERSEY

RCA DOC. NO. 564-395

SEPTEMBER 1, 1974

## PREFACE

The Ground Support Equipment for the ASTP Video Tape Recorder developed and built under NASA Contract NAS 9-13767 is a modification of the original GSE developed for the SKYLAB Video Tape Recorder under contract NAS 9-27968.

The modification provides for the interleaving of Central Time Equipment (CTE) signals with the audio and video interleaver as originally developed for SKYLAB and the extraction of CTE time data for display by the splitter.

This modification required the addition of two plug-in modules and one wired in module.

## TABLE OF CONTENTS

Section		Page
1	INTRODUCTION .....	1-1
	1.1 General Description .....	1-1
	1.2 Unit Description .....	1-1
	1.3 Operating Requirements .....	1-3
	1.4 Equipment Characteristics .....	1-3
	1.5 Equipment Required .....	1-3
2	INSTALLATION .....	2-1
	2.1 Installation .....	2-1
	2.1.1 General .....	2-1
	2.1.2 Installation in Rack .....	2-1
	2.1.3 Power Connection .....	2-1
	2.1.4 Signal Connection .....	2-1
	2.2 Initial Adjustments and Tests .....	2-5
3	OPERATION .....	3-1
	3.1 Introduction .....	3-1
	3.2 Controls and Indicators .....	3-1
	3.3 Operating Procedures .....	3-1
	3.3.1 Starting Procedure .....	3-1
	3.3.2 Operation .....	3-4
4	PRINCIPLES OF OPERATION .....	4-1
	4.1 General .....	4-1
	4.2 System Operation .....	4-1
	4.2.1 Audio/CTE Splitter .....	4-1
	4.2.2 Audio Interleaver .....	4-1
	4.3 Functional Operation .....	4-2
	4.3.1 Audio/CTE Splitter .....	4-2
	4.3.2 Audio/CTE Interleaver .....	4-24
5	MAINTENANCE .....	5-1
	5.1 Introduction .....	5-1
	5.2 Preventive Maintenance .....	5-1
	5.3 Corrective Maintenance .....	5-3
	5.3.1 Alignment Procedure .....	5-3
	5.3.2 Troubleshooting .....	5-9
6	SCHEMATICS AND PARTS LISTS .....	6-1

## LIST OF ILLUSTRATIONS

Figure		Page
1-1	Audio/CTE Splitter/Interleaver . . . . .	1-2
2-1	Installation Clearance: . . . . .	2-2
2-2	Slide, Mounting . . . . .	2-2
2-3	Audio/CTE Splitter/Interleaver, Rear Panel, Interface Connections . . . . .	2-3
3-1	Audio/CTE Splitter/Interleaver, Front Panel . . . . .	3-2
3-2	Splitter V/A Input 3-Step Test Signal with no Interleaved Audio . . . . .	3-8
3-3	Splitter V/A Input 3-Step Test Signal with Interleaver Pedestal, No Audio Modulation . . . . .	3-8
3-4	Splitter V/A Input 3-Step Test Signal with Interleaved Audio . . . . .	3-8
3-5	Splitter A/G Aud Input 1-kHz Sine Wave Test Signal . . . . .	3-9
3-6	Splitter Audio Out 1, 2 or 3 . . . . .	3-9
3-7	Interleaver Vid Input 3-Step Test Signal . . . . .	3-9
3-8	Interleaver Aud Input . . . . .	3-10
3-9	Interleaver V/A Out 1 or 2, Three-Step Test Signal with Interleaved Pedestal only, No Audio Modulation . . . . .	3-10
3-10	Interleaver V/A Out 1 of 2, Three-Step Test Signal with Interleaved Audio . . . . .	3-10
3-11	Audio/CTE Splitter/Interleaver USB System Connection (setup) . . . . .	3-11
4-1	Audio/CTE Splitter/Interleaver, System Functional Block Diagram . . . . .	4-2
4-2	Splitter Functional Diagram . . . . .	4-3
4-3	Video/Audio/CTE Waveform . . . . .	4-5
4-5	Sync Stripper Timing Diagram (Splitter) . . . . .	4-6
4-6	Splitter, Clamp and Sample Timing Diagram (internal sync) . . . . .	4-8
4-7	Splitter, Clamp and Sample Timing Diagram (external sync) . . . . .	4-9
4-8	PAM Detector Functional Diagram . . . . .	4-15
4-9	PAM Detector Timing (A3) . . . . .	4-17
4-10	CTE Demux and Display Functional Diagram . . . . .	4-22
4-11	CTE Mux and Demux, Timing Diagram A . . . . .	4-23
4-12	CTE Mux and Demux, Timing Diagram B . . . . .	4-23
4-13	Interleaver Functional Diagram . . . . .	4-25
4-14	Interleaver, Timing Diagram . . . . .	4-27
4-15	CTE Mux Functional Diagram . . . . .	4-32
5-1	Audio/CTE Splitter/Interleaver, Top View . . . . .	5-2
5-2	Lamp Replacement, Audio Status Indicators . . . . .	5-3
-3	Module Nest Top View, Test Jacks and Setup Controls . . . . .	5-4
-4	Audio/CTE Splitter/Interleaver, Bottom View . . . . .	5-10
5-5	Audio/CTE Splitter/Interleaver Front Panel, Rear View . . . . .	5-11

LIST OF ILLUSTRATIONS (Continued)

Figure		Page
5-6	A1TJ1 Audio In (top), A1TJ3, TJ5 or TJ6 Audio Out (Bottom) . . . .	5-12
5-7	A1TJ4 Spkr./Intercom In (top), A1TJ2 Spkr./Intercom Out (bottom) . . . . .	5-12
5-8	A2TJ1 V-Clamp . . . . .	5-12
5-9	A2TJ1 V-Clamp (External Sync Clamp) . . . . .	5-13
5-10	A2TJ2 Sample . . . . .	5-13
5-11	A2TJ3 Clamp . . . . .	5-13
5-12	A2TJ1 V-Clamp (top), A2TJ4 Sample (bottom), Internal . . . . .	5-14
5-13	A2TJ1 V-Clamp (top), A2TJ4 Sample (bottom), External . . . . .	5-14
5-14	A3TJ1 LPF . . . . .	5-14
5-15	A2TJ2 Sync Clamp . . . . .	5-15
5-16	A3TJ3 Sync . . . . .	5-15
5-17	A3TJ4 V-Sync . . . . .	5-15
5-18	A3TJ5 V-Sync (Detector) . . . . .	5-16
5-19	A3TJ6 PAM (Detector) . . . . .	5-16
5-20	A4TJ1 Sample . . . . .	5-16
5-21	A4TJ2 Clamp . . . . .	5-17
5-22	A4TJ3 Drive . . . . .	5-17
5-23	A4TJ4 Sync . . . . .	5-17
5-24	A4TJ5 V-Sync . . . . .	5-18
5-25	A6TJ1 Input . . . . .	5-18
5-26	A6TJ2 Clipper . . . . .	5-18
5-27	A6TJ3 Audio + DC . . . . .	5-19
5-28	A6TJ4 Sample . . . . .	5-19
5-29	A6TJ5 Output . . . . .	5-19
5-30	A7TJ1 V-Clamp . . . . .	5-20
5-31	A7TJ2 Blank . . . . .	5-20
5-32	A7TJ3 S-Clamp . . . . .	5-21
5-33	A7TJ4 Sync . . . . .	5-21
5-34	A7TJ5 V-Sync . . . . .	5-21
5-35	A8TJ1 Input . . . . .	5-22
5-36A.	A8TJ2 V/A Out 1, Pedestal Only . . . . .	5-22
5-36B.	A8TJ2 V/A Out 1, Pedestal Only (scope uncalibrated) . . . . .	5-22
5-37A.	A8TJ2 V/A Out, Audio Modulation . . . . .	5-23
5-37B.	A8TJ2 V/A Out 1, Audio Modulation (scope uncalibrated) . . . . .	5-23
5-38	A8TJ3 V/A Out 2, Audio Modulation . . . . .	5-23
5-39	A9TJ1 Input . . . . .	5-24
5-40	A9TJ2 Output . . . . .	5-24
5-41	A5TJ1 Reference . . . . .	5-25
5-42	A5TJ2 Phase Detector . . . . .	5-25
5-43	A5TJ3 Error . . . . .	5-25

## LIST OF ILLUSTRATIONS (Continued)

Figure		Page
5-44	A5TJ4 VCO . . . . .	5-26
5-45	A5TJ5 V-sync . . . . .	5-26
5-46	A5TJ6 Line 17 . . . . .	5-26
5-47	A5TJ1/A5TJ4 Reference/VCO (A11TJ1/A11TJ4 is similar) . . . . .	5-27
5-48	A11TJ1 Reference . . . . .	5-27
5-49	A11TJ2 Phase Detector . . . . .	5-27
5-50	A11TJ3 Error . . . . .	5-28
5-51	A11TJ4 VCO . . . . .	5-28
5-52	A11TJ5 Line 17 . . . . .	5-28
5-53	A11TJ6 Data . . . . .	5-29
5-54	A11TJ7 Shift Register Clock . . . . .	5-29
5-55	Module Layout, A1 (Splitter Output) . . . . .	5-30
5-56	Module Layout, A2 (Video/Audio Input) . . . . .	5-31
5-57	Module Layout, A3 (Splitter Timing) . . . . .	5-32
5-58	Module Layout, A4 (External Sync) . . . . .	5-33
5-59	Module Layout, A5 (CTE Mux) . . . . .	5-34
5-60	Module Layout, A6 (Audio Input) . . . . .	5-35
5-61	Module Layout, A7 (Video Input) . . . . .	5-36
5-62	Module Layout, A8 (Interleaver Output) . . . . .	5-37
5-63	Module Layout, A9 (Audio Power Amplifier) . . . . .	5-38
5-64	Module Layout, A10 (Bessel Filter/Equalizer) . . . . .	5-39
5-65	Module Layout, A11 (CTE Demux) . . . . .	5-40
5-66	Module Layout A12 (CTE Display) . . . . .	5-41
6-1	Audio/CTE Splitter/Interleaver Schematic . . . . .	6-3
6-2	Splitter Output Schematic (A1) . . . . .	6-5
6-3	Video/Audio Input Schematic (A2) . . . . .	6-7
6-4	Splitter Timing Schematic (A3) . . . . .	6-9
6-5	External Sync Schematic (A4) . . . . .	6-11
6-6	CTE Mux Schematic (A5) . . . . .	6-13
6-7	Audio Input Schematic (A6) . . . . .	6-15
6-8	Video Input Schematic (A7) . . . . .	6-17
6-9	Interleaver Output Schematic (A8) . . . . .	6-19
6-10	Audio Power Amplifier Schematic (A9) . . . . .	6-20
6-11	Bessel Filter, Equalizer Schematic (A10) . . . . .	6-21
6-12	CTE Demux Schematic . . . . .	6-23
6-13	CTE Display Schematic (A12) . . . . .	6-25

## PARTS LISTS

	Page
Audio and Audio/CTE Splitter/Interleaver . . . . .	6-27
Board Assembly, Splitter Output (A1) . . . . .	6-41
Board Assembly, Video/Audio Input (A2) . . . . .	6-48
Board Assembly, Splitter Timing (A3) . . . . .	6-57
Board Assembly, External Sync (A4) . . . . .	6-67
Board Assembly, CTE Mux (A5) . . . . .	6-73
Board Assembly, Audio Input (A6) . . . . .	6-81
Board Assembly, Video II (A7) . . . . .	6-91
Board Assembly, Interleaver Output (A8) . . . . .	6-102
Board Assembly, Audio Power Amplifier (A9) . . . . .	6-108
Board Assembly, Bessel Filter/Equalizer (A10) . . . . .	6-113
Board Assembly, CTE Demux (A11) . . . . .	6-116
Board Assembly, GSE Display (CTE) (A12) . . . . .	6-123

## LIST OF TABLES

	Page
1-1 Physical Characteristics . . . . .	1-4
1-2 Electrical Characteristics . . . . .	1-5
2-1 Cabling Information . . . . .	2-4
3-1 Audio/CTE Splitter/Interleaver Front Panel Controls and Indicators . . . . .	3-3
5-1 Splitter Signal Levels . . . . .	5-42
5-2 Interleaver Signal Levels (Test Signals) . . . . .	5-48



## 1. INTRODUCCIÓN

## SECTION 1

### INTRODUCTION

#### 1.1 GENERAL DESCRIPTION

The Audio/CTE Splitter/Interleaver, RCA Part No. 8673734-502, is designed to perform two major functions:

Splitter Section — To extract audio and time data from an interleaved video/audio signal.

Interleaver Section — To provide a test interleaved video/audio/CTE signal for the system.

Refer to Figure 1-1. The Audio/CTE Splitter/Interleaver is a rack mounting unit 7 inches high, 19 inches wide and 20 inches deep, mounted on slides for retracting from the rack. The unit weighs approximately 40 pounds. The unit contains all operator controls on the front panel. It also contains indicators, meter, speaker and test jacks on the front panel for easily monitoring the performance of the equipment.

#### 1.2 UNIT DESCRIPTION

The basic function of the Audio/CTE Splitter/Interleaver is to extract audio and CTE time data from an interleaved video/audio/CTE signal (VTR AUDIO) and to supply this audio to three (3) audio output lines and an Audio Monitor line and the CTE time data to the CTE display on the front panel. If VTR AUDIO is not being supplied to the unit, Air/Ground Audio (A/G AUDIO) is automatically selected by the unit and supplied to its audio outputs.

The front panel provides AUDIO STATUS indicators to indicate the source of the audio supplied to the unit's outputs. A RELAY BYPASS switch is provided, to work in conjunction with the AUDIO STATUS indicators. If the SPLITTER STATUS and the RELAY STATUS of the AUDIO STATUS indicators do not agree (indicating a failure in the unit), the RELAY BYPASS switch may be set to VTR AUD or A/G AUDIO (from its NORMAL position) to maintain an appropriate audio output. The unit provides front panel controls for adjustment of the audio output levels. The SPLITTER AUD OUT LEVEL control adjusts the level of the 3 Audio Output lines from either VTR or A/G Audio inputs. The SPLITTER A/G IN LEVEL control adjusts the level of the three Audio output lines when A/G Audio is selected by the unit. The unit provides an AUDIO OUT LEVEL meter, calibrated in dBm, to indicate the level of the three Audio Output lines. Front panel test jacks are provided for monitoring SPLITTER V/A INPUT (VTR), A/G AUD INPUT, and each of the three AUDIO OUT lines. The SPEAKER/INTERCOM LEVEL control adjusts the level of the Audio Monitor output line. The unit provides a speaker input (normally looped through external intercom equipment).

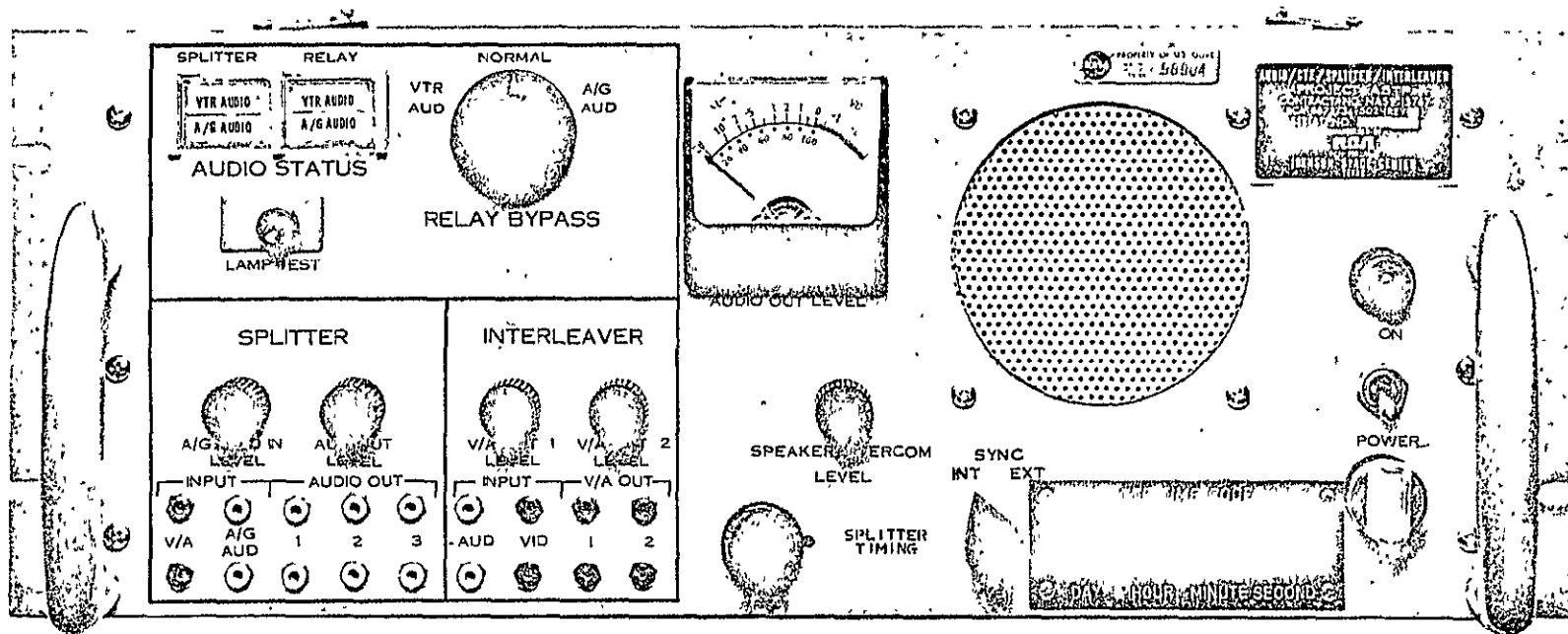

Figure 1-1. Audio/CTE Splitter/Interleaver

A Front Panel SYNC switch selects the source of sync signal used in the splitter. Either internal (INT) or external (EXT) may be selected. If INT SYNC is selected, the source of the sync signal is the Splitter Video (V/A) input signal. If EXT SYNC is selected, the source of the sync signal is the REGEN SYNC output of a processing amplifier (RCA TA-19).

The unit provides a SPLITTER TIMING (real-time null) control, which allows sampling noise to be minimized.

Front panel display of the CTE TIME CODE is also provided in day, hour, minutes and seconds.

The Interleaver section, when supplied with a video signal (TV format) and an audio signal, supplies two Interleaved Video/Audio outputs. The two V/A outputs are identical but isolated with separate front panel level controls (V/A OUT 1 LEVEL and V/A OUT 2 LEVEL). The unit provides front panel test jacks for monitoring the Interleaver AUD and VID INPUTS and V/A OUT 1 and V/A OUT 2.

The Audio/CTE Splitter/Interleaver provides a front panel POWER On-Off switch, a Power ON indicator and an indicator lamp that illuminates when the fuse is open.

All inputs and outputs, interfacing the unit with the rest of the system, are made through connectors on the rear panel of the unit. Refer to Figure 2-3.

The unit contains ten plug-in modules mounted in a module nest, a wired-in module located on the rear chassis and a wired-in module on the front panel. The three unit power supplies are also mounted on the rear chassis.

### 1.3 OPERATING REQUIREMENTS

One power source is required for operating the Audio/CTE Splitter/Interleaver, 115 V ac, 60 cycle, single phase. The power interface is made through the 115 V ac connection (J27) located at the rear of the unit (refer to Figure 2-3). All inputs and outputs are contained on connectors mounted on the rear panel of the unit (refer to Figure 2-3). The unit contains a POWER On-Off switch, a Power ON Indicator and an Indicator fuse, all mounted on the unit front panel.

### 1.4 EQUIPMENT CHARACTERISTICS

Table 1-1 lists pertinent physical characteristics and Table 1-2 electrical characteristics for the Audio/CTE Splitter/Interleaver.

### 1.5 EQUIPMENT REQUIRED

The Audio/CTE Splitter/Interleaver is a self-contained unit. No external equipment is required for the operation of the unit when operated in the Internal Sync mode.

When operated in the External Sync mode, a processing amplifier (i. e., RCA TA-19) is required.

TABLE 1-1. PHYSICAL CHARACTERISTICS

Item	Characteristics
Size	19 inches wide, 7 inches high, 20 inches deep (plus handles)
Weight	Approximately 40 pounds
Indicators	
Audio Status	Microswitch series 2
Power On	Dialco 95408-9 (with 220K resistor)
Indicator Fuse	Littelfuse 344125
Lamps	
Audio Status	14V, type 330
Power On	NE51
Lamp Test	1 momentary switch for testing AUDIO STATUS indicator lamps.
Meter	VU meter, Simpson
Power Switch	DPDT toggle
Selector Switch	Rotary, 3 position, Oak
Relays	4PDT
Test Jacks	Tip jack, metal clad type MS16108
Audio	Yellow
Video	Green
Ground	Black
15 V	Red
5 V	Orange
-15 V	Violet
Speaker	5 inches, 4 watts maximum power, 3.2 ohms
Power Supplies	Lambda, type LXS
Plug-In Modules	
A1 - 8372838	Splitter Output
A2 - 8372840	Video/Audio Input
A3 - 8372842	Splitter Timing
A4 - 8373015	External Sync
A5 - 8375683	CTE Multiplexer
A6 - 8372844	Audio Input
A7 - 8372846	Video Input
A8 - 8372848	Interleaver Output
A9 - 8372850	Audio Power Amplifier
A11 - 8375682	CTE Demultiplexer
Wired-In Modules	
A10 - 8673757	Bessel Filter/Equalizer
A12 - 8676341	CTE Display

TABLE 1-2. ELECTRICAL CHARACTERISTICS

Item	Characteristics
Power requirements:	115 volts, 60 cycles, 1 phase, 2 amperes
<u>SPLITTER</u>	
A/G Input	
Level	-12 dBm $\pm$ 3 dB (voice)
Frequency	300 Hz to 3 kHz
Impedance	600 ohms $\pm$ 10%
V/A Input	
Level	1 V pp $\pm$ 0.3 V pp
Impedance	75 ohms $\pm$ 10%
Sync Input	
Level	4.5 V pp
Impedance	75 ohms
Audio Outputs	Three identical but isolated
Level	-12 dBm ( $\pm$ 1 dB between lines)
Frequency Response	300 Hz to 3 kHz ( $\pm$ 3 dB max)
Impedance	600 ohms (balanced) $\pm$ 10%
Harmonic Distortion	At least 25 dB below nominal
S/N (no signal)	At least 30 dB below nominal
S/N (V/N = 25 dB pp/ rms B to W video)	At least 20 dB below nominal (RMS/RMS)
Audio Monitor Output	One output. Same specifications as Audio Output Lines.
<u>INTERLEAVER</u>	
Audio Input	
Level	1 V pp (flat)
Impedance	600 ohms $\pm$ 10%
Frequency	300 Hz to 3 kHz (flat)
Distortion	0.5% or better
S/N	50 dB
Video Input	
Level	1 V pp (flat)
Impedance	75 ohms $\pm$ 10%
Frequency	30 Hz to 4 MHz
Distortion	0.5% or better
S/N	50 dB
Outputs	Two identical but isolated
Level	1 V pp (variable $\pm$ 3 dB)
Frequency Response	30 Hz to 4 MHz ( $\pm$ 3 dB or less)
S/N	40 dB minimum



## SECTION 2

### INSTALLATION

#### 2.1. INSTALLATION

##### 2.1.1 General

The Audio/CTE Splitter/Interleaver should be installed in a clean, dust-free area. An air-conditioned area with low humidity and moderate temperature is preferred. Refer to Figure 2-1 (Installation Clearance) for diagram.

##### 2.1.2 Installation in Rack (Refer to Figures 2-1, 2-2)

1. The unit is shipped with the chassis section of the slides mounted on the sides of the unit as shown in Figure 2-2.
2. Assemble extender bracket to slide (cabinet section) as shown in Figure 2-2, using #10 screw and two bars supplied.

Note: Extender bracket mounting position should be varied according to requirement of particular rack.

3. Mount assembled cabinet section into rack.
4. Insert unit (chassis section slides) into intermediate section slides.

##### 2.1.3 Power Connection

The Audio/CTE Splitter/Interleaver is supplied with a power cord 7 feet  $\pm$ 6 inches long. The power cord contains a 3-wire grounding type plug for mating with a standard 3-wire grounding type convenience outlet. Since the unit may be retracted from the rack on slides, the ac power cord should be dressed in the rack to allow the unit to operate in either the normal or fully extended position.

##### 2.1.4 Signal Connection

Signal inputs and outputs are made through connectors located on the rear panel of the unit (refer to Figure 2-3). Sufficient room should be allowed for external connections (refer to Figure 2-1 for installation clearances). Refer to Table 2-1 for cabling information.



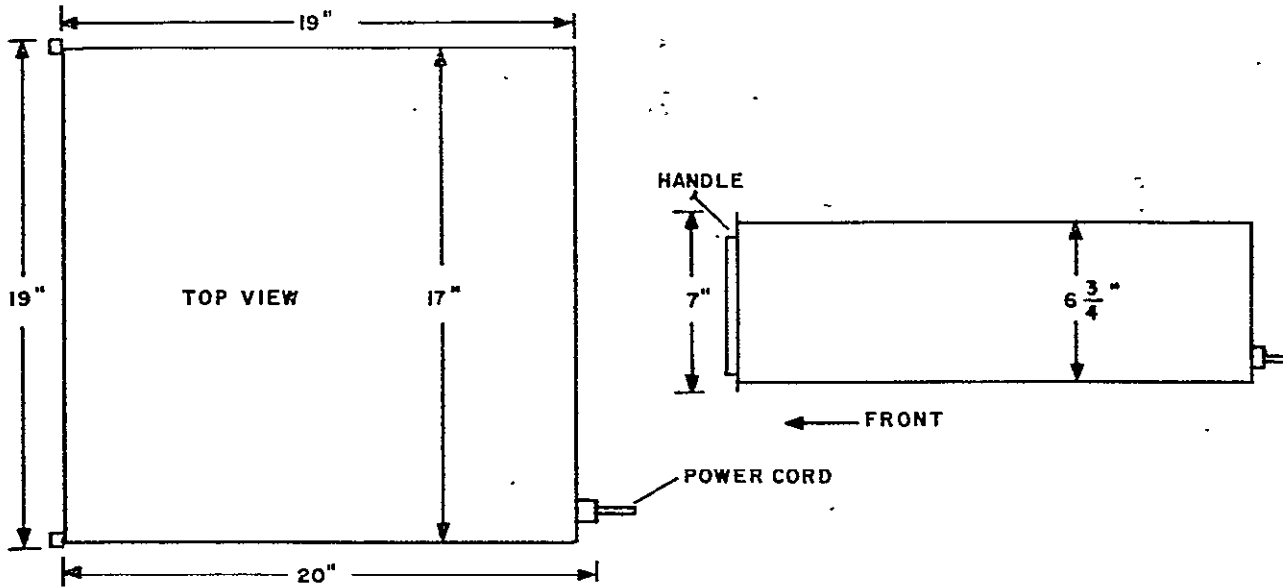

Figure 2-1. Installation Clearance

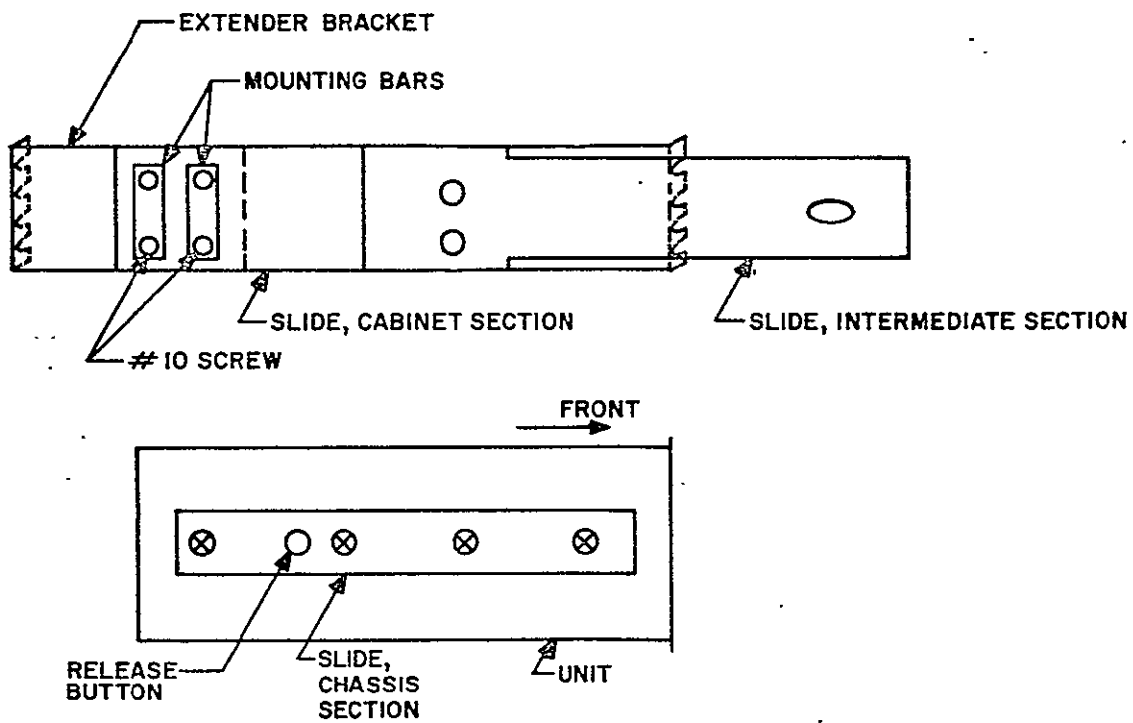

Figure 2-2. Slide, Mounting

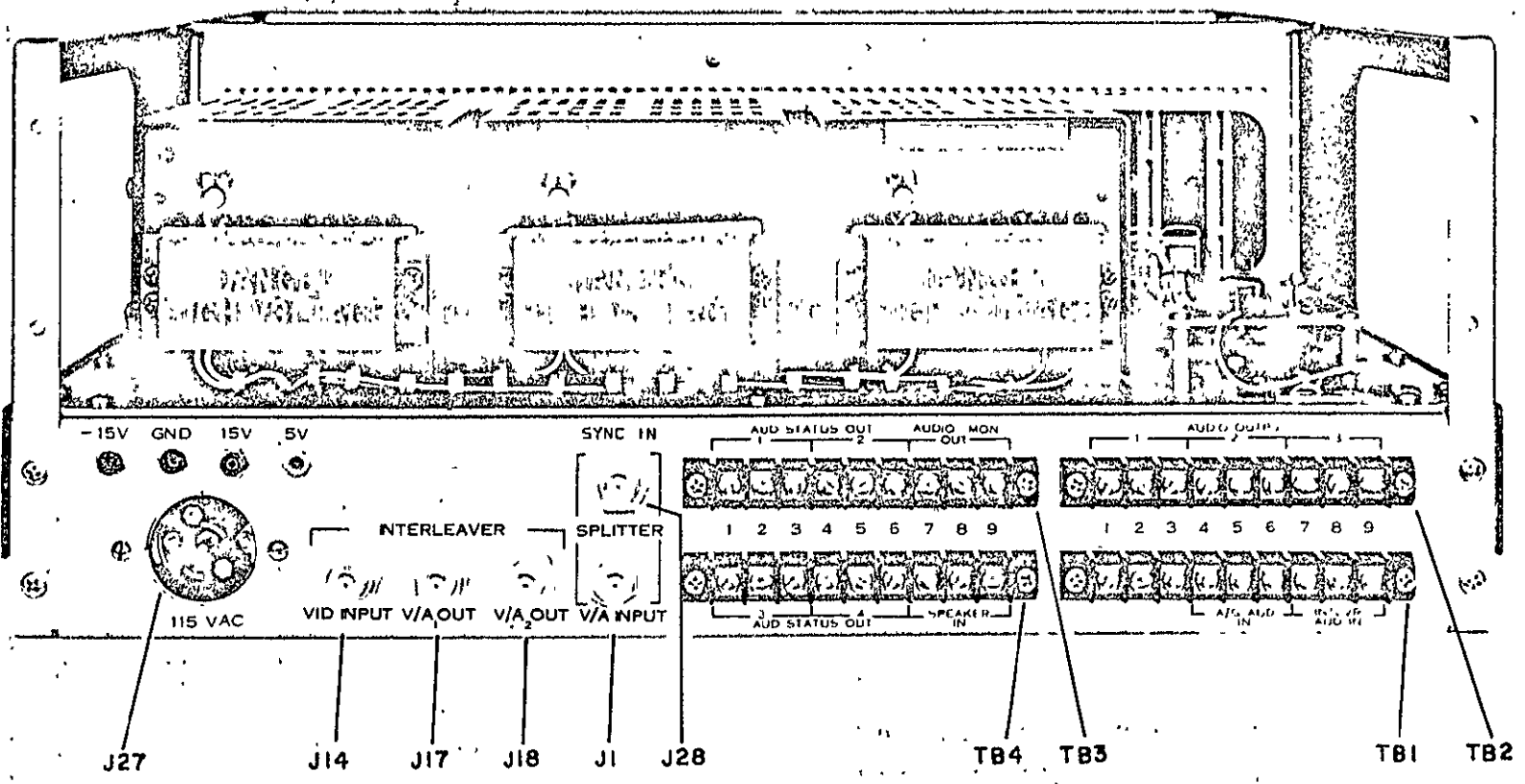

Figure 2-3. Audio/CTE Splitter/Interleaver, Rear Panel, Interface Connections

TABLE 2-1. CABLING INFORMATION

Name of Signal	Level	Frequency	Impedance (ohms)	Cable Type	Connector Type	Remarks
AC Power	115 V ac	60 Hz		3 Cond. #18	3 Pin Power	Power Cord Supplied
<u>SPLITTER</u>						
V/A Input	1 V pp	30 Hz to 4 MHz	75	Coax	BNC	Interleaved TV Signal
A/G Aud In	1 V pp	300 Hz to 3 kHz	300	TSP*	Lugs	Balanced Line
Audio Output 1, 2 or 3	1 V pp	300 Hz to 3 kHz	600	TSP*	Lugs	Balanced Line
Audio Mon Out	1 V pp	300 Hz to 3 kHz	600	TSP*	Lugs	Balanced Line
Speaker In	1 V pp	300 Hz to 3 kHz	600	TSP*	Lugs	
Audio Status Out 1, 2, 3 or 4				Hook-up Wire	Lugs	
Sync Input	4.5 V pp		75	Coax	BNC	From REGEN SYNC output of RCA TA-19 Processor Amplifier
<u>INTERLEAVER</u>						
Video Input	1 V pp	30 Hz to 4 MHz	75	Coax	BNC	TV Signal
Audio Input	1 V pp	300 Hz to 3 kHz	600	TSP*	Lugs	Balanced Line
V/A Out 1 or 2	1 V pp	DC to 4 MHz	75	Coax	BNC	Interleaved TV Signal

\*TSP - Twisted Shielded Pair

## 2.2 INITIAL ADJUSTMENTS AND TESTS

To ensure that the equipment is performing properly, conduct tests outlined in Operational Procedures, paragraph 3.3.

If the unit does not perform as specified, refer to Alignment Procedure, paragraph 5.3.1.



## SECTION 3

### OPERATION

#### 3.1 INTRODUCTION

The Audio/CTE Splitter/Interleaver consists of a splitter and an interleaver. The splitter section extracts audio and time data from an interleaved Video/Audio/CTE input. Front panel indicator lights indicate if interleaved video (VTR/AUDIO) is being received or standard video (A/G AUDIO) is being received.

The Interleaver combines an Audio and fixed word CTE signal with a Video input to form an interleaved (V/A) output for system test and alignment purposes. Two V/A outputs are provided with individual front panel level controls and test jacks.

Front panel level controls are provided for A/G Audio Input and for Audio Output. Front panel test jacks are provided for monitoring splitter V/A Input, A/G Input and for the three Audio Output lines. CTE TIME CODE information is displayed on the front panel in DAY, HOUR, MINUTE, and SECOND.

A front panel selector is provided to allow selection of either internal or external sync (REGEN SYNC from a processing amplifier).

A front panel SPLITTER TIMING control is provided to allow for adjustment of a real time null (minimum sampling noise).

#### 3.2 CONTROLS AND INDICATORS

The location of the controls and indicators for the Audio Splitter/Interleaver are shown in Figure 3-1. These controls and indicators are tabulated in Table 3-1.

#### 3.3 OPERATING PROCEDURES

##### 3.3.1 Starting Procedure

Place POWER switch (S3) in the ON position. POWER ON indicator DS5 should illuminate. Indicator fuse holder (XF1) should not be illuminated.

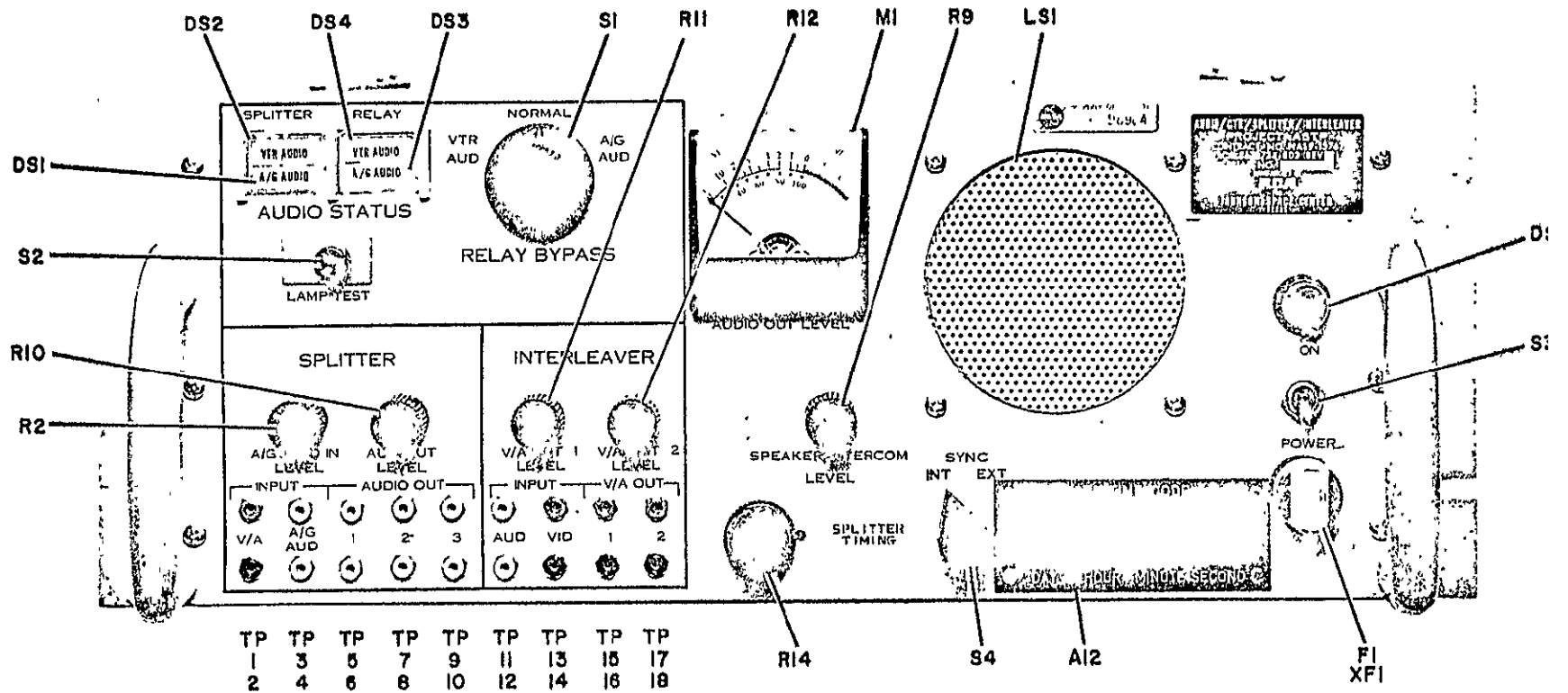

Figure 3-1. Audio/CTE Splitter/Interleaver, Front Panel

TABLE 3-1. AUDIO/CTE SPLITTER/INTERLEAVER  
FRONT PANEL CONTROLS AND INDICATORS

Item	Name	Function
DS1	A/G Audio (Splitter)	Video at splitter input <u>not</u> interleaved.
DS2	VTR Audio (Splitter)	Video at splitter input interleaved.
DS3	A/G Audio (Relay)	Audio Status Relay de-energized.
DS4	VTR Audio (Relay)	Audio Status Relay energized.
DS5	ON	115 V ac applied to unit power supplies.
F1	Fuse	Indicator fuse, lights when fuse is open.
LS1	Speaker	Monitors audio at speaker input.
M1	Audio Out Level	Monitors audio output 1 level.
R2	A/G Aud In Level	Attenuates A/G Aud In signal fed to splitter and output circuits.
R9	Speaker/Intercom Level	Controls level at Aud Monitor output.
R10	Aud Out Level	Controls level at Splitter Aud output 1, 2 and 3.
R11	V/A Out 1 Level	Controls level at V/A Out 1
R12	V/A Out 2 Level	Controls level at V/A Out 2
R14	Splitter Timing	Real time null (minimizes Splitter Sampling noise). Adjusts delay time of Splitter Sample pulse.
S1	Relay Bypass	Selector switch, provides bypass path around relay if relay does not function properly.
S2	Lamp Test	When depressed, tests DS1, DS2, DS3 and DS4.
S3	Power	Power On-Off switch.
S4	Sync	Selector switch, selects Splitter Clamp and Sample pulse from Internal or External source.
A12	CTE Display	Displays CTE Time code data.



### 3.3.2 Operation (Refer to Figure 3-1)

#### 3.3.2.1 Setup (Interleaver/Splitter Back-to-Back through USB System)

Before operating the Splitter from a Downlink signal the Audio Splitter/Interleaver should be set up as described below:

Refer to the following figures:

1. Figure 3-1. Front Panel Controls and Indicators.
2. Figure 2-3. Rear Panel.

#### Test Equipment

The following test equipment (or equivalent) is required:

1. TV Signal Generator (Telemet Stairstep generator model 3502).
2. Processing Amplifier (RCA Model TA-19).
3. Audio Signal Generator (HP 651B).
4. Oscilloscope (Tektronix 547 with type 1A1 plug-in).

#### 3.3.2.1.1 Interleaver Setup

1. Connect TV signal generator to INTERLEAVER VID IN connector (J14), located on the rear panel (refer to Figure 2-3).
2. Connect audio signal generator to INTLVR AUD IN terminals (TB1-7,8) on the rear panel (refer to Figure 2-3).
3. Monitor signal at front panel INTERLEAVER VID INPUT test jacks. Set TV signal generator for stairstep (3 steps) output. Adjust composite video for a level of 1.0 V pp (100/28 ratio, 0.22 V pp sync.) Refer to Figure 3-7.
4. Monitor signal at front panel INTERLEAVER AUD INPUT test jacks. Adjust audio signal generator for a level of 1 V pp at 1 kHz (refer to Figure 3-8).
5. Monitor signal at front panel INTERLEAVER V/A OUT 1 test jacks.  
NOTE: V/A OUT 1 (J17 - rear panel) must be terminated in 75 ohms.
6. Adjust front panel INTERLEAVER V/A OUT 1 LEVEL control for a 1 V pp signal at the INTERLEAVER V/A OUT 1 test jacks (refer to Figure 3-10).  
Observe the PAM pulse (Audio Modulation) is as shown in Figure 3-10.

### 3.3.2.1.2 Splitter Setup

1. Connect the INTERLEAVER V/A OUT 1 (J14) signal to the SPLITTER V/A INPUT Connector (J1), located on the rear panel (refer to Figure 3-11 for connections and Figure 2-3 for location of connectors).

NOTE: The Interleaver should be set up as described in paragraph 3.3.2.1.1 above before the Splitter is set up. Input signals to the Interleaver should be as specified in paragraph 3.3.2.1.1.

2. Monitor the signal at the front panel SPLITTER V/A INPUT test jacks. Adjust the INTERLEAVER V/A OUT 1 LEVEL control for a composite video signal level of 1.0 V pp at the test jacks (refer to Figure 3-4).
3. Reduce audio input to the INTLVR AUD IN terminals to zero (refer to paragraph 3.3.2.1.1, step 4).
4. Set front panel SYNC select switch in the INT position.
5. Monitor the signal at the front panel SPLITTER AUDIO OUT 1 test jacks. Unlock the SPLITTER TIMING control and rotate control for minimum noise level at the test jacks. The minimum level should occur with the SPLITTER TIMING control at mid-position; if not, refer to Sample Pulse Timing (Internal) Alignment, paragraph 5.3.1.3.2.
6. Set front panel SYNC select switch in the EXT position. Perform Clamp Delay Adjustment as described in Section 5, Maintenance, paragraph 5.3.1.3.6.1. Repeat step 5 above. Lock SPLITTER TIMING control. If minimum noise does not occur at mid-position of the SPLITTER TIMING control, refer to Sample Delay Adjustment (External), paragraph 5.3.1.3.6.2.
7. Adjust audio signal generator for a level of 1 V pp at 1 kHz (refer to paragraph 3.3.2.1.1, step 4 above).
8. Adjust the front panel SPLITTER AUDIO OUTPUT LEVEL control for 1 V pp at the SPLITTER AUDIO OUT 1 test jacks (refer to Figure 3-6).

### 3.3.2.2 Operation (Downlink Signal)

(Refer to front panel controls and indicators, Figure 3-1)

1. Set the SYNC selector switch in the EXT position.
2. Set the RELAY BYPASS switch in the NORMAL position.

3. Monitor the signal at the front panel SPLITTER V/A INPUT test jacks. The level should be 1.0 V pp (refer to Figures 3-2, 3-3 and 3-4). Observe the waveform at the SPLITTER V/A INPUT test jacks; note whether a PAM (Interleaved) pulse is present in the waveform. One of the three conditions shown in Figures 3-2, 3-3 or 3-4 should exist.

#### 3.3.2.2.1 Splitter V/A Input, No Interleaved Audio (Refer to Figure 3-2)

If no PAM (Interleaved) pulse is present in the Splitter V/A Input, both the SPLITTER and RELAY AUDIO STATUS indicators should indicate "A/G AUDIO"; if not, set the RELAY BYPASS switch (S1) in the A/G position.

Monitor front panel SPLITTER A/G AUD INPUT test jacks. If a signal is present, monitor the SPLITTER AUDIO OUT (1, 2 or 3) test jacks. Adjust SPLITTER A/G AUD IN LEVEL control for the desired level at the AUDIO OUT test jacks.

NOTE: AUD OUT LEVEL control (R10) should not be adjusted unless required.

#### 3.3.2.2.2 Splitter V/A Input, Interleaved Pedestal Only, No Audio Modulation (Refer to Figure 3-3)

If a PAM pulse is present in the V/A Input signal, both the SPLITTER and RELAY AUDIO STATUS indicators should indicate VTR AUDIO; if not, set RELAY BYPASS switch (S1) in the VTR position.

Monitor the signal at the SPLITTER AUDIO OUT (1, 2 or 3) test jacks. When a PAM pulse is present in the V/A Input signal without audio modulation, a noise only signal will appear at the SPLITTER AUDIO OUT test jacks. The noise may also be monitored on the speaker by adjusting the SPEAKER/INTERCOM LEVEL control (R9).

NOTE: The input speaker signal is normally obtained by either connecting the AUDIO MON OUT terminals (TB3-7, 8) to the SPEAKER IN terminals (TB4-7, 8) or by connecting the AUDIO MON OUT terminals to an external intercom system and looping the signal back into the SPEAKER IN terminals. Under the conditions stated above, the SPEAKER IN signal level may be adjusted with the SPEAKER/INTERCOM LEVEL control (R9), located on the front panel.

If the noise level is excessive, one of the following conditions may exist:

1. Splitter Ext Sync signal input is not in sync with the Splitter V/A Input signal; this will cause an extremely high noise level. If this condition exists, set the front panel SYNC selector switch (S4) to the INT position.

2. Splitter Timing is not properly adjusted. If required, unlock the SPLITTER TIMING control (R14) knob and adjust for minimum noise level.

If the noise level is still excessive, refer to MAINTENANCE, Section 5, in particular paragraph 5.3.1.3.2, Sample Pulse Timing (Internal) or paragraph 5.3.1.3.6, External Sync Adjustments.

#### 3.3.2.2.3 Splitter V/A Input, Interleaved Audio (Refer to Figure 3-4)

If interleaved Audio is present in the V/A Input signal, both the SPLITTER and RELAY AUDIO STATUS indicators should indicate VTR AUDIO; if not, set the RELAY BYPASS switch (S1) in the VTR position.

Monitor the signal at the SPLITTER AUDIO OUT (1, 2 or 3) test jacks. When Interleaved Audio is present in the V/A Input signal, an audio signal will appear at the SPLITTER AUDIO OUT test jacks. The level may be adjusted with the AUD OUT LEVEL control (R10). The audio output may also be monitored on the speaker by adjusting the SPEAKER/INTERCOM LEVEL control (R9). Refer to NOTE in paragraph 3.3.2.2.2 above.

If the noise level in the Audio Output signal is excessive, refer to paragraph 3.3.2.2.2 above.

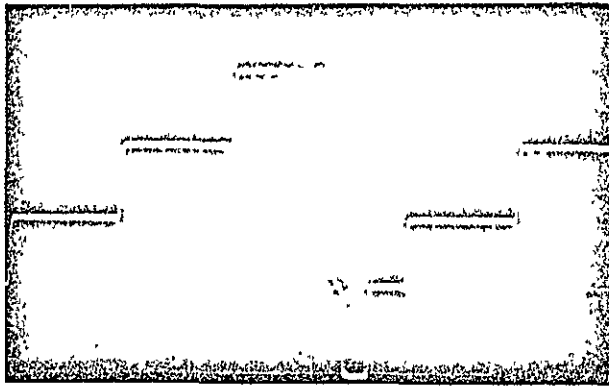

Figure 3-2. SPLITTER V/A INPUT 3-step test signal with no interleaved audio

Scope Sync - A3TJ3  
 Vert. Scale - 0.2 V/cm dc  
 Hor. Scale - 10  $\mu$ s/cm

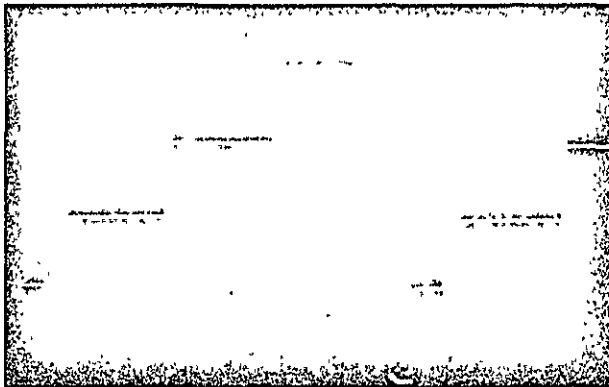

Figure 3-3. SPLITTER V/A INPUT 3-step test signal with interleaved pedestal only, no audio modulation

Scope Sync - A3TJ3  
 Vert. Scale - 0.2 V/cm dc  
 Hor. Scale - 10  $\mu$ s/cm

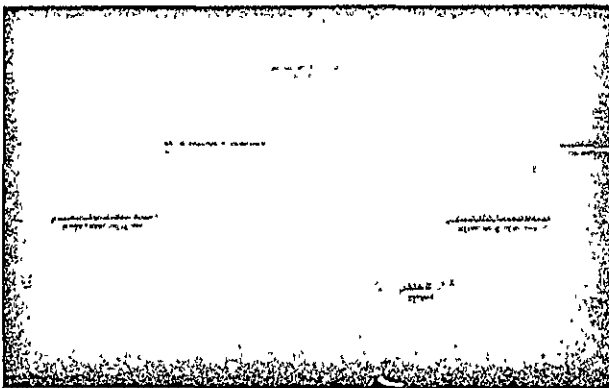

Figure 3-4. SPLITTER V/A INPUT 3-step test signal with interleaved audio

Scope Sync - A3TJ3  
 Vert. Scale - 0.2 V/cm dc  
 Hor. Scale - 10  $\mu$ s/cm

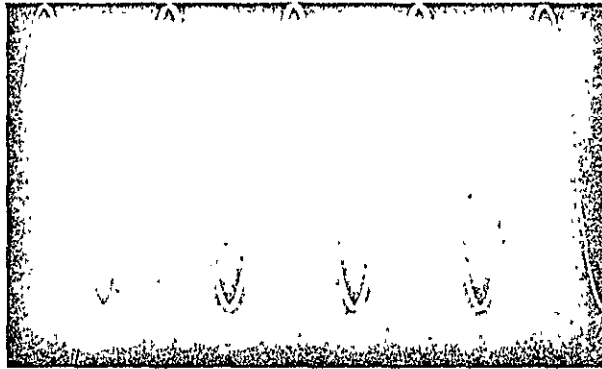

Fig 3-5. SPLITTER A/G AUD INPUT 1-kHz sine wave test signal

Scope Sync - INT  
 Vert. Scale - 0.2 V/cm  
 Hor. Scale - 0.5 ms/cm

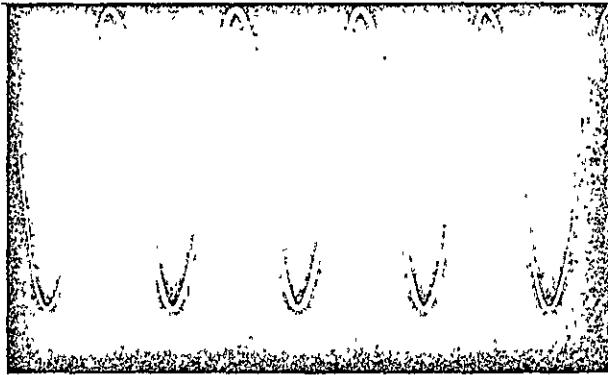

Figure 3-6. SPLITTER AUDIO OUT 1, 2 or 3

Scope Sync - INT  
 Vert. Scale - 0.2 V/cm  
 Hor. Scale - 0.5 ms/cm

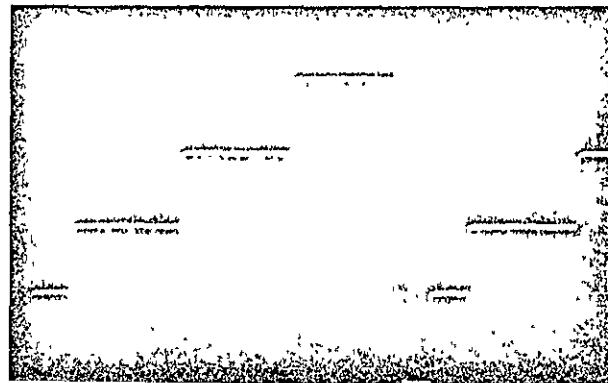

Figure 3-7. INTERLEAVER VID INPUT 3-step test signal

Scope Sync - A7TJ4  
 Vert. Scale - 0.2 V/cm dc  
 Hor. Scale - 10  $\mu$ s/cm

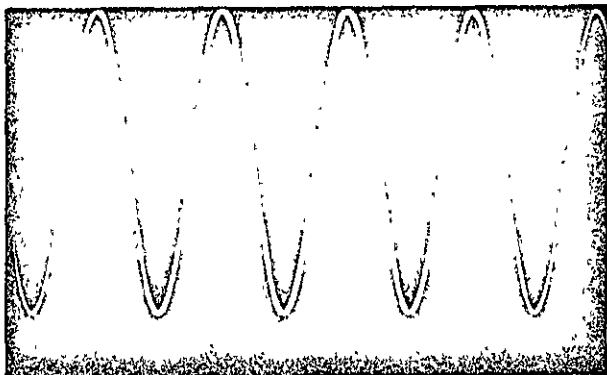

Figure 3-8. INTERLEAVER AUD INPUT

Scope Sync - INT  
 Vert. Scale - 0.2 V/cm  
 Hor. Scale - 0.5 ms/cm

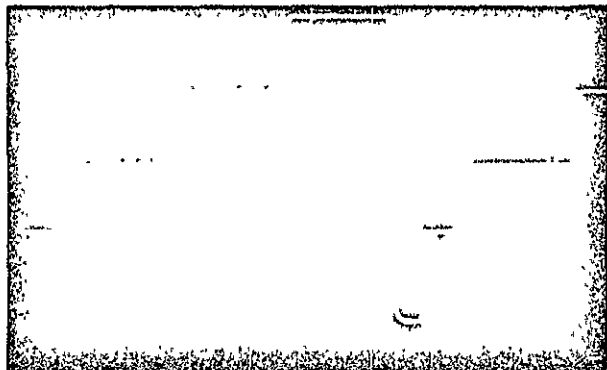

Figure 3-9. INTERLEAVER V/A OUT 1 or 2. Three-step test signal with interleaved pedestal only, no audio modulation.

Scope Sync - A7TJ4  
 Vert. Scale - 0.2 V/cm dc  
 Hor. Scale - 10  $\mu$ s/cm

(V/A OUT terminated in 75 ohms dc)

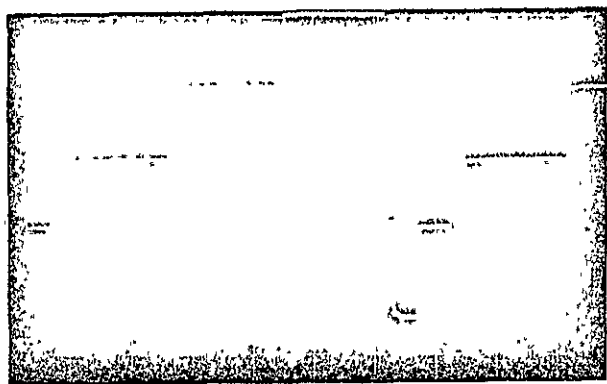

Figure 3-10. INTERLEAVER V/A OUT 1 or 2. Three-step test signal with interleaved audio.

Scope Sync - A7TJ4  
 Vert. Scale - 0.2 V/cm dc  
 Hor. Scale - 10  $\mu$ s/cm

(V/A OUT terminated in 75 ohms dc)

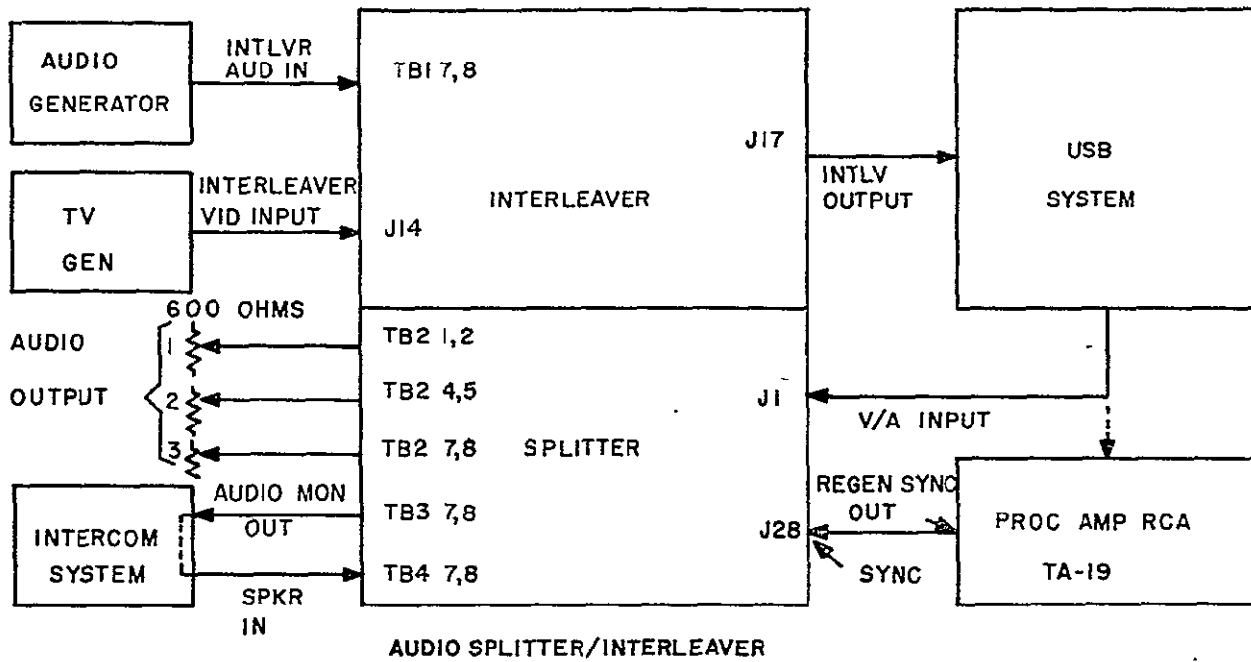

Figure 3-11. Audio/CTE Splitter/Interleaver USB System Connections (setup)



#### 4. PRINCIPLES OF OPERATION

## SECTION 4

### PRINCIPLES OF OPERATION

#### 4.1 GENERAL

The Audio/CTE Splitter/Interleaver has two main functions:

1. Audio/CTE Splitter
2. Audio/CTE Interleaver

All the controls and indicators are located on the unit front panel. All inputs and outputs are made through the rear panel.

The electronic circuits associated with the above functions are located on ten plug-in modules accessible from the top of the unit and two board assemblies, one wired into the front panel and the other into the rear chassis.

#### 4.2 SYSTEM OPERATION

(Refer to Figure 4-1)

##### 4.2.1 Audio/CTE Splitter

The Audio/CTE Splitter circuit receives either air/ground audio or video/audio/CTE (interleaved). The Splitter detects the signal being received, provides an indication of which signal is being received, and selects the proper signal to be processed.

When air/ground audio is received, the signal is processed and fed to the audio lines.

When video/audio/CTE is received, the audio is extracted from the video, processed and fed to the audio output lines, and to an Audio Monitor output. The CTE time data is displayed on the front panel CTE display.

A speaker is provided for monitoring the signal supplied to the Speaker Input terminals.

Outputs of relay closures are provided, indicating the status of the audio received (A/G audio or VTR audio).

##### 4.2.2 Audio Interleaver

The Audio Interleaver circuit receives two inputs - an audio input and a video input.

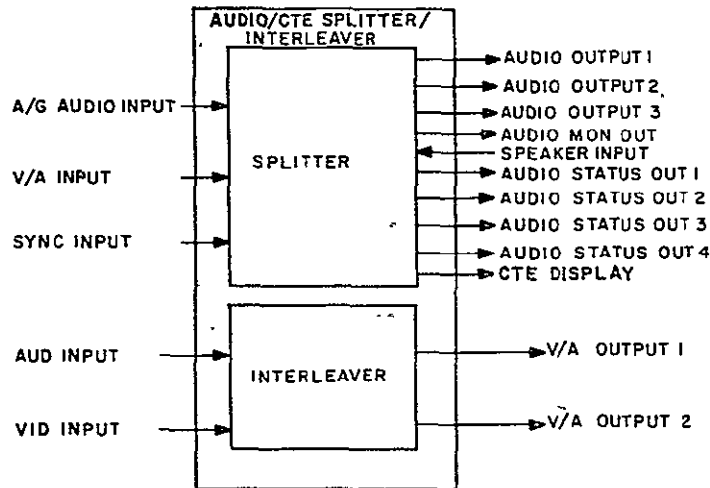

Figure 4-1. Audio/CTE Splitter/Interleaver, System Functional Block Diagram

The interleaver samples the audio at the horizontal line rate, interleaves it with the CTE time data and the video, and provides two video/audio outputs.

### 4.3 FUNCTIONAL OPERATION

#### 4.3.1 Audio/CTE Splitter

Refer to Splitter functional diagram, Figure 4-2; Video/Audio Waveform, Figure 4-3; and schematic diagram, Figure 6-1).

##### 4.3.1.1 Video/Audio

The Video/Audio (V/A) input jack (J1) is a BNC connector, located on the rear panel. The signal at J1 may be either a real time (R/T) video signal (standard TV signal) or a video/audio/CTE (VTR, interleaved) signal. (Refer to Figure 4-3).

When a real time video signal is received, the Splitter PAM Detector Circuit automatically selects the Air/Ground Audio Signal to be processed and supplied to the various Audio Out terminals (Refer to Audio Status Detector, paragraph 4.3.1.2, and Air/Ground Audio, paragraph 4.3.1.3 below). When a V/A (TV signal with interleaved audio/CTE) is received at J1, the Splitter PAM Detector Circuit automatically selects the VTR AUD to be processed by the Audio Circuits.

The video signal is fed from connector J1 through coupling capacitor C1, to the Bessel Filter/Equalizer module (A10), located on the splitter chassis. The signal enters the A10 module at pins 1 and 2 (Ground) (Refer to schematic diagram, Figure 6-11). The A10 module consists of a Bessel filter, an Equalizer and an Equalizer Bypass switch. The Bessel Filter determines the bandwidth of the splitter (1.0 MHz); the Equalizer

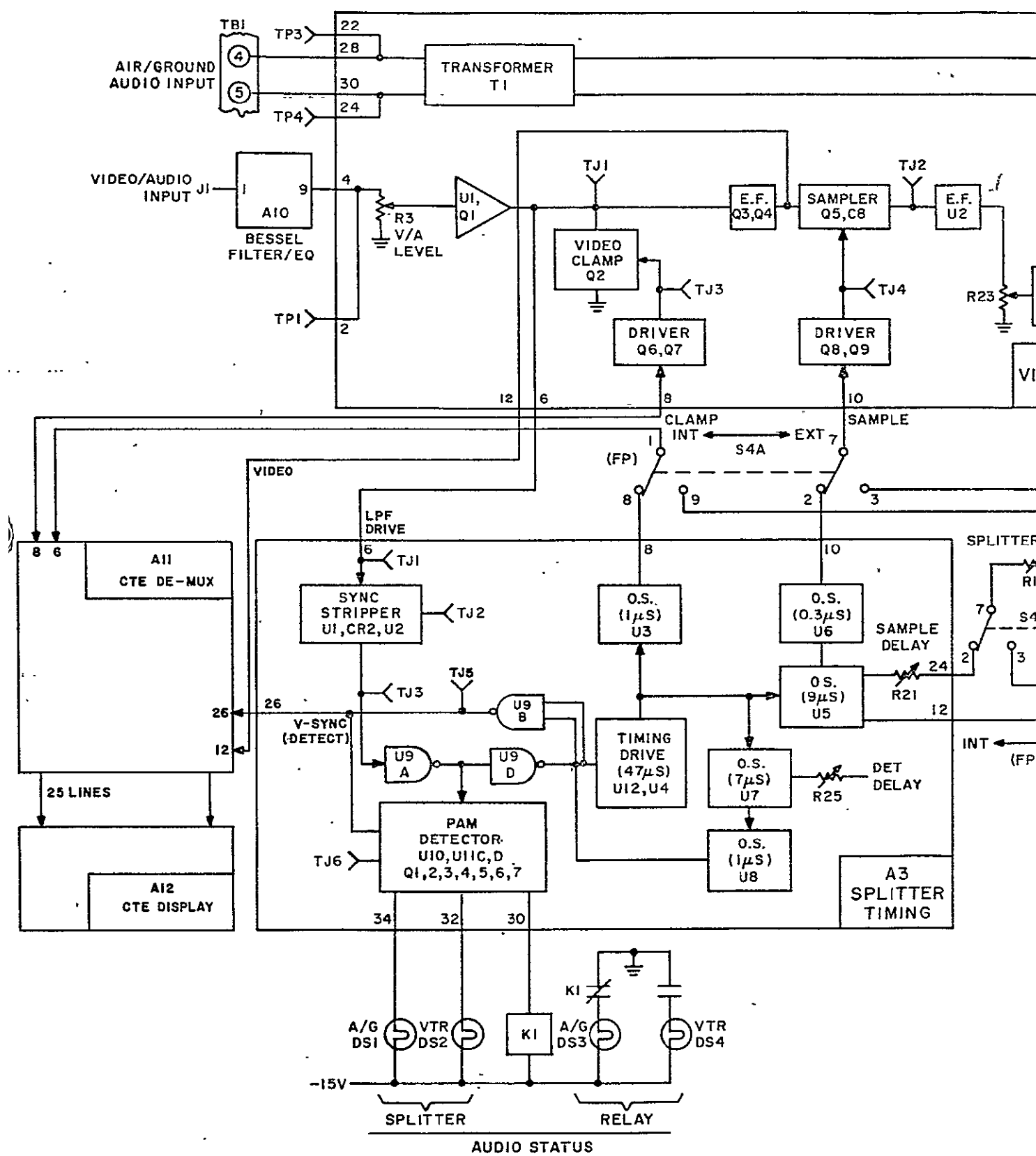

FOLDOUT FRAME

ORIGINAL PAGE IS  
OF POOR QUALITY

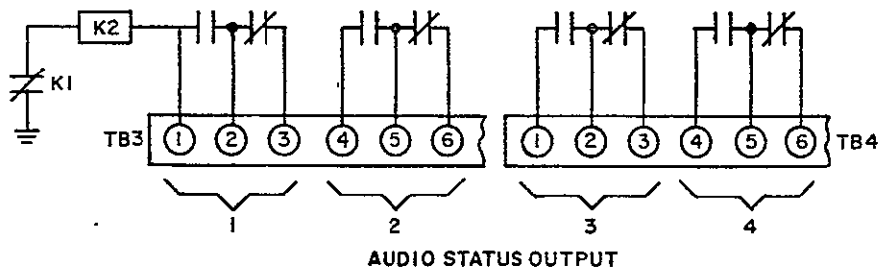
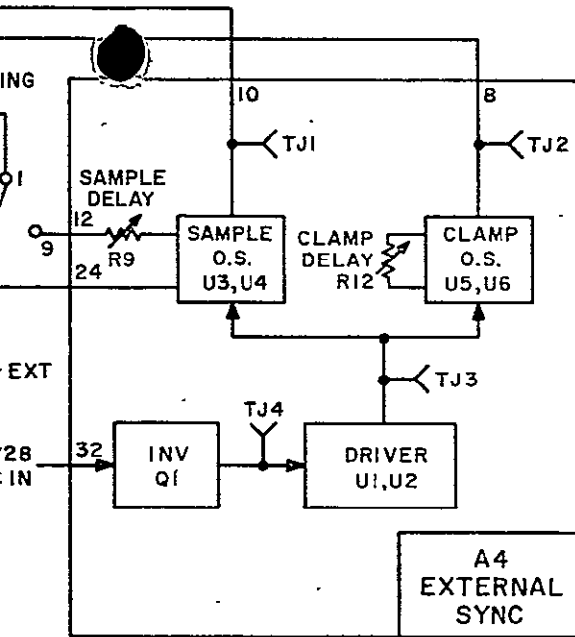
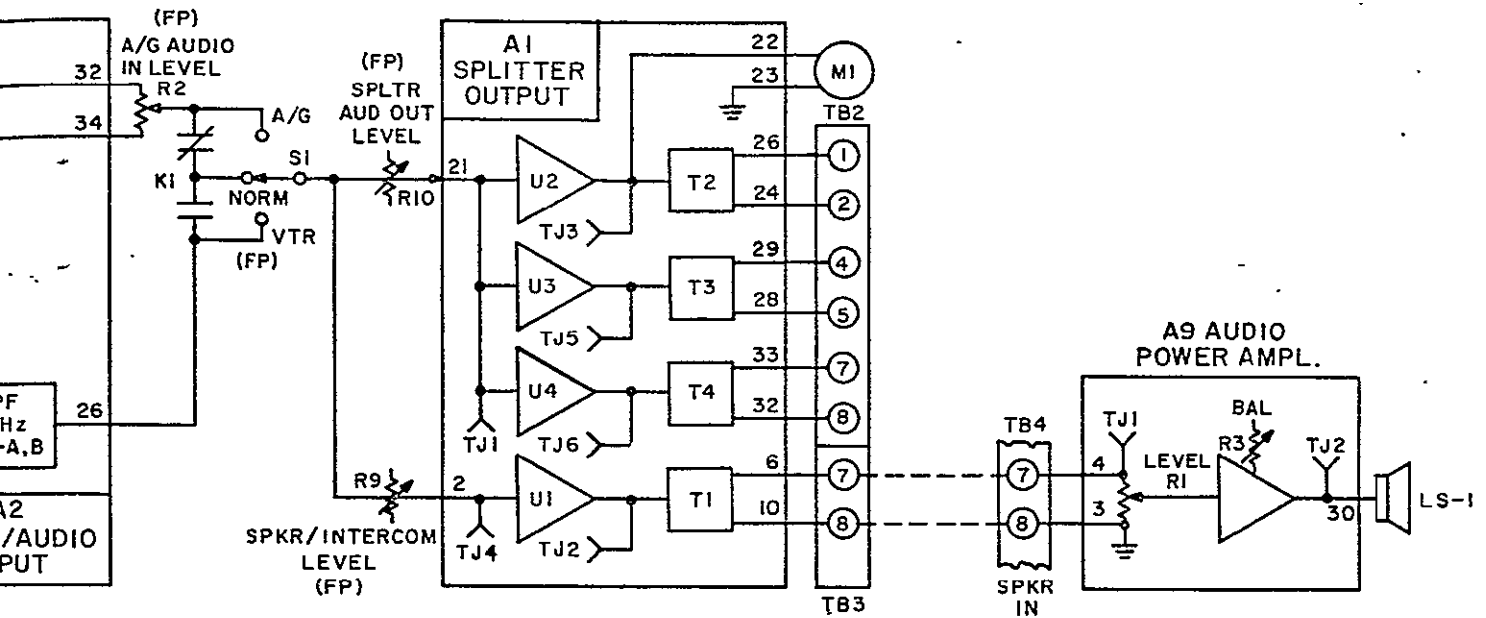

NOTE: K1 & K2 SHOWN IN DE-ENERGIZED POSITION  
FP= FRONT PANEL

Figure 4-2. Splitter Functional Diagram

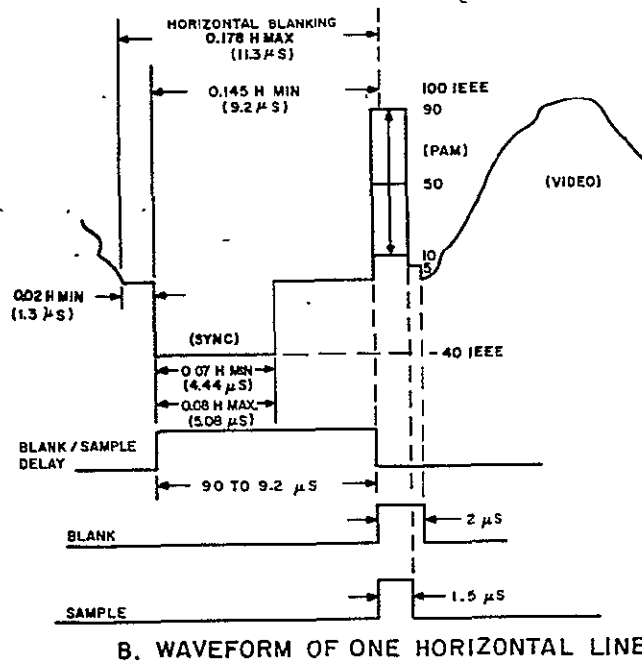
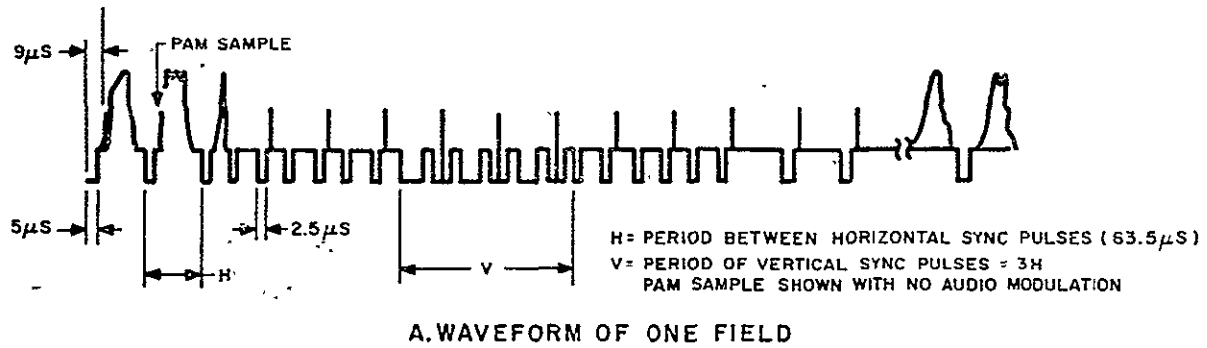

Figure 4-3. Video/Audio/CTE Waveform

circuit is designed to compensate for distortion in the USB system. The Equalizer Bypass switch removes the Equalizer from the circuit when in the BYPASSED position. NOTE: There is no equalizer circuit in this equipment. The video signal from the output of the Bessel Filter/Equalizer A10-9 and A10-10 (Ground) is fed to the V/A Input, pin 4 and pin 3 (Ground) of the Video/Audio Input module (A2). In the Video/Audio Input module (A2) (Refer to schematic diagram, Figure 6-3), the signal is fed through the V/A LEVEL control (R3), which is adjusted for the proper level at the Video Clamp (Q2), test jack TJ1. (Refer to Table 5-1 for signal levels). From the level control the video signal is fed through an amplifier stage (U1, Q1); the gain of the stage is determined by resistors R4 and R6. The signal at the output of the amplifier follows two paths, one through the sync stripper circuit and the other to the video clamp.

## 4-1.1 Sync Stripper Circuit

(Refer to functional diagram, Figure 4-4 and timing diagram, Figure 4-5).

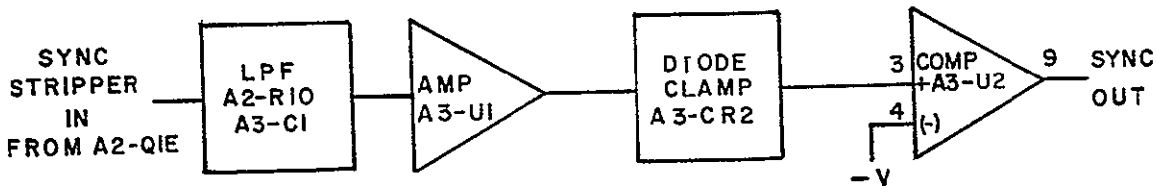

Figure 4-4. Splitter Sync Stripper Functional Diagram

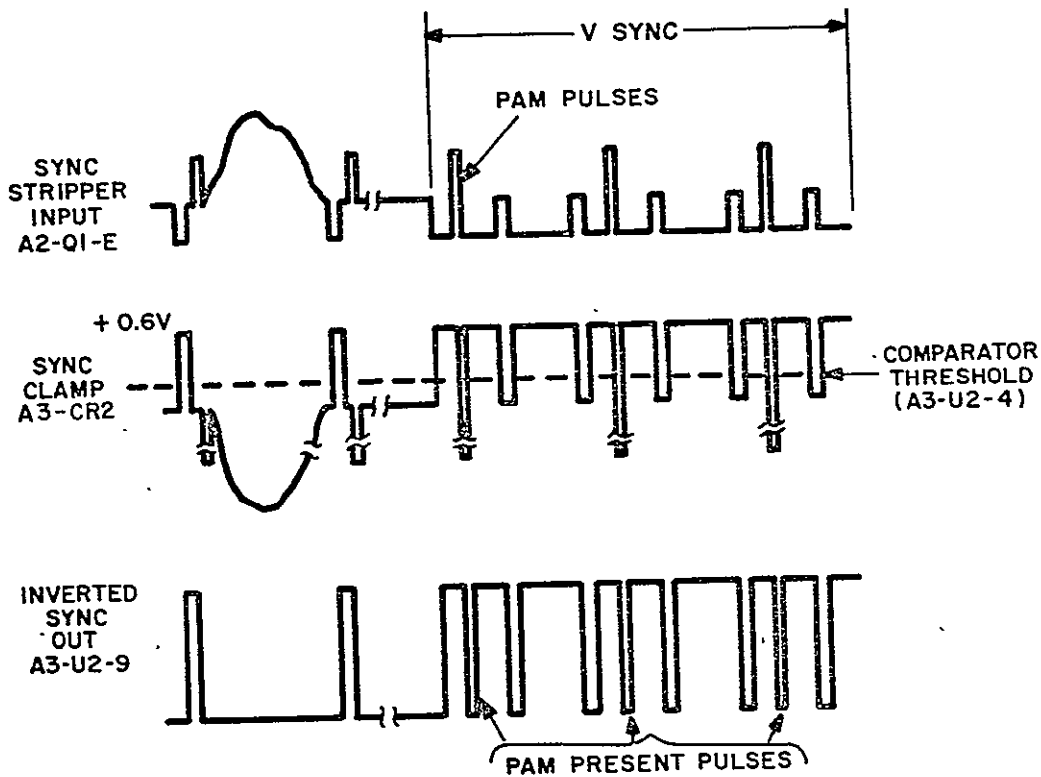

Figure 4-5. Sync Stripper Timing Diagram (Splitter)

The sync stripper detects sync from the composite TV signal (real time or V/A) and provides signal to the video clamp, timing circuits and the PAM detector circuits. When interleaver video (V/A) is received by the unit, the output signal of the sync stripper will contain a pulse (PAM present) coincident with the PAM pulse during the vertical sync period (refer to Figure 4-5).

The sync stripper consists of a low pass filter, an amplifier, a diode clamp and a comparator.

The low pass filter, consisting of A2-R10 and A3-C1, reduces the noise bandwidth of the sync stripper, thereby allowing the sync stripper circuit to detect sync in a low signal-to-noise signal. The output of the low pass filter is fed to the amplifier stage (Refer to Splitter Timing (A3) schematic diagram, Figure 6-4).

The amplifier consists of U1 and its associated circuitry. The output of the amplifier is fed to a diode clamp (C15 and CR2) which clamps the sync tips at +0.6 V.

From the diode clamp the signal is fed to the comparator circuit consisting of U2 and its associated circuitry. The signal is fed through R11 to the non-inverting input of U2. The inverting input is biased, through resistors R12 and R13, to a negative reference voltage, which causes the comparator output to be high when the input is more positive than the reference.

When the level at the comparator input becomes more negative than the reference, the comparator output saturates (goes to zero). The transition takes place very rapidly due to the positive feedback, formed by resistors R11 and R16.

The signal from the output of the sync stripper (U2) is fed to the input of inverter U9A. The output of the inverter U9A is fed to two paths, one to the Timing Circuit and the other to the PAM Detector Circuit.

#### 4.3.1.1.2 Timing Circuit

(Refer to Splitter Timing (A3) Schematic Diagram, Figure 6-4). The timing circuit, consisting of one-shots U12 and U4, generates a pulse to drive the PAM detector, the sample delay circuit and the clamp circuit. This pulse is at horizontal (line) rate.

The signal into U12 is inverted sync from the output of inverter U9D. This signal is identical to that from the sync stripper U2 (Refer to sync stripper, paragraph 4.3.1.1.1, and Figure 4-5).

The leading (positive-going) edge of the sync signal triggers one-shot U12 which generates a 4- $\mu$ s (positive-going) pulse. The 4- $\mu$ s pulse from U12 is fed to the input of one-shot U4. U4 is a non-retriggering 47- $\mu$ s one-shot. The time constant of U4 is set longer than twice horizontal rate so that retrigger will not occur at this rate (during the vertical intervals).

The 47- $\mu$ s pulse from the output of the timing circuit follows three paths, one to the Video Clamp circuit (Internal), one to the PAM Detector circuit, and one to the Sampling circuit (Internal).



### 4.3.1.1.3 Video Clamp Circuit

The Video Clamp circuit clamps the video signal (sync tip) to ground. The video clamp may be operated in two modes: Internal or External. In the Internal mode, the clamp driver source is the sync stripper (Splitter Timing module A3) output. In the External mode, the clamp driver source is the REGEN SYNC signal from an RCA TA-19 Processing Amplifier.

#### 4.3.1.1.3.1 Internal Sync

(Refer to V/A Input (A2) schematic diagram, Figure 6-3; Splitter Timing (A3) schematic diagram, Figure 6-4; and Splitter Clamp and Sample timing diagram, Figure 4-6).

The Video Clamp circuit (Internal Sync) consists of one-shot A3-U3, driver A2-Q6,7 and clamp A2-Q2. The clamp one-shot (A3-U3) receives a  $47\text{-}\mu\text{s}$  pulse from A3-U4. The leading (positive-going) edge of the input signal triggers the one-shot which generates a  $1\text{-}\mu\text{s}$  pulse (refer to timing diagram, Figure 4-6). The  $1\text{-}\mu\text{s}$  pulse from the output of U3 is fed out of the Splitter Timing module on connector pin 8 (clamp pulse). From A3-8 the clamp pulse is fed to pin 8 of the sync switch (S4A) located on the front panel. When the sync switch is in the INT position, the Internal clamp pulse is

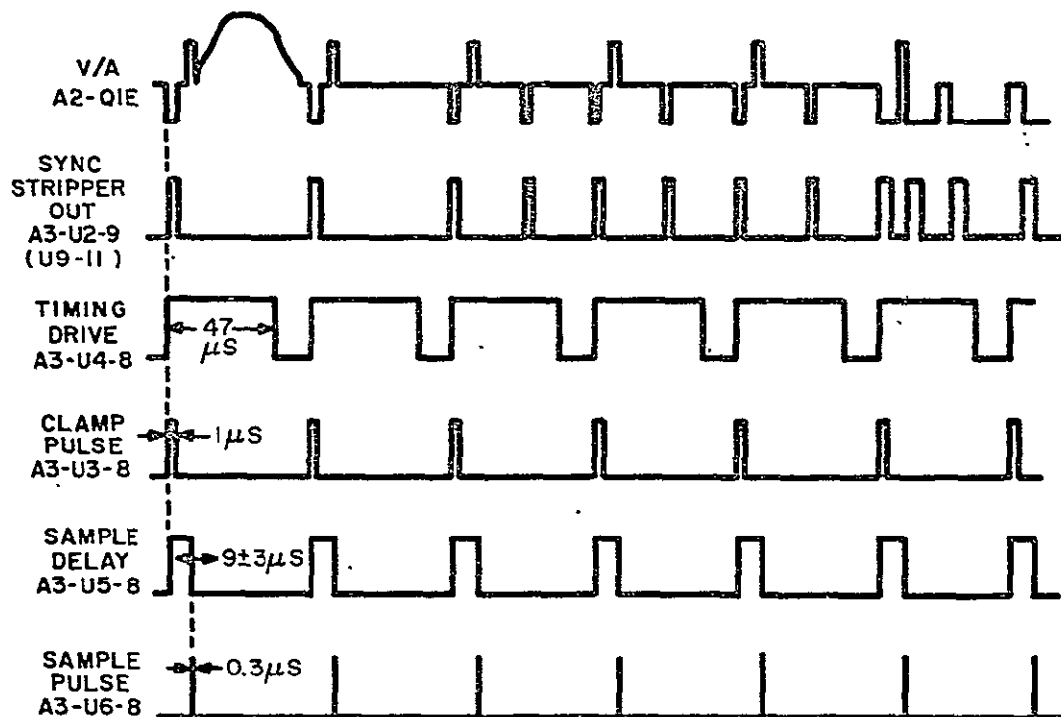

Figure 4-6. Splitter, Clamp and Sample Timing Diagram (internal sync)

fed through the switch to the Video/Audio Input module (A2). In A2 the clamp pulse is fed from connector pin 8 to the clamp driver (Q6, 7) which drives the video clamp (Q2). The video clamp is turned ON during the duration of the  $1\text{-}\mu\text{s}$  pulse and is turned OFF when the pulse is not present. Therefore, the video signal is clamped to ground for  $1\text{ }\mu\text{s}$  at the leading edge of each horizontal pulse (and at horizontal rate during the vertical interval).

The signal from the video clamp (Q2) is fed through dual emitter follower (Q3, 4) to the sampling switch (Q5).

#### 4.3.1.1.3.2 External Sync

(Refer to External Sync (A4) schematic diagram, Figure 6-5; V/A Input (A2) schematic diagram, Figure 6-3; and Splitter, Clamp and Sample timing diagram, Figure 4-7).

The external clamp circuit consists of an inverter (Q1), timing driver (U1, 2), clamp delay one-shot (U5) and clamp pulse one-shot (U6) on the A4 module, sync switch (S4A on the front panel, and clamp driver (Q6, 7) and clamp (Q2) on the A2 module.

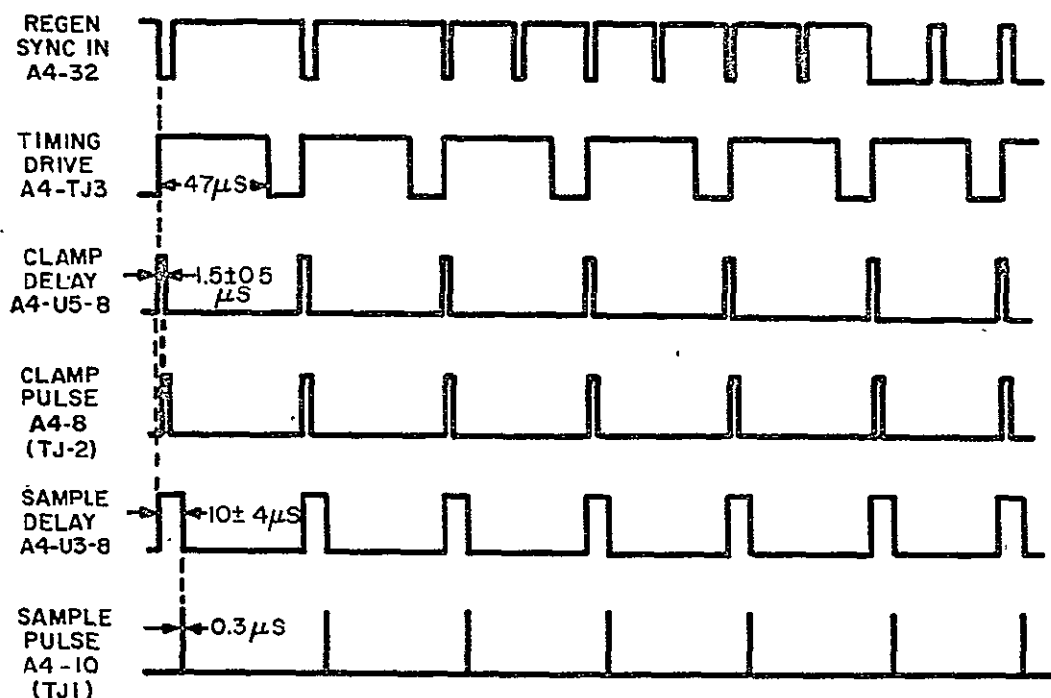

Figure 4-7. Splitter, Clamp and Sample Timing Diagram (external sync)

The External Sync signal enters the Audio/CTE Splitter/Interleaver at the SPLITTER SYNC IN connector (J28) located on the rear panel. The sync signal is fed from J28 to A4-32 and 33 (Ground).

In the A4 module the signal is fed to inverter Q1. The output of Q1 is fed to one-shot U1. U1 triggers on the leading (positive-going) edge of the input pulse and generates a  $4\text{-}\mu\text{s}$  pulse. This  $4\text{-}\mu\text{s}$  pulse is fed to one-shot U2. U2 is a non-retriggering,  $47\text{-}\mu\text{s}$  one-shot, so that output pulses occur only at the horizontal rate. The output signal from U2 follows two paths, one to the Clamp delay one-shot (U5) and the other to the Sample delay one-shot (U3).

Clamp delay one-shot (U5) triggers on the leading (positive-going) edge of the  $47\text{-}\mu\text{s}$  input pulse and generates a positive-going pulse. The width of the pulse at the output of U5 is determined by the setting of CLAMP DELAY control R12 (approximate range  $1.0$  to  $2.0\ \mu\text{s}$ ). The Clamp delay pulse is fed to the input of Clamp pulse one-shot U6. The Clamp pulse one-shot (U6) triggers on the trailing (negative-going) edge of the Clamp delay pulse; therefore, the clamp pulse one-shot (U6) generates a  $1\text{-}\mu\text{s}$  wide pulse delayed by  $1.5 \pm 0.5\ \mu\text{s}$  from the leading edge of the SPLITTER SYNC input pulse.

The clamp pulse is fed from U6 to connector pin 8. From A4-8 the clamp pulse is fed to pin 9 of the SYNC switch S4A, located on the front panel. When the SYNC switch is in the EXT position, the External clamp pulse is fed through the switch to the Video/Audio Input module (A2). In A2 the External clamp pulse follows the same path as described above for the Internal clamp pulse, paragraph 4.3.1.1.3.1.

#### 4.3.1.1.4 Sampling Circuit

The function of the Splitter Sampling circuit is to sample the V/A signal during the PAM interval, to hold the sample between PAM intervals, and to filter the sampled signal, thereby recovering the audio information.

The Sampling circuit may be operated in two modes - Internal or External. In the Internal mode, the Sampler driver source is the sync stripper (Splitter Timing module A3) output. In the External mode, the sampling circuit driver source is the REGEN SYNC signal from the RCA TA-19 Processing Amplifier.

##### 4.3.1.1.4.1 Internal Sync

(Refer to V/A Input (A2) schematic diagram, Figure 6-3; and Splitter Timing (A3) schematic diagram, Figure 6-4).

The sampling circuit consists of dual emitter follower A2-Q3, 4, sampler switch A2-Q5, hold capacitor A2-C8, isolation amplifier A2-U2, AUDIO LEVEL control A2-R23, active low pass filter A2-U3A, B sampler driver A2-Q8, 9, sample delay one-shot A3-U5, sample delay control A3-R21, sample pulse one-shot A3-U6, SPLITTER TIMING control (R14) and SYNC switch (S4A, B).

The Sample delay one-shot A3-U5 receives a  $47\text{-}\mu\text{s}$  pulse from A3-U4 (refer to paragraph 4.3.1.1.2 for description of Timing Circuit). The leading (positive-going) edge of the input signal, triggers the one-shot (refer to timing diagram, Figure 4-6) which generates a  $9 \pm 3\mu\text{s}$  pulse (adjusted by SAMPLE DELAY control A3-R21 and SPLITTER TIMING control R14). The Sample Delay pulse is fed from A3-U5 to the input of Sample pulse one-shot U6. One-shot U6 triggers on the trailing (negative-going) edge of the sample delay pulse. Therefore, the sample pulse one-shot (U6) generates a  $0.3\text{-}\mu\text{s}$  pulse, delayed by approximately  $9\mu\text{s}$  from the leading edge of the splitter sync stripper output pulse.

The sample pulse signal is fed from U6-8 to connector pin 10. From A3-10 the Sample pulse is fed to pin 2 of the SYNC switch S4A located on the front panel. When the SYNC switch is in the INT position, the Internal sample pulse is fed through the switch to the Video/Audio Input module (A2 pin 10). In A2 the Sample pulse is fed from connector pin 10 to the sampling switch driver (Q8, 9) which drives the sampling switch (Q5). The sampling switch is turned ON during the duration of the  $0.3\text{-}\mu\text{s}$  sampling pulse and is turned OFF when the pulse is not present.

During the  $0.3\text{-}\mu\text{s}$  period, when the sampling switch (Q5) is turned on, hold capacitor C8 is charged to the level of the PAM signal (at Video Clamp Q2), through emitter follower Q3, 4. During the interval between sample pulses, Sampling Switch Q5 is OPEN and Capacitor C8 "holds" the sampled PAM level.

The sampled PAM signal is fed from hold capacitor Q8 through isolation amplifier U2 to AUDIO LEVEL control R23. From the arm of R23 the sampled PAM level is fed through the low pass filter (U3A, B). This is an active four-pole Butterworth low pass filter with a cutoff frequency of 3 kHz. From the output of the low pass filter (U3B) the sampled and filtered PAM signal (audio) is fed to connector pin 26 (VTR AUDIO OUTPUT).

#### 4.3.1.1.4.2 External Sync

(Refer to V/A Input (A2) schematic diagram, Figure 6-3; External Sync (A4) schematic diagram, Figure 6-5; and Timing Diagram, Figure 4-7).

The external sampling circuit consists of dual emitter follower A2-Q3, 4, sampling switch A2-Q5, hold capacitor A2-C8, emitter follower A2-U2, AUDIO LEVEL control A2-R23, active low pass filter A2-U3A, B, and Sampler driver A2-Q8, 9 (the above components are located on the V/A Input module (A2) and are also part of the Internal Sampling circuit described above, paragraph 4.3.1.1.3.1). The external sampling circuit also consists of A4-Q1, U1, U2 (also used in external clamp circuit), Sample Delay one-shot A4-U3 and Sample pulse one-shot A4-U4. Front panel SYNC switch (S4A, B) and SPLITTER TIMING control R14 is also used.

The external sync signal enters the Audio/CTE Splitter/Interleaver unit at the SPLITTER SYNC in connector (J28), located on the rear panel. The sync is fed from J28 to A4-32 and 33 (ground).

In the A4 module the signal is fed from connector pin 32 to inverter Q1. The output of Q1 is fed to one-shot U1. U1 triggers on the leading (positive-going) edge of the input pulse and generates a 4- $\mu$ s pulse. This pulse is fed to one-shot U2. U2 is a non-retriggering 47- $\mu$ s one-shot, so that output pulses occur only at the horizontal rate. The output signal from U2 follows two paths, one to the clamp delay one-shot (U5), described in paragraph 4.3.1.1.3.2 above, and the other to the sample delay one-shot (U3).

Sample delay one-shot (U3) triggers on the leading (positive-going) edge of the 47- $\mu$ s input pulse and generates a positive-going pulse. The width of the pulse at the output (U3-8) is determined by the setting of the SAMPLE DELAY control (A4-R9) and the SPLITTER TIMING control (R14), located on the front panel; the width is approximately 10  $\mu$ s. The sample delay pulse is fed to the input of sample pulse one-shot U4. U4 triggers on the trailing (negative-going) edge of the sample delay pulse. Therefore, the sample pulse one-shot (U4) generates a 0.3- $\mu$ s wide pulse delayed by approximately 10  $\mu$ s from the leading edge of the SPLITTER SYNC input pulse.

The sample pulse is fed from U4-8 to connector pin 10. From A4-10 the sample pulse is fed to pin 3 of the SYNC switch (S4A) located on the front panel. When the SYNC switch is in the EXT position, the External sample pulse is coupled through the switch to the Video/Audio Input module (A2). In A2 the External sample pulse follows the same path described above for the Internal Sample pulse, paragraph 4.3.1.1.4.1.

#### 4.3.1.1.5 VTR Audio Processing

(Refer to Audio/CTE Splitter/Interleaver schematic diagram, Figure 6-1).

From A2-26 the VTR AUDIO OUTPUT signal is fed to a normally open contact (pin 13) of relay K1 (located on the rear of the front panel). The signal is also fed to the VTR AUD contact of the RELAY BYPASS selector switch (S1), located on the front panel.

If the relay (K1) is in the energized (VTR) position, the VTR AUD signal will be coupled through the relay to the NORMAL contact of the RELAY BYPASS selector switch. If the switch is in either the NORMAL or VTR position, the VTR AUDIO signal will be fed to the center arm of the switch (S1-1). The signal from S1-1 is fed to both the SPLITTER AUDIO OUTPUT LEVEL control and the SPEAKER/INTERCOM LEVEL control. From the arm of the SPLITTER AUDIO LEVEL control the signal is fed to the Splitter Output module (A1, pin 21). In the Splitter Output module the signal feeds three amplifiers (U2, U3, U4).

The signal to U2 is amplified and fed through resistor R20 to two paths, one to the module pin 22, which in turn drives the AUDIO OUT LEVEL meter (M1), located on the front panel and the other to output transformer T2. The transformer provides a balanced output, which is fed to module pins 26 and 24. The output impedance is determined by the parallel combination of R20 and the impedance of the AUDIO OUT LEVEL meter. From A1-26, 24 the signal is fed to terminal board TB2-1, 2, respectively, located on the rear panel (AUDIO OUTPUT 1).

The signal to U3 is amplified and fed through resistor R22 to output transformer T3. The transformer provides a balanced output, which is fed to module pins 29 and 28. The output impedance is determined by the parallel combination of R22 and R25. From A1-29, 28 the signal is fed to TB2-4, 5, respectively, (AUDIO OUTPUT 2).

The signal to amplifier U4 follows a path similar to that described for amplifier U3 above. The signal exits from the module on pins 33 and 32. From A1-33, 32 the signal is fed to TB2-7, 8, respectively (AUDIO OUTPUT 3).

From the arm of the SPEAKER/INTERCOM LEVEL control (R9) the signal is fed to the Splitter Output module (A1, pin 2). In the Splitter Output module, the signal is fed to amplifier U1. The output from U1 is fed through R18 to output transformer T1. T1 provides a balanced output, which is fed to module pins 6 and 10. From A1-6, 10 the signal is fed to TB3-7, 8, respectively, (AUDIO MON OUT).

#### 4.3.1.1.6 Speaker Amplifier System

(Refer to Audio Power Amplifier Schematic Diagram, Figure 6-10). The Speaker Amplifier System consists of the Audio Power Amplifier (A9) and the Speaker (LS1). The speaker amplifier receives an input signal from an external source and provides sufficient level to drive the front panel speaker (LS1). The input signal is normally obtained by either connecting the AUDIO MON OUT terminals (TB3-7, 8) to the SPEAKER IN terminals (TB4-7, 8) or by connecting the AUDIO MON OUT terminals to an external intercom system and looping the signal back into the SPEAKER IN terminals. Under the conditions stated above, the SPEAKER IN signal level may be adjusted with the SPEAKER/INTERCOM LEVEL control (R9), located on the front panel.

The input signal enters the unit at TB4-7, 8 (SPEAKER IN), located on the rear panel. The signal is fed from TB4-7, 8 to Audio Power Amplifier (A9) input pins 4 and 3 (Ground), respectively.

In the Audio Power Amplifier module (A9) the signal is fed from pin 4 to the high side of LEVEL control R1. From the arm of R1 the signal is fed to the input of the amplifier stage, consisting of transistors Q1, Q2, Q3, Q4 and Q5 and the associated circuitry. Balance (BAL) control R3 is adjusted to provide a symmetrically clipped signal at the amplifier output (when the amplifier is driven into limiting).

The amplifier is a complementary symmetry class B stage; transistors Q2 and Q3 form the complementary symmetry pair. The amplifier is capable of driving approximately 4 watts into the speaker (3.2 ohms) before clipping. The amplifier output signal is fed through capacitor C4 to pin 30. The signal is coupled from pin 30 and 31 (ground) to the speaker (LS1), located on the front panel.

#### 4.3.1.2 Audio Status Detector and Indicator

purpose of the Audio Status Detector is to determine whether real-time (standard) video or VTR (interleaved) Video (V/A) is being received by the Audio/CTE Splitter/Interleaver and to automatically select the correct audio to be processed.

When real-time video is received, the audio status detector will automatically select the Air/Ground audio input. When interleaved video (V/A) is received, the audio status detector will automatically select VTR AUD.

The audio selected is processed by the splitter audio circuits and supplied to the audio output terminals as described in paragraphs 4.3.1.1 and 4.3.1.3.

The audio status detector circuit provides AUDIO STATUS indicators on the front panel and relay contacts on the rear panel.

The Audio Status detector and indicators consist of:

1. Detector circuits, located on the Splitter Timing module (A3), and relay K1, located on the rear of the front panel.
2. AUDIO STATUS indicators on the front panel, four sets of SPDT relay contacts (K2), and terminal boards TB3 and TB4.

#### 3.1.2.1 PAM Detector

(Refer to PAM Detector functional diagram, Figure 4-8; PAM Detector timing diagram, Figure 4-9; and splitter timing module schematic diagram, Figure 6-4).

The PAM detector determines whether a PAM pulse is present by sampling the signal from the sync stripper. When interleaved video is present, the stripped sync signal will contain a pulse coincident with the PAM pulse during the vertical sync period (refer to Figure 4-9, U2-9).

The PAM detector consists of inverters U9A and U9D; one-shots U12, U4, U7, U8, and U10; NAND gates U9B and U11A; flip-flop U11, C and D; PAM drivers Q1, Q2, Q3 and Q4; and A/G Lamp Driver Q5, Q6 and Q7. Inverted sync from the sync stripper (comparator U2) is fed to the input of the PAM detector U9A. U9A inverts the signal and feeds composite sync to NAND gate U11A and to inverter U9D. The output of U9D is fed to Gate U9B and to one-shot U12. U12 generates a 4- $\mu$ s pulse on each leading (positive-going) edge of the sync signal. The signal from the output of U12 is fed to the input of one-shot U4. U4 is a non-retriggering 47- $\mu$ s one-shot, to prevent retrigger at twice horizontal (line) rate (or on PAM pulses). The output of U4 drives the video clamp one-shot (U3) and one-shot U7. U7 is a 7- $\mu$ s one-shot that triggers on the leading (positive) edge. The width of the output pulse may be adjusted with DET. DELAY Control R25. The output of U7 drives 1- $\mu$ s one-shot U8. U8 triggers on the trailing (negative-going) edge of the input signal; therefore the leading edge of

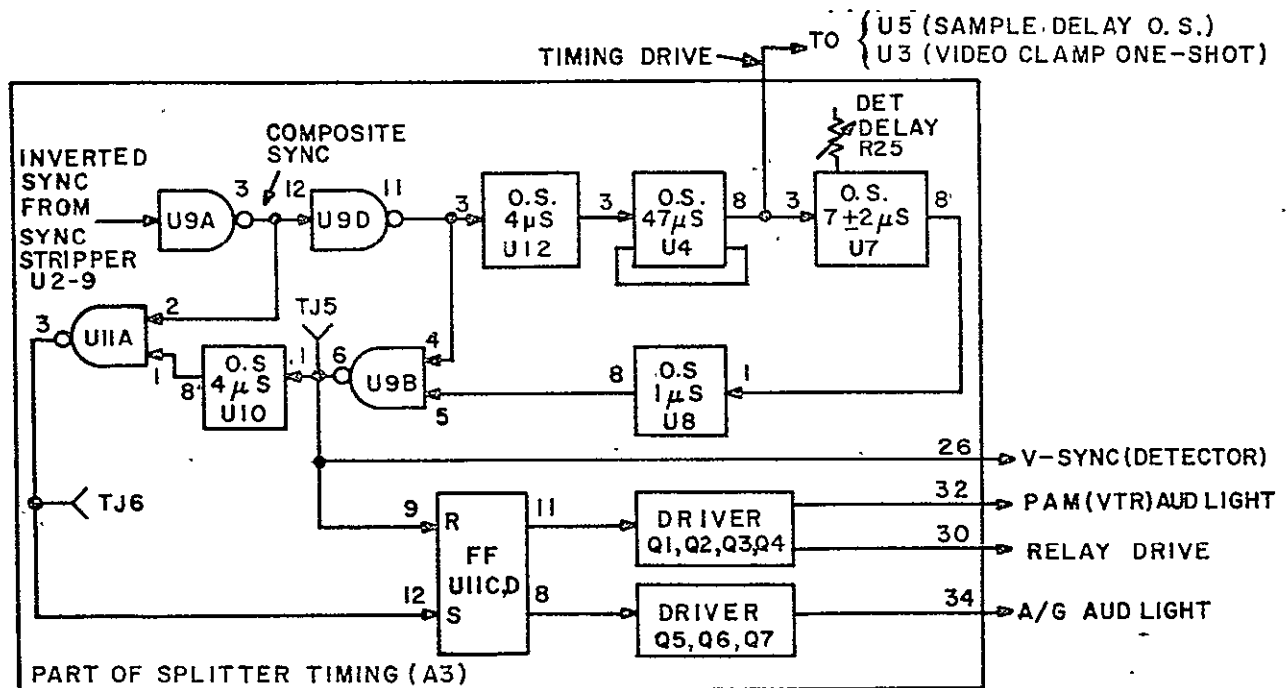

Figure 4-8. PAM Detector Functional Diagram

the signal at the output (U8-8) is delayed approximately  $7 \mu\text{s}$  from the leading edge of the input signal.

The output of U8 is fed to one input of NAND Gate U9B. The other input of U9B is composite sync from U9D. When both inputs are high, the output of NAND Gate U9B is low (this occurs three times and only during the Vertical sync period).

**NOTE:** If delay of U7 is too great (longer than  $8 \mu\text{s}$ ) and a PAM pulse is present, part of the PAM pulse will coincide with the  $1\text{-}\mu\text{s}$  pulse from U8, which will cause the output of U9B to shorten in time or disappear. If the delay of U7 is too small (less than  $5 \mu\text{s}$ ), the horizontal pulses will coincide with the pulse from U8, causing an erroneous pulse to occur at U9B-6.

The negative pulse from the output of NAND Gate U9B is fed to one-shot U10 and to the Reset input (pin 9) of Flip-Flop U11C, D. One-shot U10 triggers on the leading edge of the input pulse (negative-going) and generates a  $4\text{-}\mu\text{s}$  positive-going pulse. The output of U10 is fed to one input of NAND Gate U11A. The other input of U11A is composite sync from inverter U9A. The output of NAND Gate U11A depends on the presence of a PAM pulse (detected by the sync stripper).

**NOTE:** PAM pulses are detected by the sync stripper only in the vertical sync period. Refer to paragraph 4.3.1.1.1, sync stripper.

When both inputs to NAND Gate U11A are high, the output will be low. This will occur when a detected PAM pulse is present and coincident with the  $4\text{-}\mu\text{s}$  pulse generated by one-shot U10. The position of the  $4\text{-}\mu\text{s}$  pulse depends on the delay in one-shot U7 (adjusted by DET. DELAY Control R25).



The output of PAM NAND Gate U11A is fed to the SET input of Flip-Flop U11C, D. The RESET input is fed from V-SYNC NAND Gate U9B which will cause the FLIP-FLOP Outputs U11D-11 to be low and U11C-8 to be high. A PAM presence pulse (U11A-3) will SET the Flip-Flop and make the outputs assume the inverse state (pin 11 high, pin 8 low). If a PAM pulse is present, the signal at Flip-Flop output (U11D-11) will be as shown in Figure 4-9. Since the PAM presence pulse (U11A-3) occurs after the V-SYNC pulse (U9B-6), the signal at U11D-11 will remain high at the end of the vertical sync period.

NOTE: Flip-Flop U11C, D changes state only during the vertical sync period.

Therefore, for an interleaved input signal, the average level at U11D-11 will be high and the average level at U11C-8 will be low. When the average level at U11D-11 is high, transistor Q1 will be turned on, giving a low at its collector. The level at the base of PAM AUD LAMP DRIVER (Q3) will also be low (through emitter follower Q2) which will saturate Q3 (PNP), turning PAM (VTR) light ON. Relay driver Q4 will also be saturated, causing relay K1 (on the chassis) to operate.

When the average level at U11C-8 is low, transistor stage Q5 will be in the OFF state. Therefore, the signal at its collector will be high, giving a high at the base of A/G AUD LAMP DRIVER Q7 (through emitter follower Q6). A high at the base of Q7 will cause the A/G AUD LIGHT to be OFF.

If an interleaved signal is not present, the PAM Presence Pulse will not occur. Therefore, the V-SYNC pulses (U9B-6) will reset the Flip-Flop, causing U11D-11 to be low and U11C-8 to be high (the Flip-Flop will remain in this state in the absence of PAM pulses). The PAM LIGHT and RELAY drivers will be OFF and the A/G AUD LIGHT driver will be ON.

#### 4.3.1.2.2 Audio Status Indicators and Outputs

The AUDIO STATUS indicators consist of DS1, DS2, DS3 and DS4. The AUDIO STATUS OUTPUT are four sets of SPDT relay contacts (K2), accessible at TB3 and TB4. The condition of relay K2 and AUDIO STATUS indicators DS3 and DS4 is controlled by relay K1.

The signals from the PAM detector described in paragraph 4.3.1.2.1 above is fed out of the Splitter Timing module (A3) on pins 34 and 32 to the SPLITTER AUDIO STATUS indicators (DS1 and DS2).

#### 4.3.1.2.2.1 Real Time Video (Non-Interleaved)

If real time video is being received, the level at A3-34 will be high and the level at A3-32 will be low; this will cause the SPLITTER A/G indicator (DS1) to light and the SPLITTER VTR indicator (DS2) to be off. The level at A3-30 will be low, causing relay K1 to be in the de-energized state.

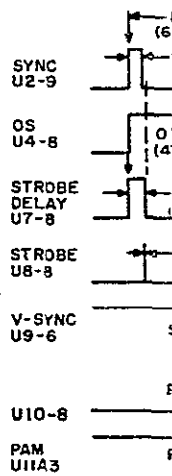

EXPANDED VIEW  
OF ABOVE DIAGRAM  
DURING V SYNC

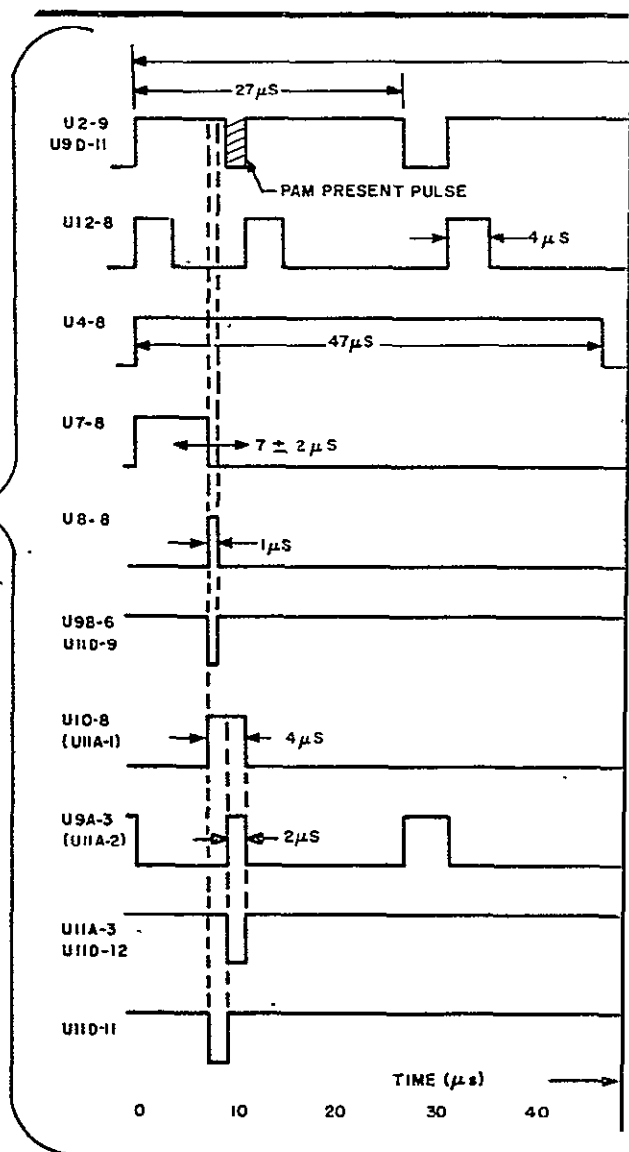

ORIGINAL PAGE IS  
 OF POOR QUALITY  
 FOLDOUT FRAME /

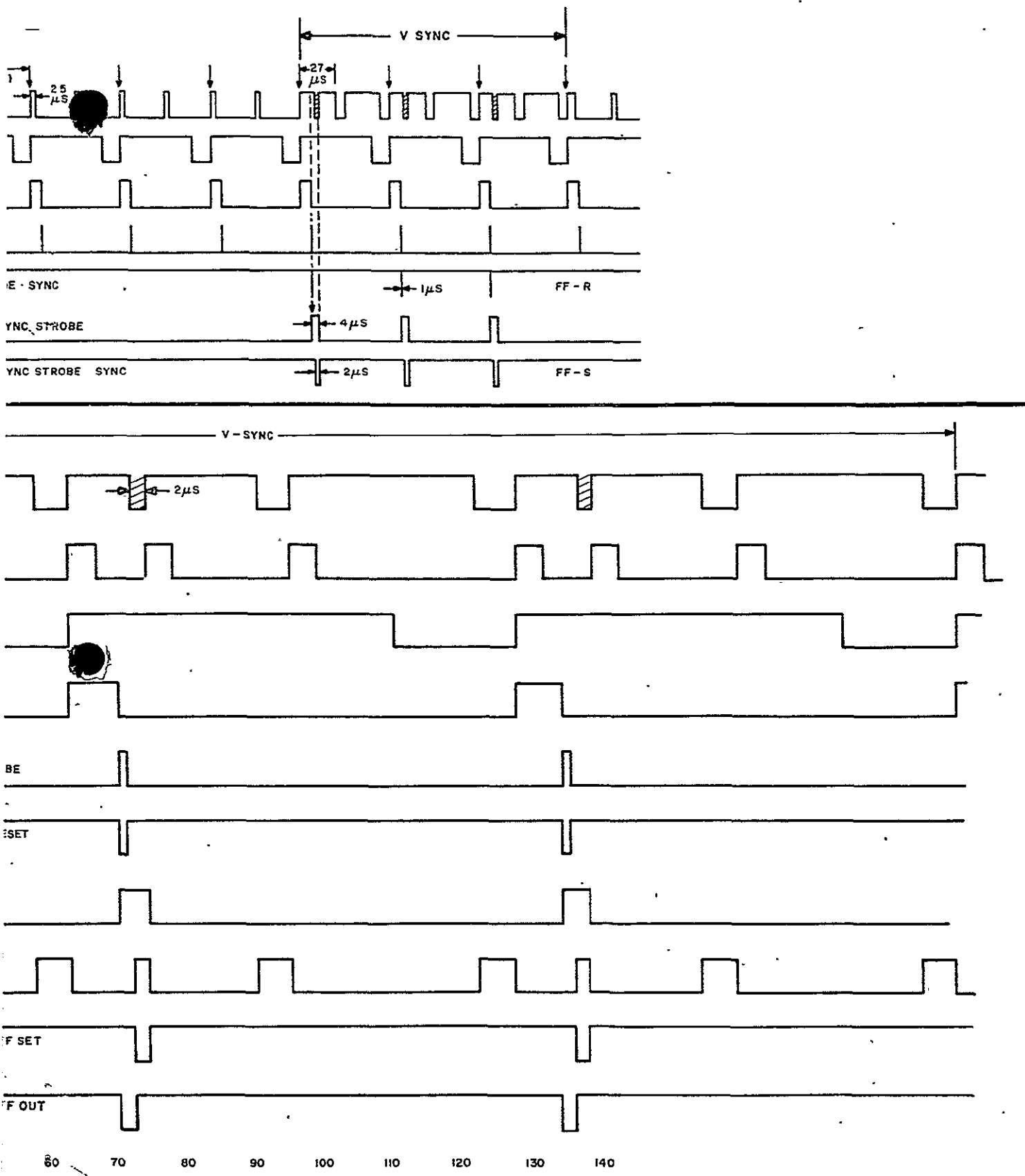

Figure 4-9. PAM Detector Timing (A3)

4-17/4-18  
 FOLDOUT FRAME  $\rightarrow$

The RELAY A/G indicator (DS3) will be illuminated, through normally closed contacts K1-8 and diode CR6 to ground. The RELAY VTR indicator (DS4) will be off (normally open contacts K1-9, 10).

When relay K1 is de-energized, relay K2 will be energized through a set of normally closed contacts (pins 14 and 15) of relay K1. Since relay K2 is energized (with real-time video in), its normally open contacts will close. The AUDIO STATUS OUT terminals will provide the following conditions:

#### REAL-TIME VIDEO

Audio Status Out	TB3 Terminal	TB4 Terminal	Relay (K2) Contacts
1	1 to 2 shorted — 2 to 3 open		13, 12 12, 11
2	4 to 5 shorted 5 to 6 open		16, 15 15, 14
3		1 to 2 shorted 2 to 3 open	10, 9 9, 8
4		4 to 5 shorted 5 to 6 open	7, 6 6, 5

#### 4.3.1.2.2.2 VTR Video (Interleaved)

When VTR Video is received, the level at A3-34 will be low and the level at A3-32 will be high; this will cause the SPLITTER A/G indicator (DS1) to be off and the SPLITTER VTR indicator (DS2) to be on. The level at A3-30 will be high, causing relay K1 to be energized. The RELAY A/G indicator (DS3) will be off (N.C. Contacts K1-8, 9 will be open). The RELAY VTR indicator (DS4) will be illuminated, through a set of N.O. contacts K1-10, 9 and diode CR6 to ground.

When relay K1 is energized, relay K2 will be de-energized (N.C. contacts K1-14, 15 will be open). With relay K2 de-energized (VTR video in), the AUDIO STATUS OUT terminals will provide the following conditions:

## INTERLEAVED VIDEO

Audio Status Out	TB3 Terminal	TB4 Terminal	Relay (K2) Contacts
1	1 to 2 open 2 to 3 shorted		13, 12 12, 11
2	4 to 5 open 5 to 6 shorted		16, 15 15, 14
3		1 to 2 open 2 to 3 shorted	10, 9 9, 8
4		4 to 5 open 5 to 6 shorted	7, 6 6, 5

### 4.3.1.3 Air/Ground Audio

The Air/Ground Audio is a balanced signal. It enters the splitter on terminal board TB1, pins 4 and 5 (located on the rear panel). The signal is then fed to the Video/Audio Input module (A2), pins 28 and 30. From pins 28 and 30 the signal is fed to the input of isolation transformer T1. The signal from the output of T1 is fed to pins 32 and 34 (ground) of the module (A2).

From (A2) the Air/Ground Audio signal is fed to the Air/Ground AUDIO IN LEVEL control (R2), located on the front panel. From the level control the signal is fed to a normally closed contact (pin 11) of relay K1 (located on the rear of the front panel). The signal is also fed to the Air/Ground AUD contact of the RELAY BYPASS selector switch (S1), located on the front panel.

If the relay (K1) is in the de-energized (A/G) position, the A/G signal will be coupled through the relay (K1-12) to the NORMAL contact of the RELAY BYPASS selector switch. If the switch is in either the normal position or in the A/G AUD position, the A/G Audio signal will be fed to the center arm of the switch. The signal from the center arm of the switch follows two paths, one to the SPLITTER AUD OUT LEVEL control (R10) and the other to the SPEAKER/INTERCOM LEVEL control (R9), both located on the front panel.

#### 4.3.1.3.1 Audio Processing

From these controls, the audio signals are processed in the Splitter Output module (A1) and fed to the Audio Output terminals as described in paragraph 4.3.1.1.5 (VTR Audio Processing).

#### 4.3.1.3.2 Speaker Amplifier System

The A/G Audio Speaker Amplifier System is the same as for the VTR audio. Refer to VTR Audio, Speaker Amplifier System, paragraph 4.3.1.1.6.

#### 4.3.1.4 Video/CTE

Refer to Splitter functional diagrams Figure 4-2; CTE demux and display functional diagram, Figure 4-10; CTE demux schematic diagram, Figure 6-12; CTE display schematic diagram, Figure 6-13, and CTE mux and demux timing diagrams, Figures 4-11 and 4-12.

The CTE demux board (A11) accepts the clamp pulse and V-sync (detector) signals as timing references to operate counters which provide the controlled clock pulses for a shift register. The board also accepts the video signal which is fed into the shift register during line 17. The line 17 parallel output information is fed to the CTE display board (A12) which transfers the CTE data to LED numerical displays.

The basic clock pulses for the shift register are derived from the 629.37 kHz VCO (A11 U3). This VCO is part of a phase-locked-loop consisting of phase detector U1, active filter U2A, amplifier U2B and a  $\div 40$  counter U4 and U5. The reference signal for this phase-locked-loop is obtained from the sync tip clamp pulse, at the horizontal line rate (15.73 kHz) after passing through inverter U6A and one shot U7. The delay timing of U7 is approximately 10 microseconds and is controlled by R16. Pulses from U7 are also applied to one input of Nand gate U13A.

The other input to U13A is obtained from set-reset flip-flop U13C, D which is triggered by the externally applied V-sync (detector) signal. The pulses from U7 are also applied to one input of Nand gate U13A.

The other input to U13A is obtained from set-reset flip-flop U13C, D which is triggered by the externally applied V-sync (detector) signal. The pulses from the U7 are then applied through inverter U13B to a  $\div 14$  counter (U15, U14A and U14B). Because the V-sync (detector) signal occurs at line 4, the output of the  $\div 14$  counter identifies line 17, at which time flip-flop U13C, D is reset. At the start of line 17 gate U8B is turned on allowing the pulses from VCO U3 to pass on to the  $\div 32$  counter (U9, U10, U12 and U11 D, E, F). The output from the  $\div 32$  counter passes through the low-to-high edge detector (U8D, U11A, B, C) to produce a strobe pulse which resets both counters.

Thus, a controlled group of 32 clock pulses synchronized to occur at line 17 passes on to shift register U17, U18, U19, U19. Simultaneously, the video signal is applied to the shift register data input through inverter U16 resulting in a serial-to-parallel conversion of the CTE information contained in line 17 of the video signal.

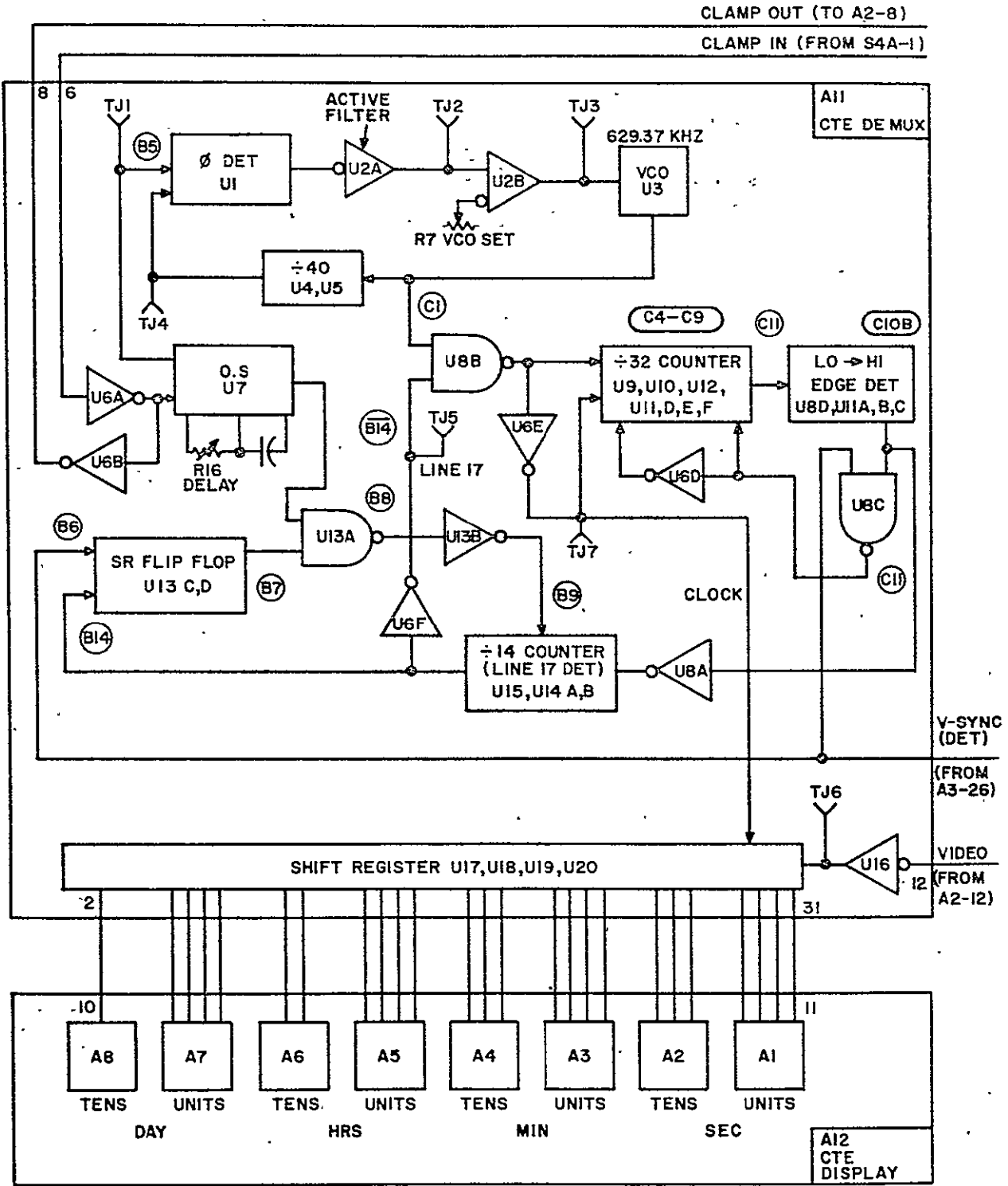

Figure 4-10. CTE Demux and Display Functional Diagram

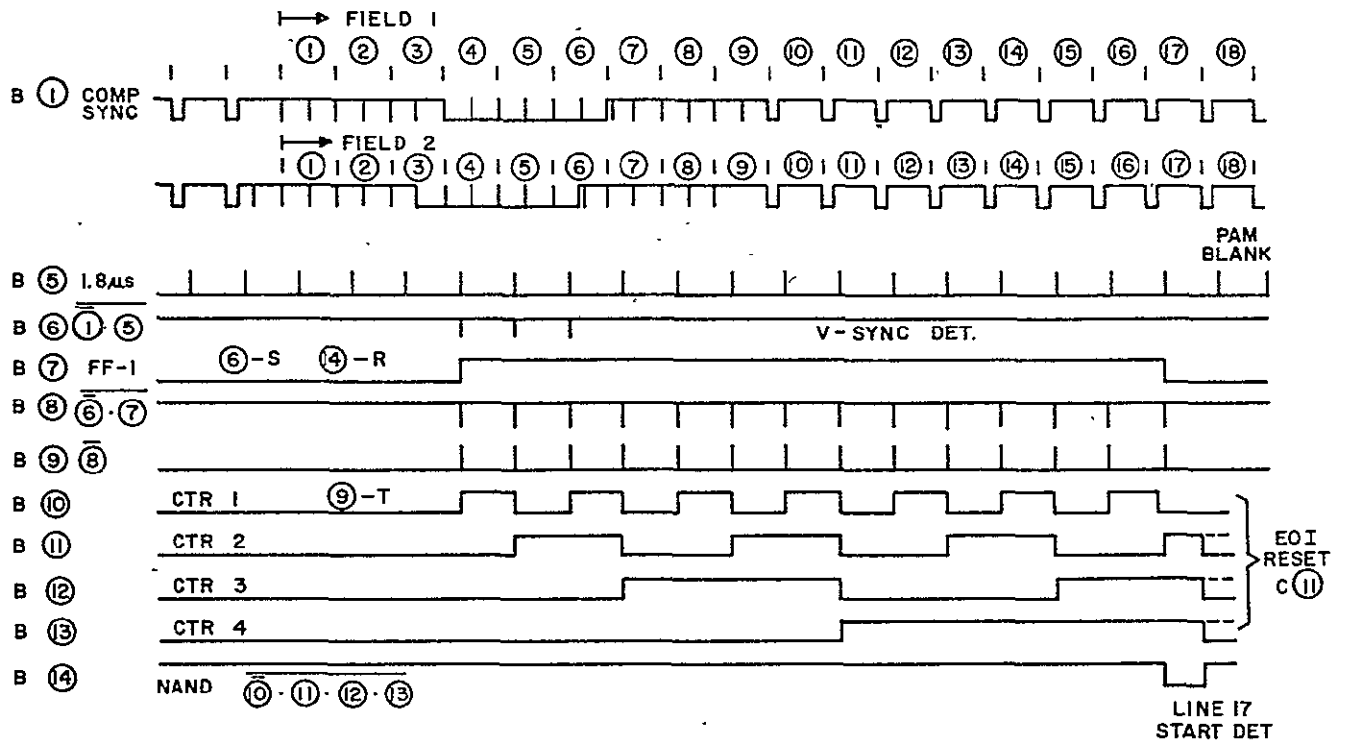

Figure 4-11. CTE Mux and Demux, Timing Diagram A

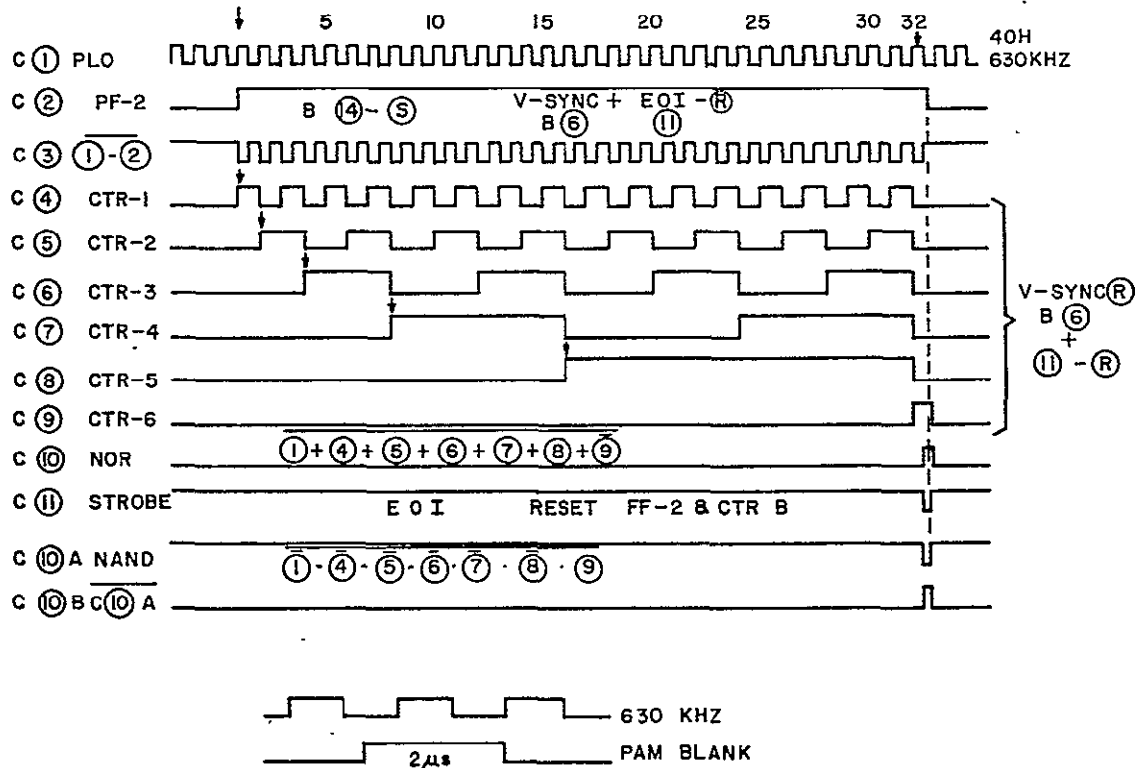

Figure 4-12. CTE Mux and Demux, Timing Diagram B



The parallel outputs of the shift register are connected to the LED display units located on the CTE Display Module (A12), which produces a numerical day-hour-minute-second display.

#### 4.3.2 Audio/CTE Interleaver

Refer to Functional Diagram, Figure 4-13; Schematic Diagram, Figure 6-1; and Timing Diagram, Figure 4-14. The Audio/CTE Interleaver Circuit receives two input signals: a video input (composite TV signal) and an audio input together with a fixed word CTE input.

The interleaver samples the audio, at the horizontal line rate (15 kHz), interleaves (multiplexes) it with the video and provides two video/audio outputs. It also interleaves the fixed word CTE input into line 17 of the composite video signal.

##### 4.3.2.1 Video Processing

The video (TV format) is supplied through BNC connector J14, through a coupling capacitor (C2), to the Video Input module (A7).

In A7 (refer to schematic diagram, Figure 6-8) the signal is fed through an input level control (R3), which is adjusted for the proper level at the Video Clamp test jack (T31). (Refer to Table 5-2 for signal levels.) From the level control, the video signal is fed through an amplifier stage (U1). The signal at the output of the amplifier (U1) follows two paths, one through the sync stripper circuit and the other to the Video Clamp.

##### 4.3.2.1.1 Sync Stripper

The sync stripper detects sync from the composite TV signal and provides sync signals to the Video Clamp and to the timing circuits.

The sync stripper consists of a low pass filter, an amplifier, a diode clamp, a comparator and an inverter.

The low pass filter consists of R30 and C13. The output of the low pass filter is fed to the amplifier stage.

The amplifier consists of U3 and its associated circuitry. The gain of the stage is determined by resistors R31 and R36. The output of the amplifier is fed to a diode clamp.

The diode clamp consists of capacitor C17 and diode CR5. The positive peaks of the signal across CR5 are clamped to ground through the diode (refer to Figure 5-32). From the diode clamp the signal is fed to the comparator circuit.

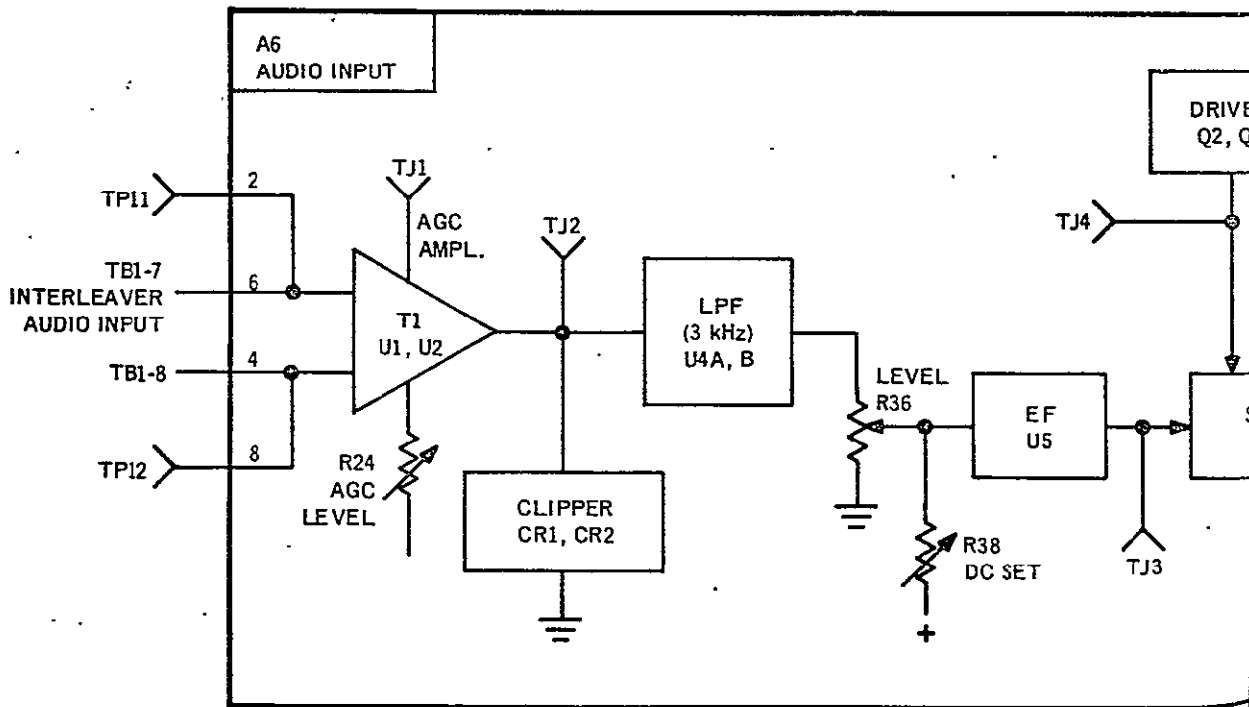
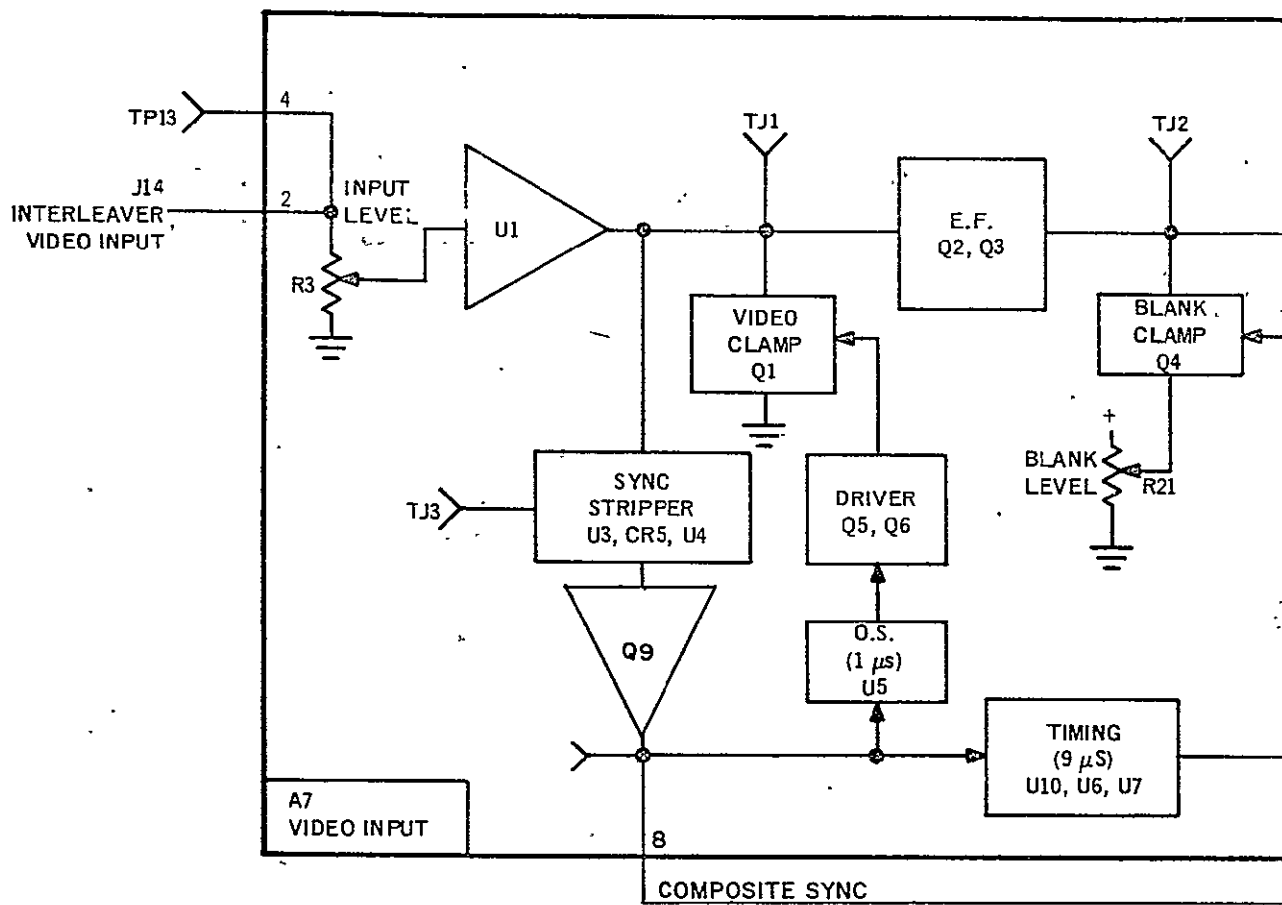

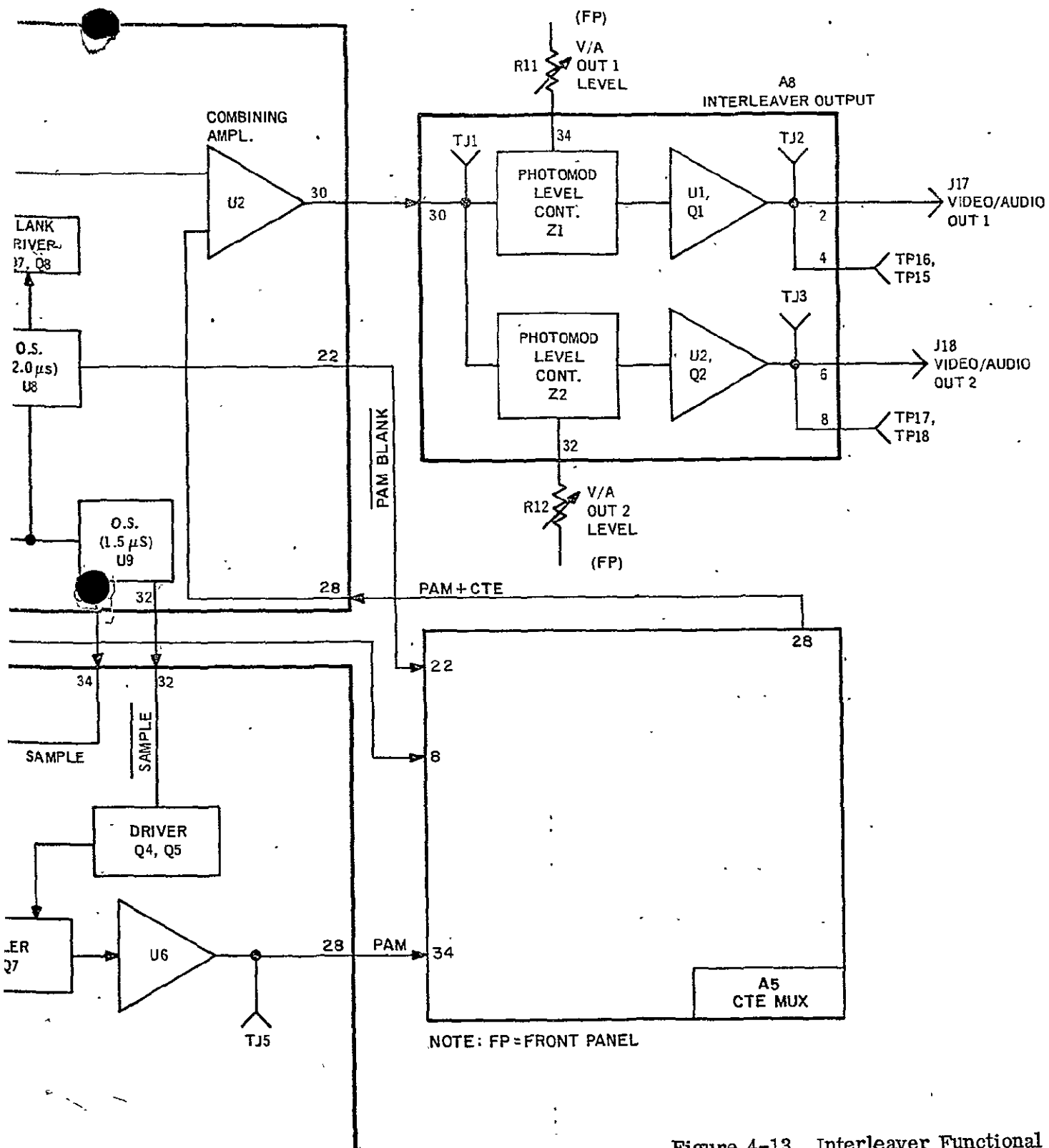

Figure 4-13. Interleaver Functional Diagram

4-25/4-26

FOLDOUT FRAME 2

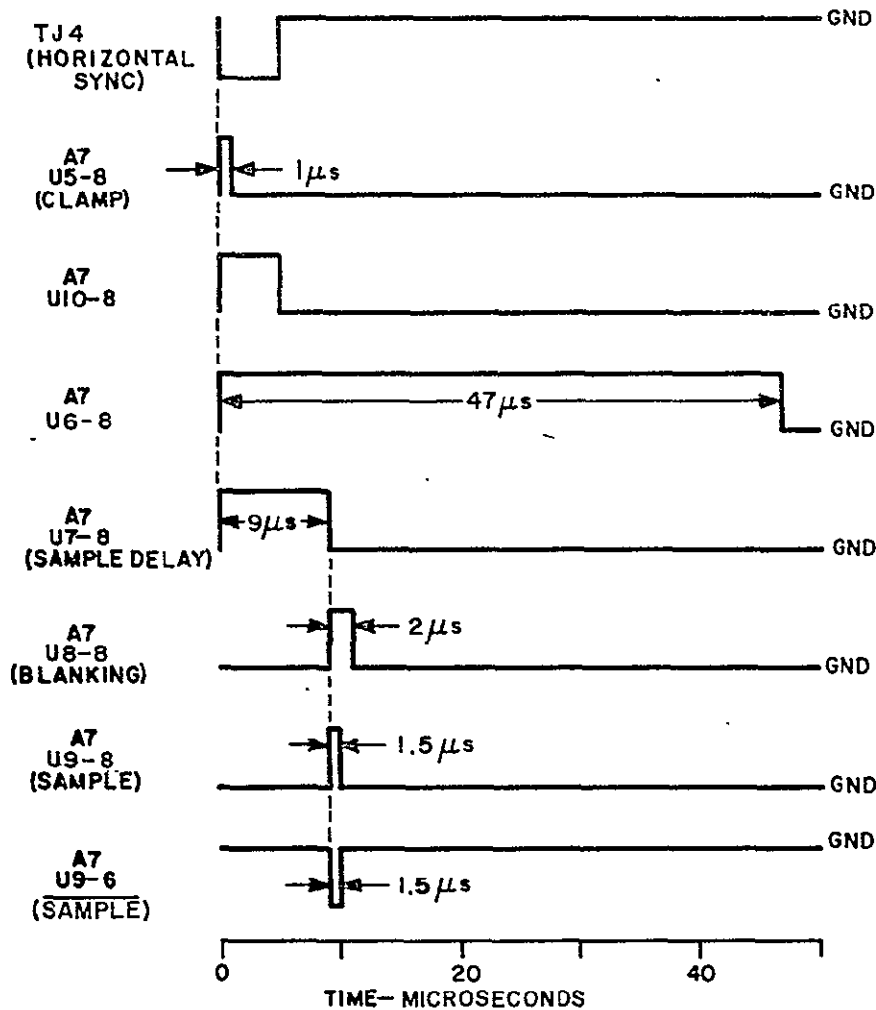

Figure 4-14. Interleaver, Timing Diagram

The comparator circuit consists of U4 and its associated circuitry. The signal is fed through R39 to the non-inverting input of U4. The inverting input is biased to a negative reference voltage, which causes the comparator output to be high when the input is more positive than the reference. When the level at the comparator input becomes more negative than the reference, the comparator output saturates (goes to zero). The transition takes place very rapidly due to the positive feedback, formed by resistors R39 and R44. The comparator circuit output is fed through an inverter, consisting of Q9, R72 and R73.

The signal from the output of the sync stripper (Q9-C) follows two paths, one to the input of one-shot U5, and the other to the input of one-shot U10.

#### 4.3.2.1.2 Video Clamp Circuit

The Video Clamp circuit consists of one-shot U5, driver Q5 and Q6, and Video Clamp Q1.

The leading (negative-going) edge of the sync signal triggers one-shot U5 (refer to timing diagram, Figure 4-14) which generates a 1- $\mu$ s (positive-going) pulse. This pulse is fed through driver Q5, Q6 which drives Video Clamp Q1. The Video Clamp is turned ON during the duration of the 1- $\mu$ s pulse and turned OFF when the pulse is not present. Therefore, the video signal is clamped to ground for 1  $\mu$ s at the leading edge of each sync pulse.

The clamped video signal is fed through dual emitter follower (Q2,3) through resistor R18 to Blanking Clamp Q4.

#### 4.3.2.1.3 Timing Circuit

The timing circuit (for blanking and audio sampling circuits) consists of one-shots U10, U6 and U7. The sync signal from the output of the sync stripper is fed to the input of one-shot U10. The leading (negative-going) edge of the sync signal triggers U10 (refer to timing diagram, Figure 4-14), which generates a 4- $\mu$ s (positive-going) pulse. The 4- $\mu$ s pulse from U10 is fed to the input of one-shot U6. U6 triggers on the leading (positive-going) edge of the 4- $\mu$ s input pulse.

U6 is a non-retriggering, 47- $\mu$ s, one-shot. The time constant of U6 is set longer than twice horizontal (line) rate so that retriggering will not occur at this rate (during the vertical interval).

The 47- $\mu$ s pulse from U6 is fed to the input of one-shot U7. U7 triggers on the leading (negative-going) edge of the 47- $\mu$ s input pulse and generates a 9- $\mu$ s delay pulse. The width of this pulse determines the timing for the beginning of the blanking and audio sampling control pulses.

The signal from the output of the timing circuit (U7) follows two paths, one to the input of the blanking circuit and the other to the input of the sampling circuit.

#### 4.3.2.1.4 Video Blanking Circuit

The video blanking circuit consists of one-shot U8, driver Q7,8, blanking clamp Q4 and blanking level control R21. Blanking one-shot U8 triggers on the trailing (negative going) edge of the 9- $\mu$ s pulse from the timing circuit. Therefore, the blanking one-shot (U8) provides a 2- $\mu$ s pulse delayed 9  $\mu$ s from the leading edge of sync.

The output of U8 is fed to the blanking driver (Q7,8), which in turn drives blanking transistor Q4. Q4 is turned ON for 2  $\mu$ s, 9  $\mu$ s after the leading edge of horizontal sync pulse (and at horizontal rate during the vertical interval). The video signal is blanked to a fixed dc level when the blanking circuit is turned ON. The blanking level may be adjusted by the BLANK level control (R21). The blanking level is normally adjusted for a dc level slightly above black level (5 IEEE units) (refer to Figure 5-31).

#### 4.3.2.2 Audio Processing

The audio signal (balanced) is supplied through input terminals (TBI-7,8) to the Audio Input module (A6).

In A6 (refer to schematic diagram, Figure 6-7) the signal is fed through a transformer (T1) to an AGC Amplifier (U1,2). The output level of the amplifier is adjusted by the AGC level control R24.

The AGC amplifier output signal is fed through resistor R26 to diode clipper CR1,2. The clipper limits the signal level to about 0.6 V p-p to prevent the sampled audio from becoming too large and extending out of the video region (into the sync region).

From the diode clipper the audio signal is fed through an active four-pole Butterworth low pass filter (U4A,B - 3 kHz cutoff) to level control R36. This level control is adjusted to provide the proper peak-to-peak sampled audio signal in the interleaved output (refer to Figure 5-37).

DC SET control R38 is adjusted to center the sampled audio symmetrically in the video region (refer to Figures 5-36 and 5-37). From the LEVEL and DC SET controls, the audio signal is fed through isolation amplifier U5 to the Audio Sampler.

##### 4.3.2.2.1 Audio Sampling Circuit

The complete audio sampling circuit consists of a one-shot (A7-U9), SAMPLE driver (Q2, Q3), SAMPLE driver (Q4, Q5), and sampler (Q6, Q7).

The sampling control pulses are generated by one-shot U9 (located on Video Input Module A7). The input to A7-U9 is the 9- $\mu$ s pulse generated in the timing circuit (A7-U10, U6, U7). One-shot A7-U9 triggers on the trailing (negative-going) edge of the 9- $\mu$ s input pulse and generates two 1.5- $\mu$ s pulses. The output signals are taken from U9-8 (SAMPLE - positive-going pulse) and U9-6 (SAMPLE - negative-going pulse). Refer to timing diagram, Figure 4-14. The sampling control pulses are fed from the VIDEO INPUT module (A7) from pins 34 and 32 to the AUDIO INPUT module (A6), pins 34 and 32.

The SAMPLE control pulse is fed to the SAMPLE driver (Q2, Q3) which generates a control pulse (refer to Figure 5-28) that drives series sampler Q6.

The SAMPLE control pulse is fed to the SAMPLE driver (Q4, Q5) which generates a control pulse that drives shunt sampler Q7.

The sampler consists of FETs Q6 and Q7. The FETs are turned ON when the control signal (at the gate) is high (ground) and are turned OFF when the control signal is low (negative). Since the SAMPLE and SAMPLE control signals are 180° out of phase, one FET is OFF when the other is ON. When the SAMPLE control pulse is high, FET Q6 is turned ON and FET Q7 is turned OFF, thereby allowing the audio signal to pass

through Q6. When the SAMPLE control pulse is low, FET Q6 is turned OFF and FET Q7 is turned ON, thereby blocking the audio signal at Q6. Since the SAMPLE control pulse is high for  $1.5 \mu\text{s}$  (delayed  $9 \mu\text{s}$  from the leading edge of sync) during each horizontal line, the audio signal is sampled for  $1.5 \mu\text{s}$  during each horizontal line (and at horizontal rate during the vertical interval).

The sampled audio is fed through a low pass filter (R57, C26), amplifier U6, and low pass filter (R73, C35) to PAM output (A6-28). The low pass filters reduce switching transients generated during sampling.

The sampled audio (PAM) is fed from A6-28 to A7-28, then to a combining amplifier (A7-U2).

#### 4.3.2.3 Video/Audio Processing

The video/audio processing circuitry consists of combining amplifier A7-U2, photomod level controls (A8-Z1, Z2), amplifiers (A8-U1, Q1 and A8-U2, Q2), and V/A OUT LEVEL controls (R11, R12- located on the front panel).

The combining amplifier (A7-U2) receives two inputs, one from blanking circuit A7-Q4 (Video) and the other from A7-28 (PAM INPUT). The two signals are linearly combined, thus forming the Video/Audio signal (refer to Figure 5-35). An audio sample occurs, for  $1.5 \mu\text{s}$ , delayed by  $9 \mu\text{s}$  from the leading edge of horizontal sync, during each horizontal line (and at horizontal rate during the vertical interval). From the combining amplifier the V/A is fed out of module A7 on pin 30 to the Inter-leaver Output module (A8), pin 30 (refer to schematic diagram, Figure 6-9).

The V/A signal from A8-30 follows two paths, one to a voltage divider formed by resistor R2 and photomod Z1, and the other to a voltage divider formed by R3 and Z2.

NOTE: A photomod consists of a lamp and a photocell; the resistance of the cell is inversely proportional to current through the lamp.

The attenuation of the photomod (A1) is controlled by the setting of front panel V/A OUT 1 LEVEL control (R11). From Z1 the signal is fed through amplifier U1, Q1; the gain of the amplifier is determined by resistor combination R2 and R9. The signal from the output of the amplifier is fed through resistor R13, which provides a 75-ohm V/A OUT at pin 2. From A8-2 the signal is fed to the VIDEO/AUDIO OUT 1 BNC connector (J17), located on the rear panel.

The signal path through photomod Z2 and amplifier U2, Q2 is identical to that described above for VIDEO/AUDIO OUT 1. The signal from the output of amplifier U2, Q2 is fed to A8-6 and to the VIDEO/AUDIO OUT 2 connector (J18).

#### 4.3.2.4 CTE Multiplexer

Refer to interleaver functional diagram, Figure 4-13; CTE mux functional diagram, Figure 4-15; CTE mux schematic diagram, Figure 6-6; and CTE mux and demux timing diagrams, Figures 4-11 and 4-12.

The CTE Multiplexer (A5) receives the PAM blank timing signal and COMPOSITE SYNC from the Video Input (A7) and multiplexes a fixed word CTE signal during the line 17 interval. It intercepts the PAM pulse, which originally went from audio input A6 to the combining amplifier on video input board A7, and adds the PAM and CTE signal together. The combined PAM plus CTE signal is then sent on to the combining amplifier on video input board A7.

The basic clock pulses for the multiplexing operation are derived from the 629.37 kHz VCO (A5 U3). This VCO is part of a phase locked loop consisting of phase detector U1, active filter U2A, amplifier U2B and a  $\div 40$  counter U4 and U5. The reference signal for this phase locked loop is obtained from the PAM blank pulse, at the horizontal line rate (15.73 kHz), after passing through inverter U6F.

The output of inverter U6F is also fed to Nand gates U7A and U7D. The second input to Nand gate U7D is obtained from the composite sync signal after passing through inverter U6A.

The output of U7D provides the V-sync pulse.

The V-sync pulse triggers latch U7B, C; thus, controlling the application of the PAM blank pulses through gate U7A and inverter U6D which are then applied to  $\div 14$  counter U9, U21. Because the V-sync pulse occurs at the 4th line the output of the  $\div 14$  counter identifies line 17, which pulse then resets FF-1 (U7 B, C) and sets FF-2 (U8A, C).

This action turns on Nand gate U10A which controls the application of VCO U3 pulses to the  $\div 32$  counter (U11, U12, U13 and U14). At the conclusion of the 32nd count the low-to-high edge detector (U10, U12) combined with the V-sync pulse through gate U8D and inverter U6B resets FF-2 (U8A, C) and both counters.

A shift register (U15, U16, U17 and U18) is wired for a parallel input fixed word (08 08 08 08) and is controlled in a shift/load operation by the V-sync pulse and a sequence of 32 clock pulses at the 629.37 kHz rate during the line 17 interval in a recirculating hookup. This CTE word out of the shift register is mixed with the PAM signal and passed through inverting amplifiers U19 and U20.



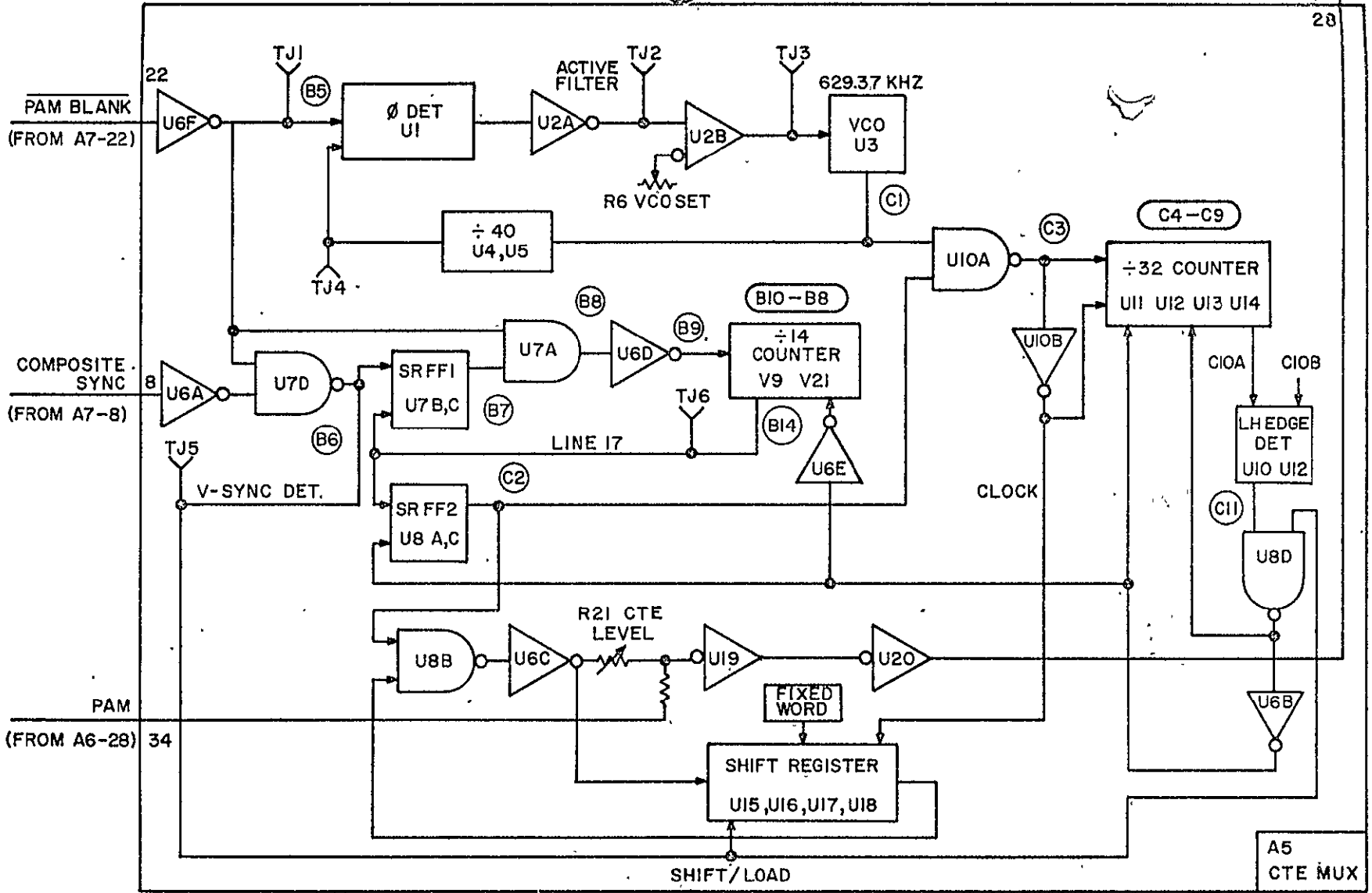

Figure 4-15. CTE Mux Functional Diagram

## SECTION 5

### MAINTENANCE

#### 5.1 INTRODUCTION

Maintenance of the Audio/CTE Splitter/Interleaver is relatively simple since it may be readily checked while installed in a rack. All inputs and outputs may be checked using an oscilloscope at test jacks on the front panel. Test jacks are provided on the plug-in modules so that key points in the circuits may be easily monitored by retracting the unit from the rack, on its slides and using an oscilloscope (refer to Figure 5-1).

This maintenance section consists of two parts: preventive maintenance and corrective maintenance.

#### 5.2 PREVENTIVE MAINTENANCE

Very little preventive maintenance is required. No lubrication is required. Periodic cleaning of the unit while installed in the rack is recommended. Power supply voltages should be checked periodically at test jacks located at the rear of the unit (refer to Figure 2-3).

A lamp test pushbutton is located on the front panel for testing the lamps of the Audio Status indicators. To ensure proper display, a periodic lamp test should be made and all defective lamps replaced. The lamps (DS1, DS2, DS3 and DS4) of the Audio Status indicators are 14-volt flange-base units. The lamp of the Power On indicator is a neon type.

#### REPLACEMENT LAMPS

1. Audio Status Indicator: Chicago Miniature #330
2. Power On Indicator: NE51

#### LAMP REPLACEMENT

Indicator Lamps DS1 through DS4 are replaced by pulling the display screen/lampholder assembly from the indicator housing. No tools are required to replace lamps. Refer to Figure 5-2.

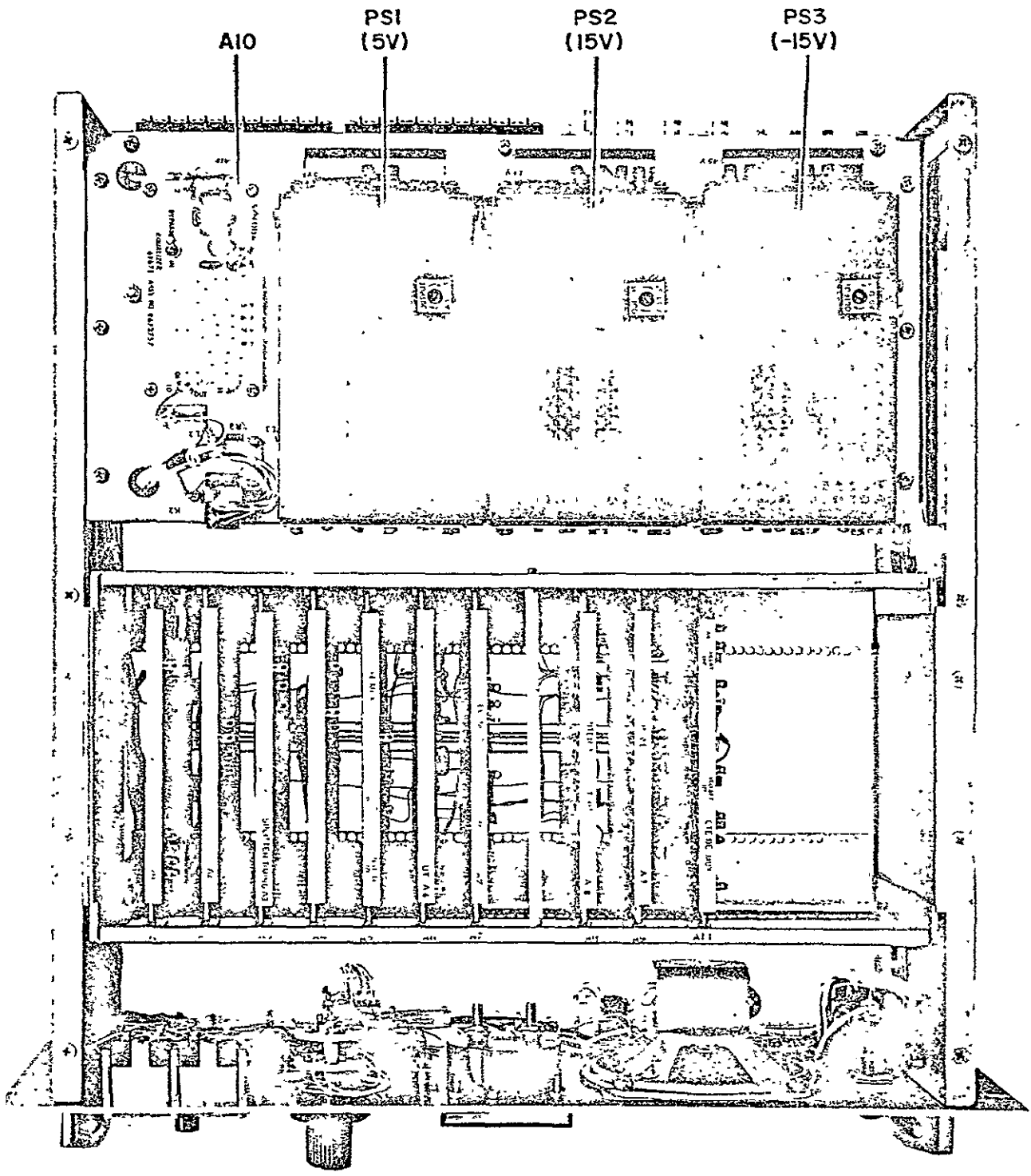

Figure 5-1. Audio/CTE Splitter/Interleaver, Top View

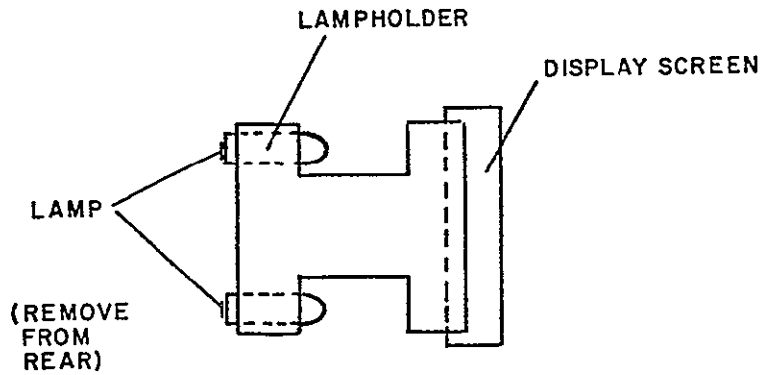

Figure 5-2. Lamp Replacement, Audio Status Indicators

1. Remove display screen/lampholder assembly from indicator housing.
2. Remove defective lamp from lampholder and replace with new lamp.
3. Replace display/lampholder into housing.

### 5.3 CORRECTIVE MAINTENANCE

#### 5.3.1 Alignment Procedure

Refer to the following figures:

1. Figure 3-1. Front Panel Controls and Indicators.
2. Figure 2-3. Rear Panel.
3. Figure 5-1. Audio/CTE Splitter/Interleaver, Top View.
4. Figure 5-3. Top View of Unit, Test Jacks and Setup Controls.

#### Test Equipment

The following test equipment (or equivalent) is required:

1. TV Signal Generator (Telemet Stairstep Generator Model 3502).
2. Processing Amplifier (RCA Model TA-19)
3. Audio Signal Generator (HP 651B)
4. DC Voltmeter.
5. Oscilloscope (Tektronix 547 with type 1A1 plug-in).

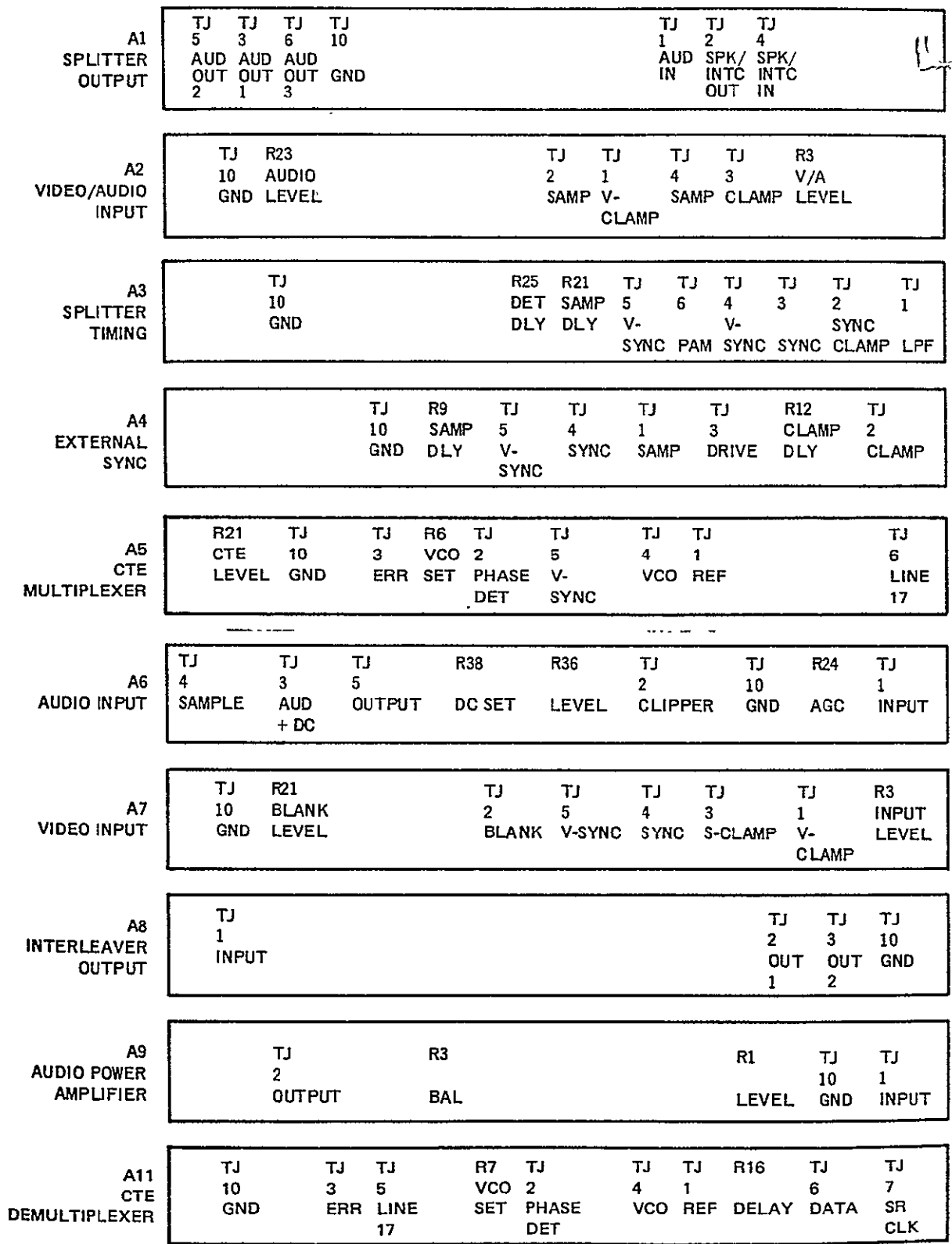

Figure 5-3. Module Nest Top View, Test Jacks and Setup Controls

### 5.3.1.1 DC Voltage Setup

(Refer to Figure 2-3 and 5-1)

Monitor dc voltages at test jacks on the rear panel. Voltage should be within 0.1 volt of specified voltage; if not, adjust corresponding power supply.

### 5.3.1.2 Interleaver Alignment (Refer to Figure 5-3 for location of test jacks and controls on the modules)

1. Connect TV signal generator to INTERLEAVER VID IN connector, J14, located on the rear panel (refer to Figure 2-3).
2. Connect audio signal generator to INTLVR AUD IN terminals TB1-7, 8 on the rear panel (refer to Figure 2-3).
3. Monitor video signal at front panel INTERLEAVER VID INPUT test jacks. Set TV signal generator for stairstep output. Adjust composite video for a level of 1.0 V p-p (100/28 ratio, 0.22 V p-p sync). Refer to Figure 3-7.
4. Monitor audio signal at front panel INTERLEAVER AUD INPUT test jacks. Adjust audio signal generator for a level of 1 V p-p at 1 kHz (refer to Figure 3-8).

#### 5.3.1.2.1 Video Gain Adjustment (Refer to Figure 5-30)

Monitor signal at test jack A7-TJ1 (V-CLAMP). Adjust A7-R3 (INPUT LEVEL) control for a level of 2 V p-p.

#### 5.3.1.2.2 Blanking level Adjustment (Refer to Figure 5-31)

Monitor signal at test jack A7-TJ2 (BLANK). Adjust A7-R21 (BLANK) control so that the blanking level is slightly more positive than black level (5 IEEE units).

#### 5.3.1.2.3 Audio AGC Level Adjustment

1. Monitor signal at test jack A6-TJ1 (input). Level should be approximately 0.8 V p-p (refer to Figure 5-25).
2. Monitor signal at A6-TJ2 (CLIPPER). Adjust A6-R24 (AGC) control for 0.5 V p-p at A6-TJ2 (refer to Figure 5-26).

NOTE: Some clipping may occur in the waveform. If limiting becomes too great at the 0.5 V p-p level, adjust A6-R24 (AGC) control to reduce the level until limiting is acceptable (as shown in Figure 5-26).

~~5.3~~ - 2.4 Video/Audio Output Adjustment (Refer to Figure 5-36A, 5-36B, 5-37A and 5-37B)

- Monitor signal at test jack A8TJ2 (OUT 1)

NOTE: V/A OUT 1 (rear panel) must be terminated in 75 ohms.

- Adjust front panel INTERLEAVER V/A OUT 1 LEVEL control for a 1-V p-p signal at A8TJ2 (refer to Figure 5-36A).
- Reduce audio input to zero (refer to paragraph 5.3.1.2, step 4).
- Adjust oscilloscope so that the black to white level of signal at A8TJ2 is 4 cm high (refer to Figure 5-36B, voltage scale uncalibrated). Observe pedestal on video pattern (blanked area); adjust A6-R38 (DC SET) control so that the peak of the PAM pedestal is 50% of the black to white level (2 cm).
- Readjust audio input level for 1-V p-p at the unit, front panel, INTERLEAVER AND INPUT (refer to paragraph 5.3.1.2, step 4) (Refer to Figure 5-37B, voltage scale uncalibrated) with oscilloscope adjust as in step 4 above, adjust A6R36 (LEVEL) for a positive modulation peak of 90% of the black-to-white level (3.6 cm). The negative peak of the modulation should be 10% of the black-to-white level (0.4 cm); if not, recheck pedestal peak (step 4 above). Reset scope level knob in calibrate position.

~~5.3~~ - 2.5 CTE Mux Adjustment (Refer to Figures 5-3 and 5-51)

- Monitor signal at A5-TJ4 (Reference).
- Connect shorting jumper between A5-TJ2 and A5-TJ10.
- Adjust A5-R6 (VCO set) for a signal frequency of 15.74 kHz at A5-TJ4.
- Remove shorting jumper.
- Monitor signal at test jack A8-TJ2 with V/A OUT 1 terminated in 75 ohms.
- Observe CTE pulses on Line 17 and adjust pulse amplitudes to equal peak white video level (100 IEEE units) by adjusting A5-R21 (CTE level control).

~~5.3~~ - 3 Splitter Alignment (Refer to Figure 5-3 for location of module test jack and controls)

- Connect the INTERLEAVER V/A OUT 1 (J17) to the SPLITTER V/A INPUT (J1), located on the rear panel (refer to Figure 2-3).

NOTE: The Interleaver should be aligned as described in paragraph 5.3.1.2 above before aligning the Splitter. Input signals to the Interleaver should be as specified in paragraph 5.3.1.2, steps 1 through 4.

2. Monitor the signal at the unit front panel SPLITTER V/A INPUT test jacks. Adjust the INTERLEAVER V/A OUT 1 LEVEL control for a composite video signal level of 1.0 V p-p at the test jacks (refer to Figure 3-4).

#### 5.3.1.3.1 Video Clamp Level Adjustment (refer to Figure 5-8)

1. Set front panel SYNC select switch in the INT position.
2. Monitor the signal at test jacks A2-TJ1 (V-CLAMP). Sync scope from A3-TJ3 (SYNC).
3. Adjust A2R3 (V/A LEVEL) control for 2.0 V p-p at A2-TJ1.

#### 5.3.1.3.2 Sample Pulse Timing (Internal) (refer to Figure 5-12)

1. Set the front panel SYNC select switch in the INT position and the SPLITTER TIMING control at mid-position (and lock).
2. Monitor the signal at test jack A2-TJ1 (V-CLAMP) using scope CH-1 and the signal at A2-TJ4 (SAMP) using scope CH-2. Use ALT sweep; sync scope from A3-TJ3 (SYNC).
3. Adjust A3-R21 (SAMP DLY) control to place the sample pulse (trailing edge) in the center of the PAM sample.

NOTE: Sample pulse position may also be observed in the PAM pulse (A2TJ1). Sample pulse timing may, therefore, be adjusted by using only one channel of the scope.

#### 5.3.1.3.3 Audio Level Adjustment (refer to Figure 5-6)

Monitor signal at A1-TJ1 (AUD IN). Rotate front panel SPLITTER AUDIO OUTPUT LEVEL control fully clockwise. Adjust A2-R23 (AUDIO LEVEL control for approximately 0.4 V-pp at A1-TJ1. Readjust front panel SPLITTER AUDIO OUTPUT LEVEL control for 0.1 V-pp at A1-TJ1.

#### 5.3.1.3.4 Audio Power Amplifier Adjustments (refer to Figures 5-39 and 5-40)

1. Connect AUDIO MON OUT Terminals (TB3-7, 8) to SPEAKER IN TERMINALS (TB4-7, 8), located on the rear panel.
2. Monitor signal at test jack A9-TJ1 (INPUT). With audio level adjusted as described in Audio Level Adjustment, paragraph 5.3.1.3.3 above, adjust front panel SPEAKER/INTERCOM LEVEL control for a signal level of 0.1 V-pp at A9TJ1.



3. Monitor signal at test jack A9-TJ2 (OUTPUT). Adjust A9-R1 (LEVEL) control for 1.0 V-pp at A9-TJ2.
4. Rotate front panel SPEAKER/INTERCOM LEVEL control until clipping occurs at A9-TJ2. Adjust A9-R3 (BAL) control for symmetrical clipping.

#### 5.3.1.3.5 Detector Timing Adjustment (refer to Figure 5-19)

1. Monitor signal at test jack A3-TJ6 (PAM). Set scope on internal SYNC.
2. Adjust A3-R25 (DET DLY) control fully clockwise. Observe waveform at test jack A3-TJ6 (PAM) and adjust A3-R25 (DET DLY control) counter-clockwise for a pulse width of 2  $\mu$ s.

NOTE: No pulse will appear until A3-R25 is rotated CCW from its extreme CW position.

#### 5.3.1.3.6 External Sync Adjustments

##### 5.3.1.3.6.1 Clamp Delay Adjustment (refer to Figure 5-9)

1. Set the front panel SYNC select switch in the EXT position. Check that the SPLITTER TIMING control is locked in the mid-position (refer to paragraph 5.3.1.3.2, step 1).
2. Monitor the signal at test jack A2-TJ1 (V-CLAMP). Sync scope internally.
3. Adjust A4-R12 (CLAMP DLY) so that the leading edge of the clamp pulse is approximately 1  $\mu$ s after the beginning of the horizontal sync pulse (as shown in Figure 5-9).

##### 5.3.1.3.6.2 Sample Delay Adjustment (refer to Figure 5-13)

1. Set SYNC select switch in EXT position and SPLITTING TIMING control at mid-position as described above in paragraph 5.3.1.3.6.1, step 1.
2. Monitor the signal at test jack A2-TJ1 (V-CLAMP) using scope CH-1 and the signal at A2-TJ4 (SAMP) using scope CH-2. Use ALT sweep; sync scope from A3-TJ3 (SYNC).
3. Adjust A4-R9 (SAMP DLY) control to place the sample pulse (trailing edge) in the center of the PAM sample.

NOTE: Sample pulse position may also be observed in the PAM pulse (A2TJ1). Sample pulse timing may, therefore, be adjusted by using only one channel of the scope.

#### 5.3.1.3.7 CTE Demux Adjustment (Refer to Figure 5-48)

1. Monitor signal at A11-TJ4 (VCO).
2. Connect shorting jumper between A11-TJ2 and A11-TJ10.
3. Adjust A11-R7 (VCO set) for a signal frequency of 15.74 kHz at A11-TJ4.
4. Remove shorting jumper.
5. Observe number sequence on the CTE Display (front panel).
6. Adjust A11-R16 (Delay) for a number sequence presentation of 08 08-08 08.

#### 5.3.2 Troubleshooting

For troubleshooting refer to the following:

Functional description, Section 4, and functional diagrams, Figure 4-2 (Splitter) and Figure 4-13 (Interleaver).

Schematic diagrams, Figure 6-1 (Audio/CTE Splitter), and Figures 6-2 through 6-10 (module schematics).

Waveforms of signals at the front panel test jacks, Figures 3-2 through 3-10

Waveforms of signals at module test jacks, Figures 5-6 through 5-54.

Location of module test jacks and controls, Figure 5-3.

Location of components on the chassis, Figures 5-1, 5-4 and 5-5.

Location of components on the modules, Figures 5-55 through 5-66.

Table 5-1, Splitter Signal levels.

Table 5-2, Interleaver Signal levels.

NOTE: Tables 5-1 and 5-2 are for use in troubleshooting and may be used in conjunction with the corresponding functional diagram (Splitter, Figure 4-2, and Interleaver, Figure 4-13).

The connectors and jacks are listed in same order as shown in the corresponding functional diagram.

Alignment Procedures, paragraph 5.3.1.

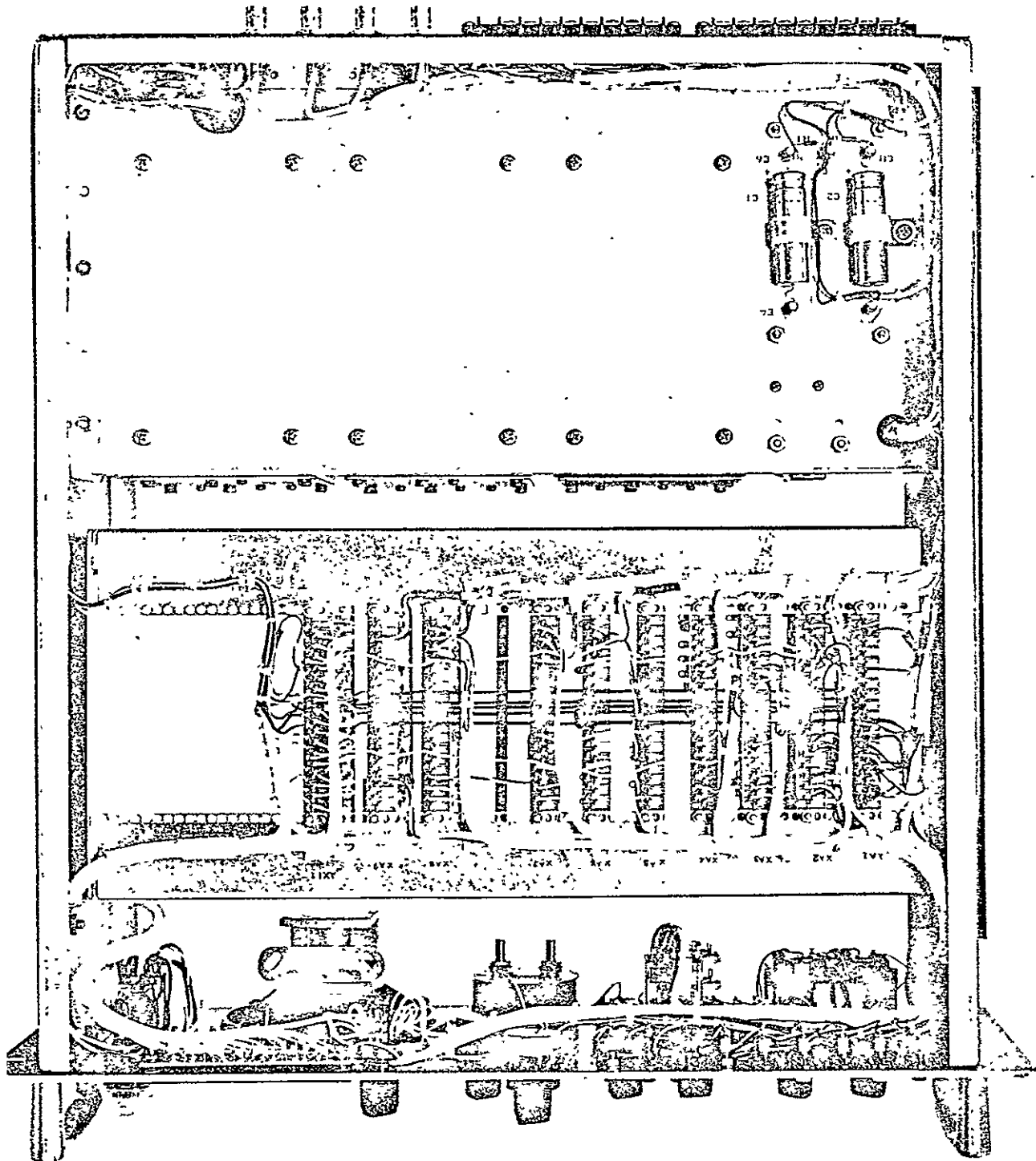

Figure 5-4. Audio/CTE Splitter/Interleaver, Bottom View

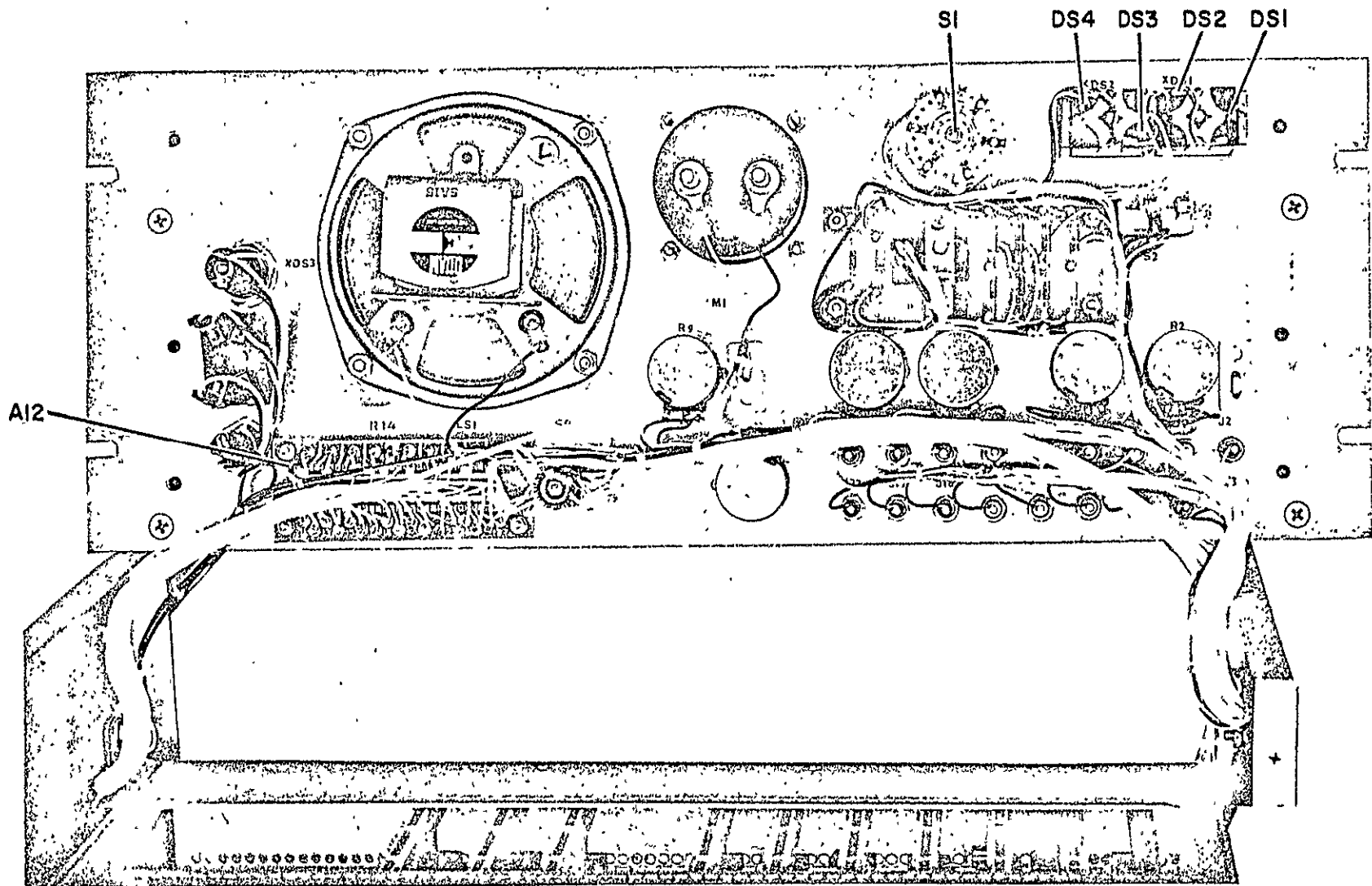

Figure 5-5. Audio/CTE Splitter/Interleaver Front Panel, Rear View

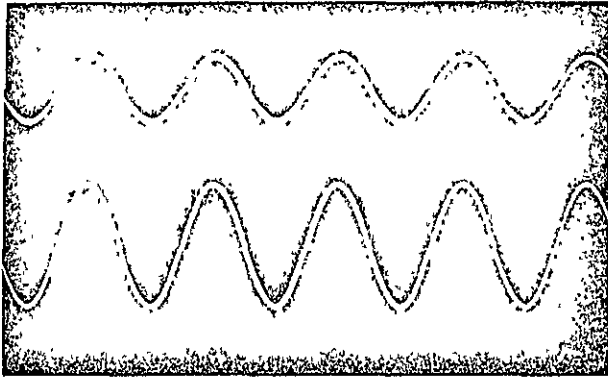

Figure 5-6. A1TJ1 Audio In (top)  
A1TJ3, TJ5 or TJ6 Audio Out (bottom)

Scope Sync - INT  
Vert. Scale - 0.1 V/cm (top)  
0.5 V/cm (bottom)  
Hor. Scale - 0.5 ms/cm

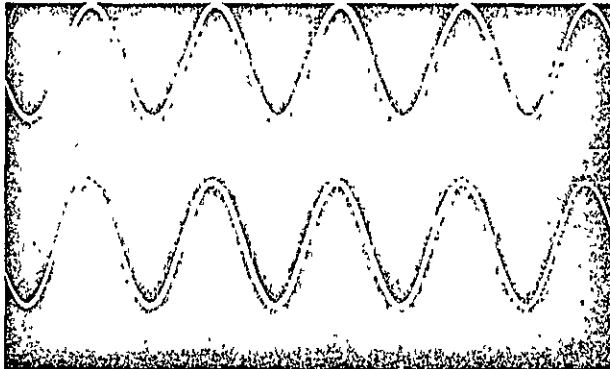

Figure 5-7. A1TJ4 Spkr./Intercom In (top)  
A1TJ2 Spkr./Intercom Out (bottom)

Scope Sync - INT  
Vert. Scale - 0.1 V/cm (top)  
0.5 V/cm (bottom)  
Hor. Scale - 0.5 ms/cm



Figure 5-8. A2TJ1 V-Clamp

Scope Sync - A3TJ3  
Vert. Scale - 0.5 V/cm dc  
Hor. Scale - 10  $\mu$ s/cm

— Gnd

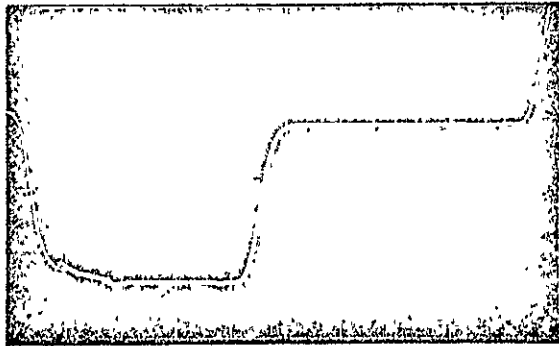

Figure 5-9. A2TJ1 V-Clamp (External Sync Clamp)

Scope Sync - INT  
 Vert. Scale - 0.2 V/cm dc  
 Hor. Scale - 1  $\mu$ s/cm

— Gnd

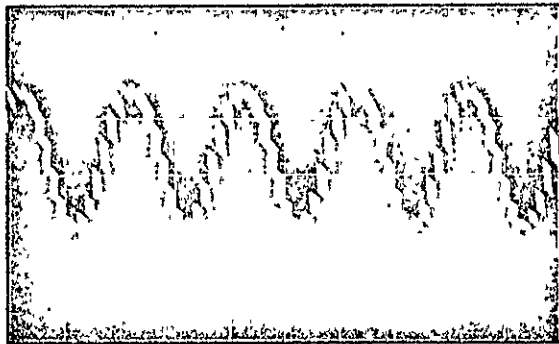

Figure 5-10. A2TJ2 Sample

Scope Sync - INT  
 Vert. Scale - 0.5 V/cm dc  
 Hor. Scale - 0.5 ms/cm

— Gnd



Figure 5-11. A2TJ3 Clamp

Scope Sync - A3TJ3  
 Vert. Scale - 5 V/cm dc  
 Hor. Scale - 1  $\mu$ s/cm

— Gnd

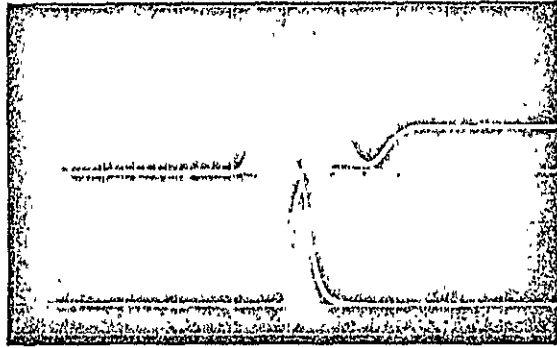

Figure 5-12. A2TJ1 V-Clamp (top)  
A2TJ4 Sample (bottom), Internal

Scope Sync - A3TJ3  
Vert. Scale - 0.5 V/cm (top)  
5.0 V/cm (bottom)  
Hor. Scale - 1  $\mu$ s/cm

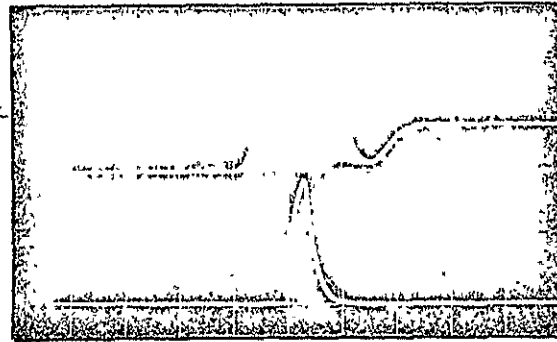

Figure 5-13. A2TJ1 V-Clamp (top)  
A2TJ4 Sample (bottom), External

Scope Sync - A3TJ3  
Vert. Scale - 0.5 V/cm (top)  
5.0 V/cm (bottom)  
Hor. Scale - 1  $\mu$ s/cm

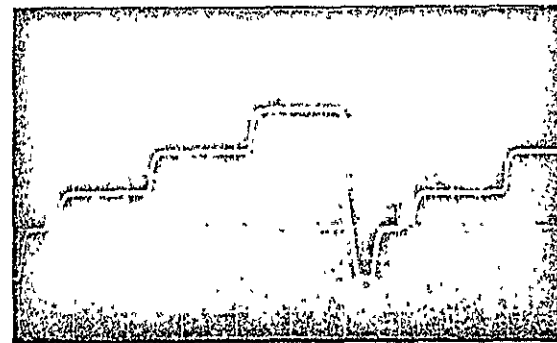

Figure 5-14. A3TJ1 LPF

Scope Sync - A3TJ3  
Vert. Scale - 0.5 V/cm dc  
Hor. Scale - 10  $\mu$ s/cm

Gnd



Figure 5-15. A3TJ2 Sync Clamp

Scope Sync - A3TJ3  
 Vert. Scale - 2.0 V/cm dc  
 Hor. Scale - 10  $\mu$ s/cm

— Gnd

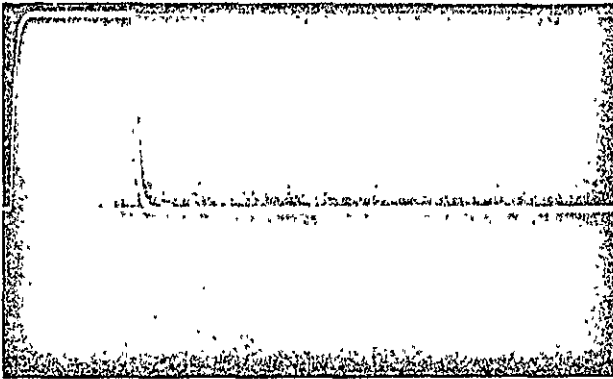

Figure 5-16. A3TJ3 Sync

Scope Sync - INT  
 Vert. Scale - 1.0 V/cm dc  
 Hor. Scale - 2  $\mu$ s/cm

— Gnd

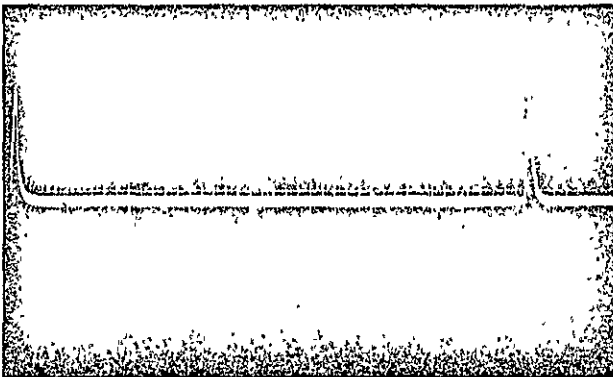

Figure 5-17. A3TJ4 V-Sync

Scope Sync - INT  
 Vert. Scale - 1.0 V/cm dc  
 Hor. Scale - 2 ms/cm

— Gnd



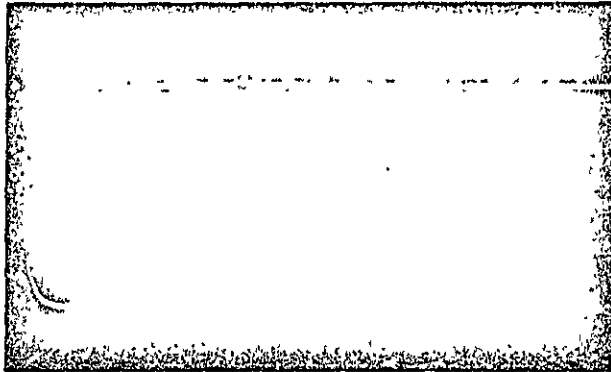

Figure 5-18. A3TJ5 V-Sync (Detector)

Scope Sync - INT  
 Vert. Scale - 1.0 V/cm dc  
 Hor. Scale - 1  $\mu$ s/cm

— Gnd

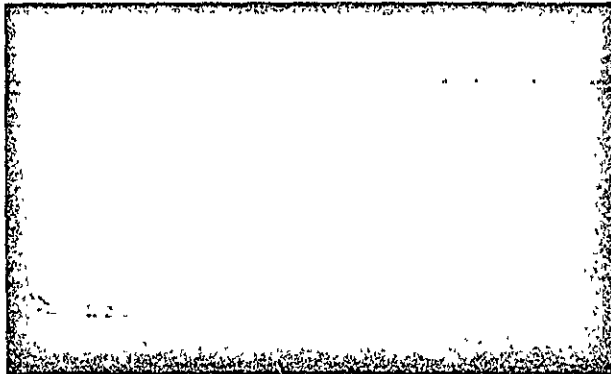

Figure 5-19. A3TJ6 PAM (Detector)

Scope Sync - INT  
 Vert. Scale - 1.0 V/cm dc  
 Hor. Scale - 1  $\mu$ s/cm

— Gnd

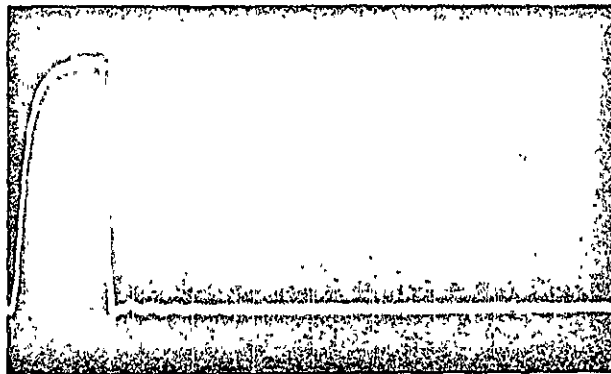

Figure 5-20. A4TJ1 Sample

Scope Sync - INT  
 Vert. Scale - 1.0 V/cm dc  
 Hor. Scale - 0.2  $\mu$ s/cm

— Gnd

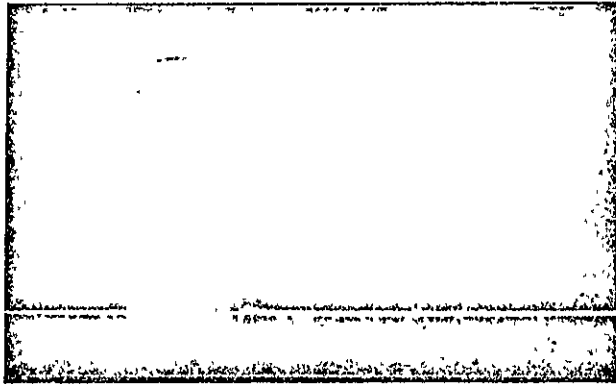

Figure 5-21. A4TJ2 Clamp

Scope Sync - INT  
Vert. Scale - 1.0 V/cm dc  
Hor. Scale - 0.5  $\mu$ s/cm

— Gnd

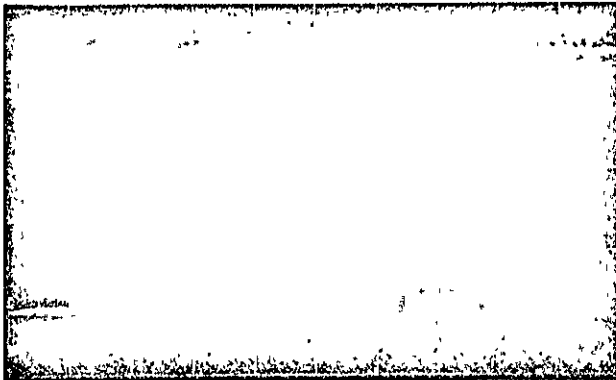

Figure 5-22. A4TJ3 Drive

Scope Sync - INT  
Vert. Scale - 1.0 V/cm dc  
Hor. Scale - 10  $\mu$ s/cm

— Gnd

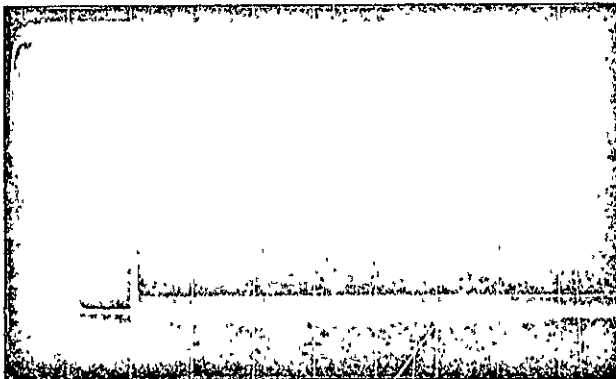

Figure 5-23. A4TJ4 Sync

Scope Sync - INT  
Vert. Scale - 1.0 V/cm dc  
Hor. Scale - 2  $\mu$ s/cm

— Gnd



Figure 5-24. A4TJ5 V-Sync

Scope Sync - INT  
 Vert. Scale - 1.0 V/cm dc  
 Hor. Scale - 2 ms/cm

Gnd

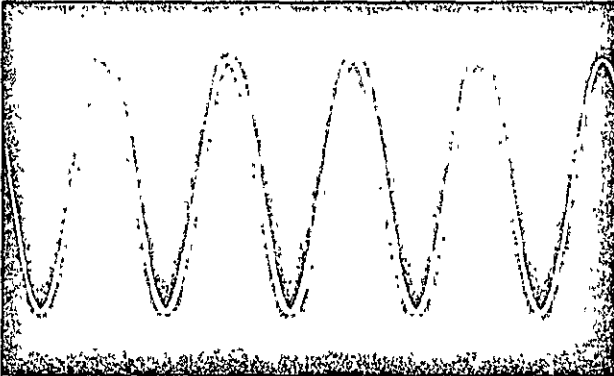

Figure 5-25. A6TJ1 Input

Scope Sync - INT  
 Vert. Scale - 0.2 V/cm  
 Hor. Scale - 0.5 ms/cm

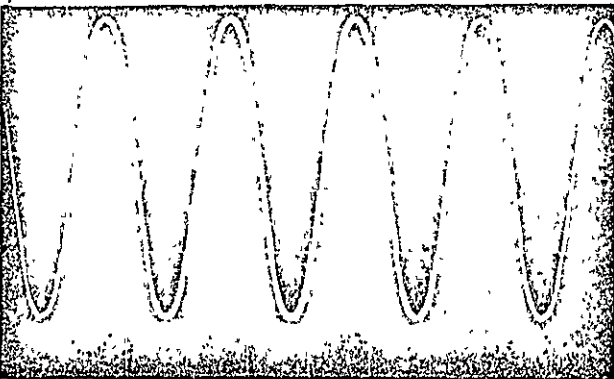

Figure 5-26. A6TJ2 Clipper

Scope Sync - INT  
 Vert. Scale - 0.1 V/cm  
 Hor. Scale - 0.5 ms/cm

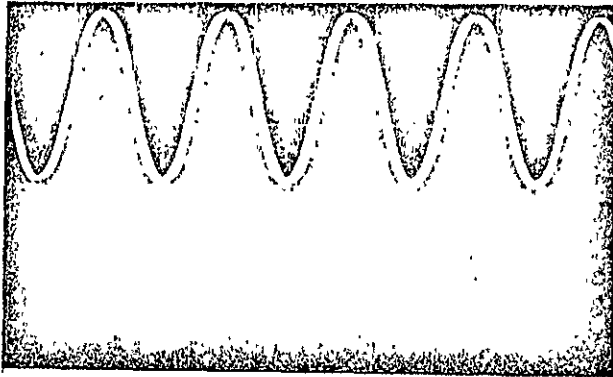

Figure 5-27. A6TJ3 Audio + DC

Scope Sync - INT  
 Vert. Scale - 0.1 V/cm dc  
 Hor. Scale - 0.5 ms/cm

Gnd



Figure 5-28. A6TJ4 Sample

Scope Sync - INT  
 Vert. Scale - 5.0 V/cm dc  
 Hor. Scale - 0.5  $\mu$ s/cm

Gnd



Figure 5-29. A6TJ5 Output

Scope Sync - A7TJ4  
 Vert. Scale - 0.5 V/cm dc  
 Hor. Scale - 0.5  $\mu$ s/cm

Gnd

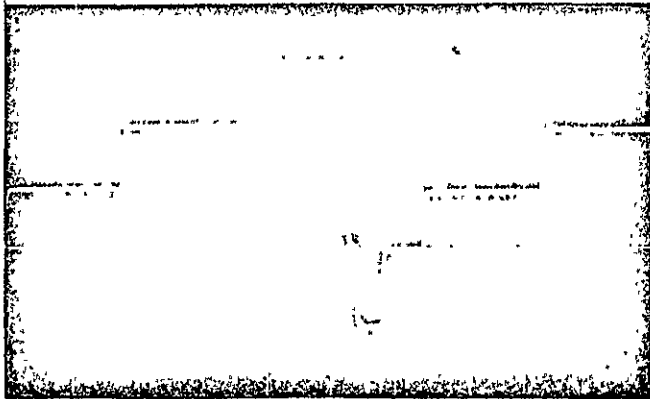

Figure 5-30. A7TJ1 V-Clamp

Scope Sync - A7TJ4  
Vert. Scale - 0.5 V/cm dc  
Hor. Scale - 10  $\mu$ s/cm

— Gnd

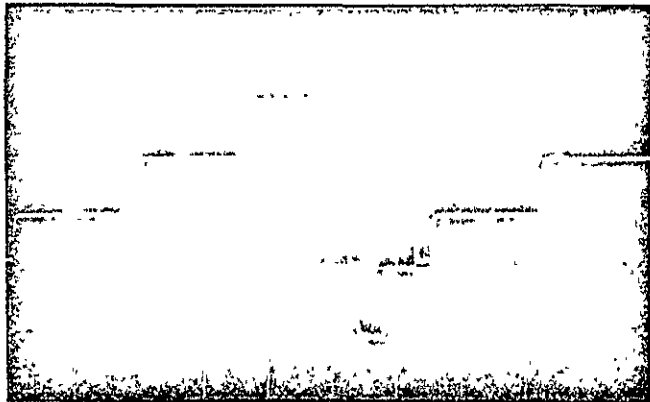

Figure 5-31. A7TJ2 Blank

Scope Sync - A7TJ4  
Vert. Scale - 0.5 V/cm dc  
Hor. Scale - 10  $\mu$ s/cm

— Gnd

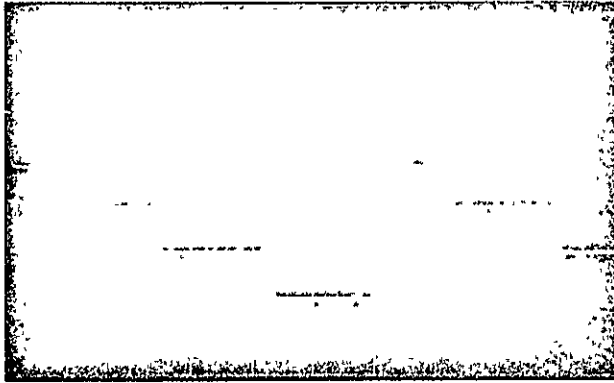

Figure 5-32. A7TJ3 S-Clamp

Scope Sync - A7TJ4  
 Vert. Scale - 2.0 V/cm dc  
 Hor. Scale - 10  $\mu$ s/cm

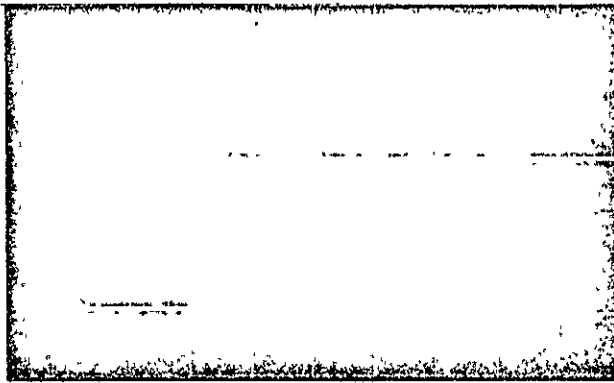

Figure 5-33. A7TJ4 Sync

Scope Sync - INT  
 Vert. Scale - 2.0 V/cm dc  
 Hor. Scale - 2  $\mu$ s/cm



Figure 5-34. A7TJ5 V-Sync

Scope Sync - INT  
 Vert. Scale - 1.0 V/cm dc  
 Hor. Scale - 2 ms/cm

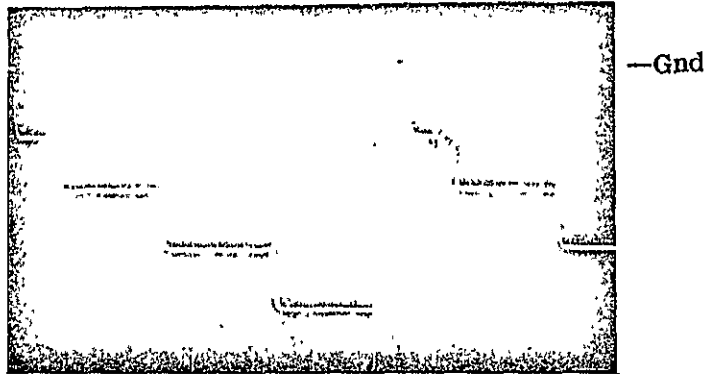

Figure 5-35. A8TJ1 Input

Scope Sync - A7TJ4  
 Vert. Scale - 0.5 V/cm dc  
 Hor. Scale - 10  $\mu$ s/cm

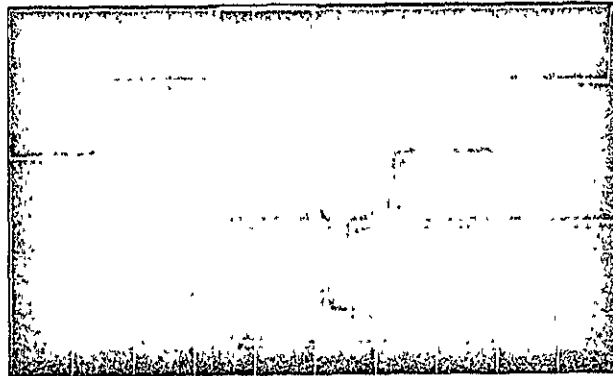
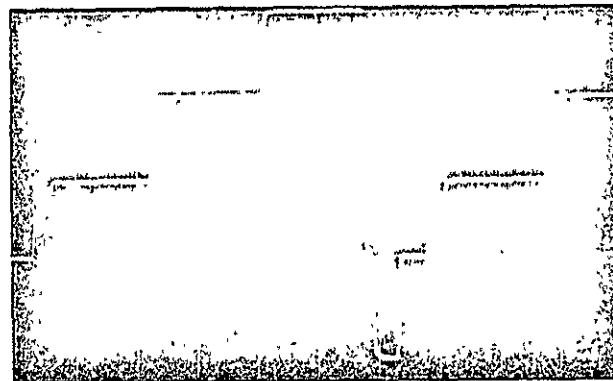

Figure 5-36A. A8TJ2 V/A OUT 1, Pedestal Only

Scope Sync - A7TJ4  
 Vert. Scale - 0.2 V/cm  
 Hor. Scale - 10  $\mu$ s/cm

Figure 5-36B. A8TJ2 V/A OUT 1, Pedestal Only  
(scope uncalibrated)

Scope Sync - A7TJ4  
 Vert. Scale - (uncalibrated)  
 Hor. Scale - 10  $\mu$ s/cm

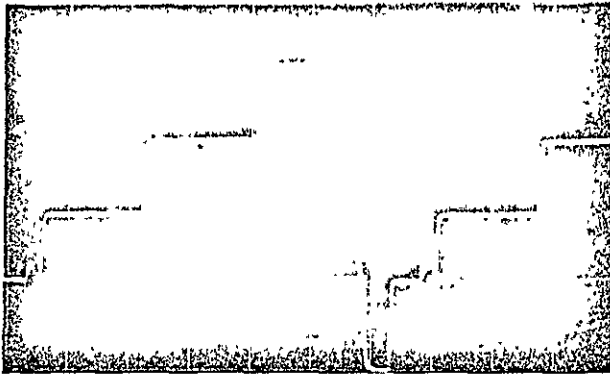

Figure 5-37A. A8TJ2 V/A OUT, Audio Modulation

Scope Sync - A7TJ4  
 Vert. Scale - 0.2 V/cm  
 Hor. Scale - 10  $\mu$ s/cm

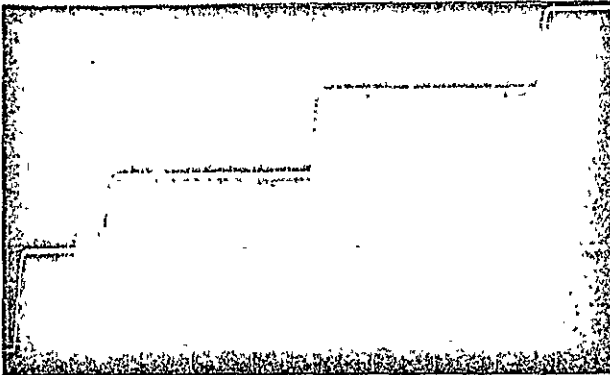

Figure 5-37B. A8TJ2 V/A OUT 1, Audio Modulation (scope uncalibrated)

Scope Sync - A7TJ4  
 Vert. Scale - (uncalibrated)  
 Hor. Scale - 5  $\mu$ s/cm

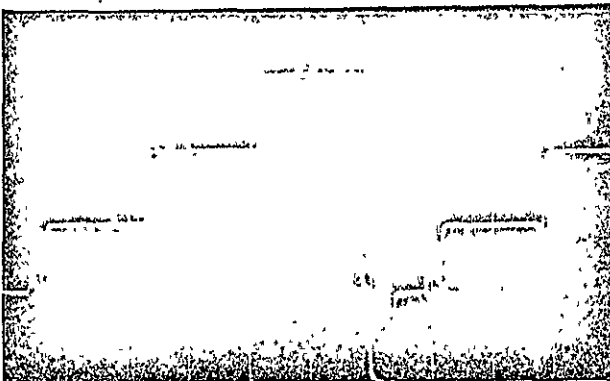

Figure 5-38. A8TJ3 V/A OUT 2, Audio Modulation

Scope Sync - A7TJ4  
 Vert. Scale - 0.2 V/cm  
 Hor. Scale - 10  $\mu$ s/cm



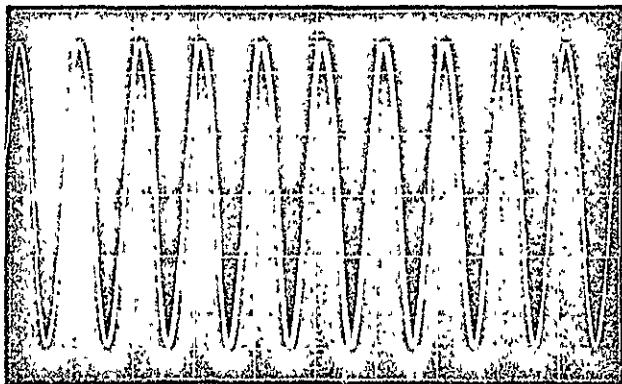

Figure 5-39. A9TJ1 Input

Scope Sync - INT  
Vert. Scale - 0.1 V/cm  
Hor. Scale - 1 ms/cm

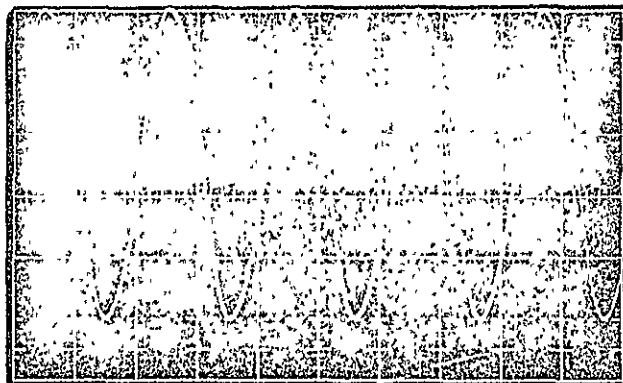

Figure 5-40. A9TJ2 Output

Scope Sync - INT  
Vert. Scale - 1.0 V/cm  
Hor. Scale - 0.5 ms/cm

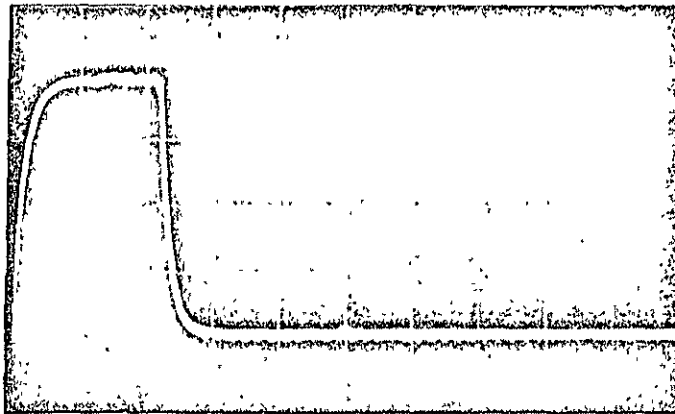

Figure 5-41. A5TJ1 Reference

Scope Sync - INT  
 Vert. Scale - 1 V/cm dc  
 Hor. Scale - 1  $\mu$ s/cm

Gnd

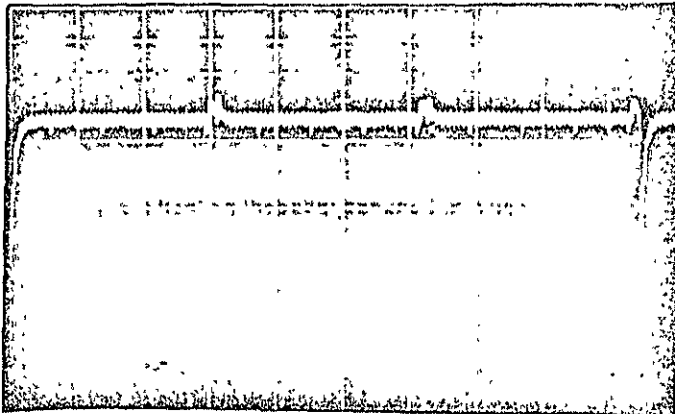

Figure 5-42. A5TJ2 Phase Detector

Scope Sync - INT  
 Vert. Scale - 0.1 V/cm dc  
 Hor. Scale - 20  $\mu$ s/cm

Gnd

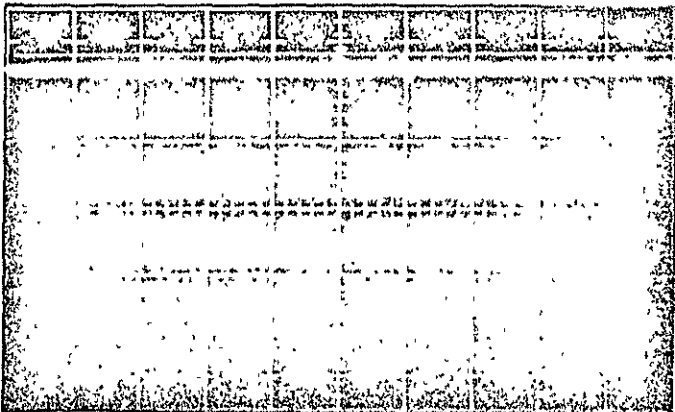

Figure 5-43. A5TJ3 Error

Scope Sync - INT  
 Vert. Scale - 1 V/cm dc  
 Hor. Scale - 20  $\mu$ s/cm

Gnd

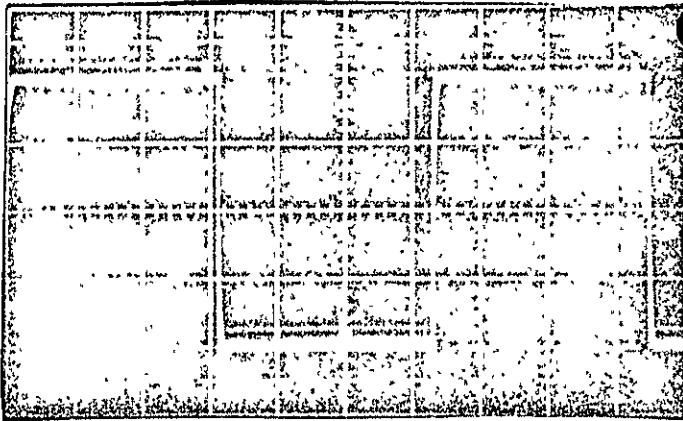

Figure 5-44. A5TJ4 VCO

Scope Sync - INT  
 Vert. Scale - 1 V/cm dc  
 Hor. Scale - 10  $\mu$ s/cm

Gnd

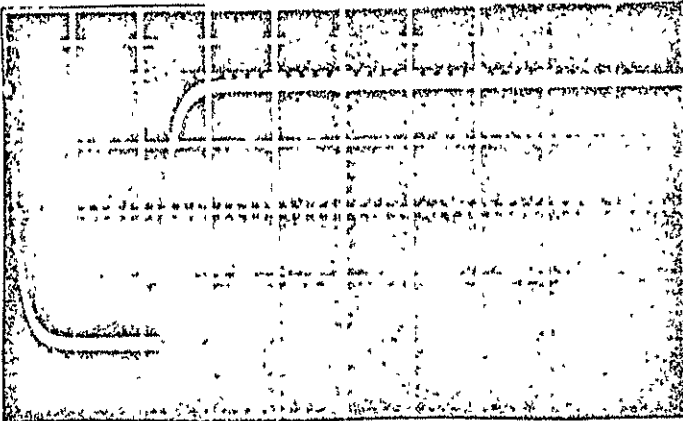

Figure 5-45. A5TJ5 V-Sync

Scope Sync - INT  
 Vert. Scale - 1 V/cm dc  
 Hor. Scale - 1  $\mu$ s/cm

Gnd

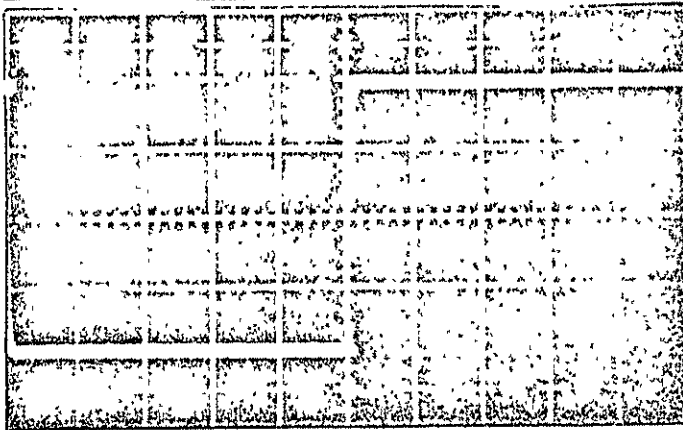

Figure 5-46. A5TJ6 Line.17

Scope Sync - INT  
 Vert. Scale - 1 V/c, dc  
 Hor. Scale - 10  $\mu$ s/cm

Gnd

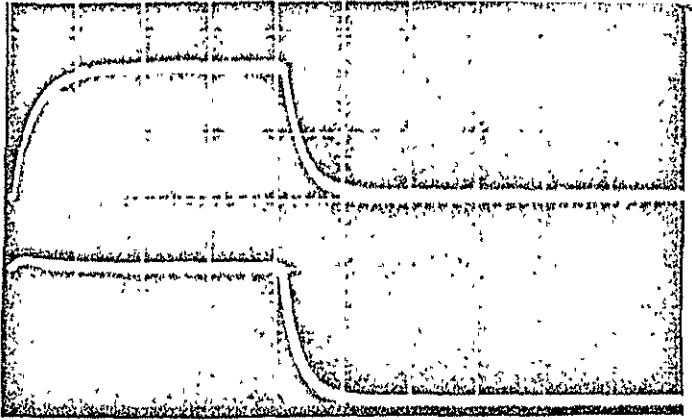

Figure 5-47. A5TJ1/A5TJ4 Reference/VCO  
(A11TJ1/A11TJ4 is similar)

Gnd

Scope Sync - INT, Ch A, Chopped  
Vert. Scale - 2 V/cm dc  
Hor. Scale - 0.5  $\mu$ s/cm

Gnd

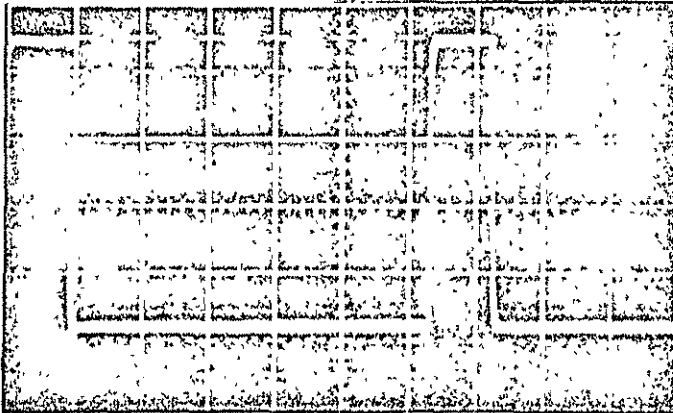

Figure 5-48. A11TJ1 Reference

Gnd

Scope Sync - INT  
Vert. Scale - 1 V/cm dc  
Hor. Scale - 10  $\mu$ s/cm

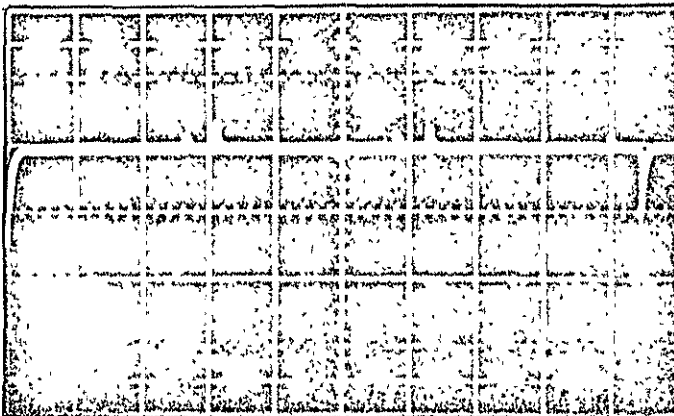

Figure 5-49. A11TJ2 Phase Detector

Gnd

Scope Sync - INT  
Vert. Scale - 0.2 V/cm dc  
Hor. Scale - 20  $\mu$ s/cm

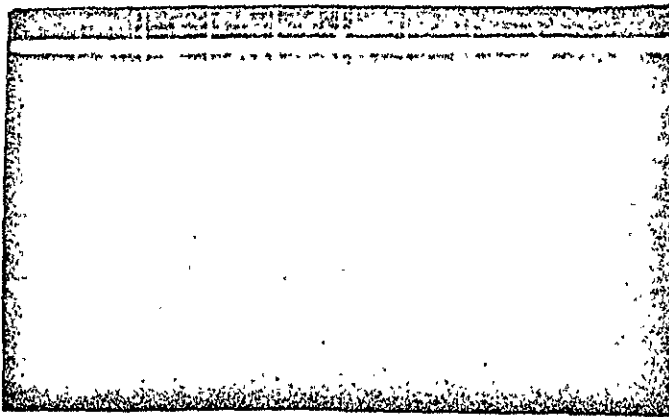

Figure 5-50. A11TJ3 Error

Scope Sync - INT  
Vert. Scale - 1V/cm dc  
Hor. Scale - 20  $\mu$ s/cm

Gnd

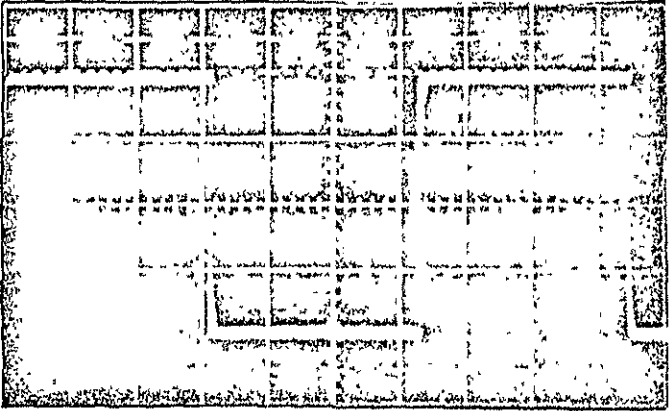

Figure 5-51. A11TJ4 VCO

Scope Sync - INT  
Vert. Scale - 1 V/cm dc  
Hor. Scale - 10  $\mu$ s/cm

Gnd



Figure 5-52. A11TJ5 Line 17

Scope Sync - INT  
Vert. Scale - 1 V/cm dc  
Hor. Scale - 10  $\mu$ s/cm

Gnd

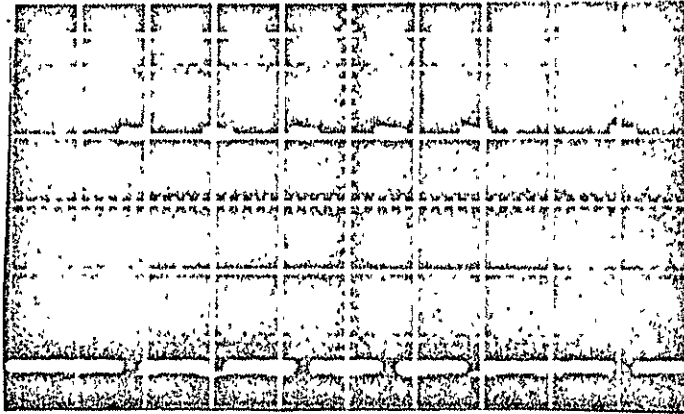

Figure 5-53. A11TJ6 Data

Scope Sync - A11TJ5  
Vert. Scale - 1 V/cm dc  
Hor. Scale - 5  $\mu$ s/cm

Gnd

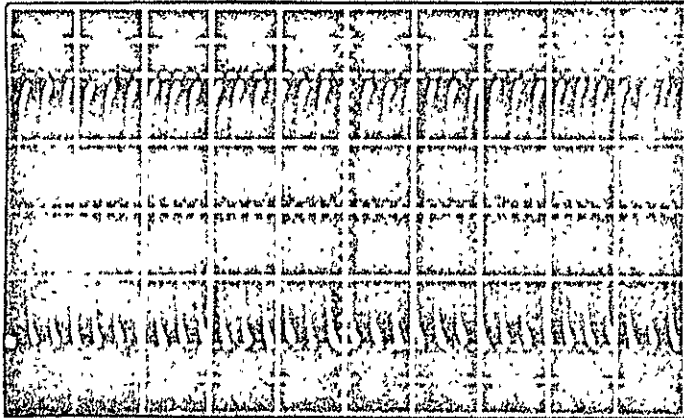

Figure 5-54. A11TJ7 Shift Register Clock

Scope Sync - A11TJ5  
Vert. Scale - 1 V/cm dc  
Hor. Scale - 5  $\mu$ s/cm

Gnd

ORIGINAL PAGE IS  
OF POOR QUALITY

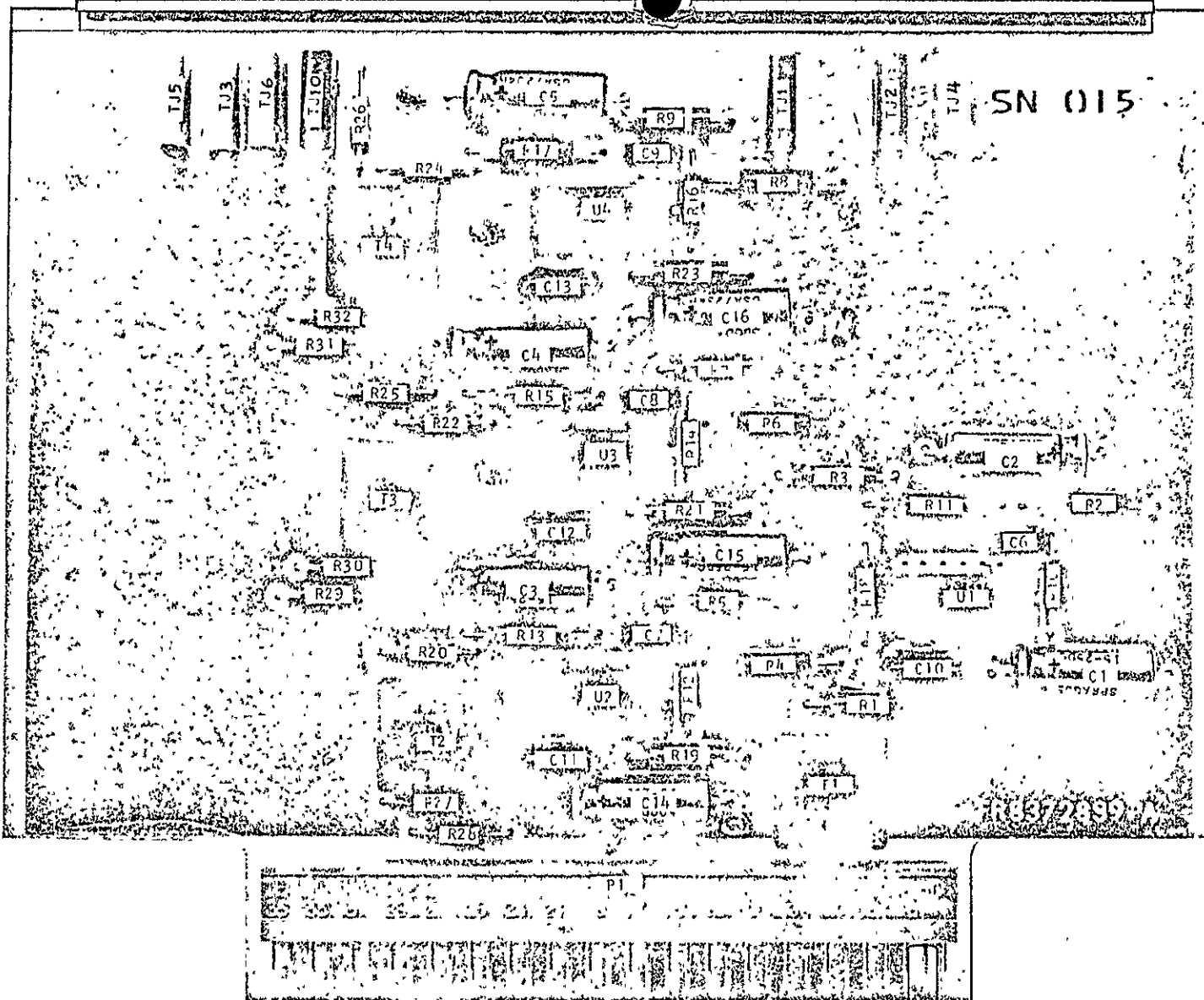

Figure 5-55. Module Layout, A1 (Splitter Output)

ORIGINAL PAGE IS  
OF POOR QUALITY

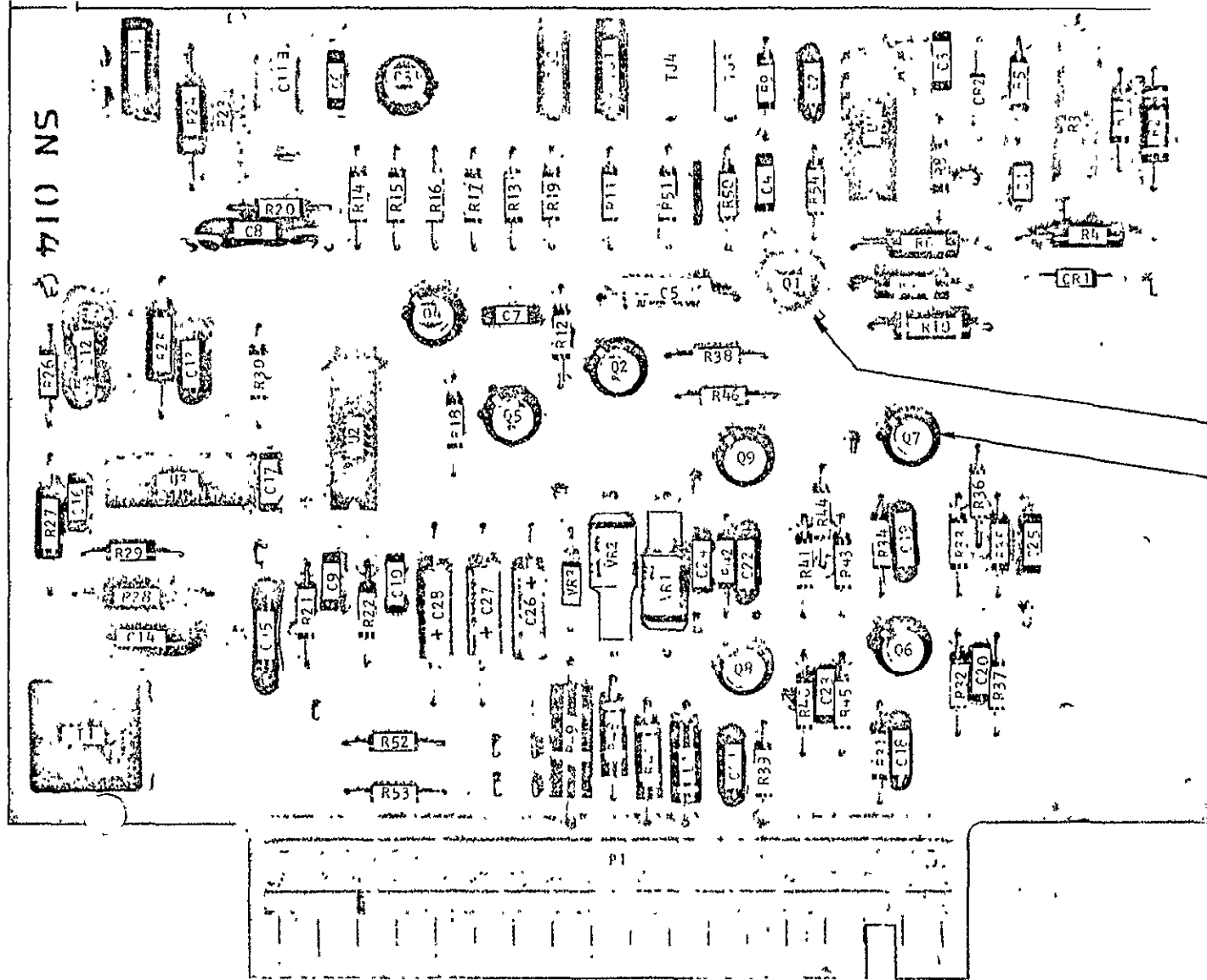

Figure 5-56. Module Layout, A2 (Video/Audio Input)



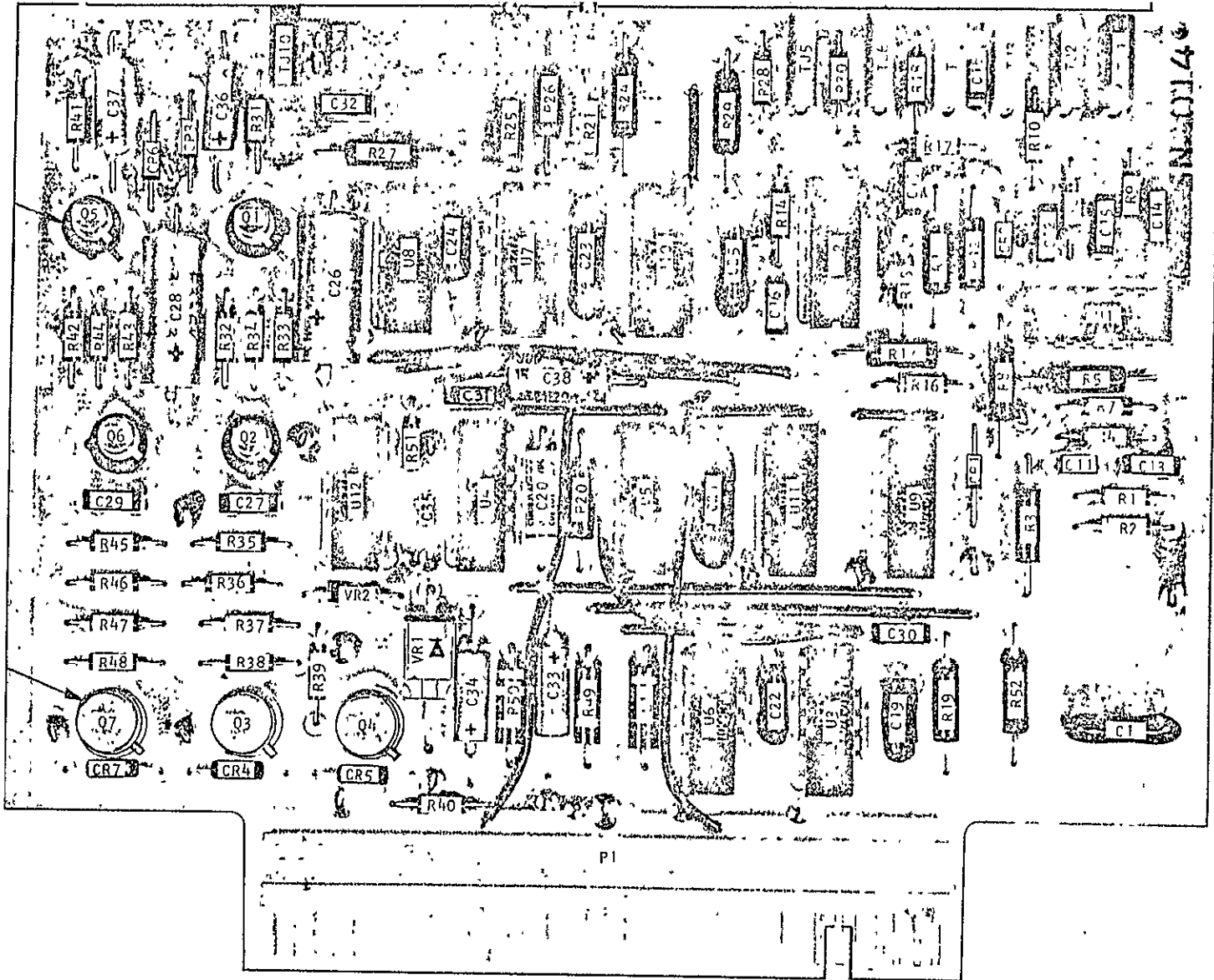

Figure 5-57. Module Layout, A3 (Splitter Timing)

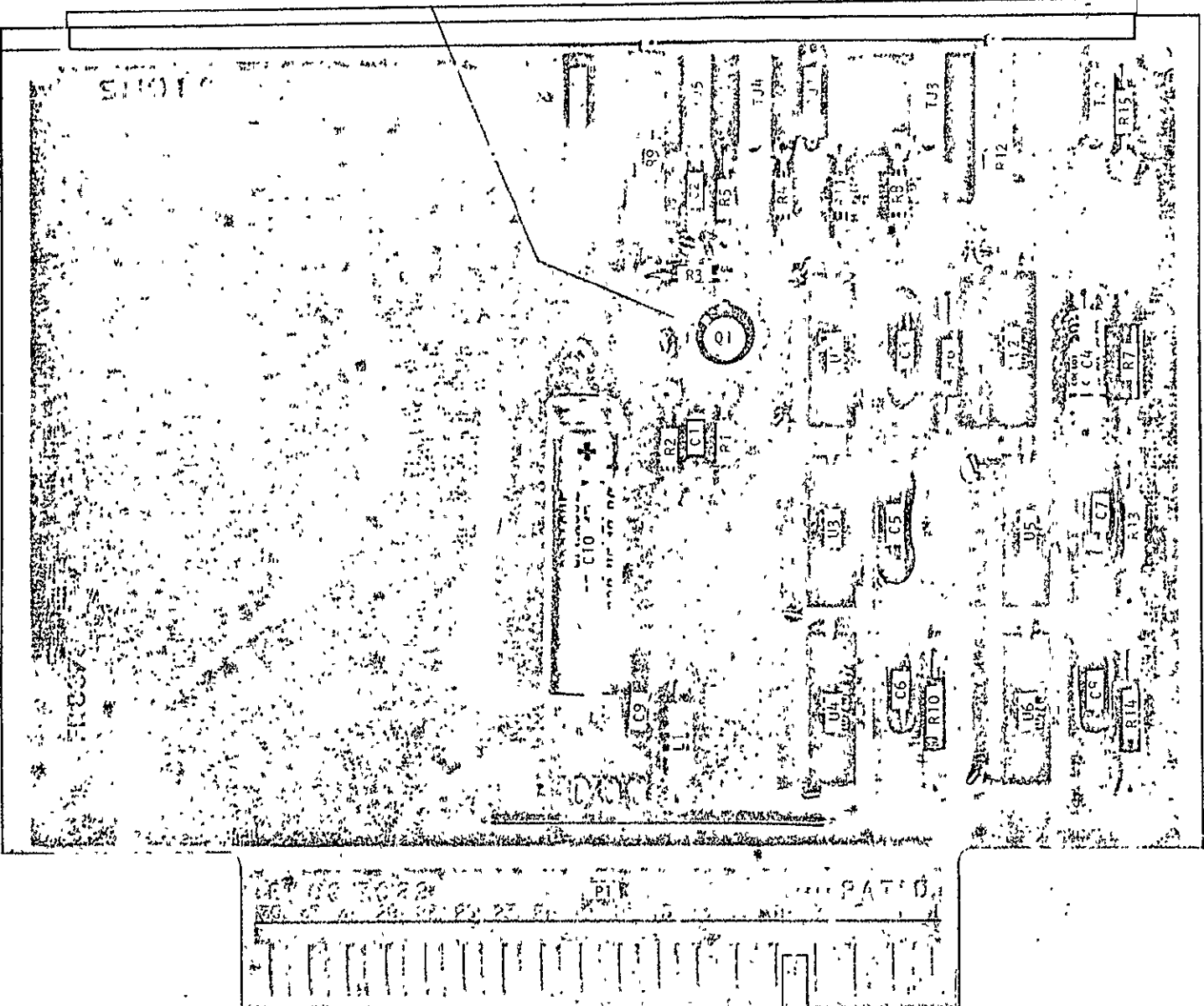

Figure 5-58. Module Layout, A4 (External Sync)

ORIGINAL PAGE IS  
OF POOR QUALITY

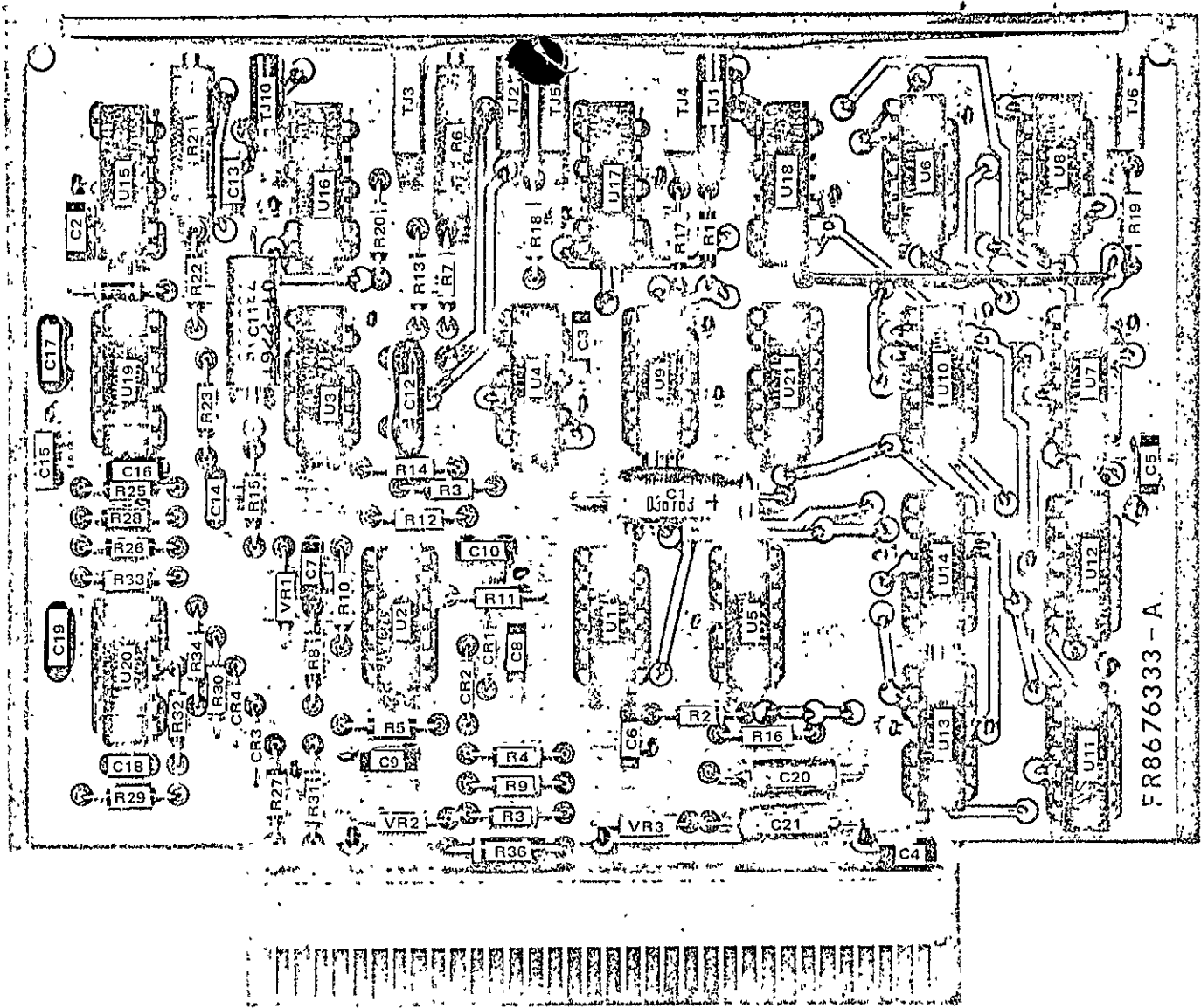

Figure 5-59. Module Layout, A5 (CTE Mux)

ORIGINAL PAGE IS  
OF POOR QUALITY

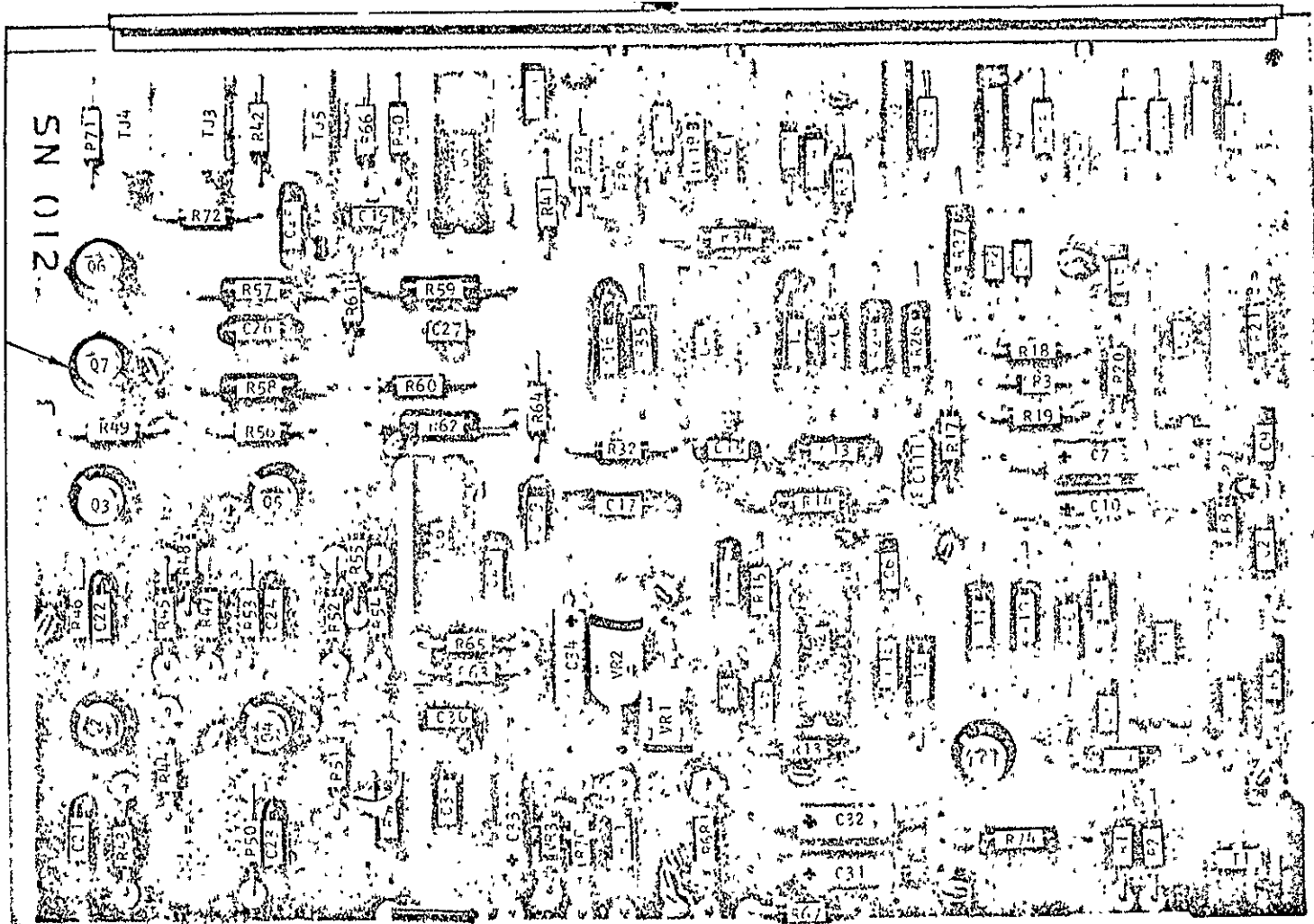

Figure 5-60. Module Layout, A6 (Audio Input)

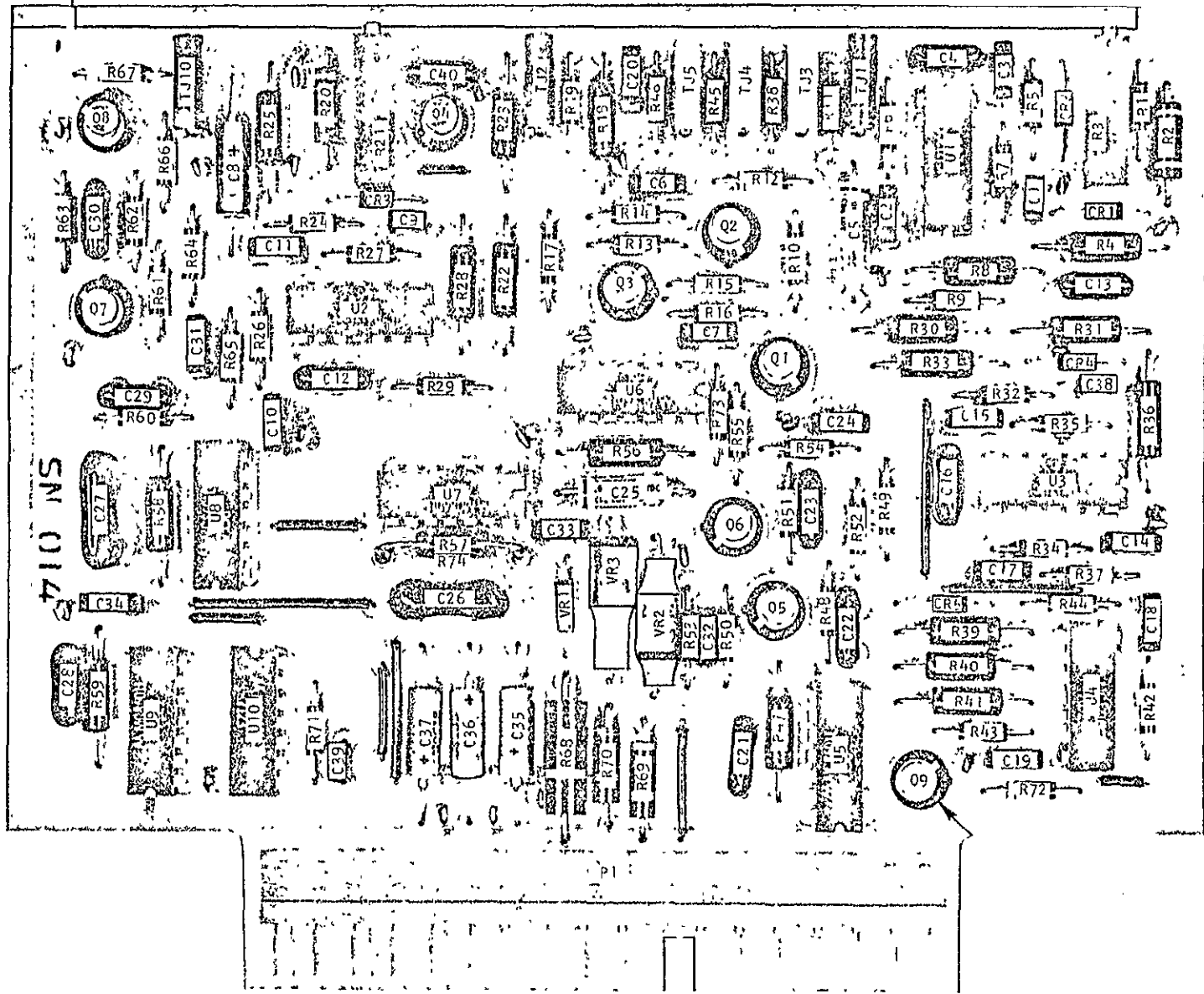

Figure 5-61. Module Layout, A7 (Video Input)

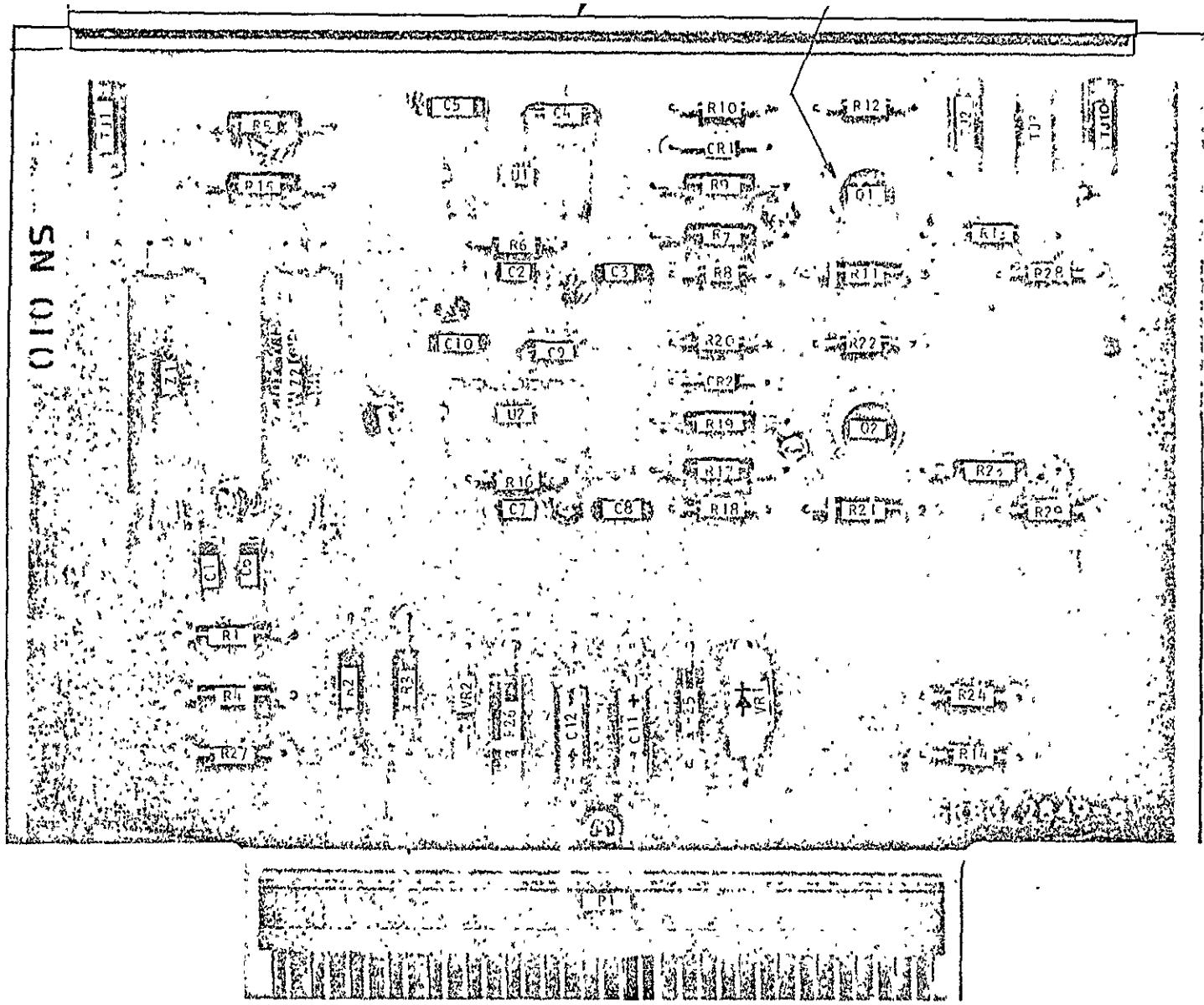

Figure 5-62. Module Layout, A8 (Interleaver Output)

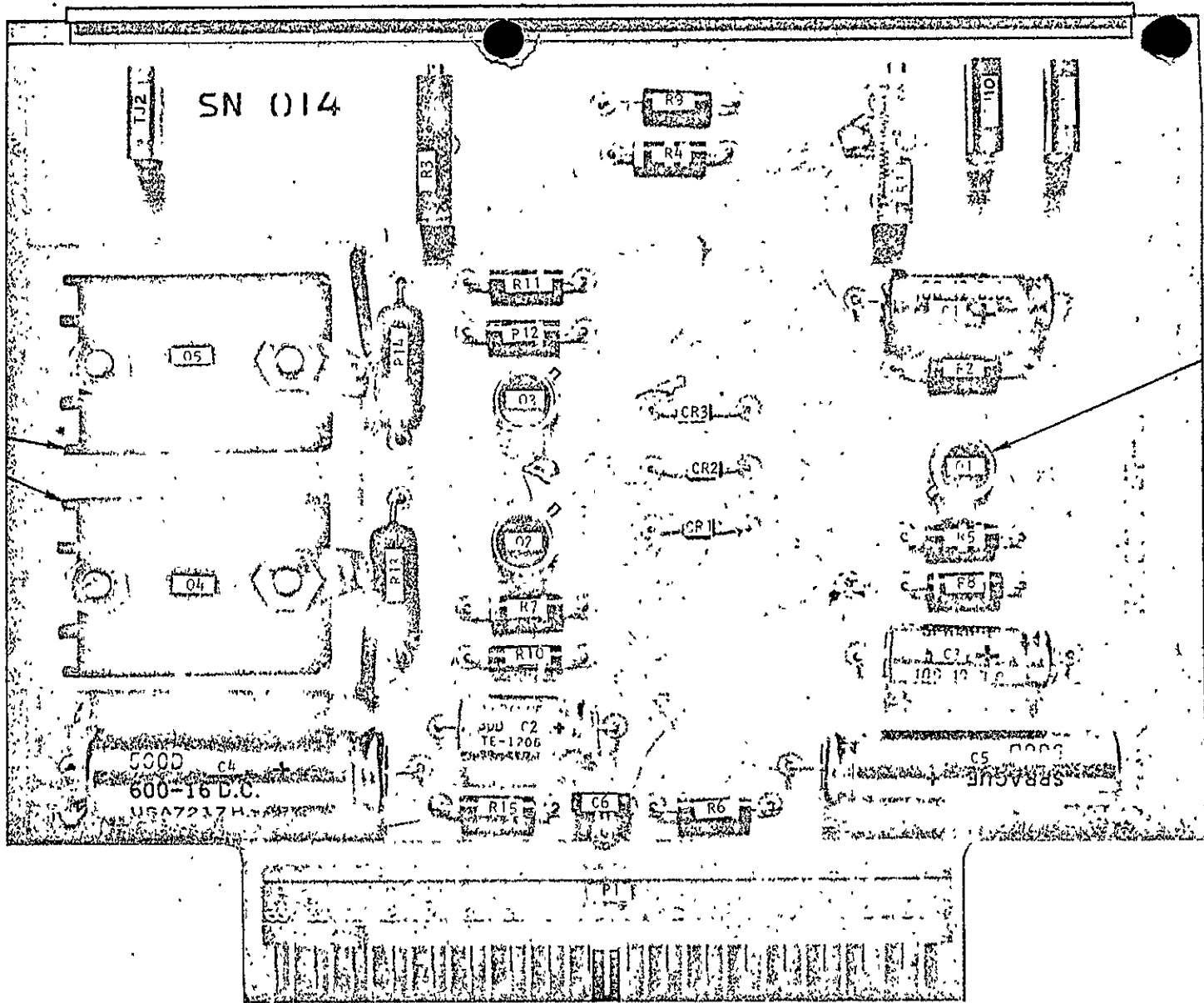

Figure 5-63. Module Layout, A9 (Audio Power Amplifier)

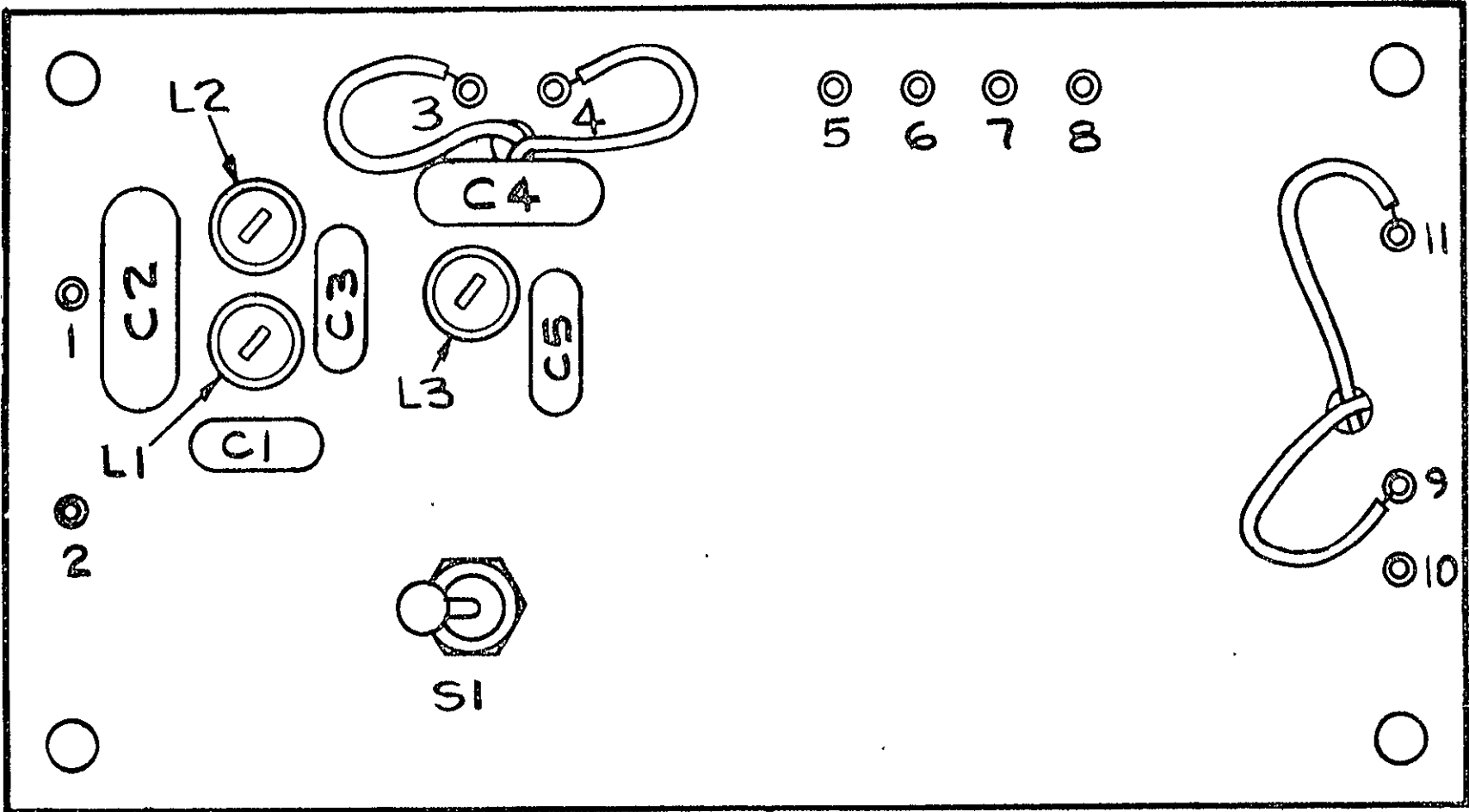

Figure 5-64. Module Layout, A10 (Bessel Filter/Equalizer)



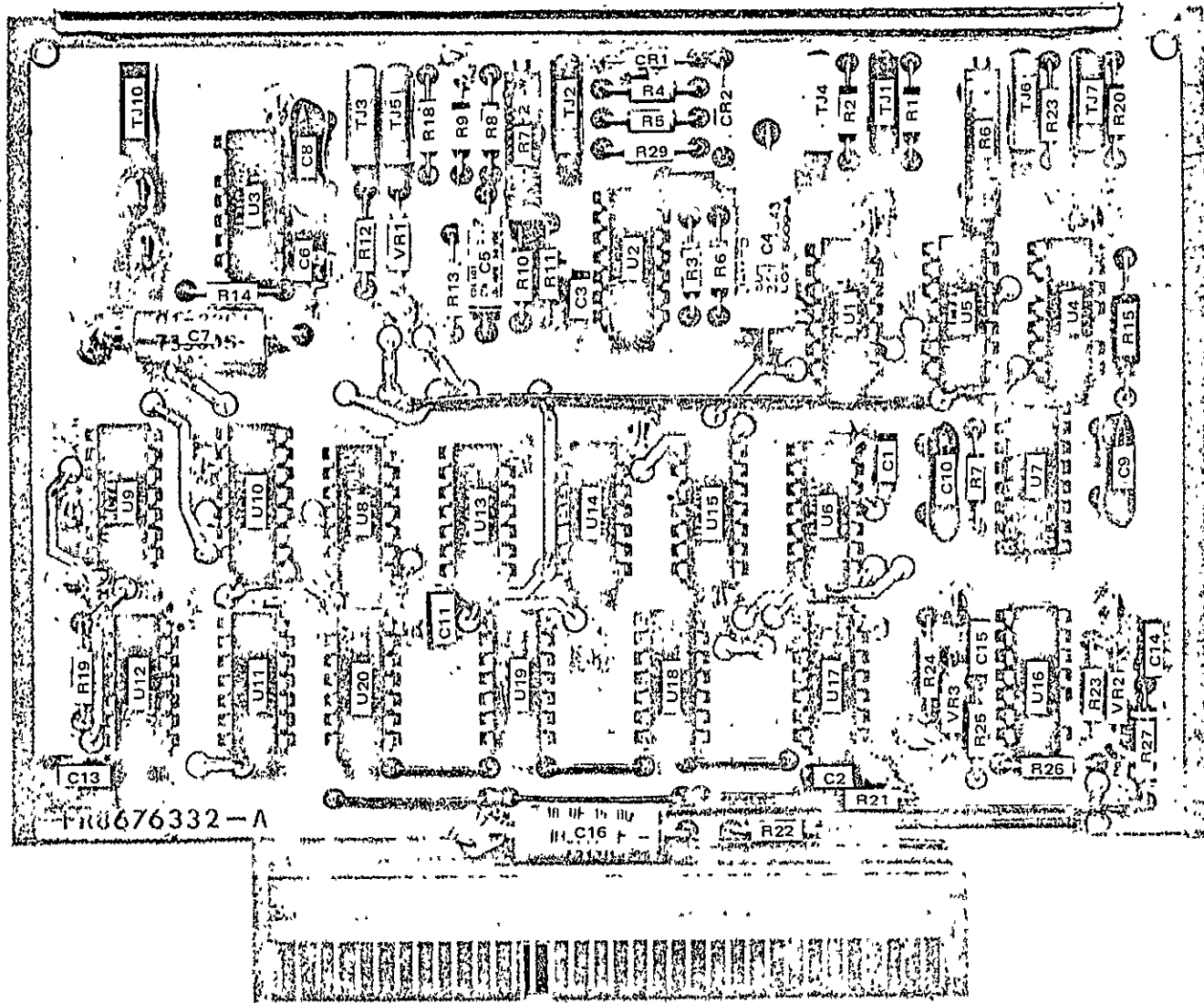

Figure 5-65. Module Layout, A11 (CTE Demux)

TABLE 5-1. SPLITTER SIGNAL LEVELS

(Refer to Splitter Functional Diagram, Figure 4-2; Audio/CTE Splitter/Interleaver Schematic, Figure 6-1; and Module Schematics, Figures 6-2, 6-3, 6-4, 6-5, 6-10, 6-11, 6-12, 6-13)

Connector or Test Jack	Designation	Description	Level	Reference Figures	Remarks
J1	Splitter V/A Input	TV Signal	1.0 V p-p		Rear Panel BNC connector.
A10-1		TV Signal	1.0 V p-p		Same as J1 signal, except ac coupled.
TP1, TP2 (Gnd. (A2-4))	Splitter V/A Input	TV Signal	1.0 V p-p	3-2, 3, 4	Front Panel test jacks. (ac coupled).
A2TJ1	V-Clamp	TV Signal	2.0 V p-p	5-8, 5-9	Sync Tip at 0 V dc.
A2TJ2	Sample	Recovered Audio (unfiltered)	1.3 V p-p	5-10	
A2-26	VTR Audio Output	Recovered Audio (filtered)	0.4 V p-p		AC coupled.
A2-6	LPF Drive	TV Signal	2.0 V p-p		AC coupled.
A2-8	Clamp	1- $\mu$ s positive-going pulse	0 to +4.1 V p-p		
A2TJ3	Clamp	1- $\mu$ s positive-going pulse	-12 to 0 V p-p	5-11	
A2-10	Sample	0.3- $\mu$ s positive-going pulse	0 to +4.0 V p-p		

TABLE 5-1. SIGNAL TEST SIGNALS

Connector or Test Jack	Designation	Description	Level	Reference Figures	Remarks
A2TJ4	Sample	0.3- $\mu$ s positive-going pulse	-12 to 0 V p-p	5-12	
TB1-4, 5	A/G AUD IN	1-kHz sine wave	1.0 V p-p		Rear Panel terminal board. Balanced signal.
A2-28, 30	A/G AUD IN	1-kHz sine wave	1.0 V p-p		AC coupled.
TP3, TP4	Splitter A/G AUD INPUT	1-kHz sine wave	1.0 V p-p	3-5	Front Panel test jacks. Same as signal at TB1-4, 5.
A2-32, 34	A/G AUDIO IN (A2 module OUT)	1-kHz sine wave	0.8 V p-p (approx.)		AC coupled.
A3-6	LPF DRIVE	TV Signal	2.0 V p-p		Same as signal at A2-6.
A3-8	Clamp	1- $\mu$ s positive-going pulse	0 to +4.1 V p-p		
A3-10	Sample	0.3- $\mu$ s positive-going pulse	0 to +4.1 V p-p		
A3TJ1	LPF	TV Signal	1.6 V p-p	5-14	AC coupled.
A3TJ2	Sync Clamp	TV Signal	6.8 V p-p	5-15	Sync tip at approx. +0.6 V

TABLE 5-1. SPLITTER SIGNAL LEVELS (Cont.)

Connector or Test Jack	Designation	Description	Level	Reference Figures	Remarks
A3TJ3	Sync	Stripped Sync positive-going pulses	3.1 V p-p	5-16	Base line at approx. -0.2 V
A3TJ4	V-Sync	200- $\mu$ s positive-going pulse	1.8 V p-p	5-17	Base line at approx. -0.2 V
A3TJ5	V-Sync(detector)	1- $\mu$ s negative-going pulse	0 to +3.7 V p-p	5-18	
A3-30	Relay Drive	DC Level	-1 V/-15 V		
A3-32	PAM AUD Light	DC Level	-2 V/-15 V		
A3-34	A/G AUD Light	DC Level	-15 V/-1 V		
J28	Splitter Sync In	TV Sync	+0.4 to -4.1 V p-p (75 ohm term)		Rear Panel BNC connector.
A4-32					Same as signal at J28.
A4 TJ4	Sync	TV Sync	0 to +4.5 V p-p	5-23	
A4 TJ5	V-Sync	200- $\mu$ s positive-going pulse	2.7 V p-p	5-24	Base line at approx. -0.6 V

TABLE 5-1. SPLITTER SIGNAL LEVELS (CONT.)

Connector or Test Jack	Designation	Description	Level	Reference Figures	Remarks
A4 TJ3	Drive	47- $\mu$ s positive-going pulse	0 to +4.2 V p-p	5-22	Note: Duty cycle greater than 50%.
A4 TJ2	Clamp	1- $\mu$ s positive-going pulse	0 to +4.1 V	5-21	
A4-8	Clamp	1- $\mu$ s positive-going pulse	0 to +4.1 V p-p		Same as signal at A4 TJ2.
A4 TJ1	Sample	0.3- $\mu$ s positive-going pulse	0 to +4.1 V p-p	5-20	
A4-10	Sample		0 to +4.1 V p-p		Same as signal at A4 TJ1.
A1 TJ1 (A1-21)	Audio In	1-kHz sine wave	0.12 V p-p	5-6	Level adjusted by front panel SPLITTER AUD OUT LEVEL control (R10). For A/G AUD the level is also adjusted by front panel SPLITTER A/G AUD IN LEVEL control (R2).
A1 TJ4 (A1-2)	Speaker/Intercom. Audio In	1-kHz sine wave	0.2 V p-p	5-7	Level adjusted by front panel SPEAKER/INTERCOM LEVEL control (R9). For A/G AUD the level is also adjusted by front panel SPLITTER A/G AUD LEVEL control (R2).

TABLE 5-1. SPLIT SIGNAL LEVELS (cont.)

Connector or Test Jack	Designation	Description	Level	Reference Figures	Remarks
A1 TJ3 (A1-22) (TP5, TP6)	Audio Out 1	1-kHz sine wave	1.1 V p-p	5-6	Refer to Audio input A1 TJ1
A1 TJ5 (TP7, TP8)	Audio Out 2	1-kHz sine wave	1.1 V p-p	5-6	Refer to A1 TJ3 (AUDIO OUT 1)
A1 TJ6 (TP9, TP10)	Audio Out 3	1-kHz sine wave	1.1 V p-p	5-6	Refer to A1 TJ3 (AUDIO OUT 1)
A1 TJ2	Speaker/Intercom Out	1-kHz sine wave	1.1 V p-p	5-7	Refer to SPEAKER/INTERCOM AUDIO IN A1 TJ4
A1-26, 24 (TB2-1, 2)	Audio Output 1	1-kHz sine wave	1.0 V p-p		TB2 on rear panel. Level adjusted by front panel SPLITTER AUD OUT LEVEL Control (R10).
A1-29, 28 (TB2-4, 5)	Audio Output 2	1-kHz sine wave	1.0 V p-p		Same as AUDIO OUT 1.
A1-33, 32 (TB2-7, 8)	Audio Output 3	1-kHz sine wave	1.0 V p-p		Same as AUDIO OUT 1.
A1-10, 6 (TB3-7, 8)	Audio Mon Out	1-kHz sine wave	1.0 V p-p		TB3 on rear panel. Level adjusted by front panel SPEAKER/INTERCOM LEVEL Control (R9).
TB4-7, 8 (A9-4, 3) (A9 TJ1)	Speaker In	1-kHz sine wave	0.5 V p-p (variable)	5-39	Audio Mon out signal (TB3-7, 8) is loop back to SPEAKER IN (TB4-7, 8)
A9 TJ2	Speaker Drive	1-kHz sine wave	5 V p-p (variable)	5-40	Level adjusted by LEVEL Control (A9R1).

TABLE 5-1. SPLITTER SIGNAL LEVELS (cont.)

Connector or Test Jack	Designation	Description	Level	Reference Figures	Remarks
A11TJ1	Reference	9 $\mu$ sec pulse	0 to +4.3 V p-p	5-48	15.73 kHz prf
A11TJ2	Phase Detector	d. c.	-0.2 V d. c.	5-49	
A11TJ3	Error	d. c.	+4.2 V d. c.	5-50	
A11TJ4	VCO	15.734 kHz sq. wave	0 to 3.9 V p-p	5-51	
A11TJ5	Line 17	50 $\mu$ sec pulse	0 to +4 V p-p	5-52	
A11TJ6	Data	2 $\mu$ sec pulses	0 to +3.5 V p-p	5-53	08080808 pattern
A11TJ7	SR Clock	32 pulses	0 to +3.8 V p-p	5-54	629.37 kHz prf

TABLE 5-2. INTERLEAVER SIGNAL LEVELS (TEST SIGNALS)

(Refer to Interleaver functional diagram, Figure 4-13; Audio/CTE Splitter/Interleaver Schematic diagram, Figure 6-1; and Module Schematics, Figures 6-6, 6-7, 6-8, 6-9)

Connector or Test Jack	Designation	Description	Level	Reference Figures	Remarks
J14	INTERLEAVER VID INPUT	TV Signal	1.0 V p-p	3-7	TV Test Signal Rear Panel BNC connector. AC coupled.
TP13	INTERLEAVER VID INPUT	TV Signal	1.0 V p-p	3-7	TV Test Signal (Front Panel) AC coupled.
A7 TJ1	V-Clamp	TV Signal	0 to +2V p-p	5-30	Adjusted by A7R3 (Input LEVEL).
A7 TJ2	Blank	TV Signal	0 to +1.8 V p-p	5-31	Blank level adjusted by A7R21 (Blank) level control.
A7 TJ3	S-Clamp	TV Signal	6 V p-p	5-32	Sync tip at approx. +0.6 V.
A7 TJ4	SYNC	Stripped sync negative-going pulses	+5 to 0 V p-p	5-33	
A7 TJ5	V-SYNC	200- $\mu$ s negative-going pulse	+3 to 0 V p-p	5-34	
TB1-7, 8 (A6-6, 4)	INTLVR AUD IN	1-kHz sine wave	1.0 V p-p		Rear Panel terminal board. 1-kHz test signal.
TP11, TP12 (A6-2, 8)	INTERLEAVER AUD INPUT	1-kHz sine wave	1.0 V p-p	3-8	Front Panel test jacks.



TABLE 5-2. INTERLEAVER SIGNAL LEVELS (TEST SIGNALS) (cont.)

Connector or Test Jack	Designation	Description	Level	Reference Figures	Remarks
A6 TJ1	INPUT	1-kHz sine wave	0.8 V p-p (approx.)	5-25	AC coupled.
A6 TJ2	CLIPPER	1-kHz sine wave	0.45 to 0.5 V p-p	5-26	Adjusted by AGC level control (A6-R24). Refer to Alignment Procedure, para. 5.3.1.2.3.
A6 TJ3	AUD + DC	1-kHz sine wave	0.27 V p-p	5-27	Audio level adjusted by LEVEL control (A6-R36). DC level adjusted by DC SET control (A6-R38). Refer to alignment procedure, para. 5.3.1.2.4.
A6 TJ4	SAMPLE	1.5- $\mu$ s positive-going pulse	-12 to 0 V p-p	5-28	
A6 TJ5	OUTPUT	PAM pulse	0 to +1.2 V p-p	5-29	
A6-28 (A7-28)	OUTPUT	PAM pulse	0 to +1.2 V p-p		Signal same as at A6 TJ5.
A8 TJ1 (A8-30) (A7-30)	INPUT (V/A)	Interleaved TV Signal	0 to +2 V p-p	5-35	

TABLE 5-2. INTERLEAVER SIGNAL LEVELS (TEST SIGNALS) (cont.)

Connector or Test Jacks	Designation	Description	Level	Reference Figures	Remarks
A8 TJ2	OUT 1 V/A	Interleaved TV Signal	0 to +1 V p-p	5-36A, 36B 5-37A, 37B	V/A OUTPUT (Interleaved). Level adjusted by front panel INTERLEAVER V/A OUT 1 LEVEL control (R11).
TP16, TP15 (Gnd.)	INTERLEAVER V/A OUT 1	Interleaved TV Signal	0 to +1 V p-p	3-9, 3-10	Front panel test jacks. Signal same as at A8 TJ2.
J17 (A8-2)	INTERLEAVER V/A OUT 1	Interleaved TV Signal	0 to +1 V p-p		Rear panel BNC connector. Signal same as at A8 TJ2 and front panel test jacks TP16, TP15.
A8 TJ3	OUT 2 (V/A)	Interleaved TV Signal	0 to +1 V p-p	5-38	V/A output (interleaved). Level adjusted by front panel INTERLEAVER V/A OUT 2 LEVEL control (R12).
TP17, TP18 (Gnd.) (A8-8, 7)	INTERLEAVER V/A OUT 2	Interleaved TV Signal	0 to +1 V p-p	3-9, 3-10	Front panel test jacks. Signal same as at A8 TJ3.
J18	INTERLEAVER V/A OUT 2	Interleaved TV Signal	0 to +1 V p-p		Rear panel BNC connector. Signal same as at A8 TJ3 and front panel test jacks TP17, TP18.

TABLE 5-2. INTERLEAVER SIGNAL LEVELS (TEST SIGNALS) (cont.)

Connector or Test Jacks	Designation	Description	Level	Reference Figures	Remarks
A5TJ1	Reference	2.1 $\mu$ sec pulse	0 to +3.8 V p-p	5-41	15.73 kHz prf
A5TJ2	Phase Detector	d. c.	+0.33 V d. c.	5-42	
A5TJ3	Error Signal	d. c.	+4.1 V d. c.	5-43	
A5TJ4	VCO	15.734 kHz sq. wave	0 to +3.9 V p-p	5-44	
A5TJ5	V-sync	2.1 $\mu$ sec pulse	0 to 3.8 V p-p	5-45	
A5TJ6	Line 17	50 $\mu$ sec pulse	0 to +3.9 V p-p	5-46	



SECTION 6

SCHEMATICS AND PARTS LISTS

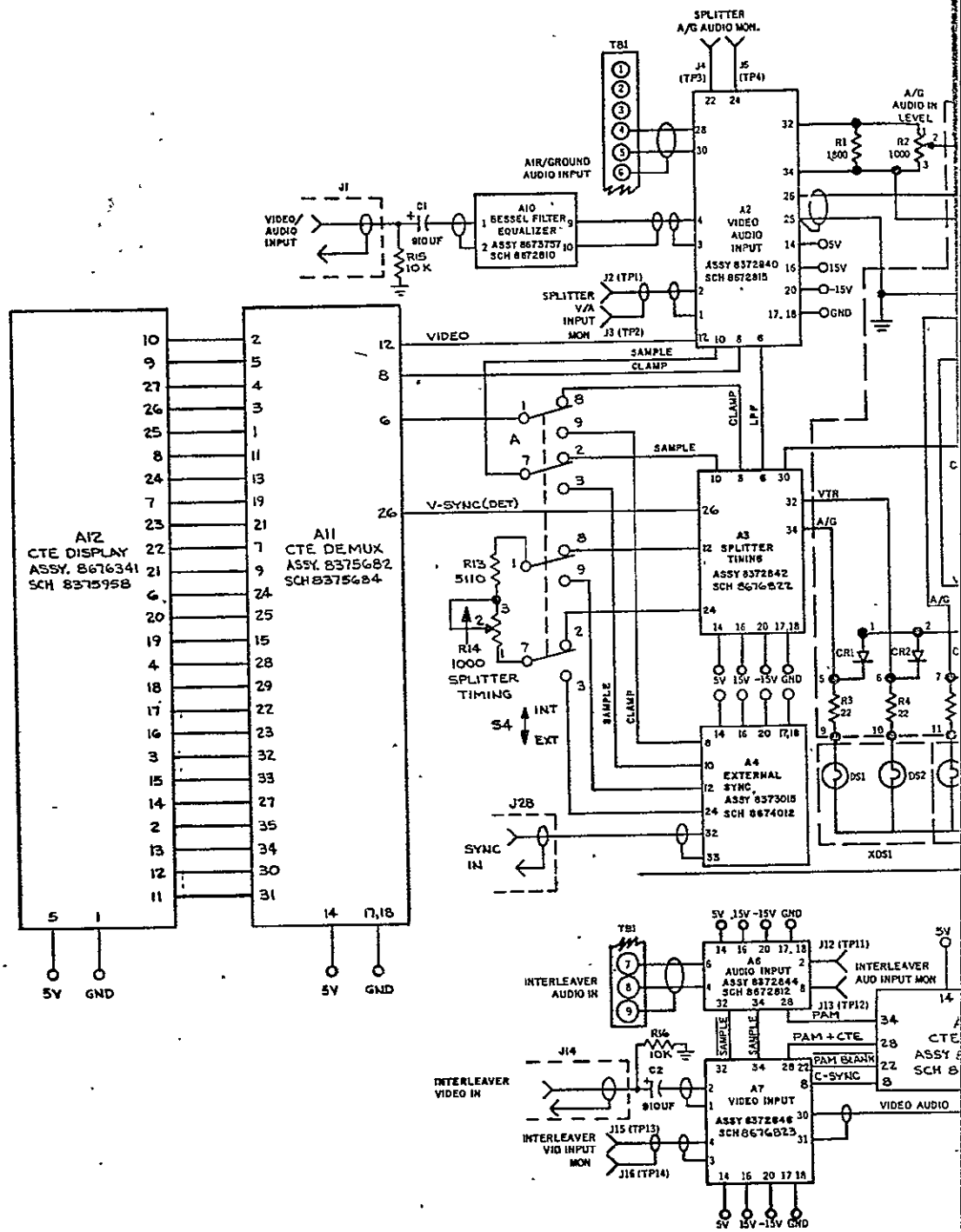

ORIGINAL PAGE IS  
OF POOR QUALITY  
FOLDOUT FRAME /

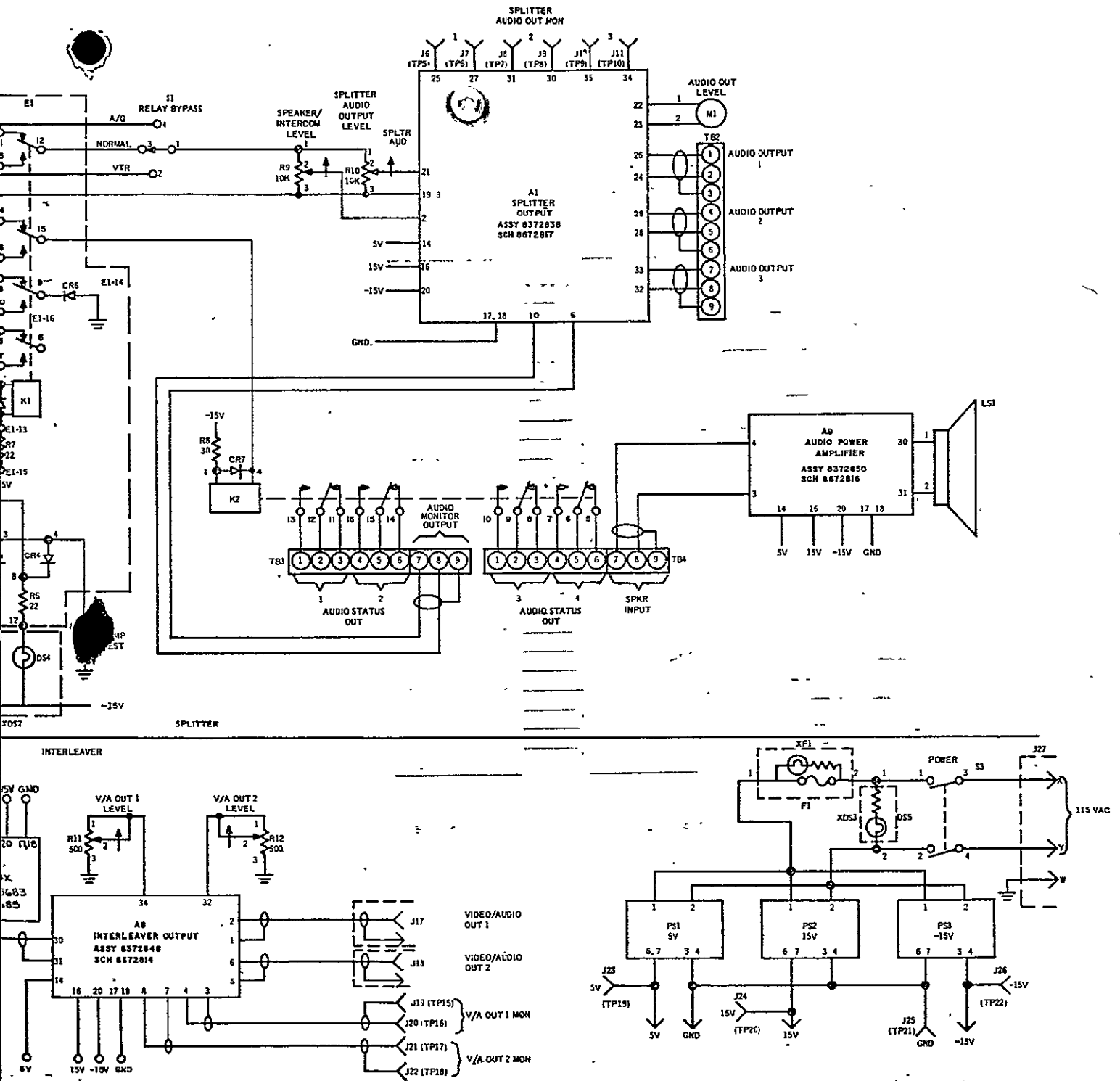
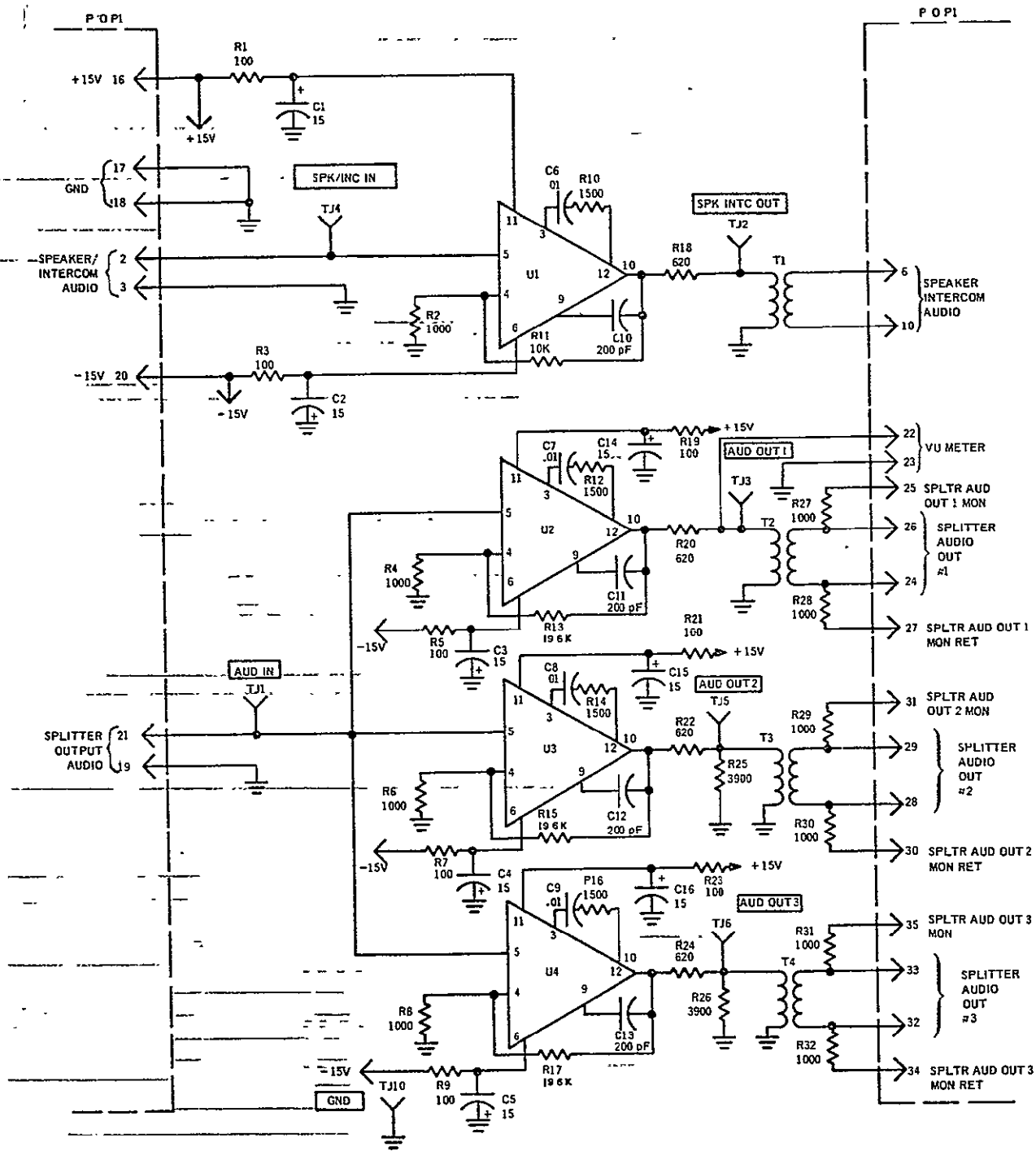

Figure 6-1. Audio/CTE Splitter/Interleaver Schematic



ALL C IN  $\mu$ F UNLESS INDICATED OTHERWISE

Figure 6-2. Splitter Output Schematic (A1)



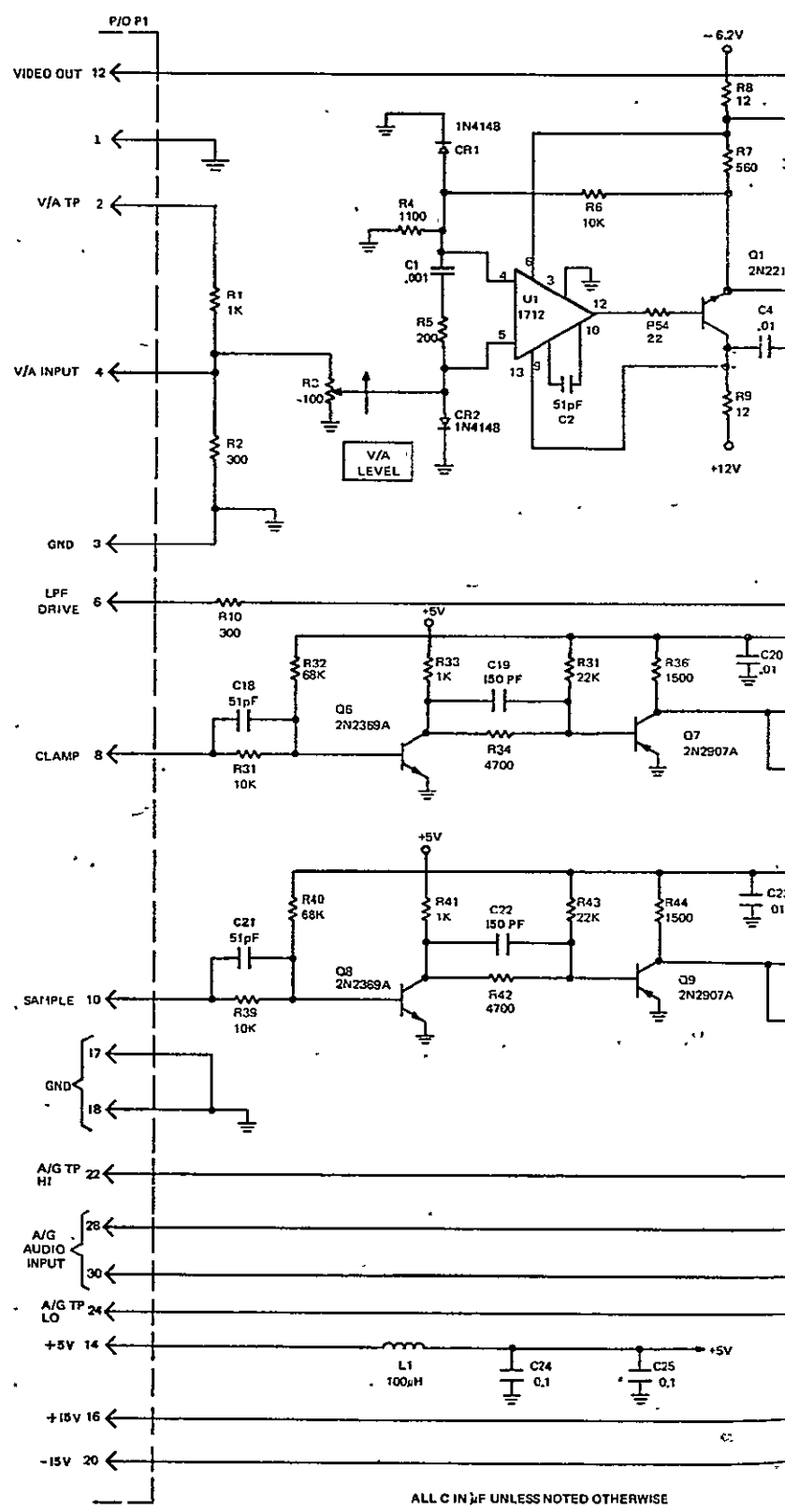

ALL C IN μF UNLESS NOTED OTHERWISE  
 ALL ODD NO ON P1 GND

ORIGINAL PAGE IS  
 OF POOR QUALITY

FOLDOUT FRAME /

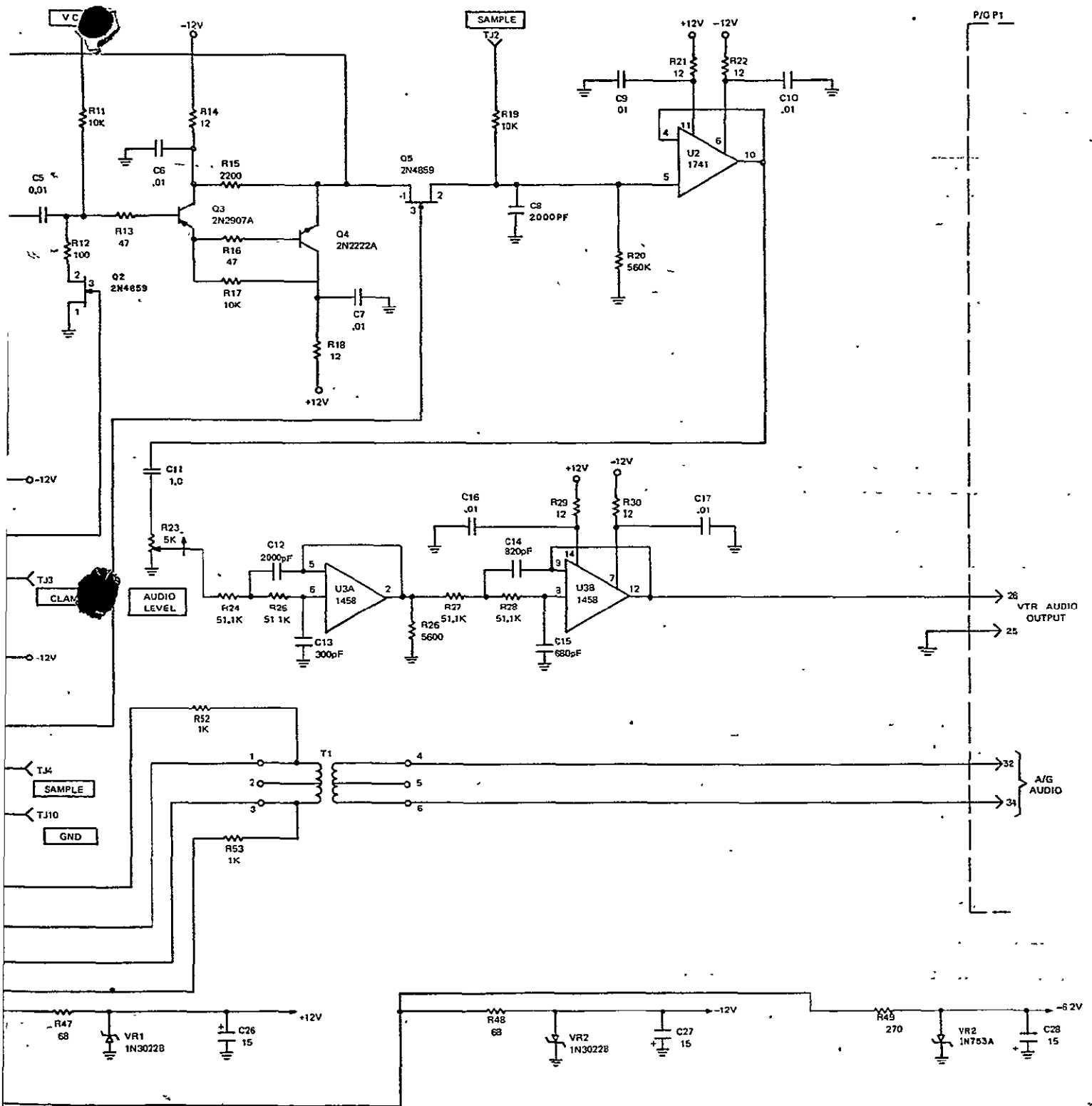
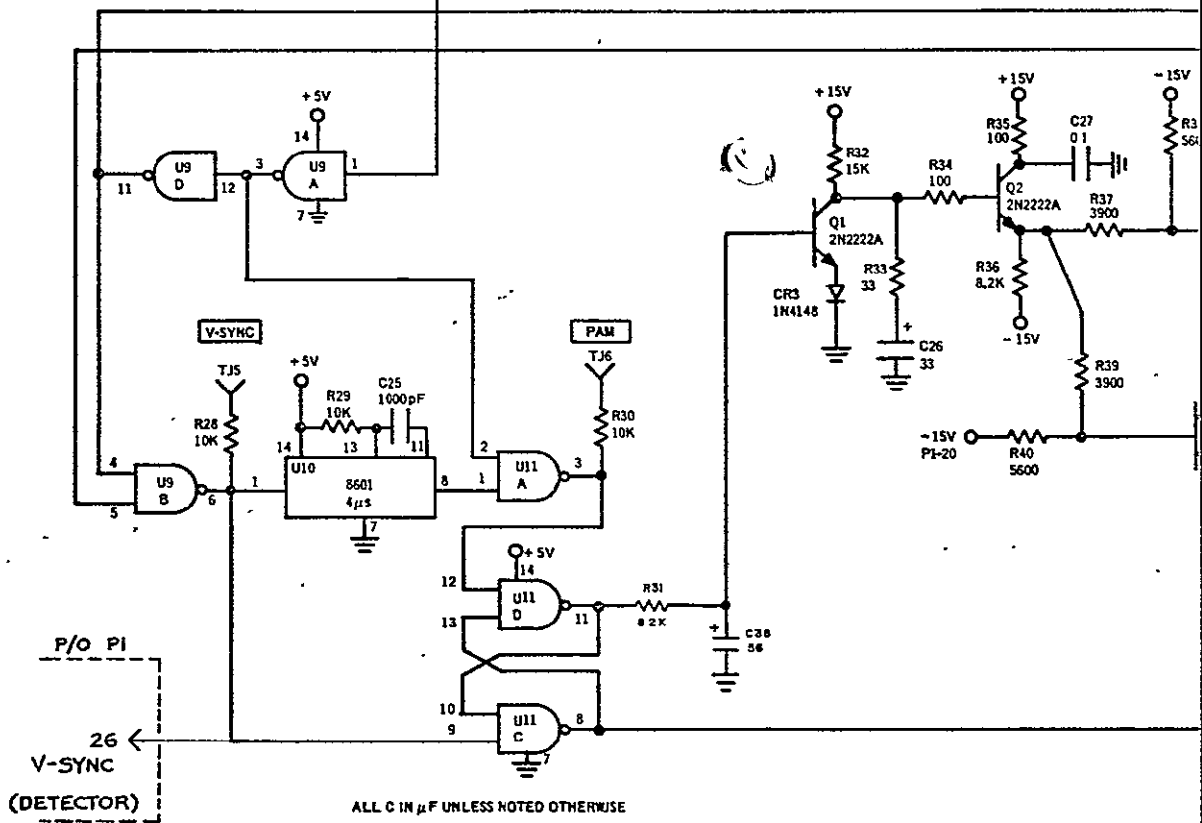
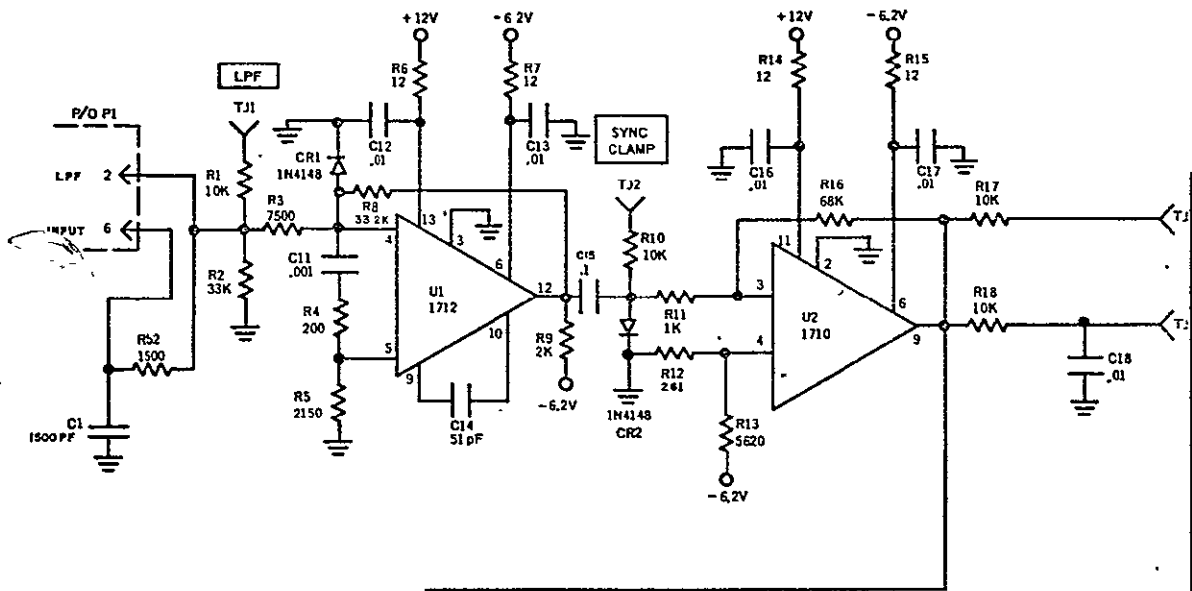

Figure 6-3. Video/Audio Input Schematic (A2)



ALL C IN  $\mu$ F UNLESS NOTED OTHERWISE  
ALL ODD NO. ON PI GND

ORIGINAL PAGE IS  
OF POOR QUALITY

FOLDOUT FRAME /

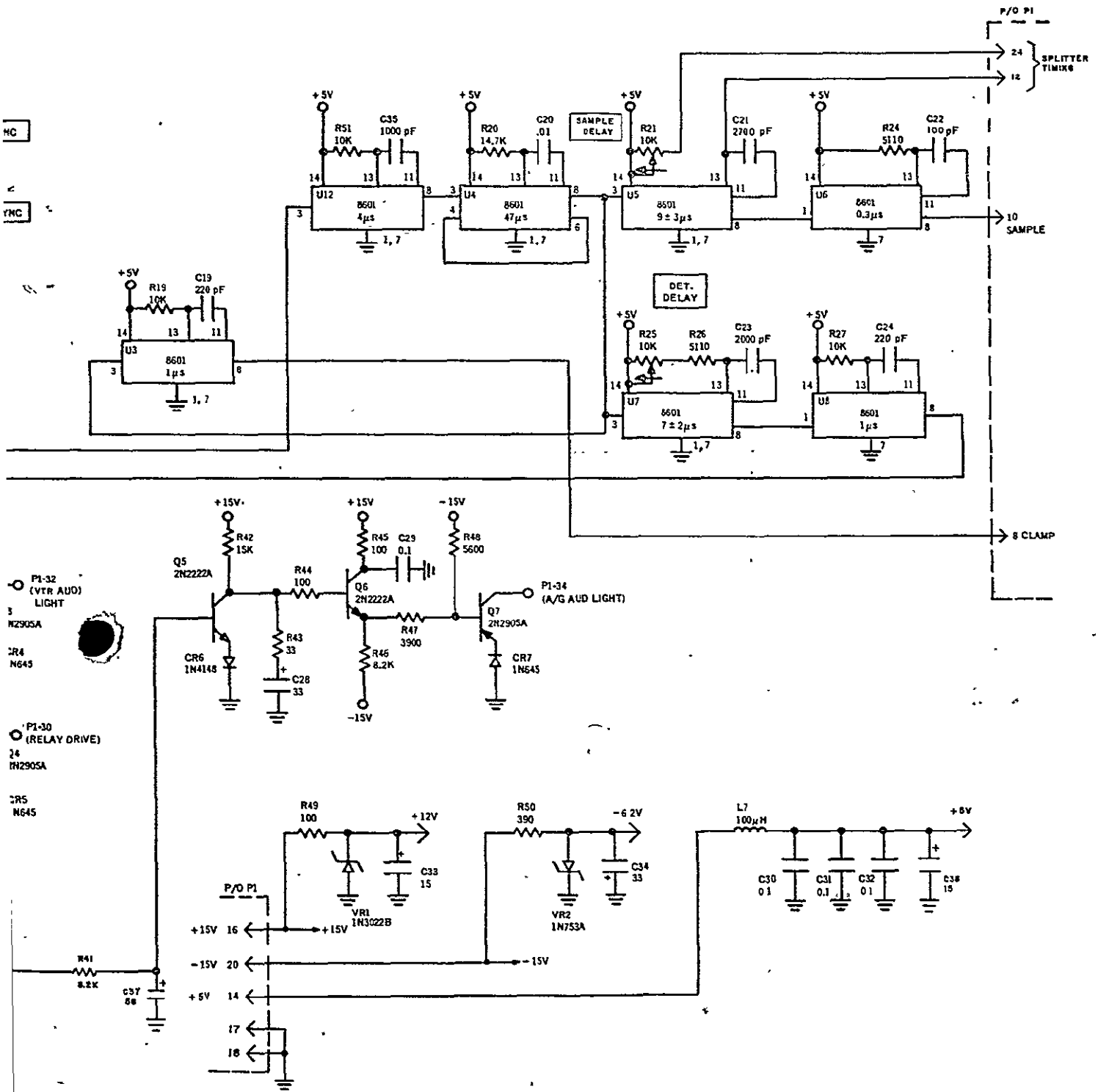
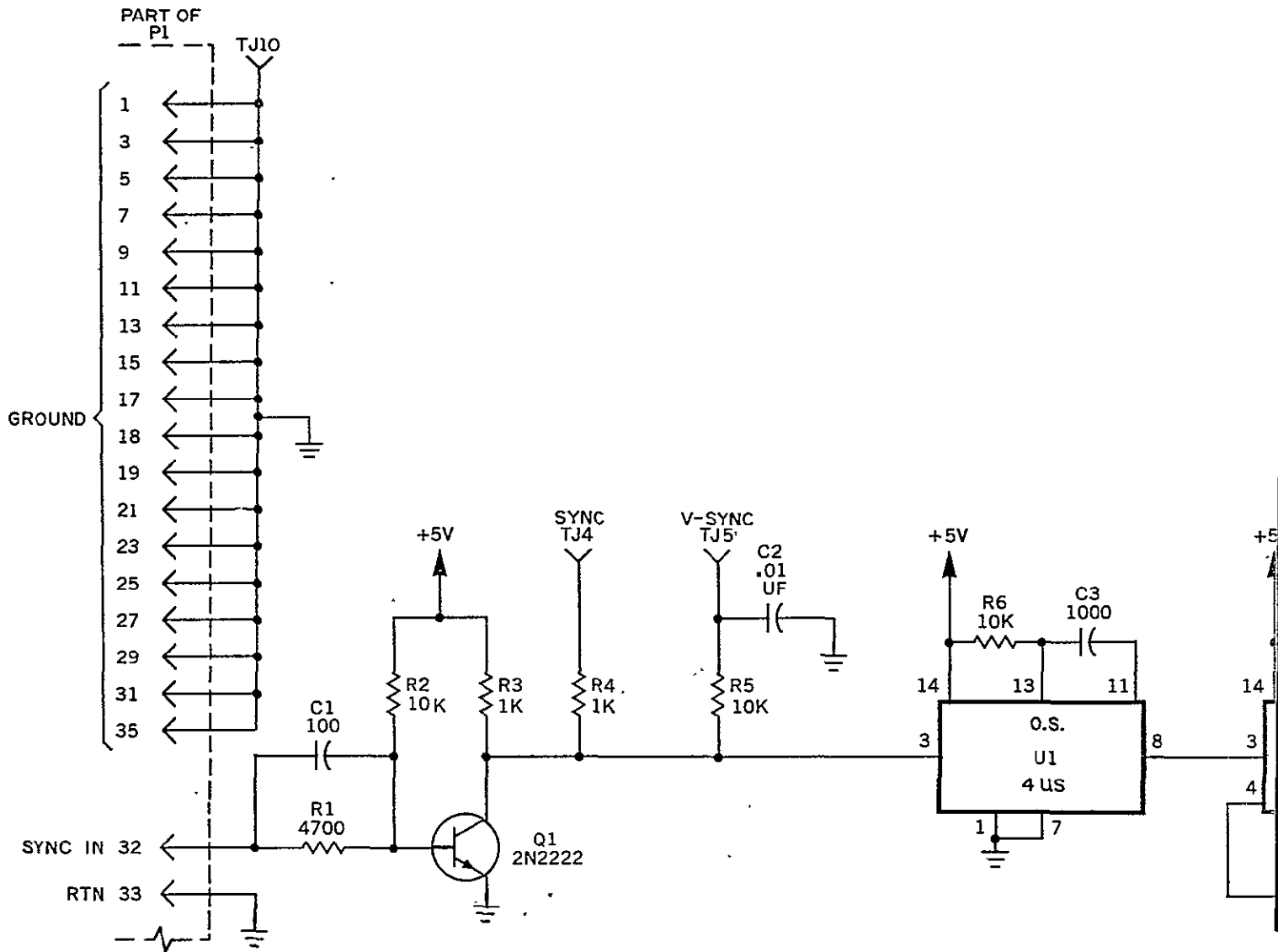

Figure 6-4. Splitter Timing Schematic (A3)

6-9/6-10

**BOLDOUT FRAG 2**



NOTES:

1. UNLESS OTHERWISE SPECIFIED  
 ALL RESISTANCE VALUES ARE IN OHMS  
 ALL CAPACITANCE VALUES ARE IN PICOFARADS  
 ALL INDUCTANCE VALUES ARE IN MICROHENRYS
2. INTEGRATED CIRCUITS ARE  
 U1 THRU U6 MC8601L

ORIGINAL PAGE IS  
 OF POOR QUALITY

FOLDOUT FRAME |

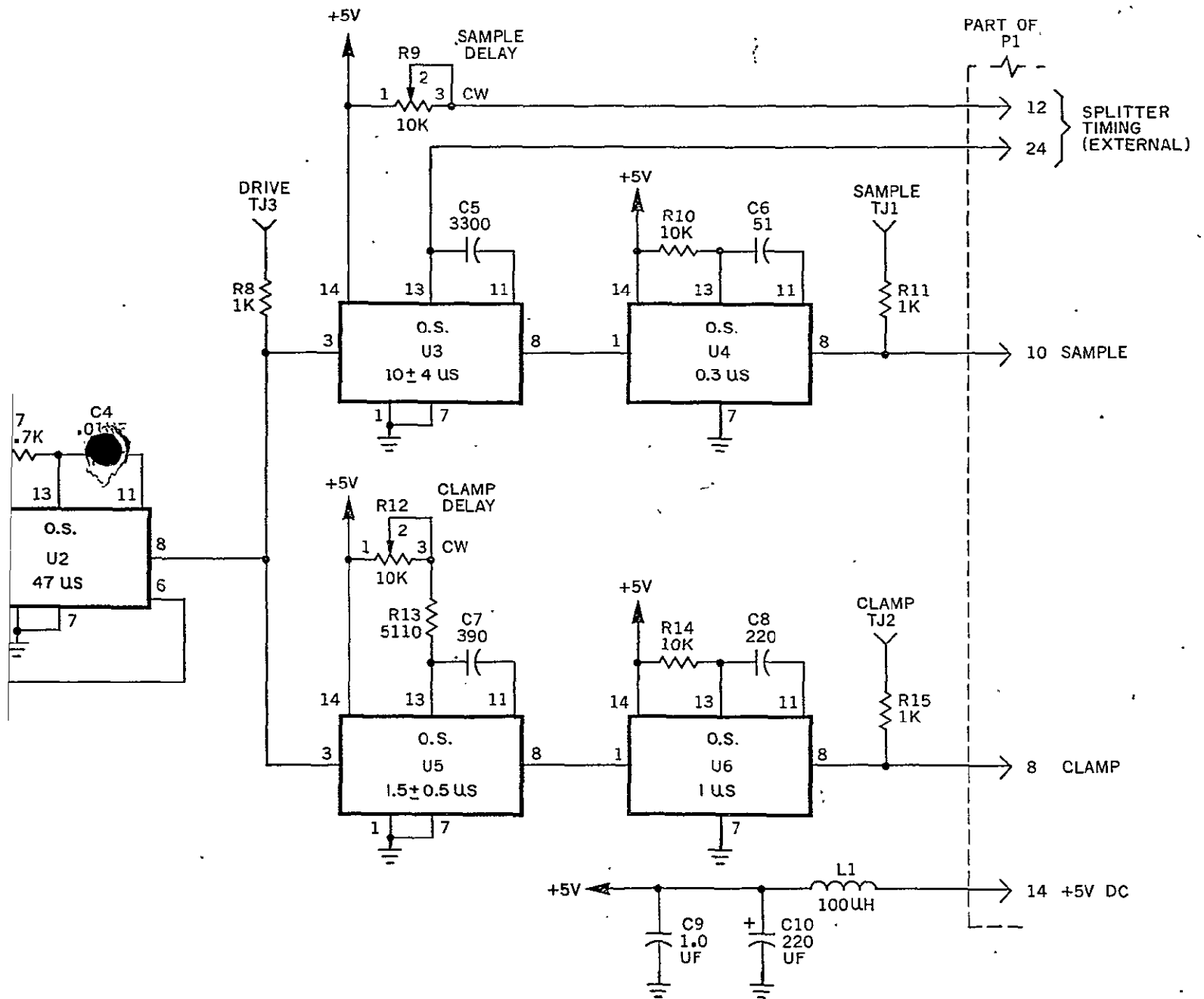
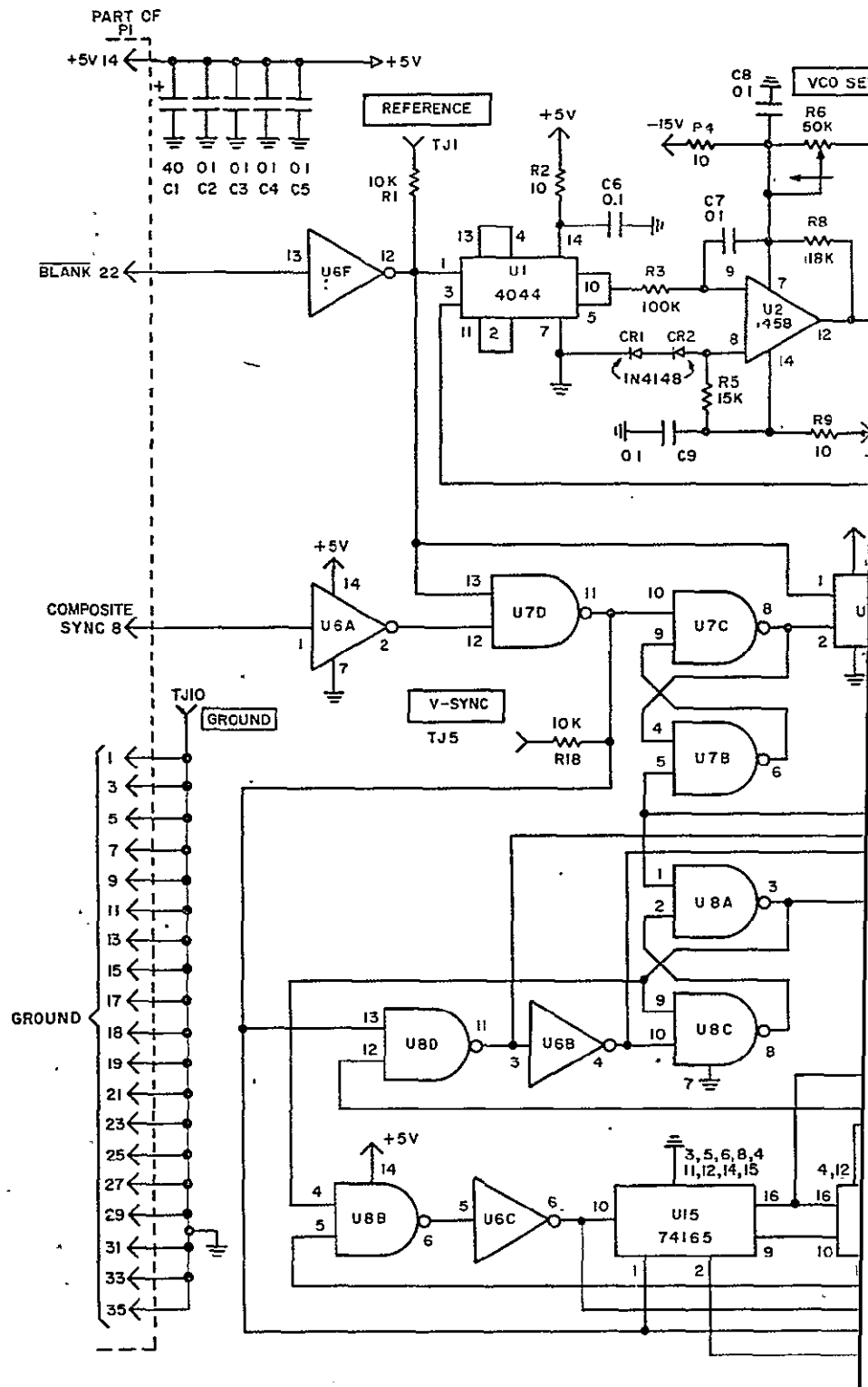

Figure 6-5. External Sync Schematic (A4)



ORIGINAL PAGE IS  
OF POOR QUALITY

FOLDOUT FRAME 1

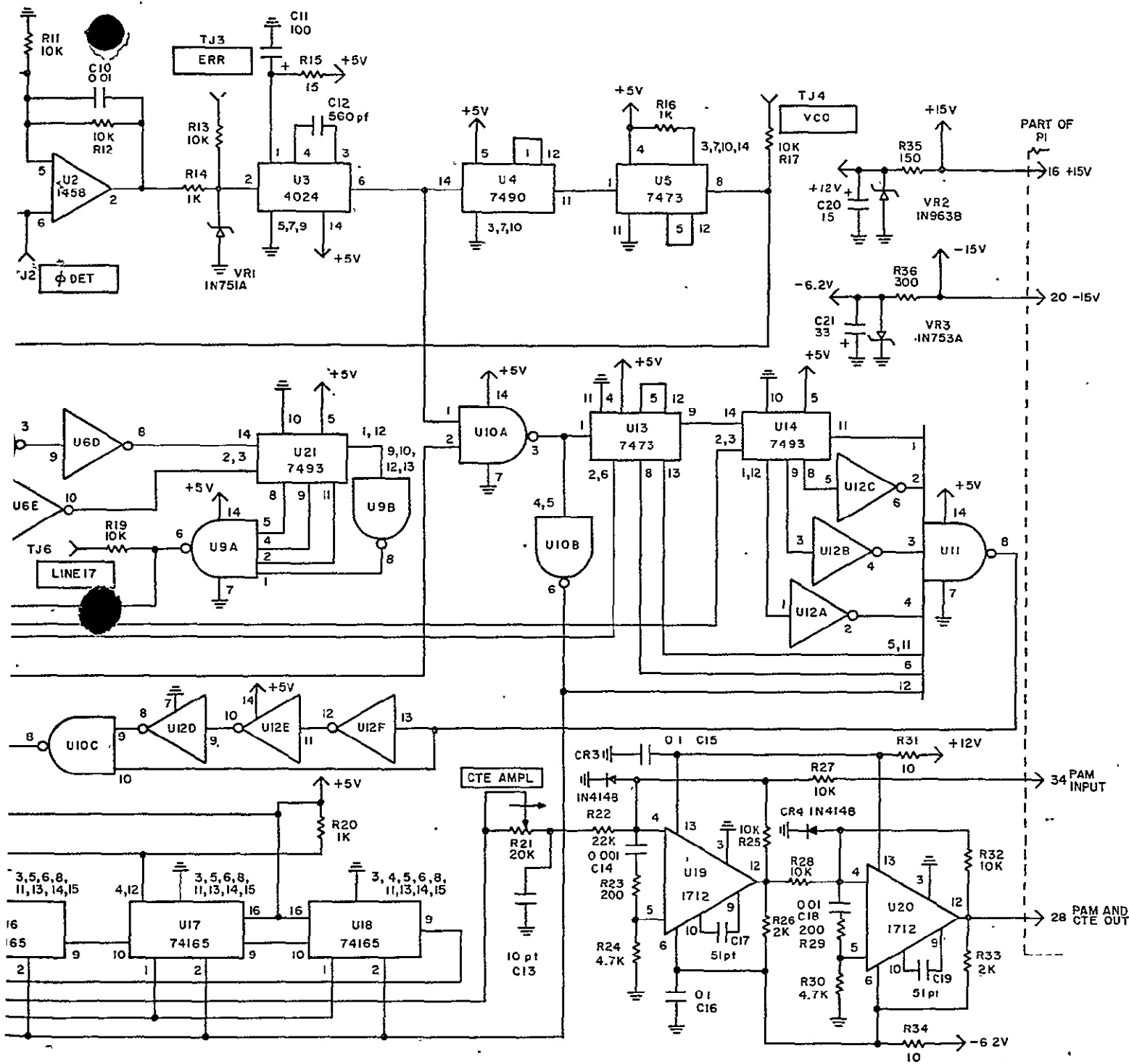
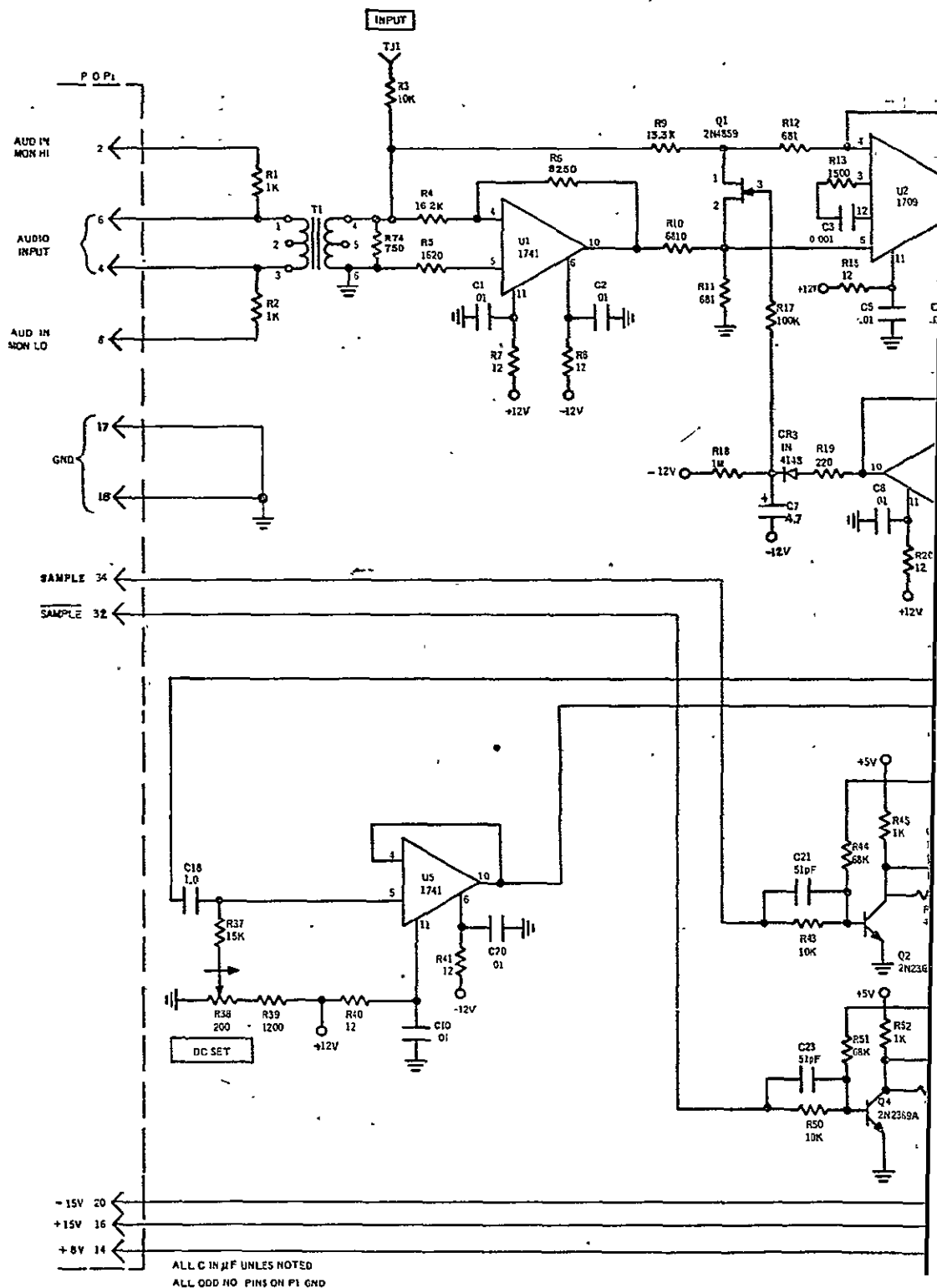

Figure 6-6. CTE Mux Schematic (A5)

6-13/6-14

FOLDOUT FRAME 2





FOLDOUT FRAME

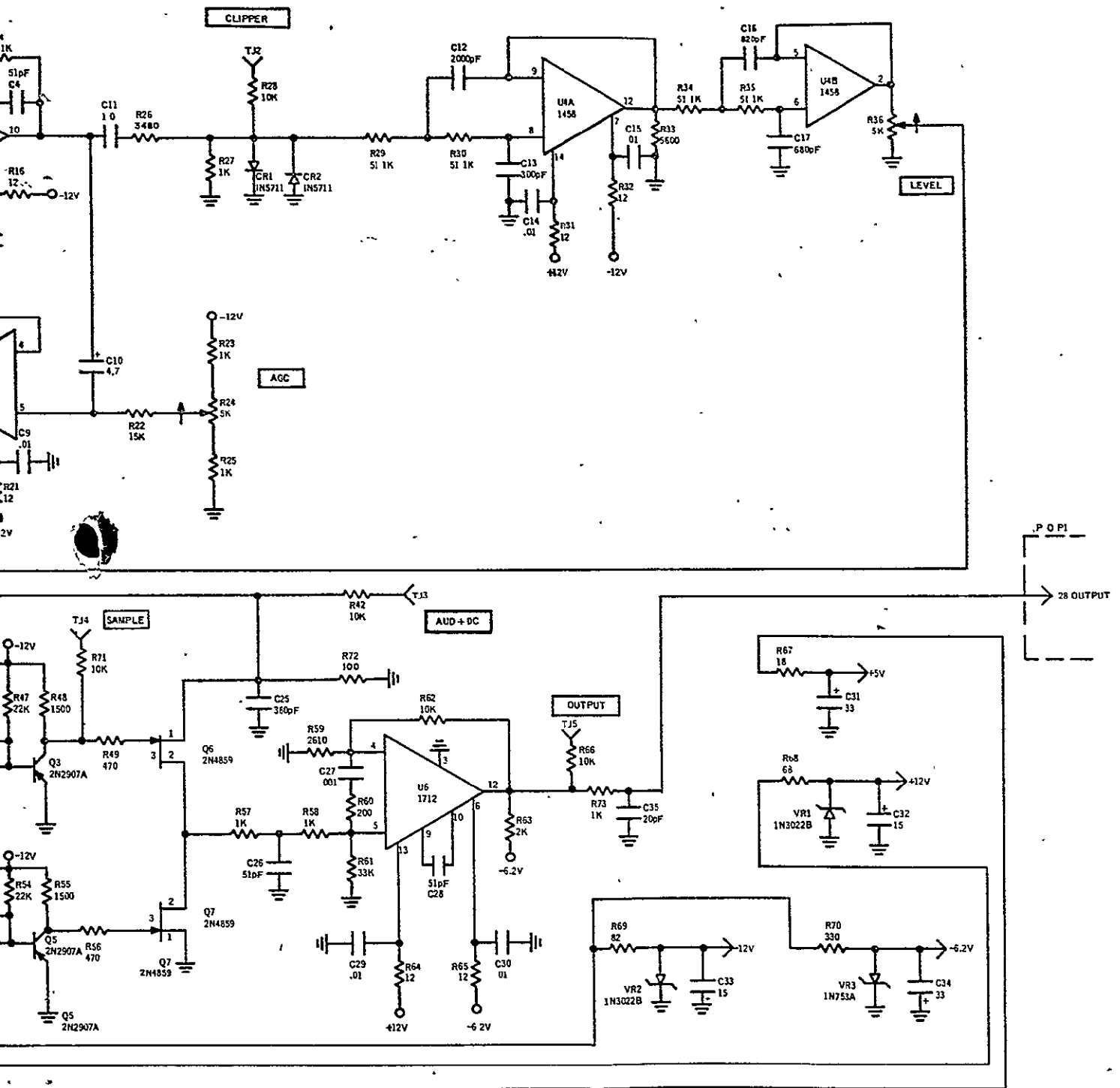
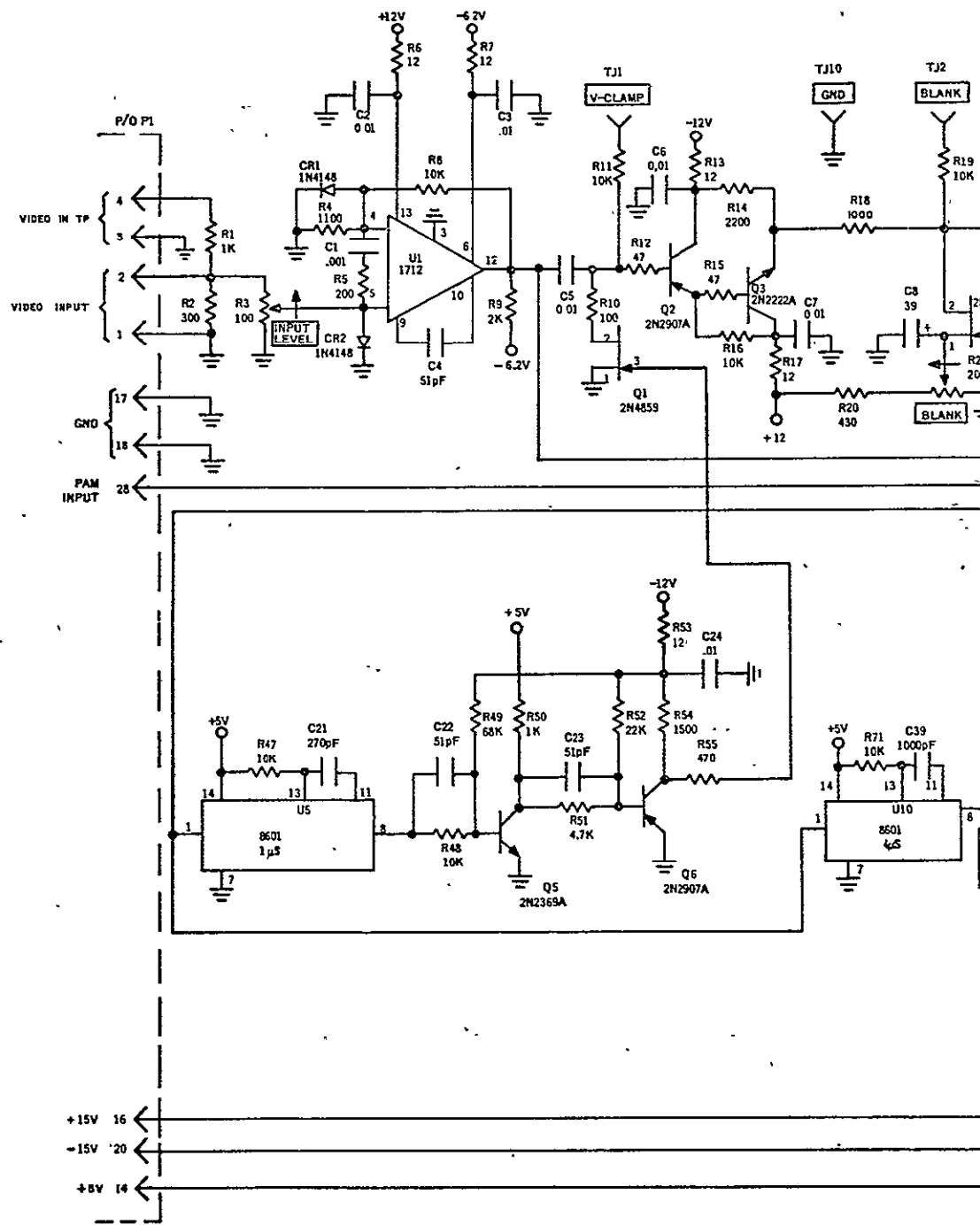

Figure 6-7. Audio Input Schematic (A6)



FOLDOUT FRAME /  
 ORIGINAL PAGE IS  
 OF POOR QUALITY

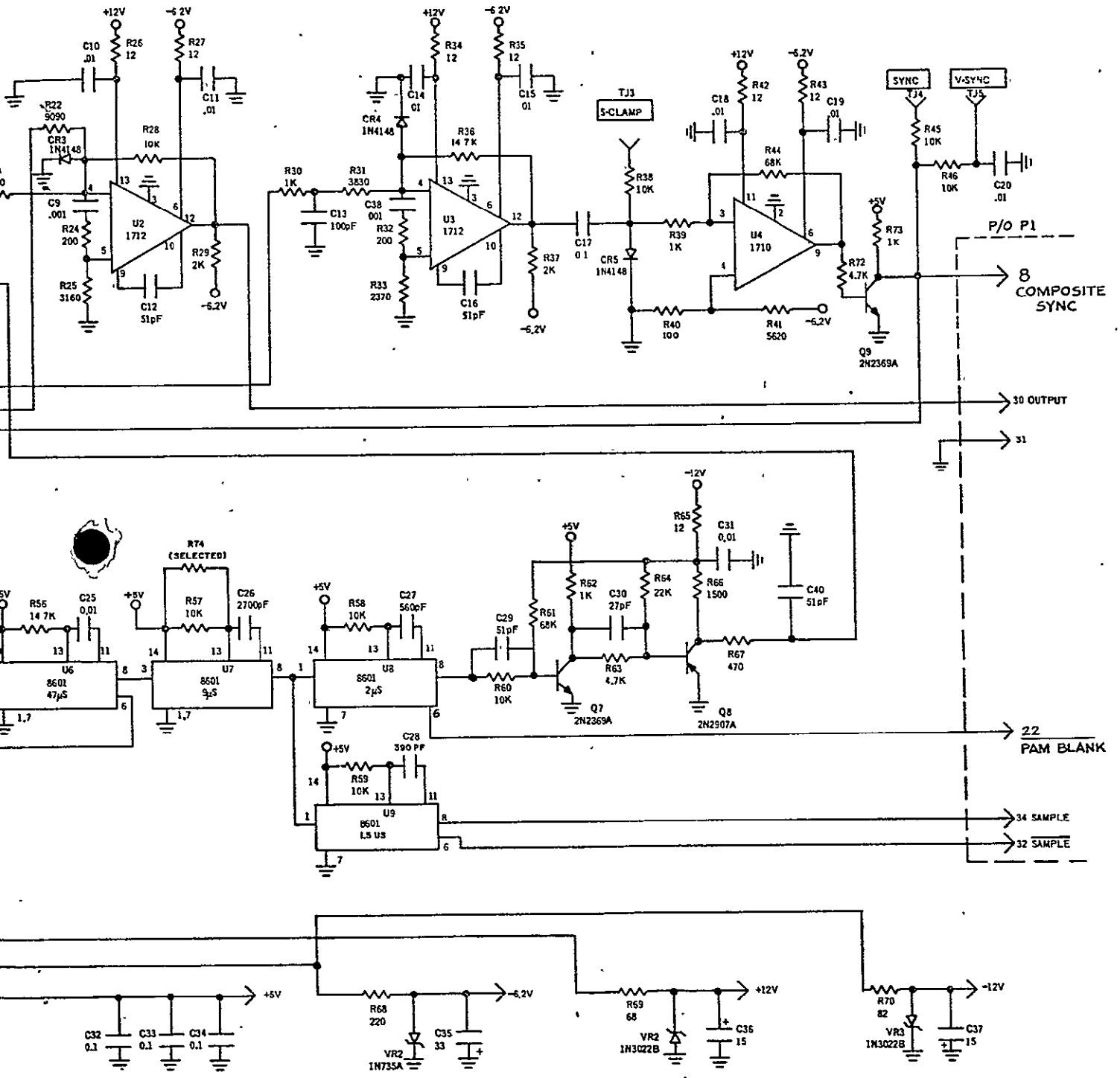

Figure 6-8. Video Input Schematic (A7)

6-17/6-18

EXHIBIT FRAME 2

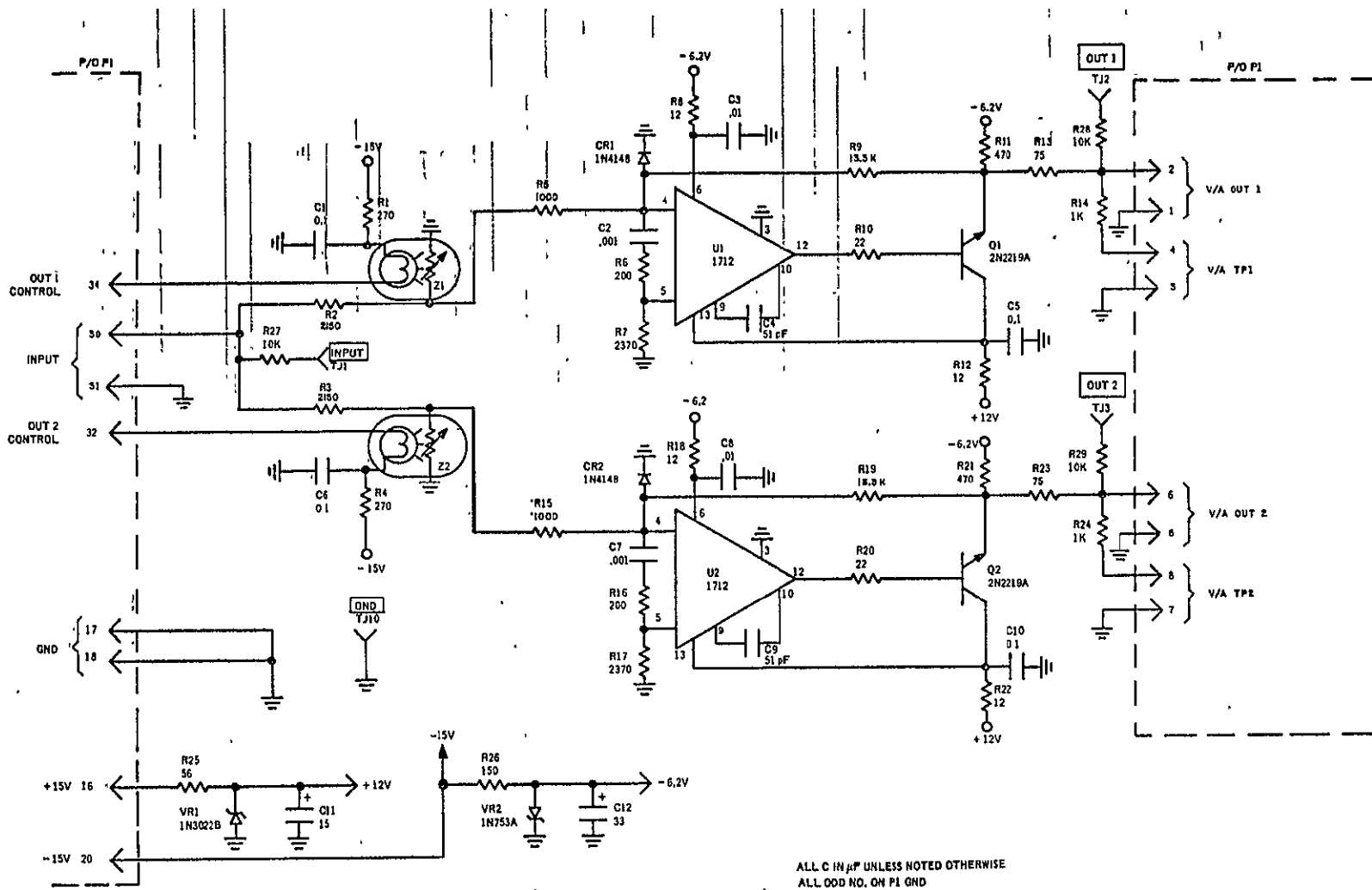

Figure 6-9. Interleaver Output Schematic (A8)

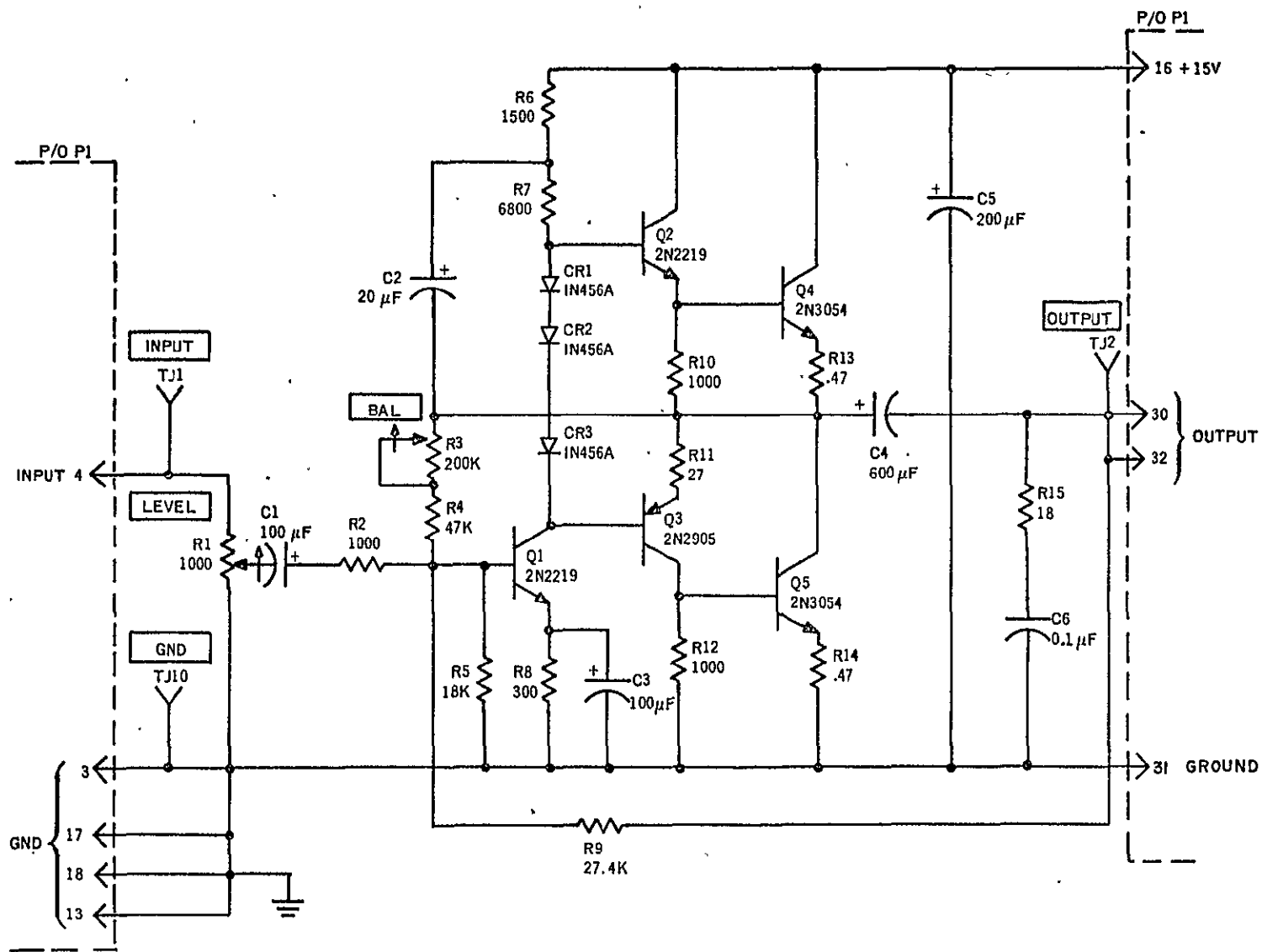

Figure 6-10. Audio Power Amplifier Schematic (A9)

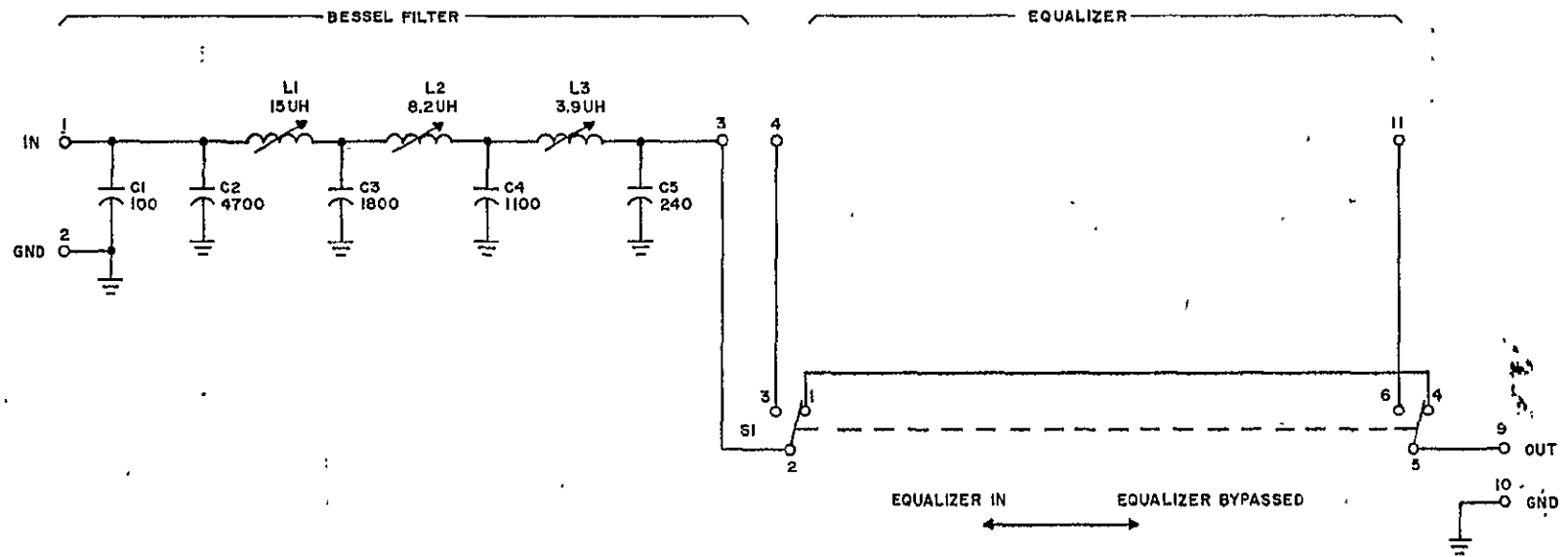
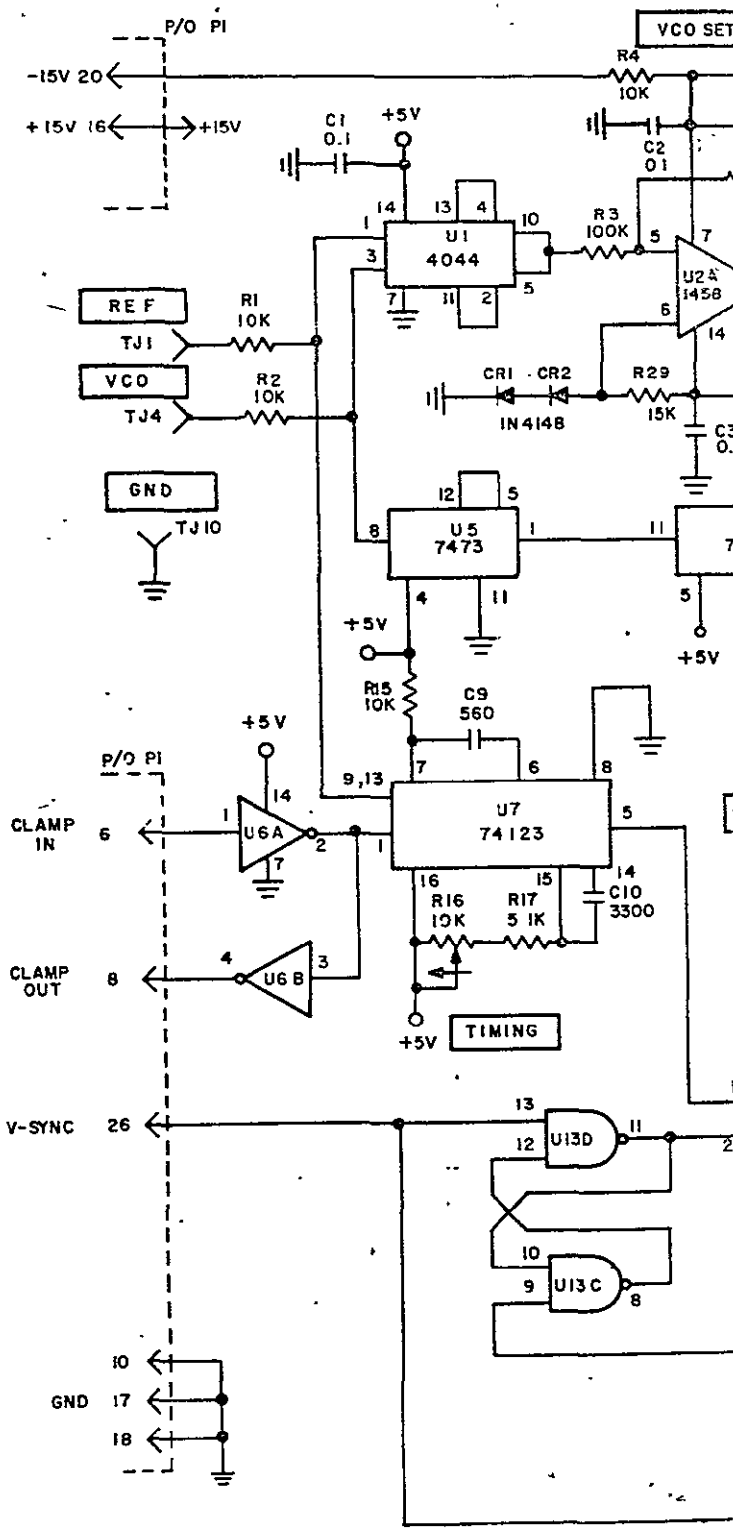

Figure 6-11. Bessel Filter, Equalizer Schematic (A10)



ORIGINAL PAGE IS  
 OF POOR QUALITY  
 FOLDOUT FRAME 1



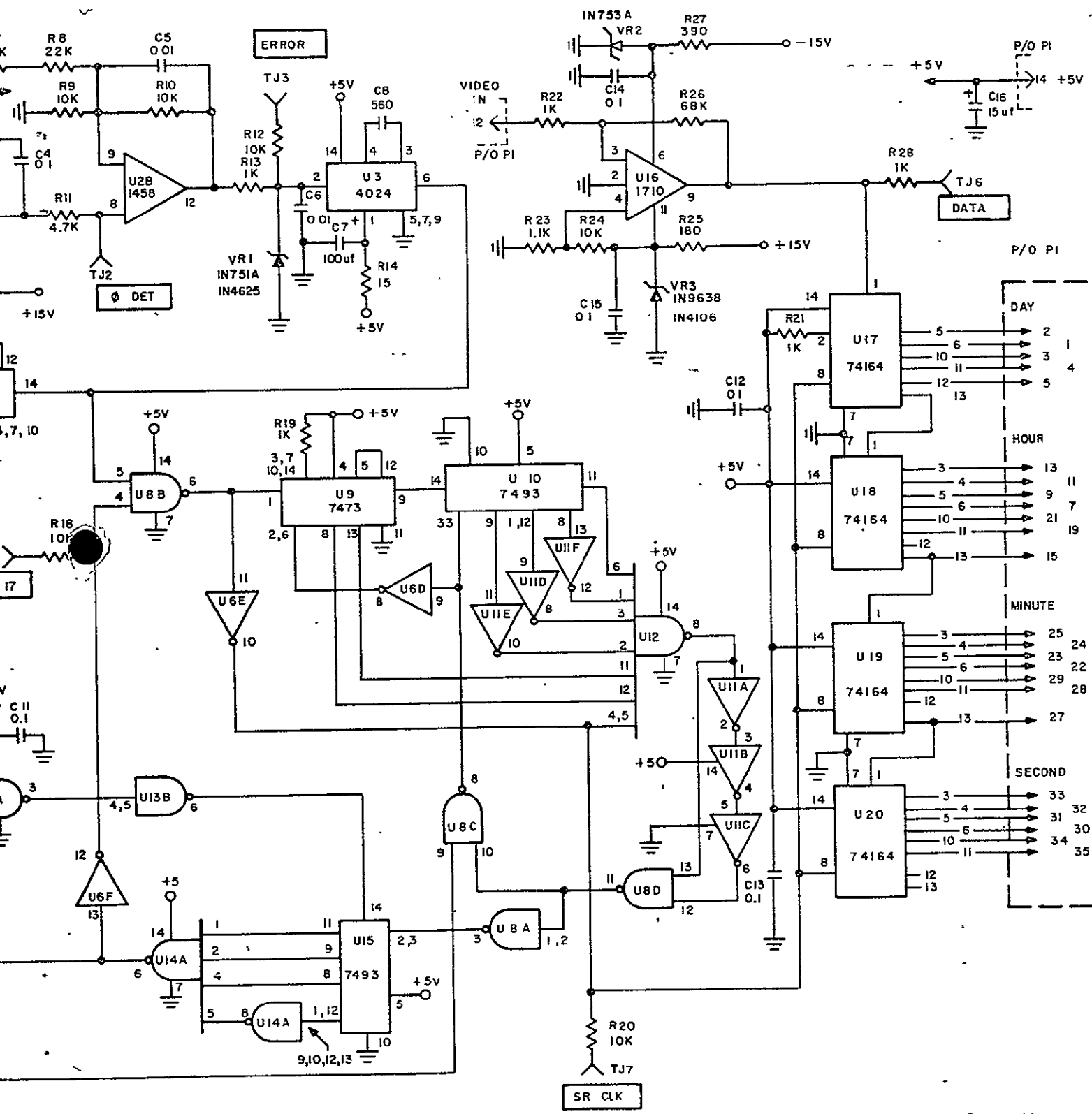

Figure 6-12. CTE Demux Schematic

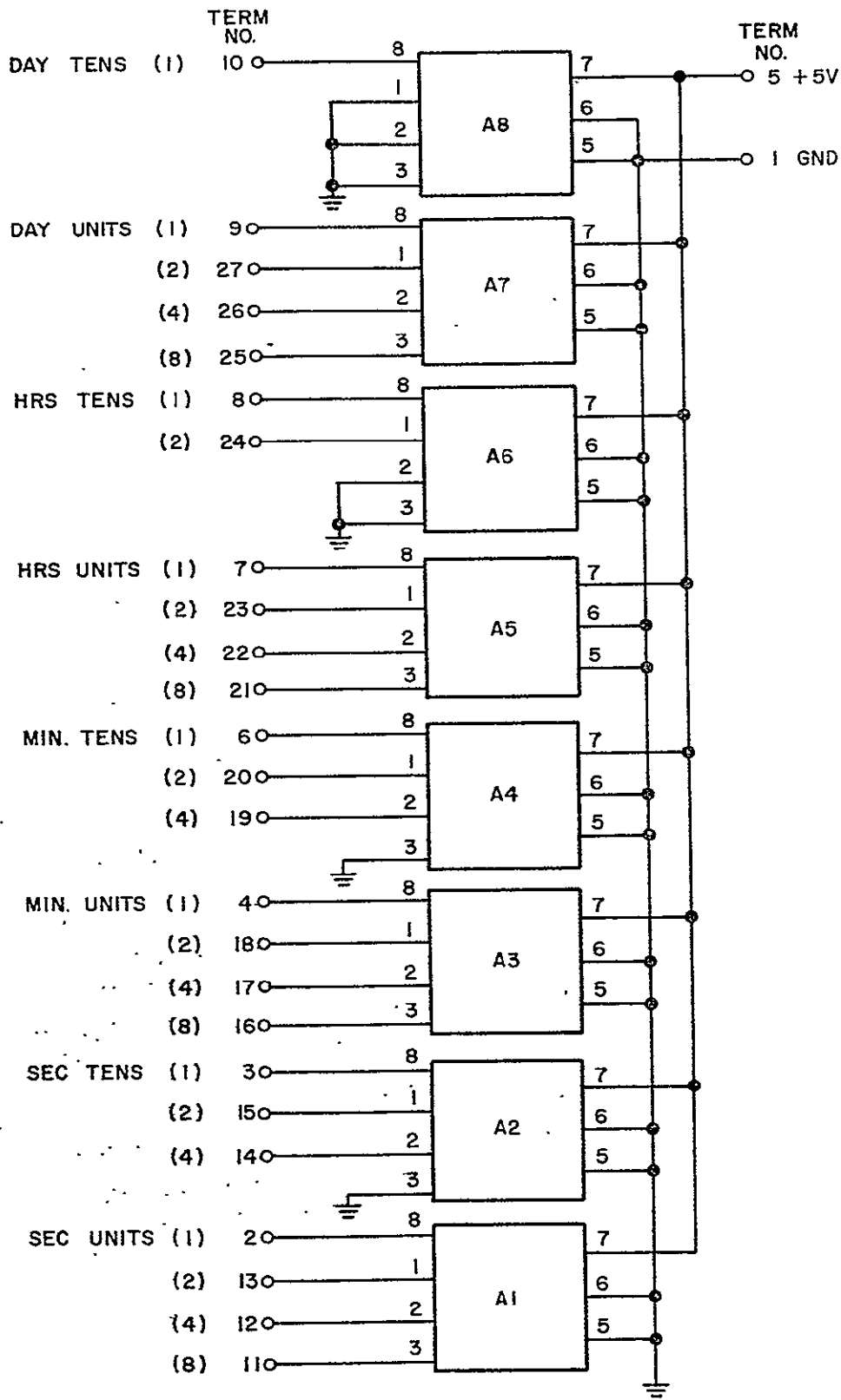

Figure 6-13. CTE Display Schematic (A12)

<b>PARTS LIST</b>	<b>TRCAT</b>	RCA CORPORATION   NEW YORK, NY	REVISION DATE	REV LTR
		<i>CAMDEN PLANT</i>		<b>PL 8673734</b>
				<b>H</b>

LIST TITLE: <b>AUDIO SPLITTER/INTERLEAVER</b> <b>AUDIO/CTE SPLITTER/INTERLEAVER</b>	PREPARED BY <i>A. N. Camp 23 Sept 1974</i>	DATE	REL	CODE IDENT NO. <b>49671</b>	SHEET 1 OF 14 SHEETS
	CHECKED BY	DATE	CONTRACT NO. <b>NAS 8-27968</b> <b>NAS 9-13767</b>		
	NEXT ASSY	USED ON			
FIRST APPLICATION					
<b>REVISIONS</b>					

LTR	DESCRIPTION	DATE	APPROVED	LTR	DESCRIPTION	DATE	APPROVED
<i>A</i>	<i>REVISED</i>						
<i>B</i>	<i>REVISED</i>						
<i>C</i>	<i>REVISED</i>						
<i>D</i>	<i>REVISED</i>						
<i>E</i>	<i>REVISED</i>						
<i>F</i>	<i>REVISED</i>						
<i>G</i>	<i>REVISED</i>						
<i>H</i>	<i>REVISED</i>						

INTERPRET SYMBOLS USED AS FOLLOWS:			
UNITS OF MEASURE (UM)	QUANTITIES	SYMBOL	
<i>A</i> — Inches <i>H</i> — Barrels <i>T</i> — Each <i>B</i> — Feet <i>J</i> — Pounds <i>C</i> — Yards <i>L</i> — Pair <i>D</i> — Ounces <i>M</i> — Set <i>E</i> — Pints <i>N</i> — Kit <i>F</i> — Quarts <i>P</i> — Roll <i>G</i> — Gallons <i>R</i> — Box, Case	<i>X</i> — Applicable document  <i>O</i> — For ref only  <i>///</i> — Not used	<i>U</i> — Govt or customer furnished  <i>K</i> — Govt or customer furnished and installed	<i>*</i> — Vendor item. See specification or source control drawing.

SPECIFICATION	DWG STATUS	SHEET/ LINE NO.	PARTS LIST					RCA		CAMDEN PLANT		REV LTR H	CODE IDENT	PL 8673734	SHEET 02.
			ITEM OR FIND NO.	QTY REQD PER DASH NO.					U M	CODE IDENT	PART OR IDENTIFYING NO.	NOMENCLATURE OR DESCRIPTION	SYM		
				505	504	503	502	501							
	P	0201	A1				1	I				8372838-501	SPLITTER OUTPUT		
	P	0202	A2				1	I				8372840-501	VIDEO/A&DIO INPUT		
	P	0203	A3				1	I				8372842-501	SPLITTER TIMING		
	P	0204	A4				1	I				8373015-501	EXTERNAL SYNC		
	E	0205	A5				1					8375683-502	CYE MUX		
	P	0206	A6				1	I				8372844-501	AUDIO INPUT		
	P	0207	A7				1	I				8372846-501	VIDEO INPUT		
	P	0208	A8				1	I				8372848-501	INTERLEAVER OUTPUT		
	P	0209	A9				1	I				8372850-501	AUDIO POWER AMPL		
	E	0210	A10				1	I				8673757-501	BGSSEL FILTER/EQUALIZER		
	E	0211	A11				1					8375682-501	CYE DEMUX		
	E	0212	A12				1					8676341-501	BD ASSY DISPLAY GSE		
MIL-C-62/2	I	0213	C1				1	I		81349		CE13C91D	CAPACITOR		
MIL-C-62/2	I	0214	C2				1	I		81349		CE13C91D	CAPACITOR		

ORIGINAL PAGE IS  
OF POOR QUALITY

SPECIFICATION	DWG STATUS	SHEET/ LINE NO.	PARTS LIST					RCA		CAMDEN PLANT	REV LTR H	CODE IDENT 49671	PL 8573734	SHEET 03
			ITEM OR FIND NO.	QTY REQD PER DASH NO.					U M	CODE IDENT	PART OR IDENTIFYING NO.	NOMENCLATURE OR DESCRIPTION	S Y M	
				505	504	503	502	501						
	I	0301	CR1				1	I	80131	1N645		DIODE		
	I	0302	CR2				1	I	80131	1N645		DIODE		
	I	0303	CR3				1	I	80131	1N645		DIODE		
	I	0304	CR4				1	I	80131	1N645		DIODE		
	I	0305	CR5				1	I	80131	1N645		DIODE		
	I	0306	CR6				1	I	80131	1N645		DIODE		
	I	0307	CR7				1	I	80131	1N645		DIODE		
	I	0309	DS1				1	I		889065624		LAMP		
	I	0310	DS2				1	I		889065624		LAMP		
	I	0311	DS3				1	I		889065624		LAMP		
	I	0312	DS4				1	I		889065624		LAMP		
	I	0313	DS5				1	I		NE81		LAMP; NEON		
	P	0316	B1				1	I		818305621		TERMINAL BOARD		
	I	0317	B2				1	I		48604328		TERMINAL; STUD; INSULA		
	I	0318	B3				1	I		48604328		TERMINAL; STUD; INSULA		
	I	0319	B4				1	I		48604328		TERMINAL; STUD; INSULA		

DEC 1320 (6/69)

SPECIFICATION	DWG STATUS	SHEET/ LINE NO.	PARTS LIST		RCA		CAMDEN PLANT		REV LTR H	CODE IDENT	PL 8573734	SHEET 06
			RCA CORPORATION NEW YORK, N Y					U M	CODE IDENT	PART OR IDENTIFYING NO.	NOMENCLATURE OR DESCRIPTION	SYM
			ITEM OR FIND NO.	QTY REQD PER DASH NO.								
			503	504	503	502	501					
	1	0401	E5				1	1		486043-8	TERMINAL; STUD; INSULATED	
	1	0402	E6				1	1		486041-8	TERMINAL; STUD	
	1	0403	E7				1	1		486041-8	TERMINAL; STUD	
	1	0404	E8				1	1		486041-8	TERMINAL; STUD	
	1	0410	F1				1	1		F02B125V2.00A	FUSE	
	1	0415	J1				1	1	74868	31-245	CONNECTOR	
MIL-C-39026/10	1	0416	J2				1	1	96906	MS16108-5A	JACK	
MIL-C-39026/10	1	0417	J3				1	1	96906	MS16108-3A	JACK	
MIL-C-39026/10	1	0418	J4				1	1	96906	MS16108-8A	JACK	
MIL-C-39026/10	1	0419	J5				1	1	96906	MS16108-8A	JACK	

ORIGINAL PAGE IS

SPECIFICATION	DWG STATUS	SHEET/ LINE NO.	PARTS LIST					RCA		CAMDEN PLANT		REV LTR H	CODE IDENT	PL 0673734	SHEET 05
			RCA CORPORATION, NEW YORK N Y					U M	CODE IDENT	PART OR IDENTIFYING NO.	NOMENCLATURE OR DESCRIPTION	SYM			
			ITEM OR FIND NO.	QTY REQD PER DASH NO.											
			303	304	303	302	301								
MIL-C-39024/10	I	0501	J6				1	I	96906	MS16108-8A	JACK				
MIL-C-39024/10	I	0502	J7				1	I	96906	MS16108-8A	JACK				
MIL-C-39024/10	I	0503	J8				1	I	96906	MS16108-8A	JACK				
MIL-C-39024/10	I	0504	J9				1	I	96906	MS16108-8A	JACK				
MIL-C-39024/10	I	0505	J10				1	I	96906	MS16108-8A	JACK				
MIL-C-39024/10	I	0506	J11				1	I	96906	MS16108-8A	JACK				
MIL-C-39024/10	I	0507	J12				1	I	96906	MS16108-8A	JACK				
MIL-C-39024/10	I	0508	J13				1	I	96906	MS16108-8A	JACK				
	I	0509	J14				1	I	74868	31-243	CONNECTOR				
MIL-C-39024/10	I	0510	J15				1	I	96906	MS16108-3A	JACK				
MIL-C-39024/10	I	0511	J16				1	I	96906	MS16108-3A	JACK				
	I	0512	J17				1	I	74868	31-243	CONNECTOR				
	I	0513	J18				1	I	74868	31-243	CONNECTOR				
MIL-C-39024/10	I	0514	J19				1	I	96906	MS16108-3A	JACK				
MIL-C-39024/10	I	0515	J20				1	I	96906	MS16108-3A	JACK				
MIL-C-39024/10	I	0516	J21				1	I	96906	MS16108-5A	JACK				
MIL-C-39024/10	I	0517	J22				1	I	96906	MS16108-3A	JACK				
MIL-C-39024/10	I	0518	J23				1	I	96906	MS16108-6A	JACK				
MIL-C-39024/10	I	0519	J24				1	I	96906	MS16108-2A	JACK				

DEC 1320 (6/69)

SPECIFICATION	DWG STATUS	SHEET/ LINE NO.	PARTS LIST					RCA		CAMDEN PLANT	REV LTR H	CODE IDENT	PL 8673734	SHEET 861
			ITEM OR FIND NO.	QTY REQD PER DASH NO.					U M	CODE IDENT	PART OR IDENTIFYING NO.	NOMENCLATURE OR DESCRIPTION	SYM	
				505	504	503	502	501						
MIL-C-39024/10	I	0601	J25					I	I	96906	MS16108-3A	JACK		
MIL-C-39024/10	I	0602	J26					I	I	96906	MS16108-10A	JACK		
	I	0603	J27					I	I	01295	7486	INTEGRATED CIRCUIT		
	I	0604	J28					I	I	74868	31-243	CONNECTOR		
	I	0608	K1					1	I	49671	T196-4C(12VDC)	RELAY		
	I	0609	K2					1	I	49671	T196-4C(12VDC)	RELAY		
	I	0611	LS1					1	I	49671	5A15	SPEAKER, 5IN. 4W		
	I	0619	M1					1	I	49671	10474	METER, VU, MODEL 1247		
	I	0615	PS1					1	I	49671	LXS-A50V	POWER SUPPLY, 5V		
	I	0616	PS2					1	I	49671	LXS-A15	POWER SUPPLY, 15V		
	I	0617	PS3					1	I	49671	LXS-A15	POWER SUPPLY, 15V		



SPECIFICATION	DWG STATUS	SHEET/ LINE NO.	PARTS LIST					RCA		CAMDEN PLANT		REV LTR H	CODE IDENT	SHEET
			RCA CORPORATION NEW YORK N Y					U M	CODE IDENT	PART OR IDENTIFYING NO.	NOMENCLATURE OR DESCRIPTION	SYM		
			ITEM OR FIND NO.	QTY REQD PER DASH NO.										
			505	504	503	502	501							
MIL-R-11/3	I	0701	R1				1	I	81349	RC20GF102K	RESISTOR			
MIL-R-94/5	I	0702	R2				1	I	81349	RV4NAYS102A	RESISTOR			
MIL-R-11/3	I	0703	R3				1	I	81349	RC20GF220K	RESISTOR			
MIL-R-11/3	I	0704	R4				1	I	81349	RC20GF220K	RESISTOR			
MIL-R-11/3	I	0705	R5				1	I	81349	RC20GF220K	RESISTOR			
MIL-R-11/3	I	0706	R6				1	I	81349	RC20GF220K	RESISTOR			
MIL-R-11/3	I	0707	R7				1	I	81349	RC20GF220K	RESISTOR			
MIL-R-11/3	I	0708	R8				1	I	81349	RC20GF330K	RESISTOR			
MIL-R-94/5	I	0709	R9				1	I	81349	RV4NAYS103A	RESISTOR			
MIL-R-94/5	I	0710	R10				1	I	81349	RV4NAYS103A	RESISTOR			
MIL-R-94/5	I	0711	R11				1	I	81349	RV4NAYS501A	RESISTOR			
MIL-R-94/5	I	0712	R12				1	I	81349	RV4NAYS501A	RESISTOR			
MIL-R-10509/1	I	0713	R13				1	I	81349	RN60D511F	RESISTOR			
MIL-R-94/5	I	0714	R14				1	I	81349	RV4NAYS102A	RESISTOR			
MIL-R-11/3	I	0715	R15				1	I	81349	RC07GF103K	RESISTOR			
MIL-R-11/3	I	0716	R16				1	I	81349	RC07GF103K	RESISTOR			

DEC 1320 (6/69)

ORIGINAL PAGE 1  
OF POOR QUALITY

SPECIFICATION	DWG STATUS	SHEET/ LINE NO.	PARTS LIST					RCA		CAMDEN PLANT		REV LTR #	CODE IDENT	PL 8673734	SHEET OF
			ITEM OR FIND NO.	QTY REQD PER DASH NO.					U M	CODE IDENT	PART OR IDENTIFYING NO.	NOMENCLATURE OR DESCRIPTION	SYM		
				503	504	503	502	501							
	I	0801	S1					I	I	76856	399731JC		SWITCH; ROTARY		
	I	0802	S2					I	I	91929	130H1A1		SWITCH; PUSHBUTTON		
	I	0803	S3					1	I	96906	M525059-22		SWITCH		
	I	0804	S4					I	I	76856	399641-513		SWITCH; ROTARY		
	I	0805	TB1					1	I	75382	599-2004-9		TERMINAL BD; 9TLS		
	I	0806	TB2					I	I	75382	599-2004-9		TERMINAL BD; 9TLS		
	I	0807	TB3					I	I	75382	599-2004-9		TERMINAL BD; 9TLS		
	I	0808	TB4					I	I	75382	599-2004-9		TERMINAL BD; 9TLS		
	P	0809	H1					1	I		8780661-501		CABLE ASSY		
	I	0810	XA1					I	I	91662	00-7008-035-163-001		RECEPTACLE		
	I	0811	XA2					I	I	91662	00-7008-035-163-001		RECEPTACLE		
	I	0812	XA3					I	I	91662	00-7008-035-163-001		RECEPTACLE		
	I	0813	XA4					I	I	91662	00-7008-035-163-001		RECEPTACLE		
	I	0814	XA5					1	I	91662	00-7008-035-163-001		RECEPTACLE		
	I	0815	XA6					I	I	91662	00-7008-035-163-001		RECEPTACLE		
	I	0816	XA7					I	I	91662	00-7008-035-163-001		RECEPTACLE		
	I	0817	XA8					I	I	91662	00-7008-035-163-001		RECEPTACLE		
	I	0818	XA9					I	I	91662	00-7008-035-163-001		RECEPTACLE		
	I	0819	XA10					/////			NA		NOT USED		

SPECIFICATION	DWG STATUS	SHEET/ LINE NO.	PARTS LIST					RCA		CAMDEN PLANT	REV LTR H	CODE IDENT	PL 8573734	SHEET 69
			ITEM OR FIND NO.	QTY REQD PER DASH NO.					U M	CODE IDENT	PART OR IDENTIFYING NO.	NOMENCLATURE OR DESCRIPTION	SYM	
				505	504	503	502	501						
		0901	XA11				1		91662	00-7008-039-163-001	RECEPTACLE			
		0903	XDS1				1	1	91929	2F203	CAMP HOUSING M3D			
		0904	XDS2				1	1	91929	2F203	CAMP HOUSING M3D			
		0905	XDS3				1	1		746936-21	CAMP HOODER			
		0908	XF1				1	1	75015	344125	FUSE HOODER			
		0910	XK1				1	1	70309	30055-2	SOCKET; RELAY			
		0911	XK2				1	1	70309	30055-2	SOCKET; RELAY			

ORIGINAL PAGE IS  
OF POOR QUALITY

SPECIFICATION	DWG STATUS	SHEET/ LINE NO.	PARTS LIST					RCA		CAMDEN PLANT		REV LTR H	CODE IDENT	PL 8673734	SHEET 10
			RCA CORPORATION NEW YORK, N Y					U M	CODE IDENT	PART OR IDENTIFYING NO.	NOMENCLATURE OR DESCRIPTION	SYM			
			ITEM OR FIND NO.	QTY REQD PER DASH NO.											
			503	504	503	502	501								
	P	1001					X					8672810	SCHEM DIAG AUDIO SPLITTER:		
	P	1002					X					8552893	W CONN LIST AUDIO SPLITTER:		
	P	1003				X						8376151	SCHEM DIAG AUD/CTE SPLITTER:		
	P	1004				X						8558422	SCHEM DIAG AUD/CTE SPLITTER:		
	P	1006					0	0				8673733	FRONT PANEL PT OF ST 9 ALTRD		
	P	1007					0	0				8673743-1	REAR PANEL PT OF ST 9 ALTRD		
	P	1008					0	0				8673746-1	CHASSIS PT OF ST 9 ALTRD		
	I	1009					1	1		26534	CCP6.75-19-3-1-402-8-2,5	CTN120-H09; CHASSISBOARD FILE			
	P	1011					1	1				8673799-2	PRINTED CARD FILE (SEE MOD)		
	I	1013					20	18		26534	ISP9-519-42	GUIDE			
	I	1014					1	1		26534	CTN120	SCIDE, SET			
	I	1015					1	1		26534	UCM94 1/4-19	TOP COVER			
	I	1016					1	1		26534	ISP8-001-96	REAR SUPPORT-EXT BRAC SET			
	I	1017					1	1		26534	H0-9	HANDLES, SET			
	P	1018					1	1				8673749-1	GRILLE; SPEAKER		
	I	1019					1	3				8155406	BRACKET		

SPECIFICATION	DWC STATUS	SHEET/ LINE NO.	PARTS LIST					RCA		CAMDEN PLANT		REV LTR H	CODE IDENT	PL 8573736	SHEET 11
			ITEM OR FIND NO.	QTY REQD PER DASH NO.					U M	CODE IDENT	PART OR IDENTIFYING NO.	NOMENCLATURE OR DESCRIPTION	SYM		
				505	504	503	502	501							
	P	1102	19				1	1				746936-01	LENS, RED		
	I	1109	21				10	1	91929	60-8006-3414			POLARIZING INSERT		
	I	1111	23				3	1	91929	2B1			BARRIER-MICRO SWITCH		
	I	1112	24				2	2	91929	2A5B			DISPLAY SCREEN		
	I	1113	25				6	6	96906	M591528-1D2B			KNDB		
	I	1114	26				1	1	96906	M591528-2F2B			KNDB		
	I	1115	27				1	1	96906	M591528-1K1B			KNDB		
	I	1116	28				1	1	49956	KL701G			LOCK, KNDB		
	I	1117	29				AR	AR		999129-99			WIRE, ELECTRICAL		
	I	1118	30				AR	AR		999129-9			WIRE, ELECTRICAL		
	I	1119	31				AR	AR		999129-2			WIRE, ELECTRICAL		

DEC 1320 (6/69)

SPECIFICATION	DWG STATUS	SHEET/ LINE NO.	PARTS LIST					RCA		CAMDEN PLANT	REV LTR H	CODE IDENT	PL 8573784	SHEET 12
			RCA CORPORATION, NEW YORK, N. Y.					U M	CODE IDENT	PART OR IDENTIFYING NO.	NOMENCLATURE OR DESCRIPTION	SYM		
			ITEM OR FIND NO.	QTY REQD PER DASH. NO.										
			505	504	503	502	501							
MIL-C-17/68	I	1202	33				AR	AR			999129-8		WIRE, ELECTRICAL	
	I	1203	34				AR	AR			999129-7		WIRE, ELECTRICAL	
	I	1204	35				AR	AR			999130-99		WIRE, ELECTRICAL	
	I	1205	36				AR	AR			999127-9		WIRE, ELECTRICAL	
	I	1206	37				AR	AR			999127-99		WIRE, ELECTRICAL	
	I	1207	38				AR	AR		81349	RG187A/U		COAX CABLE	
	I	1208	39				AR	AR		16628	83318		WIRE 24-BEIDEN	
	I	1209	40				AR	AR			999128-80		WIRE, ELECTRICAL	
	I	1210	41				AR	AR			999128-9		WIRE, ELECTRICAL	
	I	1211	42				AR	AR			999128-99		WIRE, ELECTRICAL	
	I	1212	43						16	59750	TC105A		MOUNTING PLATE	
	I	1213	44				AR	AR		59750	TC110		SOLVENT	
	I	1214	45						16	06090	D121-08		THERMOFIT SOLDER DEVICE	
	I	1215	46						30		8982998-13		TERMINAL SOLDERLESS	
MS25281	I	1216	47					2	96906	MS25281R10		CLAMP, CABLE		
MS25281	I	1217	48					1	96906	MS25281R8		CLAMP, CABLE		
MS25281	I	1218	49					1	96906	MS25281R3		CLAMP, CABLE		

SPECIFICATION	DWG STATUS	SHEET/ LINE NO.	PARTS LIST					RCA CORPORATION NEW YORK, N Y		CAMDEN PLANT	REV LTR H	CODE IDENT	PL 8573734	SHEET 12
			ITEM OR FIND NO.	QTY REQD PER DASH NO.					U M	CODE IDENT	PART OR IDENTIFYING NO.	NOMENCLATURE OR DESCRIPTION	SYM	
				505	504	503	502	501						
NAS49	I	1301	91				4	4	80205	NAS43DD0-32	SPACER.			
NAS49	I	1302	92				4	4	80205	NAS43DDI-48	SPACER			
	P	1303	93				1	1		8183638-1	SPACER			
	I	1304	94				2	2		57695-701	NUTS			
	I	1305	95				12	12	96906	MS20341-43	NUT, HEXAGON			
	I	1306	96				8	8	96906	MS20341-65	NUT, HEXAGON			
	I	1308	98				2	2	96906	MS20341-105	NUT, HEXAGON			
NAS1625	I	1309	99				2	2	80205	NAS1635-04-6	SCREW			
NAS1640	I	1310	60				2	2	80205	NAS1640-2	WASHER, LOCK			
NAS1640	I	1311	61				14	14	80205	NAS1640-4	WASHER, LOCK			
NAS1660	I	1312	62				10	10	80205	NAS1640-6	WASHER			
NAS1660	I	1313	63				12	12	80205	NAS1640-8	WASHER			
NAS1660	I	1314	64				2	2	80205	NAS1640-10	WASHER			
	I	1316	66				2	2		8924401-6	WASHER			

DEC 1320 (6/69)

ORIGINAL PAGE IS  
OF POOR QUALITY

SPECIFICATION	DWG STATUS	SHEET/ LINE NO.	PARTS LIST					RCA		CAMDEN PLANT	REV LTR H	CODE IDENT	PL 0673734	SHEET 14
			ITEM OR FIND NO.	QTY REQD PER DASH NO.					U M	CODE IDENT	PART OR IDENTIFYING NO.	NOMENCLATURE OR DESCRIPTION	S M	
				505	504	503	502	501						
MS24693	1	1401	70				2	2	00205	NAS1635-02-4	SCREW			
	1	1402	71				8	8	00205	NAS1635-04-10	SCREW			
	1	1403	72				2	2	00205	NAS1635-06-6	SCREW			
	1	1404	73				4	2	00205	NAS1635-06-20	SCREW			
	1	1405	74				12	12	00205	NAS1635-08-6	SCREW			
	1	1406	75				2	2	96906	MS24693C52	SCREW			



<b>PARTS LIST</b>		<b>RCA</b>		RCA CORPORATION   NEW YORK, NY		REVISION DATE	PL 8372838		REV LTR <b>D</b>					
LIST TITLE:  <b>BOARD ASSEMBLY SPLITTER OUTPUT</b>				PREPARED BY		DATE	REL	CODE IDENT NO. <b>49671</b>		SHEET OF <b>7</b>	1 SHEETS			
				CHECKED BY		DATE		CONTRACT NO. <b>NAS 8-27968</b>						
				<b>8673734-501</b>		<b>SKYLAB-GSE</b>		DESIGN ACTIVITY APPD		DATE				
				NEXT ASSY		USED ON		FIRST APPLICATION						
REVISIONS														
LTR	DESCRIPTION	DATE	APPROVED	LTR	DESCRIPTION	DATE	APPROVED							
A	REVISED													
B	REVISED													
C	REVISED													
D	REVISED													
INTERPRET SYMBOLS USED AS FOLLOWS:														
UNITS OF MEASURE (UM)			QUANTITIES		SYMBOL									
A—Inches B—Feet C—Yards D—Ounces E—Pints F—Quarts G—Gallons	H—Barrels J—Pounds L—Pair M—Set N—Kit P—Roll R—Box, Case	T—Each	X—Applicable document  O—For ref only	U—Govt or customer furnished *—Vendor item. See specification or source control drawing.  K—Govt or customer furnished and installed										

ORIGINAL PAGE IS  
OF POOR QUALITY

SPECIFICATION	DWG STATUS	SHEET/ LINE NO.	PARTS LIST					RCA		CAMDEN PLANT		REV LTR D	CODE IDENT	PL 8372838	SHEET 02
			ITEM OR FIND NO.	QTY REQD PER DASH NO.					U M	CODE IDENT	PART OR IDENTIFYING NO.	NOMENCLATURE OR DESCRIPTION	SYM		
				505	504	503	502	501							
	I	0201	C1						1	56289	500D156G025887	CAPACITOR			
	I	0202	C2						1	56289	500D156G025887	CAPACITOR			
	I	0203	C3						1	56289	500D156G025887	CAPACITOR			
	I	0204	C4						1	56289	500D156G025887	CAPACITOR			
	I	0205	C5						1		500D156G025887	CAPACITOR			
MIL-C-11015/19	I	0207	C6						1	81349	CK06BX103K	CAPACITOR			
MIL-C-11015/19	I	0208	C7						1	81349	CK06BX103K	CAPACITOR			
MIL-C-11015/19	I	0209	C8						1	81349	CK06BX103K	CAPACITOR			
MIL-C-11015/19	I	0210	C9						1	81349	CK06BX103K	CAPACITOR			
MIL-C-5/18	I	0212	C10						1	81349	CM05FD201J03	CAPACITOR			
MIL-C-5/18	I	0213	C11						1	81349	CM05FD201J03	CAPACITOR			
MIL-C-5/18	I	0214	C12						1	81349	CM05FD201J03	CAPACITOR			
MIL-C-5/18	I	0215	C13						1	81349	CM05FD201J03	CAPACITOR			
	I	0217	C14						1	56289	500D156G025887	CAPACITOR			
	I	0218	C15						1	56289	500D156G025887	CAPACITOR			
	I	0219	C16						1	56289	500D156G025887	CAPACITOR			

SPECIFICATION	DWG STATUS	SHEET/ LINE NO.	PARTS LIST					RCA		CAMDEN PLANT		REV LTR D	CODE IDENT	PL 8372838	SHEET 03
			ITEM OR FIND NO.	QTY REQD PER DASH NO					U M	CODE IDENT	PART OR IDENTIFYING NO.	NOMENCLATURE OR DESCRIPTION	SYM		
				505	504	503	502	501							
	I	0301	TJ1						1	00779	3-582340-1		JACK, TEST=BRN		
	I	0302	TJ2						1	00779	3-582340-2		JACK, TEST=RED		
	I	0303	TJ3						1	00779	3-582340-3		JACK, TEST=GRG		
	I	0304	TJ4						1	00779	3-582340-4		JACK, TEST=YEL		
	I	0305	TJ5						1	00779	3-582340-5		JACK, TEST=GRN		
	I	0306	TJ6						1	00779	3-582340-6		JACK, TEST=BLU		
	I	0307	TJ10						1	00779	3-582340-0		JACK, TEST=BLK		
	I	0309	P1						1	91662	00-7022-035-000-001		CONNECTOR		

DEC 1320 (6/69)

11-0

SPECIFICATION	DWG STATUS	SHEET/ LINE NO.	PARTS LIST					RCA		CAMDEN PLANT	REV LTR D	CODE IDENT	PL 8372638	SHEET 04
			ITEM OR FIND NO.	QTY REQD PER DASH NO.					U M	CODE IDENT	PART OR IDENTIFYING NO.	NOMENCLATURE OR DESCRIPTION	S M	
				503	504	503	502	501						
MIL-R-11/3	I	0401	R1						1	81349	RC20GF101K	RESISTOR		
MIL-R-10509/1	I	0402	R2						1	81349	RN60D1001F	RESISTOR		
MIL-R-11/3	I	0403	R3						1	81349	RC20GF101K	RESISTOR		
MIL-R-10509/1	I	0404	R4						1	81349	RN60D1001F	RESISTOR		
MIL-R-11/3	I	0405	R5						1	81349	RC20GF101K	RESISTOR		
MIL-R-10509/1	I	0406	R6						1	81349	RN60D1001F	RESISTOR		
MIL-R-11/3	I	0408	R7						1	81349	RC20GF101K	RESISTOR		
MIL-R-10509/1	I	0409	R8						1	81349	RN60D1001F	RESISTOR		
MIL-R-11/3	I	0410	R9						1	81349	RC20GF101K	RESISTOR		
MIL-R-11/8	I	0411	R10						1	81349	RC07GF152K	RESISTOR		
MIL-R-10509/1	I	0412	R11						1	81349	RN60D1002F	RESISTOR		
MIL-R-11/8	I	0413	R12						1	81349	RC07GF152K	RESISTOR		
MIL-R-10509/1	I	0414	R13						1	81349	RN60D1962F	RESISTOR		
MIL-R-11/8	I	0416	R14						1	81349	RC07GF152K	RESISTOR		
MIL-R-10509/1	I	0417	R15						1	81349	RN60D1962F	RESISTOR		
MIL-R-11/8	I	0418	R16						1	81349	RC07GF152K	RESISTOR		

SPECIFICATION	DWG STATUS	SHEET/ LINE NO.	PARTS LIST		RCA		CAMDEN PLANT		REV LTR 0	CODE IDENT 49671	PL 8972838	SHEET 05
			RCA CORPORATION, NEW YORK, N. Y.					U M	CODE IDENT	PART OR IDENTIFYING NO.	NOMENCLATURE OR DESCRIPTION	SYM
			ITEM OR FIND NO.	QTY REQD PER DASH NO.								
		503	504	503	502	501						
MIL-R-10509/1	I	0501	R17					1	81349	RN60D1962F	RESISTOR	
MIL-R-22684/1	I	0502	R18					1	81349	RL07S621J	RESISTOR	
MIL-R-11/3	I	0503	R19					1	81349	RC20GF101K	RESISTOR	
MIL-R-22684/1	I	0504	R20					1	81349	RL07S621J	RESISTOR	
MIL-R-11/3	I	0505	R21					1	81349	RC20GF101K	RESISTOR	
MIL-R-22684/1	I	0507	R22					1	81349	RL07S621J	RESISTOR	
MIL-R-11/3	I	0508	R23					1	81349	RC20GF101K	RESISTOR	
MIL-R-22684/1	I	0509	R24					1	81349	RL07S621J	RESISTOR	
MIL-R-11/8	I	0510	R25					1	81349	RC07GF392K	RESISTOR	
MIL-R-11/8	I	0511	R26					1	81349	RC07GF392K	RESISTOR	
MIL-R-11/8	I	0513	R27					1	81349	RC07GF102K	RESISTOR	
MIL-R-11/8	I	0514	R28					1	81349	RC07GF102K	RESISTOR	
MIL-R-11/8	I	0515	R29					1	81349	RC07GF102K	RESISTOR	
MIL-R-11/8	I	0516	R30					1	81349	RC07GF102K	RESISTOR	
MIL-R-11/8	I	0517	R31					1	81349	RC07GF102K	RESISTOR	
MIL-R-11/8	I	0518	R32					1	81349	RC07GF102K	RESISTOR	

DEC 1320 (6/69)

SPECIFICATION	DWG STATUS	SHEET/ LINE NO.	PARTS LIST					RCA		CAMDEN PLANT		REV LTR 0	CODE IDENT 49671	PL 8372838	SHEET 26
			ITEM OR FIND NO	QTY REQD PER DASH NO					U M	CODE IDENT	PART OR IDENTIFYING NO.	NOMENCLATURE OR DESCRIPTION	SYM		
				505	504	503	502	501							
	I	0601	T1					1	00348	VM14M			TRANSFORMER		
	I	0602	T2					1	00348	VM14M			TRANSFORMER		
	I	0603	T3					1	00348	VM14M			TRANSFORMER		
	I	0604	T4					1	00348	VM14M			TRANSFORMER		
	I	0607	U1					1	04713	MC1709CL			INTEGRATED CIRCUIT		
	I	0608	U2					1	04713	MC1709CL			INTEGRATED CIRCUIT		
	I	0609	U3					1	04713	MC1709CL			INTEGRATED CIRCUIT		
	I	0610	U4					1	04713	MC1709CL			INTEGRATED CIRCUIT		

ORIGINAL PAGE IS  
OF POOR QUALITY

SPECIFICATION	DWG STATUS	SHEET/ LINE NO.	PARTS LIST					RCA		CAMDEN PLANT	REV LTR D	CODE IDENT	PL 8372338	SHEET 07
			ITEM OR FIND NO.	QTY REQD PER DASH NO.					U M	CODE IDENT	PART OR IDENTIFYING NO.	NOMENCLATURE OR DESCRIPTION	SYM	
				503	504	505	502	501						
	P	0701	1					X			8372870	SCHEM DIAG, SPLITTER OUTPUT		
	P	0702	2					X			8372839	MA PATT=PW, SPLITTER OUTPUT		
	I	0704	4					X			8030018	WORKMANSHIP SPEC, BASIC		
	P	0707	7								8679774-1	HANDLE=BOARD		
	I	0714	14					AR			8533343-8	CEMENT		
	I	0715	15					AR			2010105-22	COPPER WIRE, ROUND, TINNED		
	I	0716	16					AR			2010909-812	INSULATING TUBING		
	I	0717	17					AR			2010858-920	SOLDER, TIN-LEAD ALLOY		
	I	0718	18					AR			2010573-1	FLUX, SOLDERING, ALCHL-ROBIN		

DEC 13 20 (6/69)

<b>PARTS LIST</b>		<b>IRCA</b>		RCA CORPORATION   NEW YORK, NY		REVISION DATE	PL 8372840	REV LTR <b>E</b>
LIST TITLE:  BOARD ASSEMBLY VIDEO/AUDIO INPUT				PREPARED BY		DATE	CODE IDENT NO. <b>49671</b>	SHEET OF <b>9</b> SHEETS
				CHECKED BY		DATE		
				DESIGN ACTIVITY APPD		DATE		
		8673734-501	SKYLAB-GSE	NEXT ASSY		USED ON		CONTRACT NO.  NAS 8-27968
		FIRST APPLICATION						
REVISIONS								
LTR	DESCRIPTION	DATE	APPROVED	LTR	DESCRIPTION	DATE	APPROVED	
A	REVISED							
B	REVISED							
C	REVISED							
D	REVISED							
E	REVISED							
INTERPRET SYMBOLS USED AS FOLLOWS:								
UNITS OF MEASURE (UM)			QUANTITIES		SYMBOL			
A — Inches	H — Barrels	T — Each	X — Applicable document	U — Govt or customer furnished	* — Vendor item. See specification or source control drawing.			
B — Feet	J — Pounds		O — For ref only	K — Govt or customer furnished and installed				
C — Yards	L — Pair							
D — Ounces	M — Set							
E — Pints	N — Kit							
F — Quarts	P — Roll							
G — Gallons	R — Box, Case							



SPECIFICATION	STATUS	SHEET/ LINE NO	PARTS LIST		RCA					CAMDEN PLANT	REV LTR E	CODE IDENT	PL 8372840	SHEET 02
			RCA CORPORATION, NEW YORK, N. Y.											
	DI	FIND NO.	503	504	503	502	501	U M	CODE IDENT	PART OR IDENTIFYING NO	NOMENCLATURE OR DESCRIPTION	Y M		
MIL-C-11015/18	I	0201	C1					1	81349	CK05BX102K	CAPACITOR			
MIL-C-5/18	I	0202	C2					1	81349	CM05ED510J03	CAPACITOR			
MIL-C-11015/19	I	0203	C3					1	81349	CK06BX103K	CAPACITOR			
MIL-C-11015/19	I	0204	C4					1	81349	CK06BX103K	CAPACITOR			
MIL-C-27287/1	I	0205	C5					1	81349	CTM105VAJ	CAPACITOR			
MIL-C-11015/19	I	0206	C6					1	81349	CK06BX103K	CAPACITOR			
MIL-C-11015/19	I	0207	C7					1	81349	CK06BX103K	CAPACITOR			
MIL-C-5/18	I	0208	C8					1	81349	CM06FD202J03	CAPACITOR			
MIL-C-11015/19	I	0209	C9					1	81349	CK06BX103K	CAPACITOR			
MIL-C-11015/19	I	0210	C10					1	81349	CK06BX103K	CAPACITOR			
	I	0211	C11					1	72982	8131-050-651-105M	CAPACITOR			
MIL-C-5/18	I	0212	C12					1	81349	CM06FD202J03	CAPACITOR			
MIL-C-5/18	I	0214	C13					1	81349	CM05FD301J03	CAPACITOR			
MIL-C-5/18	I	0215	C14					1	81349	CM06FD821J03	CAPACITOR			
MIL-C-5/18	I	0216	C15					1	81349	CM06FD681J03	CAPACITOR			
MIL-C-11015/19	I	0217	C16					1	81349	CK06BX103K	CAPACITOR			
MIL-C-11015/19	I	0218	C17					1	81349	CK06BX103K	CAPACITOR			

DEC 1370 (6/69)

SPECIFICATION	DWG STATUS	SHEET/ LINE NO.	PARTS LIST		RCA					CAMDEN PLANT	REV LTR E	CODE IDENT	PL 8372840	SHEET 03
			ITEM OR FIND NO.	QTY REQD PER DASH NO.					U M	CODE IDENT	PART OR IDENTIFYING NO	NOMENCLATURE OR DESCRIPTION	S M	
				505	504	503	502	501						
MIL-C-5/18	I	0301	C18						1	81349	CM05E0510J03	CAPACITOR		
MIL-C-5/18	I	0302	C19						1	81349	CM05FD151J03	CAPACITOR		
MIL-C-11015/19	I	0303	C20						1	81349	CK06BX103K	CAPACITOR		
MIL-C-5/18	I	0304	C21						1	81349	CM05E0510J03	CAPACITOR		
MIL-C-5/18	I	0305	C22						1	81349	CM05FD151J03	CAPACITOR		
MIL-C-11015/19	I	0306	C23						1	81349	CK06BX103K	CAPACITOR		
MIL-C-11015/19	I	0308	C24						1	81349	CK06BX104K	CAPACITOR		
MIL-C-11015/19	I	0309	C25						1	81349	CK06BX104K	CAPACITOR		
MIL-C-26655	I	0310	C26						1	81349	CS138E156K	CAPACITOR		
MIL-C-26655	I	0311	C27						1	81349	CS138E156K	CAPACITOR		
MIL-C-26655	I	0312	C28						1	81349	CS138C336K	CAPACITOR		
	I	0315	CR1						1	81349	1N4148	DIODE		
	I	0316	CR2						1	81349	1N4148	DIODE		
	I	0318	L1						1	96906	MS90537-37	COIL		
	I	0319	P1						1	91662	00-7022-035-000-001	CONNECTOR		

ORIGINAL PAGE IS  
OF POOR QUALITY

SPECIFICATION	DWG STATUS	SHEET/ LINE NO.	PARTS LIST		RCA		CAMDEN PLANT		REV LTR E	CODE IDENT	PL 8372840	SHEET 04	
			ITEM OR FIND NO.	QTY REQD PER DASH NO.					U M	CODE IDENT	PART OR IDENTIFYING NO.	NOMENCLATURE OR DESCRIPTION	SYM
				505	504	503	502	501					
	I	0401	Q1										
	I	0402	Q2							2N2219A		TRANSISTOR	
	I	0403	Q3							2N4859		TRANSISTOR	
	I	0403	Q3							2N2907A		TRANSISTOR	
	I	0404	Q4							2N2227A		TRANSISTOR	
	I	0405	Q5							2N4859		TRANSISTOR	
	I	0406	Q6							2N2369A		TRANSISTOR	
	I	0407	Q7							2N2907A		TRANSISTOR	
	I	0408	Q8							2N2369A		TRANSISTOR	
	I	0409	Q9							2N2907A		TRANSISTOR	
MIL-R-11/B	I	0412	R1						81349	RC076P102K		RESISTOR	
MIL-R-22684/2	I	0413	R2						81349	RL205301J		RESISTOR	
	I	0414	R3						80294	3009P1=101		RESISTOR	
MIL-R-35182/3	I	0415	R4						81349	RN60D1101F		RESISTOR	
MIL-R-22684/1	I	0416	R5						81349	RL07S201J		RESISTOR	
MIL-R-10309/1	I	0417	R6						81349	RN60D1002F		RESISTOR	
MIL-R-11/B	I	0418	R7						81349	RC206P561K		RESISTOR	

DEC 1320 (6/69)

SPECIFICATION	DWG STATUS	Struct/ LINE NO.	PARTS LIST		RCA		CAMDEN PLANT		REV LTR E	CODE IDENT	PL 8372840	SHEET 05	
			ITEM OR FIND NO.	QTY REQD PER DASH NO.					U M	CODE IDENT	PART OR IDENTIFYING NO.	NOMENCLATURE OR DESCRIPTION	S Y M
				503	504	503	502	501					
MIL-R-11/3	I	0501	R8						1	81349	RC07GF120K	RESISTOR	
MIL-R-11/3	I	0502	R9						1	81349	RC07GF120K	RESISTOR	
MIL-R-22684/2	I	0503	R10						1	81349	RL20S301J	RESISTOR	
MIL-R-11/8	I	0504	R11						1	81349	RC07GF103K	RESISTOR	
MIL-R-11/8	I	0505	R12						1	81349	RC07GF101K	RESISTOR	
MIL-R-11/8	I	0506	R13						1	81349	RC07GF470K	RESISTOR	
MIL-R-11/3	I	0507	R14						1	81349	RC07GF120K	RESISTOR	
MIL-R-11/8	I	0509	R15						1	81349	RC07GF222K	RESISTOR	
MIL-R-11/8	I	0510	R16						1	81349	RC07GF470K	RESISTOR	
MIL-R-11/8	I	0511	R17						1	81349	RC07GF103K	RESISTOR	
MIL-R-11/3	I	0512	R18						1	81349	RC07GF120K	RESISTOR	
MIL-R-11/8	I	0514	R19						1	81349	RC07GF103K	RESISTOR	
MIL-R-11/8	I	0515	R20						1	81349	RC07GF564K	RESISTOR	
MIL-R-11/3	I	0516	R21						1	81349	RC07GF120K	RESISTOR	
MIL-R-11/3	I	0517	R22						1	81349	RC07GF120K	RESISTOR	
	I	0518	R23						1	80294	3009P1-302	RESISTOR	

DEC 13 20 (6/69)

SPECIFICATION	DWG STATUS	SHEET/ LINE NO.	PARTS LIST		RCA CORPORATION NEW YORK, N. Y.		CAMDEN PLANT		REV LTR E	CODE IDENT	PL 8372840	SHEET 06	
			ITEM OR FIND NO.	QTY REQD PER DASH NO.					U M	CODE IDENT	PART OR IDENTIFYING NO.	NOMENCLATURE OR DESCRIPTION	S Y M
				505	504	503	502	501					
MIL-R-10509/1	I	0601	R24						1	81349	RN60D5112F	RESISTOR	
MIL-R-10509/1	I	0602	R25						1	81349	RN60D5112F	RESISTOR	
MIL-R-11/8	I	0603	R26						1	81349	RC07GF562K	RESISTOR	
MIL-R-10509/1	I	0604	R27						1	81349	RN60D5112F	RESISTOR	
MIL-R-10509/1	I	0605	R28						1	81349	RN60D5112F	RESISTOR	
MIL-R-11/3	I	0606	R29						1	81349	RC07GF120K	RESISTOR	
MIL-R-11/3	I	0608	R30						1	81349	RC07GF120K	RESISTOR	
MIL-R-11/8	I	0609	R31						1	81349	RC07GF102K	RESISTOR	
MIL-R-11/8	I	0610	R32						1	81349	RC07GF682K	RESISTOR	
MIL-R-11/8	I	0611	R33						1	81349	RC07GF102K	RESISTOR	
MIL-R-11/8	I	0612	R34						1	81349	RC07GF472K	RESISTOR	
MIL-R-11/8	I	0614	R35						1	81349	RC07GF222K	RESISTOR	
MIL-R-11/8	I	0615	R36						1	81349	RC07GF152K	RESISTOR	
MIL-R-11/3	I	0616	R37						1	81349	RC07GF120K	RESISTOR	
MIL-R-11/8	I	0617	R38						1	81349	RC07GF471K	RESISTOR	
MIL-R-11/8	I	0618	R39						1	81349	RC07GF103K	RESISTOR	
MIL-R-11/8	I	0619	R40						1	81349	RC07GF682K	RESISTOR	

DEC 1320 (4/69)

SPECIFICATION	DWG STATUS	SHEET/ LINE NO.	PARTS LIST		RCA		CAMDEN PLANT		REV LTR E	CODE IDENT	PL 8372840	SHEET 07	
			ITEM OR FIND NO.	QTY REQD PER DASH NO.					U M	CODE IDENT	PART OR IDENTIFYING NO.	NOMENCLATURE OR DESCRIPTION	S Y M
				503	504	505	502	501					
MIL-R-11/8	I	0701	R41						1	81349	RC07GF102K	RESISTOR	
MIL-R-11/8	I	0702	R42						1	81349	RC07GF472K	RESISTOR	
MIL-R-11/8	I	0703	R43						1	81349	RC07GF223K	RESISTOR	
MIL-R-11/8	I	0704	R44						1	81349	RC07GF152K	RESISTOR	
MIL-R-11/3	I	0705	R45						1	81349	RC07GF120K	RESISTOR	
MIL-R-11/8	I	0706	R46						1	81349	RC07GF471K	RESISTOR	
MIL-R-11/3	I	0707	R47						1	81349	RC20GF680K	RESISTOR	
MIL-R-11/3	I	0708	R48						1	81349	RC20GF680K	RESISTOR	
MIL-R-11/6	I	0709	R49						1	81349	RC22GF271K	RESISTOR	
MIL-R-11/8	I	0710	R50						1	81349	RC07GF103K	RESISTOR	
MIL-R-11/8	I	0711	R51						1	81349	RC07GF103K	RESISTOR	
MIL-R-11/8	I	0712	R52						1	81349	RC07GF102K	RESISTOR	
MIL-R-11/8	I	0713	R53						1	81349	RC07GF102K	RESISTOR	
MIL-R-11/8	I	0714	R54						1	81349	RC07GF220K	RESISTOR	
	I	0716	T1						1	00248	VM14H	TRANSFORMER	
	I	0717	TJ1						1	00779	3-582340-1	JACK, TEST-BRN	
	I	0718	TJ2						1	00779	3-582340-2	JACK, TEST-RED	
	I	0719	TJ3						1	00779	3-582340-3	JACK, TEST-ORG	

ORIGINAL PAGE IS  
OF POOR QUALITY

SPECIFICATION	DWG STATUS	SHEET/ LINE NO.	PARTS LIST					RCA		CAMDEN PLANT		REV LTR E	CODE IDENT	PL 3372840	SHEET 08
			ITEM OR FIND NO.	QTY REQD PER DASH NO.					U M	CODE IDENT	PART OR IDENTIFYING NO.	NOMENCLATURE OR DESCRIPTION	SYM		
				505	504	503	502	501							
	I	0801	TJ4					1	00779	2-582340-4			JACK, TEST-BLK		
	I	0803	TJ10					1	00779	2-582340-0			JACK, TEST-BLK		
	I	0806	U1					1	04713	MC1712CL			INTEGRATED CIRCUIT		
	I	0807	U2					1	04713	MC1741CL			INTEGRATED CIRCUIT		
	I	0808	U3					1	04713	MC1458CL			INTEGRATED CIRCUIT		
	I	0810	VR1					1		1N3022B			DIODE, ZENER		
	I	0811	VR2					1		1N3022B			DIODE, ZENER		
	I	0812	VR3					1		1N753A			DIODE, ZENER		

DEC 1320 (6/69)

SPECIFICATION	DWG STATUS	SHEET/ LINE NO.	PARTS LIST					RCA		CAMDEN PLANT	REV LTR E	CODE IDENT	PL 8372840	SHEET 09
			ITEM OR FIND NO.	QTY REQD PER DASH NO.					U M	CODE IDENT	PART OR IDENTIFYING NO.	NOMENCLATURE OR DESCRIPTION	SYM	
				503	504	503	502	501						
	P	0901	1					X			8372871	SCHEM DIAG; VIDEO/AUDIO INPUT		
	P	0902	2					X			8372841	MA PATT=PW; VIDEO/AUDIO INPUT		
	I	0904	4					X			8030018	WORKMANSHIP SPEC, BASIC		
	P	0907	7						1		8673774-2	HANDLE=BOARD		
	I	0909	9						1		8505806-4	MDUNTING PAD TD-5 PACKAGE		
	I	0910	10						8		8524995-1	SPACER, TRANSISTOR		
	I	0914	14					AR			8533343-8	CEMENT		
	I	0915	15					AR			2010105-22	COPPER WIRE, ROUND, TINNED		
	I	0916	16					AR			2010909-812	INSULATING TUBING		
	I	0917	17					AR			2010858-320	SOLDER, TIN=LEAD ALLOY		
	I	0918	18					AR			2010573-1	FLUX, SOLDERING, ALCHL=RDSIN		



<b>PARTS LIST</b>		<b>REGA</b>		RCA CORPORATION   NEW YORK, NY		REVISION DATE		PL 8372842		REV LTR <b>G</b>	
LIST TITLE:  <b>BOARD ASSEMBLY SPLITTER TIMING</b>				CAMDEN PLANT		PREPARED BY _____ DATE _____		REL _____		CODE IDENT NO. <b>49671</b>	
				8673734-501 SKYLAB-GSE		CHECKED BY _____ DATE _____		CONTRACT NO.  NAS 8-27968		SHEET OF <b>10</b> SHEETS	
				NEXT ASSY _____ USED ON _____		DESIGN ACTIVITY APPD _____ DATE _____					
				FIRST APPLICATION							
<b>REVISIONS</b>											
LTR	DESCRIPTION	DATE	APPROVED	LTR	DESCRIPTION	DATE	APPROVED				
A	REVISED										
B	REVISED										
C	REVISED										
D	REVISED										
E	REVISED										
F	REVISED										
G	REVISED										
<b>INTERPRET SYMBOLS USED AS FOLLOWS:</b>											
UNITS OF MEASURE (UM)			QUANTITIES		SYMBOL						
A — Inches	H — Barrels	T — Each	X — Applicable document	U — Govt or customer furnished	* — Vendor item. See specification or source control drawing.						
B — Feet	J — Pounds		O — For ref only	K — Govt or customer furnished and installed							
C — Yards	L — Pair										
D — Ounces	M — Set										
E — Pints	N — Kit										
F — Quarts	P — Roll										
G — Gallons	R — Box, Case										

68379

SPECIFICATION	DWG STATUS	SHEET/ LINE NO.	PARTS LIST		RCA		CAMDEN PLANT		REV LTR G	CODE IDENT	PL 8372842	SHEET 02	
			ITEM OR FIND NO	QTY REQD PER DASH NO.					U M	CODE IDENT	PART OR IDENTIFYING NO.	NOMENCLATURE OR DESCRIPTION	SYM
				505	504	503	502	501					
MIL-C-5/18	I	0201	C1					1	81349	CM06F0192J03	CAPACITOR		
	I	0202	C2					////		N/A	NOT USED		
	I	0203	C3					////		N/A	NOT USED		
	I	0204	C4					////		N/A	NOT USED		
MIL-C-5/18	I	0205	C5					////	81349	CM05F0331J03	CAPACITOR		
	I	0206	C6					////		N/A	NOT USED		
	I	0208	C7					////		N/A	NOT USED		
	I	0209	C8					////		N/A	NOT USED		
	I	0210	C9					////		N/A	NOT USED		
	I	0211	C10					////		N/A	NOT USED		
MIL-C-11015/18	I	0213	C11					1	81349	CK05BX102K	CAPACITOR		
MIL-C-11015/19	I	0214	C12					1	81349	CK06BX103K	CAPACITOR		
MIL-C-11015/19	I	0215	C13					1	81349	CK06BX103K	CAPACITOR		
MIL-C-5/18	I	0216	C14					1	81349	CM05ED510J03	CAPACITOR		
MIL-C-11015/19	I	0217	C15					1	81349	CK06BX104K	CAPACITOR		
MIL-C-11015/19	I	0218	C16					1	81349	CK06BX103K	CAPACITOR		
MIL-C-11015/19	I	0219	C17					1	81349	CK06BX103K	CAPACITOR		

ORIGINAL PAGE IS  
OF POOR QUALITY

SPECIFICATION	DWG STATUS	SHEET/ LINE NO.	PARTS LIST		CAMDEN PLANT					REV LTR G	CODE IDENT	PL 8372842	SHEET 03
			ITEM OR FIND NO.	QTY REQD PER DASH NO.					U M	CODE IDENT	PART OR IDENTIFYING NO	NOMENCLATURE OR DESCRIPTION	S M
				505	504	503	502	501					
MIL-C-11015/19	I	0301	C18						1	81349	CK06BX103K	CAPACITOR	
MIL-C-5/18	I	0302	C19						1	81349	CM05FD221J03	CAPACITOR	
MIL-C-27287/1	I	0303	C20						1	81349	CTM103VAJ	CAPACITOR	
MIL-C-5/18	I	0304	C21						1	81349	CM06FD272J03	CAPACITOR	
MIL-C-5/18	I	0305	C22						1	81349	CM05FD101J03	CAPACITOR	
MIL-C-5/18	I	0306	C23						1	81349	CM06FD202J03	CAPACITOR	
MIL-C-5/18	I	0307	C24						1	81349	CM05FD221J03	CAPACITOR	
MIL-C-5/18	I	0308	C25						1	81349	CM06FD102J03	CAPACITOR	
MIL-C-26655	I	0309	C26						1	81349	CS13BF336K	CAPACITOR	
MIL-C-11015/19	I	0310	C27						1	81349	CK06BX104K	CAPACITOR	
MIL-C-26655	I	0311	C28						1	81349	CS13BF336K	CAPACITOR	
MIL-C-11015/19	I	0312	C29						1	81349	CK06BX104K	CAPACITOR	
MIL-C-11015/19	I	0313	C30						1	81349	CK06BX104K	CAPACITOR	
MIL-C-11015/19	I	0314	C31						1	81349	CK06BX104K	CAPACITOR	
MIL-C-11015/19	I	0315	C32						1	81349	CK06BX104K	CAPACITOR	
MIL-C-26655	I	0316	C33						1	81349	CS13BE156K	CAPACITOR	
MIL-C-26655	I	0317	C34						1	81349	CS13BC336K	CAPACITOR	
MIL-C-11015/18	I	0318	C35						1	81349	CK05BX102K	CAPACITOR	
MIL-C-26655	I	0319	C36						1	81349	CS13BB566K	CAPACITOR	

DEC 1320 (6/69)

SPECIFICATION	DWG STATUS	SHEET/ LINE NO.	PARTS LIST		RCA		CAMDEN PLANT		REV LTR G	CODE IDENT	PL 8372842	SHEET 04	
			ITEM OR FIND NO.	QTY REQD PER DASH NO.					U M	CODE IDENT	PART OR IDENTIFYING NO.	NOMENCLATURE OR DESCRIPTION	S M
				505	504	503	502	501					
MIL-C-26655	I	0401	C37						1	81349	CS1388566K	CAPACITOR	
	I	0402	C38						1	56289	TE1129	CAPACITOR	
	I	0403	CR1						1	81349	1N4148	DIODE	
	I	0404	CR2						1	81349	1N4148	DIODE	
	I	0405	CR3						1	81349	1N4148	DIODE	
	I	0406	CR4						1		1N645	DIODE	
	I	0407	CR5						1		1N645	DIODE	
	I	0408	CR6						1	81349	1N4148	DIODE	
	I	0409	CR7						1		1N645	DIODE	
	I	0410	L1								N/A	NOT USED	
	I	0411	L2								N/A	NOT USED	
	I	0412	L3								N/A	NOT USED	
	I	0413	L4								N/A	NOT USED	
	I	0414	L5								N/A	NOT USED	
	I	0415	L6								N/A	NOT USED	
	I	0416	L7						1	96906	HS90327-27	COIL	
	I	0418	P1						1	91662	00-7022-035-000-001	CONNECTOR	

SPECIFICATION	DWG STATUS	SHEET/ LINE NO.	PARTS LIST					RCA		CAMDEN PLANT	REV LTR	CODE IDENT	PL 8372842	SHEET 05
			ITEM OR FIND NO.	QTY REQD PER DASH NO.					U M	CODE IDENT	PART OR IDENTIFYING NO.	NOMENCLATURE OR DESCRIPTION	SYM	
				505	504	503	502	501						
	I	0501	Q1					1			2N2222A	TRANSISTOR		
	I	0502	Q2					1			2N2222A	TRANSISTOR		
	I	0503	Q3					1			2N2905A	TRANSISTOR		
	I	0504	Q4					1			2N2905A	TRANSISTOR		
	I	0505	Q5					1			2N2222A	TRANSISTOR		
	I	0506	Q6					1			2N2222A	TRANSISTOR		
	I	0507	Q7					1			2N2905A	TRANSISTOR		
MIL-R-11/8	I	0510	R1					1	81349	RC07G#103K	RESISTOR			
MIL-R-11/8	I	0511	R2					1	81349	RC07G#333K	RESISTOR			
MIL-R-10509/1	I	0512	R3					1	81349	RN60D7501F	RESISTOR			
MIL-R-22684/1	I	0513	R4					1	81349	RL07S201J	RESISTOR			
MIL-R-10509/1	I	0514	R5					1	81349	RN60D2151F	RESISTOR			
MIL-R-11/3	I	0515	R6					1	81349	RC07G#120K	RESISTOR			
MIL-R-11/3	I	0516	R7					1	81349	RC07G#120K	RESISTOR			
MIL-R-10509/1	I	0517	R8					1	81349	RN60D3322F	RESISTOR			
MIL-R-22684/1	I	0518	R9					1	81349	RL07S202J	RESISTOR			
MIL-R-11/8	I	0519	R10					1	81349	RC07G#103K	RESISTOR			

DEC 1320 (6/69)

SPECIFICATION	DWG STATUS	SHEET/ LINE NO.	PARTS LIST					RCA		CAMDEN PLANT		REV LTR G	CODE IDENT	PL 8272842	SHEET 06
			ITEM OR FIND NO.	QTY REQD PER DASH NO.					U M	CODE IDENT	PART OR IDENTIFYING NO.	NOMENCLATURE OR DESCRIPTION	SYM		
				503	504	505	502	501							
MIL-R-10509/1	I	0601	R11						1	81349	RN60D1001F	RESISTOR			
MIL-R-10509/1	I	0602	R12						1	81349	RN60D2610F	RESISTOR			
MIL-R-10509/1	I	0603	R13						1	81349	RN60D5621F	RESISTOR			
MIL-R-11/3	I	0604	R14						1	81349	RC07GF120K	RESISTOR			
MIL-R-11/3	I	0605	R15						1	81349	RC07GF120K	RESISTOR			
MIL-R-11/B	I	0606	R16						1	81349	RC07GF683K	RESISTOR			
MIL-R-11/8	I	0608	R17						1	81349	RC07GF103K	RESISTOR			
MIL-R-11/8	I	0609	R18						1	81349	RC07GF103K	RESISTOR			
MIL-R-10509/1	I	0610	R19						1	81349	RN60D1002F	RESISTOR			
MIL-R-10509/1	I	0611	R20						1	81349	RN60D1472F	RESISTOR			
	I	0612	R21						1	80294	3009P1=103	RESISTOR			
MIL-R-10509/1	I	0614	R22					/////		81349	RN60D5111F	RESISTOR			
	I	0615	R23					/////			N/A	NOT USED			
MIL-R-10509/1	I	0616	R24						1	81349	RN60D5111F	RESISTOR			
	I	0617	R25						1	80294	3009P1=103	RESISTOR			
MIL-R-10509/1	I	0618	R26						1	81349	RN60D5111F	RESISTOR			
MIL-R-10509/1	I	0619	R27						1	81349	RN60D1002F	RESISTOR			

ORIGINAL PAGE IS  
OF POOR QUALITY

SPECIFICATION	DWG STATUS	SHEET/ LINE NO.	PARTS LIST					RCA		CAMDEN PLANT	REV LTR G	CODE IDENT	PL 8372842	SHEET 07
			ITEM OR FIND NO.	QTY REQD PER DASH NO.					U M	CODE IDENT	PART OR IDENTIFYING NO	NOMENCLATURE OR DESCRIPTION	SYM	
				505	504	503	502	501						
MIL-R-11/8	I	0701	R28					1	81349	RC07GF103K	RESISTOR			
MIL-R-10509/1	I	0702	R29					1	81349	RN60D1002F	RESISTOR			
MIL-R-11/8	I	0703	R30					1	81349	RC07GF103K	RESISTOR			
MIL-R-11/8	I	0704	R31					1	81349	RC07GF822K	RESISTOR			
MIL-R-11/8	I	0705	R32					1	81349	RC07GF153K	RESISTOR			
MIL-R-11/8	I	0706	R33					1	81349	RC07GF330K	RESISTOR			
MIL-R-11/8	I	0708	R34					1	81349	RC07GF101K	RESISTOR			
MIL-R-11/8	I	0709	R35					1	81349	RC07GF101K	RESISTOR			
MIL-R-11/8	I	0710	R36					1	81349	RC07GF822K	RESISTOR			
MIL-R-11/8	I	0711	R37					1	81349	RC07GF392K	RESISTOR			
MIL-R-11/8	I	0712	R38					1	81349	RC07GF562K	RESISTOR			
MIL-R-11/8	I	0714	R39					1	81349	RC07GF392K	RESISTOR			
MIL-R-11/8	I	0715	R40					1	81349	RC07GF562K	RESISTOR			
MIL-R-11/8	I	0716	R41					1	81349	RC07GF822K	RESISTOR			
MIL-R-11/8	I	0717	R42					1	81349	RC07GF153K	RESISTOR			
MIL-R-11/8	I	0718	R43					1	81349	RC07GF330K	RESISTOR			

DEC 13 20 (6/69)

SPECIFICATION	DWG STATUS	SHEET/ LINE NO.	PARTS LIST					RCA		CAMDEN PLANT	REV LTR G	CODE IDENT	PL 8972642	SHEET 68
			ITEM OR FIND NO.	QTY REQD PER DASH NO.					U M	CODE IDENT	PART OR IDENTIFYING NO.	NOMENCLATURE OR DESCRIPTION	S Y M	
				505	504	503	502	501						
MIL-R-11/8	I	0801	R44						1	81349	RC07GF101K	RESISTOR		
MIL-R-11/8	I	0802	R45						1	81349	RC07GF101K	RESISTOR		
MIL-R-11/8	I	0803	R46						1	81349	RC07GF522K	RESISTOR		
MIL-R-11/8	I	0804	R47						1	81349	RC07GF392K	RESISTOR		
MIL-R-11/8	I	0805	R48						1	81349	RC07GF562K	RESISTOR		
MIL-R-11/3	I	0806	R49						1	81349	RC20GF101K	RESISTOR		
MIL-R-11/3	I	0807	R50						1	81349	RC20GF391K	RESISTOR		
MIL-R-11/8	I	0808	R51						1	81349	RC07GF103K	RESISTOR		
MIL-R-10509/1	I	0809	R52						1	81349	RN60D1501F	RESISTOR		
	I	0811	TJ1						1	00779	3-582340-1	JACK, TEST-BRN		
	I	0812	TJ2						1	00779	3-582340-2	JACK, TEST-RED		
	I	0813	TJ3						1	00779	3-582340-3	JACK, TEST-ORG		
	I	0814	TJ4						1	00779	3-582340-4	JACK, TEST-YEL		
	I	0815	TJ5						1	00779	3-582340-5	JACK, TEST-GRN		
	I	0816	TJ6						1	00779	3-582340-6	JACK, TEST-BLU		
	I	0818	TJ10						1	00779	3-582340-0	JACK, TEST-BLK		



SPECIFICATION	DWG STATUS	SHEET/ LINE NO.	PARTS LIST					RCA		CAMDEN PLANT		REV LTR C	CODE IDENT	PL 8572842	SHEET 09
			ITEM OR FIND NO.	QTY REQD PER DASH NO.					U M	CODE IDENT	PART OR IDENTIFYING NO.	NOMENCLATURE OR DESCRIPTION	S Y M		
				503	304	503	502	501							
	1	0901	U1						1	04713	MC1712CL	INTEGRATED CIRCUIT			
	1	0902	U2						1	04713	MC1710CL	INTEGRATED CIRCUIT			
	1	0903	U3						1	04713	MC8601L	INTEGRATED CIRCUIT			
	1	0904	U4						1	04713	MC8601L	INTEGRATED CIRCUIT			
	1	0905	U5						1	04713	MC8601L	INTEGRATED CIRCUIT			
	1	0906	U6						1	04713	MC8601L	INTEGRATED CIRCUIT			
	1	0907	U7						1	04713	MC8601L	INTEGRATED CIRCUIT			
	1	0908	U8						1	04713	MC8601L	INTEGRATED CIRCUIT			
	1	0909	U9						1	04713	MC7400L	INTEGRATED CIRCUIT			
	1	0910	U10						1	04713	MC8601L	INTEGRATED CIRCUIT			
	1	0911	U11						1	04713	MC7400L	INTEGRATED CIRCUIT			
	1	0912	U12						1	04713	MC8601L	INTEGRATED CIRCUIT			
	1	0913	VR1						1		1N9022B	DIODE, ZENER			
	1	0914	VR2						1		1N753A	DIODE, ZENER			

DIC 1320 (6/69)

SPECIFICATION	DWG STATUS	SHEET/ LINE NO.	PARTS LIST					RCA		CAMDEN PLANT	REV LTR G	CODE IDENT	PL 8372842	SHEET 10
			ITEM OR FIND NO.	QTY REQD PER DASH NO.					U M	CODE IDENT	PART OR IDENTIFYING NO.	NOMENCLATURE OR DESCRIPTION	SYM	
				503	504	503	502	501						
	P	1001	1					X			8372872	SCHEM DIAG; SPLITTER TIMING		
	P	1002	2					X			8372843	MA PATT-PW; SPLITTER TIMING		
	I	1004	4					X			8030018	WORKMANSHIP SPEC; BASIC		
	P	1007	7						1		8673774-3	HANDLE-BOARD		
	I	1009	9						3		8505806-4	MOUNTING PAD TO-5 PACKAGE		
	I	1010	10						4		8524995-1	SPACER, TRANSISTOR		
	I	1014	14					AR			8533343-8	CEMENT		
	I	1015	15					AR			2010105-22	COPPER WIRE, ROUND, TINNED		
	I	1016	16					AR			2010909-812	INSULATING TUBING		
	I	1017	17					AR			2010838-220	SOLDER, TIN-LEAD ALLOY		
	I	1018	18					AR			2010373-1	FLUX, SOLDERING, ALCHL-ROBIN		

<b>PARTS LIST</b>		<b>RCA</b>		RCA CORPORATION   NEW YORK, NY		REVISION DATE		PL 8373015		REV LTR <b>B</b>			
LIST TITLE:  BOARD ASSEMBLY  EXTERNAL SYNC				CAMDEN PLANT		PREPARED BY _____ DATE _____		REL _____		CODE IDENT NO. <b>49671</b>		SHEET OF 6 SHEETS 1 SHEETS	
				8673734 - SKYLAB GSE		CHECKED BY _____ DATE _____		CONTRACT NO.  NAS 8-27968					
				NEXT ASSY _____ USED ON _____		DESIGN ACTIVITY APPD _____ DATE _____							
				FIRST APPLICATION									
REVISIONS													
LTR	DESCRIPTION	DATE	APPROVED	LTR	DESCRIPTION	DATE	APPROVED						
A	REVISED												
B	REVISED												
INTERPRET SYMBOLS USED AS FOLLOWS:													
UNITS OF MEASURE (UM)			QUANTITIES			SYMBOL							
A—Inches B—Feet C—Yards D—Ounces E—Pints F—Quarts G—Gallons	H—Barrels J—Pounds L—Pair M—Set N—Kit P—Roll R—Box, Case	T—Each	X—Applicable document  O—For ref only	U—Govt or customer furnished *—Vendor item. See specification or source control drawing  K—Govt or customer furnished and installed									

64379

SPECIFICATION	DWG STATUS	SHEET/ LINE NO.	PARTS LIST		RCA					CAMDEN PLANT		REV LTR B	CODE IDENT	PL 8373013	SHEET 02	
			RCA CORPORATION, NEW YORK, N Y					U M	CODE IDENT	PART OR IDENTIFYING NO.	NOMENCLATURE OR DESCRIPTION	SYM				
			ITEM OR FIND NO.	QTY REQD PER DASH NO.												
		505 504 503 502 501														
MIL-C-11015/18	I	0201	C1						1	81349	CK05BX101K	CAPACITOR				
MIL-C-11015/19	I	0202	C2						1	81349	CK06BX103K	CAPACITOR				
MIL-C-5/18	I	0203	C3						1	81349	CM06E0102J03	CAPACITOR				
MIL-C-27287/1	I	0204	C4						1	81349	CTM103VAJ	CAPACITOR				
MIL-C-5/18	I	0205	C5						1	81349	CM06E0332J03	CAPACITOR				
MIL-C-5/18	I	0206	C6						1	81349	CM05E0510J03	CAPACITOR				
MIL-C-5/18	I	0207	C7						1	81349	CM05E0391J03	CAPACITOR				
MIL-C-5/18	I	0208	C8						1	81349	CM05E0221J03	CAPACITOR				
MIL-C-11015/19	I	0209	C9						1	81349	CK06BX105K	CAPACITOR				
MIL-C-62/1	I	0210	C10						1	81349	CE11C221D	CAPACITOR				
	I	0213	L1						1	96906	MS90537-37	COIL				
	I	0216	P1						1	91662	00-7022-035-000-001	CONNECTOR				
	I	0219	Q1						1	04713	2N2222	TRANSISTOR				

ORIGINAL PAGE IS  
OF POOR QUALITY

SPECIFICATION	DWG STATUS	SHEET/ LINE NO.	PARTS LIST		RCA CORPORATION, NEW YORK, N. Y.					CAMDEN PLANT	REV LTR B	CODE IDENT 49671	PL 8373015	SHEET 03
			ITEM OR FIND NO	QTY REQD PER DASH NO.					U M	CODE IDENT	PART OR IDENTIFYING NO.	NOMENCLATURE OR DESCRIPTION	SYM	
				303	304	303	302	301						
MIL-R-11/8	I	0301	R1						1	81349	RC07GF472K	RESISTOR		
MIL-R-11/8	I	0302	R2						1	81349	RC07GF103K	RESISTOR		
MIL-R-11/8	I	0303	R3						1	81349	RC07GF102K	RESISTOR		
MIL-R-11/8	I	0304	R4						1	81349	RC07GF102K	RESISTOR		
MIL-R-11/8	I	0305	R5						1	81349	RC07GF103K	RESISTOR		
MIL-R-10509/1	I	0306	R6						1	81349	RN60D1002F	RESISTOR		
MIL-R-10509/1	I	0307	R7						1	81349	RN60U1472F	RESISTOR		
MIL-R-11/8	I	0308	R8						1	81349	RC07GF102K	RESISTOR		
	I	0309	R9						1	32997	3009P1=103	RESISTOR		
MIL-R-10509/1	I	0310	R10						1	81349	RN60D1002F	RESISTOR		
MIL-R-11/8	I	0311	R11						1	81349	RC07GF102K	RESISTOR		
	I	0312	R12						1	32997	3009P1=103	RESISTOR		
MIL-R-10509/1	I	0313	R13						1	81349	RN60D5111F	RESISTOR		
MIL-R-10509/1	I	0314	R14						1	81349	RN60D1002F	RESISTOR		
MIL-R-11/8	I	0315	R15						1	81349	RC07GF102K	RESISTOR		

DEC 1320 (6/69)

SPECIFICATION	DWG STATUS	SHEET/ LINE NO.	PARTS LIST		RCA					CAMDEN PLANT	REV LTR B	CODE IDENT	PL 4373015	SHEET 04
			ITEM OR FIND NO.	QTY REQD PER DASH NO.					U M	CODE IDENT	PART OR IDENTIFYING NO	NOMENCLATURE OR DESCRIPTION	S Y M	
				505	504	503	502	501						
	I	0401	TJ1						1	00779	3-582340-1	JACK, TEST=BRN		
	I	0402	TJ2						1	00779	3-582340-2	JACK, TEST=RFD		
	I	0403	TJ3						1	00779	3-582340-3	JACK, TEST=ORG		
	I	0404	TJ4						1	00779	3-582340-4	JACK, TEST=YEL		
	I	0405	TJ5						1	00779	3-582340-5	JACK, TEST=GRN		
	I	0407	TJ10						1	00779	3-582340-10	JACK=TEST, BLK		

SPECIFICATION	DWG STATUS	SHEET/ LINE NO.	PARTS LIST					RCA		CAMDEN PLANT		REV LTR B	CODE IDENT	SHEET
			ITEM OR FIND NO.	QTY REQD PER DASH NO.					U M	CODE IDENT	PART OR IDENTIFYING NO.	NOMENCLATURE OR DESCRIPTION	SYM	
				505	504	503	502	501						
	I	0503	U1						1	04713	HC8601L		PL 0373015	05
	I	0504	U2						1	04713	HC8601L			
	I	0505	U3						1	04713	HC8601L			
	I	0506	U4						1	04713	HC8601L			
	I	0507	U5						1	04713	HC8601L			
	I	0508	U6						1	04713	HC8601L			

DEC 1320 (6/69)

SPECIFICATION	DWG STATUS	SHEET/ LINE NO.	PARTS LIST					RCA		CAMDEN PLANT	REV LTR 8	CODE IDENT	PL 0373015	SHEET 06
			ITEM OR FIND NO.	QTY REQD PER DASH NO.					U M	CODE IDENT	PART OR IDENTIFYING NO.	NOMENCLATURE OR DESCRIPTION	S Y M	
				505	504	503	502	501						
	P	0601	1					X			8674013	SCHEM DIAG, EXTERNAL SYNC		
	P	0602	2					X			8373014	MA PATT=PW, EXTERNAL SYNC		
	I	0604	4					X			8030018	WORKMANSHIP SPEC, BASIC		
	P	0607	7						1		8673774=8	HANDLE=BOARD		
	I	0610	10						1		8524995=1	SPACER, TRANSISTOR		
	I	0614	14					AR			8533343=8	CEMENT		
	I	0615	15					AR			2010105=22	COPPER WIRE, ROUND, TINNED		
	I	0616	16					AR			2010909=612	INSULATING TUBING		
	I	0617	17					AR			2010858=320	SOLDER, TIN=LEAD ALLOY		
	I	0618	18					AR			2010573=1	FLUX, SOLDERING, ALCHL=ROSIN		

DEC 1320 (6/69)

1.11



PARTS LIST	<b>RCA</b>	RCA CORPORATION   NEW YORK, NY	REVISION DATE	PL 8375683	REV LTR -
CAMDEN NJ PLANT					

LIST TITLE:  <h1 style="text-align: center; margin: 0;">CTE MUX</h1>	PREPARED BY <i>John J. Schmitt</i>	DATE 5 AUGUST 1974	REL	CODE IDENT NO. 49671	SHEET OF 1 SHEETS
CHECKED BY		DATE	CONTRACT NO. NAS-9-13767		
NEXT ASSY	USED ON	DESIGN ACTIVITY APPD	DATE		
FIRST APPLICATION					

REVISIONS							
LTR	DESCRIPTION	DATE	APPROVED	LTR	DESCRIPTION	DATE	APPROVED

INTERPRET SYMBOLS USED AS FOLLOWS:			
UNITS OF MEASURE (UM)	QUANTITIES	SYMBOL	
A - Inches B - Feet C - Yards D - Ounces E - Pints F - Quarts G - Gallons H - Barrels J - Pounds L - Pair M - Set N - Kit P - Roll R - Box, Case T - Each	X - Applicable document  O - For ref only  /// - Not used	U - Govt or customer furnished  V - Vendor item. See specification or source control drawing.  K - Govt or customer furnished and installed	

SPECIFICATION	DWG STATUS	SHEET/ LINE NO.	PARTS LIST		RCA		CAMDEN PLANT		REV LTR	CODE IDENT	PL 8375683	SHEET 02	
			ITEM OR FIND NO.	QTY REQD PER DASH NO.					U M	CODE IDENT	PART OR IDENTIFYING NO.	NOMENCLATURE OR DESCRIPTION	S Y M
				505	504	503	502	501					
	I	0201	C1						1	81349	CE11C150D	CAPACITOR	
MIL-C-11015/19	I	0202	C2						1	81349	CK06BX104K	CAPACITOR	
MIL-C-11015/19	I	0203	C3						1	81349	CK06BX104K	CAPACITOR	
MIL-C-11015/19	I	0204	C4						1	81349	CK06BX104K	CAPACITOR	
MIL-C-11015/19	I	0205	C5						1	81349	CK06BX104K	CAPACITOR	
MIL-C-11015/19	I	0206	C6						1	81349	CK06BX104K	CAPACITOR	
MIL-C-11015/19	I	0207	C7						1	81349	CK06BX104K	CAPACITOR	
MIL-C-11015/19	I	0208	C8						1	81349	CK06BX104K	CAPACITOR	
MIL-C-11015/19	I	0209	C9						1	81349	CK06BX104K	CAPACITOR	
MIL-C-11015/19	I	0210	C10						1	81349	CK06BX103K	CAPACITOR	
MIL-C-39003/1	I	0211	C11						1	81349	CSR13C107KM	CAPACITOR	
MIL-C-5/18	I	0212	C12						1	81349	CM06FD561J03	CAPACITOR	
MIL-C-11015/18	I	0213	C13						1	81349	CK05BX100K	CAPACITOR	
MIL-C-11015/18	I	0214	C14						1	81349	CK05BX102K	CAPACITOR	
MIL-C-11015/19	I	0215	C15						1	81349	CK06BX104K	CAPACITOR	
MIL-C-11015/19	I	0216	C16						1	81349	CK06BX104K	CAPACITOR	
MIL-C-5/18	I	0217	C17						1	81349	CM05ED510J03	CAPACITOR	
MIL-C-11015/18	I	0218	C18						1	81349	CK05BX102K	CAPACITOR	
MIL-C-5/18	I	0219	C19						1	81349	CM05ED510J03	CAPACITOR	

SPECIFICATION	DWG STATUS	SHEET/ LINE NO.	PARTS LIST		RCA CORPORATION, NEW YORK, N. Y.					CAMDEN PLANT		REV LTR	CODE IDENT	PL 8375683	SHEET 03	
			ITEM OR FIND NO.	QTY REQD PER DASH NO.					U M	CODE IDENT	PART OR IDENTIFYING NO.	NOMENCLATURE OR DESCRIPTION	SYM			
				505	504	503	502	501								
MIL-C-26655	I	0301	C20						1	81349	CS138E156K					
MIL-C-26655	I	0302	C21						1	81349	CS138C336K					
MIL-S-19500/116	I	0306	CR1						1	81349	JAN1N4148					
MIL-S-19500/116	I	0307	CR2						1	81349	JAN1N4148					
MIL-S-19500/116	I	0308	CR3						1	81349	JAN1N4148					
MIL-S-19500/116	I	0309	CR4						1	81349	JAN1N4148					
	I	0312	P1						1	91662	00-7022-035-000-001					
MIL-R-11/8	I	0315	R1						1	81349	RC07GF103K					
MIL-C-11/8	I	0316	R2						1	81349	RC07GF100K					
MIL-R-11/8	I	0317	R3						1	81349	RC07GF104K					
MIL-C-11/8	I	0318	R4						1	81349	RC07GF100K					
MIL-R-11/8	I	0319	R5						1	81349	RC07GF153K					

DEC 1320 (6/69)

ORIGINAL PAGE IS  
OF POOR QUALITY

SPECIFICATION	DWG STATUS	SHEET/ LINE NO.	PARTS LIST					RCA		CAMDEN PLANT	REV LTR	CODE IDENT	PL 8375683	SHEET 04
			RCA CORPORATION, NEW YORK, N Y					U M	CODE IDENT	PART OR IDENTIFYING NO.	NOMENCLATURE OR DESCRIPTION	SYM		
			ITEM OR FIND NO.	QTY REQD PER DASH NO.										
			505	504	503	502	501							
	I	0401	R6					1	80294	3009P1-503	RESISTOR			
MIL-R-11/8	I	0402	R7					1	81349	RC07GF223K	RESISTOR			
MIL-R-11/8	I	0403	R8					1	81349	RC07GF183K	RESISTOR			
MIL-C-11/8	I	0404	R9					1	81349	RC07GF100K	RESISTOR			
MIL-R-11/8	I	0405	R10					1	81349	RC07GF472K	RESISTOR			
MIL-R-11/8	I	0406	R11					1	81349	RC07GF103K	RESISTOR			
MIL-R-11/8	I	0407	R12					1	81349	RC07GF103K	RESISTOR			
MIL-R-11/8	I	0408	R13					1	81349	RC07GF103K	RESISTOR			
MIL-R-11/8	I	0409	R14					1	81349	RC07GF102K	RESISTOR			
MIL-R-11/8	I	0410	R15					1	81349	RC07GF150K	RESISTOR			
MIL-R-11/8	I	0411	R16					1	81349	RC07GF102K	RESISTOR			
MIL-R-11/8	I	0412	R17					1	81349	RC07GF103K	RESISTOR			
MIL-R-11/8	I	0413	R18					1	81349	RC07GF103K	RESISTOR			
MIL-R-11/8	I	0414	R19					1	81349	RC07GF103K	RESISTOR			
MIL-R-11/8	I	0415	R20					1	81349	RC07GF102K	RESISTOR			
	I	0416	R21					1	80294	3009P1-203	RESISTOR			
MIL-R-11/8	I	0417	R22					1	81349	RC07GF103K	RESISTOR			
MIL-R-11/8	I	0418	R23					1	81349	RC07GF201K	RESISTOR			
MIL-R-11/8	I	0419	R24					1	81349	RC07GF472K	RESISTOR			

SPECIFICATION	DWG STATUS	SHEET/ LINE NO.	PARTS LIST					RCA CORPORATION, NEW YORK N. Y.		CAMDEN PLANT	REV LTR	CODE IDENT	PL 8375683	SHEET 05
			ITEM OR FIND NO.	QTY REQD PER DASH NO.					U M	CODE IDENT	PART OR IDENTIFYING NO.	NOMENCLATURE OR DESCRIPTION	SYM	
				505	504	503	502	501						
MIL-R-11/8	I	0501	R25					1	81349	RC07GF103K	RESISTOR			
MIL-R-11/8	I	0502	R26					1	81349	RC07GF204K	RESISTOR			
MIL-R-11/8	I	0503	R27					1	81349	RC07GF103K	RESISTOR			
MIL-R-11/8	I	0504	R28					1	81349	RC07GF103K	RESISTOR			
MIL-R-11/8	I	0505	R29					1	81349	RC07GF201K	RESISTOR			
MIL-R-11/8	I	0506	R30					1	81349	RC07GF472K	RESISTOR			
MIL-C-11/8	I	0507	R31					1	81349	RC07GF100K	RESISTOR			
MIL-R-11/8	I	0508	R32					1	81349	RC07GF103K	RESISTOR			
MIL-R-11/8	I	0509	R33					1	81349	RC07GF202K	RESISTOR			
MIL-C-11/8	I	0510	R34					1	81349	RC07GF100K	RESISTOR			
MIL-R-11/8	I	0511	R35					1	81349	RC07GF151K	RESISTOR			
MIL-R-11/8	I	0512	R36					1	81349	RC20GF301K	RESISTOR			
	I	0515	TJ1					1	00779	3-582340-1	JACK, TEST-BRN			
	I	0516	TJ2					1	00779	3-582340-2	JACK, TEST-RED			
	I	0517	TJ3					1	00779	3-582340-3	JACK, TEST-ORG			
	I	0518	TJ4					1	00779	3-582340-4	JACK, TEST-YEL			
	I	0519	TJ5					1	00779	3-582340-5	JACK, TEST-GPN			

DEC 1320 (6/69)

SPECIFICATION	DWG STATUS	SHEET/ LINE NO.	PARTS LIST					RCA		CAMDEN PLANT		REV LTR	CODE IDENT	PL 8375683.	SHEET 06
			ITEM OR FIND NO.	QTY REQD PER DASH NO.					U M	CODE IDENT	PART OR IDENTIFYING NO.	NOMENCLATURE OR DESCRIPTION	SYM		
				505	504	503	502	501							
	I	0601	TJ6						1	00779	3-582340-6			JACK, TEST-BLU	
	I	0605	TJ10						1	00779	3-582340-0			JACK, TEST-BLK	
	I	0608	U1						1	04713	MC4044L			INTEGRATED CIRCUIT	
	I	0609	U2						1	04713	MC1458L			INTEGRATED CIRCUIT	
	I	0610	U3						1	04713	MC4024L			INTEGRATED CIRCUIT	
	I	0611	U4						1	04713	MC7490L			INTEGRATED CIRCUIT	
	I	0612	U5						1	04713	MC7473L			INTEGRATED CIRCUIT	
	I	0613	U6						1	04713	MC7404L			INTEGRATED CIRCUIT	
	I	0614	U7						1	04713	MC7400L			INTEGRATED CIRCUIT	
	I	0615	U8						1	04713	MC7400L			INTEGRATED CIRCUIT	
	I	0616	U9						1	04713	MC7420L			INTEGRATED CIRCUIT	
	I	0617	U10						1	04713	MC7400L			INTEGRATED CIRCUIT	
	I	0618	U11						1	04713	MC7430L			INTEGRATED CIRCUIT	
	I	0619	U12						1	01295	SN74L04J			INTEGRATED CIRCUIT	

SPECIFICATION	DWG STATUS	SHEET/ LINE NO.	PARTS LIST		RCA		CAMDEN PLANT		REV LTR	CODE IDENT	PL 8375683	SHEET 07	
			ITEM OR FIND NO.	QTY REQD PER DASH NO.					U M	CODE IDENT	PART OR IDENTIFYING NO.	NOMENCLATURE OR DESCRIPTION	S Y M
				505	504	503	502	501					
	I	0701	U13						1	04713	MC7473L	INTEGRATED CIRCUIT	
	I	0702	U14						1	04713	MC7493L	INTEGRATED CIRCUIT	
	I	0703	U15						1	01295	SN74165J	INTEGRATED CIRCUIT	
	I	0704	U16						1	01295	SN74165J	INTEGRATED CIRCUIT	
	I	0705	U17						1	01295	SN74165J	INTEGRATED CIRCUIT	
	I	0706	U18						1	01295	SN74165J	INTEGRATED CIRCUIT	
	I	0707	U19						1	04713	MC1712L	INTEGRATED CIRCUIT	
	I	0708	U20						1	04713	MC1712L	INTEGRATED CIRCUIT	
	I	0709	U21						1	04713	MC7493L	INTEGRATED CIRCUIT	
MIL-S-19500/127	I	0711	VR1						1	81349	JAN1N751A	DIODE, ZENER	
MIL-S-19500/117	I	0712	VR2						1	81349	JAN1N963B	DIODE	
MIL-S-19500/127	I	0713	VR3						1	81349	JAN1N753A	DIODE, ZENER	

DEC 1320 (6/69)

SPECIFICATION	DWG STATUS	SHEET/ LINE NO.	PARTS LIST					RCA		CAMDEN PLANT	REV LTR	CODE IDENT	PL 8375683	SHEET 08
			ITEM OR FIND NO.	QTY REQD PER DASH NO.					U M	CODE IDENT	PART OR IDENTIFYING NO.	NOMENCLATURE OR DESCRIPTION	SYM	
				503	504	503	502	501						
	P	0801	1					X			8375685	SCHEMATIC CTE MUX		
	P	0802	2					X			8676333	MA PATT-PW, CTE MUX		
	I	0804	4					X			8030018	WORKMANSHIP SPEC, BASIC		
	P	0807	7								8673774	HANDLE-BOARD		
	I	0814	14					AR			8533343-8	CEMENT		
	I	0815	15					AR			2010105-22	COPPER WIRE, ROUND, TINNED		
	I	0816	16					AR			2010909-812	INSULATING TUBING		
	I	0817	17					AR			2010858-320	SOLDER, TIN-LEAD ALLOY		
	I	0818	18					AR			2010573-1	FLUX, SOLDERING, ALCHL-RDSIN		



<b>PARTS LIST</b>		<b>RCA</b>		RCA CORPORATION   NEW YORK, NY		REVISION DATE	PL 8372844	REV LTR <b>J</b>			
LIST TITLE:  BOARD ASSEMBLY AUDIO INPUT				CAMDEN PLANT		PREPARED BY	DATE	REL	CODE IDENT NO. <b>49671</b>	SHEET OF <b>10</b> SHEETS	
				8673734-501	SKYLAB-GSE	CHECKED BY			DATE	CONTRACT NO. NAS 8-27968	
				NEXT ASSY	USED ON	DESIGN ACTIVITY APPD		DATE			
				FIRST APPLICATION							
REVISIONS											
LTR	DESCRIPTION	DATE	APPROVED	LTR	DESCRIPTION	DATE	APPROVED				
A	REVISED			J	REVISED						
B	REVISED										
C	REVISED										
D	REVISED										
E	REVISED										
F	REVISED										
G	REVISED										
H	REVISED										
INTERPRET SYMBOLS USED AS FOLLOWS:											
UNITS OF MEASURE (UM)			QUANTITIES	SYMBOL							
A - Inches	H - Barrels	T - Each	X - Applicable document  O - For ref only	U - Govt or customer furnished  K - Govt or customer furnished and installed		* - Vendor Item. See specification or source control drawing.					
B - Feet	J - Pounds										
C - Yards	L - Pair										
D - Ounces	M - Set										
E - Pints	N - Kit										
F - Quarts	P - Roll										
G - Gallons	R - Box, Case										

98379

SPECIFICATION	DWG STATUS	SHEET/ LINE NO.	PARTS LIST		RCA		CAMDEN PLANT		REV LTR J	CODE IDENT 49671	PL 8372844	SHEET 02	
			ITEM OR FIND NO.	QTY REQD PER DASH NO.					U .M	CODE IDENT	PART OR IDENTIFYING NO.	NOMENCLATURE OR DESCRIPTION	SYM
				503	504	503	502	501					
MIL-C-11015/19	I	0201	C1						1	81349	CK06BX103K	CAPACITOR	
MIL-C-11015/19	I	0202	C2						1	81349	CK06BX103K	CAPACITOR	
MIL-C-11015/18	I	0203	C3						1	81349	CK05BX102K	CAPACITOR	
MIL-C-5/18	I	0204	C4						1	81349	CM05ED510J03	CAPACITOR	
MIL-C-11015/19	I	0205	C5						1	81349	CK06BX103K	CAPACITOR	
MIL-C-11015/19	I	0206	C6						1	81349	CK06BX103K	CAPACITOR	
MIL-C-26655	I	0208	C7						1	81349	CS1386475K	CAPACITR (SPSD BY CSR136475K-)	
MIL-C-11015/19	I	0209	C8						1	81349	CK06BX103K	CAPACITOR	
MIL-C-11015/19	I	0210	C9						1	81349	CK06BX103K	CAPACITOR	
MIL-C-26655	I	0211	C10						1	81349	CS1386475K	CAPACITR (SPSD BY CSR136475K-)	
	I	0212	C11						1	72982	8131-050-631-105M	CAPACITOR	
MIL-C-5/18	I	0214	C12						1	81349	CM06FD202J03	CAPACITOR	
MIL-C-5/18	I	0215	C13						1	81349	CM05FD301J03	CAPACITOR	
MIL-C-11015/19	I	0216	C14						1	81349	CK06BX103K	CAPACITOR	
MIL-C-11015/19	I	0217	C15						1	81349	CK06BX103K	CAPACITOR	
MIL-C-5/18	I	0218	C16						1	81349	CM06F0821J03	CAPACITOR	
MIL-C-5/18	I	0219	C17						1	81349	CM06F0681J03	CAPACITOR	

ORIGINAL PAGE IS  
OF POOR QUALITY

SPECIFICATION	DWG STATUS	SHEET/ LINE NO.	PARTS LIST		CAMDEN PLANT		REV	CODE IDENT	SYM		
			RCA CORPORATION NEW YORK, N. Y.		LTR	PL 8372844					
			ITEM OR FIND NO.	QTY REQD PER DASH NO.						U	CODE IDENT
	303	304	303	302	301	M					
	I	0301	C18					1	72982	8131-050-651-105H	CAPACITOR
MIL-C-11015/19	I	0302	C19					1	81349	CK068X103K	CAPACITOR
MIL-C-11015/19	I	0303	C20					1	81349	CK068X103K	CAPACITOR
MIL-C-5/18	I	0304	C21					1	81349	CM05ED510J03	CAPACITOR
MIL-C-5/18	I	0305	C22					1	81349	CM05FD121J03	CAPACITOR
MIL-C-5/18	I	0306	C23					1	81349	CM05ED510J03	CAPACITOR
MIL-C-5/18	I	0308	C24					1	81349	CM05FD121J03	CAPACITOR
MIL-C-5/18	I	0309	C25					1	81349	CM05FD361J03	CAPACITOR
MIL-C-5/18	I	0310	C26					1	81349	CM05ED510J03	CAPACITOR
MIL-C-11015/18	I	0311	C27					1	81349	CK058X102K	CAPACITOR
MIL-C-5/18	I	0312	C28					1	81349	CM05ED510J03	CAPACITOR
MIL-C-11015/19	I	0314	C29					1	81349	CK068X103K	CAPACITOR
MIL-C-11015/19	I	0315	C30					1	81349	CK068X103K	CAPACITOR
MIL-C-26655	I	0316	C31					1	81349	CS138C336K	CAPACITOR
MIL-C-26655	I	0317	C32					1	81349	CS138E156K	CAPACITOR
MIL-C-26655	I	0318	C33					1	81349	CS138E156K	CAPACITOR
MIL-C-26655	I	0319	C34					1	81349	CS138C336K	CAPACITOR

SPECIFICATION	DWG STATUS	SHEET/ LINE NO.	PARTS LIST					RCA		CAMDEN PLANT		REV LTR J	CODE IDENT 49671	PL 8372844	SHEET 04
			ITEM OR FIND NO.	QTY REQD PER DASH NO.					U M	CODE IDENT	PART OR IDENTIFYING NO.	NOMENCLATURE OR DESCRIPTION	SYM		
				505	504	503	502	501							
MIL-C-5/18	I	0401	C35						1	81349	CM05ED200J03		CAPACITOR		
	I	0402	CR1						1	81349	1N5711		DIODE		
	I	0403	CR2						1	81349	1N5711		DIODE		
	I	0404	CR3						1	81349	1N4148		DIODE		
	I	0405	P1						1	91662	00-70225035-000-001		CONNECTOR		
	I	0406	Q1						1		2N4859		TRANSISTOR		
	I	0407	Q2						1		2N2369A		TRANSISTOR		
	I	0408	Q3						1		2N2907A		TRANSISTOR		
	I	0409	Q4						1		2N2369A		TRANSISTOR		
	I	0410	Q5						1		2N2907A		TRANSISTOR		
	I	0411	Q6						1		2N4859		TRANSISTOR		
	I	0412	Q7						1		2N4859		TRANSISTOR		
MIL-R-11/8	I	0413	R1						1	81349	RC07GF102K		RESISTOR		
MIL-R-11/8	I	0414	R2						1	81349	RC07GF102K		RESISTOR		
MIL-R-11/8	I	0415	R3						1	81349	RC07GF103K		RESISTOR		
MIL-R-10509	I	0416	R4						1	81349	RN60D1622F		RESISTOR		

SPECIFICATION	DWG STATUS	SHEET/ LINE NO.	PARTS LIST					RCA		CAMDEN PLANT	REV LTR J	CODE IDENT	PL 0972844	SHEET 03
			ITEM OR FIND NO.	QTY REQD PER DASH NO.					U M	CODE IDENT	PART OR IDENTIFYING NO.	NOMENCLATURE OR DESCRIPTION	SYM	
				505	504	503	502	501						
MIL-R-10509/1	I	0501	R5					1	81349	RN60D1621F	RESISTOR			
MIL-R-10509/1	I	0502	R6					1	81349	RN60D8251F	RESISTOR			
MIL-R-11/3	I	0503	R7					1	81349	RC07GF120K	RESISTOR			
MIL-R-11/3	I	0504	R8					1	81349	RC07GF120K	RESISTOR			
MIL-R-10509/1	I	0505	R9					1	81349	RN60D1332F	RESISTOR			
MIL-R-10509/1	I	0506	R10					1	81349	RN60D6811F	RESISTOR			
MIL-R-10509/1	I	0508	R11					1	81349	RN60D6810F	RESISTOR			
MIL-R-10509/1	I	0509	R12					1	81349	RN60D6810F	RESISTOR			
MIL-R-11/8	I	0510	R13					1	81349	RC07GF192K	RESISTOR			
MIL-R-10509/1	I	0511	R14					1	81349	RN60D6812F	RESISTOR			
MIL-R-11/3	I	0512	R15					1	81349	RC07GF120K	RESISTOR			
MIL-R-11/3	I	0514	R16					1	81349	RC07GF120K	RESISTOR			
MIL-R-11/8	I	0515	R17					1	81349	RC07GF104K	RESISTOR			
MIL-R-11/8	I	0516	R18					1	81349	RC07GF103K	RESISTOR			
MIL-R-11/8	I	0517	R19					1	81349	RC07GF221K	RESISTOR			
MIL-R-11/3	I	0518	R20					1	81349	RC07GF120K	RESISTOR			
MIL-R-11/3	I	0519	R21					1	81349	RC07GF120K	RESISTOR			

DEC 1320 (6/69)

SPECIFICATION	DWG STATUS	SHEET/ LINE NO.	PARTS LIST		RCA		CAMDEN PLANT		REV LTR J	CODE IDENT 49671	PL 8372044	SHEET 06	
			ITEM OR FIND NO.	QTY REQD PER DASH NO.					U M	CODE IDENT	PART OR IDENTIFYING NO.	NOMENCLATURE OR DESCRIPTION	SYM
				503	504	503	502	501					
MIL-R-11/8	I	0601	R22						1	81349	RC07GF153K	RESISTOR	
MIL-R-11/8	I	0602	R23						1	81349	RC07GF102K	RESISTOR	
	I	0603	R24						1	80294	3009P1=502	RESISTOR	
MIL-R-11/8	I	0604	R25						1	81349	RC07GF102K	RESISTOR	
MIL-R-10509/1	I	0605	R26						1	81349	RN60D3481F	RESISTOR	
MIL-R-10509/1	I	0606	R27						1	81349	RN60D1001F	RESISTOR	
MIL-R-11/8	I	0608	R28						1	81349	RC07GF102K	RESISTOR	
MIL-R-10509/1	I	0609	R29						1	81349	RN60D5112F	RESISTOR	
MIL-R-10509/1	I	0610	R30						1	81349	RN60D5112F	RESISTOR	
MIL-R-11/3	I	0611	R31						1	81349	RC07GF120K	RESISTOR	
MIL-R-11/3	I	0612	R32						1	81349	RC07GF120K	RESISTOR	
MIL-R-11/8	I	0614	R33						1	81349	RC07GF562K	RESISTOR	
MIL-R-10509/1	I	0615	R34						1	81349	RN60D5112F	RESISTOR	
MIL-R-10509/1	I	0616	R35						1	81349	RN60D5112F	RESISTOR	
	I	0617	R36						1	80294	3009P1=502	RESISTOR	
MIL-R-11/8	I	0618	R37						1	81349	RC07GF153K	RESISTOR	
	I	0619	R38						1	80294	3009P1=201	RESISTOR	

C.3

ORIGINAL PAGE IS  
OF POOR QUALITY

SPECIFICATION	DWG STATUS	SHEET/ LINE NO.	PARTS LIST		RCA		CAMDEN PLANT		REV	CODE IDENT	SHEET 07
			RCA CORPORATION, NEW YORK N Y						LTR	49671	
			ITEM OR FIND NO.	QTY REQD PER DASH NO.					U	CODE	
	505	504	503	502	501	M	IDENT	IDENTIFYING NO.	DESCRIPTION	S	
MIL-R-11/8	I	0701	R39					1	81349	RC07GF122K	RESISTOR
MIL-R-11/8	I	0702	R40					1	81349	RC07GF120K	RESISTOR
MIL-R-11/8	I	0703	R41					1	81349	RC07GF120K	RESISTOR
MIL-R-11/8	I	0704	R42					1	81349	RC07GF102K	RESISTOR
MIL-R-11/8	I	0705	R43					1	81349	RC07GF102K	RESISTOR
MIL-R-11/8	I	0706	R44					1	81349	RC07GF682K	RESISTOR
MIL-R-11/8	I	0708	R45					1	81349	RC07GF102K	RESISTOR
MIL-R-11/8	I	0709	R46					1	81349	RC07GF472K	RESISTOR
MIL-R-11/8	I	0710	R47					1	81349	RC07GF222K	RESISTOR
MIL-R-11/8	I	0711	R48					1	81349	RC07GF152K	RESISTOR
MIL-R-11/8	I	0712	R49					1	81349	RC07GF471K	RESISTOR
MIL-R-11/8	I	0714	R50					1	81349	RC07GF102K	RESISTOR
MIL-R-11/8	I	0715	R51					1	81349	RC07GF682K	RESISTOR
MIL-R-11/8	I	0716	R52					1	81349	RC07GF102K	RESISTOR
MIL-R-11/8	I	0717	R53					1	81349	RC07GF472K	RESISTOR
MIL-R-11/8	I	0718	R54					1	81349	RC07GF222K	RESISTOR
MIL-R-11/8	I	0719	R55					1	81349	RC07GF152K	RESISTOR

DEC 1320 (6/69)

SPECIFICATION	DWG STATUS	SHEET/ LINE NO.	PARTS LIST					RCA		CAMDEN PLANT		REV LTR	CODE IDENT	PL 8372844	SHEET 08
			ITEM OR FIND NO.	QTY REQD PER DASH NO.					U M	CODE IDENT	PART OR IDENTIFYING NO.	NOMENCLATURE OR DESCRIPTION	SYM		
				505	504	503	502	501							
MIL-R-11/B	I	0801	R56					1	81349	RC07GF471K		RESISTOR			
MIL-R-10509/1	I	0802	R57					1	81349	RN60D1001F		RESISTOR			
MIL-R-10509/1	I	0803	R58					1	81349	RN60D1001F		RESISTOR			
MIL-R-10509/1	I	0804	R59					1	81349	RN60D2611F		RESISTOR			
MIL-R-22684/1	I	0805	R60					1	81349	RL07S201J		RESISTOR			
MIL-R-11/8	I	0806	R61					1	81349	RC07GF333K		RESISTOR			
MIL-R-10509/1	I	0808	R62					1	81349	RN60D1002F		RESISTOR			
MIL-R-22684/1	I	0809	R63					1	81349	RL07S202J		RESISTOR			
MIL-R-11/3	I	0810	R64					1	81349	RC07GF120K		RESISTOR			
MIL-R-11/3	I	0811	R65					1	81349	RC07GF120K		RESISTOR			
MIL-R-11/8	I	0812	R66					1	81349	RC07GF103K		RESISTOR			
MIL-C-11/8	I	0813	R67					1	81349	RC07GF180K		RESISTOR			
MIL-R-11/3	I	0814	R68					1	81349	RC20GF680K		RESISTOR			
MIL-R-11/3	I	0815	R69					1	81349	RC20GF820K		RESISTOR			
MIL-R-11/3	I	0816	R70					1	81349	RC20GF331K		RESISTOR			
MIL-R-11/8	I	0817	R71					1	81349	RC07GF102K		RESISTOR			
MIL-R-11/8	I	0818	R72					1	81349	RC07GF101K		RESISTOR			
MIL-R-10509/1	I	0819	R73					1	81349	RN60D1001F		RESISTOR			



SPECIFICATION	DWG STATUS	SHEET/ LINE NO.	PARTS LIST					RCA		CAMDEN PLANT	REV LTR J	CODE IDENT	PL 8372844	SHEET 09
			ITEM OR FIND NO.	QTY REQD PER DASH NO.					U M	CODE IDENT	PART OR IDENTIFYING NO.	NOMENCLATURE OR DESCRIPTION	SYM	
				505	504	503	502	501						
MIL-R-10509/1	I	0901	R74					1	81349	RN60D7500F	RESISTOR			
	I	0902	T1					1	00348	VM14H	TRANSFORMER			
	I	0903	TJ1					1	00779	3-582340-1	JACK, TEST-BRN			
	I	0904	TJ2					1	00779	3-582340-2	JACK, TEST-RED			
	I	0905	TJ3					1	00779	3-582340-3	JACK, TEST-ORG			
	I	0906	TJ4					1	00779	3-582340-4	JACK, TEST-YEL			
	I	0907	TJ5					1	00779	3-582340-5	JACK, TEST-GRN			
	I	0909	TJ10					1	00779	3-582340-0	JACK, TEST-BLK			
	I	0911	U1					1	04713	MC1741CL	INTEGRATED CIRCUIT			
	I	0912	U2					1	04713	MC1709CL	INTEGRATED CIRCUIT			
	I	0913	U3					1	04713	MC1741CL	INTEGRATED CIRCUIT			
	I	0914	U4					1	04713	MC1458CL	INTEGRATED CIRCUIT			
	I	0915	U5					1	04713	MC1741CL	INTEGRATED CIRCUIT			
	I	0916	U6					1	04713	MC1712CL	INTEGRATED CIRCUIT			
	I	0917	VR1					1		1N3022B	DIODE, ZENER			
	I	0918	VR2					1		1N3022B	DIODE, ZENER			
	I	0919	VR3					1		1N753A	DIODE, ZENER			

DEC 1320 (6/69)

ORIGINAL PAGE IS  
OF POOR QUALITY

SPECIFICATION	DWG STATUS	SHEET/ LINE NO.	PARTS LIST					RCA		CAMDEN PLANT	REV LTR J	CODE IDENT	PL 8372844	SHEET 10
			ITEM OR FIND NO.	QTY REQD PER DASH NO.					U M	CODE IDENT	PART OR IDENTIFYING NO.	NOMENCLATURE OR DESCRIPTION	S Y M	
				503	504	509	502	501						
	P	1001	1					X			8372873	SCHEM DIAG; AUDIO INPUT		
	P	1002	2					X			8372845	MA PATT-PW; AUDIO INPUT		
	I	1004	4					X			8030018	WORKMANSHIP SPEC, BASIC		
	P	1007	7						1		8673774-4	HANDLE-BOARD		
	I	1010	10						7		8526995-1	SPACER, TRANSISTOR		
	I	1014	14					AR			8533342-8	CEMENT		
	I	1015	15					AR			2010105-22	COPPER WIRE, ROUND, TINNED		
	I	1016	16					AR			2010909-012	INSULATING TUBING		
	I	1017	17					AR			2010888-320	SOLDER, TIN-LEAD ALLOY		
	I	1018	18					AR			2010573-1	FLUX, SOLDERING, ALCHL-ROSIN		

PARTS LIST



RCA CORPORATION | NEW YORK, NY

REVISION DATE

PL 8372846

REV LTR

H

CAMDEN PLANT

LIST TITLE:

BOARD ASSEMBLY  
VIDEO INPUT

PREPARED BY DATE

REL

CODE IDENT NO.

49671

SHEET 1 OF 11 SHEETS

CHECKED BY DATE

CONTRACT NO

NAS 8-27968

8673734-501

SKYLAR-GSE

NEXT ASSY

USED ON

DESIGN ACTIVITY APPD DATE

FIRST APPLICATION

REVISIONS

LTR	DESCRIPTION	DATE	APPROVED	LTR	DESCRIPTION	DATE	APPROVED
A	REVISED						
B	REVISED						
C	REVISED						
D	REVISED						
E	REVISED						
F	REVISED						
G	REVISED						
H	REVISED						

INTERPRET SYMBOLS USED AS FOLLOWS:

UNITS OF MEASURE (UM)			QUANTITIES	SYMBOL	
A — Inches	H — Barrels	T — Each	X — Applicable document	U — Govt or customer furnished	* — Vendor item. See specification or source control drawing
B — Feet	J — Pounds			K — Govt or customer furnished and installed	
C — Yards	L — Pair		O — For ref only		
D — Ounces	M — Set				
E — Pints	N — Kit				
F — Quarts	P — Roll				
G — Gallons	R — Box, Case				

64379

SPECIFICATION	DWG STATUS	SHEET/ LINE NO.	PARTS LIST		RCA CORPORATION NEW YORK, N. Y.					CAMDEN PLANT	REV LTR H	CODE IDENT	PL 8972846	SHEET 02
			ITEM OR FIND NO.	QTY REQD PER DASH NO.					U M	CODE IDENT	PART OR IDENTIFYING NO.	NOMENCLATURE OR DESCRIPTION	SYM	
				505	504	503	502	501						
MIL-C-11015/18	I	0201	C1					1	81349	CK05BX102K	CAPACITOR			
MIL-C-11015/19	I	0202	C2					1	81349	CK06BX103K	CAPACITOR			
MIL-C-11015/19	I	0203	C3					1	81349	CK06BX103K	CAPACITOR			
MIL-C-5/18	I	0204	C4					1	81349	CM05E0510J03	CAPACITOR			
MIL-C-27287/1	I	0205	C5					1	81349	CTM103VAJ	CAPACITOR			
MIL-C-11015/19	I	0206	C6					1	81349	CK06BX103K	CAPACITOR			
MIL-C-11015/19	I	0208	C7					1	81349	CK06BX103K	CAPACITOR			
MIL-C-26655	I	0209	C8					1	81349	CS13BC396K	CAPACITOR			
MIL-C-11015/18	I	0210	C9					1	81349	CK05BX102K	CAPACITOR			
MIL-C-11015/19	I	0211	C10					1	81349	CK06BX103K	CAPACITOR			
MIL-C-11015/19	I	0212	C11					1	81349	CK06BX103K	CAPACITOR			
MIL-C-5/18	I	0214	C12					1	81349	CM05E0510J03	CAPACITOR			
MIL-C-5/18	I	0215	C13					1	81349	CM05F0101J03	CAPACITOR			
MIL-C-11015/19	I	0216	C14					1	81349	CK06BX103K	CAPACITOR			
MIL-C-11015/19	I	0217	C15					1	81349	CK06BX103K	CAPACITOR			
MIL-C-5/18	I	0218	C16					1	81349	CM05E0510J03	CAPACITOR			
MIL-C-11015/19	I	0219	C17					1	81349	CK06BX104K	CAPACITOR			

ORIGINAL PAGE IS  
OF POOR QUALITY

SPECIFICATION	DWG STATUS	SHEET/ LINE NO.	PARTS LIST		RCA		CAMDEN PLANT		REV	CODE IDENT	SHEET 03
			RCA CORPORATION NEW YORK N Y					LTR	49671	PL 8372846	
			ITEM OR FIND NO	QTY REQD PER DASH NO.					U M	CODE IDENT	
505	504	503		502	501						
MIL-C-11015/19	I	0301	C18					1	81349	CK06BX103K	CAPACITOR
MIL-C-11015/19	I	0302	C19					1	81349	CK06BX103K	CAPACITOR
MIL-C-11015/19	I	0303	C20					1	81349	CK06BX103K	CAPACITOR
MIL-C-5/18	I	0304	C21					1	81349	CM05FD271J03	CAPACITOR
MIL-C-5/18	I	0305	C22					1	81349	CM05E0510J03	CAPACITOR
MIL-C-5/18	I	0306	C23					1	81349	CM05E0510J03	CAPACITOR
MIL-C-11015/19	I	0308	C24					1	81349	CK06BX103K	CAPACITOR
MIL-C-27287/1	I	0309	C25					1	81349	CTM103VAJ	CAPACITOR
MIL-C-5/18	I	0310	C26					1	81349	CM06FD272J03	CAPACITOR
MIL-C-5/18	I	0311	C27					1	81349	CM06FN561J03	CAPACITOR
MIL-C-5/18	I	0312	C28					1	81349	CM05FD291J03	CAPACITOR
MIL-C-5/18	I	0314	C29					1	81349	CM05E0510J03	CAPACITOR
MIL-C-5/18	I	0315	C30					1	81349	CM05E0270J03	CAPACITOR
MIL-C-11015/19	I	0316	C31					1	81349	CK06BX103K	CAPACITOR
MIL-C-11015/19	I	0317	C32					1	81349	CK06BX104K	CAPACITOR
MIL-C-11015/19	I	0318	C33					1	81349	CK06BX104K	CAPACITOR
MIL-C-11015/19	I	0319	C34					1	81349	CK06BX104K	CAPACITOR

DEC 1320 (6/69)

SPECIFICATION	DWG STATUS	SHEET/ LINE NO.	PARTS LIST		RCA					CAMDEN PLANT		REV	CODE IDENT	PL 8372846		SHEET
			RCA CORPORATION NEW YORK N. Y.					LTR	49671			04				
			ITEM OR FIND NO.	QTY REQD PER DASH NO.					U M	CODE IDENT	PART OR IDENTIFYING NO	NOMENCLATURE OR DESCRIPTION	S M			
	505	504	503	502	501											
MIL-C-26655	I	0401	C35					1	81349	CS198C336K	CAPACITOR					
MIL-C-26655	I	0402	C36					1	81349	CS198E156K	CAPACITOR					
MIL-C-26655	I	0403	C37					1	81349	CS198E156K	CAPACITOR					
MIL-C-11015/18	I	0404	C38					1	81349	CK05BX102K	CAPACITOR					
MIL-C-11015/18	I	0405	C39					1	81349	CK05BX102K	CAPACITOR					
MIL-C-5/18	I	0406	C40					1	81349	CM05E0510J03	CAPACITOR					
	I	0407	CR1					1	81349	1N4148	DIODE					
	I	0408	CR2					1	81349	1N4148	DIODE					
	I	0409	CR3					1	81349	1N4148	DIODE					
	I	0410	CR4					1	81349	1N4148	DIODE					
	I	0411	CR5					1	81349	1N4148	DIODE					
	I	0412	L1						96906	MS90537-37	COIL					
	I	0413	P1					1	91662	00-7022-035-000-001	CONNECTOR					
	I	0415	Q1					1		2N4859	TRANSISTOR					
	I	0416	Q2					1		2N2907A	TRANSISTOR					
	I	0417	Q3					1		2N2222A	TRANSISTOR					
	I	0418	Q4					1		2N4859	TRANSISTOR					
	I	0419	Q5					1		2N2369A	TRANSISTOR					

SPECIFICATION	DWG STATUS	SHEET/ LINE NO.	PARTS LIST					RCA		CAMDEN PLANT		REV LTR H	CODE IDENT	PL 8372846	SHEET 05
			RCA CORPORATION, NEW YORK, N. Y.					U M	CODE IDENT	PART OR IDENTIFYING NO.	NOMENCLATURE OR DESCRIPTION	S Y M			
			ITEM OR FIND NO.	QTY REQD PER DASH NO.											
			505	504	503	502	501								
	I	0501	Q6					1				2N2907A	TRANSISTOR		
	I	0502	Q7					1				2N2369A	TRANSISTOR		
	I	0503	Q8					1				2N2907A	TRANSISTOR		
	I	0504	Q9					1				2N2369A	TRANSISTOR		
MIL-R-111/8	I	0505	R1					1	81349		RC07GF102K	RESISTOR			
MIL-R-22684/2	I	0506	R2					1	81349		RL205301J	RESISTOR			
	I	0507	R3					1	80294		3009Pi=101	RESISTOR			
MIL-R-85182/3	I	0508	R4					1	81349		RN60D1101F	RESISTOR			
MIL-R-22684/1	I	0509	R5					1	81349		RL07S201J	RESISTOR			
MIL-R-11/3	I	0510	R6					1	81349		RC07GF120K	RESISTOR			
	I	0512	R7					1	81349		RC07GF120K	RESISTOR			
MIL-R-10509/1	I	0513	R8					1	81349		RN60D1002F	RESISTOR			
MIL-R-22684/1	I	0514	R9					1	81349		RL07S202J	RESISTOR			
MIL-R-11/8	I	0515	R10					1	81349		RC07GF101K	RESISTOR			
MIL-R-11/8	I	0516	R11					1	81349		RC07GF102K	RESISTOR			
MIL-R-11/8	I	0517	R12					1	81349		RC07GF470K	RESISTOR			
MIL-R-11/3	I	0518	R13					1	81349		RC07GF120K	RESISTOR			
MIL-R-11/8	I	0519	R14					1	81349		RC07GF222K	RESISTOR			

DEC 1320 (6/69)

SPECIFICATION	DWG STATUS	SHEET/ LINE NO.	PARTS LIST					RCA		CAMDEN PLANT		REV LTR H	CODE IDENT	PL 1372846	SHEET 06
			ITEM OR FIND NO.	QTY REQD PER DASH NO.					U M	CODE IDENT	PART OR IDENTIFYING NO	NOMENCLATURE OR DESCRIPTION	S M		
				505	504	503	502	501							
MIL-R-11/8	I	0601	R15					1	81349	RC07GF470K	RESISTOR				
MIL-R-11/8	I	0602	R16					1	81349	RC07GF103K	RESISTOR				
MIL-R-11/3	I	0603	R17					1	81349	RC07GF120K	RESISTOR				
MIL-R-10509/1	I	0604	R18					1	81349	RN60D1001F	RESISTOR				
MIL-R-11/8	I	0605	R19					1	81349	RC07GF103K	RESISTOR				
MIL-R-22684/2	I	0606	R20					1	81349	RL20S431J	RESISTOR				
	I	0608	R21					1	80294	3009P1-201	RESISTOR				
MIL-R-10509/1	I	0609	R22					1	81349	RN60D9091F	RESISTOR				
MIL-R-10509/1	I	0610	R23					1	81349	RN60D9091F	RESISTOR				
MIL-R-22684/1	I	0611	R24					1	81349	RL07S201J	RESISTOR				
MIL-R-10509/1	I	0612	R25					1	81349	RN60D9161F	RESISTOR				
MIL-R-11/3	I	0614	R26					1	81349	RC07GF120K	RESISTOR				
MIL-R-11/3	I	0615	R27					1	81349	RC07GF120K	RESISTOR				
MIL-R-10509/1	I	0616	R28					1	81349	RN60D1002F	RESISTOR				
MIL-R-22684/1	I	0617	R29					1	81349	RL07S202J	RESISTOR				
MIL-R-10509/1	I	0618	R30					1	81349	RN60D1001F	RESISTOR				
MIL-R-10509/1	I	0619	R31					1	81349	RN60D3831F	RESISTOR				



ORIGINAL PAGE IS  
OF POOR QUALITY

SPECIFICATION	DWG STATUS	SHEET/ LINE NO.	PARTS LIST					RCA		CAMDEN PLANT		REV LTR H	CODE IDENT	PL 8372846	SHEET 57
			ITEM OR FINO NO.	QTY REQD PER DASH NO.					U M	CODE IDENT	PART OR IDENTIFYING NO	NOMENCLATURE OR DESCRIPTION	S M		
				505	504	503	502	501							
MIL-R-22684/1	I	0701	R32					1	81349	RL07S201J		RESISTOR			
MIL-R-10509/1	I	0702	R33					1	81349	RN60D2371F		RESISTOR			
MIL-R-11/3	I	0703	R34					1	81349	RC07GF120K		RESISTOR			
MIL-R-11/3	I	0704	R35					1	81349	RC07GF120K		RESISTOR			
MIL-R-10509/1	I	0705	R36					1	81349	RN60D1472F		RESISTOR			
MIL-R-22684/1	I	0706	R37					1	81349	RL07S202J		RESISTOR			
MIL-R-11/8	I	0708	R38					1	81349	RC07GF103K		RESISTOR			
MIL-R-10509/1	I	0709	R39					1	81349	RN60D1001F		RESISTOR			
MIL-R-10509/1	I	0710	R40					1	81349	RN60D1000F		RESISTOR			
MIL-R-10509/1	I	0711	R41					1	81349	RN60D3621F		RESISTOR			
MIL-R-11/3	I	0712	R42					1	81349	RC07GF120K		RESISTOR			
MIL-R-11/3	I	0714	R43					1	81349	RC07GF120K		RESISTOR			
MIL-R-11/8	I	0715	R44					1	81349	RC07GF683K		RESISTOR			
MIL-R-11/8	I	0716	R45					1	81349	RC07GF103K		RESISTOR			
MIL-R-11/8	I	0717	R46					1	81349	RC07GF103K		RESISTOR			
MIL-R-10509/1	I	0718	R47					1	81349	RN60D1002F		RESISTOR			
MIL-R-11/8	I	0719	R48					1	81349	RC07GF103K		RESISTOR			

DEC 1320 (6/69)

SPECIFICATION	DWG STATUS	SHEET/ LINE NO.	PARTS LIST		RCA		CAMDEN PLANT		REV LTR H	CODE IDENT	PL 8372846	SHEET 08
			RCA CORPORATION NEW YORK, N. Y.						49671			
			ITEM OR FIND NO.	QTY REQD PER DASH NO.					U M	CODE IDENT	PART OR IDENTIFYING NO.	NOMENCLATURE OR DESCRIPTION
	905	904	903	902	901							
MIL-R-11/8	I	0801	R49					1	81349	RC07GF683K	RESISTOR	
MIL-R-11/8	I	0802	R50					1	81349	RC07GF102K	RESISTOR	
MIL-R-11/8	I	0803	R51					1	81349	RC07GF472K	RESISTOR	
MIL-R-11/8	I	0804	R52					1	81349	RC07GF223K	RESISTOR	
MIL-R-11/3	I	0805	R53					1	81349	RC07GF120K	RESISTOR	
MIL-R-11/8	I	0806	R54					1	81349	RC07GF192K	RESISTOR	
MIL-R-11/8	I	0808	R55					1	81349	RC07GF471K	RESISTOR	
MIL-R-10509/1	I	0809	R56					1	81349	RN60D1472F	RESISTOR	
MIL-R-10509/1	I	0810	R57					1	81349	RN60D1002F	RESISTOR	
MIL-R-10509/1	I	0811	R58					1	81349	RN60D1002F	RESISTOR	
MIL-R-10509/1	I	0812	R59					1	81349	RN60D1002F	RESISTOR	
MIL-R-11/8	I	0814	R60					1	81349	RC07GF103K	RESISTOR	
MIL-R-11/8	I	0815	R61					1	81349	RC07GF683K	RESISTOR	
MIL-R-11/8	I	0816	R62					1	81349	RC07GF102K	RESISTOR	
MIL-R-11/8	I	0817	R63					1	81349	RC07GF472K	RESISTOR	
MIL-R-11/8	I	0818	R64					1	81349	RC07GF223K	RESISTOR	
MIL-R-11/3	I	0819	R65					1	81349	RC07GF120K	RESISTOR	

SPECIFICATION	DWG STATUS	SHEET/ LINE NO	PARTS LIST					RCA		CAMDEN PLANT	REV LTR H	CODE IDENT	PL 8372846	SHEET 09
			ITEM OR FIND NO.	QTY REQD PER DASH NO.					U M	CODE IDENT	PART OR IDENTIFYING NO.	NOMENCLATURE OR DESCRIPTION	SYM	
				503	504	503	502	501						
MIL-R-11/8	I	0901	R66					1	81349	RC07GF152K	RESISTOR			
MIL-R-11/8	I	0902	R67					1	81349	RC07GF471K	RESISTOR			
MIL-R-11/6	I	0903	R68					1	81349	RC22GF221K	RESISTOR			
MIL-R-11/3	I	0904	R69					1	81349	RC20GF680K	RESISTOR			
MIL-R-11/3	I	0905	R70					1	81349	RC20GF820K	RESISTOR			
MIL-R-11/8	I	0906	R71					1	81349	RC07GF103K	RESISTOR			
MIL-R-11/8	I	0907	R72					1	81349	RC07GF472K	RESISTOR			
MIL-R-11/8	I	0908	R73					1	81349	RC07GF102K	RESISTOR			
		0909	R74					1	81349	RC07-SELET AT TEST				
	I	0912	TJ1					1	00779	3-582340-1	JACK, TEST-BRN			
	I	0913	TJ2					1	00779	3-582340-2	JACK, TEST-RED			
	I	0914	TJ3					1	00779	3-582340-3	JACK, TEST-ORG			
	I	0915	TJ4					1	00779	3-582340-4	JACK, TEST-YEL			
	I	0916	TJ5					1	00779	3-582340-5	JACK, TEST-GRN			
	I	0918	TJ10					1	00779	3-582340-0	JACK, TEST-BLK			

DEC 1320 (6/69)

SPECIFICATION	DWG STATUS	SHEET/ LINE NO.	PARTS LIST					RCA		CAMDEN PLANT		REV LTR H	CODE IDENT	PL 0372846	SHEET 10	
			ITEM OR FIND NO.	QTY REQD PER DASH NO.					U M	CODE IDENT	PART OR IDENTIFYING NO	NOMENCLATURE OR DESCRIPTION	SYM			
				505	504	503	502	501								
	I	1001	U1						1	04713	MC1712CL					INTEGRATED CIRCUIT
	I	1002	U2						1	04713	MC1712CL					INTEGRATED CIRCUIT
	I	1003	U3						1	04713	MC1712CL					INTEGRATED CIRCUIT
	I	1004	U4						1	04713	MC1710CL					INTEGRATED CIRCUIT
	I	1005	U5						1	04713	HCB601L					INTEGRATED CIRCUIT
	I	1006	U6						1	04713	HCB601L					INTEGRATED CIRCUIT
	I	1007	U7						1	04713	HCB601L					INTEGRATED CIRCUIT
	I	1008	U8						1	04713	HCB601L					INTEGRATED CIRCUIT
	I	1009	U9						1	04713	HCB601L					INTEGRATED CIRCUIT
	I	1010	U10						1	04713	HCB601L					INTEGRATED CIRCUIT
	I	1011	VR1						1		1N753A					DIODE, ZENER
	I	1012	VR2						1		1N3022B					DIODE, ZENER
	I	1013	VR3						1		1N3022B					DIODE, ZENER

ORIGINAL PAGE IS  
OF POOR QUALITY

SPECIFICATION	DWG STATUS	SHEET/ LINE NO	PARTS LIST					RCA		CAMDEN PLANT	REV LTR H	CODE IDENT	PL 4972846	SHEET 11
			ITEM OR FIND NO.	QTY REQD PER DASH NO.					U M	CODE IDENT	PART OR IDENTIFYING NO.	NOMENCLATURE OR DESCRIPTION	S Y M	
				503	504	503	502	501						
	P	1101	1					X			8372874	SCHEM DIAG; VIDEO INPUT		
	I	1102	2					X			8372847	MA PATT-PW; VIDEO INPUT		
	I	1104	4					X			8030018	WORKMANSHIP SPEC, BASIC		
	P	1107	7						1		8673774-5	HANDLE-BOARD		
	I	1110	10						8		8524995-1	SPACER, TRANSISTOR		
	I	1114	14					AR			8523343-8	CEMENT		
	I	1115	15					AR			2010105-22	COPPER WIRE, ROUND, TINNED		
	I	1116	16					AR			2010909-812	INSULATING TUBING		
	I	1117	17					AR			2010838-320	SOLDER, TIN-LEAD ALLOY		
	I	1118	18					AR			2010573-1	FLUX, SOLDERING, ALCHL-ROSIN		

DEC 1320 (6/69)

<b>PARTS LIST</b>		<b>RECA</b>		RCA CORPORATION   NEW YORK, NY		REVISION DATE	PL 8372848	REV LTR <b>D</b>	
LIST TITLE:  <div style="text-align: center;">BOARD ASSEMBLY INTERLEAVER OUTPUT</div>				PREPARED BY		DATE	REL	CODE IDENT NO. <b>49671</b>	SHEET OF <b>6</b> SHEETS
				CHECKED BY		DATE		CONTRACT NO.  NAS 8-27968	
				DESIGN ACTIVITY APPD		DATE			
				FIRST APPLICATION					
<b>REVISIONS</b>									
LTR	DESCRIPTION	DATE	APPROVED	LTR	DESCRIPTION	DATE	APPROVED		
A	REVISED								
B	REVISED								
C	REVISED								
D	REVISED								
INTERPRET SYMBOLS USED AS FOLLOWS:									
UNITS OF MEASURE (UM)			QUANTITIES		SYMBOL				
A — Inches	N — Barrels	T — Each	X — Applicable document	U — Govt or customer furnished	* — Vendor item, See specification or source control drawing.				
B — Feet	J — Pounds		O — For ref only	K — Govt or customer furnished and installed					
C — Yards	L — Pair								
D — Ounces	M — Set								
E — Pints	N — Kit								
F — Quarts	P — Roll								
G — Gallons	R — Box, Case								

SPECIFICATION	DWG STATUS	SHEET/ LINE NO	PARTS LIST		RCA		CAMDEN PLANT		REV LTR D	CODE IDENT	PL 8372848	SHEET 02
			RCA CORPORATION, NEW YORK, N Y						0	49671		
			ITEM OR FIND NO.	QTY REQD PER DASH NO.					U M	CODE IDENT	PART OR IDENTIFYING NO.	NOMENCLATURE OR DESCRIPTION
	503	504	503	502	501							
MIL-C-11015/19	I	0201	C1					1	81349	CK06BX104K	CAPACITOR	
MIL-C-11015/18	I	0202	C2					1	81349	CK05BX102K	CAPACITOR	
MIL-C-11015/19	I	0203	C3					1	81349	CK06BX103K	CAPACITOR	
MIL-C-5/18	I	0204	C4					1	81349	CM05ED510J03	CAPACITOR	
MIL-C-11015/19	I	0205	C5					1	81349	CK06BX104K	CAPACITOR	
MIL-C-11015/19	I	0206	C6					1	81349	CK06BX104K	CAPACITOR	
MIL-C-11015/18	I	0208	C7					1	81349	CK05BX102K	CAPACITOR	
MIL-C-11015/19	I	0209	C8					1	81349	CK06BX103K	CAPACITOR	
MIL-C-5/18	I	0210	C9					1	81349	CM05EN510J03	CAPACITOR	
MIL-C-11015/19	I	0211	C10					1	81349	CK06BX104K	CAPACITOR	
MIL-C-26655	I	0212	C11					1	81349	CS13BE156K	CAPACITOR	
MIL-C-26655	I	0213	C12					1	81349	CS13BC336K	CAPACITOR	
	I	0216	CR1					1	81349	1N4148	DIODE	
	I	0217	CR2					1	81349	1N4148	DIODE	

DEC 1320 (6/69)

SPECIFICATION	DWG STATUS	SHEET/ LINE NO.	PARTS LIST		RCA CORPORATION, NEW YORK N. Y.					CAMDEN PLANT	REV LTR D	CODE IDENT 49671	PL 8372848	SHEET 03
			ITEM OR FIND NO.	QTY REQD PER DASH NO.					U M	CODE IDENT	PART OR IDENTIFYING NO.	NOMENCLATURE OR DESCRIPTION	S Y M	
				503	504	502	502	501						
	I	0301	P1						1	91662	00-7022-035-000-001	CONNECTOR		
	I	0303	Q1						1		2N2219A	TRANSISTOR		
	I	0304	Q2						1		2N2219A	TRANSISTOR		
MIL-R-11/3	I	0306	R1						1	81349	RC20GF271K	RESISTOR		
MIL-R-10509/1	I	0307	R2						1	81349	RN60D2151F	RESISTOR		
MIL-R-10509/1	I	0308	R3						1	81349	RN60D2151F	RESISTOR		
MIL-R-11/3	I	0309	R4						1	81349	RC20GF271K	RESISTOR		
MIL-R-10509/1	I	0310	R5						1	81349	RN60D1001F	RESISTOR		
MIL-R-22684/1	I	0311	R6						1	81349	RL07S201J	RESISTOR		
MIL-R-10509/1	I	0312	R7						1	81349	RN60D2371F	RESISTOR		
MIL-R-11/3	I	0313	R8						1	81349	RC07GF120K	RESISTOR		
MIL-R-10509/1	I	0314	R9						1	81349	RN60D1332F	RESISTOR		
MIL-R-11/3	I	0315	R10						1	81349	RC07GF220K	RESISTOR		
MIL-R-11/3	I	0316	R11						1	81349	RC20GF471K	RESISTOR		
MIL-R-11/3	I	0317	R12						1	81349	RC07GF120K	RESISTOR		
MIL-R-10509/1	I	0318	R13						1	81349	RN60D750F	RESISTOR		
MIL-R-11/3	I	0319	R14						1	81349	RC07GF102K	RESISTOR		



SPECIFICATION	DWG STATUS	SHEET/ LINE NO.	PARTS LIST					RCA		CAMDEN PLANT	REV LTR 0	CODE IDENT 49671	PL 8372848	SHEET 04
			ITEM OR FIND NO.	QTY REQD PER DASH NO.					U M	CODE IDENT	PART OR IDENTIFYING NO.	NOMENCLATURE OR DESCRIPTION	SYM	
				505	504	503	502	501						
MIL-R-10509/1	I	0401	R15					1	81349	RN60D1001F	RESISTOR			
MIL-R-22584/1	I	0402	R16					1	81349	RC07S201J	RESISTOR			
MIL-R-10509/1	I	0403	R17					1	81349	RN60D2371F	RESISTOR			
MIL-R-11/3	I	0404	R18					1	81349	RC07GF120K	RESISTOR			
MIL-R-10509/1	I	0405	R19					1	81349	RN60D1332F	RESISTOR			
MIL-R-11/8	I	0406	R20					1	81349	RC07GF220K	RESISTOR			
MIL-R-11/3	I	0408	R21					1	81349	RC20GF471K	RESISTOR			
MIL-R-11/3	I	0409	R22					1	81349	RC07GF120K	RESISTOR			
MIL-R-10509/1	I	0410	R23					1	81349	RN60D750F	RESISTOR			
MIL-R-11/8	I	0411	R24					1	81349	RC07GF102K	RESISTOR			
MIL-R-11/3	I	0412	R25					1	81349	RC20GF560K	RESISTOR			
MIL-R-11/6	I	0414	R26					1	81349	RC32GF151K	RESISTOR			
MIL-R-11/8	I	0415	R27					1	81349	RC07GF103K	RESISTOR			
MIL-R-11/8	I	0416	R28					1	81349	RC07GF103K	RESISTOR			
MIL-R-11/8	I	0417	R29					1	81349	RC07GF103K	RESISTOR			

DEC 1320 (6/69)

SPECIFICATION	DWG STATUS	SHEET/ LINE NO.	PARTS LIST		RCA		CAMDEN PLANT		REV LTR D	CODE IDENT	PL 8372848	SHEET 05	
			ITEM OR FIND NO.	QTY REQD PER DASH NO.					U M	CODE IDENT	PART OR IDENTIFYING NO.	NOMENCLATURE OR DESCRIPTION	SYM
				503	504	503	502	501					
	I	0501	TJ1						1	00779	3-582340-1	JACK, TEST-BRN	
	I	0502	TJ2						1	00779	3-582340-2	JACK, TEST-RED	
	I	0503	TJ3						1	00779	3-582340-3	JACK, TEST-ORG	
	I	0505	TJ10						1	00779	3-582340-0	JACK, TEST-BLK	
	I	0507	U1						1	04713	MC1712CL	INTEGRATED CIRCUIT	
	I	0508	U2						1	04713	MC1712CL	INTEGRATED CIRCUIT	
	I	0510	VR1						1		1N3022B	DIODE, ZENER	
	I	0511	VR2						1		1N753A	DIODE, ZENER	
	I	0513	Z1						1	03911	CLM4012A	RESISTOR	
	I	0514	Z2						1	03911	CLM4012A	RESISTOR	

ORIGINAL PAGE IS  
OF POOR QUALITY

SPECIFICATION	DWG STATUS	SHEET/ LINE NO.	PARTS LIST		RCA		CAMDEN PLANT		REV LTR D	CODE IDENT	PL 8972848	SHEET 06
			RCA CORPORATION NEW YORK N. Y.					U M	CODE IDENT	PART OR IDENTIFYING NO.	NOMENCLATURE OR DESCRIPTION	S Y M
			ITEM OR FIND NO.	QTY REQD PER DASH NO.								
			503	504	505	502	501					
	P	0601	1					X		8372875	SCHEM DIAG; INTERLEAVER DP	
	P	0602	2					X		8372849	MA PATT-PW; INTERLEAVER DP	
	I	0604	4					X		8030018	WORKMANSHIP SPEC, BASIC	
	P	0607	7						1	8673774-6	HANDLE-BOARD	
	I	0609	9						2	8503806-4	MOUNTING PAD TO-5 PACKAGE	
	I	0614	14					AR		8533343-8	CEMENT	
	I	0615	15					AR		2010105-22	COPPER WIRE, ROUND, TINNED	
	I	0616	16					AR		2010909-812	INSULATING TUBING	
	I	0617	17					AR		2010858-320	SOLDER, TIN-LEAD ALLOY	
	I	0618	18					AR		2010579-1	FLUX, SOLDERING, ALCHLARSIN	

DIC 1320 (6/69)

<b>PARTS LIST</b>		<b>RCA</b>		RCA CORPORATION   NEW YORK, NY		REVISION DATE		PL 8372850		REV LTR <b>E</b>	
LIST TITLE:  <b>BOARD ASSEMBLY AUDIO POWER AMPLIFIER</b>						CAMDEN PLANT		CODE IDENT NO. <b>49671</b>		SHEET OF <b>5</b> SHEETS	
						PREPARED BY _____ DATE _____					
						8673734-501 SKYLAB-GSE		CONTRACT NO. <b>NAS 8-27968</b>			
						NEXT ASSY _____ USED ON _____					
FIRST APPLICATION		DESIGN ACTIVITY APPD . _____ DATE _____									

REVISIONS							
LTR	DESCRIPTION	DATE	APPROVED	LTR	DESCRIPTION	DATE	APPROVED
A	REVISED						
B	REVISED						
C	REVISED						
D	REVISED						
E	REVISED						

INTERPRET SYMBOLS USED AS FOLLOWS:			
UNITS OF MEASURE (UM)		QUANTITIES	SYMBOL
A—Inches B—Feet C—Yards D—Ounces E—Pints F—Quarts G—Gallons	H—Barrels J—Pounds L—Pair M—Set N—Kit P—Roll R—Box, Case	T—Each X—Applicable document O—For ref only	U—Govt or customer furnished *—Vendor item See specification or source control drawing. K—Govt or customer furnished and installed

ORIGINAL PAGE IS  
OF POOR QUALITY

SPECIFICATION	DWG STATUS	SHEET/ LINE NO.	PARTS LIST		RCA		CAMDEN PLANT		REV LTR E	CODE IDENT	PL 8372850	SHEET 02	
			ITEM OR FIND NO.	QTY REQD PER DASH NO					U M	CODE IDENT	PART OR IDENTIFYING NO.	NOMENCLATURE OR DESCRIPTION	SYM
				505	504	503	502	501					
MIL-C-11015/19	I	0201	C1						1	56289	500D107G012C07	CAPACITOR	
	I	0202	C2						1	56289	500D206G025C87	CAPACITOR	
	I	0203	C3						1	56289	500D107G012C07	CAPACITOR	
	I	0204	C4						1	56289	500D607G016EH7	CAPACITOR	
	I	0205	C5						1	56289	500D207G025DH7	CAPACITOR	
	I	0206	C6						1	81349	CK068X104K	CAPACITOR	
	I	0210	CR1						1		1N456A	DIODE	
	I	0211	CR2						1		1N456A	DIODE	
	I	0212	CR3						1		1N456A	DIODE	
	I	0214	TJ1						1	00779	3-582340-1	JACK, TEST=BRN	
	I	0215	TJ2						1	00779	3-582340-2	JACK, TEST=RD	
	I	0216	TJ10						1	00779	3-582340-0	JACK, TEST=BLK	
	I	0219	P1						1	91662	00-7022-035-000-001	CONNECTOR	

DEC 1320 (6/69)

SPECIFICATION	DWG STATUS	SHEET/ LINE NO.	PARTS LIST					RCA		CAMDEN PLANT		REV LTR E	CODE IDENT	PL 8372850	SHEET 03
			ITEM OR FIND NO.	QTY REQD PER DASH NO.					U M	CODE IDENT	PART OR IDENTIFYING NO.	NOMENCLATURE OR DESCRIPTION	SYM		
				505	504	503	502	501							
	I	0302	Q1						1	81349	2N2219		TRANSISTOR		
	I	0303	Q2						1	81349	2N2219		TRANSISTOR		
	I	0304	Q3						1	81349	2N2905		TRANSISTOR		
	I	0305	Q4						1		2N3056		TRANSISTOR		
	I	0306	Q5						1		2N3056		TRANSISTOR		

ORIGINAL PAGE IS  
OF POOR QUALITY

SPECIFICATION	DWG STATUS	SHEET/ LINE NO	PARTS LIST					RCA		CAMDEN PLANT	REV LTR E	CODE IDENT	PL 8372850	SHEET 04
			ITEM OR FIND NO.	QTY REQD PER DASH NO.					U M	CODE IDENT	PART OR IDENTIFYING NO.	NOMENCLATURE OR DESCRIPTION	SYM	
				505	504	503	502	501						
	I	0401	R1					1	80294	3009P1-102	RESISTOR			
MIL-R-10509/1	I	0402	R2					1	81349	RN60D1001F	RESISTOR			
	I	0403	R3					1	80294	3009P1-204	RESISTOR			
MIL-R-11/3	I	0404	R4					1	81349	RC20GF473K	RESISTOR			
MIL-R-11/3	I	0405	R5					1	81349	RC20GF183K	RESISTOR			
MIL-R-11/3	I	0406	R6					1	81349	RC20GF152K	RESISTOR			
	I	0408	R7					1	81349	RC20GF682K	RESISTOR			
MIL-R-22684/2	I	0409	R8					1	81349	RL20S301J	RESISTOR			
MIL-R-10509/1	I	0410	R9					1	81349	RN60D2742F	RESISTOR			
MIL-R-11/3	I	0411	R10					1	81349	RC20GF102K	RESISTOR			
MIL-R-11/3	I	0412	R11					1	81349	RC20GF270K	RESISTOR			
MIL-R-11/3	I	0413	R12					1	81349	RC20GF102K	RESISTOR			
MIL-R-26/4	I	0414	R13					1	81349	RW69VR47	RESISTOR			
MIL-R-26/4	I	0415	R14					1	81349	RW69VR47	RESISTOR			
MIL-R-11/3	I	0417	R15					1	81349	RC20GF180K	RESISTOR			

DEC 1320 (6/69)

SPECIFICATION	DWG STATUS	SHEET/ LINE NO.	PARTS LIST					RCA		CAMDEN PLANT	REV LTR E	CODE IDENT	PL 8372850	SHEET 03
			ITEM OR FIND NO.	QTY REQD PER DASH NO.					U M	CODE IDENT	PART OR IDENTIFYING NO	NOMENCLATURE OR DESCRIPTION	S M	
				503	504	503	502	501						
	P	0501	1					X			8372876	SCHEM DIAG, AUDIO PWR AMPL		
	P	0502	2					X			8372851	MA PATT-PW, AUDIO PWR AMPL		
	I	0504	4					X			8030018	WORKMANSHIP SPEC, BASIC		
	P	0507	7						1		8673774-7	HANDLE-BOARD		
	I	0509	9						3		8505806-4	MOUNTING PAD TD-5 PACKAGE		
	I	0512	12						2	13013	6166B	HEAT SINK		
	I	0514	14					AR			8533343-8	CEMENT		
	I	0515	15					AR			2010105-22	COPPER WIRE, ROUND, TINNED		
	I	0516	16					AR			2010909-812	INSULATING TUBING		
	I	0517	17					AR			2010858-320	SOLDER, TIN-LEAD ALLOY		
	I	0518	18					AR			2010573-1	FLUX, SOLDERING, ALCHL-RODIN		



<b>PARTS LIST</b>		<b>IRCA</b>		RCA CORPORATION   NEW YORK, NY		REVISION DATE		PL 8673757		REV LTR A			
		CAMDEN PLANT											
LIST TITLE:  BOARD ASSEMBLY BESSEL FILTER/ EQUALIZER				PREPARED BY		DATE		REL	CODE IDENT NO. 49671		SHEET OF 3 SHEETS		
				8673734-501		SKYLAB-GSE			CHECKED BY		DATE		CONTRACT NO.  NAS 8-27968
				NEXT ASSY		USED ON			DESIGN ACTIVITY APPD		DATE		
				FIRST APPLICATION									
<b>REVISIONS</b>													
LTR	DESCRIPTION	DATE	APPROVED	LTR	DESCRIPTION	DATE	APPROVED						
<b>INTERPRET SYMBOLS USED AS FOLLOWS:</b>													
UNITS OF MEASURE (UM)			QUANTITIES		SYMBOL								
A — Inches	H — Barrels	T — Each	X — Applicable document	U — Govt or customer furnished	* — Vendor Item. See specification or source control drawing.								
B — Feet	J — Pounds		0 — For ref only	K — Govt or customer furnished and installed									
C — Yards	L — Pair												
D — Ounces	M — Set												
E — Pints	N — Kit												
F — Quarts	P — Roll												
G — Gallons	R — Box, Case												

SPECIFICATION	DWG STATUS	SHEET/ LINE NO.	PARTS LIST					RCA		CAMDEN PLANT	REV LTR A	CODE IDENT	PL 8679757	SHEET 02
			ITEM OR FIND NO.	QTY REQD PER DASH NO.					U M	CODE IDENT	PART OR IDENTIFYING NO.	NOMENCLATURE OR DESCRIPTION	SYM	
				505	504	503	502	501						
MIL-C-5/18	I	0201	C1						1	81349	CM05FD101J03	CAPACITOR		
MIL-C-5/18	I	0202	C2						1	81349	CM06FD472J03	CAPACITOR		
MIL-C-5/18	I	0203	C3						1	81349	CM06FD162J03	CAPACITOR		
MIL-C-5/18	I	0204	C4						1	81349	CM06FD112J03	CAPACITOR		
MIL-C-5/18	I	0205	C5						1	81349	CM05FD241J03	CAPACITOR		
	I	0209	L1						1	72259	WEEVL15	COIL		
	I	0210	L2						1	72259	WEEVL8,2	COIL, VARIABLE		
	I	0211	L3						1	72259	WEEVL8,9	COIL (NY TRONICS)		
	I	0218	S1						1		897789001	SWITCH, TOGGLE		

SPECIFICATION	DWG STATUS	SHEET/ LINE NO.	PARTS LIST					RCA		CAMDEN PLANT	REV LTR	CODE IDENT	PL 8673757	SHEET 03
			ITEM OR FIND NO.	QTY REQD PER DASH NO.					U M	CODE IDENT	PART OR IDENTIFYING NO.	NOMENCLATURE OR DESCRIPTION	SYM	
				505	504	503	502	501						
	P	0301	1					X			8672810	SCHEM DIAG, BESSEL FLTR/EQL		
	P	0203	2					X			8673761	HA PATT-PW, BESSEL FLTR/EQL		
	P	0303	3					X			8673762	MARKING DWG, BESSEL FLTR/EQL		
	I	0304	4					X			8030018	WORKMANSHIP SPEC, BASIC		
	I	0305	5					X			2020463	MARKING METAL AND PLASTIC SH		
	I	0309	9					AR			8983173-1	PAINT, MARKING WHITE		
	I	0310	10					11			8550137-2	TERMINAL		
	I	0315	15					AR			999127-9	WIRE, ELECTRICAL		
	I	0317	17					AR			2010858-320	SOLDER, TIN-LEAD ALLOY		
	I	0318	18					AR			2010573-1	FLUX, SOLDERING, ALCHL-ROSH		

DEC 1320 (4/69)

<b>PARTS LIST</b>	<b>RCA</b>	RCA CORPORATION   NEW YORK, NY	REVISION DATE	PL 8375682	REV LTR -
LIST TITLE:  <b>CTE DE-MUX</b>		CAMDEN NJ PLANT	PREPARED BY <i>John S. Ukonar</i> 5 AUGUST 1974	DATE	CODE IDENT NO <b>49671</b>
		CHECKED BY <b>ASTP</b>	DATE	REL	SHEET 1 OF 7 SHEETS
		NEXT ASSY	USED ON	DESIGN ACTIVITY APPD	DATE
		FIRST APPLICATION		CONTRACT NO. <b>NAS-3-15707</b>	

REVISIONS					
LTR	DESCRIPTION	DATE	APPROVED	LTR	DESCRIPTION

INTERPRET SYMBOLS USED AS FOLLOWS:		
UNITS OF MEASURE (U/M)	QUANTITIES	SYMBOL
A — Inches B — Feet C — Yards D — Ounces E — Pints F — Quarts G — Gallons H — Barrels J — Pounds L — Pair M — Set N — Kit P — Roll R — Box, Case T — Each	X — Applicable document  O — For ref only  /// — Not used	U — Govt or customer furnished  K — Govt or customer furnished and installed  * — Vendor Item. See specification or source control drawing.

ORIGINAL PAGE IS  
OF POOR QUALITY

SPECIFICATION	DWG STATUS	SHEET/ LINE NO.	PARTS LIST					RCA CORPORATION, NEW YORK N Y		CAMDEN PLANT	REV LTR	CODE IDENT	PL 8375682	SHEET 02
			ITEM OR FIND NO.	QTY REQD PER DASH NO.					U M	CODE IDENT	PART OR IDENTIFYING NO.	NOMENCLATURE OR DESCRIPTION	SYM	
				505	504	503	502	501						
MIL-C-11015/19	I	0201	C1					1	81349	CK06BX104K	CAPACITOR			
MIL-C-11015/19	I	0202	C2					1	81349	CK06BX104K	CAPACITOR			
MIL-C-11015/19	I	0203	C3					1	81349	CK06BX104K	CAPACITOR			
MIL-C-27287	I	0204	C4					1	81349	CTM104VAJ	CAPACITOR			
MIL-C-27287/1	I	0205	C5					1	81349	CTM103VAJ	CAPACITOR			
MIL-C-11015/19	I	0206	C6					1	81349	CK06BX103K	CAPACITOR			
MIL-C-39003/1	I	0207	C7					1	81349	CSR13C107KM	CAPACITOR			
MIL-C-5/18	I	0208	C8					1	81349	CM06FD561J03	CAPACITOR			
MIL-C-5/18	I	0209	C9					1	81349	CM06FD561J03	CAPACITOR			
MIL-C-5/18	I	0210	C10					1	81349	CM06FD332J03	CAPACITOR			
MIL-C-11015/19	I	0211	C11					1	81349	CK06BX104K	CAPACITOR			
MIL-C-11015/19	I	0212	C12					1	81349	CK06BX104K	CAPACITOR			
MIL-C-11015/19	I	0213	C13					1	81349	CK06BX104K	CAPACITOR			
MIL-C-11015/19	I	0214	C14					1	81349	CK06BX104K	CAPACITOR			
MIL-C-11015/19	I	0215	C15					1	81349	CK06BX104K	CAPACITOR			
		0216	C16					1	81349	CE11C150D				

DEC 13 20 (6/69)

SPECIFICATION	DWG STATUS	SHEET/ LINE NO.	PARTS LIST					RCA CORPORATION, NEW YORK, N Y		CAMDEN PLANT	REV LTR	CODE IDENT	PL 8375682	SHEET 03
			ITEM OR FIND NO.	QTY REQD PER DASH NO.					U M	CODE IDENT	PART OR IDENTIFYING NO.	NOMENCLATURE OR DESCRIPTION	SYM	
				505	504	503	502	501						
MIL-S-19500/116	I	0301	CR1					1	81349	JAN1N4148	DIODE			
MIL-S-19500/116	I	0302	CR2					1	81349	JAN1N4148	DIODE			
	I	0305	P1					1	91662	00-7022-035-000-001	CONNECTOR			
MIL-R-11/8	I	0308	R1					1	81349	RC07GF103J	RESISTOR			
MIL-R-11/8	I	0309	R2					1	81349	RC07GF103J	RESISTOR			
MIL-R-11/8	I	0310	R3					1	81349	RC07GF104J	RESISTOR			
MIL-R-11/8	I	0311	R4					1	81349	RC07GF100J	RESISTOR			
MIL-R-11/8	I	0312	R5					1	81349	RC07GF100J	RESISTOR			
MIL-R-11/8	I	0313	R6					1	81349	RC07GF183J	RESISTOR			
	I	0314	R7					1	80294	3009P1-503	RESISTOR			
MIL-R-11/8	I	0315	R8					1	81349	RC07GF223J	RESISTOR			
MIL-R-11/8	I	0316	R9					1	81349	RC07GF103J	RESISTOR			
MIL-R-11/8	I	0317	R10					1	81349	RC07GF103J	RESISTOR			
MIL-R-11/8	I	0318	R11					1	81349	RC07GF472J	RESISTOR			
MIL-R-11/8	I	0319	R12					1	81349	RC07GF103J	RESISTOR			

SPECIFICATION	DWG STATUS	SHEET/ LINE NO.	PARTS LIST					RCA		CAMDEN PLANT		REV LTR	CODE IDENT	PL 8375682	SHEET 04
			ITEM OR FIND NO.	QTY REQD PER DASH NO.					U M	CODE IDENT	PART OR IDENTIFYING NO.	NOMENCLATURE OR DESCRIPTION	SYM		
				505	504	503	502	501							
MIL-R-11/8	I	0401	R13						1	81349	RC07GF102J	RESISTOR			
MIL-R-11/8	I	0402	R14						1	81349	RC07GF150J	RESISTOR			
MIL-R-10509/1	I	0403	R15						1	81349	RN60D1002F	RESISTOR			
	I	0404	R16						1	80294	3009P1-103	RESISTOR			
MIL-R-22684/1	I	0405	R17						1	81349	RLQ7S512J	RESISTOR			
MIL-R-11/8	I	0406	R18						1	81349	RC07GF103J	RESISTOR			
MIL-R-11/8	I	0407	R19						1	81349	RC07GF102J	RESISTOR			
MIL-R-11/8	I	0408	R20						1	81349	RC07GF103J	RESISTOR			
MIL-R-11/8	I	0409	R21						1	81349	RC07GF102J	RESISTOR			
MIL-R-11/8	I	0410	R22						1	81349	RC07GF102J	RESISTOR			
MIL-R-11/8	I	0411	R23						1	81349	RC07GF112J	RESISTOR			
MIL-R-11/8	I	0412	R24						1	81349	RC07GF103J	RESISTOR			
MIL-R-11/8	I	0413	R25						1	81349	RC07GF181J	RESISTOR			
MIL-R-11/8	I	0414	R26						1	81349	RC07GF683J	RESISTOR			
MIL-R-11	I	0415	R27						1	81349	RC20GF391J	RESISTOR			
MIL-R-11/8	I	0416	R28						1	81349	RC07GF102J	RESISTOR			
MIL-R-11/8	I	0417	R29						1	81349	RC07GF153J	RESISTOR			

DEC 1320 (6/69)

SPECIFICATION	DWG STATUS	SHEET/ LINE NO.	PARTS LIST					RCA CORPORATION, NEW YORK, N Y		CAMDEN PLANT	REV LTR	CODE IDENT	PL 8375682	SHEET 05
			ITEM OR FIND NO.	QTY REQD PER DASH NO.					U M	CODE IDENT	PART OR IDENTIFYING NO.	NOMENCLATURE OR DESCRIPTION	SYM	
				505	504	503	502	501						
	I	0501	TJ1					1	00779	3-582340-1	JACK, TEST-BRN			
	I	0502	TJ2					1	00779	3-582340-2	JACK, TEST-RED			
	I	0503	TJ3					1	00779	3-582340-3	JACK, TEST-ORG			
	I	0504	TJ4					1	00779	3-582340-4	JACK, TEST-YEL			
	I	0505	TJ5					1	00779	3-582340-5	JACK, TEST-GRN			
	I	0506	TJ6					1	00779	3-582340-6	JACK, TEST-BLU			
	I	0507	TJ7					1	00779	3-582340-7	JACK, TEST-VIOLET			
	I	0510	TJ10					1	00779	3-582340-0	JACK, TEST-BLK			
	I	0512	U1					1	04713	MC4044L	INTEGRATED CIRCUIT			
	I	0513	U2					1	04713	MC1458L	INTEGRATED CIRCUIT			
	I	0514	U3					1	04713	MC4024L	INTEGRATED CIRCUIT			
	I	0515	U4					1	04713	MC7490L	INTEGRATED CIRCUIT			
	I	0516	U5					1	04713	MC7473L	INTEGRATED CIRCUIT			
	I	0517	U6					1	04713	MC7404L	INTEGRATED CIRCUIT			
	I	0518	U7					1	01295	SN74123J	INTEGRATED CIRCUIT			
	I	0519	U8					1	04713	MC7400L	INTEGRATED CIRCUIT			



SPECIFICATION	DWG STATUS	SHEET/ LINE NO.	PARTS LIST					RCA CORPORATION NEW YORK, N Y		CAMDEN PLANT	REV LTR	CODE IDENT	PL 8375682	SHEET 06
			ITEM OR FIND NO.	QTY REQD PER DASH NO.					U M	CODE IDENT	PART OR IDENTIFYING NO.	NOMENCLATURE OR DESCRIPTION	SYM	
				505	504	503	502	501						
	I	0601	U9						1	04713	MC7474L	INTEGRATED CIRCUIT		
	I	0602	U10						1	04713	MC7493L	INTEGRATED CIRCUIT		
	I	0603	U11						1	01295	SN74L04J	INTEGRATED CIRCUIT		
	I	0604	U12						1	04713	MC7430L	INTEGRATED CIRCUIT		
	I	0605	U13						1	04713	MC7400L	INTEGRATED CIRCUIT		
	I	0606	U14						1	04713	MC7420L	INTEGRATED CIRCUIT		
	I	0607	U15						1	04713	MC7493L	INTEGRATED CIRCUIT		
	I	0608	U16						1	04713	MC1710L	INTEGRATED CIRCUIT		
	I	0609	U17						1	01295	SN74164J	INTEGRATED CIRCUIT		
	I	0610	U18						1	01295	SN74164J	INTEGRATED CIRCUIT		
	I	0611	U19						1	01295	SN74164J	INTEGRATED CIRCUIT		
	I	0612	U20						1	01295	SN74164J	INTEGRATED CIRCUIT		
MIL-S-19500/127	I	0615	VR1						1	81349	JAN1N751A	DIODE, ZENER		
MIL-S-19500/127	I	0616	VR2						1	81349	JAN1N753A	DIODE, ZENER		
MIL-S-19500/117	I	0617	VR3						1	81349	JAN1N963B	DIODE		

DEC 1320 (6/69)

SPECIFICATION	DWG STATUS	SHEET/ LINE NO.	PARTS LIST					RCA		CAMDEN PLANT	REV LTR	CODE IDENT	PL 8375682	SHEET 07
			ITEM OR FIND NO.	QTY REQD PER DASH NO.					U M	CODE IDENT	PART OR IDENTIFYING NO.	NOMENCLATURE OR DESCRIPTION	SYM	
				505	504	503	502	501						
	P	0701	1					X			8375684	SCHEMATIC CTE DEMUX		
	P	0702	2					X			8676332	MA PAT-PW, CTE DEMUX		
	I	0704	4					X			8030018	WORKMANSHIP SPEC, BASIC		
	P	0707	7								8673774	HANDLE-BOARD		
	I	0709	9					/////			8505806-4	MOUNTING PAD TO-5 PACKAGE		
	I	0710	10					/////			8524995-1	SPACER, TRANSISTOR		
	I	0714	14					AR			8533343-8	CEMENT		
	I	0715	15					AR			2010105-22	COPPER WIRE, ROUND, TINNED		
	I	0716	16					AR			2010909-812	INSULATING TUBING		
	I	0717	17					AR			2010858-320	SOLDER, TIN-LEAD ALLOY		
	I	0718	18					AR			2010573-1	FLUX, SOLDERING, ALCHL-ROSIN		

<b>PARTS LIST</b>	<b>RCA</b>	RCA CORPORATION   NEW YORK, NY	REVISION DATE	PL 8676341	REV LTR —
LIST TITLE: <b>DISPLAY GSE</b>		CAMDEN N.J. PLANT	PREPARED BY <i>John G. Schinner</i> 5 AUGUST 1974	REL	CODE IDENT NO. <b>49671</b>
			CHECKED BY		SHEET OF 3 SHEETS
			DESIGN ACTIVITY AND DATE		CONTRACT NO. <b>NAS-9-13767</b>
		ASTP			
		NEXT ASSY	USED ON		
		FIRST APPLICATION			

REVISIONS							
LTR	DESCRIPTION	DATE	APPROVED	LTR	DESCRIPTION	DATE	APPROVED

INTERPRET SYMBOLS USED AS FOLLOWS:			
UNITS OF MEASURE (UM)	QUANTITIES	SYMBOL	
A — Inches B — Feet C — Yards D — Ounces E — Pints F — Quarts G — Gallons H — Barrels J — Pounds L — Pair M — Set N — Kit P — Roll R — Box, Case T — Each	X — Applicable document  O — For ref only  /// — Not used	U — Govt or customer furnished  K — Govt or customer furnished and installed  * — Vendor item. See specification or source control drawing.	

RCA 2403 XPO-3 (7-73)

SPECIFICATION	DWG. STATUS	SHEET/ LINE NO.	PARTS LIST		RCA		CAMDEN PLANT		REV LTR	CODE IDENT	PL 8575341	SHEET 02	
			ITEM OR FIND NO.	QTY REQD PER DASH NO.					U M	CODE IDENT	PART OR IDENTIFYING NO.	NOMENCLATURE OR DESCRIPTION	SYM
				505	504	503	502	501					
	I	0201	A1						1	28480	HP5082-7300	LED DISPLAY	
	I	0202	A2						1	28480	HP5082-7300	LED DISPLAY	
	I	0203	A3						1	28480	HP5082-7300	LED DISPLAY	
	I	0204	A4						1	28480	HP5082-7300	LED DISPLAY	
	I	0205	A5						1	28480	HP5082-7300	LED DISPLAY	
	I	0206	A6						1	28480	HP5082-7300	LED DISPLAY	
	I	0207	A7						1	28480	HP5082-7300	LED DISPLAY	
	I	0208	A8						1	28480	HP5082-7300	LED DISPLAY	

SPECIFICATION	DWG STATUS	SHEET/ LINE NO.	PARTS LIST					RCA		CAMDEN PLANT	REV LTR	CODE IDENT	PL 8576942	SHEET 03
			RCA CORPORATION, NEW YORK, N. Y.									49671		
			ITEM OR FIND NO.	QTY REQD PER DASH NO.					U M	CODE IDENT	PART OR IDENTIFYING NO.	NOMENCLATURE OR DESCRIPTION	SYM	
505	504	503		502	501									
QQ-5-571		0302	2					X			8371958	SCHEMATIC GSE DISPLAY		
	I	0303	3				X	X			8030022	WORKMANSHIP, NASA COMPLIANT		
	I	0304	4				X	X			2020319	MECZO & MNL SOLDERING PROCESS		
	I	0305	5					X			2020341	MSTRE & FP COATING-ELEC PFS		
	I	0306	6					X			2020999	ADHESIVE-BONDING COMP TO PWB		
	E	0310	10					X			8676340	HA PATT DISPLAY, GSE		
	E	0311	11						I		8676341-502	DISPLAY GSE		
	E	0312	12					1			8676340-1	BD PW		
	I	0313	13					27			8153202-1	TERMINAL		
	I	0315	15					AR		81348	SN63WRAP2	SOLDER		
	I	0316	16					AR			2010573-1	FLUX, SOLDERING, ALCHL-RJSIN		
	I	0317	17					AR			2016185	EPOXY-POLYAMIDE COATING		
	I	0318	18					AR			8533343	EPOXY FORMULATIONS		

DEC.1320 (6/69)

6-125/6-126