

## **General Disclaimer**

### **One or more of the Following Statements may affect this Document**

- This document has been reproduced from the best copy furnished by the organizational source. It is being released in the interest of making available as much information as possible.
- This document may contain data, which exceeds the sheet parameters. It was furnished in this condition by the organizational source and is the best copy available.
- This document may contain tone-on-tone or color graphs, charts and/or pictures, which have been reproduced in black and white.
- This document is paginated as submitted by the original source.
- Portions of this document are not fully legible due to the historical nature of some of the material. However, it is the best reproduction available from the original submission.

A C C E S S - 1

Approximation Concepts Code for Efficient Structural Synthesis

PROGRAM DOCUMENTATION and USER'S GUIDE

by Hirokazu Miura and Lucien A. Schmit, Jr.

(NASA-CR-144905) ACCESS 1: APPROXIMATION  
CONCEPTS CODE FOR EFFICIENT STRUCTURAL  
SYNTHESIS PROGRAM DOCUMENTATION AND USER'S  
GUIDE (California Univ.) 94 P HC \$5.00  
CSCL 13M G3/39

N76-26581

Unclas  
44538

Prepared under Grant No. NGR-05-007-337 by  
UNIVERSITY OF CALIFORNIA, LOS ANGELES  
Los Angeles, California

for



NATIONAL AERONAUTICS AND SPACE ADMINISTRATION



1. Report No. NASA CR-144905		2. Government Accession No.		3. Recipient's Catalog No.	
4. Title and Subtitle ACCESS - 1 Approximation Concepts Code for Efficient Structural Synthesis - Program Documentation and User's Guide				5. Report Date May 1976	
				6. Performing Organization Code	
7. Author(s) Hirokazu Miura and Lucien A. Schmit, Jr.				8. Performing Organization Report No.	
9. Performing Organization Name and Address University of California, Los Angeles Los Angeles, CA				10. Work Unit No. 506-17-21-01	
				11. Contract or Grant No. NGR-05-007-337	
12. Sponsoring Agency Name and Address National Aeronautics & Space Administration Washington, DC 20546				13. Type of Report and Period Covered Contractor Report	
				14. Sponsoring Agency Code	
15. Supplementary Notes W. Jefferson Stroud, Structures & Dynamics Division, Langley Research Center, was technical monitor on this grant. This is a topical report.					
16. Abstract  This report serves as program documentation and user's guide for the ACCESS-1 computer program. ACCESS-1 is a research oriented program which implements a collection of approximation concepts to achieve excellent efficiency in structural synthesis. The finite element method is used for structural analysis and general mathematical programming algorithms are applied in the design optimization procedure.  Implementation of the computer program, preparation of input data and basic program structure are described, and three illustrative examples are given. This report together with Ref. 1 (NASA CR-2552) and the computer program give a complete account of the ACCESS-1 program.					
17. Key Words (Suggested by Author(s)) Structural synthesis Structural optimization Minimum mass design Mathematical programming ACCESS-1				18. Distribution Statement  Unclassified - Unlimited  Subject Category 39	
19. Security Classif. (of this report) Unclassified		20. Security Classif. (of this page) Unclassified		21. No. of Pages 92	22. Price* \$4.75

CONTENTS

	Pages
LIST OF FIGURES . . . . .	vi
LIST OF TABLES . . . . .	vii
SUMMARY . . . . .	1
1. Introduction . . . . .	3
2. Program Imprementation . . . . .	7
3. Program Organization . . . . .	9
4. Structural Model and Input Preparation . . . . .	11
4.1 Node/Element Numbering Scheme . . . . .	11
4.2 Symmetric Wing Model . . . . .	11
4.3 Two and Three Dimensional Structures . . . . .	12
4.4 Design Variable Linking . . . . .	12
4.5 Configuration/Material Group . . . . .	13
4.6 Computation of Constraints and Control Parameters	14
4.7 Optimizer Control Parameters - NEWSUMT Version .	16
4.8 Optimizer Control Parameters - CONMIN Version .	17
4.9 Printout Control Parameters . . . . .	18
4.10 System of Units . . . . .	18
5. Restrictions and Limitations . . . . .	19
REFERENCES . . . . .	21
FIGURES . . . . .	23
TABLES . . . . .	33
APPENDIX A. CPU TIMING ROUTINES . . . . .	43
APPENDIX B. INPUT CARD DESCRIPTION . . . . .	45
APPENDIX C. INPUT CARD EXAMPLES . . . . .	59
APPENDIX D. OUTPUT EXAMPLES . . . . .	75
APPENDIX E. EXAMPLE FOR PROGRAM MODIFICATION . . . . .	85

## LIST OF FIGURES

Figures		Pages
1.	ACCESS 1 Basic Organization . . . . .	23
2.	ACCESS 1 Program Organization (NEWSUMT Version) .	24
3.	ACCESS 1 Program Organization (CONMIN Version) . .	25
4.	ACCESS 1 Program Overlay Structure (NEWSUMT Version)	26
5.	ACCESS 1 Program Overlay Structure (CONMIN Version)	27
6.	SSP Element Model Example . . . . .	28
7.	Ten-Bar Planar Truss . . . . .	29
8.	Constraint Truncation Boundary Value vs. Truncation Factor . . . . .	30
9.	Golden Section Algorithm . . . . .	31

LIST OF TABLES

Tables	Pages
1. Function of All Routines . . . . .	33
2. Labeled COMMON Blocks . . . . .	37
3. Analysis Printout Control (IPRINT) . . . . .	40
4. Analysis Printout Control (JPRINT) . . . . .	41

## SUMMARY

This report presents information that is required for use of the ACCESS-1 computer program. ACCESS-1 is a research-oriented computer program designed to test the actual performance of various new concepts and techniques in structural synthesis. The historical and technical background of this program is described in detail in Refs. 1 and 2, together with a number of well documented numerical examples.

The current version has three types of finite elements, namely, truss elements (TRUSS), isotropic constant strain triangular membrane elements (CST), and isotropic symmetric shear panel elements (SSP). Structural weight will be minimized by modifying the sizes of these elements--cross sectional areas of TRUSS elements, and thicknesses of CST and SSP elements. Design constraints may be imposed on nodal displacements, tensile and/or compressive stresses in TRUSS elements, von Mises combined stresses in CST and SSP elements, together with the minimum and maximum bounds on cross sectional areas of TRUSS elements and on thicknesses of CST and SSP elements.

There are two distinct general optimization programs which can be used in ACCESS-1. One is CONMIN (Ref. 3) which applies a modified method of feasible directions and the other is NEWSUMT which implements a sequence of unconstrained minimization technique (SUMT), using a modified Newton's method (Ref. 4) for the unconstrained minimizations.

ACCESS-1 is an all in-core program and all routines are written in standard FORTRAN IV language. No advanced coding techniques are

used, thus engineers with basic programming experiences can modify or restructure the program for their own purposes. Consequently, one may make the best use of ACCESS-1 as a research tool to test or demonstrate new ideas or techniques through example problems of modest size. For example, the basic version of this program declares array sizes to accommodate problems having up to 210 elements, 70 nodes and 2 load conditions.



## ACCESS-1

### Approximation Concepts Code for Efficient Structural Synthesis Program Documentation and User's Guide

#### 1. Introduction

The ACCESS-1 computer program was developed to demonstrate the effectiveness of a structural synthesis capability formed by combining finite element analysis techniques and mathematical programming algorithms using an innovative collection of approximation concepts. Three types of finite elements are available: namely, truss elements of uniform cross sectional areas (TRUSS), isotropic constant strain triangular membrane elements of uniform thicknesses (CST) and isotropic symmetric shear panel elements of uniform thicknesses (SSP). Structures with prescribed configuration and material constants are optimized so that their structural weight is minimized by modifying the sizing of finite elements, i.e., cross sectional areas of TRUSS elements, thicknesses of CST and SSP elements. Design constraints may be imposed on all or selected nodal displacements, tensile and/or compressive stresses in TRUSS elements, von Mises combined stresses in CST and SSP elements, together with the minimum and maximum bounds on element sizing variables.

The fundamental structure of the ACCESS-1 program is illustrated in Fig. 1. Upon activation, the preprocessor reads input data and completes data processing which is not affected by changes of design variables (i.e., element sizes), and the results are stored in a convenient form for future retrieval. The design process control block (DPC) supervises the design iteration procedure as follows. The given initial design data is transferred to the approximate problem generator, which performs a complete finite element

structural analysis, constraint function calculation, as well as constraint deletion and sensitivity analysis of retained constraints. Values of retained constraints and their sensitivity data together with the closed form description of the weight function complete the approximate problem statement which will be transferred to the optimization algorithm (OA) block through DPC. OA will improve the design using one of the well established constrained function minimization algorithms to operate on the current approximate problem statement. An improved design is proposed to DPC and the data for structural analysis is updated based on this new proposal. This step completes one stage of the design iteration procedure. The iterative process is then continued until at least one of the termination criteria is satisfied.

Note two important features here. First, the conventional finite element method of structural analysis is divided into two parts: i.e., the preprocessor and a part of the APG block. It is desirable to include as much data processing as possible in the preprocessor. Second, the optimization algorithm is asked to improve the design with respect to the explicit but approximate problem statement, which may or may not be linear. Hence the program used in the OA block may be completely independent of structural problems and practically any inequality constrained function minimization algorithm can be used.

Currently there are two distinct general optimization program options available in ACCESS-1. One is CONMIN (Ref. 3) which applies a modified method of feasible directions and the other is NEWSUMT

which implements a sequence of unconstrained minimizations technique using a modified Newton's method (Ref. 4) for the unconstrained minimizations. Corresponding to each optimizer, a distinct main program and interface subroutines are supplied. The structure and program configuration of these two versions are shown in Figs. 2 and 3. Minor differences between these two versions (especially in the DPC block) are attributed to the fact that the NEWSUMT optimizer includes certain functions associated with the DPC block as well as those of the OA block.

All routines are written in standard FORTRAN IV language and they have been tested on: (a) the IBM 360/91 using the FORTRAN-H and WATFIV compilers at UCLA; and (b) the CDC 6600 using the FTNX compiler at UC Berkeley via a remote batch terminal located at the NASA Ames Research Center. Implementation on other types of computers will be straightforward provided those computers have the required main memory capacity. The efficiency of ACCESS-1 when applied to relatively large scale problems could be improved by using advanced coding techniques. However, in its present form, it should be possible for anyone with basic practical programming experience in FORTRAN to understand and, if necessary, to restructure or modify any of the subroutines with relative ease. If new ideas or techniques are to be tested, it usually takes a considerable amount of time and effort to develop a new computer program. Experiences show that ACCESS-1 may be used conveniently as the base program for the purpose of such experiments. An example of minor program modification is given in Appendix E, where a method to replace SSP elements with conventional symmetric pure shear elements

is described.

The ACCESS-2 program, currently being developed, will handle significantly larger problems than ACCESS-1, with more involved constraints (e.g. thermal effects, fiber composite materials, and natural frequency constraints). The ACCESS-2 program makes effective use of dynamic array allocation and auxiliary data storage, hence it can solve larger problems than ACCESS-1 using less main memory capacity. On the other hand, program modifications of ACCESS-2 will require more careful coding and data restructuring.

## 2. Program Implementation

Both the CONMIN and NEWSUMT versions of ACCESS-1 may be executed as a stand-alone program. All routines are written in standard FORTRAN IV language and use only ANS FORTRAN intrinsic functions. In addition, if a CPU timing function is available on the user's installation, useful CPU time data at the end of each stage and also at the end of a job will be printed by replacing the dummy routines CPUTIM and CTIME with appropriate ones. Examples of these routines are given in Appendix A for the IBM 360/91 at UCLA, the CDC 6600 at UC Berkeley and the IBM 360/67 at the NASA Ames Research Center.

The declared array sizes of the basic version are determined to accommodate problems with 70 elements of each type, 70 nodes, 2 load conditions and 40 design variables. If desired, the number of elements may be increased by using the space allocated to the subsequent element types, where the element type sequence is TRUSS, CST and SSP. In other words, 210 truss elements may be used, provided neither CST nor SSP elements are used, or 140 CST elements may be used, if no SSP elements are used. To accommodate problems which exceed these capacities, array sizes declared in the program must be modified accordingly.

If program overlay is not used, the basic NEWSUMT and CONMIN versions may require as much as 323 K bytes and 366 K bytes of main memory on IBM 360/91 at UCLA, respectively. On CDC 6600 computers at NASA Langley Research Center, the NEWSUMT version requires 220<sub>8</sub>K words. When program overlay is implemented as given in Figs. 4 and 5, the main memory requirements on IBM 360/91 is reduced to 270 K bytes

for both versions. Program overlay won't be so effective on CDC 6600 computers, because the proportion of program instructions in the main memory requirement is much smaller than IBM 360 series computers.

Depending on the problem and/or the choice of parameters, the declared capacity of certain arrays may be exceeded; in such cases, processing will be terminated automatically, and appropriate messages will be printed out.

### 3. Program Organization

Implementation of the basic procedure outlined in Fig. 1 is carried out as indicated in Figs. 2 and 3. Primary functions of all subroutines are listed in Table 1, and this facilitates understanding of Figs. 2 and 3. Furthermore, all key subroutines contain enough comment cards so that the computer program listings also serve as a part of the program documentation.

Data transfer between the subroutines is carried out primarily through labeled COMMON blocks. Labeled COMMON blocks appearing in each subroutine or function are summarized in Table 2. In case it is necessary to modify the array sizes, care should be taken to modify all associated array declaration statements. In addition, argument lists of the statements to call the following subroutines must be modified.

SADM05      SAD007      SAD008      SADMM8

Some users may wish to improve array allocation efficiency. This could be accomplished by allocating a few large arrays dynamically. For this purpose the following arrays are suggested as likely candidates:

DG: gradient of retained constraints

AK: master stiffness matrix

DU: gradient of displacement degrees of freedom

Note that the selective inverse matrix of AK shares the same memory position with DG.

Currently, two control parameters IDG and IOPT are not utilized for their intended purposes. Therefore, they may be used to provide additional control capability in modifying this program.

A useful example is given in Appendix D, where creation of an option to replace SSP elements with pure shear elements by modifying a part of the program is discussed. This example is shown to encourage users of this program to modify it, if required, to test new features. Another option which is already implemented in the base versions use  $IDG = 5$  to remove regionalization of stress constraints. If  $IDC = 5$  is specified in the input data, stress constraints are imposed on all stress-constrained elements. (see Sec. 4.4)



#### 4. Structural Model and Input Data Preparation

It is assumed that the reader is familiar with elastic structural analysis via the finite element displacement method, and also with associated structural modelling techniques and typical data preparation procedure. Sufficient information in preparing the input data cards is given in Appendix B, therefore explanations given in this section are limited to the subjects which require somewhat detailed technical discussion to avoid possible misunderstandings.

##### 4.1 Node/Element Numbering Scheme

The solution of linear simultaneous equations is obtained by a sequence of calls for SAD007 and SAD008. The coefficient matrix (= master stiffness matrix) is stored in a vector form within the skyline of the non-zero elements; i.e., there are no operations or no storage allocations with elements that remain zero during the solution (see Fig. 6 of Ref. 1). The coefficient matrix is decomposed to  $LDL^T$  form by SAD007 and back and forward substitutions are then carried out by SAD008. The decomposed matrix  $DL^T$  is overwritten in the memory area where the stiffness matrix is originally formed. The elements of pointer vector IIK indicate the positions of the diagonal elements for the matrix stored in a vector form. This scheme allows somewhat more flexible node/element numbering arrangement than the ordinary band equation solver. It is better, however, to take the same care in preparing data as for banded matrix solution scheme; i.e., differences among node numbers associated with an element must be kept as small as possible for all elements.

##### 4.2 Symmetric Wing Model

If the webs of a symmetric wing are modelled with SSP elements,

only an upper (or a lower) half of the wing is modelled and x,y displacements and loadings are anti-symmetric with respect to the x-y plane. Displacements and loadings in the z direction are identical for both sides of the x-y plane. For example, if a cantilever beam such as that shown in Fig. 6(a) is to be modelled using two SSP elements, then the simplified model should be that shown in Fig. 6(b). Note that only half of the loads must be applied to the node 3, since the other half is implicitly applied to the conjugate node 3' (which does not exist explicitly in the model). The neutral plane coincides with the x-y plane and SSP elements are always vertical to the x-y plane. The example 1 given in Appendix C will be helpful in understanding this feature.

#### 4.3 Two and Three Dimensional Structures

ACCESS-1 treats planar (two dimensional) and spatial (three dimensional) structures separately. If a structure is declared to be planar by specifying ID = 2, the structure lies on the x-y plane and the displacements in the z direction are automatically suppressed. In planar structures, nodes whose x and y displacement degrees of freedom are free should not be classified as boundary nodes.

#### 4.4 Design Variable Linking

General concept of design variable linking is discussed in Sec. 2.3.1 of Ref. 1. In ACCESS 1, if the sizes of some group of finite elements of the same type are controlled by a single design variable, these elements are defined to belong to the same linking group. Sizes of the elements in a linking group are modified in

proportion to the initial sizes given in the input data.

Also design variable linking groups are used to define "regions" for the regionalization of stress constraints. General idea of regionalization is given in Sec. 2.4.1 of Ref. 1. Elements which belong to the same design variable linking group form a region and only one stress constraint per group and per load condition is considered for each group in any stage of the iterative design procedure. Selection of the representative elements is not rigidly fixed, but dynamically updated at the beginning of each stage. If the location of critical stress shifts frequently within a region between two consecutive stages, iteration process may be unstable, although this type of instability was not observed in solving any of the problems given in Ref. 1. However, if the user desires to remove the regionalization of stress constraints, specify  $IDG = 5$ . Otherwise  $IDG = 0$ .

#### 4.5 Configuration/Material Group

If there are a number of elements of the same type having identical configuration and material properties, then these elements belong to the same configuration/material group. For example, the single-material planar-truss structure shown in Fig. 7 has only two configuration/material groups. Configuration/material grouping is used to achieve a reasonable compromise between limitations on main memory space and the desire for efficient run times. The element stiffness matrices in the local coordinate system for unit design variable value are identical for all elements in the same configuration/material group. It is interesting to note that the local stiffness matrices of CST elements are independent of absolute edge lengths and only depen-

dent on shape.

#### 4.6 Computation of Constraints and Control Parameters

All constraints are normalized so that the constraint function assumes the values between 0.0 and -1.0, approximately.

##### Stress Constraints

$$0.5 (\sigma - \sigma_a^{(U)}) / (\sigma_a^{(U)} - \sigma_a^{(L)}) \leq 0$$

$$0.5 (\sigma_a^{(L)} - \sigma) / (\sigma_a^{(U)} - \sigma_a^{(L)}) \leq 0$$

##### Displacement Constraints

$$0.5 (\delta - \delta_a^{(U)}) / (\delta_a^{(U)} - \delta_a^{(L)}) \leq 0$$

$$0.5 (\delta_a^{(L)} - \delta) / (\delta_a^{(U)} - \delta_a^{(L)}) \leq 0$$

##### Side Constraints

$$1.0 - D^{(U)} / D \leq 0$$

$$D^{(L)} / D - 1.0 \leq 0$$

$\sigma$  : computed stress

$\delta$  : computed displacement

$\sigma_a$  : allowable stress

$\delta_a$  : allowable displacement

D : sizing variable

(U) : upper limit

(L) : lower limit

As explained in the following section, optimization will be carried out in the linked reciprocal variable space. Therefore, for statically determinate structures, all constraints shown above are linear in this space, including side constraints.

In the preprocessor (SETCON), all constraints are identified and after deleting strictly redundant side constraints, they are enumerated and associated pointer vectors to characterize them are prepared. After structural analysis in the APG block, all constraint values are evaluated. Due to constraint regionalization and truncation based on the computed constraint values, a significant part of constraints are truncated from further consideration during the particular design stage. Then sensitivity of these retained

small set of constraints are computed with respect to the linked reciprocal variables.

•JSIGNG: sign convention of inequality constraints

Feasible regions in the design space are defined as follows:

$$h_q(\vec{D}) \leq 0 \quad q = 1, 2, \dots, \text{NTC} \quad \begin{array}{l} \text{Structural Analysis} \\ \text{CONMIN optimizer} \end{array}$$

$$h_q(\vec{D}) \geq 0 \quad q = 1, 2, \dots, \text{NTC} \quad \text{NEWSUMT optimizer}$$

However, the NEWSUMT optimizer has a built-in option to accept an analysis program, in which feasible regions are defined for non-positive values of design constraints.

This option is activated by specifying JSIGNG equal to -1.

•SPM: starting point margin

If an initial design is infeasible, the initial design is uniformly scaled up so that all constraints become satisfied with certain margins. The minimum margin for the most critical constraint is given by

$$\text{Max}_q [h_q(\vec{D})] = -(\text{SPM}-1.0).$$

If it is necessary to change the scaling procedure, the subroutine SUBALY must be modified.

•TRF, TRFINC and TRFMAX: constraint truncation control parameters

In the APG block, when all constraint function values  $h_q(D)$  are evaluated, critical and potentially critical constraints are selected to form the explicit approximate problem statement. A constraint  $h_q(\vec{D})$  is to be retained as critical or potentially critical if

$$h_q(\vec{D}) \geq C - \text{TRF} * [\text{Max}_q (h_q(\vec{D})) - C] = \text{TBV}$$

where

- $\text{Max}(h_q(\vec{D}))$ : the maximum constraint value in each type of constraint
- C: preassigned constant in SETPOS  
- 1.0 for stress and displacement constraints  
- 1.2 for side constraints
- TRF: initial value is given as an input data and modified at the end of each design iteration stage by  $\text{TRF} = \text{Min}(\text{TRF} * \text{TRFMUL}, \text{TRFMAX})$

The relation between TRF and the truncation boundary value TBV is illustrated in Fig. 8. Note that TBV is gradually lowered in absolute value so as to truncate more constraints as the design procedure converges.

#### 4.7 Optimizer Control Parameters - NEWSUMT Version

•EPSEA, EPSARS, EPSODM: convergence criteria

EPSEA: Stage convergence criterion

Iteration process will be terminated, if three consecutive stages produce designs which satisfy

$$(\text{OBJ}_p - \text{OBJ}_{p-1}) / \text{OBJ}_p < \text{EPSEA}$$

$$(\text{OBJ}_{p-1} - \text{OBJ}_{p-2}) / \text{OBJ}_{p-1} < \text{EPSEA}$$

EPSARS: Convergence criterion applied to the results of 3 sequential unconstrained minimizations without updating the approximate problem statement. This is applicable only if  $\text{MAXARS} > 3$ .

EPSODM: Convergence criterion in the golden section minimum search procedure. Convergence is achieved if at a certain state,

$$(|\text{TLL}-\text{TL}| + |\text{TL}-\text{TR}| + |\text{TR}-\text{TRR}|) / |\text{TR}+\text{TL}| \leq \text{EPSODM}$$

and

$$\text{ARR} - \text{ALL} \leq 0.05$$

are satisfied. (See Fig. 9)

- STEPMX: Maximum allowable change in any components of the design vector during a single stage in the NEWSUMT optimizer. Usually, it is not necessary to use this feature, but if some constraints are found to be highly nonlinear and errors due to the first order Taylor series expansions are excessive, this parameter will be useful to confine the design within a reasonable range during one stage of the overall iterative design procedure.
- DELTAC: Initial transition point for extended penalty functions.

#### 4.8 Optimizer Control Parameters - CONMIN Version

- EPSSTG: Same as EPSEA in §. 4.7.
- EPSVJK: Same as EPSVJK in §. 4.7.
- ITMAX: Maximum allowable number of iterations in the CONMIN optimizer. Here, one iteration is equivalent to one direction search followed by a one-dimensional minimization.
- CTL: Initial width of active region of constraints. A constraint is defined to be

$$\begin{aligned} &\text{violated if } h_q(\bar{D}) > 0 \\ &\text{active if } 0 \geq h_q(\bar{D}) \geq \text{CTL} \\ &\text{non-active if } \text{CTL} > h_q(\bar{D}) \end{aligned}$$

Note that  $\text{CTL} < 0$ . (default value = -0.01)

- CTLMIN: Upper limit of CTL. This is not an important parameter for ACCESS-1, and it is recommended that the default value of -0.001 be used.

\*DELFUN: Convergence criterion among one dimensional minimizations.

Iteration process will be terminated, if in two consecutive iterations,  $ABS(1.0-OBJ_{J-1}/OBJ_J) < DELFUN$ , and the current design is feasible.

#### 4.9 Printout Control Parameters

There are two parameters used to control the line printer output quantity, namely IPRINT and JPRINT. The greater the integer numbers assigned to these parameters, the more detailed output will be printed.

\*IPRINT controls printouts from all programs except those from optimizers. Brief summary of the output items is given in Table 3. Standard output will be obtained by assigning  $IPRINT = 2$ .

\*JPRINT controls output from optimizers (see Table 4). Standard values are 2 for NEWSUMT and 1 for CONMIN.

#### 4.10 System of Units

Input data of ACCESS 1 computer program may be prepared in any unit systems as long as they are consistent. For example, if the units for length and force are decided to be centimeter and Newton, respectively, then the unit for pressure or stress must be  $N/cm^2$ . Example problems given in Appendix C are presented both in the International System (IS) of Units and in the U.S. Customary (US) Units. Computer input data examples are prepared using numerical values associated with the us Units, simply because all the examples were presented originally in various literature in the US Units.



## 5. Restrictions and Limitations

As explained in the previous sections, the problem size which the base version can solve is limited to

- 70 elements for each element type
- 20 design variables for each type of element, but the total should not exceed 40
- 70 nodes
- 2 load conditions.

These numbers may be easily modified by changing the sizes of arrays declared in the program. However, it is not practical to solve large problems using ACCESS-1, even if the computer has large main memory capacity.

The program permits the imposition of upper bounds on element sizes as well as lower and upper bounds on positive and negative displacements or stresses, respectively. However, this type of constraint, when violated, may cause difficulties in convergence. This is because these constraints cannot be satisfied by uniformly scaling up the design variables. Both optimizers have capabilities to start from an infeasible initial design, however, the iteration history may be unstable when one or more constraints are violated, especially when the NEWSUMT version is used. This shortcoming will be eliminated in ACCESS-2.

#### REFERENCES

1. L.A. Schmit, Jr., H. Miura, "Approximation Concepts for Efficient Structural Synthesis," NASA CR-2552, March 1976
2. L.A. Schmit, Jr., H. Miura, "A New Structural Analysis/Synthesis Capability - ACCESS 1," AIAA Paper No. 75-763 presented at AIAA/ASME/SAE 16th Structures, Structural Dynamics and Materials Conference, Denver, Colorado, May 27-29, 1975, also to be published in AIAA Journal.
3. G.N. Vanderplaats, "CONMIN - A FORTRAN Program for Constrained Function Minimization," NASA-TMX-62,282, NASA Ames Research Center, Moffett Field, California 94035, August 1973.
4. R.T. Haftka, "Automated Procedure for Design of Wing Structures to Satisfy Strength and Flutter Requirements," NASA TN D-7246 NASA Langley Research Center, Hampton, Virginia 23665, July 1973.

PRECEDING PAGE BLANK NOT FILMED

PRECEDING PAGE BLANK NOT FILLED

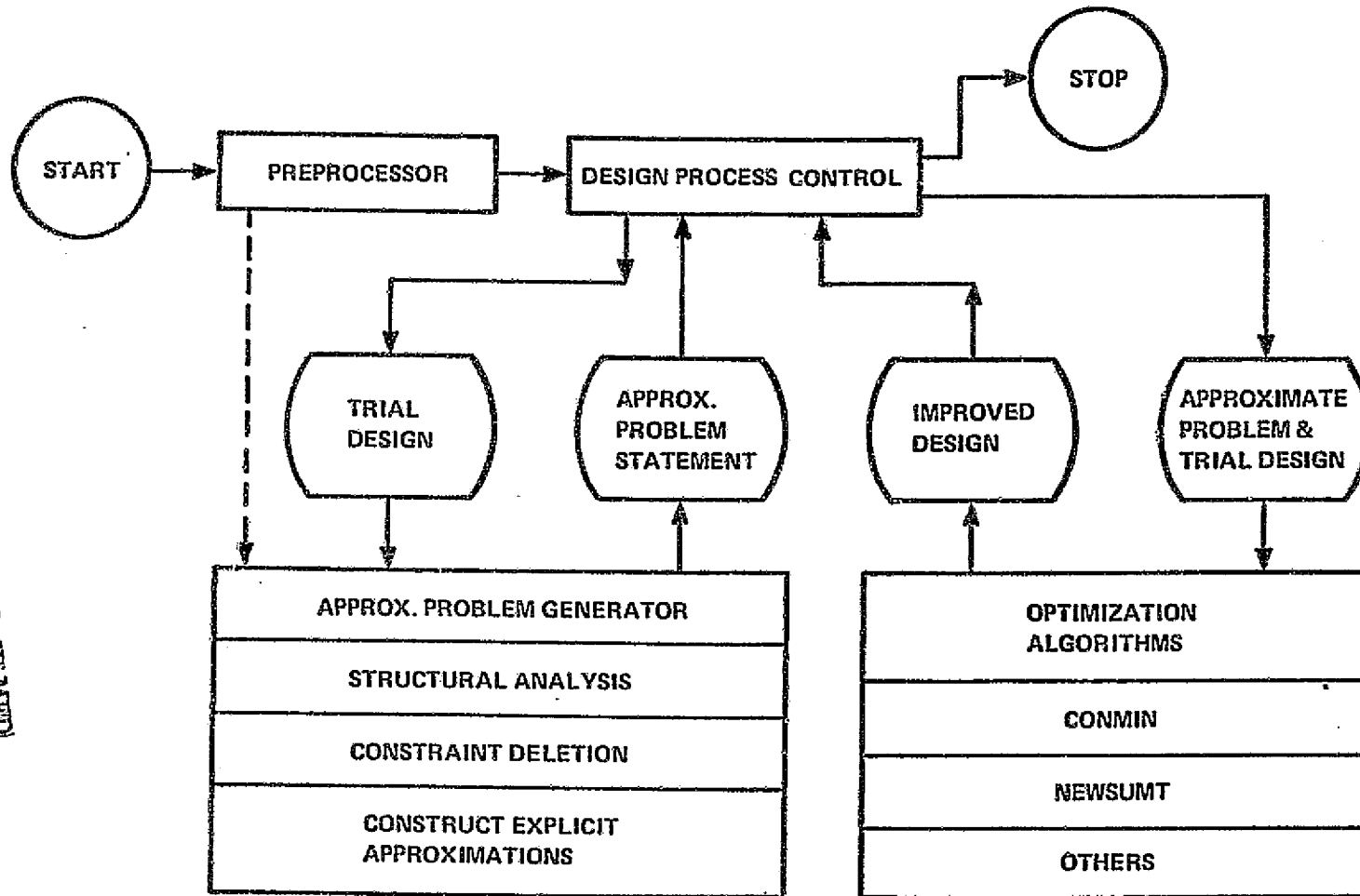
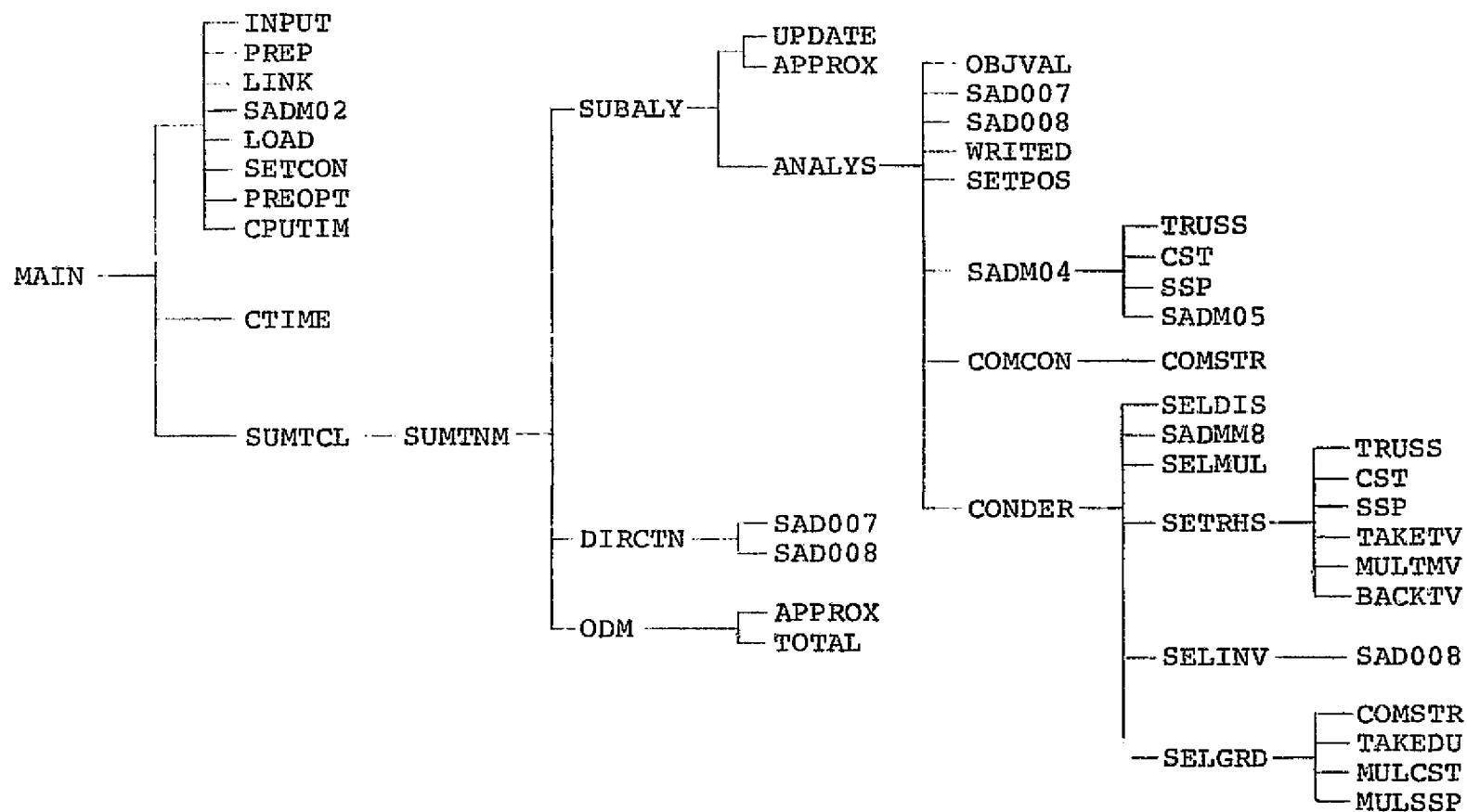

Figure 1. ACCESS 1 Basic Organization.

Fig. 2 ACCESS-1 Program Organization (NEWSUMT Version)



5,670 cards altogether (FORTRAN source program)

Fig. 3 ACCESS-1 Program Organization (CONMIN Version)

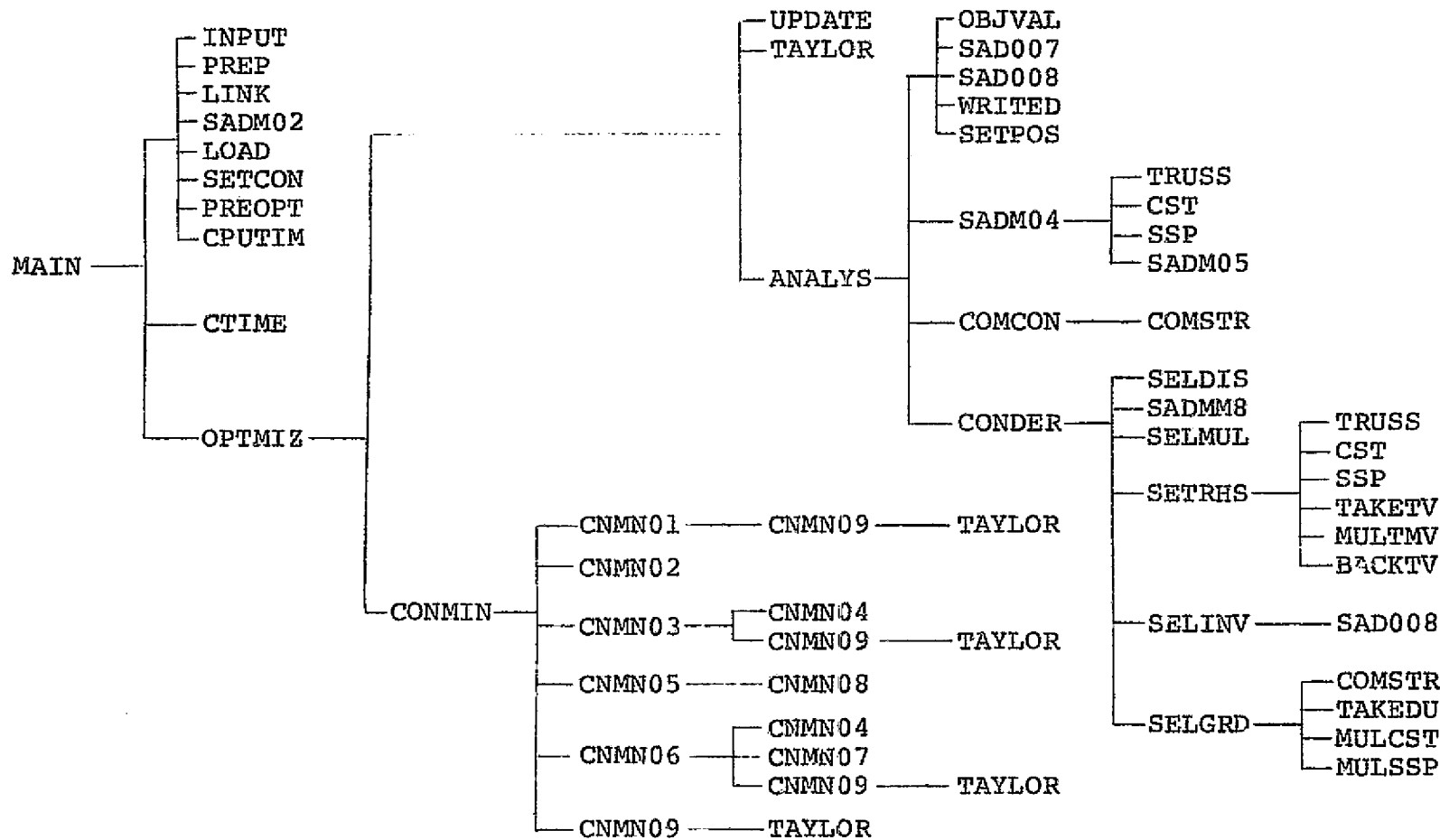

6,811 cards altogether (FORTRAN source program)

Fig. 4 ACCESS-1 Program Overlay Structure (NEWSUMT Version)  
on IBM 360/91 UCLA Campus Computing Network

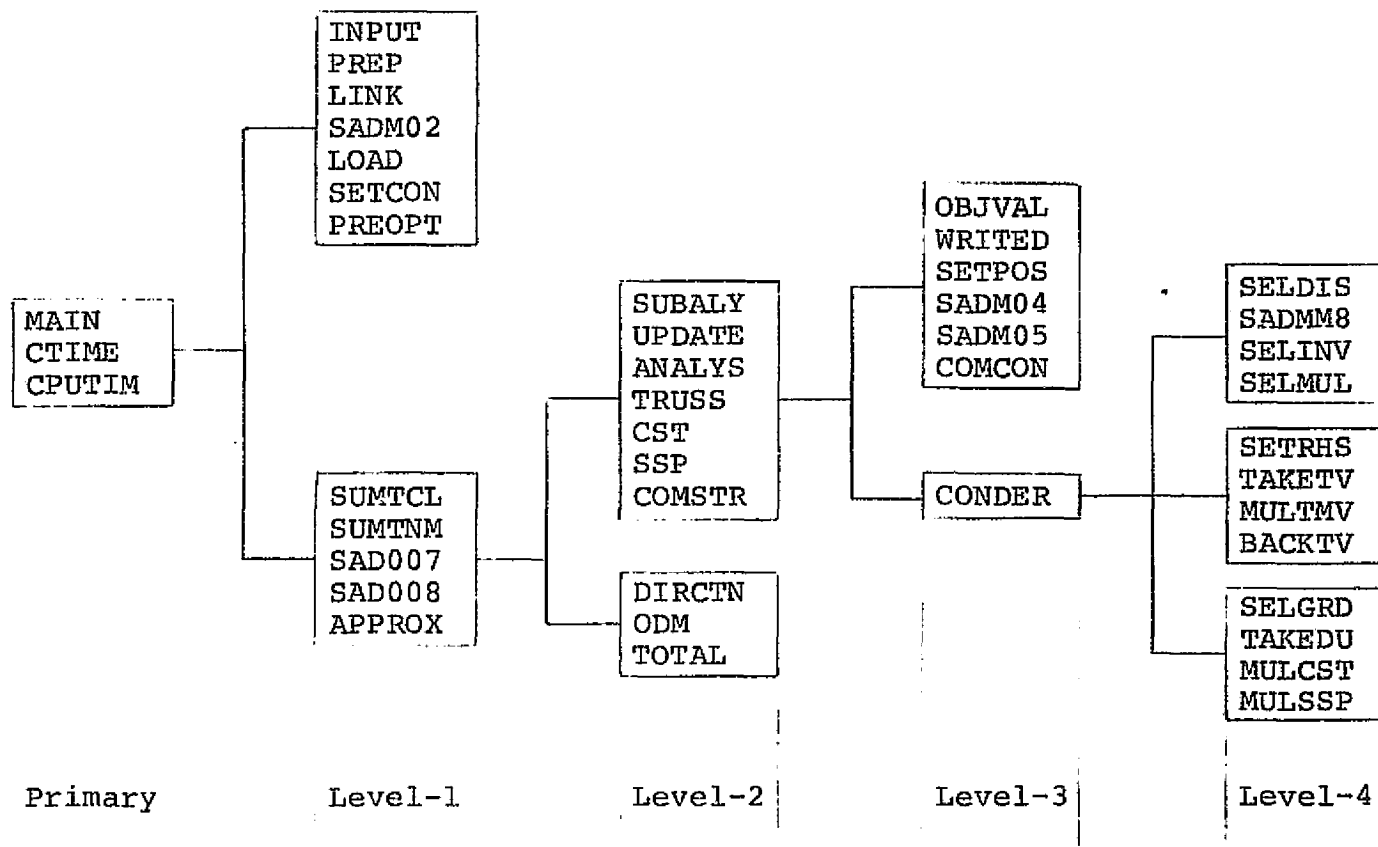
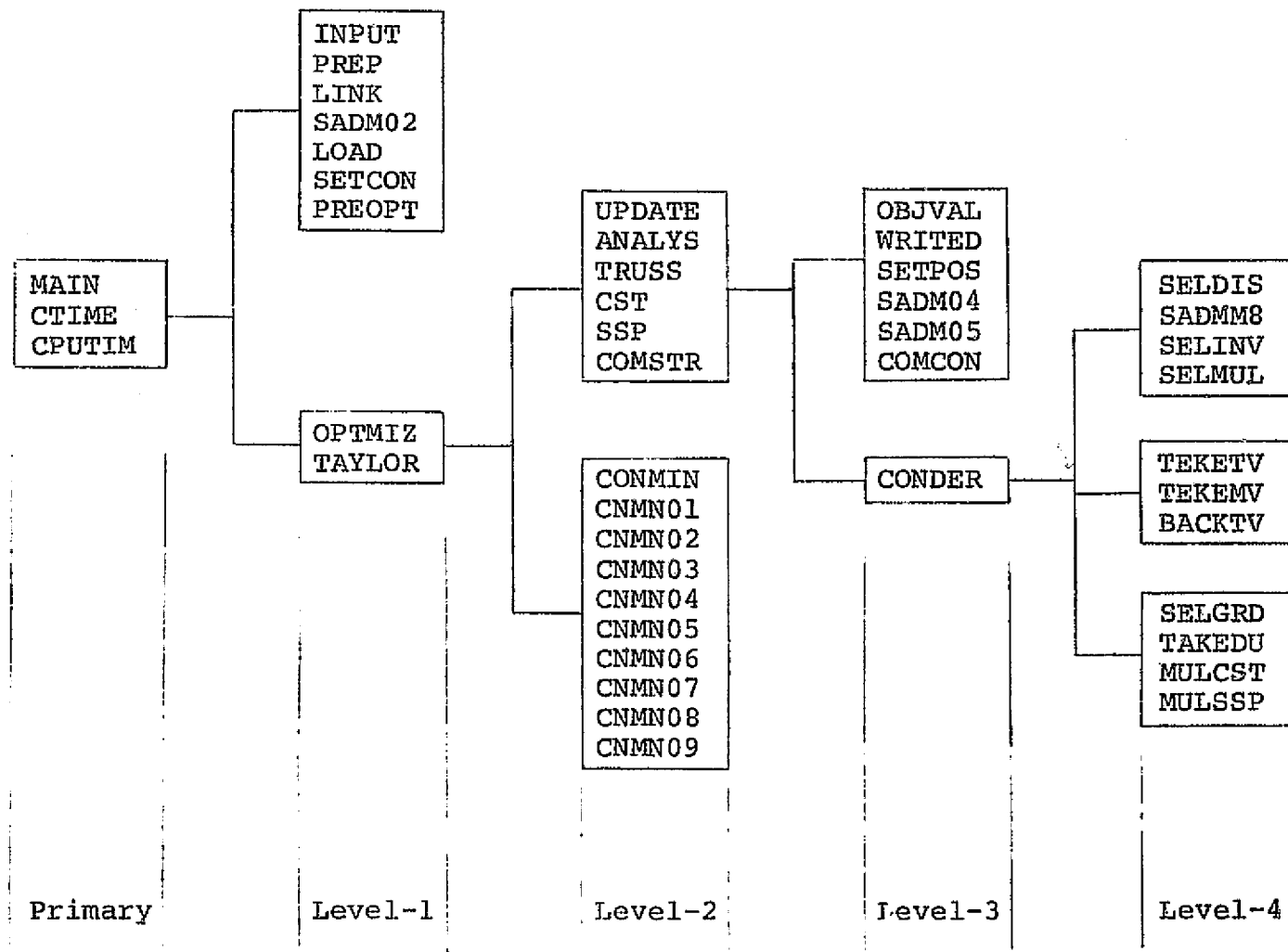

Fig. 5 ACCESS-1 Program Overlay Structure (CONMIN Version)  
on IBM 360/91 UCLA Campus Computing Network



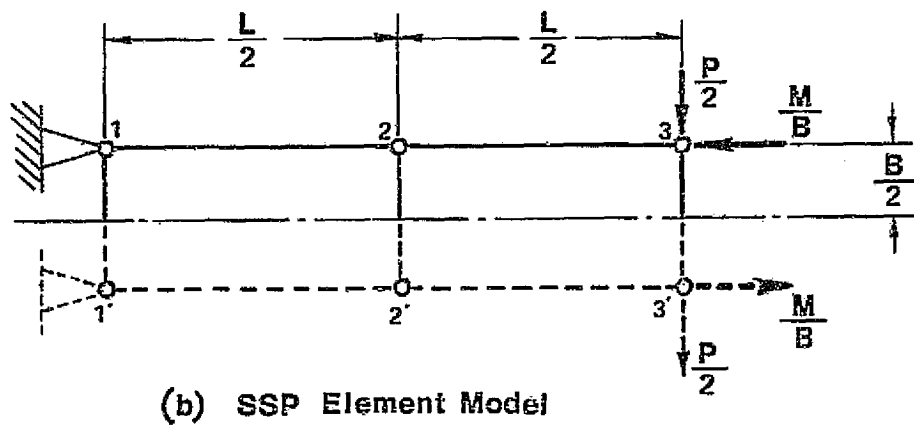
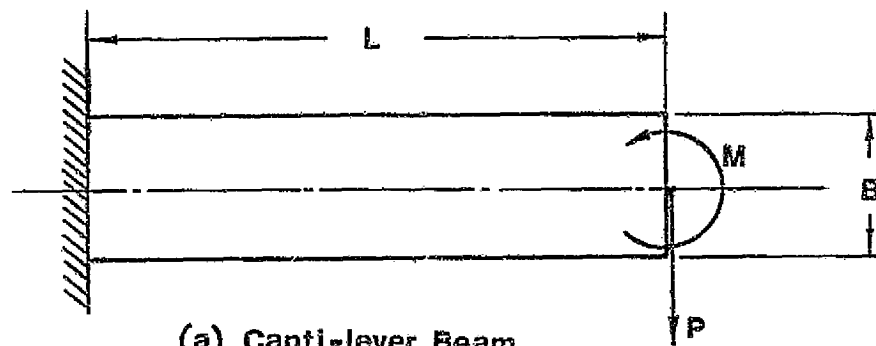
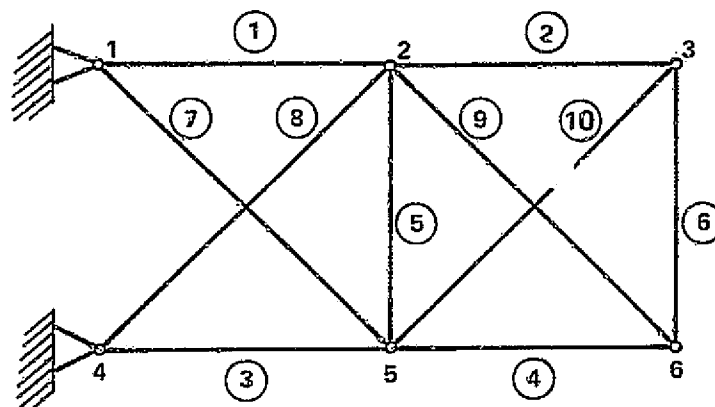

Fig. 6 SSP Element Model Example





**Configuration Material**

**Group 1** [ 1, 2, 3, 4, 5, 6 ]

**Group 2** [ 7, 8, 9, 10 ]

**Fig.7 Ten-Bar Planar Truss**

Constraints whose values fall in this region are retained to form the approximate problem statement.

Constraints whose values fall in this region are truncated.

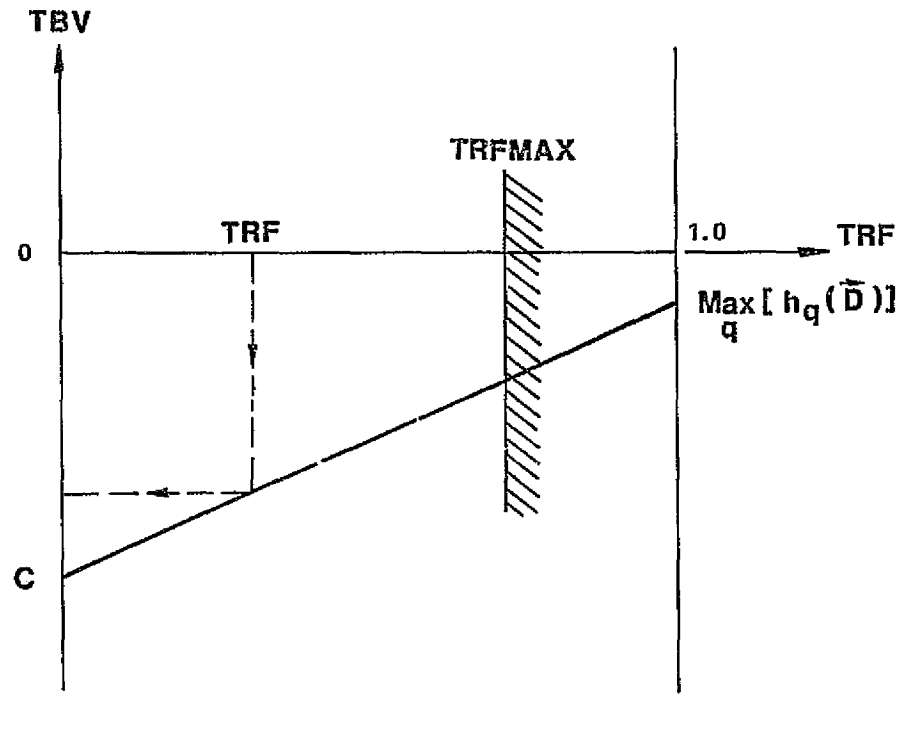

**Fig. 8 Constraint Truncation Boundary Value  
vs. Truncation Factor**

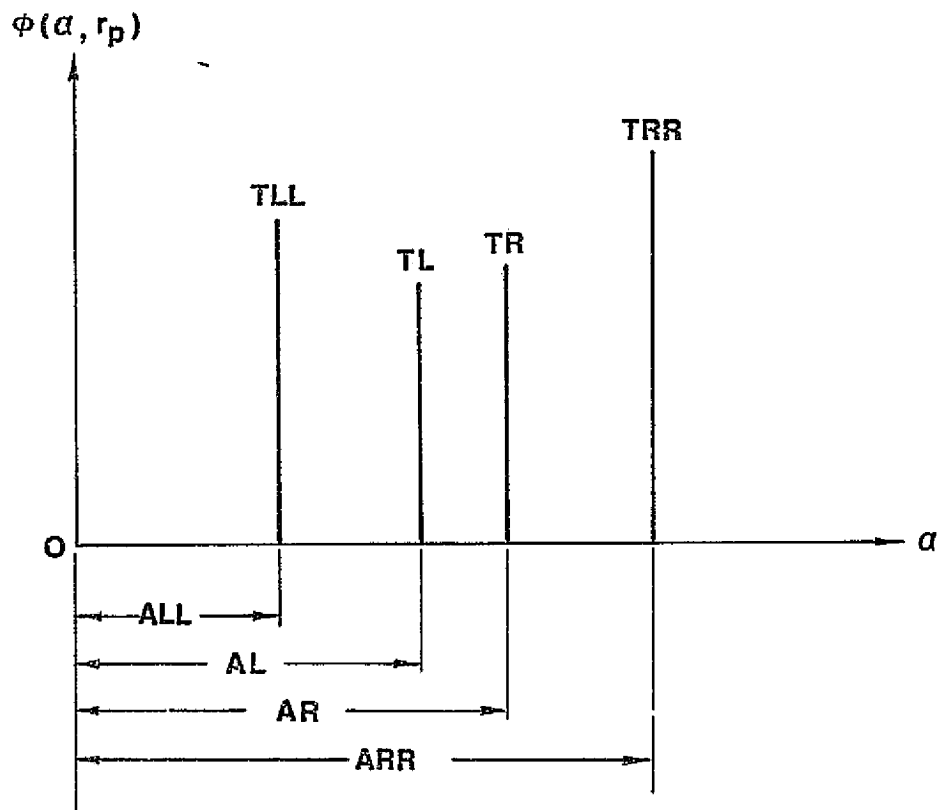

$$\frac{ARR - AR}{ARR - ALL} = \frac{AL - ALL}{ARR - ALL} = \frac{3 - \sqrt{5}}{2}$$

Fig. 9 Golden Section Algorithm

TABLE 1. FUNCTIONS OF ALL ROUTINES

ANALYS	Main subroutine in the APG block. Organize finite element structural analysis, constraint calculation, constraint deletion and selective gradient computation.
APPROX*	Computes objective function and constraint function values for the approximate, explicit problem.
BACKTV	Pseudo load vectors for displacement sensitivity computation are assembled by this routine. Given the product of element stiffness matrix and corresponding displacement state of the element, each component of the product vector is transferred to the appropriate position of the global pseudo vector.
COMCON	Computes all constraint function values based on the current analysis results.
COMSTR	Compute stress state of the specified finite element. Axial stress for TRUSS elements, three plane stress components and von Mises combined stress for CST and SSP elements.
CONDER	Organizes selective sensitivity computation of retained constraints.
CPUTIM	Dummy subroutine (c.f. Appendix A).
CST	Computes an element stiffness matrix in the global coordinate system for a given CST element.
DIRCTN*	Determines the direction vector in the NEWSUMT optimizer by means of modified Newton's algorithm.
INPUT	Reads input data except for the optimizer control cards. Writes the input data in a readable format.
LINK	Forms the initial linking table.
LOAD	Assembles load vectors for all load conditions.
MAIN*	Main program.
MULCST	Computes sensitivity of von Mises combined stress of the specified CST element, given displacement sensitivity.
MULSSP	Computes sensitivity of von Mises combined stress of the specified SSP element, given displacement sensitivity.
MULTMV	Carries out post multiplication of a vector to a symmetric square matrix stored in a vector form. Used in assembling pseudo load vectors.

\* Subroutines used in the NEWSUMT version only.

PRECEDING PAGE BLANK NOT FILMED

Table 1. FUNCTION OF ALL ROUTINES (continued)

OBJVAL	Computes structural weight at the beginning of each stage.
ODM*	Carries out one dimensional minimization by means of the golden section algorithm.
PREOPT	Check satisfaction of side constraints for the initial design. Computes element weight for unit value of sizing variable. Computes weight coefficients for the initial stage.
PREP	Identifies representative elements for each linking and configuration group. Computes element shapes, direction cosines of the local coordinate axes, and an element stiffness matrix in the local coordinate system.
SAD007	Decomposes real, symmetric positive definite matrix into a product of three matrices; i.e., a lower triangular, a diagonal and an upper triangular matrices. $[K] = [L][D][L]^T$ .
SAD008	Back and forward substitution to solve a system $[L][D][L]^T \vec{U} = \vec{P}$ for $\vec{U}$ .
SADM02	Computes two pointer vectors, JC and IIK. JC indicates boundary conditions for the displacement vectors. IIK contains the position of the diagonal elements of the master stiffness matrix.
SADM04	Assembles the master stiffness matrix, given element stiffness matrices in the global coordinate system.
SADM05	Called by SADM04 and performs additions of element stiffness matrices in appropriate positions of the master stiffness matrix.
SADMM8	Same as SAD008, except for the additional capability to skip processing some of the right hand side vectors.
SELDIS	Identifies displacement degrees of freedom, which may be associated at least one of the retained behavior constraints (displacement or stress constraints).
SELGRD	Assembles the selective gradient vectors for retained set of constraints.
SELINV	Computes selective inverse matrix of the master stiffness matrix.
SELMUL	Performs pre-multiplication of the selective inverse matrix to the right hand side vectors to obtain selective sensitivity of the displacement degrees of freedom.
SETCON	Identifies all constraints and prepares arrays used in constraint function evaluation procedure.

\* Subroutine used in the NEWSUMT vresion only.

Table 1. FUNCTION OF ALL ROUTINES (continued)

SETPOS	Set up the posture table by deleting constraints which are not likely to influence design process at current stage.
SETRHS	Set up the pseudo load vector for the displacement sensitivity computation.
SSP	Computes an element stiffness matrix in the global coordinate system for a given SSP element.
SUBALY*	Interface between the finite element analysis program and the NEWSUMT optimizer.
SUMTCL*	Reads NEWSUMT optimizer control parameters and activates NEWSUMT optimizer.
SUMTNM*	Primary routine of the design process control block (DPC) in Fig. 1. Also organizes the NEWSUMT optimizer.
TAKEDU	Picks up components of the displacement sensitivity vectors to form displacement sensitivity vectors for a given element.
TAKETV	Picks up components of the displacement vectors to form displacement vectors for a given element.
TOTAL*	Forms the total function by summing up the objective and penalty functions.
TRUSS	Computes an element stiffness matrix in the global coordinate system for a given truss element.
UPDATE	Updates the sizing variables of each finite element.
WRITED	Print nodal displacement state.

\* Subroutines used in the NEWSUMT version only. These routines must be replaced by the routines listed in the next page to implement the CONMIN version of ACCESS-1.

Table 1. FUNCTION OF ALL ROUTINES (continued)

CONMIN	Primary subroutine of the CONMIN optimizer. Organization of constrained function minimization procedure by means of the method of feasible directions.
CNMN01	Calculation of gradient information by means of the one step forward finite difference.
CNMN02	Determination of conjugate direction vector or direction of steepest descent for unconstrained function minimization.
CNMN03	Solution of one dimensional search in unconstrained minimization using 2-point quadratic, 3-point cubic and 4-point cubic interpolations, sequentially.
CNMN04	Called by CNMN03 and carry out specified interpolations.
CNMN05	Direction finding by the modified method of feasible directions.
CNMN06	Organization of constrained one dimensional minimizations.
CNMN07	Called by CNMN06 and carry out specified interpolations.
CNMN08	Special linear programming algorithm with one quadratic constraint.
CNMN09	Un-scale and re-scale design variables before and after evaluation of the objective function.
MAIN	Main program of the CONMIN version of ACCESS-1.
OPTMIZ	Implementation of all functions of the DPC(Design Process Control) block. See fig. 1.
TAYLOR	Objective and constraint function evaluations based on the current approximate problem statement.

Subroutines listed on this page are used in the CONMIN version only.

Table 2 Labeled COMMON Blocks

		(sub) routines																					
		MAIN	INPUT	PREP	LINK	SADM02	LOAD	SETCON	PREOPT	ANALYS	UPDATE	OBJVAL	SADM04	TRUSS	CST	SSP	SADM05	SAD007	SAD008	WRITED	COMCON	COMSTR	SETPOS
Labeled COMMON Blocks	BLKA01		●	●	●	●	●	●	●	●	●	●	●	●	●	●	●				●	●	●
	BLKA02		●	●	●		●	●	●	●	●	●		●	●	●					●	●	
	BLKA03			●			●		●	●													
	BLKA04			●			●	●	●				●	●	●								●
	BLKA05					●	●	●		●		●					●			●	●	●	
	BLKA06																						
	BLKA07																						
	BLKA08									●													
	BLKB02				●				●	●	●												
	BLKC01		●	●				●															
	BLKC02	●	●	●				●	●	●												●	
	BLKC03							●	●	●												●	●
	BLKC07									●												●	●
	BLKT01			●			●	●				●											
	BLKT02					●	●	●		●		●										●	●
BLKT04																							
RESULT	●			●					●														
DESIGN																							
INTERN																							
CONTRL																							
STAGEN																							
COUNIN																							
COUNT	●								●														
TIME	●								●														
OVERFL					●		●															●	

● indicates that the associated COMMON blocks must be declared in the corresponding routine.



Table 2 Labeled COMMON Blocks (continued)

		(sub) routines											NEWSUMT Version								
		CONDER	SELDIS	SETRHS	TAKEIV	MULTMV	BACKTV	SELINV	SADMM8	SELMUL	SELGRD	TAKEDU	MULCST	MULSSP	SUMTCL	SUMTNM	DIRCTN	ODM	SUBALY	APPROX	TOTAL
		Labeled COMMON Blocks																			
BLKA01	● ● ● ●								●			●	●					●			
BLKA02			● ●						●			●	●					●			
BLKA03																					
BLKA04									●			●	●								
BLKA05	● ● ● ●					●			●												
BLKA06																					
BLKA07																					
BLKA08																					
BLKB02			●						●									●			
BLKC01																					
BLKC02									●									●			
BLKC03		●								●											
BLKC07	● ● ●						●	●	●												
BLKT01																					
BLKT02	● ● ● ●					●		●	●												
BLKT04			●											● ●							
RESULT														● ● ● ● ● ●							
DESIGN														● ● ● ● ● ●							
INTERN														● ● ● ● ● ●							
CONTRL														● ● ● ● ● ● ●							
STAGEN														●				●			
COUNTN														● ●				● ●			
COUNT	●													●				● ●			
TIME	●													●				● ●			
OVERFL	●																				

● indicates that the associated COMMON blocks must be declared in the corresponding routines.

Table 2 Labeled COMMON Blocks (continued)

		(sub) routines												
		CONMIN version												
		MAIN	OPTMIZ	TAYLOR	CONMIN	CNMIN01	CNMIN02	CNMIN03	CNMIN04	CNMIN05	CNMIN06	CNMIN07	CNMIN08	CNMIN09
Labeled COMMON Blocks	BLKA01		●											
	BLKA02		●											
	BLKA08	●												
	BLKB02		●											
	BLKC02		●											
	BLKT04		●											
	RESULT	●	●	●										
	OVERFL	●												
	TIME	●	●	●										
	COUNT	●	●	●										
	TEMPOL		●	●										
	TRANSF													
	CNMIN1		●	●	●	●	●	●	●	●	●	●	●	●

● indicates that the associated COMMON blocks must be declared in the corresponding routine.

Table 3 Analysis Printout Control - IPRINT

All messages above the horizontal line corresponding to each value of IPRINT are printed.

IPRINT	Information printed
-1	Messages prior to any error termination Final results Time and counting statistics of the job
0	Input data summary
1	Reduced design variables at each stage Element sizing variables at each stage Weight information at each stage Displacement state at each stage Scaling-up information (if any)
2*	Posture table Required memory allocation for DG, DU and AK Detailed scaling-up data (if any) Stress state of all stress constrained elements
3	All constraint values Weight coefficients Gradient of retained constraints Updated linking table at each stage Basic pointer vectors, JC and IIK Load vectors
4	
5	Identification of representative elements Element data (lengths, direction cosines, element stiffness matrices in the local system)
6	Master stiffness matrix
7	Element stiffness matrices in the global system Constraint identification for all constraints

\* Standard value

Table 4 Optimizer Printout Control - JPRINT

All messages above the horizontal line corresponding to each value of JPRINT are printed.

NEWSUMT Version	
JPRINT	Information printed
0	Messages prior to any error termination
1	SUMT control parameters Iteration stage summary
2*	Maximum step warning
3	Direction vectors Response surface convergence check data
	Direction search data Detailed one dimensional minimization data
CONMIN Version	
JPRINT	Information printed
0	No printing
1*	Initial and final function information
2	First debugging level. Print all of above plus control parameters. Print function value and X-vector at each iteration.
3	Second debugging level. Print all of above plus all constraint values, number of active or violated constraints, direction vectors move parameters and miscellaneous information. The constraint parameter, BETA, printed under this option approaches zero as the optimum objective is achieved.
	Complete debugging. Print all of above plus gradients of objective function, active or violated constraint functions and miscellaneous information.

\* Standard value

APPENDIX A

CPU TIMING ROUTINES

1. UCLA IBM 360/91 FORTRAN-H version

A subroutine CPUTIM is a dummy routine and the function CTIME(1) gives the remaining CPU time in seconds. This function is not included in the FORTRAN Library, therefore a dataset SYS1.CCNFLIB must be concatenated to SYS1.FORTLIB

```
SUBROUTINE CPUTIM(T.DT.IP)
  T = 0.0
  DT = 0.0
  RETURN
END
```

2. Berkeley CDC 6600 FTRX compiler

A subroutine SECOND(T) is in the FORTRAN Library and T is CPU time in seconds used by the run.

```
SUBROUTINE CPUTIM(T.DT.IT)*
  IF(IT.LE.0) GO TO 100
  CALL SECOND(T1)
  T1 = T1 - T0
  DT = T1 - T
  T = T1
  RETURN
100 T = 0.0
  DT = 0.0
  CALL SECOND(T0)
```

\*Written by Dr. Joseph Mullen, Jr., NASA Ames Research Center

```
RETURN
```

```
END
```

```
FUNCTION CTIME(I)
```

```
DATA T,DT/0., 0./
```

```
CALL CPUTIM(T.DT.1)
```

```
CTIME = 1000.0 - T
```

```
RETURN
```

```
END
```

### 3. NASA Ames IBM 360/67 FORTRAN H

A function INTVAL and a subroutine SETTIM are in the FORTRAN Library and INTVAL gives CPU time used since the last call of SETTIM in mili-seconds units.

```
SUBROUTINE CPUTIM(T.DT.IT)
```

```
IF(IT.LE.) GO TO 100
```

```
IT1 = INTVAL(0.0)
```

```
T1 = FLOAT(IT1)/100.0
```

```
DT = T1 - T
```

```
T = T1
```

```
RETURN
```

```
100 END
```

```
FUNCTION CTIME(I)
```

```
DATA T,DT/0.,0./
```

```
CALL CPUTIM(T.DT.1)
```

```
CTIME = 1000.0 - T
```

```
RETURN
```

```
END
```

## APPENDIX B

### INPUT DATA DESCRIPTION

The input data description in the card image format given at the end of this Appendix should be referred to in preparing an input data deck for the ACCESS-1 computer program. Example problems given in Appendix C will also be helpful.

#### Input Data Cards.

#### I. Job description and heading (11, 79A1)

The first column is used as follows

0 or blank: ordinary heading card, whose content in 2-80 columns will be printed in the first part of the output list.

1 : indication of the last heading card.

2 : request for immediate normal termination of this job.

Any number of cards may be used to describe or to comment the job. Note that the last heading card must have "1" punched in the first column. Without this, all of your data may be regarded as heading cards.

#### II. Job control parameters (3I5)

IDG : not used

IPRINT: print out control (see §4.9 and Table 3)

IOPT : not used

#### III. Basic structural data

(4I5)

IN : number of nodes

ID : spatial dimensions (2 or 3) (see §4.3)

IBN: number of nodes where boundary conditions are specified.

INL: number of load conditions.

**(3I5)**

IDRT(j): number of linked design variable groups for the jth element type. (j = 1,2,3)

j = 1 TRUSS

j = 2 CST

j = 3 SSP

**(3I5)**

ICRT(j): number of configuration/material groups for the jth element type (j = 1,2,3)

**(3I5)**

IETP(j): number of jth type elements

IV. Node coordinates **(I3, 2X, 3E15.6)**

N : node number

X(N): X-coordinate of the node N

Y(N): Y-coordinate of the node N

Z(N): Z-coordinate of the node N

V. Element data

For each element type, the following sequence of cards is required.

**(I3)** : element type identification

Note ; The element type identification cards are necessary for all element types, even if the corresponding type of elements is not used in the structure.

**(2I5, 3E15.4, 3I5, 5X, I5)** : TRUSS and SSP

or **(2I5, 3E15.4, 5I5)** : CST



M : member number  
IDVRj(M) : design variable linking group number of the Mth member in the jth element type  
DVj(M) : initial size of the Mth member  
DVULj(M) : upper limit of the Mth member size  
DVLLj(M) : lower limit of the Mth member size  
ICVRj(M) : configuration group number of the Mth member  
INODj(1,M) : node number of the P local node  
INODj(2,M) : node number of the Q local node  
INODj(3,M) : node number of the R local node (CST only)  
IVC(M,j) : side constraint code of the Mth element  
-1: lower limit only  
0: non-negativity only  
1: upper limit and non-negativity  
2: both upper and lower limits  
(2I5) : CST only  
IPGR(M,K) : pressure load group number for the Kth load condition on the Mth element; put "0" or blank if no pressure load on any element for the load condition.  
Note ; CST elements require two cards per element, while TRUSS and CST elements require only one card per element.

VI. Configuration/Material group data

For each element type, the following sequence of cards is required.

(I3) : element type identification

Note ; The element type identification cards are necessary for all element types, even if the corresponding type of elements is not used in the structure.

Note: If the element type identification is given as a negative number, it indicates that the material constants for this type are identical for all the configuration/material groups, thus only the material data card for the first group is required.

(6E12.4)

ASUj(I): allowable upper stress limit for the jth element type, Ith configuration/material group

ASLj(I): allowable lower stress limit

RHOj(I): specific weight

Ej(I) : Young's modulus

RNUj(I): Poisson's ratio

#### VII. Boundary conditions

(I3, 2X, 3I5)

IBD(I): node number of the Ith boundary node

IBX(I): Boundary condition codes to x,y,z directions

IBY(I): 0: free degree of freedom

IBZ(I): 1: fixed degree of freedom

#### VIII. Load conditions

For each distinct load condition, the following sequence of cards is required.

(2I5)

ILLNOD(K): number of nodes subject to non-zero external loads for the Kth load condition

IPLTYP(K): number of pressure magnitude groups

(I3, 2X, 3E15.6)

ILLN(I,K): node number of the Ith loaded node for the Kth load condition

CLLMX(I,K): } Magnitudes of lumped external loads applied to  
CLLMY(I,K): } the Ith loaded node for the Kth load condition,  
CLLMZ(I,K): } in x,y,z directions, respectively.

(E12.4) not required if IPLTYP(K) = 0

CPLM(I,K): magnitude of the Ith pressure group for the Kth  
load condition

#### IX. Constraints

(2E15.4)

SPM: starting point margin (see §4.6)

TRF: initial truncation factor (see §4.6)

(3I5)

ISCT(J): stress constraint code for the Jth element type

1 : read the stress constraint codes ISC(m,J)  
element by element

0 : no stress constraint for all elements in the  
Jth element type

-1: all elements of the Jth type are constrained by  
lower bounds only

-2: all elements of the Jth type are constrained  
by upper bounds only

-3: all elements of the Jth type are constrained  
by upper and lower bounds

(16I5): required only for the element type whose ISCT(J) is  
positive

ISC(m,J): element stress constraint code for the mth element  
of the Jth type

-1: lower bound only

0 : no stress constraint

- 1 : upper bound only
- 2 : both upper and lower bounds

(I5)

IDCT: number of displacement degrees of freedom on which  
finite displacement constraints are imposed

(3I5, 2E15.4)

NA : node number associated with the constrained displacement degrees of freedom

JA : direction (x=1, y=2, z=3)

IDC:(JA,NA): constraint code

-1: constrained by lower limit only

0: no constraint

1: constrained by upper limit only

2: constrained by both upper and lower limits

DISUL(JA,NA): upper limit

DISLL(JA,NA): lower limit

(I5)

IVCT: side constraint code

0: no side constraint

1: apply the code specified on each element description  
card. (IVC(M,j))

## X. Optimization control

### NEWSUMT Version

(7I5)

MAXIFS: maximum allowable number of golden section iterations

MAXODM: maximum allowable number of one dimensional minimizations in an unconstrained minimization

MAXARS: maximum allowable number of unconstrained minimizations for an approximate problem statement  
 MAXNAA: maximum allowable number of iteration stages  
 JSIGNG: sign convention of constraints  
     1 : if feasible region is defined as  $h_q(\vec{D}) \geq 0$   
          $q = 1, 2, \dots, Q$   
    -1: if feasible region is defined as  $h_q(\vec{D}) \leq 0$   
          $q = 1, 2, \dots, Q$   
 JPRINT: print out control for the NEWSUMT optimizer (see §4.9 and Table 4)

**(8F8.5, F8.2, E8.1)**

EPSODM: convergence criterion among a sequence of one dimensional minimizations  
 EPSARS: convergence criterion among a sequence of unconstrained minimizations  
 EPSEA : convergence criterion among a sequence of iteration stages  
 EPSVJK: pseudo load vectors truncation criterion  
 CUTARP: response factor (or penalty multiplier) reduction ratio  
 STEPMX: maximum allowable change of design variable components for an approximate problem statement  
 DELTAC: initial transition point for the extended penalty function  
 TRFMUL: truncation factor increment ratio  
 TRFMAX: upper limit of truncation factor  
 RPMIN : minimum allowable limit for response factor

CONMIN Version

(I5, 4E15.5)

MAXSTG: maximum allowable number of iteration stages  
EPSSTG: convergence criterion among iteration stages  
TRFINC: truncation factor increment ratio  
TRFMAX: upper limit of truncation factor  
EPSVJK: pseudo load vectors truncation criterion

(2I5, 3E15.5)

JPRINT: print out control for the CONMIN optimizer (see §4.9  
and Table 4)  
ITMAX : maximum number of iterations in CONMIN  
CTL : active constraint width (see §4.8)  
CTLMIN: lower limit of CTL (see §4.8)  
DELFUN: CONMIN iteration convergence criterion

ACCESS-1 Data in Card Image Format

53

COMMENTS/TITLE CARDS (ANY NUMBER OF CARDS)				(IX, 79A1)			
1 LAST COMMENT/TITLE CARD							
ID#	IPRINT	IOPT					
IN	ID	IBN	INL				
IDRT(1)	IDRT(2)	IDRT(3)					
ICRT(1)	ICRT(2)	ICRT(3)					
IETP(1)	IETP(2)	IETP(3)					
1		X . . . . . E X	Y . . . . . E X	Z . . . . . E X			
2							
...							
n		X (n)	Y (n)	Z (n)			
...							
IN							
1		X . . . . . E X	Y . . . . . E X	Z . . . . . E X			
2							
...							
n	IDVRI (n)	DVI (n)	DVUL1 (n)	DVLL1 (n)	ICVRI (n)	INOD1 (2, n)	INOD1 (2, n)
...							
IETP(1)							IYC (n, 1)

(continued to the next page)

- Data cards which must be present in any case.
- \* TRUSS elements description.







ACCESS-1 Data in Card Image Format

(continued from the previous page)

1	2	3	4	5	6	7	8	9	10	11	12	13	14	15	16	17	18	19	20	21	22	23	24	25	26	27	28	29	30	31	32	33	34	35	36	37	38	39	40	41	42	43	44	45	46	47	48	49	50	51	52	53	54	55	56	57	58	59	60	61	62	63	64	65	66	67	68	69	70	71	72	73	74	75	76	77	78	79	80																																										
• ILLNOD(1) IPLTYP(1)		/																																																																																																																							
ILLN(1)	/	X . . . . . E X							X . . . . . E X							X . . . . . E X																																																																																																									
ILLN(2)	/	CLLMX (i, 1)														CLLMY (i, 1)														CLLMZ (i, 1)																																																																																											
ILLN(ILLNOD(1))	/																																																																																																																								
CPLM(j, 1)	/	X . . . . . E X																																																																																																																							
CPLM(IPLTYP(1), 1)	/																																																																																																																								
ILLNOD(2) IPLTYP(2)		/																																																																																																																							
ILLN(2)	/	X . . . . . E X							X . . . . . E X							X . . . . . E X																																																																																																									
ILLN(3)	/	CLLMX (i, 2)														CLLMY (i, 2)														CLLMZ (i, 2)																																																																																											
ILLN(ILLNOD(2))	/																																																																																																																								
CPLM(j, 2)	/	X . . . . . E X																																																																																																																							
CPLM(IPLTYP(2), 2)	/																																																																																																																								

LUMPED LOADS AT NODES  
LOAD CONDITION 1

PRESSURE LOADS ON CST

LUMPED LOADS AT NODES  
LOAD CONDITION 2

NOT REQUIRED IF INL = 1

PRESSURE LOADS ON CST

(continued to the next page)

• Data cards which must be present in any case.

56

ACCESS-1 Data in Card Image Format

(continued from the previous page)

	1	2	3	4	5	6	7	8	9	10	11	12	13	14	15	16	17	18	19	20	21	22	23	24	25	26	27	28	29	30	31	32	33	34	35	36	37	38	39	40	41	42	43	44	45	46	47	48	49	50	51	52	53	54	55	56	57	58	59	60	61	62	63	64	65	66	67	68	69	70	71	72	73	74	75	76	77	78	79	80										
•	SPM				x . x x x x E x				TRF				x . x x x x E x																																																																													
•	ISCT(1)	ISCT(2)	ISCT(3)																																																																																							
			ISC (m, MTYP)		(m = 1, IETP(MTYP))																																																																																					
			REQUIRED ONLY FOR ELEMENT TYPES 'MTYP' SUCH AS		ISC(MTYP) > 0																																																																																					
•	IDCT																																																																																									
	NA <sub>1</sub>	JA <sub>1</sub>					x . x x x x E x				x . x x x x E x																																																																															
	NA <sub>2</sub>	JA <sub>2</sub>																																																																																								
	⋮	⋮																																																																																								
	NA <sub>L</sub>	JA <sub>L</sub>	IDC(JA <sub>L</sub> , NA <sub>L</sub> )	DISUL(JA <sub>L</sub> , NA <sub>L</sub> )		DISLL(JA <sub>L</sub> , NA <sub>L</sub> )																																																																																				
	⋮	⋮																																																																																								
	NA <sub>IDCT</sub>	JA <sub>IDCT</sub>																																																																																								
•	IVCT																																																																																									
	NEWSUMT VERSION CONTROL CARDS																																																																																									
*	MAXIFS	MAXODM	MAXARS	MAXNAA	JSIGNG	LMODEL	JPRINT																																																																																			
	EPSODM	EPSARS	EPSEA	EPSVJK	CUTARP	DELTAC	TRFMUL	TRFMAX	STEPHX	RPMIN																																																																																
	CONMIN VERSION CONTROL CARDS																																																																																									
*	MAXSTG	EPSSTG		TRFINC		TRFMAX		EPSVJK																																																																																		
	JPRINT	ITMAX	CTL		CTLMIN		DELFUN																																																																																			
**																																																																																										
†	2																																																																																									

- Data cards which must be present in any case.
- \* Either one of the two sets of control cards must be present.
- \*\* Data cards for the other jobs may be placed directly after optimizer control cards.
- † Either this card or four blank cards will terminate this run.

57

APPENDIX C

DATA EXAMPLES

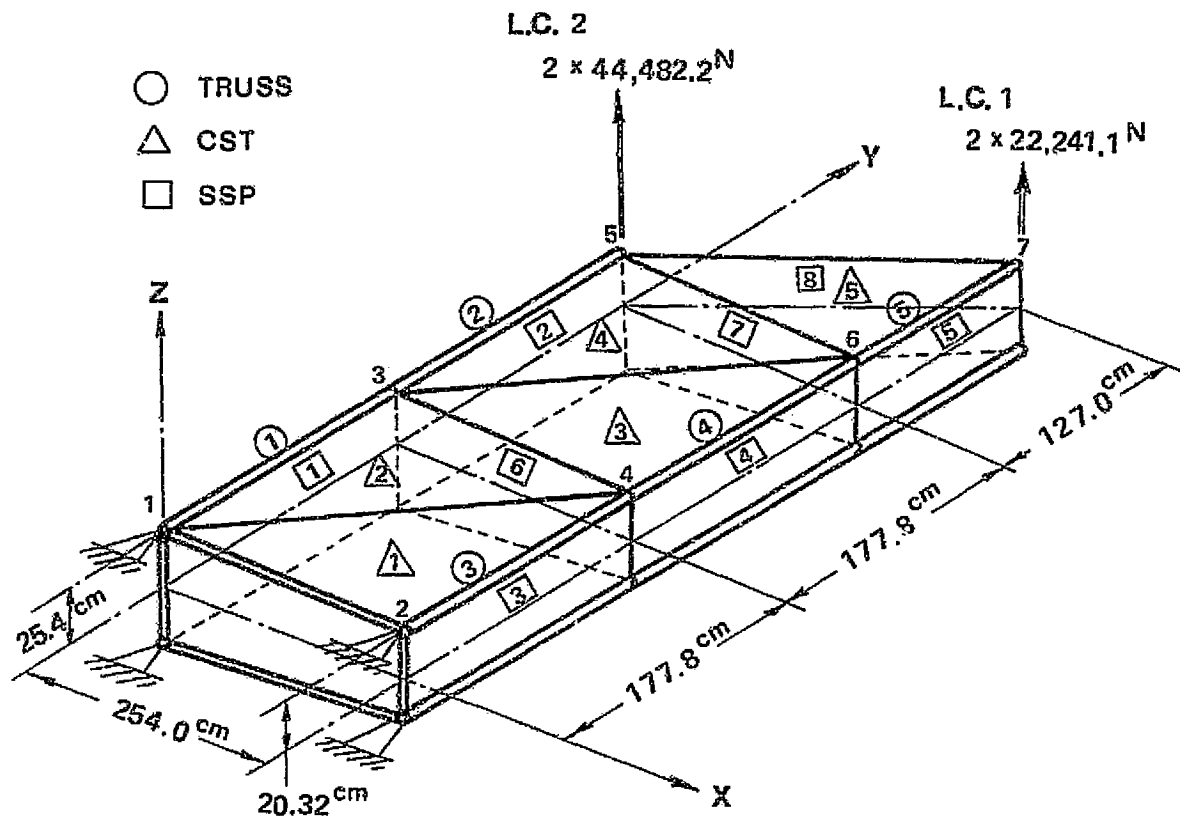

- Material: Aluminum Alloy  $E = 0.68948 \times 10^7 \text{ N/cm}^2$   
 $\rho = 0.0027680 \text{ Kg/cm}^3$
- Stress limits: Upper limit =  $0.68948 \times 10^4 \text{ N/cm}^2$   
 Lower limit =  $-0.68948 \times 10^4$  (truss only)
- Displacement limit:  $\pm 5.08 \text{ cm}$  in Z-direction for all nodes
- Side constraints: Min. area of truss elements =  $0.64516 \text{ cm}^2$   
 Min. thickness of CST and SSP =  $0.0508 \text{ cm}$
- Load conditions: Two distinct load conditions as shown above

Example 1. 18 Element Wing Box (IS Units)

PRECEDING PAGE BLANK NOT FILMED

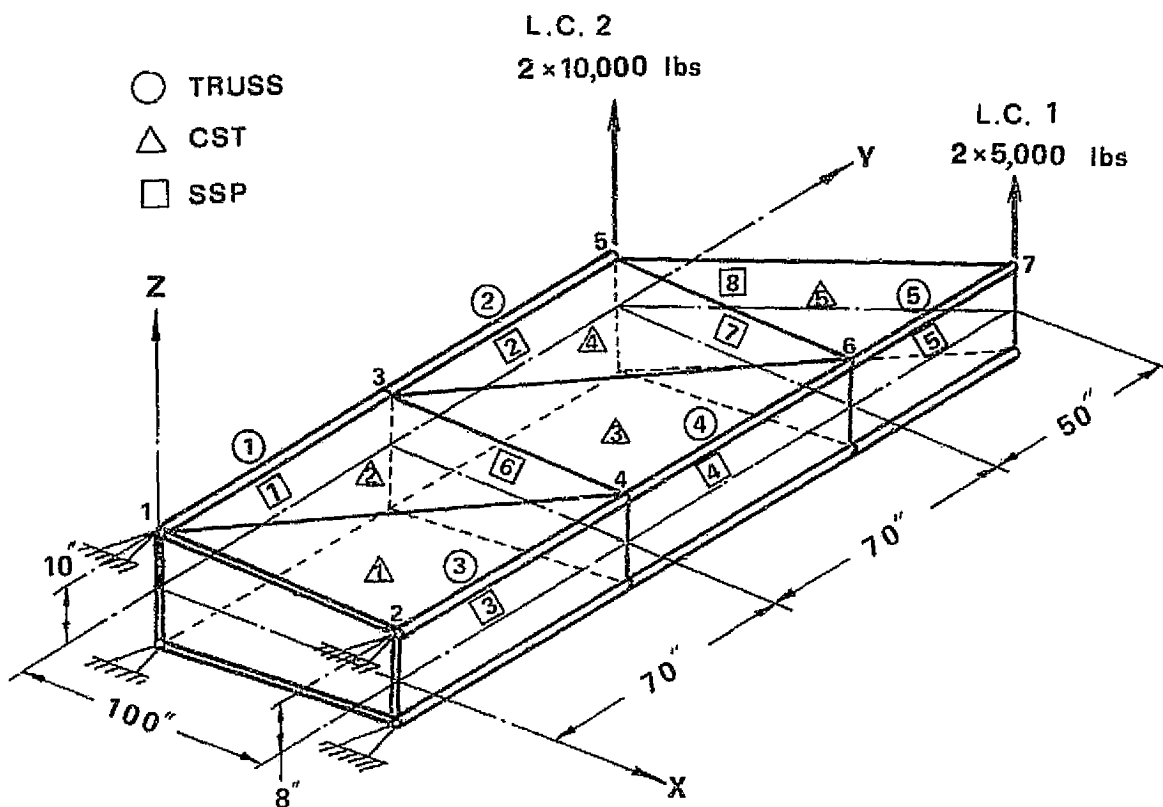

Material: Aluminum  $E = 10^7$  psi  $\rho = 0.1$  lb/in<sup>3</sup>

Stress Limits: Upper bounds =  $10^4$  psi  
 Lower bounds =  $-10^4$  psi (truss only)

Displacement Limits:  $\pm 2.0$  in. in z-direction for all nodes

Side Constraints: Min. area of truss elements 0.1 in.<sup>2</sup>  
 Min. thickness of CST and SSP 0.02 in.

Load Conditions: Two distinct load conditions as shown above.

Example 1. 18 Element Wing Box (U.S. Customary Units)  
 (Problem 8 in Ref. 1)

Example 1 18-Element Wing Box -- NEWSUMT Optimizer

ORIGINAL PAGE IS  
OF POOR QUALITY

EIGHTEEN ELEMENT WING BOX DESIGN EXAMPLE  
 REF. AFDL-TR-70-165  
 MEMS ARE MODELLED WITH SSP ELEMENTS  
 S TRUSS, S CST, AND R SSP ELEMENTS  
 16 DESIGN VARIABLES

comments

1	2	3	4	5	6	7	8	9	10	11	12	13	14	15	16
1	2	3	4	5	6	7	8	9	10	11	12	13	14	15	16
1															
2															
3															
4															
5															
6															
7															
8															
9															
10															
11															
12															
13															
14															
15															
16															
17															
18															

node coordinates

truss element data

CST element data

(continued to the next page)

Col. 10 20 30 40 50 60 70 80

3	1	1	0.196CF0	C.1000E1	C.0200E0	1	1	1	-1	SSP element data			
	2	2	0.196CE0	0.100CF1	C.0200EC	1	3	1	-1				
	3	3	0.196CF0	C.100CF1	C.0200E0	2	2	4	-1				
	4	4	0.196CF0	C.100CF1	C.0200E0	2	4	6	-1				
	5	5	0.1960E0	0.1000E1	C.0200E0	3	6	7	-1				
	6	6	0.196CF0	C.100CF1	C.0200E0	4	3	4	-1				
	7	7	0.1960F0	0.1000E1	C.0200E0	4	5	6	-1				
	8	8	0.196CE0	0.100CF1	C.0200F0	5	5	7	-1				
1	C.1000E5 -C.1000E5 0.1000EC C.1000E8				TRUSS material/config. group data								
	0.1000E5 -C.1000E5 0.1000EC C.1000E8												
2	C.1000E5 -C.1000E5 0.1000EC C.1000E8 0.3000E0				CST material/config. group data								
	0.1000E5 -C.1000E5 0.1000EC C.1000E8 0.3000EC												
3	C.1000E5 -C.1000E5 0.1000EC C.1000E8 C.3000EC				SSP material/config. group data								
	C.1000E5 -C.1000E5 0.1000EC C.1000E8 0.3000E0												
	C.1000E5 -C.1000E5 0.1000EC 0.1000E8 C.3000EC												
	C.1000E5 -C.1000E5 0.1000EC C.1000E8 0.3000E0												
	0.1000E5 -C.1000E5 0.1000EC C.1000E8 C.3000EC												
1	1	1	1	Boundary conditions									
2	1	1	1										
7	0	C.00000CF0		C.00000CEC	Load conditions								
1	0	C.00000CF0		C.00000CEC									
5	C.1500E1		C.3000F0										
	-2	-2											
3	3	2	C.2000E1		Constraints specification data								
	3	2	C.2000E1		-C.2000E1								
4	3	2	C.2000E1		-C.2000E1								
	3	2	C.2000E1		-C.2000E1								
7	3	2	C.2000E1		-0.2000E1								
	3	2	C.2000E1		-C.2000E1								
20	5	2	15	-1	1	2	0.0000	0.0020	1.0000	C.6000	100.00	1.0E-12	NEWSUMT optimizer control
4 or more blank cards, if this is the last job to be processed in this run.													
Col.	10	20	30	40	50	60	70	80					

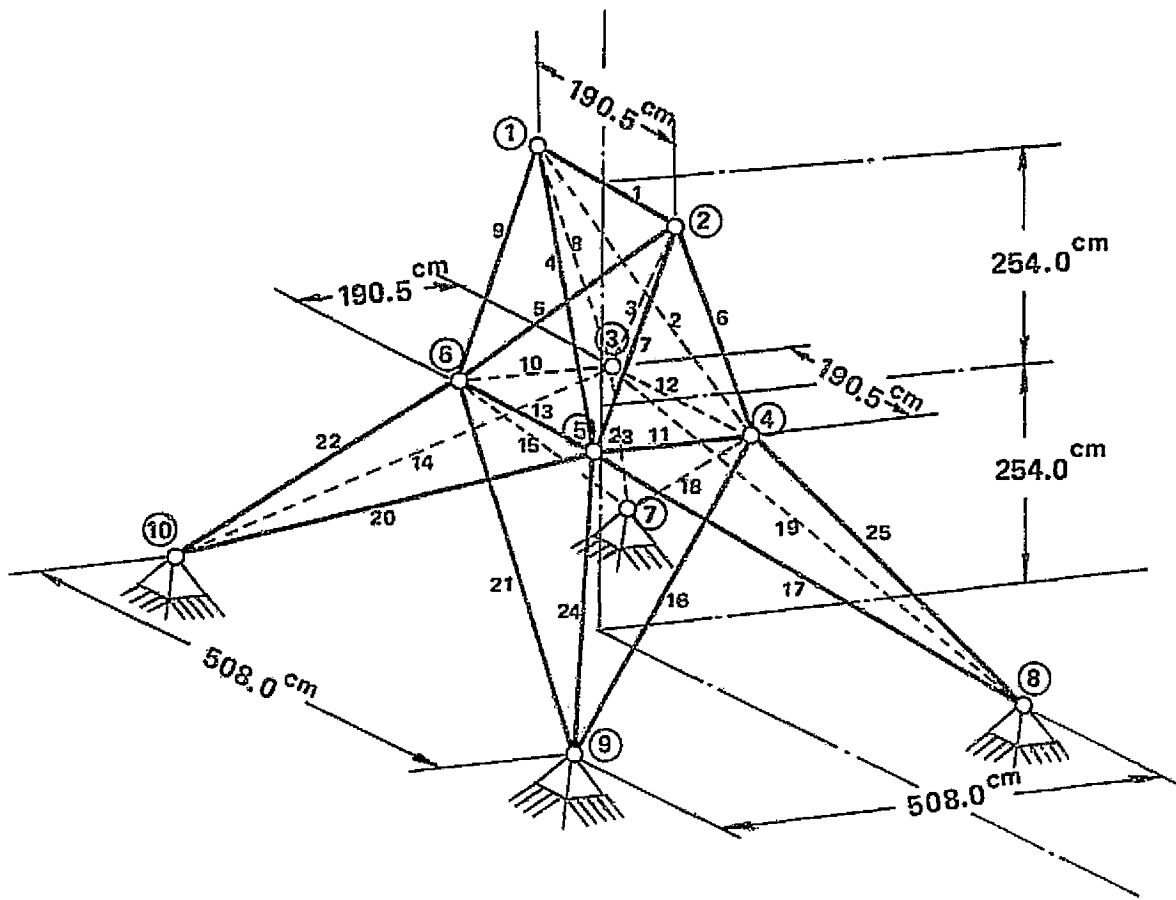

Node Numbers	Allowable Compression Stress (N/cm <sup>2</sup> )
1	24195.06
2 ~ 5	7991.02
6 ~ 9	11931.36
10, 11	24195.06
12, 13	24195.06
14 ~ 17	4660.16
18 ~ 21	4798.06
22 ~ 25	7640.76

Load Cond.	Node	External Loads (N)		
		X	Y	Z
1	1	4448.22	44482.2	-22241.1
	2	0.0	44482.2	-22241.1
	3	2224.11	0.0	0.0
	6	2224.11	0.0	0.0
2	1	0.0	88964.4	-22241.1
	2	0.0	-88964.4	-22241.1

Material:

Aluminum Alloy  $E = 0.68948 \times 10^7 \text{ N/cm}^2$   
 $\rho = 0.0027680 \text{ Kg/cm}^3$

Stress limits:

Tension = 27579.2 N/cm<sup>2</sup>  
 Compression = see table above

Displacement limits:

0.8890 cm on all nodes and in all directions

Side constraints:

Min. area = 0.064516 cm<sup>2</sup>

Example 2 25-Bar Truss (IS Units)



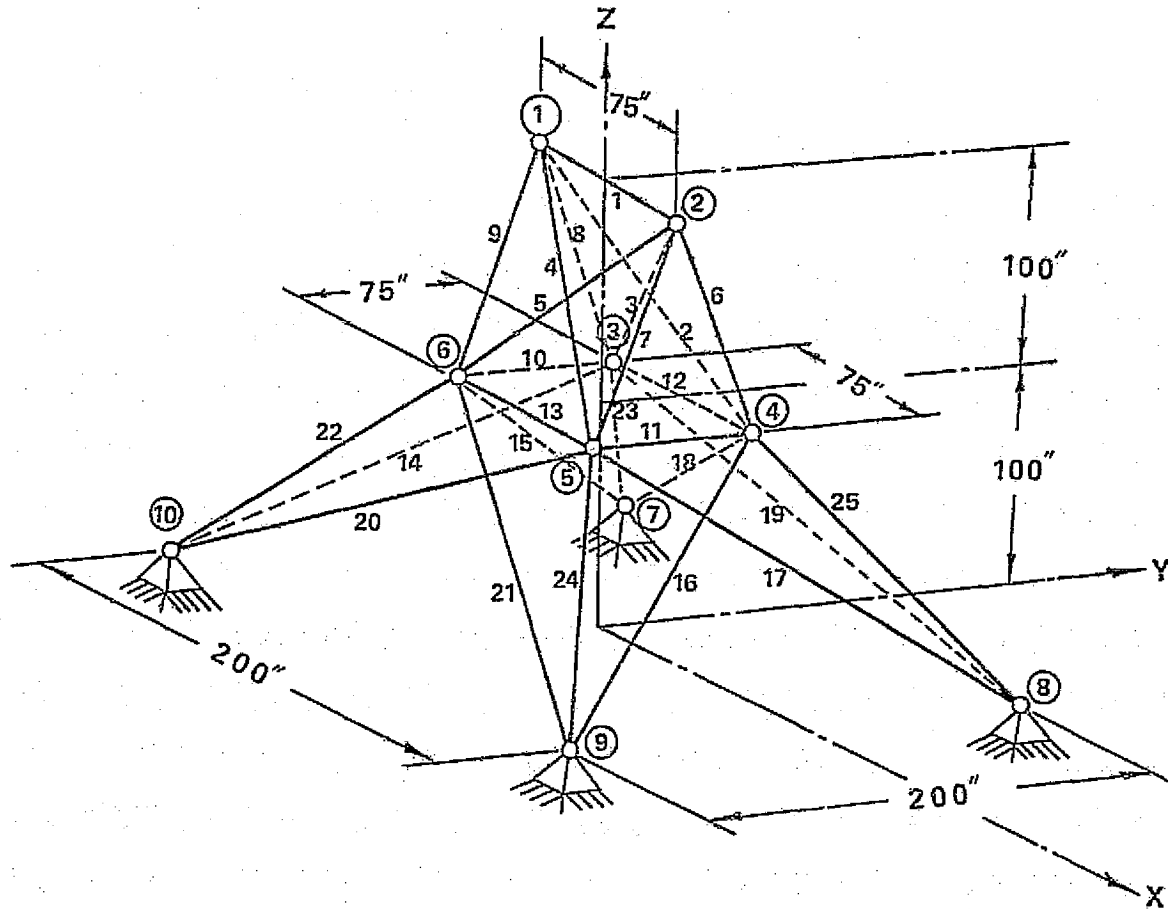

Node Numbers	Allowable Compression Stress (psi)
1	35092.0
2 ~ 5	11590.0
6, ~ 9	17305.0
10, 11	35092.0
12, 13	35092.0
14 ~ 17	6759.0
18 ~ 21	6959.0
22 ~ 25	11082.0

Load Cond.	Node	External Loads (lbs)		
		X	Y	Z
1	1	1000.0	10000.0	-5000.0
	2	0.0	10000.0	-5000.0
	3	500.0	0.0	0.0
	6	500.0	0.0	0.0
2	1	0.0	20000.0	-5000.0
	2	0.0	-20000.0	-5000.0

Material:

Aluminum,  $E=10^7$  psi,  $\rho=0.1$  pci

Stress Limits:

Tension=40000.0 psi, (see Table above for Compression)

Cross Sectional Area

Lower Limits:

0.01 in<sup>2</sup>

Upper Limits:

none specified

Displacement Limits:

0.35 in. on all nodes and in all directions

Example 2

25-Bar Truss (U.S. Customary Units)  
(Problem 5 in Ref. 1)



ORIGINAL PAGE IS  
OF POOR QUALITY

CONIN	10	0.01000000	0.01000000	0.01000000	0.01000000	0.01000000	0.01000000
CONIN	10	0.01000000	0.01000000	0.01000000	0.01000000	0.01000000	0.01000000
CONIN	10	0.01000000	0.01000000	0.01000000	0.01000000	0.01000000	0.01000000
CONIN	10	0.01000000	0.01000000	0.01000000	0.01000000	0.01000000	0.01000000
CONIN	10	0.01000000	0.01000000	0.01000000	0.01000000	0.01000000	0.01000000
CONIN	10	0.01000000	0.01000000	0.01000000	0.01000000	0.01000000	0.01000000

1	4.00000E4	-2.50999E4	0.10000E0	1.00000E7
	4.00000E4	-1.15999E4	0.10000E0	1.00000E7
	4.00000E4	-1.73099E4	0.10000E0	1.00000E7
	4.00000E4	-0.67599E4	0.10000E0	1.00000E7
	4.00000E4	-0.63599E4	0.10000E0	1.00000E7
	4.00000E4	-1.10999E4	0.10000E0	1.00000E7

truss material/config. group data

7	1	1	1
8	1	1	1
9	1	1	1
10	1	1	1

boundary conditions

1	0	0.10000000	0.10000000	-0.50000000
2	0	0.00000000	0.10000000	-0.50000000
3	0	0.50000000	0.00000000	0.00000000
4	0	0.50000000	0.00000000	0.00000000
1	0	0.00000000	0.20000000	-0.50000000
2	0	0.00000000	-0.20000000	-0.50000000

load condition 1

load condition 2

1	0	0.15000E1	0.10000E0	
1	1	0	0.35000E0	-0.35000E0
1	2	0	0.35000E0	-0.35000E0
1	3	0	0.35000E0	-0.35000E0
2	1	0	0.35000E0	-0.35000E0
2	2	0	0.35000E0	-0.35000E0
2	3	0	0.35000E0	-0.35000E0
3	1	0	0.35000E0	-0.35000E0
3	2	0	0.35000E0	-0.35000E0
3	3	0	0.35000E0	-0.35000E0
4	1	0	0.35000E0	-0.35000E0
4	2	0	0.35000E0	-0.35000E0
4	3	0	0.35000E0	-0.35000E0
5	1	0	0.35000E0	-0.35000E0
5	2	0	0.35000E0	-0.35000E0
5	3	0	0.35000E0	-0.35000E0
6	1	0	0.35000E0	-0.35000E0
6	2	0	0.35000E0	-0.35000E0
6	3	0	0.35000E0	-0.35000E0

constraint specification data

20	0.00100000	1.20000000	0.00000000	0.00000000
1	20	-0.01000000	0.00000000	0.00000000

CONMIN optimizer control  
indicates end of this run.

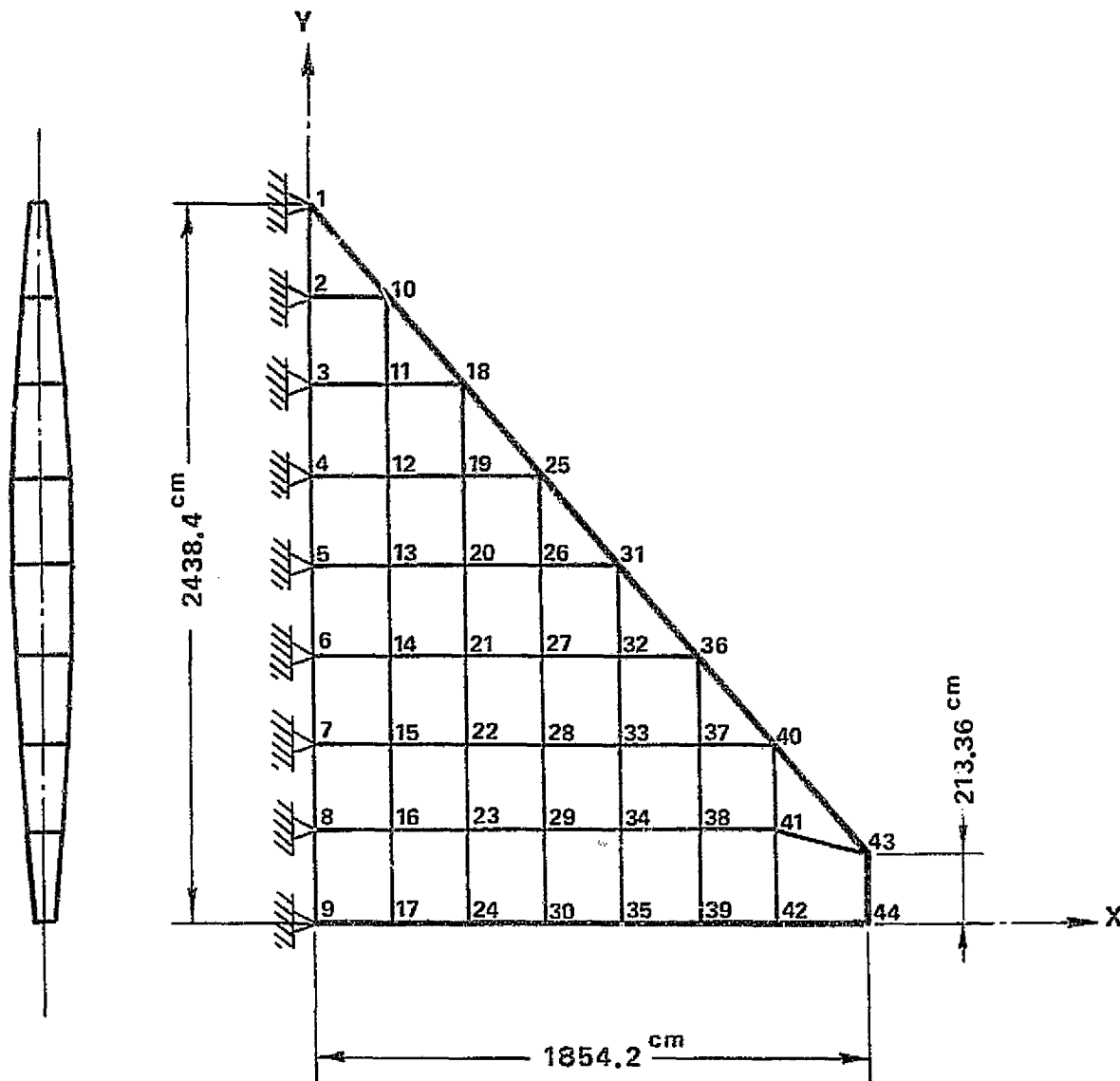

Material: Titanium  $E = 11.3061 \times 10^6 \text{ N/cm}^2$   
 $\rho = 0.0044288 \text{ Kg/cm}^3$

Stress limits: Upper limit  $86,184.38 \text{ N/cm}^2$

Displacement limits: Linear envelope with  $256.032 \text{ cm}$  at the tip nodes

Load condition:  $0.689475 \text{ N/cm}^2$  equivalent

Example 3. Delta Wing (IS Units)

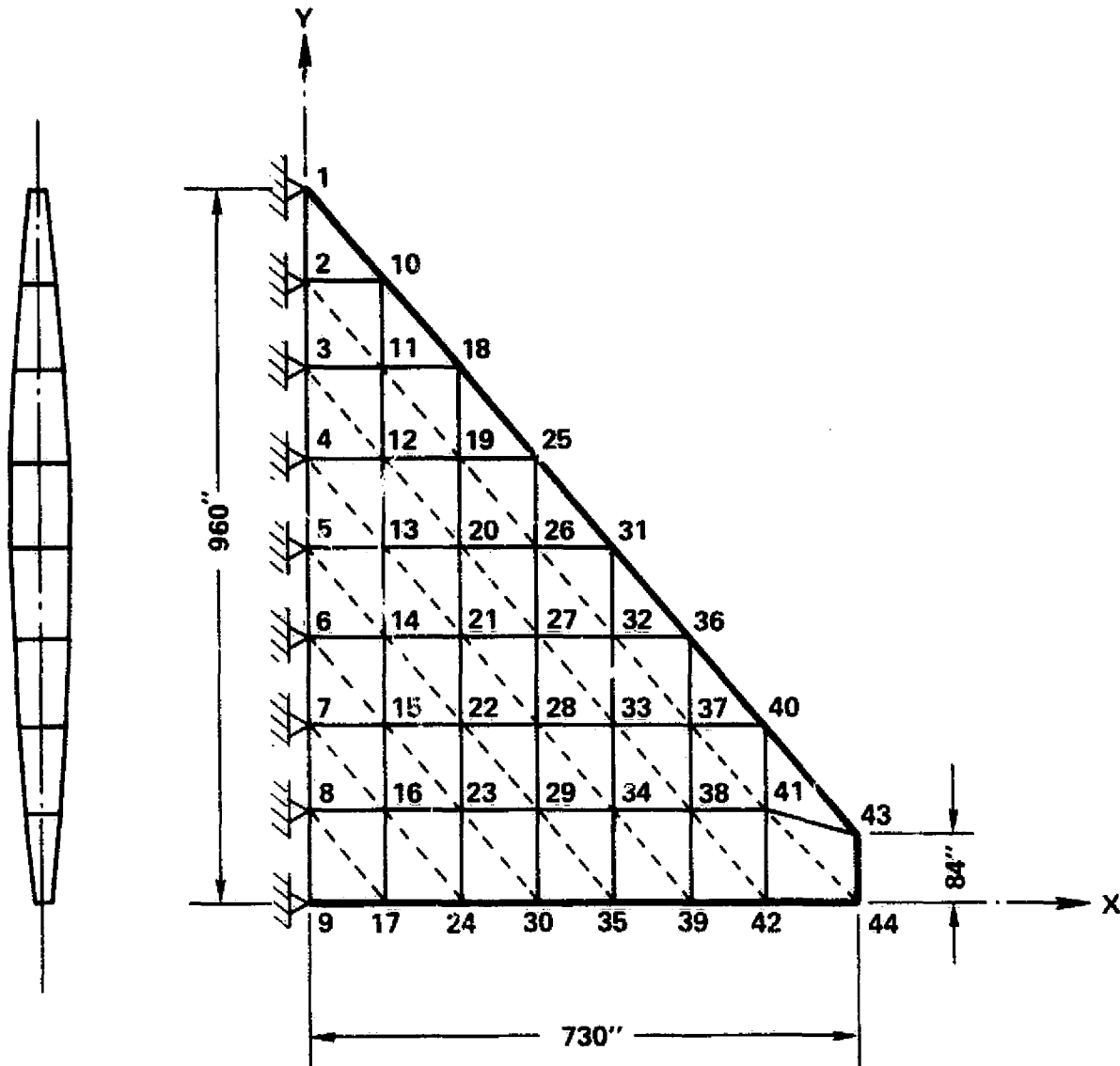

Material: Titanium  
 Stress Limits: 125,000 psi  
 Displacement Limits: Linear envelope with 100.8 inches  
 at the tip nodes.  
 Load Condition: 144 lbs/ft<sup>2</sup> equivalent.

Example 3 Delta Wing (U.S. Customary Units)  
 (Problem 10C in Ref.1)

DELTA WING DESIGN OPTIMIZATION - A \* PROBLEM 10C IN NASA-CR-5225  
 TITANIUM THIN SYMMETRIC DELTA WING DESIGN PROBLEM FOR STATIC CONSTRAINTS  
 FFF. W.J. STROUD ET AL. NASA TN D-6534, 1971  
 63 ELEMENTS 16 DESIGN VARIABLES FOR CST ELEMENTS  
 70 ELEMENTS 12 DESIGN VARIABLES FOR SSP ELEMENTS  
 STARTING POINT 1, MODEL=1

COMMENTS  
 OR HEADINGS

ORIGINAL PAGE IS  
 OF POOR QUALITY

04000	0	1
1	0.00000000	0.96000003
2	0.00000000	0.94000003
3	0.00000000	0.72000003
4	0.00000000	0.60000003
5	0.00000000	0.48000003
6	0.00000000	0.36000003
7	0.00000000	0.24000003
8	0.00000000	0.12000003
9	0.00000000	0.00000000
10	0.10000003	0.84000003
11	0.10000003	0.72000003
12	0.10000003	0.60000003
13	0.10000003	0.48000003
14	0.10000003	0.36000003
15	0.10000003	0.24000003
16	0.10000003	0.12000003
17	0.10000003	0.00000000
18	0.20000003	0.72000003
19	0.20000003	0.60000003
20	0.20000003	0.48000003
21	0.20000003	0.36000003
22	0.20000003	0.24000003
23	0.20000003	0.12000003
24	0.20000003	0.00000000
25	0.30000003	0.60000003
26	0.30000003	0.48000003
27	0.30000003	0.36000003
28	0.30000003	0.24000003
29	0.30000003	0.12000003
30	0.30000003	0.00000000
31	0.40000003	0.48000003
32	0.40000003	0.36000003
33	0.40000003	0.24000003
34	0.40000003	0.12000003
35	0.40000003	0.00000000
36	0.50000003	0.36000003
37	0.50000003	0.24000003
38	0.50000003	0.12000003
39	0.50000003	0.00000000
40	0.60000003	0.24000003
41	0.60000003	0.12000003
42	0.60000003	0.00000000
43	0.73000003	0.36000002
44	0.73000003	0.00000000

PRIMARY CONTROL PARAMETERS

NODE COORDINATES

This data was prepared initially  
 for the double precision version  
 of ACCESS 1 computer program.

1  
2

1	1	0.100000	0.020000	1	1	2	10	-1
2	1	0.100000	0.020000	2	2	11	10	-1
3	1	0.100000	0.020000	1	2	3	11	-1
4	1	0.100000	0.020000	1	10	11	18	-1
5	2	0.100000	0.020000	2	3	12	11	-1
6	2	0.100000	0.020000	1	3	4	12	-1
7	2	0.100000	0.020000	2	4	13	12	-1
8	2	0.100000	0.020000	1	4	5	13	-1
	3	0.100000	0.020000	2	5	14	13	-1
10	3	0.100000	0.020000	1	5	6	14	-1
11	3	0.100000	0.020000	2	6	15	14	-1
12	3	0.100000	0.020000	1	6	7	15	-1
13	4	0.100000	0.020000	2	7	16	15	-1
14	4	0.100000	0.020000	1	7	8	16	-1
15	4	0.100000	0.020000	2	8	17	16	-1
16	4	0.100000	0.020000	1	8	9	17	-1
17	5	0.100000	0.020000	2	11	19	18	-1
18	5	0.100000	0.020000	1	11	12	19	-1
19	5	0.100000	0.020000	2	12	20	19	-1
20	5	0.100000	0.020000	1	12	13	20	-1
21	6	0.100000	0.020000	2	13	21	20	-1
22	6	0.100000	0.020000	1	13	14	21	-1
23	6	0.100000	0.020000	2	14	22	21	-1
24	6	0.100000	0.020000	1	14	15	22	-1
25	7	0.100000	0.020000	2	15	23	22	-1
26	7	0.100000	0.020000	1	15	16	23	-1
27	7	0.100000	0.020000	2	16	24	23	-1
28	7	0.100000	0.020000	1	16	17	24	-1

Note that  
2 cards/element  
are required  
for CST.

CST  
ELEMENT  
DESCRIPTION

29	8	0.100000	0.020000	1	18	19	25	-1
30	8	0.100000	0.020000	2	19	26	25	-1
31	9	0.100000	0.020000	1	19	20	26	-1
32	9	0.100000	0.020000	1	25	26	31	-1
33	9	0.100000	0.020000	2	20	27	26	-1
34	9	0.100000	0.020000	1	20	21	27	-1
35	9	0.100000	0.020000	2	21	28	27	-1
36	9	0.100000	0.020000	1	21	22	28	-1
37	10	0.100000	0.020000	2	22	29	28	-1
38	10	0.100000	0.020000	1	22	23	29	-1
39	10	0.100000	0.020000	2	23	30	29	-1
40	10	0.100000	0.020000	1	23	24	30	-1
41	11	0.100000	0.020000	2	26	32	31	-1
42	11	0.100000	0.020000	1	26	27	32	-1
43	11	0.100000	0.020000	2	27	33	32	-1
44	11	0.100000	0.020000	1	27	28	33	-1
45	12	0.100000	0.020000	2	28	34	33	-1
46	12	0.100000	0.020000	1	28	29	34	-1
47	12	0.100000	0.020000	2	29	35	34	-1
48	12	0.100000	0.020000	1	29	30	35	-1
49	13	0.100000	0.020000	1	31	32	36	-1
50	13	0.100000	0.020000	2	32	37	36	-1
51	13	0.100000	0.020000	1	32	33	37	-1
52	13	0.100000	0.020000	1	36	37	40	-1
53	14	0.100000	0.020000	2	33	38	37	-1
54	14	0.100000	0.020000	1	33	34	38	-1
55	14	0.100000	0.020000	2	34	39	38	-1
56	14	0.100000	0.020000	1	34	35	39	-1
57	15	0.100000	0.020000	2	37	41	40	-1

**CST  
ELEMENT  
DESCRIPTION**

ORIGINAL PAGE IS  
OF POOR QUALITY



**CST**  
**ELEMENT**  
**DESCRIPTION**

48	15	0.100000	0.020000	1	37	38	41	-1
49	15	0.100000	0.020000	2	38	42	41	-1
50	15	0.100000	0.020000	1	38	39	42	-1
51	15	0.100000	0.020000	3	40	41	43	-1
52	16	0.100000	0.020000	4	41	44	43	-1
53	15	0.100000	0.020000	5	41	42	44	-1

**SSP**  
**ELEMENT**  
**DESCRIPTION**

1	11	0.020000	0.020000	10	10	11	11	-1
2	11	0.020000	0.020000	11	11	12	12	-1
3	11	0.020000	0.020000	12	12	13	13	-1
4	11	0.020000	0.020000	13	13	14	14	-1
5	11	0.020000	0.020000	14	14	15	15	-1
6	11	0.020000	0.020000	15	15	16	16	-1
7	11	0.020000	0.020000	16	16	17	17	-1
8	11	0.020000	0.020000	17	17	18	18	-1
9	11	0.020000	0.020000	18	18	19	19	-1
10	11	0.020000	0.020000	19	19	20	20	-1
11	11	0.020000	0.020000	20	20	21	21	-1
12	11	0.020000	0.020000	21	21	22	22	-1
13	11	0.020000	0.020000	22	22	23	23	-1
14	11	0.020000	0.020000	23	23	24	24	-1
15	11	0.020000	0.020000	24	24	25	25	-1
16	11	0.020000	0.020000	25	25	26	26	-1
17	11	0.020000	0.020000	26	26	27	27	-1
18	11	0.020000	0.020000	27	27	28	28	-1
19	11	0.020000	0.020000	28	28	29	29	-1
20	11	0.020000	0.020000	29	29	30	30	-1
21	11	0.020000	0.020000	30	30	31	31	-1
22	11	0.020000	0.020000	31	31	32	32	-1
23	11	0.020000	0.020000	32	32	33	33	-1
24	11	0.020000	0.020000	33	33	34	34	-1
25	11	0.020000	0.020000	34	34	35	35	-1
26	11	0.020000	0.020000	35	35	36	36	-1
27	11	0.020000	0.020000	36	36	37	37	-1
28	11	0.020000	0.020000	37	37	38	38	-1
29	11	0.020000	0.020000	38	38	39	39	-1
30	11	0.020000	0.020000	39	39	40	40	-1
31	11	0.020000	0.020000	40	40	41	41	-1
32	11	0.020000	0.020000	41	41	42	42	-1
33	11	0.020000	0.020000	42	42	43	43	-1
34	11	0.020000	0.020000	43	43	44	44	-1
35	11	0.020000	0.020000	44	44	45	45	-1
36	11	0.020000	0.020000	45	45	46	46	-1
37	11	0.020000	0.020000	46	46	47	47	-1
38	11	0.020000	0.020000	47	47	48	48	-1
39	11	0.020000	0.020000	48	48	49	49	-1
40	11	0.020000	0.020000	49	49	50	50	-1
41	11	0.020000	0.020000	50	50	51	51	-1
42	11	0.020000	0.020000	51	51	52	52	-1
43	11	0.020000	0.020000	52	52	53	53	-1
44	11	0.020000	0.020000	53	53	54	54	-1
45	11	0.020000	0.020000	54	54	55	55	-1





APPENDIX D

OUTPUT EXAMPLE -- Example 1

A part of output listing for example problem 1 (18 element box wing) is given. The NEWSUMT version was used with printout parameters as IPRINT=2 and JPRINT=2. From the beginning to the end of the first stage is listed without deletion. Printouts for the intermediate stages (i.e. stages 2 to 8) are omitted, since they are simple repetitions of the first stage output as far as the output format is concerned. The final summary of the job is included in the end.

EIGHTEEN ELEMENT WING BOX DESIGN EXAMPLE  
 REF. AFLL-TR-70-165  
 BEAMS ARE MODELLED WITH SSP ELEMENTS  
 5 TRUSS, 5 CST, AND 8 SSP ELEMENTS  
 18 DESIGN VARIABLES

PROGRAM CONTROL PARAMETERS

DATA GENERATION 0  
 PRINT OUT CONTROL 0  
 OPTIMIZATION CONTROL 0

SYSTEM PARAMETERS

NO. OF NODES 7  
 TOTAL NO. OF ELEMENTS 18  
 DIMENSION OF THE SPACE 3  
 NO. OF ELEMENT TYPES 3  
 NO. OF LOAD CONDITIONS 2

	NO. OF DV. GROUPS	NO. OF CONFIGURATION GROUPS	TOTAL NO. OF ELEMENTS
TRUSS	5	2	5
CST	3	2	6
SPEAR PANEL	8	0	8

NODE NUMBER	X	Y	Z
1	0.0	0.0	0.1000E 02
2	0.1000E 03	0.0	0.8000E 01
3	0.0	0.7000E 01	0.1000E 02
4	0.1000E 03	1.7000E 02	0.3000E 01
5	0.0	0.1000E 03	0.1000E 02
6	0.1000E 03	0.1000E 03	0.8000E 01
7	0.1000E 03	0.1000E 03	0.8000E 01

ELEMENT NO.	NODE 1	NODE 2	NODE 3	DESIGN VARIABLE GROUP	DESIGN VARIABLE INITIAL VALUE	DESIGN VARIABLE		CONFIGURATION GROUP	PRESSURE LOAD GROUP				
						UPPER BOUND	LOWER BOUND		LC=1	2	3	4	5
TRUSS ELEMENTS (DV.=CROSS SECTIONAL AREA)													
1	1	3	1	1	0.5800E 00	0.2000E 01	0.1000E 00	1					
2	1	4	2	1	0.5800E 00	0.2000E 01	0.1000E 00	1					
3	2	4	3	1	0.5800E 00	0.2000E 01	0.1000E 00	1					
4	4	6	4	1	0.5800E 00	0.2000E 01	0.1000E 00	1					
5	6	7	5	1	0.5800E 00	0.2000E 01	0.1000E 00	2					
CONSTANT STRAIN TRIANGULAR ELEMENTS (DV.=THICKNESS)													
1	1	2	4	1	0.1960E 00	0.1000E 01	0.2000E-01	1		0	0		
2	1	3	1	1	0.1960E 00	0.1000E 01	0.2000E-01	1		0	0		
3	2	4	6	2	0.1960E 00	0.1000E 01	0.2000E-01	1		0	0		
4	3	5	3	2	0.1960E 00	0.1000E 01	0.2000E-01	1		0	0		
5	5	6	7	3	0.1960E 00	0.1000E 01	0.2000E-01	2		0	0		
SYMMETRIC SHEAR ELEMENTS (DV.=THICKNESS)													
1	1	3	1	1	0.1960E 00	0.1000E 01	0.2000E-01	1					
2	1	4	2	1	0.1960E 00	0.1000E 01	0.2000E-01	1					
3	2	4	3	1	0.1960E 00	0.1000E 01	0.2000E-01	2					
4	3	5	4	1	0.1960E 00	0.1000E 01	0.2000E-01	2					
5	5	6	5	1	0.1960E 00	0.1000E 01	0.2000E-01	3					
6	4	6	6	1	0.1960E 00	0.1000E 01	0.2000E-01	4					
7	6	7	7	1	0.1960E 00	0.1000E 01	0.2000E-01	4					

CONFIGURATION GROUP

GROUP NO.	UPPER STRESS LIMIT	LOWER STRESS LIMIT	SPECIFIC WEIGHT	YOUNGS MODULUS	POISSONS RATIO
TRUSS ELEMENT					
1	0.10000E 05	-0.10000E 05	0.100000E 00	0.100000E 08	
2	0.10000E 05	-0.10000E 05	0.100000E 00	0.100000E 08	
CONSTANT STRAIN TRIANGULAR ELEMENTS					
1	0.10000E 05	-0.10000E 05	0.100000E 00	0.100000E 08	0.30000E 00
2	0.10000E 05	-0.10000E 05	0.100000E 00	0.100000E 08	0.30000E 00
SYMMETRIC SHEAR PANEL					
1	0.10000E 05	-0.10000E 05	0.100000E 00	0.100000E 08	0.30000E 00
2	0.10000E 05	-0.10000E 05	0.100000E 00	0.100000E 08	0.30000E 00
3	0.10000E 05	-0.10000E 05	0.100000E 00	0.100000E 08	0.30000E 00
4	0.10000E 05	-0.10000E 05	0.100000E 00	0.100000E 08	0.30000E 00
5	0.10000E 05	-0.10000E 05	0.100000E 00	0.100000E 08	0.30000E 00

DISPLACEMENT BOUNDARY CONDITIONS

NODE NO.	BOUNDARY CODES*			PRESCRIBED DISPLACEMENT		
	X	Y	Z	X	Y	Z
1	1	1	1	0.0	0.0	0.0
2	1	1	1	0.0	0.0	0.0

\* -1=PRESCRIBED, 0=FREE, 1=FIXED

ORIGINAL PAGE IS OF POOR QUALITY

LOAD CONDITIONS

LOAD CONDITION 1

LUMPED LOAD AT NODES

NODE NO.	MAGNITUDES OF LOADS		
	X	Y	Z
7	0.0	0.0	0.5000E 04

LOAD CONDITION 2

LUMPED LOAD AT NODES

NODE NO.	MAGNITUDES OF LOADS		
	X	Y	Z
5	0.0	0.0	3.1000E 05

CONSTRAINTS

STARTING POINT MARGIN                    5.1500E 01  
 TRUNCATION FACTOR                    3.5000E 00

STRESS CONSTRAINTS

MEMBER NO. STRESS CONSTRAINT CODE#

1333 ELEMENTS  
 ALL ELEMENTS ARE CONSTRAINED BY BOTH UPPER AND LOWER BOUNDS

131 ELEMENTS  
 ALL ELEMENTS ARE CONSTRAINED BY UPPER BOUNDS ONLY

134 ELEMENTS  
 ALL ELEMENTS ARE CONSTRAINED BY UPPER BOUNDS ONLY

\* -1 : LOWER BOUND ONLY. 0 : NO CONSTRAINTS  
 1 : UPPER BOUND ONLY. 2 : BOTH UPPER AND LOWER BOUNDS

DISPLACEMENT CONSTRAINTS

NODE NUMBER	DIRECTION	CODE #	UPPER BOUND	LOWER BOUND
3	3	2	0.2000E 01	-0.2000E 01
4	3	2	0.2000E 01	-0.2000E 01
5	3	2	0.2000E 01	-0.2000E 01
6	3	2	0.2000E 01	-0.2000E 01
7	3	2	0.2000E 01	-0.2000E 01

\* -1 : LOWER BOUND ONLY. 0 : NO CONSTRAINTS  
 1 : UPPER BOUND ONLY. 2 : BOTH UPPER AND LOWER BOUNDS

ORIGINAL PAGE IS  
OF POOR QUALITY

SIDE CONSTRAINTS

MEMBER NO.	SIDE CONSTRAINT CODE	UPPER BOUND	LOWER BOUND
<b>TRLES ELEMENTS</b>			
1	-1	0.2000E 01	0.1000E 00
2	-1	0.2000E 01	0.1000E 00
3	-1	0.2000E 01	0.1000E 00
4	-1	0.2000E 01	0.1000E 00
5	-1	0.2000E 01	0.1000E 00
<b>LST ELEMENTS</b>			
1	-1	0.1000E 01	0.2000E-01
2	-1	0.1000E 01	0.2000E-01
3	-1	0.1000E 01	0.2000E-01
4	-1	0.1000E 01	0.2000E-01
5	-1	0.1000E 01	0.2000E-01
<b>SSP ELEMENTS</b>			
1	-1	0.1000E 01	0.2000E-01
2	-1	0.1000E 01	0.2000E-01
3	-1	0.1000E 01	0.2000E-01
4	-1	0.1000E 01	0.2000E-01
5	-1	0.1000E 01	0.2000E-01
6	-1	0.1000E 01	0.2000E-01
7	-1	0.1000E 01	0.2000E-01
8	-1	0.1000E 01	0.2000E-01

\* -1 : LOWER BOUND ONLY. 0 : NO CONSTRAINTS  
1 : UPPER BOUND ONLY. 2 : BOTH UPPER AND LOWER BOUNDS

\*\*\*\*\*  
GENERAL UNCONSTRAINED FUNCTION MINIMIZATION  
BY MEANS OF  
SUMT WITH MODIFIED NEWTON METHOD  
\*\*\*\*\*

CONTROL PARAMETERS  
LMODEL 1  
JSTING -1  
JPRINT 2  
MAXNAA 10  
MAXARS 2  
MAXEDM 1  
MAXEVS 20  
STEPK 100.00  
EPSWA 0.00100  
EPSVA 0.0100  
EPSLDM 0.0100  
EPSVK 0.0  
DELTA 0.00010  
OUTAB 0.0  
CLERR 0.0000  
RPMER 0.00010  
LPMER 1.00  
LPMAX 0.00010

CONTROL PARAMETER  
LPMER 1.00

END of PREPROCESOR





TRUSS 1 -0.6000E C4  
 TRUSS 2 -0.1658E C4  
 TRUSS 3 -0.3453E C4  
 TRUSS 4 -0.1860E C4  
 TRUSS 5 -0.1637E C3

CST 5 C.2267E 04

SSP	1	0.3510E 04	-0.1256E 04	0.9062E 02	-0.1172E 04
SSP	2	0.2867E 04	-0.3510E 04	0.0000E 00	0.4491E 03
SSP	3	0.5714E 04	-0.1860E 04	0.0000E 00	0.7100E 04
SSP	4	0.4222E 04	-0.3717E 04	0.0000E 00	0.2830E 04
SSP	5	0.3411E 04	-0.2209E 04	0.0000E 00	0.2047E 04
SSP	6	0.1044E 04	-0.1284E 04	0.0000E 00	0.1837E 04
SSP	7	0.1666E 03	0.1230E 03	0.0000E 00	-0.1738E 03
SSP	8	0.1690E 04	0.4059E 03	0.0000E 00	-0.1738E 03
			-0.2346E 05	0.0000E 00	0.1043E 04

CST 1 C.3555E C4  
 CST 2 0.6029E 04  
 CST 3 0.6218E 04  
 CST 4 0.6103E 04  
 CST 5 0.6103E 04

SSP	1	0.3904E C4	-0.3791E 04	-0.1137E 04	0.4559E 04
SSP	2	0.7808E 04	-0.6245E 04	-0.7979E 03	0.7520E 03
SSP	3	0.3764E 04	-0.1690E 04	0.5686E 03	0.6826E 03
SSP	4	0.2596E 04	-0.1689E 04	-0.1027E 03	0.5572E 03
SSP	5	0.3591E 03	-0.4676E 02	0.3898E 03	0.4013E 03
SSP	6	0.8907E 03	-0.0005E 04	0.0000E 00	0.4547E 04
SSP	7	0.8957E 03	-0.1658E 04	0.0000E 00	0.4434E 04
SSP	8	0.1047E 04	-0.3450E 04	0.0000E 00	0.6036E 03
			-0.1860E 04	0.0000E 00	0.1044E 04
			-0.1637E 03	0.0000E 00	0.5430E 03
			0.8592E 03	0.0000E 00	0.1355E 03
			-0.6934E 02	0.0000E 00	-0.2990E 03
			0.7169E 03	0.0000E 00	-0.4402E 03

POSTURE TABLE

POSTURE TABLE TRUNCATION DATA  
 TRUNCATION FACTORS, SIZE = 0.500 STRESS = 0.300 DISPLACEMENT = 0.500  
 CUTOFF POINTS -1.100 -0.700 -0.800

NO. OF EFFECTIVE CONSTRAINTS = 34 NO. OF TOTAL CONSTRAINTS = 82  
 41 X IS RETAINED AS POTENTIALLY CRITICAL

EFFECTIVE CONST. NO.	CONST. NO.	VALUE OF CONSTRAINTS	TYPE	MEMBER DIRECTION	MEMBER	LOAD CONDITION
1	1	-0.8580E 00	SIDE	1	1	
2	2	-0.8580E 00	SIDE	1	2	
3	3	-0.8580E 00	SIDE	1	3	
4	4	-0.8580E 00	SIDE	1	4	
5	5	-0.8580E 00	SIDE	1	5	
6	6	-0.8580E 00	SIDE	1	6	
7	7	-0.8580E 00	SIDE	2	1	
8	8	-0.8580E 00	SIDE	2	2	
9	9	-0.8580E 00	SIDE	2	3	
10	10	-0.8580E 00	SIDE	2	4	
11	11	-0.8580E 00	SIDE	2	5	
12	12	-0.8580E 00	SIDE	2	6	
13	13	-0.8580E 00	SIDE	2	7	
14	14	-0.8580E 00	SIDE	2	8	
15	15	-0.8580E 00	SIDE	2	9	
16	16	-0.8580E 00	SIDE	2	10	
17	17	-0.8580E 00	SIDE	2	11	
18	18	-0.8580E 00	SIDE	2	12	
19	19	-0.8580E 00	SIDE	2	13	
20	20	-0.8580E 00	SIDE	2	14	
21	21	-0.8580E 00	SIDE	2	15	
22	22	-0.8580E 00	SIDE	2	16	
23	23	-0.8580E 00	SIDE	2	17	
24	24	-0.8580E 00	SIDE	2	18	
25	25	-0.8580E 00	SIDE	2	19	
26	26	-0.8580E 00	SIDE	2	20	
27	27	-0.8580E 00	SIDE	2	21	
28	28	-0.8580E 00	SIDE	2	22	
29	29	-0.8580E 00	SIDE	2	23	
30	30	-0.8580E 00	SIDE	2	24	
31	31	-0.8580E 00	SIDE	2	25	
32	32	-0.8580E 00	SIDE	2	26	
33	33	-0.8580E 00	SIDE	2	27	
34	34	-0.8580E 00	SIDE	2	28	
35	35	-0.8580E 00	SIDE	2	29	
36	36	-0.8580E 00	SIDE	2	30	
37	37	-0.8580E 00	SIDE	2	31	
38	38	-0.8580E 00	SIDE	2	32	
39	39	-0.8580E 00	SIDE	2	33	
40	40	-0.8580E 00	SIDE	2	34	
41	41	-0.8580E 00	SIDE	2	35	
42	42	-0.8580E 00	SIDE	2	36	
43	43	-0.8580E 00	SIDE	2	37	
44	44	-0.8580E 00	SIDE	2	38	
45	45	-0.8580E 00	SIDE	2	39	
46	46	-0.8580E 00	SIDE	2	40	
47	47	-0.8580E 00	SIDE	2	41	
48	48	-0.8580E 00	SIDE	2	42	
49	49	-0.8580E 00	SIDE	2	43	
50	50	-0.8580E 00	SIDE	2	44	
51	51	-0.8580E 00	SIDE	2	45	
52	52	-0.8580E 00	SIDE	2	46	
53	53	-0.8580E 00	SIDE	2	47	
54	54	-0.8580E 00	SIDE	2	48	
55	55	-0.8580E 00	SIDE	2	49	
56	56	-0.8580E 00	SIDE	2	50	
57	57	-0.8580E 00	SIDE	2	51	
58	58	-0.8580E 00	SIDE	2	52	
59	59	-0.8580E 00	SIDE	2	53	
60	60	-0.8580E 00	SIDE	2	54	
61	61	-0.8580E 00	SIDE	2	55	
62	62	-0.8580E 00	SIDE	2	56	
63	63	-0.8580E 00	SIDE	2	57	
64	64	-0.8580E 00	SIDE	2	58	
65	65	-0.8580E 00	SIDE	2	59	
66	66	-0.8580E 00	SIDE	2	60	
67	67	-0.8580E 00	SIDE	2	61	
68	68	-0.8580E 00	SIDE	2	62	
69	69	-0.8580E 00	SIDE	2	63	
70	70	-0.8580E 00	SIDE	2	64	
71	71	-0.8580E 00	SIDE	2	65	
72	72	-0.8580E 00	SIDE	2	66	
73	73	-0.8580E 00	SIDE	2	67	
74	74	-0.8580E 00	SIDE	2	68	
75	75	-0.8580E 00	SIDE	2	69	
76	76	-0.8580E 00	SIDE	2	70	
77	77	-0.8580E 00	SIDE	2	71	
78	78	-0.8580E 00	SIDE	2	72	
79	79	-0.8580E 00	SIDE	2	73	
80	80	-0.8580E 00	SIDE	2	74	
81	81	-0.8580E 00	SIDE	2	75	
82	82	-0.8580E 00	SIDE	2	76	



ORIGINAL PAGE IS  
OF POOR QUALITY

OPTIMIZATION OF MODEL NO. 1

RESPONSE FACTOR = 0.04133E 01

ACTIVE WIDTH OF CONSTRAINTS = 0.20000E-01

RESULTS SUMMARY OF THIS STAGE

NUMBER OF RESPONSE SURFACES 5  
 NUMBER OF ONE DIMENSIONAL MINIMIZATIONS 7  
 OBJECTIVE FUNCTION VALUE 0.290222E 03  
 PENALTY PART = 0.240720E 03 PENALTY WEIGHT = 0.612085E 00

TIME REQUIRED FOR OPTIMIZATION 0.2649 SEC  
 CUMULATIVE TIME UP TO THIS STAGE 0.5771 SEC

REDUCED DESIGN VARIABLES

0.2074E 03 0.0118E 01 0.2015E 01 0.2624E 01 0.2040E 01 0.1337E 01 0.3318E 01 0.3394E 01 0.7137E 00 0.3408E 00  
 0.3423E 00 0.6202E 00 0.1248E 01 0.3397E 01 0.3395E 01 0.3358E 01

CONSTRAINT VALUES

0.9727E 00 0.4414E 00 0.7544E 00 0.7017E 00 0.0576E 00 0.0030E 00 0.0014E 00 0.0537E 00 0.9272E 00 0.7407E 00  
 0.9447E 00 0.0913E 00 0.8726E 00 0.6533E 00 0.6532E 00 0.0574E 00 0.5710E-01 0.3569E 00 0.1285E 00 0.1440E 00  
 0.4838E 00 0.2613E 00 0.6316E 00 0.4291E 00 0.5317E 00 0.8968E 00 0.6053E 00 0.6533E 00 0.4014E 00 0.5886E 00  
 0.5913E 00 0.7591E 00 0.2482E 00 0.8453E 00

END OF STAGE 1

BEGINNING OF STAGE 2

\*\*\*\*\*  
 COMPLETE ANALYSIS - CONTROL = C  
 \*\*\*\*\*

CURRENT REDUCED DESIGN VECTOR

0.1000E 01 0.1000E 01 0.1000E 01 0.1000E 01 0.1000E 01 0.1000E 01 0.1000E 01 0.1000E 01 0.1000E 01 0.1000E 01 0.1000E 01  
 0.1000E 01 0.1000E 01 0.1000E 01 0.1000E 01 0.1000E 01 0.1000E 01

CURRENT DESIGN

ELEMENT TYPE 1  
 0.3665E 01 0.3143E 00 0.4863E 00 0.3392E 00 0.1307E 00  
 ELEMENT TYPE 2  
 0.1466E 00 0.1466E 00 0.5907E-01 0.5907E-01 0.5775E-01  
 ELEMENT TYPE 3  
 0.2746E 00 0.3374E 00 0.3614E 00 0.2361E 00 0.1570E 00 0.5709E-01 0.5707E-01 0.5837E-01

STRUCTURAL WEIGHT OF UPPER HALF OF ONE WING = 0.89253271E 03 CHL. WING = 0.58506543E 03

TRUSS ELEMENTS = 0.352563E 02  
 CST ELEMENTS = 0.150436E 02  
 SSP ELEMENTS = 0.588404E 02

OUTPUT FROM SUCCEEDING STAGES

FINAL RESULTS OF OPTIMIZATION

OBJECTIVE FUNCTION = 0.20148257E 03

REDUCED DESIGN VARIABLES

0.1000E 01 0.1000E 01 0.1000E 01 0.1000E 01 0.1000E 01 0.1000E 01 0.1000E 01 0.1000E 01 0.1000E 01 0.1000E 01 0.1000E 01

CONSTRAINT VALUES

0.5477E-03 0.6021E-03 0.2443E 00 0.5563E-03 0.1712E 00 0.2400E-03 0.2590E-03 0.3539E 00 -0.1931E-07 0.5154E-04  
 0.1144E-03 0.1123E-03 0.4232E-03 0.6984E-03 0.7010E-03 0.2330E-01 0.1058E 00 0.1061E 00 0.1773E 00 0.1795E 00  
 0.1000E 00 0.2184E 00 0.3037E 00 0.3741E 00 0.1884E 00 0.1581E 00 0.2541E-03

CUMULATIVE NUMBER OF RESPONSE SURFACES 10  
 CUMULATIVE NUMBER OF LINE DIMENSIONAL MINIMIZATION 4.1

NUMBER OF EXACT ANALYSES 9  
 NUMBER OF APPROXIMATE ANALYSES 411

TIME AND COUNTING STATISTICS OF THIS JOB

COMPUTATION TIME REQUIRED

INITIAL PREPARATIONS 0.2454 SEC  
 DESIGN STAGES TOTAL 4.1707  
 OPTIMIZATION 1.3750  
 APPROXIMATE FUNCTION EVALUATIONS 0.5764  
 ANALYSES 2.0884  
 UPDATING AND OBJECTIVE CALCULATIONS 0.1271  
 STIFFNESS MATRIX ASSEMBLING 0.1075  
 DECOMPOSING STIFFNESS MATRIX 0.3404  
 BACK SUBSTITUTIONS 0.0251  
 CONSTRAINT CALCULATION 0.3377  
 SET UP RESTORE TABLE 0.1754  
 CONSTRAINT GRADIENT 0.9257  
 DISPLACEMENT SELECTION 0.0211  
 RIGHT HAND SIDE SET UP 0.1744  
 SELECTIVE INVERSE MATRIX 0.1053  
 SELECTIVE MULTIPLICATION 0.1533  
 SELECTIVE BACK SUBSTITUTION 0.03  
 SELECTIVE GRADIENT OF CONSTRAINTS 0.4102

-----  
 TOTAL EXECUTION TIME 4.3671

COUNTING INFORMATION

NUMBER OF STAGES PERFORMED 8  
 NUMBER OF COMPLETE ANALYSES 9  
 NO. OF FUNCTION VALUE CALLS BY OPTIMIZER 411  
 NO. OF GRADIENT CALLS BY OPTIMIZER 411

TOTAL NUMBER OF CONSTRAINTS 82

AVERAGE NO. OF EFFECTIVE CONSTRAINTS 32

NO. OF INDEPENDENT DESIGN VARIABLES 16

ORIGINAL PAGE IS  
 OF POOR QUALITY

----- END OF JOB -----

## APPENDIX E

### PROGRAM MODIFICATION TO REPLACE SSP ELEMENTS WITH SYMMETRIC PURE SHEAR ELEMENTS

Element stiffness matrix for a pure shear element can be shown as

$$[k_e] = \frac{Et}{4(1+\nu)} \begin{bmatrix} \alpha & -1 & \alpha & 1 \\ -1 & 1/\alpha & -1 & -1/\alpha \\ \alpha & -1 & \alpha & 1 \\ 1 & 1/\alpha & 1 & -1/\alpha \end{bmatrix}$$

where

- E: Modulus of elasticity
- $\nu$ : Poisson's ratio
- t: Thickness of the element
- $\alpha$ : Aspect ratio a/b
  - a: length of the element
  - b: full depth of the element

Stress state is

$$\begin{aligned} \sigma_x &= 0 \\ \sigma_y &= 0 \\ \tau_{xy} &= \frac{E}{2(1+\nu)} \left[ \frac{\tilde{u}_p + \tilde{u}_q}{b} - \frac{\tilde{v}_p - \tilde{v}_q}{a} \right] \end{aligned}$$

where

- $\tilde{u}_p, \tilde{v}_p$ : x, y displacement of p node in local coordinate system
- $\tilde{u}_q, \tilde{v}_q$ : x, y displacement of q node in local coordinate system

Stress constraint is written as

$$|\tau_{xy}| \leq \tau_{\text{allowable}} \quad (\text{input data})$$

Only modifications to be made are stiffness matrix, stress computation and gradient of stress computation. By tracing the program

description, it will be obvious that PREP, COMSTR and MULSSP must be modified, accordingly.

Let us decide to use IOPT parameter and assume that all SSP elements are replaced by pure shear elements if IOPT = -1. The following modifications will be required.

PREP

9 lines below statement number 380

```
C=E3(I)/(12.0E0*(1.0E0+RNU3(I)))
F=2.0E0*(1.0E0+RNU3(I))/AR
IF(IOPT.EQ.-1) F=0.0 ← Insert
IH=(I-1)*10
```

COMSTR

14 lines below statement number 250

```
SXY=(V(1)+V(3))*B-(V(2)-V(4))*A
IF(IOPT.EQ.-1) GO TO 252 ←
STRMIS=SX*SX+3.0E0*SXY*SXY
STRMIS=SQRT(STRMIS) Insert
GO TO 260
252 SX=0.0
STRMIS=ABS(SXY)
260 CONTINUE
```

4 lines from the end of COMMON/BLKA04

```
R=1.0/(1.0+RNU3(I))
IF(IOPT.EQ.-1) GO TO 100 ← Insert
ARSXY=A*R*SXY
TA(6)=3.0*ARSXY
```

```

GO TO 110
100 C=0.5*R*E3(I)
    IF (SXY.LT.0.0) C=-C
    TA(1)=B*DCSPX(M)
    TA(2)=B*DCSPY(M)
    TA(3)=-A
    TA(4)=TA(1)
    TA(5)=TA(2)
    TA(6)=A

```

← Insert

```
110 DSIG=0.0
```

It must be confirmed that IOPT is transferred to all of these three subroutines: in other words, check if common block BLKA01 is declared in each of these routines.

Also the allowable upper stress limits for SSP elements should be selected properly. If the distortion energy criterion (von Mises combined stress criterion) is used,  $\tau_{\text{allowable}} = \frac{1}{\sqrt{3}} \sigma_{\text{yield}}$ . If conventional shear stress criterion is preferred,  $\tau_{\text{allowable}} = \frac{1}{2} \sigma_{\text{yield}}$ .