



**EXPERIMENTAL CLEAN COMBUSTOR PROGRAM**  
**PHASE I**  
**FINAL REPORT**

by

**R. Roberts, A. Peduzzi, G. E. Vitti**

**PRATT & WHITNEY AIRCRAFT DIVISION**  
**UNITED TECHNOLOGIES CORPORATION**

**October 1975**

Prepared for

**NATIONAL AERONAUTICS AND SPACE ADMINISTRATION**

**NASA Lewis Research Center**  
**Contract NAS3-16829**

(NASA-CR-134736) **EXPERIMENTAL CLEAN**  
**COMBUSTOR PROGRAM, PHASE 1 Final Report**  
(Pratt and Whitney Aircraft) 214 p HC \$7.25

CSCL 12E

N76-10124

Unclas  
G3/07 03042

1. Report No. CR-134736	2. Government Accession No.	3. Recipient's Catalog No.	
4. Title and Subtitle  EXPERIMENTAL CLEAN COMBUSTOR PROGRAM, PHASE I		6. Report Date October 1975	8. Performing Organization Code
		8. Performing Organization Report No. PWA-5153	10. Work Unit No.
7. Author(s) R. Roberts, A. Peduzzi, G. E. Vitti		11. Contract or Grant No. NAS3-16829	13. Type of Report and Period Covered Contract Report
9. Performing Organization Name and Address Pratt & Whitney Aircraft Division— United Technologies Corporation East Hartford, Connecticut		14. Sponsoring Agency Code	
		12. Sponsoring Agency Name and Address National Aeronautics and Space Administration Lewis Research Center 21000 Brookpark Road, Cleveland, Ohio 44135	
15. Supplementary Notes			
16. Abstract In December 1972, the National Aeronautics and Space Administration awarded Pratt & Whitney Aircraft a contract under the Experimental Clean Combustor Program to generate and demonstrate technology for development of advanced combustion systems with exhaust emissions lower than those of current aircraft engines.  Phase I of the program consisted of screening three low emission combustor concepts by testing and analyzing thirty-two configurations. Configurations were tested that met the emission goals at idle operating conditions for carbon monoxide and for unburned hydrocarbons (emission index values of 20 and 4, respectively). Configurations were also tested that met the SAE smoke number goal of 15 at sea-level take-off conditions. None of the configurations met the goal for oxides of nitrogen emissions at sea-level take-off conditions. The best configurations demonstrated oxide of nitrogen emission levels that were approximately 61 percent lower than those produced by the current JT9D-7 engine, but these levels were still approximately 24 percent above the goal of an emission index level of 10. Additional combustor performance characteristics, including lean blowout, exit temperature pattern factor and radial profile, pressure loss, altitude stability, and altitude relight characteristics were documented. The results indicated the need for significant improvement in the altitude stability and relight characteristics.  In addition to the basic program for current aircraft engine combustors, seventeen combustor configurations were evaluated for advanced supersonic technology applications. The configurations were tested at cruise conditions, and a conceptual design was evolved.			
17. Key Words (Suggested by Author(s)) Main Burner Emissions JT9D Combustor Emission Standards      CTOL Emissions AST Emissions		18. Distribution Statement	
19. Security Classif. (of this report) Unclassified	20. Security Classif. (of this page) Unclassified	21. No. of Pages 214	22. Price*

\* For sale by the National Technical Information Service, Springfield, Virginia 22151

## FOREWORD

This document describes the work conducted and completed by Pratt & Whitney Aircraft Division of United Technologies Corporation during Phase I of the Experimental Clean Combustor Program. This final report was prepared for the National Aeronautics and Space Administration (NASA) Lewis Research Center in compliance with the requirements of contract NAS3-16829.

The authors of this report wish to acknowledge Mr. Richard Niedzwiecki, NASA Project Manager of the Experimental Clean Combustor Program, for his guidance and assistance.

## TABLE OF CONTENTS

	<u>Page No.</u>
<b>SUMMARY</b>	1
<b>INTRODUCTION</b>	3
<b>CHAPTER I-EXPERIMENTAL CLEAN COMBUSTOR PROGRAM DESCRIPTION</b>	5
<b>A. GENERAL DESCRIPTION OF OVERALL PROGRAM</b>	5
<b>B. PROGRAM PLAN</b>	5
1. Phase I Program	5
2. Phase II Program	5
3. Phase III Program	6
<b>C. PROGRAM SCHEDULE</b>	6
<b>D. PROGRAM GOALS</b>	6
1. Pollution Goals	7
2. Performance Goals	8
<b>CHAPTER II-EQUIPMENT AND EXPERIMENTAL PROCEDURES</b>	11
<b>A. GENERAL DESCRIPTION OF REFERENCE ENGINE AND COMBUSTOR</b>	11
1. Reference Engine Description	11
2. Reference Combustor Description	11
3. Reference Engine Combustor Pollution Levels	15
<b>B. TEST COMBUSTOR CONCEPTS</b>	16
<b>C. TEST FACILITIES AND EQUIPMENT</b>	17
1. Test Facilities	17
2. Test Rigs	17
3. Combustor Rig Instrumentation	20
4. Data Acquisition and Recording System	26
<b>D. TEST CONDITIONS AND PROCEDURES</b>	27
1. Test Conditions	27
2. Test Procedures	29
<b>E. GASEOUS EMISSION CALCULATION AND EXTRAPOLATION PARAMETERS</b>	30
1. Fuel-Air Calculation	30
2. Combustion Efficiency Calculations	31
3. Extrapolation of Pollution Data to Engine Conditions	35
<b>F. PERFORMANCE DATA SUMMARY</b>	36

## TABLE OF CONTENTS (Cont'd)

	<u>Page No.</u>
<b>CHAPTER III-PHASE I BASIC PROGRAM</b>	<b>39</b>
<b>A. PROGRAM PLAN</b>	<b>39</b>
<b>B. COMBUSTOR CONFIGURATIONS TESTED</b>	<b>39</b>
1. Swirl-Can Combustor	39
a. General Description	41
b. Design Variations	50
2. Staged Premix Combustor	50
a. General Description	55
b. Design Variations	59
3. Swirl Vorbix Combustor	59
a. General Description	62
b. Design Variations	71
<b>C. EXPERIMENTAL EMISSIONS RESULTS</b>	<b>71</b>
1. Swirl-Can Combustor	77
2. Staged Premix Combustor	85
3. Swirl Vorbix Combustor	95
<b>D. ASSESSMENT OF RESULTS</b>	<b>95</b>
1. Test Results at Idle Conditions	98
2. Test Results at Sea-Level Take-Off Conditions	101
<b>E. COMBUSTOR PERFORMANCE</b>	<b>101</b>
1. Pressure Loss	101
2. Exit Temperature Pattern	109
3. Idle Lean Blowout	110
4. Altitude Stability and Relight Characteristics	111
5. Combustor Durability	113
<b>F. DEVELOPMENT STATUS</b>	<b>113</b>
1. Emission Reduction Status	113
2. Aerothermodynamic Status	113
3. Intermediate Power Considerations	113
4. Application of Results	116
<b>G. CONCLUDING REMARKS</b>	<b>116</b>
<b>CHAPTER IV-ADVANCED SUPERSONIC TECHNOLOGY ADDENDUM</b>	<b>118</b>
<b>A. PROGRAM PLAN</b>	<b>118</b>
<b>B. TASK 1 – AST SCREENING TESTS</b>	<b>119</b>
1. Configurations Tested	119
2. Test Results	121
<b>C. TASK 2 – AST CRUISE DESIGN</b>	<b>124</b>
1. Design Description	124
2. Test Results	124

**TABLE OF CONTENTS (Cont'd)**

	<u>Page No.</u>
<b>D. TASK 3 – CONCEPTUAL DEFINITION</b>	129
1. Study Engine Definition	129
2. Combustor Design	130
3. Estimated Pollutant Emissions	130
<b>APPENDIX A – TEST FACILITIES AND INSTRUMENTATION DESCRIPTION</b>	135
<b>APPENDIX B – COMBUSTOR HOLE PATTERNS</b>	153
<b>APPENDIX C – EXPERIMENTAL TEST DATA</b>	186
<b>APPENDIX D – NOMENCLATURE</b>	209
<b>REFERENCES</b>	210
<b>DISTRIBUTION LIST</b>	212

## LIST OF ILLUSTRATIONS

<u>Figure</u>	<u>Title</u>	<u>Page No.</u>
1	Overall Experimental Clean Combustor Program Schedule	6
2	Cross-Sectional Schematic of the JT9D-7 Reference Engine	12
3	Cross-Sectional Schematic of the JT9D-7 Reference Combustor	13
4	Target Average Radial Exhaust Temperature Profile of the JT9D-7 Reference Combustor	14
5	Schematic of the Clean Combustor Test Rig in the High-Pressure Test Facility	18
6	View of the Outer Rig Case for the Staged Premix Combustor	18
7	Construction of Staged Premix Combustor Liner and Sidewall	19
8	Experimental Clean Combustor Rig Installed in the High-Pressure Test Facility	20
9	Combination Total Temperature, Total Pressure, and Gas Sampling Annular Traversing Rake	22
10	Detailed View of Combustor Exit Annular Traversing Rake	23
11	Schematic of Fixed Exhaust Gas Sample Probe	23
12	Locations of Fixed Gas Sampling Probe Rakes	24
13	Pratt & Whitney Aircraft Emissions Measurement System	25
14	On-Line Data Acquisition System Installed at High-Pressure Combustor Test Facility	26
15	JT9D Relight Envelope	28
16	Metered and Carbon-Balance Fuel-Air Ratios for the Swirl-Can Combustor Concept	32
17	Metered and Carbon-Balance Fuel-Air Ratios for the Staged Premix Combustor Concept	33
18	Metered and Carbon-Balance Fuel-Air Ratios for the Swirl Vorbix Combustor Concept	34

LIST OF ILLUSTRATIONS (Cont'd)

<u>Figure</u>	<u>Title</u>	<u>Page No.</u>
19	Swirl-Can Combustor Concept	40
20	Swirl-Can Combustor Front-End Matrix and Liner Assembly	41
21	Swirl-Can Combustor Diffuser Modifications	43
22	Effect of Diffuser Modifications on Combustor Inlet Velocity Profile as Measured in Plexiglas Flow Visualization Rig	44
23	Effect of Diffuser Modifications on Combustor Inlet Velocity Profile as Measured in Combustor Segment Rig	45
24	Swirl-Can Combustor Flameholder Configurations	46
25	Swirl-Can Combustor Array Showing Different Flameholder Configurations	47
26	Swirl-Can Combustor Fuel Injector Configurations	49
27	Staged Premix Combustor Concept	51
28	Views of Staged Premix Combustor Configurations	52
29	Effect of Equivalence Ratio and Residence Time on Concentration of Oxides of Nitrogen in a Kinetically Limited JP-5/Air System	54
30	Premix Combustor Stability Limit Correlation Data	55
31	Staged Premix Combustor Main Burner Fuel Staging Arrangement	58
32	Staged Premix Combustor Double Main Burner Fuel Injector	59
33	Swirl Vorbix Combustor Concept	60
34	View Looking Upstream Toward Headplate Showing Orientation of Main Burner Inner and Outer Swirlers Relative to the Pilot Fuel Injector Nozzle	60
35	Front View of the Swirl Vorbix Test Section	61
36	Swirl Vorbix Combustor Schematic Showing Region Where Fuel Aspiration Occurred and Location of Corrective Hoods	64



LIST OF ILLUSTRATIONS (Cont'd)

<u>Figure</u>	<u>Title</u>	<u>Page No.</u>
37	Test Results for Swirl Vorbix Combustor Pilot Fuel Injector Flow Visualization Tests Showing Improved Atomization by Pressure Atomizing Fuel Injectors	65
38	Test Results for Swirl Vorbix Combustor Main Burner Fuel Injector Flow Visualization Tests Showing Excessive Penetration at Combustor Segment Rig Test Conditions	67
39	Swirl Vorbix Combustor Main Burner Swirler Orientations	68
40	Swirl Vorbix Combustor Liner for Configuration S4 Showing Small-Diameter Swirlers	69
41	Swirl Vorbix Combustor Liner for Configuration S8 Showing Large-Diameter Swirlers and Plugged Dilution Holes	70
42	Swirl-Can Combustor Carbon Monoxide Emission Levels as a Function of Fuel-Air Ratio at Idle Conditions	73
43	Swirl-Can Combustor Total Unburned Hydrocarbon Emission Levels as a Function of Fuel-Air Ratio at Idle Conditions	74
44	Staged Premix Combustor Carbon Monoxide Emission Levels as a Function of Fuel-Air Ratio at Idle Conditions	80
45	Staged Premix Combustor Total Unburned Hydrocarbon Emission Levels as a Function of Fuel-Air Ratio at Idle Conditions	81
46	Staged Premix Combustor Oxides of Nitrogen Emission Levels as a Function of Pilot Burner Fuel-Air Ratio at Sea-Level Take-Off Conditions	83
47	Staged Premix Combustor Combustion Efficiency as a Function of Pilot Burner Fuel-Air Ratio at Sea-Level Take-Off Conditions	84
48	Swirl Vorbix Combustor Carbon Monoxide Emission Levels as a Function of Fuel-Air Ratio at Idle Conditions	87
49	Swirl Vorbix Combustor Total Unburned Hydrocarbon Emission Levels as a Function of Fuel-Air Ratio at Idle Conditions	88

LIST OF ILLUSTRATIONS (Cont'd)

<u>Figure</u>	<u>Title</u>	<u>Page No.</u>
50	Swirl Vorbix Combustor Oxides of Nitrogen Emission Levels as a Function of Pilot Burner Fuel-Air Ratio at Sea-Level Take-Off Conditions	93
51	Swirl Vorbix Combustor Combustion Efficiency as a Function of Pilot Burner Fuel-Air Ratio at Sea-Level Take-Off Conditions	94
52	Circumferential Exit Temperature Patterns for Swirl-Can Combustor Configuration N5 at Idle Conditions	103
53	Circumferential Exit Temperature Patterns for Swirl-Can Combustor Configuration N5 at Take-Off Conditions	103
54	Circumferential Exit Temperature Patterns for Staged Premix Combustor Configuration P1 at Idle Conditions	104
55	Circumferential Exit Temperature Patterns for Staged Premix Combustor Configuration P1 at Take-Off Conditions	104
56	Circumferential Exit Temperature Patterns for Swirl Vorbix Combustor Configuration S4 at Idle Conditions	106
57	Circumferential Exit Temperature Patterns for Swirl Vorbix Combustor Configuration S4 at Take-Off Conditions	106
58	Radial Exit Temperature Patterns for Swirl-Can Combustor Configuration N5, Staged Premix Combustor Configuration P1, and Swirl Vorbix Combustor Configuration S4 at Idle Conditions	108
59	Radial Exit Temperature Patterns for Swirl-Can Combustor Configuration N5, Staged Premix Combustor Configuration P1, and Swirl Vorbix Combustor Configuration S4 at Take-Off Conditions Shown With JT9D-7 Engine Pattern	108
60	Swirl-Can Combustor Configuration N12 Altitude Stability and Relight Test Results Shown on JT9D Altitude Relight Envelope	110
61	Staged Premix Combustor Configuration P9 Altitude Stability and Relight Test Results Shown on JT9D Altitude Relight Envelope	112
62	Effect of Combustor Reference Velocity on Emissions of Oxides of Nitrogen and Combustion Efficiency at AST Cruise Condition for Configurations N4, N5, N8, P4, S3, S4, and S6	122

LIST OF ILLUSTRATIONS (Cont'd) .....

<u>Figure</u>	<u>Title</u>	<u>Page No.</u>
63	Swirl-Can Combustor Configuration N13.....	125
64	Swirl-Vorbix Combustor Configuration S10	126
65	Effect of Combustor Reference Velocity on Emissions of Oxides of Nitrogen and Combustion Efficiency at AST Cruise Condition for Configurations N13 and S10	127
66	AST Swirl Vorbix Combustor <u>Conceptual Design</u> for STF502 Engine	131
67	Correlation of Oxides of Nitrogen Emissions Data for Configuration S10	133

## LIST OF TABLES

<u>Table</u>	<u>Title</u>	<u>Page No.</u>
I	Pollution Goals for CTOL Applications and Current JT9D-7 Levels	7
II	Definition of JT9D-7 Engine Operating Conditions	8
III	Pollution Goals for AST Application at Representative Supersonic Cruise Condition	9
IV	Performance Goals	9
V	Key Specifications of the JT9D-7 Engines	13
VI	Key Operating Parameters of the JT9D-7 Reference Combustor	14
VII	Representative JT9D-7 Production Engine Emission Levels and Experimental Clean Combustor Program Goals	15
VIII	Representative JT9D-7 Production Engine Emission Levels and EPA Class T2 Standards for 1979	16
IX	Exhaust Gas Analysis Instrumentation	25
X	JT9D-7 Reference Engine Operating Conditions and Experimental Clean Combustor Sector Rig Operating Conditions	27
XI	Range of Variation of Sector Rig Operating Conditions	28
XII	Sector Rig AST Cruise Operating Conditions	29
XIII	Standard Combustor Inlet Conditions to Which Emissions Data for Oxides of Nitrogen Were Extrapolated	36
XIV	Summary of Reported Combustor Performance Parameters	37
XV	Swirl-Can Combustor Configurations	42
XVI	Staged Premix Combustor Configurations	56
XVII	Airflows for Premix Passages of Staged Premix Combustor Configurations	57
XVIII	Swirl Vorbix Combustor Configurations	63

LIST OF TABLES (Cont'd)

<u>Table</u>	<u>Title</u>	<u>Page No.</u>
XIX	Swirl-Can Combustor Emissions at Idle Conditions	72
XX	Swirl-Can Combustor Emissions at Sea Level Take-Off Conditions	76
XXI	Staged Premix Combustor Emissions at Idle Conditions	78
XXII	Staged Premix Combustor Emissions at Sea-Level Take-Off Conditions	82
XXIII	Swirl Vorbix Combustor Emissions at Idle Conditions	86
XXIV	Swirl Vorbix Combustor Emissions at Sea-Level Take-Off Conditions	90
XXV	Summary of Test Results for Best Configurations of Each Combustor Concept at Idle Conditions	96
XXVI	Summary of Test Results for Best Configurations of Each Combustor Concept at Sea-Level Take-Off Conditions	99
XXVII	Summary of Combustor Pressure Loss Test Results	102
XXVIII	Summary of Combustor Exit Temperature Pattern Factor Results	107
XXIX	Summary of Combustor Idle Lean Blowout Test Results	109
XXX	Summary of Experimental Clean Combustor Performance Status	114
XXXI	Swirl-Can Combustor Configurations Tested at AST Cruise Conditions	119
XXXII	Staged Premix Combustor Configurations Tested at AST Cruise Conditions	120
XXXIII	Swirl Vorbix Combustor Configurations Tested at AST Cruise Conditions	120
XXXIV	Summary of AST Screening Test Results	123
XXXV	Summary of AST Cruise Design Tests	128

LIST OF TABLES (Cont'd)

<u>Table</u>	<u>Title</u>	<u>Page No.</u>
XXXVI	Study Engine STF502 Combustor Inlet Conditions and Combustor Rig Inlet Conditions	129
XXXVII	Design Parameters for STF502 Combustor Conceptual Design and Swirl Vorbix Combustor Configuration S10	132
XXXVIII	Estimated STF502 Combustor Emission Levels at Supersonic Cruise at Mach 2.32 at 16.145 km	134

## SUMMARY

The Experimental Clean Combustor Program is directed toward the development and demonstration of technology for reducing combustor emissions for application to both current and future gas turbine engine combustors. The program is being conducted in three phases. Phase I, which has been completed and is the subject of this report, involved screening of combustor concepts to identify the best approaches for reducing emission levels. Phase II, which is currently in progress, is refining the best combustor concepts identified in Phase I. Phase III will consist of full-scale engine demonstration tests of the refined combustor.

Ambitious emission reduction goals were set for the program. At idle engine operating conditions, an emission index (grams of pollutant per kilogram of fuel) goal of 20 was set for carbon monoxide, and a goal of 4 was set for total unburned hydrocarbons. At sea-level take-off conditions, an emission index goal of 10 was set for oxides of nitrogen, with an SAE smoke number goal of 15.

Phase I initially involved combustors intended only for Conventional Take-Off and Landing (CTOL) applications, but the work was later expanded to include Advanced Supersonic Technology (AST) applications as well.

For the CTOL applications, three combustor concepts were tested and analyzed. These were:

1. Swirl-Can Combustor Concept
2. Staged Premix Combustor Concept
3. Swirl Vorbix Combustor Concept

Various configurations of each of these concepts were tested and analyzed to establish basic design trends, after which the results from the best configuration for each concept were compared to provide a basis for selecting the concepts to be pursued in Phase II. Testing was conducted in a 90-degree sector test rig simulating the JT9D engine combustor envelope. Testing was conducted primarily at simulated engine idle and sea-level take-off conditions. All combustor inlet conditions were the same as those produced in the engine except for the inlet pressure at sea-level take-off conditions, which was limited to 6.8 atmospheres by test facility capabilities, whereas the inlet pressure produced in the engine is 21.7 atmospheres. Suitable correction factors were applied to the data to account for this difference. Testing was also conducted at selected inlet temperatures and pressures, reference velocities, and fuel-to-air ratios to determine the effects of these variables on emissions and obtain an indication of the off-design performance of the combustor concepts. Stability and relight capability at simulated altitude conditions were also documented.

Lowest emissions at idle engine operating conditions were obtained with the staged premix combustor. The carbon monoxide emission index level was 55 percent below the goal and the total hydrocarbon emission index level was 75 percent below the goal. The swirl vorbix combustor approached but did not meet the goals, while the swirl-can combustor provided significantly higher emissions that were close to the levels produced by current production JT9D-7 combustors.

At sea-level take-off engine conditions, none of the combustors was able to meet the goal for oxides of nitrogen, although some combustor configurations provided significant improvements relative to the current production JT9D-7 combustor. The best results were obtained with the swirl vorbix and the swirl-can combustors, both of which provided approximately 60-percent lower emissions of nitrogen oxides than the current production JT9D-7 combustor. All three combustor concepts met the smoke goal.

The performance data for the combustors indicated the need for substantial improvement. Although the swirl vorbix and the swirl-can combustors operated with combustion efficiencies of 99.5 percent or higher, the staged premix combustors had lower efficiencies at sea-level take-off conditions, and both the swirl-can and the staged premix combustors require development to meet the current JT9D engine altitude relight requirements. This work was beyond the scope of Phase I.

For the Advanced Supersonic Technology applications, seventeen configurations of the three combustor concepts were evaluated at representative cruise conditions. None of the configurations tested met the nitrogen oxide emission index goal of 5, but both the swirl vorbix and swirl-can concepts met the carbon monoxide and total unburned hydrocarbon emission index goals of 5 and 1 respectively. The staged premix combustor configurations were not stable at the cruise test point, and consequently emission values have not been quoted. Best results were obtained with the swirl vorbix combustor, with a nitrogen oxide emission index value 85 percent above the goal level. On the basis of these results, a combustor configuration based on the swirl vorbix concept was evolved for Advanced Supersonic Technology engine studies.



## INTRODUCTION

When viewed on a global basis, gas-turbine powered aircraft are relatively small contributors to overall environmental pollution. However, heavy concentrations of aircraft can have a significant impact on air quality in the vicinity of airports. In addition, concern has recently arisen over the potential effects of pollutants released in the stratosphere by supersonic and newer subsonic aircraft which operate at high altitudes.

The concern with air quality in the vicinity of airports has led to the issuance of emission standards by the U. S. Environmental Protection Agency for aircraft engines manufactured after January 1979 (Reference 1). These standards limit the emissions of carbon monoxide, total unburned hydrocarbons, oxides of nitrogen, and smoke at altitudes under 914 m. Recently introduced gas turbine engines, such as the JT9D family, already meet the requirement for producing no visible smoke. However, compliance with the standards for the remaining pollutants will require substantial improvements relative to current engine emission levels.

The concern with pollutants released at high altitude relates primarily to the potential for oxides of nitrogen to combine with the ozone layer in the stratosphere. The consequences of depletion of this ozone layer have been studied by the U. S. Department of Transportation under the Climatic Impact Assessment Program, and the "Report of Findings" from this study (Reference 2) concludes that control of emissions of oxides of nitrogen at high altitude may be required in the future.

The exhaust pollutants produced by conventional combustor systems are basically the result of a combination of the following factors: nonhomogeneous fuel-air mixtures, inadequate management of local fuel-air ratio throughout the combustor, and nonoptimum residence time. Although the rudiments of pollution control are understood (Reference 3) and various control strategies have been formulated, there has not been successful implementation of these strategies into actual combustor hardware suitable for commercial aircraft application. Physical constraints on fuel vaporization, turbulent mixing rate, dilution air addition, and residence time impose absolute limits on the combustion process. In addition, the traditional requirements for uniform exit temperature distribution, combustion stability, relight capability, durability, and operational safety must be considered. Furthermore, it is desirable for commercial reasons to maintain component weight, costs, and mechanical complexity at a minimum. Thus emission control strategies must accommodate a diversified range of factors that greatly add to the development complexity of a practical low-emission combustor system.

In response to the need to develop technology that will permit the emissions standards to be met in a commercially acceptable manner, the National Aeronautics and Space Administration initiated the Experimental Clean Combustor Program in December 1972. The program is a three-phase program. Phase I has been completed and is the subject of this report.

A description of the overall program is contained in the following section, Chapter I. Chapter II describes the JT9D engine upon which the program was based, and also describes the equipment and test procedures used in the first phase of the program. Chapter III describes the testing and the results obtained during Phase I for CTOL applications, and Chapter IV describes the work conducted for AST applications. Appendices are provided with detailed descriptions of facilities and instrumentation, combustor design configurations, and test data. Nomenclature definitions and references are provided in Appendices D and E, respectively.

Phase I of the Experimental Clean Combustor Program also included a Combustion Noise Addendum. The objective of this program addendum was to acquire noise data for correlation with combustor emission and performance parameters. The results of this addendum are presented in a separate report, NASA CR-134820 (Reference 4).

## CHAPTER I

### EXPERIMENTAL CLEAN COMBUSTOR PROGRAM DESCRIPTION

#### A. GENERAL DESCRIPTION OF OVERALL PROGRAM

The Experimental Clean Combustor Program is a multiyear effort that was initiated in December 1972 and is scheduled for completion in late 1976. The program is directed towards two primary objectives:

1. The generation of the technology required to develop advanced commercial CTOL aircraft engines with lower exhaust pollutant emissions than those of current technology engines, and
2. The demonstration of the emission reductions and acceptable performance in a full-scale engine in 1976.

The program specifically addresses the development of a combustor with low emission characteristics for the Pratt & Whitney Aircraft JT9D-7 engine. However, the technology developed during the program will be able to be translated to other combustors, either for commercial or military applications, and it will also provide the foundation for developing further refinements and for identifying other avenues for continued exploration and experimental research.

#### B. PROGRAM PLAN

The program is divided into three phases, providing a step-by-step approach for developing the technology required for reducing emissions. These phases are:

Phase I - Screening of Low-Emission Combustor Concepts

Phase II - Refinement of the Best Low-Emission Concepts

Phase III - Engine Testing of the Best Combustor Concept

##### 1. PHASE I PROGRAM.

Phase I of the program involved screening of three candidate combustor concepts to provide a basis for selecting concepts for refinement in Phase II. Both CTOL and Advanced Supersonic Technology applications were studied. Details of this program are contained in the following chapters of this report and in the Combustor Noise Addendum Report (Reference 4)

##### 2. PHASE II PROGRAM

Phase II of the program is directed toward obtaining both acceptable combustor emissions and acceptable performance, with emphasis on off-design operation, exit temperature profile and pattern factor, relight capability, and engine adaptability.

The program was initiated at the conclusion of the Phase I technical effort. Two combustor concepts have been selected on the basis of the test data and experience acquired during the Phase I program, and refinement and optimization tests have been initiated. The problems inherent in a two-stage fuel system, such as manifold fill time, main burner nozzle coking, fuel nozzle coking, fuel nozzle accessibility, and fuel control requirements, are being investigated.

### 3. PHASE III PROGRAM

The objective of Phase III will be to substantiate the pollution reduction technology developed in Phases I and II in an actual engine environment. This will be achieved by testing the best combustor from the Phase II program in a full-scale JT9D engine.

#### C. PROGRAM SCHEDULE

The program schedule for the Experimental Clean Combustor Program is shown in Figure 1. Phase I was an eighteen-month effort which has been completed and Phase II is a fifteen-month effort now in progress. Phase III will be a sixteen-month effort scheduled for completion during 1976.

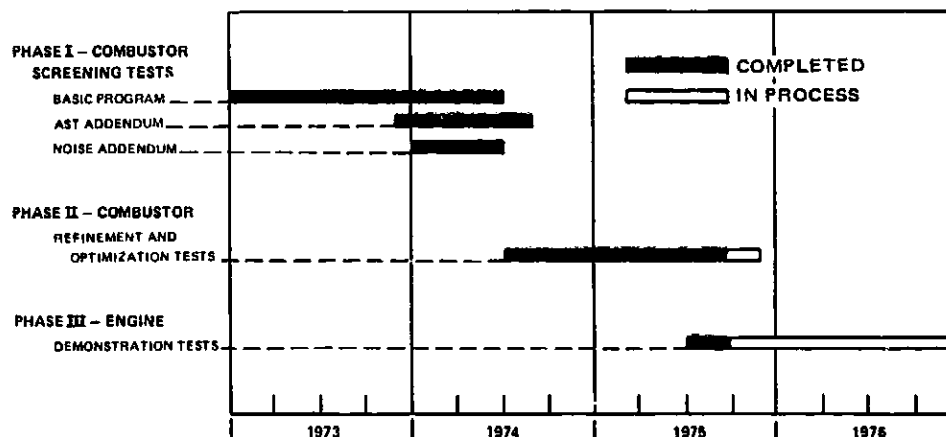

Figure 1 Overall Experimental Clean Combustor Program Schedule

#### D. PROGRAM GOALS

Program goals were defined for both pollutant emissions and combustor aerothermodynamic performance. The goals for gaseous pollutants are extremely ambitious and represent the primary focus of the Experimental Clean Combustor Program. The program goals for smoke and performance are essentially the maintenance of current JT9D-7 combustor performance levels and are imposed to ensure that the reductions in pollutant emissions are not achieved at the expense of performance or smoke levels. All goals are predicated on the use of commercial-grade Jet-A aviation turbine fuel.

## 1. POLLUTION GOALS

Pollution goals were established for ground idle and sea-level static take-off operation. The pollution goals are listed in Table I by engine operating mode. Gaseous pollutants (NO<sub>x</sub>, CO, THC) are expressed in terms of the emission index, defined as the ratio of grams of pollutant formed per kilogram of fuel consumed. Smoke concentration is expressed in terms of the S.A.E. smoke number. For comparative purposes, current emission levels of the JT9D-7 engine are also included to illustrate the magnitude of required pollution reduction.

TABLE I  
POLLUTION GOALS FOR CTOL APPLICATIONS  
AND CURRENT JT9D-7 LEVELS

Engine Mode	CO (g/kg fuel)		THC (g/kg fuel)		NO <sub>x</sub> * (g/kg fuel)		Smoke (SAE Smoke Number)	
	Goal	JT9D-7	Goal	JT9D-7	Goal	JT9D-7	Goal	JT9D-7
Ground Idle With Compressor Air Bleed	20	---	4	---	---	---	---	---
Ground Idle Without Compressor Air Bleed	20	77.0	4	29.8	---	---	---	---
Sea-Level Static Take-Off	---	---	---	---	10	31.5	15	10

\*NO<sub>2</sub> equivalent of all oxides of nitrogen.

Note: JT9D-7 data represents average production pilot lot data for combustor configuration EC 279845 adjusted to standard day conditions with specific humidity of 0.0063.

JT9D-7 combustor inlet conditions at the idle and sea-level static take-off operating modes are summarized in Table II. Two ground idle operating points are defined in Table II, corresponding to engine operation with and without fifteenth-stage compressor bleed air extraction to meet airframe requirements. Current Pratt & Whitney Aircraft experimental engine and production acceptance tests are conducted without extraction of bleed air. However, engines in the field operate with varying amounts of bleed extraction. The bleed airflow identified in Table II is considered representative. Owing to the particular design of the JT9D fuel control, compressor bleed extraction results in a drop in high-pressure compressor rotor speed and corresponding changes in combustor inlet pressure, temperature, and fuel-air ratio. Since the basis for EPA Emission Standard compliance testing is presently open to interpretation, both conditions were included in the test program.

**TABLE II**  
**DEFINITION OF JT9D-7 ENGINE OPERATING CONDITIONS**

Engine Mode	Bleed Extraction Rate (kg/sec)	JT9D-7 Combustor Inlet Conditions		
		Inlet Pressure (atm)	Inlet Temperature (K)	Fuel-to-Air Ratio
Ground Idle With Compressor Air Bleed	1.23	2.93	427.8	0.0126
Ground Idle Without Compressor Air Bleed	0	3.74	455.6	0.0105
Sea-Level Static Take-Off	0	21.71	768.9	0.0227

Note: All engine modes based on standard day sea-level static ambient conditions.

Pollution level goals were also established for the Advanced Supersonic Technology application at a representative supersonic cruise condition. These goals are shown in Table III. Particular emphasis was placed on NO<sub>x</sub> reduction in the AST Addendum testing. The CO and THC goal levels require that NO<sub>x</sub> not be reduced at the expense of increased CO and THC emission levels (and increased cruise fuel consumption).

## 2. PERFORMANCE GOALS

Performance goals were established for both CTOL and AST applications, and these goals are summarized in Table IV.

The goals for the CTOL application do not represent any appreciable departure from current operating levels except for the pattern factor and the combustion efficiency at idle engine conditions. The combustor exit temperature pattern factor goal represents a level that is difficult to achieve on a production basis. Implicit in the goal for exit temperature pattern factor is the achievement of a radial average temperature profile at the combustor exit that is substantially equivalent to that produced by the current production JT9D-7 combustor.

**TABLE III**  
**POLLUTION GOALS FOR AST APPLICATION**  
**AT REPRESENTATIVE SUPERSONIC CRUISE CONDITION**

<u>Pollutant</u>	<u>Goal</u>
CO (g/kg fuel)	5
THC (g/kg fuel)	1
NO <sub>x</sub> * (g/kg fuel)	5
Smoke (SAE Smoke Number)	15

\*NO<sub>2</sub> equivalent of all oxides of nitrogen

Representative supersonic cruise condition corresponds to combustor inlet pressure of 6.8 atm, inlet temperature of 839 K, and a fuel-to-air ratio of 0.0227.

**TABLE IV**  
**PERFORMANCE GOALS**

CTOL Application

Total Pressure Loss (%)	6
Exit Temperature Pattern Factor	0.25 at take-off
Combustion Efficiency (%)	99 or better at all operating conditions
Lean Blowout Fuel-to-Air Ratio	0.004 ±0.001
Altitude Relight Capability	
Altitude (m)	9144
Flight Mach Number	0.5 - 0.8

AST Application

Total Pressure Loss (%)	6 - 9
Exit Temperature Pattern Factor	0.25 or less
Combustion Efficiency (%)	99.8 or better

The goal for combustion efficiency of 99 percent or better at all operating conditions ensures that the engine will have high operating efficiency at all power settings, and that the reduction in the emissions of oxides of nitrogen is not achieved at the cost of engine efficiency at high power settings. Current aircraft gas turbine engines operate at combustion efficiencies greater than 99 percent at all power settings except idle.

The performance goals for AST applications apply only to the supersonic cruise condition and require a combustion efficiency of 99.8 percent or better. A range of combustor total pressure loss values is shown because AST engine cycle studies indicate that the AST turbofan engine will operate with a combustor pressure loss of 9 percent while the AST turbojet engine will operate with a combustor pressure loss of 6 percent.



## CHAPTER II

### EQUIPMENT AND EXPERIMENTAL PROCEDURES

#### A. GENERAL DESCRIPTION OF REFERENCE ENGINE AND COMBUSTOR

##### 1. REFERENCE ENGINE DESCRIPTION

The JT9D-7 engine was selected as a reference for the experimental combustor designs. This engine is the current production version of the basic JT9D engine model, which was designed and developed by Pratt & Whitney Aircraft. Since its introduction into commercial service, this engine has acquired widespread use as the powerplant for both the Boeing 747 and the Douglas DC-10-40 aircraft.

The JT9D engine is an advanced, dual-spool, axial-flow turbofan engine designed with a high overall compression ratio and a high bypass ratio. The mechanical configuration is shown in Figure 2.

The engine consists of five major modules: a fan and low-pressure compressor module, a high-pressure compressor module, a combustor module, a high-pressure turbine module, and a low-pressure turbine module. The low-pressure spool consists of a single-stage fan and a three-stage low-pressure compressor driven by a four-stage low-pressure turbine. The high-pressure spool consists of an eleven-stage high-pressure compressor driven by a two-stage high-pressure turbine. The accessory gearbox is driven through a towershaft located between the low- and high-pressure compressors. Selected key specifications for the JT9D-7 engine are listed in Table V.

##### 2. REFERENCE COMBUSTOR DESCRIPTION

The mechanical design of the JT9D reference combustor is shown in Figure 3. The combustor is annular in design with an overall length between the trailing edge of the compressor exit guide vane to the leading edge of the turbine inlet guide vane of 0.6 m. The actual burning length between the fuel nozzle face and the turbine inlet guide vane leading edge is 0.45 m. Key performance parameters of the JT9D-7 reference combustor are summarized in Table VI, and the reference combustor exit average radial temperature profile is shown in Figure 4.

The JT9D-7 combustor incorporates a number of advanced features. The primary diffuser incorporates an inner ramp and outer trip followed by a dump section, and a burner hood is used to provide a positive pressure feed to the combustor front end. The hood is indented locally in ten places downstream of each diffuser case strut. A film-cooled louver construction is used for the combustor liners. The liner assembly features inner and outer slipjoints to facilitate assembly as well as to allow for liner thermal expansion. The fuel system features direct liquid fuel injection by the use of twenty duplex-pressure atomizing fuel nozzles. As shown in Figure 3, the nozzle portion of the fuel injector is enclosed in twenty short cone modules, which provide primary zone flame stabilization. Take-off thrust augmentation is provided by water injection through the fuel nozzle heatshields.

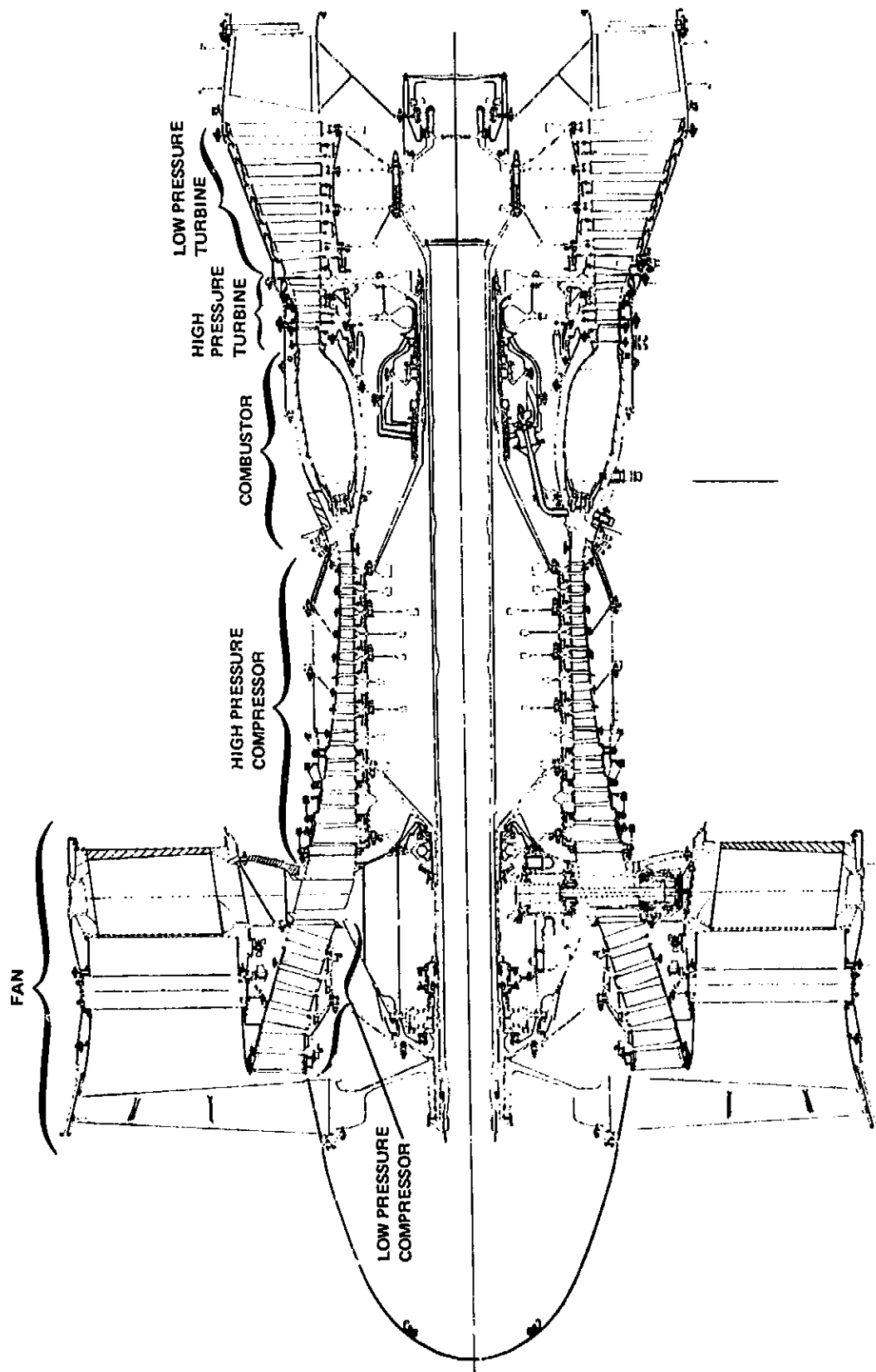

Figure 2 Cross-Sectional Schematic of the JT9D-7 Reference Engine

TABLE V

KEY SPECIFICATIONS OF THE JT9D-7 ENGINE

Weight (kg)	3982.5
Length (m)	3.912
Maximum Diameter, cold (m)	3.427
Pressure Ratio	21.7
Airflow Rate (kg/s)	691
Maximum Sea-Level Static Thrust (kN)	197
Cruise Performance	
Mach Number	0.85
Altitude (m)	10668
Thrust (kN)	44.6
Specific Fuel Consumption (kg/Ns)	$1.979 \times 10^{-5}$

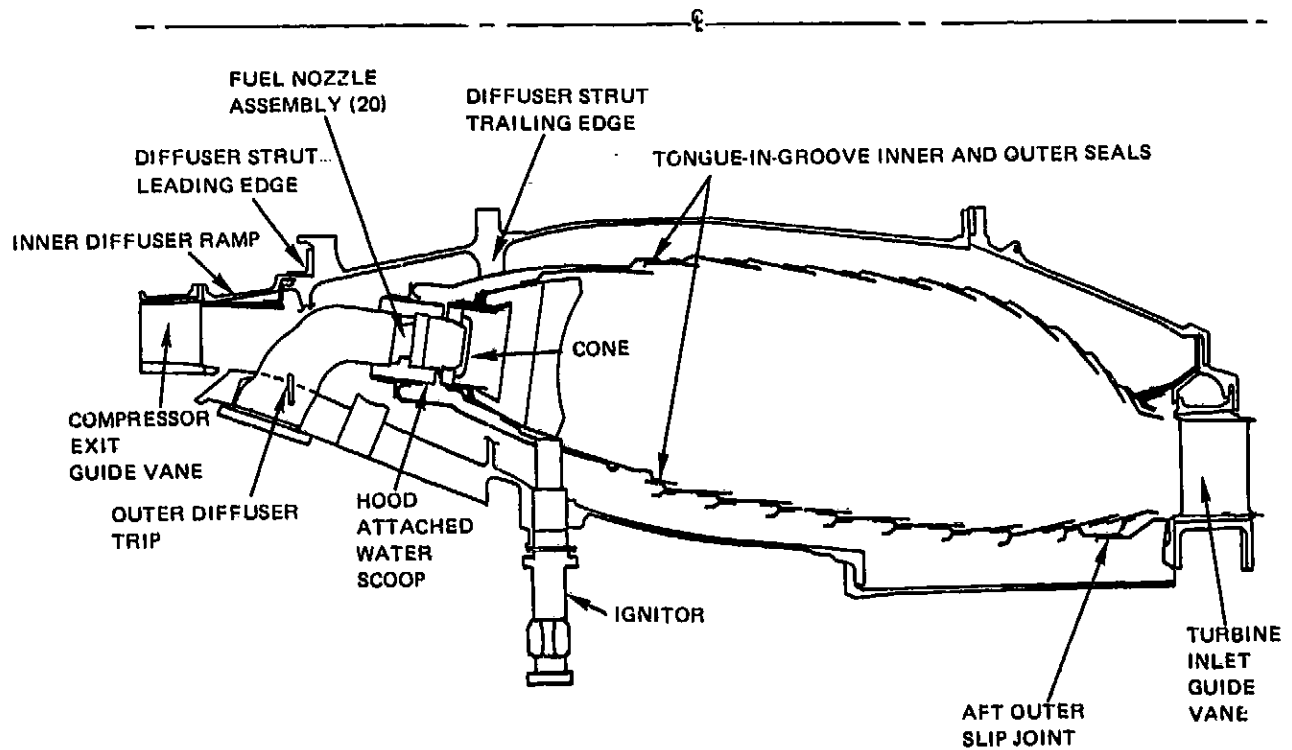

Figure 3 Cross-Sectional Schematic of the JT9D-7 Reference Combustor

TABLE VI

KEY OPERATING PARAMETERS OF THE JT9D-7  
REFERENCE COMBUSTOR

Compressor Exit Axial Mach Number	0.258
Compressor Discharge Temperature (K)	768.9
Combustor Temperature Rise (K)	763.9
Combustor Section Pressure Loss (%)	6.0
Combustor Exit Temperature Pattern Factor	0.42 ± 0.03
Average Combustor Exit Temperature (K)	1532.8

Note: All data for standard day sea-level static take-off conditions.

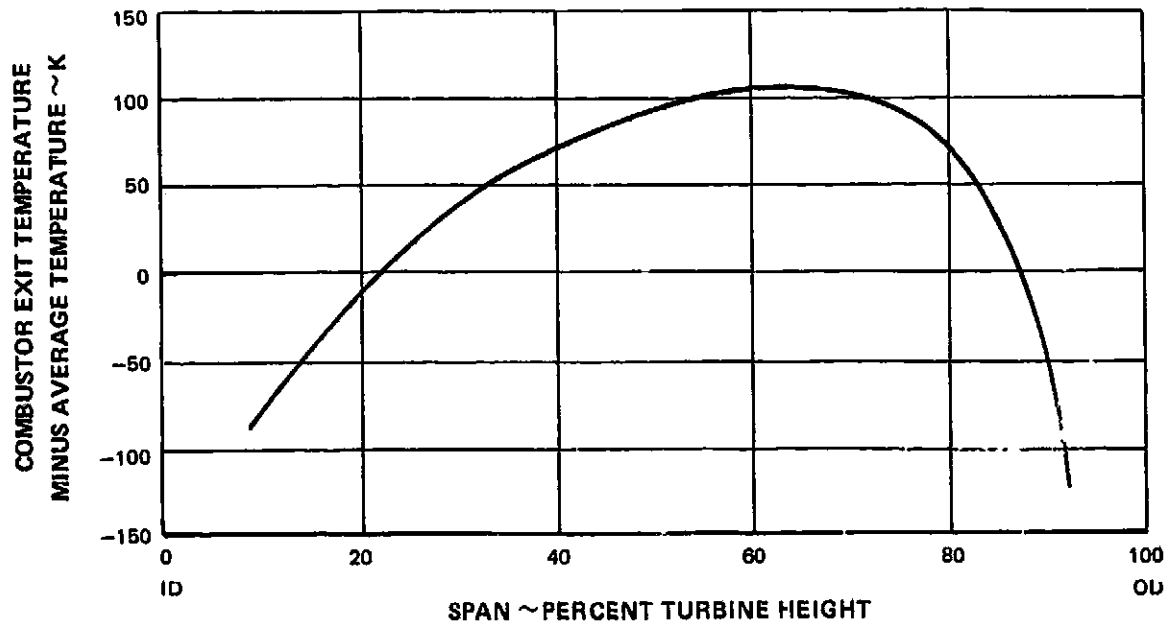

Figure 4 Target Average Radial Exhaust Temperature Profile of the JT9D-7 Reference Combustor

### 3. REFERENCE ENGINE COMBUSTOR POLLUTION LEVELS

Since the JT9D engine and combustion system were designed prior to current concerns regarding gaseous pollutants, the combustor was not specifically intended to provide low emissions. It does incorporate smoke reduction features, however, and therefore provides low smoke numbers and no visible smoke at all operating conditions.

Exhaust emissions are periodically monitored during JT9D production acceptance tests, and typical results for idle and sea-level take-off conditions are shown in Table VIII. These data represent the average emission levels for 23 production JT9D-7A engines incorporating combustor configuration EC 279845. This combustor configuration was installed in those production engines shipped between July, 1973, and December, 1974. The data have been corrected to standard day temperature and pressure and to an ambient humidity level of 6.3 g H<sub>2</sub>O/kg dry air. Jet-A fuel was used for the tests. Comparison of these emission levels with the Experimental Clean Combustor Program goals, also shown in Table VII, reveals the magnitude of the reductions required to meet the program goals. Except for the smoke level, which already meets the goals, reductions of greater than 65 percent are required.

The U. S. Environmental Protection Agency emission standards for aircraft engines are expressed in terms of an integrated EPA parameter (EPAP). This parameter combines emission rates at the engine idle, approach, climb and take-off operating modes, integrated over a specified landing-take-off cycle (Reference 1). Integrated EPAP values for the above combustor configuration are presented in Table VIII, again corrected to standard-day conditions of pressure and temperature and an ambient humidity level of 6.3 g H<sub>2</sub>O/kg dry air. These data show that a 70-percent reduction in carbon monoxide emissions, an 85-percent reduction in unburned hydrocarbon emissions, and a 39-percent reduction in the emissions of oxides of nitrogen are required to satisfy the EPA Class T2 standards for 1979.

TABLE VII  
REPRESENTATIVE JT9D-7 PRODUCTION ENGINE EMISSION LEVELS  
AND EXPERIMENTAL CLEAN COMBUSTOR PROGRAM GOALS

Operating Condition	CO (g/kg fuel)		THC (g/kg fuel)		NO <sub>x</sub> * (g/kg fuel)		Smoke (SAE Smoke Number)	
	JT9D-7	ECCP Goal	JT9D-7	ECCP Goal	JT9D-7	ECCP Goal	JT9D-7	ECCP Goal
Idle	77.0	20	29.8	4	---	---	---	---
Take-off	---	---	---	---	31.5	10	10	15

\*Nitrogen dioxide equivalent used for all oxides of nitrogen.

TABLE VIII  
 REPRESENTATIVE JT9D-7 PRODUCTION ENGINE EMISSION LEVELS  
 AND EPA CLASS T2 STANDARDS FOR 1979

<u>Pollutant</u>	<u>EPA Parameter</u> (lbm pollutant/lbf thrust/hr)	
	<u>JT9D-7</u>	<u>EPA Standard</u>
CO	14.3	4.3
THC	5.3	0.8
NO <sub>x</sub>	4.9*	3.0

\*Corrected to standard-day conditions and specific humidity of 6.3 g H<sub>2</sub>O/kg dry air.

#### B. TEST COMBUSTOR CONCEPTS

Three combustor concepts were evaluated during the Phase I program. These were:

1. Swirl-can combustor
2. Staged premix combustor
3. Swirl vortix combustor

Details of the designs and functional concepts of these combustors are included in Chapter III.

All of the combustors were designed to be compatible with the JT9D-7 engine with respect to both performance and mechanical features. Specific constraints included the combustion section structural envelope formed by the diffuser and combustor cases. No changes were made to the diffuser case struts, the turbine coolant bleed locations, the compressor exit guide vanes, or the turbine inlet guide vanes. For some combustor configurations, however, filler pieces were used to tailor the combustor section to the specific aerodynamic requirements of the low emission combustor.

The fuel systems used for the Phase I rig tests were not required to be engine quality hardware, but the combustors were designed with fuel systems that could be installed in a JT9D engine and that could operate with the overall fuel flow characteristics of the JT9D engine using the existing JT9D fuel pressurization system. Since all of the low emission concepts required zoned fuel systems having more than the twenty fuel nozzles used in the JT9D-7 combustor, modifications to the combustor housing were necessary to permit installation of the additional fuel injectors.

## C. TEST FACILITIES AND EQUIPMENT

### 1. TEST FACILITIES

The combustor tests were conducted in two test facilities. All of the emissions and performance evaluations except for the altitude relight tests were conducted in a high-pressure test facility, Stand X-903. The altitude relight testing was conducted in an altitude test facility, Stand X-306. The capabilities of these facilities are briefly summarized below, with more detailed descriptions being presented in Appendix A.

#### High-Pressure Test Facility

The high-pressure test facility used in the program is located at Pratt & Whitney Aircraft's Middletown, Connecticut plant. An important feature of this facility is that the combustor test rig is installed in a cylindrical pressure tank, and the tank pressure is maintained within 0.34 atm of the combustor inlet pressure. As a result, the combustor test rig case can employ relatively light construction while still permitting testing to be conducted at representative engine pressure levels.

Airflow for the combustor rig is supplied from compressors located in an adjacent power house. Flow rates up to 11.3 kg/s at pressures up to 47.6 atm are available. However, because of the high volumetric flow rates required by this program, the combustor inlet pressure was limited to a maximum of 6.8 atm. A direct-fired inlet heat exchanger is used to supply unvitiated inlet air at temperatures up to 839 K. A variety of liquid fuels can be supplied to the test rig. All controls and instrumentation required to operate the test stand and monitor the performance characteristics are located in an adjacent stand control room.

#### Altitude Test Facility

The altitude test facility is located at the Rentschler Airport Laboratory in East Hartford, Connecticut. It is a multiduct facility suitable for stability, ignition, and icing component testing at simulated altitude conditions.

For altitude stability and ignition testing such as conducted in this program, the test rig exhaust duct can be evacuated to pressures as low as 0.066 atm by any combination of five Ingersoll-Rand vacuum pumps rated at 5.66 m<sup>3</sup>/s free air discharge each. The inlet air can be refrigerated to temperatures as low as 225 K by a combination of four York compressors. In addition, the inlet air can be dried to a specific humidity down to 0.86 g H<sub>2</sub>O/kg air using an activated alumina dryer.

All control and instrumentation required to operate the test rig and monitor performance are contained in a control room located adjacent to the test cell.

### 2. TEST RIGS

Three complete 90-degree sector combustor rigs (one for each combustor concept) were designed and fabricated in this program. A schematic diagram of a test rig and the adapting duct work installed in the test facility is shown in Figure 5.

The combustor cases for each of the test rigs duplicated the JT9D-7 engine diffuser and combustor case design as well as the diffuser strut orientation. In addition, each case was provided with the fuel support pads and instrumentation bosses required by the particular combustor concept. The rig case for the staged premix combustor shown in Figure 6 is typical of all of the cases.

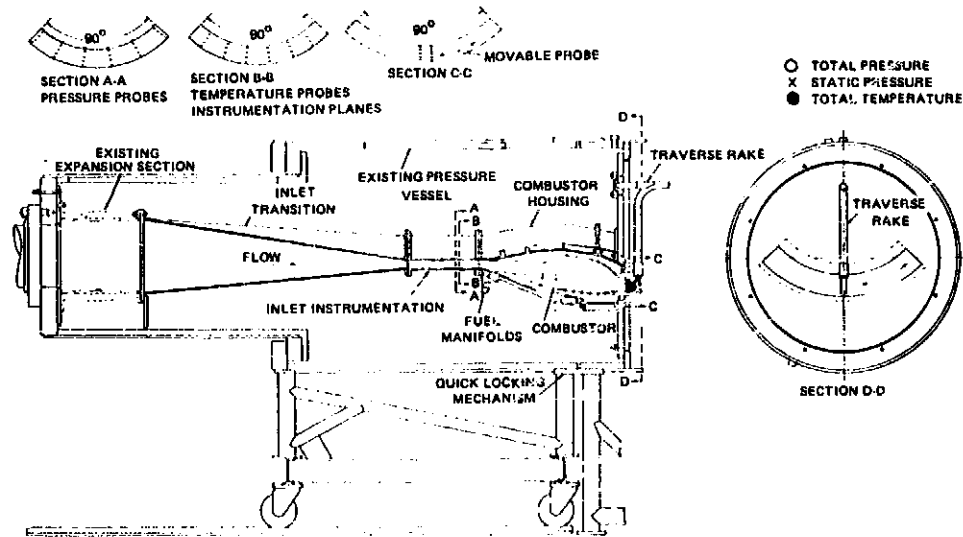

Figure 5 Schematic of the Clean Combustor Test Rig in the High-Pressure Test Facility

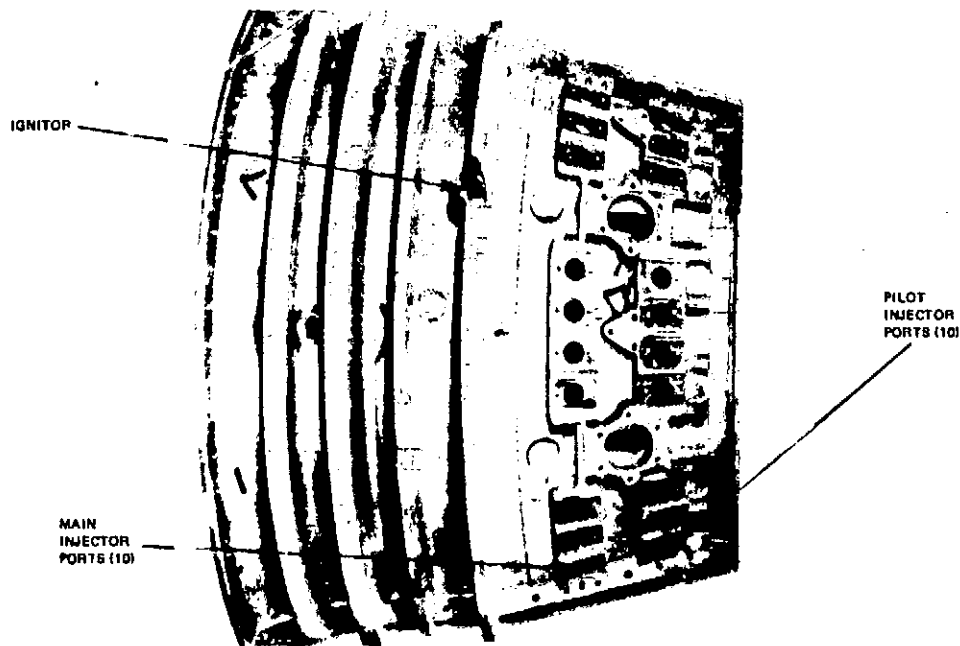

Figure 6 View of the Outer Rig Case for the Staged Premix Combustor



Structural constraints imposed by the sector rig configuration required a floating combustor sidewall support design to permit thermal expansion in only the radial and axial directions. This approach produced liner stresses that simulated those in a full hoop structure, eliminating the need for structural supports such as ribs or struts to maintain the liner shape. The rig sidewall construction and liner mounting system for the staged premix combustor are shown in Figure 7.

A separate fuel manifold system was fabricated for each of the three test rigs. The staged premix combustor and the swirl vortex combustor each required two fuel manifolds, while the swirl-can combustor required three. Since the swirl-can combustor employed low differential pressure fuel injectors, flow restrictors were installed in the fuel lines to provide equal fuel flow to each injector.

Figure 8 shows a view of a test rig installed in the test facility. The pressure vessel is open to show the placement of the fuel manifolds and the rig instrumentation.

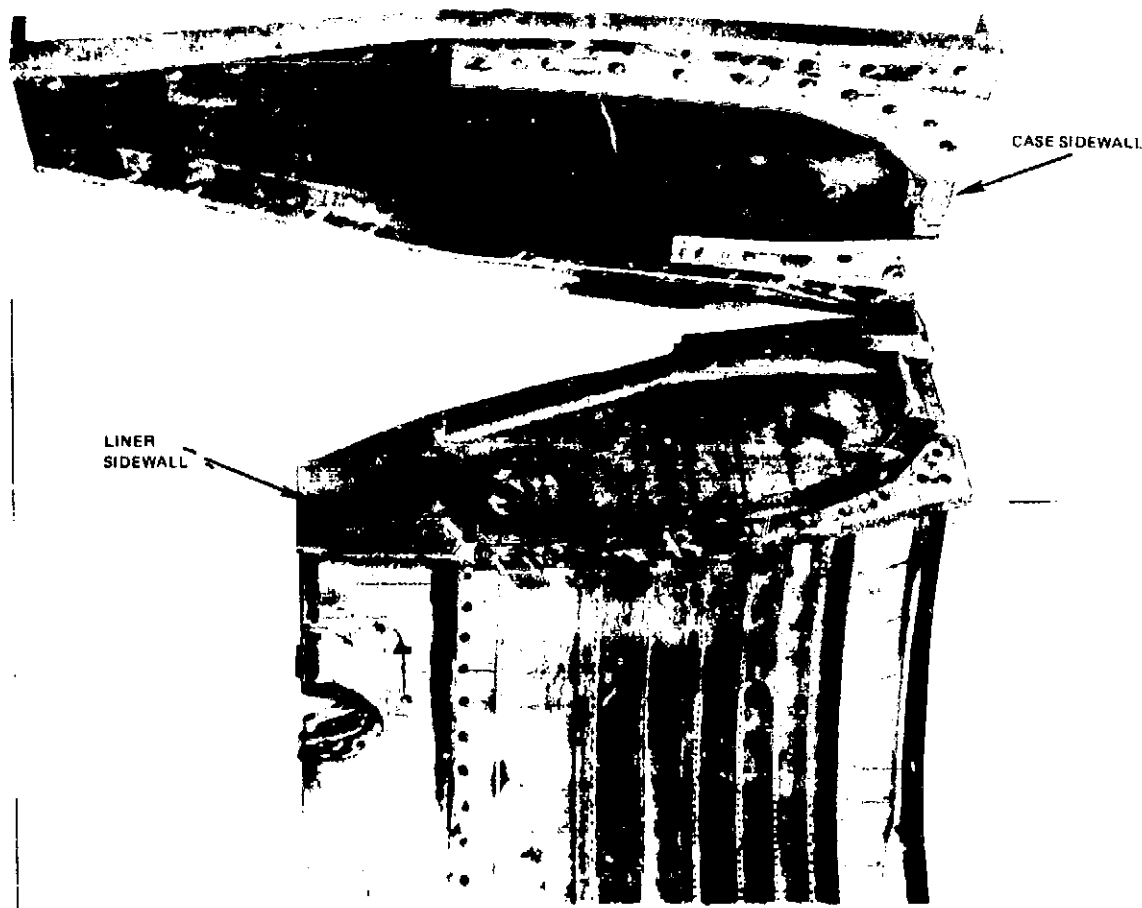

Figure 7 Construction of Staged Premix Combustor Liner and Sidewall

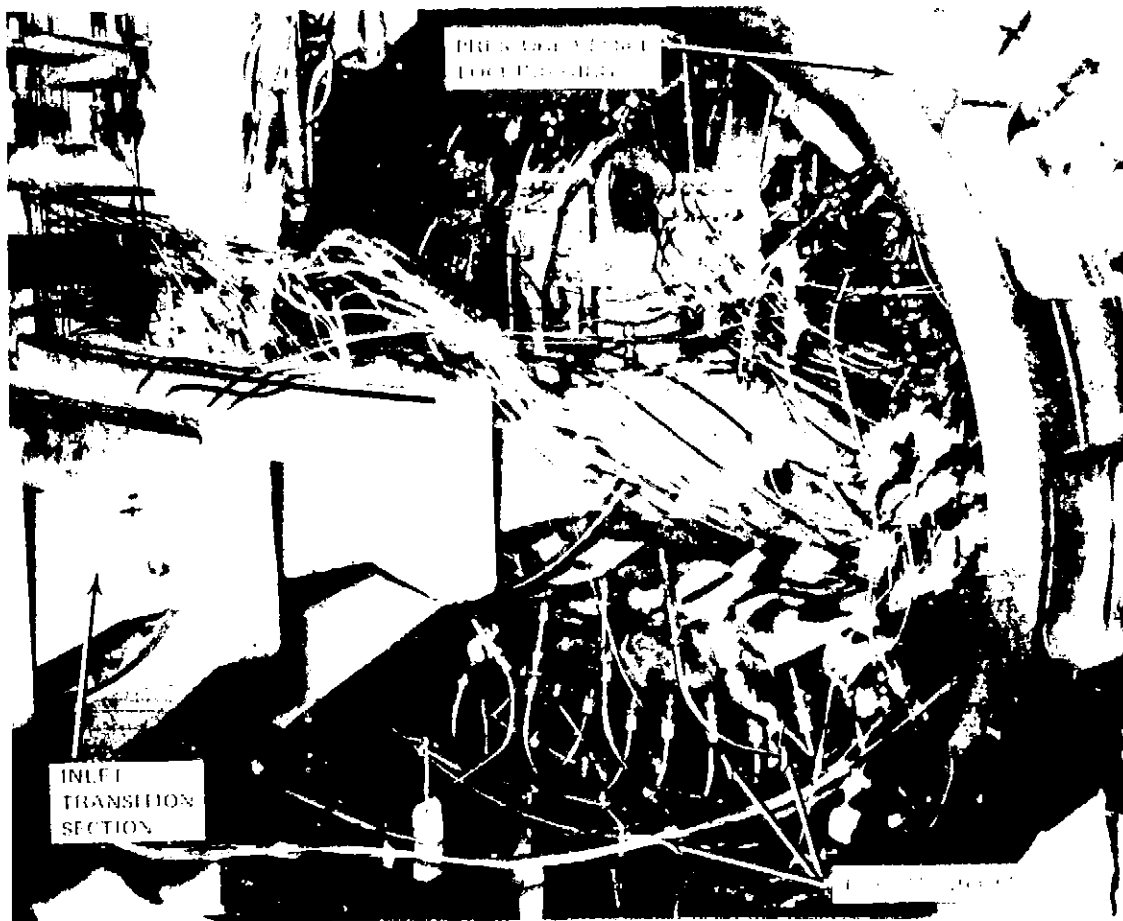

Figure 8 Experimental Clean Combustor Rig Installed in the High-Pressure Test Facility

### 3. COMBUSTOR RIG INSTRUMENTATION

Both the high-pressure test facility and the altitude test facility contained sufficient instrumentation to document the rig operating conditions.

In addition to the basic instrumentation contained by both facilities, the high-pressure test facility contained exhaust gas sampling probes, gas analysis equipment, and traversing exit plane temperature instrumentation. This exhaust plane instrumentation permitted comprehensive monitoring and documentation of both pollutant emissions and combustor performance.

The altitude test facility was equipped with sufficient exit plane temperature instrumentation to permit determination of the lit or unlit status of the test combustor for altitude stability and relight testing, and it also contained a closed circuit television system to permit observation of the flame propagation after lighting and verification that the combustor was fully lit. Exhaust gas composition was not determined during altitude testing.

A complete listing of the combustor rig instrumentation is presented in Appendix A, Section 1, and a summary of the more significant instrumentation is presented below.

### **Inlet Air Humidity Measurement**

The combustor inlet humidity was monitored in the high-pressure test facility using a Model 2740 Foxboro Dewcell Humidity Meter. Airflow at low mass flow rate was extracted from the test stand inlet duct and directed through the humidity meter. Since excess water was extracted in the compressor interstage coolers, the rig inlet specific humidity level rarely exceeded 2.2 g H<sub>2</sub>O/kg dry air.

### **Combustor Instrumentation**

The combustor inlet instrumentation consisted of six four-port total pressure rakes, six four-point Chromel-Alumel total-temperature thermocouple rakes, and twelve wall static pressure taps. This instrumentation was arranged in a fixed array at a plane simulating the axial position of the last compressor stage, as shown in Figure 5. The combustor rig airflow rate was measured using a venturi flow meter, and the fuel flow rates were measured using turbine-type flow meters.

Within the combustor, pressures were measured in the test section and along the combustor liners to permit calculation of the overall system pressure loss and flow distributions. For example, for the staged premix combustor, pressure measurements were made on the combustor liner and in the premix passage and the resulting data were combined with the effective flameholder metering area to determine the premix passage airflow rates.

Liner temperatures were measured using temperature-sensitive paints and liner skin thermocouples. In addition, fire-warning thermocouples were installed at various locations in the diffuser case and shroud areas to detect burning outside of the combustor.

At the combustor exit, temperatures and pressures were measured and gas samples were taken using a combination total temperature, total pressure, and gas sampling annular traversing rake. This rake assembly is shown in Figure 9. The temperature measurements were taken using five platinum-platinum 10 percent rhodium thermocouples positioned at centers of equal areas. The thermocouple junctions were located in a plane simulating the axial position of the first-stage turbine inlet guide vanes. Two concentric platinum 20 percent rhodium radiation shields were positioned over each thermocouple junction to reduce radiation errors. These temperature sensors were designed to measure the gas stream total temperature with an accuracy of one percent up to 1810 K. Details of the gas sampling technique are discussed in the following section.

### **Gas Sampling and Analysis**

Two gas-sampling techniques were used. One used the combined total temperature, total pressure, and gas sampling annular traversing rake, and the second used an array of fixed sample probes.

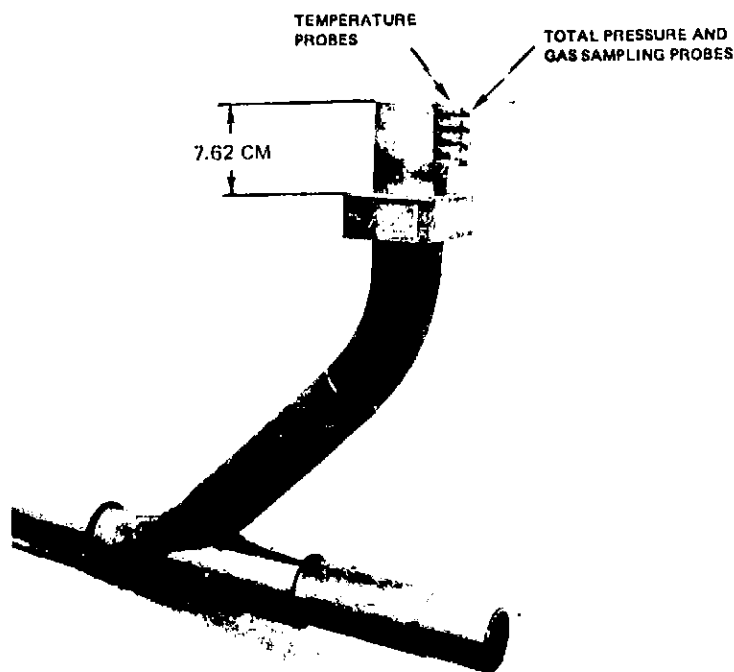

*Figure 9 Combination Total Temperature, Total Pressure, and Gas Sampling Annular Traversing Rake*

The traversing rake, which is shown in Figure 9, contained four radial sampling elements for gas analysis. Details of the individual gas sampling tubes are shown in Figure 10. As shown, four steam-cooled stainless steel sampling elements were positioned at the centers of equal annular areas. The gas sampling tubes were separated from the thermocouple rake by a three-degree circumferential arc. The tubes were supported by a steam-cooled stainless-steel pylon. Steam cooling was used to quench the sample temperature while still maintaining the temperature above the level where condensation and adsorption would occur.

The gas sample rake was constructed such that gas samples could be obtained from each separate tube. For most measurements, however, the tubes were manifolded together into a common plenum, thereby providing radially averaged data for each circumferential location. The static pressure in the plenum chamber was maintained at a level which provided a static pressure at the sampling tube inlet that approximated the free-stream static pressure. This resulted in near isokinetic gas sampling.

The fixed sample probe is shown in Figure 11 and permitted rapid data acquisition during testing while still providing a representative sample at the combustor exit. The probe consisted of four radial sampling elements connected to a single line. A total of five of these probes was used at the circumferential locations shown in Figure 12. Most of the testing was conducted with the five probes connected together to provide a single sample, although a valving system was available to permit isolation of the samples from any individual or combination of probes.

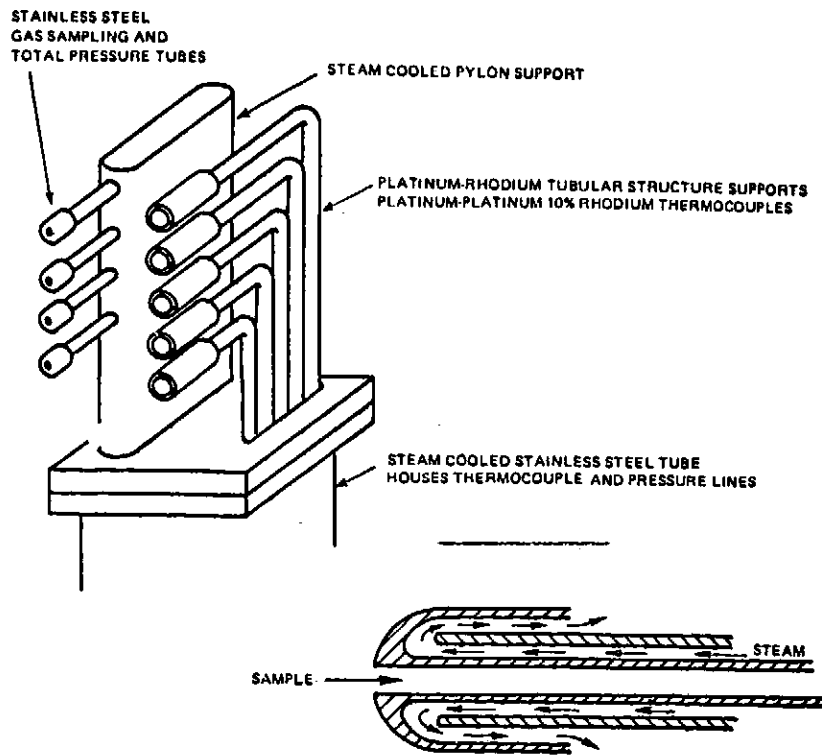

Figure 10 Detailed View of Combustor Exit Annular Traversing Rake

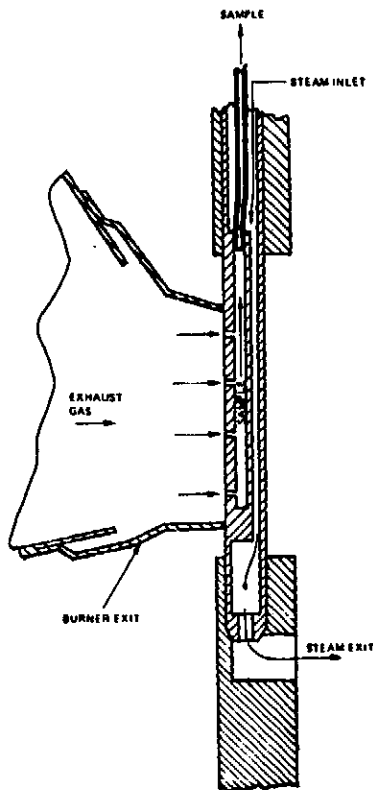

Figure 11 Schematic of Fixed Exhaust Gas Sample Probe

45

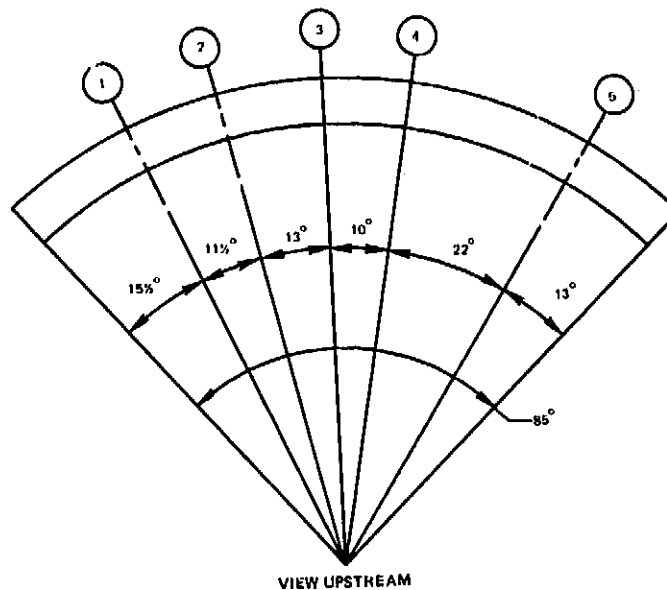

Figure 12 Locations of Fixed Gas Sampling Probe Rakes

The gas samples were analyzed using equipment and techniques which, with minor exceptions, conformed to the Society of Automotive Engineers Aerospace Recommended Practice (SAE ARP) No. 1256 (Reference 5).

The instrumentation used is listed in Table IX. This equipment was housed in modular form and permanently installed at the high-pressure test facility, as shown in Figure 13. The basic accuracy of the resulting data was dependent on the availability of reference gases with accurately known compositions. The calibration gases used in this program were the result of a continuing Pratt & Whitney Aircraft program to develop and maintain accurate standard gases.

Details of the gas analysis instrumentation are presented in Appendix A, Section 2.

#### Smoke Measurement

The smoke measurement system used in this program was designed and fabricated by Pratt & Whitney Aircraft to the specifications of SAE ARP 1179 (Reference 6).

Special features of this system include electric time controlled, solenoid actuated, stainless-steel straight-through gate valves to permit precise control over the sample volume passing through the filter. An auxiliary bypass system around the sample volume meter further enhances the precision of the system by ensuring that the meter is in the line only when a sample is actually being taken. The system is switch operated into three modes (leak check, sample, and bypass) ensuring that the operator of the system does not produce erroneous valve settings that would invalidate a sample.

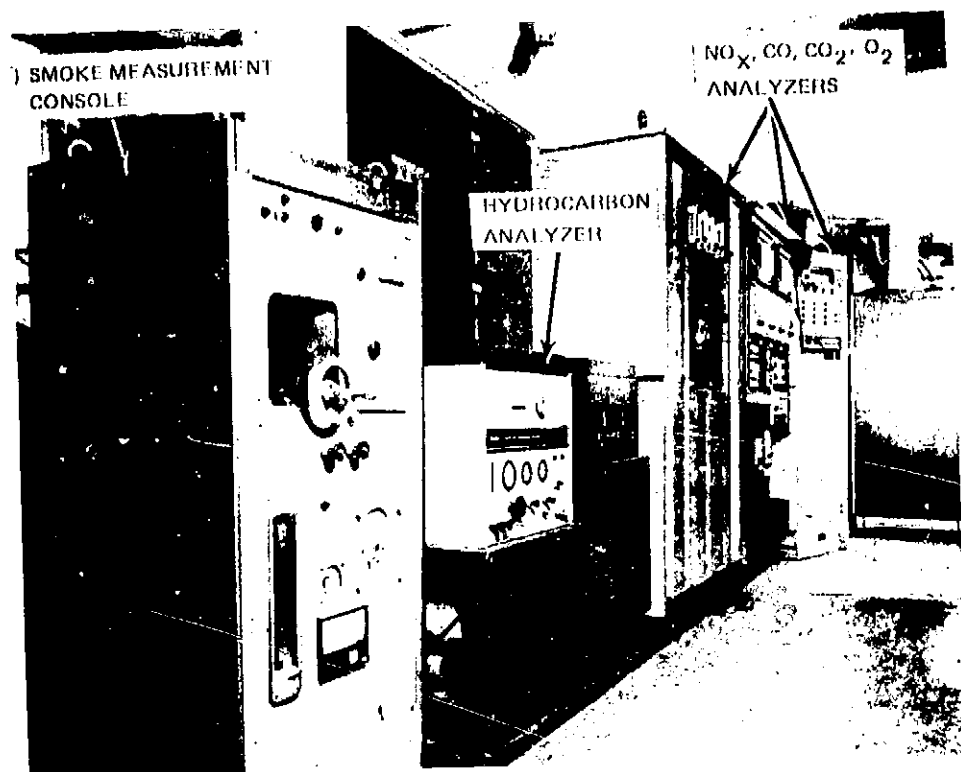

Figure 13 Pratt & Whitney Aircraft Emissions Measurement System

TABLE IX

EXHAUST GAS ANALYSIS INSTRUMENTATION

<u>Gas Constituent</u>	<u>Detection Method and Instrument—</u>
THC	Flame ionization detector Beckman Model 402
NO	Nondispersive infrared Beckman Model 315 AL
NO <sub>2</sub>	Nondispersive ultraviolet Beckman Model 255 A
CO	Nondispersive infrared Beckman Model 315 A
CO <sub>2</sub>	Nondispersive infrared Beckman Model 315 A
O <sub>2</sub>	Polarographic Beckman Model 715

Additional details of the smoke measurement system are presented in Appendix A, Section 2.

#### 4. DATA ACQUISITION AND RECORDING SYSTEM

Most of the combustor rig data obtained in the high-pressure test facility was recorded automatically and processed in real time on an XDS Sigma 8 Computer. Raw data were transmitted in terms of counts or millivolts from the test stand to the computer via a telephone link. The computer then reduced the data and converted it to the desired engineering units. The results were then returned to the test stand for display on a cathode ray tube. This data could then be reviewed, after which printed output was provided by the automatic data recording system. The printed output included raw and reduced exhaust gas species concentrations, emission indices, and carbon balance fuel-air ratio, as well as the test rig operating conditions and pertinent performance information.

The test stand data acquisition terminal is shown in Figure 14.

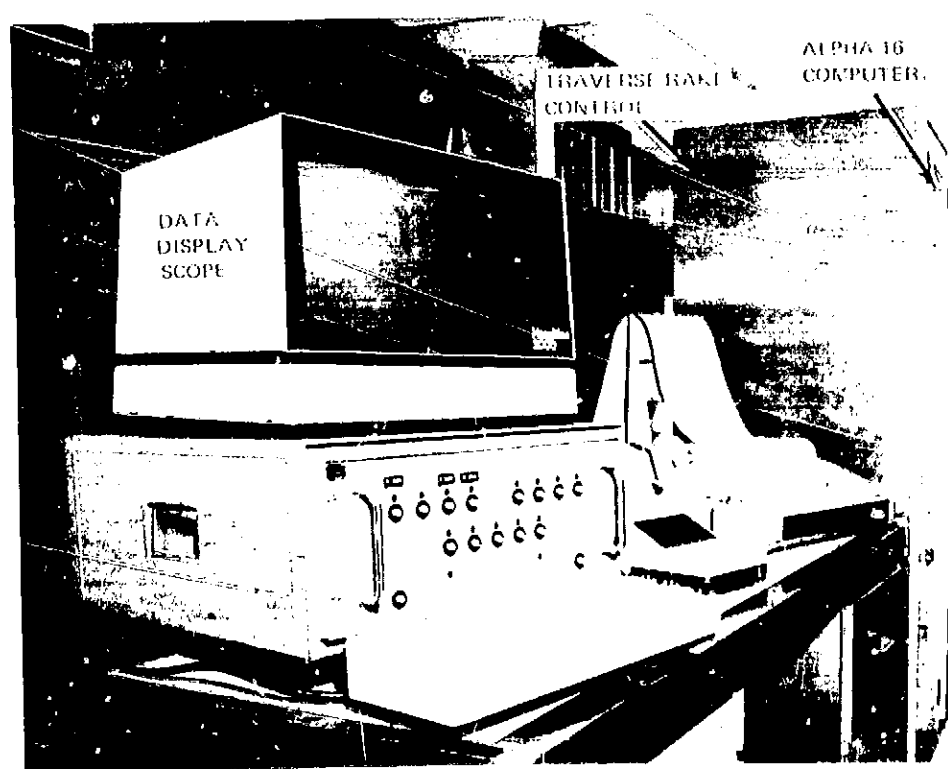

Figure 14 On-Line Data Acquisition System Installed at High Pressure Combustor Test Facility



## D. TEST CONDITIONS AND PROCEDURES

### 1. TEST CONDITIONS

#### CTOL Applications

For CTOL applications, the combustor rig test conditions were set to match the JT9D-7 engine conditions for idle and sea-level take-off as closely as possible. The idle conditions included those with and without simulation of compressor air bleed. With compressor bleed, the engine conditions are typical of those that would occur in an engine installed on an aircraft in actual service, while without compressor bleed, they simulate conditions that occur during experimental engine testing.

The test rig conditions achieved are shown in Table X together with the corresponding JT9D-7 engine conditions. As shown, all operating conditions were duplicated except for the inlet pressure and airflow at sea-level take-off conditions, which were limited by the test facility airflow capability. All testing was conducted using fuel that conformed to the American Society for Testing and Materials (ASTM) Specification Jet-A.

At high power conditions, the pilot-to-main fuel flow split was varied for selected combustor configurations. These variations were made while maintaining the total fuel flow constant. The resulting data provided a basis for determining the optimum fuel distribution between the pilot and main burners and also permitted definition of the trends relating fuel distribution, combustion efficiency, and emissions of oxides of nitrogen.

TABLE X ---

JT9D-7 REFERENCE ENGINE OPERATING CONDITIONS AND  
EXPERIMENTAL CLEAN COMBUSTOR SECTOR RIG  
OPERATING CONDITIONS

	Idle With Bleed		Idle Without Bleed		Sea-Level Take-off	
	Engine	Rig	Engine	Rig	Engine	Rig
Compressor Exit Pressure (Atm)	2.93	2.93	3.74	3.74	21.7	6.80
Compressor Exit Temperature (K)	427.8	427.8	455.6	455.6	768.9	768.9
Combustor Total Airflow (kg/s)	16.53	3.90	21.52	5.08	92.90	6.88
Combustor Fuel Flow (kg/s)	0.209	0.049	0.226	0.053	2.11	0.156
Fuel-Air Ratio	0.0126	0.0126	0.0105	0.0105	0.0227	0.0227
Engine Rated Power (%)	6	---	8.2	---	100	---

Parametric variations of combustor fuel-air ratio were also investigated for all combustor concepts at both the idle and sea-level take-off operating points, and parametric variations of inlet pressure, temperature, and reference velocity were investigated for selected combustor configurations. The ranges of these variations are shown in Table XI.

TABLE XI  
RANGE OF VARIATION OF SECTOR RIG OPERATING CONDITIONS

	Idle	Sea-Level Take-Off
Compressor Exit Total Temperature (K)	427 - 533	644 - 839
Compressor Exit Total Pressure (Atm)	--	3.4 - 6.8
Fuel-Air Ratio	0.007 - 0.0140	0.016 - 0.035
Reference Velocity (%)	±25	±25

Altitude stability and relight tests were conducted at simulated JT9D-7 engine windmilling conditions. Actual engine combustor inlet and pressure conditions were simulated while fuel flow and airflow levels were scaled for the one-quarter segment rig. The range of conditions that were simulated are shown in Figure 15, which is a typical JT9D engine relight envelope that defines the flight regime in which the engine is required to relight in the event of a blow-out.

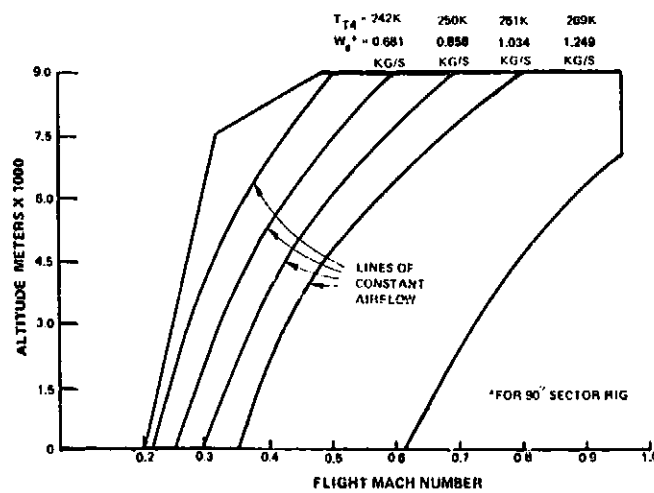

Figure 15 JT9D Relight Envelope

#### Advanced Supersonic Technology Applications

For the Advanced Supersonic Technology applications, the test conditions were selected on the basis of projected combustor operating conditions at a supersonic cruise flight condition. A basic test condition was defined, and testing was then conducted at the basic condition and also with reference velocity variations of  $\pm 25$  percent from the basic condition for most combustor configurations. The basic test condition is defined in Table XII.

TABLE XII

SECTOR RIG AST CRUISE OPERATING CONDITIONS

Compressor Exit Pressure (Atm)	6.80
Compressor Exit Total Temperature (K)	839
Combustor Total Airflow (kg/s)	6.88
Combustor Fuel Flow (kg/s)	0.156
Fuel-Air Ratio	0.0227
Combustor Exit Total Temperature (K)	1589

2. TEST PROCEDURES

The test program was conducted in a manner that would screen each combustor configuration as rapidly as possible to make optimum use of the rig test time. This approach involved not only an efficient setting of test points and rapid data acquisition, but also specific tailoring of the test program based on the preliminary results. For example, combustor configurations that exhibited higher emission levels than anticipated were evaluated for shorter periods than those which appeared more promising.

High-Pressure Testing

For the high-pressure tests, the combustor was initially lit, followed by staging of the main burner. During this period, gas samples were extracted from both the inner and outer combustor shrouds to ensure that no fuel aspiration occurred that could result in burning upstream of the combustor.

After successful lighting had been achieved, test points were usually set in the order of increasing temperature and pressure. This approach was both efficient from an operational standpoint and also ensured that a maximum amount of data would be obtained in the event that the planned test program could not be completed because of combustor durability problems. The usual sequence of testing was as follows:

1. Set idle condition and take data for three fuel-air ratios.
2. Set take-off condition and take data for three fuel-air ratios.
3. Set additional high-power conditions with various pilot-to-main burner fuel distributions while maintaining constant overall fuel-air ratio and take data.

4. Evaluate effect of parametric changes to inlet temperature, pressure, or reference velocity.
5. Set AST cruise point and take data.
6. Set idle condition and lean combustor fuel-air ratio to blowout.

At each test point, the combustor was allowed to stabilize before data were taken. When the fixed gas sample rake was used, gas samples were taken prior to traversing the exit plane rake. Otherwise, gas samples were taken from the traversing rake at the same time that exit temperature was then set to the value that would occur in flight at 9144 m, and the airflow was maintained constant while the pressure was reduced in progressive increments until blowout occurred. samples collected by the fixed gas sample rake. The fixed sample rake was used to minimize the length of time required for the sequence of sample flow rates specified in SAE ARP 1179.

Concurrent with these tests, noise data were taken on a noninterference basis. The results of these measurements are presented in NASA CR-134820, as stated previously.

#### **Altitude Stability and Relight Testing**

The altitude stability and relight testing consisted initially of mapping the minimum pressure blowout region to define the combustor stability envelope. This was accomplished by initially lighting the combustor at a simulated low-altitude, high-pressure condition. The inlet temperature was then set to the value that would occur in flight at 9144 m, and the airflow was maintained constant while the pressure was reduced in progressive increments until blowout occurred. The procedure was repeated for different airflows until the complete map was defined.

Once the stability envelope had been defined, relight tests were conducted within the envelope. The procedure used was to establish a test point and then attempt to light the combustor for thirty seconds with fuel flowing. Test results were recorded as no light, partial light, or complete light. For all successful lights, the time to ignite was also recorded.

### **E. GASEOUS EMISSION CALCULATION AND EXTRAPOLATION PARAMETERS**

The gas sample data were used to calculate the fuel-air ratio and the combustion efficiency. The reasons for using this approach and the procedures used are discussed below. In addition, the correlations used to extrapolate emissions data to engine operating conditions when the conditions could not be simulated in the test rig are presented below.

#### **1. FUEL-AIR RATIO CALCULATION**

Fuel-air ratios are generally calculated from measured flow rates for airflow and fuel flow, since these flow rates are usually known quite accurately. The alternative approach of using gas sample data to determine the carbon balance of the exhaust gases and calculating the fuel-air ratio is generally considered to be less accurate because of inherent uncertainties associated with the gas sampling process.

For this program, fuel-air ratios were determined by both techniques for each combustor concept, and the results are shown in Figures 16, 17, and 18. The results show considerable scatter, which is indicative of the inherent inaccuracies of the gas sampling technique, but they also show a significant bias for the gas sampling data to indicate higher fuel-air ratios than the metered flow data. The consistent bias exhibited by the gas sample data is attributed to the use of a sector rig configuration, where combustor liner sidewall cooling is required. In addition, the combustor shroud finger seals were known to have leaked in some tests. This leakage represented air that was measured upstream in the test rig but which did not participate in the combustion process. Consequently, the measured airflow through the test rig was higher than that which actually passed through the combustion section, resulting in a lower calculated value of fuel-air ratio than actually was produced in the combustor.

A number of diagnostic tests were performed using data from individual fixed gas sampling rakes, from the manifolded fixed gas sampling rake array, and from various combinations of the traversing sample probes. All of these data verified the bias between the metered flow fuel-air ratio values and the carbon balance fuel-air ratio values.

Since the amount of bias could be expected to vary in an unknown manner from combustor configuration to configuration, it was concluded that the uncertainties introduced by experimental errors in measuring concentrations of species in the gas samples were less than the uncertainties associated with a consistent bias of unknown magnitude. Therefore, carbon-balance fuel-air ratios have been used throughout this report.

The gas-sample carbon balance fuel-air ratio calculations were made in accordance with the procedures established in SAE ARP 1256 (Reference 5), but modified to include proper averaging of multiple-point data. The details of the computation procedure are presented in Appendix A, Section 3.

## 2. COMBUSTION EFFICIENCY CALCULATION

The combustion efficiency was calculated on a deficit basis using the measured concentrations of carbon monoxide and total unburned hydrocarbons from the gas sample data. The calculation was based on the assumption that the total concentration of unburned hydrocarbons could be assigned the heating value of methane (CH<sub>4</sub>). The equation was:

$$\eta_c = 100 - 100 \left[ \frac{4343x + 21500y}{18.4(10)^6} \right]$$

where:

x = measured carbon monoxide concentration in g/kg fuel

y = measured total unburned hydrocarbon concentration in g/kg fuel

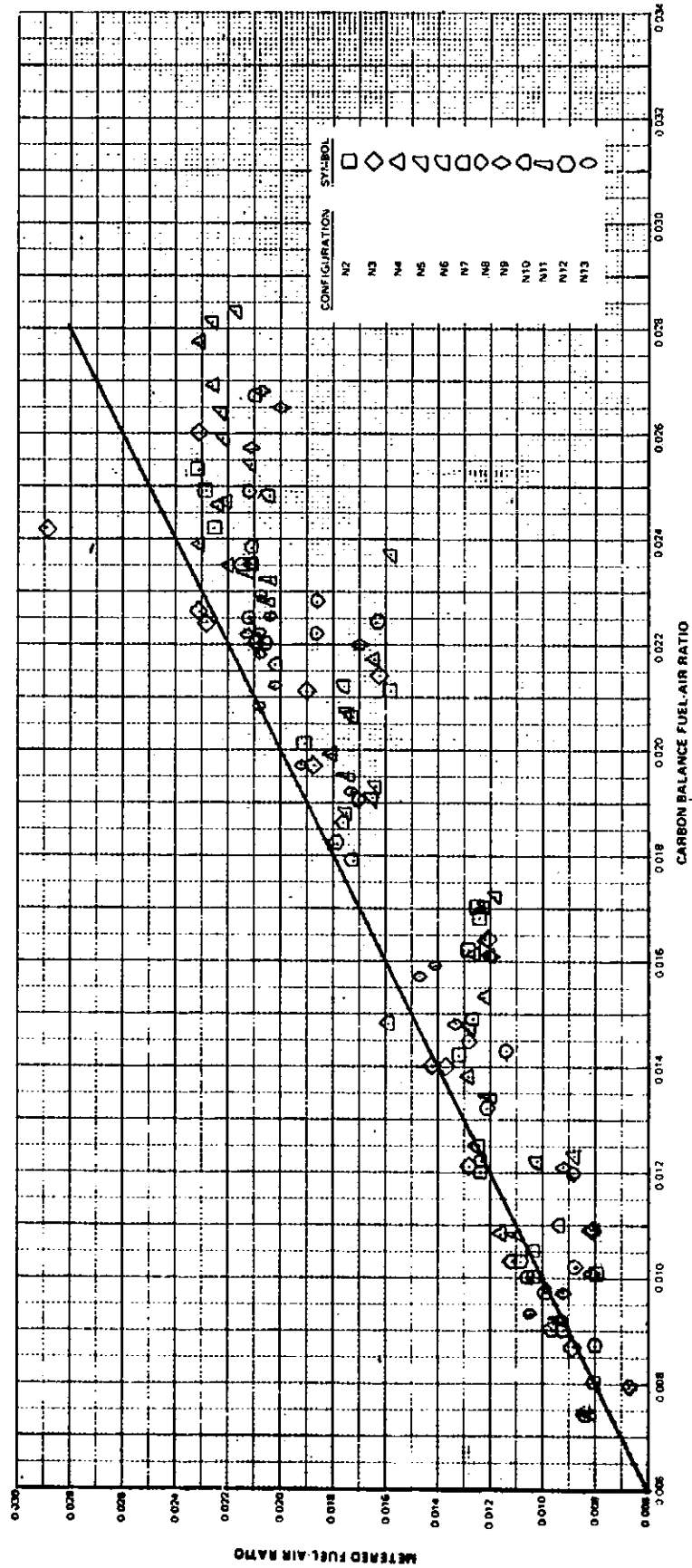

Figure 16 Metered and Carbon-Balance Fuel-Air Ratios for the Swirl Can Combustor Concept

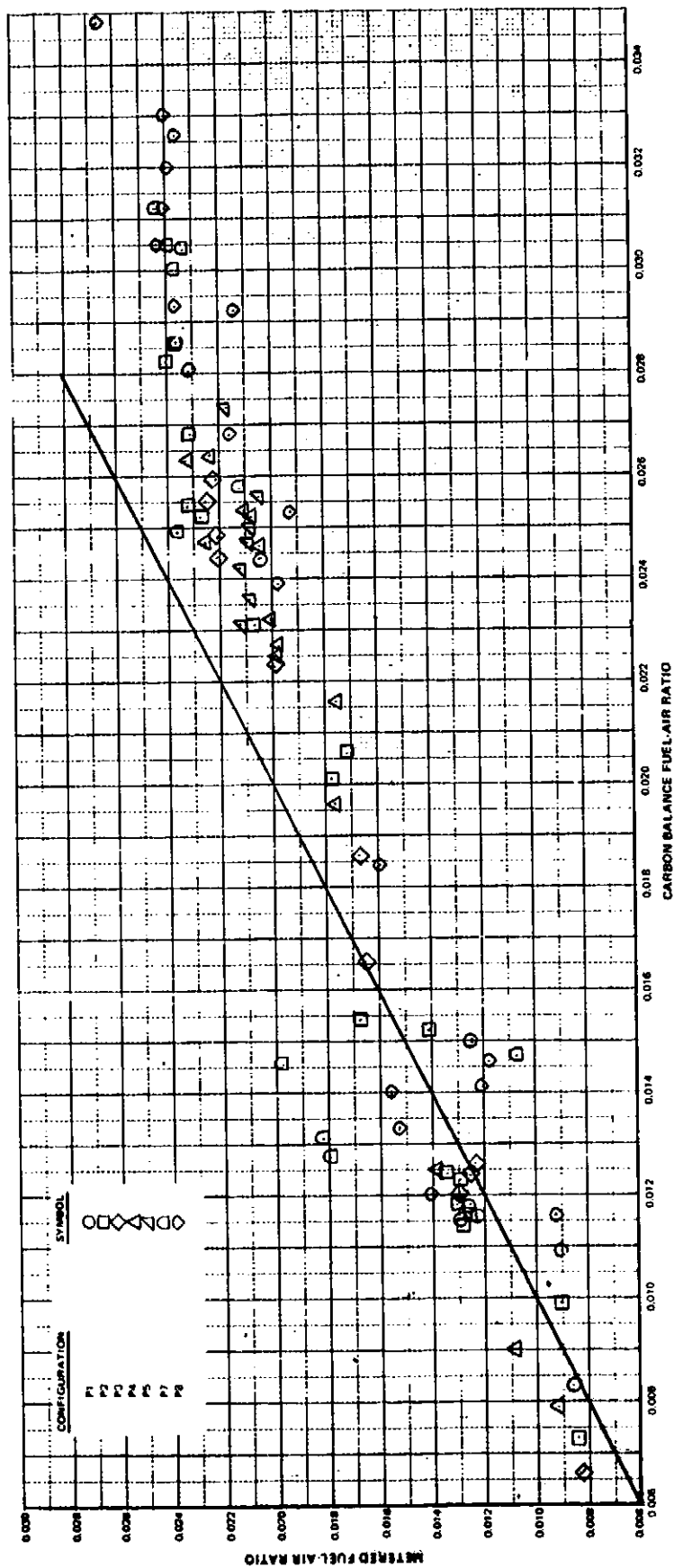

Figure 17 Metered and Carbon-Balance Fuel-Air Ratios for the Staged Premix Combustor Concept

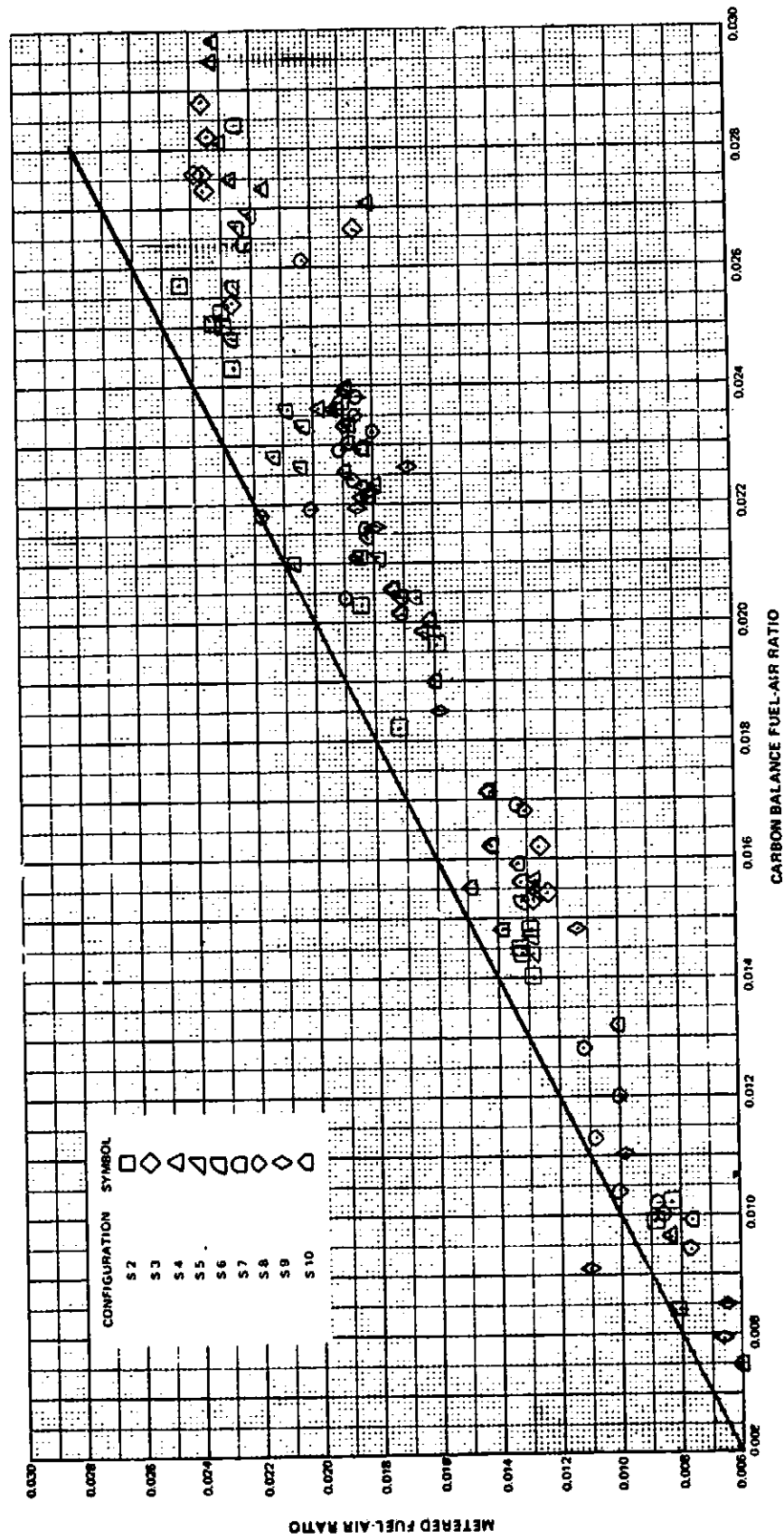

Figure 18 Metered and Carbon-Balance Fuel-Air Ratios for the Swirl Vortex Combustor Concept



### 3. EXTRAPOLATION OF POLLUTION DATA TO ENGINE CONDITIONS

Since the combustor segment rig was unable to simulate the combustor inlet pressure and humidity at sea-level take-off conditions, the emissions data for oxides of nitrogen obtained at the rig test conditions required correction to the engine conditions to permit comparison of the results with both the Experimental Clean Combustor Program goals and with the current JT9D-7 emission levels. The correlation used is as follows (Reference 7):

$$\text{NO}_x \text{ corr.} = \left( \text{NO}_x \text{ meas.} \right) \left( \frac{P_{t4 \text{ corr.}}}{P_{t4 \text{ meas.}}} \right)^{0.5} \left( \frac{V_{\text{ref. meas.}}}{V_{\text{ref. corr.}}} \right) \left( \frac{T_{t5 \text{ corr.}}}{T_{t5 \text{ meas.}}} \right) \\ \left( e^{18.8(H_{\text{meas.}} - H_{\text{corr.}})} \right) \left( e^{\left[ \frac{T_{t4 \text{ corr.}} - T_{t4 \text{ meas.}}}{288} \right]} \right)$$

where:

- $\text{NO}_x$  = Emission level of oxides of nitrogen
- $P_{t4}$  = Inlet total pressure (atm)
- $T_{t4}$  = Inlet total temperature (K)
- $V_{\text{ref.}}$  = Reference velocity (m/s)
- $H$  = Inlet specific humidity (g  $\text{H}_2\text{O}$ /kg air)
- $T_{t5}$  = Combustor exit temperature

and subscripts:

- corr. = Relates to value at corrected condition
- meas. = Relates to value at measured condition

In this program, this correlation was used to extrapolate the experimental data to the conditions shown in Table XIII. It could also be used to extrapolate the experimental data to other conditions of inlet pressure, temperature, fuel-air ratio, reference velocity, and humidity. However, the correlation factors for inlet temperature and fuel-air ratio are sensitive to the specific combustor design features, particularly to the equivalence ratio in the burning zone. Consequently, use of this correlation was restricted to relatively small adjustments.

No attempt has been made to extrapolate the data for carbon monoxide or total unburned hydrocarbons, since reliable combustion efficiency correlations are not currently available. However, increasing the pressure from the rig test pressure to the actual engine operating pressure would be expected to decrease the emission levels of these pollutants. Consequently, the emission levels reported in this report are considered to be conservative.

TABLE XIII

STANDARD COMBUSTOR INLET CONDITIONS TO WHICH EMISSIONS  
DATA FOR OXIDES OF NITROGEN WERE EXTRAPOLATED

	CTOL Applications Standard Day Sea-Level Take-Off	AST Applications Cruise
Compressor Exit Total Pressure (atm)	21.7	6.8
Compressor Exit Total Temperature (K)	768.9	839.0
Reference Velocity (m/s)		
Swirl-Can and Staged Premix Concepts	25.0	27.6
Swirl Vorbix Concept	38.0	41.9
Humidity (g/kg air)	6.29	2.00
Combustor Exit Temperature (K)	1533	1589

F. PERFORMANCE DATA SUMMARY

The combustor performance parameters which are reported as program results are listed in Table XIV. The definitions of the calculated parameters are presented below.

TABLE XIV

SUMMARY OF REPORTED COMBUSTOR PERFORMANCE PARAMETERS

<u>Parameter</u>	<u>Symbol</u>	<u>Units</u>	<u>Measured</u>	<u>Calculated</u>
Total Airflow	$W_{a4}$	kg/s	x	
Total Combustor Airflow	$W_{ab}$	kg/s		x
Pilot Fuel Flow	$W_{f \text{ pri}}$	kg/s	x	
Main Fuel Flow	$W_{f \text{ sec}}$	kg/s	x	
Total Fuel Flow	$W_{f \text{ tot}}$	kg/s	x	
Fuel Temperature	$T_{\text{fuel}}$	K	x	
Inlet Total Temperature	$T_{t4}$	K	x	
Inlet Total Pressure	$P_{t4}$	atm	x	
Reference Velocity	$V_{\text{ref}}$	m/s		x
Pattern Factor	PF	---		x
Inlet Air Humidity	H	g H <sub>2</sub> O/kg air	x	
Fuel-Air Ratio	f/a	---		x

**Total Combustor Airflow** .....

The total combustor airflow is calculated by subtracting the measured inner and outer turbine cooling air bleed flows and the estimated combustor liner sidewall cooling airflow from the total airflow.

**Reference Velocity**

The reference velocity is defined as that flow velocity that would result if the total combustor airflow, at the compressor discharge temperature and static pressure, were passed through the combustor liner at the maximum cross-sectional area. This area is 0.092 m<sup>2</sup> for the swirl-can and staged premix sector rigs, and 0.060 m<sup>2</sup> for the swirl vorbix sector rig.

**Pattern Factor**

The pattern factor at the combustor exit is defined by the expression:

$$\text{Pattern Factor} = \frac{T_{t5 \text{ max.}} - T_{t5 \text{ avg.}}}{T_{t5 \text{ avg.}} - T_{t4}}$$

where:

- $T_{t5 \text{ max.}}$  = Highest local temperature observed at the combustor exit plane
- $T_{t5 \text{ avg.}}$  = Average combustor exit temperature (calculated from the carbon-balance fuel-air ratio and the corresponding combustor inlet temperature and pressure)
- $T_{t4}$  = Combustor inlet temperature

#### **Fuel-Air Ratio**

The fuel-air ratio is the ratio of fuel flow to total combustor airflow. As discussed previously, for this program, fuel-air ratio was determined on the basis of the carbon balance of the exhaust products. Fuel-air ratio values for the pilot and main burners were determined by dividing the total fuel-air ratio determined by the carbon balance method in proportion to the measured fuel flow rates to each of the burners. Hence, the sum of the pilot and main burner fuel-air ratios equals the total carbon balance fuel-air ratio.

## CHAPTER III

### PHASE I BASIC PROGRAM

#### A. PROGRAM PLAN

As discussed in Chapter I, the basic program for Phase I involved screening of three combustor concepts: a swirl-can combustor concept, a staged premix combustor concept, and a swirl vorbix combustor concept. A total of 329.5 hours of testing were conducted, involving 32 combustor configurations. Of these, 13 were swirl-can configurations, 9 were staged premix configurations, and ten were swirl-vorbix configurations.

The work was contractually divided into two program elements. Element I consisted of the work conducted on the swirl-can combustor concept and involved 130 hours of testing, while Element II consisted of the work on the other two combustor concepts and involved 199.5 hours of testing.

The following sections present a description of each of the configurations tested (Section B) followed by a presentation and discussion of the results for all configurations (Sections C, D, and E). The development status of the concepts and concluding remarks are presented in Sections F and G, respectively.

#### B. COMBUSTOR CONFIGURATIONS TESTED

##### 1. SWIRL-CAN COMBUSTOR

###### a. General Description

The swirl-can combustor concept explored in this program was based on concepts developed by the NASA Lewis Research Center. The basic approach used to reduce pollution is to premix the fuel and air in an array of carburetor cans and then introduce the fuel-air mixture into the combustion section through swirlers in the same axial plane as the dilution air.

The configurations tested in this program were primarily based on the performance and emission data obtained in test programs conducted at the NASA Lewis Research Center (References 8 through 16) and, of course, the design requirements of the JT9D-7 reference engine. The design of the initial configuration tested in this program is shown in Figure 19, and a photograph of the carburetor can head plate array is shown in Figure 20. The 90-degree combustor segments tested in the program contained 27 swirl cans in three rows, simulating a full combustor containing 120 swirl cans with 40 cans in each row.

As shown in Figure 19, each swirl can module is constructed with three basic components: a carburetor can, a swirler, and a flame stabilizer. The carburetor consists of a short can with a reduced diameter at the inlet to prevent fuel spillage. Fuel is supplied through low-pressure-drop fuel injectors 1.78 cm upstream of the swirlers. These injectors are supported at the center of the swirler hub by centering legs. The flame stabilizers are hexagonal and are designed to provide a high degree of mixing at the perimeter while stabilizing combustion in their wake.

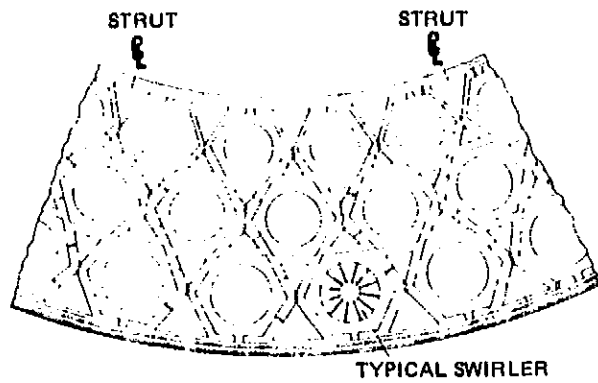

FLAME STABILIZERS  
AND BLOCKAGE ARRAY

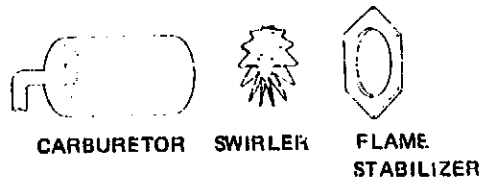
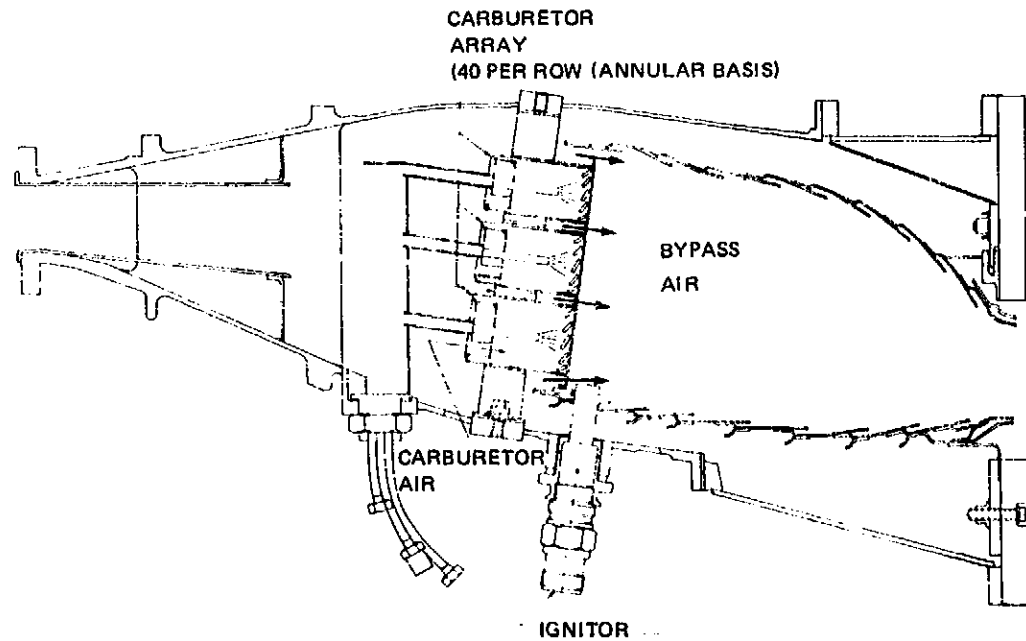

MODULE  
COMPONENTS

ORIGINAL PAGE IS  
OF POOR QUALITY.

Figure 19 Swirl-Can Combustor Concept

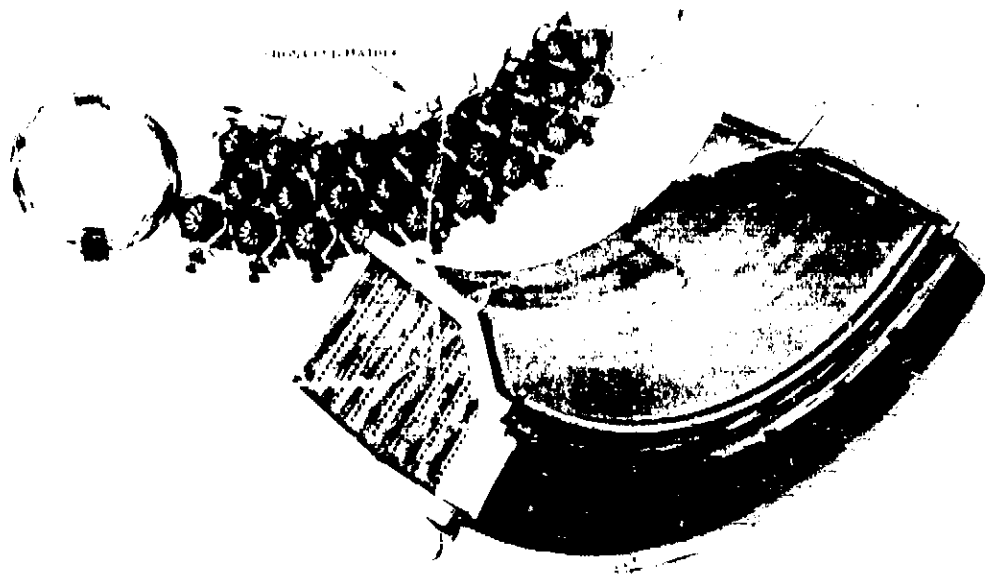

*Figure 20 Swirl-Can Combustor Front-End Matrix and Liner Assembly*

The swirl can modules are assembled together with blockage triangles in the headplate. The airflow split between the combustion and dilution air and the combustor pressure loss are controlled by proper sizing of the blockage triangles. For the initial design, the airflow split provided 19 percent of the flow through the carburetor cans, 60 percent of the flow through the array around the cans, and 21 percent of the flow for combustor liner cooling.

The fuel system was designed to permit separate control of the fuel to each of the three rows of swirl can modules. This approach permitted fuel staging, with fuel being supplied only to the inner or the outer row of cans during idle operation, thereby providing a richer, more stable burning zone. The carburetor equivalence ratio at idle conditions was approximately 2.3. At take-off conditions, fuel was supplied to all rows of swirl can modules on an equal area basis, resulting in a carburetor equivalence ratio of approximately 1.7.

#### **b. Design Variations**

The screening tests for the swirl-can combustor concept involved five major variations to the configuration. These were:

1. Variations to the combustor inlet aerodynamics,
2. Variations in the carburetor equivalence ratio,
3. Variations to the flameholding techniques,
4. Variations in the fuel injector technique, and
5. Addition of liner dilution air.

These variations are summarized in Table XV and discussed in detail in the following sections.

TABLE XV  
SWIRL-CAN COMBUSTOR CONFIGURATIONS

Configuration	Sea-Level Take-off* Carburetor Equivalence Ratio	Flameholder Type	Fuel Injector Type (Pressure Drop)	Liner Dilution Air	Primary Diffuser	
					Length (m)	Remarks
N1	1.0	Hexagonal	Low	No	0.17	
N2	1.7	Hexagonal	Low	No	0.07	
N3	1.0	Hexagonal	Low	No	0.07	
N4	1.0	Hexagonal	High	No	0.07	
N5	0.65	Hexagonal	Low	No	0.07	
N6	1.0	Hexagonal with sheltered zone	Low	No	0.10	
N7	1.0	Hexagonal with 1.3 cm recessed swirlers	Low	No	0.10	Plus 76% blockage screen
N8	1.0	Hexagonal with 1.3 cm recessed swirlers	Low	No	0.10	Plus V-gutter
N9	1.1	Outer swirler flameholder*	Low	No	0.10	Plus 76% blockage screen
N10	1.5	Hexagonal with swirler blockage plate	Low	No	0.10	Plus 76% blockage screen
N11	1.7	Hexagonal with swirler blockage plate	Low	Yes	0.10	Plus 76% blockage screen
N12	NA	Outer swirler flameholder*	High	No	0.10	Plus 76% blockage screen
N13	1.0	Outer swirler flameholder	Low	No	0.10	Plus 76% blockage screen

\*In outer zone, outer and inner swirlers produced co-rotating flows. In inner and middle zones, outer and inner swirlers produced counter-rotating flows.

### Combustor Inlet Aerodynamics

The initial configuration of the swirl-can combustor, designated N1, sustained damage to portions of the combustor front end and fuel system, and also experienced localized thermal distress in the combustor liner and housing. This damage was attributed to four causes:

1. Maldistribution of the diffuser airflow, producing nonuniform feed pressure to the modules and fuel spillage from the carburetors,
2. Low combustor pressure loss (1.5 percent instead of 2.9 percent),
3. Diffuser strut wakes, and
4. Fuel injector support wakes.



In an attempt to correct the diffuser airflow maldistribution, three diffuser configurations were investigated. These are shown in Figure 21 and involved various reductions of the pre-diffuser section length. This modification combined with increasing the combustor liner pressure drop and removal of the fuel injector heat shields eliminated the fuel aspiration problem.

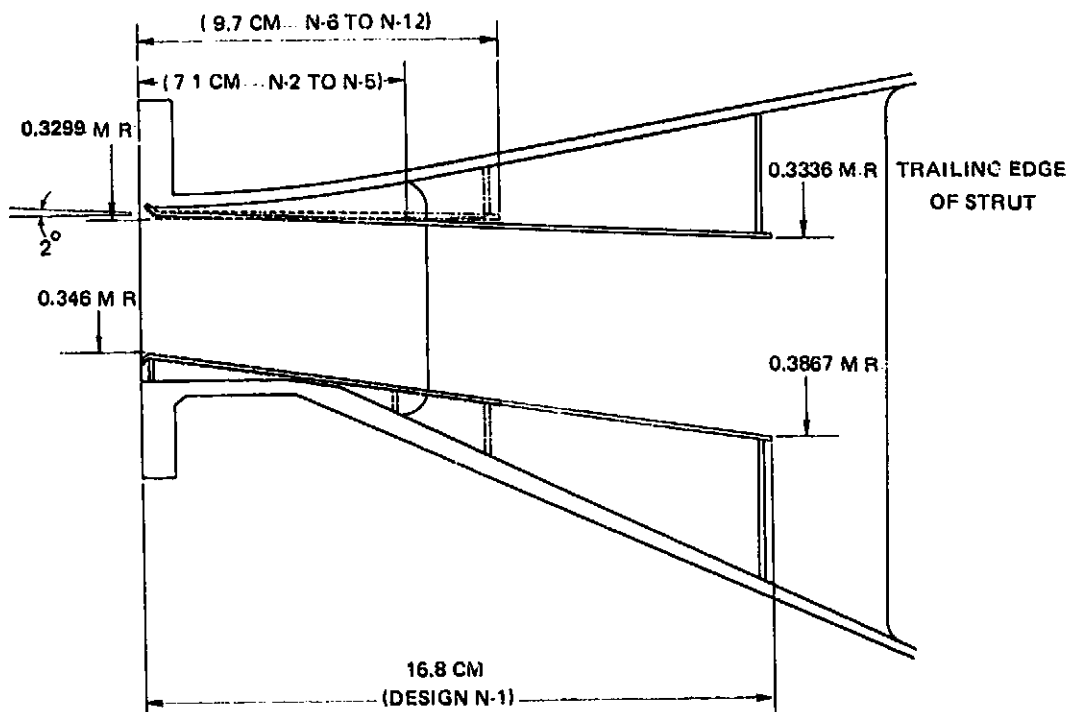

Figure 21 Swirl-Can Combustor Diffuser Modifications

These modifications did not provide a satisfactory combustor headplate airflow distribution, however, and, therefore, a number of flow control devices were investigated in a two-dimensional Plexiglas airflow rig. Included were flow splitters, trips, and screens. The 9.7 cm pre-diffuser was used for these tests. The best results were obtained with a 76-percent blockage screen located downstream of the diffuser strut trailing edge. The combustor approach velocity profiles measured in the Plexiglas rig with and without the screen are shown in Figure 22, and the corresponding profiles measured in the high-pressure sector rig are shown in Figure 23. This screen was used in Configuration N7 and in Configurations N9 through N13.

#### Carburetor Equivalence Ratio

Three carburetor equivalence ratios (0.65, 1.00, and 1.70) were provided at take-off conditions to determine the effect of equivalence ratio on the emissions of oxides of nitrogen. The changes in equivalence ratio were achieved by changing the swirler vane angle to allow either more or less airflow to enter the swirl can modules. The pressure loss was maintained approximately constant by varying the size of the blockage triangles.

## Flameholder Design

Four different flameholder designs were investigated. These were:

1. Hex flameholder
2. Sheltered zone flameholder
3. Hex flameholder with recessed swirler
4. Outer swirler flameholder.

These designs are shown in Figure 24, and photographs of each type of flameholder installed in the array are presented in Figure 25.

Each of the flameholders was evaluated with a carburetor equivalence ratio of approximately 1.0 and low-pressure drop fuel injectors.

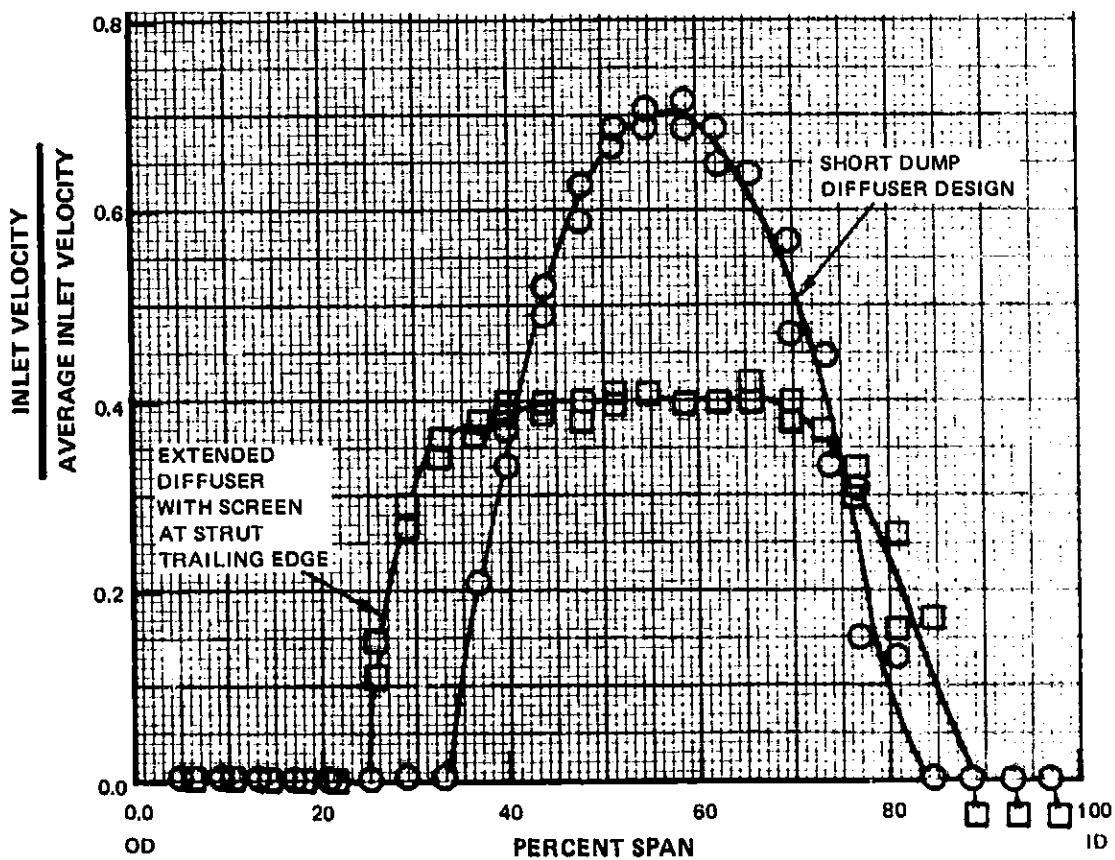

Figure 22 Effect of Diffuser Modifications on Combustor Inlet Velocity Profile as Measured in Plexiglas Flow Visualization Rig

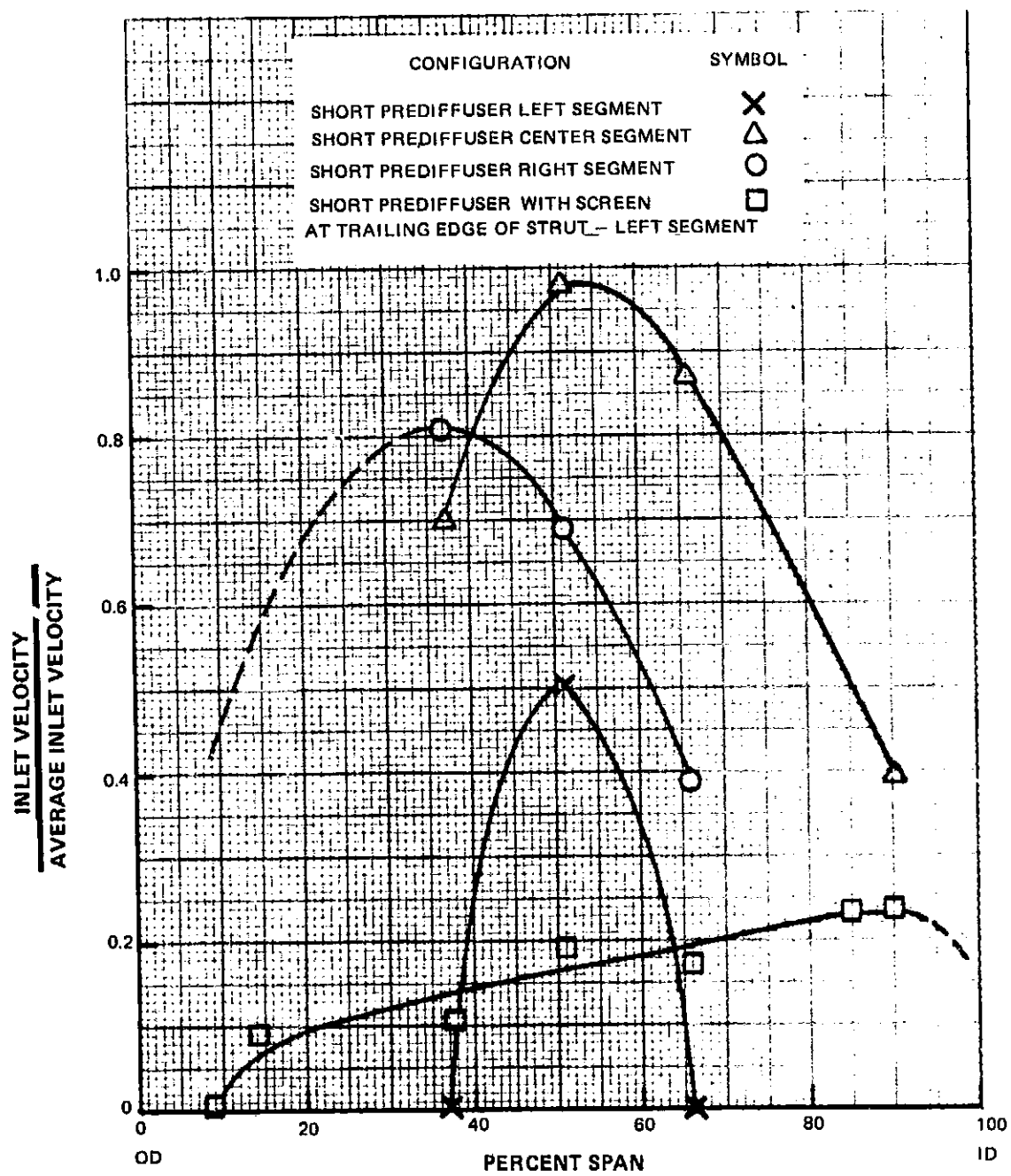

Figure 23 Effect of Diffuser Modifications on Combustor Inlet Velocity Profile as Measured in Combustor Segment Rig

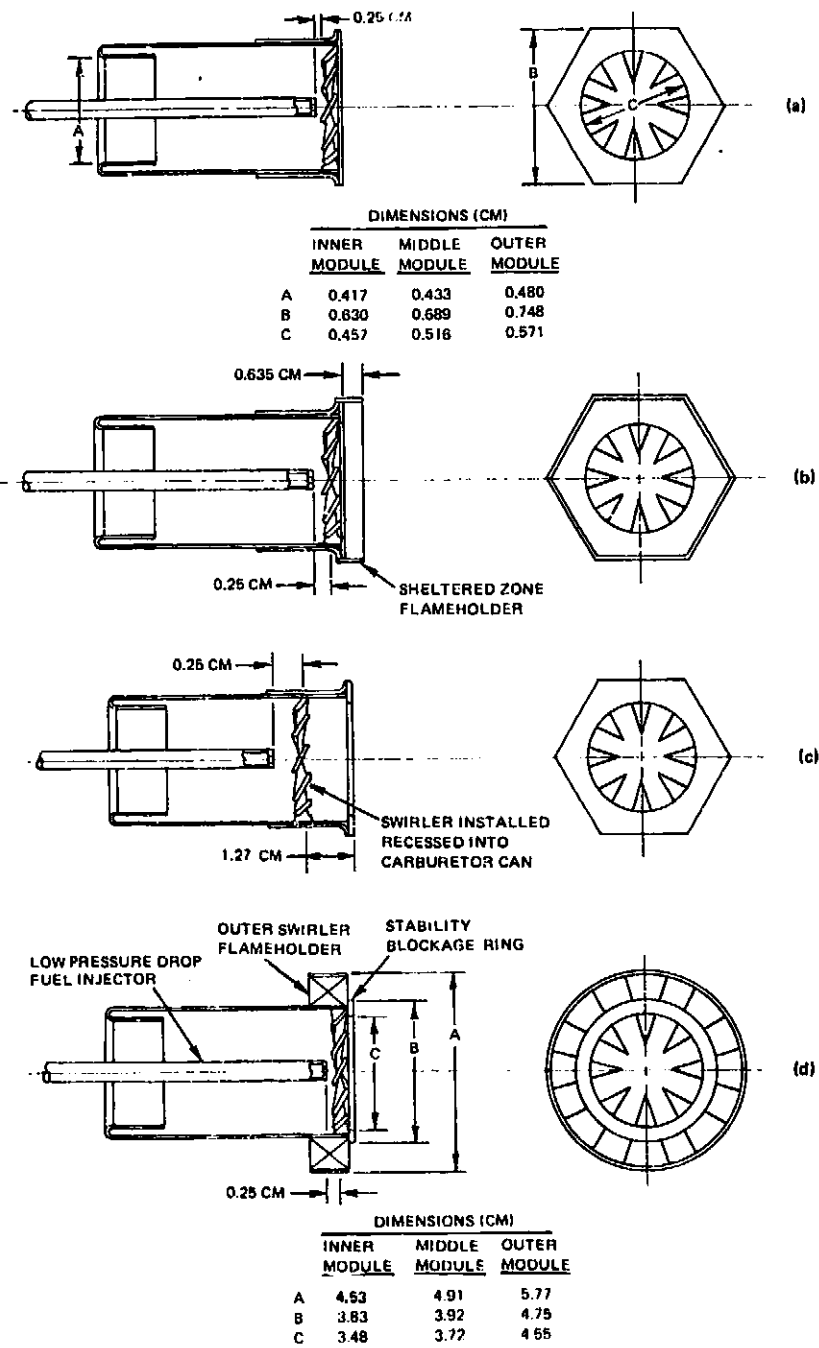
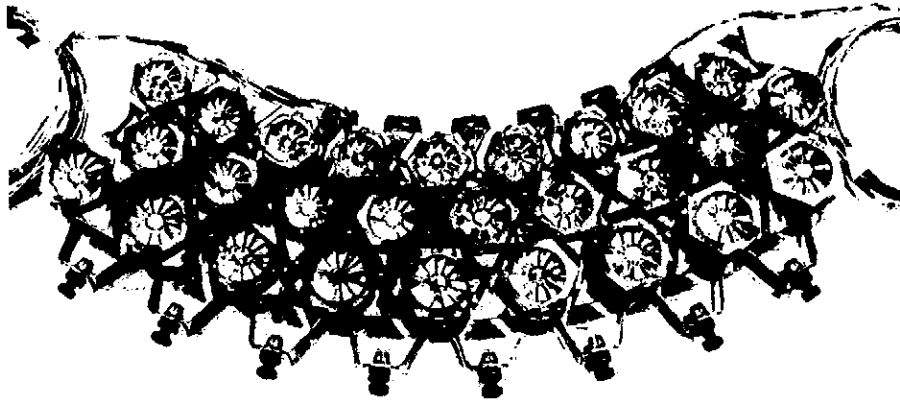

Figure 24 Swirl-Can Combustor Flameholder Configurations

(A) HEX DESIGN



(B) SHELTERED ZONE DESIGN

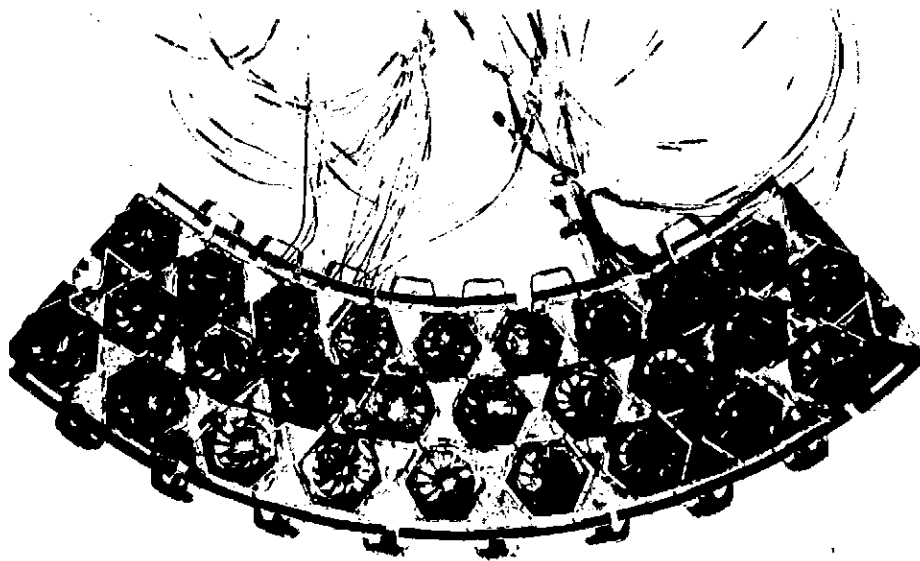
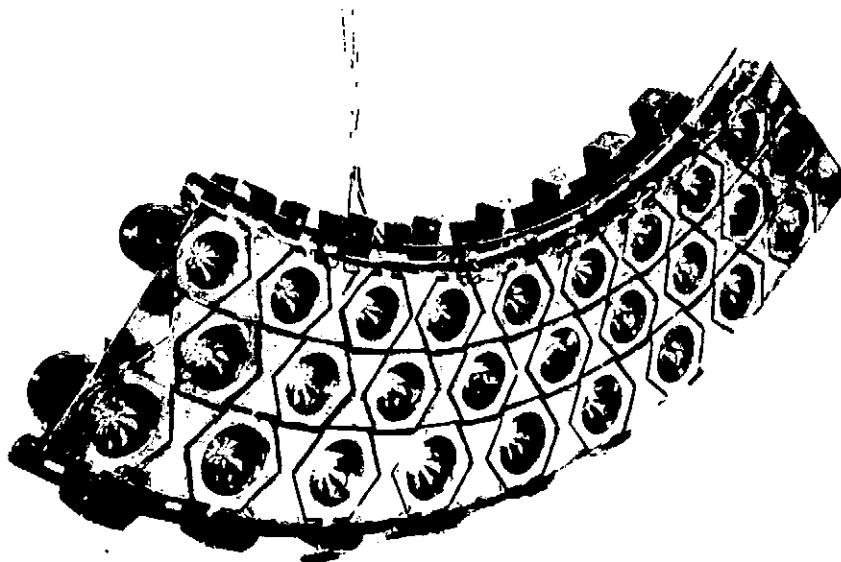
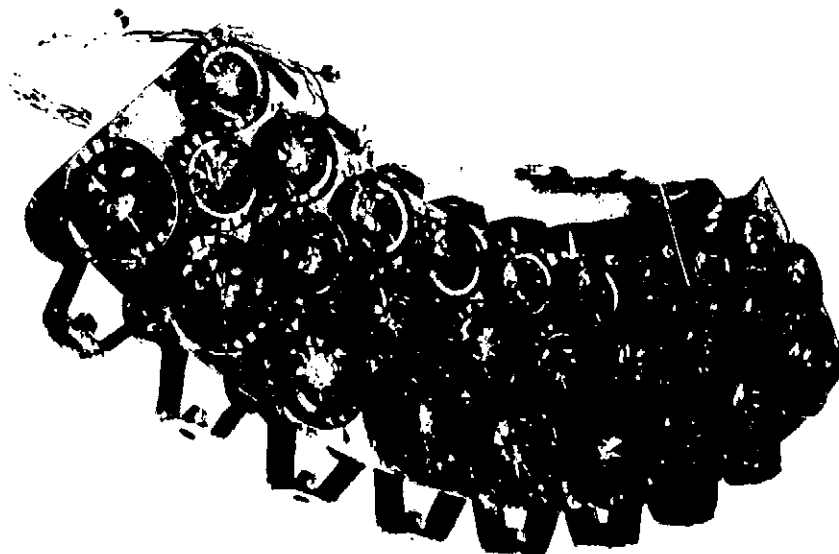

Figure 25 Swirl-Can Combustor Array Showing Different Flameholder Configurations

(C) HEX WITH RECESSED SWIRLER DESIGN



(D) OUTER SWIRLER DESIGN



*Figure 25 Continued*

## Fuel Injection Techniques

Three fuel injection techniques were evaluated. These were:

1. Low pressure drop injectors
2. Pressure atomizing injectors located upstream of the swirler holder
3. Pressure atomizing injectors protruding through the swirlers

The designs of these injectors are shown in Figure 26.

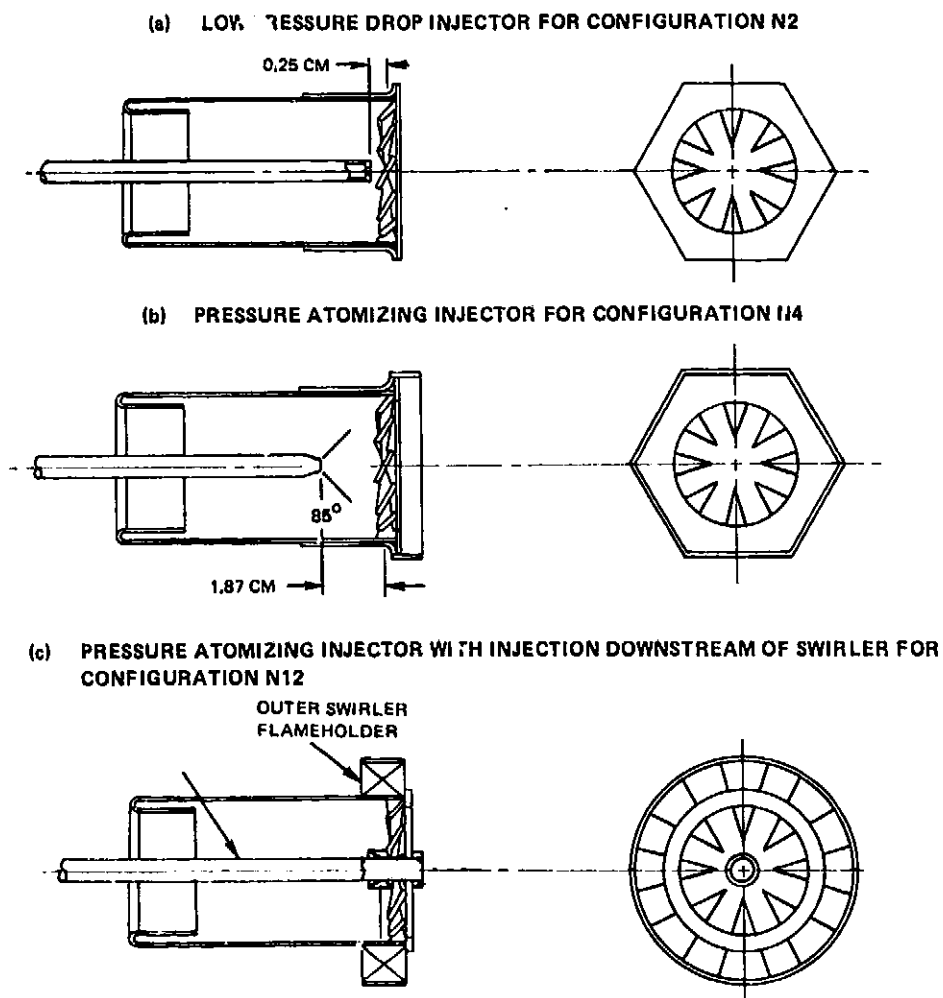

Figure 26 Swirl-Can Combustor Fuel Injector Configurations

### Dilution Air Addition

One configuration was tested with dilution air holes located immediately downstream of the headplate array. Testing was conducted with carburetor equivalence ratios of 1.5 and 1.7 and with a dilution airflow of approximately 6.8 percent of the total combustor airflow. The combustor pressure loss was allowed to vary in order to expedite test hardware procurement.

## 2. STAGED PREMIX COMBUSTOR

### a. General Description

The design of the staged premix combustor was based on previous Pratt & Whitney Aircraft development work with this combustor concept. The basic objective of the design is to control the mixture uniformity and strength, thereby controlling the time-temperature history of the combustion gases and reducing the emission of pollutants.

The design of the combustor is shown in Figure 27, and photographs of selected configurations are shown in Figure 28. The key characteristic of the combustor is the use of two burning zones with premixing of the fuel and air prior to injection into each burning zone. The two combustion zones are required because such design variables as mixture preparation, recirculation residence time, and quench rate must be carefully controlled within narrow limits in premixing systems, and achievement of this control throughout the combustor operating range is difficult with a single combustion zone.

The two premixing passages and combustion zones are axially displaced, with the pilot burner system located further upstream. This displacement avoids rapid quenching of the pilot combustion process by the cool main burner air during low power operation. FINWALL<sup>®</sup> liners are used in the pilot burner to minimize the quantity of cooling air required, further reducing the tendency for premature quenching.

Each combustion system has its own independent fuel injectors, premix passage, flameholder, and combustion volume. High fuel source density in conjunction with pressure atomizing fuel injectors are used in both the pilot and the main premixing passages to promote fuel atomization, vaporization, and premixing with air.

The primary design factors affecting the staged premix combustor evaluated in this program were the premixing passage equivalence ratio, the potential for autoignition in the premixing passage, and the flameholder design. Each of these factors are discussed below.

### Premixing Passage Equivalence Ratio

In the staged premix combustor, fuel is furnished only to the pilot burner during idle and part-power operation and to both the pilot and the main burner systems during high power operation. Consequently, the equivalence ratio for the pilot burner system was selected to produce low levels of carbon monoxide and total unburned hydrocarbons, which are the predominant pollutants at low power, while the equivalence ratio for the main burner system was selected to produce low levels of oxides of nitrogen, which is the main pollutant at high power levels.



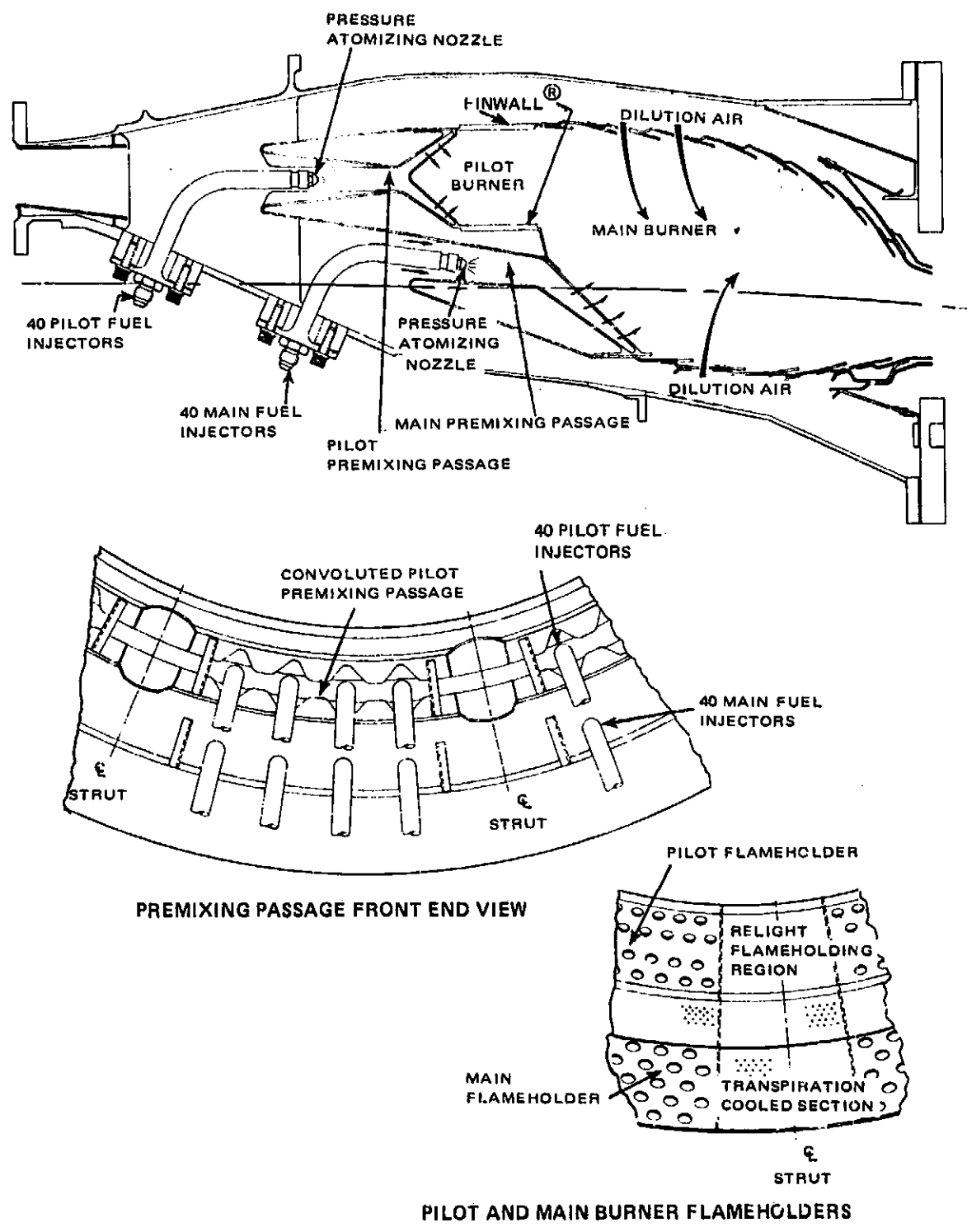
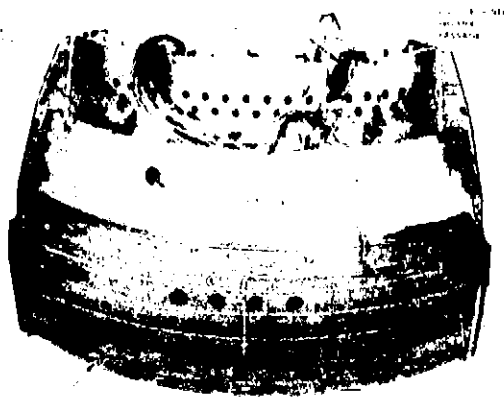

Figure 27 Staged Premix Combustor Concept



EXTERIOR SIDE VIEW



DETAIL OF CIRCULAR-HOLE FLAMEHOLDERS

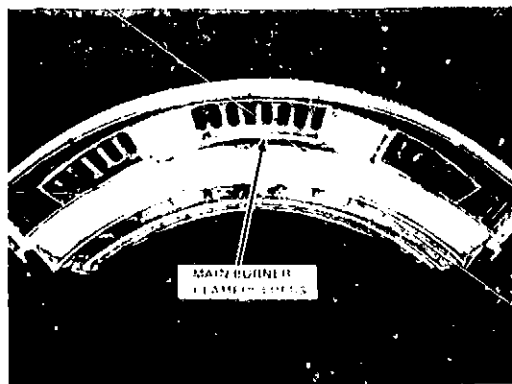

DETAIL OF MAIN BURNER  
SLOTTED FLAMEHOLDERS



DETAIL OF PILOT BURNER  
SLOTTED FLAMEHOLDERS

Figure 28 Views of Staged Premix Combustor Configurations

For the initial staged premix combustor configuration, a pilot burner equivalence ratio of 1.0 at idle conditions was selected on the basis of previously obtained emissions data for an experimental can-annular premix combustor. These data showed that minimum carbon monoxide and unburned hydrocarbons were obtained with a premix passage equivalence ratio of 1.0, a hot-soak region downstream of the pilot flameholder, and gradual addition of dilution air.

For take-off conditions, both the pilot and the main burner premixing passages were designed to operate at an equivalence ratio of approximately 0.7. This level was selected on the basis of an estimate of the combined combustion zone residence time and computation of the formation rate of oxides of nitrogen in a kinetically limited system. Two factors were assumed

to contribute to the pilot zone residence time. These were the time to achieve complete combustion, and the recirculation zone residence time. Combustion volume and flow rate in the pilot zone were used to compute the combustion time, employing the correlation presented in Reference 17. At rig pressure levels, the required combustion volume ranged from 0.0368 to 0.0425 m<sup>3</sup>. Using the upper limit, a combustion zone residence time of 1.5 ms was established. The recirculation zone residence time in the flameholder wake was estimated using a correlation presented in Reference 18. The recirculation residence time was then added directly to the combustion zone residence time, resulting in a total estimated pilot zone residence time of 2.0 ms. Actually, this estimate is higher than the true residence time since less than 20 percent of the pilot zone flow would be expected to recirculate.

On the basis of this estimate and nitrogen oxide formation kinetics, the concentrations of oxides of nitrogen were computed, assuming equilibrium hydrocarbon thermochemistry. The results are shown in Figure 29 for sea-level take-off operating conditions and residence times of 1.0 and 2.0 ms. These computations show that, when dilution air is accounted for, the equivalence ratio required to meet the program goals for oxides of nitrogen emissions is approximately 0.70.

#### **Autoignition**

Since the premixing passage contains a combustible mixture at high temperature, the residence time of the gases in the premixing passage is limited by the time required for autoignition to occur. At high power operating conditions, the autoignition delay time is sufficiently short that it constitutes a significant design factor.

In the staged premix combustor concept evaluated in this program, both the pilot and the main burner premixing passages were designed with an autoignition safety factor of two at maximum sea-level take-off hot-day conditions. At this condition, the autoignition delay time is predicted to be approximately 3.6 ms, and, therefore, the combustor was designed to operate with a maximum premixing passage residence time of 1.8 ms.

#### **Flameholder Design**

Both the pilot and the main flameholders were designed to be independently stable. This was achieved by using perforated plate flameholders which provide a region for stable combustion in the wake of the web area between adjacent flameholder holes. The design was based on the correlation of stability limits shown in Figure 30, which was presented in Reference 18 and experimentally verified by Pratt & Whitney Aircraft.

Those portions of the flameholders behind the diffuser struts were cooled using methods consistent with the stability requirements. The portions of the pilot flameholder located directly behind the struts were convectively cooled by means of a false-wall construction. This type of construction acts to minimize cooling air introduction in the plane of the flameholder, which could adversely affect stability and idle emissions. The main flameholder had less stringent stability requirements and the portions behind the struts, therefore, were transpiration cooled.

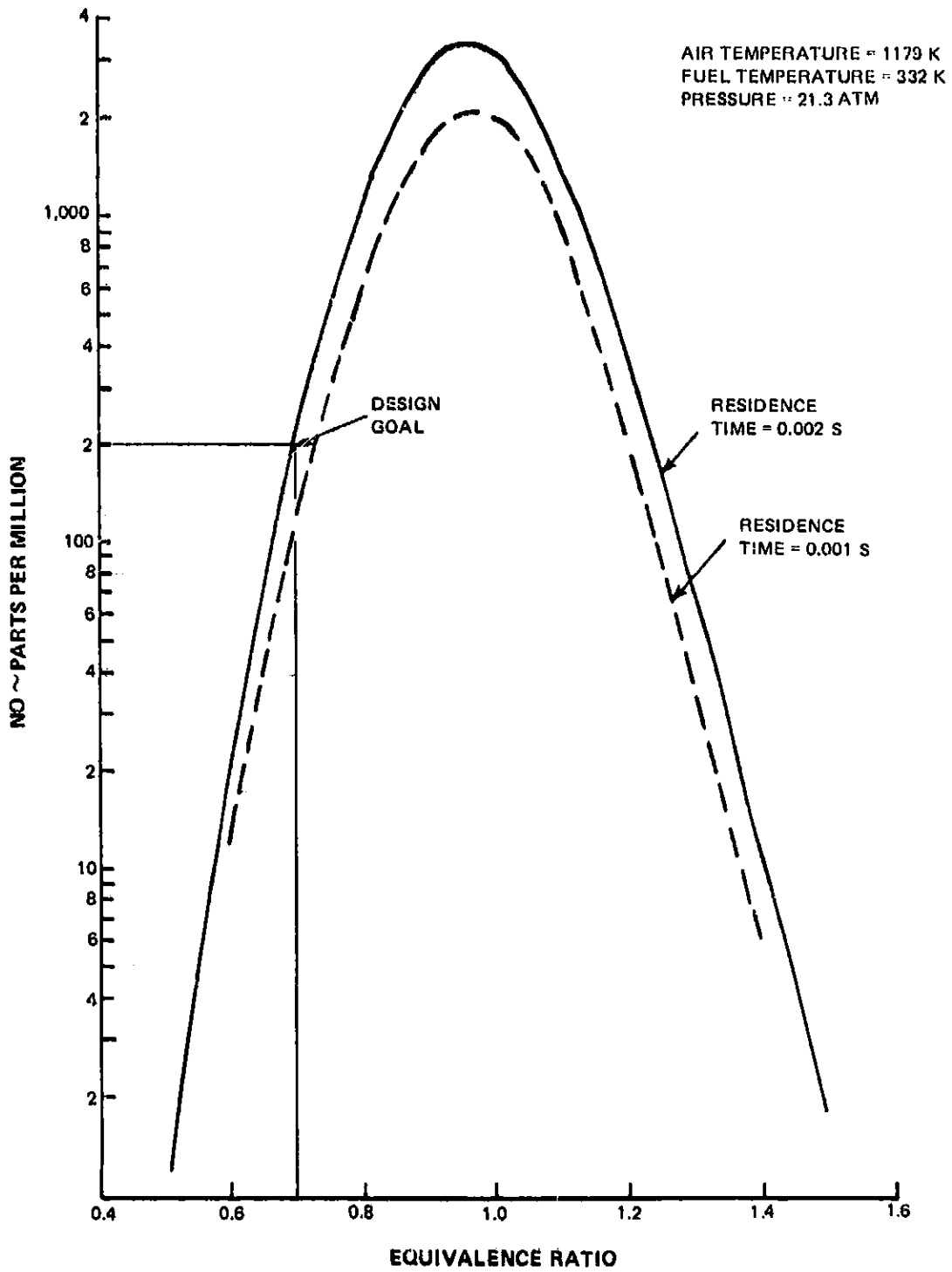

Figure 29 Effect of Equivalence Ratio and Residence Time on Concentration of Oxides of Nitrogen in a Kinetically Limited JP-5/Air System

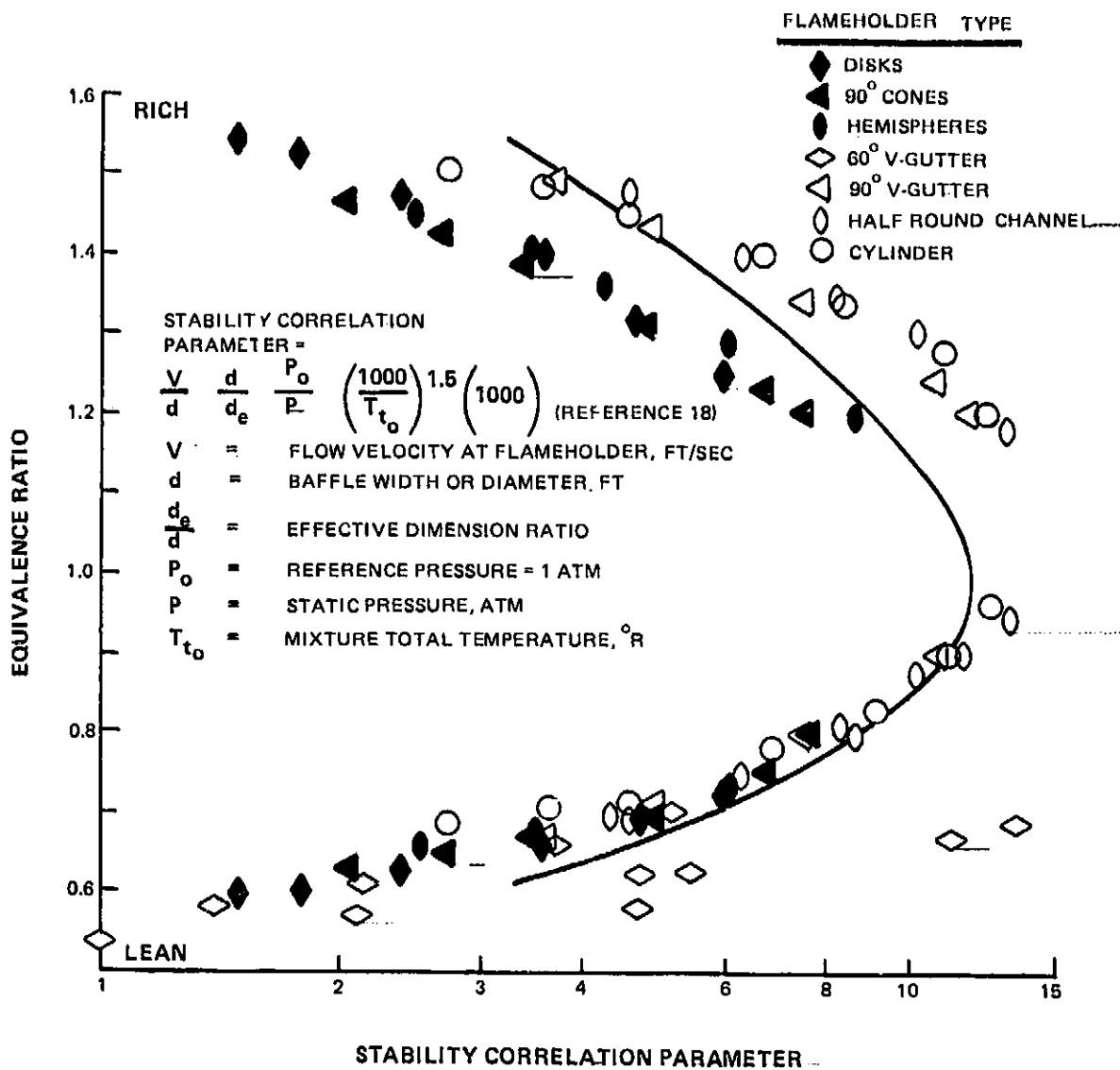

Figure 30 Premix Combustor Stability Limit Correlation Data

Both the pilot and the main premixing passages were compartmented to exclude wakes generated by the diffuser case struts. Forty pilot and forty main fuel injectors (on a full annular basis) were used.

#### b. Design Variations

Nine combustor configurations of the staged premix combustor concept were tested. These configurations included four parametric design modifications as follows:

1. Diffuser-combustor airflow distribution,
2. Fuel-air mixture preparation, including fuel staging and number of secondary injectors,

3. Pilot-main burner fuel flow split, and
4. Flameholder design.

The configurations are summarized in Table XVI, and complete specifications are presented in Appendix B. Each of the modifications is discussed in detail below.

TABLE XVI  
STAGED PREMIX COMBUSTOR CONFIGURATIONS

Configuration	Flameholder Hole Pattern	Equivalence Ratio at Idle (Pilot Only)	Equivalence Ratio at Take-off (Pilot and Main)*	Number of Injectors		Dilution Air (Percent)
				Pilot	Main	
P1	Circular	1.00	0.83	10	10	28
P2	Circular	0.98	0.77	10	10	22
P3	Circular	0.94	0.73	10	10	15
P4	Circular	0.89	0.69	10	10	13
P5	Circular	0.89	0.69	10	10**	13
P6	Circular	0.84	0.52	10	10	0
P7	Slotted	0.84	0.52	10	10	0
P8	Slotted	0.84	0.52	10	20	0
P9	Slotted	0.90***	0.56***	10	10	6.9***

\*Average equivalence ratio for pilot burner plus main burner premix passages

\*\*Main burner fuel injector fuel distribution tests

\*\*\*Design values, not measured

#### Diffuser-Combustor Airflow Distribution

Testing of the initial staged premix combustor configuration (designated P1) revealed that the feed pressure to the main burner premixing passage was inadequate, resulting in deficient main burner flameholder airflow. The approach used to correct this deficiency consisted of increasing the main burner flameholder area (Configurations P2 and P4), and extending the diffuser downstream (Configuration P3). As shown in Table XVII, these measures were collectively effective in increasing the main burner premix passage airflow from 21.8 percent of the total combustor airflow to 27.4 percent, but this level still fell short of the design airflow of 28.5 percent. In addition, the main burner premixing passage also experienced a low total pressure feed on the outer splitter, indicating a nonuniform radial flow distribution feeding the outer passage. This type of flow maldistribution compromised the ability of the combustor to achieve a homogeneous fuel distribution in the main burner premixing passage.

TABLE XVII

AIRFLOWS FOR PREMIX PASSAGES OF STAGED PREMIX  
COMBUSTOR CONFIGURATIONS

<u>Configuration</u>	<u>Airflow (Percent Combustor Total Airflow)</u>	
	<u>Pilot</u>	<u>Main</u>
Design	18.5	28.5
P1	18.4	21.8
P2	18.9	24.5
P3	20.0*	26.1
P4	20.8	27.4
P5	20.8	27.4
P6	24.6	32.4
P7	22.1	42.7
P8	27.4	42.7
P9	25.5	39.8

\*Estimated

The cause of this maldistribution was identified as a part of another program conducted on a similar combustor in the JT9D diffuser case. This study revealed intense diffuser strut wakes that propagated to the axial location of the main burner premix passage.

Subsequently, a substantial increase in the main burner premix passage flow was achieved in Configurations P7 and P8 through elimination of the liner dilution airflow. Some dilution airflow was added for Configuration P9 to increase the equivalence ratio of the pilot burner premixing passage. This configuration was used only for altitude stability and relight tests using only the pilot burner.

**Fuel-Air Mixture Preparation**

Two modifications to the fuel-air mixture preparation were explored in conjunction with the diffuser-combustor airflow distribution modifications. One of these involved circumferential fuel staging of the main combustor, and the second involved changing the number of main burner fuel injectors.

The circumferential staging configuration was intended to provide additional fuel flow in the center regions between the diffuser struts and reduced fuel in the regions adjacent to the struts to offset the effects of the reduced airflow downstream of the struts, with the effect of producing a more uniform fuel-air ratio downstream of the flameholder. This was achieved by dividing the injectors into two zones, in Configuration P5, as shown in Figure 31. The

six injectors adjacent to the struts or the rig sidewall were manifolded together as Zone 1, and the remaining four injectors constituted Zone 2. A Zone 1 to Zone 2 fuel flow ratio of 1.5 would provide equal fuel flow to all injectors. With this arrangement, the fuel flow split between the pilot and main burners remained unchanged, with 18 percent of the fuel being provided to the pilot burner and 82 percent to the main burner.

In Configuration P8, the number of main burner fuel injectors was increased from 10 to 20, while maintaining the fuel injector pressure drop. This was achieved by substituting the dual-nozzle main fuel injector shown in Figure 32 for the original, single-nozzle injector. Otherwise, Configuration P8 was geometrically identical to Configuration P7, which incorporated slotted pilot and main flameholders and no liner dilution air. The increased fuel source density was expected to provide a more uniform fuel-air mixture at the flameholder.

#### Flameholder Design...

The initial series of staged premix combustor configurations (Configurations P1 through P6) incorporated circular holes in the pilot and main flameholders. To assess the effect of hole shape, Configurations P7, P8, and P9 incorporated slotted holes in the flameholders. The two flameholder designs are shown in Figure 28.

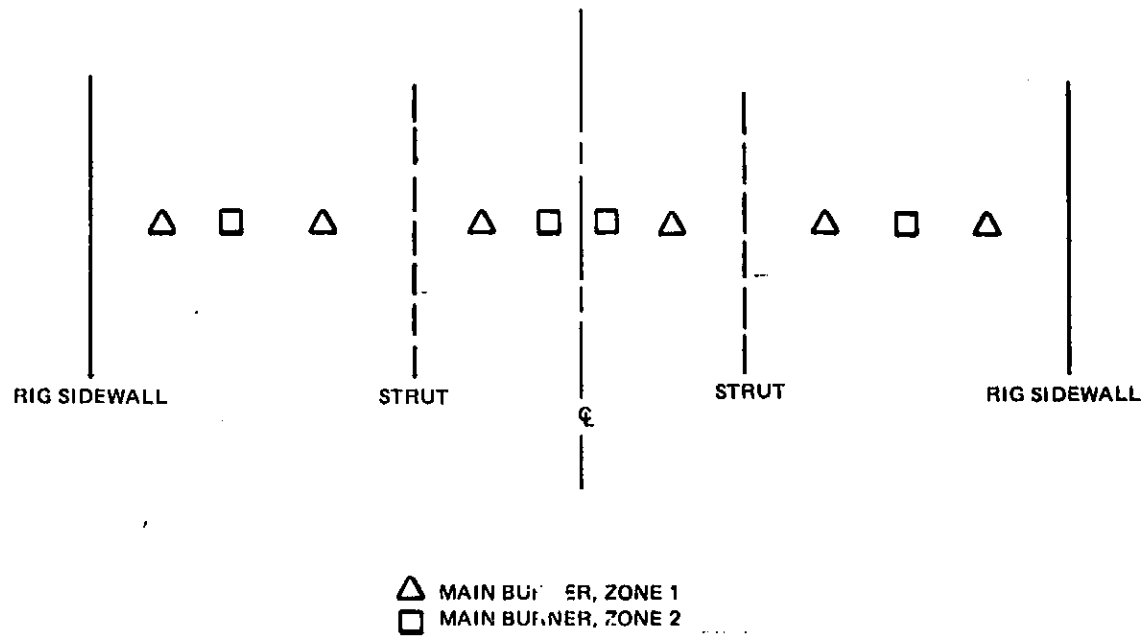

Figure 31 Staged Premix Combustor Main Burner Fuel Staging Arrangement



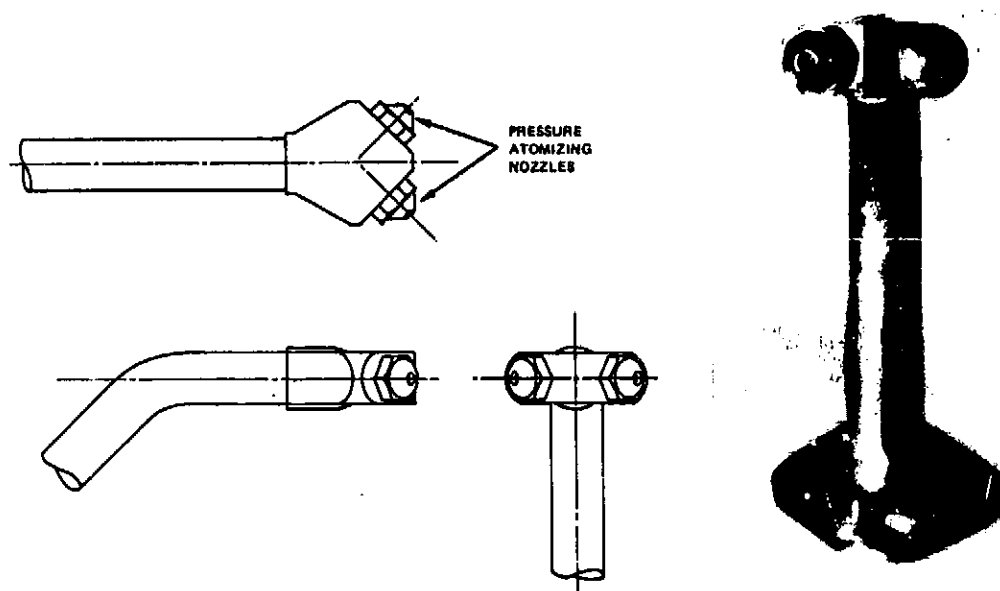

Figure 32 Staged Premix Combustor Double Main Burner Fuel Injector

### 3. SWIRL VORBIX COMBUSTOR

#### a. General Description

The objective of the swirl vorbix combustor is to provide a relatively long combustion residence time at low power settings to minimize carbon monoxide and unburned hydrocarbon emissions and to provide rapid burning and quenching of the combustion reaction at high power levels to minimize the formation of oxides of nitrogen. The combustor features a combination of vortex burning and mixing (from which the acronym "vorbix" was derived) in a multiple burner arrangement with the burners spaced axially along the combustor axis. The design for the initial configuration is shown in Figure 33, and photographs illustrating some of the combustor features are presented in Figures 34 and 35.

The pilot burner is a conventional swirl-stabilized, direct-fuel injector combustor using thirty fuel injectors (on a full annular basis). The pilot burner is sized to provide the required heat release rate for idle operation at high efficiency. Emissions of carbon monoxide and unburned hydrocarbons are minimized at idle operating conditions by (1) maintaining a sufficiently high pilot burner equivalence ratio to ensure complete burning of the fuel, (2) incorporating FINWALL<sup>®</sup> material in the walls of each module to minimize and delay the introduction of cooling air, and (3) circumferentially swirling the cooling air leaving the FINWALL<sup>®</sup> walls to reduce the quenching action of the coolant.

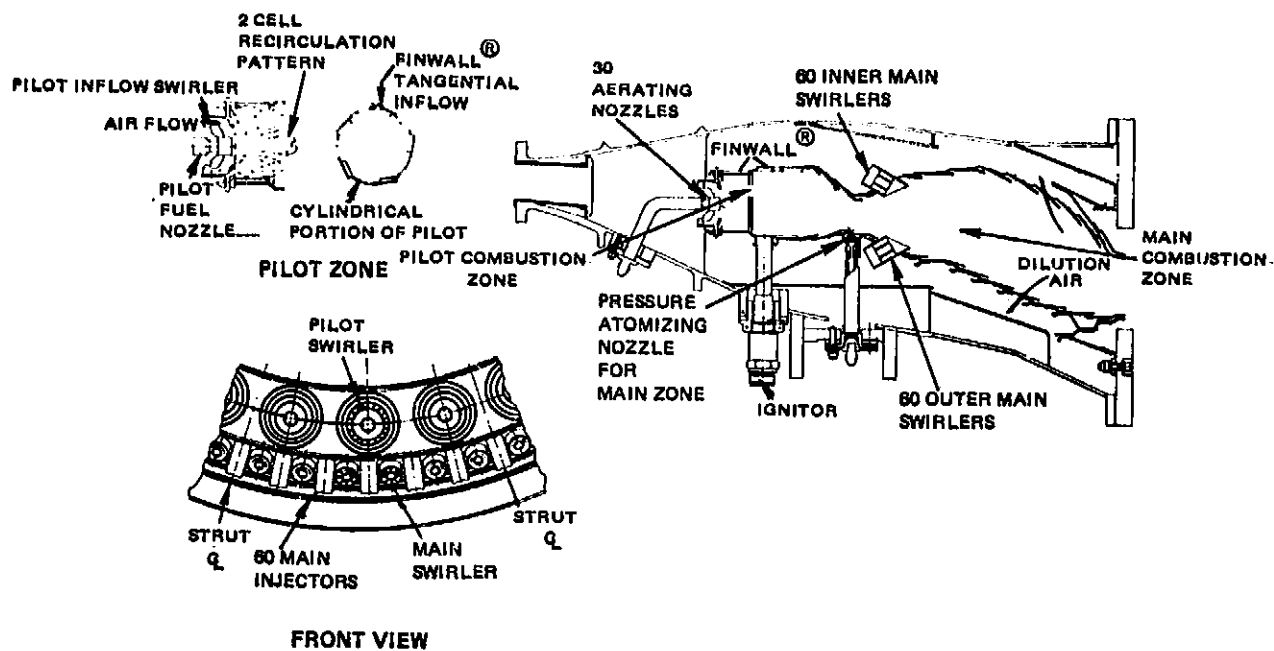

Figure 33 Swirl Vorbix Combustor Concept

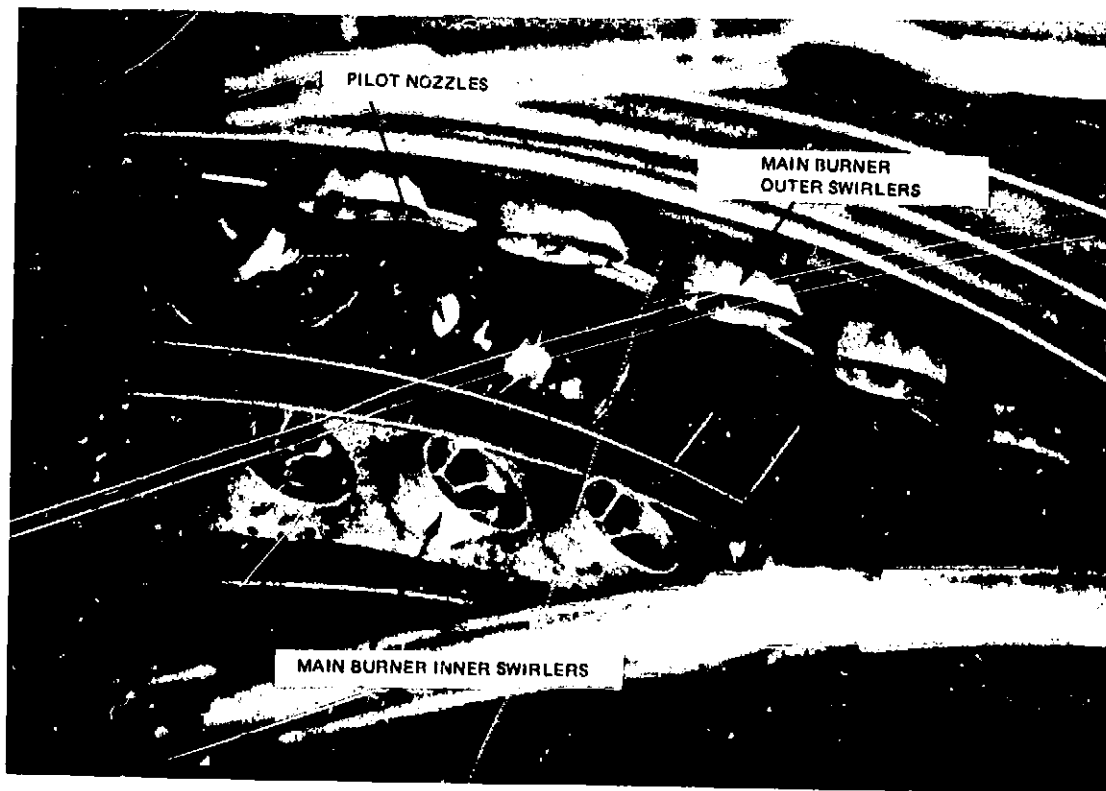

Figure 34 View Looking Upstream Toward Headplate Showing Orientation of Main Burner Inner and Outer Swirlers Relative to the Pilot Fuel Injector Nozzle

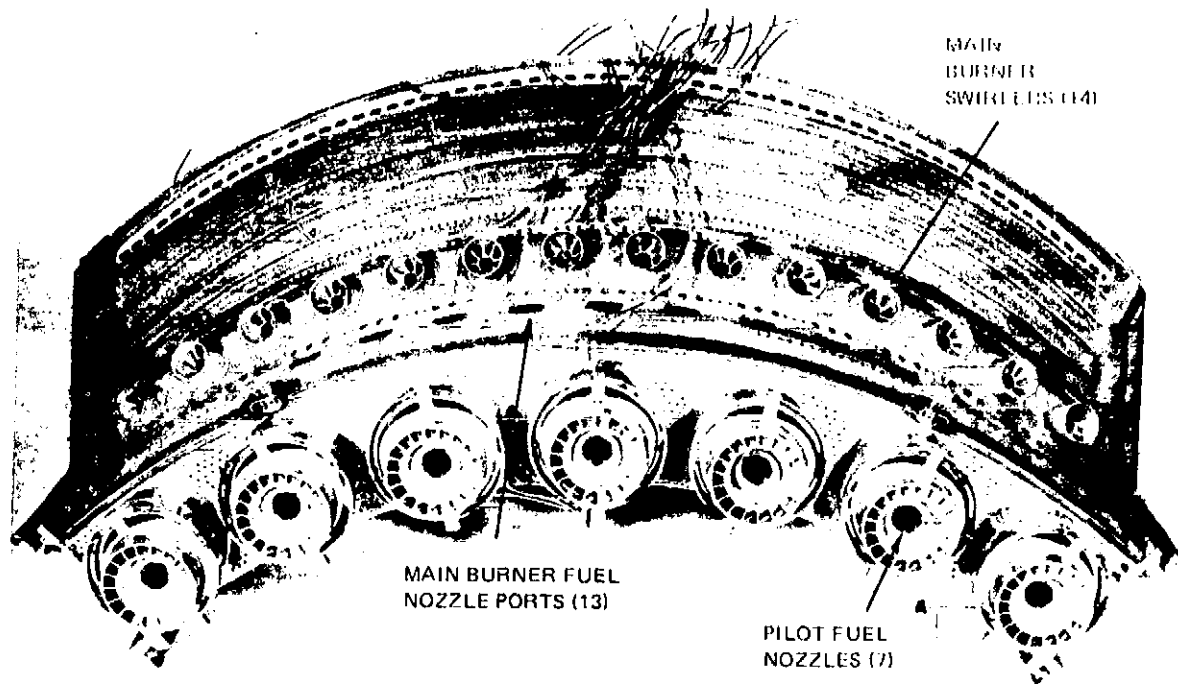

Figure 35 Front View of the Swirl Vortex Test Section

The pilot burner operates at an equivalence ratio of about 0.75 during idle operation. At take-off conditions, the pilot exhaust equivalence ratio is reduced to 0.50 or lower to reduce the temperature of the flow through the pilot burner section, thereby reducing the time that the flow remains at high temperatures and pressures at which oxides of nitrogen are formed. The minimum equivalence ratio for the pilot burner is determined by the overall combustor stability characteristics (lean blowout limit) and by the need to maintain sufficient pilot burner energy to vaporize and ignite the main burner fuel.

At high power conditions, main burner fuel is introduced through fuel injectors located at the outer wall of the liner at the pilot burner discharge location, as shown in Figure 33. Either thirty or sixty fuel injectors were used in this program (on a full annular combustor basis). Main burner air for combustion and dilution is introduced through sixty swirlers positioned on each side of the combustor (again on a full annular combustor basis). The hot exhaust products and fuel vapor mixture from the pilot burner are then entrained by the swirling main burner jets, providing partial premixing before autoignition of the main burner fuel occurs. The main combustion process, in which most of the fuel is consumed at high power conditions, proceeds rapidly at the interface of the swirling main burner jets and the fuel-rich mixture of pilot burner combustion products and main burner fuel. It is this rapid combustion and subsequent rapid quenching that reduces the residence time of the combustion gases at high temperature and reduces the formation of oxides of nitrogen.

Proper sequencing of the main burner fuel vaporization, fuel-air premixing, autoignition, and dilution is essential to the success of this combustor concept. Sequencing can be adjusted by varying the point of the main burner fuel injection, the location of the swirlers, the reference velocity, the equivalence ratio, and a number of other design parameters. The spacing between the main burner air swirlers, the direction of rotation of the jets, and the relative position of the fuel injectors also affect the degree of fuel dispersion and jet penetration.

**b. Design Variations** —

Six design variations were evaluated in the Phase I screening program for the swirl vortex combustor. These were:

1. Modifications to correct FINWALL<sup>®</sup> aspiration and diffuser airflow distribution,
2. Pilot injector type and airflow schedule,
3. Main burner fuel source density and fuel spray penetration,
4. Main burner swirler type and orientation and air schedule,
5. Main burner fuel injector angle, and
6. Pilot-to-main burner fuel flow split.

These design modifications are summarized in Table XVIII, and complete specifications are included in Appendix B. Details of the modifications are presented below.

**Modifications to Correct FINWALL<sup>®</sup> Aspiration and Diffuser Airflow Distribution**

Testing of the initial swirl vortex combustor (Configuration S1) was terminated shortly after ignition of the pilot burner because unburned hydrocarbons were detected in the combustor shroud. Subsequent inspection revealed that fuel aspiration had occurred from the pilot zone FINWALL<sup>®</sup> panels, as shown in Figure 36. The fuel aspiration was apparently caused by radial airflow around the bulkhead, creating a depressed static pressure at the entrance of the FINWALL<sup>®</sup> panel coolant holes and causing localized upstream aspiration of the fuel between the pilot module. This situation was corrected by the addition of inner and outer hoods, as shown in Figure 36.

Configurations S1 and S3 also exhibited an undesirable diffuser discharge pressure profile at the swirler face, producing flows at the inner shroud that were higher than the design values and flows at the outer shroud that were lower than the design values. Subsequent configurations (Configurations S4 through S10) incorporated a revised pilot burner diffuser that was canted towards the outer shroud and that also was lengthened to provide a more uniform airflow distribution.

TABLE XVIII  
SWIRL VORBIK COMBUSTOR CONFIGURATIONS

Configuration	Pilot Burner				Main Burner				Throat Height (cm)
	Injector Type	Swirler	Dilution Airflow	Swirler Type	Swirler Orientation	Dilution Air	Fuel Injector Number	Angle to Flow (Degrees)	
S1	Aerated	Baseline	Yes	Straight Vane	Type I	Yes	13	90	3.3
S2	Aerated	Baseline	Yes	Straight Vane	Type I	Yes	13	90	3.3
S3	Aerated	Baseline With Blockage Ring	Yes	Straight Vane	Type I	Yes	7 <sup>a</sup>	90	3.3
S4	Aerated Plus Air Scoop	Baseline With Blockage Ring	Yes	Curved Vane	Type II	Yes	13 <sup>b</sup>	90	3.3
S5	Aerated Plus Air Scoop	Baseline With Blockage Ring	Yes	Curved Vane	Type II	Yes	7 <sup>a,b</sup>	90	3.3
S6	Aerated Plus Air Scoop	Baseline With Increased Blockage Ring	Yes	Curved Vane	Type II	Yes	7 <sup>a,b</sup>	90	3.3
S7	Aerated Plus Air Scoop	Baseline With Increased Blockage Ring	Yes	Curved Vane	Type II	Yes	13	90	3.3
S8	Pressure Atomized	Baseline	No	High Flow Straight Vane	Type III	No	13	90	3.3
S9	Pressure Atomized	Baseline With Blockage Ring	Yes	High Flow Straight Vane	Type III	No	13	24	3.3
S10	Pressure Atomized	Baseline	No	High Flow Straight Vane	Type III	No	13	24	2.5

Notes: Except for Configuration S1, all configurations had pilot zone hood installed to prevent fuel aspiration.

- a. Main burner fuel injectors in line with pilot burner fuel injectors.
- b. Reduced pressure drop fuel injectors.

Fuel Injectors Types:

- I - Inner and outer swirl in direction of fuel flow.
- II - Inner swirl in opposition to fuel flow and outer swirl in direction of fuel flow.
- III - Inner and outer swirl co-rotational.

ORIGINAL PAGE IS  
OF POOR QUALITY

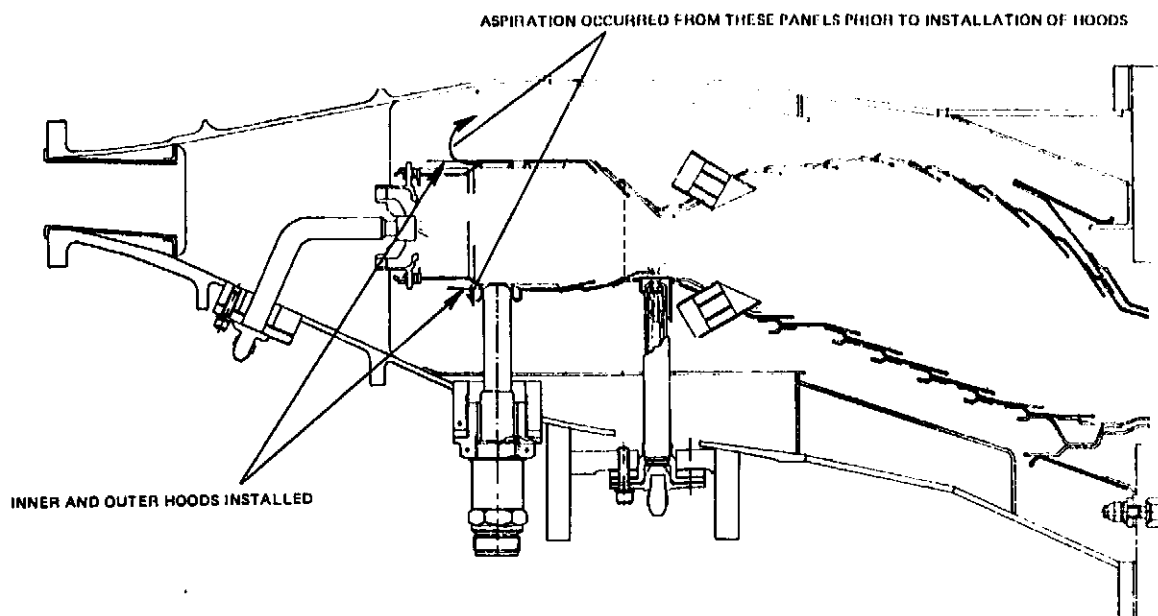

*Figure 36 Swirl Vortex Combustor Schematic Showing Region Where Fuel Aspiration Occurred and Location of Corrective Hoods*

#### **Pilot Injector Type and Airflow Schedule**

The initial swirl vortex combustor configurations (S1 through S7) incorporated an aerating pilot fuel injector which used the combustor pressure drop to achieve fuel atomization. These configurations consistently operated at efficiencies in the range of 93 to 95 percent with associated emissions of carbon monoxide and total unburned hydrocarbons that were higher than desirable.

The initial approaches for improving the performance involved changing the pilot burner airflow distribution and adding an air scoop to increase the pressure drop across the fuel nozzles (Configuration S4). Neither of these approaches provided any significant improvement.

In view of these results, flow visualization tests were conducted to determine if a simplex pressure atomizing fuel injector would provide better fuel atomizing than the aerating fuel injectors. The fuel injectors were mounted in a pilot burner swirler and plenum and fed with nitrogen to simulate the test rig nozzle-swirler airflow at simulated engine idle air pressure and density. A 3-percent pressure drop was maintained across the swirler for all of the tests. The results of these tests are shown in Figure 37 and demonstrate that the pressure atomizing fuel injectors provide significantly better atomization than the aerating injectors.

On the basis of these results, the pressure atomizing fuel injectors were used for Configurations S8 through S10.



P/N 33420

AIR BLAST TYPE NOZZLE  
 TANK PRESS. = 2.84 ATM  
 SWIRLER  $\Delta P$  = 0.088 ATM  
 FUEL FLOW = 0.0069 KG/S  
 (IDLE BURNER PRESS. SIMULATION)



P/N 33420

AIR BLAST TYPE NOZZLE  
 TANK PRESS. = 1.79 ATM  
 SWIRLER  $\Delta P$  = 0.0540 ATM  
 FUEL FLOW = 0.0069 KG/S  
 (IDLE AIR DENSITY SIMULATION)



P/N 33420

AIR BLAST TYPE NOZZLE  
 TANK PRESS. = 6.6 ATM  
 SWIRLER  $\Delta P$  = 0.204 ATM  
 FUEL = 0.0078 KG/S  
 (SLTO BURNER PRESS. SIMULATION)



P/N 27700-11

PT6 TYPE NOZZLE  
 TANK PRESS. = 2.84 ATM  
 SWIRLER  $\Delta P$  = 0.088 ATM  
 FUEL FLOW = 0.0069 KG/S  
 (IDLE BURNER PRESS. SIMULATION)



P/N 27700-11

PT6 TYPE NOZZLE  
 TANK PRESS. = 1.79 ATM  
 SWIRLER  $\Delta P$  = 0.054 ATM  
 FUEL FLOW = 0.0069 KG/S  
 (IDLE AIR DENSITY SIMULATION)

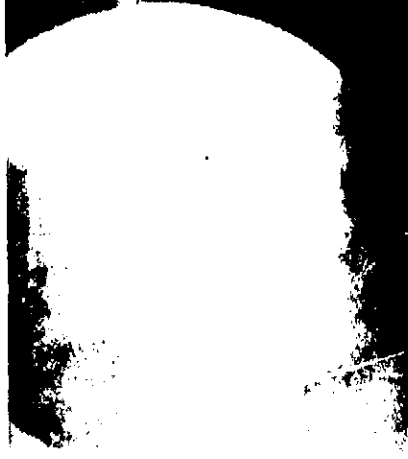

P/N 27700-11

PT6 TYPE NOZZLE  
 TANK PRESS. = 6.6 ATM  
 SWIRLER  $\Delta P$  = 0.204 ATM  
 FUEL FLOW = 0.0078 KG/S  
 (SLTO BURNER PRESS. SIMULATION)

Figure 37 Test Results for Swirl Vorbix Combustor Pilot Fuel Injector Flow Visualization Tests Showing Improved Atomization Provided by Pressure Atomizing Fuel Injectors

### Main Burner Fuel Source Density and Fuel Spray Penetration

Four configurations were tested to determine the effect of fuel source density and fuel spray penetration. Initially, a comparison was made between the performance of Configuration S4 with 13 main burner fuel injectors (60 on a full annular combustor basis) and Configuration S5 with 7 main burner fuel injectors (30 on a full annular combustor basis). In both cases, the total fuel flow remained the same.

Subsequently, two additional configurations were tested. These were Configuration S6 with seven main burner fuel injectors and Configuration S7 with 13 main burner fuel injectors. These configurations differed from the previous two in two respects. First, the pilot burner included swirler blockage to increase the relative equivalence ratio of the pilot burner. Secondly, the fuel injectors used in Configuration S6 were modified to reduce the pressure drop, thereby providing a fuel jet penetration equal to that provided in Configuration S7. Without the modification, the penetration of the fuel from the injectors in Configuration S6 would be substantially higher than that for Configuration S7 since the total fuel flow rate remained the same but the number of injectors in Configuration S6 was one half that in Configuration S7.

The inner main burner swirlers experienced some damage during this series of tests, leading to a series of flow visualization tests to determine the fuel spray penetration of the main burner injectors. A pressure atomizing nozzle was mounted at a right angle to a rectangular duct, simulating the swirl vortex combustor throat section. Nitrogen flow was then used to simulate a range of fuel-to-air momentum ratios that encompassed both the test rig operating conditions as well as engine operating conditions. The results are shown in Figure 38 and indicate that excessive penetration occurs with high pressure drop injectors at the rig operating conditions, explaining the damage to the inner main burner swirlers.

### Main Burner Swirler Type and Orientation and Air Schedule

Since the vortex combustor main burner fuel was injected in close proximity to the swirlers, the swirler orientation influenced the fuel penetration, distribution, and mixing. To explore this effect, three different swirler orientations were investigated, as shown in Figure 39. As shown, Configurations S1 through S3, which had seven main burner fuel injectors, incorporated a swirler orientation that was in the direction of the fuel flow on both the inner and outer liner walls. Configurations S4 through S7 incorporated swirlers in the outer liner that were oriented in the direction of the fuel flow and swirlers in the inner liner that were oriented in the direction opposite to the fuel flow. The final set, Configurations S8 through S10, incorporated co-rotational swirlers.

In addition to being co-rotational, the swirlers used in Configurations S8 through S10 also had approximately twice the effective flow area of the other configurations. This difference is illustrated in the photographs presented in Figures 40 and 41. To compensate for the increased flow area of the larger swirlers, all dilution air holes were eliminated in Configurations S8 through S10. In addition, because of the larger diameter of the swirlers, it was necessary to stagger their axial locations on the inner liner. However, the swirlers were positioned as closely as possible to the main burner fuel injection locations to provide rapid dilution of the fuel.



$(\rho V)_{\text{FUEL}} / (\rho V)_{\text{AIR}}$  AT RIG CONDITIONS = 695



P/N 27700-11 PT6 TYPE NOZZLE (A)

FUEL FLOW = 0.0076 KG/S  
FUEL  $\Delta P$  = 19.1 ATM  
AIR DENSITY = 1.458 KG/M<sup>3</sup>  
AIR VELOCITY = 26.52 M/S  
 $(\rho V)_{\text{FUEL}} / (\rho V)_{\text{AIR}} = 1.236$

$(\rho V)_{\text{FUEL}} / (\rho V)_{\text{AIR}}$  AT ENGINE CONDITIONS = 218



P/N 27700-11 PT6 TYPE NOZZLE (B)

FUEL FLOW = 0.0076 KG/S  
FUEL  $\Delta P$  = 19.1 ATM  
AIR DENSITY = 1.634 KG/M<sup>3</sup>  
AIR VELOCITY = 34.44 M/S  
 $(\rho V)_{\text{FUEL}} / (\rho V)_{\text{AIR}} = 917$



P/N 27700-11 PT6 TYPE NOZZLE (C)

FUEL FLOW = 0.0076 KG/S  
FUEL  $\Delta P$  = 19.1 ATM  
AIR DENSITY = 1.922 KG/M<sup>3</sup>  
AIR VELOCITY = 39.32 M/S  
 $(\rho V)_{\text{FUEL}} / (\rho V)_{\text{AIR}} = 683$

P/N 27700-11 PT6 TYPE NOZZLE (D)

FUEL FLOW = 0.0076 KG/S  
FUEL  $\Delta P$  = 19.1 ATM  
AIR DENSITY = 2.339 KG/M<sup>3</sup>  
AIR VELOCITY = 42.67 M/S  
 $(\rho V)_{\text{FUEL}} / (\rho V)_{\text{AIR}} = 517$



P/N 27700-11 PT6 TYPE NOZZLE (E)

FUEL FLOW = 0.0076 KG/S  
FUEL  $\Delta P$  = 19.1 ATM  
AIR DENSITY = 4.133 KG/M<sup>3</sup>  
AIR VELOCITY = 40.28 M/S  
 $(\rho V)_{\text{FUEL}} / (\rho V)_{\text{AIR}} = 311$



P/N 27700-11 PT6 TYPE NOZZLE (F)

FUEL FLOW = 0.0076 KG/S  
FUEL  $\Delta P$  = 19.1 ATM  
AIR DENSITY = 4.229 KG/M<sup>3</sup>  
AIR VELOCITY = 43.28 M/S  
 $(\rho V)_{\text{FUEL}} / (\rho V)_{\text{AIR}} = 282$

Figure 38 Test Results for Swirl Vorbix Combustor Main Burner Fuel Injector Flow Visualization Tests Showing Excessive Penetration at Combustor Segment Rig Test Conditions

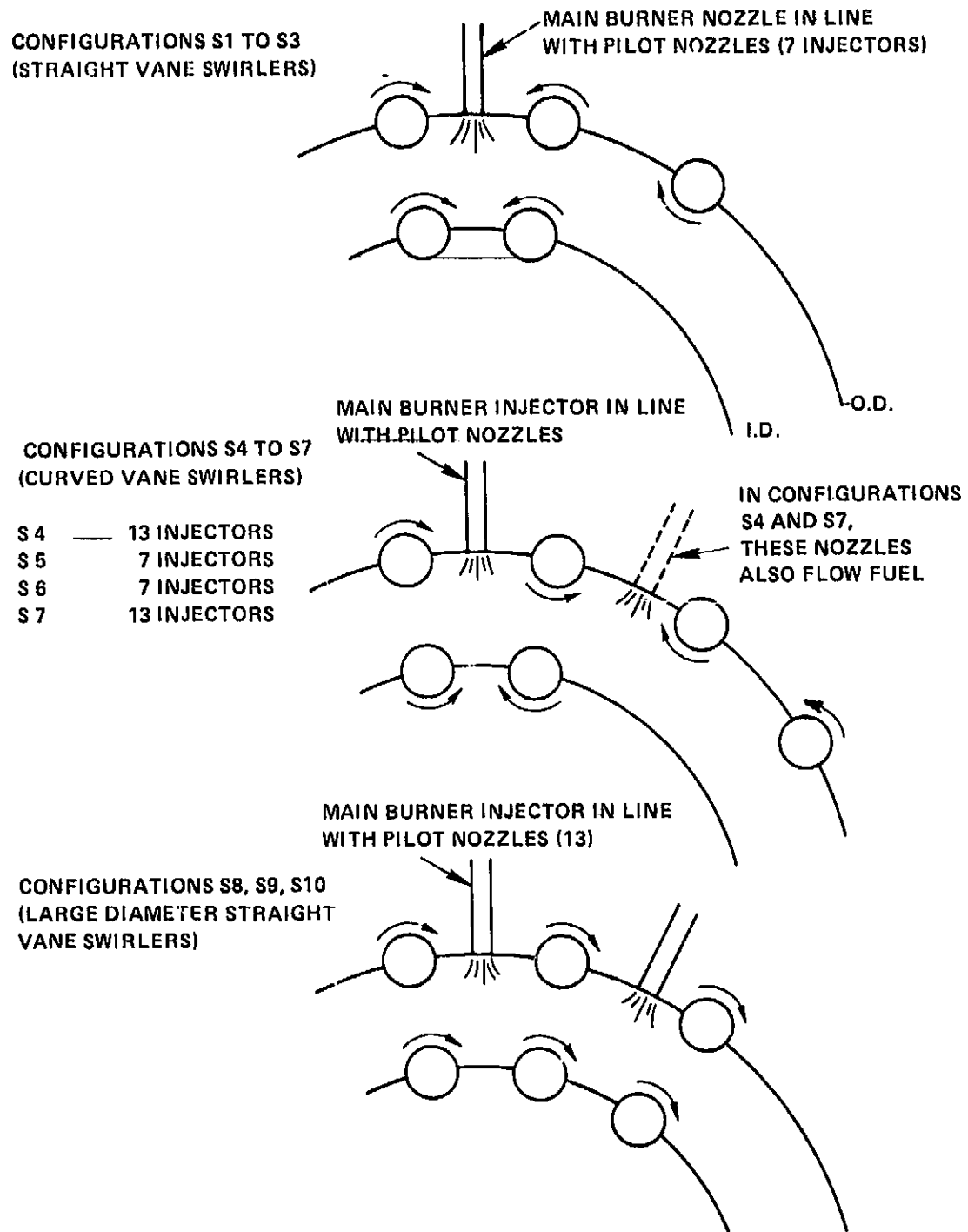

Figure 39 Swirl Vortex Combustor Main Burner Swirler Orientations

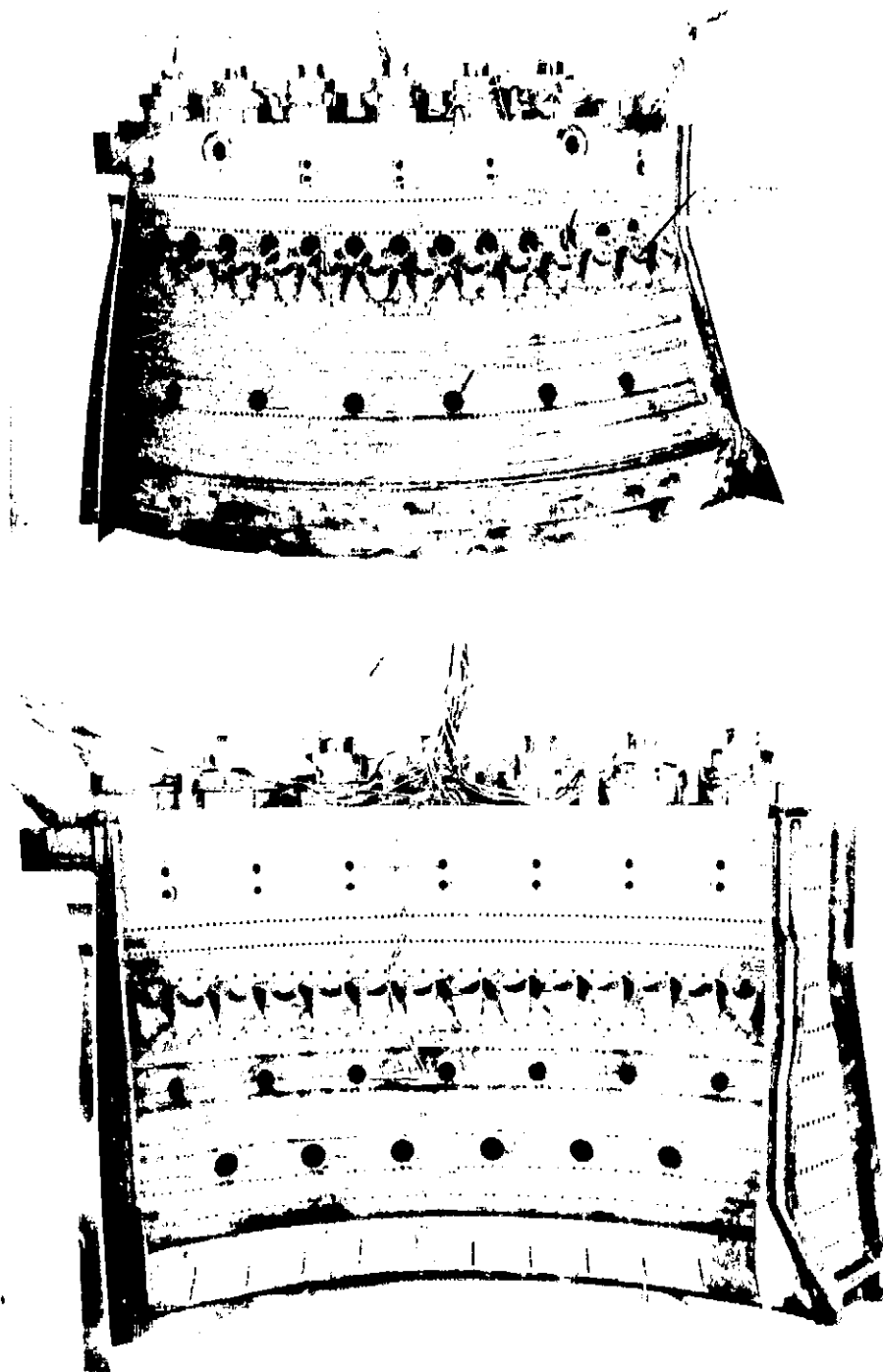
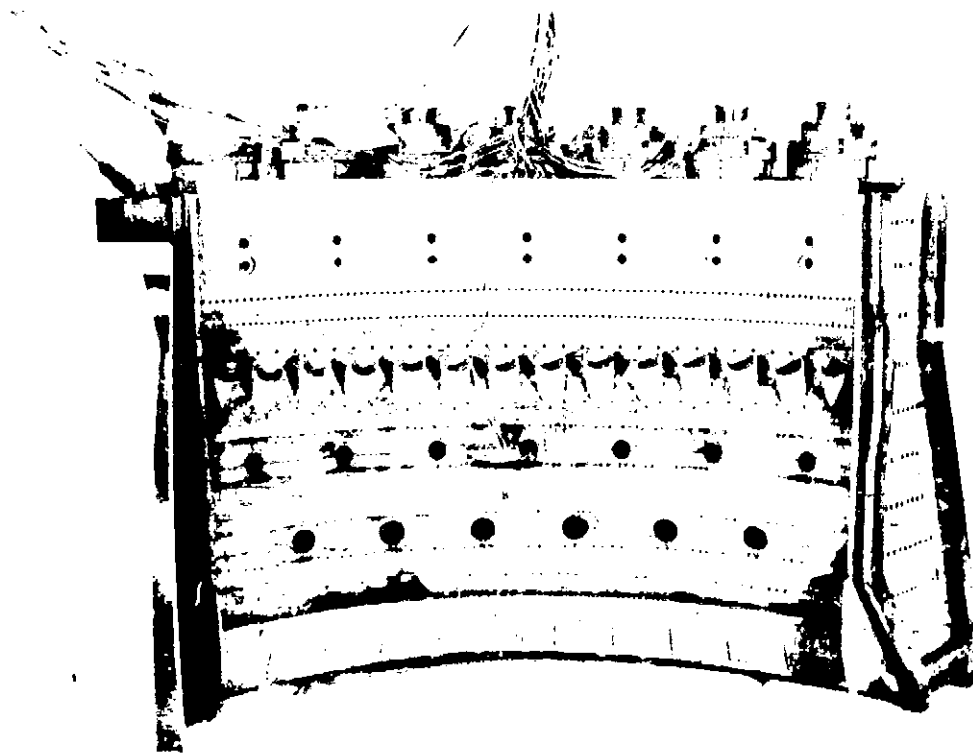
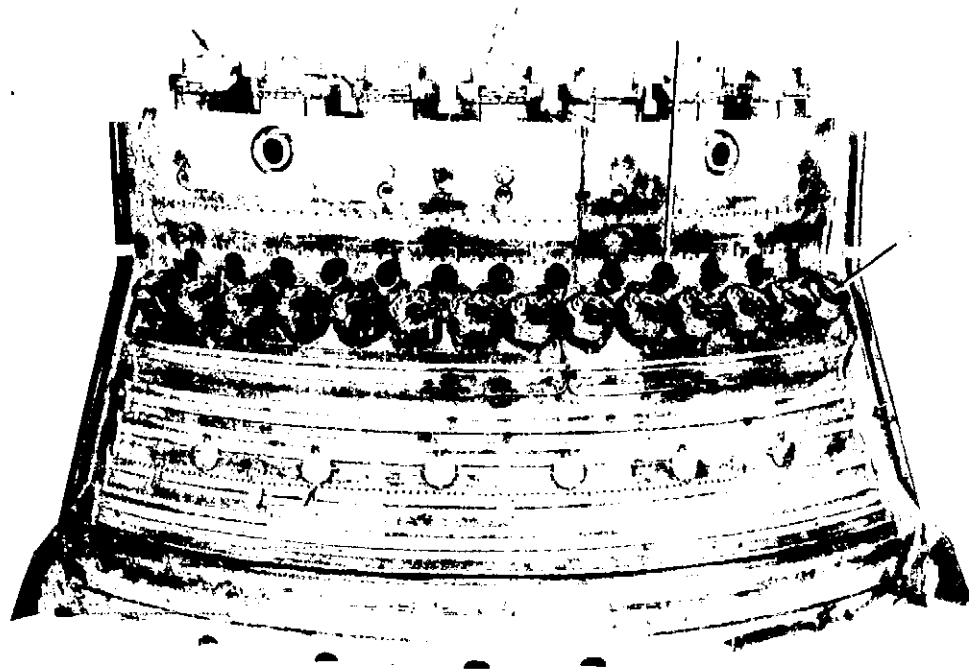

Figure 40 Swirl Vortex Combustor Liner for Configuration S4 Showing Small-Diameter Swirlers



*Figure 41 Swirl Vortex Combustor Liner for Configuration S8 Showing Large-Diameter Swirlers and Plugged Dilution Holes*

## **Main Burner Fuel Injection Angle**

In Configurations S9 and S10, the main burner fuel injector supports were modified to inject the fuel downstream at an angle of 66 degrees from the normal orientation. With this orientation, fuel was injected in the vicinity of the air swirler discharge. Injection of the fuel in a lower velocity region (relative to the throat area) with an axial velocity component resulted in a more uniform fuel distribution over a wider range of fuel injection pressure drops.

## **C. EXPERIMENTAL EMISSIONS RESULTS**

This section summarizes the emissions data obtained during the Phase I program. The data are grouped by combustor concept. The discussions for each concept include a tabular summary of emissions data at idle and take-off conditions, plots showing the effects of fuel-air ratio variations at idle conditions and a discussion of the effects of significant configurational changes. In addition, for the staged premix combustor and the swirl vortex combustor, plots are presented to show the effect of pilot-to-main burner fuel split at constant overall fuel-air ratio on emissions of oxides of nitrogen and to show the effect of pilot burner fuel-air ratio on combustion efficiency at take-off conditions.

In evaluating the tabulated data presented in this section, it is important to note the data reduction procedures used in the data preparation. First, at idle conditions, it was rarely possible to operate at precisely the design point fuel-air ratios, and, therefore, the data reported at these conditions have been determined by interpolation using plots of emissions as functions of fuel-air ratio. Second, the data reported for oxides of nitrogen have been corrected for humidity effects at both idle and sea-level take-off conditions. Third, since it was not possible to simulate the JT9D-7 engine sea-level take-off combustor inlet pressures in the combustor segment test rig, emissions data were obtained at a lower pressure and are reported on this basis (with oxides of nitrogen emissions corrected for humidity) in the tables in this section. In addition, the tables for sea-level take-off conditions include oxides of nitrogen emission data that has been corrected to the JT9D-7 engine design point conditions.

The various configurations that were tested are described in Chapter III, Section B and in Appendix B, and complete tabulations of the data obtained with each configuration are presented in Appendix C.

### **1. SWIRL-CAN COMBUSTOR**

#### **Test Results at Idle Conditions**

The emissions test results obtained at idle conditions for the swirl-can combustor are shown in Table XIX for the design-point fuel-air ratio. The effects of fuel-air ratio on emissions of carbon monoxide and total unburned hydrocarbons are shown in Figures 42 and 43, respectively.

Review of Table XIX reveals that none of the configurations met or approached the emissions goals, nor did any of the configurations achieve the current JT9D-7 combustor emission

levels. The best configuration produced carbon monoxide emissions that were six times the goal and emissions of unburned hydrocarbons that were ten times the goal.

TABLE XIX  
SWIRL-CAN COMBUSTOR EMISSIONS AT IDLE CONDITIONS

Configuration	Emission Index (g/kg fuel)			Combustion Efficiency (Percent)	Remarks
	Oxides of Nitrogen	Carbon Monoxide	Total Unburned Hydrocarbons		
<b>WITH BLEED</b>					
Goals	--	20	4	99.1	
JT9D-7 Combustor	--	--	--	--	
N1	--	--	--	--	Emissions data not obtained.
N2	2.0	166	293	61.8	Fuel to outer row only.
N3	2.2	143	253	67.1	Fuel to outer row only.
N3	2.2	117	61	90.1	Fuel to inner row only.
N4	1.0	146	305	60.9	Fuel to outer row only.
N4	1.6	108	98	86.0	Fuel to inner row only, fuel-air ratio = 0.011.
N5	1.1	100	430	47.4	Fuel to outer row only.
N5	1.0	124	310	61.1	Fuel to all rows, fuel-air ratio = twice design.
N6	1.6	135	237	69.1	Fuel to outer row only.
<b>WITHOUT BLEED</b>					
Goals	--	20	4	--	
JT9D-7 Combustor	3.3	77	29.8	94.7	
N7	1.6	181	291	61.7	Fuel to outer row only.
N8	1.3	414	425	41.6	Fuel to outer row only.
N9	2.4	165	405	48.8	Fuel to outer row only.
N10	2.1	105	92	86.8	Fuel to outer row only.
N10	0.9	119	42	92.3	Fuel to inner row only.
N11	2.2	78.5	53.5	91.3	Fuel to outer row only.
N12	1.5	212	180	74.0	Fuel to outer row only.
N13	1.2	66	885	--	Fuel-air ratio = 0.0092

Notes: Combustor rig conditions with bleed were inlet pressure of 2.93 atm, inlet temperature of 428 K, and fuel-air ratio of 0.0126.

Combustor rig conditions without bleed were inlet pressure of 3.74 atm, inlet temperature of 456 K, and fuel-air ratio of 0.0105.

Data for oxides of nitrogen have been corrected to combustor inlet air humidity of 6.3 g H<sub>2</sub>O/kg dry air.

Although the emission goals for idle conditions were not met, several trends were identified. First, increasing the combustor fuel-air ratio generally increased combustion efficiency. The only exception was Configuration N12, in which the fuel was injected directly into the combustion zone.

ORIGINAL PAGE IS  
OF POOR QUALITY

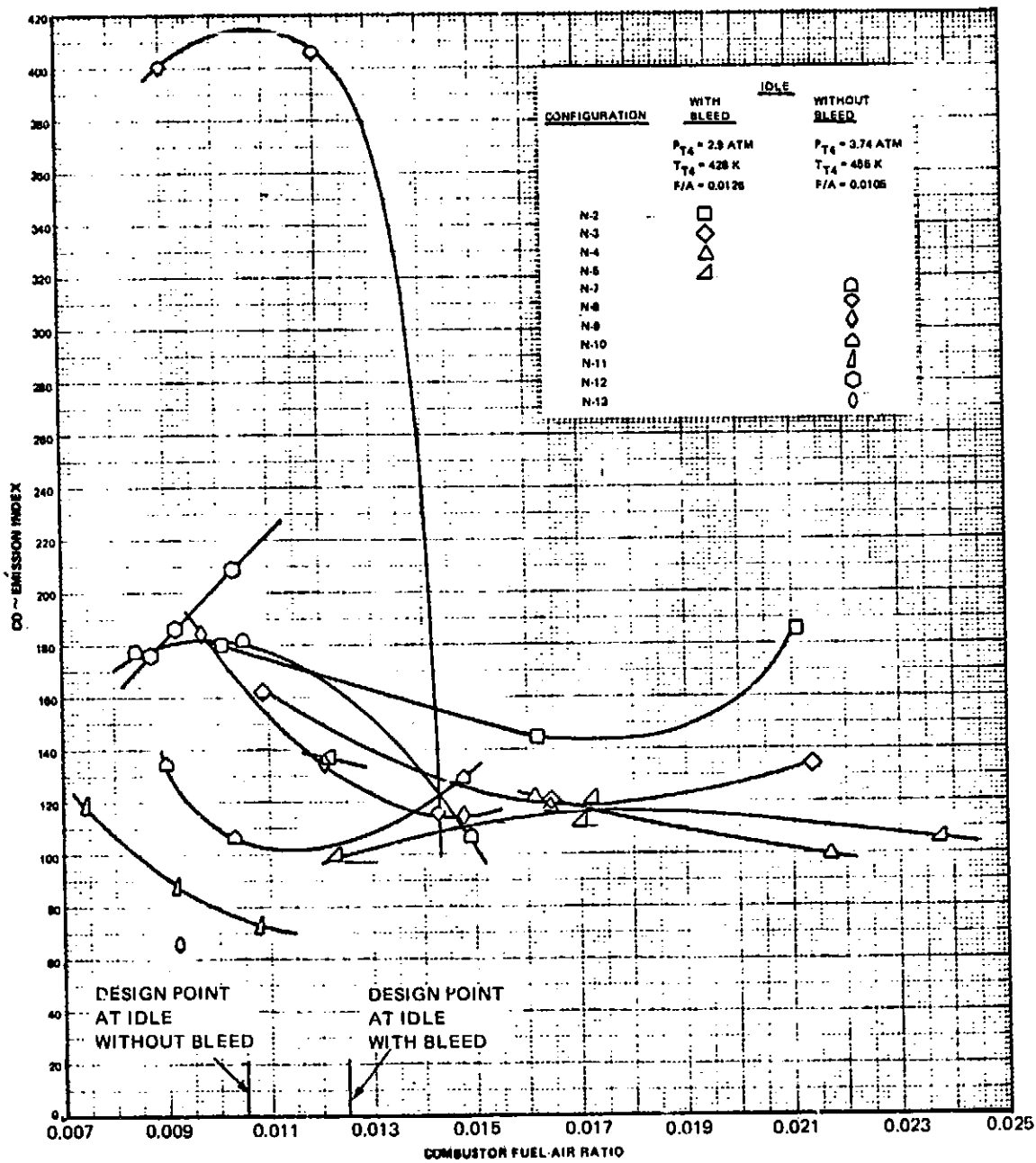

Figure 42 Swirl-Can Combustor Carbon Monoxide Emission Levels as a Function of Fuel-Air Ratio at Idle Conditions

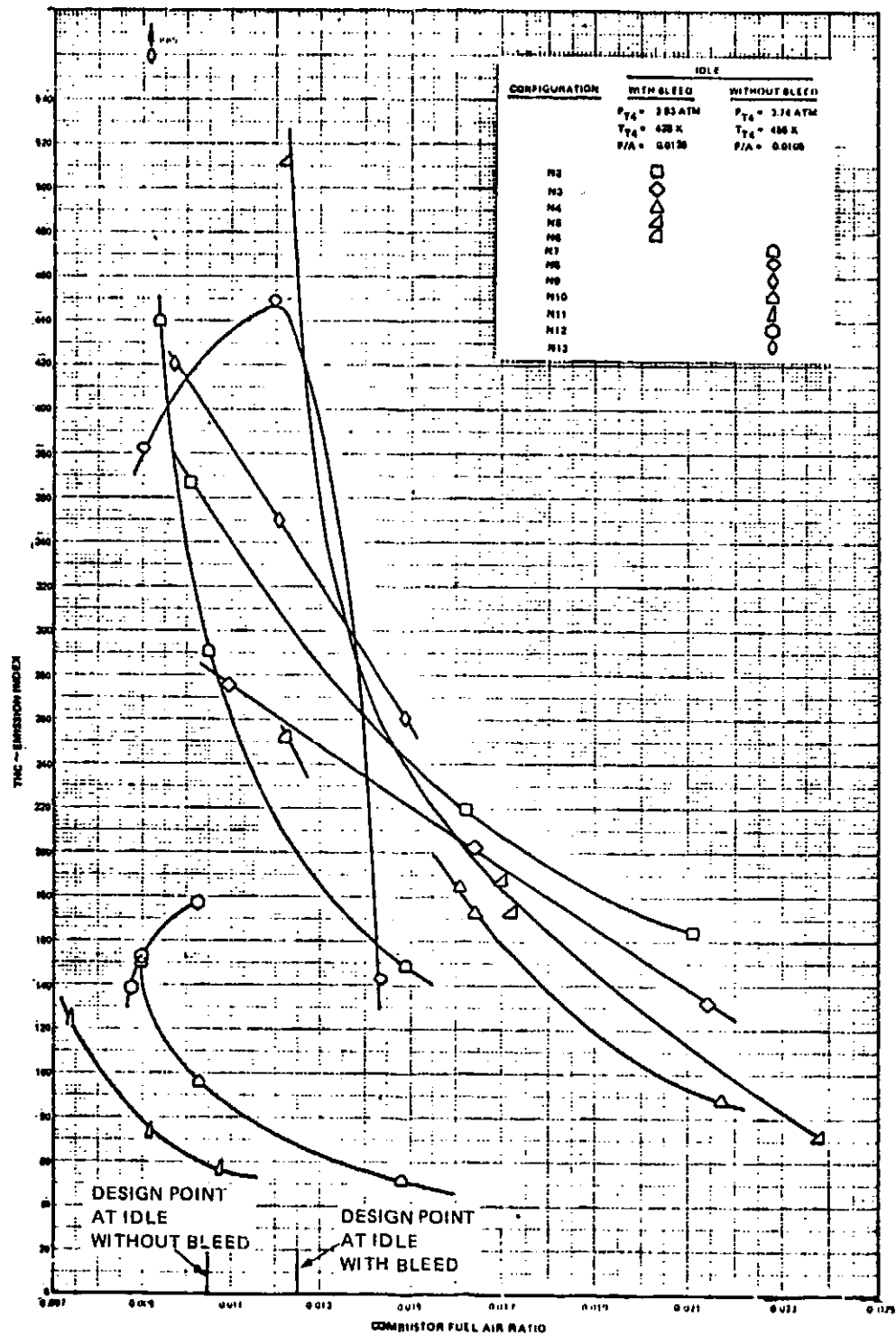

Figure 23 Swirl-Can Combustor Total Unburned Hydrocarbon Emission Levels as a Function of Fuel-Air Ratio at Idle Conditions



Secondly, the combustion efficiencies all fall within a relatively narrow band except for Configurations N10 and N11, which were tested with very high equivalence ratios and were tested at conditions simulating no compressor bleed. These results show that the wide range of geometries tested had little effect on combustor efficiency and emissions at idle conditions.

Thirdly, the use of the inner row of carburetor modules instead of the outer row provided a significant improvement in emissions and efficiency. This result is unfortunate from a mechanical design viewpoint, since use of the outer row at idle offers the advantage of permitting the use of ignitors installed in the outer combustor case, avoiding the problems associated with providing ignition from the inner combustor liner.

Finally, a sector approach to idle operation provided lower emissions and higher efficiency than the use of a single row of carburetor modules. This approach was demonstrated with Configuration N5 in which fuel was supplied to all carburetor modules in the combustor sector rig, using an overall fuel-air ratio that was twice the fuel-air ratio used when only the inner or outer row was used. This condition corresponds to firing a 180-degree section of a full annular combustor with an overall fuel-air ratio equal to the design fuel-air ratio at idle conditions. It should be noted that with this arrangement, fuel is supplied to 60 modules on a full annular basis rather than the 40 modules used when the outer row of modules is used. As a result, the individual carburetor modules actually operate at lower fuel-air ratios using the segment approach than they do using the outer row approach. Consequently, the improvement in combustion efficiency obtained by using all rows in one sector of the combustor is greater than the loss in efficiency associated with the reduced fuel-air ratio of the individual modules.

#### **Test Results at Sea-Level Take-Off Conditions**

The test results for the swirl-can combustor at simulated sea-level take-off conditions are shown in Table XX. Overall, the swirl-can combustor configurations provided significantly lower emissions of oxides of nitrogen at the design point than the JT9D-7 combustor, and efficiency levels generally exceeded 99.5 percent at the sea-level take-off fuel-air ratio. The best configuration, N9, exhibited a 57 percent reduction in emissions of oxides of nitrogen relative to the JT9D-7 combustor and a combustion efficiency of 99.5 percent. Even with this reduction in emissions, however, the emission index of oxides of nitrogen remained 36 percent above the goal. Smoke levels were generally low (below SAE Smoke Number 4) except for Configuration N12 in which the fuel was injected directly into the combustion zone, producing an SAE Smoke Number of 67.

The effects of the carburetor equivalence ratio were investigated with Configurations N2 with an equivalence ratio of 1.7, N3 with an equivalence ratio of 1.0, and N5 with an equivalence ratio of 0.65. The results indicated that the lowest emissions were obtained using an equivalence ratio of 1.0.

TABLE XX

SWIRL-CAN COMBUSTOR EMISSIONS AT SEA-LEVEL TAKE-OFF CONDITIONS

Configuration	Overall Fuel-Air Ratio	Combustor Test Rig Conditions						Emission Index (g/kg fuel)			Combustion Efficiency (Percent)	Oxides of Nitrogen Emission Index Corrected to Engine Design Take-off Conditions (g/kg fuel)
		Fuel Split (Percent)		Oxides of Nitrogen	Carbon Monoxide	Unburned Hydrocarbons	Total					
		Outer Row	Middle Row					Inner Row				
Goals JT9D-7 Combustor	--	--	--	--	--	--	--	--	--	99.0	10.0	
N2	0.0227	41	33	26	12.5	6.3	0.4	99.8	21.4	99.3	31.5	
N2	0.0142	41	0	59	9.0	19.8	1.9	99.3	19.1	99.3	19.1	
N3	0.0227	40	33	27	9.9	13.3	0.6	99.6	15.5	99.6	15.5	
N3	0.0140	100	0	0	8.1	55.7	5.7	98.1	15.8	98.1	15.8	
N3	0.0140	27	34	39	7.6	50.9	6.1	98.1	15.0	98.1	15.0	
N3	0.0197	27	34	39	8.6	22.1	1.9	99.3	16.4	99.3	16.4	
N4	0.0227	42	34	24	9.1	5.7	2.5	99.3	17.1	99.3	17.1	
N4	0.0247	36	42	22	10.5	4.8	0.8	99.8	19.2	99.8	19.2	
N5	0.0227	40	34	26	10.7	10.2	1.2	99.6	20.8	99.6	20.8	
N6	0.0227	42	34	24	10.2	6.6	0.3	99.8	19.8	99.8	19.8	
N7	0.0227	44	35	21	10.3	3.7	0	99.9	18.4	99.9	18.4	
N7	0.0097	100	0	0	9.8	17.0	2.9	99.3	21.4	99.3	21.4	
N7	0.0222	50	22	28	9.5	4.6	0.1	99.8	17.2	99.8	17.2	
N8	0.0227	41	35	24	11.1	6.9	0.2	99.8	19.6	99.8	19.6	
N9	0.0227	42	34	24	7.5	14.3	1.4	99.5	13.6	99.5	13.6	
N9	0.010	100	0	0	10.2	29.3	6.6	98.5	25.2	98.5	25.2	
N10	0.0227	24	33	25	13.5	1.8	0	100	24.0	100	24.0	
N11	0.0227	42	34	24	12.2	5.4	0.4	99.8	23.4	99.8	23.4	
N12	0.0227	42	34	24	13.2	12.5	0.2	99.7	22.0	99.7	22.0	
N13	0.0227	43	33	24	10.8	6.6	1.7	99.8	19.3	99.8	19.3	
N13	0.0222	34	43	23	9.9	18.1	0.4	99.5	17.9	99.5	17.9	
N13	0.0157	38	32	30	9.3	40.7	2.5	98.7	18.1	98.7	18.1	
N13	0.0218	39	38	23	9.8	16.2	0.3	99.6	17.5	99.6	17.5	
N13	0.0208	41	40	19	9.6	19.4	0.4	99.5	18.4	99.5	18.4	

Notes: Combustor test rig conditions were inlet pressure of 6.8 atm, inlet temperature of 768.9 K, and inlet airflow rate of 6.88 kg/s.

Engine design conditions were combustor inlet pressure of 21.7 atm, combustor inlet temperature of 768.9 K, and combustor inlet airflow rate of 92.9 kg/s.

ORIGINAL PAGE IS OF POOR QUALITY

Four different flameholder designs were investigated. These were:

1. Hex flameholder (Configurations N1 to N5)
2. Sheltered zone flameholder (Configuration N6)
3. Recessed swirler with hex flameholder (Configurations N7 and N8)
4. Outer swirler flameholder (Configurations N9, N12, and N13)

The relative merits of these various configurations were assessed by comparing the results obtained with Configurations N3, N6, N7, N8, and N9, all of which incorporated low pressure drop fuel injectors and had a carburetor equivalence ratio of 1.0. This comparison indicated that the lowest emissions of oxides of nitrogen were provided using the outer swirler flameholder configuration. With this configuration, combustion efficiencies in excess of 99.4 percent were demonstrated at rig take-off conditions.

Three fuel injection techniques were investigated consisting of:

1. Low pressure drop injectors (Configurations N1 to N3, N5 to N11, and N13)
2. Pressure atomizing injectors located upstream of the carburetor tube swirlers (Configuration N4)
3. Pressure atomizing injectors protruding through the swirlers, spraying fuel downstream of the carburetor swirlers (Configuration N12)

Comparison of the data for Configurations N3 and N4, both of which were tested at a carburetor equivalence ratio of 1.0, both of which had hex flameholders, and both of which had the same inlet diffuser configuration, shows that both configurations produced approximately the same emission levels. Configuration N12, however, produced significantly higher emissions of nitrogen oxides. All three configurations exhibited combustion efficiencies in excess of 99.4 percent at the design sea-level take-off condition.

Combustor Configurations N10 and N11 were tested to determine the effect of liner dilution air on the swirl-can combustor emission level. Aside from the addition of dilution air through both the inner and outer liners in Configuration N11, the two configurations were identical. The results showed that the addition of dilution air had a very small effect on emissions, although it did tend to reduce the sensitivity of the combustor emissions to changes in the fuel-air ratio.

## **2. STAGED PREMIX COMBUSTOR**

### **Test Results at Idle Conditions**

The emissions test results obtained at idle conditions for the staged premix combustor are shown in Table XXI for the design-point fuel-air ratio.

TABLE XXI

## STAGED PREMIX COMBUSTOR EMISSIONS AT IDLE CONDITIONS

<u>Configuration</u>	<u>Emission Index (g/kg fuel)</u>			<u>Combustion Efficiency (Percent)</u>
	<u>Oxides of Nitrogen</u>	<u>Carbon Monoxide</u>	<u>Total Unburned Hydrocarbons</u>	
<u>WITH BLEED</u>				
Goals	—	20	4	99.1
JT9D-7 Combustor	—	—	—	—
P1	4.2	24	0.5	98.8
P2	4.3	68	0	98.4
P3	3.8	9	1	99.8
P4	3.9	73	2	98.0
P5	3.9	73	2	98.0
<u>WITHOUT BLEED</u>				
Goals	—	20	4	99.0
JT9D-7 Combustor	3.3	77	29.8	94.7
P7	Unstable at design fuel-air ratio			
P8	Unstable at design fuel-air ratio			

Notes: Combustor rig conditions with bleed were inlet pressure of 2.93 atm, inlet temperature of 428 K, and fuel-air ratio of 0.0126.

Combustor rig conditions without bleed were inlet pressure of 3.74 atm, inlet temperature of 456 K, and fuel-air ratio of 0.0105.

Data for oxides of nitrogen have been corrected to combustor inlet air humidity of 6.3 g H<sub>2</sub>O/kg dry air.

Review of these data shows that the staged premix combustor provided excellent performance at idle conditions. The best results were obtained with Configuration P3, which exceeded all of the program goals for idle conditions.

Two flameholder configurations were tested, one with circular holes (Configurations P1 through P5), and the other with slots (Configurations P7 and P8). The best results were obtained with the circular holes. The configurations with slotted flameholders were unstable at idle operating conditions because these configurations also incorporated no dilution air holes in the combustor liners. The result was a high airflow loading of the premix passage, producing a high flameholder reference velocity and a low pilot passage equivalence ratio.

Carbon monoxide emissions were found to be strongly influenced by the fuel-air ratio. As shown in Figure 44, each configuration demonstrated an optimum fuel-air ratio for minimum carbon monoxide emissions, although the optimum fuel-air ratio was not the same for all configurations. The lowest carbon monoxide emissions were provided by Configuration P3, for which the optimum fuel-air ratio was equal to the design point fuel-air ratio for idle without compressor bleed.

The emissions of unburned hydrocarbons (Figure 45) are insensitive to fuel-air ratio for fuel-air ratios above 0.012, but they rise rapidly as the fuel-air ratio decreases below 0.012.

#### Test Results at Sea-Level Take-Off Conditions

The test results for the staged premix combustor at simulated sea-level take-off conditions are shown in Table XXII. Generally, the combustion efficiencies of these combustor configurations were poor, with high carbon monoxide emissions. A strong trade was evident between efficiency and emissions of nitrogen oxides, with those configurations that met the efficiency goal tending also to have high emissions of oxides of nitrogen. Smoke levels were low, with all configurations operating with SAE Smoke Numbers of 6 or lower. Configurations P7 and P8, which incorporated slotted flameholders and no combustor liner dilution air, were unstable at the sea-level take-off design point, and hence were not scaled to the design point.

A series of tests was conducted to determine the effect of varying the fuel flow split between the pilot and main burner, thereby altering the equivalence ratio in each of the burners but maintaining the overall fuel-air ratio at the design point. Figure 46 shows that changing the fuel flow split has a significant effect on the emissions of oxides of nitrogen, with the minimum emissions occurring at a pilot burner fuel-air ratio of approximately 0.007. The reason for the observed trend is that both burning zones operate at an equivalence ratio of approximately 0.7 at the design point fuel-air ratio and fuel split. Changing the fuel split increases the equivalence ratio of one burning zone while decreasing the equivalence ratio of the other. Since the production of oxides of nitrogen increases exponentially with combustion equivalence ratio, a shift in the fuel flow split in either direction away from the split that provides near optimum equivalence ratios in each burning zone results in a substantial increase in emissions of oxides of nitrogen. Figure 47 shows that changing the fuel-flow split to provide less fuel flow to the pilot burner than the design level results in a decrease in combustion efficiency. Increasing the fuel flow to the pilot burner above the design value has a negligible effect on efficiency.

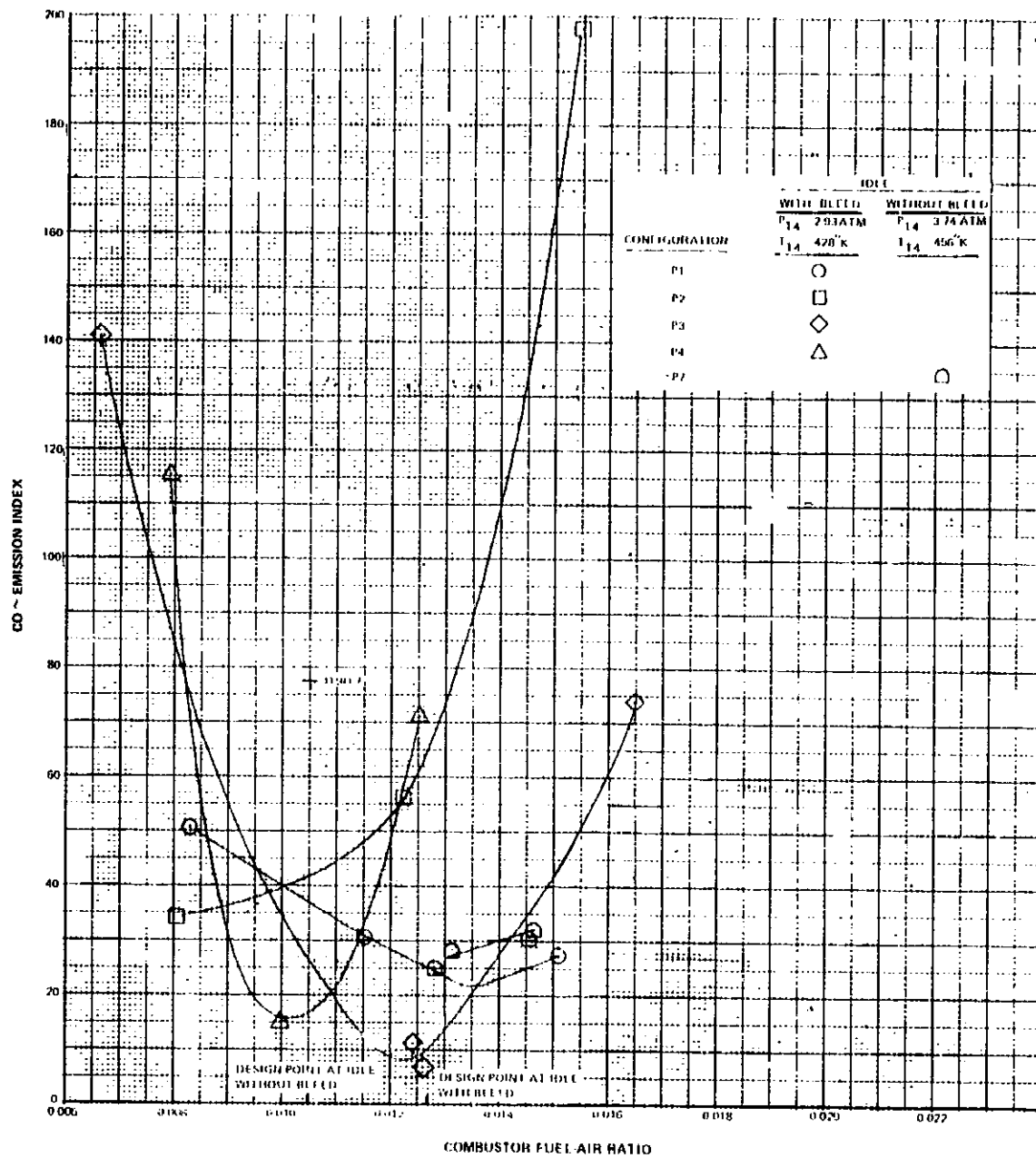

Figure 44 Staged Premix Combustor Carbon Monoxide Emission Levels as a Function of Fuel-Air Ratio at Idle Conditions

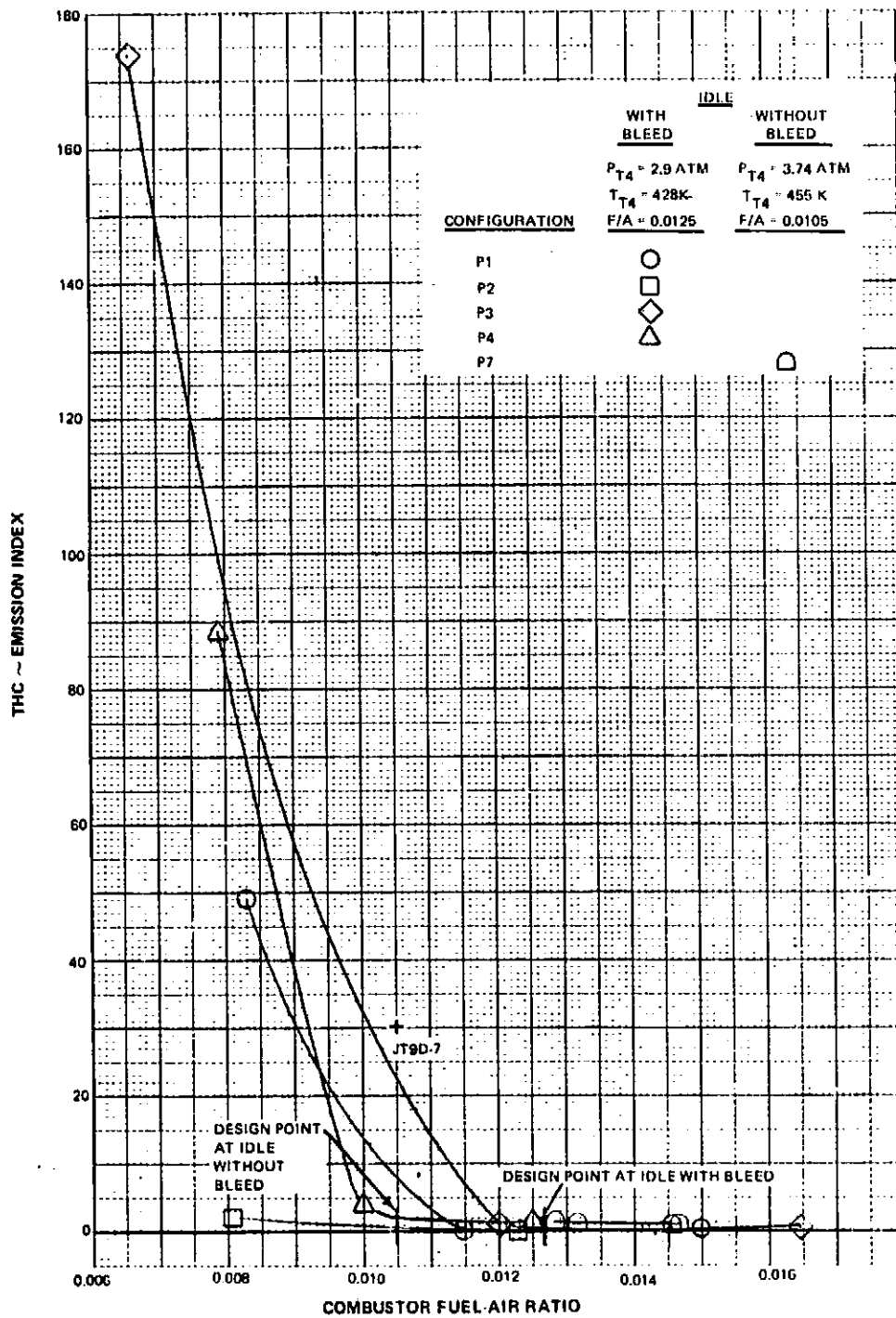

Figure 45 Staged Premix Combustor Total Unburned Hydrocarbon Emission Levels as a Function of Fuel-Air Ratio at Idle Conditions

TABLE XXII

STAGED PREMIX COMBUSTOR EMISSIONS AT SEA-LEVEL TAKE-OFF CONDITIONS

Configuration	Pilot Fuel-Air Ratio	Main Burner Sector Fuel Split (Percent)*	Combustor Test Rig Conditions Emission Index (g/kg fuel)				Combustion Efficiency (Percent)	Oxides of Nitrogen Emission Index Corrected to Engine Design Take-Off Conditions (g/kg fuel)
			Overall Fuel-Air Ratio	Oxides of Nitrogen	Carbon Monoxide	Total Unburned Hydrocarbons		
Goals	--	--	--	--	--	--	99.0	10.0
JT9D-7 Combustor	--	--	--	--	--	--	--	31.5
P1	0.0081	--	0.0206	8.6	14.9	0.7	99.6	16.0
P1	0.0096	--	0.0244	12.4	10.5	0.1	99.7	21.3
P2	0.0079	--	0.0227	11.5	36.0	1.5	99.0	21.8
P2	0.0099	--	0.0099	11.5	0.9	0.5	99.9	28.7
P2	0	--	0.0152	15.1	36.2	1.7	99.0	32.8
P2	0.0092	--	0.0231	12.5	28.2	0.7	99.3	23.6
P2	0.0101	--	0.0254	14.8	20.8	0	99.5	25.3
P3	0.0075	--	0.0227	9.0	65.7	8.2	97.5	17.5
P3	0.0026	--	0.0267	12.9	57.5	2.8	98.3	22.0
P3	0.0047	--	0.0244	10.4	92.2	31.8	94.1	19.6
P3	0.0089	--	0.0223	9.3	39.5	1.4	98.9	17.2
P3	0.0100	--	0.0255	11.7	23.3	0.3	99.4	20.6
P3	0.0124	--	0.0248	12.1	37.3	1.1	99.0	22.1
P4	0.0084	--	0.0216	6.4	47.5	12.2	97.5	11.8
P4	0.0088	--	0.0225	10.2	31.7	3.5	98.8	18.5
P4	0.0024	--	0.0252	11.7	62.7	24.0	95.7	19.9
P4	0.0048	--	0.0232	9.7	87.9	57.6	91.2	17.7
P4	0.0068	--	0.0227	10.3	50.3	2.5	98.5	19.5
P4	0.0077	--	0.0196	7.8	71.0	15.6	96.5	15.0
P4	0.0102	--	0.0263	13.0	28.9	0.8	99.3	21.4
P4	0.0122	--	0.0246	14.0	46.7	3.8	98.4	24.6
P5	0.0045	54.4	0.0256	9.4	84.2	43.9	94.3	17.2
P5	0.0047	56.6	0.0273	9.8	76.3	37.2	93.9	17.1
P5	0.0044	62.7	0.0247	9.7	80.3	41.2	92.6	18.1
P5	0.0045	58.9	0.0250	9.6	85.8	45.9	92.6	17.6
P5	0.0043	66.3	0.0242	9.8	79.7	50.2	92.3	17.7
P5	0.0042	71.3	0.0235	9.8	79.4	53.0	91.9	19.0
P5	0.0040	50.0	0.0221	9.4	81.6	58.2	91.3	17.5
P7	0.0090	--	0.0300	5.2	70.5	80.1	89.0	--
P7	0.0096	--	0.0304	7.4	9.1	8.8	98.8	--
P7	0.0102	--	0.0257	24.0	39.4	196.5	76.1	--
P7	0.0123	--	0.0312	8.6	12.1	5.4	99.1	--
P7	0.0130	--	0.0305	7.5	15.4	15.5	97.8	--
P8	0.0106	--	0.0268	1.2	291.0	205.0	69.2	--
P8	0.0122	--	0.0312	6.0	17.1	6.6	96.4	--
P8	0.0135	--	0.0348	7.2	3.6	2.6	99.6	--
P8	0.0117	--	0.0292	6.8	17.1	23.6	96.8	--
P8	0.0126	--	0.0326	9.5	5.1	18.7	97.7	--
P8	0.0130	--	0.0330	9.1	5.3	35.4	95.7	--
P8	0.0109	--	0.0109	4.3	4.6	31.6	96.2	--
P8	0.0146	--	0.0146	9.0	1.7	105.2	87.7	--
P8	0	--	0.0133	3.0	37.6	288.0	65.9	--
P8	0	--	0.0140	0.2	39.8	402.3	52.1	--
P8	0	--	0.0243	12.0	11.0	3.2	99.4	--
P8	0	--	0.0305	12.0	41.4	4.0	98.6	--

Notes: \*Represents ratio of fuel to six injectors adjacent to passage sidewalls divided by total main burner fuel flow.

Combustor test rig conditions were inlet pressure of 6.8 atm, inlet temperature of 768.9 K, and inlet airflow rate of 6.88 kg/s.

Engine design conditions were combustor inlet pressure of 21.7 atm, combustor inlet temperature of 768.9 K, and combustor inlet airflow rate of 92.9 kg/s.

ORIGINAL PAGE IS  
OF POOR QUALITY



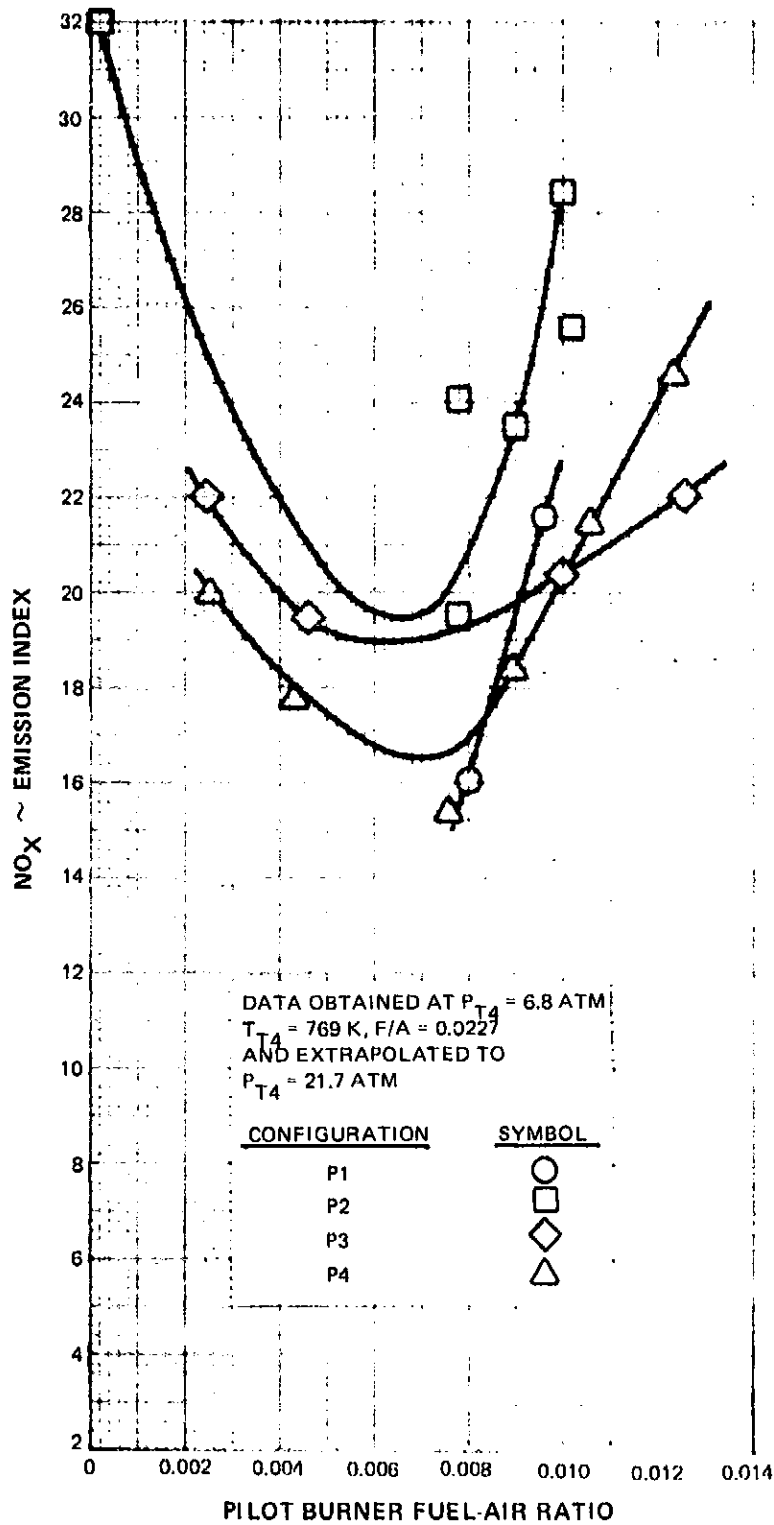

Figure 46 Staged Premix Combustor Oxides of Nitrogen Emission Levels as a Function of Pilot Burner Fuel-Air Ratio at Sea-Level Take-Off Conditions

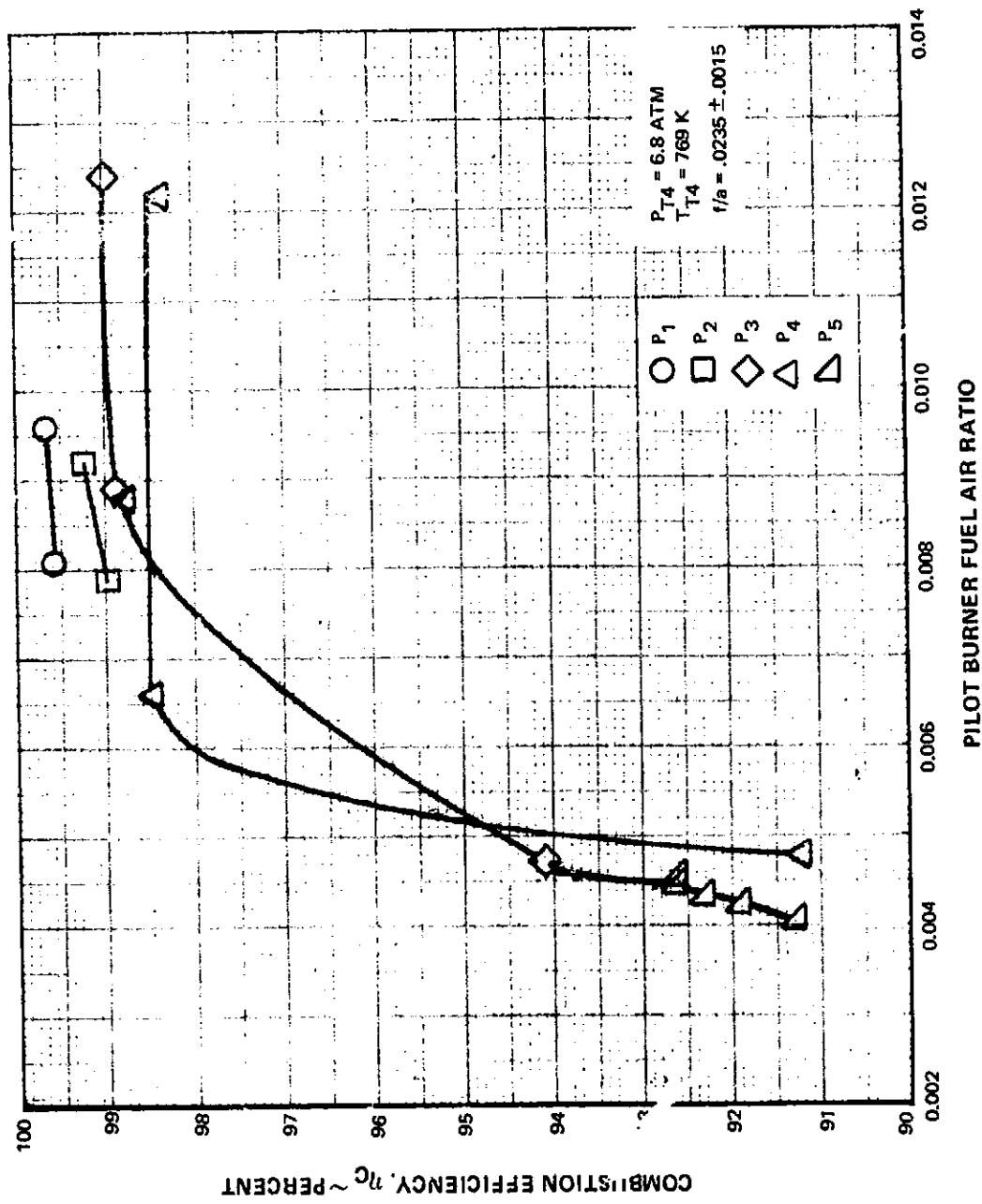

Figure 47 Staged Premix Combustor Combustion Efficiency as a Function of Pilot Burner Fuel-Air Ratio at Sea-Level Take-Off Conditions

C.2

The effect of fuel-air mixture preparation was evaluated in two tests. In the first, the circumferential distribution of fuel in Configuration P5 was modified by dividing the main burner fuel injectors into two groups, one group consisting of six injectors adjacent to the compartment sidewalls, and the other consisting of four injectors in the center portions of the compartments. Tests were conducted with various fuel splits between the two groups of injectors, while maintaining the total fuel flow constant. The results showed no significant effect of fuel flow distribution on either emissions of oxides of nitrogen or combustion efficiency, even when the fuel flow rate to the injectors adjacent to the compartment walls was reduced 17 percent below the design value or increased 19 percent above the design value.

In the second test to evaluate the effect of fuel-air mixture preparation, the number of fuel injectors in the main burner was doubled through the use of dual fuel injectors (Configuration P8). Since the fuel flow through each injector was one-half that of the configurations with the design number of injectors, the dual injectors were modified to provide the same pressure drop, thereby maintaining the same fuel droplet characteristics. The results of these tests indicated that doubling the number of injectors produced no significant effect on the emissions characteristics of the combustor.

An attempt was made to determine the effect of using a flameholder with slots instead of circular holes. Due to the very lean premix passage equivalence ratio, the configurations with the slotted flameholder were unstable at the sea-level take-off design point. Data were recorded at higher values of overall fuel-air ratio, but could not be scaled to an unstable operating point. Thus a direct comparison with the circular flameholder data was precluded.

### **3. SWIRL VORBIX COMBUSTOR**

#### **Test Results at Idle Conditions**

The emissions test results obtained at idle conditions for the swirl vorbix combustor are shown in Table XXIII. At idle, only the pilot zone was fired. The best configuration, Configuration S8, closely approached the emission goals for idle conditions (without compressor bleed) with a carbon monoxide emission index of 29 compared with the goal of 20 and an unburned hydrocarbon emission index of 4.5 compared with the goal of 4.0.

The effects of fuel-air ratio on the emissions of carbon monoxide are shown in Figure 48. The trends are similar for Configurations S2 through S7, with increasing fuel-air ratio producing a substantial decrease in carbon monoxide emissions. In contrast, Configurations S8 through S10 tended to produce lower carbon monoxide emissions at lower fuel-air ratios.

All configurations exhibited similar trends with respect to the effect of fuel-air ratio on the emissions of unburned hydrocarbons. As shown in Figure 49, emissions of unburned hydrocarbons decreased when the fuel-air ratio was increased.

Peak efficiency levels were not as high as those for the staged premix combustor, but the combustion efficiency of the swirl vorbix combustor was less sensitive to fuel-air ratio than that of the staged premix combustor.

TABLE XXIII

## SWIRL VORBIX COMBUSTOR EMISSIONS AT IDLE CONDITIONS

<u>Configuration</u>	<u>Emission Index (g/kg fuel)</u>			<u>Combustion Efficiency (Percent)</u>
	<u>Oxides of Nitrogen</u>	<u>Carbon Monoxide</u>	<u>Total Unburned Hydrocarbons</u>	
WITH BLEED				
Goals	—	20	4	99.1
JT9D-7 Combustor	—	—	—	—
S2	2.9	68	28	95.1
S3	2.1	68	29	95.0
S4	2.9	71	37	94.0
S5	2.9	71	37	94.0
S6	3.0	76	33	94.4
S7	3.0	76	33	94.4
WITHOUT BLEED				
Goals	—	20	4	99.0
JT9D-7 Combustor	3.3	77	29.8	94.7
S8	5.1	29	4.5	98.8
S9	4.0	57	13	97.1
S10	4.3	68	6.6	97.7

Notes: Combustor rig conditions with bleed were inlet pressure of 2.93 atm, inlet temperature of 428 K, and fuel-air ratio of 0.0126.

Combustor rig conditions without bleed were inlet pressure of 3.74 atm, inlet temperature of 456 K, and fuel-air ratio of 0.0105.

Data for oxides of nitrogen have been corrected to combustor inlet air humidity of 6.3 g H<sub>2</sub>O/kg dry air.

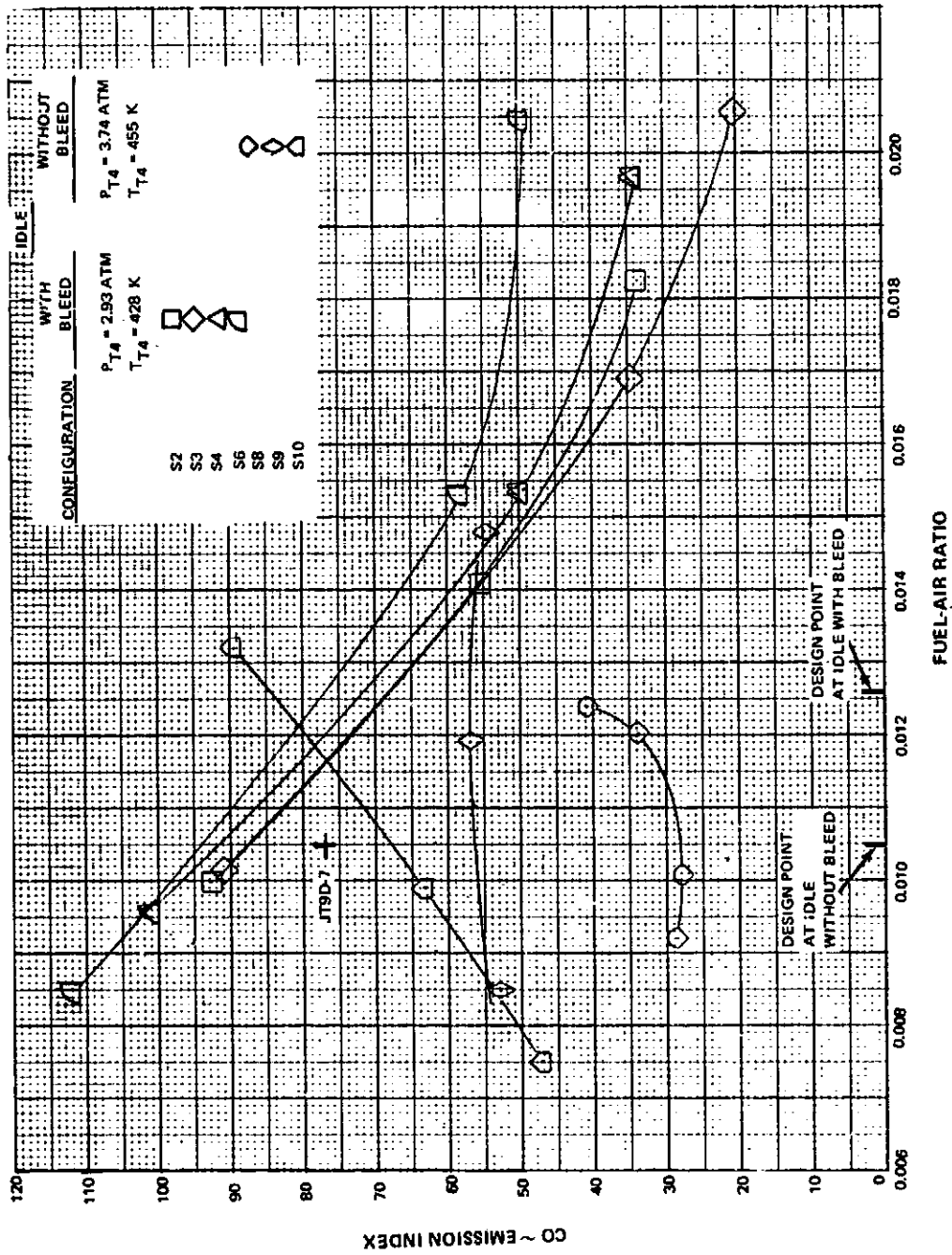

Figure 48 Swirl Vortex Combustor Carbon Monoxide Emission Levels as a Function of Fuel-Air Ratio at Idle Conditions

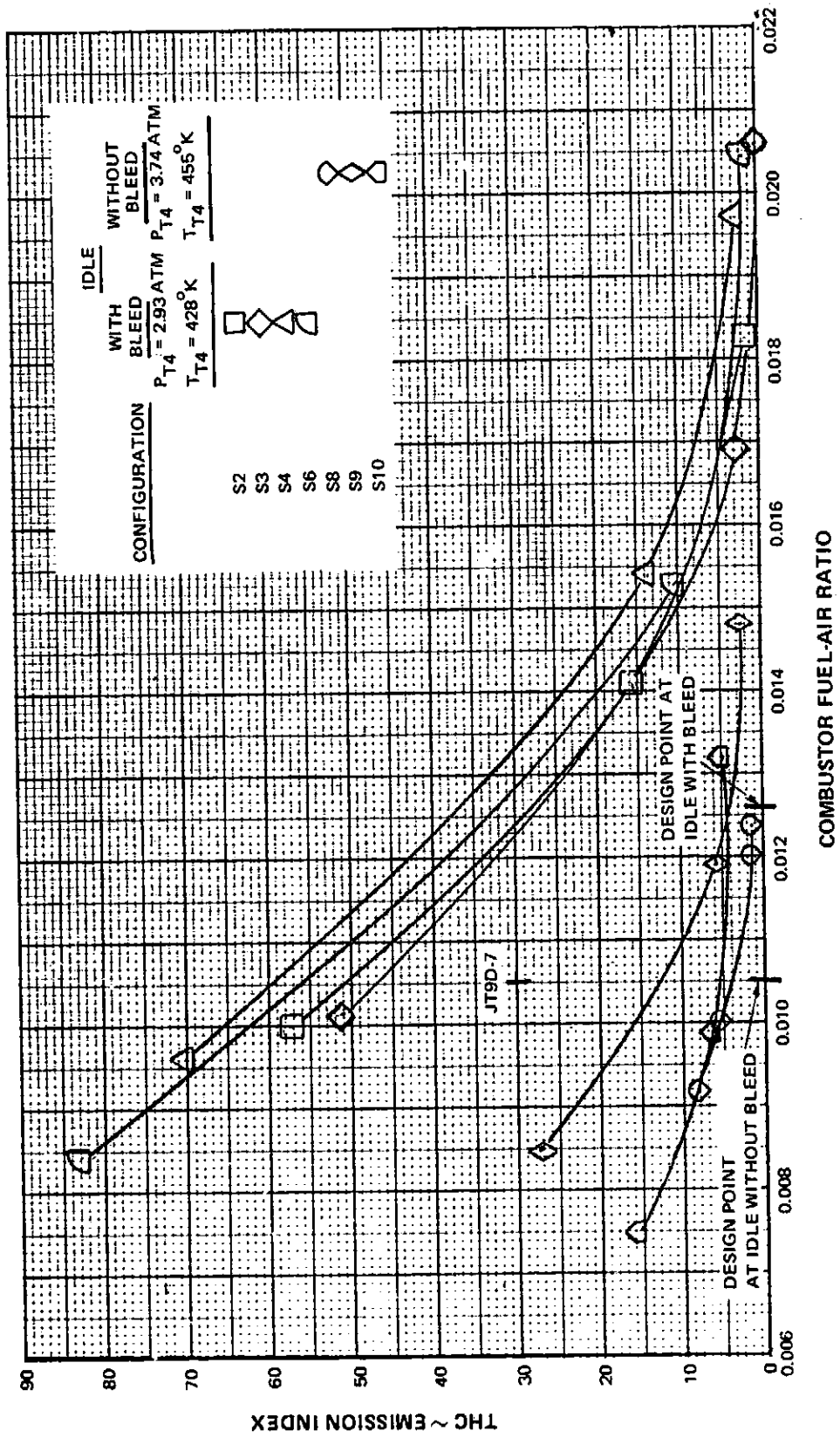

Figure 49 Swirl Vorbix Combustor Total Unburned Hydrocarbon Emission Levels as a Function of Fuel-Air Ratio at Idle Conditions

Configurations S2 through S7 incorporated numerous changes to the pilot burner that had been expected to improve the emissions at idle conditions. Included were changes to the pilot swirler airflow, changes to the pilot burner dilution flow, and the addition of an air scoop to increase the pressure drop across the fuel nozzles. However, none of these significantly improved the emission levels.

Configurations S8 through S10 incorporated fuel injectors with improved pressure atomizing fuel spray characteristics and incorporation of high airflow rate main burner swirlers. In addition, these configurations were tested at idle conditions without simulated compressor bleed, resulting in an operating point with higher combustor inlet temperature and pressure than that used for the previous configurations. The results indicated a significant improvement in emissions, but, because all the design changes as well as the change in operating point were made simultaneously, the individual effects of the changes cannot be separated. It is known that the change in operating point would tend to reduce the emissions of carbon monoxide and unburned hydrocarbons. However, it is believed that the improved fuel injectors probably also produced a significant effect.

The effect of decreasing the throat and rear liner height was assessed by comparing the data for Configuration S8, which had a throat height of 3.3 cm, with that for Configuration S10, which had a throat height of 2.5 cm. These configurations otherwise were identical. The data indicate that the reduction in throat height produced a significant increase in carbon monoxide emissions and a small increase in the emissions of unburned hydrocarbons, while reducing the emissions of oxides of nitrogen.

#### **Test Results at Sea-Level Take-Off Conditions**

The test results for the swirl vorticity combustor at simulated sea-level take-off conditions are presented in Table XXIV. The swirl vorticity combustors exhibited very low levels of emissions of oxides of nitrogen with high combustion efficiency. The best results were obtained with Configuration S10, which demonstrated an emission index for oxides of nitrogen of 12.4 at a combustion efficiency of 99.7 percent. This was the lowest emission level for oxides of nitrogen achieved in the program at the sea-level take-off design point in a configuration that also provided high combustion efficiency. SAE Smoke Numbers varied with configuration, with values ranging from 1 for Configuration S9 to 14 for Configuration S10 to 41 for Configuration S6.

The swirl vorticity combustors generally exhibited a decrease in the emissions of oxides of nitrogen as the fuel split was shifted to provide a higher fuel-air ratio for the main burner and a lower fuel-air ratio to the pilot burner, as shown in Figure 50. The reason for this trend is that reducing the fuel-air ratio of the pilot burner reduces the temperature of the flow through the pilot burner section, thereby reducing the time that the flow remains at the high temperatures and pressures at which oxides of nitrogen are formed. Decreasing the pilot burner fuel-air ratio below approximately 0.002 results in instability which is reflected in a decrease in overall combustion efficiency, as shown in Figure 51.

TABLE XXIV

## SWIRL VORBIX COMBUSTOR EMISSIONS AT SEA-LEVEL TAKE-OFF CONDITIONS

Configuration	Pilot Fuel-Air Ratio	Overall Fuel-Air Ratio	Combustor Test Rig Conditions				Combustion Efficiency (Percent)	Oxides of Nitrogen Emission Index Corrected to Engine Design Take-Off Conditions (g/kg fuel)
			Oxides of Nitrogen	Carbon Monoxide	Total Unburned Hydrocarbons	—		
Goals	—	—	—	—	—	99.0	10.0	
JT9D-7	—	—	—	—	—	—	31.5	
S2	0.0055	0.0148	9.0	16.6	0.7	99.5	19.3	
S2	0.0064	0.0243	10.5	11.5	0.1	99.7	17.9	
S2	0.0072	0.0205	10.8	4.4	0.1	99.9	20.4	
S2	0.0084	0.0258	11.6	13.0	0.1	99.7	19.7	
S2	0.0088	0.0252	11.3	9.9	0	99.8	19.9	
S2	0.0120	0.0250	13.5	5.7	0	99.9	23.6	
S3	0.0086	0.0226	14.5	4.9	0.1	99.9	26.6	
S3	0.0090	0.0254	11.5	7.0	0.3	99.8	25.4	
S3	0.0058	0.0154	10.5	7.3	0.1	99.8	21.7	
S3	0.0070	0.0276	12.6	7.8	0	99.8	19.5	
S3	0.0096	0.0282	14.2	6.0	0.2	99.8	22.1	
S3	0.0134	0.0288	16.9	5.1	0	99.9	25.2	
S4	0.0027	0.0236	9.2	27.2	1.3	99.2	16.7	
S4	0.0049	0.0236	10.3	10.6	0.2	99.7	18.8	
S4	0.0057	0.0156	10.1	9.9	0.2	99.8	21.5	
S4	0.0073	0.0236	11.5	5.9	0.1	99.9	20.8	
S4	0.0081	0.0223	11.6	4.0	0	99.9	21.6	
S4	0.0084	0.0227	12.1	3.9	0.1	99.9	23.3	
S4	0.0108	0.0298	12.5	10.0	0	99.8	19.4	
S4	0.0122	0.0240	14.7	3.0	0.1	99.9	26.9	
S4	0.0042	0.0042	6.3	70.8	79.6	89.0	19.3	
S4	0.0105	0.0295	11.7	9.9	0	99.8	23.6	
S4	0.0099	0.0273	14.1	7.8	0.1	99.8	20.7	



TABLE XXIV (Continued)

SWIRL VORBITZ COMBUSTOR EMISSIONS AT SEA-LEVEL TAKE-OFF CONDITIONS

Configuration	Pilot Fuel-Air Ratio	Overall Fuel-Air Ratio	Combustor Test Rig Conditions					Oxides of Nitrogen Emission Index Corrected to Engine Design Take-Off Conditions (g/kg fuel)
			Emission Index (g/kg fuel)		Total Unburned Hydrocarbons	Combustion Efficiency (Percent)		
			Oxides of Nitrogen	Carbon Monoxide				
S5	0.0051	0.0144	9.3	8.6	0.2	99.8	20.2	
S5	0.0075	0.0211	11.6	4.0	0	99.9	22.0	
S5	0.0101	0.0269	12.5	8.3	0.1	99.8	20.8	
S5	0.0096	0.0267	10.2	21.6	0	99.5	23.8	
S6	0.0012	0.0221	10.4	19.7	7	99.5	17.8	
S6	0.0026	0.0026	7.4	101.5	45.1	92.3	23.5	
S6	0.0021	0.0228	10.3	13.6	0.2	99.6	17.3	
S6	0.0045	0.0226	11.7	5.3	0	99.9	20.4	
S6	0.0054	0.0147	11.0	5.9	0.1	99.9	23.6	
S6	0.0069	0.0233	12.6	5.9	0	99.9	21.9	
S6	0.0076	0.0211	12.0	4.4	0.1	99.9	22.2	
S6	0.0095	0.0264	13.0	8.6	0	99.8	21.9	
S7	0.0082	0.0237	13.1	6.5	0	99.8	22.5	
S7	0.0092	0.0284	12.9	10.7	0	99.8	21.0	
S8	0.0022	0.0229	6.8	67.8	37.1	94.1	12.6	
S8	0.0030	0.0204	7.6	34.4	3.0	98.8	14.4	
S8	0.0033	0.0219	8.5	3.8	0.4	99.6	15.5	
S8	0.0046	0.0238	8.4	4.8	0	99.9	15.5	
S8	0.0056	0.0168	8.3	11.0	0.2	99.7	18.1	
S8	0.0070	0.0234	9.4	3.0	0	99.9	17.1	
S8	0.0082	0.0232	10.4	2.8	0	99.9	19.7	
S8	0.0091	0.0261	11.4	2.3	0.1	99.9	20.2	
S8	0.0103	0.0232	10.4	2.8	0	99.9	22.5	

TABLE XXIV (Continued)

## SWIRL VORBIX COMBUSTOR EMISSIONS AT SEA-LEVEL TAKE-OFF CONDITIONS

Configuration	Pilot Fuel-Air Ratio	Overall Fuel-Air Ratio	Combustor Test Rig Conditions				Combustion Efficiency (Percent)	Oxides of Nitrogen Emission Index Corrected to Engine Design Take-Off Conditions (g/kg fuel)
			Emission Index (g/kg fuel)		Total Unburned Hydrocarbons	Carbon Monoxide		
			Oxides of Nitrogen	Carbon Monoxide				
S9	0.0066	0.0227	9.6	4.7	0.2	99.9	17.1	
S9	0.0022	0.0226	2.8	178.0	190.0	73.6	6.6	
S9	0.0045	0.0223	8.0	11.9	1.5	99.6	14.6	
S9	0.0054	0.0152	8.2	7.5	2.9	99.5	17.5	
S9	0.0078	0.0222	10.3	3.6	0.2	99.9	19.0	
S9	0.0079	0.0079	19.0	4.3	0.5	99.9	47.1	
S9	0.0100	0.0221	12.4	2.4	0.1	99.9	22.7	
S10	0.0021	0.0225	1.9	142.0	153.8	78.7	3.7	
S10	0.0033	0.0220	5.0	60.2	33.5	94.7	9.1	
S10	0.0046	0.0046	8.9	19.0	1.9	99.4	20.5	
S10	0.0044	0.0221	7.0	13.8	0.3	99.7	13.5	
S10	0.0047	0.0239	7.4	9.4	0.8	99.7	12.4	
S10	0.0054	0.0159	8.4	24.0	1.3	99.3	16.7	
S10	0.0065	0.0190	9.2	7.7	0.2	99.8	17.7	
S10	0.0069	0.0233	9.8	3.3	0.4	99.9	16.6	
S10	0.0077	0.0227	11.7	3.0	0.2	99.9	20.3	

Notes: Combustor test rig conditions were inlet pressure of 6.8 atm, inlet temperature of 768.9 K, and inlet airflow rate of 6.88 kg/s.

Engine design conditions were combustor inlet pressure of 21.7 atm, combustor inlet temperature of 768.9 K, and combustor inlet airflow rate of 92.9 kg/s.

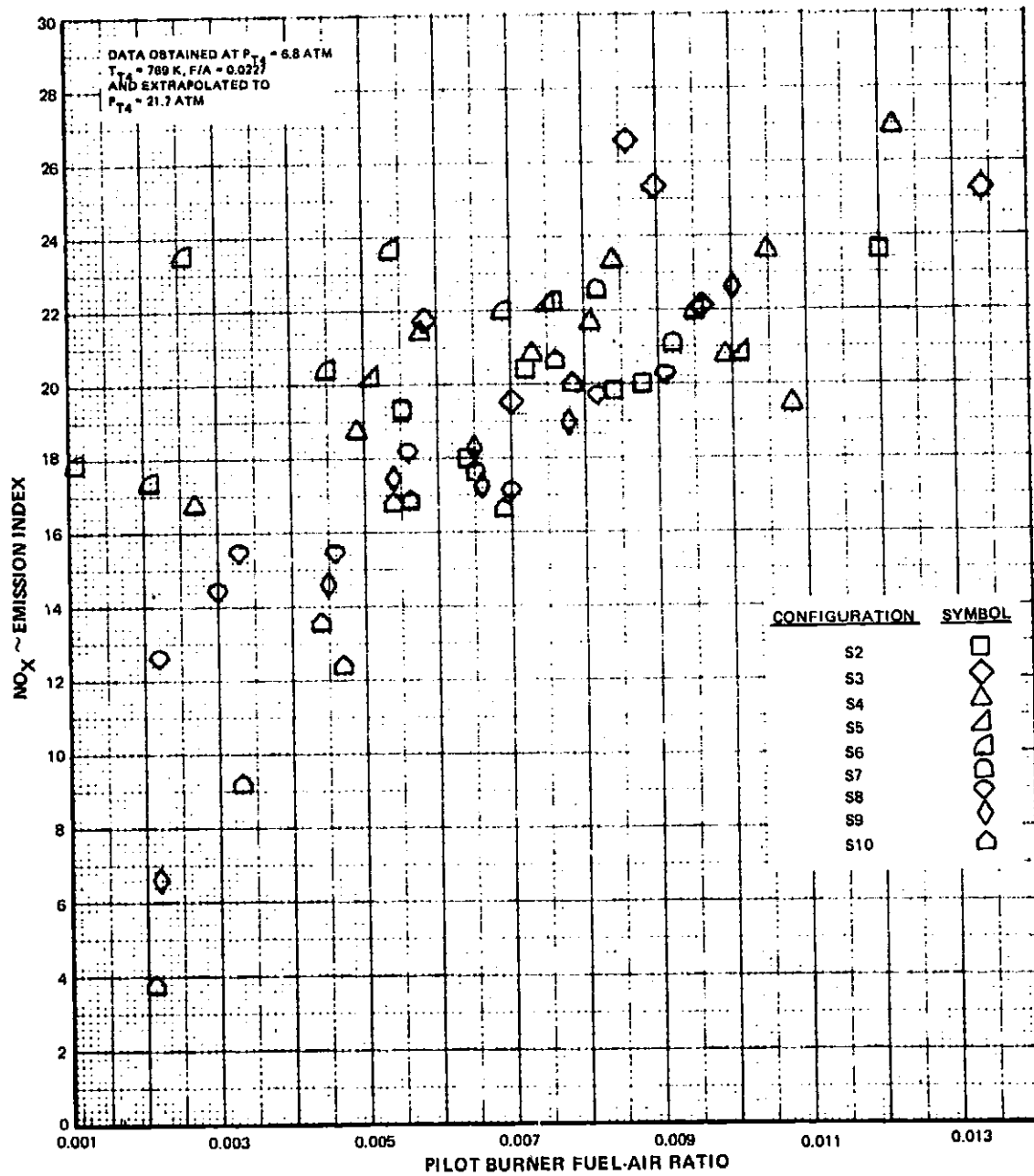

Figure 50 Swirl Vortex Combustor Oxides of Nitrogen Emission Levels as a Function of Pilot Burner Fuel-Air Ratio at Sea-Level Take-off Conditions

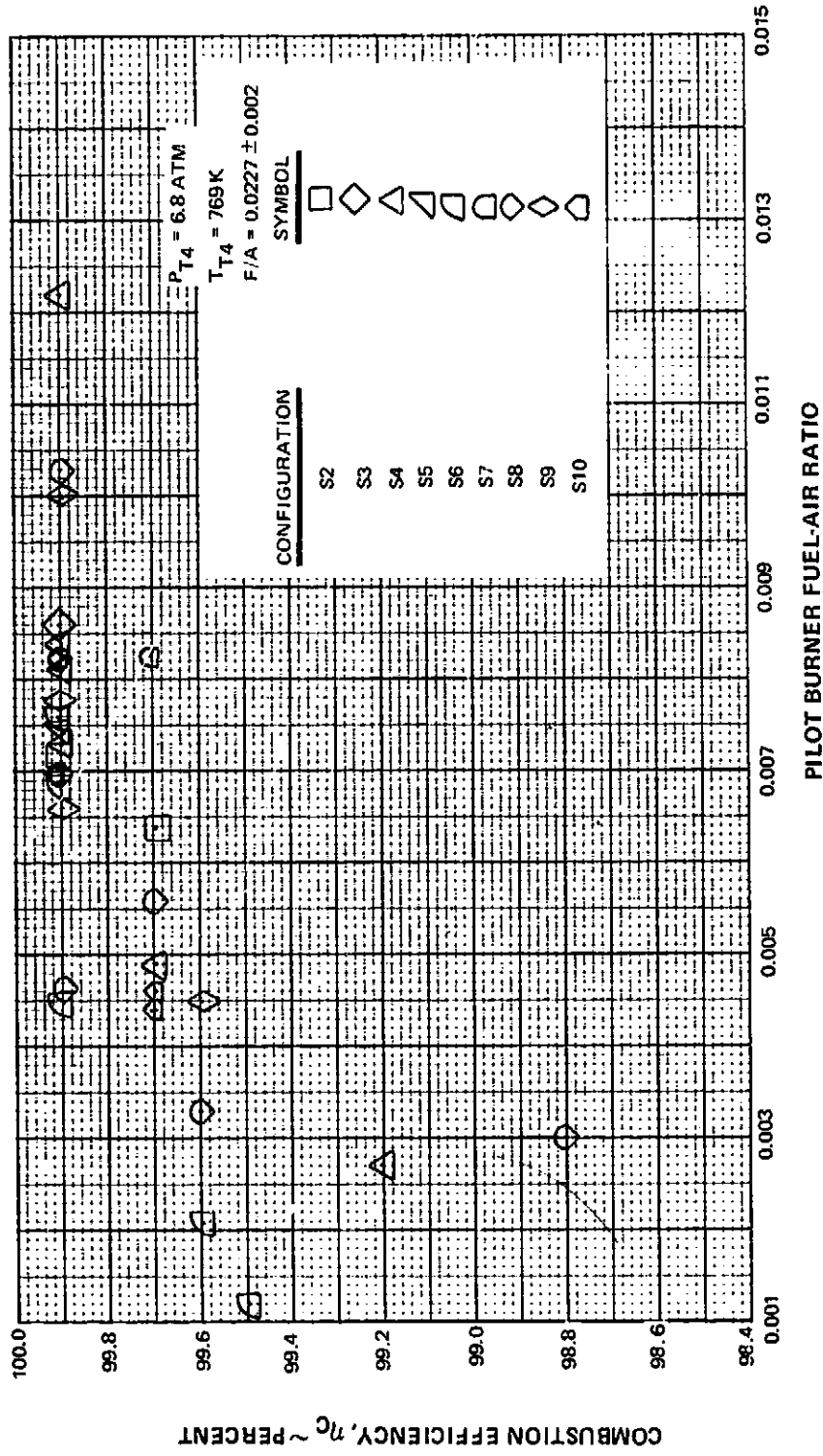

Figure 51 Swirl Vortex Combustor Combustion Efficiency as a Function of Pilot Burner Fuel-Air Ratio at Sea-Level Take-off Conditions

A series of tests were conducted to determine the effects of fuel source density on the emissions of oxides of nitrogen. In one test, the number of fuel injectors was changed from 7 to 13 without changing the fuel injector design, and in another, the number was changed with an accompanying change in design to maintain the fuel injector pressure drop and, therefore, the spray characteristics. Neither test resulted in any significant change in emissions.

Combustor Configurations S8 through S10 incorporated main burner swirlers with a flow area that was approximately twice that of the previous configurations. Because of the increased size of these swirlers, axial staggering on the inner wall was required, although the swirlers were positioned as close to the main burner fuel injectors as possible to promote rapid dilution of the fuel. In addition, to compensate for the increased flow through the swirlers, the liner dilution holes were blocked. These configurations demonstrated substantially lower emissions of oxides of nitrogen, but the specific effect of the increased swirler flow area could not be identified since a number of other changes were incorporated at the same time.

The effect of changing the main burner fuel injection angle was evaluated in Configuration S9, which incorporated fuel injectors that injected the fuel downstream at an angle of 66 degrees from the direction used for the other configurations. With this change, the main burner fuel was injected into the vicinity of the main burner air swirler discharge. This change produced a small improvement in emissions, reducing the emission index for oxides of nitrogen from 15.5 to 14.6 at a combustion efficiency of 99.6 percent.

The effect of combustor throat height was evaluated in Configuration S10 in which the throat height was reduced from the 3.3 cm used in the previous configurations to 2.5 cm. In addition, the main burner liner was narrowed to assess the impact of reduced mixture residence time both in the vicinity of the throat and in the main burner combustion zone. The pilot combustion zone was the same as that in Configuration S8. This configuration produced the lowest emission level achieved in the program at sea-level take-off conditions, with an emissions index for oxides of nitrogen of 12.4 at a combustion efficiency of 99.7 percent.

#### D. ASSESSMENT OF RESULTS

##### 1. TEST RESULTS AT IDLE CONDITIONS.....

The test results obtained at idle operating conditions for the best combustor configurations from each concept are shown in Table XXV. Results are presented for both the idle condition with simulated compressor bleed and the idle condition without simulated compressor bleed, since data were obtained at both conditions and insufficient data are available to permit correcting either set of data to the other set of conditions. Generally, the idle conditions with compressor bleed would be expected to produce higher emissions since the combustor inlet temperature and pressure are lower, both of which are known to produce higher emissions, and because the fuel flow rate is lower, resulting in less effective fuel atomization.

TABLE XXV

SUMMARY OF TEST RESULTS FOR BEST CONFIGURATIONS OF EACH COMBUSTOR CONCEPT AT IDLE CONDITIONS

Combustor Concept and Configuration	Operating Condition	Emission Index (g/kg fuel)				Combustion Efficiency (Percent)
		Carbon Monoxide	Unburned Hydrocarbons	Oxides of Nitrogen	Total	
Goals	With and without bleed	20	4	—	—	99.1
JT9D-7 Combustor	Without bleed	77	29.8	3.3	—	94.7
Swirl Can Configuration N3 (Inner row of carburetor modules only)	With bleed	117	61	2.2	—	90.1
Swirl Can Configuration N11 (Outer row of carburetor modules only)	Without bleed	78.5	58.5	2.2	—	91.3
Staged Premix Configuration P3	With bleed	9	1	3.8	—	99.8
Staged Premix Configurations P7,P8	Without bleed	Unstable at design point				—
Swirl Vorbix Configuration S3	With bleed	68	29	2.1	—	95.0

TABLE XXV (Continued)

SUMMARY OF TEST RESULTS FOR BEST CONFIGURATIONS OF EACH COMBUSTOR CONCEPT AT IDLE CONDITIONS

Combustor Concept and Configuration	Operating Condition	Emission Index (g/kg fuel)			Combustion Efficiency (Percent)
		Carbon Monoxide	Unburned Hydrocarbons	Oxides of Nitrogen	
Swirl Vorbix Configuration S8	Without bleed	29	4.5	5.1	98.8

Notes: Combustor rig conditions with bleed were inlet pressure of 2.93 atm, inlet temperature of 428 K, and fuel-air ratio of 0.0126.

Combustor rig conditions without bleed were inlet pressure of 3.74 atm, inlet temperature of 456 K, and fuel-air ratio of 0.0105.

Data for oxides of nitrogen have been corrected to combustor inlet air humidity of 6.3 g H<sub>2</sub>O/kg dry air.

The staged premix combustor, Configuration P3, provided the best results at idle conditions in the program. It was the only configuration that produced emission levels that were better than the program goals for carbon monoxide and total unburned hydrocarbons at idle conditions. Since this configuration was tested at idle conditions with simulated compressor bleed, still lower emissions would be expected if it were tested without simulated bleed. Since the staged premix concept is sensitive to premix passage fuel-air ratio, a resizing of the pilot zone airflow schedule to achieve stoichiometric burning at the lower fuel-air ratio would be required to maintain minimum idle emissions. None of the staged premix combustor configurations were successfully tested at the idle condition without simulated bleed. Tests were attempted with Configurations P7 and P8, but both were unstable at the fuel-air ratio of 0.0105 corresponding to the unbled condition.

The swirl vortex combustor did not meet the emission goals for the program at idle conditions, but it approached the goals and demonstrated a substantial improvement from the emission levels of the JT9D-7 combustor. The best results were obtained with Configuration S8, which was tested without simulated bleed. This configuration demonstrated an emission index for carbon monoxide of 29, which is 45 percent above the goal, but 62 percent below the JT9D-7 level. It also demonstrated an emission index for total unburned hydrocarbons of 4.5, which is only 13 percent above the goal, and is 85 percent below the JT9D-7 level. Configuration S3 provided the best swirl vortex combustor results at idle with compressor bleed.

The swirl-can combustor provided poor performance at idle conditions. The best results were obtained with Configuration N3 at idle conditions with bleed, with fuel supplied only to the inner row of carburetor modules. Slightly lower emission levels were obtained with Configuration N11 at idle conditions without bleed, but the difference is small, and testing of this configuration at idle conditions with bleed would be expected to result in emission levels higher than those demonstrated by Configuration N3. None of the swirl-can combustor configurations produced emissions at idle as low as those produced by the JT9D-7 combustor. Generally, the results showed that the swirl can combustor emissions can be reduced by fueling only the inner carburetor module row or by sector burning, but these techniques are not sufficient alone to meet the program emission goals. Analysis of the results suggests that the head plate dilution air is being added too rapidly, causing premature reaction quenching. A sheltered or otherwise isolated pilot zone might provide acceptable emissions at low power.

## 2. TEST RESULTS AT SEA-LEVEL TAKE-OFF CONDITIONS

The test results obtained at sea-level take-off conditions for the best configurations of each combustor concept are presented in Table XXVI. Emissions data for oxides of nitrogen have been corrected to actual JT9D-7 engine operating conditions. The other data are presented at combustor rig test conditions. Operation of the test combustors at the higher pressures would be expected to result in higher efficiencies than those reported.

Overall, none of the combustors met the emissions goal for oxides of nitrogen at the required combustion efficiency for the sea-level take-off conditions. The best combustor did provide a substantial improvement in emissions of oxides of nitrogen relative to the current JT9D-7 combustor, however.



TABLE XXVI

SUMMARY OF TEST RESULTS FOR BEST CONFIGURATIONS OF  
EACH COMBUSTOR CONCEPT AT SEA-LEVEL TAKE-OFF  
CONDITIONS

<u>Combustor Concept and Configuration</u>	<u>Oxides Of Nitrogen Emission Index Corrected to Engine Design Take-off Conditions (g/kg fuel)</u>	<u>Combustion Efficiency (Percent)</u>	<u>SAE Smoke Number</u>
Goals	10.0	99.0	15
JT9D-7 Combustor	31.5	99.99	10
Swirl Can Configuration N9	13.6	99.5	1
Staged Premix Configuration P3	20.6	99.4	6
Swirl Vorbix Configuration S10	12.4	99.7	14

Notes: Oxides of Nitrogen data corrected to engine conditions with combustor inlet pressure of 21.7 atm, combustor inlet temperature of 768.9 K, and combustor inlet airflow rate of 92.9 kg/s.

Combustion efficiency (based on gas sample) and SAE Smoke Number are recorded data at test rig conditions with inlet pressure of 6.8 atm, inlet temperature of 768.9 K, and inlet airflow rate of 6.88 kg/s.

The swirl vortex combustor, Configuration S10, provided the lowest emissions of oxides of nitrogen at the sea-level take-off condition. Although it did not meet the goal, it provided a 61 percent reduction in emissions of oxides of nitrogen relative to the JT9D-7 combustor, with an efficiency of 99.7 percent. The smoke level of the swirl vortex combustors varied with configurations. Configuration S10 marginally met the goal with an SAE Smoke Number of 14 at the combustor segment rig operating conditions, but higher smoke levels would be expected at actual engine operating pressures.

The best swirl-can combustor configuration (N9) exhibited a 57-percent reduction in emissions of oxides of nitrogen relative to the JT9D-7 combustor at an efficiency of 99.5 percent. All of the swirl-can combustors provided low smoke levels, with the N9 configuration providing an SAE Smoke Number of 1.0.

Staged premix combustor Configuration P3, which was the best of the staged premix combustors tested, exhibited significantly higher emissions of oxides of nitrogen than did the swirl vortex and swirl can combustors. However, it still demonstrated a 35-percent reduction in emissions of oxides of nitrogen relative to the JT9D-7 combustor. Taken as a class, the staged premix combustors were deficient in combustion efficiency at high power levels. Smoke levels were low for all configurations. The high emissions and low efficiency levels are not characteristic of combustors with lean combustion of prevaporized, homogeneous fuel-air mixtures. Since the combustor premix passages were nominally sized for lean fuel-air ratio (equivalence ratio of 0.7), it appears that only limited premixing and vaporization were actually accomplished in the configurations tested in this program.

## E. COMBUSTOR PERFORMANCE

In addition to the combustor emissions measurements, performance measurements were made during the Phase I screening tests. Included were measurements of pressure loss, exit temperature pattern, idle lean blowout, altitude stability and relight characteristics, and durability. The results of these measurements are summarized below.

### 1. PRESSURE LOSS

The measured values of combustor, diffuser, and system pressure loss are summarized in Table XXVII for all configurations tested. As shown, the overall combustor section loss was generally held close to the goal of 6 percent except for Configurations N7 and N9 through N13. These configurations incorporated a diffuser blockage screen to improve the airflow distribution at the combustor headplate raising the pressure loss by approximately 2.1 percent. This approach was used as an expedient method of improving the airflow in the screening tests and is not considered to be a realistic approach for engine application.

### 2. EXIT TEMPERATURE PATTERN

Exit temperature traverse data were taken at the idle and the simulated take-off operating conditions. The resulting data were plotted as circumferential profiles which were then reduced to the form of combustor exit temperature pattern factor and average radial profile.

#### Circumferential Profiles

The circumferential temperature profiles were reviewed to identify the areas of nonuniformity (which are undesirable since they represent hot spots that have an adverse effect on turbine durability) and to relate the areas of nonuniformity to specific features of the combustor where possible. The influence of the sector combustor rig sidewall cooling is readily apparent in all the profiles.

The circumferential temperature profiles for a representative swirl-can combustor at idle and take-off conditions are shown in Figures 52 and 53, respectively. Both profiles, but particularly the profile for idle conditions, show regions of increased temperature in line with the diffuser struts. Since the fuel was distributed uniformly at the combustor headplate, these regions indicate reduced airflow directly downstream of the struts.

The circumferential temperature profiles for a staged premix combustor are shown in Figures 54 and 55. At idle conditions, the highest temperatures occurred in line with the struts, apparently because the sheltered regions downstream of the struts acted as flameholders for the pilot burner. In addition, in Configuration P1, for which the data are shown, no liner dilution air was supplied to that portion of the circumference occupied by the strut compartments, which increased the degree of nonuniformity in the temperature profile. At take-off conditions, the profiles were reversed, with the region behind the struts being characterized by lower temperatures. The reason for this was that no main burner fuel injectors were located in the strut compartments to prevent fuel aspiration in the strut wake.

ORIGINAL PAGE IS  
OF POOR QUALITY

TABLE XXVII

SUMMARY OF COMBUSTOR PRESSURE LOSS TEST RESULTS

<u>Configuration</u>	<u>Overall Pressure Loss (Percent)</u>	<u>Combustor Pressure Loss (Percent)</u>	<u>Diffuser Pressure Loss (Percent)</u>
Goal	< 6.0		
JT9D-7	5.5	3.0	2.5
Swirl-Can Combustor			
N1	4.0	1.5	2.5
N2	4.6	2.2	2.4
N3	5.3	2.7	2.6
N4	5.1	2.4	2.7
N5	5.6	2.9	2.7
N6	5.7	2.9	2.8
N7	8.2*	3.2	2.9
N8	5.9	2.8	3.1
N9	7.4*	2.3	3.0
N10	9.0*	3.5	3.4
N11	9.4*	4.2	3.1
N12	7.5*	2.3	3.1
N13	7.4*	2.3	3.0
Staged Premix Combustor			
P1	6.6	3.1	3.5
P2	4.9	2.6	2.3
P3	5.3	3.0	2.3
P4	5.6	2.6	3.0
P5	5.6	2.6	3.0
P6			
P7	6.1	2.9	3.2
P8	6.1	2.9	3.2
P9			
Swirl Vorbix Combustor			
S1	5.0	2.2	2.8
S2	5.7	3.0	2.7
S3	5.5	3.0	2.5
S4	6.1	3.1	3.0
S5	6.1	3.1	3.0
S6	6.7	3.7	3.0
S7	6.7	3.7	3.0
S8	5.6	2.6	3.0
S9	5.6	2.6	3.0
S10	5.6	2.6	3.0

\*Includes diffuser screen pressure loss of 2.1 percent.

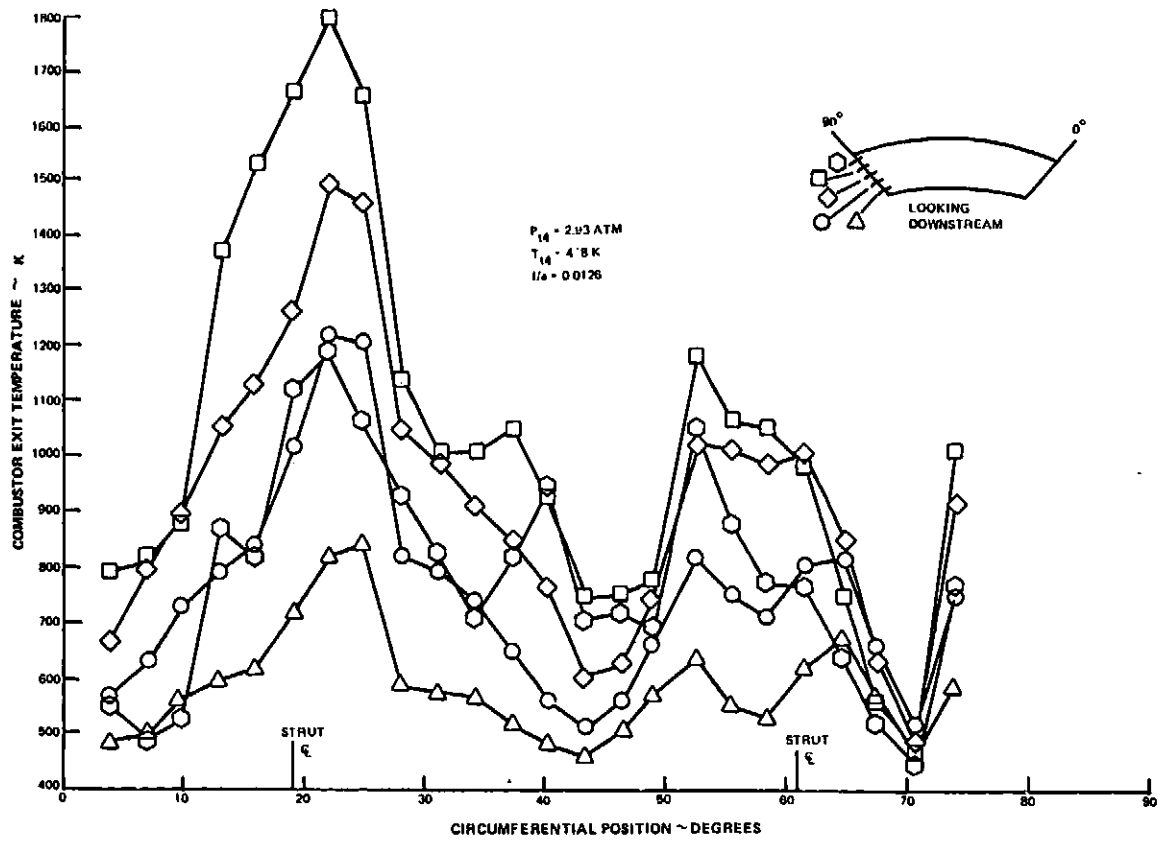

Figure 52 Circumferential Exit Temperature Patterns for Swirl-Can Combustor Configuration N5 at Idle Conditions .

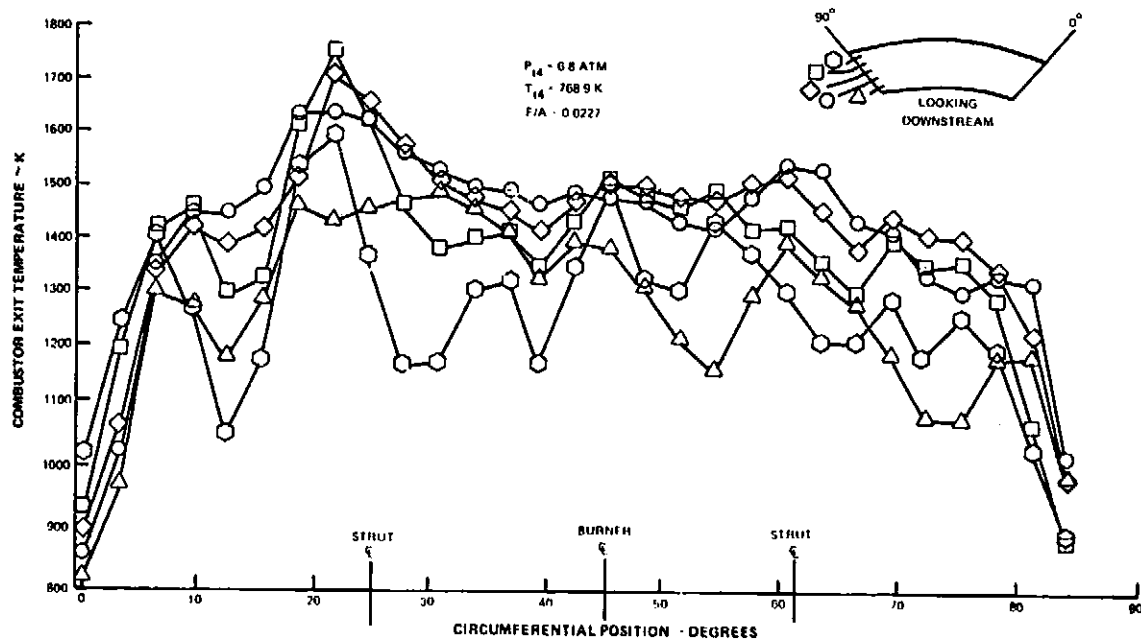

Figure 53 Circumferential Exit Temperature Patterns for Swirl-Can Combustor Configuration N5 at Take-off Conditions

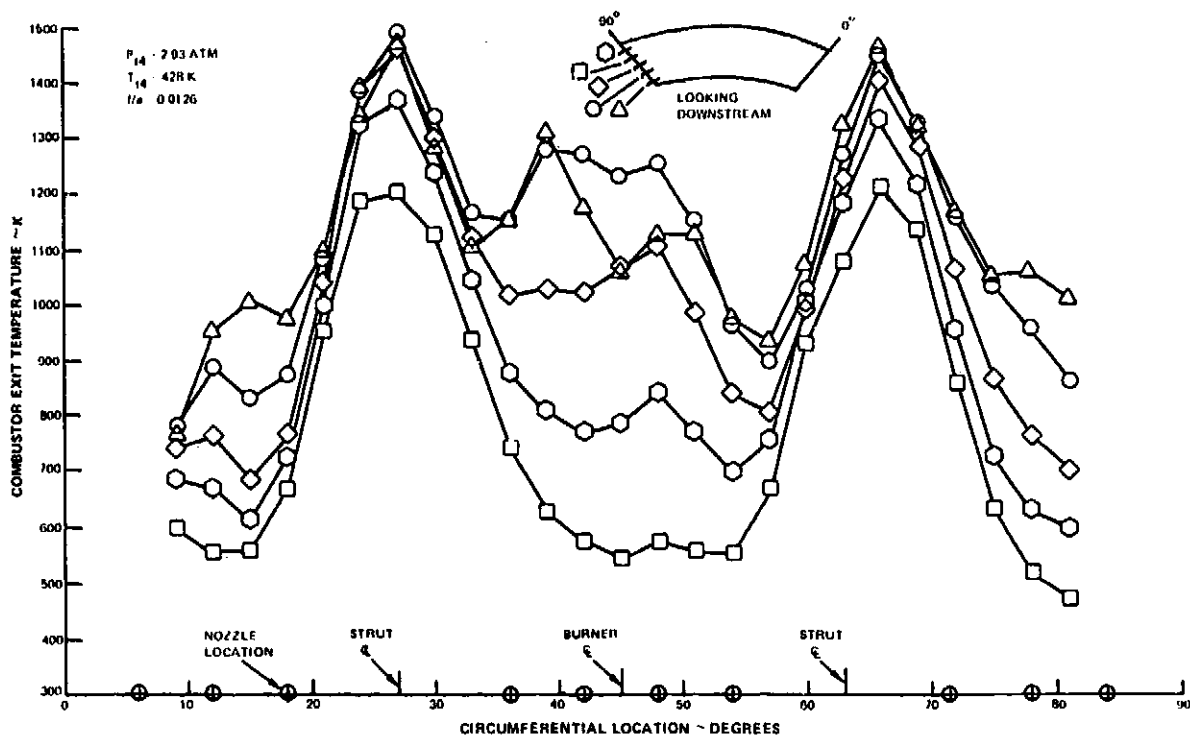

Figure 54 Circumferential Exit Temperature Patterns for Staged-Premix Combustor Configuration P1 at Idle Conditions

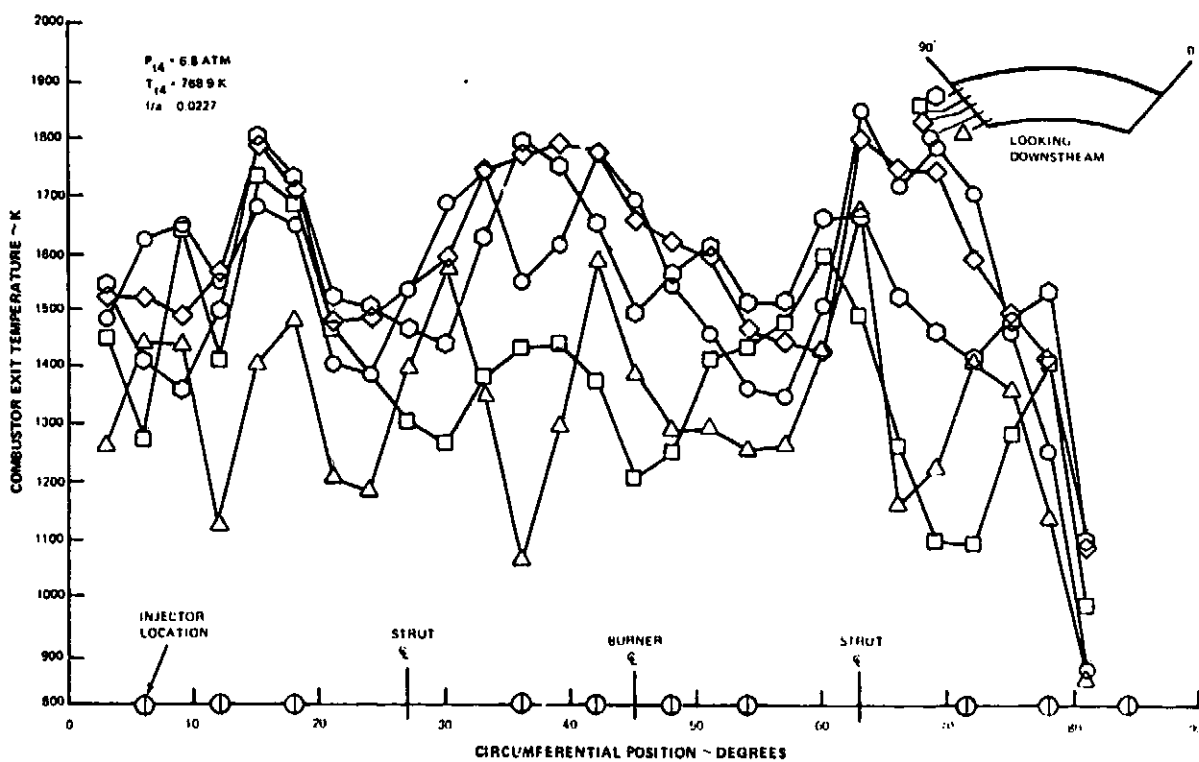

Figure 55 Circumferential Exit Temperature Patterns for Staged-Premix Combustor Configuration P1 at Take-off Conditions

The swirl vortex combustor exhibited the most uniform circumferential temperature profiles of the three concepts investigated. At idle conditions, the temperature profile exhibited some nonuniformity attributable to the diffuser strut wakes, as shown in Figure 56, but overall, the profile is relatively uniform. At take-off conditions, the temperature profile did not exhibit periodic nonuniformities that could be related to either diffuser strut wakes or to the location of the pilot fuel injectors, as shown in Figure 57.

#### **Pattern Factor**

The combustor exit temperature pattern factors for each configuration are summarized in Table XXVIII. It should be noted that inadequate durability of the traverse rake thermocouples hindered the acquisition of data, and a number of tests were conducted with fewer than five operational thermocouples. For these tests, the pattern factor was calculated on the basis of the maximum temperature observed using the remaining functioning thermocouples. Average combustor exit temperatures were determined on the basis of the gas sample (carbon balance) fuel-air ratio.

Review of the data indicates that the pattern factors at take-off conditions were generally in the range of 0.5 to 0.6 for all three combustor concepts. Although these values are substantially higher than the goal of 0.25, it is anticipated that the pattern factors at take-off conditions can be reduced significantly with development. The high pattern factors at idle are not of particular concern, since the average temperature levels are low, and the high pattern factors at this condition therefore do not impose durability problems in the turbine.

#### **Radial Exit Temperature Profiles**

The average combustor exit radial profiles were determined from the exit temperature traverse data. In general, it was found that the radial profile varied considerably with configurational changes.

Representative profiles for each concept at idle conditions are shown in Figure 58. The profiles were strongly influenced by the location of the pilot zone. The swirl can combustor exhibits a profile with a high peak near the outer wall, while the staged premix combustor is biased toward the inner wall. The swirl vortex combustor exhibits a nearly flat profile, consistent with its axially staged design. Although temperature profiles at idle are not generally of concern, the severely peaked profile of the swirl-can combustor at idle could require consideration of its affect on the turbine.

Figure 59 presents the average radial temperature profiles for the combustor concepts at take-off conditions. All three exhibit a peak at the center, whereas the target profile for the JT9D-7 engine provides a peak near the 70 percent span location. The radial profile goal is considered to be achievable with additional combustor development, although the task would be difficult in those combustor concepts which do not provide liner dilution flow.

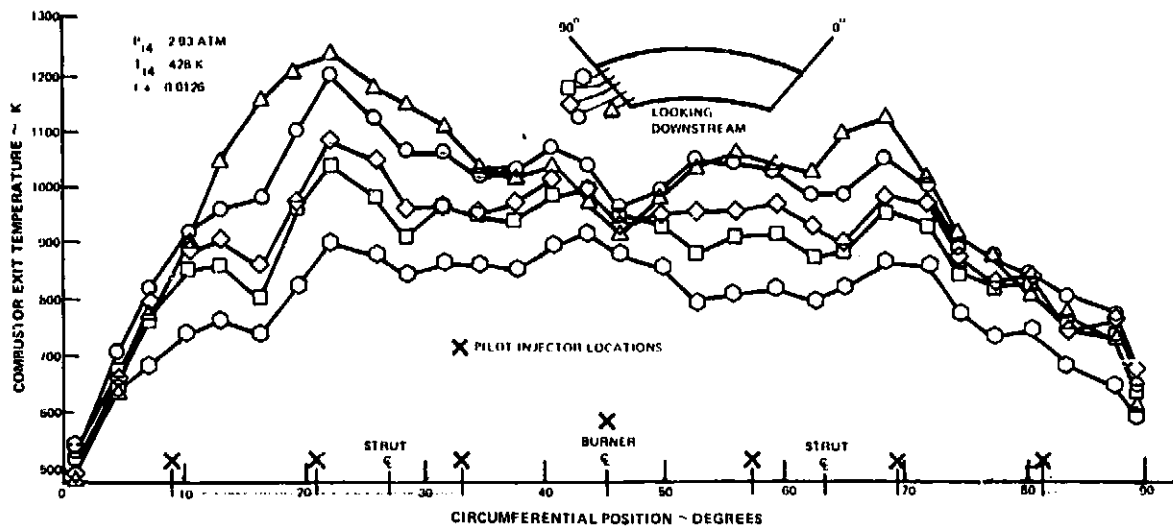

Figure 56 Circumferential Exit Temperature Patterns for Swirl Vortex Combustor Configuration S4 at Idle Conditions

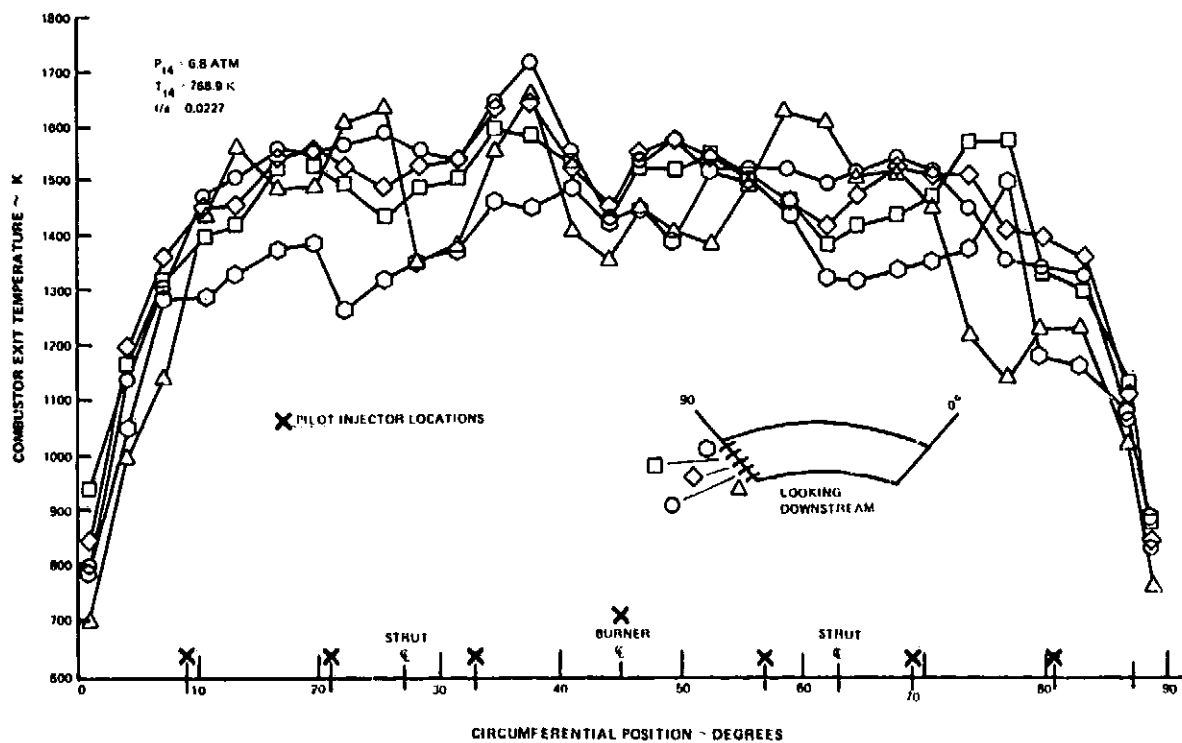

Figure 57 Circumferential Exit Temperature Patterns for Swirl Vortex Combustor Configuration S4 at Take-off Conditions



TABLE XXVIII

SUMMARY OF COMBUSTOR EXIT TEMPERATURE  
PATTERN FACTOR RESULTS

Configuration	Pattern Factor		
	Idle With Bleed Conditions	Idle Without Bleed Conditions	Take-off Conditions
Goal	--	--	< 0.25
JT9D-7	--	--	0.42
Swirl-Can Combustor			
N2	0.50	--	0.50
N3	1.07	--	0.88
N4	1.05	--	0.73
N5	2.01	--	0.77
N6	1.70	--	0.48
N7	--	1.99	0.53
N8	--	1.82	--
N9	--	1.86	--
N12	--	1.04	0.63
Staged Premix Combustor			
P1	1.14	--	0.51
P2	1.50	--	--
P3	1.94	--	0.50
P4	1.05	--	0.49
P8	--	0.61	--
Swirl Vorbix Combustor			
S2	0.36	--	0.54
S3	0.45	--	0.65
S4	0.67	--	0.57
S5	--	--	0.58
S6	--	--	0.57
S7	--	--	0.93
S8	--	0.58	--
S9	--	0.52	0.51
S10	--	--	0.49

Notes: Combustor rig idle conditions with bleed were inlet pressure of 2.93 atm, inlet temperature of 428 K, and fuel-air ratio of 0.0126.

Combustor rig idle conditions without bleed were inlet pressure of 3.74 atm, inlet temperature of 456 K, and fuel-air ratio of 0.0105.

Combustor rig take-off conditions were inlet pressure of 6.8 atm, inlet temperature of 768.9 K, and fuel-air ratio of 0.0227.

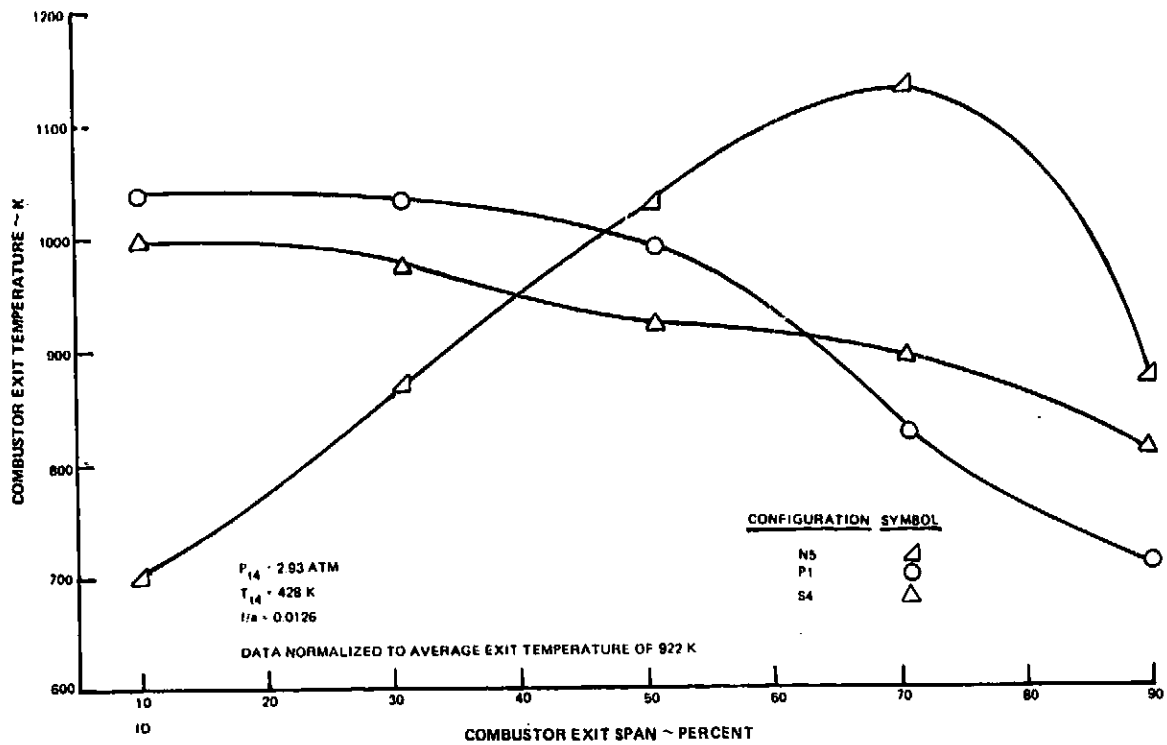

Figure 58 Radial Exit Temperature Patterns for Swirl-Can Combustor Configuration N5, Staged Premix Combustor Configuration P1, and Swirl Vorbix Combustor Configuration S4 at Idle Conditions

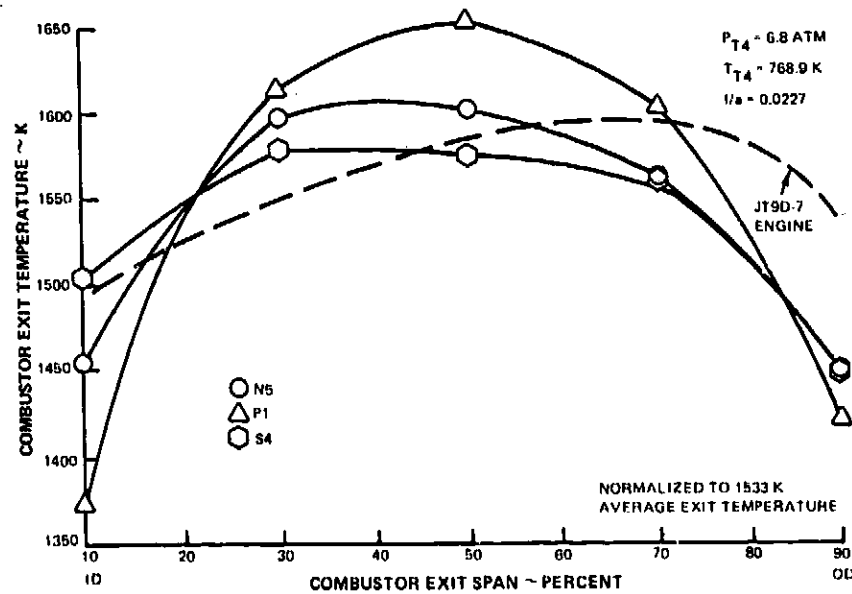

Figure 59 Radial Exit Temperature Patterns for Swirl-Can Combustor Configuration N5, Staged Premix Combustor Configuration P1, and Swirl Vorbix Combustor Configuration S4 at Take-off Conditions Shown With JT9D-7 Engine Pattern

### 3. IDLE LEAN BLOWOUT

Idle lean blowout data were taken for selected combustor configurations, and the results are shown in Table XXIX. The best results were obtained with the swirl vorbix combustor concept, for which most configurations demonstrated lean blowout limits that were comparable to those of the JT9D-7 combustor. This result was expected, since the pilot burner of the swirl vorbix combustor is similar in design to a conventional burner. The swirl-can combustor configurations exhibited considerably higher lean blowout limits with two configurations, N10 and N11, demonstrating just marginally acceptable limits of 0.0050 and 0.0043, respectively. None of the staged premix combustor configurations approached the JT9D-7 lean blowout limit of 0.004. Both the staged premix and the swirl-can combustor concepts will require some design changes to improve idle stability.

TABLE XXIX

#### SUMMARY OF COMBUSTOR IDLE LEAN BLOWOUT TEST RESULTS

Configuration	Lean Blowout Fuel-Air Ratio	
	Idle With Bleed Conditions	Idle Without Bleed Conditions
JT9D-7		< 0.004
Swirl-Can Combustor		
N3	0.0058	--
N4	0.0058	--
N5	0.0079	--
N10	--	0.0056
N11	--	0.0043
Staged Premix Combustor	0.0076	--
P2	0.0058	--
P3	0.0065	--
P4	0.0082	--
Swirl Vorbix Combustor		
S2	0.0056	--
S3	0.0034	--
S4	0.0037	--
S5	0.0037	--
S6	0.0044	--
S7	0.0044	--
S9	--	0.0044
S10	--	0.0041

Notes: Combustor rig idle conditions with bleed were inlet pressure of 2.92 atm and inlet temperature of 428 K.

Combustor rig idle conditions without bleed were inlet pressure of 3.74 atm and inlet temperature of 456 K.

It should be noted that no attempt was made in these tests to simulate actual engine conditions during lean blowout, since idle pressure and flow levels were maintained during the lean blowout tests. In an engine subjected to a snap deceleration, fuel flow would drop essentially instantaneously, while the inertia of the rotating machinery would slow the response of the airflow. This lag results in a lean bucket on the transient fuel-air ratio curve. Since the lean bucket occurs at pressure and temperature levels higher than the idle values, the rig values of lean blowout may be considered conservative.

#### 4. ALTITUDE STABILITY AND RELIGHT CHARACTERISTICS

Altitude stability and relight tests were conducted on the swirl-can and staged premix combustors to assess the capability of low-emission combustors to satisfy current engine relight requirements. The swirl-vortex combustor was not altitude stability tested. However, since it incorporates many of the features of conventional combustors, such as direct-fuel injection into the combustion zone and swirl stabilized recirculation, this concept should be capable of meeting current engine relight requirements with sufficient development.

The swirl-can combustor relight tests were conducted in Configuration N12, which contained outer swirl flameholders and pressure atomizing nozzles spraying through the center of the carburetor swirlers. Only the outer row of carburetor can modules were fueled for these tests. As shown in Figure 60, this combustor fell considerably short of the JT9D altitude relight envelope. The highest minimum pressure blowout occurred at only 5500 m, compared with the design level of 9000 m. Relight capability ranged from 4000 m at the lowest value of combustor airflow investigated to 1500 m at the highest airflow. Use of a 20 J ignition system instead of a 4 J system did not significantly improve the lighting capability. Propagation was generally slow, in some instances requiring 30 seconds or more to reach the fully lit condition.

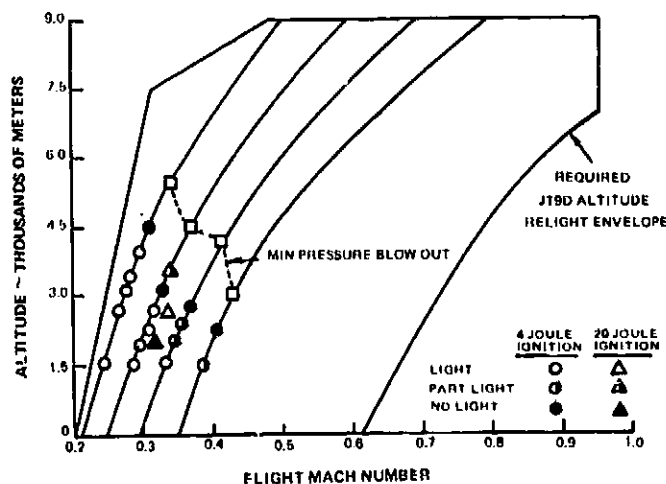

Figure 60 Swirl-Can Combustor Configuration N12 Altitude Stability and Relight Test Results Shown on JT9D Altitude Relight Envelope

The staged premix combustor relight tests were conducted on Configuration P9. This configuration featured slotted flameholders in both the pilot and main burning zones, and used liner-dilution air to divert air away from the premix passage and increase the premix passage equivalence ratio. Only the pilot zone was fueled for the stability and relight tests. The results are shown in Figure 61 and indicate considerably better altitude stability and relight capability for the staged premix combustor than for the swirl-can combustor, although it still fell short of the JT9D requirement. Minimum pressure blowout occurred from 7000 m to 8550 m. Lights, however, were obtained only to a maximum of 2350 m using the conventional JT9D engine 4J ignition system when fuel was flowed to all of the pilot-zone fuel nozzles. Flowing fuel to every other fuel nozzle in addition to the two nozzles adjacent to the ignitor and using a 20 J ignition source improved the relight performance, increasing the maximum relight altitude to 6100 m. All of the lights obtained propagated rapidly, generally in less than one second.

## 5. COMBUSTOR DURABILITY

Durability problems were encountered in all three combustor concepts, but they were generally localized and related to specific design deficiencies. Overall, the combustor liner durability was found to be satisfactory in all concepts. It should be noted, however, that the maximum combustor rig inlet pressure was limited to 6.8 atm, precluding a durability assessment at full engine take-off pressure conditions.

In the swirl-can combustor concept, the durability problems were associated with upstream burning caused by fuel aspiration. This burning was usually confined to areas of deficient airflow upstream of the combustor, generally in the wake of the diffuser struts and fuel injector supports. The problem was greatly reduced by modification of the prediffuser contour and by reducing the fuel injector strut blockage. Installation of a screen at the diffuser strut trailing edge completely eliminated the problem. Certain swirl-can combustor configurations also exhibited evidence of excessive flameholder temperatures, but the test conditions could be controlled to prevent damage.

The staged premix combustor concept exhibited durability problems with both the pilot and the main burning zone flameholders. Excessive temperatures were recorded during nearly every test, and localized melting was a common occurrence. Analysis indicated that local cracking generally preceded melting, with the cracking being caused by the thermal stresses produced by mounting the hot flameholder in a relatively cool, rigid framework. The problem could be alleviated by changing the design to permit the flameholder to float in its support, but the metal temperatures would still exceed those required for long-term durability. Some improvement was obtained during the program by the use of transpiration-cooled flameholders in the later configurations, but flameholder durability continues to be a primary problem area for premix combustors. Another serious problem with premix combustors is autoignition. The problem was not encountered in this program. However, the combustors were designed for autoignition safety at full engine pressure up to 21.7 atm whereas actual testing was conducted at 6.8 atm, providing a very large autoignition safety margin.

Durability problems with the swirl vortex combustor concept were confined to the throat and the main burner dilution air swirler areas. The throat region experienced excessive metal temperatures as a result of the combination of two factors: it is exposed to a high velocity, high temperature gas stream; and the cooling louvers are in the wake of the pilot zone, resulting in reduced coolant air feed pressure. The problems in the swirler region resulted from the fact that the swirlers were immersed in the burning gas stream, and the fact that the swirler installation blocked the cooling louvers immediately downstream. All of these problems appear solvable with detailed combustor design refinement.

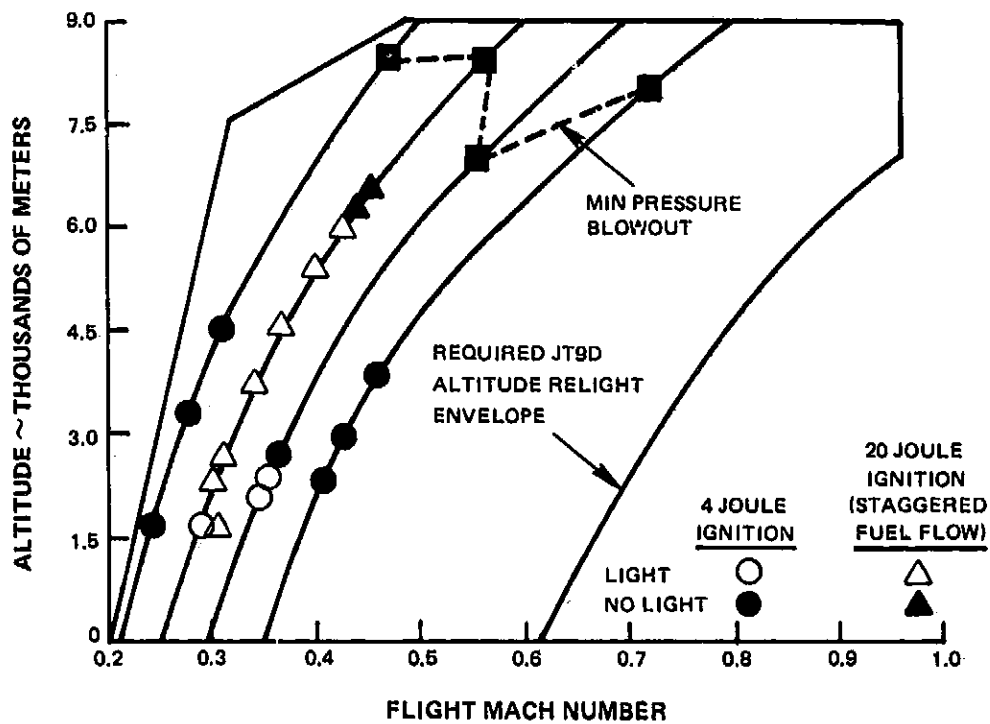

Figure 61 Staged Premix Combustor Configuration P9 Altitude Stability and Relight Test Results Shown in JT9D Altitude Relight Envelope

## F. DEVELOPMENT STATUS

### 1. EMISSION REDUCTION STATUS

The Phase I pollutant emission goals were not achieved by any of the combustor concepts investigated in this program. The swirl-can and swirl vorbix concepts demonstrated the lowest  $\text{NO}_x$  emission rates at the take-off test condition, achieving levels more than 50 percent below the current JT9D-7 production engine level. The staged premix concept met the idle CO and THC goals. No single configuration demonstrated minimum emissions at both the idle and take-off test conditions, complicating the selection of a single most promising concept.

The swirl-can combustor concept appears to be effective in reducing emissions of oxides of nitrogen at high power levels. The data indicate that additional emission reduction could be achieved through an increase in the reference velocity. The emissions at idle conditions, however, are well above the goals, and a major redesign would be required to meet the goals at these conditions while still retaining the demonstrated low emissions of oxides of nitrogen at high power.

In contrast, the staged premix combustor easily met the emissions goals for low power conditions, but provided the least reduction in oxides of nitrogen emissions at high power of any of the concepts investigated. In addition, a serious off-design combustion efficiency problem was identified. This concept, therefore, warrants additional development to capitalize on its low-power emissions, but requires considerable development to meet all of the performance requirements.

The swirl vorbix combustor provided a balance between low emissions at idle conditions and low emissions at high power. It approached the goals at the idle condition, and it provided the lowest emissions of oxides of nitrogen at high power of any of the concepts investigated. The smoke levels were marginally acceptable, however, at the combustor rig simulated take-off conditions. The smoke level would be expected to increase at full engine take-off pressures.

### 2. AEROTHERMODYNAMIC STATUS

Although the primary emphasis of the program was the reduction of pollutant emissions, a secondary objective was the identification of operational and performance problem areas requiring further development in Phase II. On the basis of these results, the amount of development required for each of the concepts to meet the selected performance requirements was estimated. These estimates are summarized in Table XXX.

### 3. INTERMEDIATE POWER CONSIDERATIONS

A qualitative assessment of the off-design emissions and performance characteristics of each of the combustor concepts was made on the basis of data obtained during the program. The power conditions addressed were the approach power conditions (approximately 30 percent of take-off thrust) and the high altitude cruise condition.

TABLE XXX

SUMMARY OF EXPERIMENTAL CLEAN COMBUSTOR  
PERFORMANCE STATUS

	Development Status*		
	Swirl-Can Combustor	Staged Premix Combustor	Swirl Vorbix Combustor
Pressure Loss	1	1	1
Exit Temperature Pattern Factor	3	3	3
Radial Exit Temperature Profile	3	3	3
Durability	2	3	2
Carboning and Nozzle Coking	2	2	2
Idle Stability (Lean Blowout)	2	3	1
Altitude Relight Characteristics	3	3	2

- \*Development Status Code:
1. Currently meets requirement
  2. Should meet requirement with normal development
  3. Should meet requirement with extensive development.

The approach power condition is most critical for the staged combustors since this power level is close to the desired staging level. Approach power could be achieved, therefore, either on the pilot burner alone, operating near its maximum fuel-air ratio, or on both the pilot and main burners. In either case, the combustor inlet temperature and pressure levels are substantially below the take-off levels, and the overall fuel-air ratio will be approximately two-thirds the take-off level. From an aircraft operational standpoint, use of both the pilot and the main burners during approach is desirable since it provides a more rapid engine acceleration rate.

Test results from the staged premix and swirl vorbix combustors indicate that the pilot burner should operate at or close to its idle design fuel air ratio at the approach power condition if both burners are used. The reason for this is that the combustion efficiency is strongly dependent on the pilot fuel-air ratio, with relatively high pilot fuel-air ratios being required at low combustor inlet temperatures and pressures. However, if the pilot burner is operated at a fuel-air ratio close to its idle design point, the main burner must operate at a fuel-air ratio well below its design point. The effect of this type of operation was assessed by reviewing the data obtained at test rig simulated take-off conditions. These conditions approximated the combustor inlet pressure that would occur at approach. The inlet temperature in the rig was, of course, higher than that which would occur at approach, and, therefore, the efficiency based on the rig data will also be higher than would actually be achieved at approach. The relative differences among the three combustor concepts, however, are still believed to be valid. These results show that the swirl vorbix combustor exhibits only a small decrease in efficiency with decreasing fuel-air ratio, while the staged premix combustor exhibits a much greater loss in efficiency. The swirl-can combustor demonstrated an intermediate efficiency loss.



On the basis of these results, it appears that the swirl vortex combustor is the most likely of the three concepts to provide acceptable combustion efficiency at approach conditions using both stages, while the staged premix combustor will encounter serious efficiency problems when operated as a two-stage system at intermediate power.

High altitude cruise operation is characterized by reduced combustor inlet temperature and pressure relative to sea-level take-off conditions, but the overall fuel-air ratio is close to the sea-level take-off value. When compared to the simulated take-off conditions used in the test rig, only the cruise inlet temperature is significantly different from the rig conditions. A small increase in the pilot burner fuel-air ratio could compensate for the reduced inlet temperature at cruise conditions. Therefore, since none of the combustor concepts exhibited serious efficiency problems at simulated rig take-off conditions, it appears that they should also provide acceptable efficiency at cruise conditions. However, minimizing emissions of oxides of nitrogen at cruise conditions will represent a compromise with cruise combustion efficiency.

#### 4. APPLICATION OF RESULTS

The Phase I combustor configurations have been specifically designed for installation in the JT9D family of engines. As a result, no major gas flowpath or structural changes will be required to adapt one of the concepts from this program to a production JT9D engine. However, it is evident that the two-stage concepts as a class are considerably more complex than the conventional single-stage design they would replace. In particular, the number of fuel injectors is substantially greater, with attendant increases in the number of combustor case ports and fuel manifold complexity. The degree of fuel management needed to separately control the pilot and main burner fuel flows independent of the total fuel flow will result in an increase in the complexity of the fuel control. In addition, the increased volume occupied by the external fuel system, including the fuel manifolds, staging valves, and fuel control unit will probably require revision of the aircraft nacelle layout. Consequently, although it is premature to assess the actual magnitude of the impact, it is clear that incorporation of a two-stage combustor in a production engine will increase the engine complexity, weight, and cost.

In addressing the problems of intermediate power efficiency, the designer has the freedom to vary the pilot burner-to-main burner fuel split, to change the main-burner staging point, and, if necessary, to depart from the pilot and main burner designs which were specifically optimized for idle and sea-level take-off conditions, respectively. However, the combustor concepts impose constraints with respect to high altitude flight operation including stable operation in both zones and high efficiency at all steady-state cruise points. Any reduction in efficiency at cruise is reflected in a significant increase in aircraft fuel consumption. This is considered to be an unacceptable trade for reduced emissions at sea level.

Combustor hardware durability remains an unknown at this time. Although all of the combustor concepts studied in this program were designed with adequate cooling and structural integrity to withstand long-duration cyclic tests in an engine, experience indicates that problems in combustors often involve localized overheating which frequently are not identified until engine cyclic endurance testing is performed. The design problem is made more difficult by the unconventional design of the two-stage combustor approaches.

The pattern factor and radial profile data obtained during Phase I are considered to be reasonable with respect to achievement of acceptable performance, given sufficient development, although refinement of the exit temperature distribution will be more difficult in those designs which employ no aft liner dilution air. In addition, any diversion of quenching air to the downstream dilution holes for the purpose of exit temperature pattern control will tend to compromise the control of emissions of oxides of nitrogen at high power levels.

Improvements in combustor lean blowout and altitude relight characteristics can be approached through local fuel enrichment, either through modification of the combustor airflow split, changes in the fuel injector design, or by addition of an auxiliary fuel system. The principal impact of these changes would probably be an increase in hardware complexity.

#### G. CONCLUDING REMARKS

The Phase I Experimental Clean Combustor Program work explored three candidate low emission combustion concepts, defining their potential for reducing emissions, qualitatively characterizing their performance, and identifying areas requiring additional development. From these results, it has been possible to select two promising concepts for refinement and optimization in Phase II in preparation for final selection of a single concept for engine testing in Phase III.

The concepts selected for Phase II are a swirl vortex concept and a hybrid concept. These concepts represent an attempt to include features that will be effective in simultaneously reducing emissions at both idle and high power conditions. The designs draw directly on the design trends that were identified in Phase I but which involved hardware modifications that were beyond the scope of the Phase I screening program.

The Phase II swirl vortex combustor was evolved directly from the Phase I swirl vortex combustor, Configuration S10. The primary difference between the two is that in the Phase II combustor the pilot zone volume has been increased in order to improve the carbon monoxide and unburned hydrocarbon emissions at idle conditions. This was accomplished by moving the vortex throat location downstream approximately 3.8 cm, while maintaining the pilot zone liner height at the Phase I value. In addition, the main burning zone residence time has been reduced by the downstream displacement of the throat. This change is expected to provide additional reduction in the emissions of oxides of nitrogen at high power conditions.

The hybrid combustor concept combines pilot zone features of the staged premix combustor (Configuration P3) with the main burning zone features of the swirl-can concept, primarily from Configuration N9. It is intended that this approach will combine the excellent emissions characteristics of the staged premix combustor at idle conditions with the good emissions of the swirl-can concept at high power conditions.

The Phase II program places considerable emphasis on intermediate power performance, which is an area that was not addressed in detail during Phase I. Five power settings will be simulated, including approach (30 percent of take-off thrust), climb (85 percent of take-off thrust), and cruise, as well as idle and take-off power settings. At the approach power setting, techniques will be investigated for improving combustion efficiency, including circumferential staging and single-zone operation. Testing at idle and take-off conditions will verify that the emissions reductions demonstrated during Phase I are maintained. Performance characteristics including exit temperature distribution, idle stability, and relight characteristics will be more thoroughly explored during this phase. Possible trades between emission reduction capability and performance will be investigated. The Phase II program will culminate with the selection and optimization of a single concept for the Phase III engine demonstration test.

## CHAPTER IV

### ADVANCED SUPERSONIC TECHNOLOGY ADDENDUM

#### A. PROGRAM PLAN

The work conducted under the Advanced Supersonic Technology (AST) Addendum was directed toward the accomplishment of two objectives. The first was the reduction of the emission of oxides of nitrogen at supersonic flight conditions without compromising other combustor requirements such as efficiency, stability, and low emission characteristics at other operating conditions. The second objective was to prepare a conceptual combustor design for potential AST engine application.

The program was divided into three tasks, as follows:

Task 1 - AST Screening Tests

Task 2 - AST Cruise Design

Task 3 - AST Conceptual Design

Task 1 consisted of testing the most promising combustor configurations from Elements I and II of the basic Experimental Clean Combustor Program at simulated supersonic cruise conditions. These tests were conducted concurrently with the basic program testing.

Task 2, which was conducted following completion of the screening tests, consisted of re-designing, fabricating, and testing the two most promising concepts identified in Task 1, using one concept from each of the basic program elements.

Task 3 consisted of preparing a conceptual design of an AST combustor concept for a specific AST study engine cycle and geometric configuration, without the constraints of the CTOL designs. This combustor was specifically intended to produce minimum emissions of oxides of nitrogen consistent with high efficiency at the supersonic cruise condition while maintaining reasonable assurance of efficient operation at other power levels.

The AST supersonic cruise condition was defined in Chapter I and represented the conditions that would exist for a JT9D-7 combustor run at AST cruise inlet temperature and pressure. These conditions resulted in a combustor reference velocity of 27.6 m/s for the swirl-can and staged premix combustor concepts and a reference velocity of 41.9 m/s for the swirl vortex combustor concept. However, AST engine designs currently under study are characterized by lower pressure ratios and somewhat higher combustor reference velocities than current CTOL engines. Consequently, the test program included parametric variations of the combustor reference velocity for selected combustor configurations to provide a more comprehensive definition of the emission trends.

The performance and emission goals for this work were also defined in Chapter I.

## B. TASK I -- AST SCREENING TESTS

### 1. CONFIGURATIONS TESTED

A total of seventeen combustor configurations were selected from Elements I and II for testing at the AST cruise conditions. These configurations are identified in Tables XXXI, XXXII and XXXIII. Included were nine swirl-can combustor configurations, three staged premix combustor configurations, and five swirl vorbix combustor configurations.

TABLE XXXI  
SWIRL-CAN COMBUSTOR CONFIGURATIONS  
TESTED AT AST CRUISE CONDITIONS

Configuration	Sea Level Take-off Carburetor Equivalence Ratio	Flameholder Type	Fuel Injector Type (Pressure Drop)	Liner Dilution Air	Remarks
N3	1.0	Hexagonal	Low	No	
N4	1.0	Hexagonal	High	No	
N5	0.65	Hexagonal	Low	No	
N6	1.0	Hexagonal with sheltered zone	Low	No	
N7	1.0	Hexagonal with 1.3 cm recessed swirlers	Low	No	Diffuser included 76% blockage screen
N8	1.0	Hexagonal with 1.3 cm recessed swirlers	Low	No	Diffuser included V-gutter
N9	1.1	Outer swirler flameholder*	Low	No	Diffuser included 76% blockage screen
N10	1.5	Hexagonal with swirler blockage plate	Low	No	Diffuser included 76% blockage screen
N12	NA	Outer swirler flame- holder*	High	No	Diffuser included 76% blockage screen

\*In outer zone, outer and inner swirlers produced co-rotating flows. In inner and middle zones, outer and inner swirlers produced counter-rotating flows.

TABLE XXXII

STAGED PREMIX COMBUSTOR CONFIGURATIONS  
TESTED AT AST CRUISE CONDITIONS

Configuration	Flameholder Hole Pattern	Equivalence Ratio at Idle (Pilot Only)	Equivalence Ratio at Take-off (Pilot and Main)*	Number Injectors		Dilution Air (Percent)
				Pilot	Main	
P4	Circular	0.89	0.69	10	10	13
P7	Slotted	0.84	0.52	10	10	0
P8	Slotted	0.84	0.52	10	20	0

\*Average equivalence ratio for pilot burner plus main burner premix passages

TABLE XXXIII

SWIRL VORBIX COMBUSTOR CONFIGURATIONS  
TESTED AT AST CRUISE CONDITIONS

Configuration	Pilot			Main Burner					
	Injector Type	Swirler	Dilution Airflow	Swirler Type	Swirler Orientation	Dilution Air	Fuel Injector		Throat Height (cm)
							Number	Angle to Flow (Degrees)	
S3	Aerated	Baseline With Blockage Ring	Yes	Straight Vane	Type I	Yes	7 <sup>a</sup>	90	3.3
S4	Aerated Plus Air Scoop	Baseline With Blockage Ring	Yes	Curved Vane	Type II	Yes	13 <sup>b</sup>	90	3.3
S6	Aerated Plus Air Scoop	Baseline With Increased Block- age Ring	Yes	Curved Vane	Type II	Yes	7 <sup>a, b</sup>	90	3.3
S8	Pressure Atomized	Baseline	No	High Flow Straight Vane	Type III	No	13	90	3.3
S9	Pressure Atomized	Baseline With Blockage Ring	Yes	High Flow Straight Vane	Type III	No	13	24	3.3

Notes: All configurations had pilot zone hood installed to prevent fuel aspiration.

- a. Main burner fuel injectors in line with pilot burner fuel injectors.  
b. Reduced pressure drop fuel injectors

Fuel Injector Types:

- I -- Inner and outer swirl in direction of fuel flow  
II -- Inner swirl in opposition to fuel flow and outer swirl in direction of fuel flow  
III -- Inner and outer swirl co-rotational

## 2. TEST RESULTS

The pollutant emission data obtained during Task 1 are summarized in Table XXXIV. The data are actually measured results without correction for humidity since the low humidity levels existing in the combustor sector rig are believed to be representative of actual humidity levels in the stratosphere.

The swirl-can combustor configurations exhibited emission indices for oxides of nitrogen between 11.3 and 18.1 g/kg fuel for a wide range of design features. The effects of the various configurational changes on emissions of nitrogen oxides at the AST cruise conditions were similar to those observed for the CTOL take-off tests, with configuration N9 (which featured an outer flameholder swirler) again demonstrating the lowest emissions of nitrogen oxides. The emissions of carbon monoxide and total hydrocarbons were better than the goals, and consequently, the efficiency surpassed the goal.

The staged premix combustor configurations all exhibited poor efficiency at the AST cruise operating condition. In addition, Configurations P7 and P8, which had very lean premix passage equivalence ratios, were not stable at the AST cruise fuel-air ratio.

The swirl vorbix combustor configurations generally exhibited high combustor efficiency at the AST cruise condition, with two configurations achieving the goals for carbon monoxide and total unburned hydrocarbon emissions. Similar to the swirl-can combustor configurations, the swirl vorbix combustor configurations produced emission indices for oxides of nitrogen in the range of 13.1 to 18.3.

The effects of reference velocity on emissions of oxides of nitrogen and combustion efficiency are shown in Figure 62. All configurations demonstrated a decrease in emissions of oxides of nitrogen that was approximately proportional to the increase in reference velocity. The reference velocity produced only small effects on the combustion efficiency for the range of velocities tested. Where an effect was observed, increasing the reference velocity increased the efficiency.

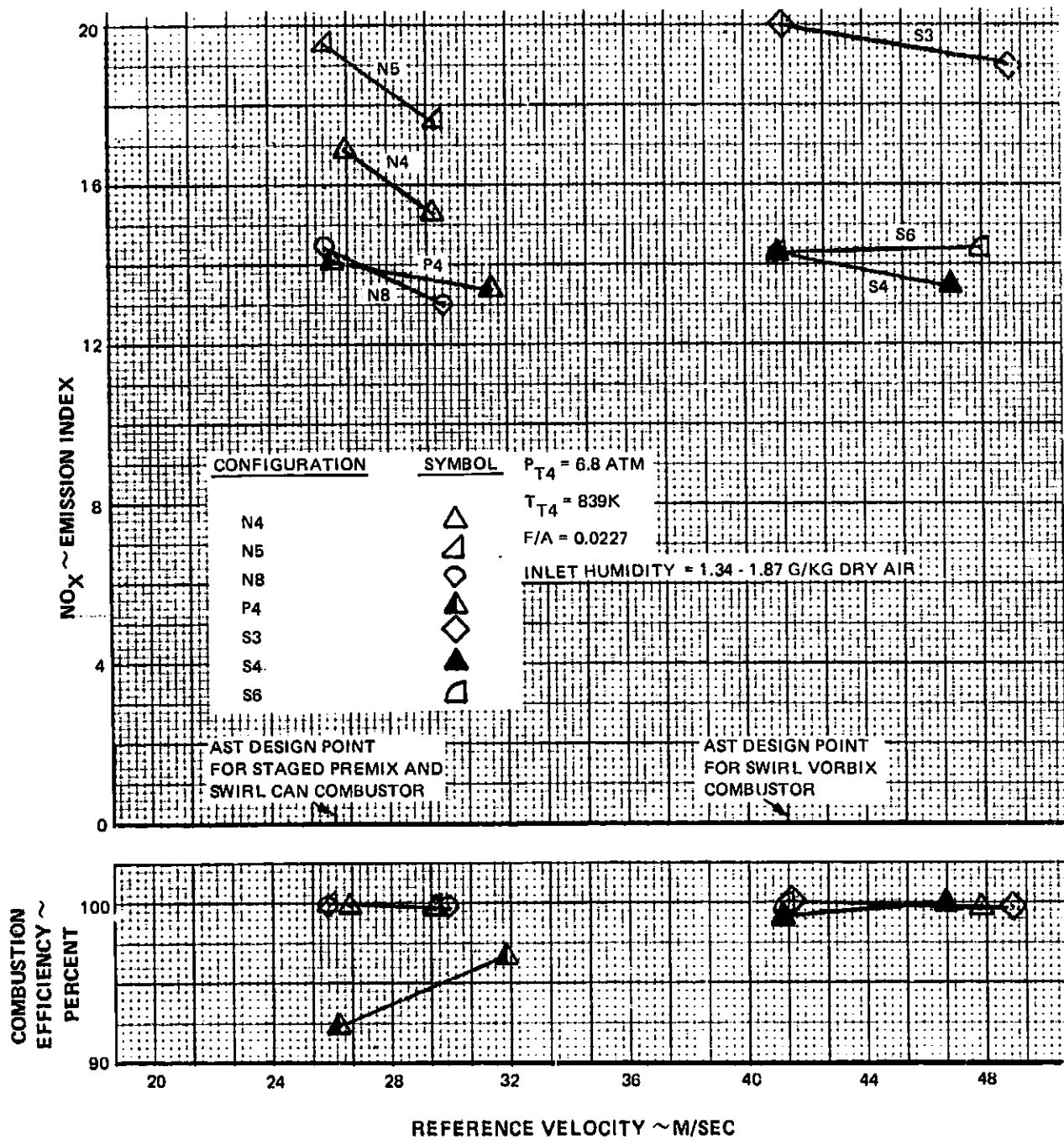

Figure 62 Effect of Combustor Reference Velocity on Emissions of Oxides of Nitrogen and Combustion Efficiency at AST Cruise Condition for Configurations N4, N5, N8, P4, S3, S4, and S6.



TABLE XXXIV  
SUMMARY OF AST SCREENING TEST RESULTS

Configuration	Inlet Total Pressure (atm)	Inlet Total Temperature (K)	Inlet Air Humidity (g H <sub>2</sub> O/kg air)	Carbon Balance Fuel-Air Ratio		Reference Velocity (m/s)	Uncorrected Observed Emission Index Values			Emission Index for Oxides of Nitrogen Corrected to AST Cruise Condition	
				Pilot	Overall		Carbon Monoxide	Total Unburned Hydrocarbons	Oxides of Nitrogen		Gas Sample Efficiency (%)
<b>Swift-Cen Combustor</b>											
N3	7.87	836	1.6*	---	0.0224	22.9	6.9	0.2	13.9	99.3	11.7
N4	6.76	832	1.6*	---	0.0277	27.4	4.3	0.9	16.9	99.8	15.9
N5	6.81	836	1.6*	---	0.0259	26.8	5.5	0.1	19.5	99.9	18.1
N6	6.73	834	2.0	---	0.0212	30.8	4.0	0.2	13.4	99.9	15.8
N7	6.84	840	1.8	---	0.0230	26.8	3.9	0	15.8	99.9	15.0
N8	6.88	832	1.86	---	0.0222	26.8	3.6	0	14.4	99.9	14.5
N9	6.78	843	1.6*	---	0.0265	28.3	4.7	0.5	12.0	99.8	11.3
N10	6.75	847	2.11	---	0.0220	27.7	2.3	0	17.6	99.9	17.4
N12	6.72	833	2.61	---	0.0205	27.7	10.2	0.1	14.7	99.8	15.5
<b>Staged Premix Combustor</b>											
P4	6.83	830	1.67	0.0797	0.0253	27.1	71.3	51.0	14.2	92.4	14.3
P7	6.67	842	1.70	0.1063	0.0236	26.8	7.1	4.0	10.9	99.4	---
P8	6.83	843	1.94	0.1083	0.0320	26.2	3.2	12.4	8.9	98.5	---
<b>Swift Vortice Combustor</b>											
S3	6.80	843	1.6*	0.0737	0.0273	41.2	5.0	0.1	20.5	99.8	18.3
S4	6.73	835	1.86	0.0709	0.0275	42.1	9.5	0	14.4	99.0	13.7
S6	6.69	841	1.42	0.0794	0.0236	42.1	6.7	0	14.4	99.8	14.3
S8	6.76	841	2.02	0.0761	0.0224	42.1	2.4	0	13.3	99.9	13.4
S9	6.91	845	1.83	0.0730	0.0216	43.5	6.5	0.5	12.7	99.8	13.1

\*Estimated Values

## C. TASK 2 – AST CRUISE DESIGN

### 1. DESIGN DESCRIPTION

On the basis of the Task 1 results, swirl-can combustor Configuration N9 and swirl-vorvix combustor Configuration S9 were selected for redesign, fabrication, and testing in Task 2. Both of these configurations employed high dilution air mixing rates, and each produced the lowest emissions of oxides of nitrogen within its concept group. Both configurations also demonstrated high combustion efficiency at the AST cruise condition.

The design modifications made to these configurations were directed toward reducing the residence time of the combustion products at elevated temperature through an increase in the combustor reference velocity, since the results of Task 1 of the AST Addendum and the results of Task IV of the basic program indicated that this approach was promising for further reducing emissions of oxides of nitrogen.

In the swirl-can combustor, the combustor reference velocity was increased by reducing the aft liner height. The resulting configuration, designated N13, is shown in Figure 63.

In the swirl-vorvix combustor, the local velocity at the main burner throat section was increased by reducing the geometric throat height and by decreasing the main burner liner volume. The resulting configuration is shown in Figure 64 and was designated S10.

### 2. TEST RESULTS

Configurations N13 and S10 were tested at the AST cruise condition and also at the JT9D-7 engine idle and sea-level take-off conditions. (Results from these latter points are presented in Chapter III.) The pollutant emission results obtained at the AST cruise condition are presented in Table XXXV, and the effects of combustor reference velocity are shown in Figure 65.

The best results were obtained with the swirl vorvix combustor, which demonstrated an emission index for oxides of nitrogen of 9.3 with an efficiency of 99.8 percent at the design combustor reference velocity. Increasing the combustor reference velocity 20 percent above the design value further reduced the emissions index for oxides of nitrogen to 8.5.

The results for the swirl-can combustor indicated that the reduction in the combustor aft liner height was not effective in reducing emissions of oxides of nitrogen. In fact, small increases in the emissions of both oxides of nitrogen and carbon monoxide were observed. It is possible that the decrease in aft liner height caused an increase in liner velocity that produced pressure gradients that adversely affected the recirculation and mixing of the flow at the headplate assembly.

Based on these results, it appears that the swirl vorvix combustor concept holds the greater promise for further reduction in the emissions of oxides of nitrogen at the AST cruise condition. Realization of this potential would require optimization of the combustor reference velocity as well as optimization of the fuel split between the pilot and main burners. Consideration would also need to be given to the requirements for acceptable pollutant emissions and performance at low altitude operating conditions.

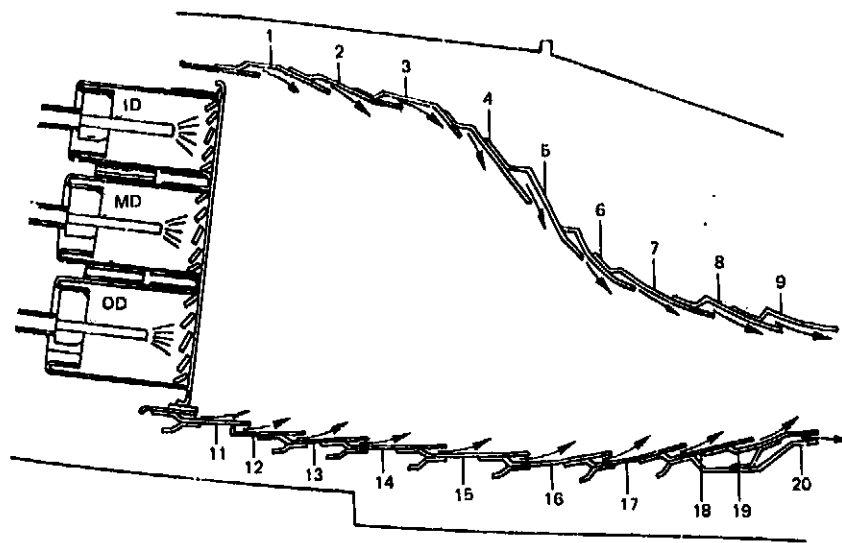

LOUVER COOLING HOLE SCHEME

I.D.			
LOUVER	DIA $\times 10^{-3}$ M	NO. OF HOLES	AREA $\times 10^{-4}$ M <sup>2</sup>
1	2.64	128	3.496
2	2.54	66	3.361
3	1.32	90	1.232
4	1.32	90	1.232
5	1.32	90	1.232
6	1.32	90	1.238
7	1.32	90	1.232
8	1.32	90	1.232
9	2.38	84	3.742

O.D.			
LOUVER	DIA $\times 10^{-3}$ M	NO. OF HOLES	AREA $\times 10^{-4}$ M <sup>2</sup>
11	2.44	155	7.258
12	1.32	149	2.039
13	1.39	182	2.787
14	1.32	162	2.225
15	1.32	184	2.252
16	1.32	184	2.252
17	1.32	184	2.252
18	1.32	180	2.464
19	1.32	174	2.387
20	2.19	70	2.619

SWIRLER ACD

ID 0.06646M<sup>2</sup>  
 MD 0.08092M<sup>2</sup>  
 OD 0.09761M<sup>2</sup>

AIRSWIRLERS ACD

ID 0.0949M<sup>2</sup>  
 MD 0.1194M<sup>2</sup>  
 OD 0.1451M<sup>2</sup>

INJECTORS LOW  $\Delta P$

TURBINE COOLING

ID 7 @ (0.02227 M) (0.02728 M<sup>2</sup>)  
 OD 16 @ (0.01386M) (0.002425 M<sup>2</sup>)  
 SIDEWALL COOLING AREA (0.001727 M<sup>2</sup>)

ORIGINAL PAGE IS  
 OF POOR QUALITY

Figure 63 Swirl-Can Combustor Configuration N13

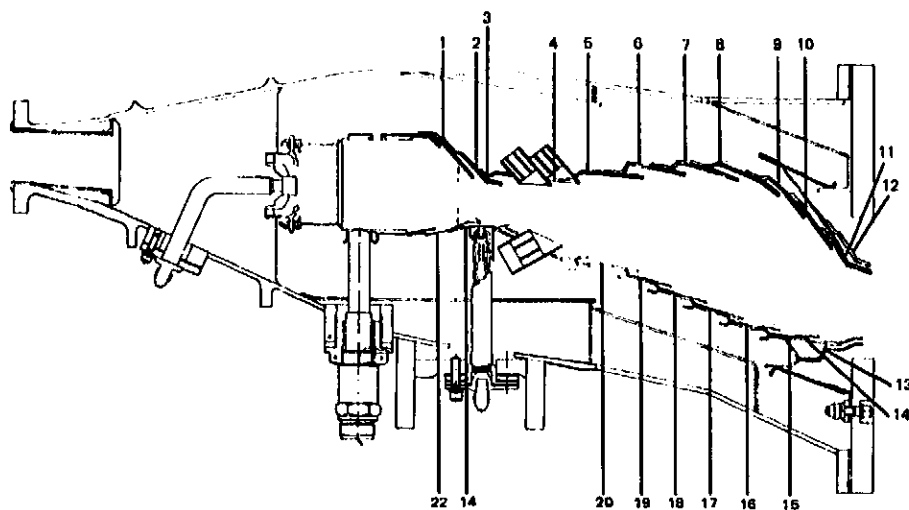

LOUVER COOLING HOLE SCHEME

I. D.

LOUVER	DIA. X 10 <sup>-3</sup> M	NO. OF HOLES	AREA X 10 <sup>-4</sup> M <sup>2</sup>
1	1.894	48	1.497
2	1.702	106	2.406
3	2.376	37	1.639
4	1.613	76	1.565
5	1.511	61	1.452
6	1.321	76	1.039
7	1.511	84	1.503
8	1.321	64	0.645
9	1.511	87	1.561
10	1.321	139	1.903
11	2.184	89	3.336
12	2.489	78	3.793

O. D.

LOUVER	DIA. X 10 <sup>-3</sup> M	NO. OF HOLES	AREA X 10 <sup>-4</sup> M <sup>2</sup>
13	2.376	99	4.380
14	1.778	131	3.282
15	1.397	106	1.626
16	1.397	56	1.471
17	1.321	104	1.408
18	1.613	100	2.045
19	1.613	97	1.881
20	1.854	85	2.297
21	2.870	51	3.277
22	1.854	53	1.432

		M	M <sup>2</sup>
PILOT SWIRLER	70	.01321	0.00235
PILOT SWIRLER COOLING	224	0.00139	0.000343
MAIN SWIRLER	28	0.0168	0.01192
BULKHEAD COOLING	20	0.00282	0.000577
ID SWIRLER COOLING	43	0.00409	0.000468
	42	0.00206	0.0001387
	70	0.00170	0.000159
OD SWIRLER COOLING	43	0.00485	0.000792
	42	0.00269	0.0002406
	70	0.00221	0.000266
PILOT NOZZLE P/N 27700-11			.0001984
NOZZLE P/N 27700-11			
<b>TURBINE COOLING</b>			
ID	70	0.0223	0.002728
OD	16	0.0139	0.002426
SIDEWALL COOLING AREA 0.00196 m <sup>2</sup>			
FINWALL <sup>®</sup> COOLING 0.33% WAB			

Figure 64 Swirl-Vorbix Combustor Configuration S10

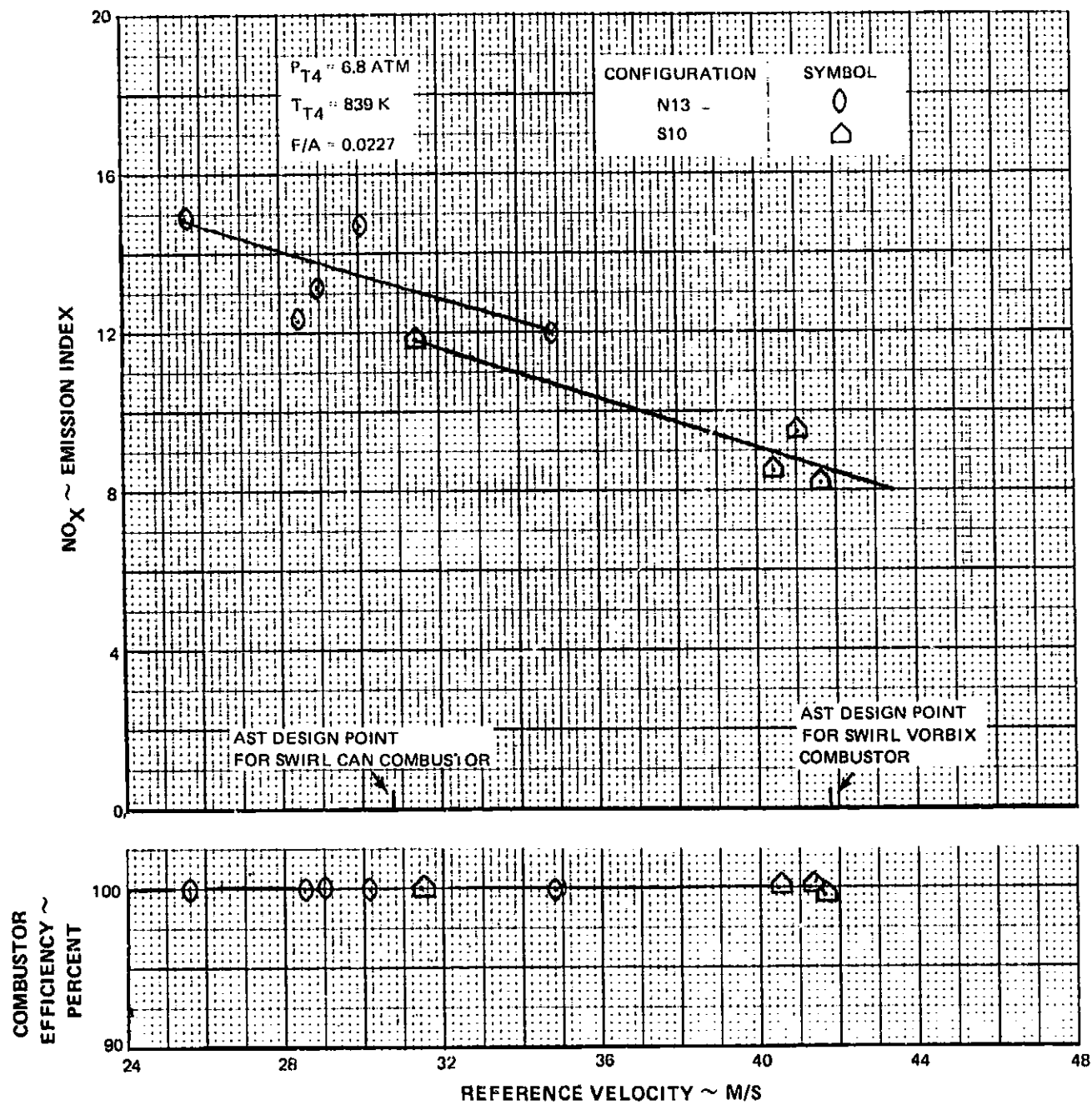

Figure 65 Effect of Combustor Reference Velocity on Emissions of Oxides of Nitrogen and Combustion Efficiency at AST Cruise Condition for Configurations N13 and S10.

ORIGINAL PAGE IS  
OF POOR QUALITY

TABLE XXXV

SUMMARY OF AST CRUISE DESIGN TESTS

Configuration	Inlet Total Pressure (atm)	Inlet Total Temperature (K)	Inlet Air Humidity (g H <sub>2</sub> O/kg air)	Carbon Balance		Reference Velocity (m/s)	Uncorrected Observed Emission Index Values			Emission Index for Oxides of Nitrogen Corrected to AST Cruise Condi- tion	
				Fuel-Air Ratio Pilot	Overall		Carbon Monoxide	Total Unburned Hydrocarbons	Oxides of Nitrogen		Gas Sample Efficiency (%)
Swirl-Can Combustor N13	6.78	840	1.72	---	0.0722	21.9	6.1	0	15.0	99.9	---
	6.85	851	1.74	---	0.0229	33.5	8.9	0.1	12.0	99.8	---
	6.70	839	1.74	---	0.0225	26.2	7.3	0.1	13.1	99.8	12.4
Swirl Vortex Combustor S10	6.87	834	1.99	0.0858	0.0230	41.3	4.5	0.1	9.5	99.9	9.3
	6.78	838	2.04	0.0753	0.0200	42.0	15.0	0.7	8.2	99.6	---
	6.90	836	1.6*	0.0128	0.0223	49.4	9.4	0.1	8.5	99.9	---
	6.87	841	1.6*	0.0180	0.0229	29.3	3.6	0	11.8	99.9	---

\*Estimated

## D. TASK 3 – CONCEPTUAL DEFINITION

### 1. STUDY ENGINE DEFINITION

A duct-burning turbofan engine cycle, which had been defined under the Pratt & Whitney Aircraft "Advanced Supersonic Propulsion System Technology Study," Contract NAS3-16948, was selected as the basis for the Task 3 conceptual design. This engine is designated Study Turbofan STF502.

The combustor inlet conditions at sea-level take-off and supersonic cruise conditions for the STF502 engine are presented in Table XXXVI. The AST cruise conditions used in the combustor segment tests are also shown for reference. As shown, the STF502 engine combustor inlet temperature and pressure levels are considerably higher than the AST cruise inlet conditions used in this study.

TABLE XXXVI

STUDY ENGINE STF502 COMBUSTOR INLET CONDITIONS  
AND COMBUSTOR RIG INLET CONDITIONS

	Combustor Rig AST Cruise Test Conditions	Study Engine STF502	
		Sea-Level Take-off Design Condition	Supersonic Cruise Design Condition
Inlet Temperature (K)	839	683	894.3
Inlet Pressure (atm)	6.8	14.0	9.95
Combustor Fuel-Air Ratio	0.0227	0.0210	0.0230
Inlet Airflow Rate (kg/s)	29.15*	151.5	98.0
Inlet Flow Parameter (kg $\sqrt{K/s}$ m <sup>2</sup> atm)	1817	1625	1740

Notes: Flow Parameter =  $W_{a4} \sqrt{T_{t4}} / A_4 P_{t4}$  where  $W_{a4}$  is the inlet airflow rate,

$T_{t4}$  is the inlet total temperature,  $A_4$  is the inlet area, and  $P_{t4}$  is the inlet total pressure.

\*Inlet airflow rate calculated on full annular combustor basis.

AST STF502 supersonic cruise condition is Mach 2.32 at 16.154 km.

## 2. COMBUSTOR DESIGN

The conceptual design for the STF502 combustor was based on the swirl-vorbix combustor Configuration S10. The basic design approach consisted of scaling the pertinent combustor design parameters from the S10 configuration to the STF502 geometry and flow conditions. However, in view of the observed trend for reduced emissions of oxides of nitrogen with increasing reference velocity, the combustor residence times in both the pilot and the main burner zones were reduced approximately 12 percent. Although the primary design point was the sea-level take-off condition, care was taken to maintain design values that would be acceptable at the supersonic cruise condition.

The resulting design is shown in Figure 66, and the dimensions and design parameter values are summarized in Table XXXVII, together with the corresponding values for the S10 configuration. As shown, the conceptual design for the STF502 engine combustor does not differ significantly from the S10 configuration with respect to the basic design parameters. The overall dimensions are much larger, however, because of the relatively high through flow and low pressure of the STF502 engine. The higher airflow and lower pressure result in a combustor length-to-height ratio that is about 20 percent lower in the STF502 combustor than in the S10 configuration. The pilot burner for the STF502 combustor was sized by scaling the fuel loading parameter, as described in Reference 17.

Several features were added to the design on the basis of experience with the annular vorbix concept. To improve durability, scoops have been added to the cooling louvers in the vicinity of the throat, and the main swirlers have been recessed. In addition, the main burner fuel nozzles have been mounted in floating conical guides to provide a positive seal between the shroud and the liner while allowing for nozzle and liner tolerances and for thermal growth.

## 3. ESTIMATED POLLUTANT EMISSIONS

Pollutant emission levels for the STF502 combustor were estimated on the basis of the measured emissions from the Configuration S10 combustor, and the results are shown in Table XXXVIII.

The emissions levels for oxides of nitrogen were scaled using the scaling technique described in Chapter II. The correlation obtained using the scaling parameter described in Chapter II is shown in Figure 67 and indicates an emission index for oxides of nitrogen of 9.3.

The emissions of carbon monoxide and total unburned hydrocarbons were assumed to be equal to those measured for Configuration S10 at the AST cruise condition. Since the STF502 combustor inlet temperature and pressure are higher than the test conditions at which the Configuration S10 data were obtained, actual carbon monoxide and total unburned hydrocarbon emissions from the STF502 combustor would be expected to be lower than the values quoted in Table XXXVIII.



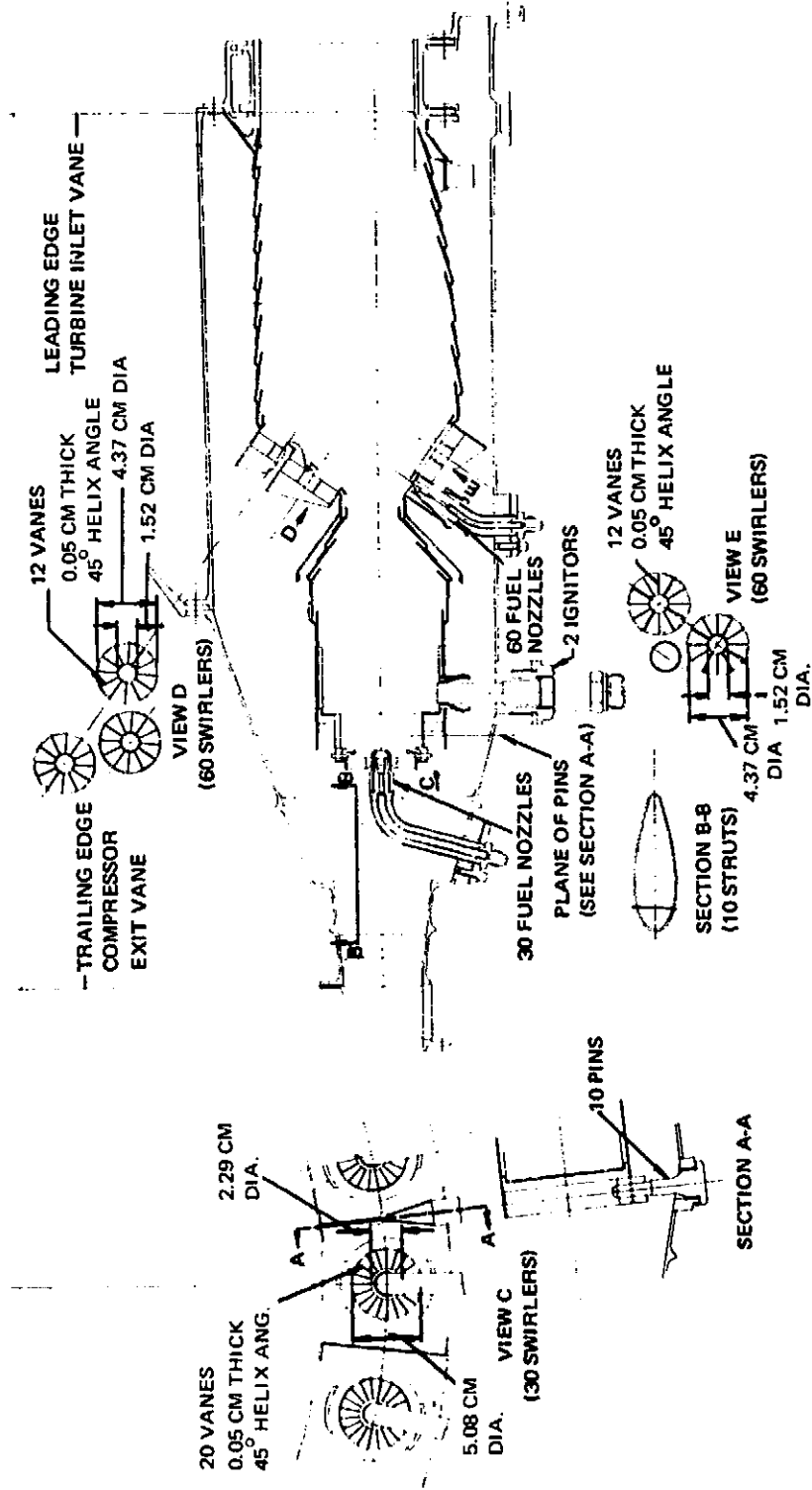

Figure 66 AST Swirl Vorbix Combustor Conceptual Design for STF502 Engine

TABLE XXXVII

DESIGN PARAMETERS FOR STF502 COMBUSTOR CONCEPTUAL DESIGN  
AND SWIRL VORBIX COMBUSTOR CONFIGURATION S10

	Swirl Vorbix Combustor Configuration S10		STF502 Combustor	
	Take-Off	Supersonic Cruise	Take-Off	Supersonic Cruise
Compressor Exit Inner Radius (cm)	32.78		43.18	
Compressor Exit Outer Radius (cm)	36.46		49.02	
Turbine Inlet Inner Radius (cm)	41.54		37.59	
Turbine Inlet Outer Radius (cm)	46.92		49.02	
Combustor Section Length (cm)	60.64		64.77	
Main Burner Zone Volumetric Heat Release Rate (J/hr atm m <sup>3</sup> )	2.4(10) <sup>8</sup>	2.4(10) <sup>8</sup>	2.3(10) <sup>8</sup>	2.3(10) <sup>8</sup>
Pilot Burner Zone Volumetric Heat Release Rate (J/hr atm m <sup>3</sup> )	1.1(10) <sup>8</sup>	1.1(10) <sup>8</sup>	1.25(10) <sup>8</sup>	1.25(10) <sup>8</sup>
Main Burner Zone Residence Time (ms)	2.9	2.8	2.7	2.6
Pilot Burner Zone Residence Time (ms)	4.8	4.7	4.2	4.1
Throat Velocity (m/s)	121.9	126.8	121.9	126.5
Combustor Pressure Loss (%)	3.0	3.3	3.0	3.4
Pilot Burner Airflow (% Total Combustor Flow)	29.0	29.0	30.0	30.0
Main Burner Swirler Airflow (% Total Combustor Flow)	55.0	55.0	55.0	55.0

Note: AST STF502 supersonic cruise condition is Mach 2.32 at 16.154 km.

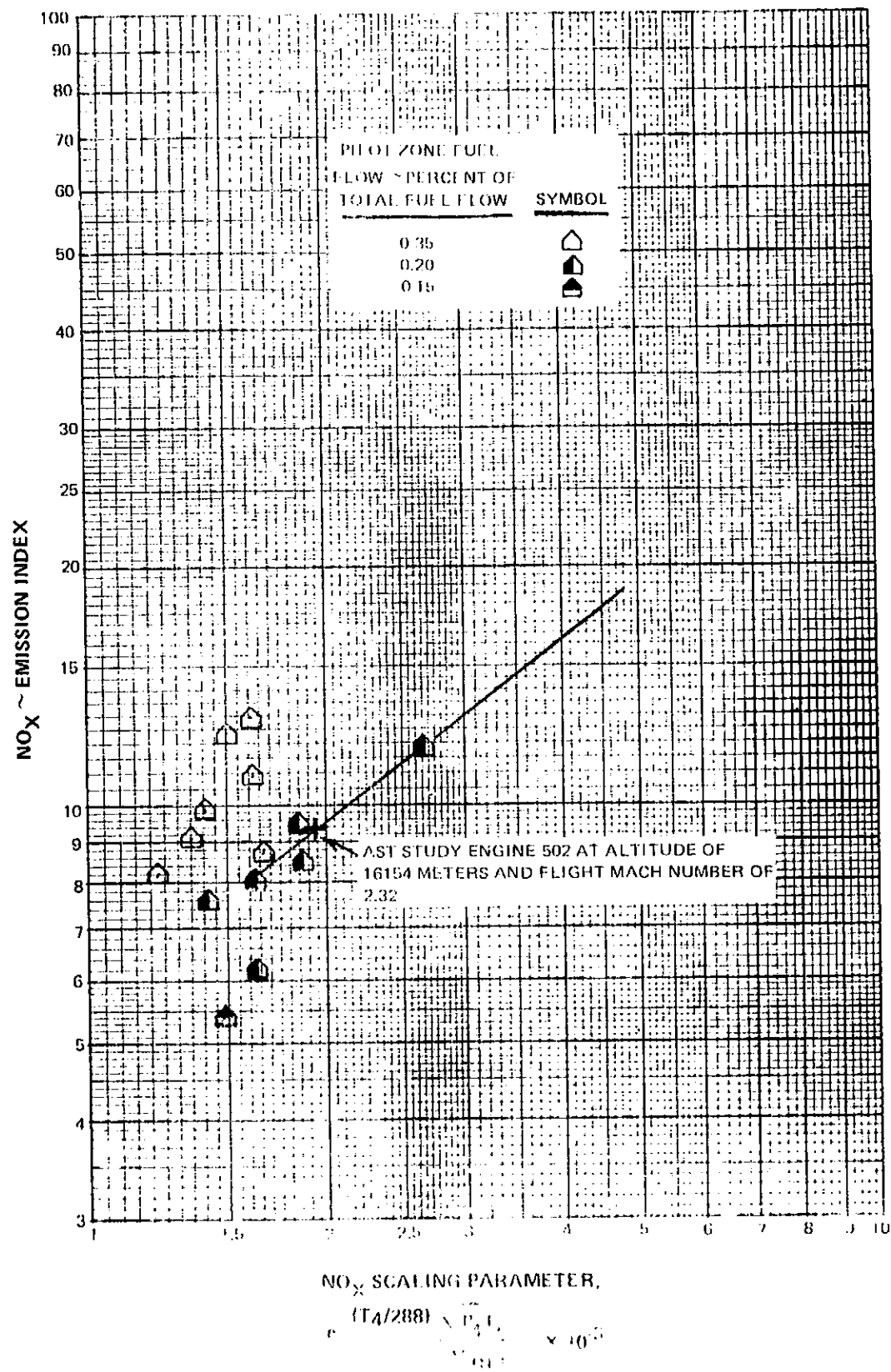

Figure 67 Correlation of Oxides of Nitrogen Emissions Data for Configuration S10

TABLE XXXVIII

ESTIMATED STF502 COMBUSTOR EMISSION LEVELS AT SUPERSONIC  
CRUISE AT MACH 2.32 AT 16.145 KM

Combustor Operating Conditions	
Combustor Inlet Temperature (K)	894.3
Combustor Inlet Pressure (atm)	9.95
Combustor Fuel-Air Ratio	0.023
Estimated Emission Index (g/kg fuel)	
Oxides of Nitrogen	9.3
Carbon Monoxide	4.5
Total Unburned Hydrocarbons	0.1
Combustor Efficiency (%)	99.9

## APPENDIX A

### TEST FACILITIES AND INSTRUMENTATION DESCRIPTION

#### A.1 TEST FACILITIES

##### MIDDLETOWN HIGH PRESSURE FACILITY

X-903 test stand is a general purpose, high pressure combustion test facility designed for experimental development of gas turbine combustors. X-903, which is illustrated in Figure A-1, is one of three high pressure combustion component stands used to evaluate such components as segmental primary combustors, or any other components requiring a high capacity air and fuel supply. This stand is located in the Middletown, Connecticut, test facility.

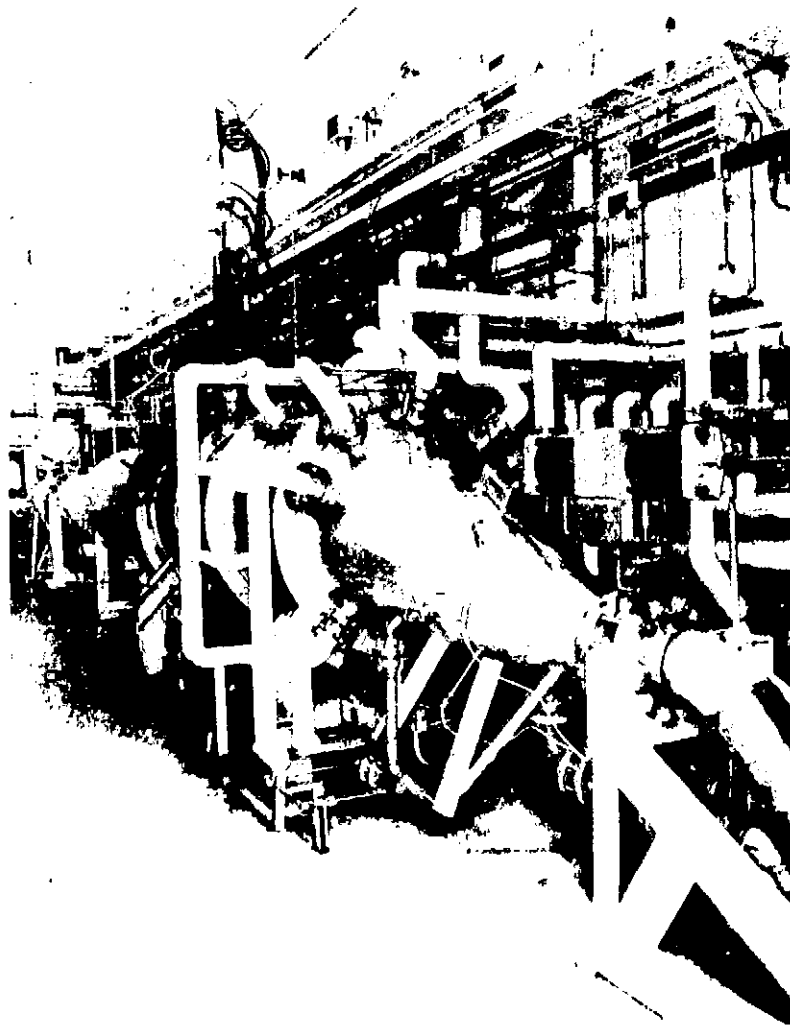

*Figure A-1 View of High Pressure Test Stand. Water Spray for Cooling Exhaust is in the Foreground. Exhaust is Ducted Down into Underground Plenum (X-34346)*

The combustor test rig is mounted within a cylindrical pressure tank. Tank pressurization is automatically controlled to within 0.34 atm. In this manner, the pressure load is supported by the facility pressure vessel, permitting the experimental hardware to be of relatively light construction. Combustor rigs up to 1.07 m in diameter and 2.34 m in length can be mounted in the facility pressure tank. A retractable tank section and a breech locking mechanism have been incorporated into the pressure vessel design to facilitate rig access.

The stand is supplied 11.34 kg/sec of air at 47.6 atm maximum from two Carrier air compressors and one Allis Chalmers booster compressor, which is located in an adjacent building. The air can be heated to 922K in a nonvitiated air heater. The test centerline is equipped with an inlet flow valve, a flowmeter, and a discharge line backpressure valve. The exhaust ducting is water cooled and connected to an outside silencer pit.

Four individual fuel systems can each supply 0.416 m<sup>3</sup> of fuel at up to 1,022 atm to the test stand. The present fuels are Jet-A, No. 2 fuel oil, methanol, and heavy distillate, but these may be changed depending on the specific type of test program. Fuel storage tanks are as follows: two 75.71 meter<sup>3</sup> tanks, one 34.07 meter<sup>3</sup> tank; and one 32.28 meter<sup>3</sup> tank. A portable tanker and pipeline heating equipment are used for the heavy distillate fuel.

The stand is supplied with process water from 5.08 to 55.5 atm and steam from 2.02 to 28.2 atm. An auxiliary air supply of 11.34 g/sec at 28.2 atm is available, in addition to the shop and instrument air. Electric power at 12-2300 volts alternating current, or 12 volts direct current is available in the stand or in the building.

X-903 stand is connected to a data acquisition and gas sample analysis system located in a trailer that is permanently attached to the building. This system has a tieline to the Sigma 8 computer in East Hartford, Connecticut. In addition to the Automatic Data Recording (ADR) system, the stand back-up instrumentation is sufficient to monitor all critical rig parameters, plus all equipment. The monitoring instrumentation and controls are located in an air conditioned control room adjacent to the stand with an observation window. This control room is common with several other stands.

The exhaust duct has provisions to accept either a linear or a 360 degree annular probe rake.

Some of the particular characteristics of the X-903 test stand are described below:

#### Air Supply, Ducting and Valves

- Process Air:
  - Nonvitiated
  - 11.34 kg/s at 47.6 atm, 0.254 m header
  - Preheater (nonvitiated) 922K

- Inlet Air Line:
  - 0.203 m diameter pipe
  - 0.203 m control valve
  - ventral flowmeter
  
- Exhaust Line:
  - 1.016 m diameter with backpressure valve, increasing to 0.406 m to underground silencer pit outside
  - The test chamber exhaust has a water cooled jacket, followed by direct water spray condition.
  
- Shop Air:
  - One 0.025 m and one 0.018 m supply line, 8.49 atmg
  
- Instrument Air:
  - One 0.013 m supply line, 3.04 atm
  
- Auxiliary Cooling Air:
  - One 0.038 m line, 28.2 atm, 0.113 kg/s

Instrumentation

7 Misc. 0.114 m Gages	3.04 -- 69.07 atm
7 0.114 m Receiver Gages	69.1 atm
3 Barton Differential Pressure Gages	5.08 m H <sub>2</sub> O - 3.72 atm
4 Pyrovanes	0 -- 1922K
1 API Temperature Indicator	0 -- 1922K
1 Brown vertical scale indicator	0 -- 1922K
2 Moore recording controller	0 -- 52.06 atm
16 Miscellaneous air regulators	0 -- 3.04 atm
1 Multiplexer	36 pts
1 Digital Gauge	0 -- 35.04 atm
1 Digital Gauge	0 -- 1644K, 56 pts
1 Digital counter, cps	6 Channel
1 Digital counter, cps	4 Channel
1 Panalarm	14 Position
1 Davis gas analyzer	4 pts
1 Brown Recorder	0 -- 1367K 1 pt
E -- 2260 Data Acquisition System/Sigma 8 interface	
59 temperatures UTR	
99 pressure	
6 flows	

Rake 10 temperatures, 10 pressures, 10 emissions, traverse control  
 Exhaust Emissions Analysis Equipment  
 NO, NO<sub>2</sub>, NO<sub>x</sub>, CO, CO<sub>2</sub>, O<sub>2</sub>, SAE Smoke No., THC

### Fuel Supply (Fuels subject to change)

- Fuels -- Jet "A", # 2 Fuel, Methanol, Heavy Distillate

For each of these fuels Jet "A" # 2 Fuel, Methanol:

5.68 meter<sup>3</sup>/hr at 2.70 atm, 0.038 m Supply Line

2.50 meter<sup>3</sup>/hr at 103.11 atm, 0.051 Supply Line

0.038 m Return Line

For Heavy Distillate Fuel: (header in stand)

4.54 meter<sup>3</sup>/hr at 3.04 atm at pumping station

2.50 meter<sup>3</sup>/hr at 55.46 atm, 0.018 m Supply Line

0.018 m Return Line

Lines Trace heated

### Water Supply

- Process Water:
  - 1-0.102 m line 5.08 atm
  - 2-0.076 m lines 31.8 m<sup>3</sup>/hr total at 55.46 atmAll process water filtered through strainer and 0.069 cm filter.

### Steam Supply

1-0.025 m, 2.20 atm space heater supply

1-0.076 m, 11.21 atm header maximum available flow 0.907 kg/s

1-0.051 m, 28.23 atm header

### Ventilation System

Exhaust blower on roof, air drawn in through wall louvres. Maximum air flow 4.57 m<sup>3</sup>/s  
- one room change per minute.

### Safety and Fire Protection Equipment

- 1-0.102 m fire water line with fog nozzles
- Davis fuel vapor detectors
- North wall has blowout doors

### ALTITUDE TEST FACILITY

X-306 test stand is a general purpose altitude facility used for stability, ignition and icing component testing at simulated altitude conditions to 0.102 m HgA and flight Mach number to 2.0. The facility is a multi-centerline installation consisting of one 0.76 m diameter duct (a), one 0.31 x 0.41 m rectangular duct (b), and two 0.31 m diameter ducts (c & d) connected to a common exhaust. Inlets are cross teed together to supply ambient, heated, nonvitiated, heated vitiated, or refrigerated air. An external view of a typical rig installation is shown in Figure A-2.



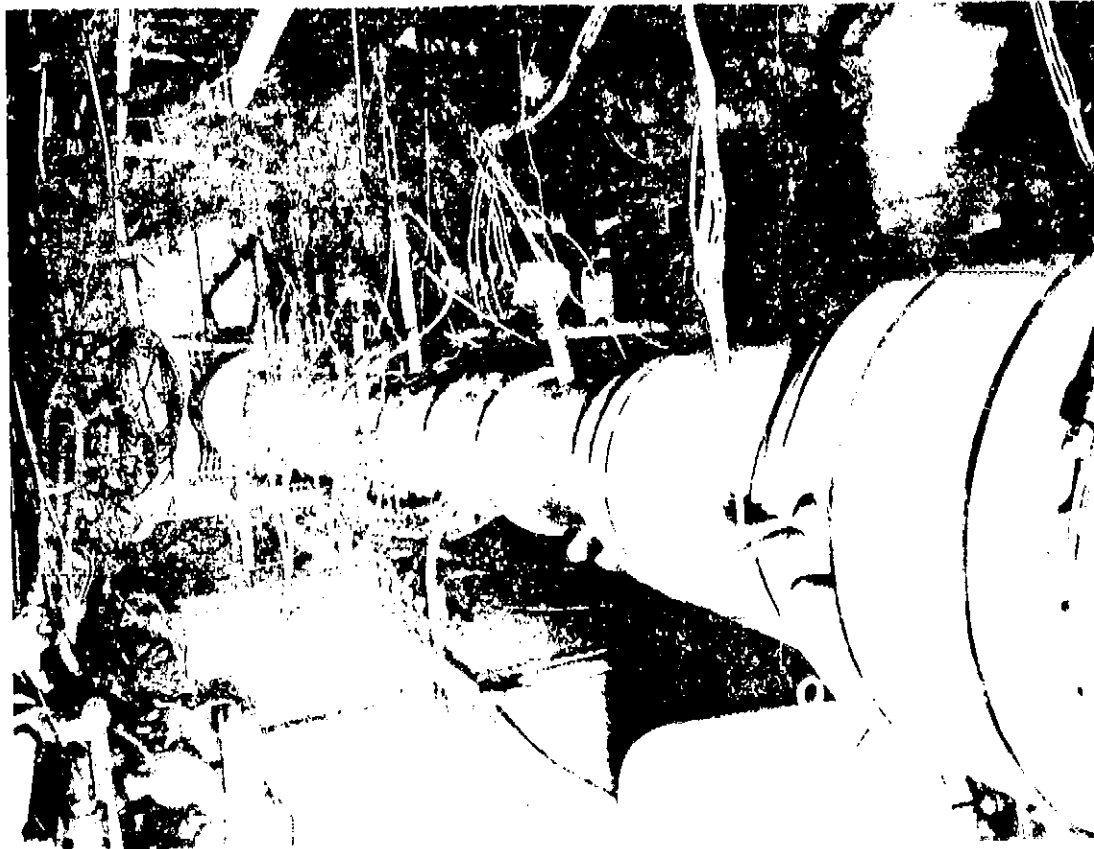

*Figure A-2 X-306 Test Stand for Combustion Component Development and Anti-Icing Investigations (X-15008)*

The combustor rig exhaust duct can be evacuated to  $6.75 \times 10^3 \text{ N/m}^2$  by any combination of five  $3.36 \times 10^5 \text{ W}$  HP Ingersoll-Rand vacuum pumps rated at  $5.66 \text{ m}^3/\text{s}$  free air discharge each. Either ambient, heated nonvitiated, heated vitiated, or refrigerated air can be supplied to the test rig inlet. Ambient outside air is ducted directly to the test combustor. Heated air is supplied up to  $145\text{K}$  (nonvitiated) by means of two liquid fuel fired heat exchangers in parallel rated at  $3.628 \text{ kg/s}$  each, for all four branches (A, B, C, and D) and/or heated to  $2055\text{K}$  (A and B only) by means of separate burners (vitiated). Refrigerated air can be supplied to  $201\text{K}$  at  $1.63 \times 10^4 \text{ kg/min}$  by a combination of four York Compressors and dried in an activated Alumina Dryer to a water content of

$$8.5 \times 10^{-4} \text{ kg of H}_2\text{O/kg of Dry Air}$$

All controls and instrumentation to operate the test rig and monitor their performance are contained in an air conditioned control room located adjacent to the test cell. Observation windows are provided between the control room and test cell to permit inspection of the cell interior during rig operation. Safety and fire protection equipment are provided for the control of hazardous operating conditions or use in the event of an emergency. Special portable instrumentation is supplied as required, for example, Automatic Data Recording (ADR) equipment.

Air Supplies:

- Shop Air: 0.472 m<sup>3</sup>/s, 7.13 atm, 0.076 m diameter outlet
- Inlet Air: 7.26 kg/s ambient  
4.54 kg/s refrigerated to 226K
- Spencer Blower Air: 5.19 m<sup>3</sup>/s ambient to H/E burners
- Vacuum System: 5 units rated at 5.66 m<sup>3</sup>/s
- Inlet Duct Sizes: 0.457 m I.D. 0.305 m  
(C&D) or 0.508 m, 0.203 m, and 0.102 m parallel  
refrigerated ducts
- Exhaust Duct  
Sizes: 0.914 m I.D., 0.762 m I.D. (A) and  
0.305 m I.D. All above tee into  
1.524 m I.D. water jacketed duct to the  
Vacuum Pumps.
- Exhaust Valves: One each 0.762 m, 0.305 m and 0.152 m  
in vacuum control duct
- Intake Valves: One each, 0.076 m, 0.152 m and 0.406 m  
refrigeration duct and one 0.457 m  
ambient supply duct
- Air Measuring  
Systems: One each 0.508 m, 0.203 m and 0.102 m  
Venturis in refrigerated duct system  
One 0.457 m Venturi in ambient supply  
duct system

Test Instrumentation:

- 4 Brown potentiometers (covering a temperature range from 200  
to 1922 K)
- 11 Thermocouple switches (28 point each)
- 30 pressure gauges (0 to 99 atm)

150 "U" tubes

7 panels of gauges and controls for refrigeration  
and vacuum unit controls

1 fuel flow digital flow indicator – P&WA Design

5 stabilized glass fuel rotometers (0 to 1905 Kg/hr

10 Honeywell Protectovane Temperature Indicators (256 to 1367K)

2 Davis Gas Samplers

Electric Power Supply:

- Alternating Current – 120 volt, 60 cps, 1-phase  
240 volt, 60 cps, 3-phase  
460 volt, 60 cps, 3-phase
- Direct Current – 24 volt at 150 amps

Fuel Supply:

- Hydrocarbon fuels: JP-4, JP-5, and special fuels can be supplied from 6 underground tanks from 7.57 to 37.85 meter<sup>3</sup> capacities totaling forty two thousand gallons through – 0.013 m pipes up to 0.189 m<sup>3</sup> (9979 Kg/hr) at 4.06 atm. Propyl nitrate and hydrogen peroxide are available from special tanks.. Oxygen and nitrogen gas are supplied from cylinders stored outside the test cell.

Water Supply:

- City Water – 0.757 m<sup>3</sup>, 7-13 atm, 0.951 m diameter outlet,  
Recirculated tower cooled water; 0.126 m<sup>3</sup>/s  
3.04 atm, 0.102 m diameter outlet.

Steam Supply:

- Low Pressure Steam – 431 Kg/hr, 3.72 atm, 417K, 0.038 m diameter outlet.

Safety and Fire Protection Equipment

- Safety equipment consists of a Cardox CO<sub>2</sub> System to flood or modulated squirt into chamber or rig as required from a 4119 Kg tank supply and a hose reel supply from the same tank. Portable CO<sub>2</sub> and Ansul bottles are available as required. A.M.S.A. detector system periodically samples critical areas and triggers a visual-audio alarm in area. Fog sprays and foamite are piped into the chambers.



TABLE A.2.1  
GAS ANALYSIS INSTRUMENTATION

<u>Component</u>	<u>Range</u>	<u>Instrument and Detection Method</u>	<u>Instrument Error - % Full Scale.....</u>
THC	0-1 ppmv	Flame Ionization Detector	± 5.0
	Intermediate ranges		± 1.0
	0-10%	Beckman Model 402	± 1.0
NO	0-200 ppmv	Non Dispersive Infrared	± 2.5
	0-500 ppmv	Beckman Model 315 AL	± 1.0
	0-1000 ppmv		± 1.0
NO <sub>2</sub>	0-200 ppmv	Non Dispersive Ultra Violet	± 2.0
	0-500 ppmv	Beckman Model 225A	± 1.0
CO	0-100 ppmv	Non Dispersive Infra Red	± 2.0
	0-1000	Beckman Model 315A	± 1.0
	0-1%		± 1.0
	0-7%		± 1.0
CO <sub>2</sub>	0-2%	Non Dispersive Infrared	± 1.0
	0-5%	Beckman Model 315A	± 1.0
	0-18%		± 1.0
O <sub>2</sub>	0-1%	Polargraphic	± 1.0
	0-5%	Beckman Model 715	± 1.0
	0-10%		± 1.0
	0-25%		± 1.0

Individual stainless steel sample lines are used to transfer the gas sample from the fixed exhaust rake array or the traverse rake to the gas analysis instrumentation. A schematic of the gas sample transfer system is shown in Figure A.2.2. Since the individual sample lines are not manifolded until outside the rake body, the capability exists to provide complete radial and circumferential documentation of exhaust constituent variation. However, the bulk of the emissions traverse data were taken with the radial probes manifolded together, immediately upstream of the gas analysis instruments. The sample transfer lines were steam-traced to maintain sample gas temperature in excess of 423K, above the condensation point of water and unburned hydrocarbon species present in the sample. As shown in Figure A.2.2, the gas sampling rake(s) and sample transfer system were also utilized to measure combustor exit total pressure. This was accomplished by dead-ending the gas sampling lines upstream of the emissions measurement meters and individually connecting the lines to a pressure readout system.

Gas composition measurements were made in accordance with the specifications of SAE ARP 1256 with the following additions:

- (1) In addition to measuring the constituents described in the ARP, a measurement was also made of oxygen in order to more meaningfully construct a total mass balance.

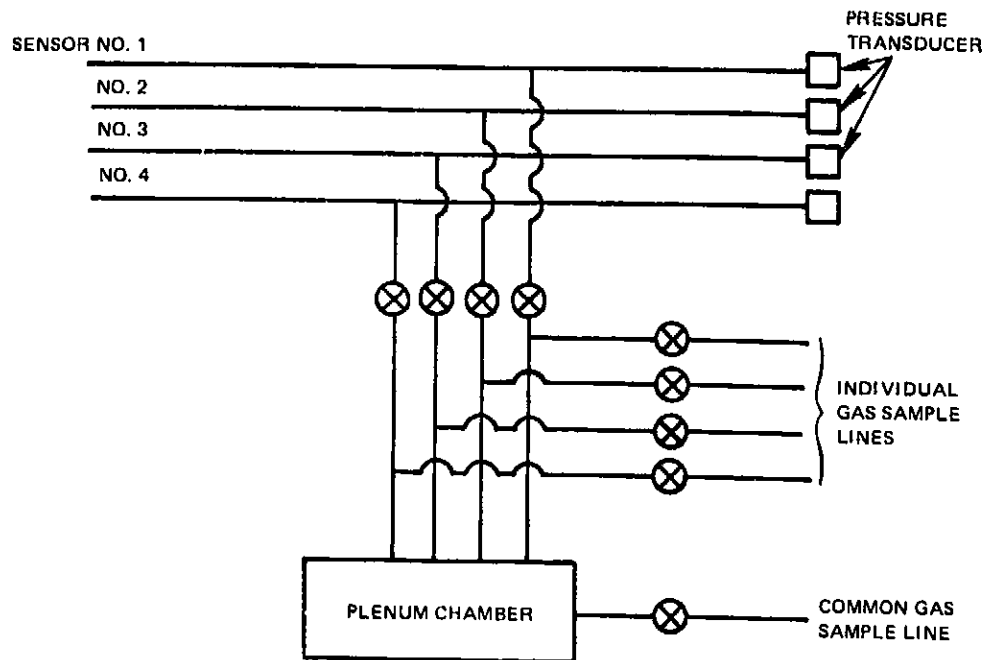

Figure A.2.2 Schematic of Gas Sample Transfer System

- (2) As a more meaningful test of representative sample collection, average measured values of total carbon ( $\text{CO}_2$ , CO, THC) was compared with the total carbon computed from the measured values of air and fuel flow. The ARP requires comparison only on the basis of measured  $\text{CO}_2$ .
- (3) The sampling system maintained the sample gas temperature at 423K to the flame ionization detector and 323K to all other gas analysis instrumentation. This is implied in the ARP, but is not clear in the equipment schematic drawing.

In exception to ARP 1256, the standard hydrocarbon reference gas was certified methane in air, traceable to the National Bureau of Standards (NBS). Because ARP 1256 is engine-oriented, a traverse pattern consistent with the requirement for representative sampling at the combustor rig exhaust plane was substituted for the sampling locations specified in the ARP.

Three systems are available for data logging and processing. The primary data system consists of an on-line Sigma 8 computer, providing essentially real-time data recording and analysis. The gas analyzer outputs are digitized and, on command, are sent via a telephone line to the Sigma 8 computer located in East Hartford, Connecticut, where emission data reduction is carried out utilizing equations comparable to those specified in ARP 1256. After the data have been processed, they are presented visually on a digital scope display at the test stand or printed, as command, in the computer graphics laboratory. As a back up data system, the analyzer outputs are also digitized and on command recorded on paper punch tape through use of a Beckman data logging system with Talley 120 Punch. The paper tape is compatible

with an IBM 370 computer, which was available for off-line special data reduction and validation programs. The third system consists of two Texas Instruments four pen records which monitor the output of the instruments and provide a continuous real time record for either immediate inspection or subsequent analysis. This system is especially helpful when troubleshooting problems after the test.

### A.2.2 CALIBRATION GASES

The basic accuracy of exhaust gas concentration measurements depends on the availability of accurately known reference gases. The calibration, zero, and span gases used in this study are the result of a continuing in-house program to develop and maintain accurate standard gases.

ARP 1256 specifies calibration gas certified by the vendor to an accuracy of one percent and span gas to a stated accuracy of  $\pm 2$  percent. It has been Pratt & Whitney Aircraft's experience that gases, while purchased to a certified or stated accuracy, are occasionally significantly different due to errors in blending or inherent instability of the gas in its container. Errors in blending lead to a consistent bias as long as that particular calibration gas is used. Instability normally leads to a reduction in actual concentration levels to an unpredictable new level. To relieve this situation, a set of reference standards are maintained in the Pratt & Whitney Aircraft Standards Laboratory which are carefully, and frequently in the case of unstable gases, analyzed by various appropriate analytical techniques. Where practical, additional analyses are performed by other agencies. These reference materials are maintained as transfer standards.

A summary of calibration gases and methods used for verification analysis is given in Table A.2.II. Instruments utilized for the analyses specified in Table A.2.II are:

TABLE A.2.II  
CALIBRATION GASES

<u>Gas</u>	<u>Source</u>	<u>Stability in Range of Interest</u>	<u>Analysis</u>
H/C	NBS	Stable	g. c., FID, mass spectrometer
CO	Vendor	Unstable in low concentrations	NDIR, g.c., mass spectrometer
CO <sub>2</sub>	Vendor	Stable	NDIR, g.c., mass spectrometer
NO	Vendor	Stable	PDS, Saltzman with oxidizer, mass spectrometer, NDIR, Chemiluminescence
NO <sub>2</sub>	Vendor	Unstable	PDS, Saltzman, mass spectrometer, NDUV, Chemiluminescence
O <sub>2</sub>	NBS/Air	Stable	g.c. mass spectrometer, amperometric

g.c. : gas chromatograph  
FID : Flame Ionization Detector

1. Gas Chromatographs (g.c.): Hewlett Packard Research Grade 7620A with FID; Perkin Elmer 800 with Thermal Conductivity detector; Perkin Elmer 820 with FID and Thermal Conductivity detectors; Barber Coleman cryogenic chromatograph with Thermal Conductivity detector.
2. TECO Model 10A Chemiluminescence Analyzer.
3. Mass Spectrometer: CEC Model 21-130

### A.2.3 SMOKE MEASUREMENT

Combustor exhaust smoke concentration was determined using a smoke measuring system that conforms to specifications of the Society of Automotive Engineers Aerospace Recommended Practice 1179 and the Environmental Protection Agency, as specified in Reference A.2.1. The smoke measuring system (smoke meter), is a semiautomatic electro-mechanical device which incorporates a number of features to permit the recording of smoke data with precision and relative ease of operation. A view of the smoke measurement console is shown in Figure A.2.3. Dimensions of the filter holder and a schematic of the sampling system are shown in Figure A.2.4. The filter holder has been constructed with a 2.54 cm diameter — spot size, a diffusion angle  $\theta$  of 0.127 radians and a converging angle  $\alpha$  of 0.48 radian.



Figure A.2.3 SAE/EPA Smoke Meter



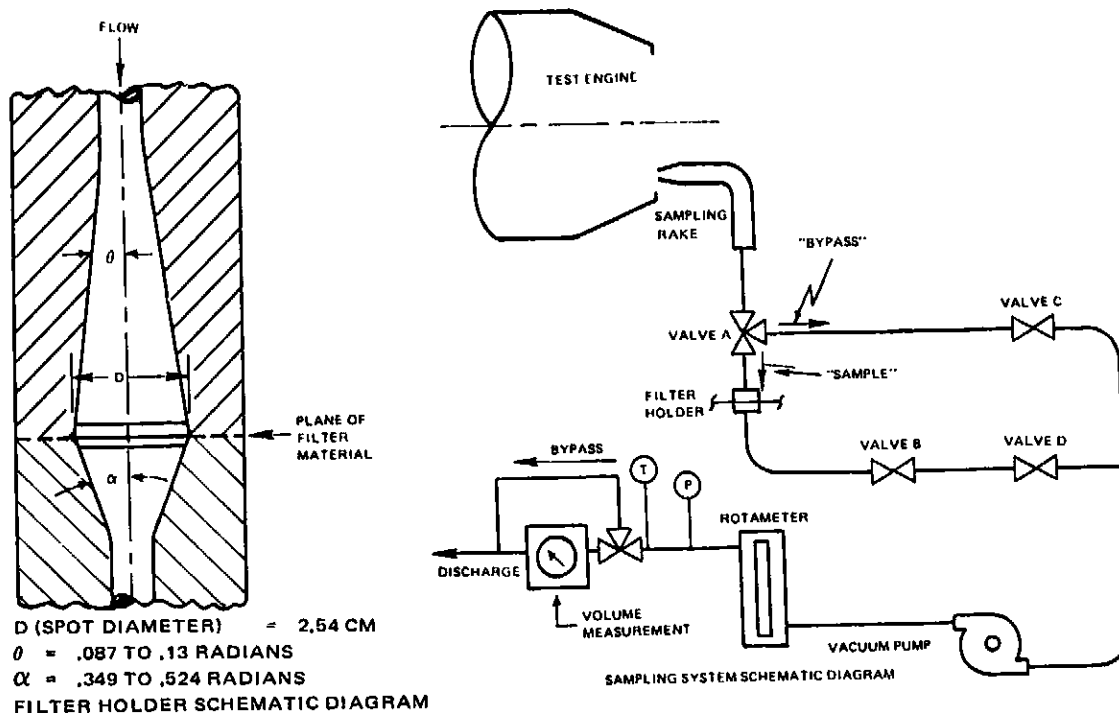

Figure A.2.4 Details of SAE/EPA Smoke Meter Construction (75-5325)

The unit is designed to minimize variability resulting from operator to operator differences. One of these features is a time controlled, solenoid activated main sampling valve (Valve A, See Figure A.2.4) having "closed", "sample", and "bypass" positions. This configuration permits close control of the sample size over relatively short sample times. In addition, this timing system operates a bypass system around a positive displacement volume measurement meter to ensure that the meter is in the circuit only when a sample is being collected or during the leak check mode. Other design features include automatic temperature control for the sample line and filter holder, and silicon rubber filter holders with support screens for ease of filter handling.

A Photovolt Model 670 reflection meter with a type Y search unit conforming to ASA Ph 2.17-1958 "Standard for Diffuser Reflection Density" is used to determine the reflectance of the clean and stained filters.

Calibration of the reflectance meter is accomplished through the use of a set of Hunter Laboratory, NBS traceable, reflectance plaques which range in 15 steps from 3 to 96 percent. Clean Whatman No. 4 filter paper has a nominal reflectance value of 80 percent, which is within this range. The measured reflectance values are least-squares fitted, tested for linearity, and the gas sample weight flow per unit filter area are computed by an IBM 370 digital computer. The reported smoke number is determined from the reflectance corresponding to a sample rate per unit area of  $0.0230\text{m}^2$ .

### A.3 EMISSIONS DATA REDUCTION CALCULATION PROCEDURES

#### A.3.1 DETERMINATION OF AVERAGE EMISSION INDICES – RAKE IN THE MIXING MODE

The total mass flow of any given constituent of the combustor exhaust is

$$W_x = \int_{R_1}^{R_2} \int_{\theta_1}^{\theta_2} m_x(r, \theta) \rho(r, \theta) v_z(r, \theta) r dr d\theta \quad \text{Equation (1)}$$

where:

- $W_x$  = mass flow of x
- $m_x(r, \theta)$  = mass concentration of x at  $(r, \theta)$
- $\rho(r, \theta)$  = density of exhaust gas at  $(r, \theta)$
- $v_z(r, \theta)$  = z component of exhaust velocity at  $(r, \theta)$

The geometry is shown in Figure A.3.1.

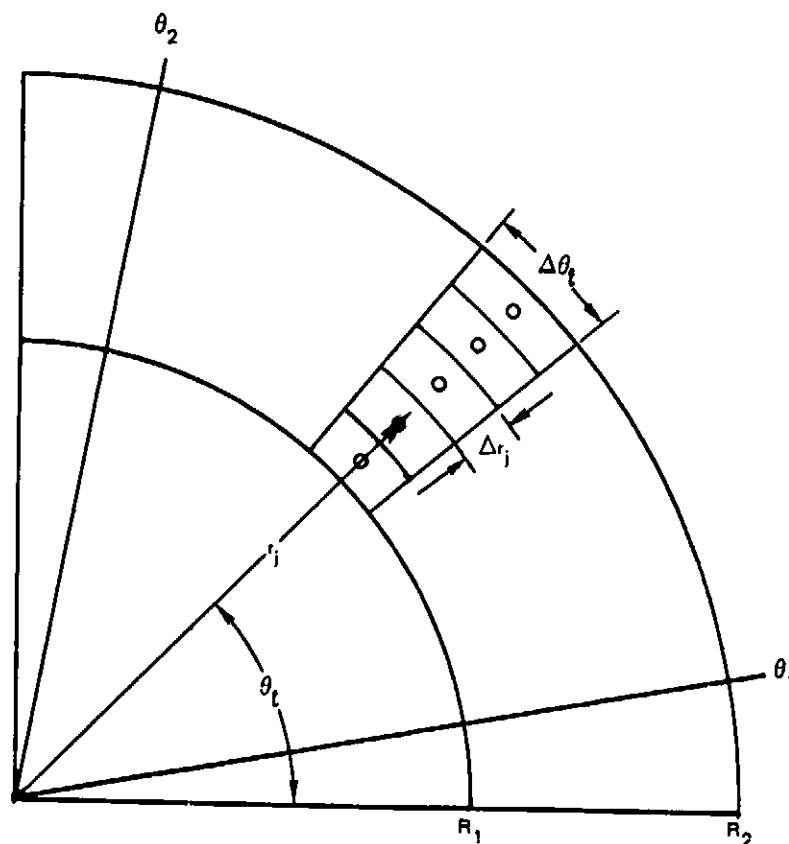

Figure A.3.1 Sample Geometry of One Quadrant Annular Combustor

The emissions instrumentation measures composition by volume or equivalently mole fraction of each constituent. The concentration by weight is obtained from the volumetric composition as follows.

where: 
$$m_x(r, \theta) = \frac{n_x}{n}(r, \theta) \frac{M_x}{M_{ex}} \quad \text{Equation (2)}$$

where  $\frac{n_x}{n}(r, \theta)$  = measured mole fraction of x at  $(r, \theta)$   $\left(\frac{\text{moles } x}{\text{mole exhaust}}\right)$   
 $M_x$  = molecular weight of x  
 $M_{ex}$  = mean molecular weight of exhaust at  $(r, \theta)$

The mean molecular weight of the exhaust gas is:

$$M_{ex} = \sum_i M_i \frac{n_i}{n} \quad \text{Equation (3)}$$

where:  $M_i$  = molecular weight of the  $i^{\text{th}}$  constituent.

Unless otherwise specified,  $(n_i/n)$  is assumed to be taken under wet or actual conditions. Measurements are made dry and corrected to wet values before used in these equations.

$R_1, R_2$  = INNER AND OUTER RADII OF THE BURNER ANNULUS  
 $\theta_1, \theta_2$  = ANGULAR LIMITS OF THE TOTAL BURNER SECTOR BEING MEASURED.  
 $\theta_t$  = RAKE AZIMUTHAL POSITION  
 $\Delta\theta_t$  = ANGLE INCREMENT OF THE SECTOR CENTERED ON  $\theta_t$   
 $r_j$  = RADIAL POSITION OF THE  $M^{\text{TH}}$  PROBE  
 $\Delta r_j$  = RADIAL INCREMENT OF THE ELEMENTARY AREA CENTERED ON  $(r_j, \theta_t)$

$r_j \Delta r_j \Delta\theta_t$  = CONSTANT  
 $J$  = NUMBER OF RADIAL INCREMENTS  
 $L$  = NUMBER OF AZIMUTHAL SECTORS

When a multipoint rake is used in the mixing mode, equation (1) requires that each probe on the rake yield a fraction of the total sample that is proportional to the local mass flow at that particular probe. This requirement is satisfied by a rake that samples isokinetically. This type of rake is traversed at the combustor exit plane to procure data at various azimuthal positions and the results combined to obtain total emission indices. The theory and procedure for combining measurements from various rake positions is briefly described below.

The average mass concentration of the exhaust constituent x obtained with the rake at azimuthal position  $\theta_c$  is;

$$\overline{m_x}_{\theta\ell} = \frac{1}{(\rho v)_{\theta\ell} \Delta a_{\theta\ell}} \sum_{j=1}^J m_x(r_j, \theta_\ell) \rho(r_j, \theta_\ell) V(r_j, \theta_\ell) r_j \Delta r_j \Delta \theta_\ell \quad \text{Equation (4)}$$

where

- $(\rho v)_{\theta\ell}$  = average mass flow per unit area in the  $\ell$  sector
- $\Delta a_{\theta\ell}$  = area of the  $\ell$  sector
- $\theta_\ell$  = angular position of the rake when sampling the  $\ell$  sector
- $\Delta \theta_\ell$  = angular width of the  $\ell$  sector
- $r_j$  = radius to the  $j^{\text{th}}$  probe
- $\Delta r_j$  = radial width of the area increment at  $r_j$
- $J$  = number of radial probe points

The probe points will be positioned at centers of equal area so that,

$$r_j \Delta r_j \Delta \theta_\ell = \Delta a_{\theta\ell} / J \quad \text{Equation (5)}$$

and consequently the rake measured average value is;

$$\overline{m_x}_{\theta\ell} = \frac{1}{(\rho v)_{\theta\ell} J} \sum_{j=1}^J m_x(r_j, \theta_\ell) \rho(r_j, \theta_\ell) V(r_j, \theta_\ell) \quad \text{Equation (6)}$$

where

$$(\rho v)_{\theta\ell} = \frac{1}{J} \sum_{j=1}^J \rho(r_j, \theta_\ell) V(r_j, \theta_\ell) \quad \text{Equation (7)}$$

In order to remain consistent with equation (1), the values obtained from several azimuthal positions of the rake must be weighted by the mass flow in each sector to procure an overall average for the particular combustor. That is:

$$\overline{m_x} = \frac{1}{\sum_{\ell=1}^L (\rho v)_{\theta\ell} \Delta a_{\theta\ell}} \sum_{\ell=1}^L (\rho v)_{\theta\ell} \Delta a_{\theta\ell} \overline{m_x}_{\theta\ell} \quad \text{Equation (8)}$$

where:  $L$  = number of azimuthal sectors

Total pressure and temperature and static pressure measurements at the combustor exit plane are used to obtain the mass flow distribution data necessary to complete the averaging process. The mass flow in each sector is obtained using equation (7)

where:

$$\rho(r_j, \theta_\rho) v(r_j, \theta_\rho) = \sqrt{\frac{2 P_s [P_t(r_j, \theta_\rho) - P_s]}{B R T(r_j, \theta_\rho)}} \quad \text{Equation (9)}$$

and

$P_t(r_j, \theta_\rho)$	=	Total Pressure at $(r_j, \theta_\rho)$
$P_s$	=	Static Pressure in the measurement plane (independent of position)
$T(r_j, \theta_\rho)$	=	Temperature at $(r_j, \theta_\rho)$
$R$	=	Gas constant of the mixture
$B$	=	Correction for compressibility effects
	=	$(1 + \frac{M^2}{4} + \frac{(2-k)M^4}{24} + \dots)$
$M$	=	Mach number
$k$	=	Ratio of specific heats

The emission indices can be calculated from the average mass concentration as follows:

$$W_x = W_t \overline{m_x} \quad \text{Equation (10)}$$

$$I_x = \frac{W_x}{F} \quad M_x = \left(1 + \frac{1}{F/A}\right) \overline{M_x} \quad \text{Equation (11)}$$

where

$W_x$	=	Total mass flow of x
$W_t$	=	Total mass flow of exhaust
$I_x$	=	Mass flow of x per unit mass of fuel
$W_t$	=	$A + F$
$A$	=	metered air flow
$F$	=	metered fuel flow

During portions of the experimental test program, the traverse rake was used to sample each point independently to allow emission concentration and flow distributions to be determined. In this case, the average emission index was computed similarly to the above except that the summations extend over each of the area elements. That is:

$$\bar{m}_x = \frac{1}{\bar{\rho v a}} \sum_{\ell=1}^L \sum_{j=1}^J m_x(r_j, \theta_{\ell}) \rho(r_j, \theta_{\ell}) v(r_j, \theta_{\ell}) r_j \Delta r_j \Delta \theta_{\ell} \quad \text{Equation (12)}$$

where

$$\bar{\rho v} = \frac{1}{a} \sum_{\ell=1}^L \sum_{j=1}^J \rho(r_j, \theta_{\ell}) v(r_j, \theta_{\ell}) r_j \Delta r_j \Delta \theta_{\ell} \quad \text{Equation (13)}$$

and  $a$  is the total flow area and  $\bar{\rho v}$  is determined by equation 9.

Again, the final emission indices can be calculated as in equation (11).

### A.3.2 CALCULATION OF FUEL-AIR RATIO

The fuel-air ratio can be calculated from both fuel and airflow measurements a carbon balance determined by the exhaust gas species concentration measurements. Following ARP 1256, the fuel-air ratio is computed as follows:

$$(F/A) = \frac{M_c + \alpha M_H \left[ \left( \frac{n_{CO}}{n} \right) + \left( \frac{n_{CO2}}{n} \right) + \left( \frac{n_C}{n} \right) \right]}{M_{air} \left[ 100 - \frac{n_{CO}}{n} \left( \frac{1}{2} + \frac{\alpha}{4} \right) - \left( \frac{n_{CO2}}{n} \right) \left( \frac{\alpha}{4} \right) \right]} \quad \text{Equation (14)}$$

where:

$\alpha$  = hydrogen to carbon ratio in the fuel

and the values of  $\left( \frac{\bar{n}_x}{n} \right)$  are obtained from the flow weighted mass concentrations  $\bar{m}_x$  as follows;

$$\left( \frac{\bar{n}_x}{n} \right) = \left( \frac{\bar{M}_{cx}}{M_x} \right) \bar{m}_x \quad \text{Equation (15)}$$

where  $M_{cx}$  = mean molecular weight of the exhaust gas

**APPENDIX B**  
**COMBUSTOR HOLE PATTERNS**

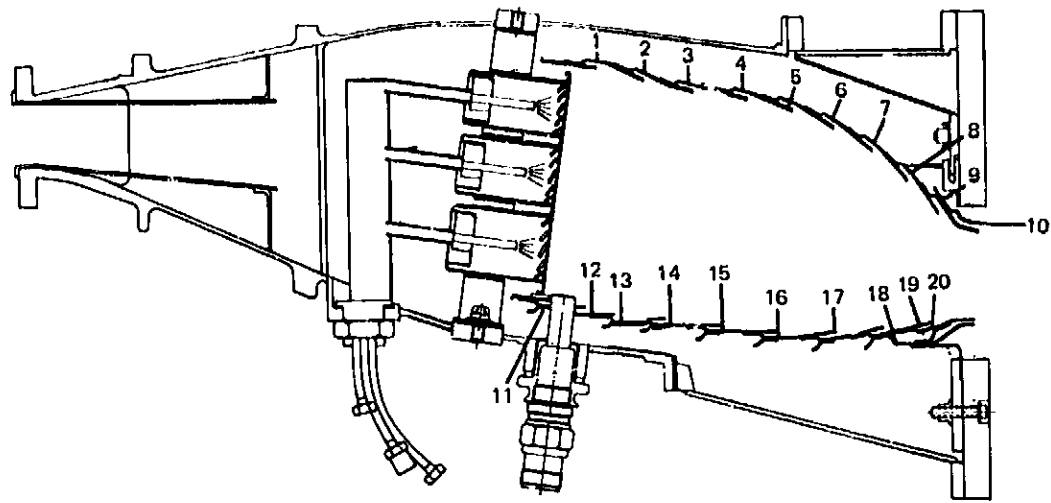

**TURBINE COOLING**

ID 7 AT 0.877d = 4.229 IN<sup>2</sup>  
 OD 16 AT 0.547d = 3.760 IN<sup>2</sup>  
 SIDE WALL COOLING AREA = 2.678 IN<sup>2</sup>

I. D.				O. D.			
LOUVER	DIA.	#HOLES	AREA IN <sup>2</sup>	LOUVER	DIA.	#HOLES	AREA IN <sup>2</sup>
1	0.100	128	1.007	11	0.096	155	1.125
2	0.100	66	0.521	12	0.052	149	0.316
3	0.052	103	0.219	13	0.055	182	0.432
4	0.052	84	0.179	14	0.052	162	0.345
5	0.052	84	0.179	15	0.052	184	0.391
6	0.052	90	0.192	16	0.052	184	0.391
7	0.052	114	0.242	17	0.052	184	0.391
8	0.052	126	0.267	18	0.052	180	0.382
9	0.052	115	0.244	19	0.052	174	0.370
10	0.0938	84	0.580	20	0.086	70	0.406

SWIRLER    ACD  
 ID        1.548  
 MD        1.944  
 OD        2.349  
 BYPASS AREA    31.837  
 INJECTORS        LOW ΔP

Figure B-1 Liner Hole Pattern for Swirl-Can Modular Combustor Configuration N-1



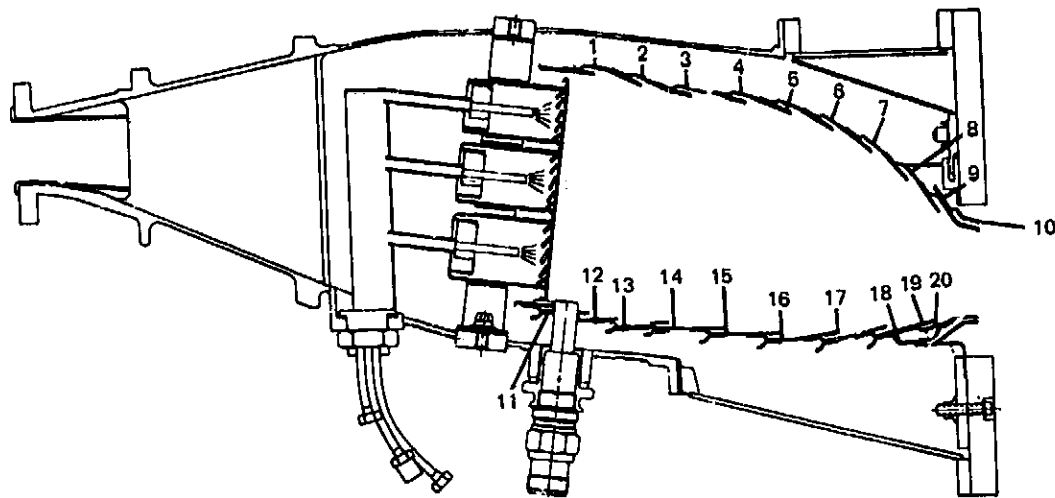

**TURBINE COOLING**

ID 7 AT 0.877d = 4.229 IN<sup>2</sup>  
 ID 16 AT 0.547d = 3.760 IN<sup>2</sup>  
 SIDE WALL COOLING AREA = 2.678 IN<sup>2</sup>

I. D.				O. D.			
LOUVER	DIA.	#HOLES	AREA IN <sup>2</sup>	LOUVER	DIA.	#HOLES	AREA IN <sup>2</sup>
1	0.100	128	1.007	11	0.096	155	1.125
2	0.100	66	0.521	12	0.052	149	0.316
3	0.052	103	0.219	13	0.055	182	0.432
4	0.052	84	0.179	14	0.052	162	0.345
5	0.052	84	0.179	15	0.052	184	0.391
6	0.052	90	0.192	16	0.052	184	0.391
7	0.052	114	0.242	17	0.052	184	0.391
8	0.052	126	0.267	18	0.052	180	0.382
9	0.052	115	0.244	19	0.052	174	0.370
10	0.0938	84	0.580	20	0.086	70	0.406

**SWIRLER ACD**

ID 1.548  
 MD 1.944  
 OD 2.349  
 BYPASS AREA 17.315 (GROSS IN<sup>2</sup>)  
 INJECTORS LOW ΔP

**MODIFICATIONS**

- SHORTENED DUMP DIFFUSER
- REMOVED FUEL NOZZLE SUPPORT HEAT SHIELDS
- REDUCED WIDTH OF NOZZLE CENTERING LEGS
- MOVED FUEL NOZZLE FROM 0.6 TO 0.1 INCH FROM SWIRLER
- MODIFIED BLOCKAGE TRIANGLES

Figure B-2 Liner Hole Pattern for Swirl-Can Modular Combustor Configuration N-2

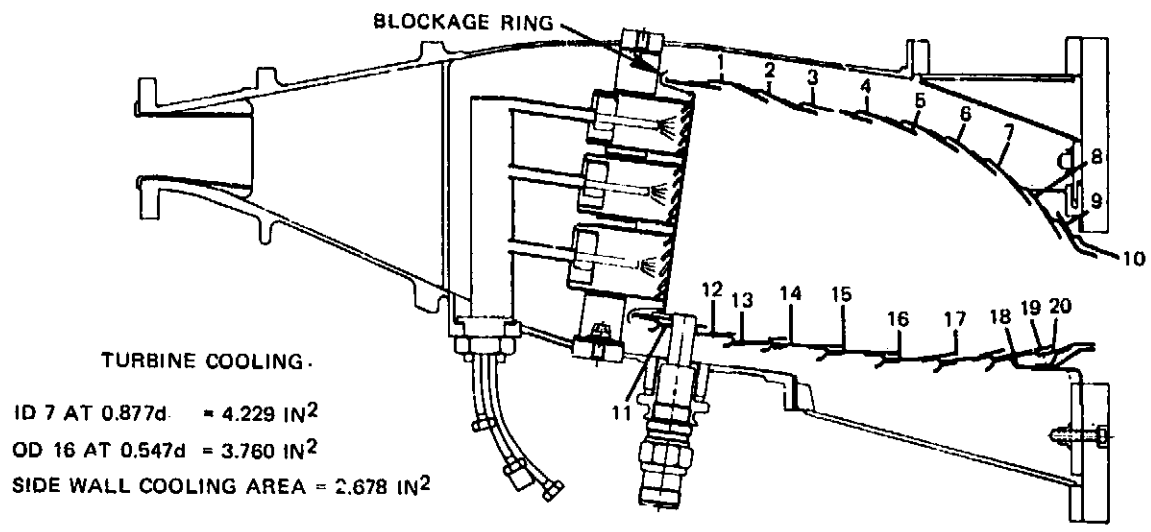

I. D.				O. D.			
LOUVER	DIA.	# HOLES	AREA IN <sup>2</sup>	LOUVER	DIA.	# HOLES	AREA IN <sup>2</sup>
1	0.100	128	1.007	11	0.096	155	1.125
2	0.100	66	0.521	12	0.052	149	0.316
3	0.052	103	0.219	13	0.055	182	0.432
4	0.052	84	0.179	14	0.052	162	0.345
5	0.052	84	0.179	15	0.052	184	0.391
6	0.052	90	0.192	16	0.052	184	0.391
7	0.052	114	0.242	17	0.052	184	0.391
8	0.052	126	0.267	18	0.052	180	0.382
9	0.052	115	0.244	19	0.052	174	0.370
10	0.0938	84	0.580	20	0.086	70	0.406

SWIRLER ACD  
 ID 2.538  
 MD 3.186  
 OD 3.843  
 BYPASS AREA 10.611 (GROSS IN<sup>2</sup>)  
 INJECTORS LOW ΔP

**MODIFICATIONS**

- INCREASE SWIRLER FLOW (33° VANE ANGLE)
- REDUCE BYPASS FLOW
- REDUCE OD AND ID BYPASS AIR WITH BLOCKAGE RINGS

1-SLOT AT EACH MODULE  
 (O.D. 0.150 x 1.125)  
 (I.D. 0.150 x 1.000)

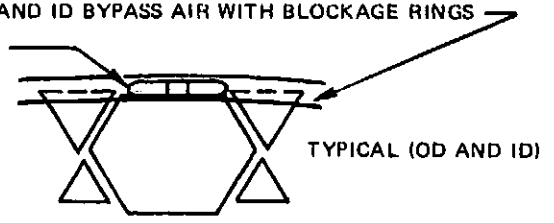
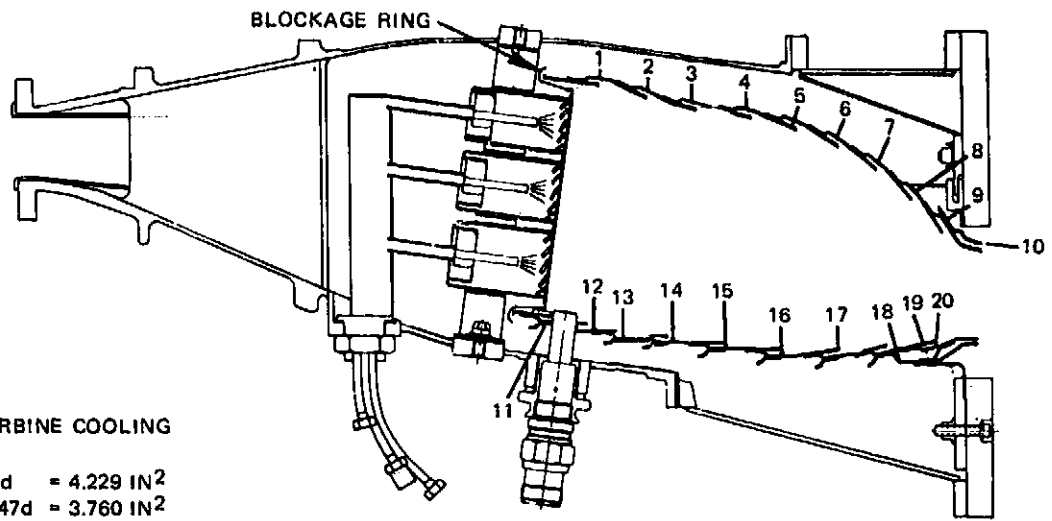

Figure B-3 Liner Hole Pattern for Swirl-Can Modular Combustor Configuration N-3



TURBINE COOLING  
 ID 7 AT 0.877d = 4.229 IN<sup>2</sup>  
 OD 16 AT 0.547d = 3.760 IN<sup>2</sup>  
 SIDE WALL COOLING AREA = 2.678 IN<sup>2</sup>

I. D.				O. D.			
LOUVER	DIA.	#HOLES	AREA IN <sup>2</sup>	LOUVER	DIA.	#HOLES	AREA IN <sup>2</sup>
1	0.100	128	1.007	11	0.096	155	1.125
2	0.100	66	0.521	12	0.052	149	0.316
3	0.052	103	0.219	13	0.055	182	0.432
4	0.052	84	0.179	14	0.052	162	0.345
5	0.052	84	0.179	15	0.052	184	0.391
6	0.052	90	0.192	16	0.052	184	0.391
7	0.052	114	0.242	17	0.052	184	0.391
8	0.052	126	0.267	18	0.052	180	0.382
9	0.052	115	0.242	19	0.052	174	0.370
10	0.0938	84	0.580	20	0.086	70	0.406

SWIRLER                    ACD  
 ID                            2.538  
 MD                            3.186  
 OD                            3.843  
 BYPASS AREA            10.611 (GROSS IN<sup>2</sup>)

MODIFICATIONS: REFERENCE CONFIGURATION N-3

- SAME AS CONFIGURATION N-3 WITH PRESSURE ATOMIZING NOZZLES
- I.D. P/N 27700-12
- M.D. P/N 27700-11
- O.D. P/N 27700-11

Figure B-4 Liner Hole Pattern for Swirl-Can Modular Combustor Configuration N-4

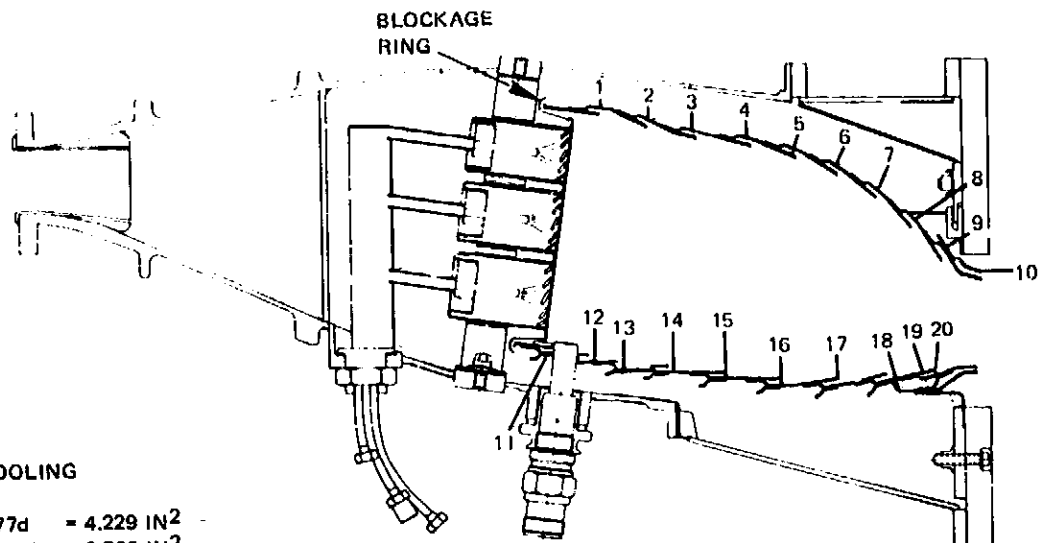

**TURBINE COOLING**

ID 7 AT 0.877d = 4.229 IN<sup>2</sup>  
 OD 16 AT 0.547d = 3.760 IN<sup>2</sup>  
 SIDE WALL COOLING AREA = 2.678 IN<sup>2</sup>

I. D.				O. D.			
LOUVER	DIA.	# HOLES	AREA IN <sup>2</sup>	LOUVER	DIA.	# HOLES	AREA IN <sup>2</sup>
1	0.100	128	1.007	11	0.096	155	1.125
2	0.100	66	0.521	12	0.052	149	0.316
3	0.052	103	0.219	13	0.055	182	0.432
4	0.052	84	0.179	14	0.052	162	0.345
5	0.052	84	0.179	15	0.052	184	0.391
6	0.052	90	0.192	16	0.052	184	0.391
7	0.052	114	0.242	17	0.052	184	0.391
8	0.052	126	0.267	18	0.052	180	0.382
9	0.052	115	0.244	19	0.052	174	0.370
10	0.0938	84	0.580	20	0.086	70	0.406

SWIRLER      ACD  
 ID            3.505  
 MD            4.400  
 OD            5.307  
 BYPASS AREA    7.318 IN<sup>2</sup> (GROSS)

MODIFICATIONS: REFERENCE CONFIGURATION N-4

- USE LOW ΔP FUEL INJECTORS
- REDUCE BYPASS AIR FLOW
- OPEN SWIRLERS:
  - ID -- 42° VANE ANGLE
  - MD -- 42° VANE ANGLE
  - OD -- 40° VANE ANGLE

Figure B-5 Liner Hole Pattern for Swirl-Can Modular Combustor Configuration N-5

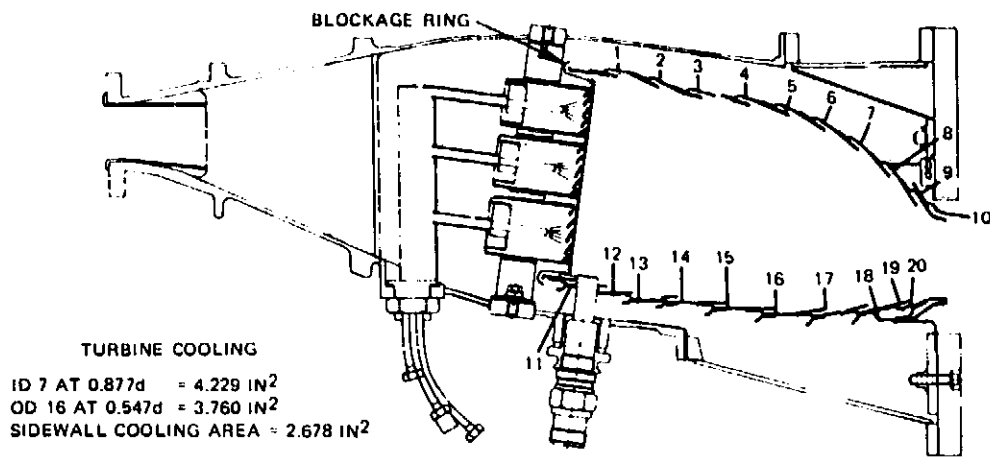

I D				O D			
LOUVER	DIA.	# HOLES	AREA IN <sup>2</sup>	LOUVER	DIA.	# HOLES	AREA IN <sup>2</sup>
1	0.100	128	1.007	11	0.096	155	1.125
2	0.100	66	0.521	12	0.052	149	0.316
3	0.052	103	0.219	13	0.055	182	0.432
4	0.052	84	0.179	14	0.052	162	0.345
5	0.052	84	0.179	15	0.052	184	0.391
6	0.052	90	0.192	16	0.052	184	0.391
7	0.052	114	0.242	17	0.052	184	0.391
8	0.052	126	0.267	18	0.052	180	0.382
9	0.052	115	0.244	19	0.052	174	0.370
10	0.0938	84	0.580	20	0.086	70	0.406

SWIRLER      ACD  
 ID            2.538  
 MD            3.186  
 OD            3.843  
 BYPASS AREA 10.611 (GROSS IN<sup>2</sup>)

MODIFICATIONS: REFERENCE CONFIGURATION N-5

- MODIFY SWIRLERS AND BYPASS AREA TO CONFIGURATION N-3
- ADD 0.200 IN. EXTENSIONS TO HEX FLAMEHOLDER TO DELAY BYPASS AIR QUENCH
- LOW ΔP INJECTORS

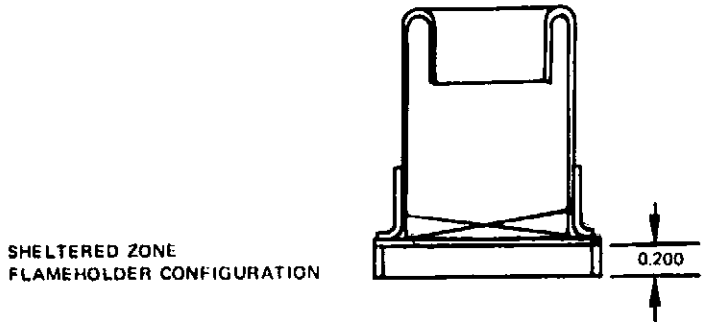
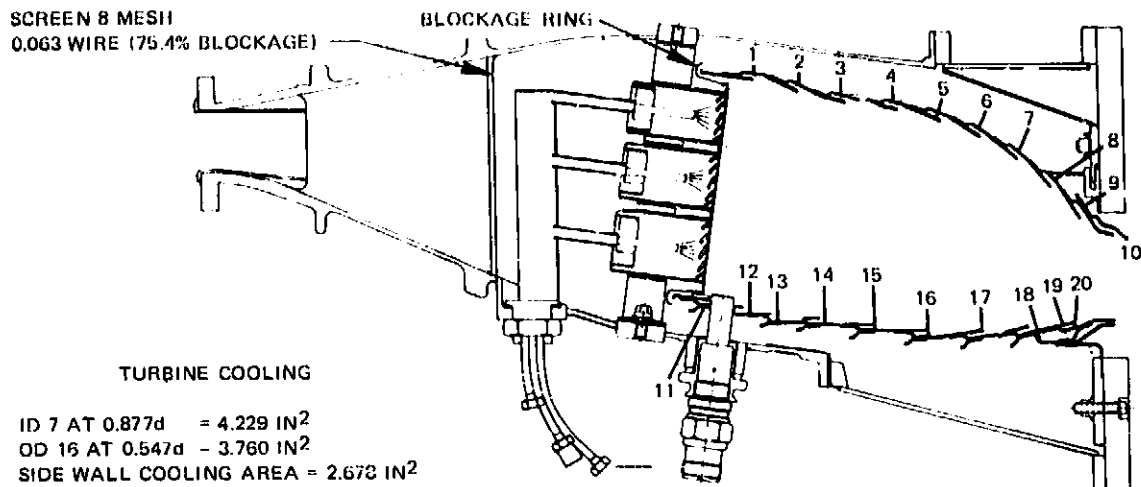

Figure B-6 Liner Hole Pattern for Swirl-Can Modular Combustor Configuration N-6



I. D.				O. D.			
LOUVER	DIA.	# HOLES	AREA IN <sup>2</sup>	LOUVER	DIA.	# HOLES	AREA IN <sup>2</sup>
1	0.100	128	1.007	11	0.096	155	1.125
2	0.100	66	0.521	12	0.052	149	0.316
3	0.052	103	0.219	13	0.055	182	0.432
4	0.052	84	0.179	14	0.052	162	0.345
5	0.052	84	0.179	15	0.052	184	0.391
6	0.052	90	0.192	16	0.052	184	0.391
7	0.052	114	0.242	17	0.052	184	0.391
8	0.052	126	0.267	18	0.052	180	0.382
9	0.052	115	0.242	19	0.052	174	0.370
10	0.0938	84	0.580	20	0.086	70	0.406

SWIRLER      ACD  
ID            2.538  
MD            3.186  
OD            3.843

BYPASS AREA 10.611 (GROSS IN<sup>2</sup>)

MODIFICATIONS: REFERENCE CONFIGURATION N-6

- RECESS SWIRLERS 0.500 INCH UPSTREAM  
HOLD 0.100 DIM. BETWEEN FUEL INJECTOR AND SWIRLER
- ADD SCREEN TO TRAILING EDGE OF STRUTS (75.4% BLOCKAGE)
- INSTALL ACOUSTIC PROBES

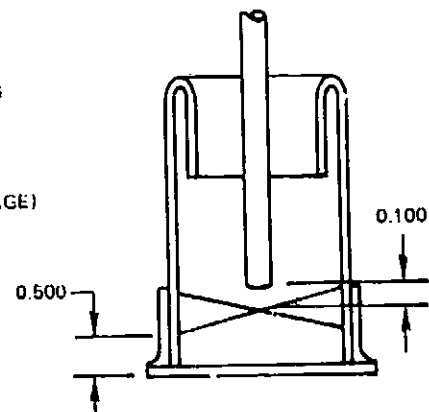
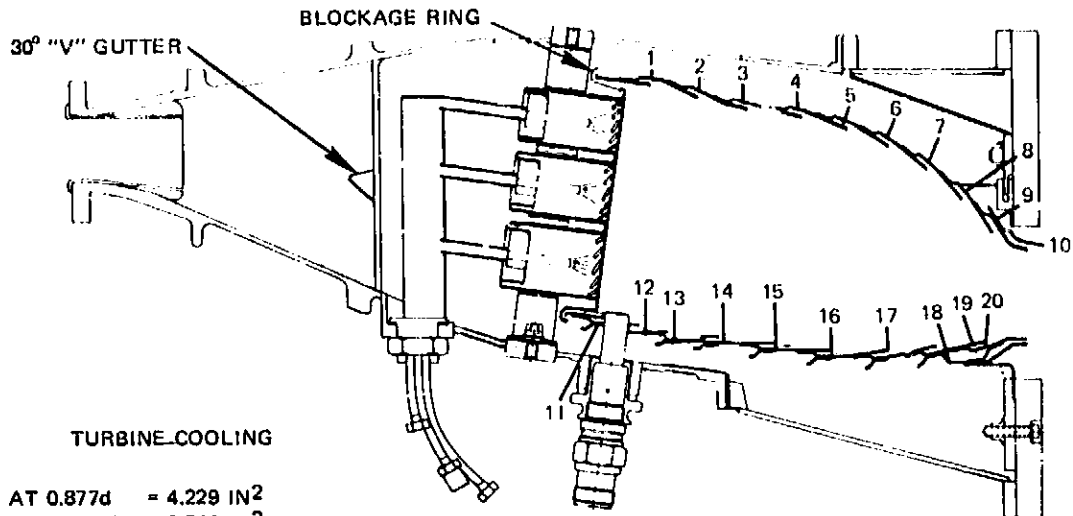

Figure B-7 Liner Hole Pattern for Swirl-Can Modular Combustor Configuration N-7



TURBINE COOLING

ID 7 AT 0.877d = 4.229 IN<sup>2</sup>  
 OD 16 AT 0.547d = 3.760 IN<sup>2</sup>  
 SIDE WALL COOLING AREA = 2.678 IN<sup>2</sup>

I. D.				O. D.			
LOUVER	DIA.	# HOLES	AREA IN <sup>2</sup>	LOUVER	DIA.	# HOLES	AREA IN <sup>2</sup>
1	0.100	128	1.007	11	0.096	155	1.125
2	0.100	66	0.521	12	0.052	149	0.316
3	0.052	103	0.219	13	0.055	182	0.432
4	0.052	84	0.179	14	0.052	162	0.345
5	0.052	84	0.179	15	0.052	184	0.391
6	0.052	90	0.192	16	0.052	184	0.391
7	0.052	114	0.242	17	0.052	184	0.391
8	0.052	126	0.267	18	0.052	180	0.382
9	0.052	115	0.244	19	0.052	174	0.370
10	0.0938	84	0.580	20	0.086	70	0.406

SWIRLER      ACD  
 ID      2.538  
 MD      3.186  
 OD      3.843  
 BYPASS AREA 10.611 (GROSS IN<sup>2</sup>)

MODIFICATIONS: REFERENCE CONFIGURATION N-7

• REMOVE SCREEN AND INSTALL "V" GUTTER

Figure B-8 Liner Hole Pattern for Swirl-Can Modular Combustor Configuration N-8

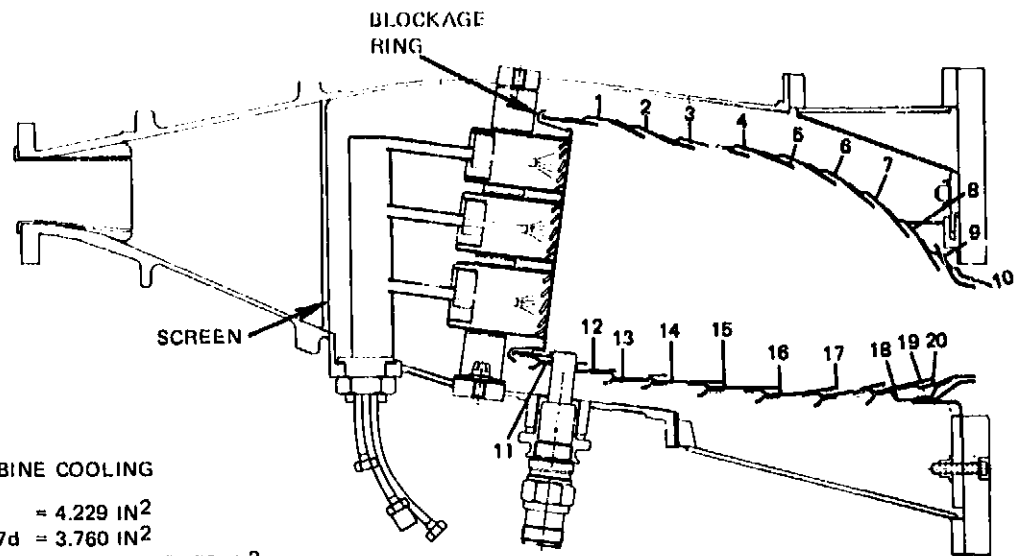

TURBINE COOLING  
 ID 7 AT 0.877d = 4.229 IN<sup>2</sup>  
 OD 16 AT 0.547d = 3.760 IN<sup>2</sup>  
 SIDE WALL COOLING AREA = 2.678 IN<sup>2</sup>

I. D.				O. D.			
LOUVER	DIA.	# HOLES	AREA IN <sup>2</sup>	LOUVER	DIA.	# HOLES	AREA IN <sup>2</sup>
1	0.100	128	1.007	11	0.096	155	1.125
2	0.100	66	0.521	12	0.052	149	0.316
3	0.052	103	0.219	13	0.055	182	0.432
4	0.052	84	0.179	14	0.052	162	0.345
5	0.052	84	0.179	15	0.052	184	0.391
6	0.052	90	0.192	16	0.052	184	0.391
7	0.052	114	0.242	17	0.052	184	0.391
8	0.052	126	0.267	18	0.052	180	0.382
9	0.052	115	0.244	19	0.052	174	0.370
10	0.0938	94	0.580	20	0.086	70	0.406

SCREEN 8 MESH  
 0.063 WIRE  
 75.4% BLOCKAGE

SWIRLER ACD  
 ID 2.538  
 MD 3.186  
 OD 3.843

AIR SWIRLERS  
 ID 3.735  
 MD 4.702  
 OD 5.715

MODIFICATION: REFERENCE CONFIGURATION N-3

- ALL BYPASS AIR WILL PASS THROUGH AIR SWIRLERS AROUND EACH CARBURETOR
- INSTALL SCREEN (SAME AS CONFIGURATION N-7)

Figure B-9 Liner Hole Pattern for Swirl-Can Modular Combustor Configuration N-9



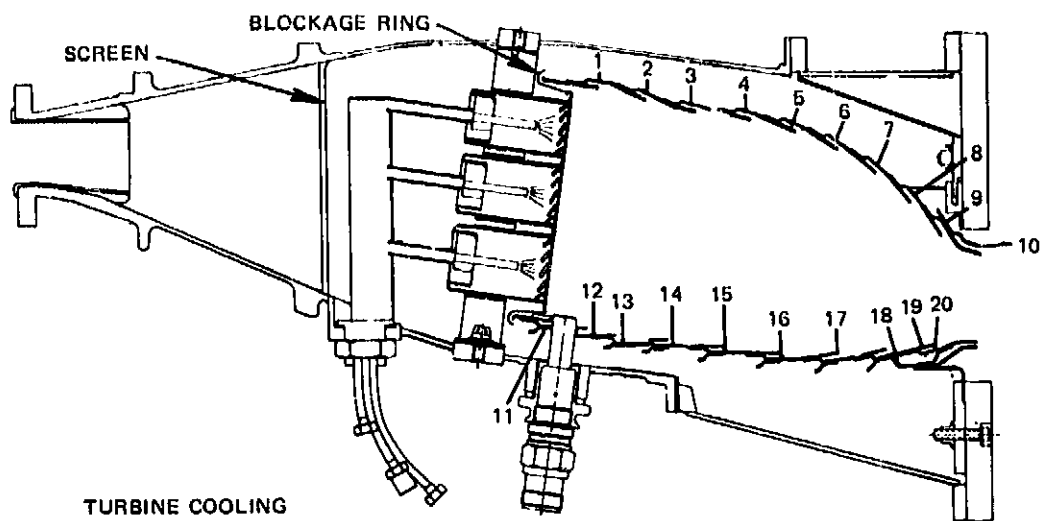

**TURBINE COOLING**

ID 7 AT  $0.877d = 4.229 \text{ IN}^2$   
 OD 16 AT  $0.547d = 3.760 \text{ IN}^2$   
 SIDE WALL COOLING AREA =  $2.678 \text{ IN}^2$

I. D.				O. D.			
LOUVER	DIA.	#HOLES	AREA IN <sup>2</sup>	LOUVER	DIA.	#HOLES	AREA IN <sup>2</sup>
1	0.100	128	1.007	11	0.096	155	1.125
2	0.100	66	0.521	12	0.052	149	0.316
3	0.052	103	0.219	13	0.055	182	0.432
4	0.052	84	0.179	14	0.052	162	0.345
5	0.052	84	0.179	15	0.052	184	0.391
6	0.052	90	0.192	16	0.052	184	0.391
7	0.052	114	0.242	17	0.052	184	0.391
8	0.052	126	0.267	18	0.052	180	0.382
9	0.052	115	0.244	19	0.052	174	0.370
10	0.0938	84	0.580	20	0.086	70	0.406

SWIRLER      ACD  
 ID            0.982  
 MD            1.233  
 OD            1.487

BYPASS AREA 10.611 (GROSS IN<sup>2</sup>)

**MODIFICATIONS REFERENCE CONFIGURATION N-7**

- INSTALL SWIRLER BLOCKAGE PLATES TO INCREASE CAN EQUIVALENCE RATIO

*Figure B-10 Liner Hole Pattern for Swirl-Can Modular Combustor Configuration N-10*

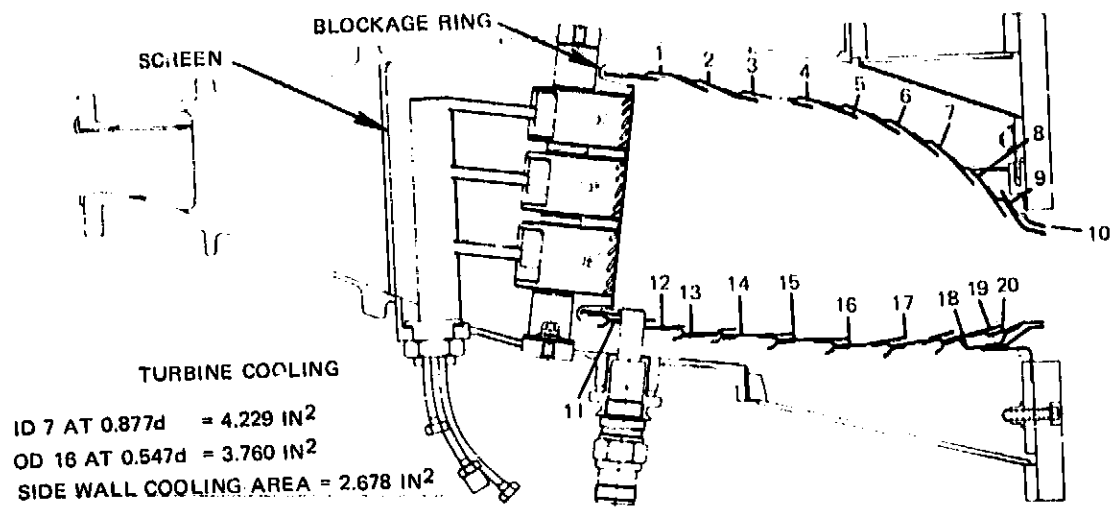

I. D.				O. D.			
LOUVER	DIA.	#HOLES	AREAIN <sup>2</sup>	LOUVER	DIA.	#HOLES	AREAIN <sup>2</sup>
1	0.100	128	1.007	11	0.096	155	1.125
2	0.100	66	0.521	12	0.052	149	0.316
3	0.052	103	0.219	13	0.055	182	0.432
4	0.052	84	0.179	14	0.052	162	0.345
5	0.052	84	0.179	15	0.052	184	0.391
6	0.052	90	0.192	16	0.052	184	0.391
7	0.052	114	0.242	17	0.052	184	0.391
8	0.052	126	0.267	18	0.052	180	0.382
9	0.052	115	0.244	19	0.052	174	0.370
10	0.0938	84	0.580	20	0.086	70	0.406

SWIRLER                      ACD  
 ID                              0.982  
 MD                              1.233  
 OD                              1.487

BYPASS AREA 10.611 (GROSS AREA)  
 DILUTION HOLES (ROW 3)                      9 AT 0.676 DIAMETER = 1.936 IN<sup>2</sup>  
 DILUTION HOLES (ROW 14)                      9 AT 0.676 DIAMETER = 1.936 IN<sup>2</sup>

MODIFICATIONS: REFERENCE CONFIGURATION N-10  
 • ADD DILUTION HOLES

Figure B-11 Liner Hole Pattern for Swirl-Can Modular Combustor Configuration N-11

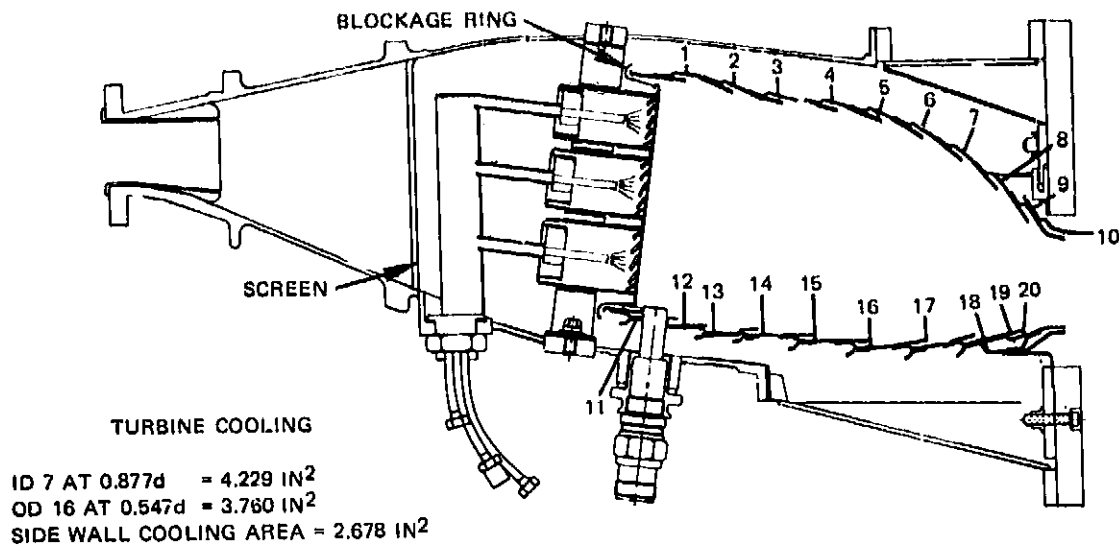

I. D.				O. D.			
LOUVER	DIA.	#HOLES	AREA IN <sup>2</sup>	LOUVER	DIA.	#HOLES	AREA IN <sup>2</sup>
1	0.100	128	1.007	11	0.096	155	1.125
2	0.100	66	0.521	12	0.052	149	0.316
3	0.052	103	0.219	13	0.055	182	0.432
4	0.052	84	0.179	14	0.052	162	0.345
5	0.052	84	0.179	15	0.052	184	0.391
6	0.052	90	0.192	16	0.052	184	0.391
7	0.052	114	0.242	17	0.052	184	0.391
8	0.052	126	0.267	18	0.052	180	0.382
9	0.052	115	0.244	19	0.052	174	0.370
10	0.0938	84	0.580	20	0.086	70	0.406

SWIRLER            ACD  
 ID                2.538  
 MD                3.186  
 OD                3.843

AIR SWIRLERS  
 ID                3.735  
 MD                4.702  
 OD                5.712

MODIFICATIONS: REFERENCE CONFIGURATION N-9

- LENGTHEN FUEL INJECTORS
- INSTALL HOLE IN FUEL-AIR SWIRLERS FOR INJECTORS
- USE PRESSURE ATOMIZING NOZZLES

Figure B-12 Liner Hole Pattern for Swirl-Can Modular Combustor Configuration N-12 (Relight Configuration)

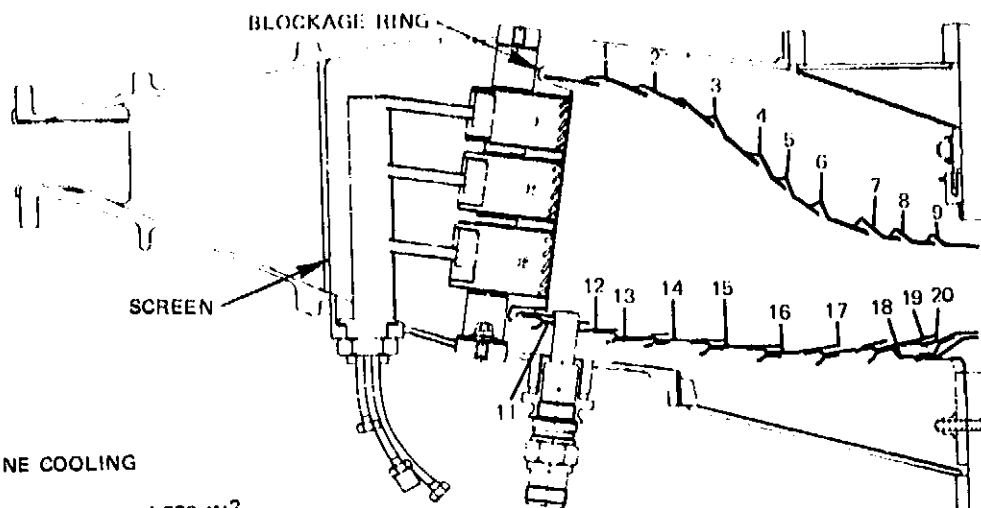

TURBINE COOLING

ID 7 AT 0.877d = 4.229 IN<sup>2</sup>  
 OD 16 AT 0.547d = 3.760 IN<sup>2</sup>  
 SIDE WALL COOLING AREA = 2.678 IN<sup>2</sup>

I. D.				O. D.			
LOUVER	DIA.	# HOLES	AREA IN <sup>2</sup>	LOUVER	DIA.	# HOLES	AREA IN <sup>2</sup>
1	0.100	128	1.007	11	0.096	155	1.125
2	0.100	66	0.521	12	0.052	149	0.316
3	0.052	90	0.191	13	0.055	182	0.432
4	0.052	90	0.191	14	0.052	162	0.345
5	0.052	90	0.191	15	0.052	184	0.391
6	0.052	90	0.191	16	0.052	184	0.391
7	0.052	90	0.191	17	0.052	184	0.391
8	0.052	90	0.191	18	0.052	180	0.382
9	0.0938	84	0.580	19	0.052	174	0.370
				20	0.086	70	0.406

SWIRLER      ACD  
 ID            2.538  
 MD            3.186  
 OD            3.843

AIR SWIRLERS  
 ID            3.735  
 MD            4.702  
 OD            5.712

MODIFICATION: REFERENCE CONFIGURATION N-9

• REDUCE LINER HEIGHT

Figure B-13 Liner Hole Pattern for Swirl-Can Modular Combustor Configuration N-13 (AST Configuration)

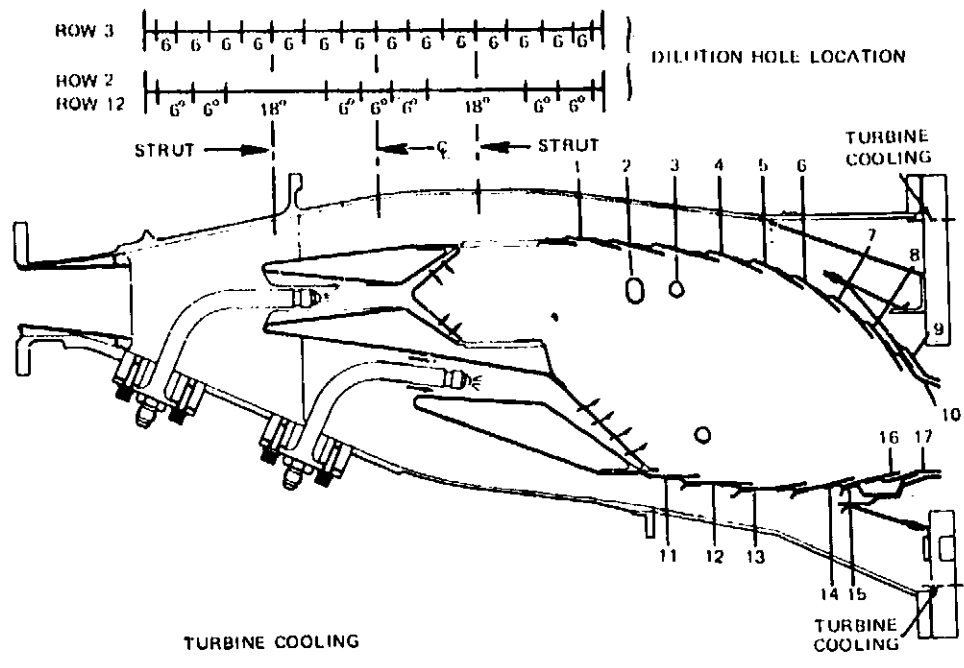

ID 7 AT 0.827d - 4.229 IN<sup>2</sup>  
 OD 16 AT 0.547d - 3.760 IN<sup>2</sup>  
 SIDE WALL COOLING AREA - 3.534 IN<sup>2</sup>

I.D				O.D			
LOUVER	DIA	# HOLES	AREA IN <sup>2</sup>	LOUVER	DIA	# HOLES	AREA IN <sup>2</sup>
1	0.0781	78	0.373	11	0.055	164	0.389
2	0.055	118	0.280	12	0.0625	152	0.466
3	0.052	96	0.214	13	0.0625	145	0.444
4	0.052	104	0.221	14	0.052	163	0.346
5	0.052	92	0.195	15	0.052	162	0.344
6	0.052	81	0.172	16	0.093	123	0.835
7	0.052	123	0.261	17	0.086	71	0.412
8	0.052	122	0.259				
9	0.0625	121	0.371				
10	0.110	61	0.579				

PILOT FLAMEHOLDER	94 AT 0.315 = 7.326
MAIN FLAMEHOLDER	112 AT 0.364 = 11.655
ID DILUTION SLOTS (ROW 2)	10 AT 1.187x.7 = 7.257
ID DILUTION HOLES (ROW 3)	15 AT 0.743 = 6.504
OD DILUTION HOLES (ROW 12)	10 AT 0.787 = 4.865
PILOT FLAMEHOLDER WEEP AREA	250 AT 0.060 = 0.707
MAIN FLAMEHOLDER WEEP AREA	75 AT 0.060 = 0.212
MAIN FLAMEHOLDER TRANS. COOLING	1120 AT 0.042 = 1.552
BULKHEAD TRANS. COOLING	580 AT 0.055 = 1.378
PILOT NOZZLE (PN 27700-11)	
MAIN NOZZLE (PN 27700-13)	
FINWALL <sup>®</sup> COOLING 2.6% W <sub>AB</sub>	

Figure B-14 Liner Hole Pattern for Staged Premix Combustion Configuration P-1



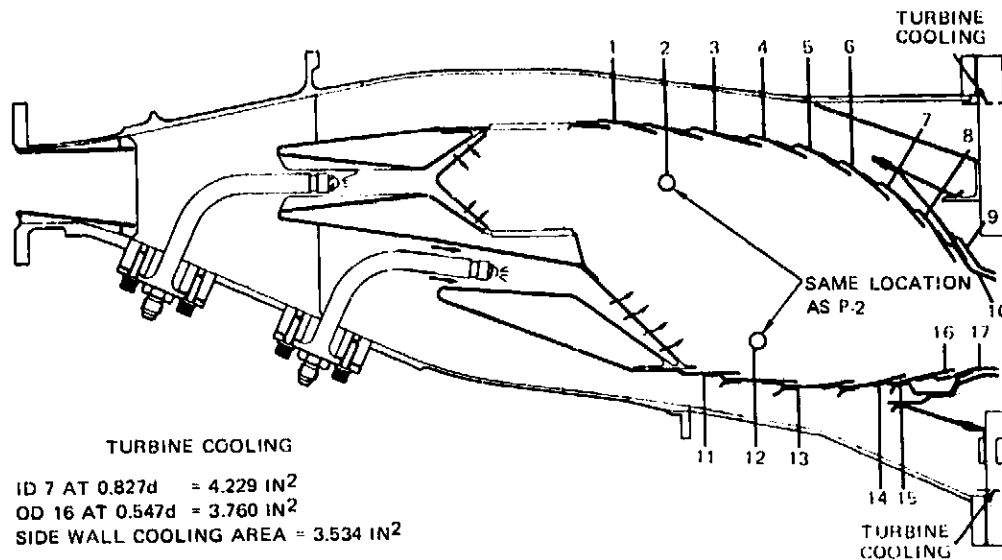

TURBINE COOLING  
 ID 7 AT 0.827d = 4.229 IN<sup>2</sup>  
 OD 16 AT 0.547d = 3.760 IN<sup>2</sup>  
 SIDE WALL COOLING AREA = 3.534 IN<sup>2</sup>

I D				O D			
LOUVER	DIA	#HOLES	AREA IN <sup>2</sup>	LOUVER	DIA	#HOLES	AREA IN <sup>2</sup>
1	0.0781	78	0.373	11	0.055	164	0.389
2	0.055	118	0.280	12	0.0625	152	0.466
3	0.052	96	0.204	13	0.0625	145	0.444
4	0.052	104	0.221	14	0.052	163	0.346
5	0.052	92	0.195	15	0.052	162	0.344
6	0.052	81	0.172	16	0.093	123	0.835
7	0.052	123	0.261	17	0.086	71	0.412
8	0.052	122	0.259				
9	0.0625	121	0.371				
10	0.110	61	0.579				

PILOT FLAMEHOLDER	94 AT 0.315	7.326	MODIFICATIONS REFERENCE
MAIN FLAMEHOLDER	112 AT 0.411	14.859	CONFIGURATION P 2
ID DILUTION HOLES (ROW 2)	14 AT 0.699	5.756	• ELIMINATE ID DILUTION AIR (ROW 5)
OD DILUTION HOLES (ROW 12)	10 AT 0.616	2.983	• REDUCE OD DILUTION AIR
PILOT FLAMEHOLDER WEEP AREA	250 AT 0.100	1.964	• FEED BULKHEAD COOLING AND OD
MAIN FLAMEHOLDER WEEP AREA	75 AT 0.060	0.212	FINWALL PANEL WITH 0.5x0.5 IN
MAIN FLAMEHOLDER TRANSPIRATION COOLING			SLOTS ON TIP OF PILOT PASSAGE
BULKHEAD TRANSPIRATION COOLING	1120 AT 0.042	1.552	• EXTEND DII FUSER RAMPS BY 1.000
MAIN FH (FUEL) TRANSPIRATION COOLING	580 AT 0.055	1.378	INCH
PILOT NOZZLE (PN 27700-11)			
MAIN NOZZLE (PN 27700-13)			
FINWALL <sup>TM</sup> COOLING 2.6% W <sub>AB</sub>			

Figure B-16 Liner Hole Pattern for Staged Premix Combustor Configuration P-3

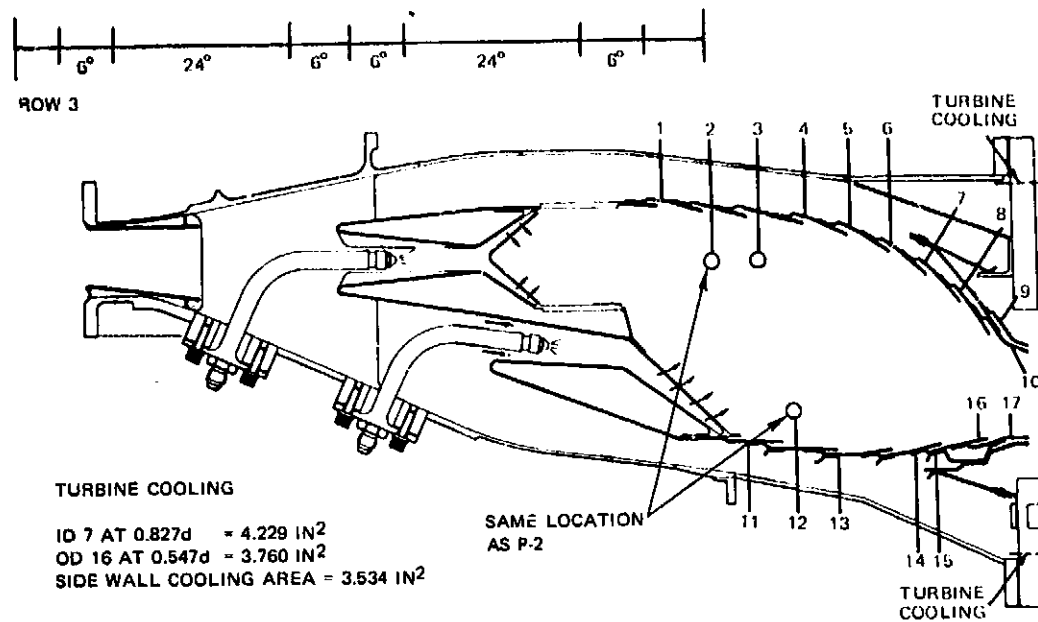

I.D.				O.D.			
LOUVER	DIA.	#HOLES	AREA IN <sup>2</sup>	LOUVER	DIA.	#HOLES	AREA IN <sup>2</sup>
1	0.0781	59	0.280	11	0.055	123	0.292
2	0.055	89	0.210	12	0.0625	114	0.350
3	0.052	96	0.204	13	0.0625	109	0.333
4	0.052	104	0.221	14	0.052	122	0.260
5	0.052	92	0.195	15	0.052	123	0.258
6	0.052	81	0.172	16	0.093	123	0.835
7	0.052	92	0.196	17	0.086	71	0.412
8	0.052	122	0.259				
9	0.0625	121	0.371				
10	0.110	61	0.579				

PRIMARY FLAMEHOLDER 94 AT 0.315 = 7.326  
 MAIN FLAMEHOLDER 112 AT 0.434 = 16.573  
 ID DILUTION HOLES (ROW 2) 10 AT 0.699 = 3.837  
 ID DILUTION HOLES (ROW 3) 7 AT 0.528 = 1.535  
 OD DILUTION HOLES (ROW 12) 10 AT 0.616 = 2.983  
 PILOT FLAMEHOLDER WEEP AREA 250 AT 0.100 = 1.964  
 MAIN FLAMEHOLDER WEEP AREA 75 AT 0.060 = 0.212  
 MAIN FLAMEHOLDER TRANSPIRATION COOLING 1120 AT 0.042 = 1.552  
 BULKHEAD TRANSPIRATION COOLING 580 AT 0.055 = 1.378  
 MAIN FLAMEHOLDER (FUEL) TRANSPIRATION COOLING 275 AT 0.042 = 0.381  
 PILOT NOZZLE (PN 27700-11)  
 MAIN NOZZLE (PN 27700-13)  
 FINWALL<sup>®</sup> COOLING 2.6% W<sub>AB</sub>

MODIFICATIONS

- MODIFY DILUTION HOLE PATTERN ON ID
- INCREASE MAIN FLAMEHOLDER HOLES
- TRANSPIRATION COOL MAIN FLAMEHOLDER (AROUND F.H. HOLES)
- REDUCE LINER COOLING IN ROWS 1,2,7,11,12,13,14,15

Figure B-17 Liner Hole Pattern for Staged Premix Combustion Configuration P-4



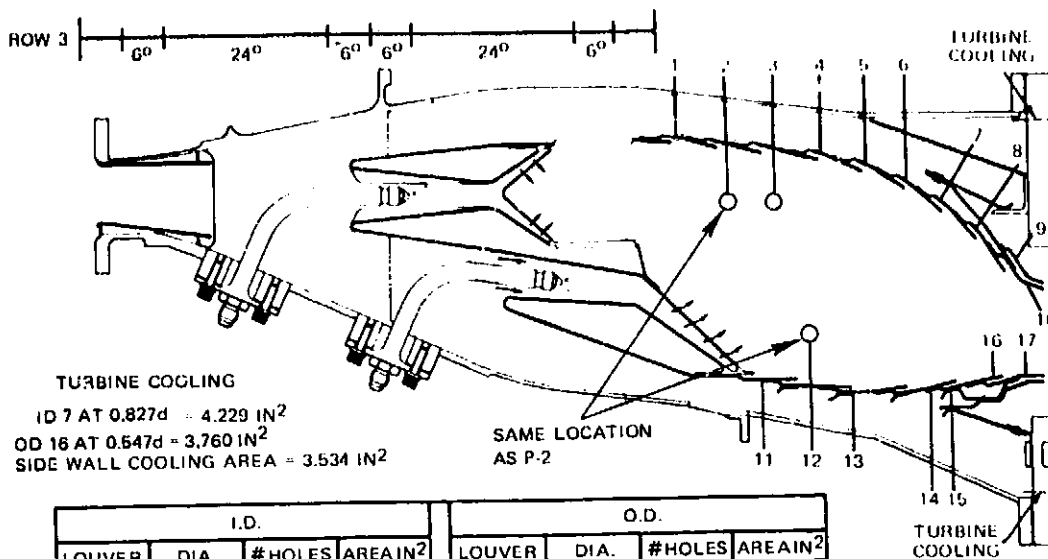

TURBINE COOLING  
 ID 7 AT 0.827d = 4.229 IN<sup>2</sup>  
 OD 16 AT 0.647d = 3.760 IN<sup>2</sup>  
 SIDE WALL COOLING AREA = 3.534 IN<sup>2</sup>

I.D.				O.D.			
LOUVER	DIA.	#HOLES	AREA IN <sup>2</sup>	LOUVER	DIA.	#HOLES	AREA IN <sup>2</sup>
1	0.0781	59	0.280	11	0.055	123	0.292
2	0.055	89	0.210	12	0.0625	114	0.350
3	0.052	96	0.204	13	0.0625	109	0.333
4	0.052	104	0.221	14	0.052	122	0.260
5	0.052	92	0.195	15	0.052	123	0.258
6	0.052	81	0.172	16	0.093	123	0.835
7	0.052	92	0.196	17	0.086	71	0.412
8	0.052	122	0.259				
9	0.0625	121	0.371				
10	0.110	61	0.579				

- PILOT FLAMEHOLDER 94 AT 0.315 = 7.326
- MAIN FLAMEHOLDER 112 AT 0.434 = 16.573
- ID DILUTION HOLES (ROW 2) 10 AT 0.699 = 3.837
- ID DILUTION HOLES (ROW 3) 7 AT 0.528 = 1.535
- OD DILUTION HOLES (ROW 12) 10 AT 0.616 = 2.983
- PILOT FLAMEHOLDER WEEP AREA 250 AT 0.100 = 1.964
- MAIN FLAMEHOLDER WEEP AREA 75 AT 0.060 = 0.212
- MAIN FLAMEHOLDER TRANSPIRATION COOLING 1120 AT 0.042 = 1.552
- BULKHEAD TRANSPIRATION COOLING 580 AT 0.055 = 1.378
- MAIN FH (FUEL) TRANSPIRATION COOLING 275 AT 0.042 = 0.381
- PILOT NOZZLE (PN 27700-11)
- MAIN NOZZLE (PN 27700-13)
- FINWALL<sup>®</sup> COOLING (2.6% W<sub>AB</sub>)

MODIFICATIONS: REFERENCE CONFIGURATION P-4

● STAGE MAIN FUEL SYSTEM

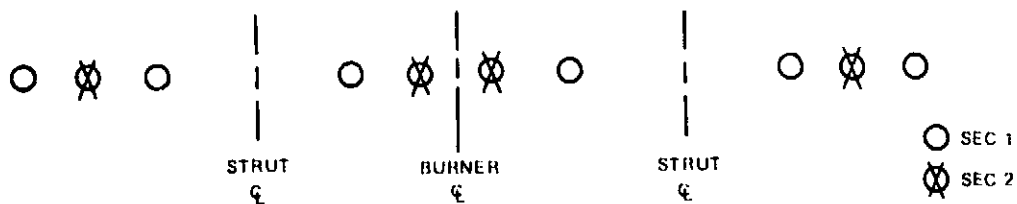
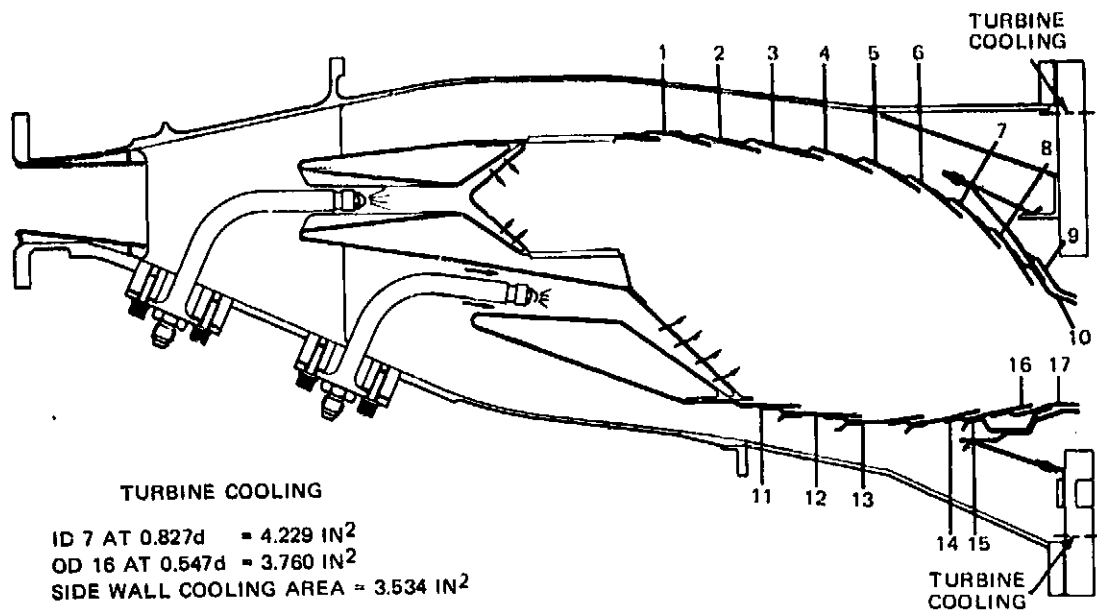

Figure B-18 Liner Hole Pattern for Premix Combustor Configuration P-5



TURBINE COOLING  
 ID 7 AT 0.827d = 4.229 IN<sup>2</sup>  
 OD 16 AT 0.547d = 3.760 IN<sup>2</sup>  
 SIDE WALL COOLING AREA = 3.534 IN<sup>2</sup>

I.D.				O.D.			
LOUVER	DIA.	#HOLES	AREA IN <sup>2</sup>	LOUVER	DIA.	#HOLES	AREA IN <sup>2</sup>
1	0.0781	59	0.280	11	0.055	123	0.292
2	0.055	89	0.210	12	0.0625	114	0.350
3	0.052	96	0.204	13	0.0625	109	0.333
4	0.052	104	0.221	14	0.052	122	0.260
5	0.052	92	0.195	15	0.052	123	0.258
6	0.052	81	0.172	16	0.093	123	0.835
7	0.052	92	0.196	17	0.086	71	0.412
8	0.052	122	0.259				
9	0.0625	121	0.371				
10	0.110	61	0.579				

PILOT FLAMEHOLDER	94 AT 0.315 = 7.326
MAIN FLAMEHOLDER	112 AT 0.434 = 16.573
PILOT FLAMEHOLDER WEEP AREA	250 AT 0.100 = 1.964
MAIN FLAMEHOLDER WEEP AREA	75 AT 0.060 = 0.212
MAIN FLAMEHOLDER TRANSPIRATION COOLING	1120 AT 0.042 = 1.552
BULKHEAD TRANSPIRATION COOLING	680 AT 0.055 = 1.378
PILOT NOZZLE (PN 27700-11)	
MAIN NOZZLE (PN 27700-13)	
FINWALL <sup>®</sup> COOLING 2.6% W <sub>AB</sub>	

MODIFICATIONS: REFERENCE CONFIGURATION P-5

•BLOCK ALL DILUTION AIR OD AND ID

Figure B-19 Liner Hole Pattern for Stages Premix Combustor Configuration P-6

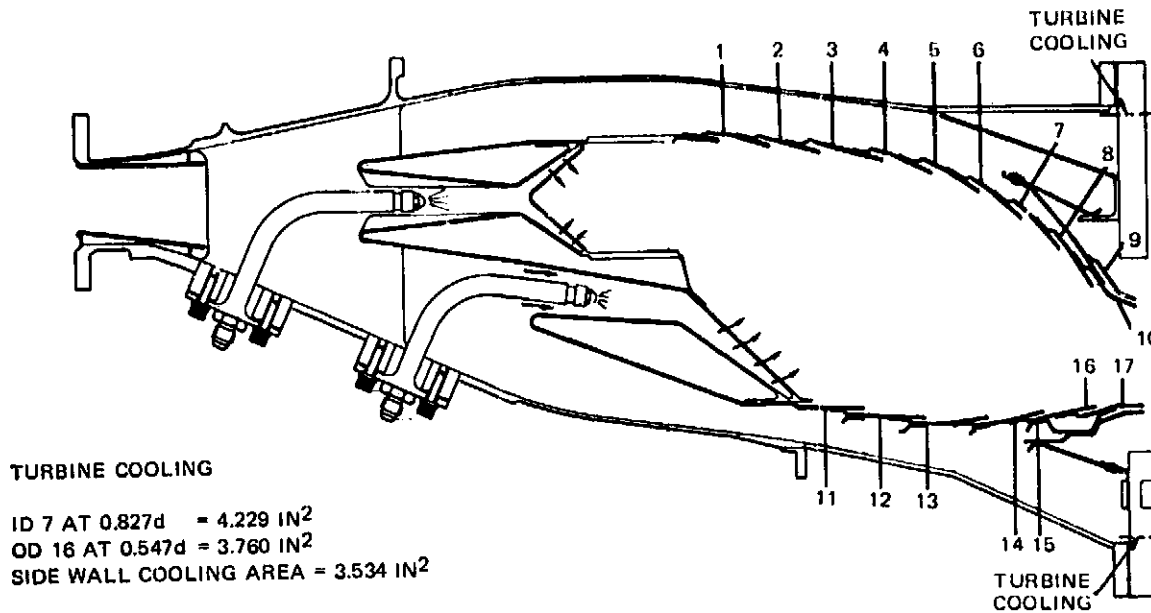

TURBINE COOLING

ID 7 AT 0.827d = 4.229 IN<sup>2</sup>  
 OD 16 AT 0.547d = 3.760 IN<sup>2</sup>  
 SIDE WALL COOLING AREA = 3.534 IN<sup>2</sup>

I.D.				O.D.			
LOUVER	DIA.	#HOLES	AREA IN <sup>2</sup>	LOUVER	DIA.	#HOLES	AREA IN <sup>2</sup>
1	0.0781	59	0.280	11	0.055	123	0.292
2	0.055	89	0.210	12	0.0625	114	0.350
3	0.052	96	0.204	13	0.0625	109	0.333
4	0.052	104	0.221	14	0.052	122	0.260
5	0.052	92	0.195	15	0.052	123	0.258
6	0.052	81	0.172	16	0.093	123	0.835
7	0.052	92	0.196	17	0.086	71	0.412
8	0.052	122	0.259				
9	0.0625	121	0.371				
10	0.110	61	0.579				

PILOT FLAMEHOLDER (SLOTS)	40 AT 1.1 X .222 = 9.345
MAIN FLAMEHOLDER (SLOTS)	20 AT 1.75 X .603 = 19.544
PILOT FLAMEHOLDER TRANSPIRATION	136 AT 0.042 = 0.188
MAIN FLAMEHOLDER TRANSPIRATION	119 AT 0.042 = 0.165
PILOT FLAMEHOLDER WEEP AREA	172 AT 0.100 = 1.351
MAIN FLAMEHOLDER WEEP AREA	34 AT 0.100 = 0.267
MAIN TRANSPIRATION COOLING	1120 AT 0.042 = 1.552
BULKHEAD TRANSPIRATION COOLING	580 AT 0.055 = 1.378
PILOT NOZZLE (PN 27700-11)	
MAIN NOZZLE (PN 27700-13)	
FINWALL <sup>®</sup> COOLING 2.6% WAB	

MODIFICATIONS: REFERENCE CONFIGURATION P-6

•INSTALL SLOTTED FLAMEHOLDER

Figure B-20 Liner Hole Pattern for Staged Premix Combustor Configuration P-7

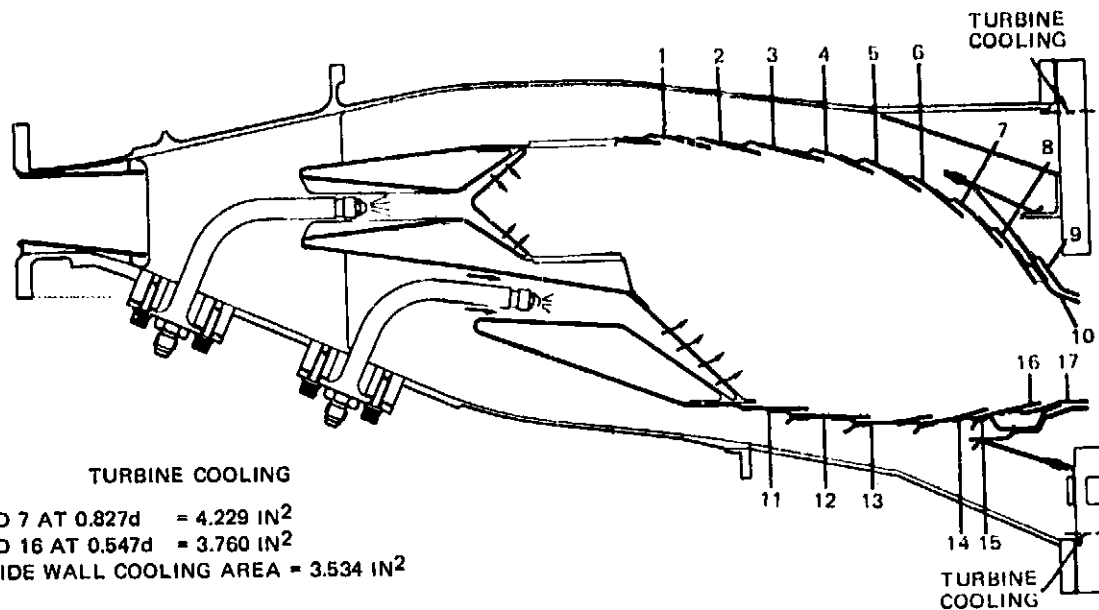

I.D.				O.D.			
LOUVER	DIA.	#HOLES	AREA IN <sup>2</sup>	LOUVER	DIA.	#HOLES	AREA IN <sup>2</sup>
1	0.0781	59	0.280	11	0.055	123	0.292
2	0.055	89	0.210	12	0.0625	114	0.350
3	0.052	96	0.204	13	0.0625	109	0.333
4	0.052	104	0.221	14	0.052	122	0.260
5	0.052	92	0.195	15	0.052	123	0.258
6	0.052	81	0.172	16	0.093	123	0.835
7	0.052	92	0.196	17	0.086	71	0.412
8	0.052	122	0.259				
9	0.0625	121	0.371				
10	0.110	61	0.579				

PILOT FLAMEHOLDER (SLOTS)	40 AT 1.1 X 0.222 = 9.345
MAIN FLAMEHOLDER (SLOTS)	20 AT 1.75 X .603 = 19.544
PILOT FLAMEHOLDER TRANSPIRATION	136 AT 0.042 = 0.188
MAIN FLAMEHOLDER TRANSPIRATION	119 AT 0.042 = 0.165
PILOT FLAMEHOLDER WEEP AREA	172 AT 0.100 = 1.351
MAIN FLAMEHOLDER WEEP AREA	34 AT 0.100 = 0.267
MAIN TRANSPIRATION COOLING	1120 AT 0.042 = 1.552
BULKHEAD TRANSPIRATION COOLING	580 AT 0.055 = 1.378
PILOT NOZZLE (PN 27700-11)	
MAIN NOZZLE (PN 27700-12)	
FINWALL <sup>®</sup> COOLING 2.6% W <sub>AB</sub>	

MODIFICATIONS: REFERENCE CONFIGURATION P-6

- DOUBLE NUMBER OF MAIN FUEL INJECTORS

Figure B-21 Liner Hole Pattern for Staged Premix Combustor Configuration P-8

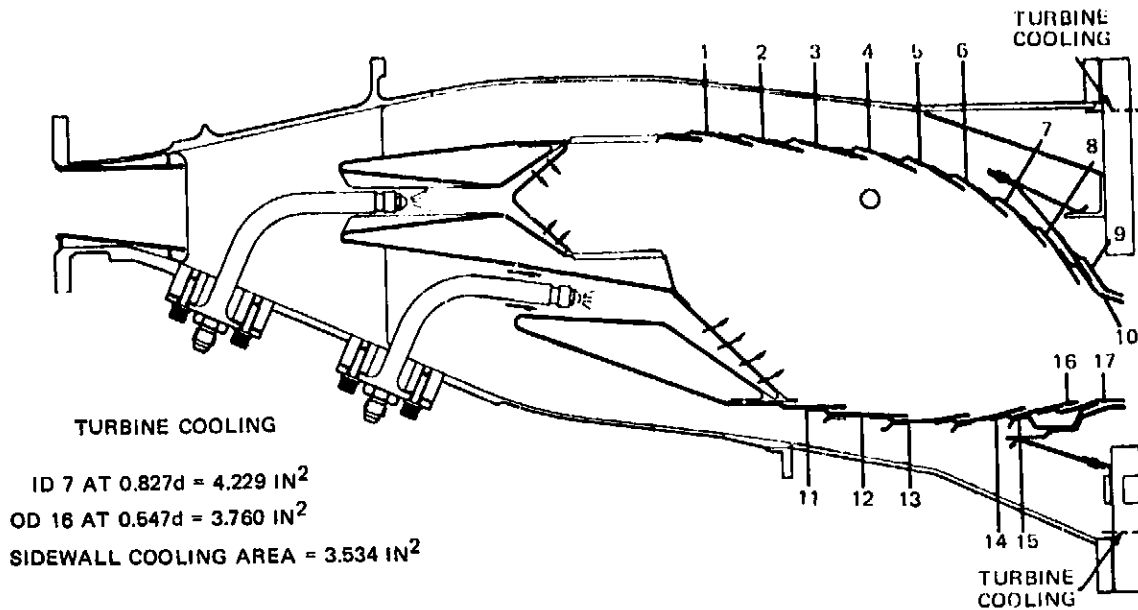

I.D.				O.D.			
LOUVER	DIA.	#HOLES	AREA IN <sup>2</sup>	LOUVER	DIA.	#HOLES	AREA IN <sup>2</sup>
1	0.0781	59	0.280	11	0.055	123	0.292
2	0.055	89	0.210	12	0.0625	114	0.350
3	0.052	96	0.204	13	0.0625	109	0.333
4	0.052	104	0.221	14	0.052	122	0.260
5	0.052	92	0.195	15	0.052	123	0.258
6	0.052	81	0.172	16	0.093	123	0.835
7	0.052	92	0.196	17	0.086	71	0.412
8	0.052	122	0.259				
9	0.0625	121	0.371				
10	0.110	61	0.579				

- |                                       |                                    |
|---------------------------------------|------------------------------------|
| PILOT FLAMEHOLDER (SLOTS)             | 40 AT $1.1 \times 0.222 = 3.345$   |
| MAIN FLAMEHOLDER (SLOTS)              | 20 AT $1.75 \times 0.603 = 19.544$ |
| PILOT FLAMEHOLDER TRANSPIRATION       | 136 AT $0.042 = 0.188$             |
| MAIN FLAMEHOLDER TRANSPIRATION        | 119 AT $0.042 = 0.165$             |
| ID DILUTION HOLES (ROW 4)             | 15 AT $0.569d = 3.814$             |
| PILOT FLAMEHOLDER WEEP AREA           | 172 AT $0.100 = 1.351$             |
| MAIN FLAMEHOLDER WEEP AREA            | 34 AT $0.100 = 0.267$              |
| MAIN TRANSPIRATION COOLING            | 1120 AT $0.042 = 1.552$            |
| BULKHEAD TRANSPIRATION COOLING        | 580 AT $0.055 = 1.378$             |
| PILOT NOZZLE (PN 27700-11)            |                                    |
| MAIN NOZZLE (PN 27700-12)             |                                    |
| FINWALL <sup>®</sup> COOLING 2.6% WAB |                                    |

MODIFICATIONS: REFERENCE CONFIGURATION P-6

- DOUBLE NUMBER OF MAIN FUEL INJECTORS
- ADD DILUTION HOLES

Figure B-22 Liner Hole Pattern for Staged Premix Combustor Configuration P-9

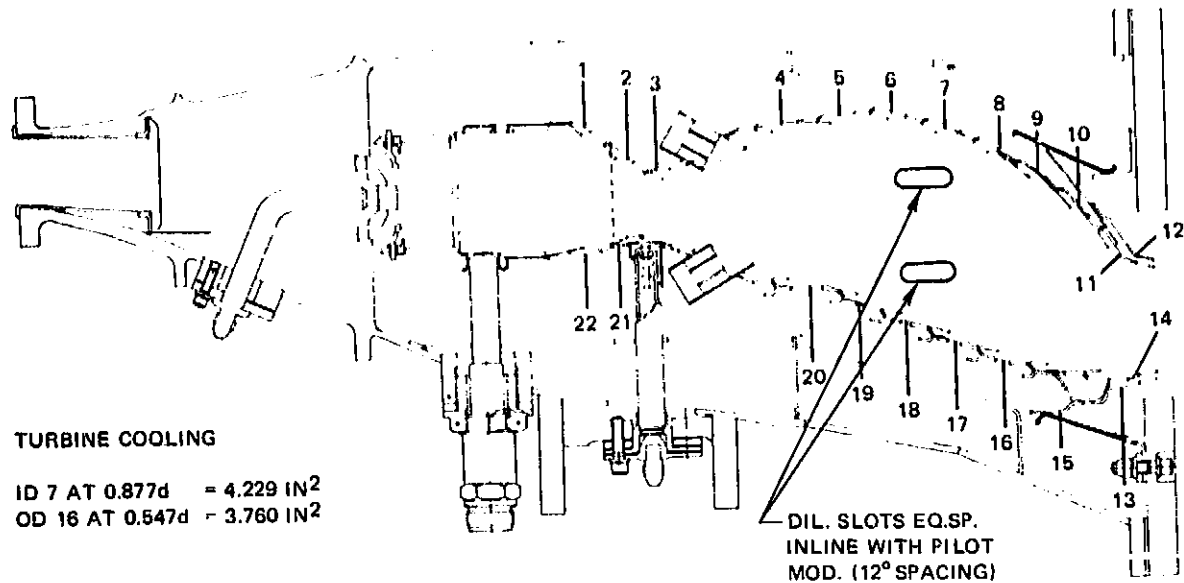

I.D.				O.D.			
LOUVER	DIA.	#HOLES	AREA IN <sup>2</sup>	LOUVER	DIA.	#HOLES	AREA IN <sup>2</sup>
1	0.0985	97	0.739	13	0.0935	99	0.679
2	0.067	106	0.373	14	0.070	131	0.504
3	0.0935	74	0.508	15	0.055	142	0.337
4	0.0635	102	0.323	16	0.055	128	0.304
5	0.0595	108	0.300	17	0.052	104	0.218
6	0.052	76	0.161	18	0.0635	133	0.421
7	0.0595	84	0.233	19	0.0635	130	0.411
8	0.052	64	0.134	20	0.073	113	0.473
9	0.0595	116	0.322	21	0.113	102	1.023
10	0.052	139	0.295	22	0.073	106	0.443
11	0.086	89	0.517				
12	0.098	78	0.588				

		IN <sup>2</sup>			
PILOT SWIRLER	7 AT 0.638 = 4.466 (ACD)	ID SWIRLER	43 AT 0.161 = 0.880		
PILOT SWIRLER COOLING	224 AT 0.055 = 0.532	COOLING	42 AT 0.081 = 0.215		
MAIN SWIRLER	28 AT 0.316 = 8.840 (ACD)		70 AT 0.067 = 0.246		
PILOT DILUTION (ID)	7 AT 0.248 = 0.338	OD SWIRLER	43 AT 0.191 = 1.232		
PILOT DILUTION (OD)	5 5 AT 0.278 = 0.303	COOLING	42 AT 0.106 = 0.373		
MAIN DILUTION (ID) (SLOTS)	7 AT 1.59 x 0.46 = 4.802		70 AT 0.087 = 0.412		
DILUTION (OD) (SLOTS)	7 AT 1.61 x 0.47 = 4.965				
BULKHEAD COOLING	20 AT 0.111 568 AT 0.040 = 0.895				

PILOT NOZZLE AIR BLAST (PN 33420) ACD = 0.096 IN<sup>2</sup> PER NOZZLE  
 MAIN NOZZLE PT6 (PN 27700-11)

Figure B-23 Liner Hole Pattern for Swirl Vortex Combustor Configuration S-1

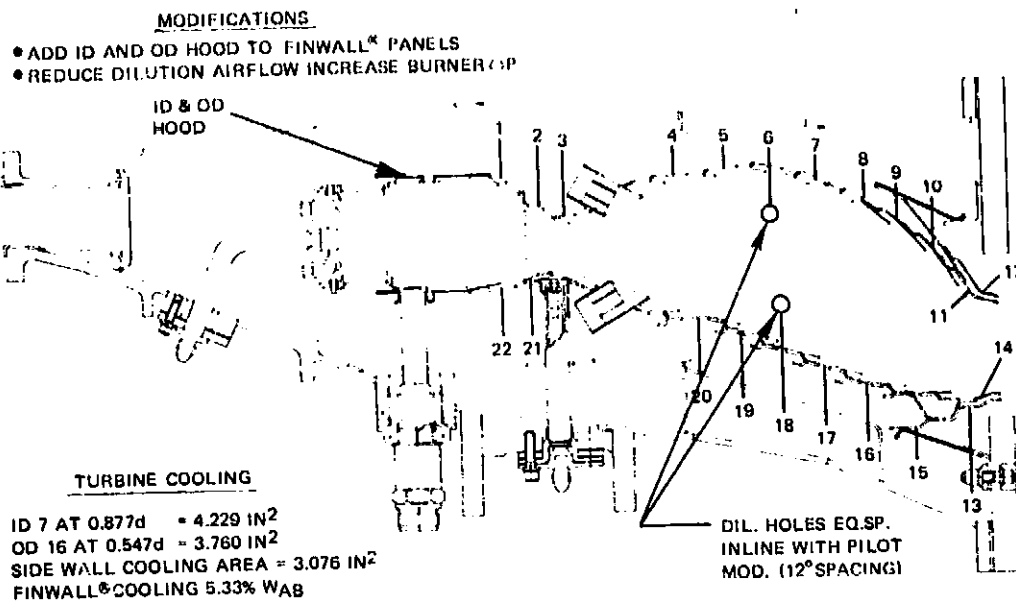

I.D.				O.D.			
LOUVER	DIA.	# HOLES	AREA IN <sup>2</sup>	LOUVER	DIA.	# HOLES	AREA IN <sup>2</sup>
1	0.0985	97	0.739	13	0.0935	99	0.679
2	0.067	106	0.373	14	0.070	131	0.504
3	0.0935	74	0.508	15	0.055	142	0.337
4	0.0635	102	0.323	16	0.055	128	0.304
5	0.0595	108	0.300	17	0.052	104	0.218
6	0.052	76	0.161	18	0.0635	133	0.421
7	0.0595	84	0.233	19	0.0635	130	0.411
8	0.052	64	0.134	20	0.073	113	0.473
9	0.0595	116	0.322	21	0.113	102	1.023
10	0.052	139	0.295	22	0.073	106	0.443
11	0.086	89	0.517				
12	0.098	78	0.588				

IN<sup>2</sup>

PILOT SWIRLER	7 AT 0.638	= 4.466 (ACD)	ID SWIRLER	43 AT 0.161	= 0.880
PILOT SWIRLER COOLING	224 AT 0.055	= 0.532	COOLING	42 AT 0.081	= 0.215
MAIN SWIRLER	28 AT 0.316	= 8.840 (ACD)		70 AT 0.067	= 0.246
PILOT DILUTION (ID)	7 AT 0.248	= 0.336	OD SWIRLER	43 AT 0.191	= 1.232
PILOT DILUTION (OD)	5 AT 0.278	= 0.303	COOLING	42 AT 0.106	= 0.373
MAIN DILUTION (ID)	7 AT 0.459	= 1.158		70 AT 0.087	= 0.412
DILUTION (OD)	7 AT 0.459	= 1.158			
BULKHEAD COOLING	20 AT 0.111	558 AT 0.040	= 0.895		

PILOT NOZZLE AIR BLAST (PN 33420) ACD = 0.096 IN<sup>2</sup> PER NOZZLE  
 MAIN NOZZLE PT6 (PN 27700-11)

Figure B-24 Hole Liner Pattern for a Swirl Vortex Combustor Configuration S-2

**MODIFICATIONS**

- USE 7 FUEL INJ. INLINE WITH PILOT MODULES
- REINDEX DIL. HOLES BETWEEN PILOT MODULES (6 ID & OD)
- REDUCE PILOT SWIRLER ACD
- REINDEX MAIN SWIRLERS AS SHOWN BELOW

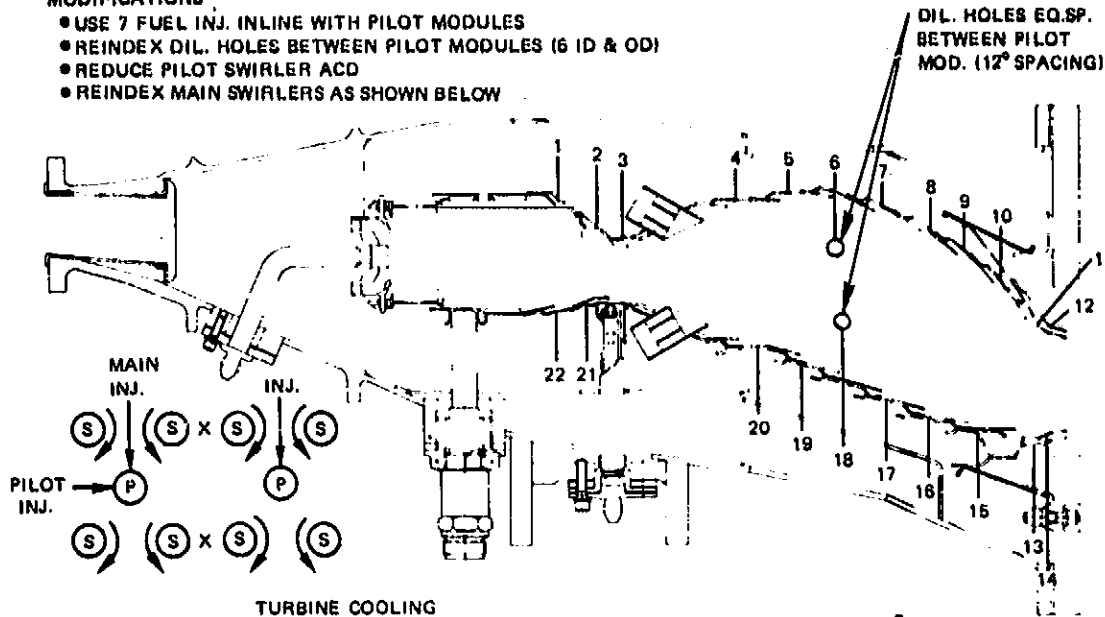

**TURBINE COOLING**  
 ID 7 AT 0.877d = 4.229 IN<sup>2</sup>  
 OD-16 AT 0.547d = 3.760 IN<sup>2</sup>

SIDE WALL COOLING AREA = 3.076 IN<sup>2</sup>  
 FINWALL<sup>®</sup> COOLING 5.33% WAB

I.D.				O.D.			
LOUVER	DIA.	# HOLES	AREA IN <sup>2</sup>	LOUVER	DIA.	# HOLES	AREA IN <sup>2</sup>
1	0.0985	97	0.739	13	0.0935	99	0.879
2	0.067	106	0.373	14	0.070	131	0.504
3	0.0935	74	0.508	15	0.055	142	0.337
4	0.0635	102	0.323	16	0.055	128	0.304
5	0.0595	108	0.300	17	0.062	104	0.218
6	0.052	76	0.161	18	0.0635	133	0.421
7	0.0595	84	0.233	19	0.0635	130	0.411
8	0.052	64	0.134	20	0.073	113	0.473
9	0.0595	116	0.322	21	0.113	102	1.023
10	0.052	139	0.295	22	0.073	106	0.443
11	0.088	89	0.517				
12	0.098	78	0.588				

IN <sup>2</sup>			
PILOT SWIRLER	7 AT 0.520	= 3.641 (AC <sub>D</sub> )	
PILOT SWIRLER COOLING	224 AT 0.055	= 0.532	ID SWIRLER COOLING { 43 AT 0.161 = 0.880 42 AT 0.081 = 0.215 70 AT 0.067 = 0.246
MAIN SWIRLER	28 AT 0.316	= 8.840 (AC <sub>D</sub> )	
PILOT DILUTION (ID)	7 AT 0.248	= 0.338	
PILOT DILUTION (OD)	5 AT 0.278	= 0.303	OD SWIRLER COOLING { 43 AT 0.191 = 1.232 42 AT 0.106 = 0.373 70 AT 0.087 = 0.412
MAIN DILUTION (ID) (SLOTS)	6 AT 0.496	= 1.158	
DILUTION (OD) (SLOTS)	6 AT 0.496	= 1.158	
BULKHEAD COOLING	20 AT 0.111	558 AT 0.040 = 0.895	

PILOT NOZZLE AIR BLAST (PN 33420) ACD = 0.096 IN<sup>2</sup> PER NOZZLE  
 MAIN NOZZLE PT6 (PN 27700-11)

Figure B-25 Liner Hole Pattern for Swirl Vorbix Combustor Configuration S-3



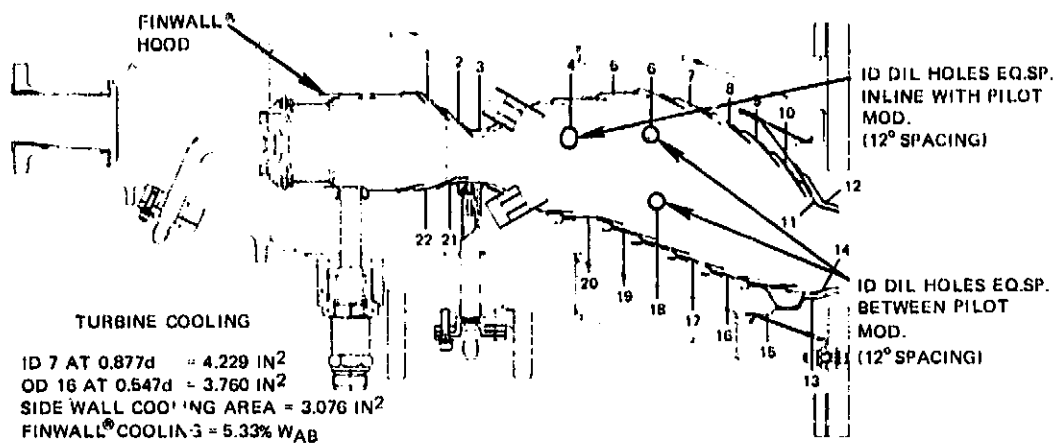

I.D.				O.D.			
LOUVER	DIA.	# HOLES	AREA IN <sup>2</sup>	LOUVER	DIA.	# HOLES	AREA IN <sup>2</sup>
1	0.0785	97	0.469	13	0.0935	99	0.679
2	0.067	106	0.373	14	0.070	131	0.504
3	0.0935	37	0.254	15	0.055	106	0.252
4	0.0635	76	0.241	16	0.055	96	0.228
5	0.0595	81	0.225	17	0.052	104	0.218
6	0.052	76	0.161	18	0.0635	100	0.317
7	0.0595	84	0.233	19	0.0635	97	0.309
8	0.052	64	0.134	20	0.073	85	0.356
9	0.0595	87	0.242	21	0.113	76	0.762
10	0.052	139	0.295	22	0.073	106	0.443
11	0.086	89	0.517				
12	0.098	78	0.588				

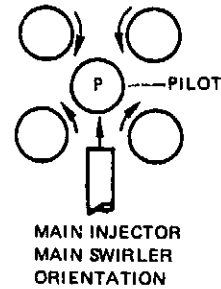

PILOT SWIRLER 7 AT 0.520 = 3.641 IN<sup>2</sup>

PILOT SWIRLER COOLING 224 AT 0.056d = 0.532

MAIN SWIRLER 28 AT 0.316 = 8.840 (AC<sub>D</sub>)

PILOT DILUTION (ID) 7 AT 0.248d = 0.338

PILOT DILUTION (OD) 5 AT 0.278d = 0.303

MAIN DILUTION (ID) 6 AT 0.712d = 2.389

DILUTION (OD) 6 AT 0.712d = 2.389

BULKHEAD COOLING 20 AT 0.111d + 658 AT 0.040 = 0.895

ID SWIRLER COOLING 13 AT 0.161d = 0.265

54 AT 0.081d = 0.278

42 AT 0.067d = 0.148

OD SWIRLER COOLING 13 AT 0.191d = 0.372

54 AT 0.106d = 0.476

42 AT 0.087d = 0.250

PILOT NOZZLE AIR BLAST (PN 33420) ACD = 0.096 IN<sup>2</sup> PER NOZZLE

MAIN NOZZLE (PN 32301-8) (13 LOCATIONS)

MODIFICATIONS: REFERENCE CONFIGURATION S-3

- RELOCATE MAIN SWIRLERS (USE CURVED VANE SWIRLERS FROM FT4)
- MODIFY FINWALL ● HOOD ATTACHMENT SCHEME
- ADD 7 COMB. HOLES IN LOUVER 5 (1.374 IN<sup>2</sup>) 0.500 DIAMETER
- INCREASE ID AND OD DILUTION AIR HOLE DIAMETER TO (0.712)
- INSTALL SCOOP TO FEED AERATING NOZZLE
- REDUCE LINER COOLING
- MODIFY DIFFUSER TO UNIFORMLY FEED FRONT END

Figure B-26 Liner Hole Pattern for Swirl Vortex Combustor Configuration S-4

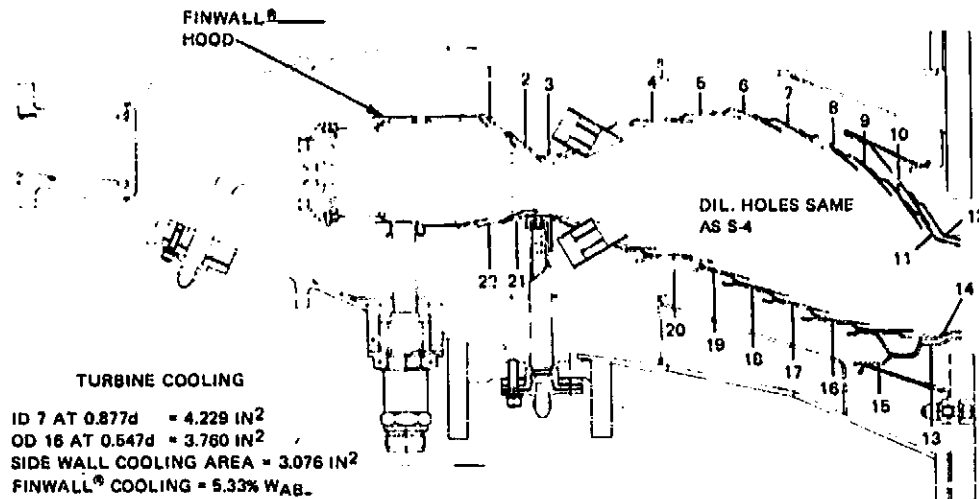

I.D.				O.D.			
LOUVER	DIA.	# HOLES	AREA IN <sup>2</sup>	LOUVER	DIA.	# HOLES	AREA IN <sup>2</sup>
1	0.0786	97	0.469	13	0.0935	99	0.679
2	0.087	108	0.373	14	0.070	131	0.504
3	0.0935	37	0.254	15	0.055	106	0.252
4	0.0635	76	0.241	16	0.055	96	0.228
5	0.0595	81	0.225	17	0.062	104	0.218
6	0.052	76	0.161	18	0.0635	100	0.317
7	0.0595	84	0.233	19	0.0635	97	0.309
8	0.062	64	0.134	20	0.073	85	0.356
9	0.0595	87	0.242	21	0.113	78	0.762
10	0.052	139	0.295	22	0.073	106	0.443
11	0.086	89	0.517				
12	0.098	78	0.588				

		IN. <sup>2</sup>
PILOT SWIRLER	7 AT 0.520	=3.641
PILOT SWIRLER COOLING	224 AT 0.065d.	=0.632
MAIN SWIRLERS	28 AT 0.316	=8.840 (ACD)
PILOT DILUTION (ID)	7 AT 0.248d.	=0.338
PILOT DILUTION (OD)	5 AT 0.278d.	=0.303
MAIN DILUTION (ID)	8 AT 0.712d.	=2.389
DILUTION (OD)	8 AT 0.712d.	=2.389
BULKHEAD COOLING	20 AT 0.111d. + 558 AT 0.040	= 0.895
ID SWIRLER COOLING	13 AT 0.161d.	=0.268
	54 AT 0.081d.	=0.278
	42 AT 0.067d.	=0.148
OD SWIRLER COOLING	13 AT 0.191d.	=0.372
	54 AT 0.106d.	=0.478
	42 AT 0.087d.	=0.250

PILOT NOZZLE AIR BLAST (PN 33420) ACD = 0.096 IN<sup>2</sup> PER NOZZLE  
 MAIN NOZZLE (PN 32301-8) (7 LOCATIONS)

MODIFICATIONS: REFERENCE CONFIGURATION S-4  
 ● USE 7 MAIN INJECTORS INLINE WITH PILOT INJECTORS

Figure B-27 Liner Hole Pattern for Swirl Vorbix Combustor Configuration S-5.

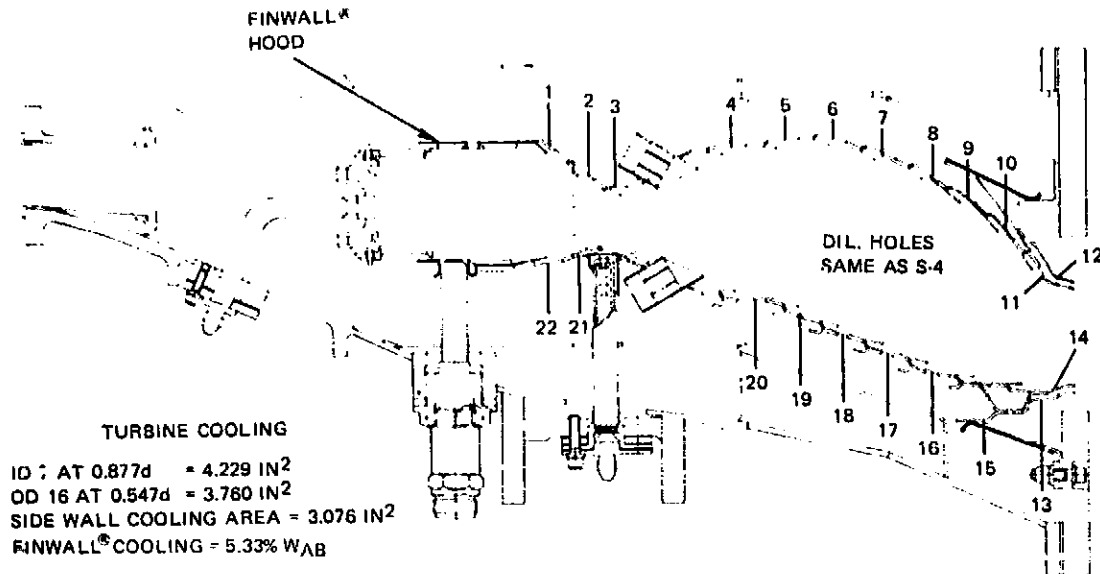

I.D.				O.D.			
LOUVER	DIA.	# HOLES	AREA IN <sup>2</sup>	LOUVER	DIA.	# HOLES	AREA IN <sup>2</sup>
1	0.0785	97	0.469	13	0.0935	99	0.679
2	0.067	106	0.373	14	0.070	131	0.504
3	0.0935	37	0.254	15	0.055	106	0.252
4	0.0635	76	0.241	16	0.055	96	0.228
5	0.0595	81	0.225	17	0.052	104	0.218
6	0.052	76	0.161	18	0.0635	100	0.317
7	0.0595	84	0.233	19	0.0635	97	0.309
8	0.052	64	0.134	20	0.073	85	0.356
9	0.0595	87	0.242	21	0.113	76	0.762
10	0.052	139	0.295	22	0.073	106	0.443
11	0.086	89	0.517				
12	0.098	78	0.588				

PILOT SWIRLER 7 AT 0.234 = 1.638 IN<sup>2</sup> (ACD)  
 PILOT SWIRLER COOLING 244 AT 0.055d. = 0.532  
 MAIN SWIRLER 22 AT 0.316 = 8.840 (ACD)  
 PILOT DILUTION (ID) 7 AT 0.248d. = 0.338  
 PILOT DILUTION (OD) 5 AT 0.278d. = 0.303  
 MAIN DILUTION (ID) 6 AT 0.721d. = 2.389 7 AT 0.500 = 1.374 (ROW 5)  
 DILUTION (OD) 6 AT 0.712d. = 2.389  
 BULKHEAD COOLING 20 AT 0.111d. + 53 AT 0.040d. = 0.895  
 ID SWIRLER COOLING 13 AT 0.161d., 54 AT 0.081d., 42 AT 0.067d. = 0.691  
 OD SWIRLER COOLING 13 AT 0.191d., 54 AT 0.06d., 42 AT 0.087d. = 1.098

PILOT NOZZLE AIR BLAST (PN 33470) ACD 0.096 IN<sup>2</sup> PER NOZZLE  
 MAIN NOZZLE PT6 (PN 32301-8) (7 LOCATIONS)

MODIFICATIONS: REFERENCE CONFIGURATION S-5  
 ● INSTALLED PILOT SWIRLER BLOCKAGE RING

Figure B-28 Liner Hole Pattern for Swirl Vorbix Combustor Configuration S-6

C-3

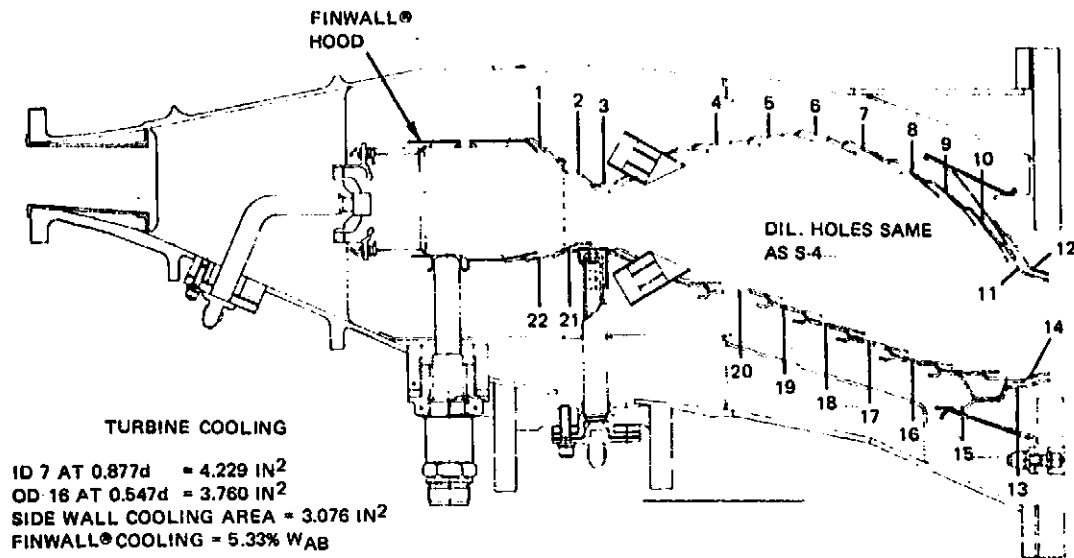

I.D.				O.D.			
LOUVER	DIA.	#HOLES	AREA IN <sup>2</sup>	LOUVER	DIA.	#HOLES	AREA IN <sup>2</sup>
1	0.0785	97	0.469	13	0.0935	99	0.679
2	0.067	106	0.373	14	0.070	131	0.504
3	0.0935	37	0.254	15	0.055	106	0.252
4	0.0635	76	0.241	16	0.055	96	0.228
5	0.0595	81	0.225	17	0.052	104	0.218
6	0.052	76	0.161	18	0.0635	100	0.317
7	0.0595	84	0.233	19	0.0635	97	0.309
8	0.052	64	0.134	20	0.073	85	0.356
9	0.0595	87	0.242	21	0.113	76	0.762
10	0.052	139	0.295	22	0.073	106	0.443
11	0.086	89	0.517				
12	0.098	78	0.588				

PILOT SWIRLER 7 AT 0.234 = 1.638 IN<sup>2</sup> (ACD)  
 PILOT SWIRLER COOLING 244 AT 0.055d. = 0.532  
 MAIN SWIRLER 28 AT 0.316 = 8.840 (ACD)  
 PILOT DILUTION (ID) 7 AT 0.248d. = 0.338  
 PILOT DILUTION (OD) 5 AT 0.278d. = 0.303  
 MAIN DILUTION (ID) 6 AT 0.712d. = 2.389 7 AT 0.500 = 1.374 (ROW 5)  
 DILUTION (OD) 6 AT 0.712d. = 2.389  
 BULKHEAD COOLING 20 AT 0.111d. + 558 AT 0.040d = 0.895  
 ID SWIRLER COOLING 13 AT 0.161d., 54 AT 0.081d., 42 AT 0.067d. = 0.691  
 OD SWIRLER COOLING 13 AT 0.191d., 54 AT 0.106d., 42 AT 0.087d. = 1.098

PILOT NOZZLE AIR BLAST (PN 33420) ACD = 0.096 IN<sup>2</sup> PER NOZZLE  
 MAIN NOZZLE PT6 (PN 27700-11)

MODIFICATIONS: REFERENCE CONFIGURATION S-6

- INSTALLED 13 MAIN INJECTORS

Figure B-29 Liner Hole Pattern for Swirl Vorbix Combustor Configuration S-7

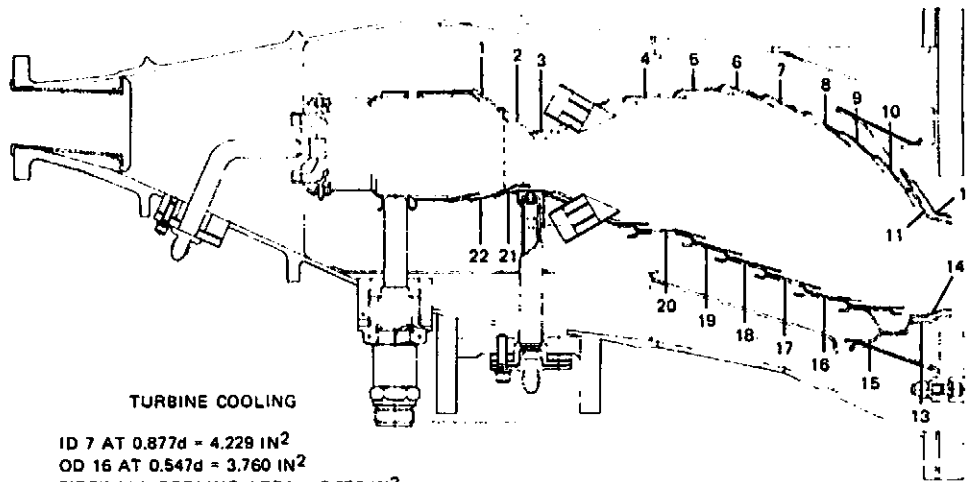

**TURBINE COOLING**

ID 7 AT 0.877d = 4.229 IN<sup>2</sup>  
 OD 16 AT 0.547d = 3.760 IN<sup>2</sup>  
 SIDEWALL COOLING AREA = 3.076 IN<sup>2</sup>  
 FINWALL<sup>®</sup> COOLING = 5.33% W<sub>AB</sub>

I. D.				O. D.			
LOUVER	DIA.	# HOLES	AREA IN <sup>2</sup>	LOUVER	DIA.	# HOLES	AREA IN <sup>2</sup>
1	0.0785	48	0.232	13	0.0935	99	0.679
2	0.067	106	0.373	14	0.070	131	0.504
3	0.0935	37	0.254	15	0.055	106	0.252
4	0.0635	76	0.241	16	0.055	96	0.228
5	0.0595	31	0.225	17	0.052	104	0.218
6	0.052	76	0.161	18	0.0635	100	0.317
7	0.059	84	0.233	19	0.0635	97	0.307
8	0.052	64	0.134	20	0.073	85	0.356
9	0.0595	87	0.242	21	0.113	51	0.508
10	0.052	139	0.295	22	0.073	53	0.222
11	0.086	89	0.517				
12	0.098	78	0.588				

PILOT SWIRLER 7 AT 0.520d = 3.641 ACD  
 PILOT SWIRLER COOLING 224 AT 0.055d = 0.532  
 MAIN SWIRLER 28 AT 0.66ACD = 18.48 ACD  
 BULKHEAD COOLING 20 AT 0.111d = 0.194  
 558 AT 0.040d = 0.701  
 ID SWIRLER COOLING 13 AT 0.181d = 0.265  
 28 AT 0.081d = 0.144  
 42 AT 0.067d = 0.148  
 OD SWIRLER COOLING 13 AT 0.191d = 0.372  
 28 AT 0.106d = 0.247  
 42 AT 0.087d = 0.250  
 PILOT NOZZLE (P/N 27700-11)  
 MAIN NOZZLE (P/N 27700-11)

**MODIFICATIONS**

- USE PRESSURE ATOMIZING PILOT NOZZLES
- REMOVE PILOT SWIRLER BLOCKAGE RINGS
- REMOVE PILOT DILUTION HOLES
- INSTALL HIGH FLOW MAIN SWIRLERS
- REMOVE DILUTION HOLES

**Figure B-30 Liner Hole Pattern for Swirl Vortex Combustor Configuration S-8**

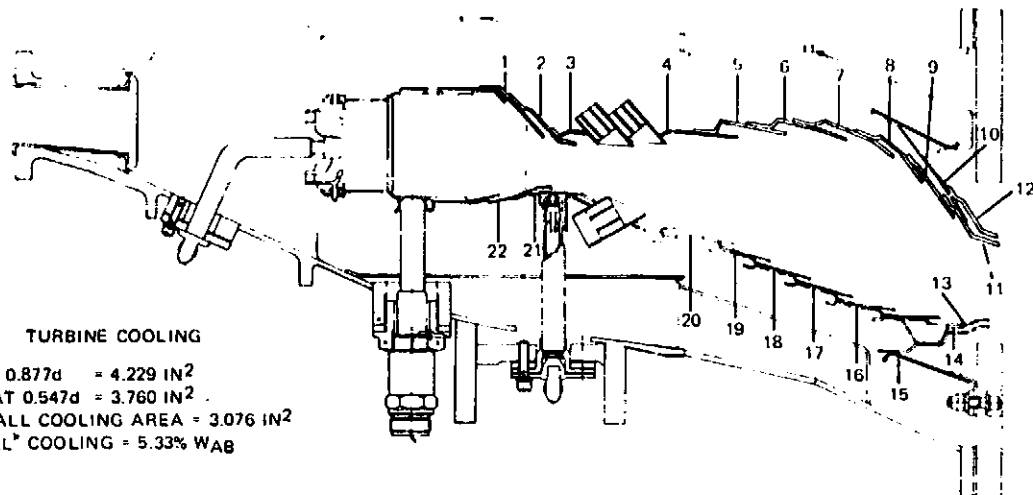

TURBINE COOLING  
 ID 7 AT 0.877d = 4.229 IN<sup>2</sup>  
 OD 16 AT 0.547d = 3.760 IN<sup>2</sup>  
 SIDE WALL COOLING AREA = 3.076 IN<sup>2</sup>  
 FINWALL\* COOLING = 5.33% WAB

I.D.				O.D.			
LOUVER	DIA.	# HOLES	AREA IN <sup>2</sup>	LOUVER	DIA.	# HOLES	AREA IN <sup>2</sup>
1	0.0785	48	0.232	13	0.0935	99	0.679
2	0.067	106	0.373	14	0.070	131	0.504
3	0.0935	37	0.254	15	0.055	106	0.252
4	0.0635	76	0.241	16	0.055	96	0.228
5	0.0595	81	0.225	17	0.052	104	0.218
6	0.052	76	0.161	18	0.0635	100	0.317
7	0.059	84	0.233	19	0.0635	97	0.307
8	0.052	64	0.134	20	0.073	85	0.356
9	0.0595	87	0.242	21	0.113	51	0.508
10	0.052	139	0.295	22	0.073	53	0.222
11	0.086	89	0.517				
12	0.098	78	0.588				

PILOT SWIRLER 7 AT 0.422 d = 3.095 ACD  
 PILOT SWIRLER COOLING 224 AT 0.055d = 0.532  
 MAIN SWIRLER 28 AT 0.66 = 18.48 ACD

PILOT SWIRLER 7 AT 0.42d = 3.095 ACD  
 PILOT SWIRLER COOLING 224 AT 0.055d = 0.532  
 MAIN SWIRLER 28 AT 0.66 = 18.48 ACD  
 PILOT DILUTION (ID) 7 AT 0.248d = 0.338  
 PILOT DILUTION (OD) 5 AT 0.278d = 0.303  
 BULKHEAD COOLING

20 AT 0.111d = 0.194  
 558 AT 0.040d = 0.701  
 13 AT 0.161d = 0.265  
 28 AT 0.081d = 0.144  
 42 AT 0.067d = 0.148  
 13 AT 0.191d = 0.372  
 28 AT 0.106d = 0.247  
 42 AT 0.087 = 0.250

ID SWIRLER COOLING

OD SWIRLER COOLING

MAIN NOZZLE (P/N 27700-11)  
 MODIFICATIONS: REFERENCE CONFIGURATION S-8

- MAIN FUEL INJECTORS ANGLED DOWNSTREAM
- REDUCE PILOT SWIRLER AIRFLOW WITH BLOCKAGE RINGS
- INSTALL PILOT DILUTION AIR HOLES

Figure B-31 Liner Hole Pattern for Swirl Vortex Combustor Configuration S-9



## APPENDIX C

### EXPERIMENTAL TEST DATA

This appendix presents a compilation of the test data acquired with the thirty-two different low-emissions combustor configurations tested during the Phase I screening evaluations. The data tabulations are arranged according to the baseline design and subsequent configuration changes. Pertinent operating parameters such as fuel and airflows, fuel-air ratio, and inlet temperature and pressure are itemized along with the corresponding emissions index (EI) value for the pollutants measured. In addition, comments pertaining to specific results are also included where appropriate.



TEST RESULTS FOR SWIRL CAN COMBUSTOR  
CONFIGURATION N2

Point Number	Airflow-Total kg/s	Airflow-Combustor kg/s	Fuel Flow - M.D. kg/s	Fuel Flow - I.D. kg/s	Fuel Flow-OD kg/s	Fuel Flow-Total kg/s	Fuel Temperature K	Inlet Total Temperature - K	Inlet Total Pressure-atm	Reference Velocity-m/s	Pattern Factor	Inlet Air Humidity g/kg air	Fuel-Air Ratio (Metered)	Fuel-Air Ratio (Carbon Balance)	CO2 - % Volume	O2 - % Volume	CO (EI)	THC (EI)	NOx (EI)	Gas Sample Combustion Efficiency	SAE Smoke Number	Comments
1A	5.02	3.98			.0485	.0485	287	439	3.07	18.0	.50	1.6*	.0122			15.8	151.7	208.8	1.7	72.0		
1B	4.94	3.89			.0485	.0485	286	436	3.07	17.7		1.6*	.0128	.0162	2.7	15.8	151.7	208.8	1.7	72.0		
3	5.06	3.97			.0628	.0628	286	433	2.87	19.2		1.6*	.0158	.0211	3.7	13.9	184.5	163.5	1.5	76.5		
2	5.02	4.02			.0319	.0319	285	435	2.93	18.9		1.6*	.0079	.0101	1.4	18.1	196.0	366.2	2.6	52.6		
4B	4.71	3.76			.0468	.0468	284	468	2.91	19.2	1.09	1.6*	.0124	.0168	3.0	15.7	145.7	155.3	1.5	78.4		
5A	4.45	3.52			.0451	.0451	284	509	2.92	19.5		1.6*	.0125	.0170	3.2	15.4	122.1	91.8	3.0	86.4		
5B	4.45	3.58			.0042	.0042	284	507	2.92	19.8	.58	1.6*	.0170				18.0	1.6	9.3	99.4		
6A	9.16	7.23	.0412	.0323	.0496	.1231	295	644	6.65	22.3		1.6*	.0228	.0249	5.0	12.4	18.0	1.6	9.3	99.3		
6B	9.22	7.27	.0536	.0344	.0666	.1566	294	645	6.82	21.9		1.6*	.0333	.0142	2.9	15.9	19.8	1.9	9.8	99.3		
10A	8.47	6.75		.0528	.0368	.0913	295	768	6.76	24.4	.46	1.6*	.0136									
10B	8.47	6.71	.0038	.0503	.0369	.0909	295	767	6.76	24.4	.50	1.6*	.0190									
9A	8.45	6.68	.0419	.0333	.0517	.1268	295	764	6.74	24.1		1.6*	.0191	.0201	4.1	13.8	7.4	.5	12.3	99.8		
9B	8.44	6.67	.0419	.0339	.0516	.1274	295	767	6.75	24.1		1.6*	.0231	.0253	5.1	12.2	5.2	.2	14.9	99.9		
8	8.52	6.70	.0504	.0392	.0650	.1546	295	768	6.93	23.8		1.6*	.0225	.0242	4.9	12.5	12.5	.6	11.0	99.6		
7	9.97	6.96	.0520	.0398	.0644	.1561	295	695	6.80	22.6		1.6*	.0225									

\*Estimated

ORIGINAL PAGE IS  
OF POOR QUALITY

TEST RESULTS FOR SWIRL CAN COMBUSTOR  
CONFIGURATION N3

Point Number	Airflow-Total kg/s	Airflow-Combustor kg/s	Fuel Flow - M.D.	Fuel Flow - I.D.	Fuel Flow-OD kg/s	Fuel Flow-Total kg/s	Fuel Temperature K	Inlet Total Temperature- K	Inlet Total Pressure-atm	Reference Velocity-m/s	Pattern Factor	Inlet Air Humidity g/kg air	Fuel-Air Ratio (Metered)	Fuel-Air Ratio (Carbon Balance)	CO <sub>2</sub> - % Volume	O <sub>2</sub> - % Volume	CO (EI)	TIC (EI)	NO <sub>x</sub> (EI)	Gas Sample Combustion Efficiency	SAB Smoke Number	Comments
1A	4.95	3.90			.0433	.0433	296.	430.	2.75	19.5	1.07	1.6*	.0122	-	-	118.6	201.7	2.2	-	-	-	
1B	4.98	3.92			.0434	.0434	296.	430.	2.78	19.5	-	1.6*	.0121	.0164	2.6	16.7	-	-	73.6	-	-	
2A	4.92	3.93			.0315	.0315	296.	432.	2.72	20.1	.87	1.6*	.0081	-	-	162.1	276.2	2.4	63.9	-	-	
2B	4.93	3.92			.0312	.0312	295.	433.	2.73	20.1	-	1.6*	.0081	.0109	1.5	18.5	-	-	-	-	-	
3A	4.91	4.22			.0574	.0574	295.	431.	2.60	22.6	1.32	1.6*	.0148	-	-	134.2	132.4	1.7	81.4	-	-	
3B	4.85	3.88			.0574	.0574	295.	431.	2.72	19.8	-	1.6*	.0162	.0214	3.5	14.2	-	-	-	-	-	
8B	8.66	6.71	.0518	.0599	.0412	.1528	289.	763.	6.72	24.4	-	1.6*	.0228	.0243	4.8	12.3	13.9	1.3	11.0	99.5	-	AST
13A	8.66	6.40	.0524	.0599	.0413	.1536	289.	841.	6.83	25.3	-	1.6*	.0289	.0242	4.9	12.2	7.7	.3	16.5	99.8	-	
10A	8.80	6.59	.0307	.0358	.0248	.0914	292.	766.	6.84	23.5	-	1.6*	.0137	.0140	2.8	16.2	50.9	6.1	8.3	98.1	-	
101	8.85	6.77	.0289	.0340	.0242	.0871	291.	650.	7.08	30.8	.88	1.6*	.0129	-	-	-	-	-	-	-	-	
20	4.83	4.17		.0367	-	.0367	294.	436.	2.88	20.1	-	1.6*	.0088	.0087	1.5	18.3	125.0	126.4	1.8	82.3	-	
110	4.92	4.23		.0542	-	.0542	293.	434.	2.91	20.1	-	1.6*	.0128	.0121	2.2	16.9	118.1	68.1	2.3	89.3	-	
108	8.61	5.77		.0350	.0350	.0350	291.	769.	6.75	21.0	-	1.6*	.0141	.0140	2.8	16.1	55.7	5.7	8.9	98.0	-	
9A	8.71	6.26	.0391	.0318	.0486	.1195	291.	762.	6.90	21.9	-	1.6*	.0190	.0211	4.2	13.4	14.7	0.8	10.7	99.6	-	
8C	8.73	5.76	.0412	.0365	.0555	.1332	290.	762.	6.68	21.0	-	1.6*	.0231	.0226	4.5	13.1	13.3	0.6	10.8	99.6	-	
13B	8.71	5.83	.0415	.0364	.0553	.1332	290.	836.	6.87	22.9	-	1.6*	.0228	.0224	4.5	13.2	6.9	0.2	13.9	99.8	-	AST
9B	8.71	6.69	.0420	.0490	.0338	.1248	290.	769.	6.79	25.0	-	1.6*	.0187	.0197	4.0	14.4	22.1	1.9	9.4	99.3	-	

\*Estimated

Comment

LBO f.o = .0058 at nominal idle conditions

TEST RESULTS FOR SWIRL CAN COMBUSTOR  
CONFIGURATION N4

Point Number	Airflow-Total kg/s	Airflow-Combustor kg/s	Fuel Flow - M. D. kg/s	Fuel Flow - I. D. kg/s	Fuel Flow-OI kg/s	Fuel Flow-Total kg/s	Fuel Temperature K	Inlet Total Temperature- K	Inlet Total Pressure-alm	Reference Velocity-m/s	Pattern Factor	Inlet Air Humidity g/kg air	Fuel-Air Ratio (Metered)	Fuel-Air Ratio (Carbon Balance)	CO <sub>2</sub> - % Volume	O <sub>2</sub> - % Volume	CO (EI)	THC (EI)	NO <sub>x</sub> (EI)	Gas Sample Combustion Efficiency	SAE Smoke Number	Comments
1	5.12	4.14					285.	411.	2.92	18.6	-	1.6*	-	-	-	-	-	-	-	-	-	-
21A	4.78	3.80			.0474	.0474	290.	438.	2.80	18.9	-	1.6*	.0126	.0161	16.4	121.4	184.8	1.3	75.5	-	-	
21C	4.87	3.88			.0476	.0476	304.	436.	2.95	18.3	-	1.6*	.0122	.0164	16.4	118.3	172.3	1.5	77.1	-	-	
21D	5.01	3.98			.0476	.0476	305.	433.	3.01	18.3	1.05	1.6*	.0119	.0217	-	-	-	-	-	-	-	-
43	4.87	3.85			.0636	.0636	306.	434.	2.89	18.6	-	1.6*	.0116	.0108	14.6	99.0	86.0	1.8	87.4	-	-	
61	4.89	3.90			-	.0452	298.	431.	2.94	18.3	-	1.6*	.0120	.0161	17.8	108.1	97.9	1.8	86.0	-	-	
54	4.66	3.71			.0447	.0447	308.	481.	2.93	19.5	-	1.6*	.0211	.0235	16.6	105.1	121.4	1.6	83.3	-	-	
78	8.77	6.90	.0499	.0326	.0587	.1414	293.	771.	6.80	25.0	-	1.6*	.0128	.0138	16.3	43.2	5.4	7.4	98.3	-	-	
910A	8.72	6.94	.0304	.0221	.0366	.0891	295.	769.	6.74	25.0	-	1.6*	.0181	.0199	14.6	10.5	3.6	9.1	99.3	-	-	
89	8.76	6.87	.0418	.0311	.0516	.1246	294.	771.	6.74	25.3	-	1.6*	.0224	.0246	12.8	6.5	1.9	10.4	99.6	-	-	
108	10.44	8.20	.0623	.0457	.0763	.1844	292.	779.	6.86	30.5	-	1.6*	.0232	.0239	13.1	2.4	1.7	14.5	99.7	-	-	
118	6.14	4.82	.0375	.0282	.0460	.1118	294.	774.	6.54	18.0	-	1.6*	.0220	.0235	13.3	5.1	1.1	11.9	99.7	-	-	
121	8.72	6.82	.0589	.0438	.0473	.1501	293.	772.	6.86	24.7	-	1.6*	.0220	.0247	13.2	4.8	0.8	11.5	99.8	-	-	
148	8.72	6.91	.0534	.0408	.0661	.1603	293.	832.	6.76	27.4	-	1.6*	.0231	.0277	12.0	4.3	0.9	16.9	99.8	-	-	
159A	9.75	7.67	.0582	.0428	.0722	.1733	292.	836.	6.90	30.2	-	1.6*	.0226	.0269	12.2	6.3	1.6	15.3	99.7	-	-	
910B	8.86	7.20	.0300	.0220	.0366	.0887	295.	776.	6.90	25.9	-	1.6*	.0122	.0153	16.2	36.1	18.6	7.5	97.0	-	-	
910C	8.78	7.03	.0294	.0215	.0366	.0876	295.	776.	6.74	25.9	96	1.6*	.0124	-	-	-	-	-	-	-	-	-
910D	8.72	7.04	.0289	.0209	.0366	.0866	295.	776.	6.78	25.9	73	1.6*	.0123	-	-	-	-	-	-	-	-	-
910E	8.70	6.92	.0286	.0206	.0365	.0858	295.	774.	6.76	25.3	1.04	1.6*	.0124	-	-	-	-	-	-	-	-	-

AST  
AST

ORIGINAL PAGE IS  
OF POOR QUALITY

\*Estimated

Comment

LBO f/a = .0058 at nominal idle conditions

TEST RESULTS FOR SWIRL CAN COMBUSTOR  
CONFIGURATION N5

Point Number	Airflow-Total kg/s	Airflow-Combustor kg/s	Fuel Flow - I.D. kg/s	Fuel Flow - M.I.D. kg/s	Fuel Flow-OD kg/s	Fuel Flow-Total kg/s	Fuel Temperature K	Inlet Total Temperature - K	Inlet Total Pressure-alm	Reference Velocity-m/s	Pattern Factor	Inlet Air Humidity g/kg air	Fuel-Air Ratio (Metered)	Fuel-Air Ratio (Carbon Balance)	CO <sub>2</sub> - % Volume	O <sub>2</sub> - % Volume	CO (EI)	THC (EI)	NO <sub>x</sub> (EI)	Gas Sample Combustion Efficiency	SAE Smoke Number	Comments
54	4.60	3.62	-	-	.0444	.0444	301.	486.	2.92	19.2	-	1.6*	.0122	.0170	3.02	15.4	97.3	81.0	2.4	88.2	-	-
21	4.95	3.91	-	-	.0462	.0462	303.	429.	2.93	18.3	-	1.6*	.0117	.0170	2.65	15.5	111.7	187.2	1.7	75.5	-	-
21	4.95	3.91	-	-	.0462	.0462	300.	431.	2.94	18.3	-	1.6*	.0118	.0172	2.72	15.9	119.8	171.5	1.7	77.1	-	-
32	4.88	3.89	-	-	.0342	.0342	301.	431.	2.90	18.3	-	1.6*	.0087	.0123	1.23	18.0	99.4	513.2	1.4	37.7	-	-
43	4.88	3.82	-	-	.0612	.0612	301.	430.	2.91	18.0	-	1.6*	.0159	.0238	4.21	13.3	104.8	71.1	2.0	89.2	-	-
68	8.87	7.06	.0497	.0376	.0610	.1483	289.	764.	6.82	25.3	-	1.6*	.0211	.0254	5.11	11.9	9.0	1.1	13.4	99.7	4	-
68	8.85	7.06	.0517	.0399	.0610	.1526	290.	768.	6.84	25.3	-	1.6*	.0217	.0283	5.03	12.2	9.8	0.9	13.6	99.7	-	-
79	8.95	7.12	.0420	.0319	.0506	.1245	290.	765.	6.95	25.0	-	1.6*	.0175	.0207	4.2	14.0	12.9	1.4	11.6	99.5	-	-
710	8.81	7.02	.0306	.0230	.0361	.0897	290.	767.	6.86	25.0	-	1.6*	.0128	.0147	2.9	16.3	42.6	4.4	9.7	98.5	-	-
79	8.82	7.04	.0376	.0288	.0463	.1129	294.	763.	6.81	25.3	.77	1.6*	.0161	-	-	-	-	-	-	-	-	-
79	8.69	6.93	.0383	.0288	.0462	.1133	294.	768.	6.76	25.3	-	1.6*	.0164	.0193	3.8	14.8	15.4	1.1	11.4	99.5	-	-
79	8.81	6.99	.0393	.0305	.0456	.1154	293.	767.	6.86	25.0	-	1.6*	.0165	.0191	3.8	15.2	15.5	1.3	13.2	99.5	-	-
141	4.95	3.91	.0219	.0165	.0259	.0643	293.	433.	2.83	19.2	1.03	1.6*	.0165	-	-	-	-	-	-	-	-	-
141	4.93	3.88	.0225	.0170	.0281	.0676	293.	434.	2.87	18.6	-	1.6*	.0175	.0188	1.84	16.2	114.7	498.2	1.1	39.1	-	-
151	4.92	3.86	.0294	.0207	.0371	.0872	297.	433.	2.90	18.3	-	1.6*	.0226	.0281	4.05	12.7	128.6	219.0	1.2	71.4	-	-
178	9.77	7.71	.0573	.0442	.0703	.1718	294.	836.	6.93	30.2	-	1.6*	.0223	.0264	5.31	12.6	6.0	0.1	17.6	99.8	-	AST
118	8.60	6.78	.0497	.0377	.0626	.1500	290.	836.	6.81	26.8	-	1.6*	.0222	.0259	5.2	12.6	5.5	0.1	19.5	99.9	-	AST
21	8.89	3.83	-	-	.0452	.0452	291.	432.	2.93	18.0	2.01	1.6*	.0117	-	-	-	-	-	-	-	-	-

\*Estimated

Comment

LBO f/a = .0058 at nominal idle conditions

TEST RESULTS FOR SWIRL CAN COMBUSTOR  
CONFIGURATION N6

Point Number	Airflow-Total kg/s	Airflow-Combustor kg/s	Fuel Flow - M.I.D.	Fuel Flow - L.D.	Fuel Flow-OD kg/s	Fuel Flow-Total kg/s	Fuel Temperature K	Inlet Total Temperature - K	Inlet Total Pressure-alm	Reference Velocity-m/s	Pattern Factor	Inlet Air Humidity g/kg air	Fuel-Air Ratio (Metered)	Fuel-Air Ratio (Carbon Balance)	CO2 - % Volume	O2 - % Volume	CO (EI)	THC (EI)	NOx (EI)	Gas Sample Combustion Efficiency	SAE Smoke Number	Comments
21	5.96	4.55	-	.0459	.0457	.0457	286.	435.	2.96	22.0	-	2.1	.0102	.0122	1.8	17.0	136.90	251.7	1.6	67.4	-	-
21	5.95	4.52	-	-	.0456	.0456	286.	435.	2.96	21.6	1.70	2.1	.0103	-	-	-	-	-	-	-	-	-
88	8.87	7.00	.0493	.0346	.0603	.1442	294.	764.	6.88	25.0	-	2.0	.0206	.0248	5.0	12.0	5.0	8.2	12.4	99.9	-	-
99	8.77	6.93	.0419	.0281	.0493	.1193	295.	764.	6.77	25.0	-	2.0	.0172	.0206	4.2	13.9	8.2	-	11.2	99.8	-	-
99	8.78	6.94	.0418	.0288	.0493	.1199	295.	762.	6.75	25.0	0.48	2.0	.0173	-	-	-	4.0	-	-	-	-	
138	9.66	7.63	.0435	.0367	.0536	.1338	295.	834.	6.73	30.8	-	2.0	.0176	.0212	4.3	13.6	4.3	0.24	13.4	99.9	-	AST

TEST RESULTS FOR SWIRL CAN COMBUSTOR  
CONFIGURATION N7

Point Number	Airflow-Total kg/s	Airflow-Combustor kg/s	Fuel Flow - M.I.D.	Fuel Flow - L.D.	Fuel Flow-OD kg/s	Fuel Flow-Total kg/s	Fuel Temperature K	Inlet Total Temperature - K	Inlet Total Pressure-alm	Reference Velocity-m/s	Pattern Factor	Inlet Air Humidity g/kg air	Fuel-Air Ratio (Metered)	Fuel-Air Ratio (Carbon Balance)	CO2 - % Volume	O2 - % Volume	CO (EI)	THC (EI)	NOx (EI)	Gas Sample Combustion Efficiency	SAE Smoke Number	Comments
78	8.77	6.69	.0504	.0240	.0321	.0615	293.	757.	6.88	23.8	-	1.84	.0215	.0235	4.8	13.0	3.5	0.0	11.5	99.9	-	-
89	8.84	6.79	.0413	.0179	.0369	.0517	294.	761.	6.87	24.1	-	1.84	.0172	.0179	3.6	14.9	8.3	0.1	10.2	99.8	-	-
106	8.76	6.79	.0298	.0497	.0303	.0627	296.	761.	6.82	24.4	-	1.83	.0124	.0120	2.4	16.7	42.2	1.8	9.3	98.8	-	-
108	8.80	6.79	.0497	.0303	.0627	.1427	295.	840.	6.84	26.8	-	1.80	.0210	.0238	4.8	12.4	4.0	0.0	15.8	99.9	-	AST
108	8.75	6.77	.0638	.0244	.0542	.1424	295.	840.	6.84	26.8	-	1.79	.0210	.0267	5.4	12.7	4.7	0.0	14.8	99.9	-	AST
128	8.90	6.72	.0478	.0321	.0625	.1424	295.	771.	6.95	24.1	-	1.77	.0212	.0225	4.6	13.5	5.4	0.0	10.5	99.9	-	-
138	8.90	6.80	.0313	.0399	.0710	.1422	294.	767.	6.82	24.7	-	1.76	.0209	.0222	4.5	13.4	4.6	0.1	10.4	99.8	-	-
148	8.78	6.22	-	-	.0616	.0616	292.	772.	6.87	22.6	-	1.74	.0099	.0097	2.0	17.5	17.0	2.8	10.7	99.2	-	-
151	5.31	4.49	-	-	.0473	.0473	294.	591.	3.64	24.1	-	1.71	.0105	.0090	1.6	18.1	127.9	95.4	1.7	85.8	-	-
161	5.18	3.77	-	-	.0389	.0389	287.	700.	3.84	22.2	-	1.67	.0103	.0090	1.8	17.5	32.0	8.1	5.8	98.3	-	-
43	8.35	6.13	-	-	.0637	.0637	285.	463.	3.79	27.5	-	1.67	.0142	.0105	1.3	17.5	181.0	291.4	1.7	61.6	-	-
21	8.35	6.16	-	-	.0494	.0494	285.	461.	3.74	25.3	-	1.67	.0104	.0084	0.8	18.5	176.5	440.0	1.3	44.4	-	-
43	8.40	6.16	-	-	.0640	.0640	285.	461.	3.81	27.5	1.99	1.67	.0103	-	-	-	-	-	-	-	-	-
32	8.45	6.16	-	-	.0783	.0783	286.	463.	3.78	27.5	-	1.68	.0173	.0149	2.5	16.1	105.8	127.8	1.2	82.5	-	-
32	8.45	6.22	.0263	-	.0649	.0912	291.	457.	3.63	25.3	-	1.58	.0141	-	-	-	-	-	-	-	-	-
78	8.81	6.81	.0499	.0304	.0628	.1431	293.	760.	6.85	24.1	-	1.68	.0210	.0235	4.7	11.4	3.0	0.2	11.9	99.9	-	-
910	8.83	6.88	.0505	.0175	.0370	.1436	293.	764.	6.88	24.7	-	1.74	.0124	.0122	2.4	16.9	38.9	2.2	9.4	98.8	-	-
910	8.80	6.84	.0306	.0177	.0370	.0850	295.	761.	6.84	24.4	.53	1.76	.0125	-	-	-	-	-	-	-	-	-

Acoustic Test Configuration

TEST RESULTS FOR SWIRL CAN COMBUSTOR  
CONFIGURATION N8

Point Number	Airflow-Total kg/s	Airflow-Combustor kg/s	Fuel Flow - M.D.	Fuel Flow - I.D.	Fuel Flow-OD kg/s	Fuel Flow-Total kg/s	Fuel Temperature K	Inlet Total Temperature- K	Inlet Total Pressure-atm	Reference Velocity-m/s	Pattern Factor	Inlet Air Humidity g/kg air	Fuel-Air Ratio (Metered)	Fuel-Air Ratio (Carbon Balance)	CO <sub>2</sub> - % Volume	O <sub>2</sub> - % Volume	CO (EI)	THC (EI)	NO <sub>x</sub> (EI)	Gas Sample Combustion Efficiency	SAE Smoke Number	Comments
21	7.64	5.92	-	-	.0502	.0502	292.	455	3.77	23.5	-	1.80	.0088	.0120	1.39	18.23	406.66	447.8	1.4	61.5	-	-
32	7.67	6.03	-	-	.0405	.0405	292.	460.	3.77	24.1	1.82	1.78	.0067	.00896	.84	19.57	400.97	380.1	1.2	46.1	-	-
32	7.66	5.97	-	-	.0406	.0406	292.	458.	3.76	24.1	-	1.80	.0068	-	-	-	-	-	-	-	-	-
43	7.73	5.91	-	-	.0671	.0671	293.	460.	3.74	24.1	-	1.81	.0087	.01016	1.50	17.65	112.74	241.5	0.9	69.1	-	-
51	6.01	4.74	-	-	.0396	.0396	293.	456.	3.76	18.3	-	1.80	.0114	.01433	2.36	16.08	115.18	141.0	1.3	80.8	-	-
810	8.76	6.93	.0289	.0238	.0357	.0884	299.	766.	6.86	24.7	-	1.83	.0128	.01447	2.89	15.78	35.32	4.9	8.5	98.6	-	-
79	8.80	6.93	.0386	.0291	.0498	.1175	298.	768.	6.93	24.7	-	1.83	.01696	.01906	3.84	13.68	14.83	1.1	10.8	99.5	-	-
68	8.79	6.89	.0506	.0350	.0601	.1457	298.	767.	6.86	24.7	-	1.86	.02120	.02488	5.01	12.25	4.50	0.2	12.5	99.9	-	-
98	8.72	6.90	.0428	.0309	.0544	.1281	298.	832.	6.88	26.8	-	1.86	.01860	.02215	4.47	13.66	3.56	0.10	14.4	99.9	-	-
108	9.81	7.71	.0463	.0362	.0611	.1436	298.	824.	6.81	30.5	-	1.88	.01864	.02285	4.61	13.53	4.57	0.0	13.0	99.9	-	-

Acoustic Test Configuration

TEST RESULTS FOR SWIRL CAN COMBUSTOR  
CONFIGURATION N9

Point Number	Airflow-Total kg/s	Airflow-Combustor kg/s	Fuel Flow - M.D.	Fuel Flow - I.D.	Fuel Flow-OD kg/s	Fuel Flow-Total kg/s	Fuel Temperature K	Inlet Total Temperature- K	Inlet Total Pressure-atm	Reference Velocity-m/s	Pattern Factor	Inlet Air Humidity g/kg air	Fuel-Air Ratio (Metered)	Fuel-Air Ratio (Carbon Balance)	CO <sub>2</sub> - % Volume	O <sub>2</sub> - % Volume	CO (EI)	THC (EI)	NO <sub>x</sub> (EI)	Gas Sample Combustion Efficiency	SAE Smoke Number	Comments
21	7.83	6.18	-	-	.0502	.0502	303.	459.	3.74	24.7	-	1.6*	.0081	.0109	0.9	18.5	90.2	624.1	1.4	25.0	-	-
33	7.90	6.17	-	-	.0699	.0699	303.	457.	3.79	24.1	-	1.6*	.0113	.0148	2.1	16.3	113.9	259.8	1.9	67.0	-	-
42	7.82	6.18	-	-	.0569	.0569	302.	454.	3.72	24.7	-	1.6*	.0092	.0121	1.5	17.5	133.7	348.7	2.1	56.1	-	-
42	7.81	6.18	-	-	.0569	.0569	301.	454.	3.73	24.7	1.86	1.6*	.0092	.0121	1.5	17.5	133.7	348.7	2.1	56.1	-	-
42	7.87	6.21	-	-	.0570	.0570	300.	456.	3.71	25.3	-	1.6*	.0092	.0097	1.1	18.3	183.7	420.2	2.8	46.6	-	-
58	8.66	6.90	.0489	.0335	.0605	.1429	302.	770.	6.78	25.0	-	1.6*	.0208	.0268	5.4	14.2	9.6	1.7	8.6	99.6	-	-
69	8.77	6.99	.0407	.0280	.0499	.1186	303.	770.	6.73	25.0	-	1.6*	.0170	.0220	4.4	15.2	16.1	2.2	8.0	99.4	-	-
710	8.75	7.04	.0293	.0197	.0358	.0848	301.	770.	6.74	25.6	-	1.6*	.0121	.0161	3.2	16.5	49.3	15.7	7.7	97.0	-	-
58	8.75	6.97	.0488	.0337	.0575	.1400	301.	770.	6.80	25.3	-	1.6*	.0211	.0257	5.2	14.0	10.0	1.1	8.8	99.6	-	-
88	8.69	7.04	.0486	.0337	.0579	.1402	300.	770.	6.78	28.3	-	1.6*	.0200	.0265	5.3	14.1	4.7	.5	12.0	99.8	-	-
581	8.80	7.08	-	-	.0579	.0579	302.	771.	6.83	25.6	-	1.6*	.0082	.0101	2.0	18.3	29.3	6.6	11.2	98.5	-	-

\* Estimate

Acoustic Test Configuration

TEST RESULTS FOR SWIRL CAN COMBUSTOR  
CONFIGURATION N10

Point Number	Airflow-Total kg/s	Airflow-Combustor kg/s	Fuel Flow - M.D.	Fuel Flow - I.D.	Fuel Flow-OD kg/s	Fuel Flow-Total kg/s	Fuel Temperature K	Inlet Total Temperature- K	Inlet Total Pressure-alm	Reference Velocity-m/s	Pattern Factor	Inlet Air Humidity	Fuel-Air Ratio (Metered)	Fuel-Air Ratio (Carbon Balance)	CO2 - % Volume	O2 - % Volume	CO(EI)	THC (EI)	TiHC (EI)	NOx (EI)	Gas Sample Combustion Efficiency	SAE Smoke Number	Comments
42	7.74	5.90			.0569	.0569	293.	458.	3.72	23.7		2.85	.0097	.0090	1.5	18.2	134.1	150.0	1.1	79.3			
421	7.89	5.94			.0942	.0942	294.	454.	3.76	23.7		2.87	.0159	.0148	2.7	16.1	129.3	50.9	1.3	91.0			
482	7.84	5.92			.0550	.0550	298.	459.	3.76	19.2		2.91	.0093	.0110	2.0	16.7	118.6	41.7	1.0	92.3			
69	8.66	6.88	.0430	.0279	.0499	.1208	299.	775.	6.82	25.0		2.06	.0176	.0186	3.8	14.3	3.6	0.3	13.0	99.9			
710	8.70	6.98	.0288	.0219	.0356	.0863	300.	772.	6.80	25.3		2.12	.0124	.0125	2.5	17.6	51.0	9.1	12.3	97.7			
58	8.73	6.94	.0450	.0337	.0605	.1392	300.	773.	6.80	25.3		2.11	.0202	.0216	4.4	14.0	2.7	0.2	14.4	99.9			AST
88	8.68	6.90	.0489	.0342	.0776	.1437	300.	847.	6.75	27.7		2.11	.0209	.0220	4.4	13.0	2.3	0.0	17.6	99.9			
21	7.80	5.98			.0502	.0502	292.	459.	3.78	25.6		2.63	.0084	.0074	1.2	18.8	127.1	200.2	1.8	73.6			
33	7.86	5.99			.0672	.0672	292.	454.	3.76	25.6		2.64	.0112	.0103	1.8	17.4	105.8	95.2	2.4	86.4			

Comment

LBO f/s = .0038 at idle condition

Acoustic Test Configuration

TEST RESULTS FOR SWIRL CAN COMBUSTOR  
CONFIGURATION N11

Point Number	Airflow-Total kg/s	Airflow-Combustor kg/s	Fuel Flow - M.D.	Fuel Flow - I.D.	Fuel Flow-OD kg/s	Fuel Flow-Total kg/s	Fuel Temperature K	Inlet Total Temperature- K	Inlet Total Pressure-alm	Reference Velocity-m/s	Pattern Factor	Inlet Air Humidity	Fuel-Air Ratio (Metered)	Fuel-Air Ratio (Carbon Balance)	CO2 - % Volume	O2 - % Volume	CO (EI)	THC (EI)	NOx (EI)	Gas Sample Combustion Efficiency	SAE Smoke Number	Comments	
21	8.05	6.16			.0507	.0507	295.	458.	3.76	25.0		2.36	.0083			17.5	117.8	123.4	1.3	82.8			
21	8.01	6.08			.0504	.0504	296.	454.	3.63	25.3		2.14	.0083	.0074	1.3	18.2	88.6	73.0	1.8	89.4			
42	8.03	6.07			.0572	.0572	296.	458.	3.73	24.4		2.15	.0094	.0092	1.7	17.6	76.6	55.5	2.5	91.7			
33	8.05	6.07			.0675	.0675	296.	454.	3.75	24.4		2.18	.0111	.0108	2.0	13.2	11.0	1.5	12.0	99.6			
69	7.93	6.28	.0373	.0266	.0451	.1090	299.	766.	6.11	25.3		2.19	.0174	.0195	3.9	15.9	21.2	5.8	10.3	98.8			SI TO Points At Reduced Pressure
710	7.88	6.29	.0257	.0186	.0321	.0764	300.	765.	6.14	25.0		2.17	.0121	.0134	2.7	18.2	4.5	0.3	13.5	99.9			
58	7.95	6.32	.0438	.0312	.0543	.1293	299.	769.	6.16	25.3		2.15	.0204	.0232	4.7	20.1	6.0	0.3	11.8	99.8			
88	6.22	4.91	.0341	.0243	.0422	.1006	300.	767.	4.77	25.3		2.28	.0205	.0228	4.6	12.0	8.1	0.5	10.8	99.7			
882	4.27	3.39	.0244	.0179	.0304	.0727	301.	766.	3.39	24.4		2.39	.0213	.0233	4.7								

Comment

LBO f/s = .0043 at nominal idle condition.

Acoustic Test Configuration

ORIGINAL PAGE IS  
OF POOR QUALITY

### TEST RESULTS FOR SWIRL CAN COMBUSTOR CONFIGURATION N12

Point Number	Airflow-Total kg/s	Airflow-Combustor kg/s	Fuel Flow - M.D.	Fuel Flow - I.D.	Fuel Flow-Q1 kg/s	Fuel Flow-Total kg/s	Fuel Temperature K	Inlet Total Temperature- K	Inlet Total Pressure-alm	Reference Velocity-m/s	Pattern Factor	Inlet Air Humidity g/kg air	Fuel-Air Ratio (Metered)	Fuel-Air Ratio (Carbon Balance)	CO <sub>2</sub> - % Volume	O <sub>2</sub> - % Volume	CO (EI)	THC (EI)	NO <sub>x</sub> (EI)	Gas Sample Combustion Efficiency	SAE Smoke Number	Comments
21	7.99	6.26			.0505	.0505	305.	452.	3.78	24.7	-	2.93	.0080	.0087	1.4	18.3	176.0	138.9	1.8	79.6	-	
42	7.99	6.17			.0573	.0573	305.	459.	3.69	25.3	-	2.84	.0092	.0090	1.4	18.3	185.7	151.8	1.9	77.9	-	
33	8.09	6.22			.0670	.0670	305.	454.	3.74	25.0	-	2.81	.0108	.0103	1.5	17.9	208.7	177.2	1.6	74.4	-	
69	8.73	6.85	.0427	.0300	.0500	.1227	302.	772.	6.80	25.0	-	2.62	.01793	.0192	3.9	14.1	11.4	0.1	13.0	99.7	-	
710	8.70	6.98	.0296	.0198	.0358	.0847	304.	771.	6.74	25.6	-	2.62	.0121	.0132	2.7	15.9	9.8	0.2	11.9	99.7	-	
58	8.75	6.96	.0481	.0345	.0598	.1423	302.	771.	6.82	25.3	-	2.61	.0163	.0224	4.5	13.2	14.6	-	13.4	99.7	-	AST
88	8.76	6.92	.0469	.0343	.0608	.1420	302.	833.	6.72	27.7	-	2.61	.0205	.0220	4.4	13.8	10.2	0.1	14.7	99.8	-	
33	8.04	6.17			.0670	.0670	306.	458.	3.69	19.5	1.04	2.82	.0109	-	-	-	-	-	-	-	-	
710	8.76	7.04	.0304	.0198	.0359	.0861	304.	772.	6.77	25.6	.63	2.63	.0122	-	-	-	-	-	-	-	-	

Acoustic Test Configuration

### TEST RESULTS FOR SWIRL CAN COMBUSTOR CONFIGURATION N13

Point Number	Airflow-Total kg/s	Airflow-Combustor kg/s	Fuel Flow - M.D.	Fuel Flow - I.D.	Fuel Flow - O.D.	Fuel Flow-Total kg/s	Fuel Temperature K	Inlet Total Temperature- K	Inlet Total Pressure-alm	Reference Velocity-m/s	Pattern Factor	Inlet Air Humidity g/kg air	Fuel-Air Ratio (Metered)	Fuel-Air Ratio (Carbon Balance)	CO <sub>2</sub> - % Volume	O <sub>2</sub> - % Volume	CO (EI)	THC (EI)	NO <sub>x</sub> (EI)	Gas Sample Combustion Efficiency	SAE Smoke Number	Comments
138-S	8.63	6.90	.0434	.0191	.0353	.4884	306	840	6.65	25.9	-	1.73	.0141	.0159	3.2	15.8	27.4	1.0	11.3	99.2	-	AST
1-8	7.42	5.94	.0530	.0272	.0414	.1216	305	840	6.78	21.9	-	1.72	.0204	.0222	4.5	14.3	6.1	0.0	15.0	99.9	-	AST
158	10.78	8.62	.0789	.0392	.0612	.1793	304	851	6.85	33.5	-	1.74	.0208	.0229	4.6	13.9	8.9	0.1	12.0	99.8	-	AST
43	7.78	6.22			.0654	.0654	302	460	3.71	22.6	-	1.75	.0105	.0092	0.4	18.8	66.2	885.0	1.2	-	-	
58	8.64	6.92	.0462	.0314	.0549	.1325	305	768	6.83	23.5	-	1.81	.0192	.0197	4.0	14.3	13.9	1.8	10.7	99.5	-	
69	8.83	7.11	.0452	.0347	.0628	.1427	305	764	6.86	23.8	-	1.85	.0202	.0212	4.3	14.5	2.2	1.8	11.2	99.7	-	
710	8.70	6.96	.0356	.0346	.0425	.1127	305	780	6.78	24.1	-	1.85	.0147	.0157	3.1	16.2	40.7	2.5	10.2	98.7	-	
88	8.73	6.98	.0559	.0328	.0566	.1453	305	773	6.75	24.4	-	1.83	.0208	.0218	4.3	14.2	16.2	0.3	10.7	99.6	-	
108	8.71	6.97	.0518	.0250	.0542	.1310	305	773	6.66	24.7	-	1.81	.0208	.0208	4.2	14.1	19.4	0.4	10.5	99.5	-	
98	8.74	7.00	.0642	.0336	.0504	.1482	304	763	6.72	24.1	-	1.81	.0213	.0222	4.4	14.0	18.1	0.4	10.8	99.5	-	AST
118	8.64	6.91	.0617	.0311	.0486	.1414	305	839	6.70	26.2	-	1.74	.0204	.0225	4.5	14.1	7.3	0.1	13.1	99.8	-	AST
128	8.66	6.93	.0523	.0258	.0410	.1191	305	837	6.90	25.6	-	1.74	.0173	.0192	3.8	15.0	12.5	0.2	12.3	99.7	-	



**TEST RESULTS FOR STAGED PREMIX COMBUSTOR  
CONFIGURATION P1**

Point Number	Airflow-Total kg/s	Airflow-Combustor kg/s	Fuel Flow - Pilot kg/s	Fuel Flow - Main kg/s	Fuel Flow-Total kg/s	Fuel Temperature K	Inlet Total Temperature - K	Inlet Total Pressure-alm	Reference Velocity-m/s	Pattern Factor	Inlet Air Humidity g/kg air	Fuel-Air Ratio (Metered)	Fuel-Air Ratio (Carbon Balance)	CO2 - % Volume	O2 - % Volume	CO (EI)	TIC (EI)	NOx (EI)	Gas Sample Combustion Efficiency	SAE Smoke Number
3B	4.93	3.86	.0628	-	.0628	292.	425.	2.98	18.3	-	1.6*	.0163	.0150	2.9	16.2	-	.5	4.6	-	-
1B	4.96	3.89	.0500	-	.0500	292.	426.	2.94	19.8	1.14	1.6*	.0128	.0151	3.0	-	27.3	0.8	3.9	-	-
1C	4.97	3.90	.0500	-	.0500	291.	425.	2.93	20.1	-	1.6*	.0129	.0115	2.3	17.4	30.8	0.1	4.5	99.3	-
2A	4.90	3.93	.0337	-	.0337	293.	428.	2.87	18.9	-	1.6*	.0086	.0083	1.6	18.6	50.4	50.1	0.9	93.0	-
2B	4.90	3.88	.0337	-	.0337	293.	426.	2.94	18.0	.90	1.6*	.0087	-	-	-	-	-	-	-	-
3A	4.86	3.81	.0629	-	.0629	292.	429.	2.90	18.0	1.06	1.6*	.0165	-	-	-	-	-	-	-	-
4A	4.72	3.75	.0474	-	.0474	292.	469.	3.15	17.7	1.05	1.6*	.0127	-	-	-	-	-	-	-	-
4B	4.72	3.79	.0474	-	.0474	292.	465.	3.15	17.7	-	1.6*	.0125	.0118	2.4	17.6	19.7	0.1	6.0	99.5	-
5A	4.70	3.68	.0453	-	.0453	291.	508.	3.15	18.9	-	1.6*	.0123	.0116	2.4	17.5	13.2	0.1	6.7	99.7	-
5B	4.48	3.51	.0453	-	.0453	291.	521.	3.14	18.0	.93	1.6*	.0130	-	-	-	-	-	-	-	-
6A	9.12	7.32	.0606	.0925	.1531	295.	646.	7.22	20.7	.55	1.6*	.0209	-	-	-	-	-	-	-	-
6B	9.24	7.46	.0675	.1056	.1732	295.	644.	6.75	22.9	.51	1.6*	.0232	-	-	-	-	-	-	-	-
6C	9.20	7.31	.0675	.1055	.1730	295.	642.	6.73	22.3	-	1.6*	.0237	.0288	5.7	10.8	20.1	0.4	10.2	99.5	-
7A	9.02	7.14	.0650	.1002	.1652	296.	696.	6.95	22.9	-	1.6*	.0232	.0281	5.6	10.5	15.1	0.0	11.7	99.6	-
10	8.45	7.07	.0471	.0734	.1205	296.	775.	6.88	25.6	-	1.6*	.0171	.0206	4.1	14.3	14.9	0.7	9.4	99.6	-
9	8.39	6.84	.0544	.0855	.1399	296.	767.	6.81	24.7	-	1.6*	.0204	.0244	4.9	12.9	10.5	0.1	13.5	99.7	-

Comment

LBO f/a = .0076 at design idle condition

\*Estimate

**ORIGINAL PAGE IS  
OF POOR QUALITY**

TEST RESULTS FOR STAGED PREMIX COMBUSTOR  
CONFIGURATION P2

Point Number	Airflow-Total kg/s	Airflow-Combustor kg/s	Fuel Flow - Pilot kg/s	Fuel Flow - Main kg/s	Fuel Flow-Total kg/s	Fuel Temperature K	Inlet Total Temperature - K	Inlet Total Pressure-atm	Reference Velocity-m/s	Pattern Factor	Inlet Air Humidity g/kg air	Fuel-Air Ratio (Metered)	Fuel-Air Ratio (Carbon Balance)	CO <sub>2</sub> - % Volume	O <sub>2</sub> - % Volume	CO (EI)	THC (EI)	NO <sub>x</sub> (EI)	Gas Sample Combustion Efficiency	SAE Smoke Number
5A	4.54	3.58	.0465	-	-	291.	505.	2.94	19.2	1.5	1.6*	.0129	-	-	-	-	-	6.3	-	-
5B	4.51	3.59	.0465	-	.0455	292.	509.	2.94	19.8	-	1.6*	.0129	.0123	2.4	16.6	54.9	0.1	-	98.7	-
4A	4.79	3.78	.0485	-	.0485	291.	458.	2.94	18.9	2.1	1.6*	.0128	-	-	16.4	67.4	0.0	5.1	98.4	-
4C	4.56	3.59	.0486	-	.0486	290.	463.	2.92	18.0	-	1.6*	.0134	.0124	2.8	16.4	67.4	0.0	5.1	98.4	-
3B	4.83	3.78	.0631	-	.0631	290.	438.	2.99	17.7	-	1.6*	.0167	.0154	2.82	15.7	197.2	0.3	4.6	95.3	-
2B	4.81	3.81	.0317	-	.0317	290.	437.	2.92	18.3	1.34	1.6*	.0083	.0154	-	-	-	-	-	95.3	-
2D	4.77	3.79	.0318	-	.0318	290.	437.	2.98	18.0	-	1.6*	.0084	.0081	1.6	18.5	34.0	2.5	2.5	98.9	-
1B	4.88	3.90	.0501	-	.0501	290.	437.	2.86	18.0	-	1.6*	.0128	.0123	2.4	16.7	57.0	0.1	4.6	98.6	-
6A	9.11	7.20	.0672	.1035	.1701	290.	647.	6.87	21.6	-	1.6*	.0237	.0014	5.1	10.9	71.2	0.3	11.3	98.3	-
6B	9.10	7.19	.0674	.1045	.1720	293.	640.	6.87	21.3	-	1.6*	.0240	.0286	5.6	10.8	37.1	0.3	11.3	99.1	-
7	9.26	7.28	.0672	.1012	.1685	293.	699.	6.87	23.8	-	1.6*	.0231	.0268	5.3	11.1	30.2	0.2	12.7	99.3	-
10	8.77	6.98	.0490	.0749	.1498	295.	759.	6.79	25.0	-	1.6*	.0177	.0201	4.0	13.8	46.5	3.0	10.7	98.6	-
9	8.78	6.96	.0561	.0852	.1413	295.	756.	6.78	25.0	-	1.6*	.0203	.0231	4.6	12.8	28.2	0.7	13.7	99.4	2
8	8.87	6.94	.0642	.0971	.1613	296.	757.	6.94	24.1	-	1.6*	.0232	.0254	5.1	11.9	20.8	0.1	16.2	99.5	-
11	8.95	7.07	.0501	.1109	.1610	295.	752.	6.84	25.0	-	1.6*	.0227	.0252	5.0	11.9	26.0	0.1	14.4	99.4	-
12	8.75	6.99	.0633	-	.0633	295.	756.	6.94	24.4	-	1.6*	.0090	.0099	2.0	17.5	.9	0.5	12.6	99.9	-
13	8.60	6.90	.0968	-	.0968	295.	765.	6.94	25.0	-	1.6*	.0140	.0152	3.0	15.4	36.2	1.7	16.5	98.9	-
110	4.99	3.93	.0494	-	.0494	278.	412.	3.01	17.1	-	1.6*	.0125	.0116	2.3	16.8	49.1	0.2	3.5	98.8	-
110	4.85	3.82	.0495	-	.0495	278.	443.	3.01	18.0	-	1.6*	.0130	.0118	2.3	16.9	54.8	0.2	4.3	98.7	-

\*Estimate

Comment

LBO f/a = .0058 at design idle conditions

TEST RESULTS FOR STAGED PREMIX COMBUSTOR  
CONFIGURATION P3

ORIGINAL PAGE  
OF POOR QUALITY

Point Number	Airflow-Total kg/s	Airflow-Combustor kg/s	Fuel Flow - Pilot kg/s	Fuel Flow - Main kg/s	Fuel Flow-Total kg/s	Fuel Temperature K	Inlet Total Temperature - K	Inlet Total Pressure-atm	Reference Velocity-m/s	Pattern Factor	Inlet Air Humidity g/kg air	Fuel-Air Ratio (Metered)	Fuel-Air Ratio (Carbon Balance)	CO <sub>2</sub> - % Volume	O <sub>2</sub> - % Volume	CO (EI)	THC (EI)	NO <sub>x</sub> (EI)	Gas Sample Combustion Efficiency	SAE Smoke Number	Comments
21A	4.89	3.82	.0472	-	.0472	289.	430.	2.91	18.0	-	1.6*	.0125	.0124	2.5	16.8	12.1	0.7	4.0	99.6	-	-
21B	4.98	3.90	.0479	-	.0479	297.	427.	2.91	18.3	-	1.6*	.0123	.0126	2.6	17.6	7.1	0.2	4.0	99.8	-	-
21C	4.93	3.86	.0479	-	.0479	297.	425.	2.87	18.3	1.94	1.6*	.0125	-	-	-	-	174.3	1.6	76.3	-	-
32	4.94	3.90	.0313	-	.0313	297.	426.	2.91	18.3	-	1.6*	.0164	.0165	3.2	16.1	74.8	0.2	4.8	98.2	-	-
43	4.88	3.80	.0622	-	.0622	297.	427.	2.88	18.0	-	1.6*	.0225	.0255	5.1	12.9	23.3	0.3	12.8	99.4	-	-
78	8.88	6.91	.0607	.0944	.1550	297.	761.	6.78	25.0	-	1.6*	.0220	.0248	4.9	13.0	37.3	1.1	13.3	99.0	-	-
138	8.84	6.99	.0774	.0766	.1541	294.	760.	6.76	25.3	-	1.6*	.0221	.0259	5.1	12.6	40.1	2.7	13.0	98.7	-	-
128	8.85	6.98	.0447	.1092	.1540	293.	760.	6.78	25.0	-	1.6*	.0221	.0244	4.5	13.2	92.2	31.8	11.3	94.1	-	-
118	8.85	6.98	.0303	.1238	.1542	293.	758.	6.79	25.3	-	1.6*	.0198	.0223	4.4	13.8	39.5	1.4	10.2	98.9	-	-
89	8.84	6.85	.0539	.0821	.1360	293.	761.	6.86	24.7	1.50	1.6*	.0168	-	-	-	-	-	-	-	-	-
910A	8.86	6.99	.047.	.0704	.1176	293.	759.	6.56	25.6	-	1.6*	.0167	.0186	3.5	15.5	98.0	18.2	5.7	95.6	-	-
910B	3.92	7.03	.0472	.0704	.1176	292.	758.	6.78	30.5	-	1.6*	.0024	.0267	5.2	13.1	57.5	2.8	14.1	98.3	-	-
908A	8.64	6.96	.0153	.1406	.1559	288.	763.	6.89	25.0	-	1.6*	.0129	.0120	2.4	17.8	10.0	0.8	4.1	99.7	-	-
21	4.88	3.77	.0490	-	.0490	286.	426.	2.93	25.3	-	1.6*	-	-	-	-	-	-	-	-	-	-

\*Estimate

Comment

LBO f/s = .0065 at design idle conditions.

TEST RESULTS FOR STAGED PREMIX COMBUSTOR  
CONFIGURATION P4

Point Number	Airflow-Total kg/s	Airflow-Combustor kg/s	Fuel Flow - Pilot kg/s	Fuel Flow - Main kg/s	Fuel Flow-Total kg/s	Fuel Temperature K	Inlet Total Temperature - K	Inlet Total Pressure- atm	Reference Velocity- m/s	Pattern Factor	Inlet Air Humidity g/kg air	Fuel-Air Ratio (Metered)	Fuel-Air Ratio (Carbon Balance)	CO <sub>2</sub> - % Volume	O <sub>2</sub> - % Volume	CO (EI)	THC (EI)	NO <sub>x</sub> (EI)	Gas Sample Combustion Efficiency	SAE Smoke Number	Comments
58	8.79	6.76	.0607	.0953	.1560	289.	767.	6.82	24.4	-	1.87	.0233	.0263	5.4	12.2	28.9	.8	14.1	99.2	-	
118	8.82	6.85	.0769	.0760	.1529	290.	763.	6.80	24.7	-	1.89	.0225	.0246	4.8	12.5	46.7	3.8	15.2	98.5	-	
108	8.77	6.94	.0411	.0949	.1360	290.	766.	6.63	25.6	-	1.91	.0197	.0227	4.5	13.5	50.3	2.5	11.2	98.5	-	
98	8.77	6.83	.0278	.1079	.1357	290.	767.	6.89	24.4	-	1.92	.0200	.0232	4.2	13.5	87.9	57.6	10.6	91.2	-	
88	8.82	6.86	.0138	.1277	.1415	290.	767.	6.93	24.4	-	1.91	.0207	.0252	4.8	12.7	62.7	24.0	12.7	95.7	-	
710	8.77	6.82	.0468	.0726	.1195	290.	765.	6.82	24.4	-	1.88	.0176	.0196	3.8	14.6	71.0	15.6	8.5	96.5	-	
128	4.46	3.47	.0303	.0470	.0773	290.	765.	3.48	24.4	-	1.82	.0223	.0264	5.1	12.2	62.8	1.2	9.8	98.4	-	SLTO at reduced pressure
138	8.70	6.94	.0289	.0717	.1018	292.	830.	6.83	27.1	-	1.67	.0210	.0253	4.7	12.8	71.3	51.0	14.2	92.4	-	AST
148	10.27	8.18	.0330	.0330	.1155	291.	834.	6.92	32.3	-	1.62	.0204	.0246	4.7	12.8	61.9	15.6	13.4	96.7	-	AST
7100	8.71	6.87	.0228	.0574	.0802	291.	772.	6.80	25.0	.49	1.46	.0170	-	-	-	-	-	-	-	-	
7115	8.69	6.80	.0231	.0658	.0889	292.	773.	6.84	24.7	.58	1.46	.0170	-	-	-	-	-	-	-	-	
21A	4.89	3.69	.0488	-	.0488	284.	444.	2.87	18.3	-	1.92	.0108	.0100	2.0	17.4	15.5	3.4	3.5	99.2	-	
21B	4.87	3.68	.0489	-	.0489	284.	434.	2.85	18.0	1.05	-	.0108	-	-	-	-	-	-	-	-	
32	4.94	3.71	.0416	-	.0416	284.	424.	2.88	17.4	-	2.01	.0091	.0079	1.5	18.5	115.9	88.4	2.2	86.9	-	
43	4.93	3.67	.0623	-	.0623	284.	424.	2.87	17.4	-	2.03	.0138	.0125	2.5	16.4	50.7	1.4	4.3	98.6	-	
710A	8.79	6.92	.0470	.0736	.1207	287.	765.	6.93	24.4	-	2.04	.0175	.0216	4.2	13.8	47.5	12.2	7.0	97.5	-	
710B	8.75	6.93	.0470	.0746	.1216	288.	765.	6.92	24.4	.58	-	.0177	-	-	-	-	-	-	-	-	
69	8.84	6.97	.0536	.0835	.1370	289.	767.	6.88	25.0	-	1.93	.0198	.0225	4.5	13.1	31.7	3.5	11.1	98.8	-	

Comment

LBO f/a = .0067 at design idle conditions.

### TEST RESULTS FOR STAGED PREMIX COMBUSTOR CONFIGURATION P5

Point Number	Airflow-Total kg/s	Airflow-Combustor kg/s	Fuel Flow - Pilot kg/s	Fuel Flow - Main I <sup>a</sup> kg/s	Fuel Flow - Main II <sup>b</sup> kg/s	Fuel Flow-Total kg/s	Fuel Temperature K	Inlet Total Temperature - K	Inlet Total Pressure-atm	Reference Velocity-m/s	Pattern Factor	Inlet Air Humidity g/kg air	Fuel-Air Ratio (Metered)	Fuel-Air Ratio (Carbon Balance)	CO <sub>2</sub> % Volume	O <sub>2</sub> % Volume	CO (EI)	THC (EI)	NO <sub>x</sub> (EI)	Gas Sample Combustion Efficiency	SAE Smoke Number	Comments
9800	8.78	6.94	.0258	.0679	.0570	.1507	293.	763.	6.82	25.0	-	1.74	.0217	.0273	5.1	11.5	76.3	37.2	10.7	93.9	-	
9800	8.72	6.86	.0253	.0658	.0504	.1419	293.	762.	6.61	25.0	-	1.74	.0207	.0250	4.6	12.4	85.6	45.9	10.5	92.5	-	
9815	8.77	6.75	.0255	.0731	.0435	.1421	294.	767.	6.73	24.7	-	1.75	.0212	.0242	4.45	12.8	79.7	50.2	10.6	92.3	-	
9805	8.76	6.84	.0255	.0686	.0485	.1425	294.	765.	6.67	25.3	-	1.74	.0209	.0247	4.54	12.5	80.3	47.3	10.6	92.6	-	
9825	8.84	6.99	.0253	.0776	.0395	.1424	294.	763.	6.68	25.6	-	1.75	.0204	.0236	4.32	13.0	79.4	53.0	10.7	91.9	-	
9845	8.77	6.75	.0254	.0836	.0336	.1426	294.	763.	6.75	24.4	-	1.75	.0212	.0231	4.20	13.3	81.6	58.2	10.2	91.3	-	
9875	8.83	7.01	.0255	.0588	.0584	.1426	292.	766.	6.76	25.3	-	1.73	.0204	.0256	4.71	12.4	84.2	43.9	10.3	92.9	-	

Comment

LBO f/a = .0067 at design idle conditions

<sup>a</sup>Secondary I refers to the six secondary injectors adjacent to struts and rig sidewalls.  
<sup>b</sup>Secondary II refers to the 4 secondary injectors in the middle of the secondary premix passage.

### TEST RESULTS FOR STAGED PREMIX COMBUSTOR CONFIGURATION P7

Point Number	Airflow-Total kg/s	Airflow-Combustor kg/s	Fuel Flow - Pilot kg/s	Fuel Flow - Main kg/s	Fuel Flow-Total kg/s	Fuel Temperature K	Inlet Total Temperature - K	Inlet Total Pressure-atm	Reference Velocity-m/s	Pattern Factor	Inlet Air Humidity g/kg air	Fuel-Air Ratio (Metered)	Fuel-Air Ratio (Carbon Balance)	CO <sub>2</sub> % Volume	O <sub>2</sub> % Volume	CO (EI)	THC (EI)	NO <sub>x</sub> (EI)	Gas Sample Combustion Efficiency	SAE Smoke Number	Comments
43	7.61	5.29	.0772	-	.0772	294.	462.	3.71	21.6	-	1.91	.0179	.0128	2.6	16.7	24.8	1.4	3.4	99.3	-	
32	8.06	5.64	.0833	-	.0833	294.	457.	3.76	22.6	-	1.91	.0182	.0131	2.6	16.8	28.5	1.3	3.2	99.2	-	
32	7.85	5.41	.0868	-	.0868	292.	457.	3.70	22.3	-	1.86	.0197	.0146	2.9	16.5	30.5	1.0	3.2	99.2	-	
32	7.85	5.43	.0867	-	.0867	292.	458.	3.70	22.3	-	1.84	.0107	.0147	2.9	16.5	32.0	0.9	3.3	99.1	-	
58	8.74	6.60	.0634	.0967	.1601	292.	766.	6.84	23.5	-	1.77	.0244	.0312	6.2	10.6	12.1	5.41	9.4	99.1	0	
69	8.78	6.48	.0547	.0818	.1365	292.	767.	6.99	22.6	-	1.75	.0212	.0257	4.1	13.5	39.4	196.5	2.6	76.1	-	
88	8.75	6.62	.0468	.1091	.1560	293.	767.	6.84	23.8	-	1.71	.0237	.0300	5.3	11.7	70.5	80.1	5.7	89.0	-	
88	8.76	6.59	.0672	.0889	.1562	293.	766.	6.93	23.2	-	1.70	.0239	.0305	6.0	11.3	15.4	15.5	8.2	97.8	-	
108	8.80	6.71	.0613	.0942	.1555	293.	764.	6.95	23.5	-	1.70	.0233	.0304	6.0	11.3	9.1	8.8	8.1	98.8	-	AST
118	8.71	6.58	.0603	.0944	.1546	295.	842.	6.67	26.8	-	1.70	.0236	.0249	6.0	11.4	7.1	4.0	10.7	99.4	0	

Acoustic Test Configuration

TEST RESULTS FOR STAGED PREMIX COMBUSTOR  
CONFIGURATION P8

Point Number	Airflow Total kg/s	Airflow-Combustor kg/s	Fuel Flow - Pilot kg/s	Fuel Flow - Main kg/s	Fuel Flow-Total kg/s	Fuel Temperature K	Inlet Total Temperature - K	Inlet Total Pressure- atm	Reference Velocity-m/s	Pattern Factor	Inlet Air Humidity g/kg air	Fuel-Air Ratio (Metered)	Fuel-Air Ratio (Carbon Balance)	CO <sub>2</sub> - % Volume	O <sub>2</sub> - % Volume	CO (EI)	THC (EI)	NO <sub>x</sub> (EI)	Gas Sample Combustion Efficiency	SAE Smoke Number	Comments
581	8.81	6.72	.0783	-	.0783	297.	770.	6.92	23.8	-	1.94	.0117	.0146	2.7	17.1	1.7	105.2	9.8	87.7	-	
582	8.84	6.75	.0608	-	.0608	296.	770.	6.72	24.7	-	1.93	.0090	.0109	2.2	18.2	4.6	31.6	4.6	96.2	-	
583	6.35	5.05	.0606	-	.0606	296.	770.	6.76	18.0	-	1.94	.0120	.0141	2.8	17.3	1.7	13.7	19.7	98.4	-	
584	6.33	4.98	.0457	-	.0457	296.	768.	6.82	17.4	-	1.89	.0092	.0106	2.1	18.3	1.6	13.2	8.7	98.4	-	
684	6.37	4.94	-	.1165	.1165	295.	770.	6.74	17.7	-	1.87	.0236	.0293	5.7	12.7	45.5	3.7	16.2	98.5	-	
6835	6.43	4.81	-	.0947	.0947	295.	771.	6.71	17.4	-	1.87	.0197	.0239	4.9	14.0	13.0	3.1	16.4	98.3	-	
683	6.31	4.69	-	.0742	.0742	295.	767.	6.80	16.5	-	1.87	.0159	.0184	3.5	15.9	27.9	60.2	11.9	92.3	-	
681	8.69	6.56	-	.1593	.1593	295.	768.	6.76	23.8	-	1.94	.0243	.0305	6.0	12.2	41.4	4.0	13.1	98.6	-	
682	8.74	6.59	-	.1264	.1264	295.	768.	6.86	23.5	-	1.94	.0192	.0243	4.9	14.1	11.0	3.2	13.0	99.4	-	
685	8.64	6.63	-	.1025	.1025	295.	770.	7.09	22.9	-	1.93	.0155	.0140	1.7	17.5	39.8	402.3	.2	52.1	-	
6850	8.76	6.71	-	.1015	.1015	294.	769.	6.48	25.6	-	1.91	.0152	.0133	1.9	17.8	37.6	288.1	3.2	65.4	-	
11	6.38	4.36	.0609	-	.0609	296.	459.	3.68	17.4	-	2.40	.014	.0120	2.4	17.9	18.6	2.6	3.1	99.3	-	
11	6.55	4.52	.0606	-	.0606	295.	460.	3.69	18.0	.61	2.36	.0134	-	-	-	-	-	-	-	-	
28	7.87	6.59	.0615	.0963	.1578	297.	773.	6.83	23.8	-	2.01	.0240	.0312	6.0	12.11	17.1	26.9	6.6	98.8	-	
39	8.74	6.65	.0675	.1076	.1751	298.	775.	6.81	24.4	-	1.99	.0263	.0348	6.9	10.9	3.6	2.6	10.0	99.6	-	
410	8.24	6.54	.0553	.0848	.1401	298.	773.	6.77	23.8	-	1.97	.0215	.0268	3.5	14.7	291.2	205.2	1.3	69.1	1	
411	6.45	4.84	.0459	.0698	.1157	299.	773.	6.81	17.1	-	1.97	.0241	.0330	6.3	12.3	5.3	35.44	9.8	95.7	-	
411	6.46	4.84	.0443	.0699	.1141	298.	774.	6.81	17.1	-	1.96	.0236	.0326	6.4	12.1	5.1	18.7	10.3	96.4	-	
412	6.41	4.92	.0416	.0629	.1046	297.	773.	6.78	17.4	-	1.96	.0213	.0292	5.7	13.1	17.1	23.6	7.4	99.6	-	
88	8.71	6.59	.0616	.0961	.1577	296.	843.	6.83	26.2	-	1.94	.0239	.0320	6.3	12.4	3.2	12.4	8.9	98.5	0	AST

Acoustic Test Configuration

ORIGINAL PAGE IS  
OF POOR QUALITY

**TEST RESULTS FOR SWIRL VORBIK COMBUSTOR  
CONFIGURATION S2**

Point Number	Airflow-Total kg/s	Airflow-Combustor kg/s	Fuel Flow - Pilot kg/s	Fuel Flow - Main kg/s	Fuel Flow-Total kg/s	Fuel Temperature K	Inlet Total Temperature - K	Inlet Total Pressure-atm	Reference Velocity-m/s	Pattern Factor	Inlet Air Humidity g/kg air	Fuel-Air Ratio (Metered)	Fuel-Air Ratio (Carbon Balance)	CO <sub>2</sub> - % Volume	O <sub>2</sub> - % Volume	CO (EI)	THC (EI)	NO <sub>x</sub> (EI)	Gas Sample Combustion Efficiency	SAE Smoke Number
5A	4.51	3.47	.0452	-	.0452	285.	502.	2.91	29.4	-	1.6*	.0130	.0144	2.9	16.0	34.2	4.0	4.5	98.73	-
4B	4.66	3.57	.0474	-	.0474	286.	468.	2.93	28.4	-	1.6*	.0132	.0145	2.9	15.9	42.2	6.9	3.9	98.2	-
1B	4.98	3.81	.0491	-	.0491	285.	421.	2.95	27.0	-	1.6*	.0128	.0140	2.7	16.2	55.7	15.9	3.4	97.8	-
3B	4.89	3.71	.0640	-	.0640	285.	426.	2.92	27.0	-	1.6*	.0172	.0182	3.6	14.5	33.8	1.8	3.5	99.0	-
2B	4.86	3.75	.0335	-	.0335	285.	427.	2.89	27.5	-	1.6*	.0089	.0099	1.8	17.6	92.8	57.7	2.11	91.1	-
10A	8.75	6.78	.0323	.0571	.0894	285.	766.	6.82	37.9	-	1.6*	.0129	.0148	3.0	15.5	16.6	0.7	9.8	99.5	-
9B	8.69	6.70	.0433	.0800	.1234	286.	768.	6.74	37.4	-	1.6*	.0184	.0204	4.1	13.7	4.4	0.1	11.8	99.6	-
6	9.59	7.22	.0606	.1071	.1677	282.	645.	6.72	34.6	-	1.6*	.0232	.0250	5.0	12.3	16.5	0.1	7.7	99.6	-
7	9.24	7.04	.0582	.1034	.1617	282.	698.	6.76	36.0	-	1.6*	.0229	.0250	5.0	12.5	11.7	0.0	9.8	99.7	-
8	8.64	6.71	.0557	.0988	.1546	282.	767.	6.71	38.4	-	1.6*	.0230	.0252	5.0	12.2	9.9	0.0	12.4	99.8	-
11A	8.80	6.73	.0407	.1130	.1538	283.	767.	6.80	37.9	-	1.6*	.0226	.0243	4.9	12.5	11.5	0.1	11.2	99.7	-
11B	8.61	6.56	.0502	.1104	.1607	283.	763.	6.74	37.0	-	1.6*	.0244	.0257	5.2	11.9	13.0	0.1	12.7	99.7	-
12	8.77	6.69	.0730	.0814	.1545	283.	766.	6.74	37.9	-	1.6*	.0229	.0250	5.0	12.3	5.7	0.0	14.8	99.9	-
5B	4.51	3.47	.0452	-	.0452	285.	504.	2.93	29.7	0.36	1.6*	.0130	-	-	-	-	-	-	-	-
4A	4.70	3.60	.0474	-	.0474	286.	469.	2.93	28.7	0.40	1.6*	.0131	-	-	-	-	-	-	-	-
1A	4.98	3.81	.0494	-	.0494	285.	426.	2.95	27.4	0.38	1.6*	.0129	-	-	-	-	-	-	-	-
3A	4.88	3.70	.0640	-	.0640	285.	426.	2.90	22.5	0.45	1.6*	.0172	-	-	-	-	-	-	-	-
2A	4.89	3.78	.0334	-	.033	285.	425.	2.90	27.6	0.29	1.6*	.0088	-	-	-	-	-	-	-	-
10B	8.78	6.91	.0326	.0573	.0881	285.	763.	6.81	38.7	0.40	1.6*	.0128	-	-	-	-	-	-	-	-
9A	8.71	6.75	.0449	.0794	.1245	286.	768.	6.78	38.2	0.54	1.6*	.0182	-	-	-	-	-	-	-	-

\*Estimate

Comment

LBO f/a = .0056 at nominal idle conditions

**ORIGINAL PAGE IS  
OF POOR QUALITY**

**TEST RESULTS FOR SWIRL VORBIK COMBUSTOR  
CONFIGURATION S3**

Point Number	Airflow-Total kg/s	Airflow-Combustor kg/s	Fuel Flow - Pilot kg/s	Fuel Flow - Main** kg/s	Fuel Flow-Total kg/s	Fuel Temperature K	Inlet Total Temperature- K	Inlet Total Pressure-atm	Reference Velocity-m/s	Pattern Factor	Inlet Air Humidity g/kg air	Fuel-Air Ratio (Metered)	Fuel-Air Ratio (Carbon Balance)	CO <sub>2</sub> - % Volume	O <sub>2</sub> - % Volume	CO (EI)	THC (EI)	NO <sub>x</sub> (EI)	Gas Sample Combustion Efficiency	SAE Smoke Number	Comments	
1B	4.97	3.79	.0487	-	.0487	295.	431.	3.00	27.0	.45	1.6*	.0129	-	-	-	-	-	-	-	-	-	-
51B	9.56	7.27	.0577	.1015	.1592	295.	611.	6.46	34.0	.65	1.6*	.0219	-	-	-	-	-	-	-	-	-	-
1A	4.89	3.72	.0488	-	.0488	294.	431.	2.98	26.6	-	1.6*	.0133	.0169	3.3	15.9	33.9	3.1	3.5	98.8	-	-	-
32	4.92	3.82	.0316	-	.0316	296.	431.	2.90	28.0	-	1.6*	.0083	.0102	1.9	17.9	91.1	51.6	1.4	91.8	-	-	-
43	4.96	3.78	.0600	-	.0600	297.	432.	2.91	28.0	-	1.6*	.0159	.0206	4.1	14.4	19.7	0.3	3.4	99.5	-	-	-
61	3.73	2.88	.0364	-	.0364	296.	427.	2.90	32.1	-	1.6*	.0126	.0162	3.2	15.7	37.6	0.9	3.6	99.0	-	-	-
51A	6.16	4.68	.0597	-	.0597	296.	427.	2.91	35.1	-	1.6*	.0128	.0153	3.0	16.2	47.4	0.4	2.9	98.8	-	-	-
78	8.77	6.80	.0574	.1016	.1589	300.	769.	6.79	36.5	-	1.6*	.0234	.0282	5.6	11.9	6.0	0.2	15.5	99.8	6	-	-
89	8.75	6.83	.0449	.0817	.1265	304.	767.	6.78	38.4	-	1.6*	.0185	.0226	4.6	13.8	4.9	0.1	14.0	99.9	-	-	-
110	8.65	6.73	.0311	.0581	.0892	305.	777.	6.74	38.4	-	1.6*	.0133	.0154	3.1	16.1	7.3	0.1	11.5	99.9	-	-	-
1211	8.1	6.54	.0149	.1170	.1546	307.	777.	6.80	57.0	-	1.6*	.0236	.0276	5.5	12.1	7.8	0.0	13.8	99.9	-	-	-
1312	8.54	6.57	.0715	.0834	.1549	308.	788.	6.76	37.9	-	1.6*	.0236	.0288	5.8	11.7	5.1	0.0	18.5	99.9	-	-	-
148	8.62	6.65	.0571	.1013	.1584	311.	843.	6.80	41.2	-	1.6*	.0239	.0276	5.5	12.4	5.0	0.1	20.5	99.9	-	-	AST
158	9.73	7.73	.0650	.1176	.1826	313.	841.	6.82	48.3	-	1.6*	.0236	.0273	5.5	12.4	5.5	0.2	19.0	99.8	-	-	AST
118	10.92	8.61	.0676	.1277	.1953	308.	765.	6.90	48.8	-	1.6*	.0227	.0254	5.1	13.1	7.0	0.3	12.6	99.8	-	-	-

\*Estimate

Comment

LBO f/s = .0034 at nominal idle condition

\*\*Seven Secondary injectors downstream of primary injector locations.



TEST RESULTS FOR SWIRL VORBIX COMBUSTOR  
CONFIGURATION S4

Point Number	Airflow-Total kg/s	Airflow-Combustor kg/s	Fuel Flow - Pilot kg/s	Fuel Flow - Main I *** kg/s (7 Nozzles)	Fuel Flow - Main I *** kg/s (6 Nozzles)	Fuel Flow-Total kg/s	Fuel Temperature K	Inlet Total Temperature - K	Inlet Total Pressure-atm	Reference Velocity-m/s	Pattern Factor	Inlet Air Humidity g/kg air	Fuel-Air Ratio (Metered)	Fuel-Air Ratio (Carbon Balance)	CO2 - % Volume	O2 - % Volume	CO (EI)	THC (EI)	NOx (EI)	Gas Sample Combustion Efficiency	SAE Smoke Number	Comments
21	4.88	3.72	.0477	-	-	.0477	300.	426.	2.91	26.6	.67	1.5*	.0127	-	-	-	-	-	-	-	-	-
810	8.91	6.86	.0469	.0436	.0364	.1269	289.	760.	6.81	38.4	.57	1.5*	.0185	-	-	-	-	-	-	-	-	-
21	4.87	3.72	.0479	-	-	.0479	300.	425.	2.91	27.0	-	1.53	.0127	.0154	3.0	15.2	49.2	13.6	3.7	97.2	-	-
43	4.88	3.69	.0613	-	-	.0613	300.	426.	2.93	26.6	-	1.53	.0164	.0198	3.9	13.7	33.7	2.9	3.7	98.9	-	-
32	4.90	3.77	.0317	-	-	.0317	301.	426.	2.93	27.0	-	1.53	.0083	.0096	1.7	18.3	101.6	71.0	2.5	89.3	-	-
68	8.59	6.53	.0851	.0522	.0439	.0961	291.	763.	6.80	36.5	-	1.48	.0232	.0298	6.0	10.4	10.0	0.0	13.7	99.8	29	-
79	8.94	6.881	.0446	.0423	.0362	.1231	289.	765.	6.81	38.4	-	1.36	.0179	.0223	4.5	13.6	4.0	-	12.8	99.9	-	-
810	9.00	6.98	.0322	.0310	.0253	.0885	290.	765.	6.90	38.4	-	1.34	.0127	.0156	3.2	15.8	9.9	0.2	11.1	99.7	-	-
8	8.98	7.02	.0469	.0442	.0355	.1267	289.	761.	6.89	38.4	-	1.34	.0181	.0227	4.6	13.2	3.9	0.1	13.3	99.9	-	-
98	10.62	8.21	.0680	.0666	.0564	.1911	288.	759.	6.86	46.4	-	1.37	.0233	.0295	5.9	10.6	9.9	0.0	12.9	99.8	-	-
108	7.65	5.98	.0467	.0458	.0365	.1290	290.	757.	6.85	32.6	-	1.43	.0216	.0273	5.5	11.4	7.8	0.1	15.4	99.8	-	-
148	8.85	6.88	.0661	.0354	.0281	.1296	290.	760.	6.79	38.4	-	1.52	.0189	.0240	4.8	12.8	3.0	0.1	16.1	99.9	-	-
138	8.80	6.79	.0398	.0484	.0420	.1302	290.	759.	6.82	37.5	-	1.54	.0192	.0236	4.8	12.8	5.9	0.1	12.6	99.8	-	-
128	8.78	6.81	.0259	.0568	.0485	.1311	290.	757.	6.86	37.5	-	1.57	.0193	.0236	4.8	12.6	10.6	0.2	11.3	99.7	-	-
118	8.76	6.77	.0153	.0631	.0552	.1336	290.	758.	6.86	37.5	-	1.61	.0198	.0236	4.7	13.1	27.2	1.3	10.1	99.8	-	-
1181	8.67	6.78	.0258	-	-	.0258	288.	758.	6.87	37.0	-	1.66	.0038	.0042	0.8	19.8	70.8	79.6	6.9	90.1	-	AST
158	8.73	6.77	.0232	.0702	.0598	.1532	291.	835.	6.73	42.1	-	1.86	.0226	.0275	5.5	11.7	9.5	0.0	14.4	99.0	-	AST
168	9.83	7.56	.0266	.0810	.0665	.1741	290.	833.	6.86	46.4	-	1.87	.0230	.0281	5.6	11.3	9.5	0.0	13.5	99.8	-	AST

Comment

LBO f/a = .0037 at nominal idle condition

\*Estimate

\*\*\*Seven Main Injectors Downstream of Pilot Injectors

\*\*\*Remaining Six Main Injectors

ORIGINAL PAGE IS  
OF POOR QUALITY

TEST RESULTS FOR SWIRL VORBIX COMBUSTOR  
CONFIGURATION S5

Point Number	Airflow-Total kg/s	Airflow-Combustor kg/s	Fuel Flow - Pilot kg/s	Fuel Flow - Main ** kg/s	Fuel Flow-Total kg/s	Fuel Temperature K	Inlet Total Temperature- K	Inlet Total Pressure-atm	Reference Velocity-m/s	Pattern Factor	Inlet Air Humidity g/kg air	Fuel-Air Ratio (Metered)	Fuel-Air Ratio (Carbon Balance)	CO <sub>2</sub> - % Volume	O <sub>2</sub> - % Volume	CO (EI)	THC (EI)	NO <sub>x</sub> (EI)	Gas Sample Consumption Efficiency	SAE Smoke Number
188	8.84	6.88	.0447	.0800	.1247	287.	757.	6.87	37.9	.58	1.5*	.0181	-	-	-	-	-	-	-	-
58	8.59	6.67	.0552	.0922	.1474	306.	765.	6.76	37.4	-	1.50	.0221	.0269	5.4	11.3	8.3	0.1	13.7	99.8	-
198	8.90	6.92	.0321	.0572	.0893	293.	758.	6.80	38.4	-	1.71	.0129	.0144	2.8	16.3	8.6	0.2	10.1	99.8	-
188	8.89	6.94	.0447	.0796	.1243	287.4	760.	6.91	37.9	-	1.75	.0179	.0211	4.3	14.0	4.0	0.0	12.6	99.9	-
18	4.37	3.37	.0273	.0491	.0764	292.	760.	3.42	37.4	-	1.97	.0225	.0267	5.3	12.0	21.6	0.0	11.0	99.5	-

SLTO at Reduced  
Pressure

\* Estimate  
\*\* Seven Main Injectors Downstream of Pilot Injector Locations

TEST RESULTS FOR SWIRL VORBIK COMBUSTOR  
CONFIGURATION S6

Point Number	Airflow-Total kg/s	Airflow-Combustor kg/s	Fuel Flow - Pilot kg/s	Fuel Flow - Main* kg/s	Fuel Flow-Total kg/s	Fuel Temperature K	Inlet Total Temperature - K	Inlet Total Pressure- atm	Reference Velocity- m/s	Pattern Factor	Inlet Air Humidity g/kg air	Fuel-Air Ratio (Metered)	Fuel-Air Ratio (Carbon Balance)	CO <sub>2</sub> - % Volume	O <sub>2</sub> - % Volume	CO (EI)	THC (EI)	NO <sub>x</sub> (EI)	Gas Sample Combustion Efficiency	SAE Smoke Number	Comments
69	8.81	6.79	.0446	.0800	.1246	285.	769.	6.85	37.9	S7	1.85	.0185	-	-	58.2	10.5	3.6	-	-	-	
21	4.83	3.65	.0486	-	.0486	282.	426.	2.94	26.1	-	1.75	.0132	.0153	3.0	15.7	58.2	83.0	2.8	97.4	-	
32	5.02	3.84	.0317	-	.0317	281.	422.	2.94	27.5	-	1.73	.0081	.0084	1.6	18.6	112.3	2.1	3.4	96.4	-	
43	4.94	3.71	.0623	-	.0623	281.	425.	2.95	26.6	-	1.50	.0166	.0204	4.0	14.3	49.9	2.1	3.4	98.6	-	
587	8.91	6.81	.0550	.0985	.1535	288.	761.	6.87	37.4	-	1.51	.0226	.0264	5.3	12.1	8.6	0.0	14.2	99.8	41	
69	8.81	6.77	.0446	.0797	.1243	285.	769.	6.85	37.9	-	1.51	.0184	.0211	4.3	14.2	4.4	0.0	13.2	99.9	-	
710	8.80	6.83	.0320	.0566	.0886	285.	766.	6.84	37.9	-	1.51	.0129	.0147	3.0	16.2	5.9	0.1	12.0	99.8	-	
118	8.85	6.81	.0410	.0971	.1381	285.	768.	6.92	37.4	-	1.51	.0203	.0233	4.7	13.2	5.9	0.0	13.8	99.9	-	
108	8.84	6.75	.0274	.1105	.1379	285.	770.	6.94	37.4	-	1.51	.0204	.0226	4.6	13.4	5.3	0.0	12.8	99.9	-	
98	8.67	6.62	.0135	.1272	.1407	285.	768.	6.99	36.0	-	1.51	.0213	.0228	4.6	13.4	13.6	0.2	11.3	99.7	-	
88	8.83	6.73	.0076	.1318	.1394	285.	766.	7.06	36.0	-	1.49	.0207	.0221	4.4	13.8	19.7	0.7	11.4	99.4	-	AST
128	8.70	6.67	.0131	.1320	.1451	284.	841.	6.69	42.1	-	1.42	.0218	.0236	4.8	13.5	6.7	0.0	14.4	99.8	-	AST
138	10.01	7.61	.0235	.1489	.1724	284.	839.	6.85	47.4	-	1.34	.0227	.0248	5.0	12.9	5.9	0.0	14.4	99.9	-	
148	8.68	6.79	.0130	-	.0130	289.	770.	6.93	37.9	-	1.36	.0019	.0026	0.5	20.2	101.5	45.1	8.2	92.3	-	

Comment

LBO f/z = .0044 at design idle condition

\*Seven Main injectors downstream of pilot injector locations.

TEST RESULTS FOR SWIRL VORBIK COMBUSTOR  
CONFIGURATION S7

Point Number	Airflow-Total kg/s	Airflow-Combustor kg/s	Fuel Flow - Pilot kg/s	Fuel Flow - Main kg/s	Fuel Flow-Total kg/s	Fuel Temperature K	Inlet Total Temperature - K	Inlet Total Pressure- atm	Reference Velocity- m/s	Pattern Factor	Inlet Air Humidity g/kg air	Fuel-Air Ratio (Metered)	Fuel-Air Ratio (Carbon Balance)	CO <sub>2</sub> - % Volume	O <sub>2</sub> - % Volume	CO (EI)	THC (EI)	NO <sub>x</sub> (EI)	Gas Sample Combustion Efficiency	SAE Smoke Number	Comments
69	8.7273	6.6856	.0441	.0831	.1272	288.	770.	6.83	37.4	-	1.6*	.0190	.0237	4.8	12.9	6.5	0.0	14.3	96.8	-	
58	8.8343	6.7831	.0525	.0999	.1525	288.	770.	6.81	38.4	-	1.67	.0225	.0284	5.7	11.2	10.7	0.0	14.1	99.7	-	
5813	8.9550	6.8621	.0557	.0533	.1519	291.	740.	6.80	37.4	-	1.62	.0221	.0264	5.7	12.1	10.2	0.0	12.3	99.8	-	
69	8.7082	6.6457	.0441	.0855	.1296	289.	770.	6.89	36.9	93	1.50	.0195	-	-	-	-	-	-	-	-	

Comment

LBO f/z = .0044 at nominal idle conditions

\*Estimate

ORIGINAL PAGE IS  
OF POOR QUALITY

TEST RESULTS FOR SWIRL VORBIX COMBUSTOR  
CONFIGURATION S8

Test Number	Airflow-Total kg/s	Airflow-Combustor kg/s	Fuel Flow - Pilot kg/s	Fuel Flow - Main kg/s	Fuel Flow-Total kg/s	Fuel Temperature K	Inlet Total Temperature - K	Inlet Total Pressure-atm	Reference Velocity-m/s	Pattern Factor	Inlet Air Humidity g/kg air	Fuel-Air Ratio (Metered)	Fuel-Air Ratio (Carbon Balance)	CO <sub>2</sub> - % Volume	O <sub>2</sub> - % Volume	CO (EI)	THC (EI)	NO <sub>x</sub> (EI)	Gas Sample Combustion Efficiency	SAE Smoke Number	Comments
21	6.99	5.29	.0527	-	.0527	291.	450.	3.73	31.7	-	1.88	.0100	.0120	2.4	17.0	33.8	1.8	5.3	99.0	-	
32	7.14	5.49	.0422	-	.0422	291.	472.	3.88	33.5	-	1.87	.0077	.0094	1.9	18.0	28.6	8.7	4.6	98.3	-	
32	7.16	5.48	.0422	-	.0422	291.	457.	3.83	31.2	58	1.87	.0077	-	-	-	-	-	-	-	-	
32	6.50	4.94	.0423	-	.0423	290.	459.	3.73	20.3	-	1.87	.0086	.0100	2.0	17.7	28.1	5.7	5.9	98.7	-	
32	5.742	4.36	.0380	-	.0380	290.	459.	3.74	26.6	-	1.87	.0087	.0102	2.0	17.6	23.3	4.3	6.7	98.9	-	
43	7.203	5.42	.0607	-	.0607	290.	456.	3.80	31.2	-	1.87	.0112	.0127	2.6	16.6	41.2	1.5	7.0	98.9	-	
2	7.14	5.10	.0394	.0703	.1097	293.	463.	3.65	31.2	-	2.67	.0217	.0218	3.8	13.6	123.0	66.1	1.7	89.4	-	
3	7.14	5.28	.0525	-	.0525	292.	462.	3.64	33.5	-	2.72	.0100	.0104	2.1	17.5	31.7	6.2	3.0	98.5	-	
4	7.18	5.28	.0570	-	.0570	292.	462.	3.70	33.1	-	2.71	.0108	.0113	2.3	17.2	32.0	3.6	3.8	98.8	-	
69	8.81	6.91	.0442	.0788	.1230	295.	752.	6.83	37.9	-	2.05	.0180	.0232	4.7	12.9	2.8	0.0	11.3	99.9	-	
710	8.86	6.94	.0316	.0584	.0901	297.	751.	6.83	37.9	-	2.03	.0131	.0168	3.4	15.9	11.0	0.2	9.0	99.7	-	
58	8.79	6.86	.0489	.0888	.1376	298.	750.	6.82	37.4	-	2.02	.0203	.0261	5.3	12.1	2.3	0.1	12.3	99.9	-	
1145	8.82	6.93	.0556	.0680	.1236	299.	753.	6.86	37.0	-	2.01	.0185	.0235	4.7	13.5	3.1	0.0	10.2	99.9	-	
920	8.722	6.84	.0249	.1000	.1249	299.	751.	6.83	32.4	-	2.00	.0185	.0238	4.8	13.4	4.8	0.0	9.1	99.9	-	
810	8.650	6.73	.0123	.1141	.1265	299.	748.	6.84	36.5	-	1.99	.0190	.0229	4.3	13.6	67.8	37.1	7.3	98.4	-	
1030	8.75	6.80	.0371	.0874	.1245	299.	750.	5.82	37.0	-	2.00	.0185	.0235	4.7	13.5	3.1	0.0	10.3	99.9	-	
128	8.92	6.94	.0250	.1055	.1255	297.	826.	6.81	42.1	-	2.01	.0183	.0216	4.4	13.7	2.9	0.0	11.9	99.9	2	AST
128	8.68	6.81	.0250	.1012	.1262	298.	841.	6.76	42.1	-	2.03	.0187	.0224	5.4	13.6	2.4	0.0	13.3	99.9	-	AST
815	8.82	6.71	.0188	.1076	.1264	298.	771.	6.74	38.4	-	2.06	.0150	.0204	4.0	14.4	34.4	3.0	8.2	98.8	-	
815	8.700	6.65	.0197	.1126	.1323	299.	769.	6.74	37.9	-	2.07	.0201	.0219	4.4	13.8	13.9	0.4	9.2	99.6	-	

Acoustic Test Configuration

TEST RESULTS FOR SWIRL VORBIK COMBUSTOR  
CONFIGURATION S9

Point Number	Airflow-Total kg/s	Airflow-Combustor kg/s	Fuel Flow - Pilot kg/s	Fuel Flow - Main kg/s	Fuel Flow-Total kg/s	Fuel Temperature K	Inlet Total Temperature - K	MeI Total Pressure-alm	Reference Velocity-m/s	Pattern Factor	Inlet Air Humidity g/kg air	Fuel-Air Ratio (Metered)	Fuel-Air Ratio (Carbon Balance)	CO2 - % Volume	O2 - % Volume	CC (EI)	THC (EI)	NOx (EI)	Gas Sample Combustion Efficiency	SAE Smoke Number	Comments
21	7.62	5.80	.0525		.0525	297.	458.	3.70	37.0	-	2.09	.0098	.0119	2.4	17.1	56.9	6.0	4.6	98.0	-	
32	7.79	5.97	.0389		.0389	296.	459.	3.71	37.9	-	1.99	.0065	.0085	1.7	17.9	54.2	27.7	3.5	95.5	-	
43	7.73	5.88	.0661		.0661	296.	456.	3.75	37.0	-	2.00	.0113	.0148	3.0	16.4	54.7	2.7	3.8	98.4	-	
69	8.65	6.96	.0445	.0810	.1255	295.	772.	6.84	39.3	-	1.90	.0181	.0222	4.7	14.1	3.6	0.1	11.2	99.9	-	
1145	8.70	6.84	.0567	.0682	.1249	295.	772.	6.82	38.8	-	1.91	.0183	.0221	4.5	14.0	2.4	0.2	13.5	99.9	-	
1030	8.69	6.75	.0375	.0873	.1248	295.	771.	6.82	38.4	-	1.91	.0185	.0219	4.4	14.0	5.1	1.5	10.3	99.9	-	
920	8.67	6.88	.0553	.1004	.1257	295.	772.	6.84	38.8	-	1.91	.0184	.0223	4.5	14.0	11.9	190.0	8.7	99.5	-	
810	8.69	7.55	.0124	.1137	.1261	295.	772.	6.78	43.0	-	1.91	.0168	.0226	3.5	15.3	178.	2.9	3.1	73.6	-	
710	8.67	6.89	.0318	.0578	.0896	295.	771.	6.85	38.8	-	1.90	.0150	.0152	3.1	16.4	7.5	0.5	6.9	99.5	-	
58	8.70	6.82	.0381	.0695	.1076	295.	772.	6.80	38.8	-	1.88	.0159	.0185	3.7	15.5	6.6	0.5	10.1	95.8	1	AST
128	8.85	7.11	.0249	.1013	.1262	295.	845.	6.91	43.5	-	1.83	.0179	.0216	4.4	14.3	6.5	0.5	12.7	99.8	6	
128	8.77	6.77	.0441		.0441	295.	773.	6.97	37.4	-	1.79	.0066	.0079	1.6	18.7	4.3	.5	20.7	99.8	-	
21	7.92	5.80	.0525		.0525	297.	-	3.70	36.5	0.52	2.01	.0110	.0091	-	-	-	-	-	-	-	
58	8.70	7.06	.0381	.0696	.1077	295.	771.	6.81	39.1	0.56	1.88	.0153	-	-	-	-	-	-	-	-	
58	6.70	6.70	.0381	.0696	.1077	295.	772.	6.82	37.9	0.51	1.87	.0161	-	-	-	-	-	-	-	-	

Comment

LBO f/a = .0044 at design idle condition

Acoustic Test Configuration

TEST RESULTS FOR SWIRL VORBITX COMBUSTOR  
CONFIGURATION S10

Point Number	Airflow-Total kg/s	Airflow-Combustor kg/s	Fuel Flow - Pilot kg/s	Fuel Flow - Main kg/s	Fuel Flow-Total kg/s	Fuel Temperature K	Inlet Total Temperature - K	Inlet Total Pressure-atm	Reference Velocity-m/s	Pattern	Inlet Air Humidity g/kg air	Fuel-Air Ratio (Metered)	Fuel-Air Ratio (Carbon Balance)	CO <sub>2</sub> - % Volume	O <sub>2</sub> - % Volume	CO (EI)	THC (EI)	NOx (EI)	Gas Sample Combustion Efficiency	SAB Smoke Number	Comments	
21	6.79	5.48	.0505		.0505	300.	454.	3.92	37.8		1.72	.0076	.0099	2.0		63.6	6.6	4.7	97.7			
43	6.55	5.29	.0635		.0635	300.	453.	3.80	36.9		1.72	.010	.0132	2.6		89.5	5.0	3.7	97.3			
32	6.57	5.30	.0386		.0386	300.	456.	3.80	37.2		1.71	.006	.0075	2.5		47.1	15.9	3.3	97.0			
710	8.60	6.88	.0318	.0578	.0896		765.	6.86	36.6		1.7*	.0133	.0159	3.3		20.0	1.3	9.1	99.4			
69	8.56	6.85	.0445	.0810	.1255		767.	6.88	36.3			.0187	.0225	4.9		142.0	0.2	12.9	99.9			
810	8.55	6.84	.0125	.1136	.1261		767.	6.84	36.3			.0189	.0225	3.7		9.4	0.8	8.1	99.7			
920	8.54	6.83	.0252	.1012	.1263		769.	6.84	36.3			.0189	.0225	5.1		3.3	0.4	10.8	99.9			
1030	8.58	6.87	.0384	.0880	.1264		768.	7.04	36.6			.0188	.0233	4.9		29.4	1.2	8.2	99.2			
710	8.79	6.74	.0319	.0566	.0885	307.	763.	6.25	37.8		1.83	.0132	.01557	3.1	16.0	7.7	0.2	9.9	99.8			
58	8.80	6.81	.0377	.0712	.1089	308.	768.	6.84	38.1		2.10	.0160	.0190	3.8	14.7	3.1	0.1	12.3	99.9	14		
69	8.80	6.77	.0440	.0794	.1234	308.	762.	6.96	36.9		2.00	.0182	.0214	4.3	13.8	3.1	0.1	9.9	99.8			
920	8.93	6.92	.0249	.1007	.1256	310.	764.	6.75	39.3		2.00	.0182	.0221	4.4	14.0	13.8	0.3	7.6	99.6			
1115	8.72	6.65	.0186	.1066	.1253	310.	762.	6.88	36.7		1.97	.0189	.0221	4.2	14.0	60.2	33.5	5.4	94.7		AST	
118	8.79	6.79	.0251	.0996	.1247	311.	834.	6.87	41.3		1.99	.0184	.0230	4.6	14.0	4.5	0.1	9.5	99.9		AST	
138	8.69	6.71	.0191	.0763	.0953	311.	837.	6.88	40.8		2.01	.0142	.0171	3.2	16.0	100.7	24.4	6.1	94.8		AST	
128	8.74	6.77	.0217	.0874	.1091	311.	838.	6.78	42.0		2.04	.0161	.0200	4.0	14.8	15.0	0.7	8.2	99.6		AST	
82	9.71	7.29	.0667	.0420	.1086	311.	521.	6.71	28.3		1.75	.0149	.0155	3.0	15.8	45.5	14.8	5.1	96.0			
82	9.98	7.67	.0664	.0425	.1088	302.	592.	6.89	33.0		1.84	.0142	.0162	3.2	16.0	65.0	8.1	7.7	97.5			
83	10.03	7.78	.0568	.0505	.1073	303.	605.	6.82	34.6		1.86	.0138	.0148	2.9	16.0	45.5	13.2	7.7	97.4			
93	8.80	7.04	.0235	.0938	.1173	303.	737.	6.89	29.6		1.3*	.0171	.0201	4.1		40.8	5.4	6.2	98.4			
96	8.78	7.03	.0351	.0841	.1192		739.	6.92	29.6		1.9*	.0173	.0205	4.3		11.6	0.5	8.7	99.7			
95	8.82	7.06	.0477	.0704	.1181		736.	6.92	29.5			.0171	.0204	4.3		8.8	0.1	11.8	99.9			
710	8.62	8.89	.0319	.0577	.0896		766.	6.88	30.4	49		.0132										AST
148	10.18	8.14	.0212	.1159	.1471		836.	6.90	41.4			.0185	.0223	4.7		9.4	0.1	8.5	99.9			
1120	8.61	6.89	.0253		.0248		768.	7.01	30.5			.0036	.0046	1.0		19.0	1.9	9.7	99.3			
158	7.43	5.94	.0218	.0855	.1073		841.	6.87	29.3			.0184	.0229	4.8		3.6	0.0	11.8	99.9		AST	

Comment

LBO f/a r .0041 design idle conditions

\*Estimate

## APPENDIX D

### NOMENCLATURE

EI	Emission Index ~ g pollutant/kg fuel
F/A	kg fuel/kg air in
H	Specific Humidity ~ gH <sub>2</sub> O/ kg dry air
LBO	Lean Blowout
P	Pressure ~ atm
PF	Pattern Factor
ΔP	Pressure Loss ~ atm
T	Temperature ~ K
V	Velocity ~ m/s
V <sub>ref</sub>	Combustor Reference Velocity ~ m/s
W <sub>a</sub>	Airflow ~ kg/s
W <sub>f</sub>	Fuel Flow ~ kg/s
M	Flow Parameter ~ kg√K/m <sup>2</sup> atm s
δ	Density ~ kg/m <sup>3</sup>
η <sub>c</sub>	Combustion Efficiency
φ, ER	Equivalency Ratio

### SUBSCRIPTS

b	Burner
s	Static Conditions
t	Total Condition
4	Compressor Exit Station (JT9D-7)
5	Turbine Inlet Station (JT9D-7)

## REFERENCES

1. Environmental Protection Agency: "Control of Air Pollution From Aircraft and Aircraft Engines; Emission Standards and Test Procedures for Aircraft," Federal Register 38 (136) Part II: 19076 (July 17, 1973).
2. Grobecker, A. J.; Coroniti, S. C.; and Cannon, R. H., Jr.: "Report of Findings - The Effects of Stratospheric Pollution By Aircraft, Executive Summary,": U. S. Department of Transportation, DOT-TST-75-50 December, 1974.
3. Roberts, R., and Goldberg, P.: "Low Emission Combustor Design for Aircraft Gas Turbine," 67th Annual APCA meeting, June 9-13, 1974.
4. Sofrin, T., and Ross, D. A.: "Noise Addendum Experimental Clean Combustor Program," Phase I Final Report, NASA CR-134820, October 1975.
5. "Procedure for the Continuous Sampling and Measurement of Gaseous Emissions From Aircraft Turbine Engines," SAE Aerospace Recommended Practice 1256, October 1971.
6. "Aircraft Gas Turbine Engine Exhaust Smoke Measurement," SAE Aerospace Recommended Practice 1179, May 1970.
7. Niedzwiecki, R. W., and Jones, R. E.: "Parametric Test Results of a Swirl Can Combustor," NASA TMX-68247, June, 1973.
8. Niedzwiecki, R. W., and Jones, R. E.: "Pollution Measurements of a Swirl-Can Combustor," NASA TMX-68160, November, 1972.
9. Niedzwiecki, R. W.; Trout, A. M.; and Mularz, E. J.: "Performance of a Swirl-Can Combustor at Idle Conditions," NASA TMX-2578, June, 1972.
10. Niedzwiecki, R. W., and Meyer, H. M.: "Performance of a Short Modular Turbojet Combustor Segment Using ASTM A-1 Fuel," NASA TN D-6167, February 1971.
11. Briehl, D. C., and Ingebo, R. D.: "Effect of Fuel Distribution and Flame Stabilization Techniques on Combustion Stability Limits for Swirl-Can Combustor Modules Burning ASTM A-1 Fuel," NASA TMX-2185. February 1971.
12. Niedzwiecki, R. W.; Juhasz, A. J.; and Anderson, D. N.: "Performance of a Swirl-Can Primary Combustor to Outlet Temperatures of 3600°F (2256°K)," NASA TMX-52902, September 1970.
13. Niedzwiecki, R. W.: "Preliminary Tests of a Simplified Modular Turbojet Combustor," NASA TN-D-5688, March, 1970.
14. Niedzwiecki, R. W., and Meyer, H. M.: "Performance of a 48-Module Swirl-Can Turbojet Combustor Segment at High Temperatures Using ASTM A-1 Fuel," NASA TN D-5597, December, 1969.



#### REFERENCES (Cont'd)

15. Niedzwiecki, R. W., and Jones, R. E.: "Combustion Stability of Single Swirl-Can Combustor Modules Using ASTM A-1 Liquid Fuel," NASA TN D-5436, October, 1969.
16. Butze, H. F.; Trout, A. M.; and Meyer, H. M.: "Performance of Swirl-Can Turbojet Combustors at Simulated Supersonic Combustor Inlet Conditions," NASA TN D-4996, January 1969.
17. Odgers, J., and Carrier, C.: "Modelling of Gas Turbine Combustors; Considerations of Combustion Efficiency and Stability," ASME 72 WA&GT-1, September, 1972.
18. Ozawa, R. I.: "Survey of Basic-Data on Flame Stabilization and Propagation for High Speed Combustion Systems," The Marquardt Company Technical Report, AFAPL-TR-70-81, January, 1971.