

140
NASA CONTRACTOR
REPORT

NASA CR-61386

SKYLAB EXPERIMENT PERFORMANCE
EVALUATION MANUAL

Appendix R: Experiment T020 Foot Controlled
Maneuvering Unit (MSFC)

By B. B. Tonetti
Teledyne Brown Engineering Company
Huntsville, Alabama

March 1972

FACILITY FORM 602	N72-27920	
	(ACCESSION NUMBER)	(THRU)
	70	G3
	(PAGES)	(CODE)
	61386	31
	(NASA CR OR TMX OR AD NUMBER)	(CATEGORY)

Prepared for

NASA-GEORGE C. MARSHALL SPACE FLIGHT CENTER
Marshall Space Flight Center, Alabama 35812

Reproduced by
NATIONAL TECHNICAL
INFORMATION SERVICE
U S Department of Commerce
Springfield VA 22151

70

1. REPORT NO. NASA CR-61386		2. GOVERNMENT ACCESSION NO.		3. RECIPIENT'S CATALOG NO.	
4. TITLE AND SUBTITLE Skylab Experiment Performance Evaluation Manual Appendix R: Experiment T020 Foot Controlled Maneuvering Unit (MSFC)				5. REPORT DATE March 1972	
				6. PERFORMING ORGANIZATION CODE	
7. AUTHOR(S) B. B. Tonetti				8. PERFORMING ORGANIZATION REPORT #	
9. PERFORMING ORGANIZATION NAME AND ADDRESS Teledyne Brown Engineering Company Huntsville, Alabama				10. WORK UNIT NO.	
				11. CONTRACT OR GRANT NO. NAS8-21804	
12. SPONSORING AGENCY NAME AND ADDRESS National Aeronautics and Space Administration Washington, D.C. 20546				13. TYPE OF REPORT & PERIOD COVERED Contractor Report	
				14. SPONSORING AGENCY CODE	
15. SUPPLEMENTARY NOTES Prepared for Astronautics Laboratory, Science and Engineering					
16. ABSTRACT This appendix contains a series of analyses for Experiment T020, Foot Controlled Maneuvering Unit (MSFC), to be used for evaluating the performance of the Skylab corollary experiments under preflight, inflight and post-flight conditions. Experiment contingency plan workaroud procedure and malfunction analyses are presented in order to assist in making the experiment operationally successful.					
17. KEY WORDS Skylab Experiments			18. DISTRIBUTION STATEMENT Unclassified - Unlimited		
19. SECURITY CLASSIF. (of this report) Unclassified		20. SECURITY CLASSIF. (of this page) Unclassified		21. NO. OF PAGES 70	22. PRICE \$3.00

ACKNOWLEDGEMENTS

The appendices to this manual are prepared by the following personnel:

Appendix M: Thomas, O. H., Experiment S-150, Galactic X-Ray Mapping, Teledyne Brown Engineering Company, Huntsville, Alabama, 1-14-72.

Appendix N: Purushotham, K. S., Experiment S-183, Ultraviolet Panorama, Teledyne Brown Engineering Company, Huntsville, Alabama, 3-9-72.

Appendix R: Tonetti, B. B., Experiment T-020, Foot Controlled Maneuvering Unit, Teledyne Brown Engineering Company, Huntsville, Alabama, 3-31-72.

APPENDIX R. EXPERIMENT T-020, FOOT CONTROLLED
MANEUVERING UNIT (MSFC)

Prepared By

B. B. Tonetti

/

TABLE OF CONTENTS

	Page
SECTION I. Experiment T-020, Foot Controlled Maneuvering Unit Pre-Flight Operations Evaluation Analysis	R-7
SECTION II. Experiment T-020, Foot Controlled Maneuvering Unit Interface Block Diagram .	R-29
SECTION III. Experiment T-020, Foot Controlled Maneuvering Unit Systems Diagram	R-31
SECTION IV. Experiment T-020, Foot Controlled Maneuvering Unit Data Requirements Summary	R-33
SECTION V. Experiment T-020, Foot Controlled Maneuvering Unit Data Request Forms	R-35
SECTION VI. Experiment T-020, Foot Controlled Maneuvering Unit Engineering Change Requests	R-43
SECTION VII. Experiment T-020, Foot Controlled Maneuvering Unit Evaluation Sequence	R-45
SECTION VIII. Experiment T-020, Foot Controlled Maneuvering Unit Malfunction and Contingency Plan Outline	R-58
SECTION IX. Experiment T-020, Foot Controlled Maneuvering Unit Malfunction Analyses . . .	R-64
SECTION X. Conclusions and Recommendations	R-66
REFERENCES	R-67

LIST OF ILLUSTRATIONS

Figure	Title	Page
R-1.	Experiment T-020, Foot Controlled Maneuvering Unit Functional Block Diagram	R-21
R-2.	Experiment T-020, Foot Controlled Maneuvering Unit Interface Block Diagram and Definition	R-30
R-3.	Experiment T-020, Foot Controlled Maneuvering Unit Systems Diagram	R-32

LIST OF TABLES

Table	Title	Page
R-I.	Experiment T-020, Foot Controlled Maneuvering Unit Pre-Flight Operation Evaluation Analysis . . .	R-8
R-II.	Experiment T-020, Foot Controlled Maneuvering Unit Data Requirements Summary	R-34
R-III.	Experiment T-020, Foot Controlled Maneuvering Unit Evaluation Sequence	R-46
R-IV.	Experiment T-020, Foot Controlled Maneuvering Unit Malfunction and Contingency Plan Outline - Experiment Preparation (P)	R-59
R-V.	Experiment T-020, Foot Controlled Maneuvering Unit Malfunction and Contingency Plan Outline - Experiment Operation (O)	R-62
R-VI.	Experiment T-020, Foot Controlled Maneuvering Unit Malfunction and Contingency Plan Outline - Experiment Termination (T)	R-63

DEFINITION OF SYMBOLS

Symbol	Definition
ALL	Test Pilot/Observer/Pilot
ASMU	Automatically Stabilized Maneuvering Unit
BA	Backpack Assembly
BATT	Battery
CDR	Commander
DAC	Data Acquisition Camera
FCMU	Foot Controlled Maneuvering Unit
FO	Functional Objective
FBD	Functional Block Diagram
g	Gravity
HHMU	Hand Held Maneuvering Unit
HOSC	Huntsville Operation Support Center
IVA	Intra-Vehicular Activity
MF	Mounting Fixture
MSFC	Marshall Space Flight Center
N ₂	Gaseous Nitrogen
OBS	Observer
OWS	Orbital Workshop
PA	Platform Assembly
P _{ft}	Total probability of failure
PGA	Propulsion Gas Assembly

DEFINITION OF SYMBOLS (Continued)

Symbol	Definition
PLT	Pilot
psia	Pounds per square inch absolute
psig	Pounds per square inch gage
P_s	Probability of success
PSS	Propellant Supply Subsystem
SPT	Scientist Pilot
SSS	Seat Support Structure
TBD	To be determined
TBS	To be supplied
TP	Test Pilot

SECTION I.

EXPERIMENT T-020, FOOT CONTROLLED MANEUVERING UNIT
PRE-FLIGHT OPERATIONS EVALUATION ANALYSIS

TABLE R-1. EXPERIMENT T-020, FOOT CONTROLLED MANEUVERING UNIT PRE-FLIGHT OPERATION EVALUATION ANALYSIS (Sheet 1 of 13)

FUNCTIONAL BLOCK NUMBER AND TITLE	EXPECTED RANGE AND DIMENSION OF VARIABLES			CRITICALITY CATEGORY NUMBER*	REMARKS
	MIN.	NOM.	MAX.		
3.0 Analyze and predict facet performance profile for Skylab Experiment T-020, Foot Controlled Maneuvering Unit.				N/A	Refer to functional item 3.1.
3.1 Make explicit statements about objectives in qualitative and quantitative terms.				N/A	The objectives of Experiment T-020 are: <ul style="list-style-type: none"> • Add to the knowledge of the design of simple maneuvering devices and determine their limitations using an experimental (test bed) device. • Obtain correlation between inflight and ground-based simulation experiments. • Obtain subjective comparison with other maneuvering experiments, Automatically Stabilized Maneuvering Unit (ASMU), and Hand Held Maneuvering Unit (HHMU). Reference documents 1 and 2.
3.1.1 Specify duration that the experiment is required to operate and provide useful information.				N/A	Experiment T-020 has an operational requirement of conducting 3 shirtsleeve runs and 2 pressure suit runs. These 5 runs, in addition to the preparation, debriefing, and other operational time requirements, total 772 min or approximately 13 hr. The operational time will be dispersed throughout the flight of SL-2 or SL-3. The actual flight time for each run is expected to last 30 min. The preparation, debriefing, and other operational time expenditures for each shirtsleeve run is 94 min, and for each pressure suit run 170 min. Reference documents 1 and 2.
3.1.2 Specify the type of criteria that are to be maximized or minimized.				N/A	Experiment results and conditions to be maximized: <ul style="list-style-type: none"> • Commonality of ground simulation and in-flight maneuvering tasks • Test subject comments • Ascertain subjective operational acceptability ratings assigned by the subjects • Sequence photography from the Foot Controlled Maneuvering Unit (FCMU) mounted camera and the Orbital Workshop (OWS) mounted camera. Reference documents 1, 2, and 3.

*Criticality Category Number Definition:

- Category I--Experiment and equipment whose failure could adversely affect crew safety.
- Category II--Experiment and equipment whose failure could result in not achieving a primary mission objective, but does not adversely affect crew safety.
- Category IIIa--Experiment and equipment whose failure could result in not achieving a secondary mission objective, but which does not adversely affect crew safety or preclude the achievement of any primary mission objective.
- Category IIIb--Experiment and equipment whose failure could not result in a loss of primary or secondary mission objectives and does not adversely affect crew safety.

TABLE R-1. EXPERIMENT T-020, FOOT CONTROLLED MANEUVERING UNIT PRE-FLIGHT OPERATION EVALUATION ANALYSIS (Sheet 2 of 13)

FUNCTIONAL BLOCK NUMBER AND TITLE	EXPECTED RANGE AND DIMENSION OF VARIABLES			CRITICALITY CATEGORY NUMBER	REMARKS
	MIN.	NOM.	MAX.		
3.1.3 Specify the percentage of acceptable max. /min. for each objective.	30%	45%	60%	N/A	<p>It is expected that a minimum performance value of approximately 50 percent of the total requirement will be acceptable. The Functional Objectives (FO) of Experiment T-020 are:</p> <ul style="list-style-type: none"> • FO-1 --Perform various maneuvers (Mode I) while flying the FCMU in shirtsleeves. • FO-2 --Perform various maneuvers (Mode II) while flying the FCMU suited. <p>Total percentage of acceptable max. /min. Reference document 4.</p>
3.1.4 Specify the experiment constraints:				N/A	<ul style="list-style-type: none"> • Musts --Ear protection must be provided for all crewmen during experiment operation. --A fully charged battery is required for each experiment operation. The battery charger for experiment M-509 will be used for charging the T-020 experiment. • Must Notes --Adequate lighting (20 ft candles from high intensity lights) is required. • Wants --The time between experiment runs of both T-020 and M-509 must be governed by a need to maintain the OWS cabin partial pressure of oxygen at 3.6 ± 0.3 psia and total pressure less than 5.4 psia to preclude cabin venting. • Don't Wants --The allowable cluster acceleration must not exceed 1×10^{-3} deg/sec² and 1.5×10^{-4} g along any axis. --The maximum allowable spacecraft rate must not exceed 6 deg/min about any axis. • Don't Wants --Experiments M-172, M-509, S-019, S-020, S-063, S-073, S-149, S-183, T-003, T-013, T-025, and T-027 cannot be performed during T-020 operation. • Don't Wants --Airflow in the OWS forward compartment shall be less than 15 ft/min and as uniform as possible. • Don't Wants --N/A <p>Reference documents 1 through 4.</p>

TABLE R-1. EXPERIMENT T-020, FOOT CONTROLLED MANEUVERING UNIT PRE-FLIGHT OPERATION EVALUATION ANALYSIS (Sheet 3 of 13)

FUNCTIONAL BLOCK NUMBER AND TITLE	EXPECTED RANGE AND DIMENSION OF VARIABLES		CRITICALITY CATEGORY NUMBER	REMARKS
	MIN.	NOM. MAX.		
<p>3.1.5 Specify experiment operational tolerances:</p> <ul style="list-style-type: none"> • Must • Must Nots • Wants • Don't Wants 			N/A	<p>Refer to functional item 3.1.4.</p>
<p>3.2 Define decision rules and success criteria for the experiment objectives.</p>			N/A	<p>If the experiment is lost, the probability of success (P_s) is equal to 0.0. If the experiment is compromised and minimum information is salvaged, $P_s = 0.1 \rightarrow 0.5$; if the maximum information is salvaged, $P_s = 0.5 \rightarrow 0.9$. If the experiment is complete as scheduled, $P_s = 1.0$. The success criteria are:</p> <ul style="list-style-type: none"> • Successful completion of prescribed modes of flight including attitude control, gross and precise maneuvering. • Adequate data to evaluate the performance and orientation of the FCMU.
<p>3.3 Specify the experiment priority (numerical statement) for a given Skylab flight designation.</p>			N/A	<p>Experiment T-020 is assigned a flight scheduling precedence priority number of 200. T-020 flight assignment scheduling is ill defined because of inconsistent documentation; but, it is expected that the experiment will be assigned to SL-3.</p> <p>Reference documents 1, 2, 4, and 5.</p>
<p>3.4 Briefly describe and list the major subsystems for Experiment T-020.</p>			N/A	<p>Refer to functional items 3.4.1 and 3.4.2.</p>
<p>3.4.1 Describe the major functions.</p>			N/A	<p>Crew members will fly the FCMU inside the forward compartment of the OWS.</p> <p>The FCMU is a framework with a saddle-type seat and restraining straps to hold the astronaut in the proper fixed position astride the unit. Two 4-nozzle thruster assemblies are attached to the framework outboard of the astronaut's seat, and canted away from the body by 15 deg. The thrusters provide translation accelerations on the order of 0.1 ft/sec² and nominal attitude accelerations of 4 deg/sec². The astronaut's feet are attached to</p>

TABLE R-1. EXPERIMENT T-020, FOOT CONTROLLED MANEUVERING UNIT PRE-FLIGHT OPERATION EVALUATION ANALYSIS (Sheet 4 of 13)

FUNCTIONAL BLOCK NUMBER AND TITLE	EXPECTED RANGE AND DIMENSION OF VARIABLES			CRITICALITY CATEGORY NUMBER	REMARKS
	MIN.	NOM.	MAX.		
3.4.1 (Concluded)					<p>individual pedal-type controllers by a foot-restraint system compatible with the shirtsleeve and pressure suit modes. An umbilical is permanently attached to the FCMU and connects the propellant gas supply in the backpack to the FCMU.</p> <p>The backpack consists of simple frame and harness, a propellant isolation valve, a harness clip assembly, the M-509 Propellant Supply Subsystem (PSS) and the M-509 battery. The harness clip assembly is used to turn the battery power to the DAC on and off and to activate the battery powered isolation valve.</p> <p>The Mounting Fixture (MF) stores the FCMU and Backpack Assembly (BA), not the PSS and battery, during launch and after experiment runs. The MF provides aids and restraints for mounting and dismounting the FCMU.</p> <p>Reference document 2.</p>
3.4.2 List the major components.				N/A	<p>The major subsystem components are:</p> <ul style="list-style-type: none"> • Mounting Fixture • Backpack Assembly • Platform Assembly (PA) • Seat Support Structure (SSS) <p>Reference documents 1, 2, and 6.</p>
3.5 Define the T-020 Experiment/ Carrier subsystem interface:				N/A	<p>A set of Functional Block Diagrams (FBD) is submitted as Figure R-1 and is used as a subsystem component listing. Critical subsystem components will be identified and evaluated for failure and correlated to possible experiment/carrier interface problems.</p>

TABLE R-1. EXPERIMENT T-020, FOOT CONTROLLED MANEUVERING UNIT PRE-FLIGHT OPERATION EVALUATION ANALYSIS (Sheet 5 of 13)

FUNCTIONAL BLOCK NUMBER AND TITLE	EXPECTED RANGE AND DIMENSION OF VARIABLES		CRITICALITY CATEGORY NUMBER	REMARKS
	MIN.	NOM. MAX.		
3.5 (Concluded) <ul style="list-style-type: none"> • Operational --Pointing and Control --Crew Safety --Sequence --Operability 				
3.5.2 Backpack Assembly (BF)			N/A	Refer to functional item 3.5.2.1.1.
3.5.2.1.1 Specify the total probability of failure (P_{ft}) for the pressure vessel.		nil	I	The pressure vessel is the major component of the M-509 PSS. It is used to provide gaseous nitrogen to the T-020 thrusters. The pressure vessel is physically attached to the T-020 BA and has a dual wall design. The inner wall is the actual pressure container and the external wall is a protection shell. The pressure vessel is designed to carry 1500 in. ³ at a nominal operating pressure of 300 psig. The probability of pressure vessel failure is considered remote; however, if the pressure vessel should rupture, the following interface is severely compromised: <ul style="list-style-type: none"> • Crew Safety --Pressure vessel rupture could result in crew injury or fatality. Damage to the crew or to critical components located in the forward compartment of the OWS could be caused by high velocity fragments from the ruptured pressure vessel or by FCMU collisions. The following cues can be used to determine the failure of the pressure vessel: <ul style="list-style-type: none"> • Explosive rupture will cause metal fragments to injure or kill the astronaut and observer, damage internal OWS systems and components, or cause possible mission abort conditions • Rupture or fracture of the pressure vessel, that is not considered explosive in nature, can impart an uncontrolled thrust vector to the manned experiment. This would cause the test pilot to become unstabilized and gyrate in an uncontrolled manner. Reference documents 1, 2, and 7.
3.5.2.1.4.5 Specify the P_{ft} for the low pressure regulator.		0.02	IIIa	The low pressure regulator reduces the high pressure from the pressure vessel to 145 ± 10 psig for exit through the thruster assemblies.

TABLE R-1. EXPERIMENT T-020, FOOT CONTROLLED MANEUVERING UNIT PRE-FLIGHT OPERATION EVALUATION ANALYSIS (Sheet 6 of 13)

FUNCTIONAL BLOCK NUMBER AND TITLE	EXPECTED RANGE AND DIMENSION OF VARIABLES		CRITICALITY CATEGORY NUMBER	REMARKS
	MIN.	NOM. MAX.		
3.5.2.1.4.5 (Concluded)				<p>If the low pressure regulator should fail, the following situation could occur:</p> <ul style="list-style-type: none"> • Mechanical <ul style="list-style-type: none"> --Failure of the regulator to reduce pressure will activate the PSS relief valve. The relief valve is activated at 205 ± 15 psig. --If the regulator fails in open or closed positions, another PSS could be substituted. This would require additional experiment time and could impact scheduling. <p>The following indication can be used to determine the failure of the low-pressure regulator:</p> <ul style="list-style-type: none"> • A loud noise is produced by the activation of the zero thrust PSS relief valve. <p>Reference documents 1 and 2.</p>
3.5.2.1.4.7 Specify the P_{ft} for the propellant system quick disconnect.		0.01	IIIa	<p>The propellant system quick disconnect is the interface between the M-509 PSS and the T-020 backpack isolation valve hose assembly.</p> <p>If the quick disconnect should fail, the following situation could occur:</p> <ul style="list-style-type: none"> • Mechanical <ul style="list-style-type: none"> --Leakage, due to improper fit, could introduce unwanted thrust vectors into the FCMU assembly. --Inability of the astronaut to connect the isolation valve hose assembly to the quick disconnect. <p>The following indications can be used to determine the failure of the propellant system quick disconnect:</p> <ul style="list-style-type: none"> • Physically unable to make the proper connection • Audible leakage from quick disconnect. <p>Reference documents 1 and 8.</p>
3.5.2.2 Specify the P_{ft} for the M-509 battery.		0.01	I	<p>The battery is provided by Experiment M-509. The battery receives charge from the M-509 battery charger. The battery provides power for the Data Acquisition Camera (DAC) in the SSS and power to activate the T-020 propellant isolation valve. The battery is rated at 28 Vdc and 6 A-hr.</p> <p>If the battery should fail, the following situation could occur:</p>

TABLE R-1. EXPERIMENT T-020, FOOT CONTROLLED MANEUVERING UNIT PRE-FLIGHT OPERATION EVALUATION ANALYSIS (Sheet 7 of 13)

FUNCTIONAL BLOCK NUMBER AND TITLE	EXPECTED RANGE AND DIMENSION OF VARIABLES		CRITICALITY CATEGORY NUMBER	REMARKS
	MIN.	NOM. MAX.		
3.5.2.2 (Concluded)				<ul style="list-style-type: none"> • Electrical <ul style="list-style-type: none"> --The DAC would not function or function improperly --The propellant isolation valve would fail to close. • Crew Safety <ul style="list-style-type: none"> --If the battery were to fail below TBD V while the Test Pilot (TP) was performing maneuvers, and a failure occurred in the pressure system downstream of the isolation valve, the TP would have no ability to immediately shut off the thrust. The TP may attempt to shut off the propellant by manually turning off the PSS supply valve; this would be difficult and require additional time the TP did not have considering the seriousness of his condition due to such a failure. <p>The following indications can be used to determine the failure of the battery:</p> <ul style="list-style-type: none"> • Improper charge reading from battery tester before installation • Failure of the DAC to operate • Failure of the isolation valve to close.
3.5.2.4.3 Specify the P_{ft} for the PSS supply valve.	0.01		IIIa	<p>The gas supply valve is an integral part of the M-509 PSS. This valve controls the flow of GN_2 propellant from the PSS to the propellant isolation valve hose assembly.</p> <p>The probability of PSS supply valve failure is small. If the supply valve should fail, the following situation could occur:</p> <ul style="list-style-type: none"> • Mechanical <ul style="list-style-type: none"> --The propellant flow from the PSS could not be controlled while out of the T-020 backpack --The pressure vessel could not be recharged. • Sequence <ul style="list-style-type: none"> --If the supply valve fails, another PSS could be substituted. <p>The following indications can be used to determine the failure of the PSS supply valve:</p> <ul style="list-style-type: none"> • Inability of the astronaut to open or close the valve handle • Improper thruster response, i.e., propellant flow in closed position or no propellant flow in open position. <p>Reference documents 1 and 2.</p>

TABLE R-1. EXPERIMENT T-020, FOOT CONTROLLED MANEUVERING UNIT PRE-FLIGHT OPERATION EVALUATION ANALYSIS (Sheet 8 of 13)

FUNCTIONAL BLOCK NUMBER AND TITLE	EXPECTED RANGE AND DIMENSION OF VARIABLES		CRITICALITY CATEGORY NUMBER	REMARKS
	MIN.	NOM. MAX.		
3.5.2.5 Specify the P_{ft} for the harness clip assembly.		0.01	I	<p>The harness clip assembly contains the propellant isolation valve activation switch and the on-off camera switch. The harness clip assembly places these switches within easy reach of the TP during experiment runs.</p> <p>If the switches should fail, the following situation could occur:</p> <ul style="list-style-type: none"> • Refer to functional item 3.5.2.2. <p>The following indications can be used to determine the failure of the harness clip assembly:</p> <ul style="list-style-type: none"> • Failure of the DAC to operate • Failure of the isolation valve to close. <p>Reference documents 1 and 9.</p> <p>The BA propulsion connection is the interface between the T-020 propellant isolation valve and the propulsion umbilical hose.</p> <p>If the propulsion connection should fail, the following situation could occur:</p> <ul style="list-style-type: none"> • Refer to functional item 3.5.2.1.4.7. <p>The following indication can be used to determine the failure of the propulsion connection:</p> <ul style="list-style-type: none"> • Refer to functional item 3.5.2.1.4.7. <p>Reference documents 1 and 9.</p> <p>The isolation valve hose assembly is the interface between the M-509 PSS quick disconnect and the T-020 propellant isolation valve. One hose end is permanently connected to the isolation valve; the other end mates with the propellant system quick disconnect.</p> <p>If the isolation valve hose assembly should fail, the following situation could occur:</p> <ul style="list-style-type: none"> • Mechanical <ul style="list-style-type: none"> --Rupture of this flex hose could result in crew injury due to violent motion and collision from rupture and possible whipping action of the hose.
3.5.2.8 Specify the P_{ft} for the BA propulsion connection.		0.01	IIIa	
3.5.2.10 Specify the P_{ft} for the isolation valve hose assembly.		0.01	I	

TABLE R-1. EXPERIMENT T-020, FOOT CONTROLLED MANEUVERING UNIT PRE-FLIGHT OPERATION EVALUATION ANALYSIS (Sheet 9 of 13)

FUNCTIONAL BLOCK NUMBER AND TITLE	EXPECTED RANGE AND DIMENSION OF VARIABLES			CRITICALITY CATEGORY NUMBER	REMARKS
	MIN.	NOM.	MAX.		
3.5.2.10 (Concluded)					<ul style="list-style-type: none"> • Crew Safety --Because the hose is upstream of the isolation valve, the TP has no ability to immediately shutoff the propellant. He may attempt to shutoff the propellant by manually turning off the PSS supply valve; this would be difficult and require additional time the TP did not have considering the seriousness of his condition due to such a failure. <p>The following indication can be used to determine the failure of the isolation valve hose assembly:</p> <ul style="list-style-type: none"> • Violent motion of FCMU and possible whipping action of the hose. <p>Reference documents 1 and 8.</p>
3.5.2.11 Specify the P_{ft} for the propellant isolation valve.		0.01		1	<p>The propellant isolation valve is an integral part of the T-020 BA and interfaces with the backpack propulsion connector and the isolation valve hose. The isolation valve allows the crew to shut off the flow of propellant from the isolation valve to the propulsion umbilical. The valve is electrically controlled by a switch on the harness clip assembly, which receives power from the battery in the backpack.</p> <p>If the propellant isolation valve should fail, the following situation could occur:</p> <ul style="list-style-type: none"> • Electrical --The isolation valve is normally in the open position; an electrical failure would not allow the TP to close the valve. • Crew Safety --The isolation valve allows the TP to quickly shut off the propellant in the event of a pressure system failure downstream of the isolation valve. If a pressure system failure occurred and the TP could not quickly shut off the propellant, he could be injured from collisions due to the uncontrolled gyrations caused by the escaping propellant. <p>The following indication can be used to determine the failure of the propellant isolation valve:</p> <ul style="list-style-type: none"> • When the isolation valve switch is activated, propellant continues to flow when the foot assemblies are cycled. <p>Reference documents 1 and 8.</p> <p>Refer to functional item 3.5.4.3.</p>
3.5.3 Platform Assembly (PA).				N/A	

S&E-ASTN-OI(6-71)

TABLE R-1. EXPERIMENT T-020, FOOT CONTROLLED MANEUVERING UNIT PRE-FLIGHT OPERATION EVALUATION ANALYSIS (Sheet 10 of 13)

FUNCTIONAL BLOCK NUMBER AND TITLE	EXPECTED RANGE AND DIMENSION OF VARIABLES			CRITICALITY CATEGORY NUMBER	REMARKS
	MIN.	NOM.	MAX.		
3.5.3.1 Specify the P_{ft} for the thrust control valve input propellant lines.		0.01		II	<p>The thrust control valve input propellant lines provide propellant to the thrust control valves from the SSS manifold.</p> <p>If a thrust control valve input propellant line should fail, the following situation could occur:</p> <ul style="list-style-type: none"> • Mechanical <ul style="list-style-type: none"> --A rupture or excessive leak from any of the lines would introduce unwanted thrust vectors and make the FCMU uncontrollable and inoperable. Crew safety would be unaffected because the TP could immediately activate the isolation valve, shutting off the propellant flow. <p>The following indication can be used to determine the failure of the thrust control valve input propellant lines:</p> <ul style="list-style-type: none"> • Uncontrollable gyrations of the FCMU assembly. <p>Reference documents 1 and 10.</p>
3.5.3.2 Specify the F_{ft} for the foot pedal assemblies.		nil		II	<p>The shoe plates, strapped to the TP's footwear, are attached to the foot pedal assemblies. By manipulating his feet on the foot pedal assemblies, the TP controls the motion of the FCMU.</p> <p>Because of the simplicity of design and components, the probability of failure is considered remote. If a foot pedal assembly should fail, the following situation could occur:</p> <ul style="list-style-type: none"> • Mechanical <ul style="list-style-type: none"> --Difficulty in cycling foot pedal assemblies • Operational <ul style="list-style-type: none"> --The TP would be unable to accurately control the movements of the FCMU. <p>The following indications can be used to determine the failure of the foot pedal assemblies:</p> <ul style="list-style-type: none"> • Difficulty in moving the foot plate of the foot pedal assembly, i. e., to raise or lower the heel, toe, or entire foot • Inability to achieve the proper maneuvers with the correct foot movements. <p>Reference documents 1 and 11.</p>

S&E-ASTN-OI(6-71)

TABLE R-1. EXPERIMENT T-020, FOOT CONTROLLED MANEUVERING UNIT PRE-FLIGHT OPERATION EVALUATION ANALYSIS (Sheet 11 of 13)

FUNCTIONAL BLOCK NUMBER AND TITLE	EXPECTED RANGE AND DIMENSION OF VARIABLES			CRITICALITY CATEGORY NUMBER	REMARKS
	MIN.	NOM.	MAX.		
3.5.3.3 Specify the P_{ft} for the thrust control valves.		0.05		II	<p>Four thrust control valves regulate the amount of propellant which flows to the thrusters. The thrust control valves are controlled by mechanical interfaces with the foot pedal assemblies. A thrust control valve is normally in the closed position. To actuate the valve, force is applied to the foot pedal assembly which is transferred to two pintle assemblies.</p> <p>If a thrust control valve should fail, the following situation could occur:</p> <ul style="list-style-type: none"> • Mechanical <ul style="list-style-type: none"> --Forces applied to the foot pedal assemblies would not produce the proper corresponding thruster activation --Free flow from thrusters. • Operational <ul style="list-style-type: none"> --The TP would be unable to accurately control the movements of the FCMU. <p>The following indications can be used to determine the failure of a thrust control valve:</p> <ul style="list-style-type: none"> • Inability to achieve the proper maneuvers with the correct foot movements • Audible free flow from thrusters. <p>Reference documents 1, 11, and 12.</p>
3.5.3.4 Specify the P_{ft} for the thrust control valve output propellant lines.		0.01		II	<p>The thrust control valve propellant output lines route the propellant from the thrust control valves to the thruster.</p> <p>If a line should fail, the following situation could occur:</p> <ul style="list-style-type: none"> • Refer to functional item 3.5.3.1. <p>The following indication can be used to determine the failure of a line:</p> <ul style="list-style-type: none"> • Refer to functional item 3.5.3.1. <p>Reference documents 1 and 10.</p>
3.5.4 Seat Support Structure (SSS).				N/A	<p>Refer to functional item 3.5.4.3.</p>

S&E-ASTN-OT(6-71)

TABLE R-1. EXPERIMENT T-020, FOOT CONTROLLED MANEUVERING UNIT PRE-FLIGHT OPERATION EVALUATION ANALYSIS (Sheet 12 of 13)

FUNCTIONAL BLOCK NUMBER AND TITLE	EXPECTED RANGE AND DIMENSION OF VARIABLES			CRITICALITY CATEGORY NUMBER	REMARKS
	MIN.	NOM.	MAX.		
3.5.4.3 Specify the P_{ft} for the propulsion umbilical.		0.01		II	<p>The propulsion umbilical routes the propellant from the backpack propulsion connector to the SSS. The propulsion umbilical is permanently attached to the SSS. It is connected by a dummy connector to the mounting fixture during launch and storage.</p> <p>If the propulsion umbilical should fail, the following situation could occur:</p> <ul style="list-style-type: none"> • Mechanical <ul style="list-style-type: none"> --Rupture or excessive leak in the umbilical or its connections would introduce unwanted thrust vectors and make the FCMU uncontrollable. Crew safety would be unaffected because the TP could immediately activate the isolation valve to a closed position and thereby stop propellant flow. <p>The following indications can be used to determine the failure of the propulsion umbilical.</p> <ul style="list-style-type: none"> • Uncontrollable gyrations of the FCMU assembly • Whipping motions of the umbilical • Audible evidence of leakage in line or at connection points. <p>Reference documents 1 and 13.</p>
3.5.4.6 Specify the P_{ft} for the split image mirror assembly.		0.03		II	<p>The split image mirror assembly is an integral part of the SSS. The mirror assembly is designed to provide pointing vector information for determining the orientation of the FCMU during maneuvers. This film constitutes a major source of experiment data. The information from the film will be used to correlate ground simulations with the inflight experiment runs.</p> <p>If the split image mirror assembly should fail, the following situation could occur:</p> <ul style="list-style-type: none"> • Mechanical <ul style="list-style-type: none"> --Breakage of the mirrors is considered remote; however, contamination of the surfaces of the mirrors will reduce the film resolution and corresponding film quality. <p>The following indications can be used to determine the failure of the split image mirror assembly:</p> <ul style="list-style-type: none"> • Examine the mirror for particle or condensation contamination • Examine the return film taken by the DAC in the SSS. <p>Reference documents 1 and 13.</p>

TABLE R-1. EXPERIMENT T-020, FOOT CONTROLLED MANEUVERING UNIT PRE-FLIGHT OPERATION EVALUATION ANALYSIS (Sheet 13 of 13)

FUNCTIONAL BLOCK NUMBER AND TITLE	EXPECTED RANGE AND DIMENSION OF VARIABLES		CRITICALITY CATEGORY NUMBER	REMARKS
	MIN.	NOM. MAX.		
3.5.4.7 Specify the P_{ft} for the Data Acquisition Camera (DAC).		0.01	II	<p>The DAC is placed in the SSS and is used in cooperation with the split image mirror assembly to provide pictures for determining FCMU orientation.</p> <p>If the DAC should fail, the following situation could occur:</p> <ul style="list-style-type: none"> • Data <ul style="list-style-type: none"> -- Loss of the DAC due to electrical or mechanical malfunction will result in the loss of a primary source of experiment data. <p>The following indications can be used to determine the failure of the DAC:</p> <ul style="list-style-type: none"> • Cannot start DAC • Camera starts and immediately stops. <p>Reference documents 1, 2, and 14.</p>
3.5.4.7.1 Specify the P_{ft} for the color interior film SO-168.		0.5	II	<p>Color interior film SO-168 will be used for both the DAC in the SSS and the camera in the forward dome. The film will be used to evaluate the performance of the FCMU and to obtain information for correlating ground simulations of the FCMU with actual zero-g flights.</p> <p>If the film should fail, the following situation could occur:</p> <ul style="list-style-type: none"> • Data <ul style="list-style-type: none"> -- The film for this experiment is subject to degradation due to radiation fogging and low light levels. The pictures, which will result from these anticipated conditions, are expected to be of dubious quality, but may be acceptable for engineering purposes. <p>The following indications can be used to determine the failure of the film:</p> <ul style="list-style-type: none"> • Higher than anticipated radiation levels in orbit • Examination of the film upon return. <p>Reference documents 1, 2, and 15.</p>

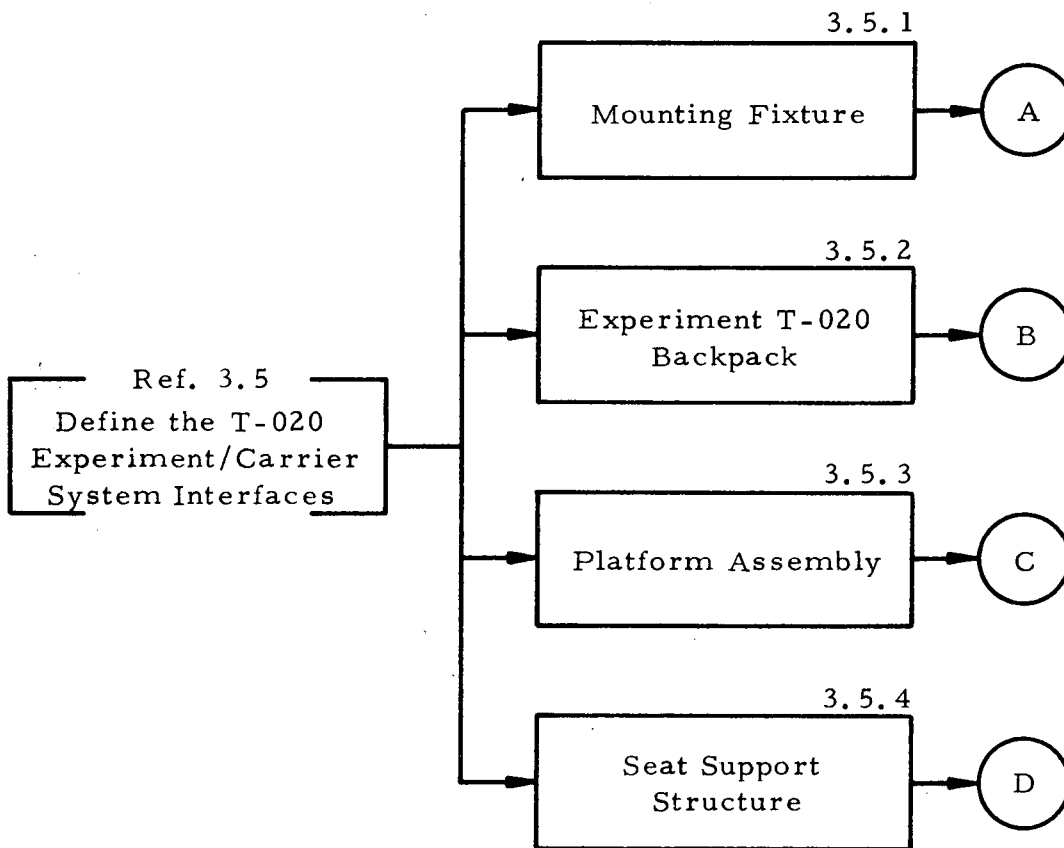

FIGURE R-1. EXPERIMENT T-020, FOOT CONTROLLED MANEUVERING UNIT FUNCTIONAL BLOCK DIAGRAM (Sheet 1 of 8)

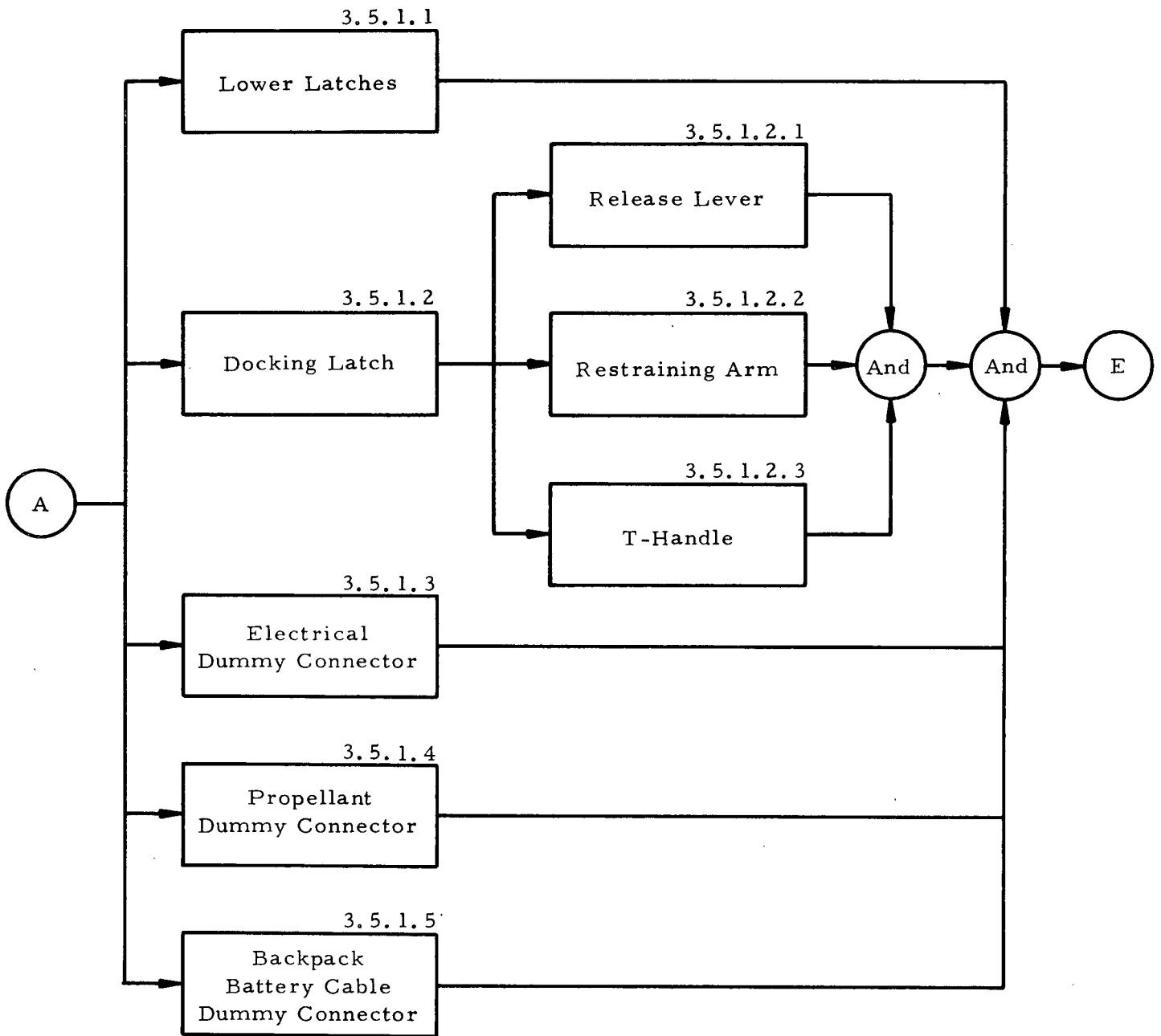

FIGURE R-1. EXPERIMENT T-020, FOOT CONTROLLED MANEUVERING UNIT FUNCTIONAL BLOCK DIAGRAM (Sheet 2 of 8)

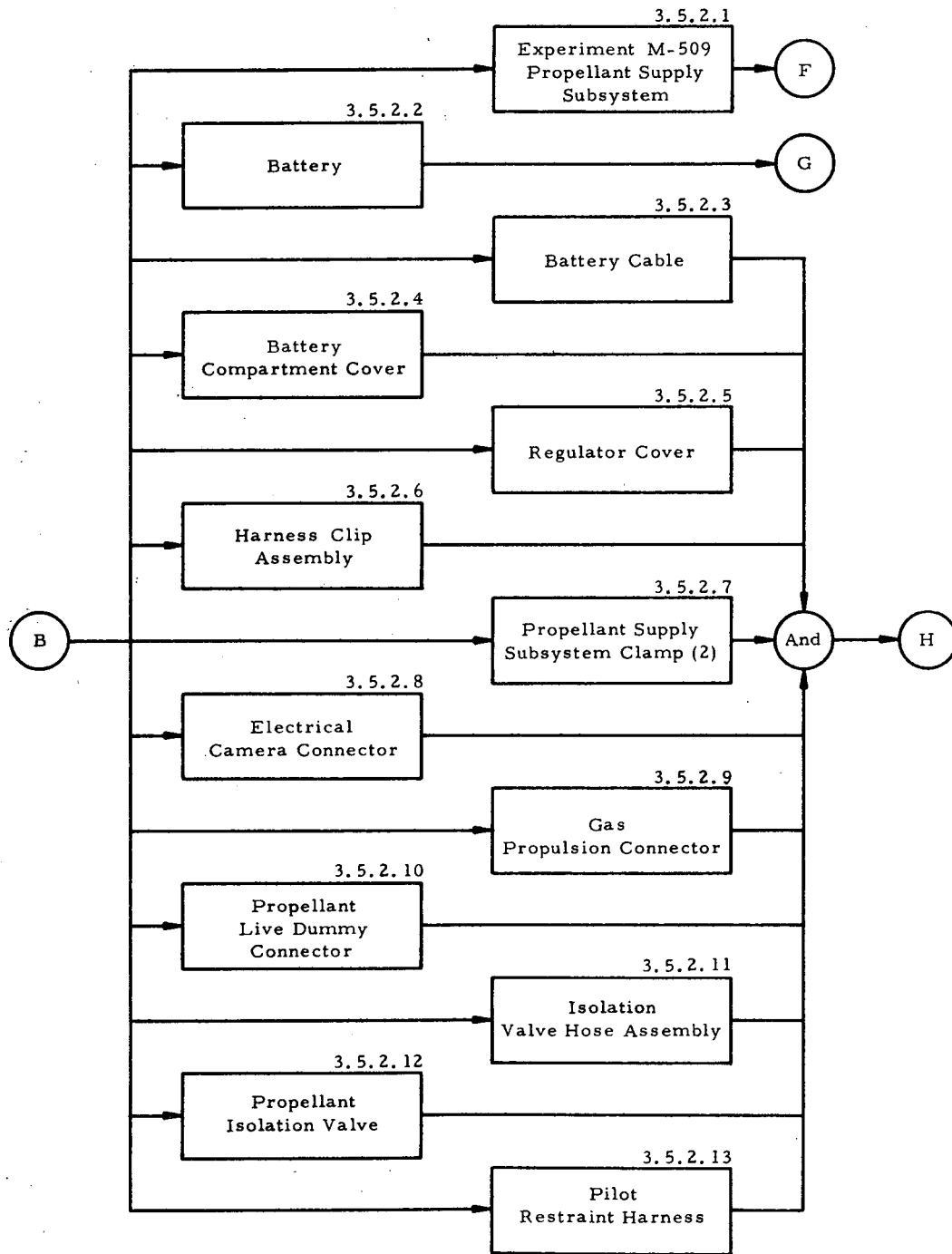

FIGURE R-1. EXPERIMENT T-020, FOOT CONTROLLED MANEUVERING UNIT FUNCTIONAL BLOCK DIAGRAM (Sheet 3 of 8)

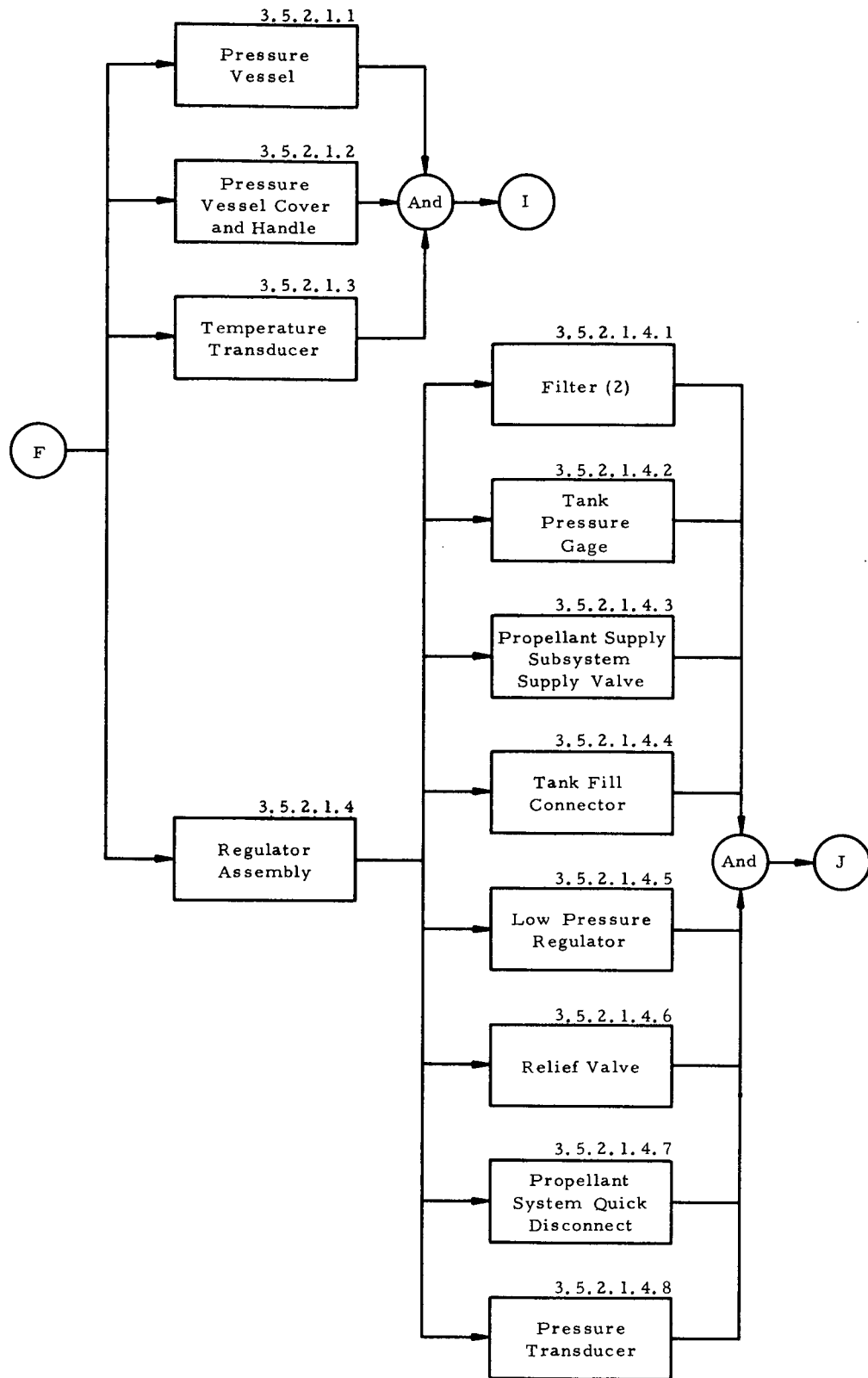

FIGURE R-1. EXPERIMENT T-020, FOOT CONTROLLED MANEUVERING UNIT FUNCTIONAL BLOCK DIAGRAM (Sheet 4 of 8)

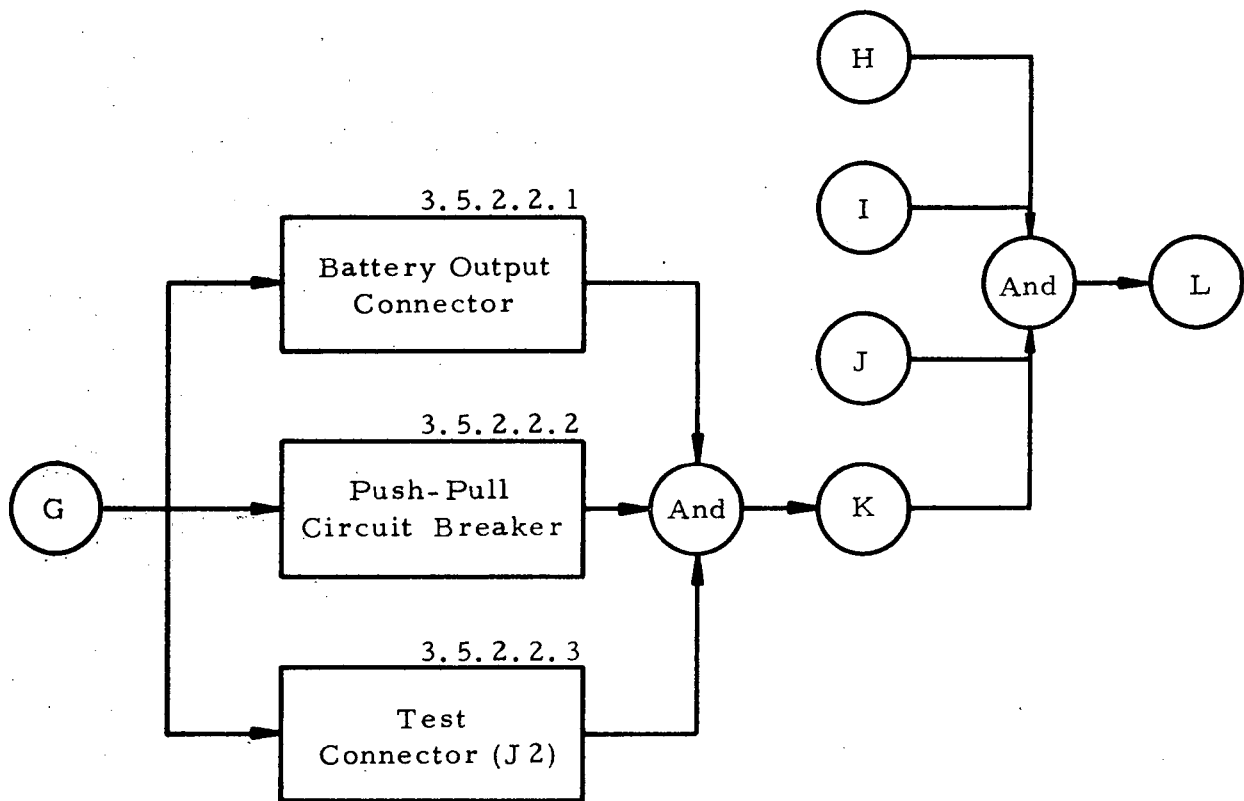

FIGURE R-1. EXPERIMENT T-020, FOOT CONTROLLED MANEUVERING UNIT FUNCTIONAL BLOCK DIAGRAM (Sheet 5 of 8)

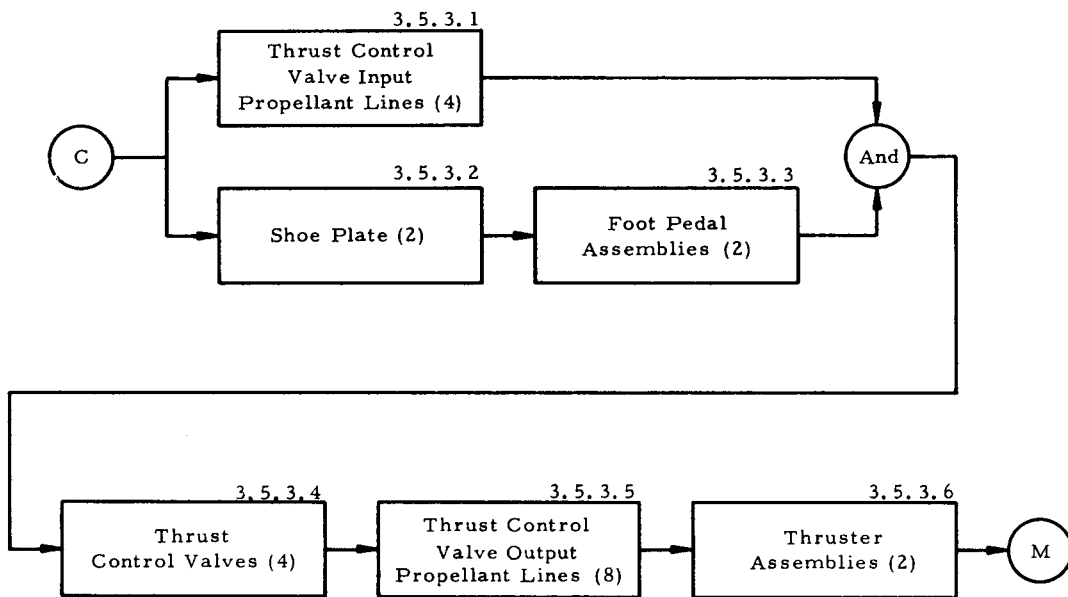

FIGURE R-1. EXPERIMENT T-020, FOOT CONTROLLED MANEUVERING UNIT FUNCTIONAL BLOCK DIAGRAM (Sheet 6 of 8)

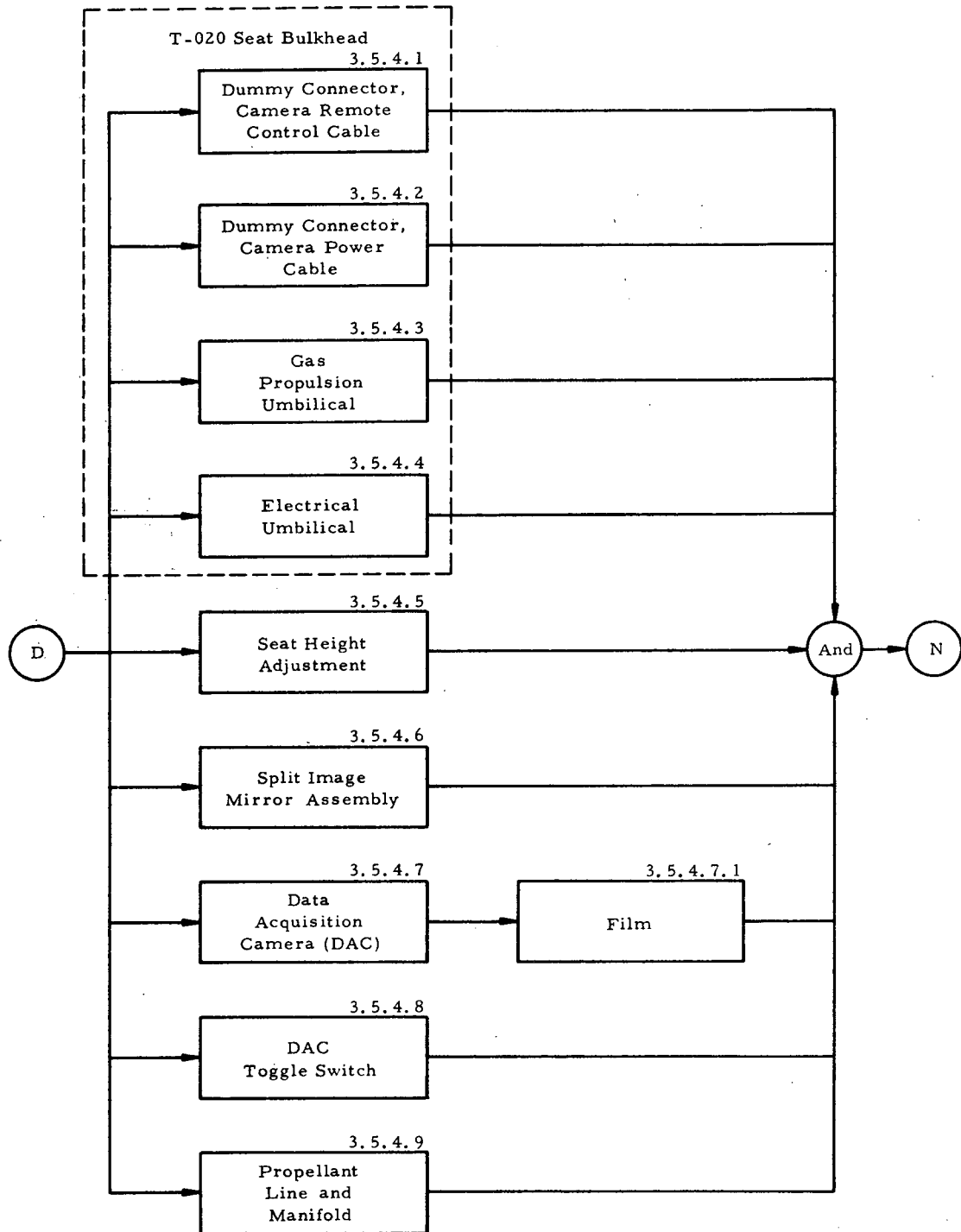

FIGURE R-1. EXPERIMENT T-020, FOOT CONTROLLED MANEUVERING UNIT FUNCTIONAL BLOCK DIAGRAM (Sheet 7 of 8)

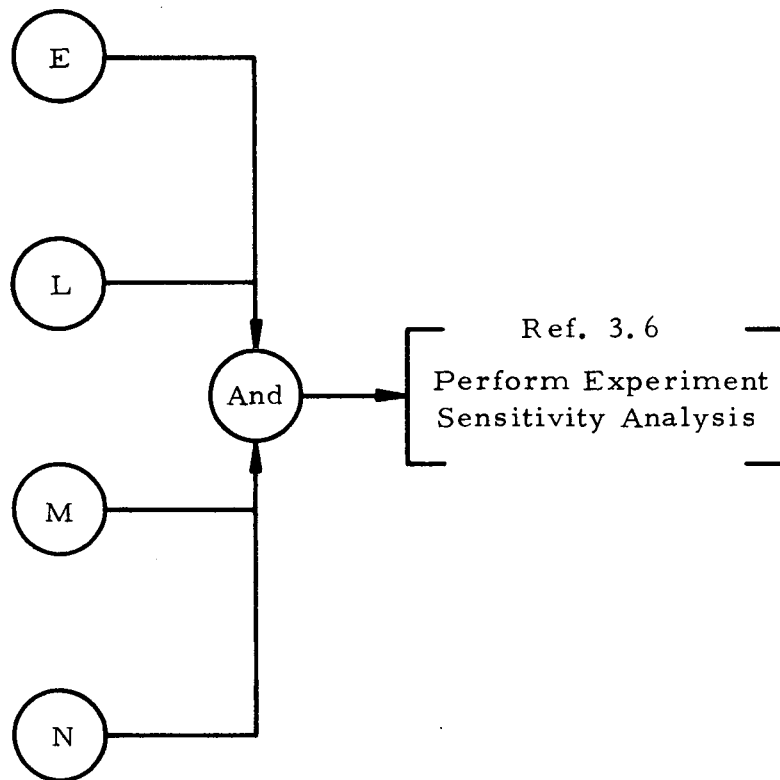
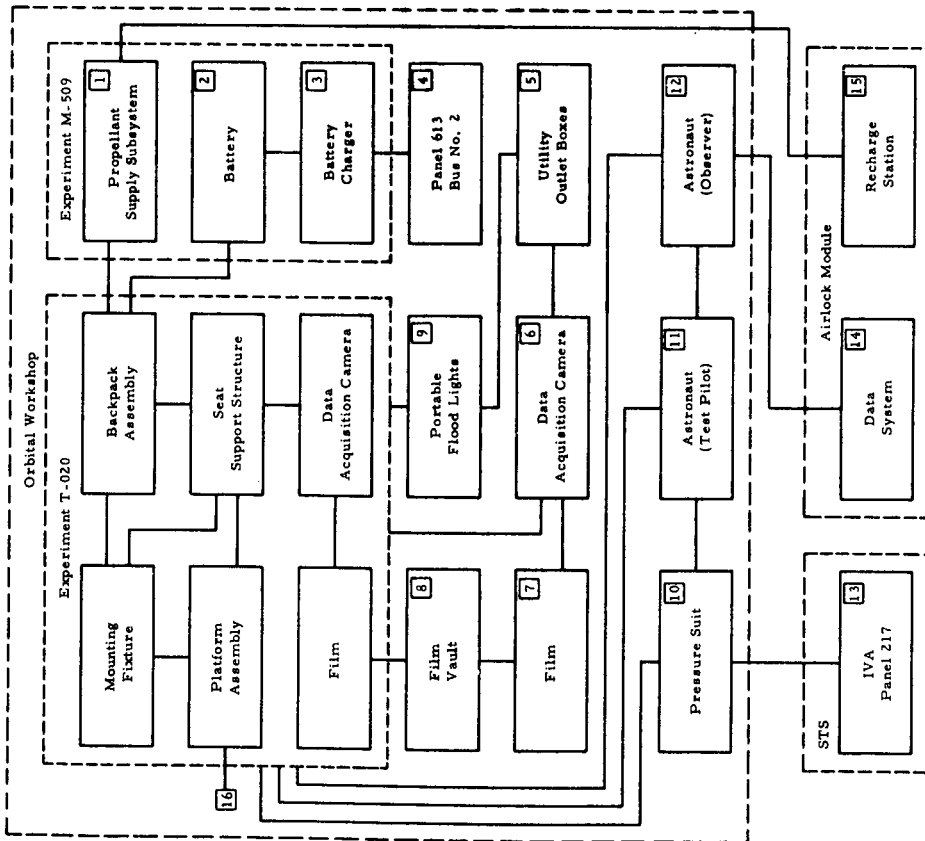

FIGURE R-1. EXPERIMENT T-020, FOOT CONTROLLED MANEUVERING UNIT FUNCTIONAL BLOCK DIAGRAM (Sheet 8 of 8)

SECTION II.
EXPERIMENT T-020, FOOT CONTROLLED MANEUVERING
UNIT INTERFACE BLOCK DIAGRAM



Code	Data Source	Remarks
1	D7141-M509 D7099-M509	There is a mechanical interface between the PSS and T-020 experiment backpack, and the PSS and AM recharging station. The gaseous nitrogen propellant is obtained by using the M-509 PSS. The M-509 PSS is secured in the T-020 backpack that is worn by the astronaut.
2	Crew	There are electrical and mechanical interfaces between the M-509 battery, the T-020 backpack and the M-509 battery charger. The M-509 battery supplies electrical power for operating the DAC in the FCMU, and for actuating the T-020 propellant isolation valve (located internal to the backpack). The M-509 battery is secured internal to the T-020 backpack.
3	Crew	There is an electrical interface between the M-509 battery charger and the OWS power panel 613. The battery charger is used to charge the M-509 batteries and is located at the M-509 ASMU support structure.
4	M7003-440 M7004-440	There is an electrical interface between the OWS power panel 613 and the M-509 battery charger. Panel 613 is located at station E in the crew quarters area.
5	Crew	There are electrical interfaces among the OWS utility outlet boxes, data acquisition camera, and portable flood lights. The utility outlet boxes (2) provide power to the DAC and portable flood lights and are located near Position I and Position III in the forward OWS work section.
6	Crew	There is a support interface between the DAC, in the forward dome section, and the T-020 experiment. The DAC will use a wide angle lens to obtain film coverage of the T-020 experiment runs.
7	Crew	There is a support interface between the film and the DAC, mounted in the FCMU, and the DAC mounted in the forward dome. Both cameras will use color interior film SO-168; however, the DAC in the FCMU will use the magazine containing 140 ft of film while the forward dome DAC will use the magazine containing 400 ft of film. Experiment T-020 has assigned for photographic coverage 6 magazines loaded with 140 ft of film and 1 magazine loaded with 400 ft of film.
8	Crew	There is a support interface between the film used by both DAC's and the film vault. The film vault will provide environmental protection for the T-020 film, SO-168.
9	Crew	There is a support interface between the portable flood lights and Experiment T-020. The flood lights will illuminate the experiment during the test sequences. Refer to Code 5 for the electrical interface between the OWS and the portable flood lights.
10	Crew	There are mechanical and electrical interfaces between the pressure suit and the IVA Panel 217. The TP will wear the pressure suit during Phase II of the experiment runs. The pilot will be strapped to the SS, with the T-020 BA strapped to his back. The Life Support Umbilical (LSU), which is connected to the IVA Panel in the STS, provides communications, oxygen, and suit cooling.
11	Crew	There is a crew safety interface between the FCMU and the astronaut. Refer to Code 9 for TP crew safety interface with the pressure suit. The astronaut, in the role of TP, will interface with the FCMU by mounting the SSS, wearing the BA, and locking his shoes onto the P.A.
12	Crew	There is a crew safety interface among the observer, the T-020 Experiment, and the TP. There is an electrical interface between the observer and the AM Data System. The observer will assist the TP in experiment preparation and equipment donning. He will also provide voice comments on the performance of Experiment T-020 and TP. These comments will be recorded by the AM Data System and dumped as required.
13	Crew	Refer to Code 10
14	K502-512	Refer to Code 12
15	D232-504 D233-504 D234-503 D235-502 D236-502 D257-502	There is a mechanical interface between Experiment M-509 recharge station and the PSS. The M-509 PSS pressure vessels are recharged with gaseous nitrogen at the M-509 recharge station located in the lower hatch area of the AM.
16	D711-436 D237-537	There is an environmental interface between Experiment T-020 and the OWS. During T-020 experiment runs, the FCMU will release gaseous nitrogen into the OWS atmosphere. The time between experiment operations for both T-020 and M-509 is governed by a need to maintain the OWS cabin partial pressure of oxygen at 3.6 ± 0.3 psia and the total pressure less than 5.4 psia. This precludes activating the cabin pressure relief valve in the CM and AM.

FIGURE R-2. EXPERIMENT T-020, FOOT CONTROLLED MANEUVERING UNIT INTERFACE BLOCK DIAGRAM AND DEFINITION

SECTION III.
EXPERIMENT T-020, FOOT CONTROLLED MANEUVERING
UNIT SYSTEMS DIAGRAM

SECTION IV.
EXPERIMENT T-020, FOOT CONTROLLED MANEUVERING
UNIT DATA REQUIREMENTS SUMMARY

TABLE R-II. EXPERIMENT T-020, FOOT CONTROLLED MANEUVERING UNIT DATA REQUIREMENTS SUMMARY

Measurement Name	Range and Dimension of Variable	Measurement Number	Telemetry Assignment Channel	Data Return	Data Time	Remarks
<ul style="list-style-type: none"> • Pressure: Pressure Control System Habitability Area, Low Range Sensor No. 1 	0 to 8 psia	D711-436	WP1B074A25HE47	Analog	Real Time	Recording required only during periods of recharging Experiment M-509 PSS bottles.
<ul style="list-style-type: none"> • Pressure: Oxygen Partial Pressure 	0 to 330 mm Hg	D237-537	WP1B064A13HO78	Analog	Real Time	Recording required only during periods of recharging Experiment M-509 PSS bottles.
<ul style="list-style-type: none"> • Pressure: N₂ Supply Bottle No. 1 	0 to 4000 psia	D232-504	WP1B154A16HC68	Analog	All Time	Recording required only during periods of recharging Experiment M-509 PSS bottles.
<ul style="list-style-type: none"> • Pressure: N₂ Supply Bottle No. 2 	0 to 4000 psia	D233-504	WP1B054A21HF46	Analog	All Time	Recording required only during periods of recharging Experiment M-509 PSS bottles.
<ul style="list-style-type: none"> • Pressure: N₂ Supply Bottle No. 3 	0 to 4000 psia	D234-503	WP1B054A26HF55	Analog	All Time	Recording required only during periods of recharging Experiment M-509 PSS bottles.
<ul style="list-style-type: none"> • Pressure: N₂ Supply Bottle No. 4 	0 to 4000 psia	D235-503	WP1B054A31HF64	Analog	All Time	Recording required only during periods of recharging Experiment M-509 PSS bottles.
<ul style="list-style-type: none"> • Pressure: N₂ Supply Bottle No. 5 	0 to 4000 psia	D236-502	WP1B054A08HF66	Analog	All Time	Recording required only during periods of recharging Experiment M-509 PSS bottles.
<ul style="list-style-type: none"> • Pressure: N₂ Supply Bottle No. 6 	0 to 4000 psia	D257-502	WP1B054A04HF65	Analog	All Time	Recording required only during periods of recharging Experiment M-509 PSS bottles.
<ul style="list-style-type: none"> • ATM Digital Computer Word 	0 or 5 Vdc	K382-702	N/A	Digital	All Time	Required for OA Rates (Roll, Pitch, and Yaw).
<ul style="list-style-type: none"> • Pressure: Experiment M-509, Propellant Supply Subsystem Tank 	0 to 3000 psia	N/A	N/A	N/A	Real Time	Read Pressure Gage.
<ul style="list-style-type: none"> • Astronaut Voice Comments and Recording 	N/A	N/A	N/A	N/A	N/A	
<ul style="list-style-type: none"> • Log Book 	N/A	N/A	N/A	N/A	N/A	
<ul style="list-style-type: none"> • Onboard TV (OWS) 	TBD	N/A	N/A	N/A	Intermittent	
<ul style="list-style-type: none"> • Onboard Timing (GMT) 	TBD	K502-512	WPIA124A04D107 WPIA045A03D107 WPIA046A03D107 WPIA047A03D107	Event	Real Time	Real/All

SECTION V.

EXPERIMENT T-020, FOOT CONTROLLED MANEUVERING UNIT
DATA REQUEST FORMS

DATA REQUEST FORM Skylab Program		DRF Control No.	Date 8-11-71
		Exp/Sys No. ASTN-SDI/OWS/T-020	Revision
Mission SL-2/3	Period of Interest Flight/Experiment Manned	Op. Need Date	Rev Date
Request Contact		Data Recipient	Date Req All Time
Name	Name	W. A. Clarke	Qty 1
Organization	Address	MSFC, S&E-ASTN-SDI	
Phone	Phone	205-453-3811	

Reference Document:

MRD Content

Detailed Requirements:

Voice transcripts of astronaut comments are needed from MSC for all T-020 checkout, startup, sequencing, temperature and pressure measurements, and film stowage activities. The voice transcripts should be available to S&E-ASTN-SDI as soon as possible after experiment startup.

Onboard TV, located in the OWS, is required to record T-020 experiment setup, operation, and disassembly.

Comments & Explanation:

These data will be used to measure and evaluate the integrity of experiment/carrier interfaces so that the Skylab Mission Evaluation reporting requirements can be fulfilled (See OMSF Program Directive 35, M-D ML3200.138, 5-71).

Originator Name W. A. Clarke Organization MSFC, S&E-ASTN-SDI Phone 205-453-3811 Signature _____ Date _____		Integrator Name _____ Organization _____ Phone _____ Signature _____ Date _____	
Request Approval Name _____ Organization _____ Phone _____ Signature _____ Date _____		Implementing Agency Name _____ Organization _____ Phone _____ Signature _____ Date _____	

DATA REQUEST FORM Skylab Program		DRF Control No.		Date 12-2-71
		Exp/Sys No. ASTN-SD/OWS/T020-034		Revision
Mission SL-1/2, 3 & 4	Period of Interest Flt		Op. Need Date	Rev Date
Request Contact		Data Recipient		Date Req
Name	Name		Mr. W. R. Bock	
Organization	Address		S&E-ASTN-SDF	
Phone	Phone		MSFC, Alabama 35812 205-453-3810	
Reference Document:				
MRD Content				
Detailed Requirements:				
<u>MOPS Format for Experiments T020, S183 and Proton Spectrometer</u> Provide MOPS format for the following parameters associated with experiment T020 Foot-Controlled Maneuvering Unit and S183.				
Comments & Explanation:				
Originator		Integrator		
Name	W. R. Bock	Name	J. R. Riquelmy	
Organization	MSFC/S&E-ASTN-SDF	Organization	S&E-ASTN-SDF	
Phone	205-453-3810	Phone	205-453-3810	
Signature	Date	Signature	Date	
Request Approval		Implementing Agency		
Name	Name		Name	
Organization	Organization		Organization	
Phone	Phone		Phone	
Signature	Date	Signature	Date	

DRF Contr. No.

Exp/Sys No.

ASTN-SD/OWS/T020-034

Revision

Date

12-2-71

Detailed Requirements:EXPERIMENT T020

<u>Meas. No.</u>	<u>Title</u>
D7111 436	PRESS, PCS, H/A Low Range Sens 1
D232 504	" N ₂ Supply Bottle 1
D233 504	" N ₂ Supply Bottle 2
D235 503	" N ₂ Supply Bottle 4
D236 502	" N ₂ Supply Bottle 5

EXPERIMENT S183

K7000 S183	Shutter Open
K7001 S183	Film Plate in Focal Plane
K7002 S183	Film Plate Returned to Carrousel

PROTON SPECTROMETER

C0028 806	TEMP, Detector Head
C0029 806	TEMP, Electronic Package
K0021 806	Digital Word
M0005 806	Total Dose Count Rate D ₄
M0006 806	Accidental Coincidence D ₁ /D ₂ Voltage

DATA REQUEST FORM Skylab Program		DRF Control No.	Date 8-11-71
		Exp/Sys No. ASTN-SDI/OWS/T-020	Revision 1
Mission SL-2/3	Period of Interest Flight/Experiment Manned	Op. Need Date	Rev Date 3-23-72
Request Contact		Data Recipient	Date Req
Name	Name	W. Bock	Real Time
Organization	Address	MSFC, S&E-ASTN-SDF	Qty
Phone	Phone	205-453-3810	1
Reference Document:			
MRD Content			
Detailed Requirements:			
<p>The Payload Integration Section (S&E-ASTN-SDI) requires the capability to monitor the T-020 experiment data.</p> <p>Voice loop of astronaut comments is needed for initializing procedures, startup of the experiment, and T-020 pressure measurements.</p> <p>Scheduling of T-020 and M-509 is constrained by OWS total pressure and oxygen partial pressure limits.</p>			
Comments & Explanation:			
<p>These data will be used to measure and evaluate the integrity of experiment/carrier interfaces so that the Skylab Mission Evaluation reporting requirements can be fulfilled (See OMSF Program Directive 35, M-D ML3200.138, 5-71).</p>			
Originator		Integrator	
Name	J. W. Stokes	Name	
Organization	MSFC, S&E-ASTN-SMH	Organization	
Phone	205-453-3747	Phone	
Signature		Signature	
Date		Date	
Request Approval		Implementing Agency	
Name		Name	
Organization		Organization	
Phone		Phone	
Signature		Signature	
Date		Date	

DRF Control No.	Exp/Sys No. ASTN-SDI/OWS/T-020	Revision 1	Date 3-23-72
-----------------	-----------------------------------	---------------	-----------------

Detailed Requirements:

<u>MEAS. NO.</u>	<u>MEAS. NAME</u>
D711-436	Pressure: Pressure Control System Habitability Area, Low Range Sensor No. 1
D237-537	Pressure: Oxygen Partial Pressure
K502-512	Onboard Timing (GMT)

DATA REQUEST FORM Skylab Program		DRF Control No.	Date 8-11-71
		Exp/Sys No. ASTN-SDI/OWS/T-020	Revision 1
Mission SL-2/3	Period of Interest Flight/Experiment Manned	Op. Need Date	Rev Date 3-23-72
Request Contact		Data Recipient	Date Req All Time
Name	Name	W. Bock	Qty 1
Organization	Address	MSFC, S&E-ASTN-SDF	
Phone	Phone	205-453-3810	
Reference Document:			
MRD Content			
Detailed Requirements:			
<p>The Payload Integration Section (S&E-ASTN-SDI) requires the capability to monitor the T-020 experiment operational time.</p> <p>A GMT time correlation is needed when the experiment is initialized "START" and terminated when the experiment ends.</p> <p>Provide MOPS format for the following parameters associated with Experiment T-020.</p>			
Comments & Explanation:			
<p>These data will be used to measure and evaluate the integrity of experiment/carrier interfaces so that the Skylab Mission Evaluation reporting requirements can be fulfilled (See OMSF Program Directive 35, M-D ML3200.138, 5-71).</p>			
Originator		Integrator	
Name	J. W. Stokes	Name	
Organization	MSFC, S&E-ASTN-SMH	Organization	
Phone	205-453-3747	Phone	
Signature		Signature	
Date		Date	
Request Approval		Implementing Agency	
Name		Name	
Organization		Organization	
Phone		Phone	
Signature		Signature	
Date		Date	

DRF Control No.	Exp/Sys No. ASTN-SDI/OWS/T-020	Revision 1	Date 8-11-71
-----------------	-----------------------------------	---------------	-----------------

Detailed Requirements:

<u>MEAS. NO.</u>	<u>MEAS. NAME</u>
K502-512	Onboard Timing (GMT)
N/A	Pressure: Experiment M-509, Propellant Supply Subsystem Tank
D232-504	Pressure: N ₂ Supply Bottle No. 1
D233-503	Pressure: N ₂ Supply Bottle No. 2
D234-503	Pressure: N ₂ Supply Bottle No. 3
D235-503	Pressure: N ₂ Supply Bottle No. 4
D236-502	Pressure: N ₂ Supply Bottle No. 5
D257-502	Pressure: N ₂ Supply Bottle No. 6

SECTION VI.

EXPERIMENT T-020, FOOT CONTROLLED MANEUVERING
UNIT ENGINEERING CHANGE REQUESTS

Engineering Change Requests for Experiment T-020 are N/A.

SECTION VII.

EXPERIMENT T-020, FOOT CONTROLLED MANEUVERING
UNIT EVALUATION SEQUENCE

TABLE R-III. EXPERIMENT T-020, FOOT CONTROLLED MANEUVERING UNIT EVALUATION SEQUENCE (Sheet 1 of 12)

<u>Assignments</u>	<u>Conditions</u>	<u>Requirements</u>
<p>Mission:</p> <ul style="list-style-type: none"> • SL-3 <p>Orbital Assembly:</p> <ul style="list-style-type: none"> • OWS <p>Carrier:</p> <ul style="list-style-type: none"> • Stored on the OWS floor between OWS Positions I and IV, at OWS Sta. No. 437.997. 	<p>Crew:</p> <ul style="list-style-type: none"> • The CDR acts as the TP and the SPT acts as an observer. • Five experiment test runs are required: <ul style="list-style-type: none"> --Unsuited mode (3) --Suited mode (2) <p>Experiment:</p> <ul style="list-style-type: none"> • Experiment S-019 is performed by the PLT during T-020 preparation. • The PLT is involved in ATM activities during T-020 operation. <p>Ground Support:</p> <ul style="list-style-type: none"> • N/A 	<p>Functional Objectives</p> <ul style="list-style-type: none"> • FO-1: Perform various maneuvers (Mode I) while flying the FCMU in shirtsleeves. • FO-2: Perform various maneuvers (Mode II) while flying the FCMU suited.

Experiment Evaluation Team - Key Personnel Locator

<u>Name</u>	<u>Responsibility</u>	<u>Office Address, Symbol, and Telephone Number</u>
Mr. D. E. Hewes	Principal Investigator (PI)	Langley Research Center, Hampton, Virginia, 703-827-3348
Mr. H. Clarke	Experiment Developer (ED)	Langley Research Center, Hampton, Virginia, 703-827-3348
Mr. E. O. Walker	MSFC Experiment Manager (EM)	MSFC, Bldg. 4201, PM-SL-DP, 205-453-3183
Mr. J. W. Stokes	S&E Integration Engineer (IE)	MSFC, Bldg. 4610, S&E-ASTN-SMH, 205-453-3747
Mr. W. R. Bock	Technical Discipline Manager (TDM)	MSFC, Bldg. 4610, S&E-ASTN-SDF, 205-453-3810
Mr. B. B. Tonetti	Experiment Operations Engineer (EOE)	Teledyne Brown Engineering Company, Huntsville, Alabama, ASD-SHI, 205-532-1561
Mr. G. Batiuk	Mission Operations Design Support (MODS)	Martin Marietta Corporation, Denver, Colorado, 303-794-3145
Mr. L. Browne	MMC Experiment Integration Engineer (EIE)	Martin Marietta Corporation, Denver, Colorado, 303-794-3983

TABLE R-III. EXPERIMENT T-020, FOOT CONTROLLED MANEUVERING UNIT EVALUATION SEQUENCE (Sheet 2 of 12)

Operation Step Number*	Recorder Number	Measurement Name, Number, and Signal	Return		Data				Contingencies			
			Telemetry Channel	Asst/Chanel	Functions**	Frequency***	Range and Dimension of Variables	Limits of Concern	Satellite/Anomaly	Evaluation Remarks****	See Contingency Plan Number	Remarks
P-60 min		Experiment Evaluation Team manned and available. Contact Experiment T-020, Technical Discipline Manager, S&E-ASTN-SD: HOSC Telephone No. TBD, Astronautics Laboratory Telephone No. 205-453-3810.										
P 1.0		Acquire status of recharge N ₂ bottles:										
TBS		Pressure: N ₂ Supply Bottle No. 1 D232-504	WP1B154A16HC68	A	D (4)	Range: 0 to 4000 psia	TBD					
TBS		Pressure: N ₂ Supply Bottle No. 2 D233-504	WP1B054A21HF46	A	D (4)	Range: 0 to 4000 psia	TBD					
TBS		Pressure: N ₂ Supply Bottle No. 3 D234-503	WP1B054A26HF55	A	D (4)	Range: 0 to 4000 psia	TBD					
TBD		Pressure: N ₂ Supply Bottle No. 4 D235-503	WP1B054A31HF64	A	D (4)	Range: 0 to 4000 psia	TBD					
TBD		Pressure: N ₂ Supply Bottle No. 5 D236-502	WP1B054A08HF66	A	D (4)	Range: 0 to 4000 psia	TBD					
TBD		Pressure: N ₂ Supply Bottle No. 6 D257-502	WP1B054A04HF65	A	D (4)	Range: 0 to 4000 psia	TBD					

* P - Preparation
 O - Operations
 T - Termination
 L - Lift-off (Booster)
 ASTN-72-1-OT (Jan 72)

** E - Event
 H - Housekeeping
 A - Analog
 D - Digital

*** C - Continuous
 I - Intermittent
 D - Discrete
 (Specified number of times)

**** R - Real Time
 N - Near/Real Time
 A - All Time

TABLE R-III. EXPERIMENT T-020, FOOT CONTROLLED MANEUVERING UNIT EVALUATION SEQUENCE (Sheet 3 of 12)

Operation Step Number*	Crewman**	Test Procedure	Evaluation (Check One)		See Contingency Plan Number	Remarks
			Satisfactory	Anomally		
P-10 min GMT 20:20 for SL-3		Commence experiment preparation.				
P 2.0	TP	Unstow and set up Experiment T-020:				
P 2.1		Unlock, raise, and lock handlebars in position.				
P 2.2		Unstow FCMU restraint straps and secure waist belt to handlebars.				
P 2.3		Secure harness clip assembly to BA harness and verify that the isolation valve switch is in closed position.				
P 2.4		Release the calfax fastener holding the BA and secure to the floor.				
P 2.5		Verify thruster assemblies are properly oriented per decal. Verify key lock on the thruster assembly is tight.				
P 3.0		Set up the photographic equipment:				
P 3.1	OBS	Obtain film magazines for the FCMU/DAC and the dome mounted DAC.				
P 3.2	OBS	Set up dome mounted DAC, remote operation cable, and portable flood lights.				
P 3.3	TP	Place film in FCMU/DAC and partially engage onto dovetail of FCMU.				
P 3.4	TP	Disconnect remote frame rate camera cable from dummy receptacle and connect to FCMU/DAC.			P34A1 P34A2 P34A3	
P 3.5	TP	Disconnect power cable from dummy receptacle and connect to FCMU/DAC.			P35A1 P35A2 P35A3	

*P - Preparation
 O - Operations
 T - Termination
 L - Lift-off (Booster)
 **TP - Test Pilot (Commander)
 OBS - Observer (Science Pilot)
 PLT - Pilot
 ALL - TP/OBS/PLT

TABLE R-III. EXPERIMENT T-020, FOOT CONTROLLED MANEUVERING UNIT EVALUATION SEQUENCE (Sheet 4 of 12)

Operation Step Number**	Crewman**	Test Procedure	Evaluation (Check One)		See Contingency Plan Number	Remarks
			Satisfactory	Anomally		
P 3.6	TP	Slide FCMU/DAC to operating position in the SSS and secure.				
P 4.0	TP	Install battery in BA:				
P 4.1		Verify battery compartment is open and circuit breaker BATT is open.				
P 4.2		Remove BATT connector dust cover and stow it on dummy receptacle behind telemetry receiver.				
P 4.3		Remove battery from M-509 ASMU donning station and install in BA.				
P 4.4		Close and latch battery compartment and connect battery cable to battery.				
P 5.0	TP	Install PSS in BA:				
P 5.1		Verify both PSS clamps are open and remove isolation valve hose assembly from dummy connector on regulator cover and secure.				
P 5.2		Open regulator cover, install PSS, and close PSS clamps.				
P 5.3		Verify PSS supply valve is closed, connect propellant supply quick disconnect, and close regulator cover.				
P 6.0		Don support and T-020 equipment.				
P 6.1		Don support equipment:				
P 6.1.1		Mode I (sleeve):				
P 6.1.1.1	TP	Obtain and don bump hat.				
P 6.1.1.2	ALL	Obtain and don ear pieces and universal ear tubes.				

*P - Preparation
O - Operations
T - Termination
L - Lift-off (Booster)

**TP - Test Pilot (Commander)
OBS - Observer (Science Pilot)
PLT - Pilot
ALL - TP/OBS/PLT

TABLE R-III. EXPERIMENT T-020, FOOT CONTROLLED MANEUVERING UNIT EVALUATION SEQUENCE (Sheet 5 of 12)

Operation Step Number*	Crewman**	Test Procedure	Evaluation (Check One)		See Contingency Plan Number	Remarks
			Satisfactory	Anomally		
P 6.1.2		Mode II (IVA pressure suit):				
P 6.1.2.1	TP/OBS	Obtain and don pressure suit.				
P 6.1.2.2	OBS/PLT	Obtain and don ear pieces and universal ear tubes.				
P 6.1.3	OBS	Connect communications cable and establish communications with the Astronaut Communicator.				
P 6.2		Don T-020 equipment:				
P 6.2.1	TP	Don waist belt and adjust as required (Mode I).				
P 6.2.2	TP	Verify PSS supply valve is closed, and don both shoe plates.				
P 6.2.3	TP	Mount FCMU and lock shoe plates onto foot controllers.				
P 6.2.4	OBS	Verify circuit breaker BATT is open, release backpack from floor, and connect outer strap to FCMU.				
P 6.2.5	TP/OBS	Don BA, attach, and adjust restraint straps.				
P 6.2.6	TP	Secure harness clip assembly to shoulder strap or Pressure Control Unit (Mode II).				
P 6.2.7	OBS	Unstow electrical and propulsion umbilicals from base of mounting fixture.				
P 6.2.8	OBS	Remove dust covers from electrical and propulsion quick disconnects on BA.				
P 6.2.9	OBS	Connect electrical and propulsion umbilicals to their respective BA quick disconnects.				
P 6.2.10	TP	Pressurize IVA suit (Mode II).				

*P - Preparation
O - Operations
T - Termination
L - Lift-off (Booster)

**TP - Test Pilot (Commander)
OBS - Observer (Science Pilot)
PLT - Pilot
ALL - TP/OBS/PLT

TABLE R-111. EXPERIMENT T-020, FOOT CONTROLLED MANEUVERING UNIT EVALUATION SEQUENCE (Sheet 6 of 12)

Operation Step Number*	Crewman**	Test Procedure	Evaluation (Check One)		See Contingency Plan Number	Remarks
			Satisfactory	Anomalous		
P 6.2.11	OBS	Unlock T-handle near right side of mounting fixture docking latch, raise docking latch, pull yoke latch release button, and rotate yoke down.				
P 6.2.12	OBS	Rotate both lower latches to midposition.				
P 6.2.13	OBS	Adjust FCMU length:				
P 6.2.13.1		Pull T-Handle and turn 90° to release.				
P 6.2.13.2		Test Pilot relax legs.				
P 6.2.13.3		Adjust seat height until the reference markers on the foot pedals are aligned.				
P 6.2.13.4		Turn T-handle 90° to lock.				
P 6.2.14	OBS	Lock the T-handle near the right side of the docking latch.				
P 7.0		Perform operational checkout of T-020 experiment:				
P 7.1	TP	Verify the harness clip assembly propellant isolation switch is closed.				
P 7.2	OBS	Verify the PSS supply valve is open and BATT circuit breaker is closed.			P72A1	
P 7.3	TP/OBS	Cycle foot controllers and verify no thruster response.			P73A1 P73A2 P73A3 P73A4	
P 7.4	TP	Open propellant isolation valve and verify thruster response.			P73A1 P73A2 P73A3 P73A4	

*P - Preparation
O - Operations
T - Termination
L - Lift-off (Booster)
**TP - Test Pilot (Commander)
OBS - Observer (Science Pilot)
PLT - Pilot
ALL - TP/OBS/PLT

TABLE R-111. EXPERIMENT T-020, FOOT CONTROLLED MANEUVERING UNIT EVALUATION SEQUENCE (Sheet 7 of 12)

Operation Step Number*	Crewman**	Test Procedure	Evaluation (Check One)		See Contingency Plan Number	Remarks
			Satisfactory	Anomally		
P 7.5	TP/OBS	<p>Command the following and verify proper thruster response:</p> <ul style="list-style-type: none"> • + Pitch • - Pitch • Head first translation • Feet first translation. <p>Close the propellant isolation valve.</p> <p>Set the FCMU/DAC frame rate to 6 fps.</p> <p>Operate the FCMU/DAC using the harness clip assembly switch.</p>				
P 7.6	TP					
P 7.7	OBS					
P 7.8	TP					
P 7.9	OBS	Verify FCMU/DAC operation.				
P 7.10	TP	Turn off FCMU/DAC, set frame rate for 2 fps, and repeat Operation Step Numbers P 6.8 and P 6.9.				
P 7.11	OBS	Release both lower latches.				
P 7.12	TP	Unlock FCMU release safety lever and open FCMU release and unlock.				
P 7.13	TP	Grip handlebars and torque FCMU out of mounting fixture.				
P 7.14	OBS	Position TP in center of OWS and verify correct FCMU length adjustment.				
					P78A1 P78A2 P78A3 P78A4	

*P - Preparation
O - Operations
T - Termination
L - Lift-off (Booster)

**TP - Test Pilot (Commander)
OBS - Observer (Science Pilot)
PLT - Pilot
ALL - TP/OBS/PLT

TABLE R-III. EXPERIMENT T-020, FOOT CONTROLLED MANEUVERING UNIT EVALUATION SEQUENCE (Sheet 8 of 12)

Operation Step Number*	Data										Contingencies			
	Return					Data					Evaluation Remarks***	Contingency Plan Number	Remarks	
	Recorder Number	Measurement Name, Number, and Signal	Telemetry Assignment Channel	Functions*	Frequency***	Range and Dimension of Variables	Limits of Concern	Satisfactory Check	Abnormality	Remarks***				
O 1.0	Commence experiment operations:													
O 1.1	Acquire status of OWS:													
TBS	Pressure: Pressure Control System Habitability Area, Low Range Sensor No. 1 D7111-436	WP1B074A25HE47	A	C	Range: 0 to 8 psia	TBD				R				
TBS	Pressure: Oxygen Partial Pressure D237-537	WP1B064A13HO78	A	C	Range: 0 to 330 mm Hg	TBD				R				
TBS	ATM Digital Computer Word K382-702	TBD	D	C	Range: 0 or 5 Vdc	TBD				A				

* P - Preparation
O - Operations
T - Termination
L - Lift-off (Booster)
ASTN-72-1-OT (Jan 72)

** E - Event
H - Housekeeping
A - Analog
D - Digital

*** C - Continuous
I - Intermittent
D - Discrete
(Specified number of times)

**** R - Real Time
N - Near/Real Time
A - All Time

TABLE R-111. EXPERIMENT T-020, FOOT CONTROLLED MANEUVERING UNIT EVALUATION SEQUENCE (Sheet 9 of 12)

Operation Step Number*	Crewman**	Test Procedure	Evaluation (Check One)		See Contingency Plan Number	Remarks
			Satisfactory	Anomally		
O 1.2	TP	<p>Open propellant isolation valve and perform Mode I testing (shirtsleeve):</p> <p>Run 1 TBD Run 2 TBD Run 3 TBD.</p> <p>Open propellant isolation valve and perform Mode II testing (pressure suit):</p> <p>Run 4 TBD Run 5 TBD.</p> <p>Note:</p> <p>The anticipated maneuvering tasks consist of the following elements (Reference document Z):</p> <ul style="list-style-type: none"> • Attitude Changes --± 90° pitch, roll, and yaw • Maneuvers --Pitch --Translation feet first --Arrest motion at target • Tumble Recovery --OBS will set TP into an indiscriminate rotation not to exceed 10 deg/sec. TP is to stop rotation. • Docking --TP is to dock at the FCMU mounting fixture. <p>Propellant supply is exhausted during an experiment run: Shut off PSS supply valve.</p>			<p>O12A1 O12A2 O12B1 O12C1 O12D1</p> <p>O13A1 O13A2 O13B1 O13C1 O13D1</p>	
O 1.3	TP					
O 1.4						
O 1.4.1	OBS					

*P - Preparation
O - Operations
T - Termination
L - Lift-off (Booster)

**TP - Test Pilot (Commander)
OBS - Observer (Science Pilot)
PLT - Pilot
ALL - TP/OBS/PLT

TABLE R-III. EXPERIMENT T-020, FOOT CONTROLLED MANEUVERING UNIT EVALUATION SEQUENCE (Sheet 10 of 12)

Operation Step Number*	Crewman**	Test Procedure	Evaluation (Check One)		See Contingency Plan Number	Remarks
			Satisfactory	Anomally		
O 1.4.2	TP	Cycle foot controllers to bleed system and close isolation valve.				
O 1.4.3	OBS	Return TP to mounting fixture.				
O 1.4.4	OBS	Remove PSS (Reference T 2.0).				
O 1.4.5	OBS	Install new PSS (Reference P 4.0).				
O 1.4.6	OBS	Turn on PSS supply valve.				
O 1.4.7	OBS	Position TP in center of OWS.				
O 1.4.8	TP	Resume experiment run.				
T 1.0		Commence Experiment Termination:				
T 1.1	OBS	Move subject to mounting fixture.				
T 1.2	TP	Grip handlebars and torque FCMU into lower latches.				
T 1.3	OBS	Rotate both lower latches to mid position.				
T 1.4	TP	Open FCMU, release and engage docking latch, and lock T-handle.				
T 1.5	TP	Push camera button to OFF.				
T 1.6	OBS	Close PSS supply valve.				
T 1.7	TP	Open isolation valve and activate thrusters to bleed manifold.				
T 1.8	OBS	Open circuit breaker BATT.				
T 1.9	TP	Lock FCMU release safety lever and lower the docking latch assembly...				

*P - Preparation
O - Operations
T - Termination
L - Lift-off (Booster)

**TP - Test Pilot (Commander)
OBS - Observer (Science Pilot)
PLT - Pilot
ALL - TP/OBS/PLT

TABLE R-III. EXPERIMENT T-020, FOOT CONTROLLED MANEUVERING UNIT EVALUATION SEQUENCE (Sheet 11 of 12)

Operation Step Number*	Crewman**	Test Procedure	Evaluation (Check One)		See Contingency Plan Number	Remarks
			Satisfactory	Anomally		
T 1.10	TP	Depressurize Propulsion Gas Assembly (PGA) (Phase II only)				
T 1.11	TP	Unlock T-handle on right side of the docking latch.				
T 1.12	OBS	Shorten the FCMU (Reference P 5.2.13).				
T 1.13	OBS	Lock the T-handle on the right side of the docking latch.				
T 1.14	TP	Remove remote control clip from restraint harness and stow.				
T 1.15	OBS	Disconnect the electrical and propulsion umbilicals and stow on the mounting fixture.				
T 1.16	OBS	Install dust covers on the BA electrical and propulsion quick disconnects.				
T 1.17	TP	Release restraint harness.				
T 1.18	OBS	Disengage BA from FCMU and secure BA to the floor.				
T 1.19	TP	Dismount FCMU.				
T 1.20	OBS	Secure waist belt (if used) to handlebars, remove left and right shoe plates, and install in foot controllers.				
T 1.21		Doff and secure support equipment:				
T 1.21.1	OBS	Disconnect communication cable.				
T 1.21.2		Mode I (shirtsleeve):				
T 1.21.2.1	TP	Doff and secure bump hat.				
T 1.21.2.2	ALL	Doff and secure ear pieces and universal ear tubes.				
T 1.21.3		Mode II (pressure suit):				

*P - Preparation
O - Operations
T - Termination
L - Lift-off (Booster)

**TP - Test Pilot (Commander)
OBS - Observer (Science Pilot)
PLT - Pilot
ALL - TP/OBS/PLT

TABLE R-111. EXPERIMENT T-020, FOOT CONTROLLED MANEUVERING UNIT EVALUATION SEQUENCE (Sheet 12 of 12)

Operation Step Number*	Crewman**	Test Procedure	Evaluation (Check One)		See Contingency Plan Number	Remarks
			Satisfactory	Anomally		
T 1.21.3.1	TP/OBS	Doff and secure pressure suit.				
T 1.21.3.2	OBS/PLT	Doff and secure ear pieces and universal ear tubes.				
T 2.0	TP	Remove PSS from BA				
T 2.1		Open regulator cover and close PSS supply valve.				
T 2.2		Activate thrusters to bleed manifold.				
T 2.3		Disconnect pressure system quick disconnect and install dust cover on PSS quick disconnect.				
T 2.4		Open both PSS clamps and remove PSS assembly.				
T 2.5		Close regulator cover and connect backpack PSS flexible hose to dummy connector on regulator cover.				
T 3.0	TP	Remove battery from BA.				
T 3.1		Open circuit breaker BATT and verify.				
T 3.2		Disconnect and restrain battery cable.				
T 3.3		Open battery compartment, remove battery, and stow battery at M-509 donning station.				
T 3.4		Remove dust cover from dummy receptacle and install cover on BATT connector.				

*P - Preparation
O - Operations
T - Termination
L - Lift-off (Booster)

**TP - Test Pilot (Commander)
OBS - Observer (Science Pilot)
PLT - Pilot
ALL - TP/OBS/PLT

SECTION VIII.

EXPERIMENT T-020, FOOT CONTROLLED MANEUVERING UNIT
MALFUNCTION AND CONTINGENCY PLAN OUTLINE

TABLE R-IV. EXPERIMENT T-020, FOOT CONTROLLED MANEUVERING UNIT MALFUNCTION AND CONTINGENCY PLAN OUTLINE - EXPERIMENT PREPARATION (P) (Sheet 1 of 3)

Operation Step Number	Experiment/Crew Tasks	Possible Malfunction	Contingency Plan	Remarks (malfunctions, corrections, results)
P 3.4	Disconnect remote frame rate camera cable from dummy receptacle and connect to FCMU/DAC.	P34A Cannot install remote cable.	P34A1 Verify that cable connector pins are clean and not damaged or bent. P34A2 Verify cable connector plug is installed on camera receptacle placard REMOTE. P34A3 Continue experiment in degraded mode. Partial loss of DAC frame rate is expected.	
P 3.5	Disconnect power cable from dummy receptacle and connect to FCMU/DAC.	P35A Cannot install power cable.	P35A1 Verify that power connector pins are clean and not damaged or bent. P35A2 Verify connector plug is installed on camera receptacle placard POWER.	
P 7.2	Verify that the PSS supply valve is open and that the BAT circuit breaker is closed.	P72A The PSS supply valve fails to open.	P35A3 Continue experiment in degraded mode. The DAC will not operate. P72A1 Replace M-509 PSS assembly and continue with experiment.	
P 7.3	Cycle foot controllers and verify no thruster response.	P72A Thruster response occurs due to isolation valve malfunction.	P73A1 Recycle isolation valve activation switch. P73A2 Remove battery and check charge; if below TBD V, replace the battery. P73A3 Malfunction may be due to faulty PSS supply valve. Replace M-590 PSS. P73A4 If malfunction continues, terminate experiment.	

P

TABLE R-IV. EXPERIMENT T-020, FOOT CONTROLLED MANEUVERING UNIT MALFUNCTION AND CONTINGENCY PLAN OUTLINE - EXPERIMENT PREPARATION (P) (Sheet 2 of 3)

Operation Step Number	Experiment/Crew Tasks	Possible Malfunction	Contingency Plan	Remarks (malfunctions, corrections, results)
P 7. 4	Open propellant isolation valve and verify thruster response.	P74A No thruster response.	<p>P74A1 Refer to:</p> <ul style="list-style-type: none"> • P73A1 • P73A2 • P73A3 • P73A4. 	
P 7. 8	Operate the FCMU/DAC using the harness clip assembly switch.	P78A The FCMU/DAC is inoperative.	<p>P78A1 Verify that the power cable is properly installed.</p> <p>P78A2 Check the charge on the battery; if below TBD V, replace the battery.</p> <p>P78A3 Verify that the film magazine is firmly secured in the camera.</p> <p>P78A4 Place DAC clip assembly selector switch in 2 fps mode, and start the camera. If the DAC operates at 2 fps, then use this setting and continue the experiment.</p> <p>Note:</p> <p>All DAC operations should be attempted by energizing the camera for short periods of time. There is a probability that the camera motor and electronics can be damaged if the unit is activated, even though the camera will not run.</p> <p>P78A5 Remove the film magazine, depress and hold the DAC safety interlock switch, keep hands clear of drive gear, and depress and release DAC operate button on harness clip assembly.</p>	

P

TABLE R-IV. EXPERIMENT T-020, FOOT CONTROLLED MANEUVERING UNIT MALFUNCTION AND CONTINGENCY PLAN OUTLINE - EXPERIMENT PREPARATION (P) (Sheet 3 of 3)

Operation Step Number	Experiment/Crew Tasks	Possible Malfunction	Contingency Plan	Remarks (malfunctions, corrections, results)
P 7.8 (Concluded)		<p>P78B The FCMU/DAC starts and immediately stops (overload circuit is operating).</p>	<p>Note: Do not release interlock switch while operating the camera. P78B1 Replace the film magazine. It is probably jammed. P78B2 Refer to P 78A2 and continue with experiment.</p>	

P

TABLE R-V. EXPERIMENT T-020, FOOT CONTROLLED MANEUVERING UNIT MALFUNCTION AND CONTINGENCY PLAN OUTLINE - EXPERIMENT OPERATION (O)

Operation Step Number	Experiment/Crew Tasks	Possible Malfunction	Contingency Plan	Remarks (malfunctions, corrections, results)
O 2.1	Open propellant isolation valve and perform Mode I testing (shirtsleeve)	<p>O21A Undesirable propellant output thrust vector occurs.</p> <p>O21B Rupture of flex hose results in inability to control the flight unit. This induces an uncontrolled motion.</p> <p>O21C Rupture of manifold and thrust control valve or nozzles.</p> <p>O21D Mechanical interface failures of the foot pedal assemblies and thrust control valves result in loss of FCMU mechanical control.</p> <p>O22A Reference:</p> <ul style="list-style-type: none"> • O21A • O21B • O21C • O21D. 	<p>O21A1 TP must close isolation valve to shut off propellant supply.</p> <p>O21A2 Observer gives aid and assistance to TP to regain control of FCMU assembly.</p> <p>O21B1 Reference:</p> <ul style="list-style-type: none"> • O21A1 • O21A2. <p>O21C1 Reference:</p> <ul style="list-style-type: none"> • O21A1 • O21A2. <p>O21D1 Reference:</p> <ul style="list-style-type: none"> • O21A1 • O21A2. <p>O22A1 Reference:</p> <ul style="list-style-type: none"> • O21A1 • O21B1 • O21C1 • O21D1. 	
O 2.2	Open propellant isolation valve and perform Mode II testing (pressure suit).			

O

TABLE R-VI. EXPERIMENT T-020, FOOT CONTROLLED MANEUVERING UNIT MALFUNCTION AND CONTINGENCY PLAN OUTLINE - EXPERIMENT TERMINATION (T)

Operation Step Number	Experiment/Crew Tasks	Possible Malfunction	Contingency Plan	Remarks (malfunctions, corrections, results)
			<p>No contingency plans are anticipated for the Termination section of the experiment at this time.</p>	

T

SECTION IX.

EXPERIMENT T-020, FOOT CONTROLLED MANEUVERING
UNIT MALFUNCTION ANALYSES

Malfunction Analyses for Experiment T-020 are TBS.

SECTION X. CONCLUSIONS AND RECOMMENDATIONS

1. Experiment T-020 is a simple experiment involving uncomplicated equipment and procedures; however, the experiment uses a pressurized gas propulsion system that creates a potential for injury or fatality. Although the probability of a Category I failure is small, the experiment hardware directly concerned with crew safety has been closely examined.
2. The photographic film correlation data have the greatest probability of failure. Film quality is expected to be marginal because the T-020 film will be used in a low light level environment, subjected to the degrading effects of radiation, and pushed beyond its normal film speed. Tests that have been performed to evaluate the separate effects of radiation and inadequate illumination resulted in film of marginal quality.

REFERENCES

1. Skylab Experiment Operations Handbook. Vol. I: Experiment Descriptions, MSC-00924, Manned Spacecraft Center, Houston, Texas, November 19, 1971.
2. Experiment Requirements Document for Foot Controlled Maneuvering Unit (Experiment T-020). Repository No. SE-010-026-2H, CCBD No. 800-71-0086, October 11, 1970.
3. Mission Operations Design Support. Vol. III, Rev. A: OWS Experiments, ED-2002-537, Marshall Space Flight Center, Huntsville, Alabama, March 31, 1971.
4. Mission Requirements. Vol. II: Second Skylab Mission SL-3, I-MRD-0010, Manned Spacecraft Center, Houston, Texas, Marshall Space Flight Center, Huntsville, Alabama, August 1, 1971.
5. Skylab Program Directive No. 43B (Draft). NASA Office of Manned Space Flight, Washington, D. C., February 14, 1972.
6. Mounting Fixture, Experiment T-020. Dwg. No. 8380T010200, Martin Marietta, Denver, Colorado, April 8, 1970.
7. Orbital Workshop (OWS) Reliability Evaluation Report. Vol. X: Failure Mode Effect and Criticality Analysis of Experiments System, MDC-G0433A, McDonnell Douglas Astronautics Company - Western Division, Huntington Beach, California, Rev. December 1971.
8. Propellant Isolation Valve Hose Assembly, Experiment T-020. Dwg. No. LX-812748, Langley Research Center, Hampton, Virginia, October 13, 1970.
9. Electrical Installation, Experiment T-020. Dwg. No. 8380T010160, Martin Marietta, Denver, Colorado, January 29, 1970.
10. Plumbing and Component Assembly, Experiment T-020. Dwg. No. 8380T010150, Martin Marietta, Denver, Colorado, December 12, 1969.
11. Foot Pedal Assembly, Experiment T-020. Dwg. No. 8380T010131, Martin Marietta, Denver, Colorado, December 5, 1969.

REFERENCES (Concluded)

12. Platform Assembly, Experiment T-020. Dwg. No. 8380T010130, Martin Marietta, Denver, Colorado, March 3, 1970.
13. Structure Assembly, Experiment T-020. Dwg. No. 8380T010143, Martin Marietta, Denver, Colorado, January 7, 1970.
14. PhotoEquipment for Manned Space Flight Handbook. MSC-CF-E-68-12, Manned Spacecraft Center, Houston, Texas, June 20, 1968.
15. Development of Skylab Environmental Protection for Photographic Film. NASA TM X-64 614, Marshall Space Flight Center, Huntsville, Alabama, September 1, 1971.
16. Skylab Experiments System Handbook. Manned Spacecraft Center, Houston, Texas, October 29, 1971.