

N65-30696

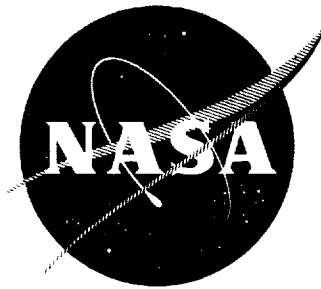

TOPICAL REPORT      **VOLUME 5**      APPENDIX

**BRUSHLESS ROTATING ELECTRICAL GENERATORS  
FOR SPACE AUXILIARY POWER SYSTEMS**

by

**J. N. Ellis and F. A. Collins**

prepared for

**NATIONAL AERONAUTICS AND SPACE ADMINISTRATION**

**CONTRACT NO. NAS 3-2783**

*LEAR SIEGLER, INC.*



*POWER EQUIPMENT DIVISION  
CLEVELAND 1, OHIO*

### NOTICE

This report was prepared as an account of Government sponsored work. Neither the United States, nor the National Aeronautics and Space Administration (NASA), nor any person acting on behalf of NASA:

- A.) Makes any warranty or representation, expressed or implied, with respect to the accuracy, completeness, or usefulness of the information contained in this report, or that the use of any information, apparatus, method, or process disclosed in this report may not infringe privately owned rights; or
- B.) Assumes any liabilities with respect to the use of, or for damages resulting from the use of any information, apparatus, method or process disclosed in this report.

As used above, "person acting on behalf of NASA" includes any employee or contractor of NASA, or employee of such contractor, to the extent that such employee or contractor of NASA, or employee of such contractor prepares, disseminates, or provides access to, any information pursuant to his employment or contract with NASA, or his employment with such contractor.

Requests for copies of this report  
should be referred to:

National Aeronautics and Space Administration  
Office of Scientific and Technical Information  
Washington, D. C. 20546  
Attention: AFSS-A

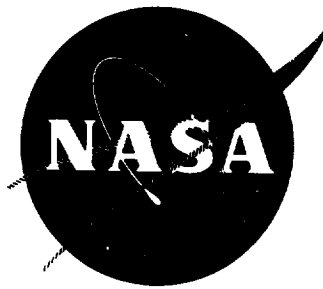

TOPICAL REPORT

BRUSHLESS ROTATING ELECTRICAL GENERATORS  
FOR SPACE AUXILIARY POWER SYSTEMS

by

J. N. Ellis and F. A. Collins

prepared for

NATIONAL AERONAUTICS AND SPACE ADMINISTRATION

April 26, 1965

Contract No. NAS 3-2783

Technical Management  
Howard A. Shumaker  
NASA Lewis Research Center  
Space Power System Division  
Solar and Chemical Power Branch

LEAR SIEGLER, INC.  
Power Equipment Division  
Cleveland, Ohio



**DISTRIBUTION LIST OF REPORTS FOR  
NASA CONTRACT NO. NAS3-2783**

---

National Aeronautics & Space Administration  
Marshall Space Flight Center  
Huntsville, Alabama  
Attention: James C. Taylor (M-ASTR-R) (1)  
Richard Boehme (M-ASTR-EC) (1)

National Aeronautics & Space Administration  
Goddard Space Flight Center  
Greenbelt, Maryland  
Attention: F.C. Yagerhofer (1)  
H. Carleton (1)

National Aeronautics & Space Administration  
Manned Spacecraft Center  
Houston, Texas 77001  
Attention: A.B. Eickmeier (SEDD) (1)  
Jerome H. Grayson (Site 8) (1)

National Aeronautics & Space Administration  
Lewis Research Center  
21000 Brookpark Road  
Cleveland, Ohio 44135  
Attention: N.T. Musial, Patent Counsel (1)  
George Mandel, Library (3)  
R.L. Cummings, Auxiliary Power Generation Office (1)  
Charles Corcoran, Electrical Systems Section (1)  
A.W. Nice, Space Electric Power Office (1)  
E.A. Koutnik, Space Electric Power Office (1)  
H.A. Shumaker, Auxiliary Power Generation Office (3)  
Dave Repas, Electrical Systems Section (1)  
John E. Dilley, NF500-309 (1)  
\* Vincent F. Hlavin, MS3-14 (1)  
Report Control Office, MS5-5 (1)

\* Final Report

National Aeronautics & Space Administration  
4th and Maryland Avenue, S. W.  
Washington, D. C. 20025  
Attention: James R. Miles, Sr. (SL) (1)  
                  P.T. Maxwell (RPP) (1)  
                  A. M. Greg Andrus (FC) (1)

National Aeronautics & Space Administration  
Scientific and Technical Information Facility  
Box 5700  
Bethesda 14, Maryland (6) plus two reproducible copies

TKM Electric Co  
820 Linden Ave.  
Rochester, New York  
Attention: Earl Dix (1)

Leece Neville Co  
5109 Hamilton Ave.  
Cleveland, Ohio  
Attention: David Goldman (1)

Delco Remy  
Anderson, Indiana  
Attention: Bill Edmondson (1)

Northern Research & Engrg. Corp.  
219 Vassar St.  
Cambridge, Mass.  
Attention: George Smith (1)

Rotax Limited  
Chandos Road  
Willesden Junction  
London NW 10, England  
Attention: E. J. Dawes (1)

## TABLE OF CONTENTS

<b>SELECTION CRITERIA &amp; MECHANICAL STUDIES FOR AC GENERATORS</b>	<b>VOL. I</b>
<b>BRIEF DESCRIPTIONS AND SCHEMATICS</b>	<b>SECTION A, VOL. I</b>
Wound Pole, Salient Pole Generator	Page A-1
Wound-Rotor, Non-Salient-Pole Generator	Page A-8
Rotating Coil Lundell	Page A-15
Single, Inside, Stationary Coil Lundell Generator	Page A-25
Two, Inside, Stationary Coil Lundell Generator (Becky Robinson)	Page A-33
Two, Outside-Coil Lundell	Page A-41
Single, Outside-Coil Lundell	Page A-46
Axial Air Gap Lundell	Page A-52
Homopolar Inductor	Page A-59
Permanent-Magnet Generator	Page A-73
How to Start a Design	Page A-116
<b>GENERATOR SELECTION CRITERIA</b>	<b>SECTION B, VOL. I</b>
Discussion	Page B-1
Family Tree Diagram of Generators	Page B-4
Comparison Chart for Brushless AC Generator Applications (Good-Better-Best Type Comparison)	Page B-5

Approximate Dimensions for Homopolar Inductor and Two, Outside Coil Lundell AC Generators	Page B-6
Weight vs. Output, Wound-Pole, Salient-Pole, Synchronous Generator	Page B-7
Volume vs. Output for Wound-Pole, Salient-Pole Synchronous Generator	Page B-8
Weight vs. Output, Two, Inside, Stationary Coil Lundell (Becky Robinson) with 4 Poles	Page B-9
Weight vs. Output, Two, Inside, Stationary Coil Lundell (Becky Robinson) with 6 Poles	Page B-10
Weight vs. Output, Two, Inside, Stationary Coil Lundell (Becky Robinson) with 8 Poles	Page B-11
Weight vs. Output, Two, Outside Coil or Single, Outside Coil Lundell (4 Poles)	Page B-12
Weight vs. Output, Two, Outside Coil or Single, Outside Coil Lundell (6 Poles)	Page B-13
Weight vs. Output, Two, Outside Coil or Single, Outside Coil Lundell (8 Poles)	Page B-13a
Weight vs. Output, Homopolar Inductor (4 Poles)	Page B-14
Weight vs. Output, Homopolar Inductor (6 Poles)	Page B-15
Weight vs. Output, Homopolar Inductor (8 Poles)	Page B-15a



Jet Propulsion Laboratory  
4800 Oak Grove Drive  
Pasadena, California  
Attention: G. E. Sweetnam (1)

Diamond Ordnance Fuze Laboratories  
Connecticut Ave. & Van Ness Street, N.W.  
Washington, D.C.  
Attention: R.B. Goodrich (Branch 940) (1)

U. S. Army Research & Development Laboratory  
Energy Conversion Branch  
Fort Monmouth, New Jersey  
Attention: H. J. Byrnes (SIGRA/SL-PSP) (1)

Engineers Research & Development Laboratory  
Electrical Power Branch  
Fort Belvoir, Virginia  
Attention: Ralph E. Hopkins (1)

Reliance Electric & Engs. Company  
24701 Euclid Avenue  
Cleveland, Ohio 44117 (1)

Sundstrand Aviation-Denver  
2480 West 70th Avenue  
Denver, Colorado 80221  
Attention: Robert Boyer (1)

Thompson Ramo Wooldridge, Inc.  
7209 Platt Avenue  
Cleveland, Ohio 44104  
Attention: Mr. Wellington (1)

Westinghouse Electric Corporation  
Aerospace Electrical Div.  
Lima, Ohio (1)

G. M. Defense Research Lab.  
General Motors Corporation  
Santa Barbara, California (1)

Aerojet-General Corporation  
Azusa, California (1)

Allis-Chalmers  
Norwood Works  
Milwaukee, Wisconsin (1)

<b>Armour Research Foundation</b> <b>10 West 35th Street</b> <b>Chicago, Illinois 60616</b>	<b>(1)</b>
<b>A. O. Smith Corporation</b> <b>Milwaukee, Wisconsin</b>	<b>(1)</b>
<b>Astra, Incorporated</b> <b>Box 226</b> <b>Raleigh, North Carolina</b>	<b>(1)</b>
<b>General Dynamics Corporation</b> <b>1601 Brookpark Road</b> <b>Cleveland, Ohio</b> <b>Attention: George Vila</b>	<b>(1)</b>
<b>Materials Research Corporation</b> <b>Orangeburg, New York 10962</b> <b>Attention: Vernon E. Adler</b>	<b>(1)</b>
<b>Aeronautical Systems Division</b> <b>Wright Patterson Air Force Base</b> <b>Dayton, Ohio</b> <b>Attention: ASRMFP-3</b>	<b>(1)</b>
<b>University of Pennsylvania</b> <b>Power Information Center</b> <b>Moore School Building</b> <b>200 South 33rd Street</b> <b>Philadelphia, Pennsylvania 19104</b>	<b>(1)</b>
<b>Duke University</b> <b>College of Engineering</b> <b>Department of Electrical Engineering</b> <b>Durham, North Carolina</b> <b>Attention: T.G. Wilson</b>	<b>(1)</b>
<b>Naval Research Laboratory</b> <b>Washington, D.C. 20025</b> <b>Attention: B.J. Wilson (Code 5230)</b>	<b>(1)</b>
<b>Bureau of Naval Weapons</b> <b>Department of the Navy</b> <b>Washington, D.C. 20025</b> <b>Attention: W. T. Beatson (Code RAEE-52)</b> <b>                  Milton Knight (Code RAEE-511)</b>	<b>(1)</b> <b>(1)</b>

Battelle Memorial Institute  
505 King Avenue  
Columbus, Ohio 43201 (1)

Dynatech Corporation  
17 Tudor Street  
Cambridge, Massachusetts 02139 (1)

AiResearch Division  
The Garrett Corporation  
Los Angeles, California 90045 (1)

Motor and Generator Dept.  
General Electric Company  
3001 East Lake Road  
Erie, Pennsylvania (1)

IMC Magnetics Corp.  
6058 Walker Avenue  
Maywood, California  
Attention: M. L. Rice (1)

Detroit Arsenal  
Center Line, Michigan  
Attention: Mr. Walter Slabiak/SMOTA-RCP. 4 (1)

Wright Machinery Company  
Division of Sperry Rand Corporation  
Durham, North Carolina  
Attention: P. H. Trickey (1)

Aerospace Corporation  
P. O. Box 95085  
Los Angeles, California 90045  
Attention: Library Technical Documents Group (1)

Giannini Control Corporation  
1600 South Mountain Avenue  
Duarte, California 91010  
Attention: Miss Cecily J. Surace, Library (1)

Carrier Research & Development Co.  
Division of Carrier Corp.  
Carrier Parkway  
Syracuse, New York 13201  
Attention: John Law, Jr. (1)



$C_m$ and $C_q$ , Curve 9	Page F-12
Magnetization Curve, Pure Iron, Curve 10	Page F-13
Magnetization Curve, M-43 Silicon Irons, Curve 11A	Page F-14
Magnetization Curve, M36, Curve 11B	Page F-14
Magnetization Curve M-22, Curve 11C and 11E	Page F-14
Magnetization Curve M-15, Curve 11D	Page F-14
Magnetization Curve, 1% Max. Carbon, Curve 12	Page F-18
Magnetization Curve, Cobalt- Iron, Curve 13	Page F-19
Magnetization Curve For Cast and Forged Cobalt-Iron Alloy, Curve 13b	Page F-21
Magnetization Curve, 4620, 4130, 4140, 6302, Curve 14	Page F-22
Magnetization Curve, 6427, Hy-TUF 410 SS, VASCOJET, Curve 15	Page F-23
Magnetization Curve, 1095, P-6, Curve 16	Page F-24
Magnet Stabilization Point ( $A_T$ ) Versus Out-of-Stator Leakage Permeance for Alnico V and Alnico VI, Curve 17	Page F-25
Magnet Stabilization Point ( $A_T$ ) Versus Out-of-Stator Leakage Permeance for Alnico VIII, Curve 18	Page F-26

Magnet Stabilization Point ( $A_T$ ) Versus Out-of-Stator Leakage Permeance for Alnico V7, Curve 19	Page F-27
Demagnetization Curves for High Energy Product Cast Alnicos, Curve 20	Page F-28
Demagnetization Curve for Cast Alnico VIII, Curve 21	Page F-29
Demagnetization Curve for Cast Alnico VIII, Curve 22	Page F-30
Demagnetization Curve for Cast Alnico V7, Curve 23	Page F-31
Demagnetization Curve for Cast Alnico VI, Curve 24	Page F-32
Demagnetization Curve for Cast Alnico V, Curve 25	Page F-33
Iron Losses for Cobalt-Iron Alloy, Curve 13a	Page F-20
Iron Losses for Si-Fe Alloys at Various Frequencies, Curve 11H	Page F-17
Iron Losses for Silicone-Iron Alloys, at 400 cps, Curve 11F	Page F-15
Iron Losses for Si-Fe Alloys at 60 cps, Curve 11G	Page F-16
Curve Points of Magnetic Metals	Page F-34
Magnetic Properties of Cr-Ni Steels	Page F-36
<b>MASTER DESIGN MANUAL (SALIENT-POLE, WOUND-POLE, SYNCHRONOUS AC GENERATOR</b>	<b>SECTION G, VOL. II</b>
Input Sheet	Page G-01

Output Sheet	Page G-03
Design Procedure	Page G-1
<b>DESIGN MANUAL FOR NON-SALIENT, WOUND-ROTOR, SYNCHRONOUS AC GENERATOR</b>	<b>SECTION H, VOL. II</b>
Input Sheet	Page H-01
Output Sheet	Page H-02
Design Procedure	Page H-1
<b>DESIGN MANUAL FOR ROTATING-COIL AC LUNDELL TYPE GENERATORS</b>	<b>SECTION J, VOL. II</b>
Input Sheet	Page J-01
Output Sheet	Page J-03
Design Procedure	Page J-1
<b>DESIGN MANUAL FOR SINGLE, INSIDE, STATIONARY-COIL AC LUNDELL- TYPE GENERATOR</b>	<b>SECTION K, VOL. II</b>
Input Sheet	Page K-01
Output Sheet	Page K-03
Design Manual	Page K-1
<b>DESIGN MANUAL FOR TWO, INSIDE- COIL, STATIONARY-COIL AC LUNDELL- TYPE GENERATOR (BECKY ROBINSON PATENT)</b>	<b>SECTION L, VOL. II</b>
Input Sheet	Page L-01
Output Sheet	Page L-04
Design Manual	Page L-1

**DESIGN MANUAL FOR TWO COIL AND  
SINGLE-COIL, OUTSIDE COIL AC  
LUNDELL-TYPE GENERATORS**

**SECTION M, VOL. II**

**Input Sheet**

**Page M-01**

**Output Sheet**

**Page M-03**

**Design Manual For Two-Coil Lundell**

**Page M-1**

**Design Manual For One-Coil Lundell**

**Page M-41**

**DESIGN MANUAL FOR AXIAL AIR-GAP,  
STATIONARY-COIL, SALIENT-POLE,  
SYNCHRONOUS AC GENERATOR**

**SECTION N, VOL. III**

**Discussion**

**Page N-1**

**Design Sheet**

**Page N-4**

**Design Manual**

**Page N-5**

**DESIGN MANUAL FOR HOMOPOLAR  
INDUCTOR, AC GENERATOR**

**SECTION P, VOL. III**

**Input Sheet**

**Page P-01**

**Output Sheet**

**Page P-03**

**Design Manual**

**Page P-1**

**DESIGN MANUAL FOR PERMANENT  
MAGNET, SALIENT-POLE AC  
GENERATORS**

**SECTION R, VOL. III**

**Discussion**

**Page R-1**

**Input Sheet**

**Page R-01**

**Output Sheet**

**Page R-03**

**Design Manual**

**Page R-22**



EQUIVALENT CIRCUITS

SECTION S, VOL. III

SYMBOL TABLES

SECTION T, VOL. III

GENERATOR THERMAL ANALYSIS  
COMPUTER PROGRAM (FORTRAN)

SECTION CA, VOL. IV

SALIENT-POLE WOUND-POLE  
SYNCHRONOUS GENERATOR COMPUTER  
PROGRAM AND TEST DATA

SECTION GA, VOL. IV

Computer Input 30 KVA Generator

Page GA-1

Computer Output 30 KVA Generator

Page GA-2

Test Data 30 KVA Generator

Page GA-5

Computer Program (Fortran)

Page GA-14

NON-SALIENT-POLE, WOUND-ROTOR  
SYNCHRONOUS GENERATOR COMPUTER  
PROGRAM AND TEST DATA

SECTION HA, VOL. IV

Computer Input 120 KVA Generator

Page HA-1

Computer Output 120 KVA Generator

Page HA-2

Test Data 120 KVA Generator

Page HA-4

Computer Program (Fortran)

Page HA-29

ROTATING-COIL LUNDELL, A-C  
GENERATOR COMPUTER PROGRAM  
AND TEST DATA

SECTION JA, VOL. IV

Computer Input 840 Watt Generator

Page JA-1

Computer Output 840 Watt Generator

Page JA-5

Test Data 840 Watt Generator

Page JA-7

Computer Program 840 Watt Generator	Page JA-25
<b>INSIDE, SINGLE-COIL, STATIONARY- COIL LUNDELL, A-C GENERATOR COMPUTER PROGRAM AND TEST DATA</b>	Page KA, VOL. IV
Computer Input	Page KA-1
Computer Output	Page KA-3
Computer Program	Page KA-22
<b>INSIDE, TWO-COIL STATIONARY COIL LUNDELL A-C GENERATOR COMPUTER PROGRAM AND TEST DATA</b>	SECTION LA, VOL. IV
Computer Input 30 KVA Generator	Page LA-3
Computer Output 30 KVA Generator	Page LA-1
Test Data 30 KVA Generator	Page LA-6
Computer Program	Page LA-37
<b>TWO-COIL AND SINGLE-COIL OUTSIDE- COIL, LUNDELL, A-C GENERATOR COMPUTER PROGRAM AND TEST DATA</b>	SECTION MA, VOL. V
Computer Input 840 Watt Generator	Page MA-1
Computer Output 840 Watt Generator	Page MA-3
Test Data 840 Watt Generator	Page MA-7
Computer Program	Page MA-20
<b>HOMOPOLAR INDUCTOR A-C GENERATOR COMPUTER PROGRAM AND TEST DATA</b>	SECTION PA, VOL. V
Computer Input	Page PA-01

Computer Output	Page PA-03
Test Data	Page PA-05
Computer Program	Page PA-19
<b>PERMANENT MAGNET A-C GENERATOR COMPUTER PROGRAM AND TEST DATA</b>	<b>SECTION RA, VOL. V</b>
Computer Input	Page RA-1
Computer Output	Page RA-3
Test Data	Page RA-5
Computer Program	Page RA-22
<b>DERIVATIONS</b>	<b>SECTION SA, VOL. V</b>
Pole Face Losses in Solid-Pole Generators	Page SA-1
Graphical Flux Analysis	Page SA-29
The Maximum $\frac{l}{d}$ Ratio for Rotating Coil Lundell A-C Generators	Page SA-38
The Maximum $\frac{l}{d}$ Ratio for Two, Inside, Stationary- Coil Lundell A-C Generators	Page SA-40
The Development of Equations Describing the Weights of Electromagnetic Parts for Three Generator Types	Page SA-43
Generator Stator Ampere Load- ing - A Discussion	Page SA-50
Grouping of Fractional Slot Windings	Page SA-53
Distribution Factor	Page SA-58

Fractional Slot Distribution Factor	Page SA-60
Skew Factor	Page SA-61
Pitch Factor	Page SA-64
Reactances, Per-Unit System	Page SA-67
Synchronous Reactance	Page SA-69
Reactance of Armature Reaction	Page SA-72
Transient Reactance	Page SA-74
Subtransient Reactance	Page SA-78
Negative Sequence Reactance	Page SA-79
Zero Sequence Reactance	Page SA-79
Leakage Reactance	Page SA-80
Potier Reactance	Page SA-86
Time Constants	Page SA-89
Resistance	Page SA-95
Generator Voltage and Output Equations	Page SA-96
$C_m$	Page SA-100
$C_q$	Page SA-103
Permeance Calculations	Page SA-110
<b>EFFECT OF INCREASING THE AIR GAP</b>	<b>SECTION TA, VOL. V</b>

## FIGURES

	<u>Figure No.</u>	<u>Page No.</u>
Wound-Pole, Salient-Pole AC Generator	A-1	A-1
Wound-Pole, Salient-Pole AC Generator	A-2	A-4
Wound-Pole, Rotating-Rectifier AC Generator	A-3	A-5
Wound-Pole Synchronous AC Generator	A-4	A-6
Photograph of Wound-Pole Synchronous Generator	A-5	A-7
Field Form for Non-Salient Pole Wound-Pole AC Generator	A-6	A-9
Rotor Views - NSP AC Generator	A-7	A-10
Photograph of Rotor & Stator (NSP Generator)	A-8	A-11
Photograph of Rotor & Stator (NSP Generator)	A-9	A-12
Exploded View of Complete NSP AC Generator	A-10	A-13
Rotating-Coil Lundell AC Generator	A-11	A-14
Step 1 of Conversion to Outside-Coil Lundell	A-12	A-15
Step 2 of Conversion	A-13	A-16

	<u>Figure No.</u>	<u>Page No.</u>
Conversion of Rotating-Coil to Stationary-Coil Lundell	A-14	A-17
How to Make a Becky-Robinson Lundell	A-15	A-18
How to Make a Homopolar Inductor	A-16	A-19
Patent Drawing, Rotating Coil Lundell	A-17	A-20
Photo Rotating-Coil Lundell	A-18	A-21
Rotor, Rotating-Coil Lundell	A-19	A-22
Photo, Rotating Coil Lundell	A-20	A-23
Single-Inside, Stationary-Coil Lundell	A-21	A-24
Single-Inside, Stationary-Coil Lundell	A-22	A-26
Single-Inside, Stationary-Coil Lundell	A-23	A-27
Single-Inside, Stationary-Coil Lundell Patent Drawing	A-24	A-29
Photo of Single, Inside, Stationary-Coil Lundell	A-24a	A-30
Photo of Single, Inside, Stationary-Coil Lundell	A-24	A-31
MG Set	A-26	A-32
Two-Inside Stationary Coil Lundell	A-27	A-33
Two-Inside Stationary Coil Lundell Photo	A-28	A-36

	<u>Figure No.</u>	<u>Page No.</u>
Two-Inside Stationary Coil Lundell Photo	A-29	A-37
Two-Inside Stationary Coil Lundell Photo	A-30	A-38
Two-Inside Stationary Coil Lundell Flux Circuit	A-31	A-39
Two-Inside Stationary Coil Lundell Flux Circuit	A-32	A-40
Two-Outside Coil Lundell Flux Circuit Schematics	A-33	A-42
Two-Outside Coil Lundell Drawing	A-34	A-43
Two-Outside Coil Lundell Patent Drawing	A-35	A-44
Photo Two-Outside Coil Lundell	A-36	A-45
Single-Coil Outside Coil Lundell	A-37	A-48
Pole Configuration	A-38	A-49
Single Coil Outside-Coil Lundell	A-39	A-50
Pole Configuration	A-40	A-51
Axial Air-Gap Lundell	A-41	A-52
Axial Air-Gap Lundell Patent Drawing	A-42a	A-55
Axial Air-Gap Lundell Rotor Photo	A-42c	A-56
Axial Air-Gap Lundell Stator Photo	A-42b	A-57
Double Axial-Gap Generator	A-42c	A-58

	<u>Figure No.</u>	<u>Page No.</u>
Homopolar Inductor	A-43	A-59
Homopolar Inductor	A-44	A-60
Homopolar Inductor Rotor	A-45	A-64
Homopolar Inductor Rotor	A-46	A-66
Patent Drawing for Homopolar Inductor	A-47a	A-68
Patent Drawing for Homopolar Inductor	A-47b	A-69
Permanent-Magnet AC Generator	A-48	A-73
PM Rotor Types	A-49	A-77
Earliest PM Generator	A-50	A-78
Patent Drawing for Axial Gap PM Generator	A-51	A-79
PM Hysteresis Loop	A-52	A-81
PM Hysteresis Loop	A-53	A-84
Volt Ampere Characteristic	A-54	A-86
Saturation Curve	A-55	A-88
Saturation Curve & $B_r$	A-56	A-89
Air Gap Shear Line	A-57	A-90
$F_{dm}$	A-58	A-91
Short Circuit Stabilization	A-59	A-92
Out of Stator Permeance Shear Line	A-60	A-93
In-Stator Permeance Shear Line	A-61	A-96



	<u>Figure No.</u>	<u>Page No.</u>
Useful Flux	A-62	A-98
Construction of Load Points On The PM Generator Hysteresis Loop	A-63	A-99
Air Gap Energy Storage	A-64	A-100
Air Gap Energy Storage	A-65	A-101
Vector Diagram	A-66	A-105
Vector Diagrams for AC Generators Having High Stator Winding Resistance	A-67	A-106
Vector Diagrams for AC Generators Having Low Stator Winding Resistance	A-68	A-107
Locus of Terminal Voltage	A-69	A-108
Locus of Terminal Voltage	A-70	A-109
Volt-Ampere Characteristic	A-71	A-110
Weight vs. Rating for Salient-Pole Wound-Pole, Rotating-Rectifier AC Generators	B-1 B-1	B-7 B-7
Volume vs. Rating for Salient-Pole Wound-Pole, Rotating-Rectifier AC Generators	B-2	B-8
Weight Breakdown for Two, Inside- Coil Lundell Generators (Becky- Robinson)	B-3 B-4 B-5	B-9 B-10 B-11
Weight Breakdown for a Two-Coil Outside-Coil, Lundell Generator	B-6 B-7 B-8	B-12 B-13 B-14

	<u>Figure No.</u>	<u>Page No.</u>
Weight Breakdown for a Homopolar Inductor AC Generator	B-9	B-15
	B-10	B-16
	B-11	B-17
Weight vs. Rating for Wound Stators	B-12	B-18
Weight vs. Stator O. D. for Disk- Type Lundell Generators	B-13	B-19
KVA Output vs. Stator O. D. for Disk-Type Lundell Generators	B-14	B-20
Pole-Face Loss Curves	B-15	B-22
	B-16	B-23
	B-17	B-24
	B-18	B-25
Heat Dissipation From a Generator Rotor	B-19	B-26
Induction Motor Speed Torque Curves	B-20	B-28
Lundell Motor Speed Torque Curves	B-21	B-30
Wound Pole Motor Speed-Torque Curves	B-22	B-31
Induced Field Voltage During Start of Salient, Wound Pole Motor	B-23	B-34
Alternator Configuration for Thermal Analysis	CA-1	C-60
Friction Design Charts	CA-2	C-61
Homopolar Inductor Rotor	D-1	D-8a

	<u>Figure No.</u>	<u>Page No.</u>
Outside Coil Lundell Rotor	D-2	D-8b
Becky Robinson Rotor	D-3	D-8c
Rotor Model	D-4	D-8d
Bearing Stiffness Curves	D-5	D-8e
Critical Speeds for Outside-Coil Lundell	D-6	D-8f
Critical Speeds for Inside-Coil Lundell	D-7	D-8g
Dynamic Response for Homopolar Inductor	D-8	D-8h
Dynamic Response for Homopolar Inductor	D-9	D-8i
Dynamic Response for Homopolar Inductor	D-10	D-8j
Absolute Viscosity of Various Gases	E-1	E-11a
Self Acting Gas Bearings	E-7	E-22a
Tilting-Pad Bearing Schematic	E-8	E-22b
Load Calculating Charts for Cylindrical Journal Bearings	E-9	E-22c
Curves for Tilting-Pad Bearings	E-10	E-22d
Self Acting Thrust Bearings	E-11	E-43a
Pressure Rise in Bearing Caps	E-12	E-43b
Friction Vectors in Bearings	E-13	E-43c
Spiral-Groove Thrust Bearings	E-14	E-43d

	<u>Figure No.</u>	<u>Page No.</u>
Curvature Effects on Load and Bearing Stiffness	E-15	E-43e
End-Leakage in Spiral-Grooved Bearings	E-16	E-43f
Effects of Grooves on Pressure Profile	E-17	E-43g
Hydrostatic Bearing Stiffness vs. Restrictor Coefficient	E-21	E-54a
Hydrostatic Bearing Stiffness vs. Restrictor Coefficient	E-22	E-54b
Hydrostatic Bearing Flow vs. Restrictor Coefficient	E-23	E-54c
Hydrostatic Bearing Flow vs. Restrictor Coefficient	E-24	E-54d
Hybrid Journal Bearing Load vs. Compressibility Number	E-25	E-54e
P <sub>1</sub> , Pole Head Leakage Permeance	J-4	J-9
P <sub>2</sub> , Pole Head Side Leakage Permeance	J-5	J-11
P <sub>3</sub> Pole Body End Leakage Permeance	J-6	J-12
P <sub>4</sub> Pole Body Side Leakage Permeance	J-8	J-15
P <sub>5</sub> Coil Leakage Permeance	J-9	J-16
P <sub>7</sub> Stator Leakage Permeance	J-10	J-18
MMF Drops	J-11	J-19
Diagram of Leakages	J-12	J-20

	<u>Figure No.</u>	<u>Page No.</u>
Pole Dimensions	K-2	K-7
Rotor & Stator Dimensions	K-3	K-9
Permeance Path P <sub>2</sub>	K-4	K-11
Permeance Path P <sub>3</sub> , P <sub>5</sub>	K-5	K-12
Permeance Path P <sub>1</sub> , P <sub>2</sub> , P <sub>4</sub>	K-6	K-13
MMF Drops and Leakage Fluxes	K-7	K-14
Becky Robinson Lundell Pole Types and Dimensions	L-2	L-8
Rotor Dimensions	L-3	L-10
Types of Auxiliary Gap and Gap Dimensions	L-4	L-11
Rotor Dimensions	L-5	L-13
Leakage Permeance P <sub>3</sub>	L-6	L-17
Leakage Permeance P <sub>4</sub> and MMF Drops	L-7	L-18
Leakage Permeance P <sub>4</sub>	L-8	L-19
Leakage Permeance P <sub>4</sub>	L-9	L-20
Coil Leakage Permeance P <sub>5</sub>	L-10	L-22
Coil Leakage Permeance P <sub>6</sub>	L-11	L-23
Coil Leakage Permeances P <sub>5</sub> and P <sub>6</sub>	L-12	L-24
Leakage Permeance P <sub>7</sub> from Stator to Rotor	L-13	L-25

	<u>Figure No.</u>	<u>Page No.</u>
Outside-Coil Lundell Stator and Rotor Dimensions	M-3	M-9
Leakage Permeance $P_1$	M-4	M-13
Leakage Permeance $P_2$	M-5	M-14
Leakage Permeance $P_3$	M-6	M-15
Leakage Permeance $P_4$	M-7	M-16
MMF Drops and Leakage Paths in Outside-Coil Lundell	M-8	M-17
Three Possible Locations and Permeances $P_5, P_7$	M-9	M-18
Leakage Flux $\phi_7$ From Stator to Rotor	M-10	M-21
Leakage Permeances for I-coil Outside-Coil Lundell	M-14	M-52
Stator Leakage Flux $\phi_7$	M-15	M-53
MMF Drops in Outside-Coil Lundell and Leakage Flux $\phi_7$	M-16	M-54
Disk-Type Lundell Generator	N-1	N-2
Flux Circuit for Disk-Type Lundell	N-2	N-3
Design Sheet for Disk-Type Lundell	N-3	N-4
Pole Dimensions	N-4a	N-26
Pole Dimensions	N-4b	N-26
Rotor Leakage Permeances	N-5	N-27
Rotor Leakage Permeance $P_4$	N-6	N-29

	<u>Figure No.</u>	<u>Page No.</u>
Homopolar Inductor Housing Type 1 Item (78)		P-8
Types 2 and 3		P-9
Homopolar Inductor Shaft Dimensions Item (78a)		P-10
PM Generator	R-1	R-2
Rotor Leakage Permeances	R-2	R-4
Rotor Leakage Permeance $P_1$	R-3	R-5
Curve for $P_1$	R-5	R-7
Rotor Leakage Permeance $P_s$	R-6	R-8
Rotor Leakage Permeance $P_f$	R-7	R-9
Curve for Leakage Permeance $P_2$	R-8	R-10
Rotor Leakage Permeance $P_{s1}$	R-9	R-11
Rotor Pole Tip Leakage	R-10	R-13
Rotor Leakage Permeance $P_{s2}$	R-11	R-14
Rotor Leakage Permeance $P_3$	R-12	R-15
Curve for $P_3$	R-13	R-16
Magneti Comparisons	R-14	R-20
Magnet Comparisons	R-15	R-21
Equivalent-Circuit Representation for Synchronous AC Generator Carrying a Balanced Load		S-33

	<u>Figure No.</u>	<u>Page No.</u>
Equivalent-Circuit Representation for Synchronous AC Generator Carrying a Balanced Load		S-35
Equivalent Circuit for Synchronous AC Generator Carrying an Unbalanced Load		S-73
Equivalent Circuit for Synchronous AC Generator Carrying an Unbalanced Load		S-74



## TABLES

List of Cobalt Steels	Page A-111
Table of PM Steel Characteristics	Page A-113
Table of PM Steel Characteristics	Page A-114
Table of PM Steel Composition	Page A-115
Family Tree of Brushless AC Generators	Page B-4
Comparison Chart for Brushless AC Generators	Page B-4
Approx. Dimensions for Homopolar Inductors and for Outside-Coil Lundell AC Generators	Page B-6
Gas Bearings	Page E-7
Operating Requirements of Gas Bearing Types	Page E-8
Gas Lubricated Journal Bearing Family Tree	Page E-9
Gas Lubricated Thrust Bearing Family Tree	Page E-10
Required Design Information	Page E-11
Bearing Parameter for Maximum Load Capacity	Page E-41
Bearing Tolerance Ranges	Page E-42
Effects of Grooves in Gas Bearings	Page E-43

<b>Alloy Classes Useful as Base Materials for Shaft and/or Bearings</b>	<b>Page E-76</b>
<b>Material Combinations that Have Been Used for Large Bearings</b>	<b>Page E-77</b>
<b>Bearing (Rolling Element) Life Dispersion Curve</b>	<b>Page E-82</b>
<b>Speed and Size of Light and Extra Light Superprecision Ball Bearings</b>	<b>Page E-84</b>
<b>Inner-Race RPM for Oil Jet or Oil-Mist Lubrication Extra Light Series Ball Bearings</b>	<b>Page E-85</b>
<b>Limiting Speeds for Grease Lubricated Ball Bearings</b>	<b>Page E-86</b>
<b>Temperature Limitation of Ball Bearings</b>	<b>Page E-87</b>

Section A



Section B



Section CA or Section C



Section D



Section E



Section F



Section GA or Section G



Section HA or Section H



Section JA or Section J



Section KA or Section K



Section LA or Section L



Section MA or Section M



Section N



Section PA or Section P



Section RA or Section R



Section SA or Section S



Section TA or Section T



( )

1941

1942

1943

1944

1945

1946

1947

1948

1949

1950

1951

1952

1953

1954

1955

1956

1957

1958

1959

1960

1961

1962

1963

1964

1965

1966

1967

1968

1969

1970

1971

1972

1973

1974

1975

1976

1977

1978

1979

1980

1981

1982

1983

1984

1985

1986

1987

1988

1989

1990

1991

1992

1993

1994

1995

1996

1997

1998

1999

2000

2001

2002

2003

2004

2005

2006

2007

2008

2009

2010

2011

2012

2013

2014

2015

2016

2017

2018

2019

2020

2021

2022

2023

2024

2025

TWO-COIL AND ONE-COIL, OUTSIDE-COIL,  
LUNDELL, A-C GENERATOR  
COMPUTER PROGRAM AND TEST DATA

1  
2  
3  
4  
5  
6  
7  
8  
9  
10  
11  
12  
13  
14  
15  
16  
17  
18  
19  
20  
21  
22  
23  
24  
25  
26  
27  
28  
29  
30  
31  
32  
33  
34  
35  
36  
37  
38  
39  
40  
41  
42  
43  
44  
45  
46  
47  
48  
49  
50  
51  
52  
53  
54  
55  
56  
57  
58  
59  
60  
61  
62  
63  
64  
65  
66  
67  
68  
69  
70  
71  
72  
73  
74  
75  
76  
77  
78  
79  
80  
81  
82  
83  
84  
85  
86  
87  
88  
89  
90  
91  
92  
93  
94  
95  
96  
97  
98  
99  
100

TWO OR SINGLE COIL OUTSIDE COIL LUNDELL

5-7-65

MODEL *Brushless* EWO DESIGN NO(1) *M-1*

PARAMETERS	(2)	KVA	GENERATOR KVA	1.04	0	FUND/MAX OF FLD FLUX	(71)	C <sub>1</sub>	CONSTANTS
(3)	E	LINE VOLTS	15	0	WINDING CONSTANT	(72)	C <sub>w</sub>		
(4)	E <sub>ph</sub>	PHASE VOLTS	8.7	0	POLE CONSTANT	(73)	C <sub>p</sub>		
(5)	m	PHASES	3	0	END EXTENSION ONE TURN	(48)	LE		
(5a)	f	FREQUENCY	200	0	DEMAGNETIZATION FACTOR	(74)	C <sub>m</sub>		
(6)	p	POLES	12	0	CROSS MAGNETIZING FACTOR	(75)	C <sub>g</sub>		
(7)	RPM	RPM	2000	.64	POLE EMBRACE	(77)	α		
(8)	I <sub>ph</sub>	PHASE CURRENT	40	.45	WIDTH OF POLE(NARROW END)	(76)	bp1		
(9)	PF	POWER FACTOR	.95	1.15	WIDTH OF POLE(WIDTH END)	(76)	bp2		
(9a)	K <sub>c</sub>	ADJ. FACTOR	1.0	.2	POLE THICKNESS (NARROW END)	(76)	tp1		
(10)		OPTIONAL LOAD POINT	1.25	.4	POLE THICKNESS (WIDE END)	(76)	tp2		
STATOR STACK	(11)	d	STATOR I.D.	4.80	1.15	POLE LENGTH	(76)	l <sub>p</sub>	POLE
	(12)	D	STATOR O.D.	6.63	4.76	ROTOR DIAMETER	(11a)	d <sub>r</sub>	
	(13)		GROSS CORE LENGTH	1.0	0	WEIGHT OF ROTOR IRON	(157)	(-)	
	(14)	n <sub>v</sub>	NO. OF DUCTS	0	7	POLE FACE LOSS FACTOR	(187)	(K <sub>1</sub> )	
	(15)	b <sub>y</sub>	WIDTH OF DUCT	0	0	PERM OF LEAKAGE PATH 1	(80)	P <sub>1</sub>	
STATOR SLOT	(16)	K <sub>i</sub>	STACKING FACTOR STATOR	.93	0	PERM OF LEAKAGE PATH 2	(81)	P <sub>2</sub>	PERMEANCE
	(19)	k	WATTS/LB.	5.0	0	PERM OF LEAKAGE PATH 3	(82)	P <sub>3</sub>	
	(20)	B	DENSITY	77.4	0	PERM OF LEAKAGE PATH 4	(83)	P <sub>4</sub>	
	(21)		TYPE OF SLOT	3	12.4	PERM OF LEAKAGE PATH 5	(84)	P <sub>5</sub>	
	(22)	b <sub>o</sub>	SLOT OPENING	.120	18.3	PERM OF LEAKAGE PATH 7	(86)	P <sub>7</sub>	
	(22)	b <sub>1</sub>	SLOT WIDTH TOP	.160	22.2	PERM OF LEAKAGE PATH	(86a)	P <sub>8</sub>	
	(22)	b <sub>2</sub>		.160	2.8	DIA. OF END BELL AT SMALLEST SECT	(78)	d <sub>y2</sub>	
	(22)	b <sub>3</sub>		.250	.35	THICKNESS OF END BELL " "	(78)	ly2	
	(22)	b <sub>4</sub>	SLOT WIDTH	.205	.150	THICKNESS OF HOUSING SECTION	(78)	ly	
	(22)	h <sub>o</sub>		.020	1.7	LENGTH OF HOUSING SECTION	(78)	ly	
STATOR WINDING	(22)	h <sub>1</sub>		.500	1.0	LENGTH OF PERM PATH 1	(80a)	l <sub>1</sub>	FIELD
	(22)	h <sub>2</sub>		0	2	NO. OF FIELD COILS	(146b)	N <sub>co</sub>	
	(22)	h <sub>3</sub>		0	350	NO. OF FIELD TURNS/COIL	(146)	N <sub>f</sub>	
	(22)	h <sub>4</sub>	SLOT DEPTH	.550	12	MEAN LENGTH OF FLD. TURN	(147)	l <sub>if</sub>	
	(22)	h <sub>1</sub>		.030	.0403	FLD. COND. DIA. OR WIDTH	(148)		
	(22)	h <sub>w</sub>		.001	0	FLD. COND. THICKNESS	(149)		
	(23)	Q	NO. OF SLOTS	36	100	FLD. TEMP IN °C	(150)	X <sub>f</sub> °C	
	(28)		TYPE OF WDG.	1	.694	RESISTIVITY OF FLD. COND. @ 20 °	(151)	ρ <sub>f</sub>	
	(29)		TYPE OF COIL	0	1	NO LOAD SAT.	(87)		
	(30)	n <sub>s</sub>	CONDUCTORS/SLOT	14	0	FRICTION & WINDAGE	(183)	(F&W)	
GAP	(31)	γ	SLOTS SPANNED	3	38.3	SPECIAL PERMEANCE	64a	λ <sub>s</sub>	MATRIX
	(32)	c	PARALLEL CIRCUITS	2	11E	STATOR LAM MATERIAL	M22	(18)	
	(33)		STRAND DIA. OR WIDTH	.0508	13	POLE MATERIAL	1010	(18)	
	(34)	N <sub>st</sub>	STRANDS/CONDUCTOR IN DEPTH	1	12	YOKE MATERIAL	1010	(18)	
	(34a)	N' <sub>st</sub>	STRANDS/CONDUCTOR	2					
	(39)		STATOR STRAND T'KNS.	0					
	(35)	d <sub>b</sub>	DIA. OF PIN	.25					
	(36)	l <sub>o2</sub>	COIL EXT. STR. PORT	.2					
	(37)	h <sub>st</sub>	UNINS. STRD. HT.	.0508		STATOR SLOT DAMPER SLOT		POLE REMARKS	
	(38)	h' <sub>st</sub>	DIST. BTWN. C <sub>L</sub> OF STD.	.053					
(42a)		PHASE BELT ANGLE	60						
(40)	γ <sub>sk</sub>	STATOR SLOT SKEW	0						
(50)	X °C	STATOR TEMP °C	100						
(51)	ρ <sub>s</sub>	RES'TVY STA. COND. @ 20 °C	.694						
(78)	l <sub>g2</sub>	LENGTH OF GAP (g2)	1.20						
(78)	d <sub>g2</sub>	DIAMETER AT GAP (g2)	2.0						
(59)	g	MAIN AIR GAP	.018						
(59a)	g2	AUXILIARY AIR GAP	.020						

(a) Open Slots

(b) Constant Slot Width

**TYPE 1**  
(Type 5 is an open slot with 1 conductor per slot)

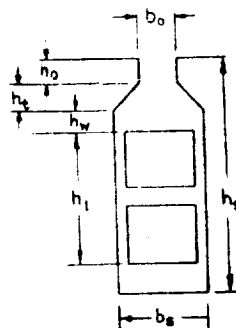
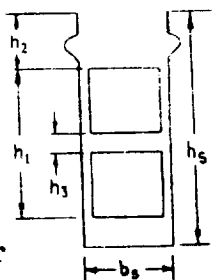

**TYPE 2**

(c) Constant Tooth Width

(d) Round Slots

**TYPE 3**

$b_s$  for type 3 is

$$b_s = \frac{b_1 + b_3}{2}$$

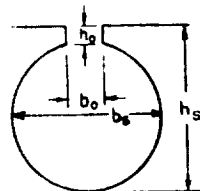
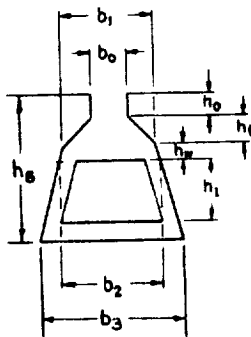

**TYPE 4**



**TWO OR SINGLE COIL OUTSIDE COIL LUNDELL**  
**SUMMARY OF DESIGN CALCULATIONS - - - - - (OUTPUT)**

*40 AMPS 5/7/65*

MODEL NO.	EWO	DESIGN NO	150	200	OPTIONAL
(17) ( $l_s$ ) SOLID CORE LENGTH	.93000	1.25550			
(24) ( $h_c$ ) DEPTH BELOW SLOT	.36500	.92250			
(26) ( $\tau_s$ ) SLOT PITCH	.41895	1.00935			
(27) ( $\tau_s/3$ ) SLOT PITCH 1/3 DIST. UP	.45095	.43450			
(42) ( $K_{sk}$ ) SKFW FACTOR	1.00000	.65952			
(43) ( $K_d$ ) DIST. FACTOR	1.00000	2.38137			
(44) ( $K_p$ ) PITCH FACTOR	.99999	.86321			
(45) ( $n_c$ ) EFF. CONDUCTORS	251.99999	.40680			
(46) ( $a_c$ ) COND. AREA	.00405	668.36000			
(47) ( $S_s$ ) CURRENT DENSITY (STA.)	4936.30000	1.62137			
(49) ( $l_s$ ) 1/2 MEAN TURN LENGTH	3.68130	103.18640			
(53) ( $R_{ph}$ ) COLD STA. RES. @ 20° C	.02792	98.05278			
(54) ( $R_{ph}$ ) HOT STA. RES. @ X° C	.03680	43.21403			
(55) ( $E_{Ftop}$ ) EDDY FACTOR TOP	1.01840	201.23918			
(56) ( $E_{Fbot}$ ) EDDY FACTOR BOT	1.00260	146.40043			
(62) ( $\lambda_i$ ) STATOR COND. PERM.	16.12100	57.75085			
(63) ( $\lambda_o$ ) END PERM.	9.22020	.21372			
(65) ( ) WT. OF STA COPPER	2.54410	160.93725			
(66) ( ) WT. OF STA IRON	3.27120	141.62478			
(41) ( $\tau_p$ ) POLE PITCH	1.25660	141.62478			
(57) ( ) WT. OF ROTOR IRON	.00000	146.40043			
(145) ( $v_r$ ) PERIPHERAL SPEED	2492.33600	144.01261			
(153) ( $a_{cf}$ ) FLD COND. AREA	.00127	38.76238			
(154) ( $R_f$ ) COLD FLD RES - 20° C	2.28620	.04674			
(155) ( $R_f$ ) HOT FLD RES - X° C	3.01310	.00869			
(156) ( ) WT OF FLD COPPER	1.71880	.03289			
(80) ( $P_1$ ) PERM OF LEAKAGE PATH 1	.23710	.61000			
(81) ( $P_2$ ) PERM OF LEAKAGE PATH 2	2.41030	410.99000			
(82) ( $P_3$ ) PERM OF LEAKAGE PATH 3	.50657	22.58800			
(83) ( $P_4$ ) PERM OF LEAKAGE PATH 4	1.18210	27.25500			
(84) ( $P_5$ ) PERM OF LEAKAGE PATH 5	12.40000	46.34600			
(86) ( $P_7$ ) PERM OF LEAKAGE PATH 7	18.30000	33.27200			
(86a) ( $P_8$ ) PERM OF LEAKAGE PATH 8	22.20000	1.37760			
(180) (FSC) SHORT CIR NI	1339.28700	.66393			
(181) (SCR) SHORT CIR. RATIO	.53400	192.78000			
			150	200	OPTIONAL
(119) ( $I_g$ ) (100a) LEAKAGE FLUX	20.473	( $I_{gp}$ ) (197a) 50.953	.000	.000	.000
(119) ( $I_{pt}$ ) (102a) TOTAL FLUX POLE	26.000	( $I_{ptf}$ ) (213a) 46.749	.000	.000	.000
( $B_p$ ) (103a) POLE DENSITY	56.522	( $B_{pt}$ ) (213b) 101.620	.000	.000	.000
( $B_{g2}$ ) (122) AUX. GAP DENSITY	22.327	( $B_{g2L}$ ) (224) 41.229	.000	.000	.000
( $B_{y2}$ ) (125) END BELL DENSITY	56.105	( $B_{y2L}$ ) (228) 104.410	.000	.000	.000
( $B_y$ ) (126a) HOUSING DENSITY	52.690	( $B_{y1}$ ) (229b) 97.296	.000	.000	.000
( $F_{nl}$ ) (127) TOTAL NI/COIL	715.190	( $F_{fl}$ ) (236) 1967.300	.000	.000	.000
( $I_{fl}$ ) (127a) FIELD AMP./COIL	1.021	( $I_{ff}$ ) (237) 2.810	.000	.000	.000
( $S_f$ ) (127c) CUR. DENSITY FIELD	801.400	( $S_{ff}$ ) (239) 2204.400	.000	.000	.000
( $E_{fl}$ ) (127b) FIELD VOLTS/COIL	4.671	( $E_{ff}$ ) (238) 16.936	.000	.000	.000
( $w_c$ ) (185) STA CORE LOSS	2.790	( $w_c$ ) (185) 2.790	2.790	2.790	2.790
( $w_{nl}$ ) (184) STA TOOTH LOSS	3.961	( $w_{fl}$ ) (242) 6.299	.000	.000	.000
( $I^2 R_s$ ) (194) STATOR CU LOSS	.000	( $I^2 R_f$ ) (245) 176.640	.000	.000	.000
( ) (195) EDDY LOSS	.000	( ) (246) 1.854	.000	.000	.000
( $w_{pnl}$ ) (186) POLE FACE LOSS	25.608	( $w_{pfl}$ ) (243) 74.630	.000	.000	.000
( $I^2 R_f$ ) (182) FIELD COIL LOSS	2.386	( $I^2 R_{ff}$ ) (241) 47.597	.000	.000	.000
(F&W) (183) F&W LOSS	12.813	(F&W) (183) 12.813	12.813	12.813	12.813
( ) (196) TOTAL LOSSES	47.558	( ) (247) 322.625	.000	.000	.000
( ) ( ) PERCENT EFF.	.000	( ) (251) 75.455	.000	.000	.000

DESIGNER \_\_\_\_\_

DATE \_\_\_\_\_

**TWO OR SINGLE COIL OUTSIDE COIL LUNDELL**

**NO LOAD SATURATION OUTPUT SHEET**

ITEMS ↓ % VOLTS	(3) (E) VOLTS	(91) B <sub>t</sub> STA. TOOTH DENSITY	(97) F <sub>t</sub> STA. TOOTH NI	(94) B <sub>c</sub> STA. CORE DENSITY	(98) F <sub>c</sub> STA. CORE NI	(96) F <sub>g</sub> MAIN GAP DENSITY
	(100a) φ <sub>ℓ</sub> LEAKAGE FLUX	(102a) φ <sub>PT</sub> TOTAL FLUX/POLE	(103a) B <sub>p</sub> POLE DENSITY	(125) B <sub>y2</sub> END BELL DENSITY	(126a) B <sub>y</sub> HOUSING DENSITY	(127) F <sub>nl</sub> TOTAL NI
80%	12.00000 16.36852	37.07680 20.79848	1.00413 45.21410	26.61760 44.88040	.53820 42.14798	154.2240 572.74510
90%	13.50000 18.41840	41.71140 23.39893	1.16975 50.86724	29.94480 50.49077	.59777 47.41781	173.5020 643.70284
100%	15.00000 20.47308	46.34600 26.00018	1.37763 56.52213	33.27200 56.10502	.66393 52.69050	192.78000 715.19500
110%	16.50000 22.53202	50.98060 28.60213	1.62244 62.17856	36.59920 61.72390	.73741 57.96635	212.05800 787.5196
120%	18.00000 24.59598	55.61520 31.20493	1.91075 67.83680	39.92640 67.34973	.81903 63.24634	231.33600 861.4856
130%	19.50000 26.66640	60.24980 33.80880	2.25030 73.49739	43.25360 72.98541	.92087 68.53237	250.61400 937.683
140%	21.00000 28.74384	64.88440 36.41384	2.65020 79.16052	46.58080 78.63329	1.03561 73.82494	269.89200 1017.16820
150%	22.50000 30.84343	69.51900 39.02257	3.25327 84.83167	49.90800 84.30538	1.16465 79.13381	289.17000 1101.20370
160%	24.00000 32.96386	74.15360 41.63477	4.04631 90.51038	53.23520 90.03001	1.30976 84.47359	308.44800 1198.95540

INPUT PARAMETERS

1.04	15.	8.7	3.	200.	12.	2000.	50.	.95	1.
1.25	4.8	6.63	1.	0.	0.	.93	5.	77.4	3.
.12	.16	.16	.25	.205	.02	.5	0.	0.	.55
.03	.001	36.	1.	0.	14.	3.	2.	.0508	1.
2.	0.	.25	.2	.0508	.053	60.	0.	100.	.694
1.2	2.	.018	.02	0.	0.	0.	0.	0.	0.
.64	.45	1.15	.2	.4	1.15	4.76	0.	7.	0.
0.	0.	0.	12.4	18.3	22.2	2.8	.35	.15	1.7
1.	2.	350.	12.	.0403	0.	100.	.694	1.	0.
38.3									

SATURATION CURVE VALUES FOR STATOR

132.	18.	1.	40.	2.	66.
5.	76.	8.	85.	14.5	102.
101.	114.	300.	132.	1000.	

SATURATION CURVE VALUES FOR POLE

140.	0.	1.6	10.	2.3	20.
3.3	30.	4.2	60.	7.3	70.
9.2	80.	12.5	85.	15.	90.
20.	100.	40.	108.	100.	112.
160.	126.	500.	140.	1000.	

SATURATION CURVE VALUES FOR YOKE

140.	0.	1.6	10.	2.3	20.
3.3	30.	4.2	60.	7.3	70.
9.2	80.	12.5	85.	15.	90.
20.	100.	40.	108.	100.	112.
160.	126.	500.	140.	1000.	

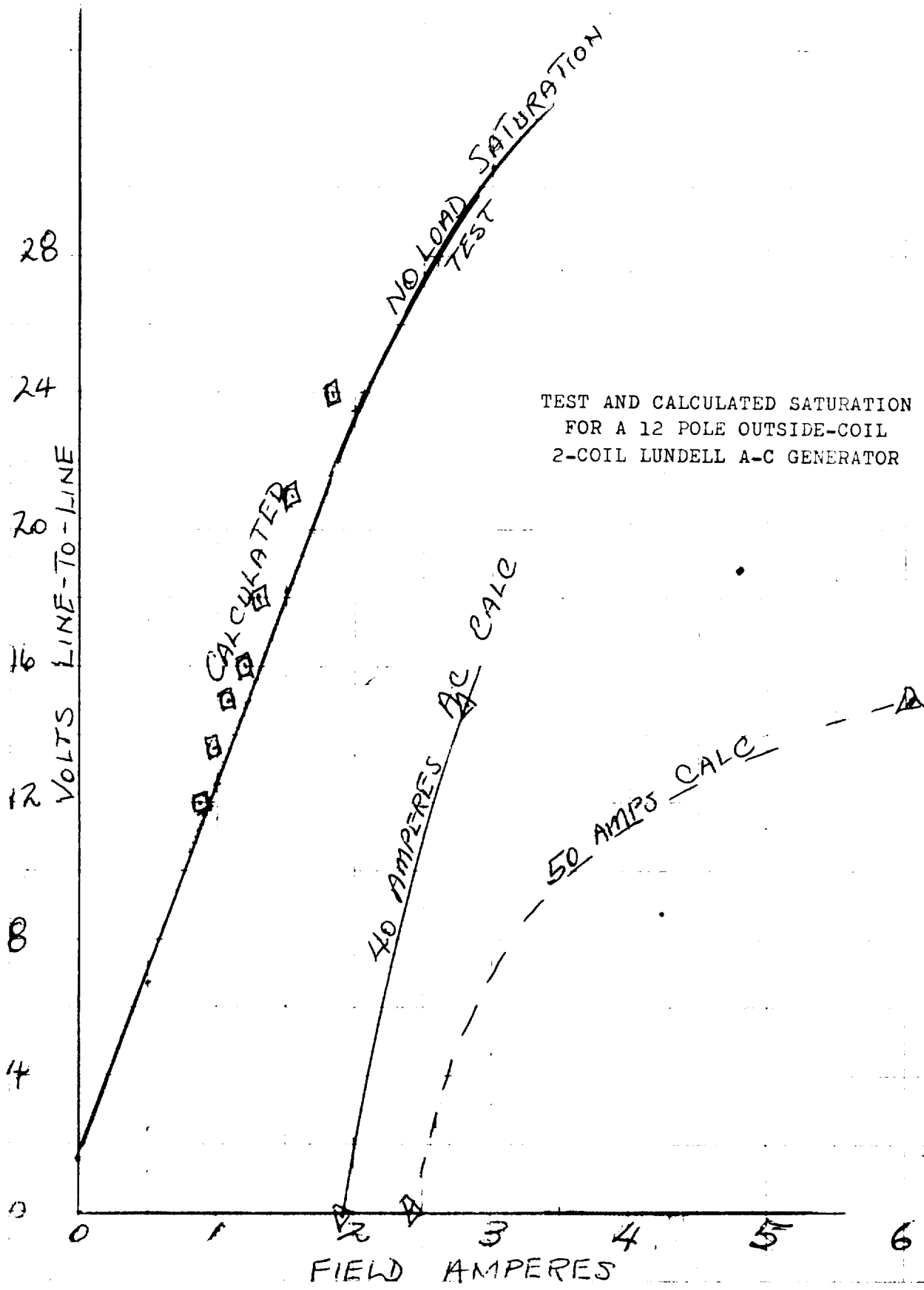

COMPUTER PROCEDURE FOR  
SINGLE OR 2 COIL  
OUTSIDE COIL LUNDELL DESIGN CALCULATIONS

1. Clear core (no switch control).
2. Insert output Form #1 into typewriter, set margin for correct output.
3. Load pass #1 followed by input #1 (output printed plus punched cards).
4. Reset and load pass #2 followed by output from pass #1 (output punched cards).
5. Reset and load pass #3 followed by output from pass #2 (output punched cards).
6. Reset and load pass #4 followed by output from pass #3 (output punched cards).
7. Reset and load pass #5 followed by saturation curve values\* and output from pass #4 (output punched cards).
8. Reset and load pass #6 followed by output from pass #5 (output printed plus punch cards).
9. Reset and load pass #7 followed by output from pass #6 (output punched cards).
10. Reset and load pass #8 followed by saturation curve values\* and output from pass #7 (output punched cards).
11. Reset and load pass #9 followed by output from pass #8 (output printed plus punched cards if no load saturation curve required).
12. If there is punch card output from pass #9 a no load saturation curve is required. Insert output Form #2 into typewriter and reset margin. Load pass #10 followed by saturation curve values and output from pass #9 (output printed).

\* Saturation curves are loaded in order shown on Input Form #1.

ALL INPUT PARAMETERS ARE IN FORMAT F7.0 (FIG. 1)

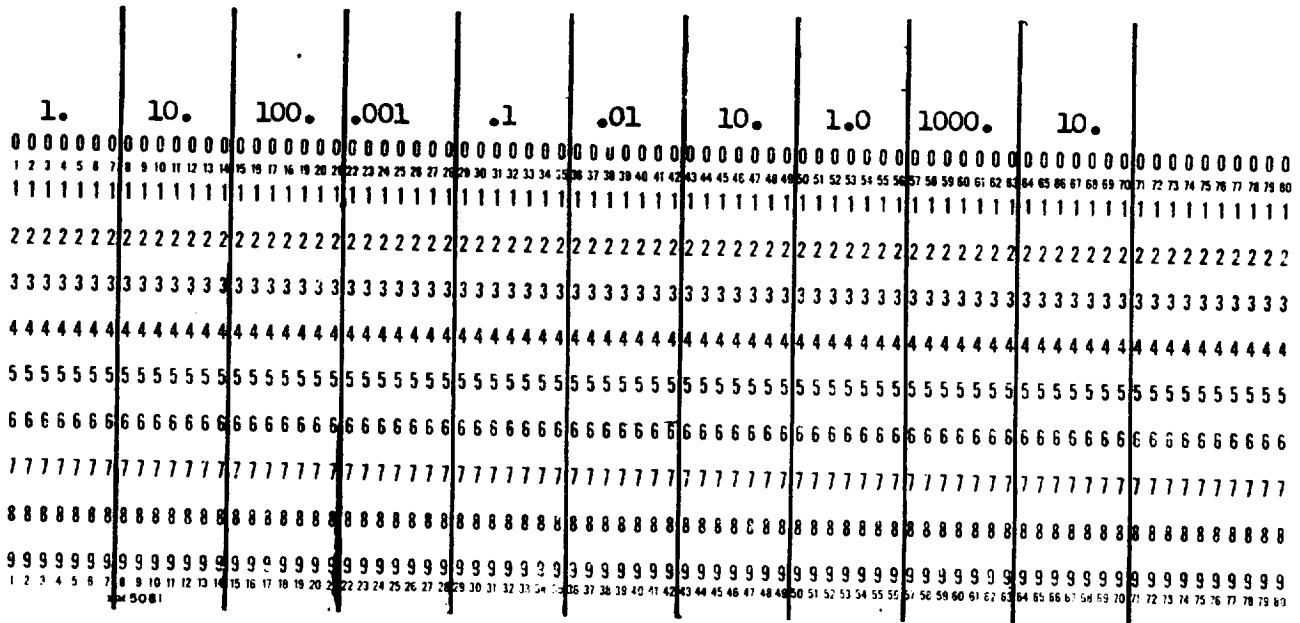

FIG. 1

ALL SATURATION CURVE VALUES ARE IN FORMAT F10.0 (FIG. 2)  
(ALL SATURATION CURVES MUST HAVE 5 CARDS)

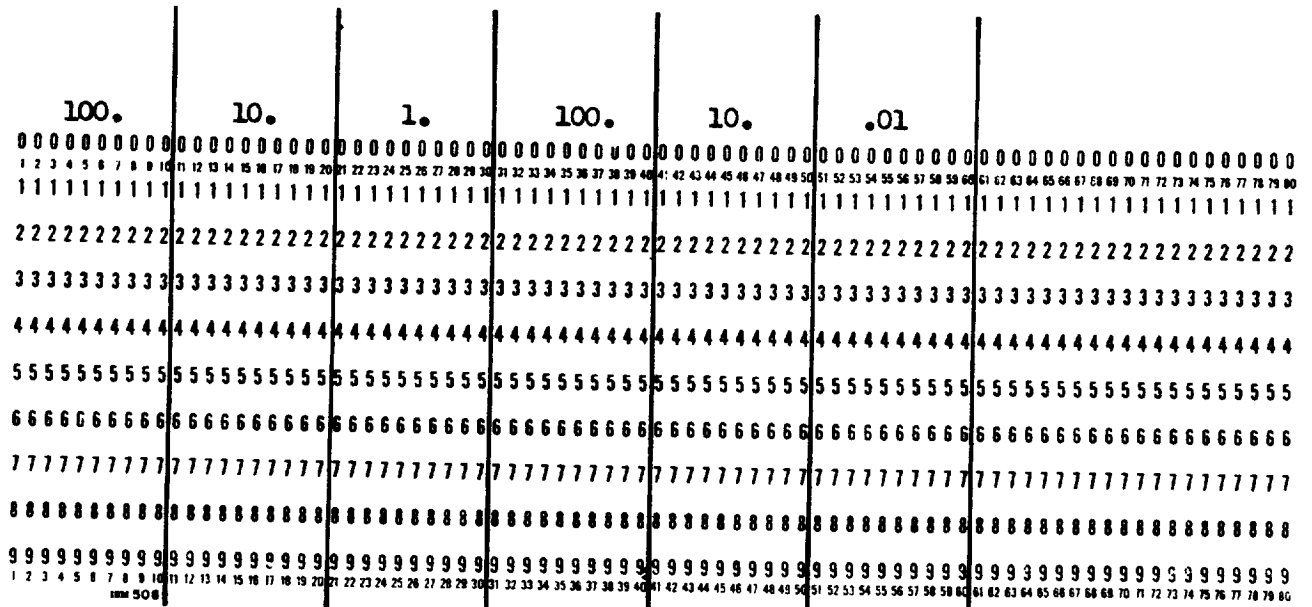

FIG. 2

SINGLE )  
 OR ) OUTSIDE COIL LUNDELL  
 TWO COIL )

<u>Calculation Number</u>	<u>Electrical Symbol</u>	<u>Fortran Symbol</u>
-------------------------------	------------------------------	---------------------------

A, a

(128)	A	A
(46)	a <sub>c</sub>	AC
(153)	a <sub>cf</sub>	AS
(70)	A <sub>g2</sub>	A2
(124)	A <sub>y2</sub>	AY2
(79)	a <sub>p</sub>	AP

B, b

(20)	B	BK
(22)	b <sub>o</sub>	BO
(94)	B <sub>c</sub> ,	BC1
(76)	b <sub>p1</sub>	BP1
(76)	b <sub>p2</sub>	BP2
(95)	B <sub>g</sub> ,	BG1
(122)	B <sub>g2</sub>	BG2
(224)	B <sub>g2</sub> FL	BG2 L ·
(58)	b <sub>t</sub>	
(57a)	b <sub>t</sub> 1/3	SM
(91)	B <sub>T</sub> ,	BT1
(57)	b <sub>tm</sub>	TM



<u>Calculation Number</u>	<u>Electrical Symbol</u>	<u>Fortran Symbol</u>
(126a)	$B_y$	BY
(229b)	$B_yL$	BYL
(228)	$B_{y2}L$	BY2L
(15)	$b_v$	BV
(125)	$B_{y2}$	BY2
		<u>C, c</u>
(32)	c	C
(71)	$C_1$	C1
(74)	$C_M$	CM
(73)	$C_P$	CP
(75)	$C_q$	CQ
(72)	$C_W$	CW
		<u>D, d</u>
(12)	D	DU
(11)	d	DI
(35)	$d_b$	DB
(11a)	$d_r$	DR
(78)	$d_{g2}$	DG2
(78)	$d_{y2}$	DY2

<u>Calculation Number</u>	<u>Electrical Symbol</u>	<u>Fortran Symbol</u>
		<u>E, e</u>
(3)	E	EE
(55)	EF <sub>TOP</sub>	ET
(56)	EF <sub>BOT</sub>	EB
(238)	E <sub>FFL</sub>	EPFL
(127b)	E <sub>FNL</sub>	EPNL
(4)	E <sub>PH</sub>	EP
		<u>F, f</u>
(5a)	f	F
(98)	F <sub>c</sub>	FC
(236)	F <sub>FL</sub>	FFL
(96)	F <sub>g</sub>	FG
(123)	F <sub>g2</sub>	FG2
(225)	F <sub>g2FL</sub>	FG2L
(127)	F <sub>NL</sub>	FNL
(104)	F <sub>P</sub>	FP
(126b)	F <sub>y</sub>	FY
(180)	F <sub>SC</sub>	FSC
(97)	F <sub>T</sub>	FT
(183)	F & W	WF
(126)	F <sub>y2</sub>	FY2

<u>Calculation Number</u>	<u>Electrical Symbol</u>	<u>Fortran Symbol</u>
(229c)	F <sub>y</sub> L	FYL
(229)	F <sub>y2</sub> L	FY2L
		<u>G, g</u>
(59)	g	GC
(59a)	g <sub>2</sub>	G2
(69)	g <sub>e</sub>	GE
		<u>H, h</u>
(24)	h <sub>c</sub>	HC
(38)	h <sub>ST</sub>	SD
(39)	h <sub>ST</sub>	SH
		<u>I, i</u>
(237)	I <sub>FFL</sub>	AIFL
(127a)	I <sub>FNL</sub>	AINL
(8)	I <sub>PH</sub>	PI
(182)	I <sup>2</sup> R <sub>F</sub>	FEL
(241)	I <sup>2</sup> R <sub>F</sub>	FCUL
(194)	I <sup>2</sup> R	PS
(245)	I <sup>2</sup> R <sub>L</sub>	SCUL

<u>Calculation Number</u>	<u>Electrical Symbol</u>	<u>Fortran Symbol</u>
		<u>K, k</u>
(19)	k	WL
(9a)	K <sub>c</sub>	CK
(43)	K <sub>d</sub>	DF
(63)	K <sub>e</sub>	EK
(16)	K <sub>i</sub>	SF
(44)	K <sub>p</sub>	CF
(67)	K <sub>s</sub>	CC
(42)	K <sub>SK</sub>	FS
(2)	K <sub>VA</sub>	VA
(61)	K <sub>X</sub>	FF

		<u>L, l</u>
(13)	l	CL
(80)	l <sub>1</sub>	AL1
(80)	l <sub>2</sub>	AL2
(82)	l <sub>3</sub>	AL3
(48)	L <sub>E</sub>	EL
(36)	l <sub>e2</sub>	CE
(161)	L <sub>F</sub>	SI
(78)	l <sub>g2</sub>	ALG2

<u>Calculation Number</u>	<u>Electrical Symbol</u>	<u>Fortran Symbol</u>
(76)	$l_P$	ALP
(17)	$l_S$	SS
(49)	$l_t$	HM
(147)	$l_{tf}$	FE
(78)	$l_y$	ALY
		<u>M, m</u>
(5)	m	PN
		<u>N, n</u>
(146a)	$N_{CO}$	COILS
(146)	$N_F$	PT
(45)	$n_e$	EC
(30)	$n_S$	SC
(34)	$N_{ST}$	SN
(34a)	$N'_{ST}$	SN1
(14)	$n_V$	HV
		<u>P, p</u>
(6)	p	PX
(9)	PF	PF
(80)	$P_1$	P1
(81)	$P_2$	P2
(82)	$P_3$	P3

<u>Calculation Number</u>	<u>Electrical Symbol</u>	<u>Fortran Symbol</u>
(83)	P <sub>4</sub>	P4
(84)	P <sub>5</sub>	P5
(86)	P <sub>7</sub>	P7
<u>Q, q</u>		
(23)	Q	QQ
(25)	q	QN
<u>R, r</u>		
(154)	R <sub>f</sub> (cold)	FK
(155)	R <sub>f</sub> (hot)	FR
(7)	RPM	RPM
(53)	R <sub>SPH</sub> (cold)	RG
(54)	R <sub>RPH</sub> (hot)	RP
<u>S, s</u>		
(181)	SCR	SCR
(127c)	S <sub>F</sub>	CD
(47)	S <sub>S</sub>	S
<u>T, t</u>		
(177)	T <sub>a</sub>	TA
(178)	T' <sub>d</sub>	T5
(176)	T' <sub>do</sub>	TC

<u>Calculation Number</u>	<u>Electrical Symbol</u>	<u>Fortran Symbol</u>
(78)	$t_y$	TY
(78)	$t_{y2}$	TY2
		<u>V, v</u>
(145)	$V_r$	VR
		<u>W, w</u>
(185)	$W_C$	WQ
(186)	$W_{NPL}$	WN
(243)	$W_{PFL}$	WNL
(242)	$W_{TFL}$	WTFL
(184)	$W_{TNL}$	WT
		<u>X, x</u>
(129)	X	XR
(131)	$X_{ad}$	XD
(132)	$X_{aq}$	XQ
(133)	$X_d$	XA
(167)	$X'_d$	XS
(168)	$X''_d$	XX
(166)	$X'_{du}$	XU
(160)	$X'_F$	XF

<u>Calculation Number</u>	<u>Electrical Symbol</u>	<u>Fortran Symbol</u>
(150)	$X_f$ °C	T2
(130)	$X_\rho$	XL
(169)	$X_q''$	XY
(134)	$X_q$	XB
(50)	$X_s$ °C	TI
(170)	$X_2$	XN
(172)	$X_o$	XO
		<u>Y, y</u>
(31)	y	YY
		<u>Ø</u>
(108)	$\text{Ø}_{g2}$	PG2
(221)	$\text{Ø}_{g2L}$	PG2L
(100)	$\text{Ø}_l$	PL
(118)	$\text{Ø}_{l5}$	PL5
(99)	$\text{Ø}_{l7}$	PL7
(226)	$\text{Ø}_{5L}$	PL5L
(207)	$\text{Ø}_{7L}$	PL7L
(92)	$\text{Ø}_p$	FQ



<u>Calculation Number</u>	<u>Electrical Symbol</u>	<u>Fortran Symbol</u>
(213)	$\emptyset_{PL}$	FQL
(102)	$\emptyset_{PT}$	PLT
(88)	$\emptyset_T$	TG
(227)	$\emptyset_{y2L}$	PG2L
		<u><math>\Upsilon</math></u>
(41)	$\Upsilon_p$	TP
(26)	$\Upsilon_s$	TS
(40)	$\Upsilon_{SK}$	SK
(27)	$\Upsilon_{S 1/3}$	TT
		<u><math>\lambda</math></u>
(64)	$\lambda_E$	EW
(62)	$\lambda_i$	PC
(64a)	$\lambda_z$	<u><math>\rho</math></u> ALZ
(151)	$\rho_f$	RR
(152)	$\rho_f$ (hot)	
(51)	$\rho_s$	RS
		<u><math>\alpha</math></u>
(77)	$\alpha$	PE

```

C   PASS 1  OUTSIDE COIL LUNDELL
1  FORMAT(E11.5,E11.5,E11.5,E11.5,E11.5,E11.5)
2  FORMAT(F7.0,F7.0,F7.0,F7.0,F7.0,F7.0,F7.0,F7.0,F7.0,F7.0)
3  FORMAT(9X F12.5,2X F12.5)
7  READ2,VA,EE,EP,PN,F,PX,RPM,PI,PF,CK
   READ2,POL,DI,DU,CL,HV,BV,SF,WL,BK,ZZ
   READ2,B0,B1,B2,B3,BS,H0,HX,HY,HZ,HS
   READ2,HT,HW,QQ,W,RF,SC,YY,C,DW,SN
   READ2,SN1,DW1,DB,CE,SH,SD,PBA,SK,T1,RS
   READ2,ALG2,DG2,GC,G2,C1,CW,CP,EL,CM,CQ
   READ2,PE,BP1,BP2,TP1,TP2,ALP,DR,WR,D1,P1
   READ2,P2,P3,P4,P5,P7,P8,DY2,TY2,TY,ALY
   READ2,AL1,COILS,PT,FE,RD,RT,T2,RR,SNL,WF
   READ1,ALZ
   SS=SF*(CL-HV*BV)
   HC=(DU-DI-2.0*HS)*0.5
   QN=QQ/(PX*PN)
   TS=3.142*DI/QQ
   IF(ZZ-4.0)9,10,9
9  TT=(0.667*HS+DI)*3.142/QQ
   GO TO 11
10 TT=3.1416*(DI+2.*H0+1.32*BS)/QQ
11 IF(ZZ-1.0)12,12,13
12 B0=BS
   CC=(5.*GC+BS)*TS/((5.*GC+BS)*TS-BS*BS)
   GO TO 14
13 QC=(4.44*GC+0.75*B0)*TS
   CC=QC/(QC-B0*B0)
14 CS=YY/(PN*QN)

```

```

TP=3.1416*D1/PX
IF(SK)18,18,19
18 FS=1.0
GO TO 20
19 FS=SIN(1.571*SK/TP)*TP/(1.571*SK)
20 IF(PBA-60.)21,21,22
21 D=1.0
GO TO 95
22 D=2.0
95 I=QN
U=I
IF(QN-U)23,23,24
24 U=PX*PN
XX=U
N=U
DO 25 K=1,N
Z=U/XX
I=Z
Z1=I
IF(Z-Z1)26,26,25
26 ZY=QQ/XX
I=ZY
Z1=I
IF(ZY-Z1)27,27,25
25 XX=XX-1.
23 ZY=QN
27 DF=SIN(.5236*D)/(ZY*D*SIN(.5236/ZY))
CF=SIN(YY*1.571/(PN*QN))
EC=QQ*SC*CF*FS/C

```

```

GE=CC*GC
  IF(C1)29,28,29
28 C1=0.649*LOG(PE)+1.359
29 IF(CW)30,30,31
30 CW=0.707*EE*C1*DF/(EP*PN)
31 IF(CP)32,32,33
32 CP=PE*(LOG(GC/TP)*.0378+1.191)
33 IF(EL)34,34,42
34 IF(RF)35,35,41
35 IF(PX-2.0)36,36,37
36 U=1.3
  GO TO 40
37 IF(PX-4.0)38,38,39
38 U=1.5
  GO TO 40
39 U=1.7
40 EL=3.142*U*YY*(DI+HS)/QQ+0.5
  GO TO 42
41 EL=2.0*CE+3.142*(0.5*HX+DB)+YY*TS*TS/SQRT(TS*TS-BS*BS)
42 AA=1.571*PE
  AB=3.142*PE
  IF(CM)43,43,44
43 CM=(AB+SIN(AB))/(SIN(AA)*4.)
44 IF(CQ)45,45,46
45 CQ=(0.5*COS(AA)+AB-SIN(AB))/(4.0*SIN(AA))
46 RB=(T1+234.5)*0.00394*RS
  PRINT3,SS,CC,HC,GE,TS,C1,TT,CW,FS,CP,DF,EL,CF,CM,EC,CQ
  PUNCH1,VA,EE,EP,PN,F,PX
  PUNCH1,RPM,PI,PF,CK,POL,DI

```

PUNCH1,DU,CL,SS,HC,SF,QN  
PUNCH1,WL,BK,ZZ,BO,B1,B2  
PUNCH1,B3,BS,HO,HX,HY,HZ  
PUNCH1,HS,HT,HW,QQ,W,RF  
PUNCH1,SC,YY,C,TS,SN,DB  
PUNCH1,CE,SH,SD,TT,SK,RB  
PUNCH1,TP,D1,FE,RD,RT,COILS  
PUNCH1,T2,RR,SNL,WF,PE,SN1  
PUNCH1,DW1,BP1,BP2,TP1,TP2,ALP  
PUNCH1,DR,WR,DY2,TY2,TY,ALY  
PUNCH1,P1,P2,P3,P4,P5,P7  
PUNCH1,G2,DG2,ALG2,AL1,P8  
PUNCH1,GE,CS,CF,FS,EC,DF  
PUNCH1,RS,GC,PT,C1,CW,CP  
PUNCH1,EL,CM,CQ,DW,CC,PBA  
PUNCH1,ALZ  
PAUSE  
END

```

C    PASS 2  OUTSIDE COIL LUNDELL
1  FORMAT(E11.5,E11.5,E11.5,E11.5,E11.5,E11.5)
    DIMENSION DA(8),DX(6),DY(8),DZ(8)
    READ 1,VA,EE,EP,PN,F,PX
    READ 1,RPM,PI,PF,CK,POL,DI
    READ 1,DU,CL,SS,HC,SF,QN
    READ 1,WL,BK,ZZ,B0,B1,B2
    READ 1,B3,BS,HO,HX,HY,HZ
    READ 1,HS,HT,HW,QQ,W,RF
    READ 1,SC,YY,C,TS,SN,DB
    READ 1,CE,SH,SD,TT,SK,RB
    READ 1,TP,D1,FE,RD,RT,COILS
    READ 1,T2,RR,SNL,WF,PE,SN1
    READ 1,DW1,BP1,BP2,TP1,TP2,ALP
    READ 1,DR,WR,DY2,TY2,TY,ALY
    READ 1,P1,P2,P3,P4,P5,P7
    READ 1,G2,DG2,ALG2,AL1,P8
    READ 1,GE,CS,CF,FS,EC,DF
    READ 1,RS,GC,PT,C1,CW,CP
    READ 1,EL,CM,CQ,DW,CC,PBA
    READ 1,ALZ
    DT=DW1
    IF(ZZ-3.0)49,50,51
49  SM=TT-BS
    GO TO 53
50  SM=(3.1416*(D1+2.*HS)/QQ)-B3
    GO TO 53
51  IF(ZZ-4.0)50,52,49
52  SM=TT-.94*BS

```

53 HM=CL+EL  
IF (DT) 61,61,62  
61 AC=0.785\*DW\*DW\*SN1  
GO TO 72  
62 ZY=0.0  
DA(1)=0.05  
DA(2)=0.072  
DA(3)=0.125  
DA(4)=0.165  
DA(5)=0.225  
DA(6)=0.438  
DA(7)=0.688  
DA(8)=1.5  
DX(1)=0.000124  
DX(2)=0.00021  
DX(3)=0.00021  
DX(4)=0.00084  
DX(5)=0.00189  
DX(6)=0.00189  
DY(1)=0.000124  
DY(2)=0.000124  
DY(3)=0.00084  
DY(4)=0.00084  
DY(5)=0.00189  
DY(6)=0.00335  
DY(7)=0.00754  
DY(8)=0.03020  
DZ(1)=0.000124  
DZ(2)=0.000124

DZ(3)=0.000124

DZ(4)=0.00335

DZ(5)=0.00335

DZ(6)=0.00754

DZ(7)=0.0134

DZ(8)=0.0302

63 IF(DT-.05)201,201,200

200 JA=0

JB=0

JC=0

JD=0

64 JA=JA+1

JB=JB+1

JC=JC+1

JD=JD+1

IF(DT-DA(JA))65,65,64

201 D=0

IF(ZY)71,71,54

65 IF(DW-0.188)66,66,67

66 CY=DX(JB-1)

CZ=DX(JB)

GO TO 70

67 IF(DW-0.75)68,68,69

68 CY=DY(JC-1)

CZ=DY(JC)

GO TO 70

69 CY=DZ(JD-1)

CZ=DZ(JD)

70 D=CY+(CZ-CY)\*(DT-DA(JA-1))/(DA(JA)-DA(JA-1))



IF(ZY)71,71,54  
 71 AC=(DT\*DW-D)\*SN1  
 72 IF(RT)73,73,74  
 73 AS=0.785\*RD\*RD  
 GO TO 55  
 74 ZY=1.0  
 DT=RT  
 DW=RD  
 GO TO 63  
 54 AS=RT\*RD-D  
 55 S=PI/(C\*AC)  
 CY=PT \*FE\*0.000001/AS  
 FK=RR\*CY  
 FR=(T2+234.5)\*FK\*0.00394  
 RC=0.321\*PT \*FE\*AS  
 IF(SH)202,203,202  
 203 ET=1  
 EB=1  
 GO TO 204  
 202 AA=0.584+(SN\*SN-1.0)\*0.0625\*(SD\*CL/(SH\*HM))\*\*2.0  
 AB=(SH\*SC\*F\*AC/(BS\*RB))\*\*2.0  
 ET=AA\*AB\*0.00335+1.0  
 EB=ET-0.00168\*AB  
 204 RY=SC\*QQ\*0.000001\*HM/(PN\*AC\*C\*C)  
 RG=RS\*RY  
 RP=RB\*RY  
 A=PI\*SC\*CF/(C\*TS)  
 PUNCH1,VA,EE,EP,PN,F,PX  
 PUNCH1,RPM,PI,PF,CK,POL,DI

PUNCH1,DU,CL,SS,HC,SF,QN  
PUNCH1,WL,BK,ZZ,BO,B1,B2  
PUNCH1,B3,BS,HO,HX,HY,HZ  
PUNCH1,HS,HT,HW,QQ,W,RF  
PUNCH1,SC,YY,C,TS,SN,DB  
PUNCH1,CE,SH,SD,TT,SK,RB  
PUNCH1,TP,D1,FE,RD,RT,COILS  
PUNCH1,T2,RR,SNL,WF,PE,SN1  
PUNCH1,DW1,BP1,BP2,TP1,TP2,ALP  
PUNCH1,DR,WR,DY2,TY2,TY,ALY  
PUNCH1,P1,P2,P3,P4,P5,P7  
PUNCH1,G2,DG2,ALG2,AL1  
PUNCH1,GE,CS,CF,FS,EC,DF  
PUNCH1,RS,GC,PT,C1,CW,CP  
PUNCH1,EL,CM,CQ,DW,CC,PBA  
PUNCH1,HM,SM,AS,AC,ET,EB  
PUNCH1,S,FK,FR,RC,RG,RP  
PUNCH1,A,P8,ALZ  
PAUSE  
END

```

C    PASS 3  OUTSIDE COIL LUNDELL
1  FORMAT(E11.5,E11.5,E11.5,E11.5,E11.5,E11.5)
    READ 1,VA,EE,EP,PN,F,PX
    READ1 ,RPM,PI,PF,CK,POL,DI
    READ 1,DU,CL,SS,HC,SF,QN
    READ 1,WL,BK,ZZ,B0,B1,B2
    READ 1,B3,BS,HO,HX,HY,HZ
    READ 1,HS,HT,HW,QQ,W,RF
    READ 1,SC,YY,C,TS,SN,DB
    READ 1,CE,SH,SD,TT,SK,RB
    READ 1,TP,D1,FE,RD,RT,COILS
    READ 1,T2,RR,SNL,WF,PE,SN1
    READ 1,DW1,BP1,BP2,TP1,TP2,ALP
    READ 1,DR,WR,DY2,TY2,TY,ALY
    READ 1,P1,P2,P3,P4,P5,P7
    READ 1,G2,DG2,ALG2,AL1
    READ 1,GE,CS,CF,FS,EC,DF
    READ 1,RS,GC,PT,C1,CW,CP
    READ 1,EL,CM,CQ,DW,CC,PBA
    READ 1,HM,SM,AS,AC,ET,EB
    READ 1,S,FK,FR,RC,RG,RP
    READ 1,A,P8,ALZ
    IF (PBA-60.0)105,105,108
105 IF (CS-0.667)106,106,107
106 FF=0.25*(6.0*CS-1.0)
107 FF=0.25*(3.*CS+1.0)
    GO TO 75
108 IF (CF-0.667)109,109,110
109 FF=0.05*(24.0*CS-1.0)

```

```

GO TO 75
110 FF=0.75
75 CX=FF/(CF*CF*DF*DF)
Z=CX*20.0/(PN*QN)
BT=3.142*DI/QQ-BO
ZA=BT*BT/(16.0*TS*GC)
ZB=0.35*BT/TS
ZC=HO/BO
ZD=HX*0.333/BS
ZE=HY/BS
IF(ZZ-2.0) 76,77,78
76 PC=Z*(ZE+ZD+ZA+ZB)
GO TO 82
77 PC=Z*(ZC+(2.0*HT/(BO+BS)))+(HW/BS)+ZD+ZA+ZB)
GO TO 82
78 IF(ZZ-4.0) 79,80,81
79 PC=Z*(ZC+(2.0*HT/(BO+B1)))+(2.0*HW/(B1+B2))+(HX*0.333/B2)+ZA+ZB)
GO TO 82
80 PC=Z*(ZC+0.62)
GO TO 82
81 PC=Z*(ZE+ZD+(0.5*GC/TS)+(0.25*TS/GC)+0.6)
82 EK=EL/(10.0**((0.103*YY*TS+0.402)))
IF(DI-8.0) 83,83,84
83 EK=SQRT(EK)
84 ZF=.612*LOG(10.0*CS)
EW=6.28*EK*ZF*(TP**((0.62-(0.228*LOG(ZF)))))/(CL*DF*DF)
87 ZA=3.1416*(DI+HS)/QQ
IF(ZZ-3.0) 88,89,88
88 TM=ZA-BS

```

GO TO 90

89  $TM = (3.1416 * (D1 + 2. * HS) / QQ) - B3$

90  $WI = (TM * QQ * SS * HS + (DU - HC) * 3.142 * HC * SS) * 0.283$

IF (WF) 445, 446, 445

446  $WF = 2.52E-6 * (DR ** 2.5) * ALP * RPM ** 1.5$

445  $WC = .321 * HM * QQ * AC * SC$

PUNCH1, VA, EE, EP, PN, F, PX

PUNCH1, RPM, PI, PF, CK, POL, DI

PUNCH1, DU, CL, SS, HC, SF, QN

PUNCH1, WL, BK, ZZ, B0, B1, B2

PUNCH1, B3, BS, HO, HX, HY, HZ

PUNCH1, HS, HT, HW, QQ, W, RF

PUNCH1, SC, YY, C, TS, SN, DB

PUNCH1, CE, SH, SD, TT, SK, RB

PUNCH1, TP, D1, FE, RD, RT, COILS

PUNCH1, T2, RR, SNL, WF, PE, SN1

PUNCH1, DW1, BP1, BP2, TP1, TP2, ALP

PUNCH1, DR, WR, DY2, TY2, TY, ALY

PUNCH1, P1, P2, P3, P4, P5, P7

PUNCH1, HM, SM, AS, AC, ET, EB

PUNCH1, S, FK, FR, RC, RG, RP

PUNCH1, G2, DG2, ALG2, AL1

PUNCH1, GE, CS, CF, FS, EC, DF

PUNCH1, RS, GC, PT, C1, CW, CP

PUNCH1, EL, CM, CQ, DW, CC, PBA

PUNCH1, FF, CX, PC, EK, EW, TM

PUNCH1, A, WI, WC, P8, ALZ

PAUSE

END

```

C      PASS 4  OUTSIDE COIL LUNDELL
1  FORMAT(E11.5,E11.5,E11.5,E11.5,E11.5,E11.5)
      READ1 ,VA,EE,EP,PN,F,PX
      READ1 ,RPM,PI,PF,CK,POL,DI
      READ 1,DU,CL,SS,HC,SF,QN
      READ 1,WL,BK,ZZ,BO,B1,B2
      READ 1,B3,BS,HO,HX,HY,HZ
      READ 1,HS,HT,HW,QQ,W,RF
      READ 1,SC,YY,C,TS,SN,DB
      READ 1,CE,SH,SD,TT,SK,RB
      READ 1,TP,D1,FE,RD,RT,COILS
      READ 1,T2,RR,SNL,WF,PE,SN1
      READ 1,DW1,BP1,BP2,TP1,TP2,ALP
      READ 1,DR,WR,DY2,TY2,TY,ALY
      READ 1,P1,P2,P3,P4,P5,P7
      READ 1,HM,SM,AS,AC,ET,EB
      READ 1,S,FK,FR,RC,RG,RP
      READ 1,G2,DG2,ALG2,AL1
      READ 1,GE,CS,CF,FS,EC,DF
      READ 1,RS,GC,PT,C1,CW,CP
      READ 1,EL,CM,CQ,DW,CC,PBA
      READ 1,FF,CX,PC,EK,EW,TM
      READ 1,A,WI,WC,P8,ALZ
      IF(P1)400,401,400
401  P1=3.19*BP1*TP1/AL1
400  IF(P2)402,403,402
403  AL2=TP-(BP1+BP2)/2.
      P2=3.19*(ALP*(TP2+TP1)/2.)/AL2
402  IF(P3)404,405,404

```

```

405 R4=AL1+CL/2.
      P3=((3.*BP1+BP2)/4.)*LOG(R4/AL1)*6.28/3.1416
404 IF(P4)409,407,409
407 P4=(3.19*ALP/3.1416)*LOG(1.+(BP1+BP2)/(AL2*2.))
      IF(PX-4.)408,408,409
408 P4=P4*1.5
409 TG=6.E6*EE/(CW*EC*RPM)
      BT1=TG/(QQ*SS*SM)
      FQ=TG*CP/PX
      BC1=FQ/(2.*HC*SS)
      BG1=TG/(3.1416*DI*CL)
      FG=BG1*GE/.00319
      AY2=3.1416*DY2*TY2
      A2=3.1416*DG2*ALG2
      AP=BP2*TP2
      AY=3.1416*TY*(DU+TY)
      WQ=(DU-HC)*1.42*HC*SS*(BC1/BK)**2.0*WL
      WT= SM *QQ*SS*HS*0.453*(BT1/BK)**2.0*WL
132 D2=BG1**2.5*0.000061
      D3=(0.0167*QQ*RPM)**1.65*0.000015147
      IF(TS-0.9)133,133,134
133 D4=TS**1.285*0.81
      GO TO 137
134 IF(TS-2.0)135,135,136
135 D4=TS**1.145*0.79
      GO TO 137
136 D4=TS**0.79*0.92
137 D7=B0/GC
      IF(D7-1.7)138,138,139

```

138  $D5=D7^{**2.31*0.3}$   
GO TO 144

139 IF (D7-3.0) 140, 140, 141

140  $D5=D7^{**2.0*0.35}$   
GO TO 144

141 IF (D7-5.0) 142, 142, 143

142  $D5=D7^{**1.4*0.625}$   
GO TO 144

143  $D5=D7^{**0.965*1.38}$

144  $D6=10.0^{**}(0.932*C1-1.606)$   
BA=3.142\*D1\*CL  
WN=D1\*D2\*D3\*D4\*D5\*D6\*BA  
PUNCH1,VA,EE,EP,PN,F,PX  
PUNCH1,RPM,PI,PF,CK,POL,DI  
PUNCH1,DU,CL,SS,HC,SF,QN  
PUNCH1,WL,BK,ZZ,BO,B1,B2  
PUNCH1,B3,BS,HO,HX,HY,HZ  
PUNCH1,HS,HT,HW,QQ,W,RF  
PUNCH1,SC,YY,C,TS,SN,DB  
PUNCH1,CE,SH,SD,TT,SK,RB  
PUNCH1,TP,D1,FE,RD,RT,COILS  
PUNCH1,T2,RR,SNL,WF,PE,SN1  
PUNCH1,DW1,BP1,BP2,TP1,TP2,ALP  
PUNCH1,DR,WR,DY2,TY2,TY,ALY  
PUNCH1,HM,SM,AS,AC,ET,EB  
PUNCH1,S,FK,FR,RC,RG,RP  
PUNCH1,G2,DG2,ALG2,AL1  
PUNCH1,GE,CS,CF,FS,EC,DF  
PUNCH1,RS,GC,PT,C1,CW,CP



PUNCH1,EL,CM,CQ,DW,CC,PBA

PUNCH1,FF,CX,PC,EK,EW,TM

PUNCH1,A,WI,WC,WN,WT,WQ

PUNCH1,TG,FQ,BC1,BT1,BG1,FG

PUNCH1,P1,P2,P3,P4,P5,P7

PUNCH1,PX,ALP,A2,G2,AY2,AY

PUNCH1,DU,DY2,ALY,PT,FK,AS

PUNCH1,COILS,HC,AP,HS,P8,ALZ

PAUSE

END

```

C   PASS 5  OUTSIDE COIL LUNDELL
      DIMENSION AI(90)
      1 FORMAT(E11.5,E11.5,E11.5,E11.5,E11.5,E11.5)
888  FORMAT(F10.0,F10.0,F10.0,F10.0,F10.0,F10.0)
      K=1
823  READ888, AI(K), AI(K+1), AI(K+2), AI(K+3), AI(K+4), AI(K+5)
      K=K+6
      IF(K-89)823,824,824
824  DO 825 J=1,20
      READ 1,R1,R2,R3,R4,R5,R6
825  PUNCH1,R1,R2,R3,R4,R5,R6
      READ1 ,TG,FQ,BC1,BT1,BG1,FG
      READ1 ,P1,P2,P3,P4,P5,P7
      READ1 ,PX,ALP,A2,G2,AY2,AY
      READ1 ,DU,DY2,ALY,PT,FK,AS
      READ 1,COILS,HC,AP,HS,P8,ALZ
      LOAD=1
      COREL=3.1416*(DU-HC)/(4.*PX)
      X=BT1
      NA=1
      K=1
      GO TO 802
806  FT=HS*AT
      X=BC1
      K=2
      NA=1
      GO TO 802
807  FC=COREL*AT
      FS=FT+FC

```

```

PL=(2.*(FG+FT)+FC)*(P1+P2+P3+P4)*.001*PX
PLT=FQ+(PL*2./PX)
BP=PLT/AP
X=BP
NA=31
K=3
GO TO 802
808 FP=ALP*AT
PL7=.001*P7*(FC+FT+FG+FP)
PL8=P8*(2.*FG+2.*FT+FC)*.001
PG2=PLT*PX/2.+PL7+PL8
BG2=PG2/A2
FG2=BG2*G2/.00319
Z=FG2+FP+FG+FT+FC
IF(COILS-1.)817,818,817
817 BY=PG2/AY
821 NA=61
X=BY
K=5
GO TO 802
810 FY=AT*ALY
IF(COILS-1.)820,822,820
820 PL5=.001*P5*(Z+FY)
818 IF(COILS-1.0)814,815,814
814 BY2=(PG2+PL5)/AY2
GO TO 816
815 BY2=PG2/AY2
816 X=BY2
K=4

```

```

NA=61
GO TO 802
809 FY2=((DU-DY2)/6.)*AT
      IF(COILS-1.)822,826,822
826 PL5=.002*P5*(Z+FY2)
      BY=(PG2+PL5)/AY
      GO TO 821
822 FNL=(FY+FY2+FG2+FP+FG+FT+FC/2.)*2.
      AINL=FNL/(PT*COILS)
      CD=AINL/AS
      EPNL=AINL*FK*COILS
      PUNCH1,TG,FQ,BC1,BT1,BG1,FG
      PUNCH1,P1,P2,P3,P4,P5,P7
      PUNCH1,A2,AY2,AY,BP,BY,BY2
      PUNCH1,BG2,FG2,FNL,AINL,CD,EPNL
      PUNCH1,AP,PL,PLT,FC,FT,P8
      PUNCH1,PL8,ALZ
      PAUSE
802 IF(AI(NA)-X)830,831,831
831 NA=NA+3
835 IF(AI(NA)-X)833,834,834
833 NA=NA+2
      GO TO 835
834 AX=AI(NA)
      BB1=AI(NA-2)
      DC=AI(NA+1)
      D=AI(NA-1)
      XX=(AX-BB1)/(.4343*(LOG(DC)-LOG(D+.0001)))
      Y=AX-XX*.4343*LOG(DC)

```

AT=EXP(2.306\*(X-Y)/XX)

GO TO (838,839),LOAD

838 GO TO (806,807,808,809,810),K

830 GO TO (836,837),LOAD

836 PRINT 850,

850 FORMAT (17HMACHINE SATURATED)

PAUSE

END

C PASS 6 OUTSIDE COIL LUNDELL

3 FORMAT(9X F12.5,2X F12.5)

870 FORMAT(9X F12.5,2X F12.5/)

1 FORMAT(E11.5,E11.5,E11.5,E11.5,E11.5,E11.5)

READ1 ,VA,EE,EP,PN,F,PX

READ1 ,RPM,PI,PF,CK,POL,DI

READ1 ,DU,CL,SS,HC,SF,QN

READ1 ,WL,BK,ZZ,BO,B1,B2

READ1 ,B3,BS,HO,HX,HY,HZ

READ1 ,HS,HT,HW,QQ,W,RF

READ1 ,SC,YY,C,TS,SN,DB

READ1 ,CE,SH,SD,TT,SK,RB

READ1 ,TP,D1,FE,RD,RT,COILS

READ1 ,T2,RR,SNL,WF,PE,SN1

READ1 ,DW1,BP1,BP2,TP1,TP2,ALP

READ1 ,DR,WR,DY2,TY2,TY,ALY

READ1 ,HM,SM,AS,AC,ET,EB

READ1 ,S,FK,FR,RC,RG,RP

READ1 ,G2,DG2,ALG2,AL1

READ1 ,GE,CS,CF,FS,EC,DF

READ1 ,RS,GC,PT,C1,CW,CP

READ1 ,EL,CM,CQ,DW,CC,PBA

READ1 ,FF,CX,PC,EK,EW,TM

READ1 ,A,WI,WC,WN,WT,WQ

READ1 ,TG,FQ,BC1,BT1,BG1,FG

READ1 ,P1,P2,P3,P4,P5,P7

READ1 ,A2,AY2,AY,BP,BY,BY2

READ1 ,BG2,FG2,FNL,A1NL,CD,EPNL

READ1,AP,PL,PLT,FC,FT,P8

```

READ 1,PL8,ALZ
XR=.0707*A*DF/(BG1*C1)
XL=XR*(PC+EW+ALZ)
XD=90.*EC*PI*CM*DF/(2.*PX*(FG+FG2))
XQ=CQ*XD/(CM*C1)
XA=XL+XD
XB=XL+XQ
VR=3.1416*DR*RPM/12.
AGE=((FG+FG2)/(FG))*GE
PEE=(P1+P2+P3+P4)*PX+P5+P8
ALF=PEE/CL
ALA=6.38*D1/(PX*AGE)
XF=XD*(1.-(C1/CM)/(2.*CP+ALF*1.273/ALA))
SI=PT*PT*PEE*1.E-8*COILS
XU=XL+XF
XS=.88*XU
XX=XS
XY=XB
XN=.5*(XX+XY)
IF(W)414,415,414
415 X0=0.
GO TO 422
414 IF(CS-1.)417,418,417
418 AKX=1.
AKX1=1.
GO TO 419
417 AA=(3.*YY/(PN*QN))
AKX=AA-2.
IF(AA/3.-.667)420,420,421

```

```

420 AKX1=.75*AA-.25
      GO TO 419
421 AKX1=.75*AA+.25
419 ABL=(AKX/(CF**2))*07*ALA
      XO=AKX*(ABL+PC)/AKX1
      XO=XR*(XO+(1.667*(HX+3.*HZ)))/(PII*QN*CF**2*DF**2*BS)+.2*EW)
422 TC=SI/(FK*COILS)
      RA=PN*PI*PI*RG/(VA*1000.)
      TA=XN/(628.32*F*RA)
      T5=XS*TC/XA
      T4=2./F
      FSC=XA*.02*(FG+FG2)
      SCR=FNL/FSC
      PRINT3,AC,A,S,XR,HM,XL,RG,XD,RP,XQ,ET,XA,EB,XB,PC,XF,EW,SI,WC,XU
      PRINT3,WI,XS,TP,XX,WR,XY,VR,XN,AS,XO,FK,TC,FR,TA,RC,T5,P1,T4
      PRINT3,P2,TG,P3,FQ,P4,BG1,P5,BT1,P7,BC1,P8,FT,FSC,FC
      PRINT870,SCR,FG
      PUNCH1,B0,GC,PI,PN,EP,ET
      PUNCH1,EB,SC,C,XB,XD,PF
      PUNCH1,EE,TG,BT1,FQ,BC1,FG
      PUNCH1,HS,DU,HC,PX,P1,P2
      PUNCH1,P3,P4,P5,P7,BP,ALP
      PUNCH1,BG2,A2,G2,AY2,AY,BY2
      PUNCH1,DY2,BY,ALY,PT,AS,FK
      PUNCH1,XA,RG,WF,WQ,WT,WN
      PUNCH1,SNL,POL,RP,FR,PL,PLT
      PUNCH1,FC,AI NL,CD,EPNL,FNL,FT
      PUNCH1,COILS,AP,P8,PL8,CK
      PAUSE

```



END

```

C PASS 7 OUTSIDE COIL LUNDELL
  DIMENSION GB(4),AE(4),DX(4)
1 FORMAT(E11.5,E11.5,E11.5,E11.5,E11.5,E11.5)
  READ1 ,BO,GC,PI,PN,EP,ET
  READ1 ,EB,SC,C,XB,XD,PF
  READ1 ,EE,TG,BT1,FQ,BC1,FG
  READ1 ,HS,DU,HC,PX,P1,P2
  READ1 ,P3,P4,P5,P7,BP,ALP
  READ1 ,BG2,A2,G2,AY2,AY,BY2
  READ1 ,DY2,BY,ALY,PT,AS,FK
  READ1 ,XA,RG,WF,WQ,WT,WN
  READ1 ,SNL,POL,RP,FR,PL,PLT
  READ1 ,FC,AI NL,CD,EPNL,FNL,FT
  READ 1,COILS,AP,P8,PL8,CK
  AXX=BO/GC
  IF (AXX-1.) 964,965,964
965 AKSC=2.6
  GO TO 957
964 IF (AXX-3.75) 955,955,956
955 AKSC=10.**.178/((AXX-1.)**.334)
  GO T0957
956 AKSC=10.**.11/((AXX-1.)**.174)
957 XX1=PI*PI*PN
  XX3=3.*EP*PI*PF
  XX2=(ET+EB)/2.-1.
  XX4=AKSC*PI*SC/(C*FG)
  GB(1)=1.
  GB(2)=1.5
  GB(3)=2.

```

```

GB(4)=POL
AN=ATAN(SQRT(1.-PF*PF)/PF)
AN1=SIN(AN)
DO 777 K=1,4
YB=GB(K)
AA  =ATAN((AN1+XB*YB/100.)/PF)
AE(K)=COS(AA-AN)+XA*SIN(AA)*YB/100.
777 DX(K)=.93*XD*YB*SIN(AA)/100.
PUNCH1,AE(1),AE(2),AE(3),AE(4)
PUNCH1,DX(1),DX(2),DX(3),DX(4)
PUNCH1,B0,GC,PI,PN,EP,ET
PUNCH1,EB,SC,C,XB,XD,PF
PUNCH1,EE,TG,BT1,FQ,BC1,FG
PUNCH1,HS,DU,HC,PX,P1,P2
PUNCH1,P3,P4,P5,P7,BP,ALP
PUNCH1,BG2,A2,G2,AY2,AY,BY2
PUNCH1,DY2,BY,ALY,PT,AS,FK
PUNCH1,XA,RG,WF,WQ,WT,WN
PUNCH1,XX1,XX2,XX3,XX4,SNL,POL
PUNCH1,RP,FR,PL,PLT,FC,FT
PUNCH1,AI NL,CD,EPNL,FNL,COILS,AP
PUNCH1,P8,PL8,CK
PAUSE
END

```

```

C      PASS 8  OUTSIDE COIL LUNDELL
      DIMENSION AI(90)
      DIMENSION AE(4),DX(4),BPL(4),BYL(4),BY2L(4),BG2L(4),PLL(4),PTLL(4)
      DIMENSION FFL(4),AIFL(4),CDD(4),EPFL(4)
      1 FORMAT(E11.5,E11.5,E11.5,E11.5,E11.5,E11.5)
888  FORMAT(F10.0,F10.0,F10.0,F10.0,F10.0,F10.0)

      K=1
823  READ888, AI(K),AI(K+1),AI(K+2),AI(K+3),AI(K+4),AI(K+5)
      K=K+6
      IF(K-89)823,824,824
824  READ1 ,AE(1),AE(2),AE(3),AE(4)
      READ1 ,DX(1),DX(2),DX(3),DX(4)
      READ1 ,BO,GC,PI,PN,EP,ET
      READ1 ,EB,SC,C,XB,XD,PF
      READ1 ,EE,TG,BT1,FQ,BC1,FG
      READ1 ,HS,DU,HC,PX,P1,P2
      READ1 ,P3,P4,P5,P7,BP,ALP
      READ1 ,BG2,A2,G2,AY2,AY,BY2
      READ1 ,DY2,BY,ALY,PT,AS,FK
      READ1 ,XA,RG,WF,WQ,WT,WN
      READ1,XX1,XX2,XX3,XX4,SNL,POL
      READ1,RP,FR,PL,PLT,FC,FT
      READ1 ,AINL,CD,EPNL,FNL,COILS,AP
      READ 1,P8,PL8,CK
      LOAD=2
      DO 900 J=1,4
      AED=AE(J)
      AA=AED*FG+(1.+PF)*FT+FC
      PLL(J)=PL*AA /(FG+FT+FC)

```

```

P8LL=PLL(J)*PL8/PL
IF (PF-.95)880,880,881
881 PR=FQ*CK
GO TO 882
880 PR=FQ*(AED-DX(J))
882 PTLL(J)=PR+(PLL(J)*2./PX)
X=PTLL(J)/AP
BPL(J)=X
NA=31
K=1
GO TO 802
841 FPL= AT* ALP
PL7L=P7*.001*AA
PG2L=(PTLL(J)*PX/2.)+PL7L+P8LL
BG2L(J)=PG2L/A2
FG2L=BG2L(J)*G2/.00319
IF (COILS-1.)855,851,855
855 BYL(J)=PG2L/AY
859 NA=61
X=BYL(J)
K=3
GO TO 802
843 FYL=ALY*AT
IF (COILS-1.)856,857,856
856 PL5L=P5*.001*(AA+FPL+FYL+FG2L)
851 IF (COILS-1.)852,853,852
852 X=(PG2L+PL5L)/AY2
GO TO 854
853 X=PG2L/AY2

```

```

854 BY2L(J)=X
      NA=61
      K=2
      GO TO 802
842 FY2L=AT*(DU-DY2)/2.
      IF(COILS-1.)857,858,857
858 PL5L=P5*.002*(AA+FPL+FY2L+FG2L)
      BYL(J)=(PG2L+PL5L)/AY
      GO TO 859
857 FFL(J)=(FG2L+FYL+FPL+FY2L+AA)*2.
      AIFL(J)=FFL(J)/(PT*COILS)
      CDD(J)=AIFL(J)/AS
900 EPFL(J)=AIFL(J)*FR*COILS
837 JA=JA/3
      PUNCH 860,JA
860 FORMAT (13)
      IF(JA)861,862,861
861 DO 863 J=1,JA
      PUNCH1,PLL(J),PTLL(J),BY2L(J),BYL(J),BG2L(J),BPL(J)
863 PUNCH1,FFL(J),AIFL(J),CDD(J),EPFL(J)
862 PUNCH1,EE,TG,BT1,FQ,BC1,FG
      PUNCH1,HS,DU,HC,PX,P1,P2
      PUNCH1,P3,P4,P5,P7,BP,ALP
      PUNCH1,BG2,A2,G2,AY2,AY,BY2
      PUNCH1,DY2,BY,ALY,PT,AS,FK
      PUNCH1,XA,RG,WF,WQ,VT,VN
      PUNCH1,XX1,XX2,XX3,XX4,SNL,POL
      PUNCH1,RP,FR,PF,COILS,AP,P8
      PUNCH1,AIHL,CD,EPIL,FNL,PL,PLT

```

PAUSE

802 IF (AI (NA)-X) 830, 831, 831

831 NA=NA+3

835 IF (AI (NA)-X) 833, 834, 834

833 NA=NA+2

GO TO 835

834 AX=AI (NA)

BB1=AI (NA-2)

DC=AI (NA+1)

D=AI (NA-1)

XX= (AX-BB1) / (.4343 \* (LOG (DC) - LOG (D+.0001)))

Y=AX-XX\*.4343\*LOG (DC)

AT=EXP (2.306 \* (X-Y) / XX)

GO TO (838, 839), LOAD

838 GO TO (806, 807, 808, 809, 810), K

839 JA=JA+1

GO TO (841, 842, 843), K

830 GO TO (836, 837), LOAD

836 PRINT 850,

850 FORMAT (17HMACHINE SATURATED)

PAUSE

END

```

C    PASS 9  OUTSIDE COIL LUNDELL
      DIMENSION BPL(4),BG2L(4),FFL(4),AIFL(4),CDD(4),EPFL(4),FCUL(4)
      DIMENSION WNL(4),STTL(4),SCUL(4),EDDL(4),TOTL(4),PEFF(4),GB(4)
      DIMENSION PLL(4),PTLL(4),BYL(4),BY2L(4)
961  FORMAT(F11.3,8X F11.3,F11.3,F11.3,F11.3)
860  FORMAT (13)
      1  FORMAT (E11.5,E11.5,E11.5,E11.5,E11.5,E11.5)
      DO 705  N=1,4
      PLL(N)=0
      PTLL(N)=0
      BPL(N)=0
      BG2L(N)=0
      BYL(N)=0
      BY2L(N)=0
      FFL(N)=0
      AIFL(N)=0
      CDD(N)=0
      EPFL(N)=0
      FCUL(N)=0
      WNL(N)=0
      STTL(N)=0
      SCUL(N)=0
      EDDL(N)=0
      TOTL(N)=0
705  PEFF(N)=0
      READ860,JA
      IF(JA)702,703,702
702  DO 704  J=1,JA
      READ1 ,PLL(J),PTLL(J),BY2L(J),BYL(J),BG2L(J),BPL(J)

```



```

704 READ1 ,FFL(J),AIFL(J),CDD(J),EPFL(J)
703 READ1 ,EE,TG,BT1,FQ,BC1,FG
      READ1 ,HS,DU,HC,PX,P1,P2
      READ1 ,P3,P4,P5,P7,BP,ALP
      READ1 ,BG2,A2,G2,AY2,AY,BY2
      READ1 ,DY2,BY,ALY,PT,AS,FK
      READ1 ,XA,RG,WF,WQ,WT,WN
      READ1 ,XX1,XX2,XX3,XX4,SNL,POL
      READ1 ,RP,FR ,PF,COILS,AP,P8
      READ1 ,AINL,CD,EPNL,FNL,PL,PLT
      IF(SNL)707,706,707
707 PUNCH1,TG,BT1,FQ,BC1,FG,HS
      PUNCH1,DU,HC,PX,P1,P2,P3
      PUNCH1,P4,P5,P7,AP,ALP,A2
      PUNCH1,G2,AY,AY2,DY2,ALY,COILS
      PUNCH1,EE,P8
706 FEL=AINL*AINL*FK
      TL=FEL+WT+WQ+WN+WF
      ABX=0
      IF(JA)714,712,714
714 IF(JA-4) 708,709,708
709 IF(POL)708,710,708
710 JA=JA-1
708 GB(1)=1.
      GB(2)=1.5
      GB(3)=2.
      GB(4)=POL
      DO 711 K=1,JA
      YB=GB(K)

```

```

FCUL(K)=AIFL(K)**2*FR*COILS
STTL(K)=( (.0027*XA*YB)**2*2.+1.)*WT
WNL(K)=( (XX4*YB)**2+1.)*WN
SCUL(K)=XX1*RP*YB
EDDL(K)=SCUL(K)*XX2
TOTL(K)=EDDL(K)+SCUL(K)+WNL(K)+STTL(K)+FCUL(K)+WQ+WF
711 PEFF(K)=XX3*YB*100./(XX3*YB+TOTL(K))
712 IF (POL) 958, 959, 958
958 PRINT 961, PL, PLL(1), PLL(2), PLL(3), PLL(4)
PRINT 961, PLT, PTLL(1), PTLL(2), PTLL(3), PTLL(4)
PRINT 961, BP, BPL(1), BPL(2), BPL(3), BPL(4)
PRINT 961, BG2, BG2L(1), BG2L(2), BG2L(3), BG2L(4)
PRINT 961, BY2, BY2L(1), BY2L(2), BY2L(3), BY2L(4)
PRINT 961, BY, BYL(1), BYL(2), BYL(3), BYL(4)
PRINT 961, FNL, FFL(1), FFL(2), FFL(3), FFL(4)
PRINT 961, AINL, AIFL(1), AIFL(2), AIFL(3), AIFL(4)
PRINT 961, CD, CDD(1), CDD(2), CDD(3), CDD(4)
PRINT 961, EPNL, EPFL(1), EPFL(2), EPFL(3), EPFL(4)
PRINT 961, WQ, WQ, WQ, WQ, WQ
PRINT 961, WT, STTL(1), STTL(2), STTL(3), STTL(4)
PRINT 961, ABX, SCUL(1), SCUL(2), SCUL(3), SCUL(4)
PRINT 961, ABX, EDDL(1), EDDL(2), EDDL(3), EDDL(4)
PRINT 961, WN, WNL(1), WNL(2), WNL(3), WNL(4)
PRINT 961, FEL, FCUL(1), FCUL(2), FCUL(3), FCUL(4)
PRINT 961, WF, WF, WF, WF, WF
PRINT 961, TL, TOTL(1), TOTL(2), TOTL(3), TOTL(4)
PRINT 961, ABX, PEFF(1), PEFF(2), PEFF(3), PEFF(4)
PAUSE
959 PRINT 961, PL, PLL(1), PLL(2), PLL(3)

```

PRINT961,PLT,PTLL(1),PTLL(2),PTLL(3)  
PRINT961,BP,BPL(1),BPL(2),BPL(3)  
PRINT961,BG2,BG2L(1),BG2L(2),BG2L(3)  
PRINT961,BY2,BY2L(1),BY2L(2),BY2L(3)  
PRINT961, BY,BYL(1),BYL(2),BYL(3)  
PRINT961,FNL,FFL(1),FFL(2),FFL(3)  
PRINT961,AI NL,AIFL(1),AIFL(2),AIFL(3)  
PRINT961,CD,CDD(1),CDD(2),CDD(3)  
PRINT961,EPNL,EPFL(1),EPFL(2),EPFL(3)  
PRINT961,WQ,WQ,WQ,WQ  
PRINT961,WT,STTL(1),STTL(2),STTL(3)  
PRINT961,ABX,SCUL(1),SCUL(2),SCUL(3)  
PRINT961,ABX,EDDL(1),EDDL(2),EDDL(3)  
PRINT961,WN,WNL(1),WNL(2),WNL(3)  
PRINT961,FEL,FCUL(1),FCUL(2),FCUL(3)  
PRINT961,WF,WF,WF,WF  
PRINT961,TL,TOTL(1),TOTL(2),TOTL(3)  
PRINT961,ABX,PEFF(1),PEFF(2),PEFF(3)  
PAUSE  
END

```

C    PASS 10  OUTSIDE COIL LUNDELL
      DIMENSION AI(90)
      1  FORMAT(E11.5,E11.5,E11.5,E11.5,E11.5,E11.5)
      888  FORMAT(F10.0,F10.0,F10.0,F10.0,F10.0,F10.0)
      878  FORMAT(F12.5,F12.5,F12.5,F12.5,F12.5,F12.5)
      879  FORMAT(F12.5,F12.5,F12.5,F12.5,F12.5,F12.5//)
      K=1
      823  READ888, AI(K), AI(K+1), AI(K+2), AI(K+3), AI(K+4), AI(K+5)
      K=K+6
      IF(K-89)823,824,824
      824  READ1, TG, BT1, FQ, BC1, FG, HS
      READ1 , DU, HC, PX, P1, P2, P3
      READ1 , P4, P5, P7, AP, ALP, A2
      READ1 , G2, AY, AY2, DY2, ALY, COILS
      READ1, EE, P8
      COREL=3.1416*(DU-HC)/(4.*PX)
      LOAD=1
      YB=.8
      DO 800 N=1,9
      R1=BT1*YB
      R2=FQ*YB
      R3=BC1*YB
      R4=FG*YB
      R5=EE*YB
      X=R1
      NA=1
      K=1
      GO TO 802
      806  FT=HS*AT

```

```

X=R3
K=2
NA=1
GO TO 802
807 FC=COREL*AT
FS=FT+FC
PL=(2.*(R4+FT)+FC)*(P1+P2+P3+P4)*.001*PX
PLT=R2+(PL*2./PX)
BP=PLT/AP
X=BP
NA=31
K=3
GO TO 802
808 FP=ALP*AT
PL7=.001*P7*(FC+FT+R4+FP)
PL8=P8*(2.*R4+2.*FT+FC)*.001
PG2=PLT*PX/2.+PL7+PL8
BG2=PG2/A2
FG2=BG2*G2/.00319
Z=FG2+FP+R4+FT+FC
IF(COILS-1.)817,818,817
817 BY=PG2/AY
821 NA=61
X=BY
K=5
GO TO 802
810 FY=AT*ALY
IF(COILS-1.)820,822,820
820 PL5=.001*P5*(Z+FY)

```

```

818 IF (COILS-1.0)814,815,814
814 BY2=(PG2+PL5)/AY2
      GO TO 816
815 BY2=PG2/AY2
816 X=BY2
      K=4
      NA=61
      GO TO 802
809 FY2=((DU-DY2)/6.)*AT
      IF (COILS-1.)822,826,822
826 PL5=.002*P5*(Z+FY2)
      BY=(PG2+PL5)/AY
      GO TO 821
822 FNL=(FY+FY2+FG2+FP+R4+FT+FC/2.)*2.
      PRINT878,R5,R1,FT,R3,FC,R4
      PRINT879,PL,PLT,BP,BY2,BY,FNL
800 YB=YB+.1
      PAUSE
802 IF (AI (NA)-X)830,831,831
831 NA=NA+3
835 IF (AI (NA)-X)833,834,834
833 NA=NA+2
      GO TO 835
834 AX=AI (NA)
      BB1=AI (NA-2)
      DC=AI (NA+1)
      D=AI (NA-1)
      XX= (AX-BB1)/(.4343*(LOG(DC)-LOG(D+.0001)))
      Y=AX-XX*.4343*LOG(DC)

```

AT=EXP(2.306\*(X-Y)/XX)

GO TO (838,839),LOAD

838 GO TO (806,807,808,809,810),K

839 JA=JA+1

GO TO (841,842),K

830 GO TO (836,837),LOAD

836 PRINT 850,

850 FORMAT (17HMACHINE SATURATED)

PAUSE

END





HOMOPOLAR INDUCTOR A-C GENERATOR  
COMPUTER PROGRAM AND TEST DATA

( )

# HOMOPOLAR COMPUTER DESIGN (INPUT)

MODEL	EWO	DESIGN NO(1)						
PARAMETERS	(2) KVA	GENERATOR KVA	80	0.0	FUND/MAX OF FIELD FLUX	(71)	C <sub>1</sub>	CONSTANTS
	(3) E	LINE VOLTS	208	0.0	WINDING CONSTANT	(72)	C <sub>w</sub>	
	(4) E <sub>ph</sub>	PHASE VOLTS	120	0.0	POLE CONST.	(73)	C <sub>p</sub>	
	(5) m	PHASES	3	0.0	END EXTENSION ONE TURN	(48)	LE	
	(5a) f	FREQUENCY	400	0.0	DEMAGNETIZATION FACTOR	(74)	C <sub>m</sub>	
	(6) p	POLES	4	0.0	CROSS MAGNETIZING FACTOR	(75)	C <sub>q</sub>	
	(7) RPM	RPM	12000	3.88	POLE WIDTH	(76)	b <sub>p</sub>	
	(8) I <sub>ph</sub>	PHASE CURRENT	223	3.425	POLE LENGTH	(76)	p	
	(9) PF	POWER FACTOR	.75	1.5	POLE HEIGHT	(76)	h <sub>p</sub>	
	(9a) K <sub>c</sub>	ADJ. FACTOR	1.0	1.25	POLE HEIGHT (EFFECTIVE)	(76)	h' <sub>p</sub>	
(10)	OPTIONAL LOAD POINT	0.0	.67	POLE EMBRACE	(77)	u <sub>c</sub>	ROTOR STACK	
(11) d	STATOR I.D.	7.5	7.38	ROTOR DIAMETER	(11a)	d <sub>r</sub>		
(12) D	STATOR O.D.	10.357	1.0	STACKING FACTOR (ROTOR)	(16)	K <sub>i</sub>		
(13)	GROSS CORE LENGTH	3.31	0	WEIGHT OF ROTOR IRON	(157)	(-)		
(14) n <sub>v</sub>	NO. OF DUCTS	0.0	7	POLE FACE LOSS FACTOR	(187)	(K <sub>1</sub> )		
(15) b <sub>v</sub>	WIDTH OF DUCT	0.0	0.0	WIDTH OF SLOT OPENING	(135)	b <sub>bo</sub>		
(16) K <sub>i</sub>	STACKING FACTOR (STATOR)	.92	0.0	HEIGHT OF SLOT OPENING	(135)	b <sub>bo</sub>		
(19) k	WATTS/LB.	15	0.0	DAMPER BAR DIA. OR WIDTH	(136)	( )		
(20) B	DENSITY	77.4	0.0	RECTANGULAR BAR THICKNESS	(137)	h <sub>bl</sub>		
(21)	TYPE OF SLOT	2	0.0	RECTANGULAR SLOT WIDTH	(135)	b <sub>bl</sub>		DAMPER BAR
(22) b <sub>o</sub>	SLOT OPENING	.050	0.0	NO. OF DAMPER BARS	(138)	nb		
(22) b <sub>1</sub>	SLOT WIDTH TOP	0.0	0.0	DAMPER BAR LENGTH	(139)	b		
(22) b <sub>2</sub>		0.0	0.0	DAMPER BAR PITCH	(140)	b		
(22) b <sub>3</sub>		0.0	0.0	RESISTIVITY OF DAMP. BAR @ 20°	(141)	D		
(22) b <sub>s</sub>	SLOT WIDTH	.162	0.0	DAMPER BAR TEMP °C	(142)	X <sub>a</sub> °C		
(22) h <sub>o</sub>		.015	5.57	SHAFT DIAMETER	(78a)	D <sub>sh</sub>		
(22) h <sub>1</sub>		.492	0.0	SHAFT I.D.	(78a)	d <sub>sh</sub>		
(22) h <sub>2</sub>		0.0	3.8	SHAFT EXT. DIAMETER	(78a)	d' <sub>sh</sub>		
(22) h <sub>3</sub>		0.0	2.6	LENGTH OF SHAFT	(78a)	sh		
(22) h <sub>s</sub>	SLOT DEPTH	.537	1	TYPE OF YOKE	(78)		SHAFT	
(22) h <sub>t</sub>		.030	.60	YOKE THICKNESS	(78)	t <sub>y</sub>		
(22) h <sub>w</sub>		.030	0.0	YOKE THICKNESS	(78)	t <sub>ye</sub>		
(23) Q	NO. OF SLOTS	72	0.0	YOKE THICKNESS	(78)	t <sub>yr</sub>		
(28)	TYPE OF WDG.	1	0.0	YOKE I.D.	(78)	d <sub>yc</sub>		
(29)	TYPE OF COIL	1	8.58	YOKE THICKNESS	(78)	t <sub>yr</sub>		
(30) n <sub>s</sub>	CONDUCTORS/SLOT	2	10.31	FIELD I.D.	(78)	d <sub>yc</sub>		
(31) y	SLOTS SPANNED	13	2.60	FIELD COIL INSIDE DIA.	(78)	d <sub>cell</sub>		
(32) c	PARALLEL CIRCUITS	2	292	FIELD COIL OUTSIDE DIA.	(78)	D <sub>cell</sub>		
(33)	STRAND DIA. OR WIDTH	.212	29.7	FIELD COIL WIDTH	(78)	b <sub>cell</sub>		
(34) N	STRANDS/CONDUCTOR	1.0	.072	NO. OF FIELD TURNS	(146a)	NF		
(34a) N' <sub>st</sub>	STRANDS/CONDUCTOR	1.0	0	MEAN LENGTH OF FLD. TURN	(147)	tr		
(39)	STATOR STRAND T'KNS	.125	200	FLD. COND. DIA. OR WIDTH	(148)			
(35) d	DIA. OF PIN	.50	.694	FLD. COND. THICKNESS	(149)			
(36) e <sub>2</sub>	COIL EXT. STR. PORT	.25	1.0	FLD. TEMP IN °C	(150)	X <sub>t</sub> °C		
(37) h <sub>st</sub>	UNINS. STRD. HT.	.212	0.0	RESISTIVITY OF FLD. COND. @ 20°	(151)	f		
(38) h' <sub>st</sub>	DIST. BTWN. CL OF STD.	.218	0.0	NO LOAD SAT.	(87)			
(42a)	PHASE BELT/ANGLE	60	0.0	FRICTION & VIBRAGE	(183)	(F&V)		
(40) s <sub>k</sub>	STATOR SLOT SKEW	0.0	0.0	LEAKAGE PERMEANCE	(80c)	P <sub>m</sub>		
(50) X <sub>s</sub> °C	STATOR TEMP °C	200	0.0	LEAKAGE PERMEANCE	(84a)	P <sub>5</sub>		
(51) s	RES'TVY STA. COND. @ 20° C	.694	4130	LEAKAGE PERMEANCE	(85a)	P <sub>6</sub>		
(59) g <sub>min</sub>	MINIMUM AIR GAP	.060	M-22	LEAKAGE PERMEANCE	(86a)	P <sub>7</sub>		
(59a) g <sub>max</sub>	MAXIMUM AIR GAP	.060	4130	ROTOR LAM MTR'L	(18)			
				STATOR LAM. MTR'L	(18)			
				YOKE MTR'L	(18)			

DESIGNER \_\_\_\_\_

DATE \_\_\_\_\_

REV. A

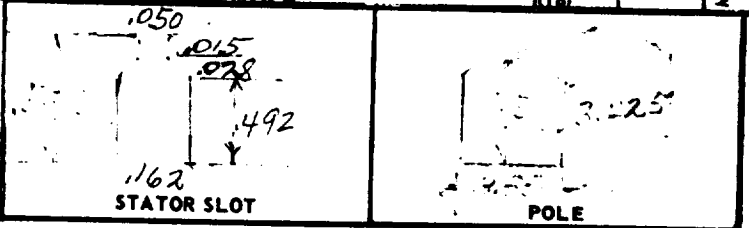

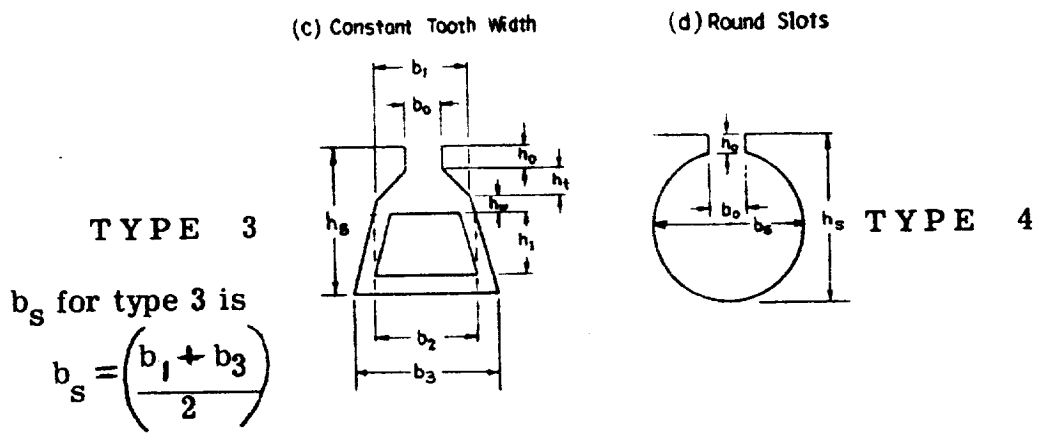
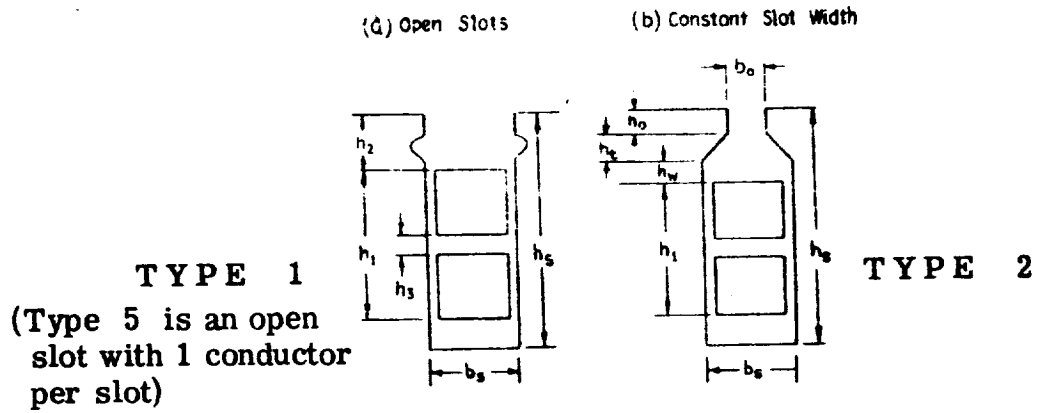

SUMMARY OF DESIGN CALCULATIONS - HOMOPOLAR INDUCTOR (OUTPUT)

MODEL	EWO	DESIGN NO.			
(17) ( $l_s$ )	SOLID CORE LENGTH	3.04520	1.02570	CARTER COEFFICIENT	(67) ( $K_c$ )
(24) ( $h_c$ )	DEPTH BELOW SLOT	.89150	78.00015	AIR GAP AREA PER STATOR	(68) (-)
(26) ( $T_s$ )	SLOT PITCH	.32729	194.37944	AIR GAP PERM	(70c) ( $\lambda_a$ )
(27) ( $T_s/3$ )	SLOT PITCH 1/3 DIST. UP	.34292	.06154	EFFECTIVE AIR GAP	(69) ( $g_e$ )
(42) ( $K_{sk}$ )	SKREW FACTOR	1.00000	1.09909	FUND/MAX OF FLD. FLUX	(71) (C1)
(43) ( $K_d$ )	DIST. FACTOR	.95613	.42926	WINDING CONST.	(72) (C <sub>w</sub> )
(44) ( $K_p$ )	PITCH FACTOR	.90636	.68180	POLE CONST.	(73) (C <sub>p</sub> )
(45) ( $n_e$ )	EFF. CONDUCTORS	65.25800	7.74061	END. EXT. ONE TURN	(48) (L <sub>E</sub> )
(46) ( $a_c$ )	COND. AREA	.02566	.85350	DEMAGNETIZING FACTOR	(74) (C <sub>M</sub> )
(47) ( $s_s$ )	CURRENT DENSITY (STA.)	4345.20000	.42932	CROSS MAGNETIZING FACTOR	(75) (C <sub>q</sub> )
(49) ( $l_t$ )	1/2 MEAN TURN LENGTH	11.05000	617.55104	AMP COND/IN	(128) (A)
(53) ( $R_{ph}$ )	COLD STA. RES. @ 20° C	.00717	.79807	REACTANCE FACTOR	(129) (X)
(54) ( $R_{pm}$ )	HOT STA. RES @ X° C	.01227	16.12237	LEAKAGE REACTANCE	(130) ( $X_L$ )
(55) ( $EF_{top}$ )	EDDY FACTOR TOP	2.00020	145.50284	REACTANCE OF	(131) ( $X_{ad}$ )
(56) ( $EF_{bot}$ )	EDDY FACTOR BOT	1.14130	66.59649	ARMATURE REACTION	(132) ( $X_{aq}$ )
(62) ( $\lambda_i$ )	STATOR COND. PERM.	2.71830	161.62521	SYN REACT DIRECT AXIS	(133) ( $X_d$ )
(64) ( $\lambda_e$ )	END PERM.	7.38255	82.71886	SYN REACT QUAD AXIS	(134) ( $X_q$ )
(65) (-)	WT. OF STA COPPER	26.21200	23.10636	FIELD LEAKAGE REACT	(160) ( $X_f$ )
(66) (-)	WT. OF STA IRON	58.27200	.62965	FIELD SELF INDUCTANCE	(161) (L <sub>f</sub> )
(80c) ( $P_m$ )	LEAKAGE PERMEANCE	46.71117	.00000	DAMPER	(163) ( $X_{Dd}$ )
(84a) (P5)	LEAKAGE PERMEANCE	21.05326	.00000	LEAKAGE REACT	(165) ( $X_{Dp}$ )
(85a) (P6)	LEAKAGE PERMEANCE	16.69846	39.22873	UNSAT. TRANS. REACT	(166) ( $X'_{du}$ )
(86a) (P7)	LEAKAGE PERMEANCE	12.30902	34.52128	SAT. TRANS. REACT	(167) ( $X'_{d}$ )
(153) ( $a_{CF}$ )	FLD. COND. AREA	.00406	34.52100	SUB. TRANS. REACT DIRECT AX.	(168) ( $X''_{d}$ )
(154) (R <sub>F</sub> )	COLD FLD RES @ 20° C	1.47900	32.71800	SUB. TRANS. REACT QUAD AX.	(169) ( $X''_{q}$ )
(155) (R <sub>F</sub> )	HOT FLD RES @ X° C	2.53190	58.61950	NEG SEQUENCE REACT	(170) (X <sub>2</sub> )
(156) (-)	WT. OF FLD. COPPER	11.32800	2.39774	ZERO SEQUENCE REACT	(172) (X <sub>0</sub> )
(157) (-)	WT. OF ROTOR IRON	.00000	3712.50000	TOTAL FLUX	(88) ( $\phi_T$ )
(145) ( $V_r$ )	PERIPHERAL SPEED	23202.00000	632.80000	FLUX PER POLE	(92) ( $\phi_p$ )
			47.59600	GAP DENSITY	(95) ( $B_g$ )
(176) ( $T_{do}$ )	OPEN CIR. TIME CONST.	.42572	97.91675	TOOTH DENSITY	(91) ( $B_t$ )
(177) ( $T_a$ )	ARM TIME CONST.	.01018	49.18050	CORE DENSITY	(94) ( $B_c$ )
(178) ( $T'_d$ )	TRANS TIME CONST.	.09093	40.69794	TOOTH AMPERE TURNS	(97) (F <sub>t</sub> )
(179) ( $T''_d$ )	SUB TRANS TIME CONST.	.00500	2.56671	CORE AMPERE TURNS	(98) (F <sub>c</sub> )
(180) (F <sub>sc</sub> )	SHORT CIR. NI	2968.00000	918.22000	GAP AMPERE TURNS	(96) (F <sub>g</sub> )

	PERCENT LOAD	0	100	150	200	OPTIONAL
( $\phi_m$ ) (91a)	LEAKAGE FLUX	42.890	171.764	239.154	307.245	.000
(F <sub>stm</sub> ) (96a)	GAP AMPERE TURNS	960.650	2348.686	3126.427	3919.002	.000
(B <sub>p</sub> ) (104b)	POLE DENSITY	50.845	68.333	77.910	87.962	.000
(B <sub>t</sub> ) (91c)	TOOTH DENSITY	97.916	110.912	117.707	124.574	.000
(B <sub>sh</sub> ) (113)	SHAFT DENSITY	59.465	89.907	106.319	123.341	.000
(B <sub>c</sub> ) (94)	CORE DENSITY	49.180	69.633	80.139	91.529	.000
(B <sub>yc</sub> ) (125a)	COIL YOKE DENSITY	73.591	115.486	138.154	.000	.000
(F <sub>nl</sub> ) (127)	TOTAL NI	2199.800	6016.900	11967.000	.000	.000
(I <sub>fnl</sub> ) (127a)	FIELD AMPS	7.533	20.605	40.982	.000	.000
(S <sub>f</sub> ) (127c)	CUR. DENS. (FLD.)	11.142	52.171	103.764	.000	.000
(E <sub>f</sub> ) (127b)	FIELD VOLTS	1851.270	5063.601	10070.987	.000	.000
(I <sup>2</sup> R <sub>f</sub> ) (182)	FIELD LOSS	83.939	1075.044	2252.569	.000	.000
(F&W) (183)	F&W LOSS	1678.700	1678.700	1678.700	1678.700	1678.700
(W <sub>nl</sub> ) (184)	STA TOOTH LOSS	231.640	430.804	646.878	.000	.000
(W <sub>c</sub> ) (185)	STA CORE LOSS	220.980	443.002	586.764	.000	.000
(W <sub>pnf</sub> ) (186)	POLE FACE LOSS	571.680	799.610	1084.524	.000	.000
(W <sub>dnl</sub> ) (193)	DAMPER LOSS	.000	.000	.000	.000	.000
(I <sup>2</sup> R <sub>s</sub> ) (194)	STATOR CU LOSS	.000	1831.700	4121.325	.000	.000
(-) (195)	EDDY LOSS	.000	1045.442	2352.246	.000	.000
(-) (196)	TOTAL LOSSES	2786.939	7304.304	14723.007	.000	.000
(-) (-)	RATING (KW)	.000	60.210	90.315	.000	.000
(-) (-)	PERCENT EFF.	.000	89.181	85.983	.000	.000

**HOMOPOLAR**  
**NO LOAD SATURATION OUTPUT SHEET**

ITEMS VOLTS	(3) (E) VOLTS	(96a) (F <sub>g</sub> m) AIR GAP A.T.	(94) (B <sub>c</sub> ) CORE DENSITY	(98) (F <sub>c</sub> ) CORE A.T.	(91) (B <sub>t</sub> ) TOOTH DENSITY	(97) (F <sub>t</sub> ) TOOTH A.T.
	(104b) (B <sub>p</sub> ) POLE DENSITY	(106a) (F <sub>p</sub> ) POLE A.T.	(113) (B <sub>sh</sub> ) SHAFT DENSITY	(114) (F <sub>sh</sub> ) SHAFT A.T.	(125a) (B <sub>yc</sub> ) YOKE DENSITY	(127) (F <sub>nl</sub> ) TOTAL A.T. (N.L.)
80%	166.27200 50.20037	768.52306 44.36387	48.55613 57.96235	2.51178 77.68069	78.33340 71.13030	4.99137 1742.0747
90%	187.05600 50.52312	864.58844 44.38257	48.86832 58.71500	2.53909 77.75708	88.12507 72.36169	11.3575 1947.8840
100%	207.84000 50.84588	960.65383 44.40128	49.18050 59.46763	2.56671 77.83353	97.91675 73.59307	40.6979 2199.89540
110%	228.62400 51.16864	1056.71920 44.42000	49.49269 60.22027	2.59462 77.91005	107.70842 74.82445	95.8777 2503.63030
120%	249.40800 51.49139	1152.78450 44.43872	49.80487 60.97292	2.62284 77.98666	117.50010 76.05584	193.67678 2892.64930
130%	270.19200 51.81415	1248.84990 44.45745	50.11705 61.72556	2.65137 78.06333	127.29177 77.28722	388.32247 3475.4099
140%	MACHINE SATURATED					
150%						
160%						

TEST SATURATION CURVES AND CALCULATED SATURATION POINTS FOR A 12000 RPM, 80 KVA, 400 CPS, HOMOPOLAR INDUCTOR

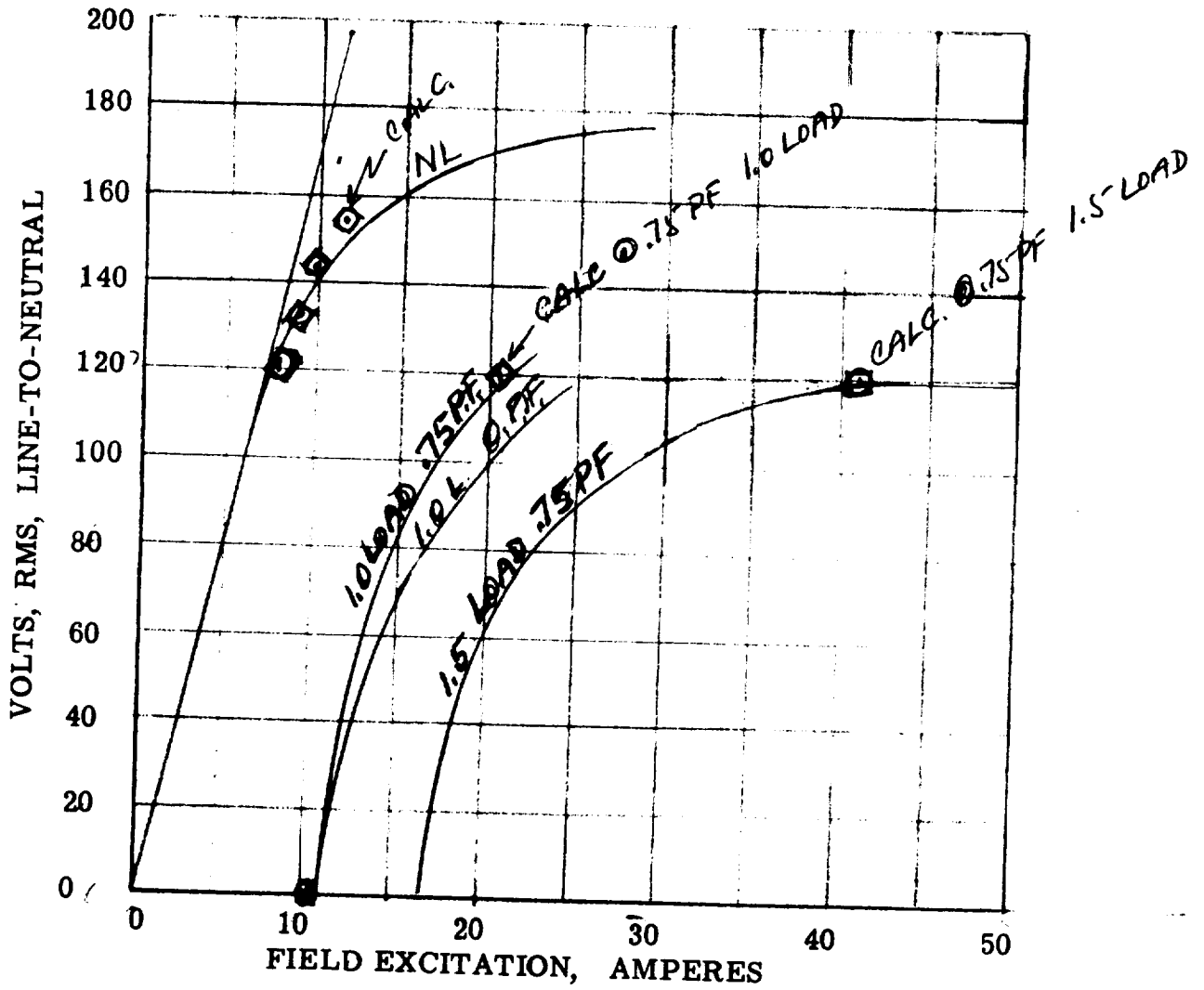

TEST VALUES OF LOSSES FOR A  
12000 RPM, 80 KVA, 400 CPS,  
HOMOPOLAR INDUCTOR A-C  
GENERATOR

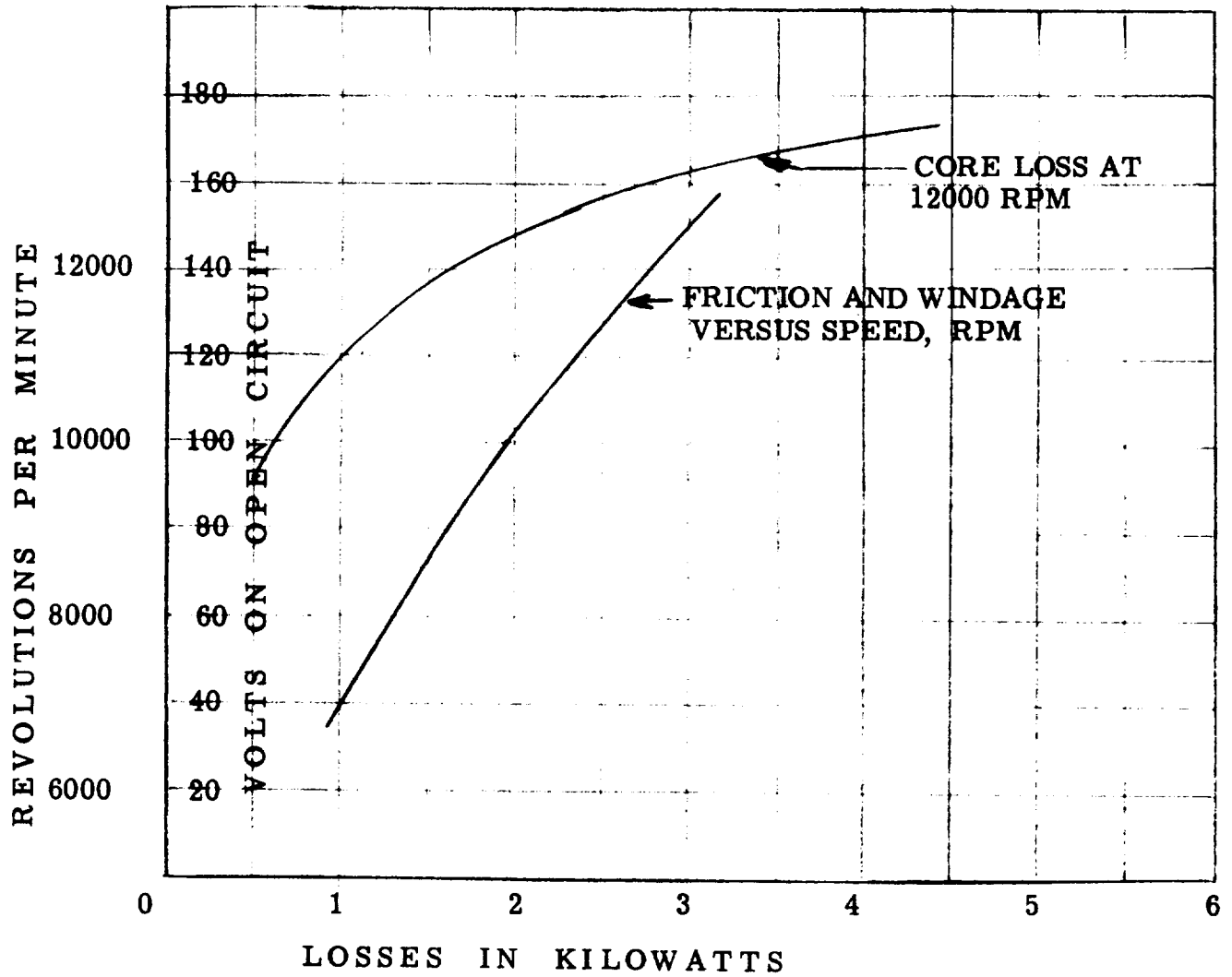



TEST EFFICIENCY VALUES FOR A 12000 RPM,  
80 KVA, 400 CPS, HOMOPOLAR INDUCTOR, A-C  
GENERATOR

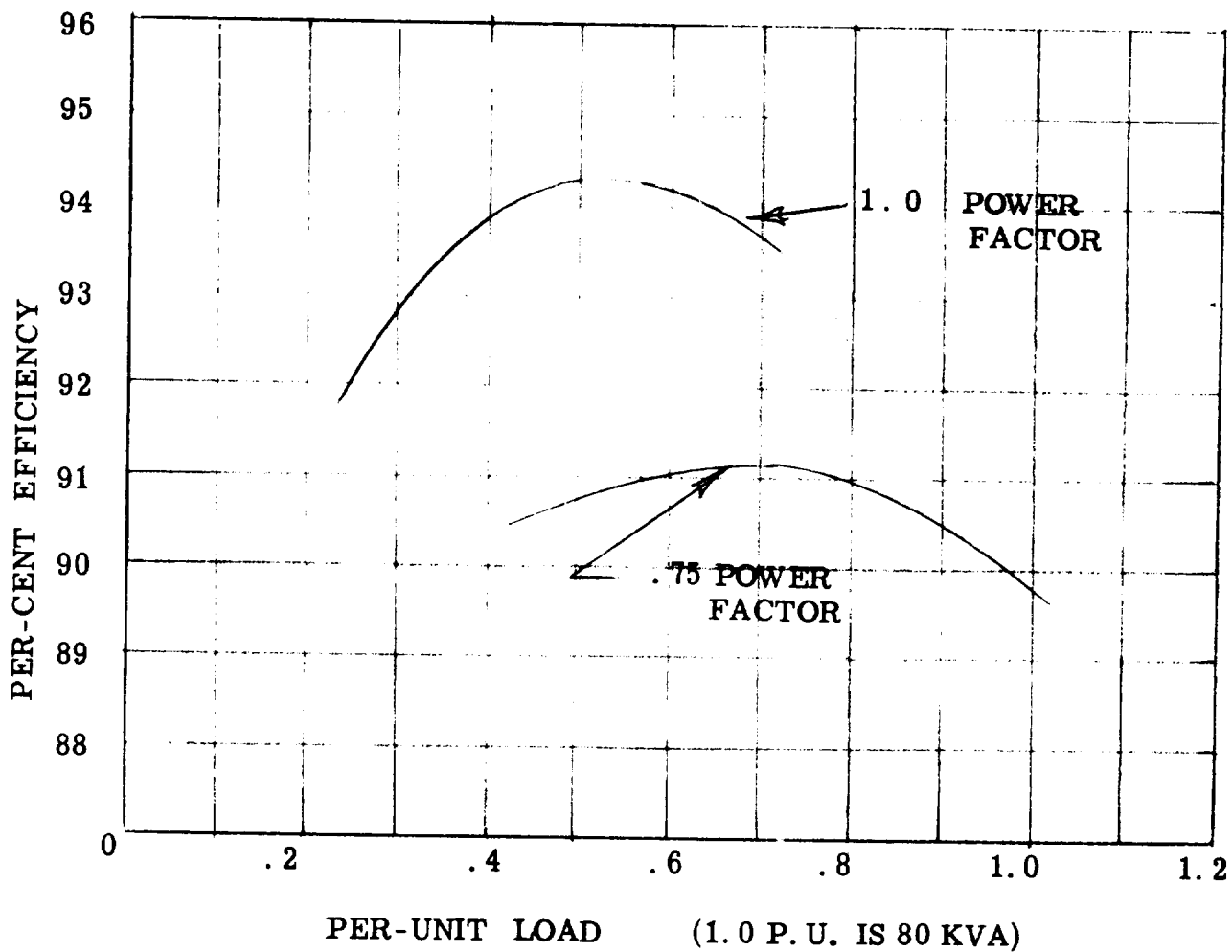

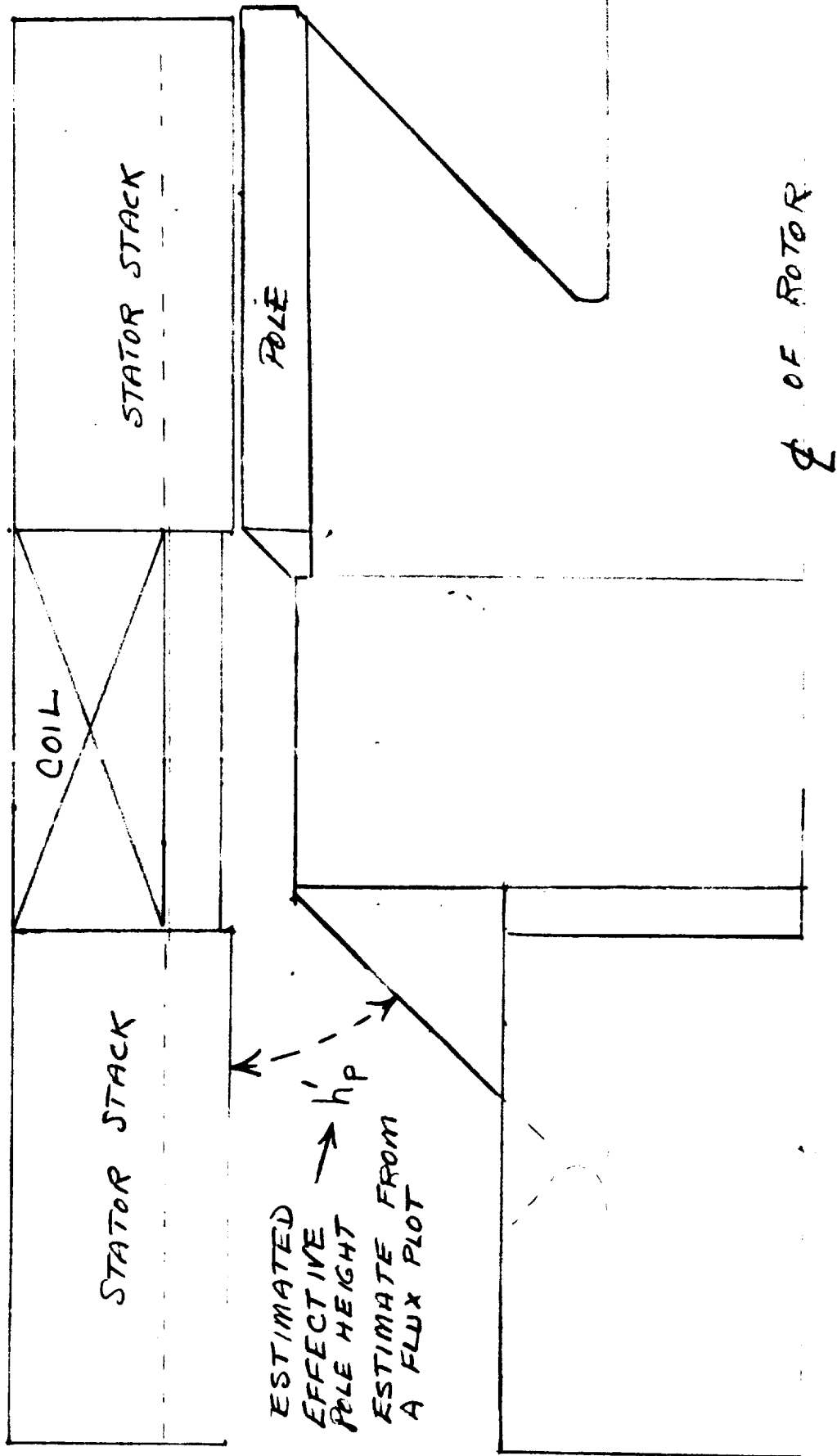

COMPUTER PROCEDURE FOR  
HOMOPOLAR DESIGN CALCULATIONS

1. Clear core (no switch control).
2. Insert output Form #1 into typewriter, set margin for correct output, and set typewriter for single space.
3. Load pass #1 followed by input parameters (output punched cards).
4. Reset and Load pass #2 followed by output from pass #1 (output printed plus punched cards).
5. Reset and Load pass #3 followed by output from pass #2 (output printed plus punched cards).
6. Reset and Load pass #4 followed by output from pass #3 (output printed plus punched cards).
7. Reset and Load pass #5 followed by output from pass #4 (output printed plus punched cards).
8. Reset and Load pass #6 followed by saturation curve values\* and output from pass #5 (output printed and punched cards).
9. Reset and Load pass #6A followed by output from pass #6 (output punched cards).
10. Reset and Load pass #7 followed by output from pass #6A (output punched cards).
11. Reset and Load pass #8 followed by saturation curve values\* and output from pass #7 (output printed and punched cards).

12. Reset and Load pass #9 followed by output from pass #8 (output printed plus punched cards if no load saturation curve required).
13. If there is punched card output from pass #9, a no load saturation curve is required. Insert output Form #2 into typewriter and reset margin. Load pass #10 followed by saturation curve values\* and output from pass #9 (output printed).

\* Saturation curve values are loaded in order shown on Input Form #1.

ALL INPUT PARAMETERS ARE IN FORMAT F7.0 (FIG. 1)

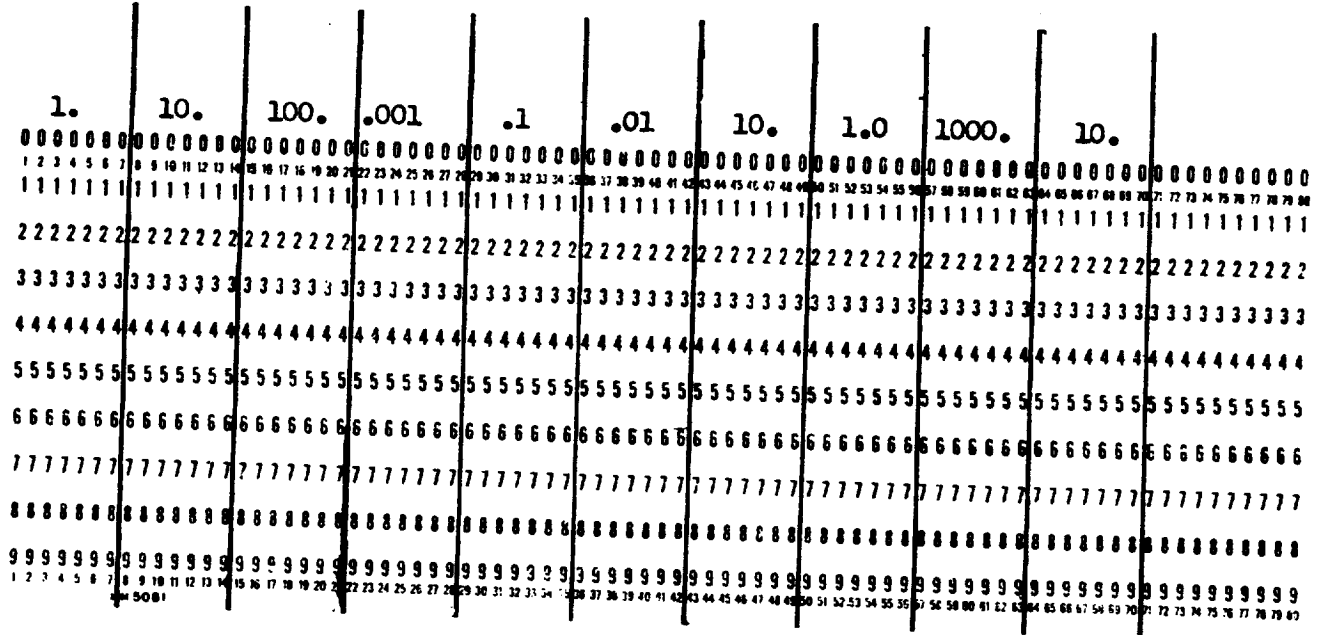

FIG. 1

ALL SATURATION CURVE VALUES ARE IN FORMAT F10.0 (FIG. 2)  
(ALL SATURATION CURVES MUST HAVE 5 CARDS)

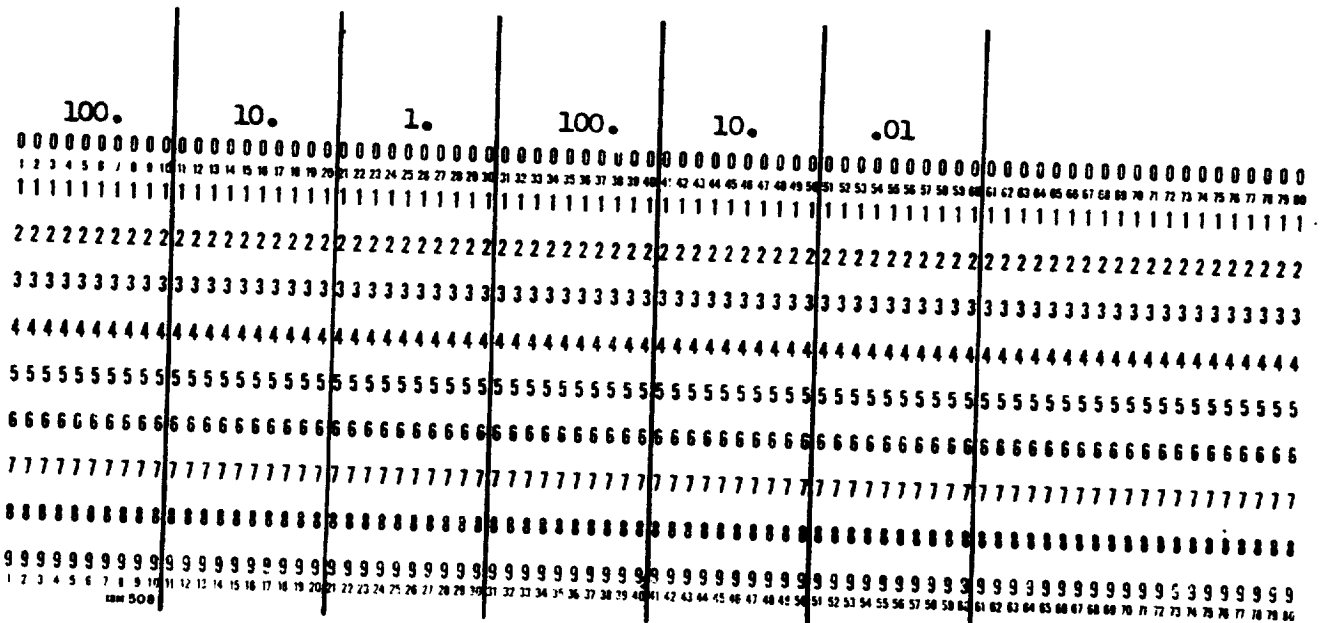

FIG. 2

HOMOPOLAR INDUCTOR

<u>CALCULATION NUMBER</u>	<u>ELECTRICAL SYMBOL</u>	<u>FORTRAN SYMBOL</u>
	<u>A, a</u>	
(46)	A <sub>c</sub>	AC
(68)	A <sub>g</sub>	GA
(79)	A <sub>p</sub>	AP
(128)	A	A
(91b)	AT	ATH
(94a)	A <sub>c</sub>	ACR
(112)	A <sub>sh</sub>	ASH
(124a)	A <sub>y</sub>	AY
(124b)	A <sub>yc</sub>	AYC
(124c)	A <sub>yr</sub>	AYR
(144)	A <sub>cd</sub>	AB
(153)	A <sub>cf</sub>	AS
	<u>B, b</u>	
(15)	b <sub>v</sub>	BV
(20)	B	BK
(22)	b <sub>o</sub>	BO
(22)	b <sub>1</sub>	B1
(22)	b <sub>2</sub>	B2
(22)	b <sub>3</sub>	B3
(22)	b <sub>s</sub>	BS
(57)	b <sub>tm</sub>	TM
(57a)	b <sub>t</sub> 1/3	SM
(76)	b <sub>p</sub>	BP

<u>CALCULATION NUMBER</u>	<u>ELECTRICAL SYMBOL</u>	<u>FORTRAN SYMBOL</u>
(78)	$b_{coil}$	BCOIL
(91)	$B_t$	BT
(91c)	$B'_t$	BT
(94)	$B_c$	BC
(95)	$B_g$	BG
(104b)	$B_p$	BP
(113)	$B_{sh}$	BSH
(125a)	$B_{yc}$	BYC
(126a)	$B_y$	BY
(135)	$b_{bo}$	WO
(135)	$b_{bl}$	B
(200b)	$B_{pL}$	BPL
(200g)	$B_{CL}$	BCL
(202c)	$B'_{shL}$	BSHL
(205)	$B_{TL}$	BTL
(213b)	$B_{PL}$	BPL
(215a)	$B_{SHL}$	BSHL
(228a)	$B_{YCL}$	BYCL
(229a)	$B_{YL}$	BYL
	<u><math>C, c</math></u>	
(32)	$C$	C
(60)	$C_x$	CX
(71)	$C_1$	C1

<u>CALCULATION NUMBER</u>	<u>ELECTRICAL SYMBOL</u>	<u>FORTRAN SYMBOL</u>
(72)	$C_w$	CW
(73)	$C_p$	CP
(74)	$C_m$	CM
(75)	$C_q$	CQ
<u><math>D, d</math></u>		
(11)	d	DI
(11a)	$d_r$	DR
(12)	D	DU
(35)	$d_b$	DB
(78)	$d_{yc}$	DYC
(78)	$d_{coil}$	PCOIL
(76)	$D_{coil}$	DCOIL
(78a)	$d'_{sh}$	DISH
(78a)	$d_{sh}$	DSH
<u><math>E, e</math></u>		
(3)	E	EE
(4)	$E_{ph}$	EP
(55)	$E_{F_{top}}$	ET
(56)	$E_{F_{Bot}}$	EB
(127)	$E_f$	EF
(198)	$e_d$	ED
(238)	$E_{FFL}$	EF



<u>CALCULATION NUMBER</u>	<u>ELECTRICAL SYMBOL</u>	<u>FORTRAN SYMBOL</u>
	<u>F, f</u>	
(5a)	f	F
(96)	F <sub>g</sub>	FH
(96a)	F <sub>g+M</sub>	FGM
(97)	F <sub>T</sub>	FT
(98)	F <sub>c</sub>	FC
(106a)	F <sub>p</sub>	FP
(114)	F <sub>SH</sub>	FSH
(125b)	F <sub>yc</sub>	FYC
(125d)	F <sub>yr</sub>	FYR
(126b)	F <sub>y</sub>	FY
(127)	F <sub>NL</sub>	FNL
(180)	F <sub>sc</sub>	FSC
(183)	F & W	WF
(198b)	F <sub>dm</sub>	FGML
(199)	F <sub>g'L</sub>	FGL
(200)	F' <sub>TL</sub>	FTL
(200c)	F' <sub>PL</sub>	FPL
(201)	F <sub>CL</sub>	FCL
(202d)	F <sub>SHL</sub>	FSHL
(203)	F <sub>GL</sub>	FGL
(206)	F <sub>TL</sub>	FTL
(213L)	F <sub>PL</sub>	FPL
(216a)	F <sub>SHL</sub>	FSHL

<u>CALCULATION NUMBER</u>	<u>ELECTRICAL SYMBOL</u>	<u>FORTRAN SYMBOL</u>
(228b)	$F_{ycL}$	FYCL
(228d)	$F_{yrL}$	FYRL
(229b)	$F_{yL}$	FYL
(236)	$F_{FL}$	FFL
	<u><math>G, g</math></u>	
(59)	$g$	GC
(69)	$g_e$	GE
	<u><math>H, h</math></u>	
(22)	$h_0$	HO
(22)	$h_1$	HX
(22)	$h_2$	HY
(22)	$h_3$	HZ
(22)	$h_s$	HS
(22)	$h_t$	HT
(22)	$h_w$	HW
(24)	$h_c$	HC
(37)	$h_{st}$	SH
(38)	$h'_{st}$	SD
(76)	$h_p$	HP
(76)	$h'_p$	HPL
(135)	$h_{bo}$	HD
(135)	$h_b$	DD
(137)	$h_{b1}$	H

<u>CALCULATION NUMBER</u>	<u>ELECTRICAL SYMBOL</u>	<u>FORTRAN SYMBOL</u>
	<u>I, i</u>	
(8)	$I_{PH}$	PI
(127a)	$I_{FNL}$	FI
(182)	$I^2_{RF}$	PR
(237)	$I_{FFL}$	FI
(241)	$I^2_{RF}$	PR
	<u>K, k</u>	
(2)	$K_{VA}$	VA
(9a)	$K_c$	CK
(16)	$K_i$	RK
(19)	k	WL
(42)	$K_{SK}$	FS
(43)	$K_d$	DF
(44)	$K_p$	CF
(61)	$K_x$	FF
(63)	$K_E$	EK
(67)	$K_s$	CC
	<u>L, l</u>	
(13)	l	L
(17)	$l_s$	SS
(36)	$l_{e2}$	CE
(48)	$L_E$	EL
(49)	$l_t$	HM

<u>CALCULATION NUMBER</u>	<u>ELECTRICAL SYMBOL</u>	<u>FORTRAN SYMBOL</u>
(76)	$l_p$	PL
(139)	$l_b$	SB
(147)	$l_{tf}$	FE
(161)	$L_F$	SI
	<u><math>M, m</math></u>	
(5)	$m$	PN
	<u><math>N, n</math></u>	
(14)	$n_v$	HV
(30)	$n_s$	SC
(34)	$N_{st}$	SN
(34a)	$N'_{st}$	SNL
(45)	$n_e$	EC
(138)	$n_b$	BN
(146)	$N_F$	PT
	<u><math>O, o</math></u>	
	<u><math>P, p</math></u>	
(6)	$p$	PX
(9)	$P_F$	PF
(80c)	$P_m$	PM
(84a)	$P_5$	P5
(85a)	$P_6$	P6
(86a)	$P_7$	P7

<u>CALCULATION NUMBER</u>	<u>ELECTRICAL SYMBOL</u>	<u>FORTRAN SYMBOL</u>
	<u>Q, q</u>	
(23)	Q	QQ
(25)	q	QN
	<u>R, r</u>	
(7)	R <sub>PM</sub>	RPM
(53)	R <sub>SPH</sub>	RG
(54)	R <sub>SPH</sub> (HOT)	RP
(154)	R <sub>f</sub> (COLD)	FK
(155)	R <sub>f</sub> (HOT)	FR
	<u>S, s</u>	
(127c)	S <sub>F</sub>	CDD
(181)	S <sub>CR</sub>	SCR
(239)	S <sub>FL</sub>	CDD
	<u>T, t</u>	
(78)	t <sub>yr</sub>	TYR
(78)	t <sub>yc</sub>	TYE
(78)	t <sub>y</sub>	TY
(176)	T' <sub>do</sub>	TC
(177)	T <sub>a</sub>	TA
(178)	T' <sub>d</sub>	T5
(179)	T <sup>n</sup> <sub>d</sub>	T4

<u>CALCULATION NUMBER</u>	<u>ELECTRICAL SYMBOL</u>	<u>FORTRAN SYMBOL</u>
	<u>U, u</u>	
	<u>V, v</u>	
(145)	V <sub>r</sub>	VR
	<u>W, w</u>	
(184)	WTNL	ST
(185)	W <sub>C</sub>	WQ
(186)	W <sub>NPL</sub>	WN
(193)	W <sub>DNL</sub>	WD
(242)	W <sub>TFL</sub>	ST
(243)	W <sub>PFL</sub>	PP
(244)	W <sub>DFL</sub>	DL
	<u>X, x</u>	
(50)	X <sub>S</sub> <sup>o</sup> C	T1
(129)	X	XR
(130)	X <sub>L</sub>	XL
(131)	X <sub>ad</sub>	XD
(132)	X <sub>aq</sub>	XQ
(133)	X <sub>d</sub>	XA
(134)	X <sub>q</sub>	XB
(142)	X <sub>D</sub> <sup>o</sup> C	T3
(150)	X <sub>C</sub> <sup>o</sup> C	T2

<u>CALCULATION NUMBER</u>	<u>ELECTRICAL SYMBOL</u>	<u>FORTRAN SYMBOL</u>
(160)	$X_F$	XF
(163)	$X_{Dd}$	X1
(165)	$X_{Dq}$	X2
(166)	$X'^D_u$	XU
(167)	$X'^d$	XS
(168)	$X''_d$	XX
(169)	$X'''_q$	XY
(170)	$X_2$	XN
(172)	$X_0$	XO
	<u><math>Y, y</math></u>	
(31)	$y$	YY
	<u><math>\tau</math></u>	
(26)	$\tau_s$	TS
(27)	$\tau_{s1/3}$	TT
(40)	$\tau_{sk}$	SK
(41)	$\tau_p$	TP
(140)	$\tau_b$	TB
	<u><math>\lambda</math></u>	
(62)	$\lambda_i$	PC
(64)	$\lambda_E$	EW
(70c)	$\lambda_a$	AG

<u>CALCULATION NUMBER</u>	<u>ELECTRICAL SYMBOL</u>	<u>FORTRAN SYMBOL</u>
	<u><math>\phi</math></u>	
(88)	$\phi_T$	TG
(91a)	$\phi_m$	PHM
(92)	$\phi_P$	FQ
(99)	$\phi_7$	PH7
(112a)	$\phi_{SH}$	PSH
(118a)	$\phi_5$	PH5
(121a)	$\phi_6$	PH6
(198c)	$\phi_{mL}$	PML
(200a)	$\phi'_{PL}$	PPL
(200d)	$\phi'_{5L}$	PH5L
(200e)	$\phi'_{6L}$	PH6L
(200f)	$\phi_{CL}$	PCL
(202)	$\phi'_{7L}$	PH7L
(202b)	$\phi'_{SHL}$	PSHL
(202e)	$\phi_{mL}$	PML
(207a)	$\phi_{7L}$	PH7L
(213)	$\phi_{PL}$	PPL
(214a)	$\phi_{SHL}$	PSHL
(220a)	$\phi_{6L}$	PH6L
(226a)	$\phi_{5L}$	PH5L
	<u><math>\rho</math></u>	
(51)	$\rho_s$	RS
(141)	$\rho_D$	RE
(151)	$\rho_F$	RR



<u>CALCULATION NUMBER</u>	<u>ELECTRICAL SYMBOL</u>	<u>FORTRAN SYMBOL</u>
(77)	$\frac{\alpha}{\alpha}$	PE
(198a)	$\frac{\theta}{\theta}$	AN
(187)	$\frac{K}{K_1}$	D1
(188)	$K_2$	I
(189)	$K_3$	D3
(190)	$K_4$	D4
(191)	$K_5$	D5
(192)	$K_6$	D6

```

C    PASS 1 HOMOPOLAR INDUCTOR
      DIMENSION DA(8),DX(6),DY(8),DZ(8)
      1  FORMAT(E11.5,E11.5,E11.5,E11.5,E11.5,E11.5)
      2  FORMAT(F7.0,F7.0,F7.0,F7.0,F7.0,F7.0,F7.0,F7.0,F7.0,F7.0)
      33 READ2,VA,EE,EP,PN,F,PX,RPM,PI,PF,CK
          READ2,POL,DI,DU,CL,HV,BV,SF,WL,BK,ZZ
          READ2,B0,B1,B2,B3,BS,H0,HX,HY,HZ,HS
          READ2,HT,HW,QQ,W,RF,SC,YY,C,DW,SN
          READ2,SN1,DW1,DB,CE,SH,SD,PBA,SK,T1,RS
          READ2,GC,GP,C1,CW,CP,EL,CM,CQ,BP,PL
          READ2,HP,HP1,PE,DR,RK,WR,D1,WO,HD,DD
          READ2,H,B,BN,SB,TB,RE,T3,DSH,DISH,DISH1
          READ2,ALH,TYPY,TY,TYE,TYR,DYC,PCOIL,DCOIL,BCOIL,PT
          READ2,FE,RD,RT,T2,RR,SNL,WF,PM,P5,P6
          READ2,P7
          SS=SF*(CL-HV*BV)
          HC=(DU-DI-2.0*HS)*0.5
          ZY=0.7*HS
          IF(HC-ZY) 33,33,5
      5  QN=QQ/(PX*PN)
          TS=3.142*DI/QQ
          IF(ZZ-4.0)29,30,29
      29 TT=(0.667*HS+DI)*3.142/QQ
          GO TO 31
      30 TT=3.1416*(DI+2.*H0+1.32*BS)/QQ
      31 IF(ZZ-1.0)6,6,7
      6  B0=BS
          CC=(5.0*GC+BS)*TS/((5.0*GC+BS)*TS-BS*BS)
          GO TO 8

```

```

7 QC=(4.44*GC+0.75*B0)*TS
  CC=QC/(QC-B0*B0)
8 CS=YY/(PN*QN)
  TP=3.142*DI/PX
  IF(SK)32,32,92
32 FS=1.0
  GO TO 34
92 FS=SIN(1.571*SK/TP)*TP/(1.571*SK)
34 IF(PBA-60.)9,9,10
  9 D=1.0
  GO TO 95
10 D=2.0
95 I=QN
  U=I
  IF(QN-U)36,36,35
35 U=PX*PN
  XX=U
  N=U
  DO 11 K=1,N
  Z=U/XX
  I=Z
  Z1=I
  IF(Z-Z1)12,12,11
12 ZY=QQ/XX
  I=ZY
  Z1=I
  IF(ZY-Z1)37,37,11
11 XX=XX-1.
36 ZY=QN

```

37  $DF = \sin(1.571 * D / PN) / (ZY * D * \sin(1.571 / (PN * ZY)))$

$CF = \sin(YY * 1.571 / (PN * QN))$

$EC = QQ * SC * CF * FS / C$

$DT = DW1$

IF(DT) 13,13,14

13  $AC = 0.785 * DW * DW * SN1$

GO TO 24

14  $ZY = 0.0$

$DA(1) = 0.05$

$DA(2) = 0.072$

$DA(3) = 0.125$

$DA(4) = 0.165$

$DA(5) = 0.225$

$DA(6) = 0.438$

$DA(7) = 0.688$

$DA(8) = 1.5$

$DX(1) = 0.000124$

$DX(2) = 0.00021$

$DX(3) = 0.00021$

$DX(4) = 0.00084$

$DX(5) = 0.00189$

$DX(6) = 0.00189$

$DY(1) = 0.000124$

$DY(2) = 0.000124$

$DY(3) = 0.00084$

$DY(4) = 0.00084$

$DY(5) = 0.00189$

$DY(6) = 0.00335$

$DY(7) = 0.00754$

DY(8)=0.03020  
DZ(1)=0.000124  
DZ(2)=0.000124  
DZ(3)=0.000124  
DZ(4)=0.00335  
DZ(5)=0.00335  
DZ(6)=0.00754  
DZ(7)=0.0134  
DZ(8)=0.0302  
93 IF(DT-.05)94,94,15  
15 JA=0  
JB=0  
JC=0  
JD=0  
16 JA=JA+1  
JB=JB+1  
JC=JC+1  
JD=JD+1  
IF(DT-DA(JA))17,17,16  
94 D=0  
IF(ZY)23,23,27  
17 IF(DW-0.188)18,18,19  
18 CY=DX(JB-1)  
CZ=DX(JB)  
GO TO 22  
19 IF(DW-0.75)20,20,21  
20 CY=DY(JC-1)  
CZ=DY(JC)  
GO TO 22

21 CY=DZ(JD-1)  
     CZ=DZ(JD)  
 22 D=CY+(CZ-CY)\*(DT-DA(JA-1))/(DA(JA)-DA(JA-1))  
     IF(ZY)23,23,27  
 23 AC=(DT\*DW-D)\*SN1  
 24 IF(RT)25,25,26  
 25 AS=0.785\*RD\*RD  
     GO TO 28  
 26 ZY=1.0  
     DT=RT  
     DW=RD  
     GO TO 93  
 27 AS=RT\*RD-D  
 28 S=PI/(C\*AC)  
     PUNCH1,VA,EE,EP,PN,F,PX  
     PUNCH1,RPM,PI,PF,CK,POL,DI  
     PUNCH1,DU,CL,SS,HC,SF,QN  
     PUNCH1,WL,BK,ZZ,BO,B1,B2  
     PUNCH1,B3,BS,HO,HX,HY,HZ  
     PUNCH1,HS,HT,HW,QQ,W,RF  
     PUNCH1,SC,YY,C,TS,SN,DB  
     PUNCH1,CE,SH,SD,TT,SK,T1  
     PUNCH1,RS,GC,GP,C1,CW,CP  
     PUNCH1,EL,CM,CQ,BP,PL,HP  
     PUNCH1,PE,DR,RK,CC,WR,D1  
     PUNCH1,WO,HD,DD,H,B,BN  
     PUNCH1,SB,TB,RE,T3,DSH,DISH  
     PUNCH1,ALH,TYPY,PCOIL,DCOIL,BCOIL,TY  
     PUNCH1,TYE,TYR,DYC,PT,FE,RD

PUNCH1,RT,T2,RR,SNL,WF,CS

PUNCH1,AS,FS,TP,DF,CF,EC

PUNCH1,AC,S,HP1,DISH1,PM,P5

PUNCH1,P6,P7,PBA

PAUSE

END

```

C PASS 2 HOMOPOLAR INDUCTOR
1 FORMAT(E11.5,E11.5,E11.5,E11.5,E11.5,E11.5)
3 FORMAT(9X F12.5,2X F12.5)
  READ 1,VA,EE,EP,PN,F,PX
  READ 1,RPM,PI,PF,CK,POL,DI
  READ 1,DU,CL,SS,HC,SF,QN
  READ 1,WL,BK,ZZ,B0,B1,B2
  READ 1,B3,BS,HO,HX,HY,HZ
  READ 1,HS,HT,HW,QQ,W,RF
  READ 1,SC,YY,C,TS,SN,DB
  READ 1,CE,SH,SD,TT,SK,T1
  READ 1,RS,GC,GP,C1,CW,CP
  READ 1,EL,CM,CQ,BP,PL,HP
  READ 1,PE,DR,RK,CC,WR,D1
  READ 1,WO,HD,DD,H,B,BN
  READ 1,SB,TB,RE,T3,DSH,DISH
  READ 1,ALH,TYPY,PCOIL,DCOIL,BCOIL,TY
  READ 1,TYE,TYR,DYC,PT,FE,RD
  READ 1,RT,T2,RR,SNL,WF,CS
  READ 1,AS,FS,TP,DF,CF,EC
  READ 1,AC,S,HP1,DISH1,PM,P5
  READ1,P6,P7,PBA
  GA=3.142*DI*CL
  AG=6.38*DI/(PX*GC*CC)
  GE=CC*GC
  IF(C1) 44,43,44
43 C1=(0.649*LOG(PE)+1.359)*((GC/GP)**0.352)
44 IF(CW)45,45,46
45 CW=0.707*EE*C1*DF/(EP*PN)

```



```

46 TG=6.000000.0*EE/(CW*EC*RPM)
    BG=TG/GA
    IF(CP)47,47,48
47 CP=(GC/GP)**0.41*PE*(LOG(GC/TP)*.0378+1.191)
48 FQ=TG*CP/PX
    IF(ZZ-3.0)49,50,51
49 SM=TT-BS
    GO TO 53
50 SM=(3.1416*(DI+2.*HS)/QQ)-B3
    GO TO 53
51 IF(ZZ-4.0)50,52,49
52 SM=TT-.94*BS
53 IF(EL) 54,54,62
54 IF(RF) 55,55,61
55 IF(PX-2.0) 56,56,57
56 U=1.3
    GO TO 60
57 IF(PX-4.0) 58,58,59
58 U=1.5
    GO TO 60
59 U=1.7
60 EL=3.142*U*YY*(DI+HS)/QQ+0.5
    GO TO 62
61 EL=2.0*CE+(3.142*(0.5*HX+DB))+(YY*TS*TS/(SQRT(TS*TS-BS*BS)))
62 HM=CL+EL
    RX=RS*0.000001
    RB=(T1+234.5)*0.00394*RX
    IF(SH)37,38,40
38 ET=1

```

EB=1  
 GO TO 39  
 40 AA=0.584+(SN\*SN-1.0)\*0.0625\*(SD\*CL/(SH\*HM))\*2.0  
 AB=(SH\*SC\*F\*AG/(BS\*RB\*1000000.0))\*\*2.0  
 ET=AA\*AB\*0.00335+1.0  
 EB=ET-0.00168\*AB  
 39 IF (CM)63,63,64  
 63 AA=SIN(3.142\*PE)  
 AB=SIN(1.571\*PE)\*4.0  
 CM=(3.142\*PE+AA)/AB  
 64 PRINT3,SS,CC,HC,GA,TS,AG,TT,GE,FS,C1,DF,CW,CF,CP,EC,EL,AC,CM  
 PUNCH1,VA,EE,EP,PN,F,PX  
 PUNCH1,RPM,PI,PF,CK,POL,DI  
 PUNCH1,DU,CL,SS,HC,SF,QN  
 PUNCH1,WL,BK,ZZ,BO,B1,B2  
 PUNCH1,B3,BS,HO,HX,HY,HZ  
 PUNCH1,HS,HT,HW,QQ,W,GE  
 PUNCH1,SC,YY,C,TS,BG,TG  
 PUNCH1,FQ,TT,HM,SM,GA,EC  
 PUNCH1,GC,C1,CW,CP,RX,RB  
 PUNCH1,EL,CM,CQ,BP,HP,HP1  
 PUNCH1,PL,PE,DR,RK,CC,WR  
 PUNCH1,D1,WO,HD,DD,H,B  
 PUNCH1,BN,SB,TB,RE,T3,DSH  
 PUNCH1,DISH,ALH,TYPY,PCOIL,DCOIL,BCOIL  
 PUNCH1,TY,TYE,TYR,DYC,PT,FE  
 PUNCH1,RD,RT,T2,RR,SNL,WF  
 PUNCH1,CS,AS,ET,TP,DF,CF  
 PUNCH1,EB,AC,S,AG,SM,DISH1

PUNCH1,PM,P5,P6,PM,PBA

PAUSE

END

C PASS 3 HOMOPOLAR INDUCTOR

1 FORMAT(E11.5,E11.5,E11.5,E11.5,E11.5,E11.5)

3 FORMAT(9X F12.5,2X F12.5)

READ1, VA,EE,EP,PN,F,PX

READ1, RPM,PI,PF,CK,POL,DI

READ1, DU,CL,SS,HC,SF,QN

READ1, WL,BK,ZZ,BO,B1,B2

READ1, B3,BS,HO,HX,HY,HZ

READ1, HS,HT,HW,QQ,W,GE

READ1, SC,YY,C,TS,BG,TG

READ1 ,FQ,TT,HM,SM,GA,EC

READ 1,GC,C1,CW,CP,RX,RB

READ 1,EL,CM,CQ,BP,HP,HP1

READ 1,PL,PE,DR,RK,CC,WR

READ 1,D1,WO,HD,DD,H,B

READ 1,BN,SB,TB,RE,T3,DSH

READ 1,DISH,ALH,TYPY,PCOIL,DCOIL,BCOIL

READ 1,TY,TYE,TYR,DYC,PT,FE

READ 1,RD,RT,T2,RR,SNL,WF

READ 1,CS,AS,ET,TP,DF,CF

READ 1,EB,AC,S,AG,SM,DISH1

READ1,PM,P5,P6,P7,PBA

FGML=.45\*EC\*PI\*CM\*DF/PX

A=PI\*SC\*CF/(C\*TS)

RY=SC\*QQ\*HM/(PN\*AC\*C\*C)

RG=RX\*RY\*2.

RP=RB\*RY\*2.

IF(CQ)69,69,70

69 AA=1.571\*PE

```

AB=3.1416*PE
CQ=(0.5*COS(AA)+AB-SIN(AB))/(4.0*SIN(AA))
70 XR=.0707*A*DF/(C1*BG)
ZX=YY/(PN*QN)
IF(ZZ-5.)350,351,350
351 FF=1.0
GO TO 75
350 IF(PBA-60.)352,353,352
353 IF(ZX-.667)354,355,355
355 D=.75
Z=.25
GO TO 74
354 D=1.5
Z=-.25
GO TO 74
352 IF(ZX-.667)356,357,357
357 FF=.75
GO TO 75
356 D=1.2
Z=-.05
74 FF=D*ZX+Z
75 CX=FF/(CF*CF*DF*DF)
Z=CX*20.0/(PN*QN)
BT=3.142*D1/QQ-B0
ZA=BT*BT/(16.0*TS*GC)
ZB=0.35*BT/TS
ZC=H0/B0
ZD=HX*0.333/BS
ZE=HY/BS

```

```

IF(ZZ-2.0) 76,77,78
76 PC=Z*(ZE+ZD+ZA+ZB)
   GO TO 82
77 PC=Z*(ZC+(2.0*HT/(B0+BS)))+(HW/BS)+ZD+ZA+ZB)
   GO TO 82
78 IF(ZZ-4.0) 79,80,81
79 PC=Z*(ZC+(2.0*HT/(B0+B1)))+(2.0*HW/(B1+B2))+(HX*0.333/B2)+ZA+ZB)
   GO TO 82
80 PC=Z*(ZC+0.62)
   GO TO 82
81 PC=Z*(ZE+ZD+(0.5*GC/TS)+(0.25*TS/GC)+0.6)
82 WC=.642*SC*QQ*AC*HM
   ZA=3.1416*(D1+HS)/QQ
   IF(ZZ-3.0) 88,89,88
88 TM=ZA-BS
   GO TO 86
89 TM=(3.1416*(D1+2.*HS)/QQ)-B3
86 WI=(TM*QQ*SS*HS+(DU-HC)*3.142*HC*SS)*.566
   AN=0.0
100 AN=AN+0.005
   AL=COS(AN)
   IF(PF-AL) 100,100,101
101 VR=0.262*DR*RPM
   AP=BP*PL*RK
   FH=BG*GE/0.00319
   ZG=PT*FE*0.000001/AS
   FK=RR*ZG
   FR=(T2+234.5)*FK*0.00394
   RC=.321*PT*FE*AS

```

PRINT3,S,CQ,HM,A,RG,XR  
PUNCH1,VA,EE,EP,PN,F,PX  
PUNCH1,RPM,PI,PF,CK,POL,D1  
PUNCH1,DU,CL,SS,HC,PC,QN  
PUNCH1,WL,BK,ZZ,BO,PE  
PUNCH1,XR,BS,CQ,HX,HY,HZ  
PUNCH1,HS,WC,AC,QQ,W,GE  
PUNCH1,SC,YY,C,TS,BG,TG  
PUNCH1,FQ,TT,EL,AG,GA,FGML  
PUNCH1,RG,GC,RP,C1,TP,CP  
PUNCH1,DF,CM,CF,BP,HP,HP1  
PUNCH1,PL,EB,DR,RK,CC,WR  
PUNCH1,D1,WO,HD,DD,H,B  
PUNCH1,BN,SB,TB,RE,T3,DSH  
PUNCH1,DISH,ALH,TYPY,PCOIL,DCOIL,BCOIL  
PUNCH1,TY,TYE,TYR,DYC,PT,FE  
PUNCH1,RD,RT,T2,RR,SNL,WF  
PUNCH1,CS,AS,ET,SM,HO,HT  
PUNCH1,B1,B3,SM,DISH1,PM,P5  
PUNCH1,TM,WI,AN,VR,AP,FH  
PUNCH1,FK,FR,RC,AL,P6,P7  
PAUSE  
END

```

C      PASS 4 HOMOPOLAR INDUCTOR
1  FORMAT(E11.5,E11.5,E11.5,E11.5,E11.5,E11.5)
3  FORMAT(9X F12.5,2X F12.5)
      READ1, VA,EE,EP,PN,F,PX
      READ1, RPM,PI,PF,CK,POL,DI
      READ1, DU,CL,SS,HC,PC,QN
      READ 1,WL,BK,ZZ,BO,PE
      READ 1,XR,BS,CQ,HX,HY,HZ
      READ1, HS,WC,AC,QQ,W,GE
      READ1, SC,YY,C,TS,BG,TG
      READ 1,FO,TT,EL,AG,GA,FGML
      READ1, RG,GC,RP,C1,TP,CP
      READ 1,DF,CM,CF,BP,HP,HP1
      READ 1,PL,EB,DR,RK,CC,WR
      READ 1,D1,WO,HD,DD,H,B
      READ 1,BN,SB,TB,RE,T3,DSH
      READ 1,DISH,ALH,TYPY,PCOIL,DCOIL,BCOIL
      READ 1,TY,TYE,TYR,DYC,PT,FE
      READ 1,RD,RT,T2,RR,SNL,WF
      READ 1,CS,AS,ET,SM,HO,HT
      READ 1,B1,B3,SM,DISH1,PM,P5
      READ 1,TM,WI,AN,VR,AP,FH
      READ 1,FK,FR,RC,AL,P6,P7
      EK=EL/(10.0**(0.103*YY*TS+0.402))
      IF(DI-8.0) 83,83,84
83  EK=SQRT(EK)
84  ZF=.612*LOG(10.0*CS)
      EW=6.28*EK*ZF*(TP**(0.62-(0.228*LOG(ZF))))/(CL*DF*DF)
      XL=(PC+EW)*XR*2.

```



```

XD=XR*AG*C1*CM
XQ=XR*CQ*AG
IF(PM)341,340,341
340 PM=10.02*DR*CL/(PX*(HP1+GC))
341 IF(P5)343,342,343
342 P5=1.675*(DCOIL-PCOIL)*(DCOIL+PCOIL)/BCOIL
343 IF(P6)345,344,345
344 P6=2.5*(PCOIL-DI)*(PCOIL+DI)/BCOIL
345 IF(P7)347,346,347
346 P7=2.5*(DI+DISH1)*(DU-DI)/(DU-DISH1)
347 RL=(P5+P6+PM*PX/4.)/CL
XF=(1.0-C1/((1.273*RL/AG+2.0*CP)*CM))*XD
SI=PT*PT*(PX*.3927*CP*AG*PL+RL)*1.E-8
IF(BN)307,306,307
306 X1=0
P2=0
X2=0
GO TO 308
307 IF(DD)103,103,102
102 ZG=0.62
GO TO 104
103 ZG=0.333*H/B
104 ZF=HD/W0+ZG+.5
BD=ZF*6.38
BE=(BH-(BP-1.0)*TB)*2.127/GE
P1=(BD+BE)*RL*COS((BN-1.0)*TB*1.572/TP)/(BD+BE+RL)
X1=XR*P1
P2=(ZF+GC/TB)*20.0*TB/TP
X2=XR*P2

```

308 XA=XL+XD  
XB=XL+XQ  
XU=XL+XF  
XS=0.88\*XU  
PRINT3,RP,XL,ET,XD,EB,XQ  
PRINT3,PC,XA,EW,XB,WC,XF,WI,SI,PM,X1,P5,X2,P6,XU,P7,XS  
PUNCH1,VA,EE,EP,PN,F,PX  
PUNCH1,RPM,PI,PF,CK,POL,DI  
PUNCH1,DU,CL,SS,HC,PC,QN  
PUNCH1,WL,BK,ZZ,BO,XD,XQ  
PUNCH1,XR,BS,PE,HX,HY,HZ  
PUNCH1,HS,AC,QQ,W,GE  
PUNCH1,SC,YY,C,TS,BG,TG  
PUNCH1,FQ,TT,EW,AG,GA,FGML  
PUNCH1,RG,GC,RP,C1,AP,P2  
PUNCH1,DF,WF,CF,FH,BP,PM  
PUNCH1,P5,P6,P7,HP,HP1  
PUNCH1,PL,EB,DR,RK,CC,WR  
PUNCH1,D1,W0,SI,DD,H,B  
PUNCH1,BN,SB,TB,RE,T3,DSH  
PUNCH1,DISH,ALH,TYPY,PCOIL,DCOIL,BCOIL  
PUNCH1,TY,TYE,TYR,DYC,PT,VR  
PUNCH1,RD,RT,SNL,CS,AS,ET  
PUNCH1,FK,FR,XA,XB,AN,AL  
PUNCH1,RC,HD,XS,XL,X1,X2  
PUNCH1,SM,DISH1,TP  
PAUSE  
END

C PASS 5 HOMOPOLAR INDUCTOR

1 FORMAT(E11.5,E11.5,E11.5,E11.5,E11.5,E11.5)

3 FORMAT(9X F12.5,2X F12.5)

READ1, VA,EE,EP,PN,F,PX

READ1, RPM,PI,PF,CK,POL,DI

READ1, DU,CL,SS,HC,PC,QN

READ1, WL,BK,ZZ,BO,XD,XQ

READ 1,XR,BS,PE,HX,HY,HZ

READ 1,HS,AC,QQ,W,GE

READ1, SC,YY,C,TS,BG,TG

READ 1,FQ,TT,EW,AG,GA,FGML

READ1, RG,GC,RP,C1,AP,P2

READ 1,DF,WF,CF,FH,BP,PM

READ 1,P5,P6,P7,HP,HP1

READ 1,PL,EB,DR,RK,CC,WR

READ 1,D1,WO,SI,DD,H,B

READ 1,BN,SB,TB,RE,T3,DSH

READ 1,DISH,ALH,TYPY,PCOIL,DCOIL,BCOIL

READ 1,TY,TYE,TYR,DYC,PT,VR

READ 1,RD,RT,SNL,CS,AS,ET

READ 1,FK,FR,XA,XB,AN,AL

READ 1,RC,HD,XS,XL,X1,X2

READ 1,SM,DISH1,TP

IF(BN)105,105,106

105 XX=XS

XY=XB

GO TO 107

106 XX=XL+X1

XY=XL+X2

```

107 XN=(XX+XY)*0.5
    TC=SI /FK
    RA=PN*PI*PI*RP*0.001/VA
    TA=XN/(628.4*F*RA)
    T5=XS*TC/XA
    IF (F-60.0) 108, 108, 109
108 T4=0.035
    GO TO 110
109 T4=0.005
110 IF (WF) 111, 111, 112
111 WF=DR**2.5*(RPM**1.5)*PL*0.00000252
112 IF (ZZ-1.0) 301, 301, 302
301 B0=BS
302 GT=B0/GC
    IF (GT-1.0) 304, 304, 303
304 AA=2.6
    GO TO 115
303 IF (GT-3.75) 113, 114, 114
113 AA=10.0**0.178/((GT-1.0)**0.334)
    GO TO 115
114 AA=10.0**0.11/((GT-1.0)**0.174)
115 GF=AA*PI*SC/(C*FH)
305 IF (SC-1.0) 121, 121, 122
120 A5=0.0
    GO TO 129
121 AX=1.0
    AY=1.0
    GO TO 125
122 AX=3.0*YY/(PN*QN)-2.0

```

```

IF(CS-0.667)123,124,124
123 AY=1.5*YY/(PN*QN)-0.25
GO TO 125
124 AY=.75*YY/(PN*QN)+0.25
125 A3=AX*P2/AY
A4=0.07*AX*AG/(CF*CF)
IF(AX)120,120,126
126 IF(BN)127,127,128
127 A5=A4
GO TO 129
128 A5=(A4+A3)/(A3*A4)
129 IF(W)130,130,131
130 X0=0.0
GO TO 132
131 AA=(3.0*HZ+HX)*1.667/(PN*QN*CF*CF*DF*DF*BS)
X0=((PC+A5)*AX/AY+AA+0.2*EW)*XR
132 AA=W0/(GC*CC)
VT=0
IF(AA)148,147,148
148 IF(AA-0.65)145,147,146
145 VT=LOG(10.0*AA)*(-0.242)+0.59
GO TO 147
146 VT=0.327-(AA*0.266)
147 EZ=(ET+EB)*0.5-1.0
AA=PN*PI*PI
PU=AA*RG
PV=AA*RP
VV=EP*PI*PF*.003
FSC=XA*FH*0.01*2

```

ACR=(DU-2.\*HC)\*3.1416\*PE\*SS/PX

ATH=QQ\*SS\*SM

PRINT3,AS,XX,FK,XY,FR,XN,RC,XO,WR,TG,VR,FQ

PRINT348,BG

348 FORMAT(23X,F12.5)

PUNCH1,VA,EE,EP,PN,F,PX

PUNCH1,RPM,PI,PF,CK,POL,TB

PUNCH1,BO,GC,HP,HP1,PL,DR

PUNCH1,SB,RE,T3,PT,T5,T4

PUNCH1,WO,DD,H,BN,GF,VT

PUNCH1,SNL,TS,CC,BG,FK,AP

PUNCH1,FQ,FR,XD,FH,GA,HC

PUNCH1,AN,AL,XA,WF,TC,TA

PUNCH1,AS,HS,B,GE,BP,XB

PUNCH1,EZ,PU,VV,FSC,PV,HD

PUNCH1,QN,DSH,DISH,ALH,TYPY,PCOIL

PUNCH1,DCOIL,BCOIL,TY,TYE,TYR,DYC

PUNCH1,C1,DI,CL,QQ,GA,SM

PUNCH1,DU,FGML,ATH,PM,ACR,P5

PUNCH1,P6,P7,TT,SS,BK,WL

PUNCH1,TG,DISH1,TP,D1

PAUSE

END

```

C    PASS 6 HOMOPOLAR INDUCTOR
      DIMENSION AI(90)
      1 FORMAT(E11.5,E11.5,E11.5,E11.5,E11.5,E11.5)
250  FORMAT(9X F12.5,2X F12.5/)
888  FORMAT(F10.0,F10.0,F10.0,F10.0,F10.0,F10.0)
      3 FORMAT(9X F12.5,2X F12.5)
      K=1
823  READ888, AI(K), AI(K+1), AI(K+2), AI(K+3), AI(K+4), AI(K+5)
      K=K+6
      IF(K-89)823, 199, 199
199  READ 1, VA, EE, EP, PN, F, PX
      READ 1, RPM, PI, PF, CK, POL, TB
      READ 1, BO, GC, HP, HP1, PL, DR
      READ 1, SB, RE, T3, PT, T5, T4
      READ 1, WO, DD, H, BN, GF, VT
      READ 1, SNL, TS, CC, BG, FK, AP
      READ 1, FQ, FR, XD, FH, GA, HC
      READ 1, AN, AL, XA, WF, TC, TA
      READ 1, AS, HS, B, GE, BP, XB
      READ 1, EZ, PU, VV, FSC, PV, HD
      READ 1, QN, DSH, DISH, ALH, TYPY, PCOIL
      READ 1, DCOIL, BCOIL, TY, TYE, TYR, DYC
      READ 1, C1, D1, CL, QQ, GA, SM
      READ 1, DU, FGML, ATH, PM, ACR, P5
      READ 1, P6, P7, TT, SS, BK, WL
      READ 1, TG, DISH1, TP, D1
      PHM=PM*FH*.001
      FGM=FH+PX*PHM*GE/(.00319*GA)
      BP=(FQ+PHM)/AP

```

X=BP  
NA=31  
K=1  
GO TO 802  
805 FP=HP\*AT  
PH5=P5\*(FGM+FH)\*.001  
PH6=P6\*(FGM+FH)\*.001  
PH7=P7\*FGM\*.001  
PSH=(PX\*FQ/2.)+PX\*PHM+PH7  
BT=(TG+PHM\*PX)/ATH  
X=BT  
NA=1  
K=2  
GO TO 802  
806 FT=HS\*AT  
BC=(FQ+PHM)/ACR  
X=BC  
NA=1  
K=3  
GO TO 802  
807 FC=HC\*AT  
ASH=(DSH\*\*2-DISH\*\*2)\*.7854  
BSH=PSH/ASH  
NA=31  
K=4  
X=BSH  
GO TO 802  
808 FSH=ALH \*AT  
AY=TY\*(DU+TY)\*3.1416



```

      IF(TYPY-2.)816,815,822
822  ALY=1.334*CL
      GO TO 821
816  AYR=0
      AYC=0
      ALY=BCOIL+.667*CL
      ALYR=0
      ALYC=0
      GO TO 817
815  ALY=.667*CL
821  AYC=DYC+TYE
      AYR=TYR*(DU+2.*TY)*3.1416
      ALYC=BCOIL
      ALYR=DYC-DU
817  Z=PSH+PH5+PH6
      X=Z/AY
      BY=X
      NA=61
      K=5
      GO TO 802
809  FY=ALY*AT
      IF(TYPY-1.)818,819,818
818  X=Z/AYC
      BYC=X
      NA=61
      K=6
      GO TO 802
810  FYC=ALYC*AT
      X=Z/AYR

```

NA=61

K=7

GO TO 802

811 FYR=ALYR\*AT

820 FNL=2.\*(FGM+FT+FC+FP)+FSH+FY+FYC+FYR

PRINT3,TC,BT,TA,BC,T5,FT,T4,FC

PRINT250,FSC,FH

PUNCH1,ATH,FT,FGML,PM,FNL,FH

PUNCH1,GE,PX,GA,FQ,XA,PHM

PUNCH1,AP,HP,D1,P5,P6,P7

PUNCH1,ALH,BT,HS,ACR,HC,AY

PUNCH1,ALY,AYC,ALYC,AYR,ALYR

PUNCH1,PT,FK,FR,AS,VA,EE

PUNCH1,PN,F,RPM,PI,PF,POL

PUNCH1,BO,GC,DR,SB,RE,T3

PUNCH1,WO,DD,H,BN,GF,VT

PUNCH1,SNL,TS,CC,BG,WF,TB

PUNCH1,B,BP,XB,EZ,PU,VV

PUNCH1,FSC,PV,HD,QN,XD,EP

PUNCH1,SM,DU,SS,QQ,BK,WL

PUNCH1,TT,BC,BSH,ASH,TG,BYC

PUNCH1,TP,AN,AL,TYPY,C1,FGM

PUNCH1,CK

PAUSE

802 IF(AI(NA)-X)830,831,831

831 NA=NA+3

835 IF(AI(NA)-X)833,834,834

833 NA=NA+2

GO TO 835

834 AA=AI (NA)  
BB1=AI (NA-2)  
DC=AI (NA+1)  
D=AI (NA-1)  
XX=(AA-BB1)/(.4343\*(LOG(DC)-LOG(D+.0001)))  
Y=AA-XX\*.4343\*LOG(DC)  
AT=EXP(2.306\*(X-Y)/XX)  
GO TO (805,806,807,808,809,810,811),K  
830 PRINT850  
850 FORMAT(17HMACHINE SATURATED)  
PAUSE  
819 FYC=0  
FYR=0  
BYC=BY  
GO TO 820  
END

```

C      PASS 6A HOMOPOLAR INDUCTOR
1  FORMAT(E11.5,E11.5,E11.5,E11.5,E11.5,E11.5)
      READ 1,ATH,FT,FGML,PM,FNL,FH
      READ 1,GE,PX,GA,FQ,XA,PHM
      READ 1,AP,HP,D1,P5,P6,P7
      READ 1,ALH,BT,HS,ACR,HC,AY
      READ 1,ALY,AYC,ALYC,AYR,ALYR
      READ 1,PT,FK,FR,AS,VA,EE
      READ 1,PN,F,RPM,PI,PF,POL
      READ 1,BO,GC,DR,SB,RE,T3
      READ 1,WO,DD,H,BN,GF,VT
      READ 1,SNL,TS,CC,BG,WF,TB
      READ 1,B,BP,XB,EZ,PU,VV
      READ 1,FSC,PV,HD,QN,XD,EP
      READ 1,SM,DU,SS,QQ,BK,WL
      READ 1,TT,BC,BSH,ASH,TG,BYC
      READ 1,TP,AN,AL,TYPY,C1,FGM
      READ 1,CK
      IF(RE)309,309,311
309  WD=0.0
      WU=0.0
      GO TO 178
311  FS1=2.0*QN*PN*F
      FS2=2.0*FS1
      M=0
150  IF(M-1)151,152,178
151  RM=RE
      GO TO 153
152  RM=RE*(T3+234.5)/254.5

```

```

153 AA=(FS1/RM)**0.5*DD*0.32
    AB=(FS2/RM)**0.5*DD*0.32
    IF(AA-2.5) 160,160,161
160 V1=1.0-0.15*AA+0.3*AA*AA
    GO TO 162
161 V1=AA
162 IF(AB-2.5) 163,163,164
163 V2=1.0-0.15*AB+0.3*AB*AB
    GO TO 165
164 V2=AB
165 IF(H-B) 167,166,167
166 VC=0.75/V1
    GO TO 169
167 IF(DD) 166,168,166
168 VC=H/(3.0*B*V1)
169 VS=HD/WO+VT+VC
    VG=TB/(CC*GC)
    Q1=1.0-(1.0/(((B0*0.5/GC)**2.0+1.0)**0.5))
    QZ=B0/TS
    Q2=1.05*SIN(QZ*2.844)
    IF(QZ-0.37)170,170,171
170 Q3=0.46
    GO TO 172
171 Q3=0.23*SIN(10.46*QZ-2.1)+0.23
172 Q4=SIN(6.283*TB/TS-1.571)+1.0
    Q5=SIN(12.566*TB/TS-1.571)+1.0
    IF(H)173,173,174
173 AB=0.785*DD*DD
    GO TO 175

```

174 AB=H\*DD  
 175 W2=PX\*BN\*SB\*RM\*1.246/(AB\*1000.)  
 W3=(Q2/(2.0\*VS+(VG/Q4)))\*\*2.0\*V1  
 W5=(Q3/(2.0\*VS+(VG/Q5)))\*\*2.0\*V2  
 WD=(TS\*BG\*Q1\*CC)\*\*2.0\*W2\*(W3+W5)  
 M=M+1  
 IF(M-1)176,176,177  
 176 WU=WD  
 177 GO TO 150  
 178 PUNCH1,ATH,FT,FGML,PM,FNL,FH  
 PUNCH1,GE,PX,GA,FQ,XA,PHM  
 PUNCH1,AP,HP,P5,P6,P7  
 PUNCH1,ALH,BT,HS,ACR,HC,AY  
 PUNCH1,ALY,AYC,ALYC,AYR,ALYR  
 PUNCH1,PT,FK,FR,AS,VA,EE  
 PUNCH1,PN,F,RPM,PI,PF,POL  
 PUNCH1,BO,GC,DR,SB,RE,T3  
 PUNCH1,WO,DD,H,BN,GF,VT  
 PUNCH1,SNL,TS,CC,BG,WF,TB  
 PUNCH1,B,BP,XB,EZ,PU,VV  
 PUNCH1,FSC,PV,HD,QN,XD,EP  
 PUNCH1,SM,DU,SS,QQ,BK,WL  
 PUNCH1,TT,BC,BSH,ASH,TG,BYC  
 PUNCH1,TP,AN,AL,TYPY,WU,WD  
 PUNCH1,C1,FGM,D1,CK  
 PAUSE  
 END

```

PASS 7 NONPOLAR INDUCTOR
DIMENSION GX(4),YA(4),ED(4),FGX(4)
1 FORMAT(E11.5,E11.5,E11.5,E11.5,E11.5,E11.5)
READ 1,ATH,FT,FGML,PM,FNL,FH
READ 1,GE,PX,GA,FQ,XA,PHM
READ 1,AP,HP,P5,P6,P7
READ 1,ALH,BT,HS,ACR,HC,AY
READ 1,ALY,AYC,ALYC,AYR,ALYR
READ 1,PT,FK,FR,AS,VA,EE
READ 1,PN,F,RPM,PI,PF,POL
READ 1,B0,GC,DR,SB,RE,T3
READ 1,W0,DD,H,BN,GF,VT
READ 1,SNL,TS,CC,BG,WF,TB
READ 1,B,BP,XB,EZ,PU,VV
READ 1,FSC,PV,HD,QN,XD,EP
READ 1,SM,DU,SS,QQ,BK,WL
READ 1,TT,BC,BSH,ASH,TG,BYC
READ 1,TP,AN,AL,TYPY,WU,WD
READ 1,C1,FGM,D1,CK
D2=BG**2.5*0.000061
D3=(0.0167*QQ*RPM)**1.65*0.000015147
IF(TS-0.9) 133,133,134
133 D4=TS**1.285*0.81
GO TO 137
134 IF(TS-2.0) 135,135,136
135 D4=TS**1.145*0.79
GO TO 137
136 D4=TS**0.79*0.92
137 D7=B0/GC

```

```

      IF(D7-1.7) 138,138,139
138 D5=D7**2.31*0.3
      GO TO 144
139 IF(D7-3.0) 140,140,141
140 D5=D7**2.0*0.35
      GO TO 144
141 IF(D7-5.0) 142,142,143
142 D5=D7**1.4*0.625
      GO TO 144
143 D5=D7**0.965*1.38
144 D6=10.0**(0.932*C1-1.606)
      WN=D1*D2*D3*D4*D5*D6*GA
      WT=(SM)*QQ*SS*HS*0.453*(BT/BK)**2.0*WL
      WQ=(DU-HC)*1.42*HC*SS*(BC/BK)**2.0*WL
      YA(1)=100.
      YA(2)=66.66667
      YA(3)=50.
      IF(POL)310,320,310
320 ED(4)=0
      GX(4)=0
      FGX(4)=0
      JA=3
      GO TO 330
310 YA(4)=100./POL
      JA=4
330 DO 99 K=1,JA
      AA=ATAN((XB/YA(K)+SIN(AN))/AL)
      BB=AA-AN
      ED(K)=XA*SIN(AA)/YA(K)+COS(BB)

```



```

      FGX(K)=FGML*100./YA(K)
      IF(PF=.95)213,213,212
212  GX(K)=FQ*CK
      GO TO 99
213  GX(K)=(ED(K)-(.93*XD*SIN(AA)/YA(K)))*FQ
      99 CONTINUE
      IF(POL)820,821,820
820  AJ=4
      GO TO822
821  AJ=3
822  PUNCH1,ED(1),ED(2),ED(3),ED(4),AJ,BC
      PUNCH1,GX(1),GX(2),GX(3),GX(4),FGM
      PUNCH1,FGX(1),FGX(2),FGX(3),FGX(4)
      PUNCH1,FT,PF,PM,FH,PX
      PUNCH1,GE,AP,HP,P5,P6
      PUNCH1,P7,PHM,ASH,ALH,BT,ATH
      PUNCH1,HS,HC,ACR,TYPY,AY,AYC
      PUNCH1,AYR,ALY,ALYC,ALYR,BP,BSH
      PUNCH1,BYC,FNL,TG,GA,FQ,TP
      PUNCH1,POL,PU,FK,PV,FR,WU
      PUNCH1,WD,PT,AS,WF,WQ,GF
      PUNCH1,WT,XA,VV,WN,EZ,SNL
      PUNCH1,FH,PX,GE,AP,HP
      PUNCH1,P5,P6,P7,ASH,ALH,ATH
      PUNCH1,HS,HC,ACR,TYPY,AY,AYC
      PUNCH1,AYR,ALY,ALYC,ALYR,BC,BT
      PUNCH1,TG,GA,FQ,TP,EP,PM
      PAUSE
      END

```

C PASS 8 HOMOPOLAR INDUCTOR

4 FORMAT (F11.3,8X F11.3,F11.3,F11.3,F11.3)

888 FORMAT(F10.0,F10.0,F10.0,F10.0,F10.0,F10.0)

DIMENSION FFL(5),BSHLL(4),BCL(4),BTL(4),BPLL(4),BYCL(4),FGLL(4)

DIMENSION GX(4),ED(4),PMLL(4),AI(90),FGX(4)

1 FORMAT(E11.5,E11.5,E11.5,E11.5,E11.5,E11.5)

K=1

823 READ888, AI(K),AI(K+1),AI(K+2),AI(K+3),AI(K+4),AI(K+5)

K=K+6

IF(K-89)823,199,199

199 READ 1,ED(1),ED(2),ED(3),ED(4),AJ,BC

READ 1,GX(1),GX(2),GX(3),GX(4),FGM

READ1 ,FGX(1),FGX(2),FGX(3),FGX(4)

READ 1,FT,PF,PM,FH,PX

READ1 ,GE,AP,HP,P5,P6

READ 1,P7,PHM,ASH,ALH,BT,ATH

READ 1,HS,HC,ACR,TYPY,AY,AYC

READ1,AYR, ALY,ALYC,ALYR,BP,BSH

READ1,BYC,FNL,TG,GA,FQ,TP

DO 886 J=1,4

PMLL(J)=0

FFL(J+1)=0

BSHLL(J)=0

BCL(J)=0

BTL(J)=0

BPLL(J)=0

BYCL(J)=0

886 FGLL(J)=0

JA=AJ

```

DO 885 J=1,JA
PPL=GX(J)
EDD=ED(J)
FGML=FGX(J)
FTL=FT*(1.+PF)
PML=PM*(FGML+FH*EDD)*.001
ZZ=PX*GE/(.00319*GA)
FGL=FH*EDD+PML*ZZ
BPL=(PPL+PML)/AP
NA=31
K=1
X=BPL
GO TO 802
870 FPL=AT*HP
Z=FGL+FTL+FPL
PH5L=P5*.002*Z
PH6L=P6*.002*Z
PH7L=P7*.001*Z
PSHL=(PPL*PX/2.)+PX*PML+PH7L
BSHL=PSHL/ASH
X=BSHL
NA=31
K=2
GO TO 802
871 FSHL=ALH*AT
PML=PM*(FGML+FGL)*.001
PMLL(J)=PML
PPLL=PPL+PML
X=PPLL/AP

```

BPLL(J)=X

NA=31

K=3

GO TO 802

872 FPL=AT\*HP

FGL=FH\*EDD+PML\*ZZ

FGLL(J)=FGL

X=(TG+PX\*PML)/ATH

BTL(J)=X

NA=1

K=4

GO TO 802

873 FTL=AT\*HS

Z=FTL+FGL+FPL

PH7L=P7\*Z\*.001

PSHL=(PPLL\*PX/2.)+PX\*PML/2.+PH7L

X=PSHL/ASH

NA=31

K=5

BSHLL(J)=X

GO TO 802

874 FSHL=ALH\*AT

Z=2.\*Z+FSHL

PH5L=P5\*Z\*.001

PH6L=P6\*Z\*.001

PCL=PPLL+(PH5L+PH6L)/PX

X=PCL/ACR

BCL(J)=X

NA=1

```

      K=6
      GO TO 802
875 FCL=AT*HC
      IF (TYPY-1.)880,881,880
881 PY=PSHL+PH6L+PH5L
      GO TO 882
880 PY=PSHL+PH6L
882 X=PY/AY
      NA=61
      K=7
      GO TO 802
876 FYL=AT*ALY
      IF (TYPY-1.)883,884,883
883 PY=PSHL+PH6L+PH5L
      X=PY/AYC
      BYCL(J)=X
      NA=61
      K=8
      GO TO 802
877 FYCL=AT*ALYC
      X=PY/AYR
      NA=61
      K=9
      GO TO 802
878 FYRL=AT*ALYR
889 FFL(J+1)=2.*(FGL+FTL+FCL+FPL)+FSHL+FYL+FYCL+FYRL
885 CONTINUE
      PRINT4,PHM,PMLL(1),PMLL(2),PMLL(3),PMLL(4)
      PRINT4,FGM,FGLL(1),FGLL(2),FGLL(3),FGLL(4)

```

```

PRINT4,BP,BPLL(1),BPLL(2),BPLL(3),BPLL(4)
PRINT4,BT,BTL(1),BTL(2),BTL(3),BTL(4)
PUNCH1,BT,BTL(1),BTL(2),BTL(3),BTL(4)
PRINT4,BSH,BSHLL(1),BSHLL(2),BSHLL(3),BSHLL(4)
PRINT4,BC,BCL(1),BCL(2),BCL(3),BCL(4)
PUNCH1,BC,BCL(1),BCL(2),BCL(3),BCL(4)
PRINT4,BYC,BYCL(1),BYCL(2),BYCL(3),BYCL(4)
PUNCH1,FNL,FFL(2),FFL(3),FFL(4),FFL(5)
DO 887 K=1,8
  READ 1,R1,R2,R3,R4,R5,R6
887 PUNCH1,R1,R2,R3,R4,R5,R6
  PAUSE
884 FYCL=0
  FYRL=0
  BYCL(J)=X
  GO TO 889
802 IF(AI(NA)-X)830,831,831
831 NA=NA+3
835 IF(AI(NA)-X)833,834,834
833 NA=NA+2
  GO TO 835
834 AA=AI(NA)
  BB1=AI(NA-2)
  DC=AI(NA+1)
  D=AI(NA-1)
  XX=(AA-BB1)/(.4343*(LOG(DC)-LOG(D+.0001)))
  Y=AA-XX*.4343*LOG(DC)
  AT=EXP(2.306*(X-Y)/XX)
GO TO (870,871,872,873,874,875,876,877,878),K

```

830 GO TO 885

PAUSE

END

```

C PASS 9 HOMOPOLAR INDUCTOR
DIMENSION PR(5),F1(5),PS(5),G(5),DL(5),PP(5),EX(5),ST(5),VA(5)
DIMENSION P(5),E(5),PZ(5),SP(5),FFL(5),CDD(5),EF(5)
DIMENSION BTL(5),BCL(5),WQL(5)
1 FORMAT(E11.5,E11.5,E11.5,E11.5,E11.5,E11.5)
4 FORMAT (F11.3,8X F11.3,F11.3,F11.3,F11.3)
READ1,BT,BTL(2),BTL(3),BTL(4),BTL(5)
READ1,BC,BCL(2),BCL(3),BCL(4),BCL(5)
READ1,FNL,FFL(2),FFL(3),FFL(4),FFL(5)
READ 1,POL,PU,FK,PV,FR,WU
READ 1,WD,PT,AS,WF,WQ,GF
READ 1,WT,XA,VV,WN,EZ,SNL
READ 1,FH,PX,GE,AP,HP
READ 1,P5,P6,P7,ASH,ALH,ATH
READ 1,HS,HC,ACR,TYPY,AY,AYC
READ 1,AYR,ALY,ALYC,ALYR,BC,BT
READ 1,TG,GA,FQ,TP,EP,PM
PRINT4,FNL,FFL(2),FFL(3),FFL(4),FFL(5)
FFL(1)=FNL
BTL(1)=BT
BCL(1)=BC
G(1)=0
G(2)=1
G(3)=1.5
G(4)=2.
G(5)=POL
PW=PU
FW=FK
WW=WU

```



```

DO 183 M=1,5
  FI(M)=FFL(M)/PT
  EF(M)=FI(M)*FW
  CDD(M)=FI(M)/AS
  UA=G(M)
  PR(M)=FI(M)*FI(M)*FW
  IF(FI(M))198,197,198
198 PS(M)=PW*UA*UA
  WQL(M)=WQ*(BCL(M)/BC)**2
  X=WF+WQL(M)
  GM=(GF*UA)**2.0+1.0
  ST(M)=(2.0*(0.0027*XA*UA)**1.8+1.0)*WT*(BTL(M)/BT)**2
  VA(M)=VV*UA
181 DL(M)=GM*WW
  PP(M)=GM*WN
  EX(M)=EZ*PS(M)
  SP(M)=PP(M)+DL(M)+PR(M)+PS(M)+EX(M)+ST(M)+X
  P(M)=(SP(M)/1000.)+VA(M)
  IF(GM)185,184,185
184 PZ(M)=0
  E(M)=0
  GO TO 186
185 PZ(M)=(SP(M)/P(M))*1
  E(M)=100.0-PZ(M)
186 FW=FR
  WW=WD
183 PW=PV
  PRINT4,FI(1),FI(2),FI(3),FI(4),FI(5)
  PRINT4,EF(1),EF(2),EF(3),EF(4),EF(5)

```

```
PRINT4,CDD(1),CDD(2),CDD(3),CDD(4),CDD(5)
PRINT4, PR(1),PR(2),PR(3),PR(4),PR(5)
PRINT4, WF,WF,WF,WF,WF
PRINT4, ST(1),ST(2),ST(3),ST(4),ST(5)
PRINT4,WQL(1),WQL(2),WQL(3),WQL(4),WQL(5)
PRINT4, PP(1),PP(2),PP(3),PP(4),PP(5)
PRINT4, DL(1),DL(2),DL(3),DL(4),DL(5)
PRINT4, PS(1),PS(2),PS(3),PS(4),PS(5)
PRINT4, EX(1),EX(2),EX(3),EX(4),EX(5)
PRINT4, SP(1),SP(2),SP(3),SP(4),SP(5)
PRINT4, VA(1),VA(2),VA(3),VA(4),VA(5)
PRINT4, E(1),E(2),E(3),E(4),E(5)
IF(SNL)191,191,190
190 PUNCH1,FH,PX,GE,AP,HP
PUNCH1,P5,P6,P7,ASH,ALH,ATH
PUNCH1,HS,HC,ACR,TYPY,AY,AYC
PUNCH1,AYR,ALY,ALYC,ALYR,BC,BT
PUNCH1,TG,GA,FQ,TP,EP,PM
191 PAUSE
197 PS(M)=0
GM=0
ST(M)=0
WQL(M)=0
X=0
VA(M)=0
GO TO 181
END
```

```

C   PASS 10 HOMOPOLAR INDUCTOR
    DIMENSION AI(90)
245 FORMAT(F12.5,F12.5,F12.5,F12.5,F12.5,F12.5)
246 FORMAT(F12.5,F12.5,F12.5,F12.5,F12.5,F12.5//)
    1 FORMAT(E11.5,E11.5,E11.5,E11.5,E11.5,E11.5)
888 FORMAT(F10.0,F10.0,F10.0,F10.0,F10.0,F10.0)
    K=1
823 READ888, AI(K), AI(K+1), AI(K+2), AI(K+3), AI(K+4), AI(K+5)
    K=K+6
    IF(K-89)823, 199, 199
199 READ 1, FH, PX, GE, AP, HP
    READ 1, P5, P6, P7, ASH, ALH, ATH
    READ 1, HS, HC, ACR, TYPY, AY, AYC
    READ 1, AYR, ALY, ALYC, ALYR, BC, BT
    READ 1, TG, GA, FQ, TP, EP, PM
    R=.7
    FF=TG
    FG=FH
    DO 247 L=1, 9
    R=R+.1
    TG=FF*R
    FH=FG*R
    V=1.732*EP*R
    PHM=PM*FH*.001
    FGM=FH+PX*PHM*GE/(.00319*GA)
    BP=(FQ+PHM)/AP
    X=BP
    NA=31
    K=1

```

GO TO 802

805 FP=HP\*AT

PH5=P5\*(FGM+FH)\*.001

PH6=P6\*(FGM+FH)\*.001

PH7=P7\*FGM\*.001

PSH=(PX\*FQ/2.)+PX\*PHM+PH7

BT=(TG+PHM\*PX)/ATH

X=BT

NA=1

K=2

GO TO 802

806 FT=HS\*AT

BC=(FQ+PHM)/ACR

X=BC

NA=1

K=3

GO TO 802

807 FC=HC\*AT

BSH=PSH/ASH

NA=3 1

K=4

X=BSH

GO TO 802

808 FSH=ALH \*AT

817 Z=PSH+PH5+PH6

X=Z/AY

BY=X

NA=6 1

K=5

```

GO TO 802
809 FY=ALY*AT
      IF(TYPY-1.)818,819,818
818 X=Z/AYC
      BYC=X
      NA=61
      K=6
      GO TO 802
810 FYC=ALYC*AT
      X=Z/AYR
      NA=61
      K=7
      GO TO 802
811 FYR=ALYR*AT
820 FNL=2.*(FGM+FT+FC+FP)+FSH+FY+FYC+FYR
      PRINT245,V,FGM,BC,FC,BT,FT
247 PRINT246,BP,FP,BSH,FSH,BYC,FNL
      PAUSE
802 IF(AI(NA)-X)830,831,831
831 NA=NA+3
835 IF(AI(NA)-X)833,834,834
833 NA=NA+2
      GO TO 835
834 AA=AI(NA)
      BB1=AI(NA-2)
      DC=AI(NA+1)
      D=AI(NA-1)
      XX=(AA-BB1)/(.4343*(LOG(DC)-LOG(D+.0001)))
      Y=AA-XX*.4343*LOG(DC)

```

AT=EXP(2.306\*(X-Y)/XX)

GO TO (805,806,807,808,809,810,811),K

830 PRINT850

850 FORMAT(17HMACHINE SATURATED)

PAUSE

819 FYC=0

FYR=0

BYC=BY

GO TO 820

END

PERMANENT-MAGNET A-C GENERATOR  
COMPUTER PROGRAM AND TEST DATA

( )



MODEL NO.

FWO

DESIGN NO. (1)

PARAMETERS	(1)	(2)	(3)	(4)	(5)	(6)	(7)	(8)	(9)	(10)	(11)	(12)	(13)	(14)	(15)	(16)	(17)	(18)	(19)	(20)	(21)	(22)	(23)	(24)	(25)	(26)	(27)	(28)	(29)	(30)	(31)	(32)	(33)	(34)	(35)	(36)	(37)	(38)	(39)	(40)	(41)	(42)	(43)	(44)	(45)	(46)	(47)	(48)	(49)	(50)	(51)	(52)	(53)	(54)	(55)	(56)	(57)	(58)	(59)	(60)	(61)	(62)	(63)	(64)	(65)	(66)	(67)	(68)	(69)	(70)	(71)	(72)	(73)	(74)	(75)	(76)	(77)	(78)	(79)	(80)	(81)	(82)	(83)	(84)	(85)	(86)	(87)	(88)	(89)	(90)	(91)	(92)	(93)	(94)	(95)	(96)	(97)	(98)	(99)	(100)	(101)	(102)	(103)	(104)	(105)	(106)	(107)	(108)	(109)	(110)	(111)	(112)	(113)	(114)	(115)	(116)	(117)	(118)	(119)	(120)	(121)	(122)	(123)	(124)	(125)	(126)	(127)	(128)	(129)	(130)	(131)	(132)	(133)	(134)	(135)	(136)	(137)	(138)	(139)	(140)	(141)	(142)	(143)	(144)	(145)	(146)	(147)	(148)	(149)	(150)	(151)	(152)	(153)	(154)	(155)	(156)	(157)	(158)	(159)	(160)	(161)	(162)	(163)	(164)	(165)	(166)	(167)	(168)	(169)	(170)	(171)	(172)	(173)	(174)	(175)	(176)	(177)	(178)	(179)	(180)	(181)	(182)	(183)	(184)	(185)	(186)	(187)	(188)	(189)	(190)	(191)	(192)	(193)	(194)	(195)	(196)	(197)	(198)	(199)	(200)	(201)	(202)	(203)	(204)	(205)	(206)	(207)	(208)	(209)	(210)	(211)	(212)	(213)	(214)	(215)	(216)	(217)	(218)	(219)	(220)	(221)	(222)	(223)	(224)	(225)	(226)	(227)	(228)	(229)	(230)	(231)	(232)	(233)	(234)	(235)	(236)	(237)	(238)	(239)	(240)	(241)	(242)	(243)	(244)	(245)	(246)	(247)	(248)	(249)	(250)	(251)	(252)	(253)	(254)	(255)	(256)	(257)	(258)	(259)	(260)	(261)	(262)	(263)	(264)	(265)	(266)	(267)	(268)	(269)	(270)	(271)	(272)	(273)	(274)	(275)	(276)	(277)	(278)	(279)	(280)	(281)	(282)	(283)	(284)	(285)	(286)	(287)	(288)	(289)	(290)	(291)	(292)	(293)	(294)	(295)	(296)	(297)	(298)	(299)	(300)	(301)	(302)	(303)	(304)	(305)	(306)	(307)	(308)	(309)	(310)	(311)	(312)	(313)	(314)	(315)	(316)	(317)	(318)	(319)	(320)	(321)	(322)	(323)	(324)	(325)	(326)	(327)	(328)	(329)	(330)	(331)	(332)	(333)	(334)	(335)	(336)	(337)	(338)	(339)	(340)	(341)	(342)	(343)	(344)	(345)	(346)	(347)	(348)	(349)	(350)	(351)	(352)	(353)	(354)	(355)	(356)	(357)	(358)	(359)	(360)	(361)	(362)	(363)	(364)	(365)	(366)	(367)	(368)	(369)	(370)	(371)	(372)	(373)	(374)	(375)	(376)	(377)	(378)	(379)	(380)	(381)	(382)	(383)	(384)	(385)	(386)	(387)	(388)	(389)	(390)	(391)	(392)	(393)	(394)	(395)	(396)	(397)	(398)	(399)	(400)	(401)	(402)	(403)	(404)	(405)	(406)	(407)	(408)	(409)	(410)	(411)	(412)	(413)	(414)	(415)	(416)	(417)	(418)	(419)	(420)	(421)	(422)	(423)	(424)	(425)	(426)	(427)	(428)	(429)	(430)	(431)	(432)	(433)	(434)	(435)	(436)	(437)	(438)	(439)	(440)	(441)	(442)	(443)	(444)	(445)	(446)	(447)	(448)	(449)	(450)	(451)	(452)	(453)	(454)	(455)	(456)	(457)	(458)	(459)	(460)	(461)	(462)	(463)	(464)	(465)	(466)	(467)	(468)	(469)	(470)	(471)	(472)	(473)	(474)	(475)	(476)	(477)	(478)	(479)	(480)	(481)	(482)	(483)	(484)	(485)	(486)	(487)	(488)	(489)	(490)	(491)	(492)	(493)	(494)	(495)	(496)	(497)	(498)	(499)	(500)	(501)	(502)	(503)	(504)	(505)	(506)	(507)	(508)	(509)	(510)	(511)	(512)	(513)	(514)	(515)	(516)	(517)	(518)	(519)	(520)	(521)	(522)	(523)	(524)	(525)	(526)	(527)	(528)	(529)	(530)	(531)	(532)	(533)	(534)	(535)	(536)	(537)	(538)	(539)	(540)	(541)	(542)	(543)	(544)	(545)	(546)	(547)	(548)	(549)	(550)	(551)	(552)	(553)	(554)	(555)	(556)	(557)	(558)	(559)	(560)	(561)	(562)	(563)	(564)	(565)	(566)	(567)	(568)	(569)	(570)	(571)	(572)	(573)	(574)	(575)	(576)	(577)	(578)	(579)	(580)	(581)	(582)	(583)	(584)	(585)	(586)	(587)	(588)	(589)	(590)	(591)	(592)	(593)	(594)	(595)	(596)	(597)	(598)	(599)	(600)	(601)	(602)	(603)	(604)	(605)	(606)	(607)	(608)	(609)	(610)	(611)	(612)	(613)	(614)	(615)	(616)	(617)	(618)	(619)	(620)	(621)	(622)	(623)	(624)	(625)	(626)	(627)	(628)	(629)	(630)	(631)	(632)	(633)	(634)	(635)	(636)	(637)	(638)	(639)	(640)	(641)	(642)	(643)	(644)	(645)	(646)	(647)	(648)	(649)	(650)	(651)	(652)	(653)	(654)	(655)	(656)	(657)	(658)	(659)	(660)	(661)	(662)	(663)	(664)	(665)	(666)	(667)	(668)	(669)	(670)	(671)	(672)	(673)	(674)	(675)	(676)	(677)	(678)	(679)	(680)	(681)	(682)	(683)	(684)	(685)	(686)	(687)	(688)	(689)	(690)	(691)	(692)	(693)	(694)	(695)	(696)	(697)	(698)	(699)	(700)	(701)	(702)	(703)	(704)	(705)	(706)	(707)	(708)	(709)	(710)	(711)	(712)	(713)	(714)	(715)	(716)	(717)	(718)	(719)	(720)	(721)	(722)	(723)	(724)	(725)	(726)	(727)	(728)	(729)	(730)	(731)	(732)	(733)	(734)	(735)	(736)	(737)	(738)	(739)	(740)	(741)	(742)	(743)	(744)	(745)	(746)	(747)	(748)	(749)	(750)	(751)	(752)	(753)	(754)	(755)	(756)	(757)	(758)	(759)	(760)	(761)	(762)	(763)	(764)	(765)	(766)	(767)	(768)	(769)	(770)	(771)	(772)	(773)	(774)	(775)	(776)	(777)	(778)	(779)	(780)	(781)	(782)	(783)	(784)	(785)	(786)	(787)	(788)	(789)	(790)	(791)	(792)	(793)	(794)	(795)	(796)	(797)	(798)	(799)	(800)	(801)	(802)	(803)	(804)	(805)	(806)	(807)	(808)	(809)	(810)	(811)	(812)	(813)	(814)	(815)	(816)	(817)	(818)	(819)	(820)	(821)	(822)	(823)	(824)	(825)	(826)	(827)	(828)	(829)	(830)	(831)	(832)	(833)	(834)	(835)	(836)	(837)	(838)	(839)	(840)	(841)	(842)	(843)	(844)	(845)	(846)	(847)	(848)	(849)	(850)	(851)	(852)	(853)	(854)	(855)	(856)	(857)	(858)	(859)	(860)	(861)	(862)	(863)	(864)	(865)	(866)	(867)	(868)	(869)	(870)	(871)	(872)	(873)	(874)	(875)	(876)	(877)	(878)	(879)	(880)	(881)	(882)	(883)	(884)	(885)	(886)	(887)	(888)	(889)	(890)	(891)	(892)	(893)	(894)	(895)	(896)	(897)	(898)	(899)	(900)	(901)	(902)	(903)	(904)	(905)	(906)	(907)	(908)	(909)	(910)	(911)	(912)	(913)	(914)	(915)	(916)	(917)	(918)	(919)	(920)	(921)	(922)	(923)	(924)	(925)	(926)	(927)	(928)	(929)	(930)	(931)	(932)	(933)	(934)	(935)	(936)	(937)	(938)	(939)	(940)	(941)	(942)	(943)	(944)	(945)	(946)	(947)	(948)	(949)	(950)	(951)	(952)	(953)	(954)	(955)	(956)	(957)	(958)	(959)	(960)	(961)	(962)	(963)	(964)	(965)	(966)	(967)	(968)	(969)	(970)	(971)	(972)	(973)	(974)	(975)	(976)	(977)	(978)	(979)	(980)	(981)	(982)	(983)	(984)	(985)	(986)	(987)	(988)	(989)	(990)	(991)	(992)	(993)	(994)	(995)	(996)	(997)	(998)	(999)	(1000)
PARAMETERS	(2)	KVA	GENERATOR KVA	1.05	1.075	FUND. MAX OF FIELD FLUX	(71)	C <sub>1</sub>	CONSTANTS																																																																																																																																																																																																																																																																																																																																																																																																																																																																																																																																																																																																																																																																																																																																																																																																																																																																																																																																																																																																																															
	(3)	F	LINE VOLTS	115	119	WINDING CONSTANT	(72)	C <sub>w</sub>																																																																																																																																																																																																																																																																																																																																																																																																																																																																																																																																																																																																																																																																																																																																																																																																																																																																																																																																																																																																																																
	(4)	F <sub>ph</sub>	PHASE VOLTS	66.5	65.7	POLE CONST.	(73)	C <sub>p</sub>																																																																																																																																																																																																																																																																																																																																																																																																																																																																																																																																																																																																																																																																																																																																																																																																																																																																																																																																																																																																																																
	(5)	m	PHASES	3	0	END EXTENSION ONE TURN	(48)	LE																																																																																																																																																																																																																																																																																																																																																																																																																																																																																																																																																																																																																																																																																																																																																																																																																																																																																																																																																																																																																																
	(5a)	f	FREQUENCY	400	84	DEMAGNETIZATION FACTOR	(74)	C <sub>m</sub>																																																																																																																																																																																																																																																																																																																																																																																																																																																																																																																																																																																																																																																																																																																																																																																																																																																																																																																																																																																																																																
	(6)	p	POLES	6	61	CROSS MAGNETIZING FACTOR	(75)	C <sub>q</sub>																																																																																																																																																																																																																																																																																																																																																																																																																																																																																																																																																																																																																																																																																																																																																																																																																																																																																																																																																																																																																																
	(7)	RPM	RPM	8000	1.38	POLE HEAD WIDTH	(76)	b <sub>h</sub>																																																																																																																																																																																																																																																																																																																																																																																																																																																																																																																																																																																																																																																																																																																																																																																																																																																																																																																																																																																																																																
	(8)	I <sub>ph</sub>	PHASE CURRENT	5	1.0	MAGNET WIDTH	(76)	b <sub>p</sub>																																																																																																																																																																																																																																																																																																																																																																																																																																																																																																																																																																																																																																																																																																																																																																																																																																																																																																																																																																																																																																
	(9)	PF	POWER FACTOR	1.0	1.82	POLE HEAD HEIGHT	(76)	h <sub>h</sub>																																																																																																																																																																																																																																																																																																																																																																																																																																																																																																																																																																																																																																																																																																																																																																																																																																																																																																																																																																																																																																
STATOR STACK	(11)	d	STATOR I.D.	3.75	812	MAGNET HEIGHT	(76)	h <sub>f</sub>	ROTOR STACK																																																																																																																																																																																																																																																																																																																																																																																																																																																																																																																																																																																																																																																																																																																																																																																																																																																																																																																																																																																																																															
	(12)	D	STATOR O.D.	5.54	1.625	MAGNET LENGTH	(76)	p																																																																																																																																																																																																																																																																																																																																																																																																																																																																																																																																																																																																																																																																																																																																																																																																																																																																																																																																																																																																																																
	(13)		GROSS CORE LENGTH	1.625	1.625	POLE HEAD LENGTH	(76)	n																																																																																																																																																																																																																																																																																																																																																																																																																																																																																																																																																																																																																																																																																																																																																																																																																																																																																																																																																																																																																																
	(14)	n <sub>y</sub>	NO. OF DUCTS	0	.71	POLE EMBRACE	(77)	o <sub>c</sub>																																																																																																																																																																																																																																																																																																																																																																																																																																																																																																																																																																																																																																																																																																																																																																																																																																																																																																																																																																																																																																
	(15)	b <sub>v</sub>	WIDTH OF DUCT	0	3.716	ROTOR DIAMETER	(11a)	d <sub>r</sub>																																																																																																																																																																																																																																																																																																																																																																																																																																																																																																																																																																																																																																																																																																																																																																																																																																																																																																																																																																																																																																
	(16)	K <sub>i</sub>	STACKING FACTOR (STATOR)	.92	1.0	STACKING FACTOR (ROTOR)	(16)	K <sub>i</sub>																																																																																																																																																																																																																																																																																																																																																																																																																																																																																																																																																																																																																																																																																																																																																																																																																																																																																																																																																																																																																																
	(19)	k	WATTS/LB.	15	0	WEIGHT OF ROTOR IRON	(157)	(-)																																																																																																																																																																																																																																																																																																																																																																																																																																																																																																																																																																																																																																																																																																																																																																																																																																																																																																																																																																																																																																
	(20)	B	DENSITY	77.4	7.0	POLE FACE LOSS FACTOR	(187)	(K <sub>1</sub> )																																																																																																																																																																																																																																																																																																																																																																																																																																																																																																																																																																																																																																																																																																																																																																																																																																																																																																																																																																																																																																
STATOR SLOT	(21)		TYPE OF SLOT	3	0	WIDTH OF SLOT OPENING	(135)	b <sub>bo</sub>	DAMPER BAR																																																																																																																																																																																																																																																																																																																																																																																																																																																																																																																																																																																																																																																																																																																																																																																																																																																																																																																																																																																																																															
	(22)	b <sub>o</sub>	SLOT OPENING	.090		HEIGHT OF SLOT OPENING	(135)	h <sub>bo</sub>																																																																																																																																																																																																																																																																																																																																																																																																																																																																																																																																																																																																																																																																																																																																																																																																																																																																																																																																																																																																																																
	(22)	b <sub>1</sub>	SLOT WIDTH TOP	.186		DAMPER BAR DIA. OR WIDTH	(136)	( )																																																																																																																																																																																																																																																																																																																																																																																																																																																																																																																																																																																																																																																																																																																																																																																																																																																																																																																																																																																																																																
	(22)	b <sub>2</sub>		.190		RECTANGULAR BAR THICKNESS	(137)	h <sub>b1</sub>																																																																																																																																																																																																																																																																																																																																																																																																																																																																																																																																																																																																																																																																																																																																																																																																																																																																																																																																																																																																																																
	(22)	b <sub>3</sub>		.266		RECTANGULAR SLOT WIDTH	(135)	b <sub>b1</sub>																																																																																																																																																																																																																																																																																																																																																																																																																																																																																																																																																																																																																																																																																																																																																																																																																																																																																																																																																																																																																																
	(22)	b <sub>s</sub>	SLOT WIDTH	.226		NO. OF DAMPER BARS	(138)	n <sub>b</sub>																																																																																																																																																																																																																																																																																																																																																																																																																																																																																																																																																																																																																																																																																																																																																																																																																																																																																																																																																																																																																																
	(22)	h <sub>o</sub>		.031		DAMPER BAR LENGTH	(139)	b																																																																																																																																																																																																																																																																																																																																																																																																																																																																																																																																																																																																																																																																																																																																																																																																																																																																																																																																																																																																																																
	(22)	h <sub>1</sub>		0		DAMPER BAR PITCH	(140)	b																																																																																																																																																																																																																																																																																																																																																																																																																																																																																																																																																																																																																																																																																																																																																																																																																																																																																																																																																																																																																																
	(22)	h <sub>2</sub>		0		RESISTIVITY OF DAMP. BAR @ 20 °	(141)	D																																																																																																																																																																																																																																																																																																																																																																																																																																																																																																																																																																																																																																																																																																																																																																																																																																																																																																																																																																																																																																
	(22)	h <sub>3</sub>		0	0	DAMPER BAR TEMP °C	(142)	X <sub>o</sub> °C																																																																																																																																																																																																																																																																																																																																																																																																																																																																																																																																																																																																																																																																																																																																																																																																																																																																																																																																																																																																																																
	(22)	h <sub>s</sub>	SLOT DEPTH	.51	0	FRICTION & WINDAGE	(183)	F & W																																																																																																																																																																																																																																																																																																																																																																																																																																																																																																																																																																																																																																																																																																																																																																																																																																																																																																																																																																																																																																
	(22)	h <sub>f</sub>		.050	.9	MAGNET RED FACTOR	(508)	C																																																																																																																																																																																																																																																																																																																																																																																																																																																																																																																																																																																																																																																																																																																																																																																																																																																																																																																																																																																																																																
	(22)	h <sub>w</sub>		0	10	MAGNET HYST. SLOPE	(519a)	h																																																																																																																																																																																																																																																																																																																																																																																																																																																																																																																																																																																																																																																																																																																																																																																																																																																																																																																																																																																																																																
	(23)	Q	NO. OF SLOTS	36	C-24	MAGNET MATERIAL	(18)	AL-VI																																																																																																																																																																																																																																																																																																																																																																																																																																																																																																																																																																																																																																																																																																																																																																																																																																																																																																																																																																																																																																
	STATOR WINDING	(28)		TYPE OF WDG.	1	C-12	ROTOR HEAD LAM	(18)		SOLID	MTR'L																																																																																																																																																																																																																																																																																																																																																																																																																																																																																																																																																																																																																																																																																																																																																																																																																																																																																																																																																																																																																													
(29)			TYPE OF COIL	0	C-11-C	STATOR LAM. MATERIAL	(18)	M 22																																																																																																																																																																																																																																																																																																																																																																																																																																																																																																																																																																																																																																																																																																																																																																																																																																																																																																																																																																																																																																
(30)		n <sub>s</sub>	CONDUCTORS/SLOT	18	C-17	P <sub>o</sub> / P <sub>m</sub> CURVE DATA	( )																																																																																																																																																																																																																																																																																																																																																																																																																																																																																																																																																																																																																																																																																																																																																																																																																																																																																																																																																																																																																																	
(31)		y	SLOTS SPANNED	5	Curve No. 5 Section F																																																																																																																																																																																																																																																																																																																																																																																																																																																																																																																																																																																																																																																																																																																																																																																																																																																																																																																																																																																																																																			
(32)		c	PARALLEL CIRCUITS	1																																																																																																																																																																																																																																																																																																																																																																																																																																																																																																																																																																																																																																																																																																																																																																																																																																																																																																																																																																																																																																				
(33)			STRAND DIA. OR WIDTH	.0508																																																																																																																																																																																																																																																																																																																																																																																																																																																																																																																																																																																																																																																																																																																																																																																																																																																																																																																																																																																																																																				
(34)		N <sub>st</sub>	STRANDS/CONDUCTOR	1																																																																																																																																																																																																																																																																																																																																																																																																																																																																																																																																																																																																																																																																																																																																																																																																																																																																																																																																																																																																																																				
(34a)		N' <sub>st</sub>	STRANDS/CONDUSTOR	1																																																																																																																																																																																																																																																																																																																																																																																																																																																																																																																																																																																																																																																																																																																																																																																																																																																																																																																																																																																																																																				
(39)			STATOR STRAND T'KNS	0																																																																																																																																																																																																																																																																																																																																																																																																																																																																																																																																																																																																																																																																																																																																																																																																																																																																																																																																																																																																																																				
(35)		d <sub>b</sub>	DIA. OF PIN	.1																																																																																																																																																																																																																																																																																																																																																																																																																																																																																																																																																																																																																																																																																																																																																																																																																																																																																																																																																																																																																																				
(36)	ø2	COIL EXT. STR. PORT	.2																																																																																																																																																																																																																																																																																																																																																																																																																																																																																																																																																																																																																																																																																																																																																																																																																																																																																																																																																																																																																																					

(a) Open Slots

(b) Constant Slot Width

**TYPE 1**  
(Type 5 is an open slot with 1 conductor per slot)

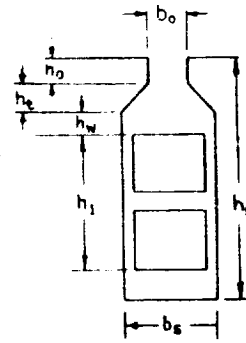
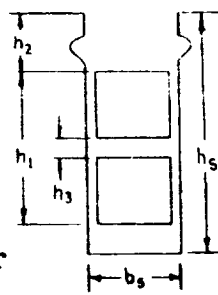

**TYPE 2**

(c) Constant Tooth Width

(d) Round Slots

**TYPE 3**

$b_s$  for type 3 is

$$b_s = \frac{b_1 + b_3}{2}$$

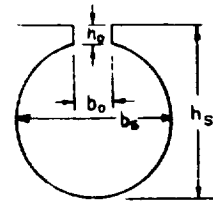
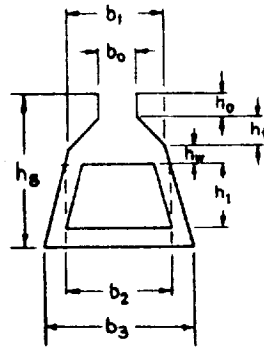

**TYPE 4**

MODEL	EAG	DESIGN NO.		
(24) (h <sub>c</sub> )	SOLID CORE LENGTH	1.49500	1.20950	CARTER COEFFICIENT (67) (K <sub>c</sub> )
(26) (a <sub>s</sub> )	DEPTH BELOW SLOT	.38500	12.14656	AIR GAP AREA (68) (-)
(27) (a <sub>s</sub> 1/3)	SLOT PITCH	.32729	193.96247	AIR GAP PERM (70a) (a)
(42) (K <sub>sk</sub> )	SLOT PITCH 1/3 DIST. UP	.35698	.02055	EFFECTIVE AIR GAP (69) (a <sub>e</sub> )
(43) (K <sub>d</sub> )	SKEW FACTOR	1.00000	1.07500	FUND/MAX OF FLD. FLUX (71) (C <sub>1</sub> )
(44) (K <sub>p</sub> )	DIST. FACTOR	.96591	.41900	WINDING CONST. (72) (C <sub>w</sub> )
(45) (a <sub>s</sub> )	PITCH FACTOR	.96596	.65700	POLE CONST. (73) (C <sub>p</sub> )
(46) (a <sub>c</sub> )	EFF. CONDUCTORS	625.94000	3.66032	END. EXT. ONE TURN (48) (L <sub>F</sub> )
(47) (S <sub>a</sub> )	COND. AREA	.00202	.84000	DEMAGNETIZING FACTOR (74) (C <sub>M</sub> )
(49) (r <sub>1</sub> )	CURRENT DENSITY (STA.)	2468.10000	.61000	CROSS MAGNETIZING FACTOR (75) (C <sub>a</sub> )
(53) (R <sub>ph</sub> )	1/2 MEAN TURN LENGTH	5.28530	265.62000	AMP COND/IN (128) (A)
(54) (R <sub>ph</sub> )	COLD STA. RES. @ 20° C	.39110	.98245	REACTANCE FACTOR (129) (X)
(55) (EF <sub>top</sub> )	HOT STA. RES. @ X C	.47691	12.89013	LEAKAGE REACTANCE (130) (X <sub>q</sub> )
(56) (EF <sub>bot</sub> )	EDDY FACTOR TOP	1.00000	40.71703	SYN REACT DIRECT AXIS (133) (X <sub>d</sub> )
(62) (i)	EDDY FACTOR BOT	1.00000	.00000	DAMPER (163) (X <sub>Dd</sub> )
(64) (c)	STATOR COND. PERM.	5.33720	.00000	LEAKAGE REACT (165) (X <sub>Dq</sub> )
(65) (-)	END PERM.	7.78310	12.89000	UNSAT. TRANS. REACT (166) (X <sub>du</sub> )
(66) (-)	WT. OF STA COPPER	2.22710	11.34300	SUB. TRANS. REACT DIRECT AX. (168) (X'' <sub>d</sub> )
(41) (p)	WT. OF STA IRON	3.82910	11.34300	SUB. TRANS. REACT QUAD AX. (169) (X'' <sub>q</sub> )
(509) P <sub>i</sub>	POLE PITCH	1.96370	5.67160	NEG. SEQUENCE REACT (170) (X <sub>2</sub> )
(510) P <sub>o</sub>	PERMEANCE IN STATOR	16.79500	8.61000	ZERO SEQUENCE REACT (172) (X <sub>o</sub> )
(507) P <sub>m</sub>	PERMEANCE OUT STATOR	23.60000	328.86000	TOTAL FLUX (88) (φ <sub>t</sub> )
(511) P <sub>g</sub>	PERMEANCE MAGNET	.90055	36.01000	FLUX PER POLE (92) (φ <sub>p</sub> )
(157) (-)	PERMEANCE AIR GAP	162.55000	17.17500	GAP DENSITY (95) (B <sub>g</sub> )
(145) (v <sub>r</sub> )	WT. OF ROTOR IRON	.00000	40.66400	TOOTH DENSITY (91) (B <sub>t</sub> )
	WT. OF MAGNETS	2.24050	31.28200	CORE DENSITY (94) (B <sub>c</sub> )
	PERIPHERAL SPEED	7788.70000	18.42701	SHORT CIRCUIT AMPS (522) (I <sub>sc</sub> )

(102a) POLE FLUX	36.01000		
(103a) POLE DENSITY	24.62200		
(183) F&W LOSS	77.99700	77.99700	(183)
(184) STA TOOTH LOSS	7.73540	8.02617	(242)
(185) STA CORE LOSS	10.32300	10.32300	(185)
(186) POLE FACE LOSS	59.56300	98.92551	(243)
(193) DAMPER LOSS	.00000	.00000	(244)
(194) STATOR CU LOSS	.00000	35.76800	(245)
(195) EDDY LOSS	.00000	.00000	(246)
(196) TOTAL LOSSES	155.61840	231.03968	(247)
(-) RATING (KW)	.00000	.99590	(248)
(-) RATING & LOSSES	.15561	1.22693	(249)
(-) PERCENT LOSSES	100.00000	18.83056	(250)
(-) PERCENT EFF.	.00000	81.16944	(251)

VOLTS @ 0 LOAD AMPS	99.78900
VOLTS @ 1/4 LOAD AMPS	98.92900
VOLTS @ 1/2 LOAD AMPS	97.60700
VOLTS @ 3/4 LOAD AMPS	95.81200
VOLTS @ 4/4 LOAD AMPS	93.52800
VOLTS @ 5/4 LOAD AMPS	90.72900
VOLTS @ 3/2 LOAD AMPS	87.37800

INPUT PARAMETERS FOR PERMANENT MAGNET DESIGN

1.05	115.	66.5	3.	400.	6.	8000.	5.	1.0	3.75
5.54	1.625	0.	0.	.92	15.	77.4	3.	.090	.186
.19	.266	.226	.031	0.	0.	0.	.51	.05	0.
36.	1.	0.	18.	5.	1.	.0508	1.	1.	0.
.25	.25	0.	0.	60.	0.	75.	.694	.017	.02
1.075	.419	.657	0.	.84	.61	1.38	1.	.182	.872
1.625	1.625	.71	3.716	1.	0.	7.	0.	0.	0.
0.	0.	0.	0.	0.	0.	0.	0.	.9	10.

PO/PM CURVE

340.	0.	1500.	20.	1250.	32.
1100.	35.	1000.	85.	640.	130.
500.	150.	385.	187.	315.	257.
280.	340.	200.			

CALCULATED AND TEST PERFORMANCE FOR A  
PERMANENT MAGNET A-C GENERATOR BEFORE  
SHORT-CIRCUITING. THE TEST POINT AT SHORT  
CIRCUIT WAS OBTAINED AT 6000 RPM AND SINCE  
THE GENERATOR DEMAGNETIZED SLIGHTLY UPON  
SHORT-CIRCUIT, THE CALCULATED POINT AND  
THE TEST POINT CANNOT BE EXPECTED TO MATCH.

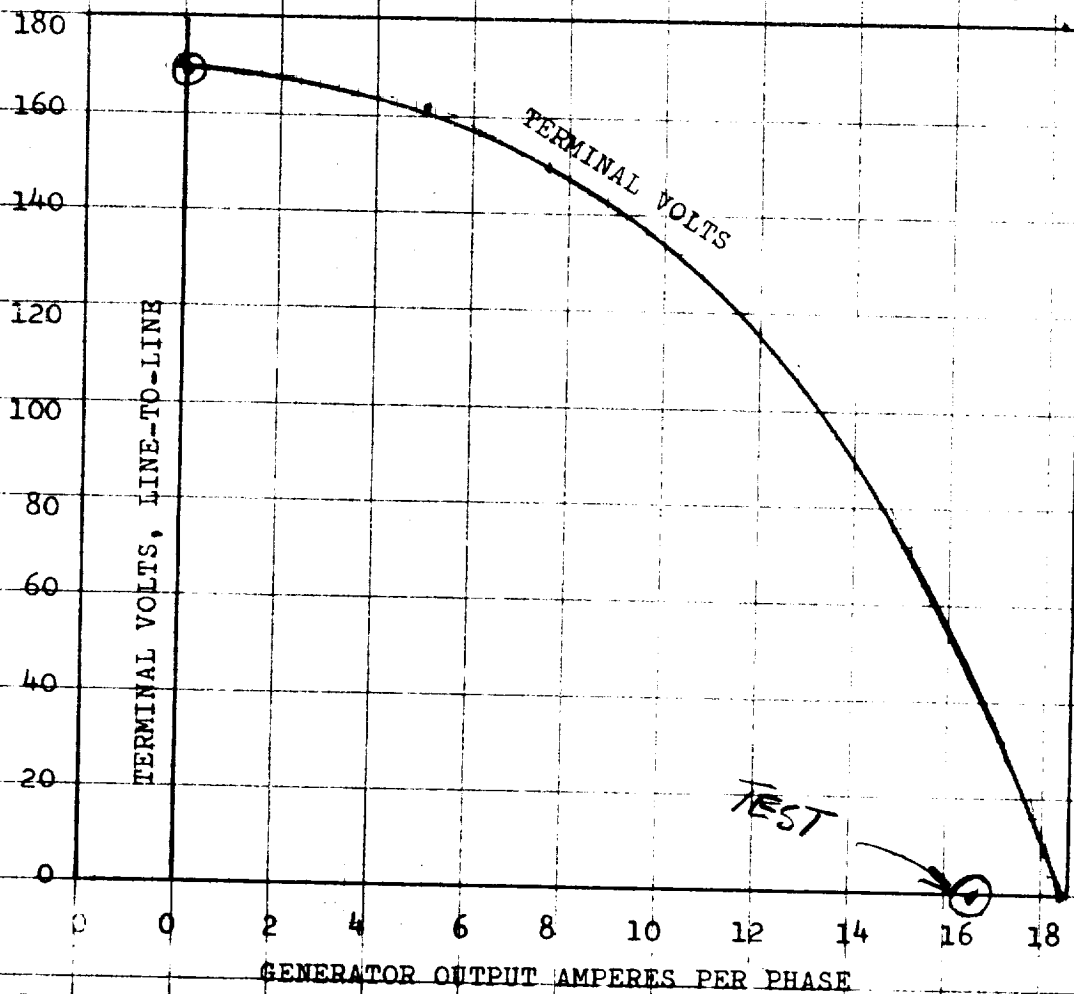

TESTS SHOWING THE EFFECT  
OF SHORT-CIRCUITS ON THE  
OUTPUT VOLTAGE OF THE  
EXAMPLE PERMANENT MAGNET  
A-C GENERATOR

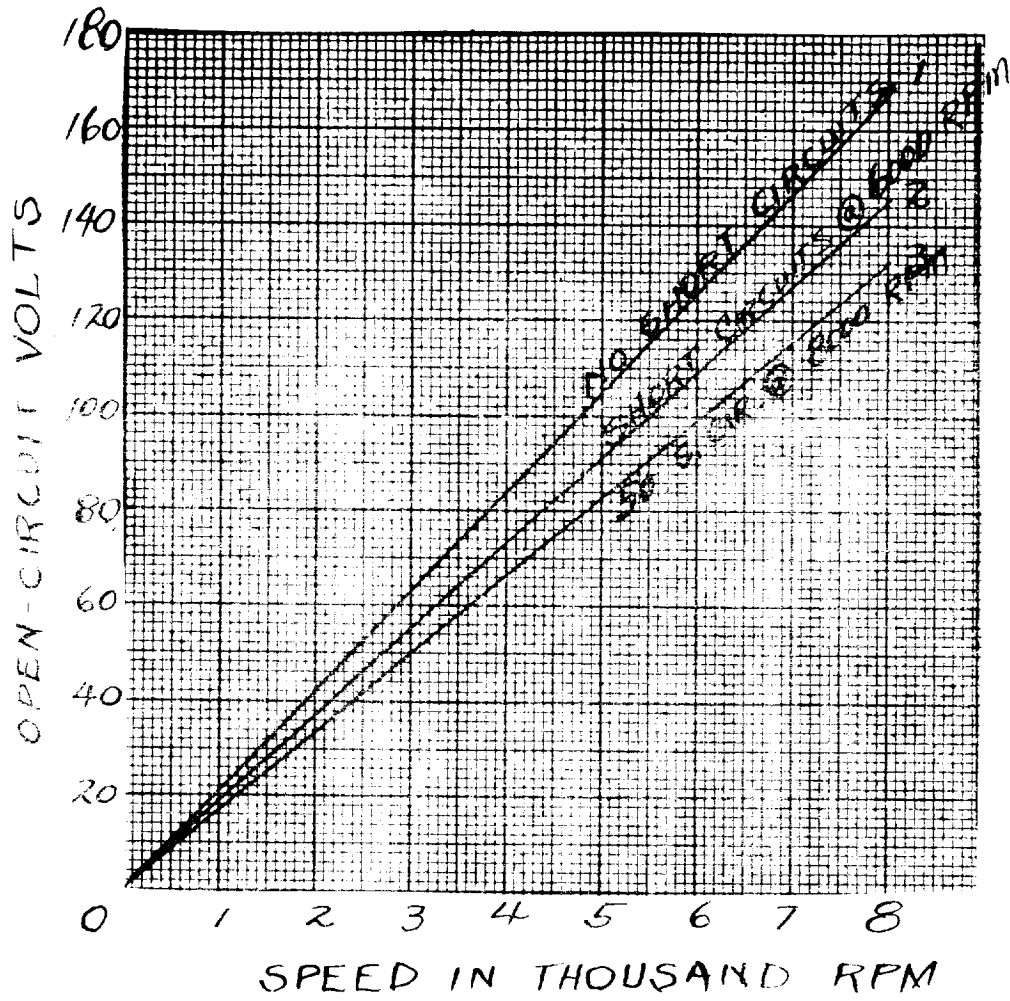

TEST PERFORMANCE OF A P.M.G. AT 8000 RPM  
GENERATOR WAS SUPPLYING A RESISTIVE LOAD  
AND HAD BEEN SHORT-CIRCUIT STABILIZED AT  
6000 RPM

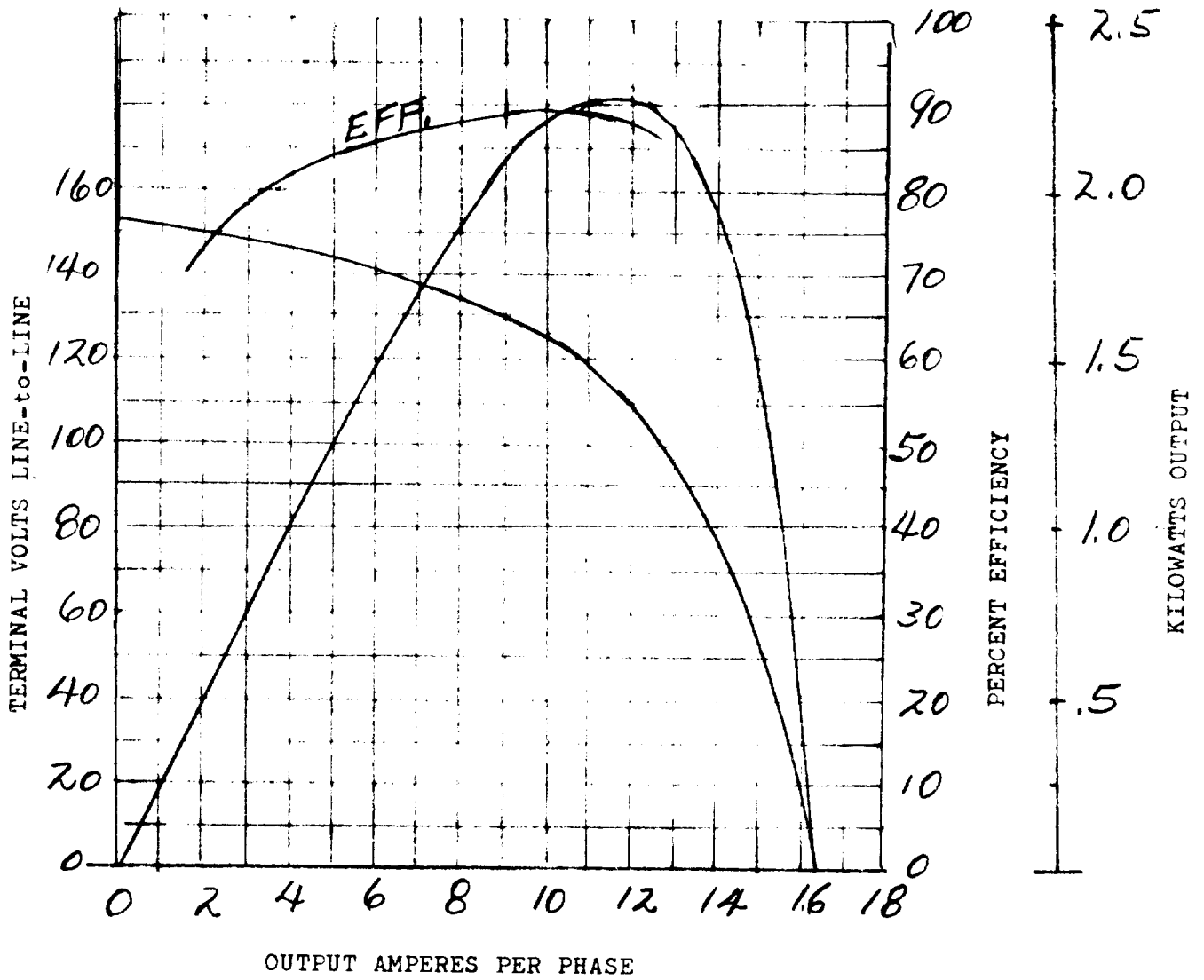

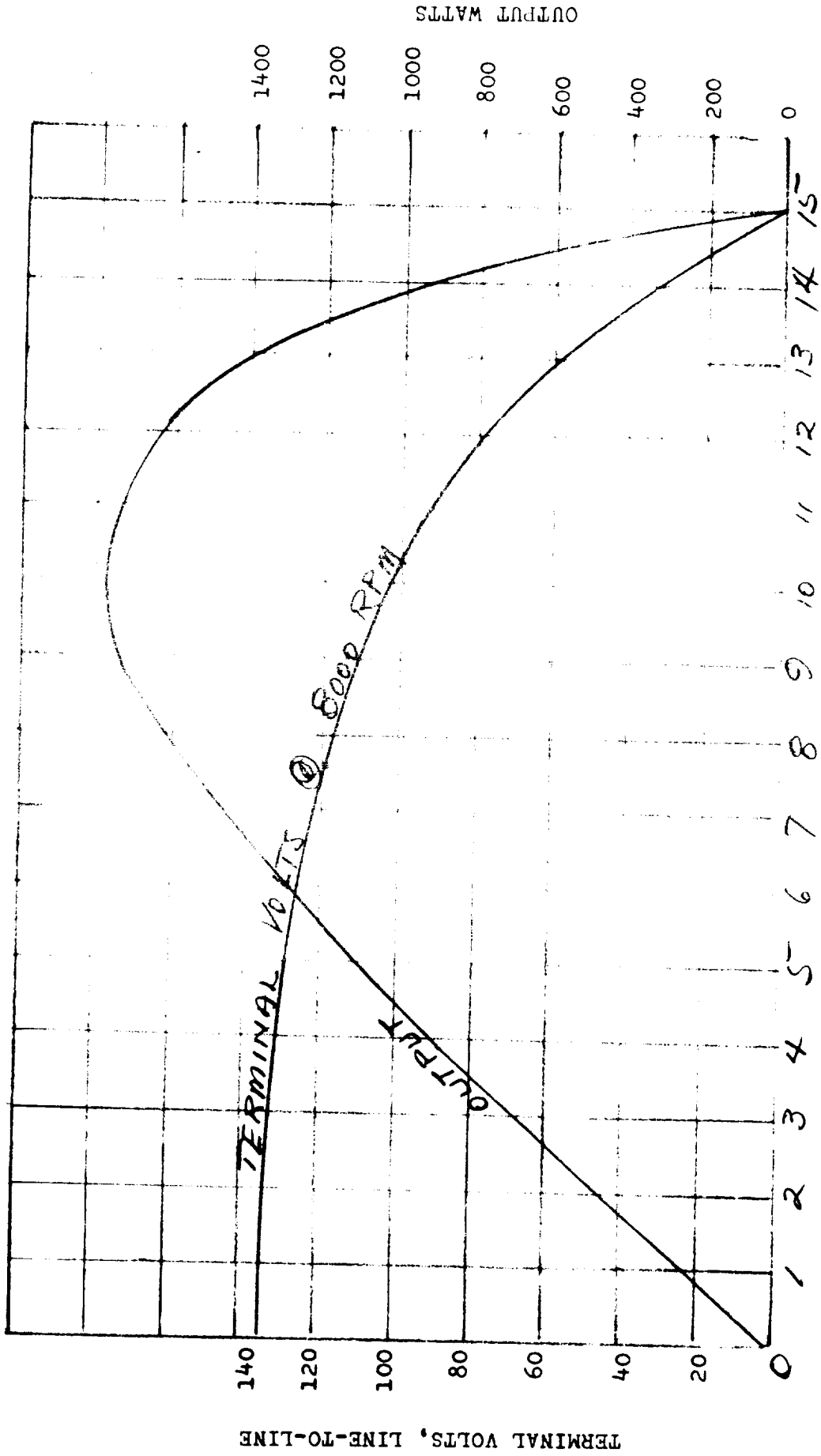

LINE CURRENT, AMPERES

P.M. GENERATOR OUTPUT CHARACTERISTIC AFTER THE GENERATOR WAS SHORT-CIRCUITED 50 TIMES



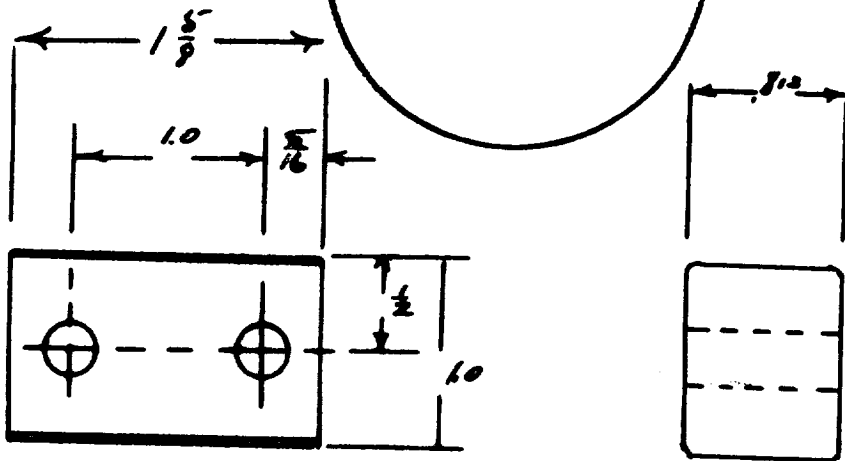
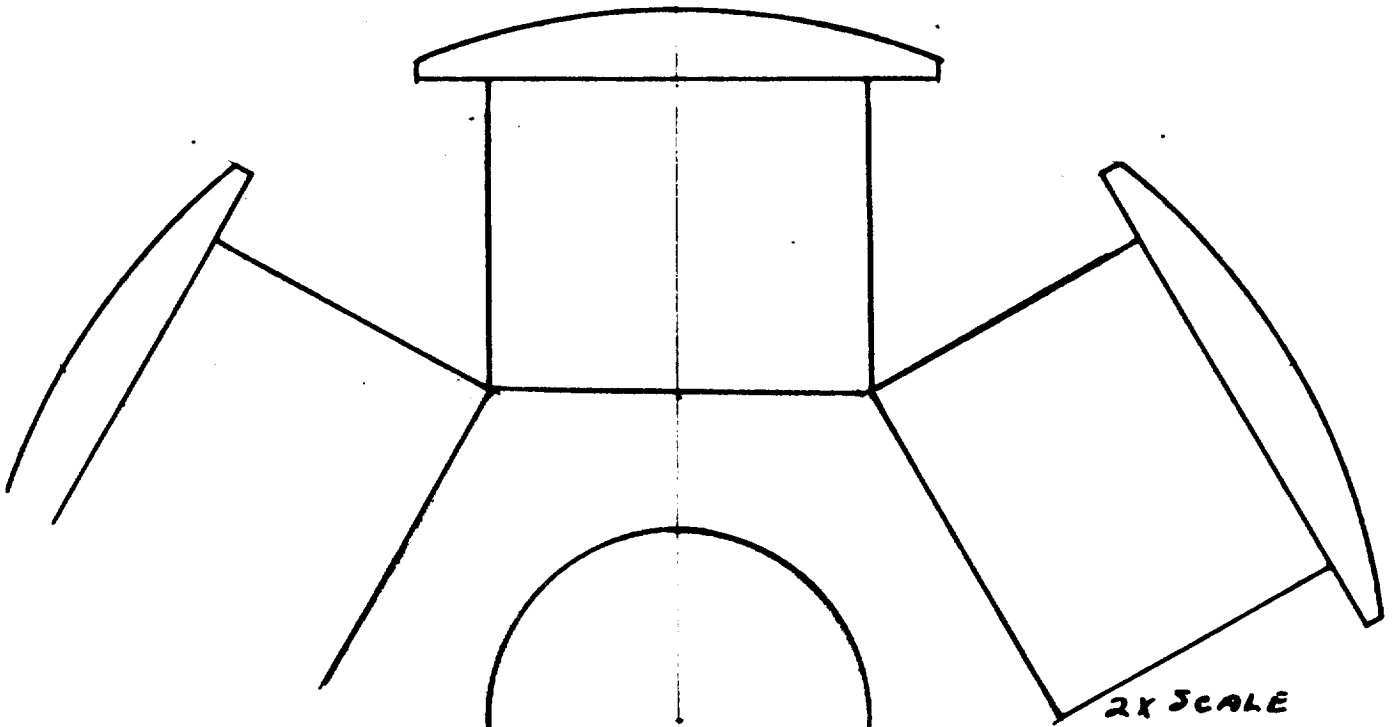

$\frac{9}{32} \pm \frac{1}{32}$  DIA - 2 HOLES  
 CAST ALNICO VI

SCALE = 1:1

COMPUTER PROCEDURE FOR  
PERMANENT MAGNET DESIGN CALCULATIONS

1. Clear core (no switch control).
2. Insert output Form #1 into typewriter, set margin for correct output, and set typewriter for single spacing.
3. Load pass #1 followed by input parameters (output punched cards).
4. Load pass #2 followed by output from pass #1 (output printed plus punched cards).
5. Load pass #3 followed by output from pass #2 (output printed plus punched cards).
6. Load pass #4 followed by output from pass #3 (output punched cards).
7. Load pass #5 followed by output from pass #4 (output punched cards).
8. Load pass #6 followed by PO/FIN values and output from pass # 5 (output punched cards).
9. Load pass #7 followed by output from pass #6 (output printed and punched cards).
10. Load pass #8 followed by output from pass #7 (output printed).

ALL INPUT PARAMETERS ARE IN FORMAT F7.0 (FIG. 1)

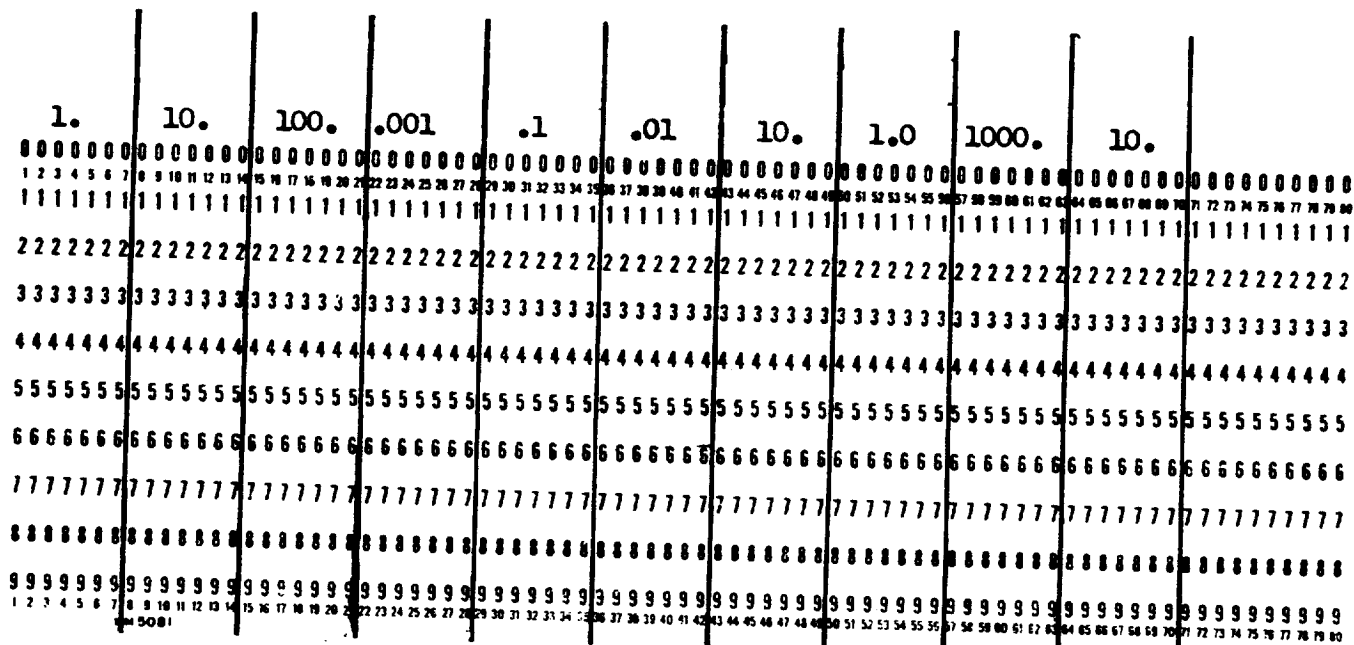

FIG. 1

ALL SATURATION CURVE VALUES ARE IN FORMAT F10.0 (FIG. 2)  
(ALL SATURATION CURVES MUST HAVE 5 CARDS)

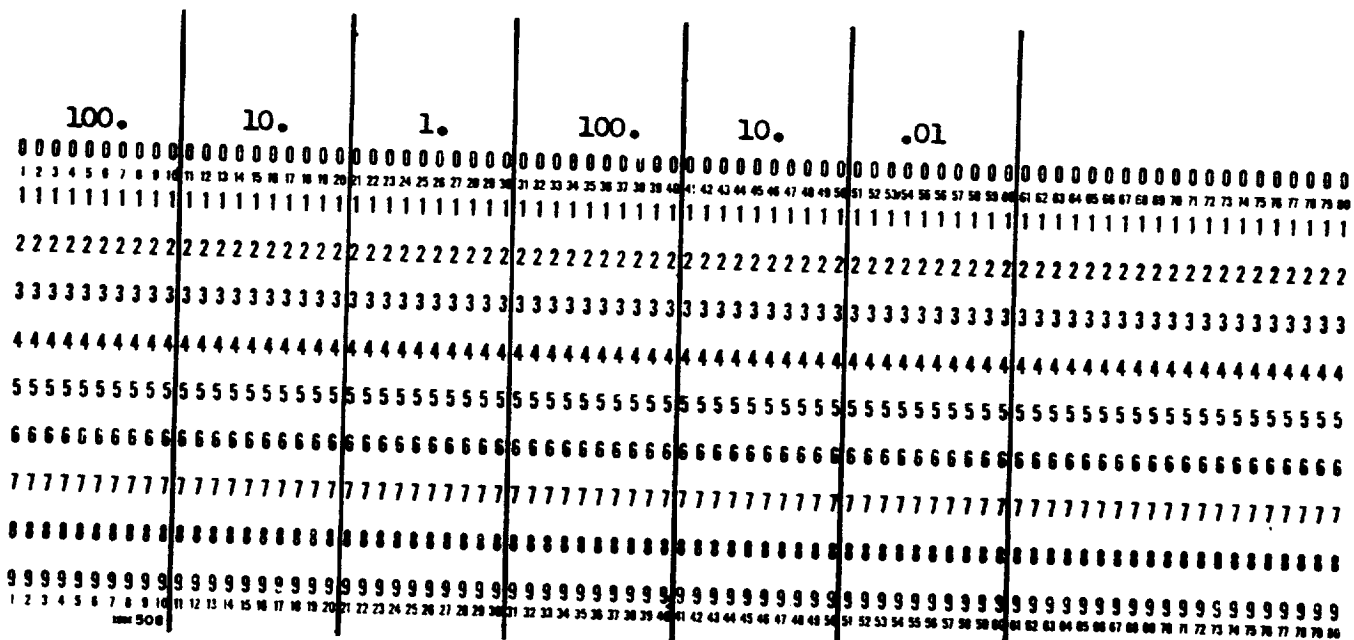

FIG. 2

PERMANENT MAGNET GENERATOR

<u>CALCULATION NUMBER</u>	<u>ELECTRICAL SYMBOL</u>	<u>FORTRAN SYMBOL</u>
	<u>A, a</u>	
(46)	A <sub>c</sub>	AC
(68)	A <sub>g</sub>	GA
(79)	A <sub>p</sub>	AP
(128)	A	A
(501)	a <sub>1</sub>	A1
(502)	a <sub>2</sub>	A2
(516)	A <sub>T</sub>	Y
(519)	A <sub>x</sub>	AX
(520)	A <sub>1</sub>	A1
	<u>B, b</u>	
(15)	b <sub>v</sub>	BV
(20)	B	BK
(22)	b <sub>0</sub>	B0
(22)	b <sub>1</sub>	B1
(22)	b <sub>2</sub>	B2
(22)	b <sub>3</sub>	B3
(22)	b <sub>s</sub>	BS
(57)	b <sub>tm</sub>	TM

<u>CALCULATION NUMBER</u>	<u>ELECTRICAL SYMBOL</u>	<u>FORTRAN SYMBOL</u>
(57a)	$b_{t1/3}$	SM
(76)	$b_p$	BP
(91)	$B_t$	TE
(94)	$B_c$	BX
(95)	$B_g$	FH
	<u><math>C, c</math></u>	
(32)	C	C
(60)	$C_x$	CX
(71)	$C_l$	CL
(72)	$C_w$	CW
(73)	$C_p$	CP
(74)	$C_m$	CM
(75)	$C_q$	CQ
(508)	C	ACM
	<u><math>D, d</math></u>	
(11)	d	DI
(11a)	$d_r$	DR
(12)	D	DU
(35)	$d_b$	DB

<u>CALCULATION NUMBER</u>	<u>ELECTRICAL SYMBOL</u>	<u>FORTRAN SYMBOL</u>
	<u>E, e</u>	
(3)	E	EE
(4)	$E_{PH}$	EP
(55)	$E_F$ (top)	ET
(56)	$E_F$ (bot)	EB
(516)	$E_{NL}$	ENL
(525)	$E_{FL}$	EL
	<u>F, f</u>	
(5a)	f	F
(96)	$F_g$	FH
(183)	F & W	WF
	<u>G, g</u>	
(69)	$\xi_e$	GE
(59)	$\xi_{min}$	GC
(59g)	$\xi_{max}$	GP
	<u>H, h</u>	
(22)	$h_o$	HO
(22)	$h_l$	HX

<u>CALCULATION NUMBER</u>	<u>ELECTRICAL SYMBOL</u>	<u>FORTTRAN SYMBOL</u>
(22)	$h_2$	HY
(22)	$h_3$	HZ
(22)	$h_s$	HS
(22)	$h_t$	HT
(22)	$h_w$	HW
(24)	$h_c$	HC
(37)	$h_{st}$	SH
(38)	$h'_{st}$	SD
(137)	$h_{b1}$	H
(76)	$h_h$	HH
(76)	$h_f$	HF
(519a)	$h$	AH
	<u>I, i</u>	
(8)	$I_{PH}$	PI
(245)	$I^2R$	PS
	<u>K, k</u>	
(2)	$K_{VA}$	VA
(16)	$K_i$	RK
(19)	$k$	WL
(42)	$K_{sk}$	FS

<u>CALCULATION NUMBER</u>	<u>ELECTRICAL SYMBOL</u>	<u>FORTRAN SYMBOL</u>
(43)	$K_d$	DF
(44)	$K_p$	CF
(61)	$K_x$	FF
(63)	$K_E$	EK
(67)	$K_s$	CC
	<u><math>L, l</math></u>	
(13)	$l$	L
(17)	$l_s$	SS
(36)	$l_{e2}$	CE
(48)	$L_E$	EL
(49)	$l_t$	HM
(76)	$l_p$	PL
(139)	$l_b$	SB
	<u><math>M, m</math></u>	
(5)	$m$	PN
	<u><math>N, n</math></u>	
(14)	$n_v$	HV
(30)	$n_s$	SC
(34)	$N_{st}$	SN



<u>CALCULATION NUMBER</u>	<u>ELECTRICAL SYMBOL</u>	<u>FORTRAN SYMBOL</u>
(34a)	$N'_{st}$	SNL
(45)	$n_e$	EC
(138)	$n_b$	BN
	<u><math>P, p</math></u>	
(6)	P	PX
(9)	$P_F$	PF
(500)	$P_1$	P1
(503)	$P_2$	P2
(504)	$P_3$	P3
(505)	$P_{s1}$	PS1
(506)	$P_{s2}$	PS2
(507)	$P_m$	PM
(509)	$P_i$	PII
(510)	$P_o$	PO
(511)	$P_g$	PG
	<u><math>Q, q</math></u>	
(23)	Q	QQ
(25)	q	QN

<u>CALCULATION NUMBER</u>	<u>ELECTRICAL SYMBOL</u>	<u>FORTRAN SYMBOL</u>
	<u>R, r</u>	
(7)	R <sub>PM</sub>	RPM
(53)	R <sub>SPH</sub>	RG
(54)	R <sub>SPH</sub> (Hot)	RP
	<u>S, s</u>	
(47)	S <sub>S</sub>	S
	<u>V, v</u>	
(145)	v <sub>r</sub>	VR
	<u>W, w</u>	
(184)	W <sub>TNL</sub>	WT
(185)	W <sub>L</sub>	WQ
(186)	W <sub>NPL</sub>	WN
(193)	W <sub>DNL</sub>	WD
(242)	W <sub>TFL</sub>	ST
(243)	W <sub>PFL</sub>	PP
(244)	W <sub>DFL</sub>	DL

<u>CALCULATION NUMBER</u>	<u>ELECTRICAL SYMBOL</u>	<u>FORTRAN SYMBOL</u>
	<u>X, x</u>	
(50)	$X_s^{\circ}C$	T1
(129)	X	XR
(130)	$X_e$	XL
(142)	$X_D^{\circ}C$	T3
(163)	$X_{Dd}$	X1
(165)	$X_{Dq}$	X2
(166)	$X'_{DU}$	XU
(167)	$X'_d$	XS
(168)	$X''_d$	XX
(170)	$X_2$	XN
(523)	$X_d$ ohms	XD
	<u>Y, y</u>	
(31)	y	YY
	<u>T</u>	
(26)	$T_s$	TS
(27)	$T_{s1/3}$	TT
(40)	$T_{sk}$	SK
(41)	$T_p$	TP
(140)	$T_b$	TB

<u>CALCULATION NUMBER</u>	<u>ELECTRICAL SYMBOL</u>	<u>FORTRAN SYMBOL</u>
	<u><math>\lambda</math></u>	
(62)	$\lambda_i$	PC
(64)	$\lambda_E$	EW
(70c)	$\lambda_a$	AG
(80b)	$\lambda_{s1}$	SL
(81b)	$\lambda_{t1}$	TL
(82b)	$\lambda_{e1}$	ES
	<u><math>\phi</math></u>	
(88)	$\phi_T$	TG
(92)	$\phi_p$	FQ
	<u><math>\rho</math></u>	
(51)	$\rho_s$	RS
(141)	$\rho_D$	RE
	<u><math>\alpha</math></u>	
(77)	$\alpha$	PE
	<u><math>\sigma</math></u>	
(198a)	$\sigma$	AN

<u>CALCULATION NUMBER</u>	<u>ELECTRICAL SYMBOL</u>	<u>FORTRAN SYMBOL</u>
	<u>K</u>	
(187)	K <sub>1</sub>	D1
(188)	K <sub>2</sub>	D2
(189)	K <sub>3</sub>	D3
(190)	K <sub>4</sub>	D4
(191)	K <sub>5</sub>	D5
(192)	K <sub>6</sub>	D6

```

C    PASS 1 PERMANENT MAGNET
    DIMENSION DA(8),DX(6),DY(8),DZ(8)
    1 FORMAT(E11.5,E11.5,E11.5,E11.5,E11.5,E11.5)
    2 FORMAT(F7.0,F7.0,F7.0,F7.0,F7.0,F7.0,F7.0,F7.0,F7.0,F7.0)
33  READ2,VA,EE,EP,PN,F,PX,RPM,PI,PF,DI
    READ2,DU,CL,HV,BV,SF,WL,BK,ZZ,BO,B1
    READ2,B2,B3,BS,HO,HX,HY,HZ,HS,HT,HW
    READ2,QQ,W,RF,SC,YY,C,DW,SN,SN1,DW1
    READ2,DB,CE,SH,SD,PBA,SK,T1,RS,GC,GP
    READ2,C1,CW,CP,EL,CM,CQ,BH,BP,HH,HF
    READ2,PL,ALN,PE,DR,RK,WR,D1,WO,HD,DD
    READ2,H,B,BN,SB,TB,RE,T3,WF,ACM,AH
    SS=SF*(CL-HV*BV)
    HC=(DU-D1-2.0*HS)*0.5
    ZY=0.7*HS
    IF(HC-ZY) 33,33,5
    5  QN=QQ/(PX*PN)
    TS=3.142*D1/QQ
    IF(ZZ-4.0)29,30,29
29  TT=(0.667*HS+D1)*3.142/QQ
    GO TO 31
30  TT=3.1416*(D1+2.*HO+1.32*BS)/QQ
31  IF(ZZ-1.0)6,6,7
    6  BO=BS
    CC=(5.0*GC+BS)*TS/((5.0*GC+BS)*TS-BS*BS)
    GO TO 8
    7  QC=(4.44*GC+0.75*BO)*TS
    CC=QC/(QC-BO*BO)
    8  CS=YY/(PN*QN)

```

```

TP=3.142*D1/PX
IF(SK)32,32,92
32 FS=1.0
GO TO 34
92 FS=SIN(1.571*SK/TP)*TP/(1.571*SK)
34 IF(PBA-60.)9,9,10
9 D=1.0
GO TO 95
10 D=2.0
95 I=QN
U=I
IF(QN-U)36,36,35
35 U=PX*PN
XX=U
N=U
DO 11 K=1,N
Z=U/XX
I=Z
Z1=I
IF(Z-Z1)12,12,11
12 ZY=QQ/XX
I=ZY
Z1=I
IF(ZY-Z1)37,37,11
11 XX=XX-1.
36 ZY=QN
37 DF=SIN(1.571*D/PN)/(ZY*D*SIN(1.571/(PN*ZY)))
CF=SIN(YZ*1.571/(PN*QN))
EC=QQ*SC*CF*FS/C

```

DT=DW1  
IF(DT) 13,13,14  
13 AC=0.785\*DW\*DW\*SN1  
GO TO 28  
14 ZY=0.0  
DA(1)=0.05  
DA(2)=0.072  
DA(3)=0.125  
DA(4)=0.165  
DA(5)=0.225  
DA(6)=0.438  
DA(7)=0.688  
DA(8)=1.5  
DX(1)=0.000124  
DX(2)=0.00021  
DX(3)=0.00021  
DX(4)=0.00084  
DX(5)=0.00189  
DX(6)=0.00189  
DY(1)=0.000124  
DY(2)=0.000124  
DY(3)=0.00084  
DY(4)=0.00084  
DY(5)=0.00189  
DY(6)=0.00335  
DY(7)=0.00754  
DY(8)=0.03020  
DZ(1)=0.000124  
DZ(2)=0.000124



DZ(3)=0.000124  
 DZ(4)=0.00335  
 DZ(5)=0.00335  
 DZ(6)=0.00754  
 DZ(7)=0.0134  
 DZ(8)=0.0302  
 93 IF(DT-.05)94,94,15  
 15 JA=0  
     JB=0  
     JC=0  
     JD=0  
 16 JA=JA+1  
     JB=JB+1  
     JC=JC+1  
     JD=JD+1  
     IF(DT-DA(JA))17,17,16  
 94 D=0  
     GO TO 23  
 17 IF(DW-0.188)18,18,19  
 18 CY=DX(JB-1)  
     CZ=DX(JB)  
     GO TO 22  
 19 IF(DW-0.75)20,20,21  
 20 CY=DY(JC-1)  
     CZ=DY(JC)  
     GO TO 22  
 21 CY=DZ(JD-1)  
     CZ=DZ(JD)  
 22 D=CY+(CZ-CY)\*(DT-DA(JA-1))/(DA(JA)-DA(JA-1))

23 AC=(DT\*DW-D)\*SN1

28 S=PI/(C\*AC)

PUNCH1,VA,EE,EP,PH,F,PX

PUNCH1,RPM,PI,PF,DI,AC,S

PUNCH1,DU,CL,SS,HC,SF,QN

PUNCH1,WL,BK,ZZ,BO,B1,B2

PUNCH1,B3,BS,HO,HX,HY,HZ

PUNCH1,HS,HT,HW,QQ,W,RF

PUNCH1,SC,YY,C,TS,SI,DB

PUNCH1,CE,SH,SD,TT,SK,T1

PUNCH1,RS,GC,GP,C1,CW,CP

PUNCH1,EL,CM,CQ,BH,BP,HH

PUNCH1,HF,PL,ALN,PE,DR,RK

PUNCH1,CC,WR,D1,WO,HD,DD

PUNCH1,H,B,BN,SB,TB,RE

PUNCH1,T3,WF,CS,FS,TP,DF

PUNCH1,CF,EC,ACM,AH,PBA

PAUSE

END

```

C    PASS 2 PERMANENT MAGNET
1  FORMAT(E11.5,E11.5,E11.5,E11.5,E11.5,E11.5)
3  FORMAT(9X F12.5,2X F12.5)
   READ1, VA,EE,EP,PN,F,PX
   READ 1,RPM,PI,PF,DI,AC,S
   READ1, DU,CL,SS,HC,SF,QN
   READ1, WL,BK,ZZ,BO,B1,B2
   READ1, B3,BS,HO,HX,HY,HZ
   READ1, HS,HT,HW,QQ,W,RF
   READ1, SC,YY,C,TS,SN,DB
   READ1, CE,SH,SD,TT,SK,T1
   READ1, RS,GC,GP,C1,CW,CP
   READ1, EL,CM,CQ,BH,BP,HH
   READ 1,HF,PL,ALN,PE,DR,RK
   READ1, CC,WR,D1,WO,HD,DD
   READ1, H,B,BN,SB,TB,RE
   READ 1,T3,WF,CS,FS,TP,DF
   READ 1,CF,EC,ACM,AH,PBA
   GA=3.142*DI*CL
   AG=6.38*DI/(PX*GC*CC)
   GE=CC*GC
   IF(C1) 44,43,44
43  C1=(0.649*LOG(PE)+1.359)*((GC/GP)**0.352)
44  IF(CW)45,45,46
45  CW=0.707*EE*C1*DF/(EP*PN)
46  TG=6000000.0*EE/(CW*EC*RPM)
   BG=TG/GA
   IF(CP)47,47,48
47  CP=(GC/GP)**0.41*PE*(LOG(GC/TP)*.0378+1.191)

```

```

48 FQ=TG*CP/PX
   IF(ZZ-3.0)49,50,51
49 SM=TT-BS
   GO TO 53
50 SM=(3.1416*(DI+2.*HS)/QQ)-B3
   GO TO 53
51 IF(ZZ-4.0)50,52,49
52 SM=TT-.94*BS
53 TE=TG/(QQ*SS*SM)
   BX=0.5*FQ/(HC*SS)
   IF(EL) 54,54,62
54 IF(RF) 55,55,61
55 IF(PX-2.0) 56,56,57
56 U=1.3
   GO TO 60
57 IF(PX-4.0) 58,58,59
58 U=1.5
   GO TO 60
59 U=1.7
60 EL=3.142*U*YY*(DI+HS)/QQ+0.5
   GO TO 62
61 EL=2.0*CE+(3.142*(0.5*HX+DB))+(YY*TS*TS/(SQRT(TS*TS-BS*BS)))
62 HM=CL+EL
   RY=SC*QQ*HM/(PN*AC*C*C)
   RX=RS*0.000001
   RB=(T1+234.5)*0.00394*RX
   RG=RX*RY
   RP=RB*RY
   IF(SH)37,38,40

```

```

38 ET=1
   EB=1
   GO TO 39
40 AA=0.584+(SN*SN-1.0)*0.0625*(SD*CL/(SH*HM))*2.0
   AB=(SH*SC*F*AC/(BS*RB*1000000.0))*2.0
   ET=AA*AB*0.00335+1.0
   EB=ET-0.00168*AB
39 IF(CM)63,63,64
63 AA=SIN(3.142*PE)
   AB=SIN(1.571*PE)*4.0
   CM=(3.142*PE+AA)/AB
64 A=PI*SC*CF/(C*TS)
   PRINT3,SS,CC,HC,GA,TS,AG,TT,GE,FS,C1,DF,CW,CF,CP,EC,EL,AC,CM
   PUNCH1,VA,EE,EP,PN,F,PX
   PUNCH1,RPM,PI,PF,DI,ACM
   PUNCH1,DU,CL,SS,HC,SF,QN
   PUNCH1,WL,BK,ZZ,B0,B1,B2
   PUNCH1,B3,BS,HO,HX,HY,HZ
   PUNCH1,HS,HT,HW,QQ,W,GE
   PUNCH1,SC,YY,C,TS,BG,TG
   PUNCH1,FQ,TE,BX,TT,HM,SM
   PUNCH1,RG,GC,RP,C1,CW,CP
   PUNCH1,EL,CM,CQ,BH,BP,HH
   PUNCH1,HF,ALN,PL,PE,DR,RK
   PUNCH1,CC,WR,D1,WO,HD,DD
   PUNCH1,H,B,BN,SB,TB,RE
   PUNCH1,T3,WF,CS,ET,AH,EC
   PUNCH1,TP,DF,CF,EB,AC,S
   PUNCH1,AG,A,SM,PBA

```

PAUSE

END

```

C      PASS 3 PERMANENT MAGNET
1  FORMAT(E11.5,E11.5,E11.5,E11.5,E11.5,E11.5)
3  FORMAT(9X F12.5,2X F12.5)
      READ1, VA,EE,EP,PN,F,PX
      READ 1,RPM,PI,PF,DI,ACM
      READ1, DU,CL,SS,HC,SF,QN
      READ1, WL,BK,ZZ,B0,B1,B2
      READ1, B3,BS,HO,HX,HY,HZ
      READ1, HS,HT,HW,QQ,W,GE
      READ1, SC,YY,C,TS,BG,TG
      READ1, FQ,TE,BX,TT,HM,SM
      READ1, RG,GC,RP,C1,CW,CP
      READ1, EL,CM,CQ,BH,BP,HH
      READ 1,HF,ALN,PL,PE,DR,RK
      READ1, CC,WR,D1,W0,HD,DD
      READ1, H,B,BN,SB,TB,RE
      READ 1,T3,WF,CS,ET,AH,EC
      READ1, TP,DF,CF,EB,AC,S
      READ 1,AG,A,SM,PBA
      IF(CQ)69,69,70
69  AA=1.571*PE
      AB=3.1416*PE
      CQ=(0.5*COS(AA)+AB-SIN(AB))/(4.0*SIN(AA))
70  XR=.0707*A*DF/(C1*BG)
      IF(ZZ-5.)350,351,350
351 FF=1.0
      GO TO 75
350 IF(PBA-60.)352,353,352
353 IF(CS-.667)354,355,355

```

```

355 D=.75
      Z=.25
      GO TO 74
354 D=1.5
      Z=-.25
      GO TO 74
352 IF(CS-.667)356,357,357
357 FF=.75
      GO TO 75
356 D=1.2
      Z=-.05
74  FF=D*CS+Z
75  CX=FF/(CF*CF*DF*DF)
      Z=CX*20.0/(PN*QN)
      BT=3.142*D1/QQ-B0
      ZA=BT*BT/(16.0*TS*GC)
      ZB=0.35*BT/TS
      ZC=H0/B0
      ZD=HX*0.333/BS
      ZE=HY/BS
      IF(ZZ-2.0) 76,77,78
76  PC=Z*(ZE+ZD+ZA+ZB)
      GO TO 82
77  PC=Z*(ZC+(2.0*HT/(B0+BS))+(HW/BS)+ZD+ZA+ZB)
      GO TO 82
78  IF(ZZ-4.0) 79,80,81
79  PC=Z*(ZC+(2.0*HT/(B0+B1))+(2.0*HW/(B1+B2))+(HX*0.333/B2)+ZA+ZB)
      GO TO 82
80  PC=Z*(ZC+0.62)

```



```

      GO TO 82
81  PC=Z*(ZE+ZD+(0.5*GC/TS)+(0.25*TS/GC)+0.6)
82  EK=EL/(10.0**(0.103*YY*TS+0.402))
      IF(DI-8.0) 83,83,84
83  EK=SQRT(EK)
84  ZF=.612*LOG(10.0*CS)
      EW=6.28*EK*ZF*(TP**(0.62-(0.228*LOG(ZF))))/(CL*DF*DF)
      IF(PN-3.0)85,86,86
85  ZC=0.1*DI*SIN(3.0*YY/(PN*QN))*1.57/(PX*GE*CF)
      GO TO 87
86  ZC=0.0
87  XL=(PC+EW+ZC)*XR
      XD=XR*AG*C1*CM
      XQ=XR*CQ*AG
      WC=0.321*SC*QQ*AC*HM
      PRINT3,S,CQ,HM,A,RG,XR,RP,XL
      PUNCH1,VA,EE,EP,PN,F,PX
      PUNCH1,RPM,PI,PF,DI,EC,PE
      PUNCH1,DU,CL,SS,HC,PC,QN
      PUNCH1,WL,BK,ZZ,BO,XD,AH
      PUNCH1,XR,BS,XL,HX,HY,HZ
      PUNCH1,HS,WC,AC,QQ,W,GE
      PUNCH1,SC,YY,C,TS,BG,TG
      PUNCH1,FQ,TE,BX,TT,EW,AG
      PUNCH1,RG,GC,RP,C1,TP,CP
      PUNCH1,DF,CM,CF,BH,BP,HH
      PUNCH1,HF,PL,ALN,EB,DR,RK
      PUNCH1,CC,WR,D1,WO,HD,DD
      PUNCH1,H,B,BN,SB,TB,RE

```

PUNCH1,T3,ACM,WF,CS

PUNCH1,ET,SM

PAUSE

END

```

C      PASS 4 PERMANENT MAGNET
3  FORMAT(9X F12.5,2X F12.5)
1  FORMAT(E11.5,E11.5,E11.5,E11.5,E11.5,E11.5)
      READ1, VA,EE,EP,PN,F,PX
      READ 1,RPM,PI,PF,DI,EC,PE
      READ1, DU,CL,SS,HC,PC,QN
      READ 1,WL,BK,ZZ,BO,XD,AH
      READ1, XR,BS,XL,HX,HY,HZ
      READ1, HS,WC,AC,QQ,W,GE
      READ1, SC,YY,C,TS,BG,TG
      READ1, FQ,TE,BX,TT,EW,AG
      READ1, RG,GC,RP,C1,TP,CP
      READ1, DF,CM,CF,BH,BP,HH
      READ 1,HF,PL,ALN,EB,DR,RK
      READ1, CC,WR,D1,WO,HD,DD
      READ1, H,B,BN,SB,TB,RE
      READ 1,T3,ACM,WF,CS
      READ 1,ET,SM
      ZA=3.1416*(D1+HS)/QQ
      IF(ZZ-3.0) 88,89,88
88  TM=ZA-BS
      GO TO 90
89  TM=(3.1416*(D1+2.*HS)/QQ)-B3
90  WI=(TM*QQ*SS*HS+(DU-HC)*3.142*HC*SS)*0.283
      AN=0.0
100 AN=AN+0.005
      AL=COS(AN)
      IF(PF-AL) 100,100,101
101 VR=0.262*DR*RPM

```

```

AP=BP*PL*ACM
FH=BG*GE/0.00319
IF (BN)307,306,307
306 X1=0
    P2=0
    X2=0
    GO TO 308
307 IF (DD)103,103,102
102 ZG=0.62
    GO TO 104
103 ZG=0.333*H/B
104 BD=(HD/WO+ZG+0.5)*6.38
    BE=(BH-(BN-1.0)*TB)*2.127/GE
    P1=(BD+BE)*RL*COS((BN-1.0)*TB*1.572/TP)/(BD+BE+RL)
    X1=XR*P1
    P2=(HD/WO+ZG+0.5+GC/TB)*20.0*TB/TP
    X2=XR*P2
308 XU=XL+XF
    XS=0.88*XU
    IF (BN)105,105,106
105 XX=XS
    GO TO 107
106 XX=XL+X1
107 XN=(XX+XY)*0.5
110 IF (WF)111,111,112
111 WF=DR**2.5*(RPM**1.5)*PL*0.00000252
112 WQ=(DU-HC)*1.42*HC*SS*(BX/BK)**2.0*WL
    WT=(SM)*QQ*SS*HS*0.453*(TE/BK)**2.0*WL
    PUNCH1,VA,EE,EP,PN,F,PX

```

PUNCH1,RPM,PI,PF,DI,PC,WC  
PUNCH1,DU,CL,SS,HC,PC,QN  
PUNCH1,WL,BK,ZZ,BO,XD,WI  
PUNCH1,XR,BS,HX,HY,HZ,EC  
PUNCH1,HS,AC,QQ,W,GE,HD  
PUNCH1,SC,YY,C,TS,BG,TG  
PUNCH1,FQ,TE,BX,TT,EW,AG  
PUNCH1,RG,GC,RP,C1,AP,P2  
PUNCH1,DF,CF,FH,BP,HH,AL  
PUNCH1,HF,ALN,PL,EB,DR,RK  
PUNCH1,CC,WR,D1,WO,HD,DD  
PUNCH1,H,B,BN,SB,TB,RE  
PUNCH1,T3,VR,WT,ACM,AH  
PUNCH1,WQ,WF,CS,ET,TP,X1  
PUNCH1,XX,XN,XL,CM,CP,PE  
PUNCH1,X2,XU,XS,AN  
PAUSE  
END

```

C PASS 5 PERMANENT MAGNET
1 FORMAT(E11.5,E11.5,E11.5,E11.5,E11.5,E11.5)
3 FORMAT(9X F12.5,2X F12.5)
  READ1, VA,EE,EP,PN,F,PX
  READ 1,RPM,PI,PF,DI,PC,WC
  READ1, DU,CL,SS,HC,PC,QN
  READ 1,WL,BK,ZZ,BO,XD,WI
  READ 1,XR,BS,HX,HY,HZ,EC
  READ 1,HS,AC,QQ,W,GE,HD
  READ1, SC,YY,C,TS,BG,TG
  READ1, FQ,TE,BX,TT,EW,AG
  READ1, RG,GC,RP,C1,AP,P2
  READ 1,DF,CF,FH,BP,HH,AL
  READ 1,HF,ALN,PL,EB,DR,RK
  READ1, CC,WR,D1,WO,HD,DD
  READ1, H,B,BN,SB,TB,RE
  READ1 ,T3,VR,WT,ACM,AH
  READ 1,WQ,WF,CS,ET,TP,X1
  READ 1,XX,XN,XL,CM,CP,PE
  READ 1,X2,XU,XS,AN
  GT=B0/GC
  IF(GT-1.0)304,304,303
304 AA=2.6
  GO TO 115
303 IF(GT-3.75)113,114,114
113 AA=10.0**0.178/((GT-1.0)**0.334)
  GO TO 115
114 AA=10.0**0.11/((GT-1.0)**0.174)
115 GF=AA*PI*SC/(C*FH)

```

```

-   305 IF(SC-1.0)121,121,122
-   120 A5=0.0
-       GO TO 129
-   121 AX=1.0
-       AY=1.0
-       GO TO 125
-   122 AX=3.0*YY/(PN*QN)-2.0
-       IF(CS-0.667)123,124,124
-   123 AY=1.5*YY/(PN*QN)-0.25
-       GO TO 125
-   124 AY=.75*YY/(PN*QN)+0.25
-   125 A3=AX*P2/AY
-       A4=0.07*AX*AG/(CF*CF)
-       IF(AX)120,120,126
-   126 IF(BN)127,127,128
-   127 A5=A4
-       GO TO 129
-   128 A5=(A4+A3)/(A3*A4)
-   129 IF(W)130,130,131
-   130 X0=0.0
-       GO TO 132
-   131 AA=(3.0*HZ+HX)*1.667/(PN*QN*CF*CF*DF*DF*BS)
-       X0=((PC+A5)*AX/AY+AA+0.2*EW)*XR
-   132 D2=BG**2.5*0.000061
-       D3=(0.0167*QQ*RPM)**1.65*0.000015147
-       IF(TS-0.9) 133,133,134
-   133 D4=TS**1.285*0.81
-       GO TO 137
-   134 IF(TS-2.0) 135,135,136

```

```

135 D4=TS**1.145*0.79
      GO TO 137
136 D4=TS**0.79*0.92
137 D7=B0/GC
      IF(D7-1.7) 138,138,139
138 D5=D7**2.31*0.3
      GO TO 144
139 IF(D7-3.0) 140,140,141
140 D5=D7**2.0*0.35
      GO TO 144
141 IF(D7-5.0) 142,142,143
142 D5=D7**1.4*0.625
      GO TO 144
143 D5=D7**0.965*1.38
144 D6=10.0**(0.932*C1-1.606)
      BA=3.142*D1*CL
      WN=D1*D2*D3*D4*D5*D6*BA
      UY=(SL+ES+TL)*ALN*0.00638
      VT=0.
      AA=W0/(GC*CC)
      IF(AA)148,147,148
148 IF(AA-0.65)145,145,146
145 VT=LOG(10.0*AA)*(-0.242)+0.59
      GO TO 147
146 VT=0.327-(AA*0.266)
147 UZ=(DU-HC)*0.7850/PX
      EZ=(ET+EB)*0.5-1.0
      AA=PN*PI*PI
      PU=AA*RG

```



WRM=BP\*PL\*HF\*.283\*PX

PV=AA\*RP

VV=EP\*PI\*PF\*.003

PUNCH1,VA,EE,EP,PN,F,PX

PUNCH1,RPM,PI,PF,TB,BO,GC

PUNCH1,HH,HF,ALN,DR,SB,RE

PUNCH1,T3,W0,DD,H,BN,GF

PUNCH1,VT,TS,CC,BG,AP,FQ

PUNCH1,TE,BX,FH,WQ,WT,AN

PUNCH1,RP,WF,HS,B,GE,BP

PUNCH1,WN,UZ,EZ,PU,VV,XD

PUNCH1,PV,HD,QN,XO,TG,VR

PUNCH1,PC,WC,WR,WI,TP,DI

PUNCH1,X1,X2,XU,XS,ET,EB

PUNCH1,XX,PL,ACM,AH,EW,CM

PUNCH1,PE,AG,XN,CP,CL,EC

PUNCH1,XL,WRM,DF

PAUSE

END

```

C    PASS 6 PERMAMENT MAGNET
      DIMENSION AI(30)
      1 FORMAT(E11.5,E11.5,E11.5,E11.5,E11.5,E11.5)
888  FORMAT(F10.0,F10.0,F10.0,F10.0,F10.0,F10.0)
      K=1
823  READ888, AI(K), AI(K+1), AI(K+2), AI(K+3), AI(K+4), AI(K+5)
      K=K+6
      IF(K-29)823,199,199
199  READ 1,VA,EE,EP,PN,F,PX
      READ 1,RPM,PI,PF,TB,BO,GC
      READ 1,HH,HF,ALN,DR,SB,RE
      READ 1,T3,W0,DD,H,BN,GF
      READ 1,VT,TS,CC,BG,AP,FQ
      READ 1,TE,BX,FH,WQ,WT,AN
      READ 1,RP,WF,HS,B,GE,BP
      READ 1,WN,UZ,EZ,PU,VV,XD
      READ 1,PV,HD,QN,XO,TG,VR
      READ 1,PC,WC,WR,WI,TP,DI
      READ 1,X1,X2,XU,XS,ET,EB
      READ 1,XX,PL,ACM,AH,EW,CM
      READ 1,PE,AG,XN,CP,CL,EC
      READ 1,XL,WRM,DF
      PD=FQ/AP
      Z=COS(3.1416/PX)
      TAN=SIN(3.1416/PX)/Z
      A2=((DI/2.-GC-HH-HF)*TAN-BP/2.)*Z*2.
      A1=((DI/2.-GC-HH)*TAN-BP/2.)*Z*2.
      IF(A2-.2)401,401,400
401  P1=3.19*PX*PL/3.1416

```

```

GO TO 402
400 P1=PL*PX*(1.-(A2/(A1-A2))*LOG(1.+(A1-A2)/A2))*3.19
402 P2=1.66*(1.+1.23*LOG(1./(1.-PE)))*PL
P3=HF*1.66*(1.+1.23*LOG(1.+2./((A1+A2)/BP)))
PS1=6.38*HH*PL/(TP-BP)
PS2=2.*HH*P2/PL
PM=PL*BP*ACM/(2.*HF)
P11=PS1+PS2+P1+P3
P0=P11+P2
PG=.785*AG*CP*CL
PW=P11+PG
X=P0/PM
NA=1
GO TO 802
805 ENL=.001*(EP*Y/PD)*(P0/PM+AH)*(PW/PM-P11/PM)/(PW/PM+AH)
PUNCH1,VA,EE,EP,PN,F,PX
PUNCH1,RPM,PI,PF,TB,BO,GC
PUNCH1,HH,HF,ALN,DR,SB,RE
PUNCH1,T3,W0,DD,H,BN,GF
PUNCH1,VT,TS,CC,BG,FQ,Y
PUNCH1,TE,BX,FH,WQ,WT,AN
PUNCH1,WF,HS,B,GE,BP,PW
PUNCH1,WN,UZ,EZ,PU,VV,PD
PUNCH1,PV,HD,QN,XO,TG,VR
PUNCH1,PC,WC,WR,WI,TP,DI
PUNCH1,X1,X2,XU,XS,ENL,PG
PUNCH1,XX,PL,AH,EW,RP,PM
PUNCH1,PE,AG,XN,CP,CL,EC
PUNCH1,XL,WRM,DF,CM,ET,EB

```

```

PUNCH1,FQ,BG,TG,BX,TE
PUNCH1,P11,PO
PAUSE
802 IF(AI(NA)-X)830,831,831
831 NA=NA+3
835 IF(AI(NA)-X)833,834,834
833 NA=NA+2
      GO TO 835
834 AA=AI(NA)
      BB1=AI(NA-2)
      DC=AI(NA+1)
      D=AI(NA-1)
      XXX=(AA-BB1)/(.4343*(LOG(DC)-LOG(D+.0001)))
      Y=AA-XXX*.4343*LOG(DC)
      Y=EXP(2.306*(X-Y)/XXX)
      GO TO 805
830 PRINT850
850 FORMAT(17HMACHINE SATURATED)
      PAUSE
      END

```

```

C   PASS 7 PERMANENT MAGNET
    DIMENSION EL(6)
3   FORMAT(9X F12.5,2X F12.5)
1   FORMAT(E11.5,E11.5,E11.5,E11.5,E11.5,E11.5)
    READ 1,VA,EE,EP,PN,F,PX
    READ 1,RPM,PI,PF,TB,BO,GC
    READ 1,HH,HF,ALN,DR,SB,RE
    READ 1,T3,WO,DD,H,BN,GF
    READ 1,VT,TS,CC,BG,FQ,Y
    READ 1,TE,BX,FH,WQ,WT,AN
    READ 1,WF,HS,B,GE,BP,PW
    READ 1,WN,UZ,EZ,PU,VV,PD
    READ 1,PV,HD,QN,XO,TG,VR
    READ 1,PC,WC,WR,WI,TP,DI
    READ 1,X1,X2,XU,XS,ENL,PG
    READ 1,XX,PL,AH,EW,RP,PM
    READ 1,PE,AG,XN,CP,CL,EC
    READ 1,XL,WRM,DF,CM,ET,EB
    READ 1,FQ,BG,TG,BX,TE
    READ 1,PII,PO
    PW=PII+PG
    AX=Y*(PO/PM+AH)/(PII/PM+AH)
    A1=Y*(PO/PM+AH)/(PW/PM+AH)
    AZ=PI
326 HD1=.45*AZ*EC*CM*DF/(PX*HF)
    AISC=(ENL*(AX-A1-HD1)/(AX-A1))/SQRT(RP**2+(XL*EP*.01/PI)**2)
    D=AISC-AZ
    IF(D)322,323,323
322 D=-D

```

```

323 IF(D-.05)324,325,325
325 AZ=(AISC-AZ)/2.+AZ
      GO TO 326
324 XD=ENL/AISC
      XDPU=XD*PI*100./EP
      TPF=SIN(AN)/COS(AN)
      SPF=SIN(1.5708-AN)
      CPF=COS(1.5708-AN)
      Z=.25
      DO 327 K=1,6
      AZ=Z*PI
      X=(AZ*XD-AZ*RP*TPF)
      B=X*SPF/ENL
      B=ATAN(B/SQRT(1.-B**2))
      EL(K)=ENL*COS(B)-X*CPF-AZ*RP/PI
327 Z=Z+.25
      PRINT3,ET,XDPU,EB,X1,PC,X2,EW,XU,WC,XS
      PRINT3,WI,XX,TP,XN,PII,XO,PO,TG,PM,FQ
      PRINT3,PG,BG,WR,TE,WRM,BX,VR,AISC
      PRINT321,FQ
      PRINT3,PD
321 FORMAT (/9X F12.5)
      PUNCH1,F,PX,TB,BO,GC,SB
      PUNCH1,RE,T3,W0,DD,H,BN
      PUNCH1,TS,CC,BG,B,HD,QN
      PUNCH1,EZ,XDPU,WT,WF,WQ,VV
      PUNCH1,ENL,EL(1),EL(2),EL(3),EL(4),EL(5)
      PUNCH1,EL(6),PU,PV,GF,WI
      PAUSE

```

END

```

C   PASS 8 PERMANENT MAGNET GENERATOR
    DIMENSION PR(2),PS(2),G(2),DL(2),PP(2),EX(2),ST(2),VA(2)
    DIMENSION P(2),E(2),PM(2),SP(2),EL(6)
1   FORMAT(E11.5,E11.5,E11.5,E11.5,E11.5,E11.5)
3   FORMAT(9X,F12.5,2X,F12.5)
    READ 1,F,PX,TB,BO,GC,SB
    READ 1,RE,T3,WO,DD,H,BN
    READ 1,TS,CC,BG,B,HD,QN
    READ 1,EZ,XDPU,WT,WF,WQ,VV
    READ 1,ENL,EL(1),EL(2),EL(3),EL(4),EL(5)
    READ 1,EL(6),PU,PV,GF,WN
    IF(RE)309,309,311
309 WD=0.0
    WU=0.0
    GO TO 178
311 FS1=2.0*QN*PN*F
    FS2=2.0*FS1
    M=0
150 IF(M-1)151,152,178
151 RM=RE
    GO TO 153
152 RM=RE*(T3+234.5)/254.5
153 AA=(FS1/RM)**0.5*DD*0.32
    AB=(FS2/RM)**0.5*DD*0.32
    IF(AA-2.5) 160,160,161
160 V1=1.0-0.15*AA+0.3*AA*AA
    GO TO 162
161 V1=AA
162 IF(AB-2.5) 163,163,164

```



```

163 V2=1.0-0.15*AB+0.3*AB*AB
    GO TO 165
164 V2=AB
165 IF(H-B) 167,166,167
166 VC=0.75/V1
    GO TO 169
167 IF(DD) 166,168,166
168 VC=H/(3.0*B*V1)
169 VS=HD/WO+VT+VC
    VG=TB/(CC*GC)
    Q1=1.0-(1.0/(((B0*0.5/GC)**2.0+1.0)**0.5))
    QZ=B0/TS
    Q2=1.05*SIN(QZ*2.844)
    IF(QZ-0.37)170,170,171
170 Q3=0.46
    GO TO 172
171 Q3=0.23*SIN(10.46*QZ-2.1)+0.23
172 Q4=SIN(6.283*TB/TS-1.571)+1.0
    Q5=SIN(12.566*TB/TS-1.571)+1.0
    IF(H)173,173,174
173 AB=0.785*DD*DD
    GO TO 175
174 AB=H*DD
175 W2=PX*BN*SB*RM*1.246/(AB*1000.)
    W3=(Q2/(2.0*VS+(VG/Q4)))**2.0*V1
    W5=(Q3/(2.0*VS+(VG/Q5)))**2.0*V2
    WD=(TS*BG*Q1*CC)**2.0*W2*(W3+W5)
    M=M+1
    IF(M-1)176,176,177

```

```

176 WU=WD
177 GO TO 150
178 G(1)=0
      G(2)=1
      PW=PU
      WW=WU
      DO 183 M=1,2
      UA=G(M)
      PS(M)=PW*UA*UA
      X=WF+WQ
      GM=(GF*UA)**2.+1.
      ST(M)=(2.0*(0.0027*XDPU*UA)**1.8+1.0)*WT
      VA(M)=VV*UA
      DL(M)=GM *WW
      PP(M)=GM*WN
      EX(M)=EZ*PS(M)
      SP(M)=PP(M)+DL(M)+PS(M)+EX(M)+ST(M)+X
      P(M)=(SP(M)/1000.)+VA(M)
      IF(GM)185,184,185
184 PM(M)=0
      E(M)=0
      GO TO 186
185 PM(M)=(SP(M)/P(M))*1
      E(M)=100.-PM(M)
186 WW=WD
183 PW=PV
      PRINT3,WF,WF
      PRINT3,ST(1),ST(2)
      PRINT3,WQ,WQ

```

```
PRINT3,PP(1),PP(2)
PRINT3,DL(1),DL(2)
PRINT3,PS(1),PS(2)
PRINT3,EX(1),EX(2)
PRINT3,SP(1),SP(2)
PRINT3,VA(1),VA(2)
PRINT3,P(1),P(2)
PRINT3,PM(1),PM(2)
PRINT3,E(1),E(2)
PRINT321,ENL
PRINT4,EL(1),EL(2),EL(3),EL(4),EL(5),EL(6)
4 FORMAT(9X,F12.5)
321 FORMAT (/9X F12.5)
PAUSE
END
```



DERIVATIONS

1  
2  
3  
4  
5  
6  
7  
8  
9  
10  
11  
12  
13  
14  
15  
16  
17  
18  
19  
20  
21  
22  
23  
24  
25  
26  
27  
28  
29  
30  
31  
32  
33  
34  
35  
36  
37  
38  
39  
40  
41  
42  
43  
44  
45  
46  
47  
48  
49  
50  
51  
52  
53  
54  
55  
56  
57  
58  
59  
60  
61  
62  
63  
64  
65  
66  
67  
68  
69  
70  
71  
72  
73  
74  
75  
76  
77  
78  
79  
80  
81  
82  
83  
84  
85  
86  
87  
88  
89  
90  
91  
92  
93  
94  
95  
96  
97  
98  
99  
100

## POLE-FACE LOSSES IN SOLID POLE GENERATORS

### IN BRIEF

Pole-face losses in solid rotor generators can limit the rotational speed, the output, or both. The following article discusses the calculation of, and the design limits imposed by the pole face losses.

### GENERAL STATEMENT

Paradoxically, the solid rotor machine is proposed for high speeds and high air-gap flux densities when it cannot operate at speeds or loadings comparable to those of the laminated pole generators, without the penalty of high losses in the solid pole faces.

A solid-pole Lundell generator that operates over a speed range of two to one may require de-rating at the maximum speed because of pole-face losses. This de-rating is required because of the pole face losses under load - not the no load losses.

When the wide speed range generator operates at its maximum speed, the gap density is reduced and the reduction of losses due to the reduced flux density is greater than the loss increase due to the increase in tooth ripple frequency. The result at no load is a reduction in pole face losses. At full load though, the same stator current flows and the armature mmf is the same as it was at the lower speed.

Because of the doubled slot frequency, the pole face load losses at the top speed will be of the order of 3 times as great as at the 1/2 speed condition. The actual increase in pole face losses under load depends upon the slot opening, air gap length, ampere loading, and gap density.

### SOURCE OF THE FORMULAE

T. Spooner and I. F. Kinnard "Surface Iron Losses with Reference to Laminated

Materials" Trans. AIEE, Vol. 43, 1924, pp 262-281.

The above reference points out that the following factors influence pole face losses:

1. Air gap induction  $B_g$
2. Field form  $C$ .
3. Ratio of slot width to single air gap  $\frac{b_s}{g}$
4. Tooth frequency  $f_t$
- \*5. Tooth pitch  $\tau_s$  or slot pitch
6. Resistivity of material ( $\rho$ )
7. Thickness of individual laminations  $t$
8. Hysteresis Coefficient  $\gamma$
9. Insulation between laminations
10. Effect of punching

\* We use different symbol than Spooner and Kinnard

In the equation -

Pole face losses =  $W_S = K_1 K_2 K_3 K_4 K_5 K_6$  (Bore area), the hysteresis coefficient is not used, the interlamination resistance is assumed high, no burrs are assumed to be shorting the laminations and the effect of work-hardening is assumed to be removed by annealing.

In the paper, Spooner and Kinnard summarize that as a rough approximation, surface losses vary as:

$$(B_g)^2, (f_t)^{1.5}, \frac{b_s}{g} \text{ }^{1 \text{ to } 2} (\tau_s)^1$$

In the text of the paper, higher exponents are used and the constant  $K_1$  is adjusted to give the required accuracy. The exponents used in the curves given in the design manuals of this report are about 30% higher than the rough approximation given by Spooner and Kinnard, and account for interlaminated currents caused by imperfect insulation.



CURVE 2

From Kennard and Spooner "Surface Iron Losses with Respect to Laminated Materials", Trans. AIEE, Vol. 43, 1924, pp 262-281.

DRAWN BY J.A.T.

REFER TO ITEM (186) IN SALIENT POLE DESIGN MANUAL FOR SAMPLE USE OF THIS CURVE

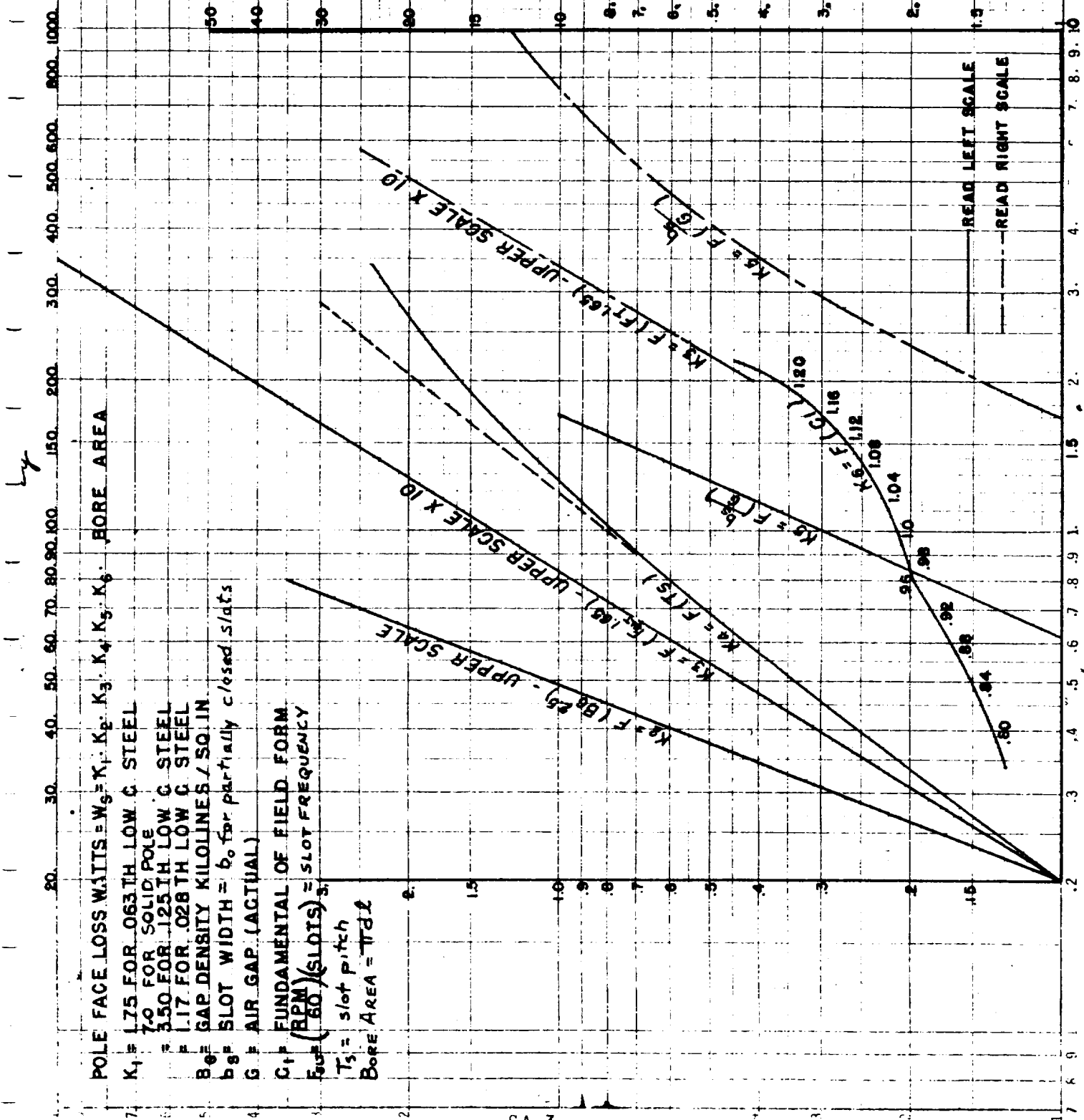

25  
b/s/g

## SOLID-POLE P. F. LOSSES

For this study, tests were made on solid-pole generators using 4130 pole steel. Tests correlated within 5% of calculated losses when the constant  $K_1 = 7.0$  was used. Load losses in the pole face are calculated just as for laminated poles.

Note: If the rotor is not relieved at the leading and trailing edges of the pole, the losses will be higher than those calculated with  $K_1 = 7.0$ . Such a condition might exist when 316 steel or Inconel X is welded between poles and the weldment is cylindrical. In such cases, the armature reaction flux causes high losses in the interpolar area. This discussion and calculation assumes that best conditions exist.

## NO-LOAD POLE FACE LOSSES

The pole face losses are a function of the stator bore area, and when the stator tooth pitch is constant, the losses are a function of the rotor diameter. They are also functions of the gap density and under load they are functions of the stator loading. Since the RPM determines the tooth ripple frequency, the P. F. losses are a function of the RPM.

The flux density and speed of a specific, solid pole generator, are limited by the amount of heat that can be dissipated from the surface of the poles so without considering the output of the generator, the effect of slot pitch and air gap density on pole face losses can be observed, while the generator operates at no-load.

With a specified air gap density and specified slot pitch, the pole face losses can be made high enough to cause the machine to fail and this can happen without load being applied. It can happen to a laminated pole or to a solid pole generator.

The no load pole face losses in a solid pole generator are of the order of six (6) times as great, for the same stator design, as those in the pole faces of a

laminated rotor. For this reason only the design limits for the solid pole generators are investigated here.

No load pole face losses are = fn ( $B_g$ ,  $\frac{b_s}{g}$ ,  $f_t$ ,  $\tau_s$ ,  $C_1$ ) where

$B_g$  = air gap density, Kilolines/in<sup>2</sup>

$b_s$  = slot opening, inches

$g$  = air gap length, inches

$f_t$  = tooth ripple, cycles/sec

$\tau_s$  = tooth pitch on stator, inches

$C_1$  = fundamental of field form (a ratio)

For most of the following discussion, the following values are assumed fixed:

$$\frac{b_s}{g} = 2.0$$

$$\tau_s = .3''$$

$$C_1 = 1.0$$

Since  $\tau_s = .3$ , now the number of teeth is a function of  $d$ .

$$\text{No. Teeth} = \frac{\pi d}{.3}$$

$$f_t = \frac{\pi d}{.3} \cdot \frac{\text{RPM}}{60}$$

PFL at NL =  $K_1 K_2 K_3 K_4 K_5 K_6$  (Bore Area)

$$K_1 = 7.0$$

$$K_2 = \text{fn}(B_g) = .8 \text{ for } 45 \text{ Kilolines/in}^2 \text{ gap density}$$

$$K_3 = \text{fn } (f_T)^{1.65} = \text{fn } \left[ \frac{\pi d}{.3} \frac{(\text{RPM})}{60} \right]^{1.65}$$

$$K_4 = \text{fn } (\tau_s) = .175$$

$$K_5 = \text{fn } \left( \frac{b_s}{g} \right) = 1.45$$

$$K_6 = \text{fn } (C_1) = .22$$

$$\text{PFL at NL} = (7.0) .8 (K_3) (.175) 1.45 (.22) (\text{Bore Area})$$

$$= .313 K_3 (\text{Area}) \text{ for Bg} = 45 \text{ Kilolines/in}^2$$

$$= .235 K_3 (\text{Area}) \text{ for Bg} = 40 \text{ Kilolines/in}^2$$

$$= .11 K_3 (\text{Area}) \text{ for Bg} = 30 \text{ Kilolines/in}^2$$

$$= .039 K_3 (\text{Area}) \text{ for Bg} = 20 \text{ Kilolines/in}^2$$

Rotor Dia. In.	RPM	No-Load Pole Face Loss in Watt/in <sup>2</sup> $\tau_s = .3$			
		Bg = 45	Bg = 40	Bg = 30	Bg = 20
4	2,000	.72	.54	.25	.09
"	4,000	2.28	1.7	.8	.284
"	8,000	7.2	5.4	2.5	.9
"	12,000	14.1	10.6	4.9	1.76
"	24,000	44	33	15.4	5.5
"	48,000	128	96	45	16
6	2,000	1.4	1.05	.49	.17
"	4,000	4.4	3.3	1.54	.55
"	8,000	14	10.5	4.9	1.75
"	12,000	27	20.2	9.5	3.37
"	24,000	86	64.5	30	10.7
"	48,000	272	204	95	34

POLEFACE LOSSES IN A SOLID POLEFACE AT  
 NO LOAD AS A FUNCTION OF SPEED WHEN  
 THE GAP DENSITY  $B_g = 45 \text{ KL/IN}^2$   
 $b_g/g = 2.0$  SLOT PITCH  $\tau_s = .30$

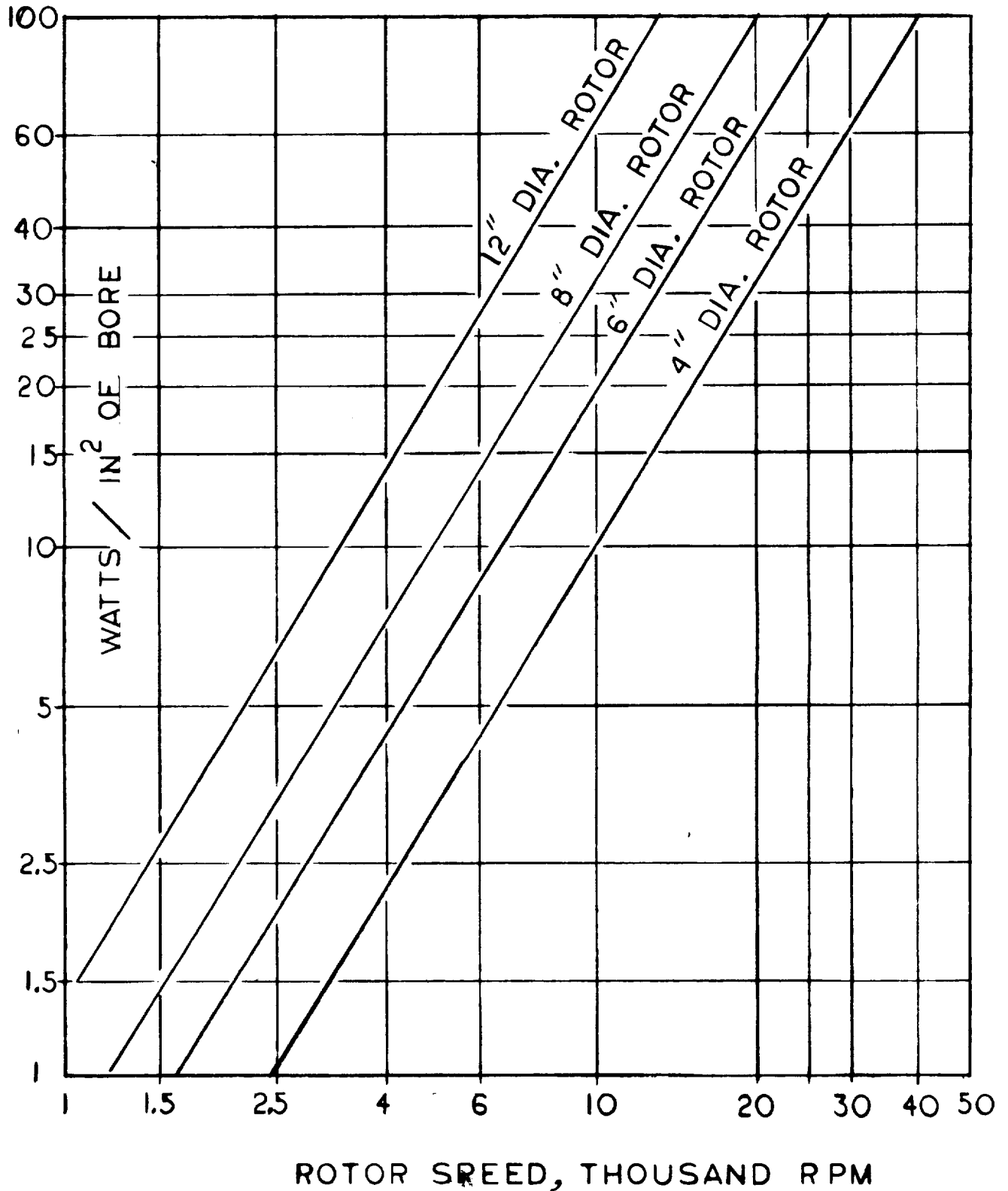

CURVE SA-1

POLE FACE LOSSES IN A SOLID POLE FACE  
 AT NO LOAD AS A FUNCTION OF SPEED AND  
 AIR GAP DENSITY FOR A 4.0 DIA. ROTOR.

$\frac{b}{\rho_s} = 2.0$       SLOT PITCH =  $\tau_s = .30$

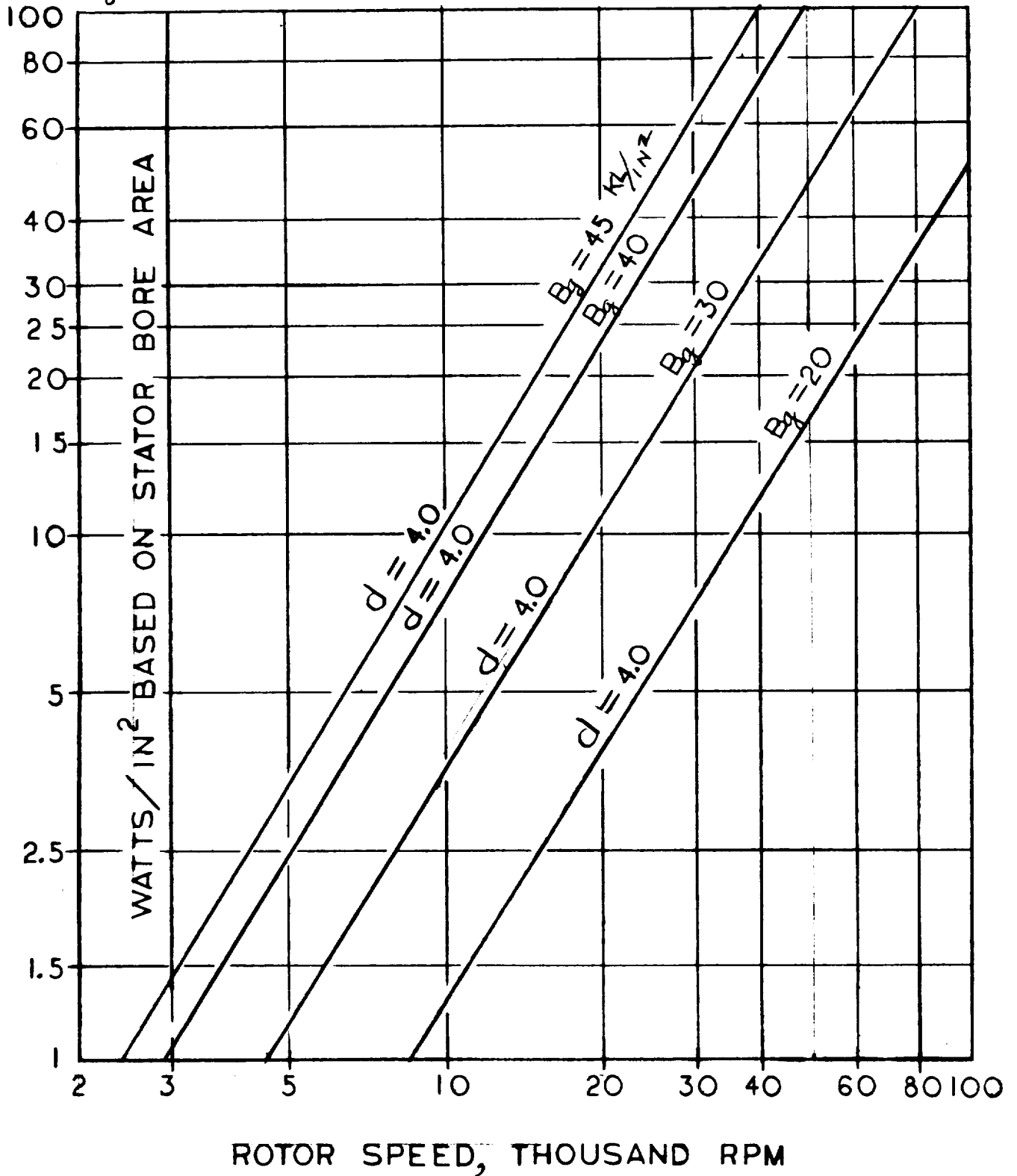

POLEFACE LOSSES IN A SOLID POLEFACE AT NO LOAD  
 AS A FUNCTION OF SPEED AND AIR-GAP DENSITY  
 FOR A 6.0" DIA. ROTOR.  $b_{yg} = 2.0$  SLOT PITCH,  $\gamma_s = .30$

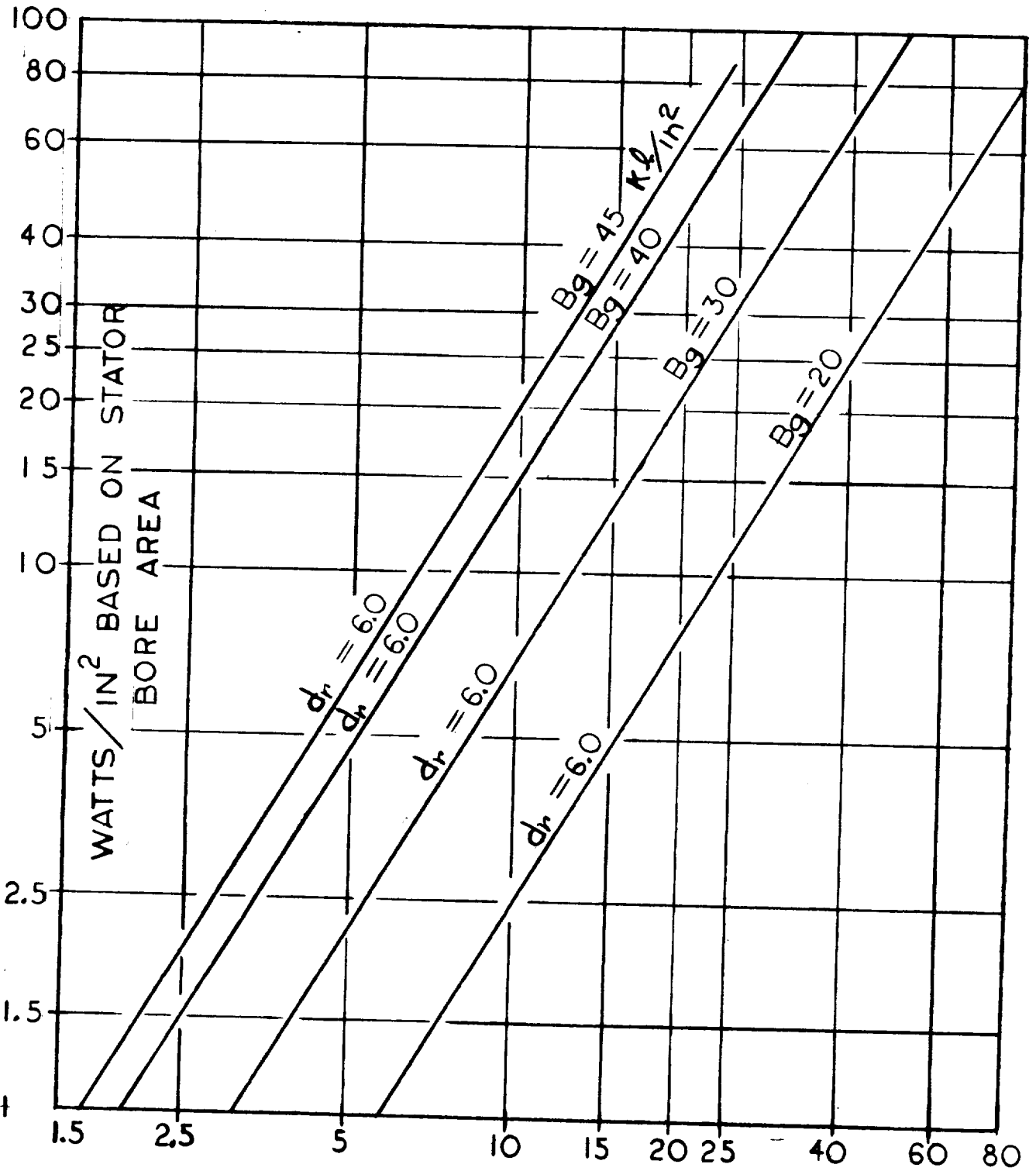

ROTOR SPEED, THOUSAND RPM

SA-9

CURVE SA-3

## DISSIPATING THE POLE FACE LOSSES

If the pole face losses are to be dissipated to gas similar to air or if the machine is force ventilated with air, the best coefficient that could be expected is 0.10 watts/in<sup>2</sup> of surface/°C rise above the air. See curve SA4 from Luke and curve SA5 from A. D. Moore.

If 25 watts/in<sup>2</sup> is to be dissipated from the rotor surface, the temperature rise of the rotor surface in this case will be  $\frac{25}{.10} = 250^{\circ}\text{C}$  above the cooling air or gas. Similarly, if 50 watts/in<sup>2</sup> must be dissipated, then the temperature rise of the rotor will be 500°C above the cooling air.

If room temperature cooling air can be used in sufficient quantity, 40 watts/in<sup>2</sup> might possibly be dissipated from the generator rotor surface. If a heat transfer coefficient of .10 w/in<sup>2</sup>/°C can be obtained, the rotor temperature will be approximately 800°F or 425°C.

A cooling coefficient more likely to be obtained is .08 watts/in<sup>2</sup>/°C and this value has been used on curve SA6 to show probable rotor temperatures associated with various no-load pole face loss levels.

## EFFECT OF REDUCING GAP DENSITY

If a high-speed generator is designed and the PF losses are too great at say 45 kilolines/in<sup>2</sup> air gap density, reducing the flux density will reduce the pole-face, no-load losses by the ratio of gap densities raised to the power 2.5. The factor for gap density is  $K_2$ .

Bg	$K_2$
20	.10
25	.18
30	.28
40	.6
45	.8



SURFACE HEAT DISSIPATION FROM  
A GENERATOR ROTOR.

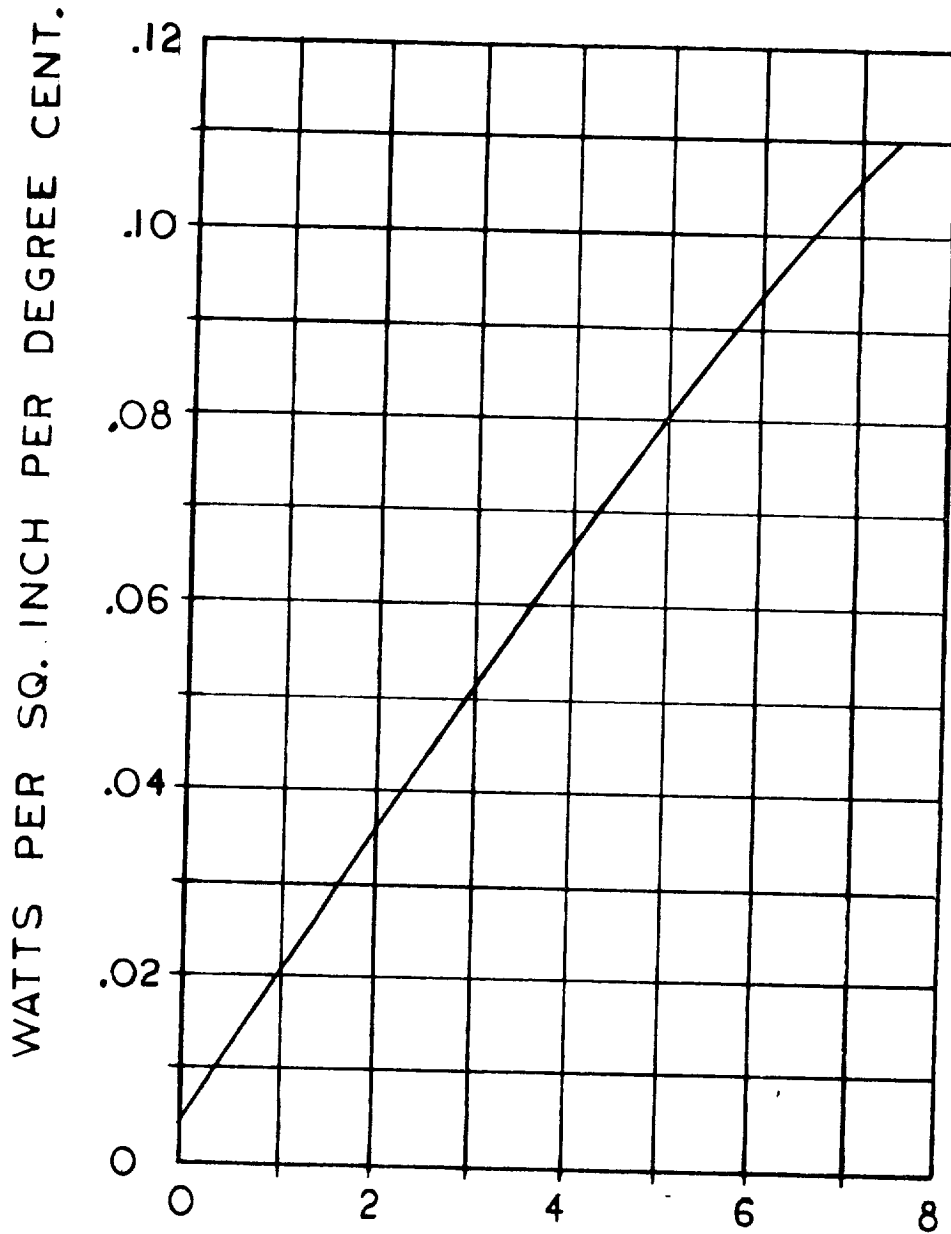

AVERAGE AIR VELOCITY THROUGH  
MACHINE IN THOUSANDS OF FEET  
PER MINUTE.

FROM LUKE: HEATING OF RAILWAY  
MOTORS. AIEE TRANS 1922 VOL 41  
PP 165-173.

WATTS DISSIPATED FROM THE ROTOR OF AN ELECTRICAL MACHINE WHEN FORCED-AIR COOLING IS USED.

FROM A. D. MOORE: FUNDAMENTALS OF ELECTRICAL DESIGN. MCGRAW HILL 1927 PAGE 134.

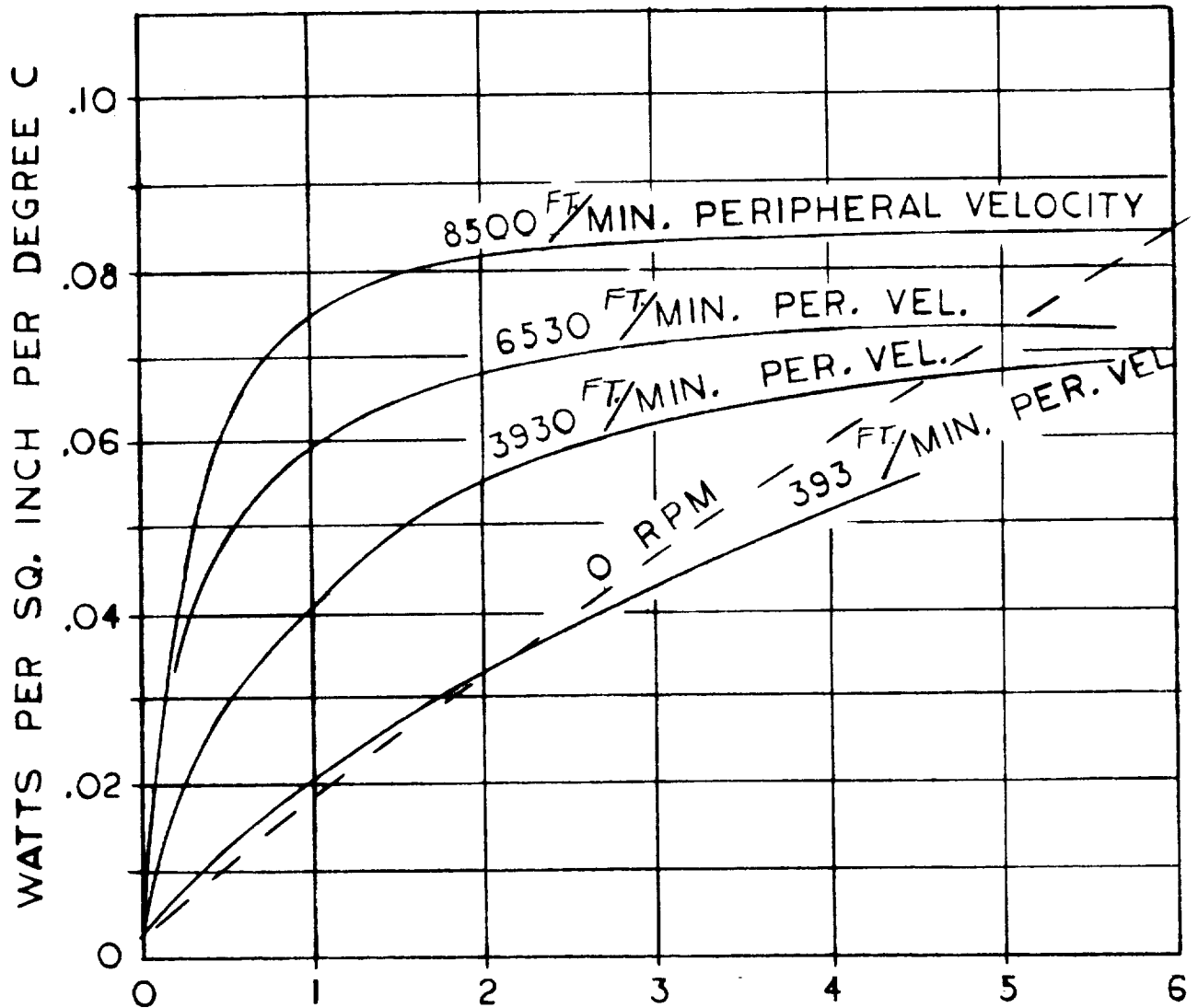

AVERAGE COOLING AIR VELOCITY THROUGH THE MACHINE AIR-GAP - THOUSANDS OF FEET PER MINUTE.

CURVE SA-5

NO LOAD POLE FACE LOSSES FOR A SOLID-ROTOR  
 GENERATOR HAVING 6.0 DIA. ROTOR AND A TOOTH  
 PITCH OF .3"  $bs/g = 2.0$

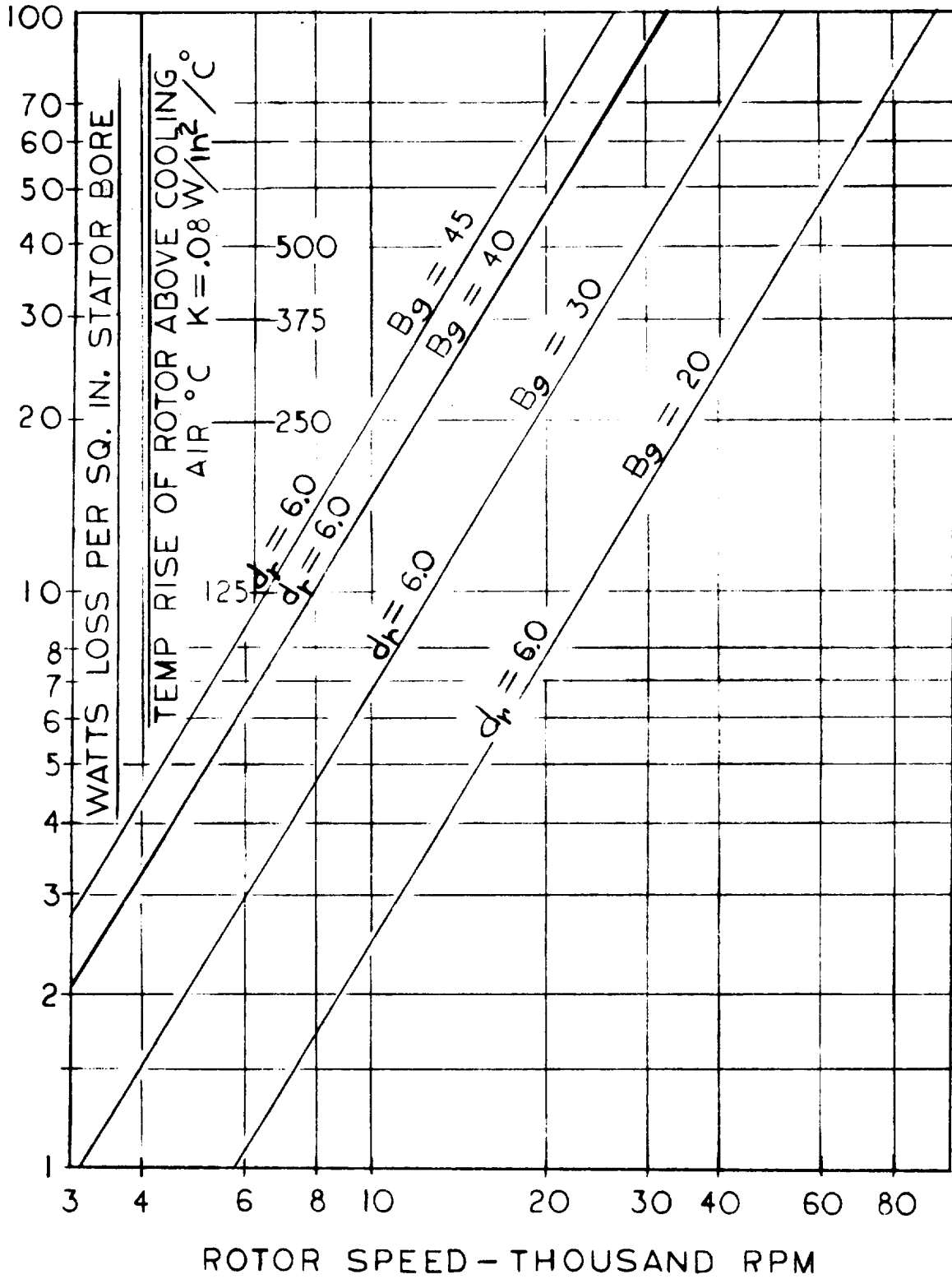

## EFFECT OF VARYING SLOT PITCH

When the slot pitch is varied, the pole face loss varies as the slot ripple frequency variation raised to the 1.65 power and varies as the tooth pitch variation raised to the 1.26 power. The no-load pole-face loss will decrease as the tooth or slot pitch is increased.

The net change in the loss as the slot pitch increases is approximately (ratio of slots)<sup>1.65</sup> (ratio of slot pitches)<sup>1.26</sup>.

In the tabulation for diameter = 4.0",  $B_g = 40 \text{ Kl/in}^2$ ,  $\tau_s = .3"$ , RPM = 12000, the NLPFL = 10.6 watts/in<sup>2</sup> of stator bore.

If the slot pitch is increased to .6", the NLPFL will be reduced to 8.1 watts/in<sup>2</sup> of stator bore area.

## EFFECT OF SLOT OPENING

Completely closing the slots can have only limited effect in reducing pole face losses since the bridge closing the slot must saturate before the machine can operate. The saturated bridge represents an effective opening in the slot and the ratio  $\frac{b_s}{g}$  is some definite value. In considering the effect of closing the slot with a bridge, a smaller effective opening can be assumed such as  $\frac{b_s}{g} = 1.0$ . The pole face loss at no load varies approximately as the ratio

$$\left( \frac{\frac{b_{s2}}{g}}{\frac{b_{s1}}{g}} \right)^{1.3} = \left( \frac{b_{s2}}{b_{s1}} \right)^{1.3}$$

So, by reducing the slot opening to 1/2 its original width, the no-load losses can be reduced to about 1/2.4 of the initial no-load value. This applies to the no load losses only and the pole-face losses under load may be much higher because of the reduced slot opening. Load losses in the pole-face are a function of the stator loading and of the slot opening to air gap ratio ( $b_s/g$ ). This can be expressed as a function of  $b_s/g$  and a function of  $(X_{ad})^2$ .

## LOAD LOSSES IN THE POLE FACE

Under load, the pole face losses are increased. This increase is due to the armature mmf wave and resulting flux wave which has a saw tooth shape.

The higher the current loading in the stator, the more pronounced the saw tooth shape of the flux wave becomes when the machine is fully loaded. This effect is a function of the ratio -

$$\left[ \frac{\text{series conductors/slot} \times I_{ph} K_{sc}}{\text{no load air gap ampere turns}} \right]^2 \quad (\text{NLPFL})$$

where  $K_{sc}$  is a modifying factor describing the effect of  $\frac{b}{g}$ . The smaller the opening, the sharper the step or saw-tooth in the armature reaction flux wave.

E.I. Pollard treated the pole face load losses in his paper "Load Losses in Salient Pole Synchronous Machines", AIEE Trans., Vol. 54, 1935, pp 1332-1340. His work shows that if the slot opening to air gap ratio is made too small, the result may be an increase in total pole face losses. See curve SA-7.

In the rotor sizes 4.0" dia. to 8.0" dia., an air gap length of .030" is reasonable to assume. If the following values are assumed:

ampere loading = 900 ampere wires per inch of stator bore periphery,  
 $bs/g = 2.0$ ,  $B_g = 40 \text{ Kl/in}^2$ , then the air gap ampere turns are about 400 and from curve

$$\begin{aligned} \text{PF load losses} &= \left[ \frac{K_{sc} I_{ph} N_s}{\text{AGAT}} \right]^2 \quad \text{NLPFL} \\ &= \left[ \frac{1.4 (270)}{400} \right]^2 \quad \text{NLPFL} \end{aligned}$$

PF Load Losses = .91 x no load PF losses

where  $N_s$  = conductors/slot

$$I_{ph} N_s = 900 \times .3 = \text{ampere wire loading} \times \text{slot pitch}$$

LOAD LOSSES IN THE POLE FACE  
 FROM E.I. POLLARD: LOAD LOSSES IN  
 SALIENT POLE SYNCHRONOUS MACHINES,  
 AIEE TRANS. VOL. 54 1935 PP 1332 1340.

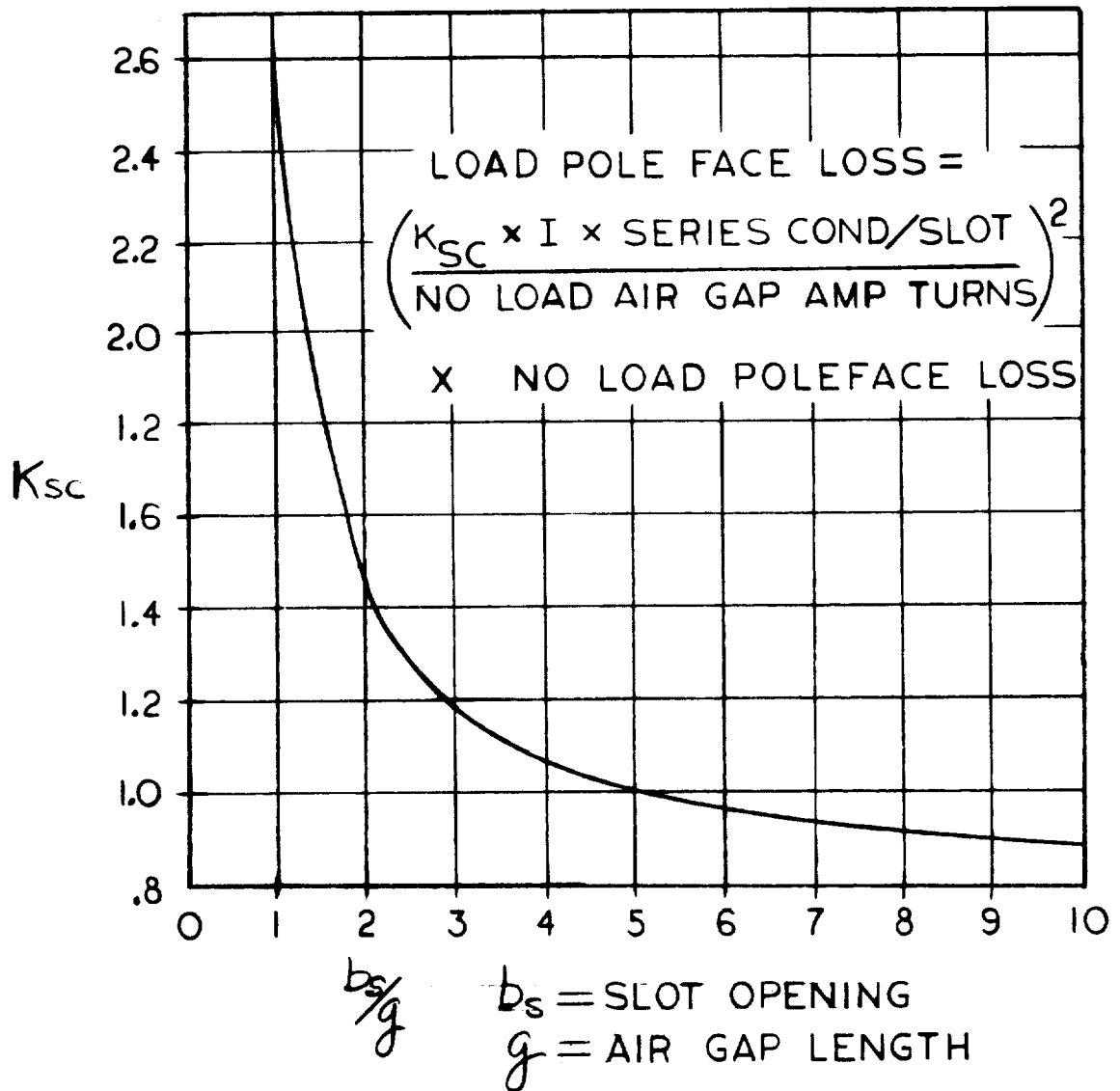

SOLID POLE FACE

POLE FACE LOSSES AT NO LOAD AND AT FULL  
 LOAD FOR 4.0" DIA. ROTOR AT VARIOUS GAP  
 DENSITIES.  $A=900$   $b_s/g=2.0$   $\gamma_s=.3$

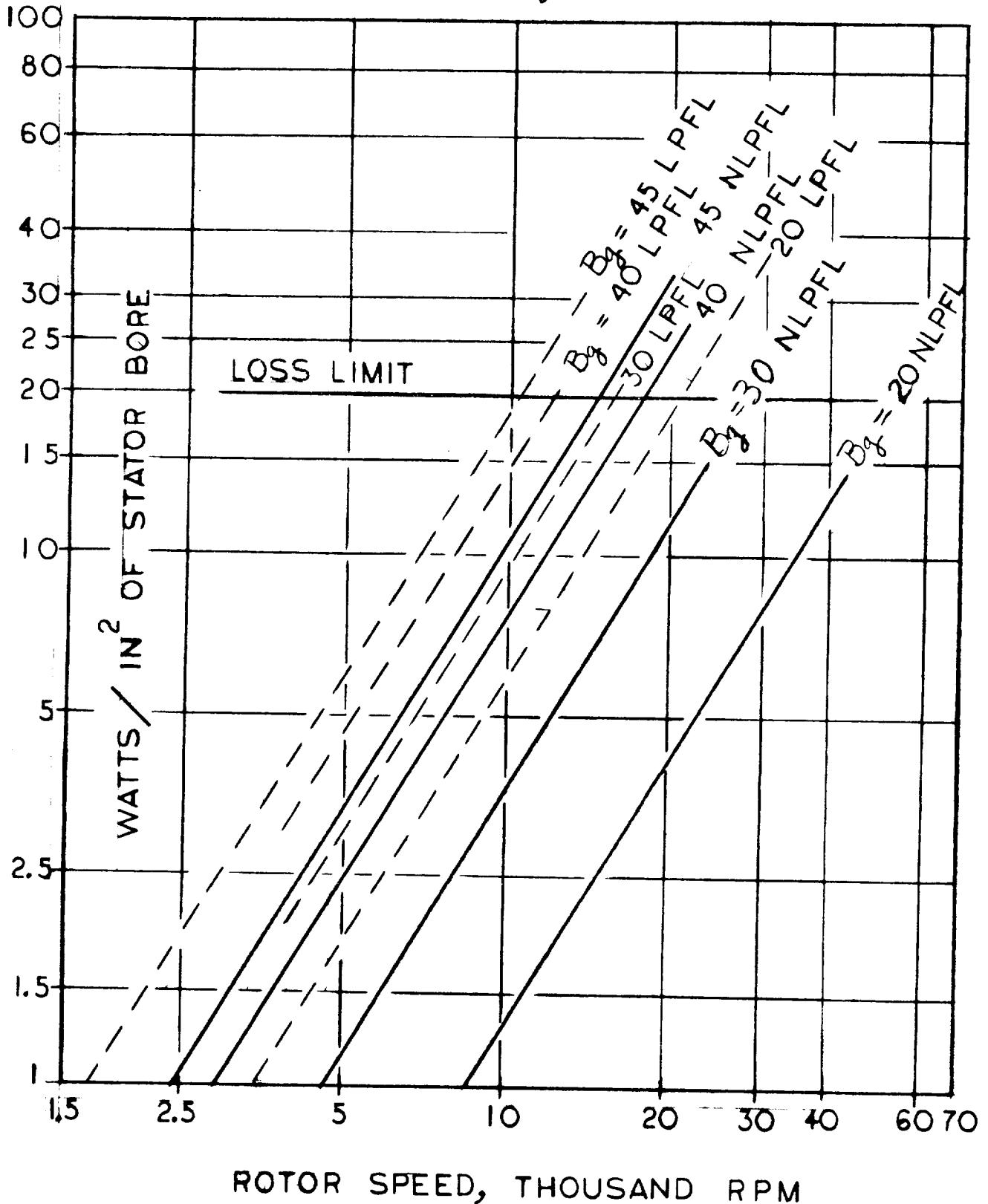

POLE FACE LOSSES AT NO LOAD AND AT FULL LOAD  
FOR 6.0" DIA. ROTOR AT VARIOUS GAP DENSITIES.

$A = 900$

$b_s/g = 2.0$

$\gamma_s = 3$

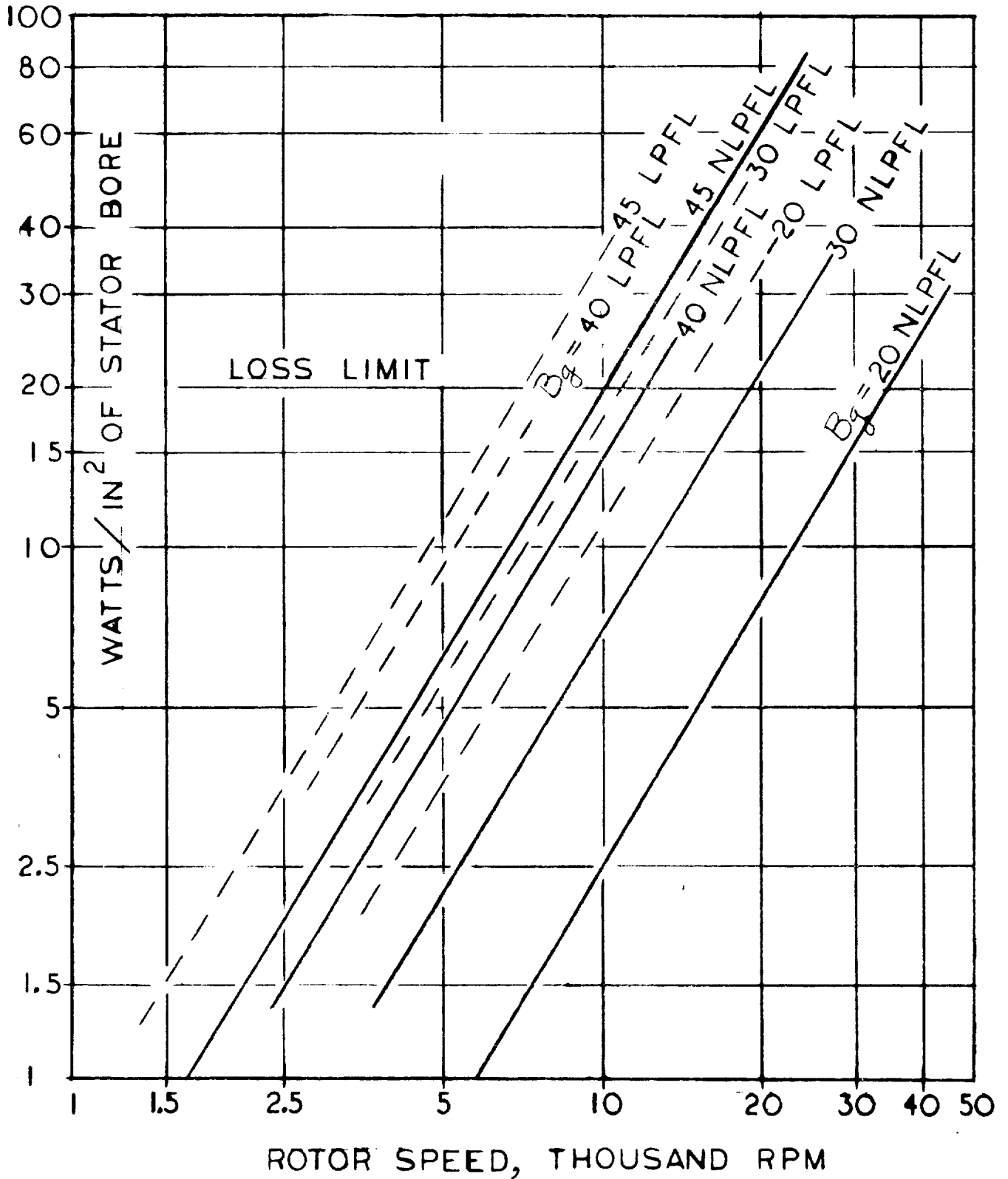



POLEFACE LOSSES AT NO LOAD AND AT FULL LOAD  
FOR 8.0" DIA. ROTOR AT VARIOUS GAP DENSITIES

GAP DENSITIES:  $A=900$ ,  $b_s/g = 2.0$ ,  $\gamma_s = .30$

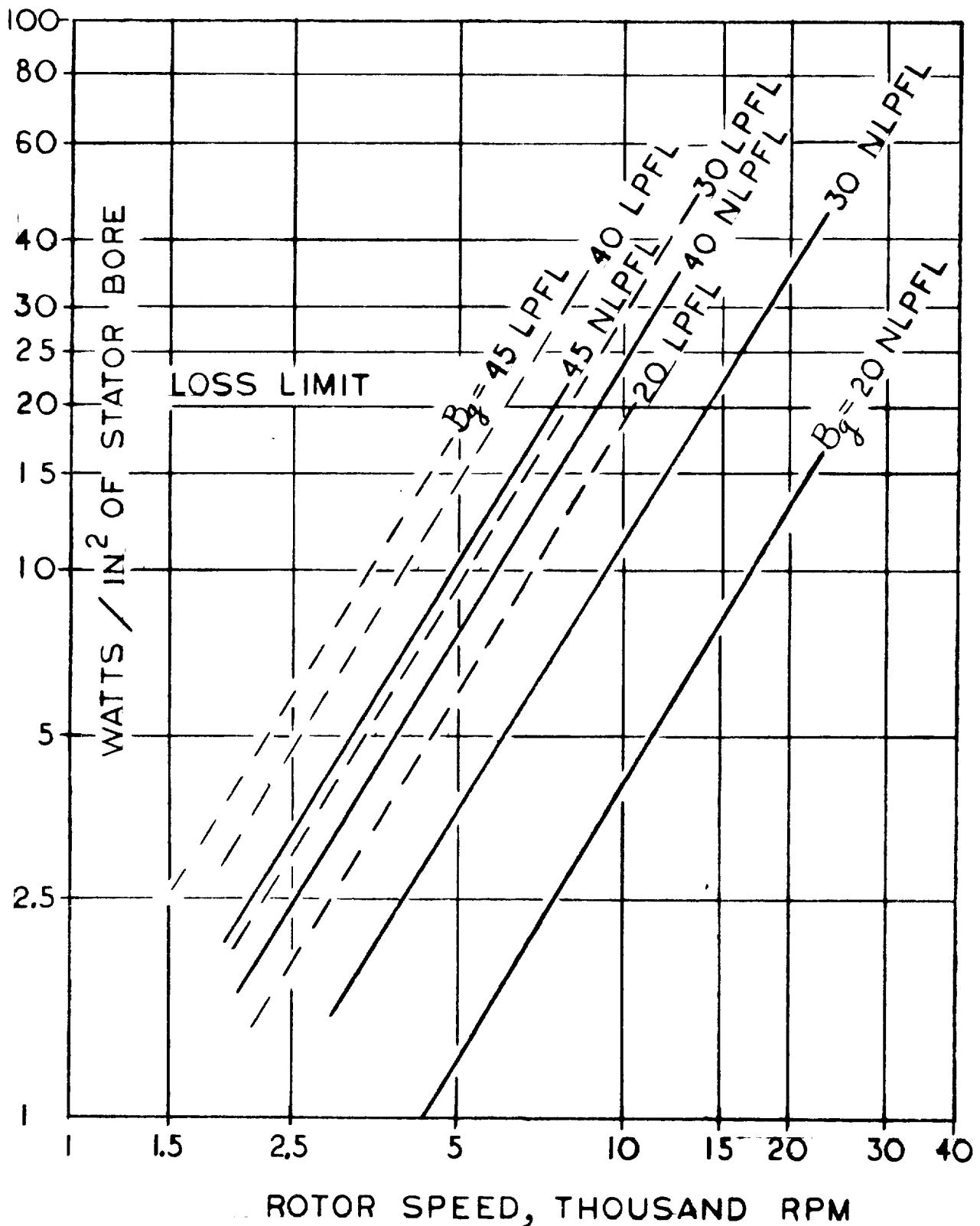

CURVE SA-10

POLE FACE LOSSES AT NO LOAD AND AT FULL  
 LOAD FOR 12.0" DIA. ROTOR AT VARIOUS GAP  
 DENSITIES,  $A=900$   $b/g=2.0$   $\gamma_s=30$

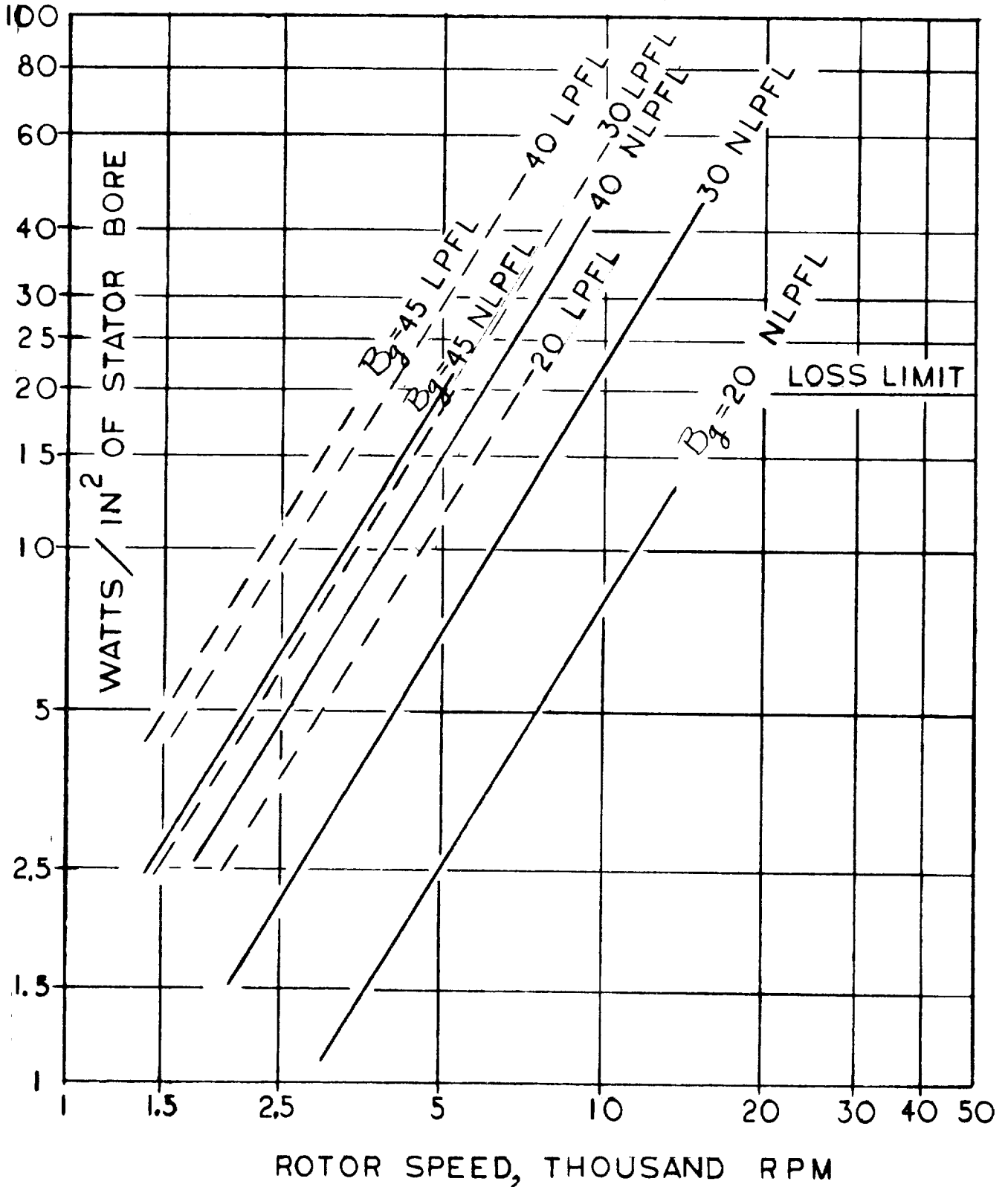

CURVE SA-11

POLEFACE LOSSES AT NO LOAD AND AT FULL LOAD  
 FOR ROTORS OF VARIOUS DIAMETERS  $B_g = 30 \text{ KL/IN}^2$   
 $A = 900 \text{ AW/IN}$  SLOT PITCH = .4  $b_s/g = 20$

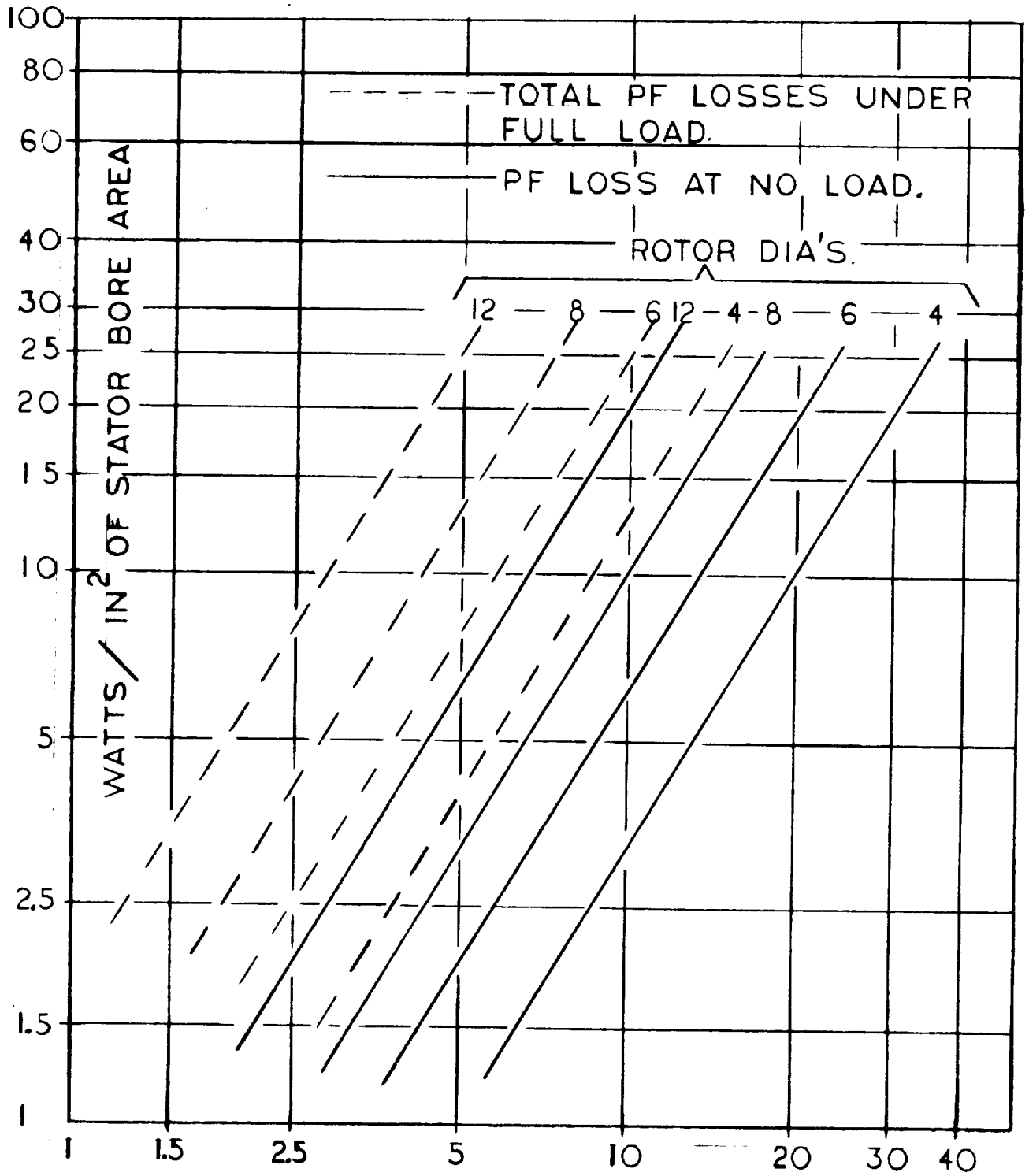

ROTOR SPEED, THOUSAND RPM

CURVE SA-12

ROTOR DIA. VS ROTOR SPEED FOR SOLID POLE FACE ALTERNATORS  
 LIMITED TO 20 WATTS / IN<sup>2</sup> POLE FACE LOSSES BASED ON STATOR  
 BORE AREA  $B_g = 30 \text{ KL} / \text{IN}^2$   $b/g = 2.0$   $C_1 = 1.0$

$A = 900$  AMP WIRES  
 INCH  
 SLOT PITCH = .30

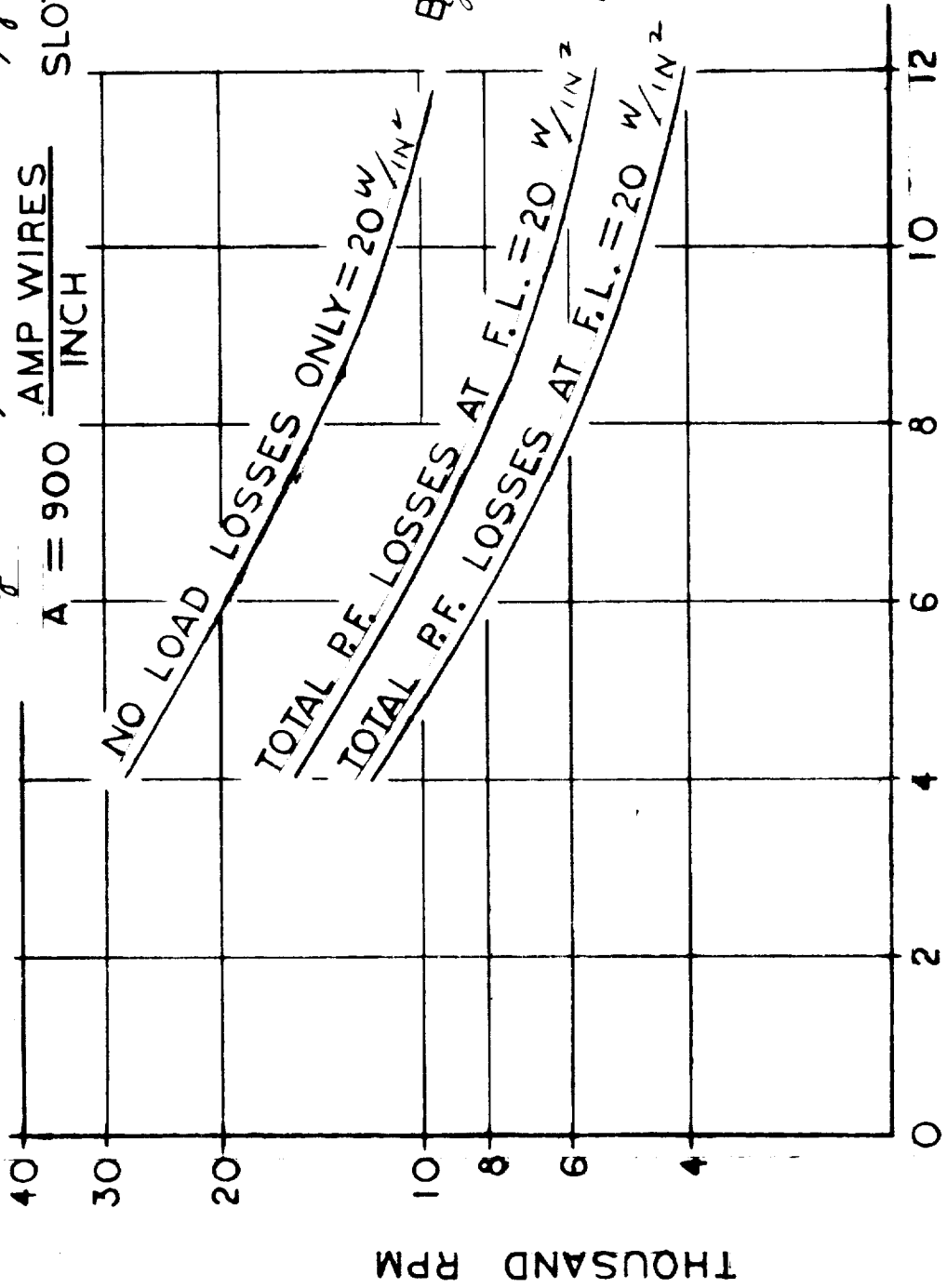

ROTOR DIA. VS ROTOR SPEED FOR SOLID POLE FACE ALTERNATORS LIMITED TO 20 WATTS PER SQ. INCH BASED ON THE STATOR BORE AREA. A COMPARISON OF LOSSES WHEN ONLY THE SLOT PITCH IS CHANGED. NOTE THAT WHEN THE SLOT PITCH IS INCREASED THE NO-LOAD LOSSES ARE REDUCED BUT UNDER LOAD THE TOTAL PF LOSSES INCREASE.

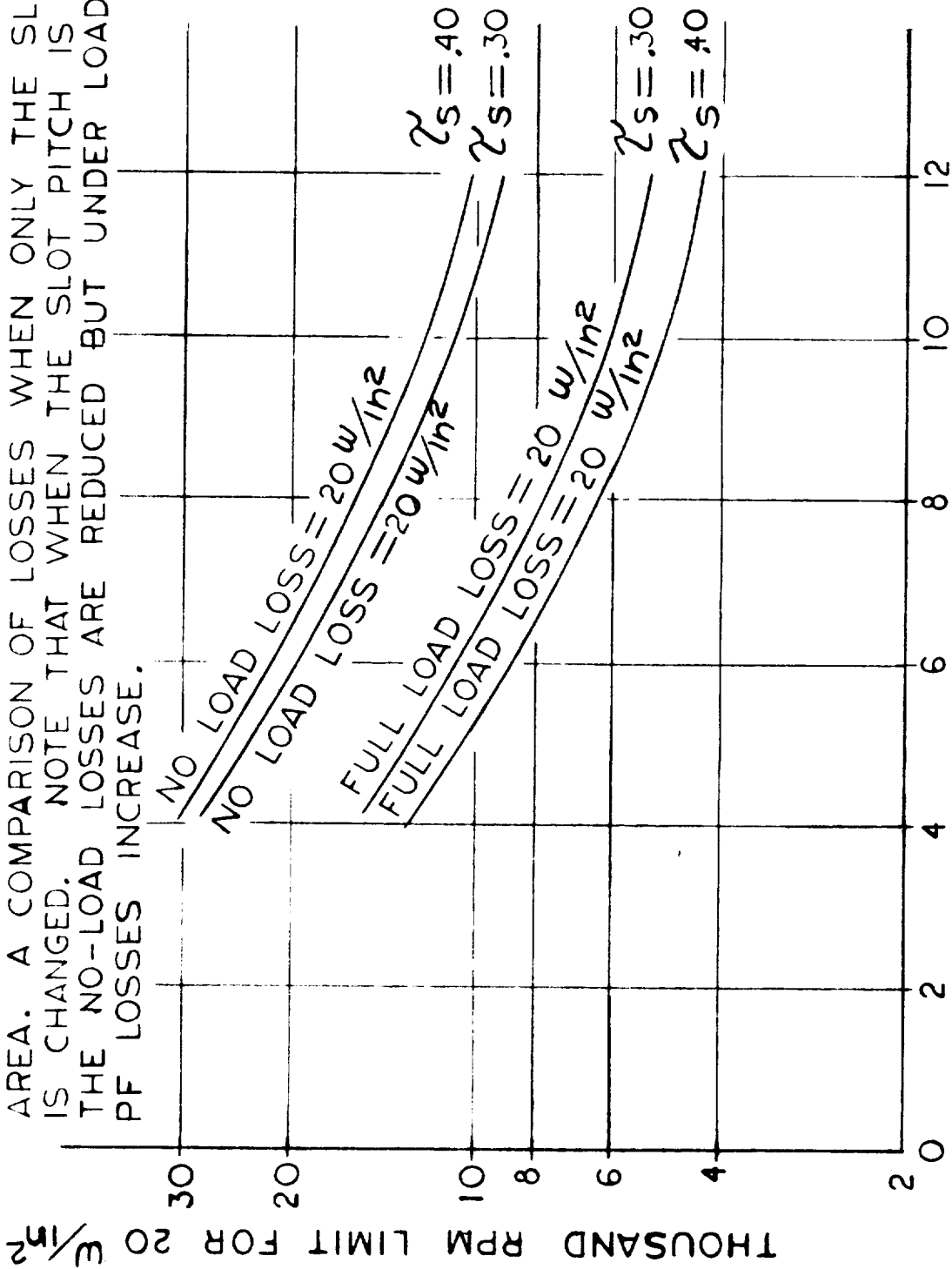

AGAT = 400 = ampere turns drop across main air gap

$K_{sc}$  = loss factor from curve

The pole-face load losses are added to the no-load pole-face losses.

When the air gap density is decreased, the ampere turns drop across the air gap decreased in direct proportion and the pole-face load losses increase as the square of the change in gap density. For example, the factor just calculated above for a 40 Kl/in<sup>2</sup> gap density was .91 (NLPFL). When the gap density in the same machine is reduced to 30 Kl/in<sup>2</sup> but the ampere loading is maintained at 900 AW/in<sup>2</sup>, the loss eqn. becomes -

$$\text{PFLL} = \left[ \frac{1.42 (270)}{300} \right]^2 \quad \text{NLPFL} = 1.63 \text{ (NLPFL)}$$
$$\text{or PFLL} = \left( \frac{4}{3} \right)^2 (.91) \text{ NLPFL} = 1.63 \text{ (NLPFL)}$$

We have already discussed how the reduction of the air gap flux density reduces the pole face no load loss per square inch of stator bore area by

$\left( \frac{B_{g2}}{B_{g1}} \right)^{2.5}$  and in the case of a reduction from 40 Kl/in<sup>2</sup> to 30 Kl/in<sup>2</sup> the reduction in NLPFL is  $\left( \frac{3}{4} \right)^{2.5} = .488$ .

The full load PFL increased by  $\left( \frac{4}{3} \right)^2$  or 1.78 so the total load loss was reduced from 1.0 to 1.78 (.488) = .87 a reduction of 13%.

### SLOTING THE ROTOR TO REDUCE THE POLE-FACE LOSSES

Figure 1 shows graphically what happens when a solid pole-face is slotted to reduce pole face losses, when the slot approximates 50% of the pole surface.

Assuming that the air gap flux density is unity, the initial pole face density at its surface was also unity.

When the rotor was slotted to the extent that 50% of the surface was removed, the density in 1/2 the remaining surface or 1/4 of the initial surface became 1.74 times the initial value or 1.74 per unit. The surface density in the remaining 1/4 of the initial surface increased to 2 times the surface density or 2.0 per unit. The average increase in total pole face losses based upon the increase in gap density at the surface of the pole is 2.4 times. However, the increased air gap density in the region of the pole surface reduces the effect of the slot ripple and tends to reduce the load losses. These effects can nearly enough offset the effect of grooving to make the pole face losses about the same with or without grooving.

Experiments made in support of this study showed insignificant results when the rotor was grooved approximately with .020-.03 wide grooves, and only 50% of the initial surface was left.

Figure SA1 shows the results obtainable when the rotor grooving is about 10 to 12% of the surface area. This amount of grooving does not change the rotor surface loss a significant amount. To realize a satisfactory reduction in pole face losses, the lands formed by the grooving should be thin; .020" width is a good maximum for 400 cps generators.

To satisfy the requirement for lamination-thickness lands, and only 12% loss of surface, the grooves should be only about .0025" wide and the requirement for such an extremely narrow slot imposes a difficult manufacturing problem. Some methods that can be used to cut the narrow grooves are: diamond sawing with narrow saw or wire, electric-discharge machining with small diameter wire used as electrodes, and electron-beam machining.

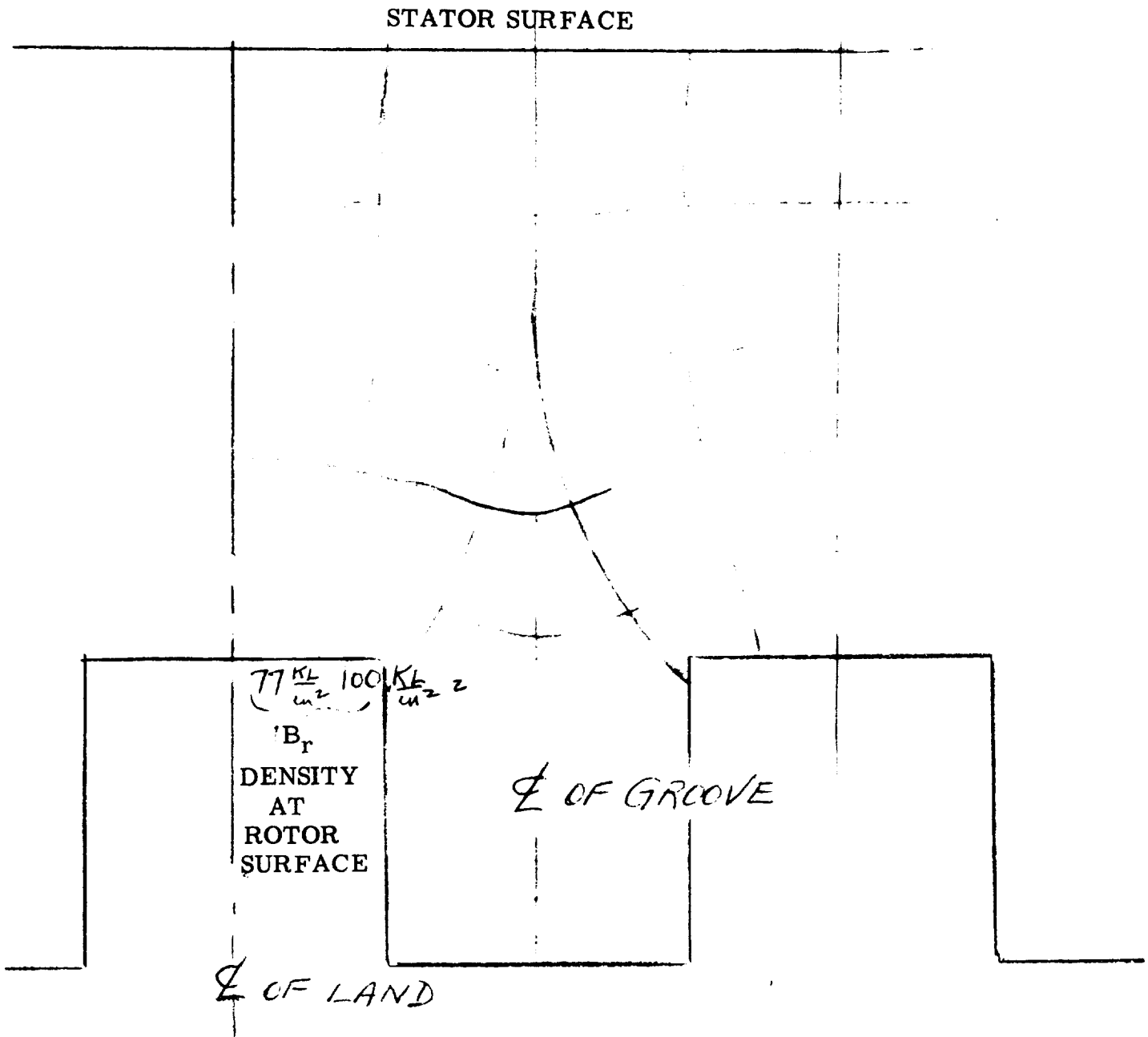

DISTRIBUTION OF SURFACE FLUX DENSITIES  
 WHEN A ROTOR POLE-HEAD HAS 50% OF ITS  
 SURFACE CUT AWAY BY GROOVING--ASSUME  
 AN AIR-GAP DENSITY OF 50 KILOLINES PER INCH<sup>2</sup>

FIGURE SA-1



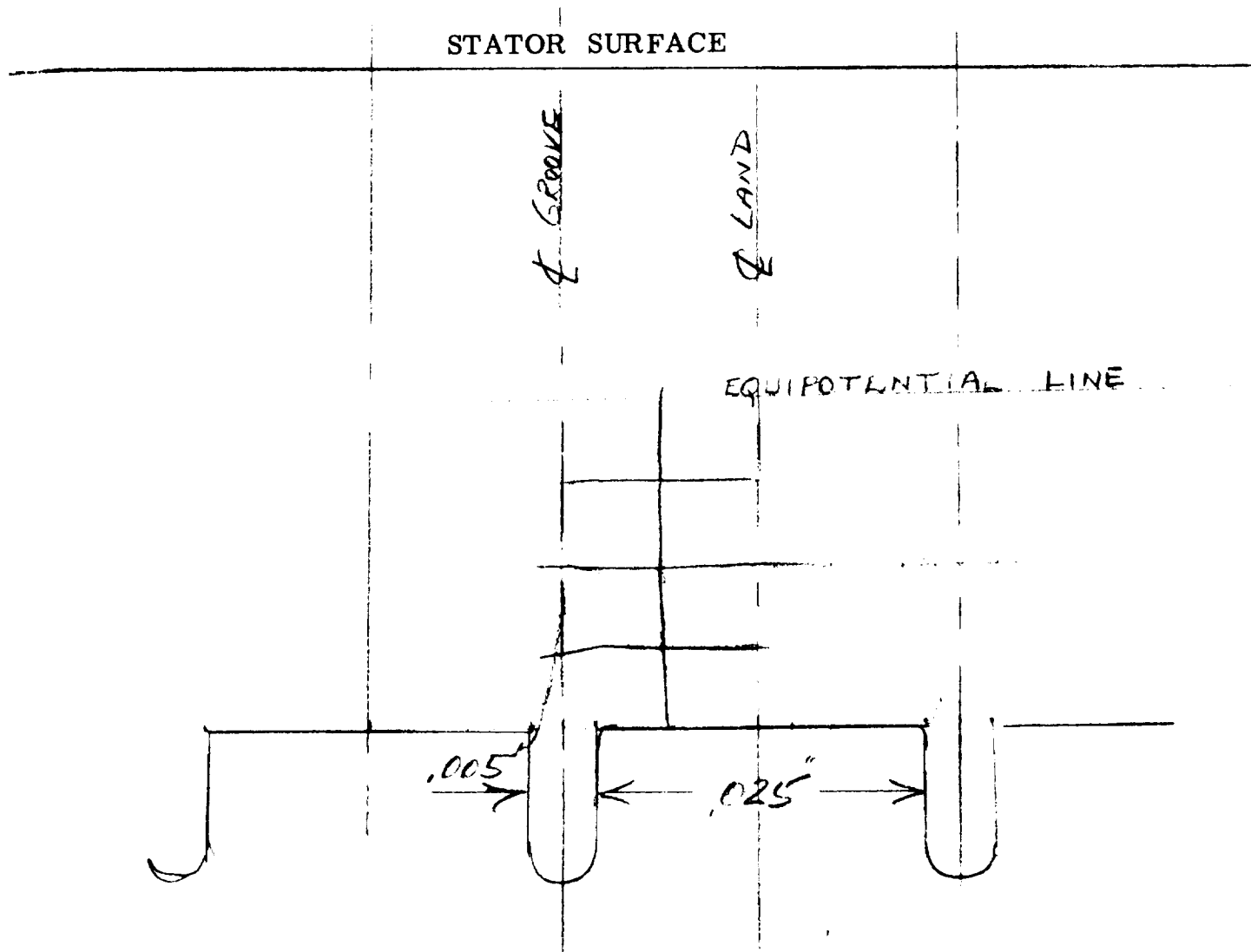

WITH .025" LANDS AND .005" WIDE SLOTS,  
 THE POLE SURFACE FLUX DENSITY IS 109%  
 THAT OF A SMOOTH POLE FACE

FIGURE SA-2

## **FLUX-PLOTTING**

## GRAPHICAL FLUX ANALYSIS

Graphical flux analysis is the quickest and most direct solution to many field problems. Irregular or complex fields that yield slowly to mathematical analysis, if at all, can be solved graphically. Manual plots are used to solve heat-flow, air-flow, dielectric field, and flux field problems.

In this study, only flux field distributions are mapped, and only the simplest case is considered -- that is, the case where the iron surfaces are equipotential surfaces and the space between the iron surfaces has the permeability of air. The same total field potential exists across the air space regardless of any change in dimension or configuration.

The permeability of air is constant, so if the field gradient per unit of linear measurement (ampere turns per inch) across the air space changes, the flux density must change by the same ratio.

In making flux plots, the flux is considered to consist of tubes of flux. In a three dimensional field, a single tube is conceived of as looking like this:

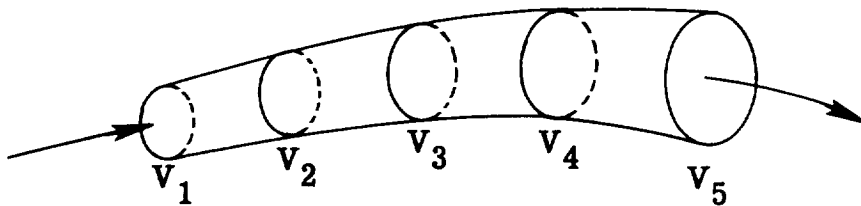

In a two dimensional field, the depth of the tube is constant and the tube looks like this:

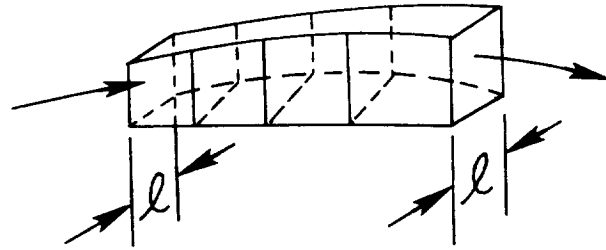

If the number of lines of flux in a tube is held constant, and the depth of the tube is constant, the sides of the tube of flux must converge or diverge in direct ratio to the change in field gradient.

By choosing the scale of field gradient and flux density, the area of flux tube enclosed by the sides of the tube and the equipotential field gradient lines become a square.

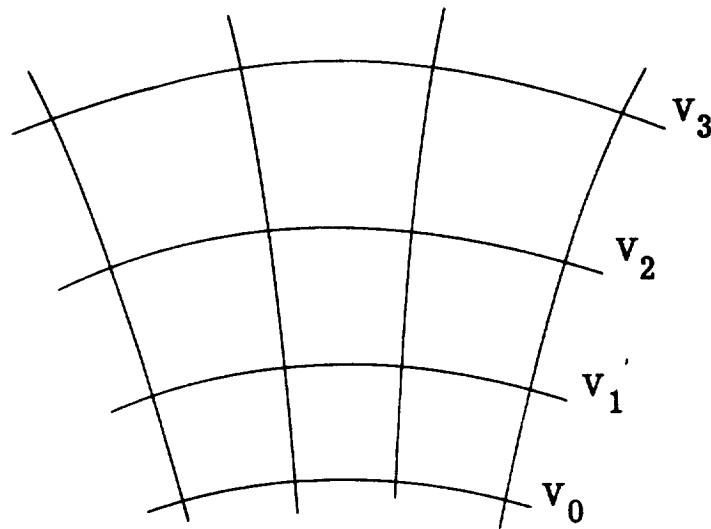

The lines of flux must cross equipotential lines at right angles and enter the iron at right angles. The corners of the areas so defined are right angles and if the squares are successfully divided into fourths, the smaller squares become more closely true squares. In any of the squares, the two dividing lines used to divide the square into four squares will be closely equal in length.

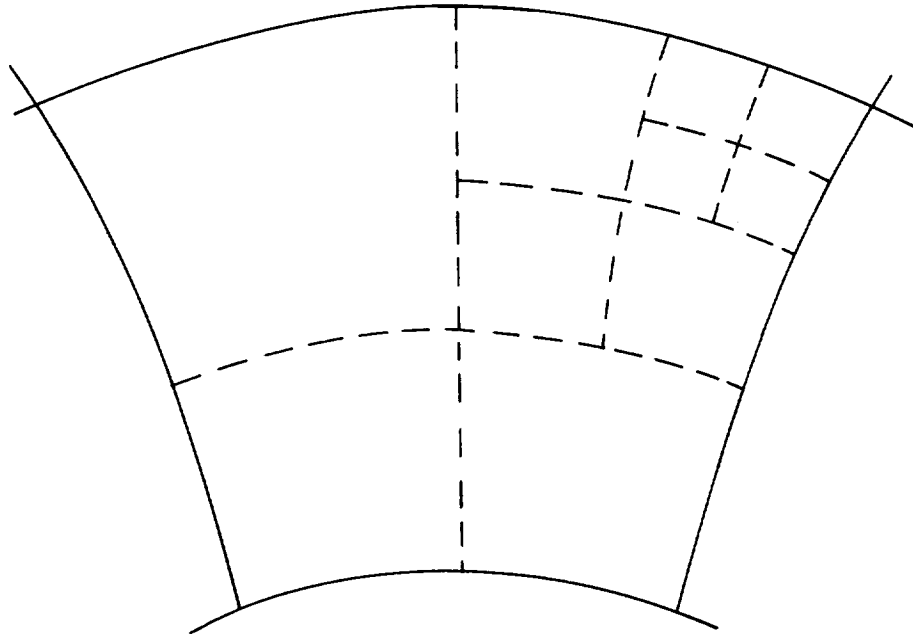

To start a map or flux plot, draw the area to be mapped as large in scale as practical. Ink the boundaries of the iron so erasures will not remove them. Also, ink in the lines of symmetry.

Draw in the middle an equipotential line and then start the plot in the most irregular region or at a corner and a line of symmetry.

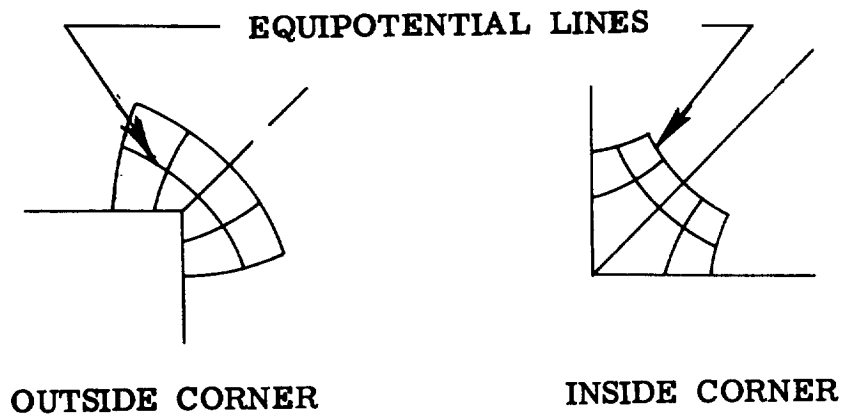

Start the maps with large sweeping curves and close the map before trying to perfect the detailed areas.

Use 2H pencil for easy erasures with minimum smudging.

Make large squares and divide only where necessary to check map accuracy or to obtain accurate density.

Intersections between flux lines and equipotential lines must be right angles at all times or the map can not be made accurately.

When the tubes of equal flux are divided, they are most easily divided into multiples of two.

A map can not be forced. However, useable accuracy can be obtained without a precise map, and the operator should exercise his own judgment as to the accuracy required.

To move lines a small amount, try widening the line with pencil and removing the unwanted portion with a sharp-pointed eraser.

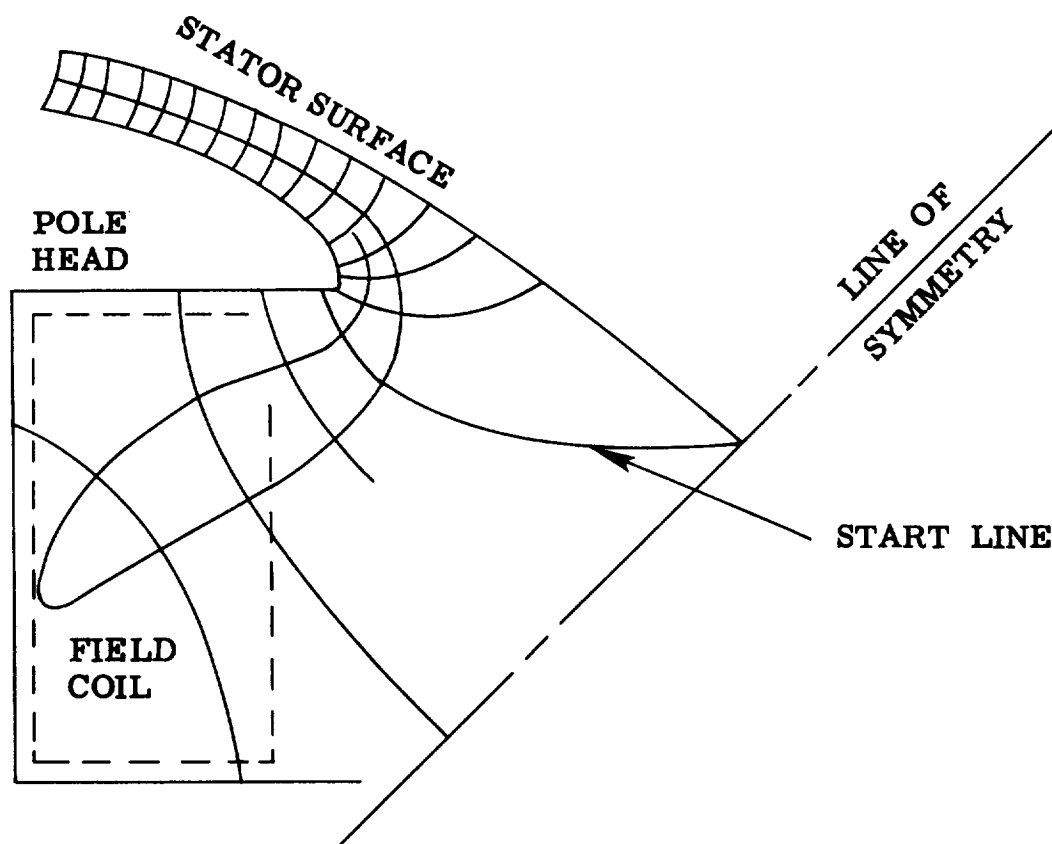

To determine, by means of a freehand flux plot, the no load field form of an electromagnetic machine:

1. Make the flux plot in the manner described in the literature, with all intersections of flux lines and equipotential lines at right angles and with all curvilinear squares capable of being divided into smaller, curvilinear squares.

2. The distance from centerline between poles to the centerline of the pole is 90 electrical degrees. Divide this arc on the stator surface into  $10^\circ$  increments.

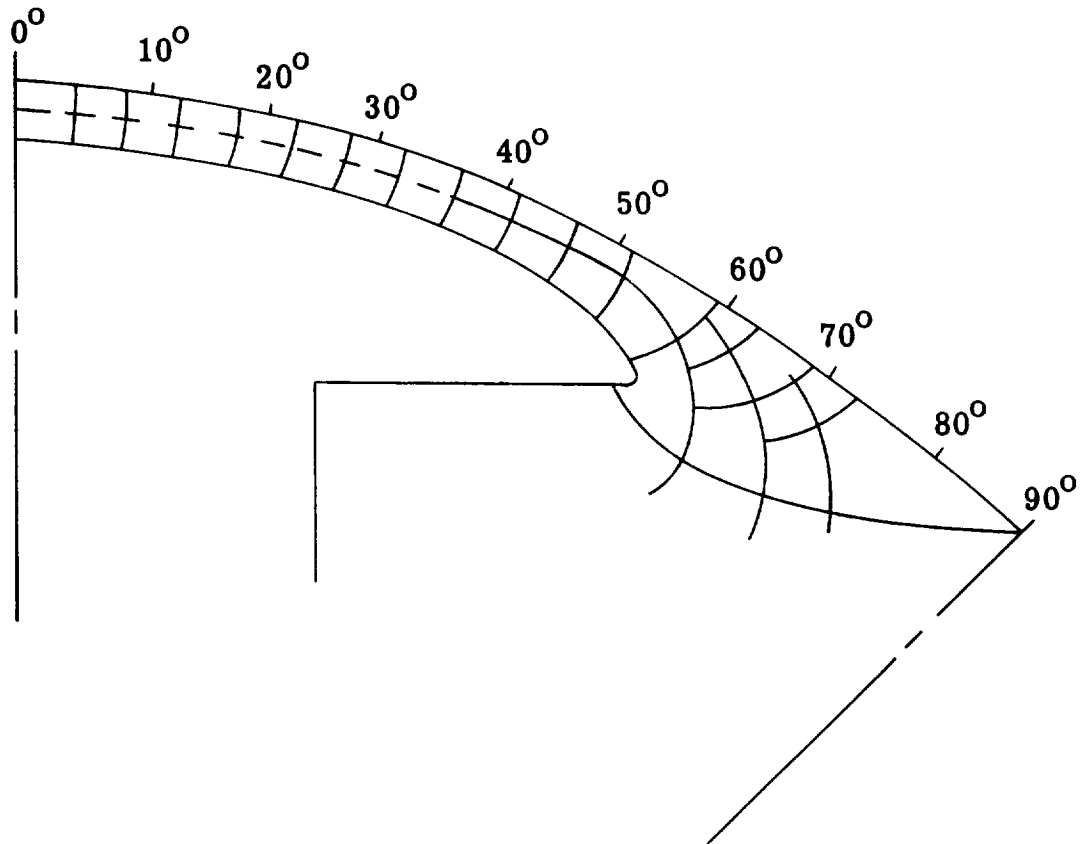

3. At any point on the stator surface, the distance from the surface to the first equipotential line is proportional to the flux density at that point. A plot of flux density, therefore, is a plot of the ratio of distance from the stator surface to the first equipotential line. Where the equipotential lines have been further divided, the distance ratios increase proportionately.



4. The maximum density (usually at the pole head centerline) can be used as a one per unit; 1.0 or 100%.

$$C_1 = \text{Ratio} \frac{\text{Fundamental}}{\text{Actual}} = \frac{2}{\pi} \int_0^{\pi} f(\theta) \sin \theta d\theta$$

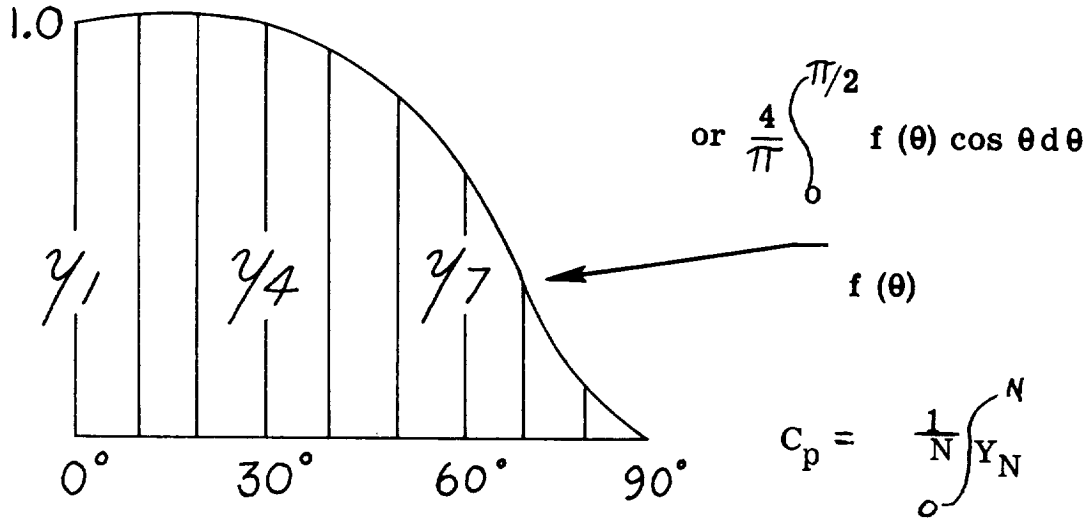

Cos 0° = 1.000
Cos 10° = .985
Cos 20° = .940
Cos 30° = .866
Cos 40° = .766
Cos 50° = .643
Cos 60° = .500
Cos 70° = .342
Cos 80° = .173
Cos 90° = .000

Y1 (.5) =
Y2 (.985) =
Y3 (.940) =
Y4 (.866) =
Y5 (.766) =
Y6 (.643) =
Y7 (.500) =
Y8 (.342) =
Y9 (.173) =

(.5) Y1 =
Y2 =
Y3 =
Y4 =
Y5 =
Y6 =
Y7 =
Y8 =
Y9 =

$$C_1 = \frac{9 \left[ \sum \frac{1}{9} y_i \right]}{9}$$

$$C_p = \frac{9 \left[ \sum Y_i \right]}{9}$$

Ref: Mathematics of Modern Engineering, Vol 1, pp 73-92, Doherty and Keller.

References to use for a study of Flux-Mapping techniques are:

- "Graphical Flux Analysis in Transformer Design", M. G. Leonard, Electro-Technology, Oct., 1961, pp 122-128.
- "Fundamentals of Electrical Design", A. D. Moore, McGraw-Hill Book.
- "Electromagnetic Devices", H. C. Roters, John-Wiley & Sons Book.
- Notes on Air-Gap and Interpolar Induction, F. W. Carter, IEE Proc. (British), Vol 29, 1900, p 925.
- Air Gap Induction, F. W. Carter, El. World, Vol. 38, p 884.
- Sketches of Magnetic Fields in Iron, Th. Lehmann, Rev. Gen. El., Vol. 17, 1926
- Mapping Magnetic and Electrostatic Fields, A. C. Moore, El. J., Vol. 23, 1926, p 355.
- Fundamental Theory of Flux Plotting, A. R. Stevenson, G. E. Rev., Vol. 29, 1926, p 797.
- Graphical Determination of Magnetic Fields, R. W. Wieseman, AIEE Trans., Vol. 46, 1927, p 430.
- Graphical Determination of Magnetic Fields, E. E. Johnson and C. H. Green, AIEE Trans., Vol. 46, 1927, p 136.
- Graphical Determination of Magnetic Fields, A. R. Stevenson and R. H. Park, AIEE Trans., Vol. 46, 1927, p 112.
- The Interpolar Fields of Saturated Circuits, T. Lehmann, AIEE Trans., Vol. 46, 1927, p 1411.
- A Practical Application of Graphical Flux Mapping, J. F. Calvert, El. J., Vol. 24, 1927, p 543.

- Graphical Flux Mapping, J. F. Calvert and A. M. Harrison, El. J., Vol. 25, 1928. Theory and General Discussion, p 147; Fields of Non-Salient Pole Synchronous Machines, p 179; D-C Motors and Generators, p 399; D-C Motor, Salient Pole Synchronous Machine, Universal Motor, etc., p 510.
- Analytical Determination of Magnetic Fields, B. L. Robertson and I. A. Terry, AIEE Trans., Vol. 48, 1929, p 1242.
- Magnetic Fields in Machinery Windings, J. F. H. Douglas, AIEE Trans., Vol. 54, 1935, p 959.

# THE MAXIMUM $\frac{l}{d}$ RATIO FOR ROTATING COIL LUNDELL GENERATORS

## In Brief

The maximum practical  $\frac{l}{d}$  ratio for a rotating coil Lundell generator is .3.

## Discussion

The flux circuit of a rotating-coil Lundell generator can be represented by the mmf drops below:

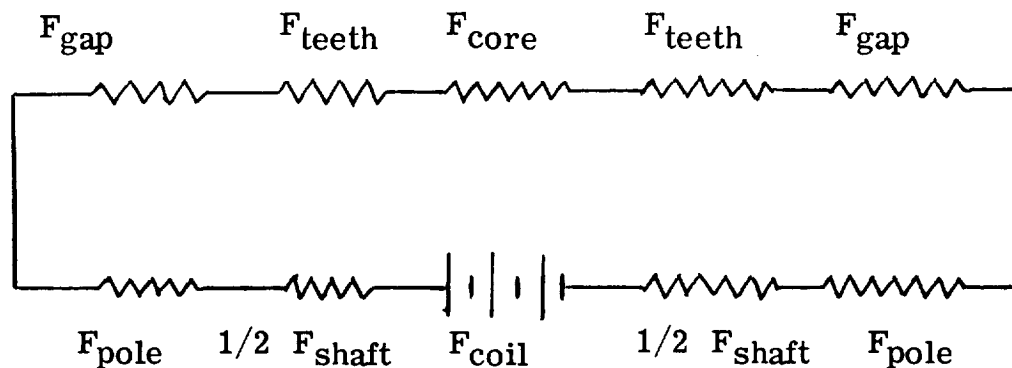

The rotor shaft completes the flux circuit, and the area of the shaft limits the useful stator length by limiting the amount of flux that can be carried inside the excitation coil.

When a maximum length machine is made, about .50% of the stator bore cross-section area is used up or made unavailable because of the thickness of the cantilevered poles at their bases.

Another 20% of the stator bore cross-section area must be used for an excitation coil and only about 30% of the area can be utilized for shaft.

Assumptions are:

$$\text{Area Shaft} = .3 \frac{\pi d^2}{4}$$

$$\text{Gap Density} = 35 \text{ Kl/in}^2$$

$$\text{Shaft Density at FL} = 100 \text{ Kl/in}^2$$

$$\text{Pole Embrace} = .6$$

Total Flux at FL = 2.5 x useful flux. (This assumes that the leakage flux is 1-1/2 times the useful flux).

Then:

Total Pole Flux =  $\pi d l (35) C_p$  Kilolines for all poles (this flux links the stator winding).

Half of this flux passes through the shaft.

Total Shaft Flux at FL =

$$\begin{aligned} \phi_{sh} &= 2.5 \frac{\phi_T C_p}{2} = \frac{2.5(.6)}{2} \pi d l (35) \\ &= 26.2 \pi d l \end{aligned}$$

$$\phi_{sh} \text{ also} = 100 \frac{\pi d^2}{4} (.3) = 7.5 \pi d^2 = B_{sh} \text{ (Area of Shaft)}$$

$$26.2 \pi d l = 7.5 \pi d^2$$

$$l = \frac{7.5}{26.2} d = .286d$$

This can be rounded off to .3.

THE MAXIMUM  $\frac{l}{d}$  RATIO FOR TWO, INSIDE, STATIONARY COIL LUNDELL GENERATORS (OR BECKY-ROBINSON GENERATORS)

In Brief

The maximum practical  $\frac{l}{d}$  ratio for a Becky-Robinson type of stationary-coil Lundell Generator is approximately:

$$\frac{l}{d} = .53$$

Discussion

The flux circuit of a two-coil Lundell generator of the Becky-Robinson type is represented by the mmf drops shown below.

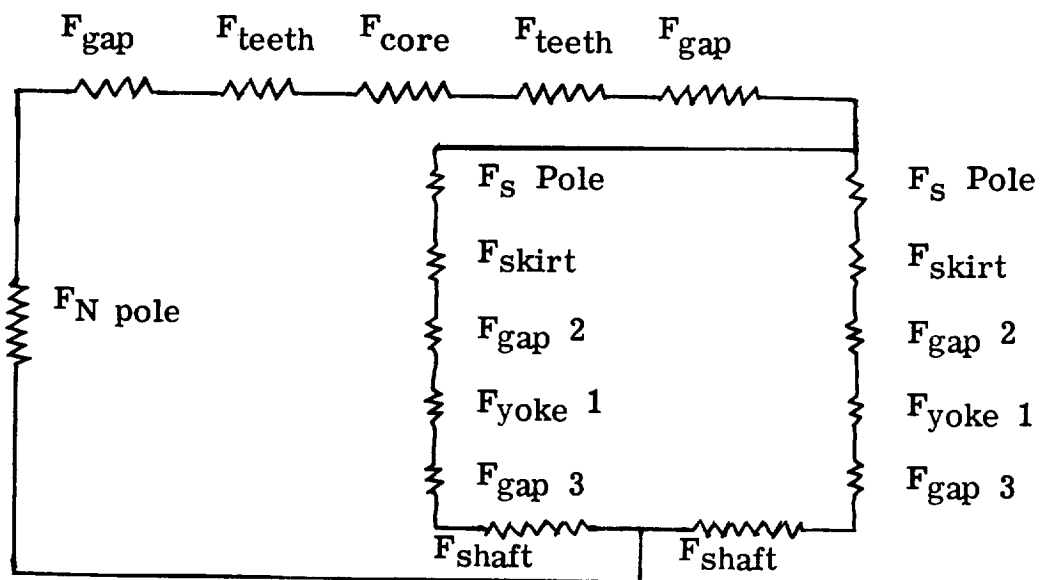

Note that the flux in one parallel branch circuit must pass through the rotor skirt, or flux collector ring, into the yoke and back through the shaft.

The combined shaft and flux collector ring areas must carry the equivalent of the total flux that passes into and back out of the stator. The areas of the combined skirt or collector ring and shaft cannot greatly exceed 60% of the total cross-section area of the stator bore because of the room needed for the excitation coil.

The following assumptions are now made:

$$\text{Shaft and skirt area} = .6 \frac{\pi d^2}{4}$$

$$\text{Shaft and skirt density} = 100 \text{ K}\ell/\text{in}^2$$

$$\text{Air-Gap density} = 35 \text{ K}\ell/\text{in}^2$$

$$\text{Total flux in shaft} = 2.5 \text{ times useful flux}$$

The combined areas of the rotor skirt plus shaft should be equal to the combined shaft areas at the two ends or skirt area = shaft area.

$$\begin{aligned} 2.5 \times \text{shaft flux} &= .6 \frac{\pi d^2}{4} (100) \\ &= 15 \pi d^2 \end{aligned}$$

$$\text{Useful flux} = \frac{(15)}{2.5} \pi d^2 = 6 \pi d^2$$

$$\text{Also, Useful flux} = \frac{\pi d \ell (35)}{2} C_p \text{ K}\ell \text{ in shaft}$$

$$6 \pi d^2 = \frac{35 \pi d \ell}{2} \quad (C_p = .65)$$

$$6d = \frac{35 \ell (.65)}{2} = 11.4 \ell$$

or  $\ell = \frac{6d}{11.4} = .53 d$

TWO-COIL, INSIDE-COIL LUNDELL  
OR BEKEY-ROBINSON GENERATOR

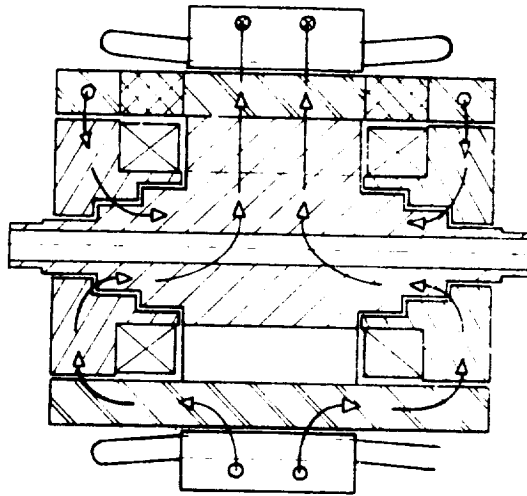



THE DEVELOPMENT OF EQUATIONS DESCRIBING THE WEIGHTS  
OF ELECTROMAGNETIC PARTS FOR THREE GENERATOR TYPES

A weight breakdown is made for the electromagnetic parts of 1) two, inside, stationary-coil Lundell generators (Becky-Robinson Generators), 2) two, outside-coil Lundell generators (Rice Generators) and 3) Homopolar Inductors.

In order to have simple but realistic relationships between the three generator types mentioned above, some simplifying assumptions have been made.

1. In all cases, the tooth width is equal to the slot width.
2. A pole embrace of .65 is used and the pole constant is therefore approximately .65.
3. The gap density  $B_g$  is  $50 \text{ K}\ell/\text{in}^2$  for one set of calculations, and  $35 \text{ K}\ell/\text{in}^2$  for another set of calculations.
4. To keep the machine reactances of the 4 pole, 6 pole, 8 pole generators approximately constant for comparison purposes, we have assumed that the gap density is constant and that ampere wires divided by poles times air gap length is also constant.

$$\frac{A}{P g_e} = \text{constant.}$$

For 4-pole a-c generators  $A = 600$

For 6-pole a-c generators  $A = 700$

For 8-pole a-c generators  $A = 800$

As a matter of academic interest, the gaps are:

8-pole generator gap =  $g$

6-pole generator gap =  $1.16 g$

4-pole generator gap =  $1.5 g$

In the programs note that all the reactance formulae are multiplied by a common factor designated as  $X$ .

$$X = \frac{A K_d}{2 C_1 B_g (10)} = AK. \quad \text{When } B_g \text{ is constant, then}$$

$$X_{ad} = X C_1 C_m \lambda_a = AK' \frac{d}{P g_e} = \text{constant and } \frac{A}{P g_e} = \text{constant.}$$

The constant-reactance approximation as stated is inaccurate by the variation in  $d$  when the number of poles is changed.

This variation in diameter ( $\pm 10\%$ ) can be compensated for by further changing the length of the air-gap to keep the reactance constant. The assumption is realistic enough to allow useful weight comparisons between the three types of generators.

### SLOT DEPTH ( $h_s$ )

If a stator loading of 800 ampere wires/inch of stator is assumed and the slot width is equal to the tooth width there are 800 amperes in 1/2 inch of stator bore periphery. For 8,000 ampere/in<sup>2</sup> current density in the stator winding and a slot fill factor of 2/3,  $\frac{800}{8000(2/3)} = .150$  in<sup>2</sup> of slot is needed. The slot must be about  $\frac{.150}{.5} = .3$ " deep. For a machine with a stator bore diameter of 6", a .3" deep slot is .05 d and this slot depth estimate has been used in all calculations.

### CORE DEPTH ( $h_c$ )

The useful flux per pole in the stator is  $\phi_p = \frac{\pi d \ell B_g C_p}{P} K_l$ , and the area of the bore cross-section is  $h_c \ell$ . If the core density is 80 Kℓ/in<sup>2</sup> then,

$$\begin{aligned} \frac{\phi_p}{2 A_c} &= 80 \text{ and} \\ h_c &= \frac{\pi d \ell B_g C_p}{2 P 80 \ell} = \frac{\pi (B_g) .65 d}{2 (80) P} \\ &= \frac{.01275 (B_g) d}{P} \end{aligned}$$

For 50 Kℓ/in<sup>2</sup> gap density  $h_c = .638 \frac{d}{P}$

For 35 Kℓ/in<sup>2</sup> gap density  $h_c = .446 \frac{d}{P}$

## OUTSIDE DIAMETER OF STATOR (D)

The outside diameters of the stators are  $d + 2h_s + 2h_c$

$$h_s = .05 d \text{ in all cases}$$

$$h_c = .638 \frac{d}{P} \text{ for } 50 \text{ K}\ell / \text{in}^2$$

$$= .446 \frac{d}{P} \text{ for } 35 \text{ K}\ell / \text{in}^2$$

$$D = (1.1) d + \frac{1.276d}{P} \text{ for } 50 \text{ K}\ell / \text{in}^2 \text{ gap density}$$

$$= (1.1 + .319) d = 1.419 d \text{ for } 4P$$

$$= (1.1 + .212) d = 1.312 d \text{ for } 6P$$

$$= (1.1 + .16) d = 1.26 d \text{ for } 8P$$

$$D = 1.1 d + .892 \frac{d}{P} \text{ for } 35 \text{ K}\ell / \text{in}^2 \text{ gap density}$$

$$= (1.1 + .223) d = 1.32 d \text{ for } 4P$$

$$= (1.1 + .147) d = 1.25 d \text{ for } 6P$$

$$= (1.1 + .111) d = 1.21 d \text{ for } 8P$$

## YOKE THICKNESS HOMOPOLAR INDUCTOR

The leakage flux of the homopolar inductor is assumed to be all of the flux that is not useful in generating voltage and is assumed to be .4 the useful flux. This is a low estimate that can only be realized with careful design and is an estimate that makes the homopolar inductor compare favorably with the other machines.

any diameter of the end-bell the weight of the end bell must be

$$\begin{aligned} \text{EB wt.} &= \pi (D + t_y) t_y \left[ \frac{D-d}{2} \right] .283 + \text{flux shoe weight estimated at} \\ .125 \text{ (END-BELL WEIGHT)} &= \text{EB wt.} = \pi (1.125) .283 \left[ D + t_y \right] t_y \left[ \frac{D-d}{2} \right] \text{ lbs.} \end{aligned}$$

### ROTORS OF OUTSIDE-COIL LUNDELLS

The length of the rotors for outside-coil Lundells must be about  $3\ell$  to accommodate the flux-collector rings at the rotor ends. When the environment and speed permits the rotor can be made approximately 50% solid.

$$\begin{aligned} \text{Wt. of rotor} &= \frac{\pi d^2}{4} \frac{3}{2} d (.5) (.283) \\ &= .166 d^3 \text{ lbs.} \end{aligned}$$

### ROTOR AND FIELD-COILS FOR TWO, INSIDE-COIL LUNDELLS (BECKY ROBINSON)

To accommodate the field coils and yokes in the rotor ends, the rotor of the two, inside, stationary-coil Lundell must be approximately  $2\ell$  long. Since  $\ell = \frac{d}{2}$ , the rotor length is  $\frac{2d}{2} = d$ . The rotor is considered 80% solid to account for the coils and yokes.

$$\text{Rotor wt.} = \frac{\pi d^2}{4} d (.283) = .333 d^3 \text{ lbs.}$$

## GENERATOR STATOR AMPERE LOADING

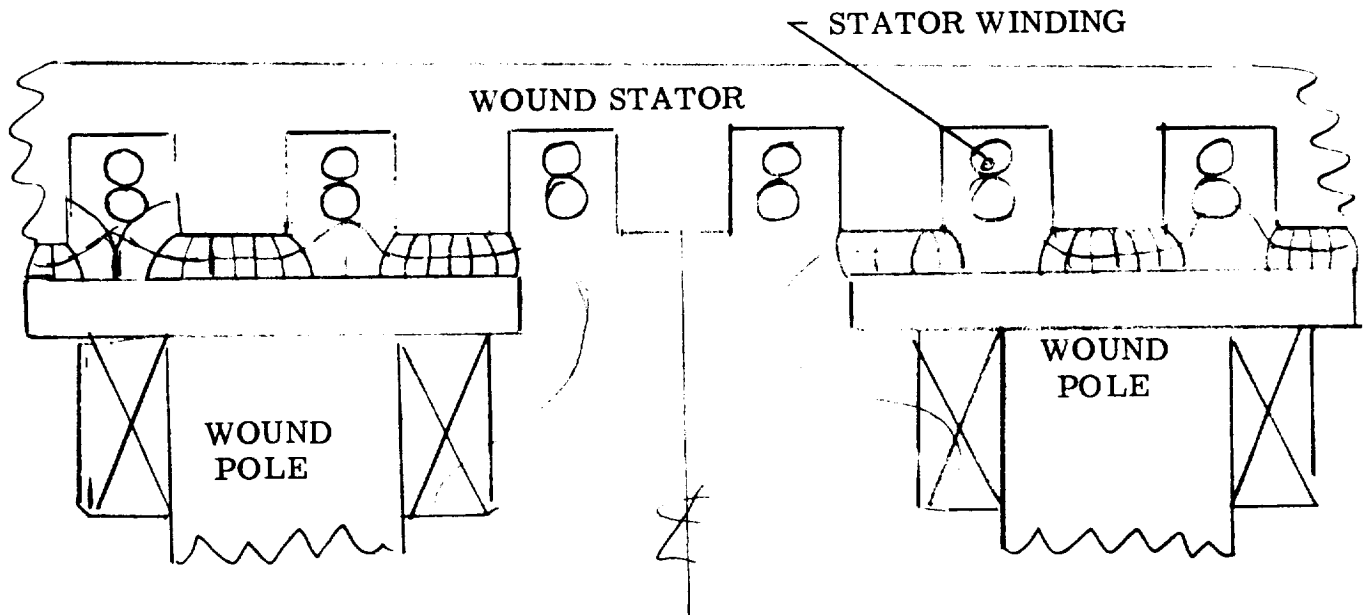

If:

- 1) The slots occupy 50% of the space in the stator bore area.
- 2) The no load flux density in the iron is  $100 \text{ K}\ell/\text{in}^2$ .

Then the air gap density will be  $50 \text{ K}\ell/\text{in}^2$  at no load.

In practice, the air gap density may vary from  $20 \text{ K}\ell/\text{in}^2$  for a permanent-magnet generator to  $65 \text{ K}\ell/\text{in}^2$  for a low-reactance wound-pole generator. Solid-pole generators usually operate at moderate gap densities because of pole-face losses ,

The ampere-wires per inch of bore periphery  $A$  represents the current loading of the generator and the output power. If the value  $A$  is doubled and all else held constant, the power output doubles. In a 30 KVA, 8-pole MIL-G-6099A generator for aircraft, the value  $A$  will be about 700 to 800. The tooth width will about equal the slot width, the gap density is approximately  $50 \text{ K}\ell/\text{in}^2$  and the tooth no load density is about  $100 \text{ K}\ell/\text{in}^2$ .

$$\text{Yoke area} = \pi (D + t_y) t_y$$

$$= \pi (D) t_y \text{ approximately}$$

$$\text{Yoke flux} = \frac{\pi d \ell B_g C_p}{2} \text{ Kilolines of useful flux}$$

$$\text{Yoke flux} = 80 \times \text{yoke area}$$

$$\ell = \frac{d}{2}$$

$$\text{Yoke area} = \frac{\pi d^2 B_g C_p}{4(70)}$$

$$\pi D t_y = \frac{\pi d^2 B_g C_p}{280}$$

$$t_y = \frac{d^2 B_g (.65)}{D(280)}$$

$$= \frac{d (50) .65}{1.42 (280)} = .0817 d$$

For 4 poles and  $B_g = 50$

$$\text{Yoke weight} = \pi (D + t_y) t_y \frac{d}{2} \times 3 (.283)$$

$$= \pi (1.42 + .082) .082 \frac{d^3}{2} \times 3 (.283)$$

$$= .164 d^3 \text{ lbs. for } B_g = 50 \text{ and } P = 4.$$

$\rho = .283 \text{ lb/in}^3$

### ROTOR, HOMOPOLAR INDUCTOR

The rotor of the homopolar inductor is assumed to be 60% solid on the ends and 100% solid in the center section between the stators. The diameter of the center section or shaft area is .8 d. The rotor length is  $\ell$  per section

or  $\frac{d}{2}$  per section.

$$\begin{aligned} \text{Rotor weight} &= \left[ \frac{\pi d^2}{4} \frac{d}{2} (.60) \times 2 + \right. \\ &\quad \left. + \frac{\pi (d \times .8)^2}{4} \frac{d}{2} \right] .283 \text{ lbs.} \\ &= \frac{.283}{8} d^3 [1.2 + .64] = .204 d^3 \text{ lbs.} \end{aligned}$$

### YOKE AND END-BELLS OF OUTSIDE-COIL LUNDELL GENERATORS

The useful flux in the yoke is  $\frac{\pi d \ell B_g C_p}{2}$  Kilolines and the leakage flux is  $\frac{2}{3}$  as great as the useful flux. The flux density in the yoke, due to the useful flux alone is  $60 \text{ K}\ell / \text{in}^2$ .

$$\text{Area yoke} = \pi D t_y \text{ approx.}$$

$$t_y = \text{thickness of yoke} = \frac{\pi \frac{d^2}{4} .65(B_g)}{\pi D (60)}$$

$$\text{Yoke length} = 3\ell = 3\frac{d}{2}$$

$$\text{Yoke weight} = \pi (D + t_y) t_y \frac{3}{2} d (.283) \text{ lbs.}$$

The end bells of the two, outside coil Lundell generators must carry the yoke flux and must have approximately constant cross-section area from the outer yoke to the auxiliary air gap. If  $\pi d_{EB}$  (thickness) = constant at



The limit of ampere loading on the stator is reached when additional rotor ampere turns, which would be necessary to overcome more armature reaction and armature voltage drop, only serve to force more flux across the rotor leakage paths.

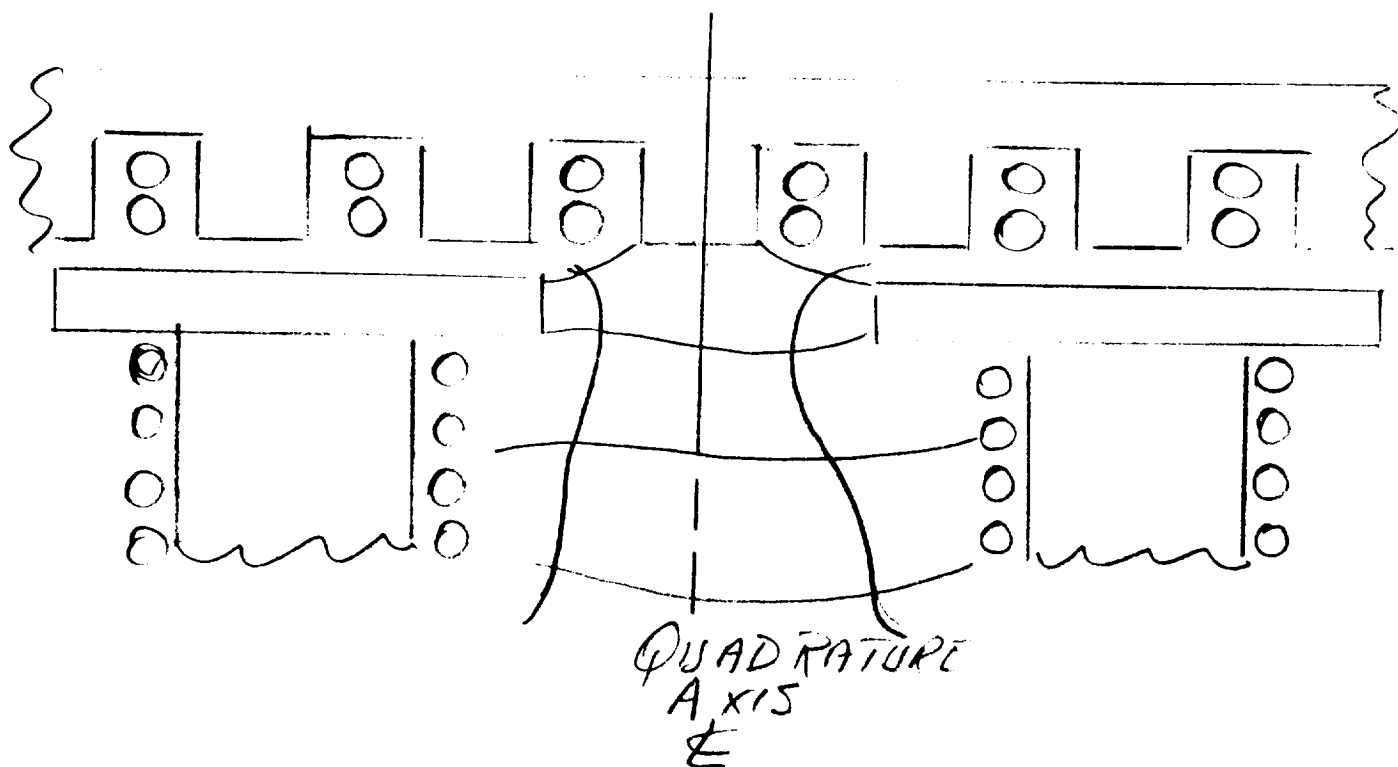

A small (1 KW) conventional, 8000 rpm, 400 cycle permanent magnet generator with block-type salient-pole magnets will produce about 600 ampere wires/inch at maximum output. The regulation is about 40% at such a load and in order to maintain a useable voltage level about 250 ampere wires/inch is the usual limit.

A 10 KVA, 4-pole, wound rotor, salient-pole MIL-G-6099A generator may have a rated load output of about 500 to 600 ampere-wires per inch.

A 30 KVA, 2-pole, 400 cps, non-salient pole generator may only be able to carry 400 ampere-wires/inch if it is to meet MIL-G-6099A performance requirements.

There is no direct and clear-cut way to arrive at the maximum stator loading. For different applications, the load limit may be entirely different. In general though, for any of the electromagnetic generators we are likely to be interested in the loading A will

probably lie between 600 and 900. For very small machines and PM generators, this value may be as low as 200 while for large synchronous condensers on utility systems (50,000 KVA) the value may be 1200.

The ampere loading of the stator is related to the reactances of the machine.

If wire is wound through an iron or steel machine, it acquires inductance.

$$L = \frac{N\Phi}{i} = \frac{N(Ni)\mu}{i}$$
$$= N^2\mu$$

Where  $\mu$  = permeance

This indicates that since the output current is fixed in any specific application, the inductance of the stator winding will vary directly as the square of the conductors/inch used or as  $A^2$ .

## GROUPING OF FRACTIONAL SLOT WINDINGS

When the stator is comprised of a winding having fractional slots per pole, the grouping of the coils can be determined by the following method.

Express the ratio of the number of slots to the number of poles as an improper fraction reduced to its lowest terms. The denominator will then represent the number of poles in a repeatable section and the numerator will then be the number of slots in a repeatable section. If the number of slots in a repeatable section is not divisible by the number of phases a balanced polyphase winding cannot be obtained.

The maximum number of parallel paths in the winding is found by dividing the number of poles of the machine by the number of poles in a repeatable section. This gives the maximum possible number of parallels.

To determine the grouping lay out a table having as many horizontal divisions as there are slots per repeatable section, and as many vertical divisions as there are poles per repeatable section. Divide the horizontal divisions into m number of phases and using a pitch of  $y = \text{poles per repeatable section}$  lay out the winding.

As an example consider a 3 phase, 20 pole, 84 slot machine, then  $84/20 = 21/5 = (\text{slots per repeatable section})/(\text{poles per repeatable section})$ . The maximum number of parallels possible =  $20/5 = 4$ , and the available number of parallels will then be 4 and 2. Lay out the table as follows with  $y = 5$  and throw = 1-6.

	1	2	3	4	5	6	7	8	9	10	11	12	13	14	15	16	17	18	19	20	21
1	x					x					x					x					x
2					x					x					x						x
3				x					x					x					x		
4			x					x					x					x			
5		x					x					x					x				
	Phase a							Phase c							Phase b						

The grouping will thus be 21211-21211 = 21211 = and repeat 3 x 4 = 12 times.

The coils will then be placed as follows:

Slot No.	1	2	3	4	5	6	7	8	9	10	11	12	13	14	15	16	17	18	19	20	21
Phase of	+	+	-	+	+	-	+	-	-	+	-	-	+	-	+	+	-	+	+	-	+
Coil	a	a	c	b	b	a	c	b	b	a	c	c	b	a	c	c	b	a	a	c	b
Grouping	2	1	2	1	1	2	1	2	1	2	1	1	2	1	2	1	2	1	1	1	1

Another way of accomplishing the same result as that given above is as follows:

Since there are 5 poles per repeatable section and 21 slots per repeatable section there must be 7 slots per phase in each repeatable section with these 7 slots occupying positions over 5 poles. The coils in a section may be arranged in any order but the best arrangement in general is that which gives the largest distribution factor. Usually the most symmetrical arrangement of the coils is best, or in this case 12121. Laying out the winding of the previous example for the 12121 arrangement gives:

Slot No.	1	2	3	4	5	6	7	8	9	10	11	12	13	14	15	16	17	18	19	20	21
Phase of	+	-	-	+	-	-	+	-	+	+	-	+	+	-	+	-	-	+	-	-	+
Coil	a	c	c	b	a	a	c	b	a	a	c	b	b	a	c	b	b	a	c	c	b
Grouping	1	2	1	2	1	1	2	1	2	1	2	1	1	2	1	2	1	2	1	1	1

which is the same as that arrived at previously with the exception that it is displaced several slots.

### THE SLOT STAR

The two above methods of grouping can be verified by the slot star method.

In general let the number of slots per phase per pole  $q$  be represented as  $q = N/B = a + b/B$ . where  $a$  is an integer. Then the winding repeats itself after each  $B$  poles and the number of recurrent groups is equal to  $P/B$ . Each

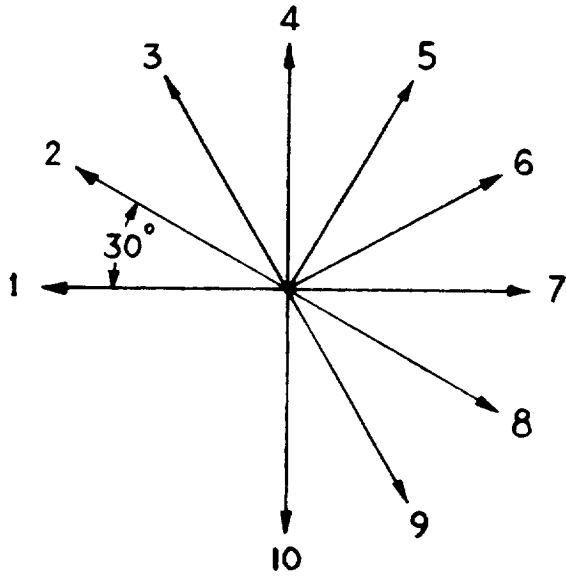

FIGURE SA-1

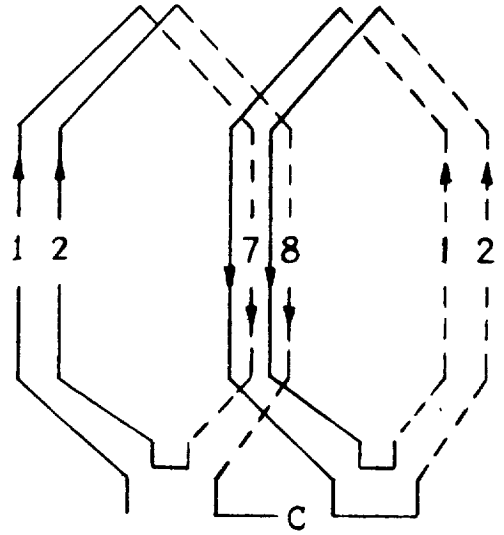

FIGURE SA-2

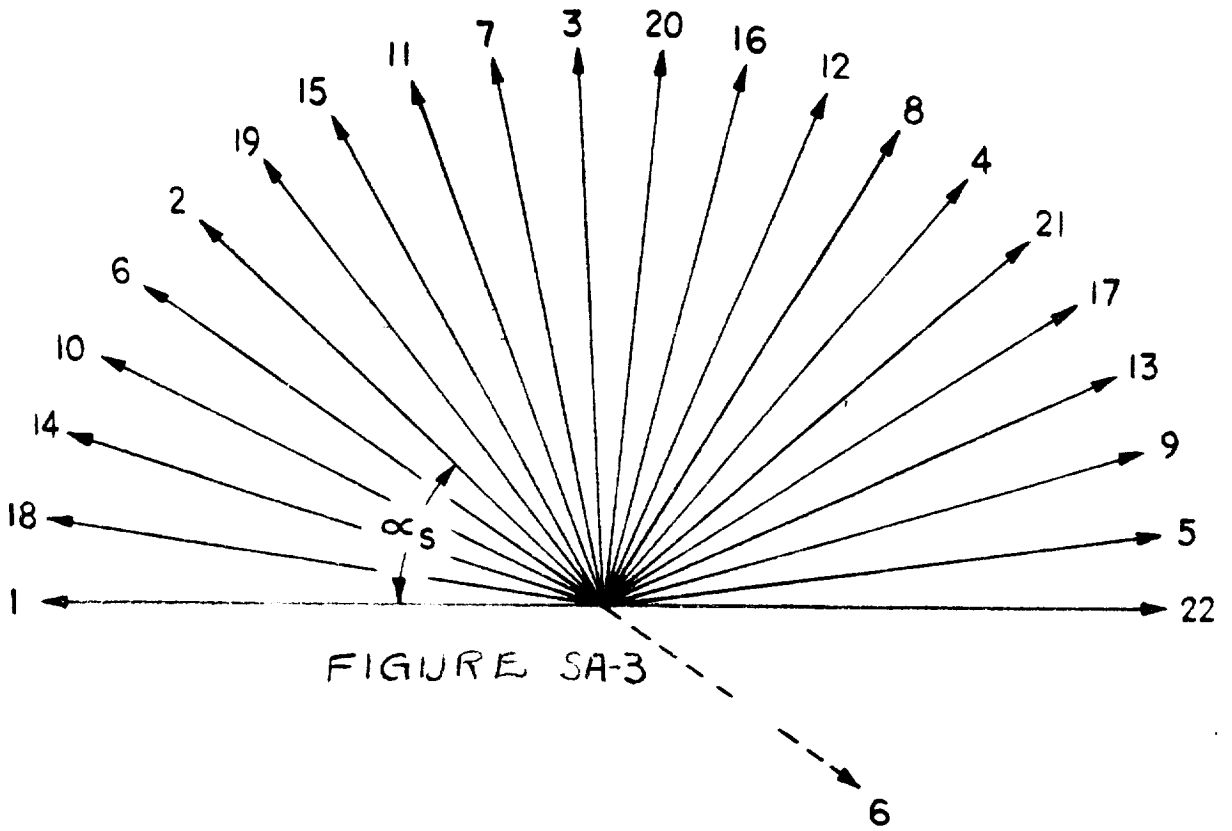

FIGURE SA-3

phase has  $N$  slots in  $B$  poles. Further, each phase has  $B - b$  coil groups with  $a$  coils and  $b$  coil groups with  $a + 1$  coils in  $B$  poles. If  $B/m$  equals an integer there cannot be a perfectly balanced fractional slot winding.

Apply the above rules to the 3 phase, 20 pole, 84 slot example gives  $q = 84 / (20 \times 3) = 7/5 = 1 + 2/5$ . Thus the winding repeats itself after each 5 poles the number of recurrent groups is  $20/5 = 4$ . Each phase has 7 slots in 5 poles and each phase had  $5 - 2 = 3$  coil groups with 1 coil and 2 coil groups with  $1 + 1 = 2$  coils in 5 poles.

The slot star of a 2 pole, 3 phase integral slot winding with  $q$  equals two is shown in Figure 1. The angle between two adjacent slots is  $\alpha_s = 180^\circ / mq = 30^\circ$ .

Two adjacent vectors correspond to two adjacent slots and thus slots 1, 2, 7, and 8 belong to phase I, slots 3, 4, 9, and 10 belong to phase II and so on. Vector 7 with which the second pole starts is shifted  $180^\circ$  with respect to vector 1, and the same applies for vectors 2 and 8, 3 and 9, etc. Therefore the bottom half of the slot star is the same as the top half except that their vectors are shifted by  $180^\circ$ .

The four coils of phase 1 are shown in Figure 2 with the solid lines representing the tops of the slots and the dotted lines representing the bottom. The connector  $C$  takes care that all the emfs add together and thus the slot star of this example is completely represented by only half of the circle.

The above type of star will then apply to the integral slot windings in general.

In the fractional slot winding,  $B$  poles make the recurrent group and just as for the integral slot winding the slot star of  $B$  poles is represented by half of a circle.

Figure 3 shows the slot star of the 20 pole, 3 phase, 84 slot example. There are 5 poles in  $B$  with  $7 \times 3 = 21$  slots per recurrent group.  $\alpha_s = 180 / (3 \times 1.4)$

=  $42$  and  $6/7^{\circ}$ . Thus the angles which correspond to the slots are:

Slot No.    1        2        3        4        5        6  
 $\alpha_s - 0 \quad 42 \ 6/7 \quad 85 \ 5/7 \quad 128 \ 4/7 \quad 171 \ 3/7 \quad 214 \ 2/7 = 34 \ 2/7$  etc.

Since the largest distribution factor for the fundamental is obtained when the slots belonging to each group are closest together, the first seven slots in the slot star will be assigned to phase a. The second seven to phase c, and the last seven to phase b. Thus slots 1, 18, 14, 10, 6, 2, and 19 are phase a; 15, 11, 7, 3, 20, 16, and 12 are phase c; and 8, 4, 21, 17, 13, 9, and 5 are phase b.

The grouping then becomes

Slot No.	1	2	3	4	5	6	7	8	9	10	11	12	13	14	15	16	17	18	19	20	21
Phase of Coil	+	+	-	+	+	-	+	-	-	+	-	-	+	-	+	+	-	+	+	-	+
	a	a	c	b	b	a	c	b	b	a	c	c	b	a	c	c	b	a	a	c	b
Grouping	2	1	2	1	1	2	1	2	1	1	2	1	1	2	1	2	1	2	1	1	

This is identical with the grouping of the first method and therefore verifies its accuracy.

In the integral slot winding the beginnings of the phases are displaced by 120 and 240 electrical degrees. Also in the fractional slot windings the distances between the beginnings of the phases can be made 120 and  $240^{\circ}$ . This will be the case when the beginnings are placed in slots 1,  $1 + N$ , and  $1 + 2N$  when B is an even number, and in slots 1,  $1 + 2N$ , and  $1 + (1 + m)N$ , when B is an odd number. This arrangement of the beginnings of the phases will place them far apart from each other mechanically while it is often desirable to have them near to each other. In order to place the beginnings of the phases near to each other the beginnings can be placed approximately 120 and 240 electrical degrees apart and the windings still will be balanced. This is due to the fact that

in the fractional slot winding the emfs of the consecutive coil groups are not in phase and the sequence of the geometric addition of the single emfs is of no influence on the resultant phase emf. So in the example considered the beginnings of the phases can be placed in slot 1 for phase a, slot 4 for phase b, and slot 7 for phase c. The angles between the beginnings are then  $128\frac{4}{7}^\circ$ , and  $257\frac{1}{7}^\circ$ .

### DISTRIBUTION FACTOR

The voltages induced in the separate coils of a distributed winding are not in exact phase and their resultant is therefore less than would be produced in a concentrated winding having the same number of turns. The ratio of the voltages produced by distributed and concentrated windings having the same number of turns is called the distribution factor. In the case of integral slots per phase per pole it can be derived as follows:

$\theta$  = electrical angle per phase group

$$\theta = q \alpha_s$$

$$\sin \frac{\alpha_s}{2} = \frac{e/2}{r} = \frac{e}{2r}$$

$$r = \frac{e}{2 \sin \frac{\alpha_s}{2}}$$

$$\sin \frac{\theta}{2} = \sin \frac{q \alpha_s}{2} = \frac{E}{2r}$$

$$E = 2r \sin \frac{q \alpha_s}{2} = 2 \left( \frac{e}{2 \sin \frac{\alpha_s}{2}} \right) \sin \frac{q \alpha_s}{2} = \frac{e \sin \frac{q \alpha_s}{2}}{\sin \frac{\alpha_s}{2}}$$



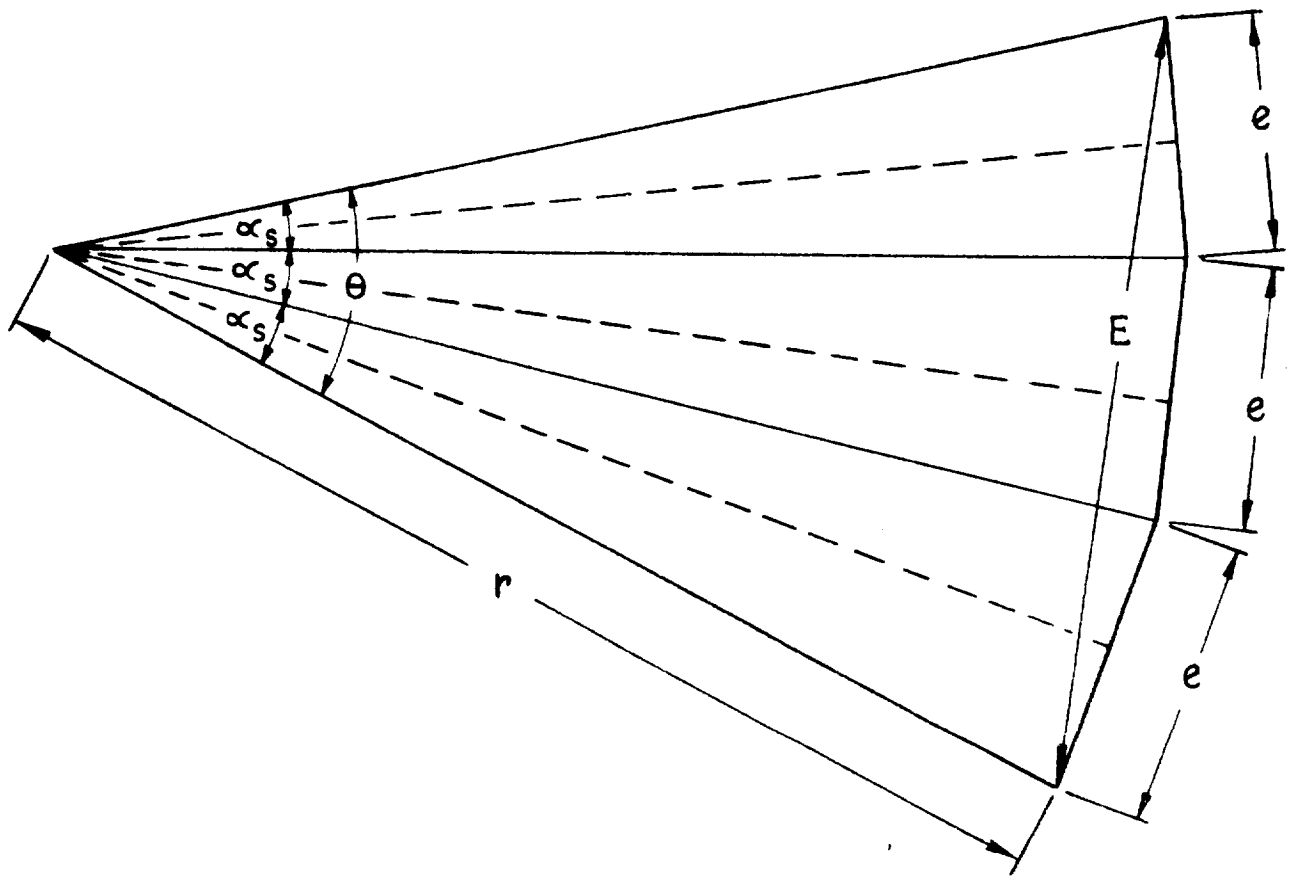

$$\text{Thus } K_d = \left( \frac{e \sin \frac{q \alpha_s}{2}}{\sin \frac{\alpha_s}{2}} \right) \div qe = \frac{\sin \frac{q \alpha_s}{2}}{q \sin \frac{\alpha_s}{2}}$$

Since a displacement of  $\alpha_s$  between the slots is  $n \alpha_s$  for the  $n$ th harmonic,

$$K_{dn} \text{ for the } n\text{th harmonic is } K_{dn} = \frac{\sin \frac{qn \alpha_s}{2}}{q \sin \frac{n \alpha_s}{2}}$$

### FRACTIONAL SLOT DISTRIBUTION FACTOR

Refer to the slot star shown in Figure 3 of the section titled "Grouping of Fractional Slot Windings" and it will be noted that to determine  $K_d$  for a fractional slot winding it is necessary to distinguish between the angle between two slots  $\alpha_s$  and the angle between two vectors  $\alpha_m$ . This latter angle is the magnetic field angle between the slots of the recurrent group and this angle determines the phase difference between the vectors. The magnetic field angle is  $\alpha_m = 180^\circ / Nm$  where  $N$  is the same as in "Grouping of Fractional Slot Windings".

It can be seen from the slot star that the fractional slot winding thus behaves like a winding with  $N$  slots per phase per pole shifted with respect to each other by the magnetic field angle  $\alpha_m$ . Therefore the distribution factor is

$$K_d = \frac{\sin \frac{N \alpha_m}{2}}{N \sin \frac{\alpha_m}{2}}$$

The general effect of distributing a winding is to smooth out the wave form by diminishing the amplitude of the harmonics with respect to the fundamental. The distribution of the armature copper loss is also improved.

The distribution factor of the three phase winding is greater than that of the two phase winding and for this reason the three phase winding is used where there is a free choice of the number of phases. The distribution factor of the single phase winding is much smaller than that of either 3 or 2 phase windings because the winding is distributed over a larger arc.

In general only 2/3 of the slots per pole are used in winding single phase machines. The reason for this can be best shown by an example. Let the number of slots per pole equal 9, and if all slots were wound then  $\alpha_s = 180^\circ/9 = 20^\circ$ , and

$$K_d = \frac{\sin\left(9 \times \frac{20}{2}\right)}{9 \times \sin 10^\circ} = \frac{1}{1.563} = .640$$

If only 6 slots are wound

$$K_d = \frac{\sin(6 \times 10)}{6 \times \sin 10} = .832$$

Thus, for 9 slots the number of effective turns is only  $\frac{9 \times .640}{6 \times .832} = 1.15$  times the number of effective turns obtained when using 6 slots, and therefore by using 50% more copper with its additional 50% more loss, only 15% more voltage has been obtained.

### SKEW FACTOR

It can be noted in the table of distribution factors that some harmonics have the same distribution factor as the fundamental. These harmonics are called the slot harmonics and their orders are

$$n = \left[ K(2mq) \right] \pm 1 = K \left( \frac{Q}{p/2} \right) \pm 1 \quad \text{where } K \text{ is an integer}$$

The slot harmonics which correspond to  $K = 1$  (slot harmonics of the first order) are among the most troublesome harmonics in AC machines. Their influence, as well as the influence of other harmonics of higher order, can be reduced by skewing and for this reason stator or rotor slots are sometimes

skewed. The skewing also reduces the flux variation in the fringing of the flux at the pole tips due to the slots entering and leaving the polar region. Such a flux variation oftentimes contributes to noise.

Skewing has the same effect as the distribution of a winding over a larger zone because it reduces the interlinkages between the field and stator windings. This distribution factor due to skewing is called the skew factor.

For slots that have a large number of slots per coil group the path of the vectors being added approaches the arc of a circle, and when this happens the distribution factor can be expressed as the ratio of the chord AE to the arc AE and

$$\sin \frac{q \alpha_s}{2} = \frac{1/2 \text{ chord AE}}{R}$$

$$\text{chord AE} = 2R \sin \frac{q \alpha_s}{2}$$

$$\text{arc AE} = Rq \alpha_s$$

$$K_d = \frac{2R \sin \frac{q \alpha_s}{2}}{Rq \alpha_s} = \frac{\sin \frac{q \alpha_s}{2}}{\frac{q \alpha_s}{2}}$$

If  $Z$  is the arc which the coil group occupies per pole and  $t_p$  is the pole pitch then

$$\frac{q \alpha_s}{2} = \frac{Z \pi}{t_p} \text{ and } K_d = \frac{\sin \frac{Z \pi}{t_p}}{\frac{Z \pi}{t_p}}$$

Let  $t_{sk}$  be the slot skew in inches for a length equal to the core length of the machine and the skew factor  $K_{sk}$  is

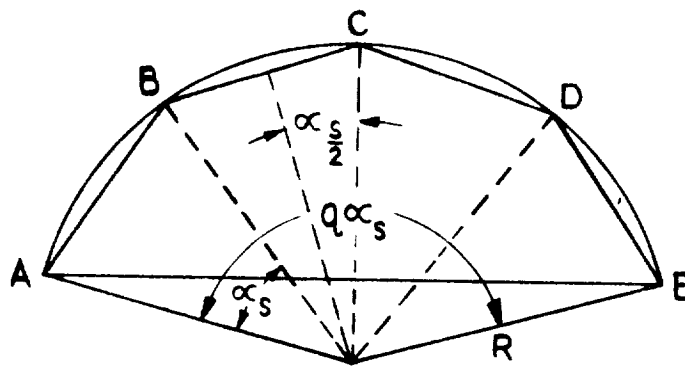
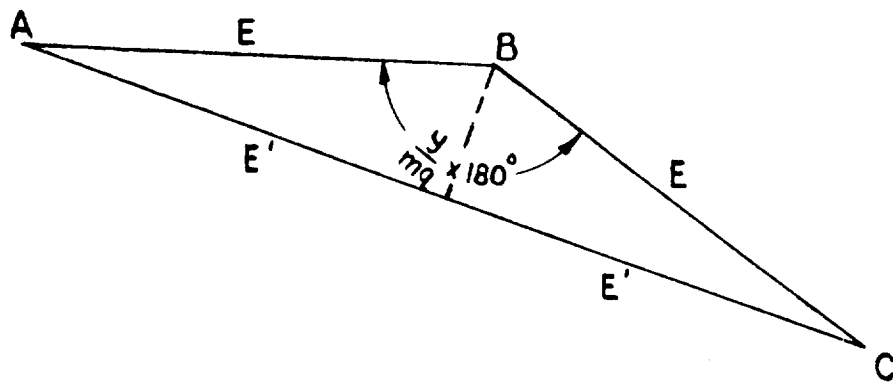

$$K_{sk} = \frac{\sin \frac{t_{sk} \pi}{2t_p}}{\frac{t_{sk}}{t_p} \frac{\pi}{2}} \text{ (fundamental) } \& \ K_{nsk} = \frac{\sin n \frac{t_{sk} \pi}{2t_p}}{n \frac{t_{sk} \pi}{2t_p}} \text{ (nth harmonic)}$$

The influence of skewing is negligible for the fundamental, small for the harmonics of low order, and very considerable for the harmonics of higher order. A skew which is equal to one stator slot pitch makes the influence of the dangerous slot harmonics almost negligible.

### PITCH FACTOR

Fractional pitch windings decrease the length of end connections, reduce slot reactance, and provide a means for improving the wave form. They can be used to eliminate any one harmonic from the voltage wave as well as to reduce other harmonics. However, they require a few more turns or a greater flux for the same voltage than a full pitch winding.

Since the two sides of a coil of a fractional pitch winding do not lie under the centers of adjacent poles at the same instant the voltages induced in them are not in phase when considered around the coil. The voltage produced is therefore less than that which would be produced in a full pitch winding. The voltage generated in any single turn is the vector difference of the voltages generated in the two inductors which form the active sides of the turn. If the throw in slots is  $y$ , then  $(y/mq) \times 180^\circ$  will be the angle of phase difference between the turns and  $K_p$  is then derived as follows:

$AB = BC = E$ ; since  $AB = BC$ , angle  $C = \text{angle } A$ , and the bisector of  $(y/mq) \times 180^\circ$  will be perpendicular to  $AC$  and will bisect  $AC$  into two equal parts  $E'$ ; thus

$$K_p = 2E'/2E = E'/E = \sin \left[ (y/mq) \times (180^\circ/2) \right] = \sin \left( \frac{y}{mq} \times 90^\circ \right)$$

Since the displacement for any harmonic such as the  $n$ th is  $n$  times the phase

displacement of the fundamental,  $K_p$  for any harmonic  $n$  is

$$K_p = \sin\left(\frac{ny}{mq} \times 90^\circ\right)$$

Any harmonic can be eliminated by choosing a pitch that makes the pitch factor zero for that harmonic. Thus to eliminate the  $n$ th harmonic it is only necessary to select a pitch such that  $n(y/mq) \times 90^\circ$  equals  $180^\circ$ ,  $360^\circ$ ,  $540^\circ$ , etc. (any multiple of  $180^\circ$ ). Eliminating any one harmonic also reduces other harmonics and the fundamental by different amounts. A pitch of  $5/6$  will give minimum fifth and seventh harmonics and should theoretically give a minimum additional rotor surface loss under load conditions.

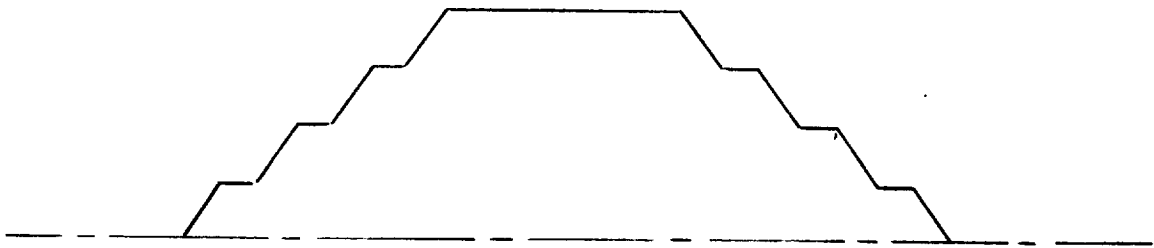
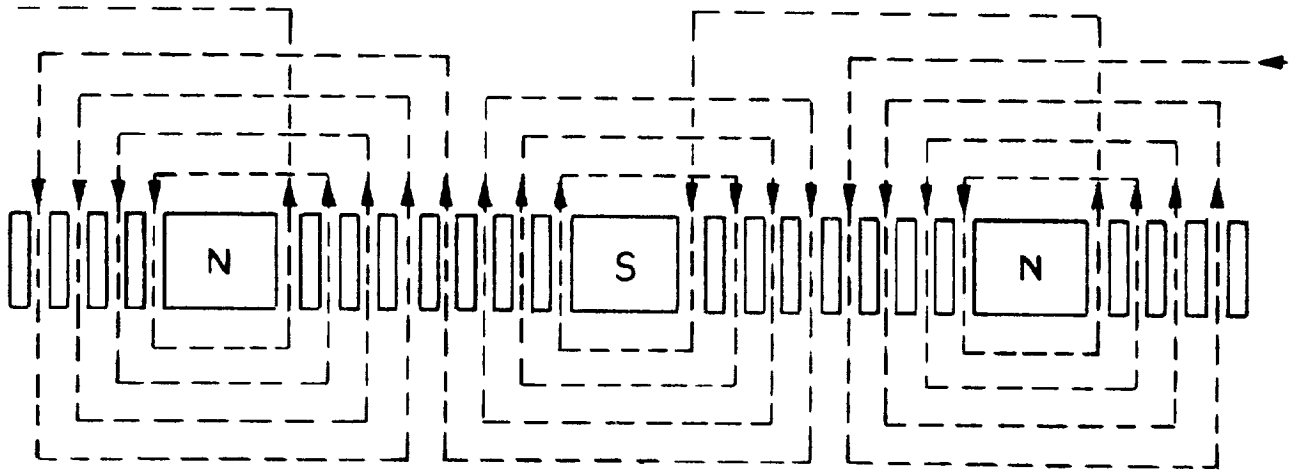



## Reactances

Machine reactances are sometimes expressed in ohms but are more often given in per cent or in per unit. The per unit system is discussed in Appendix A of *Electric Machinery* by Fitzgerald and Kingsley, pages 543-546. In our treatment of generators, the per unit values of the various reactances are obtained by dividing the ohmic value of the reactance by the base ohmic value, which is the phase voltage divided by the phase current or  $E_{ph}/I_{ph}$ .

When the generator values are expressed in P. U. (or per cent which is 100 x P. U.), all generators can be compared by the same standards. A 50,000 KW, 60 cycle generator and a 1 KW, 1000 cycle generator look pretty much alike as far as their reactances and per unit values are concerned.

Per unit values can be easily used in system studies and the values are easy to convert to a new base when used in a system involving several machines.

Nearly all of the formulae in this study are arranged to give per cent values. To convert to ohmic values, multiply the per cent value by

$$\frac{E_{ph}}{I_{ph}} \times \frac{1}{100}$$

Any rotating electrical machine has only one zero-sequence reactance and only one negative-sequence reactance but it has several positive-sequence reactances. These positive sequence reactances depend upon the angular position of the rotor and upon whether the positive-sequence currents are steady or are suddenly applied.

## SYNCHRONOUS REACTANCE

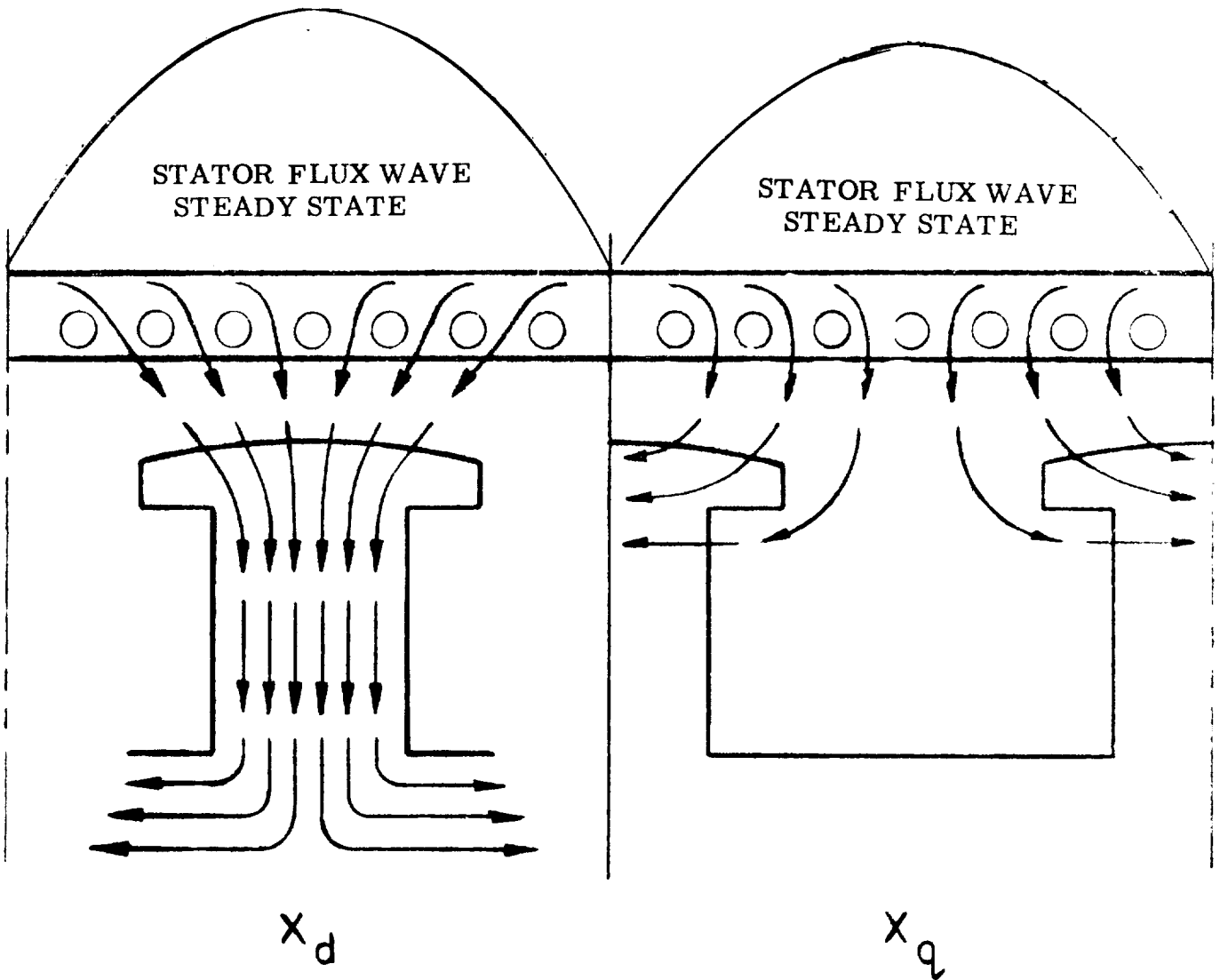

When a generator operates on a steady state symmetrical short circuit condition its terminal voltage is zero and its saturation is negligible. Since there is no terminal voltage the net stator linkage must be zero, and thus the stator linkage due to its current acting alone must be exactly equal and opposite in direction to the stator linkage due to the field current acting alone. If the field current were acting alone with the stator open-circuited a certain terminal voltage would exist, and since the armature linkage has the same value as the field linkage, the voltage which must be applied to produce the stator current must be exactly the same as the terminal voltage induced under open circuit.

Therefore the unsaturated synchronous impedance is the ratio of the phase voltage on open circuit resulting from a certain field current to the steady state short circuit stator current resulting from the same field current. Further, since the value of the effective resistance is usually very small in comparison with the reactance it can be neglected, and the impedance and reactance are then equal. Thus

$$X_d = \frac{E \text{ (open circuit)}}{I \text{ (short circuit)}} \text{ ohms}$$

and since the voltage drop due to the stator current is due to the fictitious reactance  $X_{ad}$  and the actual reactance  $X_l$

$$X_d = X_{ad} + X_l$$

#### Direct Axis Synchronous Reactance $X_d$

Definition AIEE TEST CODE 503, Para. 1.820

"The direct-axis synchronous reactance is the ratio of the fundamental component of reactive armature voltage due to the fundamental direct-axis component of armature current, to this component of current under steady-state conditions and at rated frequency.

#### Quadrature Axis Synchronous Reactance $X_q$

Definition AIEE TEST CODE 583, Para. 1.830

"The quadrature-axis synchronous reactance is the ratio of the fundamental component of reactive armature voltage, due to the fundamental quadrature-axis component of armature current, to this component of current under steady-state conditions and at rated frequency.

## FLUX CIRCUIT FOR STEADY STATE CONDITIONS

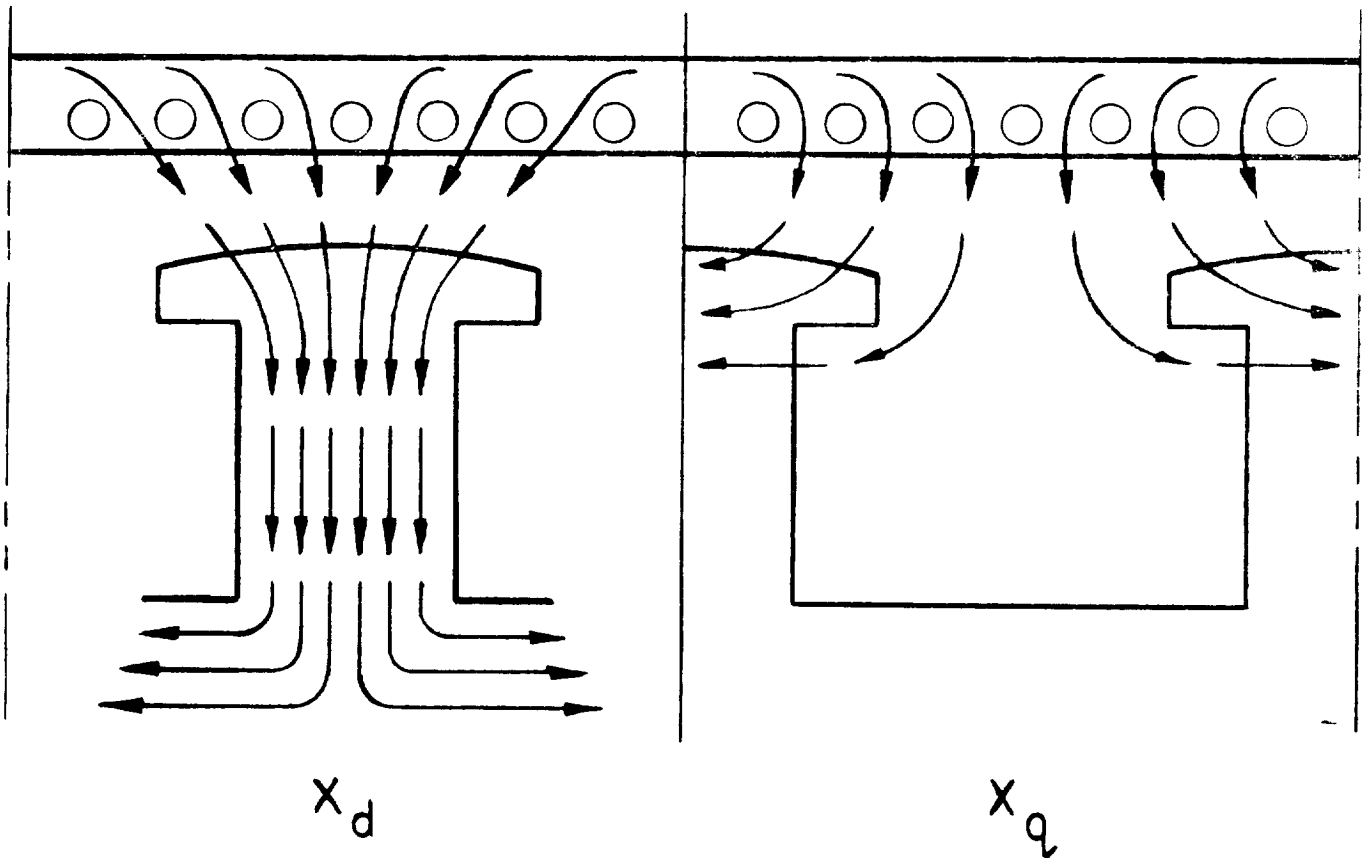

The above schematics show the circuits for steady-state fluxes in the direct axis and the quadrature axis. The two conditions shown would be obtained when testing for the synchronous reactances,  $X_d$ , and  $X_q$ . Under steady state loading conditions, the stator flux wave is stationary with respect to the rotor poles, since it is traveling at synchronous speed. Therefore, the damper circuit and the field windings have no effect on the flux.

## REACTANCE OF ARMATURE REACTION

Since the shape of the resultant MMF wave is independent of the direction of armature reaction the effect produced by the MMF's of the field and stator windings can be found by treating the two forces as if they each acted alone, and thus the forces may be replaced by the voltages they would cause if acting separately. If this substitution is made the voltage due to armature reaction may be considered as being a voltage drop due to a fictitious reactance  $X_{ad}$ , and this is called the reactance of armature reaction. It is not an actual reactance but under steady operating conditions may be considered as such in order to simplify the methods of calculation. It is in phase with the voltage drop due to leakage reactance  $I_{ph} X_l$ , and the sum of these two reactances is the synchronous reactance  $X_d$ .

If the effect of saturation is neglected the saturation curve becomes a straight line, and then any change in flux with its corresponding change in voltage, produced by any change in MMF is proportional to the change in MMF. Thus, if an unsaturated condition is assumed, the reactance of armature reaction in per unit value can be seen to be the ratio of the MMF of armature reaction to the MMF required by the field to force the flux across the air gap, or

$$X_{ad} = \frac{F_{DM}}{F_g} \quad (\text{percent})$$

$$\text{Since } F_{DM} = \frac{\sqrt{2} n_e C_M I_{ph} K_d}{\pi p} \quad \text{and } F_g = \frac{B_g g_e}{3.19}$$

$$X_{ad} = \frac{\sqrt{2} n_e C_M I_{ph} K_d}{\pi p B_g g_e} \times \frac{3.19}{\sqrt{2} C_1} = \frac{6.38 n_e C_M I_{ph} K_d C_1}{\sqrt{2} \pi p B_g g_e C_1}$$

$$I_{ph} = \frac{A \pi d}{Q n_s K_p} = \frac{A \pi d}{n_e} \left( \text{from } A = \frac{I_{ph} n_s K_p}{t_s} \quad \text{and } t_s = \frac{\pi d}{Q} \right)$$

$$\lambda_a = \frac{6.38 d}{P g_e} \quad \text{and} \quad X = \frac{A K_d}{\sqrt{2} C_1 B_g}$$

$$X_{ad} = \frac{6.38 d A \pi n_e C_M C_1 K_d}{\sqrt{2} n_e \pi P g_e B_g C_1} = X \lambda_a C_M C_1$$

## FLUX CIRCUIT FOR TRANSIENT CONDITIONS

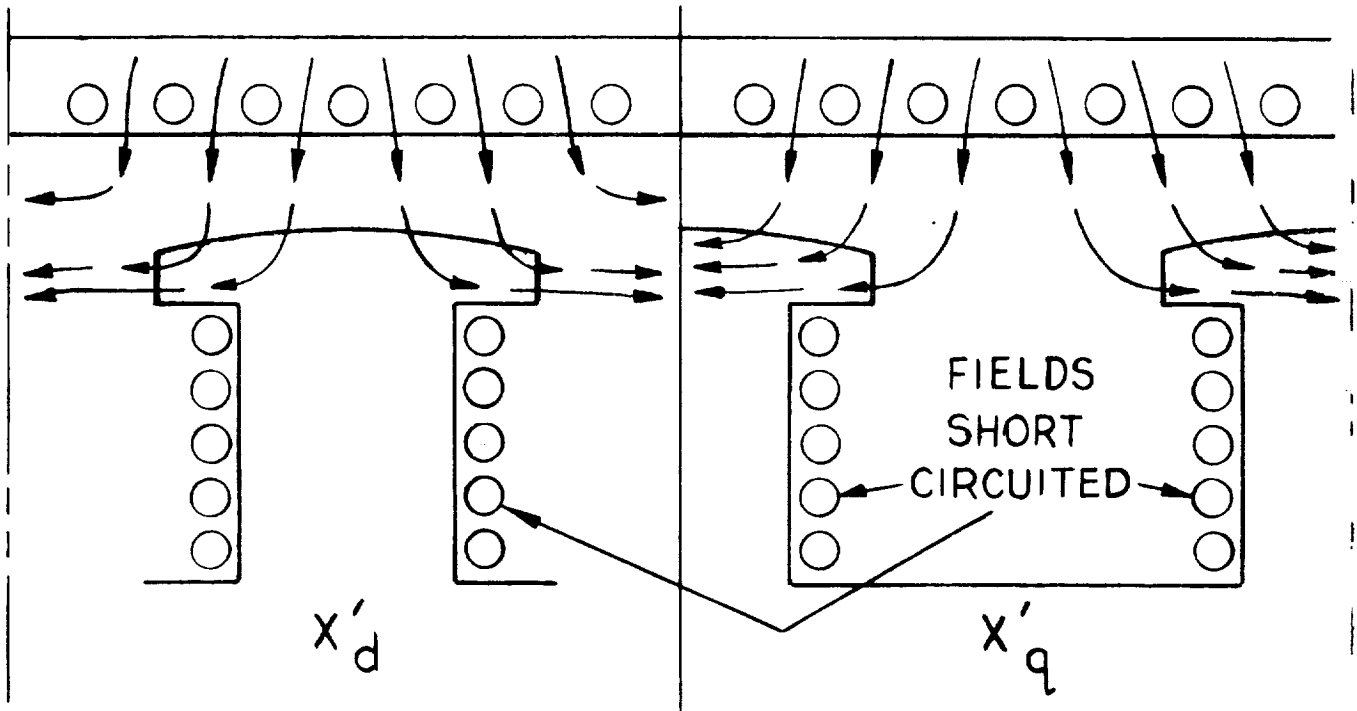

The two schematics above show the flux circuits for transient conditions in the salient-pole, wound-pole synchronous generator. These conditions obtain when tests are made for  $X'_d$  and  $X'_q$  or when the stator armature reaction flux wave is changing with respect to the poles.

### $X'_d$ Transient Reactance

When armature current is abruptly applied to a synchronous generator it may cause the sudden appearance of an opposing mmf opposite each field pole tending to establish flux through the pole core.

In a laminated salient pole rotor with wound poles, the transient flux is opposed by currents in the field winding. These initial currents decay until only the internal impedance  $X'_d$  opposes the current flow.

The permeance of the leakage path for the transient flux determines the armature transient current level.



## TRANSIENT REACTANCE IN THE STATIONARY- COIL BRUSHLESS GENERATORS

In the solid-rotor or stationary-coil, a-c generators, the field-coil is separated from the main air-gap by two auxiliary air-gaps. The transient flux is prevented from passing through the field coil and is shunted through the field leakage paths. These field leakage paths are large and the resulting transient reactance is large.

The following sketches show the path of the transient flux in a two, inside, stationary-coil, Lundell generator, or Becky-Robinson generator. This sketch is generally representative of the condition existing in any of the stationary-coil generators.

During the first cycle or two of the transient, the flux will be opposed by eddy currents in the rotor surface. These eddy currents reduce the transient reactance by about 15% during these first one or two cycles.

UNSATURATED TRANSIENT REACTANCE -- ( $X'_{du}$ )

When current is suddenly applied to a generator stator (a step load) there is no flux linkage with the field winding during the first instant, and during that first instant all flux due to the armature mmf is forced through the field coil leakage paths.

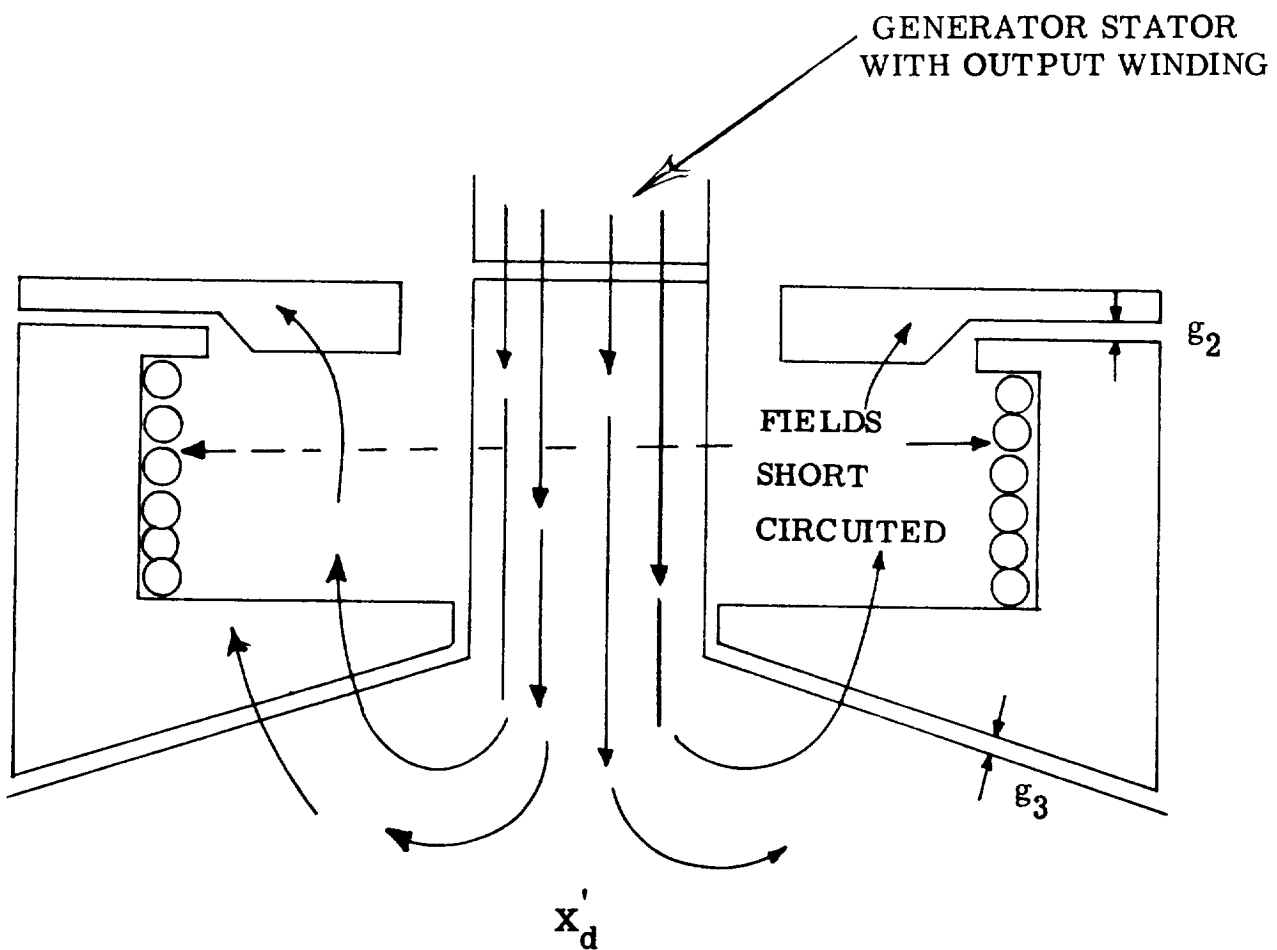

TRANSIENT FLUX IN THE NORTH POLE OF A BECKWITH-ROBINSON LUNDELL, A-C GENERATOR

TRANSIENT FLUX IN THE SOUTH POLE OF A BECKY-ROBINSON, LUNDELL A-C GENERATOR

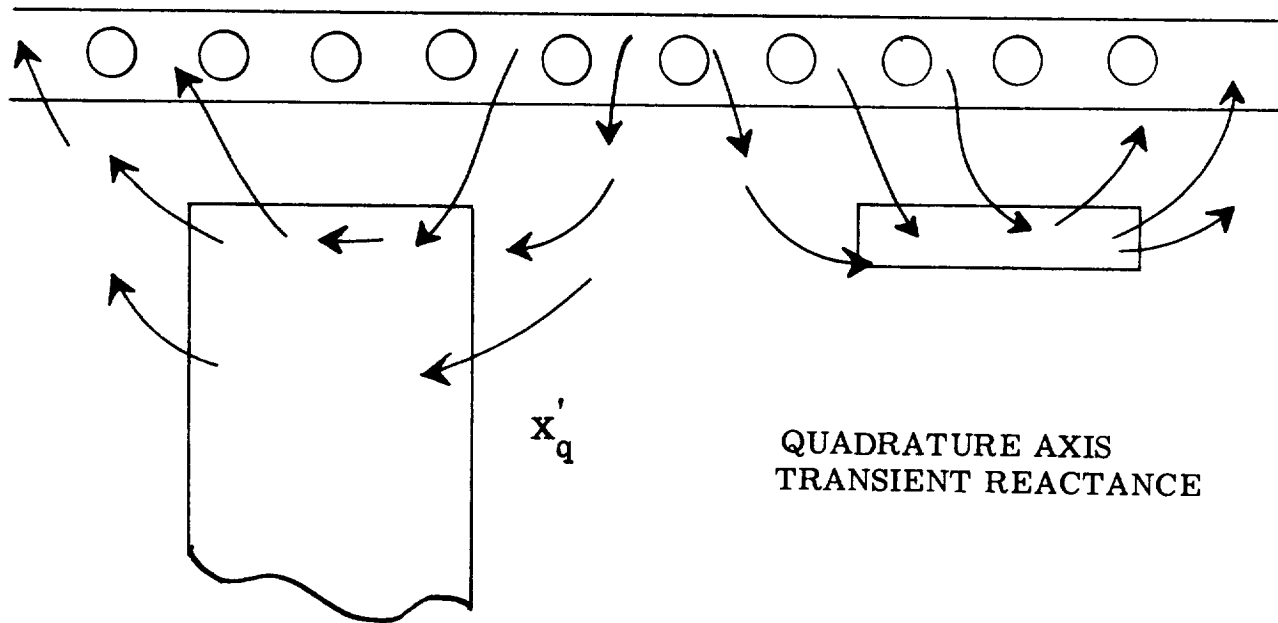
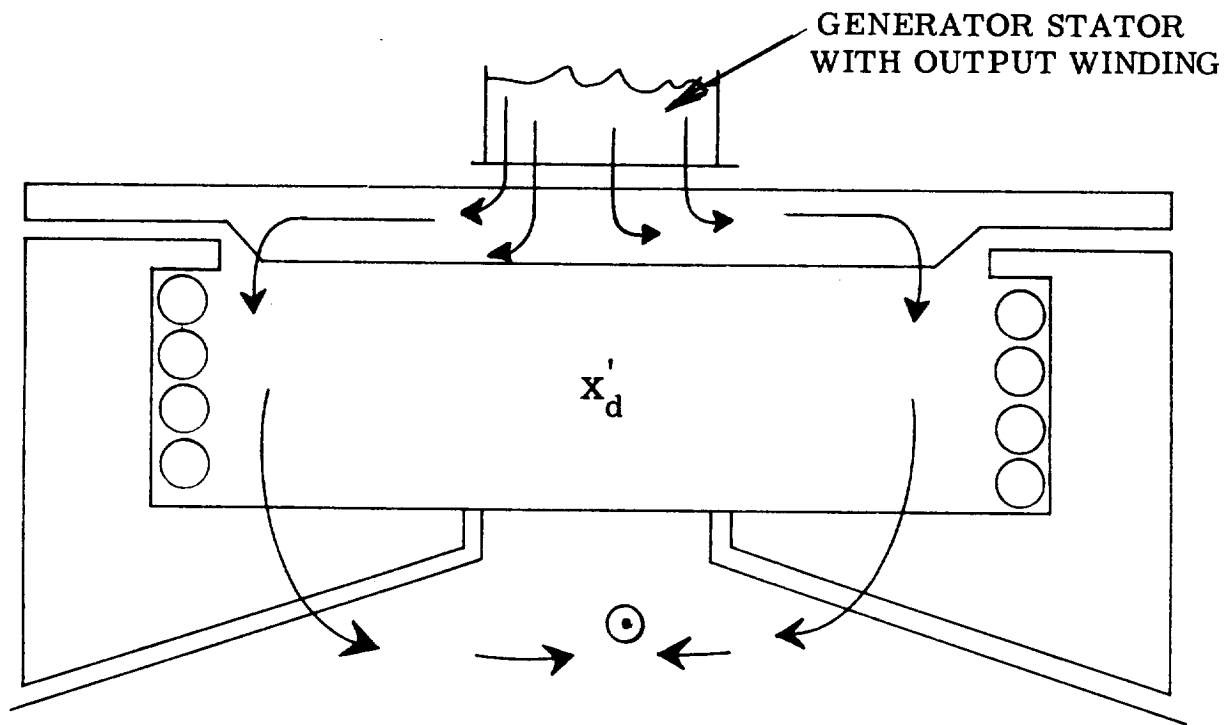

## FLUX CIRCUIT FOR SUBTRANSIENT CONDITIONS

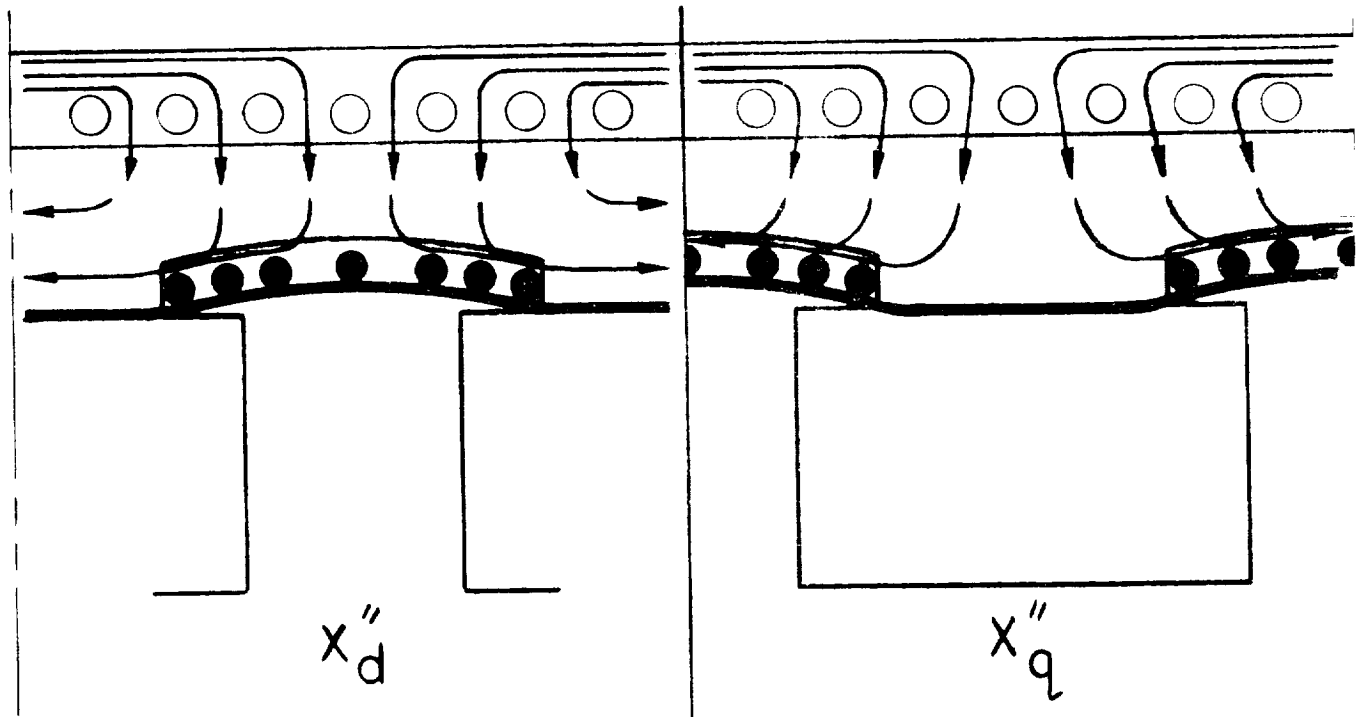

### $X''_d$ Subtransient Reactance

If armature current is abruptly applied to a synchronous generator which has a damper circuit on the rotor poles, or which generator has a solid pole face, currents will be set up in the damper circuit or pole surface. These currents oppose the change of flux linkages in the rotor circuit and the permeance of the path of the transient leakage flux determines the level of the transient current in the armature.

The subtransient current decays quickly leaving the transient current, which decays less quickly until at last only the steady state current limited by  $X_d$  remains.

The subtransient reactance of solid-rotor machines is about 15% lower than the transient reactance of the same machine.

## X<sub>2</sub> Negative-Sequence Reactance

Negative sequence currents applied to the stator produce a mmf rotating backwards at synchronous speed. With respect to the rotor which is rotating forward at synchronous speed, the negative sequence mmf and flux waves are rotating backwards at twice synchronous speed.

Currents of twice rated frequency are induced in all rotor circuits keeping the flux linkages of those circuits at almost constant zero value. The flux due to the negative sequence armature current is forced into paths of low permeance which do not link any rotor circuits. These paths are the same as for the subtransient flux.

Since the negative-sequence flux wave alternately meets permeances of the two rotor axes corresponding to subtransient reactance  $X_d''$  and  $X_q''$  it is usually calculated as

$$X_2 = \frac{X_d'' + X_q''}{2}$$

the arithmetical mean.

## X<sub>0</sub> Zero-Sequence Reactance

Zero-sequence currents in the armature produce slot-leakage, end-leakage, and differential-leakage fluxes, but not the same leakages as are produced by positive-sequence current. The leakage flux produced is small and  $X_0$  is the smallest of all the reactances; lower than  $X_d''$ .

The value of  $X_0$  varies through a wide range and depends upon the coil pitch. It is least for 2/3 pitch.

## LEAKAGE REACTANCE

In addition to the demagnetizing action of armature reaction there also exists a voltage drop due to the leakage fluxes. The lines of leakage flux go partly across the slot from one wall to the other (slot leakage), partly from tooth top to tooth top, (tooth tip), partly from phase belt to phase belt (zig zag), and partly in the end windings (end leakage). Each of the leakage fluxes is directly proportional to the current which produces it because its reluctance is principally in air.

Consider first the slot leakage flux. This flux includes all the flux which links the portion of the conductors that are embedded in the iron, but which does not enter the air gap. Assume an integral slot, full pitched winding, and assume that the flux passes directly across the slot. The effect of the notches at the wedge will be neglected and the current density in the conductors will be assumed constant. Also, for simplification, the distance between the top and bottom coil will be assumed negligible.

The flux produced by the element in the bottom of the slot will surround this element. It passes across the slot above the element and returns in the iron below it. The flux will thus encircle part of the coil plus all of the slot above the coil. For the part above the coil the flux will proportion itself equally over the distance  $h_{1/2} + h_2$ , and since the inductance  $L$  equals  $\frac{3.19n_s^2 a}{4\ell 10^8}$  the  $L$  per slot per inch of core length for this part is:

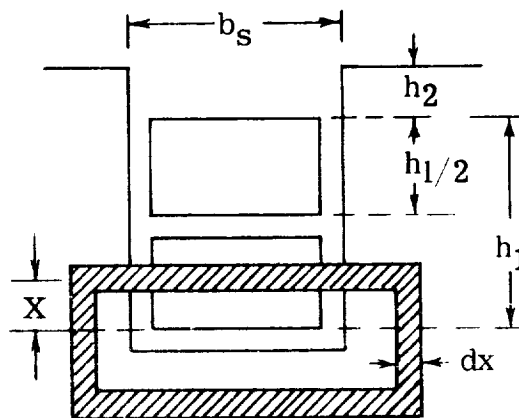

$$L = \frac{3.19n_s^2 (h_{1/2} + h_2)}{4b_s 10^8}$$

For the inductance of the part of the coil itself consider the element  $dx$  enclosing

part of the conductor. The L per slot per inch of core length for this part will

be equal to  $\frac{3.19}{10^8} \sum \frac{N_x^2}{R_x}$  and since  $N_x = \frac{x}{h_{1/2}} \frac{n_s}{2}$  and  $R_x = \frac{b_s}{dx}$  then

$$L = \frac{3.19}{10^8} \int_0^{L_{1/2}} \frac{x^2 n_s^2 dx}{h_{1/2}^2 4b_s} = \frac{3.19 n_s^2 h_{1/2}^3}{10^8 h_{1/2}^2 4b_s^3} = \frac{3.19 n_s^2}{4b_s 10^8} \times \frac{h_{1/2}}{3}$$

and the total inductance of the bottom coil side is

$$L_B = \frac{3.19 n_s^2}{4b_s 10^8} \left( h_{1/2} + h_2 + \frac{h_{1/2}}{3} \right) = \frac{3.19 n_s^2}{10^8} \left( \frac{h_{1/2}}{3b_s} + \frac{h_2}{4b_s} \right)$$

In the same manner the inductance of the top coil side will be that due to its own current plus that due to the flux in the part  $h_2$  above the coil and thus:

$$L_T = \frac{3.19 n_s^2}{4b_s 10^8} \left( \frac{h_{1/2}}{3} + h_2 \right) = \frac{3.19 n_s^2}{10^8} \left( \frac{h_{1/2}}{12b_s} + \frac{h_2}{4b_s} \right)$$

Since a full pitched winding has been assumed, the currents of both coil sides will be in phase in all slots and the mutual inductance in the top coil due to the current in the bottom coil will be equal to that in the bottom coil due to the current in the top. Thus  $L_M$  in the top coil due to  $i$  in the bottom coil will be

$$L_M = \frac{3.19 n_s^2}{4 \ell 10^8} \sum \text{current in the top coil enclosed by the flux from}$$

the bottom.

At the distance  $x$  the current enclosed is

$$\left(\frac{x}{h_{1/2}}\right) dx \text{ and } L_M = \frac{3.19n_s^2}{4b_s 10^8 h_{1/2}} \int_0^{h_{1/2}} x dx = \frac{3.19n_s^2}{10^8} \left(\frac{h_{1/2}}{8b_s}\right)$$

For the portion above the slot

$$L_M = \frac{3.19n_s^2}{10^8} \left(\frac{h_2}{4b_s}\right)$$

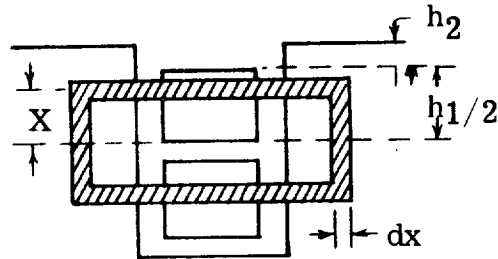

as in the previous cases.

Therefore, since total inductance is  $L_T + L_B + 2L_M$  the total inductance per slot per inch of core length is

$$L = \frac{3.19n_s^2}{10^8} \left( \frac{h_{1/2}}{12b_s} + \frac{h_2}{4b_s} + \frac{h_{1/2}}{3b_s} + \frac{h_2}{4b_s} + \frac{2h_{1/2}}{8b_s} + \frac{2h_2}{4b_s} \right) = \frac{3.19n_s^2}{10^8} \left( \frac{2h_{1/2}}{3b_s} + \frac{h_2}{b_s} \right)$$

Since the portion of the slot between the coils has been neglected it can now be included by making  $h_{1/2}$  in the above derivation equal to

$\frac{h_1}{2}$  and the formula for  $L$  will then be:

$$L = \frac{3.19n_s^2}{10^8} \left( \frac{h_1}{3b_s} + \frac{h_2}{b_s} \right)$$

The tooth tip and zigzag leakage components have been derived by Kilgore with flux plotting methods and these have been determined to be

$$\frac{b_t^2 n_s^2 3.19}{16t_s g 10^8} \text{ and } \frac{.35b_t n_s^2 3.19}{t_s 10^8}$$



Adding these to the slot leakage portion gives

$$L = \frac{3.19n_s^2}{10^8} \left( \frac{h_1}{3b_s} + \frac{h_2}{b_s} + \frac{b_t^2}{16t_s g} + \frac{.35b_t}{t_s} \right)$$

The above derivation has been based upon a full pitched integral slot winding. When the winding is chorded, however, as is usually the case in polyphase machines, the currents in the two coil sides in a certain number of slots will be out of phase and the coefficient of self inductance will be smaller than for the full pitch case. For the slots in which both the bottom and top layer belong to the same phase the conditions are the same as for full pitch. Both coil sides carry currents of the same phase and the phase angle between the currents is zero. In the slots in which the bottom layer and top layer belong to different phases, the phase angle  $\beta$  between the currents is not zero and the mutual inductance between the two layers will be reduced. The reduction factor is equal to  $\cos\beta$ .

Two reduction factors have to be used:  $K_{xco}$  for the slot part in which the conductors lie, and  $K_{xt}$  for the part above the conductors. Thus  $L$  becomes

$$L = \frac{3.19n_s^2}{10^8} \left[ K_{xco} \left( \frac{h_1}{3b_s} \right) + K_{xt} \left( \frac{h_2}{b_s} \right) + \frac{b_t^2}{16t_s g} + \frac{.35b_t}{t_s} \right]$$

The factors  $K_{xco}$  and  $K_{xt}$  will vary according to the percent pitch and when they are derived they are found to be independent of the number of slots per phase per pole. Hence, since they depend solely upon the percent pitch, they have been combined into a single factor  $K_x$  which is reasonably accurate for most machines. It is determined as follows:

$$K_x = \frac{1}{4} \left( \frac{3y}{mq} + 1 \right) \text{ for three phase machines}$$

$$K_x = \frac{y}{mq} \text{ for two phase machines}$$

Therefore the leakage inductance per slot finally becomes

$$L = \frac{3.19n_s^2}{10^8} K_x \left( \frac{h_2}{b_s} + \frac{h_1}{3b_s} + \frac{b_t^2}{16t_s g} + \frac{.35b_t}{t_s} \right)$$

and the per unit reactance per phase will be

$$X_s = 2\pi f L \frac{Q \ell}{m} \frac{I_{ph}}{E_{ph}} \quad \text{where}$$

$$I_{ph} = \frac{A \pi d}{Q K_p n_s}$$

$$E_{ph} = \frac{1}{\sqrt{2}} n_s C_1 B_g \ell \frac{\pi d \text{RPM}}{60} 10^{-8} \frac{Q}{m} K_p K_d$$

(see total flux derivation)

$$X_s = \frac{2\pi f \text{RPM} 3.19n_s^2 K_x Q A \pi d \sqrt{2}}{m 120 10^8 Q K_p n_s n_s C_1 B_g \ell \pi d \text{RPM} Q K_p K_d} \left( \frac{h_2}{b_s} + \frac{h_1}{3b_s} + \frac{b_t}{16t_s g} + \frac{.35b_t}{t_s} \right) \frac{\sqrt{2}}{\sqrt{2}}$$

Substituting  $Q = pmq$

$$X_s = \frac{20pAmK_x}{m^2 qpK_p^2 C_1 B_g K_d \sqrt{2}} \left( \frac{h_2}{b_s} + \frac{h_1}{3b_s} + \frac{b_t^2}{16t_s g} + \frac{.35b_t}{t_s} \right) \frac{K_d}{K_d}$$

$$\text{Let } C_x = \frac{K_x}{K_p^2 K_d^2} \quad \text{and since } X = \frac{AK_d}{\sqrt{2} C_1 B_g}$$

$$X_s = X C_x \frac{20}{mq} \left( \frac{h_2}{b_s} + \frac{h_1}{3b_s} + \frac{b_t^2}{16t_s g} + \frac{.35b_t}{t_s} \right)$$

Many attempts have been made to determine accurate formulas for the end winding leakage reactance, but the one that appears to be most promising for small machines is the one proposed by E. C. Barnes in AIEE Volume 70-1951. Expressed in per cent notation this formula will be:

$$\% X_E = 6.28f \left(\frac{n_s}{C}\right)^2 q^2 K_p^2 pm \left[\frac{\phi_{EL_E}}{2n}\right] \frac{I_{ph}}{E_{ph}} K_E 10^{-6}$$

where  $\frac{\phi_{EL_E}}{2n}$  is proportional to the pole pitch and is taken from Graph No. 1 and  $K_E$  is proportional to the ratio of the calculated  $L_E$  to the  $L_E$  of Graph No. 1.

$$K_E = \sqrt{\frac{\text{calculated } L_E}{L_E \text{ from Graph \#1}}} \quad (\text{for } d \text{ below } 8'' \text{ diameter})$$

$$\text{and } K_E = \frac{\text{calculated } L_E}{L_E \text{ from Graph \#1}} \quad (\text{for } d \text{ above } 8'' \text{ diameter})$$

$$\text{Since } I_{ph} = \frac{CA\pi d}{QK_p n_s} \quad \text{and } E_{ph} = \frac{n_s C_1 B_g \ell \pi d \text{RPM} QK_p K_d}{\sqrt{2} C 60 M 10^8}$$

$$\% X_E = 6.28f \left(\frac{n_s}{C}\right)^2 q^2 K_p^2 pm \left[\frac{\phi_{EL_E}}{2n}\right] K_E \frac{\sqrt{2}}{\sqrt{2}} \left[ \frac{CA\pi d}{QK_p n_s} \frac{\sqrt{2} 60 10^8 mc}{n_s C_1 B_g \ell \pi d \text{RPM} QK_p K_d 10^6} \right]$$

$$\text{Multiplying by } \frac{K_d}{K_d} \text{ and substituting } f = \frac{P(\text{RPM})}{2 \times 60}; \quad X = \frac{100AK_d}{\sqrt{2} C_1 B_g}; \quad q = \frac{Q}{pm}$$

$$\text{gives } \% X_E = X \frac{6.28 P \text{RPM}}{2 \times 60} \frac{Q^2 pm}{p^2 m^2} \left[\frac{Q_E L_E}{2n}\right] K_E \frac{2 \times 60m}{Q \ell \text{RPM} K_d^2}$$

$$\% X_E = X \frac{6.28}{\ell K_d^2} \left[\frac{Q_E L_E}{2n}\right] K_E$$

## POTIER REACTANCE

The terminal voltage of an alternator under load differs from its open circuit voltage at the same field excitation. This difference is due to a voltage drop through the armature caused by leakage reactance, armature effective resistance, and armature reaction. The relative importance of the three factors depends upon the power factor of the load. With a reactive load at zero power factor the decrease in the terminal voltage is due almost entirely to the armature reaction and the armature leakage reactance. Under this condition the effective resistance drop is in quadrature with the terminal voltage, and since it is small in magnitude, it has little influence on the change in the terminal voltage caused by a change in load. Likewise, the resultant field  $F_{NL}$  is almost exactly equal to the algebraic difference between  $F_{NL}$  and  $F_{DM}$ , and the terminal voltage  $E$  is nearly equal to the algebraic difference between  $E_g$  and  $I\phi X$ . Under these conditions the armature reaction subtracts almost directly from the impressed field and the armature leakage reactance drop subtracts almost directly from the generated voltage. It follows from this that if an open circuit characteristic  $OB$ , and a curve  $CD$  are plotted as in Figure 14, showing the variation in the terminal voltage with excitation for the condition of constant stator current at a reactive power factor of zero, the two curves are so related that any two points, as  $E$  and  $F$ , which correspond to the same degree of saturation and consequently to the same generated voltage, are displaced from each other horizontally by an amount equal to the armature reaction and vertically by an amount equal to the leakage reactance drop.

$GF$  represents the armature reaction in equivalent field amperes and  $GE$  represents the leakage reactance drop in volts. The armature leakage reactance per phase for a Y connected generator is thus  $X = \frac{EG}{\sqrt{3} I}$  and this reactance is called the Potier reactance. The triangle  $EJF$  is known as the Potier Triangle.

If the leakage reactance is constant and the increase in field current necessary to balance a given number of ampere turns of armature reaction is independent of the saturation of the magnetic circuit, Potier triangles drawn between the open circuit saturation curve and the zero power factor curve at points corresponding to different degrees of saturation would be identical. Under these conditions the zero power factor curve would have the same shape as the open circuit saturation curve but would be displaced from the open circuit curve by a distance equal to the length of the hypotenuse of the Potier triangle. Actually, the field pole leakage increases somewhat with an increase in saturation, and for this reason the number of field ampere turns which are necessary to balance a fixed number of ampere turns of armature reaction is not quite constant. In spite of this change in field pole leakage, the curves have nearly enough the same shape for practical purposes and are assumed to have the same shape when determining generator performance.

In order to make use of the Potier method to construct a zero power factor curve it is necessary to locate two points on the Potier triangle. Figure 14 shows how the method is applied. A triangle OCL is constructed with OC equal to the amperes corresponding to short circuit ampere turns ( $F_{sc} = X_d F_g$ ). The altitude LT is made equal to  $IX_{pl}$  where Potier's reactance is calculated by a partly empirical method and

$$X_p = X_l + \left[ \frac{F_{TR} + F_{CR}}{F_{TR} + F_{CR} + F_T + F_C} \right] X_{FS}$$

$$X_{FS} = \left( \frac{\lambda_{rs}}{\frac{2d}{P_g} + \lambda_{rs}} \right) X_d$$

As the point L of the triangle is moved along the no load saturation curve, point C traces the zero power factor saturation curve.

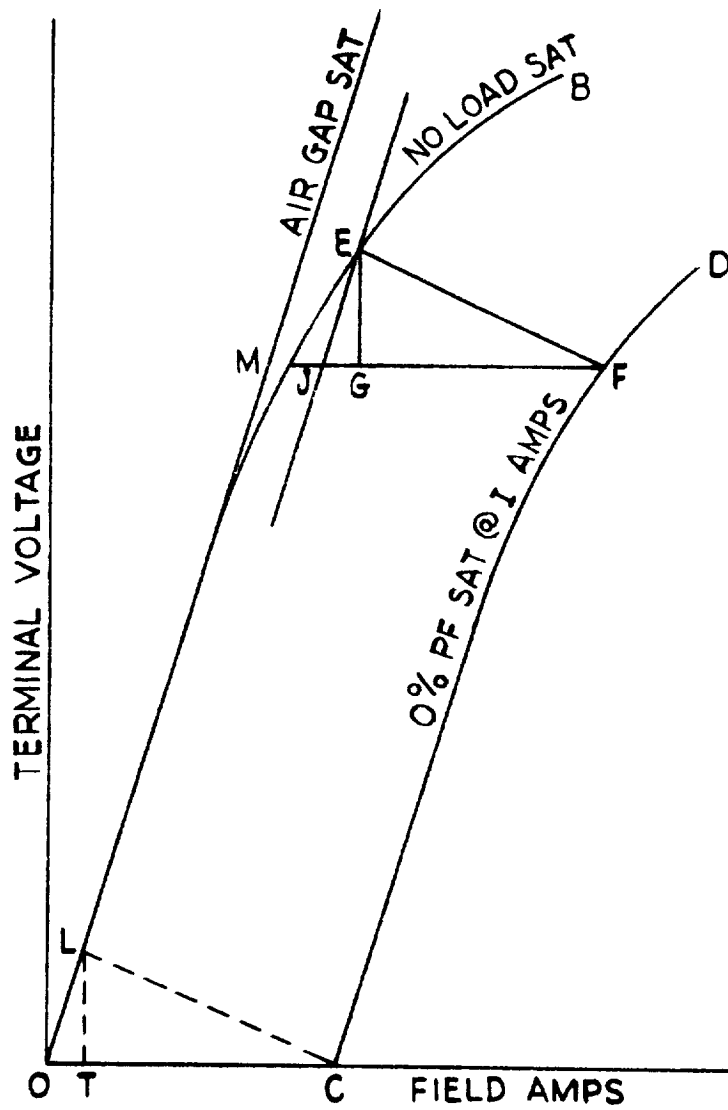

FIGURE 14

## TRANSIENT AND SUBTRANSIENT REACTANCES AND TIME CONSTANTS

Figure 9 shows the short circuit current in one phase of a three phase alternator that has had all three phases shorted when operating at no load. The line of drawn midway between the two sides of the envelope is called the direct current component and has different magnitudes in the three phases. The envelope of the alternating component is redrawn in Figure 10 with its axis horizontal, i. e., with the direct current component eliminated. The alternating components are the same in all three phases. When an alternating voltage is short circuited through an inductance and a resistance in series, the short circuit current will consist of two components. These components are the unidirectional or DC component which decreases logarithmically to zero, and an alternating component which is fixed by the voltage, the resistance, and the reactance of the circuit, and is constant when the resistance and reactance are constant.

In the short circuited generator the reactance is not constant until the condition equivalent to synchronous reactance is reached. When a sudden change occurs in the stator current the armature reactance is no longer constant, and under this condition voltages are induced by the changing armature reaction in the field winding, and in any other closed windings on the field structure. As the stator current builds up the voltages of the field structure will build up simultaneously, tending to maintain constant the total number of ampere turns acting on the magnetic circuit. These voltages cause transient currents in these parts.

In a polyphase generator the alternating components of the short circuit stator currents produce armature reaction which is fixed in direction with respect to the poles but decreases from an initial value to a final value fixed by the steady state short circuit currents. To balance this increase in armature reaction there must be an increase in the field current. This increase in field current is in the same direction as the initial field current since the armature reaction caused by lagging currents is demagnetizing. The change in field current decreases and becomes zero, when steady state conditions are reached.

The D.C. components in the stator currents produce a resultant MMF which is fixed with respect to the stator but has fundamental frequency with respect to the field. To balance this the field current must contain an alternating component of fundamental frequency. This alternating component in the field current produces an MMF of fundamental frequency in the air gap which is fixed in direction with respect to the field poles. This MMF can be resolved into two oppositely rotating components, each of which rotates at synchronous speed with respect to the stator. The component which rotates in the direction of the rotor balances the the stator MMF caused by the D.C. components in the stator currents. The oppositely rotating component rotates at double synchronous speed with respect to the stator winding and must be balanced by second harmonic components in the transient stator currents. All except the fundamental alternating components decrease to zero when steady state conditions have been reached and the fundamental alternating components become the steady state short circuit currents.

Consider the elementary generator shown in Figure 11. The stator winding is open and the rotor winding is excited by a D.C. current of magnitude  $I_f$ . At the time  $t = 0$ , when the axes of both windings are perpendicular to each other, the stator winding is suddenly short circuited. As stated previously, the total flux interlinked with each winding under this condition will remain constant. Thus, the total flux interlinked with the field winding at  $t = 0$  will consist of two parts; one part going through the path of the main flux, and the other part going through the leakage path of the rotor. The total flux interlinked with the armature at  $t = 0$  is zero.



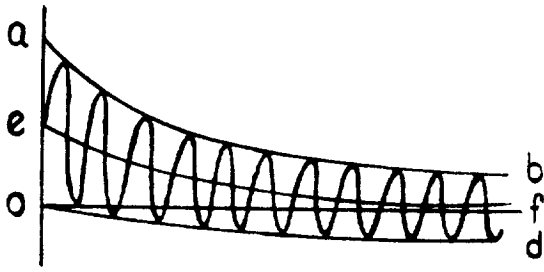

FIGURE 9

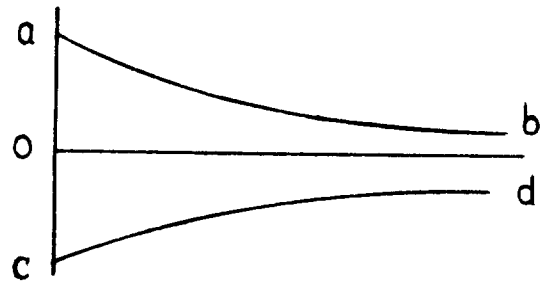

FIGURE 10

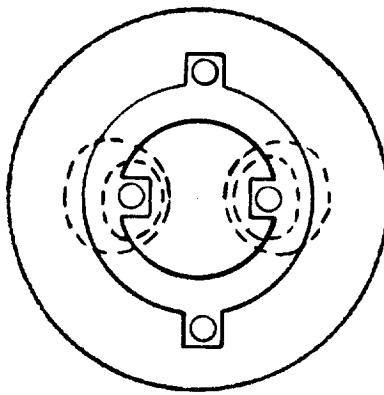

FIGURE 11

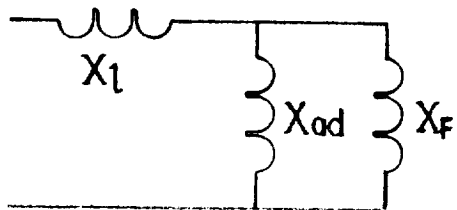

FIGURE 12

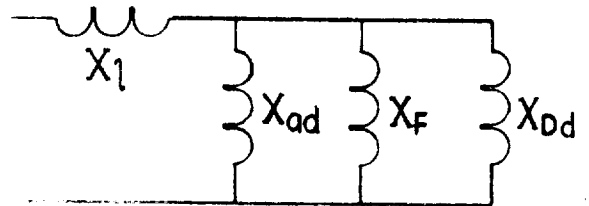

FIGURE 13

During the time  $t$  the rotor moves through an angle  $a = \omega t$  and this produces a current  $i_a$  in the stator winding and also forces a current  $i_f$  to flow in the field winding in order to sustain the field flux interlinkage. The transient currents  $i_a$  and  $i_f$  are determined by the angle  $a$  as well as the leakage fluxes of both windings and they become a maximum when  $a = \pi/2$ , a quarter period after the short circuit occurred.

It can be shown that the maximum transient stator current is determined by the equivalent circuit of Figure 12, and the reactance that corresponds to this circuit is the direct axis unsaturated transient reactance,  $X'_{du}$ . The field reactance,  $X_F$ , is given in Kilgore's paper as

$$X_F = X \frac{4}{\pi} C_M^2 \lambda_F$$

and therefore the unsaturated transient reactance becomes

$$X'_{du} = X \ell + X_F \left( \frac{X_{ad}}{X_F + X_{ad}} \right)$$

The saturated transient reactance has been determined empirically and is approximately 88% of the unsaturated value.

In the determination of the transient reactance only the field winding of the rotor was considered. If there is a damper winding in the poles, or if eddy currents are possible in the rotor iron, subtransient currents similar to the transient currents of the field winding are induced in these circuits. These circuits will support the field winding for a few cycles and therefore they have to be considered as acting in parallel with the field winding. The equivalent circuit for this case is shown in Figure 13.  $X_{Dd}$  is the leakage reactance of the damper winding and eddy current circuits together in the direct axis, and per Kilgore's paper

$$X_{Dd} = X \lambda_{Dd}$$

where  $X_{Dd} = \frac{3.19p}{d} [g + \delta_d + h_{r2}]$

$\delta$  is a depth of penetration factor and varies as  $\sqrt{\frac{1}{f}}$ . It is equal to 1.2 at 60 cycles and  $(\sqrt{\frac{60}{400}}) (1.2)$  at 400 cycles. The subtransient reactance is therefore

$$X_d'' = X_l + X_{Dd}$$

The rate of decrease of the transient and subtransient currents will be determined by the time constants of the windings involved. The damper winding and eddy current circuits have much larger ratios of resistance to leakage reactance than the field winding and therefore their influence will be much shorter in duration than that of the field winding. As a matter of fact, the damper winding and eddy current circuits influence the currents only during the first few cycles. The field winding determines the decrease of the amplitudes for a much longer time. The change of the amplitudes during the short circuit period is such that the amplitudes are determined first by the subtransient reactance  $X_d''$ , then by the transient reactance  $X_d'$ , and finally by the synchronous reactance  $X_d$ .

The total self inductance of the field winding is

$$L_f = \frac{N_f^2 \mu_r}{10^8} [C_F (3.19 \frac{t_p}{g_e}) + \lambda_F]$$

where  $C_f$  is the ratio of the interlinkages of the field with its own flux to the maximum interlinkages that would be produced with a uniform gap and a concentrated field winding.

## TIME CONSTANTS

The time constant is the time in seconds required for the particular component to decay to 36.8% of its initial value. The time constant  $T'_{do}$  is the time constant of the field winding with the armature circuit open and with negligible external resistance and inductance in the field circuit. Therefore, the open circuit time constant is

$$T'_{do} = \frac{L_f}{R_f}$$

The armature time constant is the time constant of the DC component and is

$$T_a = \frac{X_2}{2\pi f r_a} \quad \text{where } r_a = \frac{\text{stator } I^2 R \text{ (KW)}}{\text{rated KVA}}$$

The transient time constant  $T'_d$  is the time constant of the transient reactance component of the alternating wave and with good approximation is

$$T'_d = \frac{X'_d}{X_d} T'_{do}$$

The subtransient time constant  $T''_d$  is the time constant of the subtransient reactance component of the alternating wave and is approximately .005 second for 400 cycle machines. (from tests of 60 cycle machines  $T''_d \approx .035$  second or 2.1 cycles).

## Resistances

### Positive Sequence Resistance $r_1$

The positive sequence resistance of an a-c machine is its a-c armature resistance  $r$  which is greater than the d-c armature resistance  $r_a$  because of non-uniform current density and local iron loss.  $r_1$  is usually disregarded in system studies except in the case of a 3 phase short circuit near the generator terminals.

### Zero-Sequence Resistance $r_0$

This resistance is small and is usually neglected unless a resistor is used in the neutral of a wye connected machine.

It is the sum of the d-c resistance of the three phases (in a 3 phase machine). If a neutral resistor is used, add 3 x the resistor also.

### Negative Sequence Resistance $r_2$

The negative sequence power input to the armature supplies 1/2 of the copper losses of the rotor circuits. The other 1/2 of rotor copper losses are supplied mechanically.

The negative sequence resistance depends upon the resistance of the damper circuit if there is one. It is equal to 1/2 the rotor damper circuit resistance plus the stator resistance

$$r_2 = R_s + \frac{1}{2} R_r$$

## GENERATOR VOLTAGE AND OUTPUT EQUATIONS

To begin a generator design when there is no required envelope or other size limitation, time can be saved by using an output formula that relates rotor size to output kva. The output equation is given here and then developed from the relation  $E = N_c \ell v B_{\max} 10^{-8}$

$$\text{Output kva} = \frac{d_r^2 \ell (\text{RPM}) A B_g}{90 \times 10^7}$$

where  $d_r$  = rotor diameter which is for practical purposes the same as the stator I. D. (inches)

$\ell$  = stator length in inches

A = ampere wires/inch of bore periphery

$B_g$  = gap density in kilolines/in<sup>2</sup>

All electromagnetic generators convert mechanical energy to electrical energy through a change of flux linking the conductors of the output winding.

The voltage generated in a single conductor is -

$$E = \ell v B_{\max} 10^{-8}$$

$$e/\text{coil} = 2 E_{\max} \sin \omega t K_p$$

$$E_{\text{ph}} = \frac{e_{\text{rms}}}{\text{Coil}} \times \frac{\text{Coils in Series}}{\text{phase}} \times K_d$$

$$= \frac{e_{\text{rms}}}{\text{Coil}} \times \frac{\text{Total Slots } K_d}{\text{Phases} \times \text{Parallels}}$$

$$= \frac{2 \ell v B_{\max} 10^{-8}}{\sqrt{2}} \times \frac{Q K_d}{mc} \times N_s$$

( $N_s$  = Conductors/Slot)

$$\phi_T = B_g \pi d_r \ell$$

$$B_{\max} \text{ Fundamental} = C_1 B_g$$

$$\ell_v B_{\max} \text{ Fund} = C_1 \phi_T \times \frac{\text{RPM}}{60}$$

$$E \text{ phase} = C_1 \phi_T \frac{\text{RPM}}{60} \times \frac{K_p N_s Q K_d 10^{-8}}{\sqrt{2} m c}$$

$$= \frac{C_1 \phi_t \frac{\text{RPM}}{60} N_e K_d \times 10^{-8}}{\sqrt{2} m}$$

( $N_e$  = total effective conductors in the stator =  $\frac{Q N_s K_p}{C}$ )

$$\phi_T = \frac{60 E_{ph}}{\text{RPM } N_e} \times \frac{\sqrt{2} m}{C_1 K_d} = \frac{60 E_{LL} \sqrt{2} m 10^8}{\text{RPM } N_e C_1 K_d \frac{E_{LL}}{E_{ph}}}$$

$$C_w = \text{Winding Constant} = \frac{C_1 K_d \frac{E_{LL}}{E_{ph}}}{\sqrt{2} m}$$

$$\phi_T = \frac{60 \times 10^5 \times E_{LL}}{\text{RPM } C_w N_e}$$

$$C_w \text{ for 3 phase} = .39 C_1$$

$$C_w \text{ for 2 phase } (90^\circ) = .319 C_1$$

$$C_w \text{ for 3 phase} = .225 C_1$$

The derived voltage equation can be found in the AIEE Paper No. 50-201 dated August, 1950, "Design Calculations for A. C. Generators" by David Ginsberg,

$$E_{LL} = \frac{\Phi_T (\text{RPM}) C_w N_e}{60 (10^5)}$$

Where  $\Phi_T$  = Hypothetical total flux in the air gap of the machine (in kilolines). This is the maximum density over the pole times the area of the stator bore.

$N_e$  = Total effective conductors in the machine.

RPM = Revolutions per minute.

$C_w$  = Winding Constant

$$= \frac{E_{LL}}{m E_{ph}} \times \frac{C_1 K_d}{\sqrt{2}} = .39 C_1 \text{ for a 3 phase machine}$$

Where  $m$  = No. of phases

$K_d$  = Distribution Factor = .955

$C_1$  = Ratio  $\frac{\text{Maximum Fundamental}}{\text{Actual Maximum}}$  of the flux wave. This value is 1.0 for a sine wave and a sine wave is assumed in the formula.

Then 
$$\text{KVA} = \frac{I_L E_{LL} \sqrt{3}}{10^{-3}}$$

$$\text{KVA} = \left( \frac{\Phi_T \text{RPM} C_w N_e}{60 \times 10^5} \right) I \sqrt{3} \times 10^{-3}$$

$$\Phi_T = B_{\text{gap}} \times \text{Area Gap}$$



$$I = \frac{A\pi d}{N_e} \text{ since } A = \frac{N_e I_{ph}}{\pi d} = \text{ampere wires per inch of stator bore periphery}$$

$$KVA = \frac{B_g (\pi d l_c) RPM (.39 C_1) N_e \sqrt{3} A \pi d}{60 \times 10^8 N_e}$$

$$= \frac{B_g 9.85 d^2 l_c RPM .39 C_1 A \sqrt{3}}{60 \times 10^8}$$

$$KVA = \frac{B_g (d^2 l_c) (RPM) A}{90 \times 10^7}$$

The basic equation.

If a pole embrace is used that gives other than  $C_1 = 1.0$  (or if the maximum of the fundamental flux wave is not equal to the maximum of the actual flux wave), the KVA formula should be multiplied by  $C_1$ .

Note: Liwschitz-Garik and Whipple in "Electric Machinery" Vol. 2, appendix 8, pp 553-557 derived an equivalent formula for either motors or generators.

*Cm*

### DIRECT AXIS COMPONENT OF ARMATURE REACTION

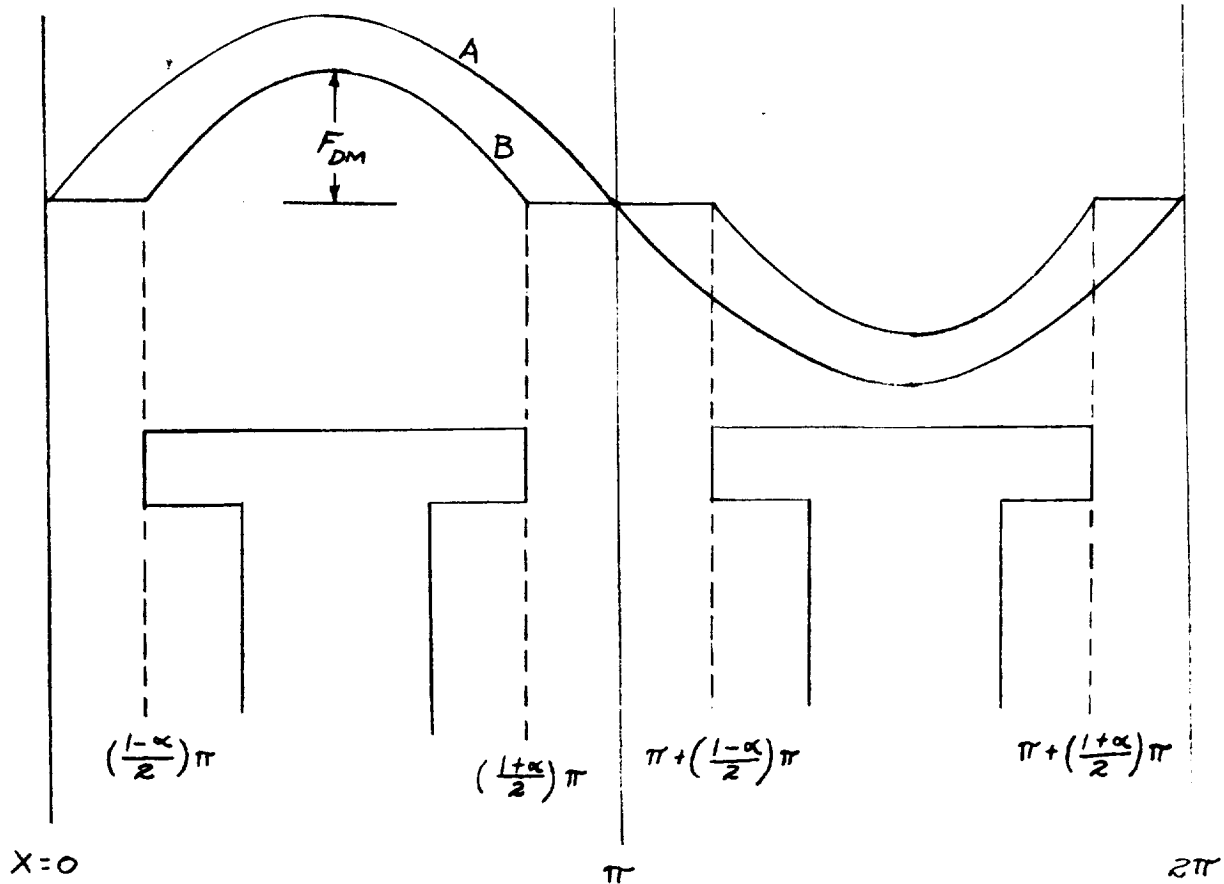

When the air gap under the pole is constant the field produced by the direct axis armature reaction MMF wave A will have the approximate shape B insofar as its reaction on the field pole is concerned. Since this MMF produces very little demagnetizing effect in the interpolar region it is sufficient to consider only the fundamental of the effective part of the MMF curve (the part which lies under the pole). The amplitude of this fundamental is given by the equation

$$A_1 = \frac{1}{\pi} \int_0^{2\pi} f(x) \sin x dx$$

If the ratio of the pole arc to the pole pitch is designated as  $\alpha$  then

$$f(x) = 0 \text{ from } x = 0 \text{ to } x = \left(\frac{1-\alpha}{2}\right)\pi$$

$$f(x) = F_{DM} \sin x \text{ from } \left(\frac{1-\alpha}{2}\right)\pi \text{ to } \left[\left(\frac{1-\alpha}{2}\right)\pi + \alpha\pi\right] = (1+\alpha)\frac{\pi}{2}$$

$$f(x) = 0 \text{ from } \left(\frac{1+\alpha}{2}\right)\pi \text{ to } \pi + \left(\frac{1-\alpha}{2}\right)\pi$$

$$f(x) = F_{DM} \sin x \text{ from } \pi + \left(\frac{1-\alpha}{2}\right)\pi \text{ to } \pi + (1+\alpha)\frac{\pi}{2}$$

$$A_1 = \frac{1}{\pi} \left[ \int_{\left(\frac{1-\alpha}{2}\right)\pi}^{\left(\frac{1+\alpha}{2}\right)\pi} F_{DM} \sin^2 x \, dx + \int_{\pi + \left(\frac{1-\alpha}{2}\right)\pi}^{\pi + (1+\alpha)\frac{\pi}{2}} F_{DM} \sin^2 x \, dx \right]$$

$$\int \sin^2 x \, dx = \frac{1}{2}x - \frac{1}{4}\sin 2x$$

$$A_1 = \frac{F_{DM}}{\pi} \left[ \left( \frac{1}{2}x - \frac{1}{4}\sin 2x \right) \Big|_{\left(\frac{1-\alpha}{2}\right)\pi}^{\left(\frac{1+\alpha}{2}\right)\pi} + \left( \frac{1}{2}x - \frac{1}{4}\sin 2x \right) \Big|_{\pi + \left(\frac{1-\alpha}{2}\right)\pi}^{\pi + (1+\alpha)\frac{\pi}{2}} \right]$$

$$A_1 = \frac{F_{DM}}{\pi} \left[ \left( \frac{1+\alpha}{4} - \frac{1}{4}\sin(\pi + \alpha\pi) \right) - \left( \frac{1-\alpha}{4} + \frac{1}{4}\sin(\pi - \alpha\pi) \right) + \left( \frac{\pi}{2} + (1+\alpha)\frac{\pi}{4} \right) - \frac{1}{4}\sin(2\pi + \pi + \alpha\pi) - \frac{\pi}{2} - \left( \frac{1-\alpha}{4} + \frac{1}{4}\sin(2\pi + \pi - \alpha\pi) \right) \right]$$

$$\sin(x+y) = \sin x \cos y + \cos x \sin y$$

$$\sin(\pi + \alpha\pi) = -\sin \alpha\pi$$

$$\sin(3\pi + \alpha\pi) = -\sin \alpha\pi$$

$$\sin(\pi - \alpha\pi) = +\sin \alpha\pi$$

$$\sin(3\pi - \alpha\pi) = +\sin \alpha\pi$$

$$A_1 = \frac{F_{DM}}{\pi} \left[ \frac{\pi}{4} + \frac{\alpha\pi}{4} + \frac{1}{4}\sin \alpha\pi - \frac{\pi}{4} + \frac{\alpha\pi}{4} + \frac{1}{4}\sin \alpha\pi + \frac{\pi}{2} + \frac{\pi}{4} + \frac{\alpha\pi}{4} + \frac{1}{4}\sin \alpha\pi - \frac{\pi}{2} - \frac{\pi}{4} + \frac{\alpha\pi}{4} + \frac{1}{4}\sin \alpha\pi \right]$$

$$A_1 = \frac{F_{DM}}{\pi} \left[ \alpha\pi + \sin \alpha\pi \right]$$

The amplitude of the fundamental of the field MMF will be

$$A_{if} = \frac{1}{\pi} \int_{(1-\alpha)\frac{\pi}{2}}^{(1+\alpha)\frac{\pi}{2}} N_f I_f \sin x \, dx + \int_{\pi + (1-\alpha)\frac{\pi}{2}}^{\pi + (1+\alpha)\frac{\pi}{2}} N_f I_f \sin x \, dx$$

$$A_{if} = \frac{N_f I_f}{\pi} \left[ (-\cos x) \Big|_{(1-\alpha)\frac{\pi}{2}}^{(1+\alpha)\frac{\pi}{2}} + (-\cos x) \Big|_{\pi + (1-\alpha)\frac{\pi}{2}}^{\pi + (1+\alpha)\frac{\pi}{2}} \right]$$

$$A_{if} = \frac{N_f I_f}{\pi} \left[ -\cos\left(\frac{\pi}{2} + \frac{\pi\alpha}{2}\right) + \cos\left(\frac{\pi}{2} - \frac{\pi\alpha}{2}\right) - \cos\left(\frac{3\pi}{2} + \frac{\pi\alpha}{2}\right) + \cos\left(\frac{3\pi}{2} - \frac{\pi\alpha}{2}\right) \right]$$

$$\cos(x+y) = \cos x \cos y - \sin x \sin y$$

$$\cos\left(\frac{\pi}{2} + \frac{\pi\alpha}{2}\right) = -\sin \frac{\pi\alpha}{2}$$

$$\cos\left(\frac{3\pi}{2} + \frac{\pi\alpha}{2}\right) = -\sin \frac{\pi\alpha}{2}$$

$$\cos\left(\frac{\pi}{2} - \frac{\pi\alpha}{2}\right) = \sin \frac{\pi\alpha}{2}$$

$$\cos\left(\frac{3\pi}{2} - \frac{\pi\alpha}{2}\right) = \sin \frac{\pi\alpha}{2}$$

$$A_{if} = \frac{N_f I_f}{\pi} \left[ \sin \frac{\pi\alpha}{2} + \sin \frac{\pi\alpha}{2} + \sin \frac{\pi\alpha}{2} + \sin \frac{\pi\alpha}{2} \right] = \frac{N_f I_f}{\pi} \left( 4 \sin \frac{\pi\alpha}{2} \right)$$

The demagnetizing factor in the direct axis is found by equating  $A$ , and  $A_{if}$

$$\frac{N_f I_f}{\pi} \left( 4 \sin \frac{\pi\alpha}{2} \right) = \frac{F_{DM}}{\pi} (\alpha\pi + \sin \alpha\pi)$$

$$N_f I_f = \frac{F_{DM}}{\pi} (\alpha\pi + \sin \alpha\pi) \frac{\pi}{4 \sin \frac{\pi\alpha}{2}} = C_M F_{DM}$$

$$\text{where } C_M = \frac{\alpha\pi + \sin \alpha\pi}{4 \sin \frac{\alpha\pi}{2}}$$

Although this derivation has been based on the assumption that the air gap under the pole is constant, the formula is much more accurate than might appear. The formula has been checked by flux plots over a wide range of pole shapes from 4 to 88 poles and found to be reasonable accurate

Cg

QUADRATURE AXIS COMPONENT OF ARMATURE REACTION

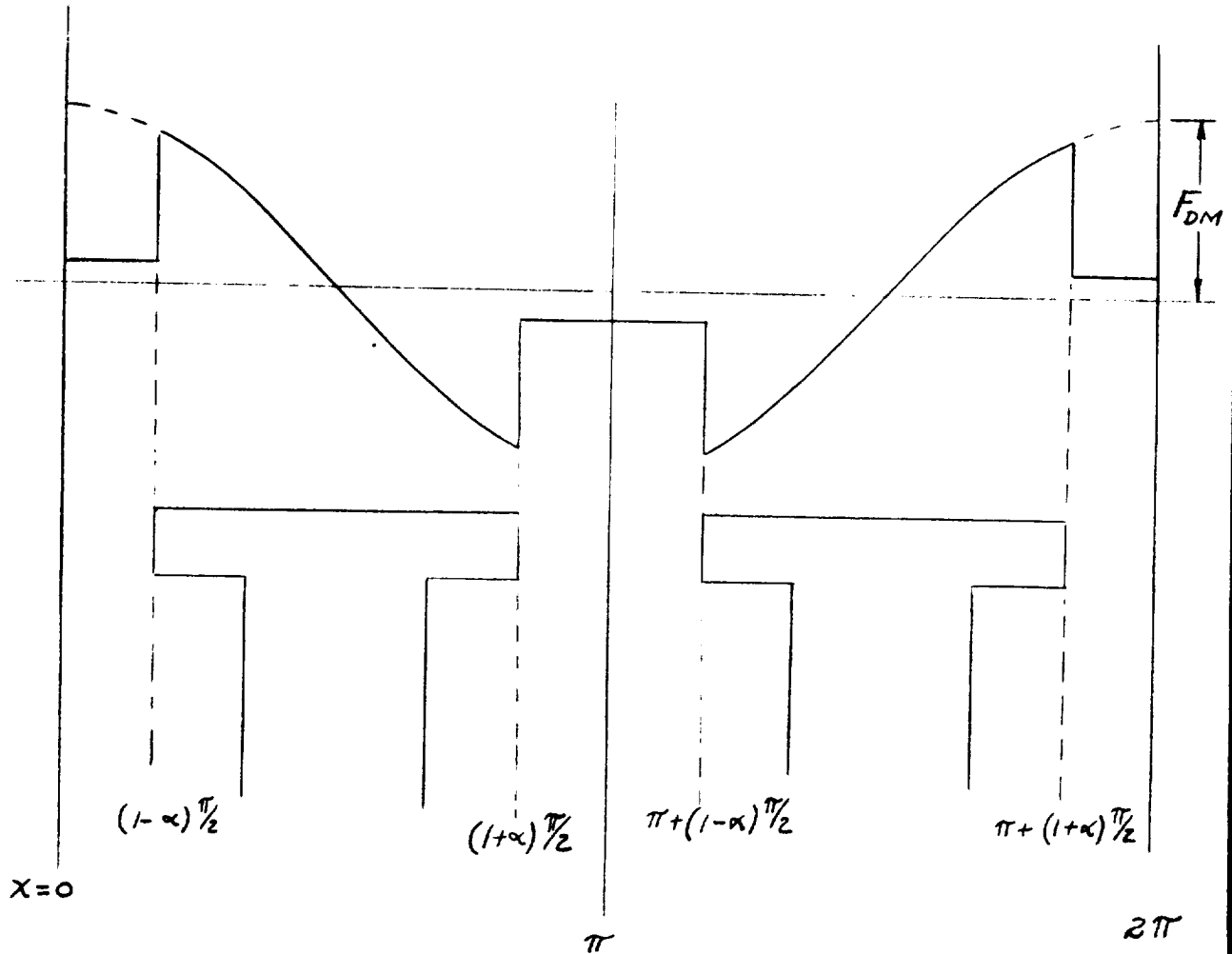

For all practical purposes the armature MMF in the quadrature axis will have the shape indicated insofar as its reaction on the field is concerned. If the assumption ( justified by practice ) is made that the magnitude of the constant part over the interpolar space is equal to  $1/8 F_{DM}$ , the fundamental of this wave will then be found by the equation

$$A_1 = \frac{1}{\pi} \int_0^{2\pi} f(x) \cos x \, dx$$

$$f(x) = \frac{1}{8} F_{DM} \text{ from } x = 0 \text{ to } x = (1-\alpha)\frac{\pi}{2}$$

$$f(x) = F_{DM} \cos x \text{ from } (1-\alpha)\frac{\pi}{2} \text{ to } (1+\alpha)\frac{\pi}{2}$$

$$f(x) = -\frac{1}{8} F_{DM} \text{ from } (1+\alpha)\frac{\pi}{2} \text{ to } \pi + (1-\alpha)\frac{\pi}{2}$$

$$f(x) = F_{DM} \cos x \text{ from } \pi + (1-\alpha)\frac{\pi}{2} \text{ to } \pi + (1+\alpha)\frac{\pi}{2}$$

$$f(x) = \frac{1}{8} F_{DM} \text{ from } \pi + (1+\alpha)\frac{\pi}{2} \text{ to } 2\pi$$

$$A_1 = \left[ \begin{aligned} & \frac{1}{\pi} \int_0^{(1-\alpha)\frac{\pi}{2}} \frac{F_{DM}}{8} \cos x dx + \frac{1}{\pi} \int_{(1-\alpha)\frac{\pi}{2}}^{(1+\alpha)\frac{\pi}{2}} F_{DM} \cos^2 x dx \\ & - \frac{1}{\pi} \int_{(1+\alpha)\frac{\pi}{2}}^{\pi+(1-\alpha)\frac{\pi}{2}} \frac{F_{DM}}{8} \cos x dx + \frac{1}{\pi} \int_{\pi+(1-\alpha)\frac{\pi}{2}}^{\pi+(1+\alpha)\frac{\pi}{2}} F_{DM} \cos^2 x dx + \frac{1}{\pi} \int_{\pi+(1+\alpha)\frac{\pi}{2}}^{2\pi} \frac{F_{DM}}{8} \cos x dx \end{aligned} \right]$$

$$\int \cos x dx = \sin x$$

$$\int \cos^2 x dx = \frac{1}{2}x + \frac{1}{4}\sin 2x$$

$$A_1 = \frac{F_{DM}}{8\pi} \left[ (\sin x) \Big|_0^{(1-\alpha)\frac{\pi}{2}} - (\sin x) \Big|_{(1-\alpha)\frac{\pi}{2}}^{\pi+(1-\alpha)\frac{\pi}{2}} + (\sin x) \Big|_{\pi+(1-\alpha)\frac{\pi}{2}}^{2\pi} \right] \\ + \frac{F_{DM}}{\pi} \left[ \left( \frac{1}{2}x + \frac{1}{4}\sin 2x \right) \Big|_{(1-\alpha)\frac{\pi}{2}}^{\pi+(1-\alpha)\frac{\pi}{2}} + \left( \frac{1}{2}x + \frac{1}{4}\sin 2x \right) \Big|_{\pi+(1-\alpha)\frac{\pi}{2}}^{\pi+(1+\alpha)\frac{\pi}{2}} \right]$$

$$A_1 = \frac{F_{DM}}{8\pi} \left[ \sin\left(\frac{\pi}{2} - \frac{\pi\alpha}{2}\right) - \sin\left(\frac{3\pi}{2} - \frac{\pi\alpha}{2}\right) + \sin\left(\frac{\pi}{2} + \frac{\pi\alpha}{2}\right) - \sin\left(\frac{3\pi}{2} + \frac{\pi\alpha}{2}\right) \right] \\ + \frac{F_{DM}}{\pi} \left[ \frac{\pi}{4} + \frac{\alpha\pi}{4} + \frac{1}{4}\sin(\pi + \alpha\pi) - \frac{1}{4} + \frac{\alpha\pi}{4} - \frac{1}{4}\sin(\pi - \alpha\pi) + \frac{3\pi}{4} + \frac{\alpha\pi}{4} \right. \\ \left. + \frac{1}{4}\sin(3\pi + \alpha\pi) - \frac{3\pi}{4} + \frac{\alpha\pi}{4} - \frac{1}{4}\sin(3\pi - \alpha\pi) \right]$$

$$\sin(x+y) = \sin x \cos y + \cos x \sin y$$

$$\sin(x-y) = \sin x \cos y - \cos x \sin y$$

$$\sin\left(\frac{\pi}{2} - \frac{\pi\alpha}{2}\right) = \cos \frac{\pi\alpha}{2}$$

$$\sin\left(\frac{3\pi}{2} - \frac{\pi\alpha}{2}\right) = -\cos \frac{\pi\alpha}{2}$$

$$\sin\left(\frac{\pi}{2} + \frac{\pi\alpha}{2}\right) = \cos \frac{\pi\alpha}{2}$$

$$\sin\left(\frac{3\pi}{2} + \frac{\pi\alpha}{2}\right) = -\cos \frac{\pi\alpha}{2}$$

$$\sin(\pi + \alpha\pi) = -\sin \alpha\pi$$

$$\sin(\pi - \alpha\pi) = \sin \alpha\pi$$

$$\sin(3\pi + \alpha\pi) = -\sin \alpha\pi$$

$$\sin(3\pi - \alpha\pi) = \sin \alpha\pi$$

$$A_1 = \frac{F_{DM}}{8\pi} \left[ \cos \frac{\pi\alpha}{2} + \cos \frac{\pi\alpha}{2} + \cos \frac{\pi\alpha}{2} + \cos \frac{\pi\alpha}{2} \right] + \frac{F_{DM}}{\pi} \left[ \frac{\pi}{4} + \frac{\alpha\pi}{4} - \sin \frac{\alpha\pi}{4} \right. \\ \left. - \frac{\pi}{4} + \frac{\alpha\pi}{4} - \sin \frac{\alpha\pi}{4} + \frac{3\pi}{4} + \frac{\alpha\pi}{4} - \sin \frac{\alpha\pi}{4} - \frac{3\pi}{4} + \frac{\alpha\pi}{4} - \sin \frac{\alpha\pi}{4} \right]$$

$$A_1 = \frac{F_{DM}}{2\pi} \left( \cos \frac{\pi\alpha}{2} \right) + \frac{F_{DM}}{\pi} (\alpha\pi - \sin \alpha\pi) = \frac{F_{DM}}{\pi} \left( \frac{1}{2} \cos \frac{\pi\alpha}{2} + \alpha\pi - \sin \alpha\pi \right)$$

The amplitude of the fundamental of the field MMF was derived in the determination of  $C_M$  and

$$A_{1f} = \frac{N_f I_f}{\pi} 4 \sin \frac{\alpha\pi}{2}$$

The demagnetizing factor in the quadrature axis is found by equating  $A_1$  and  $A_{1f}$

$$\frac{N_f I_f}{\pi} 4 \sin \frac{\pi\alpha}{2} = \frac{F_{DM}}{\pi} \left( \frac{1}{2} \cos \frac{\pi\alpha}{2} + \alpha\pi - \sin \alpha\pi \right)$$

$$N_f I_f = F_{DM} \left[ \frac{\frac{1}{2} \cos \frac{\pi\alpha}{2} + \alpha\pi - \sin \alpha\pi}{4 \sin \frac{\pi\alpha}{2}} \right] = F_{DM} C_q$$

where

$$C_q = \frac{\frac{1}{2} \cos \frac{\pi\alpha}{2} + \alpha\pi - \sin \alpha\pi}{4 \sin \frac{\pi\alpha}{2}}$$

VECTOR DIAGRAM AND CALCULATION OF LOAD  
EXCITATION OF A SALIENT POLE GENERATOR

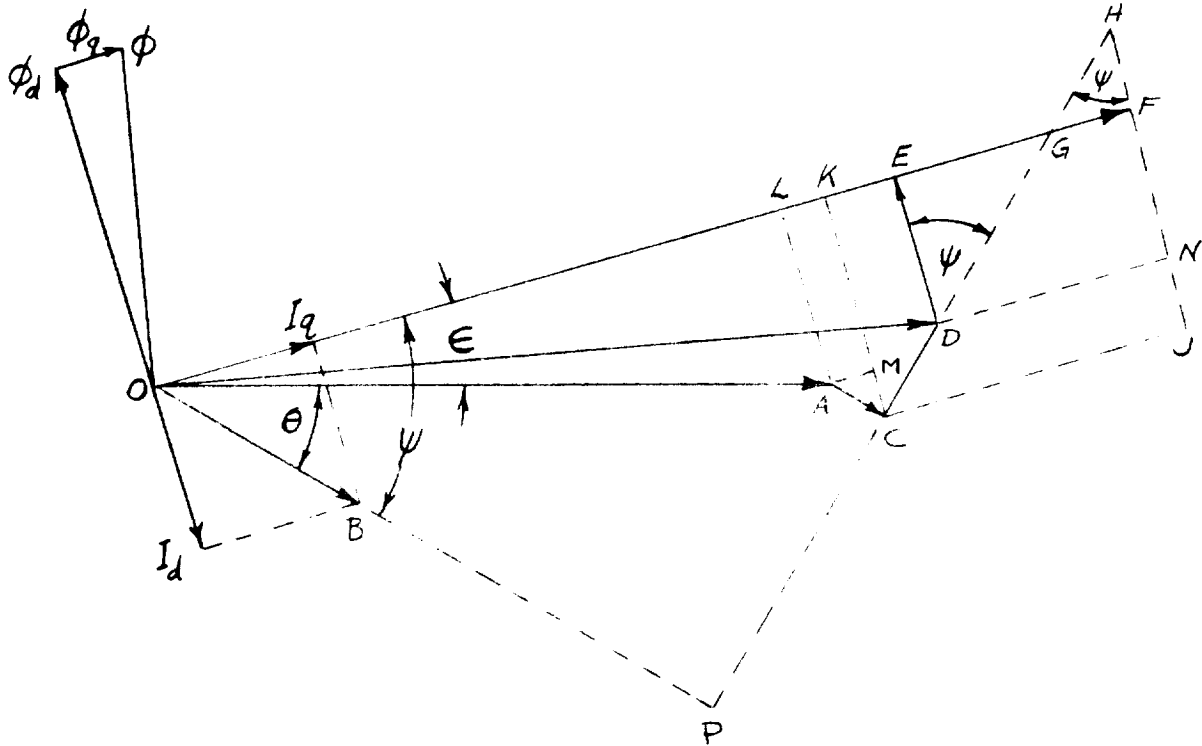

The vector diagram for a salient pole generator is as shown above.  $OA$  is the terminal voltage  $E_{ph}$  and  $OB$  is the phase current  $I_{ph}$  drawn at the proper power factor angle  $\theta$ .  $AC$  is the effective resistance drop  $I_{ph} r_e$  and  $CD$  is the leakage reactance drop  $I_{ph} X_l$ . The stator current is divided into a direct axis component  $I_d$  and a quadrature axis component  $I_q$ , and  $I_d X_{ad}$  will thus be the voltage induced in the stator by the direct axis flux  $\phi_d$  and  $I_q X_{aq}$  will be the voltage induced in the stator by the cross flux  $\phi_q$ . The voltage  $I_q X_{aq}$  will be in quadrature with  $\phi_q$  and it is represented by  $DE$ . Likewise, the voltage  $I_d X_{ad}$  will be in quadrature with  $\phi_d$  and it is represented by  $EF$ . The voltage  $OF$  is the voltage that would exist at no load with excitation corresponding to rated load, neglecting saturation, and this voltage is represented by the symbol  $e_d$ .



Consider the triangle  $OI_q B$  and

$$\sin \psi = \frac{I_d}{OB} = \frac{I_d}{I_{ph}} ; \quad I_d = I_{ph} \sin \psi$$

$$\cos \psi = \frac{I_q}{OB} = \frac{I_q}{I_{ph}} ; \quad I_q = I_{ph} \cos \psi$$

The triangles  $OI_q B$  and  $DEG$  are similar because  $EG$  is perpendicular to  $I_q B$ ,  $GD$  is perpendicular to  $BO$ , and  $DE$  is perpendicular to  $OI_q$ . Thus angle  $O$  is equal to angle  $D$ . Also, triangles  $DEG$  and  $HFG$  are similar because  $DE$  is parallel to  $HF$ ,  $EG$  is concentric with  $FG$ , and  $GD$  is concentric with  $GH$ , and therefore angle  $D$  and angle  $H$  are equal. From a similar triangle relationship the angle  $A$  of triangle  $AMC$  is also equal to  $\psi$ .

From triangle  $DHN$

$$\sin \psi = \frac{DN}{DH} = \frac{I_d X_{ad}}{DH}$$

$$DH = \frac{I_d X_{ad}}{\sin \psi} = \frac{I_d X_{ad}}{I_d / I_{ph}} = I_{ph} X_{ad}$$

$$CH = I_{ph} X_{ad} + I_{ph} X_l = I_{ph} X_d$$

$$CJ = KF = CH \sin \psi = I_{ph} X_d \sin \psi$$

$$OL = OA \cos \epsilon = E_{ph} \cos \epsilon$$

$$AM = LK = I_{ph} r_e \cos \psi$$

Thus the nominal voltage  $e_d$  is derived as

$$e_d = OL + LK + KF$$

$$e_d = E_{ph} \cos \epsilon + I_{ph} (r_e \cos \psi + X_d \sin \psi)$$

In the per unit system of notation  $E_{ph}$  and  $I_{ph}$  are unity at rated load conditions and if resistance is neglected the nominal voltage equation becomes

$$e_d = \cos \epsilon + X_d \sin \psi$$

From triangle DEG

$$\cos \psi = \frac{DE}{DG} = \frac{I_q X_{aq}}{DG}$$

$$DG = \frac{I_q X_{aq}}{\cos \psi} = \frac{I_q X_{aq}}{I_q / I_{ph}} = I_{ph} X_{aq}$$

$$CG = CD + DG = I_{ph} X_d + I_{ph} X_{aq} = I_{ph} X_q$$

Therefore, if resistance is again neglected the angles  $\epsilon$  and  $\psi$  can be determined by

$$\tan \psi = \frac{PG}{OP} = \frac{I_{ph} X_q + E_{ph} \sin \theta}{E_{ph} \cos \theta} = \frac{X_q + \sin \theta}{\cos \theta}$$

When load is applied to the generator the flux wave shape will be distorted and the wave form under load will be less effective in generating voltage than the no load wave form. The reason for this is that the fundamental of the wave form under load is relatively less than that of the no load form for an equal total flux per pole under each condition. Therefore the flux per pole under load conditions will be greater than that required at no load, and the flux per pole under load is

$$\Phi_{PL} = \Phi_p [e_d - .93 X_{ad} \sin \psi]$$

The leakage flux under load will also increase and

$$\Phi_{LL} = \Phi_L \left[ \frac{e_d F_g + (1 + \cos \theta) F_T + F_c}{F_g + F_T + F_c} \right]$$

The total flux per pole in the rotor thus becomes

$$\Phi_{PLL} = \Phi_{PL} + \Phi_{LL}$$

and the density of the pole under load is

$$B_{PL} = \frac{\Phi_{PLL}}{a_p}$$

The total ampere turns per pole under load can thus be calculated as

$$F_L = e_d F_g + (1 + \cos \theta) F_T + F_c + F_{PL}$$

#### SINGLE PHASE CALCULATIONS

When two phases of a normal three phase generator are used for single phase operation the machine reactances are first calculated on the basis of a three phase machine and the single phase reactances then become:

$$\begin{aligned}
 X_{ad}(1\phi) &= \frac{X_{ad}(3\phi)}{\sqrt{3}} \\
 X_d(1\phi) &= \frac{X_d(3\phi) + X_2(3\phi)}{\sqrt{3}} \\
 X_q(1\phi) &= \frac{X_q(3\phi) + X_2(3\phi)}{\sqrt{3}} \\
 X'_d(1\phi) &= \frac{X'_d(3\phi) + X_2(3\phi)}{\sqrt{3}} \\
 X''_d(1\phi) &= \frac{X''_d(3\phi) + X_2(3\phi)}{\sqrt{3}}
 \end{aligned}$$

The negative sequence component of the single phase armature reaction wave will induce large currents in the damper winding and this will cause high damper losses under load conditions. Until further experience is accumulated it is not felt advisable to exceed current densities of 10,000 amps/sq. in. in the damper bars under normal load conditions when the current is calculated in the following manner.

$$\text{NEG. SEQ. A.T.} = \frac{[X_{ad}(3\text{phase})] F_g}{\sqrt{3}}$$

$$I_{\text{RMS PER BAR}} = \frac{(\pi)(\text{NEG. SEQ. A.T.})}{(\sqrt{2})(\tau_b + 1)}$$



EFFECT OF INCREASING THE AIR GAP

1 2 3 4 5 6 7 8 9 10 11 12 13 14 15 16 17 18 19 20 21 22 23 24 25 26 27 28 29 30 31 32 33 34 35 36 37 38 39 40 41 42 43 44 45 46 47 48 49 50 51 52 53 54 55 56 57 58 59 60 61 62 63 64 65 66 67 68 69 70 71 72 73 74 75 76 77 78 79 80 81 82 83 84 85 86 87 88 89 90 91 92 93 94 95 96 97 98 99 100

## THE EFFECT OF INCREASING THE AIR-GAP

The losses and reactances of a 30 KVA, 320 CPS, 4800 rpm aircraft generator were calculated for various air-gap lengths. The stator and its output winding were both held unchanged for the range of air-gap lengths.

As would be expected under these conditions, the field excitation requirement soon limits the output and, for this particular machine, the thermal limit for continuous full load operation would be reached when the air-gap was increased from .035" to .055", an increase of 57%.

1-Pole A-C  
 changed

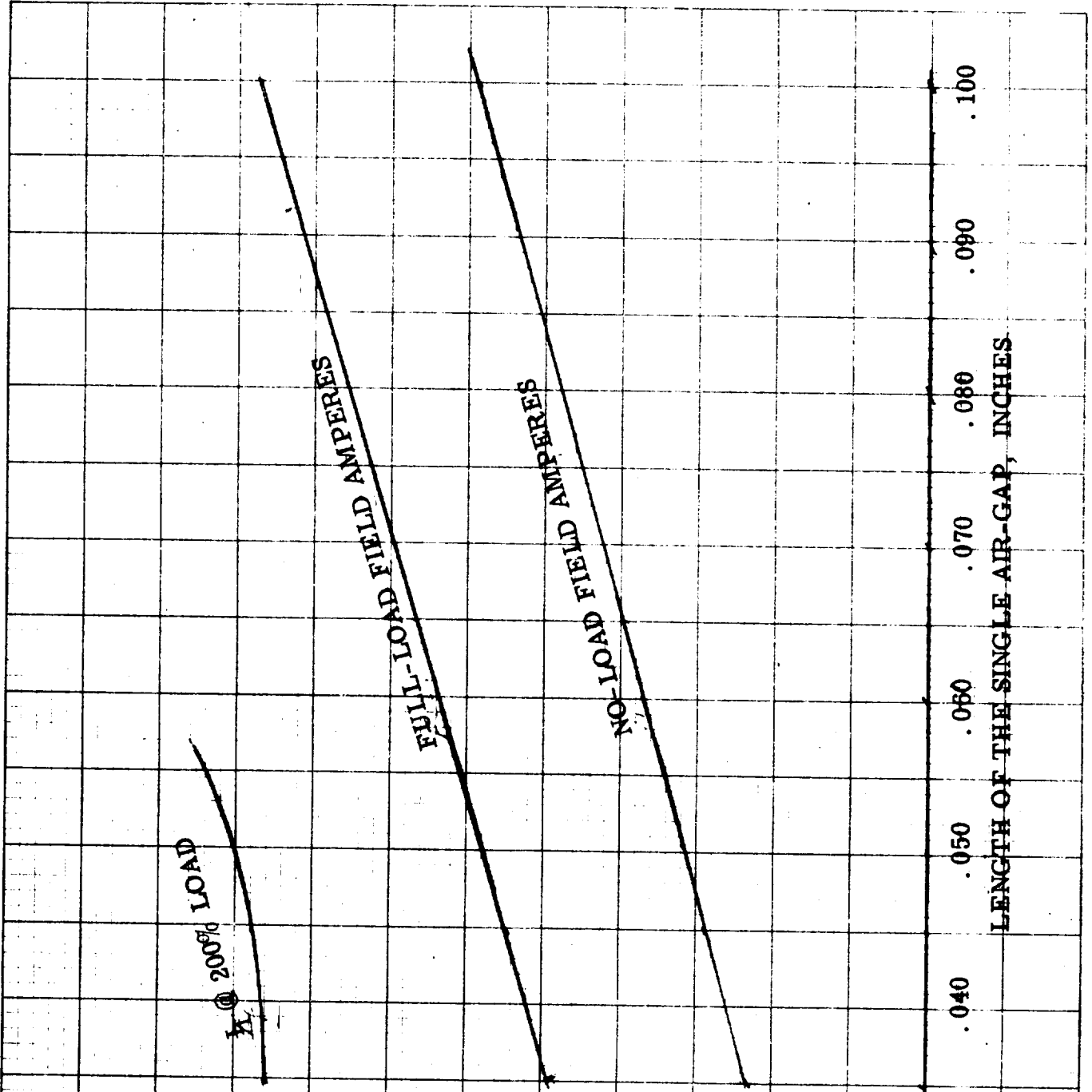

Field Current	
I <sub>1-1/2L</sub> 150% Load	I <sub>2L</sub> 200% Load
32	43
	44
	47



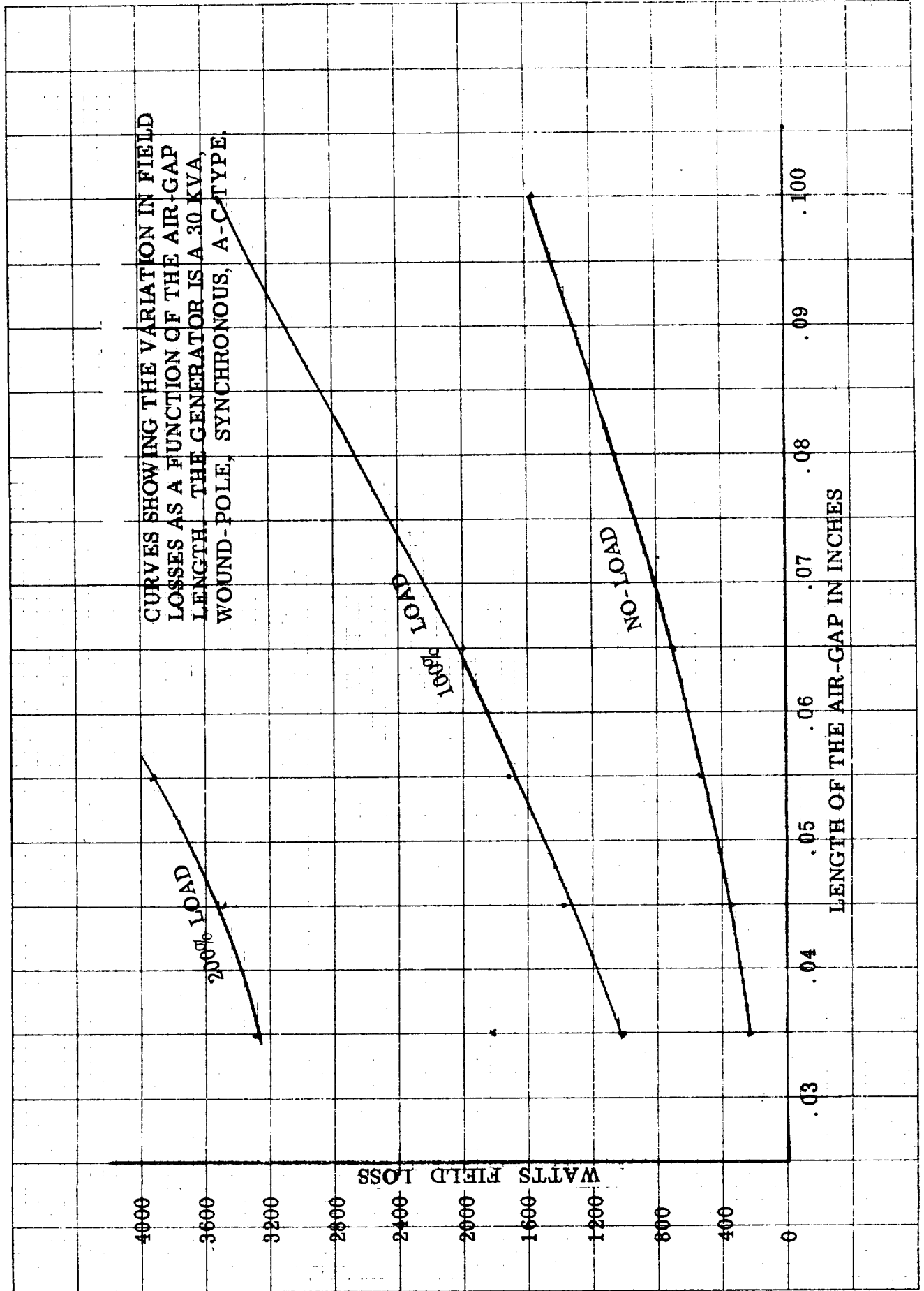

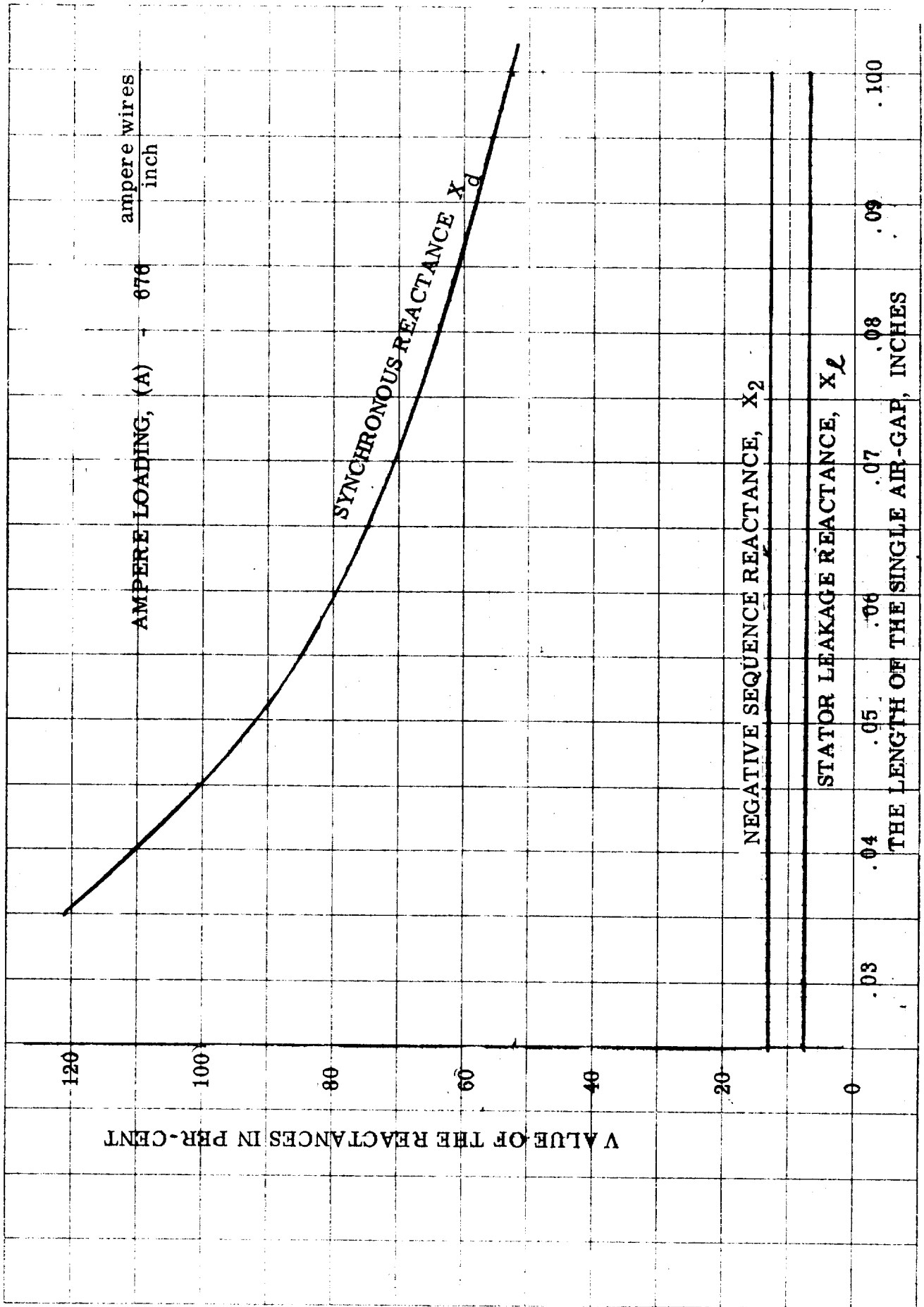

# SALIENT POLE SYNCHRONOUS DESIGN SHEET

STATOR	ROTOR			
Punching I.D. <u>7.25</u>	Single Gap <u>.035</u> $g_e$ <u>.0379</u>			
Punching O.D. <u>9.25</u>	Rotor Diameter <u>7.18</u>			
Core Length <u>3.0</u>	Peripheral Speed _____			
DBS x 2 <u>1.132</u>	Pole Pitch <u>2.84</u> $\alpha$ <u>.71</u>			
Slots <u>8 x 2 = 16</u> <u>96</u>	Pole Area <u>3.17</u>			
Size Slots <u>.122 x .434</u>	Side Leakage <u>.809</u>			
Carter Coeff. <u>1.082</u>	End Leakage <u>.419</u>			
Type Wdg. <u>ser. Y</u>	Tip Leakage <u>.655</u>			
Throw <u>83.3%</u> <u>1 - 11</u>	Leakage Flux <u>26</u>			
Skew & Dist. Fact. <u>.995</u> <u>.958</u>	Pole Density <u>99.1</u>			
Chord Fact. <u>.966</u>	Grade Of Iron <u>M 36</u> <u>22 ga.</u>			
Cond. Per Slot <u>2</u>	No. Damper Bars <u>5</u>	<b>SATURATION</b>		
Total Eff. Cond. <u>184.8</u>	Bar Size <u>.156 dia.</u>			
Cond. Size <u>.075 x .162</u> <u>SGHF</u>	Bar Pitch <u>.403</u> $h_p$ <u>.038</u> $b_p$ <u>.040</u>			
Cond. Area <u>.01194</u>	Turns Per Pole <u>68</u>			
Current Density <u>6970</u>	Cond. Size <u>#14</u> <u>.071 dia.</u>			
Wdg. Const. <u>.397</u> <u>C1</u> <u>1.018</u>	Cond. Area <u>SGSF</u> <u>.00322</u>			
Total Flux <u>3550</u>	Mean Turn <u>10.13</u>			
Gap Area <u>68.4</u>	Res. At <u>300f</u> <u>1.79</u>			
Gap Density <u>52.0</u>	Wt. Of Copper _____			
Pole Const. <u>.650</u>	Wt. Of Iron _____			
Flux Per Pole <u>288</u>	% Load	0	100	
Tooth Pitch <u>.238</u>	Amps.	11.6	24.6	
Tooth Density <u>107</u>	Volts	20.8	44.0	
Core Density <u>92</u>	Amps/In. <sup>2</sup>	3600	7650	
Grade Of Iron <u>M 22</u> <u>29 ga.</u>	Field Leak. React. <u>14.1</u>	Sta. I <sup>2</sup> R	-	815 (300° F)
1/2 Mean Turn <u>6.99</u>	Field Self Induct. <u>.184</u>	Eddy	87	(300° F)
Res. Per Ph. At <u>300° F</u> <u>.0391</u>	Damp. Leak. X <sub>Dd</sub> <u>4.30</u> X <sub>Dq</sub> <u>5.35</u>	Rot. I <sup>2</sup> R	239	1082
Eddy Fact. Top <u>1.185</u>	<b>REACT.-TIME CONST.</b>	Σ Losses	2732	
Eddy Fact. Bottom <u>1.026</u>	Synch. X <sub>d</sub> <u>121.0</u> X <sub>q</sub> <u>76.7</u>	Rating	22500	
Demag. Fact. C <sub>m</sub> <u>.84</u> C <sub>q</sub> <u>.52</u>	Unsat. Trans. <u>22.1</u>	Rtg. + Loss	25232	
Amp. Cond. Per In. <u>.676</u>	Sat. Trans. <u>19.5</u>	% Loss	10.8	
React. Factor <u>.867</u>	Subtrans. X <sub>d</sub> <u>12.30</u> X <sub>q</sub> <u>13.35</u>	% Eff.	89.2	
Cond. Perm. <u>3.56</u>	Neg. Sequence <u>12.8</u>	Stator Watts/In. <sup>2</sup>	15.8	
End Perm. <u>5.45</u>	Zero Sequence <u>3.5</u>	Rotor Watts/In. <sup>2</sup>	18.0	
Leakage React. <u>152.5</u>	Open Circ. Time Con. <u>300° F</u> <u>.103</u>			
Air Gap Perm. <u>68.7</u>	Arm. Time Con. <u>.00234</u>			
React. Of Arm. X <sub>ad</sub> <u>113</u> X <sub>aq</sub> <u>68.7</u>	Trans. Time Con. <u>.0166</u>			
Wt. Of Copper _____	Subtrans. Time Con. <u>.0065</u>			
Wt. Of Iron _____				

Type Cooling Air

30 KVA    75 % PF    208 volts    83.4 Amps.    3 Ph.    320 Cycles    4800 RPM

Pole-face Loss Curves for a Wide Speed Range,  
 Solid-Pole 40 KVA Generator Operating at  
 8,000 RPM and With a N.L. Gap Density of  
 28 K $\ell$ /in<sup>2</sup>

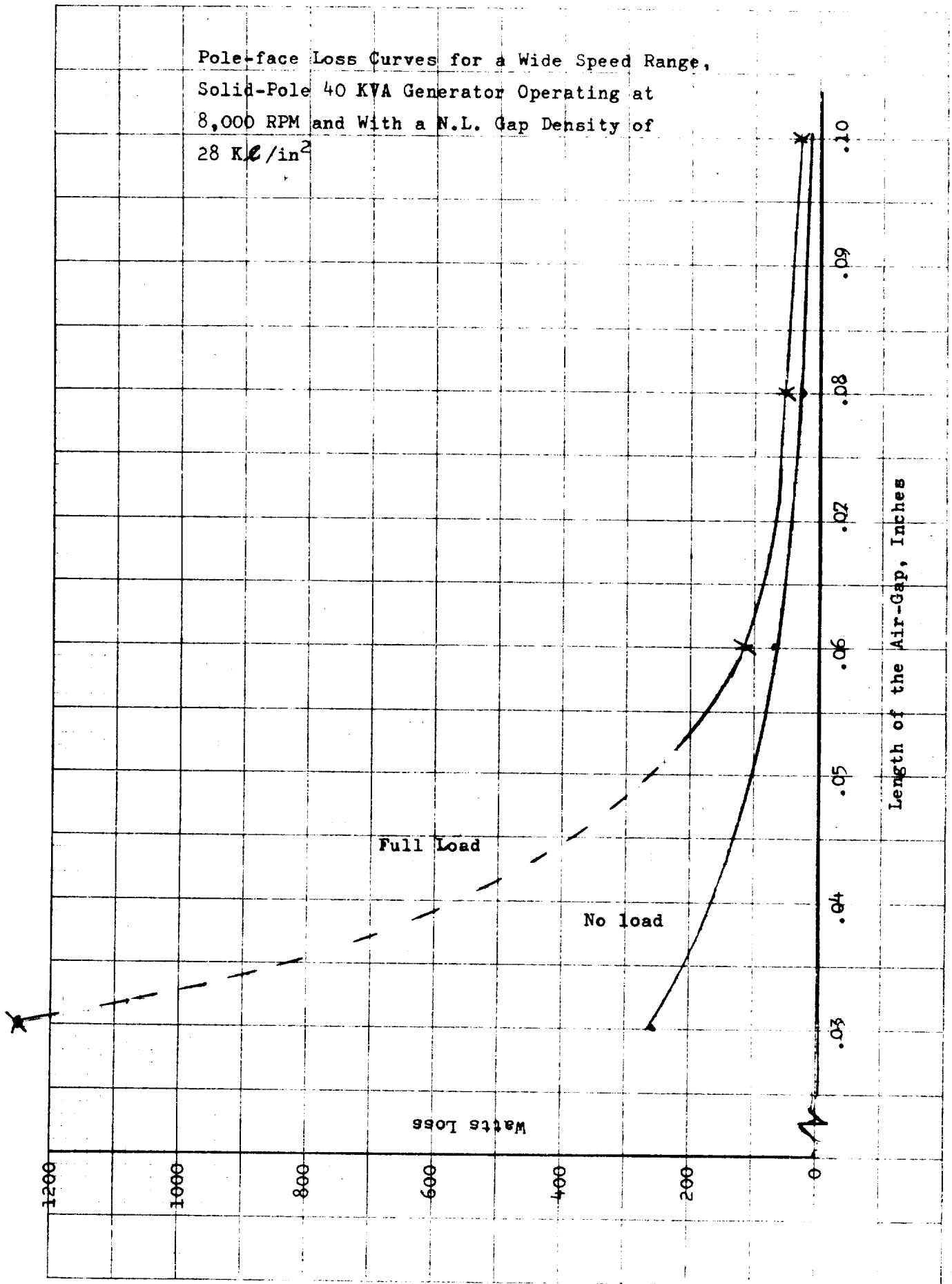

5 X 5 TO 12 INCH 46 0860  
 KLUFFEL & BESSLER CO.

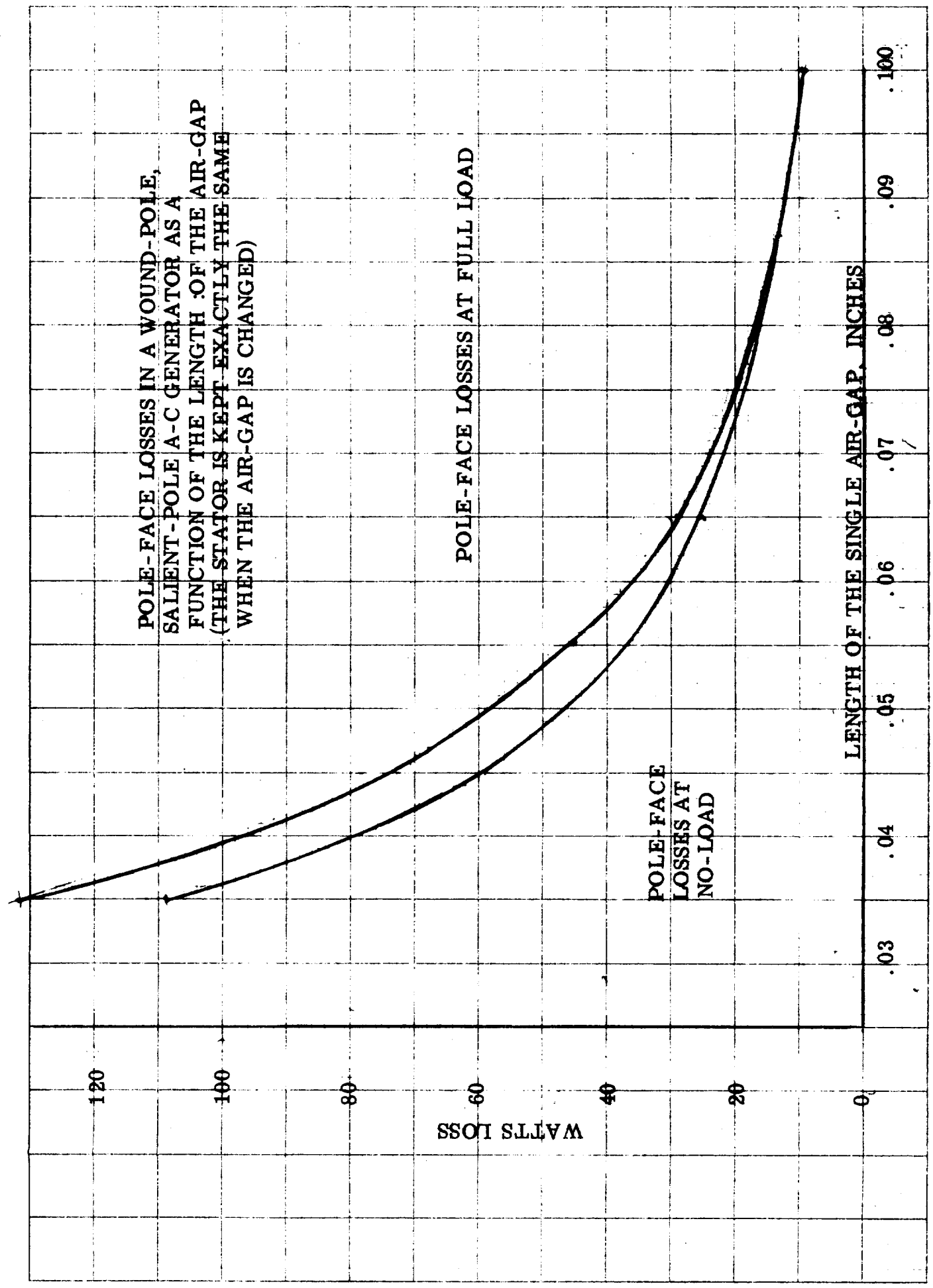

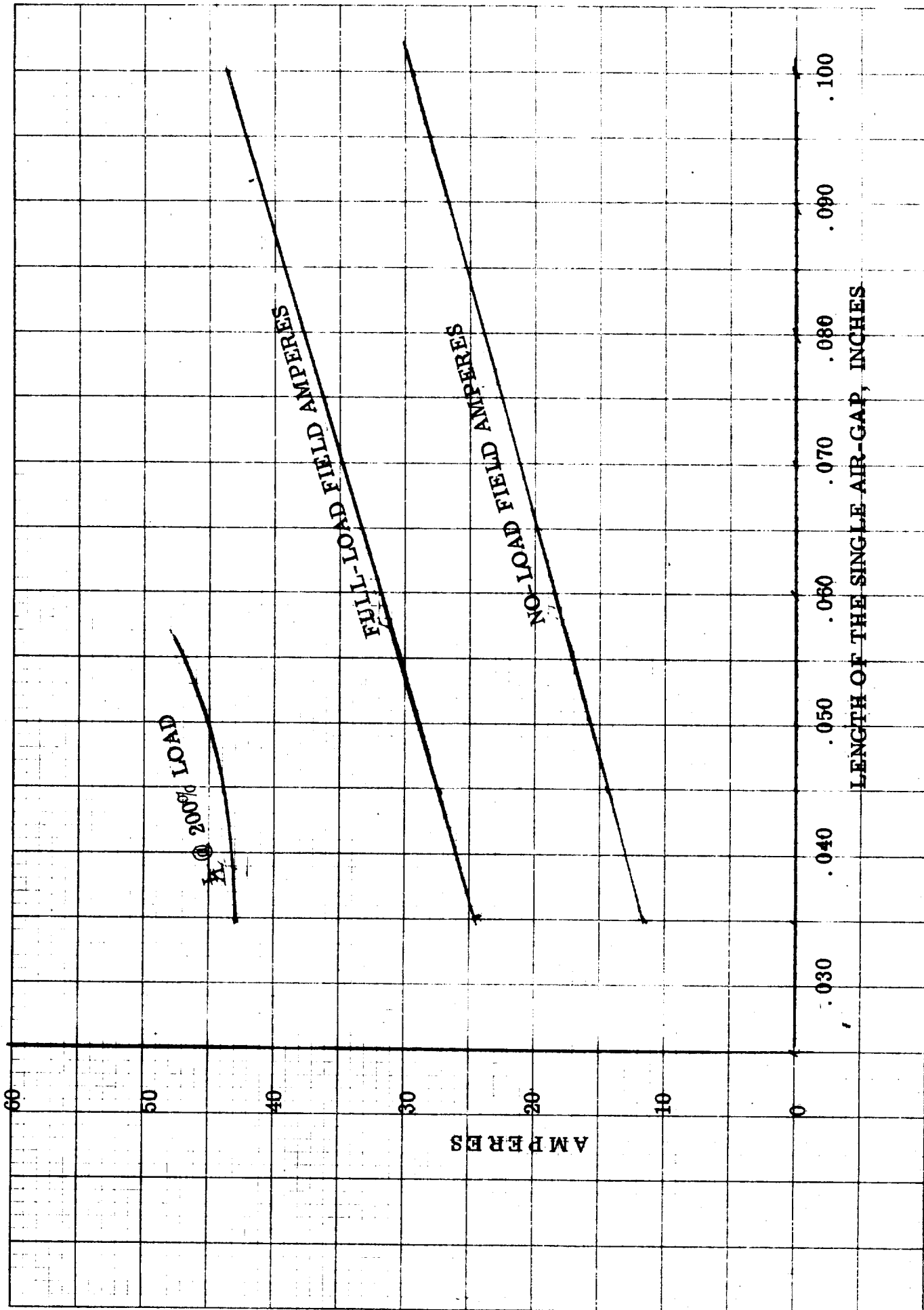

Pole-Face Loss Curves for a Solid-Pole 40 KVA  
 Generator Operating At 4400 RPM and With a  
 N. L. Gap Density of 50 Kℓ/in<sup>2</sup>

