

FACILITY FORM 902

N65-30693

(ACCESSION NUMBER)

(PAGES)

(NASA CR OR TMX OR AD NUMBER)

(THRU)

(CODE)

(CATEGORY)

GPO PRICE \$

CSFTI PRICE(S) \$

Hard copy (HC)

Microfiche (MF)

7.15

2.00

ff 653 July 65

TABLE OF CONTENTS

SELECTION CRITERIA & MECHANICAL STUDIES FOR AC GENERATORS	VOL. I
BRIEF DESCRIPTIONS AND SCHEMATICS	SECTION A, VOL. I
Wound Pole, Salient Pole Generator	Page A-1
Wound-Rotor, Non-Salient-Pole Generator	Page A-8
Rotating Coil Lundell	Page A-15
Single, Inside, Stationary Coil Lundell Generator	Page A-25
Two, Inside, Stationary Coil Lundell Generator (Becky Robinson)	Page A-33
Two, Outside-Coil Lundell	Page A-41
Single, Outside-Coil Lundell	Page A-43
Axial Air Gap Lundell	Page A-52
Homopolar Inductor	Page A-59
Permanent-Magnet Generator	Page A-73
How to Start a Design	Page A-116
GENERATOR SELECTION CRITERIA	SECTION B, VOL. I
Discussion	Page B-1
Family Tree Diagram of Generators	Page B-4
Comparison Chart for Brushless AC Generator Applications (Good-Better-Best Type Comparison)	Page B-5

Approximate Dimensions for Homopolar Inductor and Two, Outside Coil Lundell AC Generators	Page B-6
Weight vs. Output, Wound-Pole, Salient- Pole, Synchronous Generator	Page B-7
Volume vs. Output for Wound-Pole, Salient-Pole Synchronous Generator	Page B-8
Weight vs. Output, Two, Inside, Stationary Coil Lundell (Becky Robinson) with 4 Poles	Page B-9
Weight vs. Output, Two, Inside, Stationary Coil Lundell (Becky Robinson) with 6 Poles	Page B-10
Weight vs. Output, Two, Inside, Stationary Coil Lundell (Becky Robinson) with 8 Poles	Page B-11
Weight vs. Output, Two, Outside Coil or Single, Outside Coil Lundell (4 Poles)	Page B-12
Weight vs. Output, Two, Outside Coil or Single, Outside Coil Lundell (6 Poles)	Page B-13
Weight vs. Output, Two, Outside Coil or Single, Outside Coil Lundell (8 Poles)	Page B-13a
Weight vs. Output, Homopolar Inductor (4 Poles)	Page B-14
Weight vs. Output, Homopolar Inductor (6 Poles)	Page B-15
Weight vs. Output, Homopolar Inductor (8 Poles)	Page B-15a

Weight vs. Output for Wound, Laminated Stators of AC Electro- magnetic Generators	Page B-16
Weight vs. Output, Axial Air-Gap Lundell	Page B-17
Stator Diameter vs. Output for Disk-Type Lundell	Page B-18
Pole Face Losses at No-Load and Full-Load for Rotors of Various Diameters	Page B-19
Rotor Diameter vs. Rotor Speed for Solid Pole Face Alternators Limited to 20 Watts/in ² Pole Face Losses Based on Stator Bore Area	Page B-20
Comparison of No-Load and Full- Load Losses When the Slot Pitch is Changed	Page B-21
Pole-Face Losses in a Solid Pole Face Rotor at No-Load as a Function of Speed	Page B-22
Surface Heat Dissipation from a Generator Rotor	Page B-23
Discussion of the Performance of Synchronous Generators When Used as Motors	Page B-24
MECHANICAL AND THERMAL STUDIES	VOL. I
GENERATOR THERMAL ANALYSIS	SECTION C, VOL. I
Table of Contents	Page C-0
Rotor Friction Analysis	Page C-A-1

GENERATOR ROTOR DYNAMICS	SECTION D, VOL. I
Table of Contents	Page D-0
DISCUSSION OF GAS BEARINGS	SECTION E, VOL. I
Table of Contents	Page E-0
Rolling Contact Bearings	Page E-81
DESIGN FORMULAE FOR BRUSHLESS A-C GENERATORS	VOL. II
DESIGN CURVES & TABLES	SECTION F, VOL. II
Chord Factors, Table 1	Page F-1
Distribution Factors, Table 2	Page F-2
Wire Table, Round Copper Table 3	Page F-3
Wire Table, Round Half Size Table 4	Page F-4
End-Winding Constant, Curve 1	Page F-5
Pole Face Loss Constants, Curve 2	Page F-6
Pole Face Load Loss Factor, Curve 3	Page F-7
C_1 and C_p , Salient Pole, Curve 4	Page F-8
C_1 , C_m and C_p Non-Salient Pole, Curve 4a, 4b	Page F-7a, b
C_x , Curve 5	Page F-9
Damper Loss Constants, Curve 7	Page F-10
Damper Loss Constants, Curve 8	Page F-11

C_m and C_q , Curve 9	Page F-12
Magnetization Curve, Pure Iron, Curve 10	Page F-13
Magnetization Curve, M-43 Silicon Irons, Curve 11A	Page F-14
Magnetization Curve, M36, Curve 11B	Page F-14
Magnetization Curve M-22, Curve 11C and 11E	Page F-14
Magnetization Curve M-15, Curve 11D	Page F-14
Magnetization Curve, 1% Max. Carbon, Curve 12	Page F-18
Magnetization Curve, Cobalt- Iron, Curve 13	Page F-19
Magnetization Curve For Cast and Forged Cobalt-Iron Alloy, Curve 13b	Page F-21
Magnetization Curve, 4620, 4130, 4140, 6302, Curve 14	Page F-22
Magnetization Curve, 6427, Hy-TUF 410 SS, VASCOJET, Curve 15	Page F-23
Magnetization Curve, 1095, P-6, Curve 16	Page F-24
Magnet Stabilization Point (A_T) Versus Out-of-Stator Leakage Permeance for Alnico V and Alnico VI, Curve 17	Page F-25
Magnet Stabilization Point (A_T) Versus Out-of-Stator Leakage Permeance for Alnico VIII, Curve 18	Page F-26

Magnet Stabilization Point (A_T) Versus Out-of-Stator Leakage Permeance for Alnico V7, Curve 19	Page F-27
Demagnetization Curves for High Energy Product Cast Alnicos, Curve 20	Page F-28
Demagnetization Curve for Cast Alnico VIII, Curve 21	Page F-29
Demagnetization Curve for Cast Alnico VIII, Curve 22	Page F-30
Demagnetization Curve for Cast Alnico V7, Curve 23	Page F-31
Demagnetization Curve for Cast Alnico VI, Curve 24	Page F-32
Demagnetization Curve for Cast Alnico V, Curve 25	Page F-33
Iron Losses for Cobalt-Iron Alloy, Curve 13a	Page F-20
Iron Losses for Si-Fe Alloys at Various Frequencies, Curve 11E	Page F-17
Iron Losses for Silicone-Iron Alloys, at 60 cps, Curve 11F	Page F-15
Iron Losses for Si-Fe Alloys at 60 cps, Curve 11G	Page F-16
Curve Points of Magnetic Materials	Page F-34
Magnetic Properties of Cr-Ni Steels	Page F-36
MASTER DESIGN MANUAL (SALENT-POLE, WOUND-POLE, SYNCHRONOUS AC GENERATOR	SECTION G, VOL. II
Input Sheet	Page G-01

Output Sheet	Page G-03
Design Procedure	Page G-1
DESIGN MANUAL FOR NON-SALIENT, WOUND-ROTOR, SYNCHRONOUS AC GENERATOR	SECTION H, VOL. II
Input Sheet	Page H-01
Output Sheet	Page H-02
Design Procedure	Page H-1
DESIGN MANUAL FOR ROTATING-COIL AC LUNDELL TYPE GENERATORS	SECTION J, VOL. II
Input Sheet	Page J-01
Output Sheet	Page J-03
Design Procedure	Page J-1
DESIGN MANUAL FOR SINGLE, INSIDE, STATIONARY-COIL AC LUNDELL- TYPE GENERATOR	SECTION K, VOL. II
Input Sheet	Page K-01
Output Sheet	Page K-03
Design Manual	Page K-1
DESIGN MANUAL FOR TWO, INSIDE- COIL, STATIONARY-COIL AC LUNDELL- TYPE GENERATOR (BECKY ROBINSON PATENT)	SECTION L, VOL. II
Input Sheet	Page L-01
Output Sheet	Page L-04
Design Manual	Page L-1

**DESIGN MANUAL FOR TWO COIL AND
SINGLE-COIL, OUTSIDE COIL AC
LUNDELL-TYPE GENERATORS**

SECTION M, VOL. II

Input Sheet	Page M-01
Output Sheet	Page M-03
Design Manual For Two-Coil Lundell	Page M-1
Design Manual For One-Coil Lundell	Page M-41

**DESIGN MANUAL FOR AXIAL AIR-GAP,
STATIONARY-COIL, SALIENT-POLE,
SYNCHRONOUS AC GENERATOR**

SECTION N, VOL. III

Discussion	Page N-1
Design Sheet	Page N-4
Design Manual	Page N-5

**DESIGN MANUAL FOR HOMOPOLAR
INDUCTOR, AC GENERATOR**

SECTION P, VOL. III

Input Sheet	Page P-01
Output Sheet	Page P-03
Design Manual	Page P-1

**DESIGN MANUAL FOR PERMANENT
MAGNET, SALIENT-POLE AC
GENERATORS**

SECTION R, VOL. III

Discussion	Page R-1
Input Sheet	Page R-01
Output Sheet	Page R-03
Design Manual	Page R-22

EQUIVALENT CIRCUITS	SECTION S, VOL. III
SYMBOL TABLES	SECTION T, VOL. III
GENERATOR THERMAL ANALYSIS COMPUTER PROGRAM (FORTRAN)	SECTION CA, VOL. IV
SALIENT-POLE WOUND-POLE SYNCHRONOUS GENERATOR COMPUTER PROGRAM AND TEST DATA	SECTION GA, VOL. IV
Computer Input 30 KVA Generator	Page GA-1
Computer Output 30 KVA Generator	Page GA-2
Test Data 30 KVA Generator	Page GA-5
Computer Program (Fortran)	Page GA-14
NON-SALIENT-POLE, WOUND-ROTOR SYNCHRONOUS GENERATOR COMPUTER PROGRAM AND TEST DATA	SECTION HA, VOL. IV
Computer Input 120 KVA Generator	Page HA-1
Computer Output 120 KVA Generator	Page HA-2
Test Data 120 KVA Generator	Page HA-4
Computer Program (Fortran)	Page HA-29
ROTATING-COIL LUNDELL, A-C GENERATOR COMPUTER PROGRAM AND TEST DATA	SECTION JA, VOL. IV
Computer Input 840 Watt Generator	Page JA-1
Computer Output 840 Watt Generator	Page JA-5
Test Data 840 Watt Generator	Page JA-7

Computer Program 840 Watt Generator	Page JA-25
INSIDE, SINGLE-COIL, STATIONARY- COIL LUNDELL, A-C GENERATOR COMPUTER PROGRAM AND TEST DATA	Page KA, VOL. IV
Computer Input	Page KA-1
Computer Output	Page KA-3
Computer Program	Page KA-22
INSIDE, TWO-COIL STATIONARY COIL LUNDELL A-C GENERATOR COMPUTER PROGRAM AND TEST DATA	SECTION LA, VOL. IV
Computer Input 30 KVA Generator	Page LA-3
Computer Output 30 KVA Generator	Page LA-1
Test Data 30 KVA Generator	Page LA-6
Computer Program	Page LA-37
TWO-COIL AND SINGLE-COIL OUTSIDE- COIL, LUNDELL, A-C GENERATOR COMPUTER PROGRAM AND TEST DATA	SECTION MA, VOL. V
Computer Input 840 Watt Generator	Page MA-1
Computer Output 840 Watt Generator	Page MA-3
Test Data 840 Watt Generator	Page MA-7
Computer Program	Page MA-20
HOMOPOLAR INDUCTOR A-C GENERATOR COMPUTER PROGRAM AND TEST DATA	SECTION PA, VOL. V
Computer Input	Page PA-01

Computer Output	Page PA-03
Test Data	Page PA-05
Computer Program	Page PA-19
PERMANENT MAGNET A-C GENERATOR COMPUTER PROGRAM AND TEST DATA	SECTION RA, VOL. V
Computer Input	Page RA-1
Computer Output	Page RA-3
Test Data	Page RA-5
Computer Program	Page RA-22
DERIVATIONS	SECTION SA, VOL. V
Pole Face Losses in Solid-Pole Generators	Page SA-1
Graphical Flux Analysis	Page SA-29
The Maximum $\frac{l}{d}$ Ratio for Rotating Coil Lundell A-C Generators	Page SA-38
The Maximum $\frac{l}{d}$ Ratio for Two, Inside, Stationary- Coil Lundell A-C Generators	Page SA-40
The Development of Equations Describing the Weights of Electromagnetic Parts for Three Generator Types	Page SA-43
Generator Stator Ampere Load- ing - A Discussion	Page SA-50
Grouping of Fractional Slot Windings	Page SA-53
Distribution Factor	Page SA-58

Fractional Slot Distribution Factor	Page SA-60
Skew Factor	Page SA-61
Pitch Factor	Page SA-64
Reactances, Per-Unit System	Page SA-67
Synchronous Reactance	Page SA-69
Reactance of Armature Reaction	Page SA-72
Transient Reactance	Page SA-74
Subtransient Reactance	Page SA-78
Negative Sequence Reactance	Page SA-79
Zero Sequence Reactance	Page SA-79
Leakage Reactance	Page SA-80
Potier Reactance	Page SA-86
Time Constants	Page SA-89
Resistance	Page SA-95
Generator Voltage and Output Equations	Page SA-96
C_m	Page SA-100
C_q	Page SA-103
Permeance Calculations	Page SA-110

EFFECT OF INCREASING THE AIR GAP

SECTION TA, VOL. V

FIGURES

	<u>Figure No.</u>	<u>Page No.</u>
Wound-Pole, Salient-Pole AC Generator	A-1	A-1
Wound-Pole, Salient-Pole AC Generator	A-2	A-4
Wound-Pole, Rotating-Rectifier AC Generator	A-3	A-5
Wound-Pole Synchronous AC Generator	A-4	A-6
Photograph of Wound-Pole Synchronous Generator	A-5	A-7
Field Form for Non-Salient Pole Wound-Pole AC Generator	A-6	A-9
Rotor Views - NSP AC Generator	A-7	A-10
Photograph of Rotor & Stator (NSP Generator)	A-8	A-11
Photograph of Rotor & Stator (NSP Generator)	A-9	A-12
Exploded View of Complete NSP AC Generator	A-10	A-13
Rotating-Coil Lundell AC Generator	A-11	A-14
Step 1 of Conversion to Outside-Coil Lundell	A-12	A-15
Step 2 of Conversion	A-13	A-16

	<u>Figure No.</u>	<u>Page No.</u>
Conversion of Rotating-Coil to Stationary-Coil Lundell	A-14	A-17
How to Make a Becky-Robinson Lundell	A-15	A-18
How to Make a Homopolar Inductor	A-16	A-19
Patent Drawing, Rotating Coil Lundell	A-17	A-20
Photo Rotating-Coil Lundell	A-18	A-21
Rotor, Rotating-Coil Lundell	A-19	A-22
Photo, Rotating Coil Lundell	A-20	A-23
Single-Inside, Stationary-Coil Lundell	A-21	A-24
Single-Inside, Stationary-Coil Lundell	A-22	A-26
Single-Inside, Stationary-Coil Lundell	A-23	A-27
Single-Inside, Stationary-Coil Lundell Patent Drawing	A-24	A-29
Photo of Single, Inside, Stationary- Coil Lundell	A-24a	A-30
Photo of Single, Inside, Stationary- Coil Lundell	A-24	A-31
MG Set	A-26	A-32
Two-Inside Stationary Coil Lundell	A-27	A-33
Two-Inside Stationary Coil Lundell Photo	A-28	A-36

	<u>Figure No.</u>	<u>Page No.</u>
Two-Inside Stationary Coil Lundell Photo	A-29	A-37
Two-Inside Stationary Coil Lundell Photo	A-30	A-53
Two-Inside Stationary Coil Lundell Flux Circuit	A-31	A-39
Two-Inside Stationary Coil Lundell Flux Circuit	A-32	A-40
Two-Outside Coil Lundell Flux Circuit Schematics	A-33	A-42
Two-Outside Coil Lundell Drawing	A-34	A-43
Two-Outside Coil Lundell Patent Drawing	A-35	A-44
Photo Two-Outside Coil Lundell	A-36	A-45
Single-Coil Outside Coil Lundell	A-37	A-48
Pole Configuration	A-38	A-49
Single Coil Outside-Coil Lundell	A-39	A-50
Pole Configuration	A-40	A-51
Axial Air-Gap Lundell	A-41	A-52
Axial Air-Gap Lundell Patent Drawing	A-42a	A-55
Axial Air-Gap Lundell Rotor Photo	A-42c	A-56
Axial Air-Gap Lundell Stator Photo	A-42b	A-57
Double Axial-Gap Generator	A-42c	A-58

	<u>Figure No.</u>	<u>Page No.</u>
Homopolar Inductor	A-43	A-59
Hemopolar Inductor	A-44	A-60
Homopolar Inductor Rotor	A-45	A-64
Homopolar Inductor Rotor	A-46	A-66
Patent Drawing for Homopolar Inductor	A-47a	A-68
Patent Drawing for Homopolar Inductor	A-47b	A-69
Permanent-Magnet AC Generator	A-48	A-73
PM Rotor Types	A-49	A-77
Earliest PM Generator	A-50	A-78
Patent Drawing for Axial Gap PM Generator	A-51	A-79
PM Hysteresis Loop	A-52	A-81
PM Hysteresis Loop	A-53	A-84
Volt Ampere Characteristic	A-54	A-86
Saturation Curve	A-55	A-88
Saturation Curve & B_r	A-56	A-89
Air Gap Shear Line	A-57	A-90
F_{dm}	A-58	A-91
Short Circuit Stabilization	A-59	A-92
Out of Stator Permeance Shear Line	A-60	A-93
In-Stator Permeance Shear Line	A-61	A-96

	<u>Figure No.</u>	<u>Page No.</u>
Useful Flux	A-62	A-98
Construction of Load Points On The PM Generator Hysteresis Loop	A-63	A-99
Air Gap Energy Storage	A-64	A-100
Air Gap Energy Storage	A-65	A-101
Vector Diagram	A-66	A-105
Vector Diagrams for AC Generators Having High Stator Winding Resistance	A-67	A-106
Vector Diagrams for AC Generators Having Low Stator Winding Resistance	A-68	A-107
Locus of Terminal Voltage	A-69	A-108
Locus of Terminal Voltage	A-70	A-109
Volt-Ampere Characteristic	A-71	A-110
Weight vs. Rating for Salient-Pole Wound-Pole, Rotating-Rectifier AC Generators	B-1 B-1	B-7 B-7
Volume vs. Rating for Salient-Pole Wound-Pole, Rotating-Rectifier AC Generators	B-2	B-8
Weight Breakdown for Two, Inside- Coil Lundell Generators (Becky- Robinson)	B-3 B-4 B-5	B-9 B-10 B-11
Weight Breakdown for a Two-Coil Outside-Coil, Lundell Generator	B-6 B-7 B-8	B-12 B-13 B-14

	<u>Figure No.</u>	<u>Page No.</u>
Weight Breakdown for a Homopolar Inductor AC Generator	B-9	B-15
	B-10	B-16
	B-11	B-17
Weight vs. Rating for Wound Stators	B-12	B-18
Weight vs. Stator O.D. for Disk- Type Lundell Generators	B-13	B-19
KVA Output vs. Stator O.D. for Disk-Type Lundell Generators	B-14	B-20
Pole-Face Loss Curves	B-15	B-22
	B-16	B-23
	B-17	B-24
	B-18	B-25
Heat Dissipation From a Generator Rotor	B-19	B-26
Induction Motor Speed Torque Curves	B-20	B-28
Lundell Motor Speed Torque Curves	B-21	B-30
Wound Pole Motor Speed-Torque Curves	B-22	B-31
Induced Field Voltage During Start of Salient, Wound Pole Motor	B-23	B-34
Alternator Configuration for Thermal Analysis	CA-1	C-60
Friction Design Charts	CA-2	C-61
Homopolar Inductor Rotor	D-1	D-8a

	<u>Figure No.</u>	<u>Page No.</u>
Outside Coil Lundell Rotor	D-2	D-8b
Becky Robinson Rotor	D-3	D-8c
Rotor Model	D-4	D-8d
Bearing Stiffness Curves	D-5	D-8e
Critical Speeds for Outside-Coil Lundell	D-6	D-8f
Critical Speeds for Inside-Coil Lundell	D-7	D-8g
Dynamic Response for Homopolar Inductor	D-8	D-8h
Dynamic Response for Homopolar Inductor	D-9	D-8i
Dynamic Response for Homopolar Inductor	D-10	D-8j
Absolute Viscosity of Various Gases	E-1	E-11a
Self Acting Gas Bearings	E-7	E-22a
Tilting-Pad Bearing Schematic	E-8	E-22b
Load Calculating Charts for Cylindrical Journal Bearings	E-9	E-22c
Curves for Tilting-Pad Bearings	E-10	E-22d
Self Acting Thrust Bearings	E-11	E-43a
Pressure Rise in Bearing Caps	E-12	E-43b
Friction Vectors in Bearings	E-13	E-43c
Spiral-Groove Thrust Bearings	E-14	E-43d

	<u>Figure No.</u>	<u>Page No.</u>
Curvature Effects on Load and Bearing Stiffness	E-15	E-43e
End- Leakage in Spiral-Grooved Bearings	E-16	E-43f
Effects of Grooves on Pressure Profile	E-17	E-43g
Hydrostatic Bearing Stiffness vs. Restrictor Coefficient	E-21	E-54a
Hydrostatic Bearing Stiffness vs. Restrictor Coefficient	E-22	E-54b
Hydrostatic Bearing Flow vs. Restrictor Coefficient	E-23	E-54c
Hydrostatic Bearing Flow vs. Restrictor Coefficient	E-24	E-54d
Hybrid Journal Bearing Load vs. Compressibility Number	E-25	E-54e
P ₁ , Pole Head Leakage Permeance	J-4	J-9
P ₂ , Pole Head Side Leakage Permeance	J-5	J-11
P ₃ Pole Body End Leakage Permeance	J-6	J-12
P ₄ Pole Body Side Leakage Permeance	J-8	J-15
P ₅ Coil Leakage Permeance	J-9	J-16
P ₇ Stator Leakage Permeance	J-10	J-18
MMF Drops	J-11	J-19
Diagram of Leakages	J-12	J-20

	<u>Figure No.</u>	<u>Page No.</u>
Pole Dimensions	K-2	K-7
Rotor & Stator Dimensions	K-3	K-9
Permeance Path P_2	K-4	K-11
Permeance Path P_3, P_5	K-5	K-12
Permeance Path P_1, P_2, P_4	K-6	K-13
MMF Drops and Leakage Fluxes	K-7	K-14
Becky Robinson Lundell Pole Types and Dimensions	L-2	L-8
Rotor Dimensions	L-3	L-10
Types of Auxiliary Gap and Gap Dimensions	L-4	L-11
Rotor Dimensions	L-5	L-13
Leakage Permeance P_3	L-6	L-17
Leakage Permeance P_4 and MMF Drops	L-7	L-18
Leakage Permeance P_4	L-8	L-19
Leakage Permeance P_4	L-9	L-20
Coil Leakage Permeance P_5	L-10	L-22
Coil Leakage Permeance P_6	L-11	L-23
Coil Leakage Permeances P_5 and P_6	L-12	L-24
Leakage Permeance P_7 from Stator to Rotor	L-13	L-25

	<u>Figure No.</u>	<u>Page No.</u>
Outside-Coil Lundell Stator and Rotor Dimensions	M-3	M-9
Leakage Permeance P_1	M-4	M-13
Leakage Permeance P_2	M-5	M-14
Leakage Permeance P_3	M-6	M-15
Leakage Permeance P_4	M-7	M-16
MMF Drops and Leakage Paths in Outside-Coil Lundell	M-8	M-17
Three Possible Locations and Permeances P_5, P_7	M-9	M-18
Leakage Flux ϕ_7 From Stator to Rotor	M-10	M-21
Leakage Permeances for i-coil Outside-Coil Lundell	M-14	M-52
Stator Leakage Flux ϕ_7	M-15	M-53
MMF Drops in Outside-Coil Lundell and Leakage Flux ϕ_7	M-16	M-54
Disk-Type Lundell Generator	N-1	N-2
Flux Circuit for Disk-Type Lundell	N-2	N-3
Design Sheet for Disk-Type Lundell	N-3	N-4
Pole Dimensions	N-4a	N-26
Pole Dimensions	N-4b	N-26
Rotor Leakage Permeances	N-5	N-27
Rotor Leakage Permeance P_4	N-6	N-29

	<u>Figure No.</u>	<u>Page No.</u>
Homopolar Inductor Housing Type 1 Item (78)		P-8
Types 2 and 3		P-9
Homopolar Inductor Shaft Dimensions Item (78a)		P-10
PM Generator	R-1	R-2
Rotor Leakage Permeances	R-2	R-4
Rotor Leakage Permeance P_1	R-3	R-5
Curve for P_1	R-5	R-7
Rotor Leakage Permeance P_s	R-6	R-8
Rotor Leakage Permeance P_f	R-7	R-9
Curve for Leakage Permeance P_2	R-8	R-10
Rotor Leakage Permeance P_{s1}	R-9	R-11
Rotor Pole Tip Leakage	R-10	R-13
Rotor Leakage Permeance P_{s2}	R-11	R-14
Rotor Leakage Permeance P_3	R-12	R-15
Curve for P_3	R-13	R-16
Magneti Comparisens	R-14	R-20
Magnet Comparisons	R-15	R-21
Equivalent-Circuit Representation for Synchronous AC Generator Carrying a Balanced Load		S-33

	<u>Figure No.</u>	<u>Page No.</u>
Equivalent-Circuit Representation for Synchronous AC Generator Carrying a Balanced Load		S-35
Equivalent Circuit for Synchronous AC Generator Carrying an Unbalanced Load		S-73
Equivalent Circuit for Synchronous AC Generator Carrying an Unbalanced Load		S-74

TABLES

List of Cobalt Steels	Page A-111
Table of PM Steel Characteristics	Page A-113
Table of PM Steel Characteristics	Page A-114
Table of PM Steel Composition	Page A-115
Family Tree of Brushless AC Generators	Page B-4
Comparison Chart for Brushless AC Generators	Page B-4
Approx. Dimensions for Homopolar Inductors and for Outside-Coil Lundell AC Generators	Page B-6
Gas Bearings	Page E-7
Operating Requirements of Gas Bearing Types	Page E-8
Gas Lubricated Journal Bearing Family Tree	Page E-9
Gas Lubricated Thrust Bearing Family Tree	Page E-10
Required Design Information	Page E-11
Bearing Parameter for Maximum Load Capacity	Page E-41
Bearing Tolerance Ranges	Page E-42
Effects of Grooves in Gas Bearings	Page E-43

Alloy Classes Useful as Base Materials for Shaft and/or Bearings	Page E-76
Material Combinations that Have Been Used for Large Bearings	Page E-77
Bearing (Rolling Element) Life Dispersion Curve	Page E-82
Speed and Size of Light and Extra Light Superprecision Ball Bearings	Page E-84
Inner-Race RPM for Oil Jet or Oil-Mist Lubrication Extra Light Series Ball Bearings	Page E-85
Limiting Speeds for Grease Lubricated Ball Bearings	Page E-86
Temperature Limitation of Ball Bearings	Page E-87

VALUES OF K_{dn} FOR INTEGRAL-SLOT, 3ϕ WINDINGS - TABLE F-2

n	K_{dn} - HARMONIC DISTRIBUTION FACTORS									
	2	3	4	5	6	7	8	9	10	∞
1	.966	.960	.958	.957	.957	.957	.956	.955	.955	.955
3	.707	.667	.654	.646	.644	.642	.641	.640	.637	.636
5	.259	.217	.205	.200	.197	.195	.194	.194	.193	.191
7	-.259	-.177	-.158	-.149	-.145	-.143	-.141	-.140	-.140	-.126
9	-.707	-.333	-.270	-.247	-.236	-.229	-.225	-.222	-.220	-.212
11	-.966	-.177	-.126	-.110	-.102	-.097	-.095	-.093	-.092	-.087
13	-.966	.217	.126	.102	.092	.086	.083	.081	.079	.073
15	-.707	.667	.270	.200	.172	.150	.150	.145	.141	.127
17	-.259	.960	.158	.102	.084	.075	.070	.066	.064	.056
19	.259	.960	-.205	-.110	-.084	-.072	-.066	-.062	-.060	-.059
21	.707	.667	-.654	-.247	-.172	-.143	-.127	-.118	-.112	-.091
23	.966	.217	-.958	-.149	-.092	-.072	-.063	-.057	-.054	-.041
25	.966	-.177	-.958	.200	.102	.075	.063	.056	.052	.038
27	.707	-.333	-.654	.646	.236	.158	.127	.111	.101	.071
29	.259	-.177	-.205	.957	.145	.086	.066	.056	.050	.033
31	-.259	.217	.158	.957	-.197	-.097	-.070	-.057	-.050	-.031

33	-.709	.667	.270	.646	-.644	-.229	-.150	-.118	-.101	-.058
35	-.966	.960	.126	.200	-.957	-.143	-.083	-.062	-.052	-.027
37	-.966	.960	-.126	-.149	-.957	.195	.095	.066	.054	.026
39	-.707	.667	-.270	-.247	-.644	.642	.225	.145	.112	.049
41	-.259	.217	-.158	-.110	-.197	.957	.141	.081	-.060	.023
43	.259	-.177	.205	.102	.145	.957	-.194	-.093	-.064	-.022
45	.707	-.333	.654	.200	.236	.642	-.641	-.222	-.141	-.042
47	.966	-.177	.958	.102	.132	.195	-.956	-.140	-.060	-.020
49	.966	.217	.958	-.110	-.092	-.143	-.956	.194	.092	.019
51	.707	.667	.654	-.247	-.172	-.229	-.641	.640	.220	.038
53	.259	.960	.205	-.149	-.084	-.097	-.194	.955	.140	.018
55	-.259	.960	-.158	.200	.084	.086	.141	.955	-.193	-.017
57	-.707	.667	-.270	.646	.172	.158	.225	.640	-.639	-.033
59	-.966	.217	-.126	.957	.092	.075	.095	.194	-.955	-.016
61	-.966	-.177	.126	.957	-.102	-.072	-.093	-.140	-.955	.016
63	-.707	-.333	.270	.646	-.236	-.143	-.150	-.222	-.639	.030
65	-.259	-.177	.158	.200	-.145	-.072	-.070	-.093	-.193	.015

ROUND COPPER WIRE

TABLE F-3

SIZE AWG	BARE DIAMETER	AREA in ²	Ω/1000' @25°C	SINGLE FORMVAR	HEAVY FORMVAR	SINGLE GLASS FORMVAR	BARE WT. #/1000'	SINGLE GLASS SILICONE	DOUBLE GLASS SILICONE
36	.0050	.000196	424	.0056	.0060		.0757		
35	.0056	.000246	338	.0062	.0066		.0949		
34	.0063	.000312	266	.0070	.0074		.1201		
33	.0071	.000396	210	.0079	.0084		.1526		
32	.0080	.000503	165	.0088	.0094	.0121	.1937		
31	.0089	.000622	134	.0097	.0104	.0130	.2398		
30	.0100	.000785	106	.0108	.0116	.0142	.3025	.0132	.0152
29	.0113	.000100	831	.0122	.0130	.0156	.3866	.0145	.0165
28	.0126	.000125	66.4	.0135	.0144	.0169	.4806	.0158	.0178
27	.0142	.000158	52.6	.0152	.0161	.0186	.6101	.0174	.0194
26	.0159	.000194	41.7	.0169	.0179	.0203	.7650	.0191	.0211
25	.0179	.000252	33.0	.0191	.0200	.0224	.970	.0211	.0231
24	.0201	.000317	26.2	.0213	.0223	.0263	1.273	.0251	.0276
23	.0226	.000401	20.7	.0238	.0249	.0289	1.546	.0274	.0301
22	.0254	.000507	16.4	.0266	.0277	.0317	1.937	.0303	.0328
21	.0285	.000638	13.0	.0299	.0310	.0349	2.459	.0335	.0360
20	.0320	.000804	10.2	.0334	.0346	.0384	3.049	.0370	.0395
19	.0360	.00102	8.14	.0374	.0386	.0424	3.900	.0404	.0434
18	.0403	.00126	6.59	.0418	.0431	.0468	4.914	.0452	.0488
17	.0453	.00159	5.22	.0469	.0482	.0519	6.213	.0503	.0528
16	.0508	.00204	4.07	.0524	.0538	.0575	7.812	.0558	.0583
15	.0571	.00255	3.26	.0588	.0602	.0639	9.57	.062	.0646
14	.0641	.00322	2.58	.0659	.0673	.0710	12.44	.0691	.0716
13	.072	.00407	2.04	.0738	.0753	.0789	15.69	.0770	.0795
12	.0808	.00515	1.61	.0827	.0842	.0877	19.76	.0858	.0883
11	.0907	.00650	1.28	.0927	.0942	.0977	24.90	.0957	.0982
10	.102	.00817	1.02	.1039	.1055	.1089	31.43	.1069	.1094
9	.114	.0102	.814	.1165	.1181	.1225	39.62	.1204	.1254
8	.129	.0131	.634	.1276	.1323	.1366	49.98	.1345	.1395
7	.144	.0163	.510	.1465	.1482	.1525	63.03	.1503	.1553
6	.162	.0206	.403	.1643	.1661	.1703	79.44	.1680	.1730
5	.182	.0260	.319	.1842	.1861	.1902	100.2	.1879	.1929
4	.204	.0327	.254				126.3	.2103	.2153
3	.229	.0412	.202				159.3		
2	.258	.0523	.159				200.9		
0	.325	.0830	.100						
2/0	.365	.105	.0791						
4/0	.460	.166	.0500						

TABLE F-4

HALF-SIZE, ROUND, COPPER WIRE

SIZE AWG	BARE DIAMETER	AREA □"	BARE WT #/1000'	Ω/1000' @ 20°C
1/0½	.3071	.0741	285.5	.1100
1½	.2734	.0587	226.3	.1387
2½	.2435	.0466	179.5	.1749
3½	.2169	.0370	142.4	.2204
4½	.1931	.0293	112.9	.2781
5½	.1720	.0232	89.6	.3506
6½	.1532	.0184	71.0	.4419
7½	.1364	.0146	56.3	.5574
8½	.1215	.0116	44.7	.7025
9½	.1082	.0092	35.4	.8859
10½	.0963	.00728	28.1	1.118
11½	.0858	.00578	22.3	1.409
12½	.0764	.00458	17.7	1.778
13½	.0680	.00363	14.0	2.243
14½	.0606	.0288	11.1	2.824
15½	.0540	.00229	8.83	3.557
16½	.0481	.00182	7.00	4.482
17½	.0428	.00144	5.54	5.661
18½	.0381	.00114	4.39	7.143
19½	.0340	.000907	3.50	8.972
20½	.0302	.000716	2.76	11.37
21½	.0269	.000568	2.19	14.33
22½	.0240	.000452	1.74	18.01
23½	.0214	.000360	1.39	22.65
24½	.0190	.000284	1.09	28.73
25½	.0169	.000224	.864	36.31
26½	.0151	.000179	.690	45.49
27½	.0134	.000141	.544	57.75
28½	.0120	.000113	.436	72.02
29½	.0106	.000088	.340	92.27
30½	.0095	.000071	.273	114.85

CURVE F-1

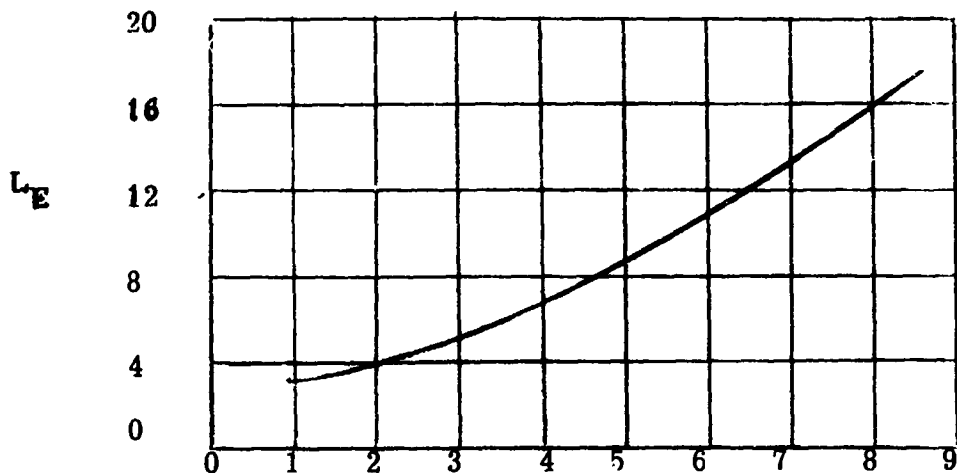

: COIL SPAN AT AIR-GAP = $y t_s$

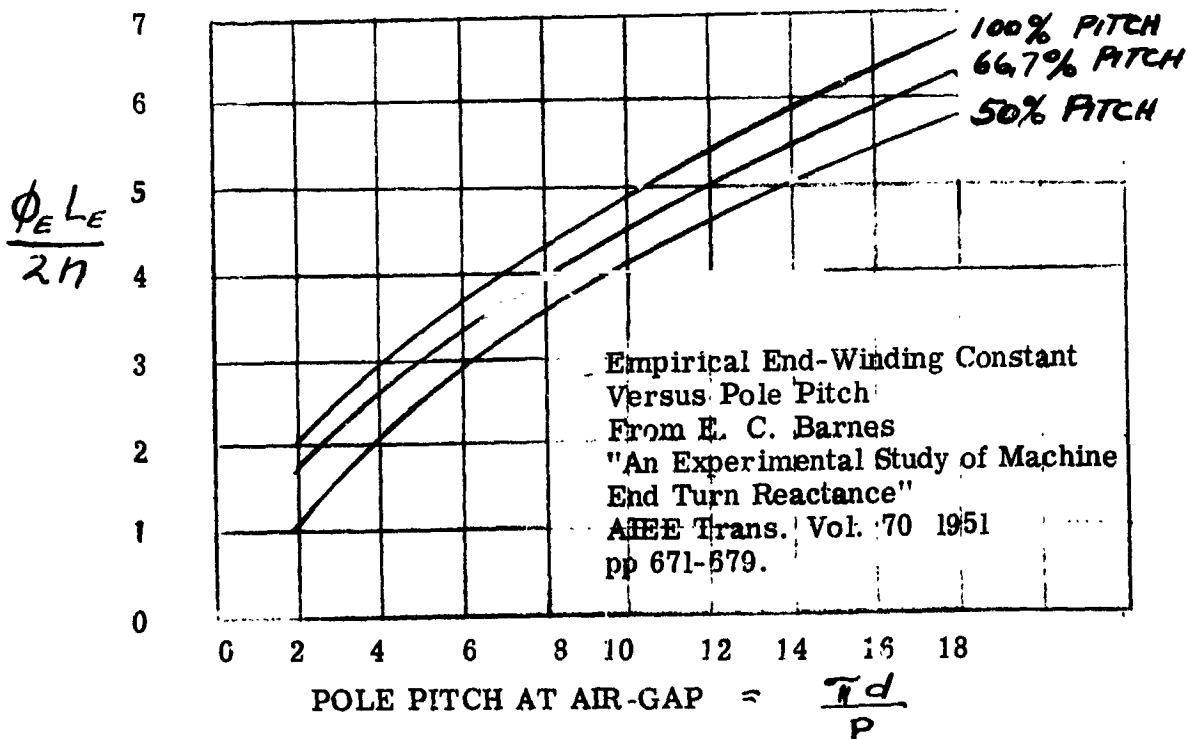

CURVE F-2

From Kuffel and Spohrer "Surface Iron Losses with Respect to Laminated Materials", Trans. AIEE, Vol. 43, 1924, pp 262-261.

REFER TO ITEM (186) IN SALIENT POLE DESIGN MANUAL FOR SAMPLE USE OF THIS CURVE

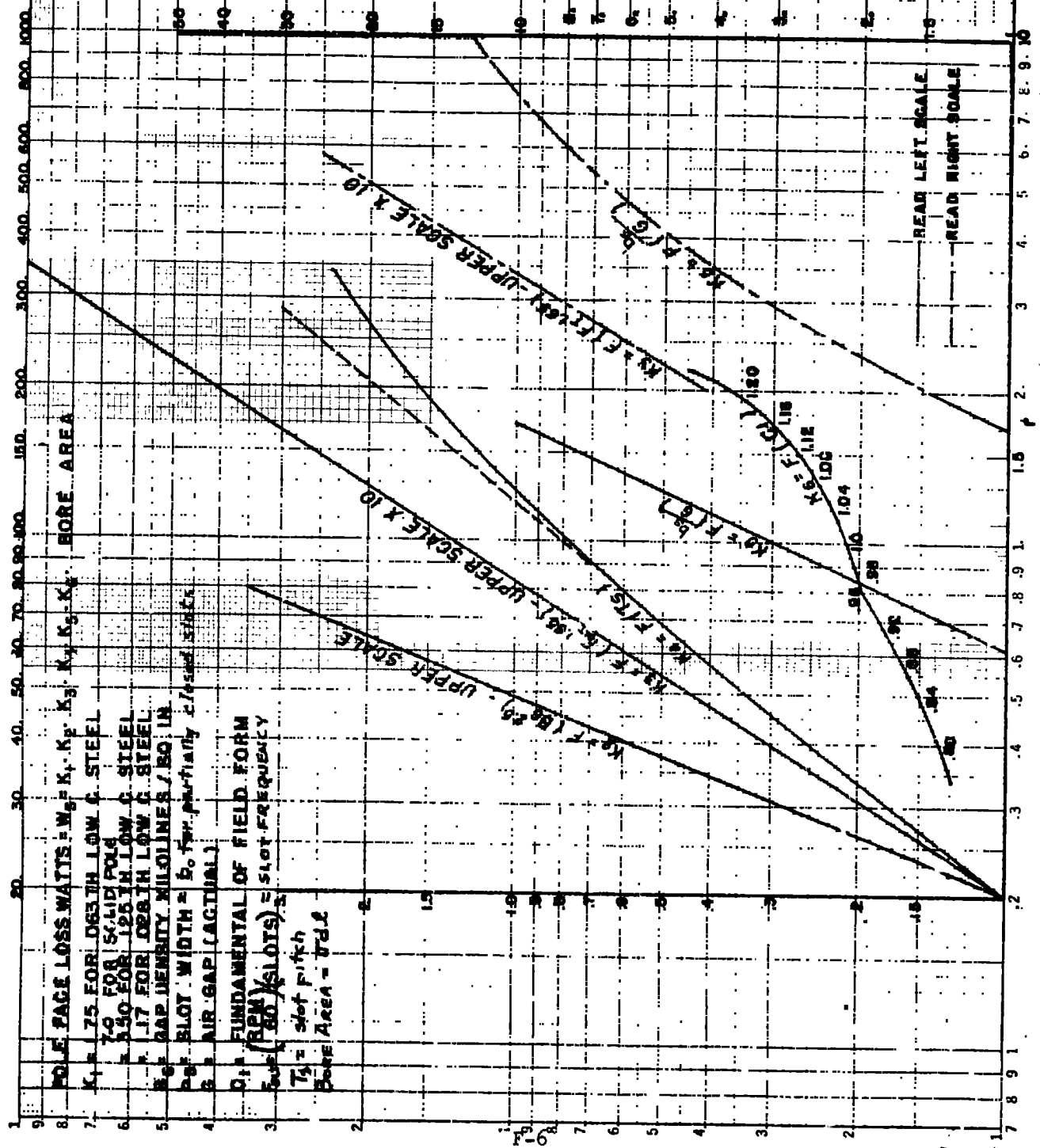

DRAWN BY
 J.A.V.

CURVE F-3

From E. I. Pollard "Load Losses In Salient-Pole Synchronous Machines" AIEE Trans. Vol. 54 1935 . PP 1332-1340

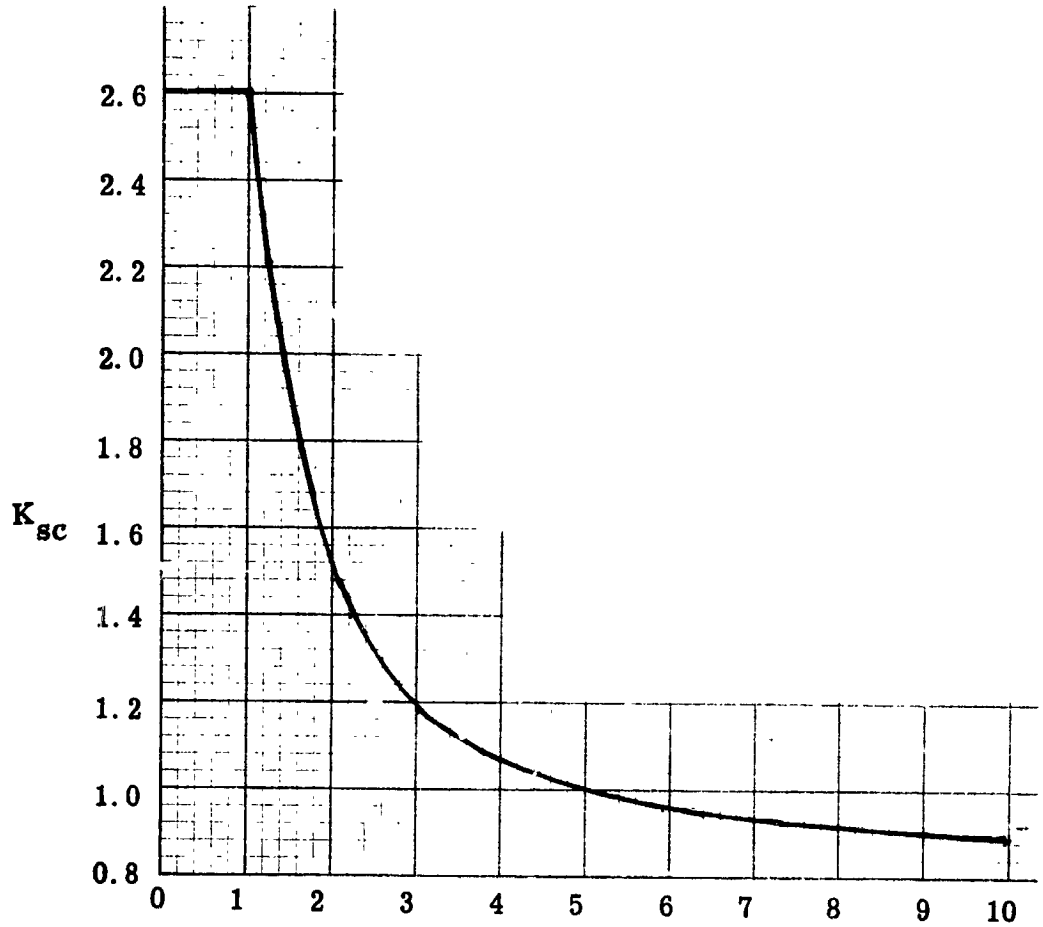

$$b_s/g = \frac{\text{Slot opening}}{\text{air-gap}}$$

K&E 10 X 10 TO THE CM. 359-14 KEUFFEL & ESSER CO. MADE IN U.S.A.

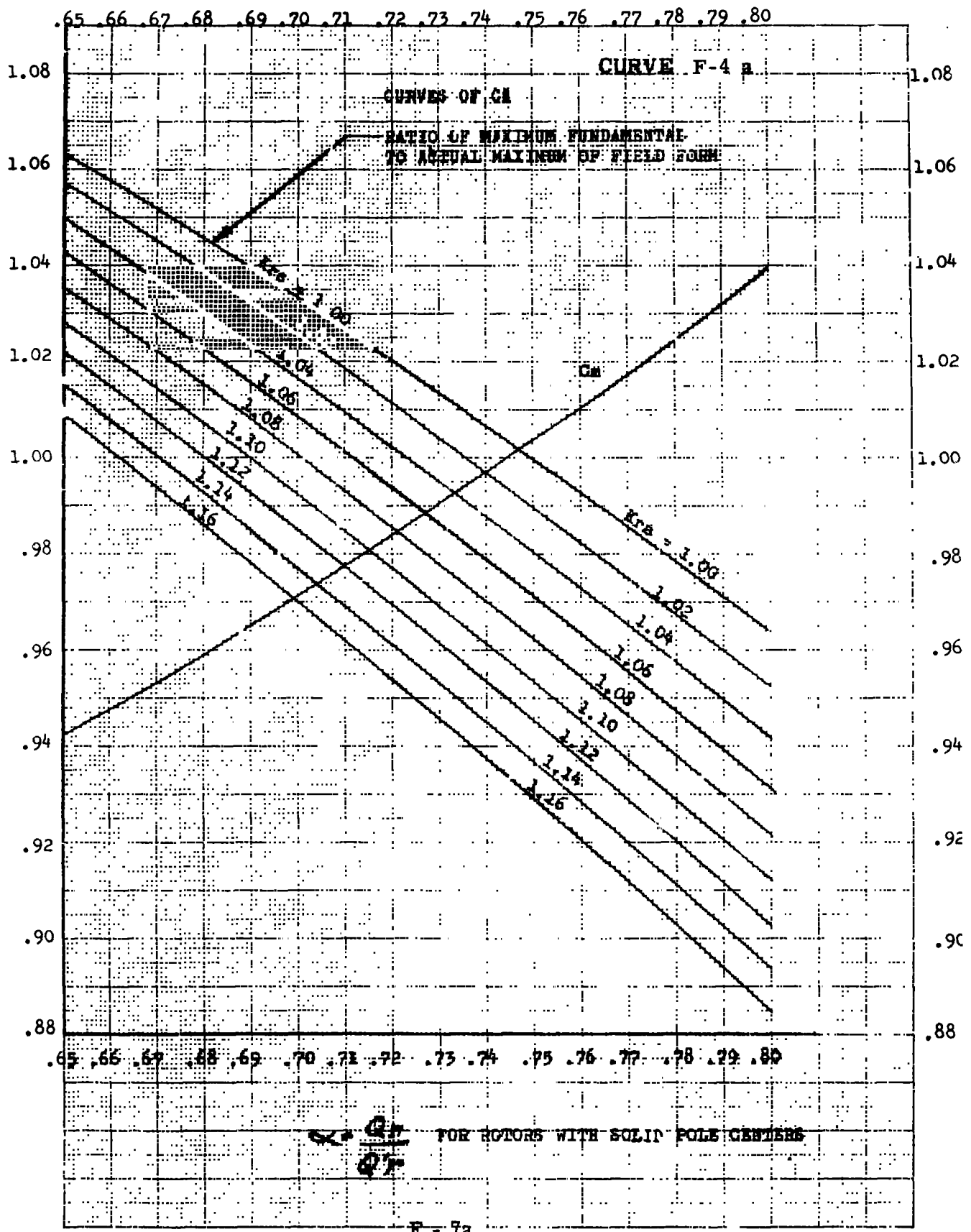

$\frac{G_1}{Q_1}$ FOR ROTORS WITH SOLID POLE CENTERS

10 X 10 TO THE U M 353-14
KOPPELSEY & CO

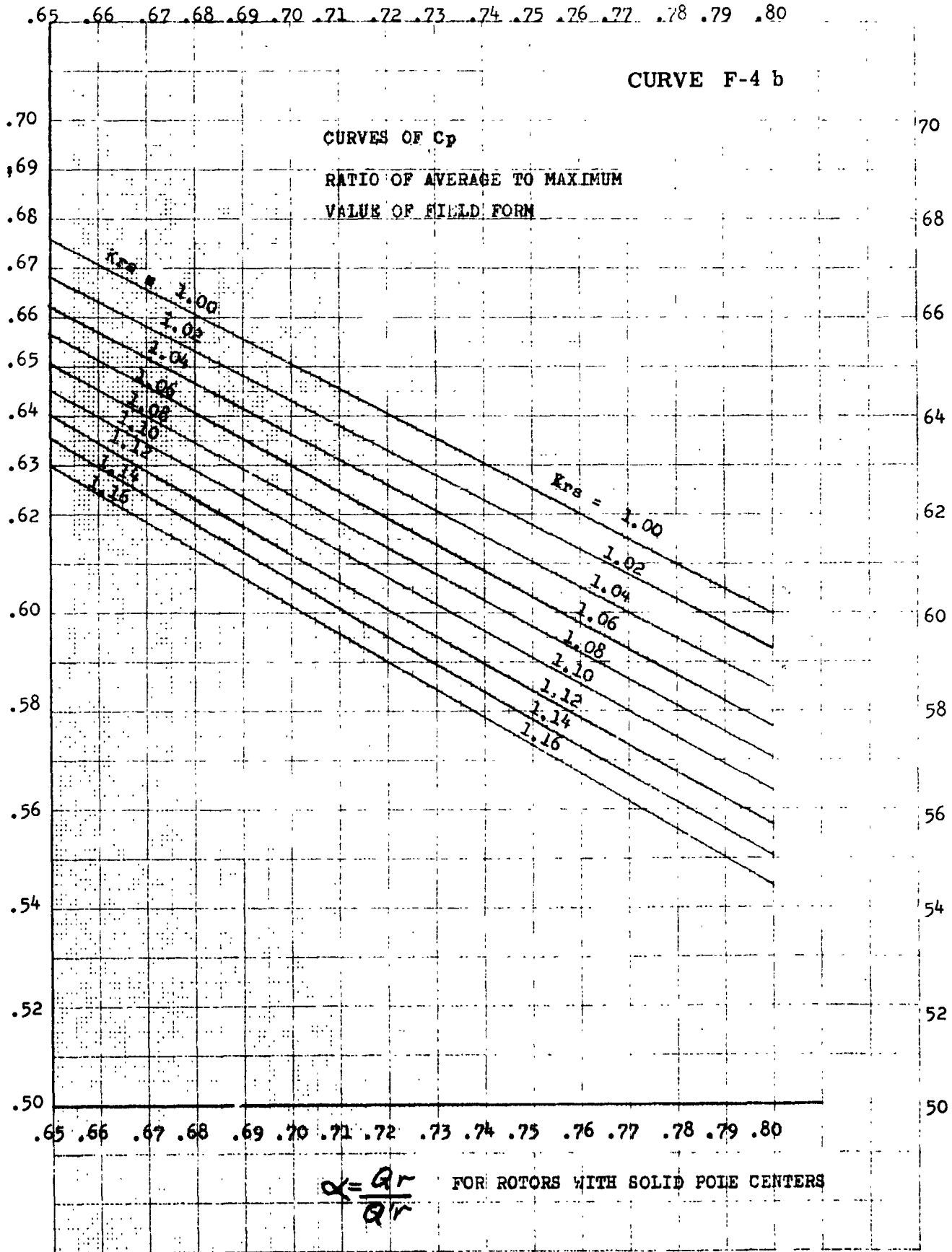

F - 7b

PITTSBURGH, PENNSYLVANIA
204-303-1500

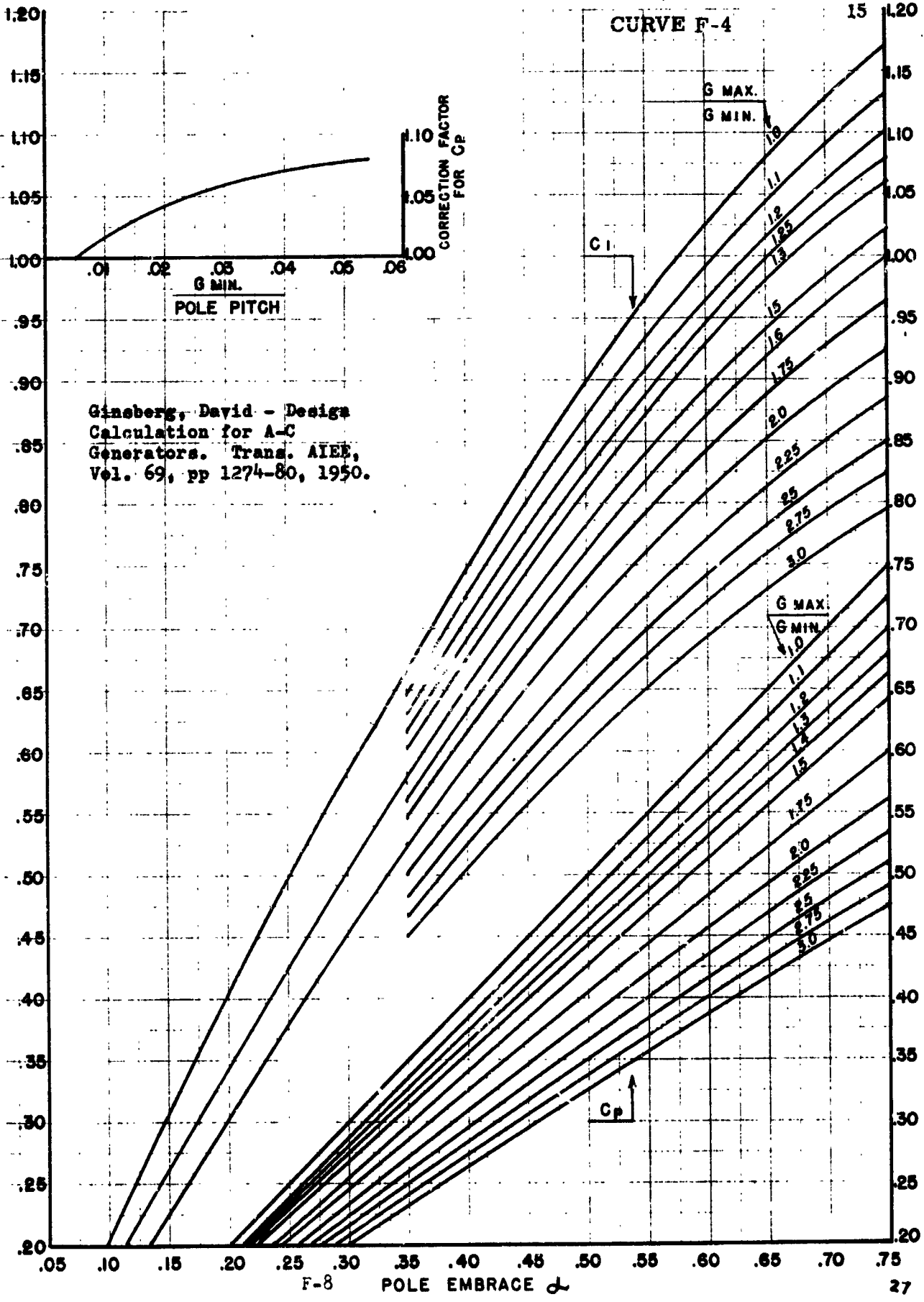

CURVE F-5

SLOT REACTANCE FACTOR

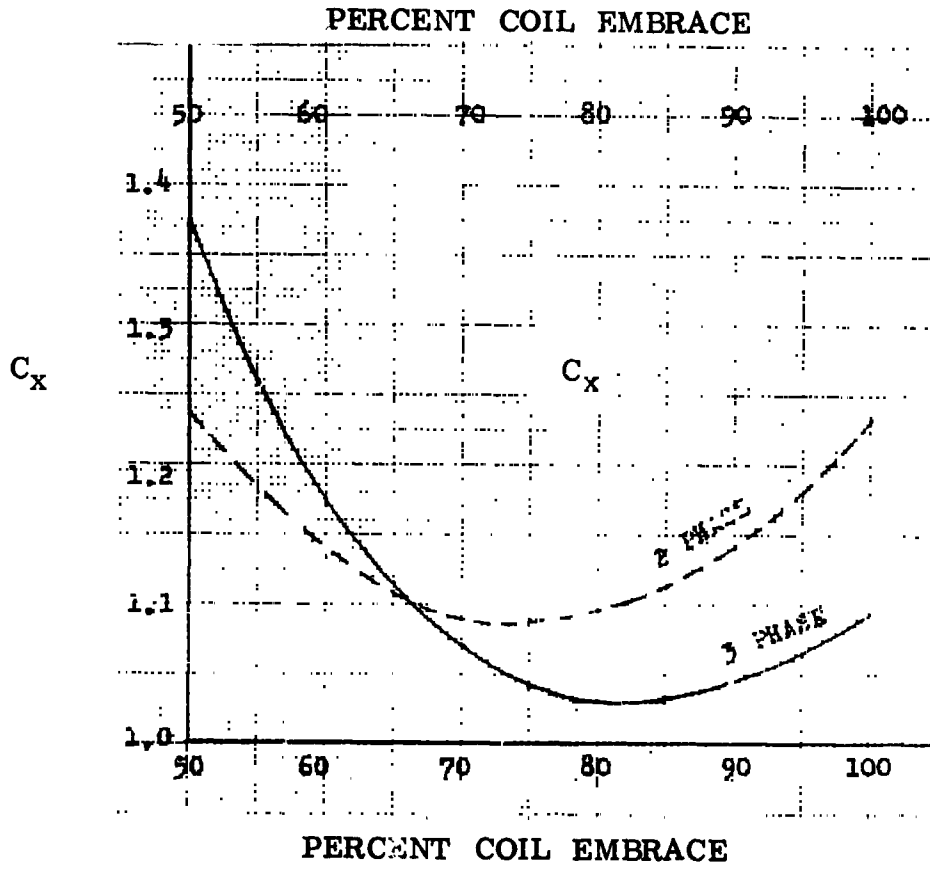

$$W_{DNL} = \frac{1.246 \rho n_b l_w c}{a_b \times 10^3} [\tau_s B_g k_p k_g]^2 \times \left\{ k_{f1} \left[\frac{k_{w1}}{2\lambda_s + [\lambda_g/k_{\phi 1}]} \right]^2 + k_{f2} \left[\frac{k_{w2}}{2\lambda_s + [\lambda_g/k_{\phi 2}]} \right]^2 \right\}$$

$$\lambda_s = \frac{h_r}{b_r} + \lambda_t + \lambda_c$$

$$\lambda_g = \frac{\tau_b}{k_g g}$$

$$\lambda_c = .75 / k_{f1} \text{ for round bars}$$

$$\lambda_c = \frac{h_{b1}}{3b_{b1} k_{f1}} \text{ for rectangular bars}$$

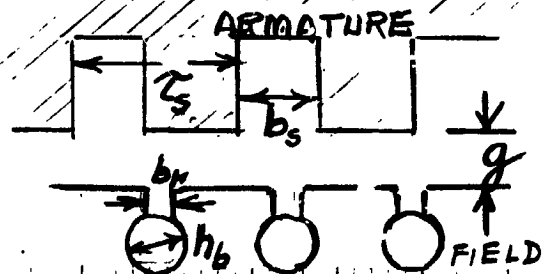

$\frac{b_o}{g}$ (OPEN SLOTS) OR $\frac{b_o}{g}$ (SEMI-CLOSED SLOTS)

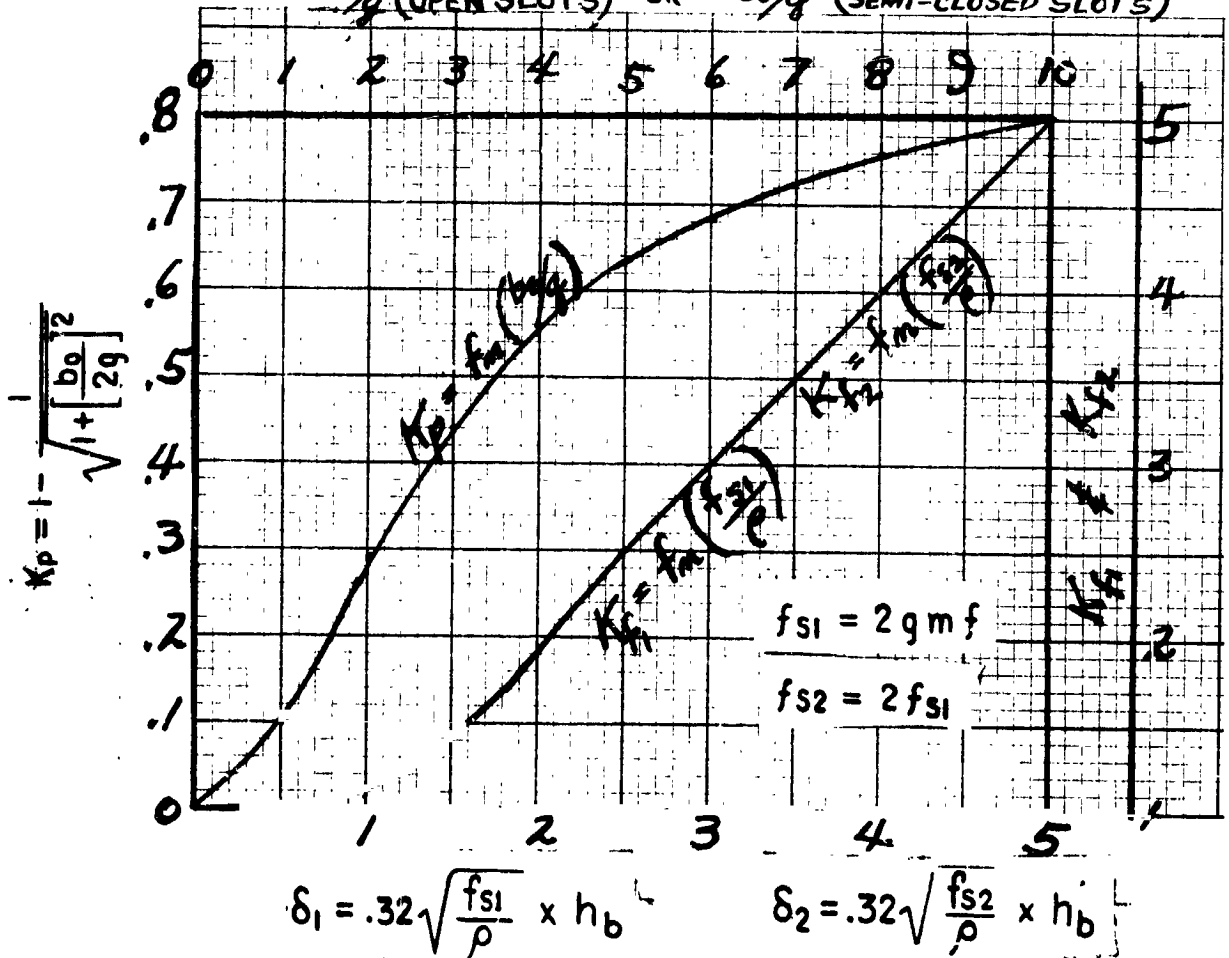

K = total Carter coefficient
 ρ_g = damper bar resistivity, ohm-inch (10^{-6})
 a_b = bar area, square inches
 p = number of poles
 l_b = length of bar, inches
 n_b = number of bars per pole
 B_g = air-gap density, Kilolines/in²

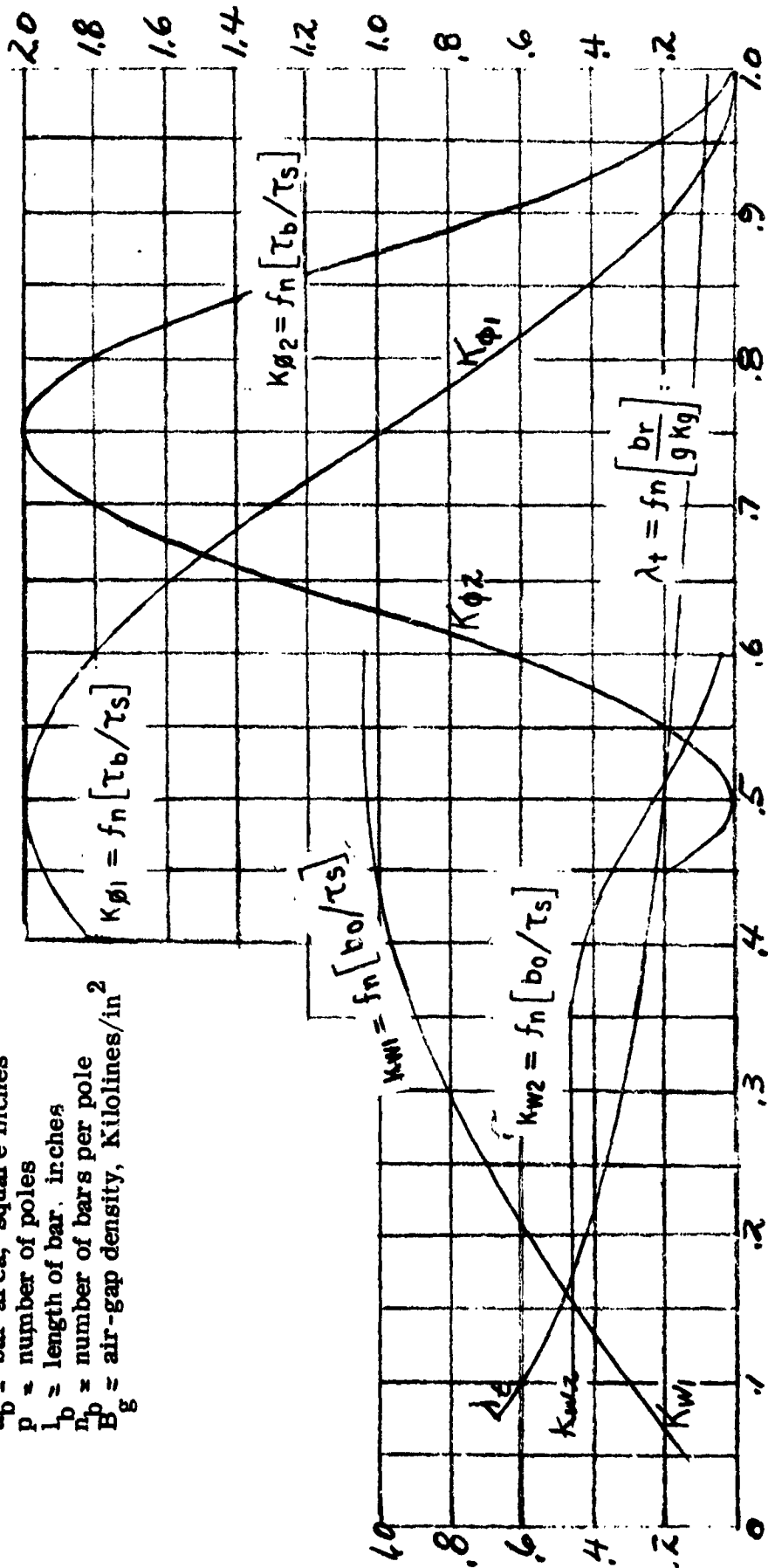

F-11

CURVE F-8

NO-LOAD DAMPER LOSS

CURVE F-9

SALIENT-POLE MACHINE CONSTANTS, C_m & C_q

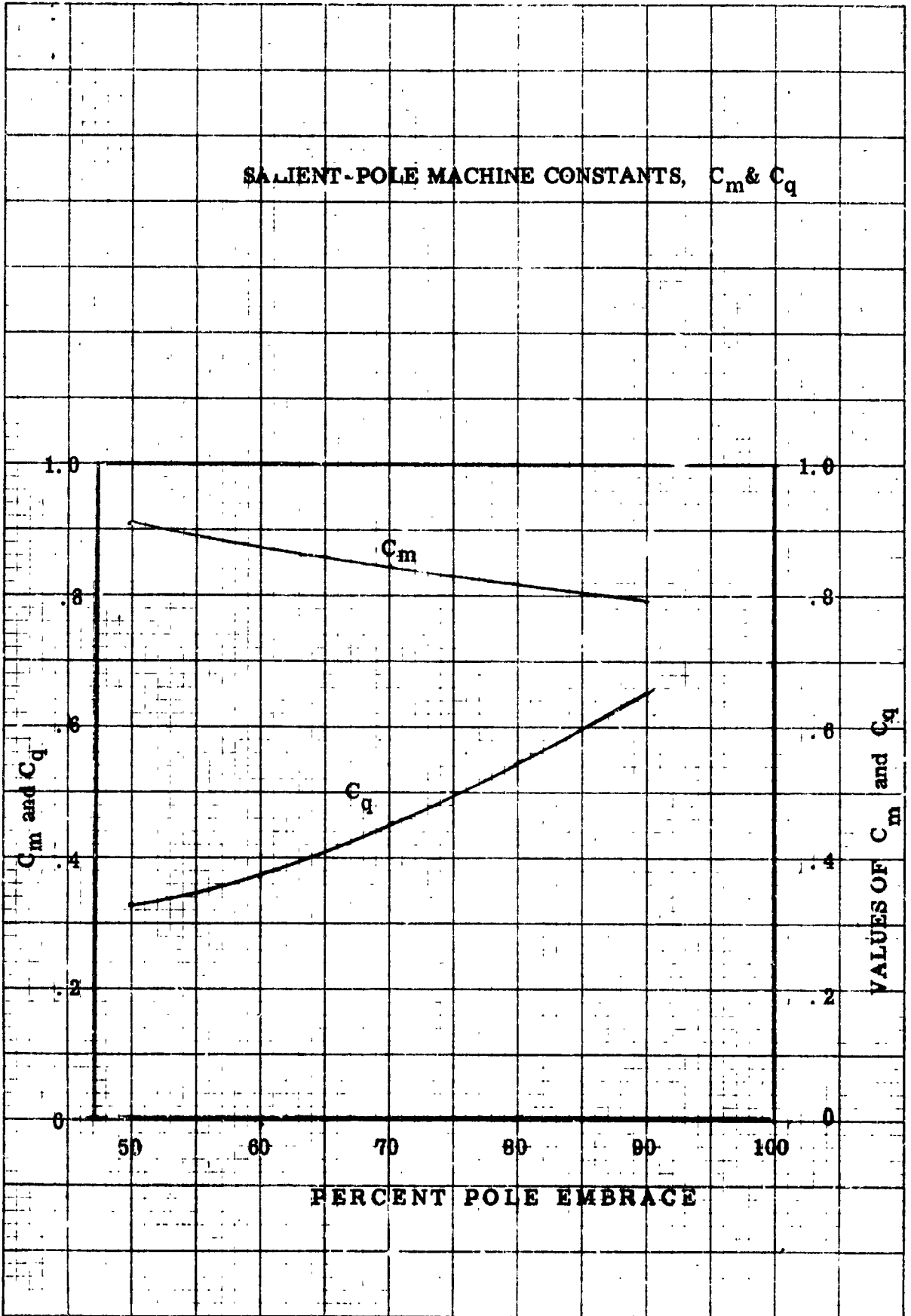

K&E 5 X 5 TO 1/2 INCH 46 0860
7 X 10 "INC" (E)
MADE IN U.S.A.
KEUFFEL & ESSER CO.

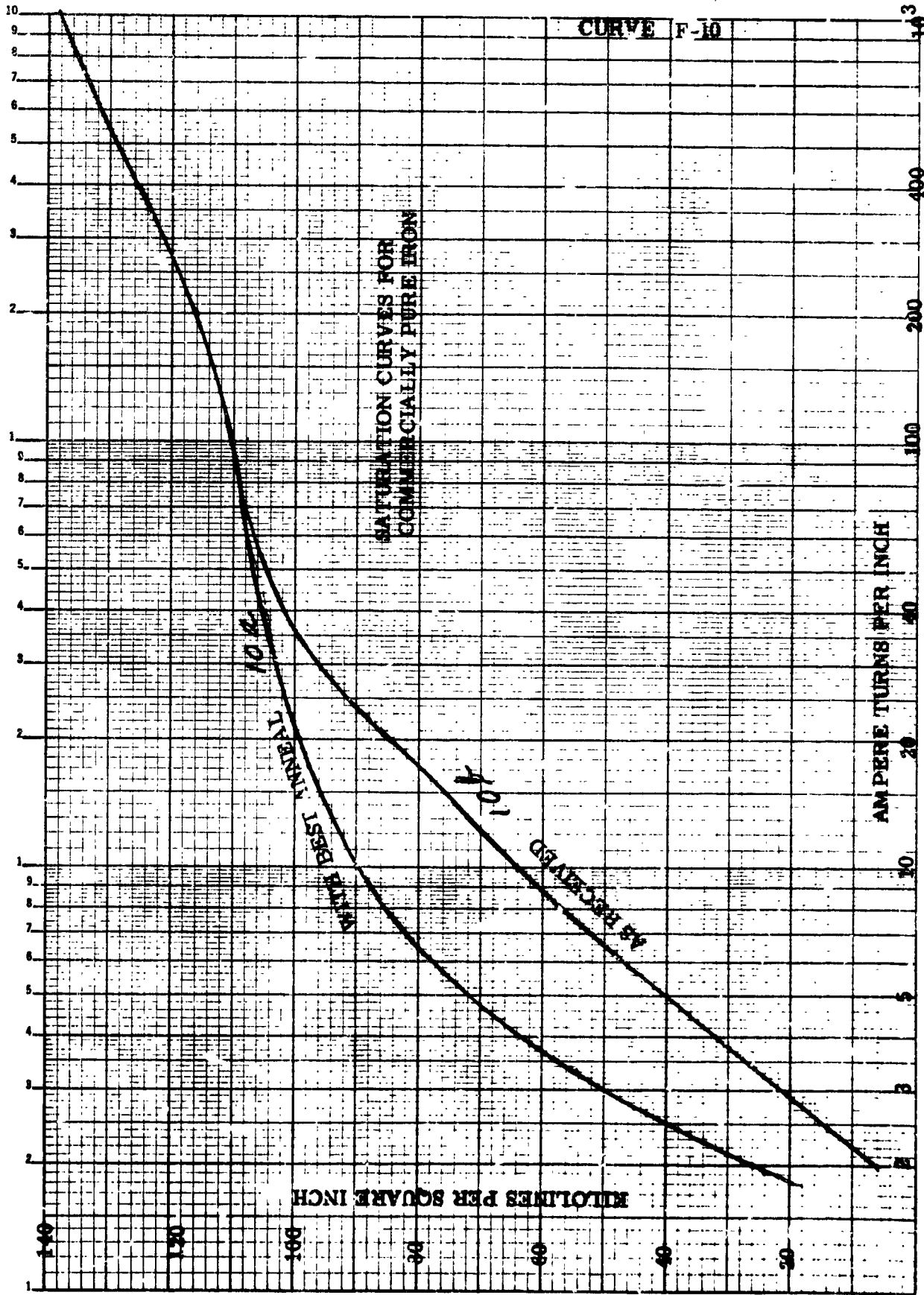

CURVE F-11 f

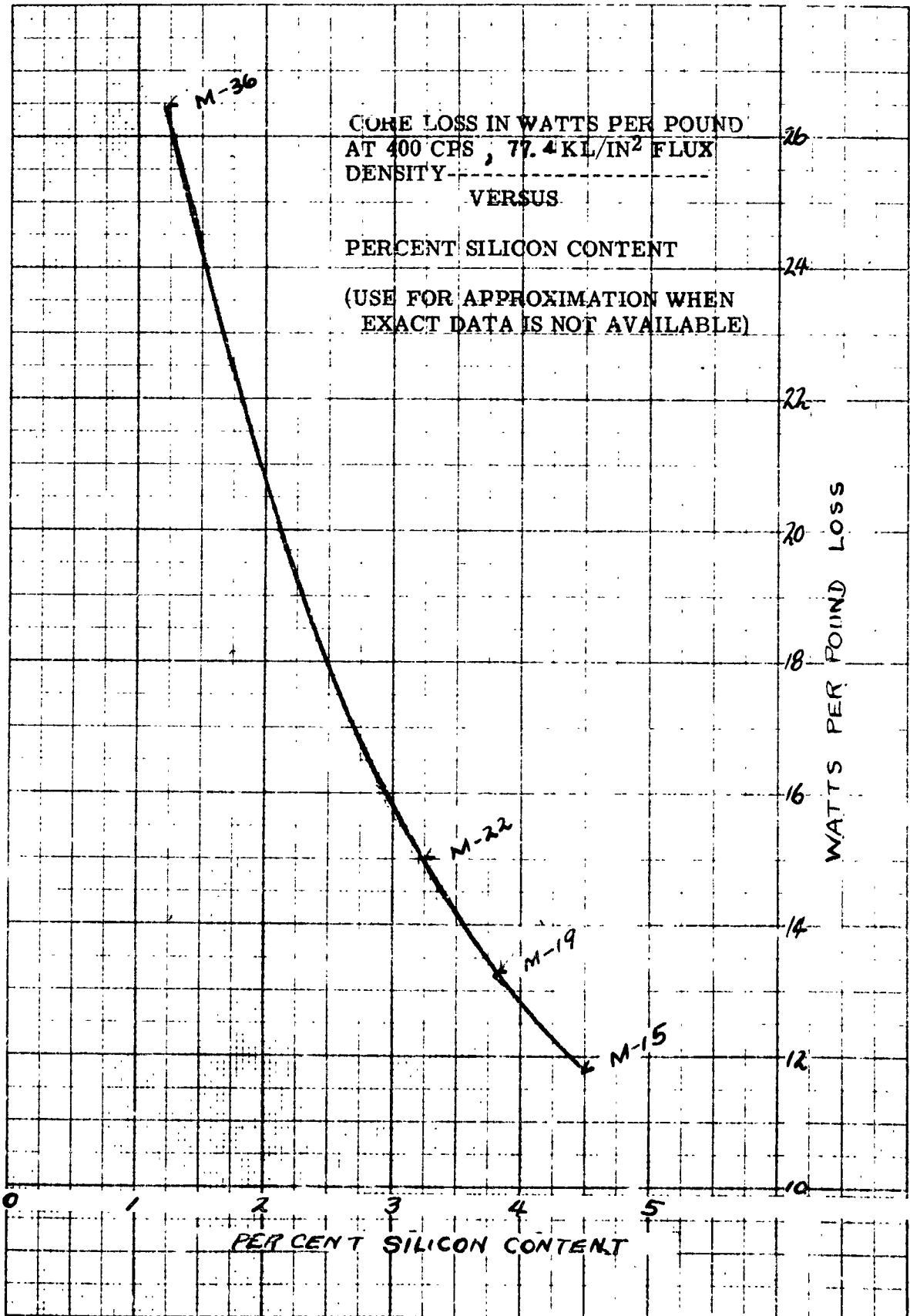

EUGENE DIETZGEN CO
PRINTED IN U.S.A.

NO 340-20 DIETZGEN GRAF
20 x 20 PER V. H.

CURVE F-11 G

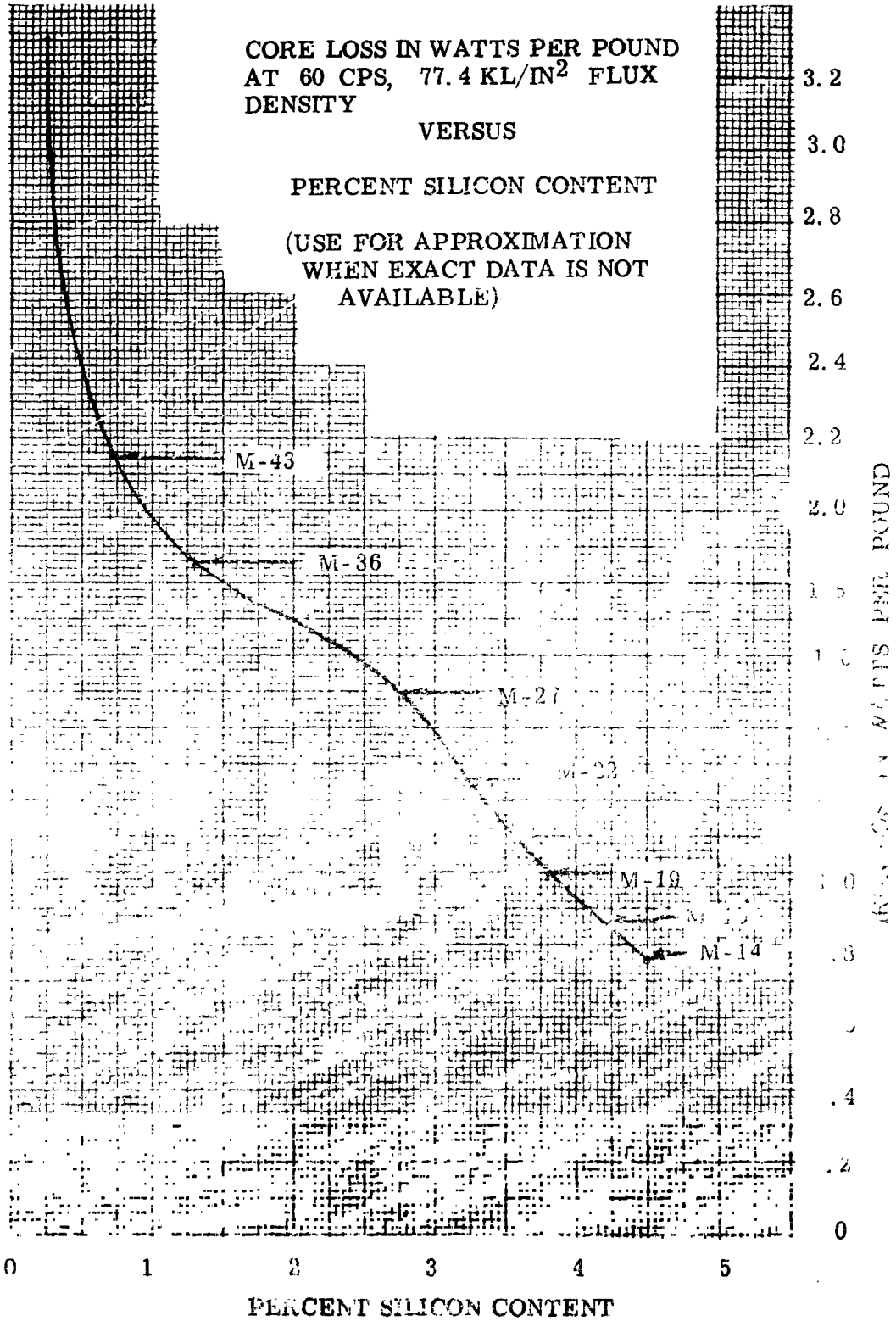

CURVE F-11 h
CORE LOSS VERSUS FREQUENCY FOR THREE
GRADES OF SILICON STEEL AT 77.4 KL/IN²
FLUX DENSITY

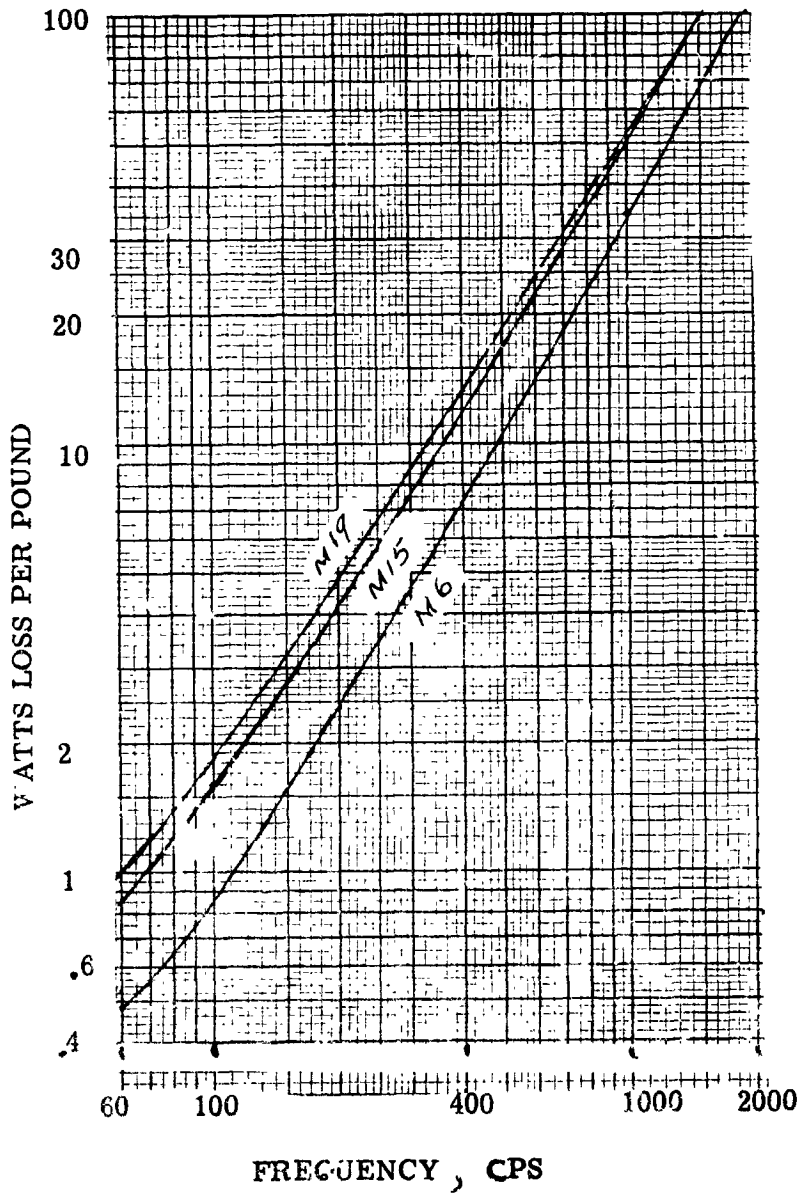

CURVE F-12

SENILE A. MITCHELL 352 71
 OFFICE OF THE DIRECTOR
 U.S. AIR FORCE

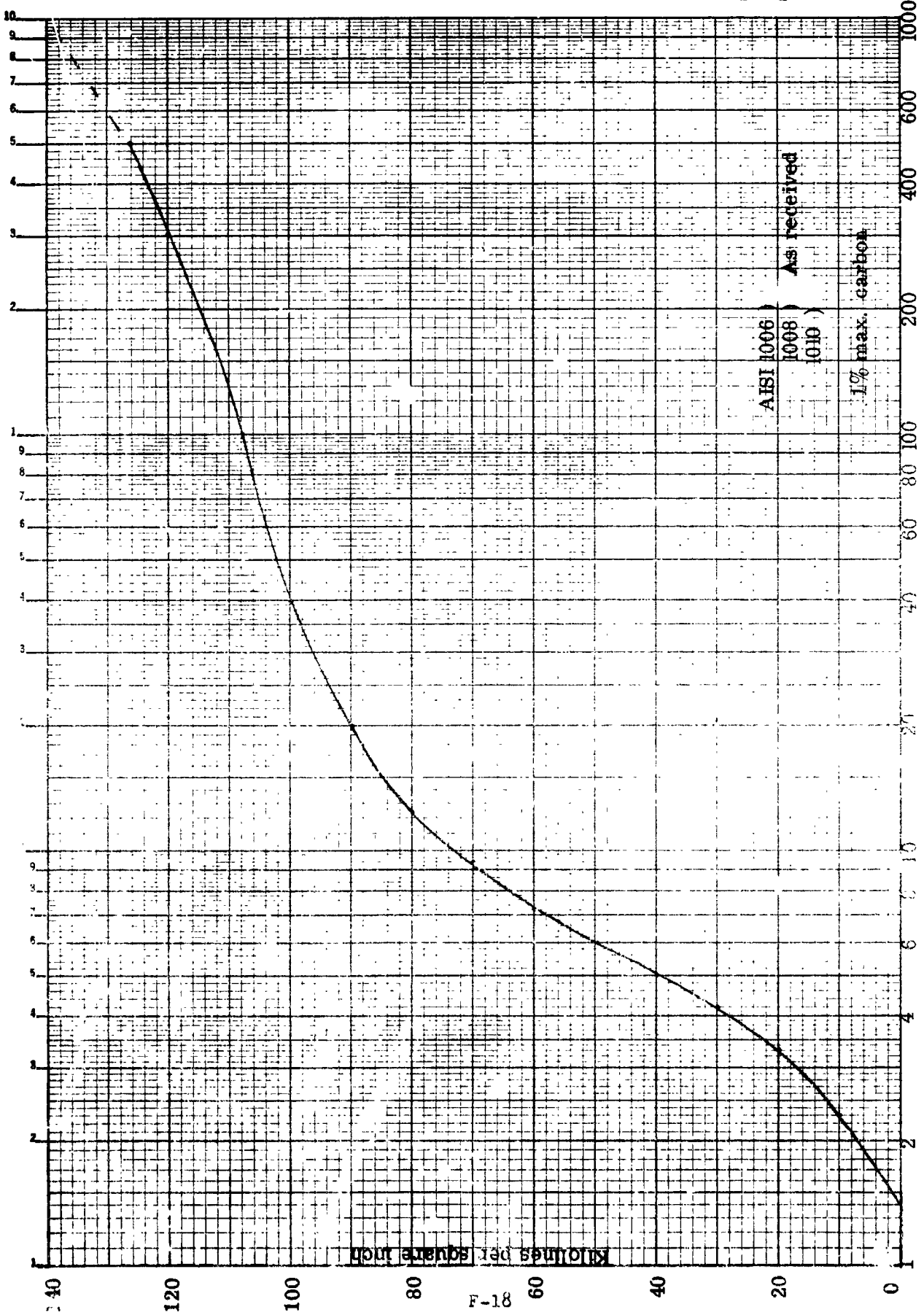

Average Thickness per inch

Kilograms per square inch

F-18

CURVE F-13

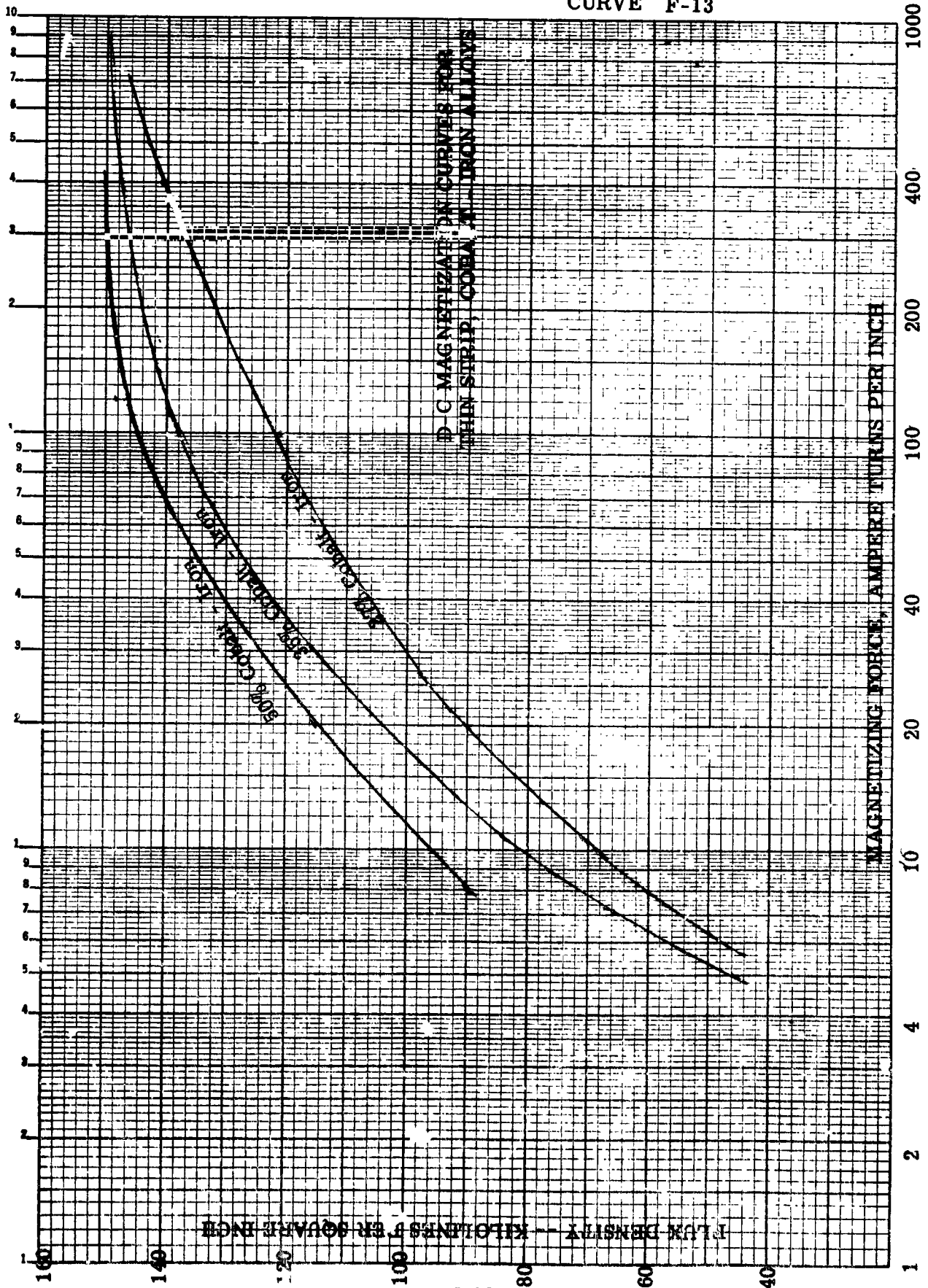

CURVE F-13 a

KE SEMI-LOGARITHMIC 359 71
 KEUFFEL & ESSER CO. MADE IN U.S.A.
 3 CIRCLES X 70 DIVIS

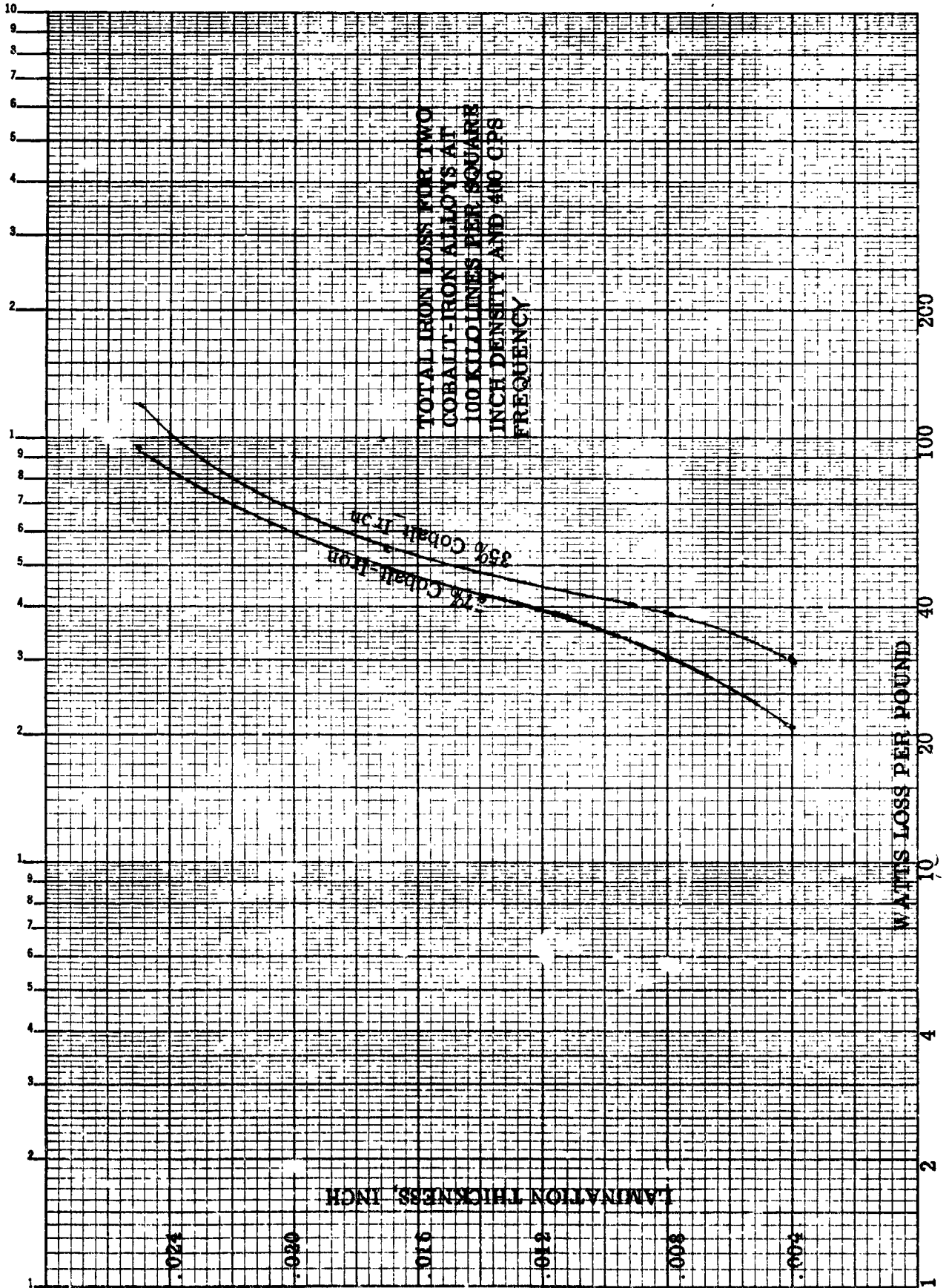

CURVE F-13 b

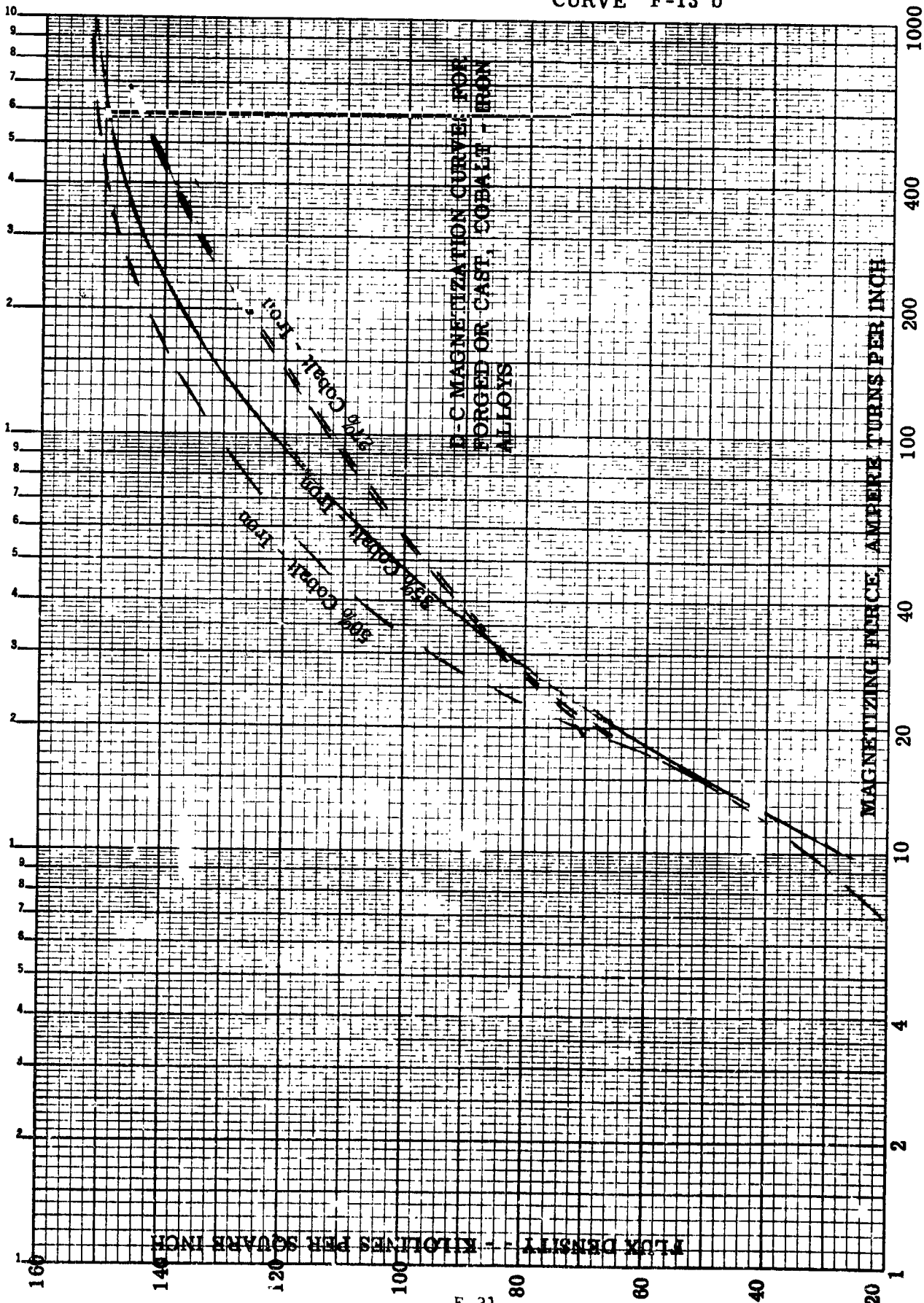

CURVE F-14

K&E SEMI-LOGARITHMIC 359-71
 KEUFFEL & ESSER CO. MADE IN U.S.A.
 3 CYCLES X 70 DIVISIONS

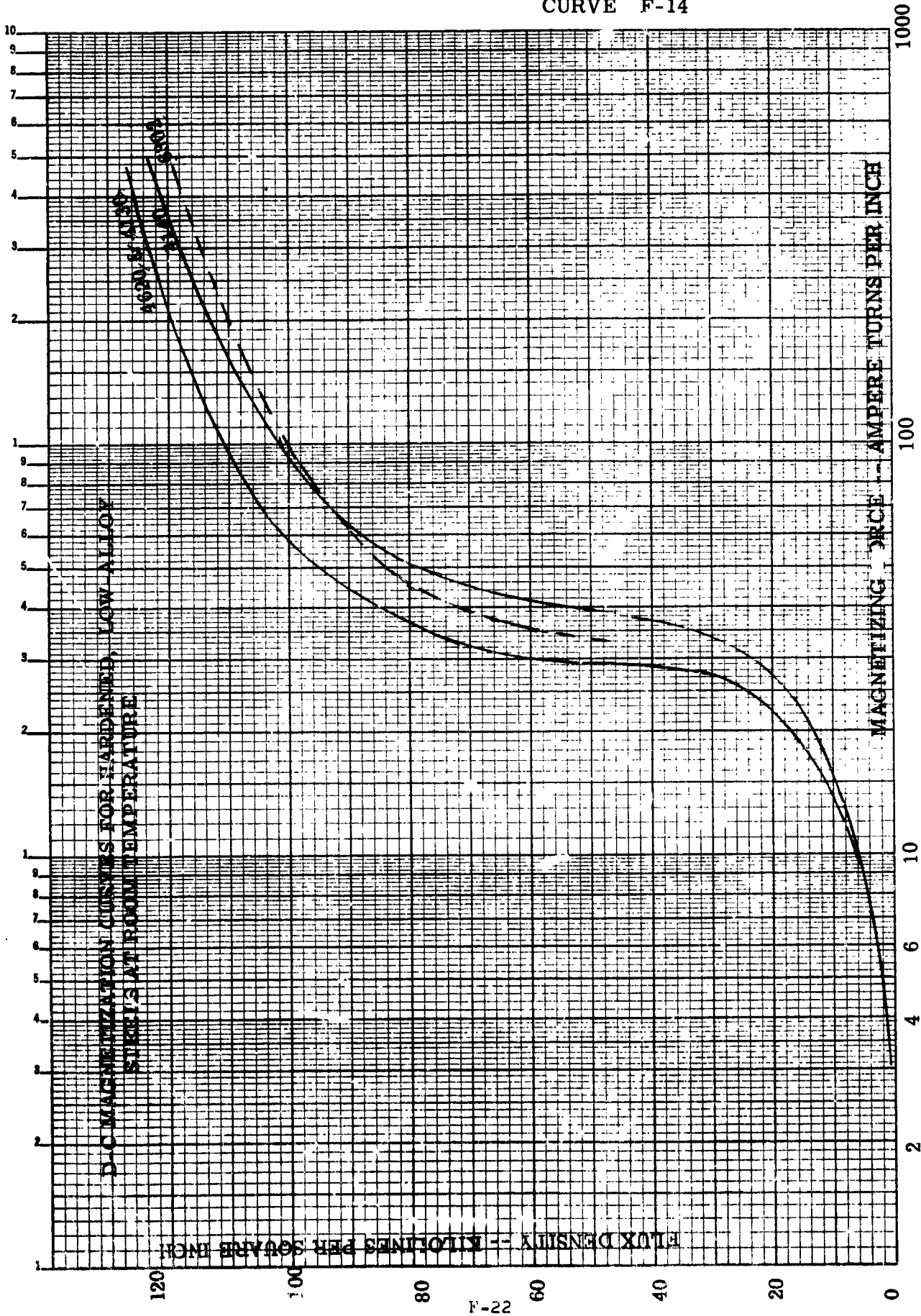

CURVE F-15

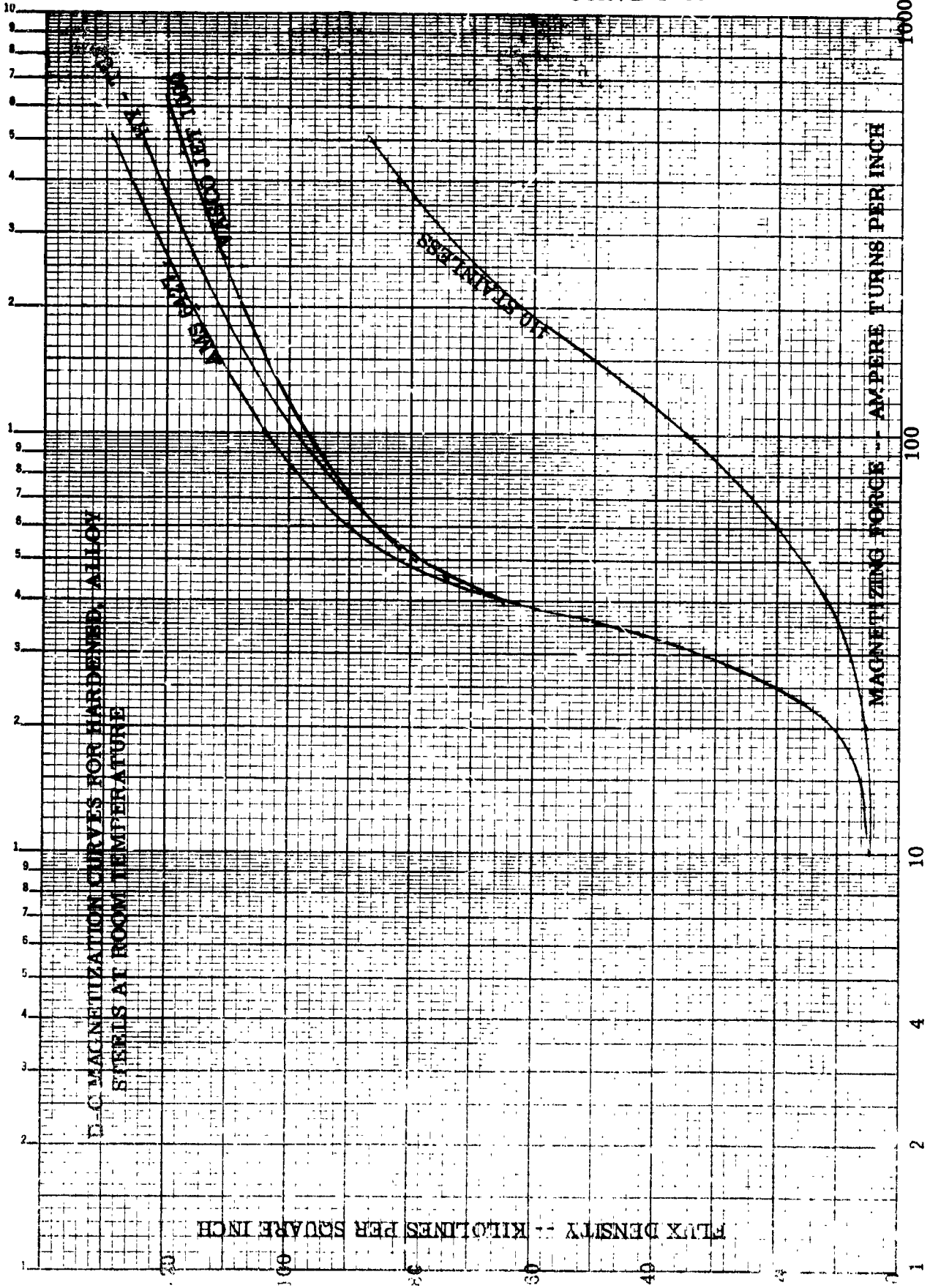

CURVE F-16

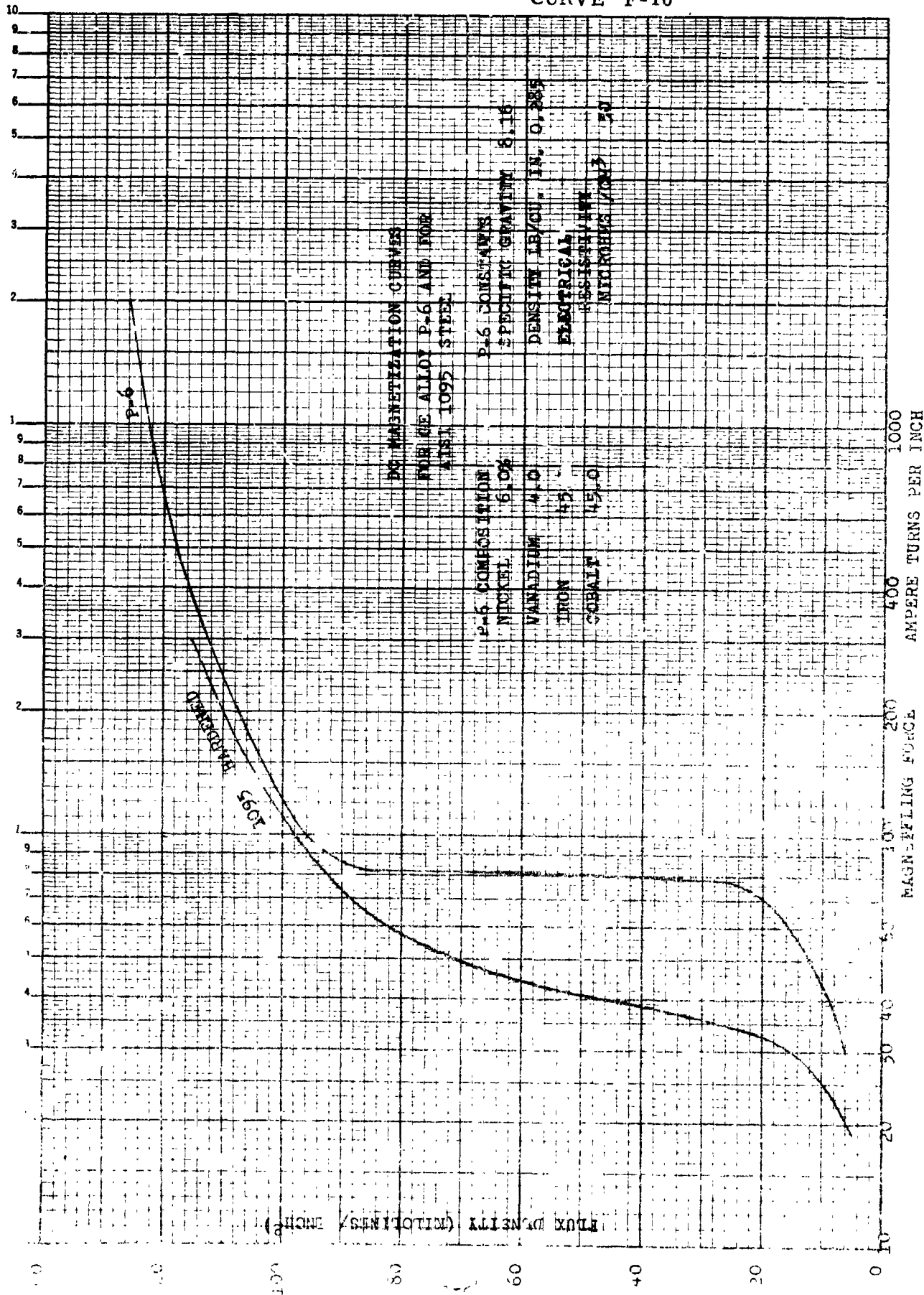

P. M. GENERATOR DESIGN MANUAL

CURVE F-17

(A_T)
 MAGNET STABILIZATION POINT VERSUS THE
 OUT-OF-STATOR LEAKAGE PERMEANCE

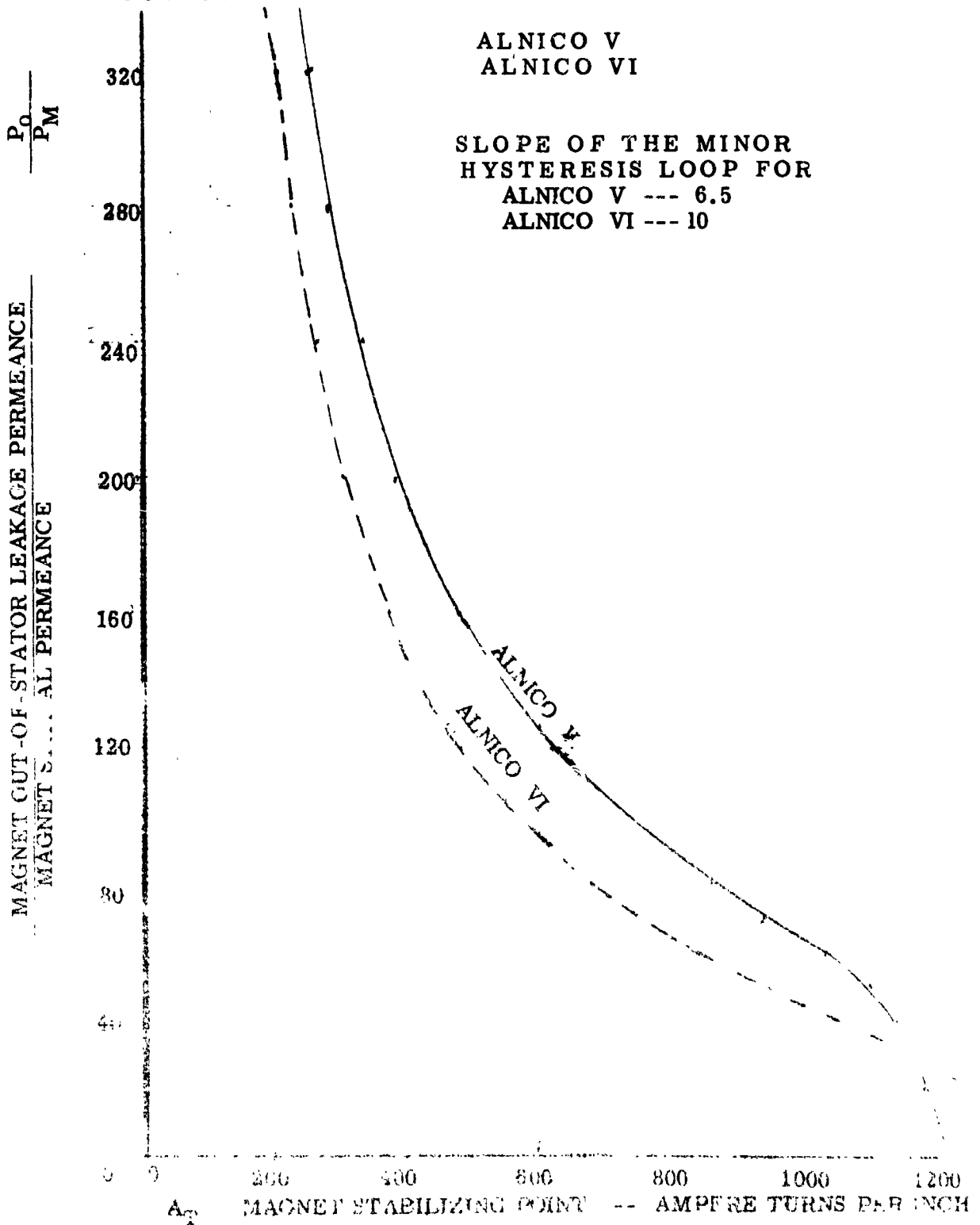

(A_T)
 MAGNET STABILIZATION POINT VERSUS
 OUT-OF-STATOR LEAKAGE PERMEANCE

CAST ALNICO VIII

----- ARNOLD ENGRG. CO.
 _____ GENERAL MAGNETIC CORP.

SLOPE OF THE MINOR HYSTERESIS
 LOOP FOR ----- IS 8.1

SLOPE OF THE MINOR HYSTERESIS
 LOOP FOR _____ IS 7.5

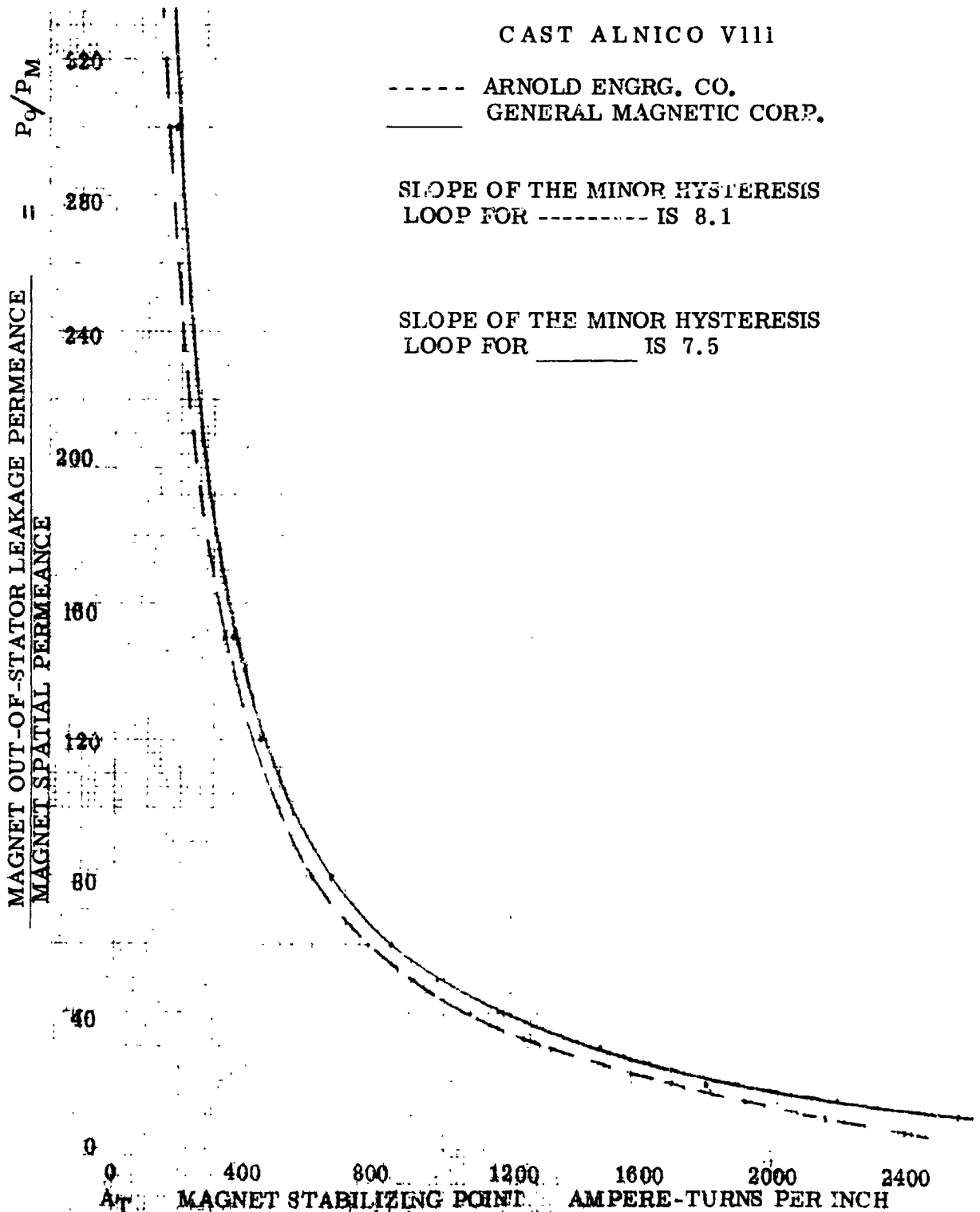

P. M. GENERATOR DESIGN MANUAL

CURVE F-19

(A_T)
MAGNET STABILIZATION POINT VERSUS
OUT-OF-STATOR LEAKAGE PERMEANCE

ALNICO V 7
(U (INDIANA STEEL PRODUCTS))

SLOPE OF THE MINOR
HYSTERESIS LOOP IS 3.5

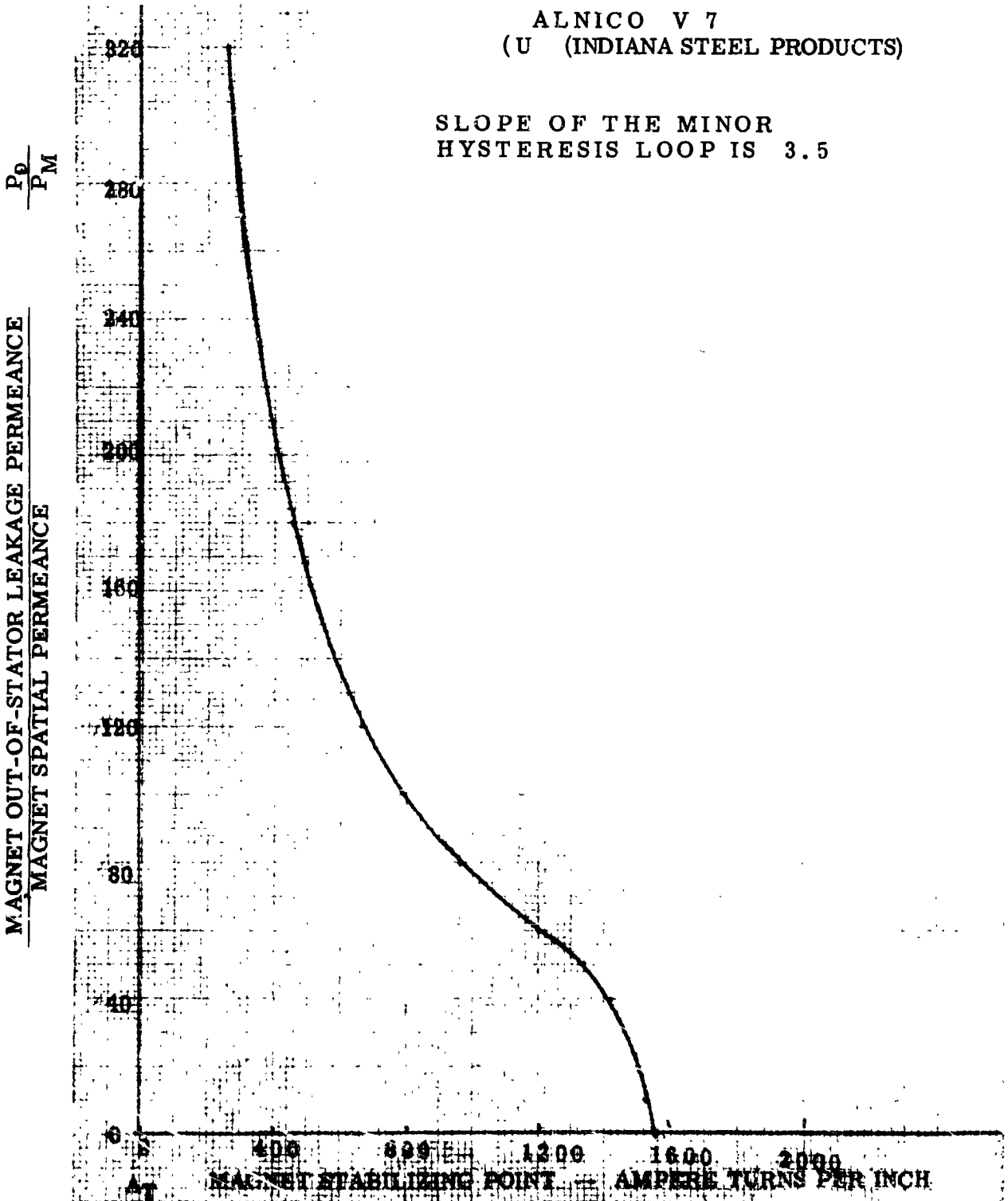

DEMAGNETIZATION CURVES FOR HIGH ENERGY

PROJECT CAST ALNICOS

CURVE F-20

1-2-63

1. ALNICUS USM-75 (U. S. MAGNET & ALLOY)
2. ALNICO V-7 (INDIANA STEEL)
3. ALNICO V (AVERAGE FOR ALL MANUFACTURERS)
4. ALNICO VI (AVG. FOR ALL MANUFACTURERS)
5. ALNICO VIII (GENERAL MAGNETIC)
6. ALNICO VII-S (INDIANA STEEL)
7. ALNICO VIII (ARNOLD ENG.)

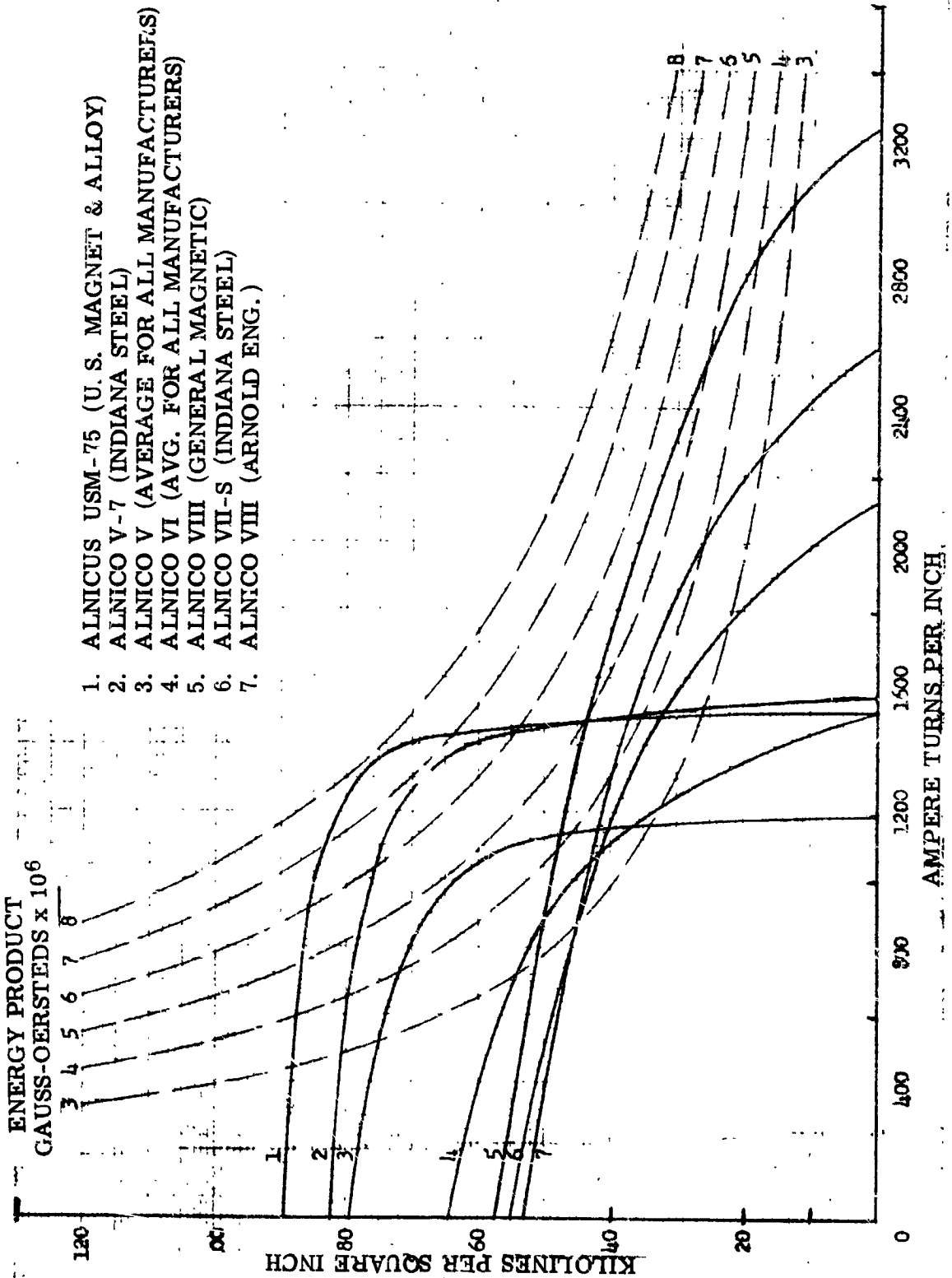

SHOWING

DEMAGNETIZATION CURVE FOR CAST ALNICO VIII
(GENERAL MAGNETIC CORP.)

CURVE F-21

DATE 12-19-62

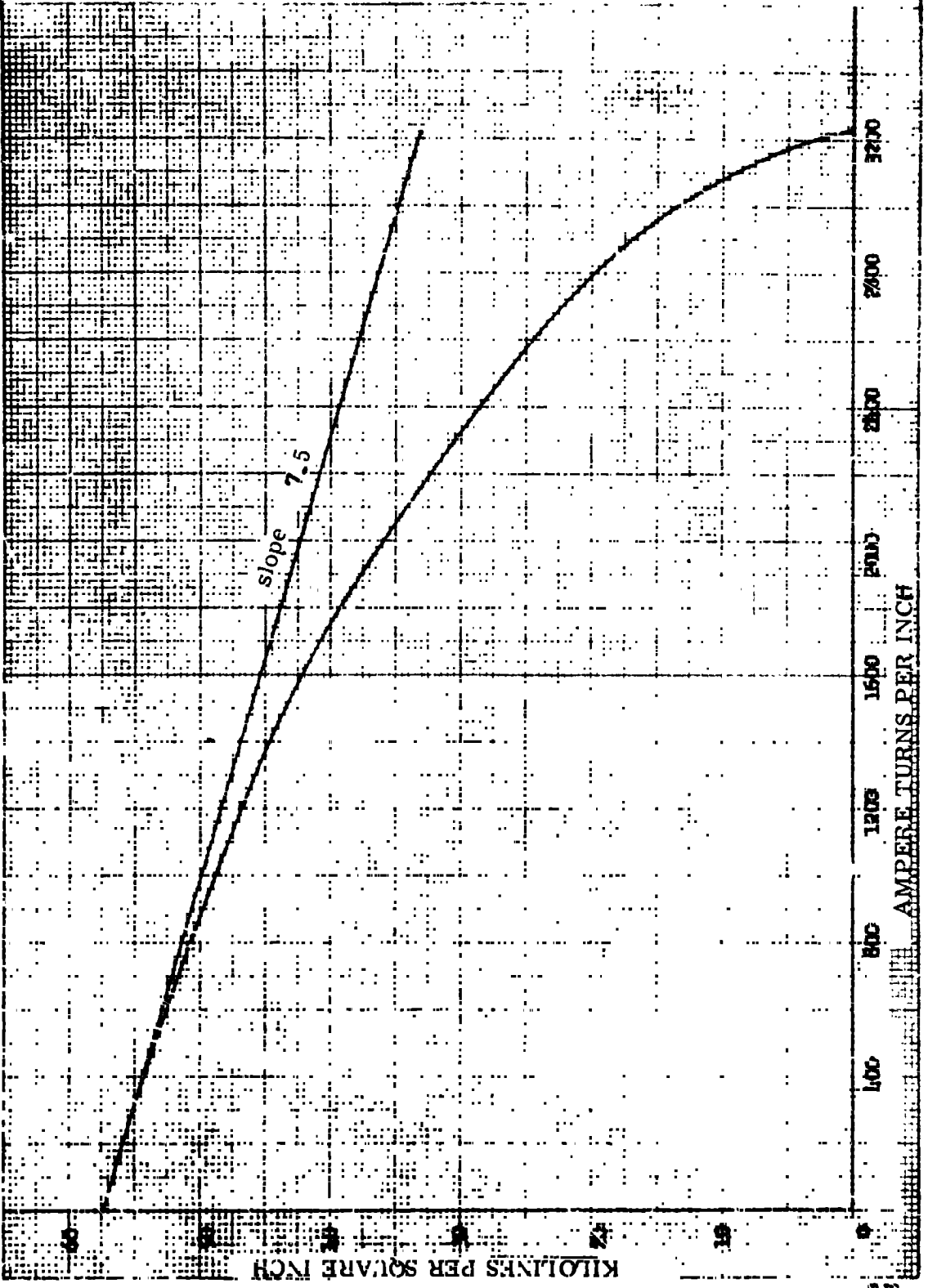

DEMAGNETIZATION CURVE FOR CAST ALNICO VIII
(ARNOLD ENGINEERING CO.)

CURVE F-22

12-19-62

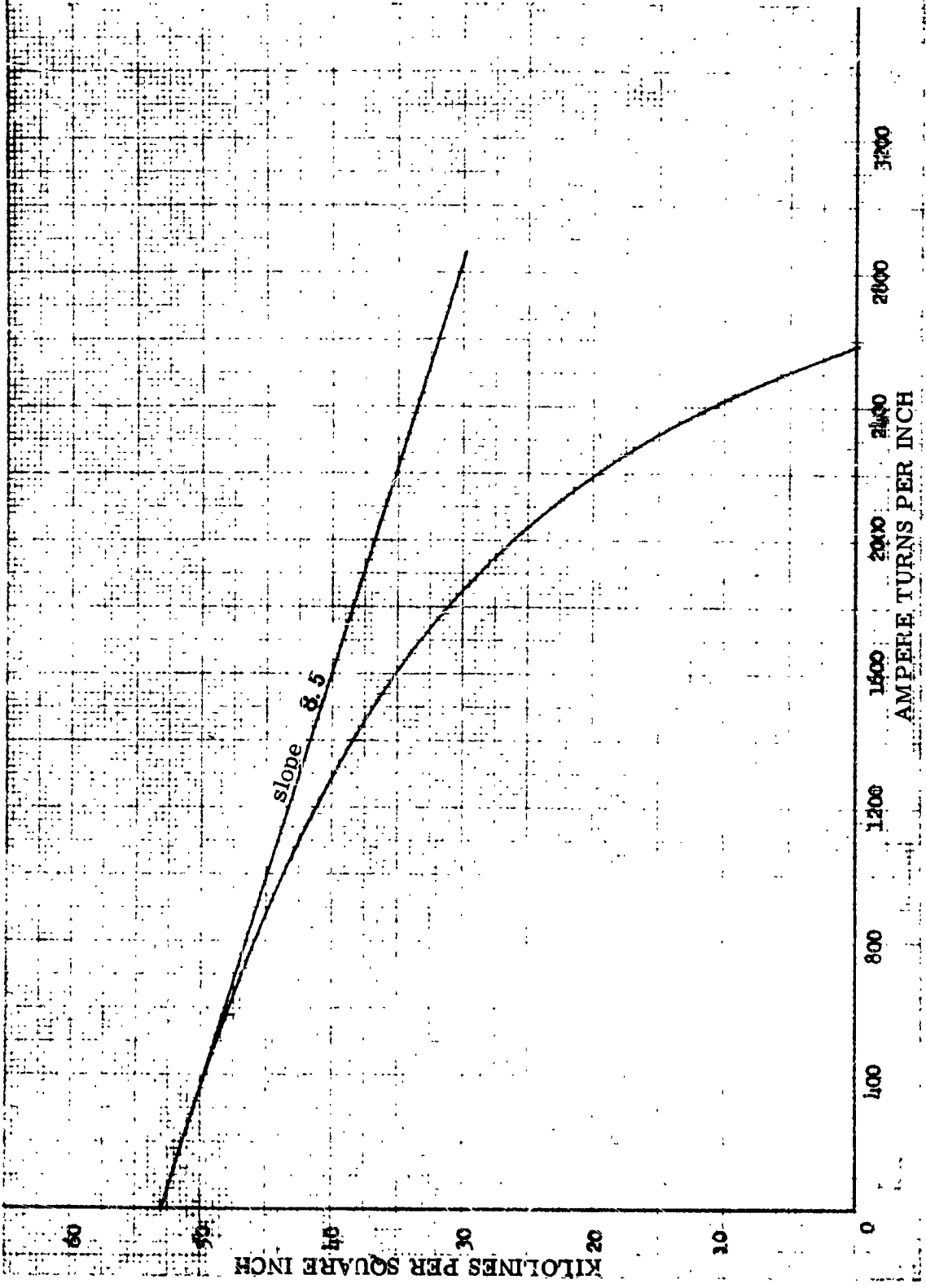

SHOWING

DEMAGNETIZATION CURVE FOR CAST ALNICO V-7
(INDIANA STEEL PRODUCTS)

CURVE F-23

DATE 12-19-62

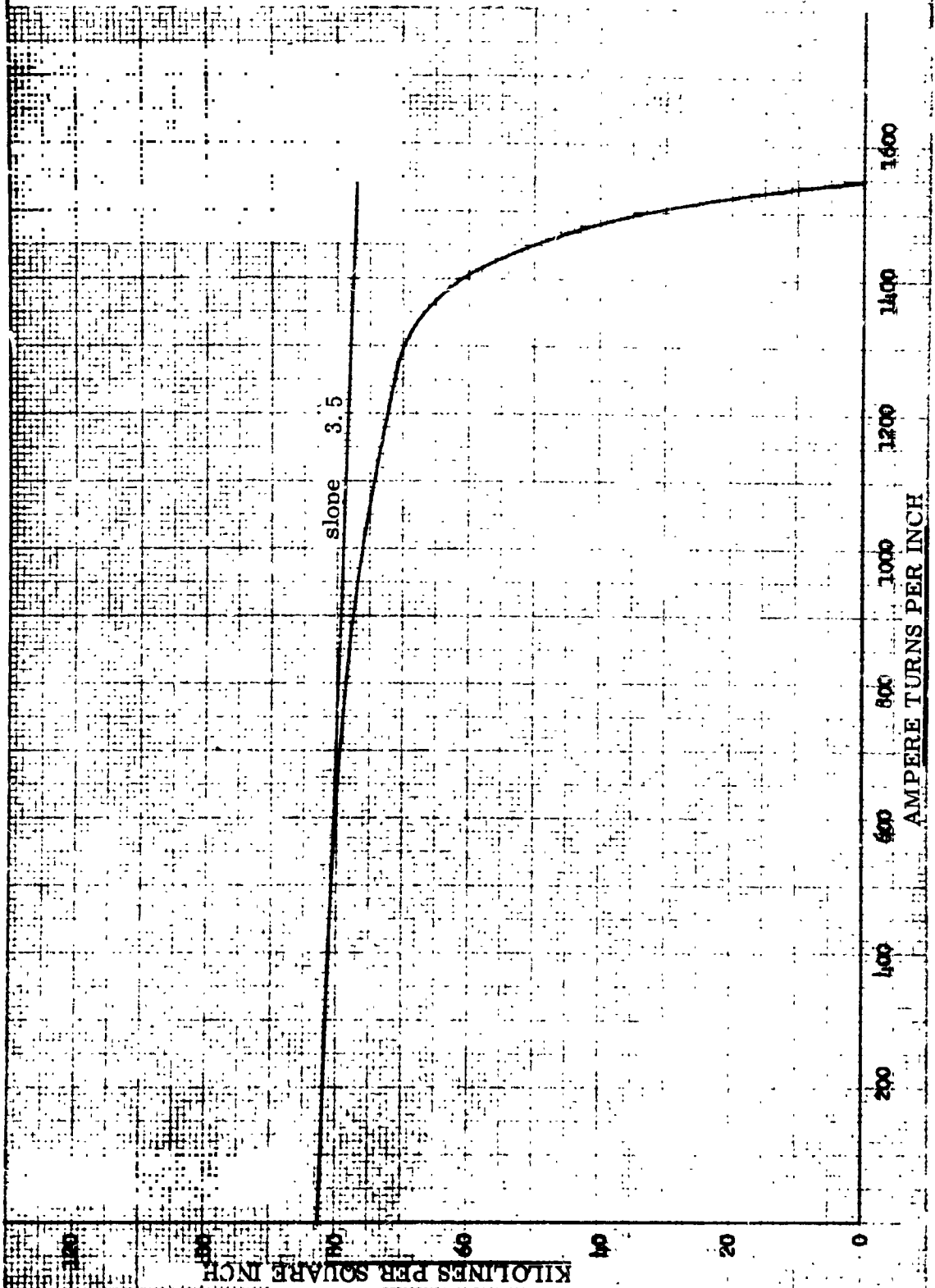

DEMAGNETIZATION CURVE FOR CAST ALNICO VI
(AVG. FOR ALL MANUFACTURERS)

CURVE F-24

12-19-62

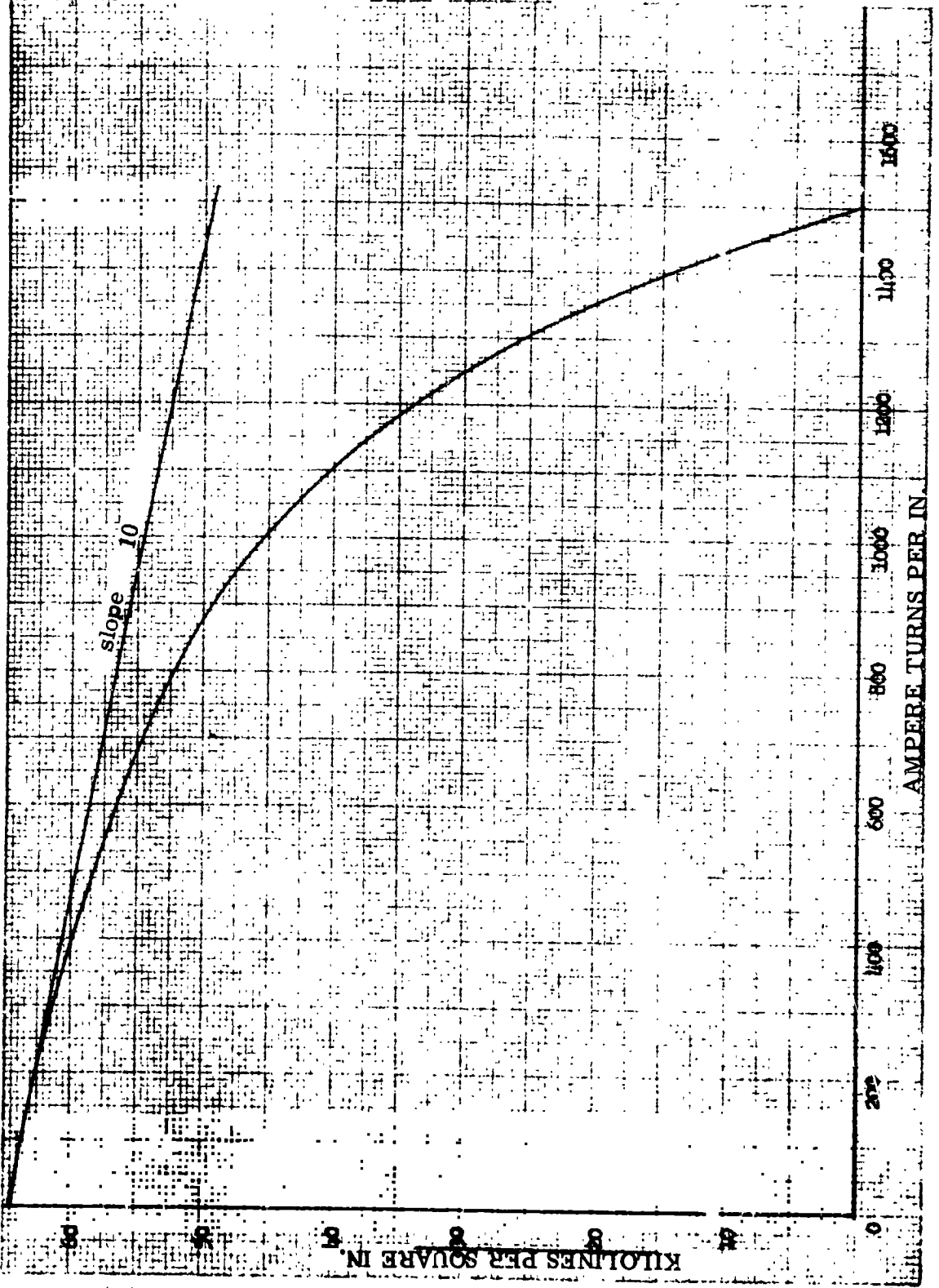

DEMAGNETIZATION CURVE FOR CAST ALNICO V
(AVG. FOR ALL MANUFACTURERS)

CURVE F-25

12-19-62

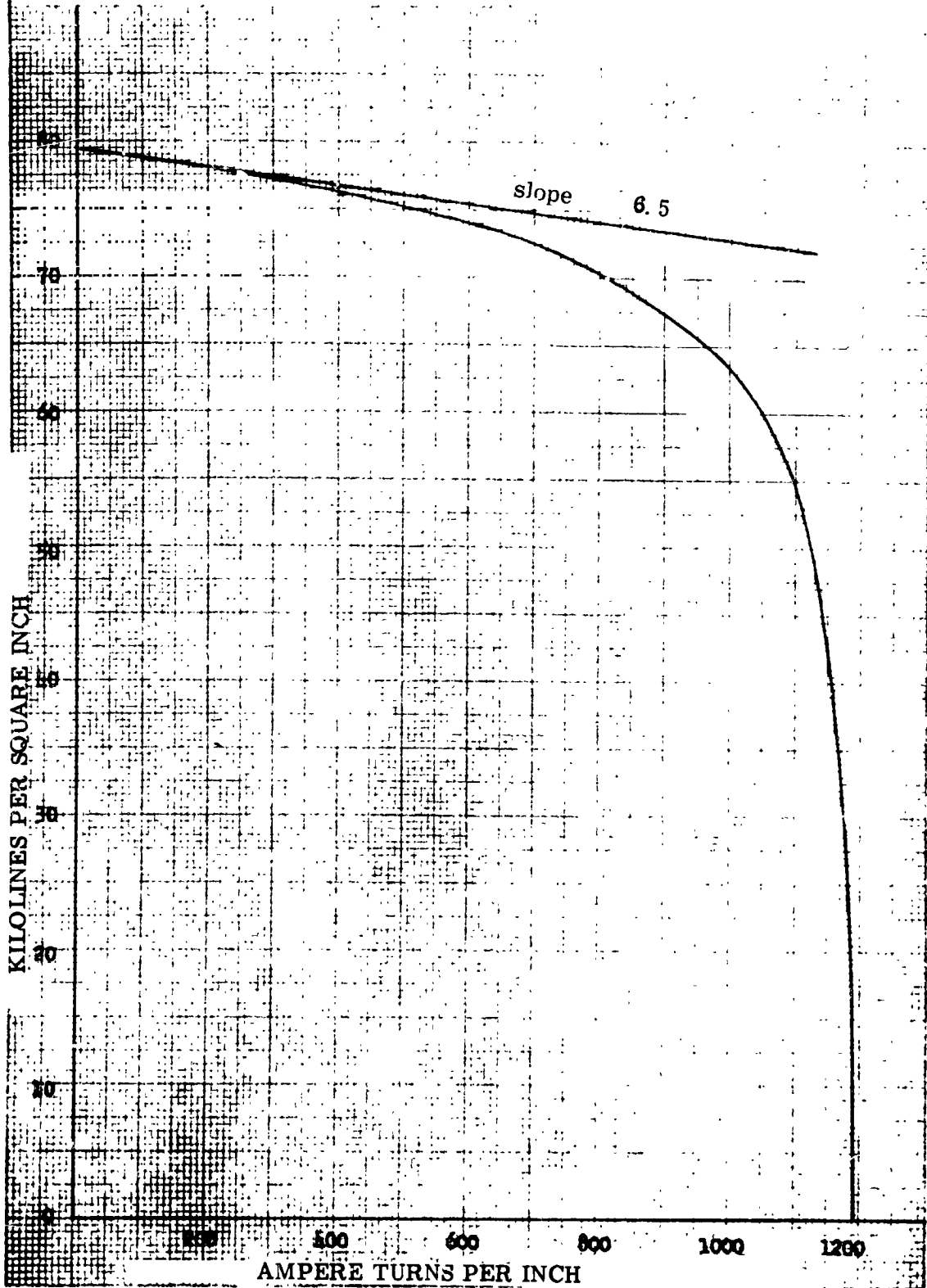

CURIE POINTS OF THE MAGNETIC MATERIALS
USED IN GENERATORS, MOTORS AND INDUCTORS

Material	Curie Point °C
Iron	770
Cobalt	1130
Nickel	358
50 Co 3 Mn 47 Fe (Permendur)	980
49 Co 2 V 49 Fe (2 V Permendur)	980
35 Co 5 Cr 6 Mn .7 Ni 63 Fe	960
27 Co 5 Cr 6 Mn .7 Ni 71 Fe	940
Silicon-Iron 2 Si	756
Silicon-Iron 8 Si	720
Silicon-Iron 11 Si	690
65 Permalloy 65 Ni - Iron	620
79 Ni Permalloy	580
7-70 Perminvar 70 Ni 7 Co - Fe	650
Perminvar 45 Ni 25 Co - Fe	720
Perminvar 45 Ni 25 Co 7.5 Mo - Fe	535
79 Ni 4 Mo - Fe (P-Alloy)	460
79 Ni 5 Mo - Fe (Supermalloy)	400
47 Ni 3 Mo - Fe (Nonimax)	510
43 Ni 3.25 Si - Fe (Sinimax)	510
76 Ni 1.5 Cr 4 Cu - Fe (Mu-Metal)	450

CURIE POINTS OF THE MAGNETIC MATERIALS
USED IN GENERATORS, MOTORS AND INDUCTORS

(Continued)

Material	Curie Point °C
36 Ni - Fe (Invar)	275
42 Ni - Fe	400
50 Ni - Fe (Deltamax)	510
15 AL 3.3 Mo - Fe (Thermencil)	400
Alnico 5 - 24 Co 14 Ni 8 AL 3 Cu	880
Alnico 6 - 24 Co 15 Ni 8 AL 3 Cu 1.25 Ti	880
Chrome Steel .9 C .3 Mn 3.5 Cr	745
3% Cobalt Steel 1.0 C 3 Co 4 Cr .4 Mo	804
17% Cobalt Steel .8 C 17 Co 25 Cr 8 W	840
36% Cobalt Steel .7 C 36 Co 4 Cr 5 W	890

MAGNETIC PROPERTIES OF Cr Ni STEELS

AISI Type No.	% Cr	% Ni	% Cold Reduction	Magnetic Permeability		Tensile Strength Lb/Sq. In.
				H = 50 Oersteds	H = 200 Oersteds	
Special	19.2	8.4	0	1.0042	1.0048	89, 100
			8.3	1.128	1.136	120, 400
			16.7	5.70	6.23	138, 200
			27.8	13.6	14.1	156, 000
			48.0	49.0	33.4	202, 000
301	17.6	7.8	0	1.0027	1.0028	95, 000
			19.5	1.148	1.257	140, 600
			55.0	14.8	19.0	222, 400
302	18.4	9.0	0	1.0025	1.0035	95, 300
			20.0	1.0076	1.011	130, 200
			44.0	1.050	1.120	171, 000
			68.0	1.59	2.70	214, 000
			84.0	2.15	6.65	236, 000
304	19.0	10.7	0	1.0037	1.0040	81, 000
			13.8	1.0048	1.0060	101, 100
			32.0	1.0371	1.062	145, 900
			65.0	1.540	2.12	180, 400
			84.5	2.20	4.75	202, 800
308	17.9	11.7	0	1.0032	1.0044	88, 200
			18.5	1.0040	1.0054	129, 100
			34.5	1.017	1.020	154, 700
			52.5	1.049	1.063	175, 900
			84.0	1.093	1.142	197, 800
310	24.3	20.7	0	1.0018	1.0035	107, 800
			14.7	1.0016	1.0041	128, 100
			26.8	1.0018	1.0043	155, 000
			64.2	1.0019	1.0041	192, 600
316 2.4% MO.	17.5	13.4	0	1.0030	1.0040	83, 600
			20.8	1.0030	1.0043	117, 800
			45.0	1.0040	1.0065	159, 900
			60.8	1.0065	1.0072	178, 000
			81	1.0070	1.0100	194, 100

MAGNETIC PROPERTIES OF Cr Ni STEELS (Cont)

AISI Type No.	% Cr	% Ni	% Cold Reduction	Magnetic Permeability		Tensile Strength Lb/Sq. In.
				H = 50 Oersteds	H = 200 Oersteds	
321						
0.68% Ti	18.3	10.3	0	1.0033	1.0035	87,800
			16.5	1.018	1.023	123,200
			41.5	1.40	1.61	162,200
			53.5	2.44	3.34	174,400
			70.5	6.76	9.40	201,300
347						
0.95% Cb.	18.4	10.7	0	1.0037	1.0044	94,800
			13.5	1.0074	1.0085	118,200
			40.0	1.062	1.088	166,100
			60.0	1.245	1.445	179,300
			90.0	1.97	4.12	216,500

Ref: Heat treatment and physical properties of the Austenitic Chromium - Ni Steels - International Nickel Co. Bulletin

NON-MAGNETIC STEELS

The Chrome-Nickel steels of the 300 series are used as non-magnetic spacers and support members in rotor weldments, braces and other structural locations where it is desirable to use a material with a permeability of one (1).

Some of the 300 series steels are non-magnetic in the "soft" condition but when they are work hardened part of the steel changes phase and becomes magnetic. The 18-3 steel (see 301 on chart) becomes useless for non-magnetic needs when cold reduced 25% to 50%.

INPUT AUXILIARY DATA SHEET

Auxiliary information taken from the design manuals to be used in conjunction with input sheets for convenience.

- A. All dimensions for lengths, widths, and diameters are to be given in inches.
- B. Resistivity inputs, Items (141) and (151) are to be given in micro-ohm-inches.

The following items along with an explanation of each are tabulated here for convenience. For complete explanation of each item number, refer to design manuals.

- | <u>Item No.</u> | <u>Explanation</u> |
|-----------------|--|
| (9) | Power factor to be given in per unit. For example for 90% P.F., insert <u>.90</u> . |
| .9a) | Adjustment Factor - For P.F. < .95 insert <u>1.0</u> |
| | For P.F. > .95 insert <u>1.05</u> |
| (10) | Optional Load Point -- Where load data output is required at a point other than those given as standard on the input sheet. Example: For load data output at 155% load, insert <u>1.55</u> . |
| (14) | Number of radial ducts in stator. |
| (15) | Width of radial ducts used in Item (14). |
| (18) | Magnetization curve of material used to be submitted as defined in Item (18). |
| (19) | Watts/Lb. to be taken from a core loss curve at the density given in Item (20) (Stator). |
| (20) | Density in kilolines/in ² . This value must correspond to density used to pick Item (19) usually use 77.4 KL/in ² . |
| (21) | Type of slot - For open slot Type A, insert <u>1.0</u> . |
| | For partially open slot Type B with constant slot width, insert <u>2.0</u> . |
| | For partially open slot Type C with constant tooth width, insert <u>3.0</u> . |
| | For round slot Type D, insert <u>4.0</u> . |
| | For additional information, refer to figure adjacent to input sheet which shows a picture of each slot. |
| (22) | For stator slot dimension - for dimensions that do not apply to the slot insert <u>0.0</u> .
Use Table below as guide for input. |

<u>Symbol</u>	<u>Item</u>	<u>Slot Type</u>			
		<u>1</u>	<u>2</u>	<u>3</u>	<u>4</u>
b ₀	(22)	0.0	*	*	*
b ₁	↓	0.0	0.0	*	0.0
b ₂		0.0	0.0	*	0.0
b ₃		0.0	0.0	*	0.0
b _s		*	*	$\frac{\phi}{2}$	*
h ₀		0.0	*	*	*
h ₁		*	*	*	0.0
h ₂		*	0.0	0.0	0.0
n ₃		*	*	0.0	0.0
h _s		*	*	*	*
h _t		0.0	*	*	0.0
h _w		0.0	*	*	0.0

* = insert actual value.

$$\phi = b_s = \frac{b_1 + b_3}{2}$$

SALIENT POLE COMPUTER DESIGN (INPUT)

MODEL _____ EWO _____ DESIGN NO(1) _____

	PARAMETERS	UNIT	DESCRIPTION	FORMULA	NO.	SYMBOL	
	(2)	KVA	GENERATOR KVA		(71)	C_1	CONSTANTS
	(3)	E	LINE VOLTS		(72)	C_w	
	(4)	E_{ph}	PHASE VOLTS		(73)	C_p	
	(5)	m	PHASES		(48)	L_E	
	(5a)	f	FREQUENCY		(74)	C_m	
	(6)	p	POLES		(75)	C_g	
	(7)	RPM	RPM		(76)	h_h	
	(8)	I_{ph}	PHASE CURRENT		(76)	b_p	
	(9)	PF	POWER FACTOR		(76)	h_h	
	(9a)	K_c	ADJ. FACTOR		(76)	h_f	
	(10)		OPTIONAL LOAD POINT		(76)	λ_p	ROTOR STACK
	(11)	d	STATOR I.D.		(76)	λ_n	
	(12)	D	STATOR O.D.		(77)	α_c	
	(13)	λ	GROSS CORE LENGTH		(11a)	d_r	
	(14)	n_v	NO. OF DUCTS		(16)	K_i	
	(15)	b_v	WIDTH OF DUCT		(157)	(-)	
	(16)	K_i	STACKING FACTOR (STATOR)		(187)	(K_i)	
	(19)	k	WATTS/LB.		(135)	b_{bo}	
	(20)	B	DENSITY		(135)	h_{bo}	
	(21)		TYPE OF SLOT		(136)	()	
	(22)	b_o	SLOT OPENING		(137)	h_w	
	(22)	b_l	SLOT WIDTH TOP		(135)	b_w	
	(22)	b_2			(138)	n_b	
	(22)	b_3			(139)	λ_b	
	(22)	b_s	SLOT WIDTH		(140)	τ_b	
	(22)	h_o			(141)	β_b	
	(22)	h_1			(142)	$x_b \text{ } ^\circ\text{C}$	
	(22)	h_2			(146a)	N_p	
	(22)	h_3			(147)	λ_w	FIELD
	(22)	h_s	SLOT DEPTH		(148)		
	(22)	h_t			(149)		
	(22)	h_w			(150)	$x_f \text{ } ^\circ\text{C}$	
	(28)	Q	NO. OF SLOTS		(151)	A	
	(28)		TYPE OF WDG.		(87)		
	(29)		TYPE OF COIL		(183)	(F&W)	
	(30)	n_s	CONDUCTORS/SLOT		(18)		
	(31)	γ	SLOTS SPANNED		(18)		
	(32)	c	PARALLEL CIRCUITS		(18)		
	(33)		STRAND DIA. OR WIDTH				
	(34)	N_{st}	STRANDS/CONDUCTOR				
	(34a)	N_{st}	STRANDS/CONDUCTOR				
	(35)		STATOR STRAND TURNS				
	(36)	d_b	DIA. OF PIN				
	(36)	λ_{s2}	COIL EXT. STR. PORT				
	(37)	h_{st}	UNINS. STRD. HT.				
	(38)	h_{st}	DIST. BTWN. CL OF STD.				
	(38a)		PHASE BELT/ANGLE				
	(38)	τ_{sk}	STATOR SLOT SKEW				
	(39)	$x_s \text{ } ^\circ\text{C}$	STATOR TEMP $^\circ\text{C}$				
	(41)	γ_s	RES'TVY STA. COND. $^\circ\text{C}$				
GAP	(39)	g_{min}	MINIMUM AIR GAP				
	(39a)	g_{max}	MAXIMUM AIR GAP				

DESIGNER _____ DATE _____

(a) Open Slots

(b) Constant Slot Width

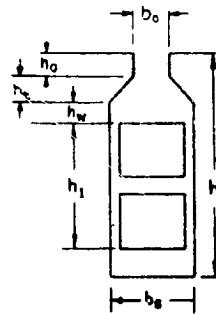
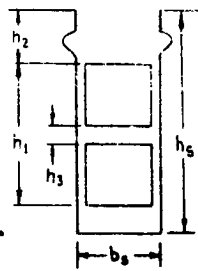

TYPE 1
 (Type 5 is an open slot with 1 conductor per slot)

TYPE 2

(c) Constant Tooth Width

(d) Round Slots

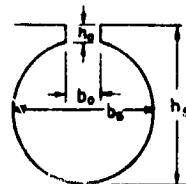
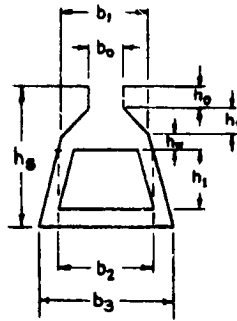

TYPE 3
 b_s for type 3 is

$$b_s = \frac{(b_2 + b_3)}{2}$$

TYPE 4

SUMMARY OF DESIGN CALCULATIONS -- SALIENT POLE (OUTPUT)

MODEL		FWO	DESIGN NO.		
STATOR	(17) (l_s)	SOLID CORE LENGTH		CARTER COEFFICIENT	(67) (K_a)
	(24) (h_c)	DEPTH BELOW SLOT		AIR GAP AREA	(68) (\cdot)
	(26) (T_s)	SLOT PITCH		AIR GAP PERM	(70c) (λ_a)
	(27) ($T_s 1/3$)	SLOT PITCH 1/3 DIST. UP		EFFECTIVE AIR GAP	(69) (g_a)
	(42) (K_{sk})	SKEW FACTOR		FUND/MAX OF FLD. FLUX	(71) (C_1)
	(43) (K_d)	DIST. FACTOR		WINDING CONST.	(72) (C_w)
	(44) (K_p)	PITCH FACTOR		POLE CONST.	(73) (C_p)
	(45) (η_m)	EFF. CONDUCTORS		END. EXT. ONE TURN	(48) (L_E)
	(46) (a_c)	COND. AREA		DEMAGNETIZING FACTOR	(74) (C_d')
	(47) (S_s)	CURRENT DENSITY (STA.)		CROSS MAGNETIZING FACTOR	(75) (C_q)
	(49) (l_t)	1/2 MEAN TURN LENGTH		AMP CONDUCT/IN	(128) (A)
	(53) (R_{phi})	COLD STA. RES. $\sim 20^\circ C$		REACTANCE FACTOR	(129) (X)
	(54) (R_{ph})	HGT STA. RES. $\sim X^\circ C$		LEAKAGE REACTANCE	(130) (X_g)
	(55) (EF_{top})	EDDY FACTOR TOP		REACTANCE ϕ	(131) (X_{ad})
(56) (EF_{bot})	EDDY FACTOR BOT		ARMATURE REACTION	(132) (X_{ag})	
(62) (λ_s)	STATOR COND. PERM.		SYN REACT DIRECT AXIS	(133) (X_d)	
(64) (λ_e)	END PERM.		SYN REACT QUAD AXIS	(134) (X_q)	
(65) ()	WT. OF STA COPPER		FIELD LEAKAGE REACT	(160) (X_f)	
(66) ()	WT. OF STA IRON		FIELD SELF INDUCTANCE	(161) (L_f)	
ROTOR	(41) (T_p)	POLE PITCH		DAMPER	(163) (X_{Dd})
	(79) (a_p)	POLE AREA		LEAKAGE REACT	(165) (X_{Dq})
	(82b) (λ_{eg})	POLE END LEAK PERM.		UNSAT. TRANS. REACT	(166) (X'_{du})
	(81b) (λ_{tg})	POLE TIP LEAK PERM.		SAT. TRANS. REACT	(167) (X''_{d})
	(80b) (λ_{s2})	POLE SIDE LEAK PERM.		SUB. TRANS. REACT DIRECT AX.	(168) (X''_{d})
	(153) (a_{CF})	FLD. COND. AREA		SUB. TRANS. REACT QUAD AX.	(169) (X''_{q})
	(154) (R_F)	COLD FLD RES $\sim 20^\circ C$		NEG SEQUENCE REACT	(170) (X_2)
	(155) (R_F)	HOT FLD RES $\sim X^\circ C$		ZERO SEQUENCE REACT	(172) (X_0)
	(156) ()	WT OF FLD COPPER		TOTAL FLUX	(88) (ϕ/τ)
	(157) ()	WT OF ROTOR IRON		FLUX PER POLE	(92) (ϕ/p)
(145) (V_r)	PERIPHERAL SPEED		GAP DENSITY	(95) (B_g)	
TIME CONSTANTS	(176) (T_{do})	OPEN CIR. TIME CONST.		TOOTH DENSITY	(91) (B_t)
	(177) (T_a)	ARM TIME CONST.		CORE DENSITY	(94) (B_c)
	(178) (T''_d)	TRANS TIME CONST.		TOOTH AMPERE TURNS	(97) (F_t)
	(179) (T'''_d)	SUB TRANS TIME CONST.		CORE AMPERE TURNS	(98) (F_c)
	(180) (F_{sc})	SHORT CIR NI		GAP AMPERE TURNS	(96) (F_g)
(181) (SCR)	SHORT CIR RATIO				

VARIABLE LOAD	PERCENT LOAD		0	100	150	200	OPTIONAL
	(100)	(100)					
(ϕ) (100a) LEAK FLUX			(117a) (197a)				
(ϕ_{pt}) (102a) POLE FLUX			(117b) (215a)				
(B_p) (103a) POLE DENSITY			(117c) (213b)				
(F_p) (104a) POLE NI			(117d) (213c)				
(F_{ni}) (127) TOTAL NI			(117e) (251)				
(η_m) (127a) FIELD AMPS			(117f) (237)				
(S_F) (127c) CUR. DENS. (FLD)			(117g) (239)				
(E_r) (127d) FIELD VOLTS			(117h) (238)				
($I^2 R_r$) (182) ROTOR LOSS			(117i) (241)				
($F&W$) (183) F&W LOSS			(117j) (183)				
(W_{ml}) (184) STA TOOTH LOSS			(117k) (182)				
(W_c) (185) STA CORE LOSS			(117l) (185)				
(W_{ml}) (186) POLE FACE LOSS			(117m) (243)				
(W_{ml}) (193) DAMPER LOSS			(117n) (244)				
($I^2 R_s$) (194) STATOR CU LOSS			(117o) (245)				
(-) (195) EDDY LOSS			(-) (246)				
(-) (196) TOTAL LOSSES			(-) (247)				
(-) () RATING (KW)			(-) (248)				
(-) () RATING & LOSSES			(-) (249)				
(-) () PERCENT LOSSES			(-) (250)				
(-) () PERCENT EFF.			(-) (251)				

REMARKS

G-03

DESIGNER

REV A

NO LOAD SATURATION OUTPUT SHEET

ITEMS VOLTS	(3) (E) VOLTS	(96) (F _g) AIR GAP A.T.	(91) (B _r) TOOTH DENSITY	(97) (F _r) TOOTH A.T.	(94) (B _c) CORE DENSITY	(98) (F _c)
	(98a) (F _s) STATOR A.T.	(100a) (Φ) LEAKAGE FLUX	(102a) (Φ _{pp}) TOTAL FLUX/POLE	(103A) (B _p) POLE DENSITY	(104a) (F _p) POLE A.T.	(127) (F _{nl}) TOTAL A.T. (N _l)
80%						
90%						
100%						
110%						
120%						
130%						
140%						
150%						
160%						

G-04

REV. A

SALIENT POLE COMPUTER DESIGN MANUAL

- | | | |
|------|----------|--|
| (1) | -- | <u>DESIGN NUMBER</u> - To be used for filing purposes |
| (2) | KVA | <u>GENERATOR KVA</u> |
| (3) | E | <u>LINE VOLTS</u> |
| (4) | E_{PH} | <u>PHASE VOLTS</u> - For 3 phase, wye connected generator

$E_{PH} = \frac{(\text{Line Volts})}{\sqrt{3}} = \frac{(3)}{\sqrt{3}}$ <p style="text-align: center;">For 3 phase, delta connected generator</p> $E_{PH} = (\text{Line Volts}) = (3)$ |
| (5) | m | <u>PHASES</u> - Number of |
| (5a) | f | <u>FREQUENCY</u> - In cycles per second |
| (6) | P | <u>POLES</u> - Number of |
| (7) | RPM | <u>SPEED</u> - In revolutions per minute |
| (8) | I_{PH} | <u>PHASE CURRENT</u> - In amperes at rated load |
| (8) | P.F. | <u>POWER FACTOR</u> - Given in per unit |
| (9a) | K_c | <u>ADJUSTMENT FACTOR</u> - When P.F. = 0. to .95 set $K_c = 1.$;
when P.F. = .95 to 1. set $K_c = 1.05$ |
| (10) | -- | <u>LOAD POINTS</u> - The computer program has standard outputs for 0, 100%, 150%, 200% load points plus one optional load point that can be any value between 0 and 2 p.u. If no optional calculation is desired, insert 0.0 for item (10) on the input sheet. |

- (11) d STATOR PUNCHING I. D. - The inside diameter of the stator punching in inches
- (11a) d_r ROTOR PUNCHING O. D. - The outside diameter of the rotor punching in inches
- (12) D PUNCHING O. D. - The outside diameter of the stator punching in inches
- (13) l GROSS CORE LENGTH - In inches
- (14) n_v RADIAL DUCTS - Number of
- (15) b_v RADIAL DUCT WIDTH - In inches
- (16) K_i STACKING FACTOR - This factor allows for the coating (core plating) on the punchings, the burrs due to slotting, and the deviations in flatness. Approximate values of K_i are given below.

<u>THICKNESS OF LAMINATIONS (INCHES)</u>	<u>GAGE</u>	<u>K_i</u>
.014	29	0.92
.018	26	0.93
.025	24	0.95
.028	23	0.97
.063	--	0.98
.125	--	0.99

(17) l_s

SOLID CORE LENGTH - The solid length is the gross length times the stacking factor. If ventilating ducts are used, their length must be subtracted from the gross length also.

$$l_s = (K_1) \left[(l) - (n_v) (b_v) \right] = (16) \left[(13) - (14) (15) \right]$$

(18) --

LAMINATION MATERIAL - This input is used in selecting the proper magnetization curves for the stator and rotor material. Where curves are available on card decks, use the proper identifying code. Where card decks are not available submit data in the following manner:

The magnetization curve must be available on semi-log paper. Typical curves are shown in Section F on Curve F15. Draw straight line segments through the curve starting with zero density. Record the coordinates of the points where the straight line segments intersect. Submit these coordinates as input data for the magnetization curve. The maximum density point must be submitted first.

Refer to Figure below for complete sample

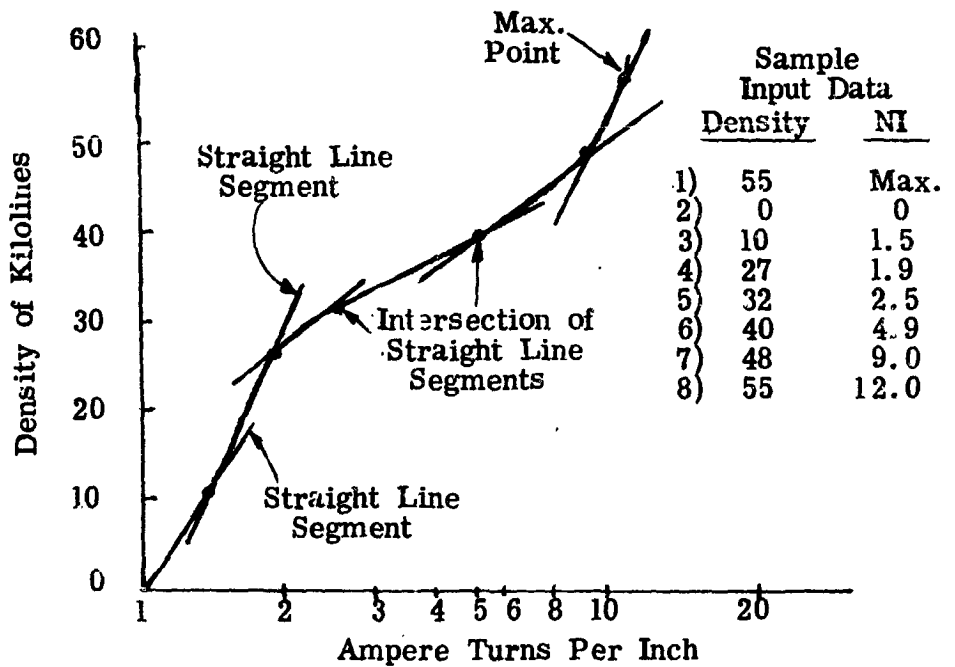

(19) k

WATTS/LB - Core loss per lb of stator lamination material.

Must be given at the frequency specified. Curve F-11a provides losses at 400 cps and 77.4 kilolines/in².

(20) B

DENSITY - This value must correspond to the density used in Item (19) to pick the watts/lb. The density that is usually used is 77.4 kilolines/in².

(21)

1
2
3
4
5

TYPE OF STATOR SLOT - Designate the type of slot from the

following figure .

For (a) slot use 1. as an input

For (b) slot use 2. as an input

For (c) slot use 3. as an input

For (d) slot use 4. as an input

Type 5. is not a slot but instead a particular situation for an open slot where the winding has only one conductor per slot.

(a) Open Slots

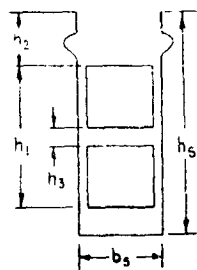

(b) Constant Slot Width

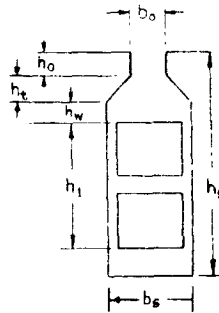

* Note: For slot type C,

$$b_s = \frac{(b_1) + (b_3)}{2}$$

* (c) Constant Tooth Width

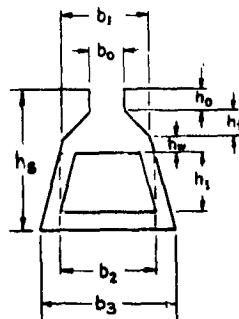

(d) Round Slots

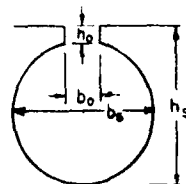

(22)

b₀

b₁

b₂

b₃

b_s

h₀

h₁

h₂

h₃

h_s

h_t

h_w

ALL SLOT DIMENSIONS - Given in inches per item(21).

Where the dimension does not apply to the slot being used, insert 0. on input sheet.

For slot type C

$$b_s = \frac{(b_1) + (b_3)}{2} = \frac{(22) + (22)}{2}$$

(23)

Q

STATOR SLOTS - Number of

(24)

h_c

DEPTH BELOW SLOTS - The depth of the stator core below the slots. (in inches)

Due to mechanical strength reasons, h_c should never be less than 70% of h_s.

$$h_c = \frac{(D) - [(d) + 2(h_s)]}{2} = \frac{(12) - [(11) + 2(22)]}{2}$$

(25)

q

SLOTS PER POLE PER PHASE

$$q = \frac{(Q)}{(P)(m)} = \frac{(23)}{(6)(5)}$$

(26)

τ_s

STATOR SLOT PITCH, inches

$$\tau_s = \frac{\pi(d)}{Q} = \frac{\pi(11)}{(23)}$$

(27)	$\tau_{s1/3}$	<p><u>STATOR SLOT PITCH</u> - 1/3 distance up from narrowest section For slot (a), (b), (c), and (e) --(in inches)</p>
		$\tau_{s1/3} = \frac{\pi \left[\overline{(d)} + .66 \overline{(h_s)} \right]}{\overline{(Q)}} \quad \frac{\pi \left[\overline{(11)} + .66 \overline{(22)} \right]}{\overline{(23)}}$
		<p>For slot (d)</p>
		$\tau_{s1/3} = \frac{\pi \left[\overline{(d)} + 2 \overline{(h_0)} + 1.32 \overline{(b_s)} \right]}{\overline{(Q)}}$ $= \frac{\pi \left[\overline{(11)} + 2 \overline{(22)} + 1.32 \overline{(22)} \right]}{\overline{(23)}}$
(28)	--	<p><u>TYPE OF WINDING</u> - Record whether the connection is "wye" or "delta". For "wye" conn use 1. for input. For "delta" use 0. for input</p>
(29)	--	<p><u>TYPE OF COIL</u> - Record whether random wound or formed coils are used. For random wound coils use 0. for input. For formed coils use 1. for input.</p>
(30)	n_s	<p><u>CONDUCTORS PER SLOT</u> - The actual number of conductors per slot. For random wound coils use a space factor of 75% to 80%. Where space factor is the percent of the total slot area that is available for insulated conductors after all other insulation areas have been subtracted out.</p>
(31)	γ	<p><u>THROW</u> - Number of slots spanned. For example, with a coil side in slot 1 and the other coil side in slot 10, the throw is 9.</p>

(31a)

PER UNIT OF POLE PITCH SPANNED - Ratio of the number of slots spanned to the number of slots in a pole pitch. This value must be between 1.0 and 0.5 to satisfy the limits of this program.

$$= \frac{(Y)}{(m)(q)} = \frac{(31)}{(5)(25)}$$

(32)

C

PARALLEL PATHS, No. of - Number of parallel circuits per phase.

(33)

--

STRAND DIA. OR WIDTH - In inches. For round wire, use strand diameter. For rectangular wire, use strand width. This must be the largest of the two dimensions given for a rectangular wire.

(34)

NST

NUMBER OF STRANDS PER CONDUCTOR IN DEPTH -

Applies to rectangular wire. To reduce eddy current loss a stranded conductor is often used. For example, when the space available for one conductor is .250 width x .250 depth, the actual conductor can be made up of 2 or 3 strands in depth as shown. For round wire insert 1.0

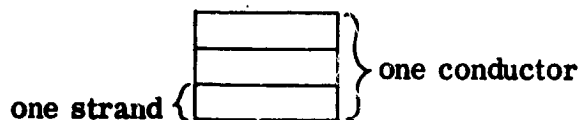

- (34a) N'_{ST} NUMBER OF STRANDS PER CONDUCTOR - This number applies to the strands in depth and/or width and is used in calculating the conductor area. Item (34) is different in that it deals with strands in depth only and is used in calculating eddy factors.
- (35) d_b DIAMETER OF BENDER PIN - in inches - This pin is used in forming coils. Use .25 inch for stator O.D. < 8 inches use .50 inches for stator O.D. > 8 inches.
- (36) l_{e2} COIL EXTENSION BEYOND CORE in Inches - Straight portion of coil that extends beyond stator core.
- (37) h_{ST} HEIGHT OF UNINSULATED STRAND in Inches - This value is the vertical height of the strand and is used in eddy factor calculations. Set this value = 0 for round wire.
- (38) h'_{ST} DISTANCE BETWEEN CENTERLINES OF STRANDS IN DEPTH in inches.
- (39) - STATOR COIL STRAND THICKNESS in inches - For rectangular conductors only. For round wire insert 0. on input sheet. This must be the narrowest dimension of the two dimensions given for a rectangular wire.
- (40) τ_{SK} SKEW - Stator slot skew in inches at stator I.D.

(41) τ_p POLE PITCH in inches.

$$\tau_p = \frac{\pi(d)}{(P)} = \frac{\pi(11)}{(6)}$$

(42) K_{SK} SKREW FACTOR - The skew factor is the ratio of the voltage induced in the coils to the voltage that would be induced if there were no skew.

When $\tau_{SK} = 0$, $K_{SK} = 1$

$$K_{SK} = \frac{\sin \left[\frac{\pi(\tau_{SK})}{2(\tau_p)} \right]}{\frac{\pi(\tau_{SK})}{2(\tau_p)}} = \frac{\sin \left[\frac{\pi(40)}{2(41)} \right]}{\frac{\pi(40)}{2(41)}}$$

(42a) PHASE BELT ANGLE - Input

For phase belt angle = 60° insert 60 on input sheet.

For phase belt angle = 120° insert 120 on input sheet.

(43) K_d DISTRIBUTION FACTOR - The distribution factor is the

ratio of the voltage induced in the coils to the voltage that would be induced if the windings were concentrated in a single slot. See Table F-2 for compilation of distribution factors for the various harmonics.

(44) K_P

PITCH FACTOR - The ratio of the voltage induced in the coil to the voltage that would be induced in a full pitched coil. See Table F-1 for compilation of the pitch factors for the various harmonics.

$$K_P = \sin \left[\frac{(Y)}{(m)(q)} \times 90^\circ \right] = \sin \left[\frac{(31)}{(5)(25)} \times 90^\circ \right]$$

(45) n_e

TOTAL EFFECTIVE CONDUCTORS - The actual number of effective series conductors in the stator winding taking into account the pitch and skew factors but not allowing for the distribution factor.

$$n_e = \frac{(Q)(n_s)(K_P)(K_{SK})}{(C)} = \frac{(23)(30)(44)(42)}{(32)}$$

(46) a_c

CONDUCTOR AREA OF STATOR WINDING in (inches)² -

The actual area of the conductor taking into account the corner radius on square and rectangular wire. See the following table for typical values of corner radii

$$\text{If (39) = 0 then } a_c = 25\pi(\text{Dia})^2 = .25\pi(33)^2$$

$$\text{If (39) } \neq 0 \text{ then } a_c = (N_{ST}) \left[(\text{strand width}) (\text{strand depth}) - (.858 r_c^2) \right] = (34a) \left[(33) (39) - (.858 r_c^2) \right]$$

where $.858 r_c^2$ is obtained from Table below.

(39)	(33) .188	.189 (33) .75	(33) .751
.050	.000124	.000124	.000124
.072	.000210	.000124	.000124
.125	.000210	.00084	.000124
.165	.000840	.00084	.003350
.225	.001890	.00189	.003350
.438	--	.00335	.007540
.688	--	.00754	.01340
--	--	.03020	.03020

For 60° phase belt angle and $q = \text{integer}$ when
 $(42a) = 60$ and $(25) = \text{integer}$.

$$K_d = \frac{\sin 30^\circ}{(q) \sin [30/(q)]} = \frac{\sin 30^\circ}{(25) \sin [30/(25)]}$$

For 60° phase belt angle and $(q) \neq \text{integer} = N/B$
 reduced to lowest terms.

When $(43a) = 60$ and $(25) \neq \text{integer} = N/B$ reduced
 to lowest terms

$$K_d = \frac{\sin 30^\circ}{(N) \sin [30/(N)]} = \frac{\sin 30^\circ}{(43) \sin [30/(43)]}$$

For 120° phase belt angle and $(q) = \text{integer}$

When $(43a) = 120$ and $(25) = \text{integer}$

$$K_d = \frac{\sin 60^\circ}{2(q) \sin [30/(q)]} = \frac{\sin 60^\circ}{2(25) \sin [30/(25)]}$$

For 120° phase belt angle and $q \neq \text{integer}$

When $(43a) = 120$ and $(25) \neq \text{integer} = N/B$ re-
 duced to lowest terms

$$K_d = \frac{\sin 60^\circ}{2(N) \sin [30/(N)]} = \frac{\sin 60^\circ}{2(43) \sin [30/(43)]}$$

(47) S_S CURRENT DENSITY - Amperes per square inch of stator conductor

$$S_S = \frac{(\bar{i}_{PH})}{(C)(a_c)} = \frac{(8)}{(32)(46)}$$

(48) L_E END EXTENSION LENGTH in inches - Can be an input or output.

For L_E to be output, insert 0. on input sheet.

For L_E to be input, calculate per following:

When (29) = 0 then:

$$L_E = \frac{.5 + K_T \pi y \overline{[d + h_s]}}{Q} = .5 + \frac{\begin{matrix} 1.3 \text{ If } (6) = 2 \\ 1.5 \text{ If } (6) = 4 \\ 1.7 \text{ If } (6) > 4 \end{matrix} \pi(31) \overline{[(11) + (22)]}}{(23)}$$

When (29) = 1. then:

$$L_E = 2(\ell_{e2}) + \pi \left[\frac{h_1}{2} + (d_b) \right] + y \left[\frac{\tau_s^2}{\sqrt{\tau_s^2 - b_s^2}} \right]$$

$$= 2 \times (36) + \pi \left[\frac{(22)}{2} + (35) \right] + (31) \left[\frac{(26)^2}{\sqrt{(26)^2 - (22)^2}} \right]$$

(49) ℓ_t 1/2 MEAN TURN - The average length of one conductor in inches

$$\ell_t = (\ell) + (L_E) = (13) + (48)$$

(50) $X_S^{\circ}C$ STATOR TEMP $^{\circ}C$. - Input temp at which F. L. losses will be calculated. No load losses and cold resistance will be calculated at $20^{\circ}C$.

(51)

 ρ_s

RESISTIVITY OF STATOR WINDING - In micro ohm-inches @ 20°C. If tables are available using units other than that given above, use factors below for conversion to ohm-inches.

ρ	ohm-cm	ohm-in	ohm-cir mil/ft
1 ohm-cm =	1.000	0.3937	6.015×10^6
1 ohm-in =	2.540	1.000	1.528×10^7
1 ohm-cir mil/ft =	1.662×10^{-7}	6.545×10^{-8}	1.000

Conversion Factors for Electrical Resistivity

(52)

 ρ_s
(hot)

RESISTIVITY OF STATOR WINDING - Hot at $X_s^\circ\text{C}$ in micro ohm-inches

$$\rho_{S(\text{hot})} = \rho_s \left[\frac{(X_s^\circ\text{C}) + 234.5}{254.5} \right] = (51) \left[\frac{(50) + 234.5}{254.5} \right]$$

(53)

 R_{SPH}
(cold)

STATOR RESISTANCE/PHASE - Cold @ 20°C in ohms

$$R_{SPH(\text{cold})} = \frac{(\rho_s)(n_s)(Q)(l_t)}{(m)(a_c)(C)^2} \times 10^{-6} = \frac{(51)(30)(23)(49)}{(5)(46)(32)^2} \times 10^{-6}$$

(54)

 R_{SPH}
(hot)

STATOR RESISTANCE/PHASE - Calculated @ $X^\circ\text{C}$ in ohms

$$R_{SPH(\text{hot})} = \frac{(\rho_{S \text{ hot}})(n_s)(Q)(l_t)}{(m)(a_c)(C)^2} \times 10^{-6} = \frac{(52)(30)(23)(49)}{(5)(46)(32)^2} \times 10^{-6}$$

(55)

EF
(top)

EDDY FACTOR TOP - The eddy factor of the top coil. Calculate this value at the expected operating temperature of the machine. For round wire

$$EF_{\text{top}} = 1$$

$$\begin{aligned}
 EF_{\text{top}} &= 1 + \left\{ .584 + \frac{[N_{\text{st}}]^2 - 1}{16} \left[\frac{(h_{\text{st}}) \ell}{(h_{\text{st}}) t} \right]^2 \right\} 3.35 \times 10^{-3} \\
 &\quad \left[\frac{(h_{\text{st}})(n_{\text{s}})(f)(a_{\text{c}})}{(b_{\text{s}})(\rho_{\text{shot}})} \right]^2 \\
 &= 1 + \left\{ .584 + \frac{[(34)^2 - 1]}{16} \left[\frac{(38)(13)}{(37)(49)} \right]^2 \right\} 3.35 \times 10^{-3} \\
 &\quad \left[\frac{(37)(30)(5a)(46)}{(22)(52)} \right]^2
 \end{aligned}$$

(56) EF
(bot)

EDDY FACTOR BOTTOM - The eddy factor of the bottom coil at the expected operating temperature of the machine. For round wire $EF_{(\text{bot})} = 1$

$$\begin{aligned}
 EF_{(\text{bot})} &= (EF_{(\text{top})}) - 1.677 \left[\frac{(h_{\text{st}})(n_{\text{s}})(f)(a_{\text{c}})}{(b_{\text{s}})(\rho_{\text{shot}})} \right]^2 \times 10^{-3} \\
 &= (55) - 1.677 \left[\frac{(37)(30)(5a)(46)}{(22)(52)} \right] 10^{-3}
 \end{aligned}$$

(57) b_{tm}

STATOR TOOTH WIDTH 1/2 way down tooth in inches -
For slots type (a), (b), (d) and (e), item (21).

$$b_{\text{tm}} = \frac{\pi [(d) + (h_{\text{s}})]}{(Q)} - (h_{\text{s}}) = \frac{\pi [(11) + (22)]}{(23)} - (22)$$

For slot type (c), item (21).

$$b_{tm} = \frac{\pi[(d) + 2(h_s)]}{(Q)} - (b_3) = \frac{\pi[(11) + 2(22)]}{(23)} - (22)$$

(57a) $b_{t1/3}$

STATOR TOOTH WIDTH 1/3 distance up from narrowest section

For slots type (a), (b) and (e)

$$b_{t 1/3} = (\tau_s 1/3) - (b_s) = (27) - (22)$$

For slot type (c)

$$b_{t 1/3} = b_{tm} = (57)$$

For slot type (d)

$$b_{t 1/3} = (\tau_{1/3}) - \frac{2\sqrt{2}}{3} (b_s) = (27) - .94(22)$$

(58) b_t

TOOTH WIDTH AT STATOR I. D. in inches -

For partially closed slot

$$b_t = \frac{\pi(d)}{(Q)} - (b_0) = \frac{\pi(11)}{(23)} - (22)$$

For open slot

$$b_t = \frac{\pi(d)}{(Q)} - (b_s) = \frac{\pi(11)}{(23)} - (22)$$

(59) g_{min}

MINIMUM AIR GAP in inches - For concentric pole face

$g_{min} = g_{max}$ For non concentric pole face

g_{min} = gap at the center of the pole.

(59g) g_{max}

MAXIMUM AIR GAP in inches

(30)

 C_X REACTANCE FACTOR - Used in calculating conductor permeance

and is dependent on the pitch and distribution factor.

This factor can be obtained from Curve F-5 with an assumed K_d of .955 or calculated as shown

$$C_X = \frac{(K_X)}{(K_P)^2 (K_d)^2} = \frac{(61)}{(44)^2 (43)^2}$$

(61)

 K_X

Factor to account for difference in phase current in coil sides in same slot.

For 60° phase belt winding, ie when $(42a) = 60$

$$K_X = 1/4 \left[\frac{3(y)}{(m)(q)} + 1 \right] \text{ where } 2/3 \leq (y)/(m)(q) \leq 1.0$$

$$K_X = 1/4 \left[\frac{3(31)}{(5)(25)} + 1 \right] \text{ where } 2/3 \leq (31a) \leq 1.0$$

or

$$K_X = 1/4 \left[\frac{6(y)}{(m)(q)} - 1 \right] \text{ where } 1/2 \leq (31a) \leq 2/3$$

$$K_X = 1/4 \left[\frac{6(31)}{(5)(25)} - 1 \right] \text{ where } 1/2 \leq (31a) \leq 2/3$$

For 120° phase belt winding, ie when $(42a) = 120$

$$K_X = .75 \text{ when } 2/3 \leq (y)/(m)(q)$$

$$K_X = .75 \text{ when } 2/3 \leq (31a)$$

or

$$K_X = .05 \left[\frac{24(y)}{(m)(q)} - 1 \right] \text{ where } 1/2 \leq \frac{(y)}{(m)(q)} \leq 2/3$$

$$K_X = .05 \left[\frac{24(31)}{(3)(25)} - 1 \right] \text{ where } 1/2 \leq (31a) \leq 2/3$$

(62) λ_i

CONDUCTOR PERMEANCE - The specific permeance for the portion of the stator current that is embedded in the iron. This permeance depends upon the configuration of the slot. (flux lines per ampere turn, per inch of stator stack).

(a) Open Slots

(a) For open slots

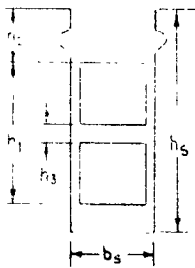

$$\lambda_i = (C_X) \frac{20}{(m)(q)} \left[\frac{(h_2)}{(b_s)} + \frac{(h_1)}{3(b_s)} + \frac{(b_t)^2}{16(\tau_s)(g)} + \frac{.35(b_t)}{(\tau_s)} \right]$$

$$\lambda_i = (60) \frac{20}{(5)(25)} \left[\frac{(22)}{(22)} + \frac{(22)}{3(22)} + \frac{(58)^2}{16(26)(59)} + \frac{.35(58)}{(26)} \right]$$

(b) Constant Slot Width (b) For partially closed slots with constant slot width



$$\lambda_i = (C_X) \frac{20}{(m)(q)} \left[\frac{(h_o)}{(b_o)} + \frac{2(h_t)}{(b_o) + (b_s)} + \frac{(h_w)}{(b_s)} + \frac{(h_1)}{3(b_s)} + \frac{(b_t)^2}{16(\tau_s)(g)} + \frac{.35(b_t)}{(\tau_s)} \right]$$

$$\lambda_i = (60) \frac{20}{(5)(25)} \left[\frac{(22)}{(22)} + \frac{2(22)}{(22) + (22)} + \frac{(22)}{(22)} + \frac{(22)}{3(22)} + \frac{(58)^2}{16(26)(59)} + \frac{.35(58)}{(26)} \right]$$

(c) Constant Tooth Width (c) For partially closed slots (tapered sides)

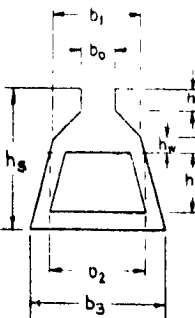

$$\lambda_i = (C_X) \frac{20}{(m)(q)} \left[\frac{(h_o)}{(b_o)} + \frac{2(h_t)}{(b_o) + (b_1)} + \frac{2(h_w)}{(b_1) + (b_2)} + \frac{(h_1)}{3(b_2)} + \frac{(b_t)^2}{16(\tau_s)(g)} + \frac{.35(b_t)}{(\tau_s)} \right]$$

$$\lambda_i = (60) \frac{20}{(5)(25)} \left[\frac{(22)}{(22)} + \frac{2(22)}{(22) + (22)} + \frac{2(22)}{(22) + (22)} + \frac{(22)}{3(22)} + \frac{(58)^2}{16(26)(59)} + \frac{.35(58)}{(26)} \right]$$

(d) Round Slots

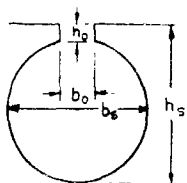

(d) For round slots

$$\lambda_i = (C_X) \frac{20}{(m)(q)} \left[.62 + \frac{(h_o)}{(b_o)} \right]$$

$$\lambda_i = (60) \frac{20}{(5)(25)} \left[.62 + \frac{(22)}{(22)} \right]$$

(e) For open slots with a winding of one conductor per slot

$$\lambda_i = (C_X) \frac{20}{(m)(q)} \left[\frac{(h_2)}{(b_s)} + \frac{(h_1)}{3(b_s)} + .6 + \frac{(g)}{2(\tau_s)} + \frac{(\tau_s)}{4(g)} \right]$$

$$\lambda_i = (60) \frac{20}{(5)(25)} \left[\frac{(22)}{(22)} + \frac{(22)}{3(22)} + .6 + \frac{(59)}{2(26)} + \frac{(26)}{4(59)} \right]$$

(63) K_E

LEAKAGE REACTIVE FACTOR for end turn

$$K_E = \frac{\text{Calculated value } (L_E)}{\text{Value } (L_E) \text{ from Curve F-1}} \text{ (For machines where } (11) > 8'' \text{)}$$

where $L_E = (48)$ and abscissa of Graph 1 = $(\gamma)(\tau_s) = (31)(26)$

$$K_E = \sqrt{\frac{\text{Calculated value of } (L_E)}{\text{Value } (L_E) \text{ from Curve F-1}}} \text{ (For machines where } (11) < 8'' \text{)}$$

(64) λ_E

END WINDING PERMEANCE - The specific permeance for the end extension portion of the stator winding*

$$\lambda_E = \frac{6.28(k_s)}{(L)(K_d)^2} \left[\frac{\phi_E L_E}{2n} \right] = \frac{6.28(63)}{(13)(43)^2} \left[\frac{Q_E L_E}{2n} \right]$$

The term $\left[\frac{\phi_E L_E}{2n} \right]$ is obtained from Curve F-1

The symbols used in this (term) do not apply to those of this design manual. Reference information for the symbol origin is included on Curve F-1.

* See (62) for units

(65) -- WEIGHT OF COPPER - The weight of stator copper in lbs.
 #'s copper = .321(n_s)(Q)(a_c)(ℓ_t) = .321(30)(23)(46)(49)

NOTE: This answer is given in lbs. based on the density of copper. If any other material is used, the answer on output sheet can be converted by the designer by multiplying by the ratio of densities.

(66) -- WEIGHT OF STATOR IRON - in lbs.

$$\begin{aligned} \text{'s iron} &= .283 \left\{ (b_{tm})(Q)(\ell_s)(h_s) + \pi \left[(D) - (h_c) \right] (h_c)(\ell_s) \right\} \\ &.283 \left\{ (57)(23)(17)(22) + \pi \left[(12) - (24) \right] (24)(17) \right\} \end{aligned}$$

(67) K_s CARTER COEFFICIENT

$$K_s = \frac{(\tau_s) \left[5(g) + (b_s) \right]}{(\tau_s) \left[5(g) + (b_s) \right] - (b_s)^2} \quad (\text{For open slots})$$

$$K_s = \frac{(26) \left[5(59) + (22) \right]}{(26) \left[5(59) + (22) \right] - (22)^2}$$

$$K_s = \frac{\tau_s \left[4.44(g) + .75(b_o) \right]}{\tau_s \left[4.44(g) + .75(b_o) \right] - (b_o)^2} \quad (\text{For partially closed slots})$$

$$K_s = \frac{(26) \left[4.44(59) + .75(22) \right]}{(26) \left[4.44(59) + .75(22) \right] - (22)^2}$$

(68) A_g AIR GAP AREA - The area of the gap surface at the stator bore

$$\text{Gap Area} = \pi(d)(L) = \pi(11)(13) \text{ (in square inches)}$$

(69) g_e EFFECTIVE AIR GAP (in square inches)

$$g_e = (K_g)(g) = (67)(59)$$

(70c) λ_a AIR GAP PERMEANCE - The specific permeance of the air gap
(See (62) for units.)

$$\lambda_a = \frac{6.38(d)}{(P)(g_e)} = \frac{6.38(11)}{(6)(69)}$$

(71) C_1 THE RATIO OF MAXIMUM FUNDAMENTAL of the field form
to the actual maximum of the field form - This term
can be an input or output. For C_1 to be output insert
0. on input sheet and the computer program will
calculate it. For C_1 to be input, determine C_1
as follows:

For pole heads with only one radius, C_1 is obtained
from curve F-4. The abscissa is "pole embrace" (α)
= (77). The graphical flux plotting method of deter-
mining C_1 is explained in the section titled "Deriva-
tions" in the Appendix

(72) C_w WINDING CONSTANT - The ratio of the RMS line voltage for a
full pitched winding to that which would be induced
in all the phase conductors in series if the density were
uniform and equal to the maximum value. This value

can be an input or output. To have the program calculate C_W , insert 0. on input sheet. For C_W to be an input, calculate as follows:

$$C_W = \frac{(E)(C_1)(K_d)}{\sqrt{2} (E_{PH})(m)} = \frac{(3)(71)(43)}{\sqrt{2} (4)(5)}$$

Assuming $K_d = .955$, then $C_W = .225 C_1$ for three phase delta machines and $C_W = .390 C_1$ for three phase star machines.

(73) C_P

POLE CONSTANT - The ratio of the average to the maximum value of the field form. This ratio can be an input or output. To have the program calculate C_P , insert 0. on input sheet. For C_P to be an input, determine as follows:

For pole heads with more than one radius C_P is calculated from the same field form that was used to determine C_1 , and this method is described in the section titled "Derivations" in the Appendix

For pole heads with only one radius, C_P is obtained from curve F-4. Note the correction factor at the top of the curve.

(74) C_M

DEMAGNETIZING FACTOR - direct axis - This factor can be an input or output. For C_M to be an output, insert 0. on input sheet. For C_M to be an input, determine as follows:

$$C_M = \frac{(\alpha)\pi + \sin[(\alpha)\pi]}{4 \sin[(\alpha)\pi/2]} = \frac{(77)\pi + \sin[(77)\pi]}{4 \sin[(77)\pi/2]}$$

C_M can also be obtained from curve F-9

(75) C_q

CROSS MAGNETIZING FACTOR - quadrature axis - This factor can be an input or output. For C_q to be an output, insert 0 on input sheet. For C_q to be an input, determine as follows:

$$C_q = \frac{1/2 \cos[(\alpha)\pi/2] + (\alpha)\pi - \sin[(\alpha)\pi]}{4 \sin[(\alpha)\pi/2]} \left. \vphantom{C_q} \right\} \begin{array}{l} \text{valid for} \\ \text{concentric} \\ \text{poles} \end{array}$$

$$= \frac{1/2 \cos[(77)\pi/2] + (77)\pi - \sin[(77)\pi]}{4 \sin[(77)\pi/2]}$$

C_q can also be obtained from curve F-9

(76) --

POLE DIMENSIONS LOCATIONS

Where:

- b_h = width of pole head
- b_p = width of pole body
- h_h = height of pole head at center
- h_f = height of pole body
- l_p = length of pole body
- l_h = length of pole head

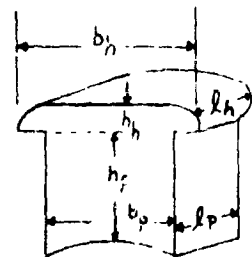

all dimensions in inches

(77) α

POLE EMBRACE

$$\alpha = \frac{b_h}{\tau_p} = \frac{(76)}{(41)}$$

(79) a_p POLE AREA - The effective cross sectional area of the pole.

$$a_p = (l_r)(l_p)(K_1) = (76)(76)(16) \text{ (square inches)}$$

(80b) λ_{sl} POLE SIDE LEAKAGE PERMEANCE - See (62) for units

$$\lambda_{sl} = \left\{ \frac{(h_f)}{\pi/(P) [(d_r) - 2(h_h) - .5(h_f)] - (b_p)} \right\}$$

$$= \left\{ \frac{(76)}{\pi/(6) [(11a) - 2(76) - .5(76)] - (76)} \right\}$$

(81b) λ_{tl} POLE TIP LEAKAGE PERMEANCE - See (62) for units

$$\lambda_{tl} = \left\{ \frac{2 [(h_h) + (g) - (\tau_p)/18]}{(\tau_p) - (b_h)} \right\}$$

$$= \left\{ \frac{2 [(76) + (59) - (41)/18]}{(41) - (76)} \right\}$$

(82b) λ_{el} POLE END LEAKAGE PERMEANCE - See (62) for units

$$\lambda_{el} = \left\{ \frac{2 [(\ell_h) - (\ell)] + (h_f) + .25(b_p)}{(\ell)} \right\}$$

$$= \left\{ \frac{2 [(76) - (13)] + (76) + .25(76)}{(13)} \right\}$$

(87) -- NO LOAD SATURATION CALCULATIONS - The equations, items (88) to (127) are used to calculate points for the no-load saturation curve. Insert 1. on input sheet for "No Load Sat." The computer will cal-

culate the no load saturation points at 80, 90, 100, 110, 120, 130, 140, 150 and 160% of rated volts. If the complete saturation data is not necessary, insert 0. on input sheet and the computer will calculate only the 100% volt data.

(88) ϕ_T TOTAL FLUX IN KILO LINES

$$\phi_T = \frac{6(E)10^6}{(C_W)(n_e)(RPM)} = \frac{6(3)10^6}{(72)(45)(7)}$$

(91) B_t TOOTH DENSITY in Kilo Lines/in² - The flux density in the stator tooth at 1/3 of the distance from the minimum section.

$$B_t = \frac{\phi_T}{(Q)(L_s)(b_{t1/3})} = \frac{(88)}{(23)(17)(57a)}$$

(92) ϕ_P FLUX PER POLE in Kilo Lines

$$\phi_P = \frac{(\phi_T)(C_P)}{(P)} = \frac{(88)(73)}{(6)}$$

(94) B_c CORE DENSITY in Kilo Lines/in² - The flux density in the stator core

$$B_c = \frac{(\phi_P)}{2(h_c)(L_s)} = \frac{(92)}{2(24)(17)}$$

(95) B_g GAP DENSITY in Kilo Lines/in² - The maximum flux density in the air gap

$$B_g = \frac{(\phi_T)}{\pi(d)(L)} = \frac{(88)}{\pi(11)(13)}$$

(96) F_g AIR GAP AMPERE TURNS - The field ampere turns per pole required to force flux across the air gap when operating at no load with rated voltage.

$$F_g = \frac{(B_g)(g_e) \times 10^3}{3.19} = \frac{(95)(69) \times 10^3}{3.19}$$

(97) F_T STATOR TOOTH AMPERE TURNS

$$F_T = h_s \left[\text{NI/in at density } B_t \right]$$

$$= (22) \left[\text{Look-up on stator magnetization curve given in (18) @ density (91)} \right]$$

(98) F_c STATOR CORE AMPERE TURNS

$$F_c = \left[\frac{\pi[(D) - (h_c)]}{4(P)} \right] \left[\text{NI/in @ density of } (B_c) \right]$$

$$= \left[\frac{\pi[(12) - (24)]}{4(6)} \right] \left[\text{Look-up on stator magnetization curve given in (18) @ density (94)} \right]$$

(98a) F_s STATOR AMPERE TURNS, total

$$F_s = (F_T) + (F_c) = (97) + (98)$$

(100a) ϕ_l LEAKAGE FLUX - at no load

$$\phi_l = .00638 \left[(\lambda_{sl}) + (\lambda_{el}) + (\lambda_{tl}) \right] \left[(F_g) + (F_s) \right] (\ell_P)$$

$$= .00638 \left[(80b) + (82b) + (81b) \right] \left[(96) + (98a) \right] (76)$$

(102a) ϕ_{PT}

TOTAL FLUX PER POLE - at no load

$$\phi_{PT} = \phi_P + \phi_l = (92) + (100a)$$

(103a) B_P

POLE DENSITY - The flux density at the base of the pole.

Note that no provision is made in this manual for calculating the density in the spider section. It is, therefore, important to remember not to restrict the flux area through this section.

$$B_P = \frac{(\phi_{PT})}{(a_P)} = \frac{(102a)}{(79)}$$

(104a) F_P

POLE AMPERE TURNS - at no load. The ampere turns per pole

required to force the flux through the pole and spider at no load rated voltage. In general the spider density is kept fairly low and its ampere turns can be neglected. The no load pole ampere turns per pole are calculated as the product of $[(h_f) + (h_h)]$ times the NI per inch at the density (B_P). Use magnetization curve submitted per item (18) for rotor.

$$\begin{aligned} F_P &= [(h_f) + (h_h)] [NI/in @ density (B_P)] \\ &= [(76) + (76)] [Look-up on rotor magnetization \\ &\quad \text{curve given in (18) @ density(103a)}] \end{aligned}$$

(127) F_{NL}

TOTAL AMPERE TURNS - at no load. The total ampere turns per pole required to produce rated voltage at no load.

$$F_{NL} = [(F_g) + (F_S) + (F_P)] = [(96) + (98a) + (104a)]$$

(127a) I_{FNL}

FIELD CURRENT - at no load

$$I_{FNL} = (F_{NL}) / (N_P) = (127) / (146a)$$

(127b) E_F

FIELD VOLTS - at no load. This calculation is made with cold field resistance at 20°C for no load condition.

$$E_F = (I_{FNL})(R_{f \text{ cold}}) = (127a)(154)$$

(127c) S_F

CURRENT DENSITY - at no load. Amperes per square inch of field conductor.

$$S_F = (I_{FNL}) / (a_{cf}) = (127a)(153)$$

(128) A

AMPERE CONDUCTORS per inch - The effective ampere conductors per inch of stator periphery. This factor indicates the "specific loading" of the machine. Its value will increase with the rating and size of the machine and also will increase with the number of poles. It will decrease with increases in voltage or frequency. A is generally higher in single phase machines than in polyphase ones.

$$A = \frac{(I_{PH})(n_s)(K_P)}{(C)(\tau_s)} = \frac{(8)(30)(44)}{(32)(26)}$$

(129) X

REACTANCE FACTOR - The reactance factor is the quantity by which the specific permeance must be multiplied to give percent reactance. Specific permeance is defined as the average flux per pole per inch of core length produced by unit ampere turns per pole.

$$X = \frac{100(A)(K_d)}{\sqrt{2}(C_1)(B_g) \times 10^3} = \frac{100(128)(43)}{\sqrt{2}(71)(95) \times 10^3}$$

(130) X_l

LEAKAGE REACTANCE - The leakage reactance of the stator for steady state conditions. When (5) = 3, calculate as follows:

$$X_l = X[(\lambda_i) + (\lambda_E)] = (129)[(62) + (64)] \text{ percent}$$

In the case of two phase machines a component due to belt leakage must be included in the stator leakage reactance. This component is due to the harmonics caused by the concentration of the MMF into a small number of phase belts per pole and is negligible for three phase machines. When (5) = 2, calculate as follows:

$$\lambda_B = \frac{0.1(d)}{(P)(g_e)} \left[\frac{\sin \left[\frac{3(y)}{(m)(q)} 90^\circ \right]}{(K_P)} \right] = \frac{0.1(11)}{(6)(69)} \left[\frac{\sin \left[\frac{3(31)}{(5)(25)} 90^\circ \right]}{(44)} \right]$$

$$X_l = X[(\lambda_i) + (\lambda_E) + (\lambda_B)] \text{ where } \lambda_B = 0 \text{ for 3 phase machines.}$$

$$X_l = (79)[(62) + (64) + (130)] \text{ percent}$$

(131) X_{ad}

REACTANCE - direct axis - This is the fictitious reactance due to armature reaction in the direct axis. (in percent)

$$X_{ad} = (X)(\lambda_a)(C_1)(C_M) = (129)(70c)(71)(74)$$

(132) X_{aq}

REACTANCE - quadrature axis - This is the fictitious reactance due to armature reaction in the quad axis. (percent)

$$X_{aq} = (X)(C_q)(\lambda_a) = (129)(75)(70c)$$

(133)	X_d	<u>SYNCHRONOUS REACTANCE</u> - direct axis - The steady state short circuit reactance in the direct axis. (percent)
		$X_d = (X_\ell) + (X_{ad}) = (130) + (131)$
(134)	X_q	<u>SYNCHRONOUS REACTANCE</u> - quadrature axis - The steady state short circuit reactance in the quadrature axis.
		$X_q = (X_\ell) + (X_{aq}) = (130) + (132) \text{ (percent)}$
(135)	--	<u>DAMPER SLOT DIMENSIONS</u>
		<p> b_{bo} - width of slot opening h_{bo} - height of slot opening h_b - diameter of round slot h_{b1} - height of bar section of slot b_{b1} - width of rectangular slot </p>
		All dimensions in inches
(136)	--	<u>DAMPER BAR DIA OR WIDTH</u> inches
(137)	h_{b1}	<u>DAMPER BAR THICKNESS</u> in inches - Damper bar thickness considered equal to damper bar slot height per item (135). Set this item = 0 for round bar.
(138)	n_b	<u>NUMBER OF DAMPER BARS PER POLE</u>
(139)	l_b	<u>DAMPER BAR LENGTH</u> in inches
(140)	τ_b	<u>DAMPER BAR PITCH</u> in inches
(141)	ρ_D	<u>RESISTIVITY</u> of damper bar @ 20°C in micro ohm-inches - Refer to table given in item (51) for conversion factors.

(142)	X_D °C	<u>DAMPER BAR TEMP °C</u> - Input temp at which damper losses are to be calculated.
(143)	ρ_D (hot)	RESISTIVITY of damper bar @ X_D °C $\rho_{D(\text{hot})} = (\rho_D) \left[\frac{(X_D \text{ °C}) + 234.5}{254.5} \right] = (141) \left[\frac{(142) + 234.5}{254.5} \right]$
(144)	a_{cd}	<u>CONDUCTOR AREA OF DAMPER BAR</u> - Calculate same as stator conductor area If (137) = 0 $a_{cd} = .25 \pi (\text{damper bar dia})^2 = .25 \pi (136)^2$ If (137) \neq 0 $a_{cd} = (h_{b1}) (\text{damper bar width}) = (137)(136)$
(145)	V_r	<u>PERIPHERAL SPEED</u> - The velocity of the rotor surface in feet per minute $V_r = \frac{\pi (d_r)(\text{RPM})}{12} = \frac{\pi (11a)(7)}{12}$
(143a)	N_P	<u>NUMBER OF FIELD TURNS PER POLE</u>
(147)	ℓ_{tr}	<u>MEAN LENGTH OF FIELD TURN</u> , inches
(148)	--	<u>FIELD CONDUCTOR DIA OR WIDTH</u> in inches
(149)	--	<u>FIELD CONDUCTOR THICKNESS</u> in inches - Set this item = 0. for round conductor

(150)	$X_f^{\circ}\text{C}$	<u>FIELD TEMP IN $^{\circ}\text{C}$</u> - Input temp at which full load field loss is to be calculated.
(151)	ρ_f	<u>RESISTIVITY</u> of rotor field conductor @ 20°C in micro ohm-inches. Refer to table given in item (51) for conversion factors.
(152)	ρ_f (hot)	<u>RESISTIVITY</u> of rotor field conductor at $X_f^{\circ}\text{C}$ $\rho_f \text{ (hot)} = \rho_f \left[\frac{(X_f^{\circ}\text{C}) + 234.5}{254.5} \right] = (151) \left[\frac{(150) + 234.5}{254.5} \right]$
(153)	a_{cf}	<u>CONDUCTOR AREA OF ROTOR FIELD WDG</u> - Calculate same as stator conductor area (46) except substitute $\left\{ \begin{array}{l} (149) \text{ for } (39) \\ (148) \text{ for } (33) \end{array} \right.$
(154)	R_f (cold)	<u>COLD FIELD RESISTANCE @ 20°C</u> $R_f \text{ (cold)} = (\rho_f) \frac{(N_p)(P)(\ell_{tr}) \times 10^{-6}}{(a_{cf})} = (151) \frac{(146)(6)(147) \times 10^{-6}}{(153)}$
(155)	R_f (hot)	<u>HOT FIELD RESISTANCE</u> - Calculated at $X_f^{\circ}\text{C}$ (103) $R_f \text{ (hot)} = (\rho_f \text{ hot}) \frac{(N_p)(P)(\ell_{tr}) \times 10^{-6}}{(a_{cf})} = (152) \frac{(146a)(6)(147) \times 10^{-6}}{(153)}$
(156)	--	<u>WEIGHT OF ROTOR FIELD COPPER</u> in lbs <p>The answer is given in lbs. based on the density of copper. If any other material is used, the answer on the output sheet can be converted by the designer by multiplying by the ratio of densities.</p>

$$\begin{aligned} \# \text{'s of copper} &= .321(N_p)(P)(L_{tr})(a_{cf}) \\ &= .321(146)(6)(147)(153) \end{aligned}$$

(157) --

WEIGHT OF ROTOR IRON - Because of the large number of different pole shapes, one standard formula cannot be used for calculating rotor iron weight. Therefore the computer will not calculate rotor iron weight. The space is allowed on the input sheet for record purposes only. By inserting 0. in the space allowed for rotor iron weight, the computer will show "0." on the output sheet. If the rotor iron weight is available and inserted on input sheet, then the output sheet will show this same weight on the output sheet.

(158) λ_b

PERMEANCE OF DAMPER BAR - The permeance of that portion of the damper bar that is embedded in pole iron.

(See (62) for units)

For round slot

$$\lambda_b = 6.38 \left[\frac{(h_{bo})}{(b_{bo})} + .62 + .5 \right] = 6.38 \left[\frac{(135)}{(135)} + .62 + .5 \right]$$

For rectangular slot

$$\lambda_b = 6.38 \left[\frac{(h_{bo})}{(b_{bo})} + \frac{(h_{b1})}{3(b_{b1})} + .5 \right] = 6.38 \left[\frac{(135)}{(135)} + \frac{(135)}{3(135)} + .5 \right]$$

(159) λ_{pt}

PERMEANCE OF END PORTION OF DAMPER BARS

$$\begin{aligned} \lambda_{pt} &= 6.38 \left\{ \frac{(b_h) - (r_b) [(n_b) - 1]}{3(g_e)} \right\} \\ &= 6.38 \left\{ \frac{(76) - (140) [(138) - 1]}{3(69)} \right\} \end{aligned}$$

(160) X_F FIELD LEAKAGE REACTANCE in percent

$$X_F = (X_{ad}) \left[1 - \frac{[(C_1)/(C_m)]}{2(C_p) + \frac{4(\lambda_a^2)}{\pi(\lambda_a)}} \right]$$

$$= (131) \left[1 - \frac{[(71)/(74)]}{2(73) + \frac{4(161f)}{\pi(70c)}} \right]$$

(161) L_f FIELD SELF INDUCTANCE, henries

$$L_f = (N_p)^2 (P)(\ell_p) \left[(C_p)(\lambda_a) \frac{\pi}{2} + (\lambda_f) \right] \times 10^{-8}$$

$$= (146a)^2 (6)(76) (73)(70c) \frac{\pi}{2} - (161f) \times 10^{-8}$$

(161f) λ_F ROTOR LEAKAGE PERMEANCE (See (52) for units)

$$\lambda_F = 4.25 \left[(\lambda_{sl}) + 1.5(\lambda_{tl}) \right] + 6.38(\lambda_{el})$$

$$= 4.25 \left[(80b) + 1.5(81b) \right] + 6.38(82b)$$

(162) λ_{Dd} PERMEANCE OF DAMPER BAR - in direct axis

$$\lambda_{Dd} = \left\{ \cos \left[\frac{\{(n_b) - 1\} (\tau_b) \pi}{2(\tau_p)} \right] \right\} \left\{ \frac{\{(\lambda_b) + (\lambda_{Pt})\} (\lambda_F)}{\lambda_b + \lambda_{Pt} + \lambda_F} \right\}$$

$$= \left\{ \cos \left[\frac{\{(158) - 1\} (140)}{2(41)} \right] \right\} \left\{ \frac{\{(158) + (159)\} (161f)}{(158) + (159) + (161f)} \right\}$$

(163) X_{Dd} DAMPER LEAKAGE REACTANCE - in direct axis (percent)

$$X_{Dd} = X(\lambda_{Dd}) = (129)(162)$$

(164) λ_{Dq} PERMEANCE IN QUADRATURE AXIS See (62) for units

For round slot

$$\begin{aligned} \lambda_{Dq} &= \frac{20(\tau_b)}{(\tau_p)} \left[\frac{(h_{bo})}{(b_{bo})} + .62 + .5 + \frac{(g)}{(\tau_b)} \right] \\ &= \frac{20(140)}{(41)} \left[\frac{(135)}{(135)} + .62 + .5 + \frac{(59)}{(140)} \right] \end{aligned}$$

For rectangular slot

$$\begin{aligned} \lambda_{(Dq)} &= \frac{20(\tau_b)}{(\tau_p)} \left[\frac{(h_{bo})}{(b_{bo})} + \frac{(h_{b1})}{3(b_{b1})} + .5 + \frac{(g)}{(\tau_b)} \right] \\ &= \frac{20(140)}{(41)} \left[\frac{(135)}{(135)} + \frac{(135)}{3(135)} + .5 + \frac{(59)}{(140)} \right] \end{aligned}$$

(165) X_{Dq} DAMPER LEAKAGE REACTANCE - in quadrature axis (percent)

$$X_{Dq} = X(\lambda_{Dq}) = (129)(164)$$

(166) X'_{du} UNSATURATED TRANSIENT REACTANCE (percent)

$$X'_{du} = (X_l) + (X_f) = (130) + (160)$$

(167) X'_d SATURATED TRANSIENT REACTANCE (percent)

$$X'_d = .83(X'_{du}) = .88(166)$$

(168)	X_d''	<u>SUBTRANSIENT REACTANCE</u> in direct axis (percent)
		When damper bars exist, i. e. when(138) $\neq 0$
		$X_d'' = (X_\ell) + (X_{Dd}') = (130) + (163)$
		When no damper bars exist, i. e. when(138) = 0
		$X_d'' = (X_d') = (167)$
(169)	X_q''	<u>SUBTRANSIENT REACTANCE</u> in quadrature axis (percent)
		When damper bar exists, i. e. when(138) $\neq 0$
		$X_q'' = (X_\ell) + (X_{Dq}') = (130) + (165)$
		When no damper bars exist, i. e. when(138) = 0
		$X_q'' = X_q = (134)$
(170)	X_2	<u>NEGATIVE SEQUENCE REACTANCE</u> - The reactance due to the field which rotates at synchronous speed in a direction opposite to that of the rotor. (percent)
		$X_2 = .5 [X_d'' + X_q''] = .5 [(168) + (169)]$
(172)	X_0	<u>ZERO SEQUENCE REACTANCE</u> - The reactance drop across any one phase (star connected) for unit current in each of the phases. The machine must be star connected for otherwise no zero sequence current can flow and the term then has no significance. (in percent)

If (28) = 0 Then $X_o = 0$

If (28) $\neq 0$ Then

$$X_o = X \left\{ \frac{(K_{x0})}{(K_{x1})} [(\lambda_i) + (\lambda_{Bo})] + \frac{1.667 [(h_1) + 2(h_3)]}{(m)(q)(K_p)^2 (K_d)^2 (b_s)} + .2(\lambda_E) \right\}$$

$$= (129) \left\{ \frac{(173)}{(174)} [(62) + (175)] + \frac{1.667 [(22) + 2(22)]}{(5)(25)(44)^2 (43)^2 (22)} + .2(64) \right\}$$

(173) K_{x0}

If (30) = 1 Then $K_{x0} = 1$

If (30) $\neq 1$ Then $K_{x0} = \frac{3(y)}{(m)(q)} - 2$

$$= \frac{3(31)}{(5)(25)} - 2$$

(174) K_{x1}

If (30) = 1 Then $K_{x1} = 1$

If (30) $\neq 1$ Then:

$$K_{x1} = \left[\frac{3(y)}{4(m)(q)} + \frac{1}{4} \right] = \left[\frac{3(31)}{4(5)(25)} + \frac{1}{4} \right] \quad \text{If (31a)} \geq .667$$

$$K_{x1} = \left[\frac{3(y)}{4(m)(q)} - \frac{1}{4} \right] = \left[\frac{3(31)}{4(5)(25)} - \frac{1}{4} \right] \quad \text{If (31a)} < .667$$

(175) λ_{Bo}

If (92) = 0 Then:

$$\lambda_{Bo} = \frac{(K_{x0})}{(K_p)^2} [.07(\lambda_a)] = \frac{(173)}{(44)^2} [.07(70c)]$$

If (138) $\neq 0$ Then $\lambda_{Bo} = \frac{\frac{(K_{x0})}{(K_{x1})} (\lambda_{Dq}) + \frac{(K_{x0})}{(K_p)^2} [.07(\lambda_a)]}{\left\{ \frac{(K_{x0})}{(K_{x1})} (\lambda_{Dq}) \right\} \left\{ \frac{(K_{x0})}{(K_p)^2} [.07(\lambda_a)] \right\}}$

$$= \frac{(173)}{(174)} (164) + \frac{(173)}{(44)^2} [.07(70c)]$$

$$\left\{ \frac{(173)}{(174)} (164) \right\} \left\{ \frac{(173)}{(44)^2} [.07(70c)] \right\}$$

$$\text{If } (K_{XO}) = 0, (\lambda_{bo}) = 0$$

$$(173) = 0, (175) = 0$$

(176) T'_{do}

OPEN CIRCUIT TIME CONSTANT - The time constant of the field winding with the stator open circuited and with negligible external resistance and inductance in the field circuit. Field resistance at room temperature (20°C) is used in this calculation. (seconds)

$$T'_{do} = \frac{L_F}{R_F} = \frac{(161)}{(154)}$$

See appendix for explanation of time constants

(177) T_a

ARMATURE TIME CONSTANT - Time constant of the D.C. component. In this calculation stator resistance at room temperature (20°C) is used. (seconds)

$$T_a = \frac{X_2}{200\pi(f)(r_a)} = \frac{(170)}{200\pi(5a)(177)}$$

$$\text{where } r_a = \frac{(m)(I_{PH})^2 (R_{SPH \text{ cold}})}{(\text{Rated KVA}) \times 10^3} = \frac{(5)(8)^2 (53)}{(2) \times 10^3}$$

(178) T'_d

TRANSIENT TIME CONSTANT - The time constant of the transient reactance component of the alternating wave. (seconds)

$$T'_d = \frac{(X'_d)}{(X_d)} (T'_{do}) = \frac{(167)}{(133)} (176)$$

(179)	T_d''	<p><u>SUBTRANSIENT TIME CONSTANT</u> - The time constant of the subtransient component of the alternating wave. This value has been determined empirically from tests on large machines. Use following values.</p> <p>$T_d'' = .035$ second at 60 cycle</p> <p>$T_d'' = .005$ second at 400 cycle</p>
(180)	F_{SC}	<p><u>SHORT CIRCUIT AMPERE TURNS</u> - The field ampere turns required to circulate rated stator current when the stator is short circuited.</p> <p>$F_{SC} = (X_d) (F_g) = (133)(26)$</p>
(181)	SCR	<p><u>SHORT CIRCUIT RATIO</u> - The ratio of the field current to produce rated voltage on open circuit to the field current required to produce rated current on short circuit.</p> <p>Since the voltage regulation depends on the leakage reactance and the armature reaction, it is closely related to the current which the machine produces under short circuit conditions, and therefore is directly related to the SCR.</p> <p>$SCR = \frac{F_{NL}}{F_{SC}} = \frac{(127)}{(180)}$</p>

(182) I^2R_R ROTOR I^2R - at no load. The copper loss in the field winding is calculated with cold field resistance at 20°C for no load condition. (watts)

$$\text{Rotor } I^2R = (I_{FNL})^2 (R_{f \text{ cold}}) = (127a)^2 (154)$$

(183) **F & W** FRICITION & WINDAGE LOSS (Watts) - Note: Write 0 on input sheet when computer is to calculate F & W. Insert actual value when known.

To ratio from test data, assume that F & W loss varies as the 5/2 power of the rotor diameter and as the 3/2 power of the RPM.

The formula below gives an approximate answer when test data is not available. For a more rigorous treatment use the information given in the rotor friction analysis appended to the thermal analysis section (Section C, Vol. 1).

$$\begin{aligned} F \& W &= 2.52 \times 10^{-6} (d_r)^{2.5} (\ell_h) (\text{RPM})^{1.5} \\ &= 2.52 \times 10^{-6} (11a)^{2.5} (76) (7)^{1.5} \end{aligned}$$

For gases or fluids other than standard air, the fluid density and viscosity must be considered. The formula given in the manual can be modified by the factors

$$\left(\frac{\rho}{.0765} \right)^{.8} \left(\frac{\mu}{.0435} \right)^{.2}$$

where

- ρ - density - Lbs FT⁻³
- μ - viscosity LBS FT⁻¹ HR⁻¹
- .0765 - density std. air
- .0435 - viscosity std. air

(184) W_{TNL} STATOR TEETH LOSS - at no load. The no load loss (W_{TNL}) consists of eddy current and hysteresis losses in the iron. For a given frequency the no load tooth loss will vary as the square of the flux density. (watts)

$$W_{\text{TNL}} = .453(b_{t1/3})(Q)(\ell_s)(h_s)(K_Q)$$

$$= .453(57a)(23)(17)(22)(184)$$

$$\text{Where } K_Q = (k) \left[\frac{(B_t)}{(B)} \right]^2 = (19) \left[\frac{(91)}{(20)} \right]^2$$

(185) W_c STATOR CORE LOSS - The stator core losses are due to eddy currents and hysteresis and do not change under load conditions. For a given frequency the core loss will vary as the square of the flux density (B_c). (watts)

$$W_c = 1.42 \left[(D) - (h_c) \right] (h_c)(\ell_s)(K_Q)$$

$$= 1.42 \left[(12) - (24) \right] (24)(17)(185)$$

$$\text{Where } K_Q = (k) \left[\frac{(B_c)}{(B)} \right]^2 = (19) \left[\frac{(94)}{(20)} \right]^2$$

(186)

W_{NPL}

POLE FACE LOSS - at no load. The pole surface losses are

due to slot ripple caused by the stator slots. They depend upon the width of the stator slot opening, the air gap, and the stator slot ripple frequency. The no load pole face loss (W_{PNL}) can be obtained from Curve F-2. Curve F-2 is plotted on the bases of open slots. In order to apply this curve to partially open slots, substitute b_o for b_s . For a better understanding of Curve F-2, use the following sample.

K_1 as given on Curve F-2 is derived empirically and depends on lamination material and thickness. Those values given on Curve F-2 have been used with success. K_1 is an input and must be specified. See item (187) for values of K_1 .

K_2 is shown as being plotted as a function of $(B_G)^{2.5}$. Also note that upper scale is to be used. Another note in the lower right hand corner of graph indicates that for a solid line (—), the factor is read from the left scale, and for a broken or dashed line (— - — -), the right scale should be read. For example, find K_2 when $B_g = 30$ kilo lines. First locate 30 on upper scale. Read down to the intersection of solid line plot of $K_2 = \text{fn}(B_G)^{2.5}$. At this intersection read the left scale for K_2 . $K_2 = .28$. Also refer to item (188) for K_2 calculations.

K_3 is shown as a solid line plot as a function of $(F_{SLT})^{1.65}$. The note on this plot indicates that the upper scale X 10 should be used. Note $F_{SLT} = \text{slot}$

frequency. For an example, find K_3 when $\tau_{SLT} = 1000$. Use upper scale X 10 to locate 1000. Read down to intersection of solid line plot of $K_3 = f(F_{SLT})^{1.65}$. At this intersection read the left scale for K_3 . $K_3 = 1.35$. Also refer to item (189) for K_3 calculations.

For K_4 use same procedure as outlined above except use lower scale. Do not confuse the dashed line in this plot with the note to use the right scale. The note does not apply in this case. Read left scale. Also refer to item (190) for K_4 calculations.

For K_5 use bottom scale and substitute b_o for b_g when using partially closed slot. Read left scale when using solid plot. Use right scale when using dashed plot. Also refer to item (191) for K_5 calculations.

For K_6 use the scale attached for C_1 and read K_6 from left scale. Also refer to item (192) for K_6 calculations.

The above factors (K_2), (K_3), (K_4), (K_5), (K_6) can also be calculated as shown in (188), (189), (190), (191), (192), respectively.

$$\begin{aligned}
 W_{PNL} &= \pi(d)(\ell)(K_1)(K_2)(K_3)(K_4)(K_5)(K_6) \\
 &= \pi(11)(13)(187)(188)(189)(190)(191)(192)
 \end{aligned}$$

(187) K_1 K_1 is derived empirically and depends on lamination material and thickness. The values used successfully for K_1 are shown on Curve F-2. They are:

- $K_1 = 1.17$ for .028 lam thickness, low carbon steel
- $= 1.75$ for .063 lam thickness, low carbon steel
- $= 3.5$ for .125 lam thickness, low carbon steel
- $= 7.0$ for solid core

K_1 is an input and must be specified on input sheet.

(188) K_2 K_2 can be obtained from Curve F-2 (see item (186) for explanation) or it can be calculated as follows:

$$K_2 = f_n(B_G) = 6.1 \times 10^{-5} (B_G)^{2.5}$$

$$= 6.1 \times 10^{-5} (95)^{2.5}$$

(189) K_3 K_3 can be obtained from Curve F-2 (see item (186) for explanation) or it can be calculated as follows:

$$K_3 = f_n(F_{SLT}) = 1.5147 \times 10^{-5} (F_{SLT})^{1.65}$$

$$= 1.5147 \times 10^{-5} (189)^{1.65}$$

$$\text{Where } F_{SLT} = \frac{(\text{RPM})}{60} (Q)$$

$$= \frac{(7)}{60} (23)$$

(190) K_4 K_4 can be obtained from Curve F-2 (see item (186) for explanation) or it can be calculated as follows:

For $\tau_s \leq .9$

$$K_4 = f_n(\tau_s) = .81(\tau_s)^{1.285}$$

$$= .81(26)^{1.285}$$

For $.9 \leq \tau_s \leq 2.0$

$$\begin{aligned} K_4 = \ln(b_s) &= .79(\tau_s)^{1.145} \\ &= .79(26)^{1.145} \end{aligned}$$

For $\tau_s > 2.0$

$$\begin{aligned} K_4 = \ln(b_s) &= .92(\tau_s)^{.79} \\ &= .92(26)^{.79} \end{aligned}$$

(191) K_5

K_5 can be obtained from Curve F-2 (see item (186 for explanation) or it can be calculated as follows:

For $(b_s) / (g) \leq 1.7$

$$\begin{aligned} K_5 = \ln(b_s/g) &= .3 \left[(b_s) / (g) \right]^{2.31} \\ &= .3 \left[(22) / (59) \right]^{2.31} \end{aligned}$$

NOTE: For partially open slots substitute b_o for b_s in equations shown.

For $1.7 < (b_s) / (g) \leq 3$

$$\begin{aligned} K_5 = \ln(b_s/g) &= .35 \left[(b_s) / (g) \right]^2 \\ &= .35 \left[(22) / (59) \right]^2 \end{aligned}$$

For $3 < (b_s) / (g) \leq 5$

$$\begin{aligned} K_5 = \ln(b_s/g) &= .625 \left[(b_s) / (g) \right]^{1.4} \\ &= .625 \left[(22) / (59) \right]^{1.4} \end{aligned}$$

For $(b_s)/(g) > 5$

$$K_5 = \frac{1}{\sqrt{2}} \left[\frac{(b_s)}{g} \right] / (g) = 1.38 \left[\frac{(b_s)}{g} \right]^{.965}$$

$$= 1.38 \left[\frac{(22)}{(59)} \right]^{.965}$$

(192) K_6 K_6 can be obtained from Curve F-2 (see item (186) for explanation) or it can be calculated as follows:

$$K_6 = f_1(C_1) = 10 \left[.9323(C_1) - 1.60596 \right]$$

$$= 10 \left[.9323(71) - 1.60596 \right]$$

(193) W_{DNL} DAMPER LOSS - at no load at 20°C. This loss is produced by slot ripple in the damper winding. At no load this loss is calculated from curves F-7 and F-8.

$$W_{DNL} = \frac{1.246(P)(n_b)(l_b)(\rho_D)}{(a_{cd}) \times 10^3} \left[(\tau_s)(B_g)(K_{P1})(K_g) \right]^2$$

$$\left\{ (K_{f1}) \left[\frac{K_{W1}}{2(\lambda_s) + [(\lambda_g)/(K_{\phi 1})]} \right]^2 \right.$$

$$\left. + (K_{f2}) \left[\frac{(K_{W2})}{2(\lambda_s) + [(\lambda_g)/(K_{\phi 2})]} \right]^2 \right\}$$

$$W_{DNL} = \frac{1.246(6)(138)(139)(141)}{(144) \times 10^3} \left[(26)(95)(193)(193) \right]^2$$

$$\left\{ (193) \left[\frac{(193)}{2(193) + [(1.33)/(193)]} \right]^2 \right.$$

$$\left. + (193) \left[\frac{(193)}{2(193) + [(193)/(193)]} \right]^2 \right\}$$

$$\begin{aligned} \text{Where } K_{P1} &= 1 - \frac{1}{\sqrt{1 + \left[\frac{(b_s)}{2(g)} \right]^2}} \\ &= 1 - \frac{1}{\sqrt{1 + \left[\frac{(22)}{2(59)} \right]^2}} \end{aligned}$$

NOTE: Substitute b_o for b_s when partially opened stator slot is used.

K_{P1} can also be obtained from curve F-7 where abscissa is $(b_s)/(g)$ or $(b_o)/(g) = (22)/(59)$

$$\text{Where } \bar{K}_g = (K_s) = (67)$$

$$\text{Where } g' = (K_g)(g) = (193)(59)$$

Where K_{f1} & K_{f2} are obtained from curve F-7

Where the abscissa is S_1 or S_2

$$S_1 = .32 \sqrt{\frac{(f_{S1})}{(\tau_D)}} (h_b) = .32 \sqrt{\frac{(193)}{(141)}} \quad (136)$$

$$S_2 = .32 \sqrt{\frac{(f_{S2})}{(\tau_D)}} (h_b) = .32 \sqrt{\frac{(193)}{(141)}} \quad (136)$$

$$\text{Where } f_{S1} = 2qmf = 2(25)(5)(5a)$$

$$f_{S2} = 2(f_{S1})$$

Where K_{W1} and K_{W2} are obtained from curve F-8 where the abscissa is $(b)/(\tau_s)$ for open slots or $(b_c)/(\tau_s)$ for semi-enclosed slots $(b_s)/(\tau_s) = (22)/(26)$

(193) (Cont.)

Where λ_t is obtained from curve F-7

Where the abscissa is $(b_{bo}) / (g') = \frac{(135)}{(193)}$

When (91) = 0 or when (90) = (91)

$$\lambda_C = \frac{.75}{(K_{f1})} = \frac{.75}{(193)} \text{ For round or square slots}$$

When (137) = 0 and when (136) \neq (137)

$$\lambda_C = \frac{(h_{b1})}{3(b_{b1})(K_{f1})} = \frac{(137)}{3(135)(193)}$$

$$\text{Where } \lambda_S = \frac{(h_{bo})}{(b_{bo})} + (\lambda_t) + (\lambda_C)$$

$$= \frac{(135)}{(135)} + (193) + (193)$$

$$\text{Where } \lambda_g = \frac{(\tau_b)}{(g')} = \frac{(140)}{(193)}$$

Where $K_{\phi 1}$ and $K_{\phi 2}$ are obtained from curve F-8

Where the abscissa is $(\tau_b) / (\tau_s) = (140) / (26)$

(194) I^2R STATOR I^2R - at no load. This item = 0. Refer to item (245)
for 100% load stator I^2R . (in watts)

(195) -- EDDY LOSS - at no load. This item = 0. Refer to item (246)
for 100% load eddy loss. (in watts)

(196) -- TOTAL LOSSES - at no load. Sum of all losses. (in watts)

$$\begin{aligned} \text{Total losses} &= (\text{Rotor } I^2R) + (\text{F \& W}) + (\text{Stator Teeth Loss}) \\ &+ (\text{Stator Core Loss}) + (\text{Pole Face Loss}) \\ &+ (\text{Damper Loss}) \end{aligned}$$

$$= (182) + (183) + (184) + (185) + (186) + (193)$$

NOTE: The output sheet shows the next items to be:
 (Rating), (Rating + Losses), (% Losses), (% efficiency).
 These items do not apply to the no load calculation
 since the rating is zero. Refer to items (248), (249)
 (177), (178) for these calculations under load.

Item (100) through (127c) have been calculated for 0%
 load or no load. They should all be repeated now for
 100% load.

(197a) ϕ_{ll}

LEAKAGE FLUX PER POLE at 100% load

$$\phi_{ll} = \phi_l \left\{ \frac{(e_d)(F_g) + [1 + \cos(\theta)](F_T) + (F_C)}{(F_g) + (F_T) + (F_C)} \right\}$$

$$= (100a) \frac{(198)(96) + [1 + \cos(198a)](97) + (98)}{(96) + (97) + (98)}$$

(198) e_d

Where $e_d = \cos \epsilon + \frac{(X_d)}{100} \sin \psi$

$$= \cos(198a) + \frac{(133)}{100} \sin(193a)$$

(198a) θ

Where $\theta = \cos^{-1}[(\text{Power Factor})]$

$$= \cos^{-1}[(9)]$$

Where $\psi = \tan^{-1} \left[\frac{\sin(\theta) + \frac{(X_q)}{(100)}}{\cos(\theta)} \right]$

$$= \tan^{-1} \left[\frac{\sin(160b) + (134)/(100)}{\cos(198a)} \right]$$

Where $\epsilon = \psi - \theta = (198a) - (198a)$

(213)	ϕ_{PL}	<p><u>FLUX PER POLE at 100% load, Kilolines</u> FOR P.F. 0 TO .95</p> $\phi_{PL} = (\phi_P) \left[(e_d) - \frac{.93(X_{ad})}{100} \sin(\psi) \right]$ $= (92) \left[(198) - \frac{.93(131)}{100} \sin(198a) \right]$ <p>FOR P.F. .95 TO 1.0 $\phi_{PL} = (\phi_P)(K_c) = (92)(9a)$</p>
(213a)	ϕ_{PTL}	<p><u>TOTAL FLUX PER POLE at 100% load, Kilolines</u></p> $\phi_{PTL} = \phi_{PL} + \phi_{ll} = (213) + (197a)$
(213b)	B_{PL}	<p><u>FLUX DENSITY AT BASE OF POLE at 100% load, Kl/in²</u></p> $B_{PL} = \frac{\phi_{PTL}}{a_P} = \frac{(213a)}{(79)}$
(213c)	F_{PL}	<p><u>AMPERE TURNS PER POLE at 100% load</u></p> $F_{PL} = [(h_f) + (h_h)] [NI/in @ density (B_{PL})]$ $= [(76) + (76)] \text{ Look-up ampere turns/inch on rotor magnetization curve given in (18) at density (213b)}$
(236)	F_{FL}	<p><u>TOTAL AMPERE TURNS PER POLE at 100% load - The total ampere turns per pole required to produce rated load.</u></p> $F_{FL} = (e_d)(F_g) + [1 + \cos(\theta)] (F_T) + (F_C) + (F_{PL})$ $= (198)(96) + [1 + \cos(198a)](97) + (98) + (213c)$
(237)	I_{FFL}	<p><u>FIELD CURRENT at 100% load, amperes</u></p> $I_{FFL} = (F_{FL}) / (N_P) = (236) / (146a)$

(238) FIELD CURRENT at 100% load - The field current calculation is made with the field resistance at the expected temperature at 100% load.

$$\text{Field Volts} = (I_{FFL}) R_{f \text{ hot}} = (237) (155)$$

(239) S_{FL} CURRENT DENSITY at 100% load - amperes per square inch

$$\text{Current Density} = (I_{FFL}) / (a_{cl}) = (237) / (153)$$

(241) I²R_R ROTOR I²R at 100% load - The copper loss in the field winding is calculated with hot field resistance at expected temperature for 100% load condition. (watts)

$$\text{Rotor I}^2\text{R} = (I_{FFL})^2 (R_{f \text{ hot}}) = (237)^2 (155)$$

(242) W_{TFL} STATOR TEETH LOSS at 100% load - The stator tooth loss under load increases over that of no load because of the parasitic fluxes caused by the ripple due to the rotor damper bar slot openings. (watts)

$$W_{TFL} = \left\{ 2 \left[.27 \frac{(X_d)}{100} \frac{(\% \text{ Load})}{100} \right]^{1.8} + 1 \right\} (W_{TNL})$$

$$= \left\{ 2 \left[.27 \frac{(133)}{100} \frac{(\% \text{ Load})}{100} \right]^{1.8} + 1 \right\} \quad (134)$$

(243) W_{PFL} POLE FACE LOSS at 100% load (watts)

$$W_{PFL} = \left\{ \left[\frac{(K_{sc})(I_{PH}) \frac{(\% \text{ Load})}{100} (n_s)}{(C)(F_g)} \right]^2 + 1 \right\} (W_{PNL})$$

$$= \left\{ \left[\frac{(243)(8) 1 (30)}{(32)(96)} \right]^2 + 1 \right\} \quad (186)$$

(K_{sc}) is obtained from Curve F-3

(244) W_{DFL} DAMPER LOSS at 100% load (watts)

$$W_{DFL} = \left\{ \frac{(K_{sc})(I_{PH}) \left(\frac{\% \text{ Load}}{100}\right) (t_s)}{(C)(F_g)} \right\}^2 (W_{INL})$$

$$= \left\{ \frac{(244)(8) 1 (30)}{(32)(96)} \right\}^2 (193)$$

(K_{sc}) is obtained from Curve F-3

(245) $I^2 R_L$ STATOR $I^2 R$ at 100% load - The copper loss based on the resistance of the winding. Calculate at the temperature expected operating temperature. (watts)

$$I^2 R_L = (m)(I_{PH})^2 (R_{SPH \text{ hot}}) \left(\frac{\% \text{ Load}}{100}\right)$$

$$= (5)(8)^2 (54) 1.$$

(246) -- EDDY LOSS - Stator $I^2 R$ loss due to skin effect (watts)

$$\text{Eddy Loss} = \left[\frac{(EF_{\text{top}}) + (EF_{\text{bot}})}{2} - 1 \right] (\text{Stator } I^2 R)$$

$$= \left[\frac{(55) + (56)}{2} - 1 \right] (245)$$

(247) -- TOTAL LOSSES at 100% load - sum of all losses at 100% load

$$\begin{aligned} \text{Total Losses} &= (\text{Rotor } I^2 R) + (F \& W) + (\text{Stator Teeth Loss}) \\ &+ (\text{Stator Core Loss}) + (\text{Pole Face Loss}) \\ &+ (\text{Damper Loss}) + (\text{Stator } I^2 R) + (\text{Eddy Loss}) \\ &= (241) + (183) + (242) + (185) + (243) + (244) + (245) + (246) \\ &= \text{watts} \end{aligned}$$

(24b) -- RATING IN KILOWATTS at 100% load

$$\text{Rating} = 3(E_{PH})(I_{PH}) \quad (\text{P. F.}) \frac{(\% \text{ Load})}{100}$$

$$= 3(4)(8) \quad (9)(1.)$$

(249) -- RATING & Σ LOSSES = (248) + (247) $\times 10^{-3}$

(250) -- % LOSSES = $\left[\frac{\Sigma \text{ Losses}}{(\text{Rating} + \Sigma \text{ Losses})} \right] 100$

$$= \left[\frac{(247) \times 10^{-3}}{(249)} \right] 100$$

(251) -- % EFFICIENCY = 100% - % Losses

$$= 100\% - (250)$$

Item(197a) through (251) are 100% load calculations.

These items can be recalculated for any load condition by simply inserting the values that correspond to the % load being calculated. The factor $\frac{(\% \text{ Load})}{100}$ takes care of (I_{PH}) as it changes with load.

Note that values for F & W (183) and W_C (Stator Core Loss) (185) do not change with load, therefore they can be calculated only once.

INPUT AUXILIARY DATA SHEET

Auxiliary information taken from the design manuals to be used in conjunction with input sheets for convenience.

A. All dimensions for lengths, widths, and diameters are to be given in inches.

B. Resistivity inputs, Rems (141) and (151) are to be given in micro-ohm-inches.

The following items along with an explanation of each are tabulated here for convenience. For complete explanation of each item number, refer to design manuals.

- | | |
|----------------|--|
| <u>Rem No.</u> | <u>Explanation</u> |
| (9) | Power factor to be given in per unit. For example for 90% P.F., insert <u>.90</u> . |
| (9a) | Adjustment Factor - For P.F. < .95 insert <u>1.0</u>
For P.F. > .95 insert <u>1.05</u> |
| (10) | Optional Load Point -- Where load data output is required at a point other than those given as standard on the input sheet. Example: For load data output at 155% load, insert <u>1.55</u> . |
| (14) | Number of radial ducts in stator. |
| (15) | Width of radial ducts used in Item (14). |
| (18) | Magnetization curve of material used to be submitted as defined in Rem (18). |
| (19) | Watts/Lb. to be taken from a core loss curve at the density given in Rem (20) (Stator). |
| (20) | Density in kilolines/in ² . This value must correspond to density used to pick Item (19) usually use 77.4 KL/in ² . |
| (21) | Type of slot - For open slot Type A, insert <u>1.0</u> .
For partially open slot Type B with constant slot width, insert <u>2.0</u> .
For partially open slot Type C with constant tooth width, insert <u>3.0</u> .
For round slot Type D, insert <u>4.0</u> .
For additional information, refer to figure adjacent to input sheet which shows a picture of each slot. |
| (22) | For stator slot dimension - for dimensions that do not apply to the slot insert <u>0.0</u> .
Use Table below as guide for input. |

<u>Symbol</u>	<u>Rem</u>	<u>Slot Type</u>			
		<u>1</u>	<u>2</u>	<u>3</u>	<u>4</u>
b ₀	(22)	0.0	*	*	*
b ₁	↓	0.0	0.0	*	0.0
b ₂		0.0	0.0	*	0.0
b ₃		0.0	0.0	*	0.0
b _g		*	*	$\frac{b_1 + b_3}{2}$	*
h ₀		0.0	*	*	*
h ₁		*	*	*	0.0
h ₂		*	0.0	0.0	0.0
h ₃		*	*	0.0	0.0
h _g		*	*	*	*
h _t		0.0	*	*	0.0
h _w		0.0	*	*	0.0

* = insert actual value.

$$\phi = b_g = \frac{b_1 + b_3}{2}$$

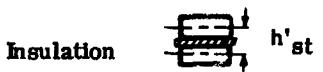
<u>Item No.</u>	<u>Explanation</u>	
(28)	Type of winding - for wye connected winding insert <u>1.0</u> . for delta connected winding insert <u>0.0</u> .	
(29)	Type of coil - for formed wound (rect. wire), insert <u>1.0</u> . for random wound (round wire) insert <u>0.0</u> .	
(30)	Slots spanned - Example - for slot span of 1-10, insert <u>9.0</u> .	
(33)	For round wire insert diameter. For rectangular wire insert wire width.	
(34)	Strands per conductor in depth only.	
(34a)	Total strands per conductor in depth and width.	
(35)	Diameter of coil head forming pin. Insert .25 for stator O.D. < 8 inches; Insert .50 for stator O.D. > 8 in.	
(37)	Use vertical height of strand for round wire, insert <u>0.0</u> .	
(38)	Distance between centerline of strands in depth.	
(39)	Stator strand thickness -- use narrowest dimension of the two dimensions given for a rectangular wire. For round wire insert <u>0.0</u> .	
(40)	Stator slot skew in inches.	
(42a)	Phase belt angle - for 60° phase belt, insert <u>60°</u> . for 120° phase belt, insert <u>120°</u> .	
(48)	See explanation of items (71), (72), (73), (74) and (75). Same applies here.	
(87)	When no load saturation output data is required at various voltages, insert <u>1.0</u> . When no load saturation information is not required, insert <u>0.0</u> .	
(137)	Damper bar thickness -- use damper bar slot height for rectangular bar. For round bar insert <u>0.0</u> .	
(138)	Number of damper bars per pole.	
(140)	Damper bar pitch in inches.	
(148)	For round wire insert diameter. For rectangular wire insert wire width.	
(149)	For rectangular wire insert wire thickness. For round wire insert <u>0.0</u> .	
(187)	Pole face loss factor. For rotor lamination thickness .028 in. or less, insert <u>1.17</u> . For rotor lamination thickness .029 in. to .063 in. insert <u>1.75</u> . For rotor lamination thickness .064 in. to .125 insert <u>3.5</u> . For solid rotor insert <u>7.0</u> .	
(71)	If the values of these constants are available, insert the actual number. If they are not available, insert 0.0 and the computer will calculate the values and record them on the output.	
(72)		
(73)		
(74)		

NON-SALIENT-POLE DESIGN (INPUT)

MODEL _____ EWO _____ DESIGN NO.(1) _____ BY _____

	PARAMETERS	UNIT	DESCRIPTION	UNIT	CONSTANT	
PARAMETERS	(2)	KVA	GENERATOR KVA			FUND/MAX OF FIELD FLUX (71) C ₁
	(3)	E	LINE VOLTS			WINDING CONSTANT (72) C _w
	(4)	E _{ph}	PHASE VOLTS			POLE CONST. (73) C _p
	(5)	m	PHASES			END EXTENSION ONE TURN (48) L _E
	(5a)	f	FREQUENCY			DEMAGNETIZATION FACTOR (74) C _m
	(6)	p	POLES			TYPE ROTOR 1, 2
	(7)	RPM	RPM			SLOTS PUNCHED (300) Q' _r
	(8)	I _{ph}	PHASE CURRENT			SLOTS WOUND (301) Q' _r
	(9)	PF	POWER FACTOR			SLOTS IN POLE CENTER (302a) N _{rc}
	(10)		OPTIONAL LOAD POINT			WIDTH OF SLOT OPENING (303) b _{rc}
STATOR STACK	(11)	d	STATOR I.D.			HEIGHT OF SLOT OPENING (303) h _{r2}
	(12)	D	STATOR O.D.			SLOT DEPTH BELOW WEDGE (303) h _{r1}
	(13)	ℓ	GROSS CORE LENGTH			SLOT WIDTH (303) b _r
	(14)	n _v	NO. OF DUCTS			SLOT DEPTH (303) h _r
	(15)	b _v	WIDTH OF DUCT			SLOT PITCH (304) t _{rs}
	(16)	K _s	STACKING FACTOR (STATOR)			ROTOR STACK LENGTH (305) ℓ _r
	(19)	k	WATTS/LB.			ROTOR STACKING FACTOR (16) K _s
	(20)	B	DENSITY			ROTOR DIAMETER (11a) d _r
STATOR SLOT	(21)		TYPE OF SLOT			ROTOR I.D. (PCHGS.) (314a) d _s
	(22)	b _o	SLOT OPENING			HEIGHT VENT HOLES (314b) b _{th}
	(22)	b ₁	SLOT WIDTH TOP			WEIGHT OF ROTOR IRON (157) (-)
	(22)	t ₂				POLE FACE LOSS FACTOR (187) (K ₁)
	(22)	t ₃				NO. OF FIELD TURNS/POLE (146a) N _p
	(22)	b _s	SLOT WIDTH			MEAN LENGTH OF I.D. TURN (147) ℓ _{tr}
	(22)	h _o				FLD. COND. DIA. OR WIDTH (148)
	(22)	h ₁				FLD. COND. THICKNESS (149)
	(22)	h ₂				FLD. TEMP IN °C (150) X _f °C
	(22)	h ₃				RESISTIVITY OF FIELD COND. @ 20° (151) ρ _f
	(22)	h _s	SLOT DEPTH			NO LOAD SAT. (87)
	(22)	h _t				FRIC'ION & WINDAGE (183) (F&W)
	(22)	h _w				ROTOR LAM MTR'L (18)
	(23)	Q	NO. OF SLOTS			STATOR LAM. MTR'L (CURVE) (18)
STATOR WINDING	(28)		TYPE OF WDG.			
	(29)		TYPE OF COIL			
	(30)	n _s	CONDUCTORS/SLOT			
	(31)	y	SLOTS SPANNED			
	(32)	c	PARALLEL CIRCUITS			
	(33)		STRAND DIA. OR WIDTH			
	(34)	N _{st}	STRANDS/CONDUCTOR			
	(34a)	N' _{st}	STRANDS/CONDUCTOR			
	(39)		STATOR STRAND T'KMS			
	(35)	d _b	DIA. OF PIN			
	(36)	ℓ _{o2}	COIL EXT. STR. PORT			
	(37)	h _{st}	UNINS. STRD. HT.			
	(38)	h' _{st}	DIST. BTWN. CL OF STD.			
	(42a)		PHASE BELT/ANGLE			
	(40)	τ _{sk}	STATOR SLOT SKEW			
	(50)	X _s °C	STATOR TEMP °C			
(51)	ρ _s	RES'TVY STA. COND. @ 20° C				
(59)	g _{min}	MINIMUM AIR GAP				

STATOR SLOT	ROTOR SLOT
SLOTTED POLE-CENTER 2 SOLID POLE-CENTER 1	

REMARKS :

(a) Open Slots

(b) Constant Slot Width

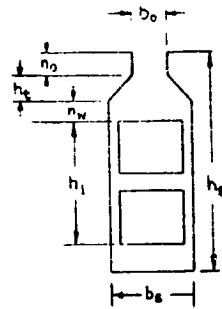
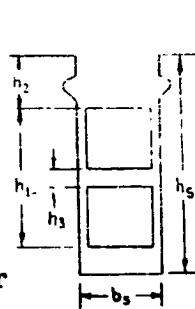

TYPE 1
 (Type 5 is an open slot with 1 conductor per slot)

TYPE 2

(c) Constant Tooth Width

(d) Round Slots

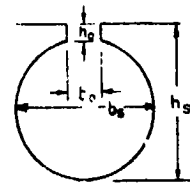
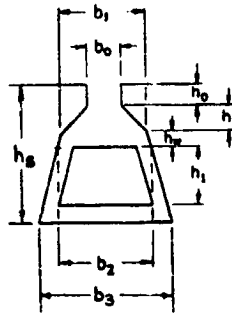

TYPE 3
 b_s for type 3 is

$$b_s = \left(\frac{b_2 + b_3}{2} \right)$$

TYPE 4

SUMMARY OF DESIGN CALCULATIONS - NON-SALIENT - POLE (OUTPUT)

MODEL _____ EWO _____ DESIGN NO. _____

K	(17) (l_a)	SOLID CORE LENGTH			CARTER COEFFICIENT	(67) (K_a)	GAP
	(24) (h_c)	DEPTH BELOW SLOT			AIR GAP AREA	(68) (-)	
	(26) (γ_a)	SLOT PITCH			AIR GAP PERM	(70c) (λ_a)	
	(27) ($\gamma_a/3$)	SLOT PITCH 1/3 DIST. UP			EFFECTIVE AIR GAP	(69) (g_a)	CONSTANTS
	(42) (K_{sk})	SKEW FACTOR			FUND/MAX OF FLD. FLUX	(71) (C_1)	
	(43) (K_d)	DIST. FACTOR			WINDING CONST.	(72) (C_w)	
	(44) (K_p)	PITCH FACTOR			POLE CONST.	(73) (C_p)	
	(45) (γ_a)	EFF. CONDUCTORS			END. EXT. ONE TURN	(48) (L_E)	REACTANCE
	(46) (a_c)	COND. AREA			DEMAGNETIZING FACTOR	(74) (C_M)	
	(47) (S_a)	CURRENT DENSITY (STA.)			AMP COND/IN	(128) (A)	
(49) (l_t)	1/2 MEAN TURN LENGTH			REACTANCE FACTOR	(129) (X)		
(53) (R_{ph})	COLD STA. RES. @ 20° C			LEAKAGE REACTANCE	(130) (X_q)		
(54) (R_{ph})	HOT STA. RES. @ X ° C			REACTANCE OF	(131) (X_{od})		
(55) (EF_{top})	EDDY FACTOR TOP			ARMATURE REACTION			
(56) (EF_{bot})	EDDY FACTOR BOT.			SYN REACT DIRECT AXIS	(133) (X_d)		
(62) (λ_l)	STATOR COND. PERM.			FIELD LEAKAGE REACT	(160) (X_f)		
(64) (λ_g)	END PERM.			FIELD SELF INDUCTANCE	(161) (L_f)		
(65) ()	WT. OF STA COPPER			UNSAT. TRANS. REACT	(166) (X'_{du})	MAGNETIZATION	
(66) ()	WT. OF STA IRON			SAT. TRANS. REACT	(167) (X'_d)		
(312b) (λ_{ra})	ROTOR SLOT LEAK PER			SUR. TRANS. REACT	(166) (X''_d)		
(153) (σ_{CF})	FLD. COND. AREA			NEG SEQUENCE REACT	(170) (X_2)		
(154) (R_F)	COLD FLD RES @ 20° C			ZERO SEQUENCE REACT	(172) (X_c)		
(155) (R_F)	HOT FLD RES. @ X ° C			TOTAL FLUX	(88) (ϕ_t)		
(156) ()	WT OF FLD COPPER			FLUX PER POLE	(92) (ϕ_p)		
(157) ()	WT OF ROTOR IRON			GAP DENSITY	(95) (B_g)		
(145) (V_r)	PERIPHERAL SPEED			TOOTH DENSITY	(91) (B_t)		
(176) (T_{do})	OPEN CIR. TIME CONST.			CORE DENSITY	(94) (B_c)		
(177) (T_o)	ARM TIME CONST.			TOOTH AMPERE TURNS	(97) (F_t)		
(178) (T'_d)	TRANS TIME CONST.			CORE AMPERE TURNS	(98) (F_c)		
(179) (T''_d)	SUB TRANS TIME CONST.			GAP AMPERE TURNS	(96) (F_g)		
(180) (F_{sc})	SHORT CIR NI						
(181) (SCR)	SHORT CIR RATIO						

	PERCENT LOAD	0	100	150	200	OPTIONAL
VARIABLE LOAD	(25) (312) LEAK FLUX		(ϕ_{lps}) (312a)			
	(26) (313) FLUX IN P.C.		(ϕ_{rel}) (318)			
	(B_{pd}) (314) POLE DENSITY		(B_{pel}) (19)			
	(B_{rc}) (315) ROTOR CORE DENSITY		(B_{pel}) (21)			
	(I_{nl}) (127) TOTAL FI		(F_{fl}) (236)			
	(I_{nl}) (127a) FIELD AMPS		(I_{fl}) (237)			
	(S_F) (127c) CUR. DENS. (FLD)		(S_{fl}) (239)			
	(E_F) (127b) FIELD VOLTS		(E_{fl}) (238)			
	(R_r) (182) ROTOR LOSS		($I^2 R_r$) (241)			
	(F&W) (183) F&W LOSS		(F&W) (183)			
	(W_{ml}) (184) STA TOOTH LOSS		(W_{ml}) (242)			
	(W_c) (185) STA CORE LOSS		(W_c) (185)			
	(W_{pfl}) (186) POLE FACE LOSS		(W_{pfl}) (243)			
	($I^2 R_a$) (194) STATOR CU LOSS		($I^2 R_a$) (245)			
	() (195) EDDY LOSS		() (246)			
() (196) TOTAL LOSSES		() (247)				
() () RATING (KW)		() (248)				
() () RATING & LOSSES		() (249)				
() () PERCENT LOSSES		() (250)				
() () PERCENT EFF.		() (251)				

DESIGNER _____

DATE _____

NO LOAD SATURATION OUTPUT SHEET
NON-SALIENT POLE, WOUND-POLE

ITEMS VOLTS	(3) (E) VOLTS	(96) (F _g) AIR GAP A.T.	(91) (B _g) TOOTH DENSITY	(97) (F _t) TOOTH A.T.	(94) (B _c) CORE DENSITY	(98) (F _c)
	(98a) (F _s) STATOR A.T.	(312) ϕ_{Lg} LEAKAGE FLUX	(313) ϕ_{rc} TOTAL FLUX/POLE	(314) B_{pc} POLE DENSITY	(315) (F _{pc}) POLE A.T.	(127) (F _{nl}) TOTAL A.T. (N.L.)
80%						
90%						
100%						
110%						
120%						
130%						
140%						
150%						
160%						

H-04

**NON-SALIENT POLE, WOUND-POLE A. C. GENERATOR
DESIGN COMPUTER MANUAL**

(1)	--	DESIGN NUMBER
(2)	KVA	GENERATOR KVA
(3)	E	LINE VOLTS
(4)	E_{PH}	PHASE VOLTS
(5)	m	PHASES
(5a)	f	FREQUENCY
(6)	P	POLES
(7)	RPM	SPEED
(8)	I_{PH}	PHASE CURRENT
(9)	P. F.	POWER FACTOR
(9a)	K_c	ADJUSTMENT FACTOR
(10)	--	LOAD POINTS
(11)	d	STATOR PUNCHING I.D.
(11a)	d_r	ROTOR O.D.
(12)	D	PUNCHING O.D.
(13)	l	GROSS STATOR CORE LENGTH
(14)	n_v	RADIAL DUCTS
(15)	b_v	RADIAL DUCT WIDTH
(16)	K_1	STACKING FACTOR
(17)	l_s	SOLID CORE LENGTH
(18)		MATERIAL

(19)	k	WATTS / LB
(20)	B	DENSITY
(21)		TYPE OF STATOR SLOT
(22)		ALL SLOT DIMENSIONS
(23)	Q	STATOR SLOTS
(24)	h_c	DEPTH BELOW SLOTS
(25)	q	SLOTS PER POLE PER PHASE
(26)	τ_s	STATOR SLOT PITCH
(27)	$\tau_s^{1/3}$	STATOR SLOT PITCH
(28)	--	TYPE OF WINDING
(29)	---	TYPE OF COIL
(30)	n_s	CONDUCTORS PER SLOT
(31)	γ	THROW
(31a)		PER UNIT OF POLE PITCH SPANNED
(32)	C	PARALLEL PATHS
(33)	--	STRAND DIA. OR WIDTH
(34)	N_{ST}	NUMBER OF STRANDS PER CONDUCTOR IN DEPTH
(34a)	N'_{ST}	NUMBER OF STRANDS PER CONDUCTOR
(35)	d_b	DIAMETER OF BENDER PIN
(36)	ℓ_{e2}	COIL EXTENSION BEYOND CORE
(37)	h_{ST}	HEIGHT OF UNINSULATED STRAND
(38)	h'_{ST}	DISTANCE BETWEEN CENTERLINES OF STRANDS IN DEPTH

(39)	--	STATOR COIL STRAND THICKNESS
(40)	τ_{SK}	SKEW
(41)	τ_P	POLE PITCH
(42)	K_{SK}	SKEW FACTOR
(42a)		PHASE BELT ANGLE
(43)	K_d	DISTRIBUTION FACTOR
(44)	K_p	PITCH FACTOR
(45)	n_e	TOTAL EFFECTIVE CONDUCTORS
(46)	a_c	CONDUCTOR AREA OF STATOR WINDING
(47)	S_S	CURRENT DENSITY
(48)	L_E	END EXTENSION LENGTH
(49)	l_t	1/2 MEAN TURN
(50)	$X_s^{\circ C}$	STATOR TEMPERATURE
(51)	ρ_s	RESISTIVITY OF STATOR WINDING
(52)	ρ_s (hot)	RESISTIVITY OF STATOR WINDING
(53)	R_{SPH} (cold)	STATOR RESISTANCE/PHASE
(54)	R_{SPH} (hot)	STATOR RESISTANCE/PHASE
(55)	EF (top)	EDDY FACTOR TOP
(56)	EF (bot)	EDDY FACTOR BOTTOM

(57)	b_{tm}	STATOR TOOTH WIDTH
(57a)	$b_t 1/3$	STATOR TOOTH WIDTH
(58)	b_t	TOOTH WIDTH AT STATOR I.D. IN INCHES
(59)	g	MAIN AIR GAP IN INCHES
(60)	C_X	REDUCTION FACTOR used in calculating (62)
(61)	K_X	Factor used in calculating (60)
(62)	λ_i	SLOT LEAKAGE PERMEANCE
(63)	K_E	LEAKAGE REACTIVE FACTOR
(64)	λ_E	END WINDING FLUX LEAKAGE PERMEANCE
(65)	--	WEIGHT OF COPPER
(66)	--	WEIGHT OF STATOR IRON
(67)	K_S	CARTER COEFFICIENT
(68)	A_g	MAIN AIR GAP AREA
(69)	g_e	EFFECTIVE GAP - The effective single air gap.

$g_e = K_g K_r g$ (for rotors with slotted pole centers) = (67)(308)(
 $g_e = K_g g$ (for rotors with solid pole centers) = (67)(59)

(70c) λ_a

AIR GAP PERMEANCE

(71) C_1

THE RATIO OF MAXIMUM FUNDAMENTAL of the field

form to the actual maximum of the field form.

FOR A ROTOR WITH SOLID CENTER SECTION

$$C_1 = \frac{4}{\pi} \cos\left(\frac{\pi \alpha}{2}\right) \left[\frac{K_r - 1}{K_r} \right] + \frac{8}{\pi^2 K_r \alpha} \sin\left(\frac{\pi \alpha}{2}\right)$$

$$C_1 = \frac{4}{\pi} \cos \frac{\pi (302)}{2} \left[\frac{(308) - 1}{(308)} \right] + \frac{8}{\pi^2 (308)(302)} \sin \frac{\pi (302)}{2}$$

FOR A ROTOR WITH SLOTTED CENTER SECTION - When

the center is slotted instead of solid the K_r applies to the complete rotor. Therefore, by making K_r equal to unity in the above equation we will get an answer that is independent of the effect of rotor slots and

$$C_1 = \frac{8}{\pi^2 \alpha} \sin\left(\frac{\pi \alpha}{2}\right) = \frac{8}{\pi^2 (302)} \sin\left(\frac{\pi (302)}{2}\right)$$

When using this value of C_1 , it is necessary to include K_r in g_e and

$$g_e = K_r K_g g = (69) = (67)(308)(59)$$

(72) C_w

WINDING CONSTANT

(73) C_p

PCIE CONSTANT - The ratio of the average to the maximum value of the field form.

BASED ON A ROTOR WITH A SOLID CENTER SECTION

$$C_p = 1 - \alpha + \frac{\alpha}{2K_r} = 1 - (302) + \frac{(302)}{2(308)}$$

BASED ON A ROTOR WITH SLOTTED CENTER SECTION

When the center is slotted instead of solid K_r is included in the effective gap and K_r becomes unity in the C_p equation.

$$C_p = 1 - \alpha + \frac{\alpha}{2} = 1 - \frac{\alpha}{2} = 1 - \frac{(302)}{2}$$

(74) C_M

DEMAGNETIZING FACTOR

$$C_M = \frac{\pi^2}{8} \frac{\alpha}{\sin \frac{\pi\alpha}{2}} = \frac{\pi^2}{8} \frac{(302)}{\sin \frac{\pi(302)}{2}}$$

Ref: Quarterly report page 80 (Appendix).

(87) --

NO LOAD SATURATION NOTE

(88) ϕ_T

TOTAL FLUX IN KILOLINES

(91) B_t

TOOTH DENSITY IN KILOLINES/in²

(92) ϕ_P

FLUX PER POLE IN KILOLINES

(94) B_c

CORE DENSITY IN KILOLINES/in²

(95) B_g

GAP DENSITY IN KILOLINES/in²

(96)	F_g	<u>AIR-GAP AMPERE-TURNS</u>
(97)	F_T	<u>STATOR TOOTH AMPERE TURNS</u>
(98)	F_c	<u>STATOR CORE AMPERE-TURNS</u>
(98a)	F_s	<u>STATOR AMPERE TURNS</u>
(104a)	F_R	<u>ROTOR AMPERE TURNS OR POLE AMPERE TURNS</u> at no-load. The ampere turns per pole required to force the flux through the pole center and rotor core at no-load, rated voltage. The core density should be low enough at no-load to ignore. $F_R = F_{pc} + F_{rc} = (316) + (317)$
(127)	F_{NL}	<u>THE TOTAL NO-LOAD AMPERE TURNS PER POLE REQUIRED TO PRODUCE RATED VOLTAGE AT NO-LOAD</u> $F_{NL} = F_g + F_s + F_R = (95) + (98a) + (104a)$
(127a)	I_{FNL}	<u>FIELD CURRENT AT NO-LOAD</u>
(127b)	E_F	<u>FIELD VOLTS AT NO-LOAD</u>
(127c)	S_F	<u>CURRENT DENSITY AT NO-LOAD AMPS/IN² IN FIELD CONDUCTOR</u>
(128)	A	<u>AMPERE CONDUCTORS PER INCH</u>
(129)	X	<u>REACTANCE FACTOR</u>
(130)	X_ℓ	<u>LEAKAGE REACTANCE</u>
(131)	X_{ad}	<u>REACTANCE DIRECT AXIS REACTANCE OF ARMATURE REACTION</u>
(133)	X_d	<u>SYNCHRONOUS REACTANCE</u> $X_d = X_\ell + X_{ad} = (130) + (131)$
(145)	V_r	<u>PERIPHERAL SPEED OF ROTOR</u>

(146a) N_p

TURNS PER POLE - The total number of field turns per pole.

$$N_p = \frac{n_r Q_r}{2p} = \frac{(306)(301)}{2(6)}$$

(147) l_{tr}

MEAN TURN - The mean length of rotor turn. This value must be calculated from a layout of the rotor winding.

(148)

FIELD CONDUCTOR DIAMETER OR WIDTH (INCHES)

(149)

FIELD CONDUCTOR THICKNESS (INCHES)

Set = 0 for round

(150) K_f °C

FIELD TEMP. IN °C

(151) ρ_f

RESISTIVITY OF ROTOR WINDING AT 20°C OHM INCHES x 10⁻⁶

Refer to item (51) for conversion factors.

(152) ρ_f RESISTIVITY OF ROTOR WINDING AT $X_f^\circ\text{C}$

(153) a_{cf} AREA OF CONDUCTOR - The actual area of the conductor taking into account the corner radius.

(154) R_f (cold) COLD FIELD RESISTANCE AT 20°C

(155) R_f (hot) HOT FIELD RESISTANCE AT $X^\circ\text{C}$

(156) WEIGHT OF COPPER - The weight in lbs. of the field winding.

$$\text{Lbs.} = .321 N_p P \ell_{t_r} a_{cr} = .321 (146a)(6)(147)(153)$$

(157) WEIGHT OF IRON - The weight in lbs. of the rotor iron.

$$\begin{aligned} \# &= .283 \left[\pi (d_r - h_r) - Q_r b_r \right] \ell_{rs} h_r + \\ &+ .283 \pi (d_s + h'_{rc}) h_{rc} \ell_{rs} \\ &= .283 \left\{ \left[\pi (11a) - (303) \right] - (301)(303) \right\} (305a)(303) + \\ &.283 \pi \left[(314a) + (330) \right] (330)(305a) \end{aligned}$$

For slotted pole centers $Q_r = Q'_r$

$$(300) = (301)$$

(160) X_F FIELD LEAKAGE REACTANCE - The leakage reactance of the field winding.

$$X_F = X \frac{4}{\mu} C_M^2 \lambda_F, = (129) \frac{4}{\mu} (74)^2 (332)$$

(161) L_F FIELD SELF INDUCTANCE - The total self inductance of the field winding.

$$L_F = \frac{N_F^2 p \ell_r}{10^8} \left[C_F \left(3.19 \frac{\tau_p}{g_e} \right) + \lambda_F \right] \text{ (Henries)}$$

$$= \frac{(146a)(6)(305)}{10^8} \left[(331) 3.19 \frac{(41)}{(69)} + (332) \right]$$

(163) X_{Dd} DAMPER LEAKAGE REACTANCE - The leakage reactance of the effective damper and eddy current circuits.

$$X_{Dd} = X \lambda_{Dd}$$

$$\lambda_{Dd} = \frac{3.19p}{d} (g + \gamma_d + h_{r2})$$

where γ_d = depth of penetration factor

$$\gamma_d = 0.47 \sqrt{\frac{400}{f}}$$

$$\lambda_{Dd} = \frac{3.19 (6)}{(11)} \left\{ (59) + (163) + (303) \right\}$$

(166) X'_{du} UNSATURATED TRANSIENT REACTANCE - The transient reactance due to the field winding, assuming unsaturated conditions.

$$X'_{du} = X'_\chi + X_F \left(\frac{X_{ad}}{X_F + X_{ad}} \right) =$$

$$= (130) + (160) \left(\frac{(131)}{(160) + (131)} \right)$$

(167) X'_d SATURATED TRANSIENT REACTANCE - The transient reactance due to the field winding assuming normally saturated conditions.

$$X'_d = 0.88 X'_{du} = 0.88 (166)$$

(168) X''_d SUBTRANSIENT REACTANCE - The subtransient reactance due to the eddy current circuits.

$$X''_d = X'_\chi + X_{Dc} = (130) + (163)$$

(170) X_2 NEGATIVE SEQUENCE REACTANCE - The reactance due to the field which rotates at synchronous speed in a direction opposite to that of the rotor.

$$X_2 = X''_d = (168)$$

(172) X_0

ZERO SEQUENCE REACTANCE - The reactance drop across any one phase (star connected) for unit zero sequence current in each of the phases. The machine must be star connected for otherwise no zero sequence current can flow and the term has no significance.

$$X_0 = X \left[\frac{K_{X0}}{K_{X1}} (\lambda_i + \lambda_{Dd}) + \frac{20(h_1 + 2h_3)}{12mq K_p^2 K_d^2 b_s} + 0.2 \lambda_E \right]$$
$$= (129) \left\{ \frac{(173)}{(174)} \left[(62) + (163) \right] + \frac{1.667 \left[(22) + 2(22) \right]}{(5)(25)(44)^2 (43)^2 (22)} + .2(64) \right\}$$

(173) K_{X0}

If (30) = 1 Then $K_{X0} = 1$

If (30) \neq 1 Then $K_{X0} = \frac{3(\gamma)}{(m)(q)} - 2$
 $= \frac{3(31)}{(5)(25)} - 2$

(174) K_{X1}

If (30) = 1 Then $K_{X1} = 1$

If (30) \neq 1 Then:

$$K_{X1} = \left[\frac{3(\gamma)}{4(m)(q)} + \frac{1}{4} \right] = \left[\frac{3(31)}{4(5)(25)} + \frac{1}{4} \right] \quad \text{If } (31a) \geq .667$$

$$K_{X1} = \left[\frac{3(\gamma)}{4(m)(q)} - \frac{1}{4} \right] = \left[\frac{3(31)}{4(5)(25)} - \frac{1}{4} \right] \quad \text{If } (31a) < .667$$

(176)	T'_{do}	<u>OPEN CIRCUIT TIME CONSTANT</u>
(177)	T_a	<u>ARMATURE TIME CONSTANT</u>
(178)	T'_d	<u>TRANSIENT TIME CONSTANT</u>
(179)	T''_d	<u>SUBTRANSIENT TIME CONSTANT</u>
(180)	F_{sc}	<u>SHORT CIRCUIT AMPERE TURNS</u>
(181)	S_{CR}	<u>SHORT CIRCUIT RATIO</u>
(182)	I^2R_R	<u>ROTOR I^2R AT NO LOAD</u>
(183)	F & W	<u>FRICITION & WINDAGE LOSS</u>

(184) W_{TNL} STATOR TEETH LOSS AT NO LOAD

(185) W_c STATOR CORE LOSS

(186) W_{NPL} POLE FACE LOSS AT NO LOAD

(196) TOTAL LOSSES AT NO LOAD

$$\begin{aligned} & \text{Rotor } I^2R + F \text{ \& } W + \text{Stator Teeth Losses} + \\ & \text{Stator Core Loss} + \text{Pole Face Loss} \\ & = (182) + (133) + (184) + (185) + (186) \end{aligned}$$

(198) e_d The voltage that would be generated at no load and no saturation -- the air gap voltage behind the synchronous reactance.

$$\begin{aligned} e_d &= \cos(\epsilon) + \frac{X_d}{100} \sin(\psi) \\ &= \cos(198) + \frac{(133)}{100} \sin(198) \end{aligned}$$

$$\begin{aligned} \text{Where } \psi &= \tan^{-1} \left[\frac{\sin(\Theta) + \frac{X_d}{100}}{\cos \Theta} \right] \\ &= \tan^{-1} \left[\frac{\sin(198) + \frac{(133)}{100}}{\cos(198a)} \right] \end{aligned}$$

(198a) Θ POWER FACTOR ANGLE

$$\begin{aligned} &= \cos^{-1} [\text{PF}] \\ &= \cos^{-1} [\Theta] \end{aligned}$$

$$\text{Where } \epsilon = (\psi) - (\Theta) = (198) - (198a)$$

(236)	F_{FL}	<u>TOTAL AMPERE TURNS PER POLE REQUIRED @100% LOAD</u>
		$F_{FL} = e_d F_g + \left[(1 + \cos \theta) F_T \right] + F_c + F_{PCL} + F_{rcL}$ $= (198)(96) + (97) \left[1 + \cos(198a) \right] + (98) + (320) + (322)$
(237)	I_{FFL}	<u>FIELD CURRENT @100% LOAD</u>
		$I_{FFL} = \frac{F_{FL}}{N_p} = \frac{(236)}{(146a)}$
(238)	E_{FFL}	<u>FIELD VOLTS @100% LOAD</u>

(239)		<u>CURRENT DENSITY IN FIELD CONDUCTORS AT 100% LOAD</u>
(241)	I^2R_R	<u>ROTOR I^2R AT 100% LOAD</u>
(242)	W_{TFL}	<u>STATOR TEETH LOSS AT 100% LOAD</u>
(243)	W_{PFL}	<u>POLE FACE LOSS AT 100% LOAD</u>
(244)	W_{DFL}	<u>DAMPER LOSS AT 100% LOAD</u>
(245)	I^2R	<u>STATOR I^2R AT 100% LOAD</u>
(246)		<u>EDDY LOSS AT 100% LOAD</u>
(247)		<u>TOTAL LOSSES AT 100% LOAD</u>
(248)		<u>RATING IN WATTS AT 100% LOAD</u>
(249)		<u>KW RATING PLUS LOSSES</u>
(250)		<u>% LOSSES</u>
(251)		<u>EFFICIENCY</u>

(300) Q'_r

SLOTS PUNCHED - The total number of slots punched in the rotor. If the rotor is built with a solid pole center section Q'_r is the number of slot pitches on the rotor circumference.

(301) Q_r

SLOTS WOUND - The total number of slots that are wound.

(302) α

RATIO OF SLOTS WOUND TO SLOTS PUNCHED

$$\alpha = \frac{Q_r}{Q'_r} = \frac{(3c1)}{(3cc)}$$

(302a) N_{rc}

NO. OF SLOTS IN POLE CENTER

(303) -

SIZE SLOTS - The width of the rotor slot (b_r) and the depth of the rotor slot (h_r).

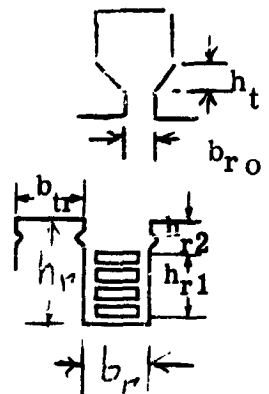

(304) τ_{rs}

TOOTH PITCH - The rotor slot pitch at the rotor diameter.

$$\tau_{rs} = \frac{\pi d_r}{Q'_r} = \frac{\pi (11\Delta)}{(3cc)}$$

(305) l_r

CORE LENGTH - The overall length of the rotor core.

(305a) l_{rs}

SOLID LENGTH OF ROTOR CORE

$$l_{rs} = K_1 l_r = (16)(305)$$

(306) n_r

CONDUCTORS PER SLOT - The number of rotor conductors per slot.

(307) X_p

POTIER REACTANCE - The reactance determined by the Potier triange.

$$X_p = X_{\lambda} + \left[\frac{F_R}{F_s + F_R} \right] X_{Fs} = (130) + \left[\frac{(104a)(307)}{(98a) + (104a)} \right]$$

$$X_{Fs} = \left[\frac{\lambda_{rs}}{\frac{2d}{p g_e} + \lambda_{rs}} \right] (X_d)$$
$$= \left[\frac{(312a)}{\frac{2(11)}{(6)(69)} + (312b)} \right] (133)$$

(308) K_T

CARTER'S COEFFICIENT ROTOR - The Carter coefficient for the rotor slots.

For open slots -

$$K_T = \frac{t_{rs} (5g + b_r)}{t_{rs} (5g + b_r) - b_r^2} = \frac{(304) \left[5(59) + (303) \right]}{304 \left[5(59) + (303) \right] - (303)^2}$$

For partially closed slots -

$$K_T = \frac{t_{rs} (4.44g + 0.75 b_{ro})}{t_{rs} (4.44g + 0.75 b_{ro}) - b_{ro}^2} = \frac{(304) \left[4.44 (59) + 0.75 (303) \right]}{(304) \left[4.44(59) + 0.75 (303) \right] - (303)^2}$$

(311) ϕ_{gp}

FLUX IN POLE CENTER - The portion of the total flux in each pole center.

$$\phi_{gp} = \left[\frac{Q'_r - Q_c + p}{Q'_r} \right] \frac{\phi_T}{p} =$$
$$\left[\frac{(300) - (301) + (6)}{(300)} \right] \frac{(88)}{(6)} \quad (88)$$

(312) ϕ_{L_s}

LEAKAGE FLUX - The rotor slot leakage flux in Kilolines in each pole center.

$$\phi_{L_s} = \frac{(F_g + F_s) \lambda_r \lambda_{rs}}{1000} =$$
$$\left[(96) + (98a) \right] (305) (312b) 10^{-3}$$

(312a) ϕ_{L_s}

SLOT LEAKAGE FLUX IN EACH POLE CENTER AT 100% LOAD

$$\phi_{L_s} = \phi_{L_s} \left\{ \frac{(e_d)(F_g) + [1 + \cos(\theta)](F_T) + (F_C)}{(F_g) + (F_T) + (F_C)} \right\}$$
$$= (212) \left\{ \frac{(198)(96) + [1 + \cos(198a)](97) + (98)}{(96) + (97) + (98)} \right\}$$

(312h) λ_{rs}

The rotor slot leakage permeance per inch of stator length.

For either open or semi-closed slots

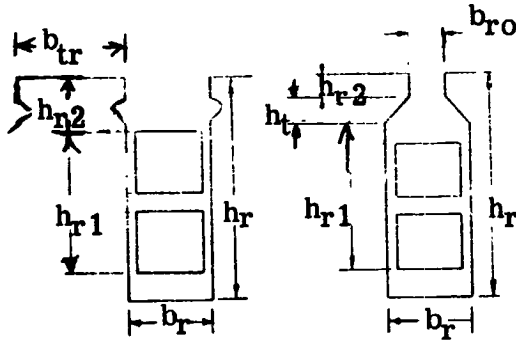

$$\lambda_{rs} = \frac{12.76P}{Q_r} \left[\frac{h_{r2}}{b_{ro}} + \frac{2h_t}{b_{ro} + b_r} + \right. \\ \left. + \frac{.35 (\tau_{rs} - b_{ro})}{\tau_{rs}} + \frac{g}{2\tau_{rs}} \right]$$

$$\lambda_{rs} = \frac{12.76(3)}{(301)} \left[\frac{(303)}{(303)} + \frac{2(303)}{(303) + (303)} + \right. \\ \left. + \frac{.35 [(304) - (303)]}{(304)} + \frac{(59)}{2(304)} \right]$$

(313) ϕ_{rc}

TOTAL FLUX IN THE POLE CENTER

$$\phi_{rc} = \phi_{gp} + \phi_{ls}$$

$$\phi_{rc} = (311) + (312)$$

(314) B_{pc}

CENTER SECTION DENSITY - The flux

density of the center section

of the rotor at a section half

way down the rotor tooth. @ No Load

$$B_{pc} = \frac{\Phi_{rc}}{b_p \mu_{rs}} = \frac{(313)}{(314)(305a)}$$

$$\text{where } b_p = \left[\frac{\overline{\mu}(d_r - h_r)}{p} \right] \left[\frac{Q'_r - Q_r - p}{Q_r} \right] - b_r \text{ (solid centers)}$$

$$b_p = \left[\frac{\overline{\mu}(11a) - (303)}{(6)} \right] \left[\frac{(300) - (301) - (6)}{(301)} \right] - (303)$$

$$b_p = \left[\frac{\overline{\mu}(d_r - h_r)}{p} \right] \left[\frac{Q'_r - Q_r - p}{Q'_r} \right] - (n_{rc} - 1)b_r \text{ (slotted centers)}$$

$$b_p = \left[\frac{\overline{\mu}(11a) - (303)}{(6)} \right] \left[\frac{(300) - (301) - (6)}{(301)} \right] - \left[(302a) - 1 \right] (303)$$

(314a)

d_s

INNER DIAMETER OF ROTOR PUNCHINGS, inches

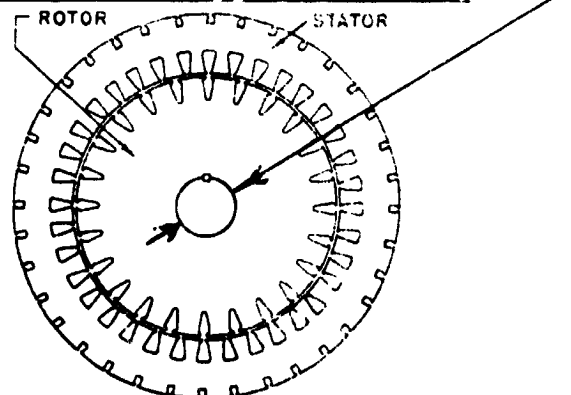

(314b) b_{rh}

HEIGHT OF VENTILATING HOLES IN ROTOR CORE AREA

(315) B_{rc}

CORE DENSITY - The flux density in the rotor core @ No Load

$$B_{rc} = \frac{\phi_{rc}}{2h_{rc}\mathcal{L}_{rs}} = \frac{(313)}{2(315)(305a)}$$

$$\text{where } 2h_{rc} = d_r - 2h_r - d_s - 2b_{rh}$$

$$= (11a) - 2(303) - (314a) - 2(314b)$$

(316) F_{PC}

AMPERE TURN DROP IN THE POLE CENTER AT NO LOAD

$$F_{PC} = h_r \left[\text{NI/in. @ } B_{PC} \right]$$

$$= (303) \left[\text{Look up rotor magnetization curve given in (18) at density (314).} \right]$$

(317)	F_{rc}	<u>AMPERE TURN DROP IN THE ROTOR CORE</u>
$F_{rc} = \frac{\pi (d_s + h_{rc})}{4p} \left[\text{NI/in. @ density } B_{rc} \right]$ $= \pi \left[\frac{(314a) + (315)}{4(6)} \right] \left[\text{Look up rotor punching magnetization curve given in (18) at density (315).} \right]$		
(318)	ϕ_{PCL}	<u>FLUX IN THE POLE CENTER AT FULL LOAD</u>
$\phi_{PCL} = \phi_{gp} + \phi_{ls} = (311) + (312a)$		
(319)	B_{PCL}	<u>DENSITY IN THE POLE CENTER AT FULL LOAD</u>
$B_{PCL} = \frac{\phi_{PCL}}{b_p l_{rs}} = \frac{(318)}{(314)(305a)}$		
(320)	F_{PCL}	<u>AMPERE TURN DROP IN POLE CENTER AT FULL LOAD</u>
$F_{PCL} = h_r \left[\text{NI/in. @ } B_{PCL} \right]$ $= (303) \left[\text{Look up rotor punching magnetization curve given in (18) at density (319).} \right]$		

(321) B_{rcL} THE FLUX DENSITY IN THE ROTOR CORE AT 100% LOAD

$$B_{rcL} = \frac{\phi_{PCL}}{2h_{rc} l_{rs}} = \frac{(318)}{2(315)(305a)}$$

(322) F_{rcL} AMPERE TURNS DROP PER POLE IN THE ROTOR CORE AT 100% LOAD

$$F_{rcL} = \frac{\tilde{\mu} (d_s - h_{rc})}{4P} \quad NI @ B_{rcL}$$

$$F_{rcL} = \tilde{\mu} \left[\frac{(314a) + (315)}{4(\mu)} \right] \quad \left[\begin{array}{l} \text{Look up rotor magnetization} \\ \text{curve given in (18) at density} \\ \text{(321).} \end{array} \right]$$

(330) h'_{rc} (330) = $h'_{rc} = \frac{d_r - 2h_r - d_s}{2} = \frac{(11a) - 2(303) - (314a)}{2}$

(331) C_F RATIO OF FIELD INTERLINKAGE WITH ITS OWN FLUX TO THE MAXIMUM INTERLINKAGE OF A CONCENTRATED FIELD WINDING

BASED ON A ROTOR WITH SOLID CENTER SECTION

$$C_F = 1 - \alpha + \frac{\alpha}{3K_r} = 1 - (302) + \frac{(302)}{3(308)}$$

BASED ON A ROTOR WITH SLOTTED CENTER SECTION

When the center is slotted instead of solid K_r is included in the effective gap and K_r becomes unity in the C_F equation.

$$C_F = 1 - \alpha - \frac{\alpha}{3} = 1 - \frac{2\alpha}{3} = 1 - \frac{2(302)}{3}$$

(332) λ_F

LEAKAGE PERMEANCE OF THE FIELD WINDING

$$\lambda_F = \lambda_{rs} + \lambda_{FE}$$
$$= (312b) + (333)$$

(333) λ_{FE}

LEAKAGE PERMEANCE OF THE ROTOR WINDING END EXTENSION

$$\lambda_{FE} = \frac{6.28}{l_r} \left[\frac{\phi_E L_E}{2n} \right] \quad \frac{6.28}{(305)} \left[\frac{Q_E L_E}{2n} \right]$$

$\frac{\phi_E L_E}{2n}$ is taken from the 50% pitch curve of Graph #1

INPUT AUXILIARY DATA SHEET

Auxiliary information taken from the design manuals to be used in conjunction with input sheets for convenience.

- A. All dimensions for lengths, widths, and diameters are to be given in inches.
- B. Resistivity inputs, Items (141) and (151) are to be given in micro-ohm-inches.

The following items along with an explanation of each are tabulated here for convenience. For complete explanation of each item number, refer to design manuals.

- | <u>Item No.</u> | <u>Explanation</u> |
|-----------------|--|
| (9) | Power factor to be given in per unit. For example for 90% P.F., insert <u>.90</u> . |
| (9a) | Adjustment Factor - For P.F. < .95 insert <u>1.0</u>
For P.F. > .95 insert <u>1.05</u> |
| (10) | Optional Load Point -- Where load data output is required at a point other than those given as standard on the input sheet. Example: For load data output at 155% load, insert <u>1.55</u> . |
| (14) | Number of radial ducts in stator. |
| (15) | Width of radial ducts used in Item (14). |
| (18) | Magnetization curve of material used to be submitted as defined in Item (18). |
| (19) | Watts/lb. to be taken from a core loss curve at the density given in Item (20) (Stator). |
| (20) | Density in kilolines/in ² . This value must correspond to density used to pick Item (19) usually use 77.4 KL/in ² . |
| (21) | Type of slot - For open slot Type A, insert <u>1.0</u> .
For partially open slot Type B with constant slot width, insert <u>2.0</u> .
For partially open slot Type C with constant tooth width, insert <u>3.0</u> .
For round slot Type D, insert <u>4.0</u> .
For additional information, refer to figure adjacent to input sheet which shows a picture of each slot. |
| (22) | For stator slot dimension - for dimensions that do not apply to the slot insert <u>0.0</u> .
Use Table below as guide for input. |

<u>Symbol</u>	<u>Item</u>	<u>Slot Type</u>			
		<u>1</u>	<u>2</u>	<u>3</u>	<u>4</u>
b ₀	(22)	0.0	*	*	*
b ₁	↓	0.0	0.0	*	0.0
b ₂		0.0	0.0	*	0.0
b ₃		0.0	0.0	*	0.0
b _s		*	*	∅	*
h ₀		0.0	*	*	*
h ₁		*	*	*	0.0
h ₂		*	0.0	0.0	0.0
h ₃		*	*	0.0	0.0
h _s		*	*	*	*
h _t		0.0	*	*	0.0
h _w		0.0	*	*	0.0

* = insert actual value.

$$\varnothing = b_s = \frac{b_1 + b_3}{2}$$

Item No. Explanation

(28) Type of winding - for wye connected winding insert 1.0.
for delta connected winding insert 0.0.

(29) Type of coil - for formed wound (rect. wire), insert 1.0.
for random wound (round wire) insert 0.0.

(30) Slots spanned - Example - for slot span of 1-10, insert 9.0.

(33) For round wire insert diameter. For rectangular wire insert wire width.

(34) Strands per conductor in depth only.

(34a) Total strands per conductor in depth and width.

(35) Diameter of coil head forming pin. Insert .25 for stator O.D. < 8 inches:
Insert .50 for stator O.D. > 8 in.



(37) Use vertical height of strand for round wire, insert 0.0.

(38) Distance between centerline of strands in depth.



(39) Stator strand thickness -- use narrowest dimension of the two dimensions given for a rectangular wire. For round wire insert 0.0.

(40) Stator slot skew in inches.

(42a) Phase left angle - for 60° phase belt, insert 60°.
for 120° phase belt, insert 120°.

(48) See explanation of items (71), (72), (73), (74) and (75). Same applies here.

(87) When no load saturation output data is required at various voltages, insert 1.0.
When no load saturation information is not required, insert 0.0.

(137) Damper bar thickness -- use damper bar slot height for rectangular bar. For round bar insert 0.0.

(138) Number of damper bars per pole.

(140) Damper bar pitch in inches.

(148) For round wire insert diameter. For rectangular wire insert wire width.

(149) For rectangular wire insert wire thickness. For round wire insert 0.0.

(187) Pole face loss factor. For rotor lamination thickness .028 in. or less, insert 1.17.
For rotor lamination thickness .029 in. to .063 in. insert 1.75.
For rotor lamination thickness .064 in. to .125 insert 3.5.
For solid rotor insert 7.0.

(71) } If the values of these constants are available, insert the actual number. If they are
(72) } not available, insert 0.0 and the computer will calculate the values and record them on
(73) } the output.
(74) }
(75) }

ROTATING COIL LUNDELL COMPUTER DESIGN - - - - - (INPUT)

MODEL _____ EWO _____ DESIGN NO(1) _____

	PARAMETERS	DESCRIPTION	UNIT	CONSTANTS
PARAMETERS	(2)	KVA GENERATOR KVA		FUND/MAX OF FLD FLUX (71) C_1
	(3)	E LINE VOLTS		WINDING CONSTANT (72) C_w
	(1)	E_{ph} PHASE VOLTS		POLE CONSTANT (73) C_p
	(5)	m PHASES		END EXTENSION ONE TURN (48) $L_{\bar{e}}$
	(5a)	f FREQUENCY		DEMAGNETIZATION FACTOR (74) C_m
	(6)	p POLES		CROSS MAGNETIZING FACTOR (75) C_q
	(7)	RPM RPM		POLE EMBRACE (77) α
	(8)	I_{ph} PHASE CURRENT		WIDTH OF POLE (NARROW END) (76) b_{p1}
	(9)	PF POWER FACTOR		WIDTH OF POLE (WIDE END) (76) b_{p2}
	(9a)	K_c ADJ. FACTOR		POLE THICKNESS (NARROW END) (76) $'p_1$
(10)	OPTIONAL LOAD POINT		POLE THICKNESS (WIDE END) (76) $'p_2$	
STATOR STACK	(11)	d STATOR I.D.		POLE LENGTH (76) ρ_p
	(12)	D STATOR O.D.		ROTOR DIAMETER (11a) d_r
	(13)	ρ GROSS CORE LENGTH		WEIGHT OF ROTOR IRON (157) (-)
	(14)	n_v NO. OF DUCTS		POLE FACE LOSS FACTOR (187) (K_1)
	(15)	b_v WIDTH OF DUCT		FLUX PLATE THICKNESS (78) (t_{fp})
	(16)	K_f STACKING FACTOR (STATOR)		FLUX PLATE DIAMETER (78) (d_{fp})
	(19)	k WATTS/LB.		SHAFT O.D.(FLUX CARRYING PORT.) (78) (d_s)
(20)	B DENSITY		SHAFT LENGTH(FLUX CARRYING PORT) (78) (l_{sh})	
STATOR SLOT	(21)	TYPE OF SLOT		PERM OF LEAKAGE PATH 1 (80) P_1
	(22)	b_0 SLOT OPENING		PERM OF LEAKAGE PATH 2 (81) P_2
	(22)	b_1 SLOT WIDTH TOF		PERM OF LEAKAGE PATH 3 (82) P_3
	(22)	b_2		PERM OF LEAKAGE PATH 4 (83) P_4
	(22)	b_3		PERM OF LEAKAGE PATH 5 (84) P_5
	(22)	b_s SLOT WIDTH		PERM OF LEAKAG. PATH 7 (86) P_7
	(22)	h_0		OUTSIDE DIAMETER OF FLD COIL (78) d_{oc}
	(22)	h_1		LENGTH OF FIELD COIL (76) ρ_{oc}
	(22)	h_2		NO. OF FIELD TURNS/COIL (146) N_f
	(22)	h_3		MEAN LENGTH OF FLD. TURN (147) ρ_f
	(22)	h_s SLOT DEPTH		FLD. COND. DIA. OR WIDTH (148) ρ_c
STATOR WINDING	(22)	h_t		FLD. COND. THICKNESS (149) ρ_{ct}
	(22)	h_w		FLD. TEMP IN °C (150) X_f °C
	(23)	Q NO. OF SLOTS		RESISTIVITY OF FIELD COND @ 20° (151) ρ_f
	(28)	TYPE OF WDG.		NO LOAD SAT. (87)
	(29)	TYPE OF COIL		FRICITION & WINDAGE (183) (F&W)
	(30)	n_s CONDUCTORS/SLOT		SPECIAL PERMEANCE (648) λ_z
	(31)	γ SLOTS SPANNED		STATOR LAM MATERIAL (18)
	(32)	c PARALLEL CIRCUITS		POLE MATERIAL (18)
	(33)	STRAND DIA. OR WIDTH		SHAFT MATERIAL (18)
	(34)	N_{st} STRANDS/CONDUCTOR IN DEPTH		
(34a)	N'_{st} STRANDS/CONDUCTOR			
(39)	STATOR STRAND T'KNS.			
(35)	d_b DIA. OF PIN			
(36)	ρ_{s2} COIL EXT. STR. PORT			
(37)	h_{st} UNINS. STRD. HT.			
(38)	N'_{st} DIST. BTWN. CL OF STD.			
(42a)	PHASE BELT ANGLE			
(40)	T_{sk} STATOR SLOT SKEW			
(50)	X °C STATOR TEMP °C			
(51)	ρ_s RES'TVY STA. COND. @ 70 °C			
GAP	(59)	g MAIN GAP		

ROTATING COIL LUNDELL

SUMMARY OF DESIGN CALCULATIONS - - - - - (OUTPUT)

	MODEL NO.	EWO	DESIGN NO.		
STATOR	(17) (l_a)			SOLID CORE LENGTH	CARTER COEFFICIENT (67) (K_g)
	(24) (h_c)			DEPTH: BELOW SLOT	EFFECTIVE AIR GAP (69) (g_g)
	(26) (T_p)			SLOT PITCH	FUND/MAX OF FLD FLUX (71) (C_1)
	(27) ($T_p^{1/3}$)			SLOT PITCH 1/3 DIST. UP	WINDING CONST. (72) (C_w)
	(42) (K_{sk})			SKEW FACTOR	POLE CONST. (73) (C_p)
	(43) (K_d)			DIST. FACTOR	END. EXT. ONE TURN (48) (L_E)
	(44) (K_p)			PITCH FACTOR	DEMAGNETIZING FACTOR (74) (C_M)
	(45) (η_c)			EFF. CONDUCTORS	CROSS MAGNETIZING FACTOR (75) (C_q)
	(46) (a_c)			COND. AREA	AMP COND/IN (128) (A)
	(47) (S_g)			CURRENT DENSITY (STA.)	REACTANCE FACTOR (129) (X)
(49) (l_t)			1/2 MEAN TURN LENGTH	LEAKAGE REACTANCE (130) (X_g)	
(53) (R_{ph})			COLD SEA. RES. @ 20° C	REACTANCES OF (131) (X_{ad})	
(54) (R_{ph})			HOT STA. RES. @ X° C	ARMATURE REACTION (132) (X_{aq})	
(55) (EF_{top})			EDDY FACTOR TOP	SYN REACT DIRECT AXIS (133) (X_d)	
(56) (EF_{bot})			EDDY FACTOR BOT	SYN REACT QUAD AXIS (134) (X_q)	
(62) (λ)			STATOR COND. PERM.	FIELD LEAKAGE REACT (160) (X'_f)	
(64) (λ_n)			END PERM.	FIELD SELF INDUCTANCE (161) (L_f)	
(65) (-)			WT. OF STA COPPER	L.SAT. TRANS. REACT (166) (X'_{dl})	
(66) (-)			WT. OF STA. IRON	SAT. TRANS. REACT (167) (X'_d)	
ROTOR	(41) (T_p)			POLE PITCH	NEG SEQUENCE REACT (170) (X_2)
	(157) (-)			WT. OF ROTOR IRON	ZERO SEQUENCE REACT (172) (X_0)
	(143) (V_r)			PERIPHERAL SPEED	OPEN CIR. TIME CONST. (176) (T_{do})
	(153) (a_{cl})			FLD COND. AREA	ARM TIME CONST. (177) (T_a)
FIELD	(154) (R_f)			COLD FLD RES. @ 20° C	TRANS. TIME CONST. (178) (T'_d)
	(155) (R_f)			HOT FLD RES. @ X° C	SUB TRAN TIME CONST. (179) (T''_d)
	(156) (-)			WT. OF FLD COPPER	TOTAL FLUX (88) (ϕ_T)
PERMEANCE	(80) (P_1)			PERM OF LEAKAGE PATH 1	FLUX PER POLE (92) (ϕ_p)
	(81) (P_2)			PERM OF LEAKAGE PATH 2	GAP DENSITY (MAIN) (95) (B_g)
	(82) (P_3)			PERM OF LEAKAGE PATH 3	TOOTH DENSITY (91) (B_T)
	(83) (P_4)			PERM OF LEAKAGE PATH 4	CORE DENSITY (94) (B_c)
	(84) (P_5)			PERM OF LEAKAGE PATH 5	TOOTH AMPERE TURNS (97) (F_t)
	(85) (P_7)			PERM OF LEAKAGE PATH 7	CORE AMPERE TURNS (98) (F_c)
	(180) (F_{sc})			SHORT CIR NI	GAP AMPERE TURNS (MAIN) (96) (F_g)
(181) (S_{CR})			SHORT AIR RATIO		

PERCENT LOAD	0	100	150	200	OPTIONAL
(ϕ_g) (100a) LEAKAGE FLUX		(ϕ_{gg}) (197a)			
(ϕ_{PT}) (102a) TOTAL FLUX/POLE		(ϕ_{PT}) (213a)			
(B_p) (103a) POLE DENSITY		(B_{pl}) (213b)			
(B_{sh}) (113) SHAFT DENSITY		(B_{shi}) (232)			
(F_{nl}) (127) TOTAL NI		(F_{nl}) (256)			
(I_{nl}) (127a) FIELD AMPERES		(I_{fn}) (237)			
(S_f) (127a) CUR. DEN. FLD.		(S_{fL}) (239)			
(E_{fnl}) (127b) FIELD VOLTS		(E_{fn}) (238)			
(W_c) (188) STA CORE LOSS		(W_c) (185)			
(W_{nl}) (184) STA TOOTH LOSS		(W_{nl}) (242)			
($2 R_a$) (194) STATOR CU LOSS		($2 R_L$) (245)			
(-) (196) EDDY LOSS		(-) (246)			
(W_{nl}) (184) POLE FACE LOSS		(W_{nl}) (243)			
($2 R_f$) (182) FIELD COIL LOSS		($2 R_f$) (241)			
(P_{AW}) (183) F&W LOSS		(P_{AW}) (183)			
(-) (196) TOTAL LOSSES		(-) (247)			
(-) (-) PERCENT EFF.		(-) (251)			

**ROTATING COIL LUNDELL
NO LOAD SATURATION OUTPUT SHEET**

ITEMS % VOLTS	(3) (E) VOLTS	(91) B_t STA. TOOTH DENSITY	(97) F_t STATOR TOOTH N.I.	(94) B_c STA. CORE DENSITY	(98) F_c STA. CORE N.I.	(96) F_g GAP N.I.
	(100a) ϕ_l LEAKAGE FLUX	(102a) ϕ_{pt} TOTAL FLUX/POLE	(103a) B_p POLE DENSITY	(104a) f_p POLE H.I.	(113) B_{sh} SHAFT DENSITY	(127) F_{nl} TOTAL N.I.
80%						
90%						
100%						
110%						
120%						
130%						
140%						
150%						
160%						

(a) Open Slots

(b) Constant Slot Width

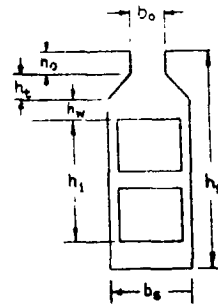
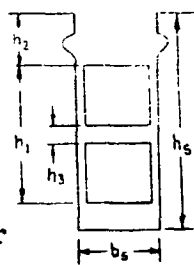

TYPE 1
(Type 5 is an open slot with 1 conductor per slot)

TYPE 2

(c) Constant Tooth Width

(d) Round Slots

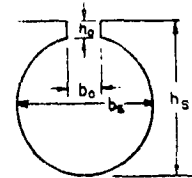
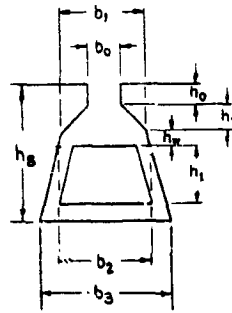

TYPE 3
 b_s for type 3 is

$$b_s = \frac{b_1 + b_3}{2}$$

TYPE 4

INSIDE-COIL ROTATING-COIL LUNDELL GENERATOR

(1)	--	DESIGN NUMBER
(2)	KVA	GENERATOR KVA
(3)	E	LINE VOLTS
(4)	E_{PH}	PHASE VOLTS
(5)	m	PHASES
(5a)	f	FREQUENCY
(6)	P	POLES
(7)	RPM	SPEED
(8)	I_{PH}	PHASE CURRENT
(9)	P. F.	POWER FACTOR
(9a)	K_c	ADJUSTMENT FACTOR
(10)	--	LOAD POINTS
(11)	d	STATOR PUNCHING I.D.
(11a)	d_r	ROTOR O.D.
(12)	D	PUNCHING O.D.
(13)	l	GROSS STATOR CORE LENGTH
(14)	n_v	RADIAL DUCTS
(15)	b_v	RADIAL DUCT WIDTH
(16)	K_i	STACKING FACTOR
(17)	l_s	SOLID CORE LENGTH

(18)

MATERIAL - This input is used in selecting the proper magnetization curves for stator,

yoke, pole, and shaft; when different materials are used. Separate spaces are provided on the input sheet for each section mentioned above. Where curves are available on card decks, used the proper identifying code. Where card decks are not available submit data in the following manner:

The magnetization curve must be available on semi-log paper. Typical curves are shown in this manual on Curves F-15 & 16. Draw straight line segments through the curve starting with zero density. Record the coordinates of the points where the straight line segments intersect. Submit these coordinates as input data for the magnetization curve. The maximum density point must be submitted first.

Refer to Figure below for complete sample

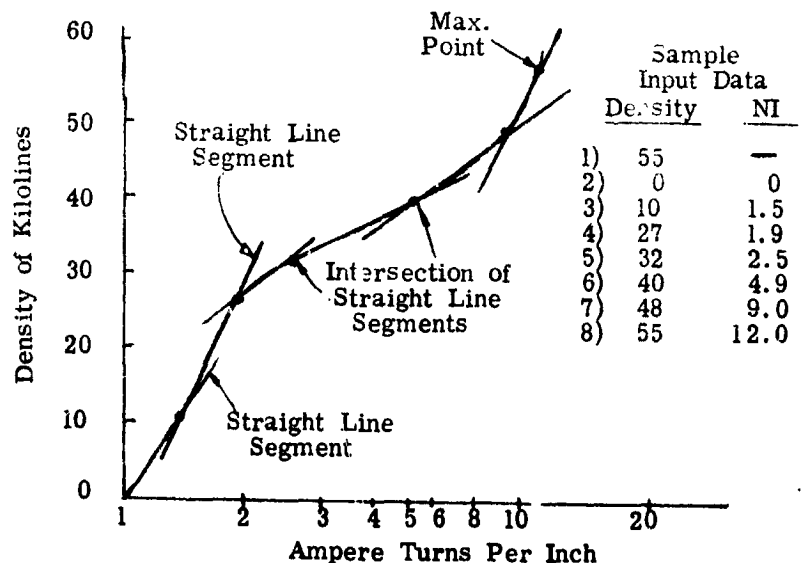

(19)	k	WATTS LB
(20)	B	DENSITY
(21)		TYPE OF STATOR SLOT
(22)		ALL SLOT DIMENSIONS
(23)	Q	STATOR SLOTS
(24)	h_c	DEPTH BELOW SLOTS
(25)	q	SLOTS PER POLE PER PHASE
(26)	τ_s	STATOR SLOT PITCH
(27)	$\tau_s^{1/3}$	STATOR SLOT PITCH
(28)	--	TYPE OF WINDING
(29)	--	TYPE OF COIL
(30)	n_s	CONDUCTORS PER SLOT
(31)	γ	THROW
(31a)		PER UNIT OF POLE PITCH SPANNED
(32)	C	PARALLEL PATHS
(33)	--	STRAND DIA. OR WIDTH
(34)	N_{ST}	NUMBER OF STRANDS PER CONDUCTOR IN DEPTH
(34a)	N'_{ST}	NUMBER OF STRANDS PER CONDUCTOR
(35)	d_b	DIAMETER OF BENDER PIN
(36)	ℓ_{e2}	COIL EXTENSION BEYOND CORE
(37)	h_{ST}	HEIGHT OF UNINSULATED STRAND
(38)	h'_{ST}	DISTANCE BETWEEN CENTERLINES OF STRANDS IN DEPTH

(39)	--	STATOR COIL STRAND THICKNESS
(40)	τ_{SK}	SKEW
(41)	τ_P	POLE PITCH
(42)	K_{SK}	SKEW FACTOR
(42a)		PHASE BELT ANGLE
(43)	K_d	DISTRIBUTION FACTOR
(44)	K_p	PITCH FACTOR
(45)	n_e	TOTAL EFFECTIVE CONDUCTORS
(46)	a_c	CONDUCTOR AREA OF STATOR WINDING
(47)	S_S	CURRENT DENSITY
(48)	L_E	END EXTENSION LENGTH
(49)	l_t	1/2 MEAN TURN
(50)	X_S °C	STATOR TEMP °C
(51)	ρ_s	RESISTIVITY OF STATOR WINDING
(52)	ρ_s (hot)	RESISTIVITY OF STATOR WINDING
(53)	R_{SPH} (cold)	STATOR RESISTANCE/PHASE
(54)	R_{SPH} (hot)	STATOR RESISTANCE/PHASE
(55)	EF (top)	EDDY FACTOR TOP
(56)	EF (bot)	EDDY FACTOR BOTTOM

(57)	b_{tm}	<u>STATOR TOOTH WIDTH</u>
(57a)	$b_{t \ 1/3}$	<u>STATOR TOOTH WIDTH</u>
(58)	b_t	<u>TOOTH WIDTH AT STATOR I.D. IN INCHES</u>
(59)	g	<u>MAIN AIR GAP IN INCHES</u>
(60)	C_X	<u>REDUCTION FACTOR</u>
(61)	K_X	<u>FACTOR TO ACCOUNT FOR DIFFERENCE</u> in phase current in coil sides in same slot.
(62)	λ_i	<u>CONDUCTOR PERMEANCE</u>
(63)	K_E	<u>LEAKAGE REACTIVE FACTOR</u>
(64)	λ_E	<u>END WINDING PERMEANCE</u>
(64a)	λ_z	<u>SPECIAL LEAKAGE PERMEANCE</u> - For machines having a section of the pole that is approximately a full pole pitch wide, an additional leakage permeance must be added to the slot and end-turn leakage permeances. This permeance is that of the leakage path from one pole into a tooth top and from tooth top back into the adjacent pole. The leakage is similar to Zig Zag leakage and by increasing the stator leakage re- actance, can reduce the output of the generator significantly. This same leakage can be used to

purposely limit the output of the generator and make it current limited. The presence of this additional leakage can be good or bad depending upon what is wanted from the generator. The important thing is for the designer to be aware that it is there.

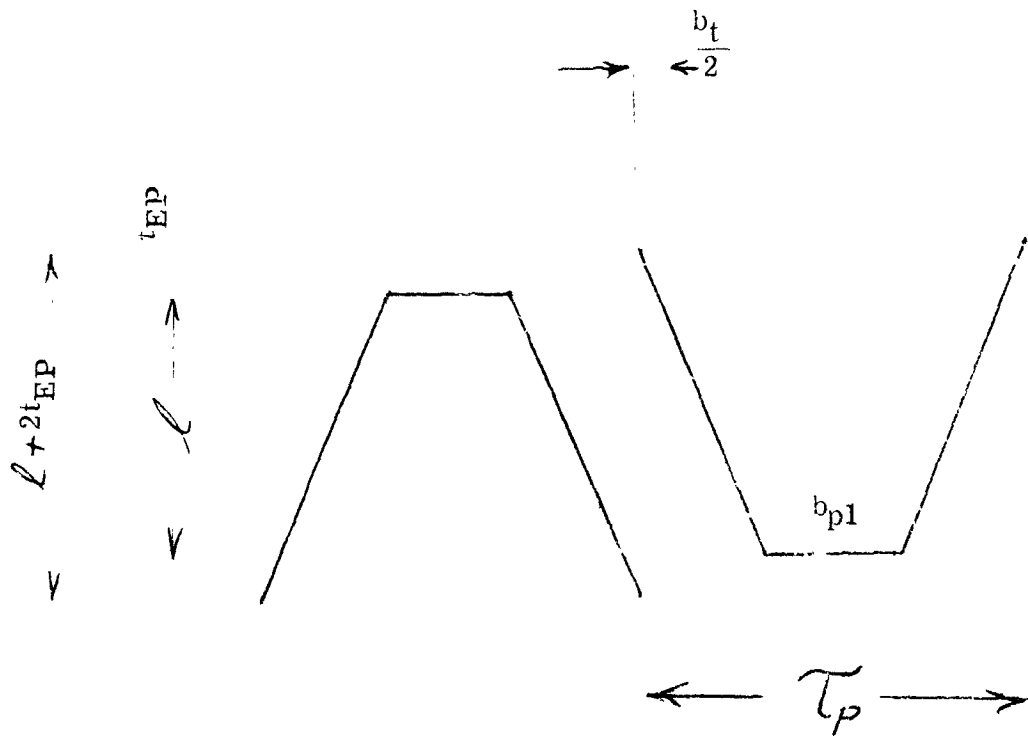

$$\lambda_z = (C_X) \frac{20}{(m)(q)} \frac{\text{area of pole over tooth when tooth is on cent. line between poles}}{2 l s_e}$$

$$\lambda_z = (C_X) \frac{20}{(m)(q)} \frac{b_t (\tau_p - b_{p1}) (l + 2 t_{EP}) \frac{(\tau_p - b_{p1})}{\tau_p}}{2 l s_e}$$

This calculation is not programmed and the value λ_z must be given as an input on the input sheet. If the pole embrace at the base of the pole is appreciably less than one, the input for λ_z is zero. If the pole embrace is near unity, the designer may be forced to estimate the value λ_z instead of using the calculation given above.

(65)	--	<u>WEIGHT OF COPPER</u>
(66)	--	<u>WEIGHT OF STATOR IRON</u>
(67)	K_s	<u>CARTER COEFFICIENT</u>
(68)	--	<u>MAIN AIR GAP AREA</u>
(69)	g_e	<u>EFFECTIVE AIR GAP</u>
(70c)	λ_a	<u>AIR GAP PERMEANCE</u>
(71)	C_1	<u>THE RATIO OF MAXIMUM FUNDAMENTAL</u> of the field form to the actual maximum of the field form

(72) C_W

WINDING CONSTANT

(73) C_P

POLE CONSTANT

(74) C_M

DEMAGNETIZING FACTOR

(75) C_q

CROSS MAGNETIZING FACTOR

(76) --

POLE DIMENSIONS -

b_{p2} = width of pole at edge of stator stack

b_{p1} = width of pole at end

t_{p2} = thickness of pole at edge of stator stack

t_{p1} = thickness of pole at end

l_{co} = length of coil

l_p = length of pole

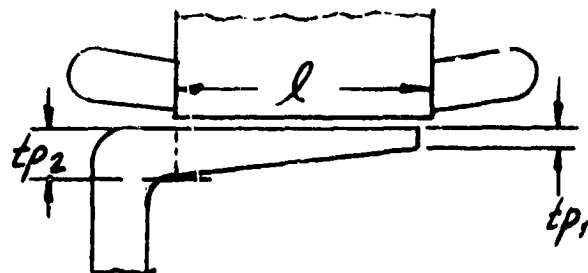
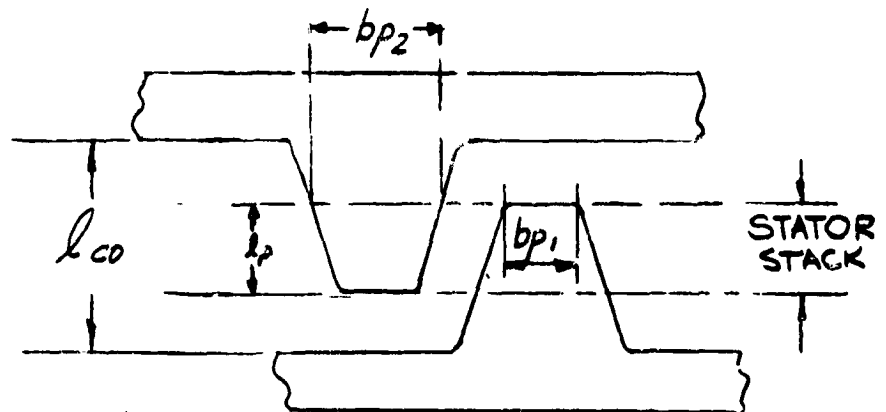

(77) α

POLE EMBRACE -

$$= \frac{(b_{p1}) + (b_{p2})}{2\gamma_p} = \frac{(76) + (76)}{2(41)}$$

(77a) --

Items immediately following deal with the calculation of rotor and stator leakage permeances.

Illustrations are included to help identify the permeance areas and to locate the flux leakage paths. The computer program will handle the calculation of permeances P_1 , P_2 , P_3 and P_4 either of two ways:

1. P_1 through P_4 can be calculated by the computer. For this case, insert 0.0 on the input sheet for P_1 through P_4 .
2. P_1 through P_4 can be calculated by the designer. For this case, insert the actual calculated value on the input sheet for P_1 through P_4 .

Permeance P_5 and P_7 must be calculated by the designer and the calculated value must be inserted on the input sheet. The computer will not calculate these two permeance values because of the various possible field coil locations.

(78) --

ROTOR, COIL AND SHAFT DIMENSIONS - These dimensions are inputs and are required in the calculations that follow:

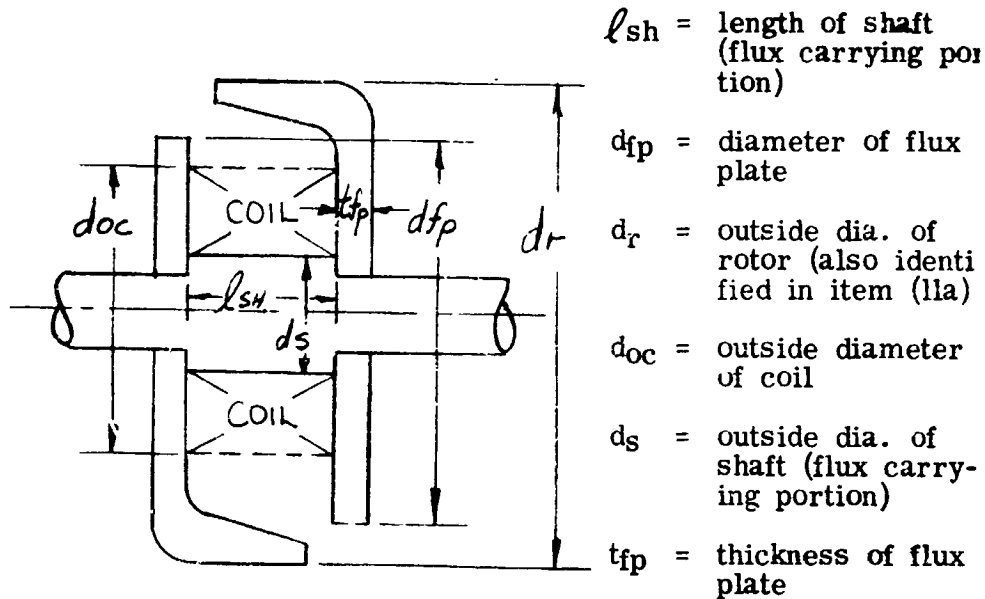

(79) a_p

POLE AREA - The effective cross-sectional area of the pole.

$$a_p = (b_{p2})(t_{p2}) = (76)(76)$$

(80) P_1

POLE HEAD END LEAKAGE - This input can be either 0.0 or the actual value if available. Refer to Item (77a) for explanation. See Figure J-4 for location.

$$P_1 = \frac{6.28(b_{p1})}{\pi} \ln \frac{r_1}{r_2} = \frac{6.28(76)}{\pi} \ln \frac{(80b)}{(80a)}$$

P₁ POLE HEAD LEAKAGE

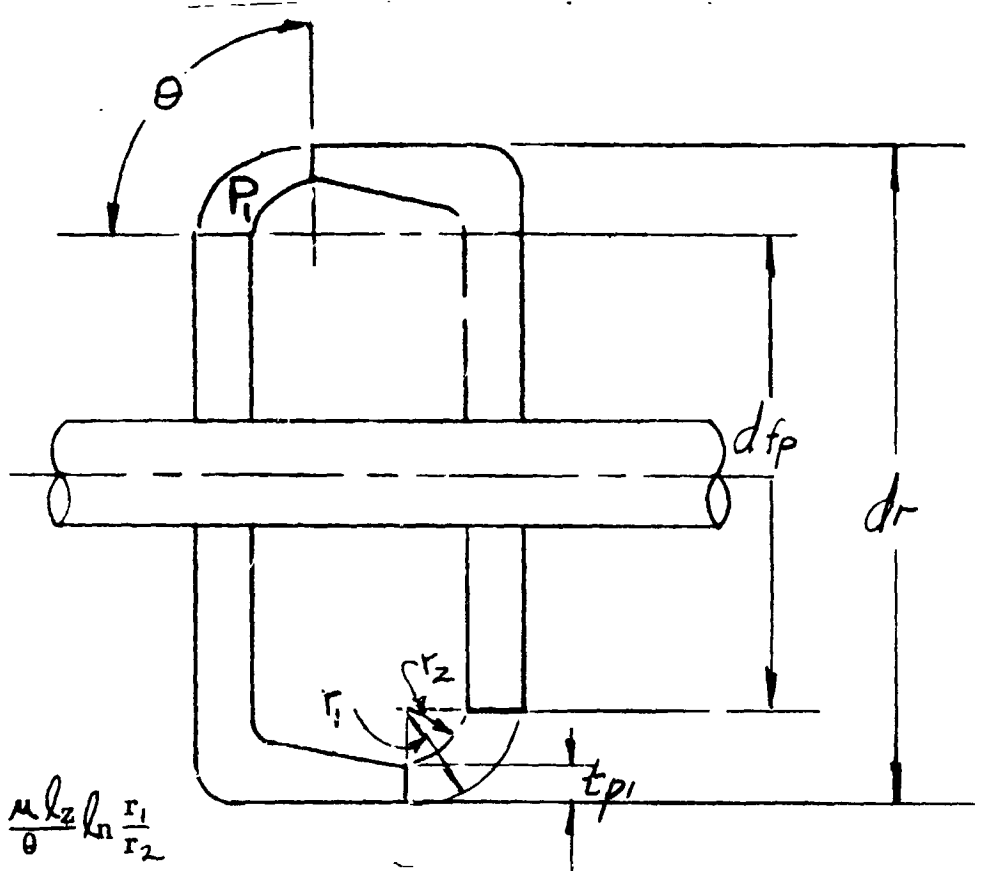

$$P = \frac{\mu h_z l_n}{\theta} \ln \frac{r_1}{r_2}$$

$$r_2 = \frac{d_r - d_{fp}}{2}$$

$$r_1 = r_2 + t_{p1}$$

$$P_1 = 2 \frac{(3.19) b_{p1}}{\pi} \ln \frac{r_1}{r_2}$$

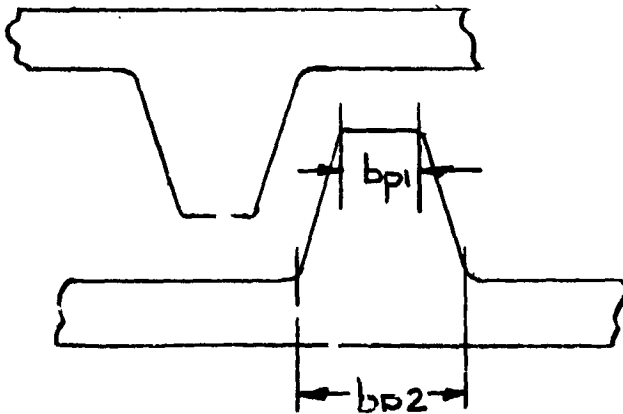

Fig. J-4

$$(80a) \quad r_2 = \frac{(d_r) - (d_{fp})}{2} = \frac{(11a) - (78)}{2}$$

$$(80b) \quad r_1 = (r_2) + (t_{p1}) = (80a) + (76)$$

(81) P_2 POLE HEAD SIDE LEAKAGE - This input can be either 0.0 or the actual value if available. Refer to Item (77a) for explanation. See Figure J-5 for location.

$$P_2 = \frac{3.19 \left\{ \mu_p \left[\frac{(t_{p2}) + (t_{p1})}{2} \right] \right\}}{\ell_2} = \frac{3.19 \left\{ (76) \left[\frac{(76) + (76)}{2} \right] \right\}}{(81a)}$$

(81a) ℓ_2 LENGTH OF PERMEANCE PATH 2

$$\ell_2 = \tau_p - \left[\frac{(b_{p1}) + (b_{p2})}{2} \right] = (41) - \left[\frac{(76) + (76)}{2} \right]$$

(82) P_3 POLE BODY END LEAKAGE - This input can be either 0.0 or the actual value if available. Refer to Item (77a) for explanation. See Figure J-6 for location.

$$P_3 = \frac{6.28 \left\{ \frac{3(b_{p1}) + (b_{p2})}{4} \right\}}{\pi} \ln \frac{(r_3)}{(r_4)} = \frac{6.28 \left\{ \frac{3(76) + (76)}{4} \right\}}{\pi} \ln \frac{(82a)}{(82b)}$$

$$(82a) \quad -- \quad r_3 = (r_4) + \frac{\ell_p}{2} = (80b) + \frac{(76)}{2}$$

$$(82b) \quad -- \quad r_4 = (r_1) = (80b)$$

P₂ POLE HEAD SIDE LEAKAGE

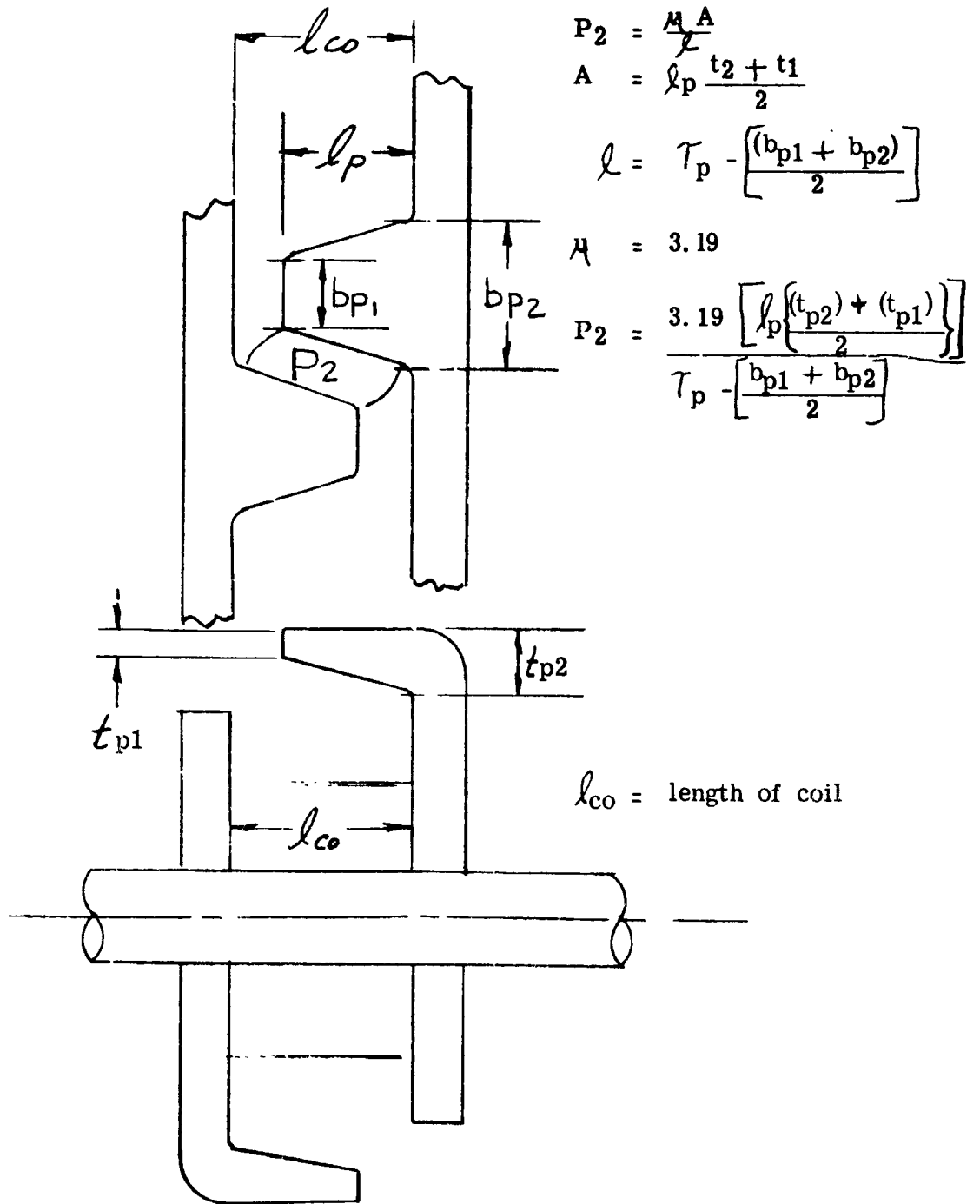

Fig. J-5

P_3 POLE BODY END LEAKAGE

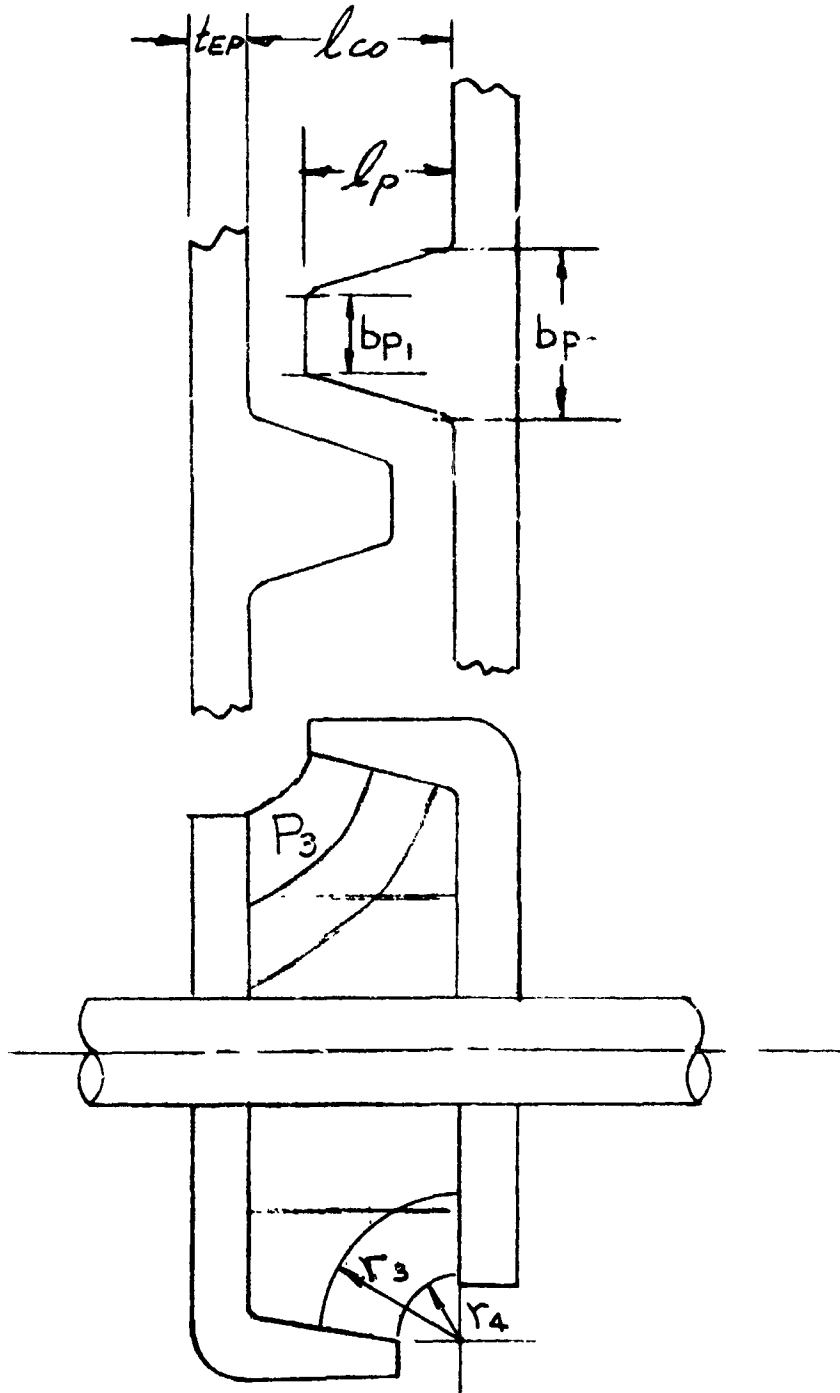

Fig. J-6

(83) P₄

POLE BODY SIDE LEAKAGE - This input can be either 0.0 or the actual value if available. Refer to Item (77a) for explanation. See Figure J-7, J-8 for location.

When (6) > 4

$$P_4 = \frac{3.19(l_p)}{\pi} \ell_n \left[1 + \frac{(b_{p1}) + (b_{p2})}{2 (\bar{Z})} \right]$$
$$= \frac{3.19(76)}{\pi} \ell_n \left[1 + \frac{(76) + (76)}{2 (83)} \right]$$

$$\text{Where } (\bar{Z}) = \tau_p - \left[\frac{(b_{p1}) + (b_{p2})}{2} \right] = (41) - \left[\frac{(76) + (76)}{2} \right]$$

When (6) < 4

$$P_4 = \frac{3.19(l_p)}{\pi} \frac{3}{2} \ell_n \left[1 + \frac{(b_{p1}) + (b_{p2})}{2 (\bar{Z})} \right]$$
$$= \frac{3.19(76)}{\pi} \frac{3}{2} \ell_n \left[1 + \frac{(76) + (76)}{2 (83)} \right]$$

(84) P₅

FIELD COIL LEAKAGE PERMEANCE, ROTOR - This input can be either 0.0 or the actual value if available. Refer to Item (77a) for explanation. See Figure J-9 for location.

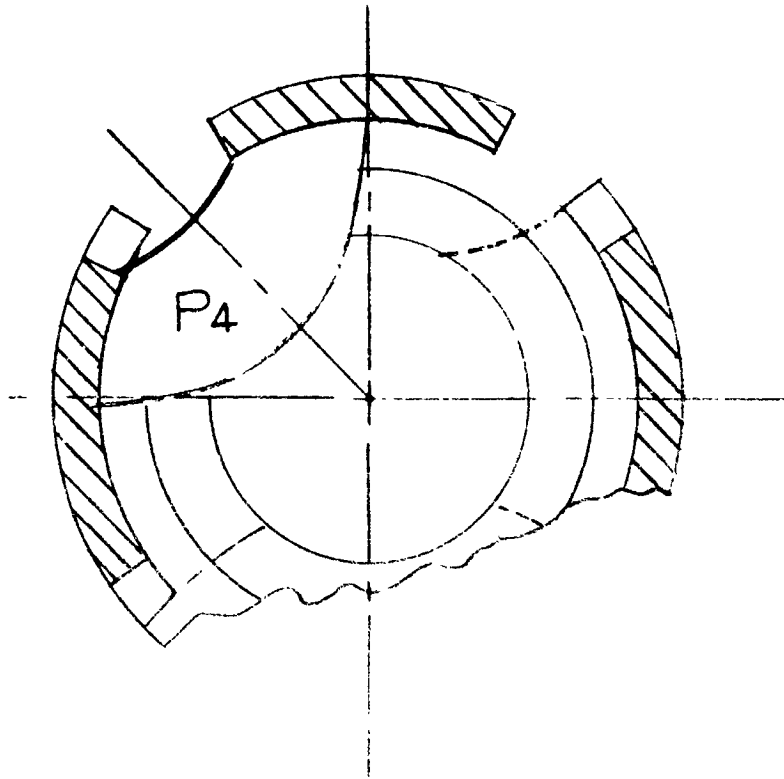

P_4 IN A FOUR-POLE MACHINE

Fig. J-7

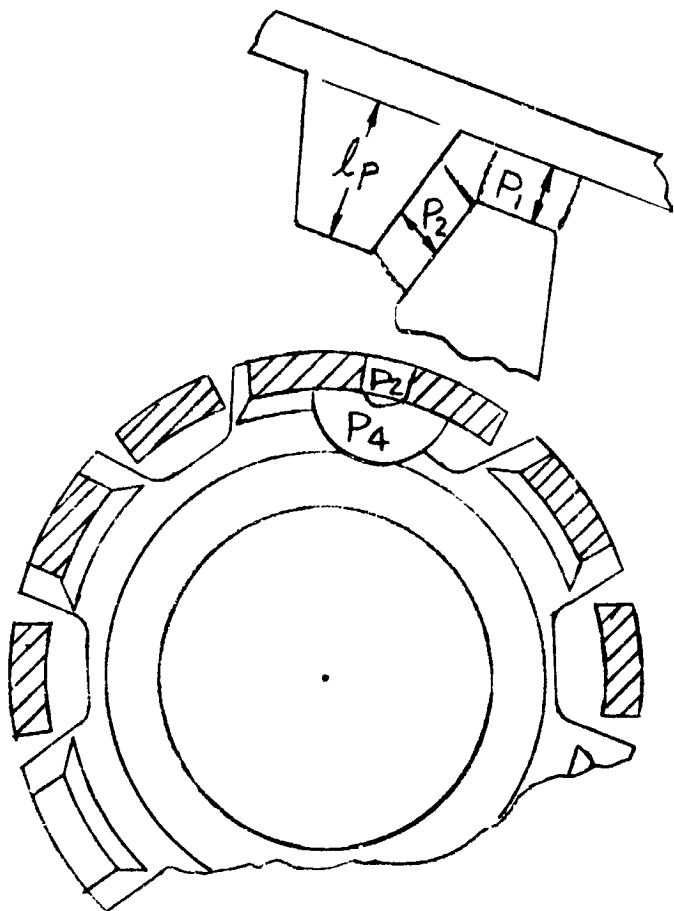

Fig. J-8

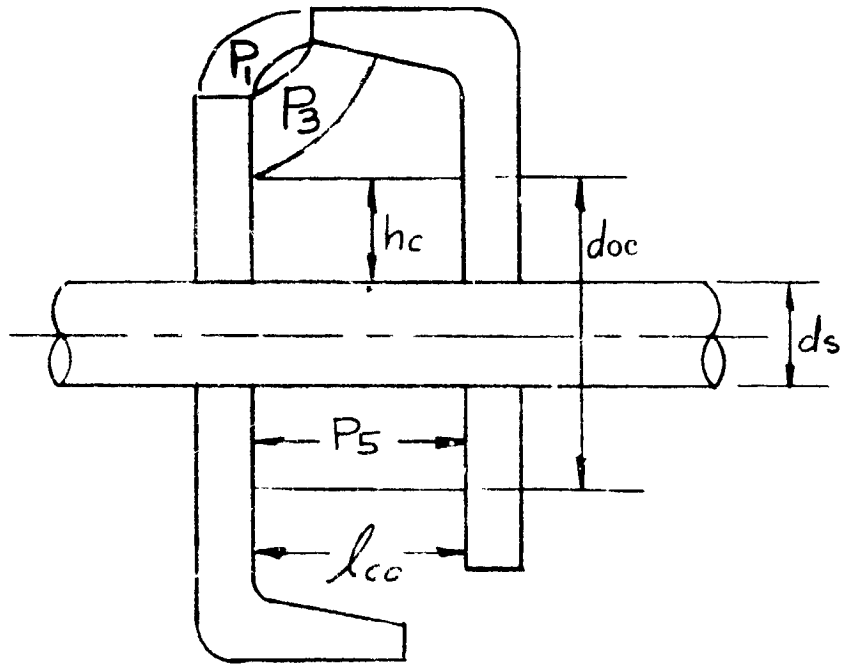

Fig. J-9

$$\begin{aligned}
 P_5 &= \frac{3.19 \pi}{(\ell_{co})} \left[\frac{(d_{co})^2}{4} - \frac{(d_s)^2}{4} \right] \frac{2}{3} \\
 &= \frac{3.19 \pi}{(76)} \left[\frac{(78)^2}{4} - \frac{(78)^2}{4} \right] \frac{2}{3}
 \end{aligned}$$

(86) P7

STATOR TO COIL YOKE LEAKAGE - This input can be either 0.0 or the actual value if available. Refer to Item (77a) for explanation. See Figure J-10 for location.

$$\begin{aligned}
 P_7 &= \frac{2.5(D + d_{fp})(D-d)}{D-d_{fp}} \\
 &= \frac{2.5 [(12) + (78)] [(12)-(11)]}{(12)-(78)}
 \end{aligned}$$

(87)

Equations immediately following, deal with the saturation at no-load. When no-load saturation data is desired for different voltages, insert 1. on the input sheet for "no-load saturation". The computer will then calculate no-load saturation points at 80, 90, 100, 110, 120, 130, 140, 150, and 160% of rated volts. If only the saturation data at 100% load is needed, insert 0. on the input sheet.

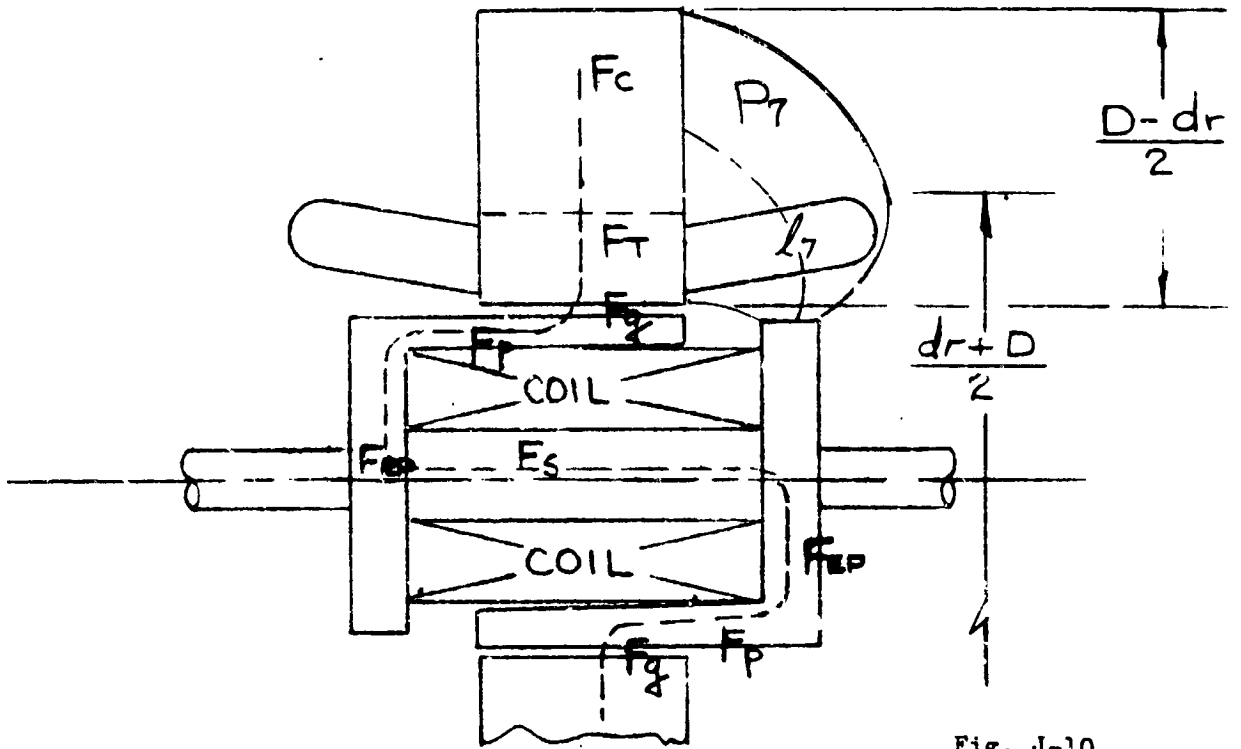

Fig. J-10

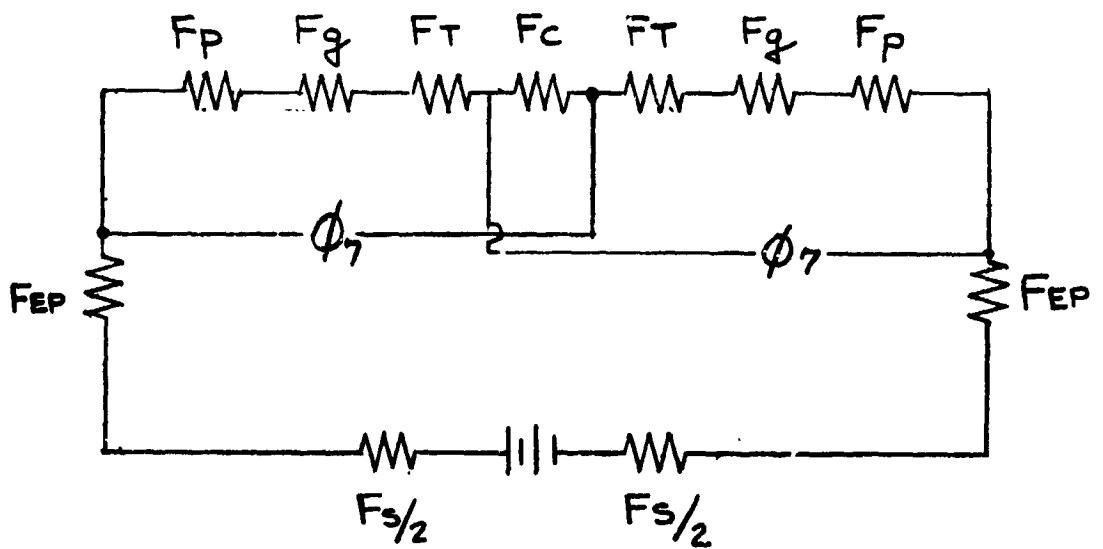
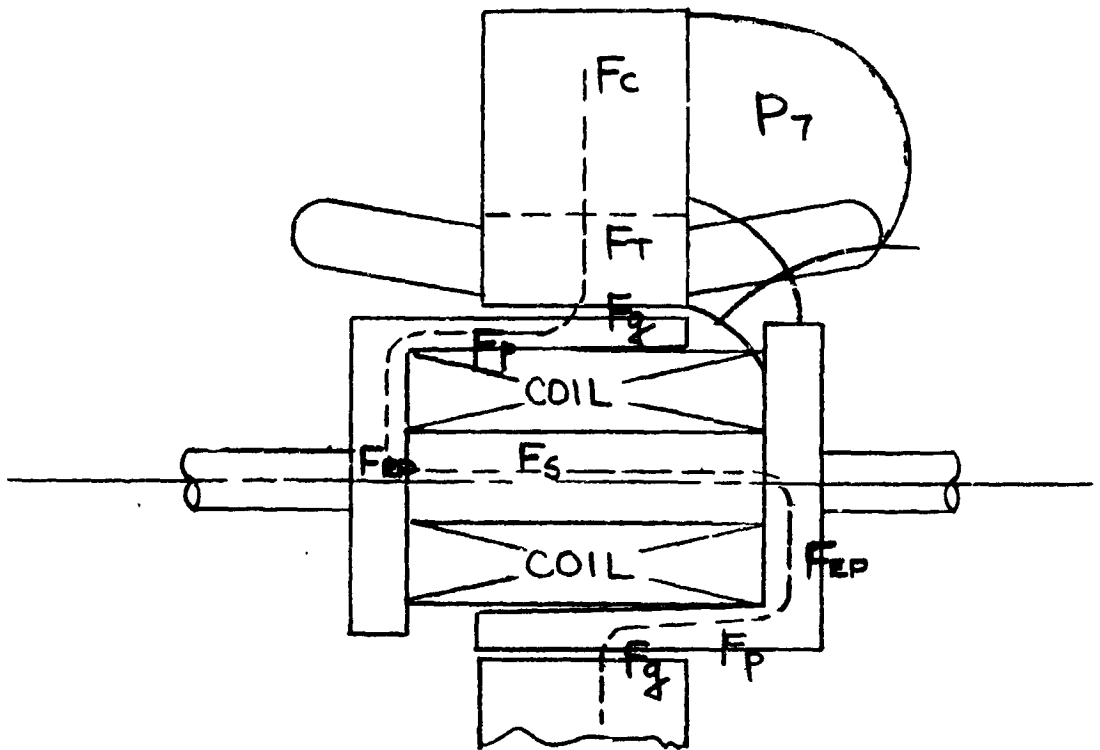

Fig. J-11

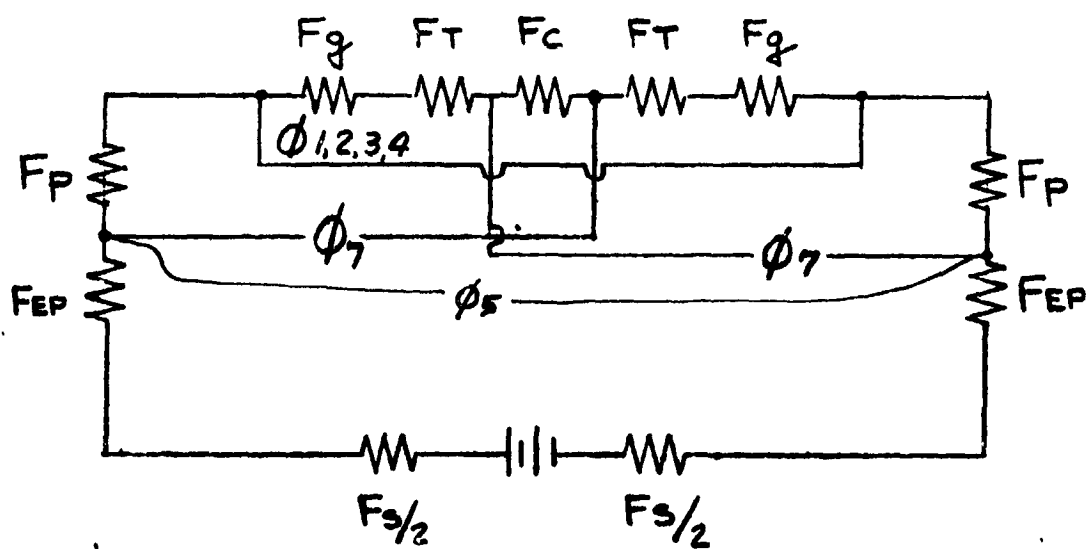
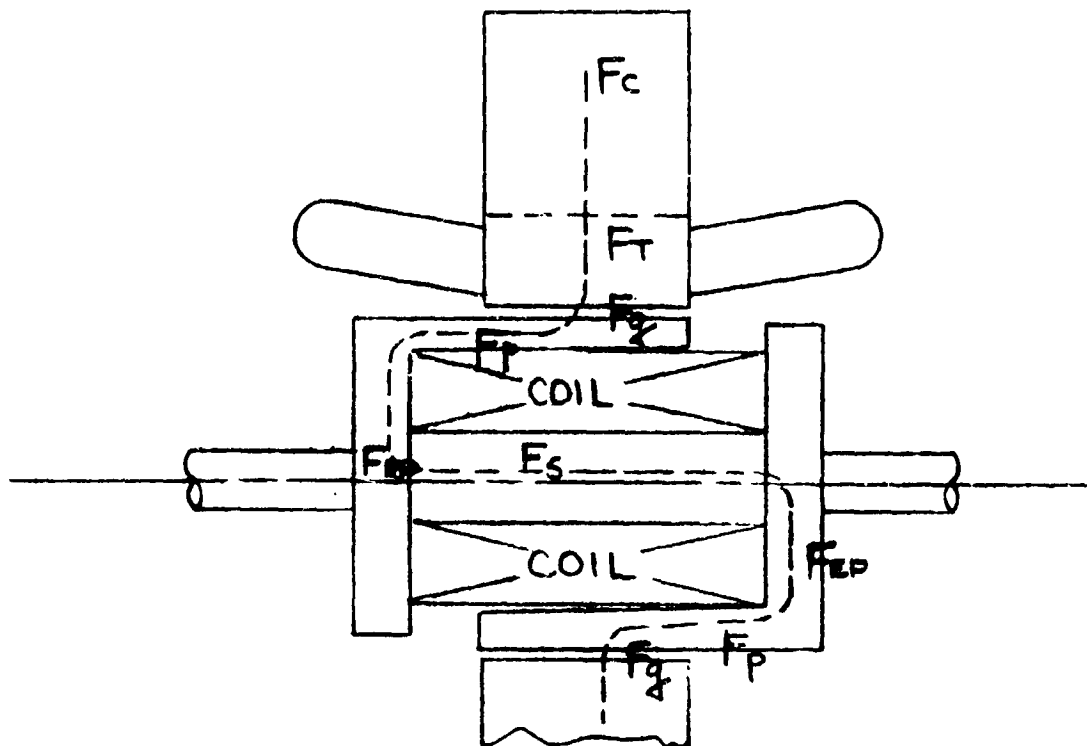

Fig. J-12

(88)	ϕ_T	<u>TOTAL FLUX</u> in Kilolines
(91)	B_t	<u>TOOTH DENSITY</u> in Kilolines/in ²
(92)	ϕ_P	<u>FLUX PER POLE</u> in Kilolines
(94)	B_c	<u>CORE DENSITY</u> in Kilolines/in ²
(95)	B_g	<u>GAP DENSITY</u> in Kilolines/in ²
(96)	F_g	<u>AIR GAP AMPERE TURNS</u>
(97)	F_T	<u>STATOR TOOTH AMPERE TURNS</u>
(98)	F_c	<u>STATOR CORE AMPERE TURNS</u>
(98a)	F_s	<u>STATOR AMPERE TURNS, total</u>
(99)	ϕ_7	<u>LEAKAGE FLUX FROM THE STATOR TO THE FLUX PLATE AT THE END OF THE ROTOR</u> - The same flux leaks from the rotor to the stator on one side & leaks out from the stator to the rotor on the other side. This flux does not pass through the air gap but does pass through the rotor shaft and flux plates.

$$\begin{aligned}\phi_7 &= (P_7) \left[(F_P) + (F_g) + (F_T) + (F_c) \right] \times 10^{-3} \\ &= (86) \left[(104a) + (96) + (97) + (98) \right] \times 10^{-3}\end{aligned}$$

(100a) ϕ_l

LEAKAGE FLUX - at no load

$$\begin{aligned}\phi_l &= (P_e) [2(F_g) + 2F_T + F_c] \times 10^{-3} \\ &= (160a) [2(96) + 2(97) + (98)] \times 10^{-3}\end{aligned}$$

(102a) ϕ_{PT}

TOTAL FLUX PER POLE - at no load

$$\phi_{PT} = \phi_p + \frac{2(\phi_l)}{(P)} (92) + \frac{2(100a)}{(6)}$$

(103a) B_p

POLE DENSITY - The apparent flux density at the base of the pole.

$$B_p = \frac{(\phi_{PT})}{(ap)} = \frac{(102a)}{(79)}$$

(104a) F_p

POLE AMPERE TURNS - at no load. The ampere turns per pole required to force the flux through the pole and flux plate at no load rated voltage. In general the flux plate density is kept fairly low and its ampere turns can be neglected. The no load pole ampere turns per pole are calculated as the product of (ℓ_p) times the NI per inch at the density (B_p). Use magnetization curve submitted per Item (18) for rotor.

$$\begin{aligned}F_p &= (\ell_p) [NI/in @ density (B_p)] \\ &= (76) [Look up on rotor magnetization curve \\ &\quad \text{given in (18) @ density (103a)}]\end{aligned}$$

(111) ϕ_{SH}

FLUX IN SHAFT AND END PLATES - at no load.

$$\begin{aligned}\phi_{SH} &= (\phi_{PT}) \frac{(P)}{2} + \phi_7 + \phi_5 \\ &= (102a) \frac{(6)}{2} + (99) + (118)\end{aligned}$$

NOTE: No provision is made for calculating the density in the end flux plates. Make the plates thick enough that the periphery of the pole at its base times the thickness of the plate is equal to the cross-sectional area of the pole at its junction with the plate.

(113) B_{SH}

FLUX DENSITY OF SHAFT - at no load.

$$B_{SH} = \frac{(\phi_{SH})}{(a_s)} = \frac{(111)}{(113)}$$

$$\text{Where } a_s = \frac{\pi(d_s)^2}{4} = \frac{\pi(78)^2}{4}$$

(114) F_{SH}

AMPERE TURNS DROP IN SHAFT AT B_s

$$\begin{aligned}F_{SH} &= \ell_{SH} \left[\text{NI/in @ density } (B_{SH}) \right] \\ &= (78) \left[\text{Look up on shaft magnetization curve} \right. \\ &\quad \left. \text{given in (18) at density (113)} \right]\end{aligned}$$

(118) ϕ_5

LEAKAGE FLUX ACROSS COIL AT NO LOAD (Kilolines)

$$\begin{aligned}\phi_5 &= P_5 \left[2(F_g) + 2(F_T) + (F_C) + 2(F_p) \right] \times 10^{-3} \\ &= (84) \left[2(96) + 2(97) + (98) + 2(104a) \right] \times 10^{-3}\end{aligned}$$

(127)	F _{NL}	<u>TOTAL AMPERE TURNS</u> - at no load. The total ampere turns per pole required to produce rated voltage at no load. $F_{NL} = [2(F_g)+2(F_S)+2(F_P)+(F_{SH})] = [(96)+(98a)+(104a)+(114$
(127a)	I _{FNL}	<u>NO LOAD FIELD CURRENT</u> $I_{FNL} = \frac{F_{NL}}{N_F} = \frac{(127)}{(146)}$
(127b)	E _{FNL}	<u>NO LOAD FIELD VOLTS PER COIL</u> $E_{FNL} = (I_{FNL}) (R_{F(cold)})$ $= (127a)(154)$
(127c)	S _F	<u>CURRENT DENSITY IN FIELD CONDUCTOR</u> - At no load
(128)	A	<u>AMPERE CONDUCTORS</u> per inch
(129)	X	<u>REACTANCE FACTOR</u>
(130)	X _ℓ	<u>LEAKAGE REACTANCE</u> of the stator

$$X_{\ell} = (X) [(\lambda_i) + (\lambda_e) + (\lambda_z)]$$

$$= (129) [(62) + (64) + (64a)]$$

λ_z is explained under item (64a) and should be zero in most designs.

(131)	X_{ad}	<u>REACTANCE</u> - direct axis
(132)	X_{aq}	<u>REACTANCE</u> - quadrature axis
(133)	X_d	<u>SYNCHRONOUS REACTANCE</u>
(134)	X_q	<u>SYNCHRONOUS REACTANCE</u> - quadrature axis
(145)	V_r	<u>PERIPHERAL SPEED</u>
(146)	N_F	<u>NUMBER OF FIELD TURNS</u>
(147)	l_{tF}	<u>MEAN LENGTH OF FIELD TURN</u>

(148) -- FIELD CONDUCTOR DIA OR WIDTH in inches

(149) -- FIELD CONDUCTOR THICKNESS in inches - Set this item = 0.
for round conductor.

(150) X_f °C FIELD TEMP IN °C

(151) ρ_f RESISTIVITY of field conductor @ 20°C in micro ohm-inches.

(152) ρ_f
(hot) RESISTIVITY of field conductor at X_f °C

(153) a_{cf} CONDUCTOR AREA OF FIELD WINDING

(154) R_f
(cold) COLD FIELD RESISTANCE @ 20°C

$$R_f \text{ (cold)} = (\rho_f) \frac{(N_f) (\ell_{tf}) \times 10^{-6}}{(a_{cf})} = (151) \frac{(146)(147) \times 10^{-6}}{(153)}$$

(155) R_f
(hot) HOT FIELD RESISTANCE - Calculated at X_f °C (103)

$$R_f \text{ (hot)} = (\rho_f \text{ hot}) \frac{(N_f) (\ell_{tf}) \times 10^{-6}}{(a_{cf})} = (152) \frac{(146)(147) \times 10^{-6}}{(153)}$$

(156) -- WEIGHT OF FIELD COIL in lbs.

$$\# \text{'s of copper} = .321(N_f)(\ell_{tf})(a_{cf})$$

$$= .321(146) (147)(153)$$

Also refer to note given in item (65).

(157) -- WEIGHT OF ROTOR IRON

(160) X_F FIELD LEAKAGE REACTANCE

(160a) P_e

ROTOR LEAKAGE PERMEANCE

$$P_e = P [P_1 + P_2 + P_3 + P_4]$$
$$= (6) [(80) + (81) + (82) + (83)]$$

(161) L_f

FIELD SELF INDUCTANCE

$$L_f = (N_f)^2 (\ell) (p) \left[C_p (\lambda_a) \frac{\ell}{2} + (\lambda_f) \right] \times 10^{-8}$$
$$= (99)^2 (13) (6) \left[(73)(70c) \frac{\ell}{2} + (161f) \right] \times 10^{-8}$$

(161f) λ_F

ROTOR LEAKAGE PERMEANCE per inch of stator stack

$$\lambda_F = \frac{P_e}{(\ell)(p)} = \frac{(160a)}{(13)(6)}$$

(166) X'_{du}

UNSATURATED TRANSIENT REACTANCE

(167) X'_d

SATURATED TRANSIENT REACTANCE

(168) X''_d

SUBTRANSIENT REACTANCE in direct axis

$$X''_d = (X'_d) = (167)$$

(169) X''_q

SUBTRANSIENT REACTANCE in quadrature axis

$$X''_q = (X_q) = (134)$$

(170) X_2

NEGATIVE SEQUENCE REACTANCE

(172) X_0

ZERO SEQUENCE REACTANCE

(173) K_{x0}

(175) λ_{Bo}

$$\lambda_{Bo} = \frac{(K_{x0})}{(K_p)^2} [.07(\lambda_a)] = \frac{(173)}{(44)^2} [.07(70c)]$$

(176)	T'_{do}	<u>OPEN CIRCUIT TIME CONSTANT</u>
(177)	T_a	<u>ARMATURE TIME CONSTANT</u>
(178)	T'_d	<u>TRANSIENT TIME CONSTANT</u>
(179)	T''_d	<u>SUBTRANSIENT TIME CONSTANT</u>
(180)	F_{SC}	<u>SHORT CIRCUIT AMPERE TURNS</u> = $(X_d) 2(F_g) = (133) 2 (96)$
(181)	SCR	<u>SHORT CIRCUIT RATIO</u>
(182)	$I^2 R_F$	<u>FIELD $I^2 R$</u>
(183)	F&W	<u>FRICTION & WINDAGE LOSS</u>
(184)	W_{TNL}	<u>STATOR TEETH LOSS</u>
(185)	W_c	<u>STATOR CORE LOSS</u>
(186)	W_{NPL}	<u>POLE FACE LOSS</u>
(187)	K_1	
(188)	K_2	
(189)	K_3	
(190)	K_4	
(191)	K_5	
(192)	K_6	

(194)	I^2R	<u>STATOR I^2R</u> - at no load.
(195)	--	<u>EDDY LOSS</u> - at no load.
(196)	--	<u>TOTAL LOSSES</u> - at no load. Sum of all losses. Total losses = (Field I^2R) + (F&W) + (Stator Teeth Loss) + (Stator Core Loss) + (Pole Face Loss) = (182) + (183) + (184) + (185) + (186)
(196a)	ϕ_{pl}	<u>LEAKAGE FLUX PER POLE</u> at 100% load
(198)	e_d	
(193a)	θ	
(207)	ϕ_{7L}	<u>STATOR TO ROTOR FLUX LEAKAGE</u> at full load. $\phi_{7L} = (P_7) \left[(e_d)(F_g) + (F_{PL}) + \right. \\ \left. (F_T) \left[1 + (\cos \theta) \right] + (F_C) \right] \times 10^{-3}$ $= (86) \left[(198)(96) + (213c) + \right. \\ \left. (97) \left[1 + (9) \right] + (98) \right] \times 10^{-3}$
(213)	ϕ_{pL}	<u>FLUX PER POLE</u> at 100% load
(213a)	ϕ_{pTL}	<u>TOTAL FLUX PER POLE</u> at 100% load $\phi_{pTL} = \phi_{pL} + \frac{2(\phi_{7L})}{(P)} = (213) + \frac{2(196a)}{(8)}$
(213b)	B_{pL}	<u>FLUX DENSITY AT BASE OF POLE</u> at 100% load

(213c)	F_{PL}	<u>AMPERE TURNS PER POLE at 100% load</u>
		$F_{PL} = \ell_p \left[\text{NI/in @ density } (B_{PL}) \right]$ $= (76) \left[\text{Look up ampere turns/inch on rotor magnetization curve given in (18) at density (213b)} \right]$
(226)	ϕ_{5L}	<u>LEAKAGE FLUX ACROSS COIL AT FULL LOAD (Kilolines)</u>
		$\phi_{5L} = P_5 \left[2e_d F_g + 2F_{PL} + 2F_T (1 + \cos \theta) + F_c \right] 10^{-3}$ $= (84) \left[2(198)(96) + 2(213c) + 2(97) (1 + (9)) + (98) \right] \times 10^{-3}$
(231a)	ϕ_{SHL}	$= \phi_{PTL} \frac{(P)}{2} + (\phi_{7L}) + (\phi_{5L}) = (213a) \frac{(6)}{2} + (207) + (226)$
(232)	B_{SHL}	<u>SHAFT FLUX DENSITY at full load.</u>
		$B_{SL} = \frac{(\phi_{SHL})}{(a_s)} = \frac{(231a)}{(113)}$
(233)	F_{SHL}	<u>AMPERE TURN DROP IN SHAFT at full load</u>
		$F_{SHL} = \ell_{SH} \left[\text{NI/in on shaft magnetization curve at density } (B_{SHL}) \right]$ $= (78) \left[\text{Look up on shaft magnetization curve given in (18) at density (232)} \right]$

(236)	F_{FL}	<p><u>TOTAL AMPERE TURNS PER POLE</u> at 100% load - The total ampere turns per pole required to produce rated load</p> $F_{FL} = 2 \left[(e_d)(F_g) + [1 + (\cos \theta)](F_T) + (F_c) + (F_{PL}) \right] + (F_{SHL})$ $= 2 \left[(198)(96) + [1 + (9)](97) + (98) + (213c) \right] + (233)$
(237)	I_{FFL}	<p><u>FIELD CURRENT</u> at 100% load</p> $I_{FFL} = (F_{FL}) / (N_F) = (236) / (146)$
(238)	E_{FFL}	<u>FIELD VOLTS</u> at 100% load
(239)	S_{FL}	<u>CURRENT DENSITY</u> at 100% load
(241)	$I^2_{R_{FI}}$	<u>FIELD I^2R</u> at 100% load
(242)	W_{TFI}	<u>STATOR TEETH LOSS</u> at 100% load
(243)	W_{PFI}	<u>POLE FACE LOSS</u> at 100% load
(245)	$I^2_{R_L}$	<u>STATOR I^2R</u> at 100% load
(246)	--	<u>EDDY LOSS</u>
(247)	--	<p><u>TOTAL LOSSES</u> at 100% load - sum of all losses at 100% load</p> <p>Total Losses = (Field I^2R) + (F&W) + (Stator Teeth Loss) + (Stator Core Loss) + (Pole Face Loss) + (Stator I^2R) + (Eddy Loss)</p> $= (241) + (183) + (242) + (185) + (243) + (245) + (246)$
(248)	--	<u>RATING IN KILOWATTS</u> at 100% load

(249) -- RATING AND LOSSES

(250) -- % LOSSES

(25i) -- % EFFICIENCY

These items can be recalculated for any load condition by simply inserting the values that correspond to the % load being calculated.

Values for F&W (183) and W_C (Stator Core Loss) (185) do not change with load.

INPUT AUXILIARY DATA SHEET

Auxiliary information taken from the design manuals to be used in conjunction with input sheets for convenience.

- A. All dimensions for lengths, widths, and diameters are to be given in inches.
- B. Resistivity inputs, Items (141) and (151) are to be given in micro-ohm-inches.

The following items along with an explanation of each are tabulated here for convenience. For complete explanation of each item number, refer to design manuals.

- | <u>Item No.</u> | <u>Explanation</u> |
|-----------------|--|
| (9) | Power factor to be given in per unit. For example for 90% P.F., insert <u>.90</u> . |
| (9a) | Adjustment Factor - For P.F. < .95 insert <u>1.0</u>
For P.F. > .95 insert <u>1.05</u> |
| (10) | Optional Load Point -- Where load data output is required at a point other than those given as standard on the input sheet. Example: For load data output at 155% load, insert <u>1.55</u> . |
| (14) | Number of radial ducts in stator. |
| (15) | Width of radial ducts used in Item (14). |
| (18) | Magnetization curve of material used to be submitted as defined in Item (18). |
| (19) | Watts/Lb. to be taken from a core loss curve at the density given in Item (20) (Stator). |
| (20) | Density in kilolines/in. ³ . This value must correspond to density used to pick Item (19) usually use 77.4 K _{LL} /in. ³ . |
| (21) | Type of slot - For open slot Type A, insert <u>1.0</u> .
For partially open slot Type B with constant slot width, insert <u>2.0</u> .
For partially open slot Type C with constant tooth width, insert <u>3.0</u> .
For round slot Type D, insert <u>4.0</u> .
For additional information, refer to figure adjacent to input sheet which shows a picture of each slot. |
| (22) | For stator slot dimension - for dimensions that do not apply to the slot insert <u>0.0</u> .
Use Table below as guide for input. |

<u>Symbol</u>	<u>Item</u>	<u>Slot Type</u>			
		<u>1</u>	<u>2</u>	<u>3</u>	<u>4</u>
b ₀	(22)	0.0	*	*	
b ₁	↓	0.0	0.0	*	
b ₂		0.0	0.0	*	0.0
b ₃		0.0	0.0	*	0.0
b _s		*	*	*	*
h ₀		0.0	*	*	*
h ₁		*	*	*	0.0
h ₂		*	0.0	0.0	0.0
h ₃		*	*	0.0	0.0
h _s		*	*	*	*
h _t		0.0	*	*	0.0
h _w		0.0	*	*	0.0

* = insert actual value.
b₁ + b₃

INSIDE-COIL, STATIONARY-COIL LUNDELL GENERATOR
COMPUTER DESIGN - - - - - (INPUT)

MODEL	EWO	DESIGN NO(1)								
PARAMETERS	(2)	FVA	GENERATOR KVA			RATIO MAX TO MIN OF FUND	(71)	C1	CONSTANTS	
	(3)	E	LINE VOLTS			WINDING CONSTANT	(72)	Cw		
	(4)	L _{ph}	PHASE VOLTS			POLE CONSTANT	(73)	Cp		
	(5)	m	PHASES			END EXTENSION ONE TURN	(48)	LE		
	(5a)	f	FREQUENCY			DEMAGNETIZATION FACTOR	(74)	Cm		
	(6)	p	POLES			CROSS MAGNETIZING FACTOR	(75)	Cd		
	(7)	RPM	RPM			POLE EMBRACE	(77)	oc		
	(8)	I _{ph}	PHASE CURRENT			WIDTH OF POLE (NARROW END)	(76)	b p1		
	(9)	PF	POWER FACTOR			WIDTH OF POLE (WIDE END)	(76)	b p2		
	(9a)	Kc	ADJ. FACTOR			POLE THICKNESS (NARROW END)	(76)	t p1		
(10)		OPTIONAL LOAD POINT			POLE THICKNESS (WIDE END)	(76)	t p2	POLE & ROTOR		
STATOR STACK	(11)	d	STATOR I.D.			POLE LENGTH	(76)		l p	
	(12)	D	STATOR O.D.			ROTOR DIAMETER	(11a)		dr	
	(13)		GROSS CORE LENGTH			WEIGHT OF ROTOR IRON	(157)		(-)	
	(14)	n _v	NO. OF DUCTS			POLE FACE LOSS FACTOR	(187)	Ki		
	(15)	b _v	WIDTH OF DUCT			SHAFT O.D.(FLUX CARRYING PART)	(78)	d _s	SHAFT	
	(16)	K ₁	STACKING FACTOR(STATOR)			SHAFT LENGTH " " "	(78)	l _{sh}		
	(19)	k	WATTS/LB.			PERM OF LEAKAGE PATH 1	(80)	P1	PERMEANCE	
	(20)	B	DENSITY			PERM OF LEAKAGE PATH 2	(91)	P2		
(21)		TYPE OF SLOT			PERM OF LEAKAGE PATH 3	(82)	P3			
(22)	b _o	SLOT OPENING			PERM OF LEAKAGE PATH 4	(83)	P4			
(22)	b ₁	SLOT WIDTH TOP			PERM OF LEAKAGE PATH 5	(84)	P5			
(22)	b ₂				PERM OF LEAKAGE PATH 7	(86)	P7			
(22)	b ₃				LENGTH OF PERM PATH 1	(80a)	l ₁			
(22)	b _s	SLOT WIDTH			LENGTH OF PERM PATH 2	(81a)	l ₂			
(22)	h _o				LENGTH OF PERM PATH 3	(82a)	l ₃			
STATOR SLOT	(22)	h ₁			OUTSIDE DIA. OF FIELD COIL	(78)	d _{co}	FIELD		
	(22)	h ₂			LENGTH OF FIELD COIL	(76)	l _{co}			
	(22)	h ₃			NO. OF FIELD TURNS/COIL	(146)	Nf			
	(22)	h _s	SLOT DEPTH			MEAN LENGTH OF FLD. TURN	(147)		l _{tf}	
	(22)	h _t				FLD. COND. DIA. OR WIDTH	(148)			
	(22)	h _w				FLD. COND. THICKNESS	(149)			
	(23)	Q	NO. OF SLOTS			FLD. TEMP IN °C	(150)		X _f °C	
	(28)		TYPE OF WDG.			RESISTIVITY OF FLD. COND @ 20°	(151)		ρ _f	
	(29)		TYPE OF COIL			NO LOAD SAT.	(87)			
	(30)	n _s	CONDUCTORS/SLOT			FRICTION & WINDAGE	(183)		(F&W)	
STATOR WINDING	(31)	γ	SLOTS SPANNED			SPECIAL PERMEANCE	64a	μ _z		
	(32)	c	PARALLEL CIRCUITS			STATOR LAM MATERIAL	(10)			
	(33)		STRAND DIA. OR WIDTH			POLE MATERIAL	(18)			
	(34)	N _{st}	STRANDS/CONDUCTOR IN DEPTH			SHAFT MATERIAL	(18)			
	(34a)	N' _{st}	STRANDS/CONDUCTOR			<table border="1" style="width: 100%; height: 100%;"> <tr> <td style="width: 50%; text-align: center;">STATOR SLOT DAMPER SLOT</td> <td style="width: 50%; text-align: center;">POLE REMARKS</td> </tr> </table>			STATOR SLOT DAMPER SLOT	POLE REMARKS
	STATOR SLOT DAMPER SLOT	POLE REMARKS								
	(39)		STATOR STRAND T'KNS.							
	(35)	d _b	DIA. OF PIN							
	(36)	l _{o2}	COIL EXT. STR. PORT							
	(37)	h _{st}	UNINS. STRD. HT.							
(38)	h' _{st}	DIST. BTWN. C ₁ OF STD.								
(42a)		PHASE BELT ANGLE								
(40)	T _{sk}	STATOR SLOT SKEW								
(50)	X °C	STATOR TEMP °C								
(51)	ρ _s	RES'TVY STA. COND. @ 20° C								
GAP	(78)	l _{a3}	AXIAL LENGTH OF GAP (g3)			<table border="1" style="width: 100%; height: 100%;"> <tr> <td style="width: 50%;"></td> <td style="width: 50%;"></td> </tr> </table>				
	(78)	d _{a3}	DIAMETER AT GAP (g3)							
	(78)	d _{a2}	DIAMETER AT GAP (g2)							
	(59)	g	MAIN AIR GAP							
(59a)	g2	AUXILIARY GAP (g2)								
(59b)	g3	AUXILIARY GAP (g3)								

DESIGNER _____ DATE _____

(a) Open Slots

(b) Constant Slot Width

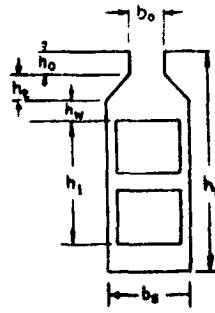
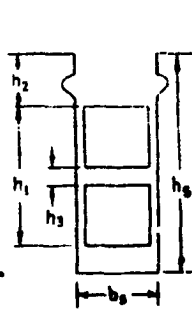

TYPE 1
 (Type 5 is an open slot with 1 conductor per slot)

TYPE 2

(c) Constant Tooth Width

(d) Round Slots

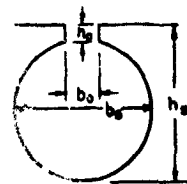
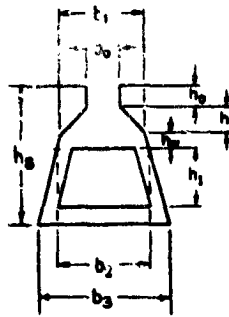

TYPE 3

b_s for type 3 is

$$b_s = \frac{b_1 + b_3}{2}$$

TYPE 4

**INSIDE-COIL, STATIONARY-COIL LUNDELL GENERATOR
SUMMARY OF DESIGN CALCULATIONS - - - - - (OUTPUT)**

MODEL NO. _____ EWO _____ DESIGN NO. _____

TYPICAL	ITEM NO.	DESCRIPTION	PERCENT LOAD				
			0	100	50	200	
CONSTANTS	(17) (L_g)	SOLID CORE LENGTH					
	(24) (h_c)	DEPTH BELOW SLOT					
	(26) (T_s)	SLOT PITCH					
	(27) $(T_s/3)$	SLOT PITCH 1/3 DIST. UP					
	(42) (K_{sk})	SKEW FACTOR					
	(43) (K_d)	DIST. FACTOR					
	(44) (K_p)	PITCH FACTOR					
	(45) (n_e)	EFF. CONDUCTORS					
	(46) (a_c)	COND. AREA					
	(47) (S_a)	CURRENT DENSITY (STA.)					
	(49) (l_f)	1/2 MEAN TURN LENGTH					
	(53) (R_{ph})	COLD STA. RES. @ 20°C					
	(54) (R_{ph})	HOT STA. RES. @ X°C					
	(55) (EF_{top})	EDDY FACTOR TOP					
	REACTANCE	(56) (EF_{bot})	EDDY FACTOR BOT				
(62) (λ_1)		STATOR COND. PERM.					
(63) (λ_e)		END PERM.					
(65) ()		WT. OF STA COPPER					
(66) ()		WT. OF STA. IRON					
(41) (T_p)		POLE PITCH					
(157) (-)		WT. OF ROTOR IRON					
(145) (V_r)		PERIPHERAL SPEED					
(153) (a_{cp})		FLD. COND. AREA					
(154) (R_F)		COLD FLD. RES. @ 20°C					
(155) (R_F)		HOT FLD. RES. @ X°C					
(156) (-)		WT OF FLD. COPPER					
(80) (P_1)		PERM OF LEAKAGE PATH 1					
(81) (P_2)		PERM OF LEAKAGE PATH 2					
TIME CONST.		(82) (P_3)	PERM OF LEAKAGE PATH 3				
	(83) (P_4)	PERM OF LEAKAGE PATH 4					
	(84) (P_5)	PERM OF LEAKAGE PATH 5					
	(86) (P_7)	PERM OF LEAKAGE PATH 7					
	(160) (F_{SC})	SHORT CIR NI					
	(181) (SCR)	SHORT CIR RATIO					
	(160) (F_{SC})	SHORT CIR NI					
	(181) (SCR)	SHORT CIR RATIO					
	MAGNETIZATION	(100) (ϕ_{90})	TOTAL FLUX				
		(93) (ϕ_p)	FLUX PER POLE				
		(95) (B_g)	GAP DENSITY (MAIN)				
		(91) (B_r)	TOOTH DENSITY				
		(94) (B_c)	CORE DENSITY				
		(97) (F_1)	TOOTH AMPERE TURNS				
		(98) (F_c)	CORE AMPERE TURNS				
(96) (F_g)		GAP AMPERE TURNS (MAIN)					
(100) (ϕ_{90})		TOTAL FLUX					
(93) (ϕ_p)		FLUX PER POLE					
(95) (B_g)		GAP DENSITY (MAIN)					
(91) (B_r)		TOOTH DENSITY					
(94) (B_c)		CORE DENSITY					
(97) (F_1)		TOOTH AMPERE TURNS					
(98) (F_c)		CORE AMPERE TURNS					
(96) (F_g)	GAP AMPERE TURNS (MAIN)						
OPTIONAL	(100) (ϕ_{90})	LEAKAGE FLUX					
	(102) (ϕ_{90})	TOTAL FLUX/POLE					
	(103) (B_p)	POLE DENSITY					
	(122) (B_{g2})	AUX GAP(2) DENSITY					
	(119) (B_{g3})	AUX GAP(3) DENSITY					
	(113) (B_{ph})	SHAFT DENSITY					
	(127) (F_{nl})	TOTAL NI					
	(127a) (I_{nl})	FIELD AMPERES					
	(127c) (I)	CUR. DEN. FLD.					
	(127b) (E_{fl})	FIELD VOLTS					
	(186) (W_c)	STA CORE LOSS					
	(184) (W_{st})	STA TOOTH LOSS					
	(194) $(I^2 R_s)$	STATOR CU LOSS					
	(195) $(-)$	EDDY LOSS					
	(186) (W_{pf})	POLE FACE LOSS					
(182) $(I^2 R_f)$	FIELD COIL LOSS						
(183) $(P\&W)$	P&W LOSS						
(196) $(-)$	TOTAL LOSSES						
(-)	PERCENT EFF.						

DESIGNER _____ DATE _____ REV. A

**INSIDE-COIL, STATIONARY-COIL LUNDELL
NO LOAD SATURATION OUTPUT SHEET**

ITEMS % VOLTS	(3) (E) VOLTS	(95) (B _g) MAIN GAP DENSITY	(122) (B _{g2}) DENSITY (g2)	(119) (B _{g3}) DENSITY (g3)	(94) (B _c) STA CORE DENSITY	(91) (B _t) STA TOOTH DE
	(100a) (L)) LEAKAGE FLUX	(102) (D _g) TOTAL FLUX/POLE	(103a) (B _p) POLE DENSITY	(113) (B _{sh}) SHAFT DENSITY	(127) (F _{nl}) TOTAL N. I.	_____
80%						
90%						
100%						
110%						
120%						
130%						
140%						
150%						
160%						

INSIDE-COIL, STATIONARY-COIL, LUNDELL, A.C. GENERATOR

(1)	--	DESIGN NUMBER
(2)	KVA	GENERATOR KVA
(3)	E	LINE VOLTS
(4)	E_{PH}	PHASE VOLTS
(5)	m	PHASES
(5a)	f	FREQUENCY
(6)	P	POLES
(7)	RPM	SPEED
(8)	I_{PH}	PHASE CURRENT
(9)	P. F.	POWER FACTOR
(9a)	K_c	ADJUSTMENT FACTOR
(10)	--	LOAD POINTS
(11)	d	STATOR PUNCHING I.D.
(11a)	d_r	ROTOR O.D.
(12)	D	PUNCHING O.D.
(13)	l	GROSS STATOR CORE LENGTH
(14)	n_v	RADIAL DUCTS
(15)	b_v	RADIAL DUCT WIDTH
(16)	K_1	STACKING FACTOR
(17)	l_s	SOLID CORE LENGTH

(18)

MATERIAL - This input is used in selecting the proper magnetization curves for stator, pole, shaft; when different materials are used. Separate spaces are provided on the input sheet for each section mentioned above. Where curves are available on card decks, used the proper identifying code. Where card decks are not available submit data in the following manner:

The magnetization curve must be available on semi-log paper. Typical curves are shown in this manual on Curves F15 and F16. Draw straight line segments through the curve starting with zero density. Record the coordinates of the points where the straight line segments intersect. Submit these coordinates as input data for the magnetization curve. The maximum density point must be submitted first.

Refer to Figure below for complete sample

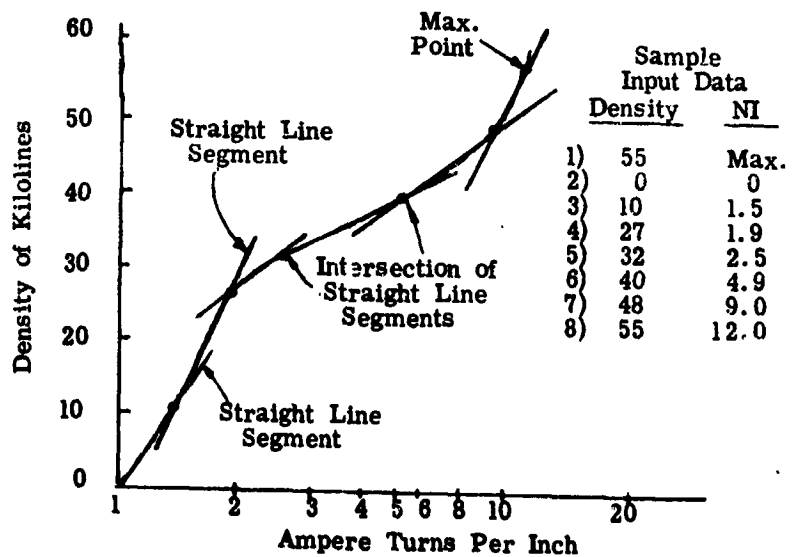

(19)	k	WATTS/LB
(20)	B	DENSITY
(21)		TYPE OF STATOR SLOT
(22)		ALL SLOT DIMENSIONS
(23)	Q	STATOR SLOTS
(24)	h_r	DEPTH BELOW SLOTS
(25)	q	SLOTS PER POLE PER PHASE
(26)	τ_s	STATOR SLOT PITCH
(27)	$\tau_s^{1/3}$	STATOR SLOT PITCH
(28)	--	TYPE OF WINDING
(29)	--	TYPE OF COIL
(30)	n_s	CONDUCTORS PER SLOT
(31)	γ	THROW
(31a)		PER UNIT OF POLE PITCH SPANNED
(32)	C	PARALLEL PATHS
(33)	--	STRAND DIA. OR WIDTH
(34)	N_{ST}	NUMBER OF STRANDS PER CONDUCTOR IN DEPTH
(34a)	N'_{ST}	NUMBER OF STRANDS PER CONDUCTOR
(35)	d_b	DIAMETER OF BENDER PIN
(36)	ℓ_{e2}	COIL EXTENSION BEYOND CORE
(37)	h_{ST}	HEIGHT OF UNINSULATED STRAND
(38)	h'_{ST}	DISTANCE BETWEEN CENTERLINES OF STRANDS IN DEPTH

(39)	--	STATOR COIL STRAND THICKNESS
(40)	τ_{SK}	SKEW
(41)	τ_P	POLE PITCH
(42)	K_{SK}	SKEW FACTOR
(42a)		PHASE BELT ANGLE
(43)	K_d	DISTRIBUTION FACTOR
(44)	K_p	PITCH FACTOR
(45)	n_e	TOTAL EFFECTIVE CONDUCTORS
(46)	a_c	CONDUCTOR AREA OF STATOR WINDING
(47)	S_S	CURRENT DENSITY
(48)	L_E	END EXTENSION LENGTH
(49)	l_t	1/2 MEAN TURN
(50)	X_s °C	STATOR TEMP °C
(51)	ρ_s	RESISTIVITY OF STATOR WINDING
(52)	ρ_s (hot)	RESISTIVITY OF STATOR WINDING
(53)	R_{SPH} (cold)	STATOR RESISTANCE/PHASE
(54)	R_{SPH} (hot)	STATOR RESISTANCE/PHASE
(55)	E_F (top)	EDDY FACTOR TOP
(56)	E_F (bot)	EDDY FACTOR BOTTOM

(57)	b_{tm}	<u>STATOR TOOTH WIDTH</u>
(57a)	$b_t 1/3$	<u>STATOR TOOTH WIDTH</u>
(58)	b_t	<u>TOOTH WIDTH AT STATOR I. D.</u>
(59)	g	<u>MAIN AIR GAP</u> in inches
(59a)	g_2	<u>AUXILIARY GAP, INNER</u> - in inches
(59b)	g_3	<u>AUXILIARY GAP, OUTER</u> - in inches
(60)	C_X	<u>REDUCTION FACTOR</u>
(61)	K_X	<u>FACTOR TO ACCOUNT FOR DIFFERENCE</u> in phase current in coil sides in same slot.
(62)	λ_i	<u>CONDUCTOR PERMEANCE</u>
(63)	K_E	<u>LEAKAGE REACTIVE FACTOR</u> for end turn
(64)	λ_E	<u>END WINDING PERMEANCE</u>
(64a)	λ_z	<u>SPECIAL LEAKAGE PERMEANCE</u> - For machines having a section of the pole that is approxi- mately a full pole-pitch wide, an additional leakage permeance must be added to the slot and end-turn leakage permeances. This permeance is that of the leakage path from one pole into a tooth top and from tooth top back into the adjacent pole. The leakage

(64a) Cont'd.

is similar to Zig Zag leakage and by increasing the stator leakage reactance, can reduce the output of the generator significantly.

This same leakage can be used to purposely limit the output of the generator and make it current limited. The presence of this additional leakage can be good or bad depending upon what is wanted from the generator. The important thing is for the designer to be aware that it is there.

In many cases, the designer should estimate the specific permeances λ_z since the pole base will be more or less than a full pole pitch wide and the following formula will not suffice.

(64a) Cont.

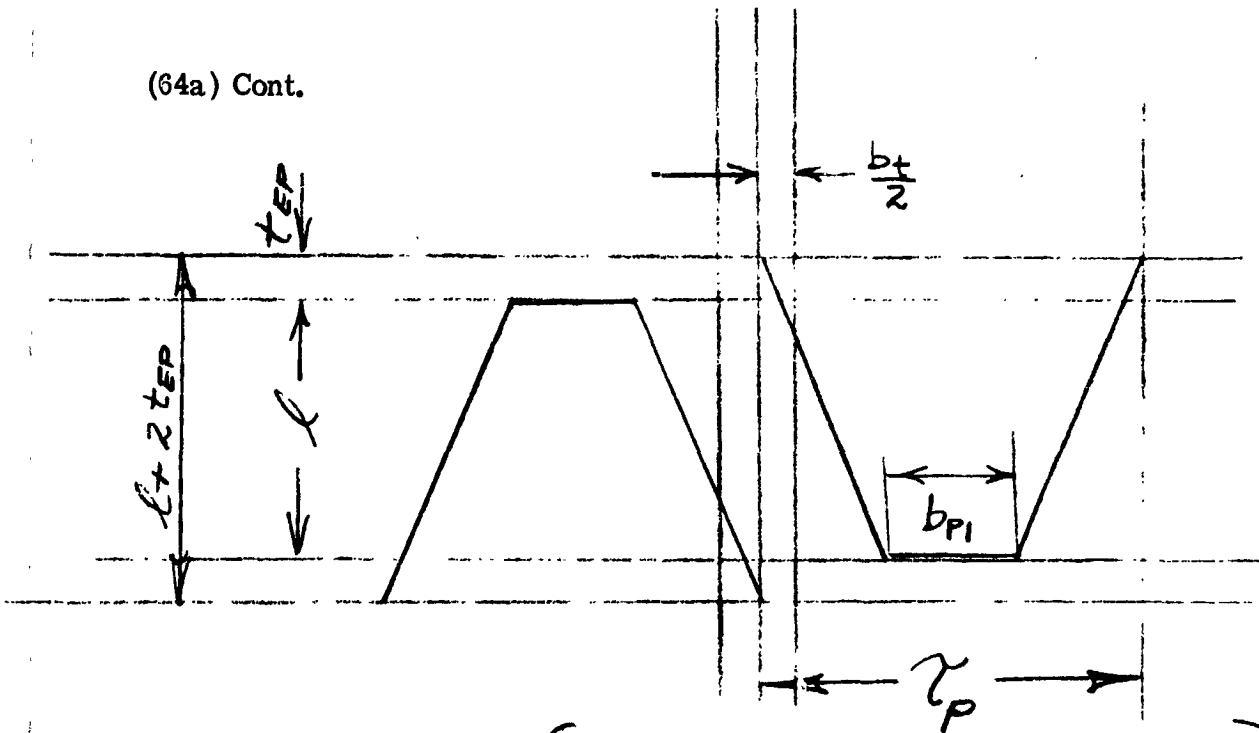

$$\lambda_z = (C_X) \frac{20}{(m)(q)} \left\{ \frac{\text{area of pole over tooth when tooth is on centerline between poles}}{2 l g} \right\}$$

$$\lambda_z = (C_X) \frac{20}{(m)(q)} \left\{ \frac{b_t (\tau_p - b_{p1}) (l + 2 t_{EP}) \left(\frac{\tau_p - b_{p1}}{\tau_p} \right)}{2 l g} \right\}$$

(65)	--	<u>WEIGHT OF COPPER</u>
(66)	--	<u>WEIGHT OF STATOR IRON - in lbs.</u>
(67)	K_s	<u>CARTER COEFFICIENT</u>
(68)	A_g	<u>MAIN AIR GAP AREA</u>
(69)	ϵ_e	<u>EFFECTIVE AIR GAP</u>

(70)	A_{g2}	<u>AREA OF AUXILIARY AIR GAP</u> $A_{g2} = \frac{\pi}{4} (d_{g2})^2 = \frac{\pi}{4} (87)^2$
(70a)	A_{g3}	<u>AREA OF OUTER AUXILIARY AIR GAP</u> $A_{g3} = \pi (d_{g3}) (l_{g3}) = (87) (87)$
(71)	C_1	<u>THE RATIO OF MAXIMUM FUNDAMENTAL</u> of the field form to the actual maximum of the field form -
(72)	C_W	<u>WINDING CONSTANT</u>
(73)	C_P	<u>POLE CONSTANT</u>
(74)	C_M	<u>DEMAGNETIZING FACTOR</u> - direct axis
(75)	C_q	<u>CROSS MAGNETIZING FACTOR</u> - quadrature axis
(76)		<u>POLE DIMENSION LOCATIONS</u> b_{p2} - width of pole at edge of stator stack (wide end). b_{p1} - width of pole at end (narrow end). t_{p2} - thickness of pole at edge of stator stack. t_{p1} - thickness of pole at end. l_{co} - length of coil. l_p - length of pole.

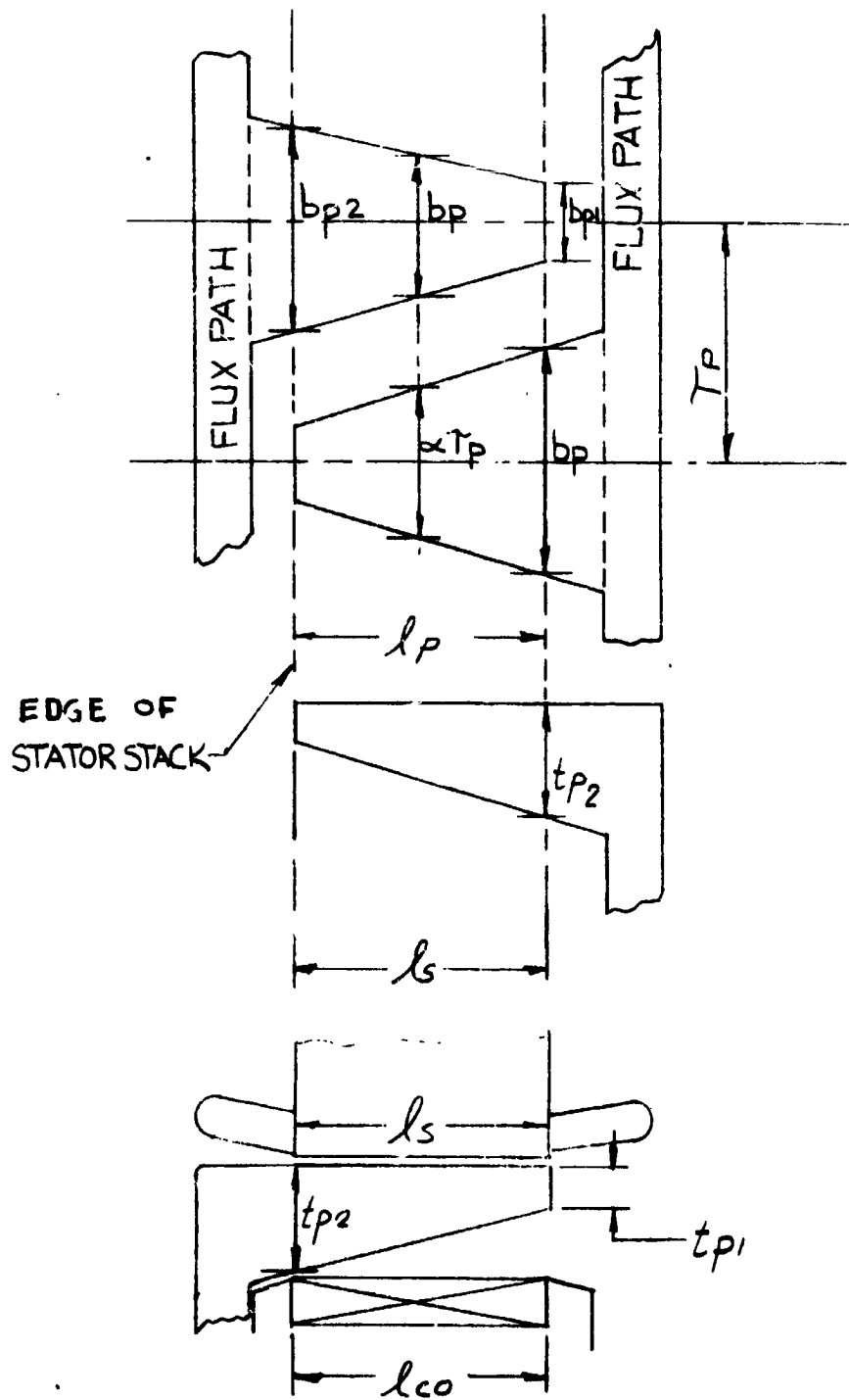

Fig. K-2

(77)

α

POLE EMBRACE

$$\alpha = \frac{(b_{p1}) + (b_{p2})}{2 (\tau_p)} = \frac{(75) + (76)}{2 (41)}$$

(77a)

Items immediately following, deal with the calculation of rotor and stator leakage permeances. Illustrations are included to help identify the permeance areas and paths of the leakage fluxes. The computer program will handle the permeance calculations either of two ways:

- 1) P_1 through P_7 can be calculated by the computer. For this case, insert 0.0 on the input sheet.
- 2) P_1 through P_7 can be calculated by the designer. For this case, insert the actual calculated value on the input sheet.

Permeance calculations P_1 through P_7 are all based on the equations

$$P = \frac{u (\text{area})}{\ell}$$

Where $u = 3.19$

Area = cross-sectional area perpendicular to ℓ

ℓ = length of permeance leakage path

Many of the equations used in this section are taken from Roter's "Electromagnetic Devices". Refer to the appendix for an explanation of each condition.

(78)

ROTOR AND STATOR DIMENSIONS

l_{g3} - axial length of air gap (g3)

d_{g3} - diameter at air gap (g3)

d_{g2} - diameter of the circle containing flux in gap (g2)

d_s - diameter of shaft (equal to coil inside diameter)

l_{SH} - length of shaft (flux carrying portion)

t_{fp} - thickness of flux plate

d_{oc} - outside diameter of coil

l_{co} - length of coil (axial length)

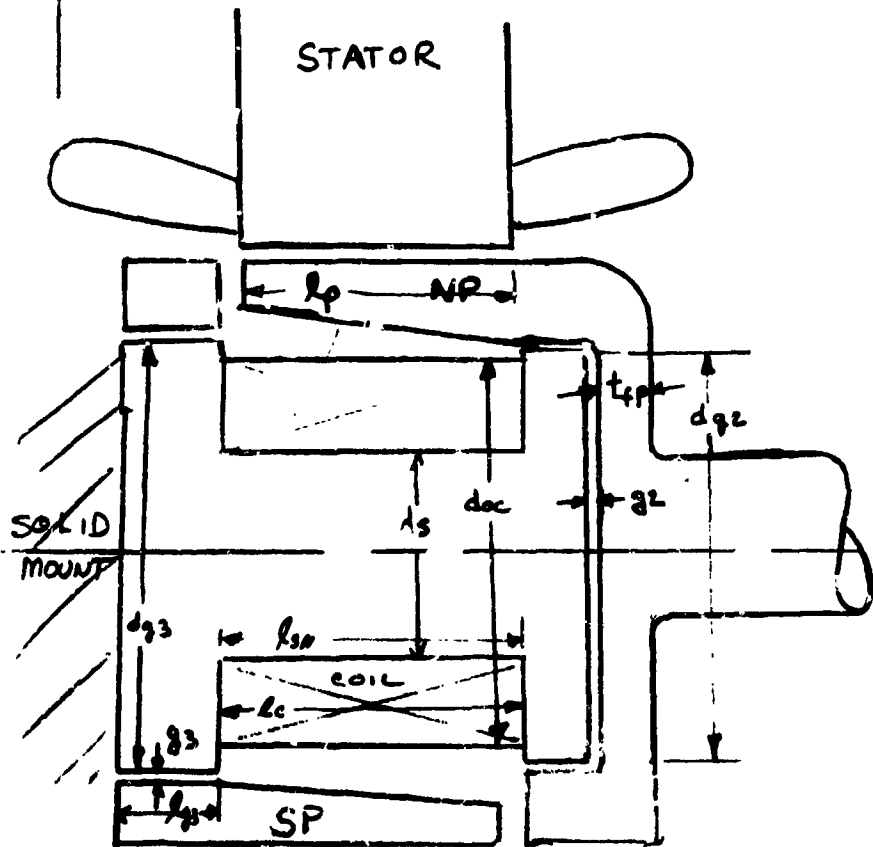

Fig. K-3

(79) a_p POLE AREA - The effective cross sectional area of the pole.

$$a_p = (b_{p2}) (t_{p2}) = (76) (76)$$

(80) P_1 POLE HEAD END LEAKAGE - This input can be either 0.0 or the actual value if available. Refer to item 86 for explanation. See Figure K4 for location.

$$P_1 = \frac{3.19 (b_{p1}) (t_{p1})}{l_1} = \frac{3.19 (76) (76)}{(80a)}$$

(80a) l_1 LENGTH OF PERMEANCE PATH P_1 - l_1 is the length of permeance path P_1 and must be obtained from design layout. Note this value (l_1) must appear as a input when $P_1 = 0.0$

(81) P_2 POLE HEAD SIDE LEAKAGE - This input can be either 0.0 or the actual value if available. Refer to item 86 for explanation. See Figure K4 for location.

$$P_2 = 3.19 \frac{[(t_{p1}) + (t_{p2})]}{2} \frac{(l_p)}{(l_2)}$$
$$= 3.19 \frac{[(76) + (76)]}{2} \frac{(76)}{(81a)}$$

(81a) l_2 LENGTH OF PERMEANCE PATH P_2 - l_2 is the length of permeance path P_2 and must be obtained from design layout. Note: This value (l_2) must appear as an input when $P_2 = 0.0$

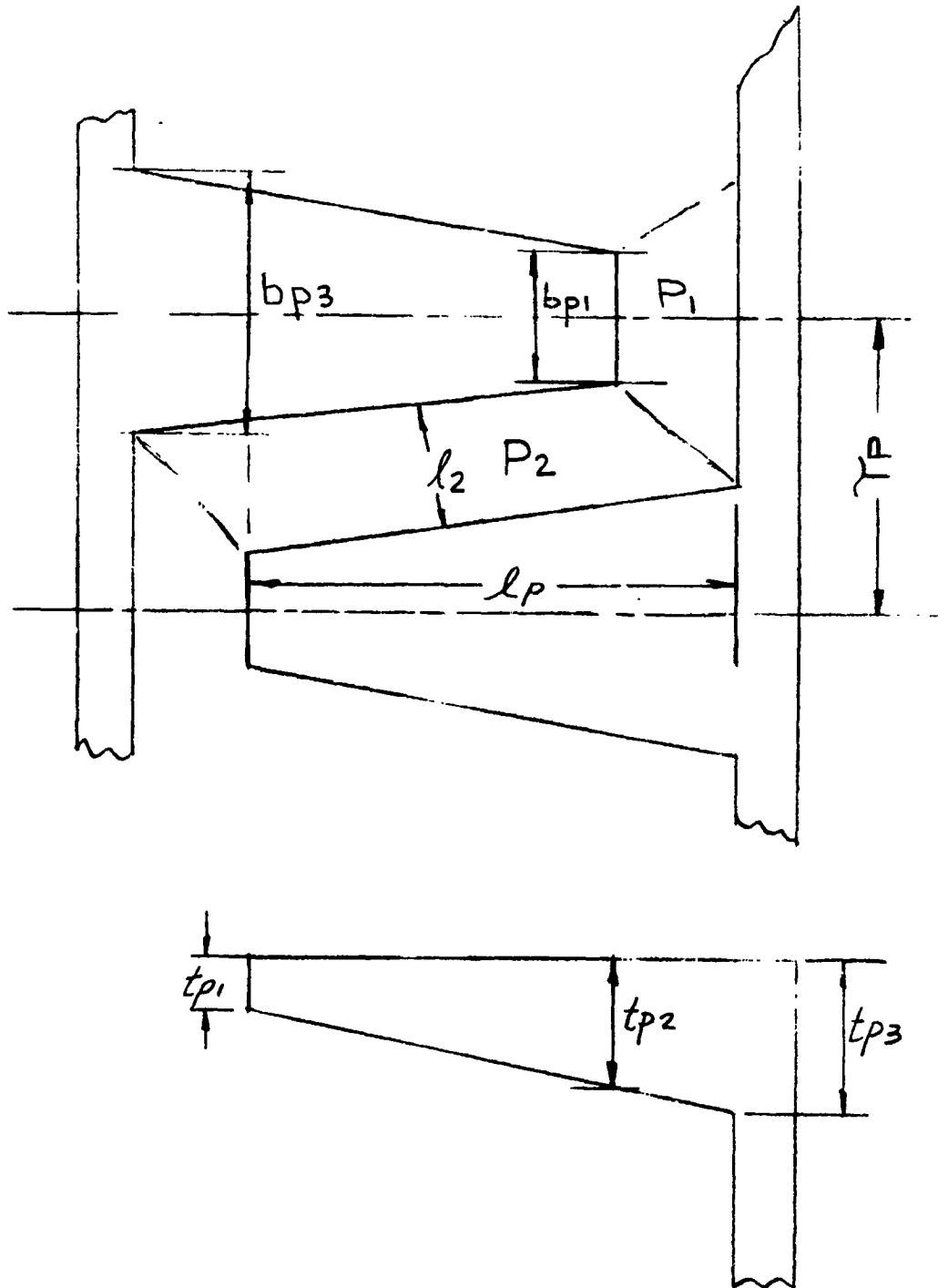

Fig. K-4

K-11

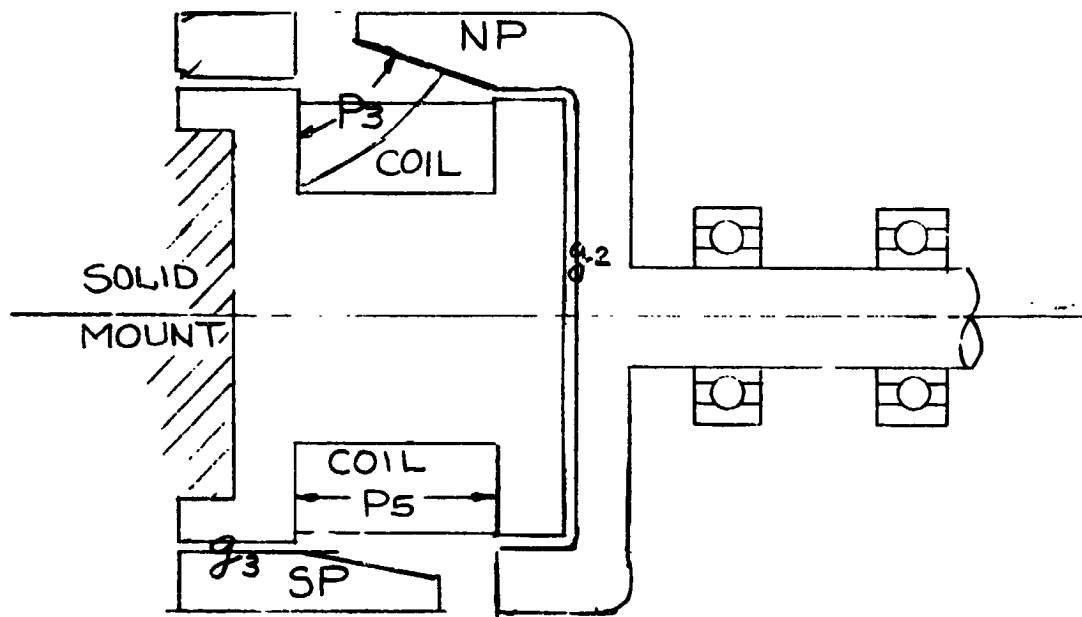

Fig. K-5

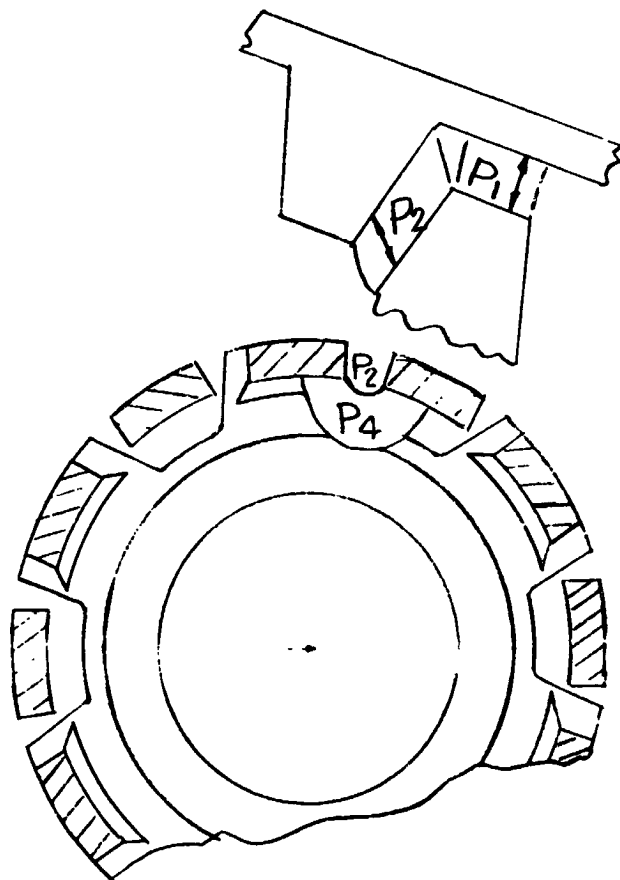

Fig. K-6

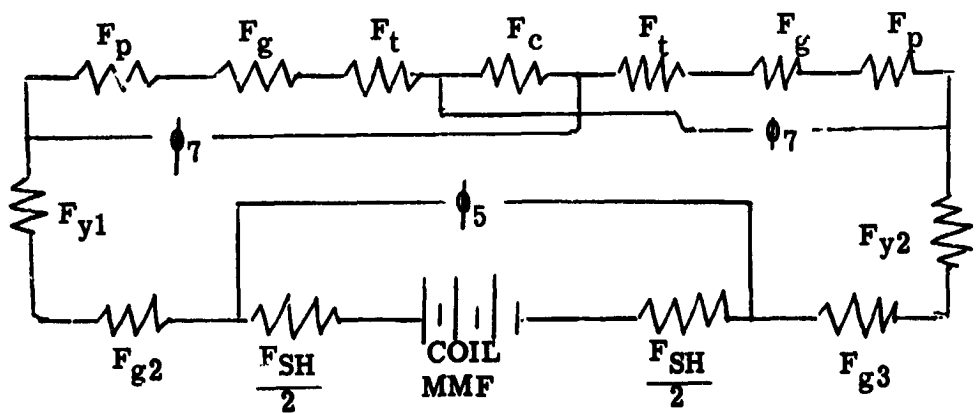
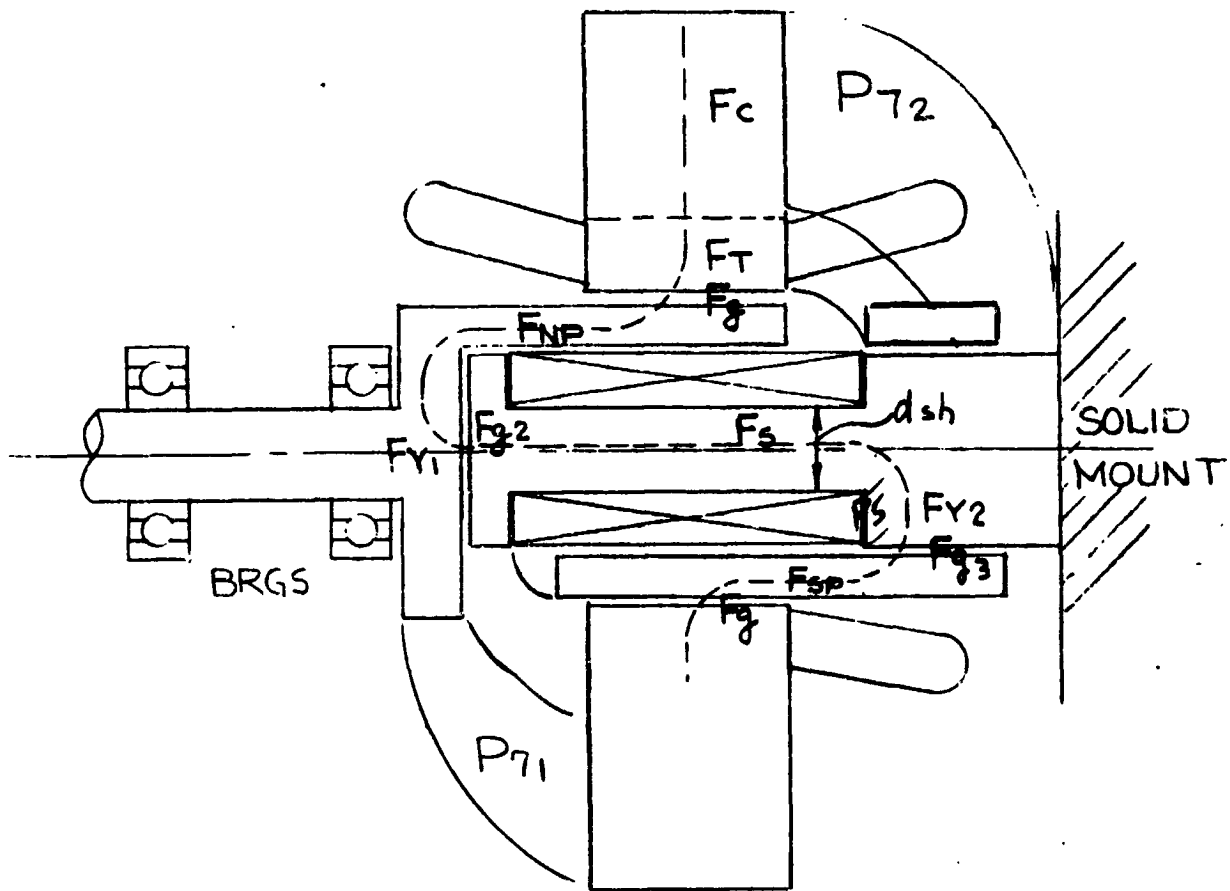

Fig. K-7

(82)

 P_3 POLE UNDERSIDE TO FLUX PLATE LEAKAGE PERMEANCE -

This input can be either 0.0 or the actual value if available. Refer to item 86 for explanation. See Figure K5 for location.

$$P_3 = 3.19 \left[\frac{3 (b_{p1}) + (b_{p2})}{8} \right] \frac{(\ell_p)}{(\ell_3)}$$

$$- 3.19 \left[\frac{3 (76) + (76)}{8} \right] \frac{(76)}{(82a)}$$

(82a)

 ℓ_3 LENGTH OF PERMEANCE PATH P_3 - ℓ_3 is the length of

permeance path P_3 and must be obtained from design layout. Note: This value (ℓ_3) must appear as an input when $P_2 = 0.0$

(83)

 P_4 POLE UNDERSIDE TO POLE UNDERSIDE LEAKAGE PERMEANCE

This input can be either 0.0 or the actual value if available. Refer to item 77a for explanation. See Figure K6 for location.

For 6 poles or more i. e. when (6) \geq 6 calculate as follows:

$$*P_4 = \frac{3.19 (\ell_p)}{\pi} \ln \left[1 + \frac{(b_{p1}) + (b_{p2})}{(\Sigma)} \right]$$

$$- \frac{3.19 (76)}{\pi} \ln \left[1 + \frac{(76) + (76)}{(83)} \right]$$

$$\text{where } z = \gamma_p - \left[\frac{(b_{p1}) + (b_{p2})}{2} \right] = (41) - \left[\frac{(76) + (76)}{2} \right]$$

For 4 poles i. e. when (6) = 4 calculate as follows:

$$*P_4 = \frac{3.19 (l_p)}{\pi} \cdot \frac{3}{2} \ln \left[1 + \frac{(b_{p1}) + (b_{p2})}{z} \right]$$

$$= \frac{3.19 (76)}{\pi} \cdot \frac{3}{2} \ln \left[1 + \frac{(76) + (76)}{83} \right]$$

(84)

P₅

FIELD COIL LEAKAGE PERMEANCE - This input can be either 0.0 or the actual value if available. Refer to item 77a for explanation. See Figure F-7 for location.

$$P_5 = \frac{3.19}{(l_{CO})} \frac{\pi}{4} \left[(d_{OC})^2 - (d_S)^2 \right] \frac{z}{3}$$

$$= \frac{3.19}{(78)} \frac{\pi}{4} \left[(78)^2 - (78)^2 \right] \frac{z}{3}$$

(86)

P₇

STATOR TO ROTOR LEAKAGE PERMEANCE - This input can be either 0.0 or the actual value if available. Refer to item 86 for explanation. See Figure F-7 for location.

$$P_7 = 2.5 (D + d_r)$$

$$= 2.5 \left[(12) + (11a) \right]$$

(87)

The next set of calculations deals with the no load saturation. When the no load saturation data is required at various voltages, insert 1. on the input sheet for "No Load Sat.". The computer will then calculate the complete no load saturation curve at 80, 90, 100, 110, 120, 130, 140, 150, and 160% of rated volts. When complete saturation data is not necessary, insert 0. on the input sheet and the computer will calculate 100% volt data.

(88)	ϕ_T	<u>TOTAL FLUX IN KILO LINES</u>
(91)	B_t	<u>TOOTH DENSITY</u> in Kilo Lines/in ²
(92)	ϕ_P	<u>FLUX PER POLE</u> in Kilo Lines
(94)	B_c	<u>CORE DENSITY</u> in Kilo Lines/in ²
(95)	B_g	<u>GAP DENSITY</u> in Kilo Lines/in ²
(96)	F_g	<u>AIR GAP AMPERE TURNS</u>
(97)	F_T	<u>STATOR TOOTH AMPERE TURNS</u>
(98)	F_c	<u>STATOR CORE AMPERE TURNS</u>
(98a)	F_s	<u>STATOR AMPERE TURNS, total</u>
(99)	ϕ_7	<u>STATOR TO SHAFT AND FLUX PLATE LEAKAGE FLUX -</u>

The leakage flux from the stator to the yoke and rotor, all of which crosses the auxiliary air gaps (g_2) and (g_3)

$$\phi_7 = \left[(F_P) + (F_g) + (F_T) + (F_c) \right] (P_7) \times 10^{-3}$$

$$= \left[(104a) + (96) + (97) + (98) \right] (86) \times 10^{-3}$$

The items to follow are to be calculated for variable loads. The first set

of calculations are at no load. These calculations will then be repeated for 100% load. Any variation in load would be a repeat of the 100% load calculations with the proper percent load inserted.

(100a)	ϕ_r	<u>ROTOR LEAKAGE FLUX</u> - at no load $\phi_r = (p) \left[\frac{2(F_g) + 2(F_T) + (F_c)}{(P_1) + (F_2) + (P_3) + (P_4)} \right] \times 10^{-3}$ $= (6) \left[\frac{2(96) + 2(97) + (98)}{(80) + (81) + (82) + (83)} \right] \times 10^{-3}$
(102a)	ϕ_{PT}	<u>TOTAL FLUX PER POLE</u> - at no load $\phi_{PT} = \phi_P + \frac{2(\phi_r)}{p} = (92) + \frac{2(100a)}{(6)}$
(103a)	B_p	<u>POLE DENSITY</u> in Kilolines per square inch.

(104a) F_p

POLE AMPERE TURNS - at no load. The ampere turns per pole required to force the flux through the pole at no-load rated voltage. The no load pole ampere turns per pole are calculated as the product of (l_p) times the NI per inch at the density (B_p). Use magnetization curve submitted per Item (18) for rotor.

$$F_p = (l_p) \left[\text{NI/in @ density } (B_p) \right]$$
$$= (76) \left[\begin{array}{l} \text{Look up on rotor magnetization curve} \\ \text{given in (18) @ density (103a)} \end{array} \right]$$

(108) ϕ_{g2}

FLUX CROSSING THE AUXILIARY AIR GAP - Kilolines

$$\phi_{g2} = (\phi_{PT}) \frac{(P)}{2} + (\phi_7)$$
$$= (102a) \frac{(6)}{2} + (96)$$

(111) ϕ_{SH}

FLUX IN SHAFT

$$\phi_{SH} = (\phi_{g2}) + (\phi_5) = (108) + (118)$$

(112) A_s

AREA OF SHAFT in inches² - cross-sectional to flux

$$\text{Where } A_s = \frac{\pi}{4} (d_s)^2 = \frac{\pi}{4} (78)^2$$

(113) B_{sh} FLUX DENSITY IN SHAFT

$$B_s = \frac{\phi_{sh}}{A_s} = \frac{(111)}{(112)}$$

(114) F_{sh} AMPERE TURN DROP IN SHAFT

$$F_{sh} = [l_{sh}] \left[\text{NI/inch at density } (B_{sh}) \right]$$

$$= (78) \left[\begin{array}{l} \text{Look up on shaft magnetization curve} \\ \text{given in (18) at density (113)} \end{array} \right]$$

(118) ϕ_5 COIL LEAKAGE FLUX

$$\phi_5 = P_5 \left[(F_{g2}) + 2(F_g) + 2(F_p) + 2(F_T) + (F_c) + (F_{g3}) \right] \times 10^{-3}$$

$$= (84) \left[(123) + 2(96) + 2(104a) + 2(97) + (98) + (120) \right] \times 10^{-3}$$

(119) B_{g3} AUXILIARY AIR GAP (g_3) DENSITY - Note the flux

crossing air gap (g_2) is equal the flux crossing air gap (g_3)

$$B_{g3} = \frac{\phi_{g2}}{A_{g3}} = \frac{(108)}{(70a)}$$

(120) F_{g3} AUXILIARY AIR GAP (g_3) AMPERE TURNS

$$F_{g3} = \frac{(F_{g3})(g_3)(\phi^3)}{3.19} = \frac{(119)}{3.19} (59b) \times 10^3$$

(120a) -- YOKE - No provision is made in this manual for calculating the flux densities in the section designated y_1 and y_2 in Fig. K-7, page K-14. Make sure that the underside periphery of the pole base times the thickness of the flux plate y_1 is equal to the cross-section of the pole base; or that the flux plate is equal to the pole thickness. The pole areas are assumed to be equal.

(122) B_{g2} AUXILIARY GAP (g_2) DENSITY

$$B_{g2} = \frac{\phi_{g2}}{A_{g2}} = \frac{(108)}{(70)}$$

(123) F_{g2} AUXILIARY AIR GAP (g_2) AMPERE TURNS

$$F_{g2} = \frac{(B_{g2})}{3.19} (g_2) \times 10^3 = \frac{(122)}{3.19} (59a) \times 10^3$$

(127) F_{NL} TOTAL AMPERE TURNS - at no load. The total ampere turns per pole required to produce rated voltage at no load.

$$\begin{aligned} F_{NL} &= 2(F_g) + 2(F_T) + (F_c) + (F_{sh}) + \\ &\quad (F_{g3}) + (F_{g2}) + (F_p) \\ &= 2(96) + 2(97) + (98) + (114) + \\ &\quad (120) + (123) + (104a) \end{aligned}$$

(127a) I_{FNL} FIELD CURRENT - at no load.

$$I_{FNL} = (F_{NL}) / (N_F) = (127) / (146)$$

(127b) E_F FIELD VOLTS - at no load.

(127c) S_F CURRENT DENSITY - at no load.

(128) A AMPERE CONDUCTORS per inch

(129) X REACTANCE FACTOR

(130) X_ℓ LEAKAGE REACTANCE

$$X_\ell = X \left[\lambda_i + \lambda_e + \lambda_z \right]$$

$$= (129) \left[(62) + (64) + (64a) \right]$$

λ_z is explained under item (64a) and should be zero in most cases.

(131) X_{ad} REACTANCE - direct axis - This is the fictitious

reactance due to armature reaction in the direct axis.

$$X_{ad} = \frac{.9(N_e)(I_{PH})(C_M)(K_d) \times 100}{(P) \left[(2F_g) + (F_{g2}) + (F_{g3}) \right]} = \frac{.9(45)(8)(74)(43) \times 100}{(6) \left[2(96) + (123) + (120) \right]}$$

(132)	X_{aq}	<u>REACTANCE</u> - quadrature axis - This is the fictitious reactance due to armature reaction in the quadrature axis.
		$X_{aq} = \frac{(C_q)(X_{ad})}{(C_m)(C_1)} = \frac{(71)(131)}{(74)(75)}$
(133)	X_d	<u>SYNCHRONOUS REACTANCE</u> - direct axis
(134)	X_q	<u>SYNCHRONOUS REACTANCE</u>
(145)	V_r	<u>PERIPHERAL SPEED</u>

- (146) N_F NUMBER OF FIELD TURNS TOTAL
- (147) l_{tf} MEAN LENGTH OF FIELD TURN
- (148) -- FIELD CONDUCTOR DIA OR WIDTH in inches
- (149) -- FIELD CONDUCTOR THICKNESS in inches - Set this
item = 0 for round conductor
- (150) $X_f^{\circ C}$ FIELD TEMP IN $^{\circ}C$ - Input temp at which full load field
loss is to be calculated.
- (151) ρ_f RESISTIVITY of field conductor @ $20^{\circ}C$ in micro ohm-
inches. Refer to table given in Item (51)
for conversion factors.
- (152) ρ_f
(hot) RESISTIVITY of field conductor at $X_f^{\circ}C$
- (153) a_{cf} CONDUCTOR AREA OF FIELD WINDING
- (154) R_f
(cold) COLD FIELD RESISTANCE @ $20^{\circ}C$
$$R_f \text{ (cold)} = (\rho_f) \frac{(N_f)(l_{tf}) \times 10^{-6}}{(a_{cf})} = (151) \frac{(146)(147) \times 10^{-6}}{(153)}$$
- (155) R_f
(hot) HOT FIELD RESISTANCE - Calculated at $X_f^{\circ}C$ (103)
$$R_f \text{ (hot)} = (\rho_f \text{ hot}) \frac{(N_f)(l_{tf}) \times 10^{-6}}{(a_{cf})} = (152) \frac{(146)(147) \times 10^{-6}}{(153)}$$

(156) -- WEIGHT OF FIELD COPPER in lbs

$$\# \text{'s of copper} = .321(N_f)(l_{tf})(a_{cf})$$

$$= .321(146)(147)(153)$$

NOTE: Also refer to note given in item (65).

(157) -- WEIGHT OF ROTOR IRON

(160) X_F THE EFFECTIVE FIELD LEAKAGE REACTANCE (X_F)

The reactance which added to the stator leakage reactance gives the transient reactance

$$X'_{du}$$

$$X_F = X_{ad} \left[1 - \frac{\frac{C_1}{C_m}}{2C_p + \frac{4}{\pi} \frac{\lambda_F}{\lambda_a}} \right]$$

$$X_F = (131) \left[1 - \frac{\frac{(71)}{(74)}}{2(73) + \frac{4}{\pi} \frac{(160)}{(160)}} \right]$$

$$\lambda_a = \frac{6.38d}{P_{ge'}} = \frac{6.38(11)}{(6)(160)}$$

$$\lambda_F = \frac{P_e}{l} = \frac{(160a)}{(13)}$$

$$\text{Where } g'_e = (g_e) \left[\frac{2(F_g) + (F_{g2}) + (F_{g3})}{2(F_g)} \right] = (69) \left[\frac{2(96) + (123) + (120)}{2(96)} \right]$$

(160a) P_e FIELD LEAKAGE PERMEANCE

$$\begin{aligned} P_e &= (p) \left[P_1 + P_2 + P_3 + P_4 \right] + P_5 \\ &= (6) \left[(80) + (81) + (82) + (83) \right] + (84) \end{aligned}$$

(160b) P_r ROTOR LEAKAGE PERMEANCE

$$\begin{aligned} P_r &= p \left[P_1 + P_2 + P_3 + P_4 \right] \\ &= (6) \left[(80) + (81) + (82) + (83) \right] \end{aligned}$$

(161) L_f FIELD SELF-INDUCTANCE

$$L_f = (N_F)^2 \times P_e \times 10^{-8} = (146)^2 (160a) \times 10^{-8}$$

(166) X'_{du} UNSATURATED TRANSIENT REACTANCE

(167) X'_d SATURATED TRANSIENT REACTANCE

(168) X''_d SUBTRANSIENT REACTANCE in direct axis

$$X''_d = (X'_d) = (167)$$

(169) X''_q SUBTRANSIENT REACTANCE in quadrature axis

$$X''_q = X_q = (134)$$

(170)	X_2	<u>NEGATIVE SEQUENCE REACTANCE</u>
(172)	X_0	<u>ZERO SEQUENCE REACTANCE</u>
(173)	K_{X0}	
(174)	K_{X1}	
(175)	λ_{Bo}	$\lambda_{Bo} = \frac{(K_{X0})}{(K_P)^2} [.07(\lambda_a)] = \frac{(173)}{(44)^2} [.07(175)]$ <p>Where $\lambda_a = \frac{6.38(d)}{(P)(g_e)} = \frac{6.38(11)}{6(69)}$</p>
(176)	T'_{do}	<u>OPEN CIRCUIT TIME CONSTANT</u>
(177)	T_a	<u>ARMATURE TIME CONSTANT</u>
(178)	T'_d	<u>TRANSIENT TIME CONSTANT</u>
(179)	T''_{do}	<u>SUBTRANSIENT TIME CONSTANT</u>
(180)	F_{SC}	<u>SHORT CIRCUIT AMPERE TURNS</u> - The field ampere turns required to circulate rated stator current when the stator is short circuited.

$$\begin{aligned}
 F_{SC} &= \frac{(X_d)}{100} \left[2(F_g) + (F_{g2}) + (F_{g3}) \right] \\
 &= \frac{(133)}{100} \left[2(96) + (123) + (120) \right]
 \end{aligned}$$

(181)	SCR	<u>SHORT CIRCUIT RATIO</u>
(182)	I^2R_F	<p><u>FIELD I^2R</u> - at no load. The copper loss in the field winding is calculated with cold field resistance at 20°C for no load condition.</p> <p>Field $I^2R = (I_{FNL})^2 (R_f \text{ cold}) = (127a)^2 \text{ (154)}$</p>

(183)

F & W

FRICION & WINDAGE LOSS (KW) - Note: Write 0 on input

sheet when computer is to calculate F & W. Insert actual value when known.

To ratio from test data, assume that F & W loss varies as the 5/2 power of the rotor diameter and as the 3/2 power of the RPM.

The formula below gives an approximate answer when test data is not available. For a more rigorous treatment use the information given in the rotor friction analysis appended to the thermal analysis section (Section C, Vol. 1).

$$F\&W = 2.52 \times 10^{-6} (d_r)^{2.5} (\text{RPM})^{1.5} (\rho)$$

$$= 2.52 \times 10^{-6} (11a)^{2.5} (7)^{1.5} (76)$$

For gases or fluids other than standard air, the fluid density and viscosity must be considered. The formula given in the manual can be modified by the factors

$$\left(\frac{\rho}{.0765} \right)^{.8} \left(\frac{u}{.0435} \right)^{.2}$$

where

ρ = density - lbs FT⁻³

μ = viscosity LBS FT⁻¹ HR⁻¹

.0765 = density std. air

.0435 = viscosity std. air

(184)	W_{TNL}	<u>STATOR TEETH LOSS</u> - at no load.
(185)	W_c	<u>STATOR CORE LOSS</u>
(186)	W_{NPL}	<u>POLE FACE LOSS</u> - at no load.
(187)	K_1	
(188)	K_2	
(189)	K_3	
(190)	K_4	
(191)	K_5	
(192)	K_6	
(194)	I^2R	<u>STATOR I²R</u> - at no load.
(195)	--	<u>EDDY LOSS</u> - at no load.

(196)

--

TOTAL LOSSES - at no load. Sum of all losses.

$$\begin{aligned} \text{Total Losses} &= (\text{Field } I^2R) + (\text{F\&W}) + (\text{Stator Teeth Loss}) \\ &+ (\text{Stator Core Loss}) + (\text{Pole Face Loss}) \\ &= (182) + (183) + (184) + (185) + (186) \end{aligned}$$

NOTE: The output sheet shows the next items to be: (Rating), (Rating + Losses), (% Losses), (% Efficiency). These items do not apply to the no load calculation since the rating is zero.

(196a)

 ϕ_{ll} LEAKAGE FLUX PER POLE at 100% load

$$\begin{aligned} \phi_{ll} &= \phi_l \left\{ \frac{(e_d)(F_g) + [1 + \cos(\theta)] (F_T) + (F_C)}{(F_g) + (F_T) + (F_C)} \right\} \\ &= (100a) \left\{ \frac{(198)(96) + [1 + \cos(198a)] (97) + (98)}{(96) + (97) + (98)} \right\} \end{aligned}$$

(198)

 e_d

$$\text{Where } e_d = \cos \epsilon + \frac{(X_d)}{100} \sin \psi$$

$$= \cos(198a) + \frac{(133)}{100} \sin (198b)$$

(198a) θ Where $\theta = \cos^{-1} \left[\text{(Power Factor)} \right]$
 $= \cos^{-1} \left[(9) \right]$

Where $\Psi = \tan^{-1} \left[\frac{\sin(\theta) + (X_g)/(100)}{\cos(\theta)} \right]$
 $= \tan^{-1} \left[\frac{\sin(198a) + (124)/(100)}{\cos(198a)} \right]$

Where $\epsilon = \Psi - \theta = (198a) - (198a)$

(207) ϕ_{7L} FLUX LEAKAGE FROM STATOR TO ROTOR

$$\phi_{7L} = (P_7) \left[(e_d)(F_g) + (F_{PL}) + (F_T) \left[1 + \cos(\theta) \right] + (F_C) \right] \times 10^{-3}$$

$$= (86) \left[(198) (96) + (213c) + (97) \left[1 + \cos(198a) \right] + (98) \right] \times 10^{-3}$$

(213) ϕ_{PL} FLUX PER POLE at 100% load

(213a) ϕ_{PTL} TOTAL FLUX PER POLE at 100% load

$$\phi_{PTL} = \phi_{PL} + \frac{2(\phi_{7L})}{(P)} = (213) + \frac{2(196a)}{(8)}$$

(213b) B_{PL} FLUX DENSITY AT BASE OF POLE at 100% load

(213c) F_{PL} AMPERE TURNS PER POLE at 100% load

$$F_{PL} = (l_p) \left[\text{NI/in @ density } (B_{PL}) \right]$$

$$= (76) \left[\begin{array}{l} \text{I look up ampere turns/inch on rotor} \\ \text{magnetization curve given in (18) at} \\ \text{density (213b)} \end{array} \right]$$

(221)	ϕ_{g2L}	<u>TOTAL FLUX IN AUXILIARY AIR GAP</u> under load
		$\phi_{g2L} = (\phi_{PTL}) \frac{(P)}{2} + (\phi_{7L})$
		$= (213a) \cdot \frac{(6)}{2} + (207)$
(224)	B_{g2L}	<u>FLUX DENSITY IN AUXILIARY AIR GAP</u> under load
		$B_{g2L} = \frac{\phi_{g2L}}{(A_{g2})} = \frac{(221)}{(70)}$
(225)	F_{g2L}	<u>AUXILIARY AIR GAP AMPERE TURN DROP</u> under load
		$F_{g2L} = (B_{g2L}) \frac{(g_2)}{3.19} \times 10^3 = (224) \frac{(59a)}{3.19} \times 10^3$
(226)	ϕ_{5L}	<u>COIL LEAKAGE FLUX UNDER LOAD</u>
		$\phi_{5L} = (P_5) \left[2(ed)(F_g) + 2(F_{PL}) + (F_{g2L}) + (F_c) + (F_{g3L}) + 2(F_T) \left[1 + \cos(\theta) \right] \right] \times 10^{-3}$
		$= (84) \left[2(198)(96) + 2(213c) + (225) + (98) + (231) + 2(97) \left[1 + \cos(198a) \right] \right] \times 10^{-3}$
(230)	B_{g3L}	<u>AUXILIARY GAP (g_3) FLUX DENSITY</u> - note the flux in air gap (g_2) is equal to flux in gap (g_3)
		$B_{g3L} = \frac{(\phi_{g2L})}{(A_{g3})} = \frac{(221)}{(70a)}$

(231) F_{g3L} AUXILIARY GAP (g_3) AMPERE TURN DROP under load

$$F_{g3L} = \frac{(B_{g3L})(g_3)}{3.19} \times 10^3 = \frac{(230)(59b)}{3.19} \times 10^3$$

(231a) ϕ_{SHL} SHAFT FLUX

$$\phi_{SHL} = (\phi_{g2L}) + (\phi_{5L}) = (221) + (226)$$

(232) B_{SHL} SHAFT DENSITY

$$B_{SHL} = \frac{(\phi_{SHL})}{(A_s)} = \frac{(231a)}{(112)}$$

(233) F_{SHL} SHAFT AMPERE TURN DROP

$$F_{SHL} = (l_{SH}) \left[\text{NI/inch @ } (B_{SHL}) \right]$$

$$= (78) \left[\begin{array}{l} \text{Look upon shaft magnetization curve @} \\ \text{density (232)} \end{array} \right]$$

(236) F_{FL} TOTAL AMPERE TURNS under load

$$F_{FL} = (F_{SHL}) + 2(F_{PL}) + (F_{g2L}) + (F_{g3L}) + (F_c) +$$

$$2(F_g)(e_d) + 2(F_T) [1 + \cos(\theta)]$$

$$= (233) + 2(213c) + (225) + (231) + (98) +$$

$$2(96)(198) + 2(97) [1 + \cos(198a)]$$

(237) I_{FFL} FIELD AMPERES under load

$$I_{FFL} = \frac{(F_{FL})}{(N_F)} = \frac{(236)}{(146)}$$

(239) -- CURRENT DENSITY at 100% load

(238)	E_{FFL}	<u>FIELD VOLTS</u> at 100% load
(241)	I^2R_{FL}	<u>FIELD I^2R</u> at 100% load
(242)	W_{TFL}	<u>STATOR TEETH LOSS</u> at 100% load
(243)	W_{PFL}	<u>POLE FACE LOSS</u> at 100% load
(245)	I^2R_L	<u>STATOR I^2R</u> at 100% load
(246)	--	<u>EDDY LOSS</u>
(247)	--	<u>TOTAL LOSSES</u> at 100% load - sum of all losses at 100% load.
		$\begin{aligned} \text{Total Losses} &= (\text{FIELD } I^2R) + (F\&W) + (\text{Stator Teeth Loss}) \\ &\quad + (\text{Stator Core Loss}) + (\text{Pole Face Loss}) \\ &\quad + (\text{Stator } I^2R) + (\text{Eddy Loss}) \\ &= (241) + (183) + (242) + (185) + (243) + (245) + (246) \end{aligned}$
(248)	--	<u>RATING IN KW</u>
(249)	--	<u>RATING & LOSSES</u>
(250)	--	<u>% LOSSES</u>

(251)

--

% EFFICIENCY

Item (196a) through (251) are 100% load calculations.

These items can be recalculated for any load condition by simply inserting the values that correspond to the % load being calculated. The factor $\frac{(\% \text{ Load})}{100}$ takes care of (I_{PH}) as it changes with load.

Note that values for F&W (183) and W_C (Stator Core Loss) (185) do not change with load, therefore, they can be calculated only once.

INPUT AUXILIARY DATA SHEET

Auxiliary information taken from the design manuals to be used in conjunction with input sheets for convenience.

A. All dimensions for lengths, widths, and diameters are to be given in inches.

B. Resistivity inputs, Items (141) and (151) are to be given in micro-ohm-inches.

The following items along with an explanation of each are tabulated here for convenience. For complete explanation of each item number, refer to design manuals.

- | <u>Item No.</u> | <u>Explanation</u> |
|-----------------|--|
| (9) | Power factor to be given in per unit. For example for 90% P.F., insert <u>.90</u> . |
| (9a) | Adjustment Factor - For P.F. < .95 insert <u>1.0</u>
For P.F. > .95 insert <u>1.05</u> |
| (10) | Optional Load Point -- Where load data output is required at a point other than those given as standard on the input sheet. Example: For load data output at 155% load, insert <u>1.55</u> . |
| (14) | Number of radial ducts in stator. |
| (15) | Width of radial ducts used in Item (14). |
| (18) | Magnetization curve of material used to be submitted as defined in Item (18). |
| (19) | Watts/Lb. to be taken from a core loss curve at the density given in Item (20) (Stator). |
| (20) | Density in kilolines/in ² . This value must correspond to density used to pick Item (19) usually use 77.4 KL/in ² . |
| (21) | Type of slot - For open slot Type A, insert <u>1.0</u> .
For partially open slot Type B with constant slot width, insert <u>2.0</u> .
For partially open slot Type C with constant tooth width, insert <u>3.0</u> .
For round slot Type D, insert <u>4.0</u> .
For additional information, refer to figure adjacent to input sheet which shows a picture of each slot. |
| (22) | For stator slot dimension - for dimensions that do not apply to the slot insert <u>0.0</u> .
Use Table below as guide for input. |

<u>Symbol</u>	<u>Item</u>	<u>Slot Type</u>			
		<u>1</u>	<u>2</u>	<u>3</u>	<u>4</u>
b ₀	(22)	0.0	*	*	*
b ₁		0.0	0.0	*	0.0
b ₂		0.0	0.0	*	0.0
b ₃		0.0	0.0	*	0.0
b _s		*	*	φ	*
h ₀		0.0	*	*	*
h ₁		*	*	*	0.0
h ₂		*	0.0	0.0	0.0
h ₃		*	*	0.0	0.0
h _s		*	*	*	*
h _t		0.0	*	*	0.0
h _w		0.0	*	*	0.0

* = insert actual value.

$$\varphi = b_s = \frac{b_1 + b_3}{2}$$

TWO-COIL LUNDELL (BECKY-ROBINSON TYPE)

COMPUTER DESIGN - - - - - (INPUT)

MODEL _____ EWO _____ DESIGN NO(1) _____

PARAMETERS	(2)	KVA	GENERATOR KVA		FUND/MAX OF FIELD FLUX	(71)	C ₁	CONSTANTS		
	(3)	E	LINE VOLTS		WINDING CONSTANT	(72)	C _w			
	(4)	E _{ph}	PHASE VOLTS		POLE CONSTANT	(73)	C _p			
	(5)	m	PHASES		END EXTENSION ONE TURN	(48)	LE			
	(5a)	f	FREQUENCY		DEMAGNETIZATION FACTOR	(74)	C _m			
	(6)	p	POLES		CROSS MAGNETIZING FACTOR	(75)	C _g			
	(7)	RPM	RPM		POLE EMBRACE	(77)	ε _c			
	(8)	I _{ph}	PHASE CURRENT		WIDTH OF NORTH POLE (END)	(76)	b _{np(end)}			
	(9)	P F	POWER FACTOR		WIDTH OF SOUTH POLE (END)	(76)	b _{sp(end)}			
	(9a)	K _c	ADJ. FACTOR		WIDTH OF NORTH POLE (MID)	(76)	b _{np(mid)}			
	(10)		OPTIONAL LOAD POINT		WIDTH OF SOUTH POLE (MID)	(76)	b _{sp(mid)}			
STATOR STACK	(11)	d	STATOR I.D.		LENGTH OF NORTH POLE	(76)	l _{np}	POLE		
	(12)	D	STATOR O.D.		LENGTH OF SOUTH POLE	(76)	l _{sp}			
	(13)	ℓ	GROSS CORE LENGTH		ROTOR DIAMETER	(11a)	d _r			
	(14)	n _v	NO. OF DUCTS		HEIGHT OF NORTH POLE	(78)	h _{np}			
	(15)	b _v	WIDTH OF DUCT		POLE FACE LOSS FACTOR	(187)	(K ₁)			
	(16)	K ₁	STACKING FACTOR (STATOR)		WIDTH OF SLOT OPENING	(135)	b _{ho}			
	(19)	k	WATTS/LB.		HEIGHT OF SLOT OPENING	(135)	h _{ho}			
STATOR SLOT	(20)	B	DENSITY		DAMPER BAR DIA. OR WIDTH	(136)	()	DAMPER BAR		
	(21)		TYPE OF SLOT		RECTANGULAR BAR THICKNESS	(137)	h _{bl}			
	(22)	b _o	SLOT OPENING		RECTANGULAR SLOT WIDTH	(135)	b _{bl}			
	(22)	b ₁	SLOT WIDTH TOP		NO. OF DAMPER BARS/POLE	(138)	n _b			
	(22)	b ₂			DAMPER BAR LENGTH	(139)	ℓ _b			
	(22)	b ₃			DAMPER BAR PITCH	(140)	T _b			
	(22)	b _s	SLOT WIDTH		RESISTIVITY OF DAMP. BAR @ 20°	(141)	ρ _D			
	(22)	h _o			DAMPER BAR TEMP °C	(142)	X _{oC}			
	(22)	h ₁			DAMPER BAR END RING MEAN DIA.	(170)	d _{dr}			
	(22)	h ₂			DAMPER BAR END RING AREA	(170)	a _{dr}			
	(22)	h ₃			NO. OF FIELD TURNS/COIL	(146)	N _F			
	(22)	h _s	SLOT DEPTH		MEAN LENGTH OF FLD. TURN	(147)	ℓ _f	FIELD		
	(22)	h _t			FLD. COND. DIA. OR WIDTH	(148)				
(22)	h _w			FLD. COND. THICKNESS	(149)					
(23)	Q	NO. OF SLOTS		FLD. TEMP IN °C	(150)	X _f °C				
(28)		TYPE OF WDG.		RESISTIVITY OF FIELD COND @ 20°	(151)	ρ _f				
(29)		TYPE OF COIL		NO LOAD SAT.	(87)					
(30)	n _s	CONDUCTORS/SLOT		FRICITION & WINDAGE	(183)	(F&W)				
STATOR WINDING	(31)	y	SLOTS SPANNED		<table border="1" style="width:100%; height:100%;"> <tr> <td style="width:50%; text-align:center;">STATOR SLOT</td> <td style="width:50%; text-align:center;">POLE</td> </tr> <tr> <td style="width:50%; text-align:center;">DAMPER SLOT</td> <td style="width:50%; text-align:center;">REMARKS</td> </tr> </table>		STATOR SLOT	POLE	DAMPER SLOT	REMARKS
	STATOR SLOT	POLE								
	DAMPER SLOT	REMARKS								
	(32)	c	PARALLEL CIRCUITS							
	(33)		STRAND DIA. OR WIDTH							
	(34)	N _{st}	STRANDS/CONDUCTOR INDEPTH							
	(34a)	N' _{st}	STRANDS/CONDUCTOR							
	(39)		STATOR STRAND T'KNS.							
	(35)	d _b	DIA. OF PIN							
	(36)	ℓ _{e2}	COIL EXT. STR. PORT							
	(37)	h _{st}	UNINS. STRD. HT.							
(38)	h' _{st}	DIST. BTWN. CL OF STD.								
(42a)		PHASE BELT ANGLE								
(40)	T _{sk}	STATOR SLOT SKEW								
(50)	X °C	STATOR TEMP °C								
(51)	ρ _s	RESISTIVITY STA. COND. @ 20 °C								
AIR GAP	(59a)		TYPE OF GAP g ₃		DESIGNER _____ DATE _____					
	(59)	g	MAIN AIR GAP							
	(59a)	g _R	AUX GAP							
	(59)	g ₂ g	EFFECTIVE g ₃							

TWO-COIL LUNDLL (BECKY-ROBINSON TYPE)

COMPUTER DESIGN - - - - - (INPUT)

MODEL _____ EWO _____ DESIGN NO(1) _____

PERMEANCE	(80)	P ₁	PERM OF LEAKAGE PATH 1	
	(81)	P ₂	PERM OF LEAKAGE PATH 2	
	(82)	P ₃	PERM OF LEAKAGE PATH 3	
	(83)	P ₄	PERM OF LEAKAGE PATH 4	
	(84)	P ₅	PERM OF LEAKAGE PATH 5	
	(85)	P ₆	PERM OF LEAKAGE PATH 6	
	(86)	P ₇	PERM OF LEAKAGE PATH 7	
	(80a)	ℓ ₁	LENGTH OF LEAKAGE PATH 1	
	(81a)	ℓ ₂	LENGTH OF LEAKAGE PATH 2	
	(85)	ℓ ₆	LENGTH OF LEAKAGE PATH 6	
(84)	ℓ _c	LENGTH OF LEAKAGE ACROSS COIL		
ROTOR DIMENSIONS	(73)	d _{ir}	INSIDE DIA OF ROTOR TUBE	
	(78)	d _g	INSIDE DIA OF HOLLOW SHAFT	
	(78)	h _y	HEIGHT OF COIL YOKE	
	(78)	ℓ _y	LENGTH OF COIL YOKE	
	(78)	ℓ _{sk}	LENGTH OF ROTOR SKIRT	
	(78)	ℓ _{γ4}	EFFECTIVE LENGTH OF SHAFT	
	(78)	ℓ _{g2}	HORIZONTAL LENGTH OF GAP g ₂	
	(78)	T _{sp}	THICKNESS OF SOUTH POLE	
(78)	T _{sk}	THICKNESS OF ROTOR SKIRT		
GAP g ₃ DIMENSIONS	(78)	d _{to}	TAPERED GAP DIMENSIONS	
	(78)	d ₁₁		
	(78)	d ₁		
	(78)	d ₂		
	(78)	d ₃	STEPPED GAP DIMENSIONS	
	(78)	d ₄		
	(78)	d ₅		
	(78)	ℓ _{s1}		
	(78)	ℓ _{s2}		
	(78)	ℓ _{s3}	STEPPED GAP HORIZONTAL LENGTHS	
	(78)	ℓ _{s4}		
	(78)	ℓ _{s5}		
(78)	d _{es}	EFFECTIVE SHAFT O.D.		
MATERIAL	(243)	W _{PHR}	POLE FACE HARMONIC LOSS	
	(244)	W _{DHR}	DAMPER BAR HARMONIC LOSS	
	(157)		WEIGHT OF ROTOR IRON	
	(18)		STATOR LAM. MTK'L	
(18)		SOUTH POLE, TUBE & SKIRT		
(18)		NORTH POLE, SPIDER & SHAFT		
(18)		COIL YOKE		

(a) Open Slots

(b) Constant Slot Width

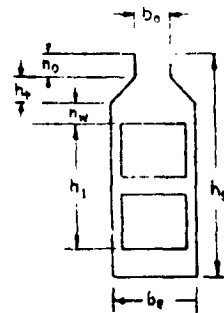
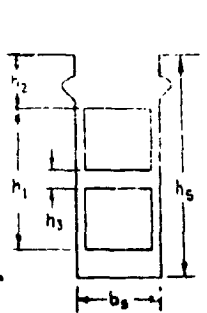

TYPE 1
 (Type 5 is an open slot with 1 conductor per slot)

TYPE 2

(c) Constant Tooth Width

(d) Round Slots

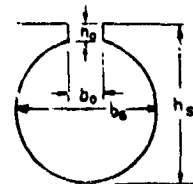
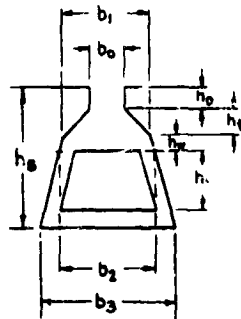

TYPE 3

b_s for type 3 is

$$b_s = \frac{b_2 + b_3}{2}$$

TYPE 4

TWO-COIL LUNDELL (BECKY-ROBINSON TYPE)
SUMMARY OF DESIGN CALCULATIONS - - - - - (OUTPUT)

	MODEL	EWO	DESIGN NO.	
STATOR	(17) (l_a)	SOLID CORE LENGTH		CARTER COEFFICIENT (67) (K_a)
	(24) (h_c)	DEPTH BELOW SLOT		EFFECTIVE AIR GAP (69) (g_e)
	(26) (T_s)	SLOT PITCH		FUND/MAX OF FIELD FLUX (71) (C_1)
	(27) (T_s 1/3)	SLOT PITCH 1/3 DIST. UP		WINDING CONST. (72) (C_w)
	(42) (K_{sk})	SKEW FACTOR		POLE CONST. (73) (C_p)
	(43) (K_d)	DIST. FACTOR		END. EXT. ONE TURN (48) (L_F)
	(44) (K_p)	PITCH FACTOR		DEMAGNETIZING FACTOR (74) (C_M)
	(45) (n_a)	EFF. CONDUCTORS		CROSS MAGNETIZING FACTOR (75) (C_q)
	(46) (a_e)	COND. AREA		AMP COND/IN (128) (A)
	(47) (S)	CURRENT DENSITY (STA.)		REACTANCE FACTOR (129) (X)
	(49) (l_t)	1/2 MEAN TURN LENGTH		LEAKAGE REACTANCE (130) (X_g)
	(53) (R_{ph})	COLD STA. RES. @ 20°C		REACTANCE OF ARMATURE REACTION (131) (X_{ad})
	(54) (R_{ph})	HOT STA. RES.		ARMATURE REACTION (132) (X_{ag})
	(55) (EF_{top})	EDDY FACTOR TOP		SYN REACT DIRECT AXIS (133) (X_d)
	(56) (EF_{bot})	EDDY FACTOR BOT		SYN REACT QUAD AXIS (134) (X_q)
	(62) (λ_1)	STATOR COND. PERM.		FIELD LEAKAGE REACT (160) (X'_f)
(64) (λ_e)	END PERM.		FIELD SELF INDUCTANCE (161) (L_f)	
(65) ()	WT. OF STA. COPPER		DAMPER (163) (X_{Dd})	
(66) ()	WT. OF STA. IRON		LEAKAGE REACTANCES (165) (X_{Dq})	
ROTOR	(41) (T_p)	POLE PITCH		UNSAT. TRANS. REACT (166) (X'_{du})
	(157) (-)	WT. OF ROTOR IRON		SAT. TRANS. REACT (187) (X'_d)
	(145) (V_r)	PERIPHERAL SPEED		SUB. TRANSREACT DIRECT AX. (168) (X''_d)
	(153) (a_{ct})	FLD COND. AREA		SUB. TRANSREACT QUAD AX. (169) (X''_q)
FIELD	(154) (R_f)	COLD FLD RES. @ 20°C		NEG. SEQUENCE REACT (170) (X_2)
	(155) (R_f)	HOT FLD RES.		ZERO SEQUENCE REACT (172) (X_0)
	(156) (-)	WT. OF FLD. COPPER		TOTAL FLUX (90) (ϕ_T)
	(176) (T'_{d0})	OPEN CIR. TIME CONST.		FLUX PER POLE (93) (ϕ_p)
TIME CONST.	(177) (T_a)	ARM TIME CONST.		GAP DENSITY (MAIN) (95) (B'_g)
	(178) (T'_d)	TRANS TIME CONST.		TOOTH DENSITY (91) (B'_t)
	(179) (T''_d)	SUB TRANS TIME CONST.		CORE DENSITY (94) (B'_c)
	(80) (P_1)	PERM OF LEAKAGE PATH 1		TOOTH AMPERE TURNS (97) (F'_t)
PERMEANCE	(81) (P_2)	PERM OF LEAKAGE PATH 2		CORE AMPERE TURNS (98) (F'_e)
	(82) (P_3)	PERM OF LEAKAGE PATH 3		GAP AMPERE TURNS (MAIN) (96) (F'_g)
	(83) (P_4)	PERM OF LEAKAGE PATH 4		SHORT CIR NI (180) (F_{SC})
	(84) (P_5)	PERM OF LEAKAGE PATH 5		SHORT CIR RATIO (181) (SCR)
	(85) (P_6)	PERM OF LEAKAGE PATH 6		
	(86) (P_7)	PERM OF LEAKAGE PATH 7		

	PERCENT LOAD	0	100	150	200	OPTIONAL
VARIABLE LOAD	(B_{np}) (116) N.P. DENSITY		(B_{np11}) (234)			
	(B_{sp}) (105) S.P. DENSITY		(B_{sp11}) (215)			
	(B_{y2}) (125) COIL YOKE DENSITY		(B_{y211}) (228)			
	(B_{y4}) (113) SHAFT DENSITY		(B_{y411}) (232)			
	(B_{g3}) (119) AUX. GAP(g3) DENSITY		(B_{g311}) (230)			
	(B_{g2}) (122) AUX. GAP(g2) DENSITY		(B_{g211}) (224)			
	(F_{nl}) (127) TOTAL NI		(F_{nl}) (236)			
	(I_f) (127a) FIELD AMPERES		(I_{f11}) (237)			
	(S_f) (127c) CUR. DEN. FLD.		(S_{f11}) (239)			
	(E_{f11}) (127b) FIELD VOLTS		(E_{f11}) (238)			
	(W_g) (185) STA CORE LOSS		(W_{g11}) (185)			
	(W_{ml}) (184) STA TOOTH LOSS		(W_{ml11}) (242)			
	(W_{dp}) (193) DAMPER LOSS		(W_{dp11}) (244)			
	($I_2 R_2$) (194) STATOR CU LOSS		($I_2 R_{211}$) (245)			
	(-) (195) EDDY LOSS		(-) (246)			
	(W_{p11}) (186) POLE FACE LOSS		(W_{p11}) (243)			
	($I_2 R_f$) (182) FIELD COIL LOSS		($I_2 R_{f11}$) (241)			
	($F&W$) (183) F&W LOSS		($F&W$) (183)			
	(-) (196) TOTAL LOSSES		(-) (247)			
	(-) (-) PERCENT EFF.		(-) (251)			

TWO-COIL LUNDELL (BECKY-ROBINSON TYPE)

NO LOAD SATURATION OUTPUT SHEET

ITEMS → VOLTS	(3) (E) VOLTS	(95) B'_g DENSITY MAIN GA.	(122) B_{g2} DENSITY g_2	(119) B_{g3} DENSITY g_3	(94) B'_c DENSITY STATOR CORE	(91) B'_T DENSITY STATOR TOOTH
	(125) B_{y2} CYL YOKE	(105) B_{SP} DENSITY S. P.	(116) B_{NP} DENSITY N. P.	(113) B_{y4} SHAFT DENSITY	(93) ϕ'_p FLUX PER POLE	(127) F_{NL} TOTAL NI
80%						
90%						
100%						
110%						
120%						
130%						
140%						
150%						
160%						

TWO-COIL LUNDELL (BECKEY-ROBINSON TYPE)
COMPUTER DESIGN MANUAL

(1)	--	DESIGN NUMBER
(2)	KVA	GENERATOR KVA
(3)	E	LINE VOLTS
(4)	E_{PH}	PHASE VOLTS
(5)	m	PHASES
(5a)	f	FREQUENCY
(6)	P	POLES
(7)	RPM	SPEED
(8)	I_{PH}	PHASE CURRENT
(9)	P. F.	POWER FACTOR
(9a)	K_c	ADJUSTMENT FACTOR
(10)	--	LOAD POINTS
(11)	d	STATOR PUNCHING I.D.
(11a)	d_r	ROTOR O.D.
(12)	D	PUNCHING O.D.
(13)	ℓ	GROSS STATOR CORE LENGTH
(14)	n_v	RADIAL DUCTS
(15)	b_v	RADIAL DUCT WIDTH
(16)	K_1	STACKING FACTOR
(17)	ℓ_s	SOLID CORE LENGTH

(18)

MATERIAL - This input is used in selecting the proper magnetization curves for stator; tube, south pole and skirt; yoke; north pole, spider and shaft; when different materials are used. Separate spaces are provided on the input sheet for each section mentioned above. Where curves are available on card decks, used the proper identifying code. Where card decks are not available submit data in the following manner:

The magnetization curve must be available on semi-log paper. Typical curves are shown in this manual on Curves F15 and F16. Draw straight line segments through the curve starting with zero density. Record the coordinates of the points where the straight line segments intersect. Submit these coordinates as input data for the magnetization curve. The maximum density point must be submitted first.

Refer to Figure below for complete sample

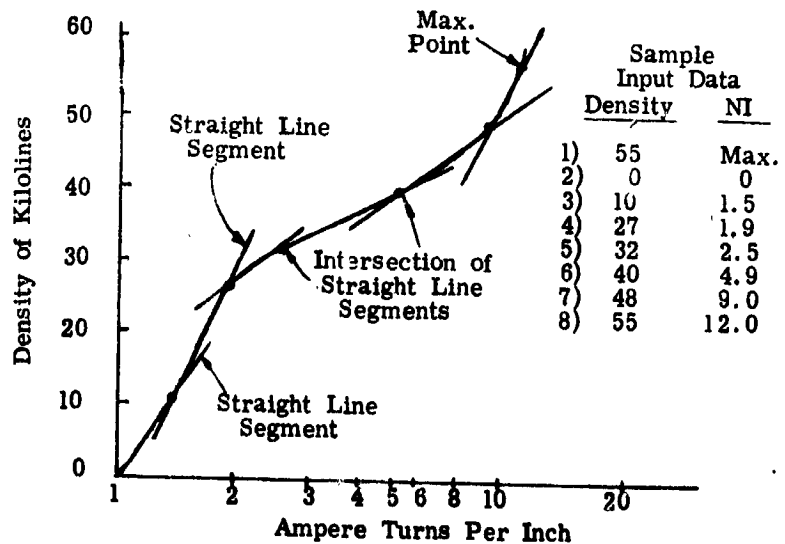

(19)	k	WATTS/LB
(20)	B	DENSITY
(21)		TYPE OF STATOR SLOT
(22)		ALL SLOT DIMENSIONS
(23)	Q	STATOR SLOTS
(24)	h_c	DEPTH BELOW SLOTS
(25)	q	SLOTS PER POLE PER PHASE
(26)	τ_s	STATOR SLOT PITCH
(27)	$\tau_s^{1/3}$	STATOR SLOT PITCH
(28)	--	TYPE OF WINDING
(29)	--	TYPE OF COIL
(30)	n_s	CONDUCTORS PER SLOT
(31)	γ	THROW
(31a)		PER UNIT OF POLE PITCH SPANNED
(32)	C	PARALLEL PATHS
(33)	--	STRAND DIA. OR WIDTH
(34)	N_{ST}	NUMBER OF STRANDS PER CONDUCTOR IN DEPTH
(34a)	N'_{ST}	NUMBER OF STRANDS PER CONDUCTOR
(35)	d_b	DIAMETER OF BENDER PIN
(36)	ℓ_{e2}	COIL EXTENSION BEYOND CORE
(37)	h_{ST}	HEIGHT OF UNINSULATED STRAND
(38)	h'_{ST}	DISTANCE BETWEEN CENTERLINES OF STRANDS IN DEPTH

(39)	--	STATOR COIL STRAND THICKNESS
(40)	τ_{SK}	SKEW
(41)	τ_P	POLE PITCH
(42)	K_{SK}	SKEW FACTOR
(42a)		PHASE BELT ANGLE
(43)	K_d	DISTRIBUTION FACTOR
(44)	K_p	PITCH FACTOR
(45)	n_e	TOTAL EFFECTIVE CONDUCTORS
(46)	a_c	CONDUCTOR AREA OF STATOR WINDING
(47)	S_S	CURRENT DENSITY
(48)	L_E	END EXTENSION LENGTH
(49)	l_t	1/2 MEAN TURN
(50)	X_s °C	STATOR TEMP °C
(51)	ρ_s	RESISTIVITY OF STATOR WINDING
(52)	$\rho_{s(hot)}$	RESISTIVITY OF STATOR WINDING
(53)	R_{SPH} (cold)	STATOR RESISTANCE/PHASE
(54)	R_{SPH} (hot)	STATOR RESISTANCE/PHASE
(55)	EF (top)	EDDY FACTOR TOP
(56)	EF (bot)	EDDY FACTOR BOTTOM

(57)	b_{tm}	STATOR TOOTH WIDTH
(57a)	$b_{t1/3}$	STATOR TOOTH WIDTH
(58)	b_t	TOOTH WIDTH AT STATOR I.D. IN INCHES
(59)	g	MAIN AIR GAP IN INCHES
(59a)	g_2	AUXILIARY AIR GAP in inches. Refer to Figure 3
(59b)		TYPE OF GAP g_3 . Refer to Figure 4 For stepped gap use <u>1.</u> on input sheet. For tapered gap use <u>2.</u> on input sheet.
(59c)	g_3	AIR GAP (g_3) in inches. Refer to Figure 4 When (59b) = <u>2.</u> then $(g_3) = (g_{3e})$ (59c) = (59f) When (59b) = <u>1.</u> go on to (59d)
(59d)	g_{3-1}	AIR GAP g_{3-1} in inches. Refer to Figure 4
(59e)	g_{3-2}	AIR GAP g_{3-2} in inches. Refer to Figure 4
(59f)	g_{3e}	EFFECTIVE AIR GAP LENGTH TO BE SPECIFIED ON INPUT SHEET When (59b) = <u>2.</u> then $g_{3e} = g_3$ or (59f) = (59c) When (59d) = (59e), then $g_{3E} = (59d)$ When (59d) \neq (59e), then $g_{3E} = \frac{(59d) + (59e)}{2}$
(60)	C_X	REDUCTION FACTOR
(61)	K_X	<u>FACTOR TO ACCOUNT FOR DIFFERENCE</u> in phase current in coil sides in same slot.
(62)	λ_1	CONDUCTOR PERMEANCE
(63)	K_E	LEAKAGE REACTIVE FACTOR
(64)	λ_E	END WINDING PERMEANCE

- (65) -- WEIGHT OF COPPER
 (66) -- WEIGHT OF STATOR IRON
 (67) K_g CARTER COEFFICIENT
 (68) A_g MAIN AIR GAP AREA
 (69) g_e EFFECTIVE AIR GAP
 (70) A_{g2} AUXILIARY AIR GAP (g_2) AREA

$$= \pi [(d_{ir}) + (g_2)] (\ell_{g2})$$

$$= \pi [(78) + (59a)] (78)$$

- (70a) A_{g3} AUXILIARY AIR GAP (g_3) AREA

When (59b) = 1.0 calculate as follows:

$$A_{g3} = \pi \{ (d_{s1}) (\ell_{s1}) + (d_{s2}) (\ell_{s2}) + (d_{s3}) (\ell_{s3}) + (d_{s4}) (\ell_{s4}) + (d_{s5}) (\ell_{s5}) \} +$$

$$\pi \left\{ \frac{(d_{os})^2 - (d_{s1})^2}{4} \right\}$$

= All dimensions located at item (78)

NOTE: Number of steps limited to 5 in this program.

When (59b) = 2.0 calculate as follows:

$$A_{g3} = \frac{\pi}{2} [(d_{to}) + (d_{t1})] \sqrt{4(\ell_{y4})^2 + [(d_{to}) - (d_{t1})]^2}$$

$$A_{g3} = \frac{\pi}{2} [(78) + (78)] \sqrt{4(78)^2 + [(78) - (78)]^2}$$

(71)	C_1	<u>THE RATIO OF MAXIMUM FUNDAMENTAL</u> of the field form to the actual maximum of the field form.
(72)	C_W	<u>WINDING CONSTANT</u>
(73)	C_p	<u>POLE CONSTANT</u>
(74)	C_M	<u>DEMAGNETIZING FACTOR</u>
(75)	C_q	<u>CROSS MAGNETIZING FACTOR</u>
(75a)	--	<u>TYPE OF POLE</u> - This computer program is presently set up to handle two types of pole shapes: 1) A rectangular or square type of pole. 2) A hexagonal type. Refer to Figure L-2

Type 1 (Rectangular or Square Pole)

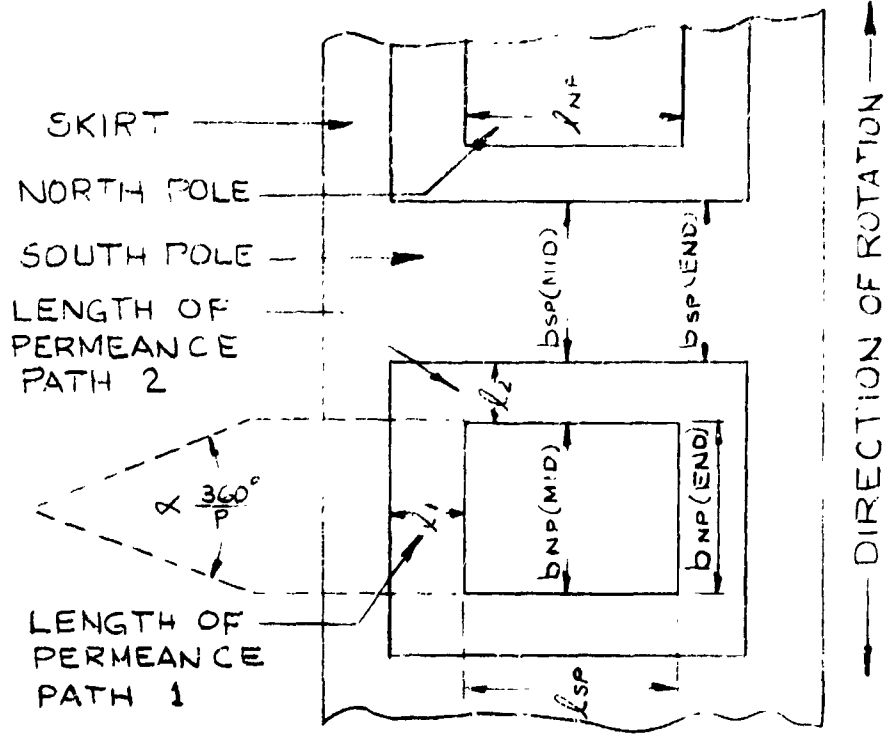

Type 2 (Hexagonal Pole)

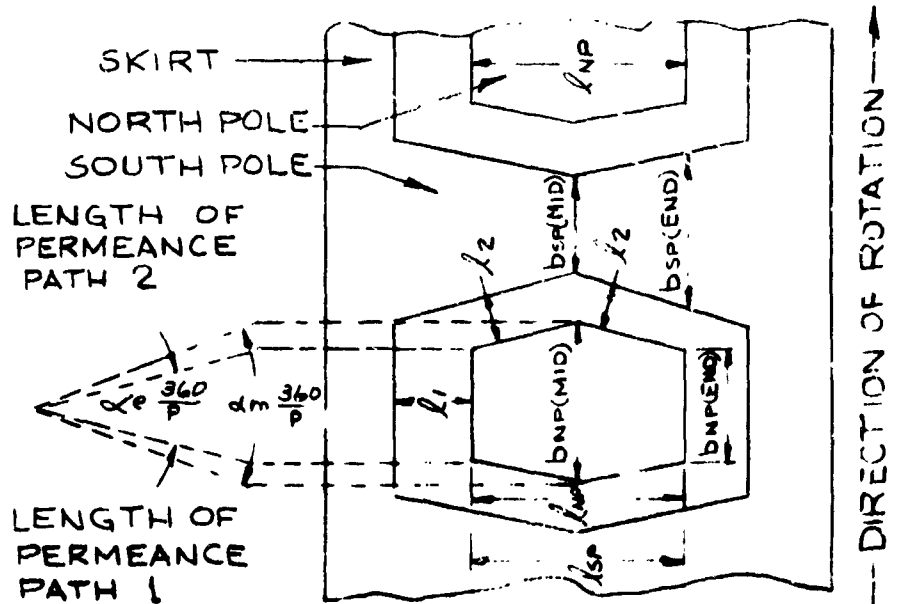

The above sections represent a view into the north and south pole from main air gap. This program is presently set up to handle only two types of pole shapes: 1) Rectangular or square, 2) Hexagonal.

Figure L-2

(76)

--

POLE DIMENSION LOCATIONS per Figure L-2

All dimensions given in inches.

$b_{sp}(\text{end})$ - Width of south pole at end of stator stack.

$b_{sp}(\text{mid})$ - Width of south pole at middle of south pole.

$b_{np}(\text{end})$ - Width of north pole at end of north pole.

$b_{np}(\text{mid})$ - Width of north pole at middle of north pole.

l_{sp} - Length of south pole.

l_{np} - Length of north pole.

(77)

α

POLE EMBRACE - This value must be recorded on the input sheet.

When $b_{np}(\text{end}) = b_{np}(\text{mid})$

$$\alpha = \frac{[b_{np}(\text{end})]}{(\tau_p)} = \frac{(76)}{(41)}$$

When $b_{np}(\text{end}) \neq b_{np}(\text{mid})$

$$\alpha = \frac{(\alpha_e) + (\alpha_m)}{2} = \frac{(77) + (77)}{2}$$

$$\text{Where } \alpha_e = \frac{[b_{np}(\text{end})]}{(\tau_p)} = \frac{(76)}{(41)}$$

$$\alpha_m = \frac{[b_{np}(\text{mid})]}{(\tau_p)} = \frac{(76)}{(41)}$$

(77a)

The next eleven (11) items deal with the calculation of rotor and stator leakage permeance. A number of illustrations are included to help identify and locate the

actual path. This computer program is set up to handle the permeance calculations two ways:

- 1) P_1 through P_7 can be calculated by computer. For this program insert 0. on input sheet.
- 2) P_1 through P_7 can be calculated by designer. For this case insert actual calculated value on input sheet.

Permeance calculations P_1 through P_7 are all based on the equation

$$P = \frac{\mu (\text{area})}{l}$$

Where $\mu = 3.19$

Area l = cross sectional area perpendicular to
= length of path

(78)

ROTOR DIMENSION LOCATIONS per Figure B-10

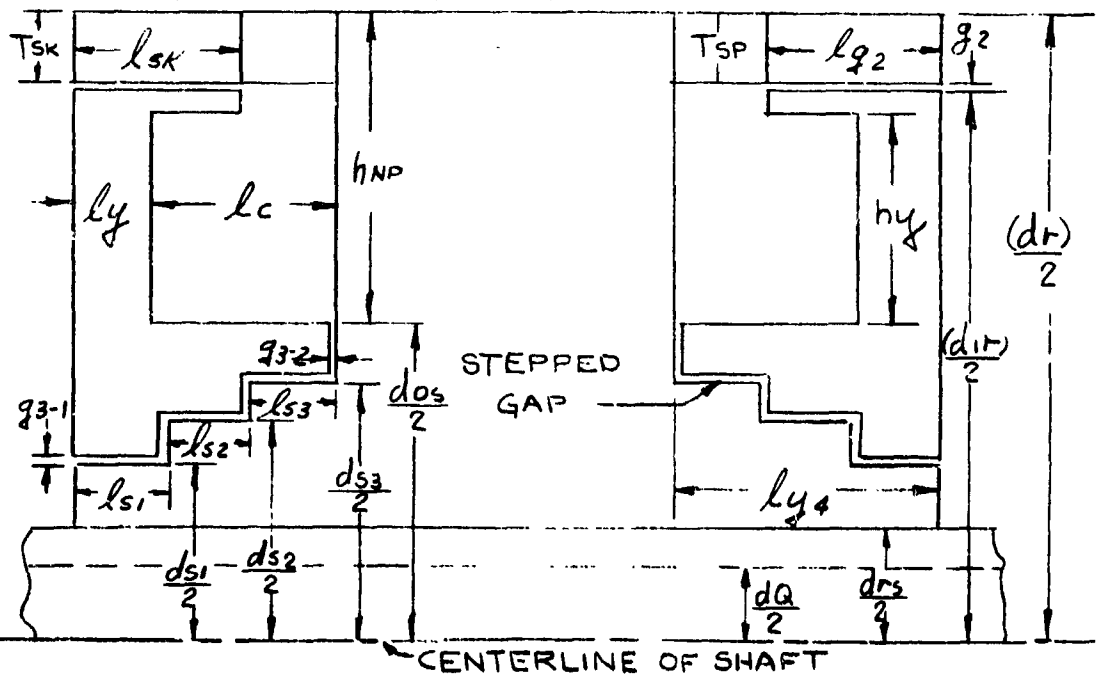

Figure L-3

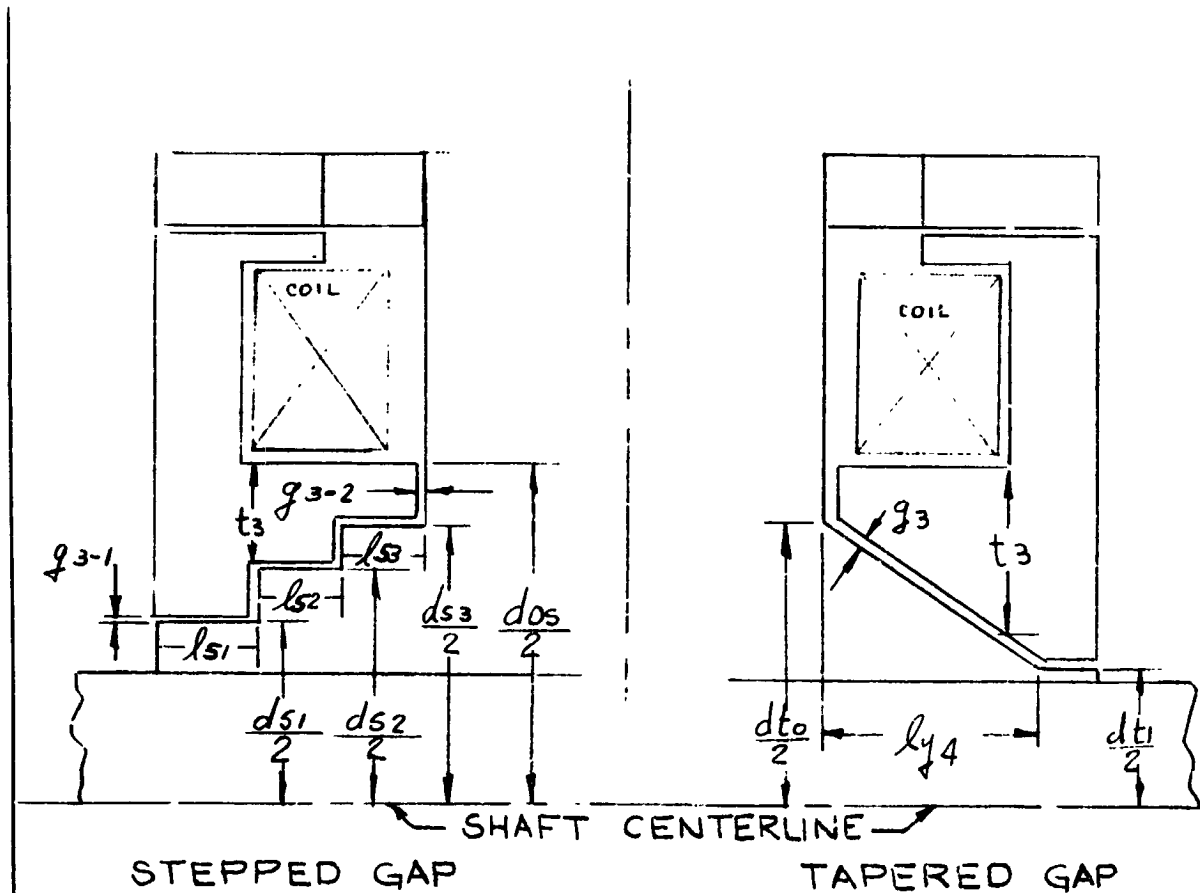

Figure L-4

(78)

- | | |
|----------|--|
| d_{s1} | } Diameters of steps in stepped gap g_3 . Computer program is set up to handle a maximum of 5 steps. Where the dimensions do not apply, insert 0.0 on input sheet. |
| d_{s2} | |
| d_{s3} | |
| d_{s4} | |
| d_{s5} | |
| d_{o3} | |
| l_{s1} | } Horizontal length of stepped gap g_3 . Computer program is set up to handle a maximum of 5 steps. |
| l_{s2} | |
| l_{s3} | |
| l_{s4} | |
| l_{s5} | |

(78)
(CONT'D)

- d_{ir} = inside diameter of tube.
 d_Q = inside diameter of hollow shaft.
 d_{to} For tapered gap only. Insert 0.0 on input sheet
 d_{tl} when stepped gap is used.
 h_{np} = Height of north pole.
 h_y = Height of yoke.
 l_y = Length of yoke.
 l_{y4} = Effective length of shaft - the portion carrying flux.
 l_{g2} = Horizontal length of g_2 .
 l_{sk} - Length of rotor skirt.
 T_{sp} = Thickness of south pole.
 T_{sk} = Thickness of rotor skirt.

All dimensions given in inches.

All dimensions listed above that apply should be filled out on input sheet. Where the dimensions do not apply, insert 0.0 on input sheet.

(79) a_{np}

NORTH POLE AREA - The effective cross-sectional area of the north pole.

When $b_{np}(\text{end}) = b_{np}(\text{mid})$

$$a_{np} = (l_{np}) [b_{np}(\text{end})] \\ = (76) (76)$$

When $b_{np}(\text{end}) \neq b_{np}(\text{mid})$

$$a_{np} = \frac{(l_{np})}{2} [(b_{np}(\text{end}) + b_{np}(\text{mid}))] \\ = \frac{(76)}{2} [(76) + (76)]$$

When radially tapered poles are used, use the dimensions at the base of the pole to calculate the area.

(79a) a_{sp}

SOUTH POLE AREA - The effective cross-sectional area of south pole. Cross-sectional to the path of flux at the point in line with edge of stator stack.

$$\begin{aligned} a_{sp} &= (b_{sp}(\text{end})) (T_{sp}) \\ &= (76) (78) \end{aligned}$$

(79b) a_{sk}

AREA OF SKIRT - At entry edge of auxiliary air gap g_2 in inches².

$$\begin{aligned} a_{sk} &= \pi \left[(d_r) - (T_{sk}) \right] (T_{sk}) \\ &= \pi \left[(11a) - (78) \right] (78) \end{aligned}$$

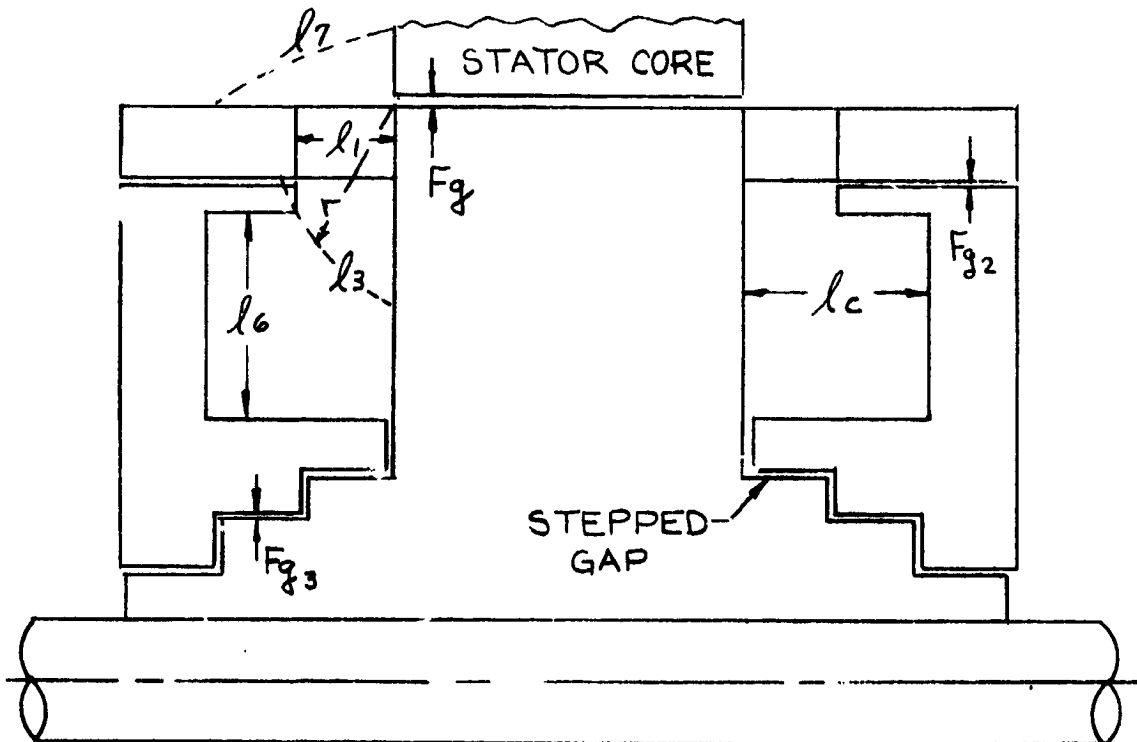

Figure L-5

(80) P₁

POLE HEAD END LEAKAGE PERMEANCE - This input

can be either 0.0 or the actual value if available.

Refer to Item (77a) for explanation. See Figure L 2 for location.

$$P_1 = 3.19 \frac{[(b_{np}(\text{end})) + (\ell_2)] [(T_{sp}) (p)]}{(\ell_1)}$$
$$= 3.19 \frac{[(76) + (81a)] [(78) (6)]}{(80a)}$$

(80a) ℓ_1

Where ℓ_1 = length of leakage path P₁ and must be specified on input sheet. Refer to Figure L 2 for location.

(81) P₂

POLE HEAD SIDE LEAKAGE PERMEANCE - Refer to

Figure L 2

This input can be either 0.0 or the actual value if available. Refer to Item (77a) for explanation.

When $b_{np}(\text{end}) = b_{np}(\text{mid})$

$$P_2 = 3.19 \frac{[(\ell_{np}) + (\ell_1)] (T_{sp})(P)}{(\ell_2)}$$

$$P_2 = 3.19 \frac{[(76) + (80a)] (78) (6)}{(81a)}$$

When $b_{np}(\text{end}) \neq b_{np}(\text{mid})$

$$P_2 = 6.28 \frac{\left[\frac{1}{2} \sqrt{[b_{np}(\text{mid}) - b_{np}(\text{end})]^2 + (\ell_{np})^2} + \frac{\ell_1}{2} \right] (T_{sp})(P)}{(\ell_2)}$$

$$6.28 \frac{\left[\frac{1}{2} \sqrt{[(76) - (76)]^2 + (76)^2} + \frac{(80a)}{2} \right] (78)(6)}{(81a)}$$

(81a) l_2 LENGTH OF LEAKAGE PATH P_2 and must be specified on input sheet. Refer to Figure L2 for location.

(82) P_3 POLE BODY END LEAKAGE PERMEANCE - Refer to Figure L5

This input can be either 0.0 or the actual value if available. Refer to Item (77a) for explanation.

$$P_3 = 3.19 \frac{[b_{np}(\text{end})] [(h_{np}) - (T_{sp})] (P)}{l_3}$$

$$= 3.19 \frac{[(76)] [(78) - (78)] (6)}{(82a)}$$

(82a) l_3 LENGTH OF PERMEANCE PATH P_3

$$= [(d_r) - (d_{os})] \frac{\pi}{8} - (T_{sp})$$

$$= [(11a) - (78)] \frac{\pi}{8} - (78)$$

(83) P_4 POLE BODY SIDE LEAKAGE PERMEANCE - This input can be either 0.0 or the actual value if available. Refer to Item (77a) for explanation. This calculation varies with the number of poles. The four-pole calculation differs from the six-pole calculation but the 6, 8, 10 and 12 pole calculations are the same. Refer to Figures L7, L8, L9

When $(6) = 4$ and $b_{np}(\text{end}) = b_{np}(\text{mid})$

$$P_4 = 3.19 \frac{\left[\frac{(d_r)}{2} - (T_{sp}) \right] \left[(\ell_{np}) + (\ell_1) \right]}{(\ell_4)} (P)$$

$$= 3.19 \frac{\left[\frac{(11a)}{2} - (78) \right] \left[(76) + (80a) \right]}{(83)} (6)$$

Where $\ell_4 = \frac{(d_r) - (d_{os})}{2} - (T_{sp})$

$$= \frac{(11a) - (78)}{2} - (78)$$

When $(6) = 4$ and $b_{np}(\text{end}) \neq b_{np}(\text{mid})$

$$P_4 = 3.19 \frac{\left[\frac{(d_r)}{2} - (T_{sp}) \right] \left[\frac{1}{4} \sqrt{[(b_{np}(\text{mid}) - b_{np}(\text{end}))^2 + (\ell_{np})^2 + \frac{(\ell_1)^2}{2}]^{1/2}} \right]}{(\ell_4)} 2(P)$$

$$= 3.19 \frac{\left[\frac{(11a)}{2} - (78) \right] \left[\frac{1}{4} \sqrt{[(76) - (76)]^2 + (76)^2 + \frac{(80a)^2}{2}} \right]}{(83)} 2(6)$$

When $(6) \geq 6$ and $b_{np}(\text{end}) = b_{np}(\text{mid})$

$$P_4 = 3.19 \frac{\left[\frac{(d_r) - d_{os}}{2} - (T_{sp}) \right] \left[(\ell_{np}) + (\ell_1) \right]}{(\ell_{4a})} (P)$$

$$= 3.19 \frac{\left[\frac{(11a) - (78)}{2} - (78) \right] \left[(76) + (80a) \right]}{(83)} (6)$$

Where $\ell_{4a} = \left[\frac{(d_r)}{2} - (T_{sp}) \right] \sin \frac{2\pi}{(P)} \left[1 - \frac{(\alpha)}{4} \right] - \frac{(b_{np}(\text{end}))}{2}$

$$= \left[\frac{(11a)}{2} - (78) \right] \sin \frac{2\pi}{(6)} \left[1 - \frac{(77)}{4} \right] - \frac{(76)}{2}$$

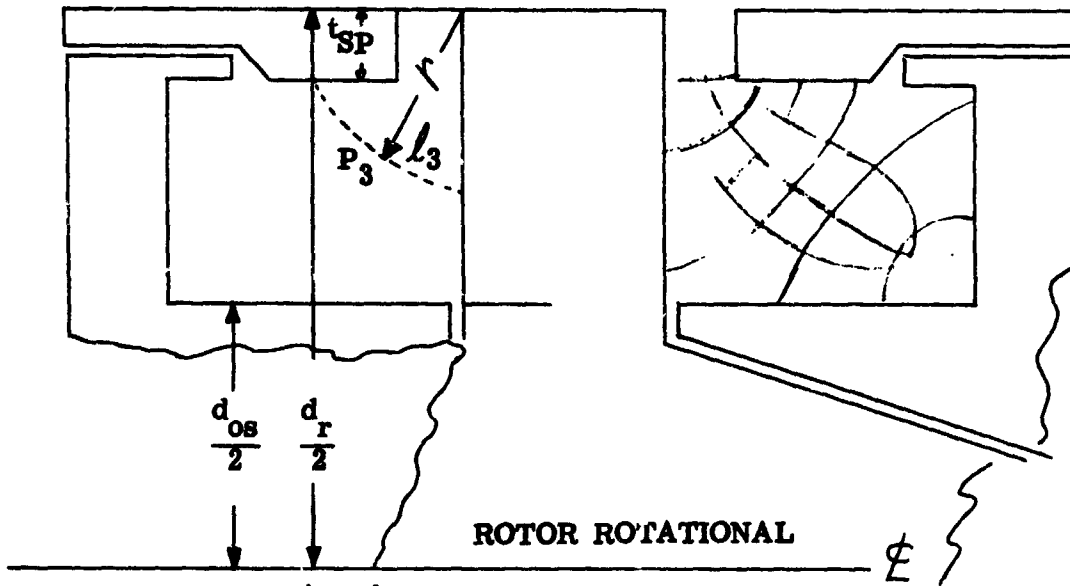

$$n \text{ above} = \frac{d_r - d_{os}}{4}$$

$$l_3 = \left(\frac{d_r - d_{os}}{4} \frac{\pi}{2} \right) - t_{SP} = (d_r - d_{os}) \frac{\pi}{8} - t_{SP}$$

$$P_3 = \frac{3.19 b_{HP} (P - t_{SP}) P}{l_3}$$

Figure L-6

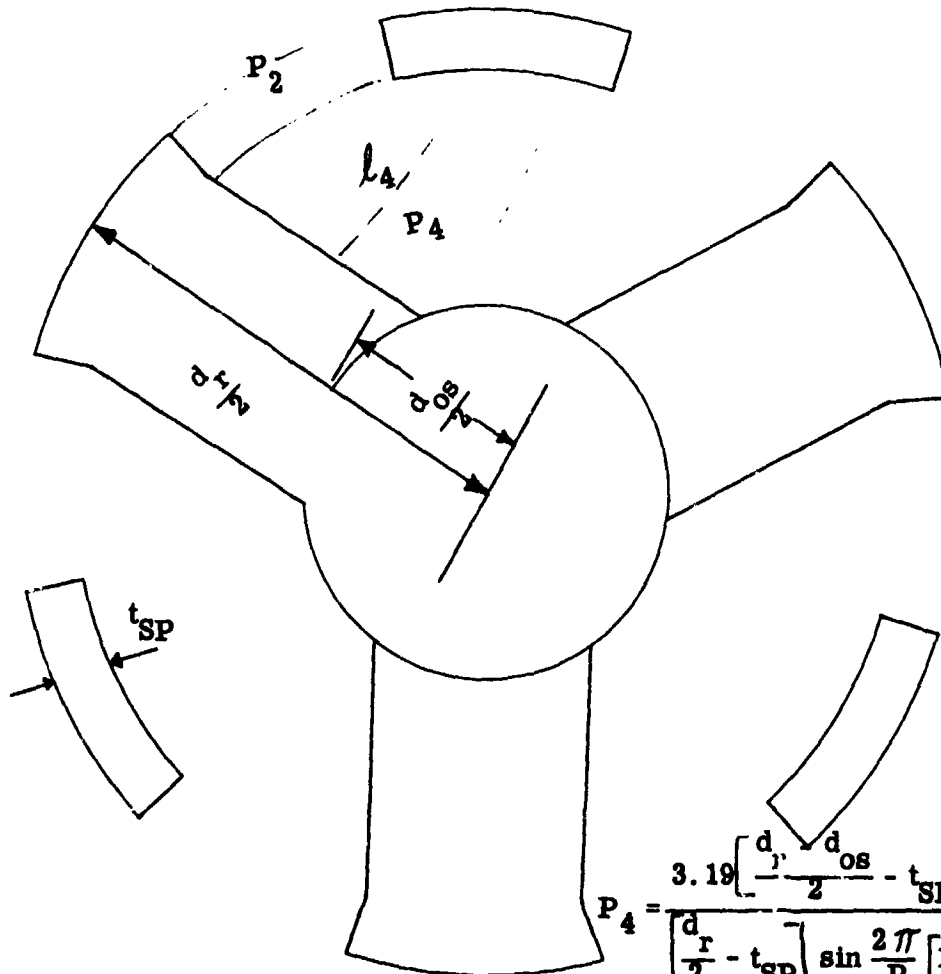

$$P_4 = \frac{3.19 \left[\frac{d_r}{2} - \frac{d_{os}}{2} - t_{SP} \right] (l_{NP} + l_1) P}{\left[\frac{d_r}{2} - t_{SP} \right] \sin \frac{2\pi}{P} \left[1 - \frac{\infty}{4} \right] - \frac{b_{NP}}{2}}$$

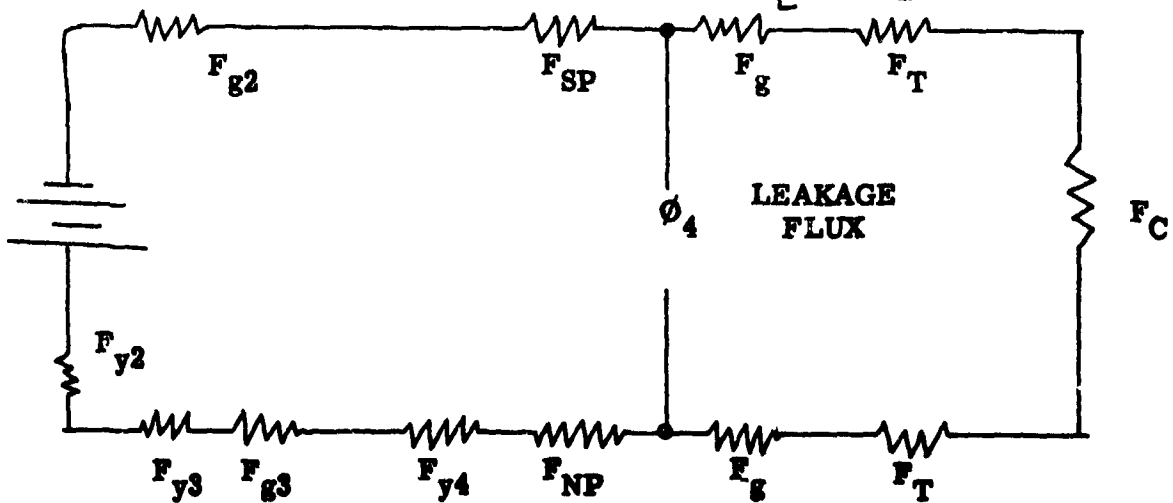
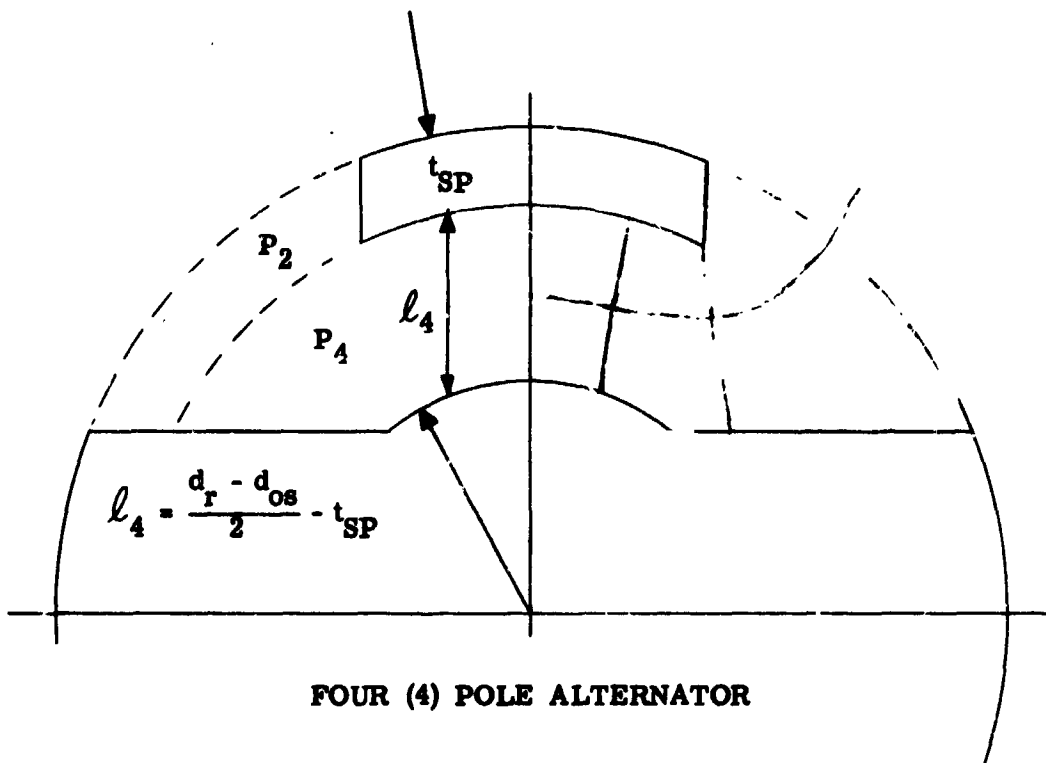
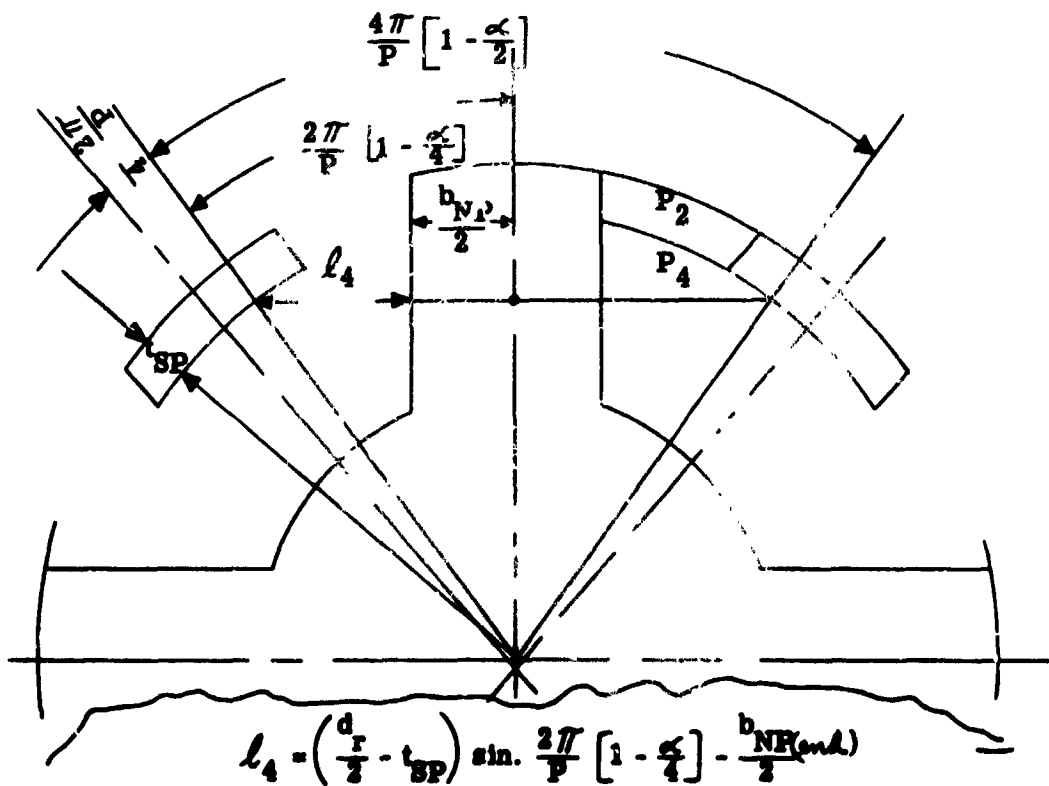

Figure L-7



FOUR (4) POLE ALTERNATOR



EIGHT (8) POLE ALTERNATOR

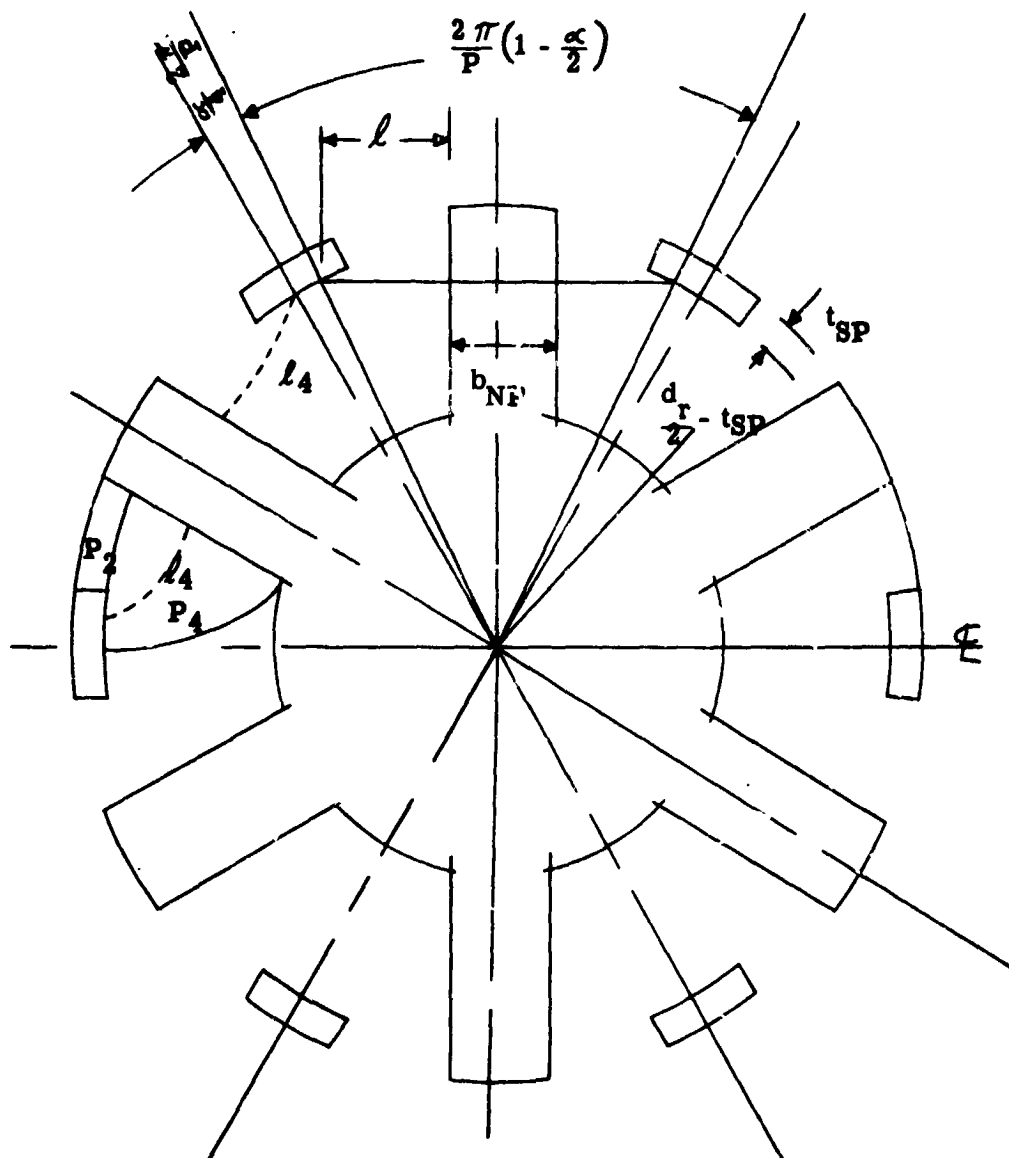

TWELVE (12) POLE ALTERNATOR

$$l_4 = \left(\frac{d_r}{2} - t_{SP} \right) \sin \frac{2\pi}{P} \left[1 - \frac{\alpha}{4} \right] - \frac{b_{NF''}}{2} \text{ (end)}$$

Figure L-9

When $(6) \neq 6$ and $b_{np}(\text{end}) \neq b_{np}(\text{mid})$

$$P_4 = 6.28 \frac{\left[\frac{(d_r)}{2} - (T_{sp}) \right] \left[\frac{1}{4} \sqrt{[(b_{np}(\text{mid}) - b_{np}(\text{end}))^2 + (\ell_{np})^2] + \frac{(\ell_1)}{2}} \right]}{(L4a)} (P)$$

$$= 6.28 \frac{\left[\frac{(11a)}{2} - (78) \right] \left[\frac{1}{4} \sqrt{[(76) - (76)]^2 + (76)^2 + \frac{(80a)}{2}} \right]}{(83)} (6)$$

(84) P5

COIL LEAKAGE PERMEANCE TO A NORTH POLE - This

input can be either 0.0 or the actual value if available. Refer to Item (77a) for explanation.

See Figure 10 for location.

$$P_5 = 3.19 \frac{(b_{np} \text{ end})(\ell_6) \frac{2}{3}}{(\ell_c)} (P)$$

$$= 3.19 \frac{(76)(85) \frac{2}{3}}{(84)} (6)$$

Where ℓ_c = length of leakage path P5 and must be specified on the input sheet. Refer to Figure L 10 for location.

NOTE: This covers the leakage for both ends of rotor.

(85) P6

COIL LEAKAGE PERMEANCE TO SOUTH POLE - This input

can be either 0.0 or the actual value if available.

Refer to Item (77a) for explanation. See Figure L 11 for location.

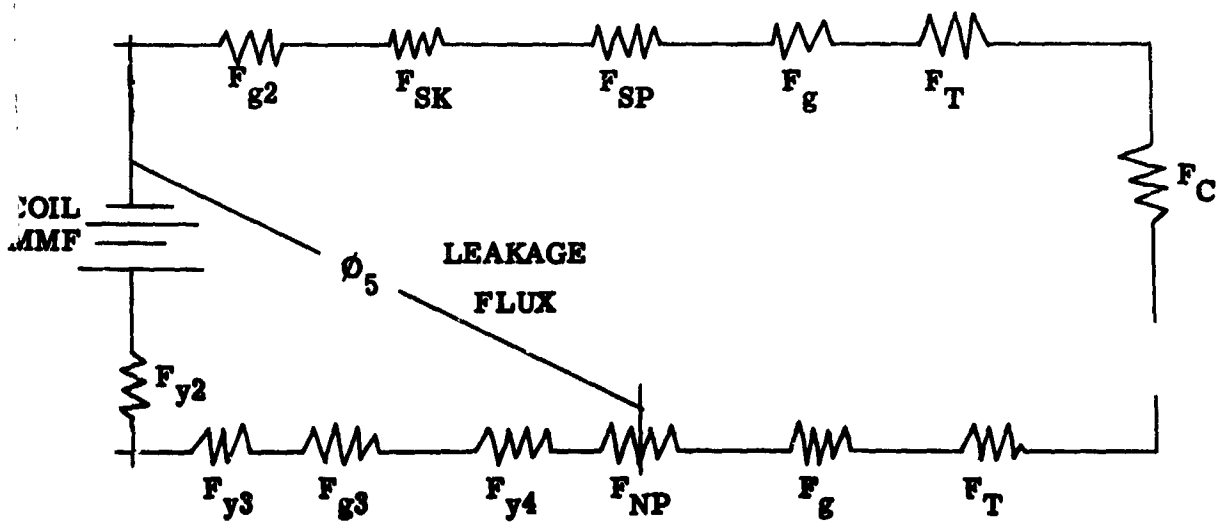
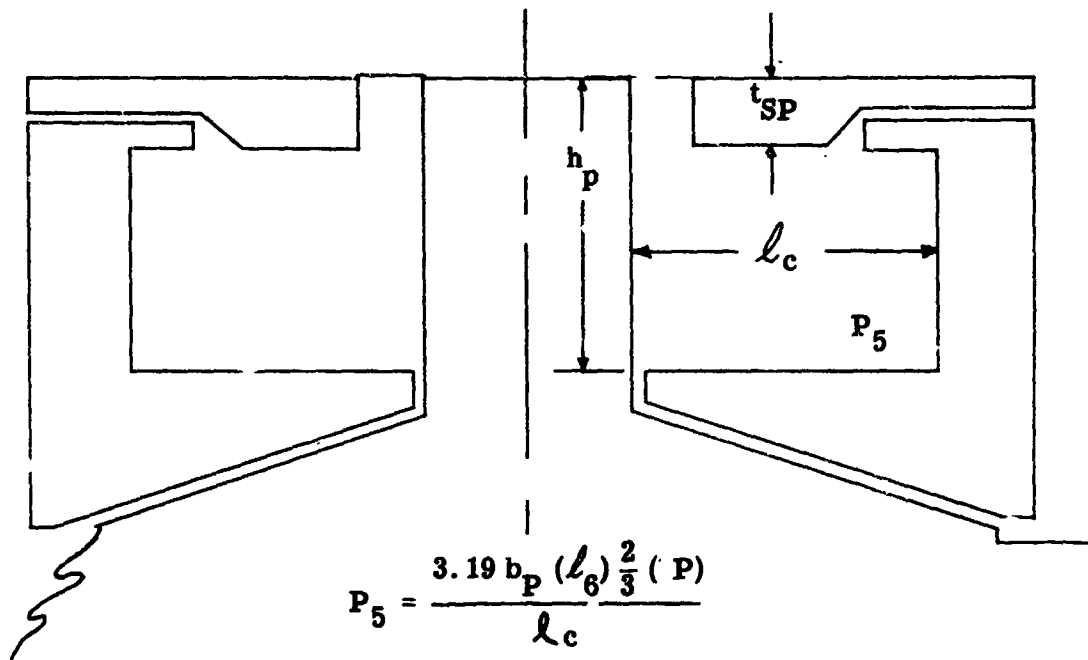
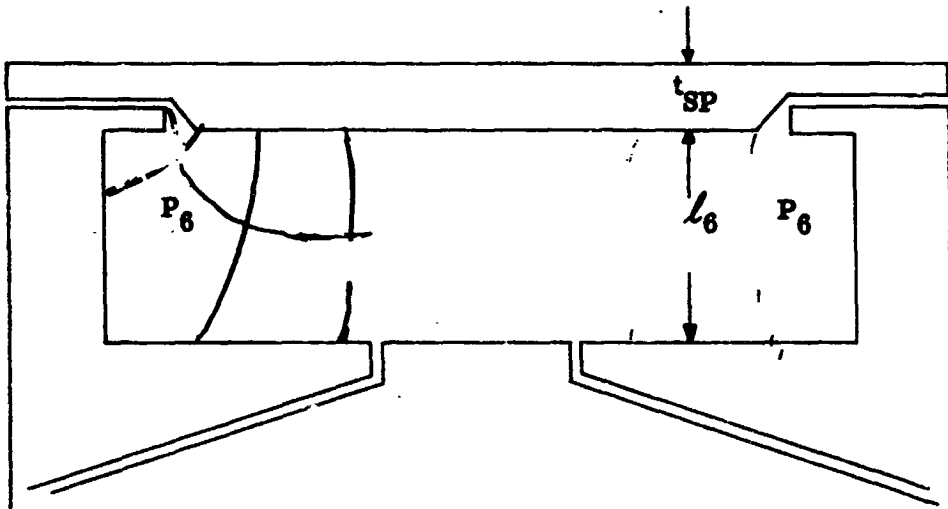
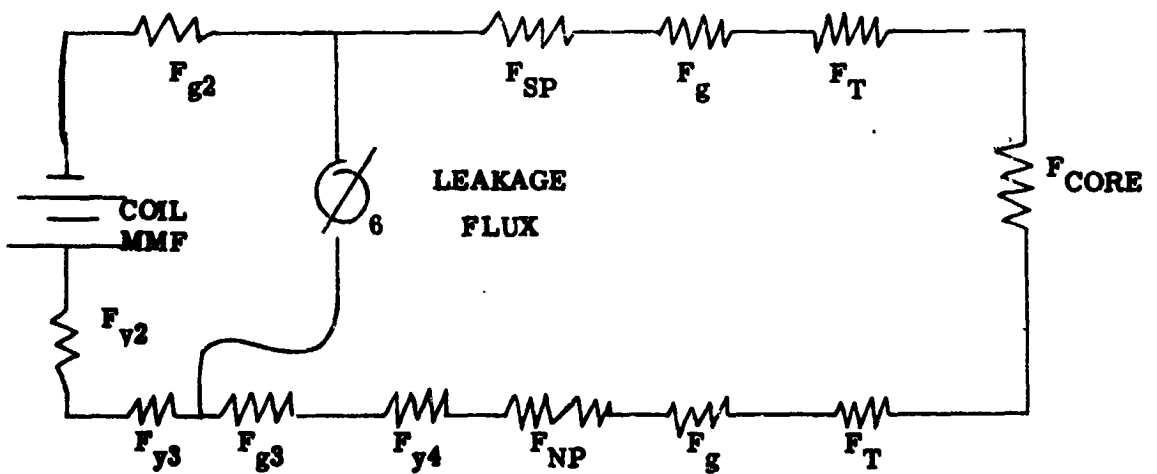

Figure L-10



FLUX LEAKAGE ACROSS FIELD COILS



$$P_6 = \frac{3.19 l_c \alpha (d_r - 2t_{SP}) \frac{\pi}{P} (P)}{l_6}$$

$$= \frac{3.19 l_c \alpha (d_r - 2t_{SP}) \pi}{l_6}$$

Figure L-11

Leakage Fluxes ϕ_5 and ϕ_6
(Leakage across the field coil ϕ_6 ,
and through the field coil ϕ_5)

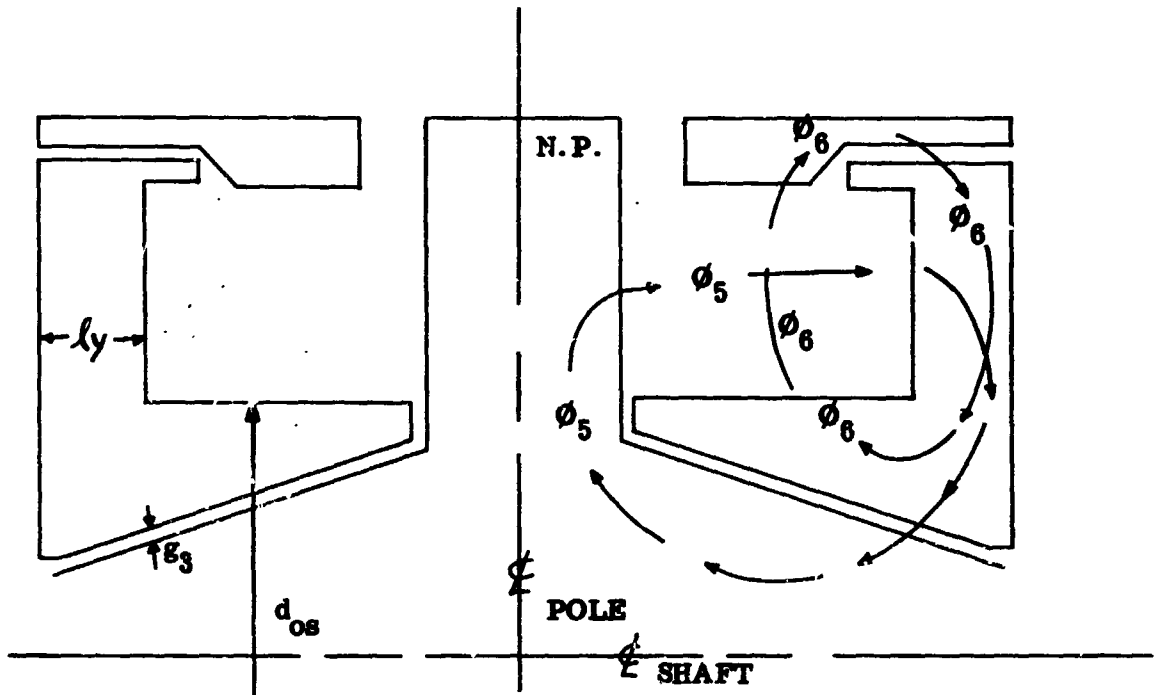

d_{os} = diameter of outer shaft

A_{y2} = area of yoke at smallest section

$$A_{y2} = (d_{os})(ly)\pi$$

The leakage flux ϕ_5 and ϕ_6 add to the flux in the yoke member y_2 but of the two leakage fluxes, only ϕ_5 adds to the flux crossing air gap g_3 .

Figure L-12

LEAKAGE FLUX FROM STATOR
 BACK-IRON TO ROTOR SKIRT - PATH 7

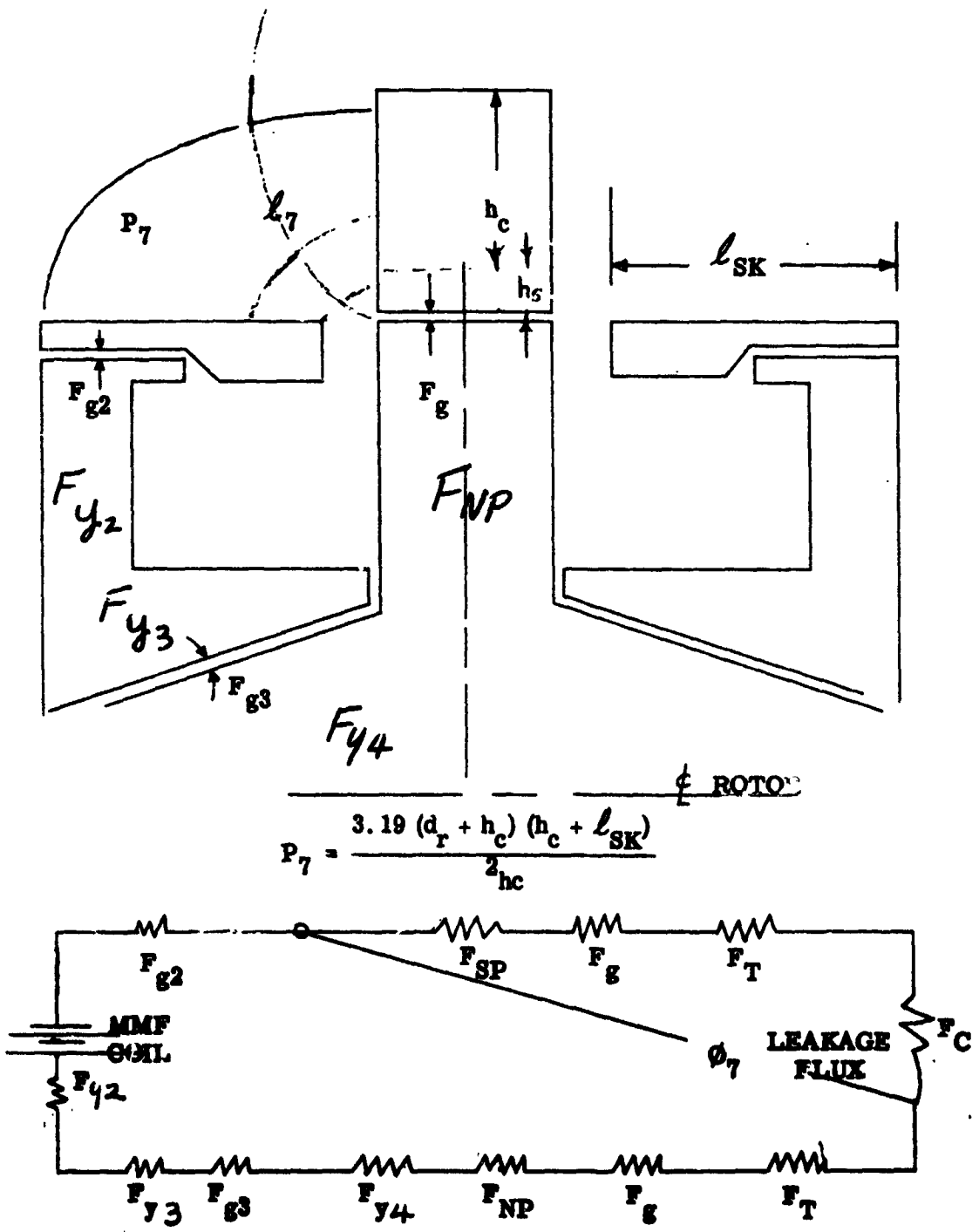

Figure L-13

$$P_6 = \frac{3.19(\ell_c)(\alpha) \left[(d_r) - 2(T_{sp}) \right] \frac{\pi}{(P)}}{(\ell_6)}$$

$$= \frac{3.19(84)(77) \left[(11a) - 2(78) \right] \frac{\pi}{(6)}}{(85)}$$

Where ℓ_6 = Length of leakage path P_6 and must be specified on the input sheet. Refer to Figure L-11 for location.

NOTE: This covers the leakage for both ends of the rotor.

(86) P7

STATOR CORE TO ROTOR SKIRT FLUX LEAKAGE -

Permeance path. This input can be either 0.0 or the actual value if available. Refer to Item (77a) for explanation. See Figure L-13 for location.

$$P_7 = 3.19 \frac{\frac{\pi}{4} \left[(d_r) + (h_c) + (h_s) \right] \left[(h_c) + (h_s) + (\ell_{sk}) \right]}{(\ell_7)}$$

$$P_7 = 3.19 \frac{\frac{\pi}{4} \left[(11a) + (24) + (22) \right] \left[(24) + (22) + (78) \right]}{(86)}$$

$$\text{Where } \ell_7 = \frac{\pi \left[(h_c) + (h_s) \right]}{2} = \frac{\pi \left[(24) + (22) \right]}{2}$$

The leakage is from 1/2 the stator end surface calculated on each side of the stator, making the total leakage surface calculated as follows:

$$\text{Area} = \pi \left[(d_r) + (h_c) + (h_s) \right] \left[\frac{(h_c) + (\ell_{sk})}{2} \right]$$

However, 1/2 of the leakage is useful and generates voltage in the stator conductors. So for tooth density, pole density and air-gap flux calculations, the leakage flux area is:

$$\begin{aligned} \text{Area} &= \frac{1}{2} \pi \left[(d_r) + (h_c) + (h_s) \right] \left[\frac{(h_c) + (\ell_{sk})}{2} \right] \\ &= \frac{\pi}{4} \left[(d_r) + (h_c) + (h_s) \right] \left[(h_c) + (h_s) + (\ell_{sk}) \right] \\ &= \frac{\pi}{4} \left[(11a) + (24) + (22) \right] \left[(24) + (22) + (78) \right] \end{aligned}$$

(87)

--

NO LOAD SATURATION CALCULATIONS - The next set of calculations deals with the no load saturation.

When the no load saturation data is required at various voltages, insert 1. on input sheet for "No Load Sat." The computer will then calculate no load saturation @ 80, 90, 100, 110, 120, 130, 140, 150 and 160% of rated volts. When the complete saturation data is not necessary, insert 0. on input sheet and the computer will calculate the 100% volt data.

(88) ϕ_T TOTAL FLUX IN KILOLINES

$$\phi_T = \frac{6(E)10^6}{(C_w)(N_e)(RPM)} \frac{6(3)10^6}{(72)(45)(7)}$$

(89) ϕ'_7 ESTIMATED VALUE OF LEAKAGE FLUX ϕ_7

$$\phi'_7 = .01 (\phi_T)$$

$$= .01 (88)$$

Complete the next set of calculations Item (90) through Item (99) using ϕ'_7 , the estimated value. If the calculated value (ϕ_7) Item (99) agrees within $\pm 10\%$ of the estimated value (ϕ'_7), Item (89), use all of the items, (90) through (99) as final and proceed on with calculations. If the calculated value ϕ_7 , Item (99), does not agree within $\pm 10\%$ of the estimated value (ϕ'_7) then recalculate items (89) through (99) using ϕ_7 item (99) as the estimated value for ϕ'_7 .

(90) ϕ'_T ESTIMATED TOTAL FLUX - including estimated value of ϕ_7

$$\phi'_T = (\phi_T) + (\phi'_7)$$

$$= (88) + (89)$$

(91) B'_T ESTIMATED STATOR TOOTH DENSITY

$$B'_T = \frac{\phi'_T}{(Q)(l_s)(b_t 1/3)} = \frac{(90)}{(23)(17)(57a)}$$

(92) ϕ_P FLUX PER POLE

$$\phi_P = \frac{(\phi_T)(C_P)}{(P)} \frac{(88)(73)}{(6)}$$

(93) ϕ'_P ESTIMATED FLUX PER POLE including leakage flux ϕ'_7

$$\phi'_P = \frac{(\phi'_T)(C_P)}{(P)} = \frac{(90)(73)}{(6)}$$

(94) B'_c ESTIMATED STATOR CORE DENSITY

$$B'_c = \frac{(\phi'_P)}{2(h_c)(l_s)} = \frac{(93)}{2(24)(17)}$$

(95) B'_g ESTIMATED MAIN GAP DENSITY

$$B'_g = \frac{\phi'_T}{\pi(d)(l)} = \frac{(90)}{\pi(11)(13)}$$

(96) F'_g ESTIMATED MAIN GAP AMPERE TURNS

$$F'_g = \frac{(B'_g)(g_e)}{3.19} \times 10^3 = \frac{(95)(69)}{3.19} \times 10^3$$

(97) F'_T ESTIMATED STATOR TOOTH AMPERE TURNS

$$F'_T = (h_s) \left[\text{NI/inch at density } (B'_T) \right]$$

$$= (22) \left[\begin{array}{l} \text{look up on stator magnetization curve} \\ \text{given in (18) at density (91)} \end{array} \right]$$

(98) F'_c ESTIMATED STATOR CORE AMPERE TURNS

$$F'_c = \left\{ \frac{\pi[(D) - (h_c)]}{4(P)} \right\} \left[\text{NI/inch at density } (B'_c) \right]$$

$$F'_c = \left\{ \frac{\pi[(12)-(24)]}{4(6)} \right\} \left[\text{Look up on stator magnetization curve at density (94)} \right]$$

(99) ϕ_7

CALCULATED VALUE OF LEAKAGE FLUX through path l_7 .

See Figure L13. Leakage from stator back iron to rotor skirt. (In kilolines).

$$\begin{aligned}\phi_7 &= (P_7) \left[(F'_g) + (F'_T) + (F'_c) \right] \times 10^{-3} \\ &= (86) \left[(96) + (97) + (98) \right] \times 10^{-3}\end{aligned}$$

Next compare the estimated value of ϕ'_7 , Item (89) with the calculated value of ϕ_7 , Item (99).

If $1.10 (\phi_7) \geq (\phi'_7) \geq .90 (\phi_7)$ then use ϕ_7 and continue with calculations. If ϕ_7 does not fall within the limits given above, then recalculate Item (89) through (99) using ϕ_7 , Item (99) as estimated value of ϕ'_7 .

(100) ϕ_1

POLE HEAD END LEAKAGE FLUX. (In kilolines)

$$\begin{aligned}\phi_1 &= (P_1) \left[2(F'_g) + 2(F'_T) + 2(F'_c) \right] \times 10^{-3} \\ &= (80) \left[2(96) + 2(97) + 2(98) \right] \times 10^{-3}\end{aligned}$$

(101) ϕ_2

POLE HEAD SIDE LEAKAGE. (In kilolines)

$$\begin{aligned}\phi_2 &= (P_2) \left[2(F'_g) + 2(F'_T) + 2(F'_c) \right] \times 10^{-3} \\ &= (81) \left[2(96) + 2(97) + 2(98) \right] \times 10^{-3}\end{aligned}$$

(102) ϕ_3

POLE BODY END LEAKAGE. (In kilolines)

$$\begin{aligned}\phi_3 &= (P_3) \left[2(F'_g) + 2(F'_T) + 2(F'_c) \right] \times 10^{-3} \\ &= (82) \left[2(96) + 2(97) + 2(98) \right] \times 10^{-3}\end{aligned}$$

(103) ϕ_4 POLE BODY SIDE LEAKAGE. (In kilolines)

$$\begin{aligned}\phi_4 &= (P_4) \left[2(F'_g) + 2(F'_T) + 2(F'_c) \right] \times 10^{-3} \\ &= (83) \left[2(96) + 2(97) + 2(98) \right] \times 10^{-3}\end{aligned}$$

(104) B'_{np} NORTH POLE FLUX DENSITY - First calculation. This item will be recalculated in Step (116) including flux ϕ_5 .

$$\begin{aligned}B'_{np} &= \phi_p + \frac{(\phi_1) + (\phi_2) + (\phi_3) + (\phi_4) + (\phi_7)}{(P)} \\ &= (92) + \frac{(100) + (101) + (102) + (103) + (99)}{(6)} \\ &= \frac{(79)}{(79)}\end{aligned}$$

(105) B_{sp} SOUTH POLE FLUX DENSITY

$$\begin{aligned}B_{sp} &= (\phi_p) + \frac{(\phi_1) + (\phi_2) + (\phi_3) + (\phi_4) + (\phi_7)}{(P)} \\ &= (92) + \frac{(100) + (101) + (102) + (103) + (99)}{(6)} \\ &= \frac{2(79a)}{2(79a)}\end{aligned}$$

(106) F'_{np} NORTH POLE AMPERE TURN DROP - First calculation.

This item will be recalculated in Item (117) including Flux ϕ_5 .

$$\begin{aligned}F'_{np} &= (h_{np}) \left[\text{NI/inch at density } (B'_{np}) \right] \\ &= (78) \left[\text{Look up on north pole magnetization} \right. \\ &\quad \left. \text{curve given in (18) at density (104).} \right]\end{aligned}$$

(107) F_{sp}

SOUTH POLE AMPERE TURN DROP

When $b_{np}(\text{end}) = b_{np}(\text{mid})$

$$F_{sp} = \frac{(l_{sp})}{3} \left[\text{NI/inch at density } (B_{sp}) \right]$$

$$F_{sp} = \frac{(76)}{3} \left[\text{Look up on south pole or tube magneti-} \right. \\ \left. \text{zation curve given in (18, at density (105))} \right]$$

When $b_{np}(\text{end}) \neq b_{np}(\text{mid})$

$$F_{sp} = \frac{(l_{sp})}{2} \left[\text{NI/inch at density } (B_{sp}) \right]$$

$$= \frac{(76)}{2} \left[\text{Look up on south pole or tube magneti-} \right. \\ \left. \text{zation curve given in (18) at density (105)} \right]$$

(108) ϕ_{g2}

AUXILIARY AIR GAP g_2 FLUX

$$\phi_{g2} = \frac{[(\phi_p)(P)] + (\phi_1) + (\phi_2) + (\phi_3) + (\phi_4) + (\phi_7)}{4} \\ = \frac{[(92)(6)] + (100) + (101) + (102) + (103) + (99)}{4}$$

(109) B'_{g2}

FLUX DENSITY IN AUXILIARY GAP - First calculation.

$$B'_{g2} = \frac{(\phi_{g2})}{(A_{g2})} = \frac{(108)}{(70)}$$

(110) F'_{g2}

AMPERE TURN DROP ACROSS AUXILIARY AIR GAP -

First calculation.

$$F'_{g2} = \frac{(B'_{g2})(g_2)}{3.19} \times 10^3 = \frac{(109)(6.3a)}{3.19} \times 10^3$$

(112) A_{y4} AREA OF SHAFT - in inches² - cross-sectional to flux in shaft.

$$A_{y4} = \left[\frac{\pi(d_{os})^2}{4} \right] - \left[\frac{\pi(d_Q)^2}{4} \right]$$

$$= \frac{\pi(78)^2}{4} - \frac{\pi(78)^2}{4}$$

NOTE: When a solid shaft is used, the second term will drop out because $d_Q = 0$.

(113) B_{y4} FLUX DENSITY OF SHAFT

$$B_{y4} = \frac{(\phi_p)(P) + (\phi_1) + (\phi_2) + (\phi_3) + (\phi_4) + (\phi_7)}{4 (A_{y4})}$$

$$= \frac{(92)(6) + (100) + (101) + (102) + (103) + (99)}{4 (112)}$$

(114) F_{y4} SHAFT AMPERE TURN DROP

$$F_{y4} = (\ell_{y4}) \left[\text{NI/inch at density } (B_{y4}) \right]$$

$$= (78) \left[\begin{array}{l} \text{Look up on shaft magnetization curve} \\ \text{given in (18) at density (113)} \end{array} \right]$$

NOTE: This magnetization curve for shaft and spider can be synthesized into one curve when the effective cross-sectional area of the shaft is made up of two separate materials. This does not affect the present computer program. Only the magnetization curve that is submitted must be corrected.

(115) ϕ'_5

LEAKAGE FLUX FROM NORTH POLE (SPIDER POLE)
THROUGH THE FIELD COIL - First calculation.

Items (116) through (118) will be calculated using this value of ϕ'_5 . A new value for ϕ'_5 will then be calculated in Item (118). This new value must be within +10% of Item (115) or calculation (115) through (118) must be repeated using the new value of (F_{np}) Item (117) in (115).

$$\begin{aligned}\phi'_5 &= P_5 \left[(F'_{g2}) + (F_{sp}) + 2(F'_g) + 2(F'_T) + 2(F'_c) + (F'_{np}) \right] \times 10^{-3} \\ &= (84) \left[(110) + (107) + 2(96) + 2(97) + 2(98) + (106) \right] \times 10^{-3}\end{aligned}$$

(116) B_{np}

NORTH POLE FLUX DENSITY - This value will supersede the value calculated in (104).

$$\begin{aligned}B_{np} &= \frac{\phi_p + \frac{(\phi_{.1}) + (\phi_{.2}) + (\phi_{.3}) + (\phi_{.4}) + (\phi_{.7}) + (\phi'_5)}{(P)}}{(a_{np})} \\ &= (92) + \frac{(100) + (101) + (102) + (103) + (99) + (115)}{(79)}\end{aligned}$$

(117) F_{np}

NORTH POLE AMPERE TURN DROP - This value will supersede the value calculated in (106).

$$\begin{aligned}F_{np} &= h_{np} \left[\text{NI/inch at density } (B_{np}) \right] \\ &= (78) \left[\text{Look up on north pole magnetization} \right. \\ &\quad \left. \text{curve given in (18) at density (116).} \right]\end{aligned}$$

(118) ϕ_5 LEAKAGE FLUX FROM NORTH POLE (spider pole)
through the field coil. Second Calculation.

$$\phi_5 = P_5 \left[(F'_{g2}) + (F_{sp}) + 2(F'_g) + 2(F'_T) + 2(F'_c) + (F_{np}) \right] \times 10^{-3}$$

$$= (84) \left[(110) + (107) + 2(96) + 2(97) + 2(98) + (117) \right] \times 10^{-3}$$

This item, ϕ_5 , must be within +10% of the first calculation ϕ_5 , Item (115), or must recalculate Items (115) through (118) using (F_{np}) , Item (117), in the second calculation of (115).

(119) B_{g3} FLUX DENSITY IN AIR GAP g_3

$$B_{g3} = \frac{(\phi_p)(P) + (\phi_1) + (\phi_2) + (\phi_3) + (\phi_4) + (\phi_7) + (\phi_5)}{4(A_{g3})}$$

$$= \frac{(92)(6) + (100) + (101) + (102) + (103) + (99) + (118)}{4(70a)}$$

(120) F_{g3} AMPERE TURN DROP ACROSS GAP g_3

When (59b) = 2.0 calculate as follows:

$$F_{g3} = \frac{B_{g3}}{3.19} (g_3) \times 10^3 = \frac{(119)}{3.19} (59c) \times 10^3$$

When (59b) = 1.0, calculate as follows:

$$F_{g3} = \frac{B_{g3}}{3.19} (g_{3e}) \times 10^3 = \frac{(119)}{3.19} (.7f) \times 10^3$$

(121) ϕ_6 LEAKAGE FLUX ACROSS FIELD COIL FROM INNER YOKE TO SOUTH POLE TUBE in kilolines.

$$\begin{aligned}\Phi_6 &= (P_6) \left[(F_{sp}) + 2(F'_3) + 2(F'_T) + 2(F'_c) + (F_{np}) + (F_{y4}) + (F_{g3}) \right] \times 10^{-3} \\ &= (85) \left[(107) + 2(96) + 2(97) + 2(98) + (117) + (114) + (120) \right] \times 10^{-3}\end{aligned}$$

(122) B_{g2}

FINAL FLUX DENSITY IN AUXILIARY GAP g₂

$$\begin{aligned}&= \frac{(\Phi_p)(P) + (\Phi_1) + (\Phi_2) + (\Phi_3) + (\Phi_4) + (\Phi_7) + (\Phi_6)}{4(A_{g2})} \\ &= \frac{(92)(j) + (100) + (101) + (102) + (103) + (99) + (121)}{4(69a)}\end{aligned}$$

(123) F_{g2}

$$\text{FINAL } F_{g2} = \frac{(B_{g2})(g_2)}{3.19} \times 10^3 = \frac{(122)(59a)}{3.19} \times 10^3$$

(124) A_{y2}

CROSS-SECTIONAL AREA OF YOKE location per Figure L12

$$\begin{aligned}A_{y2} &= \pi(d_{os})(l_y) \\ &= \pi(78)(78)\end{aligned}$$

(125) B_{y2}

DENSITY OF COIL YOKE

$$\begin{aligned}B_{y2} &= \frac{(\Phi_p)(P) + (\Phi_1) + (\Phi_2) + (\Phi_3) + (\Phi_4) + (\Phi_7) + (\Phi_5)}{4(A_{y2})} \\ &= \frac{(92)(6) + (100) + (101) + (102) + (103) + (99) + (118)}{4(124)}\end{aligned}$$

(126) F_{y2}

AMPERE TURN DROP IN COIL YOKE

$$\begin{aligned}F_{y2} &= \frac{(h_y)}{3} \left[\text{NI/inch at density } (B_{y2}) \right] \\ &= \frac{(78)}{3} \left[\text{Look up on yoke magnetization curve} \right. \\ &\quad \left. \text{given in (18) at a density (125)} \right]\end{aligned}$$

(127) F_{NL} TOTAL AMPERE TURNS AT NO LOAD PER CIRCUIT

$$F_{NL} = 2(F'_g) + 2(F'_T) + 2(F'_c) + (F_{np}) + (F_{sp}) + (F_{g2}) + (F_{y2}) + (F_{g3}) + (F_{y4})$$
$$= 2[(96) + (97) + (98)] + (117) + (107) + (123) + (126) + (120) + (114)$$

(127a) I_{FNL} NO LOAD FIELD CURRENT PER COIL

$$I_{FNL} = \frac{F_{NL}}{N_F} = \frac{(127)}{(146)}$$

(127b) E_{FNL} NO LOAD FIELD VOLTS PER COIL

$$E_{FNL} = (I_{FNL})(R_F(\text{cold}))$$
$$= (127a)(154)$$

(127c) S_F CURRENT DENSITY IN FIELD CONDUCTOR - At no load

(128) A AMPERE CONDUCTORS per inch

(129) X REACTANCE FACTOR -

(130) X_g LEAKAGE REACTANCE -

(131) X_{ad} REACTANCE - direct axis - This is the fictitious reactance due to armature reaction in the direct axis.

$$X_{ad} = \frac{.9(n_e)(I_{ph})(C_m)(K_d)}{P[2(F'_g) + (F_{g2}) + (F_{g3})]} \times 100$$

$$X_{ad} = \frac{.9(45)(8)(74)(43)}{6[2(96) + (123) + (120)]} \times 100$$

(132)	X_{aq}	<u>REACTANCE</u> - Quadrature axis - This is the fictitious reactance due to armature reaction in the quadrature axis.
		$X_{aq} = \frac{(C_q)(X_{ad})}{(C_m)(C_l)}$ $X_{aq} = \frac{(75)(131)}{(74)(71)}$
(133)	X_d	<u>SYNCHRONOUS REACTANCE</u> - direct axis -
(134)	X_q	<u>SYNCHRONOUS REACTANCE</u> - quadrature axis - The steady
(135)	--	<u>DAMPER SLOT DIMENSIONS</u>
(136)	--	<u>DAMPER BAR DIA OR WIDTH</u> in inches
(137)	h_{bl}	<u>DAMPER BAR THICKNESS</u> in inches -
(138)	n_b	<u>NUMBER OF DAMPER BARS PER POLE</u>
(139)	l_b	<u>DAMPER BAR LENGTH</u> in inches
(140)	τ_b	<u>DAMPER BAR PITCH</u> in inches
(141)	ρ_D	<u>RESISTIVITY</u> of damper bar @ 20°C in micro ohm-inches -
(142)	$X_D^{\circ C}$	<u>DAMPER BAR TEMP</u> °C -
(143)	ρ_D (hot)	<u>RESISTIVITY</u> of damper bar @ $X_D^{\circ C}$

(144)	a_{cd}	<u>CONDUCTOR AREA OF DAMPER BAR</u> -
(145)	V_r	<u>PERIPHERAL SPEED</u> -
(146)	N_F	<u>NUMBER OF FIELD TURNS PER COIL</u>
(147)	l_{tF}	<u>MEAN LENGTH OF FIELD TURN</u>
(148)	--	<u>FIELD CONDUCTOR DIA OR WIDTH</u> in inches
(149)	--	<u>FIELD CONDUCTOR THICKNESS</u> in inches -
(150)	$X_f^{\circ C}$	<u>FIELD TEMP IN $^{\circ}C$</u> -
(151)	ρ_f	<u>RESISTIVITY</u> of field conductor @ $20^{\circ}C$ in micro ohm-inches.
(152)	ρ_f (hot)	<u>RESISTIVITY</u> of field conductor at $X_f^{\circ}C$
(153)	a_{cf}	<u>CONDUCTOR AREA OF FIELD WINDING</u> -
(154)	R_f (cold)	<u>COLD FIELD RESISTANCE @ $20^{\circ}C$</u> per coil

$$R_f(\text{cold}) = \rho_f \frac{(N_F)(l_{tF}) \times 10^{-6}}{(a_{cf})} = (151) \frac{(146)(147)}{(153)} \times 10^{-6}$$

(155) R_f
(hot)

HOT FIELD RESISTANCE - Calculated at $X_f^{\circ}C$ (103) - (Per coil)

$$R_f(\text{hot}) = \rho_{f \text{ hot}} \frac{(N_f)(\ell_{tf}) \times 10^{-6}}{(a_{cf})} = (152) \frac{(146)(147) \times 10^{-6}}{(153)}$$

(156) --

WEIGHT OF FIELD COIL in lbs. - per coil

The answer is given in lbs. based on the density of copper. If any other material is used, the answer on the output sheet can be converted by the designer by multiplying by the ratio of densities.

$$\begin{aligned} \# \text{'s of copper} &= .321 (N_f)(\ell_{tf})(a_{cf}) \\ &= .321 (146)(147)(153) \end{aligned}$$

(157) --

WEIGHT OF ROTOR IRON -

(158) λ_b

PERMEANCE OF DAMPER BAR -

(159) λ_{pt}

PERMEANCE OF END PORTION OF DAMPER BARS

$$\begin{aligned} \lambda_{pt} &= 6.38 \left\{ \frac{(b_{np(\text{end})} - (\tau_b) [(n_b) - 1])}{3(g_e)} \right\} \\ &= 6.38 \left\{ \frac{(76) - (140) [(138) - 1]}{3(69)} \right\} \end{aligned}$$

(160) X_F

THE EFFECTIVE FIELD LEAKAGE REACTANCE - The

reactance which added to the stator leakage reactance gives the transient reactance X'_{du} .

When unit fundamental armature ampere turns are suddenly applied on the direct axis, an initial field current (I_f) will be induced. The value of this initial field current will be just enough to make the net flux interlinking the field because of the field current and the armature current zero. The field ampere turns will equal the armature ampere turns.

$$X_F = X_{ad} \left[1 - \frac{\frac{C_1}{C_m}}{2C_p + \frac{4}{\pi} \frac{\lambda_F}{\lambda_a}} \right]$$

$$X_F = (131) \left[1 - \frac{\frac{(71)}{(74)}}{2(73) + \frac{4}{\pi} \frac{(16/a)}{(160)}} \right]$$

$$\lambda_a = \frac{6.38d}{P_{ge'}} = \frac{6.38(11)}{(6)(160)}$$

Where:

$$\begin{aligned} g'_e &= (g_e) \left[\frac{2(F'_g) + (F_{g2}) + (F_{g3})}{2(F'_g)} \right] \\ &= (69) \left[\frac{2(96) + (123) + (120)}{2(96)} \right] \end{aligned}$$

$$(160a) \quad P_e = \frac{\phi_{g2} @ NL}{(I_{fNL})(N_f) @ NL}$$

$$P_e = \frac{(108)}{(127a)(146)}$$

(161) L_F FIELD INDUCTANCE

$$L_F = 2(N_f)^2 P_e 10^{-8}$$

$$= 2(146)^2 (160a) \times 10^{-8}$$

(161a) λ_F SPECIFIC PERMEANCE OF FIELD

$$\lambda_F = \frac{P_1 + P_2 + P_3 + P_4 + P_5 + P_6}{\mathcal{L}}$$

$$= \frac{(80) + (31) + (82) + (83) + (84) + (85)}{(13)}$$

(162) λ_{Dd} PERMEANCE OF DAMPER BAR - in direct axis

$$\lambda_{Dd} = \left\{ \cos \left[\frac{\{(n_b) - 1\} (\tau_b) \pi}{2(\tau_p)} \right] \right\} \left\{ \frac{\{(\lambda_b) + (\lambda_{Pt})\} (\lambda_F)}{\lambda_b + \lambda_{Pt} + \lambda_F} \right\}$$

$$= \left\{ \cos \left[\frac{\{(138) - 1\} (140) \pi}{2(41)} \right] \right\} \left\{ \frac{\{(158) + (159)\} (161a)}{(158) + (159) + (161a)} \right\}$$

(163) X_{Dd} DAMPER LEAKAGE REACTANCE - in direct axis

$$X_{Dd} = X(\lambda_{Dd}) = (129)(162)$$

- (164) γ_{Dq} PERMEANCE IN QUADRATURE AXIS
- (165) X_{Dq} DAMPER LEAKAGE REACTANCE - in quadrature axis
- (166) X'_{du} UNSATURATED TRANSIENT REACTANCE
- (167) X'_d SATURATED TRANSIENT REACTANCE
- (168) X''_d SUBTRANSIENT REACTANCE in direct axis
- (169) X''_q SUBTRANSIENT REACTANCE in quadrature axis
- (170) X_2 NEGATIVE SEQUENCE REACTANCE - The reactance due

to the field which rotates at synchronous speed in a direction opposite to that of the rotor

$$X_2 = \frac{X_m [4(\xi) + 4(\xi)^2 + (n)^2]}{n^2 + 4 [1 + (\xi)]^2} + X_l$$

$$= \frac{(170) [4(170) + 4(170)^2 + (170)^2]}{(170)^2 + 4 [1 + (170)]^2} + (130)$$

Where $\xi = \frac{(X_D)}{(X_m)} = \frac{(170)}{(170)}$

Where $X_m = \frac{X_{ad}}{(C_1)(C_m)} \left[\frac{2(F'_g) + (F_{g2}) + (F_{g3})}{(F_{NL})} \right]$

$$= \frac{(131)}{(71)(74)} \left[\frac{2(96) + (123) + (120)}{(127)} \right]$$

For Round Slots:

$$\begin{aligned} X_D &= \frac{20(X)}{(n_b)} \left[.62 + \frac{(h_{bo})}{(b_{bo})} \right] + \frac{5(X_m)}{6(n_b)^2} \\ &= \frac{20(129)}{(138)} \left[.62 + \frac{(135)}{(135)} \right] + \frac{5(170)}{6(138)^2} \end{aligned}$$

For Rectangular Slots:

$$\begin{aligned} X_D &= \frac{20(X)}{N_b} \left[\frac{(h_{bl})}{3(b_{bl})} + \frac{(h_{bo})}{(b_{bo})} \right] + \frac{5(X_m)}{6(N_b)^2} \\ &= \frac{20(129)}{(138)} \left[\frac{(135)}{3(135)} + \frac{(135)}{(135)} \right] + \frac{5(170)}{6(138)^2} \end{aligned}$$

$$\text{Where } n = \frac{R_D}{X_m} = \frac{(170)}{(170)}$$

Where R_D = Damper bar resistance

$$\begin{aligned} &= \frac{100(X)(P)(l_{hot})}{(f)(l_s)} \left[\frac{l_b}{(n_b)(a_{cd})(P)} + \frac{.637(d_{dr})}{(a_{dr})(P)^2} \right] \\ &= \frac{100(129)(6)(143)}{(5a)(17)} \left[\frac{(139)}{(138)(144)(6)} + \frac{.637(170)}{(170)(6)^2} \right] \end{aligned}$$

Where d_{dr} = mean diameter of damper end ring. Must be given on input sheet.

Where a_{dr} = cross-sectional area of damper end ring. Must be given on input sheet.

(171) Z_2

NEGATIVE SEQUENCE IMPEDANCE - approximate calculation.

$$Z_2 = R_2 + j X_2 = \sqrt{R^2 + X^2}$$

$$Z_2 = (171) + j(170) = \sqrt{(171)^2 + (170)^2}$$

$$\text{Where: } R_2 = \frac{2(R_D)}{(n)^2 + 4 [1 + (\xi)^2]} + R_s \text{ (hot)}$$

$$= \frac{2(170)}{(170)^2 + 4 [1 + (170)]} + (54)$$

(172) X_0

ZERO SEQUENCE REACTANCE -

(173) K_{x0}

(174) K_{x1}

(175) λ_{B0}

(176) T'_{do}

OPEN CIRCUIT TIME CONSTANT - The time constant of the field winding with the stator open circuited and with negligible external resistance and inductance in the field circuit. Field resistance at room temperature (20°C) is used in this calculation.

$$T'_{do} = \frac{L_F}{2(R_F)} = \frac{(161)}{2(154)}$$

(177)	T_a	<u>ARMATURE TIME CONSTANT</u> -
(178)	T'_d	<u>TRANSIENT TIME CONSTANT</u> -
(179)	T''_d	<u>SUBTRANSIENT TIME CONSTANT</u> -
(180)	F_{SC}	<u>SHORT CIRCUIT AMPERE TURNS</u> - The field ampere turns required to circulate rated stator current when the stator is short circuited.
		$F_{SC} = \frac{(X_d)}{100} \left[2(F'_g) + (F_{g2}) + (F_{g3}) \right]$ $= \frac{(133)}{100} \left[2(96) + (123) + (120) \right]$
(181)	SCR	<u>SHORT CIRCUIT RATIO</u> -
(182)	I^2R_R	<u>FIELD COIL I^2R</u> - at no load. The copper loss in the field winding is calculated with cold field resistance at 20°C for no load condition. (Loss for 2 coils.) Rotor $I^2R = 2(I_{FNL})^2 (R_f \text{ cold}) = 2(127a)^2$ (154)

(183)

F&W

FRICITION & WINDAGE LOSS - Note: Write 0 on input

sheet when computer is to calculate F & W. Insert actual value when known.

To ratio from test data, assume that F & W loss varies as the 5/2 power of the rotor diameter and as the 3/2 power of the RPM.

The formula below gives an approximate answer when test data is not available. For a more rigorous treatment use the information given in the rotor friction analysis appended to the thermal analysis section (Section C, Vol. 1).

$$F\&W = 2.52 \times 10^{-6} (d_r)^{2.5} (\rho_{NP} + \rho_1 + \rho_2) (RPM)^{1.5}$$

$$= 2.52 \times 10^{-6} (11a)^{2.5} [(76)+(80a)+(78)] (7)^{1.5}$$

For gases or fluids other than standard air, the fluid density and viscosity must be considered.

The formula given in the manual can be modified by the factors.

$$\left(\frac{(\rho)}{.0765} \right)^{.8} \left(\frac{\mu}{.0435} \right)^{.2}$$

where

- ρ - density - Lbs FT⁻³
- μ - viscosity LBS FT⁻¹ HR⁻¹
- .0765 - density std. air
- .0435 - viscosity std. air

(184)	W_{TNL}	<u>STATOR TEETH LOSS</u> -
(185)	W_c	<u>STATOR CORE LOSS</u> -
(186)	W_{NPL}	<u>POLE FACE LOSS</u> -
(187)	K_1	
(188)	K_2	
(189)	K_3	
(190)	K_4	
(191)	K_5	
(192)	K_6	
(193)	W_{DNL}	<u>DAMPER LOSS</u> -
(194)	I^2R	<u>STATOR I^2R</u> -

(135) -- EDDY LOSS -

(196) -- TOTAL LOSSES - at no load.

NOTE: The output sheet shows the next items to be: (Rating), (Rating + Losses), (% Losses), (% Efficiency). These items do not apply to the no load calculation since the rating is zero. Refer to Items (248), (249), (250), (251) for these calculations under load.

(197) E_{NL} LOAD CALCULATIONS - Run through sample at 100% load.

$$E_{NL} = (E_{PH}) + (I_{PH})(R_{PH})$$

$$= (4) + (8)(54)$$

(198) e_d

(198a) θ POWER FACTOR ANGLE

(199) F_{gL1}

AIR GAP AMPERE TURNS UNDER LOAD - If there were no change in stator leakage flux from stator core to rotor skirt from the no load condition calculated in Item (96).

$$F_{gL1} = (e_d)(F'_g) = (198)(96)$$

(200) F_{TL1}

STATOR TEETH AMPERE TURN DROP AT FULL LOAD

First approximation.

$$\begin{aligned} F_{TL1} &= (F'_T) [i + (P.F.)] \\ &= (97) [1 + (.9)] \end{aligned}$$

(201) F_{CL}

STATOR CORE AMPERE TURN DROP -

The first approximation for the stator core density at no-load is used for the full-load calculation. The change in core density due to the change in ϕ_7 is not regarded as significant.

$$\begin{aligned} F_{CL} &= F'_C \\ &= (98) \end{aligned}$$

(202) ϕ_{7L1}

LEAKAGE FLUX FROM STATOR BACK-IRON TO ROTOR

SKIRT - First approximation - in kilolines.

$$\begin{aligned} \phi_{7L1} &= (P_7) [(F_{gL1}) + (F_{TL1}) + (F_{CL})] \times 10^{-3} \\ &= (86) [(199) + (200) + (201)] \times 10^{-3} \end{aligned}$$

(203) F'_{gL} TOTAL AIR GAP AMPERE TURNS AT FULL LOAD

$$F'_{gL} = F_{gLI} + \frac{(\phi_{7LI})(g_e) \times 10^3}{(A_g) 3.19} = (199) + \frac{(202)(69) \times 10^3}{(68) 3.19}$$

(204) ϕ_{TLI} THEORETICAL FLUX AT FULL LOAD - first approximation.

$$\phi_{TLI} = (\phi_{NL}) + \frac{(\phi_{7LI})}{(C_p)}$$

$$= (204) + \frac{(202)}{(73)}$$

Where $\phi_{NL} = (\phi_T) \left[\frac{(E_{NL})}{(E_{PH})} \right]$

$$= (88) \left(\frac{(197)}{(4)} \right)$$

(205) B_{TL} STATOR TOOTH DENSITY AT FULL LOAD ABOVE NORTH POLE

$$B_{TL} = \frac{(\phi_{TLI})}{(Q)(l_s)(bt \ 1/3)} = \frac{(204)}{(23)(17)(57a)}$$

(206) F_{TL} STATOR TOOTH AMPERE TURNS AT FULL LOAD

$$F_{TL} = (h_s) \left[\text{NI/inch at density } (B_{TL}) \right] \left[1 + (\text{P.F.}) \right]$$

$$= (22) \left[\text{Look up on stator magnetization curve given in (18) at density (205)} \right] \left[1 + (9) \right]$$

(207) ϕ_{7L}

LEAKAGE FLUX FROM STATOR BACK-IRON TO ROTOR SKIRT - second application.

$$\begin{aligned}\phi_{7L} &= (P_7) \left[(F'_{gL}) + (F_{TL}) + (F_{CL}) \right] \times 10^{-3} \\ &= (86) \left[(203) + (206) + (201) \right] \times 10^{-3}\end{aligned}$$

(208) ϕ_{TL}

THEORETICAL FLUX AT F.L. - second approximation.

$$\begin{aligned}\phi_{TL} &= (\phi_{NL}) + \frac{(\phi_{7L})}{(C_p)} \\ &= (204) + \frac{(207)}{(73)}\end{aligned}$$

(208a) F_{gL}

$$\begin{aligned}F_{gL} &= F'_{gL} + \frac{(\phi_{7L})(g_e) 10^3}{3.19 (A_g)} \\ &= (203) + \frac{(207)(69) 10^3}{3.19 (68)}\end{aligned}$$

The next four items cover the flux leakages from pole to pole in the rotor. (In kilolines)

(209) ϕ_{1L}

$$\begin{aligned}\phi_{1L} &= (P_1) \left[2(F_{gL}) + 2(F_{TL}) + 2(F_{CL}) \right] \times 10^{-3} \\ &= (80) \left[2(208a) + 2(206) + 2(201) \right] \times 10^{-3}\end{aligned}$$

(210) ϕ_{2L}

$$\begin{aligned}\phi_{2L} &= (P_2) \left[2(F_{gL}) + 2(F_{TL}) + 2(F_{CL}) \right] \times 10^{-3} \\ &= (81) \left[2(208a) + 2(206) + 2(201) \right] \times 10^{-3}\end{aligned}$$

(211) ϕ_{3L}

$$\begin{aligned}\phi_{3L} &= (P_3) \left[2(F_{gL}) + 2(F_{TL}) + 2(F_{CL}) \right] \times 10^{-3} \\ &= (82) \left[2(208a) + 2(206) + 2(201) \right] \times 10^{-3}\end{aligned}$$

$$\begin{aligned}
 (212) \quad \phi_{4L} \quad \phi_{4L} &= (P_4) \left[2(F_{gL}) + 2(F_{TL}) + 2(F_{CL}) \right] \times 10^{-3} \\
 &= (83) \left[2(208a) + 2(206) + 2(201) \right] \times 10^{-3}
 \end{aligned}$$

(213) ϕ_{PL} FLUX PER POLE AT FULL LOAD

For P.F. = 0.0 to .95

$$\begin{aligned}
 \phi_{PL} &= \phi_{PNL} \left[(e_d) - \frac{.93(X_{ad})}{100} \sin(\psi) \right] \\
 &= (213) \left[(198) - \frac{.93(131)}{100} \sin(198) \right]
 \end{aligned}$$

Where $\phi_{PNL} = \frac{(\phi_{TL})(C_P)}{(P)}$

$$= \frac{(208)(73)}{(6)}$$

For P.F. .95 to 1.0

$$\begin{aligned}
 \phi_{PL} &= (K_c)(\phi_{PNL}) \\
 &= (9a)(213)
 \end{aligned}$$

(214) ϕ_{SPFL} SOUTH POLE FLUX AT FULL LOAD

$$\begin{aligned}
 \phi_{SPFL} &= \frac{(\phi_{PL})}{2} + \frac{(\phi_{1L}) + (\phi_{2L}) + (\phi_{3L}) + (\phi_{4L})}{2(P)} \\
 &= \frac{(213)}{2} + \frac{(209) + (210) + (211) + (212)}{2(6)}
 \end{aligned}$$

(215) B_{SPFL} FLUX DENSITY IN SOUTH POLE AT FULL LOAD

$$B_{SPFL} = \frac{(\phi_{SPFL})}{(a_{SP})} = \frac{(214)}{(79a)}$$

(216) F_{SPFL} SOUTH POLE AMPERE TURNS

When $b_{np}(\text{end}) = b_{np}(\text{mid})$

$$F_{SP-FL} = \frac{\ell_{SP}}{3} \left[\text{NI/inch at density } (B_{SPFL}) \right]$$

$$\frac{(76)}{3} \left[\text{Look up on tube magnetization curve given in (18) at density (215)} \right]$$

When $b_{np}(\text{end}) \neq b_{np}(\text{mid})$

$$\frac{\ell_{SP}}{2} \left[\text{NI/inch at density } B_{SPFL} \right]$$

$$\frac{(76)}{2} \left[\text{Look up on tube magnetization curve given in (18) at density (215)} \right]$$

(217) ϕ_{NPFL} NORTH POLE FLUX - First approximation without leakage

ϕ_{5L} .

$$\phi_{NPFL} = (\phi_{PL}) + \frac{(\phi_{1L}) + (\phi_{2L}) + (\phi_{3L}) + (\phi_{4L})}{(P)}$$

$$(213) + \frac{(209) + (210) + (211) + (212)}{(6)}$$

(218) B'_{NPFL} NORTH POLE DENSITY AT FULL LOAD - first approximation.

$$B'_{NPFL} = \frac{(\phi_{NPFL})}{(a_{NP})} = \frac{(217)}{(79)}$$

(219) F'_{NPFL} NORTH POLE AMPERE TURN DROP - first approximation.

$$F'_{NPFL} = (h_{NP}) \left[\text{NI/inch at density } (B'_{NPFL}) \right]$$

$$(78) \left[\text{Look up on N/P magnetization curve given in (18) at density (218)} \right]$$

(220) ϕ_{6L} LEAKAGE ACROSS FIELD COIL - from rotor shaft outer diameter to the inner surface of the rotor skirt.

$$\begin{aligned}\phi_{6L} &= (P_6) \left[(F_{SPFL}) + (F'_{NPFL}) + 2(F_{gL}) + 2(F_{TL}) + 2(F_{CL}) \right] \times 10^{-3} \\ &= (85) \left[(216) + (219) + 2(208a) + 2(206) + 2(201) \right] \times 10^{-3}\end{aligned}$$

(221) ϕ_{SKFL} FLUX AT THE SKIRT ENTRY EDGE OF AUXILIARY AIR GAP (g2) - at full load.

$$\begin{aligned}\phi_{SKFL} &= (\phi_{SPFL}) \frac{(P)}{2} + \frac{(\phi_{6L})}{2} \\ &= (214) \frac{(6)}{2} + \frac{(220)}{2}\end{aligned}$$

(222) B_{SKFL} DENSITY AT THE SKIRT ENTRY EDGE OF AUXILIARY AIR GAP (g2) - at full load.

$$B_{SKFL} = \frac{\phi_{SKFL}}{a_{SK}} = \frac{(22.)}{(79b)}$$

(223) F_{SKFL} ROTOR SKIRT AMPERE TURN DROP -

$$\begin{aligned}F_{SKFL} &= (\beta_{SK}) \left[\text{NI/inch at density } B_{SKFL} \right] \\ &= (78) \left[\text{Look up on skirt magnetization curve given in (18) at density (222)} \right]\end{aligned}$$

This value of ampere turns should be insignificant.

The calculation of F_{SKFL} is in this program only for a check on a possible bottleneck.

(224) B_{g2FL} FLUX DENSITY IN AUXILIARY AIR GAP - at full load.

$$B_{g2FL} = \frac{(\phi_{SKFL})}{(A_{g2})} = \frac{(221)}{(70)}$$

(225) F_{g2FL} AMPERE TURN DROP IN AUXILIARY GAP

$$F_{g2FL} = \frac{(B_{g2FL})}{3.19} (g_2) \times 10^3$$

$$= \frac{(224)}{3.19} (59a) \times 10^3$$

(226) ϕ_{L5} LEAKAGE FLUX THROUGH FIELD COIL FROM NORTH POLE TO YOKE (y_2)

$$\phi_{L5} = (P_5) \left[(F'_{NPFL}) + 2(F_{gL}) + 2(F_{TL}) + 2(F_c) + (F_{SPFL}) + (F_{g2FL}) \right] \times 10^{-3}$$

$$= (84) \left[(219) + 2(208a) + 2(206) + 2(201) + (216) + (225) \right] \times 10^{-3}$$

(227) ϕ_{y2FL} FLUX IN COIL YOKE - At y_2 the smallest cross-section of yoke.

$$\phi_{y2FL} = (\phi_{SKFL}) + \frac{(\phi_{L5})}{2}$$

$$= (221) + \frac{(226)}{2}$$

(228) B_{y2FL} FLUX DENSITY IN COIL YOKE - At y_2 the smallest cross-section of yoke.

$$B_{y2FL} = \frac{(\phi_{y2FL})}{(A_{y2})} = \frac{(227)}{(124)}$$

- (229) F_{y2FL} AMPERE TURN DROP IN THE YOKE SECTION y_2 . This value should be insignificant and the calculation is here to call attention to a possible saturation point. If the yoke section is made straight, of uniform thickness, all of the ampere turn drop will be in the lower half of the yoke.

$$F_{y2FL} = \frac{1}{3} (h_y) \left[\text{NI/inch at density } (B_{y2FL}) \right]$$

$$= \frac{1}{3} (78) \left[\text{NI/inch at density } (228) \right]$$

- (230) B_{g3FL} DENSITY OF AIR GAP g_3 - at full load.

$$B_{g3FL} = \frac{(\Phi_{y2FL})}{(A_{g3})} = \frac{(227)}{(70a)}$$

- (231) F_{g3FL} AMPERE TURN DROP ACROSS AIR GAP (g_3) - at full load.

For stepped air gap i.e. when (59b) = 1.0 calculate as follows:

$$F_{g3FL} = \frac{B_{g3FL} (g_{3e})}{3.19} \times 10^3$$

$$= \frac{(230)(59f)}{3.19} \times 10^3$$

For tapered air gap i.e. when (59b) = 2 calculate as follows:

$$F_{g3FL} = \frac{B_{g3FL} (g_3)}{3.19} \times 10^3 = \frac{(230)(59c)}{3.19} \times 10^3$$

(232) B_{y4FL} FLUX DENSITY IN SHAFT AT ENTRY TO NORTH POLE

$$B_{y4FL} = \frac{(\phi_{y2FL})}{(A_{y4})} = \frac{(227)}{(112)}$$

(233) F_{y4FL} AMPERE TURN DROP IN SHAFT

$$F_{y4FL} = \frac{(l_{y4})}{2} \left[\text{NI/inch at density } (B_{y4FL}) \right]$$
$$= \frac{(78)}{2} \left[\text{Look up on shaft magnetization curve} \right]$$

given in (i8) at density (232)

(234) B_{NPFL} FLUX DENSITY IN NORTH POLE AT BASE

$$B_{NPFL} = \frac{2(\phi_{y2FL})}{4(a_{NP})} = \frac{2(227)}{4(79)}$$

(235) F_{NPFL} NORTH POLE AMPERE TURN DROP

$$F_{NPFL} = (h_{NP}) \left[\text{NI/inch at density } (B_{NPFL}) \right]$$
$$= (78) \left[\text{Look up on north pole magnetization} \right]$$

curve given in (18) at density (234)

(236) F_{FL} FULL LOAD AMPERE TURNS

$$F_{FL} = 2(F_g) + 2(F_T) + 2(F_c) + (F_{SP}) + (F_{NP}) + (F_{SK}) + (F_{g2}) + (F_{y2}) + (F_{g3FL}) + (F_{y4})$$

$$2(208) + 2(206) + 2(201) + (216) + (235) + (223) + (225) + (229) + (231) + (233)$$

(237) I_{FFL} FIELD CURRENT - at 100% load per coil

$$I_{FFL} = \frac{(F_{FL})}{(N_F)} = \frac{(236)}{(146)}$$

(238) E_{FFL} FIELD VOLTS - at 100% load per coil. This calculation is made with hot field resistance at the expected temperature at 100% load.

$$E_{FFL} = (I_{FFL})(R_F \text{ hot})$$

$$= (237)(155)$$

(239) S_{FL} CURRENT DENSITY OF FIELD CONDUCTOR - at 100% load.

$$\text{Current Density} = \frac{(I_{FFL})}{(a_{cf})} = \frac{(237)}{(153)}$$

(240) -- Items (197) through (239) cover full load saturation calculations at 100% load. In order to calculate for any load other than 100% load, use the following procedure:

Recalculate Item (197) as follows:

$$E_{NL} = E_{PH} + I_{PH} (\text{Per Unit Load}) R_{PH}$$

$$= (4) + (8) (\text{Per Unit Load}) (54)$$

Recalculate Item (198) as follows:

$$= \tan^{-1} \left[\frac{\sin \Theta + (X_d)(\text{Per Unit Load})}{\cos \Theta} \right]$$

$$= \tan^{-1} \left[\frac{\sin(161) + (134)(\text{Per Unit Load})}{\cos(198)} \right]$$

$$e_d = \cos(\epsilon) + (X_d)(\text{Per Unit Load}) \sin(\psi)$$

$$= \cos(\epsilon) + (133)(\text{Per Unit Load}) \sin(240)$$

Recalculate Item (213)

For P.F. = 0.0 to .95

$$\begin{aligned}\phi_{PL} &= \phi_{PNL} \left[(e_d) - \frac{.93 (X_d)(P.U. LOAD)}{100} \sin (\psi) \right] \\ &= (213) \left[(240) - \frac{.93(131)(P.U. LOAD)}{100} \sin (240) \right]\end{aligned}$$

With the changes made as shown in Item (240), recalculate Items (197) through (239) at the % load required using per unit load = $\frac{\% \text{ load being used}}{100}$.

(241) I^2R_R FIELD COIL I^2R at 100% load - The copper loss in the field windings calculated with hot field resistance at expected temperature for 100% load condition. (for two coils).

$$\text{Rotor } I^2R = 2 (I_{FFL})^2 (R_F \text{ hot}) = 2(237)^2 \quad (155)$$

(242) W_{TFL} STATOR TEETH LOSS at 100% load - The stator tooth loss under load increases over that of 1.0 load because of the parasitic fluxes caused by the ripple due to the rotor damper bar slot openings.

$$\begin{aligned}W_{TFL} &= \left\{ 2 \left[.4(X_d) \right]^{(e_x)} + 1 \right\} W_{TNL} \\ &= \left\{ 2 \left[.4(133) \right]^{(2.07)} + 1 \right\} \quad (184)\end{aligned}$$

$$\text{Where } (e_x) = 1.8 \text{ if } \left[\frac{.4(X_d)}{100} \right] < 1.0$$

$$(e_x) = 2.0 \text{ if } \left[\frac{.4(133)}{100} \right] > 1.0$$

(243) W_{PFL} POLE FACE LOSS at 100% load

$$W_{PFL} = \left\{ \frac{(K_{SC})(I_{PH}) \left(\frac{\% \text{ Load}}{100} \right) (n_s)}{(C) (F_{gL})} \right\}^2 + 1 \left\{ (W_{PNL}) + (W_{PHR}) \right\}$$
$$= \left\{ \frac{(243) (8) 1 (30)}{(32) (208a)} \right\}^2 + 1 \left\{ (186) + (243) \right\}$$

(K_{SC}) is obtained from Graph 3

Where W_{PHR} = pole face harmonic loss

The pole face harmonic loss calculation is not included in this design manual; however, a space has been provided on the input sheet for the pole face harmonic loss if the designer calculates it by some other means. This calculated loss will be added to the normal pole face harmonic loss and the output will include both. When the calculated value of pole face harmonic loss is not available insert 0.0 on the input sheet. When the calculated value of pole face harmonic loss is available, insert the actual value on the input sheet in watts.

(244) W_{DFL} DAMPER LOSS at 100% load

$$W_{DFL} = \left\{ \left[\frac{(K_{SC})(I_{PH}) \left(\frac{\% \text{ Load}}{100} \right) (n_S)}{(C)(F_{gL})} \right]^2 + 1 \right\} (W_{DNL}) \times \frac{(P_{D \text{ hot}})}{(P_{D \text{ cold}})} + (W_{DHR})$$

$$= \left\{ \left[\frac{(244) (8) 1 (30)}{(32)(166)} \right]^2 + 1 \right\} (193) \frac{(143)}{(141)} + (244)$$

(K_{SC}) is obtained from Graph 3

Where W_{DHR} = Damper bar harmonic loss

The damper bar harmonic loss calculation is not included in this design manual; however, a space has been provided on the input sheet for the damper bar harmonic loss if the designer calculates it by some other means. This calculated loss will be added to the normal damper harmonic loss and the output will include both. When the calculated value of the damper bar harmonic loss is not available, insert 0.0 on the input sheet. When the calculated value of damper harmonic loss is available, insert the actual value on the input sheet in watts.

(245)	I^2R	<u>STATOR I^2R at 100% load -</u>
(246)	--	<u>EDDY LOSS -</u>
(247)	--	<u>TOTAL LOSSES at 100% load - sum of all losses at 100% load.</u> Total Losses = (FIELD I^2R) + (F&W) + (Stator Teeth Loss) + (Stator Core Loss) + (Pole Face Loss) + (Damper Loss) + (Stator I^2R) + (Eddy Loss) = (241)+(183)+(242)+(185)+(243)+(244)+(245)+(246)
(248)	--	<u>RATING IN KILOWATTS at 100% load</u>
(249)	--	<u>RATING & ϵ LOSSES</u>
(250)	--	<u>% LOSSES</u>
(251)	--	<u>% EFFICIENCY</u>

INPUT AUXILIARY DATA SHEET

Auxiliary information taken from the design manuals to be used in conjunction with input sheets for convenience.

- A. All dimensions for lengths, widths, and diameters are to be given in inches.
- B. Resistivity inputs, Items (141) and (151) are to be given in micro-ohm-inches.

The following items along with an explanation of each are tabulated here for convenience. For complete explanation of each item number, refer to design manuals.

- | <u>Item No.</u> | <u>Explanation</u> |
|-----------------|--|
| (9) | Power factor to be given in per unit. For example for 90% P.F., insert <u>.90</u> . |
| (9a) | Adjustment Factor - For P.F. < .95 insert <u>1.0</u>
For P.F. > .95 insert <u>1.05</u> |
| (10) | Optional Load Point -- Where load data output is required at a point other than those given as standard on the input sheet. Example: For load data output at 155% load, insert <u>1.55</u> . |
| (14) | Number of radial ducts in stator. |
| (15) | Width of radial ducts used in Item (14). |
| (18) | Magnetization curve of material used to be submitted as defined in Item (18). |
| (19) | Watts/Lb. to be taken from a core loss curve at the density given in Item (20) (Stator). |
| (20) | Density in kilolines/in ² . This value must correspond to density used to pick Item (19) usually use 77.4 KL/in ² . |
| (21) | Type of slot - For open slot Type A, insert <u>1.0</u> .
For partially open slot Type B with constant slot width, insert <u>2.0</u> .
For partially open slot Type C with constant tooth width, insert <u>3.0</u> .
For round slot Type D, insert <u>4.0</u> .
For additional information, refer to figure adjacent to input sheet which shows a picture of each slot. |
| (22) | For stator slot dimension - for dimensions that do not apply to the slot insert <u>0.0</u> .
Use Table below as guide for input. |

<u>Symbol</u>	<u>Item</u>	<u>Slot Type</u>			
		<u>1</u>	<u>2</u>	<u>3</u>	<u>4</u>
b ₀	(22)	0.0	*	*	*
b ₁	↓	0.0	0.0	*	0.0
b ₂		0.0	0.0	*	0.0
b ₃		0.0	0.0	*	0.0
b _B		*	*	φ	*
h ₀		0.0	*	*	*
h ₁		*	*	*	0.0
h ₂		*	0.0	0.0	0.0
h ₃		*	*	0.0	0.0
h _B		*	*	*	*
h _t		0.0	*	*	0.0
h _w		0.0	*	*	0.0

* = insert actual value.

$$\varphi = b_B = \frac{b_1 + b_3}{2}$$

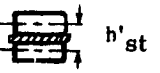
<u>Item No.</u>	<u>Explanation</u>	
(28)	Type of winding - for wye connected winding insert <u>1.0</u> . for delta connected winding insert <u>0.0</u> .	
(29)	Type of coil - for formed wound (rect. wire), insert <u>1.0</u> . for random wound (round wire) insert <u>0.0</u> .	
(30)	Slots spanned - Example - for slot span of 1-10, insert <u>9.0</u> .	
(33)	For round wire insert diameter. For rectangular wire insert wire width.	
(34)	Strands per conductor in depth only.	
(34a)	Total strands per conductor in depth and width.	
(35)	Diameter of coil head forming pin. Insert .25 for stator O.D. < 8 inches; Insert .50 for stator O.D. > 8 in.	
(37)	Use vertical height of strand for round wire, insert <u>0.0</u> .	
(38)	Distance between centerline of strands in depth.	Insulation 
(39)	Stator strand thickness -- use narrowest dimension of the two dimensions given for a rectangular wire. For round wire insert <u>0.0</u> .	
(40)	Stator slot skew in inches.	
(42a)	Phase belt angle - for 60° phase belt, insert <u>60°</u> . for 120° phase belt, insert <u>120°</u> .	
(48)	See explanation of items (71), (72), (73), (74) and (75). Same applies here.	
(87)	When no load saturation output data is required at various voltages, insert <u>1.0</u> . When no load saturation information is not required, insert <u>0.0</u> .	
(137)	Damper bar thickness -- use damper bar slot height for rectangular bar. For round bar insert <u>0.0</u> .	
(138)	Number of damper bars per pole.	
(140)	Damper bar pitch in inches.	
(148)	For round wire insert diameter. For rectangular wire insert wire width.	
(149)	For rectangular wire insert wire thickness. For round wire insert <u>0.0</u> .	
(187)	Pole face loss factor. For rotor lamination thickness .028 in. or less, insert <u>1.17</u> . For rotor lamination thickness .029 in. to .063 in. insert <u>1.75</u> . For rotor lamination thickness .064 in. to .125 in. insert <u>3.5</u> . For solid rotor insert <u>7.0</u> .	
(71) }	If the values of these constants are available, insert the actual number. If they are not available, insert 0.0 and the computer will calculate the values and record them on the output.	
(72)		
(73)		
(74)		
(75)		

TWO OR SINGLE COIL OUTSIDE COIL LUNDELL

MODEL _____ EWO _____ DESIGN NO.(1) _____

	(2)	KVA	GENERATOR KVA		FUND/MAX OF FLD FLUX	(71)	C ₁	
PARAMETERS	(3)	E	LINE VOLTS		WINDING CONSTANT	(72)	C _w	CONSTANTS
	(4)	E _{ph}	PHASE VOLTS		POLE CONSTANT	(72)	C _p	
	(5)	m	PHASES		END EXTENSION ONE TURN	(48)	L _E	
	(5a)	f	FREQUENCY		DEMAGNETIZATION FACTOR	(74)	C _b	
	(6)	p	POLES		CROSS MAGNETIZING FACTOR	(75)	C _a	
	(7)	RPM	RPM		POLE EMBRACE	(77)	α	
	(8)	I _{ph}	PHASE CURRENT		WIDTH OF POLE(NARROW END)	(74)	b _{p1}	
	(9)	PF	POWER FACTOR		WIDTH OF POLE(WIDTH END)	(76)	b _{p2}	
	(9a)	K _c	ADJ. FACTOR		POLE THICKNESS (NARROW END)	(76)	p _{p1}	
	(10)		OPTIONAL LOAD POINT		POLE THICKNESS (WIDE END)	(76)	p _{p2}	
STATOR STACK	(11)	d	STATOR I.D.		POLE LENGTH	(76)	l _p	POLE
	(12)	D	STATOR O.D.		ROTOR DIAMETER	(11a)	d _r	
	(13)		GROSS CORE LENGTH		WEIGHT OF ROTOR IRON	(157)	(-)	
	(14)	n _v	NO. OF DUCTS		POLE FACE LOSS FACTOR	(187)	(K ₁)	
	(15)	b _v	WIDTH OF DUCT		PERM OF LEAKAGE PATH 1	(80)	P ₁	
	(16)	K ₁	STACKING FACTOR STATOR		PERM OF LEAKAGE PATH 2	(81)	P ₂	
	(19)	k	WATTS/LB.		PERM OF LEAKAGE PATH 3	(82)	P ₃	
	(20)	S	DENSITY		PERM OF LEAKAGE PATH 4	(83)	P ₄	
STATOR SLOT	(21)		TYPE OF SLOT		PERM OF LEAKAGE PATH 5	(84)	P ₅	PERMEANCE
	(22)	b _o	SLOT OPENING		PERM OF LEAKAGE PATH 7	(86)	P ₇	
	(22)	b ₁	SLOT WIDTH TOP		PERM OF LEAKAGE PATH 8	(86a)	P ₈	
	(22)	b ₂			DIA. OF END BELL AT SMALLEST SECT	(78)	d _{y2}	
	(22)	b ₃			THICKNESS OF END BELL " "	(78)	t _{y2}	
	(22)	b _s	SLOT WIDTH		THICKNESS OF HOUSING SECTION	(78)	t _y	
	(22)	h _o			LENGTH OF HOUSING SECTION	(78)	l _y	
	(22)	h ₁			LENGTH OF PERM PATH 1	(80a)	l ₁	
	(22)	h ₂			NO. OF FIELD COILS	(146b)	K _{co}	
	(22)	h ₃			NO. OF FIELD TURNS/COIL	(146)	N _F	
STATOR WINDING	(22)	h _s	SLOT DEPTH		MEAN LENGTH OF FLD. TURN	(147)	l _{MF}	FIELD
	(22)	h _t			FLD. COND. DIA. OR WIDTH	(148)		
	(22)	h _w			FLD. COND. THICKNESS	(149)		
	(23)	Q	NO. OF SLOTS		FLD. TEMP IN °C	(150)	X ₁ °C	
	(28)		TYPE OF WDG.		RESISTIVITY OF FLD. COND. @ 20 °C	(151)	ρ ₁	
	(29)		TYPE OF COIL		NO LOAD SAT.	(87)		
	(30)	n _s	CONDUCTORS/SLOT		FRICTION & WINDAGE	(183)	(F&W)	
	(31)	y	SLOTS SPANNED		SPECIAL PERMEANCE	(144)	λ ₇	
	(32)	c	PARALLEL CIRCUITS		STATOR LAM MATERIAL	(18)		
	(33)		STRAND DIA. OR WIDTH		POLE MATERIAL	(18)		
GAP	(34)	N _{st}	STRANDS/CONDUCTOR IN DEPTH		YOKE MATERIAL (FLUX PLATE)	(18)		MATR'L
	(34a)	N' _{st}	STRANDS/CONDUCTOR					
	(39)		STATOR STRAND T'KNS.					
	(35)	d _b	DIA. OF PIN					
	(36)	l _{e2}	COIL EXT. STR. PORT					
	(37)	h _{st}	UNINS. STRD. HT.		STATOR SLOT		POLE	
	(38)	h' _{st}	DIST. BTW. C _L OF STD.		DAMPER SLOT		REMARKS	
	(42a)		PHASE BELT ANGLE					
	(40)	γ _{sk}	STATOR SLOT SKEW					
	(50)	X °C	STATOR TEMP °C					
(51)	ρ _s	RES'TVY STA. COND. @ 20 °C						
(78)	l _{g2}	LENGTH OF GAP (g2)						
(78)	d _{g2}	DIAMETER AT GAP (g2)						
(59)	g	MAIN AIR GAP						
(59a)	g ₂	AUXILIARY AIR GAP						

DESIGNER _____ DATE _____

(a) Open Slots

(b) Constant Slot Width

TYPE 1
(Type 5 is an open slot with 1 conductor per slot)

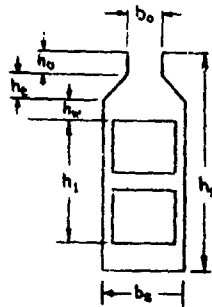
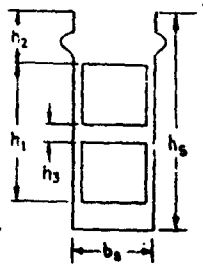

TYPE 2

(c) Constant Tooth Width

(d) Round Slots

TYPE 3
 b_s for type 3 is
$$b_s = \frac{b_1 + b_3}{2}$$

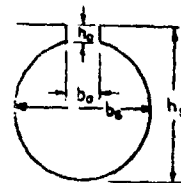
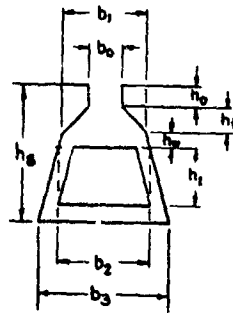

TYPE 4

TWO OR SINGLE COIL OUTSIDE COIL LUNDELL
SUMMARY OF DESIGN CALCULATIONS - - - - - (OUTPUT)

MODEL NO. _____ EWO _____ DESIGN NO. _____

STATOR	(17) (l_s)	SOLID CORE LENGTH		CARTER COEFFICIENT	(67) (K_s)	CONSTANTS
	(24) (h_c)	DEPTH BELOW SLOT		EFFECTIVE AIR GAP	(69) (g_e)	
	(26) (τ_s)	SLOT PITCH		FUND/MAX OF FLC. FLUX	(71) (C_s)	
	(27) ($\tau_s/3$)	SLOT PITCH 1/3 DIST. UP		WINDING CONST.	(72) (C_w)	
	(42) (K_{sk})	SKEW FACTOR		POLE CONST.	(73) (C_p)	
	(43) (K_d)	DIST. FACTOR		END. EXT. OMF TURN	(48) (LE)	
	(44) (K_p)	PITC. FACTOR		DEMAGNETIZING FACTOR	(74) (C_M)	
	(45) (γ_e)	EFF. CONDUCTORS		CROSS MAGNETIZING FACTOR	(75) (C_g)	
	(46) (σ_c)	COND. ARFA		AMP COND/IN	(128) (A)	
	(47) (S_a)	CURRENT DENSITY (STA.)		REACTANCE FACTOR	(129) (X)	
	(49) (l_t)	1/2 MEAN TURN LENGTH		LEAKAGE REACTANCE	(130) (X_g)	
	(53) (R_{ph})	COLD STA. RES. @ 20° C		REACTANCE DIRECT AXIS	(131) (X_{od})	
	(54) (R_{ph})	HOT STA. RES. @ X° C		REACTANCE QUAD. AXIS	(132) (X_{og})	
	(55) (E_{Ftop})	EDDY FACTOR TOP		SYN REACT DIRECT AXIS	(133) (X_d)	
	(56) (E_{Fbot})	EDDY FACTOR BOT		SYN REACT QUAD AXIS	(134) (X_g)	
(62) (λ_1)	STATOR COND. PER %		FIELD LEAKAGE REACT	(160) (X_f)		
(63) (λ_o)	END PERM		FIELD SELF INDUCTANCE	(161) (L_f)		
(65) ()	WT. OF STA COPPER		UNSAT. TRANS. REACT	(166) (X'_{dU})		
(66) ()	WT. OF STA IRON		SAT. TRANS. REACT	(167) (X'_{dS})		
(41) (τ_p)	POLE PITCH		SUB. TRANS REACT DIRECT AX.	(168) (X''_{dU})		
(157) (-)	WT. OF ROTOR IRON		SUB. TRANS REACT QUAD AX.	(169) (X''_{dS})		
(145) (V_r)	PERIPHERAL SPEED		NEG SEQUENCE REACT	(170) (X_2)		
FIELD	(153) (σ_{cf})	FLD COND. AREA		ZERO SEQUENCE REACT	(172) (X_o)	TIME CONST.
	(154) (R_f)	COLD FLD RES @ 20° C		OPEN CIR. TIME CONST.	(176) (T'_{do})	
	(155) (R_f)	HOT FLD RES @ X° C		ARM TIME CONST.	(177) (T_a)	
	(156) (-)	WT OF FLD COPPER		TRANS TIME CONST.	(178) (T'_{d})	
PERMEANCE	(80) (P_1)	PERM OF LEAKAGE PATH 1		SUB. TRANS TIME CONST.	(179) (T''_{d})	MAGNETIZATION
	(81) (P_2)	PERM OF LEAKAGE PATH 2		TOTAL FLUX	(88) (C_w)	
	(82) (P_3)	PERM OF LEAKAGE PATH 3		FLUX PER POLE	(92) (C_p)	
	(83) (P_4)	PERM OF LEAKAGE PATH 4		GAP DENSITY (MAIN)	(95) (B_g)	
	(84) (P_5)	PERM OF LEAKAGE PATH 5		TOOTH DENSITY	(91) (B_t)	
	(86) (P_7)	PERM OF LEAKAGE PATH 7		CORE DENSITY	(94) (B_c)	
	(86a) (P_8)	PERM OF LEAKAGE PATH 8		TOOTH AMPERE TURNS	(97) (F_t)	
	(180) (FSC)	SHORY CIR NI		CORE AMPERE TURNS	(98) (F_c)	
	(181) (SCR)	SHORT CIR. RATIO		GAP AMPERE TURNS (MAIN)	(96) (F_g)	

PERCENT LOAD		0	100	150	200	OPTIONAL
g	(100a) LEAKAGE FLUX	(g_{p0}) (197a)				
p	(102a) TOTAL FLUX/POLE	(g_{pt1}) (213a)				
B_p	(103a) POLE DENSITY	(B_{p1}) (213b)				
B_{g2}	(122) AUX. GAP DENSITY	(B_{g2L}) (224)				
g_2	(125) END GELL DENSITY	(B_{y2L}) (228)				
y	(126a) HOUSING DENSITY	(B_{y1}) (229b)				
F_{nl}	(127) TOTAL NI/COIL	(F_{f1}) (236)				
i_{nl}	(127a) FIELD AMP./COIL	(I_{ff1}) (237)				
i	(127c) CUR. DENSITY FIELD	(S_{ff1}) (239)				
E_{fnl}	(127b) FIELD VOLTS/COIL	(E_{ff1}) (238)				
W_c	(185) STA CORE LOSS	(W_c) (185)				
W_{nl}	(184) STA TOOTH LOSS	(W_{ff1}) (242)				
W_{R_s}	(194) STATOR CU LOSS	($I^2 R_s$) (245)				
(-)	(195) EDDY LOSS	(-) (246)				
W_{pnl}	(186) POLE FACE LOSS	(W_{pff1}) (243)				
R_f	(182) FIELD COIL LOSS	($I^2 R_f$) (241)				
(F&W)	(183) F&W LOSS	(F&W) (183)				
(-)	(196) TOTAL LOSSES	(-) (247)				
(-)	(-) PERCENT EFF.	(-) (251)				

DESIGNER _____ DATE _____

TWO OR
SINGLE COIL OUTSIDE COIL LUNDELL
NO LOAD SATURATION OUTPUT SHEET

ITEMS → % VOLTS	(3) (E) VOLTS	(91) B _s STA. TOOTH DENSITY	(97) F _t STA. TOOTH NI	(94) B _c STA. CORE DENSITY	(96) F _c STA. CORE NI	(96) F _g MAIN GAP DENS
	(100a) ϕ_L LEAKAGE FLUX	(102a) ϕ_{PT} TOTAL FLUX/POLE	(103a) B _p POLE DENSITY	(125) B _{y2} END BELL DENSITY	(126a) B _y HOUSING DENSITY	(127) F _{nl} TOTAL NI
85%						
90%						
100%						
110%						
120%						
130%						
140%						
150%						
160%						

M-04

REV.

TWO-COIL OUTSIDE-COIL LUNDELL
DESIGN COMPUTER MANUAL

(1)	--	DESIGN NUMBER
(2)	KVA	GENERATOR KVA
(3)	E	LINE VOLTS
(4)	E_{PH}	PHASE VOLTS
(5)	m	PHASES
(5a)	f	FREQUENCY
(6)	P	POLES
(7)	RPM	SPEED
(8)	I_{PH}	PHASE CURRFNT
(9)	P. F.	POWER FACTOR
(9a)	K_c	ADJUSTMENT FACTOR
(10)	--	LOAD POINTS
(11)	d	STATOR PUNCHING I.D.
(11a)	d_r	ROTOR O.D.
(12)	D	PUNCHING O.D.
(13)	l	GROSS STATOR CORE LENGTH
(14)	n_v	RADIAL DUCTS
(15)	b_v	RADIAL DUCT WIDTH
(16)	K_1	STACKING FACTOR
(17)	l_s	SOLID CORE LENGTH

(18)

MATERIAL - This input is used in selecting the proper magnetization curves for stator, yoke, pole, when different materials are used. Separate spaces are provided on the input sheet for each section mentioned above. Where curves are available on card decks, used the proper identifying code. Where card decks are not available submit data in the following manner:

The magnetization curve must be available on semi-log paper. Typical curves are shown in this manual on Curves F15 & F16. Draw straight line segments through the curve starting with zero density. Record the coordinates of the points where the straight line segments intersect. Submit these coordinates as input data for the magnetization curve. The maximum density point must be submitted first.

Refer to Figure below for complete sample

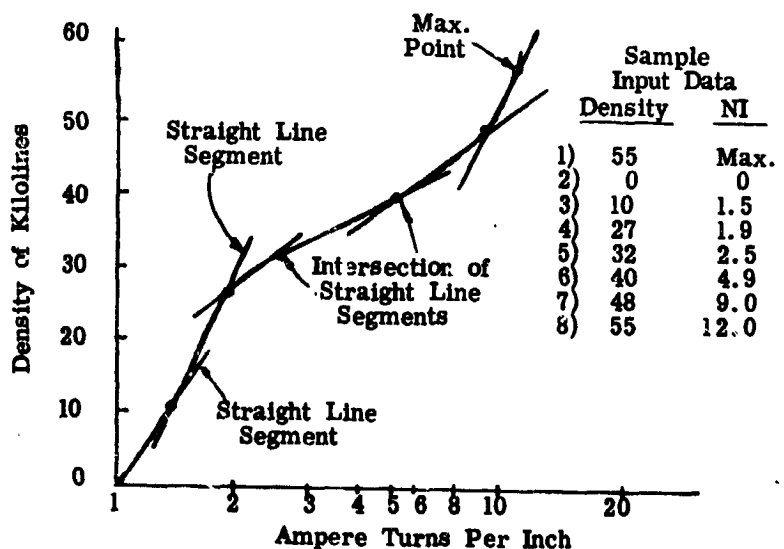

(19)	k	WATTS/LB
(20)	B	DENSITY
(21)		TYPE OF STATOR SLOT
(22)		ALL SLOT DIMENSIONS
(23)	Q	STATOR SLOTS
(24)	h_c	DEPTH BELOW SLOTS
(25)	q	SLOTS PER POLE PER PHASE
(26)	τ_s	STATOR SLOT PITCH
(27)	$\tau_s^{1/3}$	STATOR SLOT PITCH
(28)	--	TYPE OF WINDING
(29)	--	TYPE OF COIL
(30)	n_s	CONDUCTORS PER SLOT
(31)	γ	THROW
(31a)		PER UNIT OF POLE PITCH SPANNED
(32)	C	PARALLEL PATHS
(33)	--	STRAND DIA. OR WIDTH
(34)	N_{ST}	NUMBER OF STRANDS PER CONDUCTOR IN DEPTH
(34a)	N'_{ST}	NUMBER OF STRANDS PER CONDUCTOR
(35)	d_b	DIAMETER OF BENDER PIN
(36)	ℓ_{e2}	COIL EXTENSION BEYOND CORE
(37)	h_{ST}	HEIGHT OF UNINSULATED STRAND
(38)	h'_{ST}	DISTANCE BETWEEN CENTERLINES OF STRANDS IN DEPTH

(39)	--	STATOR COIL STRAND THICKNESS
(40)	τ_{SK}	SKREW
(41)	τ_P	POLE PITCH
(42)	K_{SK}	SKEW FACTOR
(42a)		PHASE BELT ANGLE
(43)	K_d	DISTRIBUTION FACTOR
(44)	K_p	PITCH FACTOR
(45)	n_e	TOTAL EFFECTIVE CONDUCTORS
(46)	a_c	CONDUCTOR AREA OF STATOR WINDING
(47)	S_S	CURRENT DENSITY
(48)	L_E	END EXTENSION LENGTH
(49)	l_t	1/2 MEAN TURN
(50)	X_S °C	STATOR TEMP °C
(51)	ρ_s	RESISTIVITY OF STATOR WINDING
(52)	ρ_s (Ect)	RESISTIVITY OF STATOR WINDING
(53)	R_{SPH} (cold)	STATOR RESISTANCE/PHASE
(54)	R_{SPH} (hot)	STATOR RESISTANCE/PHASE
(55)	EF (top)	EDDY FACTOR TOP
(56)	EF (bot)	EDDY FACTOR BOTTOM

(57)	b_m	STATOR TOOTH WIDTH
(57a)	$b_t 1/3$	STATOR TOOTH WIDTH
(58)	b_t	TOOTH WIDTH AT STATOR I.D. IN INCHES
(59)	g	MAIN AIR GAP IN INCHES
(59a)	g_2	AUXILIARY AIR GAP in inches
(60)	C_X	REDUCTION FACTOR
(61)	K_X	FACTOR TO ACCOUNT FOR DIFFERENCE in phase current in coil sides in same slot.
(62)	λ_i	CONDUCTOR PERMEANCE
(63)	K_E	LEAKAGE REACTIVE FACTOR
(64)	λ_E	END WINDING PERMEANCE
(64a)	λ_z	SPECIAL LEAKAGE PERMEANCE - For machines having a section of the pole that is approxi- mately a full pole-pitch wide, an additional leakage permeance must be added to the slot and end-turn leakage permeances. This permeance is that of the leakage path from one pole into a tooth top and from tooth top back into the adjacent pole. The leakage

(64a) Cont'd.

is similar to Zig Zag leakage and by increasing the stator leakage reactance, can reduce the output of the generator significantly.

This same leakage can be used to purposely limit the output of the generator and make it current limited. The presence of this additional leakage can be good or bad depending upon what is wanted from the generator. The important thing is for the designer to be aware that it is there.

In many cases, the designer should estimate the specific permeance λ_z since the pole base will be more or less than a full pole pitch wide and the following formula will not suffice.

(64a) Cont'd.

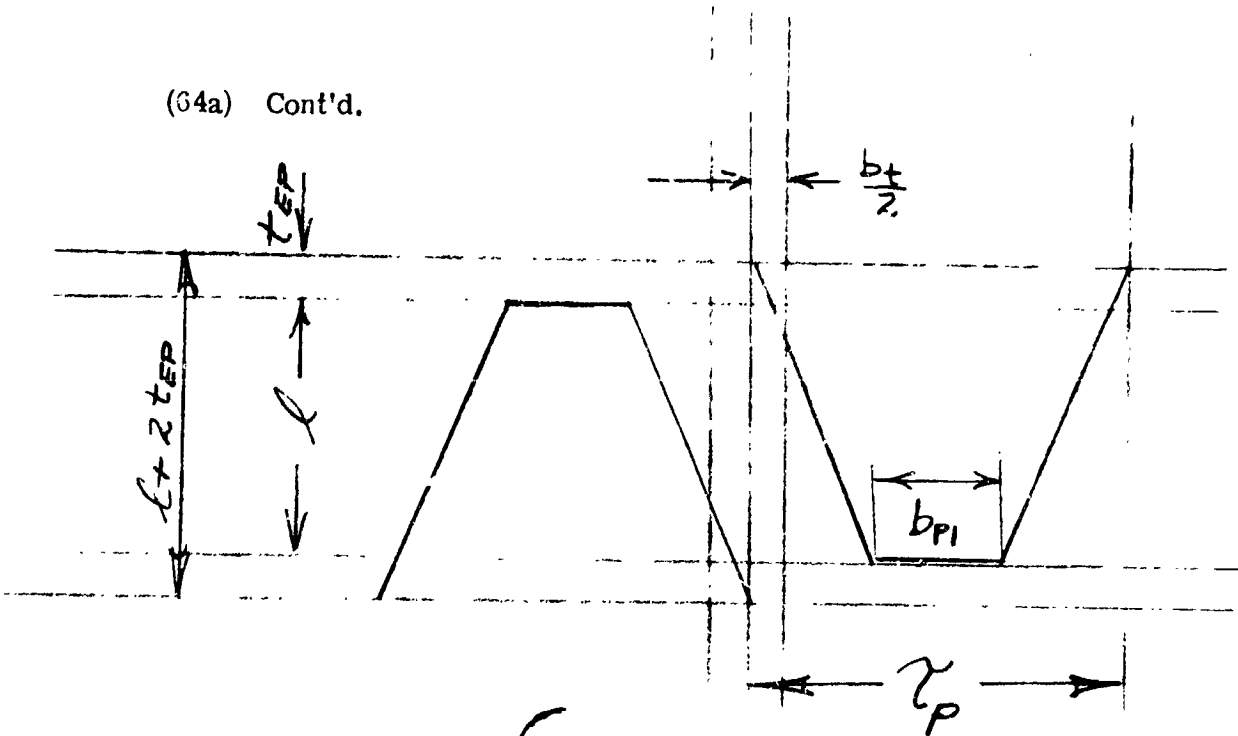

$$\lambda_z = (C_X) \frac{20}{(m)(q)} \left\{ \frac{\text{area of pole over tooth when tooth is on centerline between poles}}{2 l g} \right\}$$

$$\lambda_z = (C_X) \frac{20}{(m)(q)} \left\{ \frac{b_t (\tau_p - b_{p1}) (l + 2 t_{EP}) (\tau_p - b_{p1})}{2 l g \tau_p} \right\}$$

(65)	--	WEIGHT OF COPPER
(66)	--	WEIGHT OF STATOR IRON
(67)	K_g	CARTER COEFFICIENT
(68)	A_g	MAIN AIR GAP AREA
(69)	g_e	EFFECTIVE AIR GAP
(70)	A_{g2}	AREA OF AUXILIARY AIR GAP

$$A_{g2} = \pi (d_{g2}) (l_{g2}) = \pi (78)(78)$$

- (71) C_1 THE RATIO OF MAXIMUM FUNDAMENTAL of the field form to the actual maximum of the field form.
- (72) C_W WINDING CONSTANT
- (73) C_P POLE CONSTANT
- (74) C_M DEMAGNETIZING FACTOR
- (75) C_q CROSS MAGNETIZING FACTOR
- (76) POLE DIMENSION LOCATIONS

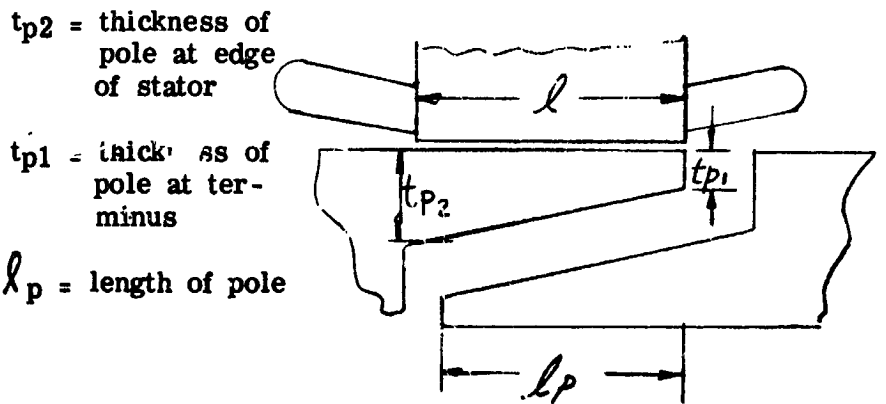
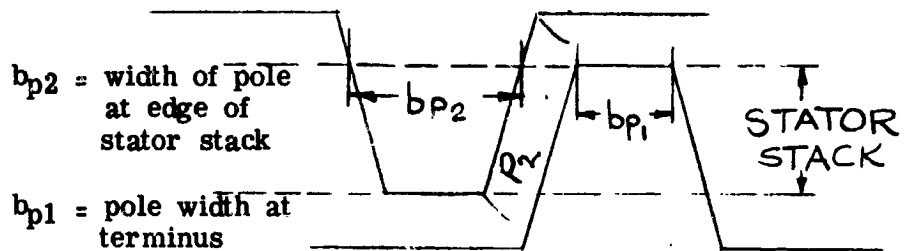

(77)

POLE EMBRACE

$$\alpha = \frac{b_{p1} + b_{p2}}{2(t_p)} = \frac{(76) + (76)}{2(41)}$$

(77a)

--

Items immediately following deal with the calculation of rotor and stator leakage permeances.

Illustrations are included to help identify the permeance areas and to locate the flux leakage paths. The computer program will handle the calculation of permeances P_1 , P_2 , P_3 and P_4 either of two ways:

1. P_1 through P_4 can be calculated by the computer. For this case, insert 0.0 on the input sheet for P_1 through P_4 .
2. P_1 through P_4 can be calculated by the designer. For this case, insert the actual calculated value on the input sheet for P_1 through P_4 .

Permeance P_5 and P_7 must be calculated by the designer and the calculated value must be inserted on the input sheet. The computer will not calculate these two permeance values because of the various possible field coil locations.

Permeance calculations P_1 through P_7 are all based on the equation $P = \frac{\mu(\text{area})}{\mathcal{L}}$

Where: $\mu = 3.19$

Area ▪ cross-sectional area perpendicular
 to the leakage flux.

l ▪ length of flux leakage path

Many of the equations used in this section are
taken from Roter's "Electromagnetic Devices".

Refer to the Appendix for the Roter's formulae.

(78)

--

ROTOR AND STATOR DIMENSIONS

l_{g2} = axial length of gap (g2)

d_{y2} = diameter of yoke (end bell section) at narrowest section

d_{g2} = rotor diameter at auxiliary air gap

l_y = half of the effective length of yoke

t_{y2} = thickness of end bell section of yoke

t_y = thickness of housing section of yoke

d_r = rotor diameter at main air gap

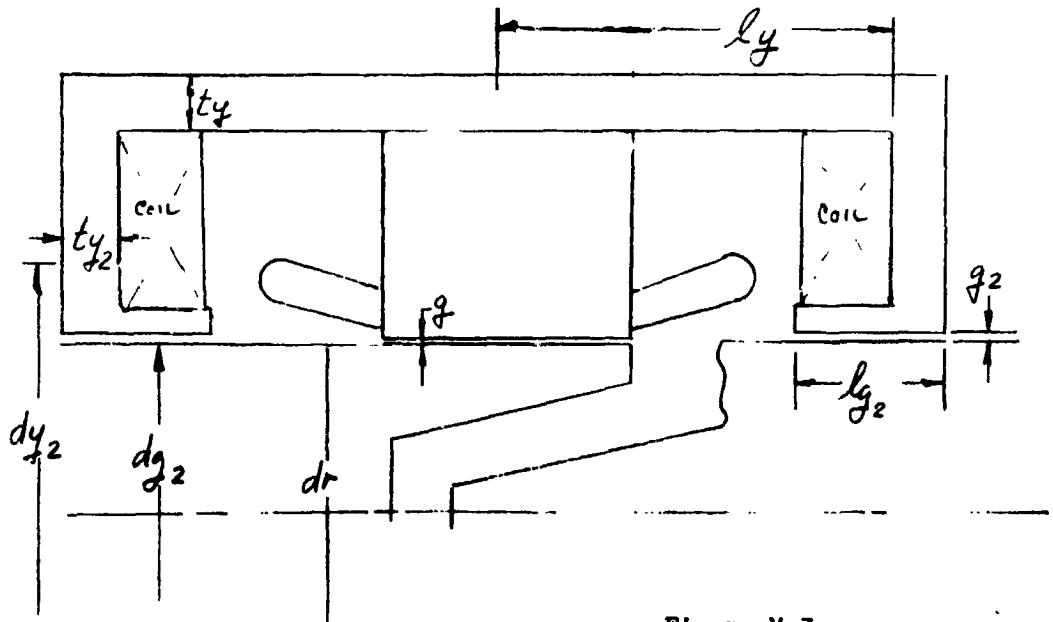

Figure M-3

(79) a_p POLE AREA - The effective cross-sectional area of the pole.

$$a_p = (b_{p2})(t_{p2}) = (76)(76)$$

(80) P_1 POLE HEAD END LEAKAGE - This can be either 0.0 or the actual value if available. Refer to Item (7a) for explanation. See Figure M-4 for location.

$$P_1 = \frac{3.19 (b_{p1})(t_{p1})}{(l_1)} = \frac{3.19 (76)(76)}{(80a)}$$

(80a) l_1 l_1 = length of permeance path P_1 and must be obtained from design layout. Must be given on input sheet when $P_1 = 0.0$.

(81) P_2 POLE HEAD SIDE LEAKAGE - This input can be either 0.0 or the actual value if available. Refer to Item (7a) for explanation. See Figure M-5 for location.

$$P_2 = \frac{3.19 \left\{ (l_p) \left[\frac{(t_{p2}) + (t_{p1})}{2} \right] \right\}}{(l_2)} = \frac{3.19 \left\{ (76) \left[\frac{(76) + (76)}{2} \right] \right\}}{(81a)}$$

(81a) l_2 LENGTH OF PERMEANCE PATH P_2 IN INCHES

$$l_2 = (r_p) - \left[\frac{(b_{p1}) + (b_{p2})}{2} \right] = (41) - \left[\frac{(76) + (76)}{2} \right]$$

(82)

P₃POLE BODY END LEAKAGE - This input can be either

0.0 or the actual value if available. Refer to Item (86) for explanation. See Figure M6 for location.

$$P_3 = \frac{6.28}{\pi} \left[\frac{3 (b_{p1}) + (b_{p2})}{4} \right] \ell_n \frac{(r_3)}{(r_4)}$$

$$= \frac{6.28}{\pi} \left[\frac{3 (76) + (76)}{4} \right] \ell_n \frac{(82b)}{(82c)}$$

(82b)

r₄r₄ = ℓ₁ = (80a) = length of permeance path P₁

(82c)

r₃r₃ = (ℓ₁) + $\frac{(\ell)}{2}$ = (80a) + $\frac{(13)}{2}$

(83)

P₄POLE BODY SIDE LEAKAGE - This input can be either 0.0

or the actual value if available. Refer to Item (77a) for explanation. See Figure M7 for location.

When (6) > 4

$$P_4 = \frac{3.19 (\ell_p)}{\pi} \ell_n \left[1 + \frac{(b_{p1}) + (b_{p2})}{2 (Z)} \right]$$

$$= \frac{3.19(76)}{\pi} \ell_n \left[1 + \frac{(76) + (76)}{2(83)} \right]$$

Where

$$Z = (\tau_p) - \left[\frac{(b_{p1}) + (b_{p2})}{2} \right] = (41) - \left[\frac{(76) + (76)}{2} \right]$$

When (6) ≤ 4

$$P_4 = \frac{3.19 (l_p)}{\pi} \frac{3}{2} l_n \left[1 + \frac{(b_{p1}) + (b_{p2})}{2 Z} \right]$$
$$= \frac{3.19 (76)}{\pi} \frac{3}{2} l_n \left[1 + \frac{(76) + (76)}{2(83)} \right]$$

(84) P5

COIL LEAKAGE PERMEANCE PER COIL - This permeance

must be calculated by the designer and the calculated value must be inserted on the input sheet. Refer to Fig. M-8 & M-9, which show the location of the coil. This value is to be given on a per coil basis. Refer to the appendix for permeance formulae.

(86) P7

STATOR TO FRAME AND ROTOR LEAKAGE PERMEANCE -

Refer to Fig. M-8 & M-9 for location. This permeance is actually broken down into three parts: P71 leakage to yoke; P72 leakage to shaft; P73 leakage to rotor pole. In this design manual, the three permeances are added and treated as a single leakage. The same condition applies to P7 and P5. The designer must calculate P7 and insert the calculated value on the input sheet. Refer to the appendix for formulae.

(86a)

P₈

FLUX PLATE TO FLUX PLATE LEAKAGE PERMEANCE

This permeance must be calculated by the designer and the value must be inserted on the input sheet. Location per Figure M-8.

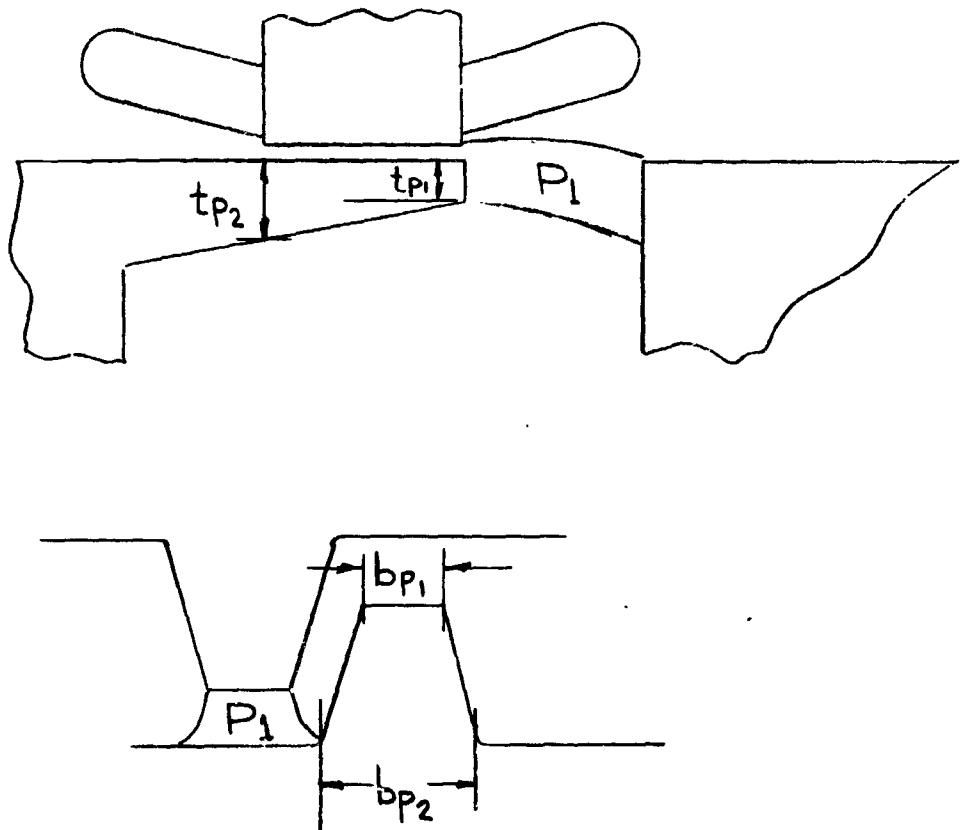

LEAKAGE PERMEANCE P₁

Figure M-4

P_2 POLE HEAD SIDE LEAKAGE

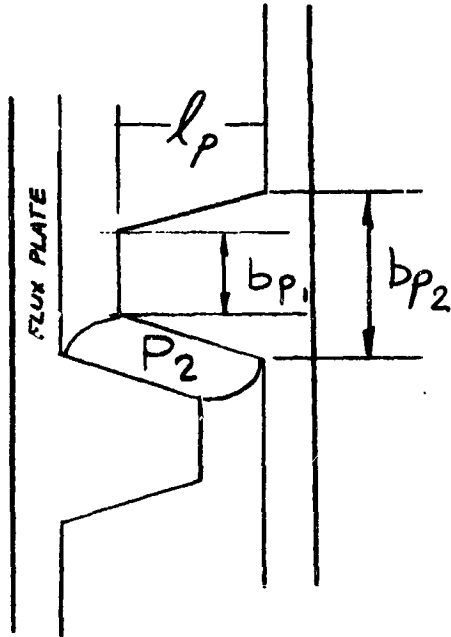

Figure M-5

P₃ POLE BODY END LEAKAGE

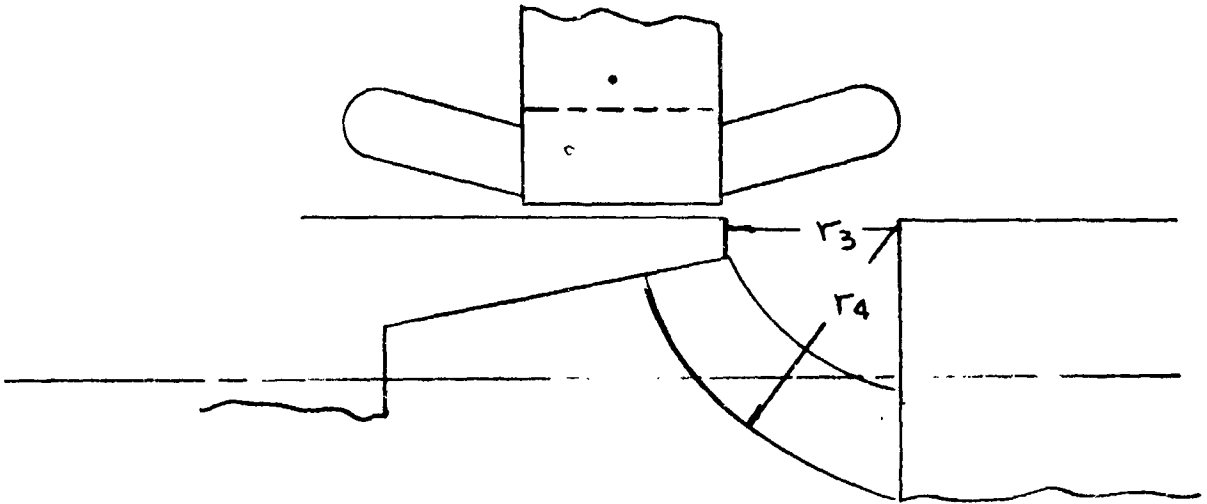

Figure M-6

P_4 POLE BODY LE/

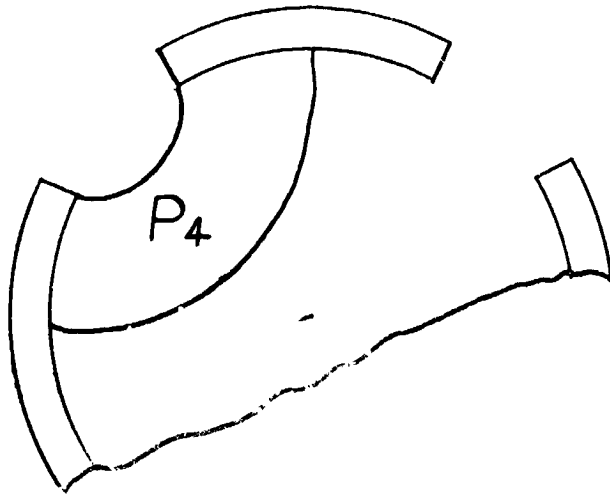

Figure M-7

FLUX CIRCUIT FOR THE TWO-COIL,
OUTSIDE-COIL LUNDELL

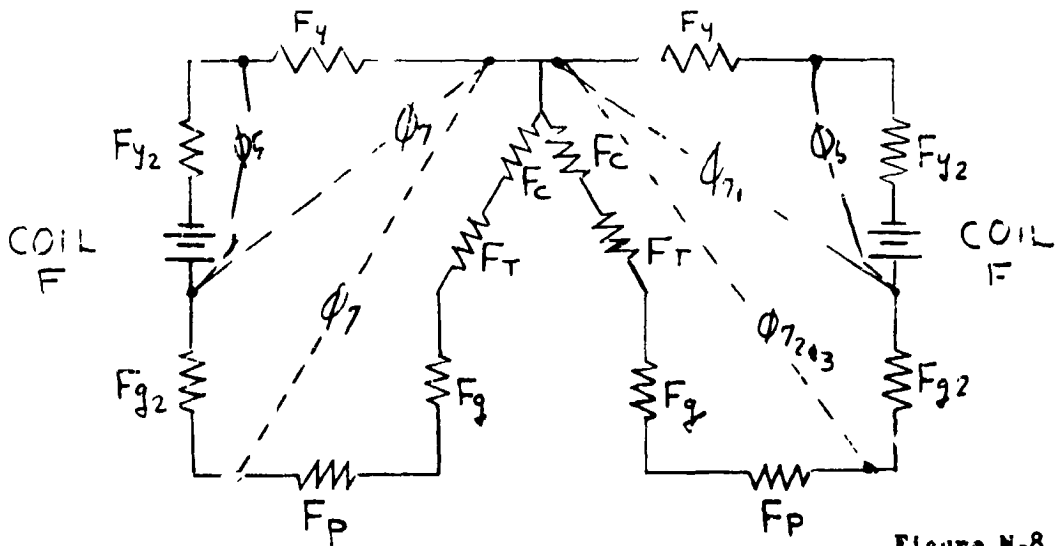
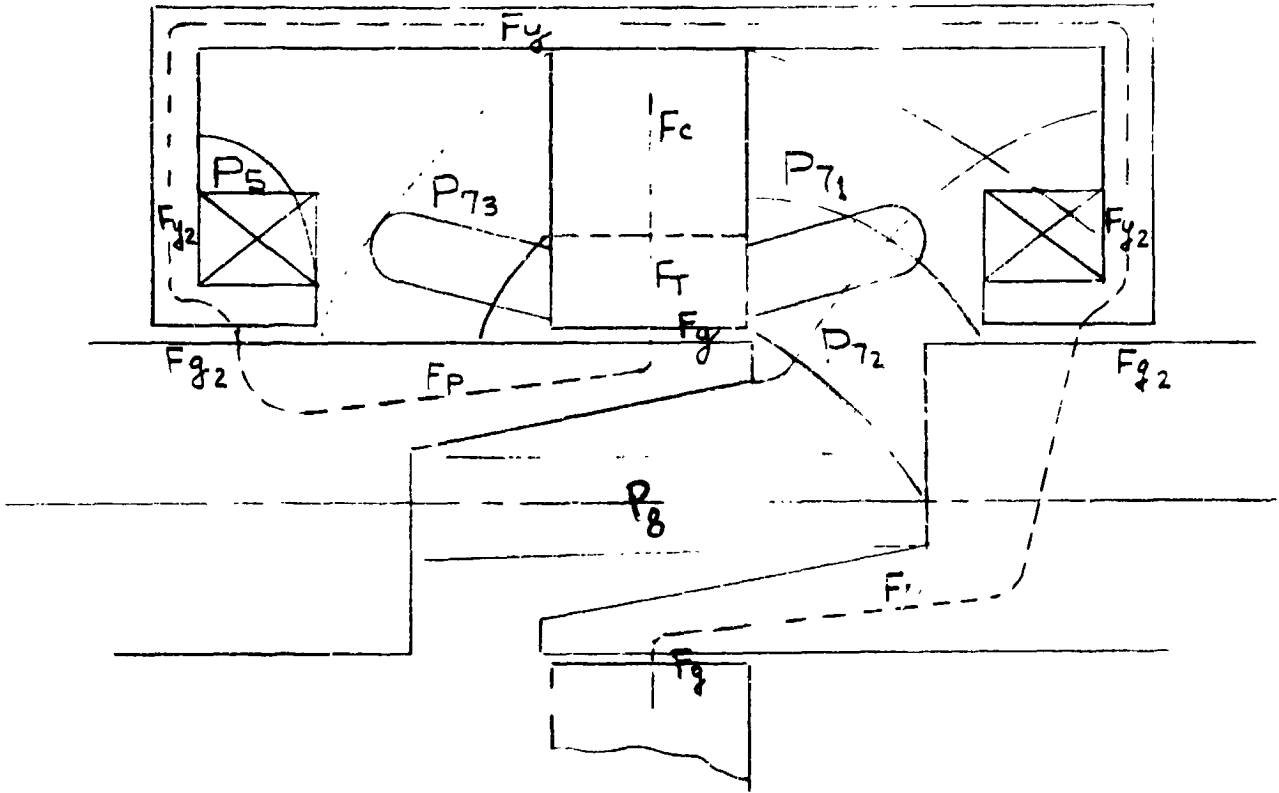
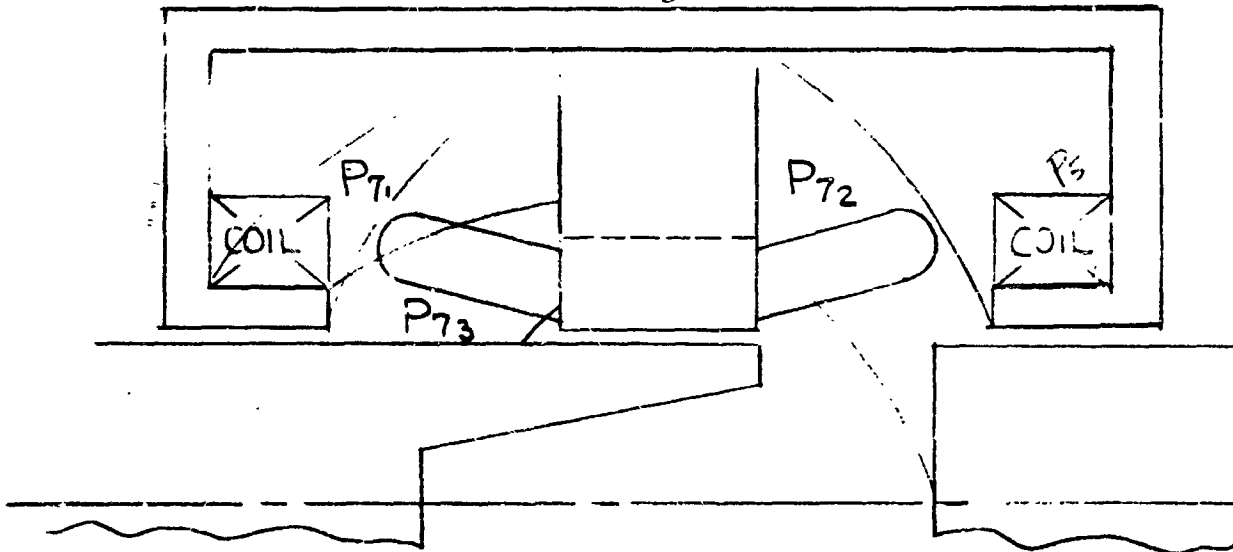

Figure M-8

P_5 = Coil Leakage Permeance
 P_7 = Stator Leakage Permeances

Figure M-9

Design A



Design B

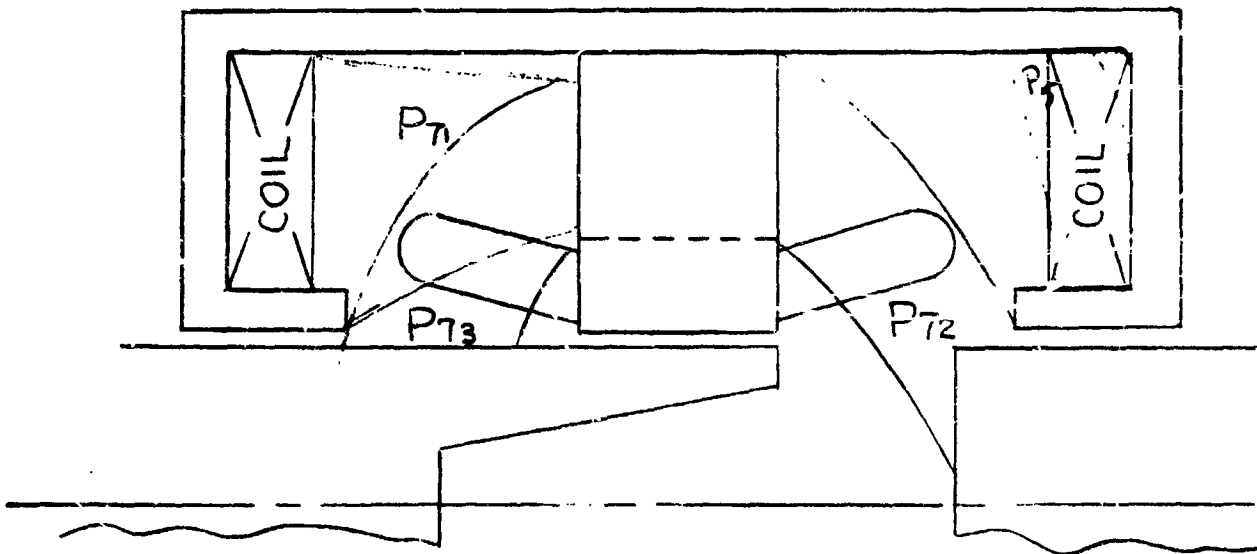

Design C

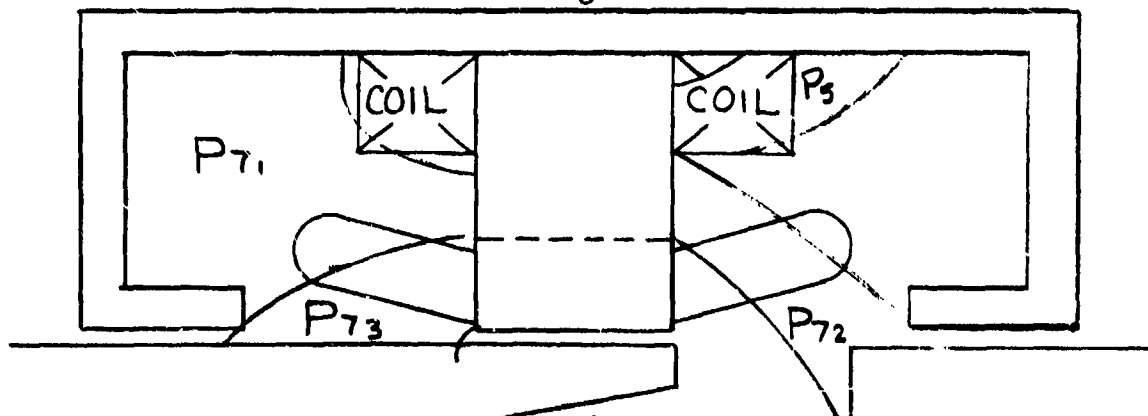

(87)

--

The next set of calculations deals with the no load saturation. The equations in this section can be used to calculate the no load saturation for any voltage. When the no load saturation data is required at various voltages insert 1. on the input sheet for "No Load Sat.". The computer will then calculate the no load saturation curve at 80, 90, 100, 110, 120, 130, 140, 150, and 160% of rated volts. When the complete saturation data is not necessary, insert 0. on the input sheet and the computer will calculate the 100% volt data.

(88)

ϕ_T

TOTAL FLUX IN KILOLINES

(91)

B_t

TOOTH DENSITY

(92)

ϕ_p

FLUX PER POLE

(94)

B_c

CORE DENSITY

(95)

B_g

GAP DENSITY

(96)

F_g

AIR GAP AMPERE TURNS

(97)

F_T

STATOR TOOTH AMPERE TURNS

(98)

F_c

STATOR CORE AMPERE TURNS

(98a) F_s

STATOR AMPERE TURNS

(99) ϕ_7

STATOR TO YOKE LEAKAGE FLUX - The

leakage flux from the stator to the yoke.

$$\begin{aligned}\phi_7 &= [(F_c) + (F_T) + (F_g) + (F_p)](L) 10^{-3} \\ &= [(98) + (97) + (96) + (104a)](86) 10^{-3}\end{aligned}$$

The items to follow are to be calculated for variable loads. These calculations will then be repeated for 100% load.

(100a) ϕ_2

ROTOR LEAKAGE FLUX - at no load

$$\begin{aligned}\phi_2 &= (P) [2(F_g) + 2(F_T) + (F_c)] \\ &\quad [(P_1) + (P_2) + (P_3) + (P_4)] \times 10^{-3} \\ &= (6) [2(96) + 2(97) + (98)] \\ &\quad [(80) + (81) + (82) + (83)] \times 10^{-3}\end{aligned}$$

(102a) ϕ_{PT}

TOTAL FLUX PER POLE - at no load

$$\phi_{PT} = (\phi_P) + \frac{2(\phi_2)}{(P)} = (92) + \frac{2(100a)}{(6)}$$

These surfaces are at
the same magnetic potential.

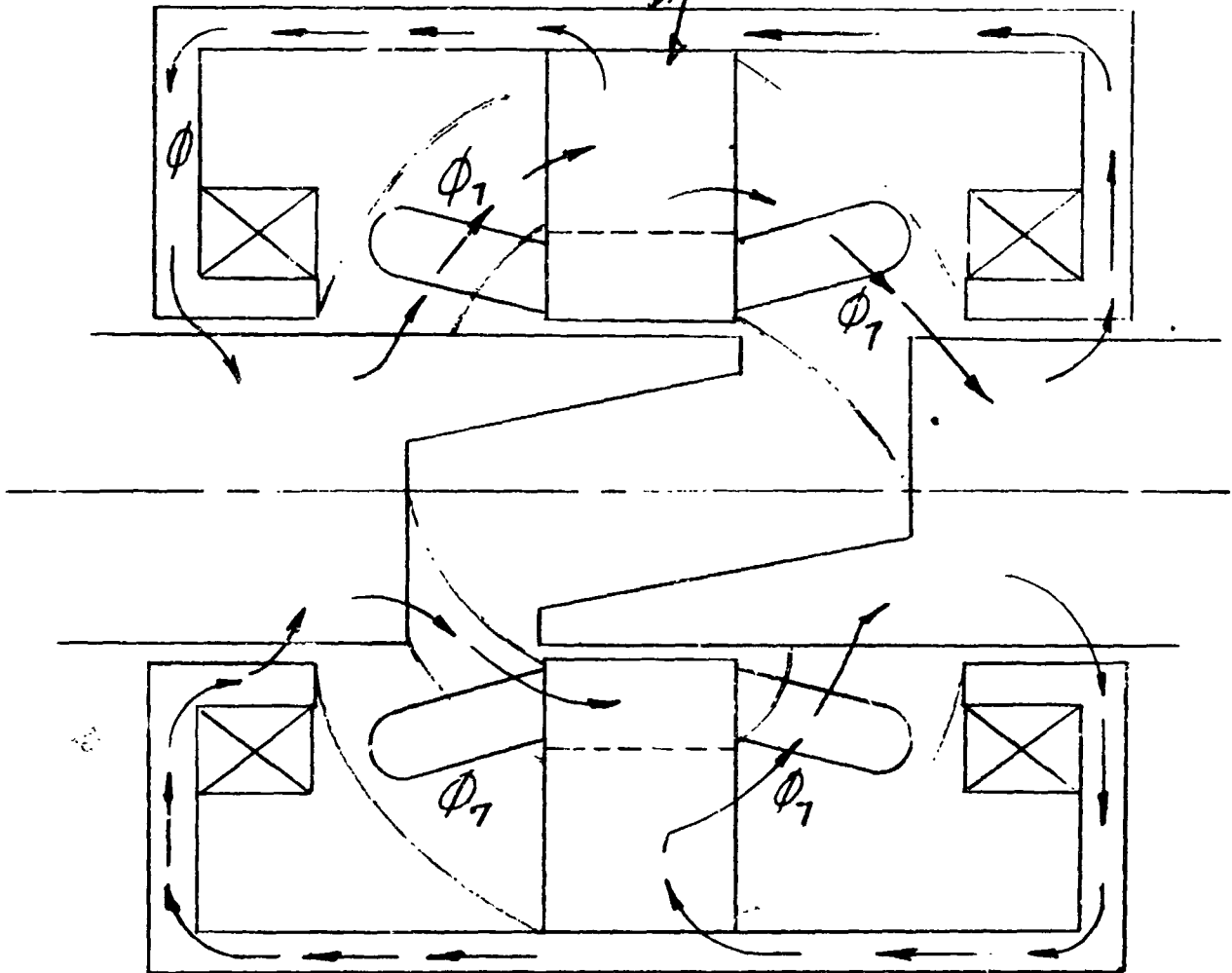
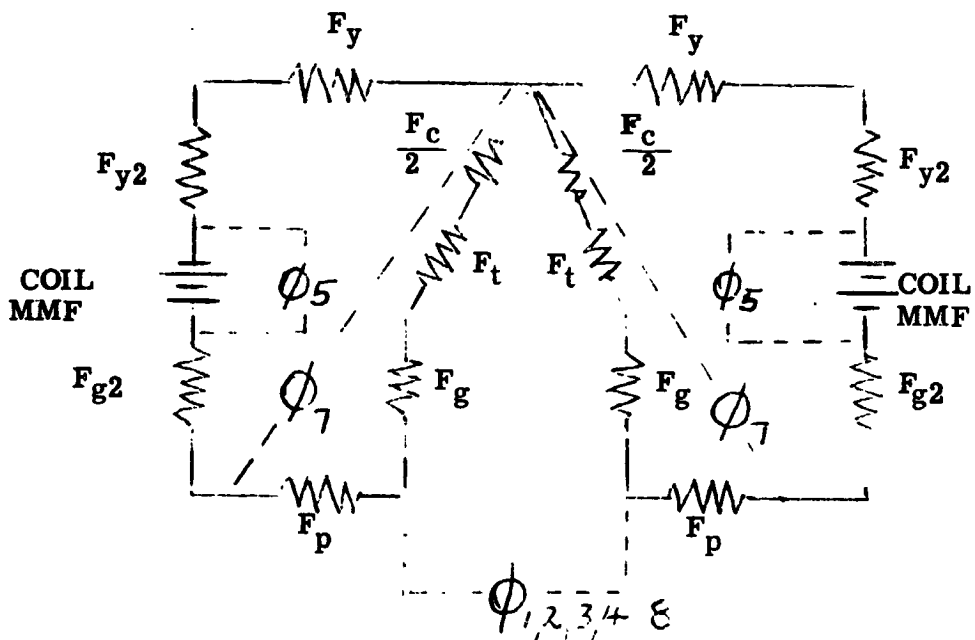

Figure M-10

The sketch above shows the leakage flux Φ_7 leaking from the stator to the rotor. In a 2-pole generator of this configuration, the leakage flux, Φ_7 can cause a rotating couple on the rotor.



Schematic representation of the flux circuit of a two, outside-coil Lundell, a-c generator. The mmf drops in the circuit are shown by solid lines. The flux leakage paths are shown by dashed lines.

Figure M-11

(103a) B_P POLE DENSITY - The apparent flux density at the base of the pole. Note that no provision is made in this manual for calculating the density in the flux plate. It is, therefore, important to remember not to restrict the flux area through this section.

$$B_P = \frac{(\phi_{PT})}{(a_P)} = \frac{(102a)}{(79)} \text{ Kilolines/in}^2$$

(103b) ϕ_8 FLUX PLATE TO FLUX PLATE LEAKAGE FLUX (KILOLINES)

$$\begin{aligned} \phi_8 &= (P_8) \left[2(F_g) + 2(E_r) + (F_c) \right] \times 10^{-3} \\ &= (86a) \left[2(96) + 2(97) + (98) \right] \times 10^{-3} \end{aligned}$$

(104a) F_P POLE AMPERE TURNS - at no load. The ampere turns per pole required to force the flux through the pole and spider at no load rated voltage. The no load pole ampere turns per pole are calculated as the product of (l_P) times the NI per inch at the density (B_P). Use magnetization curve submitted per item (18) for rotor.

$$\begin{aligned} F_P &= (l_P) \left[\text{NI/in @ density } (B_P) \right] \\ &= (76) \left[\text{Look up on rotor magnetization} \right. \\ &\quad \left. \text{curve given in (18) @ density (103a)} \right] \end{aligned}$$

(108) ϕ_{g2} AUXILIARY GAP (g_2) flux in kilolines.

$$\begin{aligned} \phi_{g2} &= \phi_{PT} \frac{(P)}{2} + (\phi_7) + (\phi_8) \\ &= (102a) \frac{(6)}{2} + (99) + (103b) \end{aligned}$$

(118) ϕ_5 COIL LEAKAGE FLUX PER COIL (Kilolines)

$$\phi_5 = (P_5) \left[(F_{g2}) + F_y + (F_p) + (F_g) + (F_T) + (F_C) \right] \times 10^{-3}$$

$$\phi_5 = (84) \left[(123) + (126b) + (104a) + (96) + (97) + (98) \right] \times 10^{-3}$$

(122) B_{g2} AUXILIARY GAP (g_2) FLUX DENSITY

$$B_{g2} = \frac{(\phi_{g2})}{(A_{g2})} = \frac{(108)}{(70)}$$

(123) F_{g2} AUXILIARY AIR GAP AMPERE TURNS

$$F_{g2} = \frac{(B_{g2})}{3.19} (g_2) \times 10^3 = \frac{(122)}{3.19} (59a) \times 10^3$$

(124) A_{y2} AREA OF END BELL SECTION OF YOKE AT SMALLEST SECTION

$$A_{y2} = \pi (d_{y2})(t_{y2}) = \pi (78)(78)$$

(124a) A_y AREA OF HOUSING PORTION OF YOKE

$$\begin{aligned} A_y &= \pi \left[(D) + (t_y) \right] (t_y) \\ &= \pi \left[(12) + (78) \right] (78) \end{aligned}$$

(125) B_{y2} FLUX DENSITY IN END BELL SECTION OF YOKE @ N. L.

at narrowest part

$$B_{y2} = \frac{(\phi_{g2} + \phi_5)}{(A_{y2})} = \frac{(108) + (118)}{(124)}$$

(126) F_{y2} AMPERE TURN DROP IN END BELL SECTION OF YOKE

@ N. L.

$$F_{y2} = \left[\frac{(D)-(d_{y2})}{6} \right] \left[\text{NI/inch @ } (B_{y2}) \right]$$
$$= \left[\frac{(12)-(78)}{6} \right] \left[\text{Look up on yoke magnetization curve @ density (125)} \right]$$

(126a) B_y DENSITY IN HOUSING SECTION OF YOKE @ N. L.

$$B_y = \frac{(\phi_{g2})}{A_y} = \frac{(108)}{(124a)}$$

(126b) F_y AMPERE TURN DROP IN HOUSING SECTION OF YOKE

using 1/2 total length of housing

$$F_y = (\ell_y) \left[\text{NI/inch at density } (B_y) \right]$$
$$= (78) \left[\text{Look up on yoke magnetization curve @ density (126a)} \right]$$

(127) F_{NL} TOTAL AMPERE TURN DROP @ N. L.

$$F_{NL} = 2 \left[(F_y) + (F_{y2}) + (F_{g2}) + (F_p) + (F_g) + (F_T) + \frac{(F_c)}{2} \right]$$
$$= 2 \left[(126b) + (126) + (123) + (104a) + (96) + (97) + \frac{(98)}{2} \right]$$

(127a) I_{FNL} FIELD CURRENT - at no load

$$I_{FNL} = \frac{(F_{NL})}{(N_F)(N_{CO})} = \frac{(127)}{(146)(146a)}$$

(127b)	E_F	<p><u>FIELD VOLTS</u> - at no load. This calculation is made with cold field resistance at 20° C for no load condition.</p> $E_F = (I_{FNL}) / (R_f \text{ cold})(N_{CO}) = 127a / (154)(146a)$
(127c)	S_F	<p><u>CURRENT DENSITY</u> - at no load.</p>
(128)	A	<p><u>AMPERE CONDUCTORS</u> per inch</p>
(129)	X	<p><u>REACTANCE FACTOR</u></p>
(130)	X_ℓ	<p><u>LEAKAGE REACTANCE</u> - in per cent,</p> $X_\ell = X \left[\lambda_i + \lambda_E + \lambda_z \right]$ $= (129) \left[(62) + (64) + (64a) \right]$ <p>λ_z is explained under item (64a) and should be zero in most cases.</p>
(131)	X_{ad}	<p><u>REACTANCE</u> - direct axis - This is the fictitious reactance due to armature reaction in the direct axis (in per cent).</p> $X_{ad} = \frac{.9(n_e)(I_{PH})(C_m)(K_d) \times 100}{2(P) (F_g + F_{g2})} = \frac{.9(45)(8)(74)(43) \times 100}{2(6) \left[(96) + (123) \right]}$

(132

X_{aq}

REACTANCE - quadrature axis - This is the fictitious reactance due to armature reaction in the quadrature axis (in per cent).

$$X_{aq} = \frac{(C_q)(X_{ad})}{(C_m)(C_1)} = \frac{(75)(131)}{(74)(71)}$$

(133)

X_d

SYNCHRONOUS REACTANCE - direct axis - (%)

(134)	X_q	<u>SYNCHRONOUS REACTANCE</u> - quadrature axis (%)
(145)	V_r	<u>PERIPHERAL SPEED</u>
(146)	N_F	<u>NUMBER OF FIELD TURNS</u> per coil
(146a)	N_{CO}	<u>NUMBER OF FIELD COILS</u> - One basic computer program is used for the single-coil and two-coil Lundell generators. This item is used in the computer program as a code for distinguishing one from the other. Coils are connected in series.
(147)	l_{tf}	<u>MEAN LENGTH OF FIELD TURN</u> - inches
(148)	--	<u>FIELD CONDUCTOR DIA OR WIDTH</u> in inches
(149)	--	<u>FIELD CONDUCTOR THICKNESS</u> in inches - Set this item = 0. for round conductor.
(150)	$X_f^{\circ C}$	<u>FIELD TEMP IN $^{\circ}C$</u>
(151)	ρ_f	<u>RESISTIVITY</u> of field conductor
(152)	ρ_f (hot)	<u>RESISTIVITY</u> of field conductor
(153)	a_{cf}	<u>CONDUCTOR AREA OF FIELD WDG</u>
(154)	R_f (cold)	<u>COLD FIELD RESISTANCE @ $20^{\circ}C$</u> per coil
$R_f \text{ (cold)} = (\rho_f) \frac{(N_f) (l_{tf}) \times 10^{-6}}{(a_{cf})} = (151) \frac{(146) (147) \times 10^{-6}}{(153)}$		

(155) R_f
(hot)

HOT FIELD RESISTANCE - Calculated at $X_f^{\circ}C$ (103)
per coil.

$$R_f \text{ (hot)} = (\rho_{f \text{ hot}}) \frac{(N_f) (\ell_{tf}) \times 10^{-6}}{(a_{cf})} = (152) \frac{(146) (147) \times 10^{-6}}{(153)}$$

(156) --

WEIGHT OF FIELD COIL in lbs - per coil

$$\begin{aligned} \# \text{'s of copper} &= .321 (N_f) (\ell_{tf}) (a_{cf}) \\ &= .321 (146) (147) (153) \end{aligned}$$

NOTE: This answer is given in lbs. based on density of copper. If any other material is used, the answer on output sheet can be converted by the designer by multiplying by the ratio of densities.

(157) --

WEIGHT OF ROTOR IRON - Because of the large number of different pole shapes, one standard formula cannot be used for calculating rotor iron weight. Therefore the computer will not calculate rotor iron weight. The space is allowed on the input sheet for record purposes only. By inserting 0. in the space allowed for rotor iron weight, the computer will show "0" on the output sheet. If the rotor iron weight is available and inserted on input sheet, then the output sheet will show this same weight on the output sheet.

(160)

 X_F THE EFFECTIVE FIELD LEAKAGE REACTANCE - The

reactance which added to the stator leakage reactance gives the transient reactance X'_{du} .

When unit fundamental armature ampere turns are suddenly applied on the direct axis, an initial field current (I_f) will be induced. The value of this initial field current will be just enough to make the net flux interlinking the field because of the field current and the armature current zero. The field ampere turns

$$X_F = X_{ad} \left[1 - \frac{\frac{C_1}{C_m}}{2C_p + \frac{4}{\pi} \frac{\lambda_F}{\lambda_a}} \right]$$

$$X_F = (131) \left[1 - \frac{\frac{(71)}{(74)}}{2(73) + \frac{4}{\pi} \frac{(160)}{(160)}} \right]$$

$$\lambda_a = \frac{6.38(d)}{(P)g_e'} = \frac{6.38(11)}{(6)(160)}$$

$$g_e' = g_e \left[\frac{F_g - F_{g2}}{F_g} \right] = (69) \left[\frac{(96) - (123)}{(96)} \right]$$

$$\lambda_F = \frac{P_e}{l} = \frac{(160a)}{(13)}$$

(160a)	P_e	<u>FIELD LEAKAGE PERMEANCE</u> $P_e = P [P_1 + P_2 + P_3 + P_4] + P_5 + P_8$ $= (6) [(80) + (81) + (82) + (83)] + (84) + (86a)$
(161)	L_f	<u>FIELD SELF-INDUCTANCE</u> $L_f = (N_F)^2 (P_e) (N_{CC}) \times 10^{-8}$ $= (146)^2 (160a) (146a) \times 10^{-8}$
(166)	X'_{du}	<u>UNSATURATED TRANSIENT REACTANCE</u>
(167)	X'_d	<u>SATURATED TRANSIENT REACTANCE</u>
(168)	X''_d	<u>SUBTRANSIENT REACTANCE</u> in direct axis
(169)	X''_q	<u>SUBTRANSIENT REACTANCE</u> in quadrature axis
(170)	X_2	<u>NEGATIVE SEQUENCE REACTANCE</u>
(172)	X_0	<u>ZERO SEQUENCE REACTANCE</u>
(173)	K_{x0}	
(174)	K_{x1}	
(175)	λ_{Bo}	

(176) T'_{do}

OPEN CIRCUIT TIME CONSTANT - The time constant of the field winding with the stator open circuited and with negligible external resistance and inductance in the field circuit. Field resistance at room temperature (20°C) is used in this calculation.

$$T'_{do} = \frac{(L_F)}{(R_F)(N_{CO})} = \frac{(161)}{(154)(146a)}$$

(177) T_a

ARMATURE TIME CONSTANT

(178) T'_d

TRANSIENT TIME CONSTANT

(180) F_{SC}

SHORT-CIRCUIT AMPERE-TURNS--The field ampere-turns required to circulate rated line amperes in a three-phase short circuit at the machine terminals.

$$F_{SC} = \frac{(X_d)}{100}^2 [F_g + F_{g2}]$$
$$= \frac{(133)}{100}^2 [(96) + (123)]$$

(181) SCR

SHORT CIRCUIT RATIO

(182)

I^2R_F

FIELD I^2R - at no load. The copper loss in the field winding is calculated with cold field resistance at 20°C for no load condition.

$$\begin{aligned}\text{Field } I^2R &= (I_{FNL})^2 (R_{f \text{ cold}}) (N_{CO}) \\ &= (127a)^2 (154)(146a)\end{aligned}$$

(183)

F&W

FRICITION & WINDAGE LOSS - The best results are obtained by using existing data. For ratioing purposes, the loss can be assumed to vary approximately as the 5/2 power of the rotor diameter and as the 3/2 power of the RPM. When no existing data is available, the following calculation can be used for an approximate answer. Insert 0. when computer is to calculate F&W. Insert actual F&W when available. Use same value for all load conditions.

$$\begin{aligned} \text{F\&W} &= 2.52 \times 10^{-6} (d_T)^{2.5} (\rho) (\text{RPM})^{1.5} \\ &= 2.52 \times 10^{-6} (11a)^{2.5} (76) (7)^{1.5} \end{aligned}$$

For gases or fluids other than standard air, the fluid density and viscosity must be considered. The formula given in the manual can be modified by the factors

$$\left(\frac{\rho}{.0765} \right)^{.8} \left(\frac{\mu}{.0435} \right)^{.2}$$

where ρ = density - Lbs FT⁻³
 μ = viscosity LBS FT⁻¹ HR⁻¹
.0765 = density std. air
.0435 = viscosity std. air

(184)	W_{TNL}	<u>STATOR TEETH LOSS</u> - at no load.
(185)	W_c	<u>STATOR CORE LOSS</u>
(186)	W_{NPL}	<u>POLE FACE LOSS</u> - at no load.
(187)	K_1	
(188)	K_2	
(189)	K_3	
(190)	K_4	
(191)	K_5	
(192)	K_6	
(194)	I^2R	<u>STATOR I^2R</u> - at no load.
(195)	--	<u>EDDY LOSS</u> - at no load.
(196)	--	<u>TOTAL LOSSES</u> - at no load. Sum of all losses
		Total losses = (Field I^2R) + (F&W) + (Stator Teeth Loss)
		+ (Stator Core Loss) + (Pole Face Loss)
		= (182) + (183) + (184) + (185) + (186)
		The N. L. calculations should all be repeated now for 100% load.

(197a) ϕ_{ll}

LEAKAGE FLUX PER POLE at 100% load

$$\phi_{ll} = \phi_l \left\{ \frac{(e_d)(F_g) + [1 + \cos(\theta)](F_T) + (F_C)}{(F_g) + (F_T) + (F_C)} \right\}$$
$$= (100a) \left\{ \frac{(198)(96) + [1 + \cos(198a)](97) + (98)}{(96) + (97) + (98)} \right\}$$

(198) e_d

where $e_d = \cos \epsilon + \frac{(X_d)}{100} \sin \psi$

$$= \cos(198a) + \frac{(133)}{100} \sin(198a)$$

(198a) θ

Where $\theta = \cos^{-1} [(\text{Power Factor})]$

$$= \cos^{-1} [(9)]$$

Where $\psi = \tan^{-1} \left[\frac{\sin(\theta) + \frac{(X_q)}{(100)}}{\cos(\theta)} \right]$

$$= \tan^{-1} \left[\frac{\sin(198a) + \frac{(134)}{(100)}}{\cos(198a)} \right]$$

Where $\epsilon = \psi - \theta = (198a) - (198a)$

(198b) ϕ_{8L}

LEAKAGE FLUX BETWEEN FLUX PLATES @ F.L. (Kilolines)

$$\phi_{8L} = (\phi_8) \frac{(\phi_{ll})}{(\phi_l)} = (103b) \left[\frac{(196a)}{(100a)} \right]$$

(207) ϕ_{7L} FLUX LEAKAGE FROM STATOR TO YOKE UNDER LOAD

(one side of stator only)

$$\begin{aligned}\phi_{7L} &= (P_7) \left\{ (F_{PL}) + (e_d)(F_g) + (F_T) [1 + \cos(\theta)] + (F_c) \right\} \times 10^{-3} \\ &= (86) \left\{ (213c) + (198)(96) + (97) [1 + \cos(198a)] + (98) \right\} \times 10^{-3}\end{aligned}$$

(213) ϕ_{PL} FLUX PER POLE at 100% load

For P. F. .0 to .95

$$\begin{aligned}\phi_{PL} &= (\phi_P) \left[(e_d) - \frac{.93(X_{ad})}{100} \sin(\psi) \right] \\ &= (92) \left[(198) - \frac{.93(131)}{100} \sin(198a) \right]\end{aligned}$$

For P. F. .95 to 1.0

$$\phi_{PL} = (\phi_P)(K_c) = (92)(9a)$$

(213a) ϕ_{PTL} TOTAL FLUX PER POLE at 100% load

$$\phi_{PTL} = \phi_{PL} + \frac{2(\phi_{fl})}{(P)} = (213) + \frac{2(197a)}{(6)}$$

(213b) B_{PL} FLUX DENSITY AT BASE OF POLE at 100% load

$$B_{PL} = \frac{\phi_{PTL}}{a_p} = \frac{(213a)}{(79)}$$

(213c) F_{PL} AMPERE TURNS PER POLE at 100% load

$$F_{PL} = (\ell_p) \left[\text{NI/in @ density } (B_{PL}) \right]$$

$$= (76) \left[\text{Look up ampere turns/inch on rotor magnetization curve given in (18) at density (213b)} \right]$$

(221) ϕ_{g2L} FLUX CROSSING THE AUXILIARY AIR GAP under load

$$\phi_{g2L} = (\phi_{PTL}) \frac{(P)}{2} + (\phi_{7L}) + (\phi_{8L})$$

$$= (213a) \frac{(8)}{2} + (207) + (198b)$$

(224) B_{g2L} FLUX DENSITY IN AUXILIARY GAP (g_2) under load

$$B_{g2L} = \frac{(\phi_{g2L})}{(A_{g2})} = \frac{(221)}{(70)}$$

(225) F_{g2L} AUXILIARY AIR GAP AMPERE TURN DROP under load

$$F_{g2L} = \frac{(B_{g2L})(g_2)}{3.19} \times 10^3 = \frac{(224)}{3.19} (59a) \times 10^3$$

(226) ϕ_{5L} COIL LEAKAGE FLUX under load

$$\phi_{5L} = (P_5) \left[(F_{yL}) + (F_{PL}) + (F_{g2L}) + (e_d)(F_g) + F_T \left[1 + \cos(\theta) \right] + F_c \right] \times 10^{-3}$$

$$= (84) \left[(229c) + (213c) + (225) + (198)(96) + (97) \left[1 + \cos(198a) \right] + (98) \right] \times 10^{-3}$$

(227) ϕ_{y2L} FLUX IN END-BELL SECTION OF THE YOKE under load

$$\phi_{y2L} = (\phi_{g2L}) + \phi_{5L}$$

$$= (221) + (226)$$

(228) B_{y2L} DENSITY IN END-BELL SECTION OF YOKE AT THE SMALLEST AREA SECTION under load

$$B_{y2L} = \frac{\phi_{y2L}}{A_{y2}} = \frac{(227)}{(124)}$$

(229) F_{y2L} AMPERE TURN DROP IN END-BELL SECTION OF YOKE under load.

$$F_{y2L} = \left[\frac{(D)-(d_{y2})}{6} \right] \left[\text{NI/inch @ density } (B_{y2L}) \right]$$

$$= \left[\frac{(12)-(78)}{6} \right] \left[\text{Look up on yoke magnetization curve given in (18) at density (228)} \right]$$

(229b) B_{yL} FLUX DENSITY IN THE HOUSING SECTION OF THE YOKE under load.

$$B_{yL} = \frac{(\phi_{g2L})}{(A_y)} \quad \begin{matrix} (221) \\ (124a) \end{matrix}$$

(229c) F_{yL} AMPERE TURN DROP THROUGH THE HOUSING SECTION OF THE YOKE under load, using 1/2 total length of housing.

$$F_y = (l_y) \left[\text{NI/inch @ density } (B_{yL}) \right]$$

$$= (78) \left[\begin{array}{l} \text{Look up on yoke magnetization curve given} \\ \text{in (18) @ density (229b)} \end{array} \right]$$

(236) F_{FL} TOTAL AMPERE TURN DROP at full load

$$= 2 \left[(F_{g2L}) + (F_{yL}) + (F_{y2L}) + (F_{PL}) + (e_d)(F_g) + (F_T) \left[1 + \cos(\theta) \right] + \frac{F_c}{2} \right] \times 10^{-3}$$

$$= 2 \left[(225) + (229c) + (229) + (213c) + (198)(96) + (97) \left[1 + \cos(1.3a) \right] + \frac{(98)}{2} \right] \times 10^{-3}$$

(237) I_{FFL} FIELD CURRENT under load

$$I_{FFL} = (F_{FL}) / (N_F)(N_{CO}) = (236) / (146)(146a)$$

(239) S_{FL} CURRENT DENSITY at 100% load

$$\text{Current Density} = (I_{FFL}) / (a_{cf}) = (237) / (153)$$

(238) E_{FFL} FIELD VOLTS at 100% load - This calculation is made with hot field resistance at expected temperature at 100% load.

$$\text{Field Volts} = (I_{FFL})(R_f \text{ hot})(N_{CO}) = (237)(155)(146a)$$

(241) I^2R_{FL} FIELD I^2R at 100% load - The copper loss in the field winding is calculated with hot field resistance at expected temperature for 100% load condition.

$$\text{Field } I^2R = (I_{FL})^2 (R_{F \text{ hot}}) (N_{CO}) - (237)^2 (155) (146a)$$

(242) W_{TFL} STATOR TEETH LOSS at 100% load - The stator tooth loss under load increases over that of no load because of the parasitic fluxes caused by the ripple due to the rotor damper bar slot openings.

$$W_{TFL} = \left\{ 2 \left[.27 \frac{(X_d)}{100} \frac{(\% \text{ Load})}{100} \right]^{1.8} + 1 \right\} W_{TNL}$$

$$= \left\{ 2 \left[.27 \frac{(133)}{100} - 1 \right]^{1.8} + 1 \right\} (184)$$

(243) W_{PFL} POLE FACE LOSS at 100% load

$$W_{PFL} = \left\{ \frac{(K_{SC})(I_{PH}) \frac{(\% \text{ Load})}{100} (n_s)}{(C)(F_g)} + 1 \right\} (W_{PNL})$$

$$= \left\{ \frac{[(243)(8) 1 (30)]}{(32)(96)} + 1 \right\} (186)$$

(K_{SC}) is obtained from Curve F-3

(245) I^2R_L STATOR I^2R at 100% load - The copper loss based on the D. C. resistance of the winding. Calculate at the maximum expected operating temperature.

$$I^2R = (m)(I_{PH})^2 (R_{SPH \text{ hot}})$$

$$= (5)(8)^2 (54)$$

(246) -- EDDY LOSS - Stator I^2R loss due to skin effect

$$\text{Eddy Loss} = \left[\frac{(EF \text{ top}) + (EF \text{ bot})}{2} - 1 \right] (\text{Stator } I^2R)$$

$$= \left[\frac{(55) + (56)}{2} - 1 \right] (245)$$

(247) -- TOTAL LOSSES at 100% load - sum of all losses at 100% load

$$\begin{aligned} \text{Total Losses} = & (\text{Field } I^2R) + (\text{F\&W}) + (\text{Stator Teeth Loss}) + \\ & (\text{Stator Core Loss}) + (\text{Pole Face Loss}) + \\ & (\text{Stator } I^2R) + (\text{Eddy Loss}) \end{aligned}$$

$$= (241) + (183) + (242) + (185) + (243) + (245) + (246)$$

(248) -- RATING IN KILOWATTS at 100% load

$$\text{Rating} = 3(E_{PH})(I_{PH}) (P. F.) \times 10^{-3}$$

$$= 3(4)(8) (9) \times 10^{-3}$$

(249) -- RATING PLUS LOSSES = (248) + (247) x 10⁻³

(250) -- % LOSSES = $\frac{\text{Losses} \times (100)}{\text{Rating Plus Losses}}$
 $= \frac{(247) \times 10^{-3} \times 10^2}{(249)}$

(251) -- % EFFICIENCY = 100% - % Losses
= 100% - (250)

These items can be recalculated for any load condition by simply inserting the values that correspond to the % load being calculated.

Values for F&W (183) and W_C (Stator Core Loss) (185) do not change with load.

SINGLE-COIL, OUTSIDE-COIL LUNDELL
DESIGN, COMPUTER MANUAL

(1)	--	DESIGN NUMBER
(2)	KVA	GENERATOR KVA
(3)	E	LINE VOLTS
(4)	E_{PH}	PHASE VOLTS
(5)	m	PHASES
(5a)	f	FREQUENCY
(6)	P	POLES
(7)	RPM	SPEED
(8)	I_{PH}	PHASE CURRENT
(9)	P. F.	POWER FACTOR
(9a)	K_c	ADJUSTMENT FACTOR
(10)	--	LOAD POINTS
(11)	d	STATOR PUNCHING I.D.
(11a)	d_r	ROTOR O.D.
(12)	D	PUNCHING O.D.
(13)	l	GROSS STATOR CORE LENGTH
(14)	n_v	RADIAL DUCTS
(15)	b_v	RADIAL DUCT WIDTH
(16)	K_1	STACKING FACTOR
(17)	l_s	SOLID CORE LENGTH

(18)

MATERIAL - This input is used in selecting the proper magnetization curves for stator, yoke $\frac{1}{2}$, pole.

Separate spaces are provided on the input sheet for each section mentioned above. Where curves are available on card decks, use the proper identifying code. Where card decks are not available submit data in the following manner:

The magnetization curve must be available on semi-log paper. Typical curves are shown in this manual on Curves F15 & F16. Draw straight line segments through the curve starting with zero density. Record the coordinates of the points where the straight line segments intersect. Submit these coordinates as input data for the magnetization curve. The maximum density point must be submitted first.

Refer to Figure below for complete sample

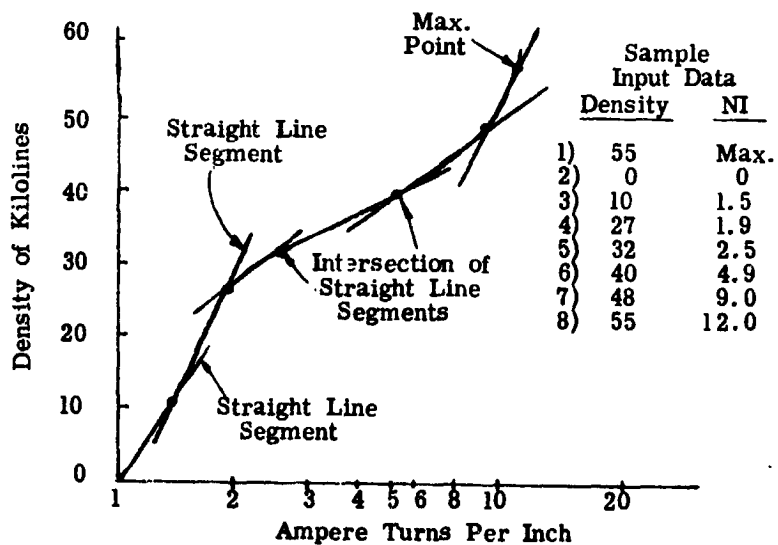

(19)	k	WATTS LB
(20)	B	DENSITY
(21)		TYPE OF STATOR SLOT
(22)		ALL SLOT DIMENSIONS
(23)	Q	STATOR SLOTS
(24)	h_c	DEPTH BELOW SLOTS
(25)	q	SLOTS PER POLE PER PHASE
(26)	τ_s	STATOR SLOT PITCH
(27)	$\tau_s^{1/3}$	STATOR SLOT PITCH
(28)	--	TYPE OF WINDING
(29)	--	TYPE OF COIL
(30)	n_s	CONDUCTORS PER SLOT
(31)	γ	THROW
(31a)		PER UNIT OF POLE PITCH SPANNED
(32)	C	PARALLEL PATHS
(33)	--	STRAND DIA. OR WIDTH
(34)	N_{ST}	NUMBER OF STRANDS PER CONDUCTOR IN DEPTH
(34a)	N'_{ST}	NUMBER OF STRANDS PER CONDUCTOR
(35)	d_b	DIAMETER OF BENDER PIN
(36)	ℓ_{e2}	COIL EXTENSION BEYOND CORE
(37)	h_{ST}	HEIGHT OF UNINSULATED STRAND
(38)	h'_{ST}	DISTANCE BETWEEN CENTERLINES OF STRANDS IN DEPTH

(39)	--	STATOR COIL STRAND THICKNESS
(40)	τ_{SK}	SKEW
(41)	τ_P	POLE PITCH
(42)	K_{SK}	SKEW FACTOR
(42a)		PHASE BELT ANGLE
(43)	K_d	DISTRIBUTION FACTOR
(44)	K_p	PITCH FACTOR
(45)	n_e	TOTAL EFFECTIVE CONDUCTORS
(46)	a_c	CONDUCTOR AREA OF STATOR WINDING
(47)	S_s	CURRENT DENSITY
(48)	L_E	END EXTENSION LENGTH
(49)	l_t	1/2 MEAN TURN
(50)	X_s °C	STATOR TEMP °C
(51)	ρ_s	RESISTIVITY OF STATOR WINDING
(52)	$\rho_{s(hot)}$	RESISTIVITY OF STATOR WINDING
(53)	$R_{SPH(cold)}$	STATOR RESISTANCE/PHASE
(54)	$R_{SPH(hot)}$	STATOR RESISTANCE/PHASE
(55)	$EF(top)$	EDDY FACTOR TOP
(56)	$EF(bot)$	EDDY FACTOR BOTTOM

(57)	b_{tm}	<u>STATOR TOOTH WIDTH</u>
(57a)	$b_t \frac{1}{3}$	<u>STATOR TOOTH WIDTH</u>
(58)	b_t	<u>TOOTH WIDTH AT STATOR I. D.</u> in inches
(59)	g	<u>MAIN AIR GAP</u> in inches
(59a)	g_2	<u>AUXILIARY AIR GAP</u> in inches
(60)	C_X	<u>REDUCTION FACTOR</u>
(61)	K_X	<u>FACTOR TO ACCOUNT FOR DIFFERENCE</u> in phase current in coil sides in same slot
(62)	λ_i	<u>CONDUCTOR PERMEANCE</u>
(63)	K_E	<u>LEAKAGE REACTIVE FACTOR</u>
(64)	λ_E	<u>END WINDING PERMEANCE</u>
(64a)	λ_z	<u>SPECIAL LEAKAGE PERMEANCE</u> - For machines having a section of the pole that is approximately a full pole-pitch wide, an additional leakage permeance must be added to the slot and end-turn leakage permeances. This permeance is that of the leakage path from one pole into a tooth top and from tooth

(64a) Cont'd.

top back into the adjacent pole. The leakage is similar to Zig Zag leakage and by increasing the stator leakage reactance, can reduce the output of the generator significantly.

This same leakage can be used to purposely limit the output of the generator and make it current limited. The presence of this additional leakage can be good or bad depending upon what is wanted from the generator. The important thing is for the designer to be aware that it is there.

In many cases, the designer should estimate the specific permeance λ_z since the pole base will be more or less than a full pole pitch wide and the following formula will not suffice.

(64a) Cont'd.

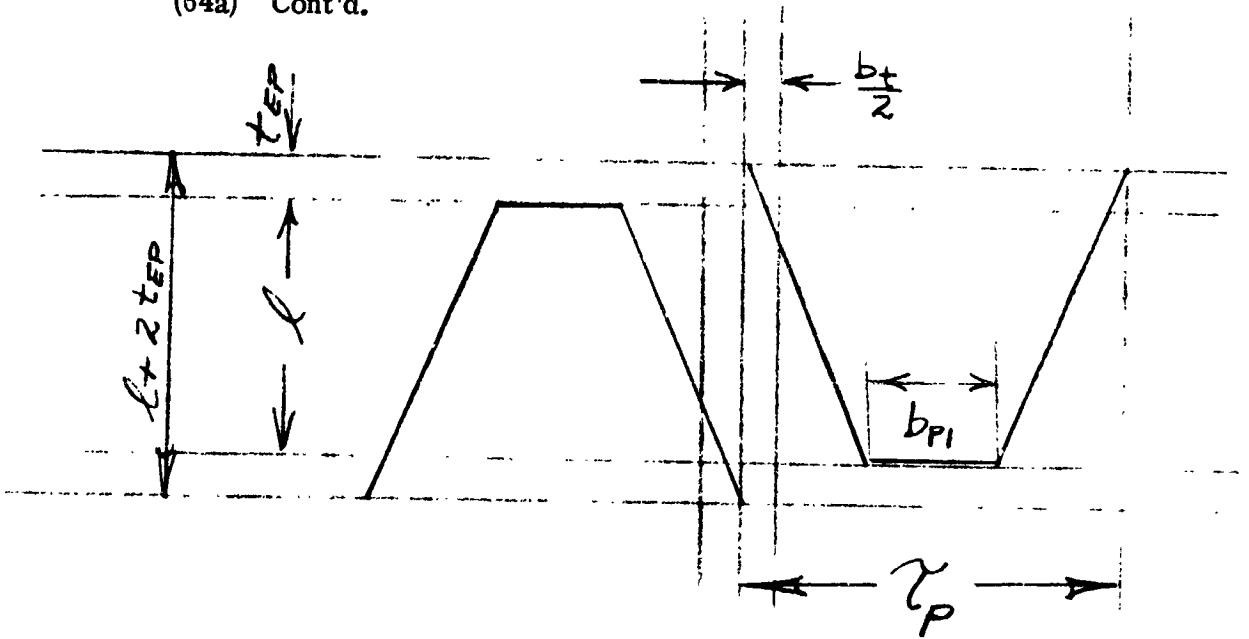

$$\lambda_z = (C_X) \frac{20}{(m)(q)} \left\{ \frac{\text{area of pole over tooth when tooth is on centerline between poles}}{2 l g} \right\}$$

$$\lambda_z = (C_X) \frac{20}{(m)(q)} \left\{ \frac{b_t (\tau_p - b_{p1}) (l + 2 t_{EP}) \frac{(\tau_p - b_{p1})}{\tau_p}}{2 l g} \right\}$$

(65)	--	<u>WEIGHT OF COPPER</u>
(66)	--	<u>WEIGHT OF STATOR IRON</u>
(67)	K_s	<u>CARTER COEFFICIENT</u>
(68)	--	<u>MAIN AIR GAP AREA</u>
(69)	g_e	<u>EFFECTIVE AIR GAP</u>

(70)

A_{g2}

AREA OF AUXILIARY AIR GAP

$$A_{g2} = \pi (d_{g2})(l_{g2}) = \pi (78)(78)$$

(71)

C_1

THE RATIO OF MAXIMUM FUNDAMENTAL of the field

form to the actual maximum of the field form

(72)

C_W

WINDING CONSTANT-

(73)

C_P

POLE CONSTANT

(74)

C_M

DEMAGNETIZING FACTOR

(75)

C_q

CROSS MAGNETIZING FACTOR

(76)

--

POLE DIMENSION LOCATIONS

b_{p2} = width of pole
at edge of
stator stack

b_{p1} = pole width at
terminus

t_{p2} = thickness of
pole at edge
of stator

t_{p1} = thickness of
pole at ter-
minus

l_p = length of pole

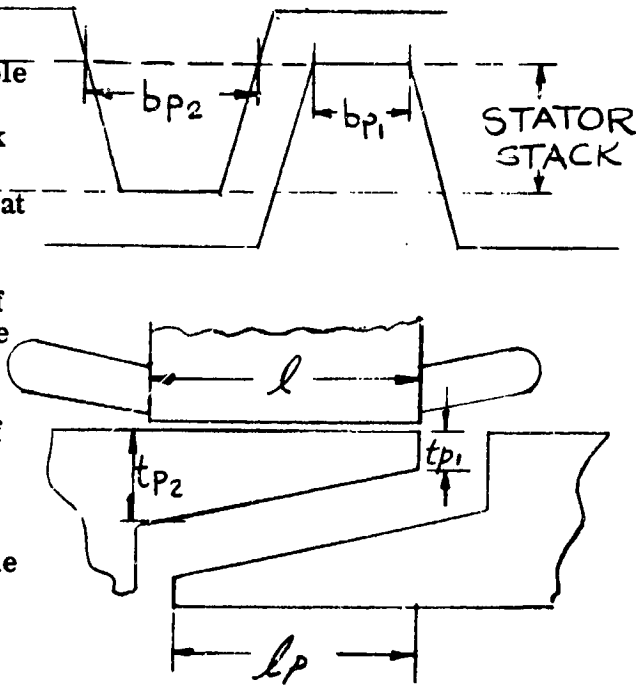

(77)

α

POLE EMBRACE

$$\alpha = \frac{r_{p1} + b_{p2}}{2(\tau_p)} = \frac{(76) + (70)}{2(41)}$$

(77a)

--

Items immediately following deal with the calculation of rotor and stator leakage permeances.

Illustrations are included to help identify the permeance areas and to locate the flux leakage paths. The computer program will handle the calculation of permeances P_1 , P_2 , P_3 and P_4 either of two ways:

1. P_1 through P_4 can be calculated by the computer. For this case, insert 0.0 on the input sheet for P_1 through P_4 .
2. P_1 through P_4 can be calculated by the designer. For this case, insert the actual calculated value on the input sheet for P_1 through P_4 .

Permeance P_5 and P_7 must be calculated by the designer and the calculated value must be inserted on the input sheet. The computer will not calculate these two permeance values because of the various possible field coil locations.

Permeance calculations P_1 through P_7 are all based on the equation $P = \frac{\mu(\text{area})}{l}$

Where $\mu = 3.19$

Area ▪ cross-sectional area perpendicular to the leakage flux.

l ▪ length of flux leakage path

Many of the equations used in this section are taken from Roter's "Electromagnetic Devices". Refer to the Appendix for the Roter's formulae.

(78)

-- ROTOR AND STATOR DIMENSIONS

l_{g2} = axial length of gap (g2)

d_{y2} = diameter of yoke (end bell section) at narrowest section

d_{g2} = rotor diameter at auxiliary air gap

l_y = effective length of yoke $\frac{c}{2}$

t_{y2} = thickness of end bell section of yoke

t_y = thickness of housing section of yoke

d_r = rotor diameter at main air gap

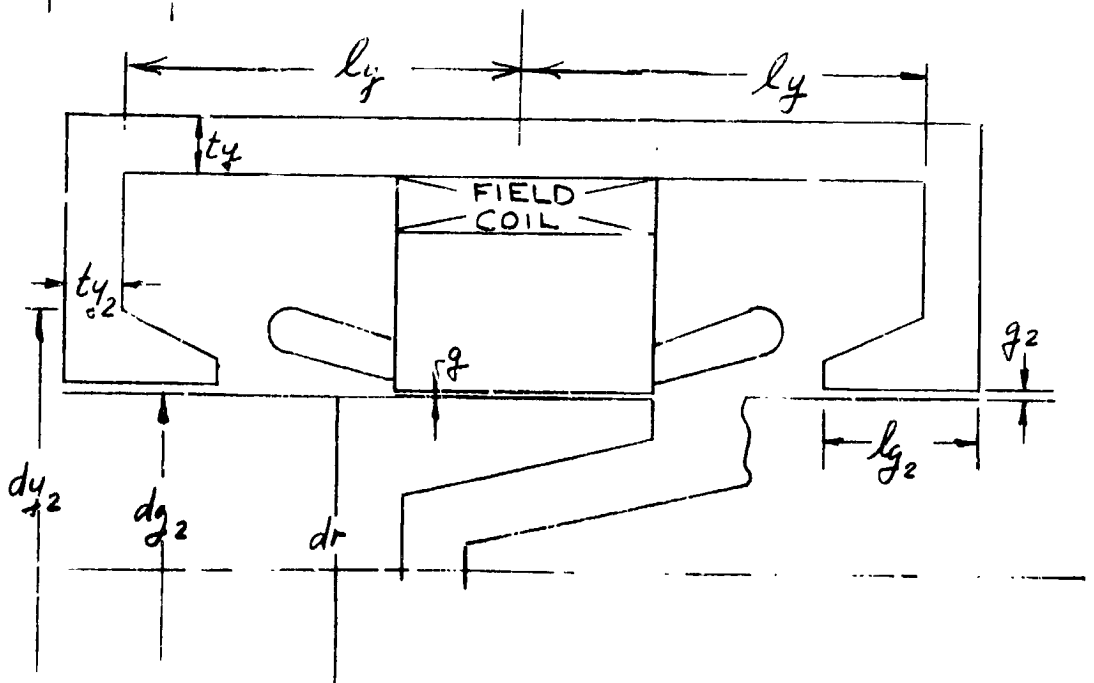

P_2 POLE HEAD SIDE LEAKAGE

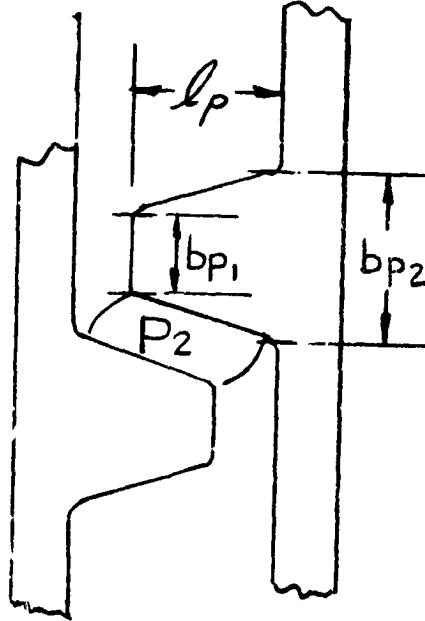

P_3 POLE BODY LEAKAGE

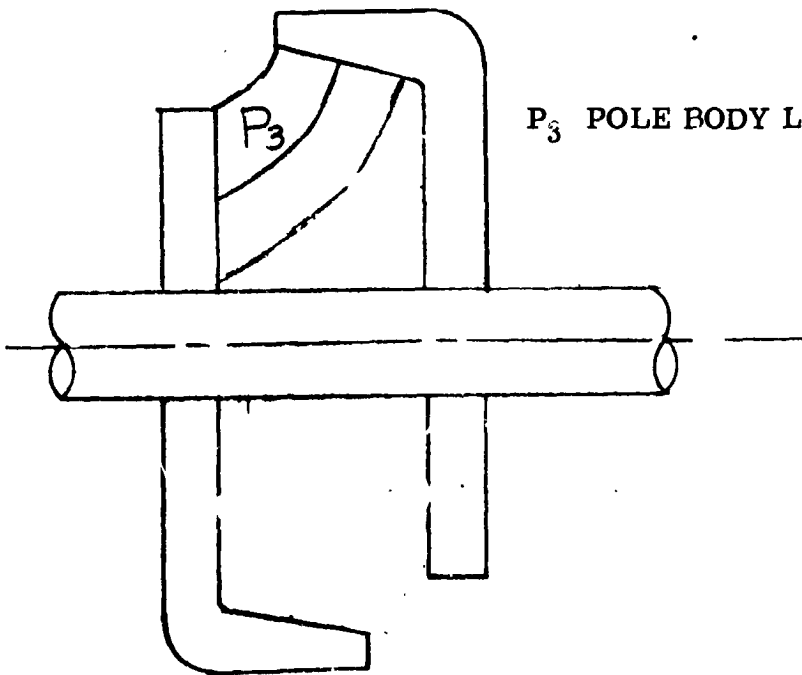
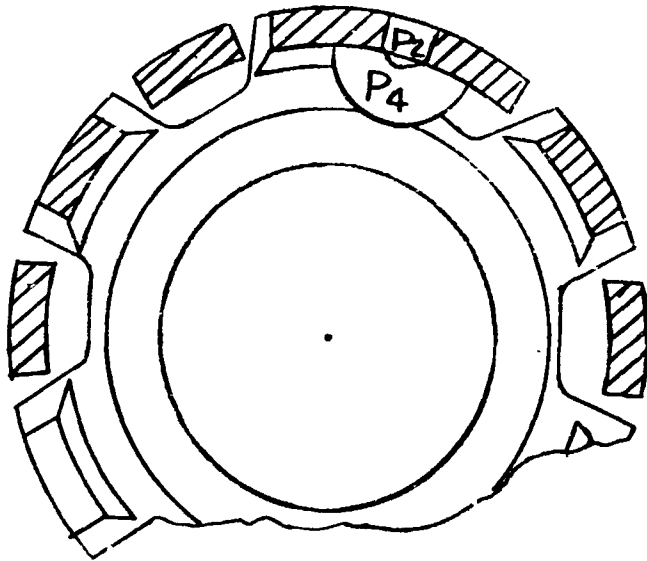
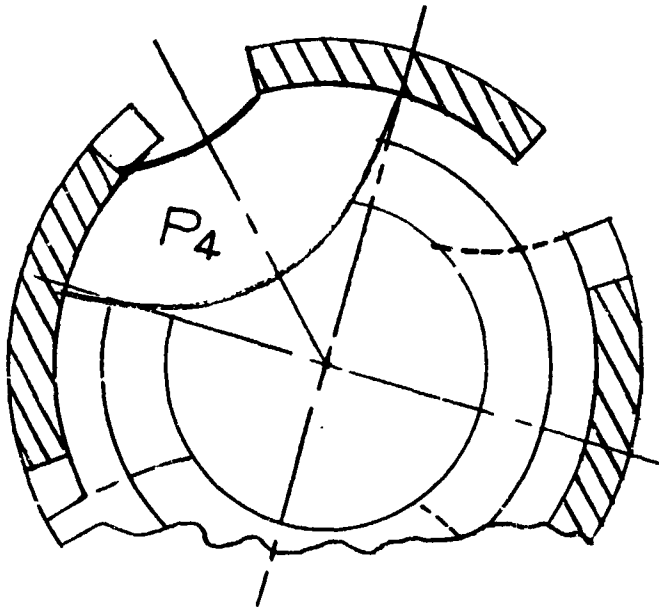

Figure M-12



P_4 IN A 12 POLE GENERATOR



P_4 IN A 4 POLE GENERATOR

Figure M-13

(79) a_p POLE AREA - The effective cross sectional area of the pole

$$a_p = (b_{p2})(t_{p2}) = (76)(76)$$

(80) P_1 POLE HEAD END LEAKAGE - This can be either 0.0 or the actual value if available. Refer to Item (77a) for explanation. See Figure M-4.

$$P_1 = \frac{3.19 (b_{p1})(t_{p1})}{\ell_1} = \frac{3.19 (76)(76)}{(80a)}$$

(80a) ℓ_1 ℓ_1 = length of permeance path P_1 and must be obtained from design layout. Must be given on input sheet when $P_1 = 0$.

(81) P_2 POLE HEAD SIDE LEAKAGE - This input can be either 0.0 or the actual value if available. Refer to Item (86) for explanation. See Figure M-12.

$$P_2 = \frac{3.19 \left\{ (\ell_p) \left[\frac{(t_{p2}) + (t_{p1})}{2} \right] \right\}}{(\ell_2)} = \frac{3.19 \left\{ (76) \left[\frac{(76) + (76)}{2} \right] \right\}}{(81a)}$$

(81a) ℓ_2 LENGTH OF PERMEANCE PATH P_2 in inches

$$\ell_2 = T_p - \left[\frac{(b_{p1}) + (b_{p2})}{2} \right] = (41) - \left[\frac{(76) + (76)}{2} \right]$$

(82)

P₃POLE BODY END LEAKAGE - This input can be either

0.0 or the actual value if available. Refer to Item (86) for explanation. See Figure M-12 location.

$$P_3 = \frac{6.28}{\pi} \left[\frac{3(b_{p1}) + (b_{p2})}{4} \right] \ell_n \frac{(r_3)}{(r_4)}$$

$$= \frac{6.28}{\pi} \left[\frac{3(76) + (76)}{4} \right] \ell_n \frac{(82b)}{(82c)}$$

(82b)

r₃r₃ = ℓ₁ = (80a) = length of permeance path P₁

(82c)

r₄r₄ = (ℓ₁) + $\frac{(\ell)}{2}$ = (80a) + $\frac{(13)}{2}$

(83)

P₄POLE BODY SIDE LEAKAGE - This input can be either 0.0

or the actual value if available. Refer to Item (77a) for explanation. See Figure M-13 for location.

When (6) > 4

$$P_4 = \frac{3.19(\ell_p)}{\pi} \ell_n \left[1 + \frac{(b_{p1}) + (b_{p2})}{2(Z)} \right]$$

$$= \frac{3.19(76)}{\pi} \ell_n \left[1 + \frac{(76) + (76)}{2(83)} \right]$$

Where $Z = T_p - \left[\frac{(b_{p1}) + (b_{p2})}{2} \right] = 41 - \left[\frac{(76) + (76)}{2} \right]$

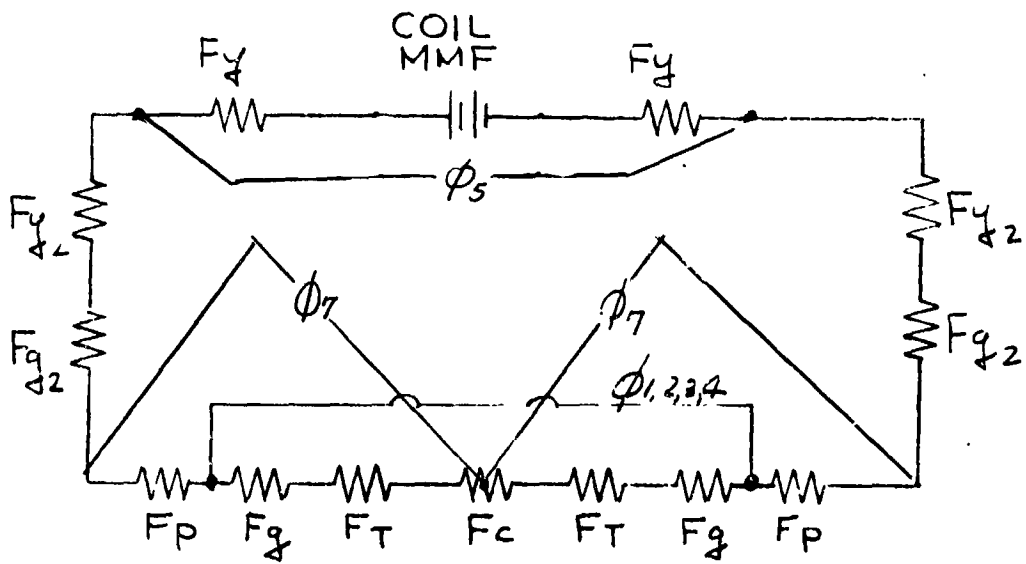
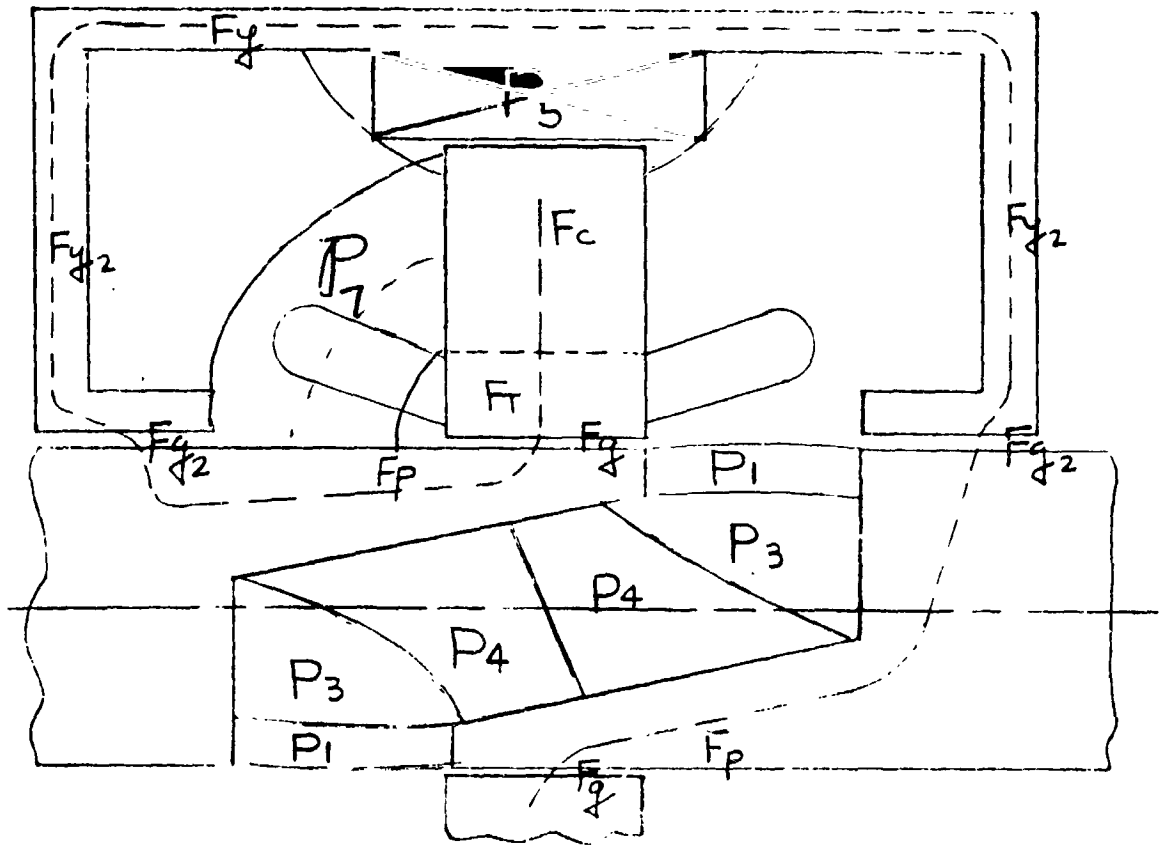

Figure M-14

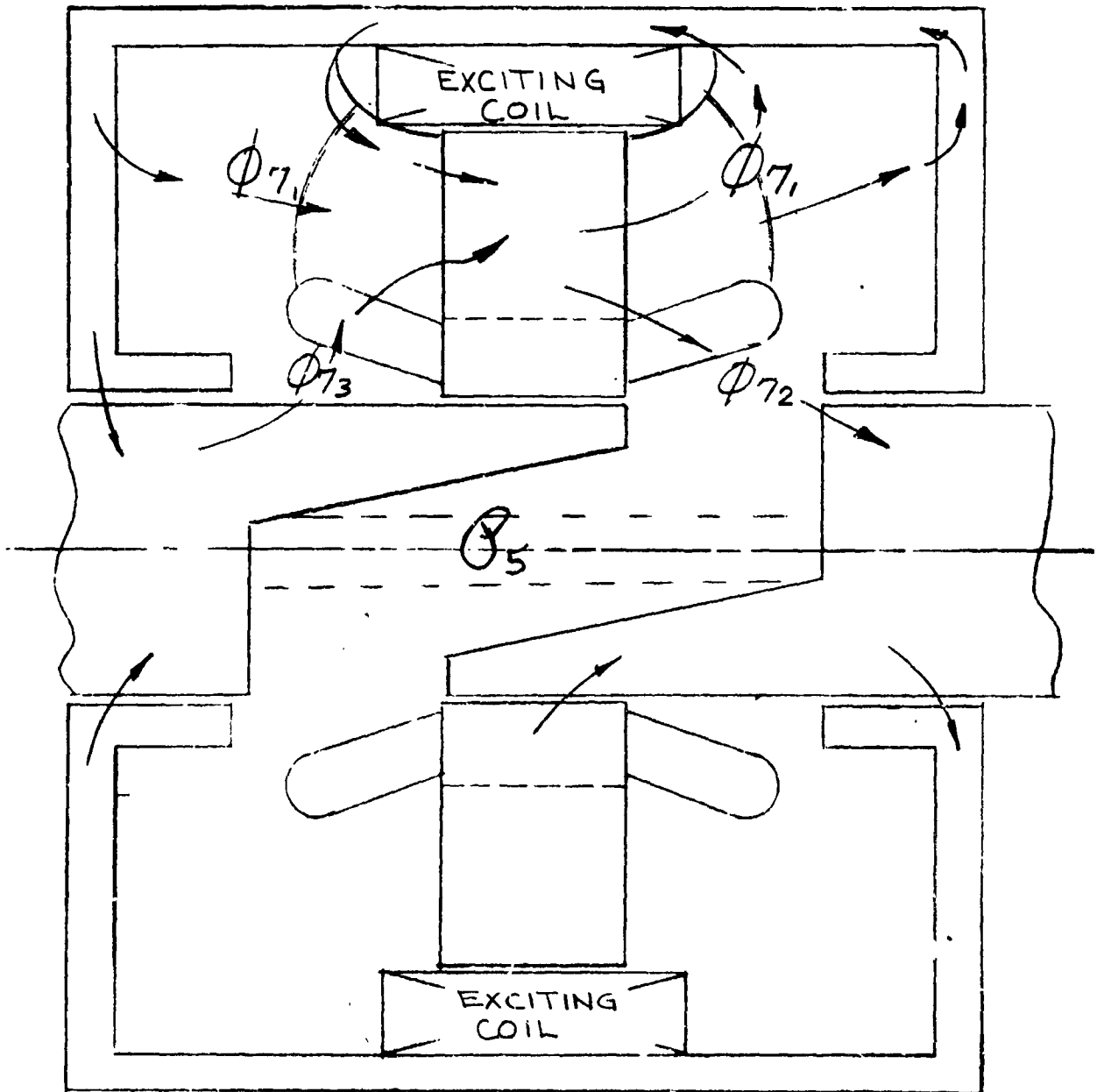

Figure M-15

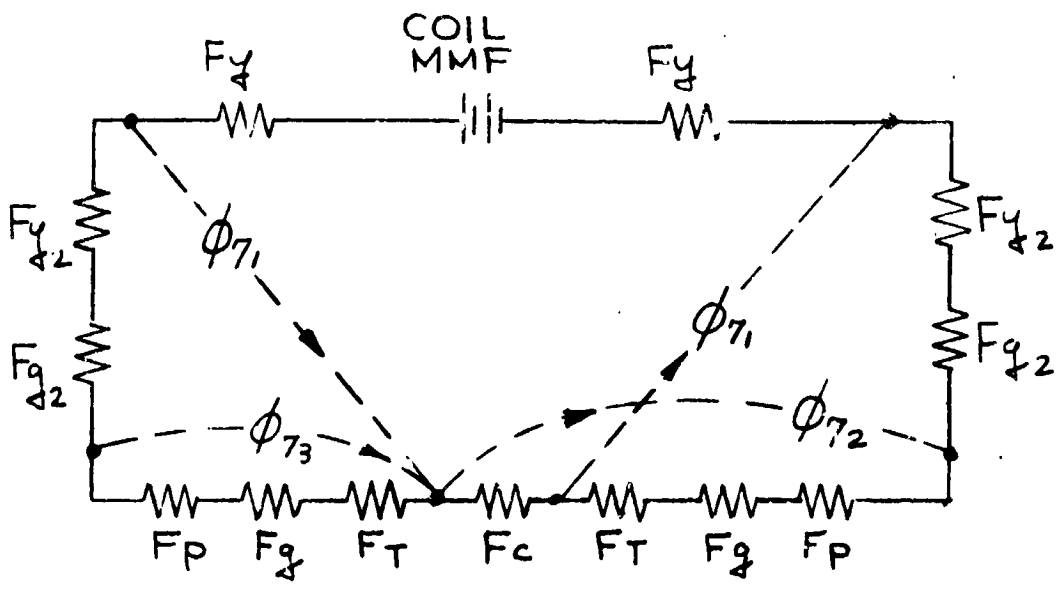
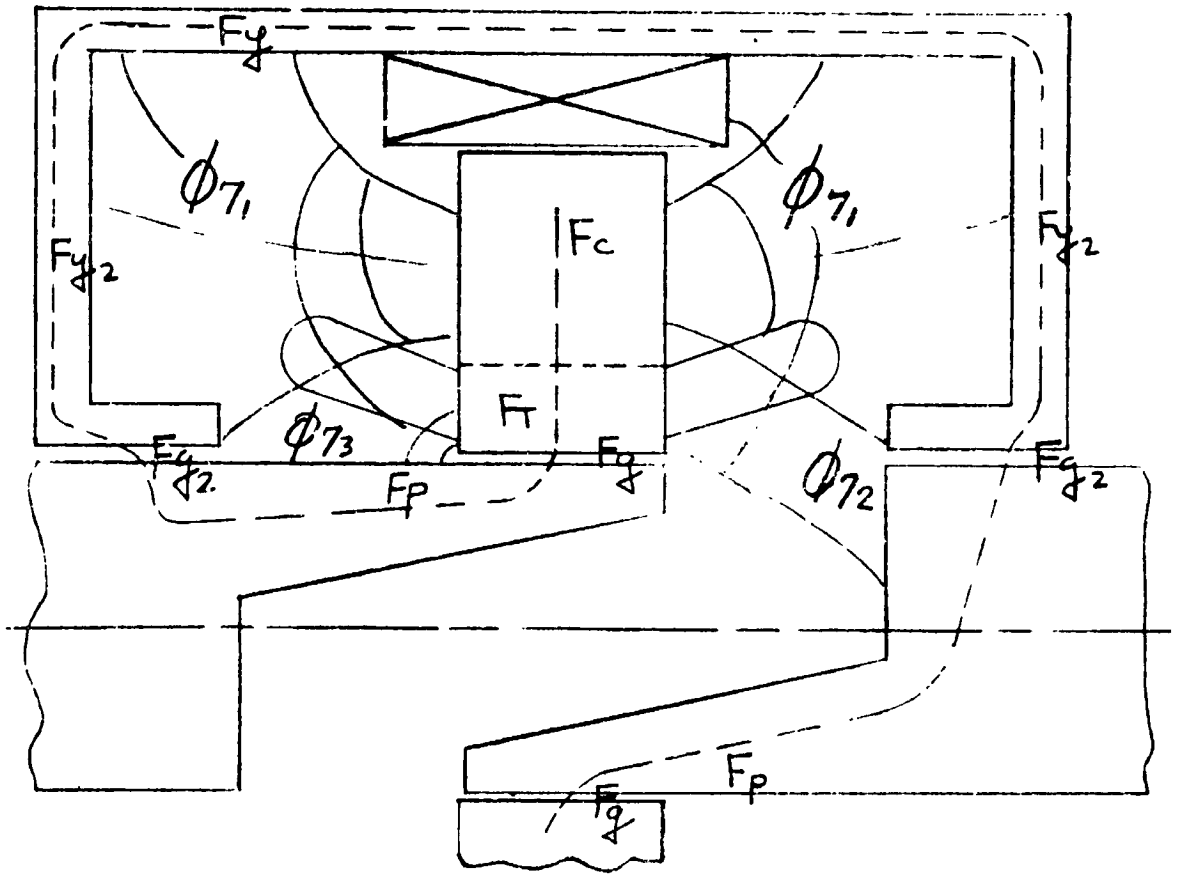

Figure M-16

When $(6) \leq 4$

$$P_4 = \frac{3.19 (l_p)}{\pi} \frac{3}{2} l_n \left[1 + \frac{(b_{p1}) + (b_{p2})}{2(Z)} \right]$$
$$= \frac{3.19 (76)}{\pi} \frac{3}{2} l_n \left[1 + \frac{(76) + (76)}{2(83)} \right]$$

(84)

P₅

COIL LEAKAGE PERMEANCE - This permeance must be

calculated by the designer and the calculated value must be inserted on the input sheet.

Refer to Figure M-14 which shows the location of the coil.

(86)

P₇

STATOR TO FRAME AND ROTOR LEAKAGE PERMEANCE

Refer to Figure M-14 for location. This permeance is actually broken down into three parts: P₇₁ leakage to yoke; P₇₂ leakage to shaft; P₇₃ leakage to rotor pole. In this design manual, the three permeances are added and treated as a single leakage. The same condition applies to P₇ and P₅. The designer must calculate P₇ and insert the calculated value on the input sheet.

(36a)	P_8	<u>FLUX PLATE TO FLUX PLATE LEAKAGE PERMEANCE</u>
		<p>This permeance must be calculated by the designer and the value must be inserted on the input sheet.</p> <p>Location per Figure M-5</p>
(87)	--	<p>The next set of calculations deals with the no load saturation. When the no load saturation data is required at various voltages, insert 1. on the input sheet for "no load sat". The computer will then calculate the complete no load saturation curve at 80, 90, 100, 110, 120, 130, 140, 150 and 160% of rated volts. When the complete saturation data is not necessary, insert 0. on the input sheet and the computer will calculate the 100% volts data.</p>
(88)	ϕ_T	<u>TOTAL FLUX IN KILOLINES</u>
(91)	B_t	<u>TOOTH DENSITY</u>
(92)	ϕ_P	<u>FLUX PER POLE</u>
(94)	B_c	<u>CORE DENSITY</u>

(95)	B_g	<u>GAP DENSITY</u>
(96)	F_g	<u>AIR GAP AMPERE TURNS</u>
(97)	F_T	<u>STATOR TOOTH AMPERE TURNS</u>
(98)	F_c	<u>STATOR CORE AMPERE TURNS</u>
(98a)	F_s	<u>STATOR AMPERE TURNS</u>
(99)	ϕ_7	<u>STATOR TO YOKE LEAKAGE FLUX - The</u> leakage flux from the stator to the yoke.

$$\begin{aligned} \phi_7 &= \left[(F_c) + (F_T) + (F_g) + (F_p) \right] (P_7) \times 10^{-3} \\ &= \left[(98) + (97) + (96) + (104a) \right] (86) \times 10^{-3} \end{aligned}$$

The items that follow will be calculated for variable loads. The first set of calculations are at no load. The calculations will then be repeated for 100% load.

For other values of load, the same calculations are repeated with the proper per cent load inserted.

(100a)

 ϕ_l ROTOR LEAKAGE FLUX - at no load

$$\begin{aligned}\phi_l &= (P) \left[2(F_g) + 2(F_T) + (F_c) \right] \times \\ &\quad \left[(P_1) + (P_2) + (P_3) + (P_4) \right] \times 10^{-3} \\ &= (6) \left[2(96) + 2(97) + (98) \right] \times \\ &\quad \left[(80) + (81) + (82) + (83) \right] \times 10^{-3}\end{aligned}$$

(102a)

 ϕ_{PT} TOTAL FLUX PER POLE - at no load

$$\phi_{PT} = (\phi_P) + \frac{2(\phi_l)}{(P)} = (92) + \frac{2(100a)}{(6)}$$

(103a)

 B_p POLE DENSITY - The apparent flux density at the base

of the pole. Note that no provision is made in this manual for calculating the density in the flux plate. It is, therefore, important to remember not to restrict the flux area through this section.

$$B_p = \frac{(\phi_{PT})}{(ap)} = \frac{(102a)}{(79)}$$

(103b)

 ϕ_8 FLUX PLATE TO FLUX PLATE

$$\begin{aligned}\phi_8 &= P_8 \left[2(F_g) + 2(F_T) + F_c \right] \times 10^{-3} \\ &= (86a) \left[2(96) + 2(97) + (98) \right] \times 10^{-3}\end{aligned}$$

(104a) F_P

POLE AMPERE TURNS - at no load. The ampere turns per pole required to force the flux through the pole and spider at no load rated voltage. The no load pole ampere turns per pole are calculated as the product of (l_P) times the NI per inch at the density (B_P). Use magnetization curve submitted per item (18) for rotor.

$$F_P = (l_P) \left[\text{NI/in @ density } (B_P) \right]$$
$$= (76) \left[\begin{array}{l} \text{Look up on rotor magnetization} \\ \text{curve given in (18) @ density (103a)} \end{array} \right]$$

(108) ϕ_{g2}

AUXILIARY GAP (g_2) flux in kilolines.

$$\phi_{g2} = \phi_{PT} \frac{(P)}{2} + \phi_7 + \phi_8 = (102) \frac{(6)}{2} + (99) + (103b)$$

(118) ϕ_5

COIL LEAKAGE FLUX

$$\phi_5 = 2(P_5) \left[(F_{g2}) + (F_{y2}) + (F_P) + (F_g) + (F_T) + (F_C) \right] \times 10^{-3}$$

$$\phi_5 = 2(84) \left[(123) + (126) + (104a) + (96) + (97) + (98) \right] \times 10^{-3}$$

(122) B_{g2}

AUXILIARY GAP (g_2) FLUX DENSITY

$$B_{g2} = \frac{(\phi_{g2})}{(A_{g2})} = \frac{(108)}{(70)}$$

(123) F_{g2} AUXILIARY AIR GAP AMPERE TURNS

$$F_{g2} = \frac{(B_{g2})}{3.19} (g_2) \times 10^3 = \frac{(122)}{3.19} (59a) \times 10^3$$

(124) A_{y2} AREA OF END BELL SECTION OF YOKE AT SMALLEST SECTION

$$A_{y2} = \pi (d_{y2})(t_{y2}) = \pi (78)(78)$$

(124a) A_y AREA OF HOUSING PORTION OF YOKE

$$\begin{aligned} A_y &= \pi [(D) + (t_y)] (t_y) \\ &= \pi [(12) + (78)] (78) \end{aligned}$$

(125) B_{y2} FLUX DENSITY IN END BELL SECTION OF YOKE @ N. L.

NOTE: The flux in the yoke is equal to the flux crossing the auxiliary gap (g).

$$B_{y2} = \frac{(\Phi_{g2})}{(A_{y2})} = \frac{(108)}{(124)}$$

(126) F_{y2} AMPERE TURN DROP IN END BELL SECTION OF YOKE

@ N. L.

$$\begin{aligned} F_{y2} &= \left[\frac{(D) - (d_{y2})}{6} \right] \left[\text{NI/inch @ } (B_{y2}) \right] \\ &= \left[\frac{(12) - (78)}{6} \right] \left[\text{Look up on yoke magnetization curve @} \right. \\ &\quad \left. \text{density (125)} \right] \end{aligned}$$

(126a)	B_y	<u>DENSITY IN HOUSING SECTION OF YOKE @ N. L.</u>
		$B_y = \frac{(\phi_{g2}) + (\phi_5)}{A_y} = \frac{(108) + (.8)}{(124a)}$
(126b)	F_y	<u>AMPERE TURN DROP IN HOUSING SECTION OF YOKE</u>
		using 1/2 total length of housing
		$F_y = (\ell_y) \left[\text{NI/inch at density } (B_y) \right]$ $= (178) \left[\text{Look up on yoke magnetization curve @ density} \right]$ $(126a)$
(127)	F_{NL}	<u>TOTAL AMPERE TURN DROP AROUND CIRCUIT @ N. L.</u>
		$F_{NL} = 2 \left[(F_y) + (F_{y2}) + (F_{g2}) + (F_p) + (F_g) + (F_T) + \frac{(F_c)}{2} \right]$ $= 2 \left[(126b) + (126c) + (123) + (104) + (96) + (97) + \frac{(98)}{2} \right]$
(127a)	I_{FNL}	<u>FIELD CURRENT</u> - at no load
		$I_{FNL} = (F_{NL}) / (N_F) = (127) / (146)$
(127b)	E_F	<u>FIELD VOLTS</u> - at no load. This calculation is made with cold field resistance at 20°C for no load condition.
		$E_F = (I_{FNL})(R_f \text{ cold}) = (127a)(154)$
(127c)	S_F	<u>CURRENT DENSITY</u>

(128) A AMPERE CONDUCTORS per inch

(129) X REACTANCE FACTOR

(130) X_{ℓ} LEAKAGE REACTANCE in per cent

$$X_{\ell} = X \left[\lambda_i + \lambda_e + \lambda_z \right]$$
$$= (129) \left[(62) + (64) + (64a) \right]$$

λ_z is explained under item (64a) and should be zero in most designs.

(131) X_{ad} REACTANCE - direct axis - This is the fictitious reactance due to armature reaction in the direct axis. (in per cent)

$$X_{ad} = \frac{.9 (N_e)(I_{PH})(C_m)(K_d) \times 100}{2P \left[(F_g) + (F_{g2}) \right]} = \frac{.9(45)(8)(74)(43) \times 100}{2(6) \left[(96) + (123) \right]}$$

(132) X_{aq} REACTANCE - quadrature axis - This is the fictitious reactance due to armature reaction in the quadrature axis (in per cent).

$$X_{aq} = \frac{(C_q)(X_{ad})}{(C_m)(C_l)} = \frac{(75)(131)}{(74)(71)}$$

(133) X_d SYNCHRONOUS REACTANCE - %

(134) X_q SYNCHRONOUS REACTANCE - quadrature axis - %

(145)	V_r	<u>PERIPHERAL SPEED</u>
-------	-------	-------------------------

(146)	N_F	<u>NUMBER OF FIELD TURNS</u>
-------	-------	------------------------------

(146a)	N_{CO}	<u>NUMBER OF FIELD COILS</u> - One basic computer program is used for the single-coil and two-coil Lundell generators. This item is used in the computer program as a code for distinguishing one from the other.
--------	----------	---

- (147) l_{tF} MEAN LENGTH OF FIELD TURN INCHES.
- (148) -- FIELD CONDUCTOR DIA OR WIDTH in inches
- (149) -- FIELD CONDUCTOR THICKNESS in inches - Set this item
= 0. for round conductor

(150) X_f °C FIELD TEMP IN °C

(151) ρ_f RESISTIVITY of field conductor

(152) ρ_f
(hot) RESISTIVITY of field conductor

(153) a_{cf} CONDUCTOR AREA OF FIELD WDG

(154) R_f
(cold) COLD FIELD RESISTANCE @ 20°C

$$R_f \text{ (cold)} = (\rho_f) \frac{(N_F)(l_{tf})}{(a_{cf})} \times 10^{-6} = (151) \frac{(146)(147)}{(153)} \times 10^{-6}$$

(155) R_f
(hot) HOT FIELD RESISTANCE - Calculated at X_f °C(103)

$$R_f \text{ (hot)} = (\rho_{f \text{ hot}}) \frac{(N_F)(l_{tf})}{(a_{cf})} \times 10^{-6} = (152) \frac{(146)(147)}{(153)} \times 10^{-6}$$

(156) -- WEIGHT OF FIELD COIL in lbs.

$$\# \text{'s of copper} = .321 (N_F)(l_{tf})(a_{cf})$$

$$= .321(146)(6)(147)(153)$$

Also refer to note in item (65)

(157)

--

WEIGHT OF ROTOR IRON - Because of the large number of different pole shapes, one standard formula cannot be used for calculating rotor iron weight. Therefore, the computer will not calculate rotor iron weight. The space is allowed on the input sheet for record purposes only. By inserting 0. in the space allowed for rotor iron weight, the computer will show "0." on the output sheet. If the rotor iron weight is available and inserted on input sheet, then the output sheet will show this same weight on the output sheet.

(160)

X_F

THE EFFECTIVE FIELD LEAKAGE REACTANCE - The

reactance which added to the stator leakage reactance gives the transient reactance X'_{du} .

When unit fundamental armature ampere turns are suddenly applied on the direct axis, an initial field current (I_f) will be induced. The value of this initial field current will be just enough to make the net flux interlinking the field because of the field current and the armature current zero. The field ampere turns will equal the armature ampere turns.

$$X_F = X_{ad} \left[1 - \frac{\frac{C_1}{C_m}}{2C_p + \frac{4}{\pi} \frac{\lambda_F}{\lambda_a}} \right]$$

$$X_F = (131) \left[1 - \frac{\frac{(71)}{(74)}}{2(73) + \frac{4}{\pi} \frac{(160)}{(160)}} \right]$$

$$\lambda_a = \frac{6.38d}{P_{ge'}} = \frac{6.38(11)}{(6)(160)}$$

$$g'_e = g_e \left[\frac{F_g - F_{g2}}{F_g} \right] = (69) \left[\frac{(96) - (123)}{(96)} \right]$$

$$\lambda_F = \frac{P_e}{\ell} = \frac{(160a)}{(13)}$$

(160a) P_e

FIELD LEAKAGE PERMEANCE (flux lines/ampere turn)

$$\begin{aligned} P_e &= \mu \left[\underline{P_1} + P_2 + P_3 + \underline{P_4} \right] + P_5 \\ &= (6) \left[(80) + (31) + (82) + (83) \right] + (84) \end{aligned}$$

(161) L_f

FIELD SELF-INDUCTANCE (henry)

$$\begin{aligned} L_f &= N_F^2 (P_e) \times 10^{-8} \\ &= (146)^2 (160a) \times 10^{-8} \end{aligned}$$

(165)	X'_{du}	<u>UNSATURATED TRANSIENT REACTANCE</u>
(167)	X'_d	<u>SATURATED TRANSIENT REACTANCE</u>
(168)	X''_d	<u>SUBTRANSIENT REACTANCE</u> in direct axis
(169)	X''_q	<u>SUBTRANSIENT REACTANCE</u> in quadrature axis
(170)	X_2	<u>NEGATIVE SEQUENCE REACTANCE</u>
(172)	X_0	<u>ZERO SEQUENCE REACTANCE</u>
(173)	K_{x0}	
(174)	K_{x1}	
(175)	λ_{B0}	
(176)	T'_{do}	<p><u>OPEN CIRCUIT TIME CONSTANT</u> - The time constant of the field winding with the stator open circuited and with negligible external resistance and inductance in the field circuit. Field resistance at room temperature (20°C) is used in this calculation.</p> $T'_{do} = \frac{L_F}{R_F} = \frac{(161)}{(154)}$
(177)	T_a	<u>ARMATURE TIME CONSTANT</u>
(178)	T'_d	<u>TRANSIENT TIME CONSTANT</u>

(180)

F_{SC}

SHORT CIRCUIT AMPERE TURNS

SHORT-CIRCUIT AMPERE-TURNS--The field ampere-turns required to circulate rated line amperes in a three-phase short circuit at the machine terminals.

$$\begin{aligned} F_{SC} &= \frac{(X_d)^2}{100} [F_g + F_{g2}] \\ &= \frac{(133)^2}{100} [(96) + (123)] \end{aligned}$$

(181) SCR SHORT CIRCUIT RATIO

(182) I^2R_F FIELD I^2R - at no load. The copper loss in the field winding is calculated with cold field resistance at 20°C for no load condition.

$$\text{Field } I^2R = (I_{FNL})^2(R_f \text{ cold}) = (127a)^2 (154)$$

(183) F&W FRICTION & WINDAGE LOSS - The best results are obtained by using existing data. For ratioing purposes, the loss can be assumed to vary approximately as the 5/2 power of the rotor diameter and as the 3/2 power of the RPM. When no existing data is available, the following calculation can be used for an approximate answer. Insert 0. when computer is to calculate F&W. Insert actual F&W when available. Use same value for all load conditions.

$$F\&W = 2.52 \times 10^{-6} (d_r)^{2.5} (\text{RPM})^{1.5} (l_p)$$

$$= 2.52 \times 10^{-6} (11a)^{2.5} (7)^{1.5} (76)$$

For gases or fluids other than standard air, the fluid density and viscosity must be considered. The formula given in the manual can be modified by the factors

$$\left(\frac{\rho}{.0765}\right)^{.8} \left(\frac{\mu}{.0435}\right)^{.2}$$

where ρ = density - Lbs FT⁻³
 μ = viscosity LBS FT⁻¹ HR⁻¹
 .0765 = density std. air
 .0435 = viscosity Std air

- | | | |
|-------|-----------|-------------------------------------|
| (184) | W_{TNL} | <u>STATOR TEETH LOSS</u> |
| (185) | W_c | <u>STATOR CORE LOSS</u> |
| (186) | W_{NPL} | <u>POLE FACE LOSS</u> - at no load. |
| (187) | K_1 | |
| (188) | K_2 | |
| (189) | K_3 | |
| (190) | K_4 | |
| (191) | K_5 | |

(192) K_6

(194) I^2R STATOR I^2R - at no load.

(195) -- EDDY LOSS - at no load.

(196) -- TOTAL LOSSES - at no load.

The N. L. calculations should all be repeated
now for 100% load.

(196a) ϕ_{ll} LEAKAGE FLUX PER POLE at 100% load

$$\begin{aligned}\phi_{ll} &= \phi_l \left\{ \frac{(e_d)(F_g) + [1 + \cos(\theta)](F_T) + (F_C)}{(F_g) + (F_T) + (F_C)} \right\} \\ &= (100) \left\{ \frac{(198)(96) + [1 + \cos(198a)](97) + (98)}{(96) + (97) + (98)} \right\}\end{aligned}$$

(198) e_d Where $e_d = \cos \epsilon + \frac{(X_d)}{100} \sin \Psi$
 $= \cos(198a) + \frac{(133)}{100} \sin(198b)$

(198a) θ Where $\theta = \cos^{-1} [(\text{Power Factor})]$
 $= \cos^{-1} [(9)]$

$$\begin{aligned}\text{Where } \Psi &= \tan^{-1} \left[\frac{\sin(\theta) + (X_q) / (100)}{\cos(\theta)} \right] \\ &= \tan^{-1} \left[\frac{\sin(198a) + (134) / (100)}{\cos(198a)} \right]\end{aligned}$$

Where $\epsilon = \Psi - \theta = (198a) - (198a)$

(198b) ϕ_{8L} LEAKAGE FLUX BETWEEN FLUX PLATES AT F.L. (Kilolines)

$$\phi_{8L} = \frac{(\phi_{2\ell})}{(\phi_{\ell})} (\phi_8) = (103b) \frac{(196a)}{(100a)}$$

(207) ϕ_{7L} FLUX LEAKAGE FROM STATOR TO YOKE UNDER LOAD

(one side of stator only)

$$\begin{aligned} \phi_{7L} &= (P7) \left[(F_{PL}) + (e_d)(F_g) + (F_T) [1 + \cos(\theta)] + (F_c) \right] \times 10^{-3} \\ &= (86) \left[(213c) + (198)(96) + (97) [1 + \cos(198a)] + (98) \right] \times 10^{-3} \end{aligned}$$

(213) ϕ_{PL} FLUX PER POLE at 100% load

For P. F. .0 to .95

$$\begin{aligned} \phi_{PL} &= (\phi_P) \left[(e_d) - \frac{.93(X_{ad})}{100} \sin(\psi) \right] \\ &= (92) \left[(198) - \frac{.93(131)}{100} \sin(198a) \right] \end{aligned}$$

For P. F. .95 to 1.0

$$\phi_{PL} = (\phi_P)(K_c) = (92)(9a)$$

(213a) ϕ_{PTL} TOTAL FLUX PER POLE at 100% load

$$\phi_{PTL} = \phi_{PL} + \frac{2(\phi_{\ell})}{P} = (213) + \frac{2(196a)}{(6)}$$

(213b) B_{PL} FLUX DENSITY AT BASE OF POLE at 100% load

$$B_{PL} = \frac{\phi_{PTL}}{a_p} = \frac{(213a)}{(79)}$$

(213c) F_{PL} AMPERE TURNS PER POLE at 100% load

$$F_{PL} = (\ell_p) \left[N_{\text{a/in @ density } (B_{PL})} \right]$$

$$= (76) \left[\text{Look up ampere turns/inch on rotor magnetization curve given in (18) at density (213b)} \right]$$

(221) ϕ_{g2L} FLUX CROSSING THE AUXILIARY AIR GAP under load

$$\phi_{g2L} = (\phi_{PTL}) \frac{(P)}{2} + \phi_{7L} + (\phi_{8L})$$

$$= (213a) \frac{(6)}{2} + (207) + (198b)$$

(224) B_{g2L} FLUX DENSITY IN AUXILIARY GAP (g_2) under load

$$B_{g2L} = \frac{(\phi_{g2L})}{(A_{g2})} = \frac{(221)}{(70)}$$

(225) F_{g2L} AUXILIARY AIR GAP AMPERE TURN DROP under load

$$F_{g2L} = \frac{(B_{g2L})(g_2)}{3.19} \times 10^3 = \frac{(224)}{3.19} (59a) \times 10^3$$

(226) ϕ_{5L} COIL LEAKAGE FLUX under load

$$\phi_{5L} = 2(P_5) \left\{ (F_{y2L}) + (F_{g2L}) + (F_{PL}) + (e_d)(F_g) + (F_T) [1 + \cos(\theta)] + (F_C) \right\} \times 10^{-3}$$

$$= 2(97) \left\{ (229) + (225) + (164) + (198)(96) + (97) [1 + \cos(198a)] + (98) \right\} \times 10^{-3}$$

(227) ϕ_{y2L} FLUX IN END-BELL SECTION OF THE YOKE under load

$$\phi_{y2L} = (\phi_{g2L})$$

$$= (221)$$

(228) B_{y2L} DENSITY IN END-BELL SECTION OF YOKE AT THE SMALLEST AREA SECTION under load

$$B_{y2L} = \frac{\phi_{y2L}}{A_{y2}} = \frac{(227)}{(124)}$$

(229) F_{y2L} AMPERE TURN DROP IN END-BELL SECTION OF YOKE

under load.

$$F_{y2L} = \left[\frac{(D)-(d_{y2})}{6} \right] \left[\text{NI/inch @ density } (B_{y2L}) \right]$$

$$= \left[\frac{(12)-(78)}{6} \right] \left[\begin{array}{l} \text{Look up on yoke magnetization curve} \\ \text{given in (18) at density (228)} \end{array} \right]$$

(229b) B_{yL} FLUX DENSITY IN THE HOUSING SECTION OF THE YOKE

under load.

$$B_{yL} = \frac{(\phi_{g2L}) + (\phi_{5L})}{A_y} = \frac{(221) + (226)}{(124a)}$$

(229c) F_{yL} AMPERE TURN DROP THROUGH THE HOUSING SECTION OF THE YOKE under load using 1/2 total length of housing.

$$F_y = (l_y) \left[NI/\text{inch @ density } (B_{yL}) \right]$$

$$= (78) \left[\text{Look up on yoke magnetization curve given in (18) @ density (229b)} \right]$$

(236) F_{FL} TOTAL AMPERE TURN DROP at full load

$$= 2 \left[(F_{g2L}) + (F_{yL}) + (F_{y2L}) + (F_{PL}) + (e_d)(F_g) + (F_T) \left[1 + \cos(\theta) \right] + F_c \right] \times 10^{-3}$$

$$= 2 \left[(225) + (229c) + (229) + (213c) + (198)(96) + (97) \left[1 + \cos(198a) \right] + (98) \right] \times 10^{-3}$$

(237) I_{FFL} FIELD CURRENT under load

$$I_{FFL} = (F_{FL}) / (N_F) = (236) / (146)$$

(239) CURRENT DENSITY at 100% load

$$\text{Current Density} = (I_{FFL}) / (a_{cf}) = (237) / (153)$$

(238) E_{FFL} FIELD VOLTS at 100% load - This calculation is made with hot field resistance at expected temperature at 100% load.

$$\text{Field Volts} = (I_{FFL})(R_f \text{ hot}) = (237)(155)$$

(241) I^2R_{FL} FIELD I^2R at 100% load - The copper loss in the field winding is calculated with hot field resistance at expected temperature for 100% load condition.

$$\text{Field } I^2R = (I_{FFL})^2(R_F \text{ hot}) = (237)^2(155)$$

(242) W_{TFL} STATOR TEETH LOSS at 100% load - The stator tooth loss under load increases over that of no load because of the parasitic fluxes caused by the ripple due to the rotor damper bar slot openings.

$$W_{TFL} = \left\{ 2 \left[.27 \frac{(X_d)}{100} \frac{(\% \text{ Load})}{100} \right]^{1.8} + 1 \right\} (W_{TNL})$$

$$= \left\{ 2 \left[.27 \frac{(133)}{100} 1 \right]^{1.8} + 1 \right\} (184)$$

(243) W_{PFL} POLE FACE LOSS at 100% load

$$W_{PFL} = \left\{ \left[\frac{(K_{SC})(I_{PH}) \frac{(\% \text{ Load})}{100} (n_s)}{(C)(F_g)} \right]^2 + 1 \right\} (W_{PNL})$$

$$= \left\{ \left[\frac{(243)(8) 1 (30)}{(32)(96)} \right]^2 + 1 \right\} (186)$$

(K_{SC}) is obtained from Curve F-3

(245) I^2R_L STATOR I^2R at 100% load - The copper loss based on the D. C. resistance of the winding. Calculate at the maximum expected operating temperature.

$$I^2R = (m)(I_{PH})^2 (R_{SPH \text{ hot}})$$

$$= (5)(8)^2 (54)$$

(246) -- EDDY LOSS - Stator I^2R loss due to skin effect

$$\text{Eddy Loss} = \left[\frac{(EF \text{ top}) + (EF \text{ bot})}{2} - 1 \right] (\text{Stator } I^2R)$$

$$= \left[\frac{(55) + (56)}{2} - 1 \right] (245)$$

(247) -- TOTAL LOSSES at 100% load - sum of all losses at 100% load

$$\begin{aligned} \text{Total Losses} = & (\text{Field } I^2R) + (\text{F\&W}) + (\text{Stator Teeth Loss}) + \\ & (\text{Stator Core Loss}) + (\text{Pole Face Loss}) + \\ & (\text{Stator } I^2R) + (\text{Eddy Loss}) \end{aligned}$$

$$= (241) + (183) + (242) + (185) + (243) + (245) + (246)$$

(248) -- RATING IN KILOWATTS at 100% load

$$\text{Rating} = 3(E_{PH})(I_{PH}) \quad (\text{P. F.}) \quad \times 10^{-3}$$

$$= 3(4)(8) \quad (9) \quad \times 10^{-3}$$

(249) -- RATING PLUS LOSSES = (248) + (247) x 10⁻³

(250) -- % LOSSES = $\frac{\text{Losses} \times (100)}{\text{Rating Plus Losses}}$
 $= \frac{(247) \times 10^{-3} \times 10^2}{(249)}$

(251) -- % EFFICIENCY = 100% - % Losses
= 100% - (250)

These items can be recalculated for any load condition by simply inserting the values that correspond to the % load being calculated.

Values for F&W (183) and W_C (Stator Core Loss) (185) do not change with load.