

NASA TECHNICAL NOTE

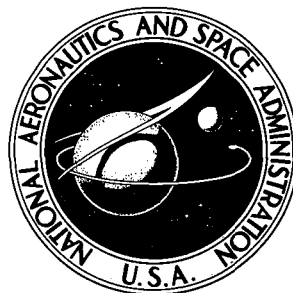

NASA TN D-1730

NASA TN D-1730

**THE N-BODY CODE - A GENERAL
FORTRAN CODE FOR THE NUMERICAL
SOLUTION OF SPACE MECHANICS
PROBLEMS ON AN IBM 7090 COMPUTER**

by William C. Strack and Vearl N. Huff

*Lewis Research Center
Cleveland, Ohio*

TECHNICAL NOTE D-1730

THE N-BODY CODE - A GENERAL FORTRAN CODE FOR THE
NUMERICAL SOLUTION OF SPACE MECHANICS

PROBLEMS ON AN IBM 7090 COMPUTER

By William C. Strack and Vearl N. Huff

Lewis Research Center
Cleveland, Ohio

NATIONAL AERONAUTICS AND SPACE ADMINISTRATION

CONTENTS

	Page
SUMMARY	1
INTRODUCTION	1
STATEMENT OF PROBLEM	2
Origin Body Gravitational Field and Oblateness Perturbations	2
Celestial Body Perturbations	3
Propulsive Thrust	4
Aerodynamic Forces	4
Other Forces	6
METHOD OF SOLUTION	6
Integration Variables	6
Rectangular coordinates	6
Orbit elements	7
Integration Method	7
Origin Translation	8
THE CODE AND ITS USAGE	8
Ephemerides	9
Multistage Vehicles	9
Step-Size, Output, and Termination Controls	9
Computer Output	10
Computer Input	10
CODING	11
General	11
Examples	12
APPENDIXES	
A - SYMBOLS	16
B - VECTOR RESOLUTION	19
C - TRANSFORMATION EQUATIONS FROM ORBIT ELEMENTS TO RECTANGULAR COORDINATES	21
D - RUNGE-KUTTA AND LOW-ORDER INTEGRATION SCHEMES WITH ERROR CONTROL	23
E - GLOSSARY OF VARIABLES	26
F - LEWIS RESEARCH CENTER EPHEMERIS	34
G - INPUT-DATA REQUIREMENTS	38
H - PROGRAM LISTING	47
I - EXAMPLE II: LUNAR ORBITING PROBE	85
REFERENCES	90

THE N-BODY CODE - A GENERAL FORTRAN CODE FOR THE
NUMERICAL SOLUTION OF SPACE MECHANICS
PROBLEMS ON AN IBM 7090 COMPUTER

By William C. Strack and Vearl N. Huff

SUMMARY

A general astronomical integration code designed for a large class of problems in space mechanics that may be solved by numerical integration is described. The equations of motion provide for the effects of up to eight gravitating celestial bodies, oblateness and aerodynamic forces from the celestial body at the problem origin, propulsion system thrust, and rotation of the body at the origin. The coding in this report is intended for use on an IBM 7090. An earlier version was reported in NASA Technical Note D-1455 and was designed for use on an IBM 704.

INTRODUCTION

The general problems of space mechanics (i.e., n-bodies plus nonconservative forces such as thrust) cannot be solved analytically. Therefore, numerical integration through the use of computing machinery is usually employed.

Several codes have been written for the numerical solution of problems in orbit mechanics; for example, the Themis Code of reference 1 is a double-precision code intended primarily for close satellites or interplanetary coasting flight. Reference 2 describes a space-trajectory program of considerable merit. A listing of several other trajectory codes may be found in reference 3.

The general purpose code described herein has several distinctive features not all of which are found in any one of the previously available codes. As described herein, this code is designed to operate on an IBM 7090 computer that has a 32,000 word (32 K) memory. The fact that the program is written in FORTRAN should make it applicable to installations having other types of equipment that accept the FORTRAN language. An earlier version of this program designed for an IBM 704 with an 8-K core and at least 1 K of drum storage has been previously published in reference 4. This report has incorporated a number of improvements. The most important ones are: (1) only one core load is required, (2) all stage data for multistage vehicles may be loaded simultaneously, (3) the third harmonic term is included in the Earth's oblateness equations, and (4) there are additional program controls available that provide increased flexibility.

The program is compartmented into 25 subroutines to facilitate modifications

for specific problems. The integration is carried out in either rectangular coordinates or orbit elements at the option of the user. A compact ephemeris that occupies about one-seventh of a reel of tape is utilized for positions and velocities of the planets (except Mercury) and the Moon. An atmosphere is included so that aerodynamic forces may be considered.

STATEMENT OF PROBLEM

The problem to be solved may be stated as follows: Given certain initial conditions, compute, using three degrees of freedom, the path of an object, such as a space vehicle, subject to any or all of the following forces:

Origin body gravitational field

Other celestial body gravitational fields

Propulsive thrust

Aerodynamic forces

Any other defined forces

Alternately, in equation form, with respect to a noninertial Cartesian coordinate system,

$$\ddot{\vec{r}} = \nabla U + \left[k^2 \sum_{i=1}^n m_i \nabla \left(\left| \frac{1}{\vec{r} - \vec{r}_i} \right| - \frac{\vec{r} \cdot \vec{r}_i}{r_i^3} \right) \right] + \frac{\vec{F}}{m} + \frac{\vec{L}}{m} + \frac{\vec{D}}{m} + \frac{\vec{X}}{m} \quad (1)$$

where n equals the number of perturbing bodies and ∇ denotes the del operator. (All symbols are defined in appendix A.)

Origin Body Gravitational Field and Oblateness Perturbations

The first term, ∇U , in the equation of motion (eq. (1)) represents the gravitational forces due to the origin body. When the origin body is spherical and made up of homogeneous layers, this term becomes simply $-\mu\vec{r}/r^3$. In the case of the Earth, however, the effect of oblateness may be important, and additional terms must be added to account for the oblateness effects. The expression for the gravitational potential U of an oblate spheroid may be written, according to reference 5, as

$$U = \frac{k^2 m_r}{r} \left\{ 1 + J \left(\frac{R_r}{r} \right)^2 \left[\frac{1}{3} - \left(\frac{z}{r} \right)^2 \right] + H \left(\frac{R_r}{r} \right)^3 \left[\frac{3}{5} - \left(\frac{z}{r} \right)^2 \right] \frac{z}{r} + \frac{2}{35} \left(\frac{R_r}{r} \right)^4 \left[3 - 30 \left(\frac{z}{r} \right)^2 + 35 \left(\frac{z}{r} \right)^4 \right] \right\} \quad (2)$$

where the x,y plane lies in the equatorial plane. The components of gravitational acceleration are as follows:

$$\begin{aligned}
 U_x &= \frac{\partial U}{\partial x} = \frac{k^2 m_r}{r^2} \left\{ -1 + J \left(\frac{R_r}{r} \right)^2 \left[5 \left(\frac{z}{r} \right)^2 - 1 \right] + H \left(\frac{R_r}{r} \right)^3 \left[7 \left(\frac{z}{r} \right)^2 - 3 \right] \frac{z}{r} \right. \\
 &\quad \left. + \mathcal{Q} \left(\frac{R_r}{r} \right)^4 \left[-\frac{3}{7} + 6 \left(\frac{z}{r} \right)^2 - 9 \left(\frac{z}{r} \right)^4 \right] \right\} \frac{x}{r} \\
 U_y &= \frac{\partial U}{\partial y} = \frac{k^2 m_r}{r^2} \left\{ -1 + J \left(\frac{R_r}{r} \right)^2 \left[5 \left(\frac{z}{r} \right)^2 - 1 \right] + H \left(\frac{R_r}{r} \right)^3 \left[7 \left(\frac{z}{r} \right)^2 - 3 \right] \frac{z}{r} \right. \\
 &\quad \left. + \mathcal{Q} \left(\frac{R_r}{r} \right)^4 \left[-\frac{3}{7} + 6 \left(\frac{z}{r} \right)^2 - 9 \left(\frac{z}{r} \right)^4 \right] \right\} \frac{y}{r} \\
 U_z &= \frac{\partial U}{\partial z} = \frac{k^2 m_r}{r^2} \left\{ -1 + J \left(\frac{R_r}{r} \right)^2 \left[5 \left(\frac{z}{r} \right)^2 - 3 \right] + H \left(\frac{R_r}{r} \right)^3 \left[7 \left(\frac{z}{r} \right)^2 - 6 + \frac{3}{5} \left(\frac{z}{r} \right)^2 \right] \frac{z}{r} \right. \\
 &\quad \left. + \mathcal{Q} \left(\frac{R_r}{r} \right)^4 \left[-\frac{15}{7} + 10 \left(\frac{z}{r} \right)^2 - 9 \left(\frac{z}{r} \right)^4 \right] \right\} \frac{z}{r} \tag{3}
 \end{aligned}$$

The first terms exist for a spherical planet composed of concentric layers of uniform density. The terms containing J, H, and \mathcal{Q} are frequently called the second, third, and fourth harmonic terms, respectively, while J, H, and \mathcal{Q} are known as the harmonic coefficients.

It is expected that oblateness perturbations need to be computed only for the origin body, since at large distances, such as that between celestial bodies, the gravitational field of an oblate body is essentially an inverse-square field. Consideration of oblate bodies other than the Earth requires only different values of J, H, and \mathcal{Q} if that body's rotation axis is parallel to the z-axis. When the body has triaxial asymmetry or when the z-axis cannot conveniently be aligned with the rotation axis of the origin body, the equations must be extended if oblateness is to be included.

Celestial Body Perturbations

The presence of more than one gravitating body in addition to the object results in the inclusion of the second term of equation (1). The evaluation of this term requires a knowledge of the positions of the bodies as a function of time. The degree of precision desired determines the method to be used to obtain the positions such as elements of ellipses or an ephemeris.

Propulsive Thrust

The propulsive acceleration is completely specified by a direction and a magnitude. The thrust direction may be referred to the velocity vector by two angles: α , the angle between the velocity and the thrust vectors and β , the angle between the orbit plane and the velocity-thrust plane. The sense of each angle is indicated in sketch (a).

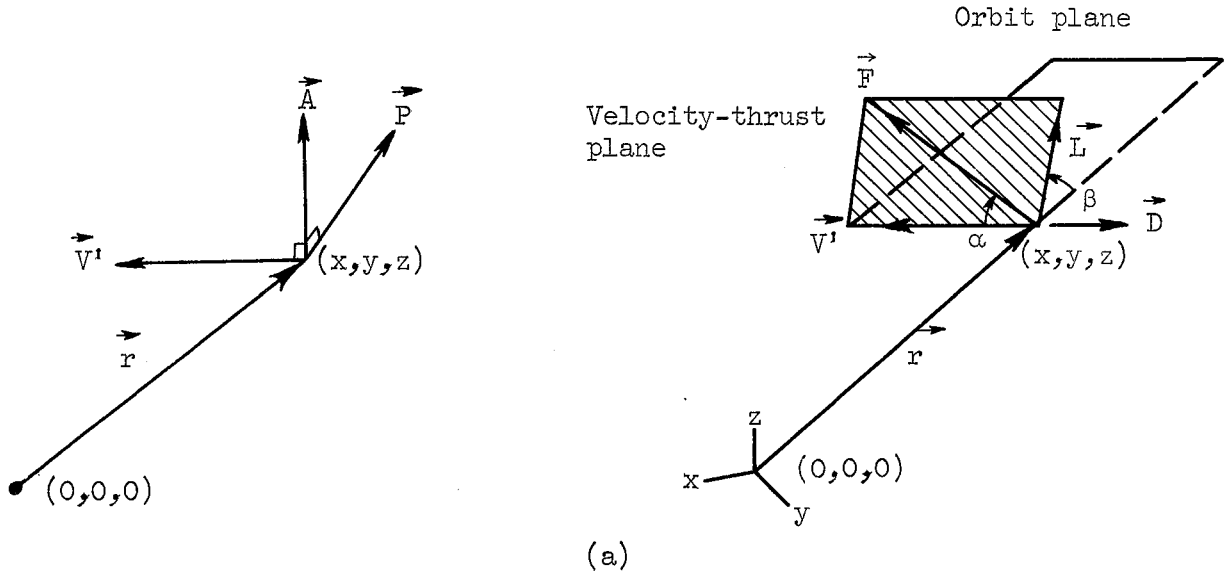

The velocity may be referenced with respect to one of several coordinate systems. If the computation refers to a takeoff of a rocket or winged vehicle, the coordinate system rotating with the Earth may be preferred. In such cases the relative velocity (i.e., the velocity of the object relative to the atmosphere) will serve to orient the thrust vector. Resolution of the thrust-vector components along the x,y,z axes is shown in appendix B.

The thrust magnitude for most types of problems is of the form

$$F = F(\dot{m}, I, t, \dots)$$

Any such function (or even a more complicated relation) may quite easily be inserted into the program. For many space powerplants, the rocket engine thrust equation

$$F = -\dot{m}I g_c - PA_e \tag{4}$$

is sufficient and is used as a standard in the present program.

Aerodynamic Forces

The aerodynamic forces are usually divided into the two components, lift and drag. The drag force is directed opposite to the relative wind vector, and the lift vector is perpendicular to the relative wind vector. The angles α and β , defined in the previous section, serve as the angles of attack and roll, respec-

tively. Yaw effects are not considered. Resolution of the lift and drag vectors into components along the x, y, z axes is given in appendix B.

The magnitudes of the lift and drag forces may be conveniently determined through use of a tabular group of coefficients in relatively simple equations. The lift and drag magnitudes may then be expressed (as is usual in aerodynamics) as

$$L = C_L(\alpha, N_M) q S \quad (5)$$

$$D = C_D(C_L, N_M) q S \quad (6)$$

where

$$\alpha = \alpha(t)$$

$$C_L = f_1(N_M) \sin \alpha$$

$$C_D = C_{D,0} + C_{D,i} = C_{D,0}(N_M) + f_2(N_M) C_L^2$$

$$q = \frac{1}{2} \rho (V')^2$$

$$\rho = \rho(P, T) = \rho(h)$$

If $\alpha(t)$, $C_{D,0}(N_M)$, $f_1(N_M)$, and $f_2(N_M)$ are assumed to be quadratic functions and β is assumed to be constant, the expressions for α , β , C_L , $C_{D,0}$, and $C_{D,i}$ become

$$\alpha = a_{11} + a_{12}t + a_{13}t^2$$

$$\beta = \beta_0$$

$$C_L = (a_{21} + a_{22}N_M + a_{23}N_M^2) \sin \alpha$$

$$C_{D,0} = a_{31} + a_{32}N_M + a_{33}N_M^2$$

$$C_{D,i} = (a_{41} + a_{42}N_M + a_{43}N_M^2) C_L^2$$

where the quadratic constants $a_{i,j}$ may have different values for different regions of the independent variables t and N_M .

It should be remembered that these choices are arbitrary and are not restrictive because other functions may easily be used by simply changing the equations where they appear in the program. In fact, any propulsion system and aerodynamic configuration can presumably be incorporated by writing proper thrust and aerodynamic subroutines.

Pressure, temperature, and density are determined as functions of altitude in accordance with the U.S. Standard Atmosphere, 1962. The atmospheric data

are in the form of a short table, which may be altered conveniently to account for a different atmospheric model.

Other Forces

The \vec{X} forces may be any forces such as electrostatic, magnetic, or solar radiation pressure that affect the trajectory. While these forces are not considered further herein, their inclusion would usually be feasible and would be similar to thrust, lift, and drag.

METHOD OF SOLUTION

A description of several numerical integration techniques and their relative merits are contained in reference 6. A straightforward method for finding the position of the object as a function of time is to integrate the total acceleration of the object expressed in rectangular components. An example of this method is Cowell's method (ref. 6).

However, when the system under investigation consists of two nonoblate bodies (one of which is the object) with no forces other than gravitational attraction forces, an exact analytical solution for the motion of the body exists. Further, if the conditions of the actual problem are such as to approximate the two-body problem closely, another approach is to use the exact two-body solution as a basis and simply integrate the changes in the two-body parameters, since they should be slowly varying. This technique, sometimes called the "variation of parameters," will be referred to as "integration of orbit elements."

Since problems both remote and near to the exact two-body problem are encountered in orbit mechanics and since either type of problem is solved more efficiently by using the technique most suitably applicable, it was considered desirable to use either of the previously mentioned integration techniques at will. Accordingly, two methods of integration are provided in the program, namely, rectangular coordinates and orbit elements.

Integration Variables

To use either of these integration techniques, it is necessary to select a suitable set of variables. Because a differential equation may determine the mass of the object (i.e., spacecraft), mass has been selected as a variable to be integrated. Selection of the remaining parameters follows in the subsequent paragraphs.

Rectangular coordinates. - In the first technique, the total acceleration components \ddot{x} , \ddot{y} , and \ddot{z} are integrated to obtain x , y , and z where x , y , and z are the rectangular components of the origin to object radius \vec{r} . The positive x -axis points in the direction of the mean vernal equinox of 1950.0. The positive y -axis lies in the mean equator of 1950.0 and is perpendicular to and counterclockwise from the positive x -axis. The z -axis points north and

completes the righthanded orthogonal set. The integration in rectangular coordinates involves numerical solution of three second-order differential equations; that is, a double integration is required for integrating the accelerations to obtain velocities and the velocities to obtain positions. The rectangular variables have advantages of complete generality and a minimum amount of computing per step.

Orbit elements. - In the variation-of-parameters technique, a set of six independent two-body parameters called orbit elements are integrated. These six parameters may be arbitrarily chosen from a host of possibilities. The set selected for this program is composed of the eccentricity e , the argument of pericenter ω , the equatorial longitude of ascending node Ω , the inclination of the orbit plane to the equatorial plane i , the mean anomaly M , and the semilatus rectum p . The transformation equations from orbit elements to rectangular coordinates are given in appendix C.

The integration of orbit elements requires the numerical solution of six first-order differential equations. The rather involved transformation by which the three second-order differential equations in \ddot{x} , \ddot{y} , and \ddot{z} are reduced to six first-order equations in \dot{e} , $\dot{\omega}$, $\dot{\Omega}$, \dot{i} , \dot{M} , and \dot{p} is contained in reference 7. Integration in orbit elements is frequently advantageous because the smaller orbit-element derivatives may permit larger integration intervals that result in fewer steps. In the special case of two-body motion, the derivatives are zero (except \dot{M} , which is a constant).

Mathematical difficulties may arise occasionally with most sets of orbit elements. In particular, for the selected set, these occur when e approaches unity (parabolic trajectory), which causes a loss of numerical accuracy in the frequently used quantity $(1 - e^2)$, and when an asymptote is approached too closely, which causes numerical difficulties in the iterative solution for eccentric anomaly from Kepler's equation. The selected solution to these difficulties is to shift temporarily to rectangular-coordinate integration whenever the difficulty arises.

Integration Method

It is clear that regardless of the choice of integration technique, the magnitudes of the derivatives of the variables to be integrated may vary considerably along the trajectory. With fixed step size (constant intervals in time), the integration scheme will take unnecessary steps in the regions where the changes in the derivatives are small and thus will waste computing time and increase roundoff error. When the derivatives are large and change rapidly, a fixed step size will result in large truncation error (error due to excessive step size). Thus, in the interest of computing accuracy and economy, use of variable step size along the trajectory becomes desirable.

One of the integration schemes that allows variable step-size control to be incorporated easily is the Runge-Kutta scheme. For this and other reasons, it was decided to use a fourth-order Runge-Kutta method with variable step-size control.

Truncation error and step size may be controlled by examining the relative errors between the fourth-order Runge-Kutta integration scheme and a lower-order integration procedure. The arbitrarily chosen low-order integration scheme was an unequal-interval Simpson rule method. Details of the fourth-order Runge-Kutta integration method and the step-size control are given in appendix D. Roundoff error may be reduced by accumulating the integration variables in double precision.

Origin Translation

As noted previously, machine computing time and roundoff error may be minimized by maximizing the integration interval. The largest intervals are possible in orbit elements when the celestial body at the problem origin is the one that has the greatest influence on the vehicle motion. For this and sometimes other reasons, it may become desirable to translate the problem origin occasionally as the vehicle moves along its path.

Such translations of the origin may be made when the object enters a body's "sphere of influence," that is, the sphere about a body within which the greatest influence upon the object is due to forces originating from that particular body. In this program, the orientation of the coordinate system is always aligned with the system determined by the Earth's mean equator and equinox of 1950.0, as is standard in astronomy.

THE CODE AND ITS USAGE

The stated problem was programmed in FORTRAN routines that are separately designed to accomplish one task but when combined form a complete program. This feature facilitates modifications.

The program is labeled as a general-purpose code, but an efficient general-purpose code cannot be a reality. As a result, this code is not especially general, but an attempt has been made to retain efficiency and to provide for easy modification of the routines to recover generality as needed. For example, the program is an "open system"; that is, it solves an initial-value problem. There is no link provided to obtain specific end conditions. Provision of this link is left to the user for his specific needs. In particular, when certain end conditions of a trajectory are to be met by determining the correct initial conditions (two-point boundary-value problem), the user may program an iteration scheme to compute initial conditions from end conditions of previous runs. Figure 1 is a simplified diagram that shows how the various major subprograms (and exits) are arranged.

In the following sections, the program is sometimes discussed in terms of the FORTRAN variables and routines. A glossary of these variables is given in appendix E.

Ephemerides

To determine the position of each celestial body, there is offered a choice between ellipses and a precision ephemeris. Any appropriate ellipse data may be used, and an example of such data is given in table I.

The precision-ephemeris tape that is used in the program was so made that position and velocity were obtainable through the use of a fifth-order polynomial whose coefficients are stored on tape. The details concerning the making of the tape and its structure are given in appendix F. This master tape is a merged ephemeris containing all the planets (except Mercury), the Moon, and the Earth-Moon barycenter from October 25, 1960 to about 2000 (except for the Moon, which has an ending date of 1970).

Direct use of the master merged ephemeris tape would, in general, waste computing time, since excess tape handling would occur in order to bypass data not required for the particular problem. To minimize tape handling during execution, a shorter merged ephemeris containing only that data needed for a specific problem is constructed at execution time. Several of these working ephemerides may be constructed before the integration of the problem. (Several problems may be loaded simultaneously with the same ephemeris, or each problem may require a distinct ephemeris, or several ephemerides may be desired for a single problem.)

Multistage Vehicles

The code is designed to handle the case of multistage vehicles in the following way: The stage data for all stages is intended to be loaded simultaneously. This results in several initial values of those parameters classified as stage parameters. Also, this may be expensive in terms of machine storage if either the number of stage parameters or number of stages is large. Therefore, only parameters of a basic group were defined to be arrays, and the number of stages was limited to 10. This group is composed of values for the initial mass, propellant flow rate, vacuum specific impulse, engine exit area, aerodynamic reference area, burning time, initial integration step size, and an input identification number. The input identification number is a provision that allows other parameters to be loaded just prior to integration of a particular stage.

Step-Size, Output, and Termination Controls

Truncation error and step size are controlled by computing the relative errors between the Runge-Kutta integration and the lower-order integration procedure. If the greatest relative error between the methods is greater than a maximum limit (ERLIMT), the integration step will be repeated after a smaller step size is computed. In either case, a new step size is computed from the relative errors of the previous steps and is intended to result in an error that is close to a reference value (EREF). Further, the step size may then be reduced by the output controls. In any case, a step can be no larger than three times the size of the previous successful step. (See appendix D.)

Output is sometimes desired at specific points along the trajectory, while at other times this is unimportant. This option is provided for the user so that he may choose output to occur at equal intervals in step number or equal time intervals (which places a constraint on the step size). Also, he may choose to change from one mode to another along the trajectory. These choices of output spacing are effected through the use of the FORTRAN variables MODOUT, DELMAX, STEPS, and TMIN, which is explained under the MODOUT entry of table II, a table of program control parameters.

In addition to the output control discussed in the previous paragraph, there is another facility that may be quite useful. The integration process may be interrupted at an arbitrary point along the trajectory where the point in question is not necessarily a specific time. For instance, it may be desirable to interrupt the flight at a specific altitude, velocity, dynamic pressure, and so forth. If the point is indeed attained along the path (it may not be), output occurs, input cards may be read in, and a decision is made whether to continue the stage, terminate the stage, or terminate the flight. The control of this facility is described under the entries in table II for LOOKX, XLOOK, LOOKSW, SWLOOK, and END.

Computer Output

A basic output format was programed to serve as a basis for modification and is illustrated in table III. It is intended that a user of the code modify the output to suit his purpose. In addition to examining the normal output, it is sometimes desirable to examine the error-control data such as the relative errors in the integration variables along the path. These data are printed as a single block after completion of a stage if the sign of the input error reference value EREF is negative. The sign of EREF is irrelevant in the error-control portion of the program, since its absolute value is taken.

Computer Input

The user has a choice of three possible sets of input data that specify position and velocity: (1) six orbital elements, (2) three Cartesian components of velocity and position, and (3) latitude, longitude, azimuth, elevation, velocity, altitude, and time.

The third set mentioned is programed for the Earth only, where the latitude and longitude are the geocentric latitude and longitude measured from the equator and Greenwich, respectively. The azimuth angle is measured in a plane tangent to the sphere of radius r at the point on the sphere determined by the geocentric latitude and longitude, and relative to the local meridian, positive eastward from north. The elevation angle is then measured in a plane normal to the tangent plane, positive outward (sketch (b)). The tangent plane is taken to be horizontal with the effects of oblateness and rotation considered if these effects are "on." If oblateness and rotation are "off," the horizontal is perpendicular to the radial direction. This input option ignores the correction between universal time and ephemeris time and between the instantaneous equator and equinox and the mean equator and equinox of 1950.0.

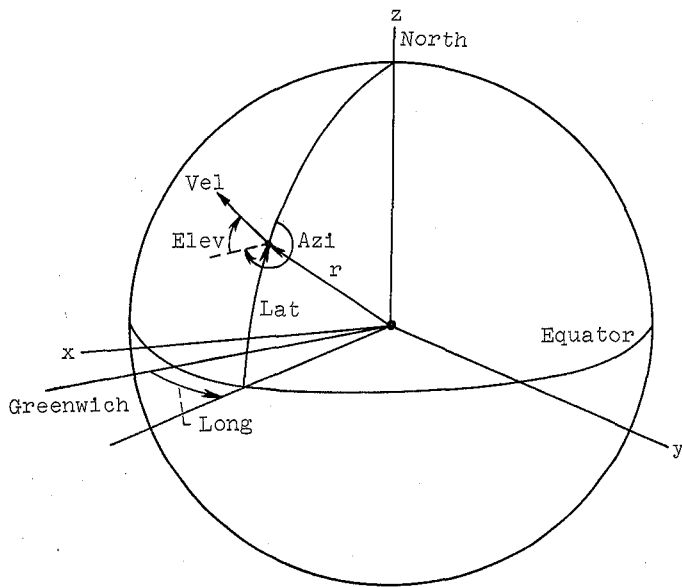

Long = longitude measured from Greenwich in Earth's equatorial plane, positive east

Lat = latitude, measured positive north, geocentric

Azi = azimuth angle, measured east from north from local meridian

Elev = elevation angle, positive outward

Vel = vehicle's initial velocity

r = radius of vehicle from Earth's center

(b)

A list of input instructions is contained in appendix G along with an input check list.

The input routine described in reference 8 was used because of its simplicity; however, another input routine may be used if it is desired.

CODING

General

Appendix H contains the code listing of the program. A magnetic tape is available (from Lewis) so that the code listing in printed form and/or on cards can be reproduced. In addition, the tape contains the merged ephemeris data in proper format for use with the code.

Some of the FORMAT statements are of the G-type. These statements will print output in I, E, or F format depending on the nature of the variable. Fixed-point variables will take the I format, while floating-point variables will assume the F format unless the magnitude of the variable falls outside the useful F range, in which case the E format is used. FORTRAN facilities that do not accept the G-type format statements may easily substitute E-type formats.

A condensed description of the program supervisory control is shown in the flow diagram of figure 2. Table IV is a map of COMMON allocation (blanks are left for the user) and table II contains a description of the program control parameters. The elements of the integration variable array (XPRIM) are given in table V. The assumed values of the astronomical constants are given in table VI. These values are consistent with those given in reference 9.

Examples

Two examples of code usage are presented. The first example, which is described in the following paragraph, is a problem of raising a low-altitude satellite into a 24-hour orbit by using tangential, low acceleration. The other example is a more complex problem involving a ground-launched lunar probe with a three-stage rocket, which is described in appendix I. Both problems were selected to illustrate the usage of the program rather than to attempt a detailed analysis of the example problem.

For Example I for low-tangential thrust, the trajectory to be determined is that used to raise a 3850-kilogram package from an initial 300-statute-mile circular equatorial orbit to a 24-hour orbit using a 60,000-watt nuclear electric system with a specific impulse of 2540 seconds and an overall efficiency of 40 percent. The required engine parameters may be calculated as follows:

Thrust force:

$$F = \frac{2P_w \eta}{I g_c} = \frac{2 \times 60,000 \times 0.4}{2540 \times 9.80665} = 1.927 \text{ newtons}$$

Initial acceleration:

$$\frac{F}{m_0} = \frac{1.927}{3850} = 5.0051948 \times 10^{-4} \text{ m/sec}^2$$

Propellant flow rate:

$$-\dot{m} = \frac{F}{I g_c} = \frac{1.927}{2540 \times 9.80665} = 7.7361935 \times 10^{-5} \text{ kg/sec}$$

A detailed account is given in the following paragraphs for the solution of this problem by the prescribed program. Only those features of the program that have a direct bearing on this particular problem are discussed. Additional program features are discussed in the account of the second example problem. It may prove beneficial to refer to figure 2 during these two discussions. Also, all statement numbers referred to in the following text correspond to the program listing in appendix H.

It is assumed in the program that all memory data stores are cleared (set equal to zero) before operation begins. Control begins when the main program is entered. Then a set of so-called "standard data" is "initialized" by executing SUBROUTINE STDATA. Before initializing, STDATA clears that area of COMMON C no longer needed.

The next step is calling for input at statement 8. The following list of parameters constitutes the input:

Parameter	FORTRAN name	Value
Initial mass, m_0 , kg	RMASS	3850
Semilatus rectum, p , m	P	6.86×10^6
Specific impulse, I , sec	SIMP	2540
Flow rate, \dot{m} , kg/sec	FLOW	7.7361935×10^{-5}
Time limit, sec	TB	^a 42590.2
Initial step size, sec	DELT	^a 1500
Step number limit, steps	STEPMX	^a 2000
Frequency of output, steps/output	STEPS	^a 200

^aAssumed value.

Variables such as eccentricity and mean anomaly that are initially zero are not included in this list, since all memory data stores are initially zero.

In accordance with the input routine of reference 8, the input cards may appear as

```

$DATA=1, $TABLE, 83=RMASS, 718=P, 103=SIMP,          $$ IDENTIFICATION AND
93=FLOW, 143=DELT, 73=TB, 26=STEPMX, 27=STEPS/      $$ TABLE DEFINITION
                                                    $$
RMASS=3850, SIMP=2540, FLOW=7.7361935E-5 $$ VEHICLE MASS, ISP, MASS FLOW
P=6.86E6, TB=42590.2, STEPMX=2000          $$ SEMILATUS-RECTUM, TIME LIMIT, STEP LIMIT
DELT=1500, STEPS=200                       $$ INITIAL STEP SIZE, OUTPUT EVERY 200TH STEP

```

where the entries between the \$TABLE and slash (/) reference the subsequent entries to the second argument C of the calling statement. Thus, for example, STEPS is equivalent to C(27), the 27th location from the beginning of COMMON C.

Part 11 of SUBROUTINE ORDER computes the gravitational constants μ and $\sqrt{\mu}$. Next, SUBROUTINE STAGE is called where the stage data for the first (and only) stage are moved into the proper stores for use in the SUBROUTINE NBODY. The vacuum value, PUSHO, for the thrust is computed, and then SUBROUTINE NBODY is called to integrate the path.

The next sequence is that of integrating the first two steps. These two steps are of equal size and are integrated before an error check is made. If the first two steps are satisfactory (determined by statement 25), the remaining steps are integrated while the relative error is being checked at the end of each step. Parts 1 and 5 of NBODY are concerned solely with this starting phase. Part 1 sets up the starting sequence and causes the initial conditions to appear on the output sheet. Parts 2 to 4 accomplish the Runge-Kutta integration for a single step.

The derivatives used in the integration are obtained from SUBROUTINE EQUATE. The first half of this subroutine finds the Cartesian coordinates and velocities through use of Kepler's equation. SUBROUTINE THRUST is called to determine the components of the thrust acceleration in the Cartesian coordinate system. (After

control is returned to SUBROUTINE EQUATE, the thrust acceleration is resolved into circumferential, radial, and normal components.) Finally, the derivatives of the orbit elements are calculated, and a return is made to NBODY.

After the Runge-Kutta integration is performed, the error check is made in part 5B (part 6 after the starting sequence) by computing the difference between the Runge-Kutta integration and the low-order integration. SUBROUTINE ERRORZ is called to determine the largest of the relative errors. If the largest of the relative errors is greater than the limit value, ERLIMIT (set in STDATA), part 8, which computes a smaller step size for the same interval, is entered and control is returned to part 1. If the greatest relative error is smaller than the limit value, part 7, which advances the variables of integration, is entered and calls SUBROUTINE STEP to compute the next step size and print out the variables of the first step. Part 7 also counts the revolutions past the x-axis and adjusts the argument of pericenter and mean anomaly to within $\pm\pi$ to retain accuracy in the sine-cosine routines. If the step size exceeds 1/2 revolution, the revolution count may be short by an integral number. Control is finally transferred to part 1 to begin computation of the next step.

The problem is terminated when the time limit TTB is reached. This check is done in SUBROUTINE STEP. Had the problem exceeded the step number limit STEPMX, it would have terminated at that point. In either case, control is returned to the main program to begin the next problem. When no data for another problem are given, the execution is terminated (i.e., control is returned to the monitor by SUBROUTINE INPUT as a result of an end-of-file on tape 7). The output of the last step is

```
STEP= 822. + 46.    ECCENTRICITY= 2.37439758E-04  OMEGA= 1.57424484
TIME= 42590.200    SEMILATUS R.= 6898546.50      TRU A= 1.57107785
JDAY= 2440000.4927  MEAN ANOMALY= 1.57060298      NODE= 0
ALFA= 0            PATH ANGLE= 1.36042929E-02  INCL= 0
```

```
V= 7601.36401      R= 6898546.94      REFER=EARTH ORBIT 1
VX= 26.5485928     X=-6898498.81     RMASS= 3846.70511
VY=-7601.31769     Y=-25731.9050    REVS.= 7.50059360
VZ=-0              Z=-0              DELT= 312.139160
```

The time histories of several trajectory parameters for this example are shown as solid lines in figure 3. The oscillations of the eccentricity and mean anomaly cause a rather small step size, as noted in the figure. To indicate how exercising care in selecting the input can increase the computational efficiency, the same problem may again be run with the following initial values (according to ref. 10) of eccentricity and mean anomaly:

$$e_0 = \frac{2(F/m_0)p^2}{\mu}$$

$$M_0 = \frac{\pi}{2} - 3e_0 - \frac{e_0 V_0}{2I g_c}$$

The input cards for this case make use of the algebraic properties of the input routine to compute the desired value of these parameters. The cards are

```

$DATA=1,$TABLE,83=RMASS,718=P,103=SIMP,          $$ IDENTIFICATION AND
93=FLOW,143=DELTA,73=TB,26=STEPMX,27=STEPS/      $$ TABLE DEFINITION
                                                    $$
RMASS=3850,SIMP=2540,FLOW=7.7361935E-5 $$ VEHICLE MASS, ISP, MASS FLOW
P=6.86E6,TR=42590.2,STEPMX=2000                $$ SEMILATUS-RECTUM, TIME LIMIT, STEP LIMIT
DELTA=1500,STEPS=200                            $$ INITIAL STEP SIZE, OUTPUT EVERY 200TH STEP
$TABLE,713=E,717=MA,714=OMEGA/ E=2*5.0051948E-4*P*P/3.983667E14 $$ ECCENTRICITY
MA=-7620.429/SIMP/9.80665-6*E+3.1415926/2,STEPS=5 $$ MEAN ANOMALY, OUTPUT CONTROL
OMEGA=-2*E-MA $$ ADJUST OMEGA (TO START PATH ON THE X-AXIS)

```

The dashed lines in figure 3 show the time histories of the same trajectory parameters when initial values of e and M given immediately preceding are used. The increase in average step size is 15 to 1. To compare the accuracy of this approximation with the exact case ($e_0 = M_0 = 0$), the final time was chosen when the corresponding orbit positions were identical (when the true anomalies were equal). At $t = 42,590.2$ seconds, the orbit positions are nearly identical, and, at this time, the values of position and velocity may be compared as follows:

	Case A: $e_0 = M_0 = 0$	Case B: e_0 and $M_0 \neq 0$
Radius, m	6898546.94	6898546.94
Velocity, m/sec	7601.36401	7601.36407
Number of steps	822	55

For most purposes the two answers would be accepted as equivalent, and case B would be preferred because less computer time is required.

Lewis Research Center
National Aeronautics and Space Administration
Cleveland, Ohio, July 12, 1963

APPENDIX A

SYMBOLS

\vec{A}	relative angular momentum per unit mass, $\vec{r} \times \vec{V}$ (appendix B)
A_e	engine exit area, m^2
$a_{i,j}$	coefficients for quadratic functions
C_D	total drag coefficient
$C_{D,i}$	induced drag coefficient
$C_{D,0}$	zero angle-of-attack drag coefficient
C_L	lift coefficient
D	drag force, newtons
\mathcal{D}	fourth harmonic coefficient in oblateness equations
E	eccentric anomaly, radians
e	eccentricity
F	thrust force, newtons
f_1, f_2	functions of Mach number
g_c	gravitational conversion factor, 9.80665 m/sec^2 (sometimes referred to as standard Earth gravity)
H	third harmonic coefficient in oblateness equations
h	altitude above Earth's surface, m
I	vacuum specific impulse, sec
i	orbit inclination to mean equator of 1950.0, radians
J	second harmonic coefficient in oblateness equations
k^2	universal gravitational constant, $1.32452139 \times 10^{20}$, $m^3/(\text{sec}^2)(\text{sun mass units})$
L	lift force, newtons
M	mean anomaly, radians
m	object mass, kg

m_i	mass of i^{th} perturbing body, sun mass units
m_r	mass of reference body plus m , sun mass units
N_M	Mach number
P	atmospheric pressure, newtons/m ²
\vec{P}	$\vec{V}' \times \vec{A}$ (appendix B)
P_w	power, w
p	semilatus rectum, m
q	dynamic pressure, $\frac{1}{2} \rho (V')^2$, newtons/m ²
R_r	radius of reference body, m
r	radius from origin to object, m
r_i	radius from origin to i^{th} perturbing body, m
S	aerodynamic reference area, m ²
T	temperature, °K
t	time, sec
U	gravitational potential
U_x, U_y, U_z	x, y, z accelerations due to gravity, m/sec ²
V	absolute velocity, m/sec
V'	relative velocity, m/sec
v	true anomaly, radians
X	forces acting on object other than gravity, thrust, lift, drag, and perturbations due to perturbing bodies
x, y, z	components of r , m
α	angle between thrust and velocity vectors (sketch (a)), deg
β	angle of rotation of thrust out of orbit plane (sketch (a)), deg
η	power efficiency factor
μ	$k^2 m_r$
ρ	atmospheric density, kg/m ³

ω argument of pericenter, radians

Ω equatorial longitude of ascending node, radians

Subscript:

0 initial value

APPENDIX B

VECTOR RESOLUTION

Relative Velocity

The relative velocity is defined as the velocity of the object with respect to the origin body. If the origin body is assumed to rotate about the z-axis, this velocity is given by

$$\vec{V}' = \vec{V} - \vec{\omega} \times \vec{r} \quad (\text{B1})$$

In x,y,z component form,

$$V'_x = V_x + \omega y \quad (\text{B2a})$$

$$V'_y = V_y - \omega x \quad (\text{B2b})$$

$$V'_z = V_z \quad (\text{B2c})$$

In the following sections, the atmosphere of the origin body is assumed to rotate as a solid body at the rate $\vec{\omega}$.

Thrust Resolution Along x,y,z Axes

The thrust direction is specified with respect to the relative velocity vector \vec{V}' by the angles α and β , as shown in sketch (a) (p. 4). For resolution of thrust vector into x,y,z components, it is convenient to define vectors \vec{A} and \vec{P} normal to and within the r, \vec{V}' plane, respectively, such that \vec{V}' , \vec{A} , and \vec{P} form an orthogonal set. Thus,

$$\vec{A} \equiv \vec{r} \times \vec{V}' = \text{relative angular momentum per unit mass} \quad (\text{B3})$$

$$\vec{P} \equiv \vec{V}' \times \vec{A} \quad (\text{B4})$$

The thrust vector can then be resolved in the $\vec{V}', \vec{A}, \vec{P}$ set as:

$$\vec{F} \cdot \vec{V}' = FV' \cos \alpha \quad (\text{B5a})$$

$$\vec{F} \cdot \vec{A} = FA \sin \alpha \sin \beta \quad (\text{B5b})$$

$$\vec{F} \cdot \vec{P} = FP \sin \alpha \cos \beta \quad (\text{B5c})$$

Solving for \vec{F} yields

$$\vec{F} = \frac{F}{P^2} (V' \cos \alpha \vec{A} \times \vec{P} + A \sin \alpha \sin \beta \vec{P} \times \vec{V}' + P \sin \alpha \cos \beta \vec{P}) \quad (\text{B6})$$

or, in x,y,z component form,

$$F_x = \frac{F}{P^2} \left[V' \cos \alpha (A_y P_z - A_z P_y) + A \sin \alpha \sin \beta (P_y V'_z - P_z V'_y) + P \sin \alpha \cos \beta P_x \right] \quad (B7a)$$

$$F_y = \frac{F}{P^2} \left[V' \cos \alpha (A_z P_x - A_x P_z) + A \sin \alpha \sin \beta (P_z V'_x - P_x V'_z) + P \sin \alpha \cos \beta P_y \right] \quad (B7b)$$

$$F_z = \frac{F}{P^2} \left[V' \cos \alpha (A_x P_y - A_y P_x) + A \sin \alpha \sin \beta (P_x V'_y - P_y V'_x) + P \sin \alpha \cos \beta P_z \right] \quad (B7c)$$

Aerodynamic Lift and Drag Resolution Along x,y,z Axes

The drag vector \vec{D} is aligned with the relative velocity vector \vec{V}' and is therefore given in x,y,z components as

$$\vec{D} = -D \frac{V'_x}{V'} - D \frac{V'_y}{V'} - D \frac{V'_z}{V'} \quad (B8)$$

The lift vector \vec{L} may be resolved into components along the previously defined orthogonal set \vec{V}' , \vec{A} , and \vec{P} by the following relations:

$$\vec{L} \cdot \vec{V}' = 0 \quad (B9a)$$

$$\vec{L} \cdot \vec{A} = LA \sin \beta \quad (B9b)$$

$$\vec{L} \cdot \vec{P} = LP \cos \beta \quad (B9c)$$

Solving for \vec{L} yields

$$\vec{L} = \frac{L}{P^2} (A \sin \beta \vec{P} \times \vec{V}' + P \cos \beta \vec{P}) \quad (B10)$$

or, in x,y,z component form,

$$L_x = \frac{L}{P^2} \left[A \sin \beta (P_y V'_z - P_z V'_y) + P \cos \beta P_x \right] \quad (B11a)$$

$$L_y = \frac{L}{P^2} \left[A \sin \beta (P_z V'_x - P_x V'_z) + P \cos \beta P_y \right] \quad (B11b)$$

$$L_z = \frac{L}{P^2} \left[A \sin \beta (P_x V'_y - P_y V'_x) + P \cos \beta P_z \right] \quad (B11c)$$

APPENDIX C

TRANSFORMATION EQUATIONS FROM ORBIT ELEMENTS
TO RECTANGULAR COORDINATES

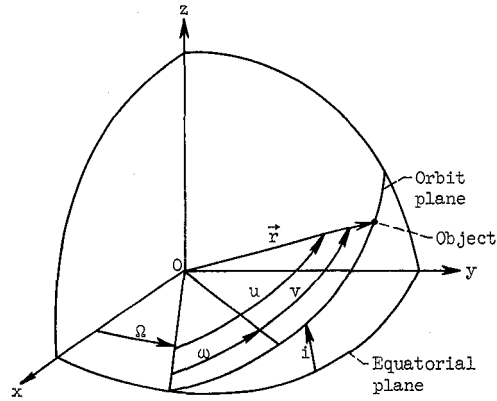

(c)

From spherical trigonometry used in reference to the celestial sphere shown in sketch (c), the following relations may be derived for the position coordinates:

$$x = r(\cos \Omega \cos u - \sin \Omega \sin u \cos i) \quad (C1a)$$

$$y = r(\sin \Omega \cos u + \cos \Omega \sin u \cos i) \quad (C1b)$$

$$z = r(\sin u \sin i) \quad (C1c)$$

where

$$r = \frac{p}{1 + e \cos v} \quad (C2a)$$

$$u = \omega + v \quad (C2b)$$

and v can be obtained from

$$\cos v = \frac{\cos E - e}{1 - e \cos E} \quad (C2c)$$

and

$$M = E - e \sin E \quad (C2d)$$

The velocity components may be obtained by differentiating the position equations using the two-body relations $\dot{u} = \dot{v} = \frac{\sqrt{\mu p}}{r^2}$ and $\dot{r} = \sqrt{\frac{\mu}{p}} e \sin v$:

$$\dot{x} = -\sqrt{\frac{\mu}{p}} (N \cos i \sin \Omega + Q \cos \Omega) \quad (\text{C3a})$$

$$\dot{y} = \sqrt{\frac{\mu}{p}} (N \cos i \cos \Omega - Q \sin \Omega) \quad (\text{C3b})$$

$$\dot{z} = \sqrt{\frac{\mu}{p}} (N \sin i) \quad (\text{C3c})$$

where

$$N = e \cos \omega + \cos u \quad (\text{C4a})$$

$$Q = e \sin \omega + \sin u \quad (\text{C4b})$$

APPENDIX D

RUNGE-KUTTA AND LOW-ORDER INTEGRATION

SCHEMES WITH ERROR CONTROL

The Runge-Kutta formula used is of fourth-order accuracy in step size h . It is of the form

$$X \Big|_1^2 \equiv X_2 - X_1 = \frac{1}{6} (k_1 + 2k_2 + 2k_3 + k_4) \quad (D1)$$

where

X = a dependent variable

$X \Big|_1^2$ = increment in the dependent variable

h_2 = increment in the independent variable t

$$k_1 = h_2 \dot{X}_2(t_1, X_1)$$

$$k_2 = h_2 \dot{X}_2 \left(t_1 + \frac{h_2}{2}, X_1 + \frac{k_1}{2} \right)$$

$$k_3 = h_2 \dot{X}_2 \left(t_1 + \frac{h_2}{2}, X_1 + \frac{k_2}{2} \right)$$

$$k_4 = h_2 \dot{X}_2(t_1 + h_2, X_1 + k_3)$$

A lower-order formula may be found by utilizing the three derivatives at $t = t_0, t_1$, and t_2 . If $h_1 = t_1 - t_0$ and $h_2 = t_2 - t_1$, the following Lagrangian interpolation formula gives the derivative at any time $t_0 \leq t \leq t_2$:

$$\dot{X} \equiv \dot{X}_0 \frac{(t - t_1)(t - t_2)}{h_1(h_1 + h_2)} - \dot{X}_1 \frac{(t - t_0)(t - t_2)}{h_1 h_2} + \dot{X}_2 \frac{(t - t_0)(t - t_1)}{h_2(h_1 + h_2)} \quad (D2)$$

Integration of this equation from t_1 to t_2 yields

$$X' \Big|_1^2 = \frac{1}{6} \left[\left(\frac{h_2}{h_1} \right)^2 \left(\frac{-h_2}{1 + \frac{h_2}{h_1}} \right) \dot{X}_0 + \frac{h_2}{h_1} (h_2 + 3h_1) \dot{X}_1 + \left(2h_2 + \frac{h_2}{1 + \frac{h_2}{h_1}} \right) \dot{X}_2 \right] \quad (D3)$$

The difference in the increments over the interval h_2 between the Runge-Kutta scheme and the low-order scheme may be divided by a nominal value of the dependent variable \bar{X} to obtain the relative error δ_2 . Thus,

$$\delta_2 = \left| \frac{X'_1 - X_1}{\bar{X}} \right|^2 \quad (D4)$$

The error is expected to vary as approximately the fifth power of h , which leads to

$$\delta = Ah^5 \quad (D5a)$$

(where A is a suitable coefficient) or in the logarithmic form

$$\log \delta = A' + 5 \log h \quad (D5b)$$

where

$$A' = \log A \quad (D6a)$$

Let it be assumed that A' will vary linearly with t , the variable of integration. Then A' at a time corresponding to t_3 can be found from A' at two previous points t_1 and t_2 as

$$A'_3 = A'_2 + \frac{A'_2 - A'_1}{t_2 - t_1} (t_3 - t_2) \quad (D6b)$$

and if $h_3 = (t_3 - t_2)$ and $h_2 = (t_2 - t_1)$,

$$A'_3 = A'_2 + (A'_2 - A'_1) \frac{h_3}{h_2} \quad (D6c)$$

and on this basis δ_3 would be predicted to be

$$\log \delta_3 = A'_3 + 5 \log h_3 \quad (D7)$$

It is desired that δ_3 should approximate $\bar{\delta}$, the reference error; therefore,

$$\log h_3 = \frac{1}{5} (\log \bar{\delta} - A'_3) \quad (D8)$$

Each dependent variable has an associated relative error and would lead to computation of a different step size for each variable; however, the maximum relative error of all variables may be selected for δ . Obviously, inaccurate predictions of step size can occur when the maximum relative error shifts from one variable to another or when any sudden change occurs. When a step size produces

an excessively large error ($\delta > \delta_{\text{limit}}$), a reduced step size must be used. It may be obtained from the reference error δ as

$$h_3 = \exp\left[\frac{1}{5} (\log \delta - A_2')\right] \quad (\text{D9})$$

Starting the integration. - The Runge-Kutta scheme is simple to start, since integration from X_n to X_{n+1} requires no knowledge of X less than X_n . Since the error control coefficient A has no value at $t = 0$, a prediction of the second step size is difficult. To overcome this difficulty, two equal size first steps may be made before checking the error. The A for the first step may be arbitrarily set equal to the A for the second step so that h_3 may be predicted. The low-order integration scheme equation in this case becomes, with $h_2 = h_1$,

$$\left. X' \right|_1^2 = \frac{h_1}{3} (\dot{X}_0 + 4\dot{X}_1 + \dot{X}_2) \quad (\text{D10})$$

Failures. - Should two consecutive predictions of the same step fail to produce an error δ less than δ_{limit} , a return to the starting procedure will be made with a third prediction on step size, which is no larger than one-half of the second estimate. The step-size control described here will operate stably with nearly constant error per step only for a well-behaved function. For most problems it will repeat a step occasionally to reduce a large error, and on sharp corners it will restart. This action is not regarded as objectionable. The objective is to attain a desired level of accuracy with a minimum total number of steps.

APPENDIX E

GLOSSARY OF VARIABLES

VARIABLE	COMMON LOCATION	DEFINITION
A (700)	C(11)	ARRAY CONTAINING THE INITIAL DATA AND THE PROGRAM CONTROL VARIABLES
A1	B(10)	ERROR CONTROL PARAMETER DEFINED BY EQ. (D6A) AT T(1)
A2	B(11)	ERROR CONTROL PARAMETER DEFINED BY EQ. (D6A) AT T(2)
ACOE1	B(12)	INTERPOLATION POLYNOMIAL COEFFICIENT FOR VARIABLE STEP SIZE, EQ. (D3)
ACOE2	B(13)	INTERPOLATION POLYNOMIAL COEFFICIENT FOR VARIABLE STEP SIZE, EQ. (D3)
ACOE3	B(14)	INTERPOLATION POLYNOMIAL COEFFICIENT FOR VARIABLE STEP SIZE, EQ. (D3)
AEXIT1 (10)	A(103)	ENGINE EXIT AREAS FOR AT MOST 10 STAGES, M**2
AEXIT	B(3)	AEXIT1(NSTAGE)
AK (3)	A(51)	RUNGE KUTTA COEFFICIENTS, SET IN STDATA
ALPHA	A(49)	ANGLE BETWEEN VELOCITY AND THRUST VECTORS, SEE SKETCH (A)
ALT	A(4)	VEHICLE ALTITUDE ABOVE EARTH, M
AM	B(90)	TOTAL VEHICLE ANGULAR MOMENTUM PER UNIT MASS, M**2/ SEC
AMASS (30)	A(347)	PERMANENT LIST OF BODY MASSES IN ORDER OF PNAME LIST, SET IN STDATA, MASSES FROM ELIPS DATA BEGIN AT AMASS (21), SUN MASS UNITS
AMC (3)	B(87)	X, Y, Z COMPONENTS OF ANGULAR MOMENTUM PER UNIT MASS, **2)/SEC
AMSQRD	B(91)	SQUARE OF TOTAL ANGULAR MOMENTUM PER UNIT MASS, M**4/ SEC**2
AREA1 (10)	A(113)	AERODYNAMIC REFERENCE AREAS FOR AT MOST 10 STAGES, M**2
AREA	B(6)	AREA1(NSTAGE)
ASYMPT	A(7)	SEE TABLE II
ATMN	A(21)	SEE TABLE II
AU	A(29)	ASTRONOMICAL UNIT, M
AW (4)	A(55)	RUNGE KUTTA COEFFICIENTS, SET IN STDATA
AZI	A(35)	INITIAL AZIMUTH ANGLE, USED WHEN IMODE = 4, SEE SKETCH (B), DEGREES

B (800)	C(1111)	ARRAY CONTAINING INTERNAL PARAMETERS NOT UNDER USER CONTROL
BETA	A(50)	ANGLE BETWEEN VELOCITY-THRUST PLANE AND ORBIT PLANE, SEE SKETCH(A)
BMASS (8)	B(137)	BODY MASSES SELECTED FROM AMASS LIST IN SEQUENCE CORRESPONDING TO BNAME LIST
BNAME (8)	B(122)	ORDERED LIST OF BCD BODY NAMES
BODYCD (10)	A(143)	ORIGINAL UNORDERED LIST OF BCD BODY NAMES READ IN AT INPUT
BODYL (10)	B(153)	AUXILIARY ORDERED LIST OF BCD BODY NAMES
CD	A(165)	TOTAL DRAG COEFFICIENT
CDI	A(163)	INDUCED DRAG COEFFICIENT
CHAMP	B(25)	SMALLEST CRITICAL RADIUS (RBCRIT(J)) WITHIN WHICH OBJECT LIES
CINCL	B(55)	COSINE OF INCLINATION
CIRCUM	B(82)	CIRCUMFERENTIAL COMPONENT OF TOTAL PERTURBATIVE ACCELERATION,M/SEC**2
CL	A(164)	LIFT COEFFICIENT
CLEAR	C(3)	SEE TABLE II
COEFN (192)	A(407)	STORAGE ARRAY FOR COEFFICIENTS USED TO COMPUTE ALPHA, CL,CDI,CD OR OTHER PARAMETERS
COMPA (3)	B(63)	COMPONENTS OF TOTAL PERTURBATIVE ACCELERATION ALONG X ,Y,Z AXES.
CONSU	A(31)	SEE TABLE II
CONSTU	A(32)	SEE TABLE II
COSALF	B(48)	COSINE OF ALPHA
COSBET	B(49)	COSINE OF BETA
COSTRU	B(53)	COSINE OF TRU
COSV	B(57)	COSINE OF THE ARGUMENT OF LATITUDE
D (1100)	C(2111)	ARRAY WHERE SAVED DATA IS STORED FOR LATER USE. ARRAYS A,XPRIM,AND XPRIMB MAY BE SAVED.
DELMAX	A(19)	SEE TABLE II
DEL	A(43)	OUTPUT CONTROL PARAMETER USED IN STEP
DELT1 (10)	A(133)	INITIAL STEP SIZES FOR AT MOST 10 STAGES,SEC
DELT	B(1)	DELT1(NSTAGE)
DENSITY	B(29)	ATMOSPHERIC DENSITY,KG/M**3
DONE	B(39)	CONTROL PARAMETER FROM STEP WHICH INFORMS NBODY TO STOP INTEGRATING

DRAG (3)	B(69)	X,Y,Z COMPONENTS OF THE DRAG ACCELERATION,M/SEC**2
DTOFFJ	A(23)	JULIAN DATE OF TAKEOFF
E2	B(18)	LARGEST OF THE RELATIVE ERRORS BETWEEN R-K AND LOW-ORDER INTEGRATION METHODS,EQ. (D4)
EFMRS (7)	B(130)	LIST OF BCD BODY NAMES WHOSE POSITIONS ARE TO BE DETERMINED FROM TAPE DATA
ELEV	A(36)	INITIAL ELEVATION ANGLE,USED WHEN IMODE=4, SKETCH(B), DEGREES
ELIPS (12,10)	A(167)	ELLIPSE DATA FOR PERTURBATING BODIES,READ FROM CARDS, 12 PIECES OF DATA PER BODY
EMONE	B(28)	ECCENTRICITY -1
END	A(5)	SEE TABLE II
EPAR	B(26)	SQUARE ROOT OF (ECCENTRICITY SQUARED -1)
EREF	A(13)	SEE TABLE II
ERLIMT	A(14)	SEE TABLE II
ERLOG	B(17)	NATURAL LOGARITHM OF EREF
ETOL	A(30)	SEE TABLE II
EXITA	B(392)	AEXIT(NSTAGE)/100, NEWTONS/MB
EXMODE	B(27)	ECCENTRICITY CALCULATED WHEN IMODE=3
FILE	B(22)	SEE TABLE II
FLOW1 (10)	A(83)	RATE OF PROPELLENT FLOW, KG/SEC
FLOW	B(5)	FLOW1(NSTAGE)
FORCE (3)	B(66)	X,Y,Z COMPONENTS OF THRUST ACCELERATION, M/SEC**2
GASFAC	A(46)	DEFINED IN SUBROUTINE AERO, SET IN STDATA
GEOH	B(32)	GEPOTENTIAL, M
GK2M	B(36)	GRAVITATIONAL CONSTANT,MU,OF THE SYSTEM,M**3/SEC**2
GKM	B(37)	SQUARE ROOT OF GK2M
H2	B(15)	VALUE OF DELT FOR PREVIOUS STEP
I8BODY (8)	B(177)	DEFINED IN SUBROUTINE ORDER
ICC (10)	A(153)	SEE TABLE II
IDENT (10)	A(123)	INPUT IDENTIFICATION NUMBERS ASSOCIATED WITH EACH STAGE
IMODE	A(1)	SEE TABLE II
IND (3)	A(60)	SET OF INDICES, SET IN STDATA
INDERR	B(51)	NUMBER OF SETS OF ERROR DATA, SET IN ERRORZ FOR USE IN NBODY

INLOOK	A(599)	INPUT IDENTIFICATION NUMBER FOR INPUT AFTER FINDING C (LOOKX) = XLOOK
KSUB	B(19)	INDEX OF RUNGE-KUTTA SUBINTERVALS
LAT	A(33)	INITIAL GEOCENTRIC LATITUDE, USED WHEN IMODE=4, SKETCH (B), DEGREES
LONG	A(34)	INITIAL LONGITUDE RELATIVE TO GREENWICH, USED WHEN IMODE=4, SKETCH(B), DEGREES
LOOKX	A(8)	SEE TABLE II
LOOKSW	A(9)	SEE TABLE II
ESTAGE	A(38)	TOTAL NUMBER OF STAGES INTEGRATED BEFORE RETURNING TO THE MAIN PROGRAM
MBODYS	B(42)	NUMBER OF PERTURBATING BODIES (NBDYS-1)
MODOUT	A(20)	SEE TABLE II
NBDYS	B(41)	TOTAL NUMBER OF BODIES, EXCLUDING THE VEHICLE
NCASES	A(600)	SAVED VALUE OF NCASE
NCASE	C(1)	CASE NUMBER, RAISED ONCE EACH TIME CONTROL PASSES THROUGH THE MAIN PROGRAM
NEFMRS (8)	B(185)	DEFINED IN SUBROUTINE ORDER
NEQ	A(2)	NUMBER OF EQUATIONS TO BE INTEGRATED, SET TO 8 IN STDATA
NSAVE	C(4)	SEE TABLE II
NSTAGE	A(3)	THE INDEX INDICATING THE PARTICULAR STAGE CURRENTLY BEING INTEGRATED
NSTART	B(24)	INTERNAL CONTROL IN NBDY AND EQUATE
OBLATJ	A(26)	OBLATENESS COEFFICIENT OF SECOND HARMONIC
OBLATD	A(27)	OBLATENESS COEFFICIENT OF FOURTH HARMONIC
OBLATH	A(28)	OBLATENESS COEFFICIENT OF THIRD HARMONIC
OBLATN	A(40)	SEE TABLE II
OBLAT (3)	B(75)	X,Y,Z COMPONENTS OF OBLATENESS ACCELERATION, M/SEC**2
OLDDEL	B(9)	VALUE OF DELT FOR PREVIOUS GOOD STEP
ORBELS (6)	B(116)	ARRAY OF OUTPUT VARIABLES, EITHER RECTANGULAR OR ORBIT ELEMENTS
OUTPUT	B(399)	CAUSES ABSENCE OF OUTPUT WHEN NONZERO
P (3)	B(84)	DEFINED IN EQ. (B4)

PAR (3)	B(60)	DEFINED BY EQUATIONS IN SUBROUTINE THRUST
PMAGN	B(50)	DEFINED IN EQUATION FORM BY SUBROUTINE THRUST
PNAME (30)	A(287)	PERMANENT LIST OF BODY NAMES MADE FROM PNAALIST IN SUBROUTINE ORDER, ELIPS NAMES BEGIN AT PNAME(21)
PRESS	B(33)	ATMOSPHERIC PRESSURE, MB
PSI	B(30)	PATH ANGLE, ANGLE BETWEEN PATH AND LOCAL HORIZONTAL, DEGREES
PSIR	B(398)	RELATIVE PATH ANGLE, TAKEN RELATIVE TO A ROTATING ORIGIN BODY, DEG
PUSH	A(166)	THRUST FORCE, NEWTONS
PUSHO	B(391)	VACUUM THRUST FORCE, NEWTONS
Q	B(59)	DYNAMIC PRESSURE, NEWTONS/M**2
QMAX	B(44)	MAXIMUM VALUE OF Q DEVELOPED DURING A SINGLE TRAJECTORY (SET TO ZERO WHEN CONTROL PASSES THROUGH SUBROUTINE EXTRA)
QX (3)	B(78)	X,Y,Z COMPONENTS OF PERTURBATIVE ACCELERATION DUE TO PERTURBATING BODIES, M/SEC**2
R (8)	B(102)	DISTANCES OF ALL BODIES FROM OBJECT, IN ORDER OF BNAME LIST, M
RADIAL	B(81)	RADIAL COMPONENT OF TOTAL PERTURBATIVE ACCELERATION, POSITIVE OUTWARD, M/SEC**2
RAMC (5)	B(393)	RELATIVE ANGULAR MOMENTUM PER UNIT MASS COMPONENTS, TOTAL RELATIVE ANGULAR MOMENTUM PER UNIT MASS, AND ITS SQUARE, M**2/SEC
RATM	A(22)	RADIUS OF ATMOSPHERE, M
RATMOS	B(23)	SET EQUAL TO RATM WHEN ATMN EQUALS THE REFERENCE BODY NAME, BNAME(1)
RATIO	B(58)	RATIO OF ADJACENT STEP SIZES, DELT
RB (3,8)	B(193)	X,Y,Z COMPONENTS OF DISTANCE FROM ALL BODIES TO THE OBJECT, M
RBCRIT (8)	B(145)	LIST OF SPHERE-OF-INFLUENCE RADII OF ALL BODIES IN BNAME LIST, M
RCRIT (30)	A(377)	PERMANENT LIST OF SPHERE-OF-INFLUENCE RADII CORRESPONDING TO PNAME LIST OF BODY NAMES. RADII FROM ELIPS DATA BEGIN AT RCRIT(21), M
RE	A(25)	RADIUS OF EARTH EQUATOR, M
RECALL	C(5)	SEE TABLE II
REFER (30)	A(317)	LIST OF REFERENCE BODIES CORRESPONDING TO PNAME LIST, REFERENCE BODIES FROM ELIPS DATA BEGIN AT REFER(21)
RESQRD	B(7)	SQUARE OF RE
RETURN	B(400)	CAUSES CONTROL NOT TO RETURN TO MAIN PROG. IF NONZERO

REVS	A(48)	REVOLUTION COUNTER, USED ONLY FOR OUTPUT
REVLV	B(21)	ROTATION RATE OF REFERENCE BODY WHEN ATMN=BNAME(1), RAD/SEC
RMASS1 (10)	A(73)	INITIAL MASSES FOR AT MOST 10 STAGES,KG
ROTATE	A(39)	ROTATION RATE OF A REFERENCE BODY, RAD/SEC
RSQRD	B(45)	RADIUS SQUARED OF OBJECT TO ORIGIN, M**2
SIGNAL	B(31)	SEE TABLE II
SIMP1 (10)	A(93)	SPECIFIC IMPULSES FOR AT MOST 10 STAGES, SEC
SIMP	B(2)	SIMP1(NSTAGE)
SINALF	B(46)	SINE OF ALPHA
SINBET	B(47)	SINE OF BETA
SINTRU	B(52)	SINE OF TRU
SINCL	B(54)	SINE OF INCLINATION
SINV	B(56)	SINE OF THE ARGUMENT OF LATITUDE
SPACES	B(16)	NUMBER OF EQUAL TIME UNITS UNTIL NEXT OUTPUT
SPD	A(44)	SECONDS PER DAY, SET IN STDATA, SEC/DAY
SQRDK1	A(47)	GRAVITATIONAL CONSTANT OF THE SUN, AU**3/DAY**2
SQRDK	B(35)	GRAVITATIONAL CONSTANT OF THE SUN, M**3/SEC**2
STEPMX	A(16)	SEE TABLE II
STEPS	A(17)	SEE TABLE II
STEPGO	A(41)	COUNT OF SUCCESSFUL INTEGRATION STEPS
STEPNO	A(42)	COUNT OF UNSUCCESSFUL INTEGRATION STEPS (THOSE WHICH DO NOT PASS ERROR CONTROL TEST)
SWLOOK	A(10)	SEE TABLE II
TABLT	B(20)	TIME MEASURED RELATIVE TO THE JULIAN DATE OF TAKEOFF, DAYS
TABLE (200)	C(1911)	ARRAY OF INPUT PARAMETERS AND THEIR COMMON STORE LO- CATIONS
TAPE3	C(2)	SEE TABLE II
TB (10)	A(63)	FLIGHT TIMES FOR AT MOST 10 STAGES, SEC

TDATA (6,3,7)	B(265)	COEFFICIENTS FROM EPHEMERIDES TAPE TO BE USED IN DETERMINING POSITIONS AND POSSIBLY VELOCITIES OF PERTURBATING BODIES, ONE SET FOR EACH OF 7 BODIES
TDEL (7)	B(170)	ONE-HALF OF TIME SPACING BETWEEN TWO ADJACENT ENTRIES OF LIKE BODY NAME ON EPHEMERIDES TAPE, READ FROM TAPE FOR EACH BODY
TFILE	A(6)	SEE TABLE II
TIM (7)	B(163)	TIME FOR SET OF EPHEMERIS DATA, READ FROM EPHEMERIDES TAPE, ONE FOR EACH BODY
TKICK	A(15)	INITIAL STEP SIZE OF A TRAJECTORY TO BE COMPUTED IN CLOSED-FORM, FOR USE WHEN IMODE=4, WHICH FACILITATES STARTING OF SOME TYPES OF TRAJECTORIES
TM	B(34)	ATMOSPHERIC TEMPERATURE TIMES THE RATIO OF MOLECULAR TO ACTUAL MOLECULAR WEIGHT, DEGREES KELVIN
TMAX	B(4)	SEE TABLE II
TMIN	A(18)	SEE TABLE II
TOFFT	A(24)	FRACTIONAL PART OF JULIAN DATE OF TAKEOFF, DAYS
TRSFER	B(8)	SEE TABLE II
TRU	B(40)	TRUE ANOMALY, RAD
TTEST	A(54)	SEE TABLE II
TTOL	A(45)	TIME TOLERANCE WITHIN WHICH PROBLEM TIME MINUS TMAX MUST LIE TO END STAGE
U	A(59)	ECCENTRIC ANOMALY, RAD
V	B(95)	VELOCITY OF OBJECT RELATIVE TO THE ORIGIN, M/SEC
VATM (3)	B(97)	X,Y,Z COMPONENTS OF THE RELATIVE VELOCITY, VQ,M/SEC
VEFM (3,8)	B(241)	X,Y,Z COMPONENTS OF OBJECT VELOCITY RELATIVE TO ALL BODIES, M/SEC
VEL	A(37)	INITIAL RELATIVE VELOCITY, USED WHEN IMODE=4, SKETCH (B), M/SEC
VMACH	B(38)	MACH NUMBER OF OBJECT
VQ	B(100)	VELOCITY OF OBJECT RELATIVE TO ATMOSPHERE, M/SEC
VQSQRD	B(101)	SQUARE OF VQ, M**2/SEC**2
VSQRD	B(96)	SQUARE OF V, M**2/SEC**2
VX	B(92)	X COMPONENT OF VELOCITY, M/SEC
VY	B(93)	Y COMPONENT OF VELOCITY, M/SEC
VZ	B(94)	Z COMPONENT OF VELOCITY, M/SEC
X (100)	B(401)	WORKING SET OF INTEGRATION VARIABLES
XDOT (100)	B(501)	TIME DERIVATIVES OF THE SET X

XIFT (3)	B(72)	X,Y,Z COMPONENTS OF LIFT ACCELERATION, M/SEC**2
XINC (100)	B(601)	INCREMENTS OF THE INTEGRATION VARIABLES PER STEP
XLOOK	A(12)	SEE TABLE II
XP (3,8)	B(217)	X,Y,Z COMPONENTS OF PERTURBATING BODY POSITIONS RELATIVE TO ORIGIN
XPRIM (100,2)	C(711)	TWO 100-ELEMENT SETS, THE FIRST SET CONTAINS VALUES OF THE INTEGRATION VARIABLES AT THE PREVIOUS GOOD STEP, THE SECOND SET IS UNDER THE INTEGRATION PROCESS, SEE TABLE V
XPRIMB (100,2)	C(911)	LEAST SIGNIFICANT HALF OF DOUBLE PRECISION INTEGRATION VARIABLES XPRIM
XTOL	A(11)	TOLERANCE ON THE DISCIMINATION C(LOOKX)-XLOOK TO BE SATISFIED
XWHOLE (6)	B(110)	RECTANGULAR COORDINATES AND VELOCITIES, SET ASIDE FOR USE IN ORIGIN TRANSLATIONS
ZN	B(43)	MEAN ANGULAR MOTION OF OBJECT, RAD/SEC
ZORMAL	B(83)	Z COMPONENT OF TOTAL PERTURBATIVE ACCELERATION, M/SEC**2

APPENDIX F

LEWIS RESEARCH CENTER EPHEMERIS

General Description

The ephemeris data initially available on magnetic tape were from the Themis code prepared by the Livermore Laboratory, evidently from U.S. Naval Observatory data. Later, an ephemeris was obtained from the Jet Propulsion Laboratory assembled as a joint project of the Jet Propulsion Laboratory and the Space Technology Laboratory. These data are given relative to the mean vernal equinox and equator of 1950.0 and are tabulated with ephemeris time as the argument.

An ephemeris was desired for certain uses in connection with the IBM 7090 computer that would be shorter than the original ephemeris tapes mentioned and would be as accurate as possible consistent with the length. A short investigation of the various possibilities led to adoption of fitted equations. In particular, fifth-order polynomials were simultaneously fitted to the position and velocities of a body at three points. This procedure provides continuity of position and velocity from one fit to the next, because the exterior points are common to adjacent fits. Polynomials were selected rather than another type of function, because they are easy to evaluate. Three separate polynomials are used for the x , y , and z coordinates, respectively.

Procedure Used to Fit Data

The process of computing the fitting equations is as follows:

(1) A group of 50 sets of the components of planetary position was read into the machine memory for a single planet together with differences as they existed on the original magnetic tape. The differences were verified by computation (in double precision because some data required it); and any errors were investigated, corrected, and verified. Published ephemeris data were adequate to correct all errors found.

(2) The components of velocity v_x , v_y , and v_z were computed and stored in the memory for each of the 50 positions by means of a numerical differentiation formula using ninth differences; namely,

$$\dot{X} = (T_1 - T_{-1}) \left[\frac{\Delta I_{-1} + \Delta I_{+1}}{2} - \frac{\Delta III_{-1} + \Delta III_{+1}}{12} + \frac{\Delta V_{-1} + \Delta V_{+1}}{60} - \frac{\Delta VII_{-1} + \Delta VII_{+1}}{280} + \frac{\Delta IX_{-1} + \Delta IX_{+1}}{1260} \right] \quad (F1)$$

(See ref. 11, pp. 42 and 99 for notation.) Double-precision arithmetic was used for differences, but velocities were tabulated with single precision.

(3) Coefficients C, D, E, and F in the fifth-order polynomial

$$X = X_0 + \dot{X}_0(T - T_0) + C(T - T_0)^2 + D(T - T_0)^3 + E(T - T_0)^4 + F(T - T_0)^5 \quad (F2)$$

and its derivative

$$\dot{X} = \dot{X}_0 + 2C(T - T_0) + 3D(T - T_0)^2 + 4E(T - T_0)^3 + 5F(T - T_0)^4 \quad (F3)$$

were found to fit a first point (which was far enough from the beginning point to have all differences computed) and two equally spaced points for each component of position and velocity. (The initial spacing is not important, as will be seen later.) Spacing is defined as the number of original data points fitted by one equation. Single-precision arithmetic was used.

(4) The coefficients C, D, E, and F in step (3) were then used in equations (F2) and (F3) to calculate components of all positions and velocities given in the original data and lying within the interval fitted. These values were checked with the original data. Radius R and velocity V were computed at the times tabulated in the original data. If any component of the position differed from the original data by more than $R \times 10^{-7}$ or if any velocity differed from the original by more than $V \times 10^{-6}$, the fit was considered unsatisfactory.

(5) If the fit was considered unsatisfactory, this fact was recorded, and the spacing was reduced by two data points. Steps 2 to 4 were then repeated. If the fit was considered satisfactory, this fact was recorded, and the spacing was increased by two spaces. Steps 2 to 4 were repeated. The largest satisfactory fit was identified when a certain spacing was satisfactory and the next larger fit was not satisfactory.

(6) The coefficients that corresponded to the largest satisfactory fit were recorded on tape in binary mode as follows:

Word number	Data	Mode	Definitions and/or units
1	Planet name	BCD	Six characters (first six)
2	Julian date	Floating point	Date of midpoint of fit, Julian date
3	Delta T		Number of days on each side of midpoint
4	F _x		^a AU/day ⁵
5	E _x		^a AU/day ⁴
6	D _x		^a AU/day ³
7	C _x		^a AU/day ²
8	X _x		^a AU/day
9	x		^a AU
10	F _y		^a AU/day ⁵
11	E _y		^a AU/day ⁴
12	D _y		^a AU/day ³
13	C _y		^a AU/day ²
14	y _y		^a AU/day
15	y		^a AU
16	F _z		^a AU/day ⁵
17	E _z		^a AU/day ⁴
18	D _z		^a AU/day ³
19	C _z		^a AU/day ²
20	z _z		^a AU/day
21	z		^a AU

^aExcept for Moon data, which are in Earth radii and days.

(7) As soon as a set of coefficients was selected for an interval, additional data were read from the source ephemeris tape and used to replace the points already fitted (except the last point). These data were processed as described in steps 1 and 2 so that the next 50 points were ready to be fitted. Steps 3 to 6 were then used to find the next set of coefficients, and steps 1 to 6 were repeated until all data for all planets were fitted.

Data Treated

The preceding process was applied to all data available at the time. For the Moon, the technique usually led to the use of every point in the fitted interval (i.e., only three points were fitted). Thus, a check of accuracy was not available. The error in the attempt to fit the next greater interval (five points) was not excessive, however, and it is judged that the accuracy obtained from these fits is about equal to that held on the other bodies.

Merged Ephemeris Tape

Once all the positions and velocities of all the bodies then available were fitted, the coefficients were merged in order of the starting date of each fit. The resulting tape was written in binary mode with 12 sets of fits per record.

The detail of this record is as follows:

	1st word:	FORTRAN compatible
	2nd word:	file number, fixed point in decrement
Set 1	{	3rd word: planet name, code in BCD, first six characters
		4th word: Julian date, floating point
		- etc., according to list in paragraph 6
		- 21 words
		23rd word: z
Set 2	{	24th word: planet name, code in BCD, first six characters
		25th word: Julian date, floating point
		-
		44th word: z

Successive sets follow one another with a total of 12 sets.

Set 12 (last set)	{	234th word: planet name
		235th word: Julian date, floating point
		254th word: z
		End-of-record gap

One record contains 254 words, the first is for FORTRAN compatibility, the second is a file number used for identification in the system. It is a fixed point 2. The third is the beginning of the first set of data, and 12 sets follow each with 21 words. The last word is the 254th word (counting the FORTRAN compatible word)

followed by an end-of-record gap. The remaining records are compiled in the same manner with an end-of-file recorded as a terminating mark.

Because of the merging operation, all bodies are given in one list in a random order according to the starting date of the interval. The starting date is the Julian day (word 2) minus the half interval (word 3) (see procedure, paragraph 6). The entire ephemeris occupies about one-seventh reel of tape. A summary of data is given in table VII.

APPENDIX G

INPUT-DATA REQUIREMENTS

The procedure needed to run actual problems with the aid of this routine is described herein. It is intended to permit the user with a specific problem in mind to make a complete list of data required and to select desirable operating alternatives from those available. The details of this procedure are contained in the following instructions:

(1) Provision has been made for two types of ephemeris data to specify the locations of celestial bodies that perturb the vehicle. They are ellipse data and ephemeris-tape data. If the problem does not involve perturbing bodies (except a reference body) or if elliptic data are used for all the perturbing bodies, skip to instruction 5.

(2) If the perturbing-body data are to be taken from an ephemeris tape, list the names of the ephemerides and Julian dates to be covered along with the following auxiliary information:

1st card: \$DATA = 300, \$TABLE, 2 = TAPE 3, 17 = ELIST, 29 = TBEGIN,
30 = TEND/

Other cards: TAPE 3 = 0

TBEGIN = ephemeris beginning Julian date

TEND = ephemeris ending Julian date

ELIST = (names of perturbing bodies in "ALF" format, see example in text)

The ephemerides of all planets except Earth bear the name of the planet. The ephemeris giving the distance from Earth to the Sun is called "sun," as is astronomical practice.

(3) If successive files on the ephemeris tape are to be made, punch the corresponding sets as follows:

\$DATA = 300, TAPE 3 = 0, TBEGIN = , TEND = , ELIST =

As many similar sets as are needed may be appended.

(4) If ellipse data are to be loaded from cards, they are prepared later under instruction 11.

(5) On the first execution after loading the routine, the common area is cleared whether an ephemeris tape is constructed or not. It is now necessary to load a table of variable names. Once loaded, this table will not be cleared again (except if the control variable TAPE 3 is set equal to zero). These names are for use on the input cards. If a different name is desirable for any

variable, it may be changed in the table and where it appears on the input card (ref. 7). The cards are:

\$DATA=1,\$TABLE, 33=DTOFFJ, 34=TOFFT, 711=TIME, 716=X, 717=Y, 718=Z, 713=VX, 714=VY, 715=VZ, 11.=IMODE, 713=E, 714=OMEGA, 715=NODES, 716=INCL, 717=MA, 718=P, 43=LAT, 44=LONG, 45=AZI, 46=ELEV, 14=ALT, 47=VEL, 16=TFILE, 28=TMIN, 153=BODYCD, 177=ELIPS, 30.=MODOUT, 27=STEPS, 29=DELMAX, 26=STEPMX, 23=EREF, 24=ERLIMT, 4.=NSAVE, 5=RECALL, 3=CLEAR, 18.=LOOKX, 22=XLOOK, 19.=LOOKSW, 20=SWLOOK, 609.=INLOOK, 15=END, 31=ATMN, 32=RATM, 49=ROTATE, 417=COEFN, 163.=ICC, 60=BETA, 50=OBLATN, 73=TB, 93=FLOW, 103=SIMP, 123=AREA, 143=DELTA, 83=RMASS, 113=AEXIT, 133.=IDENT, 48.=LSTAGE, 25=TKICK /

(6) The initial position and velocity of the vehicle may be given in any one of the three coordinate systems. If the initial data are given in orbit elements, skip to instruction (8). If the initial data are given in rectangular coordinates, skip to instruction (7). If the initial data are given in Earth-centered spherical coordinates, the following variables should be punched:

LAT = latitude, deg, positive north of equator

LONG = longitude, relative to Greenwich, deg

ALT = altitude above sea level, m

AZI = azimuth angle, east from north, deg

ELEV = elevation angle, horizontal to path, deg

VEL = initial relative velocity, m/sec

TKICK = size of initial vertical, nondrag step to facilitate starting, sec

If the Earth is assumed to be rotating but aerodynamic forces are not to be considered, set

ROTATE = Earth rotation rate, $7.29211585 \times 10^{-5}$ radian/sec

If integration in rectangular coordinates is desired set

IMODE = 4

or else if integration in orbit elements is desired set

IMODE = -4

Skip to instruction (9).

(7) If the initial data are in rectangular coordinates, set the following variables:

X = x-component of position in x,y,z coordinate system, m

Y = y-component of position in x,y,z coordinate system, m

Z = z-component of position in x,y,z coordinate system, m

VX = x-component of velocity in x,y,z coordinate system, m/sec

VY = y-component of velocity in x,y,z coordinate system, m/sec

VZ = z-component of velocity in x,y,z coordinate system, m/sec

If integration in rectangular coordinates is desired set

IMODE = 2

or else, if integration in orbit elements is desired set

IMODE = -2

Skip to instruction (9).

(8) If the initial data are in orbit elements, set the following variables:

E = eccentricity

OMEGA = argument of pericenter, radians

NODES = longitude of ascending node (to mean vernal equinox of 1950.0), radians

INCL = orbit inclination to mean equator of 1950.0, radians

MA = mean anomaly, radians

P = semilatus rectum, m

If integration in orbit elements is desired set

IMODE = 1

or else, if integration in rectangular coordinates is desired set

IMODE = -1

(9) To specify takeoff time, set the following variables:

DTOFFJ = Julian day number

TOFFT = fraction of day

TIME = time from previously set Julian date, sec

Takeoff occurs at the instant (ephemeris time) corresponding to the sum of the last three quantities. If a specific date or time is not required, these variables may be skipped. In that case, the SUBROUTINE STDATA sets DTOFFJ to 2440 000.

(10) To specify the origin and any perturbing bodies, list them as BODYCD = (list of body names in "ALF" format, see text example). The first body in the list is taken to be the reference body. The distances between the bodies in

this list must be computable from either ellipse data (instruction (11)) or ephemeris-tape data (instruction (2)). There may be no more than eight names in the list. Also, if the ephemeris tape is being used, the correct file must be found on it. For this purpose, set TFILE = desired ephemeris-tape file. The ephemeris files were numbered in sequence when written in instruction (2). If TFILE is not given, it will be set equal to 1.0 by the SUBROUTINE STDATA.

(11) For each body whose path is represented by an ellipse, a 12-element set of data must be loaded. A 12-element set consists of:

1. Body name in "ALF" format (maximum of six characters)
2. Reference body name in "ALF" format (maximum of six characters)
3. Mass of body, sun mass units
4. Radius of sphere of influence, m
5. Semilatus rectum, AU
6. Eccentricity
7. Argument of pericenter, radians
8. Longitude of ascending node (to mean vernal equinox of 1950.0), radians
9. Orbit inclination (to mean equator of 1950.0), radians
10. Julian day at perihelion
11. Fraction of day at perihelion
12. Period, mean solar days

It is convenient to punch a 12-element set in sequence and to separate the elements by commas on as many cards as are required. Several sets may then be loaded consecutively. The order of the sets is immaterial. Ellipse data, if present, take precedence over ephemeris-tape data. The sets are loaded consecutively, in any order, as follows:

ELIPS = set 1, set 2, set 3, . . . , set n; $n \leq 10$ (see example in appendix I)

(12) If oblateness effects of the Earth are to be included, set

OBLATN = (ALF5)EARTH

(13) Provision has been made to fly multistage vehicles with up to 10 stages. At least one stage must be loaded. There are eight parameters for each stage with provision for input-controlled modifications of other variables. The 10 values of each parameter are stored in an array corresponding to the

10 stages. Input cards are as follows:

TB = burning time for 1st stage, 2nd stage, etc., sec

FLOW = propellant flow rate for 1st stage, 2nd stage, etc., kg/sec

SIMP = vacuum specific impulse of 1st stage, 2nd stage, etc., sec

AREA = aerodynamic reference area of 1st stage, 2nd stage, etc., m²

AEXIT = engine exit area for 1st stage, 2nd stage, etc., m²

RMASS = initial mass or jettison mass for 1st stage, 2nd stage, etc., kg

DELT = initial integration step size for 1st stage, 2nd stage, etc., sec

IDENT = input identification number 1st stage, 2nd stage, etc.

TB must be loaded for as many stages as are to be flown. Others may be omitted if zero is appropriate. If RMASS(i) is not positive, the ith stage begins with the final mass of the previous stage reduced by the fixed amount RMASS(i). In the case of DELT, zero will result in use of TB/100. IDENT of a nonzero value will cause any data cards of that identification number to be read in after the stage is set up and before integration begins. This permits the user to make almost any change desired. The order of data cards is discussed in instruction (24).

(14) The thrust orientation must be specified by setting

BETA = angle β , deg (see sketch (a) (p. 4))

COEFN (I) = angle-of-attack schedule, $\alpha = \alpha(t)$ (see instruction (16))

ICC = fixed-point integer (see instruction (16))

For the special case of tangential thrust, none of the last three variables need be set.

(15) If aerodynamic forces are present, set in addition to AREA in instruction (13):

ATMN = name of body that has atmosphere, in "ALF" format, (Earth)

RAIM = radius above which atmospheric forces are not to be considered, m

ROTATE = atmospheric-rotation rate, radians/sec ($7.29211585 \times 10^{-5}$ for Earth)

BETA = angle β , deg (see sketch (a))

COEFN (I) = angle-of-attack schedule, $\alpha = \alpha(t)$, $C_L/\sin \alpha$, $C_{D,0}$, and $C_{D,i}/C_L^2$ curves (see instruction (16))

ICC = fixed-point integers (see instruction (16))

(16) If neither thrust nor aerodynamic forces are present, skip to instruction (18). The relations $\alpha(t)$, $C_L/\sin \alpha$, $C_{D,0}$, and $C_{D,i}/C_L^2$ are assumed to be quadratic functions that involve coefficients, which are located in the COEFN(J) array. The arrangement of these coefficients is best explained by an example. Suppose the function $\alpha(t)$ is as follows:

$$\alpha = \begin{cases} a_{11} + a_{12}t + a_{13}t^2 & (t_1 \leq t \leq t_2) \\ a_{21} + a_{22}t + a_{23}t^2 & (t_2 \leq t \leq t_3) \\ a_{31} + a_{32}t + a_{33}t^2 & (t_3 \leq t \leq t_4) \\ \cdot & \cdot & \cdot & \cdot & \cdot & \cdot \\ \text{etc.} & \text{etc.} \end{cases}$$

The coefficients $a_{i,j}$ should then be loaded into the COEFN(J) array as:

$$\text{COEFN}(J) = t_1, a_{11}, a_{12}, a_{13}, t_2, a_{21}, a_{22}, a_{23}, t_3, a_{31}, a_{32}, a_{33}, t_4, \dots, t_n$$

Furthermore, additional sets of coefficients for the other functions may simply be added to the COEFN(J) array, which results in a string of sets of coefficients, and can be represented, for example, as:

$$\begin{aligned} \text{COEFN}(J) &= \alpha \text{ coefficients, } C_L/\sin \alpha \text{ coefficients, } C_{D,0} \text{ coefficients, etc.} \\ &= t_1, a_{11}, a_{12}, \dots, t_n, N_{M,1}, b_{11}, b_{12}, \dots, N_{M,k}, \text{ etc.} \end{aligned}$$

The starting point in the COEFN(J) array of each function must also be loaded to identify the correct region of coefficients. To this end, the following array must also be loaded:

- ICC(1) = fixed-point value of J where α coefficients begin
- ICC(2) = fixed-point value of J where $C_L/\sin \alpha$ coefficients begin
- ICC(3) = fixed-point value of J where $C_{D,i}/C_L^2$ coefficients begin
- ICC(4) = fixed-point value of J where $C_{D,0}$ coefficients begin

For this purpose, all values in the COEFN(J) array are called coefficients (i.e., the t's and the N_M 's are coefficients). The sequence of the sets is arbitrary, since changing the sequence requires only a change in the ICC(I) array. (See appendix I for Example II, the lunar orbiting probe.)

(17) The size of the integration steps is determined primarily by the error control variables. These are loaded as:

EREF = error reference value; $\bar{\delta}$ in appendix D

ERLIMT = maximum value of δ that is acceptable on any particular step

EREF is always treated as a positive number; however, if it is loaded with a minus sign, this will cause error information to be printed at the completion of the problem. If no error control data is loaded, SUBROUTINE STDATA will set EREF = 1×10^{-6} , ERLIMT = 3×10^{-6} .

(18) The output control offers a choice on the frequency of output data as follows:

If MODOUT = 1, output will occur every n^{th} step ($n = \text{STEPS}$) until $t = \text{TMIN}$, and then MODOUT is set equal to 2 by the program

If MODOUT = 2, output occurs at equal time intervals of DELMAX until $t = \text{TMAX}$

If MODOUT = 3, output occurs at equal time intervals of DELMAX until $t = \text{TMIN}$, then MODOUT is set equal to 4 by the program

If MODOUT = 4, output occurs every n^{th} step ($n = \text{STEPS}$) until $t = \text{TMAX}$

STEPMX = maximum step limit before problem is completed

DELMAX = time interval between outputs

STEPS = number of steps between outputs

TMIN = time when MODOUT changes

Note that output control may, at times, strongly influence the integration step size especially if MODOUT is 2 or 3 and DELMAX is small. STDATA will put MODOUT = 4 and STEPS = 1.

Note that TMAX = time at start of a stage, plus the stage time, TB(NSTAGE), and is computed internally.

(19) Provision has been made to interrupt the integration procedure when an arbitrary value of an arbitrary parameter is attained. By interrupt it is meant that an output will occur at this point, input is permissible, and a decision is made whether to continue the stage, terminate the stage, or terminate the flight. Skip to instruction (20) if this facility is not desired. To cause an interrupt, set

LOOKX = COMMON C location of arbitrary parameter

XLOOK = value of C(LOOKX) where an interrupt is desired

INLOOK = input identification number for interrupt

END = a negative number if flight should be terminated, zero if stage should continue, or a positive number if stage should be terminated

If the interrupt is not desired the first time $C(\text{LOOKX}) = \text{XLOOK}$, set

LOOKSW = COMMON C location of a second arbitrary parameter

SWLOOK = value of $C(\text{LOOKSW})$, which must be equaled or exceeded before an interrupt may occur (interrupt occurs if $C(\text{LOOKX}) = \text{XLOOK}$ and $C(\text{LOOKSW}) \geq \text{SWLOOK}$)

Typically, time may be the second arbitrary parameter; thus, STDATA sets LOOKSW = 711, the COMMON location of time. INLOOK of a nonzero value will cause any data cards of that identification number to be read-in prior to the interrogation of END. The order of the cards is discussed in instruction (24).

(20) Provision has been made to save a block of initial conditions and program control parameters prior to the integration of the n^{th} stage. This allows the flight to be flown again from the n^{th} stage onward with prescribed alterations. Skip to instruction (21) if this facility is not desired. To save the program control variable array, A, and the integration variable array, XPRIM + XPRIMB, just prior to integration of the n^{th} stage, set

NSAVE = the number of the n^{th} stage

The saved data, stored in the D array, will be returned to the A and XPRIM + XPRIMB arrays after the flight is completed if

RECALL = any nonzero number

It is intended that changes in the succeeding flight will be made at the main input station ($\$DATA=1$). NSAVE and RECALL are not contained in the array A and are therefore unaffected by the save-recall sequence. The correct sequence of these controls is not always simple and an understanding of the main program and input stationing is quite desirable.

(21) If the standard set of data contained in the SUBROUTINE STDATA is not desired, set

CLEAR = any nonzero number

It is intended that this control shall be set nonzero by the $\$DATA = 99$ input station at the beginning of the main program. It is not affected by the save-recall sequencing explained in instruction (20).

(22) If the number of stages to be flown is not equal to the number of consecutive nonzero flight times, TB, set

LSTAGE = number of last stage to be flown

(23) When a transfer of origin occurs, provision has been made to read input into the program. This is done with the aid of \$DATA = 101, followed by the data statements desired.

(24) The sequencing of the input cards is not always simple and no rigid rules may be written down. Inspection of the program may be necessary to answer some questions. However, in general, the first input cards belong to the \$DATA = 300 group if an ephemerides tape is required. This group is followed by the \$DATA = 1 group, which consists of the main input for a single flight. Following this are the in-flight input cards, if any, which may be any combination of \$DATA = 101, \$DATA = INLOOK, or \$DATA = IDENT (NSTAGE) groups. The order of these groups of cards matches the order of the time sequence of events in the flight itself. For multiple flights, sets of the above groups may be added in tandem. It is usually desirable in this case, however, to read all the \$DATA = 300 sets at the same time (as in instruction (3)) to avoid excessive tape handling.

(25) Following is an input check list that may be helpful at execution time:

INPUT CHECK LIST^a

Takeoff time	Position and velocity (completely fill in one and only one block)			Reference and perturbing bodies		
	Rectangular	Orbit elements	Spherical	BODYCD =		
				Tape	Elliptic	
DTOFFJ = TOFFFT = TIME =	X = Y = Z = VX = VY = VZ = IMODE = 2	E = OMEGA = NODES = INCL = MA = P = IMODE = 1	LAT = LONG = AZI = ELEV = ALT = VEL = TKICK IMODE = 4	bTAPE 3 = 0 bTBEGIN = bTEND = bELIST = TFILE =	ELIPS =	
Output control	Error control	Restart feature	Parameter search	Atmosphere and coefficients	Oblateness - rotation	Stage data
TMIN = MODOUT = STEPS = DELMAX = STEPMX =	EREF = ERLIMT =	NSAVE = RECALL = CLEAR =	LOOKX = XLOOK = LOOKSW = SWLOOK = INLOOK = END =	ATMN = RATM = COEFN = ICC = BETA =	OBLATN = ROTATE =	TB = FLOW = SIMP = AREA = DELT = RMASS = AEXIT = IDENT = LSTAGE =

^aThe following standard data are loaded by SUBROUTINE STDATA:

```

DTOFFJ = 2440 000.0      MODOUT = 4      EREF = 1x10-6
IMODE = 1                STEPS = 1.0    ERLIMT = 3x10-6
BODYCD(1) = (ALF5)EARTH  STEPMX = 100.0  TFILE = 1.0
RMASS(1) = 1.0          LOOKSW = 711

```

^bAt input 300, setting TAPE 3 = 0 is necessary to make an ephemeris tape.

APPENDIX H

PROGRAM LISTING

```

C
C THIS MAIN PROGRAM IS THE SUPERSTRUCTURE ABOVE ALL SUBPROGRAMS.
C SUBROUTINE TAPE CLEARS COMMON 1 THRU 4000 AND MAY CONSTRUCT AN
C EPHEMERIS TAPE, ALSO, IT ALWAYS SETS TAPE3 = 0. SUBROUTINE STDATA
C LOADS A STANDARD SET OF DATA. IF RECALL DOES NOT EQUAL ZERO, A
C PREVIOUSLY SAVED SET OF DATA(FROM STAGE) IS MOVED TO THE INITIAL
C DATA LOCATION. THE MAIN INPUT STATION IS STATEMENT 8(INPUT1)
C WHERE THE VEHICLE DATA FOR ALL STAGES MAY BE LOADED. SUBROUTINE ORDER IS
C CALLED TO ORDER THE LIST OF BODIES, DETERMINE THE GRAVITATIONAL CONSTANT,
C ORIGIN ROTATION RATE, ATMOSPHERIC RADIUS, RELOCATE ELLIPTIC EPHEMERIS DATA
C AND POSITION THE EPHEMERIS TAPE.
C
C COMMON C
C
C DIMENSION A(600), B(700), C(4000),
C 1 TB(10), D(1100)
C
C EQUIVALENCE
C 1(A ,C ( 11)),(B ,C (1111)),(CLEAR ,C ( 3)),
C 2(D ,C (2111)),(LSTAGE,A ( 38)),(NCASE ,C ( 1)),
C 3(NCASES,A ( 600)),(NSTAGE,A ( 3)),(RECALL,C ( 5)),
C 4(TB ,A ( 63)),(TAPE3 ,C ( 2)),(TABLE ,C (1911))
C
C 1 CALL INPUT (99,C,TAPE)
C IF (TAPE3) 3,2,3
C 2 CALL TAPE
C 3 NCASE = NCASE + 1
C WRITE OUTPUT TAPE 6,12,NCASE
C 12 FORMAT(12H1CASE NUMBER13,1H.)
C IF (CLEAR) 5,4,5
C 4 CALL STDATA
C 5 IF (RECALL) 6,8,6
C 6 DO 7 J=1,1100
C 7 A(J) = D(J)
C WRITE OUTPUT TAPE 6,16,NSTAGE,NCASES
C 16 FORMAT(33H RECALLED INITIAL DATA FROM STAGE12,8H OF CASE14,1H.)
C 8 CALL INPUT (1,C,TAPE)
C IF (SENSE SWITCH 6) 13,14
C 13 WRITE OUTPUT TAPE 6,15
C 15 FORMAT(19HOEXIT VIA SENSE SW6)
C CALL EXIT
C 14 IF (LSTAGE) 11,9,11
C 9 DO 10 LSTAGE=1,10
C IF (TB(LSTAGE+1)) 10,11,10
C 10 CONTINUE
C LSTAGE = 10
C 11 CALL ORDER
C 17 CALL STAGE
C GO TO 1
C END
C
C SUBROUTINE AERO
C
C SUBROUTINE AERO COMPUTES THE LIFT AND DRAG ACCELERATIONS. AS IN SUBROUTINE THRUST, THESE VECTORS ARE REFERENCED TO THE RELATIVE WIND VELOCITY. COEFFICIENTS OF LIFT, INDUCED DRAG, AND DRAG AT ZERO ANGLE OF ATTACK ARE ASSUMED TO BE FUNCTIONS OF MACH NUMBER AND ANGLE OF ATTACK. TABLES OF CDI/CL**2, CL/SIN(ALPHA), AND CDO ARE ASSUMED AS FITTED QUADRATIC EQUATIONS IN THE COEFN ARRAY. GASFAC IS THE SQRTF(SPECIFIC HEAT RATIO * STANDARD ACCELERATION OF GRAVITY * UNIVERSAL GAS CONSTANT). FOR EARTH, GASFAC= 20.064881 (METERS / SEC**2 / KELVIN DEGREE)**1/2.
C
C COMMON C
C
C DIMENSION A(600), B(700), C(4000),
C 1VATM(3), P(3), XIFT(3), DRAG(3), PAR(3), X(100)
C
C EQUIVALENCE
C 1(A ,C ( 11)),(ALPHA ,A ( 49)),(AREA ,B ( 6)),
C 2(B ,C (1111)),(BETA ,A ( 50)),(CD ,A ( 165)),
C 3(CDI ,A ( 163)),(CL ,A ( 164)),(COSALF,B ( 48)),
C 4(COSBET,B ( 49)),(DNSITY,B ( 29)),(DRAG ,B ( 69)),
C 5(GASFAC,A ( 46)),(P ,B ( 84)),(PAR ,B ( 60)),
C 6(PMAGN ,B ( 50)),(Q ,B ( 59)),(R ,B ( 102)),
C 7(SINALF,B ( 46)),(SINBET,B ( 47)),(TM ,B ( 34)),
C 8(VATM ,B ( 97)),(VMACH ,B ( 38)),(VQ ,B ( 100)),
C 9(VQSQRD,B ( 101)),(X ,B ( 40)),(XIFT ,B ( 72))
C
C Q = 0.5*DNSITY*VQSQRD
C QVAL = Q*AREA/X(2)
C VMACH=SQRTF(VQSQRD/TM)/GASFAC
C
C COMPUTE THE X,Y,Z COMPONENTS OF LIFT.
C IF (ALPHA) 2,1,2
C 1 CL = 0.0
C CDI=0.0
C GO TO 4
C 2 CL = QUAD(VMACH,2)*SINALF
C AA = QVAL*CL/PMAGN
C AB = SINBET/VQ
C DO 3 K=1,3
C 3 XIFT(K) = AA*(AB*PAR(K)+COSBET*P(K))
C 7 CDI=QUAD(VMACH,3)*CL*CL
C
C COMPUTE THE X,Y,Z COMPONENTS OF DRAG.
C 4 CD = CDI*QUAD(VMACH,4)
C AC = -CD*QVAL/VQ
C DO 5 K=1,3
C 5 DRAG(K) = AC*VATM(K)
C 6 RETURN
C END

```

```

C          FUNCTION ARCTAN (Y,X)
C THE FORTRAN II LIBRARY ATANF(+ OR - Z=TAN(THETA)) USES A SINGLE
C ARGUMENT WITH ITS SIGN TO GIVE THETA IN THE FIRST (+Z) OR FOURTH
C (-Z) QUADRANT.
C
C THE ARCTAN FUNCTION MAY BE USED IF + OR - Z IS DERIVED FROM A
C FRACTION SO THAT ARCTAN (Y,X) = TAN-1 ((+OR-Y=SIN(THETA))/(+OR-X=
C COS(THETA))). THUS THE ARCTAN (Y,X) GIVES THETA IN ITS PROPER
C QUADRANT FROM -180 DEGREES TO +180 DEGREES.
C
C IF (X) 2,1,2
1 ARCTAN=SIGNF(1.57079632,Y)
GO TO 4
2 ARCTAN=ATANF(Y/X)
IF(X) 3,1,4
3 ARCTAN=ARCTAN+SIGNF(3.14159265,Y)
4 RETURN
END

```

```

C          SUBROUTINE CONVT1 (V,AMC)
C THIS ROUTINE COMPUTES -- (1) ANGULAR MOMENTUM, AMC(4)
C (2) ANGULAR MOMENTUM SQUARED, AMC(5)
C (3) X,Y,Z COMPONENTS OF ANG. MOM., AMC(J)
C (4) VELOCITY, V(4)
C (5) VELOCITY SQUARED, V(5)
C
C COMMON C
C DIMENSION A(600), B(700), C(4000),
1 AMC(3), V(5), RB(3), IND(3)
C
C EQUIVALENCE
1(A ,C ( 11)),(B ,C (1111)),(IND ,A ( 60)),
2(RB ,B ( 193))
C
C DO 1 J1=1,3
J2=IND(J1)
J3=IND(J2)
1 AMC(J3) = RB(J1)*V(J2)-RB(J2)*V(J1)
AMC(5) = AMC(1)**2+AMC(2)**2+AMC(3)**2
AMC(4) = SQRTF(AMC(5))
V(5) = V(1)**2+V(2)**2+V(3)**2
V(4) = SQRTF(V(5))
RETURN
END

```

```

C          SUBROUTINE CONVT2
C THIS ROUTINE CONVERTS RECTANGULAR COORDINATES INTO ORBIT ELEMENTS.
C RECTANGULAR COORDINATES- POSITION COMPONENTS,X,AND VELOCITY COMPONENTS,VX.
C THE ORBIT ELEMENTS ARE IN THE ORBELS ARRAY-
C (1) ECCENTRICITY (4) INCLINATION
C (2) ARGUMENT OF PERICENTER (5) MEAN ANOMALY
C (3) LONGITUDE OF ASCENDING NODE (6) SEMILATUS RECTUM
C
C COMMON C
C DIMENSION A(600), B(700), C(4000),
1 AMC(3), ORBELS(6), RB(3)
C
C EQUIVALENCE
1(A ,C ( 11)),(AM ,B ( 90)),(AMSQRD,B ( 91)),
2(AMC ,B ( 87)),(B ,C (1111)),(COSTRU,B ( 53)),
3(EPAR ,B ( 26)),(GK2M ,B ( 36)),(ORBELS,B ( 116)),
4(R ,B ( 102)),(RB ,B ( 193)),(SINTRU,B ( 52)),
5(TRU ,B ( 40)),(V ,B ( 95)),(VSRQD ,B ( 96)),
6(VX ,B ( 92)),(VY ,B ( 93)),(VZ ,B ( 94))
C
C ORBELS(6)=AMSQRD/GK2M
R=SQRTF(RB(1)**2+RB(2)**2+RB(3)**2)
TRU=ARCTAN(AM/GK2M*(RB(1)*VX+RB(2)*VY+RB(3)*VZ),ORBELS(6)-R)
IF(AMC(1)) 2,1,2
1 ORBELS(3)=0.
GO TO 3
2 ORBELS(3)=ARCTAN(AMC(1),-AMC(2))
3 ORBELS(4)=ARCTAN(SQRTF(AMC(1)**2+AMC(2)**2),AMC(3))
SNODE=SINF(ORBELS(3))
CNODE=COSEF(ORBELS(3))
AA=RB(1)*CNODE+RB(2)*SNODE
AB=RB(3)*SINF(ORBELS(4))+CNOSEF(ORBELS(4))*(RB(2)*CNODE-RB(1)*SNODE)
ORBELS(2)=ARCTAN(AB,AA)-TRU
ORBELS(1)=SQRTF(ABSF(1.+ORBELS(6))*(VSRQD/GK2M-2./R))
EPONE=SQRTF(1.+ORBELS(1))
E2M1=1.-ORBELS(1)**2
EPAR=SQRTF(ABSF(E2M1))
SINTRU=SINF(TRU)
COSTRU=COSEF(TRU)
EPAS=SQRTF(ABSF(1.-ORBELS(1))*SINTRU/(1.+COSTRU)
ETHETA=ORBELS(1)*SINTRU/(1.+ORBELS(1)*COSTRU)*EPAR
4 IF(E2M1) 5,6,6
5 ORBELS(5)=LOGF((EPONE+EPAS)/(EPONE-EPAS))-ETHETA
GO TO 7
6 ORBELS(5)=2.*ARCTAN(EPAS,EPONE)-ETHETA
7 RETURN
END

```

```

C                                     SUBROUTINE ERRORZ
C THIS SUBROUTINE COMPUTES THE RELATIVE ERRORS BETWEEN THE R-K AND LOW-ORDER
C INTEGRATION SCHEMES. IT ALSO COMPUTES THE ERROR COEFFICIENT, A, AND SAVES
C THE ERROR DATA WHEN EREF HAS A - SIGN. THE BRANCH ON IMODE DETERMINES
C WHICH SET OF NORMALIZING FACTORS ARE TO BE USED.
C
C   COMMON C
C
C   DIMENSION A(600), B(700), C(4000),
C 1  RELERR (8), XPRIM (200), XINC (100)
C
C   EQUIVALENCE
C 1(A ,C ( 11)),(A1 ,B ( 10)),(A2 ,B ( 11)),
C 2(B ,C (111)),(DELT ,B ( 1)),(E2 ,B ( 18)),
C 3(EREF ,A ( 13)),(IMODE ,A ( 1)),(INDERR,B ( 51)),
C 4(R ,B ( 102)),(STEPGO,A ( 41)),(STEPNO,A ( 42)),
C 5(V ,B ( 95)),(XINC ,B ( 601)),(XPRIM ,C ( 711))
C   EQUIVALENCE (RELERR,XINC)
C
C   E2 = 0.
C   RELERR(2) = XINC(2)/XPRIM(2)
C   IF (IMODE-1) 2,1,2
C
C   COMPUTE THE NORMALIZED INTEGRATION ERRORS FOR THE ORBIT ELEMENTS.
C 1 RELERR(3)=XINC(3)/(XPRIM(3)+1.)/10.
C   RELERR(8)=XINC(8)/XPRIM(8)/10.
C   DO 10 J=1,4
C 10 RELERR(J+3)=XINC(J+3)/62.831853
C   GO TO 3
C
C   COMPUTE THE NORMALIZED INTEGRATION ERRORS IN RECTANGULAR VARIABLES.
C 2 V1 = V+100.
C   DO 20 J=1,3
C   RELERR(J+2)=XINC(J+2)/V1
C 20 RELERR(J+5)=XINC(J+5)/R
C
C   SELECT MAXIMUM ERROR, COMPUTE ERROR COEFFICIENT, POSSIBLY SAVE ERROR DATA.
C 3 DO 5 J=2,8
C   IF (ABSF(RELERR(J))-E2) 5,5,4
C 4 K=J
C   E2 = ABSF(RELERR(J))
C 5 CONTINUE
C   E2 = E2 + 2E-8
C   A1 = A2
C   A2 = LOGF(E2)-5.*LOGF(ABSF(DELT))
C   IF (EREF) 6,7,7
C 6 WRITE TAPE 4,STEPGO,STEPNO,XPRIM(1),DELT,A2,E2,(RELERR(J),J=2,8),K
C   INDERR = INDERR + 1
C 7 RETURN
C   END

```

```

C                                     SUBROUTINE EQUATE
C THIS SUBROUTINE IS CALLED FROM NBODY TO EVALUATE THE DERIVATIVES OF THE
C VARIABLES OF INTEGRATION. EITHER RECTANGULAR COORDINATES OR ORBIT ELE-
C MENTS MAY BE USED AS THE VARIABLES OF INTEGRATION, BUT IN THE CASE OF THE
C LATTER, THE CORRESPONDING RECTANGULAR COORDINATES MUST FIRST BE FOUND.
C THIS IS DONE AT THE BEGINNING THRU THE USE OF KEPLERS EQUATION. THE
C PERTURBATING ACCELERATIONS ARE FOUND BY CALLING VARIOUS OTHER SUBROUTINES
C AND THEIR SUM RESOLVED ALONG THE X,Y,Z AXIS. FINALLY, THE DERIVATIVES
C ARE CALCULATED. IN THE CASE OF ORBIT ELEMENTS, THE X,Y,Z PERTURBATING
C ACCELERATION COMPONENTS MUST FIRST BE RESOLVED INTO CIRCUMFERENTIAL,RADIAL
C AND NORMAL COMPONENTS. THIS ROUTINE ALSO CHANGES THE INTEGRATION VARI-
C ABLES FROM ORBIT ELEMENTS TO RECTANGULAR VARIABLES IF THE ECCENTRICITY
C APPROACHES UNITY. THE X,XPRIM, AND XDOT ARRAYS ARE AS FOLLOWS.
C
C   X           ORBIT ELEMENTS           RECTANGULAR COORDINATES
C
C 1           TIME                       TIME
C 2           MASS                       MASS
C 3           ECCENTRICITY                X-VELOCITY
C 4           ARGUMENT OF PERICENTER      Y-VELOCITY
C 5           ARGUMENT OF ASC. NODE       Z-VELOCITY
C 6           INCLINATION                 X
C 7           MEAN ANOMALY                Y
C 8           SEMILATUS RECTUM            Z
C
C   COMMON C
C
C   DIMENSION A(600), B(700), C(4000),
C 1  XPRIM (100,2), VX (3), QX (3),
C 2  RB (3), NEFMRS (8), X (100),
C 3  XPRIMB (100,2), FORCE (3), XIFT (3),
C 4  DRAG (3), OBLAT (3), COMPA (3),
C 5  XDOT (100)
C

```

```

EQUIVALENCE
1A      ,C      ( 11)),(AMSRD,B      ( 91)),(ASYMPT,A      ( 71)),
2B      ,C      (1111)),(BNAME ,B      (122)),(CINCL ,B      ( 55)),
3(CIRCUM,B      ( 82)),(COMPA ,B      ( 63)),(CONSTU,A      ( 32)),
4(COSTRU,B      ( 53)),(COSV ,B      ( 57)),(DRAG ,B      ( 69)),
5(EMONE ,B      ( 28)),(EPAR ,B      ( 26)),(ETOL ,A      ( 30)),
6(EXMODE,B      ( 27)),(FLOW ,B      ( 51)),(FORCE ,B      ( 66)),
7(GKZM ,B      ( 36)),(GKM ,B      ( 37)),(IMODE ,A      ( 11)),
8(KSUB ,B      ( 19)),(MBOOYS,B      ( 42)),(NEFMRS,B      (185)),
9(INSTART,B      ( 24)),(OBLATN,A      ( 40)),(OBLAT ,B      ( 75))
EQUIVALENCE
1(PRESS ,B      ( 33)),(PUSHO ,B      ( 39)),(QX ,B      ( 78)),
2(RADIAL,B      ( 81)),(RATMDS,B      ( 23)),(RB ,B      (193)),
3(R ,B      (102)),(RSQRD ,B      ( 45)),(SINCL ,B      ( 54)),
4(SINTRU,B      ( 52)),(SINV ,B      ( 56)),(SPD ,A      ( 44)),
5(TABL ,B      ( 20)),(TOFFT ,A      ( 24)),(TRSFER,B      ( 8)),
6(TTEST ,A      ( 54)),(U ,A      ( 59)),(V ,B      ( 95)),
7(VSQRD ,B      ( 96)),(VX ,B      ( 92)),(XDOT ,B      ( 50)),
8(XIFT ,B      ( 72)),(XPRIM ,C      ( 71)),(XPRIMB,C      ( 91)),
9(X ,B      ( 40)),(ZORMAL,B      ( 83)),(ZN ,B      ( 43))
C
      TABL=X(1)/SPD+TOFFT
      IMODE=IMODE
1  GO TO (2,16,16),IMODE
C
C      STATEMENTS 2 TO 16 FIND THE RECTANGULAR POSITION AND VELOCITY FROM ORBIT
C      ELEMENTS AND TRUE ANOMALY. THE TRUE ANOMALY IS FOUND FROM ITERATIVE
C      SOLUTION OF KEPLERS EQUATION.
2  E2 = X(3)**2
   E2M1 = 1.-E2
   EMONE = X(3)-1.
   EPAR=SQRTF(ABSF(E2M1))
   VCIRCL=GKM/SQRTF(X(8))
C
C      COMPUTE SINE AND COSINE OF TRUE ANOMALY.
C      PART A. E=1
3  IF (EMONE) 10,4,5
4  SINTRU = 0.
   COSTRU = 1.
   GO TO 14
C
C      PART B. E IS GREATER THAN 1
5  DO 7 J=1,100
   DELM = X(7)-U+X(3)*SINH(U)
   ECOSU = X(3)*COSH(U)
   DELU = DELM/(1.0-ECOSU)
   U = U+DELU
6  IF (ABSF(DELM)-CONSTU) 9,9,7
7  CONTINUE
   ASYMPT = 1.0
   IF (MBOOYS) 8,23,8
8  CALL EPHMRS
   GO TO 23
9  COSU = COSH(U)
   DEM1 = 1.-X(3)*COSU
   COSTRU = (COSU-X(3))/DEM1
   SINTRU = -EPAR*SINH(U)/DEM1
   GO TO 14
C
C      PART C. E IS LESS THAN 1
10 DO 12 J=1,15
   DELM = X(7)-U+X(3)*SINF(U)
   ECOSU = X(3)*COSF(U)
   DELU = DELM/(1.0-ECOSU+0.01*ECOSU**3)
   U = U+DELU
11 IF (ABSF(DELM)-CONSTU) 13,13,12
12 CONTINUE
   WRITE OUTPUT TAPE 6,55,U,DELU
   CALL EXIT
13 COSU = COSF(U)
   DEM1 = 1.-X(3)*COSU
   COSTRU = (COSU-X(3))/DEM1
   SINTRU = EPAR*SINF(U)/DEM1
14 PDVR = 1.*X(3)*COSTRU
C
C      COMPUTE POSITION AND VELOCITY FROM ORBIT ELEMENTS AND TRUE ANOMALY.
C      ALSO, CLEAR THE PERTURBATING ACCELERATIONS.
15 SOMEGA = SINF(X(4))
   COMEGA = COSF(X(4))
   SNODE = SINF(X(5))
   CNODE = COSF(X(5))
   SINCL = SINF(X(6))
   CINCL = COSF(X(6))
   SINV=SINTRU*COMEGA+COSTRU*SOMEGA
   COSV=COSTRU*COMEGA-SINTRU*SOMEGA
   AR=COSV*CNODE-SINV*SNODE*CINCL
   B1=SINV*CNODE+COSV*SNODE*CINCL
   C1=COSV*SNODE+SINV*CNODE*CINCL
   D1=SINV*SNODE-COSV*CNODE*CINCL
   E1 = X(3)*SOMEGA+SINV
   F1 = X(3)*COMEGA+COSV
   AS=E1*CNODE+F1*SNODE*CINCL
   B2=F1*CNODE+CINCL-E1*SNODE
   R = X(8)/PDVR
   RSQRD = R*R
   SINVY=SINV*SINCL
   RB(1) = R*AR
   RB(2) = R*C1
   RB(3) = R*SINVY
   VX(1)=-VCIRCL*AS
   VX(2)=VCIRCL*B2
   VX(3)=VCIRCL*F1*SINCL
   GO TO 18

```

```

C
16 DO 17 K=1,3
   VX(K) = X(K+2)
17 RB(K) = X(K+5)
   RSQRD = RB(1)*RB(1) + RB(2)*RB(2) + RB(3)*RB(3)
   R=SQRT(RSQRD)
18 VSQRD=VX(1)*VX(1)+VX(2)*VX(2)+VX(3)*VX(3)
   V = SQRT(VSQRD)
   DO 19 I=1,15
19 FORCE(I) = 0.
C
C   TEST FOR PRESENCE OF PERTURBING BODIES.
C   IF (MBODYS) 20,21,20
20 CALL EPHMRS
21 IF (XABSF(IMODE)-1) 26,22,26
C
C   TEST FOR CHANGE FROM ORBIT ELEMENTS TO TEMPORARY RECTANGULAR
C   COORDINATES IF E IS TOO NEAR TO UNITY.
22 IF (ETOL-ABSF(EMONE)) 26,23,23
23 IF (IMODE) 54,24,24
24 IMODE=-3
   IF (INSTART) 25,54,25
25 TTEST = X(1)
27 CALL TESTTR
C
C   TEST FOR OBLATENESS PERTURBATION COMPUTATION.
26 IF (OBLATN-BNAME)30,29,30
29 CALL OBLATE
C
C   TEST FOR PRESENCE OF THRUST.
30 XDOT(2) = -FLOW
   IF (R-RATMOS) 31,31,32
31 CALL ICAO
   GO TO 33
32 PRESS=0.
33 IF (PUSHO) 37,36,37
36 ASSIGN 40 TO NDDNE
   GO TO 38
37 CALL THRUST
   ASSIGN 41 TO NDDNE
C
C   TEST FOR EXISTENCE OF ATMOSPHERE.  FIND AERODYNAMIC FORCES.
38 IF (PRESS ) 39,42,39
39 GO TO NDDNE, (40,41)
40 CALL THRUST
41 CALL AERO
C
C   SUM COMPONENTS OF THE PERTURBING ACCELERATION.
42 DO 43 J=1,3
43 COMPA(J) = -QX(J)+OBLAT(J)+FORCE(J)+XIFT(J)+DRAG(J)
44 GO TO (47,45,45),IMODE
C
C   COMPUTE DERIVATIVES FOR THE RECTANGULAR VARIABLES OF INTEGRATION.
45 AA = GK2M/R/RSQRD
   DO 46 K=1,3
   XDOT(K+5) = X(K+2)
46 XDOT(K+2) = COMPA(K)-AA*X(K+5)
   GO TO 54
C
C   COMPUTE THE DERIVATIVES OF THE ORBIT ELEMENTS.  (AFTER RESOLVING
C   PERTURBATING ACCELERATION INTO CIRCUMFERENTIAL, RADIAL, NORMAL COMPONENTS)
47 CIRCUM=COMPA(3)*COSV*SINCL-COMPA(1)*B1-COMPA(2)*D1
   RADIAL=COMPA(1)*AR+COMPA(2)*C1+COMPA(3)*SINVY
   ZORMAL=COMPA(1)*SNODE*SINCL-COMPA(2)*CNODE*SINCL+COMPA(3)*CINCL
   ZN=VCIRCL*E2M1*EPAR/X(8)
   RDVPP1 = 1./PDVR + 1.
   RDVA = E2M1/PDVR
   XDOT(8) = 2.*R/VCIRCL*CIRCUM
   IF (X(3)) 48,48,49
48 CSQRD = CIRCUM*CIRCUM
   RASQRD = RADIAL*RADIAL
   DEM1 = (4.*CSQRD+RASQRD)*VCIRCL
C
C   TEST FOR IN-PLANE PERTURBATION.
   IF (DEM1) 57,56,57
56 XDOT(3) = 0.
   XDOT(4) = 0.
   XDOT(7) = 0.
   GO TO 50
57 VDV2R=VCIRCL/R/2.
   XDOT(3) = SQRT(4.*CSQRD+RASQRD)/VCIRCL
   XDOT(4) = VDV2R*(2.*CSQRD+RASQRD)/DEM1*RADIAL
   XDOT(7) = ZN-VDV2R*(6.*CSQRD+RASQRD)/DEM1*RADIAL
   GO TO 50
49 XDOT(3) = (SINTRU*RADIAL+(PDVR-RDVA)/X(3)*CIRCUM)/VCIRCL
   XDOT(4) = (SINTRU/X(3)*RDVPP1*CIRCUM-COSTRU*RADIAL/X(3))/VCIRCL
   XDOT(7) = ZN+EPAR/VCIRCL*(COSTRU/X(3)-2./PDVR)*RADIAL-(SINTRU/X(3)*
   IRDVPPL*CIRCUM)
50 IF(SINCL) 51,52,51
51 XDOT(5) = SINV/SINCL*ZORMAL/VCIRCL/PDVR
   GO TO 53
52 XDOT(5) = 0.
53 XDOT(6) = COSV*ZORMAL/PDVR/VCIRCL
54 RETURN
55 FORMAT(41HOKEPLERS EQUATION CONVERGENCE FAILURE, U=G15.8,7H DELU=
   IG15.8)
   END

```

```

SUBROUTINE EPHMRS
C SUBROUTINE EPHMRS IS CALLED TO COMPUTE THE POSITIONS OF THE PERTURBING
C BODIES RELATIVE TO THE VEHICLE AND, FROM THESE, THEIR PERTURBING ACCELE-
C TIONS UPON THE VEHICLE. OCCASIONALLY THIS ROUTINE IS CALLED FOR THE PURPOSE
C OF TRANSLATING THE ORIGIN IN WHICH CASE (TRSFER=1) THE RELATIVE VELOCITIES
C ARE ALSO CALCULATED. IF A BODYS POSITION IS TO BE COMPUTED FROM AN ELLIPTIC
C APPROXIMATION SUBROUTINE ELIPSE IS CALLED. OTHERWISE, THE POSITION WILL BE
C CALCULATED IN EPHMRS FROM THE PRECISION TAPE EPHEMERIS. THE DO 19 LOOP
C ENCOMPASSES ALMOST THE ENTIRE EPHMRS SUBROUTINE AND ,IN EFFECT, ELIPSE TOO.
C
COMMON C
C
DIMENSION A(600), B(700), C(4000),
1 QX(3), IBODY(8), EFMRS(7), XP(3,8), RB(3,8), R (8), TIM(7),
2 NEFMRS(8), TDATA(6,3,7), TDEL(7), BMASS(8), VEFM(3,8), DATA(21)
3 , TOAT(18,7)
C
EQUIVALENCE
1(A ,C ( 11)),(AU ,A ( 29)),(B ,C (1111)),
2(BMASS ,B ( 137)),(DTOFFJ,A ( 23)),(EFMRS ,B ( 130)),
3(IBODY ,B ( 177)),(MBOBYS,B ( 42)),(NEFMRS,B ( 185)),
4(QX ,B ( 78)),(R ,B ( 102)),(RB ,B ( 193)),
5(SQRDK ,B ( 35)),(SPD ,A ( 44)),(TABLT ,B ( 20)),
6(TDATA ,B ( 265)),(TDEL ,B ( 170)),(TIM ,B ( 163)),
7(TRSFER,B ( 8)),(VEFM ,B ( 241)),(XP ,B ( 217))
EQUIVALENCE (IBF,FIB), (TOAT,TDATA)
C
PART 2. SET INDEXS, FIND POSITION IF ELLIPSE IS USED (NEFMRS = 20 OR UP).
DD 19 JB=1,MBOBYS
JB1 = JB+1
IBF = IBOBY(JB1)
IB = XABSF(IBF)
IF (NEFMRS(JB)-20) 2,2,1
1 CALL ELIPSE (JB1)
IF (TRSFER) 12,12,17
C
PART 3. TAPE EPHEMERIS IS TO BE USED. FIND DIFFERENCE (DT) BETWEEN
C CURRENT PROBLEM TIME (DTOFFJ+TABLT) AND MIDPOINT TIME (TIM) OF CURRENTLY
C STORED TAPE DATA. THEN SEE IF CURRENT DATA IS OKAY. TDEL = TIME INTERVAL
C ON EITHER SIDE OF TIM FOR WHICH CURRENT DATA IS GOOD.
2 DT = TABLT - (TIM(JB) - DTOFFJ)
IF (ABS(DT)-TDEL(JB)) 10,10,3
C
PART 4A. CURRENT DATA NOT OKAY. READ IN NEXT DATA SET. IF DT IS -,
C BACK UP THE TAPE 2 RECORDS BEFORE READING.
3 IF (DT) 4,5,5
4 BACKSPACE 3
BACKSPACE 3
5 READ TAPE 3, (DATA(I), I=1,21)
C
PART 4B. IF THIS DATA IS FOR A BODY IN THE BNAME LIST, STORE IT.
C (IF NOT STORED, WE MIGHT HAVE TO RETURN FOR IT.) IF ELLIPSE DATA IS
C PROVIDED FOR THE BODY FOUND, BY-PASS THE TAPE DATA AND READ IN NEXT SET.
DO 7 J = 1,MBOBYS
B IF ((DATA(1)+EFMRS(J))*(-DATA(1)*EFMRS(J))) 7,6,7
6 IF (NEFMRS(J)-20) 8,8,3
7 CONTINUE
GO TO 3
C
PART 4C. MOVE THE DATA INTO PLACE AND THEN GO BACK AND SEE IF IT IS OKAY.
C
8 TIM(J) = DATA(2)
TDEL(J) = DATA(3)
DO 9 JJ=1,18
TDAT(JJ,J) = DATA(JJ+3)
9 CONTINUE
GO TO 2
C
PART 5. CURRENT DATA IS OKAY. GET POSITION FROM THE POLONOMIAL
C
P = A + BX + CX**2 + DX**3 + EX**4 + FX**5.
DO 11 K=1,3
XP(K,JB1) = TDATA(1,K,JB)
DO 11 KT=2,6
XP(K,JB1) = XP(K,JB1)* DT +TDATA(KT,K,JB)
11 CONTINUE
IF (TRSFER) 12,12,15
C
PART 6. COMPUTE DISTANCE FROM REFERENCE AND FROM ROCKET .
C
12 DD 13 K=1,3
XP(K,JB1) = XP(K,IB) +XP(K,JB1)*SIGNF(AU,FIB)
13 RB(K,JB1) = RB(K,1) - XP(K,JB1)
C
PART 7. COMPUTE PERTURBING ACCELERATIONS (QX). 4194304=2**22 IS REMOVED
C TO PREVENT OVERFLOW. 2048=2**11 AND 8589934592=2**33 RESTORE THE SCALE.
C
PRSQRD = (RB(1,JB1)**2 + RB(2,JB1)**2 + RB(3,JB1)**2)/4194304.
RRELL = SQRTF(PRSQRD)
RSQRD = ( XP(1,JB1)**2 + XP(2,JB1)**2 + XP(3,JB1)**2)/4194304.
RCUBE = RSQRD * SQRTF(R SQRD)
PRCUBE = PRSQRD * RRELL
R(JB1) = RRELL*2048.
DO 14 K=1,3
14 QX(K)=SQRDK * BMASS(JB1) * ((XP(K,JB1)/RCUBE) + RB(K,JB1)/PRCUBE)/
1 8589934592. + QX(K)
GO TO 19
C
PART 8. COMPUTE VELOCITY FROM V = B + 2CX + 3DX**2 + 4EX**3 + 5FX**4
C AND FROM REFERENCE BODY VELOCITY (VEFM(IB)).
C
15 DO 16 K=1,3
VEFM(K,JB1) = 0.
DO 16 KT=1,5
16 VEFM(K,JB1) = (VEFM(K,JB1)*DT+TDATA(KT,K,JB)*FLDADF(-KT+6))
17 DO 18 K=1,3
18 VEFM(K,JB1) = VEFM(K,IB) + VEFM(K,JB1)*SIGNF(AU/SPD,FIB)
GO TO 12
19 CONTINUE
RETURN
END

```

```

C      SUBROUTINE EXTRA
C
C      THIS ROUTINE IS EXECUTED BETWEEN FLIGHTS AND MAY THEREFORE BE EXPANDED TO
C      DO ADDITIONAL COMPUTATION BETWEEN SUCCESSIVE FLIGHTS.
C
C      COMMON C
C
C      DIMENSION A(600), B(700), C(4000)
C
C      EQUIVALENCE
1(A ,C ( 11)),(B ,C (1111)),(QMAX ,B ( 44)),
2(SIGNAL,B ( 31))
C
C      SIGNAL = 0.
C      QMAX = 0.
C      RETURN
C      END

C
C      SUBROUTINE EXTRAS
C
C      THIS ROUTINE IS EXECUTED BETWEEN STAGES AND MAY THEREFORE BE EXPANDED TO
C      DO CALCULATIONS BETWEEN SUCCESSIVE STAGES OF A FLIGHT.
C
C      RETURN
C      END

C
C      SUBROUTINE ELIPSE (JB1)
C
C      THIS SUBROUTINE IS CALLED FROM EPHMRS TO COMPUTE THE POSITION OF A BODY
C      USING APPROXIMATE ELLIPTIC DATA. THE VELOCITY IS ALSO COMPUTED IF THE
C      ORIGIN IS BEING TRANSLATED (TRSFER=1.0). THE ELLIPSE DATA IS READ FROM
C      INPUT CARDS AND ORGANIZED IN SUBROUTINE ORDER. TPD IS TIME SINCE PERIHELION
C      PASSAGE, ZM IS MEAN ANOMALY, U IS ECCENTRIC ANOMALY.
C      TDATA ARRAY - (K) SEMILATUS RECTUM (K+7) PERIOD
C                   (K+1) ECCENTRICITY (K+8) SIN OMEGA
C                   (K+2) OMEGA (K+9) SIN NODE
C                   (K+3) NODE (K+10) SIN INCLINATION
C                   (K+4) INCLINATION (K+11) COS OMEGA
C                   (K+5) JD OF PERIHELION (K+12) COS NODE
C                   (K+6) FRACTIONAL PART OF (K+5) (K+13) COS INCLINATION
C
C      COMMON C
C
C      DIMENSION A(600), B(700), C(4000),
1 XP(3,8), VEFM(3,8), TDATA(121)
C
C      EQUIVALENCE
1(A ,C ( 11)),(B ,C (1111)),(CONSU ,A ( 31)),
2(OTOFFJ,A ( 23)),(TABLT ,B ( 20)),(TDATA ,B ( 265)),
3(TRSFER,B ( 8)),(VEFM ,B ( 241)),(XP ,B ( 217))
C
C      K = 18*(JB1-2)+1
C      TPD = (OTOFFJ-TDATA(K+5))+(TABLT-TDATA(K+6))
C      ZM = 6.28318533/TDATA(K+7)
C      ZM = ZM*MODF(TPD,TDATA(K+7))
C
C      GET THE SINE(SINTRU) AND THE COSINE (COSTRU) OF THE TRUE ANOMALY
C      BY ITERATING KEPLERS EQUATION. THEN COMPUTE X,Y,Z (XP).
C      U = ZM*TDATA(K+1)*SINF(ZM)+.5*TDATA(K+1)**2*SINF(2.*ZM)
C      DO 1 J=1,10
C      DELM = ZM-U+TDATA(K+1)*SINF(U)
C      DELU = DELM/(1.-TDATA(K+1)*COSF(U))
C      U = U+DELU
C      IF (ABSF(DELM)-CONSU) 2,2,1
1 CONTINUE
2 COSU = COSF(U)
C      DENOM = 1.-TDATA(K+1)*COSU
C      COSTRU = (COSU-TDATA(K+1)*COSU)/DENOM
C      R = TDATA(K)/(1.+TDATA(K+1)*COSTRU)
C      SINTRU = SQRTF(1.-TDATA(K+1)**2)*SINF(U)/DENOM
C      SINV = SINTRU*TDATA(K+11)+COSTRU*TDATA(K+8)
C      COSV = COSTRU*TDATA(K+11)-SINTRU*TDATA(K+8)
C      XP(1,JB1) = R*(COSV*TDATA(K+12)-SINV*TDATA(K+9)*TDATA(K+13))
C      XP(2,JB1) = R*(COSV*TDATA(K+9)+SINV*TDATA(K+12)*TDATA(K+13))
C      XP(3,JB1) = R*SINV*TDATA(K+10)
C      IF (TRSFER) 3,4,3
C
C      COMPUTE THE VELOCITIES FOR THE TRSFER OF ORIGIN.
3 EX = TDATA(K+1)*TDATA(K+8)+SINV
FX = TDATA(K+1)*TDATA(K+11)+COSV
CFACT = ZM*TDATA(K)/(SQRTF((1.-TDATA(K+1)**2)**3))
AX = EX*TDATA(K+12)+FX*TDATA(K+9)+TDATA(K+13)
BX = FX*TDATA(K+12)+TDATA(K+13)-EX*TDATA(K+9)
VEFM(1,JB1) = -AX*CFACT
VEFM(2,JB1) = BX*CFACT
VEFM(3,JB1) = FX*CFACT*TDATA(K+10)
4 RETURN
C      END

```



```

      REM      SUBROUTINE EXADD (A,B,C)
      REM THIS ROUTINE WILL ADD IN DOUBLE PRECISION A QUANTITY C TO THE DOUBLE
      REM PRECISION VARIABLE A+B WHERE A IS THE MOST SIGNIFICANT PART AND B IS
      REM THE LEAST SIGNIFICANT PART.
      ENTRY  EXADD
      COMMON -206
Q1  COMMON 1
Q2  COMMON 1
TEMP1 COMMON 1
TEMP2 COMMON 1
      HTR
      BCI      1,EXADD
      SXD     *-4,1
      SXD     *-4,2
EXADD SXD     *-4,4
      CLA*    1,4
      FAD*    3,4
      STQ     Q1
      FAD*    2,4
      STQ     Q2
      FAD     Q1
      STQ     Q1
      STO     TEMP1
      CLA     Q1
      FAD     Q2
      STO     TEMP2
      FAD     TEMP2
      FAD     TEMP1
      STQ     Q1
      FSB     TEMP2
      STO*    1,4
      STQ     Q2
      CLA     Q1
      FAD     Q2
      STO*    2,4
      TRA     4,4
      END

```

```

      SUBROUTINE ICAO
C  SUBROUTINE ICAO DETERMINES THE ATMOSPHERIC TEMPERATURE, PRESSURE, AND
C  DENSITY AS A FUNCTION OF ALTITUDE ABOVE THE EARTH IN ACCORDANCE WITH
C  THE 1962 U.S. STANDARD ATMOSPHERE (ICAO TO 20 KM.). A SHORT FAP
C  PROGRAM FOLLOWS ICAO WHICH PROVIDES A MEANS OF LOADING DATA INTO MACHINE.
C  IT MUST BE LOADED DIRECTLY AFTER ICAO. IF THE LENGTH OF ICAO IS CHANGED,
C  THE DATA MUST BE RELOCATED.
C
C      R IS DISTANCE TO CENTER OF EARTH IN METERS.
C      ALT IS VEHICLE ALTITUDE ABOVE EARTH IN METERS.
C      TABLE H IS METERS OF ALTITUDE FROM THE EARTH'S SURFACE AND IS
C      THE ARGUMENT OF ATMOSPHERE PROPERTY TABLE.
C      ALM IS THE MEAN SLOPE OF THE TABLE H VS. TM CURVE AT TABLE H.
C      TMR IS TM AT TABLE H.
C      REF P IS THE PRESSURE IN MILLIBARS AT TABLE H.
C      TM IS THE TEMPERATURE TIMES STD. MOLECULAR WEIGHT / ACTUAL
C      MOLECULAR WEIGHT. DEGREES KELVIN.
C      PRESS IS PRESSURE IN MILLIBARS.
C      DENSITY IS DENSITY IN KILOGRAMS PER CUBIC METER.
C      HEIGHT IS EITHER GEOPOTENTIAL ALTITUDE OR GEOMETRIC ALTITUDE IN METERS.
C
      COMMON C
C
      DIMENSION A(600), B(700), C(4000),
      1 TABLEH(23), TMR(23), REFP(23), ALM(23) , RB(3)
C
      EQUIVALENCE
      1(A ,C ( 11)),(ALT ,A ( 4)),(B ,C (1111)),
      2(DENSITY,B ( 29)), (OBLATN,A ( 40)),
      3(PRESS ,B ( 33)),(R ,B ( 102)),(RB ,B ( 193)),
      4(RE ,A ( 25)),(TABLT ,B ( 20)),(TM ,B ( 34)),
      5(RESQRD,B ( 7))
      EQUIVALENCE (TABLEH(24),TMR),(TABLEH(47),ALM),(TABLEH(70),REFP)
C
      IF (OBLATN) 102,101,102
      101 ALT = R - RE
      GO TO 103
      102 ALT = R-6356783.28/SQRTF(1.9933065783+.006693421685(RB(3)/R)**2)
      103 IF (ALT-90000.) 105,104,104
      104 HEIGHT = ALT
      GO TO 106
      105 HEIGHT = ALT/(1.0+ALT/6356766.)
      106 K=K
C
      FIND THE HEIGHT IN A TABLE OF BASE DATA. DATA ARE
      ARRANGED IN DESCENDING ALT WITH 21 REGIONS. ABOVE THAT, PRESSURE AND
      DENSITY ARE SET = 0. TEMPERATURE IS SET TO 3000.
C
      1 IF (K-22) 2,6,6
      2 IF (HEIGHT-TABLEH(K+1)) 5,3,3
      3 K = K+1
      GO TO 1
      4 K = K-1
      5 IF (K) 7,7,6
      6 HINC = HEIGHT - TABLEH(K)
      IF (H INC) 4,8,8
      7 K = 1
      8 IF (ALM(K)) 9,100,9
C

```

```

C CONTROL COMES HERE FOR NONISOTHERMAL LAYERS
9 TM = TMR(K) + ALM(K)*H INC
IF (ALT-90000.) 107,107,108
107 PRESS = REFP(K)*(TMR(K)/TM)**(.0341631947/ALM(K))
GO TO 10
108 IF (K-KC) 109,110,109
109 KC = K
C1 = RE+TABLEH(K)
C2 = TMR(K)/ALM(K)
C3 = 1./(C1-C2)
C4 = -.0341631947*RESQRD*C3/ALM(K)
110 PRESS = REFP(K)*EXPF(C4*(C3*LOGF(C1*(HINC/C2+1.)/(RE+HEIGHT))-
1 HINC/C1/(RE+HEIGHT)))
10 DENSITY = PRESS/TM/2.87053072
GO TO 13

C
C CONTROL COMES HERE FOR ISOTHERMAL LAYERS
100 IF (K-22) 11,12,12
11 TM = TMR(K)
PRESS = REFP(K)*EXPF(-.0341631947*HINC/TMR(K))
GO TO 10

C
C CONTROL COMES HERE FOR EXTREME ALTITUDES
12 PRESS = 0.0
DENSITY = 0.0
TM = 3000.
13 RETURN
END

REM THIS IS THE FAP PROGRAM WHICH LOADS ICAO DATA INTO MACHINE.
REM THE 256 IN ORG 256 WAS FOUND BY SUBTRACTING 22 FROM THE DEC LOCATION
REM OF REF P (FROM FAP LISTING OF ICAO, THIS WAS FOUND TO BE 278).
REM THUS, 278-22=256. DISCARD THE FIRST TWO BINARY CARDS AFTER ASSEMBLY
REM AND PLACE REMAINING CARDS IMMEDIATELY BEHIND ICAO BINARY DECK.
REM
REM A1 IS REF P(23)
REM A2 IS ALM(23)
REM A3 IS TMR(23)
REM A4 IS TABLE H(23)
REM
ORG 256
A1 DEC 0.,1.1918E-9,3.4502E-9,1.0957E-8,4.0304E-8,1.8838E-7
DEC 6.9604E-7,1.6852E-6,2.7926E-6,3.6943E-6,5.0617E-6,2.5217E-5
DEC 7.3544E-5,3.0075E-4,1.6438E-3,.010377,.182099,.590005
DEC 1.10905,8.68014,54.7487,226.320,1013.25
A2 DEC 0.,0.,.0011,.0017,.0026,.0033,.004,.005,.007,.01,.015,.02,.01
DEC .005,.003,0.,-.004,-.002,0.,.0028,.001,0.,-.0065
A3 DEC 0.,2700.65,2590.65,2420.65,2160.65,1830.65,1550.65,1350.65
DEC 1210.65,1110.65,960.65,360.65,260.65,210.65,180.65,180.65
DEC 252.65,270.65,270.65,228.65,216.65,216.65,288.15
A4 DEC 1E30,7E5,6E5,5E5,4E5,3E5,2.3E5,1.9E5,1.7E5,1.6E5,1.5E5,1.2E5
DEC 1.1E5,1E5,.9E5,79000.,61000.,52000.,47000.,32000.,20000.
DEC 11000.,0.
END

```

SUBROUTINE NBDODY

```

C
C NBDODY COMPUTES THE TRAJECTORY IN EITHER ORBIT ELEMENTS OR RECTANGULAR
C COORDINATES USING THE RUNGE-KUTTA TECHNIQUE. A LOWER ORDER INTEGRATION
C TECHNIQUE IS ALSO PERFORMED TO FACILITATE AUTOMATIC STEP SIZE CONTROL.
C THE X,XPRIM,XDOT,XINC,ETC. ARRAYS ARE AS FOLLOWS.
C
C X ORBIT ELEMENTS RECTANGULAR COORDINATES
C
C 1 TIME TIME
C 2 MASS MASS
C 3 ECCENTRICITY X-VELOCITY
C 4 ARGUMENT OF PERICENTER Y-VELOCITY
C 5 ARGUMENT OF ASC. NODE Z-VELOCITY
C 6 INCLINATION X
C 7 MEAN ANOMALY Y
C 8 SEMILATUS RECTUM Z
C
C
C INMODE VARIABLES
C 1 ORBIT ELEMENTS
C 2 RECTANGULAR
C 3 RECTANGULAR TEMPORARY
C 4 EARTH SPHERICAL--CHANGE TO RECTANGULAR
C -1 ORBIT ELEMENTS--CHANGE TO RECTANGULAR
C -2 RECTANGULAR--CHANGE TO ORBIT ELEMENTS
C -3 ORBIT ELEMENTS--CHANGE TO TEMPORARY RECTANGULAR
C -4 EARTH SPHERICAL -- CHANGE TO ORBIT ELEMENTS
C
C COMMON C
C DIMENSION A(600), B(700), C(4000),
1 XPRIM (100,2), XPRIMB (100,2), XDOTPM (100,2),
2 X (100), XINC (100), OLDINC (100),
3 XDOT (100), RB (3), XK (100),
4 AMC (3), AK (3), AW (4),
5 XWHOLE (6), VX (3), BEX (14)
C

```

```

EQUIVALENCE
1(A ,C ( 11)),(A1 ,B ( 10)),(A2 ,B ( 11)),
2(ACOEFL,B ( 12)),(ACOEFL2,B ( 13)),(ACOEFL3,B ( 14)),
3(AK ,A ( 51)),(AMC ,B ( 87)),(AMSQRD,B ( 91)),
4(AM ,B ( 90)),(ASYMPT,A ( 7)),(AW ,A ( 55)),
5(B ,C (1111)),(CUNSTU,A ( 32)),(DELT ,B ( 1)),
6(DONE ,B ( 39)),(E2 ,B ( 18)),(EMONE ,B ( 28)),
7(ERLIMT,A ( 14)),(ETOL ,A ( 30)),(EXMODE,B ( 27)),
8(GK2M ,B ( 36)),(H2 ,B ( 15)),(IMODE ,A ( 1)),
9(INDERR,B ( 51)),(KSUB ,B ( 19)),(MBODYS,B ( 42))
EQUIVALENCE
1(NEQ ,A ( 2)),(NSTART,B ( 24)),(OLDDEL,B ( 9)),
2(QMAX ,B ( 44)),(RATIO ,B ( 58)),(RB ,B ( 193)),
3(REVS ,A ( 48)),(IR ,B ( 102)),(STEPMX,A ( 16)),
4(STEPGO,A ( 41)),(STEPNO,A ( 42)),(TRSFER,B ( 8)),
5(STRU ,B ( 40)),(TTEST ,A ( 54)),(VSQRD ,B ( 96)),
6(VX ,B ( 92)),(XDOT ,B ( 50)),(XINC ,B ( 60)),
7(XPRIM ,C ( 71)),(XPRIMB,C ( 91)),(XWHOLE,B ( 110)),
8(X ,B ( 40)),(ERLOG ,B ( 17)),(EREF ,A ( 13)),
9(Q ,B ( 59)),(OUTPUT,B ( 399))
C
C PART 1. SET UP THE STARTING SEQUENCE FOR ERROR CONTROL AND DELAY CHECKING
C THE ERROR UNTIL TWO STEPS ARE COMPLETED. THE ASSIGNED GO TOS NSTART AND
C IBEGIN CONTROL STARTING.
NEQ = NEQ
1 DO 2 J=1,NEQ
XPRIM(J,2) = XPRIM(J,1)
XPRIMB(J,2) = XPRIMB(J,1)
2 X(J) = XPRIM(J,1)
NSTART = 0
TRSFER = 0.
H2 = DELT
DELT = DELT/2.
220 CALL EQUATE
IF (OUTPUT) 222,221,222
221 CALL OUTPUT
222 DO 3 J=1,3
XWHOLE(J)=VX(J)
3 XWHOLE(J+3) = RB(J)
C CHANGE INTEGRATION VARIABLES IF IMODE IS -.
IF (IMODE) 4,5,5
4 CALL TESTTR
GO TO 1
5 CALL TESTTR
IF (TRSFER) 1,205,1
205 ASSIGN 21 TO NSTART
C STATEMENTS 7 TO 9 INITIALIZE NREV1 AND NREV2 FOR USE IN PART 7A.
IF (RB(2)) 7,6,8
6 IF (VX(2)) 7,8,8
7 ASSIGN 37 TO NREV1
ASSIGN 35 TO NREV2
GO TO 9
8 ASSIGN 33 TO NREV1
ASSIGN 37 TO NREV2
9 DO 10 J=1,NEQ
XDOTPM(J,1) = XDOT(J)
XINC(J) = 0.
10 CONTINUE
11 KSUB = 1
ASSIGN 16 TO N
C
C PART 2. RUNGE-KUTTA SUBINTERVAL SCHEME. EQUATE PRODUCES THE NECESSARY
C DERIVATIVES XDOT(J).
12 DO 13 J=1,NEQ
XK(J) = XDOT(J) * DELT
XINC(J) = XINC(J) + AW(KSUB)*XK(J)
13 X(J) = XPRIM(J,2) + AK(KSUB)*XK(J)
14 CALL EQUATE
15 GO TO N,(16,17,18,20)
C
C PART 3. SUBINTERVALS 2, 3, AND 4, TO STATEMENT 19 FINISH A
C RUNGE-KUTTA STEP AND INCREMENT XPRIM(J,2) IN DOUBLE PRECISION.
16 KSUB = 2
ASSIGN 17 TO N
GO TO 12
17 KSUB = 3
ASSIGN 18 TO N
GO TO 12
18 DO 19 J=1,NEQ
XINC(J) = XINC(J) + AW(4) *XDOT(J) * DELT
180 CALL EXADD(XPRIM(J,2), XPRIMB(J,2), XINC(J))
X(J) = XPRIM(J,2)
19 CONTINUE
C
C PART 4. BEGIN A NEW RUNGA-KUTTA STEP. THIS ALSO GIVES DERIVATIVES
C FOR THE LOWER ORDER INTEGRATION CHECK.
ASSIGN 20 TO N
GO TO 14
20 GO TO NSTART,(27,23,21)
C
C PART 5. STARTING PHASE PROGRAM.
C PART 5A. THIS SECTION COMPLETES THE FIRST STEP OF STARTING PHASE.
21 ASSIGN 23 TO NSTART
DO 22 J=1,NEQ
OLDINC(J)=XINC(J)
XINC(J)=0.
XDOTPM(J,2) = XDOT(J)
22 CONTINUE
GO TO 11
C

```

```

C PART 5B. MAX ERROR TEST--STARTING ONLY--CHECK THE MAX ERROR AND
C EITHER ENTER RUNNING MODE OR REPEAT START WITH SMALLER STEP.
23 DO 24 J=2,NEQ
24 XINC(J) =(XINC(J)+OLDINC(J))*3.-(XDOTPM(J,1)+XDOTPM(J,2))*4.
1+XDOT(J)*DELTA
240 CALL ERRORZ
25 IF (E2-ERLIMT) 26,26,56
26 ASSIGN 27 TO NSTART
ASSIGN 11 TO IBEGIN
A1 = A2
GO TO 31
C
C PART 6. RUNNING PHASE PROGRAM.
C PART 6A. CHECK THE INTEGRATION BY INTEGRATING OVER THE LAST
C RUNGE KUTTA STEP BUT USE DOTS FOR LAST TWO INTERVALS, OLDDDEL
C AND DELT RESPECTIVELY. STATEMENT 28 IS THE LOWER INTEGRATION
C MINUS RUNGE-KUTTA INCREMENTS. ERRORZ COMPUTES THE MAXIMUM RELATIVE
C ERROR AND STATEMENT 29 TESTS THIS ERROR AGAINST THE LIMIT VALUE.
27 RATIO = DELT/OLDDDEL
HFACT=DELT/(1.+RATIO)
ACDEF1=-RATIO*RATIO*HFACT
ACDEF2=RATIO*(DELT+3.*OLDDDEL)
ACDEF3=DELT+DELT+HFACT
DO 28 J=2,NEQ
28 XINC(J) = ACDEF1*XDOTPM(J,1)+ACDEF2*XDOTPM(J,2)-6.*XINC(J)
1+ACDEF3*XDOT(J)
280 CALL ERRORZ
29 IF (E2-ERLIMT) 30,30,57
C
C PART 7A. LAST POINT OKAY. COUNT THE REVOLUTIONS PAST THE X-AXIS.
C A STEP GREATER THAN 1/2 REV. MAY FAIL TO ADD IN.
30 H2 = DELT
31 QMAX = MAXIF(Q,QMAX)
IF (RB(2)) 32,34,34
32 GO TO NREV1, (37,33)
33 ASSIGN 37 TO NREV1
ASSIGN 35 TO NREV2
GO TO 37
34 GO TO NREV2, (37,35)
35 ASSIGN 33 TO NREV1
ASSIGN 37 TO NREV2
36 REVS = REVS + 1.
37 IF (XABSF(IMODE)-1) 42,38,42
C
C PART 7B. IN ORBIT ELEMENTS. ADJUST ARGUMENT OF PERICENTER AND MEAN ANOMALY
C TO + OR - PI TO MAINTAIN ACCURACY IN SIN-COS ROUTINES.
38 IF (EMONE) 39,42,42
39 DO 41 J=4,7,3
ADJ2=INT(XPRIM(J,2)/6.28318532+SIGNF(.5,XPRIM(J,2)))
IF (ADJ2) 40,41,40
40 ADJ3 = -ADJ2*28125
400 CALL EXADD(XPRIM(J,2),XPRIMB(J,2),ADJ3)
ADJ3=-ADJ2*.0019353072
401 CALL EXADD(XPRIM(J,2),XPRIMB(J,2),ADJ3)
41 CONTINUE
C
C PART 7C. ADVANCE THE REMAINING PARAMETERS, FIND NEW STEP SIZE,
C AND TEST FOR AN ORIGIN TRANSLATION.
42 DO 43 K=1,3
XWHOLE(K)=VX(K)
43 XWHOLE(K+3) = RB(K)
DO 44 J=1,NEQ
XDOTPM(J,1) = XDOTPM(J,2)
XDOTPM(J,2) = XDOT(J)
XPRIM(J,1) = XPRIM(J,2)
XPRIMB(J,1) = XPRIMB(J,2)
XINC(J) = 0.
44 CONTINUE
OLDDDEL = DELT
45 CALL STEP
IF (DONE) 67,450,67
450 IF (NSTART) 451,1,451
451 IF (MBODYS) 46,47,46
46 CALL TESTTR
IF (TRSFER) 1,47,1
47 IF (XABSF(IMODE)-3) 11,48,11
C
C PART 7D. IF IN TEMPORARY RECTANGULAR COORDINATES, TEST FOR RETURN
C TO ORBIT ELEMENTS. FIRST, E IS FOUND. IF TIME HAS NOT ADVANCED
C SUFFICIENTLY, INTEGRATION CONTINUES IN RECTANGULAR VARIABLES (STATE. 48).
C STATEMENT 49 DETERMINES IF KEPLERS EQUATION CAUSED IMODE = 3. IF NOT,
C AN E CLOSE TO 1 CHECK IS MADE IN STATEMENT 50. IF IT DID, RECTANGULAR
C VARIABLES WILL BE USED IF THE LIMIT IS TOO SMALL (STATEMENT 52), OR
C IF E IS 5 OR GREATER (STATEMENT 53) OR IF THE PATH LIES CLOSE TO AN
C ASYMPTOTE (STATEMENT 55).
48 CALL CONV1 (VX,AMC)
EXMODE=SQRTF(1.+AMSQRD/GK2M*(VSQRD/GK2M-2./R))
EMONE=EXMODE-1.
IF ((XPRIM(1)-TTEST)*DELT) 11,11,49
49 IF (ASYMPT) 51,50,51
50 IF (ETOL-ABSF(EMONE)) 55,11,11
51 IF (EMONE) 55,55,52
52 IF (CONSTU-1.E-7) 11,53,53
53 IF (EXMODE-5.) 54,11,11
54 CALL CONV2
IF (ABSF(TRU)-2.2/SQRTF(EXMODE)) 55,55,11
55 ASYMPT = 0.0
IMODE=-2
555 CALL TESTTR
GO TO 1
C

```

```

C PART 8. COMES HERE WHEN ERROR TEST FAILED--BOTH STARTING AND RUN.
C RETRIEVE OLD POINT AND RECOMPUTE WITH SMALLER INTERVAL.
C IF TWO CONSECUTIVE TRYS FAIL (STATEMENT 59) THE STARTING SEQUENCE OCCURS.
56 ASSIGN I TO IBEGIN
57 DO 58 J=1,NEQ
XPRIM(J,2) = XPRIM(J,1)
XPRIMB(J,2) = XPRIMB(J,1)
XDOT(J)=XDOTPM(J,2)
XINC(J)= 0.
58 CONTINUE
STEPNO=STEPNO+1.
H2 = DELT
DELT=SIGNF(EXPF((ERLOG-A2)/5.),DELT)
A2 =A1
59 IF (FAIL-STEPGD) 60,61,60
60 FAIL = STEPGD
GO TO IBEGIN, (11,1)
61 ASSIGN I TO IBEGIN
IF (STEPNO + STEPGD - STEPMX) 62,62,45
62 GO TO IBEGIN, (11,1)
C
C PART 10. PRINT OUT THE ERROR INFO. IF EREF HAS A - SIGN. THEN RETURN.
67 IF (EREF) 68,72,72
68 WRITE OUTPUT TAPE 6,70
REWIND 4
DO 69 I=1,INDERR
READ TAPE 4, BEX
69 WRITE OUTPUT TAPE 6,71,BEX
REWIND 4
INDERR = 0
70 FORMAT(7H1 STEP,6X,4HTIME,6X,4HDELT,7X,2HA2,8X,2HE2,7X,4HMASS,6X,
14HE,VX,4X,8HOMEGA,VY,2X,8HNODES,VZ,3X,6HINCL,X,5X,4HMA,Y,6X,3HP,Z,
24X,1HK//)
71 FORMAT(F5.,1H+F3.,1P11G10.2,12)
72 RETURN
END
C
C SUBROUTINE ORDER
C THIS ROUTINE TAKES THE BODY LIST READ FROM CARDS AND SORTS THEM IN
C ORDER SO THAT THE DISTANCE FROM THE REFERENCE TO EACH BODY IS
C DEPENDENT UPON ALREADY COMPUTED DISTANCES ONLY.
C
C ELLIPSE DATA ARE READ INTO A BLOCK OF 120 STORES RESERVED FOR
C TEN ELLIPSES. ONE ELLIPSE IS READ INTO A 12 STORE BLOCK.
C THE SINES AND COSINES OF THE 3 ANGLES ARE COMPUTED AND STORED
C IN THE TDATA ARRAY ALONG WITH THE REST OF THE ELLIPSE DATA.
C A BLOCK IS ARRANGED AS FOLLOWS*
C
C (1) = NAME OF BODY IN BCD,ONLY 6 CHARACTERS.
C (2) = NAME OF REFERENCE BODY IN BCD,SAME RESTRICTION.
C (3) = MASS OF THE BODY IN SUN MASS UNITS.
C (4) = RADUIS INSIDE OF WHICH COORDINATES WILL BE TRANSLATED TO THIS BODY.
C (5) = SEMILATUS RECTUM IN ASTRONOMICAL UNITS.
C (6) = ECCENTRICITY OF THE ORBIT.
C (8) = LONGITUDE OF ASCENDING NODE.
C (7) = ARGUMENT OF PERIHELION.
C (9) = INCLINATION OF THE ORBIT.
C (10)= PERIGEE PASSAGE JULIAN DAY.
C (11)= PERIGEE PASSAGE FRACTION OF DAY.
C (12)= PERIOD OF THE ELLIPSE IN MEAN SOLAR DAYS.
C
C AMASS = MASS OF EACH BODY, SUN MASSES. ORDER OF PNAME.
C BMASS = SELECTED FROM AMASS. CORRESPONDS TO BNAME LIST.
C BNAME = THE ORDERED LIST OF BCD BODY NAMES. CAN BE USED IN OUTPUT.COMMON.
C BODYCD = THE ORIGINAL BCD NAMES READ FROM CARDS.
C BODY L = THE LIST OF BCD BODY NAMES WITH THE REFERENCE BODY AT TOP.
C INITIALLY EQUAL TO BODY CARD LIST (BODYCD)
C IBODY = ARRAY OF SUBSCRIPTS. WHEN A DISTANCE IS FOUND FROM EPHEMERIS, IT
C MAY BE ADDED (OR SUBTRACTED) FROM THE BODY POSITION GIVEN BY
C XPI(BODY) TO OBTAIN THE POSITION OF THE PRESENT BODY. COMMON.
C KZERO = COUNT OF ZERO REFERENCES. THERE MUST BE ONE AND ONLY ONE ZERO.
C FROM LOCATION IN BNAME LIST. NOT IN COMMON.
C MANE = ARRAY OF SUBSCRIPTS. INVERSE OF NAME. GIVES NEW LOCATION OF
C BNAME LIST IN TERMS OF BODYL. NOT IN COMMON.
C NBODYS = COUNTED INTERNALLY. TOTAL NUMBER OF BODYS.
C MBODYS = COMPUTED INTERNALLY. TOTAL NUMBER OF EPHEMERIDES (NBODYS-1).
C NAME = ARRAY OF SUBSCRIPTS. GIVES OLD LOCATION OF NAMES IN BODYL
C NEFMRS = ARRAY OF SUBSCRIPTS. GIVES LOCATION OF BODY IN PNAME LIST
C IN TERMS OF THE EFMRS LIST. STORED IN COMMON.
C NREFER = ARRAY OF SUBSCRIPTS. LOCATES THE REFERENCE BODY IN BODYL.
C ORDER OF THE ARRAY CORRESPONDS TO BODYL. NOT IN COMMON.
C NNREFER = ARRAY OF SUBSCRIPTS. LIKE NREFER BUT REFERS AND CORRESPONDS TO
C BNAME LIST. NOT IN COMMON.
C PNAME = A PERMANENT LIST OF BCD BODY NAMES. 1 WORD EACH (6 CHARACTERS
C MAX). USED TO IDENTIFY MASS, REFERENCE NAMES, ETC. THE LIST IS
C A MAXIMUM OF 30 NAMES. PRECISION TAPE NAMES ARE FROM 1 TO 20,
C ELLIPTIC NAMES ARE FROM 21 TO 30.
C REFER = A PERMANENT LIST OF BCD BODYS THAT ARE THE REFERENCES OF
C DISTANCES GIVEN IN EPHEMERIDES (TAPES OR ELLIPSE). CORRESPONDS
C TO PNAME LIST.
C
C COMMON C
C
C DIMENSION A(600), B(700), C(4000),
1 AMASS (30), BMASS (8), BNAME (8),
2 BODYL (8), EFMRS (7), IBODY (8),
3 MANE (8), NAME (8), NEFMRS (8),
3 NEFMRT (8), NNREFER (8), BODYCD (8),
4 NREFER (8), PNAME (30), RBCRIT (7),
5 RCRIT (30), REFER (30), TDATA (18,7),
6 TDEL (7), TIM (7), ELIPS (120),
7 NDUD (9), XPRIM (200)

```

```

EQUIVALENCE
1(A ,C ( 11)),(AMASS ,A ( 347)),(ATMN ,A ( 21)),
2(AU ,A ( 29)),(B ,C (1111)),(BMASS ,B ( 137)),
3(BNAME ,B ( 122)),(BODYCD,A ( 143)),(BODYL ,B ( 153)),
4(EFMRS ,B ( 130)),(ELIPS ,A ( 167)),(FILE ,B ( 22)),
5(GK2M ,B ( 36)),(GKM ,B ( 37)),(IBODY ,B ( 177)),
6(MBODYS,B ( 42)),(NBODYS,B ( 41)),(NEFMRS,B ( 185)),
7(PNAME ,A ( 287)),(RATMOS,B ( 23)),(RATM ,A ( 22)),
8(RBCRIT,B ( 145)),(RCRIT ,A ( 377)),(REFER ,A ( 317)),
9(RE ,A ( 25)),(RESQRD,B ( 7)),(REVOLV,B ( 21))
EQUIVALENCE
1(ROTATE,A ( 39)),(SPD ,A ( 44)),(SQRDK1,A ( 47)),
2(SQRDK ,B ( 35)),(TDATA ,B ( 265)),(TDEL ,B ( 170)),
3(TFILE ,A ( 6)),(TIM ,B ( 163)),(TRANSFER,B ( 8)),
4(XPRIM ,C ( 71)),(OUTPOT,B ( 399))
EQUIVALENCE (MANE(1),NOUD(2))
C
C THIS SECTION SEES WHAT ELLIPSE DATA WAS READ FROM CARDS AND PUTS THE
C NAMES IN PLACE SO THAT DATA WILL BE USED IF NEEDED. ELLIPSE DATA HAS
C PRIORITY OVER TAPE DATA BECAUSE LAST DATA IN LIST IS THAT ACTUALLY USED.
C FUNCTION COMPARF(A,B) IS EQUIVALENT TO (A-B) BUT WILL NOT OVERFLOW.
C
B COMPARF(A,B) = (A+B)*(-(A*B))
DO 2 K=1,120,12
IF (ELIPS(K)) 1,2,1
1 KOUNT = (K-1)/12+21
PNAME(KOUNT) = ELIPS(K)
REFER(KOUNT) = ELIPS(K+1)
AMASS(KOUNT) = ELIPS(K+2)
RCRIT(KOUNT) = ELIPS(K+3)
2 CONTINUE
C
C PART 0. THROW AWAY BLANKS AND DUPLICATES IN BNAME LIST.
C ALSO COUNT THE BODIES.
C
IF (TRANSFER) 4,3,4
3 BNAME(1) = BODYCD(1)
4 DO 5 K=1,8
5 BNAME(K+1) = BODYCD(K)
L = 1
BODYL(0) = 0.
DO 8 I=1,9
BODYL(I) = 0.
DO 6 K=1,L
IF (COMPARF (BNAME(I), BODYL(K-1))) 6,7,6
6 CONTINUE
BODYL(L) = BNAME(I)
L = L+1
7 BNAME(I) = 0.
8 CONTINUE
NBODYS = L-1
MBODYS = NBODYS-1
C
C PART 1. FIND THE REFERENCE BODY FOR EACH BODY IN THE LIST OF BODYS
C READ FROM CARDS. CLEAR NREFER AND BNAME.
C
DO 13 KL=1,NBODYS
NREFER(KL) = 0
NEFMRT(KL) = 0
BNAME (KL) = 0.
DO 12 KP= 1,30
IF (COMPARF(BODYL(KL),PNAME(KP))) 12,9,12
9 NEFMRT(KL) = KP
DO 11 KK = 1,8
IF (COMPARF(REFER(KP),BODYL(KR))) 11,10,11
10 NREFER(KL) = KR
11 CONTINUE
12 CONTINUE
13 CONTINUE
C
C PART 2 . COUNTS 0 REFERENCES AND SAVES TEMPORARY SET OF INDEXS.
C
14 IF (NBODYS) 24,24,15
15 KZEROS = 0
MISPEL = 0
DO 20 K = 1,NBODYS
NREFER(K) = NREFER(K)
16 IF (NEFMRT(K)) 18,17,18
17 MISPEL = MISPEL + 1
18 IF(NREFER(K)) 20,19,20
19 KZEROS = KZEROS + 1
20 CONTINUE
21 IF (KZEROS- 1) 24,22,24
22 IF (MISPEL) 24,23,24
23 IF (NBODYS-8) 28,28,24
C
C PART 3 . REPORTS ERRORS IN BODY LIST.
C
24 WRITE OUTPUT TAPE 6,25 ,NBODYS,MISPEL,KZEROS,(BODYL(K),K=1,NBODYS)
WRITE OUTPUT TAPE 6,26 ,(NREFER(K),K=1,NBODYS)
WRITE OUTPUT TAPE 6,27 ,(K,PNAME(K),REFER(K),K=1,30)
25 FORMAT (26HOGODFY BODY LIST (NBODYS =12,13H, MISSPELL =12,
1 11H, KZEROS =12,1H)/11HOBODYLIST =8(3X,A6))
26 FORMAT (11H NREFER =16,7I9)
27 FORMAT (/5(3H K3X,4HBODY4X,5HREFER5X,)/5(I3,2X,A6,2X,A6,5X))
CALL EXIT
C
C PART 4. TRACES OUT ..REFERENCE TO BODY.. RELATIONSHIPS
C
28 KK = 2
KN = 1
NAME(1) = 1
29 IF (NREFER(KN)) 24,31,30
30 NAME(KK) = NREFER(KN)
NREFER(KN) = 0
KN = NAME(KK)
KK = KK + 1
GO TO 29
C

```

```

C   PART 5. TRACES OUT ..BODY TO REFERENCE.. RELATIONSHIP
31 DO 34 KN = 1,NBODYS
   DO 34 K = 1,NBODYS
32 IF (NNREFR(K) - NAME(KN)) 34,33,34
33 NAME(KK) = K
   KK = KK + 1
34 CONTINUE
C
C   PART 6. INVERTS NAME TO MANE,STORES BNAME, BMASS, RBCRIT, AND A
C   TEMPORARY NEFMRS.
   DO 35 K = 1,NBODYS
   N = NAME(K)
   MANE(N) = K
   NEF = NEFMRT(N)
   BNAME(K) = PNAME(NEF)
   BMASS(K) = AMASS(NEF)
   RBCRIT(K) = RCRIT(NEF)
   NEFMRS(K) = NEF
35 CONTINUE
C
C   PART 7. FINDS NNREFR REFERENCE FOR BNAME LIST , ALSO TEMP. IBDY
C
   DO 36 K = 1, NBODYS
   N = NAME(K)
   NRF = NREFR(N)
   NNREFR(K) = MANE(NRF)
36 IBDY(K) = MANE(NRF)
C
C   PART 8 . FINDS IBDY FOR BACKWARD REFERENCE.
   DO 39 K=1,8
37 IF(NNREFR(K)) 24,40,38
38 N = NNREFR(K)
   IBDY(N) = -K
39 CONTINUE
C   IBDY LIST IS COMPLETE.
C
C   PART 9 . WRITES OUT EPHEMERIS LIST TO BE USED IN STORING DATA AND
C   MAKES FINAL NEFMRS LIST.
40 KK = 1
   DO 43 K=1,NBODYS
41 IF(NNREFR(K)) 42,43,42
42 EFMRS(KK) = BNAME(K)
   NEFMRS(KK) = NEFMRS(K)
   KK = KK + 1
43 CONTINUE
   NEFMRS(NBODYS) = 0
C
C   PART 10. SAVES ELLIPSE DATA
C   FILE = 0.
   IF (MBODYS) 430,480,430
430 DO 48 K=1,MBODYS
44 IF(NEFMRS(K)-20) 47,47,45
45 DO 46 J=5,12
   L = (NEFMRS(K) - 21) * 12 + J
46 TDATA(J-4,K) = ELIPS(L)
   DO 50 J=7,9
   L = (NEFMRS(K)-21)*12+J
   TDATA(J+2,K) = SIN(ELIPS(L))
47 TDATA(J+5,K) = COS(ELIPS(L))
   GO TO 48
C
C   PART 10A. LOADS A FALSE (VERY EARLY) TAPE TIME TO FORCE TAPE
C   READING BY THE EPHMRS ROUTINE. FILE = 0 UNLESS TAPE IS USED.
47 TDEL(K) = 0
   TIM(K) = 2400000.5
   FILE = 10.
48 CONTINUE
C
C   PART 11. COMPUTE GRAVITATIONAL CONSTANTS. 1.9866 E+30 = KILOGRAMS/SUN MASS
C   IF ORIGIN BODY HAS AN ATMOSPHERE, SET ROTATION RATE AND ATMOSPHERE RADIUS.
C   POSITION THE EPHEMERIDES TAPE AT THE BEGINNING OF THE CORRECT EPHEMERIS
C   BY MATCHING THE EPHEMERIS NUMBER READ FROM TAPE (FILE) WITH THE DESIRED
C   EPHEMERIS NUMBER (TFILE).
480 RESQRD = RE**2
   SQRDK = SQRDK1*AU**3/SPD**2
   GK2M = SQRDK*(BMASS(1) + XPRIM(2))/1.9866 E30
   GKM = SQRTF(GK2M)
   REVOLV = 0.
   RATMOS = 0.
   IF (ATMN-BNAME(1)) 51,49,51
49 REVOLV = ROTATE
   RATMOS = RATH
51 IF (FILE) 56,56,52
52 CALL BSFILE(3)
53 READ TAPE 3, FILE
   IF (FILE-TFILE) 54,56,55
54 CALL SKFILE(3)
   GO TO 53
55 BACKSPACE 3
   BACKSPACE 3
   GO TO 52
C
C   PART 12. WRITES THE BNAME LIST ON TAPE 6 .
56 IF (OUTPUT) 58,59,58
59 WRITE OUTPUT TAPE 6,57,BNAME(1),(BNAME(K),K=2,NBODYS)
57 FORMAT (19HREFERENCE BODY IS A6,5X,23H PERTURBING BODIES ARE
   1 7(2X,A6))
58 RETURN
   END

```

SUBROUTINE OBLATE

C THIS SUBROUTINE COMPUTES THE OBLATENESS ACCELERATIONS (OBLAT) DUE TO AN
 C AXIALLY SYMMETRIC EARTH. THE 2ND, 3RD, AND 4TH SPHERICAL HARMONIC COEFF.
 C ARE OBLATJ, OBLATH, AND OBLATO RESPECTIVELY.

C COMMON C

C DIMENSION A(600), B(700), C(4000),
 1 RB(3), OBLAT(3)

C EQUIVALENCE
 1(A ,C (11)),(B ,C (111)),(GK2M ,B (36)),
 2(OBLATJ,A (26)),(OBLATD,A (27)),(OBLATH,A (28)),
 3(OBLAT ,B (75)),(R ,B (102)),(RB ,B (193)),
 4(RE ,A (25)),(RSQRD ,B (45)),(RESQRD,B (7))

C AA = RB(3)/R
 AB = AA*AA
 IF (ABSF(AA)-1.E-6) 1,1,2
 1 AA=0.
 AB=0.
 2 AC = RESQRD/RSQRD
 AD = GK2M/RSQRD/R*AC
 AE = OBLATJ*AD
 AF = OBLATH*AD*RE/R
 AG = OBLATD*AD*AC
 AH = AE*(5.AB-1.)+AF*(7.AB-3.)+AA+AG*(6.AB-9.AB**2-0.4285714286)
 OBLAT(1) = AH*RB(1)
 OBLAT(2) = AH*RB(2)
 OBLAT(3) = (AH-2.AE+AG*(4.AB-1.714285714))*RB(3)-AF*(3.AB-0.6)*R
 3 RETURN
 END

SUBROUTINE OUTPUT

C ENTS AND RECTANGULAR COORDINATES ARE OUTPUTTED. IF THE OBJECT IS NOT WITH
 C THIS IS THE ROUTINE WHICH FORMS THE BASIC DATA OUTPUT. BOTH ORBIT ELEM-
 C IN AN ATMOSPHERE (PRESS=0.), ONE LINE OF DATA IS DELETED. LIKEWISE,
 C ONLY THOSE PERTURBING BODIES PRESENT HAVE THEIR DISTANCES OUTPUTTED.

C COMMON C

C DIMENSION A(600), B(700), C(4000),
 1 R (8), ORBELS(6), VATM(3),
 2 BNAME(8), RB(3,8), DIRCOS(3,8),
 3 XPRIM(200), RAMC(5)

C EQUIVALENCE
 1(A ,C (11)),(ALPHA ,A (49)),(ALT ,A (4)),
 2(AMC ,R (87)),(AM ,B (90)),(AREA ,B (61)),
 3(BNAME ,B (122)),(B ,C (111)),(CD ,A (165)),
 4(CL ,A (164)),(COSALF,B (48)),(COSTRU,B (53)),
 5(DTOFFJ,A (23)),(HZ ,B (15)),(IMODE ,A (1)),
 6(MBODYS,B (42)),(NBODYS,B (41)),(ORBELS,B (116)),
 7(PRESS ,B (33)),(P ,B (84)),(PSI ,B (30)),
 8(PSIR ,B (398)),(PUSH ,A (166)),(Q ,B (59)),
 9(RAMC ,B (393)),(RB ,B (193)),(REVS ,A (48))

C EQUIVALENCE
 1(R ,B (102)),(SINALF,B (46)),(SINTRU,B (52)),
 2(STEPGO,A (41)),(STEPNO,A (42)),(TABLT ,B (20)),
 3(TRU ,B (40)),(VATM ,B (97)),(VQ ,B (100)),
 4(V ,B (95)),(VX ,B (92)),(VY ,B (93)),
 5(VZ ,B (94)),(XPRIM ,C (71)),(OUTPUT,B (399))

C DAYJ=(DTCOFFJ-2.4E6)+TABLT
 ALPHA = ALPHA+57.29577951
 REV = REVS+ARCTAN1(-RB(2),-RB(1))/6.28318532 + .5
 16 CALL CONVTL(VX,AMC)
 IMODE=IMODE
 GO TO (2,1,1),IMODE
 1 CODE=6HRECTAN
 18 CALL CONVTL(VATM,AMC)
 GO TO 4
 2 DO 3 K=1,6
 3 ORBELS(K) = XPRIM(K+2)
 CODE=5HORBIT
 TRU=ARCTAN(SINTRU,COSTRU)
 4 PSI = ATANF((RB(1)*VX+RB(2)*VY+RB(3)*VZ)/AM)57.2957795
 IF (OUTPUT) 19,6,19
 6 WRITE OUTPUT TAPE 6, 11,STEPGO,STEPNO,ORBELS(1),ORBELS(2),V,R(1),B
 INAME(1),CODE,IMODE,XPRIM(1),ORBELS(6),TRU,VX,RB(1),XPRIM(2),DAYJ,D
 2RBELS(5),ORBELS(3),VY,RB(2),REV,ALPHA,PSI,ORBELS(4),VZ,RB(3),HZ

C IF WITHIN AN ATMOSPHERE COMPUTE DRAG, LIFT, G, ETC., AND PRINT EXTRA LINE.
 19 IF (PRESS) 5,7,5
 5 XIFT = Q*AREA*CL
 DRAG = Q*AREA*CD
 G = (PUSH-DRAG*COSALF+XIFT*SINALF)/XPRIM(2)/9.80665
 17 CALL CONVTL(VATM,RAMC)
 PSIR = ATANF((RB(1)*VATM(1)+RB(2)*VATM(2)+RB(3)*VATM(3))/RAMC(4))*
 1 57.2957795
 IF (OUTPUT) 7,14,7
 14 WRITE OUTPUT TAPE 6,12,ALT,PSIR,DRAG,VQ,G,PUSH

```

C IF PERTURBATING BODIES ARE PRESENT, FIND THEIR DISTANCES AND PRINT THEM.
7 IF(NBODY5) 8,10,8
8 DO 9 J=2,NBODY5
  DO 9 K=1,3
9 DIRCOS(K,J) = -RB(K,J)/R(J)
  IF (OUTPOT) 10,15,10
15 WRITE OUTPUT TAPE 6,13,
  1(BNAME(J),R(J),DIRCOS(1,J),DIRCOS(2,J),DIRCOS(3,J),J=2,NBODY5)
10 RETURN
11 FORMAT(6HSTEP=F6.,2H +F4.,3X,13HECCENTRICITY=1PG15.8,7H OMEGA=G15
1.8,4H V=G15.8,3H R=G15.8,7H REFER=A6,1X,A6,12/6H TIME=1PG14.7,14
2H SEMILATUS R.=G15.8,7H TRU A=G15.8,4H VX=G15.8,3H X=G15.8,7H RMAS
3S=G15.8/9H JDAY= 240PF10.4,15H MEAN ANOMALY=1PG15.8,7H NODE=G15.
48,4H VY=G15.8,3H Y=G15.8,7H REVS.=G15.8/6H ALFA=G14.7,14H PATH A
5NGLE=G15.8,7H INCL=G15.8,4H VZ=G15.8,3H Z=G15.8,7H DELT=G15.8)
12 FORMAT(6H ALT.=1PG14.7,14H R PATH ANGLE=G15.8,7H DRAG=G15.8,4H VR
1=G15.8,3H G=G15.8,7H PUSH=G15.8)
13 FORMAT(2(1X,A6,3H R=1PG14.7,OP3F10.6,11X))
  END

```

```

C FUNCTION QUAD (X,IC)
C THIS ROUTINE COMPUTES ANY VARIABLE, QUAD, AS A QUADRATIC FUNCTION OF X.
C QUAD = A + BX + CXX. THERE MAY BE SEVERAL SETS OF COEFFICIENTS, EACH SET
C BELONGING TO A PARTICULAR REGION OF X. THE COEFN ARRAY IS ARRANGED AS --
C X1,A1,B1,C1,X2,A2,B2,C2,X3,A3,B3,C3,X4, .....
C WHERE A1,B1,C1 ARE THE COEFFICIENTS TO BE USED FOR X BETWEEN X1 AND X2,ETC.
C AND X1 IS LESS THAN X2, X2 IS LESS THAN X3, X3 IS LESS THAN X4, ETC.
C IC IDENTIFIES WHICH DEPENDENT VARIABLE, QUAD, IS BEING SOUGHT.
C ICC(IC) DEFINES THE STARTING LOCATIONS IN THE COEFN ARRAY FOR VARIABLES X.

```

```

COMMON C
C DIMENSION A(600), B(700), C(4000),
1 COEFN(190), ICC(5)
C EQUIVALENCE
1(A ,C ( 11)),(B ,C (1111)),(COEFN ,A ( 407)),
2(ICC ,A ( 153))
C I=ICC(IC)
1 IF (X-COEFN(I)) 2,3,3
2 I = I-4
GO TO 1
3 IF(X-COEFN(I+4)) 5,5,4
4 I = I+4
GO TO 3
5 QUAD = COEFN(I+1)+X*(COEFN(I+2)+X*COEFN(I+3))
  ICC(IC)=I
  RETURN
  END

```

```

C SUBROUTINE STAGE
C THIS ROUTINE IS CALLED TO PREPARE DATA FOR USE IN NBODY. STAGE DATA IS
C TAKEN FROM PERMINENT STORES AND LOADED INTO WORKING STORES. STAGE DATA
C MAY BE SET ASIDE FOR LATER USE (IF ON NSAVE-NSTAGE). WHEN IMODE IS 4,
C CONVERSION FROM EARTH-SPHERICAL TO RECTANGULAR OR ORBIT ELEMENTS TAKES
C PLACE IN TUDS.

```

```

COMMON C
C DIMENSION A(600), B(700), C(4000),
1XPRIM(200),XPRIMB(200),TB(10),FLOW1(10),AEXIT1(10),SIMP1(10),
2AREAL(10),DELT1(10),IDENT(10),TABLE(200),RMASS1(10),D(600)
C EQUIVALENCE
1(A ,C ( 11)),(AEXIT ,B ( 3)),(AEXIT1,A ( 103)),
2(AREAL ,A ( 113)),(AREA ,B ( 6)),(B ,C (1111)),
3(DELT1 ,A ( 133)),(DELT ,B ( 1)),(D ,C (2111)),
4(DELT ,A ( 43)),(DELMAX,A ( 19)),(DONE ,B ( 39)),
5(EREF ,A ( 13)),(ERLOG ,B ( 17)),(EXITA ,B ( 392)),
6(FLOW ,B ( 5)),(FLOW1 ,A ( 83)),(IDENT ,A ( 123)),
7(IMODE ,A ( 1)),(LSTAGE,A ( 38)),(MODDOUT,A ( 20)),
8(NCASE ,C ( 1)),(NCASES,A ( 600)),(NSAVE ,C ( 4)),
9(NSTAGE,A ( 3)),(PUSHO ,B ( 391)),(RMASS1,A ( 73))
C EQUIVALENCE
1(SIMP1 ,A ( 93)),(SIMP ,B ( 2)),(TB ,A ( 63)),
2(TABLE ,C (1911)),(TKICK ,A ( 15)),(TMAX ,B ( 4)),
3(TTOL ,A ( 45)),(XPRIMB,A ( 911)),(XPRIM ,C ( 711)),
4(RETURN,B ( 400)),(OUTPOT,B ( 399))

```

```

C PART 0. SAVE INITIAL DATA IF DESIRED. LOAD STAGE DATA INTO WORKING
C STORAGE. ALLOW ADDITIONAL STAGE INPUT.
  IF (DEL) 100,99,100
  99 DEL = DELMAX-TKICK
  100 IF (NSAVE-NSTAGE) 103,101,103
  101 NCASES = NCASE
  DO 102 J=1,100
  102 DJJ = A1J
  IF (OUTPOT) 103,97,103
  97 WRITE OUTPUT TAPE 6,98,NSTAGE,NCASE
  98 FORMAT(29H SAVED INITIAL DATA FOR STAGE12,8H OF CASE14,1H.)
  103 NSTAGE = NSTAGE
  TMAX = XPRIM(1)+TB(NSTAGE)
  XPRIM(2) = 0.
  IF (RMASS1(NSTAGE)) 117,117,118
  117 XPRIM(2) = XPRIM(2)+RMASS1(NSTAGE)
  GO TO 119
  118 XPRIM(2) = RMASS1(NSTAGE)
  119 FLOW = FLOW1(NSTAGE)
  SIMP = SIMP1(NSTAGE)
  AEXIT = AEXIT1(NSTAGE)
  AREA = AREA1(NSTAGE)
  DELT = DELT1(NSTAGE)
  ID = IDENT(NSTAGE)
  3 CALL INPUT (ID,C,TABLE)
  ERLOG = LOGF(ABSF(EREF))
  TTOL = 5E-8*ABSF(TMAX)+1E-8
  PUSHO = SIMP*FLOW*9.80665
  EXITA = AEXIT*100.
  MODDOUT = MODDOUT
  IF (DELT) 105,104,105
  104 DELT = TB(NSTAGE)/100.
  DELT1(NSTAGE) = DELT
  105 GO TO (109,106,106,109), MODDOUT
  106 IF (DEL-DELMAX) 108,108,107
  107 DEL = MODF(DEL,DELMAX)
  108 IF (DEL) 114,109,114
  114 DELT = MINIF(DELT,DEL)
  109 IF (XABSF(IMODE)-4) 1,110,1
  110 CALL TUDES
  IMODE = XSIGNF(2,IMODE)
  1 CALL NBODY
  2 CALL EXTRAS
C
C PART 9. COMES HERE FOR END OF SUB TRAJECTORY.
  IF (DONE) 113,111,111
  111 DONE = 0.
  IF (NSTAGE-LSTAGE) 112,115,115
  112 NSTAGE = NSTAGE+1
  GO TO 100
  113 DONE = 0.
  115 CALL EXTRA
  IF (RETURN) 103,116,100
  116 RETURN
  END
C SUBROUTINE STEP TESTS FOR THE END OF THE PROBLEM, COMPUTES STEP SIZE, AND
C CONTROLS QUANTITY OF OUTPUT DATA. END OF PROBLEM OCCURS IF TIME = TMAX,
C STEPGO+STEPNO = STEPMX, OR C(LOOKX) = XLOOK. THE LAST OPTION ALLOWS STOP-
C PING ON A DEPENDENT VARIABLE. THE TEST FOR STOPPING AT XLOOK IS NOT MADE
C UNTIL C(LOOKSW) IS GREATER THAN SWLOOK. CONTROL ON QUANTITY OF OUTPUT IS
C
C MODDOUT=1 OUTPUT EVERY NTH STEP(N=STEPS) UNTIL TIME = TMIN, THEN
C GO TO MODE 2.
C 2 OUTPUT AT INTERVALS OF DELMAX UNTIL TIME = TMAX.
C 3 OUTPUT AT INTERVALS OF DELMAX UNTIL TIME = TMIN, THEN
C GO TO MODE 4.
C 4 OUTPUT EVERY NTH STEP UNTIL TIME = TMAX.
C
C COMMON C
C DIMENSION A(600), B(700), C(4000),
C 1 XPRIM(200), DELT1 (10)
C
C EQUIVALENCE
  1(A ,C ( 11)),(A1 ,B ( 10)),(A2 ,B ( 11)),
  2(B ,C (1111)),(DELMAX,A ( 19)),(DEL ,A ( 43)),
  3(DELT ,B ( 1)),(DONE ,B ( 39)),(E2 ,B ( 18)),
  4(END ,A ( 5)),(ERLOG ,B ( 17)),(H2 ,B ( 15)),
  5(INLOOK,A ( 599)),(LOOKSW,A ( 9)),(LOOKX ,A ( 8)),
  6(MODDOUT,A ( 20)),(NSTAGE,A ( 3)),(DELT1 ,A ( 133)),
  7(RATIO ,B ( 58)),(SIGNAL,B ( 31)),(SPACES,B ( 16)),
  8(STEPGO,A ( 4)),(STEPMX,A ( 16)),(STEPNO,A ( 42)),
  9(STEPS ,A ( 17)),(SWLOOK,A ( 10)),(TABLE ,C (1911))
C EQUIVALENCE
  1(TMAX ,B ( 4)),(TMIN ,A ( 18)),(TTOL ,A ( 45)),
  2(XLOOK ,A ( 12)),(XPRIM ,C ( 711)),(XTOL ,A ( 11)),
  3(NSTART,B ( 24)),(SWITCH,A (601)),(OUTPOT,B ( 399))
  CHECKF(A,B,C) = ABSF(A-B) - ABSF(A-C)
C
C PART 1. TEST FOR END OF THE PROBLEM (MAXIMUM PROBLEM TIME OR MAXIMUM
C NUMBER OF STEPS).
  STEPGO = STEPGO + 1.
  OUT = OUTPOT
  IF (ABSF(TMAX-XPRIM(1))-TTOL) 1,1,3
  1 DONE = 1.0
  112 CALL OUTPUT
  IF (OUTPOT) 26,111,26
  111 WRITE OUTPUT TAPE 6,2,NSTAGE
  2 FORMAT(6HSTAGE12,11H COMPLETED.//)
  GO TO 26
  3 IF (STEPGO+STEPNO-STEPMX) 7,4,4
  4 CALL OUTPUT
  WRITE OUTPUT TAPE 6,5,STEPMX
  5 FORMAT (22HSTEPGO+STEPNO=STEPMX=F6.)
  CALL EXIT
C

```

```

C PART 2. COMPUTE STEP SIZE (DELTA) AND CONTROL OUTPUT.
7 N=1
A3 = (A2-A1)*RATIO+A2
AA = (ERLOG-A3)/5.
IF ((ABS(AA)-88.028)*ABS(SWITCH)) 8,8,60
8 DELT = SIGNF(EXPF(AA),DELT)
IF (DELT/H2-3.) 10,10,9
9 DELT = 3.*H2
10 MODOUT = MODOUT
GO TO (11,15,13,21),MODOUT
11 IF(DELTA*(XPRIM(1) + 3.*DELT-TMIN)) 21,12,12
12 MODOUT = 2
DEL = TMIN - XPRIM(1)
GO TO 16
13 IF(DELTA * (XPRIM(1) - TMIN)) 15,15,14
14 MODOUT = 4
GO TO 21
15 DEL = DEL-H2
16 SPACES = INTF(DEL/DELT)+SIGNF(.9,(DEL/DELT))
17 IF(SPACES) 20, 18,20
18 CALL OUTPUT
N=2
DEL = DELMAX
IF (ABS(DEL) - ABS(DELT)) 19,16,16
19 DELT = SIGNF(DEL,DELT)
GO TO 16
20 DELT = DEL/SPACES
GO TO 23
21 IF (MODF(STEPCO,STEPS)) 23,22,23
22 CALL OUTPUT
N=2

C
C PART 3. SEARCH FOR C(LOOKX) = XLOOK UNLESS LOOKX=0.
23 IF(LOOK X) 27,42,27
27 LOOK X = LOOK X
LOOK SW = LOOK SW
OUTPOT = 1.
GO TO (44,45),N
44 CALL OUTPUT
45 IF(SWITCH) 32,28,33
28 IF(SW LOOK - C(LOOK SW)) 29,29,42
29 XTOL1 = XTOL*ABS(XLOOK)
IF (XTOL1) 31,30,31
30 XTOL1 = XTOL
31 SWITCH = -1.
GO TO 41
32 SWITCH = 1.
ASSIGN 43 TO MODE
OVER = 0.
F = 0.
T=0.
33 SLOPE = (C(LOOKX)-OLDX)/H2
GO TO MODE, (43,35)
43 IF(SLOPE * (C(LOOK X) - X LOOK)) 350,41,41
350 ASSIGN 35 TO MODE
35 IF(ABS(C(LOOK X)- X LOOK) - XTOL1) 36,36,37
60 T=1.
36 IF (OUT) 63,46,63
46 OUTPOT = 0.
CALL OUTPUT
63 IF (T) 61,47,61
61 IF (OUT) 62,51,62
51 WRITE OUTPUT TAPE 6,64, LOOKX,C(LOOKX),H2,LOOKX,SLOPE
64 FORMAT(3HOC(14,4H) = 1PG15.8,31H CONVERGENCE TROUBLE. DELT=
1G15.8,14H SLOPE OF C(14,13H) VS. TIME = G15.8//)
GO TO 62
47 IF (OUT) 62,50,62
50 WRITE OUTPUT TAPE 6,48,LOOK X, C(LOOK X)
48 FORMAT(3HOC(14,2H)=1PG15.8//)
62 LOOKX = 0
XTOL1 = 0.
SIGNAL = 1.
SWITCH = 0.
DONE = END
NSTART = 0
NSTAGE=NSTAGE
DELT = DELT/(NSTAGE)
49 CALL INPUT(INLOOK,C,TABLE)
IF (DONE) 110,42,110
110 IF (OUT) 26,111,26
37 SIGN = CHECKF(OLDX,XLOOK,C(LOOK X))
IF(SIGN) 40,40,38
40 OVER = 1.
GO TO 400
38 IF (OVER) 400,401,400
401 XGUESS = C(LOOKX)+SLOPE*DELT
IF (CHECKF(C(LOOKX),XLOOK,XGUESS)) 402,41,41
402 F = F+1.
IF (F-7.) 400,400,403
403 SLOPE = SLOPE/F
400 IF (SLOPE) 404,60,404
404 DELT = SIGNF(ABS(XLOOK-C(LOOKX))/SLOPE,SIGN*H2)
41 OLDX = C(LOOK X)
42 IF (ABS(TMAX-XPRIM(1))-ABS(DELT)) 25,26,26
25 DELT = TMAX-XPRIM(1)
GO TO (26,24,24,26),MODOUT
24 DEL = DEL-DELT
26 OUTPOT = OUT
RETURN
END

```

```

                                SUBROUTINE STDATA
C   THIS ROUTINE CLEARS THE A, XPRIM, XPRIMB ARRAYS AND LOADS A SET OF
C   STANDARD DATA INTO THE MACHINE. ANY VALUES SET HERE MAY BE OVERRITTEN BY
C   INPUT 1 IN THE MAIN PROGRAM.
C
COMMON C
C
DIMENSION A(600), B(700), C(4000),
1  PNAME (12),      AMASS (30),      XPRIM (200),
2  COEFN (190),    ICC (4),
3  AK (3),        XDOT (100),      IND (3),
4  REFER (12),    RCRIT (30),      AW (4),
5  RMASS1 (10)
C
EQUIVALENCE
1(A ,C ( 11)),(AK ,A ( 51)),(AMASS ,A ( 347)),
2(AU ,A ( 29)),(AW ,A ( 55)),(B ,C (1111)),
3(BODYCD,A ( 143)),(COEFN ,A ( 407)),(CONSTU,A ( 32)),
4(CONSU ,A ( 31)),(DTHFFJ,A ( 23)),(EREF ,A ( 13)),
5(ERLMT,A ( 14)),(ETOL ,A ( 30)),(GASFAC,A ( 46)),
6(ICC ,A ( 153)),(IMODE ,A ( 1)),(IND ,A ( 60)),
7(LOOKSW,A ( 9)),(MDDOUT,A ( 20)),(NEQ ,A ( 2)),
8(NSTAGE,A ( 3)),(OBLATD,A ( 27)),(OBLATH,A ( 28)),
9(OBLAT ,A ( 26)),(PNAME ,A ( 287)),(RCRIT ,A ( 377))
EQUIVALENCE
1(REFER ,A ( 317)),(RE ,A ( 25)),(SPD ,A ( 44)),
2(SQDK1,A ( 47)),(STEPMX,A ( 16)),(STEPS ,A ( 17)),
3(TFILE ,A ( 6)),(XDOT ,B ( 501)),(XPRIM ,C ( 711)),
4(XTOL ,A ( 11)),(RMASS1,A ( 73))
C
CLEAR INITIAL CONDITIONS AND CONTROL PARAMETERS.
DO 1 J=1,1100
1 A(J) = 0.
C
C   THE FOLLOWING NH STATEMENTS LOAD THE BODY NAMES INTO THE MACHINE.
PNAME(1) = 3HSUN
PNAME(2) = 6HMERCUR
PNAME(3) = 5HVENUS
PNAME(4) = 5HEARTH
PNAME(5) = 4HMARS
PNAME(6) = 6HJUPITE
PNAME(7) = 6HSATURN
PNAME(8) = 6HURANUS
PNAME(9) = 6HNEPTUN
PNAME(10) = 5HPLUTO
PNAME(11) = 4HMOON
PNAME(12) = 6HEARTHM
C
C   FILL OUT SUN REFERENCE LIST. INITIALIZE MASS ARRAY.
DO 2 K=1,10
RMASS1(K) = 1.
2 REFER(K+1) = PNAME(1)
REFER(12) = PNAME(1)
C
C   FILL OUT EARTH REFERENCE LIST.
REFER(1) = PNAME(4)
REFER(4) = 5HZERO+
REFER(11) = PNAME(4)
C

```

```

C   LOAD THE REMAINING STANDARD DATA.
AK(1) = 0.5
AK(2) = 0.5
AK(3) = 1.0
AMASS(1) = 1.0
AMASS(2) = 1.0/6120000.0
AMASS(3) = 1.0/408645.0
AMASS(4) = 1.0/332951.3
AMASS(5) = 1.0/3088000.0
AMASS(6) = 1.0/1047.39
AMASS(7) = 1.0/3500.0
AMASS(8) = 1.0/22869.0
AMASS(9) = 1.0/18889.0
AMASS(10) = 1.0/400000.0
AMASS(11) = AMASS(4)/81.335
AMASS(12) = AMASS(4) + AMASS(11)
AU = 1.49599 E11
AW(1) = 1./6.
AW(2) = AW(1) + AW(1)
AW(4) = AW(1)
AW(3) = 1. - (AW(2) + (AW(1) + AW(4)))
BODYCD = PNAME(4)
COEFN(1) = -1E20
COEFN(189) = 1E20
CONSTU = 1.0 E-6
CONSU = 1E-6
ETOL = 0.01
DIOFFJ = 244.E4
EREF = 1E-6
ERLIMT = 3E-6
GASFAC = 20.064881
ICC(1) = 185
ICC(2) = 185
ICC(3) = 185
ICC(4) = 185
IMODE = 1
IND(1) = 2
IND(2) = 3
IND(3) = 1
LOOKSW = 711
MODDOUT = 4
NEQ = 8
NSTAGE = 1
OBLATJ = 1.62345 E-3
OBLATH = -5.75 E-6
OBLATD = 7.875 E-6
RCRIT(1) = 1.0 E+20
RCRIT(2) = 1.0 E+8
RCRIT(3) = 6.14 E+8
RCRIT(4) = 9.25 E+8
RCRIT(5) = 5.78 E+8
RCRIT(6) = 4.81 E+10
RCRIT(7) = 5.46 E+10
RCRIT(8) = 5.17 E+10
RCRIT(9) = 8.61 E+10
RCRIT(10) = 3.81 E+10
RCRIT(11) = 1.60 E+8
RE = 6378165.
SPD = 86400.0
SQDK1 = 2.959122083 E-4
STEPMX = 100.0
STEPS = 1.
TFILE = 1.
XDOT(1) = 1.0
XPRIM(2) = RMASS1(1)
XTOL = 5E-8
WRITE OUTPUT TAPE 6,3
3 FORMAT (15HSTANDARD DATA.)
RETURN
END

```

```

SUBROUTINE TESTTR
C SUBROUTINE TESTTR MAY BE CALLED FOR ONE OF TWO REASONS, (1) TO TEST FOR AND
C POSSIBLY TRANSLATE THE ORIGIN (WHEN IMODE IS +) OR (2) TO CHANGE THE
C VARIABLES OF INTEGRATION (WHEN IMODE IS -). A TRANSLATION OF THE ORIGIN
C OCCURS WHEN THE OBJECT MOVES INTO A SPHERE OF INFLUENCE WHICH IS SMALLER
C THAN ANY OTHERS IT MAY ALSO BE IN. WHEN THIS HAPPENS, THE NAME OF THE NEW
C ORIGIN IS MOVED TO THE BEGINNING OF THE BNAME LIST AND ORDER IS
C CALLED TO REORDER THE BNAME LIST.
C
C COMMON C
C
C DIMENSION A(600), B(700), C(4000),
1 XPRIM(100,2),XPRIMB(100,2),XWHOLE(6),VEFM(3,8),VX(3),
2ORBELS(6),BMASS(8),BNAME(8),RB(3,8),RBCRIT(8),R(8)
C
C EQUIVALENCE
1(A ,C ( 11)),(AMC ,B ( 87)),(ASYMPT,A ( 7)),
2(B ,C (111)),(BMASS ,B ( 137)),(BNAME ,B ( 122)),
3(CHAMP ,B ( 25)),(DELTA ,B ( 1)),(GK2M ,B ( 36)),
4(IMODE ,A ( 1)),(NBODYS,B ( 41)),(ORBELS,B ( 116)),
5(RBCRIT,B ( 145)),(RB ,B ( 193)),(REVS ,A ( 48)),
6(R ,B ( 102)),(SQRDK ,B ( 35)),(TABLE ,C (1911)),
7(TMAX ,B ( 4)),(TRSFER,B ( 8)),(TRU ,B ( 40)),
8(TTEST ,A ( 54)),(VEFM ,B ( 241)),(VX ,B ( 92)),
9(XPRIM ,C ( 711)),(XPRIMB,C ( 911)),(XWHOLE,B ( 110))
C EQUIVALENCE
1(OUTPUT,B ( 399))
C
C IMODE = IMODE
C IF (IMODE) 12,12,1
C
C IF IMODE IS +, TEST FOR TRANSLATION OF THE ORIGIN.
C
1 CHAMP= 1.E+30
DO 4 JB=1,NBODYS
IF (R(JB)-RBCRIT(JB)) 2,4,4
2 IF (CHAMP-RBCRIT(JB)) 4,4,3
3 CHAMP = RBCRIT(JB)
NCHAMP = JB
4 CONTINUE
IF (NCHAMP-1) 26,26,5
5 TRSFER = 1.0
8 BTEMP = BNAME(1)
BNAME(1) = BNAME(NCHAMP)
BNAME(NCHAMP) = BTEMP
TTEST = 0.
REVS = 0.
IF (OUTPUT) 6,9,6
9 WRITE OUTPUT TAPE 6,10,BNAME(NCHAMP),BNAME(1)
10 FORMAT (28HOORIGIN IS TRANSLATING FROM A6,4H TO A6)
6 CALL EPHMRS
DO 11 K=1,3
VX(K) = VX(K)-VEFM(K,NCHAMP)
RB(K) = RB(K,NCHAMP)
XPRIM(K+2,1)=VX(K)
XPRIM(K+5,1)=RB(K)
XPRIMB(K+2,1) = 0.
XPRIMB(K+5,1) = 0.
XWHOLE(K)= VX(K)
11 XWHOLE(K+3) = RB(K)
GO TO 20
C
C IF IMODE IS -, CHANGE THE VARIABLES OF INTEGRATION.
C
12 DO 13 K=1,3
XPRIM(K+2,1)=XWHOLE(K)
XPRIM(K+5,1)=XWHOLE(K+3)
XPRIMB(K+2,1) = 0.
XPRIMB(K+5,1) = 0.
VX(K) = XWHOLE(K)
13 RB(K) = XWHOLE(K+3)
GO TO (16,14,15),IMODE
14 CODE = 5HORBIT
IMODE = 1
GO TO 18
15 IMODE = 3
GO TO 17
16 IMODE = 2
17 CODE = 6HRECTAN
18 NCHAMP = 1
IF (OUTPUT) 20,7,20
7 WRITE OUTPUT TAPE 6,19,CODE
19 FORMAT (33HOINTEGRATION MODE IS CHANGING TO A6)
20 GO TO (21,26,26),IMODE
21 CALL CONVT1(VX,AMC)
GK2M= SQRDK*(BMASS(NCHAMP)+XPRIM(2,1)/1.9866 E+30)
30 CALL CONVT2
C IF ORIGIN TRANSLATION CAUSES PATH TO LIE NEAR AN ASYMPTOTE, CHANGE
C INTEGRATION VARIABLES TO RECTANGULAR IF THEY ARE ORBIT ELEMENTS.
IF (ORBELS(1)-1.) 24,24,22
22 IF (ABSF(1TRU)-2.3/SQRTF(ORBELS(1))) 24,24,23
23 ASYMPT = 1.0
GO TO 15
24 DO 25 J=1,6
25 XPRIM(J+2,1) = ORBELS(J)
26 IF (TRSFER) 27,28,27
27 CALL INPUT (101,C,TABLE)
29 CALL ORDER
28 RETURN
END

```

```

C                                     SUBROUTINE THRUST
C THIS ROUTINE COMPUTES X,Y,Z THRUST ACCELERATIONS. THE THRUST VECTOR IS
C ASSUMED COINCIDENT WITH THE LONGITUDINAL AXIS OF THE VEHICLE, WHICH IS
C ORIENTED TO THE RELATIVE WIND VELOCITY BY THE ANGLE OF ATTACK (ALPHA) AND
C THE ROLL ANGLE (BETA). ALPHA IS ASSUMED TO BE A QUADRATIC FUNCTION OF TIME
C WHEREAS BETA IS ASSUMED TO BE CONSTANT.
C REVOLV IS THE EARTHS ROTATION RATE IN RADIANS/SEC (7.29211585E-5) AND THE
C FACTOR 8589934592.= 2**33 IS REMOVED TO PREVENT OVERFLOW.
C
C COMMON C
C
C DIMENSION A(600), B(700), C(4000),
1 FORCE(3), PAR(3), VATM(3), P(3), IND(3),RAMC(5),RB(3),X(100)
C
C EQUIVALENCE
1(A ,C ( 11)),(AEXIT ,B ( 3)),(ALPHA ,A ( 49)),
2(B ,C (1111)),(BETA ,A ( 50)),(COSALF,B ( 48)),
3(COSBET ,B ( 49)),(EXITA ,B ( 392)),(FLOW ,B ( 5)),
4(FORCE ,B ( 66)),(IND ,A ( 60)),(PAR ,B ( 60)),
5(PMAGN ,B ( 50)),(PRESS ,B ( 33)),(P ,B ( 84)),
6(PUSHO ,B ( 39)),(PUSH ,A ( 166)),(RAMC ,B ( 393)),
7(RATMOS ,B ( 23)),(RB ,B ( 193)),(REVOLV ,B ( 21)),
8(R ,B ( 102)),(RSQRD ,B ( 45)),(SIMP ,B ( 2)),
9(SINALF ,B ( 46)),(SINBET ,B ( 47)),(VATM ,B ( 97))
C EQUIVALENCE
1(VQ ,B ( 100)),(VQSQRD ,B ( 101)),(VX ,B ( 92)),
2(VY ,B ( 93)),(VZ ,B ( 94)),(X ,B ( 401))
C
C SINBET = SIN(BETA/57.2957795)
COSBET = COS(BETA/57.2957795)
VATM(1)=VX+REVOLV*RB(2)
VATM(2)=VY-REVOLV*RB(1)
VATM(3)=VZ
3 CALL CONVTL(VATM,RAMC)
4 ALPHA = QUAD(X(1),1)/57.2957795
SINALF=SIN(ALPHA)
COSALF=COS(ALPHA)
DO 1 J1=1,3
J2=IND(J1)
J3=IND(J2)
1 P(J1) = (VATM(J2)*RAMC(J3)-VATM(J3)*RAMC(J2))/8589934592.
PMAGN= SQRTF(P(1)*P(1)+P(2)*P(2)+P(3)*P(3))
PUSH = PUSHO-EXITA*PRESS
TDPMAG = PUSH/PMAGN/X(2)
R4 = SINBET/VQ
R5 = COSALF/RAMC(4)
DO 2 J1=1,3
J2=IND(J1)
J3=IND(J2)
PAR(J1)=P(J2)*VATM(J3)-P(J3)*VATM(J2)
2 FORCE(J1) = TDPMAG*(SINALF*(COSBET*P(J1)+R4*PAR(J1))-R5*(P(J2)*
1 RAMC(J3)-P(J3)*RAMC(J2)))
RETURN
END

```

```

C                                     SUBROUTINE TUDES
C THIS ROUTINE COMPUTES THE RECTANGULAR POSITION AND VELOCITY COMPONENTS
C WITH RESPECT TO THE EARTH MEAN EQUINOX AND EQUATOR OF 1950.0 FROM THE
C LATITUDE, LONGITUDE, AZIMUTH, ELEVATION, ALTITUDE, TOTAL VELOCITY, AND
C TIME. ALSO, WHEN TKICK DOES NOT EQUAL ZERO, A NON-DRAG VERTICAL STEP OF
C SIZE TKICK IS MADE IN CLOSED FORM (STATEMENTS 2 TO 4). THE INTEGRATION
C WILL THEN BEGIN AT TIME EQUAL TO TIME+TKICK WITH THE ORIENTATION SPECIFIED
C BY THE ABOVE FOUR ANGLES AND THE COMPUTED VALUES OF ALTITUDE AND VELOCITY.
C FOR THE CLOSED FORM APPROXIMATION, A CONSTANT FLOW RATE (FLOW), VACUUM
C SPECIFIC IMPULSE (SIMP) AND ENGINE EXIT AREA (AEXIT) ARE ASSUMED KNOWN.
C THE ATMOSPHERIC PRESSURE IS TAKEN TO BE THE SEA LEVEL VALUE.
C
C COMMON C
C
C DIMENSION A(600), B(700), C(4000),
1 SINA(4), COSA(4), ANGLEB(4), XPRIM(200)
C
C EQUIVALENCE
1(A ,C ( 11)),(AEXIT ,B ( 3)),(ALT ,A ( 4)),
2(AZI ,A ( 35)),(B ,C (1111)),(DTOFFJ ,A ( 23)),
3(ELEV ,A ( 36)),(FLOW ,B ( 5)),(GK2M ,B ( 36)),
4(LAT ,A ( 33)),(LONG ,A ( 34)),(OBLATJ ,A ( 26)),
5(OBLATN ,A ( 40)),(PRE ,A ( 25)),(RESQRD ,B ( 7)),
6(ROTATE ,A ( 39)),(SIMP ,B ( 2)),(SPD ,A ( 44)),
7(STEPGO ,A ( 41)),(STEPND ,A ( 42)),(TKICK ,A ( 15)),
8(DTOFF ,A ( 24)),(VEL ,A ( 37)),(XPRIM ,C ( 711)),
9(OUTPOT ,B ( 399))
C EQUIVALENCE (QLAT,LAT),(QLONG,LONG)
C

```

```

ALTI = 0.
VEL1 = VEL
DELL = 0.
DEL = 0.
ASSIGN 1 TO NGO
DAYS = DTOFFJ - 2433282.5
GREEN = MODF(100.0755426+.985647346DAYS+2.9015E-13DAYS**2
1+7.29211585E-5*(TOFFT*SPU+XPRIM(1))*57.2957795,360.)
SINA(1) = SIN(QLAT/57.2957795)
IF (OBLATN) 102,101,102
101 RADIUS = RE + ALT
GO TO 8
102 RADIUS=6356783.28/SQRTF(.9933065783+.006693421685*SINA(1)**2)+ALT
GO TO 8
1 XPRIM(6) = COSA(2)*COSA(1)*RADIUS
XPRIM(7) = SINA(2)*COSA(1)*RADIUS
XPRIM(8) = SINA(1)*RADIUS
RMASSO = XPRIM(2)
XPRIM(2) = XPRIM(2)-FLOW*TKICK
IF (OUTPOT) 12,11,12
11 WRITE OUTPUT TAPE 6,3,STEPGO,STEPNO,LAT,LONG,AZI,ELEV,ALT,XPRIM
11),VEL,RMASSO,(XPRIM(J),J=6,8)
3 FORMAT(6HSTEP=F5.2H +F4.4X,6H LAT.=1PG15.8,7H LONG.=G15.8,6H AZ
11.=G15.8,7H ELEV.=G15.8,6H ALT.=G15.8/6H TIME=G15.8,6H VEL.=G15.8,
6H RMASS=G15.8,4X,2HX=G15.8,5X,2HY=G15.8,4X,2HZ=G15.8)
12 IF (TKICK) 2,50,2
2 XPRIM(1) = XPRIM(1)+TKICK
B1 = LOGF(RMASSO/XPRIM(2))
SIMPSL = SIMP-AEXIT/FLOW+10332.275
VEL1 = VEL+SIMP*9.80665*B1-G*TKICK
ALTI = TKICK*(VEL-G*TKICK/2.+9.80665*SIMP*(1.-B1*XPRIM(2)/
1 (RMASSO-XPRIM(2))))
4 RADIUS = RADIUS + ALTI
GREEN = GREEN + 7.29211585E-5*TKICK*57.2957795
ASSIGN 5 TO NGO
GO TO 8
5 XPRIM(6) = COSA(2)*COSA(1)*RADIUS
XPRIM(7) = SINA(2)*COSA(1)*RADIUS
XPRIM(8) = SINA(1)*RADIUS
50 IF (OBLATN) 6,7,6
6 DEL1 = ATANF((C2-1.)/(C3-1.)*SINA(1)/COSA(1))*57.2957795-QLAT
7 DEL2 = RADIUS/G*SINA(1)*COSA(1)*ROTATE*ROTATE*57.29577951
DEL = DEL1 + DEL2
ASSIGN 10 TO NGO
8 ANGLEB(1) = QLAT + DEL
ANGLEB(2) = QLONG + GREEN
ANGLEB(3) = AZI
ANGLEB(4) = ELEV
DO 9 I=1,4
SINA(I) = SIN(ANGLEB(I)/57.2957795)
9 COSA(1) = COSF(ANGLEB(1)/57.2957795)
C1 = 5.*RESQRD/RADIUS/RADIUS*OBLATJ
C2 = C1*(SINA(1)*SINA(1)-.6)
C3 = C1*(SINA(1)*SINA(1)-.2)
G = GK2M/RADIUS/RADIUS
GO TO NGO, 11,5,10)
10 COS1 = COSA(1)*SINA(4)-COSA(4)*COSA(3)*SINA(1)
COS2 = COSA(4)*SINA(3)
XPRIM(3) = VEL1*(COS1*COSA(2)-COS2*SINA(2))-XPRIM(7)*ROTATE
XPRIM(4) = VEL1*(COS1*SINA(2)+COS2*COSA(2))+XPRIM(6)*ROTATE
XPRIM(5) = VEL1*(SINA(1)*SINA(4)+COSA(1)*COSA(3)*COSA(4))
RETURN
END

```

SUBROUTINE TAPE

```

C SUBROUTINE TAPE USES THE MASTER MERGED EPHEMERIDES TAPE (TAPE 9 AT LEWIS)
C TO COMPILE A WORKING EPHEMERIS TAPE (TAPE 3 AT LEWIS) WHICH CONTAINS ONLY
C THAT DATA NEEDED AT EXECUTION TIME. THIS MINIMIZES TAPE HANDLING DURING
C EXECUTION. 2 EPHEMERIS FILES ARE ON TAPE 9, FIRST FILE HAS DATA AND IS
C IDENTIFIED BY THE SECOND WORD OF EACH 254 WORD RECORD (FIRST WORD IS THE
C DUMMY FORTRAN COMPATIBLE WORD, SECOND WORD=2). THE SECOND FILE IS ONLY 2
C WORDS LONG, FIRST WORD IS FORTRAN COMPATIBLE, SECOND WORD=3).
C MASTER FILE 1 -- PLANETS (EXCEPT MERCURY AND EARTH), SUN, MOON, AND
C EARTH-MOON BARYCENTER FROM SEPT.25, 1960 TO ABOUT 2000.
C EACH EPHEMERIS COMPILED REQUIRES A SET OF INPUT 300 DATA. THE FIRST PIECE
C OF DATA WRITTEN ON A FILE IS THE FILE IDENTIFICATION NUMBER, FILE. EACH
C FILE IS NUMBERED CONSECUTIVELY STARTING WITH FILE=1. SINCE MOON DATA IS IN
C TERMS OF EARTH RADII, THE CONVERSION OF MOON DATA TO A.U. IS MADE BEFORE
C WRITING ON TAPE 3. THE COMMON USED IN SUBROUTINE TAPE IS LOCAL AND ALL
C BUT TAPE3 IS CLEARED BY A FINAL CLEARING LOOP.
C FUNCTION COMPARF(A,B) IS EQUIVALENT TO (A-B) BUT WILL NOT OVERFLOW.
C NORMAL INPUT - ELIST, TBEGIN, TEND, TAPE3
C
C ELIST- THE BCD LIST OF EPHEMERIS DATA NAMES TO BE PLACED ON
C TAPE 3. THE NAMES ARE READ FROM CARDS, AND IS USED TO
C MAKE THE TMAKE LIST. ELIST IS NOT CHANGED IN STORAGE UNTIL
C THE FINAL CLEAR FOR THIS SUBROUTINE.
C TMAKE- THE LIST OF EPHEMERIS NAMES WITH DUPLICATES DROPPED AND
C ZERO SPACES CLOSED IN. AS THE EPHEMERIDES ARE FINISHED THE
C NAMES ARE ERRASED FROM THIS LIST.
C TMADE- LIKE TMAKE BUT IS HELD FOR OUTPUT.
C TBEGIN- THE BEGINNING DATE EXPRESSED AS A JULIAN DAY.
C TEND- ENDING DATE EXPRESSED AS A JULIAN DAY.
C INTVAL- THE APPROX. NUMBER OF DAYS COVERED BY ONE SET OF COEFF. IT
C IS USED TO DECIDE WHICH DATA ARE TO BE ENTERED DOUBLE. THE
C DOUBLE ENTRIES PERMIT FASTER OPERATION IF REVERSAL OF
C INTEGRATION IS REQUIRED FOR ANY REASON.
C EDATE- JULIAN ENDING DATE FOR THE MASTER EPHEMERIS.
C ERTOAU- EARTH RADII PER A.U.

```

COMMON C

C

```

DIMENSION
1 C (700), TMAKE (12), LIST (30),
2 EDATE (12), INTVAL (30), KTAG (12),
3 ELIST (11), TMADE (12), INTVA (2),
4 PNAME (30), TDATUM (252), DATUM (21,12)
C
EQUIVALENCE
1( TAPE3,C( 2)),(ERTOAU,C( 3)),( KTAG,C( 4)),( FILE,C( 16)),
2( ELIST,C( 17)),(TBEGIN,C( 29)),( TEND,C( 30)),( PNAME,C( 31)),
3( KHAMP,C( 61)),( TMADE,C( 73)),( TMAKE,C( 85)),(TDATUM,C(441)),
4( EDATE,C(127)),(INTVAL,C(157)),( INTVA,C(156)),(DATUMT,C(189))
C
B COMPARF(A,B) = (A+B)*(-(A*B))
REWIND 3
DO 1 K=1,4000
1 C(K) = 0.0
C
C THE FOLLOWING NH STATEMENTS LOAD THE BODY NAMES INTO THE MACHINE.
C NOTE. THE EARTH IS NOT IN THIS LIST (NO EPHEMERIS FOR EARTH.)
C
PNAME(1) = 3HSUN
PNAME(2) = 6HMERCUR
PNAME(3) = 5HVENUS
PNAME(4) = 4HMARS
PNAME(5) = 6HJUPITE
PNAME(6) = 6HSATURN
PNAME(7) = 6HURANUS
PNAME(8) = 6HNEPTUN
PNAME(9) = 5HPLUTO
PNAME(10) = 4HMOON
PNAME(11) = 6HEARTHM
C
C PART 2. SET UP JULIAN DATES ENDING EACH EPHEMERIS.
C
EDATE(1) = 2451872.5 11/24/00
EDATE(3) = 2451848.5 10/31/00
EDATE(4) = 2451020.5 7/26/98
EDATE(5) = 2473520.5 2060
EDATE(6) = 2473520.5 2060
EDATE(7) = 2473520.5 2060
EDATE(8) = 2473520.5 2060
EDATE(9) = 2473520.5 2060
EDATE(10) = 2440916.5 11/26/70
EDATE(11) = 2451848.5 10/31/00
INTVA = 30000
INTVAL(1) = 8
INTVAL(2) = 5
INTVAL(3) = 15
INTVAL(4) = 44
INTVAL(5) = 330
INTVAL(6) = 825
INTVAL(7) = 1211
INTVAL(8) = 1172
INTVAL(9) = 1101
INTVAL(10) = 2
INTVAL(11) = 15
FILE = 1.
ERTOAU = 4.26546512 E-5
2 MOON = 0
LI = 1
C
C PART 2B. CALL INPUT AND SEE IF TAPE IS TO BE MADE. INPUT MUST ALWAYS
C MAKE TAPE3=0.0 IF TAPE IS TO BE MADE.
C
TAPE3 = 3.
8 CALL INPUT(300,C,LIST)
IF (TAPE3) 63,3,63
3 IF (FILE=1.) 20,10,20
10 CALL SKFILE(9,2)
C
C PART 3. TAPE IS TO BE MADE SO MOVE EPHEMERIS LIST TO TMAKE AND
C TO TMADE (FOR OUTPUT), CANCEL ANY ZERO OR DUPLICATE NAMES.
C
20 KOUNT = 1
DO 6 K=1,11
TMAKE(K) = 0.
TMADE(K) = 0.
4 DO 5 J=1,KOUNT
IF (COMPARF(ELIST(K),TMAKE(J-1))) 5,6,5
5 CONTINUE
TMAKE(KOUNT) = ELIST(K)
TMADE(KOUNT) = ELIST(K)
KOUNT = KOUNT+1
6 CONTINUE
KOUNT = KOUNT - 1
C
C PART 4. FIND INPUT ERRORS.
C
7 IF(TBEGIN=2437202.5) 66,9,9
9 KM = 2
11 ERROR = 0.
WRITE TAPE 3,FILE
DO 21 J=1,KOUNT
KTAG(J) = 0
12 DO 13 K=1,20
IF (COMPARF(PNAME(K),TMAKE(J))) 13,16,13
13 CONTINUE
C
C PART 5. PRINTS OUT THE MISSPELLED NAMES AND OTHER ERRORS.
C
14 PRINT 15, TMAKE(J), TBEGIN, TEND
WRITE OUTPUT TAPE 6 , 15, TMAKE(J), TBEGIN, TEND,(PNAME(K),
LEDATE(K),K=1,20)
15 FORMAT( 23H TROUBLE ON TAPE 3 MAKE / 2X,A6,10H T BEGIN= F10.1,8H
1 T END= F10.1//2(2X,A6,F20.1))
ERROR = 1.
GO TO 21
C

```

```

C   PART 4B. CHECKS DATES AND STORES INDEX FOR MOON SO THAT EARTH
C   RADII CAN BE CONVERTED TO A.U.
16  IF (10-K) 18,17,18
17  MOON = J
18  KTAG(J) = K
19  IF (EDATE(K)- TEND) 14,21,21
21  CONTINUE
    ASSIGN 36 TO NS1
    IF (ERROR) 22,22,68
C
C   PART 6. FIX UP A TAG (KTAG) TO INDICATE WHETHER TO ENTER DATA DOUBLE OR
C   NOT. KHAMP WILL BE SHORTEST INTERVAL. KTAG WILL BE NON-ZERO IF
C   ANY DATA ENTERS MORE THAN ONCE FOR 10 ENTRIES OF THE MOST
C   FREQUENT DATA.
22  KHAMP = INTVAL(0)
    DO 23 J=1,KOUNT
        K = KTAG(J)
        KHAMP = XMINOF(KHAMP,INTVAL(K))
23  CONTINUE
    KHAMP = KHAMP *10
    DO 24 J=1,KOUNT
        K = KTAG(J)
24  KTAG(J) = INTVAL(K) / KHAMP
C
C   PART 7. LOCATE FILE 2 ON TAPE 9.
25  READ TAPE 9, KFILE
26  IF (KM-KFILE) 27,31,29
27  IF (KFILE - 3) 28,28,29
28  BACKSPACE 9
    BACKSPACE 9
    CALL BSFILE(9)
    GO TO 25
C   BY PASS A FILE.
29  CALL SKFILE(9)
    GO TO 25
C
C   PART 8. THIS IS CORRECT FILE ON TAPE 9, READ DATA. THERE CAN BE UP
C   TO 12 SETS OF DATA PER RECORD. A SET OF DATA IS 21 WORDS.
31  BACKSPACE 9
32  READ TAPE 9, KTAPE,(TDATUM(I), I=1,252)
    GO TO NS1, (36,46)
C
C   PART 9. IS THIS A SATISFACTORY STARTING POINT, QUESTION MARK.
C   THE 1ST SET OF DATA FOR EACH PLANET MUST PRE DATE TBEGIN.
C   PART 9 IS EXECUTED ONLY ONCE.
36  DO 42 J=1,KOUNT
    DO 37 K=1,232,21
        IF (COMPARF(TDATUM(K),TMAKE(J))) 37,39,37
37  CONTINUE
38  LI = J
    BACKSPACE 9
    BACKSPACE 9
    GO TO 32
39  IF (TDATUM(K+1)-TDATUM(K+2)-TBEGIN) 40,40,38
40  DO 41 KJ=1,21
    K1 = K + KJ - 1
41  DATUM(KJ,J) = TDATUM(K1)
42  CONTINUE
    IF (MOON) 43,45,43
43  DO 44 KJ=4,21
44  DATUM(KJ,MOON) = DATUM(KJ,MOON)*ERTOAU
45  ASSIGN 46 TO NS1
C
C   PART 10. PUT AWAY NEEDED DATA. TEST NAME, TIME OF BEGIN AND END. DO NOT
C   WRITE TAPE 3 UNTIL TBEGIN PREDATES THE END OF THE FITTED
C   INTERVAL. 50 REPEATS OLD DATA, 57 WRITES NEW DATA. THE NAMES
C   ARE ERASED FROM TMAKE AS SOON AS THE DATA POST DATES TEND. WHEN
C   ALL NAMES ARE GONE, RETURN TO INPUT 300 TO SEE IF ANOTHER
C   EPHEMERIS IS TO BE CONSTRUCTED.
46  DO 65 K=1,232,21
    DO 47 J=1,KOUNT
        IF (COMPARF(TDATUM(K),TMAKE(J))) 47,48,47
47  CONTINUE
    GO TO 65
48  SWT = TBEGIN-TDATUM(K+1)-TDATUM(K+2)
    IF (SWT) 49,49,52
49  IF(KTAG(J)) 50,52,50
50  WRITE TAPE 3,(DATUM(KJ,J) , KJ=1,21)
52  DO 53 KJ=1,21
    K1 = K + KJ
53  DATUM(KJ,J) = TDATUM(K1-1)
    IF (J-MOON) 56,54,56
54  DO 55 KJ = 4,21
55  DATUM(KJ,J) = DATUM(KJ,J)*ERTOAU
56  IF (SWT) 57,57,58
57  WRITE TAPE 3,(DATUM(KJ,J),KJ=1,21)
58  IF(TEND-DATUM(2,J)-DATUM(3,J)) 59,59,65
59  TMAKE(J) = 0.
    DO 60 KK=1,KOUNT
        IF (TMAKE(KK)) 65,60,65
60  CONTINUE
    WRITE OUTPUT TAPE 6, 61, FILE,TBEGIN,TEND, KOUNT,(TMAKE(KK),
        IKK=1,KOUNT)
61  FORMAT(28HOEPHEMERIS COMPLETED, FILE=F3,6H, FROM F10.1,3H TO
        1 F10.1, 4H FOR I2, 18H BODIES AS FOLLOWS / 12(2X,A6))
    FILE = FILE + 1.
    END FILE 3
    GO TO 2
63  WRITE TAPE 3, FILE
    REWIND 3
    REWIND 9
    TAPE3 = 3.
    DO 64 J=3,4000
64  C(J) = 0.
    RETURN
C

```

```

65 CONTINUE
GO TO 32
66 PRINT 67, TBEGIN
WRITE OUTPUT TAPE 6,67,TBEGIN
67 FORMAT(33H TBEGIN PREDATES 2437202.5,IT IS F10.1)
68 CONTINUE
REWIND 9
END

REM BSFILE(1,J) BACKSPACES TAPE I UNTIL IT IS POSITIONED JUST
REM BEHIND THE J TH EOF MARK.
REM
ENTRY BSFILE
PZE
PZE
PZE
BCD 1BSFILE
BSFILE SXD *-4,1
SXDXD *-4,2
SXDXD *-4,4
XEC* $(TES)
TSX $(RER),4
LXD BSFILE-2,4
CLA* 1,4
TSX $(IQS),4
CLA* $(RDS)
STA BSF
ANA A07000
STA BTT1
STA BTT2
LXD BSFILE-2,4
CAL 2,4
ANA =077777700000
ERA =0007400000000
TNZ ONEARG
CLA* 2,4
TZE BACK
PDX ,1
AXC **1,4
XEC* $(TCO)
BTT1 BTTA **
TRA **1
BSF BSFA **
XEC* $(RDS)
XEC* $(USR)
AXC **1,4
XEC* $(TCO)
BTT2 BTTA **
TRA CHECK
TIX BSF,1,1
XEC* $(RDS)
BACK AXC **1,4
XEC* $(TCO)
AXC **1,4
XEC* $(TRC)
NOP
AXC **1,4
XEC* $(TEF)
NOP
LXD BSFILE-4,1
LXD BSFILE-3,2
LXD BSFILE-2,4
TRA 3,4
CHECK TXL BACK,1,1
LXD BSFILE-2,4
CLA ERR+1
STO 0
CLA* 1,4
LDQ* 2,4
ERR TSX 8,4
TXI BACK,0,14
PZE BSFILE-2,0,ERR
ONEARG CLA BSFILE-2
ADD =01000000
STO BSFILE-2
LXD CHECK,1
TRA BTT1-2
A07000 OCT 7000
END

```

```

REM SKFILE(I,J) SKIPS TAPE I OVER J EOF MARKS.
REM
ENTRY SKFILE
PZE
PZE
PZE
SKFILE SXD *-3,1
SXDX *-3,2
SXDX *-3,4
TSX $(RER),4 CHECK LAST READ
TEFA **1
TEFB **1
LXD SKFILE-1,4
CLA* 1,4 PICK UP THE TPE NUMBER
TSX $(IOS),4 SET UP THE TAPE ADDRESSES
LXD SKFILE-1,4 LOAD IT AGAIN--MAN
CAL 2,4 IS THERE A SECOND ARGUMENT
ANA =077777700000
ERA =000740000000
GOGO TNZ ONEARG NO SECOND ARGUMENT
CLA* 2,4 PICK UP THE SECOND ARGUMENT
TZE BUMP+1 DID SOME DUMMY WANT NO FILES
LOOP SUB =01000000
RDS XEC* $(RDS) READ THE TAPE
TCOA *
TCOB *
TEFA BUMP DID WE HIT
TEFB BUMP AN END OF FILE
TRA RDS GO READ SOME MORE
BUMP TNZ LOOP
LXD SKFILE-3,1
LXD SKFILE-2,2
LXD SKFILE-1,4
NDP
TRCA **1 TURN OFF TAPE CHECK
TRCB **1
TRA 3,4
DNEARG CLA SKFILE-1
ADD =01000000 SET UP XR4 FOR PROPER RETURN
STD SKFILE-1
PKD 0,,0 SET UP FOR ONE FILE
TRA RDS
END

COUNT 1200 00020
REM INPUT ROUTINE USING ARITHMETIC STATEMENTS. CF NASA TN D-1092 00030
LBL INPUT,6 00040
ENTRY INPUT 00050
REM THIS IS SUBROUTINE INPUT. ITS CALLING SEQUENCE 00060
REM CONTAINS THREE ARGUMENTS---AN IDENTIFICATION 00070
REM CODE NUMBER, THE FIRST LOCATION RELATIVE TO WHICH 00080
REM ALL DATA IS TO BE LOADED, AND THE FIRST LOCATION 00090
REM OF A TABLE TO BE USED BY THE ROUTINE. 00100
REM 00110
REM 00120
REM INCLUDED IN THIS ASSEMBLY ARE SUBROUTINES 00130
REM 1 INPUT 00140
REM 2 CHRCTR 00150
REM 3 CLEAR 00160
REM 4 COMPAR 00170
REM 5 ERROR 00180
REM 6 LODK 00190
REM 7 NAME 00200
REM 8 NUMBR 00210
REM 9 STORE 00220
REM 10 TABLE 00230
REM 11 TEST 00240
REM 12 ACCUM, FIX, FLT, BINARY 00250
REM 13 PRINX 00260
REM 14 READ. 00270
REM 00280
INTAPE PZE 0,,7 LEWIS INPUT TAPE NOT STD.
OUTAPE PZE 0,,6 FORTRAN STANDARD OUTPUT TAPE
INDX PZE STORAGE FOR IRA 00290
PZE IRB 00300
PZE IRC 00310
BCI 1,INPUT 00320
INPUT SXD INDX,1 SAVE INDEX REGISTER A. 00330
SXDX INDX+1,2 SAVE INDEX REGISTER B. 00340
SXDX INDX+2,4 SAVE INDEX REGISTER C. 00350
NZT* 1,4 IF THE IDENTIFICATION NUMBER IS Z 00360
TRA 4,4 RETURN TO THE CALLING PROGRAM. 00370
CLA =1835 00380
ADD 2,4 2,4 IS THE BASE LOCATION. 00390
STA SET 00400
STA LOCL1 00410
STA LOCL4 00420
CLA TSXBS OPEN BACKSPACE GATE 00430
STD* $(LINK) CALL CHAIN WILL BACKSPACE 00440
LOCA CLA 1,4 1,4 IS THE IDENTIFICATION NUMBER. 00450
STA NREG1 00460
AXT 36,1 INITIALIZE 36 00470
STZ 1+1,1 LOCATIONS 00480
TIX *-1,1,1 TO ZERO. 00490
STD ILOCL1 MAKE NON'ZERO. 00500
CLA 3,4 3,4 IS THE LOCATION OF THE TABLE. 00510
STA LOFCF PREPARE 00520
STA NREG1-1 00530
ADD =1835 THE 00540
STA LOCFB ARGUMENT STORAGES 00550
STA LOCKL 00560
TSX CLEAR,4 CLEAR THE VAR REGION. 00570

```

LOCA1	CLA	=007610000000	INHIBIT READING UNTIL	00580
	STO	READ.	ARRAY RECORD REFRESHED	00590
	AXT	43,2	43 FORCES RECORD TO BE FILLED	00600
	SXD	1,2	IN CHRCTR	00610
	REM	LOOK AT THE FIRST CHARACTER ON THE FIRST CARD		00620
	REM	IN SEARCH OF A \$ SIGN.		00630
LOCAA	TSX	CHRCTR,4		00640
	SUB	=H0000\$0	CHECK FOR A \$ SIGN	00650
LOCA.	STO	WORD		00660
	TSX	COMPAR,4		00670
	OCT	242517630000	D, E, FILE FLAG, T	00680
	LXA	NREG1,4	ZERO IF \$D HAS BEEN READ.	00690
	TXL	**2,4,0		00700
	TXI	**1,2,4	BEFORE \$D ADD 4 TO INDEX 2.	00710
	TXH	ERRU,2,7	JUNK	00720
	TXH	SGNDUT,2,6	\$17 BEFORE \$D. FILE FLAG. OFF	00730
	TXL	**3,2,5	\$E BEFORE \$D	00740
	TSX	READ.+1,4	CRASH READ GATE	00750
	TRA	LOCA1	SHOULD NOW HAVE \$D CARD	00760
	TXH	LOCAD,2,4	FIRST \$D.	00770
	TXH	LOCAJ,2,3	\$T AFTER \$D.	00780
	TXH	LOCCK,2,2	\$17 AFTER \$D. FILE FLAG	00790
	TXH	LOCBG,2,1	\$E AFTER \$D.	00800
	REM			00810
LOCAC	LXA	READ.,4	\$D AFTER \$D. TEST IF BUFFER	00820
	TXL	ERRU,4,0	OVERWRITTEN	00830
	REM	THIS IS THE PROGRAM RETURN.		00840
RTN	LXD	INDX,1	RESET INDEX A.	00850
	LXD	INDX+1,2	RESET INDEX B.	00860
	LXD	INDX+2,4	RESET INDEX C.	00870
	TRA	4,4	RETURN TO CALLING PROGRAM.	00880
	REM	HUNT FOR THE = SIGN OF THE \$ DATA CARD.		00890
LOCAD	CLA	=007610000000	INHIBIT READING UNTIL	00900
	STO	READ.	\$DATA FIELD SCANNED	00910
	TSX	CHRCTR,4		00920
	TSX	COMPAR,4		00930
	BCI	1,=00000		00940
	TRA	**5,2,2		00950
	TRA	ERRD	JUNK	00960
	TRA	LOCAD	ALPHABETIC	00970
	TRA	ERRD	NUMERIC	00980
	SXD	ALF,4	= SIGN	00990
	REM	USE ALF MODE TO TEST ALL CHARACTERS.		01000
	REM			01010
	REM	COMES HERE WHEN = SIGN HAS BEEN FOUND. GET THE		01020
	REM	IDENTIFICATION NUMBER FROM THE CARD.		01030
LOCAF	LXD	1,4		01040
	TXH	**2,4,43		01050
	TXH	LOCAG,4,42	CARD SCANNED OUT.	01060
	TSX	CHRCTR,4		01070
	TSX	COMPAR,4		01080
	BCI	1,\$- 0		01090
	TRA	**9,2,2		01100
	TRA	ERRM	JUNK	01110
	TRA	ERRM	ALPHABETIC	01120
LOCAE	TSX	BINARY,4	FORM BIN WD IN VAR	01130
	TRA	LOCAF	BLANK	01140
	SXD	ERSW,2	MINUS SET TO BY PASS.	01150
	TRA	LOCAF	PLUS NO EFFECT.	01160
	STO	SIGN	DOLLARS	01170
	REM	COMES HERE TO CHECK THE REGION CODE AND THE		01180
	REM	VALUE APPEARING ON THE \$DATA CARD.		01190
LOCAG	CLA	VAR	COMMA	01200
	TZE	ERRU	DATA SET NO. MISSING	01210
	ALS	18		01220
	STD	**	SAVE IDENT AT TABLE(1),	01230
NREG1	SUB	**	PLACE FIRST ARG IN THIS ADDRESS.	01240
	TNZ	RTN	0 IF CALL CODE = \$DATA CODE	01250
	STZ	ALF	ALF = 0 MEANS NO ALF INFO.	01260
	SXA	NREG1,0	INDICATE \$DATA IS READ.	01270
	REM	INST. BELOW ALSO EXECUTED AT READ., PLACED THERE BY CHRCTR		01280
TSXRD	TSX	READ.+1,4	HERE SNEAK PAST READ. GATE	01290
	SXD	TESTJK,0		01300
	TRA	LOCAN		01310
	REM			01320
	REM	COMES HERE IF IT WAS A \$ TABLE CARD.		01330
LOCAJ	TSX	TABLE,4		01340
	TRA	LOCAN3		01350
	REM			01360
	REM	COMES HERE IF AN ALPHABETIC CHARACTER WAS FOUND.		01370
LOCAK	TSX	NAME,4		01380
	TNZ	SET-1	ZERO MEANS ON LEFT OF = SIGN.	01390
	LXD	JK1,1	IF JK1 DIDNOT INCREASE THEN	01400
TESTJK	TXL	ERRL,1,**	AN = SIGN WAS NOT USED.	01410
	SXD	TESTJK,2	SAVE JK1 FOR NEXT TEST.	01420
	CLA	ILOC	SAVE SIGN OF TABLE ENTRY.	01430
	STO	ILOC1		01440
	TRA	LOCAN2		01450
	REM			01460
	LXD	JK,2	PREPARE TO ACCUMULATE THE NUMBERS	01470
SET	CLA	** ,2	IN THE PSEUDO ACCUMULATOR.	01480
	STO	TEMP		01490
	CLA	ILOC		01500
	TPL	LOCAM	MINUS MEANS FLOAT THE NUMBER.	01510
	TSX	FLT,4		01520
	TRA	LOCAM		01530
	REM			01540
	REM	COMES HERE IF NUMERIC FIELD.		01550
LOCAL	TSX	NUMBER,4		01560
	STO	TEMP		01570

LOCAM	TSX	ACCUM,4	ACCUMULATE RESULTS IN ACC.	01580
	TSX	CLEAR,4		01590
	LXA	WORD,4		01600
	PXA	0,4	+ WORD IN ACC FOR LOCAR	01610
	TXL	LOCAR,4,58	NOT COMMA	01620
	TXH	LOCAR,4,59	NOT COMMA	01630
	LXD	JK1,2	COMMA	01640
	CLA	ACC		01650
	STZ	ACC	INITIALIZE	01660
	LDQ	ILOC1	IS THIS VARIABLE FIXED POINT.	01670
	TQP	LOC1	NEGATIVE IS FIXED POINT.	01680
	TSX	FIX,4		01690
LOC1	STO	**2	STORE THE NUMBER RELATIVE TO BASE.	01700
LOCAN	LXD	JK1,2		01710
LOCAN1	TXI	**1,2,1	RAISE STORING INDEX BY ONE.	01720
LOCAN2	SXD	JK1,2	SAVE IT.	01730
LOCAN3	LXD	OPER,1	ANY OPERATORS LEFT OVER.	01740
	TXL	**3,1,0		01750
ERRL	TSX	ERROR,4		01760
	BCI	1,0(L)		01770
	CLA	ACC	ANY DATA LEFT OVER.	01780
	TNZ	ERRL		01790
	REM			01800
	REM	CALL THIS THE SWITCH HOUSE.		01810
LOCAO	TSX	CLEAR,4		01820
LOCAP	TSX	CHRCTR,4		01830
LOCAQ	TSX	COMPAR,4		01840
	BCI	1,.10000		01850
	TRA	**6,2,2		01860
	TRA	LOCAR	\$D, \$T, OR OPERATORS.	01870
	TRA	LOCAK	ALPHABETIC	01880
	TRA	LOCAL	NUMERIC	01890
	TRA	LOCAT	(SIGN	01900
	TRA	LOCAL	DECIMAL	01910
LOCAR	LXD	OPER,1	ANY OPERATORS LEFT OVER.	01920
	TKH	ERRL,1,0	HIGH MEANS ALREADY HAS OPERATOR.	01930
	SUB	=H0000\$0	SPLIT OFF \$ FROM OTHERS	01940
	TPL	LOCA.	IF + PROCESS \$ TYPE CH	01950
	REM	WHAT KIND OF OPERATOR IS THIS.		01960
	TSX	COMPAR,4		01970
	BCI	1,+/-*,0		01980
	TXH	ERRL,2,5	REMOVE THE JUNK.	01990
	TXH	LOCAN,2,4	COMMA	02000
	SXD	OPER,2	SAVE REST, WILL BRANCH IN SUB ACCU	02010
	TRA	LOCAP	AFTER BOTH OPERANDS HAVE BEEN FOUN	02020
	REM			02030
	REM	COMES HERE IF THE OCT OR ALF MODE.		02040
LOCAT	TSX	CHRCTR,4		02050
	TSX	COMPAR,4		02060
	BCI	1,0A000		02070
	TRA	**5,2		02080
	TRA	ERRL	JUNK	02090
	TRA	LOCAZ	A CHARACTER	02100
	TRA	LOCAU	O CHARACTER	02110
	REM			02120
	REM	COMES HERE IF EMPTY PARENTHESIS WERE FOUND.		02130
	TSX	CHRCTR,4	JSIGN, GET NEXT CHARACTER.	02140
	TQP	**2	MINUS FOR NEW CARD	02150
	TSX	TEST,4	INSERT COMMA IF NEEDED.	02160
	CLA	ILOC1		02170
	STO	ILOC	PREPARE TO GET VALUE OF	02180
	LXD	JK1,2	CURRENT LEFT SIDE.	02190
	TRA	SET		02200
	REM	COMES HERE IF OCTAL MODE.		02210
LOCAU	TSX	CHRCTR,4		02220
	SUB	=H00000)		02230
	TNZ	LOCAU		02240
	TRA	LOCAW) SIGN	02250
LOCAV	LDQ	VAR		02260
	RQL	3	REPLACE TOP 3 BITS	02270
	LGR	3	BY NEXT OCTAL CHARACTER	02280
	RQL	3	PUT IN BOTTOM OF MQ	02290
	STQ	VAR		02300
	REM	COMES HERE WHEN) IS FOUND.		02310
LOCAW	TSX	CHRCTR,4		02320
	TQP	**2	MINUS FOR NEW CARD	02330
	TSX	TEST,4		02340
	LXA	WORD,4	CHARACTER TO IRC	02350
	TXL	LOCAV,4,7	OCTAL DIGITS	02360
	TXL	ERRJ,4,58	ALPHABETIC, JUNK, 8, 9.	02370
	TXH	ERRJ,4,59	SPLITS (02380
LOCAZ	LXD	JK1,2	COMMA	02390
	CLA	VAR		02400
	TRA	LOC1		02410
	REM		CONVERT THE NUMBER TO BINARY.	02420
LOCAZ	TSX	BINARY,4		02430
	REM			02440
	REM	COMES HERE IF ALF MODE.		02450
LOCAZ	TSX	CHRCTR,4		02460
	TSX	COMPAR,4		02470
	BCI	1,00000		02480
	TRA	**5,2,2		02490
	TRA	ERRK	JUNK	02500
	TRA	LOCAZ	ALPHABETIC	02510
	TRA	LOCAZ	NUMERIC	02520
	REM	COMES HERE WHEN) IS FOUND		02530

LOCBA	LXA	VAR,1) SIGN	02540
	TNX	ERRK,1,0	ALF COUNT WAS ZERO.	02550
	SXD	ALF,1		02560
	TSX	CLEAR,4		02570
	TSX	CHRCTR,4	PULL THROUGH CHARACTERS AND STORE	02580
	SUB	=017	FILE FLAG, NEVER NEG.	02590
	TZE	ERRB	COUNT WENT PAST E O JOB.	02600
	TSX	STORE,4	THEM ONE AT A TIME.	02610
	TIX	**4,1,1	GO BACK TILL NCHAR = 1	02620
	LXD	J,1		02630
	LXD	MSHIFT,4		02640
	CAL	BLANK		02650
	LGR	42,4		02660
	ORS	VAR+1,1	FILL IN PARTIAL WORD WITH BLANKS.	02670
LOCBB	AXT	1,4	IRC TO 1	02680
	LXD	JK1,2		02690
	CLA	J	PREPARE TO STORE ALF WDS	02700
	STD	LOCBC1		02710
LOCBC	SXD	JK1,2		02720
	CLA	VAR+1,4		02730
LOC4	STO	**2		02740
	TXI	**1,4,1	J = J + 1	02750
LOCBC1	TXH	LOCBU,4,**		02760
	TXI	LOCBC,2,1	JK=JK+1	02770
LOCBD	STZ	ALF		02780
	TSX	CLEAR,4		02790
	TSX	CHRCTR,4	LOOK AT NEXT CHARACTER.	02800
	TQP	**2	MINUS FOR NEW CARD	02810
	TSX	TEST,4	PUT IN COMMA IF NEEDED.	02820
	SUB	=H00000,		02830
	TZE	LOGAN	GO RAISE AND STORE JK1.	02840
	REM			02850
	REM	THESE ARE ERROR CALLS		02860
ERRB	TSX	ERROR,4		02870
	BCI	1,0(B)		02880
ERRD	TSX	ERROR,4		02890
	BCI	1,0(D)		02900
ERRJ	TSX	ERROR,4		02910
	BCI	1,0(J)		02920
ERRK	TSX	ERROR,4		02930
	BCI	1,0(K)		02940
ERRM	TSX	ERROR,4		02950
	BCI	1,0(M)		02960
ERRU	TSX	ERROR,4		02970
	BCI	1,0(U)		02980
	REM			02990
	REM	\$E COMES HERE AFTER \$D		03000
LOCBG	CLA	=007610000000	NOP	03010
	STO*	\$(LINK)	CLOSE BACKSPACE GATE	03020
	TRA	LOCAC	RETURN	03030
	REM	PURPOSE OF SEND CARD IS TO PROTECT FORIEGN DATA FROM		03040
	REM	BACKSPACE WHEN CHAIN IS CALLED.		03050
	REM			03060
	REM	END OF THE MAIN SEGMENT		03070
	REM	THIS A ROUTINE TO BACKSPACE THE INPUT TAPE WHEN A		03080
	REM	CALL CHAIN IS GOING TO SPILL THE BUFFER.		03090
	REM	THIS ROUTINE IS EXECUTED FROM CHAIN VIA THE ONE		03100
	REM	WORD SUBROUTINE (LINK) WHICH CONTAINS EITHER TSX OR NOP		03110
TSXBS	TSX	LOCBS,4	TO BE STORED AT (LINK	03120
LOCBS	SXA	**4,4	SAVE INDEX 4	03130
	CLA	INTAPE	INPUT TAPE NUMBER	
	CALL	\$(IOS)	SELECT INPUT TAPE	03150
	XEC*	\$(BSR)	BACKSPACE IT	03160
	AXT	**4	RESTORE INDEX	03170
	TRA	1,4	RETURN TO THE CHAIN ROUTINE	03180
	EJECT			03190
	REM	THIS IS SUBROUTINE CHRCTR. IT STORES SUCCESSIVE		03200
	REM	CHARACTERS FROM THE CARD AT LOCATION WORD, READS		03210
	REM	SUCCESSIVE CARDS INTO THE ARRAY RECORD, AND PRINTS		03220
	REM	\$\$ TYPE CARDS. THE FIRST CHARACTER FROM A NEW CARD		03230
	REM	IS STORED IN WORD WITH A MINUS SIGN.		03240
	REM			03250
	REM			03260
CHRCTR	SXD	TEMP-10,2		03270
	SXD	TEMP-17,4		03280
	LXD	1,2	CARD COL COUNT, SAW COUNT	03290
	TXH	**2,2,83	TOO EARLY TO READ.	03300
	XEC	READ.	GATE MAY BE CLOSED	03310
	LDQ	Q	HAS UNUSED CHARACTERS FROM BEFORE	03320
	CLA	SIGN	ZERO OR \$ GOES TO TAG	03330
LOCCA	ALS	6	SHIFT LEFT 1 CHARACTER	03340
	SLW	TAG	CLEAR OR PRELOADS TAG	03350
LOCCB	LXD	ALF,4	NONZERO MEANS ALF MODE.	03360
LOCCC	TXH	LOCCD,2,43	SAW COUNT GIVES COL 81 = 43.	03370
	TXH	LOCCG,2,42	WAS COL 80 PROCESSED.	03380
LOCCD	PXD	0,0	CLEAR ACCUMULATOR.	03390
	LGL	6	SHIFT NEXT CHARACTER INTO ACC.	03400
	TIX	LOCCE,2,14	COUNT DOWN BY 14	03410
	LDQ	RECORD+3,2	LOAD NEXT WORD	03420
	TXI	**1,2,69	JUMP BACK COUNTER.	03430
LOCCE	TXH	LOCCF,4,0	RETURN IF ALF MODE.	03440
	PAX	0,1	MOVE CHR. INTO INDEX 1	03450
	TXH	LOLCF,1,48	TRA MEANS GOOD CHARACTER.	03460
	TXH	LOCC,1,47	TRA IF BLANK	03470
	TXH	LOCCF,1,43	TRA IF GOOD CHARACTER.	03480
	TXL	LOLCF,1,42	TRA IF GOOD CHARACTER.	03490
	ZET	TAG	HERE ON \$	03500
	TRA	PRINT	HERE ON \$\$ GO PRINT	03510
	TRA	LOCCA	\$ GOES TO TAG.	03520
	REM			03530

LOCCF	SXD	I,2	SAVE SAW COUNT	03540
	STQ	Q	SAVE UNUSED CHARACTERS.	03550
	ADD	TAG	ATTACH \$ SIGN IF PRESENT.	03560
	STO	WORD	SAVE THE CHARACTER AT WORD.	03570
	LDQ	SIGN	SIGN OF MQ NEGATIVE IF NEW CARD.	03580
	STZ	SIGN	CLEAR SIGN.	03590
	STZ	TAG	CLEAR TAG OF ANY \$	03600
	LXD	TEMP-17,4		03610
	LXD	TEMP-10,2		03620
	TRA	1,4	RETURN	03630
	REM	PRINT OUT THE	\$\$ CARDS.	03640
PRINT	STQ	Q		03650
	XEC*	\$(TES)	CHECK FOR QUIET BUFFERS.	03660
	XEC	READ.	FETCH NEXT CARD.	03670
	LDQ	Q		03680
	LGL	6	SPACE CONTROL SAFE IN ACC	03690
	LDQ	BLANK		03700
	AKT	4,4	FILL END OF OUTPUT	03710
	STQ	OUTBUF+19,4	BUFFER WITH BLANKS.	03720
	TIX	*-1,4,1		03730
	LGR	6	SPACE CONTROL BACK TO MQ.	03740
	STQ	OUTBUF	STORE SPACE CONTROL.	03750
	AXT	14,4		03760
	LDQ	RECORD+2,4		03770
	STQ	OUTBUF+15,4		03780
	TIX	*-2,4,1		03790
	TSX	PRINX,4		03800
	TRA	**+3		03810
LOCCG	XEC	READ.	ALMOST ALWAYS A NOP.	03820
	XEC*	\$(TES)	WAIT FOR QUIET READ BUFFER.	03830
	STZ	TAG	CLEAR THE \$\$ CHARACTERS.	03840
	AXT	14,2	FETCH CARD.	03850
	LDQ	INBUF+14,2	14 WORDS	03860
	STQ	RECORD+2,2		03870
	TIX	*-2,2,1		03880
	CLA	TSXRD	OPEN READ. GATE	03890
	STO	READ.		03900
LOCCJ	AXT	84,2	CARD COL 1 IS 84	03910
	CLS	=0	SET MINUS ZERO IN SIGN	03920
	STO	SIGN		03930
	LGL	12	SAVE COLUMN 79 AND 80	
	LDQ	BLANK	BLANK OUT COLUMN 81 TO 84	
	LGR	12	MAY HAVE LOOK AHEAD	
	STQ	RECORD+1		
	LDQ	RECORD-12		03940
	TRA	LOCCA		03950
	REM			03960
	REM		COMES HERE ON END OF FILE FLAG	03970
LOCCK	LXD	TESTJK,4		03980
	TXH	RTN,4,0	WAS DATA LOADED. YES RTN	03990
SGNOUT	XEC*	\$(TES)	WAIT FOR QUIET OUTPUT BUFFER	04000
	AXT	6,4		04010
	LDQ	OUT+6,4		04020
	STQ	OUTBUF+6,4		04030
	TIX	*-2,4,1		04040
	AXT	13,4		04050
	LDQ	BLANK		04060
	STQ	OUTBUF+19,4		04070
	TIX	*-1,4,1		04080
	TSX	PRINX,4		04090
	XEC*	\$(TES)	WAIT FOR QUIET BUFFER.	04100
LUCOUT	CALL	\$EXIT	THIS WAY OUT FOR KEEPS	04110
OUT	BCI	6,1	END OF FILE INPUT TAPE JOB COMPLETE	04120
	REM			04130
	REM		END OF THE SAP SUBROUTINE CHRCTR.	04150
	EJECT			04160
	REM		THIS IS SUBROUTINE CLEAR. IT INITIALIZES	04170
	REM		NECESSARY PARAMETERS FOR SUBROUTINE STORE.	04180
	REM			04190
	REM			04200
CLEAR	SXD	J,0	SET J TO 0.	04210
	STZ	VAR	CLEAR VAR(1).	04220
	SXD	MSHIFT,0	RESET MSHIFT.	04230
	TRA	1,4	RETURN TO CALLING PROGRAM	04240
	REM			04250
	REM		END OF THE SAP SUBROUTINE CLEAR.	04260
	REM			04270
	REM			04280
	REM		THIS IS FUNCTION COMPAR. IT EXAMINES THE CURRENT	04290
	REM		CHARACTER AND TESTS IT AGAINST THE CHARACTERS	04300
	REM		FOUND IN THE ARGUMENT. ALPHABETIC AND NUMERIC	04310
	REM		SPLITS ARE MADE IF THE CHARACTER IS NOT FOUND	04320
	REM		IN THE ARGUMENT. THESE TESTS ARE COUNTED AND	04330
	REM		THE NUMBER LEFT IN INDEX 2 CORRESPONDS TO THE	04340
	REM		SUCCESSFUL TEST. IF NO TEST IS SUCCESSFUL	04350
	REM		THEN INDEX 2 CORRESPONDS TO THE TOTAL TESTS +1.	04360
	REM			04370
COMPAR	LDQ	1,4	USE FIRST ARGUMENT IN CALLING	04380
	AXT	1,2		04390
LOCDA	PKD	0,0		04400
	LGL	6	PULL IN 1ST TEST CHARACTER.	04410
	TZE	LOCDD	DONE IF ZERO.	04420
	CAS	WORD	CHECK TEST WORD AGAINST CARD	04430
	TXI	LOCDA,2,1	CHARACTER.	04440
	TRA	LOCDC	EQUAL.	04450
LOCDB	TXI	LOCDA,2,1	NOT EQUAL. GET NEXT TEST	04460
LOCDC	CLA	WORD	CHARACTER.	04470
	TRA	2,4	PROGRAM RETURN.	04480

LOCDD	CLA	2,4	USE SECOND ARGUMENT IN THE CALLING	04490
	PDX	0,1	SEQUENCE (DECREMENT) AS THE TEST	04500
	TNX	LOCDC,1,1024	FOR ALPHABETIC-NUMERIC SPLIT.	04510
	SXD	LOCDF,1	BECOMES INCREMENT	04520
	LXA	WORD,1	CHARACTER TO IRA	04530
	TXL	LOCDC,1,9	NUMERIC	04540
	TXH	LOCDF,1,57	SPECIAL 0 ZONE, \$X	04550
	TXH	LOCDE,1,49	ALPHABETIC 0 ZONE, NO /	04560
	TIX	**2,1,32	KNOCK OFF 11 ZONE EXCEPT -	04570
	TIX	**1,1,16	KNOCK OFF 12 ZONE EXCEPT +	04580
	REM	+ AND - SIGNS WILL BE (16)10, / WILL BE (17)10		04590
	TXH	LOCDF,1,9	SPECIAL	04600
LOCDE	TXI	LOCDF,2,-1	ADJUST IRB FOR ALPHABETIC	04610
LOCDF	TXI	LOCDC,2,**	ADJUST IRB FOR SPLIT	04620
	REM		END OF THE SAP SUBROUTINE COMPAR.	04630
	EJECT			04640
	REM		THIS IS SUBROUTINE ERROR. IT IS CALLED IF AN	04650
	REM		ERROR WAS DETECTED ON ANY OF THE INPUT CARDS.	04660
	REM			04670
ERROR	SWA	**2,4	SAVE SOURCE	04680
	XEC*	\$(TES)	WAIT FOR QUIET BUFFERS	04690
	AXT	**4		04700
	CLA	1,4	GET PRINT ARGUMENT	04710
	STO	OUTBUF		04720
	AXT	1,1		04730
	CAS	R		04740
	TRA	**3	S THROUGH V	04750
	TXI	**1,1,-1	R	04760
MES&A	PXD	BLANK+4,1	A THROUGH N	04770
	ANA	=7B17		04780
	ARS	16		04790
	ACL	MES&A		04800
	STA	102.		04810
	AXT	4,4		04820
102.	LDQ	**4		04830
	STQ	OUTBUF+5,4		04840
	TIX	**2,4,1		04850
	AXT	14,4		04860
	LDQ	RECORD+2,4		04870
	STQ	OUTBUF+19,4		04880
	TIX	**2,4,1		04890
	TSX	PRINX,4		04900
	XEC*	\$(TES)	WAIT FOR QUIET BUFFER	04910
	AXT	19,2		04920
	CLA	BLANK		04930
	STO	OUTBUF+19,2		04940
	TIX	**1,2,1		04950
	LDQ	=H *	PICK UP *	04960
	LXD	1,2	SAW COUNT	04970
	TXL	**2,2,71	BACK UP IF OVER 71	04980
	TXI	**3,2,-69		04990
	RQL	6	ROTATE ACCORDING TO CHR PART.	05000
	TIX	**1,2,14	COUNT CHARACTER PART.	05010
	STQ	OUTBUF+19,2	STORE ACCORDING TO RESIDUAL	05020
	TSX	PRINX,4	PRINT THE *	05030
	XEC*	\$(TES)	WAIT FOR THE * TO BE PRINTED	05040
	LXD	ERSW,4	PICK UP ERROR SWITCH.	05050
	TXL	LOCOUT,4,0	NON ZERO MEANS TRY NEXT SET	05060
	AXT	1208,4	BYPASS MARK	05070
	SXD	BLANK,4	MARK BYPASSED CARDS	05080
	LXA	NREG1,4	NONZERO IF THIS \$DATA CARD.	05090
	TXL	**2,4,0		05100
	TSX	READ+1,4	CRASH READ GATE IF \$DATA CARD.	05110
LOC&B	TSX	CH&CTR,4	SKIP TO NEXT \$DATA AND TRY THAT SET.	05120
	TQP	LOC&B		05130
	SUB	=H0000&D		05140
	TNZ	LOC&C	TRA NOT A \$DATA CARD	05150
	STQ*	NREG1-1	PUTS - SIGN IN TABLE(1)	05160
	LXD	BLANK+7,4		05170
	SXD	BLANK,4		05180
	LXD	INDX+2,4		05190
	TRA	LOCA		05200
LOC&C	ADD	=5	TEST FOR END FILE FLAG	05210
	TZE	SGNOUT	END FILE.. GET OFF	05220
	TRA	LOC&B	OTHER	05230
	REM			05240
	REM		ERROR MESSAGES. FIRST WORD ALSO USED AS A BLANK.	05250
BLANK	BCI	4,	REDUNDANCY CHECK	05260
	BCI	4,	ILLEGAL CHARACTER	05270
	BCI	4,	NO MANTISSA BEFORE E.	05280
	BCI	4,	NO ENTRY IN TABLE	05290
	BCI	4,	\$TYPE MISSING OR WRONG	05300
	BCI	4,	EXPON. OUT OF RANGE	05310
	REM			05320
	REM		END OF THE SAP SUBROUTINE ERROR.	05330
	EJECT			05340
	REM		THIS IS SUBROUTINE LOOK. IT SEARCHES THE TABLE	05350
	REM		FOR THE NAME STORED AT LOCATION VAR. IF FOUND,	05360
	REM		THE ACC IS NON-ZERO AT THE RETURN.	05370
	REM			05380
LOOK	SXD	TEMP-12,4	SAVE INDEX REGISTER C.	05390
	CLA	J	SUBROUTINE.	05400
	STD	LOC&E		05410
	AXT	2,2	JK = 2 IN INDEX 8	05420
	AXT	1,1	J1 = 1 IN INDEX A	05430
LOC&A	CAL	**2	CAL TABV(JK).	05440
	TZE	LOC&G	NO ENTRY THIS VARIABLE	05450
	STD	LOC&D	DECREMENT HAS NEXT	05460
	ACL	=0377777000000		05470
	ANA	=0377777000000	ENTRY LOC. SAVE DECR	05480
	SUB	J	ONLY. CHECK ENTRY LENGTH.	05490
	TNZ	LOC&D	IF NOT THE SAME, LOOK AT NEXT ENTR	05500
	PXD	0,2		05510
	PDX	0,4	JM = JK IN INDEX C.	05520
				05530

LOCFB	CLA	VAR+1,1	SEE IF VAR AND THIS	05540
LOCFB	CAS	**4	ENTRY AGREE	05550
	TRA	**2	IF SO, CHECK REST OF NAME	05560
	TXI	**2,4,1	RAISE JM BY ONE.	05570
LOCFD	TXI	LOCFA-1,2,**	IF NOT SO, GO TO NEXT ENTRY.	05580
	TXI	**1,1,1	RAISE J1 BY ONE.	05590
LOCFE	TKL	LOCFB,1,**	FINISHED IF J1 IS GREATER THAN J.	05600
	TSX	CLEAR,4	CLEAR IF THE ENTRY AGREES.	05610
LOCFF	CLA*	LOCFA		05620
	STO	ILOC	SAVE COMMON INDEX AT ILOC.	05630
LOCFG	LXD	TEMP-12,4	PREPARE TO RETURN.	05640
	TRA	1,4	RETURN TO THE CALLING PROGRAM.	05650
	REM			05660
	REM			05670
	REM		END OF THE SAP SUBROUTINE LOOK.	05680
	EJECT			05690
	REM		THIS IS SUBROUTINE NAME. IT IS USED TO	05700
	REM		CORRELATE NAMES FROM INPUT CARDS WITH INTERNAL	05710
	REM		MEMORY LOCATIONS BY REFERRING TO THE TABLE.	05720
	REM			05730
	REM			05740
NAME	SXD	TEMP-20,4	SAVE INDEX C.	05750
	REM		GET THE REST OF THE VARIABLE NAME. STOP AT ANY	05760
	REM		NON ALPHANUMERIC CHARACTER.	05770
LOCGB	TSX	STORE,4		05780
LOCGB	TSX	CHRCTR,4		05790
	TQP	**2	MINUS FOR NEW CARD	05800
	TSX	TEST,4	COMMA MAY BE NEEDED.	05810
	TNZ	**3	LOOK FOR ZERO. IF ZERO, MAKE IT	05820
	ACL	=H000000	A LETTER D	05830
	STO	WORD		05840
LOCGE	TSX	COMPAR,4		05850
	BCI	1,=(0000		05860
	TRA	**5,2,1		05870
	TRA	LOCGB	JUNK OR OPERATORS	05880
	TRA	LOCGB	NUMERIC OR ALPHABETIC	05890
	TRA	LOCGB	(SIGN	05900
	STZ	ILOC1	= SIGN	05910
	REM		GO TO THE TABLE LOOKUP ROUTINE IF AN = SIGN	05920
	REM		OR AN OPERATOR WAS FOUND.	05930
LOCGF	TSX	LOOK,4	FIND THE NAME IN TABLE.	05940
	TZE	ERRT	NAME WAS FOUND IN TABLE IF NON-ZER	05950
	LXA	ILOC,2		05960
	TRA	LOCGL		05970
	REM			05980
	REM		GO TO THE TABLE VARIABLE LOOKUP ROUTINE IF A	05990
	REM		(SIGN WAS FOUND.	06000
LOCGG	TSX	LOOK,4		06010
	TNZ	LOCGB		06020
ERRT	TSX	ERROR,4		06030
	BCI	1,0(I)		06040
	REM		CONVERT THE INDEX TO BINARY.	06050
LOCGH	TSX	BINARY,4		06060
	REM		GET THE NUMERICS FOR THE INDEX TO THE VARIABLE.	06070
LOCGJ	TSX	CHRCTR,4		06080
	TXL	LOCGH,1,9	NUMERIC	06090
	TXL	ERRC,1,27	JUNK	06100
	TXH	ERRC,1,29	JUNK	06110
	TSX	CHRCTR,4) SIGN. GET NEXT CHARACTER.	06120
	TQP	**2	MINUS FOR NEW CARD	06130
	TSX	TEST,4	COMMA MAYBE NEEDED.	06140
	TSX	COMPAR,4		06150
	BCI	1,=00000		06160
	TRA	**4,2,1		06170
	TRA	LOCGB	OPERATORS	06180
	TRA	ERRL	ALPHABETIC AND NUMERIC	06190
	STZ	ILOC1	= SIGN	06200
	REM			06210
LOC GK	CLA	VAR	COMPUTE STORING INDEX.	06220
	ACL	ILOC		06230
	PAX	0,2	STORE ADDRESS AT DECREMENT WITHOUT	06240
	TXI	**1,2,-1		06250
LOCGL	SXD	JK,2	ACCUMULATOR OVERFLOW.	06260
	CLA	ILOC1		06270
	LXD	TEMP-20,4	RESTORE INDEX C.	06280
	TRA	1,4	RETURN TO CALLING PROGRAM.	06290
	REM		CONSTANTS AND ERROR CALL.	06300
ERRC	TSX	ERROR,4		06310
	BCI	1,0(C)		06320
	REM			06330
	REM		END OF THE SAP SUBROUTINE NAME.	06340
	EJECT			06350
	REM		THIS IS SUBROUTINE NUMBER. IT IS USED TO	06360
	REM		ASSEMBLE NUMERIC DATA FROM CARDS. ALL VALUES ARE	06370
	REM		TREATED AS FLOATING POINT NUMBERS IN THIS ROUTINE.	06380
	REM			06390
NUMBER	SXD	TEMP-23,4	SAVE INDEX C.	06400
	SKD	KNT2,4	INITIALIZE	06410
	STZ	KNT3	THE SUBROUTINE	06420
	STZ	KNT1	BRANCH PARAMETERS.	06430
	STZ	KNT4		06440
	STZ	TEMP		06450
	TRA	LUCHB		06460
	REM			06470
LOCHA	TSX	CHRCTR,4		06480
	TQP	**2,	MINUS MEANS FROM NEW CARD	06490
	TSX	TEST,4		06500

LOCHB	TSX	COMPAR,4	06510
	BCI	1,,E0000	06520
	TRA	**6,2,2	06530
	TRA	LOCHK	JUNK OR AN OPERATOR
	TRA	ERRE	ALPHABETIC
	TRA	LOCHC	NUMERIC
	TRA	LOCHE	E
	CLA	KNT2	DECIMAL POINT.
	TNZ	**3	ZERO MEANS THIS IS THE SECOND POIN
	TSX	ERROR,4	06590
	BCI	1,0(N)	06600
	STZ	KNT2	06610
	STZ	NEXP	06620
	TRA	LOCHA	06630
LOCHC	CLA	NEXP	COUNT THE NUMBER OF DIGITS BEHIND
	ADD	=1095	THE. IF THERE IS ONE
	STD	NEXP	06650
	LOCHD	LXA	KNT1,1
	TXH	LOCHD2,1,10	DO NOT ACCUMULATE PAST 10
LOCHD1	TSX	BINARY,4	CONVERT THE DIGIT TO BINARY.
	TZE	LOCHA	DO NOT COUNT LEADING ZEROS.
LOCHD2	TXI	**1,1,1	COUNT TOTAL NO. OF DIGITS
	SXA	KNT1,1	06700
	TRA	LOCHA	06710
	REM	COMES HERE WHEN THE EXPONENT FIELD IS	06720
	CLA	KNT1	ENCOUNTERED.
LOCHE	TNZ	LOCHH	THERE MUST BE AT LEAST ONE DIGIT
	TSX	ERROR,4	BEFORE THE E OF AN E FORMAT NUMBER
	BCI	1,0(S)	06760
LOCHF	CLA	KNT3	SEE IF EXPONENT DIGITS HAVE ARRIVE
	TRA	**2	06800
LOCHG	CLS	KNT3	SEE IF EXPONENT DIGITS HAVE ARRIVE
	TNZ	LOCHK-2	NON ZERO MEANS SIGN IS OPERATOR.
	STD	TEMP	STORE SIGN OF EXPONENT.
	CLA	KNT4	06840
	TNZ	ERRF	NONZERO MEANS MORE THAN 1 EXP SIGN
	SKD	KNT4,2	MAKE NOZERO.
	LOCHH	TSX	CHRCTR,4
	TQP	**2,	MINUS MEANS FROM NEW CARD
	TSX	TEST,4	06880
	BCI	COMPAR,4	06890
	TRA	1,+-,000	06900
	TRA	**7,2,2	06910
	TRA	LOCHK-2	OTHERS
	TRA	ERRF	ALPHABETIC
	TRA	LOCHJ	NUMERIC
	TRA	ERRF	DECIMAL
	TRA	LOCHG	MINUS
	TRA	LOCHF	PLUS
	REM	CONVERT THE EXPONENT TO BINARY.	06970
LOCHJ	CLA	TEMP	06980
	ALS	2	07000
	ADD	TEMP	07010
	ALS	1	07020
	AGL	WORD	07030
	STD	TEMP	07040
	SXD	KNT3,2	RECORD FACT FOR SECOND SIGN.
	TRA	LOCHH	07050
	REM	COMES HERE WHEN AN OPERATOR WAS FOUND.	07060
	CLA	KNT3	TEST FOR THE PRESENCE OF EXPONENT.
	TZE	ERRF	ZERO MEANS NO EXPONENT CAME.
LOCHK	CLA	KNT2	07070
	TZE	**2	07080
	STZ	NEXP	07090
	CLA	KNT1	SEE IF MORE THAN TEN NUMBERS HAVE
	SUB	=10835	BEEN CONVERTED
	TPL	**2	IF SD, USE THE DIFFERENCE IN THE
	PXD	0,0	COMPUTATION OF THE EXPONENT.
	SUB	NEXP	07100
	ADD	TEMP	07110
	STD	NEXP	07120
	REM	MANTISSA IN VAR AND THE EXPONENT IS IN NEXP.	07130
	CLA	VAR	07140
	TZE	LOCHQ	SHORT CUT IF ZERO.
	LDQ	=0233000000000	CHARACTERISTIC FOR LOW BITS
	LGR	8	LOW 8 BITS TO MQ
	RQL	8	07200
	LRS	0	BRING SIGN
	STQ	VAR	07210
	ORA	=0243000000000	CHARACTERISTIC FOR HIGH BITS
	FAD	VAR	07220
	FRN	VAR	07230
	STD	VAR	07240
	CLA	NEXP	THE EXPONENT
	AXT	1,2	PUT I IN MQ
	LDQ	=1.	EXONENT IN ACCU
LOCHL	LBT	LOCHM	FOUND NO BIT.
	TRA	ERRV,2,6	EXPONENT EXCEEDS 63
	TXH	VAR-2	07360
	STD	VAR-2	07370
	FMP	TAB+1,2	THIS FORMS 10 **NEXP
	XCA	VAR-2	SAVE IN MQ
	CLA	VAR	07400
LOCHM	ARS	1	07410
	TZE	LOCHN	10**NEXP FINISHED.
	TMI	LOCHL,2,1	07420
LOCHN	FMP	LOCHO	MULTIPLY IF PLUS.
	FRN	VAR	07430
	TRA	LOCHQ	07440
LOCHO	STQ	VAR-2	07450
	CLA	VAR	DIVIDE IF NEXP IS MINUS.
	FDP	VAR-2	07460
	XCA	VAR	ANSWER BACK TO THE ACCUM
LOCHQ	LXD	TEMP-23,4	RESTORE INDEX C.
	TRA	1,4	RETURN TO CALLING PROGRAM.
	REM	THESE ARE THE ERROR CALLS FOR SUB NUMBR.	07470
			07480
			07490
			07500
			07510
			07520
			07530
			07540
			07550
			07560
			07570

ERRE	TSX	ERRDR,4		07580
	BCI	1,0(E)		07590
ERRF	TSX	ERRDR,4		07600
	BCI	1,0(F)		07610
ERRV	TSX	ERRDR,4		07620
	BCI	1,0(V)		07630
	REM			07640
	REM	THIS IS THE FLOATING PT. TABLE USED IN DBC		07650
	DEC	1E+32,1E+16,1E+8,1E+4,1E+2	CONVERSION TABLE	07660
TAB	DEC	1E+1		07670
	REM			07680
	REM	END OF THE SAP SUBROUTINE NUMBER.		07690
	EJECT			07700
	REM	THIS IS SUBROUTINE STORE. IT STORES CHARACTERS		07710
	REM	AT THE ARRAY VAR.		07720
	REM			07730
STORE	SXD	TEMP-13,1	SAVE INDEX A.	07740
	SXD	TEMP-14,2	SAVE INDEX B.	07750
	LXD	J,1	PUT J INTO INDEX REGISTER A.	07760
LOCJA	LXD	MSHIFT,2	LOAD INDEX B WITH MSHIFT.	07770
	TIX	LOCJB,2,6	ADVANCE MSHIFT.	07780
	AXT	36,2	REFRESH MSHIFT.	07790
	TXI	**+1,1,1	RAISE J BY ONE IF MSHIFT IS OVER	07800
	STZ	VAR,1	CLEAR NEXT CELL	07810
LOCJB	CLA	WORD	LEAVE SIGN BEHIND	07820
	LDD	=0		07830
	LGR	42,2	MOVE CHARACTER	07840
	STQ	TEMP-7	PLACES TO THE LEFT.	07850
	CAL	TEMP-7		07860
	ORS	VAR+1,1	STORE THE CHARACTER AT VAR.	07870
	SXD	MSHIFT,2	SAVE MSHIFT.	07880
	SXD	J,1	SAVE J.	07890
	LXD	TEMP-13,1	RESTORE INDEX A.	07900
	LXD	TEMP-14,2	RESTORE INDEX B.	07910
	TRA	1,4	RETURN TO CALLING PROGRAM.	07920
	REM			07930
	REM	END OF THE SAP SUBROUTINE STORE.		07940
	EJECT			07950
	REM	THIS IS SUBROUTINE TABLE. IT IS USED TO		07960
	REM	CONSTRUCT A TABLE OF NAMES TO BE USED ON CARDS		07970
	REM	AND THEIR MEMORY LOCATIONS RELATIVE TO ARG 2 OF		07980
	REM	THE CALLING SEQUENCE.		07990
	REM			08000
TABLE	SXD	TEMP-15,4	SAVE INDEX C.	08010
	STZ	TEMP		08020
LOCKA	TSX	CHRCTR,4		08040
	TSX	COMPAR,4		08050
	BCI	1,,00000		08060
	TRA	**+5,2,2		08070
	TRA	LOCKD+1	JUNK	08080
	TRA	LOCKA	ALPHABETIC	08090
	TRA	LOCKD+1	NUMERIC	08100
LOCKB	STZ	TEMP	COMMA	08110
	TRA	LOCKD		08120
	REM	COMES HERE TO CONVERT THE ADDRESS TO OCTAL FOR		08130
LOCKC	CLA	TEMP	THE TABLE.	08140
	ALS	2		08150
	ADD	TEMP		08160
	ALS	1		08170
	ACL	WORD		08180
	STO	TEMP	ADDS TO MAGNITUDE	08190
	REM			08200
	REM	COMES HERE TO GET NUMERICS.		08210
LOCKD	TSX	CHRCTR,4		08220
	TSX	COMPAR,4		08230
	BCI	1,,= /000		08240
	TRA	**+7,2,2		08250
	TRA	ERRA	JUNK	08260
	TRA	ERRA	ALPHABETIC	08270
	TRA	LOCKC	NUMERIC	08280
	TRA	LOCKT	/ CHARACTER	08290
	TRA	LOCKF	= SIGN	08300
	REM			08310
	REM	COMES HERE IF A DECIMAL PT WAS FOUND.		08320
LOCKE	CAL	TEMP	DECIMAL POINT	08330
	CHS		MAKE SIGN MINUS	08340
	STO	TEMP		08350
	TRA	LOCKD		08360
	REM			08370
	REM	COMES HERE IF AN = SIGN WAS FOUND.		08380
LOCKF	TSX	CLEAR,4		08390
LOCKG	TSX	CHRCTR,4		08400
	YQP	**+2,	MINUS MEANS FROM NEW CARD	08410
	TSX	TESTT,4		08420
	TZE	LOCKH		08430
	TBX	COMPAR,4		08440
	BCI	1,, /0000		08450
	TRA	**+5,2,1		08460
	TRA	ERRG	JUNK	08470
	TRA	LOCKJ	ALPHABETIC OR NUMERIC	08480
	SXD	B,2	COMMA	08490
	SXD	B,2	SLASH	08500
	TRA	LOCKK		08510
	REM			08520
	REM	COMES HERE TO STORE CHARACTER.		08530
LOCKH	ACL	=H000000	REPLACE ZERO WITH LETTER O	08540
	STO	WORD		08550
LOCKJ	TSX	STORE,4		08560
	TRA	LOCKG		08570
	REM	COMES HERE AT END OF NAME.		08580

LOCKK	TSX	LOOK,4		08590	
	TNZ	LOCKR	GOES TO LOCKR IF THERE IS AN ENTRY	08600	
	LXD	J,1		08610	
	TXI	**1,1,1	ASSEMBLE KEY	08620	
	PXD	0,1	IRB HAS FIRST FREE LOC.	08630	
	ACL	TEMP		08640	
LOCKL	SLW	**2	STORE KEY INTO TABLE	08650	
	SXD	**1,1	ADVANCE TO END	08660	
	TXI	**1,2,**		08670	
LOCKM	CAL	VAR+1,1	MOVE NAME, 0 TO TABLE	08680	
LOCKN	XEC	LOCKL	SLW IN TABLE	08690	
	TNX	**2,1,1	TRANSFER WHEN DONE	08700	
	TXI	LOCKM,2,-1	GO BACK TO FINISH	08710	
	ARS	34	KEEP ZONE OF 1ST VAR CH.	08720	
	TZE	ERRG	WAS NUMERIC, OR J=0	08730	
	REM			08740	
	REM	REEXAMINE THE	CUT OFF CHARACTER.	08750	
LOCKP	LXD	B,2		08760	
	TXH	LOCKB,2,1	COMMA	08770	
LOCKQ	LXD	TEMP-15,4	/ CHARACTER	08780	
	TRA	1,4	RETURN.	08790	
	REM			08800	
	REM	COMES HERE TO REPLACE KEY		08810	
LOCKR	ANA	=037777700000	J+1 IN DECREMENT	08820	
	ACL	TEMP	LOCATION AND SIGN	08830	
LOCKS	XEC	LOCKL	SLW IN TABLE	08840	
	TRA	LOCKP		08850	
LOCKT	GAL	TEMP	IS / LEGAL	08860	
	TZE	LOCKQ	YES	08870	
	REM	TRA	ERRA	NO, NUMERICS WAITING	08880
	REM			08890	
	REM	THESE ARE THE ERROR CALLS.		08900	
ERRA	TSX	ERROR,4		08910	
	BCI	1,0(A)		08920	
ERRG	TSX	ERROR,4		08930	
	BCI	1,0(G)		08940	
	REM			08950	
	REM	END OF THE SAP SUBROUTINE TABLE		08960	
	EJECT			08970	
	REM	THIS IS SUBROUTINE TEST. IT LOOKS AHEAD TO CLASSIFY		08980	
	REM	A NEW CARD. ACOMMA WILL BE PUT INTO THE CURRENT		08990	
	REM	CHARACTER POSITION ONLY IF EITHER (1) THE NEXT		09000	
	REM	CARD BEGINS WITH A \$ SIGN FOLLOWED BY SOME OTHER		09010	
	REM	CHARACTER OR (2) THE NEXT CARD BEGINS WITH AN		09020	
	REM	ALPHABETIC AND AN = SIGN IS FOUND AND IT PRECEEDS		09030	
	REM	ALL , \$ AND . CHARACTERS ON THAT CARD.		09040	
	REM			09050	
	REM			09060	
TEST	SKD	TEMP-12,4	SAVE INDEX FOR RETURN.	09070	
	SUB	=H0000\$0	TEST FOR A \$ SIGN.	09080	
	TPL	LOCLA	POSITIVE MEANS \$ SIGN.	09090	
	XEC	READ.	SAFE TO REFILL BUFFER	09100	
	TXL	LOCLB,1,16	NUMBERS AND SPECIAL	09110	
	TIX	**1,1,33	FIX SO SLASH IS SPECIAL		
	TIX	*,1,16	MOD OUT ZONE	09130	
	TXH	LOCLB,1,9	SPECIALS	09140	
	REM		ALPHABETIC COME THRU.	09150	
	REM		SCAN THE CARD.	09160	
LOCLC	AKT	15,1		09170	
	LDQ	RECORD+3,1		09180	
	TXI	**1,1,69	FOR CHARACTER COUNT	09190	
	TXL	LOCLB,1,70	DONE IF WHOLE CARD SCANNED	09200	
LOCLD	PXD	0,0	OK TO SEARCH 84 COLUMNS	09210	
	LGL	6		09220	
	PAX	0,2	ZONE TO IRB	09230	
	ANA	=017	KEEP DIGIT	09240	
	SUB	=013	DIGIT PART OF ,\$.= CHR.	09250	
	TZE	LOCLJ	CHECK ZONE	09260	
	TIX	LOCLD,1,14	TRY NEXT CHARACTER	09270	
	TRA	LOCLC+1		09280	
LOCLJ	TXH	LOCLB,2,15	, . \$ NEED NO COMMA	09290	
LOCLA	AXT	84,1	84 IS CARD COL 1	09300	
	SXD	1,1	RESET CHRCTR TO BEGIN CARD	09310	
	CLA	RECORD-12		09320	
	STO	Q		09330	
	CLA	=H00000,	SUBSTITUTE A COMMA.	09340	
	STO	WORD		09350	
LOCLB	LXD	TEMP-12,4		09360	
	CLA	WORD	IN AC FOR SR NAME, TABLE	09370	
	TRA	1,4	RETURN TO THE CALLING PROGRAM.	09380	
	REM				
	REM	FOR TABLE SUB STATEMENTS			
TESTT	SKD	TEMP-12,4		09390	
	AXT	84,4	IF NEXT CARD HAS VALID	09400	
	LDQ	RECORD-12	LEFT PART OF SUBSTATEMENT	09410	
LOCNB	PXD	0,0		09420	
	LGL	6		09430	
	PAX	0,2		09440	
	TXH	LOCLB,2,48	0 ZONES EXCEPT BLANK	09450	
	TXH	LOCNC,2,47	BLANK	09460	
	TXH	LOCLB,2,27	11 ZONES AND)	09470	
	TXH	LOCLA,2,26	=	09480	
	TXH	LOCLB,2,11	12 ZONES AND 8-4	09490	
	TXH	LOCLA,2,10	=	09500	
LOCNC	TIX	LOCNB,4,14	NUMERICS AND BLANK	09510	
	LDQ	RECORD+3,4		09520	
	TNX	LOCLB,4,1		09530	
	TXI	LOCNB,4,70		09540	
	REM			09550	
	REM	END OF THE SAP SUBROUTINE TEST.		09560	
	EJECT			09570	
	REM	THE FOLLOWING FOUR SUBROUTINES ARE USED TO		09580	
	REM	CONVERT DECIMAL DIGITS TO BINARY IN VAR,		09590	
	REM	FIX FLOATING POINT NUMBERS, FLOAT FIXED POINT		09600	
	REM	NUMBERS, AND FORM ARITHMETIC RESULTS IN THE		09610	
	REM	PSEUDO ACCUMULATOR (ACC) FOR EACH OPERATION		09620	
	REM	ON A CARD.		09630	
	REM			09640	

BINARY	CLA	VAR	ACCUMULATE A SERIES OF BASE 10	09650
	ALS	2	DIGITS IN BINARY IN VAR.	09660
	ADD	VAR		09670
	ALS	1		09680
	ACL	WORD		09690
	STO	VAR		09700
	TRA	1,4		09710
	REM			09720
FLT	CLA	TEMP	CONVERT TO FLOATING POINT THE	09730
	LRS	18	CONTENTS OF THE STORAGE CALLED	09740
	DRA	=023300000000	TEMP.	09750
	FAD	=023300000000		09760
	STO	TEMP	LEAVE THE ANSWER IN TEMP.	09770
	TRA	1,4		09780
	REM			09790
FIX	UFA	=023300000000	CONV TO FIXED PT THE CONT	09800
	LRS	0	OF THE ACCUMULATOR.	09810
	ANA	=0377777		09820
	LLS	0		09830
	ALS	18	LEAVE THE FIXED POINT NUMBER IN	09840
	TRA	1,4	THE ACCUMULATOR.	09850
	REM			09860
ACCUM	LXD	OPER,2	BRANCH FOR OPERATOR	09870
	STZ	OPER	PREPARE FOR NEXT OPERATOR.	09880
	CLA	TEMP		09890
	TRA	**2,2		09900
	TRA	LOCMB	*	09910
	TRA	LOCMA	/	09920
	CHS		MINUS	09930
	FAD	ACC	PLUS	09940
ACCUM	STO	ACC	NONE	09950
	TRA	1,4		09960
	REM			09970
LOCMA	CLA	ACC	DIVIDE.	09980
	FDP	TEMP		09990
	STQ	ACC		10000
	TRA	1,4		10010
	REM			10020
LOCMB	LDQ	ACC	MULTIPLY.	10030
	FNP	TEMP		10040
	TRA	ACCUM		10050
	REM			10060
	REM			10070
	REM		END OF THE SAP SUBROUTINES ACCUM, FIX, FLOAT.	10080
	EJECT			10090
	REM		SUBROUTINE PRINX DRAINS PRINT BUFFER TO LOGICAL TAPE	
PRINX	SKA	PRINX,4	GIVEN IN DECREMENT OF OUTAPE	
	CLA	OUTAPE	BUFFERED WRITE ROUTINE	10110
	CALL	(IOS)	LOGICAL OUTPUT TAPE NUMBER	
	AXC	IOCD,4		10130
	XEC*	\$(WRS)	=WTDL 6	10140
	XEC*	\$(RCH)	=RCHL 0,4	10150
	PMA	0,4	SAVE LOC OF	10160
	STA*	\$(WTC)	IO COMMAND FOR (WER)	10170
	CLA	TSXWR	PRESET END ACTION	10180
	STO*	\$(TES)		10190
PRINX	AXT	**4		10200
	TRA	1,4		10210
TSXWR	CALL	(WER)	EXECUTED FROM (TES)	10220
IOCD	IORT	OUTBUF,,19		10230
	EJECT			10240
	REM		SUBROUTINE READ. FILLS READ BUFFER FROM LOGICAL TAPE 7.	10250
READ.	TSX	READ,+1,4	READ. GATE INITIALLY OPEN	10260
	CLA	=007610000000	CLOSE READ GATE	10270
	STO	*-2		10280
	SKA	AXT,4		10290
	CLA	INTAPE	LOGICAL INPUT TAPE NO.	10300
	CALL	(IOS)		
	AXC	IOCD,,4		10320
	XEC*	\$(RDS)	=RTDL5	10330
	XEC*	\$(RCH)	=RCHL 0,4	10340
	CLA	TSXTS	SET UP BUFFER TEST	10350
	STO*	\$(TES)		10360
AXT	AXT	**4		10370
	TRA	1,4		10380
TSXTS	TSX	**1,4	EXECUTED FROM (TES)	10390
	SKA	AXT,4	CLOSE OUT BUFFER	10400
	CLA	=007610000000	SAY BUFFER IS QUIET	10410
	STO*	\$(TES)		10420
	AXT	5,4	PRESET REDUNDANCY	10430
	SKA	RTT,4	COUNT	10440
TSXTT	AKC	**1,4		10450
	XEC*	\$(TCO)	=TCOL 0,4	10460
	AKC	RTT,4		10470
	XEC*	\$(TRC)	=TRCL 0,4	10480
	AKC	XIT,,4		10490
	XEC*	\$(TEF)	=TEFL 0,4 JOB COMPETE	10500
	TRA	AXT	RETURN	10510
RTT	AXT	**4	INTERROGATE COUNT	10520
	TIX	SKA,,4,1	GIVE ANOTHER TRY	10530
	AKT	14,4	CARD SURE BAD	10540
	CLA	INBUF+14,4	SAVE IMAGE	10550
	STO	RECORD+2,4		10560
	TIX	*-2,4,1		10570
	AXT	84,4	MAKE ERROR ROUTINE LOSE*	10580
	SXD	1,4	IN INPUT BUFFER	10590
	TSX	ERROR,4		10600
R	BGI	1,0(R)		10610
SXA.	SKA	RTT,4	SAVE COUNT	10620
	AXC	**2,4		10630
	XEC*	\$(TEF)	TURN OFF EOF IND	10640
	XEC*	\$(BSR)	BACKSPACE,	10650
	AXC	IOCD,,4		10660
	XEC*	\$(RDS)	REREAD	10670
	XEC*	\$(RCH)		10680
	TRA	TSXTT		10690
				10700

IOCD.	IORT	INBUF,,14		10710
XIT.	CLA	=0531700000000	FILE FLAG	10720
	STO	INBUF		10730
	TRA	AXT		10740
	EJECT			10750
	REM BUFFERS AND COMMON STORAGE ASSIGNMENT			10760
INBUF	BCI	7,\$E		10770
	BCI	7,		10780
OUTBUF	BCI	7,		10790
	BCI	7,		10800
	BCI	5,		10810
	REM ***** COMMON STORAGE MAP			10820
	COMMON	-203	MOVE TO TOP-3	10830
RECORD	COMMON	13	CD IMG *-12 TO**1	10840
I	COMMON	1	CHARACTER POINTER FOR CARD	10850
ERSW	COMMON	1	ERROR SWITCH ZERO = GET OFF	10860
Q	COMMON	1	UNTESTED CHARACTERS	10870
WORD	COMMON	1	CURRENT CHARACTER	10880
OPER	COMMON	1	DECR. REPRESENTS OPER.	10890
B	COMMON	1	TEMP INDEX IN SUB TABLE	10900
NEXP	SYN	8	NUMERIC VALUE OF EXPONENT	10910
J	COMMON	1	COUNTER IN SUB STORE	10920
MSHIFT	COMMON	1	COUNTER IN SUB STORE	10930
ILOC	COMMON	1	DATA BROUGHT FROM TABLE	10940
TEMP	COMMON	1	TEMPORARY STORAGES	10950
KNT1	COMMON	1	COUNTER TOTAL DIGITS	10960
KNT2	COMMON	1	NONZERO UNTIL . FOUND	10970
KNT3	COMMON	1	ZERO UNTIL DIGIT IN EXP	10980
SIGN	COMMON	1	MINUS IF SUB CHAR READS C	10990
TAG	COMMON	1	SAVES \$ IN SUB CHAR	11000
ALF	COMMON	1	NONZERO MEANS ALF MODE	11010
	COMMON	1		11020
JK	COMMON	1	SUBSCR CORR TO NAME	11030
	COMMON	13		11040
JK1	COMMON	1	CURR SUBSCR OF LEFT SIDE	11050
	COMMON	1		11060
ACC	COMMON	1	PSEUDO ACCUMULATOR	11070
ILOC1	COMMON	1	ILOC FOR LEFT SIDE	11080
KNT4	COMMON	1	NONZERO AFTER EXP SIGN	11090
VAR	COMMON	153	SPACE FOR NAMES, ETC.	11100
	END			11110

```

COUNT 1
REM ONE WORD SUBROUTINE TO CONTROL BACKSPACE OF INPUT TAPE
LBL LINK,6
ENTRY (LINK)
(LINK) NOP
END

```

APPENDIX I

EXAMPLE II: LUNAR ORBITING PROBE

This example of a lunar orbiting probe illustrates the use of the ephemeris tape and the control parameters needed to consider the effects of perturbing bodies, atmospheric forces, oblateness, rotating Earth, and thrust. No effort was made to optimize this trajectory but rather to use plausible values for illustrative purposes. It is suggested that the input instructions contained in appendix G be read prior to the following detailed discussion.

Suppose the probe was launched at Cape Canaveral on December 7, 1961, by a three-stage vehicle with stage parameters as shown in the following table:

Parameters	Stage		
	1	2	3
Initial mass, m_0 , kg	150,000	52,500	23,625
Engine exit area, A_e , m^2	3.0	1.0	.5
Vacuum specific impulse, I , sec	420	420	420
Propellant flow rate, \dot{m} , kg/sec	750	125	56.25
Burning time, t_b , sec	117	207.9	370
Aerodynamic reference area, S , m^2	7.5	4.0	2.0

Figure 4 shows the assumed variation of $C_{D,0}$, $C_{D,i}$, and C_L with Mach number as well as the angle-of-attack schedule.

The vehicle will be flown as follows: First, there will be a short nondrag vertical flight, after which the desired velocity orientation will be set, and then a turn will be executed determined by gravity and the angle-of-attack schedule until first-stage burnout. The second and third stages follow a continuation of the same turning pattern. The third stage will be powered until the eccentricity of the trajectory equals 1.10. It will then coast until it is at lunar pericenter, at which time the engine will again be turned on (with $\alpha = \pi$) until the orbit about the Moon becomes nearly circular.

The chosen integration mode will be rectangular for the powered flight, but the mode of orbit elements will be used for the coast portions. Other bodies considered besides the Earth and the vehicle are the Sun, the Moon, and Jupiter. Jupiter is included to illustrate the use of ellipse ephemerides. The Sun and Moon will illustrate the use of the tape ephemeris.

The correct firing direction and launch time remain to be determined. This determination can be made by finding approximate values and then adjusting these values after one or more shots are fired. The adjustments could be made by an

iteration scheme programed internally to make a closed system. For this example, however, they were made by hand by firing several shots at various azimuth angles close to an estimate obtained by using reference 12 and an ephemeris. From a plot of the z-direction cosine of the vehicle-Moon distance against vehicle-Earth distance, the azimuth angle that will intersect the Moon orbit can be determined. The correct launch time is found by using the previously determined azimuth angle and various times of day to determine the time of day at which the vehicle intersects the correct position in the Moon orbit (location of the Moon). This type of analysis gives an azimuth angle of about 64.5° and a time of day of about 7.0^h E.T. (E.T. is ephemeris time, which is approximately equal to Greenwich mean time.) For the present purpose, these values will be used.

The program begins by constructing the merged ephemeris tape for the Sun and Moon. This is done by SUBROUTINE TAPE in conjunction with the input shown as follows:

```

$DATA=300,$TABLE,2=TAPE3,17=ELIST,29=TBEGIN,30=TEND/ $$ ID. AND TABLE DEFINITION
TAPE3=0          $$ NECESSARY TO MAKE TAPE
ELIST=(A3)SUN,(A4)MOON  $$ LIST OF DESIRED EPHEMERIS BODIES
TBEGIN=2437640.5      $$ JULIAN BEGINNING DATE
TEND=TBEGIN+5        $$ JULIAN ENDING DATE

```

After the merged ephemeris tape is constructed, the set of standard data in SUBROUTINE STDATA is loaded, and the input is loaded as shown:

```

$DATA=1,$TABLE, 33=DTOFFJ, 34=TOFFT, 711=TIME, 716=X, 717=Y, 718=Z,
713=VX, 714=VY, 715=VZ, 11.=IMODE, 713=E, 714=OMEGA, 715=NODES,
716=INCL, 717=MA, 718=P, 43=LAT, 44=LONG, 45=AZI, 46=ELEV, 14=ALT,
47=VEL, 16=TFILE, 28=TMIN, 153=BODYCD, 177=ELIPS, 30.=MODOUT,
27=STEPS, 29=DELMAX, 26=STEPMX, 23=EREF, 24=ERLIMT, 4.=NSAVE,
5=RECALL, 3=CLEAR, 18.=LOOKX, 22=XLOOK, 19.=LOOKSW, 20=SWLOOK,
609.=INLOOK, 15=END, 31=ATMN, 32=RATM, 49=ROTATE, 417=COEFN,
163.=ICC, 60=BETA, 50=OBLATN, 73=TB, 93=FLOW, 103=SIMP, 123=AREA,
143=DELT, 83=RMASS, 113=AEXIT, 133.=IDENT, 48.=LSTAGE, 25=TKICK /

```

```

BODYCD=(A5)EARTH,(A4)MOON,(A6)JUPITE,(A3)SUN  $$ BODY NAMES, 1ST IS ORIGIN
ELIPS=(ALF6)JUPITE,(ALF3)SUN,.9547861E-3,4.81E+10,5.1913995,  $$ ELLIPTIC DATA
.0486288,.1765935,.056971884,.40587194,2433964...6664,4333.7153 $$ FOR JUPITER
COEFN=0,.4,0,.6,1,1.15306,-.16326,.010204,8,.5,,,100,,10,,,  $$ AERO. COEFF.
100,,.025,,,100,,,,,15,-.6,.04,,40,.7,,,117,,,,,1E3,180,,,1E8,ICC=24,14,19,1 $$
RMASS=150000,52500,23625  $$ STAGE MASSES
FLOW=750,125,56.25,0,56.25  $$ STAGE FLOW RATES
SIMP=420,420,420,,420  $$ STAGE SPECIFIC IMPULSES
AEXIT=3,1,.5  $$ STAGE ENGINE EXIT AREAS
AREA=7.5,4,2  $$ STAGE AERODY. REFERENCE AREAS
TB=117,207.9,400,1E7,50,3600  $$ STAGE BURNING TIMES
DELT=2,2,2,86400,2,600  $$ STAGE INITIAL INTEGRATION STEP SIZES
IDENT=,2,3,4,5,6  $$ STAGE INPUT IDENTIFICATION NUMBERS
DTOFFJ=2437640.5,TOFFT=7/24  $$ TAKE-OFF DATE AND FRACTION OF DAY
LAT=28.280,LONG=-80.571,ELEV=81.7 $$ LATITUDE, LONGITUDE, ELEVATION
AZI=64.5,ALT=10,IMODE=4  $$ AZIMUTH, ALTITUDE, INTEGRATION MODE
MODOUT=2,DELMAX=50  $$ MODE OF OUTPUT, TIME INTERVALS OF OUTPUT
STEPMX=300, OBLATN=(A5)EARTH  $$ MAXIMUM ALLOWED STEP NUMBER, OBLATE BODY
TKICK=10  $$ TIME OF THE VERTICAL NON-DRAG STEP
ROTATE=7.29211585E-5  $$ ROTATION RATE OF THE ORIGIN BODY (EARTH)
ATMN=(A5)EARTH,RATM=1E11  $$ ATMOSPHERE NAME, RADIUS OF ATMOSPHERE
EREF=1E-5,ERLIMT=5E-5  $$ REFERENCE ERROR, LIMIT ERROR

```

SUBROUTINE ORDER reorders the list of bodies putting the Sun before Jupiter (i.e., the Sun's position relative to the vehicle must be found before Jupiter's relative position can be computed). The elliptic data for finding Jupiter's position are relocated according to the computed body list. The gravitational constants, μ and $-\sqrt{\mu}$, are then calculated. The atmosphere belongs to the body at the origin (Earth) so that the rotation rate and atmospheric radius are set. The final duty of ORDER is to position the merged ephemerides tape at the beginning of the correct ephemeris. In this case, only one merged ephemeris was constructed; nevertheless, it still must be identified and spaced to the beginning of the data.

The main program now calls SUBROUTINE STAGE, which is responsible for controlling the sequencing of the stages for the flight. The data for the first stage are set into their proper locations as in example I. Before calling SUBROUTINE NBODY, however, SUBROUTINE TUDES is called (since IMODE = 4) to transform the Earth-centered spherical coordinates into rectangular coordinates. In addition, TUDES computes the closed-form solution for the initial vertical non-drag step. The path is integrated from this point on, where the initial orientation is specified by the spherical coordinates. The small error introduced by this procedure is offset by avoiding the complications associated with integrating the takeoff. One such difficulty is the thrust-direction specification when the velocity is zero, especially if the origin body is rotating.

The SUBROUTINE STAGE then calls upon SUBROUTINE NBODY to perform the integration of the first-stage path. The derivatives are supplied by SUBROUTINE EQUATE which, in turn, calls upon SUBROUTINES EPHMRS, ICAO, AERO, THRUST, and OBLATE. SUBROUTINE EPHMRS computes the perturbations that result from bodies other than the origin body. The positions of the Sun and Moon are determined

through use of the merged ephemeris tape, while the position of Jupiter is determined by SUBROUTINE ELLIPSE, which uses the ellipse data loaded on input cards.

SUBROUTINE AERO determines the aerodynamic accelerations through use of quadratic equations for the lift and drag coefficients and SUBROUTINE ICAO, which determines density, pressure, and temperature as functions of altitude. SUBROUTINE THRUST computes the thrust magnitude as a function of ambient pressure (eq. (4)) and then determines the thrust orientation relative to the x,y,z axes. Oblateness accelerations are determined in SUBROUTINE OBLATE.

The integration of the first-stage path is terminated by SUBROUTINE STEP when $t = 117$ seconds. Control is then returned to STAGE whereupon the second-stage data are set in place for integration of the second-stage path, which is terminated by STEP when $t = 324.9$ seconds.

It is required that the third-stage engine cease operating when the eccentricity of the path equals 1.10. Let it also be required that the output occur only every 100 seconds instead of every 50 seconds, as during stages one and two. These results may be obtained by placing the following cards after the previous set:

```
%D=3,DELMAX=100          $$ OUTPUT EVERY 100 SEC. FOR STAGE 3
LOOKX=1226,XLOOK=1.1,END=1,INLOOK=30  $$ STOP WHEN ECCENTRICITY = 1.1
```

These cards are read into the computer after the third-stage data are set in place (since IDENT(3) = 3), but before integration of the third-stage path begins. The third-stage burning time, 400 seconds, was purposely set high enough to allow sufficient time for the eccentricity to reach the value 1.10.

To illustrate the input facilities, the coasting third stage will be called the fourth stage, the reverse-thrust portion at the Moon a fifth stage, and the final coast portion about the Moon a sixth stage. Under these conditions, it becomes necessary to determine the initial masses of these stages. The initial masses of the fourth and fifth stages may be computed on the following input card, which is placed after the previous cards:

```
%D=30,%I,712=MASS/ RMASS(4)=MASS,MASS  $$ COMPUTE MASSES FOR STAGES 4 AND 5.
```

This card will be read into the computer immediately following the condition of $e = 1.10$, since INLOOK = 30.

The fourth-stage path is to be integrated in orbit elements with less output than previously required. The following cards are sufficient for these purposes:

\$D=4,IMODE=-2, MCDOUT=3, DELMAX=21600 \$\$ INTEGRATE IN ORBIT ELEMENTS FOR STAGE 4
 STEPS=10, TMIN=86400 \$\$ OUTPUT EVERY 6 HOURS TILL 1 DAY, THEN EVERY 10 STEPS

About a half day later, the vehicle is close enough to the Moon so that the coordinate-system origin is translated to the Moon. This translation is accompanied by a shift to rectangular integration variables, since the vehicle is approaching the Moon far out on a hyperbolic asymptote. After the origin is translated to the Moon, an input card may be read to cause termination of the fourth stage when the true anomaly about the Moon is zero:

\$D=101,LOOKX=1150, XLOCK=0 \$\$ INTEGRATE UNTIL TRUE ANOMALY IS ZERO

The fifth-stage path is integrated with reverse thrust until $e = 0.05$. The angle α is computed to be π by using the COEFN array. The termination of stage five is caused by the cards:

\$D=5,LOOKX=1226,XLOCK=.05,INLOCK=50 \$\$ STAGE 5, REVERSE THRUST UNTIL E=.05
 IMCDE=-1 \$\$ SWITCH TO RECTANGULAR COORDINATES

The sixth-stage mass is computed by the card:

\$D=50,RMASS(6)=MASS \$\$ COMPUTE MASS FOR STAGE 6.

In addition, output is desired at 10-minute intervals, which may be accomplished with the card:

\$D=6,MCDOUT=2,DELMAX=600,IMODE=-2 \$\$ OUTPUT EVERY 10 MINUTES FOR STAGE 6.

The last step output is reproduced as follows:

STEP= 181. + 18. ECCENTRICITY= 5.00567108E-02 OMEGA=-2.49327761
 TIME= 114425.91 SEMILATUS R.= 2127902.28 TRU A=-3.08236283
 JDAY= 2437642.1157 MEAN ANOMALY=-3.07620674 NODE=-1.65888368
 ALFA= 180.00000 PATH ANGLE=-0.17870317 INCL= 0.77642872
 EARTH R= 3.7524622E 08 0.099065 0.940877 0.323939
 JUPITE R= 8.4530520E 11 0.579731 -0.742897 -0.334688

V= 1441.76900 R= 2239823.88 REFER=MOON ORBIT 1
 VX= 859.314598 X= 884837.336 RMASS= 3004.18549
 VY= 868.288918 Y=-1786946.89 REVS.= 0.82317527
 VZ= 765.735352 Z= 1020144.20 DELT= 462.857422
 SUN R= 1.4697769E 11 -0.240123 -0.890528 -0.386394

REFERENCES

1. Vienop, Edna, and Brady, Joseph L.: The Themis Code: An Astronomical Numerical Integration Program for the IBM 704. UCRL 5242, Radiation Lab., Univ. Calif., May 20, 1958.
2. Holdridge, D. B.: Space Trajectories Program for the IBM 7090 Computer. TR 32-223, Jet Prop. Lab., C.I.T., Mar. 2, 1962.
3. Technical Staff of Radiation, Inc., ed.: Space Trajectories. Academic Press, Inc., 1960.
4. Strack, William C., Dobson, Wilbur F., and Huff, Vearl N.: The N-Body Code - A General FORTRAN Code for Solution of Problems in Space Mechanics by Numerical Methods. NASA TN D-1455, 1963.
5. Wilson, Raymond H., Jr.: A Gravitational Force Function for the Earth Representing All Deviations From a Spherical Geoid. Franklin Inst. Jour., vol. 268, no. 5, Nov. 1959, pp. 378-387.
6. Baker, R. M. L., Jr., et al.: Efficient Precision Orbit Computation Techniques. ARS Jour., vol. 30, no. 8, Aug. 1960, pp. 740-747.
7. Dobson, Wilbur F., Huff, Vearl N., and Zimmerman, Arthur V.: Elements and Parameters of the Osculating Orbit and Their Derivatives. NASA TN D-1106, 1962.
8. Turner, Don N., and Huff, Vearl N.: An Input Routine Using Arithmetic Statements for the IBM 704 Digital Computer. NASA TN D-1092, 1961.
9. Clarke, V. C., Jr.: Constants and Related Data Used in Trajectory Calculations at the Jet Propulsion Laboratory. TR 32-273, Jet Prop. Lab., C.I.T., May 1962.
10. Dobson, Wilbur F., Mackay, John S., and Huff, Vearl N.: Starting Conditions for Nonoscillatory Low-Thrust Planet-Escape Trajectories. NASA TN D-1410, 1962.
11. Kopal, Zdeněk: Numerical Analysis. John Wiley & Sons, Inc., 1955.
12. Weber, Richard J., Pauson, Werner M., and Burley, Richard R.: Lunar Trajectories. NASA TN D-866, 1961.

TABLE I. - ORBIT ELEMENTS AND OTHER DATA FOR ELLIPSE EPHEMERIDES

[Epoch: Sept. 23, 1960; Julian day, 2437 200.5; mean equinox and equator, 1950.0.]

Name	Reference	Mass, sun mass units	Radius of influence sphere, m	Semilatus rectum, AU	Eccentricity	Argument of pericenter, radians	Longitude of ascending node, radians	Inclination, radians	Julian day of perihelion passage	Fractional day of perihelion passage	Period, mean solar days
Mercury	Sun	1/6,120,000	10^8	0.3707315	0.205627	1.1679154	0.1896133	0.49924366	2437 163	0.283386	87.969252
Venus	Sun	1/466,645	6.14×10^8	.72329863	.006792	2.1567353	.13931743	.42703751	2437 132	.682782	224.70087
Mars	Sun	1/3,088,000	5.78×10^8	1.5104078	.093369	5.7966845	.058500499	.4310002	2437 081	.09531	686.97964
Jupiter	Sun	1/1047.39	4.81×10^{10}	5.1913995	.0486288	.1765935	.056971884	.40587194	2433 964	.6664	4333.7153
Saturn	Sun	1/3500	5.46×10^{10}	9.5554288	.0509895	1.4938359	.10416467	.39404007	2431 246	.5163	10,829.478
Uranus	Sun	1/22,869	5.17×10^{10}	19.100903	.0457866	2.9848628	.032257032	.41321621	2409 019	.272	30,587.016
Neptune	Sun	1/18,889	8.61×10^{10}	30.197622	.0045616	.3302296	.061416599	.38947933	2404 118	.842	60,612.183
Pluto	Sun	1/400,000	3.81×10^{10}	36.969138	.2502358	3.1999771	.76630286	.41231716	1639 376	.44	904,658.99
Sun	Earth	1.0	10^{20}	.99972025	.016716	4.923277	0	.4092062	2436 937.1	0	365.256

TABLE II. - PROGRAM CONTROL PARAMETERS

Control variables	COMMON location	Possible values	Setting	Description of use
ASYMPT	A(7)	0.0 or 1.0	Internal	Normally equal to 0.0; set equal to 1.0 in SUBROUTINE EQUATE when Kepler's equation fails to converge for $e > 1$, and then used to control branching in NBODY for $IMODE = 3$.
ATMN	A(21)	Any ALF coded body name	Input	Contains name of body that is to have an atmosphere. Causes SUBROUTINE AERO to be called in SUBROUTINE EQUATE if object is within that atmosphere.
CLEAR	C(3)	Any value	Input	If CLEAR = 0, SUBROUTINE STDATA is called from MAIN; if CLEAR \neq 0, SUBROUTINE STDATA is bypassed. STDATA clears the A, XPRIM, and XPRIME arrays.
CONSTU	A(32)	>0 , $\sim 10^{-8}$ to $\sim 10^{-2}$ radian	STDATA: 10^{-6} input	Controls branching in SUBROUTINE EQUATE, which determines how accurate eccentric anomaly will be computed by Kepler's equation.
CONSU	A(31)	>0 , $\sim 10^{-8}$ to $\sim 10^{-2}$ radian	STDATA: 10^{-6} input	Similar to CONSTU except that it is used in SUBROUTINE ELIPSE for perturbing bodies instead of object.
DELMAX	A(19)	Any number of seconds	Input	If MODOUT = 2 or 3, output is given only at intervals of DELMAX.
END	A(5)	Any number	Input	Used when LOOKX \neq 0. After the condition $C(LOOKX) = XLOOK$ is met, control is sent to main program if END $<$ 0, to complete the stage in process if END = 0, or begin integrating the next stage if END $>$ 0.
EREF	A(13)	Any number	STDATA: 10^{-6} input	Desired error value. Error control predicts step size such that $E2 - EREF$. If $E2 <$ 0, it will be treated as +EREF; however, error data will be recorded and printed.
ERLIMT	A(14)	Any plus number	STDATA: 3×10^{-6} input	Maximum error value that allows step in question to be passed as good step. If $E2 >$ ERLIMT, step is recomputed with smaller step size.
ETOL	A(30)	Positive number of order 0.01	STDATA: 0.01 input	If eccentricity falls in region $1 \pm ETOL$ and integration is in orbit elements, integration mode is switched to temporary rectangular until eccentricity falls outside this region.
FILE	B(22)	Any plus integer	Internal	Set equal to 10.0 in SUBROUTINE ORDER if tape data is used to determine positions, velocities, and attractions of perturbing bodies. Then read as file number of tape 3. See TFILE.
ICC(10)	A(153)	Any fixed-point integer	Input internal	Index of independent variable in COEFN array used in FUNCTION QUAD. For each set of coefficients there is an ICC. They are set at input time and are reset each time QUAD is called.
IMODE	A(1)	1,2,3,4,-1,-2,-3,-4 (fixed point)	STDATA: 1 input internal	Indicates integration mode. Must agree with input data (if input data is rectangular, IMODE should equal 2 or -2). Values indicate: 1 = orbit elements 2 = rectangular variables 3 = temporary rectangular 4 = Earth spherical change to rectangular -1 = orbit elements, change to rectangular -2 = rectangular, change to orbit elements -3 = orbit, change to temporary rectangular -4 = Earth spherical, change to orbit elements
LOOKX	A(8)	Fixed-point integer	Input	The program searches for the value $C(LOOKX) = XLOOK$ if LOOKX \neq 0. The search begins when $C(LOOKSW) \geq SWLOOK$. If and when $C(LOOKX) = XLOOK$ output occurs and program control is directed by the parameter END.
LOOKSW	A(9)	Fixed-point integer	STDATA: 711 input	The search for $C(LOOKX) = XLOOK$ does not begin until $C(LOOKSW) \geq SWLOOK$. Typically, time is the deciding parameter; therefore, STDATA sets LOOKSW = 711.
MODOUT	A(20)	1,2,3,4 (fixed point)	STDATA: 4 input internal	MODOUT = 1 Output every n^{th} step ($n = STEPS$) until TIME = TMIN, then shift to mode 2. = 2 Output at time intervals of DELMAX until TIME = TMAX. = 3 Output at time intervals of DELMAX until TIME = TMIN, then shift to mode 4. = 4 Output every n^{th} step until TIME = TMAX.
NSAVE	C(4)	0,1,2, . . . ,10 (fixed point)	Input	If the initial data (arrays A, XPRIM, and XPRIME) for the n^{th} stage is to be saved, it will occur just prior to the n^{th} stage integration if NSAVE = NSTAGE, the stage index. NSAVE = 0 is ignored (no stage data will be saved).
OBLATN	A(40)	Any ALF coded body name	Input	If oblateness effects are to be considered, loading a body name will cause SUBROUTINE OBLATE to be called from SUBROUTINE EQUATE when OBLATN matches reference body.
RECALL	C(5)	Any value	Input	If RECALL \neq 0.0, "starting" data will be restored from D array in MAIN. See NSAVE.
SIGNAL	B(31)	0.0 or 1.0	Internal	If and when $C(LOOKX) = XLOOK$, SIGNAL is set to 1.0 for use in any of the subroutines EXTRAS, EXTRA, STAGE, and so forth. EXTRA resets SIGNAL = 0.
STPEMX	A(16)	Any plus number	STDATA: 100.0 input	If $(STPEGO + STEPNO) \geq STPEMX$, problem terminates.
STEPS	A(17)	Any plus number	STDATA: 1.0 input	Used when MODOUT = 1 or 4. Output will occur at every n^{th} step where $n = STEPS$.
SWLOOK	A(10)	Any number	Input	Used when LOOKX \neq 0. Value of the parameter $C(LOOKSW)$ to be equaled or exceeded before the search for $C(LOOKX) = XLOOK$ begins.
TAPE 3	C(2)	0.0 or 3.0	Input internal	If "working" ephemeris tape is to be made, TAPE 3 must be set equal to zero through input contained in SUBROUTINE TAPE. If no tape is made, or after tape is made, TAPE 3 is set to 3.0.
TFILE	A(6)	Any plus integer	STDATA: 1.0 input	Selects which file of "working" ephemeris tape is to be used. ORDER positions tape in correct position by matching desired file number (TFILE) with code word (FILE) written at beginning of each file on tape.
TMAX	B(4)	Any number in seconds	Internal	When time = TMAX a stage is terminated.
TMIN	A(18)	Any number in seconds	Input	When time = TMIN output mode is changed. See MODOUT.
TRANSFER	B(8)	0.0 or 1.0	Internal	Normally TRANSFER = 0.0, but when origin is being translated, TRANSFER = 1.0, which causes SUBROUTINES EPHMRS and ELIPSE to compute velocities as well as positions.
TTEST	A(54)	Any number in seconds	Internal	When integration mode is changed to temporary rectangular, TTEST is set as time at which program will begin checking for return to orbit elements. See NBODY part 7D.
XLOOK	A(12)	Any number	Input	The value of $C(LOOKX)$ that is searched for as the trajectory integration proceeds providing LOOKX \neq 0.

TABLE III. - BASIC OUTPUT FORMAT

(a) Sample output

STEP=	0. + 0.	ECCENTRICITY=	1.0000000	OMEGA=	-2.64801353
TIME=	0.	SEMI LATUS R.=	1.93844640E-09	TRU A=	3.14159262
JDAY=	2437640.8350	MEAN ANOMALY=	0.	NODE=	2.02516600
ALFA=	0.	PATH ANGLE=	89.9209976	INCL=	1.57079409
ALT.=	0.1875000	R PATH ANGLE=	89.9209976	DRAG=	4.99665982E-03
SUN	R= 1.4728028E 11	-0.261730	-0.885466	-0.383989	
	V= 9.99999976E-02	R= 6373346.50	REFER=EARTH	RECTAN 2	
	VX= 3.86224359E-02	X=-2463371.37	RMASS=	150000.000	
	VY= 7.90702742E-02	Y= 5043168.50	REVS.=	0.32231534	
	VZ= 4.74994606E-02	Z= 3019569.50	DELTA=	6.00000000	
	VR= 9.99999976E-02	G= 1.49946962	PUSH=	0.	
MOON	R= 3.9293912E 08	-0.387660	-0.874846	-0.290456	

(b) Parameter identification

Output format mnemonic	Identification
STEP	Count of total number of successful integration steps to left of plus sign and count of failures on right
TIME	Time since beginning of integration process, t, sec
JDAY	Current Julian date
ECCENTRICITY	Osculating orbit eccentricity, e
SEMI LATUS R.	Semilatus rectum of osculating orbit, p, m
MEAN ANOMALY	Mean anomaly of osculating orbit, M
OMEGA	Argument of pericenter, ω , radians
TRU A	True anomaly of osculating orbit, v, radians
NODE	Equatorial longitude of ascending node of osculating orbit, Ω , radians
INCL	Orbit inclination referred to mean equator and equinox of 1950.0, i, radians
ALFA	Angle between thrust and velocity, α , deg
PATH ANGLE	Angle between path and local horizontal, deg
V, VX, VY, VZ	Velocity and its x,y,z components, V, m/sec
R, X, Y, Z	Radius and its x,y,z components, r, m
REFER	Name of reference body, followed by integration mode, IMODE
RMASS	Vehicle mass, m, kg
REVS.	Revolutions past x-axis
DELTA	Step size for current step, h, sec
ALT.	Altitude above Earth, m
R PATH ANGLE	Relative path angle, relative to Earth, deg
DRAG	Total drag force, D, newtons
VR	Velocity relative to rotating reference body
G	Total Earth g's acting on longitudinal axis of missile
PUSH	Thrust force, newtons
BNAME(1)R	Vehicle to perturbing body distance, r_1 , plus direction cosines

TABLE IV. - COMMON ALLOCATION

THE COMMON ARRAY C IS ARRANGED IN SUBARRAYS AS FOLLOWS.

- C(11) - C(710) = A (Those parameters whose initial values must be identical on different flights if the trajectories are to be identical)
- C(711) - C(910) = XPRIM (Most significant half of the double-precision integration variables)
- C(911) - C(1110) = XPRIMB (Least significant half of the double-precision integration variables)
- C(1111) - C(1910) = B (Those parameters whose initial values need not be identical on different flights if the trajectories are to be identical)
- C(1911) - C(2110) = TABLE (Table required by the input routine to locate input data)
- C(2111) - C(3210) = D (Array of initial values for A,XPRIM, and XPRIMB if restart facility is being used)

ALLOCATION FOR THE ARRAY A

1	IMODE	NEQ	NSTAGE	ALT	END	TFILE	ASYMPT	LOOKX	LOOKSW	SWLOOK
11	XTOL	XLOCK	EREF	ERLIMT	IKICK	STEPMX	STEPS	TMIN	DELMAX	MDDOUT
21	ATMN	RATM	DTOFFJ	TOFFT	RE	OBLATJ	OBLATD	OBLATH	AU	EIOL
31	CONSU	CCNSTU	LAT	LONG	AZI	ELEV	VEL	LSTAGE	ROTATE	OBLATN
41	STPGO	STEPNO	DEL	SPC	TTOL	GASFAC	SQRDK1	REVS	ALPHA	BETA
51	AK	-	-	TTEST	AW	-	-	-	U	IND
61	-	-	TB	-	-	-	-	-	-	-
71	-	-	RMASS1	-	-	-	-	-	-	-
81	-	-	FLOW1	-	-	-	-	-	-	-
91	-	-	SIMP1	-	-	-	-	-	-	-
101	-	-	AEXIT1	-	-	-	-	-	-	-
111	-	-	AREAL	-	-	-	-	-	-	-
121	-	-	IDENT	-	-	-	-	-	-	-
131	-	-	DELTI	-	-	-	-	-	-	-
141	-	-	BODYCD	-	-	-	-	-	-	-
151	-	-	ICC	-	-	-	-	-	-	-
161	-	-	CDI	CL	CD	PUSH	ELIPS	-	-	-
171	-	-	-	-	-	-	-	-	-	-
181	-	-	-	-	-	-	-	-	-	-
191	-	-	-	-	-	-	-	-	-	-
201	-	-	-	-	-	-	-	-	-	-
211	-	-	-	-	-	-	-	-	-	-
221	-	-	-	-	-	-	-	-	-	-
231	-	-	-	-	-	-	-	-	-	-
241	-	-	-	-	-	-	-	-	-	-
251	-	-	-	-	-	-	-	-	-	-
261	-	-	-	-	-	-	-	-	-	-
271	-	-	-	-	-	-	-	-	-	-
281	-	-	-	-	-	-	PNAME	-	-	-
291	-	-	-	-	-	-	-	-	-	-
301	-	-	-	-	-	-	-	-	-	-
311	-	-	-	-	-	-	REFER	-	-	-
321	-	-	-	-	-	-	-	-	-	-
331	-	-	-	-	-	-	-	-	-	-
341	-	-	-	-	-	-	AMASS	-	-	-
351	-	-	-	-	-	-	-	-	-	-
361	-	-	-	-	-	-	-	-	-	-
371	-	-	-	-	-	-	RCRIT	-	-	-
381	-	-	-	-	-	-	-	-	-	-
391	-	-	-	-	-	-	-	-	-	-
401	-	-	-	-	-	-	COEFN	-	-	-
411	-	-	-	-	-	-	-	-	-	-
421	-	-	-	-	-	-	-	-	-	-
431	-	-	-	-	-	-	-	-	-	-
441	-	-	-	-	-	-	-	-	-	-
451	-	-	-	-	-	-	-	-	-	-
461	-	-	-	-	-	-	-	-	-	-
471	-	-	-	-	-	-	-	-	-	-
481	-	-	-	-	-	-	-	-	-	-
491	-	-	-	-	-	-	-	-	-	-
501	-	-	-	-	-	-	-	-	-	-
511	-	-	-	-	-	-	-	-	-	-
521	-	-	-	-	-	-	-	-	-	-
531	-	-	-	-	-	-	-	-	-	-
541	-	-	-	-	-	-	-	-	-	-
551	-	-	-	-	-	-	-	-	-	-
561	-	-	-	-	-	-	-	-	-	-
571	-	-	-	-	-	-	-	-	-	-
581	-	-	-	-	-	-	-	-	-	-
591	-	-	-	-	-	-	-	-	INLUOK	NCASES
601	SWITCH	-	-	-	-	-	-	-	-	-
611	-	-	-	-	-	-	-	-	-	-
621	-	-	-	-	-	-	-	-	-	-
631	-	-	-	-	-	-	-	-	-	-
641	-	-	-	-	-	-	-	-	-	-
651	-	-	-	-	-	-	-	-	-	-
661	-	-	-	-	-	-	-	-	-	-
671	-	-	-	-	-	-	-	-	-	-
681	-	-	-	-	-	-	-	-	-	-
691	-	-	-	-	-	-	-	-	-	-

TABLE IV. - Continued. COMMON ALLOCATION

ALLOCATION FOR THE ARRAY B

1	DELT	SIMP	AEXIT	TMAX	FLOW	AREA	RESQRD	TRSFER	OLDDDEL	A1
11	A2	ACCEF1	ACCEF2	ACCEF3	H2	SPACES	ERLOC	E2	KSUB	TABLT
21	REVQLV	FILE	RATMOS	NSTART	CHAMP	EPAR	EXMODE	EMONE	DNS11Y	PSI
31	SIGNAL		PRESS	IM	SQRDK	GKZM	GKM	VMACH	DONE	TRU
41	NBODYS	MBOCYS	ZN	QMAX	RSQRD	SINALF	SINRET	COSALF	COSBET	PMAGN
51	INDERR	SINTRU	COSTRU	SINCL	CINCL	SINV	COSV	RATIO	Q	PAR
61	-	-	COMPA	-	-	FORCE	-	-	DRAG	-
71	-	XIFT	-	-	OBLAT	-	-	QX	-	-
81	RADIAL	CIRCUM	ZORMAL	P	-	-	AMC	-	-	AM
91	AMSQRD	VX	VY	VZ	V	VSQRD	VATH	-	-	VQ
101	VQSQRD	R	-	-	-	-	-	-	-	XWHOLE
111	-	-	-	-	-	ORBELS	-	-	-	-
121	-	BNAME	-	-	-	-	-	-	-	EFMKS
131	-	-	-	-	-	-	BMASS	-	-	-
141	-	-	-	-	KBCRIT	-	-	-	-	-
151	-	-	BODYL	-	-	-	-	-	-	-
161	-	-	TIM	-	-	-	-	-	-	TDEL
171	-	-	-	-	-	-	IBODY	-	-	-
181	-	-	-	-	NEFMRS	-	-	-	-	-
191	-	-	RB	-	-	-	-	-	-	-
201	-	-	-	-	-	-	-	-	-	-
211	-	-	-	-	-	-	XP	-	-	-
221	-	-	-	-	-	-	-	-	-	-
231	-	-	-	-	-	-	-	-	-	-
241	VEFM	-	-	-	-	-	-	-	-	-
251	-	-	-	-	-	-	-	-	-	-
261	-	-	-	-	TDATA	-	-	-	-	-
271	-	-	-	-	-	-	-	-	-	-
281	-	-	-	-	-	-	-	-	-	-
291	-	-	-	-	-	-	-	-	-	-
301	-	-	-	-	-	-	-	-	-	-
311	-	-	-	-	-	-	-	-	-	-
321	-	-	-	-	-	-	-	-	-	-
331	-	-	-	-	-	-	-	-	-	-
341	-	-	-	-	-	-	-	-	-	-
351	-	-	-	-	-	-	-	-	-	-
361	-	-	-	-	-	-	-	-	-	-
371	-	-	-	-	-	-	-	-	-	-
381	-	-	-	-	-	-	-	-	-	-
391	PUSHO	EXITA	RANC	-	-	-	-	PSIR	OUTPUT	RETURN
401	X	-	-	-	-	-	-	-	-	-
411	-	-	-	-	-	-	-	-	-	-
421	-	-	-	-	-	-	-	-	-	-
431	-	-	-	-	-	-	-	-	-	-
441	-	-	-	-	-	-	-	-	-	-
451	-	-	-	-	-	-	-	-	-	-
461	-	-	-	-	-	-	-	-	-	-
471	-	-	-	-	-	-	-	-	-	-
481	-	-	-	-	-	-	-	-	-	-
491	-	-	-	-	-	-	-	-	-	-
501	XDOT	-	-	-	-	-	-	-	-	-
511	-	-	-	-	-	-	-	-	-	-
521	-	-	-	-	-	-	-	-	-	-
531	-	-	-	-	-	-	-	-	-	-
541	-	-	-	-	-	-	-	-	-	-
551	-	-	-	-	-	-	-	-	-	-
561	-	-	-	-	-	-	-	-	-	-
571	-	-	-	-	-	-	-	-	-	-
581	-	-	-	-	-	-	-	-	-	-
591	-	-	-	-	-	-	-	-	-	-
601	XINC	-	-	-	-	-	-	-	-	-
611	-	-	-	-	-	-	-	-	-	-
621	-	-	-	-	-	-	-	-	-	-
631	-	-	-	-	-	-	-	-	-	-
641	-	-	-	-	-	-	-	-	-	-
651	-	-	-	-	-	-	-	-	-	-
661	-	-	-	-	-	-	-	-	-	-
671	-	-	-	-	-	-	-	-	-	-
681	-	-	-	-	-	-	-	-	-	-
691	-	-	-	-	-	-	-	-	-	-
701	-	-	-	-	-	-	-	-	-	-
711	-	-	-	-	-	-	-	-	-	-
721	-	-	-	-	-	-	-	-	-	-
731	-	-	-	-	-	-	-	-	-	-
741	-	-	-	-	-	-	-	-	-	-
751	-	-	-	-	-	-	-	-	-	-
761	-	-	-	-	-	-	-	-	-	-
771	-	-	-	-	-	-	-	-	-	-
781	-	-	-	-	-	-	-	-	-	-
791	-	-	-	-	-	-	-	-	-	-

TABLE IV. - Continued. COMMON ALLOCATION

ALLOCATION FOR THE ARRAY C

1	NCASE	TAPE3	CLEAR	NSAVE	RECALL					
11	IMCCE	NEG	NSTAGE	ALT	END	TFILE	ASYMPT	LOOKX	LOOKSW	SWLOOK
21	XTOL	XLOCK	EREF	ERLIMT	TKICK	STEPX	STEPS	IMIN	DELMAX	MODOUT
31	ATPA	RATP	DTOFFJ	TOFFT	RE	OBLAIJ	OBLATD	OBLATH	AU	ETOL
41	CONSU	CONSTU	LAT	LONG	AZI	ELEV	VEL	LSTAGE	ROTATE	OBLAIN
51	STEPGO	STEPNO	DEL	SPD	TTOL	GASFAC	SQRDK1	REVS	ALPHA	BETA
61	AK	-	-	TTEST	AW	-	-	-	U	IND
71	-	-	TB	-	-	-	-	-	-	-
81	-	-	RMASS1	-	-	-	-	-	-	-
91	-	-	FLOW1	-	-	-	-	-	-	-
101	-	-	SIMP1	-	-	-	-	-	-	-
111	-	-	AEXIT1	-	-	-	-	-	-	-
121	-	-	AREA1	-	-	-	-	-	-	-
131	-	-	IDENT	-	-	-	-	-	-	-
141	-	-	DELT1	-	-	-	-	-	-	-
151	-	-	RODYCD	-	-	-	-	-	-	-
161	-	-	ICC	-	-	-	-	-	-	-
171	-	-	CD1	CL	CD	PUSH	ELIPS	-	-	-
181	-	-	-	-	-	-	-	-	-	-
191	-	-	-	-	-	-	-	-	-	-
201	-	-	-	-	-	-	-	-	-	-
211	-	-	-	-	-	-	-	-	-	-
221	-	-	-	-	-	-	-	-	-	-
231	-	-	-	-	-	-	-	-	-	-
241	-	-	-	-	-	-	-	-	-	-
251	-	-	-	-	-	-	-	-	-	-
261	-	-	-	-	-	-	-	-	-	-
271	-	-	-	-	-	-	-	-	-	-
281	-	-	-	-	-	-	-	-	-	-
291	-	-	-	-	-	-	-	-	-	-
301	-	-	-	-	-	-	PNAME	-	-	-
311	-	-	-	-	-	-	-	-	-	-
321	-	-	-	-	-	-	REFER	-	-	-
331	-	-	-	-	-	-	-	-	-	-
341	-	-	-	-	-	-	-	-	-	-
351	-	-	-	-	-	-	AMASS	-	-	-
361	-	-	-	-	-	-	-	-	-	-
371	-	-	-	-	-	-	-	-	-	-
381	-	-	-	-	-	-	RCRIT	-	-	-
391	-	-	-	-	-	-	-	-	-	-
401	-	-	-	-	-	-	-	-	-	-
411	-	-	-	-	-	-	COEFN	-	-	-
421	-	-	-	-	-	-	-	-	-	-
431	-	-	-	-	-	-	-	-	-	-
441	-	-	-	-	-	-	-	-	-	-
451	-	-	-	-	-	-	-	-	-	-
461	-	-	-	-	-	-	-	-	-	-
471	-	-	-	-	-	-	-	-	-	-
481	-	-	-	-	-	-	-	-	-	-
491	-	-	-	-	-	-	-	-	-	-
501	-	-	-	-	-	-	-	-	-	-
511	-	-	-	-	-	-	-	-	-	-
521	-	-	-	-	-	-	-	-	-	-
531	-	-	-	-	-	-	-	-	-	-
541	-	-	-	-	-	-	-	-	-	-
551	-	-	-	-	-	-	-	-	-	-
561	-	-	-	-	-	-	-	-	-	-
571	-	-	-	-	-	-	-	-	-	-
581	-	-	-	-	-	-	-	-	-	-
591	-	-	-	-	-	-	-	-	-	-
601	-	-	-	-	-	-	-	-	-	-
611	SWITCH	-	-	-	-	-	-	-	INLOOK	NCASES
621	-	-	-	-	-	-	-	-	-	-
631	-	-	-	-	-	-	-	-	-	-
641	-	-	-	-	-	-	-	-	-	-
651	-	-	-	-	-	-	-	-	-	-
661	-	-	-	-	-	-	-	-	-	-
671	-	-	-	-	-	-	-	-	-	-
681	-	-	-	-	-	-	-	-	-	-
691	-	-	-	-	-	-	-	-	-	-
701	-	-	-	-	-	-	-	-	-	-
711	XPRIM	-	-	-	-	-	-	-	-	-

TABLE IV. - Continued. COMMON ALLOCATION

721	-	-	-	-	-	-	-	-	-	-
731	-	-	-	-	-	-	-	-	-	-
741	-	-	-	-	-	-	-	-	-	-
751	-	-	-	-	-	-	-	-	-	-
761	-	-	-	-	-	-	-	-	-	-
771	-	-	-	-	-	-	-	-	-	-
781	-	-	-	-	-	-	-	-	-	-
791	-	-	-	-	-	-	-	-	-	-
801	-	-	-	-	-	-	-	-	-	-
811	-	-	-	-	-	-	-	-	-	-
821	-	-	-	-	-	-	-	-	-	-
831	-	-	-	-	-	-	-	-	-	-
841	-	-	-	-	-	-	-	-	-	-
851	-	-	-	-	-	-	-	-	-	-
861	-	-	-	-	-	-	-	-	-	-
871	-	-	-	-	-	-	-	-	-	-
881	-	-	-	-	-	-	-	-	-	-
891	-	-	-	-	-	-	-	-	-	-
901	-	-	-	-	-	-	-	-	-	-
911	XPRIMB	-	-	-	-	-	-	-	-	-
921	-	-	-	-	-	-	-	-	-	-
931	-	-	-	-	-	-	-	-	-	-
941	-	-	-	-	-	-	-	-	-	-
951	-	-	-	-	-	-	-	-	-	-
961	-	-	-	-	-	-	-	-	-	-
971	-	-	-	-	-	-	-	-	-	-
981	-	-	-	-	-	-	-	-	-	-
991	-	-	-	-	-	-	-	-	-	-
1001	-	-	-	-	-	-	-	-	-	-
1011	-	-	-	-	-	-	-	-	-	-
1021	-	-	-	-	-	-	-	-	-	-
1031	-	-	-	-	-	-	-	-	-	-
1041	-	-	-	-	-	-	-	-	-	-
1051	-	-	-	-	-	-	-	-	-	-
1061	-	-	-	-	-	-	-	-	-	-
1071	-	-	-	-	-	-	-	-	-	-
1081	-	-	-	-	-	-	-	-	-	-
1091	-	-	-	-	-	-	-	-	-	-
1101	-	-	-	-	-	-	-	-	-	-
1111	DELTA	SIMP	ACXIT	TMAX	FLOW	AREA	RESWRD	TRNSFER	OLDDUEL	A1
1121	A2	ACDEF1	ACDEF2	ACDEF3	H2	SPACES	ERLOG	E2	KSUB	TABLT
1131	REVOLV	FILE	RATMOS	NSTART	CHAMP	EPAR	EXMODE	EMONE	DNSITY	PSI
1141	SIGNAL	-	PRESS	TM	SQRDK	GK2M	GKM	VMAGH	DONE	TRU
1151	NBDAYS	MBCCYS	ZN	QMAX	RSQRD	SINALF	SINBET	COSALF	COSBEI	PMAGN
1161	INDERR	SINTRU	COSTRU	SINCL	CINCL	SINV	COSV	RATIO	Q	PAR
1171	-	-	COMPA	-	-	FORCE	-	-	URAG	-
1181	-	XIFT	-	-	OBLAT	-	-	QX	-	-
1191	RADIAL	CIRCUM	ZORMAL	P	-	-	AMC	-	-	AM
1201	AMSGRD	VX	VY	VZ	V	VSQRD	VATM	-	-	VQ
1211	VCSGRD	R	-	-	-	-	-	-	-	XWHOLL
1221	-	-	-	-	-	ORBELS	-	-	-	-
1231	-	BNAME	-	-	-	-	-	-	-	EFMRS
1241	-	-	-	-	-	-	BMASS	-	-	-
1251	-	-	-	-	RBCRIT	-	-	-	-	-
1261	-	-	BODYL	-	-	-	-	-	-	-
1271	-	-	TIM	-	-	-	-	-	-	TDEL
1281	-	-	-	-	-	-	IBODY	-	-	-
1291	-	-	-	-	NEFMRS	-	-	-	-	-
1301	-	-	RB	-	-	-	-	-	-	-
1311	-	-	-	-	-	-	-	-	-	-

TABLE IV. - Continued. COMMON ALLOCATION

1321	-	-	-	-	-	-	XP	-	-	-
1331	-	-	-	-	-	-	-	-	-	-
1341	-	-	-	-	-	-	-	-	-	-
1351	VEFM	-	-	-	-	-	-	-	-	-
1361	-	-	-	-	-	-	-	-	-	-
1371	-	-	-	-	-	-	-	-	-	-
1381	-	-	-	-	-	TDATA	-	-	-	-
1391	-	-	-	-	-	-	-	-	-	-
1401	-	-	-	-	-	-	-	-	-	-
1411	-	-	-	-	-	-	-	-	-	-
1421	-	-	-	-	-	-	-	-	-	-
1431	-	-	-	-	-	-	-	-	-	-
1441	-	-	-	-	-	-	-	-	-	-
1451	-	-	-	-	-	-	-	-	-	-
1461	-	-	-	-	-	-	-	-	-	-
1471	-	-	-	-	-	-	-	-	-	-
1481	-	-	-	-	-	-	-	-	-	-
1491	-	-	-	-	-	-	-	-	-	-
1501	PUSHO	EXITA	RAMC	-	-	-	-	PSIR	OUTPUT	RETURN
1511	X	-	-	-	-	-	-	-	-	-
1521	-	-	-	-	-	-	-	-	-	-
1531	-	-	-	-	-	-	-	-	-	-
1541	-	-	-	-	-	-	-	-	-	-
1551	-	-	-	-	-	-	-	-	-	-
1561	-	-	-	-	-	-	-	-	-	-
1571	-	-	-	-	-	-	-	-	-	-
1581	-	-	-	-	-	-	-	-	-	-
1591	-	-	-	-	-	-	-	-	-	-
1601	-	-	-	-	-	-	-	-	-	-
1611	XDOT	-	-	-	-	-	-	-	-	-
1621	-	-	-	-	-	-	-	-	-	-
1631	-	-	-	-	-	-	-	-	-	-
1641	-	-	-	-	-	-	-	-	-	-
1651	-	-	-	-	-	-	-	-	-	-
1661	-	-	-	-	-	-	-	-	-	-
1671	-	-	-	-	-	-	-	-	-	-
1681	-	-	-	-	-	-	-	-	-	-
1691	-	-	-	-	-	-	-	-	-	-
1701	-	-	-	-	-	-	-	-	-	-
1711	XINC	-	-	-	-	-	-	-	-	-
1721	-	-	-	-	-	-	-	-	-	-
1731	-	-	-	-	-	-	-	-	-	-
1741	-	-	-	-	-	-	-	-	-	-
1751	-	-	-	-	-	-	-	-	-	-
1761	-	-	-	-	-	-	-	-	-	-
1771	-	-	-	-	-	-	-	-	-	-
1781	-	-	-	-	-	-	-	-	-	-
1791	-	-	-	-	-	-	-	-	-	-
1801	-	-	-	-	-	-	-	-	-	-
1811	-	-	-	-	-	-	-	-	-	-
1821	-	-	-	-	-	-	-	-	-	-
1831	-	-	-	-	-	-	-	-	-	-
1841	-	-	-	-	-	-	-	-	-	-
1851	-	-	-	-	-	-	-	-	-	-
1861	-	-	-	-	-	-	-	-	-	-
1871	-	-	-	-	-	-	-	-	-	-
1881	-	-	-	-	-	-	-	-	-	-
1891	-	-	-	-	-	-	-	-	-	-
1901	-	-	-	-	-	-	-	-	-	-
1911	TABLE	-	-	-	-	-	-	-	-	-

TABLE IV. - Continued. COMMON ALLOCATION

1921	-	-	-	-	-	-	-	-	-
1931	-	-	-	-	-	-	-	-	-
1941	-	-	-	-	-	-	-	-	-
1951	-	-	-	-	-	-	-	-	-
1961	-	-	-	-	-	-	-	-	-
1971	-	-	-	-	-	-	-	-	-
1981	-	-	-	-	-	-	-	-	-
1991	-	-	-	-	-	-	-	-	-
2001	-	-	-	-	-	-	-	-	-
2011	-	-	-	-	-	-	-	-	-
2021	-	-	-	-	-	-	-	-	-
2031	-	-	-	-	-	-	-	-	-
2041	-	-	-	-	-	-	-	-	-
2051	-	-	-	-	-	-	-	-	-
2061	-	-	-	-	-	-	-	-	-
2071	-	-	-	-	-	-	-	-	-
2081	-	-	-	-	-	-	-	-	-
2091	-	-	-	-	-	-	-	-	-
2101	-	-	-	-	-	-	-	-	-
2111	D	-	-	-	-	-	-	-	-
2121	-	-	-	-	-	-	-	-	-
2131	-	-	-	-	-	-	-	-	-
2141	-	-	-	-	-	-	-	-	-
2151	-	-	-	-	-	-	-	-	-
2161	-	-	-	-	-	-	-	-	-
2171	-	-	-	-	-	-	-	-	-
2181	-	-	-	-	-	-	-	-	-
2191	-	-	-	-	-	-	-	-	-
2201	-	-	-	-	-	-	-	-	-
2211	-	-	-	-	-	-	-	-	-
2221	-	-	-	-	-	-	-	-	-
2231	-	-	-	-	-	-	-	-	-
2241	-	-	-	-	-	-	-	-	-
2251	-	-	-	-	-	-	-	-	-
2261	-	-	-	-	-	-	-	-	-
2271	-	-	-	-	-	-	-	-	-
2281	-	-	-	-	-	-	-	-	-
2291	-	-	-	-	-	-	-	-	-
2301	-	-	-	-	-	-	-	-	-
2311	-	-	-	-	-	-	-	-	-
2321	-	-	-	-	-	-	-	-	-
2331	-	-	-	-	-	-	-	-	-
2341	-	-	-	-	-	-	-	-	-
2351	-	-	-	-	-	-	-	-	-
2361	-	-	-	-	-	-	-	-	-
2371	-	-	-	-	-	-	-	-	-
2381	-	-	-	-	-	-	-	-	-
2391	-	-	-	-	-	-	-	-	-
2401	-	-	-	-	-	-	-	-	-
2411	-	-	-	-	-	-	-	-	-
2421	-	-	-	-	-	-	-	-	-
2431	-	-	-	-	-	-	-	-	-
2441	-	-	-	-	-	-	-	-	-
2451	-	-	-	-	-	-	-	-	-
2461	-	-	-	-	-	-	-	-	-
2471	-	-	-	-	-	-	-	-	-
2481	-	-	-	-	-	-	-	-	-
2491	-	-	-	-	-	-	-	-	-
2501	-	-	-	-	-	-	-	-	-
2511	-	-	-	-	-	-	-	-	-

TABLE IV. - Concluded. COMMON ALLOCATION

2521	-	-	-	-	-	-	-	-	-	-
2531	-	-	-	-	-	-	-	-	-	-
2541	-	-	-	-	-	-	-	-	-	-
2551	-	-	-	-	-	-	-	-	-	-
2561	-	-	-	-	-	-	-	-	-	-
2571	-	-	-	-	-	-	-	-	-	-
2581	-	-	-	-	-	-	-	-	-	-
2591	-	-	-	-	-	-	-	-	-	-
2601	-	-	-	-	-	-	-	-	-	-
2611	-	-	-	-	-	-	-	-	-	-
2621	-	-	-	-	-	-	-	-	-	-
2631	-	-	-	-	-	-	-	-	-	-
2641	-	-	-	-	-	-	-	-	-	-
2651	-	-	-	-	-	-	-	-	-	-
2661	-	-	-	-	-	-	-	-	-	-
2671	-	-	-	-	-	-	-	-	-	-
2681	-	-	-	-	-	-	-	-	-	-
2691	-	-	-	-	-	-	-	-	-	-
2701	-	-	-	-	-	-	-	-	-	-
2711	-	-	-	-	-	-	-	-	-	-
2721	-	-	-	-	-	-	-	-	-	-
2731	-	-	-	-	-	-	-	-	-	-
2741	-	-	-	-	-	-	-	-	-	-
2751	-	-	-	-	-	-	-	-	-	-
2761	-	-	-	-	-	-	-	-	-	-
2771	-	-	-	-	-	-	-	-	-	-
2781	-	-	-	-	-	-	-	-	-	-
2791	-	-	-	-	-	-	-	-	-	-
2801	-	-	-	-	-	-	-	-	-	-
2811	-	-	-	-	-	-	-	-	-	-
2821	-	-	-	-	-	-	-	-	-	-
2831	-	-	-	-	-	-	-	-	-	-
2841	-	-	-	-	-	-	-	-	-	-
2851	-	-	-	-	-	-	-	-	-	-
2861	-	-	-	-	-	-	-	-	-	-
2871	-	-	-	-	-	-	-	-	-	-
2881	-	-	-	-	-	-	-	-	-	-
2891	-	-	-	-	-	-	-	-	-	-
2901	-	-	-	-	-	-	-	-	-	-
2911	-	-	-	-	-	-	-	-	-	-
2921	-	-	-	-	-	-	-	-	-	-
2931	-	-	-	-	-	-	-	-	-	-
2941	-	-	-	-	-	-	-	-	-	-
2951	-	-	-	-	-	-	-	-	-	-
2961	-	-	-	-	-	-	-	-	-	-
2971	-	-	-	-	-	-	-	-	-	-
2981	-	-	-	-	-	-	-	-	-	-
2991	-	-	-	-	-	-	-	-	-	-
3001	-	-	-	-	-	-	-	-	-	-
3011	-	-	-	-	-	-	-	-	-	-
3021	-	-	-	-	-	-	-	-	-	-
3031	-	-	-	-	-	-	-	-	-	-
3041	-	-	-	-	-	-	-	-	-	-
3051	-	-	-	-	-	-	-	-	-	-
3061	-	-	-	-	-	-	-	-	-	-
3071	-	-	-	-	-	-	-	-	-	-
3081	-	-	-	-	-	-	-	-	-	-
3091	-	-	-	-	-	-	-	-	-	-
3101	-	-	-	-	-	-	-	-	-	-
3111	-	-	-	-	-	-	-	-	-	-
3121	-	-	-	-	-	-	-	-	-	-
3131	-	-	-	-	-	-	-	-	-	-
3141	-	-	-	-	-	-	-	-	-	-
3151	-	-	-	-	-	-	-	-	-	-
3161	-	-	-	-	-	-	-	-	-	-
3171	-	-	-	-	-	-	-	-	-	-
3181	-	-	-	-	-	-	-	-	-	-
3191	-	-	-	-	-	-	-	-	-	-
3201	-	-	-	-	-	-	-	-	-	-

TABLE V. - ELEMENTS OF INTEGRATION VARIABLE ARRAY XPRIM

[XPRIM 9 to 100 are left for expansion.]

Integration variables	XPRIM							
	1	2	3	4	5	6	7	8
Rectangular variables	Time	Mass	x-Component of velocity	y-Component of velocity	z-Component of velocity	x-Component of position	y-Component of position	z-Component of position
Orbit elements	Time	Mass	Eccentricity	Argument of pericenter	Longitude of ascending nodes	Orbit inclination	Mean anomaly	Semilatus rectum

TABLE VI. - ASSUMED VALUES OF ASTRONOMICAL CONSTANTS

Constant	Assumed value	FORTRAN name	COMMON location
Astronomical unit, m	1.49599×10^{11}	AU	A(29)
Gravitational constant of the Sun, AU^3/day^2	$2.959122083 \times 10^{-4}$	SQRDKL	A(47)
Equatorial Earth radius, m	6378165.	RE	A(25)
Earth oblateness coefficient, J	1.62345×10^{-3}	OBLATJ	A(26)
Earth oblateness coefficient, \mathcal{Q}	7.875×10^{-6}	OBLATD	A(27)
Earth oblateness coefficient, H	-5.75×10^{-6}	OBLATH	A(28)
Earth radii per AU	$4.26546512 \times 10^{-5}$	ERTOAU	^a C(3)
Day, sec	86400	SPD	A(44)
Mass, reciprocal sun mass units:			
Sun	1.0	AMASS(1)	A(347)
Mercury	6,120,000	AMASS(2)	A(348)
Venus	408,645	AMASS(3)	A(349)
Earth	332951.3	AMASS(4)	A(350)
Mars	3,088,000	AMASS(5)	A(351)
Jupiter	1047.39	AMASS(6)	A(352)
Saturn	3500.0	AMASS(7)	A(353)
Uranus	22,869	AMASS(8)	A(354)
Neptune	18,889	AMASS(9)	A(355)
Pluto	400,000	AMASS(10)	A(356)
Moon	AMASS(4) \times 81.375	AMASS(11)	A(357)
Earth-Moon	AMASS(4) + AMASS(11)	AMASS(12)	A(358)
Sphere-of-influence radii, m:			
Sun	1.0×10^{20}	RCRIT(1)	A(377)
Mercury	1.0×10^8	RCRIT(2)	A(378)
Venus	6.14×10^8	RCRIT(3)	A(379)
Earth	9.25×10^8	RCRIT(4)	A(380)
Mars	5.78×10^8	RCRIT(5)	A(381)
Jupiter	4.81×10^{10}	RCRIT(6)	A(382)
Saturn	5.46×10^{10}	RCRIT(7)	A(383)
Uranus	5.17×10^{10}	RCRIT(8)	A(384)
Neptune	8.61×10^{10}	RCRIT(9)	A(385)
Pluto	3.81×10^{10}	RCRIT(10)	A(386)
Moon	1.60×10^8	RCRIT(11)	A(387)

^aLocation relative to COMMON of SUBROUTINE TAPE (TAPE has a COMMON that is independent of all other subroutines).

TABLE VII. - LEWIS RESEARCH CENTER EPHEMERIS TAPE DATA

[The beginning date of all bodies except Mars is 2437 200.5 or Oct. 23, 1960. The beginning date for Mars is 2437 202.5 or Oct. 25, 1960.]

Body	Source	End date		Number of fits	Average, days/fit	Average, deg/fit	Source checked against	Average error	Maximum error
		Gregorian	Julian						
Venus	Themis	Oct. 31, 2000	2451 848.5	968	15	24	JPL	1.7	7.3
Earth-Moon barycenter	↓	Oct. 31, 2000	2451 848.5	962	15	15	JPL	1.8	9.5
Sun	↓	Nov. 24, 2000	2451 872.5	1821	8	8	JPL Themis	5.0 .06	21.0 3.0
Moon	JPL	Nov. 26, 1970	2440 916.5	1851	2	26	JPL	.14	9.5
Mars	JPL	July 26, 1998	2451 020.5	315	44	23	↓	1.1	7.2
Jupiter	Themis	March 2, 2060	2473 520.5	110	330	27	↓	1.6	9.5
Saturn	↓	↓	↓	44	825	27	↓	1.5	8.6
Uranus	↓	↓	↓	30	1211	14	↓	.95	6.5
Neptune	↓	↓	↓	31	1172	7	↓	.52	3.2
Pluto	↓	↓	↓	33	1101	4	Themis	.41	3.2

The error in the x-component of position, with similar equations for the y- and z-components, is given by $e_x = [(x' - x)/R]10^8$ where x' = merged ephemeris position component; x = check source position component; $R^2 = x^2 + y^2 + z^2$.

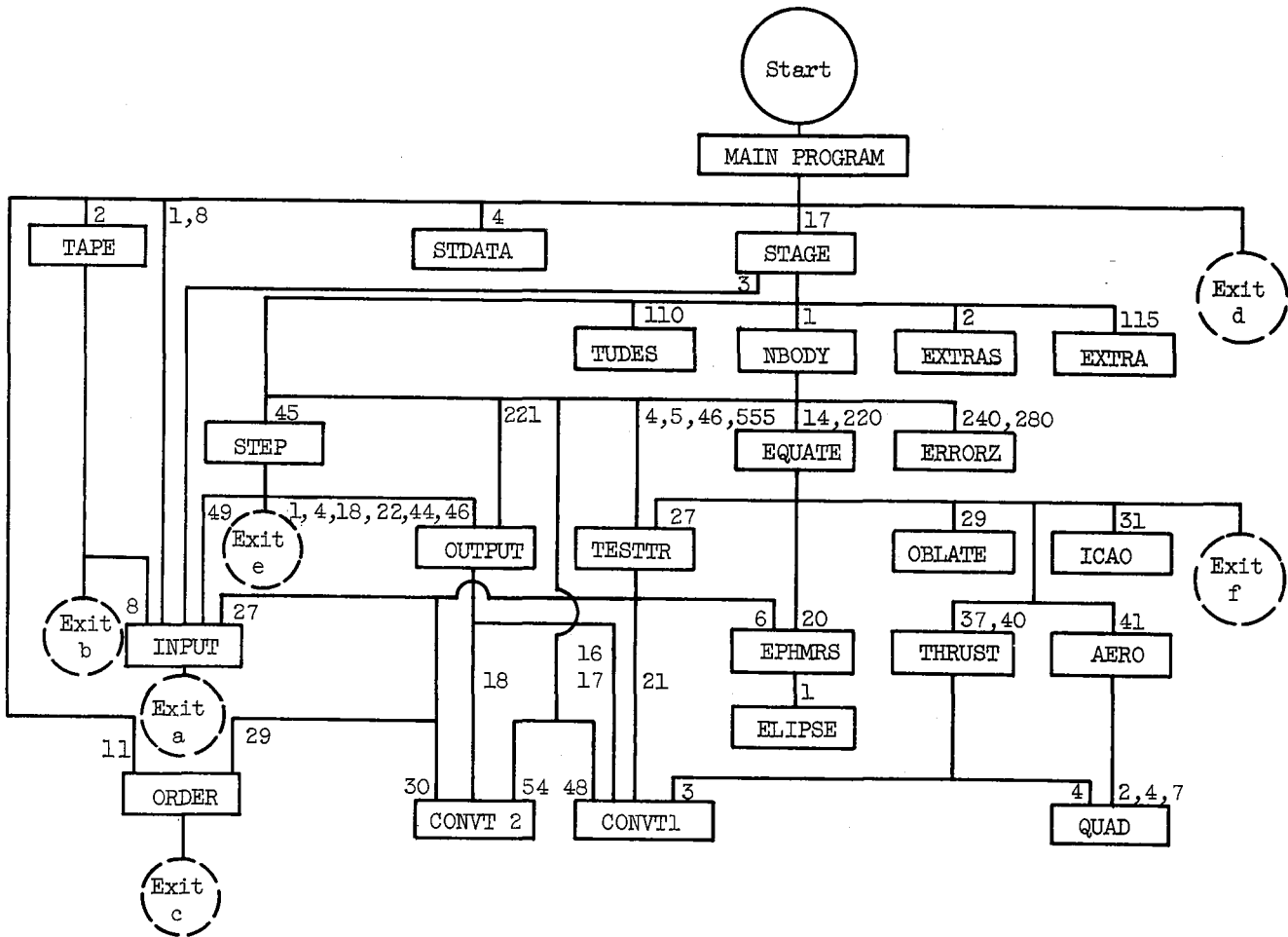

Exit	Cause of exit
a	End of data on input tape or incorrectly punched data cards
b	Illegal request of ephemeris data (misspelled names, wrong dates, etc.)
c	Illegal list of bodies (misspelled, unconnected references, etc.)
d	Sense switch 6 down (machine operator termination)
e	Number of permissible integration steps (STEPMX) exceeded
f	Nonconvergence of Kepler's equation after 15 iterations

Figure 1. - Block diagram of principal subprograms and program exits. Numbers on the block diagram are the FORTRAN calling statement numbers. A program may call only those programs located at a lower level and connected by a line. Logic decisions are not shown.

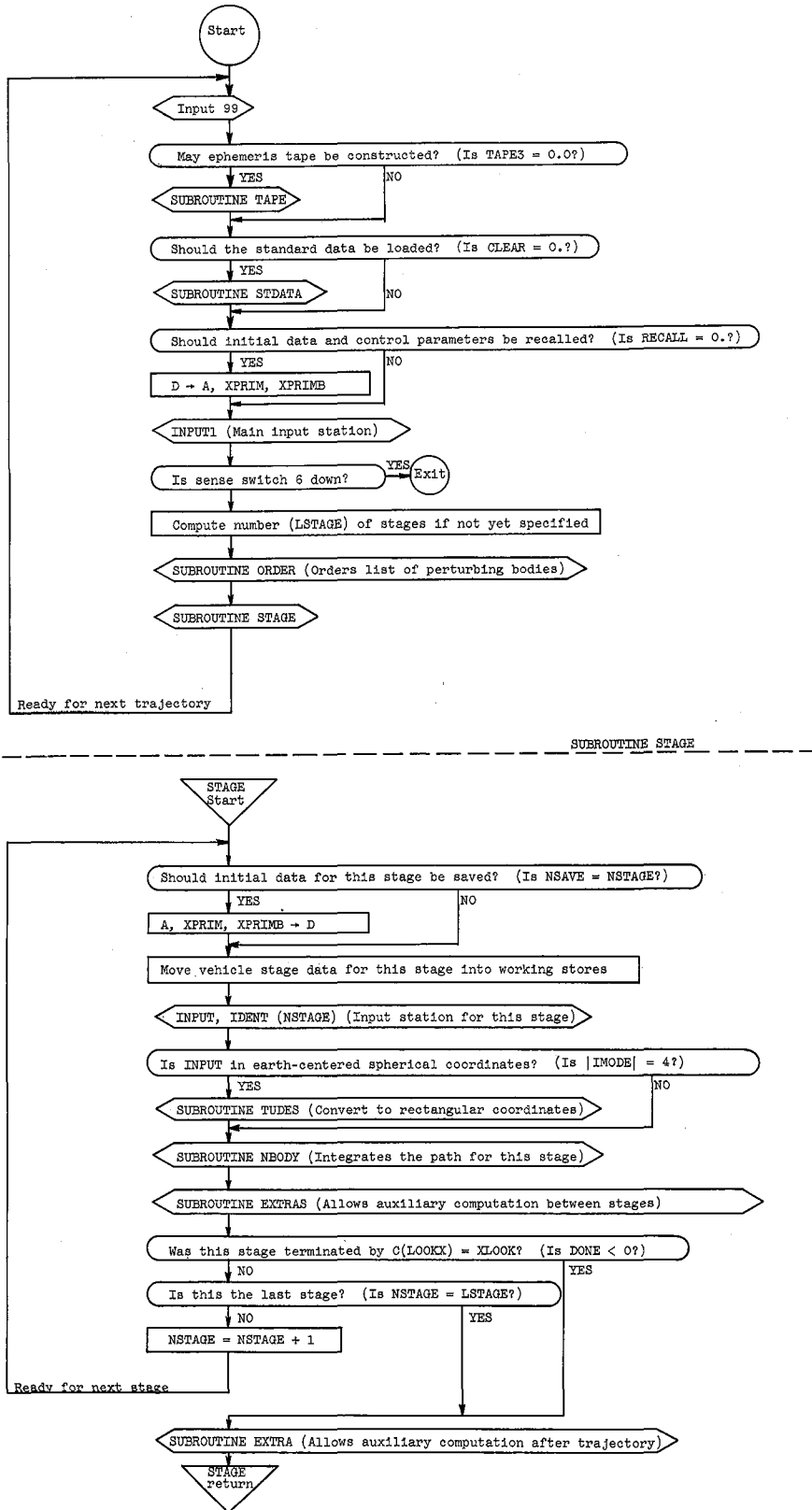

Figure 2. - Flow diagram of the main program and SUBROUTINE STAGE.

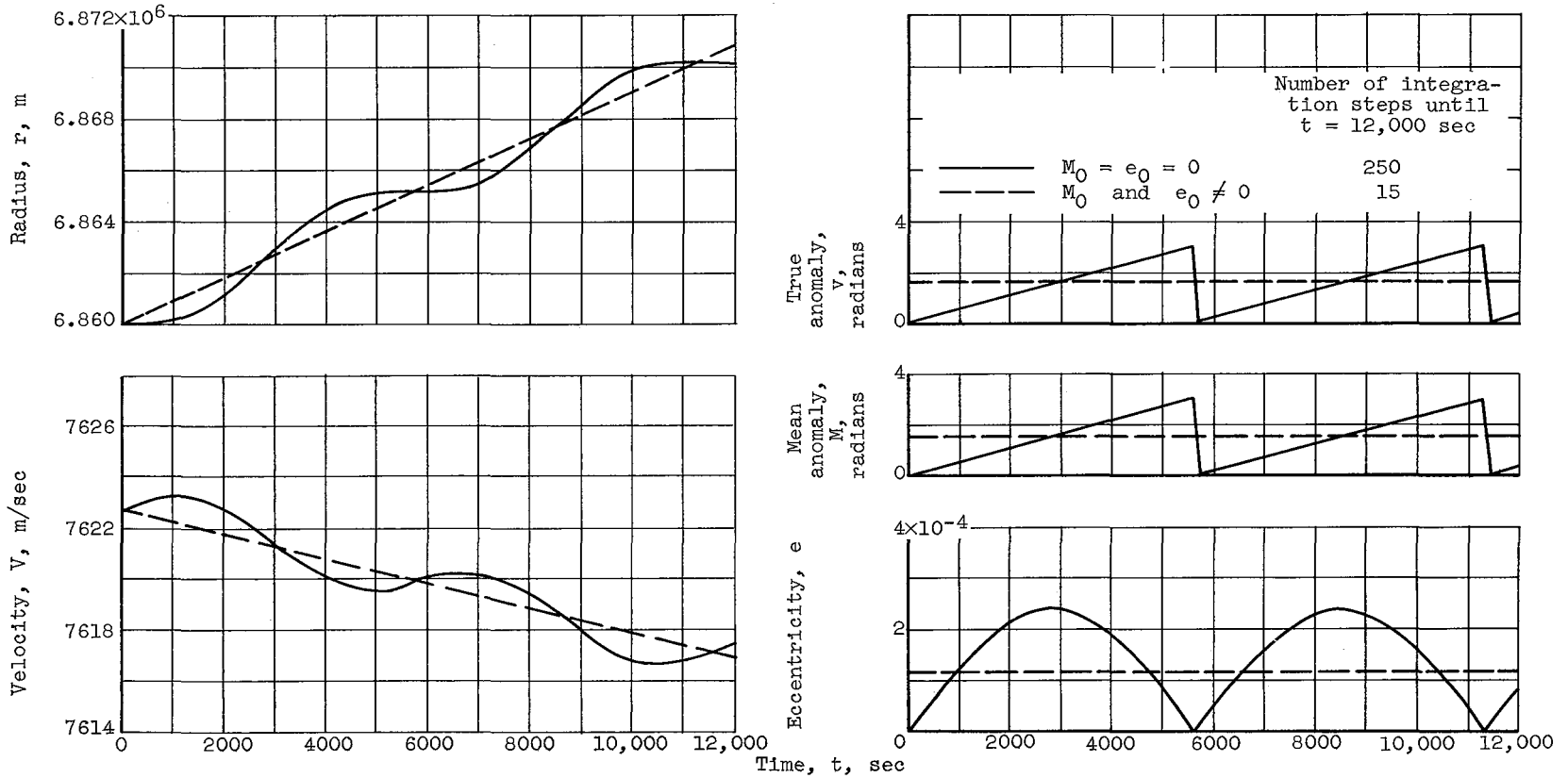
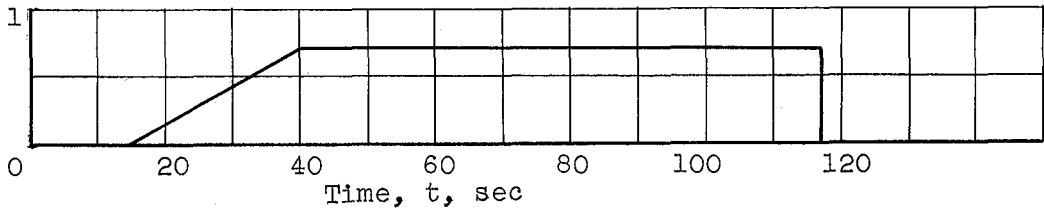
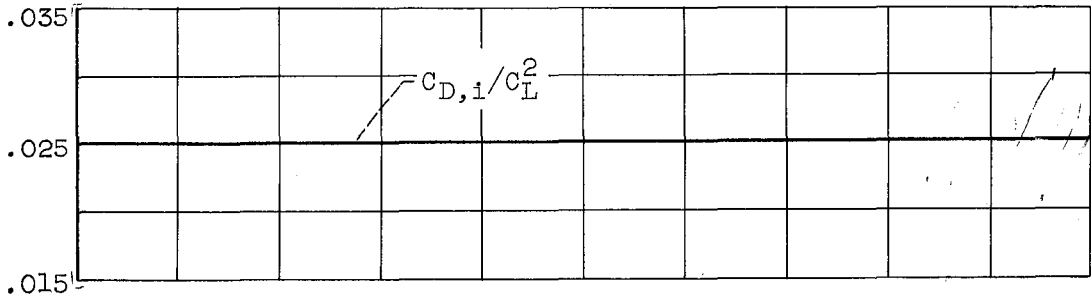

Figure 3. - Time histories of several trajectory parameters for Example I.

Angle of attack, α , deg



Ratio of induced drag coefficient to square of lift coefficient, $C_{D,i}/C_L^2$



Ratio of lift coefficient to sin of angle of attack, $C_L/\sin \alpha$

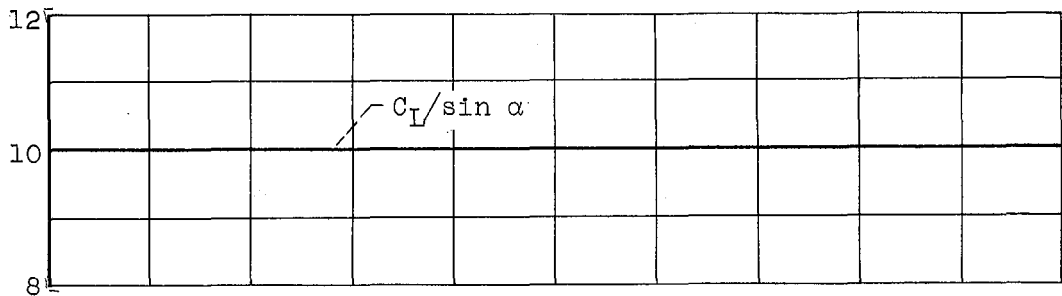

Zero angle-of-attack drag coefficient, $C_{D,0}$

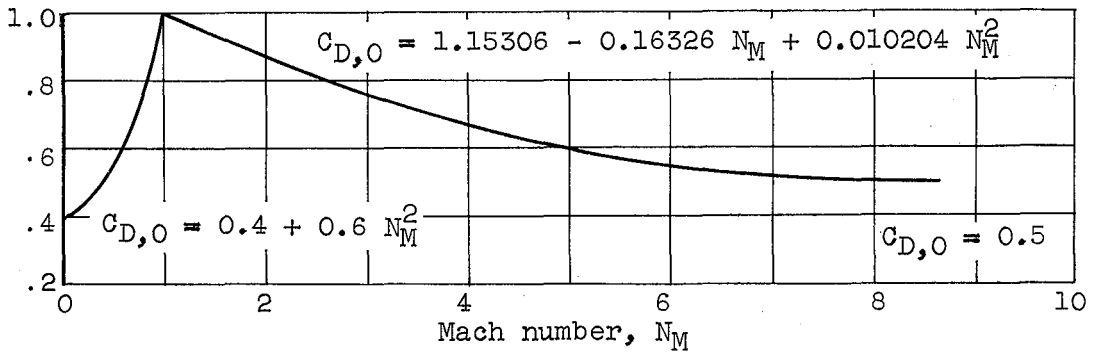

Figure 4. - Angle-of-attack schedule and variation of drag and lift coefficients with Mach number.