

Aruba 4100i Switch Series

Installation and Getting Started Guide



Part Number: 5200-8236
Published: July 2021
Edition: 1

Copyright Information

© Copyright 2021 Hewlett Packard Enterprise Development LP.

Open Source Code

This product includes code licensed under the GNU General Public License, the GNU Lesser General Public License, and/or certain other open source licenses. A complete machine-readable copy of the source code corresponding to such code is available upon request. This offer is valid to anyone in receipt of this information and shall expire three years following the date of the final distribution of this product version by Hewlett Packard Enterprise Company. To obtain such source code, send a check or money order in the amount of US \$10.00 to:

Hewlett Packard Enterprise Company
6280 America Center Drive
San Jose, CA 95002
USA

Notices

The information contained herein is subject to change without notice. The only warranties for Hewlett Packard Enterprise products and services are set forth in the express warranty statements accompanying such products and services. Nothing herein should be construed as constituting an additional warranty. Hewlett Packard Enterprise shall not be liable for technical or editorial errors or omissions contained herein. Confidential computer software. Valid license from Hewlett Packard Enterprise required for possession, use, or copying. Consistent with FAR 12.211 and 12.212, Commercial Computer Software, Computer Software Documentation, and Technical Data for Commercial Items are licensed to the U.S. Government under vendor's standard commercial license.

Links to third-party websites take you outside the Hewlett Packard Enterprise website. Hewlett Packard Enterprise has no control over and is not responsible for information outside the Hewlett Packard Enterprise website.

Acknowledgments

Microsoft® and Windows® are either registered trademarks or trademarks of Microsoft Corporation in the United States and/or other countries.

UNIX® is a registered trademark of The Open Group.

All third-party marks are property of their respective owners.

Contents	3
About this Document	5
Applicable Products	5
Related Publications	5
Introducing the Switches	6
Overview	6
Switch Features	6
Front of the Switches	7
Management ports	11
100/1000 SFP/10G SFP+ Ports (Uplink)	11
10/100/1000 BASE-T Ports (Downlink)	12
Console Ports	12
DC Power connectors	13
Alarm connector	14
Configuring alarm relays	17
Chassis LEDs and buttons on the front of the switch	23
LED Behavior	25
LED mode select button and indicator LEDs	27
Reset buttons	27
Back of the Switch	27
Power Supplies	28
Installing the switch	31
Included Parts	31
Parts not included	32
Installation Warnings	32
Installation Precautions and Guidelines	35
Grounding the switch	35
Installation Procedures for 12-port JL817A Switches	37
Prepare the Installation Site	38
Installing the Power Supplies	38
Mount the Power Supplies	39
Power-on the switch and check LEDs	48
Power off the switch	48
Mount the Switch	48
DIN Rail Mount Option	48
DIN-to-rack Mount Option	52
Aruba Side Enforcement Bracket Kit for Aruba Switches (optional)	54
User Configurable PoE Power Budget	58
Installation Procedures for 24-port JL818A Switches	61
Prepare the Installation Site	61
Horizontal and Wall Mount Option	62
Two-post Rack Mount Option	64
Four-Post Rack Mount Option	66
Install Transceivers (optional)	68

Connect the Switch to a Power Source	68
Setup for Initial Configuration	69
Connect Network Cables	69
Connecting Cables to Transceivers	69
Troubleshooting	70
Basic Troubleshooting Tips	70
Diagnosing with the LEDs	70
LED Patterns for General Switch Troubleshooting	71
Diagnostic Tips	72
Hardware Diagnostic Tests	74
Testing the switch by resetting it	74
Checking the Switch LEDs	74
Checking Console Messages	74
Testing Switch-to-Device Network Communications	75
Testing End-to-End Networking Communications	75
Specifications	76
Physical	76
Electrical	77
Power Cords	78
Environmental Specifications	79
RoHS	79
Safety and Regulatory Information	79
Connectivity Standards	80
Battery Statements:	81
Cabling and Technology Information	83
Cabling Specifications	83
Support and other resources	85
Accessing Aruba Support	85
Accessing Updates	85
Aruba Support Portal	86
My Networking	86
Warranty Information	86
Regulatory Information	86
Documentation Feedback	86

This document is intended for network administrators and support personnel.



The display and command line illustrated in this document are examples and might not exactly match your particular switch or environment.

The switch and accessory drawings in this document are for illustration only, and may not exactly match your particular switch and accessory products.

Applicable Products

- **JL817A** - Aruba 4100i 12-port 1GbE (8-port Class 4 POE and 4-port Class 6 POE) 2-port SFP+ DIN Mount Switch
- **JL818A** - Aruba 4100i 24-port 1GbE (20-port Class 4 POE and 4-port Class 6 POE) 4-port SFP+ Switch

Related Publications

- *Start Here: Installation, Safety, and Regulatory Information for the Aruba 4100i Switches*
- *AOS-S and AOS-CX Transceiver Guide*
- AOS-CX software manuals

To view and download these publications, visit the Aruba Support Portal at <https://asp.arubanetworks.com/downloads>.

Aruba 4100i networking switches are ruggedized devices offering low latency for high-speed networking with full network management capabilities.

This chapter describes these switches with the following information:

- Switch features
- Network ports
- Management ports
- Chassis and Port LEDs
- LED Mode Select Button and Mode LEDs
- LED behavior
- Power supplies

Overview

The Aruba 4100i Switch Series is a family of ruggedized networking switches, ideal for industrial environments and extreme conditions. They provide the foundation for high-performance networks supporting IoT, mobile, and cloud applications. They are for use in industrial applications. The end use environment may or may not be a restricted access location.

Switch Features

- Combinations of Class 6 and Class 4 10/100/1000 Base-T ports.
- Power supply options (JL817A):
 - Aruba 4000i POE 54VDC 240W 100-240VAC DIN Power Supply (JL819A)
 - Aruba 4000i POE 54VDC 480W 100-240VAC DIN Power Supply (JL820A)
 - Aruba 4000i POE 54VDC 240W 12-48VDC DIN Power Supply (JL821A)
- Easy management of the switch through several available interfaces:
 - **Console interface:** A full-featured, easy-to-use, VT-100 terminal interface for out-of-band or serial switch management. There is a single serial console port on the switch, using a USB Type-C connector. This port is used to connect a console to the switch. Use a common USB to USB-C cable (must be data capable). The console can be a PC or workstation running a VT-100 terminal emulator, or a VT-100 terminal. The console is also available via USB-A port using USB to Serial Adapter.
 - **Auxiliary (Aux) port:** An auxiliary port is available for downloading switch software code. This port uses a USB Type-A connector.
 - **Web browser interface:** An easy-to-use built-in graphical interface that can be accessed from common web browsers.

- **Aruba AirWave:** A powerful and easy-to-use network operations system that manages wired and wireless infrastructures. For more information, visit <https://www.arubanetworks.com/products/networking/management/airwave>.
- **Aruba Activate:** Cloud-based service that provides inventory control and facilitates Zero Touch Provisioning. (Available in future Aruba Activate release)
- **Aruba ClearPass Policy Manager:** Network policy management software for wired and wireless network devices that provide on-boarding and role-based control/security.
- **Aruba Central:** Network management software cloud platform. It offers IT organizations a simple, secure, and cost-effective way to manage and monitor Aruba switches and Aruba instant wireless APs. (Available in future Aruba Central release)
- Supports PoE Standards IEEE 802.3af, 802.3at and 802.3bt (up to 60W)
- Support for many advanced features to enhance network performance: For a description, see the AOS-CX guides for your switch.
- Ability to update the switch software. To download product updates, go to the [Aruba Support Portal](#).

JL817A - Aruba 4100i 12-port 1GbE (8-port Class 4 POE and 4-port Class 6 POE) 2-port SFP+ DIN Mount Switch

- 4 ports 10/100/1000 BaseT Class 6 PoE ports supporting up to 60W per port
- 8 ports 10/100/1000 BaseT Class 4 PoE ports supporting up to 30W per port
- 2 1/10G SFP+ ports
- 1 USB-C Console Port
- 1 RJ-45 Console Port
- 1 USB Type-A host port
- 1 Alarm socket
- 2 DC power sockets (for standby redundancy)

JL818A - Aruba 4100i 24-port 1GbE (20-port Class 4 POE and 4-port Class 6 POE) 4-port SFP+ Switch

- 4 ports 10/100/1000 BaseT Class 6 PoE ports supporting up to 60W per port
- 20 ports 10/100/1000 BaseT Class 4 PoE ports supporting up to 30W per port
- 4 1/10G SFP+ ports
- 1 USB-C Console Port
- 1 RJ-45 Console Port
- 1 USB Type-A Host port
- 1 Alarm socket

Front of the Switches

Figure 1 Front of all 4100i switches

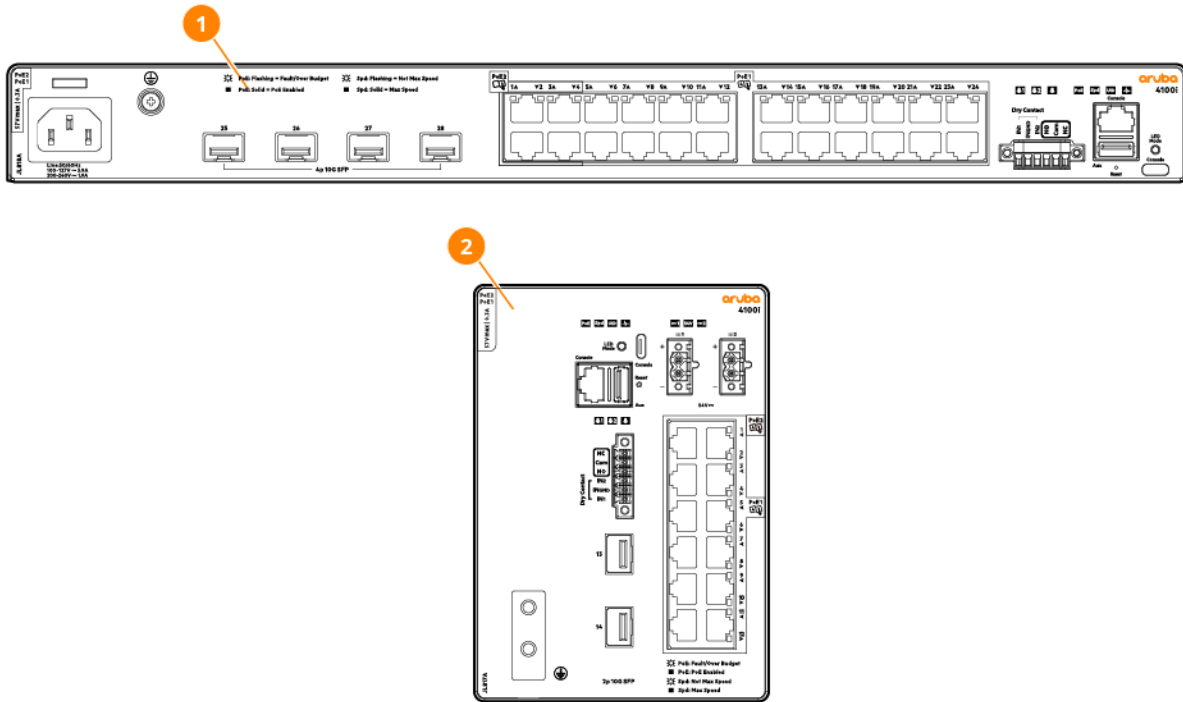

Label	Description
1	Aruba 4100i 24-port 1GbE (20-port Class 4 POE and 4-port Class 6 POE) 4-port SFP+ Switch (JL818A)
2	Aruba 4100i 12-port 1GbE (8-port Class 4 POE and 4-port Class 6 POE) 2-port SFP+ DIN Mount Switch (JL817A)

Figure 2 Front of switch (JL817A)

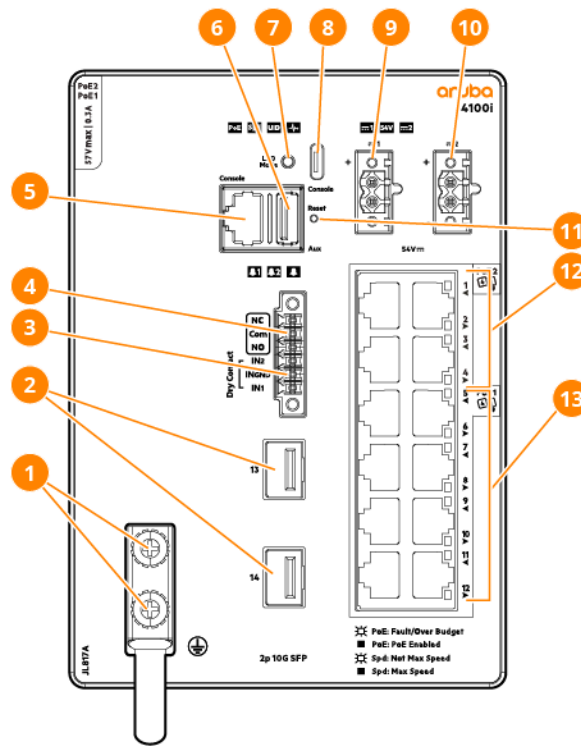

Item	Label	Description
1	Ground lug (must earth)	DIN switch grounding must be connected
2	10G SFP+ ports	SFP ports supporting 100M/1G/10GbE transceivers
3	Alarm IN terminal	Alarm 1 and 2 input terminal block
4	Alarm OUT terminal	Alarm output terminal block
5	RJ-45 console port	RJ-45 management console
6	USB auxiliary port	USB Type-A host port
7	LED Mode button	Push to toggle the display modes of port LEDs: <ul style="list-style-type: none"> ■ Activity / Link Mode (default) ■ Speed Mode ■ PoE Mode (only for PoE enabled SKUs)
8	USB-C console port	USB management console
9	DC power IN 1	PSU 1 power input terminal block
10	DC power IN 2	PSU 2 power input terminal block
11	Reset button	Hard reset - hold for 5 seconds Soft reset - press and release within 5 seconds

Item	Label	Description
12	Class 6 PoE ports	802.3bt Class 6 PoE ports supporting up to 60W of power are labeled with a silver frame (1-4)
13	Class 4 PoE ports	802.3at Class 4 PoE ports supporting up to 30W of power (5 - 12)

Figure 3 Front of switch (JL818A)

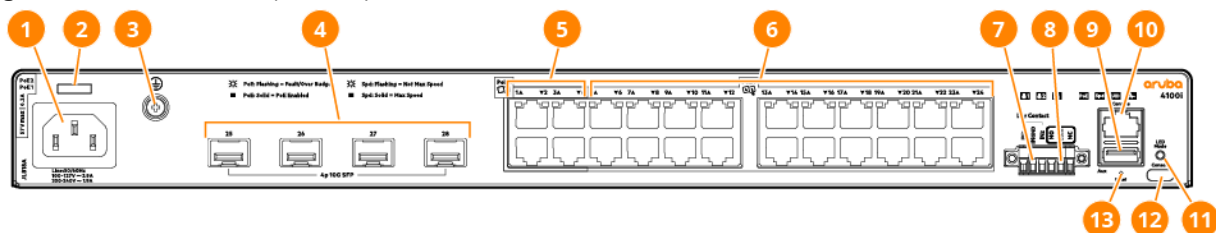

Item	Label	Description
1	AC power input	AC power input terminal block
2	Cable tie anchor	Allows for power cord to be secured by cable tie
3	Ground lug screw	Switch grounding connection (optional earth system)
4	10G SFP+ ports	SFP ports supporting 100M/1G/10GbE transceivers
5	Class 6 PoE ports	802.3bt Class 6 PoE ports supporting up to 60W of power are labeled with a silver frame (1-4)
6	Class 4 PoE ports	802.3at Class 4 PoE ports supporting up to 30W of power (5 - 24)
7	Alarm IN terminal	Alarm 1 and 2 input terminal block
8	Alarm OUT terminal	Alarm output terminal block
9	USB auxiliary port	USB Type-A host port
10	RJ-45 console port	RJ-45 management console
11	LED Mode button	Push to toggle the display modes of port LEDs: <ul style="list-style-type: none"> ■ Activity / Link Mode (default) ■ Speed mode ■ PoE mode (only for PoE enabled SKUs)
12	USB-C console port	USB management console
13	Reset button	Hard reset - hold for 5 seconds Soft reset - press and release within 5 seconds

Management ports

You can connect the switch to a PC running Microsoft Windows or to a terminal server through either the RJ-45 console port or the USB-C console port. These ports use the following connectors:

- RJ-45 console port uses a console connection with these pinout assignments:

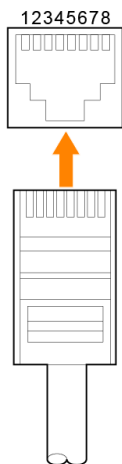

RJ-45 (Signal reference from chassis)		
Reserved	1	CTS
Reserved	2	DSR
TXD	3	RXD
Reserved	4	DCD
GND	5	GND
RXD	6	TXD
Reserved	7	DTR
Reserved	8	RTS

- USB-C console port



To use the USB-C console port, you must install the Windows USB device driver on the device that is connected to the USB-mini console port and that is running Microsoft Windows. With the Windows USB device driver, connecting and disconnecting the USB cable from the console port does not affect Windows HyperTerminal operations. Mac OS X or Linux require no special drivers.

Only the connected and active port will be able to input data. For information on using the CLI to configure the USB-C interface, see the switch software guide.



Different configurations are available. Not all ports are present in all configurations.

100/1000 SFP/10G SFP+ Ports (Uplink)

Depending on the switch model, the uplink ports support 100Mbps FX, 1G or 10G optics (no support for 10G LRM optics).

For more information on SFP/SFP+, see the *Transceiver Guide*.

10/100/1000 BASE-T Ports (Downlink)

You can set the 10/100/1000 Base-T ports to operate in 10 or 100 Mbp/s in full-duplex or half-duplex mode. You can also set these ports for speed and duplex autonegotiation in compliance with IEEE 802.3. (The default setting is autonegotiate.) When set for autonegotiation, the port receives the speed and duplex settings of the attached device and advertises its own capabilities. If the connected device also supports autonegotiation, the switch port negotiates the best connection (that is, the fastest line speed that both devices support, and full-duplex transmission if the attached device supports it) and configures itself accordingly. In all cases, the attached device must be within 328 feet (100 meters). 100BASE-TX traffic requires Category 5 cable. 10BaseT traffic can use Category 3 or Category 4 cables.

Console Ports

Aruba 4100i switches include an RJ-45 serial console port on the front of the switch. This port is used to connect a console to the switch by using an RJ-45 serial cable (not supplied). A DB9-to-RJ-45 console cable can be ordered from HPE: JL448A, Aruba X2C2 RJ45 to DB9 Console Cable.

The switch also has a USB-C console port on the front of the switch. The USB-C has precedence for input. If both cables are plugged in, the console output is echoed to both the RJ-45 and the USB-C, but the input is only accepted from the USB-C.

JL817A

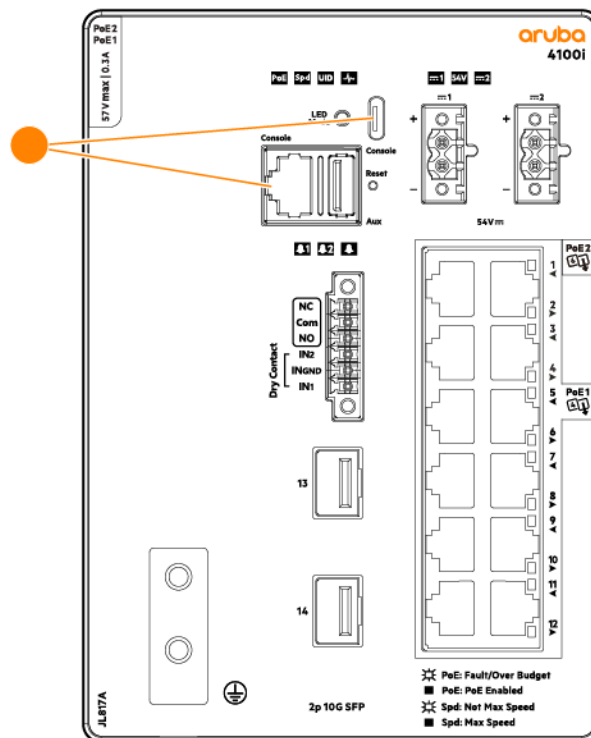

JL818A

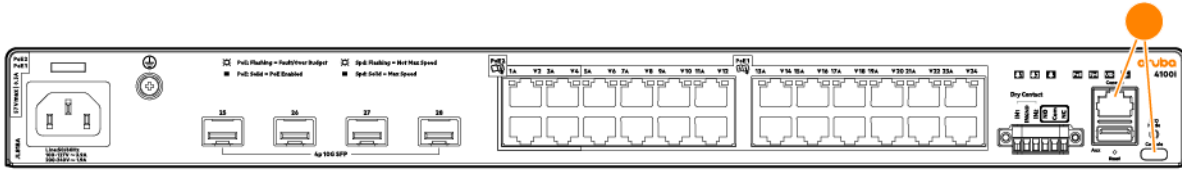

- Use of the USB-C port may require the installation of a standard USB driver. New Windows installs include the driver by default.

The console can be a PC or workstation running a VT-100 terminal emulator, or a VT-100 terminal.

The Aruba CX mobile app and the Aruba USB Bluetooth adapter enable you to configure your switch from your mobile device. For information about using the Aruba CX mobile app to configure the switch, see the *Fundamentals Guide* for your switch and software release.

DC Power connectors

(JL817A only)

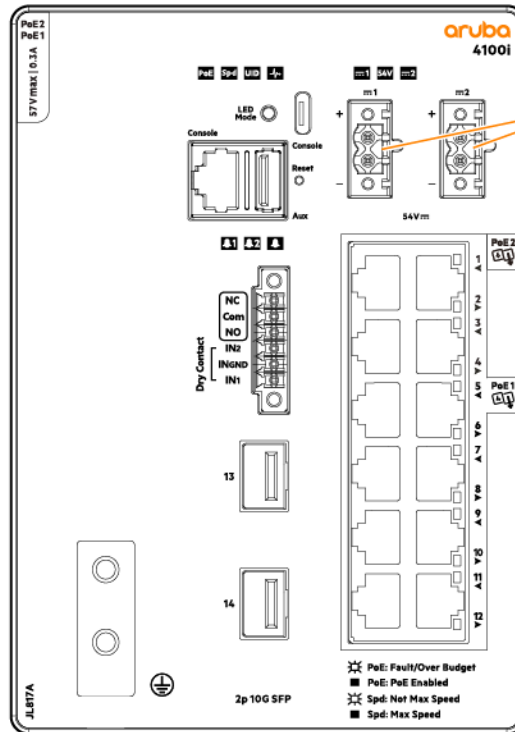

DC connection is supported for the JL817A through two connectors on the front panel of the switch. The dual-feed power supply provides primary and secondary DC power (DC-1 and DC-2). The switch is capable of operating with a single or dual power source. When using both power sources, the switch will draw power from the DC source with the higher voltage. Each of the power sources serve as redundancy to one another. The switch has an ORing controller to provide protection against reverse-polarity conditions but does NOT support summation of power for capacity when combining both power supplies together.

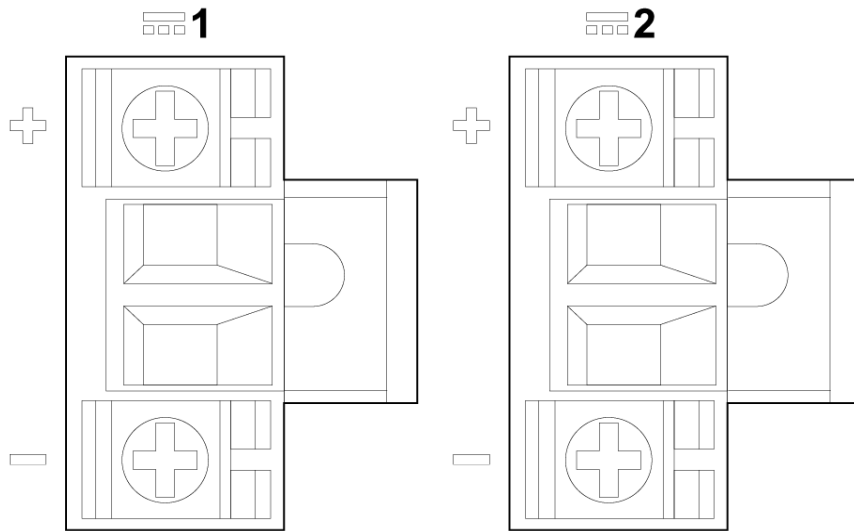

For safe and reliable DC connection, use wiring that is 14 AWG, up to 2 meters.



Ensure that the wires are secured by tightening the captive screws.

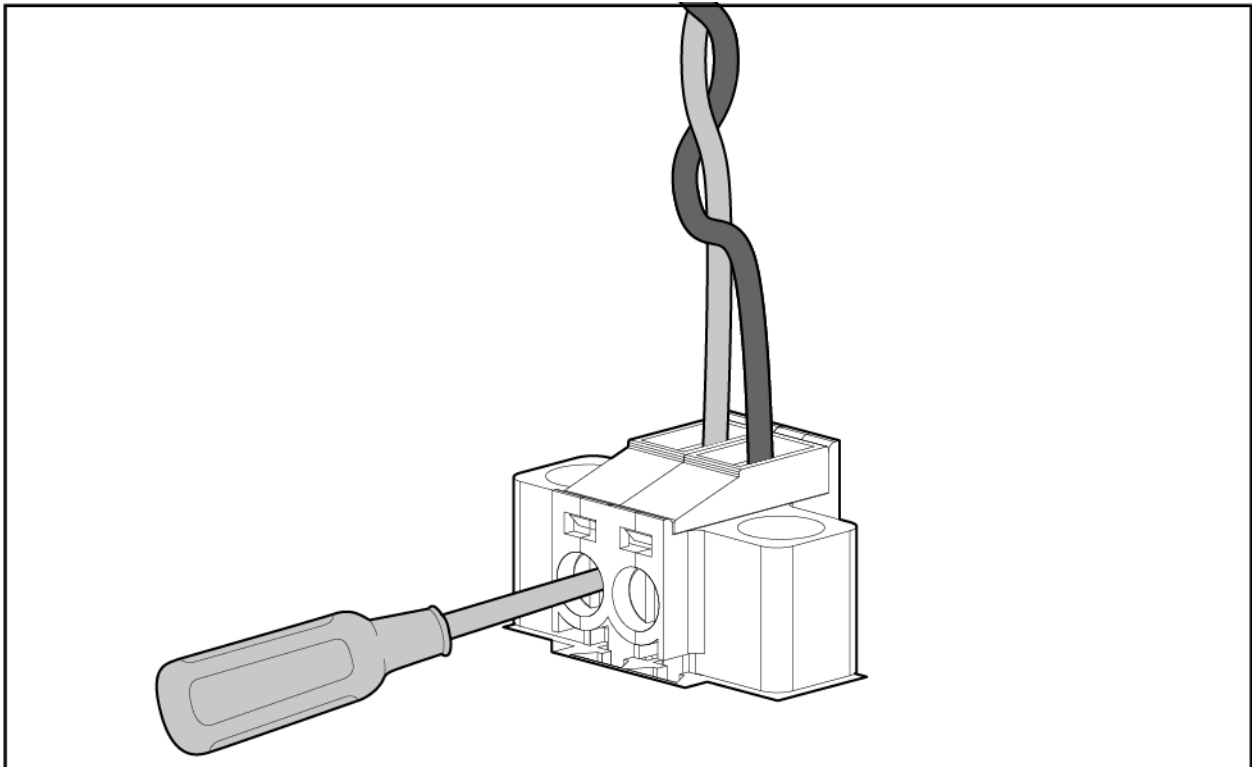

Alarm connector

JL817A

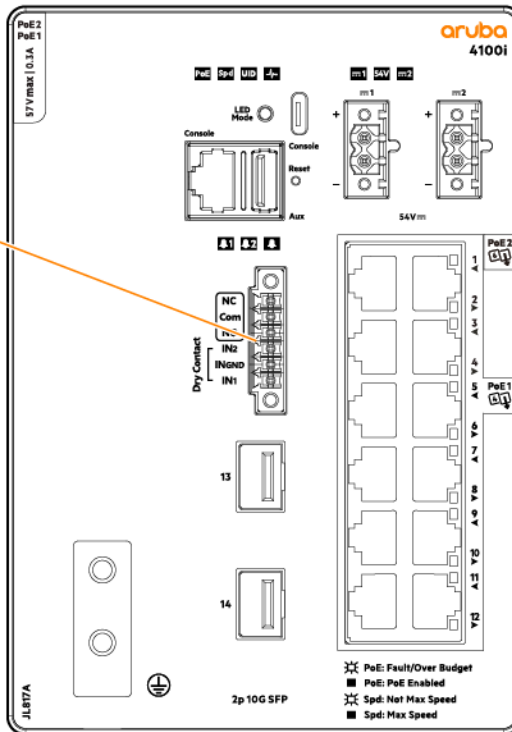

JL818A

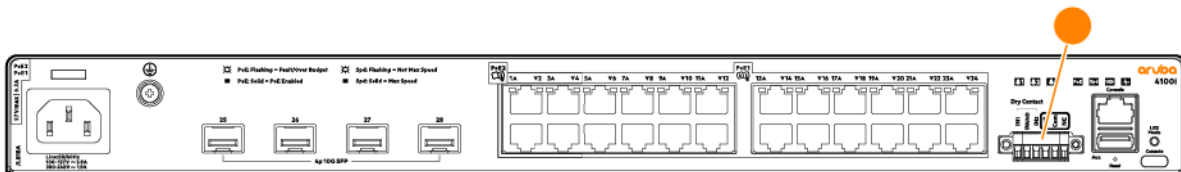

Alarm signals can be connected to the switch through the alarm connector. The switch supports two alarm inputs and one alarm output relay. The alarm connector provides six alarm wire connections.

Alarm Specifications

Input	Dry contact. Do not apply any voltage source. Open or Closed state detect (Dry Contact detection).
Output	1.0A @ 24 VDC or 0.5A @ 48VDC Max Power: 24W Supports Normally Open and Normally Closed
Wire	AWG 18-16

Alarm Label

Item	Description
NC	Alarm output normally closed
Com	Alarm output reference ground
NO	Alarm output normally open

Item	Description
IN2	Alarm input 2
INGND	Alarm input reference ground
IN1	Alarm input 1

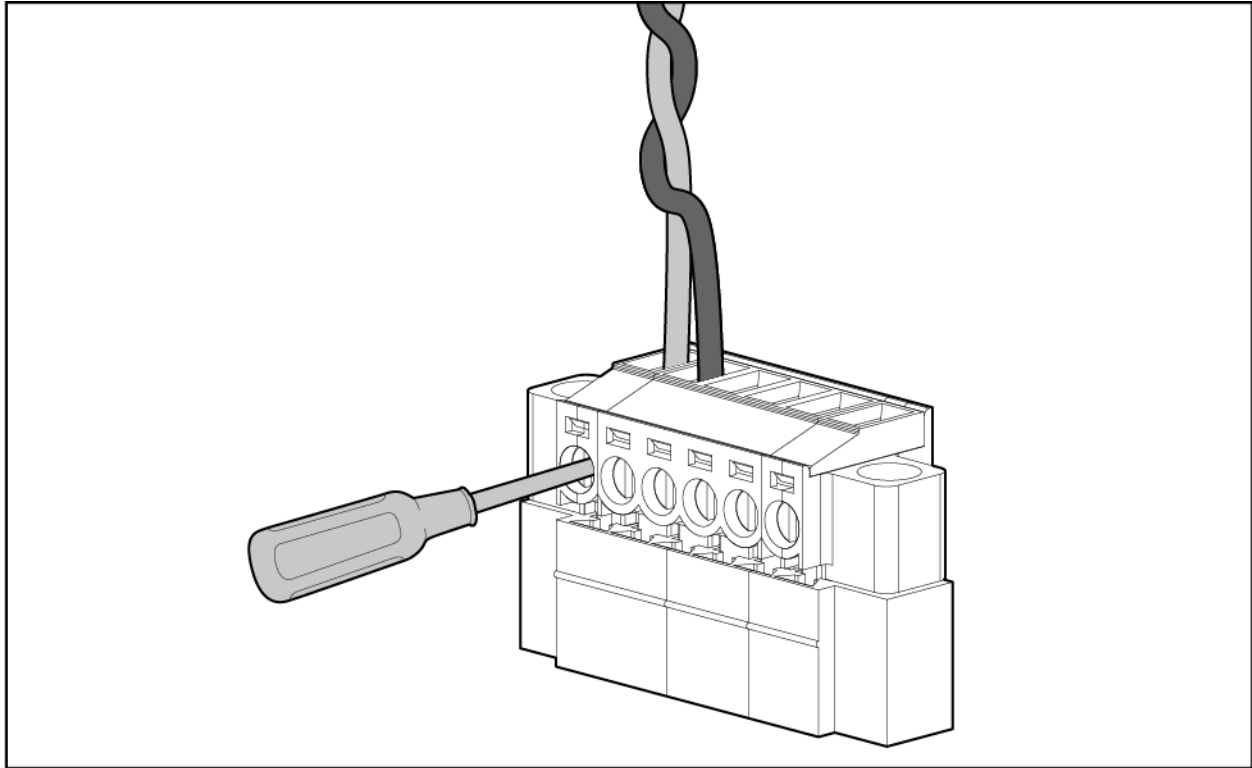

Alarms can be configured in the CLI. Each alarm input can be configured as normally open or normally closed contact and can be used for environmental, power supply or port needs. The alarm output can be connected to an external device such as a light or bell.

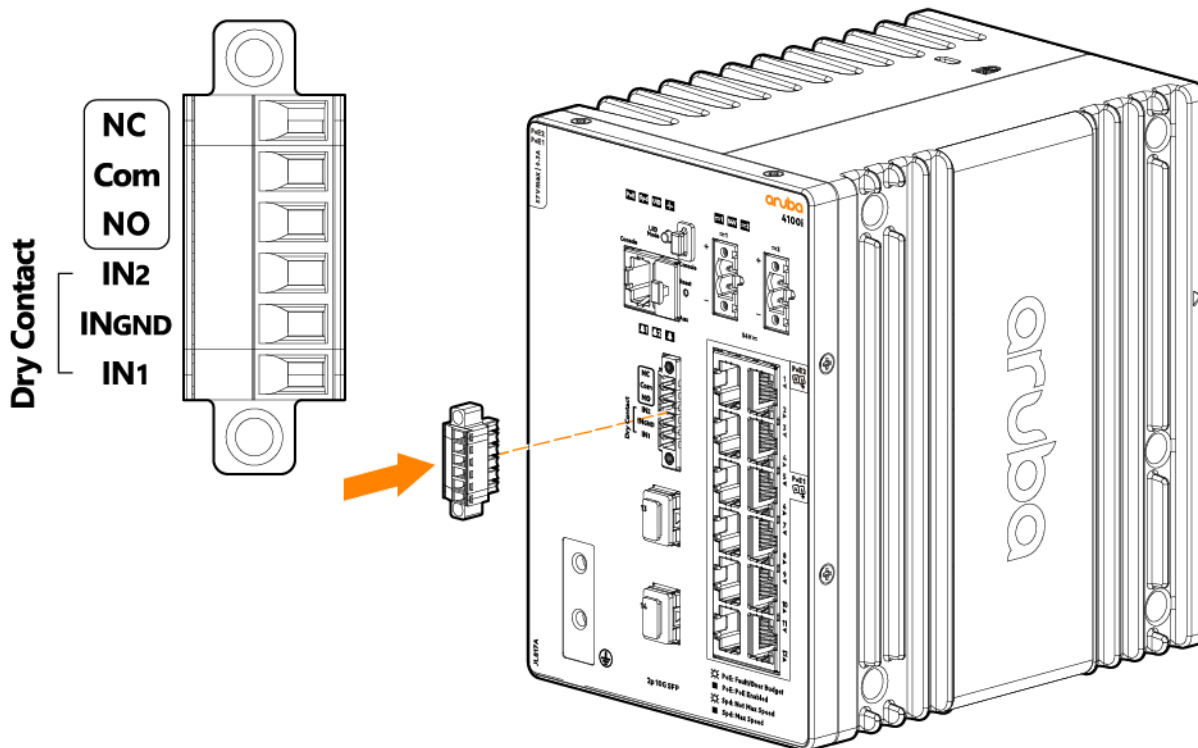

Configuring alarm relays

Industrial rugged switches have hardware alarm ports that generate an alarm on internal or external condition depending on alarm port wiring during system installation. The switch provides for 1x output alarm port that could be wired to an external device. When an external device like an external alarm bell is wired to the output port, configuring the event to output relay will trigger the bell to ring indicating the event. These events could also be configured to send syslog messages and SNMP traps. The switch also provides for 2x input alarm ports. An external device like a door or a sensor could be connected to the switch which can be configured to trigger a syslog or SNMP. These could also be forwarded to the relay circuit at the alarm output port.

To configure the alarm relays, refer to the following CLI commands. For additional CLI and software information, see the *Monitoring Guide* for your switch.

Alarm commands

alarm input

```
alarm input {IN1 | IN2} [name <STRING>] [action <LOG-AND-TRAP> | <RELAY>] [trigger <CLOSED | OPEN>]
no alarm input {IN1 | IN2} [name <STRING>] [action <LOG-AND-TRAP> | <RELAY>] [trigger <CLOSED | OPEN>]
```

Description

Configures input alarm and actions. The `no` form of this command removes the specified configuration.

Parameters

{IN1 | IN2}

Specifies the input alarm port.

name

Specifies the external device connected.

- <STRING>**
Descriptive string.
- action**
Specifies the action to be taken when the monitored event occurs.
- <LOG-AND-TRAP>**
Generates an event log and SNMP trap.
- <RELAY>**
Relays an event to alarm output port.
- trigger**
Triggers an alarm based on a normally open or closed circuit.
- <CLOSED>**
Generates an alarm event when the circuit is closed.
- <OPEN>**
Generates an alarm event when the circuit is open.

Examples

Configuring an alarm on input port 1 named Door-Sensor:

```
switch(config)# alarm input IN1 name Door-Sensor
```

Removing the configuring for an alarm on input port 1:

```
switch(config)# no alarm input IN1
```

Configuring an alarm on input port 1 with log-and-trap action:

```
switch(config)# alarm input IN1 action log-and-trap
```

Removing the configuration for an alarm on input port 1 with log-and-trap action:

```
switch(config)# no alarm input IN1 action log-and-trap
```

Configuring an alarm on input port 1 to trigger an alarm when the door sensor circuit is closed:

```
switch(config)# alarm input IN1 trigger closed
```

Command History

10.08 Featured introduced.

Command Information

4100i config Administrators or local user group members with execution rights for this command.

alarm snooze

alarm snooze [time in minutes] [repeat]

Description

Configures any active event forwarded to alarm relay to be snoozed.

Parameters

time

Specifies the value for time in minutes. The range is 0-1440 minutes.

[repeat]

Repeats the previous snooze time.

Examples

Configuring an alarm relay action for 10 minutes:

```
switch(config)# alarm snooze 10
```

Configuring an alarm relay action to be repeated with previously configured snooze time:

```
switch(config)# alarm snooze repeat
```

Command History

10.08	Featured introduced.
-------	----------------------

Command Information

4100i	config	Administrators or local user group members with execution rights for this command.
-------	--------	------------------------------------------------------------------------------------

alarm

```
alarm {temperature | power supply} [action <LOG-AND-TRAP> | <RELAY>]  
no alarm {temperature | power supply} [action <LOG-AND-TRAP> | <RELAY>]
```

Description

Configures global events to be forwarded to the output alarm port. The `no` form of this command disables the specified configuration.

Parameters

{temperature}

Selects the alarm for ambient temperatures reaching threshold limits. The threshold is 70°C. Threshold is reduced to 50°C when non-supported transceivers are detected; only the listed Aruba I-Temp transceivers listed on the product datasheet allow for the maximum of 70°C. Commercial Temp Aruba transceivers will trigger this derating of this threshold to 50°C.

{power supply}

Selects the alarm for alert events from the power supply.

log-and-trap

Generates an event log and SNMP trap

relay

Relays the event to the alarm output port.

Examples

Disabling a temperature event to remove the configuration for all actions associated with the event:

```
switch(config)# no alarm temperature
```

Configuring an alarm for a temperature event for the log-and-trap action:

```
switch(config)# alarm temperature action log-and-trap
```

Removing the configuration for the temperature event for a log-and-trap action:

```
switch(config)# no alarm temperature action log-and-trap
```

Configuring an alarm for a power-supply event for the relay action:

```
switch(config)# alarm power-supply action relay
```

Removing the configuration for the power-supply event for the relay action:

```
switch(config)# no alarm power-supply action relay
```

Command History

10.08 Featured introduced.

Command Information

4100i config Administrators or local user group members with execution rights for this command.

show alarm input

```
show alarm input [IN1 | IN2]
```

Description

Shows the alarm details for all ports or for the specified port.

Parameters

[IN1 | IN2]
 Specifies the input alarm port.

Examples

Showing details for all alarm input ports on the switch:

```
switch# show alarm input
Alarm Snooze Timer Status: inactive
-----
Input Alarm IN1, Name: Door-Sensor
-----
```

Alarm Port	Status	log-and-trap	Relay	Trigger
IN1	inactive	true	false	closed

Input Alarm IN2, Name: N/A

Alarm Port	Status	log-and-trap	Relay	Trigger
IN2	active	false	true	open

Showing details for alarm input ports IN1:

```
switch# show alarm input IN1
Alarm Snooze Timer Status: inactive
-----
Input Alarm IN1, Name: Door-Sensor
-----
Alarm Port      Status      log-and-trap  Relay      Trigger
-----
IN1             inactive   true          false     closed
```

Command History

10.08 Featured introduced.

Command Information

4100i Manager (#) Administrators or local user group members with execution rights for this command.

show alarm

show alarm [temperature | power supply]

Description

Shows all of the details of global status monitoring alarm events.

Parameters

temperature

Selects the alarm for ambient temperatures reaching threshold limits.

power supply

Selects the alarm events from the power supply.

Examples

Showing details for all global alarm events on the switch:

```
switch# show alarm
Alarm Snooze Timer Status: active
Duration remaining: 1 min 32 sec
-----
Global Alarm: Temperature
```

```

-----
Alarm Event           Status           log-and-trap      Relay
-----
Temperature           inactive         true               false

-----
Global Alarm: power-supply
-----
Alarm Event           Status           log-and-trap      Relay
-----
power-supply          active           false              true

```

Showing details for the temperature alarm:

```

switch# show alarm temperature
Alarm Snooze Timer Status: Active
Duration remaining: 5 min 36 sec
-----
Global Alarm: Temperature
-----
Alarm Event           Status           log-and-trap      Relay
-----
Temperature           inactive         true               false

```

Command History

10.08 Featured introduced.

Command Information

4100i Manager (#) Administrators or local user group members with execution rights for this command.

show alarm timer

show alarm timer

Description

Shows the status of an alarm snooze timer's status and duration.

Examples

Showing the status of an alarm snooze timer when it is inactive :

```

switch# show alarm timer
Alarm Snooze Timer Status: inactive

```

Showing the status of an active 3-minute alarm snooze timer:

```

switch# show alarm timer
Alarm Snooze Timer Status: active
Duration remaining: 2 min 55 sec

```

Command History

Command Information

4100i

Manager (#)

Administrators or local user group members with execution rights for this command.

Chassis LEDs and buttons on the front of the switch

JL817A

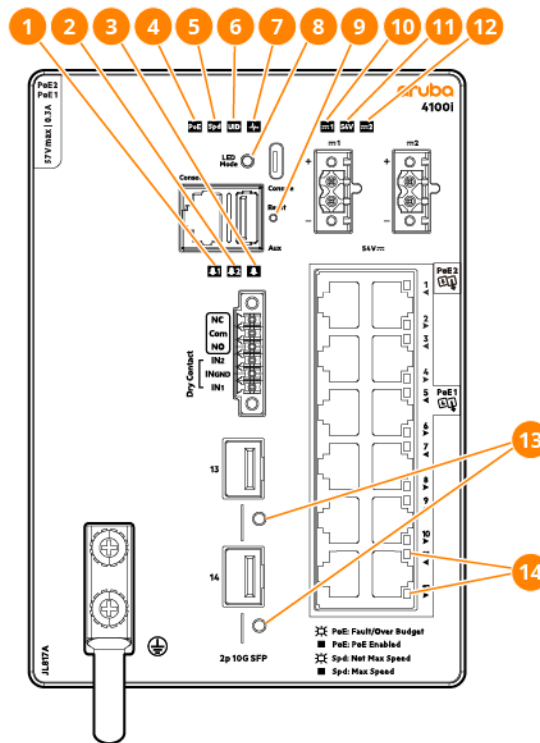

Item	Label	Description
1	Alarm 1 LED	Alarm 1 LED to show alarm input 1 status
2	Alarm 2 LED	Alarm 2 LED to show alarm input 2 status
3	Alarm OUT LED	Alarm output LED to show alarm output status
4	PoE LED	Port LEDs are showing PoE information
5	Speed LED	Port LEDs are showing speed information
6	Unit identification LED	User-configurable LED with 3 states (on, off, or flashing)
7	Global Status LED	Global status indicator (Health LED) - green and amber

Item	Label	Description
8	LED Mode button	Push to toggle the display modes of port LEDs: <ul style="list-style-type: none"> ■ Activity / Link Mode (default) ■ PoE Mode ■ Speed Mode
9	Reset button	Hard reset - hold for 5 seconds Soft reset - press and release within 5 seconds
10	Power 1 LED	PSU 1 status indicator LED
11	54V PoE LED	Power is within 52-55V range to support PoE
12	Power 2 LED	PSU 2 status indicator LED
13	10G SFP+ port LEDs	SFP ports supporting 100M/1G/10GbE transceivers
14	Switch port LEDs (RJ45)	Single LED per port to indicate Link and Mode

JL818A

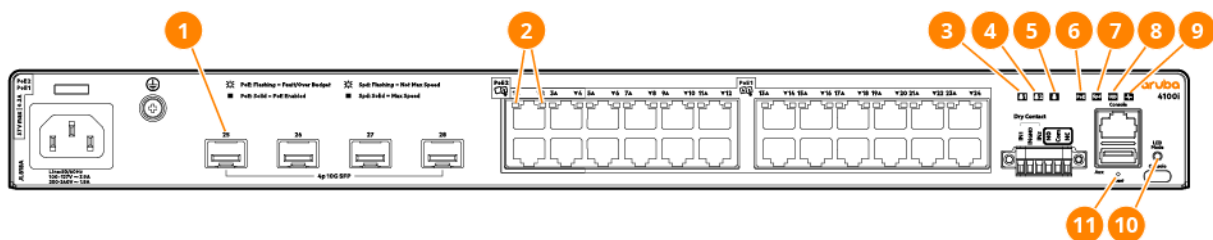

Item	Label	Description
1	10G SFP+ port LEDs	SFP ports supporting 100M/1G/10GbE transceivers
2	Switch port LEDs (RJ45)	Single LED per port to indicate Link and Mode
3	Alarm 1 LED	Alarm 1 LED to show alarm input 1 status
4	Alarm 2 LED	Alarm 2 LED to show alarm input 2 status
5	Alarm OUT LED	Alarm output LED to show alarm output status
6	PoE LED	Port LEDs are showing PoE information
7	Speed LED	Port LEDs are showing speed information
8	Unit Identification LED	User-configurable LED with 3 states (on, off and flashing)
9	Global Status LED	Global status indicator (Health) LED - green and amber

Item	Label	Description
10	LED Mode button	Push to toggle the display modes of port LEDs: <ul style="list-style-type: none"> ■ Activity / Link Mode (default) ■ PoE Mode ■ Speed Mode
11	Reset button	Hard reset - hold for 5 seconds Soft reset - press and release within 5 seconds

LED Behavior

Global Status LEDs

LED	Description
Flashing green	Self-test in progress during UBOOT, SVOS and AOS-CX
Solid green	Successfully initialized AOS-CX
Flashing amber	Recoverable faults (e.g. power supply fault)
Solid amber	Critical faults (e.g. exceeds temperature limit)
Snoring (dimmed and lights up periodically)	System is in pre-boot heating process

UID LED

LED	Description
Off	User configured the located LED : Off
On / flashing blue	User configured the locator LED : On / Flashing

Spd LED

LED	Description
Off	Speed mode not selected
Green	Speed mode selected

PoE LEDs

LED	Description
Off	PoE mode not selected.
Green	PoE mode selected.

LED	Description
Slow flashing amber	One or more ports experiencing PoE failure. PoE mode not selected.
Amber	One or more ports experiencing PoE failure. PoE mode selected.

Alarm IN LEDs

LED	Description
Off	Alarm input not configured
Green	Alarm input configured
Slow flashing amber	System received active alarm input

Alarm Out LEDs

LED	Description
Off	Alarm output not configured
Green	Alarm output configured
Slow flashing green	Active - input alarm event is forwarded to alarm output
Slow flashing amber	Active - system alarm event is forwarded to alarm output

Port Status LEDs

LED	Description
Off	No link
Solid Green (half bright)	Link present
Blinking green or solid green (full bright)	Port is sending or receiving data

System DC Input status LED (JL817A only)

LED	Description
Off	No DC input
Solid Green	DC input in normal operation
Solid amber	DC input fault or out of range

54V PoE Status LEDs (JL817A only)

LED	Description
Green	Indicates DC input is within PoE operational range
Amber	Indicates DC input is out of PoE operational range

Press the Mode Select button to switch between PoE mode or Spd Mode.

LED mode select button and indicator LEDs

The state of the switch port LEDs is controlled by the LED Mode select button. The current view mode is indicated by the mode LEDs. To step from one view mode to the next, press the button to cycle through the different modes.

Reset buttons

The Reset button is recessed from the front panel. (This design protects it from being pushed accidentally.) The button is accessible through small holes on the top of the front panel. Use pointed objects, such as unbent paper clips, to push it.

To Accomplish this:	Do this:	This will happen:
Soft reset	Press and release the Reset button.	The switch operating system is shutdown gracefully. The switch then reboots.
Hard reset	Press and hold the Reset button for more than 5 seconds, then release.	The switch reboots, similar to a power cycle. A hard reset is used, for example, when the switch CPU is in an unknown state or not responding.

Back of the Switch

- **JL817A** - Aruba 4100i 12-port 1GbE (8-port Class 4 POE and 4-port Class 6 POE) 2-port SFP+ DIN Mount Switch

The rear panel of the switch has a latch for installation on a DIN rail. The latch is spring-loaded to move down to position the switch over a DIN rail and return to the original position to secure the switch to a DIN rail.

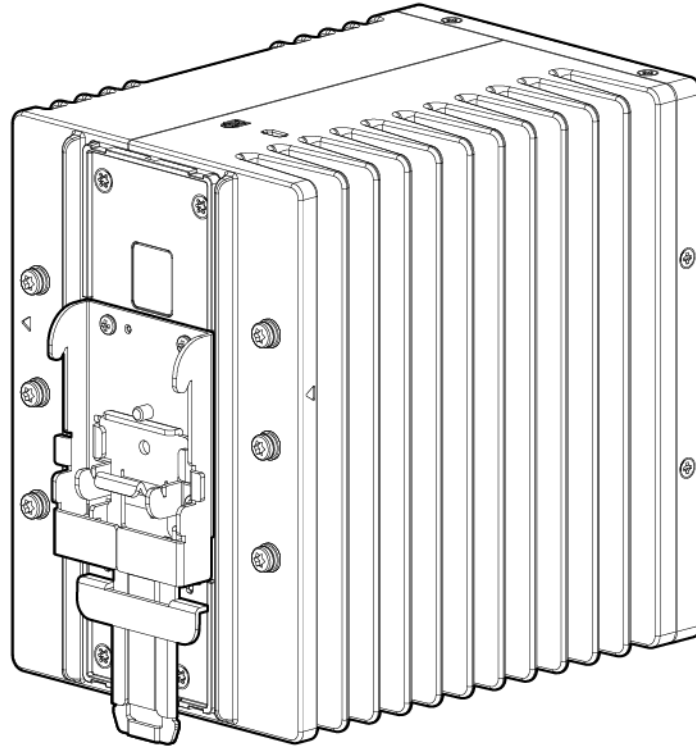

- **JL818A** - Aruba 4100i 24-port 1GbE (20-port Class 4 POE and 4-port Class 6 POE) 4-port SFP+ Switch

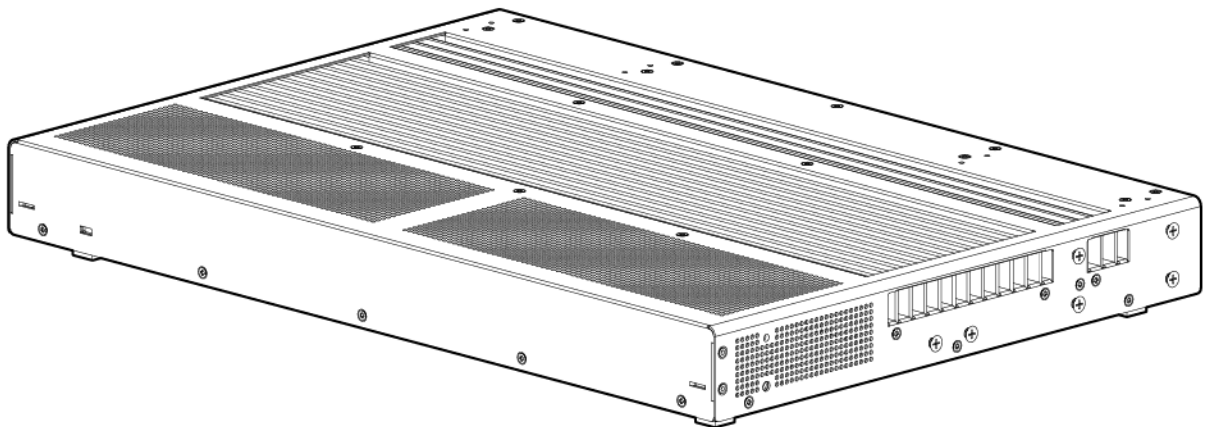

Power Supplies

(JL817A only)

The following power supplies are supported for JL817A :

- (JL819A) Aruba 4000i POE 240W AC DIN PSU
- (JL820A) Aruba 4000i POE 480W AC DIN PSU
- (JL821A) Aruba 4000i POE 240W DC-DC DIN PSU

The AC power supplies automatically adjust to any AC voltage; it is powered on when an installed power supply is connected to an active power source. The power supplies automatically adjust to any voltage between 100-127 and 200-240 volts and either 50 or 60 Hz. There are no voltage range settings required. The DC power supply accepts DC voltages between 11-55 volts.

These power supplies are IP20 rated.



Never insert or remove a power supply while the power cord or cable is connected. Verify that power has been turned off and the cord or cable has been disconnected from the power supply before installation or removal.

Figure 1 JL819A Aruba 4000i POE 240W AC DIN PSU

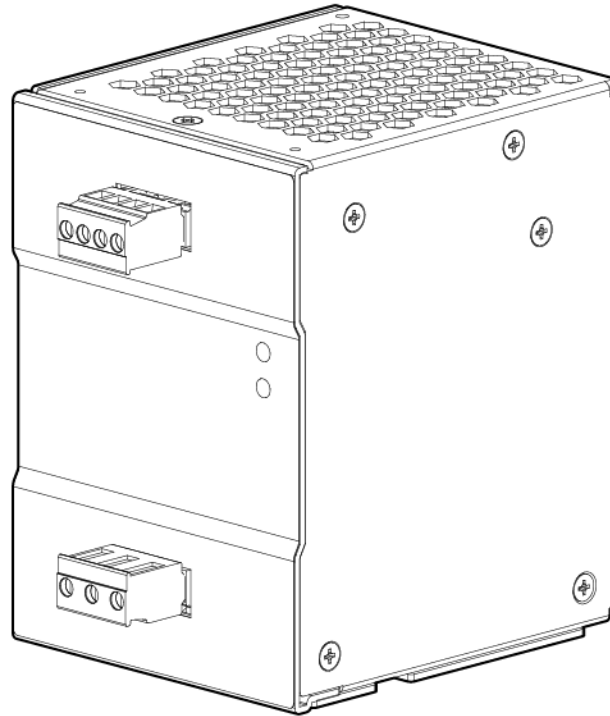

Figure 2 JL820A Aruba 4000i POE 480W AC DIN PSU

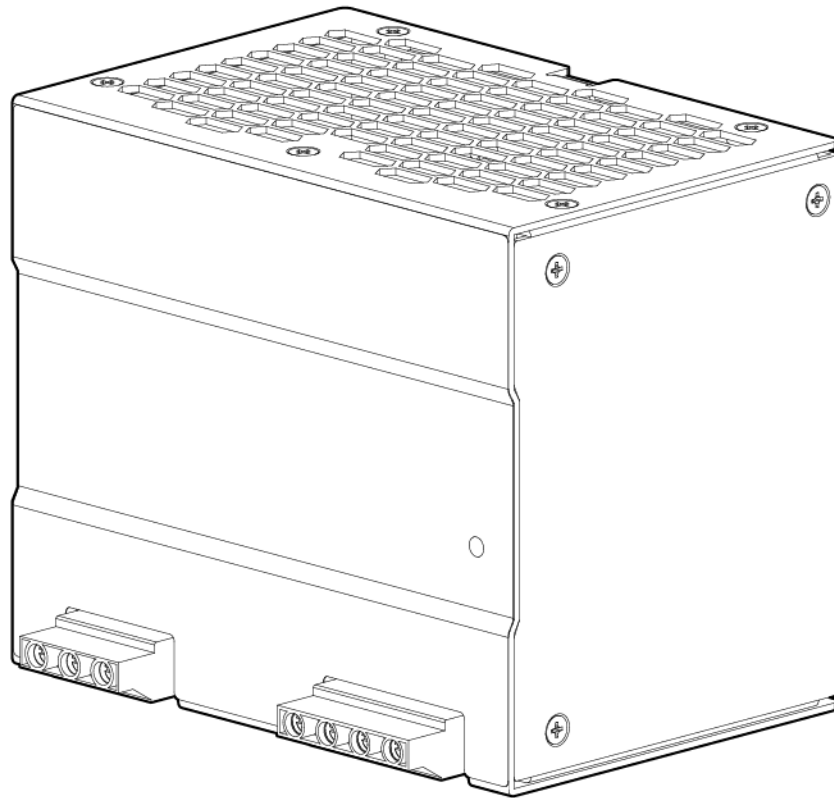
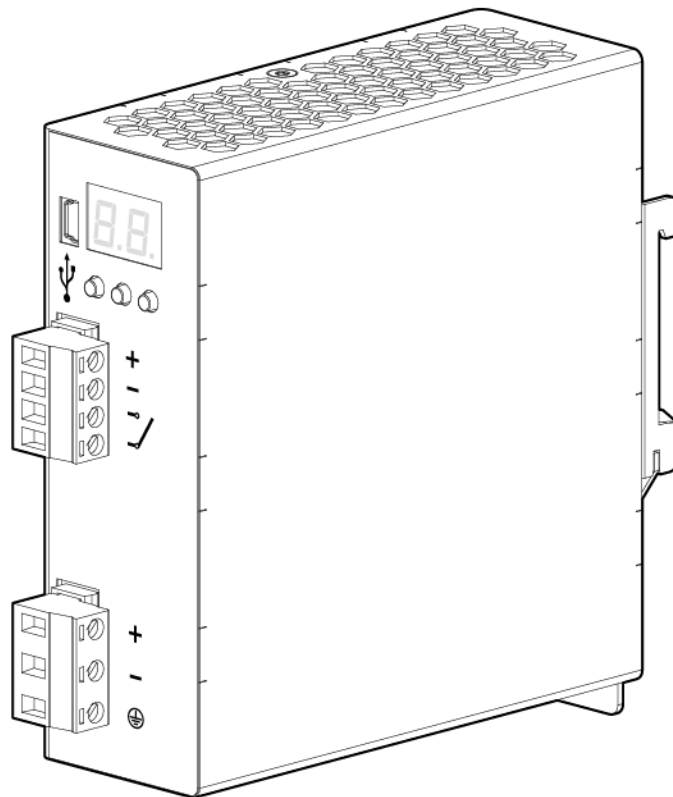

Figure 3 JL821A Aruba 4000i POE 240W DC-DC DIN PSU



The following sections show how to install and mount the switch. For more information contact your Aruba representative or Aruba authorized reseller.

Included Parts

The 4100i switch is shipped with the following components:

- Documentation kit
- JL817A does not include any accessory kit. The DIN mounting bracket is integrated to this switch.
- Accessory kit included in JL818A:
 - Two short mounting brackets for wall mount
 - Two long mounting brackets for 2-post rack mount
 - Four 16-mm M4 screws to the wall mount bracket to the wall
 - Four washers to be used together with M4 screws
 - Four wall anchors for wall mount
 - Eight countersunk head M4 screws to attach the mounting brackets to the switch
 - Four 5/8 inch number 12-24 screws to attach the switch to the rack
 - Four rubber feet
 - One cable tie
- Power cord: The following (part number or J-number/SKU) are orderable through Aruba purchasing. **(JL818A only)**

Argentina	8121-0729, J9891A
Australia/New Zealand	8121-0837, J9883A
Brazil	8121-1071, J9894A
Chile	8121-0735, J9886A
China	8121-0943, J9890A
Continental Europe/South Korea	8121-0731, J9885A
Denmark	8121-0733, J9888A
India	8121-0564, J9892A
NA Hi-Voltage (non-locking) C13 to NEMA 6-20	8120-3996, J9936A
PDU India-only	P09371-001, JL671A
Israel	8121-1004, J9899A

Japan	8121-1143, J9893A
Switzerland	8121-0738, J9898A
South Africa	8121-0737, J9897A
Taiwan	8121-0964 J9887A
Philippines/Thailand	8121-0734, J9895A
UK/Hong Kong/Singapore/Malaysia	8121-0739, J9884A
US/Canada/Mexico	8121-1141, J9896A
PDU NA/Japan/TW/Rest of World	142263-001, JL697A

製品には、同梱された電源コードをお使い下さい。
同梱された電源コードは、他の製品では使用出来ません。

Parts not included



If you have not already done so, order an Aruba rack mount kit for use with your 4100i switch.

Rack mounting your Aruba 4100i switch is supported using these rack mount kits:

- JL822A, Aruba 3U DIN-to-rack mounting kit for 2-post or 4-post racks (Ordered separately) for JL817A
- JL9583B, Aruba X414 1U Universal 4-Post Rack Mount Kit (Ordered separately) for JL818A

Installation Warnings

To help avoid personal injury or product damage when installing your switch, read the following installation precautions and guidelines.

(for JL817A)

-
- This equipment is supplied as “open type” equipment. It must be mounted within an enclosure that is suitably designed for those specific environmental conditions that will be present and appropriately designed to prevent personal injury resulting from accessibility to live parts. The enclosure must meet IP 54 or NEMA type 4 minimum enclosure rating standards.
 - Do not physically stack equipment on top of another.
 - For DIN-to-Rack installation, ensure minimum clearance:
 - Top: 1U 1.75 in. (44.5 mm)
 - Bottom: 1U 1.75 in. (44.5 mm)
 - Side: 1.0 in. (25.4 mm)
 - When mounted in an equipment cabinet, airflow around the switch must be unrestricted. To prevent overheating, ensure 40LFM of airflow with the following minimum clearances:
 - Top: 6.0 in. (152.4 mm)
 - Bottom: 3.0 in. (76.2 mm)
 - Front/ side: 1.0 in. (25.4 mm)
-



-
- Before working on equipment that is connected to power lines, remove all metallic wearables. (including rings, necklaces, and watches).
 - For installation in a restricted access location. Only trained and qualified personnel should be allowed to install, replace, or service this equipment.
 - Before performing any of the following procedures, ensure that power is removed from the DC circuit. Unit might have more than one power supply connection. All connections must be removed to de-energize the unit
 - JL817A is only intended for use with Aruba Ruggedized Power Supplies; use with other power supplies could cause serious electrical problems, including injury or death to personnel, and damage to the switch and other property.
-



-
- Surge protector is needed to achieve higher immunity level. Refer to the switch Datasheet for recommended surge protector model.
 - PSU derating applies to environmental temperature and input voltage.
 - Steel or stainless-steel DIN rail is recommended for dynamic stress installation. Aluminum DIN rail not recommended.
 - The device is designed to mount on a DIN rail that conforms to Standard EN60715.
-





-
- Before installing the switch, verify that the switch is operational by powering it on and observing the boot.
 - For 10/100/1000 ports, the cable length from a switch to an attached device cannot exceed 328 feet (100 meters).
 - Clearance to front and rear panels must meet these conditions:
 - Front-panel LEDs can be easily read.
 - Access to ports is sufficient for unrestricted cabling.
 - Front-panel direct current (DC) power connectors and the alarm connector are within reach of the connection to the DC power source.
-

(for JL818A)



-
- For rack mounting, do not physically stack equipment on top of another. Ensure an air gap of at least 2U. If only 1U or 1.75 in. (44.5 mm) of air gap is available, do not exceed 60 degrees Celsius (140 degrees Fahrenheit) ambient temperature.
 - For equipment cabinet (wall mount), airflow around the switch must be unrestricted. To prevent overheating, ensure 40LFM of airflow with the following minimum clearances:
 - Top: 6.0 inch (152.4 mm)
 - Bottom: 3.0 inch (76.2 mm)
 - Front / Sides: 1.0 inch (25.4 mm)
-

(for JL817A and JL818A)



-
- Do not mount the switch to any surface or in any orientation not supported in the installation instructions.
 - Mount devices installed in a rack or cabinet as low as possible. Put the heaviest devices at the bottom and progressively lighter devices positioned higher.
 - To prevent the rack or cabinet from becoming unstable and/or falling over, ensure that it is adequately secured.
-



-
- Do not work on the system or connect or disconnect cables during periods of lightning activity.
 - This equipment must be grounded. Never operate the equipment in the absence of a suitably installed ground conductor. Contact the appropriate electrical inspection authority or an electrician if you are uncertain that suitable grounding is available.
-



-
- If your installation requires a different power cord than the one supplied with the switch, be sure that the cord is adequately sized for the current switch requirements. In addition, be sure to use a power cord displaying the mark of the safety agency that defines the regulations for power cords in your country/region. The mark is your assurance that the power cord can be used safely with the switch. (JL818A only)
 - Do not ship any switch in a rack without checking for restrictions. Otherwise, you may void the switch warranty.
 - Ensure that the power source circuits are properly grounded. Then connect the switch to the power source by using the power cord supplied with the switch (JL818A) or via the wire terminals provided (JL817A).
 - When installing the switch, ensure that the AC outlet is near the switch. Make it easily accessible in case the switch must be powered off. (JL818A only)
 - Ensure that the power cord and network cables at the switch mounting location do not create a tripping hazard.
 - Do not install the switch in an environment where the operating ambient temperature exceeds its specification.
 - Ensure that the switch does not overload the power circuits, wiring, and over-current protection at your installation site. To determine the possibility of overloading the supply circuits, add the ampere ratings of all devices installed on the same circuit as the switch. Then compare the total with the rating limit for the circuit. The maximum ampere ratings are printed on the device near the AC power connector (JL818A) or on the power supply (JL817A).
 - Avoid blocking any ventilation openings on the sides, rear, or front of the switch.
 - Ensure that the air flow around the switch is not restricted. Leave at least 3 inches (7.6 cm) for cooling.
-

Installation Precautions and Guidelines

Review these environmental and enclosure guidelines before installation:



-
- Proper ESD protection is required whenever you handle Aruba equipment. Installation and maintenance personnel should be properly grounded by using ground straps to eliminate the risk of ESD damage to the switch. Do not touch connectors or pins on component boards. Do not touch circuit components inside the switch. When not in use, store the equipment in appropriate static-safe packaging.
 - When the switch is installed in an industrial enclosure, the temperature within the enclosure may be greater than normal room temperature outside the enclosure. Ensure temperatures inside the enclosure conform to device specifications detailed in Environmental Specifications.
-



-
- The switch meets the voltage dips and interruptions requirements of IEC 61850-3 only when powered by a redundant power supply configuration.
 - If you are responsible for the application of safety-related programmable electronic systems (PES), you need to be aware of the safety requirements in the application of the system and be trained in using the system.
 - For better EMC performance, it is suggested to use S/UTP or SF/UTP cables for copper Ethernet ports. Refer ISO/IEC11801 standard for details on S/UTP and SF/UTP.
-

Grounding the switch

To help avoid personal injury or product damage when installing your switch, read the following installation precautions and guidelines.



- This equipment must be grounded. Never defeat the ground conductor or operate the equipment in the absence of a suitably installed ground conductor. Contact the appropriate electrical inspection authority or a electrician if you are uncertain that suitable grounding is available.
- When installing or replacing the unit, the ground connection must always be made first and disconnected last.
- This equipment is intended to be grounded to comply with emission and immunity requirements. Ensure that the switch functional ground lug is connected to earth ground during normal use.



- To make sure that the equipment is reliably connected to earth ground, follow the grounding procedure instructions, and use a UL-listed ring terminal lug suitable for number 10-to-8 AWG wire.
- Use at least an 10 AWG (5.26 mm²) conductor to connect to the external grounding screw.

To ground the switch:

1. Locate the ground lug.
 - JL817A

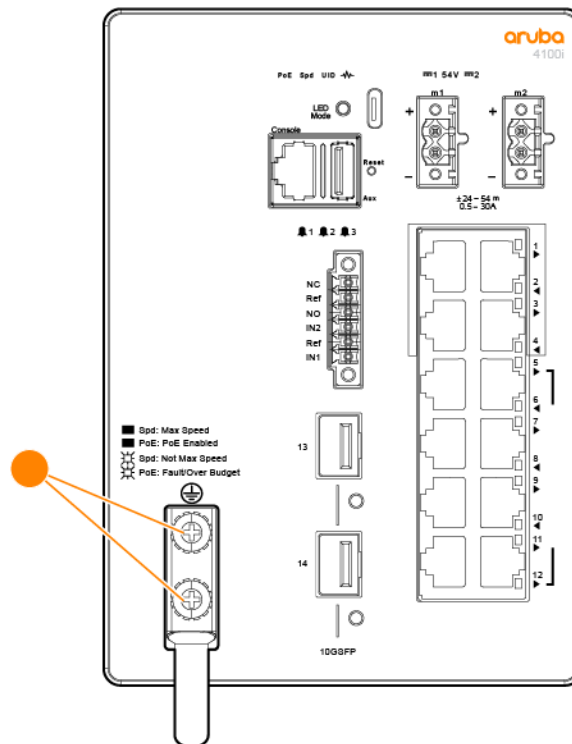

■ JL818A

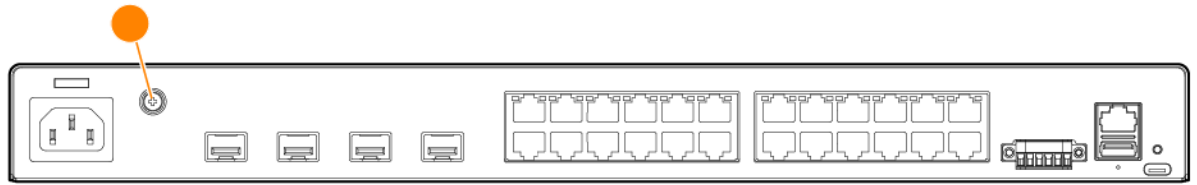

2. Use a Phillips screwdriver to remove the ground screw from the switch. Save the screws for later use.
3. Crimp and strip 7mm of the grounding wire.
4. Insert the grounding wire into the ring terminal lug, then crimp the terminal to the wire.
5. Slide the ground screw through the terminal.

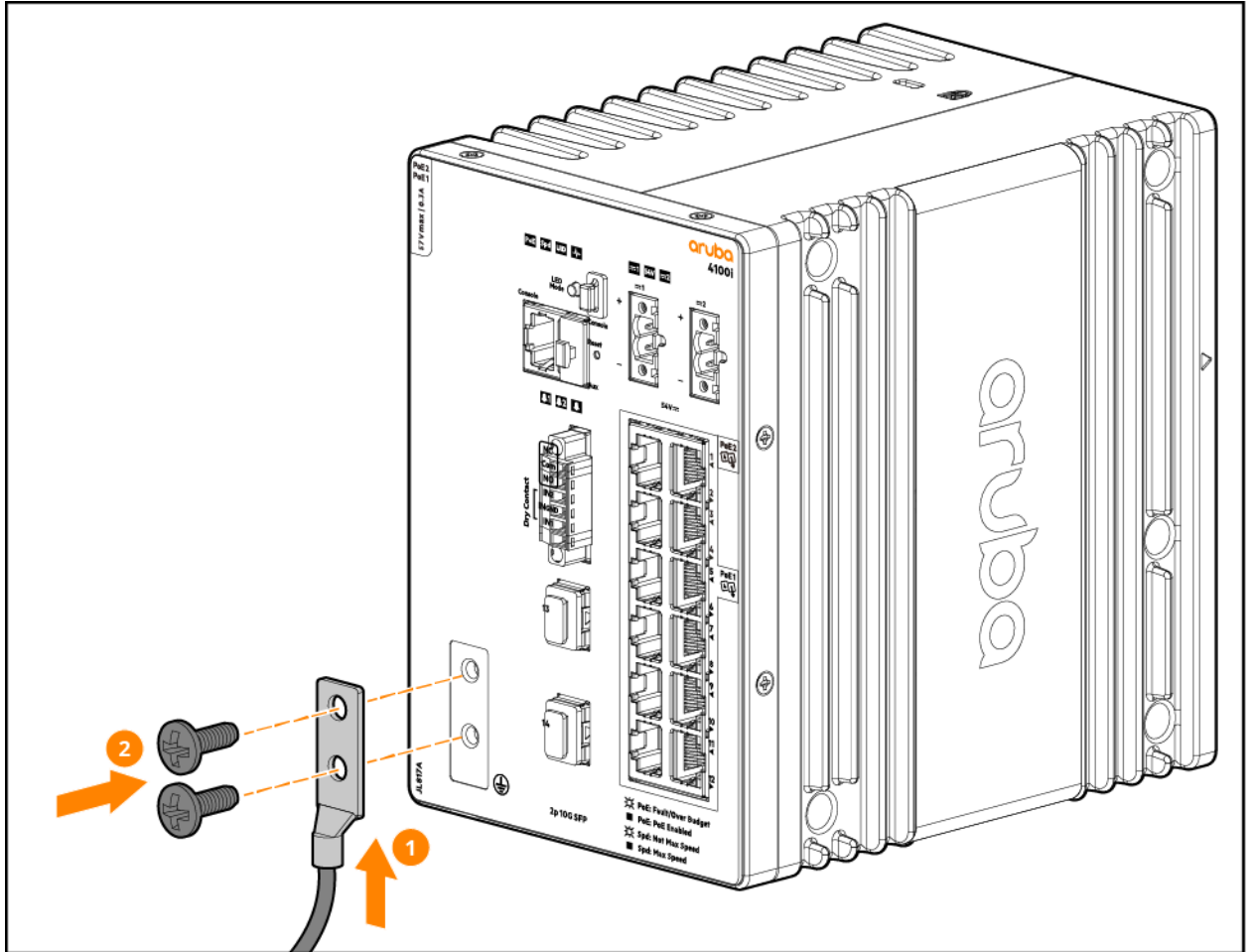

6. Insert the ground screw into the functional ground screw opening on the front panel.
7. Use a ratcheting torque screwdriver to tighten the ground screws and ring terminal to the switch front panel. The torque should not exceed 6 kg-cm (5.2 lb-in).
8. Attach the other end of the ground wire to an appropriate ground, such as a ground bus, a grounded DIN rail, or a grounded bare rack.

Installation Procedures for 12-port JL817A Switches

1. Prepare the Installation Site
2. Install power supplies
3. Power-on the switch and check LEDs
4. Power off the switch on page
5. Mount the switch on page
6. Install transceivers (optional)
7. Connect the switch to a power source
8. Setup for initial configuration

Prepare the Installation Site

Cabling Infrastructure: Ensure the cabling infrastructure meets the necessary network specifications.

Installation Location: Before installing the switch, plan its location and orientation relative to other devices and equipment:

- In the front of the switch, leave a minimum of 6 inches (15.24 cm) of space for the twisted-pair, fiber-optic, and power cabling.



To avoid personal injury or product damage, review [Installation Precautions and Guidelines on page 35](#) before starting the installation.

Installing the Power Supplies

JL818A



-
- The power supplies are built into units and must be installed in a cabinet or room (condensation free environment and indoor location) that is relatively free of conductive contaminants.
-

JL817A

Observe all warnings and guidelines prior to installing the power supply.

The JL817A must be installed with one of the following external power supplies:

Power Supplies	Dimensions	Weight
JL819A Aruba 4000i POE 240W AC DIN PSU	121 x 85 x 124.1 mm (4.76 x 3.35 x 4.86 inch)	0.96 kg (2.12 lb)
JL820A Aruba 4000i POE 480W AC DIN PSU	121 x 144 x 118.6 mm (4.76 x 5.67 x 4.67 inch)	1.37 kg (3.02 lb)
JL821A Aruba 4000i POE 240W DC-DC DIN PSU	40 x 115 x 110 mm (1.57 x 4.53 x 4.33 inch)	0.4 kg (0.88 lb)



-
- Always switch mains of input power OFF before connecting and disconnecting the input voltage to the unit. If the mains are not turned OFF, there is risk of explosion and/or severe damage.
 - To guarantee sufficient convection cooling, keep a distance of 50mm (1.97 inch) above and below the device as well as a lateral distance of 20mm (0.79 inch) to other units.
 - Note that the enclosure of the device can become very hot depending on the surrounding air temperature and load of the power supply. Do not touch to avoid burns.
 - Only plug in and unplug connectors when power is turned off.
 - Do not insert any objects into the unit.
 - Hazardous voltages may be present for up to 5 minutes after the input mains voltage is disconnected. Do not touch the unit during this time.
 - For used in a controlled environment.
-



-
- This equipment must be grounded. Never defeat the ground conductor or operate the equipment in the absence of a suitably installed ground conductor. Contact the appropriate electrical inspection authority or an electrician if you are uncertain that suitable grounding is available.
 - Before working on equipment that is connected to power lines, remove all metallic wearables (including rings, necklaces, and watches).
 - Only trained and qualified personnel should be allowed to install, replace, or service this equipment
 - Do not work on the system or connect or disconnect cables during periods of lightning activity.
 - Before performing any of the following procedures, ensure that power is removed from the DC circuit. Unit might have more than one power supply connection. All connections must be removed to de-energize the unit.
-



-
- Surge protector is needed to achieve higher immunity level.
 - PSU derating applies to environmental temperature and input voltage.
 - Steel or stainless-steel DIN rails are recommended for dynamic stress installation. Aluminum DIN rails are not recommended.
-

Mount the Power Supplies

The power supply unit can be mounted on 35mm DIN rails in accordance with EN60715. Observe all warning and cautions prior to installing the device(s).

- JL819A can be mounted either vertically or horizontally with input terminal at the bottom and at the left, respectively.

- Vertical

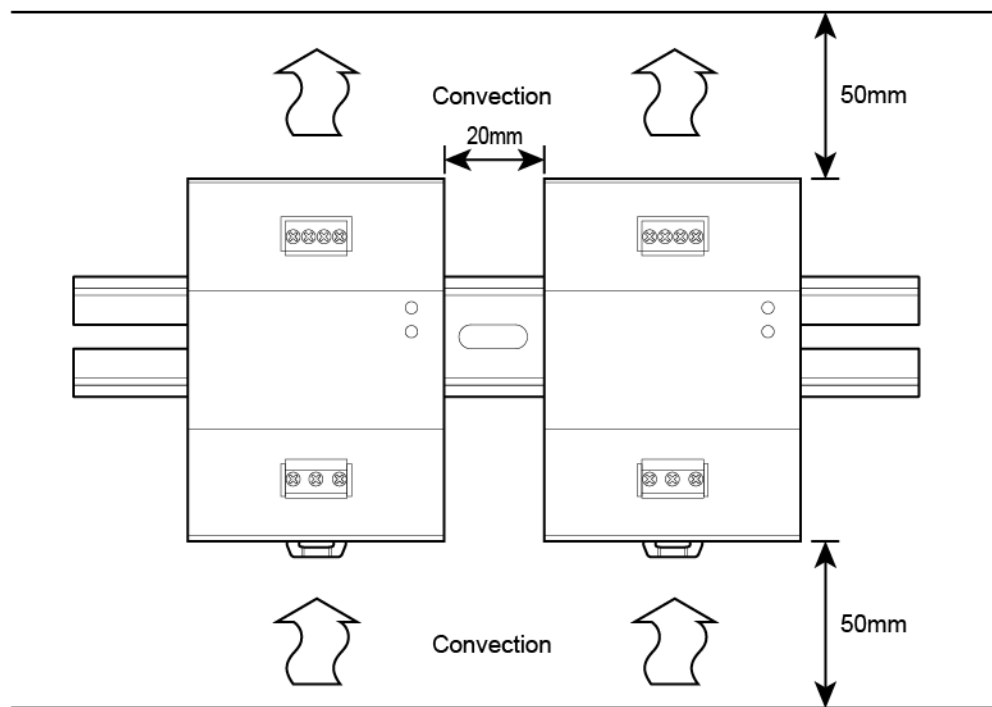

- Horizontal

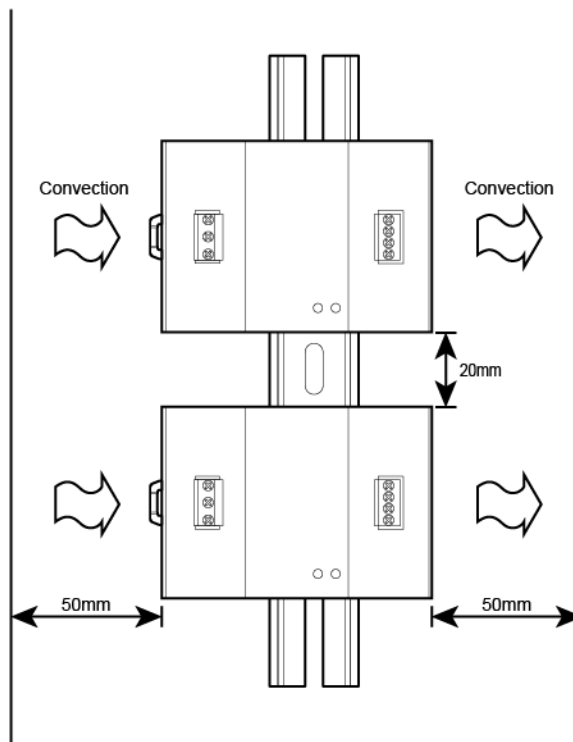

- JL820A can only be mounted vertically with the input terminal block on the left side.
- JL821A can only be mounted vertically with the input terminal block at the bottom.



Ensure suitable cooling by maintaining a proper distance between adjacent devices.

To mount the power supply:

1. Tilt the rear of the unit upwards and hook the bracket onto the DIN rail.
2. Slide the bottom of the switch forward until it clicks into place.

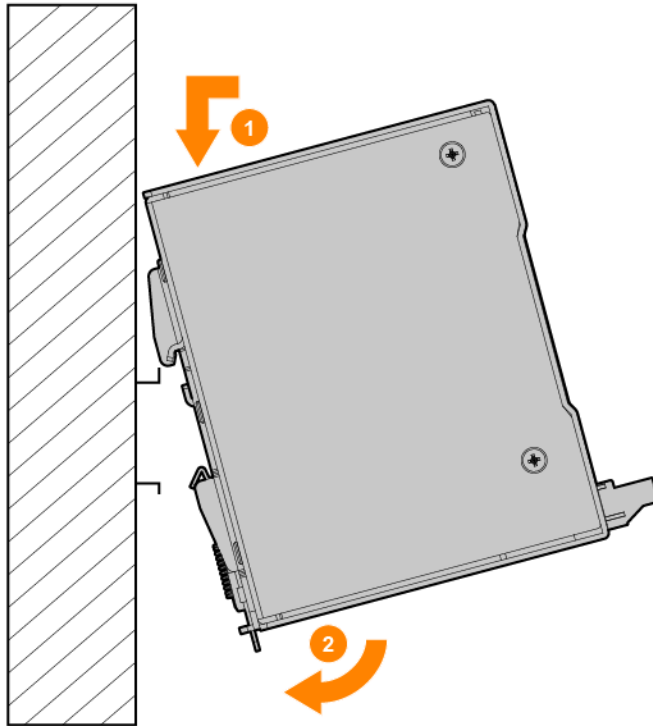

To dismantle the power supply:

1. Pull down the lever to release the latch.
2. Tilt the bottom of the unit upward.

3. Unhook the unit from the DIN rail.

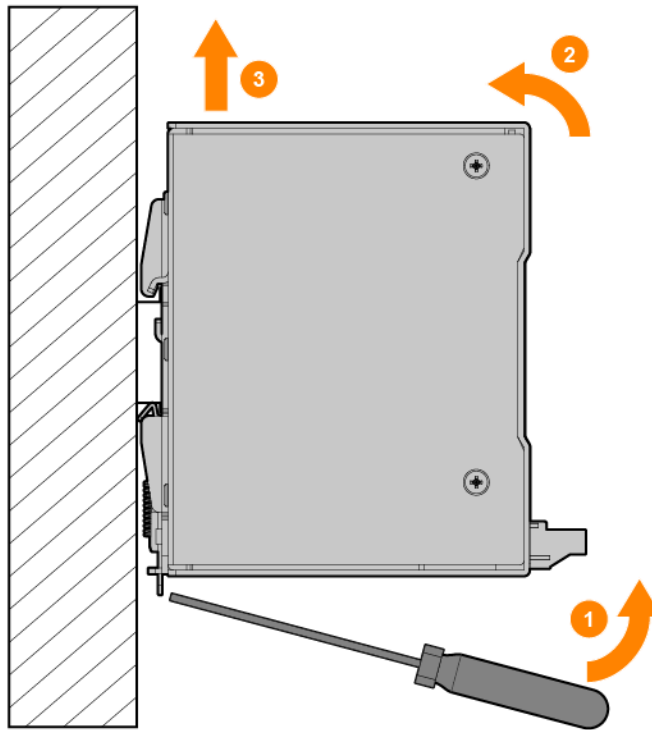

Connect and configure AC Power Supplies

JL819A

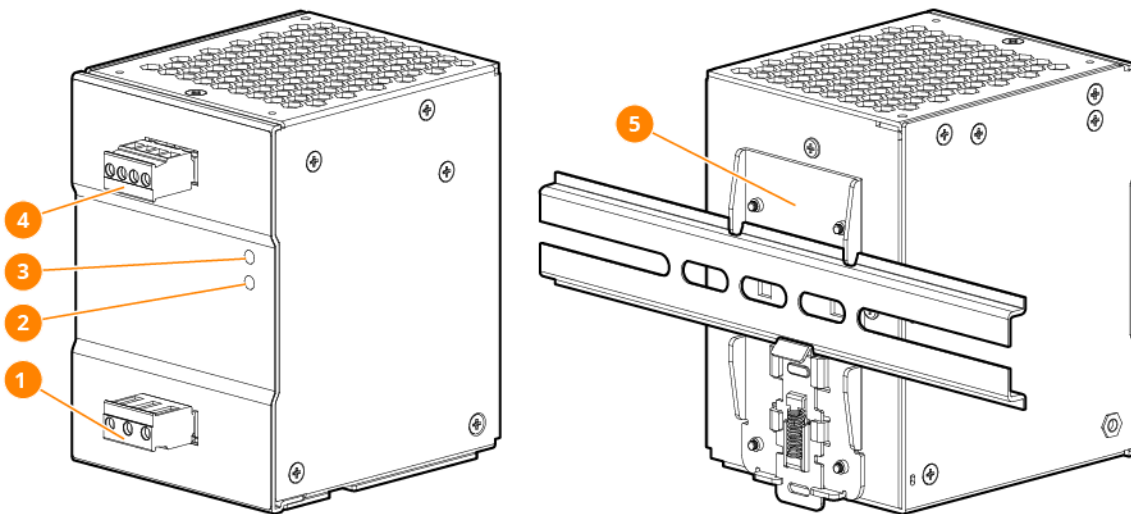

Item	Description
1	3 pin AC input connector
2	DC OK LED

Item	Description
3	DC voltage adjustment potentiometer
4	4 pin DC output connector
5	DIN rail mounting bracket

JL820A

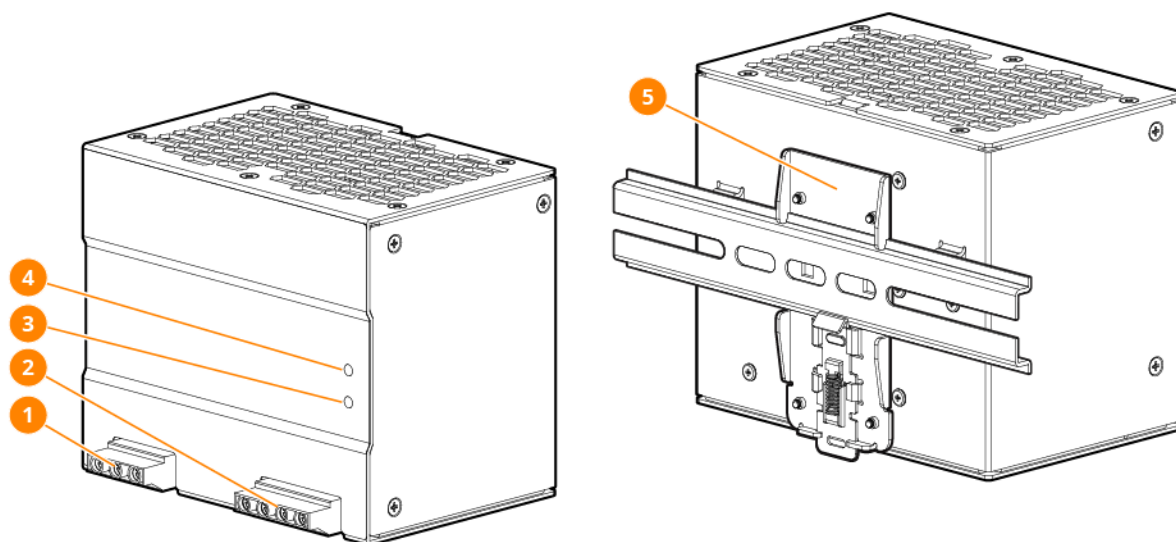

Item	Description
1	3 pin AC input connector
2	4 pin DC output connector
3	DC OK LED
4	DC voltage adjustment potentiometer
5	DIN rail mounting bracket

The terminal block connectors allow for easy and fast wiring. Use appropriate copper cables recommended for your switch.

- JL819A
 - Input range: AWG 16-12
 - Output: AWG 14, up to 2 meters
- JL820A
 - Input range: AWG 16-10
 - Output: AWG 14 AWG, up to 2 meters

To connect the power supply input:

Use L, N and PE connections of input terminal connector to establish the 100-240Vac connection.



The unit is protected with internal fuse (not replaceable) at L pin and it has been tested and approved on 20 (UL) and 16A (IEC) branch circuits without additional protection device. An external protection device is only required if the supplying branch has an ampacity greater than above.

1. Identify the wire location for N, L, and PE.

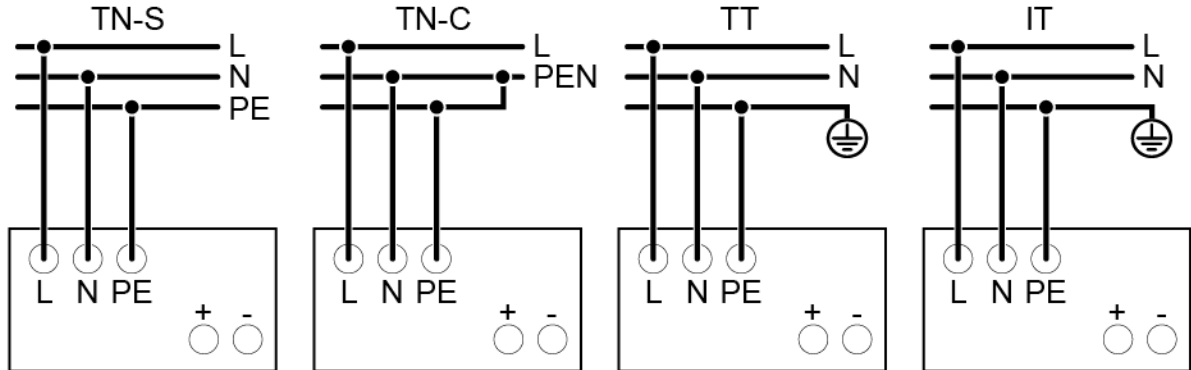

2. Using a wire stripping tool, strip each of the wires leaving 7 mm exposed.
3. Fully insert the wires into the connecting terminal block connectors.

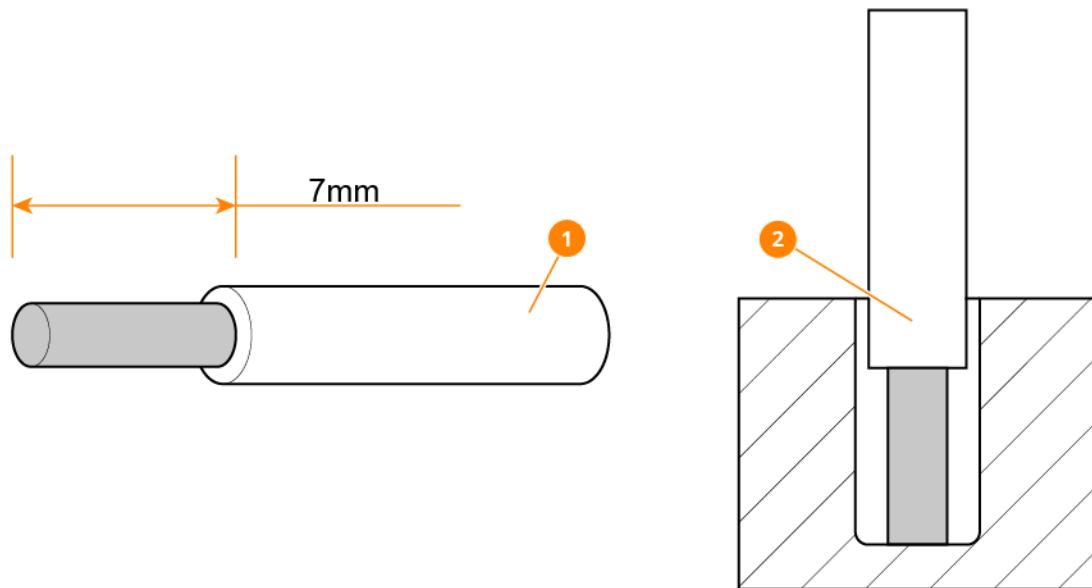

4. Using a ratcheting torque screwdriver, torque the terminal block connector captive screw to 4.67kg.cm (4.05lb in).

5. Plug the connector into the terminal block.

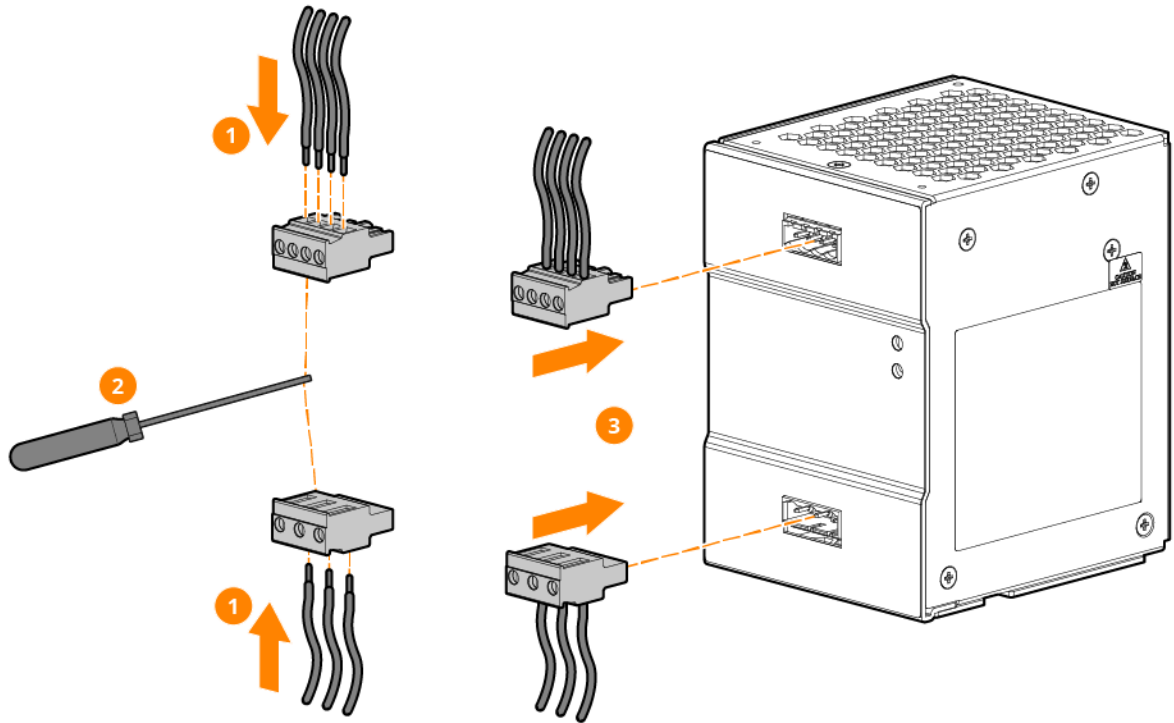

The wire must be secured to the connector and tightened before plugging into the terminal block connection.

To connect the power supply's output:

1. Use the "+" and "-" screw connections to establish the 54Vdc to the switch.

Redundancy operation

In order to ensure proper redundancy operation for the power supply unit (PSU), ensure that the output voltage difference between the two units is kept at 0.90~1.00V for 54V supplies.

Measure output voltage of PSU 1 and PSU 2. If PSU 1 is the primary unit, then V OUT of PSU 1 must be higher than PSU 2. In order to set the output voltage, connect the power supply to 50% load and set the PSU 1 and PSU 2 output voltage. Alternatively, adjust an extra 0.2V of output voltage difference between the two units at no load condition. Voltage difference during actual setup can be verified through Software command.

Connect and configure the DC power supply

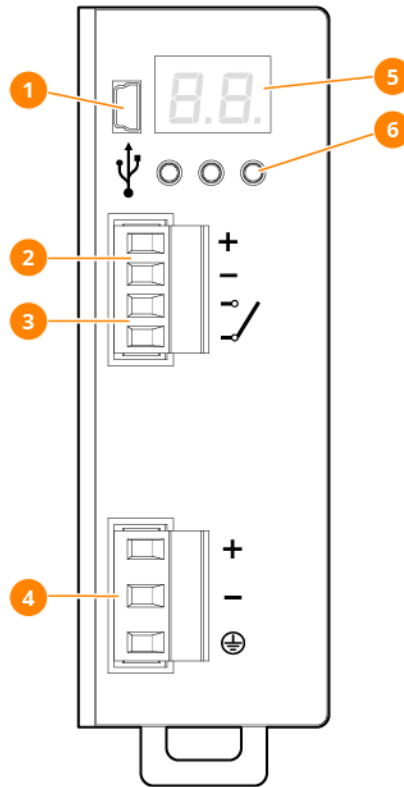

Item	Description
1	Modbus over USB: used to connect a device running POWERMASTER or custom user application. Firmware update is also possible.
2	DC Output: connected to the load. The output voltage is adjustable between 52 to 56 VDC.
3	DC-OK dry contact: normally open relay contact is available; the relay closes when the output voltage is >90% of the programmed output voltage value.
4	DC Input: input voltage supply, range is from 12 to 48 VDC.
5	Display: 2-digits LED display used to program the device and read its status.
6	Control keys: 3 push buttons are provided to navigate through menus and to select various functions.

Input connection	Output connection
<ul style="list-style-type: none"> ■ + = Positive DC ■ - = Negative DC ■ Earth ground symbol 	<ul style="list-style-type: none"> ■ + = Positive DC ■ - = Negative DC

Mini USB Type-B

- ID D+ D- +

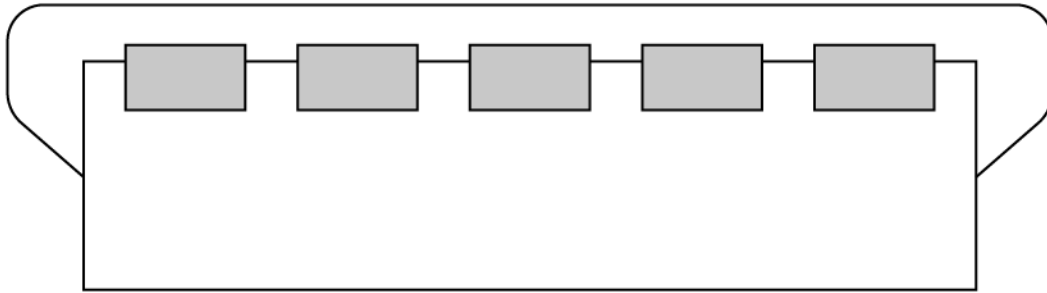

5 4 3 2 1

Mini USB-B type	Auxiliary Connection
<ul style="list-style-type: none">▪ 1 = VBUS (+5V)▪ 2 = Data (D-)▪ 3 = Data (D+)▪ 4 = Not connected (ID)▪ 5 = GND	<ul style="list-style-type: none">▪ No▪ Com

Wire connections

1. Using a wire stripping tool, strip each of the solid 12 AWG wires leaving 7 mm exposed.
2. Fully insert the wires into the connecting terminal block connectors.

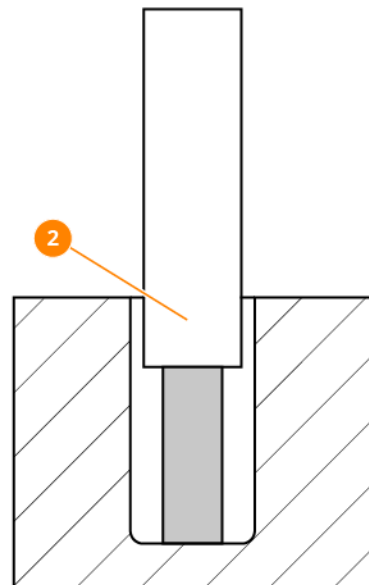
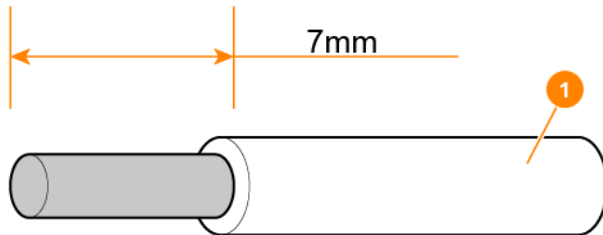

- Using a ratcheting torque screwdriver, torque the terminal block connector captive screw to 5.5 kg-cm (4.8 lb-in).

Power-on the switch and check LEDs

Prerequisites

The Aruba 4100i switch does not contain a power on/off switch. It is turned on by connecting the switch to an AC or DC power source. Check LEDs for proper switch operation. For further detail see [Checking the Switch LEDs on page 74](#)

Power off the switch



Always switch the mains input power OFF before connecting and disconnecting the input voltage to the unit. If mains are not turned off, there is a risk of explosion and/or severe damage.

Remove the power cord from the switch and from the power source.

Mount the Switch

The supported mounting options for the JL817A switch include:

- Rear mount
- Side mount



See [Installation Precautions and Guidelines on page 35](#) before mounting your switch.

When mounted in an equipment cabinet, airflow around the switch must be unrestricted. To prevent overheating, ensure 40LFM of airflow with the following minimum clearances:



- Top: 6.0 in. (152.4 mm)
 - Bottom: 3.0 in. (76.2 mm)
 - Front/ side: 1.0 in. (25.4 mm)
-

DIN Rail Mount Option

The switch is designed to be mounted onto DIN rails from the rear or the side. Attachment to DIN rail is for static mount only. For dynamic mount such as a railway application or an environment which has mild constant vibration, user should order the optional Side Bracket Enforcement Kit for rail mount enhancement. Side brackets are required for stabilizing the switch if installing in a non-stationary or extreme environment. (for rear-mount orientation only).

The switch is designed to mount on a DIN rail that conforms to Standard EN60715: TS 35mm x 7.5mm & TS 35mm x 15mm (Steel or Stainless Steel).

To mount the switch:

1. Attach the switch onto the DIN rail:
 - a. Hook the top of the bracket onto the DIN rail.

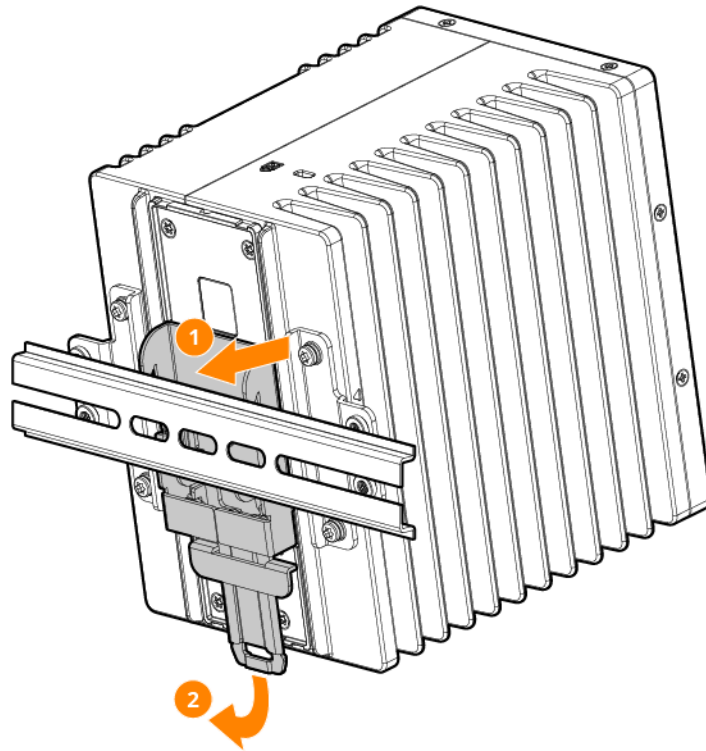

- b. Pull the metal tab using a flathead screwdriver (if needed), then hook the bottom of the switch onto the rail.

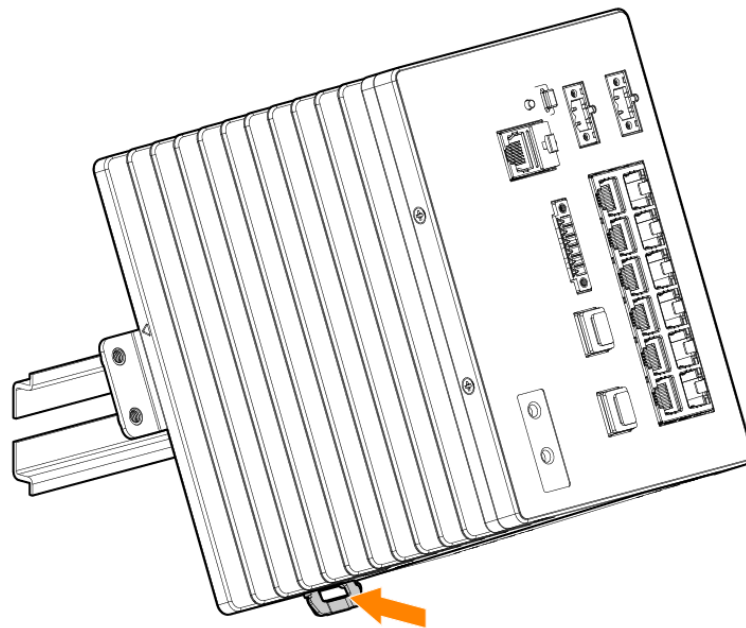

2. If needed, install the optional side enforcement brackets (5400-4042, not provided).

To mount the switch on its side:

1. Remove the Aruba cover on the side.

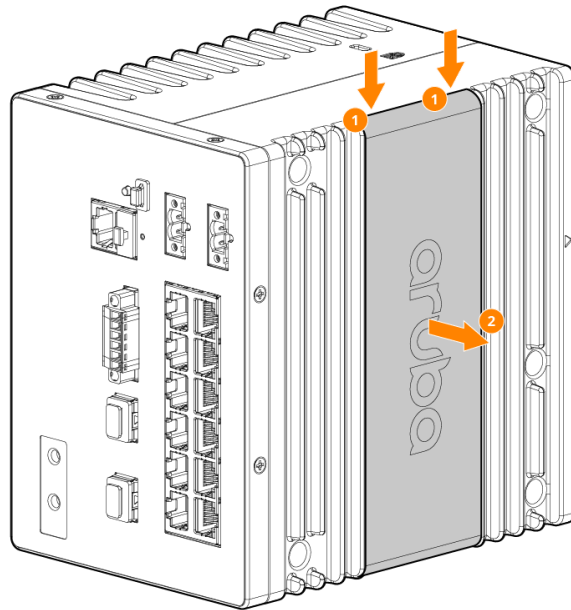

2. Remove the screws that secure the DIN bracket at the rear.

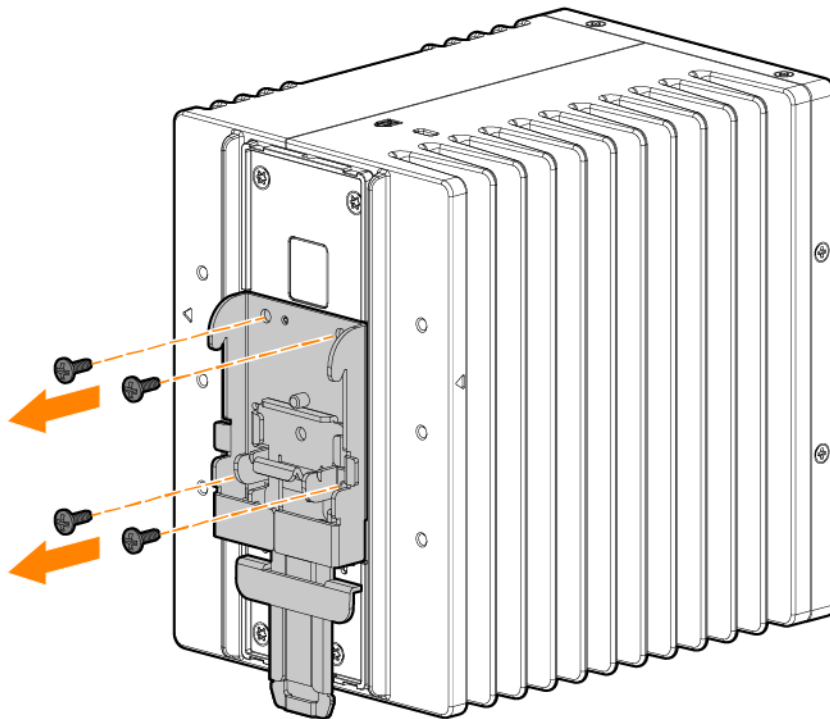

3. Transfer the DIN bracket to the side and secure with the screws removed in the previous step. Torque the screws to 7 kg-cm (6.1 lb-in).

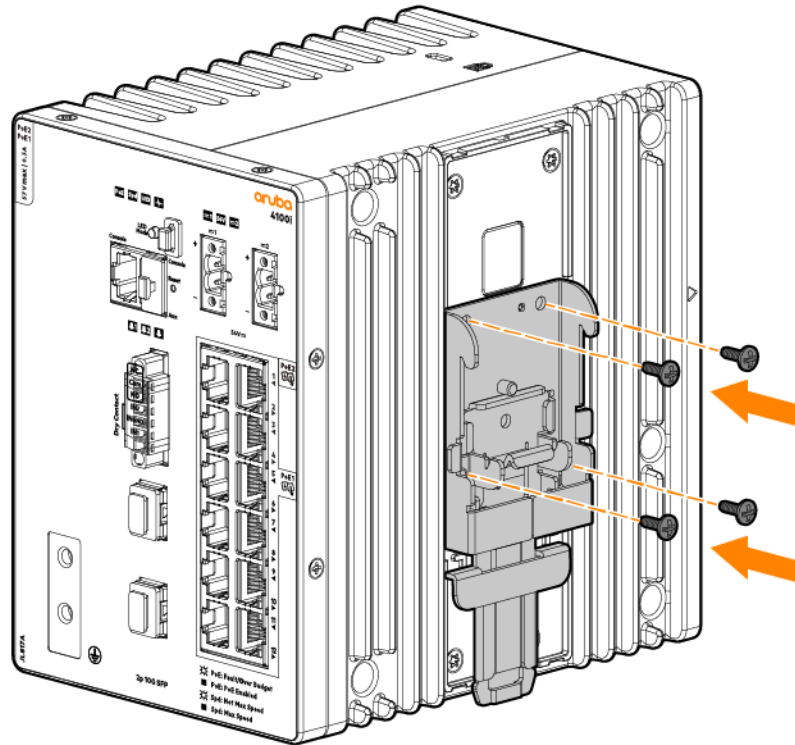

4. Snap the cover removed from step one onto the back panel.

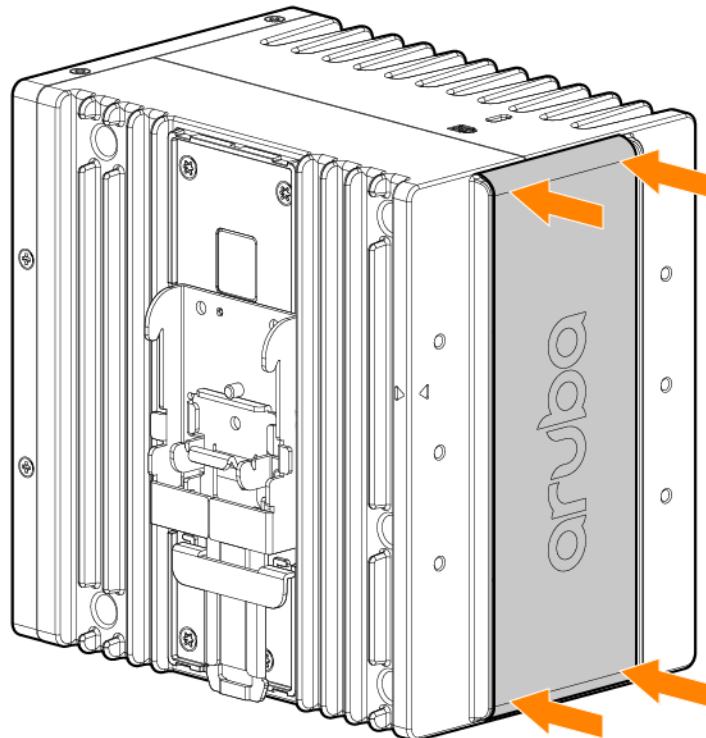

5. Attach the switch onto the DIN rail:
 - a. Hook the top of the bracket onto the DIN rail.
 - b. Pull the metal tab using a flathead screwdriver (if needed), then hook the bottom of the switch onto the rail.

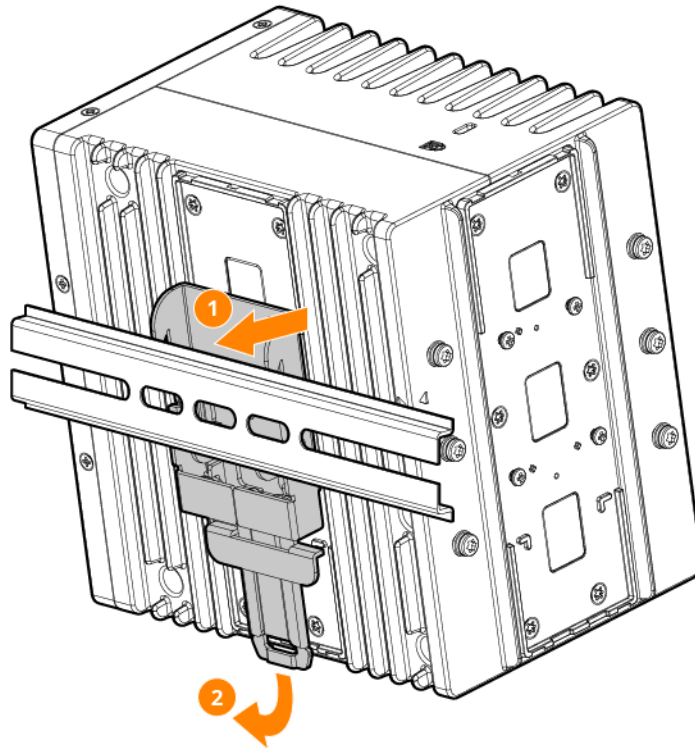

For safe operation, review the mounting precautions in [Installation Precautions and Guidelines](#), before mounting a switch.



For safe and reliable installation, use the screws that are provided .

(For JL817A, JL819A, JL820A & JL821A)



If installing in an equipment cabinet wall, ensure there is 6 inches of clearance from the top of the cabinet and is 1 inch apart from other devices.

If installing in a rack, ensure there is 1U spacing from the top/bottom equipment and 1 inch apart from other devices.

DIN-to-rack Mount Option

The switch is designed to be mounted in any EIA-standard 19-inch telco rack or communication equipment cabinet using the optional 3U DIN-to-rack mount bracket (JL822A).



For safe operation, please review the mounting precautions in [Installation Precautions and Guidelines](#), before mounting a switch.



This bracket is designed as an auxiliary tool for installing JL817A to a 19" rack cabinet. For constant or more severe vibration and shock condition, an additional reinforcement fixture, such as a tray or auxiliary support is needed to enhance the installation. For more information about enhancement kits, contact your rack cabinet manufacturer.

1. Ensure the DIN rail is at the same level as the rack.



The mounting brackets have multiple mounting holes and can be rotated. Attach the bracket in an upright position.

2. Secure the bracket with screws (not provided) based on the sequence shown below. Remove the four break-off tabs for cabling as needed.

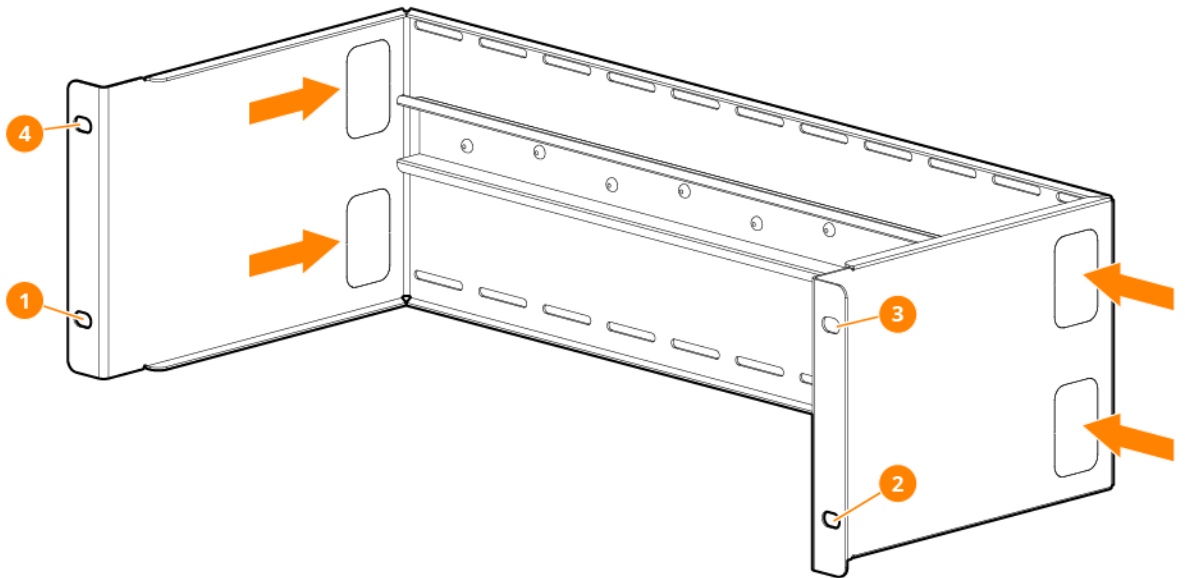

3. Predetermine the orientation of the switch in the rack, front facing or side facing, then attach the switch to the DIN rail.

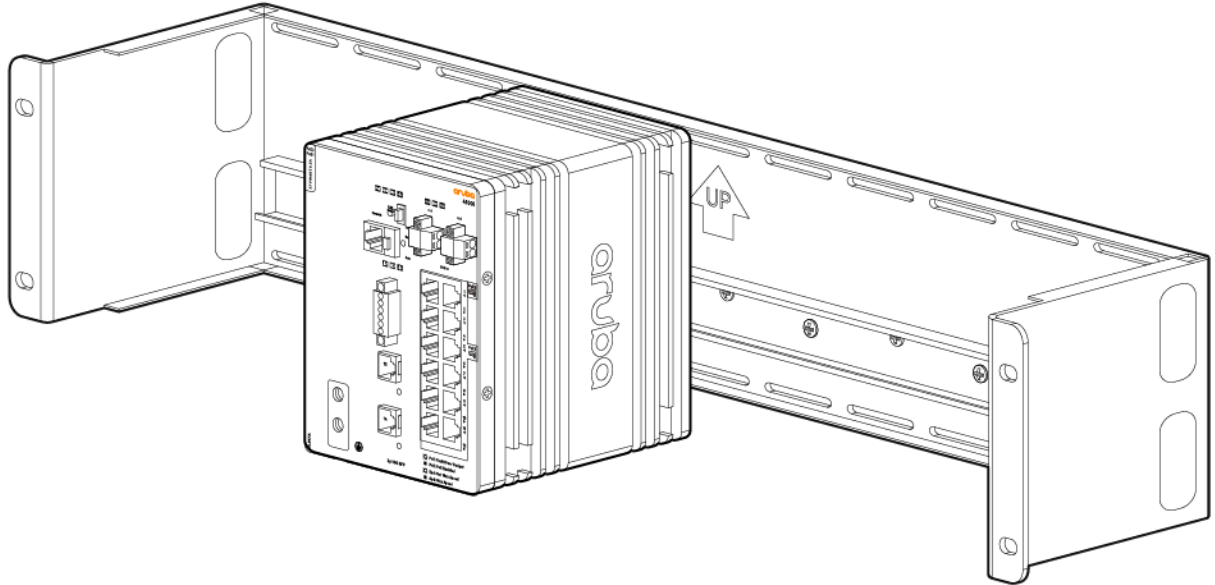

Aruba Side Enforcement Bracket Kit for Aruba Switches (optional)

The optional Aruba side enforcement bracket kit (5400-4042) is used to stabilize supported switches in extreme environments, such as railway applications. This side enforcement bracket kit reinforces the mounting solution and supports the device mounted to the DIN rail. This bracket is designed for constant or more severe vibration and shock conditions. For rear mount orientation only.



The illustrations may not match your particular switch model.

Kit Contents:

- Clip assembly: Out-bracket (2), In-bracket (2), Pre-installed screws (4)
- T-bracket (2)
- Screws with washers (4)

To install the side enforcement bracket kit:

1. Remove the existing six screws in the rear panel with a T-20 torx screwdriver.

2. Attach the T-bracket to the switch and secure with the screws removed from step one. Torque the screws down to 12 kg-cm (10.4 lb-in).

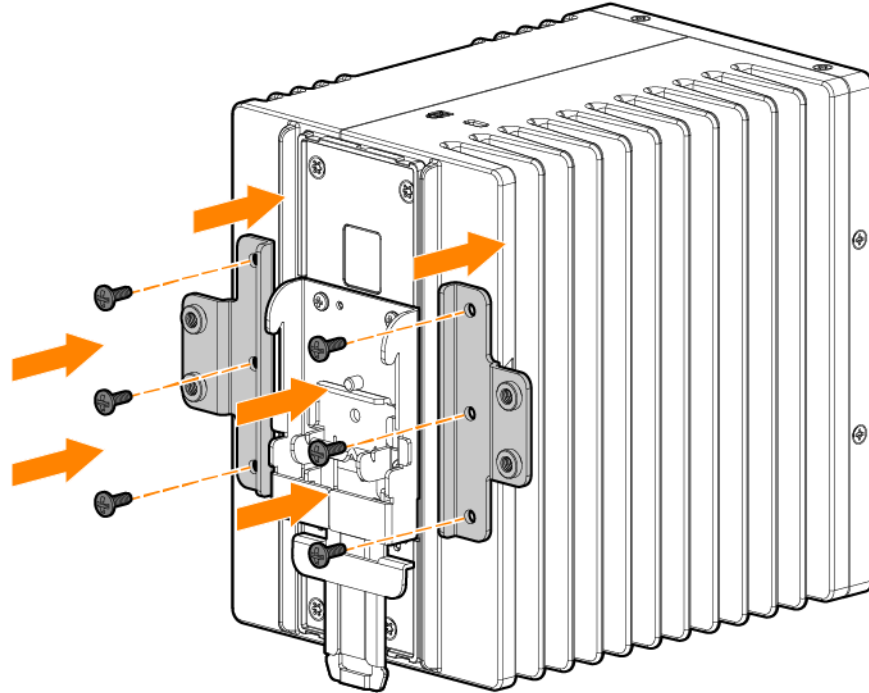

3. Attach the switch to the DIN rail:
 - a. Hook the top of the rear bracket onto the DIN rail.
 - b. Pull the metal tab using a flathead screwdriver (if needed) then hook the bottom of the switch onto the rail.

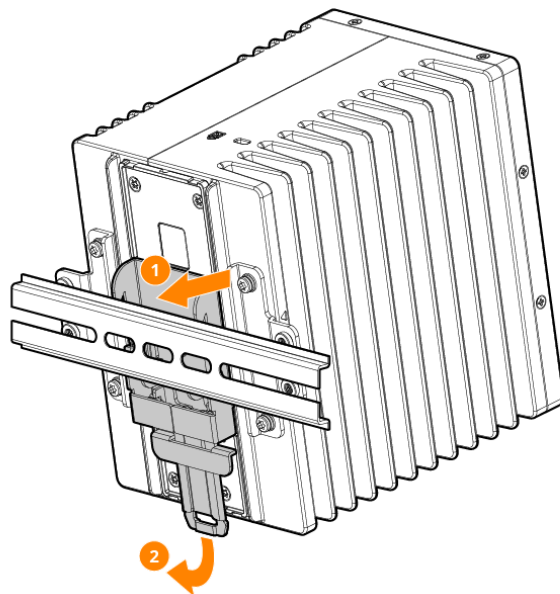

4. Loosen the two screws labeled 3 on each of the clip assembly.

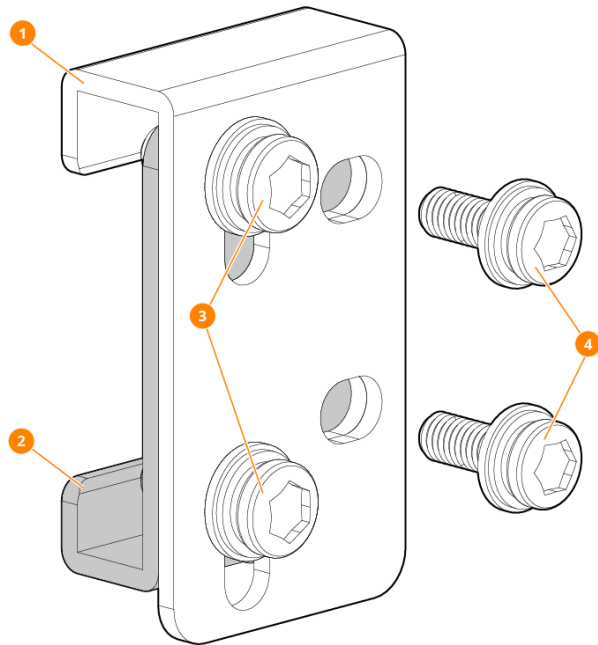

1. Attach the clip assembly to the T-bracket and rail:
 - a. Install the clip onto the bracket and rail from the top position.

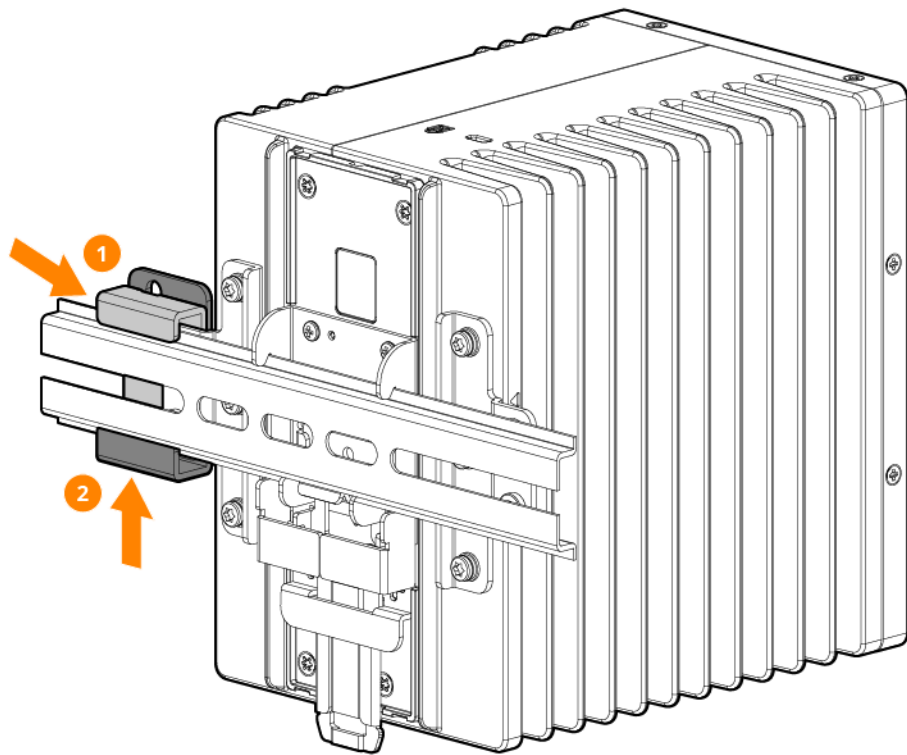

- b. Push the clip up from the bottom to get a tight fit.

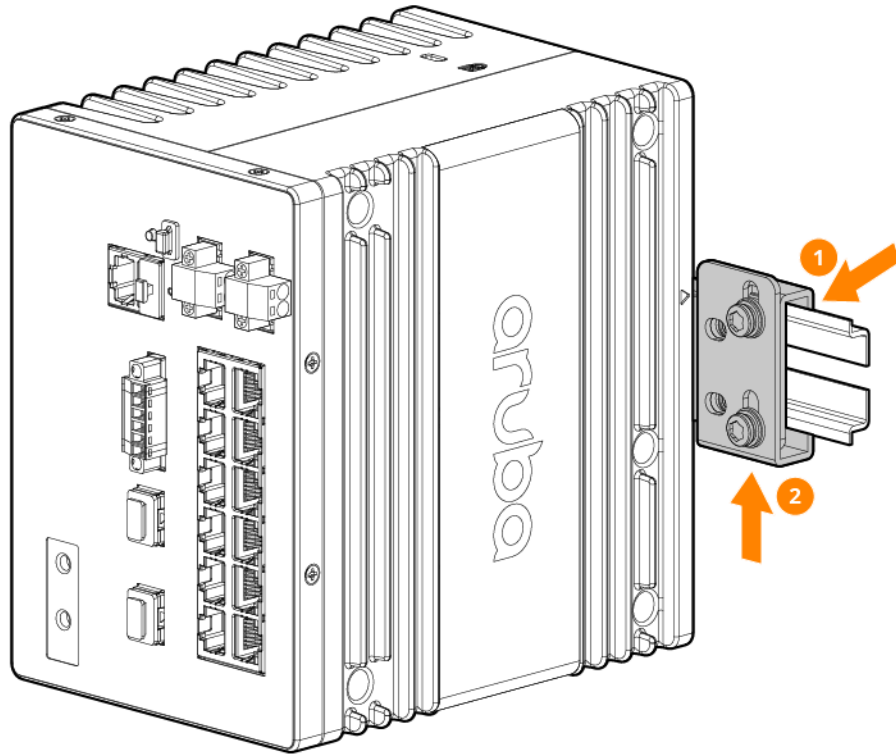

2. Using a T-20 torx screw driver, secure the clip by first installing the inner two screws, then the outer screws. Torque the inner screws to 21 kg-cm (18.2 lb-in) and the outer screws to 17 kg-cm (14.8 lb-in).

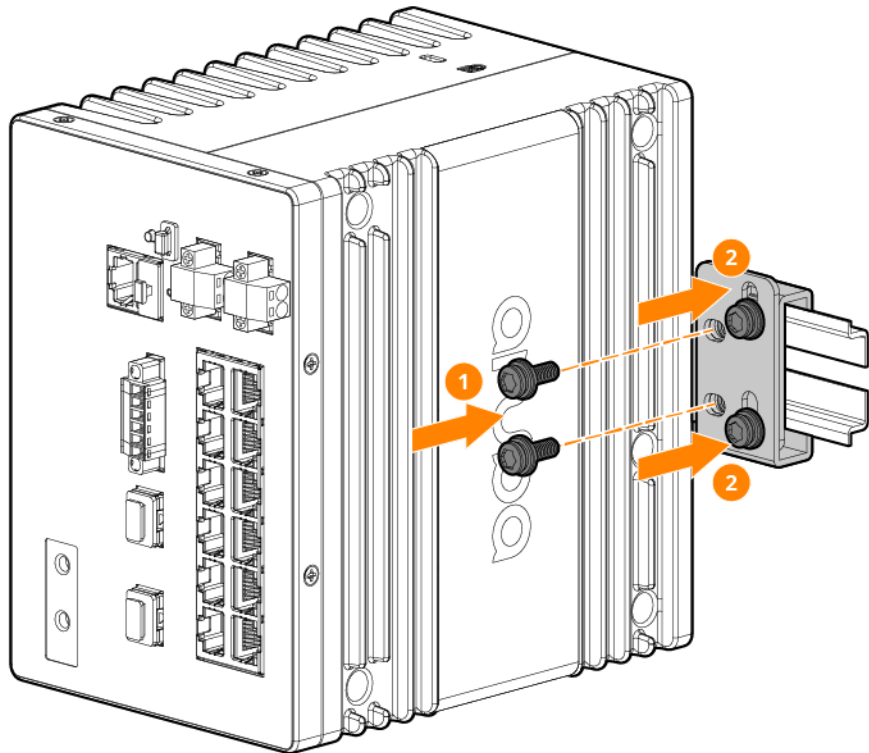

3. Repeat the assembly procedure on the other side of the switch.

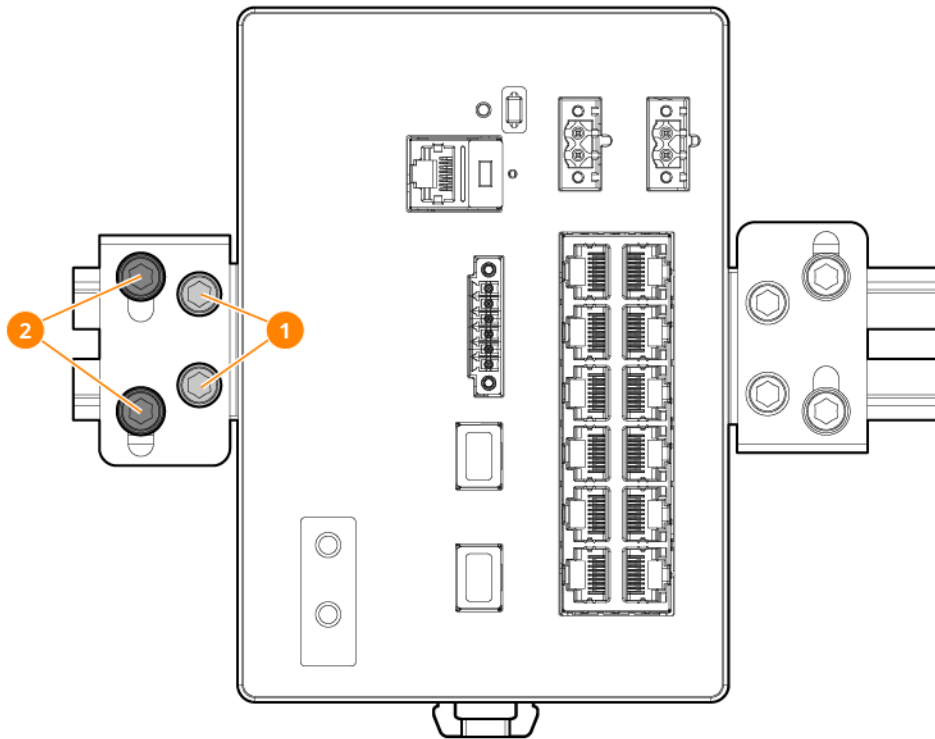

User Configurable PoE Power Budget

JL817A supported Standby Redundancy (Power ORing) but not Active Redundancy (Current Sharing). If two different external power supply units are used concurrently, the PoE Power Budget must be set with respect to the power supply with the lower power rating. Refer to *4100i Switch Series datasheet* for the PoE power budget for each External Power Supply, with derating applied.

Example: If JL820A and JL819A PSUs are used concurrently, PoE Power Budget must be set according to JL819A.

To configure the PoE budget, refer to the following CLI commands.

poe-power

```
poe-power <power-in-watts>  
no poe-power
```

Description

Configures the PoE power for the system. Supported only in ruggedized platforms which do not have capability to read PSU type and capacity. Software will validate the power given by the user is within the maximum limit supported by the platform. But the actual power values differs between PSU types and also based on the thermal derating. Onus is on the user to confirm the PoE power entered is within the specified operating limit for the connected PSU and its operating condition. The `no` form of this command removes the specified configuration.

Parameters

`power-in-watts`

Specifies the PoE budget number. Error text when the PoE power exceeds maximum limit for the platform or lower than zero.

Examples

Successful configurations with PoE budget specified:

```
switch(config)# poe-power
    Power PoE Power in watts
switch(config)# poe-power 350
See the documentation before configuring PoE power.

Do you want to continue (yes/no)? yes
switch(config)#
```

Failed configurations:

```
switch(config)# poe-power 700
Invalid power value.
Valid range is from 0 to 360.
```

Configurations with "no" commands:

```
switch(config)# no poe-power
```

```
switch(config)# no no-poe-power 300
The input value does not match the currently configured value.
```

```
switch(config)# no poe-power 350
```

Command History

10.08 Featured introduced.

Command Information

4100i config Administrators or local user group members with execution rights for this command.

show power-over-ethernet

```
show power-over-ethernet [member <MEMBER-ID>] [brief]
```

Description

Displays the status information of the full system. Displays the brief status of all port or given port if parameter brief is used. Displays the detailed status of given port.

<MEMBER-ID> Displays the detailed status of given member.
<IFNAME> Display the detailed status of given port.
brief Display the brief status of all ports or the given port.

Examples

Showing sample output for show power-over-ethernet :

```
switch# show power-over-ethernet

System Power Status

PoE Power Status           : No redundancy
Operational Power Status   : No redundancy
Total Available Power      : 360 W
Total Configured Power     : 0 W
Total Failover Pwr Avl    : 0 W
Total Redundancy Power     : 0 W
Total Power Drawn         : 0 W
Total Power Reserved       : 0 W
Total Remaining Power      : 360 W
Trap Threshold             : 80 %
Trap Enabled               : Yes
Always-on PoE Enabled     : 1/1
Quick PoE Enabled         : None
```

```
Internal Power

PS      Total Power      Status
-----
1/1     0                 Ok
1/2     0                 Absent
```

Showing sample output for power-over-ethernet brief per-port:

```
switch# show power-over-ethernet 1/1/1 brief

Status and Configuration Information for port 1/1/1

Member 1Power Status
  Available: 370 W Reserved: 55.60 W Remaining: 314.40 W
  Always-on PoE Enabled: 1/1
```

PoE Port	Pwr En	Power Priority	Pre-std Detect	Alloc Act	PSE Pwr Rsrvd	PD Pwr Draw	PoE Port Status	PD Sign	Cls	Type
1/1/1	Yes	Low	Off	Class	0.0 W	0.0 W	Denied	None	4	2

Showing sample output for power-over-ethernet brief for interface range:

```
switch# show power-over-ethernet 1/1/1-1/1/2 brief

Status and Configuration Information for port 1/1/1-1/1/2

Member 1Power Status
  Available: 370 W Reserved: 55.60 W Remaining: 314.40 W
  Always-on PoE Enabled: 1/1
```

PoE Port	Pwr En	Power Priority	Pre-std Detect	Alloc Act	PSE Pwr Rsrvd	PD Pwr Draw	PoE Port Status	PD Sign	Cls	Type
1/1/1	Yes	Low	Off	Class	0.0 W	0.0 W	Denied	None	4	2
1/1/2	Yes	Critical	Off	Usage	1.6 W	1.5 W	Delivering*	Single	0	1

Showing sample output for power-over-ethernet brief for interface range:

```
switch# show power-over-ethernet 1/1/1-1/1/2 brief
```

```
Status and Configuration Information for port 1/1/1-1/1/2
```

```
Power Status
```

```
Available: 360 W Reserved: 0.00 W Remaining: 360.00 W
```

```
Always-on PoE Enabled: 1/1
```

```
Quick PoE Enabled: None
```

PoE Port	Pwr En	Power Priority	Pre-std Detect	Alloc Act	PSE Pwr Rsrvd	PD Pwr Draw	PoE Port Status	PD Sign	Cls	Type
1/1/1	Yes	Low	Off	Usage	0.0 W	0.0 W	Searching	N/A	N/A	N/A
1/1/2	Yes	Low	Off	Usage	0.6 W	0.0 W	Searching	N/A	N/A	N/A

Showing sample output for power-over-ethernet for a missing line card:

```
switch# show power-over-ethernet 1/3 brief
```

```
Module 1/3 is not physically present.
```

Showing sample output for power-over-ethernet port when physical interface is not present:

```
switch# show power-over-ethernet 2/1/1
```

```
Interface 2/1/1 is not present.
```

Command History

10.07 or earlier

--

Command Information

4100i

Operator (>) or Manager (#)

Operators or Administrators or local user group members with execution rights for this command. Operators can execute this command from the operator context (>) only.

Installation Procedures for 24-port JL818A Switches

1. Prepare the installation site
2. Power-on the switch and check LEDs
3. Power off the switch
4. Mount the switch
5. Install transceivers (optional)
6. Connect the switch to a power source
7. Setup for initial configuration

Prepare the Installation Site

Cabling Infrastructure: Ensure the cabling infrastructure meets the necessary network specifications.

Installation Location: Before installing the switch, plan its location and orientation relative to other devices and equipment.

- In the front of the switch, leave a minimum of 6 inches (15.24 cm) of space for the twisted-pair, fiber-optic cabling and power cord.



To avoid personal injury or product damage, review [Installation Precautions and Guidelines on page 35](#) before starting the installation.

Horizontal and Wall Mount Option

The switch can be mounted on a wall or a horizontal surface.

To install the switch on a tabletop or a horizontal surface:

1. Attach the rubber feet to the square marks as shown.

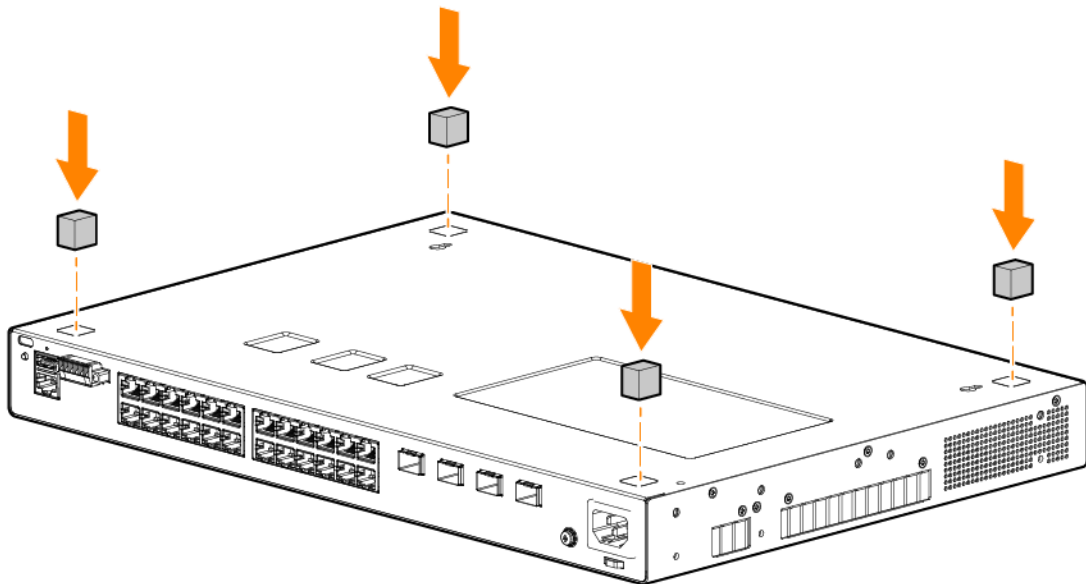

2. Place the unit onto a tabletop or a horizontal surface.

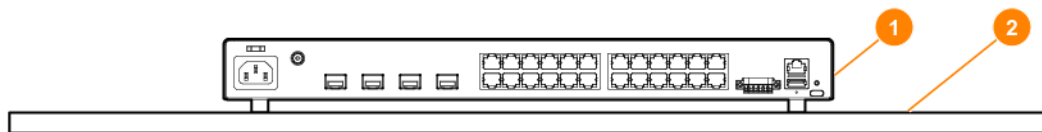

Attaching the four rubber feet to the bottom of the switch is required to provide adequate air cooling between the switch bottom and the horizontal surface.



Use a sturdy surface in an uncluttered area. Ensure that the power cord and network cables at switch mounting location will not create a tripping hazard.



Nothing should be placed on top of the switch. Ensure there is adequate ventilation spacing around the switch, at least 3 inches at the top, and 1 inch at the sides and rear.



For safe operation, review the mounting precautions in [Installation Precautions and Guidelines](#), before mounting a switch.

To install the switch onto a wall:



If installing in an equipment cabinet wall, ensure there is 6 inches of clearance to the top of the cabinet, 3 inches at the bottom and 1 inch apart from other devices.

1. Remove the pre-installed flat head screws and do not reuse. Attach the wall mount bracket to the switch and secure with the 8mm M4 screws provided.

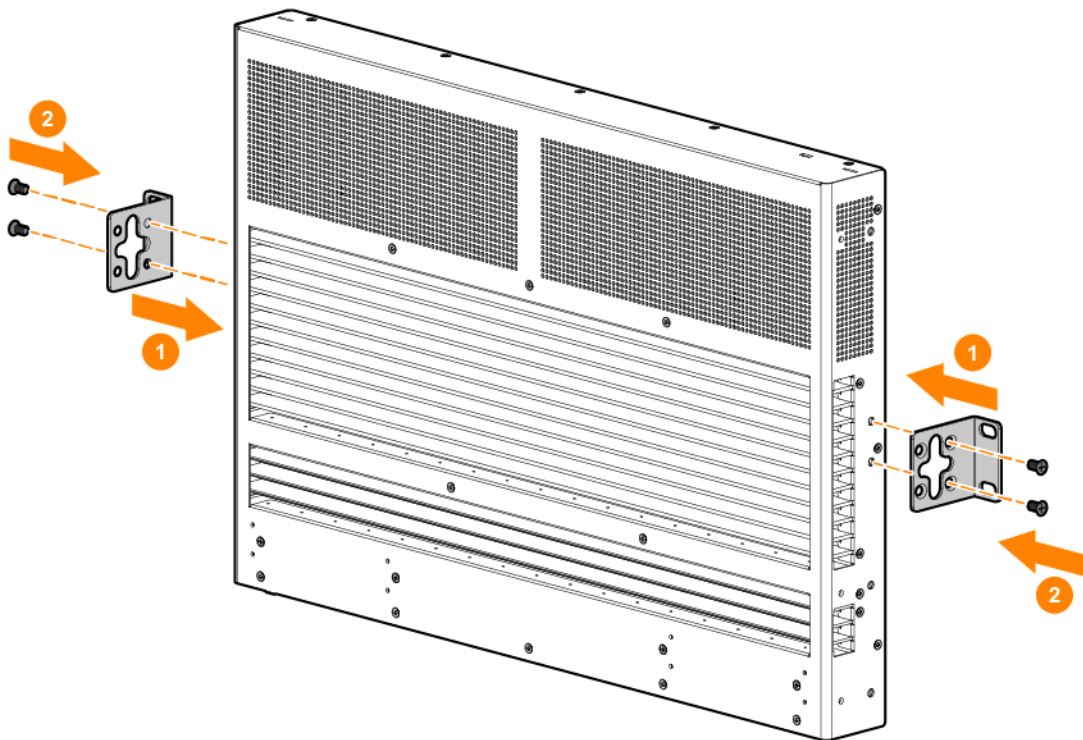

2. Secure the wall anchors to the wall and install the countersunk head M4 screws and washers.

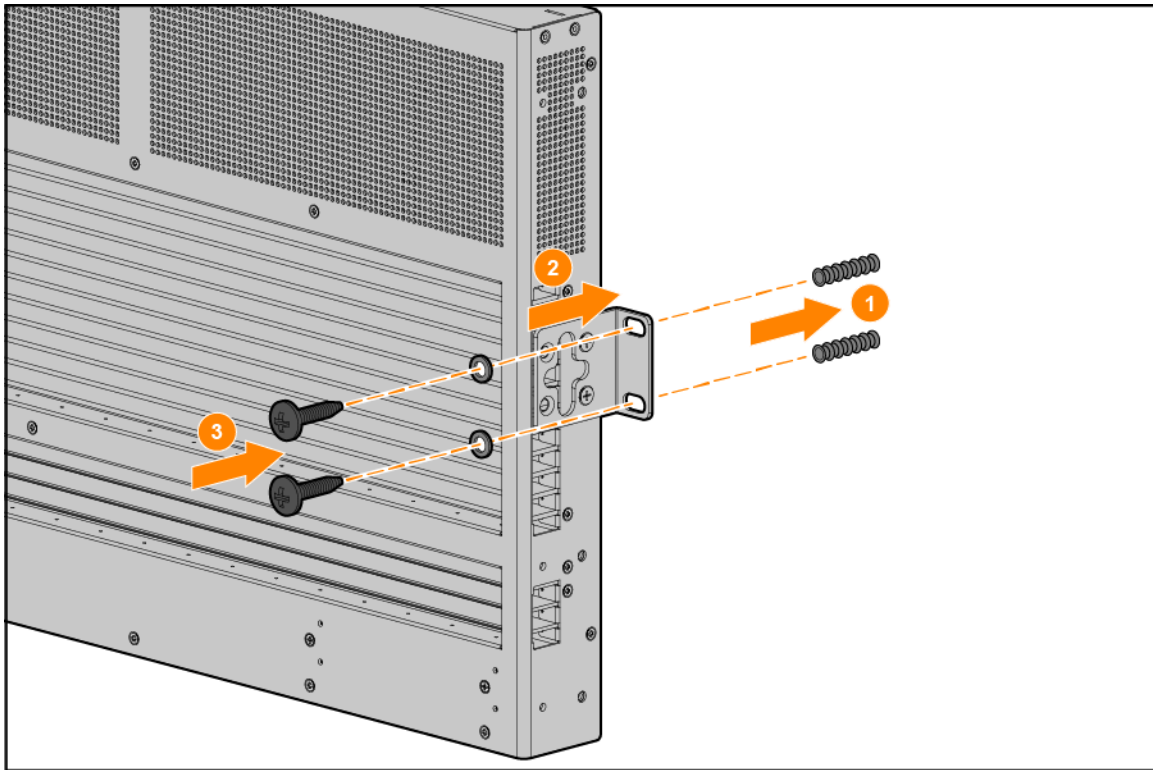

3. Ensure that the ports are facing down.



Supported walls: Concrete (cemented) or Plywood $\frac{3}{4}$ " thick.



JL818A can only be wall mounted with the ports facing downward.

Two-post Rack Mount Option

The switch is designed to be mounted in any EIA-standard 19-inch telco rack or communication equipment cabinet using the rack mount bracket.



For safe operation, please review the mounting precautions in [Installation Precautions and Guidelines](#), before mounting a switch.



For rack mounting, do not physically stack equipment on top of another. Ensure an air gap of at least 2U. If only 1U or 1.75 in. (44.5 mm) of air gap is available, do not exceed 60 degrees Celsius (140 degrees Fahrenheit) ambient temperature.



The 12-24 screws supplied with the two-post rack mount kit are the correct threading for standard EIA/TIA open 19-inch racks. If installing the switch in an equipment cabinet such as a server cabinet, use the clips and screws that came with the cabinet in place of the 12-24 screws that are supplied with the two-post rack mount kit.

Complete step 1, and plan which four holes you will be using in the cabinet and install all four clips. Then proceed to step 2.

1. Remove the pre-installed flat head screws and do not reuse. Use a Phillip's screwdriver and attach the mounting brackets to the switch with the included 8mm M4 screws.

The brackets can be attached in the front position (front of switch, port side, is flush with front of rack or extension).

Figure 1 Attaching two-post mounting brackets to the switch

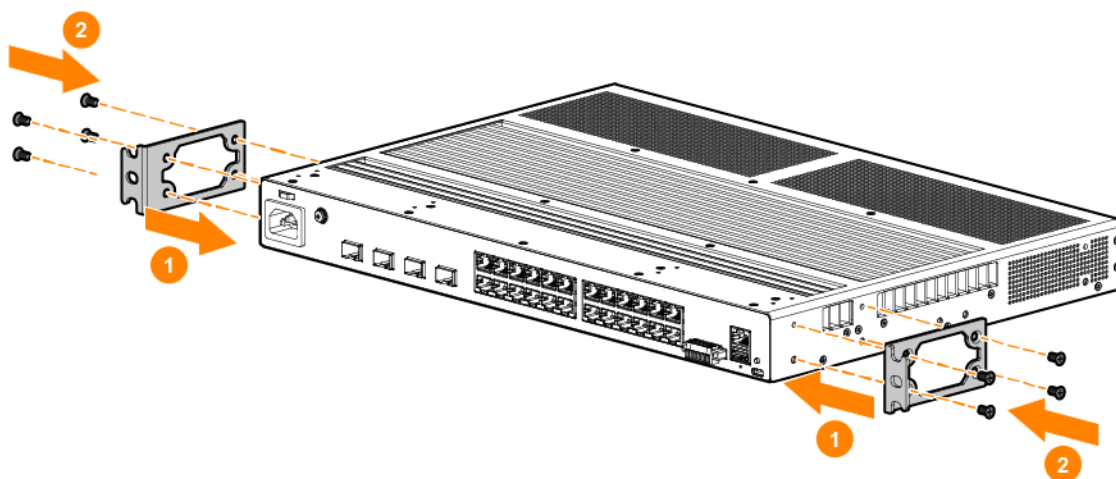

For safe, reliable installation, only use the screws provided in the accessory kit to attach the mounting brackets to the switch.



The mounting brackets have multiple mounting holes and can be rotated allowing for a wide variety of mounting options.

2. Hold the switch with attached brackets up to the rack and move it vertically until rack holes line up with the bracket holes, then insert and tighten the four countersunk M4 screws, attaching the brackets to the rack.

Figure 2 Mounting the switch in a two-post rack

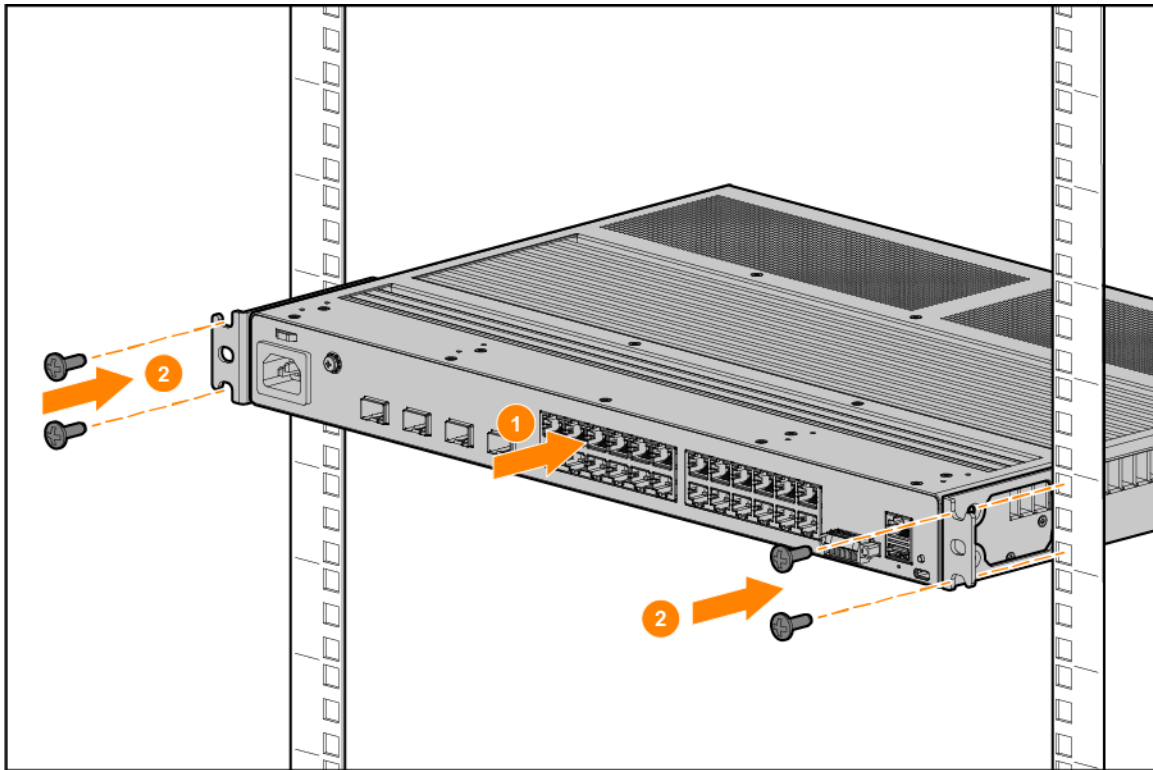

Four-Post Rack Mount Option

The Aruba 4100i switch can be mounted in four-post racks and cabinets by using the Aruba X414 1U Universal 4-Post Rack Mount Kit (JL9583B) (sold separately).



For safe operation, read the mounting precautions in [Installation Precautions and Guidelines on page 35](#) before mounting a switch.



The rack rails are intended for ease of installation only, do not use rails to support the switch in any extended position. Switch must be immediately secured with screws after installation.



For rack mounting, do not physically stack equipment on top of another. Ensure an air gap of at least 2U. If only 1U or 1.75 in. (44.5 mm) of air gap is available, do not exceed 60 degrees Celsius (140 degrees Fahrenheit) ambient temperature.



The 12-24 screws supplied with the four-post rack mount kit are the correct threading for standard EIA/TIA open 19-inch racks. If installing the switch in an equipment cabinet such as a server cabinet, use the clips and screws that came with the cabinet in place of the 12-24 screws that are supplied with four-post rack mount kit (JL9583B).

Complete step 1, and plan which holes you will be using in the cabinet and install all four clips. Then proceed to step 2.

1. Remove the pre-installed flat head screws and do not reuse. Use a Phillips screwdriver and attach the front-post and rear-post rack mount brackets to the switch with the included 8mm M4 screws.

Figure 1 Attaching four-post mounting brackets to the switch

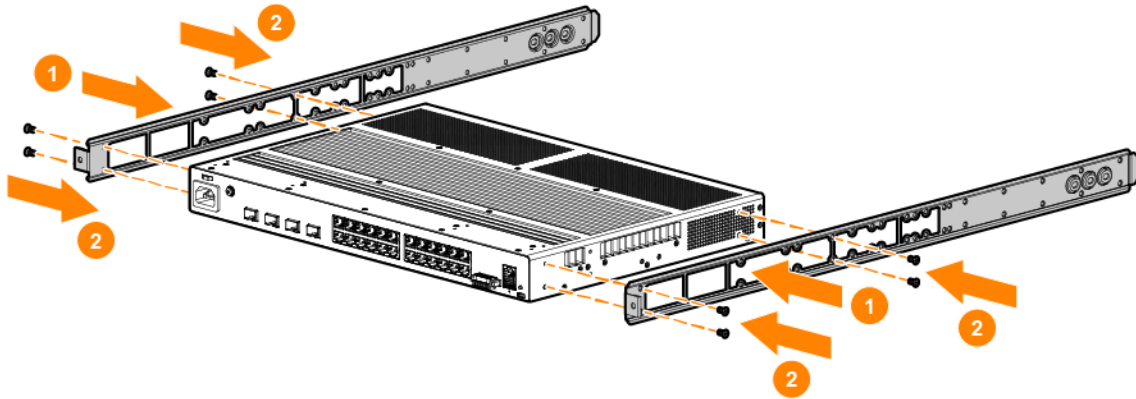

For safe, reliable installation, only use the screws provided in the accessory kit to attach the mounting brackets to the switch.

2. Attach the rack slides to the sides of the switch using eight countersunk M4 screws. Four screws per slide.
3. Install rack rail assemblies to the four-post rack, see the *Aruba Version B Switch Rail Kit installation for Aruba Switches* guide for your four-post rack (JL9583B).
4. Hold the switch with attached brackets and slide up to the rack and align, then insert the inner rack slides into the rack rail assemblies. Insert and tighten two number 10-32 screws, attaching the rack slides to the rack rail assemblies.

Figure 2 Mounting the switch in a four-post rack

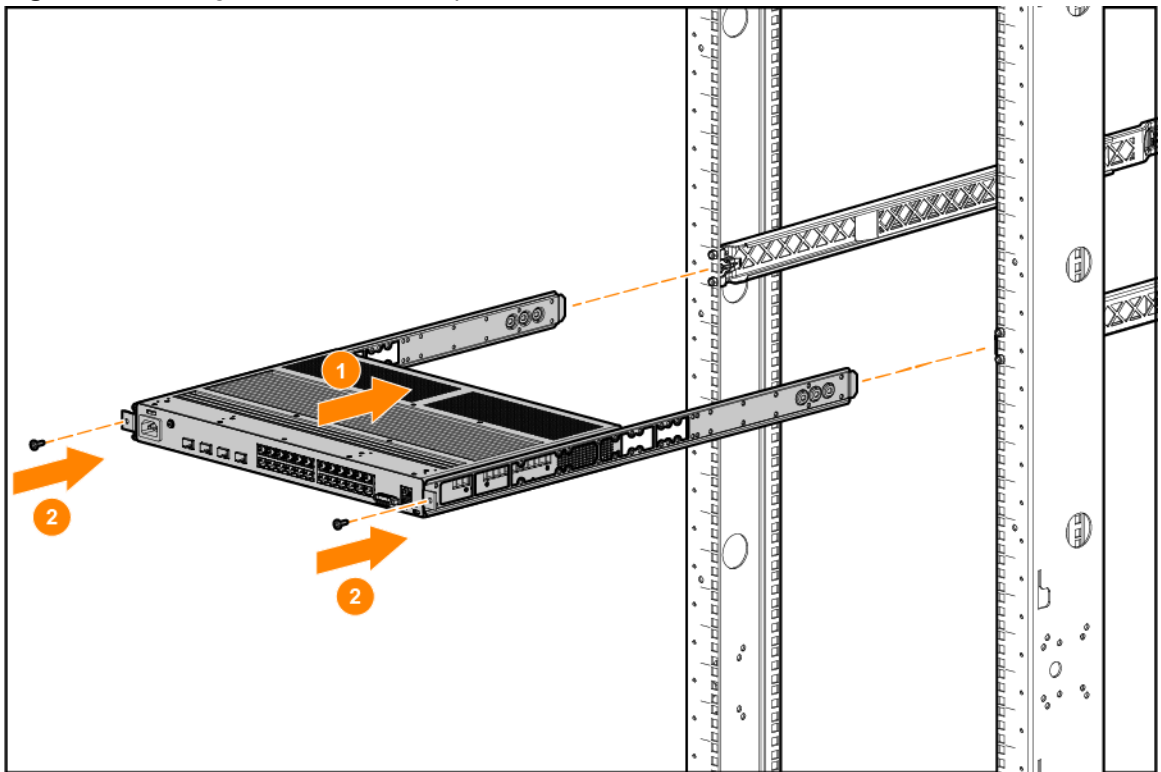

5. Secure the rear-post brackets to the rack rear posts using two number 10-32 screws.

Install Transceivers (optional)

Hold the transceiver by its sides and gently insert it into the switch until it clicks into place. When a transceiver is inserted, the switch authenticates it. This can take 1-3 seconds, with the worst case being 5 seconds.

-
- The Aruba transceivers are Class 1 laser devices. Avoid direct eye exposure to the beam coming from the transmit port.
 - The transceivers operate only at full duplex. Half duplex operation is not supported.
 - Use of supported genuine Aruba transceivers is always recommended. Non-Aruba SFP/SFP+ transceivers can be used in unsupported transceiver mode, but no support or warranty will be provided. Should you require additional transceivers, contact your Aruba sales representative or an authorized reseller.



-
- Always disconnect the network cable from a transceiver before installing it in the switch.
 - You can install or remove a transceiver from an SFP slot without having to power off the switch.
 - The switch will derate to an operating temperature range of 0°C to 50°C when using commercial grade transceivers.
 - For more transceiver support information for your switch model, see the *Transceiver Guide*.



Connect the Switch to a Power Source

1. For JL817A, plug the included power cords into the or power supply's power connector and into a nearby AC/DC power source.
2. For JL818A, plug the included power cords into the switch's power connector and into a nearby AC power source.
3. Secure the power cord plug with the cable tie.

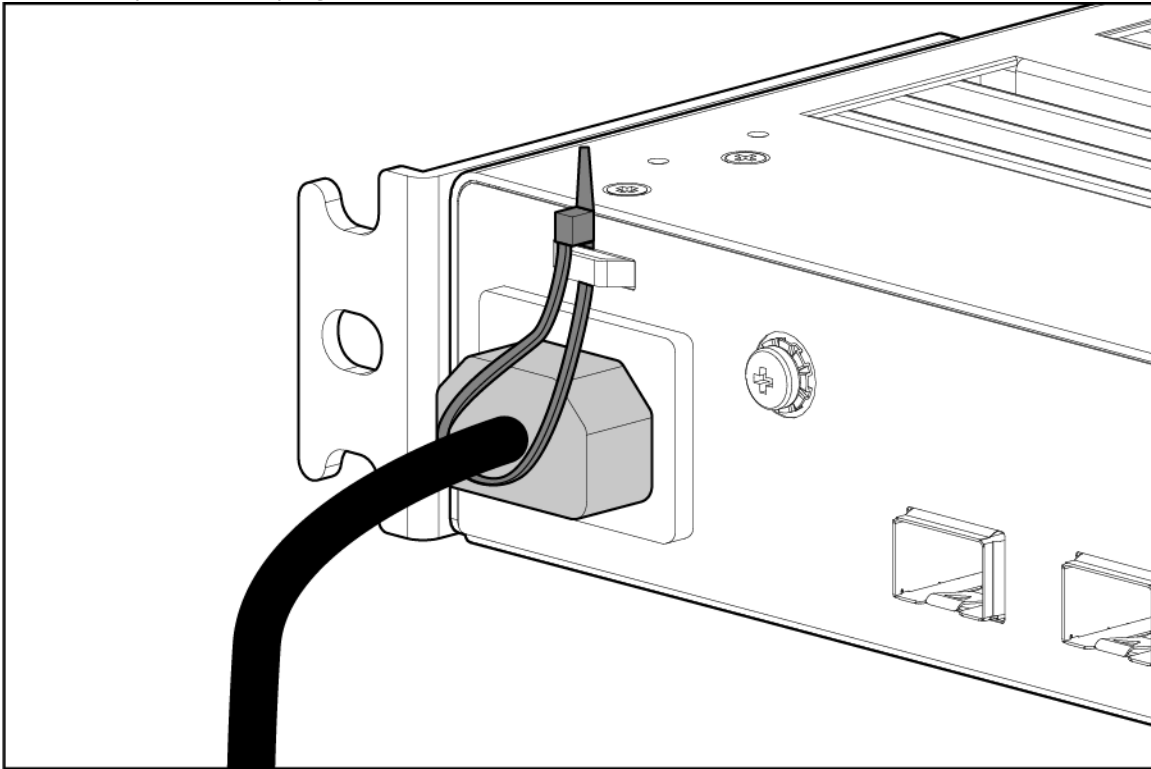

4. Check the LEDs. See [Chassis LEDs and buttons on the front of the switch on page 23](#)

Setup for Initial Configuration

Using an out-of-band serial console: Use a workstation configured with suitable VT-100 terminal emulation software and connect the workstation to the switch's RJ-45 or USB-C console port.

Connect Network Cables

Connect the network cables from the network devices or your patch panels to the RJ-45 port on the switch or to any transceivers you have installed in the switch. See [Prepare the Installation Site](#) for further details.

Connecting Cables to Transceivers

If you have any transceivers installed in the switch, the type of network connections you will need to use depends on the type of transceivers installed. See [Cabling and Technology Information](#).

For transceiver ports, and in general for all the switch ports, a network cable from an active network device is connected to the port. If the port LED does not come on when the network cable is connected to the port, see [Diagnosing with the LEDs](#) in the Troubleshooting chapter.



Ports are enabled by default.

This chapter describes how to troubleshoot your switch. This document describes troubleshooting primarily from a hardware perspective. You can perform more in-depth troubleshooting on these devices using the software tools available with the switches, including the full-featured console interface, the built-in web browser interface, Aruba Central or Aruba AirWave.

This chapter describes the following:

- [Basic Troubleshooting Tips on page 70](#)
- [Diagnosing with the LEDs on page 70](#)
- [Hardware Diagnostic Tests on page 74](#)
- [Accessing Updates on page 85](#)
- [Accessing Aruba Support on page 85](#)

Basic Troubleshooting Tips

Most problems are caused by the following situations. Check for these items first when starting your troubleshooting:

- **Faulty or loose cables.** Look for loose or obviously faulty connections. If the cables appear to be OK, make sure the connections are snug. If that does not correct the problem, try a different cable.
- **Non-standard cables.** Non-standard and miswired cables may cause network collisions and other network problems, and can seriously impair network performance. Use a new correctly-wired cable or compare your cable to the [Cabling Specifications](#), Cabling and technology information for pinouts and correct cable wiring.
- **Improper network topologies.** It is important to make sure you have a valid network topology. Common topology faults include excessive cable length and excessive repeater delays between end nodes. If you have network problems after recent changes to the network, change back to the previous topology. If you no longer experience the problems, the new topology is most likely at fault.

In addition, you should make sure that your network topology contains **no data path loops**. Between any two end nodes, there should be only one active cabling path at any time. Data path loops can cause broadcast storms that will severely impact your network performance.

For your switch, if you want to build redundant paths between important nodes in your network to provide some fault tolerance, you should enable **Spanning Tree Protocol** support on the switch. This ensures that only one of the redundant paths is active at any time, thus avoiding data path loops. Spanning tree can be enabled through the switch console or the web browser interface. For more information on spanning tree, see the *Layer 2 Bridging Guide* for your switch.



By default, ports do not run selftest at boot. To enable port selftest on boot, save the `no fastboot` configuration to the switch. See the *Diagnostics Guide* for further detail.

Diagnosing with the LEDs

LED Patterns for General Switch Troubleshooting

1. Check in the table for the LED pattern you see on your switch.
2. Refer to the corresponding diagnostic tip on the next few pages.

JL817A

PSU LEDs (JL819A, JL820A, JL821A)	Switch DC input Status LED 1 / 2	54V PoE Status LED	Global Status	Port LED	Diagnostic tip
Off with AC / DC power source connected	-	-	-	-	1
On green	On green follow PSU location	-	Snoring green (Dim - lights up periodically)	-	2
On green (Both PSUs)	Either the DC1 or DC2 LED is off/on amber, but not both	-	Flashing amber	-	3
On green	On green follow PSU location	On amber	Flashing amber	-	4
On green	On green follow PSU location	On green	Flashing amber	-	5
On green	On green follow PSU location	On green	Flashing amber	Flashing amber	6
On green	On green follow PSU location	On green	On green	Off with cable connected	7
On green	On green follow PSU location	On green	On green	On but port is not communicating	8
On green	On green follow PSU location	-	On amber	-	9

JL818A

Global Status	Port LED	Diagnostic tip
Off with power source connected	-	1
Snoring green (Dim - lights up periodically)	-	2
Flashing amber	-	5
Flashing amber	Flashing amber	6
On green	Off with cable connected	7

Global Status	Port LED	Diagnostic tip
On green	On but port is not communicating	8
On amber	-	9

Diagnostic Tips

Tip	Problem	Solution
1	Power Supply are not working with active power source.	Verify the AC or DC power source works by plugging another device into the outlet. Or try plugging the power supplies into different outlets or try different power cords. If the problem is still not resolved, both power supplies may be faulty.
2	Switch is in the progress of heating up due to power up at low temperature.	Switch will be booted up after 5 to 15 minutes of heating progress. If the switch does not boot up after 20 minutes, move the switch to a room temperature environment (>0C°). If the condition persists, call your Aruba authorized network reseller, or use the electronic support services from Aruba to get assistance.
3	The switch is not able to identifying PSU condition or DC input voltage not within supporting range.	Check the connectivity of the DC cables to both PSU and Switch terminals, or whether the DC output level of the PSU is within range. If the condition persists, the switch has failed. Call your Aruba authorized network reseller, or use the electronic support services from Aruba to get assistance.
4	System PoE disabled due to System DC input does not meet 52~56V.	Check the output voltage of the DIN PSU. DIN PSU output voltage might have moved out of the supported voltage range. DIN PSU output can be adjusted through potentiometer or control keys.
5	The switch has experienced a software failure during self-test, or a hardware component is having issues.	Check the switch Event Log for indication of the fault condition. If a port failed self-test, contact Aruba support/ <ol style="list-style-type: none"> 1. Try resetting the switch by pressing the Reset button on the front of the switch, or by power cycling the switch. 2. If the fault indication reoccurs, attach a console to the switch and configure it to operate at 115200 baud. Then, reset the switch. Messages should appear on the console screen and in the event log identifying the error condition. If necessary to resolve the problem, contact your Aruba authorized network reseller, or use the electronic support services from Aruba to get assistance.
6	The network port for which	Check the switch Event Log and show interface command output

Tip	Problem	Solution
	<p>the LED is flashing has experienced a self test, or initialization failure.</p>	<p>for indication of the fault condition. If a port failed selftest, contact Aruba support.</p> <p>If the port has a transceiver installed, verify the transceiver is either a supported Aruba transceiver. If using an unsupported SFP/SFP+ transceiver, confirm that unsupported transceiver mode is enabled. For a list of supported transceivers, see the <i>Transceiver Guide</i>.</p> <p>The transceivers are also tested when they are “hot-swapped”—installed or changed while the switch is powered on.</p> <p>To verify the transceiver has failed, remove and reinstall the transceiver without powering off the switch. If the port fault indication reoccurs, you will have to replace the transceiver. Check the event log to see why the transceiver failed. To get assistance, call your Aruba authorized network reseller, or use the electronic support services from Aruba.</p>
7	<p>The port is not able to establish link.</p>	<p>Try the following procedures:</p> <p>For the indicated port, verify that both ends of the cabling, at the switch and the connected device, are connected properly.</p> <p>Verify the connected device and switch are both powered on and operating correctly.</p> <p>Verify you have used the correct cable type for the connection:</p> <p>For fiber-optic connections, verify the transmit port on the switch is connected to the receive port on the connected device, and the switch receive port is connected to the transmit port on the connected device.</p> <p>The cable verification process must include all patch cables from any end devices, including the switch, to any patch panels in the cabling path.</p> <p>Verify the port has not been disabled through a switch configuration change. You can use the console interface, or, if you have configured an IP address on the switch, use the Web browser interface to determine the state of the port and re-enable the port if necessary.</p> <p>Verify the switch port configuration matches the configuration of the attached device. For example, if the switch port is configured as “Full-duplex”, the port on the attached device also MUST be configured as “Full-duplex”. If the configurations don't match, the results could be a very unreliable connection, or no link at all.</p> <p>Run an internal selftest on the port. For example, to run a selftest on port 1/1/12:</p> <pre data-bbox="756 1749 1433 1854">diagnostics diagnostics loopback 1/1/12</pre>

Tip	Problem	Solution
		<p>If the command reports fail, contact Support. There may be a hardware fault.</p> <p>If the other procedures don't resolve the problem, try using a different port or a different cable.</p>
8	The port gets link but does not forward traffic.	<p>Use the switch console to see if the port is part of a dynamic trunk (through the LACP feature) or to see if Spanning Tree is enabled on the switch, and to see if the port may have been put into a "blocking" state by those features. The <code>show lacp interfaces</code> command displays the port status for the LACP feature; the <code>show spanning-tree</code> command displays the port status for Spanning Tree.</p> <p>The Port LED should not be On if the port is disabled.</p> <p>Other switch features that may affect the port operation include VLANs and IGMP. Use the switch console to see how the port is configured for these features.</p> <p>Also ensure, that the device at the other end of the connection is indicating a good link to the switch. If it is not, the problem may be with the cabling between the devices or the connectors on the cable.</p>
9	System power rail failure or over/under-temperature shutdown.	<p>If failure due to power rail. System will be recovered and power cycle if failure removed.</p> <p>If failure due to over/under-temperature shutdown. System will attempt to boot after 5 minute cool down period.</p>

Hardware Diagnostic Tests

Testing the switch by resetting it

If you believe the switch is not operating correctly, you can reset the switch to test its circuitry and operating code. To reset a switch, either:

- Unplug and plug in the power cord (power cycling or disconnect power to the power supplies). Wait a minimum of five seconds after unplugging, before plugging the power cord back in.
- Reboot the switch through the CLI with the `boot system` command.



Power cycling the switch causes the switch to reset. The reset process also causes any network traffic counters and the System Up Time timer to reset to zero.

Checking the Switch LEDs

See [Diagnosing with the LEDs on page 70](#) for information on interpreting the LED patterns.

Checking Console Messages

Useful diagnostic messages may be displayed on the console screen when the switch is reset. Connect a PC running a VT-100 terminal emulator program to the switch's Console Port and configure it to run at 115200 baud, and with the other terminal communication settings. Then, when you reset the switch, note the messages that are displayed. Additionally, you can check the switch event log, which can be accessed from the console using the show events command.

Testing Switch-to-Device Network Communications

You can perform the following communication tests to verify the network is operating correctly between the switch and any connected device that can respond correctly to the communication test.

- **Link Test:** a physical layer test that sends IEEE 802.2 test packets to any device identified by its MAC address.
- **Ping Test:** a network layer test used on IP networks that sends test packets to any device identified by its IP address.

These tests can be performed through the switch console interface from a terminal connected to the switch or through a Telnet connection, or from the switch's web browser interface.

Testing End-to-End Networking Communications

Both the switch and the cabling can be tested by running an end-to-end communications test—a test that sends known data from one network device to another through the switch. For example, if you have two PCs on the network that have LAN adapters between which you can run a link-level test or Ping test through the switch, you can use this test to verify that the entire communication path between the two PCs is functioning correctly. See your LAN adapter documentation for more information on running a link test or Ping test.

Physical

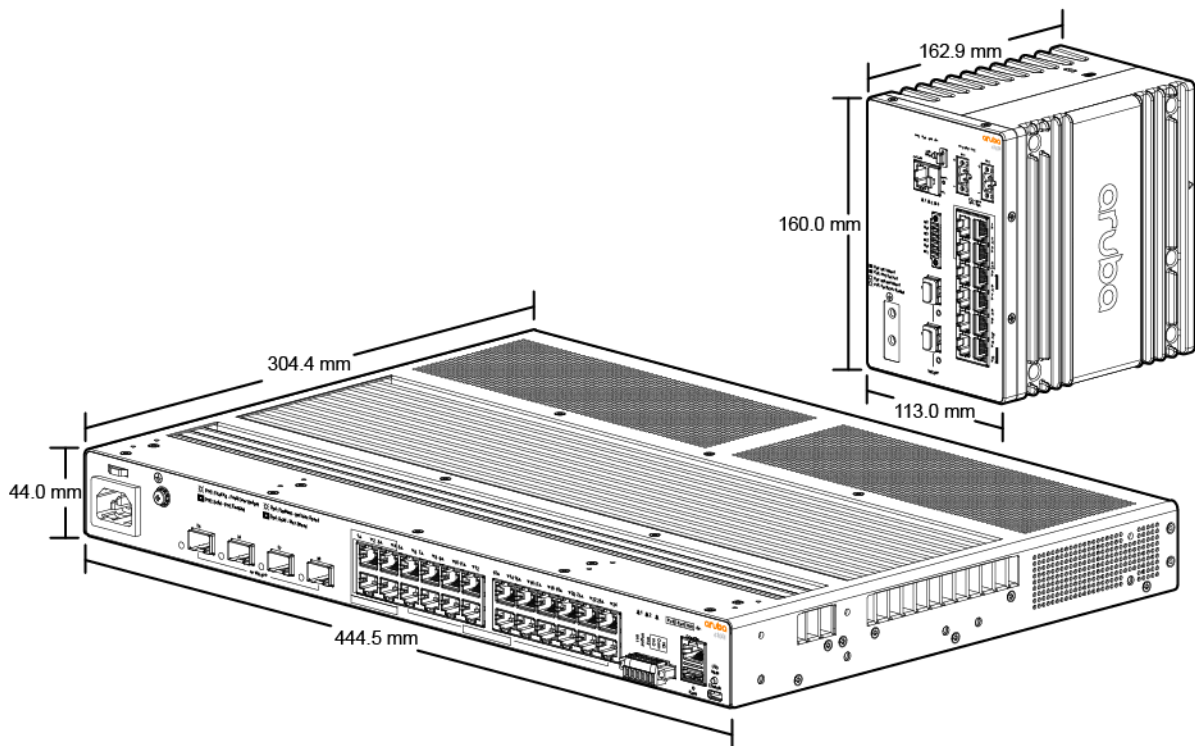

Switch	Height	Width	Depth	Weight
Aruba 4100i 12-port 1GbE (8-port Class 4 POE and 4-port Class 6 POE) 2-port SFP+ DIN Mount Switch (JL817A)	160 mm (6.3 in)	113.0 mm (4.45 in)	162.9 mm (6.4 in) 173.5 mm (6.8 in) with DIN bracket	3.84 kg (8.46 lb)
Aruba 4100i 24-port 1GbE (20-port Class 4 POE and 4-port Class 6 POE) 4-port SFP+ Switch (JL818A)	44 mm (1.73 in)	444.5 mm (17.5 in)	304.4 cm (12.0 in)	6.5 kg (14.33 lb)

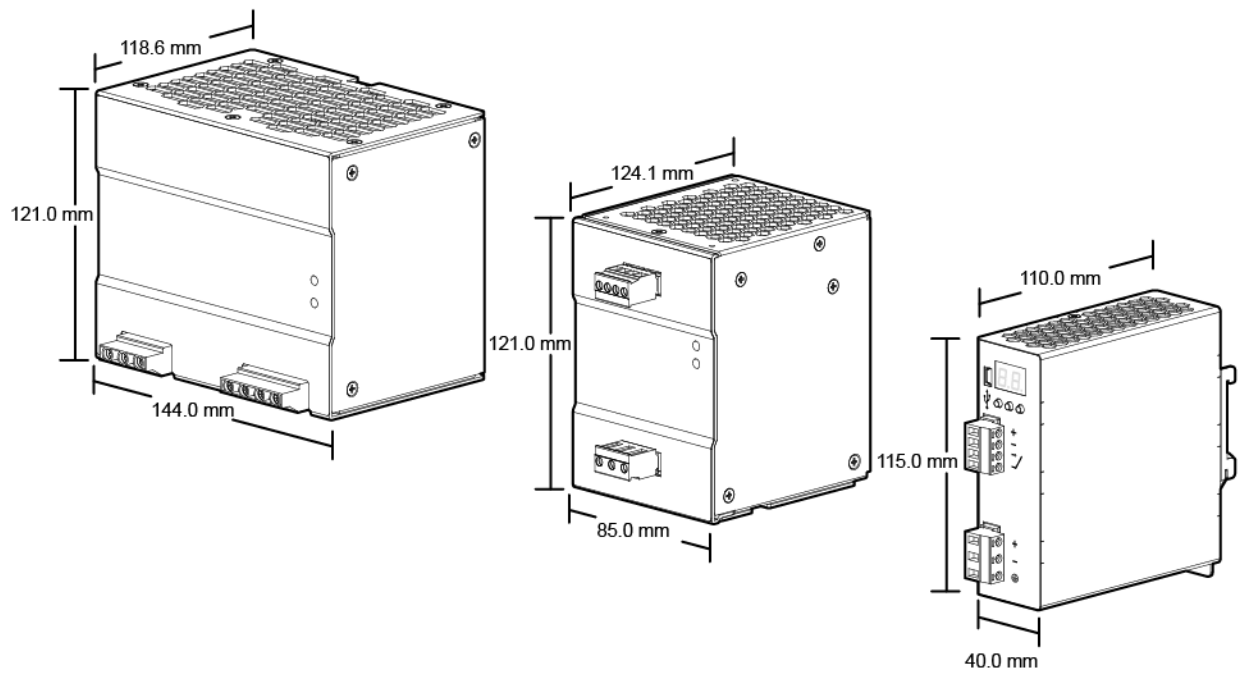

Power Supply	Height	Width	Depth	Weight
JL819A	121 mm (4.76 in)	85 mm (3.35 in)	124.1 mm (4.89 in)	0.96 kg (2.11 lbs)
JL820A	121 mm (4.76 in)	144 mm (5.67 in)	118.6 mm (4.67 in)	1.37 kg (3.0 lbs)
JL821A	115 mm (4.53 in)	40 mm (1.60 in)	110 mm (4.30 in)	0.40 kg (0.88 lbs)

Electrical

Switch Model	Switch to PSU	Power supply Description	PSU to source	Maximum Current	Frequency Range	Voltage
JL817A	AWG 14 up to 2 meters	JL821A Aruba 4000i POE 54VDC 240W 12-48VDC DIN Power Supply	AWG 12	Power supply: 12A Switch: 4.4A	N/A	DC Input Nominal to 12-48 VDC UL certified to 11-55 VDC Output 54VDC
JL817A	AWG 14 up to 2 meters	JL819A - Aruba 4000i POE 54VDC 240W	AWG 16-12	Power supply: 3.5A/1.3A	50/60Hz	AC Input 100V-240V

Switch Model	Switch to PSU	Power supply Description	PSU to source	Maximum Current	Frequency Range	Voltage
		100-240VAC DIN Power Supply		Switch: 4.4A		Output 54VDC
JL817A	AWG 14 up to 2 meters	JL820A -Aruba 4000i POE 54VDC 480W 100-240VAC DIN Power Supply	AWG 16-10	Power supply: 6A/3A Switch: 8A	50/60Hz	AC Input 100V-240V Output 54VDC
JL818A	Internal	Internal	C15 Connector	3.9A/1.9A	50/60Hz	AC Input 100V-240V

Alarm specifications

Input	Dry contact. Do not apply any voltage source. Open or Closed state detect (Dry Contact detection).
Output	1.0A @ 24 VDC or 0.5A @ 48VDC Max Power: 24W Supports Normally Open and Normally Closed
Wire	AWG 18-16

Power Cords

(JL818A)

Aruba includes the power cord intended for use with your Aruba switch and power supply. Different countries/regions may require different power cords. For a list of the power cords that apply to your switch, see [Included Parts](#).

Only Aruba-approved power cords may be used with Aruba devices. To access power cord information for your switch, see [Included Parts](#). Lost or damaged power cords must be replaced only with Aruba-approved power cords. If your installation requires a different power cord than the one supplied with the switch and/or power supply, be sure that the cord is adequately sized for the current requirements of the switch. In addition, be sure to use a power cord displaying the mark of the safety agency that defines the regulations for power cords in your country/region. The mark is your assurance that the power cord can be used safely with the switch and power supply.





Do not use a damaged or non-recommended power cord with your switch. Using such power cords voids the switch and power supply warranty. It can also cause serious electrical problems, including injury or death to personnel, and damage to the switch and other property. If you cannot verify that you have a power cord approved for use with your switch model, contact your authorized Aruba dealer or sales representative for assistance.

Environmental Specifications

Operating temperature	-40°C to 60°C, 0m/s (-40°F to 140°F, 0 LFM) sealed enclosure -40°C to 70°C, 0.2m/s (-40°F to 158°F, 40 LFM) vented enclosure -34°C to 75°C, 1m/s (-29.2°F to 167°F, 200 LFM) fan equipped enclosure
Operating relative humidity	5% to 95% (non-condensing)
Non-operating temperature	-40°C to 85°C (-40°F to 185°F) up to 15000 ft
Max operating altitude	up to 4.2 km (13800 ft)
Max non-operating altitude	4.6 km (15000 ft)
Degree of protection	IP30

RoHS

EN 63000: 2018

Safety and Regulatory Information



For important safety, environmental, and regulatory information, see Safety and Compliance Information for Server, Storage, Power, Networking, and Rack Products, available at <http://www.hpe.com/support/Safety-Compliance-EnterpriseProducts>.

Safety-EU	EN 60950-1:2006 + A11:2009 + A1:2010 + A12:2011 + A2:2013 EN 62368-1, Ed.2:2014
Safety-Worldwide	IEC 60950-1:2005 Ed.2 + Am 1:2009 + A2:2013 IEC 62368-1:2014 EN/IEC 60825-1:2014 Class 1 UL/IEC 61010-2-201 GB 4943.1:2011 CNS 14336-1 K 60950-1

North American	UL 62368-1, 2nd Edition CAN/CSA C22.2 No. 62368-1-14
EMC	EN 55032:2015/CISPR 32, Class A EN 55011:2010/CISPR 11, Class A EN 55035:2017/CISPR 35 EN 61000-3-2:2014, Class A EN 61000-3-3:2013 FCC CFR 47 Part 15: 2018 Class A ICES-003, Class A VCCI Class A CNS 13438 CNS 13438 Class A KN 35:2015
Industrial Standards Compliance	EN 61000-6-1 EN 61000-6-2 EN 61009-6-4 IEC 61850-3 / IEEE 1613 (Surge protector and STP needed)* EN 50155 / IEC 60571 EN 50121-4 (Surge protector and STP needed)* EN 50121-3-2 (Surge protector and STP needed)* NEMA TS 2-2016 EN 60529 EN 50155 & IEC 61373
RoHS	EN 63000: 2018

*Shield Twisted Pair (STP) and AC Input with SPD2-300-2P0-R surge protector, DC Input with SPD2-150-2P0-R surge protector needed.



- When selecting a fiber SFP device, make sure the device has the same (or better) operating temperature range as the switch.
- Use only an approved Laser Class 1 SFP transceiver.

Japan Power Cord Warning	製品には、同梱された電源コードをお使い下さい。 同梱された電源コードは、他の製品では使用出来ません。
---------------------------------	-------------------------------------------------------

Connectivity Standards

Technology	Compatible with these IEEE standards	EN/IEC standard compliance	Lasers
10-T, 100-TX, 1000-T	IEEE 802.3 100BASE-T IEEE 802.3u 100BASE-TX IEEE 802.3ab 1000BASE-T		
1000-SX	IEEE 802.3z 1000BASE-SX	EN/IEC 60825	Class 1 Laser Product Laser Klasse 1
1000-LX	IEEE 802.3z 1000BASE-LX	EN/IEC 60825	Class 1 Laser Product Laser Klasse 1
10-Gig SR	IEEE 802.3ae 10GBASE-SR	EN/IEC 60825	Class 1 Laser Product Laser Klasse 1
10-Gig LR	IEEE 802.3ae 10GBASE-LR	EN/IEC 60825	Class 1 Laser Product Laser Klasse 1

Battery Statements:



This switch uses a lithium battery. Do not attempt to replace the battery.



A risk of explosion exists if a battery is replaced by an incorrect type. Dispose of used batteries according to the battery disposal regulations for your country or region.



Il y a danger d'explosion s'il y a remplacement incorrect de la batterie.



Remplacer uniquement avec une batterie du même type ou d'un type équivalent recommandé par le constructeur. Mettre au rebut les batteries usagées conformément aux instructions du fabricant.



The battery supplied with this product may contain perchlorate material. Special handling may apply in California and certain other states. See <http://www.dtsc.ca.gov/hazardouswaste/perchlorate> website for more information.



The only indicator of battery failure is the failure of the switch internal clock to keep the correct time across a reboot or power cycle. If a battery failure occurs, contact your authorized Aruba representative for assistance. Batteries are not customer-serviceable and battery failures should be referred only to service personnel authorized by Aruba.



For important safety, environmental, and regulatory information, see Safety and Compliance Information for Server, Storage, Power, Networking, and Rack Products, available at <http://www.hpe.com/support/Safety-Compliance-EnterpriseProducts>.

This chapter includes switch connector information and network cable information for cables that should be used with Aruba 4100i switches.



Incorrectly wired cabling is a common cause of problems for LAN communications. Aruba recommends that you work with a qualified LAN cable installer for assistance with your cabling requirements.

Cabling Specifications

Twisted-pair copper	10 Mbps Operation	Category 3, 4 or 5, 100-ohm unshielded twisted-pair (UTP) or shielded twisted-pair (STP) cable, complying with IEEE 802.3 10BASE-T specifications.
	100 Mbps Operation	Category 5, 100-ohm UTP, or STP cable, complying with IEEE 802.3u 100BASE-TX specifications.
	1000 Mbps Operation	Category 5, 100-ohm 4-pair UTP or STP cable, complying with IEEE 802.3ab 1000BASE-T specifications—Category 5e or better is recommended.
Multimode fiber	-	62.5/125 μm or 50/125 μm (core/cladding) diameter, low metal content, graded index fiber-optic cables, complying with the ITU-T G.651 and ISO/IEC 793-2 Type A1b or A1a standards respectively.
Single mode fiber	-	9/125 μm (core/cladding) diameter, low metal content fiber-optic cables, complying with the ITU-T G.652 and ISO/IEC 793-2 Type B1 standards.

1000BASE-T cable requirements



The Category 5 networking cables that work for 100BASE-TX connections should also work for 1000BASE-T, as long as all four-pairs are connected. But, for the most robust connections, you should use cabling that complies with the Category 5e specifications, as described in Addendum 5 to the TIA-568-A standard (ANSI/TIA/EIA-568-A-5).



Because of the increased speed provided by 1000BASE-T (Gigabit-T), network cable quality is more important than for either 10BASE-T or 100BASE-TX. Cabling plants being used to carry 1000BASE-T networking must comply with the IEEE 802.3ab standards. In particular, the cabling must pass tests for Attenuation, Near-End Crosstalk (NEXT), and Far-End Crosstalk (FEXT). Additionally, unlike the cables for 100BASE-TX, the 1000BASE-T cables must pass tests for Equal-Level Far-End Crosstalk (ELFEXT) and Return Loss.



When testing your cabling, be sure to include the patch cables that connect the switch and other end devices to the patch panels on your site. The patch cables are frequently overlooked when testing cable and they must also comply with the cabling standards.

For Conducted and Radiated Immunity in accordance with EN55024, the Aruba switch is limited to Performance Criteria A with shielded cables (CAT6A).

Accessing Aruba Support

Aruba Support Services	https://www.arubanetworks.com/support-services/
Aruba Support Portal	https://asp.arubanetworks.com/
North America telephone	1-800-943-4526 (US & Canada Toll-Free Number) +1-408-754-1200 (Primary - Toll Number) +1-650-385-6582 (Backup - Toll Number - Use only when all other numbers are not working)
International telephone	https://www.arubanetworks.com/support-services/contact-support/

Be sure to collect the following information before contacting Support:

- Technical support registration number (if applicable)
- Product name, model or version, and serial number
- Operating system name and version
- Firmware version
- Error messages
- Product-specific reports and logs
- Add-on products or components
- Third-party products or components

Other websites that can be used to find information:

Airheads social forums and Knowledge Base	https://community.arubanetworks.com/
Software licensing	https://lms.arubanetworks.com/
End-of-Life information	https://www.arubanetworks.com/support-services/end-of-life/
Aruba software and documentation	https://asp.arubanetworks.com/downloads

Accessing Updates

To download product updates:

Aruba Support Portal

<https://asp.arubanetworks.com/downloads>

My Networking

<https://www.hpe.com/networking/support>

To view and update your entitlements, and to link your contracts and warranties with your profile, go to the Hewlett Packard Enterprise Support Center More Information on Access to Support Materials page:

<https://support.hpe.com/portal/site/hpsc/aae/home/>



Access to some updates might require product entitlement when accessed through the Hewlett Packard Enterprise Support Center. You must have an HPE Passport set up with relevant entitlements.

Some software products provide a mechanism for accessing software updates through the product interface. Review your product documentation to identify the recommended software update method.

To subscribe to eNewsletters and alerts:

<https://asp.arubanetworks.com/notifications/subscriptions> (requires an active Aruba Support Portal (ASP) account to manage subscriptions). Security notices are viewable without an ASP account.

Warranty Information

To view warranty information for your product, go to <https://www.arubanetworks.com/support-services/product-warranties/>.

Regulatory Information

To view the regulatory information for your product, view the Safety and Compliance Information for Server, Storage, Power, Networking, and Rack Products, available at <https://www.hpe.com/support/Safety-Compliance-EnterpriseProducts>

Aruba is committed to providing our customers with information about the chemical substances in our products as needed to comply with legal requirements, environmental data (company programs, product recycling, energy efficiency), and safety information and compliance data, (RoHS and WEEE). For more information, see <https://www.arubanetworks.com/company/about-us/environmental-citizenship/>.

Documentation Feedback

Aruba is committed to providing documentation that meets your needs. To help us improve the documentation, send any errors, suggestions, or comments to Documentation Feedback (docsfeedback-switching@hpe.com). When submitting your feedback, include the document title, part number, edition, and publication date located on the front cover of the document. For online help content, include the product name, product version, help edition, and publication date located on the legal notices page.