

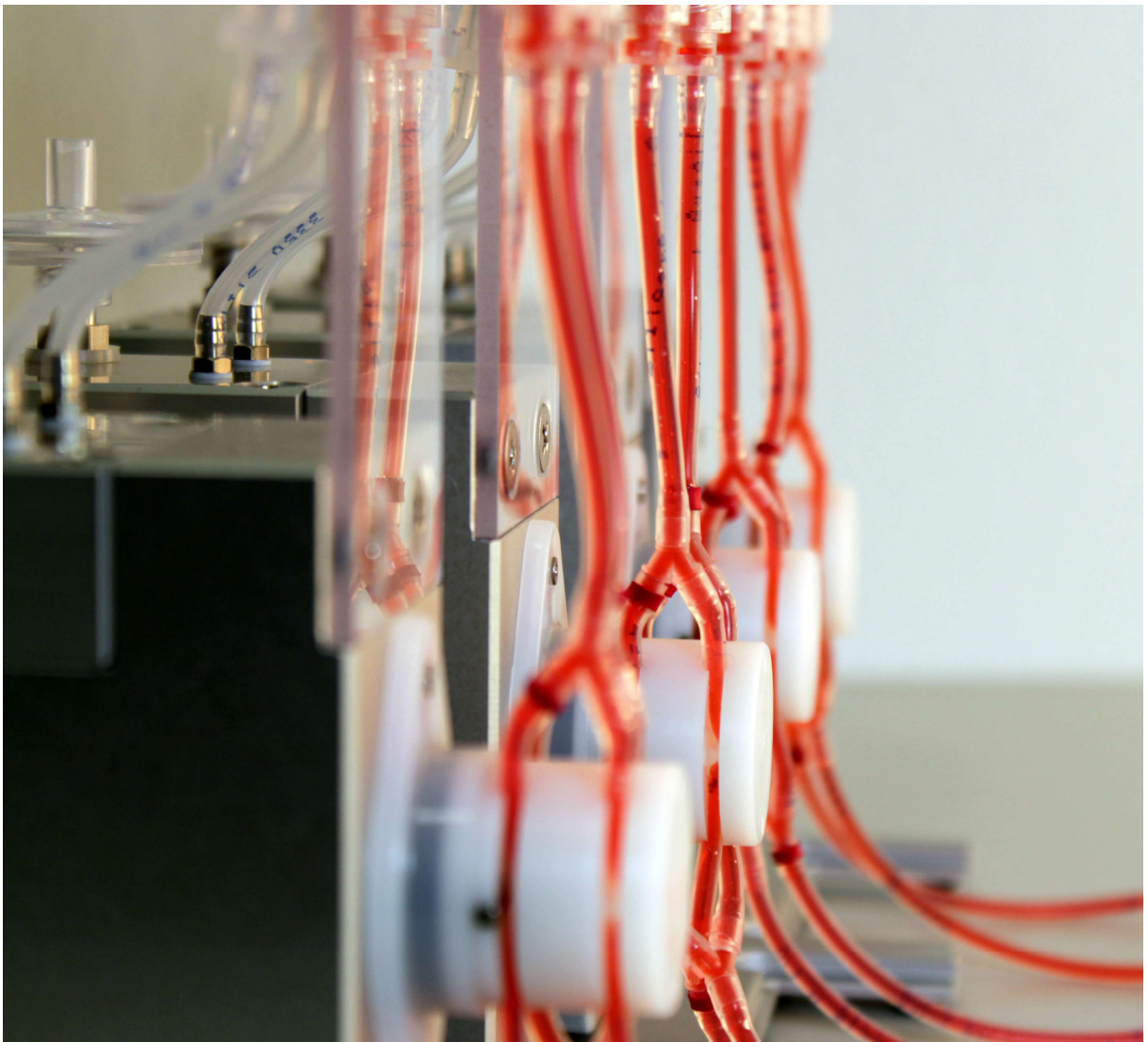

ibidi Pump System Instructions

Version 2.0



Contact

ibidi GmbH

Am Klopferspitz 19
82152 Martinsried (Munich)
Germany

free call within Germany:

Phone: 0800 00 11 11 28

Fax: 0800 00 11 11 29

international calls:

Phone: +49 89 / 520 46 17 - 0

Fax: +49 89 / 520 46 17 - 59

E-mail: info@ibidi.de

Internet: www.ibidi.com



Contents

Safety Considerations	7
Safety Symbols	7
Nomenclature	8
Regulatory Statement	10
Specifications	11
Notices	13
Limited Warranty	14
Installation Requirements	15
Installation and Connecting Cables	16
Maintenance and Operation	17
Waste Treatment	17
Preface	18
1 Equipment	19
1.1 Parts of the ibidi Pump System	19
1.2 ibidi Pump	20
1.3 Fluidic Unit	21
1.3.1 The Valve Block	22
1.3.2 The Pinch Valve	22
1.4 Perfusion Sets	23
1.5 ibidi μ -Slides	24
1.6 Slide and Perfusion Set Selection Guide	26
1.7 Computer with PumpControl Software	27
2 Quick Start Guide	28

3	Basic Setup	29
3.1	General Setup of the Components	29
3.2	Installing the PumpControl Software	30
3.3	Connecting the ibidi Pump to the Computer	30
3.4	Connecting the Fluidic Unit to the Pump	31
3.5	Drying Bottle	32
3.5.1	Components of the Drying Bottle	32
3.5.2	Assembling the Parts of the Drying Bottle	32
3.5.3	Connection of the Air Pressure Tubing and the Drying Bottle	32
4	Setting Up an Experiment With Cells	35
4.1	Degassing of Slides, Tubing, and Medium	35
4.2	Mounting a Perfusion Set on the Fluidic Unit	36
4.3	Filling the Perfusion Set with Medium	39
4.4	Sterility	40
4.5	Remove Air Bubbles from the Perfusion Set	40
4.6	Pinch-Test	40
4.7	Pre-Calibration of the Flow Rate	41
4.8	Connecting the Perfusion Set to the Slide	41
4.9	Fine-Calibration of the Flow Rate	42
5	Installation of Special Setups	43
5.1	Installation Using Two or More Fluidic Units	43
5.2	Calibration of the Flow Rate with Several Slides in Serial Connection	43
5.3	Instructions for Oscillatory Flow Experiments	44
5.3.1	Setting up the Fluidic Units	45
5.3.2	Oscillatory Experiment with Four Fluidic Units	47
5.3.3	Settings within the PumpControl Software	48
5.3.4	Equilibrating the Master and Slave Fluidic Units	48

6	Technical Details	49
6.1	Working Principle of the ibidi Pump	49
6.2	Positive Versus Negative Air Pressure	51
6.3	Flow Characteristics	52
6.4	Viscosity	53
6.5	Flow Calibration	54
6.5.1	Flow Rate Measurement	54
6.5.2	Flow Calibration in the Software	56
6.6	Shear Stress Calculations in ibidi Channel Slides	56
6.7	Working with Non-Implemented Flow Channels	58
7	Maintenance	61
7.1	Silica Beads from the Drying Bottle	61
7.2	Replacement Filters for Perfusion Sets	61
7.3	Filters of the Fluidic Unit	61
7.4	Pinch Valves of the Fluidic Unit	61
8	Troubleshooting	62
8.1	Air Bubbles	62
8.1.1	Air Bubbles When Connecting the Slide	62
8.1.2	Air Bubbles Emerging After a Few Hours	62
8.2	Cells are Detaching	62
8.2.1	Cells Detach Before Starting the Flow	62
8.2.2	Cells Detach When Connecting the Slide to the Perfusion Set	63
8.2.3	Cells detach under Flow Conditions	63
8.3	Clogged Filters	64
8.4	Pump is not Recognized by the Computer	64
8.4.1	Using PumpControl v1.5.0 or Higher	64
8.4.2	Using PumpControl v1.4.4 or Lower	64
8.4.3	Pressure Lost Error	65
8.5	ibidi Pump is not Communicating with the PumpControl Software	65
8.6	Pressure Kickback After Pressure Switch Off	65
8.7	Flow Rate is Too Low or Absent	65
8.8	Flow Rate is too High	66
8.9	Evaporation	66
8.10	Flow Direction in the Channel is Changing	66
8.11	Imbalanced Medium	67

Safety Considerations

To ensure operation safety, the ibidi Pump System must be operated correctly and maintained according to a regular schedule. Carefully read all safety precautions in this manual before operating the instrument. Note that the signal words **WARNING**, **CAUTION** and **NOTE** have specific meanings in this manual.

Safety Symbols

Do not proceed beyond a **WARNING** or **CAUTION** notice until you have performed the indicated actions.

WARNING! A potentially hazardous situation which, if not avoided, could result in serious injury or even death.

CAUTION A potentially hazardous situation which, if not avoided, could result in minor or moderate injury. It is also used to alert against damaging the equipment or the instrument.

NOTE Additional information to help achieve optimal instrument and assay performance.



This label is positioned on the back of the pump and prompts you to read the manual before using the ibidi pump.

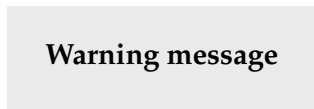

Warning messages in the text are displayed in a gray shaded box.

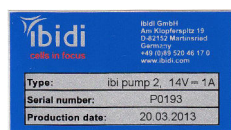

The identification label is positioned on the back panel of the pump.

Nomenclature



ibidi Pump

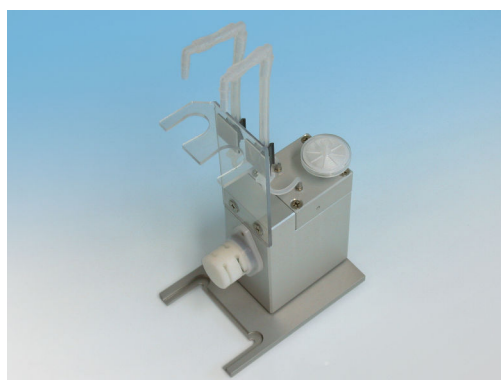

Fluidic Unit

WARNING!

- Do only operate the ibidi Pump with the provided external power supply (Sinpro MODEL NO:SPU41A-106, INPUT: AC 100-240V, 47-63 Hz, 0.93 A, OUTPUT: DC 14 V, 2.85 A max.).
- Do only use the delivered cables and plugs. If not doing so you risk electric shock and fire.
- Do not operate the ibidi Pump with substances and under conditions which do cause a risk of explosion, implosion or release of gases. Only operate the ibidi Pump with aqueous solutions.

CAUTION

- Ensure that the external power supply is easily accessible. The ibidi Pump must be installed in a manner that it does not hinder the access to the external power supply.
- The weight of the ibidi Pump is approx. 3 kg. Moving the pump during operation will pose a risk of personal injury or damage to the instrument.
- Do not attempt to open the pump controller, which would pose a risk of personal injury or damage to the instrument.
- The ibidi Pump can build pressure up to 100 mbar. Do not unplug the fluidic connections during pump operation. Pressurized liquid could emerge from the tubes and damage surrounding equipment. Excess moisture can cause the external power supply or nearby electrical equipment to short circuit.
- Only ibidi technical staff is permitted to open and service the ibidi Pump.
- Do not use extension cords. Immediately replace damaged cords, plugs, or cables to avoid a risk of personal injury or damage to the instrument.
- Do not use the ibidi Pump in the cold room.
- Do not suction in any liquid into the ibidi Pump.
- Unplug the external power supply when the ibidi Pump is not in use.

- Use ethanol or 2-propanol to clean the ibidi Pump. Other organic solvents could remove the instrument paint.
- Use the ibidi Pump for cell experiments with aqueous solutions only.
- Do not use the ibidi Pump with hazardous substances or materials that could pose a risk of infections.

Regulatory Statement

The following safety and electromagnetic standards were considered:

- IEC 61010-1:2010 + Cor. :2011 Safety requirements for electrical equipment for measurement, control and laboratory use - Part 1: General requirements
- IEC 61326-1:2006 EMC, Electrical equipment for measurement, control and laboratory use. EMC requirements. General requirements
- IEC/CISPR 11:2009, modified + A1:2010, Industrial, scientific and medical equipment - Radio-frequency disturbance characteristics - Limits and methods of measurement

Specifications

Electrical Input

External Power Supply:

Input: AC 100-240V, 47-63 Hz, 0.93 A

Output: DC 14 V, 2.85 A max. 14V (Sinpro MODEL NO:SPU41A-106)

ibidi Pump

Electrical Input

Supply voltage: 14 V DC

Standby current: 60 mA

Max. current @max. air flow: 250 mA

Max. current with 4 fluidic units: 2500 mA

Operating Conditions

Environmental operating temperature: 15-40°C (indoor use only)

Storage temperature: -5-50°C

Humidity: 80% RH up to 31°C, 30% RH up to 40°C

Operating altitude: max. 2000 m

Dimensions

Width: 170 mm

Depth: 230 mm

Height: 90 mm

Weight: 3 kg

Pressure

Pressure range 0-100 mbar

Recommended range 5-95 mbar

Fluidic Unit

Electrical Input Supplied by Pump

Switching current 110 mA (1 Fluidic Unit), 200 mA (2-4 Fluidic Units)

Hold current (state 2) 120 mA

Typical current @ 20 mbar: 130 mA (state 1) / 250 mA (state 2)

Environmental Conditions

Operating temperature 15-45°C (indoor use only)

Storage temperature -5-50°C

Humidity ≤ 100% (non-condensing)

Operating altitude max. 2000 m

Dimensions

Width 85 mm

Depth 135 mm

Height 270 mm

Weight 1.1 kg

Connections

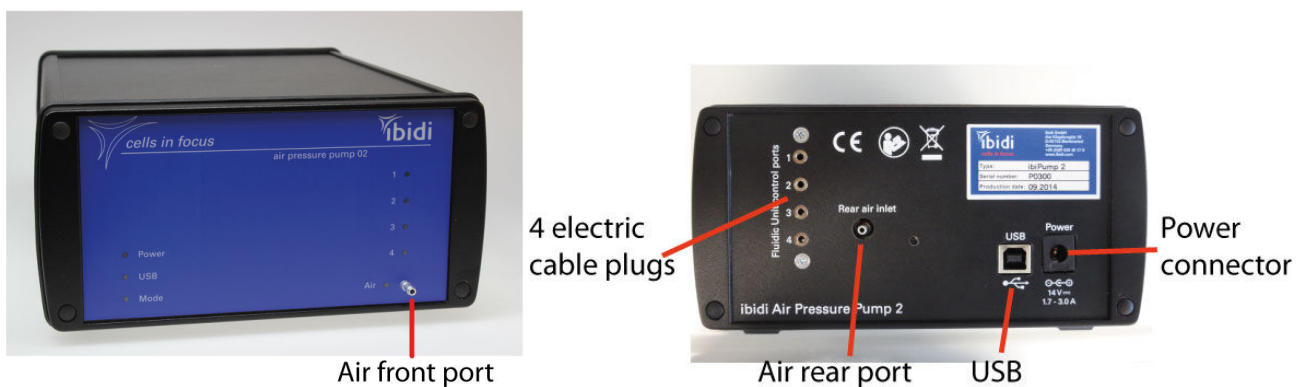

Name	Function
Air front port	Pressurized air connection to Fluidic Unit(s)
USB	USB cable connection to the computer. To setup a computer communication to the ibidi pump, the USB cable must be connected.
Power connector	External power supply (Sinpro MODEL NO:SPU41A-106, 14V)
Air rear port	Pressurized air connection to incubator (positive pressure only)
Fluidic Unit ports	Electric connection to the Fluidic Unit(s)

Notices

1. ibidi shall not be held liable, either directly or indirectly, for any consequential damage incurred as a result of product use.
2. Prohibitions on the use of ibidi software
 - Copying software for other than backup purposes
 - Transferring or licensing of the right to use software to a third party
 - Disclosure of confidential information regarding software
 - Modification of software
 - Use of software on multiple workstations, network terminals, or by other methods
3. The contents of this manual are subject to change without notice for product improvement.
4. This manual is considered complete and accurate at publication.
5. This manual does not guarantee the validity of any patent rights or other rights.
6. If an ibidi software program has failed causing an error or improper operation, this may be caused by a conflict from another program operating on the notebook (PC). In this case, take corrective action by uninstalling the conflicting product(s).
7. ibidi is a registered trademark of ibidi GmbH in Germany and other countries.

Limited Warranty

Products sold by ibidi, unless otherwise specified, are warranted for a period of one year from the date of shipment to be free of defects in materials and workmanship. If any defects in the product are found during this warranty period, ibidi will repair or replace the defective part(s) or product free of charge.

This warranty does not apply to defects resulting from the following:

- 1. Improper or inadequate installation.**
- 2. Improper or inadequate operation, maintenance, adjustment or calibration.**
- 3. Unauthorized modification or misuse.**
- 4. Use of unauthorized tubing or fluidic connectors.**
- 5. Use of consumables, disposables and parts not supplied by an authorized ibidi distributor.**
- 6. Corrosion due to the use of improper solvents, samples, or due to surrounding gases.**
- 7. Accidents beyond ibidi's control, including natural disasters.**

This warranty does not cover consumables, such as channels slides, tubes, fluidic connectors etc.

The warranty for all parts supplied and repairs provided under this warranty expires on the warranty expiration date of the original product. For inquiries concerning repair service, contact ibidi and provide the model name and serial number of your ibidi Pump.

Installation Requirements

To ensure operation safety, observe the following conditions:

1. Only operate the ibidi Pump with the provided external power supply (Sinpro MODEL NO:SPU41A-106, 14V).
2. Ensure that the external power supply is easily accessible. The ibidi pump must be installed in a manner that it does not hinder access to the external power supply.
3. Only operate the ibidi Pump with original ibidi Channel Slides.
4. Operate the ibidi Pump in a temperature range of 15-40°C (Fluidic Unit 15-45°C).
5. Operate the ibidi Pump in a humidity range of 0-80% RH, up to 31°C or 30% RH up to 40°C. The Fluidic Unit can be operated in 100% humidity (non-condensing).
6. Operate the ibidi Pump at altitudes of less than 2000 m.
7. Do not operate the ibidi Pump under conditions that pose a risk of explosion, implosion, or the release of gases.
8. Avoid strong magnetic fields and sources of high frequency. The ibidi Pump might not function properly when located near a strong magnetic field or high frequency source.
9. Avoid vibrations from vacuum pumps, centrifuges, electric motors, processing equipment, and machine tools.
10. Do not install the ibidi Pump in a location where it could be exposed to direct sunlight.
11. Install the ibidi Pump in a horizontal and stable position, which includes a table, bench or desk upon which the instrument is installed.
12. Install the ibidi Pump in a location that enables easy access for maintenance.

NOTE: The above conditions do not guarantee optimal performance of the ibidi Pump.

Installing and Connecting Cables

WARNING! to avoid risk electric shock and fire, operate the ibidi Pump with the supplied external power supply (Sinpro MODEL NO:SPU41A-106, 14V) and the supplied cables and plugs.

Connect the external power supply to the electrical outlet and then connect the external power supply to the ibidi Pump.

CAUTION Ensure that the power supply is easily accessible. The pump must be installed in a manner that does not hinder access to the power supply.

Connect the pump to the computer using the supplied USB cable.

Maintenance and Operation

Monitor the operating environment and always keep the pump to maintain a long term, stable operation. Do not place heavy objects on the instrument.

Cleaning the ibidi Pump

Unplug the external power supply cord from the ibidi Pump and electrical outlet. Use a dry or damp cloth to clean the pump.

CAUTION Only use water or 70% ethanol/2-propanol to clean the pump. Other organic solvents could remove the instrument paint.

Transporting the ibidi Pump

Unplug the power supply from the ibidi Pump and electrical outlet. Carefully transport the instrument and avoid mechanical shocks.

CAUTION The ibidi Pump weighs approximately 3 kg. Dropping the instrument while moving it could cause personal injury or damage to the pump.

Malfunction

In case of a malfunction, unplug the ibidi Pump and wait for five minutes. Reconnect the instrument. If the pump is still malfunctioning, unplug the pump, remove the power supply from the electrical outlet and contact the ibidi service department.

Repairing the ibidi Pump

Do not attempt to repair the instrument ibidi Pump. Contact the ibidi service department for instrument repairs.

CAUTION Attempting to open the instrument will pose a risk of personal injury or damage to the instrument.

Waste Treatment

Waste treatment is the responsibility of the user. Contact your institutions' waste management department or a company specializing in waste recovery. Do not dispose the ibidi Pump in a trash bin or at a public waste disposable site. For detailed information please contact the ibidi service department.

Preface

The ibidi Pump and Fluidic Unit(s) create unidirectional, oscillatory, or pulsatile flow of medium within a channel of an ibidi slide. The requirements for a pump, generating a long-term flow were formulated by scientists working with μ -Slides for perfusion studies as follows:

- Simultaneous culture and observation of cells under perfusion conditions.
- The range of applied shear stress should simulate the physiological spectrum of veins and arteries.
- The setup should be under sterile conditions.
- Mechanical stress to suspended cells should be minimized to avoid destruction and non-specific cell-activation. White blood cells are affected by mechanical squeezing.
- The volume of medium used should be as low as possible for conserving valuable reagents and for measuring soluble factors produced by cells.
- Unidirectional flow for long-term studies (up to weeks).
- Oscillatory flow can be achieved to mimic turbulent flow situations.

Using air pressure as the driving mechanism enabled splitting the setup in to a portable Fluidic Unit and Pump, as an air pressure generator. There are multiple advantages of driving the system with air pressure. The portable Fluidic Unit is a closed system connected to the pump by air tubing and a low-voltage electric cable. Both can be disconnected without compromising sterility. Therefore, the Fluidic Unit can be placed in the sterile preparation area and in standard incubators. During experiments, the Fluidic Unit can be placed close to the microscope for live cell imaging applications. This setup prevents the system from heating the incubator above 37°C, by the heat produced by the pump.

To conserve medium, the liquid is recycled between two media reservoirs of the Fluidic Unit. The Fluidic Unit is switched between two states; however the pump is supplying constant air pressure. In the first state, the medium is transferred from reservoir A to reservoir B; in the second state, the medium is transferred back to reservoir A. The simultaneous valve switching maintains unidirectional flow in the μ -Slide. This mechanism is described in detail in Section 6.1.

Sterility is maintained by air filters located on the medium reservoirs, within the pump, and at the outlet of the Fluidic Unit.

Important!

This manual is your guide for using the ibidi Pump for flow experiments with the ibidi Channel Slides. It provides instructions for first-time users, and serves as a reference for experienced users. Before using the ibidi Pump System, carefully read the entire instructions. This manual should be easily accessible at all times during instrument operation. If this manual is misplaced, request a replacement or download it from www.ibidi.com.

1 Equipment

The ibidi Pump System consists of the ibidi Pump, the Fluidic Unit(s), and disposable parts, such as Perfusion Sets and Slides. This section provides a brief overview including the nomenclature for later descriptions in this document.

1.1 Parts of the ibidi Pump System

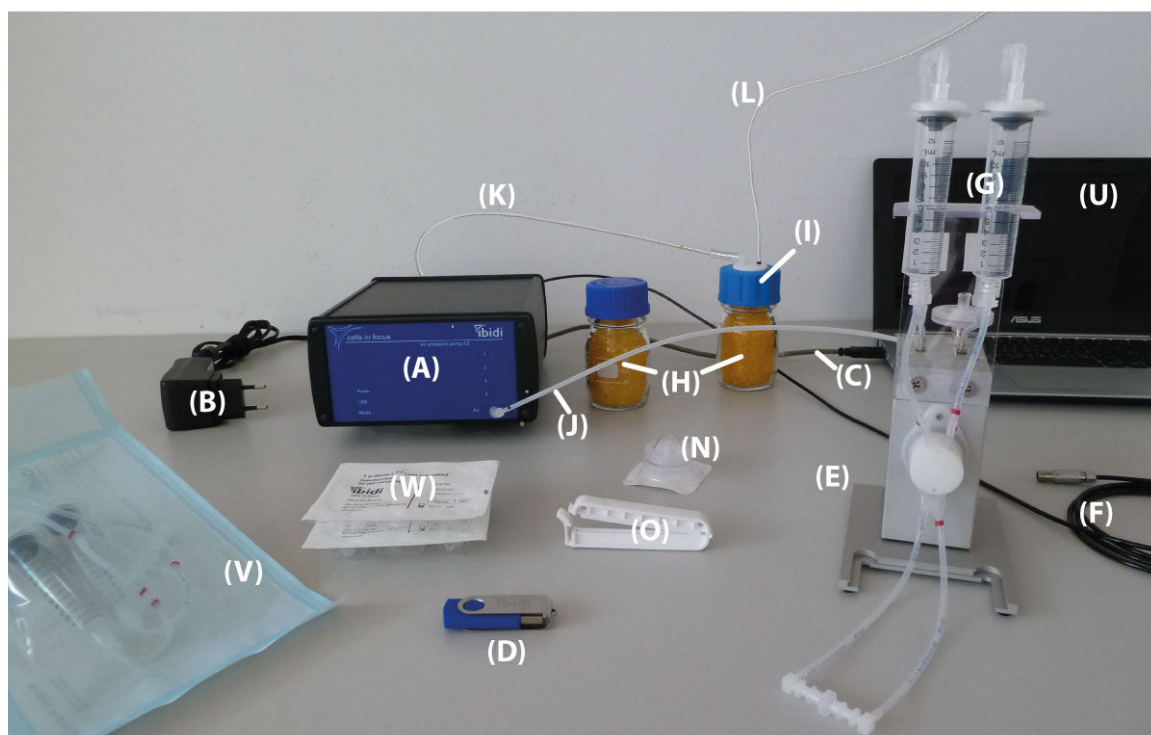

Figure 1: Basic equipment set with one ibidi Pump and one Fluidic Unit.

- | | |
|--|---|
| (A) ibidi Pump | (I) Connection cap for the drying bottle |
| (B) External Power Supply (country specific) for the ibidi Pump | (J) Air pressure tubing (2 m) to connect the pump to the Fluidic Unit (positive pressure) |
| (C) USB cable to connect the pump to your PC | (K) Short, yellow-marked air pressure tube (0.6 m); rigid air tube to connect the pump to the drying bottle |
| (D) USB thumb drive with the latest PumpControl software | (L) Long, black-marked air pressure tube (2.1 m); rigid air tube to connect the drying bottle to the inside of the incubator. |
| (E) Fluidic Unit(1-4 s) with Reservoir Holder(s) | (M) Filter for the drying bottle (inside the bottle, not shown) |
| (F) Fluidic Unit cable(1-4 s) to connect Fluidic Unit(s) and Pump (length 2 m) | (N) Sterile replacement filter (1 per Fluidic Unit) |
| (G) Non-sterile Perfusion Set(1-4 s) | |
| (H) Drying bottles filled with orange Silica beads (2) | |

(O) Hose clip (1 per Fluidic Unit)

(S) Oscillatory Flow Kit for 2 Fluidic Units (not shown)

The following parts are provided, but are only needed for experiments using more than one Fluidic Unit:

(T) Oscillatory Flow Kit for 4 Fluidic Units (not shown)

(P) Air Pressure Splitter Set for 2 Fluidic Units (not shown)

The following parts must be ordered separately:

(Q) Air Pressure Splitter Set for 3 Fluidic Units (not shown)

(U) Computer with preinstalled PumpControl software

(R) Air Pressure Splitter Set for 4 Fluidic Units (not shown)

(V) Sterile Perfusion Sets

(W) Sterile μ -Slides Luer Type

1.2 ibidi Pump

The ibidi Pump can generate air pressure up to 100 mbar. The most precise working range is 5 to 95 mbar. Additionally, the pump can set the air flow direction. When using positive pressure, the pump will expel air from the front port, and take in from the rear port. When using negative pressure the pump will take in air from the front port and expel from the rear port. The use of positive or negative pressure or air flow is detailed in Section 6.2. Optimal conditions are achieved using positive pressure for experiments. In addition to the generation of air pressure, the ibidi Pump controls the switching times of the Fluidic Unit(s). Up to four Fluidic Units can be controlled simultaneously with one pump. The pump requires a supply voltage of 14 V DC. The communication to the computer is achieved via a double shielded USB interface (see also Section 8.4.3).



Figure 2: ibidi Pump front side with air pressure front port and status LEDs.



Figure 3: Rear view of the ibidi Pump with air rear port, connections for the USB, power supply port, and electrical cables ports to the Fluidic Units.

1.3 Fluidic Unit

The Fluidic Unit holds Perfusion Set (fluidic reservoirs and tubing), and performs the switching operations to generate the unidirectional constant flow in the flow chamber. The Fluidic Unit (Figure 4) active components are the two switching valves (V1) and (V2). There are two connectors in the rear of the Fluidic Unit, one electric connection for the valve control and another for the pressurized air. Both connect the Fluidic Unit to the ibidi Pump.

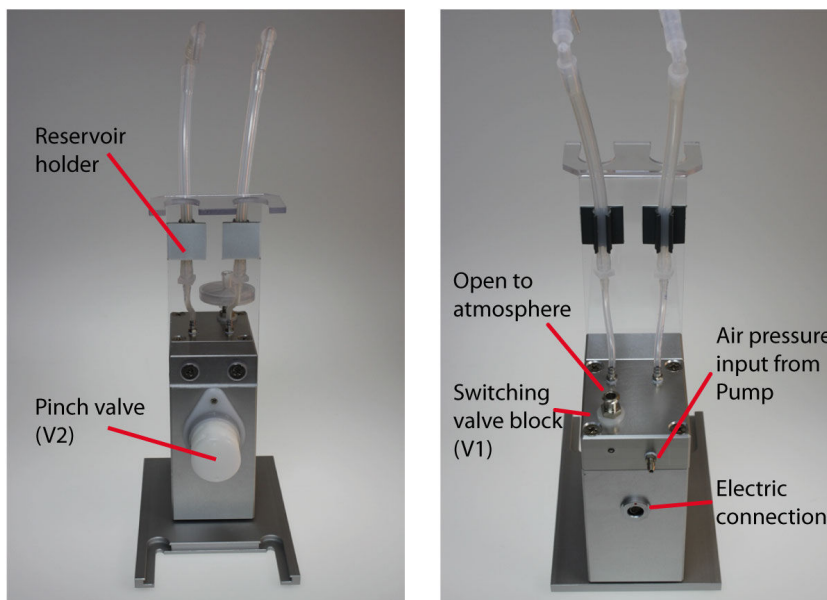

Figure 4: Front and back view of the Fluidic Unit.

The Fluidic Unit can be equipped with a choice of one of three holder sizes, for the respective syringe reservoir sizes. The Reservoir Holder can easily be exchanged by the user. The standard reservoirs are indicated in Table 2 on page 24.

Table 1: Overview of Reservoir Holders and compatible Perfusion Sets and Filter/Reservoir Sets

Reservoir Holder	Cat. No.	Compatible Perfusion Sets	Cat. No.
for Fluidic Unit, 10 ml	10976	Perfusion Set RED	10962
		Perfusion Set YELLOW/GREEN	10964
		Perfusion Set BLUE	10961
		Perfusion Set WHITE	10963
		Filter/Reservoir Set, 10 ml	10971
for Fluidic Unit, 2 ml	10977	Perfusion Set YELLOW	10965
		Perfusion Set BLACK	10966
		Filter/Reservoir Set, 2 ml	10972
for Fluidic Unit, 50 ml	10978	Filter/Reservoir Set, 50 ml	10974

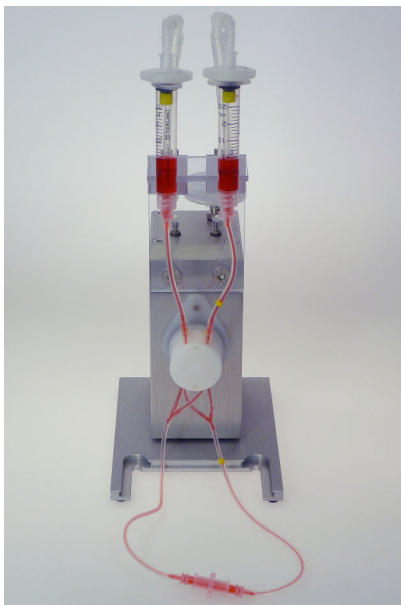

Figure 5: 2 ml syringe reservoirs

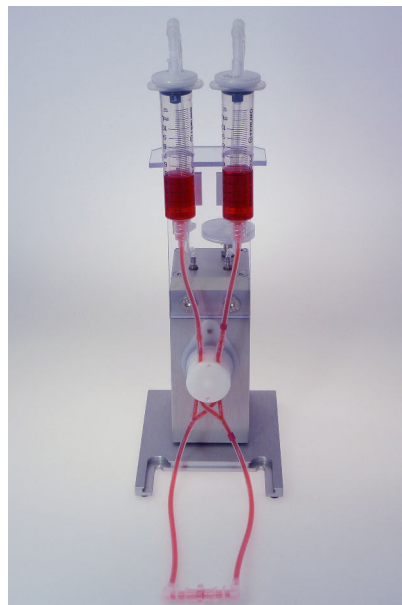

Figure 6: 10 ml syringe reservoirs

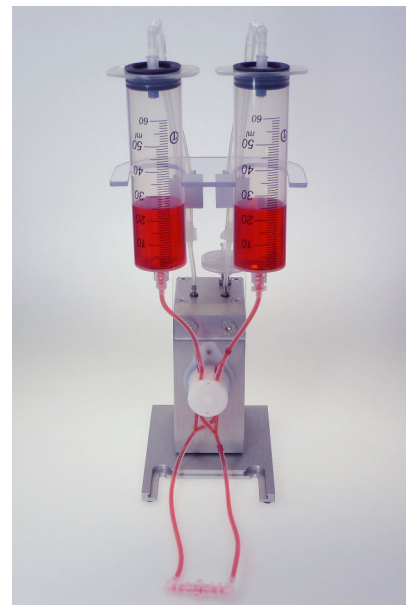

Figure 7: 50 ml syringe reservoirs

Important!

To clean the Fluidic Unit, wipe the outside with an alcohol soaked paper towel. Never spray disinfectant directly on the unit, which could damage the valve electronics.

1.3.1 The Valve Block

The valve block (V1) is located on top of the aluminum block of the Fluidic Unit. The function of the valve is to guide the air pressure either to the right or left reservoir. The valve block is a magnetic valve. Be careful not to draw any liquid into this valve!

1.3.2 The Pinch Valve

The pinch valve (V2) is on the front of the Fluidic Unit. Its function is to squeeze the tubing that is inserted into the slots. The valve provides four slots, and therefore four pieces of tubing can be

inserted at once. The valve operates with a bar that is either pushed or pulled. Therefore, either the two tubings in front slots or the two tubings in the rear slots are closed, which are the two switching states of the pinch valve.

Important!

The pinch valve must never come in contact with liquids. If medium or any other liquid contacts the pinch valve, proper function is no longer guaranteed.

1.4 Perfusion Sets

The disposable Perfusion Sets are supplied in a gas-permeable sterile package. The tubing is color-coded for easy identification. The Perfusion Sets are specifically designed for use with the Fluidic Unit. However, the Luer adapters can be connected to any suitable flow chamber with Luer connectors.



Figure 8: Sterile packaged Perfusion Set

Perfusion Set Parts: (Figure 9)

- (a) Sterile air filters, modified (0.2 µm, Teflon)
- (b) Syringe reservoirs
- (c) Silicone tubing
- (d) Branched tubes for insertion in pinch valves
- (e) Luer adapters to the slide
- (f) Female Luer Coupler for setup without slide

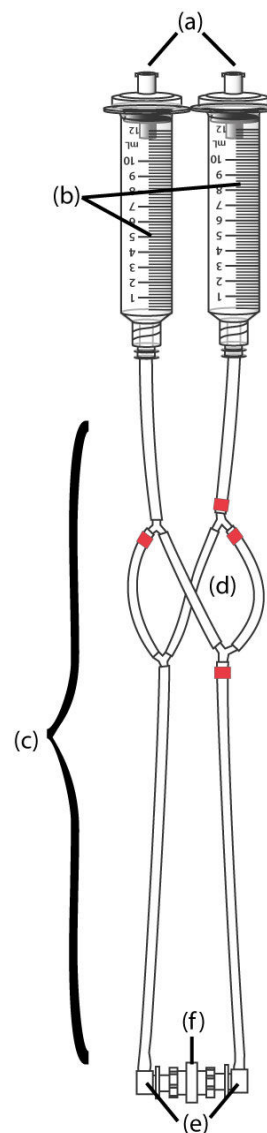

Figure 9: Description of the Perfusion Set parts.

Perfusion Set Types: The Perfusion Sets are available with multiple inner diameters and tubing lengths.

Table 2: Characteristics of the Perfusion Sets

Perfusion Set color code	ID Tubing	Tube Length	Total Working Volume	Dead Volume Tubing	Syringe Reservoir Size
Perfusion Set RED	1.6 mm	15 cm	12.3 ml	1.5 ml	10 ml
Perfusion Set YELLOW/GREEN	1.6 mm	50 cm	13.6 ml	2.8 ml	10 ml
Perfusion Set BLUE	0.8 mm	15 cm	11.3 ml	0.5 ml	10 ml
Perfusion Set WHITE	0.8 mm	50 cm	11.7 ml	0.9 ml	10 ml
Perfusion Set YELLOW	0.5 mm	15 cm	2.5 ml	0.5 ml	2 ml
Perfusion Set BLACK	0.5 mm	50 cm	11.3 ml	0.5 ml	2 ml

Sterilization and cleaning: All parts of the Perfusion Sets can be cleaned and sterilized by different techniques. Syringes, filters and slides are not autoclavable and must be removed before autoclaving or replaced with new parts. Replacement reservoirs (Filter/Reservoir Sets) are available for purchase (#10971 for 10 ml reservoirs, #10972 for 2 ml reservoirs). Best results are achieved when new Perfusion Sets are used for every experiment.

Table 3: Sterilization Compatibilities of the Perfusion Sets

	Autoclavable	Ethanol	Ethylene oxide
Filters	no	yes	yes
Syringe reservoirs	no	yes	yes
Tubing	yes	yes	yes
PP adapters	yes	yes	yes
μ -Slide	no	yes	yes

1.5 ibidi μ -Slides

For flow applications, μ -Slides with different coatings and characteristics are available. All ibidi Channel Slides provide female Luer adapters for an easy connection to any flow setup.

The μ -Slide I Luer provides a single channel for all types of flow assays. Different versions of channel heights are available.

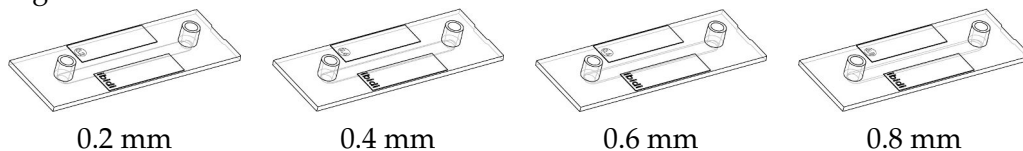

The μ -Slide VI ^{0.4} provides female Luer adapters and six independent channels for general flow assays.

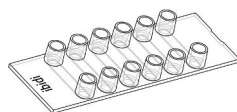

The μ -Slide y-shaped consists of a channel with a bifurcation for flow assays within inhomogeneous fields of shear stress.

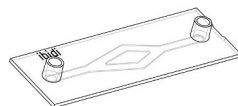

The μ -Slide VI^{0.1} provides female Luer adapters and six independent micro-channels for general flow assays.

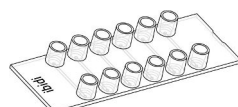

An overview of all available types is detailed in the following tables.

Table 4: ibidi channel slides, suitable for the connection to the pump system

ibidi Channel Slides to use with 10 ml Perfusion Sets				
	Channel Height	Channel Volume	Growth Area	Coating Area
μ -Slide I ^{0.2} Luer	0.2 mm	50 μ l	2.5 cm ²	5.2 cm ²
μ -Slide I ^{0.4} Luer	0.4 mm	100 μ l	2.5 cm ²	5.4 cm ²
μ -Slide I ^{0.6} Luer	0.6 mm	150 μ l	2.5 cm ²	5.6 cm ²
μ -Slide I ^{0.8} Luer	0.8 mm	200 μ l	2.5 cm ²	5.8 cm ²
μ -Slide VI ^{0.4}	0.4 mm	30 μ l	0.6 cm ²	1.2 cm ²
μ -Slide y-shaped	0.4 mm	110 μ l	2.8 cm ²	5.6 cm ²

ibidi Channel Slide to use with 2 ml Perfusion Sets				
	Channel Height	Channel Volume	Growth Area	Coating Area
μ -Slide VI ^{0.1}	0.1 mm	1.7 μ l	0.17 cm ²	0.34 cm ²

1.6 Slide and Perfusion Set Selection Guide

To set up an successful experiment, select a suitable Perfusion Set and μ -Slide for the specific application. In addition to shear stress, consider parameters, such as working volume, dead volume, and tubing length.

For the first experiment in a demo run, a red Perfusion Set (#10962) with an inner diameter of 1.6 mm and a μ -Slide I^{0.6} Luer is recommended.

An overview of all available flow rates and shear stresses are detailed in the following table with guideline values valid for standard cell culture medium at 37°C. The MIN values are based on the recommended minimal working pressure of 5 mbar. The MAX values are based on the recommended maximal working pressure of 95 mbar.

Important!

All flow rates and shear stresses are indicated for the viscosity of a standard medium at 37°C (0.0072 dyn s/cm²)!

Table 5: Flow rate and shear stress ranges of combinations of Perfusion Sets and ibidi Channel Slides.

Perfusion Set Blue				
	Flow rate		Shear stress	
	Min.	Max.	Min.	Max.
μ -Slide I ^{0.2} Luer	0.58 ml/min	5.4 ml/min	2.2 dyn/cm ²	19.9 dyn/cm ²
μ -Slide I ^{0.4} Luer	0.83 ml/min	7.0 ml/min	0.79 dyn/cm ²	6.7 dyn/cm ²
μ -Slide I ^{0.6} Luer	0.89 ml/min	7.1 ml/min	0.38 dyn/cm ²	3.1 dyn/cm ²
μ -Slide I ^{0.8} Luer	0.89 ml/min	7.1 ml/min	0.22 dyn/cm ²	1.8 dyn/cm ²
μ -Slide VI ^{0.4}	0.90 ml/min	7.1 ml/min	1.1 dyn/cm ²	9.0 dyn/cm ²
μ -Slide y-shaped	0.86 ml/min	7.2 ml/min	1.4 dyn/cm ²	11.8 dyn/cm ²
Without any Slide	0.86 ml/min	6.9 ml/min	–	–

Perfusion Set Red				
	Flow rate		Shear stress	
	Min.	Max.	Min.	Max.
μ -Slide I ^{0.2} Luer	2.0 ml/min	22.6 ml/min	7.5 dyn/cm ²	83.3 dyn/cm ²
μ -Slide I ^{0.4} Luer	4.2 ml/min	39.2 ml/min	4.0 dyn/cm ²	37.1 dyn/cm ²
μ -Slide I ^{0.6} Luer	4.4 ml/min	41.3 ml/min	1.9 dyn/cm ²	17.9 dyn/cm ²
μ -Slide I ^{0.8} Luer	4.4 ml/min	41.5 ml/min	1.1 dyn/cm ²	10.4 dyn/cm ²
μ -Slide VI ^{0.4}	4.4 ml/min	41.7 ml/min	5.6 dyn/cm ²	52.9 dyn/cm ²
μ -Slide y-shaped	4.1 ml/min	37.9 ml/min	6.8 dyn/cm ²	62.1 dyn/cm ²
Without any Slide	4.5 ml/min	42.3 ml/min	–	–

Perfusion Set White				
	Flow rate		Shear stress	
	Min.	Max.	Min.	Max.
μ-Slide I ^{0.2} Luer	0.31 ml/min	2.7 ml/min	1.1 dyn/cm ²	9.9 dyn/cm ²
μ-Slide I ^{0.4} Luer	0.35 ml/min	3.1 ml/min	0.33 dyn/cm ²	2.9 dyn/cm ²
μ-Slide I ^{0.6} Luer	0.36 ml/min	3.1 ml/min	0.16 dyn/cm ²	1.4 dyn/cm ²
μ-Slide I ^{0.8} Luer	0.36 ml/min	3.1 ml/min	0.09 dyn/cm ²	0.78 dyn/cm ²
μ-Slide VI ^{0.4}	0.33 ml/min	3.1 ml/min	0.42 dyn/cm ²	3.9 dyn/cm ²
μ-Slide y-shaped	0.36 ml/min	3.1 ml/min	0.59 dyn/cm ²	5.0 dyn/cm ²
Without any Slide	0.39 ml/min	3.2 ml/min	–	–

Perfusion Set Yellow/Green				
	Flow rate		Shear stress	
	Min.	Max.	Min.	Max.
μ-Slide I ^{0.2} Luer	1.6 ml/min	20.1 ml/min	6.1 dyn/cm ²	74.1 dyn/cm ²
μ-Slide I ^{0.4} Luer	3.1 ml/min	30.6 ml/min	2.9 dyn/cm ²	29.0 dyn/cm ²
μ-Slide I ^{0.6} Luer	3.2 ml/min	32.4 ml/min	1.4 dyn/cm ²	14.0 dyn/cm ²
μ-Slide I ^{0.8} Luer	3.4 ml/min	35.7 ml/min	0.8 dyn/cm ²	8.9 dyn/cm ²
μ-Slide VI ^{0.4}	3.3 ml/min	34.2 ml/min	4.2 dyn/cm ²	43.3 dyn/cm ²
μ-Slide y-shaped	3.1 ml/min	31.4 ml/min	5.1 dyn/cm ²	51.4 dyn/cm ²
Without any Slide	3.9 ml/min	42.5 ml/min	–	–

Perfusion Set Yellow				
	Flow rate		Shear stress	
	Min.	Max.	Min.	Max.
μ-Slide VI ^{0.1}	0.17 ml/min	0.74 ml/min	12.8 dyn/cm ²	56.7 dyn/cm ²

Perfusion Set Black				
	Flow rate		Shear stress	
	Min.	Max.	Min.	Max.
μ-Slide VI ^{0.1}	0.07 ml/min	0.33 ml/min	5.4 dyn/cm ²	25.7 dyn/cm ²

1.7 Computer with PumpControl Software

The ibidi Pump is controlled by the PumpControl Software that is installed on a laptop or a desktop computer. Using a laptop configured and approved by ibidi will ensure that all settings are correct. We cannot provide troubleshooting for a computer that was not set up by ibidi. The system requirements for the respective software versions are detailed in the [download section of the ibidi website](#).

2 Quick Start Guide

This section provides an overview for the standard setup components of the ibidi Pump System with one Fluidic Unit in an incubator. All steps are described in detail in Section 3 and 4.

1. Place the pump on the working bench and connect the power supply.
2. Place the computer with installed PumpControl next to the pump and connect the power supply.
3. Connect the computer to the pump via the USB cable.
4. Place the Fluidic Unit inside the incubator.
5. Connect the air front port of the pump to the air pressure input of the Fluidic Unit with the 2 m air pressure tubing.
6. Connect the Fluidic Unit port with the electric connection of the Fluidic Unit with the Fluidic Unit cable.
7. Install the drying bottle according to the instructions on page 32 and connect it to the air rear port.

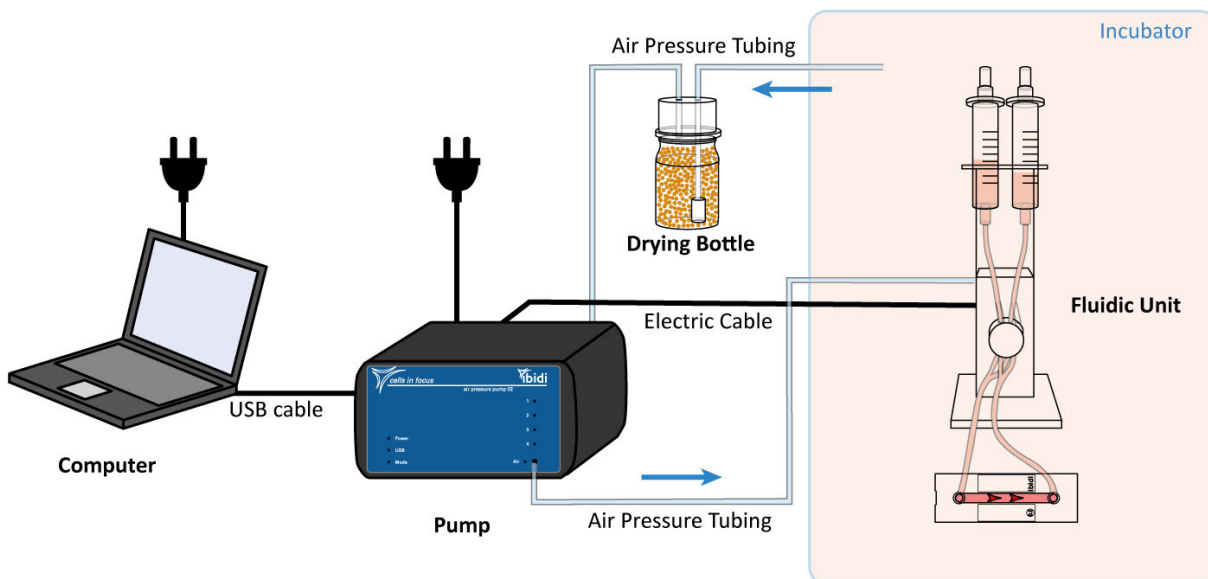

Figure 10: ibidi Pump System standard setup using positive pressure. The setup using negative pressure is shown in figure 17.

Note!

For training purposes, it is recommended to install the entire system outside the incubator, and practice controlling the flow with deionized water.

3 Basic Setup

This section details how to connect all the components for a basic setup using a 10 ml Perfusion Set. For first-time users of the ibidi Pump System, it is best to setup the system outside the incubator and practice using deionized water.

Before setting up the experiment, make sure that you have all items listed in Section 1.1.

Important!

The ibidi Pump System is intended to be used in combination with a cell culture incubator with 37°C, 5%CO₂ and 80-100% humidity!

3.1 General Setup of the Components

The computer and the pump are placed next to the incubator on a stable surface (e.g., working bench). When preparing an experiment with cells, the Fluidic Unit with the mounted Perfusion Set is placed inside the incubator. The pump remains outside and is connected to the Fluidic Unit with the electrical cable and air pressure tubing. The setup using positive pressure, which is recommended ¹, is shown in Figure 11.

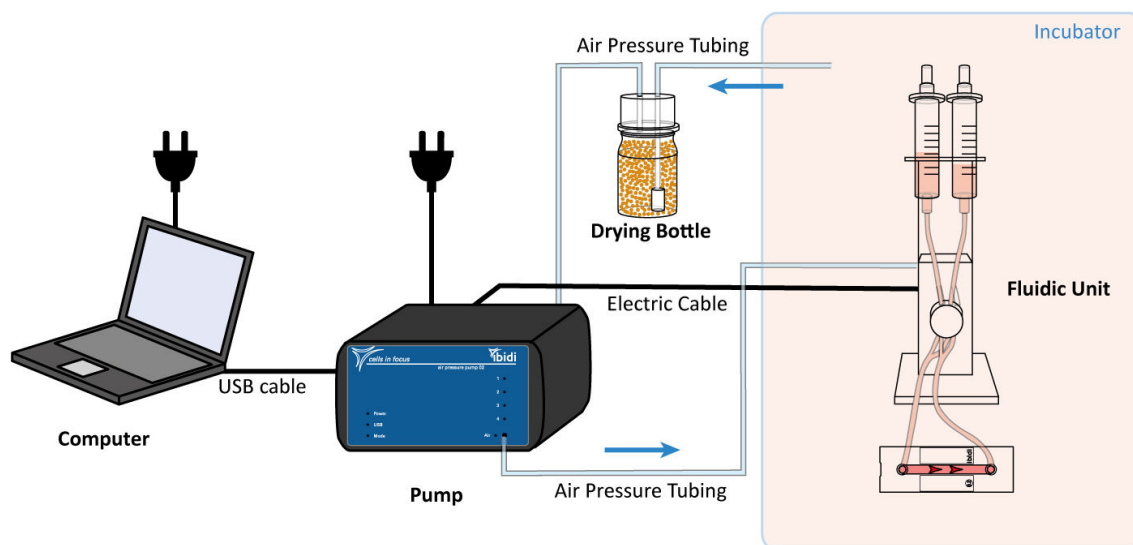

Figure 11: Positive pressure system setup of one Fluidic Unit inside the incubator. The cables and tubing are inserted through the back port of the incubator.

There are several options for leading the tubing and cable(s) inside the incubator:

- The optimal configuration is through an opening in the back of the incubator. The tubing and cable can be passed through this opening, and then sealed with a suitable modified rubber cap to prevent leakage of heat and CO₂.
- If the incubator has no back port, lead the cable and tubing through the front door. Most incubators have a rubber seal that is flexible enough to introduce the connections directly. The air pressure tubing is rigid and will not be compressed by the door.

¹The setup with negative pressure is shown in figure 17.

When working with positive pressure, the atmosphere from the incubator is drawn in through the pump’s rear port to ensure a saturation of 5% CO₂. To prevent condensation inside the pump, a drying bottle (Section 3.5) is inserted. The setup is shown in figure 11. The modified setup for negative pressure is on page 34.

3.2 Installing the PumpControl Software

The installation software for PumpControl is provided on a USB flash drive. If the setup does not auto-run after connecting the flash drive, click on the “setup.exe” file and the installation will begin. The installation includes both the PumpControl program and the runtime engine from National Instruments GmbH. Both programs will be installed following the two installation routines.

When the installation is finished and the PumpControl program is running, you will be able to program and control the ibidi Pump. The main window of the PumpControl software is shown in Figure 12. Detailed directions are in the [PumpControl instruction manual](#).

If you cannot establish communication, refer to the Troubleshooting list in Section 8.5.

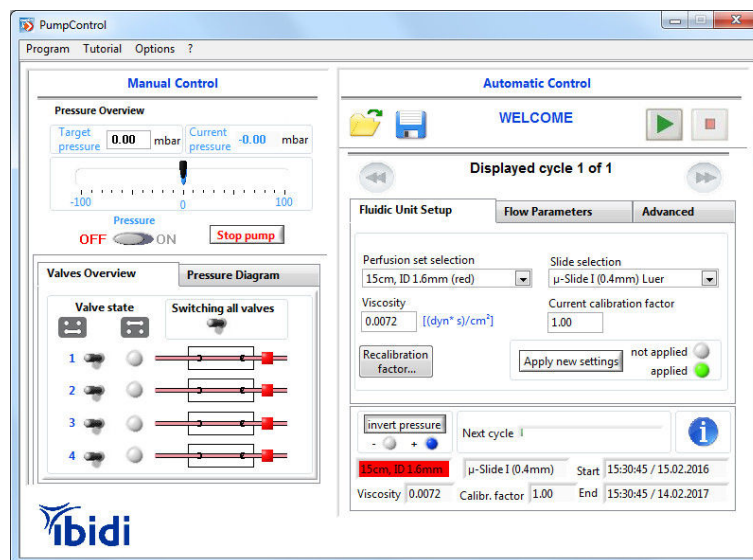

Figure 12: Main window of the PumpControl software

3.3 Connecting the ibidi Pump to the Computer

The power supply and the USB cable are included. For stability reasons, it is imperative to use the included power supply and the correct USB cable.

1. Power up the ibidi Pump with the power supply. To verify that power is connected, check the blue “Power” LED status on the front panel (Figure 13).
2. Connect the pump to the computer using the USB cable. The computer will automatically recognize the new hardware. To enable communication between the pump and the computer, two drivers are required. The drivers are automatically installed as part of the PumpControl software. After installation, the blue “USB” LED will be illuminated.



Figure 13: LEDs on the pump's front panel indicating the connected USB and power supply.

If the LED is not illuminate, refer to the Troubleshooting pages in Section 8.4.

3.4 Connecting the Fluidic Unit to the Pump

There are two connections between the pump and the Fluidic Unit:

- The Fluidic Unit cable to enable switching impulses from the pump to the Fluidic Unit.
- The air pressure tubing (2 m) that provides pressurized air to the Fluidic Unit and reservoirs.

The Fluidic Unit cable's plug is marked with a red dot that aligns with the red dot on the back of the Fluidic Unit. The other end of the electric cable is plugged into any of the Fluidic Unit ports on the back of the pump. The pump will automatically recognize which port is connected. If using positive pressure, connect the Fluidic Unit directly to the pump with the 2 m air pressure tubing (Figures 14 and 15). To ensure the correct CO₂ amount is being drawn into the pump, connect the drying bottle to the rear port of the pump and feed the second tubing into the incubator (Section 3.5).

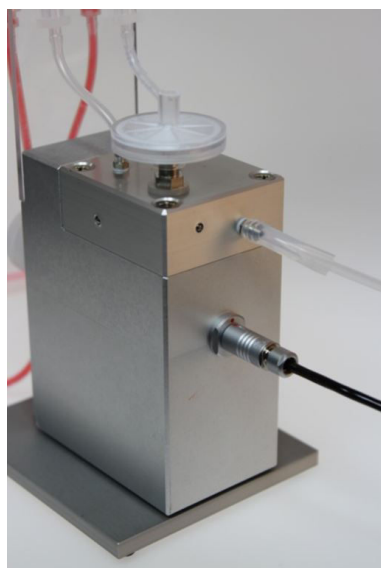

Figure 14: Rear view of the Fluidic Unit with the air pressure tubing and the electric cable connected.

3.5 Drying Bottle

The drying bottle protects the pump from moisture from the incubator. It must be inserted into the air line leading from the incubator to the pump. Failure to use the drying bottle will result in condensate inside the pump, which could damage the pump and cause it to malfunction.

3.5.1 Components of the Drying Bottle

The following parts are needed to set up the drying bottle (Figure 15):

- (A) Glass bottle with orange Silica beads
- (B) Connection cap with two openings. One opening is plugged with an Elbow Luer connector
- (C) Short yellow-marked air pressure tube (0.6 m) for connection to the pump
- (D) Long black-marked air pressure tube (2.1 m) for connection to the inside of the incubator
- (E) Drying bottle filter

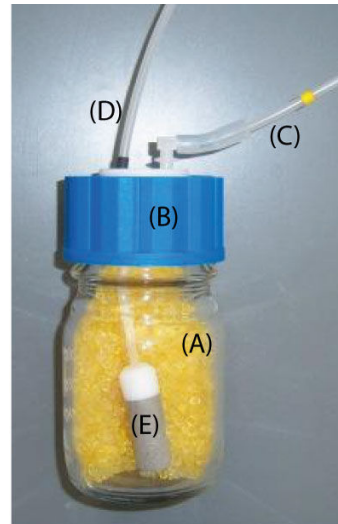

Figure 15: Components of the Drying Bottle

3.5.2 Assembling the Parts of the Drying Bottle

The drying bottle is supplied with a standard G45 cap that closes tightly. To use the drying bottle replace stock cap with the connection cap with tubing inserts.

1. Connect the yellow-marked tube to the Elbow Luer connector on the bottle cap.
2. Pass approximately 2 cm of the black-marked tube through the remaining opening of the cap until the marker reaches the cap.
3. Slide the filter on the end of the black marked tube.
4. Remove the stock cap from the drying bottle and replace it with the connection cap.
5. Turn the bottle upside down and push in the black-marked tubing until the filter reaches the bottom of the bottle.

The silica beads have an orange indicator that turns white when saturated with moisture. The silica beads can be dried and reused. Refer to Section 7.1 for detailed instructions.

3.5.3 Connection of the Air Pressure Tubing and the Drying Bottle

The drying bottle is required to protect the pump from humidity coming from the incubator. Therefore, the bottle must intersect the tubing that connects the incubator and pump.

There are two options for applying pressure (see Figures 16 and 17). The two setup options are as follows:

- Positive pressure: the pump forces air out of the front port and into the reservoirs.
- Negative pressure: the pump draws in air from the front port, and therefore from the reservoirs.

It is recommended to apply positive pressure. For details please see Section 6.2.

Positive pressure: The air is forced out by the pump into the Fluidic Unit. In this setup the air intake is from the rear port and is pumped out through the front port. To ensure that the gas mixture contains enough CO₂ it is crucial to draw in the air from inside the incubator into the rear port of the pump. However, as water vapor is also transported, the drying bottle must be integrated between the incubator and pump.

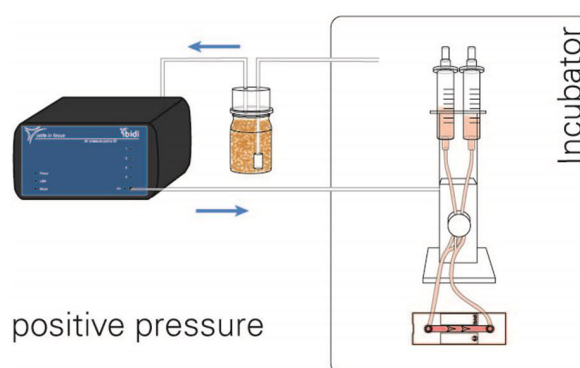

Figure 16: Setup with positive pressure.

1. Place a sufficient length of the black-marked tubing (D) inside the incubator. Make sure that liquid does not enter the tubing!
2. Connect the yellow-marked tubing (C) to the back port of the pump.
3. Connect the 2 m tubing (F) to the front port of the pump and to the Fluidic Unit (inside the incubator).

Negative pressure: The air is drawn into the pump via the Fluidic Unit from inside the incubator. Because the Fluidic Unit is placed inside the incubator where the air is saturated with CO₂, the drying bottle must be placed between the Fluidic Unit and the front port on the pump.

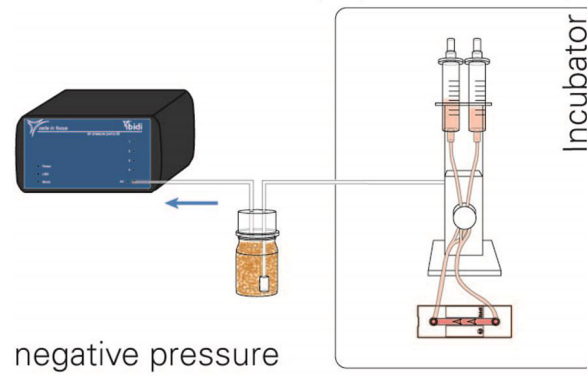

Figure 17: Setup with negative pressure.

1. Connect the black-marked tubing (D) to the Fluidic Unit (inside the incubator).
2. Connect the yellow-marked tubing (C) to the pump.

4 Setting Up an Experiment With Cells

To prepare an experiment with cells, some precautions are necessary to maintain sterility and prevent the emergence of air bubbles.

A detailed protocol for performing an experiment with HUVEC under perfusion is provided in [Application Note 13 “Endothelial Cells under Perfusion”](#).

4.1 Degassing of Slides, Tubing, and Medium

To avoid air bubbles, the degassing of all plastic components and the medium is critical. Place the slides (within the packaging), the medium for the cell seeding, and the Perfusion Set(s) (within the sterile packaging) inside the incubator one day before starting the experiment. The volume of medium needed can be added to a small vessel with a loosened cap.

This procedure is necessary because of the temperature dependency of gas solubility in water and plastic. At higher temperatures, water and plastic can absorb less gas than at lower temperatures. The solubility of O₂, N₂ and CO₂ in water is shown in Figure 18.

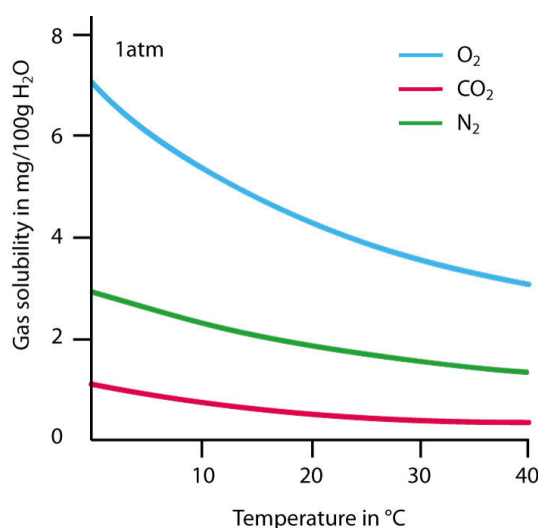

Figure 18: Solubility of O₂, N₂ and CO₂ in water at 1 atm

If components have been stored at room temperature, gases in the plastic and liquids will be released when heated in the incubator. Air bubbles will then emerge inside the slide and tubing. Degassing all plastic components before the experiment will eliminate this effect.

Important!

Each time you take the system out of the incubator, the process of gas absorption begins again. Therefore work quickly at room temperature and never leave the Fluidic Unit outside the incubator for longer than 15 minutes.

4.2 Mounting a Perfusion Set on the Fluidic Unit

Each Fluidic Unit is supplied with a non-sterile Perfusion Set for practice runs. The tubing must be inserted correctly into the valve for proper valve switching and flow direction.

To facilitate the proper insertion, the sections of the tubing are marked with colored tabs (Figure 19).

It is best to mount the Perfusion Set on the sterile working bench immediately before filling the Perfusion Set with medium.

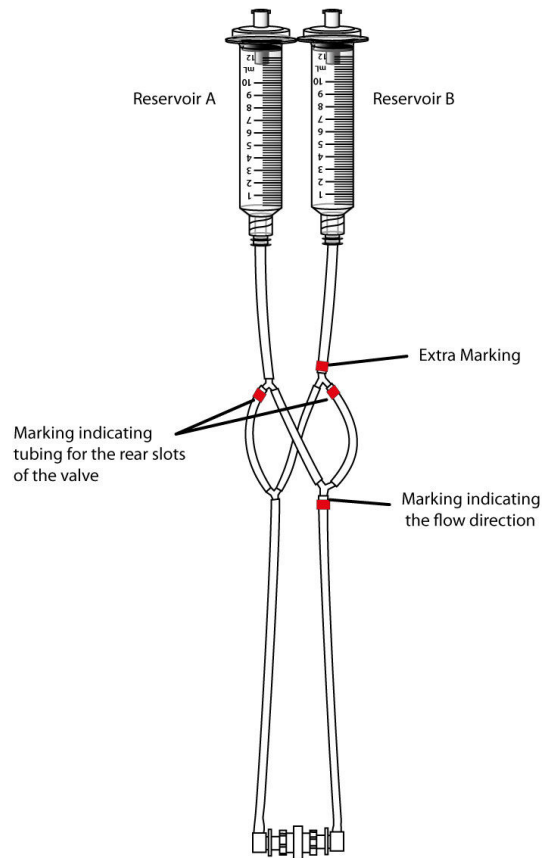

Figure 19: Colored tabs on the Perfusion Set.

To mount the Perfusion Set onto the Fluidic Unit follow these steps:

1. Place the Fluidic Unit and the packaged Perfusion Set in a laminar flow hood.
2. Open the packaging and check the Perfusion Set connections before mounting.
 - (a) Verify the connection between the reservoirs and tubing by screwing the adapters tightly into the reservoirs (Figure 20).
 - (b) Make sure the Luer adapters in the Female Luer Coupler are secure (Figure 21).

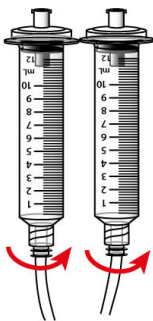

Figure 20: Screw the adapters tight into the reservoirs.



Figure 21: Secure the Luer adapters in the Female Luer Coupler.

3. Insert the reservoirs into the holder. The reservoir connected to the tubing with the extra red marking (reservoir B) must be inserted into the right side of the holder (viewed from the front). Slightly squeeze the reservoirs for easy insertion (Figure 22).
4. Begin with the valve's **right side** slots. Insert the two sections of the tubing coming from reservoir B into these slots (Figure 23).
5. Perform the same procedure for the slots on the **left side** (Figure 24).



Figure 22: Squeeze the reservoirs for insertion into the holder.



Figure 23: Insert the tubing coming from reservoir B into the right side slots. The marked tubing goes in the rear slot.

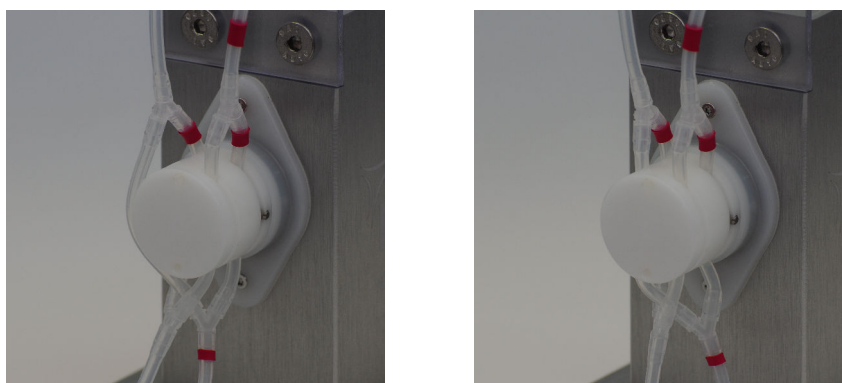

Figure 24: Insert the tubing coming from reservoir A into the left side slots. The marked tubing goes in the rear slot.

6. Check the correct position of the tubing in the openings of the pinch valve (Figure 25).

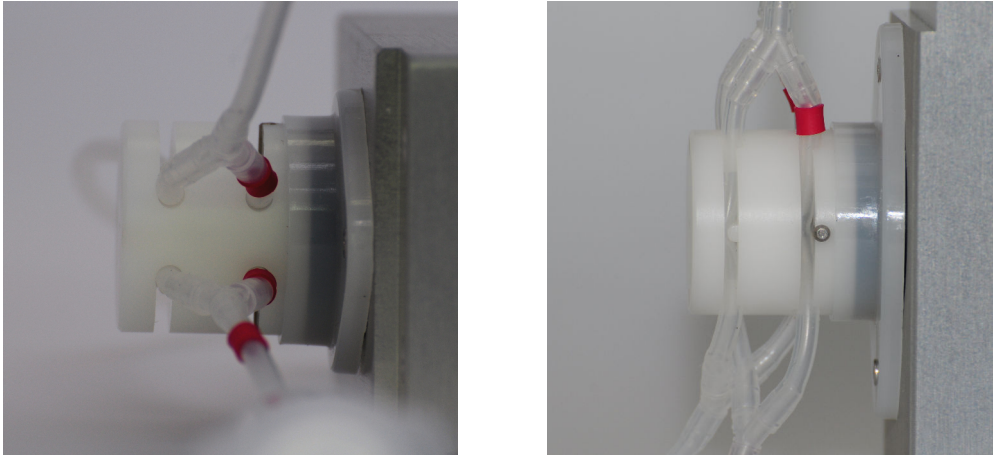

Figure 25: Top view (left) and side view (right) of properly mounted tubing in the pinch valve.

Handling Tips:

For easy mounting, stretch the tubing and move it up and down. Stretch the tubing only between the y-connectors to ensure the tubing is not disconnected (Figure 26).

Verify that the Perfusion Set is mounted correctly. Check the position of the tubing in the openings of the pinch valve. There is a pinch bolt that pinches the front or rear tubes. Make sure that the tubes are inserted such that this bolt is pinching the full diameter of the tubes by performing the pinch test with each mounted Perfusion Set (Section 4.6).

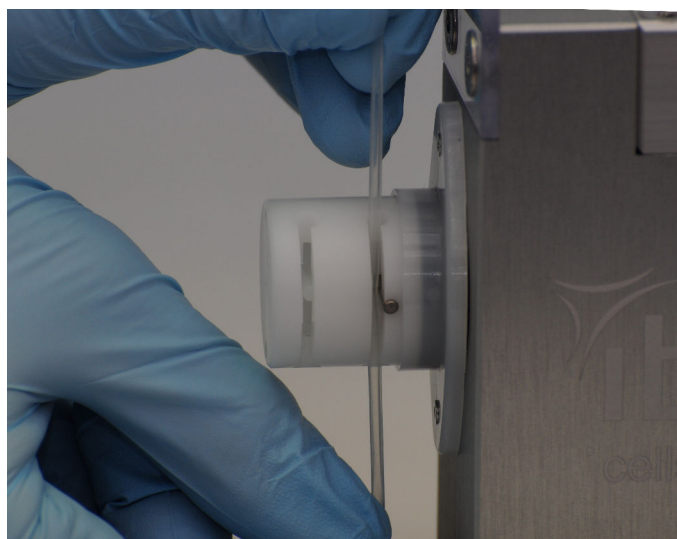

Figure 26: Move the tubing up and down while stretching for easy placement into the valve slots.

4.3 Filling the Perfusion Set with Medium

To maintain sterility inside the Perfusion Set, do not disconnect any adapter between the tubing or the reservoir filters. When filling medium into the Perfusion Set or exchanging the medium, place the Fluidic Unit with the mounted Perfusion Set in a laminar flow hood.

1. Place the Fluidic Unit with the mounted Perfusion Set in a laminar flow hood.
2. Connect the air pressure tubing to the sterile filters on the syringes and then pull off both filters from the syringe (Figure 27).
3. Fill in the required amount of medium appropriate for the Perfusion Set being used (Figure 28). The correct amount of medium is indicated in table 2 on page 24.
4. Remove the air bubbles from the Perfusion Set either by running an automated cycle or by using the pre-defined protocol in the PumpControl software as described in Section 4.6.



Figure 27: Connect the filters of the Perfusion Set to the Fluidic Unit tubing.

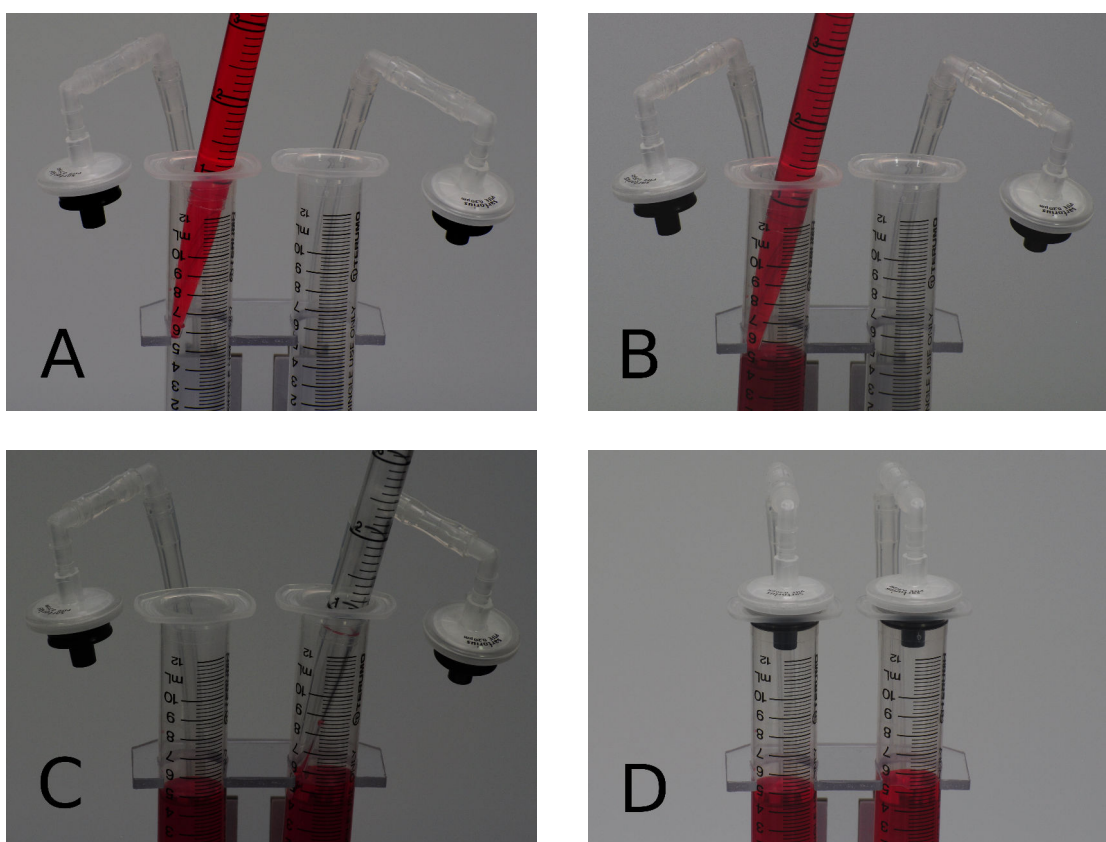

Figure 28: Fill the syringe reservoirs with medium to equal levels and connect the filters to the reservoirs again.

4.4 Sterility

All disposable parts are supplied sterile. The Fluidic Unit can be cleaned by wiping with 70% ethanol. For degassing, place the packaged slide or Perfusion Set in the incubator. The sterility is maintained if the packaging is not opened. Ensure proper sterile handling while filling the reservoirs, seeding and pre-cultivating cells as described in the [Application Note 13](#). Working in sterile conditions enables an experimental setup without the need for antibiotics.

Taking pictures on the microscope does not affect sterility. Only the air pressure tubing and the electric cable are disconnected and the Fluidic Unit can be moved to the microscope. Because the tubing system remains closed, sterility is not affected.

4.5 Remove Air Bubbles from the Perfusion Set

Once the system is set up and the Perfusion Set contains medium, remove air bubbles remaining in the branched tubing arms. To protect the cells in the channel from being flushed out, it is critical to remove all air bubbles from the Perfusion Set before connecting the slide.

To remove air bubbles, start the pump with the software. Refer to the [software manual](#) for a detailed description.

1. Equilibrate the liquid levels of the two reservoirs by applying low pressure (~20 mbar) to the Fluidic Unit using the manual control panel in the PumpControl software. Control the flow direction in the reservoirs by switching the valves. When the liquid levels are equilibrated, switch the pressure off.
2. Set an automatic cycle with a high pressure (50-80 mbar) and let the cycle run for at least 5 minutes. Then check the flow tubing to confirm that all the air bubbles have been removed.
3. Once the tubing is free from bubbles, the setup is ready for connecting to the slide.

You can also load the pre-installed setup in the software “Remove air bubbles” (Tutorial → Load demo setups → Remove air bubbles) and run it for at least 5 minutes. For best results, fill the Perfusion Set with medium right after seeding the cells and let it run during the period of cell attachment.

4.6 Pinch-Test

Important!

The pinch-test must be performed with each newly inserted Perfusion Set. This test makes sure that the tubing is inserted correctly into the pinch valve.

1. Start a perfusion program with a clearly visible flow in the reservoirs (automated cycle).
2. Pinch the tubing near the slide or near the Female Luer Coupler, if the slide is not con-

nected (Figure 29).

3. Observe the movement of the liquid levels in the reservoirs. While the tubing is pinched, the liquid should stop moving in the reservoirs. Make sure you check both switching positions (State 1 and State 2). → If there is no movement, the setup is correct, otherwise check the mounting of the Perfusion Set.

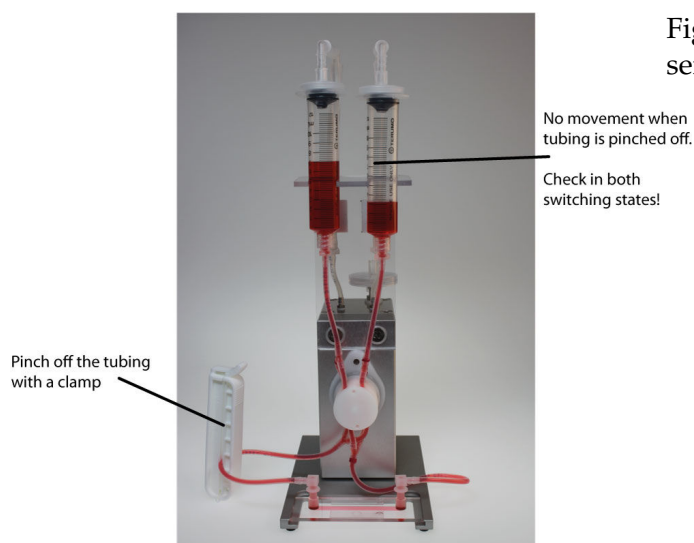

Figure 29: Pinch-test for checking the correct insertion of the tubing into the valve.

Does the liquid move (switching state 1)?: Yes No

Does the liquid move (switching state 2)?: Yes No

If the answers are “No” in both cases, the insertion is correct.

If the liquid is moving in one or both of the positions, check the insertion of the tubing in the pinch valve. Stretch the tubing and move it up and down for proper placement in the valve’s slot (Figure 26). Also check the correct allocation of the tubing (Figure 25). If this action does not correct the problem, contact ibidi or your local distributor.

4.7 Pre-Calibration of the Flow Rate

The PumpControl software provides an automatic calculation of pressure, flow rate and shear stress, once the Perfusion Set, the slide and the viscosity of the medium are set. Because of manufacturing tolerances, the values for each Perfusion Set differ slightly from the values given in the software. To obtain the required experimental flow rate, perform a system pre-calibration. The calibration procedure is detailed in Section 6.5.

For best results, perform a pre-calibration before connecting the slide to the Perfusion Set. In this step the variations of the tubing are counterbalanced. Nevertheless, it is also important to check the flow rate after connecting the slides and to do a fine-calibration, if needed (Section 4.9).

For special setups, like a custom slide, several slides in a serial connection or slides, that are not implemented in the software, perform a calibration without cells before starting the experiment (Section 5.2).

4.8 Connecting the Perfusion Set to the Slide

This section provides guides for setting up the Perfusion Set with liquid and for connecting a slide to the Perfusion Set. For a detailed description of an experiment culturing cells under flow conditions see [Application Note 13, “Endothelial Cells Under Perfusion”](#).

Three points are imperative when connecting the μ -Slide to the Perfusion Set:

- Avoid air bubbles, which can remove seeded cells from the slide.
- Maintain sterility.
- Avoid disturbance of the cells, such as strong temperature variations or fast flow impulses.

Follow these guidelines to prevent problems:

1. Once the tubing is free of bubbles, use the hose clip to clamp both tubing arms of the Perfusion Set tubes directly beneath the valve (Figure 30). This action allows the two ends of the Perfusion Set to be disconnected without emptying the medium.

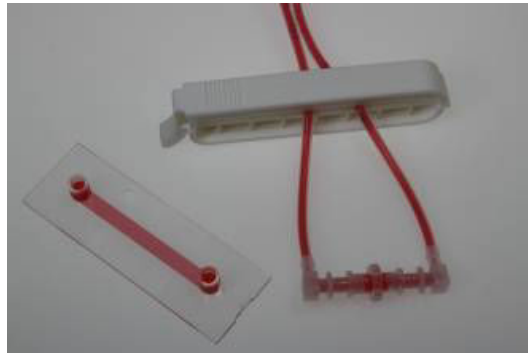

Figure 30: Clamp the tubing before opening the Female Luer Coupler of the Perfusion Set.

2. Before connecting the Perfusion Set to the μ -Slide, the reservoirs of the slide must be filled to the top to avoid the entrapment of bubbles (Figure 31). For a detailed description, refer to [Application Note 13, "Endothelial Cells Under Perfusion"](#).



Figure 31: Fill the reservoir before connecting to the Luer adapter.



Figure 32: Connect the second Luer adapter to the μ -Slide.

3. After removing the hose clip, the experiment is ready to begin.

4.9 Fine-Calibration of the Flow Rate

After connecting the slide to the Perfusion Set, a fine calibration of the flow rate is required. When using one slide per Fluidic Unit (Perfusion Set), perform a pre-calibration before connecting the slide (Section 4.7). When performing experiments using non-implemented slides or serially connected slides, perform a calibration with this special setup before starting the experiment (without cells). Enter this calibration factor in the box of the software instead of performing a pre-calibration with the Perfusion Set only.

The fine calibration procedure is the same as every other calibration step. Check the flow rate with a stop watch and calculate the calibration factor in the software as described in Section 6.5.

5 Installation of Special Setups

5.1 Installation Using Two or More Fluidic Units

This section describes using the ibidi Pump with several Fluidic Units. The setup is similar to the one Fluidic Unit setup except for the pressured air tubing. Branched air tubings for the use of two, three and four Fluidic Units are supplied with the pump. When using positive pressure, connect the Fluidic Units with the pump as shown in Figure 33 (example with 4 Fluidic Units). The rear port is connected to the drying bottle, as described in Section 3.4. Connect the Fluidic Unit cables to the Fluidic Units and the pump. Before starting the experiment, verify that all Fluidic Units are set up as described in Sections 3.4 to 4.2. For a setup with positive air pressure, the drying bottle must be installed between the rear port of the pump and the incubator (Section 3.5.3). The \times -fold branched air pressure tube is plugged directly into the front pump port.

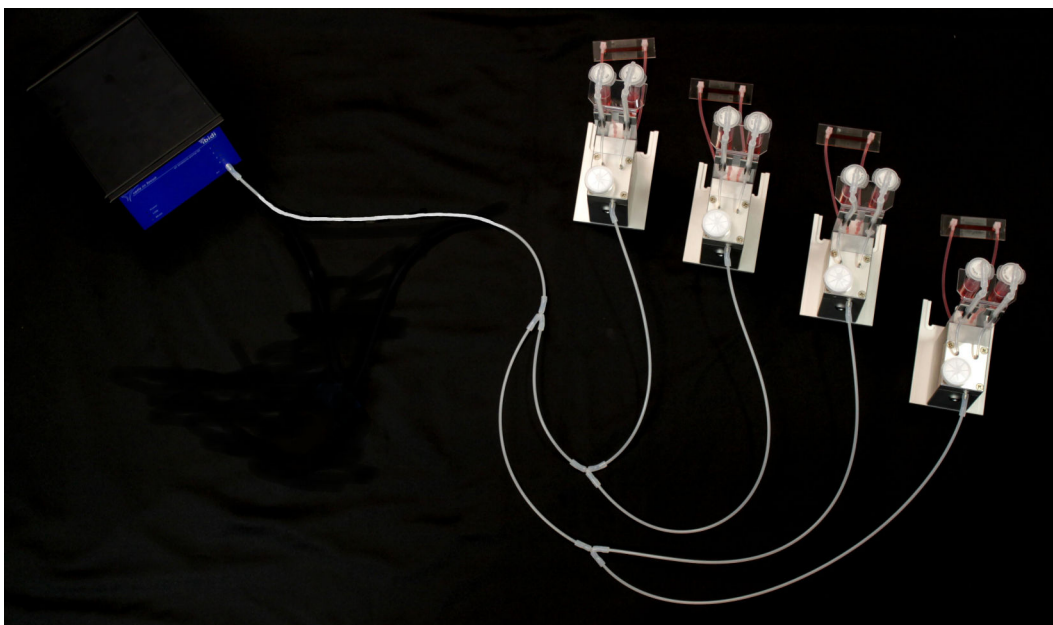

Figure 33: Connection of the ibidi Pump and four Fluidic Units.

5.2 Calibration of the Flow Rate with Several Slides in Serial Connection

A calibration before starting the experiment must be performed. When connecting several slides to one Fluidic Unit, resistance to the flow is increased, and therefore, the flow rate decreases. Because the difference could be significant, it is critical to measure the calibration factor in advance and to perform only a fine calibration after connecting the slides.

The calibration procedure is the same as described in Section 6.5. See [Application Note 25 “Serial Connection of Flow Chambers”](#) for an instruction how to connect several slides serially.

5.3 Instructions for Oscillatory Flow Experiments

For oscillatory flow applications, at least two Fluidic Units are required (one “master” and one “slave” Fluidic Unit) to separate the switching times of the two Fluidic Unit valves, switching simultaneously in unidirectional flow. The basic principle is such that the master Fluidic Unit has a long switching time t_{master} . During t_{master} the master Fluidic Unit supplies a constant air flow to one reservoir of the slave Fluidic Unit. The switching time of the slave Fluidic Unit t_{slave} can be set as a fraction of t_{master} . The flow direction is reversed each time the slave Fluidic Unit switches the valve. The master Fluidic Unit switches the air flow to the reservoirs, before the reservoirs run dry.

As a result, the setup is where one Fluidic Unit creates a unidirectional flow and one supplies oscillatory flow within the μ -Slide channel. Because only one controlling master Fluidic Unit is needed and the pump can control up to four Fluidic Units, the setup can operate up to three oscillatory slave Fluidic Units.

Important!

The lifespan of Perfusion Set’s silicone tubing is dependent on the number of switching events. The material fatigues after 300 000-500 000 pinching cycles. To prolong the lifespan of the tubing, change the position of the tubing inside the valve slightly.

For best results, do not reuse the Perfusion Sets, because material fatigue is compounded with use.

Table 6: Possible setups of oscillatory flow depending on the number of available Fluidic Units

Number of Fluidic Units	Possible setups
2 Fluidic Units	1 master, 1 slave
3 Fluidic Units	1 master, 2 slaves or 1 master, 1 slave, 1 independent
4 Fluidic Units	2 masters, 2 slaves or 1 master, 3 slaves

Note that the master Fluidic Unit can only be used for unidirectional flow experiments. All slave Fluidic Units can reverse the flow direction with switching times set by the PumpControl software.

5.3.1 Setting up the Fluidic Units

In addition to the two Fluidic Units, the respective air tubing splitters are required (Figure 34).

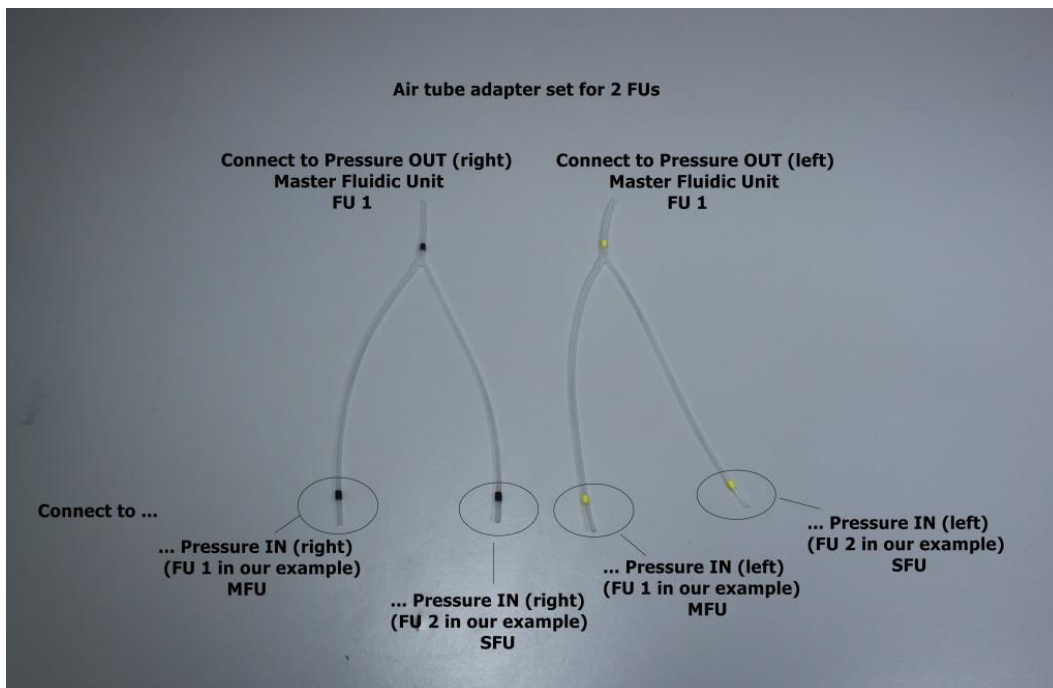

Figure 34: Air pressure splitter, for oscillatory flow for two Fluidic Units.

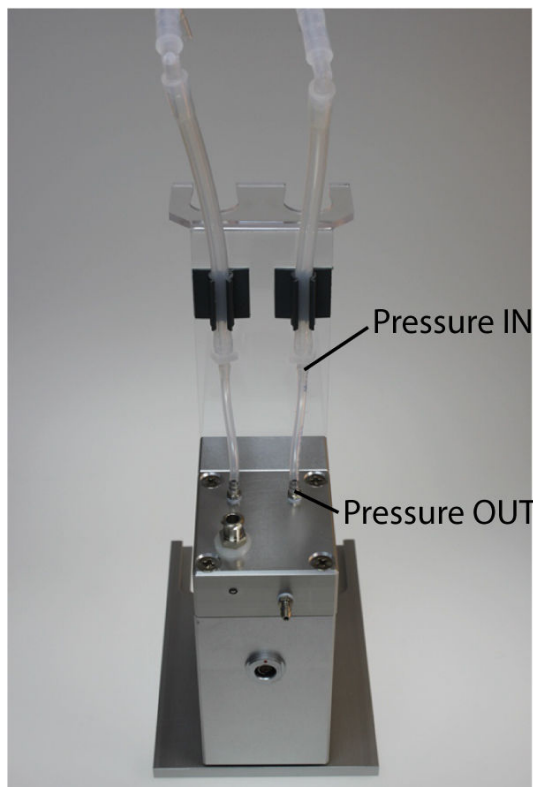

Figure 35: Parts of the Fluidic Unit

Follow the steps below for correct installation and compare with Figure 35.

1. Connect the air pressure tube of the pump to the master Fluidic Unit.
2. Use one of the splitters, such as the yellow-marked, to connect the left “Pressure OUT” port of the Master Fluidic Unit to the following:
 - (a) the left “Pressure IN” port of the master Fluidic Unit and
 - (b) the left “Pressure IN” port of the slave Fluidic Unit.
3. Repeat Step 2) with the black-marked air splitters and the right side of the master and slave Fluidic Unit.
4. Connect the pump and the two Fluidic Units with the electric cables. In this example, “Port 1” for the master Fluidic Unit and “Port 2” for the slave Unit are used (Figure 36).



Figure 36: Oscillatory flow setup with two Fluidic Units (one master and one slave).

5.3.2 Oscillatory Experiment with Four Fluidic Units

For an experiment using one master Fluidic Unit and three oscillatory slave Fluidic Units, a corresponding air pressure splitter is required (Figure 37).

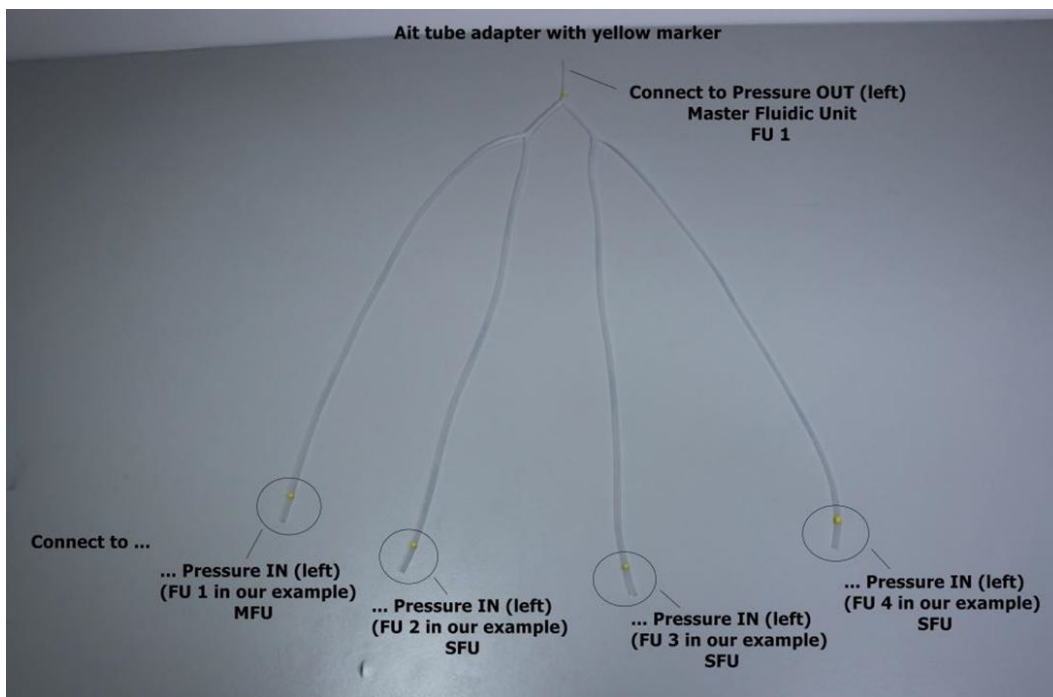

Figure 37: Air pressure splitter, for oscillatory flow for two Fluidic Units.

The setup is similar to the setup with two Fluidic Units. The air pressure is distributed by the master Fluidic Unit to the slave Fluidic Units by splitting the air pressure from the master Fluidic Unit's "Pressure OUT" to the "Pressure IN" of master and slave Fluidic Units (Figure 38).



Figure 38: Oscillatory flow setup with four Fluidic Units (one master and three slaves).

5.3.3 Settings within the PumpControl Software

Because the switching times are different for the master and the slave Fluidic Units the PumpControl software must be programmed accordingly. Set the checkboxes for “unidirectional” and “oscillatory” valves. See Figure 39 for how to correctly set the corresponding parameters.

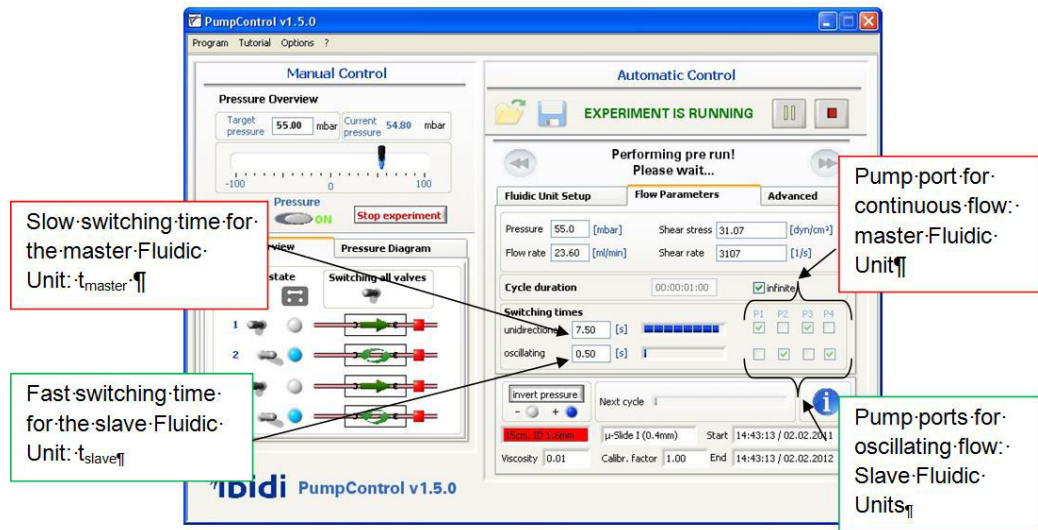

Figure 39: Settings of the PumpControl Software, when applying oscillatory flow to two master and two slave Fluidic Units.

5.3.4 Equilibrating the Master and Slave Fluidic Units

Because the master and slave Fluidic Unit(s) are connected to the same air pressure and switching time, equilibration of the liquid levels must be performed separately. To stop the liquid movement in the reservoirs of either Fluidic Unit, the Perfusion Set must be clamped with a hose clip. Adjust the reservoir liquid levels to 5 ml each and go on to the next Fluidic Unit.

Note!

Do not forget to perform a pinch-test with each Fluidic Unit (Section 4.6)!

6 Technical Details

6.1 Working Principle of the ibidi Pump

The ibidi Pump and the ibidi Fluidic Unit work together to create a unidirectional, oscillatory, or pulsatile flow of medium within ibidi channel slides. The working principle of the pump is explained in the following figure, which details air pressure, flow rate and shear stress correlations.

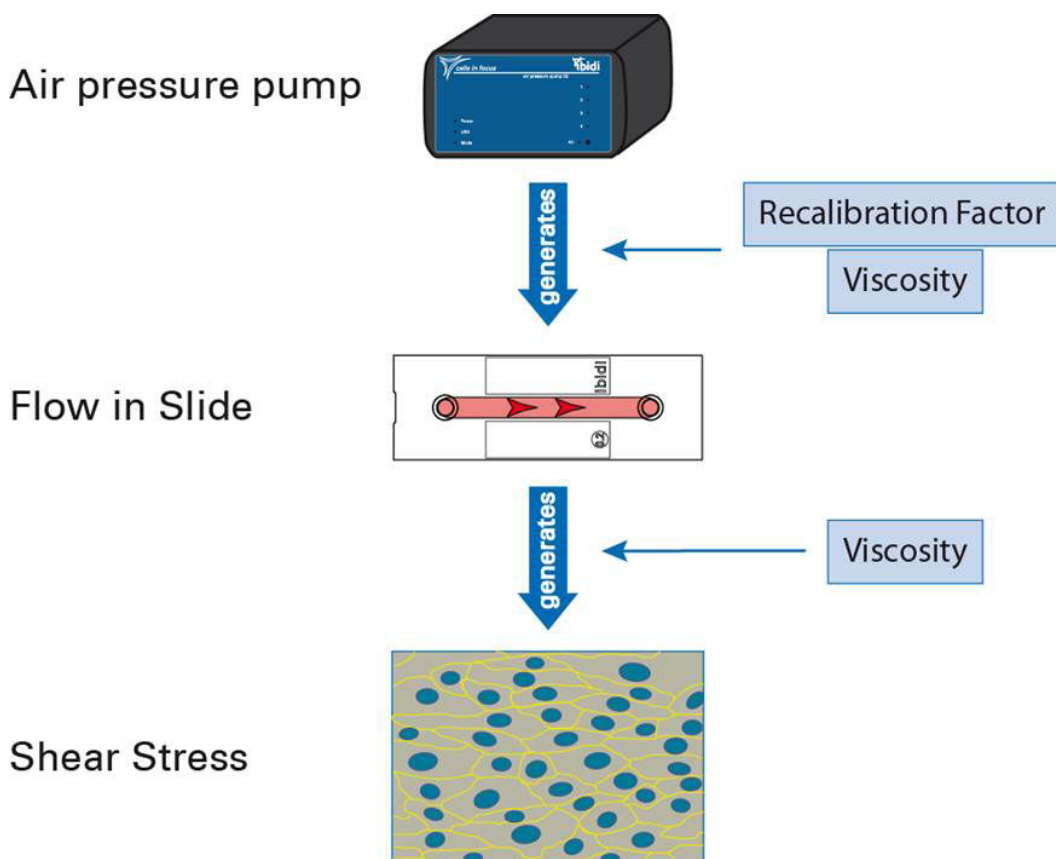

Figure 40: Working principle of flow and shear stress generation.

1. The pump generates a constant pressure (mbar) that pumps the liquid from one reservoir to the other.
2. The applied pressure results in a specific flow rate (ml/min) that is dependent on the pressure input, the viscosity of the medium, and the flow resistance of the perfusion system (tubing and slide).
3. The specific flow rate (ml/min) produces a wall shear stress (dyn/cm²) to which the cells are exposed.

The pump supplies a constant air pressure to the reservoirs of the Fluidic Unit, which generates a constant flow of medium within the ibidi channel slides. Before the reservoir runs dry, the liquid is pumped back and forth between the two media reservoirs of the Fluidic Unit. To create a unidirectional flow, two valves, labeled (V1) and (V2), are integrated in the Fluidic Unit which are switched simultaneously between two states (Figure 41).

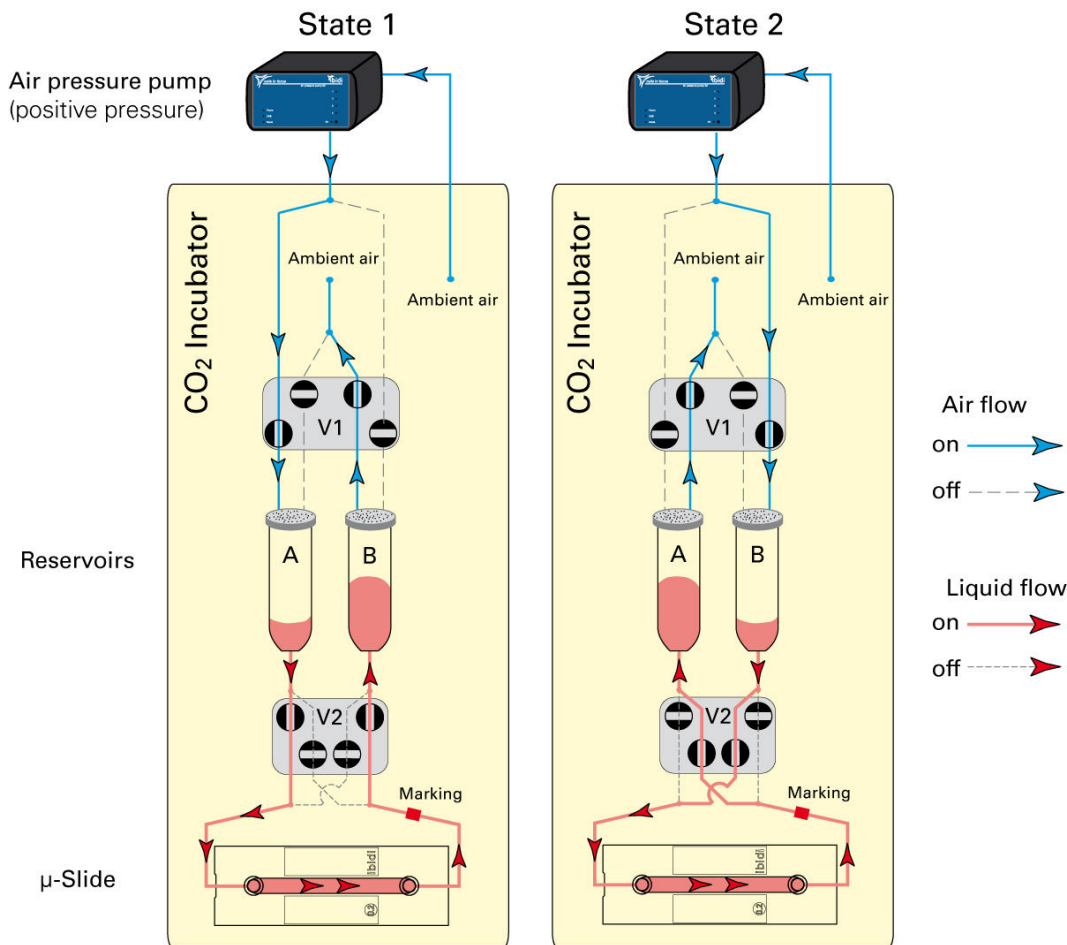

Figure 41: Working principle of the valves creating a unidirectional flow, using **positive** pressure.

Example with positive pressure In State 1, the valve (V1) is set such that the pressurized air is applied to reservoir (A), while the outlet of reservoir (B) is opened to the atmosphere. This creates a flow from reservoir (A) to reservoir (B). Valve (V2) squeezes the two tubing sections in the front slots, forcing the liquid to flow through the lower loop of the Perfusion Set. The channel is perfused from left to right.

In State 2 valve (V1) is set such that the pressurized air is applied to reservoir (B) while the outlet of reservoir (A) is opened to the atmosphere. The apparent flow direction is inverted to a flow from reservoir (B) to reservoir (A). Valve (V2) also changes state, and now pinches the two tubing sections in the rear slots, again forcing the liquid to flow through the lower loop. The crossed geometry of the Perfusion Set again directs the liquid to the channels left inlet, resulting in a perfusion from left to right.

Switching between State 1 and State 2 generates a continuous unidirectional flow of medium through the slide. Sterility is maintained by the use of air filters on top of the reservoirs. Note, that it is beneficial to supply CO₂ rich air to the medium. Therefore, the rear pump port should be connected to the incubator.

If the system is run with negative pressure, the principle remains the same, however, the flow direction is reversed (right to left).

6.2 Positive Versus Negative Air Pressure

The ibidi Pump System can be set up using positive or negative pressure. Although, best results are achieved using positive pressure, there are instances when an experiment would benefit by using negative pressure. The pros and cons of positive and negative pressure are discussed in this section.

Positive Air Pressure

When using positive air pressure, air is drawn into the ibidi Pump from the rear port. The air used to pump the medium back and forth from one reservoir to the other is filtered ambient air. Because ambient air has a low concentration of CO₂, this may not be the best atmosphere for the medium that is supplied to the cells in the μ-Slide. If the cells need a greater amount of CO₂, connect an air tube, which is part of the setup, to the inlet at the back of the pump and place the open end inside an incubator. When using this setup, make sure to use the drying bottle to prevent condensation in the pump from the warm and humid air.

Negative Air Pressure

When using negative air pressure, the pump aspirates air through the Fluidic Unit. Because the Fluidic Unit is placed inside an incubator, the air coming in contact with the medium and cells is humid and rich in CO₂. The drying bottle must be integrated between the Fluidic Unit and the pump to protect the pump from condensation.

When deciding which pressure to use, consider the following aspects. When using positive air pressure, an overpressure is created within the system. As a result, air (and also medium) is more likely to be pressed out of the system rather than drawn in. Therefore the system is less exposed to contamination or inclusion of air bubbles. Additionally the air supply is dry, which will keep the sterility filters on the Perfusion Sets dry for optimal performance. However, the setup needs additional tubing compared to the negative pressure setup.

With negative air pressure, the ambient air, that enters the reservoirs comes directly from inside the incubator and consists of the correct CO₂ concentration. However, the humid air that is drawn into through the filters could cause them to become damp and possibly blocked.

The table below shows an overview of the differences between positive and negative pressure.

	Positive Pressure (recommended)	Negative Pressure
Contamination	Less sensitive	More sensitive
CO ₂	To reach the desired CO ₂ level, gas from inside the incubator has to be connected to the pump rear port.	The incubator's atmosphere is directly applied on top of the liquid level in the reservoirs.
Air bubbles	Less sensitive	More sensitive
Performance of Perfusion Set filters	Dry air is pumped through the filters. Filters stay dry and performance loss is not likely.	Humid air is pumped through the filters. Permeability loss of filters may occur.
Physiology	More <i>in vivo</i> -like	Can barely be found <i>in vivo</i>

6.3 Flow Characteristics

Because of the geometry of the setup, the flow within the tubing and the μ -Slide channel is laminar, independent of the flow rate and type (i.e., continuous, oscillatory or pulsatile).

Working with positive pressure, the source of flow is from the tubing on the left side (front view). Applying negative pressure reverses the direction.

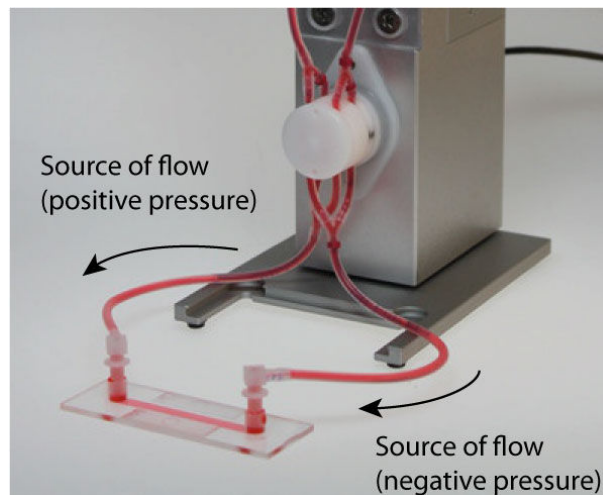

Figure 42: Source of flow with positive and negative pressure

Continuous Unidirectional Flow

The normal Fluidic Unit operation creates a continuous and unidirectional flow within the μ -Slide channel. The working principle is detailed in Section 6.1.

Oscillatory Flow

Some experiments require an oscillatory flow for simulating turbulences in vessels. These conditions are achieved by oscillatory switching of the flow direction with frequencies of approximately 2 Hz. To perform an oscillatory flow assay, at least two Fluidic Units are required. Additionally, minor tubing modifications are required to change the functionality of the Fluidic Units. With the correct setup, one Fluidic Unit will act as the “master”, which is responsible for the air pressure inside the reservoirs. The slave Fluidic Unit switches the flow direction. For more information about how to set up oscillatory flow assays, see Section 5.3.

Pulsatile Flow

To achieve pulsatile flow, two Fluidic Units are required. Contact [ibidi GmbH](#) for detailed instructions.

6.4 Viscosity

The viscosity influences the system at two points: the relationship between pressure and flow rate, and the correlation between flow rate and shear stress (Figure 46). For an exact calculation of the shear stress that the cells are being exposed to, the viscosity of the perfusion medium must be known. This information can be obtained from the supplier or by measuring the medium with a viscometer. The viscosity of water is 1 mPa s at 20°C; however, it is only 0.69 mPa s at 37°C (30 % difference!). The viscosity of water in relation to temperature is shown in Figure 43 (1 mPa s = 0.01 dyn s /cm²).

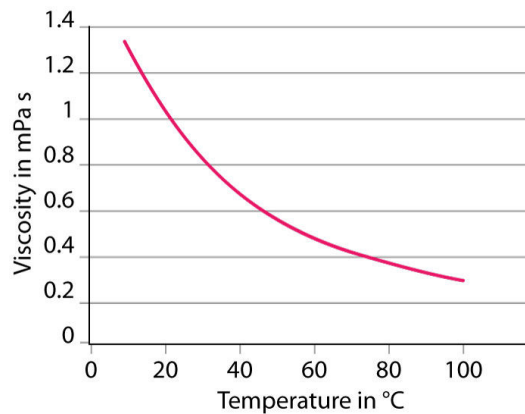

Figure 43: Viscosity of water as a function of temperature.

6.5 Flow Calibration

The PumpControl software provides an automatic calculation of pressure, flow rate and shear stress, once the Perfusion Set, the slide and the viscosity of the medium are entered. One of the three parameters (pressure, flow rate and shear stress) is chosen, and the other two parameters are automatically calculated, according to the indicated relations (calibration curve and shear stress calculation).

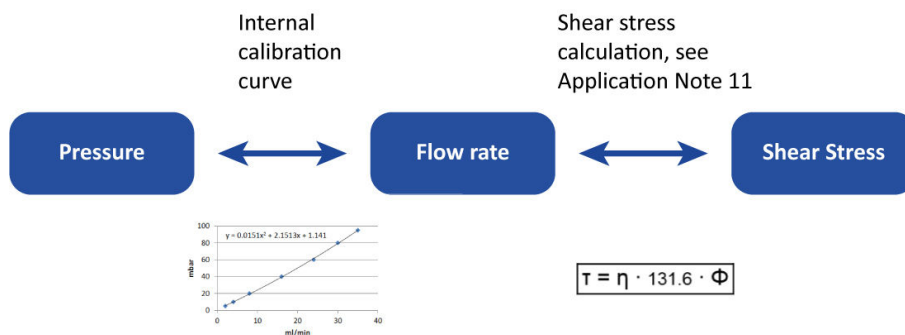

Figure 44: The correlations among pressure, flow rate and shear stress in the ibidi Pump System.

The PumpControl software is equipped with internal calibration tables for predicting the relation between pressure and flow rate. For each pair of slide and Perfusion Set, a separate calibration curve was measured. Because the tubing and the slides have small manufacture tolerances, the actual values for a specific setup might vary slightly from the values in the software. Thus, it is essential to perform a fine calibration before the experiment.

Important!

Note that the starting point of defining the experiment is the shear stress. Depending on the channel geometry and the viscosity of the medium, the relation between flow rate and shear stress is linear, according to the formula in [Application Note 11](#). Thus, after defining the shear stress, calculate the flow rate and make sure, that the correct flow rate is applied to the slide, by measuring the flow rate with a stop watch as described in Section 6.5.1.

6.5.1 Flow Rate Measurement

Based on the slide, Perfusion Set, viscosity, and shear stress required for the experiment, the flow rate must be controlled manually. The complete setup of the pump system and a stop watch are required to measure and control the flow rate.

Example measurement with a red Perfusion Set, μ -Slide I 0.4 Luer and medium at 37°C (viscosity: 0.0072 dyn*s/cm²):

Parameter	Example
Slide	μ -Slide I 0.4 Luer
Shear stress	10 dyn/cm ²
Flow rate needed	10.5 ml/min
Predicted pressure (software)	14.9 mbar

Now verify, that the system operates at this flow rate (10.5 ml/min), by measuring the flow rate as follows:

1. Set up a perfusion experiment using the tubing, slides and medium that have been equilibrated to the conditions required for the experiment.
2. Open the PumpControl software. In the first tab on the right, choose the slide and Perfusion Set from the drop-down menu. Insert a viscosity of 0.0072 dyn*s/cm² in the box. Click the “Apply Settings” button.
3. Equilibrate the fluid levels to 5 ml in both reservoirs.
4. In the second tab on the right, enter the shear stress (10 dyn/cm²) in the respective box. The flow rate and pressure are calculated automatically.
5. Run the program with an infinite time setting. The switching time should be 30 seconds.
6. Measure the time *t* (in seconds) required for the medium to flow between the 6 and 4 ml mark on the syringe (2 ml volume) with a stopwatch.

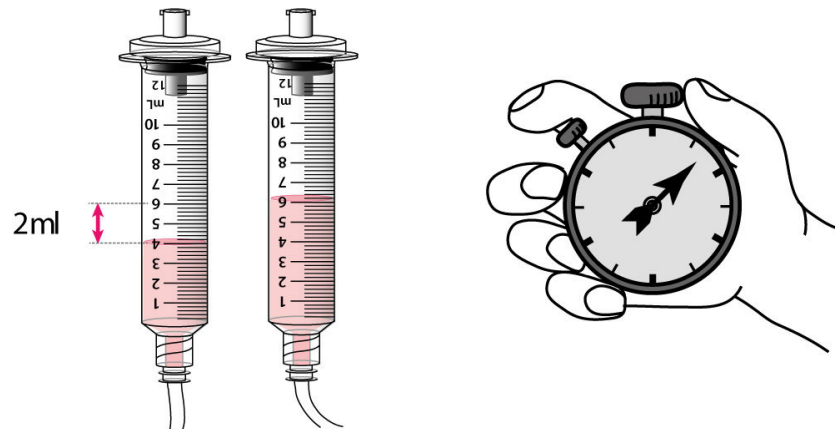

Figure 45: Equilibrate the medium to 5 ml in each syringe and measure the time of medium movement between 6 and 4 ml.

7. Conduct at least four time measurements and calculate the mean value.
8. To calculate the flow rate [ml/min], insert the time that was measured in the formula below.

$$\Phi \left[\frac{ml}{min} \right] = \frac{2ml \cdot 60 \frac{s}{min}}{t[s]} \quad (1)$$

Important!

The flow rate is temperature dependent. Perform this measurement under experimental conditions (e.g. at 37°C in the incubator).

6.5.2 Flow Calibration in the Software

Use the measured flow rate to update the PumpControl software in the “Recalibration factor” menu. Click on the “Recalibration factor” button and insert the given flow rate and the one that was measured. The software will then provide the correctly displayed flow rate, shear stress and shear rate. The recalibration factor affects the relationship between pressure and resulting flow rate (Figure 46).

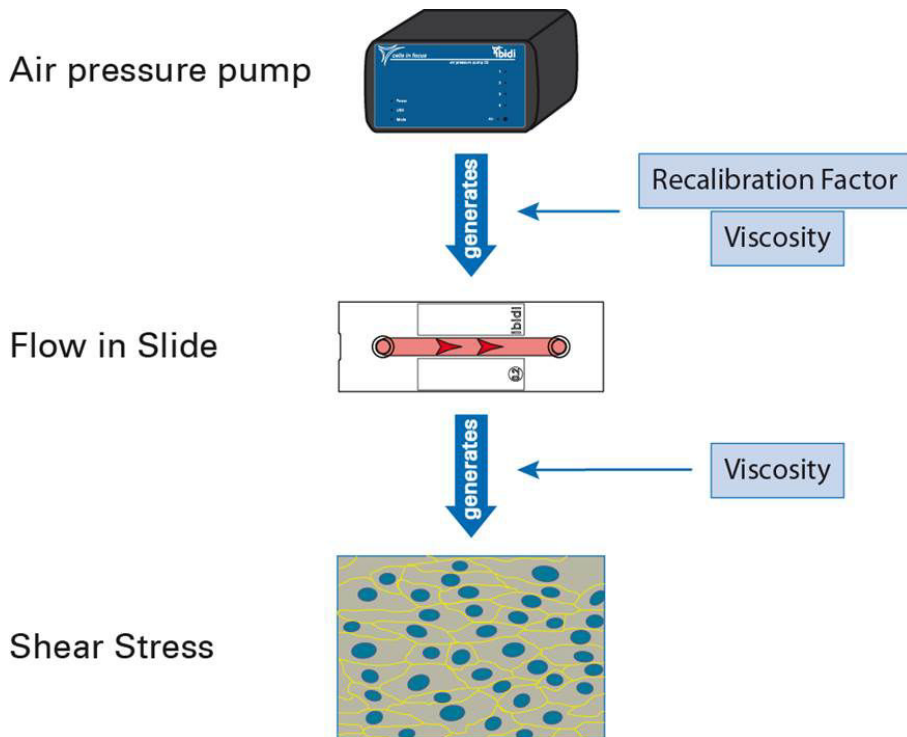
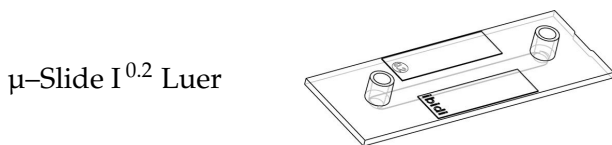

Figure 46: Influence of the calibration factor and viscosity on the parameters of the PumpControl software.

6.6 Shear Stress Calculations in ibidi Channel Slides

The wall shear stress in a μ -Slide depends on the flow rate and the viscosity of the perfusion medium. Use the following calculations to determine the flow rates for the corresponding shear stress. Detailed information is provided in [Application Note 11 “Shear Stress and Shear Rates”](#).

$$\Phi = \text{flowrate} \quad \tau = \text{shearstress} \quad \eta = \text{viscosity}$$



$$\tau \left[\frac{\text{dyn}}{\text{cm}^2} \right] = \eta \left[\frac{\text{dyn} \cdot \text{s}}{\text{cm}^2} \right] \cdot 512.9 \cdot \Phi \left[\frac{\text{ml}}{\text{min}} \right]$$

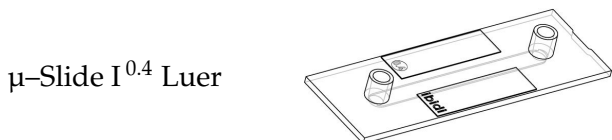

$$\tau \left[\frac{\text{dyn}}{\text{cm}^2} \right] = \eta \left[\frac{\text{dyn} \cdot \text{s}}{\text{cm}^2} \right] \cdot 131.6 \cdot \Phi \left[\frac{\text{ml}}{\text{min}} \right]$$

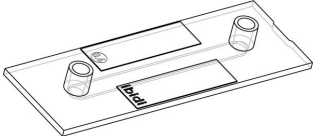
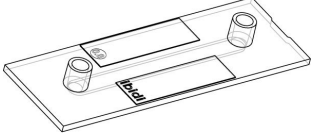
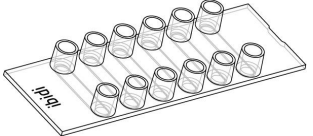
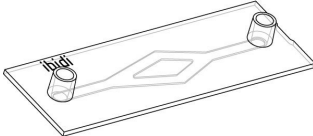
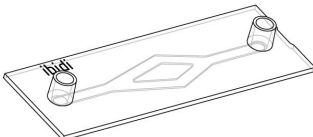
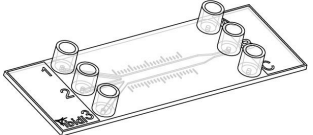
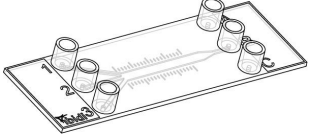
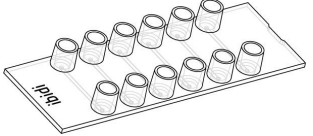
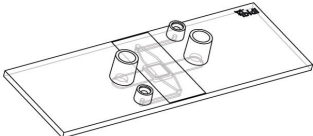
<p>μ-Slide I^{0.6} Luer</p>		$\tau \left[\frac{\text{dyn}}{\text{cm}^2} \right] = \eta \left[\frac{\text{dyn} \cdot \text{s}}{\text{cm}^2} \right] \cdot 60.1 \cdot \Phi \left[\frac{\text{ml}}{\text{min}} \right]$
<p>μ-Slide I^{0.8} Luer</p>		$\tau \left[\frac{\text{dyn}}{\text{cm}^2} \right] = \eta \left[\frac{\text{dyn} \cdot \text{s}}{\text{cm}^2} \right] \cdot 34.7 \cdot \Phi \left[\frac{\text{ml}}{\text{min}} \right]$
<p>μ-Slide VI^{0.4}</p>		$\tau \left[\frac{\text{dyn}}{\text{cm}^2} \right] = \eta \left[\frac{\text{dyn} \cdot \text{s}}{\text{cm}^2} \right] \cdot 176.1 \cdot \Phi \left[\frac{\text{ml}}{\text{min}} \right]$
<p>μ-Slide y-shaped (single channel)</p>		$\tau \left[\frac{\text{dyn}}{\text{cm}^2} \right] = \eta \left[\frac{\text{dyn} \cdot \text{s}}{\text{cm}^2} \right] \cdot 227.4 \cdot \Phi \left[\frac{\text{ml}}{\text{min}} \right]$
<p>μ-Slide y-shaped (branched channel)</p>		$\tau \left[\frac{\text{dyn}}{\text{cm}^2} \right] = \eta \left[\frac{\text{dyn} \cdot \text{s}}{\text{cm}^2} \right] \cdot 113.7 \cdot \Phi \left[\frac{\text{ml}}{\text{min}} \right]$
<p>μ-Slide III³ⁱⁿ¹ (1 mm channels)</p>		$\tau \left[\frac{\text{dyn}}{\text{cm}^2} \right] = \eta \left[\frac{\text{dyn} \cdot \text{s}}{\text{cm}^2} \right] \cdot 774.1 \cdot \Phi \left[\frac{\text{ml}}{\text{min}} \right]$
<p>μ-Slide III³ⁱⁿ¹ (3 mm channel)</p>		$\tau \left[\frac{\text{dyn}}{\text{cm}^2} \right] = \eta \left[\frac{\text{dyn} \cdot \text{s}}{\text{cm}^2} \right] \cdot 227.4 \cdot \Phi \left[\frac{\text{ml}}{\text{min}} \right]$
<p>μ-Slide VI^{0.1}</p>		$\tau \left[\frac{\text{dyn}}{\text{cm}^2} \right] = \eta \left[\frac{\text{dyn} \cdot \text{s}}{\text{cm}^2} \right] \cdot 10.7 \cdot \Phi \left[\frac{\mu\text{l}}{\text{min}} \right]$
<p>μ-Slide Membrane ibiPore Flow</p>		$\tau \left[\frac{\text{dyn}}{\text{cm}^2} \right] = \eta \left[\frac{\text{dyn} \cdot \text{s}}{\text{cm}^2} \right] \cdot 131.6 \cdot \Phi \left[\frac{\text{ml}}{\text{min}} \right]$

6.7 Working with Non-Implemented Flow Channels

This section describes the procedure for working with flow channels that are not implemented in the software. It details how to generate a defined shear stress by means of an example.

Knowledge of how to calculate the wall shear stress in the geometry of the experimental slide is required.

Principle:

1. Define the shear stress needed for the experiment.
2. Calculate the flow rate required to obtain this shear stress in the specific slide geometry.
3. Measure a calibration curve with the slide and the ibidi Pump System (with Fluidic Unit and Perfusion Set), showing the correlation between the flow rate and the pressure.
4. Determine the pressure needed for obtaining the correct flow rate.
5. Apply this pressure with the pump, dismissing the values of flow rate and shear stress.
6. Adjust the switching time.

Example:

The sticky-Slide channels are not available in the drop-down menu of the software. The formulas to generate the shear stress are in the [sticky-Slide instructions](#). For this example, the procedure detailed is for the sticky-Slide^{0.4} Luer.

$$\tau \left[\frac{\text{dyn}}{\text{cm}^2} \right] = \eta \left[\frac{\text{dyn} \cdot \text{s}}{\text{cm}^2} \right] \cdot 104.7 \cdot \Phi \left[\frac{\text{ml}}{\text{min}} \right]$$

1. Define the shear stress needed for the experiment: 10 dyn/cm²
2. Calculate the flow rate required in the sticky-Slide I^{0.4} Luer for generating the shear stress using the formulas above. The viscosity of medium at 37°C is 0.0072 dyn s/cm².

$$\Phi \left[\frac{\text{ml}}{\text{min}} \right] = \frac{\tau \left[\frac{\text{dyn}}{\text{cm}^2} \right]}{\eta \left[\frac{\text{dyn} \cdot \text{s}}{\text{cm}^2} \right] \cdot 104.7} = \frac{10}{0.0072 \cdot 104.7} = 13.3 \text{ ml/min}$$

3. Measure a calibration curve with the ibidi Pump System. Measure the respective flow rates you obtain with pressure values from 5 mbar to 95 mbar, using the setup that was chosen (Slide and Perfusion Set).

Apply the respective pressure and switch the valves manually. Measure the time required for the medium to flow from the 6 ml to the 4 ml mark on the syringe.

Display the values in a graph and calculate a trend line.

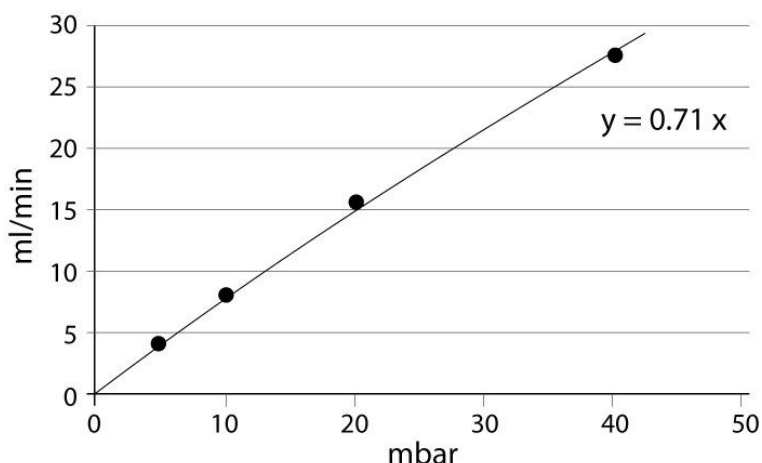

Figure 47: Example of a calibration curve showing the relation between flow rate and pressure.

- This calibration curve and the function of the trend line, enables the prediction of the pressure needed for generating the flow rate (p in mbar, Φ in ml/min).

$$\begin{aligned}
 p &= 0.71 \cdot \Phi \\
 &= 0.71 \cdot 13.6 = 9.656
 \end{aligned}$$

- In the PumpControl Software, choose the Perfusion Set being used from the drop down menu and choose the option “without any slide” from the slide drop down menu. Apply the pressure of 33.2 mbar to the Fluidic Unit and ignore the flow rate value that is indicated in the software.



Figure 48: Selection of Perfusion set red and Slide selection “without any slide”

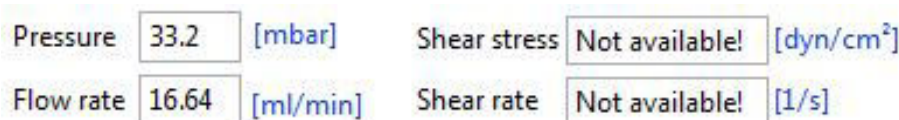

Figure 49: Inserting 33.2 mbar in the pressure box. The flow rate is 13.6 ml/min, as indicated in the calibration curve. The automatically calculated flow rate of 16.64 ml must be ignored.

Always check the flow rate when running an experiment. Because of small manufacture tolerances of the slides and tubing, the values vary slightly. Section 6.5 describes how to calibrate the system.

- The PumpControl Software does not know the correct flow rate, and therefore, the program is not able to calculate the right switching time. Insert the switching time manually.

$$\begin{aligned}
 \text{Switchingtime} &= \frac{60 \text{ s/min} \cdot 5 \text{ ml}}{\Phi} \\
 &= \frac{60 \text{ s/min} \cdot 5 \text{ ml}}{13.6 \text{ ml/min}} = 22.1 \text{ s}
 \end{aligned}$$

Insert the value of 22 s in the box "Switching times, unidirectional".

Switching times
 unidirectional [s]

7 Maintenance

Although the ibidi Pump system requires minimal maintenance, there are some parts that will have to be checked occasionally.

7.1 Silica Beads from the Drying Bottle

The Silica beads are coated with an orange indicator that turns white when saturated with moisture. The Silica beads can be used until the beads turn white. To regenerate the beads, place them in a glass Petri dish. Place the Petri dish into a drying oven at 120°C for at least 8 hours. The beads will turn orange once all moisture has been removed. After they cool to room temperature they can be returned to the drying bottle for use.

7.2 Replacement Filters for Perfusion Sets

The filters on the Perfusion Sets could become clogged if they come in contact with the medium. If the pores of the filter are blocked, the correct flow rate cannot be obtained. If this happens during an experiment, immediately exchange the filter by removing the black tubing ring and the sealing gasket from the old filter and slip both over the new filter. The filters are Teflon air filters with a pore size of 0.2 µm (Sartorius, Minisart®SRP15 17558——K).

7.3 Filters of the Fluidic Unit

The Fluidic Unit filter prevents the unit's internal components from particles and dust. Change the filter when the pores are blocked. For best performance, change the filter every 6 months, if the system is used consistently. Use a 0.2 µm Teflon air filter with a diameter of 30 mm and a male Luer Lock slip (e.g. Sartorius Minisart 16596 HY).

7.4 Pinch Valves of the Fluidic Unit

The pinch valves have a defined life time that is dependent on the number of switching events experienced. If the pinch valves are soiled or do not function properly, contact ibidi or your local distributor for replacement or repair.

8 Troubleshooting

8.1 Air Bubbles

Air bubbles are a common problem in any type of perfusion setup. Air bubbles can be avoided by following the precautions listed in this section.

8.1.1 Air Bubbles When Connecting the Slide

Problem: Air bubbles emerge in the tubing system or slide directly after connecting the Slide to the Perfusion Set.

PossibleCause	Solution
Air bubbles were introduced while filling the tubing.	To remove air bubbles in the tubing, start an automatic cycle in PumpControl with a high flow rate or load the "Remove air bubble" settings in the tutorial menu in the software.
Air bubbles were created when connecting the Slide to the Perfusion Set.	Fill the slide reservoirs to the top and remove air bubbles on the surface. When pulling out the Luer adapter from the Female Luer Coupler, hold the male Luer adapter upward so that the bubbles rise to the Female Luer Coupler instead of flushing into the Luer adapter. This procedure is shown in Section 4.8.

8.1.2 Air Bubbles Emerging After a Few Hours

Problem: Air bubbles emerge and accumulate somewhere in the tubing system after the flow starts.

Possible Cause	Solution
Medium, tubing and slides were not degassed and equilibrated at the proper temperature.	Equilibrate the system parts inside the incubator one day before starting the experiment (see Section 4.1).
Loose or leaky adapters in combination with negative pressure draw in small air bubbles into the system.	Make sure all adapters and connectors fit tightly and use positive pressure.
The humidity in the incubator is too low. When working in a heated chamber without humidification, evaporation promotes air bubble formation.	Use an incubator with at least 80% humidity.
Temperature changes along the tubing or over time.	Keep the temperature stable.

8.2 Cells are Detaching

There are multiple parameters that influence cell attachment. Monitor the cells and make a note of the time point when the cells start to appear distressed.

8.2.1 Cells Detach Before Starting the Flow

Problem: The cells look unhealthy and are not attaching to the surface before connecting them to the Perfusion Set.

Possible Cause	Solution
The cells were lacking medium with nutrients. In low channels (100 or 200 μm), the volume of medium is very low compared to cell number. This effect may appear after some hours already.	Cultivate cells in low channels for only few hours. If the cells need to be in the channel for more than a few hours, refresh the medium in the channel in short intervals or place the slide on a rocking plate.
The cell culture surface was not suitable for the specific cells.	Make sure the cells adhere to the surface under standard conditions (e.g. in a μ -Dish). If using a protein coating, make sure the concentration of the coating solution is sufficient for the channel slide. A protein coating protocol is available in Application Note 08 .
The cells were not healthy.	Try another lot or passage of cells. Especially primary cells are very variable in their fitness.
Evaporation in the slide led to increased medium concentration.	Place the slide in an extra humidity chamber (Petri dish with wet paper towel).

8.2.2 Cells Detach When Connecting the Slide to the Perfusion Set

Problem: After connecting the Perfusion Set, the cells look detached or accumulated in clusters.

Possible Cause	Solution
The cells were disturbed by too much flow at the connecting step.	Every movement of the medium results in a shear stress input. Fast movements with the medium can detach even healthy cells.
The cells were stressed by the abrupt temperature change when being placed on the metal surface of the sterile working bench.	Avoid placing slides directly on metal surfaces. For best results, place slides on the ibidi μ-Slide Rack , or a Petri dish.
The cells were stressed, because the connection step took too long.	Connecting the slides is time critical. Work as quickly as possible and make sure to have everything on hand before the connection step.
The cells were not healthy.	Try another lot or passage of cells. Especially primary cells are very variable in their fitness.

8.2.3 Cells detach under Flow Conditions

Problem: Cells detach after starting the flow experiment.

Possible Cause	Solution
The shear stress was too high. The shear stress was applied too fast.	Decrease the flow rate. Allow the cells to become accustomed to the flow starting with a very low flow rate.
Cells were not healthy. The cell number in the slide was too low. Cells could not form a confluent layer and were detached from the surface.	Try another lot or passage of cells. Seed more cells. Before starting the flow, the cells should be nearly confluent.
The coating was not stable and washed away by the flow.	Check the coating with fluorescence staining before and after applying the flow. Try alternative coatings or the ibiTreat surface.
There was too much evaporation of medium, which increased its concentration.	Check if the volume of the medium decreased. Increase the humidity in the incubator.
The CO ₂ concentration in the incubator was too low, and the medium was not equilibrated to a neutral pH.	Make sure the CO ₂ supply is sufficient and equilibrate the pH of the medium.

8.3 Clogged Filters

The reservoir filters maintain sterility of the medium. The air stream from the pump passes through the pores and therefore it is crucial, that the filters remain unclogged.

If the medium contacts the filter and clogs the pores, flow will be slowed. Usually this happens with only with one filter and results in an imbalance of the medium levels (Section 8.11).

Replace clogged filters immediately to avoid complications and damages. The filters cannot be washed or regenerated! Replacement filters with a pore size of 0.2 µm can be purchased from general laboratory suppliers (Sartorius, Minisart®SRP15 17558—K).

8.4 Pump is not Recognized by the Computer

To control the pump with a computer, the PumpControl software is required. Each pump version requires a specific version of the software. All versions of the PumpControl software and drivers can be downloaded from the [ibidi website](#). To check which firmware version to use, click on the question mark button “?” in the task menu and then click on “About...”. A new dialog box opens, that reveals the version and serial number information.

8.4.1 Using PumpControl v1.5.0 or Higher

If the latest PumpControl version has been installed, there should not be any problems with the drivers. All required drivers are installed automatically with the software. To run PumpControl v1.5.0 or higher, the firmware version of the pump must be v1.02 or higher.

8.4.2 Using PumpControl v1.4.4 or Lower

If the software did not automatically install and there is no communication between the pump and the computer, install the required drivers manually. Follow the instruction during the hardware installation and specify the location of the folder for the USB drivers which is on the PumpControl installation thumb drive under “USB driver”. If an error message occurs, go to the computer’s hardware manager and look for the “Ports”. Click on the non-functional component, which is the ibidi Pump and check the driver. Install the driver that is included on the PumpControl installation thumb

drive. Note that installation of two drivers is necessary; one for the “USB serial converter” and one for the “USB serial port”.

8.4.3 Pressure Lost Error

Problem: The program stops and the Pressure Lost error message appears.

Possible Cause: The USB cable or the power supply could have an unstable connection.

Solution: Check which type of USB cable and power supply is being used. Generally, any USB cable is suitable, but when encountering connection problems make sure to use a double shielded USB cable (e.g. Tripp Lite USB 2.0, model UR022-006).



Figure 50: Front view of the screened USB cable. The plug is formed by the outer metal casing and a thin plastic sheet at the inside.

The power supply (Sinpro MODEL NO:SPU41A-106) should have the following characteristics:

INPUT: AC 100-240 V, 47-63 Hz

OUTPUT: DC 14 V, 2.85 A max.

8.5 ibidi Pump is not Communicating with the PumpControl Software

If the PumpControl does not communicate with the pump, check that both the “Power” and the “USB” LED lights are illuminated on the front of the pump. If both LEDs are illuminated, rerun the PumpControl program. The program should not start in “Demo Mode”. If, after rerunning the program, the communication between the pump and the computer still does not work, then the “.NET” drivers are likely missing. Either download these drivers through the internet or from the [ibidi web page](#) (in the supporting material section). After extraction and installation of these drivers, the communication to the ibidi Pump should be setup.

8.6 Pressure Kickback After Pressure Switch Off

When using positive pressure, the rear port of the pump is connected to the drying bottle, which is connected to the incubator to take in CO₂-rich air. An air pressure kickback when switching the system off could result. This kickback can be caused by a vacuum that builds in the system when the tubing system is pinched or clogged, and the air supply is hindered. Make sure that the air tubes are not being squeezed and check the setup of the drying bottle. If the tubing looks fine, remove it from the rear port. If the problem persists, contact ibidi for assistance.

8.7 Flow Rate is Too Low or Absent

Problem: The pump is applying the correct pressure to the Fluidic Unit, but the flow rate is low or there is no flow visible in the Perfusion Set.

Possible Cause	Solution
There was a blockage in the tubing leading from the pump front port to the Fluidic Unit	Change the air pressure tubing.
There was a blockage in the valve block of the Fluidic Unit (valve 1).	Contact ibidi to replace the valve block.
Clogged filters were restricting air passage. When filters contact the medium or water, air flow is decreased or ceases.	Filters that become wet with water can be dried at 55°C for a few hours. Filters that are contaminated with medium must be replaced (Section 7.2).
When applying low pressure, an air bubble in the tubing can decrease or even stop the flow.	Check the tubing for air bubbles. If necessary, disconnect the slide and remove all air bubbles from the tubing with a high pressure.

8.8 Flow Rate is too High

Problem: The flow rate measured with a stop watch is much higher than indicated by the software. Variations of up to 20 % are normal caused by differences of viscosity and manufacture tolerances of the tubing and slides.

Possible reason	Solution
The tubing was not inserted correctly into the pinch valve (valve 2) and produced a “by-pass” that leads directly from the source reservoir to the sink reservoir, leading to a high flow rate.	Check the correct fit of the tubing by clamping the tubing near the slide. The pinch test is described in Section 4.6.
Wrong calibration factor	Check the flow rate again with a stop watch and insert the calibration factor in the software. This procedure is detailed in Section 6.5.

8.9 Evaporation

Problem: Long term experiments could result in medium evaporation. The amount of volume loss per day depends on the humidity in the incubator and the volume flow rate. Do not exceed a volume loss of more than 10% of the total volume.

Possible Cause	Solution
The air stream in the reservoirs results in a slight evaporation of medium, which is normal.	Depending on the requirements of the cells, exchange the medium after a few days or refill the evaporated amount of volume with sterile water.
The humidity in the incubator is not high enough.	Check the humidity of the incubator with a hygrometer. Small and low priced hygrometers are available in electronic gear shops. The minimum recommended humidity is 80 % rel. humidity.

8.10 Flow Direction in the Channel is Changing

Problem: The flow direction in the slide changes even though it is set to unidirectional flow.

Possible Cause	Solution
Perfusion Set was not mounted correctly.	Check that the tube is inserted properly.

8.11 Imbalanced Medium

If the medium is running at different flow rates at the two switching states (running from left to right or running from right to left), perform the following tests to isolate the issue.

Note!

A slight imbalance is normal because of the fluid dynamics and valve switching events, and is tolerated, as long as the reservoirs do not run dry.

Use a Perfusion Set with clean, dry filters. When the filters have been used before and were moistened with medium, the filters are clogged. If the integrity of the filters is in question, replace them (Section 7.2).

Note: Use positive pressure for this procedure.

1. Mount the Perfusion Set on the Fluidic Unit.
2. Fill the Perfusion Set with medium to equal levels in both reservoirs (the 5 ml mark for 10 ml Perfusion Sets, or the 1 ml mark in the 2 ml Perfusion Sets).
3. Remove the air bubbles from the Perfusion Set (Section 4.5).
4. Perform the pinch test (Section 4.6) and note the movement of the liquid.
 - Does the liquid move in the first switching state (running from left to right)?
Yes No
 - Does the liquid move in the second switching state (running from right to left)?
Yes No
 - If both answers are “No”, then go to step 5.
 - If one or both answers are “Yes”, the pinch valve is not operating correctly. Adjust the tubing in the pinch valve by stretching the tubing and moving it up and down (Figure 26). Perform the pinch test again. If adjusting the tubing does not fix the issue, the problem might be the pinch valve. Contact info@ibidi.com for repair.
5. Load the “Remove air bubbles” setup from the “Tutorial” menu. It does not matter which Perfusion Set is being used. Make sure the liquid levels are equilibrated. Alternatively, start the program that was running when the imbalance problem occurred.
6. Start the program and observe the liquid levels. Is there an imbalance emerging with time?
Yes No
 - If “No”, the problem was fixed by the correct insertion of the tubing.
 - If “Yes”, proceed to step 7.
7. Remove the tubing connection from the Perfusion Set and permute the filters. Reconnect to the tubing. Does the imbalance switch to the other side? For example, an observed imbalance with an excess of medium on the right side changed to the left side after switching the filters.
 - If the imbalance changed to the other side, one filter is clogged. Replace the filters and restart at step 5.
 - If the imbalance stayed on the same side, proceed to step 8.

8. Cross the tubing on top of the reservoirs (Figure 51) and see, if the problem switches to the other side. For example, the imbalance of excess medium on the right side switched to the left side after crossing the tubing.



Figure 51: Cross the tubing on top of the reservoirs to test if the problem is with the Perfusion Set or in the valve block (valve 1).

- If the imbalance remained on the same side, there might be a blockage in the branched tubing of the Perfusion Set. Substitute the Perfusion Set and try again.
- If the imbalance switched to the other side, the problem is located in-between the pump and the Perfusion Set filters. The Perfusion Set and the filters are functioning properly. Proceed to step 9.

9. Keep the tubing above the reservoirs crossed, and cross the tubing on the valve block (Figure 52).

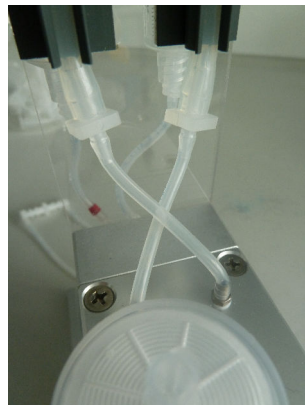

Figure 52: Crossing the tubing above the valve block (valve 1).

- If the imbalance switched to the other side, there might be a blockage in the tubing from the valve block to the reservoirs. Check the tubing for particles or debris blocking the air flow and remove the blockage if possible. If the problem persists, contact info@ibidi.com and describe the problem in detail. Refer to the tests that are described in this troubleshooting section.
- If the imbalance remained on the same side, the problem is inside the valve block. Contact ibidi at info@ibidi.com to have the valve block repaired.