

REV	CHANGE	DATE	DRN	CHK
	Drawn	02/0817	SJ	T

TOLERANCE DETAILS					
1	D	+0.011 [+0.30] -0.000 [-0.00]	6	PD	+0.000 [+0.00] -0.012 [-0.30]
2	L	±0.020 [±0.50]	7	PL	±0.016 [±0.40]
3	W	+0.008 [+0.20] -0.000 [-0.00]	8	SD	±0.006 [±0.15]
4	HD	+0.020 [+0.50] -0.008 [-0.20]	9	SL	±0.012 [±0.30]
5	HL	±0.012 [±0.30]	10	TL	+0.000 [+0.00] -0.016 [-0.40]

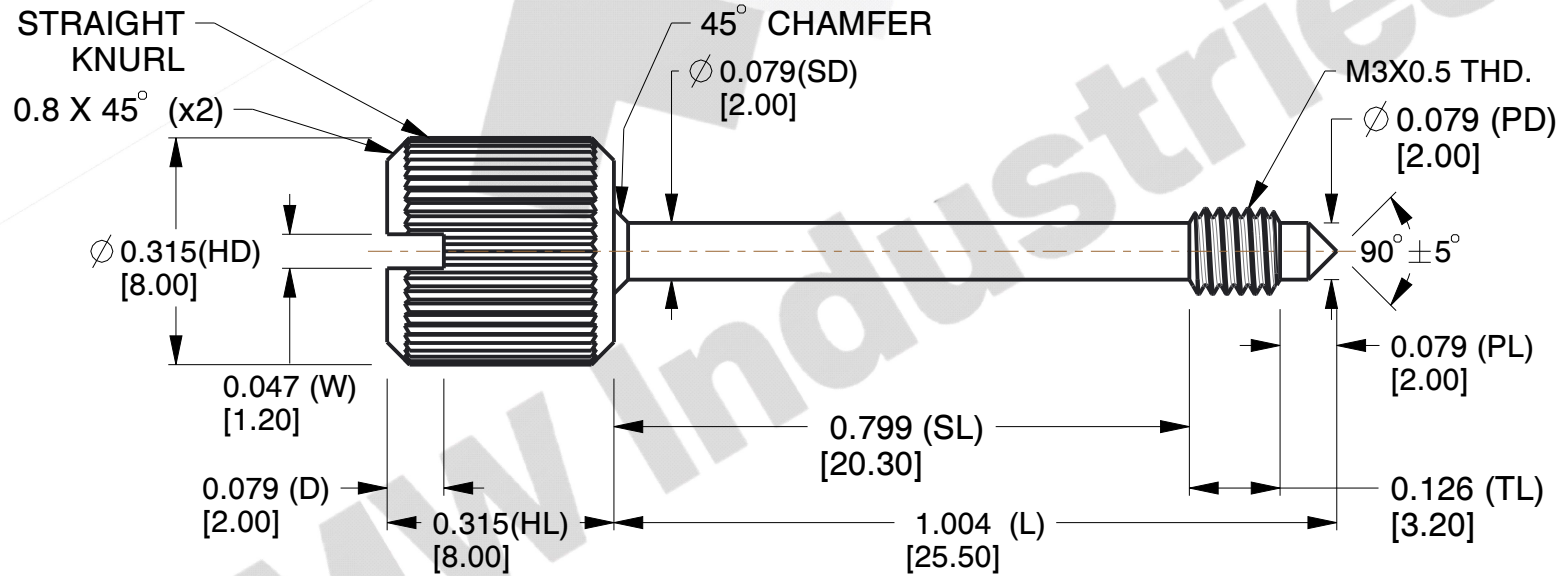

NOTES:

1. Material : Stainless Steel
2. Finish :
3. ASME Y14.5-M - 2009
4. All Drawing Dimensions are in Inches [mm]
5. Remove burrs and sharp edges
6. Changes may occur with no notice



MW Industries

95 Silvermine Rd., Seymour CT 06483
Tel: 203-888-2133, Fax: 203-888-9860

This Drawing is the Property of MW Industries. It contains confidential, proprietary information that is MW Industries property. Do not disclose to or duplicate for others except as authorized by MW Industries.

TOLERANCES
ALL DIMENSIONS ARE INCHES
(UNLESS OTHERWISE SPECIFIED)
METALLIC
LENGTHS < / = 6 INCHES ± 0.005
LENGTH > 6 INCHES ± 0.010
DIAMETERS: ± 0.005
NON-METALLIC
LENGTH: ± 0.010 DIAMETERS: ± 0.010
INTERNAL THREADS:
MINIMUM THREAD DEPTH

COMPONENT	PANEL SCREW	SCALE
M0191-SS		3.75
CAPTIVE PANEL SCREW STYLE 2		SHEET
		1 of 1