

# Indirect Air Economizer

## Ecoflair™ Indirect Air Economizer

### Operation and Maintenance Manual

990-9965D-001 / 06MC0147@00B0130

Release date: 05/2019

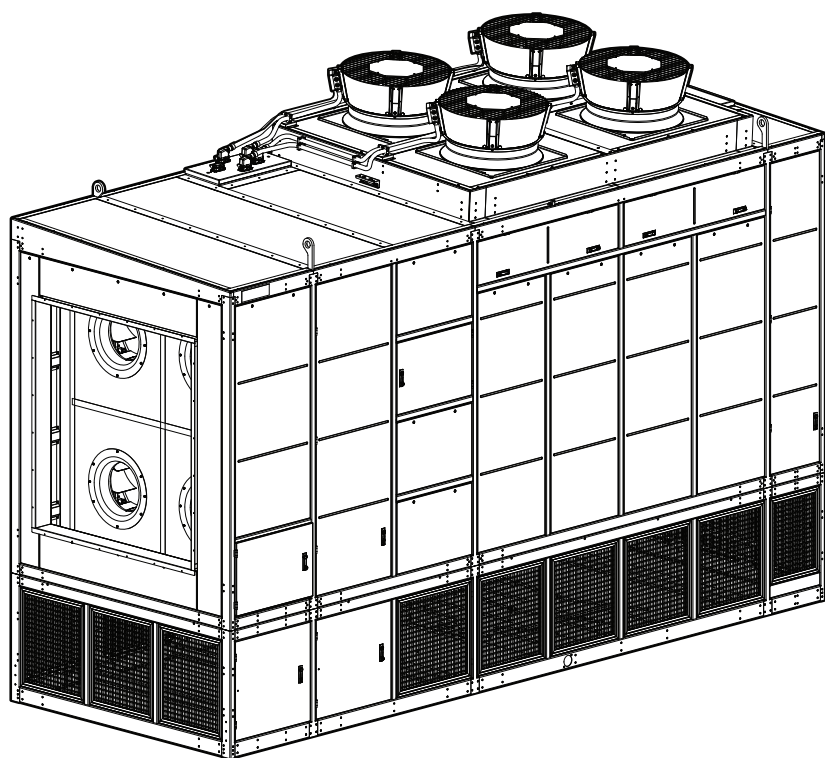

# Legal Information

The Schneider Electric brand and any trademarks of Schneider Electric SE and its subsidiaries referred to in this guide are the property of Schneider Electric SE or its subsidiaries. All other brands may be trademarks of their respective owners.

This guide and its content are protected under applicable copyright laws and furnished for informational use only. No part of this guide may be reproduced or transmitted in any form or by any means (electronic, mechanical, photocopying, recording, or otherwise), for any purpose, without the prior written permission of Schneider Electric.

Schneider Electric does not grant any right or license for commercial use of the guide or its content, except for a non-exclusive and personal license to consult it on an "as is" basis. Schneider Electric products and equipment should be installed, operated, serviced, and maintained only by qualified personnel.

As standards, specifications, and designs change from time to time, information contained in this guide may be subject to change without notice.

To the extent permitted by applicable law, no responsibility or liability is assumed by Schneider Electric and its subsidiaries for any errors or omissions in the informational content of this material or consequences arising out of or resulting from the use of the information contained herein.

# Table of Contents

<b>Safety</b> .....	7
Important Safety Instructions — SAVE THESE INSTRUCTIONS.....	7
Safety During Operation and Maintenance .....	8
<b>General Information</b> .....	10
Overview .....	10
Save These Instructions .....	10
Cross-Reference Symbol Used in This Manual.....	10
Manual Updates .....	10
Abbreviations and Terminology .....	10
Equipment Disposal.....	11
Waste Electrical and Electronic Equipment (WEEE) Disposal.....	11
Model Nomenclature.....	11
<b>Commissioning</b> .....	12
Inspection Checklists .....	12
Initial Inspection Checklist .....	12
Electrical Inspection Checklist.....	13
Mechanical Inspection Checklist .....	14
Display Interface Inspection Checklist .....	15
Start-Up Inspection Checklist.....	15
Final Inspection Checklist.....	16
<b>Operation</b> .....	17
Display Interface.....	17
Alarm LED .....	18
Status LED.....	18
Link-RX/TX (10/100) LED.....	19
Using the Display.....	20
Overview Screen .....	20
Home Screen/Main Menu .....	20
Display Controls .....	23
Using the Path Statement .....	23
Changing Settings .....	24
Tests.....	24
Logging In/Password Entry .....	26
<b>Unit Start Up/Shut Down</b> .....	27
Start the Cooling Unit.....	27
Stop the Cooling Unit.....	27
<b>Remove Power from the Unit</b> .....	28
Dual Power Supply with SCO .....	28
Single Power Supply Units .....	29
<b>Operation Modes</b> .....	30
Operational Overview .....	30
Air-to-Air Heat Exchange.....	30
Indirect Evaporative Cooling (IEC) .....	31
Trim Cooling.....	31
Water Saver .....	32
Water Operation Reserve Time.....	33
<b>General Configuration</b> .....	34

Importing/Exporting Unit Configuration .....	34
Export .....	34
Import .....	34
Unit Configuration .....	35
Thresholds .....	35
Configure the Unit .....	36
Identify the Cooling Unit .....	37
Control the Environment .....	37
Setpoints .....	37
AFC Configuration .....	38
User Security Settings .....	40
Add a New User or Edit an Existing User .....	40
Delete a User .....	40
Display Settings .....	40
Language, Date, Time, and Temperature .....	40
Screen Visibility and Audible Tones .....	41
Restore Defaults .....	41
Configure Modbus .....	41
Network Configuration .....	42
Overview .....	42
Configure the Network .....	42
<b>Unit Information .....</b>	<b>44</b>
View Status Readings .....	44
Overview Screen .....	44
Unit Status .....	46
View Individual Module Airflow Information .....	46
View Module Configuration .....	48
View Setup Settings .....	48
View Environmental Control Settings .....	49
View Thresholds .....	49
DX Circuit .....	50
Source Changeover .....	51
Energy Meter .....	51
Ultracap Capacity .....	51
Run Hours .....	52
View Run Hours .....	52
Reset Run Hours .....	52
About the Network .....	53
About the Unit .....	54
About the Module .....	54
About the Display .....	55
<b>Logs .....</b>	<b>56</b>
Event Log .....	56
View Event Log .....	56
Filter Event Log .....	57
Clear Event Log .....	57
Data Log .....	58
Export Data .....	58
<b>Alarms .....</b>	<b>59</b>
Respond to Alarms .....	59

View Active Alarms .....	59
Clear Active Alarms.....	59
Alarm Messages and Suggested Actions .....	59
<b>Network Management Card .....</b>	<b>64</b>
Quick Configuration .....	64
Overview .....	64
TCP/IP Configuration Methods.....	64
Device IP Configuration Wizard.....	65
.ini File Utility .....	65
BootP and DHCP Configuration .....	65
Remote Access to the Command Line Interface (CLI) .....	66
Local Access to the Command Line Interface (CLI).....	67
Access a Configured Unit.....	68
Overview .....	68
Web Interface .....	68
Telnet and SSH.....	69
Simple Network Management Protocol (SNMP) .....	69
FTP/SCP.....	70
Modbus.....	70
Recover From a Lost Password .....	71
<b>Updating the Firmware.....</b>	<b>72</b>
Firmware Module Files.....	72
Firmware File Transfer Methods .....	72
Firmware Upgrade Utility .....	73
Use FTP or SCP to Update One Unit .....	73
Use XMODEM to Update One Unit.....	74
Using a USB Drive to Transfer and Update Files .....	75
Update Firmware on Multiple Units .....	78
Verify Updates.....	79
Verify Success of the Transfer.....	79
Last Transfer Result Codes .....	79
Verify Version Numbers of Installed Firmware .....	79
<b>Service Menus.....</b>	<b>80</b>
Module Configuration.....	80
Environmental Control .....	81
Thresholds .....	82
Run Hours .....	82
Hardware Configuration .....	82
<b>Maintenance .....</b>	<b>84</b>
Remove Power From the Unit.....	84
Service Vestibule Power Disconnect .....	85
Fan Positions .....	86
IT Fans .....	86
Outdoor Air (OA) Fans.....	86
Filters .....	87
OA Filters.....	87
IT Air Filters .....	88
Maintenance Mode .....	89
Monthly Preventive Maintenance .....	91
Quarterly Preventive Maintenance .....	92

Semi-Annual Preventive Maintenance.....93

# Safety

## Important Safety Instructions — SAVE THESE INSTRUCTIONS

Read these instructions carefully and look at the equipment to become familiar with it before trying to install, operate, service or maintain it. The following safety messages may appear throughout this manual or on the equipment to warn of potential hazards or to call attention to information that clarifies or simplifies a procedure.



The addition of this symbol to a “Danger” or “Warning” safety message indicates that an electrical hazard exists which will result in personal injury if the instructions are not followed.



This is the safety alert symbol. It is used to alert you to potential personal injury hazards. Obey all safety messages with this symbol to avoid possible injury or death.

<b>⚠ DANGER</b>
<b>DANGER</b> indicates a hazardous situation which, if not avoided, <b>will result in death or serious injury.</b>
<b>Failure to follow these instructions will result in death or serious injury.</b>

<b>⚠ WARNING</b>
<b>WARNING</b> indicates a hazardous situation which, if not avoided, <b>could result in death or serious injury.</b>
<b>Failure to follow these instructions can result in death, serious injury, or equipment damage.</b>

<b>⚠ CAUTION</b>
<b>CAUTION</b> indicates a hazardous situation which, if not avoided, <b>could result in minor or moderate injury.</b>
<b>Failure to follow these instructions can result in injury or equipment damage.</b>

<b>NOTICE</b>
<b>NOTICE</b> is used to address practices not related to physical injury. The safety alert symbol shall not be used with this type of safety message.
<b>Failure to follow these instructions can result in equipment damage.</b>

### Please Note

Electrical equipment should only be installed, operated, serviced, and maintained by qualified personnel. No responsibility is assumed by Schneider Electric for any consequences arising out of the use of this material.

A qualified person is one who has skills and knowledge related to the construction, installation, and operation of electrical equipment and has received safety training to recognize and avoid the hazards involved.

## Safety During Operation and Maintenance

Read and adhere to the following important safety considerations when working with this equipment.

### **DANGER**

#### **HAZARD OF ELECTRIC SHOCK, EXPLOSION, OR ARC FLASH**

- Apply appropriate personal protective equipment (PPE) and follow safe electrical work practices.
- This equipment must be installed and serviced by qualified personnel only.
- Turn off all power supplying this equipment before working on or inside the equipment.
- Replace all devices, doors, and covers before turning on power to this equipment.
- Always use a properly rated voltage sensing device to confirm power is off.
- If the power supply cord is damaged, it must be replaced by an equivalent cord or assembly available from the manufacturer or its service agent.

**Failure to follow these instructions will result in death or serious injury.**

### **WARNING**

#### **ELECTRICAL HAZARD**

Before obtaining access to terminals, all supply circuits must be disconnected.

**Failure to follow these instructions can result in death, serious injury, or equipment damage.**

### **WARNING**

#### **PERSONAL PROTECTIVE EQUIPMENT REQUIRED**

During installation, authorized personnel must wear approved personal protective equipment (PPE).

**Failure to follow these instructions can result in death, serious injury, or equipment damage.**

### **WARNING**

#### **HAZARD FROM MOVING PARTS**

Keep hands, clothing, and jewelry away from moving parts. Check the equipment for foreign objects before closing the doors and starting the equipment.

**Failure to follow these instructions can result in death, serious injury, or equipment damage.**

### **WARNING**

#### **HAZARD TO EQUIPMENT OR PERSONNEL**

All work must be performed by Schneider Electric qualified personnel.

**Failure to follow these instructions can result in death, serious injury, or equipment damage.**



**⚠ CAUTION****HAZARD TO EQUIPMENT OR PERSONNEL**

Ensure that all spare parts and tools are removed from the equipment before operating.

**Failure to follow these instructions can result in injury or equipment damage.**

**⚠ CAUTION****ROTATING FAN BLADES**

- Disconnect power and wait until blades come to a complete stop before servicing fan(s).
- Do not operate equipment without the fan guards in place.

**Failure to follow these instructions can result in injury or equipment damage.**

**⚠ CAUTION****PRESSURIZED INTERIOR**

Use care when opening doors, especially at the fans: Interior pressure may cause doors to push out quickly.

**Failure to follow these instructions can result in injury or equipment damage.**

# General Information

## Overview

### Save These Instructions

This manual contains important instructions that must be followed during the installation of this equipment.

### Cross-Reference Symbol Used in This Manual



See another section of this document or another document for more information on this subject.

### Manual Updates

Schneider Electric™ policy is one of continuous technological innovation and the company reserves the right to amend any data herein without prior notice. The images shown in this manual are for descriptive purposes only and they may differ from specific models that are selected.

**NOTE:** Unit images and component identification information are examples only. The final configuration of the unit may change according to the different options.

Check for updates to this manual on the Schneider Electric Web site, [www.schneider-electric.com/support](http://www.schneider-electric.com/support). Select the **Download Documents and Software** link under the **Support** tab and enter the manual part number or SKU for your equipment in the search field. See the back cover of this manual for the part number.

### Abbreviations and Terminology

The following are abbreviations and terms used in this manual:

- IEC: Indirect evaporative cooling
- OA fans: Outdoor air fans
- EEV: Electronic expansion valve
- VFD/VSD: Variable-frequency drive/variable-speed drive
- DX: Direct expansion
- CW: Chilled water
- SCO: Source changeover
- BMS: Building management system
- HACS: Hot aisle containment system
- CACS: Cold aisle containment system
- RACS: Rack aisle containment system
- Main module: The display interface and this manual use the term “main module” to refer to the IAEC25\*\*\* section of an IAEC50\*\*\* unit that contains the display interface. If the unit is an IAEC25\*\* unit only, the unit itself is the main module.
- Expansion module: The display interface and this manual use the term “expansion module” to refer to the IAEC25\*\*\* section of an IAEC50\*\*\* unit that does not contain the display interface. If the unit is only an IAEC25\*\* unit, menus for an expansion module will not be available on the display interface.
- Module: The term “module” is used to refer to a IAEC25\*\*\* section of an IAEC50\*\*\* unit.

## Equipment Disposal

### Waste Electrical and Electronic Equipment (WEEE) Disposal



Schneider Electric products comply with international directives on the Restriction of Hazardous Substances (RoHS) in electronic and electrical equipment and the disposal of Waste Electrical and Electronic Equipment (WEEE). Dispose of any waste electronic or electrical equipment with the appropriate recycling center. Contact Schneider Electric for assistance.

## Model Nomenclature

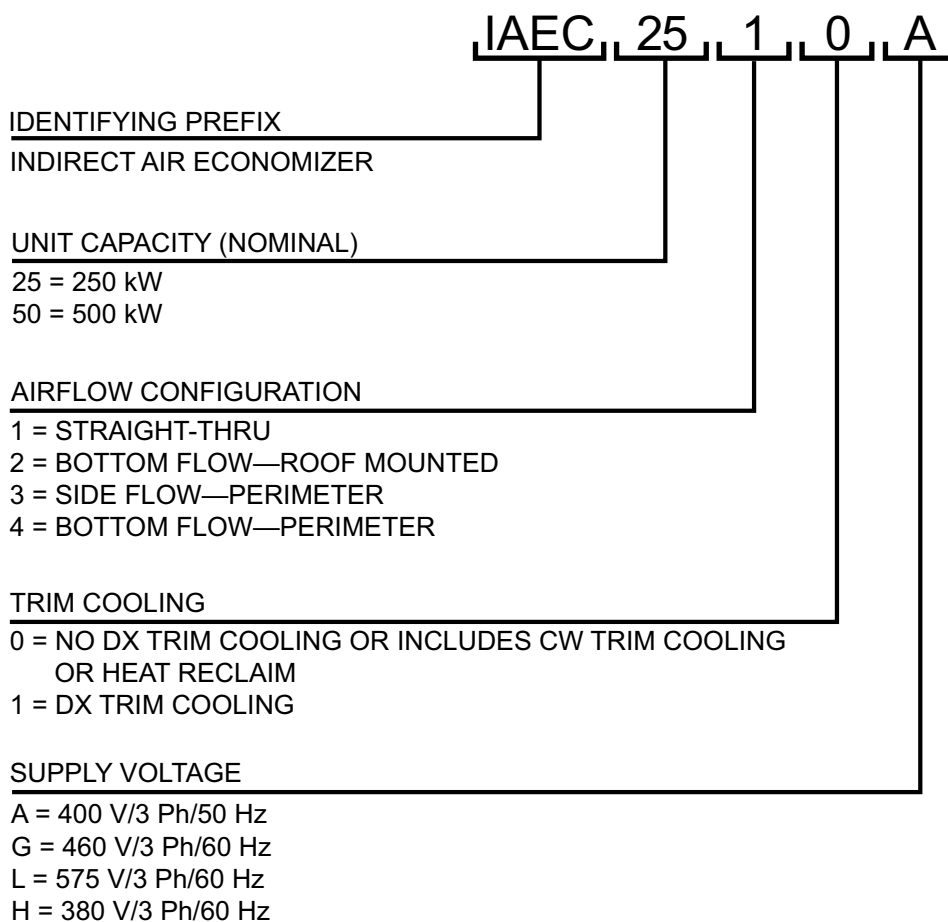

na6r455a

# Commissioning

After installation, verify that all components are working properly and the equipment is ready to begin operation.

## Inspection Checklists

### Initial Inspection Checklist

#### **⚠ WARNING**

##### **DAMAGE TO EQUIPMENT OR PERSONNEL**

Do not run service utilities in front of the fan outlet.

**Failure to follow these instructions can result in death, serious injury, or equipment damage.**

The initial inspection ensures that the equipment has been properly installed. The location of the cooling unit has been properly prepared and the cooling unit is free of damage.

**NOTE:** The vapor barrier minimizes moisture infiltration. Without a vapor barrier, it will be difficult to maintain the humidity in the room. Do not introduce unconditioned outside air into the space

##### **Ensure that**

- The installation procedure is complete according to the installation manual.
- The shipping and packaging materials have been removed and discarded.
- The upper and lower sections are properly aligned and secured with appropriate hardware.
- The supply and return ducts are installed and sealed to prevent outdoor air leakage.
- The data center environment is clean and ready for start-up. Walls and doors are installed and the room is not exposed to unconditioned outside air. The data center temperature and humidity conditions are within the acceptable operating envelope for the equipment.
- The minimum service clearance around the equipment is in accordance with local and national codes and regulations as well as the installation manual. Trash and debris have been removed from the service area.
- The (optional) service platform is installed and it allows for sufficient service clearance in accordance with local and national codes.
- There is no damage to the exterior and interior structure or panels. Access panels and hardware are installed and secure.
- If main and expansion modules are joined together, the modules are aligned, level, and the exterior roof line is sealed and capped to prevent water entry.
- The exterior roof panels and seals are not damaged or deformed.

## Electrical Inspection Checklist

### **⚠️⚠️ DANGER**

#### **HAZARD OF ELECTRIC SHOCK, EXPLOSION, OR ARC FLASH**

- Apply appropriate personal protective equipment (PPE) and follow safe electrical work practices.
- This equipment must be installed and serviced by qualified personnel only.
- Turn off all power supplying this equipment before working on or inside the equipment.
- Replace all devices, doors, and covers before turning on power to this equipment.

**Failure to follow these instructions will result in death or serious injury.**

### **⚠️⚠️ WARNING**

#### **ELECTRICAL HAZARD**

- Electrical service must conform to local and national electrical codes and regulations.
- The equipment must be grounded.

**Failure to follow these instructions can result in death, serious injury, or equipment damage.**

The electrical inspection verifies that all electrical connections are secure and correct and that the equipment is properly grounded.

#### **Ensure that**

- Incoming voltages match the phase and voltage listing on the nameplate.
- Electrical wiring complies with local and national codes and regulations.
- Equipment is properly grounded.
- Electrical connections are tight, including contactors, terminal blocks, controllers, switches, relays, auxiliary devices, and field connections.
- Check that wiring to the pump motors and water treatment system are secure and not damaged.
- Power sources are sized appropriately for the unit.
- Main and secondary (optional) electric supplies are properly wired to the power source.
- Field wiring has been installed for lighting, Modbus, alarm contact, and remote shutdown if applicable.
- Power connections between the upper and lower sections have been connected and secured properly to prevent water entry.
- Power cords for the outdoor air fans are connected and secured properly to prevent water entry.
- Components within the unit electrical panels are secured and not damaged during shipping or handling.
- Check the Modbus RTU dip switch configuration on the J5 controller in the electrical panel for the upper section. See *Configurable Input Connections* in the *Ecoflair™ Indirect Air Economizer Installation Manual*.

## Mechanical Inspection Checklist

The mechanical inspection verifies that all mechanical components and connections are secure and tight and ready for start-up.

### Ensure that

- 
- The water supply piping to the module is made of non-ferrous piping and has an appropriate method for freeze protection.

---

  - Water supply valves are open and water flow is correct based upon performance requirements of the system.

---

  - The water quality is acceptable for use with the equipment and the conductivity has been recorded.

---

  - The field installed drain line is at least the same diameter as the drain connection and is sloped downward away from the module.

---

  - The end of the field piped drain line is open to atmosphere and is not connected to any sewer or rooftop drainage system.

---

  - The piping between the upper and lower module sections has been connected properly, the joints are tight, and the piping is adequately supported.

---

  - The basin is clean and free of debris, the basin strainers are installed, and the covers and guards are in place.

---

  - The fans are able to turn freely, the blades are not distorted or bent, and the fan guards are installed and secure.

---

  - The IEC core tubes are not damaged and the gaskets are not damaged or missing.

---

  - The air filters are clean and installed correctly.

---

  - The spray nozzles and distribution piping are properly secured above the IEC core.

---

  - The water mist eliminator media located above the spray nozzles is installed and secure.

---

  - There are no signs of refrigerant leakage from any coil or piping.

---

  - There is no fin damage on the coils used for cooling or heat rejection.

---

  - The refrigerant sight glass moisture indicator level is dry.

---

  - The air temperature sensors are securely fastened in the air stream.

---

  - Any tools, parts, or loose debris has been removed from the fan compartment.

---

  - All door hinges and latches are working properly and door seals are not damaged or missing.

---

## Display Interface Inspection Checklist

The display interface inspection verifies that the sensors and internal communication links are installed properly.

### Ensure that

- The input contacts and output relays are connected correctly.
- The building management system is connected correctly.
- The network port is connected correctly and an IP address has been assigned to the equipment.

## Start-Up Inspection Checklist

The start-up inspection ensures that the equipment is operating properly after the initial start-up. This inspection verifies that all modes of operation are working correctly and that the cooling unit is ready for normal operation.

### Ensure that

- The unit is free from malfunctions, including water leaks, unusual vibrations, or other irregularities, in each mode of operation.
- The current draw is within the ratings.
  - Record the current at the main power connection of the main circuit breaker.
  - Record all current draws on the load side of any circuit breakers used for each Module.
  - Compare the circuit breaker setting for each Module to the actual current measured and the full load amps of the Module to verify that the current draws are acceptable.
- Indoor and outdoor fans are functioning properly.
- While in (optional) DX trim cooling mode, check the refrigerant pressures and temperatures. Verify that the sight glass is clear and the superheat is within normal range.
- While in (optional) CW trim cooling mode, check that the water regulating valve is working correctly and chilled water is flowing through the coil.
- The spray nozzle pattern provides water completely over the IEC core area. Ensure that the supply water fills the basin as the water level is reduced from evaporation and drain activity.
- Air filters are clean and free of debris.
- The clogged filter alarm is operating properly.
 

Cover 1/3 of the filter area to initiate the alarm.
- The conductivity sensor is calibrated using a fixed resistance device or a calibration solution.
- The water conductivity setpoint is regulated automatically by brief periods of basin draining and refilling of fresh water. The water conductivity setpoint should be approximately four times (4X) the supply water conductivity.
- The basin water pump is operating smoothly and there are no unusual noises or cavitation.
- The module is able to achieve the supply air set point.
- For units equipped with the optional ultracap power supply, the basin drain valve remains closed after removing power from the module. Once the backup power is consumed, the drain valve should open by spring actuation.

**Ensure that**

- 
- The controller display is working properly, the menu buttons are functioning, and the LEDs are normal.
- 
- For units equipped with the optional chemical-free water treatment system, ensure that the power LED is green and the alarm LED is not illuminated. A red alarm LED indicates a failure of the water treatment module.
- 

**Final Inspection Checklist**

The final inspection verifies that the system is clean, the installed options work properly, and the start-up form is sent to Schneider Electric.

**Ensure that**

- 
- The system is clean and free from debris.
- 
- Door and panels are latched and secure.
- 
- Packaging materials are disposed of properly.
- 
- There are no active alarms on the display. The system date and time have been set for the local region.
- 
- Unit documentation has been given to the customer.
- 
- The start-up form was completed and sent to Schneider Electric.
-



# Operation

## Display Interface

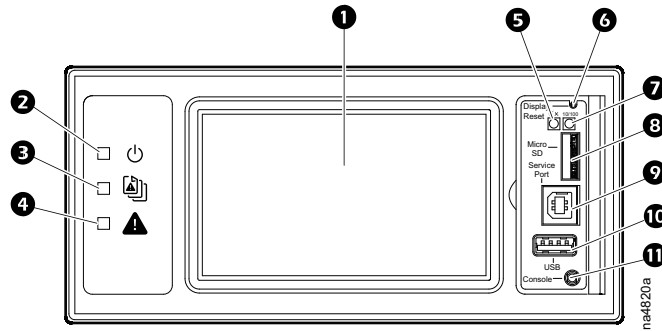

Item	Description	Function
1	LCD Display	7-inch touch-screen color display
2	Power LED	The cooling unit is powered when the LED is illuminated. Unit firmware is updating when LED is blinking.
3	Check Log LED	When this LED is illuminated, a new entry has been made to the event log.
4	Alarm LED	Displays current alarm condition of unit.
5	Status LED	Displays current network management card status.
6	Display Reset button	Resets the display microprocessor. This has no effect on the air conditioner controller.
7	Link-RX/TX (10/100) LED	Displays current network link status.
8	Micro SD card slot	Memory card expansion slot.
9	Service port	USB-B port used only by service personnel.
10	USB-A port	Supports firmware upgrades.
11	Serial Configuration port	Connects the display to a local computer to configure initial network settings or access the command line interface (CLI).

## Alarm LED

This LED indicates active alarms on the display.

Condition	Description
Off	No alarm
Solid yellow	Warning alarm
Solid red	Critical alarm

## Status LED

This LED indicates the status of the display.

Condition	Description
Off	One of the following situations exist: <ul style="list-style-type: none"> <li>The display is not receiving input power.</li> <li>The display is not operating properly. It may need to be repaired or replaced. Contact Schneider Electric Customer Support.</li> </ul>
Solid green	The display has valid TCP/IP settings.
Solid orange	A hardware malfunction has been detected in the display. Contact Schneider Electric Customer Support.
Flashing green	The display does not have valid TCP/IP settings.
Flashing orange	The display is making BOOTP requests.
Alternately flashing green and orange	If the LED is flashing slowly, the display is making DHCP requests. If the LED is flashing rapidly, the display is starting up.

## Link-RX/TX (10/100) LED

This LED indicates the network status of the display.

Condition	Description
Off	One or more of the following situations exist: <ul style="list-style-type: none"><li>• The display is not receiving input power.</li><li>• The cable or device that connects the cooling unit to the network is disconnected or not functioning properly.</li><li>• The display itself is not operating properly. It may need to be repaired or replaced. Contact Schneider Electric Customer Support.</li></ul>
Solid green	The display is connected to a network operating at 10 megabits per second (Mbps).
Solid orange	The display is connected to a network operating at 100 Mbps.
Flashing green	The display is receiving or transmitting at 10 Mbps.
Flashing orange	The display is receiving data packets at 100 Mbps.

## Using the Display

The display initializes and runs an LED test when power is applied to the cooling unit.

### Overview Screen

After start-up, the display shows an overview screen containing basic status information. Press **Home** to toggle between the main menu and overview screen. After a period of inactivity, the display reverts back to the overview screen.

**NOTE:** To maintain cleanliness and optimal performance of the touch-screen surface, it is recommended to use a soft-tip stylus when using the display. Never use sharp or hard-pointed objects on the touch-screen surface.

**NOTE:** Images are examples only to show operation of the display interface. Screens on your unit may vary.

### Home Screen/Main Menu

At any time during operation, press **Home** to return to the main menu. While on the main menu, press **Home** to toggle between the home and overview screen. To view active alarms, press **Alarms**.



See *Alarms*, page 59 for more information.

The **Alarms** button changes based on the current state of the unit.

Symbol	Description
	No alarms: No alarms are present.
	Informational: Provides details on an alarms that are not a warning or critical.
	Warning: An alarm condition requires attention and could jeopardize your data or equipment if its cause is not addressed.
	Critical: A critical alarm exists, which requires immediate action.

Main menu options appear on the display as shown in the example below.

**NOTE:** Menus will vary depending on unit type.

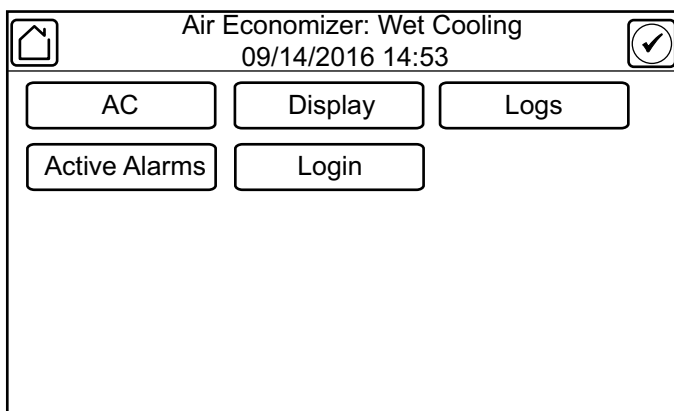

## Menu Description

- **AC:** Menus under **AC** are used to make setting changes to the overall cooling unit.

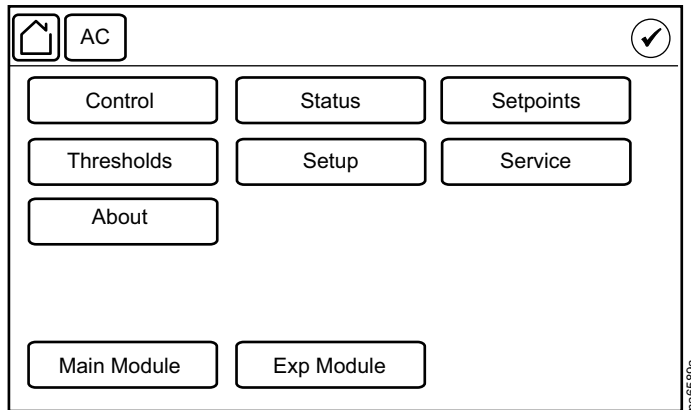

- **Control:** Configures the operation of the unit.
  - See *Configure the Unit*, page 36.
- **Status:** Displays sensor reading information and unit operation information.
  - See *Unit Status*, page 46.
- **Setpoints:** Sets various environmental setpoints for unit operation.
  - See *Setpoints*, page 37.
- **Thresholds:** Sets threshold values for alarms.
  - See *Thresholds*, page 35.
- **Setup:** Sets the water pump settings, altitude, and water basin drain time interval.
  - See *Configure the Unit*, page 36.
- **Service:** Sets the number of modules comprising the unit.
  - See *Configure the Unit*, page 36) and options for updating firmware (see *Updating the Firmware*, page 72).
- **About:** Displays physical setting information.
  - See *About the Unit*, page 54.
- **Main Module:** The menus located under **Main Module** are primarily read-only menus used to display the settings for and information about the main module. The **Service** menu under **Main Module** can be used to change settings that only affect the main module.



See *View Status Readings, page 44* and *Service Menus, page 80*.

- **Exp Module:** The menus located under **Exp Module** are the same as the **Main Module** menus and are primarily read-only menus used to display the settings for and information about the expansion module. The **Service** menu under **Exp Module** can be used to change settings that only affect the expansion module.



See *View Status Readings, page 44* and *Service Menus, page 80*.

- **Display:** Contains menus for display settings, user preferences, and user access.



See *Display Settings, page 40*.

- **Logs:** These screens save status information and record events and configuration changes.



See *Logs, page 56*.

- **Active Alarms:** Displays alarms that are currently active on the unit.



See *Alarms, page 59*.

- **Login/Logout:** Used to log into or log out of the unit.



See *Logging In/Password Entry, page 26*.

## Display Controls

To view a sub-menu, select an option from the main menu. Continue this process until the appropriate menu is active.

During navigation, the current file path is displayed at the top of the screen. Clicking on any of the headers reverts the display to the specified menu.

Menus with multiple pages use arrows to move between pages. **Forward** and **Back** advance one page at a time while **First** and **Last** move directly to the first or last page within the menu. Once changes have been made within a menu, press **OK** to confirm changes or **ESC** to cancel.

**NOTE:** Images are examples only to show operation of the display interface. Screens on your unit may vary.

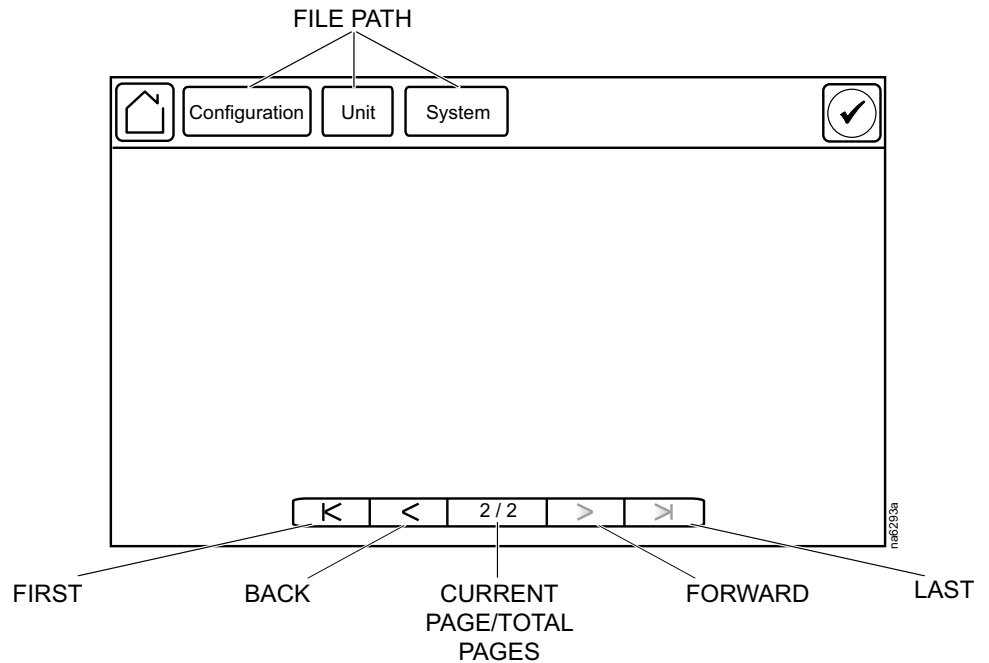

## Using the Path Statement

Select the main- and sub-menu options specified in the path statement to view or configure a setting. The path statement lists the main- and sub-menu options you select to navigate to the setting you want to view or modify. The parts of the path statement are defined in the following example:

**Path: Main > Status > Unit Overview**

**Main >** Your starting point is the main menu.

**Status >** Select this option from the main menu.

**Unit Overview >** Select this option from the sub-menu.

Subsequent options are listed and defined under the path statement.

## Changing Settings

**NOTE:** Images are examples only to show operation of the display interface. Screens on your unit may vary.

Screens that have mixed types of settings (e.g., list items and field items) require changes to be confirmed individually after being changed.

1. Select the option or enter a value for the setting to be changed.
  - a. For list items ❶, press the up and down arrows to select the setting.
  - b. For field items ❸, enter a value for the setting.
2. Press **OK** ❷ to confirm after each individual setting change.

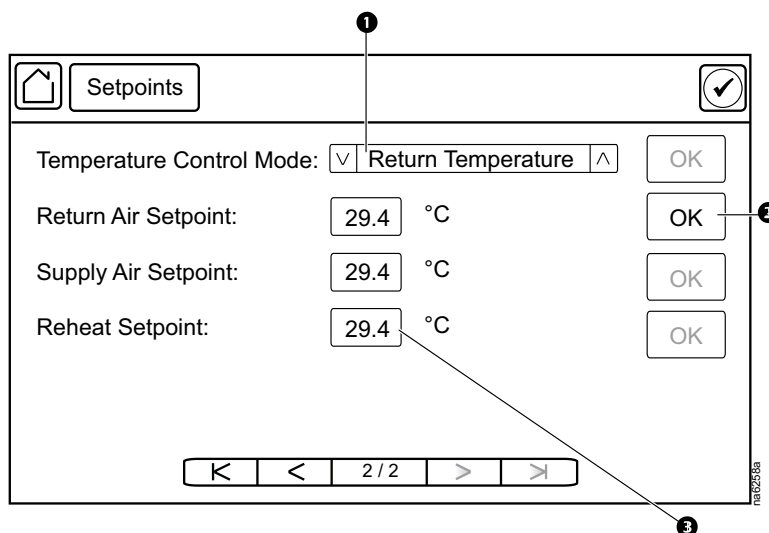

Screens that only contain field items can be confirmed together with a single **OK** button.

1. Enter a value for any or all field items ❶.
2. Press **OK** ❷ to confirm all changes at once, or press **ESC** to exit without accepting changes ❸.

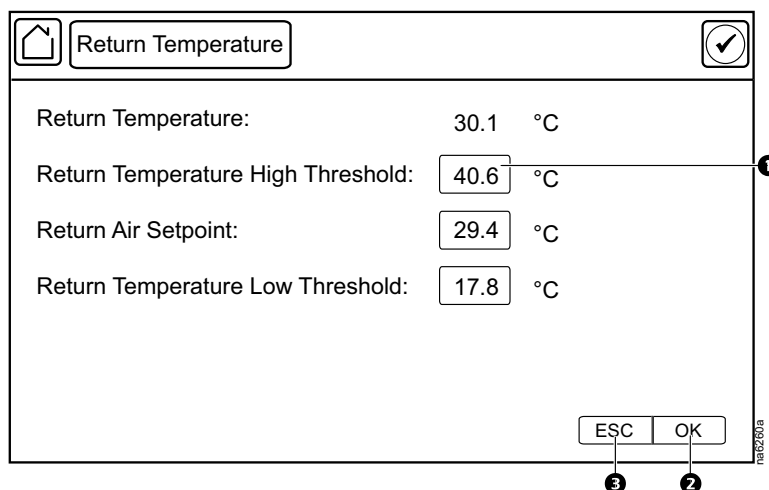

## Tests

### Calibrating the Display

**Path:** Main > Display > Tests > Display Calibration > Calibrate

Use this screen to calibrate the touch screen by touching the center of the box that appears on the screen. When you are satisfied with the calibration, let the timer run down to zero.

**NOTE:** The touch screen will need to be calibrated every time the firmware on the touch screen is updated.

**Path:** Main > Display > Tests > Display Calibration > Calibration Check

Use this screen to test the accuracy of the touch screen calibration by touching the center of the box that appears on the screen. When you are satisfied with the test, let the timer run down to zero.



## Testing Display LEDs and Annunciator

### Path: Main > Display > Tests > Annunciators

1. Press **Start** to test the display LEDs and annunciator.  
The display LEDs will cycle through a green, orange, and red illumination pattern and the annunciator will sound.
2. Press **Stop** to stop testing.

## Logging In/Password Entry

### Path: Main > Login

The unit display interface requires password verification before settings can be altered on the unit. You can log in from the main menu by selecting **Login**. While it is not required to log in to view unit configurations, it is required to make any changes.

1. Select **Login**.
2. Select your login ID with the up and down arrows ❶.  
**NOTE:** The default user ID is `apc`.
3. Enter your password in the **Pin** field ❷ with the keypad.  
**NOTE:** The default password is `1234`.
4. Select **Enter** ❸.

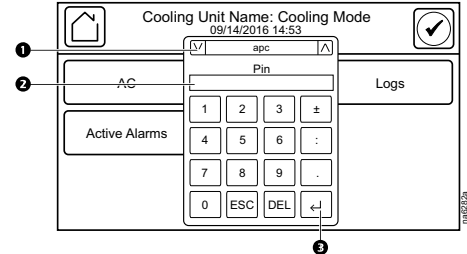

If the password was not entered from the **Login** screen on the main menu, you will be prompted to enter the password when attempting to change a setting. The unit default password is `1234`.



See *Add a New User or Edit an Existing User*, page 40 for information on editing users and passwords.

The **Home** button visually changes to signify that a user is currently logged in.

Symbol	Description
	<b>Home</b> when the system is locked.
	<b>Home</b> when the system has been unlocked by a user.



**Home** when the system is locked.



**Home** when the system has been unlocked by a user.

After the password is entered, user login remains active until the period of inactivity exceeds the **Auto Logoff** setting.



See *Screen Visibility and Audible Tones*, page 41.

# Unit Start Up/Shut Down

## Start the Cooling Unit

**Path: Main > AC > Control**

1. Select **On** for **Unit**.  
If you are not logged in, a prompt will appear to enter your password.
2. Enter your password if required.  
The cooling unit will run according to the configured settings.

## Stop the Cooling Unit

### **DANGER**

**HAZARD OF ELECTRIC SHOCK, EXPLOSION, OR ARC FLASH**

The **Off** option does not remove power from the cooling unit. You must disconnect power at the mains to remove power from the cooling unit.

**Failure to follow these instructions will result in death or serious injury.**

**Path: Main > AC > Control**

1. Select **Off** for **Unit**.  
If you are not logged in, a prompt will appear to enter your password.
2. The **Operating Mode** will now display **Air Economizer**: followed by the current cooling mode.

**NOTE:** The unit can also be stopped via an external signal connected to the **Remote On/Off**.

# Remove Power from the Unit

## Dual Power Supply with SCO

### **⚡⚠ DANGER**

#### **HAZARD OF ELECTRIC SHOCK, EXPLOSION, OR ARC FLASH**

Using the power disconnect button does not remove power from electrical components with power supplied directly from the customer. You must disconnect power at the customer power source to remove power completely from the cooling unit.

**Failure to follow these instructions will result in death or serious injury.**

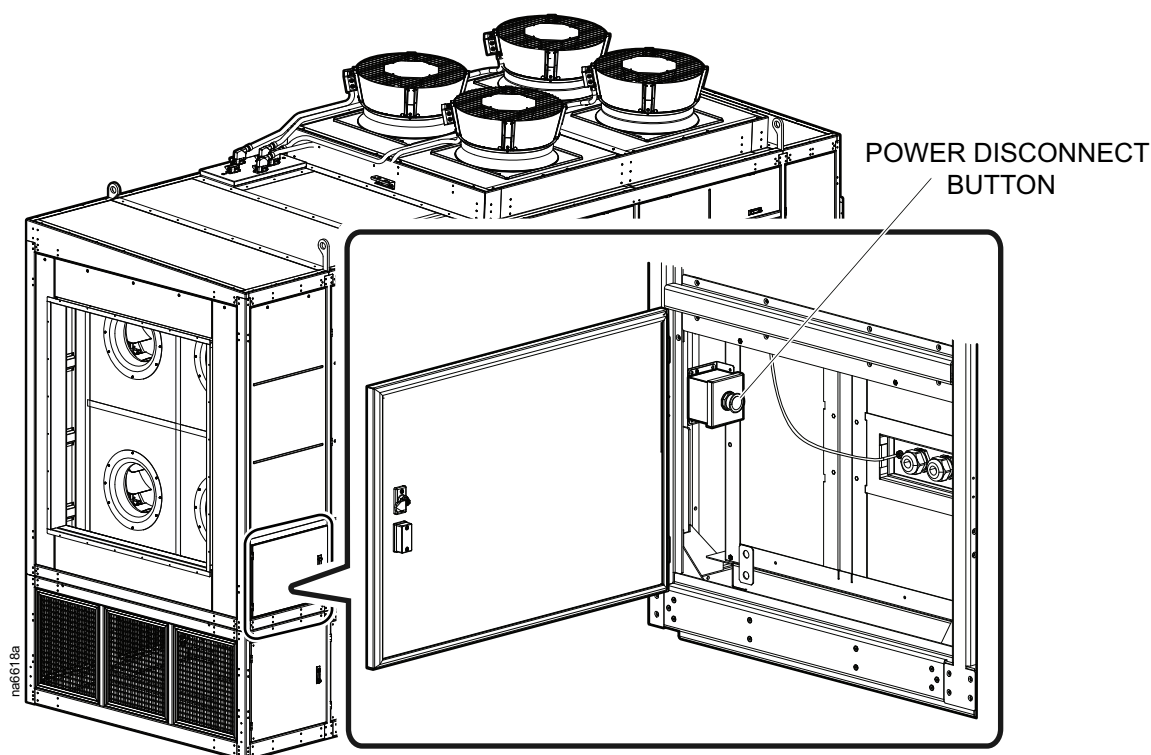

The following components in the electrical panels, if present, associated with the SCO function are still live even when the power disconnect button is activated or if Q1M and Q2M are in Lockout/Tagout state:

- Power supply connection 1 (X01)
- Power supply connection 2 (X02)
- Power supply 1 SCO motor fuse (F05)
- Power supply 2 SCO motor fuse (F06)
- Power supply 1 safety fuse (F03)
- Power supply 2 safety fuse (F04)
- SCO motor relay (K01)
- Terminal block (TB01)
- Power supply source changeover unit (PS01)
- Q1M closed status relay (K02)
- Q2M closed status relay (K03)
- Q1M/Q2M trip status relay (K04)
- Power supply 1/2 relay (K06)
- Power disconnect button status relay (K07)
- Lighting connection terminal block (TB10)
- SCO motor 1 transformer (T01)
- SCO motor 2 transformer (T02)

## Single Power Supply Units

### ⚠️⚠️ DANGER

#### HAZARD OF ELECTRIC SHOCK, EXPLOSION, OR ARC FLASH

Using the power disconnect switch does not remove power from electrical components with power supplied directly from the customer. You must disconnect power at the customer power source to remove power completely from the cooling unit.

**Failure to follow these instructions will result in death or serious injury.**

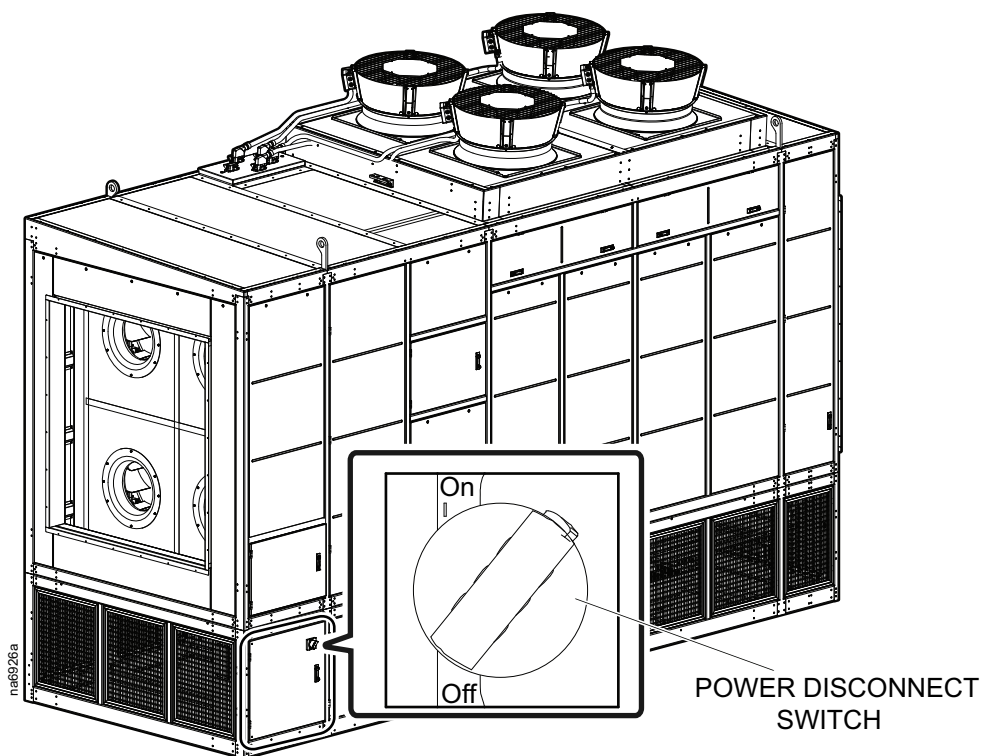

The following components in the electrical panels, if present, are still live even when the power disconnect switch is in the "Off" position or if Q1M is in Lockout/Tagout state:

- Power supply connection 1 (X01)
- Power supply 1 safety fuse (F03)
- Terminal block (TB01)
- Q1M closed status relay (K02)
- Q1M trip status relay (K04)
- Power supply 1 relay (K06)
- Lighting connection terminal block (TB10)

# Operation Modes

## Operational Overview

The Ecoflair Indirect Air Economizer is an indirect evaporative and air-to-air heat exchanger cooling solution. The Ecoflair Indirect Air Economizer has the ability to switch automatically between air-to-air and indirect evaporative heat exchange to consistently provide cooling to data centers in the most efficient way. The Ecoflair Indirect Air Economizer is able to reduce energy consumption by leveraging temperature differences between outside ambient air compared to IT return air to provide economized cooling to the data center. The Ecoflair Indirect Air Economizer meets ASHRAE 90.1/TC 9.9 requirements for efficiency and economization.

The Ecoflair Indirect Air Economizer is available in an individual nominal 250-kW main module or a main module combined with an expansion module to provide up to 500 kW of cooling capacity. Since the unit is located outside the perimeter of the data center, the Ecoflair Indirect Air Economizer takes up zero whitespace in the data center, enabling IT managers to utilize the space to increase capacity without needing to use any of that space for additional cooling units.

## Air-to-Air Heat Exchange

The Ecoflair Indirect Air Economizer uses sensors to determine the ambient air temperature and automatically switch between dry mode and wet mode. Air-to-air heat exchange is the dry mode and only requires the power of the fans to move the air (extremely energy efficient). The energy efficient outside air fan modulates airflow across the heat exchanger to maintain the IT supply air setpoint.

- When ambient air drops below 4.4°C (40°F) the system water is drained to prevent freezing. The system water will also be drained if the water concentration is too high to be diluted to a usable state or if the water in the basin has been stagnant for a set period of time.
- Only the fans are required to move the air.
- Cool air passes over the outside of the heat exchanger channels, cooling the hot IT air flowing inside.

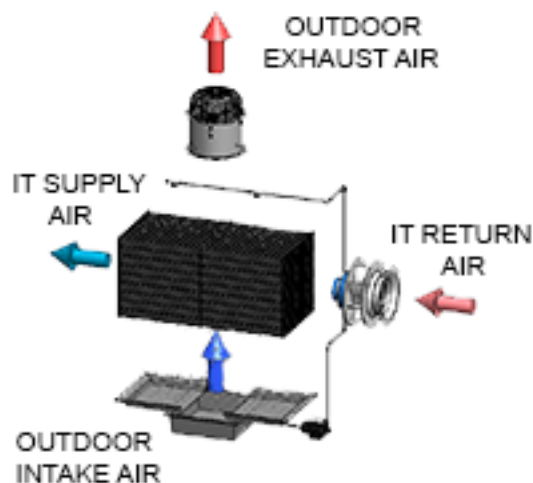

## Indirect Evaporative Cooling (IEC)

The Ecoflair Indirect Air Economizer uses sensors to determine the ambient air temperature and automatically switch between dry mode and wet mode. Indirect evaporative cooling is the wet mode and allows for economizing in hot, dry climates. Unevaporated water is collected in the basin and recirculated through the water system. The conductivity meter in the basin maintains optimal water conditions.

- Heat is removed from the IT air by evaporating water on the outside of the heat exchanger channels.
- Water is supplied evenly over the heat exchanger channels via spray nozzles.
- The adjustable IT supply air setpoint is maintained.

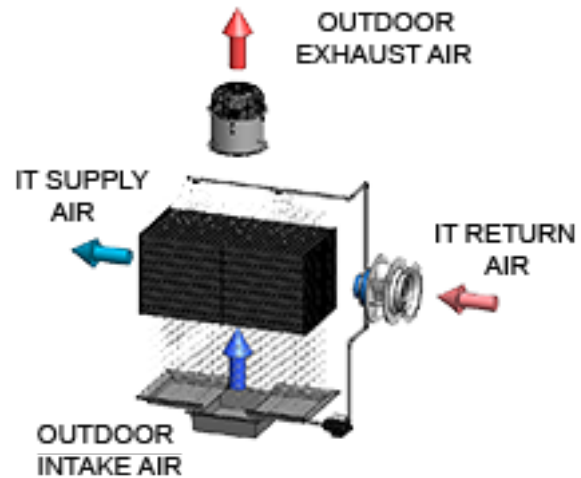

## Trim Cooling

The optional trim cooling circuit is available in two options: refrigerant system (DX) or chilled water system (CW).

### DX System

If ambient conditions do not allow evaporative cooling to meet the supply air temperature setpoint, the Ecoflair Indirect Air Economizer equipped with a refrigeration system option can provide supplemental cooling to assist in reaching the supply air temperature setpoint. The DX trim cooling option is available in two options: one compressor on one circuit or two compressors on two circuits offering nominal cooling capabilities of up to 75 kW or 125 kW, respectively, in a proportional control method. When assistance from the refrigerant circuit is requested by the controller, the circuit will start at its lowest compressor speed of 25 Hz. If the system begins to overcool (supply air temperature is less than the supply air setpoint) at this compressor speed, the outdoor air (OA) fans will begin to slow down to regulate the supply air temperature. If the lowest compressor speed is not enough to sufficiently cool the air to the supply air setpoint, the OA fans will remain at maximum speed and the compressor speed will be increased incrementally until the supply air setpoint is met or the compressors reach their maximum speed.

**NOTE:** The unit always has two cooling coils.

- Brushless, variable-speed compressors allow for optimal efficiency
- Supplements evaporative cooling to maintain the supply air temperature setpoint
- Uses R410A refrigerant



If more information is required on the performance of the DX system in your application, contact your local Schneider Electric representative.

### Chilled-Water System

The chilled water circuit is located downstream from the IEC heat exchanger.

- Available with a 2-way valve or 3-way valve configuration
- Internal piping and valves will be insulated in the factory

- Coil size can vary based on trim cooling need, inlet chilled water temperature, and water flow rate



If more information is required on the performance of the CW system in your application, contact your local Schneider Electric representative.

## Water Saver

If **Water Saver** is enabled in the **Main > AC > Setup** screen, water system operation is suspended when dry operation is sufficient for the cooling demand. This may be a higher ambient air temperature than the usual 4.4°C (40°F) transition to dry mode. When **Water Saver** mode is enabled, the unit will not switch to wet mode until the **Wet Operate Temperature Setpoint** has been exceeded and the outdoor air (OA) fan speed exceeds 65% of the maximum fan speed for a length time that varies and is calculated by the controller.

The consequence of using **Water Saver** mode is a higher OA fan speed with the resulting higher energy consumption. By default, **Water Saver** mode is disabled.



## Water Operation Reserve Time

The **Water Operation Reserve Time** determines how much water is maintained in the water basin to provide continual wet operation of the Ecoflair Indirect Air Economizer in case of short-term loss of the main water supply. The user can select to maintain the water in the basin at a volume to provide between 0 and 30 minutes nominally of continuous wet operation if the water supply is lost. This is a volume of water that is always available for use even when the water supply is operational. **Water Operation Reserve Time** is set in the **Service** menus and should only be changed by qualified personnel.

Depending on the value set for **Water Operation Reserve Time**, the water level will be maintained between 337 l (89 gal) and 488 l (129 gal). The water volume at which the water circulation pump will stop operation is 261 l (69 gal). The volume of water maintained in the water basin is calculated by the volume difference of the minimum maintained level and the pump operation stop level based on a nominal water usage rate of 0.13 l/s (2 gpm). For example, if 10 minutes is entered for the **Water Operation Reserve Time** setting, then the basin will be maintained at a water reserve volume level of 76 l (20 gal) above the pump suction connection in order to be able to provide a nominal 10 minutes of wet operation during a loss of water supply.

In wet mode, the water level is regulated between this calculated minimum level and the maximum capacity of the water basin.

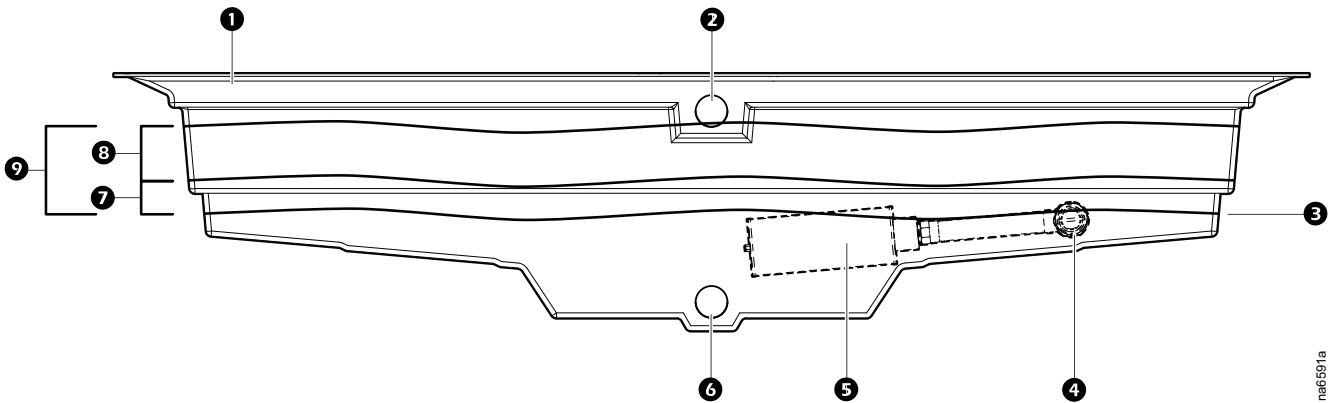

na6591a

Item	Description	Item	Description
1	Water basin	6	Drain port
2	Water overflow port	7	Water reserve time volume (always available for use)
3	Minimum required water level	8	Operational water volume
4	Pump suction connection	9	Total usable water volume
5	Water strainers—#20 mesh		

# General Configuration

## Importing/Exporting Unit Configuration

It is possible to configure a cooling unit by importing the settings of another cooling unit from a USB drive.

### Export

1. Navigate to **Main > AC > USB > Export**.
2. Insert the USB drive into the USB port on the display.
3. Press **Export**.

The configuration of the unit will be exported to the USB drive.

A message stating "Abort export of data to USB drive" will disappear when exporting is complete.

4. Remove the USB drive from the USB port.

### Import

1. Navigate to **Main > AC > USB > Import**.
2. Insert the USB drive into the USB port on the display.
3. Press **Import**.  
The configuration of the unit will be downloaded from the USB drive.
4. Press **OK** when the "Import Complete" message appears.
5. Remove the USB drive from the USB port.

## Unit Configuration

The unit configuration options are set during the commissioning of the unit.

**NOTE:** Changing the settings incorrectly can cause malfunctions to your unit. Only qualified service personnel should make changes to these settings.

**NOTE:** Displayed settings may vary based on unit configuration.

**NOTE:** Settings for the expansion module will be copied from the main module unless settings for the expansion module are changed independently in the **Main > AC > Exp Module > Service** menus. However, changing the settings independently is not recommended.

## Thresholds

### Path: Main > AC > Thresholds

Thresholds can be set to activate alarms to alert you to violations when the threshold is exceeded. The following thresholds can be set on the **Main > AC > Thresholds** screen:

**IMPORTANT:** Fields in yellow indicate that the main and expansion modules are configured differently.

**NOTE:** Changed values will appear in yellow until changes are saved.

- **Return Temperature High Threshold:** The high temperature threshold for air entering the unit. If the temperature exceeds the threshold, an alarm will occur. (Range: -40 to 100°C (-40 to 212°F); Default: 40.5°C (105°F))
- **Return Temperature Low Threshold:** The low temperature threshold for air entering the unit. If the temperature exceeds the threshold, an alarm will occur. (Range: -40 to 100°C (-40 to 212°F); Default: 23.9°C (75°F))
- **Supply Temperature High Threshold:** The high temperature threshold for air leaving the unit. If the temperature exceeds the threshold, an alarm will occur. (Range: **Supply Air Temperature Setpoint** to 100°C (**Supply Air Temperature Setpoint** to 212°F); Default: 29.4°C (85°F))
- **Supply Temperature Low Threshold:** The low temperature threshold for air leaving the unit. If the temperature exceeds the threshold, an alarm will occur. (Range: -40°C to **Supply Air Temperature Setpoint** (-40°F to **Supply Air Temperature Setpoint**); Default: 18.3°C (65°F))



See *Setpoints*, page 37 for **Supply Air Temperature Setpoint**.

## Configure the Unit

### Path: Main > AC > Service > Configuration

The setting on this screen determines how many modules are in the unit.

- **Number of Modules:** Enter '1' if the unit is a standalone 250-kW unit; enter '2' if the unit is a 500-kW unit (two 250-kW units combined).

### Path: Main > AC > Setup

**IMPORTANT:** Fields appearing as yellow indicate that the main and expansion modules are configured differently.

- **Dry Operation Drain Time:** The length of time in hours for how long the unit has to be in dry operation mode before the water in the basin is drained. (10 h – 72 h)  
**NOTE:** Dry operation mode is when the unit is only using the outdoor air (OA) fans to cool the air.
- **Lead Pump:** Select which pump is the primary pump. The other pump is the backup pump. (1 or 2)  
**NOTE:** More than one pump must be installed.
- **Pump Rotation Interval:** The length of run time in days that the that primary pump will operate before operation is switched to the backup pump. A value of '0' means the pump will never switch. (0–15 days)  
**NOTE:** More than one pump must be installed.
- **Water Saver:** If **Enable** is selected, the unit will operate in **Water Saver** mode.
- **Altitude:** Altitude can affect cooling units due to the change in air density. The altitude is used in conversions between absolute (g/Kg) and relative (%RH) humidity. Enter the distance of the unit above sea level. (0–3000 ft or meters)

### Path: Main > AC > Control

**IMPORTANT:** Fields in yellow indicate that the main and expansion modules are configured differently.

**NOTE:** Changed values will appear in yellow until changes are saved.

- **Cooling Mode:** This setting is read-only and displays the current cooling mode of the unit.
  - **Off:** The unit is not in operation.
  - **Remote Off:** The unit has been turned off by remote contact.
  - **Maintenance:** The unit is in maintenance mode for servicing.
  - **Dry Cooling:** The unit is operating in dry mode.
  - **Wet Cooling:** The unit is operating in wet mode.
  - **Dry and Trim Cooling:** The unit is operating in dry mode and conditions have been met to activate trim cooling.
  - **Wet and Trim Cooling:** The unit is operating in wet mode and conditions have been met to activate trim cooling.



See *Operation Modes*, page 30 for more information on the modes of operation.

- **Unit:** Turns the unit **On** or **Off**.
- **IT Fan Mode:** Sets the operation of the IT fans to **Automatic** or **Manual**. If **Automatic** is selected, the IT fans operate based on the unit configuration. If **Manual** is selected, the speed of the fan is entered in **Manual IT Fan Speed** or from an external source (e.g., BMS).
- **Manual IT Fan Speed:** The fan speed percentage. (15–100%)

## Identify the Cooling Unit

**Path: Main > AC > Main Module > About**

**Path: Main > AC > Exp Module > About**

- **Unit ID:** Assign a unique identification number to this cooling unit. (1–32)

**NOTE:** It is recommended to have the same **Unit ID** for the main module and the expansion module.

## Control the Environment

The Ecoflair Indirect Air Economizer provides sensible cooling while using a minimal amount of compressor energy over the course of an operating year. This is facilitated by using a natural heat exchange process across an air-to-air heat exchanger. The heat transfer process may be enhanced by indirect evaporative cooling, leveraging the outdoor wet-bulb temperature rather than the higher outdoor dry-bulb temperature. The balance of thermal energy not accommodated within the air-to-air heat exchanger is removed with a DX or CW system integral to each section of the unit.

The building management system (BMS) monitors data center differential pressure as sensed between cool supply air and hot return air serving the IT equipment within the IT space. The speed of IT fans is regulated as needed to maintain the pressure differential setpoint. Setpoint regulation is accomplished by means of a user-tunable, proportional, integral algorithm (PI) loop. The physical sensing points for differential pressure are located at the supply and return plenum, data center cool supply and hot return air plenums, and across row based containment boundaries.

## Setpoints

**Path: Main > AC > Setpoints**

A setpoint is the target value that a cooling group tries to maintain for the particular setting. The default setpoints are appropriate for most cooling applications.

**IMPORTANT:** Fields in yellow indicate that the main and expansion modules are configured differently.

**NOTE:** Changed values will appear in yellow until changes are saved.

Click **Apply** to save changes.

- **Supply Air Temperature Setpoint:** The required temperature of the air entering the IT space from the Ecoflair Indirect Air Economizer. (20.0–32.2°C (68.0–90.0°F))
- **Basin Water Conductivity Setpoint:** The conductivity level at which water will start to be partially drained from the basin to reduce conductivity of the water. (500–2500 µS/cm)
- **Basin Water Conductivity Deadband:** The conductivity level at which the basin drain actuator will close and water stops being drained from the basin. (50 – 500 µS/cm)
- **Wet Operate Temperature Setpoint:** If the ambient air temperature is below this value, the unit will not enter wet operation mode. (7.2–37.8°C (45.0–100.0°F))

## AFC Configuration

**NOTE:** Active Flow Controller devices should be connected directly to an Ecoflair Indirect Air Economizer only if a single 250-kW unit is being installed. If more than one 250-kW Ecoflair unit or a 500-kW Ecoflair unit is being installed, an Automation Server must be used.

**NOTE:** Up to four (4) AFC devices can be connected to a single 250-kW unit.

Path for Web interface settings: **Path: Main > Configuration > AFC**

Path for display interface settings: **Path: Main > AC > AFC**

The visible settings will differ depending on the selection for **Containment System: EcoAisle or Under Floor.**

### Aisle Containment

These settings are used for applications when the unit fans in the IT space are above floor. The AFC is connected via bus for a containment system environment.

- **Containment Setpoint:** This setting is used to change the bias of the controller by adjusting the contained aisle pressure threshold. **Zero** is the default setting. Only qualified service personnel can make changes to these settings.
  - Hot Aisle Containment (HACS)
    - If the cooling units seem to be under-cooling, select **Negative** or **Slightly Negative** to adjust the aisle pressure for additional cooling.
    - If the cooling units seem to be over-cooling, select **Positive** or **Slightly Positive** to adjust the aisle pressure for less cooling.
  - Cold Aisle Containment (CACS)
    - If the cooling units seem to be under-cooling, select **Positive** or **Slightly Positive** to adjust the aisle pressure for additional cooling.
    - If the cooling units seem to be over-cooling, select **Negative** or **Slightly Negative** to adjust the aisle pressure for less cooling.

Setting	Blue LED—HACS Red LED—CACS	Setpoint Green LED	Red LED—HACS Blue LED—CACS
<b>Positive</b>	< -0.008 in. ±3%	0.004 ±0.0004 in.	> 0.016 in. ±3%
<b>Slightly Positive</b>	< -0.010 in. ±3%	0.002 ±0.0004 in.	> 0.014 in. ±3%
<b>Zero</b>	< -0.012 in. ±3%	0.000 ±0.0004 in.	> 0.012 in. ±3%
<b>Slightly Negative</b>	< -0.014 in. ±3%	-0.002 ±0.0004 in.	> 0.010 in. ±3%
<b>Negative</b>	< -0.016 in. ±3%	-0.004 ±0.0004 in.	> 0.008 in. ±3%

- **Containment Systems:** Select **EcoAisle** for aisle containment installations.
- **Number of AFCs:** Select the number of AFC devices connected to the Ecoflair unit. (0–4)
- **EcoAisle Pressure Measurement Source:** Select if the aisle containment is cold-aisle containment (**CACS**), hot-aisle containment (**HACS**), or rack-aisle containment (**RACS**).
- **IT Fan Speed When AFC Not Available:** Select an IT fan speed to be used in the event that the AFC is not available to control the fans. (15–100%)

## Under Floor Application

These settings are used for applications when the unit fans in the IT space are below the floor and the AFC is also below the floor.

- **Under Floor Pressure Setpoint:** Enter the group setpoint for the pressure to be maintained under the floor. (0.0–124.42 Pa (0.0–0.5 in. WC))
- **Containment Systems:** Select **Under Floor** for under floor installations
- **Number of AFCs:** Select the number of AFC devices connected to the Ecoflair unit. (0–4)
- **Under Floor Pressure Measurement Source:** Select how the measurement is utilized: the **Minimum** value of all readings or the **Average** value of all readings.
- **IT Fan Speed When AFC Not Available:** Select an IT fan speed to be used in the event that the AFC is not available to control the fans. (15–100%)

## User Security Settings

The **Security** menus under the **Display** menu include options for user access to the unit.

### Add a New User or Edit an Existing User

**Path: Main > Display > Security**

1. Select **Add User** to add a new user or select **Edit User** to edit an existing user of the system.
2. In the **Name** field, enter the name of the user.
3. In the **Pin** field, enter a pin code for the user.
4. In the **Confirm Pin** field, re-enter the pin code of the user.
5. Press **OK** to save your settings.

### Delete a User

**Path: Main > Display > Security > Delete User**

1. Browse to the user that you wish to delete using the up and down arrows and press **OK**.
2. Press **Yes** to confirm deletion of an existing user of the system.

## Display Settings

The **Display** menus set the display interface settings, including time and date, units, passwords, and time-out. You can also adjust the contrast and sound settings.

### Language, Date, Time, and Temperature

**Path: Main > Display > Preferences**

- **Language:** Select the correct language for the display.
- **Date Format:** Select the display format for the date.
- **Temperature:** Select **Metric** or **US Customary** for temperature format.
- **Manual:** Manually enter the current and time instead of retrieving from a server.
  - **Current Date:** Enter the day, month, and year. The date is displayed on some status screens and is also used in the alarm/event log to date-stamp events.
  - **Current Time:** Enter the current time for the display.
- **Synchronize with NTP Server:** Select to sync the time and date with the Network Time Protocol server.



## Screen Visibility and Audible Tones

**Path: Main > Display > System Settings**

- **Alarm Volume:** Select the level of audio at which alarms will sound (**Off**, **Low**, **Medium**, or **High**).
- **Button Volume:** Select the volume at which a tone will be produced every time a button is pressed on the display interface. The audible tone can also be set to **Off**.
- **Brightness:** Controls the visibility of the display.
- **Enable Backlight Timeout:** **Enable** or **Disable** backlight timeout settings.
- **Backlight Timeout:** Adjust the backlight timeout settings.
  - **Minutes:** Turns off unit backlight after a specified amount of time. Timeout range is 1–60 minutes.
  - **Intensity:** Select the visibility of the display during backlight timeout.
    - **Off:** The display will remain at the normal intensity level.
    - **Very Low:** The display will be very dim.
    - **Low:** The display will be dim.
    - **Medium:** The display will dim to about half of the normal brightness.
- **Auto Logoff:** Automatically signs current user out of the system after specified amount of time. Options are 1, 5, 10, 30, or 60 minutes.

## Restore Defaults

**Path: Main > Display > Restore Defaults**

The **Restore Defaults** screen is used to restart the display and reset display settings to factory defaults.

**NOTE:** The controller settings will not be restored.

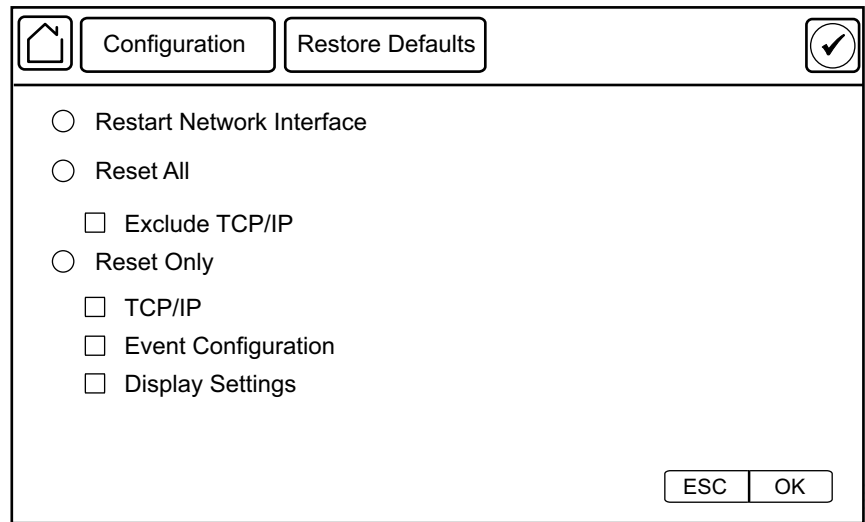

## Configure Modbus

Use the **Modbus** menu to set up communications between the cooling unit and the building management system.

**Path: Main > Display > Modbus**

- **Serial**
  - **Enable Serial Modbus:** Select to enable Modbus serial communication protocol.

- **Address:** Each Modbus device must have a unique target identification number. Enter a unique number for this cooling unit. (1–247)
- **Baud Rate:** Set to either 9600 bps or 19200 bps.
- **Parity:** Select **Even**, **Odd**, or **None**.
  - NOTE:** If you select **Even** or **Odd** parity, then select 1 stop bit on the host computer. If you select **None**, then select two stop bits on the host computer.
- **TCP**
  - **Enable Modbus TCP:** Select to enable Modbus TCP.
  - **Port:** Enter a port. The default port is 502. For additional security enter a port between 5000 and 32768 (TCP connection only).
- **Restore Port to Default:** Press to restore the **Port** to default settings (502).

## Network Configuration

### Overview

The unit is shipped with a Network Management Card (NMC) that enables you to manage the unit over your network. Configure the network settings for the unit Network Management Card from the display interface. The management card allows remote control and configuration of the equipment. Several units in the same installation area can be connected in a local network to manage the environmental conditions as a group.

### Configure the Network

#### TCP/IPv4 Settings

**Path:** Main > Display > Network > TCP/IPv4

Enable IPv4 (if applicable), and select the **Address Mode (Manual, DHCP, BOOTP)**.

- **Manual:** Enter the IP Address, subnet mask, and default gateway.
- **BootP:** Set the Network Management Card of the cooling unit to obtain its network settings from a BootP server.
- **DHCP:** Set the Network Management Card of the cooling unit to obtain its network settings from a DHCP server. Select whether or not to require vendor-specific cookies to accept the DHCP address.

#### TCP/IPv6 Settings

**Path:** Main > Display > Network > TCP/IPv6

Enable IPv6 (if applicable).

- Select **Auto Configuration** or **Manual Configuration**, and select the **DHCPv6 Mode (Router Controlled, Non-Address Information Only, Address and Other Information, or Never)**.
- For **Manual Configuration**, enter the **System IP** and **Default Gateway**.

#### Web Access Settings

**Path:** Main > Display > Network > Web Access

Enable Web (if applicable) and select the **Access Mode (HTTP or HTTPS)** and enter the **Port**.

## FTP Server Settings

**Path: Main > Display > Network > FTP Server**

Enable FTP (if applicable) and enter the **Port**.

# Unit Information

## View Status Readings

The display interface has several options for viewing the status of the cooling unit and the environment being controlled. Status readings for the overall unit are available under the **Main > AC > Status** screen; status readings for the individual modules are available under **Main > AC > Main Module > Status** and **Main > AC > Exp Module > Status**; status readings for the environment are available on the overview screen.

## Overview Screen

After start-up, the display shows an overview screen containing basic status information. Press **Home** to toggle between the main menu (home) and overview screen. After a period of inactivity, the display reverts back to the overview screen.

**NOTE:** Image shown is an example only: your available graphs may differ.

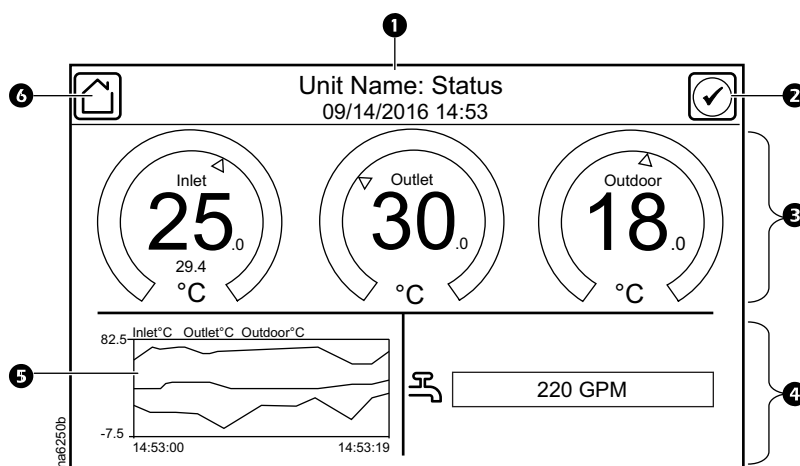

Item	Description
1	Unit operational status and current date and time
2	Alarms button
3	Gauge graphs (See <i>Gauge Graphs</i> , page 45 for more information.)
4	Bar graphs (See <i>Bar Graphs</i> , page 45 for more information.)
5	Line graphs showing data points over time
	<b>NOTE:</b> First three present will be displayed.
	<ul style="list-style-type: none"> <li>• Average commanded IT fan speed</li> <li>• Outdoor air temperature (if present)</li> <li>• Outdoor air humidity (if present)</li> <li>• Average return air humidity (if present)</li> <li>• Average supply air humidity (if present)</li> </ul>
6	Home button

### Gauge Graphs

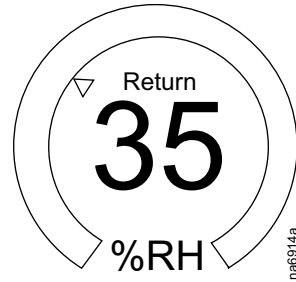
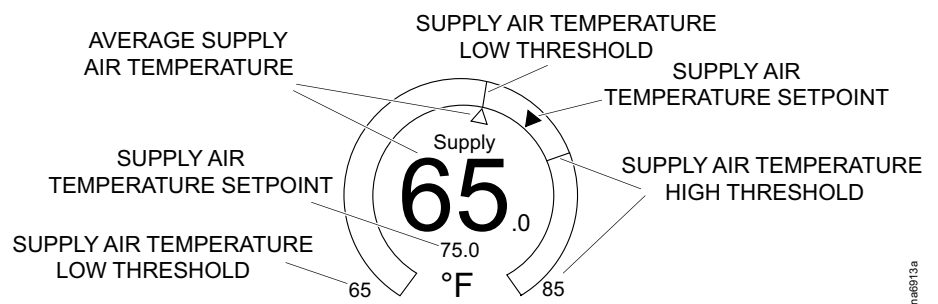
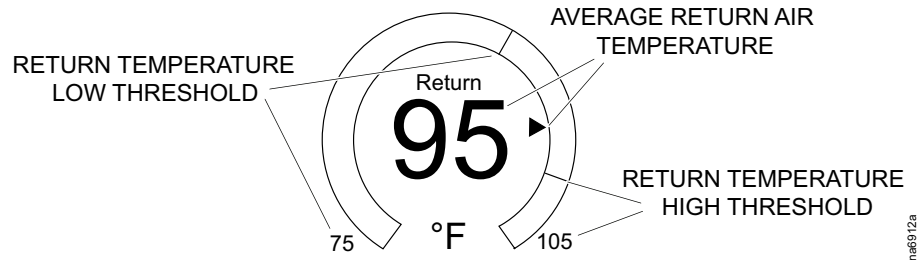

The first three sensors present will be displayed. The gauges are also color coded: green indicates that the value is within the acceptable range; blue indicates that the value is lower than the acceptable range; red indicates that the value is higher than the acceptable range.



### Bar Graphs

Two bar graphs are available to provide information about the evaporator fans and water flow.

Icon	Description
	Displays the total IT fan airflow.
	Displays the basin water conductivity for the main module and the expansion module (if present) in two separate graphs. <b>NOTE:</b> At least one water pump installed by the factory must be present. Graph will not be available if the water pump is customer controlled.

Icon	Description
	Displays the basin water level for the main module and the expansion module (if present) in two separate graphs. <b>NOTE:</b> At least one water pump installed by the factory must be present. Graph will not be available if the water pump is customer controlled.
	Displays the total compressor power of all compressors combined. <b>NOTE:</b> This will only display if one of the other three graphs is not available and if DX cooling is present.

## Unit Status

### Path: Main > AC > Status

View information related to the overall unit and the environment. These settings are read-only values.

- **Cooling Mode:** Displays the current cooling mode of the unit.
  - **Off:** The unit is not in operation.
  - **Remote Off:** The unit has been turned off by remote contact.
  - **Maintenance:** The unit is in maintenance mode for servicing.
  - **Dry Cooling:** The unit is operating in dry mode.
  - **Wet Cooling:** The unit is operating in wet mode.
  - **Dry and Trim Cooling:** The unit is operating in dry mode and conditions have been met to activate trim cooling.
  - **Wet and Trim Cooling:** The unit is operating in wet mode and conditions have been met to activate trim cooling.



See *Operation Modes*, page 30 for more information on the modes of operation.

- **Supply Air Temperature:** The average temperature of the conditioned air. (°C (°F))
- **Return Air Temperature:** The average temperature of the air entering the unit. (°C (°F))
- **Outdoor Air Temperature:** The temperature of the ambient air. (°C (°F))
- **Return Humidity:** The average humidity of the air entering the unit. (%RH)
- **Outdoor Humidity:** The humidity of the ambient air. (%RH)
- **IT Air Flow:** The total volume of IT air supplied by the unit. (CFM (l/s))
- **Commanded IT Fan Speed:** The average fan speed percentage of the IT fans.
- **Total Compressor Power:** The rate of power consumed by the compressor. (kW)
- **Compressors On:** How many compressors are currently on.

## View Individual Module Airflow Information

The information provided under **Main Module** is duplicated under **Exp Module** (if present) and applies to the respective modules.

**Path: Main > AC > Main Module > Status > Air**

**Path: Main > AC > Exp Module > Status > Air**

These settings are read-only values.

- **Cooling Mode:** Displays the current cooling mode of the unit.
  - **Off:** The unit is not in operation.
  - **Remote Off:** The unit has been turned off by remote contact.
  - **Maintenance:** The unit is in maintenance mode for servicing.
  - **Dry Cooling:** The unit is operating in dry mode.
  - **Wet Cooling:** The unit is operating in wet mode.
  - **Dry and Trim Cooling:** The unit is operating in dry mode and conditions have been met to activate trim cooling.
  - **Wet and Trim Cooling:** The unit is operating in wet mode and conditions have been met to activate trim cooling.



See *Operation Modes*, page 30 for more information on the modes of operation.

- **Supply Air 1 Temperature:** The temperature of the conditioned air from sensor 1 of this module. (°C (°F))
 

**NOTE:** Supply air temperature sensors are only available only if the unit is equipped with a trim cooling option.
- **Supply Air 2 Temperature:** The temperature of the conditioned air from sensor 2 of this module. (°C (°F))
 

**NOTE:** Supply air temperature sensors are only available only if the unit is equipped with a trim cooling option.
- **Outdoor Air Temperature:** The temperature of the ambient air. (°C (°F))
- **Outdoor Humidity:** The humidity of the ambient air. (%RH)
- **Commanded IT Fan Speed:** The fan speed percentage of the IT fans of this module.
- **Filter Differential Pressure:** The differential pressure across the air filter of this module. (Pa (in. WC))
- **IT Fan Differential Pressure:** The differential pressure used to calculate IT air flow of this module. (Pa (in. WC))
- **Damper Position:** The current position of the damper of this module. (**Open/Closed**)
- **IEC 1 Supply Air Temperature:** The temperature of the air leaving the indirect evaporative cooling (IEC) core from sensor 1 of this module. (°C (°F))
- **IEC 2 Supply Air Temperature:** The temperature of the air leaving the indirect evaporative cooling (IEC) core from sensor 1 of this module. (°C (°F))
- **DX Circuit 1 Supply Air Temperature:** The temperature of the air leaving circuit 1. (°C (°F))
- **DX Circuit 2 Supply Air Temperature:** The temperature of the air leaving circuit 2. (°C (°F))
- **IT 1 Return Air Temperature:** The temperature of the air entering the module at sensor 1. (°C (°F))
- **IT 2 Return Air Temperature:** The temperature of the air entering the module at sensor 2. (°C (°F))
- **IT 1 Return Air Humidity:** The humidity of the air entering the module at sensor 1. (%RH)
- **IT 2 Return Air Humidity:** The humidity of the air entering the module at sensor 2. (%RH)
- **IT Fan X Air Flow:** The volume of IT air supplied by each fan of the module. (CFM (l/s))
 

**NOTE:** The fan number is represented by 'X'.
- **OA Fan X Air Flow:** The volume of outdoor air moved by each fan of the module. (CFM (l/s))
 

**NOTE:** The fan number is represented by 'X'.

- **Supply Air Temperature:** The supply air temperature calculated from the air flow rate and **DX Circuit 1/2 Supply Air Temperature**. (°C (°F))

## View Module Configuration

**Path: Main > AC > Main Module > Control**

**Path: Main > AC > Exp Module > Control**

These settings are read-only values.

- **Cooling Mode:** Displays the current cooling mode of the unit.
  - **Off:** The unit is not in operation.
  - **Remote Off:** The unit has been turned off by remote contact.
  - **Maintenance:** The unit is in maintenance mode for servicing.
  - **Dry Cooling:** The unit is operating in dry mode.
  - **Wet Cooling:** The unit is operating in wet mode.
  - **Dry and Trim Cooling:** The unit is operating in dry mode and conditions have been met to activate trim cooling.
  - **Wet and Trim Cooling:** The unit is operating in wet mode and conditions have been met to activate trim cooling.



See *Operation Modes*, page 30 for more information on the modes of operation.

- **Unit:** Displays whether the unit **On** or **Off**.
- **IT Fan Mode:** Displays the operation mode of the IT fans: **Automatic** or **Manual**. If **Automatic** is selected, the IT fans operate based on the unit configuration. If **Manual** is selected, the speed of the fan is entered in **Manual IT Fan Speed**.
- **Manual IT Fan Speed:** The manually entered fan speed percentage.

## View Setup Settings

**Path: Main > AC > Main Module > Setup**

**Path: Main > AC > Exp Module > Setup**

These settings are read-only values.

- **Dry Operation Drain Time:** The length of time in hours for how long the unit has to be in dry operation mode before the water in the basin is drained.
 

**NOTE:** Dry operation mode is when the unit is only using the outdoor air (OA) fans to cool the air.
- **Lead Pump:** Displays which pump is designated as the lead pump.
 

**NOTE:** More than one pump must be installed.
- **Pump Rotation Interval:** The length of run time in days that the that lead pump will operate before operation is switched to the backup pump. A value of '0' means the pump will never switch.
 

**NOTE:** More than one pump must be installed.
- **Water Saver:** Displays whether **Water Saver** mode is set to **Enable** or **Disable**.



See *Water Saver*, page 32 for more information on **Water Saver** mode.

- **Altitude:** The distance of the unit above sea level. The altitude is also used in conversions between absolute (g/Kg) and relative (%RH) humidity.
 

**NOTE:** More than one pump must be installed.



## View Environmental Control Settings

**Path: Main > AC > Main Module > Setpoints**

**Path: Main > AC > Exp Module > Setpoints**

These settings are read-only values. Setpoints are set in the **Main > AC > Setpoints** menu.

- **Supply Air Temperature Setpoint:** Displays the current **Supply Air Temperature Setpoint**.
- **Basin Water Conductivity Setpoint:** Displays the conductivity level at which water will start to be partially drained from the basin.
- **Basin Water Conductivity Deadband:** Displays the conductivity level at which the basin drain actuator will close and water stops being drained from the basin.
- **Wet Operate Temperature Setpoint:** Displays the current **Wet Operate Temperature Setpoint**. If the ambient air temperature is below this value, the unit will not enter wet operation mode.



See *Indirect Evaporative Cooling (IEC)*, page 31 for more information on wet operation mode.

## View Thresholds

**Path: Main > AC > Main Module > Thresholds**

**Path: Main > AC > Exp Module > Thresholds**

These settings are read-only values. Thresholds are set in the **Main > AC > Thresholds** menu.

- **Return Temperature High Threshold:** Displays the high temperature threshold for air entering the unit at which an alarm will occur.
- **Return Temperature Low Threshold:** Displays the low temperature threshold for air entering the unit at which an alarm will occur.
- **Supply Temperature High Threshold:** Displays the high temperature threshold for air leaving the unit at which an alarm will occur.
- **Supply Temperature Low Threshold:** Displays the low temperature threshold for air entering the unit at which an alarm will occur.

## DX Circuit

**Path: Main > AC > Main Module > Status > DX**

**Path: Main > AC > Exp Module > Status > DX**

These settings are read-only values.

**NOTE:** Unit must be equipped with the DX option.

- **DX Circuit 1 Compressor:** Displays whether the compressor is **On** or **Off**.
- **DX Circuit 1 Supply Air Temperature:** The temperature of the air leaving the circuit. (°C (°F))
- **DX Circuit 1 Discharge Pressure:** The pressure at the discharge port of the compressor (kPa (psi))
- **DX Circuit 1 Suction Pressure:** The pressure at the suction port of the compressor. (kPa (psi))
- **DX Circuit 1 Suction Temperature:** The temperature of the refrigerant entering the compressor. (°C (°F))
- **DX Circuit 1 Superheat Temperature:** The temperature above saturation of the refrigerant entering the suction port of the compressor. (°C (°F))
- **DX Circuit 1 EEV Position:** The percentage of how far open the electronic expansion valve is. (%)
- **DX Circuit 1 VFD Frequency:** The frequency of the compressor inverter. (Hz)
- **DX Circuit 1 Compressor Power:** How much energy the compressor is consuming. (kW)
- **DX Circuit 2 Compressor:** Displays whether the compressor is **On** or **Off**.
- **DX Circuit 2 Supply Air Temperature:** The temperature of the air leaving the circuit. (°C (°F))

**NOTE:** This sensor is on the second coil; this setting is visible for 75-kW DX and 125-kW DX options.

- **DX Circuit 2 Discharge Pressure:** The pressure at the discharge port of the compressor. (kPa (psi))
- **DX Circuit 2 Suction Pressure:** The pressure at the suction port of the compressor. (kPa (psi))

**NOTE:** This sensor is on the second coil; this setting is visible for 75-kW DX and 125-kW DX options.

- **DX Circuit 2 Suction Temperature:** The temperature of the refrigerant entering the compressor. (°C (°F))
- **DX Circuit 2 Superheat Temperature:** The temperature above saturation of the refrigerant entering the suction port of the compressor. (°C (°F))

**NOTE:** This sensor is on the second coil; this setting is visible for 75-kW DX and 125-kW DX options.

- **DX Circuit 2 EEV Position:** The percentage of how far open the electronic expansion valve is. (%)

**NOTE:** This sensor is on the second coil; this setting is visible for 75-kW DX and 125-kW DX options.

- **DX Circuit 2 VFD Frequency:** The frequency of the pump inverter. (Hz)
- **DX Circuit 2 Compressor Power:** How much energy the compressor is consuming. (kW)

## Source Changeover

**Path: Main > AC > Main Module > Status > Source Changeover**

**Path: Main > AC > Exp Module > Status > Source Changeover**

These settings are read-only values.

**NOTE:** The unit must be equipped with a dual supply and source changeover.

- **Active Load Source:** Displays whether the currently active power source is the **Primary** or **Secondary** power source or the **Ultracap**.

## Energy Meter

**Path: Main > AC > Main Module > Status > Energy Meter**

**Path: Main > AC > Exp Module > Status > Energy Meter**

These settings are read-only values.

**NOTE:** The unit must be equipped with an energy meter.

- **L1–2:** The line-to-line voltage from Phase 1 to Phase 2.
- **L2–3:** The line-to-line voltage from Phase 2 to Phase 3.
- **L3–1:** The line-to-line voltage from Phase 3 to Phase 1.
- **L–L Average:** The average voltage of the line-to-line voltages between Phase 1, Phase 2, and Phase 3.
- **L1:** The current of Phase 1.
- **L2:** The current of Phase 2.
- **L3:** The current of Phase 3.
- **L–N:** The average current of Phase 1, Phase 2, and Phase 3. (A)
- **Active Power:** The active power of the unit. (kW)
- **Reactive Power:** The reactive power of the unit. (kVA)
- **Active Energy:** The active energy of the unit. (kW/hr)
- **Reactive Energy:** The reactive energy of the unit. (var/hr)
- **Power Factor:** The power factor of the unit. (0–1)
- **Frequency:** The frequency of the unit. (Hz)

## Ultracap Capacity

**Path: Main > AC > Main Module > Status > Ultracap**

**Path: Main > AC > Exp Module > Status > Ultracap**

These settings are read-only values.

**NOTE:** The unit must be equipped with an Ultracapacitor.

- **Ultracap 1 Capacity:** The charging capacity of the ultracap device. 0% means there is no charge; 100% means the device is fully charged.
- **Ultracap 2 Capacity:** The charging capacity of the ultracap device. 0% means there is no charge; 100% means the device is fully charged.

## Run Hours

### View Run Hours

**Path: Main > Main Module > Status > Run Hours**

**Path: Main > Exp Module > Status > Run Hours**

View the run hours for the module components.

**NOTE:** Available components will vary based on your unit configuration.

- IT Fan 1 Run Hrs
- IT Fan 2 Run Hrs
- IT Fan 3 Run Hrs
- IT Fan 4 Run Hrs
- OA Fan 1 Run Hrs
- OA Fan 2 Run Hrs
- OA Fan 3 Run Hrs
- OA Fan 4 Run Hrs
- Water Pump 1 Run Hrs
- Water Pump 2 Run Hrs
- Water Treatment Device Run Hrs
- Compressor 1 Run Hours
- Compressor 2 Run Hours

### Reset Run Hours

**Path: Main > AC > Main Module > Service > Run Hours**

**Path: Main > AC > Exp Module > Service > Run Hours**

The cooling unit records the number of hours each of its components has been in operation. When a component is replaced, use the **Reset** option to reset the run hours for the displayed component to zero.

**NOTE:** Available components will vary based on your unit configuration.

- Water Pump 1 Run Hrs Reset
- Water Pump 2 Run Hrs Reset
- Water Treatment Device Run Hrs Reset
- Compressor 1 Run Hours Reset
- Compressor 2 Run Hours Reset

## About the Network

View identifying information about the cooling network parameters. Select IPv4 or IPv6.

### Path: Main > Display > About > Network > IPv4

- **Enabled:** Identifies whether the specified network is **Enabled** or **Disabled**.
- **Mode:** Identifies how the IP address is obtained.
- **IP Address:** The IP address of the unit.
- **Subnet Mask:** The subnet mask for the sub-network.
- **Default Gateway:** The default gateway address used by the network.

### Path: Main > Display > About > Network > IPv6

Press **Addresses** to view all assigned IPv6 addresses.

- **Enabled:** Identifies whether the specified network is enabled or not.
- **Auto Configuration:** Displays **Yes** if the IP address is assigned automatically.
- **Manual Configuration:** Displays **Yes** if the IP address is assigned manually.
- **DHCPv6 Mode:** The DHCPv6 mode.
  - **Router Controlled:** DHCPv6 is controlled by the **M** (Managed Address Configuration Flag) and **O** (Other Stateful Configuration Flag) flags received in IPv6 Router Advertisements. When a router advertisement is received, the network management card (NMC) checks whether the **M** and **O** flags are set. The NMC interprets the state of the **M** and **O** “bits” for the following cases:
    - Neither is set: Indicates local network has no DHCPv6 infrastructure. The NMC uses Router Advertisements and/or manual configuration to get non-link-local addresses and other settings.
    - **M**, or **M** and **O** are set: In this situation, full DHCPv6 address configuration occurs. DHCPv6 is used to obtain addresses AND other configuration settings. This is known as DHCPv6 stateful. Once the **M** flag has been received, the DHCPv6 address configuration stays in effect until the interface in question has been closed, even if subsequent Router Advertisement packets are received in which the **M** flag is not set. If an **O** flag is received first, then an **M** flag is received subsequently, the NMC performs full address configuration upon receipt of the **M** flag.
    - Only **O** is set: In this situation, the NMC sends a DHCPv6 Info-Request packet. DHCPv6 is used to configure “other” settings (such as location of DNS servers), but NOT to provide addresses. This is known as DHCPv6 stateless.
  - **Address and Other Information:** DHCPv6 is used to obtain addresses AND other configuration settings. This is known as DHCPv6 stateful.
  - **Non-Address and Information Only:** DHCPv6 is used to configure “other” settings (such as locations of DNS servers), but NOT to provide addresses. This is known as DHCPv6 stateless.
  - **Never:** If this radio box is selected, DHCPv6 is NOT to be used for any configuration settings.

## About the Unit

### Path: Main > AC > About

View identifying information about the unit that is helpful when obtaining service:

- **Unit ID:** The unique identification number assigned to this unit.
- **Model Number:** The model number of the unit.
- **Serial Number:** The serial number of the unit.
- **Firmware Revision:** The firmware revision of the unit.
- **PIC1 Firmware Revision:** The firmware revision of the PIC1 processor.
- **PIC2 Firmware Revision:** The firmware revision of the PIC2 processor.
- **Hardware Revision:** The hardware revision of the unit.
- **Capacity:** The maximum cooling capacity of the unit.

### Path: Main > Display > About > Identification

View identifying information about the unit that is helpful when obtaining service:

- **Name:** The name assigned to the unit.
- **Contact:** The contact person for this unit.
- **Location:** The physical location of the unit.

## About the Module

### Path: Main > Main Module > About

### Path: Main > Exp Module > About

View identifying information about the modules that is helpful when obtaining service.

- **Unit ID:** The unique identification number assigned to this module.  
**NOTE:** It is recommended to have the same **Unit ID** for the main module and the expansion module.
- **Model Number:** The model number of the module.
- **Serial Number:** The serial number of the module.
- **Firmware Revision:** The firmware revision of the module controller.
- **Hardware Revision:** The hardware revision of the module controller.
- **PIC1 Firmware Revision:** The firmware revision of the PIC1 processor.
- **PIC2 Firmware Revision:** The firmware revision of the PIC2 processor.

## About the Display

### Path: Main > Display > About > Summary > Device

- **Model Number:** The model number of the display interface.
- **Serial Number:** The serial number of the display interface.
- **Hardware Revision:** The hardware revision of the display interface.
- **Manufacture Date:** The date the display interface was manufactured.
- **MAC Address:** The MAC address of the unit.

### Path: Main > Display > About > Summary > Firmware

View identifying revision information about the display interface firmware:

- Application
- APC OS (AOS)
- APC Boot Monitor
- Video Drive
- FPGA

# Logs

## Event Log

The **Event Log** saves status information and a message each time a change in the unit is detected. Alarms and events are recorded in the log and displayed on the **Active Alarms** screen. Status events (informational) and system configuration changes are only displayed in the event log.

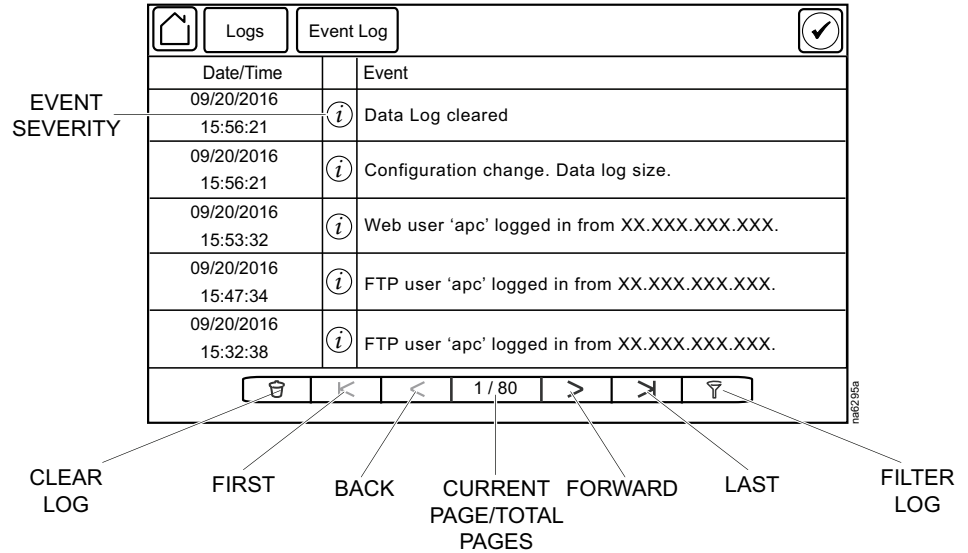

### View Event Log

**Path: Main > Logs > Event Log**

The **Event Log** keeps a record of all alarms and events. The screen displays the following:

- The name of the event.
- The severity of the event.
- The time and date the event occurred.

Use the arrows to scroll through the list of events and display the date and time for each event.



## Filter Event Log

Events in the **Event Log** can be sorted by time or severity. Events can also be displayed by **Device Events** or **System Events**. Press **ESC** to return to the previous screen without making changes; press **OK** to accept changes.

The screenshot shows the 'Filter' screen with the following elements:

- Navigation bar: Home, Logs, Event Log, Filter, Confirm (checkmark icon).
- Event Time: Radio buttons for 'Last' (selected) and 'From'. A dropdown menu shows 'All Logs'.
- Date/Time Range: Two rows of input fields. The first row shows '01/01/2001' and '00:00'. The second row shows '09/27/2016' and '13:10'.
- Filter by Severity: Checkboxes for 'Show Critical Events' (checked), 'Show Warning Events', and 'Show Informational Events'.
- Action Buttons: 'Device Events' and 'System Events'.
- Navigation: 'ESC' and 'OK' buttons.

The filter options for related **Device Events** are the following:

- Communication
- Temperature
- Fans
- Status
- Diagnostics
- Humidity
- Configuration

The filter options for related **System Events** are the following:

- Mass Configuration
- Security

## Clear Event Log

**Path: Main > Logs > Event Log**

1. Press the trash can icon in the bottom-left corner of the **Event Log** screen to clear the log. A confirmation screen is displayed.
2. Enter the Admin password to clear the log.
3. Select **Yes** to clear all of the events in the log. Select **No** to return to the **Event Log** screen.

## Data Log

The **Data Log** is a graph showing the changes over time of selected readings. Select the data point to graph and press **+** to add the data point to the graph. To remove a data point from the graph, select the data point from the list and press **-**. To clear the graph, press **CLR**.

**NOTE:** Image is an example only; your screen may differ.

## Export Data

### Path: Main > Logs > Export Data

The data export function exports a .tar file containing the following files:

- config.ini
- data.txt
- debug.txt
- event.txt

1. Insert a USB drive into the USB port of the display interface.
2. Press **Start Data Export**.
3. Confirm exporting the data to the USB drive.
4. Wait for the data to export or abort exporting by pressing **Abort Data Export**.
5. Press **OK** when the “Data exported successfully. Remove USB device.” message displays.
6. Remove the USB drive from the display interface.

# Alarms

## Respond to Alarms

When an alarm is triggered, the unit alerts you through the display by the following methods:

- LEDs on the display interface
- Alarm icon in the upper-right corner of the screen
- An optional audible alarm every 30 seconds if enabled

## View Active Alarms

The **Active Alarms** screen is accessed by pressing the alarm icon in the upper-right corner of the screen. The **Active Alarms** screen provides the number of alarms, the severity, and a brief description of the alarm.

## Clear Active Alarms

1. Press **Clear** to clear the active alarms.  
A confirmation screen is displayed.
2. Enter the Admin password to erase the alarms list.
3. Select **Yes** to erase all of the alarms. Select **No** to return to the **Active Alarms** screen.

## Alarm Messages and Suggested Actions

Alarm Message	Severity	Action Required
AFC All Sensors Fault	Critical	<ul style="list-style-type: none"> <li>• Check the CANbus connection.</li> <li>• A hardware error exists.</li> <li>• Contact Schneider Electric Technical Support if the problem persists.</li> </ul>
AFC Sensor Fault	Warning	<ul style="list-style-type: none"> <li>• Check the AFC.</li> <li>• Contact Schneider Electric Technical Support if the problem persists.</li> </ul>
Ambient Humidity Sensor Fault	Warning	<ul style="list-style-type: none"> <li>• Check the sensor connection.</li> <li>• Contact Schneider Electric Technical Support if the problem persists.</li> </ul>
Ambient Temperature Sensor Fault	Critical	<ul style="list-style-type: none"> <li>• Check the sensor connection.</li> <li>• Contact Schneider Electric Technical Support if the problem persists.</li> </ul>
Basin Severe Leak	Critical	<ul style="list-style-type: none"> <li>• Check the basin drain valve and the water supply connection.</li> <li>• Contact Schneider Electric Technical Support.</li> </ul>
Basin Water Conductivity Sensor Calibration Needed	Warning	The water conductivity sensor needs to be calibrated or water service is needed. Contact Schneider Electric Technical Support.
Basin Water Level Low	Critical	<ul style="list-style-type: none"> <li>• Check supply water flow rate.</li> <li>• Contact Schneider Electric Technical Support if the problem persists.</li> </ul>

Alarm Message	Severity	Action Required
Basin Water Overflow Alarm	Critical	<ul style="list-style-type: none"> <li>Check if the overflow port or the drain pipe are blocked.</li> <li>Contact Schneider Electric Technical Support if the problem persists.</li> </ul>
Basin Water Overflow Warning	Warning	Check the water level in the water basin and if external water (e.g., precipitation) has entered the basin. Contact Schneider Electric Technical Support if the problem persists.
Blowdown Operation Failed, Conductivity Remains High	Critical	<ul style="list-style-type: none"> <li>Check the <b>Basin Water Conductivity Setpoint</b> on the <b>Main &gt; AC &gt; Main Module/Exp Module &gt; Setpointsscreen</b> of the display interface.</li> <li>Contact Schneider Electric Technical Support.</li> </ul>
Communication Error	Critical	Contact Schneider Electric Technical Support.
Conductivity Sensor Fault	Critical	<ul style="list-style-type: none"> <li>Check the sensor connection. The sensor must be between 500 and 2500 <math>\mu\text{S}/\text{cm}</math>.</li> <li>Contact Schneider Electric Technical Support if the problem persists.</li> </ul>
Configuration Changed	Informational	Informational text only.
Configuration String Changed	Informational	Informational text only.
Controller Reset Occurred	Informational	Informational text only.
Dirty IT Filter	Warning	<ul style="list-style-type: none"> <li>Change the IT air filter.</li> <li>Contact Schneider Electric Technical Support if the problem persists.</li> </ul>
DX Circuit 'X' Compressor Start Failure	Critical	Contact Schneider Electric Technical Support.
DX Circuit 'X' Discharge Pressure Sensor Fault	Critical	<ul style="list-style-type: none"> <li>Check the sensor connection.</li> <li>Contact Schneider Electric Technical Support if the problem persists.</li> </ul>
DX Circuit 'X' Discharge Temperature Sensor Fault	Critical	<ul style="list-style-type: none"> <li>Check the sensor connection.</li> <li>Contact Schneider Electric Technical Support if the problem persists.</li> </ul>
DX Circuit 'X' Frequent Envelope Violation	Critical	Contact Schneider Electric Technical Support.
DX Circuit 'X' Frequent VFD Fault	Critical	Contact Schneider Electric Technical Support.
DX Circuit 'X' High Condensing Temperature Trip	Critical	Contact Schneider Electric Technical Support.
DX Circuit 'X' High Pressure Trip	Critical	Contact Schneider Electric Technical Support.
DX Circuit 'X' High Suction Pressure Trip	Critical	Contact Schneider Electric Technical Support.
DX Circuit 'X' Low Suction Pressure	Warning	Contact Schneider Electric Technical Support.
DX Circuit 'X' Low Suction Pressure Trip	Critical	Contact Schneider Electric Technical Support.
DX Circuit 'X' Suction Pressure Sensor Fault	Critical	<ul style="list-style-type: none"> <li>Check the sensor connection.</li> <li>Contact Schneider Electric Technical Support if the problem persists.</li> </ul>
DX Circuit 'X' Suction Temperature Sensor Fault	Critical	<ul style="list-style-type: none"> <li>Check the sensor connection.</li> <li>Contact Schneider Electric Technical Support if the problem persists.</li> </ul>

<b>Alarm Message</b>	<b>Severity</b>	<b>Action Required</b>
DX Circuit 'X' Superheat High	Warning	Contact Schneider Electric Technical Support.
DX Circuit 'X' Superheat Low	Warning	Contact Schneider Electric Technical Support.
DX Circuit 'X' VFD Alarm	Critical	Contact Schneider Electric Technical Support.
DX Circuit 'X' VFD Communication Loss	Critical	Contact Schneider Electric Technical Support.
DX Circuit 'X' VFD Configuration Failed	Critical	Contact Schneider Electric Technical Support.
DX Circuit 'X' VFD Warning	Warning	Contact Schneider Electric Technical Support.
DX Supply Air Temperature Sensor 'X' Fault	Critical	<ul style="list-style-type: none"> <li>• Check the sensor connection.</li> <li>• Contact Schneider Electric Technical Support if the problem persists.</li> </ul>
Energy Meter Communication Loss	Critical	Contact Schneider Electric Technical Support.
IEC DX Supply Temperature Readings Variate	Warning	<ul style="list-style-type: none"> <li>• Sensors need to be calibrated.</li> <li>• Contact Schneider Electric Technical Support.</li> </ul>
IEC Supply Air Temperature Sensor 'X' Fault	Critical	<ul style="list-style-type: none"> <li>• Check the sensor connection.</li> <li>• Contact Schneider Electric Technical Support if the problem persists.</li> </ul>
IEC Supply Temperature Readings Variate	Warning	<ul style="list-style-type: none"> <li>• Sensors need to be calibrated.</li> <li>• Contact Schneider Electric Technical Support.</li> </ul>
In Maintenance Mode	Warning	The unit is in maintenance mode.
IT Air Filter DP Sensor Fault	Warning	<ul style="list-style-type: none"> <li>• Check the sensor connection.</li> <li>• Contact Schneider Electric Technical Support if the problem persists.</li> </ul>
IT Fan 'X' Alarm	Critical	Contact Schneider Electric Technical Support.
IT Fan 'X' Communication Loss	Critical	Contact Schneider Electric Technical Support.
IT Fan 'X' Speed Abnormal	Warning	Contact Schneider Electric Technical Support.
IT Fan DP Sensor Fault	Critical	<ul style="list-style-type: none"> <li>• Check the sensor connection.</li> <li>• Contact Schneider Electric Technical Support if the problem persists.</li> </ul>
IT Fan Motor Temperature Low	Warning	<ul style="list-style-type: none"> <li>• The temperature is below <math>-20^{\circ}\text{C}</math> (<math>-4^{\circ}\text{F}</math>).</li> <li>• The fans will try to start again after 10 minutes.</li> </ul>
Loss of Water Management Power Circuit	Critical	Contact Schneider Electric Technical Support.
Motorized Damper Fault	Critical	Contact Schneider Electric Technical Support.
OA Fan 'X' Alarm	Critical	Contact Schneider Electric Technical Support.
OA Fan 'X' Communication Loss	Warning	Contact Schneider Electric Technical Support.
OA Fan 'X' Speed Abnormal	Warning	Contact Schneider Electric Technical Support.
Possible Debris In Basin Drain Valve	Critical	<ul style="list-style-type: none"> <li>• Check the basin drain valve for debris. Drain if necessary.</li> <li>• Contact Schneider Electric Technical Support if the problem persists.</li> </ul>
Pump 3-Phase Power Failure	Critical	<p>Check the pump power supply phase orientation.</p> <p>Contact Schneider Electric Technical Support.</p>

Alarm Message	Severity	Action Required
Pump Flow Switch Status Disagree	Critical	Contact Schneider Electric Technical Support.
Return Humidity Sensor 'X' Fault	Critical	<ul style="list-style-type: none"> <li>Check the sensor connection.</li> <li>Contact Schneider Electric Technical Support if the problem persists.</li> </ul>
Return Temperature High	Warning	<ul style="list-style-type: none"> <li>The return air temperature has exceeded the <b>Return Temperature High Threshold</b>.</li> <li>Check the threshold setting and verify that it is not too low.</li> <li>Contact Schneider Electric Technical Support if the problem persists.</li> </ul>
Return Temperature Low	Warning	<ul style="list-style-type: none"> <li>The return air temperature has exceeded the <b>Return Temperature Low Threshold</b>.</li> <li>Check the threshold setting and verify that it is not too high.</li> <li>Contact Schneider Electric Technical Support if the problem persists.</li> </ul>
Return Temperature Sensor 'X' Fault	Critical	<ul style="list-style-type: none"> <li>Check the sensor connection.</li> <li>Contact Schneider Electric Technical Support if the problem persists.</li> </ul>
Service Door Open (In Command Off Mode)	Critical	<ul style="list-style-type: none"> <li>Check if the service vestibule door is closed completely.</li> <li>Contact Schneider Electric Technical Support if the problem persists.</li> </ul>
Service Door Open (In Command On Mode)	Warning	<ul style="list-style-type: none"> <li>Check if the service vestibule door is closed completely.</li> <li>Contact Schneider Electric Technical Support if the problem persists.</li> </ul>
Service Room Shutdown Set (In Command Off Mode)	Critical	<ul style="list-style-type: none"> <li>The unit has been placed in <b>Off</b> mode by service personnel while the unit is idle.</li> <li>Check with service personnel.</li> </ul>
Service Room Shutdown Set (In Command On Mode)	Warning	<ul style="list-style-type: none"> <li>The unit has been placed in <b>Off</b> mode by service personnel while the unit is in operation.</li> <li>Check with service personnel.</li> </ul>
Return Temperature Sensor 'X' Fault	Critical	<ul style="list-style-type: none"> <li>Check the sensor connection.</li> <li>Contact Schneider Electric Technical Support if the problem persists.</li> </ul>
Source Change Over Communication Loss	Critical	Contact Schneider Electric Technical Support.
Supply Temperature High	Warning	<ul style="list-style-type: none"> <li>The supply air temperature has exceeded the <b>Supply Temperature High Threshold</b>.</li> <li>Check the threshold setting and verify that it is not too low.</li> <li>Contact Schneider Electric Technical Support if the problem persists.</li> </ul>
Supply Temperature Low	Warning	<ul style="list-style-type: none"> <li>The supply air temperature has exceeded the <b>Supply Temperature Low Threshold</b>.</li> <li>Check the threshold setting and verify that it is not too high.</li> <li>Contact Schneider Electric Technical Support if the problem persists.</li> </ul>

<b>Alarm Message</b>	<b>Severity</b>	<b>Action Required</b>
System Off	Informational	The system has been turned off. No action required.
System Off via Remote	Warning	<ul style="list-style-type: none"> <li>The system has been turned off via a digital input.</li> <li>Verify authorization of this remote command.</li> </ul>
System Smoke/Water/Fire	Critical	Check the data center for smoke, water, or fire.
Too Many AFC Sensors	Warning	<ul style="list-style-type: none"> <li>Check the number of connected sensors and remove sensors over the allowed number.</li> </ul>
Ultracap Circuit Deactive	Critical	<ul style="list-style-type: none"> <li>AC power to the unit has been lost.</li> <li>Check the power supply.</li> <li>Contact Schneider Electric Technical Support if the problem persists.</li> </ul>
Ultracap Circuit Failure	Critical	<ul style="list-style-type: none"> <li>Check the ultracap manager.</li> <li>Contact Schneider Electric Technical Support if the problem persists.</li> </ul>
Unable to Drain Basin	Critical	<ul style="list-style-type: none"> <li>Check the drain pipe for blockage.</li> <li>Contact Schneider Electric Technical Support if the problem persists.</li> </ul>
Water Basin Drain Valve Position Sensor Fault	Critical	<ul style="list-style-type: none"> <li>Check the sensor connection.</li> <li>Contact Schneider Electric Technical Support if the problem persists.</li> </ul>
Water Inlet Temperature Sensor Fault	Critical	<ul style="list-style-type: none"> <li>Check the sensor connection.</li> <li>Contact Schneider Electric Technical Support if the problem persists.</li> </ul>
Water Level Sensor Fault	Critical	<ul style="list-style-type: none"> <li>Check the sensor connection.</li> <li>Contact Schneider Electric Technical Support if the problem persists.</li> </ul>
Water Pump 1 Fault	Critical	Contact Schneider Electric Technical Support.
Water Pump 2 Fault	Critical	Contact Schneider Electric Technical Support.
Water Supply Loss	Critical	<ul style="list-style-type: none"> <li>Check the inlet water connection.</li> <li>Contact Schneider Electric Technical Support if the problem persists.</li> </ul>
Water Treatment Service Needs Maintenance	Informational	<p>Perform maintenance on the water treatment system and reset run hours.</p> <p>See <i>Reset Run Hours</i>, page 52.</p> <p>Contact Schneider Electric Technical Support if the problem persists</p>
Water Treatment System Error	Warning	Contact Schneider Electric Technical Support.

# Network Management Card

## Quick Configuration

The unit is shipped with a Network Management Card that enables the unit to be managed over a network. Configure the Network Management Card to control this unit through a network.

### Overview

You must configure the following TCP/IP settings before the Network Management Card can operate on a network:

- IP address of the Network Management Card
- Subnet mask
- Default gateway

**NOTE:** Never use the loopback address (127.0.0.1) as the default gateway address for the Network Management Card. Doing so will disable the card and will require you to reset TCP/IP settings to their defaults using a local serial login.

**NOTE:** If a default gateway is unavailable, use the IP address of a computer that is located on the same subnet as the Network Management Card and that is usually running. The Network Management Card uses the default gateway to test the network when traffic is very light.



See “Watchdog Features” in the “Introduction” of the *User Manual* or *Online Guide* for more information about the watchdog role of the default gateway.

### TCP/IP Configuration Methods

Use one of the following methods to define the TCP/IP settings needed by the Network Management Card:

- Device IP Configuration Wizard (See *Device IP Configuration Wizard*, page 65 for more information.)
- BootP or DHCP server (See *BootP and DHCP Configuration*, page 65 for more information.)
- Local computer (See *Local Access to the Command Line Interface (CLI)*, page 67 for more information.)
- Networked computer (See *Remote Access to the Command Line Interface (CLI)*, page 66 for more information.)



## Device IP Configuration Wizard

The Device IP Configuration Wizard is used to discover and configure Network Management Cards that do not have IP addresses assigned. The Device IP Configuration Wizard runs on Microsoft® Windows® 2000, Windows 2003, Windows Server® 2003, Windows Server 2012, and on 32- and 64-bit versions of Windows XP, Windows Vista, Windows 2008, Windows 7, Windows 8, Windows 10, and Windows 2012 operating systems.

The Device IP Configuration Wizard supports network management cards that have firmware version 3.x.x or higher and is for IPv4 only.

**NOTE:** Most software Firewalls must be temporarily disabled for the Wizard to discover Network Management Cards that are not configured.



To configure one or more Network Management Cards from a user configuration file, see the *User Manual* or *Online Guide*.

1. Download the Device IP Configuration Wizard from [www.schneider-electric.com](http://www.schneider-electric.com) or [www.apc.com](http://www.apc.com) (search for “Device IP Configuration Wizard”).
2. Install and run the Device IP Configuration Wizard.
3. Follow the on-screen instructions.

**NOTE:** If you leave the option **Start a Web browser when finished** enabled, you can use `apc` (the default) for both the user name and password.

## .ini File Utility

You can use the .ini file export utility to export .ini file settings from configured Network Management Cards to one or more unconfigured Network Management Cards.

## BootP and DHCP Configuration

The default **TCP/IP Configuration, DHCP**, assumes that a properly configured DHCP server is available to provide TCP/IP settings to Network Management Cards. The possible settings are **Manual**, **DHCP**, or **BOOTP**.



If neither a DHCP nor BOOTP server is available, see *Device IP Configuration Wizard*, page 65 or *Remote Access to the Command Line Interface (CLI)*, page 66 for more information on how to configure the TCP/IP settings.

**BOOTP:** For the Network Management Card to use a BOOTP server to configure its TCP/IP settings, it must find a properly-configured RFC951-compliant BOOTP server.

1. In the BOOTPTAB file of the BOOTP server, enter the MAC address of the Network Management Card, and the IP addresses of the subnet mask and default gateway, and an optional bootup file name.

**NOTE:** Look on the nameplate of the unit for the MAC address. The MAC address is also available on the display interface at **Main > About > Display > Device**

2. When the Network Management Card reboots, the BOOTP server provides it with the TCP/IP settings.
  - If you specified a bootup file name, the Network Management Card attempts to transfer that file from the BOOTP server using TFTP or FTP. The Network Management Card takes on all settings specified in the bootup file.
  - If you did not specify a bootup file name, the Network Management Card can be configured remotely by using the CLI or the Web interface. User name and password are both `apc`, by default.



To create the bootup file, see your BOOTP server documentation.

**DHCP:** You can use a RFC2131/RFC2132-compliant DHCP server to configure the TCP/IP settings for the Network Management Card.



For more details on how a DHCP can configure the network settings for a Network Management Card, see “DHCP Configuration” in the *Online Guide*.

1. The Network Management Card sends out a DHCP request that uses the following to identify itself:
  - Vendor Class Identifier (by default, APC)
  - Client Identifier (by default, the MAC address of the Network Management Card)
  - User Class Identifier (by default, the identification of the application firmware installed on the Network Management Card)
2. A properly configured DHCP server responds with a DHCP offer that includes all of the settings that the Network Management Card needs for network communication. The DHCP offer also includes the Vendor Specific Information option (DHCP option 43). If configured to do so, the Network Management Card will ignore DHCP offers that do not encapsulate the APC cookie in DHCP option 43 using the following hexadecimal format:

Option 43 = 01 04 31 41 50 43

where

- The first byte (01) is the code
- The second byte (04) is the length
- The remaining bytes (31 41 50 43) are the APC cookie (not required by default)



See your DHCP server documentation to add code to the Vendor Specific Information option.

To change the command line interface (CLI) DHCP Cookie Is setting, use the Advanced option in the TCP/IP menu.



See *Local Access to the Command Line Interface (CLI)*, page 67 for more information.

## Remote Access to the Command Line Interface (CLI)

From any computer on the same network as the Network Management Card, you can use ARP and Ping to assign an IP address to the Network Management Card and then use Telnet to access the CLI of that Network Management Card and configure the other TCP/IP settings.

**NOTE:** After a Network Management Card has its IP address configured, you can use Telnet, without first using ARP and Ping, to access that Network Management Card.

1. Use the MAC address of the Network Management Card in the ARP command to define an IP address for the Network Management Card. For example, to define an IP address of 156.205.14.141 for a Network Management Card that has a MAC address of 00 c0 b7 63 9f 67, use one of the following commands:

**NOTE:** Look on the nameplate of the unit for the MAC address. The MAC address is also available on the display interface at **Main > About > Display > Device**.

- Windows command format:

```
arp -s 156.205.14.141 00-c0-b7-63-9f-67
```

- LINUX command format:

```
arp -s 156.205.14.141 00:c0:b7:63:9f:67
```

2. Use Ping with a size of 113 bytes to assign the IP address defined by the ARP command. For the IP address defined in step 1, use one of the following Ping commands:

- Windows command format:

```
ping 156.205.14.141 -l 113
```

- LINUX command format:

```
ping 156.205.14.141 -s 113
```

3. Use Telnet to access the Network Management Card at its newly assigned IP address. For example,

```
telnet 156.205.14.141
```

4. Use `apc` for both the user name and password.

5. Contact your network administrator to obtain the IP address, subnet mask, and default gateway for the Network Management Card.

6. Use these three commands to configure network settings (text in *italics* indicates a variable):

- a. `tcpip -i yourIPAddress`

- b. `tcpip -s yourSubnetMask`

- c. `tcpip -g yourDefaultGateway`

For each variable, enter a numeric value with the format `xxx.xxx.xxx.xxx`.

For example, to set a system IP address of 156.205.14.141, enter the following command and press **ENTER**:

```
tcpip -i 156.205.14.141
```

7. Type `reboot`. The Network Management Card restarts to apply the changes.

## Local Access to the Command Line Interface (CLI)

You can use a computer connected to the serial port on the front of the display to access the CLI.

1. Select a serial port on the local computer and disable any service that uses that port.
2. Use the provided serial cable to connect the selected serial port to the serial on the front of the display.
3. Run a terminal program (such as HyperTerminal®, TeraTerm, or PuTTY) and configure the selected port for 9600 bps, 8 data bits, no parity, 1 stop bit, and no flow control.
4. Save the changes.
5. Press **ENTER**, repeatedly if necessary, to display the **User Name** prompt.
6. Use `apc` for the user name and password.
7. Contact your network administrator to obtain the IP address, subnet mask, and default gateway for the Network Management Card.

8. Use these three commands to configure network settings (text in *italics* indicates a variable):

- a. `tcpip -i yourIPAddress`
- b. `tcpip -s yourSubnetMask`
- c. `tcpip -g yourDefaultGateway`

For each variable, enter a numeric value with the format xxx.xxx.xxx.xxx. For example, to set a system IP address of 156.205.14.141, enter the following command and press **ENTER**:

```
tcpip -i 156.205.14.141
```

9. Type `reboot`. The Network Management Card restarts to apply the changes.

## Access a Configured Unit

### Overview

After the unit is running on your network, you can access the configured cooling unit through the following interfaces:

- Web interface
- Telnet/SSH
- Simple Network Management Protocol (SNMP)
- FTP/SCP
- Modbus



For more information on the interfaces, see the *Online Guide*.

### Web Interface

Use Microsoft Internet Explorer® 7.x or higher (on Windows operating systems only), or Mozilla® Firefox® 3.0.6 or higher (on all operating systems) to access the cooling unit through its Web interface. Other commonly available browsers also may work but have not been fully tested by Schneider Electric.

You can use either of the following protocols when you use the Web browser to configure display interface options or to view the event log:

- The HTTP protocol (enabled by default), which provides authentication by user name and password but no encryption.
- The HTTPS protocol, which provides extra security through Secure Sockets Layer (SSL), encrypts user names, passwords, and data being transmitted, and authenticates the Network Management Card by means of digital certificates.

To access the Web interface and configure the security of your cooling unit on the network,

1. Enter the IP address or DNS name of the cooling unit into a Web browser.
2. Enter the user name and password (both are `apc` by default).
3. To enable or disable the HTTP or HTTPS protocols, use **Main > Configuration > Network**.



For more information on selecting and configuring network security, see the UPS Network Management Card Security Handbook, available on [www.schneider-electric.com](http://www.schneider-electric.com): search for “UPS Network Management Cards.”

## Telnet and SSH

You can access the control console through Telnet and/or Secure SHell (SSH), depending on which is enabled. To enable these access methods from the Web UI, select **Configuration > Network > Console > Access**. By default, Telnet is enabled. Telnet and SSH can be enabled simultaneously.

### Telnet for Basic Access

Telnet provides the basic security of authentication by user name and password, but not the high-security benefits of encryption. To use Telnet to access the Network Management Card control console from any computer on the same network,

1. At a command prompt, use the following command line, and press **ENTER**:

```
telnet address
```

As *address*, use the Network Management Card IP address or DNS name (if configured).

2. Enter the user name and password (by default, `apc` and `apc` for an Administrator, or `device` and `apc` for a Device User).

### SSH for High-Security Access

If you use the high security of SSL for the Web interface, use Secure SHell (SSH) for access to the CLI. SSH encrypts user names, passwords, and transmitted data.

The interface, user accounts, and user access rights are the same whether you access the CLI through SSH or Telnet, but to use SSH, you must first configure SSH and have an SSH client program installed on your computer.



See the *Online Guide* for more information on configuring and using SSH.

## Simple Network Management Protocol (SNMP)

### SNMPv1 Only

After you add the latest version of PowerNet® MIB to a standard SNMP MIB browser, you can use that browser to access the device. All user names, passwords, and community names for SNMP are transferred over the network as plain text. The default read community name is **public**; the default read/write community name is **private**.

### SNMPv3 Only

For SNMP GETs, SETs, and trap receivers, SNMPv3 uses a system of user profiles to identify users. An SNMPv3 user must have a user profile assigned in the MIB software program to perform GETs and SETs, browse the MIB, and receive traps. The default settings are **no authentication** and **no privacy**.

**NOTE:** To use SNMPv3, you must have an MIB program that supports SNMPv3, and SNMPv3 must be configured correctly in the Network Management Card.

The device supports SHA or MD5 authentication and V or DES encryption.

### SNMPv1 and SNMPv3

To use StruxureWare Data Center Expert to manage the device on the public network of StruxureWare system, you must have SNMPv1 enabled in the unit

interface. Read access allows devices to receive traps from the unit. Write access is required while you set the device as a trap receiver.

To enable or disable SNMP access, you must be an Administrator. Select **Administration > Network** and select the access option under SNMPv1 or SNMPv3.

## FTP/SCP

You can use FTP (enabled by default) or Secure CoPy (SCP) to transfer downloaded firmware to the Network Management Card or to access a copy of the device event or data logs. SCP provides the higher security of encrypted data transmission and is enabled automatically when you enable SSH. FTP and SCP can be enabled simultaneously.

To access the Network Management Card through FTP or SCP, the default user name and password are `apc` and `apc` for an Administrator, or `device` and `apc` for a Device User. In the command line, use the IP address of the unit.

**NOTE:** If you enable SSL and SSH for their high-security authentication and encryption, disable FTP. To disable FTP, you must be an Administrator. Go to **Main > Configuration > Network** to enable FTP.



In the *User Manual*, see the following sections:

- To transfer firmware, see “File Transfers.”
- To retrieve a copy of the event or data log, see “How to Use FTP or SCP to Retrieve Log Files.”

## Modbus

Modbus lets you view the Network Management Card through the interface of your building management system.

The Modbus RTU interface supports 2-wire RS-485, 4-wire RS-485, plus ground MODBUS TCP.

**NOTE:** Modbus can be configured to run at either 9600 or 19200 bps. It is already configured for 8 data bits, no parity, and 1 stop bit: parity is changeable but data bits and stop bits are not.



To access the Modbus Register Map, go to the Schneider Electric website, [www.schneider-electric.com](http://www.schneider-electric.com), and search for “Modbus Register Map.”

## Recover From a Lost Password

Use a local computer (a computer that connects to the Network Management Card through the serial port) to access the command line interface (CLI).

1. Select a serial port at the local computer, and disable any service that uses that port.
2. Connect the Schneider Electric serial cable (part number 940-0299) to the selected port on the computer and to the serial port on the front of the display.
3. Run a terminal program (such as HyperTerminal®) and configure the selected port:
  - 9600 bps
  - 8 data bits
  - No parity
  - 1 stop bit
  - No flow control
4. Press the **RESET** button on the front of the display, immediately press **ENTER** on the computer keyboard, repeatedly if necessary, to display the **User Name** prompt.

**NOTE:** If you do not press the **ENTER** key before five seconds elapse, you must press the **RESET** button.

If you are unable to display the **User Name** prompt, verify the following:

- The serial port is not in use by another application.
  - The terminal settings are correct as specified in step 3.
  - The correct cable is being used as specified in step 2.
5. Press the **RESET** button on the front of the display. The Status LED will alternately flash orange and green. Immediately press the **RESET** button on the front of the display a second time while the LED is flashing to temporarily reset the user name and password to their defaults.
  6. Press **ENTER** on the computer keyboard as many times as necessary to re-display the **User Name** prompt, then use the default, **apc**, for the user name and password. (If you take longer than 30 seconds to log on after the **User Name** prompt is re-displayed, you must repeat step 5 and log on again.)
  7. At the command line interface, use the following commands to change the password setting, which has been reset to **apc**:

```
user -n <user name> -pw <user password>
```

For example, to change the Super User password to **XYZ**, type

```
user -n apc -pw XYZ
```
  8. Type **quit** or **exit** to log off, reconnect any serial cable you disconnected, and restart any service you disabled.

## Updating the Firmware

When you update the firmware on the unit, you obtain the latest features, performance improvements, and bug fixes.

Updating here means placing the module files on the unit; there is no installation required. Check regularly on [www.schneider-electric.com](http://www.schneider-electric.com) for any new updates.

**NOTE:** You will need to select the language pack if you require your display interface to be available in a language other than English.

## Firmware Module Files

A firmware version has three modules, and they must be updated (that is, placed on the unit) in this order:

Module	Description
❶ Boot monitor (bootmon)	Roughly equivalent to the BIOS of a PC
❷ American Power Conversion Operating System (AOS)	Can be considered the operating system of the unit
❸ Application	Specific to the unit device type

(Each module contains one or more Cyclical Redundancy Checks (CRCs) to protect its data from corruption.)

The boot monitor module, the AOS, and the application file names share the same basic format:

```
apc_hardware-version_type_firmware-version.bin
```

- **apc:** Indicates the context.
- **hardware-version:** "hw0n" where 'n' identifies the hardware version on which you can use this file.
- **type:** Identifies which module.
- **version:** The version number of the file.
- **bin:** Indicates that this is a binary file.

## Firmware File Transfer Methods

Update the bootmon module first, then the AOS module, and finally, the application module by placing them on the unit in that order.

Obtain the free, latest firmware version from [www.schneider-electric.com](http://www.schneider-electric.com). To update the firmware of one or more units, use one of these methods:

- On a Windows operating system, use the Firmware Upgrade Utility downloaded from the [www.schneider-electric.com](http://www.schneider-electric.com) Web site.
- On any supported operating system, use FTP or SCP to transfer the individual AOS and application firmware modules.
- For a unit that is NOT on your network, use XMODEM through a serial connection to transfer the individual firmware modules from your computer to the unit.



See *Use XMODEM to Update One Unit*, page 74.



## Firmware Upgrade Utility

The **Firmware Upgrade Utility** is part of the firmware update package available on the [www.schneider-electric.com](http://www.schneider-electric.com) website.

**NOTE:** Never use an upgrade utility designated for one product to upgrade the firmware of another product.

### Use the Utility for Updates on Windows-Based Systems

On any supported Windows operating system, the **Firmware Upgrade Utility** automates the transferring of the firmware modules, in the correct module order.

Unzip the downloaded firmware upgrade file and double-click the .exe file. Then enter the IP address, the user name, and the password in the dialog fields and click **Upgrade Now**. You can use the Ping button to test your entered details.



See *Update Firmware on Multiple Units*, page 78.

### Use the Utility for Manual Updates, Primarily on Linux

On non-Windows operating systems, the **Firmware Upgrade Utility** extracts the individual firmware modules but does not update the unit.

To extract the firmware files:

1. After obtaining the files from the downloaded firmware upgrade file, run the **Firmware Upgrade Utility** (the .exe file).
2. At the prompts, click **Next**, and then specify the directory location to which the files will be extracted.
3. When the **Extraction Complete** message displays, close the dialog box.

## Use FTP or SCP to Update One Unit

### FTP

To use FTP to upgrade a unit over the network:

1. The unit must be on the network, with its system IP, subnet mask, and default gateway configured.
2. The FTP server must be enabled at the unit.

To transfer the files, perform these steps (this procedure assumes bootmon does not need upgrading):

1. The firmware module files must be extracted.
2. At a computer on the network, open a command prompt window. Go to the directory that contains the firmware files, and list the files:  

```
C:\>cd apc  
C:\apc>dir
```
3. Open an FTP client session:  

```
C:\apc>ftp
```
4. Type **open** with the IP address of the unit, and press **Enter**. If the port setting for the FTP Server has changed from its default of 21, you must use the non-default value in the FTP command.
  - For Windows FTP clients, separate a non-default port number from the IP address by a space. For example (showing a space before 21000):

```
ftp> open 150.250.6.10 21000
```

**NOTE:** Some FTP clients require a colon instead before the port number.

5. Log on as a Super User/Administrator (`apc` is the default user name and password).
6. Upgrade the AOS. (Always upgrade the AOS before the application module).  

```
ftp> bin
```

```
ftp> put apc_hw06_aos_nnn.bin
```

 (where `nnn` is the firmware version number)
7. When FTP confirms the transfer, type `quit` to close the session.
8. After 20 seconds, repeat step 3 through step 6, using the application module file name at step 6.

## SCP

To use Secure CoPy (SCP) to update firmware for the unit, follow these steps (this procedure assumes bootmon does not need upgrading):

1. Locate the firmware modules, see *Firmware Upgrade Utility*, page 73.
2. Use an SCP command line to transfer the AOS firmware module to the unit. The following example uses `nnn` to represent the version number of the AOS module:  

```
scp apc_hw06_aos_nnn.bin apc@158.205.6.185:apc_hw05_aos_nnn.bin
```
3. Use a similar SCP command line, with the name of the application module, to transfer the application firmware module to the unit. (Always upgrade the AOS before the application module).

## Use XMODEM to Update One Unit

To use XMODEM to update one unit that is not on the network, you must extract the firmware files with the **Firmware Upgrade Utility**.

To transfer the files (this procedure assumes bootmon does not need upgrading):

1. Select a serial port at the local computer and disable any service that uses the port.
2. Connect the provided serial configuration cable to the selected port and to the serial port at the unit.
3. Run a terminal program such as HyperTerminal, and configure the selected port for 57600 bps, 8 data bits, no parity, 1 stop bit, and no flow control.
4. Press the `Reset` button on the unit, then immediately press the `Enter` key twice, or until the Boot Monitor prompt displays: `BM>`.
5. Type `XMODEM`, then press `Enter`.
6. From the terminal program menu, select `XMODEM`, then select the binary AOS firmware file to transfer using `XMODEM`. After the `XMODEM` transfer is complete, the Boot Monitor prompt returns. (Always upgrade the AOS before the application module).
7. To install the application module, repeat step 5 and step 6. In step 6, use the application module file name.
8. Type `reset` or press the `Reset` button to restart the unit.



See *Firmware Module Files*, page 72.

## Using a USB Drive to Transfer and Update Files

### Update Display Interface Firmware

1. Insert a USB drive into an available port on the PC and verify that the drive is formatted as a FAT32 file system.
2. Create a folder named **apcfirm** on the USB drive.
3. Acquire the firmware files from the local support team or the Schneider Electric Web site.
4. Unzip and extract the files to the **apcfirm** folder.
  - Operating system (\*\_aos\_\*.bin)
  - Boot monitor (\*\_bootmon\_\*.bin)
  - Application (\*\_ebg2\_\*.bin)
5. Use a text editor, like Notepad, to create a file named upload.rcf.
6. List the filename for each firmware module in the order to be transferred. An example is shown below.

**IMPORTANT:** The files must be listed in the correct order in the upload.rcf file.

- The BM (bootmon) file must be listed first: BM=apc\_hw06\_bootmon\_105.bin
- The AOS (operating system) file must be listed second: AOS=apc\_hw06\_aos\_609.bin
- The APP (application) must be listed third: APP=apc\_hw06\_ebg2\_\*.bin

**NOTE:** \* in the APP file name is the revision number and will change with each release.

7. Save the upload.rcf file in the **apcfirm** folder.

Your **apcfirm** folder should look similar to the example folder shown here:

Name	Date modified	Type	Size
apc_hw06_aos_646.bin	3/16/2017 3:55 PM	BIN File	3,058 KB
apc_hw06_bootmon_108.bin	3/16/2017 3:55 PM	BIN File	256 KB
apc_hw06_unflrtsa_600g.bin	4/20/2017 4:41 PM	BIN File	2,454 KB
upload.rcf	3/17/2017 7:16 AM	RCF File	1 KB

8. Insert the USB drive into the USB-A port on the display interface.  
A confirmation message appears on the display interface.
9. Press the **Display Reset** button to reset the display interface.  
The display interface resets and transfers files. The display will resume operation when transfer is complete.
 

**NOTE:** The touch screen will be disabled during the transfer process. There is no disruption of unit operation during the file transfer process.
10. Remove the USB drive when the file transfer is complete.
11. Check the firmware version on the touch screen display interface on the **Main > About > Display** screen.
12. To update the firmware on additional units, repeat from step 8.

## Update Controller Firmware

Before starting the transfer, make sure the USB drive is formatted in FAT32.

**Path: Main > AC > Service > USB > Firmware Download**

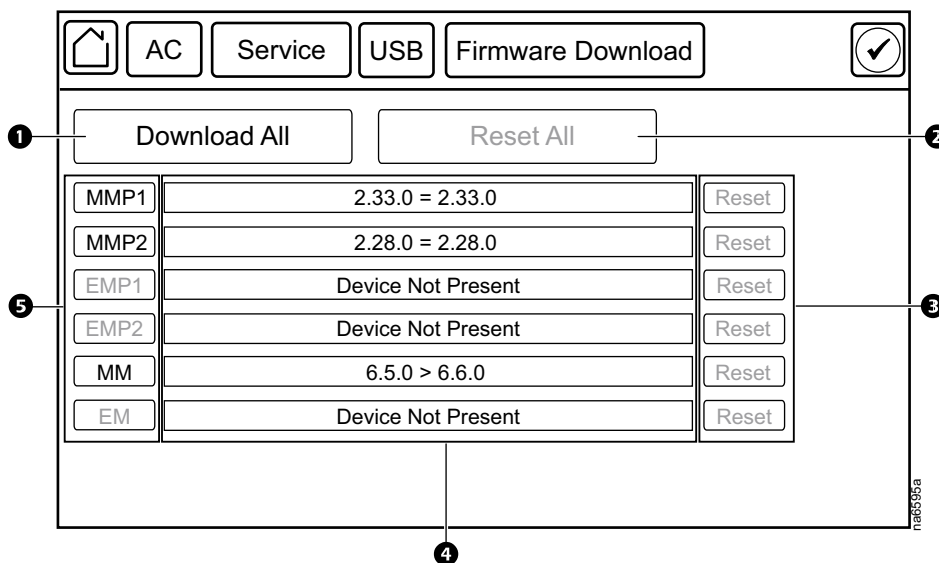

Item	Description	Function
1	Download All	Downloads all available firmware updates.
2	Reset All	Resets all controllers that have had firmware updates. This button will appear gray if no controllers need to be reset.
3	Reset	Resets the corresponding controllers individually. These buttons will appear gray if the controller cannot be reset or is not present.
4	Firmware revision	Displays the firmware revision on the USB drive on the left side of the operation symbol and the current firmware revision on the controller on the right side of the operation symbol.  <b>NOTE:</b> Make sure to check the revision numbers: the revision on the drive may not be a newer release.  = symbol An equals symbol denotes that the firmware revisions are the same. > symbol A greater than symbol denotes that the current firmware can be changed to the firmware revision on the USB drive. Device Not Present The controller is not present in the unit.
5	Controllers	Downloads the firmware for the specific controller. These buttons will appear gray if the controller firmware cannot be changed or the controller is not present.  MMP1 Main module PIC1 MMP2 Main module PIC2 EMP1 Expansion module PIC1 EMP2 Expansion module PIC2 MM Main module unit controller EM Expansion module unit controller

1. Download the firmware upgrade files and unzip them.
2. Create a folder named **fw** on the USB flash drive.
3. Place the extracted module files in the **fw** directory.
4. Use a text editor to create a file named fw.rcf. (The file extension must be .rcf, not .txt for example.)

5. In fw.rcf, add a line for each firmware module that needs to be updated. The following are examples of formatting for the file.

**NOTE:** Make sure the EB2G.cbp file remains in directory: the J5 controller may download the firmware on its own if there is no valid firmware or the personality jumpers do not match the current loaded firmware.

MMP1 = mmp1-2.33.0.cbp

MMP2 = mmp2-2.28.0.cbp

EMP1 = emp1-2.33.0.cbp

EMP2 = emp2-2.28.0.cbp

MM = EB2G-1.0.4.cbp

EM = EB2G-1.0.4.cbp

6. Place fw.rcf in the **fw** folder on the USB drive.
7. Insert the USB drive into the USB port on the display interface.
8. On the display interface, navigate to **Main > Configuration > Service > USB > Firmware Download**.
9. Select the firmware to download for the controllers individually or for all devices.
10. After downloading the firmware, reset the controllers individually or reset all.
11. Check that the update was completed successfully using the procedures in *Verify Updates, page 79*.

## Update Firmware on Multiple Units

Use one of these three methods:

- **Unit Firmware Upgrade Utility on Windows:** Use the Upgrade Utility to update multiple units.
- **Use FTP or SCP:** To upgrade multiple units using an FTP client or using SCP, write a script which automatically performs the procedure.
- **Export configuration settings:** Create a batch file and use a utility to retrieve configuration settings from multiple units and export them to other units.



Utility is available from the Knowledge Base on the Schneider Electric Web site: [www.schneider-electric.com](http://www.schneider-electric.com).

## Use the Firmware Upgrade Utility for Multiple Upgrades on Windows-Based Systems

After downloading the upgrade utility from the unit downloads page on the [www.schneider-electric.com](http://www.schneider-electric.com) website, double-click on the .exe file to run the utility (which ONLY works with IPv4) and follow these steps to upgrade your unit firmware:

1. In the utility dialog, type in an IP address, a user name, and a password, and select the **Ping** button if you need to verify the IP address.
2. Click the **Device List** button to open the `iplist.txt` file. Here you should type all unit devices to upgrade with the necessary information: IP, user name, and password. For example,  
`SystemIP=192.168.0.1`  
`SystemUserName=apc`  
`SystemPassword=apc`  
You can use an existing `iplist.txt` file if it already exists.
3. Select the **Upgrade From Device List** check box to use the `iplist.txt` file.
4. Select the **Upgrade Now** button to start the firmware version upgrade(s).
5. Select **View Log** to verify any upgrade.

## Verify Updates

### Verify Success of the Transfer

To verify whether a firmware upgrade succeeded, you can use the `xferStatus` command in the command line interface to view the last transfer result. Alternatively, you can use an SNMP GET to receive the **mfiletransferStatusLastTransferResult** OID.

**NOTE:** This is only valid for checking the success of the touch screen firmware update.

### Last Transfer Result Codes

Possible transfer errors include the TFTP or FTP server not being found, or the server refusing access, the server not finding or not recognizing the transfer file, or a corrupt transfer file.

### Verify Version Numbers of Installed Firmware

**Path: Main > AC > About**

**Path: Main > Main Module > About**

**Path: Main > Exp Module > About**

Use the display interface or the Web user interface to verify the versions of the upgraded firmware modules. You can also use an SNMP GET to the MIB II `sysDescr` OID. In the command line interface, use the `about` command.

## Service Menus

### ⚠ WARNING

#### HAZARD TO EQUIPMENT OR PERSONNEL

All work must be performed by Schneider Electric qualified personnel.

**Failure to follow these instructions can result in death, serious injury, or equipment damage.**

The **Service** menus contain settings related to the operation of the Ecoflair Indirect Air Economizer unit that should only be changed by qualified personnel.

The **Service** menus are only accessible to service personnel. If you need to access the **Service** menus, you will need to contact technical support with the code displayed in the message window. After receiving a service code from technical support, enter the code in the appropriate window on the display.

Service settings under the **Main Module** and **Exp Module** will only affect the respective module. It is recommended to have the same settings on each module after servicing is completed.

## Module Configuration

**Path: Main > AC > Main Module > Service > Control**

**Path: Main > AC > Exp Module > Service > Control**

Service settings under the **Main Module** and **Exp Module** will only affect the respective module. It is recommended to have the same settings on each module after servicing is completed.

- **Cooling Mode:** This setting is read-only and displays the current cooling mode of the module.
  - **Off:** The module is not in operation.
  - **Remote Off:** The module has been turned off by remote contact.
  - **Maintenance:** The module is in maintenance mode for servicing.
  - **Dry Cooling:** The module is operating in dry mode.
  - **Wet Cooling:** The module is operating in wet mode.
  - **Dry and Trim Cooling:** The module is operating in dry mode and conditions have been met to activate trim cooling.
  - **Wet and Trim Cooling:** The module is operating in wet mode and conditions have been met to activate trim cooling.



See *Operation Modes*, page 30 for more information on the modes of operation.

- **Unit:** Turns the module **On** or **Off**.
- **IT Fan Mode:** Sets the operation of the IT fans to **Automatic** or **Manual**. If **Automatic** is selected, the IT fans operate based on the module configuration. If **Manual** is selected, the speed of the fan is entered in **Manual IT Fan Speed**.
- **Manual IT Fan Speed:** The fan speed percentage. (15–100%)

**Path: Main > AC > Main Module > Service > Setup**

**Path: Main > AC > Exp Module > Service > Setup**

- **Dry Operation Drain Time:** The length of time in hours for how long the module has to be in dry operation mode before the water in the basin is drained. (10 h – 72 h)



**NOTE:** Dry operation mode is when the module is only using the outdoor air (OA) fans to cool the air.

- **Lead Pump:** Select which pump is the primary pump. The other pump is the backup pump. (1 or 2)

**NOTE:** More than one pump must be installed.

- **Pump Rotation Interval:** The length of run time in days that the that primary pump will operate before operation is switched to the backup pump. A value of '0' means the pump will never switch. (0–15 days)

**NOTE:** More than one pump must be installed.

- **Water Saver:** If **Enable** is selected, the module will operate in **Water Saver** mode.
- **Altitude:** Altitude can affect cooling units due to the change in air density. The altitude is used in conversions between absolute (g/Kg) and relative (%RH) humidity. Enter the distance of the unit above sea level. (0–3000 ft or meters)
- **Water Operation Reserve Time:** The **Water Operation Reserve Time** determines at what level the water in the water basin is maintained (up to a maximum capacity of 644.4 l (175.5 gal)). (0–30 minutes)
- **Cycles of Concentration:** **Cycles of Concentration** is determined by the quality of the make up water (supply water from the site). As the water in the water basin evaporates, the water becomes increasingly concentrated with minerals. **Cycles of Concentration** determines how many times the supply water can be cycled through the system before the conductivity level reaches the Basin Water Conductivity **Setpoint** and fresh water has to be added to the water supply. For example, if the supply water from the site has an initial conductivity level of 500  $\mu\text{S/cm}$  and the **Basin Water Conductivity Setpoint** is 2000  $\mu\text{S/cm}$ , **Cycles of Concentration** would be set to four (4). (1–99)

## Environmental Control

**Path: Main > AC > Main Module > Service > Setpoints**

**Path: Main > AC > Exp Module > Service > Setpoints**

Service settings under the **Main Module** and **Exp Module** menus will only affect the respective module. It is recommended to have the same settings on each module after servicing is completed.

- **Supply Air Temperature Setpoint:** The required temperature of the air entering the IT space from the Ecoflair Indirect Air Economizer. (20.0–32.2°C (68.0–90.0°F))
- **Basin Water Conductivity Setpoint:** The conductivity level at which water will start to be partially drained from the basin to reduce conductivity of the water. (500–2500  $\mu\text{S/cm}$ )
- **Basin Water Conductivity Deadband:** The conductivity level at which the basin drain actuator will close and water stops being drained from the basin. (50 – 500  $\mu\text{S/cm}$ )
- **Wet Operate Temperature Setpoint:** If the ambient air temperature is below this value, the unit will not enter wet operation mode. (7.2–37.8°C (45.0–100.0°F))

## Thresholds

**Path: Main > AC > Main Module > Service > Thresholds**

**Path: Main > AC > Exp Module > Service > Thresholds**

Service settings under the **Main Module** and **Exp Module** menus will only affect the respective module. It is recommended to have the same settings on each module after servicing is completed.

- **Return Temperature High Threshold:** The high temperature threshold for air entering the unit. If the temperature exceeds the threshold, an alarm will occur. (Range: -40 to 100°C (-40 to 212°F); Default: 40.5°C (105°F))
- **Return Temperature Low Threshold:** The low temperature threshold for air entering the unit. If the temperature exceeds the threshold, an alarm will occur. (Range: -40 to 100°C (-40 to 212°F); Default: 23.9°C (75°F))
- **Supply Temperature High Threshold:** The high temperature threshold for air leaving the unit. If the temperature exceeds the threshold, an alarm will occur. (Range: **Supply Air Temperature Setpoint** to 100°C (**Supply Air Temperature Setpoint** to 212°F); Default: 29.4°C (85°F))
- **Supply Temperature Low Threshold:** The low temperature threshold for air leaving the unit. If the temperature exceeds the threshold, an alarm will occur. (Range: -40°C to **Supply Air Temperature Setpoint** (-40°F to **Supply Air Temperature Setpoint**); Default: 18.3°C (65°F))



See *Setpoints*, page 37 for **Supply Air Temperature Setpoint**.

## Run Hours

**Path: Main > AC > Main Module > Service > Run Hours**

**Path: Main > AC > Exp Module > Service > Run Hours**



See *Reset Run Hours*, page 52.

## Hardware Configuration

**Path: Main > AC > Main Module > Service > HW CFG**

**Path: Main > AC > Exp Module > Service > HW CFG**

The **HW CFG** menu is used to configure what options are present in the module. Settings between the main module and the expansion module may differ. Press **OK** next to each setting to accept changes.

- **Number of Water Pumps:** Enter the number of water pumps installed in the module. (0, 1, or 2)
- **Number of Compressors:** Enter the number of compressors installed in the module. (0, 1, or 2)
- **Damper Device:** Select whether a damper is **Present** or **Not Present** in the module.
- **Damper Open Position DI Value:** A value of **One** opens the damper; a value of **Zero** closes the damper.
- **Ultracap Configuration:** Select whether an ultracapacitor device is **Present** or **Not Present** in the module.
- **Water Service Interval:** Enter the number of days between required servicing of the water system.

**NOTE:** At least one water pump must be installed. (7–365 days)

- **Water Treatment Device:** Select whether a **Pulse** water treatment system is installed in the module or **None**.
- **Water Operation Reserve Time:** The **Water Operation Reserve Time** determines at what level the water in the water basin is maintained (up to a maximum capacity of 644.4 l (175.5 gal)). (0–30 minutes)
- **Cycles of Concentration:** **Cycles of Concentration** is determined by the quality of the make up water (supply water from the site). As the water in the water basin evaporates, the water becomes increasingly concentrated with minerals. **Cycles of Concentration** determines how many times the supply water can be cycled through the system before the conductivity level reaches the **Basin Water Conductivity Setpoint** and fresh water has to be added to the water supply. For example, if the supply water from the site has an initial conductivity level of 500  $\mu\text{S/cm}$  and the **Basin Water Conductivity Setpoint** is 2000  $\mu\text{S/cm}$ , **Cycles of Concentration** would be set to four (4). (1–99)
- **Conductivity Sensor Range:** Select the range of values for the basin water conductivity sensor. (500–2500  $\mu\text{S/cm}$ , 2500–15000  $\mu\text{S/cm}$ )
- **Supply Air Temperature Sensor:** Select whether a supply air temperature sensor is **Present** or **Not Present** in the module.
- **Return Air Temperature Sensor:** Select whether a return air temperature sensor is **Present** or **Not Present** in the module.
- **Outdoor Air Temperature Sensor:** Select whether an outdoor air temperature sensor is **Present** or **Not Present** in the module.
- **Supply Air Humidity Sensor:** Select whether a supply air humidity sensor is **Present** or **Not Present** in the module.

**NOTE:** Select **Not Present** for this setting; Functionality for this sensor is not provided.

- **Return Air Humidity Sensor:** Select whether a return air humidity sensor is **Present** or **Not Present** in the module.
- **Outdoor Air Humidity Sensor:** Select whether an outdoor air humidity sensor is **Present** or **Not Present** in the module.
- **Number of Source Changeover:** Enter '1' if the unit has a dual power supply with source changeover.
- **Number of Power Meter:** Enter '1' if the unit is equipped with a power meter.
- **Power Meter Device:** Select the manufacturer of the power meter: **Schneider**.

# Maintenance

## Remove Power From the Unit

### **DANGER**

#### **HAZARD OF ELECTRIC SHOCK, EXPLOSION, OR ARC FLASH**

Using the power disconnect button does not remove power from electrical components with power supplied directly from the customer. You must disconnect power at the customer power source to remove power completely from the cooling unit.

**Failure to follow these instructions will result in death or serious injury.**

Remove power from the unit before performing maintenance procedures.



See *Dual Power Supply with SCO*, page 28.

## Service Vestibule Power Disconnect

### **⚡ ⚠ DANGER**

#### **HAZARD OF ELECTRIC SHOCK, EXPLOSION, OR ARC FLASH**

The **Off** option does not remove power from the cooling unit. You must disconnect power at the mains to remove power from the cooling unit.

**Failure to follow these instructions will result in death or serious injury.**

When the service vestibule room door is opened, the magnetic door switch turns off the IT fans when the door is opened. When the door shuts, the IT fans will resume operation. The power disconnect switch stops unit operation when the switch is pushed in. To resume unit operation, pull the switch back out.

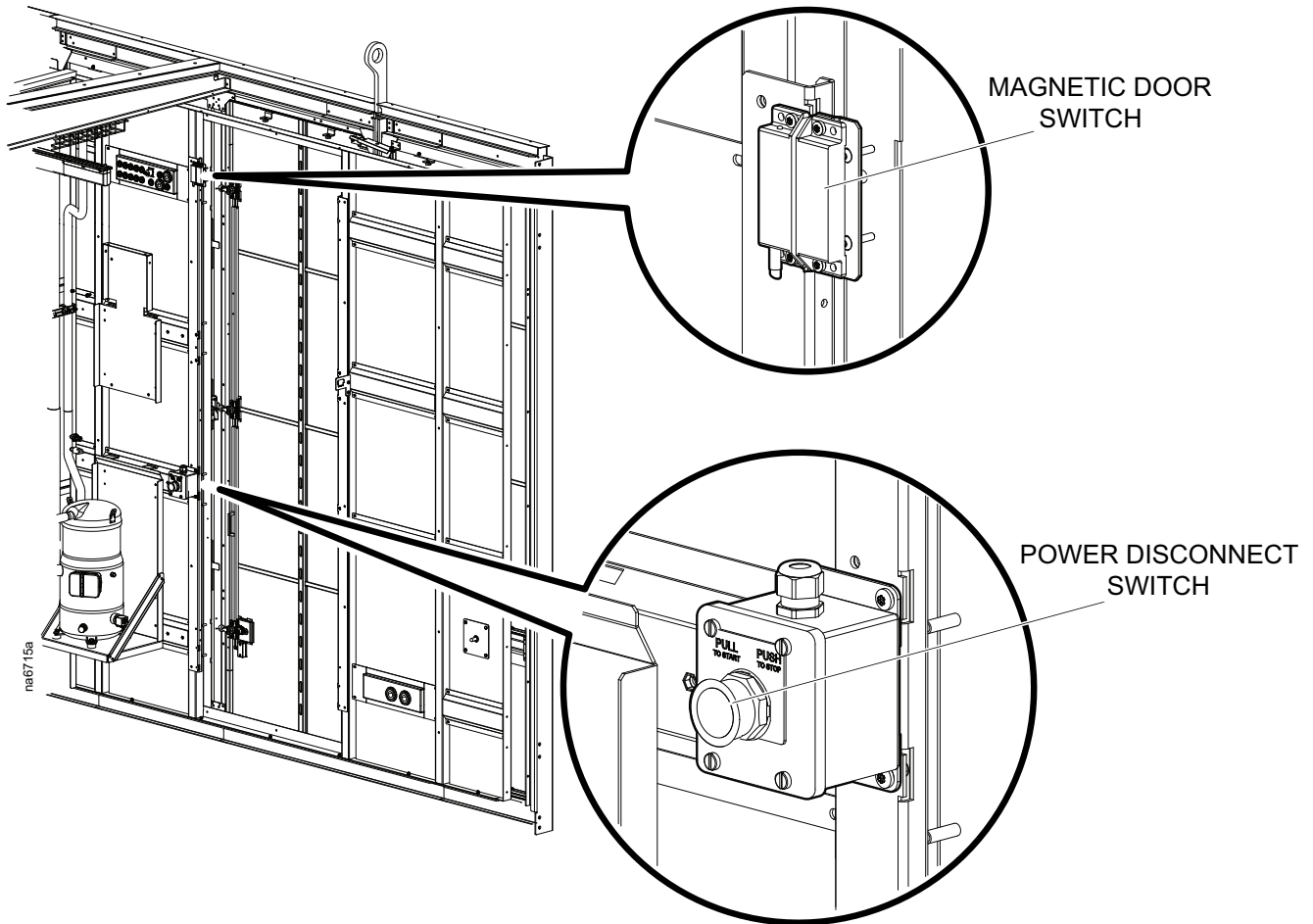

# Fan Positions

## IT Fans

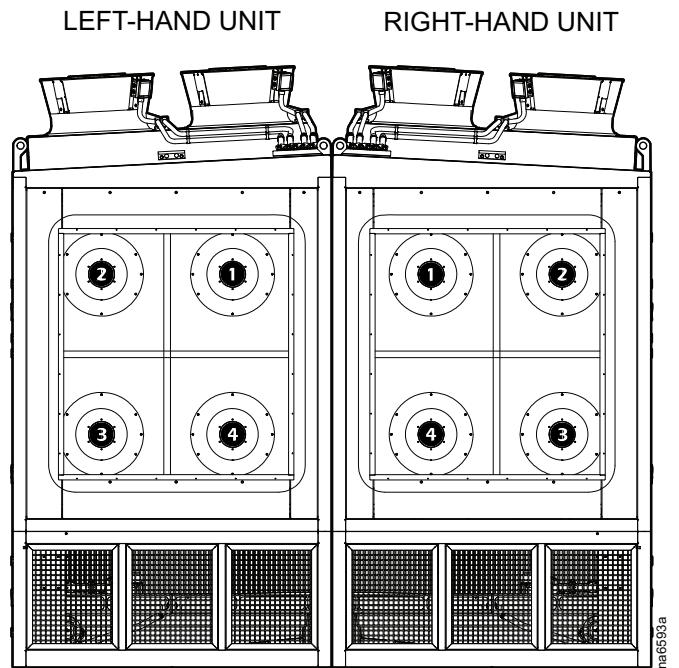

## Outdoor Air (OA) Fans

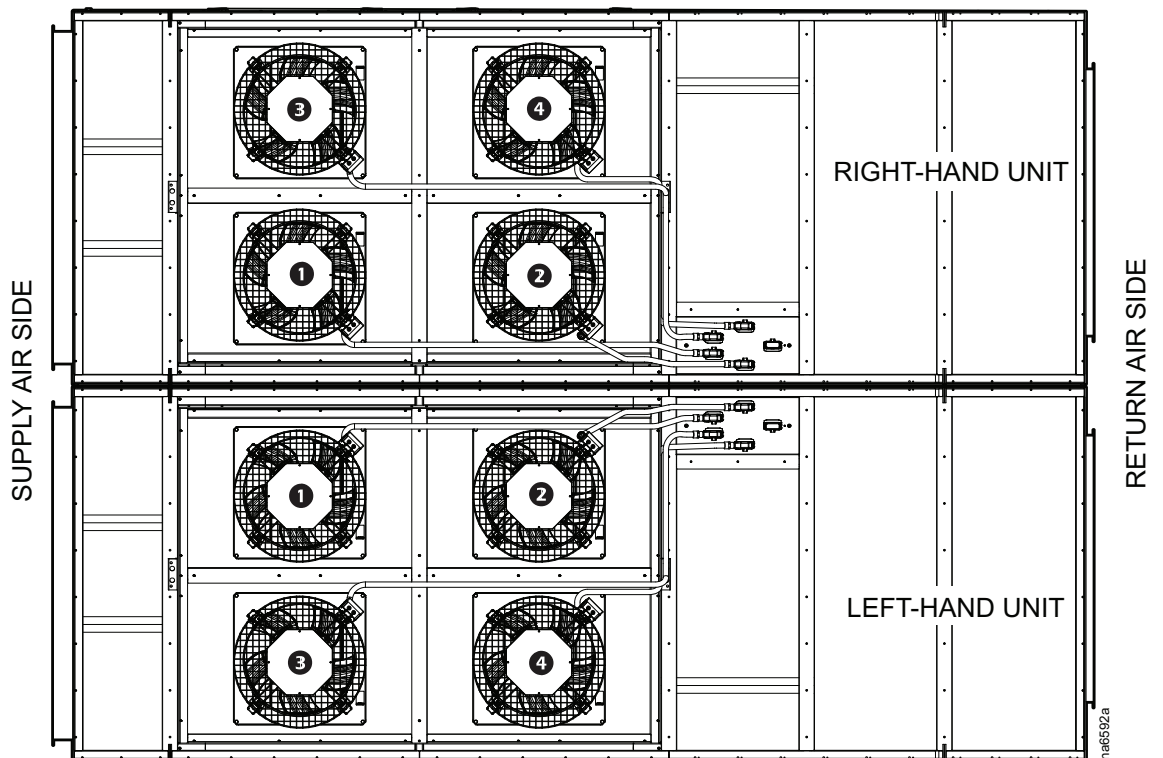

## Filters

### OA Filters

#### Removal

1. Push the filter up into the frame.
2. Angle the filter and slide it out of the frame.

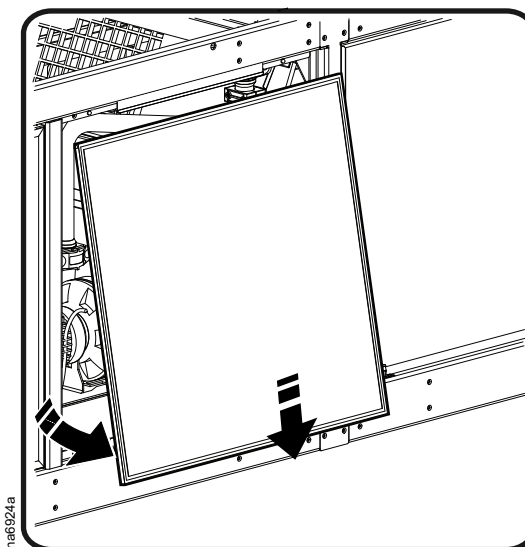

#### Installation

Reverse the removal steps to install a new OA filter.

## IT Air Filters

IT air filters are located inside the service vestibule.

1. Loosen the knobs on the filter frame.

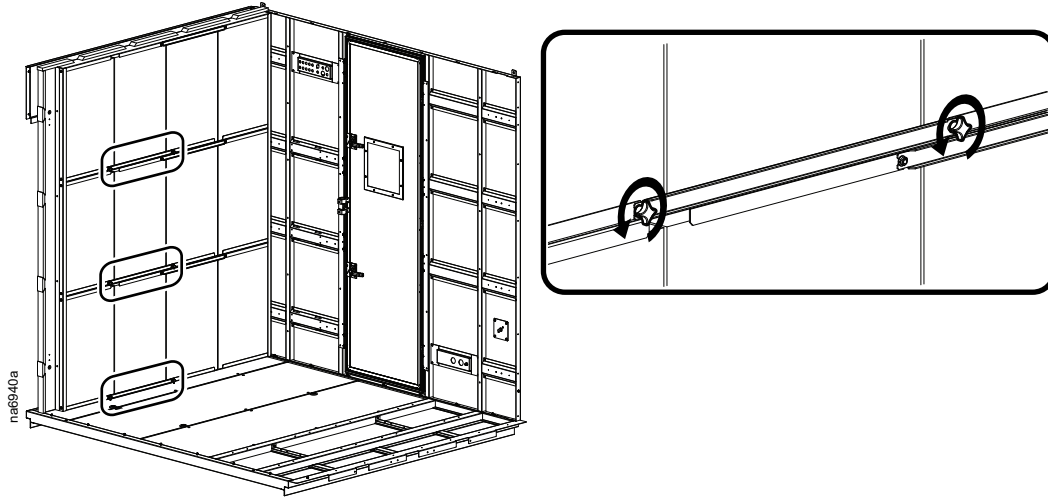

2. Remove the bracket.

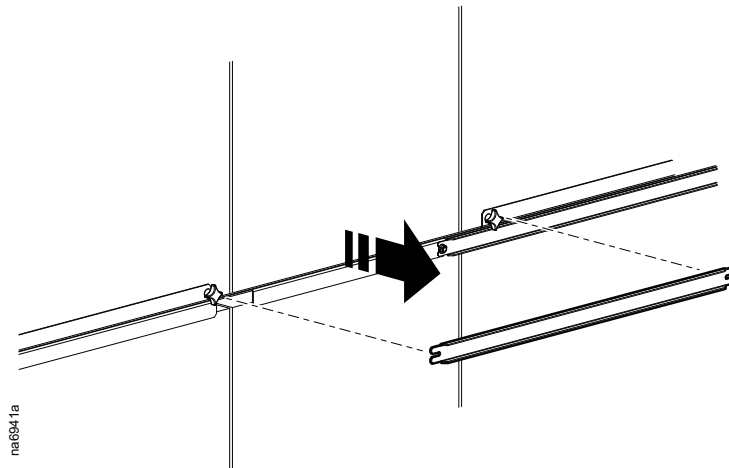

3. Remove the filter in front of the opening.

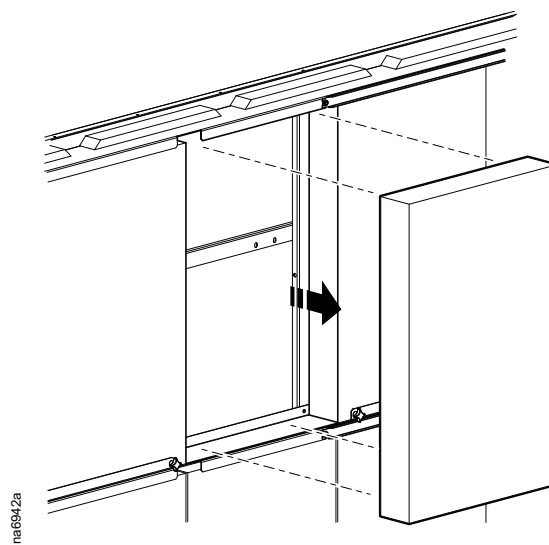



4. Slide other filters to the opening to remove.

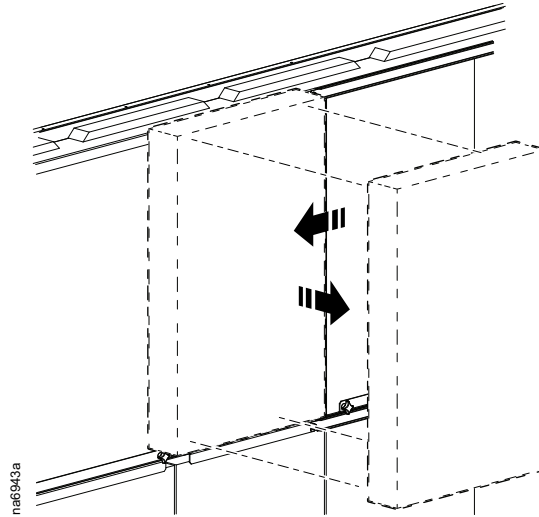

## Maintenance Mode

### NOTICE

#### UNIT MALFUNCTIONS

- Changing the settings incorrectly can cause malfunctions to your cooling unit.
- Only qualified service personnel should make changes to these settings.

**Failure to follow these instructions can result in equipment damage.**

**Path: Main > AC > Main Module > Service > Maintenance**

**Path: Main > AC > Exp Module > Service > Maintenance**

The **Maintenance** menu is used to check functionality of module components and to put the module in maintenance mode while performing routine maintenance. Qualified personnel can manually control components within the module to check for errors and mechanical issues. Press **OK** next to each setting to accept changes.

- **Drain Basin:** Select **Yes** to drain water from the basin.
- **Water Service Expiration:** Select **Reset** to reset the **Water Service Interval** counter.
- **Maintenance Mode: Enable or Disable** maintenance mode. While in maintenance mode, the module will not operate automatically. Operation of components will be controlled via the settings in this menu.
- **Maint. IT Fan Speed:** Enter a manual fan speed percentage for the IT fans to check fan functionality during maintenance. (1–100%)
- **Maint. OA Fan 1 Speed:** Enter a manual fan speed percentage for OA fan 1 to check fan functionality during maintenance. (1–100%)
- **Maint. OA Fan 2 Speed:** Enter a manual fan speed percentage for OA fan 2 to check fan functionality during maintenance. (1–100%)
- **Maint. OA Fan 3 Speed:** Enter a manual fan speed percentage for OA fan 3 to check fan functionality during maintenance. (1–100%)
- **Maint. OA Fan 4 Speed:** Enter a manual fan speed percentage for OA fan 4 to check fan functionality during maintenance. (1–100%)
- **Maint. Pump 1 Command:** Turn pump 1 **On** or **Off** to check pump functionality during maintenance.

**NOTE:** At least one water pump must be installed.

- **Maint. Pump 2 Command:** Turn pump 2 **On** or **Off** to check pump functionality during maintenance.  
**NOTE:** At least one water pump must be installed.
- **Maint. Water Fill Valve Command:** Set the water fill valve to **Open** or **Closed** to check functionality during maintenance.
- **Maint. Full System Drain Valve Command:** Set the system drain valve to **Open** or **Closed** to check functionality during maintenance.  
**NOTE:** At least one water pump must be installed.
- **Maint. Basin Drain Valve Power Command:** Applies power to the basin drain valve.  
**NOTE:** At least one water pump must be installed.
- **Maint. Basin Drain Valve Command:** Enter an open percentage for the basin water drain valve to check functionality during maintenance.  
**NOTE:** At least one water pump must be installed.
- **Maint. Outdoor Air Humidity Power Command:** The outdoor air humidity sensor may not be turned on: use this setting to apply power to the sensor.
- **Maint. Compressor 1 Start Conditions:** This is a read-only bitmap value
- **Maint. Liquid Line 1 Valve Command:** Set the liquid line valve to **Open** or **Closed** to check functionality during maintenance.  
**NOTE:** Unit must be equipped with the DX trim cooling option.
- **Maint. EEV 1 Valve Command:** Enter an open percentage for the electronic expansion valve to check functionality during maintenance.  
**NOTE:** Unit must be equipped with the DX trim cooling option.
- **Maint. VFD 1 Speed Command:** Enter a frequency for the variable speed drive to check functionality during maintenance.  
**NOTE:** Unit must be equipped with the DX trim cooling option.
- **Maint. Compressor 2 Start Conditions:** This is a read-only bitmap value.
- **Maint. Liquid Line 2 Valve Command:** Set the liquid line valve to **Open** or **Closed** to check functionality during maintenance.  
**NOTE:** Unit must be equipped with the DX trim cooling option.
- **Maint. EEV 2 Valve Command:** Enter an open percentage for the electronic expansion valve to check functionality during maintenance.  
**NOTE:** Unit must be equipped with the DX trim cooling option.
- **Maint. VFD 2 Speed Command:** Enter a frequency for the variable speed drive to check functionality during maintenance.  
**NOTE:** Unit must be equipped with the DX trim cooling option.

# Monthly Preventive Maintenance

**⚠️⚠️ DANGER**

**HAZARD OF ELECTRIC SHOCK, EXPLOSION, OR ARC FLASH**

- Apply appropriate personal protective equipment (PPE) and follow safe electrical work practices.
- This equipment must be installed and serviced by qualified personnel only.
- Turn off all power supplying this equipment before working on or inside the equipment.
- Replace all devices, doors, and covers before turning on power to this equipment.

**Failure to follow these instructions will result in death or serious injury.**

**⚠️ WARNING**

**HAZARD TO EQUIPMENT OR PERSONNEL**

All work must be performed by Schneider Electric qualified personnel.

**Failure to follow these instructions can result in death, serious injury, or equipment damage.**

Perform the following maintenance check list.

Prepared By: \_\_\_\_\_

Model Number: \_\_\_\_\_

Serial Number: \_\_\_\_\_

Date: \_\_\_\_\_

- Check the display interface: resolution, backlight, LEDs, and response.
- Verify that all alarms are clear.
- Verify that the unit is functioning normally and the temperature in the data center is being maintained at the setpoint.
- Inspect the electrical panel doors and covers for damage or loose hardware.
- Record return air temperature sensor reading: \_\_\_\_\_
- Record the supply air temperature sensor reading: \_\_\_\_\_
- Record the IT fan speed: \_\_\_\_\_
- Supply air humidity sensor reading: \_\_\_\_\_
- Check functionality of the heat trace.

## Quarterly Preventive Maintenance

 **DANGER**

**HAZARD OF ELECTRIC SHOCK, EXPLOSION, OR ARC FLASH**

- Apply appropriate personal protective equipment (PPE) and follow safe electrical work practices.
- This equipment must be installed and serviced by qualified personnel only.
- Turn off all power supplying this equipment before working on or inside the equipment.
- Replace all devices, doors, and covers before turning on power to this equipment.

**Failure to follow these instructions will result in death or serious injury.**

 **WARNING**

**HAZARD TO EQUIPMENT OR PERSONNEL**

All work must be performed by Schneider Electric qualified personnel.

**Failure to follow these instructions can result in death, serious injury, or equipment damage.**

Perform the following maintenance check list in addition to the monthly check list.

Prepared By: \_\_\_\_\_

Model Number: \_\_\_\_\_

Serial Number: \_\_\_\_\_

Date: \_\_\_\_\_

- Check the air mesh panels: remove debris and clean as needed.

---

- Inspect the water basin and remove large debris; check for leaks and excessive scale accumulation; check the water basin filters/screens, clean or replace as needed.

---

- If the module is operating in wet mode or there is standing water in the basin, obtain a water sample and perform a Legionella test. Record the test result and take appropriate actions if necessary.

---

- Check the condition of the water spray nozzles and mist eliminator media. Inspect the condition of IEC core tubes, check for excessive mineral deposits that could inhibit proper air or water flow.

---

- Review the conductivity sensor reading and compare to water sample measurement. Calibrate the conductivity sensor as needed.

---

- Verify that the unit is up to date with any applicable service bulletins.

---

- Check the water treatment system status and alarm LEDs. Check and clean the cooling fan air filter. Reset the water service interval run hours counter.

---

## Semi-Annual Preventive Maintenance

**⚠️⚠️ DANGER**

**HAZARD OF ELECTRIC SHOCK, EXPLOSION, OR ARC FLASH**

- Apply appropriate personal protective equipment (PPE) and follow safe electrical work practices.
- This equipment must be installed and serviced by qualified personnel only.
- Turn off all power supplying this equipment before working on or inside the equipment.
- Replace all devices, doors, and covers before turning on power to this equipment.

**Failure to follow these instructions will result in death or serious injury.**

**⚠️ WARNING**

**HAZARD TO EQUIPMENT OR PERSONNEL**

All work must be performed by Schneider Electric qualified personnel.

**Failure to follow these instructions can result in death, serious injury, or equipment damage.**

Perform the following maintenance check list in addition to the monthly and quarterly check lists.

Prepared By: \_\_\_\_\_

Model Number: \_\_\_\_\_

Serial Number: \_\_\_\_\_

Date: \_\_\_\_\_

- Inspect the water system piping, valves, and pump(s) for leaks, damage, or corrosion.

---

- Inspect the indoor air filters, clean or replace as necessary. Reset the air filter run hour counter.

---

- Check the IT air fans: secure any loose hardware, fan guards, or wiring.

---

- Inspect the condition of the air-to-air heat exchanger inlet tubes: check for water or air leaks .

---

- Check the refrigeration circuits for leakage: check for evidence of oil on piping, fittings, and coils.

---

- Check compressor oil level, check the condition of the compressor/VFD cables and wire harnesses.

---

- Check the evaporator coils for cleanliness and condition of the fins, distributor tubes and expansion valves.

---

- Check the condensate pan and drain line. Remove any loose debris and deposits near the drain pan outlet.

---

- Check the outdoor air fans, fan guards, and wiring. Secure any loose hardware.

---

- Check the condenser coils for cleanliness and condition of the fins and tubes.

---

- Check the roof panels and seals/gaskets for damages. Remove any loose debris from the roof.

---

- Open the electrical panels and check wiring harnesses, cabling, and terminal blocks. Inspect panel covers, hardware, and gaskets.

- 
- Check and tighten wiring terminals and lugs to proper torque. Secure any loose hardware.
- 
- Measure and record the mains input voltage and controls voltage.
- 
- Check the modes of operation, evaporative cooling, and trim cooling operation. Check the water drain and fill operation.
- 
- Review the temperature and humidity sensor status and readings, compare against a calibrated measurement. Calibrate or replace the sensors as needed.
- 
- Check the refrigeration system pressures and temperatures. Check superheat and condensing temperatures, check the refrigerant level and moisture indicator.
- 
- Measure and record the amperage readings of the fans, pump(s), and compressors.
- 
- Check the revision of firmware installed and update firmware as needed.
-

# Worldwide Customer Support

Customer support for this or any other product is available at no charge in any of the following ways:

- Visit the Schneider Electric Web site to access documents in the Schneider Electric Knowledge Base and to submit customer support requests.
  - **[www.schneider-electric.com](http://www.schneider-electric.com)** (Corporate Headquarters)  
Connect to localized Schneider Electric Web sites for specific countries, each of which provides customer support information.
  - **[www.schneider-electric.com/support/](http://www.schneider-electric.com/support/)**  
Global support searching Schneider Electric Knowledge Base and using esupport.
- Contact the Schneider Electric Customer Support Center by telephone or e-mail.  
Local, country-specific centers: go to *[www.schneider-electric.com/support/contact](http://www.schneider-electric.com/support/contact)***[www.schneider-electric.com](http://www.schneider-electric.com)** > **Support** > **Operations around the world** for contact information.

For information on how to obtain local customer support, contact the representative or other distributors from whom you purchased your product.

Schneider Electric  
35 rue Joseph Monier  
92500 Rueil Malmaison  
France

+ 33 (0) 1 41 29 70 00

[www.schneider-electric.com](http://www.schneider-electric.com)

As standards, specifications, and design change from time to time,  
please ask for confirmation of the information given in this publication.

© 2017 – 2019 Schneider Electric. All rights reserved.

990-9965D-001 / 06MC0147@00B0130