

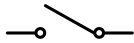





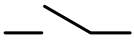

MGE Galaxy 3500 Wide (10 - 30) kVA 2 Module with Floor mount SBP Drawing guide

Sheet No.	Component /Detail	Description
1	Draw ing Guide	MGE Galaxy 3500 10-30kVA, 2 MOD Wide w ith SPB draw ing guide
2-4	Solution	MGE Galaxy 3500 Wide 10-30kVA 2 MOD, SBP, 208V
5-7	UPS	MGE Galaxy 3500 10-30kVA 208V, Wide
8	SBP	MGE Galaxy 3500 Maintenance Bypass Panel, FloorMount, 60kVA, 208V
9-10	System One Line Diagram	MGE Galaxy 3500 10-30kVA 208V 2MOD Wide w ith SPB System One Line Diagram
11	System Wiring Diagram	MGE Galaxy 3500 10-30kVA 208V 2MOD Wide w ith SPB System Control Wiring Diagram

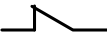
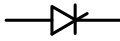
LEGEND			
SYMBOL	DESCRIPTION	SYMBOL	DESCRIPTION
	SWITCH DISCONNECT		CONVERTER
	NORMALLY OPEN CONTACT		INVERTER
	CIRCUIT BREAKER		NORMALLY CLOSED CONTACT
	STATIC SWITCH		FUSE
	BATTERY MODULE		LAMP

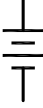
THIS DRAWING AND SPECIFICATIONS HEREIN ARE THE PROPERTY OF SCHNEIDER ELECTRIC AND SHALL NOT BE COPIED, REPRODUCED OR USED IN WHOLE OR IN PART, AS THE BASIS FOR THE MANUFACTURE OR SALE OF ITEMS WITHOUT WRITTEN PERMISSION FROM SCHNEIDER ELECTRIC. THIS DRAWING IS BASED UPON LATEST AVAILABLE INFORMATION AND IS SUBJECT TO CHANGE WITHOUT NOTICE.



TITLE: MGE GALAXY 3500
 Input: 208/220V AC 3PH SINGLE/DUAL MAINS
 Output: 208/220V AC 3PH
 10-30kVA WIDE UPS 2 MOD WITH SBP
 DRAWING GUIDE

DWG NO: G35T10K30FWSBP-2MOD

REV: 0

DRAWN BY: UMESH K 19-Oct-11

ANGLE

ENGINEER: T.MULLER 25-Oct-11

PROJECTION

PROJECT: DRAWINGS SHEET 1 OF 11

APPROVED BY: B.SHERIDAN 25-Oct-11

N/A

WEIGHT AND RUNTIME DETAILS 7

		2xG35T10KF1B4S				2xG35T10KF2B4S				2xG35T10KF3B4S				2xG35T10KF4B4S				2xG35T15KF2B4S				2xG35T15KF3B4S				2xG35T15KF4B4S				2xG35T20KF2B4S				2xG35T20KF3B4S				2xG35T20KF4B4S				2xG35T30KF3B4S				2xG35T30KF4B4S			
Battery position	No. of bat shelves	Net Weight of Solution		Runtime in Min	Net Weight of Solution		Runtime in Min	Net Weight of Solution		Runtime in Min	Net Weight of Solution		Runtime in Min	Net Weight of Solution		Runtime in Min	Net Weight of Solution		Runtime in Min	Net Weight of Solution		Runtime in Min	Net Weight of Solution		Runtime in Min	Net Weight of Solution		Runtime in Min	Net Weight of Solution		Runtime in Min	Net Weight of Solution		Runtime in Min	Net Weight of Solution		Runtime in Min												
		in lbs	in kg	in lbs	in kg	in lbs	in kg	in lbs	in kg	in lbs	in kg	in lbs	in kg	in lbs	in kg	in lbs	in kg	in lbs	in kg	in lbs	in kg	in lbs	in kg	in lbs	in kg	in lbs	in kg	in lbs	in kg	in lbs	in kg	in lbs	in kg	in lbs	in kg	in lbs	in kg												
UPS	1	980	445	6	n.a	n.a	n.a	n.a	n.a	n.a	n.a	n.a	n.a	n.a	n.a	n.a	n.a	n.a	n.a	n.a	n.a	n.a	n.a	n.a	n.a	n.a	n.a	n.a	n.a	n.a	n.a	n.a	n.a	n.a	n.a	n.a	n.a												
UPS	2	2097	952	18	2097	952	18	n.a	n.a	n.a	n.a	n.a	n.a	2097	952	10	n.a	n.a	n.a	n.a	n.a	n.a	n.a	n.a	n.a	n.a	2278	1034	6	n.a	n.a	n.a	n.a	n.a	n.a	n.a	n.a												
UPS	3	2502	1136	32	2502	1136	32	2502	1136	32	n.a	n.a	n.a	2502	1136	18	2502	1136	18	n.a	n.a	n.a	n.a	n.a	n.a	2683	1218	12	2683	1218	12	n.a	n.a	n.a	2683	1218	6	n.a	n.a	n.a									
UPS	4	2907	1320	47	2907	1320	47	2907	1320	47	2907	1320	47	2907	1320	27	2907	1320	27	2907	1320	27	2907	1320	27	3088	1402	18	3088	1402	18	3088	1402	18	3088	1402	18	3088	1402	10	3088	1402	10						

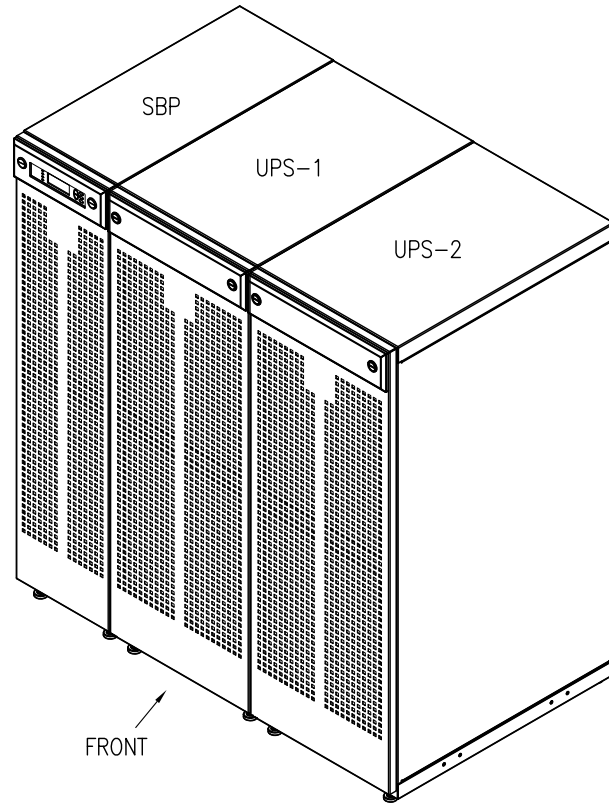

ISOMETRIC VIEW

NOTES:

1. INSTALLATION SHALL COMPLY WITH ALL APPLICABLE NATIONAL, STATE AND LOCAL CODES.
2. REFER TO PRODUCT MANUALS FOR ADDITIONAL DETAILS PRIOR TO INSTALLATION AND SITE PREPARATION WORK.
3. CABLE ENTRY IS FROM REAR SIDE OF THE UNIT OR THROUGH CONDUIT BOX.
4. FRONT AND REAR SERVICE ACCESS IS REQUIRED.
5. FOR NET WEIGHT OF UNIT, CONFIGURATION AND RUNTIME DETAILS REFER TO TABLE ABOVE.
6. FOR OPERATING TEMPERATURE PLEASE REFER SHEET -3
- △ 7. BATTERY RUN TIMES ARE THEORETICAL AND CALCULATED BASED ON DATA PROVIDED BY BATTERY MANUFACTURER ASSUMING OPTIMUM ENVIRONMENT AND LOAD CONDITIONS.

THIS DRAWING AND SPECIFICATIONS HEREIN ARE THE PROPERTY OF SCHNEIDER ELECTRIC AND SHALL NOT BE COPIED, REPRODUCED OR USED IN WHOLE OR IN PART, AS THE BASIS FOR THE MANUFACTURE OR SALE OF ITEMS WITHOUT WRITTEN PERMISSION FROM SCHNEIDER ELECTRIC. THIS DRAWING IS BASED UPON LATEST AVAILABLE INFORMATION AND IS SUBJECT TO CHANGE WITHOUT NOTICE.



TITLE: MGE GALAXY 3500
 Input: 208/220V AC 3PH SINGLE/DUAL MAINS
 Output: 208/220V AC 3PH
 10-30kVA WIDE UPS 2 MOD WITH SBP
 SOLUTION - ISOMETRIC VIEW

DWG NO: G35T10K30FWSBP-2MOD REV: 0

DRAWN BY: UMESH K 19-Oct-11

ENGINEER: T.MULLER 25-Oct-11

PROJECT: DRAWINGS SHEET 2 OF 11

APPROVED BY: B.SHERIDAN 25-Oct-11

THIRD ANGLE PROJECTION

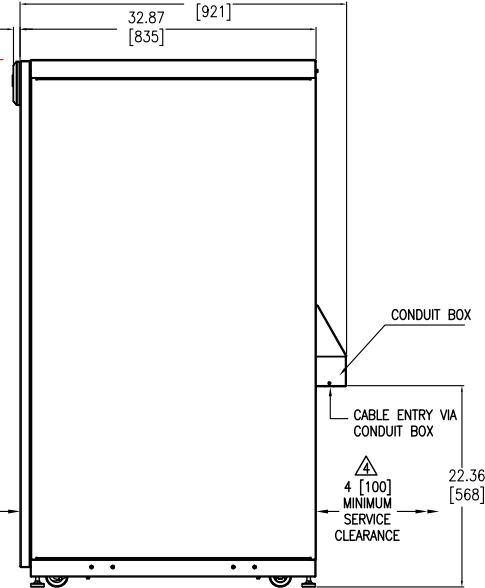
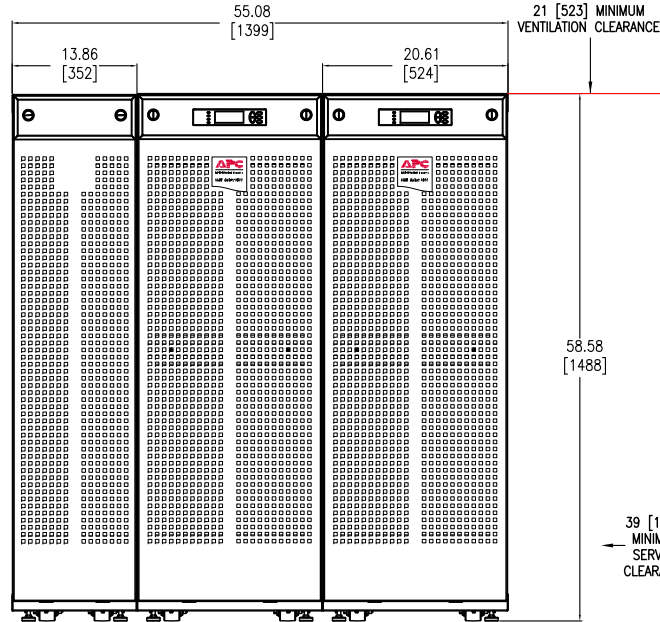
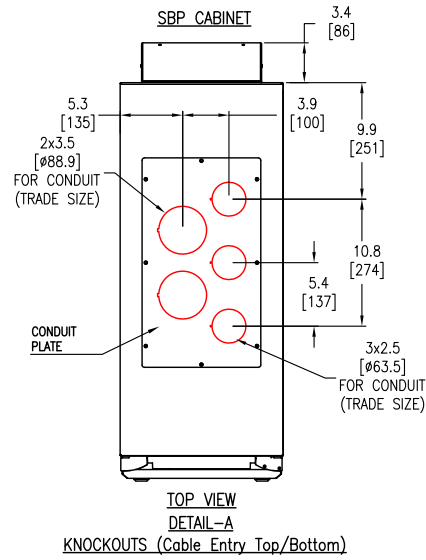
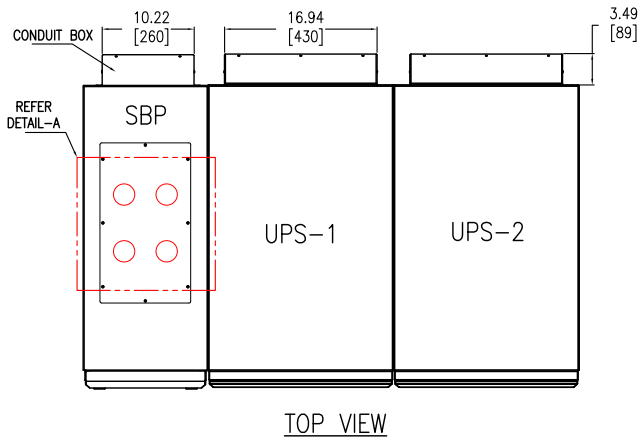

FRONT VIEW

SIDE VIEW

- NOTES:**
1. INSTALLATION SHALL COMPLY WITH ALL APPLICABLE NATIONAL, STATE AND LOCAL CODES.
 2. REFER TO PRODUCT MANUALS FOR ADDITIONAL DETAILS PRIOR TO INSTALLATION AND SITE PREPARATION WORK.
 3. ALL DIMENSIONS ARE IN INCHES (MILLIMETERS), UNLESS OTHERWISE SPECIFIED.
 - △ 4. FRONT AND REAR SERVICE CLEARANCE AND TOP COOLING CLEARANCE IS REQUIRED. FOR REAR ACCESS USE FLEXIBLE CONDUIT WITH SUFFICIENT LENGTH TO ALLOW UNIT TO BE MOVED OUT FOR SERVICE
 5. UPS & SBP COLOR: GRAY METALLIC.
 6. ENCLOSURE PROTECTION IP51.
 7. OPERATING TEMPERATURE: 32°F [0°C] MIN. TO 104°F [40°C] MAX. RECOMMENDED OPERATING RANGE: 59°F [15°C] TO 77°F [25°C].
 8. CABLE ENTRY IS FROM TOP, BOTTOM OR THROUGH REAR CONDUIT BOX.
 - △ 9. FOR UPS FLOOR LOADING DATA REFER TO SHEET 10.
 - △ 10. THIS INFORMATION PROVIDES APPROXIMATE CENTER OF GRAVITY CALCULATION.

THIS DRAWING AND SPECIFICATIONS HEREIN ARE THE PROPERTY OF SCHNEIDER ELECTRIC AND SHALL NOT BE COPIED, REPRODUCED OR USED IN WHOLE OR IN PART, AS THE BASIS FOR THE MANUFACTURE OR SALE OF ITEMS WITHOUT WRITTEN PERMISSION FROM SCHNEIDER ELECTRIC. THIS DRAWING IS BASED UPON LATEST AVAILABLE INFORMATION AND IS SUBJECT TO CHANGE WITHOUT NOTICE.



△ 9

FLOOR LOADING DATA - SBP CABINET			
SKU Number	Dimensions H x W x D Inch [mm]	Weight in lbs [kg]	Floor Loading Data
G35TSBPAR10K15F	58.7x13.8x32.9 [1490x352x835]	268 [122]	85 [415]
G35TSBPAR20K30F	58.7x13.8x32.9 [1490x352x835]	268 [122]	85 [415]

CENTER OF GRAVITY DETAILS △ 10

Rating	SKU Number	COG Details in Inches [mm]		
		X-Distance	Y-Distance	Z-Distance
10kVA	G35T10KF1B4S	9.72 [247]	25.20 [640]	15.79 [401]
	G35T10KF2B4S	9.84 [250]	22.99 [584]	15.71 [399]
	G35T10KF3B4S	9.92 [252]	22.76 [578]	15.63 [397]
	G35T10KF4B4S	9.96 [253]	23.58 [599]	15.63 [397]
15kVA	G35T15KF2B4S	9.84 [250]	22.99 [584]	15.71 [399]
	G35T15KF3B4S	9.92 [252]	22.76 [578]	15.63 [397]
20kVA	G35T20KF2B4S	9.84 [250]	22.99 [584]	15.71 [399]
	G35T20KF3B4S	9.92 [252]	22.76 [578]	15.63 [397]
30kVA	G35T30KF3B4S	10.16 [258]	23.90 [607]	15.51 [394]
	G35T30KF4B4S	10.16 [258]	24.49 [622]	15.47 [393]

SKU Number	COG Details for SBP in Inches (mm)		
	X-Distance	Y-Distance	Z-Distance
G35TSBPAR10K15F	6.92 (176)	30 (762)	12.71 (323)
G35TSBPAR20K30F			

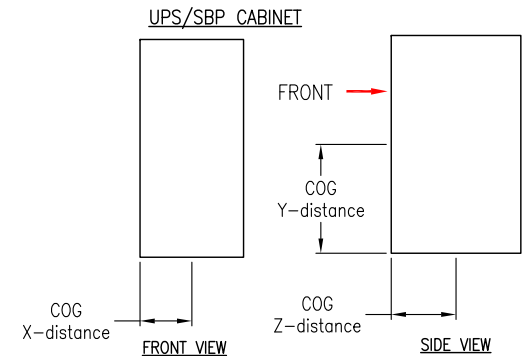

TITLE: MGE GALAXY 3500
 Input: 208/220V AC 3PH SINGLE/DUAL MAINS
 Output: 208/220V AC 3PH
 10-30kVA WIDE UPS 2 MOD WITH SBP SOLUTION- GENERAL ARRANGEMENT

DWG NO: G35T10K30FWSBP-2MOD
 DRAWN BY: UMESH K 19-Oct-11
 ENGINEER: T.MULLER 25-Oct-11

REV: 0
 THIRD ANGLE PROJECTION

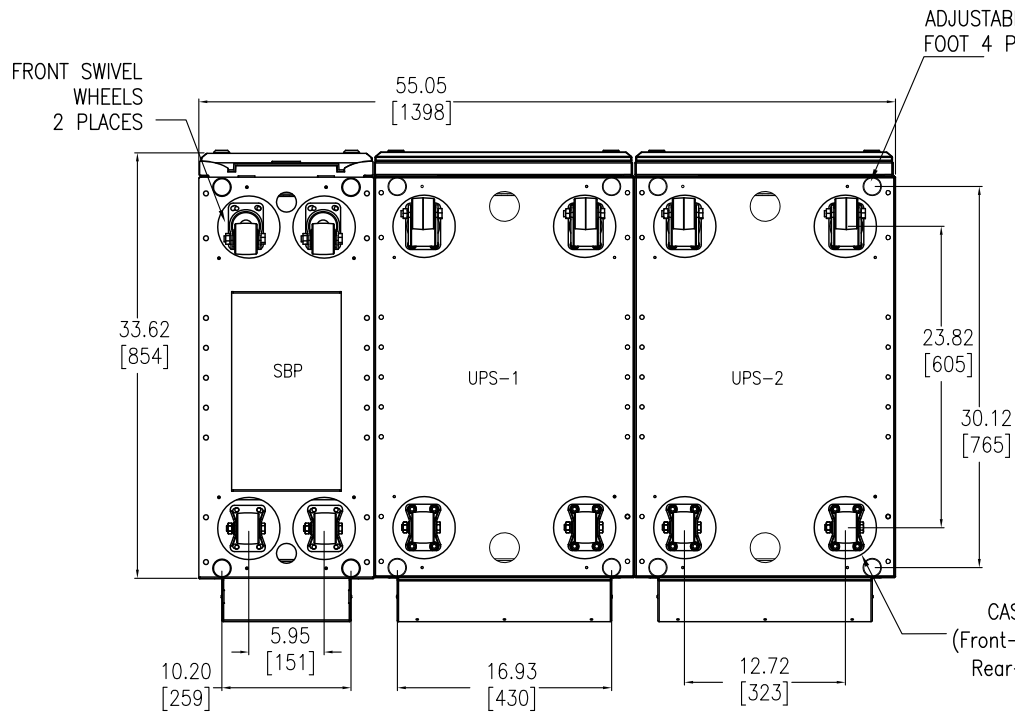

BOTTOM VIEW

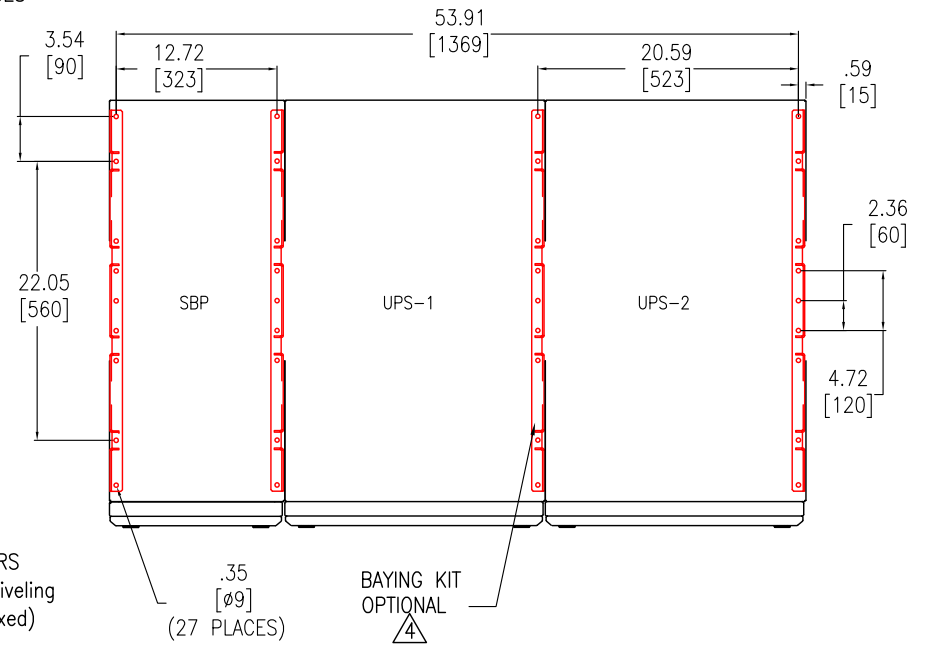

FOOT PRINT ANCHOR DETAILS VIEW

NOTES:

1. INSTALLATION SHALL COMPLY WITH ALL APPLICABLE NATIONAL, STATE AND LOCAL CODES.
2. REFER TO PRODUCT MANUALS FOR ADDITIONAL DETAILS PRIOR TO INSTALLATION AND SITE PREPARATION WORK.
3. ALL DIMENSIONS ARE IN INCHES [MILLIMETERS]. UNLESS OTHERWISE SPECIFIED.
- △4. OPTIONAL BAYING KIT PART NUMBER.
SKU # G35TOPT04- UPS TO UPS

THIS DRAWING AND SPECIFICATIONS HEREIN ARE THE PROPERTY OF SCHNEIDER ELECTRIC AND SHALL NOT BE COPIED, REPRODUCED OR USED IN WHOLE OR IN PART, AS THE BASIS FOR THE MANUFACTURE OR SALE OF ITEMS WITHOUT WRITTEN PERMISSION FROM SCHNEIDER ELECTRIC. THIS DRAWING IS BASED UPON LATEST AVAILABLE INFORMATION AND IS SUBJECT TO CHANGE WITHOUT NOTICE.



TITLE: MGE GALAXY 3500
Input: 208/220V AC 3PH SINGLE/DUAL MAINS
Output: 208/220V AC 3PH
10-30kVA WIDE UPS 2 MOD WITH SBP
SOLUTION- BOTTOM ANCHORING

DWG NO: G35T10K30FWSBP-2MOD

REV: 0

DRAWN BY: UMESH K 19-Oct-11

THIRD

ENGINEER: T.MULLER 25-Oct-11

ANGLE

PROJECT: DRAWINGS SHEET 4 OF 11

APPROVED BY: B.SHERIDAN 25-Oct-11

PROJECTION

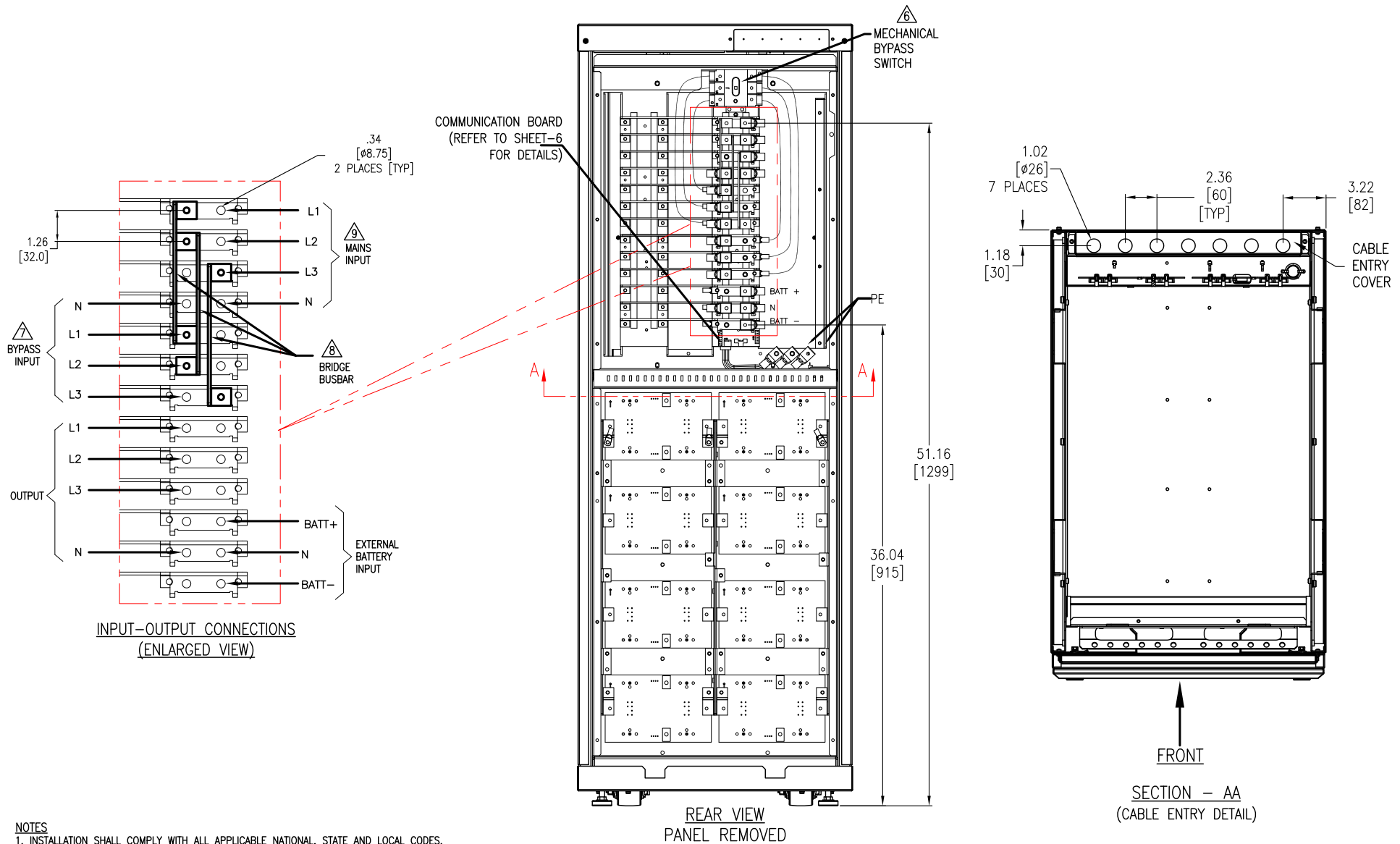

NOTES

1. INSTALLATION SHALL COMPLY WITH ALL APPLICABLE NATIONAL, STATE AND LOCAL CODES.
2. REFER TO PRODUCT MANUALS FOR ADDITIONAL DETAILS PRIOR TO INSTALLATION AND SITE PREPARATION WORK.
3. UNLESS OTHERWISE SPECIFIED, ALL DIMENSIONS ARE IN INCHES [MILLIMETERS].
4. SOME STRUCTURAL DETAILS HAVE BEEN OMITTED FOR THE PURPOSE OF CLARITY.
5. MGE GALAXY 3500 UPS IS DESIGNED FOR SINGLE AND DUAL MAINS.
SINGLE MAINS INSTALLATION IS A DEFAULT.
- △ 6. THE MECHANICAL BYPASS SWITCH MUST BE REMOVED WHEN THE UPS IS TO RUN IN PARALLEL.
- △ 7. FOR DUAL MAINS ONLY.
- △ 8. TO BE REMOVED FOR DUAL MAINS INSTALLATION.
- △ 9. MAINS INPUT SHOULD FEED NEUTRAL FOR SINGLE MAINS CONFIGURATION ONLY.
FOR DUAL MAINS CONFIGURATION MAINS INPUT SHOULD NOT FEED THE NEUTRAL

THIS DRAWING AND SPECIFICATIONS HEREIN ARE THE PROPERTY OF SCHNEIDER ELECTRIC AND SHALL NOT BE COPIED, REPRODUCED OR USED IN WHOLE OR IN PART, AS THE BASIS FOR THE MANUFACTURE OR SALE OF ITEMS WITHOUT WRITTEN PERMISSION FROM SCHNEIDER ELECTRIC. THIS DRAWING IS BASED UPON LATEST AVAILABLE INFORMATION AND IS SUBJECT TO CHANGE WITHOUT NOTICE.



TITLE: MGE GALAXY 3500
Input: 208/220V AC 3PH SINGLE/DUAL MAINS
Output: 208/220V AC 3PH
10-30KVA WIDE UPS 2 MOD WITH SBP
UPS- INTERNAL VIEW

DWG NO: G35T10K30FWSBP-2MOD

REV. 1

PROJECT: DRAWINGS SHEET 5 OF 11

DRAWN BY: JAYAPRAKASH 30-NOV-15
ENGINEER: T.MULLER 30-NOV-15
APPROVED BY: M.MAISSY 30-NOV-15

THIRD ANGLE PROJECTION

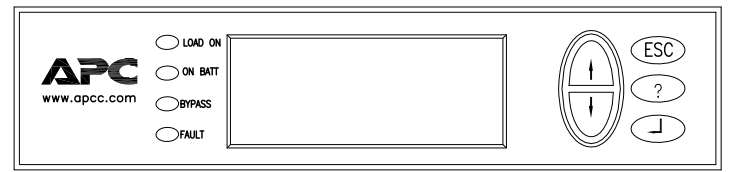
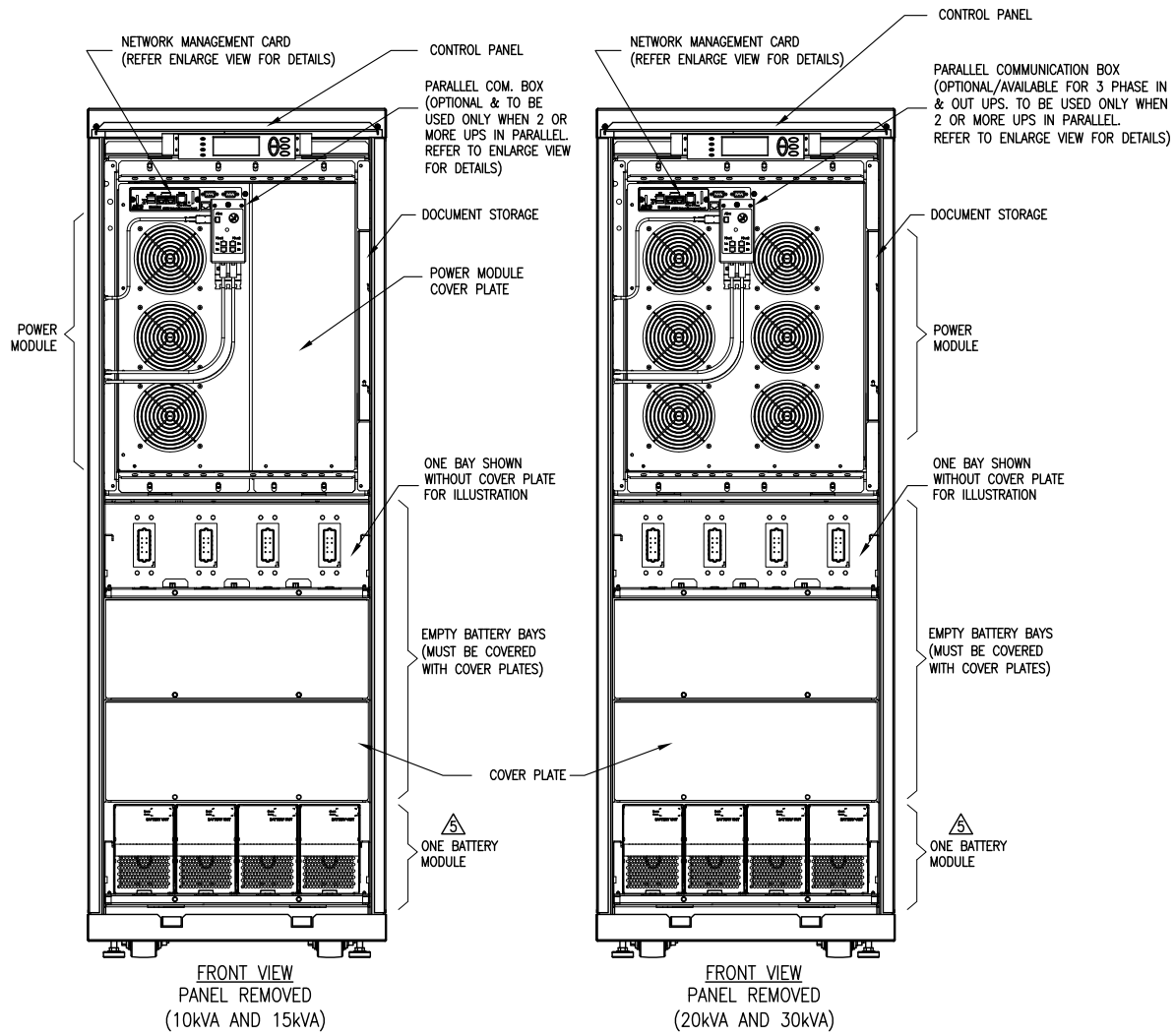

CONTROL PANEL
(ENLARGE VIEW)

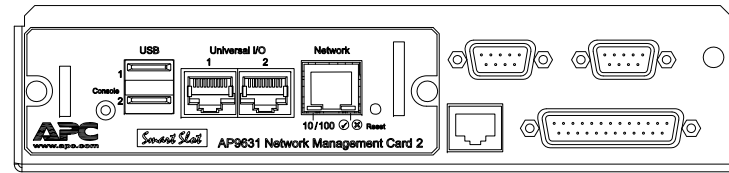

NETWORK MANAGEMENT CARD
(ENLARGE VIEW)

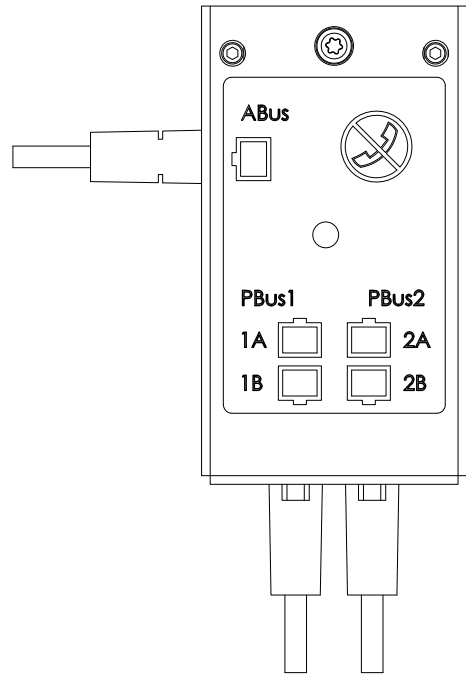

PARALLEL COMMUNICATION BOX
SKU NUMBER: SUVTOPT009
(OPTIONAL)

NOTES:

1. INSTALLATION SHALL COMPLY WITH ALL APPLICABLE NATIONAL, STATE AND LOCAL CODES.
2. REFER TO PRODUCT MANUALS FOR ADDITIONAL DETAILS PRIOR TO INSTALLATION AND SITE PREPARATION WORK.
3. UNLESS OTHERWISE SPECIFIED, ALL DIMENSIONS ARE IN INCHES [MILLIMETERS].
4. SOME STRUCTURAL DETAILS HAVE BEEN OMITTED FOR THE PURPOSE OF CLARITY.
- △ 5. THIS DRAWING REPRESENTS THE SKU WITH ONE BATTERY MODULE. PLEASE REFER TO SHEET-2 FOR DETAILS ABOUT ADDITIONAL BATTERY MODULES.

THIS DRAWING AND SPECIFICATIONS HEREIN ARE THE PROPERTY OF SCHNEIDER ELECTRIC AND SHALL NOT BE COPIED, REPRODUCED OR USED IN WHOLE OR IN PART, AS THE BASIS FOR THE MANUFACTURE OR SALE OF ITEMS WITHOUT WRITTEN PERMISSION FROM SCHNEIDER ELECTRIC. THIS DRAWING IS BASED UPON LATEST AVAILABLE INFORMATION AND IS SUBJECT TO CHANGE WITHOUT NOTICE.



TITLE: MGE GALAXY 3500
Input: 208/220V AC 3PH SINGLE/DUAL MAINS
Output: 208/220V AC 3PH
10-30kVA WIDE UPS 2 MOD WITH SBP
UPS- CONTROL PANEL
PROJECT: DRAWINGS | SHEET 6 OF 11

DWG NO: G35T10K30FWSBP-2MOD
DRAWN BY: UMESH K 19-Oct-11
ENGINEER: T.MULLER 25-Oct-11
APPROVED BY: B.SHERIDAN 25-Oct-11

REV: 0
THIRD ANGLE PROJECTION

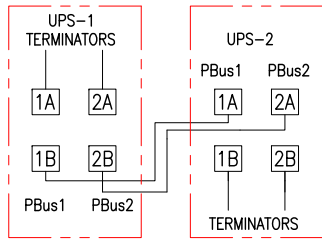

PBus CABLE LAYOUT

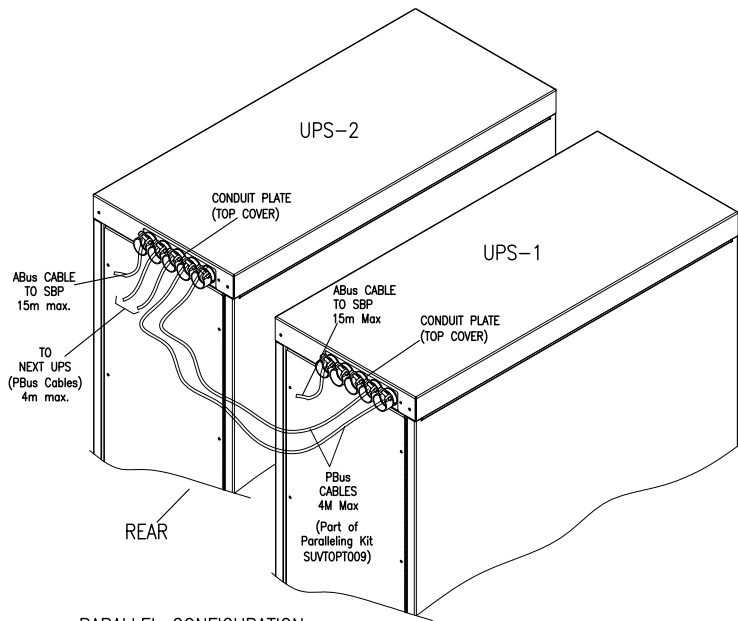

PARALLEL CONFIGURATION WIRING DETAILS

EPO WIRING OPTIONS (J108)

CONNECT THE EPO CABLE, USING ONE OF THE FOLLOWING 4 WIRING CONFIGURATIONS.

1: DRY CONTACTS NORMALLY OPEN

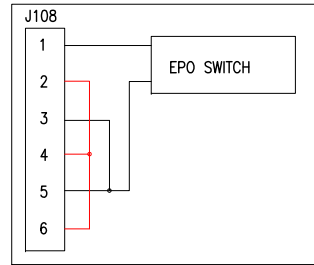

2: +24V NORMALLY OPEN

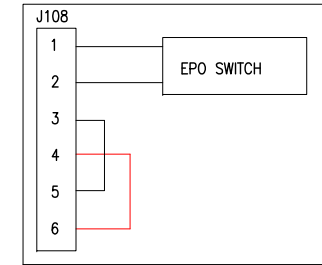

3: DRY CONTACTS NORMALLY CLOSED

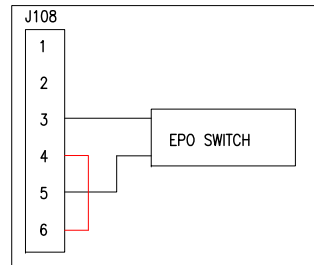

4: +24V NORMALLY CLOSED

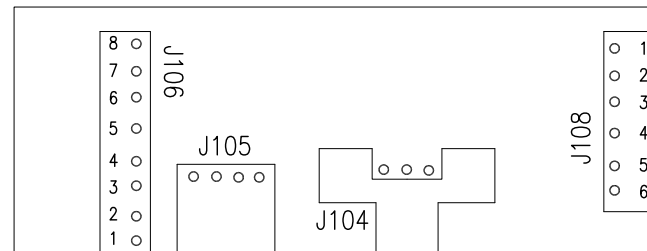
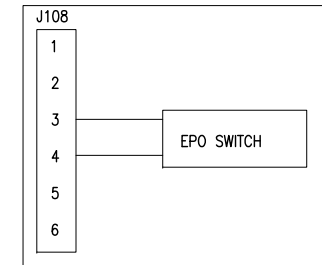

COMMUNICATION BOARD

APC SBP, AND GENERATOR CONTROL WIRING (J106)

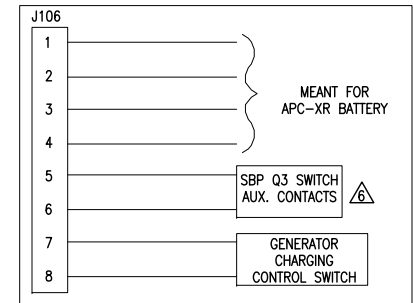

NOTES

1. INSTALLATION SHALL COMPLY WITH ALL APPLICABLE NATIONAL, STATE AND LOCAL CODES.
2. REFER TO PRODUCT MANUALS FOR ADDITIONAL DETAILS PRIOR TO INSTALLATION AND SITE PREPARATION WORK.
3. FOR COMMUNICATION CABLES USE ONLY 28-16AWG COPPER WIRE RATED MINIMUM 250V.
4. FOR SYSTEM CONTROL CONNECTIONS (CAN I/O BOARD LOCATED IN SBP), PLEASE REFER SHEET -11
- △5. THE EXTERNAL EPO +24VDC, 1500mA CIRCUIT CAN BE SUPPLIED THROUGH OTHER VENDORS.
- △6. THE EXTERNAL EPO +24VDC, 1500mA CIRCUIT CAN BE SUPPLIED THROUGH OTHER VENDORS.

THIS DRAWING AND SPECIFICATIONS HEREIN ARE THE PROPERTY OF SCHNEIDER ELECTRIC AND SHALL NOT BE COPIED, REPRODUCED OR USED IN WHOLE OR IN PART, AS THE BASIS FOR THE MANUFACTURE OR SALE OF ITEMS WITHOUT WRITTEN PERMISSION FROM SCHNEIDER ELECTRIC. THIS DRAWING IS BASED UPON LATEST AVAILABLE INFORMATION AND IS SUBJECT TO CHANGE WITHOUT NOTICE.



TITLE: MGE GALAXY 3500
Input: 208/220V AC 3PH SINGLE/DUAL MAINS
Output: 208/220V AC 3PH
10-30KVA WIDE UPS 2 MOD WITH SBP
UPS- EPO, NMC & CB

DWG NO: G35T10K30FWSBP-2MOD

ENGINEER: T.MULLER

PROJECT: DRAWINGS SHEET 7 OF 11

APPROVED BY: B.SHERIDAN

REV: 0
THIRD ANGLE PROJECTION

G35TSBPAR10K15F

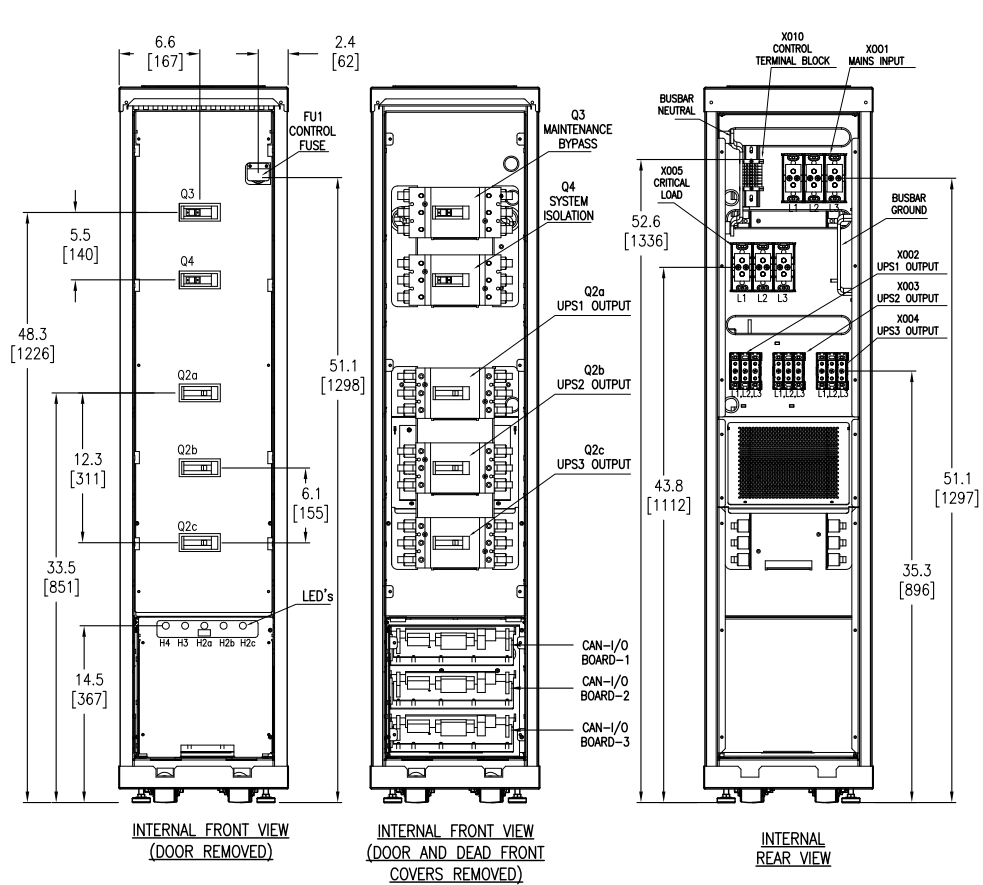

G35TSBPAR20K30F

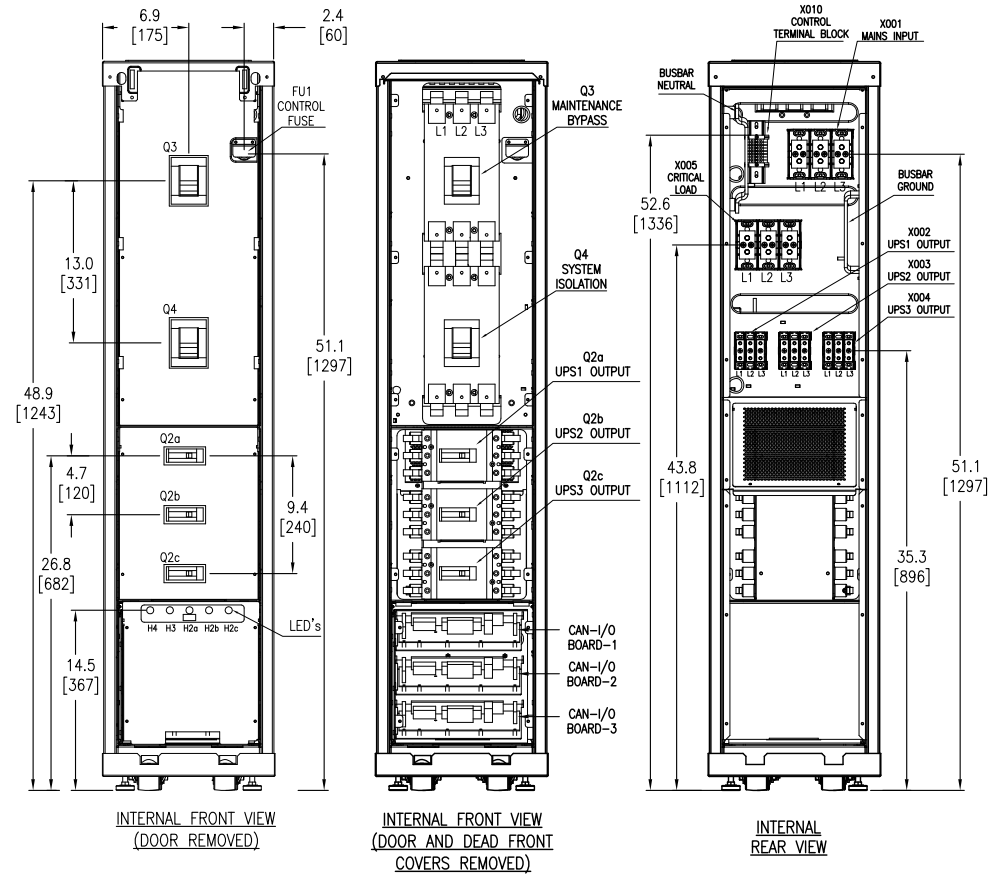

NOTES:

1. INSTALLATION SHALL COMPLY WITH ALL APPLICABLE NATIONAL, STATE AND LOCAL CODES.
2. REFER TO PRODUCT MANUALS FOR ADDITIONAL DETAILS PRIOR TO INSTALLATION AND SITE PREPARATION WORK.
3. ALL DIMENSIONS ARE IN INCHES [MILLIMETERS].
4. ALL WIRING MUST BE 3 PHASE, 4 WIRE+ GROUND PROVIDED BY WYE-SOURCE
5. FOR SKU # SBPAR10K15F
Q3 AND Q4 =175A, 600VAC.
Q2a, Q2b & Q2c = 60A, 600VAC
6. FOR SKU # SBPAR20K30F
Q3 AND Q4 =400A, 600VAC.
Q2a, Q2b & Q2c = 125A, 600VAC
7. USE COPPER CONDUCTORS RATED 75° C MINIMUM.
8. NET WEIGHT OF THE SBP UNIT 268 lbs [122 kg].
9. TORQUE VALUES:
TERMINAL BLOCKS (M6) 6.89 Nm (61 lbs-in)
TERMINAL BLOCKS (M10) 25.7 Nm (227 lbs-in)
BUSBAR (M5 OR M6) 11.3 Nm (100 lbs-in)

THIS DRAWING AND SPECIFICATIONS HEREIN ARE THE PROPERTY OF SCHNEIDER ELECTRIC AND SHALL NOT BE COPIED, REPRODUCED OR USED IN WHOLE OR IN PART, AS THE BASIS FOR THE MANUFACTURE OR SALE OF ITEMS WITHOUT WRITTEN PERMISSION FROM SCHNEIDER ELECTRIC. THIS DRAWING IS BASED UPON LATEST AVAILABLE INFORMATION AND IS SUBJECT TO CHANGE WITHOUT NOTICE.



TITLE: MGE GALAXY 3500
Input: 208/220V AC 3PH SINGLE/DUAL MAINS
Output: 208/220V AC 3PH
10-30KVA WIDE UPS 2 MOD WITH SBP
SBP- INTERNAL VIEW

DWG NO: G35T10K30FWSBP-2MOD

DRAWN BY: UMESH K 19-Oct-11
ENGINEER: T.MULLER 25-Oct-11
APPROVED BY: B.SHERIDAN 25-Oct-11

REV: 0
THIRD ANGLE PROJECTION

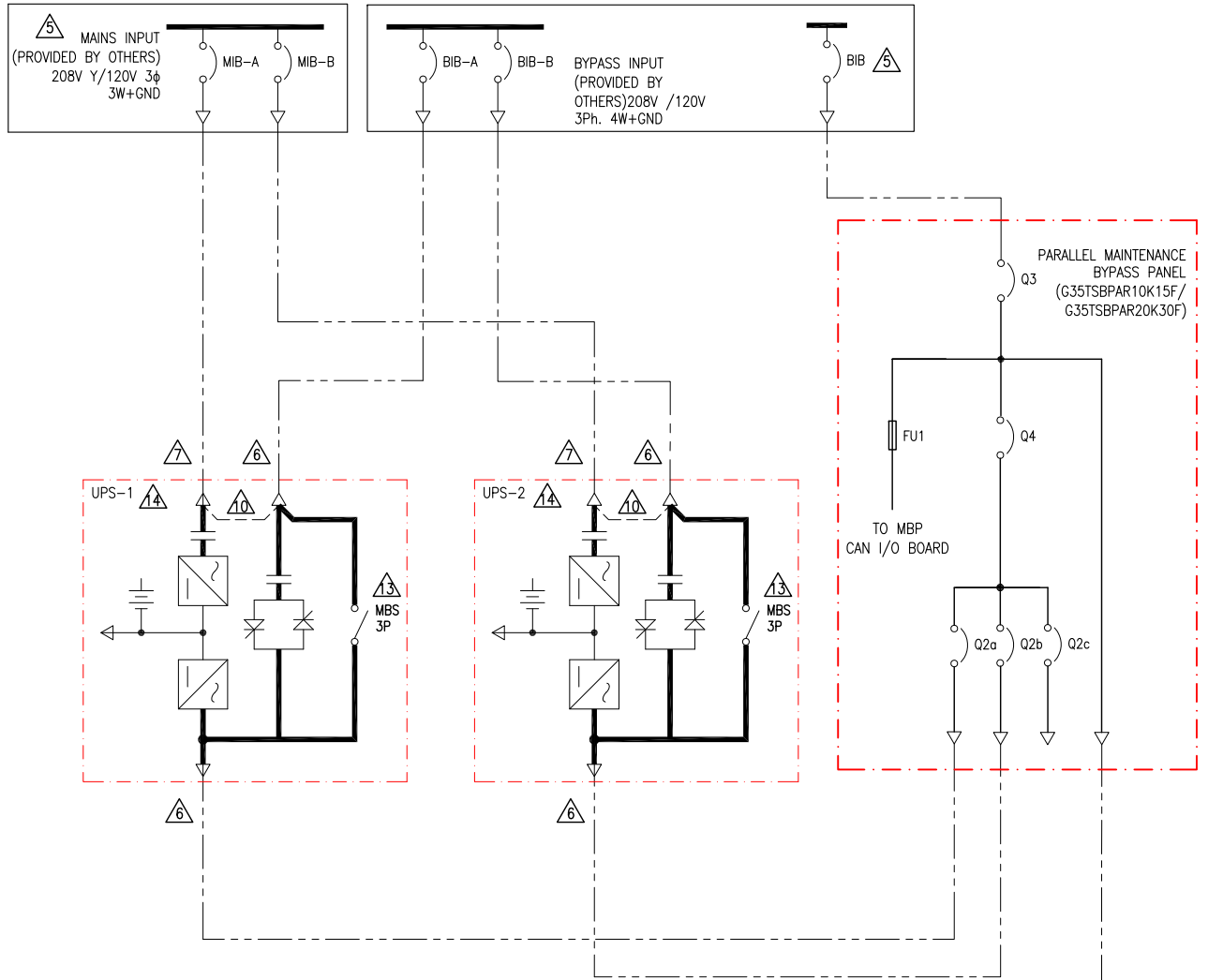

LEGEND:
 - - - - - AC CABLE - PROVIDED BY OTHERS
 _____ AC BUS

DEVICE	RATED SHORT CIRCUIT CURRENT
UPS	30kAIC SYMMETRICAL
SBP	20kAIC SYMMETRICAL

DEVICE RATING FOR G35TSBPAR10K15F (TO USE WITH 10-15 kVA UPS)

DEVICE ID	RATING	TYPE	MAKE	MODEL	ACCESSORIES
Q2a, Q2b, Q2c	60A	CB 4POLE 600V	ABB	T1N060TL-4A AUX-C 3Q 1SY 24VDC	1-Aux. Switch
Q3, Q4	175A	CB 4POLE 600V	ABB	T3N175TW-4A3, KT3AS3	1-Aux. Switch

DEVICE RATING FOR G35TSBPAR20K30F (TO USE WITH 20-30 kVA UPS)

DEVICE ID	RATING	TYPE	MAKE	MODEL	ACCESSORIES
Q2a, Q2b, Q2c	125A	CB 4POLE 600V	ABB	T3N12550S-4A, AUX-C 3Q 1SY 24VDC	1-AUX. SWITCH
Q3, Q4	400A	CB 4POLE 600V	ABB	T5N400TW-4A3, KT5AS3	1-AUX. SWITCH

- NOTES:**
1. INSTALLATION SHALL COMPLY WITH ALL APPLICABLE NATIONAL, STATE AND LOCAL CODES.
 2. PLEASE REFER TO PRODUCT MANUALS FOR ADDITIONAL DETAILS PRIOR TO INSTALLATION AND SITE PREPARATION WORK.
 3. DRAWING DEPICTS POWER SYSTEM CONNECTIONS AND IS NOT REPRESENTATIVE OF PHYSICAL LAYOUT, PLEASE REFER TO MECHANICAL DRAWINGS FOR PHYSICAL LAYOUT.
 4. ALL AC BREAKERS ARE 80% CONTINUOUS DUTY RATED WITH 2A/2B AUX CONTACTS FOR APC CONTROL AND COORDINATED WITH REQUIRED SYSTEM SETTINGS AS DETAILED IN PRODUCT DOCUMENTATION. ADDITIONAL 2A/2B AUX CONTACTS TO BE WIRED TO TERMINAL STRIP FOR CUSTOMER USE. BREAKER SIZING IS BASED ON NOMINAL MAINS VOLTAGE.

- Δ 5. AC SOURCE TO BE 208VAC, 4W, WYE CONNECTED, 3φ (CONTACT Schneider Electric IF OTHER)
- Δ 6. AC CABLING TO BE 600V RATED, 3 PHASE, 4W+GND.
- Δ 7. AC CABLING TO BE 600V RATED, 3 PHASE, 3W+GND.
- 8. DC SOURCE TO BE 384VDC WITH CENTER TAP, 3W+GND.
- 9. CABLE LUGS ARE PROVIDED BY OTHERS.
- Δ 10. REMOVABLE BUS LINK. TO BE REMOVED FOR DUAL MAINS.
- 11. UPS INPUT AND OUTPUT CABLES SHOULD BE SEGREGATED.
- 12. POWER WIRING AND CONTROL WIRING SHOULD BE SEGREGATED.
- Δ 13. SINGLE MODULE, FOR LINEUP CONFIGURATION ONLY. TO BE REMOVED FOR PARALLEL INSTALLATION.
- Δ 14. APPLICABLE SKU : REFER SHEET-3.

THIS DRAWING AND SPECIFICATIONS HEREIN ARE THE PROPERTY OF SCHNEIDER ELECTRIC AND SHALL NOT BE COPIED, REPRODUCED OR USED IN WHOLE OR IN PART, AS THE BASIS FOR THE MANUFACTURE OR SALE OF ITEMS WITHOUT WRITTEN PERMISSION FROM SCHNEIDER ELECTRIC. THIS DRAWING IS BASED UPON LATEST AVAILABLE INFORMATION AND IS SUBJECT TO CHANGE WITHOUT NOTICE.



TITLE: MGE GALAXY 3500
 Input: 208/220V AC 3PH SINGLE/DUAL MAINS
 Output: 208/220V AC 3PH
 10-30kVA WIDE UPS 2 MOD WITH SBP
 SYSTEM ONE LINE DIAGRAM

PROJECT: DRAWINGS | SHEET 9 OF 11

DWG NO: G35T10K30FWSBP-2MOD

DRAWN BY: JAYAPRAKASH 30-NOV-15
 ENGINEER: T.MULLER 30-NOV-15
 APPROVED BY: A.WARNER 30-NOV-15

REV. 1
 ANGLE PROJECTION
 N.A

Galaxy 3500® 10K to 30K UPS Frame (2 Module) with SBP Site Planning Data

Battery - Nominal Voltage : +/-192V DC

Input Voltage : 208V AC, Output Voltage : 208V AC

UPS Rating	SKU Number	System Mains Input		System Bypass Input	System Output		Battery Current(A) (in UPS Cabinet)	Recommended Over current Protection Device Ratings				UPS Mechanical Data			
		Nominal Current(A)	Maximum Current(A)	Nominal Current(A)	System output Power	Nominal Current(A)		Individual UPS Mains Input (A)	Individual UPS Bypass Input (A)	UPS System Input (A)	UPS System Output (A)	Typical Dimensions H x W x D in inches [mm] see note 15	Weight in lbs [kg] see Note 15	Floor Loading data in Lbs/ft ² [kg/m ²]	Heat Loss BTU/hr See Note 23
10KVA/8KW	G35T10KF1B4S	48.6	53.4	48.6	20KVA/16KW	55.6	27.5	35	35	70	70	58.7x20.6x33 [1491x532x838]	711 [323]	151 [737]	1938
	G35T10KF2B4S											58.7x20.6x33 [1491x532x838]	913 [415]	193 [947]	
	G35T10KF3B4S											58.7x20.6x33 [1491x532x838]	1115 [507]	236 [1156]	
	G35T10KF4B4S											58.7x20.6x33 [1491x532x838]	1318 [600]	279 [1367]	
15KVA/12KW	G35T15KF2B4S	73	80.4	73	30KVA/24KW	83.2	41.2	60	60	120	120	58.7x20.6x33 [1491x532x838]	913 [415]	151 [947]	2989
	G35T15KF3B4S											58.7x20.6x33 [1491x532x838]	1115 [507]	236 [1156]	
	G35T15KF4B4S											58.7x20.6x33 [1491x532x838]	1318 [600]	279 [1367]	
	G35T20KF2B4S											58.7x20.6x33 [1491x532x838]	979 [445]	207 [1015]	
20KVA/16KW	G35T20KF3B4S	97	106.8	97	40KVA/32KW	111	55	80	80	160	160	58.7x20.6x33 [1491x532x838]	1181 [537]	250 [1225]	4238
	G35T20KF4B4S											58.7x20.6x33 [1491x532x838]	1384 [629]	293 [1435]	
	G35T30KF3B4S											58.7x20.6x33 [1491x532x838]	1181 [537]	250 [1225]	
30KVA/24KW	G35T30KF4B4S	146	160.6	146	60KVA/48KW	166.6	82.5	125	125	250	250	58.7x20.6x33 [1491x532x838]	1384 [629]	293 [1435]	5896
	G35T30KF4B4S											58.7x20.6x33 [1491x532x838]	1384 [629]	293 [1435]	

Notes.

- Input current based on full rated output load..
 - Maximum (Max.) current is for duration of battery recharge.
 - Input and bypass cables must be run in separate conduits from output cables. Not more than three conductors in raceway assumed; ambient temperature of 30°C (86°F) assumed.
 - If initial load is less than UPS' rated output, it is recommended that AC input, battery, and AC output wiring and over current protection be sized to UPS' full load rating to accommodate possible future expansion.
 - Nominal battery voltage is shown at 2.0 volts/cell per NEC 480-2.
 - DC cables should be sized for a total maximum of less than 1% of CB rating.
 - OCPD = Over current Protection Device. Recommended represents 125% of nominal full load current (continuous) per NEC 215.
 - Minimum-sized grounding conductors to be per NEC 250-122. Parity-sized ground conductors are recommended. Neutral conductors to be sized for full capacity per NEC 310-15(b)(4).
 - Wiring requirements:
 - AC Input/Output: 3Ø, 3 or 4 wire + ground, depending on UPS configuration.
 - See Installation Manual and submittal drawings for specific instructions.
 - DC Input: 2 wire (positive and negative) + ground
 10. All wiring to be in accordance with all applicable national and/or local electrical codes.
 11. DC cabling should be sized to give < 1% voltage drop at the nominal battery discharge current using three-wire separate conductors in positive, centre-tap and negative poles
 12. Minimum access Clearance on all drawings.
 13. Bottom cable entry through removable access plates. Punch plates to suit conduit size, then replace.
 14. Control wiring and power wiring must be run in separate conduit.
 15. Weights and dimensions shown do not include battery cabinet(s), distribution cabinet(s), or other options.
 16. Backup emergency generator must be properly sized for UPS application and equipped with an isochronous governor for frequency regulation, and a UPS-compatible voltage regulator for voltage stability.
 17. Input : THDI < 5% at full load.
 18. Output : THDU < 1.5% Linear Load, < 3.5% Non Linear Load
 19. If site configuration requires an external maintenance bypass, phase parity between UPS input and UPS bypass must be ensured. Consult Schneider Electric applications engineer.
 20. References are per NEC 1999. Consult local codes for possible variations.
 21. Narrow Cabinet dimensions – 13.9 in. wide.
 22. Weight references installed weight with fully populated batteries and power modules.
 23. BTU Rating: Batteries fully charged is a continuous rating.
- Additional Notes:**
- Temperature rating of conductors: 90°C (194°F). Reference NEC Table 310-16, 75°C column, using copper conductors. 75°C (167°F) cable terminal conductors assumed.
 - Neutral conductor must be sized for 1.73 time phase current for full SMPS loads (50mm recommended)
 - BTU rating for 10-30kVA transformer cubicles with or without integrated bypass/distribution panel = 2433BTU/hr full load –batteries fully charged.
 - Ratings of the cables and overcurrent devices supplied for information only. User to consult with their engineering services before adopting

EFFICIENCY DETAILS				
SYSTEM	25% LOAD	50% LOAD	75% LOAD	100% LOAD
10KVA 400V	92.9	94.8	94.9	94.9
15KVA 400V	92.9	95.3	95.5	95.5
20KVA 400V	94.4	95.5	95.5	95.4
30KVA 400V	94.1	96	95.9	96.1
40KVA 400V	95	96	95.9	95.5

THIS DRAWING AND SPECIFICATIONS HEREIN ARE THE PROPERTY OF SCHNEIDER ELECTRIC AND SHALL NOT BE COPIED, REPRODUCED OR USED IN WHOLE OR IN PART, AS THE BASIS FOR THE MANUFACTURE OR SALE OF ITEMS WITHOUT WRITTEN PERMISSION FROM SCHNEIDER ELECTRIC. THIS DRAWING IS BASED UPON LATEST AVAILABLE INFORMATION AND IS SUBJECT TO CHANGE WITHOUT NOTICE.



TITLE: MGE GALAXY 3500
 Input: 208/220V AC 3PH SINGLE/DUAL MAINS
 Output: 208/220V AC 3PH
 10-30kVA WIDE UPS 2 MOD WITH SBP
 SITE PLANNING GUIDE
 PROJECT: DRAWINGS SHEET 10 OF 11

DWG NO: G35T10K30FWSBP-2MOD
 DRAWN BY: JAYAPRAKASH 27-JUL-16
 ENGINEER: T.MULLER 27-JUL-16
 APPROVED BY: M.MAISSY 27-JUL-16
 REV. 1
 ANGLE PROJECTION
 N.A

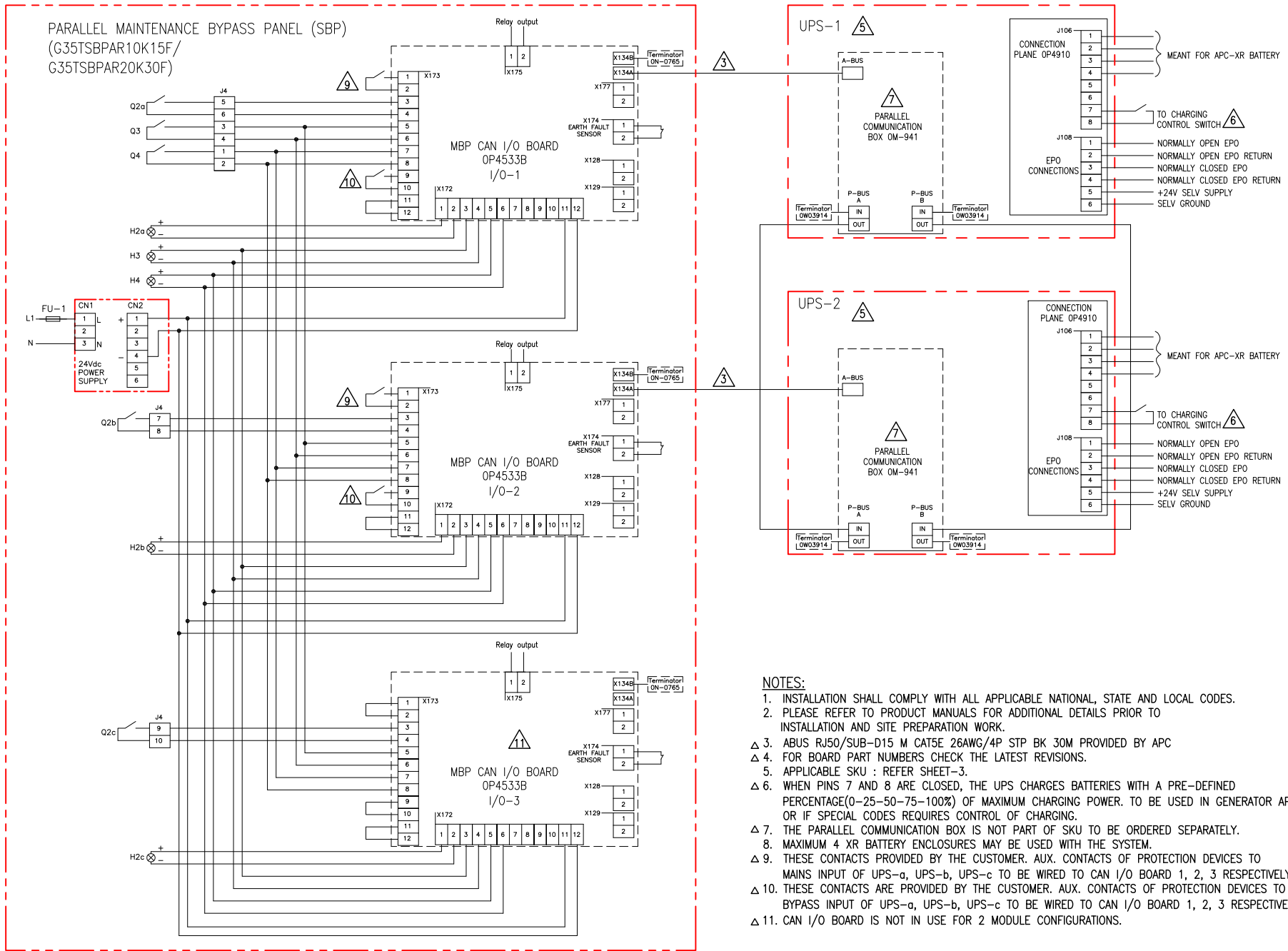

- NOTES:**
1. INSTALLATION SHALL COMPLY WITH ALL APPLICABLE NATIONAL, STATE AND LOCAL CODES.
 2. PLEASE REFER TO PRODUCT MANUALS FOR ADDITIONAL DETAILS PRIOR TO INSTALLATION AND SITE PREPARATION WORK.
 - △ 3. ABUS RJ50/SUB-D15 M CAT5E 26AWG/4P STP BK 30M PROVIDED BY APC
 - △ 4. FOR BOARD PART NUMBERS CHECK THE LATEST REVISIONS.
 5. APPLICABLE SKU : REFER SHEET-3.
 - △ 6. WHEN PINS 7 AND 8 ARE CLOSED, THE UPS CHARGES BATTERIES WITH A PRE-DEFINED PERCENTAGE(0-25-50-75-100%) OF MAXIMUM CHARGING POWER. TO BE USED IN GENERATOR APPLICATIONS, OR IF SPECIAL CODES REQUIRES CONTROL OF CHARGING.
 - △ 7. THE PARALLEL COMMUNICATION BOX IS NOT PART OF SKU TO BE ORDERED SEPARATELY.
 8. MAXIMUM 4 XR BATTERY ENCLOSURES MAY BE USED WITH THE SYSTEM.
 - △ 9. THESE CONTACTS PROVIDED BY THE CUSTOMER. AUX. CONTACTS OF PROTECTION DEVICES TO MAINS INPUT OF UPS-a, UPS-b, UPS-c TO BE WIRED TO CAN I/O BOARD 1, 2, 3 RESPECTIVELY AS SHOWN.
 - △ 10. THESE CONTACTS ARE PROVIDED BY THE CUSTOMER. AUX. CONTACTS OF PROTECTION DEVICES TO BYPASS INPUT OF UPS-a, UPS-b, UPS-c TO BE WIRED TO CAN I/O BOARD 1, 2, 3 RESPECTIVELY AS SHOWN.
 - △ 11. CAN I/O BOARD IS NOT IN USE FOR 2 MODULE CONFIGURATIONS.

THIS DRAWING AND SPECIFICATIONS HEREIN ARE THE PROPERTY OF SCHNEIDER ELECTRIC AND SHALL NOT BE COPIED, REPRODUCED OR USED IN WHOLE OR IN PART, AS THE BASIS FOR THE MANUFACTURE OR SALE OF ITEMS WITHOUT WRITTEN PERMISSION FROM SCHNEIDER ELECTRIC. THIS DRAWING IS BASED UPON LATEST AVAILABLE INFORMATION AND IS SUBJECT TO CHANGE WITHOUT NOTICE.



TITLE: MGE GALAXY 3500
 Input: 208/220V AC 3PH SINGLE/DUAL MAINS
 Output: 208/220V AC 3PH
 10-30kVA WIDE UPS 2 MOD WITH SBP
 SYSTEM WIRING DIAGRAM

DWG NO: G35T10K30FWSBP-2MOD
 DRAWN BY: UMESH K 19-Oct-11
 ENGINEER: T.MULLER 25-Oct-11
 APPROVED BY: B.SHERIDAN 25-Oct-11

REV: 0
 THIRD ANGLE PROJECTION