



Allen-Bradley

**Technical Data -
Phase II Control**

**PowerFlex®
700S High
Performance
AC Drive**





PowerFlex® 700S AC Drive Technical Data — Phase II Control

The Allen-Bradley PowerFlex® 700S AC drive, a version of PowerFlex 700 power platform, offers high performance drive control, advanced features and more built-in diagnostics for handling the most demanding drive applications. The PowerFlex 700S with DriveLogix™ combines the powerful performance and flexible control of PowerFlex AC drives with the high-performance Logix engine to produce a highly functional, cost-effective drive and control solution.



PowerFlex 700S AC Drive
with Slim Cassette



PowerFlex 700S AC Drive
with Expanded Cassette

Table of Contents

Description	Page
Packaging and Mounting	4
Start Up, Programming	5
Operation	6
Support	7
Drive Application Software	7
Performance	8
Product Selector	10
Accessories	12
Installation Considerations	22
Power Terminal Block Locations	23
Control Terminals	32
Cable Recommendations — Power	33
Cable Recommendations - Control	34
Cable Length Restrictions	35
Ratings and Protection Devices	40
Minimum Mounting Clearances	62
Frame to AC Drive Rating Cross Reference	64
Frame to DC Drive Rating Cross Reference	65
Approximate Dimensions	66
Specifications	75
Input Voltage Range/Tolerance	79
Altitude Derating	80
Carrier Derating	81
Watts Loss - Frames 10 - 13	88
Reference Materials	92

Packaging and Mounting

- The innovative bookshelf design allows **Zero Stacking™** or side-by-side mounting of the drives. With no minimum spacing required between drives, valuable panel space is conserved and installation cost is reduced.

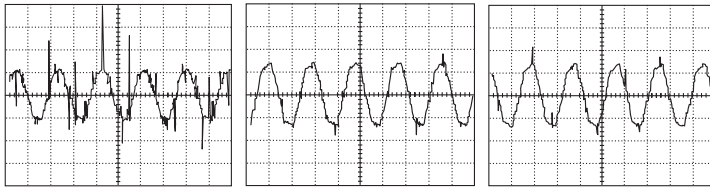

Noise Reduction Charts

- The design of the PowerFlex® family of drives incorporates proven **noise reduction components** on both the input and output of the drive. Many of the global EMC standards can be met and many noise related application concerns can be reduced or eliminated using a standard "out-of-the-box" PowerFlex drive with no additional hardware or cost. By also incorporating higher rated components and significant voltage suppression devices for both phase-to-phase and phase-to-ground protection, power conditioning concerns and the need for additional hardware are significantly reduced.

- **Pull-apart** control terminal blocks for easy wiring and quick disconnect.

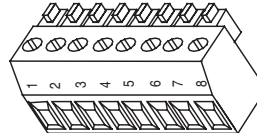

- **DriveLogix** offers embedded Logix control for application programmability and control of auxiliary functions in one package, the PowerFlex 700S with DriveLogix.
 - Common programming environment and multiple programming languages supported by all Logix platforms.
 - Ladder Diagram, Function Block Diagram, Sequential Function Chart and Structured Text.
 - Eight (8) separate tasks including one (1) continuous and seven (7) periodic. Each task can support up to 32 programs and an unlimited number of routines for program organization.
 - 1.5 Mbytes of standard user memory.
 - CompactFlash™ for non-volatile storage.
 - Local connections for up to sixteen (16) Compact I/O modules.
 - Communication options include the RS-232 port and the same optional communication daughter cards used by the FlexLogix™ controller.
 - Virtual backplane concept for program portability to other Logix platforms, seamless integration into the NetLinx™ architecture and direct drive communication.

Start Up, Programming

- The PowerFlex 700S has optimized global voltage settings for quick configuration anywhere in the world. Multiple reset defaults make setup for your voltage/frequency fast and easy.



- An optional LCD Human Interface Module (HIM) provides programming, start up information, diagnostics and other information in full, easy to understand text. The display is a 7 line by 21 character backlit LCD screen. Four styles are available; full numeric keypad, operating and programming keys only and programming only.

Integrated Software

DriveTools™ SP

A powerful new PC based software suite, for programming, configuration and troubleshooting.

- DriveExecutive™ - for online/offline configuration and management of drives and drive peripherals.
- DriveObserver™ - for real time trending of drive information.



RSLogix™ 5000

The PowerFlex 700S with DriveLogix utilizes RSLogix 5000, v13.0 or greater, with embedded DriveExecutive Lite for programming, configuration and troubleshooting the drive and embedded Logix controller.

- Single programming software package for the entire family of Logix 5000 products.
- Reduces learning curve between controllers.
- Multiple IEC1131-3 programming languages.
- Symbolic tag and structure data model.
- Integrated sequential and motion control.
- Power programming tools to increase productivity.

Operation

- **Multiple high performance motor control algorithms:** Flux Vector Control utilizes patented FORCE™ Technology for sensor and sensorless induction motor control and Brushless Permanent Magnet motor operation, provide maximum application flexibility.

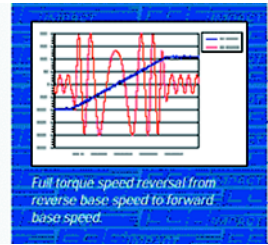

- An **array of feedback options**, including a standard incremental encoder, an optional incremental encoder, resolver, and high resolution encoder feedback interface cards optimize the accuracy of speed and position regulators. A Temposonics and Stalh SSI interface for linear feedback devices are also available.

- An integrated position loop for applications from simple indexing to electronic line shaft.

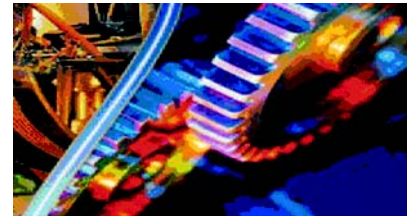

- SynchLink™, a high performance, high speed, drive-to-drive link for transmitting synchronized and application data. The SynchLink fiber optic link provides the highest level of multiple drive coordination.

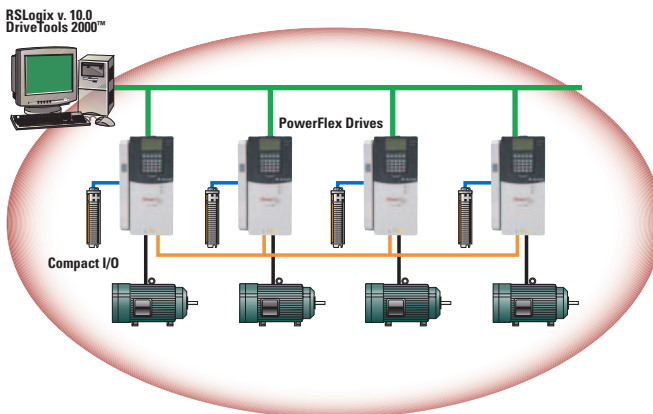

- Optional **internal communication** adapters provide fast and efficient control and/or data exchange with host controllers over popular interfaces. These interfaces include: DeviceNet™, ControlNet™, Profibus, Interbus, Remote I/O, Serial Communications and other communication networks.

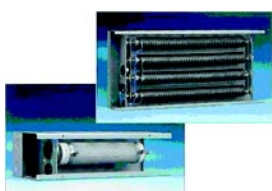

- Standard chopper transistor and separately mounted or drive mounted resistors provide cost effective dynamic braking solutions.

Support

Rockwell Automation is committed to maintaining and supporting Allen-Bradley drives and installations. Included in this commitment is start-up support and consultation for drive applications.

ProtectionPlus Drive Start-Up

With ProtectionPlus Drive Start-Up Services from Rockwell Automation, users can leverage the extensive product and industry experience of Rockwell Automation technicians to quickly commission drives and reduce the time between integration and actual start-up.

ProtectionPlus Drive Start-Up Services verify drive installation to ensure proper electrical, mechanical and environmental criteria are met. This includes verification of power and I/O wiring to the drive, custom drive configuration/tuning to meet application specific requirements, and diagnosing/troubleshooting problems that occur during a standalone drive start-up. ProtectionPlus can also extend an eligible product parts warranty and add a labor warranty. For more information about ProtectionPlus Drive Services, contact your local Rockwell Automation sales office or authorized distributor, or visit: <http://support.rockwellautomation.com/SupportPrograms/>.

SupportPlus

For consultation on high performance drive applications, the SupportPlus program is offered. SupportPlus uses expert level Rockwell Automation system engineers to support the user's engineering team. SupportPlus engineers will work with the end user to layout the appropriate architecture, configure drives, recommend programming techniques and provide application assistance on the most effective ways to implement the control solution.

For more information, please call 262-512-8176 or refer to www.ab.com/support/abdrives.

Drive Application Software

Drive Application Software brings together an outstanding range of application experience and performance drive products to provide the user with pre-engineered and the most effective drive application solutions. For more information, refer to our web site: www.ab.com/drives/drivappsw



Performance

Digital Current Regulator outperforms older style analog regulators in speed, repeatability and drift.

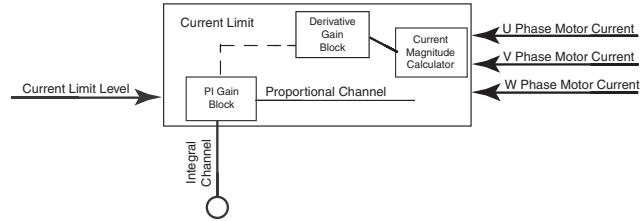

Negative Feed Forward reduces or eliminates overshoot during step speed changes. Helpful in preventing backup during stopping.

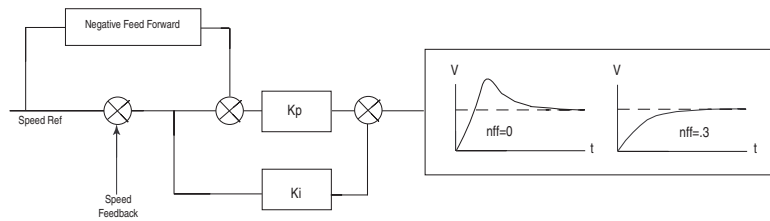

Coarse-to-Fine interpolation for **DriveLogix Motion**, direct positioning for precise control and point-to-point for indexing are all features of the **Integral Position Loop**. The loop easily handles applications such as simple indexing and electronic line shaft.

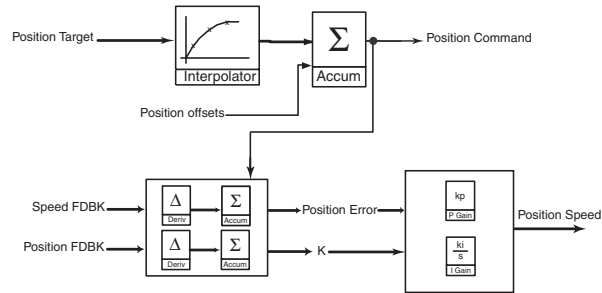

Advanced **Edge-to-Edge Algorithms** and pulse position averaging provides extremely accurate speed measurement and excellent performance at very low speed.

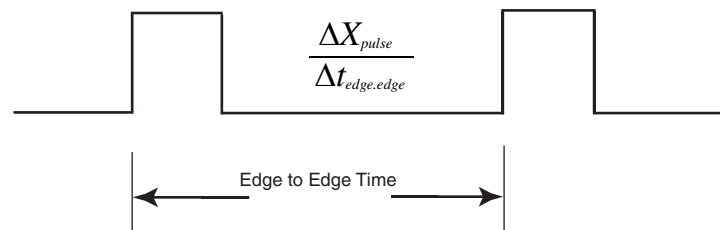

Servo Lock compensates for lost position during step loads to the velocity regulator. Offers optimum performance for draw applications and others.

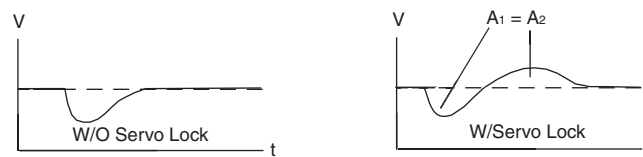

Velocity Response to Step Load

Performance, Cont.

High Speed Analog & Digital I/O execute in 0.5 mSec or less to provide fast response and fast capture for registration information and position data. Output relays, optically isolated and differentially isolated I/O are supplied.

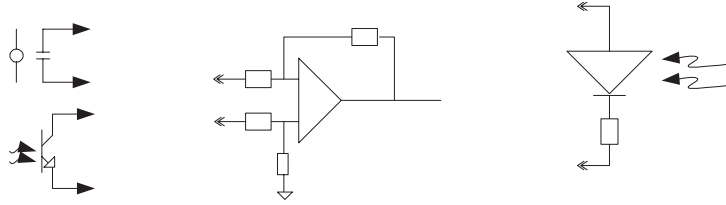

Inertia Adaptation stabilizes inertia disconnect due to gear boxes or flexible couplings. It also provides broadband resonance compensation, allowing up to 4x improvement to speed regulator bandwidth.

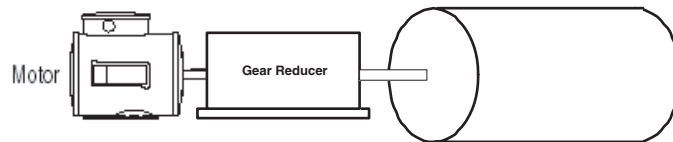

An **Enhanced Process Loop** executes six times faster than previous loops, providing greatly improved dynamic response in tension control applications.

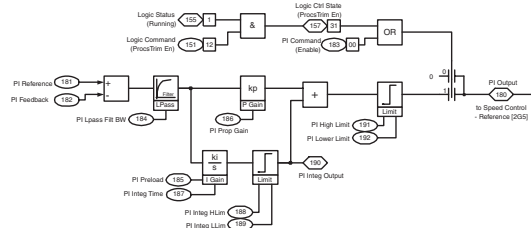

The **Control Loops** within each drive are **Synchronized**. In addition, the control loops for all drives on SynchLink are synchronized within micro-seconds. This provides exceptional link coordination and tracking for critical applications.

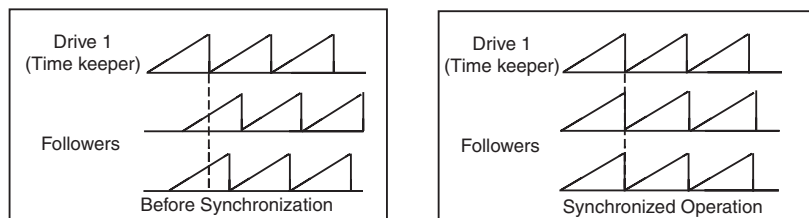

The **Enhanced Bus Regulator** reacts four times faster than previous products, providing quicker stops without over-voltage issues and outstanding performance in other regenerative applications.

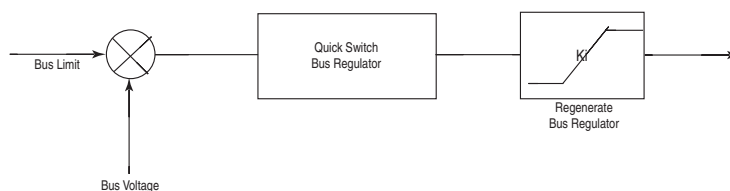

Product Selector

Catalog Number Explanation

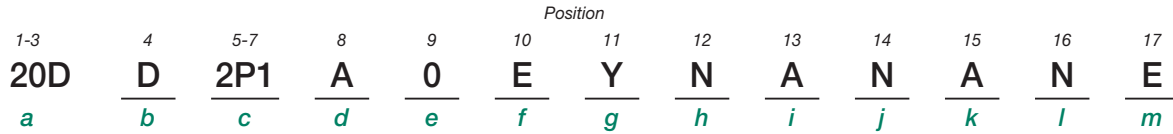

a

Drive	
Code	Type
20D	PowerFlex 700S

b

Voltage Rating			
Code	Voltage	Ph.	Prechg.
B §	240V ac	3	—
C §	400V ac	3	—
D §	480V ac	3	—
E ♣ §	600V ac	3	—
F ♣	690V ac	3	—
H ♣	540V dc	—	N
J ♣	650V dc	—	N
K ♣	810V dc	—	N
M ♣	932V dc	—	N
N	325V dc	—	Y
P	540V dc	—	Y
R	650V dc	—	Y
T	810V dc	—	Y
W	932V dc	—	Y

♣ Note: CE Certification testing has not been performed on 600V class drives, Frames 1...4. Frames 5 & 6 Only.

♣ Frames 5 & up.

§ For DC input on Frames 1...4, use the corresponding AC input code B, C, D, or E.

c1

ND Rating			
208/240V, 60Hz Input			
Code	208V Amps	240V Amps	Hp
4P2	4.8	4.2	1.0
6P8	7.8	6.8	2.0
9P6	11	9.6	3.0
015	17.5	15.3	5.0
022	25.3	22	7.5
028	32.2	28	10
042	48.3	42	15
052	56	52	20
070	78.2	70	25
080	92	80	30
104	120	104	40
130	130	130	50
154	177	154	60
192	221	192	75
260	260	260	100

c2

ND Rating		
400V, 50 Hz Input		
Code	Amps	kW
2P1	2.1	0.75
3P5	3.5	1.5
5P0	5.0	2.2
8P7	8.7	4.0
011	11.5	5.5
015	15.4	7.5
022	22	11
030	30	15
037	37	18.5
043	43	22
056	56	30
072	72	37
085	85	45
105	105	55
125	125	55
170	170	90
205	205	110
260	260	132
261	261	132
300	300	160
385	385	200
460	460	250
500	500	250
590	590	315
650	650	355
730	730	400
820	820	450
920	920	500
1K0	1030	560
1K1	1150	630
1K3	1300	710
1K4	1450	800

c3

ND Rating		
480V, 60 Hz Input		
Code	Amps	Hp
2P1	2.1	1.0
3P4	3.4	2.0
5P0	5	3.0
8P0	8	5.0
011	11	7.5
014	14	10
022	22	15
027	27	20
034	34	25
040	40	30
052	52	40
065	65	50
077	77	60
096	96	75
125	125	100
156	156	125
180	180	150
248	248	200
261	261	200
300	300	250
385	385	300
460	460	350
500	500	450
590	590	500
650	650	500
730	730	600
820	820	700
920	920	800
1K0	1030	900
1K1	1150	1000
1K3	1300	1200
1K4	1450	1250

Product Selector, Cont.

Catalog Number Explanation, Cont'd

c4

ND Rating		
600V, 60Hz Input †		
Code	Amps	Hp
1P7	1.7	1
2P7	2.7	2
3P9	3.9	3
6P1	6.1	5
9P0	9	7.5
011	11	10
017	17	15
022	22	20
027	27	25
032	32	30
041	41	40
052	52	50
062	62	60
077	77	75
099	99	100
125	125	125
144	144	150
170	170	150
208	208	200
261	261	250
325	325	350
385	385	400
416	416	450
460	460	450
502	502	500
590	590	600
650	650	700
750	750	800
820	820	900
920	920	1000
1K0	1030	1100
1K1	1180	1300

† Note: CE Certification testing has not been performed on 600V class drives Frames 1...4.

d

Enclosure	
Code	Enclosure
A	IP20, NEMA Type 1
N †	Open/IP00

† Frames 9 & up Only.

e

HIM	
Code	Operator Interface
0	Blank Cover
2	Digital LCD
3	Full Numeric LCD
5	Prog. Only LCD
C	Full Numeric LCD, Door Mount ‡

‡ Frames 10 & up only.

c5

ND Rating		
690V, 50 Hz Input †		
Code	Amps	kW
052	52	45
060	60	55
082	82	75
098	98	90
119	119	110
142	142	132
170	170	160
208	208	200
261	261	250
325	325	315
385	385	355
416	416	400
460	460	450
502	502	500
590	590	560
650	650	630
750	750	710
820	820	800
920	920	900
1K0	1030	1000
1K1	1180	1100

† Note: CE Certification testing has not been performed on 600V class drives Frames 1...4.

f

Documentation	
Code	Documents
E	Quick Start Guide
N	No Documentation

g

Brake	
Code	w/Brake IGBT ‡
Y	Yes
N	No

‡ Brake IGBT is standard on Frames 1-3 and optional on Frames 4-9 ONLY.

h

Brake Resistor	
Code	w/Resistor
Y	Yes
N	No

Not available for Frame 3 drives or larger.

i

Emission		
Code	CE Filter †	CM Choke
A ‡	Yes	Yes
B	Yes	No
N §	No	No

‡ Frames 1-6 Only.

† Frames 9 & up Only.

§ For use on a high resistive ground or ungrounded distribution system (Frame 9 only).

† Note: CE Certification testing has not been performed on 600V class drives Frames 1...4.

j

Comm Slot	
Code	Version
N	None
C	DPI ControlNet (Coax)
D	DPI DeviceNet
E	DPI EtherNet/IP
R	DPI RIO
S	DPI RS-485 DF1
1	DriveLogix ControlNet (Coax)
2	DriveLogix ControlNet Redundant (Coax)
3	DriveLogix ControlNet (Fiber)
4	DriveLogix ControlNet Redundant (Fiber)
5	DriveLogix DeviceNet (Open Conn.)
6	DriveLogix EtherNet/IP

k

Control Options				
Code	Control Option	Logic Expansion	Synch -Link	Cassette
A	Phase II	No	No	Expanded
B	Phase II	No	Yes	Expanded
C	Phase II	Yes	No	Expanded
D	Phase II	Yes	Yes	Expanded
G	Phase II	N/A	No	Slim
H	Phase II	N/A	Yes	Slim

l

Feedback	
Code	Option
N ‡	No Option
A ‡	Resolver
B ‡	Stegman Hi-Resolution Encoder
C ‡	Multi-Device Interface
E ‡	2nd Encoder
S ‡	Safe-Off (w/2nd Encoder)

‡ Expanded cassette required.

‡ One encoder interface is included with the base drive.

m

Additional Config.	
Code	Description
E	Phase II Control
K	Phase II DriveLogix5730
L †	Phase II DriveLogix5730 w/EtherNet/IP

† This is an embedded EtherNet option that is only available with DriveLogix5730.

Accessories

Accessory kits are available to supplement the drive installation or tailor the drive to the particular requirements. These may include installation issues, communications structure or others.

Communication Accessories

Description	Catalog No.
Smart Self-powered Serial Converter (RS-232) includes 1203-SFC and 1202-C10 Cables	1203-SSS
Serial Null Modem Adapter	1203-SNM
ControlNet T-Tap/Right Angle 1 Meter Coax Cable Assembly	1786-TPR

DriveLogix I/O Cables

Description	Catalog No.
DriveLogix 3 Meter RS-232 Programming Cable ❶	1756-CP3
DriveLogix5730 Compact I/O Cable 3.28 ft. (1 meter), LeftBus Cap ❶ ❷	20D-DL2-CL3
DriveLogix5730 Compact I/O Cable 3.28 ft. (1 meter), Right Bus Cap ❶ ❷	20D-DL2-CR3

SynchLink Accessories

Description	Catalog No.
SynchLink Board	20D-P2-SLB0
SynchLink Base Block (up to 4 splitter blocks)	1751-SLBA/A
SynchLink 4 Port Splitter Block	1751-SL4SP/A
SynchLink Bypass Switch Block	1751-SLBP/A
2x1 Meter Fiber Linx for Power Monitor/SynchLink	1403-CF001
2x3 Meter Fiber Linx for Power Monitor/SynchLink	1403-CF003
2x5 Meter Fiber Linx for Power Monitor/SynchLink	1403-CF005
10 Meter Fiber Linx for Power Monitor/SynchLink	1403-CF010
20 Meter Fiber Linx for Power Monitor/SynchLink	1403-CF020
50 Meter Fiber Linx for Power Monitor/SynchLink	1403-CF050
100 Meter Fiber Linx for Power Monitor/SynchLink	1403-CF100
250 Meter Fiber Linx for Power Monitor/SynchLink	1403-CF250

❶ For use with DriveLogix option only.

❷ Requires Expanded Cassette

Note: Please refer to publication number 1756-TD008 for details on SynchLink.

Accessories, Cont.

Acceptable Stegmann Encoders

SINCOS Model Number	Cycles/Rev	Built-in Mech Turns Counter
SCS-60	512	N
SCS-70		N
SCM-60		Y
SCM-70		Y
SCS-KIT-101	1024	N
SCM-KIT-101		Y
SRS-25		Y
SRS-50		Y
SRS-60		N
SRM-25		Y
SRM-50		Y
SRM-60		Y
SCS-660		N
SHS-170(1)		512

(1)Requires external power supply with sufficient current capability. Not to be used with internal power supply.

Acceptable Resolvers

Manufacturer	Mfg. Model No.
Tamagawa	TS-2014N181E32
Tamagawa	TS-2014N182E32
Tamagawa	TS-2014N185E32
Tamagawa	TS-2087N12E9
Tamagawa	TS-2087N1E9
Tamagawa	TS-2087N2E9
Tamagawa	TS-2087N5E9
Tamagawa	TS-2087N11E9
Advanced Micro Controls Inc. (AMCI)	R11X-C10/7

Motor/Resolver Type	Compatible
1326 AB 230V Primary Resolver	No
1326 AB 230V Secondary Resolver	Yes
1326 AB 460V Primary Resolver	Yes
1326 AB 460V Secondary Resolver	Yes
1326AD 230V Rare Earth	No
1326AH 460V Explosion Proof Motor Primary Resolver	Yes
1326AH 460V Explosion Proof Motor Secondary Resolver	Yes
1326AS 460V Rare Earth	Yes
MPL 460V	Yes

Accessories, Cont.

Supported Linear Sensors

Part Number Character	Characteristic
1	Input Voltage = +24V
S	SSI output
2	Data Length = 24 bits
G	Output Format = Gray Code
1	Resolution = 0.005 mn
1	Performance = Standard
02	Scale Orientation = Forward-acting Synchronized

Temposonics® III Linear sensors with MTS® part numbers ending in 1S2G1102 work with the MDI Option.

Auxiliary Power Supply

Description	Catalog No.
Auxiliary Control Power Supply	20-24V-AUX1

Accessories, Cont.

Isolation Transformers

For installations that have specific types of AC supply configurations or require drive protection due to AC line disturbances, isolation transformers are available.

Motor Rating (HP)	240V, 60 Hz, Three-Phase 240V Primary & 240V Secondary	460V, 60 Hz, Three-Phase 460V Primary & 460V Secondary	575V, 60 Hz, Three-Phase 575V Primary & 575V Secondary
	IP 32(Nema Type 3R) Catalog Number	IP 32(Nema Type 3R) Catalog Number	
0.33	1321-3TW005-AA	1321-3TW005-BB	—
0.5	1321-3TW005-AA	1321-3TW005-BB	—
0.75	1321-3TW005-AA	1321-3TW005-BB	—
1	1321-3TW005-AA	1321-3TW005-BB	1321-3TW005-CC
1.5	1321-3TW005-AA	1321-3TW005-BB	—
2	1321-3TW005-AA	1321-3TW005-BB	1321-3TW005-CC
3	1321-3TW005-AA	1321-3TW005-BB	1321-3TW005-CC
5	1321-3TW007-AA	1321-3TW007-BB	1321-3TW007-CC
7.5	1321-3TW011-AA	1321-3TW011-BB	1321-3TW011-CC
10	1321-3TW014-AA	1321-3TW014-BB	1321-3TW014-CC
15	1321-3TW020-AA	1321-3TW020-BB	1321-3TW020-CC
20	1321-3TW027-AA	1321-3TW027-BB	1321-3TW027-CC
25	1321-3TW034-AA	1321-3TW034-BB	1321-3TW034-CC
30	1321-3TW040-AA	1321-3TW040-BB	1321-3TW040-CC
40	1321-3TW051-AA	1321-3TW051-BB	1321-3TW051-CC
50	1321-3TH063-AA	1321-3TH063-BB	1321-3TH063-CC
60	1321-3TH075-AA	1321-3TH075-BB	1321-3TH075-CC
75	1321-3TH093-AA	1321-3TH093-BB	1321-3TH093-CC
100	—	1321-3TH118-BB	1321-3TH118-CC
125	—	1321-3TH145-BB	1321-3TH145-CC
150	—	1321-3TH175-BB	1321-3TH175-CC
200	—	1321-3TH220-BB	—

Line/Load Reactors

For impedance matching, protection from AC line disturbances or motor protection, reactors are available for both the input and output sides of the drive.

Input and Output Line Reactors - 240V, 60 Hz, Three-Phase

Drive Catalog Number	Duty	HP	Input Line Reactor ①		Output Line Reactor ①	
			IP 00 (Open Style) Catalog Number	IP 11 (Nema Type 1) Catalog Number	IP 00 (Open Style) Catalog Number	IP 11 (Nema Type 1) Catalog Number
3% Impedance – 240V, 60 Hz, Three-Phase						
20DB2P2	Heavy Duty	0.33	1321-3R2-D	1321-3RA2-D	1321-3R2-D	1321-3RA2-D
20DB2P2	Normal Duty	0.5	1321-3R2-D	1321-3RA2-D	1321-3R2-D	1321-3RA2-D
20DB4P2	Heavy Duty	0.75	1321-3R4-A	1321-3RA4-A	1321-3R4-A	1321-3RA4-A
20DB4P2	Normal Duty	1	1321-3R4-A	1321-3RA4-A	1321-3R4-A	1321-3RA4-A
20DB6P8	Heavy Duty	1.5	1321-3R8-A	1321-3RA8-A	1321-3R8-A	1321-3RA8-A
20DB6P8	Normal Duty	2	1321-3R8-A	1321-3RA8-A	1321-3R8-A	1321-3RA8-A
20DB9P6	Heavy Duty	2	1321-3R8-A	1321-3RA8-A	1321-3R12-A	1321-3RA12-A
20DB9P6	Normal Duty	3	1321-3R12-A	1321-3RA12-A	1321-3R12-A	1321-3RA12-A
20DB015	Heavy Duty	3	1321-3R12-A	1321-3RA12-A	1321-3R18-A	1321-3RA18-A
20DB015	Normal Duty	5	1321-3R18-A	1321-3RA18-A	1321-3R18-A	1321-3RA18-A
20DB022	Heavy Duty	5	1321-3R18-A	1321-3RA18-A	1321-3R25-A	1321-3RA25-A
20DB022	Normal Duty	7.5	1321-3R25-A	1321-3RA25-A	1321-3R25-A	1321-3RA25-A

See page 18 for Notes.

Accessories, Cont.

Input and Output Line Reactors - 240V, 60 Hz, Three-Phase, Continued

Drive Catalog Number	Duty	HP	Input Line Reactor ①		Output Line Reactor ①	
			IP 00 (Open Style)	IP 11 (Nema Type 1)	IP 00 (Open Style)	IP 11 (Nema Type 1)
			Catalog Number	Catalog Number	Catalog Number	Catalog Number
3% Impedance – 240V, 60 Hz, Three-Phase						
20DB028	Heavy Duty	7.5	1321-3R25-A	1321-3RA25-A	1321-3R35-A	1321-3RA35-A
20DB028	Normal Duty	10	1321-3R35-A	1321-3RA35-A	1321-3R35-A	1321-3RA35-A
20DB042	Heavy Duty	10	1321-3R35-A	1321-3RA35-A	1321-3R45-A	1321-3RA45-A
20DB042	Normal Duty	15	1321-3R45-A	1321-3RA45-A	1321-3R45-A	1321-3RA45-A
20DB052	Heavy Duty	15	1321-3R45-A	1321-3RA45-A	1321-3R55-A	1321-3RA55-A
20DB052	Normal Duty	20	1321-3R55-A	1321-3RA55-A	1321-3R55-A	1321-3RA55-A
20DB070	Heavy Duty	20	1321-3R80-A	1321-3RA80-A	1321-3R80-A	1321-3RA80-A
20DB070	Normal Duty	25	1321-3R80-A	1321-3RA80-A	1321-3R80-A	1321-3RA80-A
20DB080	Heavy Duty	25	1321-3R80-A	1321-3RA80-A	1321-3R100-A	1321-3RA100-A
20DB080	Normal Duty	30	1321-3R100-A	1321-3RA100-A	1321-3R100-A	1321-3RA100-A
20DB104	Heavy Duty	30	1321-3R80-A	1321-3RA80-A	1321-3R80-A	1321-3RA80-A
20DB104	Normal Duty	40	1321-3R100-A	1321-3RA100-A	1321-3R100-A	1321-3RA100-A
20DB130	Heavy Duty	40	1321-3R100-A	1321-3RA100-A	1321-3R100-A	1321-3RA100-A
20DB130	Normal Duty	50	1321-3R130-A	1321-3RA130-A	1321-3R130-A	1321-3RA130-A
20DB154	Heavy Duty	50	1321-3R130-A	1321-3RA130-A	1321-3R130-A	1321-3RA130-A
20DB154	Normal Duty	60	1321-3R160-A	1321-3RA160-A	1321-3R160-A	1321-3RA160-A
20DB192	Heavy Duty	60	1321-3R160-A	1321-3RA160-A	1321-3R160-A	1321-3RA160-A
20DB192	Normal Duty	75	1321-3R200-A	1321-3RA200-A	1321-3R200-A	1321-3RA200-A
20DB260	Heavy Duty	75	1321-3R200-A	1321-3RA200-A	1321-3R200-A	1321-3RA200-A
20DB260	Normal Duty	100	1321-3RB250-A	1321-3RAB250-A	1321-3RB250-A	1321-3RAB250-A
5% Impedance – 240V, 60 Hz, Three-Phase						
20DB2P2	Heavy Duty	0.33	1321-3R2-A	1321-3RA2-A	1321-3R2-A	1321-3RA2-A
20DB2P2	Normal Duty	0.5	1321-3R2-A	1321-3RA2-A	1321-3R2-A	1321-3RA2-A
20DB4P2	Heavy Duty	0.75	1321-3R4-B	1321-3RA4-B	1321-3R4-B	1321-3RA4-B
20DB4P2	Normal Duty	1	1321-3R4-B	1321-3RA4-B	1321-3R4-B	1321-3RA4-B
20DB6P8	Heavy Duty	1.5	1321-3R8-B	1321-3RA8-B	1321-3R8-B	1321-3RA8-B
20DB6P8	Normal Duty	2	1321-3R8-B	1321-3RA8-B	1321-3R8-B	1321-3RA8-B
20DB9P6	Heavy Duty	2	1321-3R8-B	1321-3RA8-B	1321-3R12-B	1321-3RA12-B
20DB9P6	Normal Duty	3	1321-3R12-B	1321-3RA12-B	1321-3R12-B	1321-3RA12-B
20DB015	Heavy Duty	3	1321-3R12-B	1321-3RA12-B	1321-3R18-B	1321-3RA18-B
20DB015	Normal Duty	5	1321-3R18-B	1321-3RA18-B	1321-3R18-B	1321-3RA18-B
20DB022	Heavy Duty	5	1321-3R18-B	1321-3RA18-B	1321-3R25-B	1321-3RA25-B
20DB022	Normal Duty	7.5	1321-3R25-B	1321-3RA25-B	1321-3R25-B	1321-3RA25-B
20DB028	Heavy Duty	7.5	1321-3R25-B	1321-3RA25-B	1321-3R35-B	1321-3RA35-B
20DB028	Normal Duty	10	1321-3R35-B	1321-3RA35-B	1321-3R35-B	1321-3RA35-B
20DB042	Heavy Duty	10	1321-3R35-B	1321-3RA35-B	1321-3R45-B	1321-3RA45-B
20DB042	Normal Duty	15	1321-3R45-B	1321-3RA45-B	1321-3R45-B	1321-3RA45-B
20DB052	Heavy Duty	15	1321-3R45-A	1321-3RA45-A	1321-3R55-B	1321-3RA55-B
20DB052	Normal Duty	20	1321-3R55-A	1321-3RA55-A	1321-3R55-B	1321-3RA55-B
20DB070	Heavy Duty	20	1321-3R80-B	1321-3RA80-B	1321-3R100-B	1321-3RA100-B
20DB070	Normal Duty	25	1321-3R100-B	1321-3RA100-B	1321-3R100-B	1321-3RA100-B
20DB080	Heavy Duty	25	1321-3R100-B	1321-3RA100-B	1321-3R130-B	1321-3RA130-B
20DB080	Normal Duty	30	1321-3R100-B	1321-3RA100-B	1321-3R130-B	1321-3RA130-B
20DB104	Heavy Duty	30	1321-3R80-B	1321-3RA80-B	1321-3R80-B	1321-3RA80-B
20DB104	Normal Duty	40	1321-3R100-B	1321-3RA100-B	1321-3R100-B	1321-3RA100-B
20DB130	Heavy Duty	40	1321-3R100-B	1321-3RA100-B	1321-3R100-B	1321-3RA100-B
20DB130	Normal Duty	50	1321-3R130-B	1321-3RA130-B	1321-3R130-B	1321-3RA130-B
20DB154	Heavy Duty	50	1321-3R160-B	1321-3RA160-B	1321-3R160-B	1321-3RA160-B
20DB154	Normal Duty	60	1321-3R200-B	1321-3RA200-B	1321-3R200-B	1321-3RA200-B
20DB192	Heavy Duty	60	1321-3R200-B	1321-3RA200-B	1321-3R200-B	1321-3RA200-B
20DB192	Normal Duty	75	1321-3R200-B	1321-3RA200-B	1321-3R200-B	1321-3RA200-B
20DB260	Heavy Duty	75	1321-3RB250-B	1321-3RAB250-B	1321-3RB250-B	1321-3RAB250-B
20DB260	Normal Duty	100	1321-3RB250-B	1321-3RAB250-B	1321-3RB250-B	1321-3RAB250-B

Accessories, Cont.

Input and Output Line Reactors - 480V, 60 Hz, Three-Phase

Drive Catalog Number	Duty	HP	Input Line Reactor ❶		Output Line Reactor ❶	
			IP 00 (Open Style)	IP 11 (Nema Type 1)	IP 00 (Open Style)	IP 11 (Nema Type 1)
			Catalog Number	Catalog Number	Catalog Number	Catalog Number
3% Impedance – 480V, 60 Hz, Three-Phase						
20DD1P1	Heavy Duty	0.33	1321-3R1-C	1321-3RA1-C	1321-3R2-B	1321-3RA2-B
20DD1P1	Normal Duty	0.5	1321-3R1-C	1321-3RA1-C	1321-3R2-B	1321-3RA2-B
20DD2P1	Heavy Duty	0.75	1321-3R2-A	1321-3RA2-A	1321-3R2-A	1321-3RA2-A
20DD2P1	Normal Duty	1	1321-3R2-A	1321-3RA2-A	1321-3R2-A	1321-3RA2-A
20DD3P4	Heavy Duty	1.5	1321-3R4-C	1321-3RA4-C	1321-3R4-B	1321-3RA4-B
20DD3P4	Normal Duty	2	1321-3R4-B	1321-3RA4-B	1321-3R4-B	1321-3RA4-B
20DD5P0	Heavy Duty	2	1321-3R4-B	1321-3RA4-B	1321-3R8-C	1321-3RA8-C
20DD5P0	Normal Duty	3	1321-3R4-B	1321-3RA4-B	1321-3R8-C	1321-3RA8-C
20DD8P0	Heavy Duty	3	1321-3R4-B	1321-3RA4-B	1321-3R8-B	1321-3RA8-B
20DD8P0	Normal Duty	5	1321-3R8-B	1321-3RA8-B	1321-3R8-B	1321-3RA8-B
20DD011	Heavy Duty	5	1321-3R8-B	1321-3RA8-B	1321-3R12-B	1321-3RA12-B
20DD011	Normal Duty	7.5	1321-3R12-B	1321-3RA12-B	1321-3R12-B	1321-3RA12-B
20DD014	Heavy Duty	7.5	1321-3R12-B	1321-3RA12-B	1321-3R18-B	1321-3RA18-B
20DD014	Normal Duty	10	1321-3R18-B	1321-3RA18-B	1321-3R18-B	1321-3RA18-B
20DD022	Heavy Duty	10	1321-3R18-B	1321-3RA18-B	1321-3R25-B	1321-3RA25-B
20DD022	Normal Duty	15	1321-3R25-B	1321-3RA25-B	1321-3R25-B	1321-3RA25-B
20DD027	Heavy Duty	15	1321-3R25-B	1321-3RA25-B	1321-3R35-B	1321-3RA35-B
20DD027	Normal Duty	20	1321-3R35-B	1321-3RA35-B	1321-3R35-B	1321-3RA35-B
20DD034	Heavy Duty	20	1321-3R35-B	1321-3RA35-B	1321-3R45-B	1321-3RA45-B
20DD034	Normal Duty	25	1321-3R35-B	1321-3RA35-B	1321-3R45-B	1321-3RA45-B
20DD040	Heavy Duty	25	1321-3R35-B	1321-3RA35-B	1321-3R55-B	1321-3RA55-B
20DD040	Normal Duty	30	1321-3R45-B	1321-3RA45-B	1321-3R55-B	1321-3RA55-B
20DD052	Heavy Duty	30	1321-3R45-B	1321-3RA45-B	1321-3R80-B	1321-3RA80-B
20DD052	Normal Duty	40	1321-3R55-B	1321-3RA55-B	1321-3R80-B	1321-3RA80-B
20DD065	Heavy Duty	40	1321-3R55-B	1321-3RA55-B	1321-3R80-B	1321-3RA80-B
20DD065	Normal Duty	50	1321-3R55-B	1321-3RA55-B	1321-3R80-B	1321-3RA80-B
20DD077	Heavy Duty	50	1321-3R80-B	1321-3RA80-B	1321-3R80-B	1321-3RA80-B
20DD077	Normal Duty	60	1321-3R80-B	1321-3RA80-B	1321-3R80-B	1321-3RA80-B
20DD096	Heavy Duty	60	1321-3R80-B	1321-3RA80-B	1321-3R80-B	1321-3RA80-B
20DD096	Normal Duty	75	1321-3R100-B	1321-3RA100-B	1321-3R100-B	1321-3RA100-B
20DD125	Heavy Duty	75	1321-3R100-B	1321-3RA100-B	1321-3R100-B	1321-3RA100-B
20DD125	Normal Duty	100	1321-3R130-B	1321-3RA130-B	1321-3R130-B	1321-3RA130-B
20DD156	Heavy Duty	100	1321-3R130-B	1321-3RA130-B	1321-3R130-B	1321-3RA130-B
20DD156	Normal Duty	125	1321-3R160-B	1321-3RA160-B	1321-3R160-B	1321-3RA160-B
20DD180	Heavy Duty	125	1321-3R160-B	1321-3RA160-B	1321-3R160-B	1321-3RA160-B
20DD180	Normal Duty	150	1321-3R200-B	1321-3RA200-B	1321-3R200-B	1321-3RA200-B
20DD248	Heavy Duty	150	1321-3R200-B	1321-3RA200-B	1321-3R200-B	1321-3RA200-B
20DD248	Normal Duty	200	1321-3RB250-B	1321-3RAB250-B	1321-3RB250-B	1321-3RAB250-B
20DD261	Normal Duty	150	1321-3R200-B	1321-3RA200-B	1321-3R200-B	1321-3RA200-B
20DD261	Heavy Duty	200	1321-3RB250-B	1321-3RAB250-B	1321-3RB250-B	1321-3RAB250-B
20DD300	Normal Duty	200	1321-3RB250-B	1321-3RAB250-B	1321-3RB250-B	1321-3RAB250-B

See page 18 for Notes.

Accessories, Cont.

Input and Output Line Reactors - 480V, 60 Hz, Three-Phase, Continued

Drive Catalog Number	Duty	HP	Input Line Reactor ❶		Output Line Reactor ❶	
			IP 00 (Open Style)	IP 11 (Nema Type 1)	IP 00 (Open Style)	IP 11 (Nema Type 1)
			Catalog Number	Catalog Number	Catalog Number	Catalog Number
5% Impedance – 480V, 60 Hz, Three-Phase						
20DD1P1	Heavy Duty	0.33	1321-3R1-B	1321-3RA1-B	1321-3R2-B	1321-3RA2-B
20DD1P1	Normal Duty	0.5	1321-3R1-B	1321-3RA1-B	1321-3R2-B	1321-3RA2-B
20DD2P1	Heavy Duty	0.75	1321-3R2-B	1321-3RA2-B	1321-3R2-B	1321-3RA2-B
20DD2P1	Normal Duty	1	1321-3R2-B	1321-3RA2-B	1321-3R2-B	1321-3RA2-B
20DD3P4	Heavy Duty	1.5	1321-3R4-D	1321-3RA4-D	1321-3R4-C	1321-3RA4-C
20DD3P4	Normal Duty	2	1321-3R4-D	1321-3RA4-D	1321-3R4-C	1321-3RA4-C
20DD5P0	Heavy Duty	2	1321-3R4-C	1321-3RA4-C	1321-3R8-D	1321-3RA8-D
20DD5P0	Normal Duty	3	1321-3R4-C	1321-3RA4-C	1321-3R8-D	1321-3RA8-D
20DD8P0	Heavy Duty	3	1321-3R4-C	1321-3RA4-C	1321-3R8-C	1321-3RA8-C
20DD8P0	Normal Duty	5	1321-3R8-C	1321-3RA8-C	1321-3R8-C	1321-3RA8-C
20DD011	Heavy Duty	5	1321-3R8-C	1321-3RA8-C	1321-3R12-C	1321-3RA12-C
20DD011	Normal Duty	7.5	1321-3R12-C	1321-3RA12-C	1321-3R12-C	1321-3RA12-C
20DD014	Heavy Duty	7.5	1321-3R12-C	1321-3RA12-C	1321-3R18-C	1321-3RA18-C
20DD014	Normal Duty	10	1321-3R18-C	1321-3RA18-C	1321-3R18-C	1321-3RA18-C
20DD022	Heavy Duty	10	1321-3R18-C	1321-3RA18-C	1321-3R25-C	1321-3RA25-C
20DD022	Normal Duty	15	1321-3R25-C	1321-3RA25-C	1321-3R25-C	1321-3RA25-C
20DD027	Heavy Duty	15	1321-3R25-C	1321-3RA25-C	1321-3R35-C	1321-3RA35-C
20DD027	Normal Duty	20	1321-3R35-C	1321-3RA35-C	1321-3R35-C	1321-3RA35-C
20DD034	Heavy Duty	20	1321-3R35-C	1321-3RA35-C	1321-3R45-C	1321-3RA45-C
20DD034	Normal Duty	25	1321-3R35-C	1321-3RA35-C	1321-3R45-C	1321-3RA45-C
20DD040	Heavy Duty	25	1321-3R35-C	1321-3RA35-C	1321-3R55-C	1321-3RA55-C
20DD040	Normal Duty	30	1321-3R45-C	1321-3RA45-C	1321-3R55-C	1321-3RA55-C
20DD052	Heavy Duty	30	1321-3R45-C	1321-3RA45-C	1321-3R80-C	1321-3RA80-C
20DD052	Normal Duty	40	1321-3R55-C	1321-3RA55-C	1321-3R80-C	1321-3RA80-C
20DD065	Heavy Duty	40	1321-3R55-C	1321-3RA55-C	1321-3R80-C	1321-3RA80-C
20DD065	Normal Duty	50	1321-3R55-C	1321-3RA55-C	1321-3R80-C	1321-3RA80-C
20DD077	Heavy Duty	50	1321-3R80-C	1321-3RA80-C	1321-3R80-C	1321-3RA80-C
20DD077	Normal Duty	60	1321-3R80-C	1321-3RA80-C	1321-3R80-C	1321-3RA80-C
20DD096	Heavy Duty	60	1321-3R80-C	1321-3RA80-C	1321-3R80-C	1321-3RA80-C
20DD096	Normal Duty	75	1321-3R100-C	1321-3RA100-C	1321-3R100-C	1321-3RA100-C
20DD125	Heavy Duty	75	1321-3R100-C	1321-3RA100-C	1321-3R100-C	1321-3RA100-C
20DD125	Normal Duty	100	1321-3R130-C	1321-3RA130-C	1321-3R130-C	1321-3RA130-C
20DD156	Heavy Duty	100	1321-3R130-C	1321-3RA130-C	1321-3R130-C	1321-3RA130-C
20DD156	Normal Duty	125	1321-3R160-C	1321-3RA160-C	1321-3R160-C	1321-3RA160-C
20DD180	Heavy Duty	125	1321-3R160-C	1321-3RA160-C	1321-3R160-C	1321-3RA160-C
20DD180	Normal Duty	150	1321-3R200-C	1321-3RA200-C	1321-3R200-C	1321-3RA200-C
20DD248	Heavy Duty	150	1321-3R200-C	1321-3RA200-C	1321-3R200-C	1321-3RA200-C
20DD248	Normal Duty	200	1321-3R250-C	1321-3RAB250-C	1321-3R250-C	1321-3RAB250-C
20DD261	Normal Duty	200	1321-3R200-C	1321-3RA200-C	1321-3R200-C	1321-3RA200-C
20DD261	Heavy Duty	200	1321-3RB250-C	1321-3RAB250-C	1321-3RB250-C	1321-3RAB250-C
20DD300	Normal Duty	150	1321-3RB250-C	1321-3RAB250-C	1321-3RB250-C	1321-3RAB250-C

Notes

❶ Input line reactors were sized based on the NEC fundamental motor amps. Output line reactors were sized based on the VFD rated output currents.

Accessories, Cont.

Input and Output Line Reactors - 600V, 60 Hz, Three-Phase

Drive Catalog Number	Duty	HP	Input Line Reactor ❶		Output Line Reactor ❶	
			IP 00 (Open Style)	IP 11 (Nema Type 1)	IP 00 (Open Style)	IP 11 (Nema Type 1)
			Catalog Number	Catalog Number	Catalog Number	Catalog Number
3% Impedance – 600V, 60 Hz, Three-Phase						
20DE1P7	Heavy Duty	0.5	1321-3R1-C	1321-3RA1-C	1321-3R2-B	1321-3RA2-B
20DE1P7	Normal Duty	1	1321-3R1-B	1321-3RA1-B	1321-3R2-B	1321-3RA2-B
20DE2P7	Heavy Duty	1	1321-3R2-B	1321-3RA2-B	1321-3R4-B	1321-3RA4-B
20DE2P7	Normal Duty	2	1321-3R4-D	1321-3RA4-D	1321-3R4-D	1321-3RA4-D
20DE3P9	Heavy Duty	2	1321-3R4-D	1321-3RA4-D	1321-3R4-C	1321-3RA4-C
20DE3P9	Normal Duty	3	1321-3R4-C	1321-3RA4-C	1321-3R4-C	1321-3RA4-C
20DE6P1	Heavy Duty	3	1321-3R4-C	1321-3RA4-C	1321-3R8-C	1321-3RA8-C
20DE6P1	Normal Duty	5	1321-3R8-C	1321-3RA8-C	1321-3R8-C	1321-3RA8-C
20DE9P0	Heavy Duty	5	1321-3R8-C	1321-3RA8-C	1321-3R12-C	1321-3RA12-C
20DE9P0	Normal Duty	7.5	1321-3R12-C	1321-3RA12-C	1321-3R12-C	1321-3RA12-C
20DE011	Heavy Duty	7.5	1321-3R12-C	1321-3RA12-C	1321-3R12-B	1321-3RA12-B
20DE011	Normal Duty	10	1321-3R12-B	1321-3RA12-B	1321-3R12-B	1321-3RA12-B
20DE017	Heavy Duty	10	1321-3R12-B	1321-3RA12-B	1321-3R18-B	1321-3RA18-B
20DE017	Normal Duty	15	1321-3R18-B	1321-3RA18-B	1321-3R18-B	1321-3RA18-B
20DE022	Heavy Duty	15	1321-3R18-B	1321-3RA18-B	1321-3R25-B	1321-3RA25-B
20DE022	Normal Duty	20	1321-3R25-B	1321-3RA25-B	1321-3R25-B	1321-3RA25-B
20DE027	Heavy Duty	20	1321-3R25-B	1321-3RA25-B	1321-3R35-C	1321-3RA35-C
20DE027	Normal Duty	25	1321-3R35-C	1321-3RA35-C	1321-3R35-C	1321-3RA35-C
20DE032	Heavy Duty	25	1321-3R35-C	1321-3RA35-C	1321-3R35-B	1321-3RA35-B
20DE032	Normal Duty	30	1321-3R35-B	1321-3RA35-B	1321-3R35-B	1321-3RA35-B
20DE041	Heavy Duty	30	1321-3R35-B	1321-3RA35-B	1321-3R45-B	1321-3RA45-B
20DE041	Normal Duty	40	1321-3R45-B	1321-3RA45-B	1321-3R45-B	1321-3RA45-B
20DE052	Heavy Duty	40	1321-3R45-B	1321-3RA45-B	1321-3R55-B	1321-3RA55-B
20DE052	Normal Duty	50	1321-3R55-B	1321-3RA55-B	1321-3R55-B	1321-3RA55-B
20DE062	Heavy Duty	50	1321-3R55-B	1321-3RA55-B	1321-3R80-B	1321-3RA80-B
20DE062	Normal Duty	60	1321-3R80-B	1321-3RA80-B	1321-3R80-B	1321-3RA80-B
20DE077	Heavy Duty	60	1321-3R80-B	1321-3RA80-B	1321-3R80-B	1321-3RA80-B
20DE077	Normal Duty	75	1321-3R80-B	1321-3RA80-B	1321-3R80-B	1321-3RA80-B
20DE099	Heavy Duty	75	1321-3R80-B	1321-3RA80-B	1321-3R80-B	1321-3RA80-B
20DE099	Normal Duty	100	1321-3R100-B	1321-3RA100-B	1321-3R100-B	1321-3RA100-B
20DE125	Heavy Duty	100	1321-3R100-B	1321-3RA100-B	1321-3R100-B	1321-3RA100-B
20DE125	Normal Duty	125	1321-3R130-B	1321-3RA130-B	1321-3R130-B	1321-3RA130-B
20DE144	Heavy Duty	125	1321-3R130-B	1321-3RA130-B	1321-3R130-B	1321-3RA130-B
20DE144	Normal Duty	150	1321-3R160-B	1321-3RA160-B	1321-3R160-B	1321-3RA160-B

See page 20 for Notes.

Accessories, Cont.

Input and Output Line Reactors - 600V, 60 Hz, Three-Phase, Continued

Drive Catalog Number	Duty	HP	Input Line Reactor ❶		Output Line Reactor ❶	
			IP 00 (Open Style)	IP 11 (Nema Type 1)	IP 00 (Open Style)	IP 11 (Nema Type 1)
			Catalog Number	Catalog Number	Catalog Number	Catalog Number
5% Impedance – 600V, 60 Hz, Three-Phase						
20DDE1P7	Heavy Duty	0.5	1321-3R1-B	1321-3RA1-B	1321-3R2-C	1321-3RA2-C
20DDE1P7	Normal Duty	1	1321-3R2-C	1321-3RA2-C	1321-3R2-C	1321-3RA2-C
20DE2P7	Heavy Duty	1	1321-3R2-C	1321-3RA2-C	1321-3R4-D❷	1321-3RA4-D❷
20DE2P7	Normal Duty	2	1321-3R4-D❷	1321-3RA4-D❷	1321-3R4-D❷	1321-3RA4-D❷
20DE3P9	Heavy Duty	2	1321-3R4-D❷	1321-3RA4-D❷	1321-3R4-D	1321-3RA4-D
20DE3P9	Normal Duty	3	1321-3R4-D	1321-3RA4-D	1321-3R4-D	1321-3RA4-D
20DE6P1	Heavy Duty	3	1321-3R4-D	1321-3RA4-D	1321-3R8-D	1321-3RA8-D
20DE6P1	Normal Duty	5	1321-3R8-D	1321-3RA8-D	1321-3R8-D	1321-3RA8-D
20DE9P0	Heavy Duty	5	1321-3R8-D	1321-3RA8-D	1321-3R12-C❷	1321-3RA12-C❷
20DE9P0	Normal Duty	7.5	1321-3R12-C❷	1321-3RA12-C❷	1321-3R12-C❷	1321-3RA12-C❷
20DE011	Heavy Duty	7.5	1321-3R12-C❷	1321-3RA12-C❷	1321-3R12-C	1321-3RA12-C
20DE011	Normal Duty	10	1321-3R12-C	1321-3RA12-C	1321-3R12-C	1321-3RA12-C
20DE017	Heavy Duty	10	1321-3R12-C	1321-3RA12-C	1321-3R18-C	1321-3RA18-C
20DE017	Normal Duty	15	1321-3R18-C	1321-3RA18-C	1321-3R18-C	1321-3RA18-C
20DE022	Heavy Duty	15	1321-3R18-C	1321-3RA18-C	1321-3R25-C❷	1321-3RA25-C❷
20DE022	Normal Duty	20	1321-3R25-C❷	1321-3RA25-C❷	1321-3R25-C❷	1321-3RA25-C❷
20DE027	Heavy Duty	20	1321-3R25-C❷	1321-3RA25-C❷	1321-3R35-C❷	1321-3RA35-C❷
20DE027	Normal Duty	25	1321-3R35-C❷	1321-3RA35-C❷	1321-3R35-C❷	1321-3RA35-C❷
20DE032	Heavy Duty	25	1321-3R35-C❷	1321-3RA35-C❷	1321-3R35-C❷	1321-3RA35-C❷
20DE032	Normal Duty	30	1321-3R35-C❷	1321-3RA35-C❷	1321-3R35-C❷	1321-3RA35-C❷
20DE041	Heavy Duty	30	1321-3R35-C❷	1321-3RA35-C❷	1321-3R45-C	1321-3RA45-C
20DE041	Normal Duty	40	1321-3R45-C	1321-3RA45-C	1321-3R45-C	1321-3RA45-C
20DE052	Heavy Duty	40	1321-3R45-C	1321-3RA45-C	1321-3R55-C	1321-3RA55-C
20DE052	Normal Duty	50	1321-3R55-C	1321-3RA55-C	1321-3R55-C	1321-3RA55-C
20DE062	Heavy Duty	50	1321-3R55-C	1321-3RA55-C	1321-3R80-C	1321-3RA80-C
20DE062	Normal Duty	60	1321-3R80-C	1321-3RA80-C	1321-3R80-C	1321-3RA80-C
20DE077	Heavy Duty	60	1321-3R80-C	1321-3RA80-C	1321-3R80-C	1321-3RA80-C
20DE077	Normal Duty	75	1321-3R80-C	1321-3RA80-C	1321-3R80-C	1321-3RA80-C
20DE099	Heavy Duty	75	1321-3R80-C	1321-3RA80-C	1321-3R80-C	1321-3RA80-C
20DE099	Normal Duty	100	1321-3R100-C	1321-3RA100-C	1321-3R100-C	1321-3RA100-C
20DE125	Heavy Duty	100	1321-3R100-C	1321-3RA100-C	1321-3R100-C	1321-3RA100-C
20DE125	Normal Duty	125	1321-3R130-C❷	1321-3RA130-C❷	1321-3R130-C❷	1321-3RA130-C❷
20DE144	Heavy Duty	125	1321-3R130-C❷	1321-3RA130-C❷	1321-3R130-C❷	1321-3RA130-C❷
20DE144	Normal Duty	150	1321-3R160-C❷	1321-3RA160-C❷	1321-3R160-C❷	1321-3RA160-C❷

Notes

- ❶ Input line reactors were sized based on the NEC fundamental motor amps. Output line reactors were sized based on the VFD rated output currents.
- ❷ 4% impedance.

Accessories, Cont.

Reflected Wave Reduction

Reflected Wave Reduction Device with Common Mode Choke

Description	Used with	Catalog Number (Loose Kit)
380-600V AC, 17.5A IP20 (NEMA Type1)	3.7-7.5 KW (5-10HP)	1204-RWC-17-A

Reflected Wave Reduction Device

Description	Used with	Catalog Number (Loose Kit)
380-575V AC, 9A IP 20 (NEMA Type1)	0.37-3.7 kW (0.5-5HP) 380-460V & 500-600V A Frame Devices	1204-RWR2-09-B

Terminator

Description ❶	Used with	Catalog Number (Loose Kit)
IP65 (NEMA Type4x) Connection Cable Included	0.37-1.5 kW (0.5-2HP) 460V Drives 0.75-597 kW (1-800 HP) 575V Drives	1204-TFA1
	1.5-597 kW (2-800 HP) 460V Drives 0.75-597 kW (1-800 HP) 575 Drives	1204-TFB2

❶ Correct terminator selection is dependent on motor characteristics, cable type and cable length. Refer to publication 1204-1.0 for application details before ordering.

Installation Considerations

By providing built in input MOVs (line to line and line to ground) for robust transient protection, ground fault and short circuit protection, electronic motor overload, built in noise filtering, patented reflected wave reduction software and others, the PowerFlex 700S design addresses many of the concerns in a typical installation. Below is a list of other considerations that a user may need to address.

Peak Voltage Protection for Motors with Lower Insulation Systems

While the PowerFlex 700S contains the very best in reflected wave reduction techniques, some motors may have insulation systems with values well below the NEMA standards. While these motors may perform to expectations, they must be protected from the reflected wave transients that all PWM drives produce. Refer to Page 33 for cable length recommendations and Page 21 for reflected wave reduction options.

Proper Grounding and Related Noise

The starting point for any solid drive installation is proper grounding techniques. Most commonly observed noise problems can be easily eliminated with quality installation practices. Refer to publication DRIVES-IN001, "Wiring and Grounding Guidelines for Pulse Width Modulated (PWM) AC Drives" for complete information.

The block diagram below also provides direction on other installation issues and concerns.

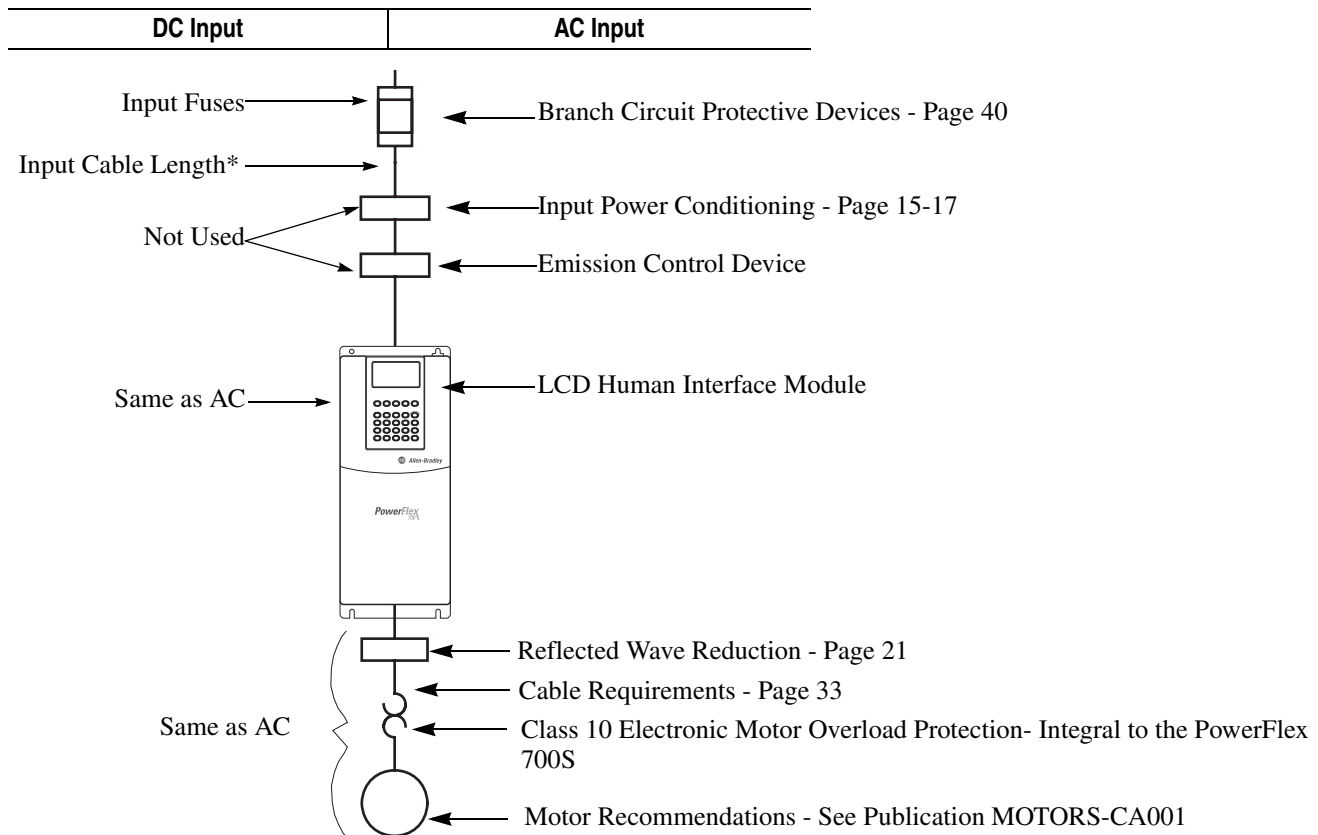

* Input Cable Length is limited. See Publication 20D-UM006 for further details.

Power Terminal Block Locations

Power Terminal Block Specifications, Frames 1 - 4

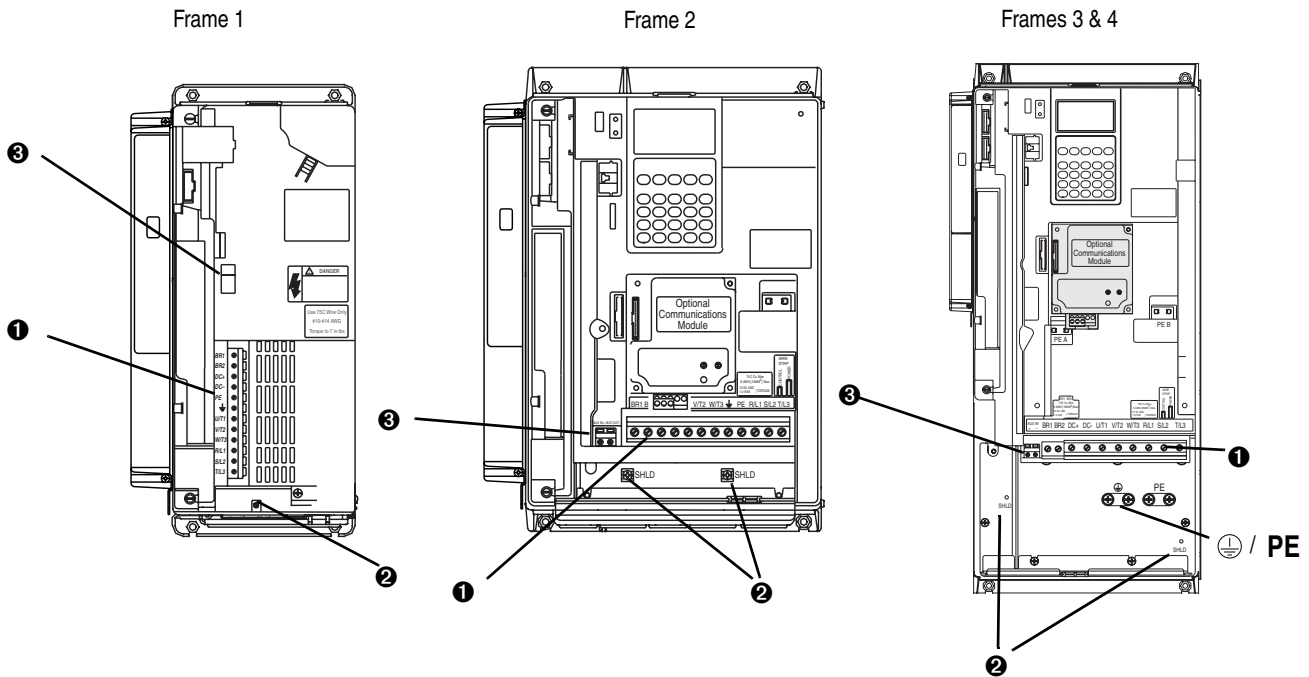

No.	Name	Frame	Description	Wire Size Range ⁽¹⁾		Torque		Terminal Bolt Size ⁽²⁾
				Maximum	Minimum	Maximum	Recommended	
1	Power Terminal Block	1	Input power and motor connections	4.0 mm ² (10 AWG)	0.5 mm ² (22 AWG)	1.7 N-m (15 lb.-in.)	0.8 N-m (7 lb.-in.)	—
		2	Input power and motor connections	10.0 mm ² (6 AWG)	0.8 mm ² (18 AWG)	1.7 N-m (15 lb.-in.)	1.4 N-m (12 lb.-in.)	—
		3	Input power and motor connections	25.0 mm ² (3 AWG)	2.5 mm ² (14 AWG)	3.6 N-m (32 lb.-in.)	1.8 N-m (16 lb.-in.)	—
			BR1, BR2	10.0 mm ² (6 AWG)	0.8 mm ² (18 AWG)	1.7 N-m (15 lb.-in.)	1.4 N-m (12 lb.-in.)	—
		4	Input power and motor connections	35.0 mm ² (1/0 AWG)	10 mm ² (8 AWG)	4.0 N-m (24 lb.-in.)	4.0 N-m (24 lb.-in.)	—
2	SHLD Terminal	1-4	Terminating point for wiring shields	—	—	1.6 N-m (14 lb.-in.)	1.6 N-m (14 lb.-in.)	—
3	AUX Terminal Block	1-4	Auxiliary Control Voltage ⁽³⁾ PS+, PS-	1.5 mm ² (16 AWG)	0.2 mm ² (24 AWG)	—	—	—

(1) Maximum/minimum sizes that the terminal block will accept - these are not recommendations.

(2) Apply counter torque to the nut on the other side of terminations when tightening or loosening the terminal bolt in order to avoid damage to the terminal.

(3) External control power: UL Installation - 300V DC, ±10%, Non UL Installation - 270-600V DC, ±10%. Frame 1-6, 100 W

Power Terminal Block Locations, Cont.

Power Terminal Specifications, Frames 5 & 6

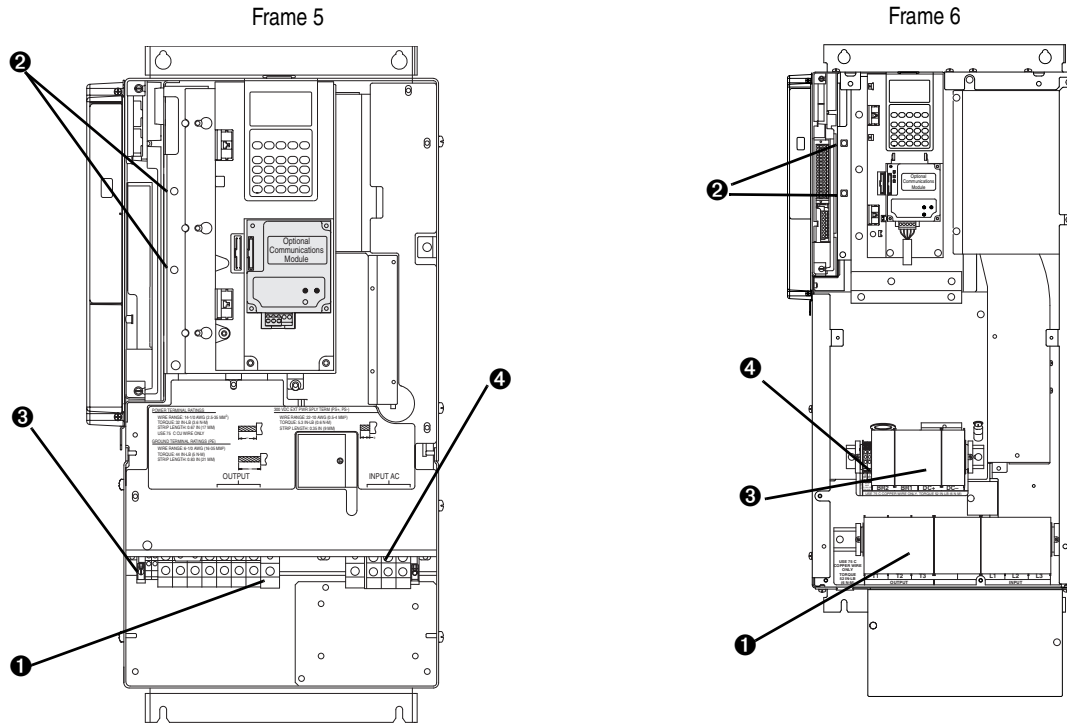

No.	Name	Frame	Description	Wire Size Range ⁽¹⁾		Torque		Terminal Bolt Size ⁽²⁾
				Maximum	Minimum	Maximum	Recommended	
❶	Power Terminal Block	5 (75 HP) ⁽³⁾	R, S, T, BR1, 2, DC+, DC-, U, V and W	50.0 mm ² (1/0 AWG)	2.5 mm ² (14 AWG)	See Note (4)	See Note (4)	—
			PE	50.0 mm ² (1/0 AWG)	4.0 mm ² (12 AWG)			—
		5 (100 HP) ⁽³⁾	R, S, T, DC+, DC-, U, V and W	70.0 mm ² (2/0 AWG)	16.0 mm ² (6 AWG)			—
			BR1, BR2	50.0 mm ² (1/0 AWG)	2.5 mm ² (14 AWG)			—
			PE	50.0 mm ² (1/0 AWG)	4.0 mm ² (12 AWG)			—
6	Input power and motor connections	120.0 mm ² (4/0 AWG) ⁽⁵⁾	2.5 mm ² (14 AWG)	6 N-m (52 lb.-in.)	6 N-m (52 lb.-in.)	—		
❷	SHLD Terminal	5 & 6	Terminating point for wiring shields	—	—	1.6 N-m (14 lb.-in.)	1.6 N-m (14 lb.-in.)	—
❸	AUX Terminal Block	5 & 6	Auxiliary Control Voltage ⁽⁶⁾ PS+, PS-	4.0 mm ² (10 AWG)	0.5 mm ² (22 AWG)	0.6 N-m (5.3 lb.-in.)	0.6 N-m (5.3 lb.-in.)	—
❹	Fan Terminal Block (Common Bus Only)	5 & 6	User Supplied Fan Voltage 0V AC, 120V AC, 240V AC	4.0 mm ² (10 AWG)	0.5 mm ² (22 AWG)	0.6 N-m (5.3 lb.-in.)	0.6 N-m (5.3 lb.-in.)	—

- (1) Maximum/minimum sizes that the terminal block will accept - these are not recommendations.
- (2) Apply counter torque to the nut on the other side of terminations when tightening or loosening the terminal bolt in order to avoid damage to the terminal.
- (3) Not all terminals present on all drives.
- (4) Refer to the terminal block label inside the drive.
- (5) If necessary, two wires can be used in parallel to any of these terminals using two lugs.
- (6) External control power: UL Installation - 300V DC, ±10%, Non UL Installation - 270-600V DC, ±10%. Frame 1-6, 100 W

Power Terminal Block Locations, Cont.

Power Terminal Block Specifications, Frame 9

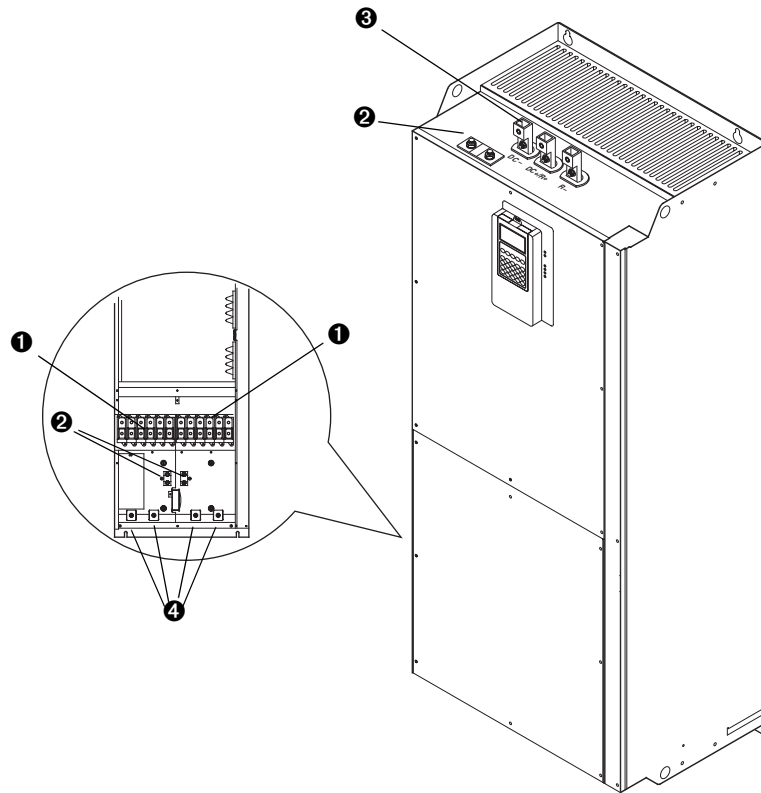

No.	Name	Frame	Description	Wire Size Range ⁽¹⁾		Torque		Terminal Bolt Size ⁽²⁾
				Maximum	Minimum	Maximum	Recommended	
1	Power Terminal Block	9 ⁽³⁾	Input Power — L1, L2, L3 Motor Connections — U/T1, V/T2, W/T3	185.0 mm ² 350 MCM	95.0 mm ² 4/0 AWG	40 N-m (340 lb.-in.)	40 N-m (340 lb.-in.)	—
2	SHLD Terminal	9	Terminating point for wiring shields	95.0 mm ² 4/0 AWG	5.0 mm ² 10 AWG	22 N-m (187 lb.-in.)	22 N-m (187 lb.-in.)	—
3	DC Bus (2 Terminals)	9 ⁽⁴⁾	DC input or external brake <i>(Internal Brake option <u>not</u> ordered)</i>	185.0 mm ² 350 MCM	95.0 mm ² 4/0 AWG	40 N-m (340 lb.-in.)	40 N-m (340 lb.-in.)	—
	DC Bus w/Brake (3 Terminals)	9 ⁽⁴⁾	DC input/internal brake <i>(Internal Brake option <u>is</u> ordered)</i>	185.0 mm ² 350 MCM	95.0 mm ² 4/0 AWG	40 N-m (340 lb.-in.)	40 N-m (340 lb.-in.)	—
4	Cable Clamp	9	Cable Clamp for Strain Relief					—

(1) Maximum/minimum sizes that the terminal block will accept - these are not recommendations.

(2) Apply counter torque to the nut on the other side of terminations when tightening or loosening the terminal bolt in order to avoid damage to the terminal.

(3) Do Not exceed maximum wire size. Parallel connections may be required.

(4) DC terminal and brake lugs can be removed.

Power Terminal Block Locations, Cont.

Power Terminal Block Specifications, Frame 10

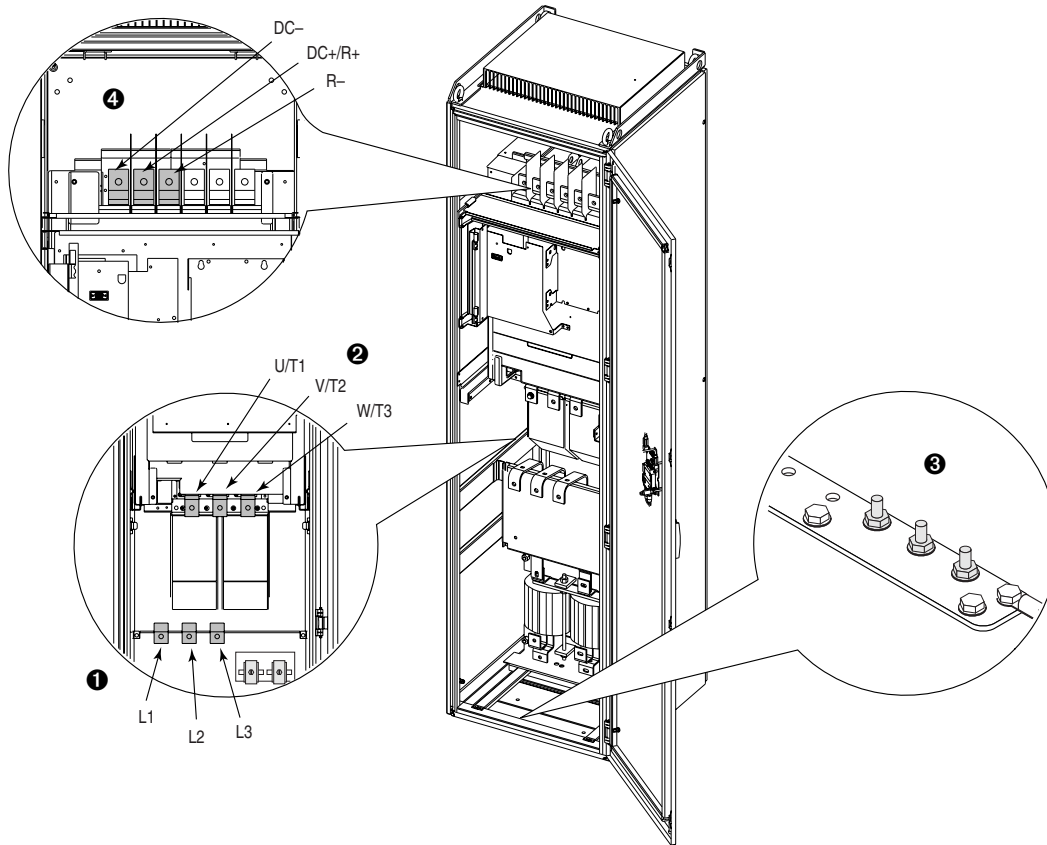

No.	Name	Description	Wire Size Range (1) (2)		Torque	Terminal Bolt Size (3) (4)
			Maximum	Minimum	Recommended	
1	Input Power Terminal Block L1, L2, L3 ⁽³⁾	Input power	300 mm ² (600 MCM)	2.1 mm ² (14 AWG)	40 N-m (354 lb.-in.)	M12
2	Output Power Terminal Block ⁽³⁾ U/T1, V/T2, W/T3	Motor connections	300 mm ² (600 MCM)	2.1 mm ² (14 AWG)	40 N-m (354 lb.-in.)	M12
3	SHLD Terminal, PE, Motor Ground ⁽³⁾	Terminating point for wiring shields	300 mm ² (600 MCM)	2.1 mm ² (14 AWG)	40 N-m (354 lb.-in.)	M10
4	DC Bus ⁽³⁾ (2 Terminals; DC-, DC+)	DC input or external brake (<i>Internal Brake option not ordered</i>)	300 mm ² (600 MCM)	2.1 mm ² (14 AWG)	40 N-m (354 lb.-in.)	M12
	DC Bus w/Brake ⁽³⁾ (3 Terminals; DC-, DC+/R+, R-)	DC input/internal brake (<i>Internal Brake option is ordered</i>)	300 mm ² (600 MCM)	2.1 mm ² (14 AWG)	40 N-m (354 lb.-in.)	M12

(1) Maximum/minimum sizes that the terminal block will accept - these are not recommendations.

(2) Do Not exceed maximum wire size. Parallel connections may be required.

(3) These connections are bus bar type terminations and require the use of lug type connectors.

(4) Apply counter torque to the nut on the other side of terminations when tightening or loosening the terminal bolt in order to avoid damage to the terminal.

Power Terminal Block Locations, Cont.

Power Terminal Specifications, Frame 11

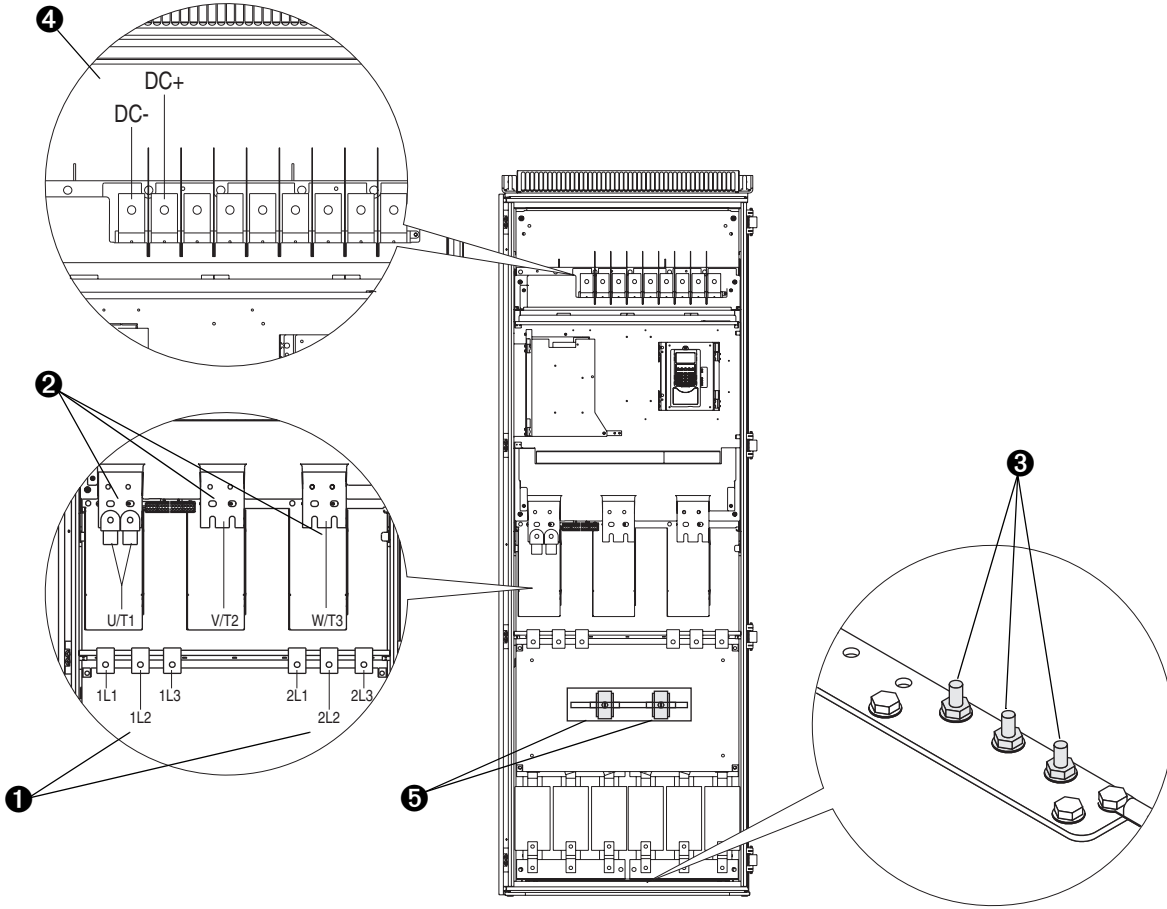

No.	Name	Description	Wire Size Range (1) (2)		Torque	Terminal Bolt Size (3) (4)
			Maximum	Minimum	Recommended	
1	Input Power Terminal Block (4) 1L1, 1L2, 1L3, 2L1, 2L2, 2L3	AC Input power	300 mm ² (600 MCM)	2.1 mm ² (14 AWG)	40 N-m (354 lb.-in.)	M12
2	Output Power Terminal Block (4) U/T1, V/T2, W/T3	Motor connections	300 mm ² (600 MCM)	2.1 mm ² (14 AWG)	40 N-m (354 lb.-in.)	M12
3	SHLD Terminal, PE, Motor Ground(4)	Terminating point for wiring shields	300 mm ² (600 MCM)	2.1 mm ² (14 AWG)	40 N-m (354 lb.-in.)	M10
4	DC Bus(4) (2 Terminals; DC-, DC+)	DC input	300 mm ² (600 MCM)	2.1 mm ² (14 AWG)	40 N-m (354 lb.-in.)	M12
5	Cable Clamp for Strain Relief					

(1) Maximum/minimum sizes that the terminal block will accept - these are not recommendations.

(2) Do Not exceed maximum wire size. Parallel connections may be required.

(3) These connections are bus bar type terminations and require the use of lug type connectors.

(4) Apply counter torque to the nut on the other side of terminations when tightening or loosening the terminal bolt in order to avoid damage to the terminal.

Power Terminal Block Locations, Cont.

Power Terminal Specifications, Frame 12

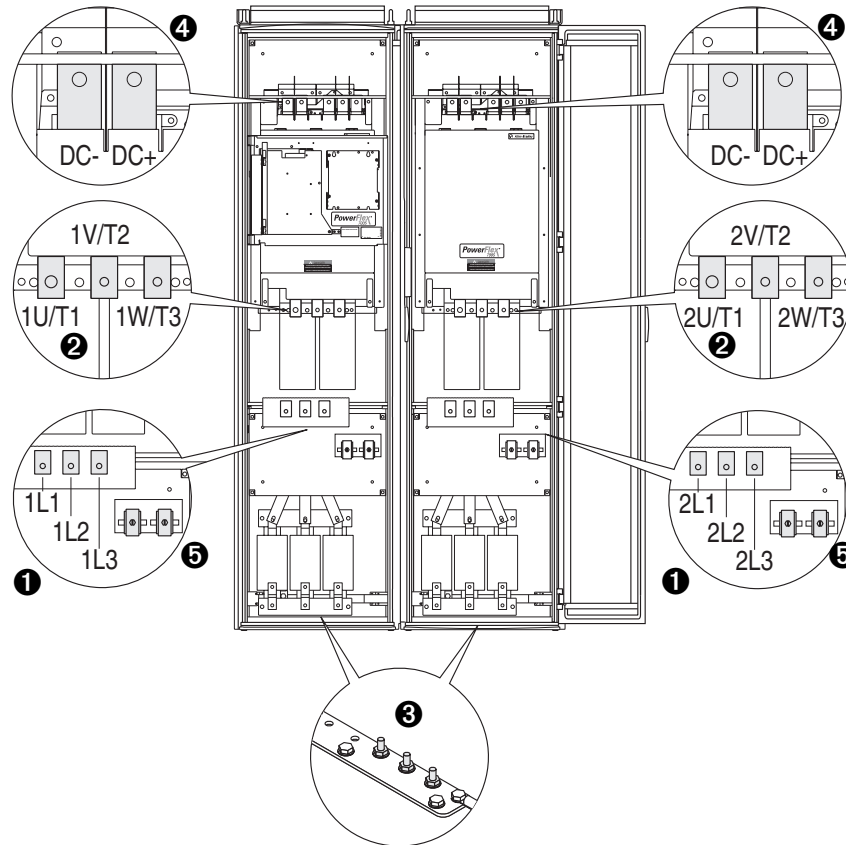

No.	Name	Description	Wire Size Range ⁽¹⁾⁽²⁾		Torque	Terminal Bolt Size ^{(3) (4)}
			Maximum	Minimum	Recommended	
1	Input Power Terminal Block 1L1, 1L2, 1L3, 2L1, 2L2, 2L3 ⁽³⁾	Input power	300 mm ² (600 MCM)	2.1 mm ² (14 AWG)	40 N-m (354 lb.-in.)	M12
2	Output Power Terminal Block ⁽³⁾ 1U/1T1, 1V/1T2, 1W/1T3, 2U/2T1, 2V/2T2, 2W/2T3	Motor connections	300 mm ² (600 MCM)	2.1 mm ² (14 AWG)	40 N-m (354 lb.-in.)	M12
3	SHLD Terminal, PE, Motor Ground ⁽³⁾	Terminating point for wiring shields	300 mm ² (600 MCM)	2.1 mm ² (14 AWG)	40 N-m (354 lb.-in.)	M10
4	DC Bus ⁽³⁾ (4 Terminals 2 DC-, 2 DC+)	DC input	300 mm ² (600 MCM)	2.1 mm ² (14 AWG)	40 N-m (354 lb.-in.)	M12
5	Cable Clamp for Strain Relief					

(1) Maximum/minimum sizes that the terminal block will accept - these are not recommendations.

(2) Do Not exceed maximum wire size. Parallel connections may be required.

(3) These connections are bus bar type terminations and require the use of lug type connectors.

(4) Apply counter torque to the nut on the other side of terminations when tightening or loosening the terminal bolt in order to avoid damage to the terminal.

Power Terminal Block Locations, Cont.

Power Terminal Specifications, Frame 13

Frame 13

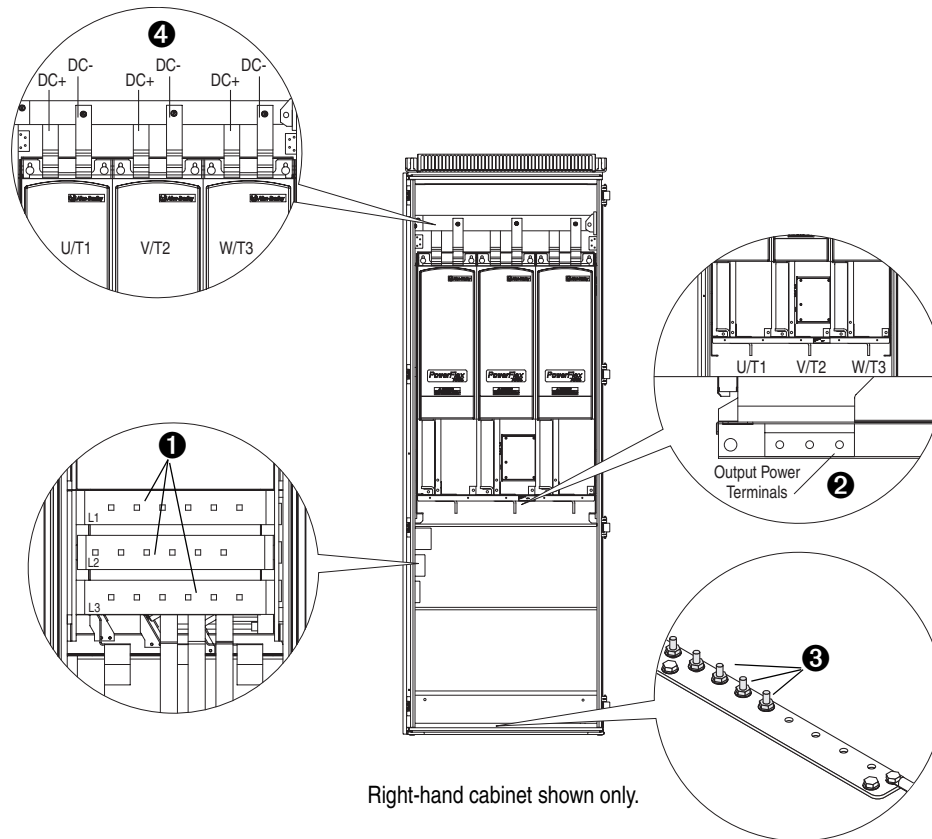

Right-hand cabinet shown only.

No.	Name	Description	Wire Size Range (1)(2)		Torque	Terminal Bolt Size (3) (4)
			Maximum	Minimum	Recommended	
1	Input Power Terminal Block L1, L2, L3 (3)	Input power	300 mm ² (600 MCM)	2.1 mm ² (14 AWG)	40 N-m (354 lb.-in.)	M12
2	Output Power Terminal Block (3) U/T1, V/T2, W/T3	Motor connections	300 mm ² (600 MCM)	2.1 mm ² (14 AWG)	40 N-m (354 lb.-in.)	M12
3	SHLD Terminal, PE, Motor Ground (3)	Terminating point for wiring shields	300 mm ² (600 MCM)	2.1 mm ² (14 AWG)	40 N-m (354 lb.-in.)	M10
4	DC Bus (3) (3 Terminals; DC-, DC+)	DC input	300 mm ² (600 MCM)	2.1 mm ² (14 AWG)	40 N-m (354 lb.-in.)	M12

(1) Maximum/minimum sizes that the terminal block will accept - these are not recommendations.

(2) Do Not exceed maximum wire size. Parallel connections may be required.

(3) These connections are bus bar type terminations and require the use of lug type connectors.

(4) Apply counter torque to the nut on the other side of terminations when tightening or loosening the terminal bolt in order to avoid damage to the terminal.

Power Terminal Blocks

Frame 1

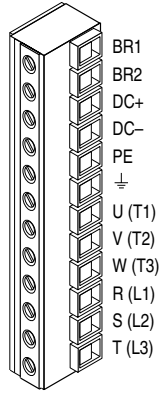

Frame 2

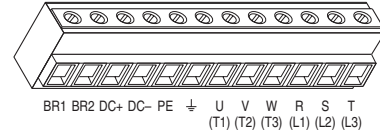

Frames 3 & 4

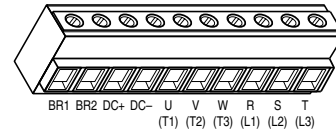

Frame 5 - 75 HP Normal Duty
480V AC Input

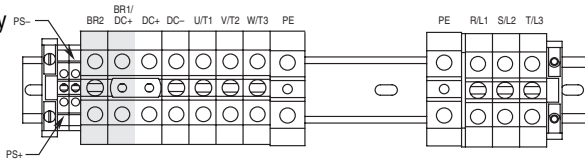

Frame 5 - 100 HP Normal Duty
480V AC Input

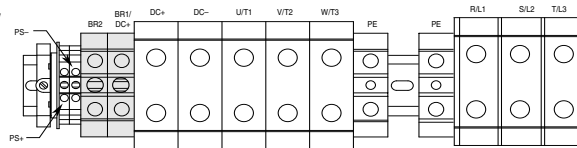

Frame 5 - 75 HP Normal Duty
650V DC Input

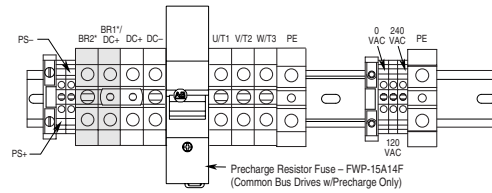

Frame 5 - 100 HP Normal Duty
650V DC Input

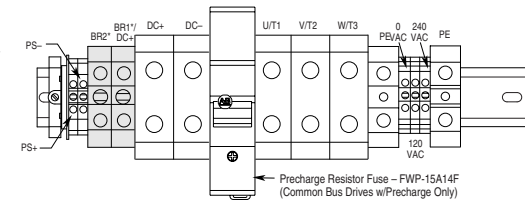

Power Terminal Blocks, Cont.

Frame 6 - 150 HP
Normal Duty
480V AC Input

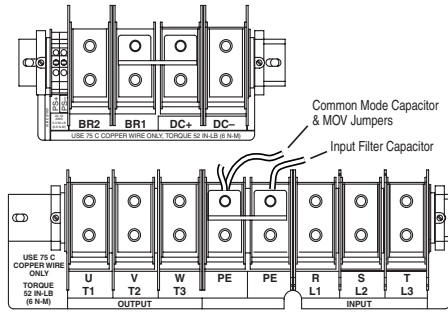

Frame 6 - 150 HP
Normal Duty
650V DC Input

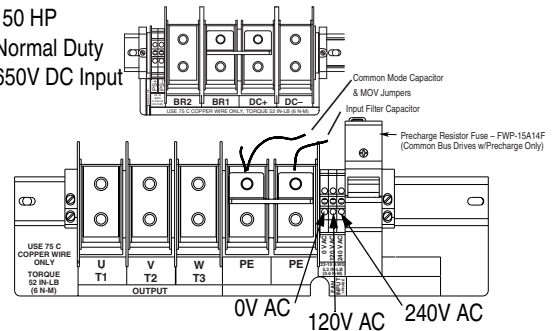

Shaded terminals (BR1 & BR2) will only be present on drives ordered with the Brake Option.

Frame 9

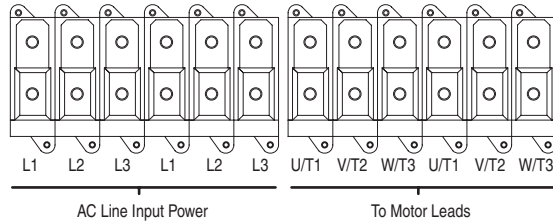

Terminal	Description	Notes
BR1	DC Brake (+)	Dynamic Brake Resistor Connection (+)
BR2	DC Brake (-)	Dynamic Brake Resistor Connection (-)
DC+	DC Bus (+)	DC Input Power or Dynamic Brake Chopper
DC-	DC Bus (-)	DC Input Power or Dynamic Brake Chopper
PE	PE Ground	Not present on 3 Frame drives
⊥	Motor Ground	Not present on 3 Frame drives
PS+	Aux +	❶
PS-	Aux -	❶
U	U (T1)	To motor
V	V (T2)	To motor
W	W (T3)	To motor
R	R (L1)	AC Line Input Power
S	S (L2)	AC Line Input Power
T	T (L3)	AC Line Input Power

❶ External control power:
UL Installation - 300V DC, ±10%, Non UL Installation - 270-600V DC, ±10%.
1-3 Frame - 40 W, 165 mA, 5 Frame - 80 W, 90 mA

Control Terminals

TB1 Terminals

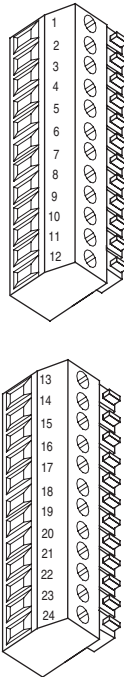

Terminal	Signal	Factory Default	Description	Related Parameter
1	Analog Input 1 Comm.	(Volt)	Bipolar, differential input, +/-10V, 0-20 mA, 13 bit + sign 20k Ohm impedance at Volt; 500 Ohm impedance at mA (1)	800
2	Analog Input 1 (+/-)			
3	Shield	NA	Analog Input Shield	
4	Analog Input 2 Comm.	(Volt)	Bipolar, differential input, +/-10V, 0-20 mA, 13 bit + sign 20k Ohm impedance at Volt; 500 Ohm impedance at mA (1)	806
5	Analog Input 2 (+/-)			
6	Analog Input 3 [NTC-] Comm.	(Volt)	Differential input, 0-10V, 10 bit (for motor control mode FOC2, this is the temperature adaptation input). (1)	812
7	Analog Input 3 [NTC+]			
8	Shield	NA	Analog Output Shield	
9	Analog Output 1 (-)	(Volt)	Bipolar, differential output, +/-10V, 0-20 mA, 11 bit + sign 2k Ohm minimum load	832, 833
10	Analog Output 1 (+)			
11	Analog Output 2 (-)	(Volt)		839, 840
12	Analog Output 2 (+)			
13	+10V Reference	NA	Rating: 20 mA maximum load (Recommend 5k Ohm pot)	
14	Reference Common	NA		
15	-10V Reference	NA		
16	Encoder A	NA	Normal current draw per channel: 20 mA	230 - 234
17	Encoder A (Not)	NA		
18	Encoder B	NA		
19	Encoder B (Not)	NA		
20	Encoder Z	NA		
21	Encoder Z (Not)	NA		
22	Encoder Reference (+)	NA	12 or 5V DC power supply for primary encoder interface Rating: 300 mA maximum	
23	Encoder Reference (-)	NA		
24	Encoder Shield	NA	Connection point for encoder shield	

(1) The Analog inputs are not isolated. However, the analog inputs can be connected in series when using current mode. Note that at 20mA the voltage source must be capable of providing 10V dc at the drive terminals for one drive - - 20V dc is required for two drives and 30V dc is required for three drives, etc.

TB2 Terminals

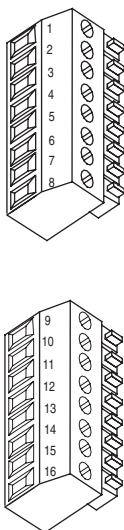

Terminal	Signal	Factory Default	Description	Related Parameter
1	24V DC Common (-)	NA	Drive supplied 24V DC logic input power Rating: 300 mA maximum load	
2	24V DC Source (+)	NA		
3	Digital Output 1		24V DC Open Collector (sinking logic) Rating: Internal Source = 150 mA max. External Source = 750 mA	846, 847
4	Digital Output 1/2 Com	NA	Common for Digital Output 1 & 2	
5	Digital Output 2		24V DC Open Collector (sinking logic) Rating: Internal Source = 150 mA max. External Source = 750 mA	851, 852
6	Relay Output 3 (NC)		Relay contact output Rating: 115V AC or 24V DC = 2 A max. Inductive/Resistive	856, 857
7	Relay Output 3 Com	NA		
8	Relay Output 3 (NO)			
9	Digital Input 1-3 Com	NA	Common for Digital Inputs 1-3	
10	Digital Input 1		High speed 12-24V DC sourcing Digital Input Load: 15 mA at 24V DC	825
11	Digital Input 2		Load: 15 mA at 24V DC sourcing	826
12	Digital Input 3		Load: 15 mA at 24V DC sourcing	827
13	Digital Input 4-6 Com	NA	Common for Digital Inputs 4-6	
14	Digital Input 4		Load: 10 mA at 24V DC sinking/sourcing	828
15	Digital Input 5		Load: 7.5 mA at 115V AC	829
16	Digital Input 6	HW Enable	Note: The 115 VAC Digital Inputs can withstand 2 milliamps of leakage current without turning on. If an output device has a leakage current greater than 2 milliamps a burden resistor is required. A 68.1K ohm resistor with a 0.5 watt rating should be used to keep the 115 VAC output below 2 milliamps.	830

Cable Recommendations — Power

Unshielded Cable

THHN, THWN or similar wire is acceptable for drive installation in dry environments provided adequate free air space and/or conduit fill rates limits are provided. **Do not use THHN or similarly coated wire in wet areas.** Any wire chosen must have a minimum insulation thickness of 15 Mils and should not have large variations in insulation concentricity.

Shielded Cable

Shielded cable contains all of the general benefits of multi-conductor cable with the added benefit of a copper braided shield that can contain much of the noise generated by a typical AC Drive. Strong consideration for shielded cable should be given in installations with sensitive equipment such as weigh scales, capacitive proximity switches and other devices that may be affected by electrical noise in the distribution system. Applications with large numbers of drives in a similar location, imposed EMC regulations or a high degree of communications/networking are also good candidates for shielded cable.

Shielded cable may also help reduce shaft voltage and induced bearing currents for some applications. In addition, the increased impedance of shielded cable may help extend the distance that the motor can be located from the drive without the addition of motor protective devices such as terminator networks. Refer to “Reflected Wave” in *Wiring and Grounding Guidelines for Pulse Width Modulated (PWM) AC Drives*, publication DRIVES-IN001.

Consideration should be given to all of the general specifications dictated by the environment of the installation, including temperature, flexibility, moisture characteristics and chemical resistance. In addition, a braided shield should be included and be specified by the cable manufacturer as having coverage of at least 75%. An additional foil shield can greatly improve noise containment.

A good example of recommended cable is Belden® 295xx (xx determines gauge). This cable has four (4) XLPE insulated conductors with a 100% coverage foil and an 85% coverage copper braided shield (with drain wire) surrounded by a PVC jacket.

Other types of shielded cable are available, but the selection of these types may limit the allowable cable length. Particularly, some of the newer cables twist 4 conductors of THHN wire and wrap them tightly with a foil shield. This construction can greatly increase the cable charging current required and reduce the overall drive performance. Unless specified in the individual distance tables as tested with the drive, these cables are not recommended and their performance against the lead length limits supplied is not known.

Armored Cable

Cable with continuous aluminum armor is often recommended in drive system applications or specific industries. It offers most of the advantages of standard shielded cable and also combines considerable mechanical strength and resistance to moisture. It can be installed in concealed and exposed manners and removes the requirement for conduit (EMT) in the installation. It can also be directly buried or embedded in concrete.

Because noise containment can be affected by incidental grounding of the armor to building steel (see Chapter 2, “Wire Types,” of publication DRIVES-IN001, *Wiring and Grounding Guidelines for Pulse Width Modulated (PWM) AC Drives*) when the cable is mounted, it is recommended the armored cable have an overall PVC jacket.

Interlocked armor is acceptable for shorter cable runs, but continuous welded armor is preferred.

Best performance is achieved with 3 spaced ground conductors, but acceptable performance below 200 HP is provided via a single ground conductor.

Cable Recommendations — Power, Cont.

Recommended Shielded/Armored Cable

Location	Rating/Type	Description
Standard (Option 1)	600V, 90°C (194°F) XHHW2/RHW-2 Anixter B209500-B209507, Belden 29501-29507, or equivalent	Four tinned copper conductors with XLPE insulation. Copper braid/aluminum foil combination shield and tinned copper drain wire. PVC jacket.
Standard (Option 2)	Tray rated 600V, 90° C (194° F) RHH/RHW-2 Anixter OLF-7xxxxx or equivalent	Three tinned copper conductors with XLPE insulation. 5 mil single helical copper tape (25% overlap min.) with three bare copper grounds in contact with shield. PVC jacket.
Class I & II; Division I & II	Tray rated 600V, 90° C (194° F) RHH/RHW-2 Anixter 7V-7xxxx-3G or equivalent	Three bare copper conductors with XLPE insulation and impervious corrugated continuously welded aluminum armor. Black sunlight resistant PVC jacket overall. Three copper grounds on #10 AWG and smaller.

Cable Recommendations - Control

Recommended Control Wire

Type	Wire Type(s)		Description	Insulation Rating
Digital I/O	Un-shielded	Per US NEC or applicable national or local code	—	300V, 60° C (140° F), Minimum
	Shielded	Multi-conductor shielded cable such as Belden 8770 (or equiv.)	0.750 mm ² (18AWG), 3 conductor, shielded.	
Standard Analog I/O	Belden 8760/9460 (or equiv.)		0.750 mm ² (18AWG), twisted pair, 100% shield with drain (5).	300V, 75-90 °C (167-194 °F)
Remote Pot	Belden 8770 (or equiv.)		0.750 mm ² (18AWG), 3 cond., shielded	
Encoder/Pulse I/O Less 30.5 m (100 ft.)	Combined:	Belden 9730 (or equivalent) (1)	0.196 mm ² (24AWG), individually shielded.	
Encoder/Pulse I/O 30.5 m (100 ft.) to 152.4 m (500 ft.)	Signal:	Belden 9730/9728 (or equivalent) (1)	0.196 mm ² (24AWG), individually shielded.	
	Power:	Belden 8790 (2)	0.750 mm ² (18AWG)	
	Combined:	Belden 9892 (3)	0.330 mm ² or 0.500 mm ² (3)	
Encoder/Pulse I/O 152.4 m (500 ft.) to 259.1 m (850 ft.)	Signal:	Belden 9730/9728 (or equivalent) (1)	0.196 mm ² (24AWG), individually shielded.	
	Power:	Belden 8790 (2)	0.750 mm ² (18AWG)	
	Combined:	Belden 9773/9774 (or equivalent) (4)	0.750 mm ² (18AWG), individually shielded pair.	
Stegmann Encoder	Stegmann 6-411682-xx cables with C12 FUR connections			
Resolver	Paige 412081 (or equiv.) Twist, capacitance, inductance and resistance specifications equal to or greater than cable specified		0.750 =mm ² (18 AWG), twisted pair	300V, 80° C (176° F) minimum
SynchLink	Versalink V-System, Lucent Technologies, Specialty Fibers Technology Division 1403-CF BLK		200/230 micron HCS (Hard Clad Silica) 650 nm (Red) Data Rate 5 Mbps	
EMC Compliance	Refer to position "i" - Emission of the Catalog Number Explanation on Page 11 for details.			

(1)Belden 9730 is 3 individually shielded pairs (2 channel plus power). If 3 channel is required, use Belden 9728 (or equivalent).

(2)Belden 8790 is 1 shielded pair.

(3)Belden 9892 is 3 individually shielded pairs (3 channel), 0.33 mm² (22 AWG) plus 1 shielded pair 0.5 mm² (20 AWG) for power.

(4)Belden 9773 is 3 individually shielded pairs (2 channel plus power). If 3 channel is required, use Belden 9774 (or equivalent).

(5)If the wires are short and contained within a cabinet which has no sensitive circuits, the use of shielded wire may not be necessary, but is always recommended.

Cable Length Restrictions

Important: In the following tables, A “●” in any of the latter columns will indicate that this drive rating can be used with an Allen-Bradley Terminator (1204-TFA1/1204-TFB2) and/or Eliminator (1204-RWR2/1204-RWC-17).

For the Terminator, the maximum cable length is 182.9 meters (600 feet) for 400/480/600V drives (not 690V). The PWM frequency must be 2 kHz. The 1204-TFA1 can be used only on low HP (below 5 HP), while the 1204-TFB2 can be used from 2-800 HP.

Eliminator (all motor insulation classes):

(1) 1204-RWR2-09

2kHz: 182.9m (600 ft.) at 400/480V and 121.9m (400 ft.) at 600V. 4 kHz: 91.4m (300 ft.) at 400/480V and 61.0m (200 ft.) at 600V.

(2) 1204-RWC-17

2 kHz: 365.8m (1200 ft.) at 400/480/600V. 4 kHz: 243.8m (800 ft.) at 400/480V and 121.9m (400 ft.) at 600V.

For both devices, power dissipation in the damping resistor limits maximum cable length.

For further information, refer to the following:

- ² Eliminator 1204-RWR2, see publication 1204-5.1
- ² Eliminator 1204-RWC, see publication 1204-IN001
- ² Terminator 1204-TFxx, see publication 1204-IN002

400V Shielded/Unshielded Cable - Meters (Feet)

Drive			No Solution				Reactor Only				Reactor + Damping Resistor				Line Reactor	Resistor			Used with ...				
Frame	kW	kHz	1000V	1200V	1488V	1600V	1000V	1200V	1488V	1600V	1000V	1200V	1488V	1600V	Cat. No.	Cat. No.	Ohms	Watts	TFA1	TFB2	RWR2	RWC	
1	0.75	2/4	7.6 (25)	83.8 (275)	83.8 (275)	83.8 (275)	91.4 (300)	152.4 (500)	152.4 (500)	152.4 (500)	152.4 (500)	152.4 (500)	152.4 (500)				50	25/50	●		●	●	
	1.5	2/4	7.6 (25)	106.9 (350)	182.9 (600)	182.9 (600)	91.4 (300)	182.9 (600)	182.9 (600)	182.9 (600)	182.9 (600)	182.9 (600)	182.9 (600)				50	25/50	●	●	●	●	
	2.2	2/4	7.6 (25)	106.9 (350)	182.9 (600)	182.9 (600)	91.4 (300)	182.9 (600)	182.9 (600)	182.9 (600)	182.9 (600)	182.9 (600)	182.9 (600)				50	25/50	●	●	●	●	
	4	2/4	7.6 (25)	106.9 (350)	243.8 (800)	243.8 (800)	91.4 (300)	243.8 (800)	243.8 (800)	243.8 (800)	243.8 (800)	243.8 (800)	243.8 (800)	243.8 (800)				50	60/120		●		●
	5.5	2/4	7.6 (25)	106.9 (350)	274.3 (900)	304.8 (1000)	91.4 (300)	274.3 (900)	304.8 (1000)	304.8 (1000)	304.8 (1000)	304.8 (1000)	304.8 (1000)	304.8 (1000)				50	60/120		●		●
	7.5	2/4	7.6 (25)	106.9 (350)	274.3 (900)	365.8 (1200)	91.4 (300)	274.3 (900)	365.8 (1200)	365.8 (1200)	365.8 (1200)	365.8 (1200)	365.8 (1200)	365.8 (1200)				50	60/120		●		●
	11	2/4	7.6 (25)	106.9 (350)	274.3 (900)	365.8 (1200)	91.4 (300)	274.3 (900)	365.8 (1200)	365.8 (1200)	365.8 (1200)	365.8 (1200)	365.8 (1200)	365.8 (1200)				50	60/120		●		
2	15	2/4	7.6 (25)	106.9 (350)	274.3 (900)	365.8 (1200)	91.4 (300)	274.3 (900)	365.8 (1200)	365.8 (1200)	365.8 (1200)	365.8 (1200)	365.8 (1200)	365.8 (1200)				50	60/120		●		
	18.5	2/4	7.6 (25)	106.9 (350)	274.3 (900)	365.8 (1200)	91.4 (300)	274.3 (900)	365.8 (1200)	365.8 (1200)	365.8 (1200)	365.8 (1200)	365.8 (1200)	365.8 (1200)				50	60/120		●		
3	22	2/4	7.6 (25)	106.9 (350)	274.3 (900)	365.8 (1200)	91.4 (300)	274.3 (900)	365.8 (1200)	365.8 (1200)	365.8 (1200)	365.8 (1200)	365.8 (1200)	365.8 (1200)				50	60/120		●		
	30	2/4	7.6 (25)	106.9 (350)	274.3 (900)	365.8 (1200)	91.4 (300)	274.3 (900)	365.8 (1200)	365.8 (1200)	365.8 (1200)	365.8 (1200)	365.8 (1200)	365.8 (1200)				50	60/120		●		
	37	2/4	12.2 (40)	91.4 (300)	274.3 (900)	365.8 (1200)	76.2 (250)	243.8 (800)	365.8 (1200)	365.8 (1200)	365.8 (1200)	365.8 (1200)	365.8 (1200)	365.8 (1200)				50	60/120		●		

* Maximum cable length is limited due to cable charging characteristics.

Cable Length Restrictions, Cont.

400V Shielded/Unshielded Cable, Continued- Meters (Feet)

Drive			No Solution				Reactor Only				Reactor + Damping Resistor				Line Reactor	Resistor		Used with ...				
Frame	kW	kHz	1000V	1200V	1488V	1600V	1000V	1200V	1488V	1600V	1000V	1200V	1488V	1600V	Cat. No.	Cat. No.	Ohms	Watts	TFA1	TFB2	RWR2	RWC
4	45	2/4	12.2 (40)	106.9 (350)	274.3 (900)	365.8 (1200)	76.2 (250)	304.8 (1000)	365.8 (1200)	365.8 (1200)	365.8 (1200)	365.8 (1200)	365.8 (1200)			50	60/120		●			
5	55	2/4	12.2 (40)	106.9 (350)	274.3 (900)	365.8 (1200)	61.0 (200)	274.3 (900)	365.8 (1200)	365.8 (1200)	365.8 (1200)	365.8 (1200)	365.8 (1200)			50	60/120		●			
	75	2/4	18.3 (60)	91.4 (300)	213.4 (700)	304.8 (1000)	45.7 (150)	243.8 (800)	365.8 (1200)	365.8 (1200)	304.8 (1000)	365.8 (1200)	365.8 (1200)			50	75/150		●			
6	90	2/4	18.3 (60)	91.4 (300)	213.4 (700)	304.8 (1000)	45.7 (150)	213.4 (700)	365.8 (1200)	365.8 (1200)	304.8 (1000)	365.8 (1200)	365.8 (1200)			50	75/150		●			
	110	2/4	24.4 (80)	91.4 (300)	213.4 (700)	274.3 (900)	45.7 (150)	182.9 (600)	365.8 (1200)	365.8 (1200)	274.3 (900)	365.8 (1200)	365.8 (1200)			50	75/150		●			
	132	2/4	24.4 (80)	91.4 (300)	182.9 (600)	243.8 (800)	45.7 (150)	152.4 (500)	365.8 (1200)	365.8 (1200)	243.8 (800)	365.8 (1200)	365.8 (1200)			50	75/150		●			
9	132	2	24.4 (80)	91.4 (300)	182.9 (600)	243.8 (800)	45.7 (150)	152.4 (500)	365.8 (1200)	365.8 (1200)	243.8 (800)	365.8 (1200)	365.8 (1200)			50	75		●			
	160	2	24.4 (80)	91.4 (300)	152.4 (500)	213.4 (700)	45.7 (150)	121.9 (400)	365.8 (1200)	365.8 (1200)	243.8 (800)	365.8 (1200)	365.8 (1200)			50	75		●			
10	200	2	24.4 (80)	76.2 (250)	121.9 (400)	182.9 (600)	36.6 (120)	91.4 (300)	304.8 (1000)	365.8 (1200)	243.8 (800)	365.8 (1200)	365.8 (1200)			25	165		●			
	250	2	24.4 (80)	76.2 (250)	99.1 (325)	167.6 (550)	36.6 (120)	76.2 (250)	304.8 (1000)	365.8 (1200)	228.6 (750)	335.3 (1100)	365.8 (1200)			25	165		●			
11	315	2	18.3 (60)	68.6 (225)	99.1 (325)	167.6 (550)	36.6 (120)	68.6 (225)	304.8 (1000)	365.8 (1200)	228.6 (750)	335.3 (1100)	365.8 (1200)			25	165		●			
	355	2	18.3 (60)	68.6 (225)	99.1 (325)	167.6 (550)	36.6 (120)	68.6 (225)	304.8 (1000)	365.8 (1200)	228.6 (750)	274.3 (900)	365.8 (1200)			25	165		●			
	400	2	18.3 (60)	68.6 (225)	99.1 (325)	167.6 (550)	36.6 (120)	68.6 (225)	304.8 (1000)	365.8 (1200)	228.6 (750)	274.3 (900)	365.8 (1200)			25	165		●			
12	450	2	18.3 (60)	68.6 (225)	99.1 (325)	167.6 (550)	36.6 (120)	68.6 (225)	304.8 (1000)	365.8 (1200)	228.6 (750)	274.3 (900)	365.8 (1200)			13	345		●			
	500	2	12.2 (40)	68.6 (225)	99.1 (325)	167.6 (550)	36.6 (120)	68.6 (225)	304.8 (1000)	365.8 (1200)	198.1 (650)	274.3 (900)	365.8 (1200)			13	345		●			
	560	2	12.2 (40)	68.6 (225)	99.1 (325)	167.6 (550)	36.6 (120)	68.6 (225)	304.8 (1000)	365.8 (1200)	198.1 (650)	274.3 (900)	365.8 (1200)			13	345		●			
13	630	2	12.2 (40)	61.0 (200)	99.1 (325)	167.6 (550)	36.6 (120)	61.0 (200)	304.8 (1000)	365.8 (1200)	198.1 (650)	274.3 (900)	365.8 (1200)			13	345					
	710	2	12.2 (40)	61.0 (200)	99.1 (325)	167.6 (550)	36.6 (120)	61.0 (200)	304.8 (1000)	365.8 (1200)	198.1 (650)	274.3 (900)	365.8 (1200)			13	345					
	800	2	12.2 (40)	61.0 (200)	99.1 (325)	167.6 (550)	36.6 (120)	61.0 (200)	304.8 (1000)	365.8 (1200)	198.1 (650)	274.3 (900)	365.8 (1200)			13	345					

Cable Length Restrictions, Cont.

480V Shielded/Unshielded Cable - Meters (Feet)

Drive			No Solution				Reactor Only				Reactor + Damping Resistor				Line Reactor	Resistor		Used with ...					
Frame	HP	kHz	1000V	1200V	1488V	1600V	1000V	1200V	1488V	1600V	1000V	1200V	1488V	1600V	Cat. No.	Cat. No.	Ohms	Watts	TFA1	TFB2	RWR2	RWC	
1	1	2/4	7.6 (25)	12.2 (40)	83.8 (275)	83.8 (275)	7.6 (25)	91.4 (300)	152.4 (500)	152.4 (500)	152.4 (500)	152.4 (500)	152.4 (500)				50	25/50	●		●	●	
	2	2/4	7.6 (25)	12.2 (40)	83.8 (275)	83.8 (275)	7.6 (25)	91.4 (300)	182.9 (600)	182.9 (600)	152.4 (500)	182.9 (600)	182.9 (600)	182.9 (600)				50	25/50	●	●	●	●
	3	2/4	7.6 (25)	12.2 (40)	106.9 (350)	152.4 (500)	7.6 (25)	91.4 (300)	182.9 (600)	182.9 (600)	152.4 (500)	182.9 (600)	182.9 (600)	182.9 (600)				50	25/50	●	●	●	●
	5	2/4	7.6 (25)	12.2 (40)	106.9 (350)	152.4 (500)	7.6 (25)	91.4 (300)	243.8 (800)	243.8 (800)	152.4 (500)	243.8 (800)	243.8 (800)	243.8 (800)				50	60/120	●	●	●	●
	7.5	2/4	7.6 (25)	12.2 (40)	106.9 (350)	152.4 (500)	7.6 (25)	91.4 (300)	304.8 (1000)	304.8 (1000)	152.4 (500)	304.8 (1000)	304.8 (1000)	304.8 (1000)				50	60/120		●		●
	10	2/4	7.6 (25)	12.2 (40)	106.9 (350)	152.4 (500)	7.6 (25)	91.4 (300)	365.8 (1200)	365.8 (1200)	152.4 (500)	365.8 (1200)	365.8 (1200)	365.8 (1200)				50	60/120		●		●
	15	2/4	7.6 (25)	12.2 (40)	106.9 (350)	152.4 (500)	7.6 (25)	91.4 (300)	365.8 (1200)	365.8 (1200)	152.4 (500)	365.8 (1200)	365.8 (1200)	365.8 (1200)				50	60/120		●		
2	20	2/4	7.6 (25)	12.2 (40)	106.9 (350)	152.4 (500)	7.6 (25)	91.4 (300)	365.8 (1200)	365.8 (1200)	182.9 (600)	365.8 (1200)	365.8 (1200)	365.8 (1200)				50	60/120		●		
	25	2/4	7.6 (25)	12.2 (40)	106.9 (350)	152.4 (500)	7.6 (25)	76.2 (250)	365.8 (1200)	365.8 (1200)	152.4 (500)	365.8 (1200)	365.8 (1200)	365.8 (1200)				50	60/120		●		
3	30	2/4	7.6 (25)	12.2 (40)	106.9 (350)	152.4 (500)	7.6 (25)	76.2 (250)	365.8 (1200)	365.8 (1200)	152.4 (500)	365.8 (1200)	365.8 (1200)	365.8 (1200)				50	60/120		●		
	40	2/4	7.6 (25)	12.2 (40)	106.9 (350)	152.4 (500)	7.6 (25)	76.2 (250)	365.8 (1200)	365.8 (1200)	121.9 (400)	365.8 (1200)	365.8 (1200)	365.8 (1200)				50	60/120		●		
	50	2/4	12.2 (40)	18.3 (60)	106.9 (350)	152.4 (500)	12.2 (40)	61.0 (200)	304.8 (1000)	365.8 (1200)	121.9 (400)	365.8 (1200)	365.8 (1200)	365.8 (1200)				50	60/120		●		
4	60	2/4	12.2 (40)	18.3 (60)	91.4 (300)	152.4 (500)	12.2 (40)	61.0 (200)	304.8 (1000)	365.8 (1200)	91.4 (300)	365.8 (1200)	365.8 (1200)	365.8 (1200)				50	60/120		●		
5	75	2/4	12.2 (40)	18.3 (60)	91.4 (300)	152.4 (500)	12.2 (40)	61.0 (200)	274.3 (900)	365.8 (1200)	91.4 (300)	365.8 (1200)	365.8 (1200)	365.8 (1200)				50	60/120		●		
	100	2/4	12.2 (40)	24.4 (80)	91.4 (300)	137.2 (450)	12.2 (40)	61.0 (200)	243.8 (800)	365.8 (1200)	91.4 (300)	365.8 (1200)	365.8 (1200)	365.8 (1200)				50	75/150		●		
6	125	2/4	12.2 (40)	24.4 (80)	91.4 (300)	137.2 (450)	12.2 (40)	61.0 (200)	243.8 (800)	365.8 (1200)	76.2 (250)	304.8 (1000)	365.8 (1200)	365.8 (1200)				50	75/150		●		
	150	2/4	12.2 (40)	24.4 (80)	91.4 (300)	137.2 (450)	12.2 (40)	61.0 (200)	243.8 (800)	304.8 (1000)	76.2 (250)	274.3 (900)	365.8 (1200)	365.8 (1200)				50	75/150		●		
	200	2/4	12.2 (40)	30.5 (100)	91.4 (300)	137.2 (450)	12.2 (40)	61.0 (200)	243.8 (800)	304.8 (1000)	61.0 (200)	274.3 (900)	365.8 (1200)	365.8 (1200)				50	75/150		●		
9	200	2	12.2 (40)	30.5 (100)	91.4 (300)	152.4 (500)	12.2 (40)	45.7 (150)	152.4 (500)	228.6 (750)	61.0 (200)	274.3 (900)	365.8 (1200)	365.8 (1200)				50	75/150		●		
	250	2	12.2 (40)	30.5 (100)	91.4 (300)	152.4 (500)	12.2 (40)	45.7 (150)	121.9 (400)	182.9 (600)	61.0 (200)	243.8 (800)	365.8 (1200)	365.8 (1200)				50	75/150		●		
10	300	2	12.2 (40)	30.5 (100)	61.0 (200)	121.9 (400)	12.2 (40)	45.7 (150)	61.0 (200)	121.9 (400)	61.0 (200)	243.8 (800)	304.8 (1000)	365.8 (1200)				25	165		●		
	350	2	12.2 (40)	30.5 (100)	61.0 (200)	121.9 (400)	12.2 (40)	45.7 (150)	61.0 (200)	121.9 (400)	61.0 (200)	243.8 (800)	304.8 (1000)	365.8 (1200)				25	165		●		
	450	2	12.2 (40)	30.5 (100)	61.0 (200)	121.9 (400)	12.2 (40)	45.7 (150)	61.0 (200)	121.9 (400)	61.0 (200)	213.4 (700)	304.8 (1000)	365.8 (1200)				25	165		●		
11	500	2	12.2 (40)	30.5 (100)	61.0 (200)	121.9 (400)	12.2 (40)	45.7 (150)	61.0 (200)	121.9 (400)	61.0 (200)	213.4 (700)	304.8 (1000)	365.8 (1200)				25	165		●		
	600	2	12.2 (40)	30.5 (100)	61.0 (200)	121.9 (400)	12.2 (40)	45.7 (150)	61.0 (200)	121.9 (400)	61.0 (200)	213.4 (700)	304.8 (1000)	365.8 (1200)				17	245		●		

* Maximum cable length is limited due to cable charging characteristics.

Cable Length Restrictions, Cont.

480V Shielded/Unshielded Cable, Continued- Meters (Feet)

Drive			No Solution				Reactor Only				Reactor + Damping Resistor				Line Reactor	Resistor		Used with ...				
Frame	HP	kHz	1000V	1200V	1488V	1600V	1000V	1200V	1488V	1600V	1000V	1200V	1488V	1600V	Cat. No.	Cat. No.	Ohms	Watts	TFA1	TFB2	RWR2	RWC
12	700	2	12.2 (40)	30.5 (100)	61.0 (200)	121.9 (400)	12.2 (40)	45.7 (150)	61.0 (200)	121.9 (400)	45.7 (150)	182.9 (600)	304.8 (1000)	365.8 (1200)			13	345		●		
	800	2	12.2 (40)	30.5 (100)	61.0 (200)	121.9 (400)	12.2 (40)	45.7 (150)	61.0 (200)	121.9 (400)	45.7 (150)	182.9 (600)	304.8 (1000)	365.8 (1200)			13	345		●		
	900	2	12.2 (40)	30.5 (100)	61.0 (200)	121.9 (400)	12.2 (40)	45.7 (150)	61.0 (200)	121.9 (400)	45.7 (150)	182.9 (600)	304.8 (1000)	365.8 (1200)			13	345				
13	1000	2	12.2 (40)	30.5 (100)	61.0 (200)	121.9 (400)	12.2 (40)	45.7 (150)	61.0 (200)	121.9 (400)	45.7 (150)	152.4 (500)	304.8 (1000)	365.8 (1200)			13	345				
	1200	2	12.2 (40)	30.5 (100)	61.0 (200)	121.9 (400)	12.2 (40)	45.7 (150)	61.0 (200)	121.9 (400)	45.7 (150)	152.4 (500)	304.8 (1000)	365.8 (1200)			13	345				
	1250	2	12.2 (40)	30.5 (100)	61.0 (200)	121.9 (400)	12.2 (40)	45.7 (150)	61.0 (200)	121.9 (400)	45.7 (150)	152.4 (500)	304.8 (1000)	365.8 (1200)			13	345				

600V Shielded/Unshielded Cable - Meters (Feet)

Drive			No Solution		Reactor Only		Reactor + Damping Resistor		Line Reactor	Resistor		Used with ...				
Frame	HP	kHz	1488V	1850V	1488V	1850V	1488V	1850V	Cat. No.	Cat. No.	Ohms	Watts	TFA1	TFB2	RWR2	RWC
1	1	2/4	30.5 (100)	121.9 (400)	121.9 (400)	121.9 (400)	121.9 (400)	121.9 (400)			50	40/80	●		●	●
	2	2/4	30.5 (100)	152.4 (500)	121.9 (400)	152.4 (500)	152.4 (500)	152.4 (500)			50	40/80	●	●	●	●
	3	2/4	30.5 (100)	152.4 (500)	121.9 (400)	182.9 (600)	182.9 (600)	182.9 (600)			50	40/80	●	●	●	●
	5	2/4	30.5 (100)	152.4 (500)	121.9 (400)	243.8 (800)	243.8 (800)	243.8 (800)			50	85/170	●	●	●	●
	7.5	2/4	30.5 (100)	152.4 (500)	121.9 (400)	304.8 (1000)	304.8 (1000)	304.8 (1000)			50	85/170		●		●
	10	2/4	30.5 (100)	152.4 (500)	121.9 (400)	365.8 (1200)	365.8 (1200)	365.8 (1200)			50	85/170		●		●
	15	2/4	30.5 (100)	152.4 (500)	121.9 (400)	365.8 (1200)	365.8 (1200)	365.8 (1200)			50	85/170		●		
2	20	2/4	30.5 (100)	152.4 (500)	121.9 (400)	365.8 (1200)	365.8 (1200)	365.8 (1200)			50	85/170		●		
	25	2/4	30.5 (100)	152.4 (500)	121.9 (400)	365.8 (1200)	365.8 (1200)	365.8 (1200)			50	85/170		●		
3	30	2/4	30.5 (100)	152.4 (500)	121.9 (400)	365.8 (1200)	365.8 (1200)	365.8 (1200)			50	85/170		●		
	40	2/4	30.5 (100)	152.4 (500)	121.9 (400)	365.8 (1200)	365.8 (1200)	365.8 (1200)			50	85/170		●		
4	50	2/4	36.6 (120)	152.4 (500)	121.9 (400)	365.8 (1200)	365.8 (1200)	365.8 (1200)			50	85/170		●		
	60	2/4	36.6 (120)	152.4 (500)	121.9 (400)	365.8 (1200)	365.8 (1200)	365.8 (1200)			50	85/170		●		
5	75	2/4	36.6 (120)	152.4 (500)	121.9 (400)	365.8 (1200)	365.8 (1200)	365.8 (1200)			50	85/170		●		
	100	2/4	42.7 (140)	152.4 (500)	121.9 (400)	304.8 (1000)	365.8 (1200)	365.8 (1200)			50	85/170		●		
6	125	2/4	42.7 (140)	152.4 (500)	121.9 (400)	304.8 (1000)	365.8 (1200)	365.8 (1200)			50	105/210		●		
	150	2/4	42.7 (140)	152.4 (500)	121.9 (400)	304.8 (1000)	365.8 (1200)	365.8 (1200)			50	105/210		●		
9	150	2	42.7 (140)	152.4 (500)	61.0 (200)	304.8 (1000)	365.8 (1200)	365.8 (1200)			50	105		●		
	200	2	42.7 (140)	152.4 (500)	61.0 (200)	304.8 (1000)	365.8 (1200)	365.8 (1200)			50	105		●		
10	250	2	42.7 (140)	152.4 (500)	61.0 (200)	304.8 (1000)	365.8 (1200)	365.8 (1200)			50	105		●		
	350	2	42.7 (140)	152.4 (500)	61.0 (200)	304.8 (1000)	365.8 (1200)	365.8 (1200)			25	195		●		
	400	2	42.7 (140)	152.4 (500)	61.0 (200)	304.8 (1000)	365.8 (1200)	365.8 (1200)			25	195		●		
	450	2	42.7 (140)	152.4 (500)	61.0 (200)	304.8 (1000)	365.8 (1200)	365.8 (1200)			25	195		●		
11	500	2	42.7 (140)	152.4 (500)	61.0 (200)	304.8 (1000)	365.8 (1200)	365.8 (1200)			25	195		●		
	600	2	42.7 (140)	152.4 (500)	61.0 (200)	304.8 (1000)	365.8 (1200)	365.8 (1200)			25	195		●		
12	700	2	42.7 (140)	152.4 (500)	61.0 (200)	304.8 (1000)	365.8 (1200)	365.8 (1200)			13	480		●		
	800	2	42.7 (140)	152.4 (500)	61.0 (200)	304.8 (1000)	365.8 (1200)	365.8 (1200)			13	480		●		
	900	2	42.7 (140)	152.4 (500)	61.0 (200)	304.8 (1000)	365.8 (1200)	365.8 (1200)			13	480				
13	1000	2	42.7 (140)	152.4 (500)	61.0 (200)	304.8 (1000)	365.8 (1200)	365.8 (1200)			17	320				
	1100	2	42.7 (140)	152.4 (500)	61.0 (200)	304.8 (1000)	365.8 (1200)	365.8 (1200)			13	480				
	1300	2	42.7 (140)	152.4 (500)	61.0 (200)	304.8 (1000)	365.8 (1200)	365.8 (1200)			13	480				

* Maximum cable length is limited due to cable charging characteristics.

Cable Length Restrictions, Cont.

690V Shielded/Unshielded Cable - Meters (Feet)

Drive			No Solution		Reactor Only		Reactor + Damping Resistor		Line Reactor	Resistor		Used with ...				
Frame	kW	kHz	1850V	2000V	1850V	2000V	1850V	2000V	Cat. No.	Cat. No.	Ohms	Watts	TFA1	TFB2	RWR2	RWC
5	45	2/4	30.5 (100)	76.2 (250)	91.4 (300)	152.4 (500)	365.8 (1200)	365.8 (1200)			50	115/230				
	55	2/4	30.5 (100)	76.2 (250)	91.4 (300)	152.4 (500)	365.8 (1200)	365.8 (1200)			50	115/230				
	75	2/4	30.5 (100)	76.2 (250)	91.4 (300)	152.4 (500)	365.8 (1200)	365.8 (1200)			50	115/230				
	90	2/4	30.5 (100)	76.2 (250)	91.4 (300)	152.4 (500)	365.8 (1200)	365.8 (1200)			50	125/250				
6	110	2/4	30.5 (100)	76.2 (250)	91.4 (300)	152.4 (500)	365.8 (1200)	365.8 (1200)			50	125/250				
	132	2/4	30.5 (100)	76.2 (250)	91.4 (300)	152.4 (500)	365.8 (1200)	365.8 (1200)			50	125/250				
9	160	2	30.5 (100)	68.6 (225)	91.4 (300)	152.4 (500)	274.3 (900)	365.8 (1200)			50	160				
	200	2	30.5 (100)	68.6 (225)	91.4 (300)	152.4 (500)	274.3 (900)	365.8 (1200)			50	160				
10	250	2	30.5 (100)	68.6 (225)	76.2 (250)	121.9 (400)	274.3 (900)	365.8 (1200)			50	160				
	315	2	30.5 (100)	68.6 (225)	76.2 (250)	121.9 (400)	274.3 (900)	365.8 (1200)			25	315				
	355	2	30.5 (100)	68.6 (225)	76.2 (250)	121.9 (400)	274.3 (900)	365.8 (1200)			25	315				
	400	2	30.5 (100)	68.6 (225)	76.2 (250)	121.9 (400)	243.8 (800)	304.8 (1000)			25	315				
11	450	2	30.5 (100)	68.6 (225)	76.2 (250)	121.9 (400)	243.8 (800)	304.8 (1000)			25	315				
	500	2	30.5 (100)	68.6 (225)	76.2 (250)	121.9 (400)	243.8 (800)	304.8 (1000)			25	315				
	560	2	30.5 (100)	68.6 (225)	61.0 (200)	91.4 (300)	243.8 (800)	304.8 (1000)			25	315				
12	630	2	30.5 (100)	68.6 (225)	61.0 (200)	91.4 (300)	243.8 (800)	304.8 (1000)			13	560				
	710	2	30.5 (100)	68.6 (225)	61.0 (200)	91.4 (300)	243.8 (800)	304.8 (1000)			13	560				
	800	2	30.5 (100)	68.6 (225)	61.0 (200)	91.4 (300)	243.8 (800)	304.8 (1000)			13	560				
13	900		30.5 (100)	68.6 (225)	61.0 (200)	91.4 (300)	243.8 (800)	304.8 (1000)			17	425				
	1000		30.5 (100)	68.6 (225)	48.8 (160)	91.4 (300)	243.8 (800)	304.8 (1000)			13	560				
	1100		30.5 (100)	68.6 (225)	48.8 (160)	91.4 (300)	243.8 (800)	304.8 (1000)			13	560				

Ratings and Protection Devices

208 Volt AC Input Protection Devices, Frames 1 - 6

Drive Catalog Number	kW Rating		PWM Freq. kHz	Temp. (1) °C	Input Ratings		Output Amps		Dual Element Time Delay Fuse		Non-Time Delay Fuse		Circuit Breaker (4) Max. (5)	Motor Circuit Protector (6) Max. (5)	140M Motor Starter with Adjustable Current Range (7)(8) Available Catalog Numbers (9)			
	ND	HD			Amps	kVA	Cont.	1 Min.	3 Sec.	Min. (2)	Max. (3)	Min. (2)				Max. (3)	Min. (2)	Max. (3)
20DB4P2	1	0.75	0.55	4	50	3.7	1.3	4.8	5.6	7.0	6	10	6	17.5	15	M-C2E-B63	M-D8E-B63	-
20DB6P8	1	1.5	1.1	4	50	6.8	2.4	7.8	10.4	13.8	10	15	10	30	30	M-C2E-C10	M-D8E-C10	M-F8E-C10
20DB9P6	1	2.2	1.0	4	50	9.5	3.4	11	12.1	17	12	20	12	40	40	M-C2E-C16	M-D8E-C16	M-F8E-C16
20DB015	1	4.0	3.0	4	50	15.7	5.7	17.5	19.3	26.3	20	35	20	70	70	M-C2E-C20	M-D8E-C20	M-F8E-C20
20DB022	1	5.5	4.0	4	50	23.0	8.3	25.3	27.8	38	30	50	30	100	100	M-C2E-C25	M-D8E-C25	M-F8E-C25
20DB028	2	7.5	5.5	4	50	29.6	10.7	32.2	38	50.6	40	70	40	125	125	-	-	M-F8E-C32
20DB042	3	11	7.5	4	50	44.5	16.0	48.3	53.1	72.5	60	100	60	175	175	-	-	M-F8E-C45
20DB052	3	15	11	4	50	51.5	18.6	56	64	86	80	125	80	200	200	-	-	M-CMNM-6300
20DB070	4	18.5	15	4	50	72	25.9	78.2	93.1	124.2	90	175	90	300	300	-	-	M-CMNM-9000
20DB080	4	22	18.5	4	50	84.7	30.5	92	117.3	156.4	110	200	110	350	350	-	-	M-CMNM-9000
20DB104	5	30	-	4	50	113	40.7	120	132	175	150	250	150	475	350	-	-	-
20DB130	5	37	-	4	50	141	44.1	130	143	175	175	275	175	500	375	-	-	M-CMNM-9000
20DB154	6	45	-	4	50	167	60.1	177	195	266	225	350	225	500	500	-	-	-
20DB192	6	55	-	4	50	208	75.0	221	243	308	300	450	300	600	600	-	-	-
20DB260	6	66	-	2	45	255	96.7	260	286	390	300	575	300	750	750	-	-	-
					50	199	71.7	205	305	410	225	450	225	600	600	-	-	-

- (1) The temperature rating listed for frame size 1-4 drives is for NEMA open types only. The adhesive tape label must be removed in order to operate at this temperature, otherwise the ambient operating temperature of these drives is 40°C.
- (2) Minimum protection device size is the lowest rated device that supplies maximum protection without nuisance tripping.
- (3) Maximum protection device size is the highest rated device that supplies drive protection. For US NEC, minimum size is 125% of motor FLA. Ratings shown are maximum.
- (4) Circuit Breaker - inverse time breaker. For US NEC, minimum size is 125% of motor FLA. Ratings shown are maximum.
- (5) Maximum allowable rating by US NEC. Exact size must be chosen for each installation.
- (6) Motor Circuit Protector - instantaneous trip circuit breaker. For US NEC minimum size is 125% of motor FLA. Ratings shown are maximum.
- (7) Bulletin 140M with adjustable current range should have the current trip set to the minimum range that the device will not trip.
- (8) Manual Self-Protected (Type E) Combination Motor Controller, UL listed for 208 Wye or Delta, 240 Wye or Delta, 480Y/277 or 600Y/347. Not UL listed for use on 480V or 600V Delta/Delta systems.
- (9) The AIC ratings of the Bulletin 140M Motor Protector may vary. See publication 140M-SG001.

Ratings and Protection Devices, Cont.

240 Volt AC Input Protection Devices, Frames 1 - 6

Drive Catalog Number	HP Rating 1/2 1 2 3 5 7.5 10 15 20 25 30 40 50 60 75 100	PWM Freq. kHz	Temp. (1) °C	Input Ratings		Output Amps		Dual Element Time Delay Fuse		Non-Time Delay Fuse		Circuit Breaker (4) Max. (5)	Motor Circuit Protector (6) Max. (5)	140M Motor Starter with Adjustable Current Range (7)(8)		
				Amps	kVA	Cont.	1 Min.	3 Sec.	Min. (2)	Max. (3)	Min. (2)			Max. (3)	Available Catalog Numbers (9)	Current Range (7)(8)
20DB4P2	1	0.75	4	50	3.3	1.4	4.2	4.8	6.4	5	8	15	7	M-C2E-B63	M-D8E-B63	-
20DB6P8	1	1.5	4	50	5.9	2.4	6.8	9	12	10	15	25	15	M-C2E-C10	M-D8E-C10	M-F8E-C10
20DB8P6	1	2	4	50	8.3	3.4	9.6	10.6	14.4	12	20	35	15	M-C2E-C10	M-D8E-C10	M-F8E-C10
20DB015	1	3	4	50	13.7	5.7	15.3	16.8	23	20	30	60	30	M-C2E-C16	M-D8E-C16	M-F8E-C16
20DB022	1	5	4	50	19.9	8.3	22	24.2	33	25	50	80	30	M-C2E-C25	M-D8E-C25	M-F8E-C25
20DB028	2	7.5	4	50	25.7	10.7	28	33	44	35	60	100	50	-	M-F8E-C32	M-CMN-4000
20DB042	3	15	4	50	38.5	16.0	42	46.2	63	50	90	150	50	-	M-F8E-C45	M-CMN-6300
20DB052	3	20	4	50	47.7	19.8	52	63	80	60	100	200	100	-	-	M-CMN-6300
20DB070	4	25	4	50	64.2	26.7	70	78	105	90	150	275	100	-	-	M-CMN-9000
20DB080	4	30	4	50	73.2	30.5	80	105	140	100	180	300	100	-	-	M-CMN-9000
20DB104	5	40	4	50	98	40.6	104	115	175	125	225	400	150	-	-	-
20DB130	5	50	4	50	122	50.7	130	143	175	100	175	300	100	-	-	M-CMN-9000
20DB154	6	60	4	50	98	40.6	104	156	175	125	225	400	150	-	-	-
20DB192	6	75	4	50	145	60.1	154	169	231	200	300	600	250	-	-	-
20DB260	6	100	2	45	180	74.9	192	211	288	175	275	500	250	-	-	-
					145	60.1	154	231	308	200	300	600	250	-	-	-
					233	96.8	260	286	390	300	575	750	400	-	-	-
					169	74.9	205	305	410	225	450	600	400	-	-	-

- (1) The temperature rating listed for frame size 1-4 drives is for NEMA open types only. The adhesive tape label must be removed in order to operate at this temperature, otherwise the ambient operating temperature of these drives is 40°C.
- (2) Minimum protection device size is the lowest rated device that supplies maximum protection without nuisance tripping.
- (3) Maximum protection device size is the highest rated device that supplies drive protection. For US NEC, minimum size is 125% of motor FLA. Ratings shown are maximum.
- (4) Circuit Breaker - inverse time breaker. For US NEC, minimum size is 125% of motor FLA. Ratings shown are maximum.
- (5) Maximum allowable rating by US NEC. Exact size must be chosen for each installation.
- (6) Motor Circuit Protector - instantaneous trip circuit breaker. For US NEC minimum size is 125% of motor FLA. Ratings shown are maximum.
- (7) Bulletin 140M with adjustable current range should have the current trip set to the minimum range that the device will not trip.
- (8) Manual Self-Protected (Type E) Combination Motor Controller. UL listed for 208 Wye or Delta, 240 Wye or Delta, 480V/277 or 600V/347. Not UL listed for use on 480V or 600V Delta/Delta systems.
- (9) The AIC ratings of the Bulletin 140M Motor Protector may vary. See publication 140M-SG001.

Ratings and Protection Devices, Cont.

400 Volt AC Input Protection Devices, Frames 1 - 6

Drive Catalog Number	kW Rating	PWM Freq. kHz	Temp. (3) °C		Input Ratings		Output Amps		Dual Element Time Delay Fuse		Non-Time Delay Fuse	Circuit Breaker (7) Max. (6)	Motor Circuit Protector (9) Max. (6)	140M Motor Starter with Adjustable Current Range (10)(11) Available Catalog Numbers (12)					
			ND	HD	Amps	kVA	1 Min.	3 Sec.	Min. (5)	Max. (6)					Min. (5)	Max. (6)			
20DC2P1	1	0.75	0.55	4	50	1.8	1.3	2.1	2.4	3.2	3	6	8	15	3	M-C2E-B25	M-D8E-B25	-	
20DC3P5	1	1.5	1.1	4	50	3.2	2.2	3.5	4.5	6.0	6	7	6	12	15	7	M-C2E-B40	M-D8E-B40	-
20DC5P0	1	2.2	1.5	4	50	4.6	3.2	5.0	5.5	7.5	6	10	6	20	20	7	M-C2E-B63	M-D8E-B63	-
20DC8P7	1	4	3.0	4	50	7.9	5.5	8.7	9.9	13.2	15	17.5	15	30	30	15	M-C2E-C10	M-D8E-C10	M-F8E-C10
20DC011	1	5.5	4	4	50	10.8	7.5	11.5	13	17.4	15	25	15	45	45	15	M-C2E-C16	M-D8E-C16	M-F8E-C16
20DC015	1	7.5	5.5	4	50	14.4	10.0	15.4	17.2	23.1	20	30	20	60	60	20	M-C2E-C20	M-D8E-C20	M-F8E-C20
20DC022	1	11	7.5	4	50	20.6	14.3	22	24.2	33	30	45	30	80	80	30	M-C2E-C25	M-D8E-C25	M-F8E-C25
20DC030	2	15	11	4	50	28.4	19.7	30	33	45	35	60	35	120	120	50	-	-	M-F8E-C32
20DC037	2	18.5	15	4	50	35.0	24.3	37	45	60	45	80	45	125	125	50	-	-	M-F8E-C45
20DC043	3	22	18.5	4	50	40.7	28.2	43	56	74	60	90	60	150	150	60	-	-	-
20DC056	3	30	22	4	50	53	36.7	56	64	86	70	125	70	200	200	100	-	-	-
20DC072	3	37	30	4	45	68.9	47.8	72	84	112	90	150	90	250	250	100	-	-	-
20DC085(1)	4	45	-	4	50	81.4	56.4	85	94	128	110	200	110	300	300	150	-	-	-
20DC105	5	55	-	4	50(4)	68.9	47.8	72	108	144	90	175	90	275	300	100	-	-	-
20DC125	5	55	-	4	50(4)	81.4	56.4	85	128	170	110	175	110	300	300	150	-	-	-
20DC140	5	75	-	4	50(4)	121.1	83.9	125	138	163	150	275	150	500	375	250	-	-	-
20DC170	6	90	-	4	50(4)	101	63.7	96	144	168	125	200	125	375	375	150	-	-	-
20DC205(2)	6	110	-	4	40(4)	135.6	94	140	154	210	200	300	200	400	400	250	-	-	-
20DC260	6	132	-	2	40(4)	121	69.6	105	158	210	200	225	150	300	300	150	-	-	-
						90	-	114	170	255	250	375	250	600	500	250	-	-	-
						-	75	94	140	210	280	300	200	550	400	250	-	-	-
						-	90	114	170	255	250	450	250	600	600	400	-	-	-
						-	90	114	170	255	313	375	250	600	500	250	-	-	-
						-	132	166	260	286	390	550	350	750	750	400	-	-	-
						-	110	205	308	410	250	450	250	600	600	400	-	-	-

(1) 20DC085 current rating is limited to 45 degrees C ambient.

(2) 20DC205 current rating is limited to 40 degrees C ambient.

(3) The temperature rating listed for frame size 1-4 drives is for NEMA open types only. The adhesive tape label must be removed in order to operate at this temperature, otherwise the ambient operating temperature of these drives is 40°C.

(4) UL Type 12/IP54 (flange mount) heatsink ambient temperature rating is 40°C/ambient of unprotected drive portion (inside enclosure) is 55°C. The ambient temperature for the UL Type 12/IP54 standalone drives is 40°C.

(5) Minimum protection device size is the lowest rated device that supplies maximum protection without nuisance tripping.

(6) Maximum protection device size is the highest rated device that supplies drive protection. For US NEC, minimum size is 125% of motor FLA. Ratings shown are maximum.

(7) Circuit Breaker - inverse time breaker. For US NEC, minimum size is 125% of motor FLA. Ratings shown are maximum.

(8) Maximum allowable rating by US NEC. Exact size must be chosen for each installation.

(9) Motor Circuit Protector - instantaneous trip circuit breaker. For US NEC minimum size is 125% of motor FLA. Ratings shown are maximum.

(10) Bulletin 140M with adjustable current range should have the current trip set to the minimum range that the device will not trip.

(11) Manual Self-Protected (Type E) Combination Motor Controller, UL listed for 208 Wye or Delta, 240 Wye or Delta, 480Y/277 or 600Y/347. Not UL listed for use on 480V or 600V Delta/Delta systems.

(12) The AIC ratings of the Bulletin 140M Motor Protector may vary. See publication 140M-SG001.

Ratings and Protection Devices, Cont.

400 Volt AC Input Protection Devices, Frames 9 - 11

Drive Catalog Number	kW Rating	kW Rating ND	FD	PWM Freq. kHz	Temp. °C	Input Ratings		Output Amps		Dual Element Time Delay Fuse		Non-Time Delay Fuse		Circuit Breaker (3) Max. (4)	Motor Circuit Protector (5) Max.	Watts Loss Watts
						Amps	Amps	Cont. 1 Min. 3 Sec.	Min. (1)	Max. (2)	Min. (1)	Max. (2)				
20DC261	9	132	-	2	40	263	261	287	410	350	550	350	700	700	400	2700
	-		110	2	40	207	205	308	410	275	450	275	600	600	300	2700
20DC300	9	160	-	2	40	302	300	330	450	400	650	400	900	900	400	3100
	-		132	2	40	247	245	368	490	350	500	350	700	700	400	3100
20DC385	10	200	-	2	40	388	385	424	600	500	850	500	1000	1100	600	4320
	-		160	2	40	302	300	450	600	400	650	400	900	900	400	4320
20DC460	10	250	-	2	40	463	460	506	770	600	1000	600	1200	1300	600	5335
	-		200	2	40	388	385	578	770	500	850	500	1000	1100	600	5335
20DC500	10	250	-	2	40	504	500	550	750	650	1000	650	1300	1500	700	5921
	-		250	2	40	423	420	630	840	550	900	550	1200	1200	600	5921
20DC590	11	315	-	2	40	594	590	649	956	750 (1 per phs) 375 (2 per phs)	1300 (1 per phs) 600 (2 per phs)	750 (1 per phs) 375 (2 per phs)	1700 (1 per phs) 850 (2 per phs)	1700	800	6620
	-		250	2	40	524	520	780	956	700 (1 per phs) 350 (2 per phs)	1100 (1 per phs) 550 (2 per phs)	700 (1 per phs) 350 (2 per phs)	1500 (1 per phs) 750 (2 per phs)	1500	700	6620
20DC650	11	355	-	2	40	655	650	715	1062	850 (1 per phs) 425 (2 per phs)	1400 (1 per phs) 700 (2 per phs)	850 (1 per phs) 425 (2 per phs)	1900 (1 per phs) 950 (2 per phs)	1900	1000	7538
	-		315	2	40	594	590	885	1062	750 (1 per phs) 375 (2 per phs)	1300 (1 per phs) 650 (2 per phs)	750 (1 per phs) 375 (2 per phs)	1700 (1 per phs) 850 (2 per phs)	1700	800	7538
20DC730	11	400	-	2	40	735	730	803	1095	1000 (1 per phs) 500 (2 per phs)	1600 (1 per phs) 800 (2 per phs)	1000 (1 per phs) 500 (2 per phs)	2100 (1 per phs) 1050 (2 per phs)	2100	1200	8312
	-		355	2	40	655	650	975	1170	850 (1 per phs) 425 (2 per phs)	1400 (1 per phs) 700 (2 per phs)	850 (1 per phs) 425 (2 per phs)	1900 (1 per phs) 950 (2 per phs)	1900	1000	8312

(1) Minimum protection device size is the lowest rated device that supplies maximum protection without nuisance tripping.
 (2) Maximum protection device size is the highest rated device that supplies drive protection. For US NEC, minimum size is 125% of motor FLA. Ratings shown are maximum.
 (3) Circuit Breaker - inverse time breaker. For US NEC, minimum size is 125% of motor FLA. Ratings shown are maximum.
 (4) Maximum allowable rating by US NEC. Exact size must be chosen for each installation.
 (5) Motor Circuit Protector - instantaneous trip circuit breaker. For US NEC minimum size is 125% of motor FLA. Ratings shown are maximum.

Ratings and Protection Devices, Cont.

400 Volt AC Input Protection Devices, Frames 12 & 13

Drive Catalog Number	kW Rating		PWM Freq. kHz	Temp. °C	Input Ratings		Output Amps		Dual Element Time Delay Fuse		Non-Time Delay Fuse		Circuit Breaker (4)	Motor Circuit Protector (6)	Watts Loss
	ND	HD			Amps	3 Sec.	1 Min.	Min. (1)	Max. (2)	Min. (1)	Max. (2)	Min. (1)			
20DC820	12	450	2	40	826	1230	902	1230	1100 (1 per phs) 650 (2 per phs)	1800 (1 per phs) 900 (2 per phs)	1100 (1 per phs) 650 (2 per phs)	2400 (1 per phs) 1200 (2 per phs)	2400	1200	9201
	-	400	2	40	735	1314	730	1314	1000 (1 per phs) 500 (2 per phs)	1600 (1 per phs) 800 (2 per phs)	1000 (1 per phs) 500 (2 per phs)	2100 (1 per phs) 1050 (2 per phs)	2100	1200	9201
20DC920	12	500	2	40	927	1380	920	1380	1200 (1 per phs) 600 (2 per phs)	2000 (1 per phs) 1000 (2 per phs)	1200 (1 per phs) 600 (2 per phs)	2600 (1 per phs) 1300 (2 per phs)	2600	1200	10670
	-	450	2	40	826	1476	820	1476	1100 (1 per phs) 550 (2 per phs)	1800 (1 per phs) 900 (2 per phs)	1100 (1 per phs) 550 (2 per phs)	2200 (1 per phs) 1100 (2 per phs)	2400	1200	10670
20DC1K0	12	560	2	40	1038	1555	1030	1555	1400 (1 per phs) 700 (2 per phs)	2200 (1 per phs) 1100 (2 per phs)	1400 (1 per phs) 700 (2 per phs)	3000 (1 per phs) 1500 (2 per phs)	3000	1400	11729
	-	500	2	35	927	1600	920	1600	1200 (1 per phs) 600 (2 per phs)	2000 (1 per phs) 1000 (2 per phs)	1200 (1 per phs) 600 (2 per phs)	2600 (1 per phs) 1300 (2 per phs)	2600	1200	11729
20DC1K1	13	630	2	40	1158	1620	1150	1620	1400 (2) 1500 (2)	2300 (2) 2500 (2)	1400 (2) 1500 (2)	3000 (2) 3400 (2)	3000	1400	13801
	-	560	2	40	1038	1620	1030	1620	1500 (2) 1500 (2)	2500 (2) 2500 (2)	1500 (2) 1500 (2)	3400 (2) 3400 (2)	3400	1500	13801
20DC1K3	13	710	2	40	1310	2079	1300	2079	1700 (2) 1700 (2)	2900 (2) 2900 (2)	1700 (2) 1700 (2)	3800 (2) 3800 (2)	3800	1700	15077
	-	630	2	40	1158	2079	1150	2079	1600 (2) 1900 (2)	2700 (2) 3000 (2)	1600 (2) 1900 (2)	3500 (2) 4200 (2)	3500	1600	16511
20DC1K4	13	800	2	40	1461	2175	1450	2175	1900 (2)	3000 (2)	1900 (2)	4200 (2)	4200	1900	16511

(1) Minimum protection device size is the lowest rated device that supplies maximum protection without nuisance tripping.

(2) Fuses and disconnect are supplied with AC input NEMA Type 1 drives.

(3) Maximum protection device size is the highest rated device that supplies drive protection. For US NEC, minimum size is 125% of motor FLA. Ratings shown are maximum.

(4) Circuit Breaker - inverse time breaker. For US NEC, minimum size is 125% of motor FLA. Ratings shown are maximum.

(5) Maximum allowable rating by US NEC. Exact size must be chosen for each installation.

(6) Motor Circuit Protector - instantaneous trip circuit breaker. For US NEC minimum size is 125% of motor FLA. Ratings shown are maximum.

Ratings and Protection Devices, Cont.

480 Volt AC Input Protection Devices, Frames 1 - 6

Drive Catalog Number	HP Rating	PWM Freq. kHz	Temp. (1) °C	Input Ratings		Output Amps		Dual Element Time Delay Fuse		Non-Time Delay Fuse		Circuit Breaker (5) Max. (6)	Motor Circuit Protector (7) Max. (6)	140M Motor Starter with Adjustable Current Range (8)(9)	Watts Loss			
				Amps	kVA	Cont. 1 Min. 3 Sec.	Min. (3)	Max. (4)	Min. (3)	Max. (4)	Available Catalog Numbers (10)							
20DD2P1	1	0.75	4	50	1.6	1.4	2.1	2.4	3.2	3	3	8	15	M-C2E-B25	-	103		
20DD3P4	1	1.5	4	50	2.6	2.2	3.4	4.5	6.0	4	4	12	15	M-C2E-B40	M-D8E-B40	117		
20DD5P0	1	3	4	50	3.9	3.2	5.0	5.5	7.5	6	6	20	20	M-C2E-B63	M-D8E-B63	135		
20DD8P0	1	5	4	50	6.9	5.7	8.0	8.8	12	10	10	30	30	M-C2E-C10	M-D8E-C10	210		
20DD011	1	7.5	4	50	9.5	7.9	11	12.1	16.5	15	20	40	40	M-C2E-C16	M-D8E-C16	243		
20DD014	1	10	4	50	12.5	10.4	14	16.5	22	17.5	30	50	50	M-C2E-C16	M-D8E-C16	271		
20DD022	1	15	10	50	19.9	16.6	22	24.2	33	25	50	80	80	M-C2E-C25	M-D8E-C25	389		
20DD027	2	20	15	50	24.8	20.6	27	33	44	35	60	100	100	-	M-F8E-C32	M-CMN-4000	467	
20DD034	2	25	20	50	31.2	25.9	34	40.5	54	40	70	125	125	-	M-F8E-C45	M-CMN-4000	519	
20DD040	3	30	25	50	36.7	30.5	40	51	68	50	90	150	150	-	M-F8E-C45	M-CMN-4000	543	
20DD052	3	40	30	50	47.7	39.7	52	60	80	60	110	200	200	-	-	M-CMN-6300	708	
20DD065	3	50	40	50	59.6	49.6	65	78	104	80	125	250	250	-	-	M-CMN-9000	767	
20DD077	4	60	-	50	72.3	60.1	77	85	116	100	170	300	300	-	-	M-CMN-9000	780	
20DD096	5	75	-	50	90.1	74.9	96	106	144	125	200	350	350	-	-	M-CMN-9000	780	
20DD125	5	100	-	50	117	97.6	125	138	163	150	250	500	375	-	-	M-CMN-9000	1157	
20DD156	6	125	-	50	146.5	121.7	156	172	234	200	350	600	450	-	-	-	1529	
20DD180	6	150	-	50	131	97.6	125	188	250	175	250	500	375	-	-	-	1895	
20DD248	6	200	-	50	169	140.5	180	198	270	225	400	600	500	-	-	-	2254	
				40	147	121.7	156	234	312	200	350	200	600	450	-	-	-	2254
				40	232.8	188	248	273	372	300	550	300	700	700	-	-	-	-
				40	169	140.5	180	270	360	225	400	225	600	500	-	-	-	-

(1) The temperature rating listed for frame size 1-4 drives is for NEMA open types only. The adhesive tape label must be removed in order to operate at this temperature, otherwise the ambient operating temperature of these drives is 40°C.
 (2) UL Type 12/IP54 (flange mount) heatsink ambient temperature rating is 40° C/ambient of unprotected drive portion (inside enclosure) is 55° C. The ambient temperature for the UL Type 12/IP54 stand-alone drives is 40° C.
 (3) Minimum protection device size is the lowest rated device that supplies maximum protection without nuisance tripping.
 (4) Maximum protection device size is the highest rated device that supplies drive protection. For US NEC, minimum size is 125% of motor FLA. Ratings shown are maximum.
 (5) Circuit Breaker - inverse time breaker. For US NEC, minimum size is 125% of motor FLA. Ratings shown are maximum.
 (6) Maximum allowable rating by US NEC. Exact size must be chosen for each installation.
 (7) Motor Circuit Protector - instantaneous trip circuit breaker. For US NEC minimum size is 125% of motor FLA. Ratings shown are maximum.
 (8) Bulletin 140M with adjustable current range should have the current trip set to the minimum range that the device will not trip.
 (9) Manual Self-Protected (Type E) Combination Motor Controller, UL listed for 208 Wye or Delta, 240 Wye or Delta, 480V/277 or 600V/347. Not UL listed for use on 480V or 600V Delta/Delta systems.
 (10) The AIC ratings of the Bulletin 140M Motor Protector may vary. See publication 140M-SG001.

Ratings and Protection Devices, Cont.

480 Volt AC Input Protection Devices, Frames 9 - 11

Drive Catalog Number	HP Rating ND	HP Rating HD	PWM Freq. kHz	Temp. °C	Input Ratings		Output Amps		Dual Element Time Delay Fuse		Non-Time Delay Fuse		Circuit Breaker (3)	Motor Circuit Protector (5)	Watts Loss
					Amps	Temp. °C	Cont.	1 Min. 3 Sec.	Min. (1)	Max. (2)	Min. (1)	Max. (2)			
20DD261	9	200	2	40	252	261	287	410	350	550	350	700	700	400	2700
		-	150	2	40	207	205	308	275	450	275	600	600	300	2700
20DD300	9	250	2	40	290	300	330	450	400	650	400	900	900	400	3100
		-	200	2	40	247	245	368	350	500	350	700	700	400	3100
20DD385	10	300	2	40	372	385	424	600	500	850	500	1100	1100	600	4320
		-	250	2	40	302	300	450	400	650	400	900	900	400	4320
20DD460	10	350	2	40	444	460	506	770	600	1000	600	1300	1300	600	5335
		-	300	2	40	338	385	578	500	850	500	1100	1100	600	5335
20DD500	10	450	2	40	483	500	550	750	650	1000	650	1500	1500	700	5921
		-	350	2	40	423	420	630	550	900	550	1200	1200	600	5921
20DD590	11	500	2	40	570	590	649	956	750 (1 per phs) 375 (2 per phs)	1300 (1 per phs) 600 (2 per phs)	750 (1 per phs) 375 (2 per phs)	1700 (1 per phs) 850 (2 per phs)	1700	800	6620
		-	450	2	40	524	520	780	700 (1 per phs) 350 (2 per phs)	1100 (1 per phs) 550 (2 per phs)	700 (1 per phs) 350 (2 per phs)	1500 (1 per phs) 750 (2 per phs)	1500	700	6620
20DD650	11	500	2	40	628	650	715	1062	850 (1 per phs) 425 (2 per phs)	1400 (1 per phs) 700 (2 per phs)	850 (1 per phs) 425 (2 per phs)	1900 (1 per phs) 950 (2 per phs)	1900	800	7538
		-	500	2	40	594	590	885	750 (1 per phs) 375 (2 per phs)	1300 (1 per phs) 650 (2 per phs)	750 (1 per phs) 375 (2 per phs)	1700 (1 per phs) 850 (2 per phs)	1700	800	7538
20DD730	11	600	2	40	705	730	803	1095	900 (1 per phs) 450 (2 per phs)	1600 (1 per phs) 800 (2 per phs)	900 (1 per phs) 450 (2 per phs)	2100 (1 per phs) 1050 (2 per phs)	2100	1000	8312
		-	500	2	40	655	650	975	850 (1 per phs) 425 (2 per phs)	1400 (1 per phs) 700 (2 per phs)	850 (1 per phs) 425 (2 per phs)	1900 (1 per phs) 950 (2 per phs)	1900	800	8312

- (1) Minimum protection device size is the lowest rated device that supplies maximum protection without nuisance tripping.
- (2) Maximum protection device size is the highest rated device that supplies drive protection. For US NEC, minimum size is 125% of motor FLA. Ratings shown are maximum.
- (3) Circuit Breaker - inverse time breaker. For US NEC, minimum size is 125% of motor FLA. Ratings shown are maximum.
- (4) Maximum allowable rating by US NEC. Exact size must be chosen for each installation.
- (5) Motor Circuit Protector - instantaneous trip circuit breaker. For US NEC minimum size is 125% of motor FLA. Ratings shown are maximum.

Ratings and Protection Devices, Cont.

480 Volt AC Input Protection Devices, Frames 12 & 13

Drive Catalog Number	HP Rating ND	HP Rating UD	PWM Freq. kHz	Temp. °C	Input Ratings Amps	Output Amps		Dual Element Time Delay Fuse		Non-Time Delay Fuse		Circuit Breaker (4) Max. (5)	Motor Circuit Protector (6) Max.	Watts Loss
						Cont.	1 Min. 3 Sec.	Min. (1)	Max. (3)	Min. (1)	Max. (3)			
200D820	12	700	-	40	792	820	902	1230	1000 (1 per phs)	1800 (1 per phs)	1000 (1 per phs)	2400 (1 per phs)	1200	9201
						730	1095	1314	900 (2 per phs)	900 (2 per phs)	500 (2 per phs)	1200 (2 per phs)		
200D920	12	800	-	40	888	920	1012	1380	450 (2 per phs)	800 (2 per phs)	900 (1 per phs)	2100	1200	9201
						820	1230	1476	1200 (1 per phs)	2000 (1 per phs)	1200 (1 per phs)	2600 (1 per phs)		
200D1K0	12	900	-	40	994	1030	1133	1555	600 (2 per phs)	1100 (2 per phs)	650 (2 per phs)	3000	1300	11729
						920	1370	1600	1200 (1 per phs)	2000 (1 per phs)	1500 (2 per phs)	2600 (1 per phs)		
200D1K1	13	1000	-	40	1110	1150	1265	1620	600 (2 per phs)	1000 (2 per phs)	600 (2 per phs)	3000	1300	13801
						1030	1545	1620	900 (2 per phs)	2300 (2)	1300 (2)	3000 (2)		
200D1K3	13	1200	-	40	1255	1300	1430	2079	1400 (2)	2500 (2)	1400 (2)	3400	1400	15077
						1150	1725	2079	1600 (2)	2900 (2)	1600 (2)	3800 (2)		
200D1K4	13	1250	-	40	1400	1450	1595	2175	1500 (2)	2700 (2)	1500 (2)	3500	1500	16511
						1200	1800	2400	1800 (2)	3000 (2)	1800 (2)	4200 (2)		

(1) Minimum protection device size is the lowest rated device that supplies maximum protection without nuisance tripping.

(2) Fuses and disconnect are supplied with AC input NEMA Type T drives.

(3) Maximum protection device size is the highest rated device that supplies drive protection. For US NEC, minimum size is 125% of motor FLA. Ratings shown are maximum.

(4) Circuit Breaker - inverse time breaker. For US NEC, minimum size is 125% of motor FLA. Ratings shown are maximum.

(5) Maximum allowable rating by US NEC. Exact size must be chosen for each installation.

(6) Motor Circuit Protector - instantaneous trip circuit breaker. For US NEC minimum size is 125% of motor FLA. Ratings shown are maximum.

Ratings and Protection Devices, Cont.

600 Volt AC Input Protection Devices, Frames 1 - 6

Drive Catalog Number	HP Rating ND	PWM Freq. kHz	Temp. ⁽¹⁾ °C	Input Ratings		Output Amps		Dual Element Time Delay Fuse		Non-Time Delay Fuse	Circuit Breaker ⁽⁵⁾ Max. (6)	Motor Circuit Protector ⁽⁷⁾ Max. (6)	140M Motor Starter with Adjustable Current Range ⁽⁸⁾⁽⁹⁾ Available Catalog Numbers ⁽¹⁰⁾					
				Amps	kVA	Cont. 1 Min.	3 Sec.	Min. ⁽³⁾	Max. ⁽⁴⁾					Min. ⁽³⁾	Max. ⁽⁴⁾			
200E1P7	1	0.75	4	50	1.3	1.4	1.7	2	2.6	2	4	2	6	15	3	M-C2E-B16	-	-
200E2P7	1	1.5	4	50	2.1	2.1	2.7	3.6	4.8	3	6	3	10	15	3	M-C2E-B25	-	-
200E3P9	1	2	4	50	3.0	3.1	3.9	4.3	5.9	6	9	6	15	15	7	M-C2E-B40	M-D8E-B40	-
200E6P1	1	5	3	4	50	5.3	5.5	6.1	9.2	9	12	9	20	20	15	M-C2E-B63	M-D8E-B63	-
200E9P0	1	7.5	5	4	50	7.8	8.1	9	13.5	10	20	10	35	30	15	M-C2E-C10	M-D8E-C10	M-F8E-C10
200E011	1	10	7.5	4	50	9.9	10.2	11	13.5	18	15	25	40	40	15	M-C2E-C10	M-D8E-C10	M-F8E-C10
200E017	1	15	10	4	50	15.4	16.0	17	18.7	25.5	20	40	60	50	20	M-C2E-C16	M-D8E-C16	M-F8E-C16
200E022	2	20	15	4	50	20.2	21.0	22	25.5	34	30	50	80	80	30	M-C2E-C25	M-D8E-C25	M-F8E-C25
200E027	2	25	20	4	50	24.8	25.7	27	33	44	35	60	100	100	50	-	-	M-F8E-C25
200E032	3	30	25	4	50	29.4	30.5	32	40.5	54	40	70	125	125	50	-	-	M-F8E-C32
200E041	3	40	30	4	50	37.6	39.1	41	48	64	50	90	150	150	100	-	-	M-F8E-C45
200E052	3	50	40	4	50	47.7	49.6	52	61.5	82	60	110	200	200	100	-	-	M-F8E-C45
200E062	4	60	50	2	45	58.2	60.5	62	78	104	80	125	80	225	100	-	-	-
200E077	5	75	-	2	45	72.3	75.1	77	85	116	90	150	90	300	100	-	-	-
200E099	5	100	-	2	50(2)	58.2	60.5	63	94	126	90	125	90	250	100	-	-	-
200E125	6	125	-	2	50(2)	72.3	75.1	77	116	138	100	175	100	300	100	-	-	-
200E144	6	150	-	2	50(2)	93	96.6	99	149	198	125	200	125	375	150	-	-	-
						135	140.5	144	158	216	175	300	175	400	250	-	-	-
						117	121.6	125	188	250	150	275	150	375	250	-	-	-

- (1) The temperature rating listed for frame size 1-4 drives is for NEMA open types only. The adhesive tape label must be removed in order to operate at this temperature, otherwise the ambient operating temperature of these drives is 40°C.
- (2) UL Type 12/IP54 (flange mount) heatsink ambient temperature rating is 40° C/ambient of unprotected drive portion (inside enclosure) is 55° C. The ambient temperature for the UL Type 12/IP54 standalone drives is 40° C.
- (3) Minimum protection device size is the lowest rated device that supplies maximum protection without nuisance tripping.
- (4) Maximum protection device size is the highest rated device that supplies drive protection. For US NEC, minimum size is 125% of motor FLA. Ratings shown are maximum.
- (5) Circuit Breaker - inverse time breaker. For US NEC, minimum size is 125% of motor FLA. Ratings shown are maximum.
- (6) Maximum allowable rating by US NEC. Exact size must be chosen for each installation.
- (7) Motor Circuit Protector - instantaneous trip circuit breaker. For US NEC minimum size is 125% of motor FLA. Ratings shown are maximum.
- (8) Bulletin 140M with adjustable current range should have the current trip set to the minimum range that the device will not trip.
- (9) Manual Self-Protected (Type E) Combination Motor Controller, UL listed for 208 Wye or Delta, 240 Wye or Delta, 480Y/277 or 600Y/347. Not UL listed for use on 480V or 600V Delta/Delta systems.
- (10) The AIC ratings of the Bulletin 140M Motor Protector may vary. See publication 140M-SG001.

Ratings and Protection Devices, Cont.

600 Volt AC Input Protection Devices, Frames 9 - 11

Drive Catalog Number	HP Rating ND	HP Rating LA	PWM Freq. kHz	Temp. °C	Input Ratings Amps	Output Amps		Dual Element Time Delay Fuse		Non-Time Delay Fuse		Circuit Breaker (3) Max. (4)	Motor Circuit Protector (6) Max.	Watts Loss	
						Cont.	1 Min.	3 Sec.	Min. (1)	Max. (2)	Min. (1)				Max. (2)
20DE170	9	150	2	40	164	Cont.	170	187	245	225	350	500	500	250	-
						1 Min.	144	216	245	200	300	400	400	200	-
20DE208	9	200	2	35	201	Cont.	208	230	289	300	450	600	600	350	-
						1 Min.	170	250	289	225	350	500	500	250	-
20DE261	10	250	2	40	252	Cont.	261	287	375	350	550	700	700	350	4206
						1 Min.	208	312	375	300	450	600	600	300	4206
20DE325	10	350	2	40	314	Cont.	325	358	470	400	700	900	900	450	4751
						1 Min.	261	392	470	350	550	700	700	400	4751
20DE385	10	400	2	40	372	Cont.	385	424	585	500	850	1100	1100	500	5527
						1 Min.	325	488	585	400	700	900	900	450	5527
20DE416	10	450	2	35	402	Cont.	416	458	585	550	900	1200	1200	550	5622
						1 Min.	325	488	585	400	700	900	900	450	5622
20DE460	11	500	2	40	444	Cont.	460	506	693	600	1000	1300	1300	600	6345
						1 Min.	385	578	693	500	800	1100	1100	500	6345
20DE502	11	500	2	40	485	Cont.	502	552	828	650	1100	1400	1400	650	6925
						1 Min.	460	690	828	600	1000	1300	1300	600	6925
20DE590	11	600	2	35	570	Cont.	590	649	885	800 (1 per phs) 400 (2 per phs)	1300 (1 per phs) 650 (2 per phs)	1700 (1 per phs) 850 (2 per phs)	1700 (1 per phs) 850 (2 per phs)	800	7539
						1 Min.	502	753	904	650 (1 per phs) 325 (2 per phs)	1100 (1 per phs) 550 (2 per phs)	1400 (1 per phs) 700 (2 per phs)	1400 (1 per phs) 700 (2 per phs)	700	7539

(1) Minimum protection device size is the lowest rated device that supplies maximum protection without nuisance tripping.
 (2) Maximum protection device size is the highest rated device that supplies drive protection. For US NEC, minimum size is 125% of motor FLA. Ratings shown are maximum.
 (3) Circuit Breaker - inverse time breaker. For US NEC, minimum size is 125% of motor FLA. Ratings shown are maximum.
 (4) Maximum allowable rating by US NEC. Exact size must be chosen for each installation.
 (5) Motor Circuit Protector - instantaneous trip circuit breaker. For US NEC minimum size is 125% of motor FLA. Ratings shown are maximum.

Ratings and Protection Devices, Cont.

600 Volt AC Input Protection Devices, Frames 12 & 13

Drive Catalog Number	HP Rating ND	HP Rating HD	PWM Freq. kHz	Temp. °C	Input Ratings Amps	Output Amps		Dual Element Time Delay Fuse		Non-Time Delay Fuse		Circuit Breaker (5) Max. (6)	Motor Circuit Protector (7) Max.	Watts Loss Watts
						Cont.	1 Min.	3 Sec.	Min. (2)	Max. (4)	Min. (2)			
20DE650	12	700	2	40	628	650	715	1062	800 (1 per phs)	1400 (1 per phs)	800 (1 per phs)	1900 (1 per phs)	900	9502
									400 (2 per phs)	700 (2 per phs)	400 (2 per phs)	950 (2 per phs)		
20DE750	12	800	2	40	724	750	825	1170	750 (1 per phs)	1300 (1 per phs)	750 (1 per phs)	1700 (1 per phs)	800	9502
									375 (2 per phs)	650 (2 per phs)	375 (2 per phs)	850 (2 per phs)		
20DE820 (1)	12	900	2	35	792	820	902	1170	950 (1 per phs)	1600 (1 per phs)	950 (1 per phs)	2200 (1 per phs)	1000	10570
									475 (2 per phs)	800 (2 per phs)	475 (2 per phs)	1100 (2 per phs)		
20DE920	13	1000	2	40	888	920	1012	1380	800 (1 per phs)	1400 (1 per phs)	800 (1 per phs)	1900 (1 per phs)	900	10570
									400 (2 per phs)	700 (2 per phs)	400 (2 per phs)	950 (2 per phs)		
20DE1K0	13	1100	2	40	994	1030	1133	1545	1000 (1 per phs)	1800 (1 per phs)	1000 (1 per phs)	2400 (1 per phs)	1100	11082
									500 (2 per phs)	900 (2 per phs)	500 (2 per phs)	1200 (2 per phs)		
20DE1K1	13	1300	2	35	1139	1180	1298	1755	800 (1 per phs)	1400 (1 per phs)	800 (1 per phs)	1900 (1 per phs)	900	11082
									400 (2 per phs)	700 (2 per phs)	400 (2 per phs)	950 (2 per phs)		
20DE1K1	13	1300	2	35	994	1030	1463	1755	1200 (3)	2000 (3)	1200 (3)	2700 (3)	1200	12690
									1000 (3)	1800 (3)	1000 (3)	2400 (3)		
20DE1K1	13	1300	2	35	994	1030	1463	1755	1300 (3)	2200 (3)	1300 (3)	3000 (3)	1300	15907
									1200 (3)	2000 (3)	1200 (3)	2700 (3)		
20DE1K1	13	1300	2	35	994	1030	1463	1755	1500 (3)	2600 (3)	1500 (3)	3500 (3)	1500	17306
									1300 (3)	2200 (3)	1300 (3)	3000 (3)		

- (1) 20DE820 drives (ND) are only capable of producing 95% of starting torque under 10 Hz.
- (2) Minimum protection device size is the lowest rated device that supplies maximum protection without nuisance tripping.
- (3) Fuses and disconnect are supplied with AC input NEMA Type 1 drives.
- (4) Maximum protection device size is the highest rated device that supplies drive protection. For US NEC, minimum size is 125% of motor FLA. Ratings shown are maximum.
- (5) Circuit Breaker - inverse time breaker. For US NEC, minimum size is 125% of motor FLA. Ratings shown are maximum.
- (6) Maximum allowable rating by US NEC. Exact size must be chosen for each installation.
- (7) Motor Circuit Protector - instantaneous trip circuit breaker. For US NEC minimum size is 125% of motor FLA. Ratings shown are maximum.

Ratings and Protection Devices, Cont.

690 Volt AC Input Protection Devices, Frames 5 & 6

Drive Catalog Number	kW Rating HP	PWM Freq. kHz	Temp. (1) °C	Input Ratings		Output Amps		Dual Element Time Delay Fuse		Non-Time Delay Fuse		Circuit Breaker (4) Max. (5)	Motor Circuit Protector (6) Max. (5)	Watts Loss
				Amps	kVA	Cont.	1 Min.	3 Sec.	Min. (2)	Max. (3)	Min. (2)			
20DF052	5	45	50	46.9	59.5	52	57	78	60	110	60	175	175	-
	-	-	37.5	4	40.1	48.0	46	69	92	50	90	50	150	150
20DF060	5	55	50	57.7	68.9	60	66	90	80	125	80	225	225	-
	-	-	45	4	46.9	59.5	52	78	104	60	110	60	175	175
20DF082	5	75	50	79.0	94.4	82	90	123	100	200	100	375	375	-
	-	-	55	2	57.7	68.9	60	90	120	80	125	80	225	225
20DF098	5	90	40	94.7	113	98	108	127	125	200	125	375	375	-
	-	-	75	2	79.0	94.4	82	123	140	100	200	100	375	375
20DF119	6	110	50	115	138	119	131	179	150	250	150	400	400	-
	-	-	90	2	92.9	113	98	147	196	125	200	125	375	375
20DF142	6	132	50	139	165.9	142	156	213	175	300	175	450	450	-
	-	-	110	2	115	137	119	179	238	150	250	150	400	400

(1) UL Type 12/IP54 (flange mount) heatsink ambient temperature rating is 40° C/ambient of unprotected drive portion (inside enclosure) is 55° C. The ambient temperature for the UL type 12/IP54 standalone drives is 40° C.
 (2) Minimum protection device size is the lowest rated device that supplies maximum protection without nuisance tripping.
 (3) Maximum protection device size is the highest rated device that supplies drive protection. For US NEC, minimum size is 125% of motor FLA. Ratings shown are maximum.
 (4) Circuit Breaker - inverse time breaker. For US NEC, minimum size is 125% of motor FLA. Ratings shown are maximum.
 (5) Maximum allowable rating by US NEC. Exact size must be chosen for each installation.
 (6) Motor Circuit Protector - instantaneous trip circuit breaker. For US NEC minimum size is 125% of motor FLA. Ratings shown are maximum.

Ratings and Protection Devices, Cont.

690 Volt AC Input Protection Devices, Frames 9 - 11

Drive Catalog Number	kW Rating HP	PWM Freq. kHz	Temp. °C	Input Ratings Amps	Output Amps		Dual Element Time Delay Fuse		Non-Time Delay Fuse		Circuit Breaker (3) Max. (4)	Motor Circuit Protector (5) Max.	Watts Loss
					Cont.	1 Min.	3 Sec.	Min. (1)	Max. (2)	Min. (1)			
20DF170	9	2	40	171	170	187	245	225	350	225	550	250	-
20DF208	9	2	35	210	144	216	245	200	300	200	500	200	-
					208	230	289	300	450	300	600	350	-
20DF261	10	2	40	263	170	250	289	225	350	225	500	250	-
					261	287	375	350	550	350	700	350	4206
20DF325	10	2	40	327	208	312	375	300	450	300	600	300	4206
					325	358	470	425	700	425	900	450	4751
20DF385	10	2	40	388	261	392	470	350	550	350	700	350	4751
					385	424	585	500	850	500	1100	500	5927
20DF416	10	2	35	419	325	488	585	450	700	450	900	450	5927
					416	458	585	550	900	550	1200	550	5622
20DF460	11	2	40	463	325	488	585	450	700	450	900	450	5622
					460	506	693	600	1000	600	1300	600	6345
20DF502	11	2	40	506	385	578	693	500	800	500	1500	500	6345
					502	552	828	700	1200	700	1400	650	6925
20DF590	11	2	35	594	460	690	828	600	1000	600	1300	600	6925
					590	649	885	800 (1 per phs)	1300 (1 per phs)	800 (1 per phs)	1700 (1 per phs)	800	7539
		2	35	506	502	753	904	325 (2 per phs)	550 (2 per phs)	325 (2 per phs)	700 (2 per phs)	650	7539
					500			400 (2 per phs)	650 (2 per phs)	400 (2 per phs)	850 (2 per phs)	1400 (1 per phs)	1400

- (1) Minimum protection device size is the lowest rated device that supplies maximum protection without nuisance tripping.
- (2) Maximum protection device size is the highest rated device that supplies drive protection. For US NEC, minimum size is 125% of motor FLA. Ratings shown are maximum.
- (3) Circuit Breaker - inverse time breaker. For US NEC, minimum size is 125% of motor FLA. Ratings shown are maximum.
- (4) Maximum allowable rating by US NEC. Exact size must be chosen for each installation.
- (5) Motor Circuit Protector - instantaneous trip circuit breaker. For US NEC minimum size is 125% of motor FLA. Ratings shown are maximum.

Ratings and Protection Devices, Cont.

690 Volt AC Input Protection Devices, Frames 12 & 13

Drive Catalog Number	kW Rating ND	PWM Freq. kHz	Temp. °C	Input Ratings Amps	Output Amps Cont. 1 Min. 3 Sec.	Dual Element Time Delay Fuse		Non-Time Delay Fuse		Circuit Breaker (5) Max. (6)	Motor Circuit Protector (7) Max.	Watts Loss
						Min. (2)	Max. (4)	Min. (2)	Max. (4)			
20DF650	12 630	2	40	655	650 715 1062	850 (1 per phs) 425 (2 per phs)	1400 (1 per phs) 700 (2 per phs)	850 (1 per phs) 425 (2 per phs)	1900 (1 per phs) 950 (2 per phs)	1900	850	9502
	-	560	40	594	590 885 1062	750 (1 per phs) 375 (2 per phs)	1300 (1 per phs) 650 (2 per phs)	750 (1 per phs) 375 (2 per phs)	1700 (1 per phs) 850 (2 per phs)	1700	800	9502
	12 710	2	40	756	750 825 1170	950 (1 per phs) 475 (2 per phs)	1600 (1 per phs) 800 (2 per phs)	950 (1 per phs) 475 (2 per phs)	2200 (1 per phs) 1100 (2 per phs)	2200	1000	10570
20DF820(1)	-	630	40	655	650 975 1170	850 (1 per phs) 425 (2 per phs)	1400 (1 per phs) 700 (2 per phs)	850 (1 per phs) 425 (2 per phs)	1900 (1 per phs) 950 (2 per phs)	1900	850	10570
	12 800	2	35	826	820 902 1170	1100 (1 per phs) 550 (2 per phs)	1800 (1 per phs) 900 (2 per phs)	1100 (1 per phs) 550 (2 per phs)	2400 (1 per phs) 1200 (2 per phs)	2400	1100	11082
	-	630	35	655	650 975 1170	850 (1 per phs) 425 (2 per phs)	1400 (1 per phs) 700 (2 per phs)	850 (1 per phs) 425 (2 per phs)	1900 (1 per phs) 950 (2 per phs)	1900	850	11082
20DF920	13 900	2	40	927	920 1012 1380	1200 (3)	1800 (3)	1200 (3)	2400 (3)	2400	1100	12690
	-	800	40	826	820 1230 1410	1100 (3)	1800 (3)	1100 (3)	2400 (3)	2400	1100	12690
20DF1K0	13 1000	2	40	1038	1030 1133 1545	1300 (3)	2200 (3)	1300 (3)	3000 (3)	3000	1300	15907
	-	900	40	927	920 1380 1755	1200 (3)	2000 (3)	1200 (3)	2700 (3)	2700	1200	15907
20DF1K1	13 1100	2	35	1189	1180 1298 1755	1500 (3)	2600 (3)	1500 (3)	3500 (3)	3500	1500	17306
	-	1000	35	1038	1030 1463 1755	1300 (3)	2200 (3)	1300 (3)	3000 (3)	3000	1300	17306

(1) 20DF820 drives (ND) are only capable of producing 95% of starting torque under 10 Hz.
 (2) Minimum protection device size is the lowest rated device that supplies maximum protection without nuisance tripping.
 (3) Fuses and disconnect are supplied with AC input NEMA Type 1 drives.
 (4) Maximum protection device size is the highest rated device that supplies drive protection. For US NEC, minimum size is 125% of motor FLA. Ratings shown are maximum.
 (5) Circuit Breaker - inverse time breaker. For US NEC, minimum size is 125% of motor FLA. Ratings shown are maximum.
 (6) Maximum allowable rating by US NEC. Exact size must be chosen for each installation.
 (7) Motor Circuit Protector - instantaneous trip circuit breaker. For US NEC minimum size is 125% of motor FLA. Ratings shown are maximum

Ratings and Protection Devices, Cont.

325 Volt DC Input Protection Devices, Frames 1 - 6

Drive Catalog Number	Frame	HP Rating		PWM Freq. kHz	Temp. °C	DC Input Ratings Amps	Output Amps ⁽⁴⁾			Non-Time Delay Fuse ⁽⁵⁾	
		ND	HD				Cont.	1 Min.	3 Sec.		Fuse
20DB015	1	5	3	4	45	16	15.3	16.8	23.0	30	HSJ30
20DB022	1	7.5	5	4	45	23.3	22	24.2	33	45	HSJ45
20DB028	2	10	7.5	4	45	30	28	33	44	60	HSJ60
20DB042	3	15	10	4	45	45	42	46.2	63	90	HSJ90
20DB052	3	20	15	4	45	55	52	63	80	100	HSJ100
20DB070	4	25	20	4	45	75.3	70	78	105	150	HSJ150
20DB080	4	30	25	4	45	85.8	80	105	140	175	HSJ175
20DN104 ⁽¹⁾	5	40	30	4	45	114.1	104 (80)	115 (120)	175 (160)	225	HSJ225
20DN130 ⁽¹⁾	5	50	40	4	45	142.6	130 (104)	143 (156)	175 (175)	250	HSJ250
20DN154 ⁽¹⁾	6	60	50	4	45	169	154 (130)	169 (195)	231 (260)	300	HSJ300
20DN192 ⁽¹⁾	6	75	60	4	45	210.6	192 (154)	211 (231)	288 (308)	400	HSJ400
20DN260 ⁽¹⁾⁽²⁾	6	100	75	4	50	272.1	260 (205)	286 (305)	390 (410)	400	HSJ400

- (1) Catalog number corresponds to output amps for these drives. Drive must be programmed to lower voltage to obtain higher currents shown at right.
- (2) Catalog number corresponds to drives with precharge only.
- (3) The temperature rating listed for frame size 1-4 drives is for NEMA open types only. The adhesive tape label must be removed in order to operate at this temperature; otherwise the ambient operating temperature of these drives is 40°C.
- (4) Frame 5 and 6 drives have dual current ratings; one for normal duty applications, and one for heavy duty applications (in parenthesis). The drive may be operated at either rating.
- (5) The power source to Common Bus inverters must be derived from AC Voltages 600V or less, as defined in NFPA70; Art 430-18 (NEC). Battery supplies or MG sets are not included. The following devices were validated to break current of the derived power DC Bus: *Disconnects*: Allen-Bradley Bulletin No. 1494, 30 to 400 A; Bulletin No. 194, 30 to 400 A, or ABB: OESA, 600 & 800 A; OESL, all sizes. *Fuses*: Ferraz Shawmut Type HSI, all sizes. For any other devices, please contact the factory.

Ratings and Protection Devices, Cont.

540 Volt DC Input Protection Devices, Frames 1 - 6

Drive Catalog Number	Frame	kW Rating		PWM Freq. kHz	Temp. (2) °C	DC Input Ratings		Output Amps			Non-Time Delay Fuse (3)
		ND	HD			Amps	Cont.	1 Min.	3 Sec.	Fuse	
20DC3P5	1	1.5	1.1	4	50	3.7	3.5	4.5	6.0	8	JKS-8
20DC5P0	1	2.2	1.5	4	50	5.3	5.0	5.5	7.5	10	JKS-10
20DC8P7	1	4	3.0	4	50	9.3	8.7	9.9	13.2	15	HSJ15
20DC011	1	5.5	4	4	50	12.6	11.5	13	17.4	20	HSJ20
20DC015	1	7.5	5.5	4	50	16.8	15.4	17.2	23.1	25	HSJ25
20DC022	1	11	7.5	4	50	24	22	24.2	33	40	HSJ40
20DC030	2	15	11	4	50	33.2	30	33	45	50	HSJ50
20DC037	2	18.5	15	4	50	40.9	37	45	60	70	HSJ70
20DC043	3	22	18.5	4	50	47.5	43	56	74	90	HSJ90
20DC056	3	30	22	4	50	61.9	56	64	86	100	HSJ100
20DC072	3	37	30	4	50	80.5	72	84	112	125	HSJ125
20DC085	4	45	37	4	50	95.1	85	108	144	150	HSJ150
20DH105 (1)	5	55	-	4	50	120.2	105	116	158	175	HSJ175
20DH125 (1)	5	55	-	4	50	95.1	85	128	170	175	HSJ175
						120.2	125	138	163	200	HSJ200
						95.1	96	144	168	200	HSJ200
20DH140 (1)	5	75	-	4	50	159	140	154	210	250	HSJ250
						120.2	105	158	210	250	HSJ250
20DH170 (1)	6	90	-	4	50	192	170	187	255	350	HSJ350
						159	140	210	280	350	HSJ350
20DH205 (1)	6	110	-	4	40	226	205	220	289	350	HSJ350
						192	170	255	313	350	HSJ350
20DH260 (1)	6	132	-	2	40	298	260	286	390	400	HSJ400
						226	205	305	410	400	HSJ400

(1) Also applies to "P" voltage class. Fuses must be applied in the (+) leg and (-) leg of the DC Common Bus.
 (2) The temperature rating listed for frame size 1-4 drives is for NEMA open types only. The adhesive tape label must be removed in order to operate at this temperature, otherwise the ambient operating temperature of these drives is 40°C.
 (3) The power source to Common Bus inverters must be derived from AC voltages 600V or less, as defined in NFPA70: Art 430-18 (NEC). Battery supplies or MG sets are not included. The following devices were validated to break current of the derived power DC Bus: *Disconnects*: Allen-Bradley Bulletin No. 1494, 30 to 400 A; Bulletin No. 194, 30 to 400 A, or ABB: OESA, 600 & 800 A; OESL, all sizes. *Fuses*: Busmann Type JKS, all sizes; Type 170M, Case Sizes 1, 2 and 3, or Ferraz Shawmut Type HSJ, all sizes. For any other devices, please contact the factory.

Ratings and Protection Devices, Cont.

540 Volt DC Input Protection Devices, Frames 9 - 13

Drive Catalog Number	Frame	kW Rating		PWM Freq. kHz	Temp. °C	DC Input Ratings		Output Amps		Fuse	Bussmann Style Fuse
		ND	HD			Amps	Cont. 1 Min.	3 Sec.			
20DH261	9	132	-	2	40	307	261	287	410	500	170M6608
		-	110	2	40	241	205	308	410	500	170M6608
20DH300	9	160	-	2	40	353	300	330	450	630	170M6610
		-	132	2	40	288	245	368	490	630	170M6610
20DH385	10	200	-	2	40	453	385	424	600	700	170M6611
		-	160	2	40	353	300	450	600	700	170M6611
20DH460	10	250	-	2	40	541	460	506	770	900	170M6613
		-	200	2	40	453	385	578	770	900	170M6613
20DH500	10	250	-	2	40	589	500	550	750	500 (2 per phs)	170M6608
		-	250	2	40	494	420	630	840	500 (2 per phs)	170M6608
20DH590	11	315	-	2	40	695	590	649	956	550 (2 per phs)	170M6609
		-	250	2	40	612	520	780	956	550 (2 per phs)	170M6609
20DH650	11	355	-	2	40	765	650	715	1062	630 (2 per phs)	170M6610
		-	315	2	40	695	590	885	1062	630 (2 per phs)	170M6610
20DH730	11	400	-	2	40	859	730	803	1095	700 (2 per phs)	170M6611
		-	355	2	40	765	650	975	1170	700 (2 per phs)	170M6611
20DH820	12	450	-	2	40	965	820	902	1230	700 (2 per phs)	170M6611
		-	400	2	40	859	730	1095	1314	700 (2 per phs)	170M6611
20DH920	12	500	-	2	40	1083	920	1012	1380	550 (3 per phs)	170M6609
		-	450	2	40	965	820	1230	1476	550 (3 per phs)	170M6609
20DH1K0	12	560	-	2	40	1213	1030	1133	1555	630 (3 per phs)	170M6610
		-	500	2	35	1083	920	1370	1600	630 (3 per phs)	170M6610
20DH1K1	13	630	-	2	40	1354	1150	1265	1620	2400	170M7107
		-	560	2	40	1213	1030	1545	1620	2400	170M7107
20DH1K3	13	710	-	2	40	1530	1300	1430	2079	2400	170M7107
		-	630	2	40	1354	1150	1725	2079	2400	170M7107
20DH1K4	13	800	-	2	40	1707	1450	1595	2175	2400	170M7107
		-	710	2	40	1413	1200	1800	2400	2400	170M7107

Ratings and Protection Devices, Cont.

650 Volt DC Input Protection Devices, Frames 1 - 6

Drive Catalog Number	HP Rating		PWM kHz	Temp. ⁽²⁾ °C	DC Input Ratings		Output Amps			Non-Time Delay Fuse ⁽³⁾	
	Frame	ND			HD	Amps	Cont.	1 Min.	3 Sec.		Fuse
20DD2P1	1	1	0.75	4	50	1.9	2.1	2.4	3.2	6	JKS-6
20DD3P4	1	2	1.5	4	50	3.0	3.4	4.5	6.0	6	JKS-6
20DD5P0	1	3	2	4	50	4.5	5.0	5.5	7.5	10	JKS-10
20DD8P0	1	5	3	4	50	8.1	8.0	8.8	12	15	HSJ15
20DD011	1	7.5	5	4	50	11.1	11	12.1	16.5	20	HSJ20
20DD014	1	10	7.5	4	50	14.6	14	16.5	22	30	HSJ30
20DD022	1	15	10	4	50	23.3	22	24.2	33	40	HSJ40
20DD027	2	20	15	4	50	28.9	27	33	44	50	HSJ50
20DD034	2	25	20	4	50	36.4	34	40.5	54	60	HSJ60
20DD040	3	30	25	4	50	42.9	40	51	68	80	HSJ80
20DD052	3	40	30	4	50	55.7	52	60	80	90	HSJ90
20DD065	3	50	40	4	50	69.6	65	78	104	100	HSJ100
20DD077	4	60	50	4	50	84.5	77	97.5	130	150	HSJ150
20DJ096 (1)	5	75	-	4	50	105.3	96	106	144	175	HSJ175
		-	60	4	50	84.5	77	116	154	175	HSJ175
20DJ125 (1)	5	100	-	4	50	137.1	125	138	163	200	HSJ200
		-	75	4	50	105.3	96	144	168	200	HSJ200
20DJ140 (1)	5	100	-	4	50	137	135	148	200	250	HSJ250
		-	75	4	50	105.3	96	144	192	250	HSJ250
20DJ156 (1)	6	125	-	4	50	171	156	172	234	300	HSJ300
		-	100	4	50	137.1	125	188	250	300	HSJ300
20DJ180 (1)	6	150	-	4	50	198	180	198	270	400	HSJ400
		-	125	4	50	171.2	156	234	312	400	HSJ400
20DJ248 (1)	6	200	-	2	40	272	248	273	372	400	HSJ400
		-	150	2	40	198	180	270	360	400	HSJ400

(1) Also applies to "R" voltage class. Fuses must be applied in the (+) leg and (-) leg of the DC Common Bus.
(2) The temperature rating listed for frame size 1-4 drives is for NEMA open types only. The adhesive tape label must be removed in order to operate at this temperature, otherwise the ambient operating temperature of these drives is 40°C.
(3) The power source to Common Bus inverters must be derived from AC Voltages 600V or less, as defined in NFPA70: Art 430-18 (NEC). Battery supplies or MG sets are not included. The following devices were validated to break current of the derived power DC Bus: *Disconnects*: Allen-Bradley Bulletin No. 1494, 30 to 400 A; Bulletin No. 194, 30 to 400 A, or ABB: OESA, 600 & 800 A; OESL, all sizes. *Fuses*: Busmann Type JKS, all sizes; Type 170M, Case Sizes 1, 2 and 3, or Ferraz Shawmut Type HSI, all sizes. For any other devices, please contact the factory.

Ratings and Protection Devices, Cont.

650 Volt DC Input Protection Devices, Frames 9 - 13

Drive Catalog Number	Frame	HP Rating		PWM Freq. kHz	Temp. °C	DC Input Ratings Amps	Output Amps			Fuse	Bussmann Style Fuse
		ND	HD				Cont.	1 Min.	3 Sec.		
20DJ261	9	200	-	2	40	294	261	287	410	500	170M6608
20DJ300	9	-	150	2	40	231	205	308	410	500	170M6608
		250	-	2	40	338	300	330	450	630	170M6610
20DJ385	10	-	200	2	40	294	245	368	490	630	170M6610
		300	-	2	40	434	385	424	600	700	170M6611
20DJ460	10	-	250	2	40	338	300	450	600	700	170M6611
		350	-	2	40	519	460	506	770	900	170M6613
20DJ500	10	-	300	2	40	434	385	578	770	900	170M6613
		450	-	2	40	564	500	550	750	500 (2 per phs)	170M6608
20DJ590	11	-	350	2	40	474	420	630	840	500 (2 per phs)	170M6608
		500	-	2	40	666	590	649	956	550 (2 per phs)	170M6609
20DJ650	11	-	450	2	40	587	520	780	956	550 (2 per phs)	170M6609
		500	-	2	40	733	650	715	1062	630 (2 per phs)	170M6610
20DJ730	11	-	500	2	40	666	590	885	1062	630 (2 per phs)	170M6610
		600	-	2	40	824	730	803	1095	700 (2 per phs)	170M6611
20DJ820	12	-	500	2	40	733	650	975	1170	700 (2 per phs)	170M6611
		700	-	2	40	925	820	902	1230	700 (2 per phs)	170M6611
20DJ920	12	-	600	2	40	824	730	1095	1314	700 (2 per phs)	170M6611
		800	-	2	40	1038	920	1012	1380	550 (3 per phs)	170M6609
20DJ1K0	12	-	700	2	40	925	820	1230	1476	550 (3 per phs)	170M6609
		900	-	2	40	1162	1030	1133	1555	630 (3 per phs)	170M6610
20DJ1K1	13	-	800	2	35	1038	920	1370	1600	630 (3 per phs)	170M6610
		1000	-	2	40	1297	1150	1265	1620	2400	170MT107
20DJ1K3	13	-	900	2	40	1162	1030	1545	1620	2400	170MT107
		1200	-	2	40	1467	1300	1430	2079	2400	170MT107
20DJ1K4	13	-	1000	2	40	1297	1150	1725	2079	2400	170MT107
		1250	-	2	40	1636	1450	1595	2175	2400	170MT107
		-	1000	2	40	1354	1200	1800	2400	2400	170MT107

Ratings and Protection Devices, Cont.

810 Volt DC Input Protection Devices, Frames 1 - 6

Drive Catalog Number	Frame	HP Rating		PWM Freq. kHz	Temp. (1) °C	DC Input Ratings		Output Amps		Fuse	Non-Time Delay Fuse(2)
		ND	HD			Amps	Cont.	1 Min.	3 Sec.		
20DE1P7	1	0.75	4	50	1.5	1.7	2	2.6	3	JKS-3	
20DE2P7	1	1.5	4	50	2.4	2.7	3.6	4.8	6	JKS-6	
20DE3P9	1	3	4	50	3.5	3.9	4.3	5.9	6	JKS-6	
20DE6P1	1	5	3	4	50	6.2	6.1	6.7	9.2	10	JKS-10
20DE9P0	1	7.5	5	4	50	9.1	9	9.9	13.5	15	HSJ15
20DE011	1	10	7.5	4	50	11.5	11	13.5	18	20	HSJ20
20DE017	1	15	10	4	50	18	17	18.7	25.5	30	HSJ30
20DE022	2	20	15	4	50	23.6	22	25.5	34	40	HSJ40
20DE027	2	25	20	4	50	29	27	33	44	50	HSJ50
20DE032	3	30	25	4	50	34.3	32	40.5	54	60	HSJ60
20DE041	3	40	30	4	50	43.9	41	48	64	70	HSJ70
20DE052	3	50	40	4	50	55.7	52	61.5	82	90	HSJ90
20DE062	4	60	50	2	45	68.0	62	78	104	125	HSJ125
20DT099	5	100	-	2	50(2)	108.6	99	109	126	150	HSJ150
		-	75	2	50(2)	84.5	77	116	138	150	HSJ150
20DT144	6	150	-	2	50(2)	158	144	158	216	200	HSJ200
		-	125	2	40(2)	137.1	125	188	250	200	HSJ200

- (1) The temperature rating listed for frame size 1-4 drives is for NEMA open types only. The adhesive tape label must be removed in order to operate at this temperature, otherwise the ambient operating temperature of these drives is 40°C.
- (2) The power source to Common Bus inverters must be derived from AC Voltages 600V or less, as defined in NFPA70; Art 430-18 (NEC). Battery supplies or MG sets are not included. The following devices were validated to break current of the derived power DC Bus:
 Disconnects: Allen-Bradley Bulletin No. 1494, 30 to 400 A; Bulletin No. 194, 30 to 400 A, or ABB: OESA, 600 & 800 A; OESL, all sizes.
 Fuses: Bussmann Type JKS, all sizes; Type 170M, Case Sizes 1, 2 and 3, or Ferraz Shawmut Type HSI, all sizes. For any other devices, please contact the factory.

932 Volt DC Input Protection Devices, Frames 5 & 6

Drive Catalog Number	Frame	kW Rating		PWM Freq. kHz	Temp. (1) °C	DC Input Ratings		Output Amps		Fuse	Non-Time Delay Fuse(2)
		ND	HD			Amps	Cont.	1 Min.	3 Sec.		
20DW098	5	90	-	2	50(2)	92.3	98	108	127	160	HSJ160
		-	75	2	50(2)	92.3	82	123	140	160	HSJ160
20DW142	6	132	-	2	50(2)	162.2	142	156	213	250	HSJ250
		-	110	2	40(2)	134.9	119	179	238	250	HSJ250

- (1) The temperature rating listed for frame size 1-4 drives is for NEMA open types only. The adhesive tape label must be removed in order to operate at this temperature, otherwise the ambient operating temperature of these drives is 40°C.
- (2) The power source to Common Bus inverters must be derived from AC Voltages 600V or less, as defined in NFPA70; Art 430-18 (NEC). Battery supplies or MG sets are not included. The following devices were validated to break current of the derived power DC Bus:
 Disconnects: Allen-Bradley Bulletin No. 1494, 30 to 400 A; Bulletin No. 194, 30 to 400 A, or ABB: OESA, 600 & 800 A; OESL, all sizes.
 Fuses: Bussmann Type JKS, all sizes; Type 170M, Case Sizes 1, 2 and 3, or Ferraz Shawmut Type HSI, all sizes. For any other devices, please contact the factory.

Ratings and Protection Devices, Cont.

810 Volt DC Input Protection Devices, Frames 9 - 13

Drive Catalog Number	Frame	HP Rating		PWM Freq. kHz	Temp. °C	DC Input Ratings		Output Amps		Fuse	Busmann Style Fuse	
		ND	HD			Amps	Temp.	Cont.	1 Min.			3 Sec.
20DK170	9	150	-	2	40	192	-	170	187	245	400	170M5608
20DK208	9	200	-	2	40	162	-	144	216	245	400	170M5608
		-	150	2	40	235	-	208	230	289	450	170M5609
20DK261	10	250	-	2	40	192	-	170	250	289	450	170M5609
		-	200	2	40	294	-	261	287	375	450	170M5609
20DK325	10	350	-	2	40	235	-	208	312	375	450	170M5609
		-	350	2	40	367	-	325	358	470	550	170M6609
20DK385	10	400	-	2	40	294	-	261	392	470	550	170M6609
		-	400	2	40	434	-	385	424	585	700	170M6611
20DK416	10	450	-	2	40	367	-	325	488	585	700	170M6611
		-	450	2	35	489	-	416	458	585	800	170M6612
20DK460	11	500	-	2	40	367	-	325	488	585	800	170M6612
		-	500	2	40	519	-	460	506	693	450 (2 per phs)	170M5609
20DK502	11	500	-	2	40	434	-	385	578	693	450 (2 per phs)	170M5609
		-	500	2	40	566	-	502	552	828	500 (2 per phs)	170M6608
20DK590	11	600	-	2	40	519	-	460	690	828	500 (2 per phs)	170M6608
		-	600	2	35	666	-	590	649	885	500 (2 per phs)	170M6608
20DK650	12	700	-	2	40	566	-	502	753	904	500 (2 per phs)	170M6608
		-	700	2	40	733	-	650	715	1062	500 (2 per phs)	170M6608
20DK750	12	800	-	2	40	666	-	590	885	1062	500 (2 per phs)	170M6608
		-	800	2	40	846	-	750	825	1170	630 (2 per phs)	170M6610
20DK820 (1)	12	900	-	2	40	733	-	650	975	1170	630 (2 per phs)	170M6610
		-	900	2	35	925	-	820	902	1170	630 (2 per phs)	170M6610
20DK920	13	1000	-	2	40	733	-	650	975	1170	630 (2 per phs)	170M6610
		-	1000	2	40	1038	-	920	1012	1380	2400	170M7107
20DK1K0	13	1100	-	2	40	925	-	820	1230	1410	2400	170M7107
		-	1100	2	40	1162	-	1030	1133	1545	2400	170M7107
20DK1K1	13	1300	-	2	40	1038	-	920	1380	1755	2400	170M7107
		-	1300	2	35	1331	-	1180	1298	1755	2400	170M7107
		-	1100	2	35	1162	-	1030	1463	1755	2400	170M7107

(1) 20DK820 drives (ND) are only capable of producing 95% of starting torque under 10 Hz.

Ratings and Protection Devices, Cont.

932 Volt DC Input Protection Devices, Frames 9 - 13

Drive Catalog Number	Frame	kW Rating		PWM Freq. kHz	Temp. °C	DC Input Ratings		Output Amps			Fuse	Bussmann Style Fuse
		ND	HD			Amps	Cont.	1 Min.	3 Sec.			
20DM170	9	160	-	2	40	200	170	187	245	315	170M3746	
		-	132	2	40	170	144	216	245	315	170M3746	
20DM208	9	200	-	2	35	245	208	230	289	400	170M5742	
		-	160	2	40	200	170	250	289	400	170M5742	
20DM261	10	250	-	2	40	307	261	287	375	500	170M5744	
		-	200	2	40	245	208	312	375	500	170M5744	
20DM325	10	315	-	2	40	383	325	358	470	630	170M5746	
		-	250	2	40	307	261	392	470	630	170M5746	
20DM385	10	355	-	2	40	453	385	424	585	700	170M6745	
		-	315	2	40	383	325	488	585	700	170M6745	
20DM416	10	400	-	2	35	490	416	458	585	700	170M6745	
		-	315	2	40	383	325	488	585	700	170M6745	
20DM460	11	450	-	2	40	542	460	506	693	855	170M5743	
		-	355	2	40	453	385	578	693	855	170M5743	
20DM502	11	500	-	2	40	591	502	552	828	1062	170M5744	
		-	400	2	40	542	460	690	828	1062	170M5744	
20DM590	11	560	-	2	35	695	590	649	885	1170	170M5744	
		-	500	2	35	591	502	753	904	1170	170M5744	
20DM650	12	630	-	2	40	765	650	715	1062	1380	170M5745	
		-	560	2	40	695	590	885	1062	1380	170M5745	
20DM750	12	710	-	2	40	883	750	825	1170	1545	170M5746	
		-	630	2	40	765	650	975	1170	1545	170M5746	
20DM820(1)	12	800	-	2	35	965	820	902	1170	1545	170M5746	
		-	630	2	35	765	650	975	1170	1545	170M5746	
20DM920	13	1000	-	2	40	1038	920	1012	1380	2400	170M7107	
		-	900	2	40	925	820	1230	1410	2400	170M7107	
20DM1K0	13	1100	-	2	40	1162	1030	1133	1545	2400	170M7107	
		-	1000	2	40	1038	920	1360	1755	2400	170M7107	
20DM1K1	13	1300	-	2	35	1331	1180	1298	1755	2400	170M7107	
		-	1100	2	35	1162	1030	1463	1755	2400	170M7107	

(1) 20DM820 drives (ND) are only capable of producing 95% of starting torque under 10 Hz.

Minimum Mounting Clearances

Frames 1-6

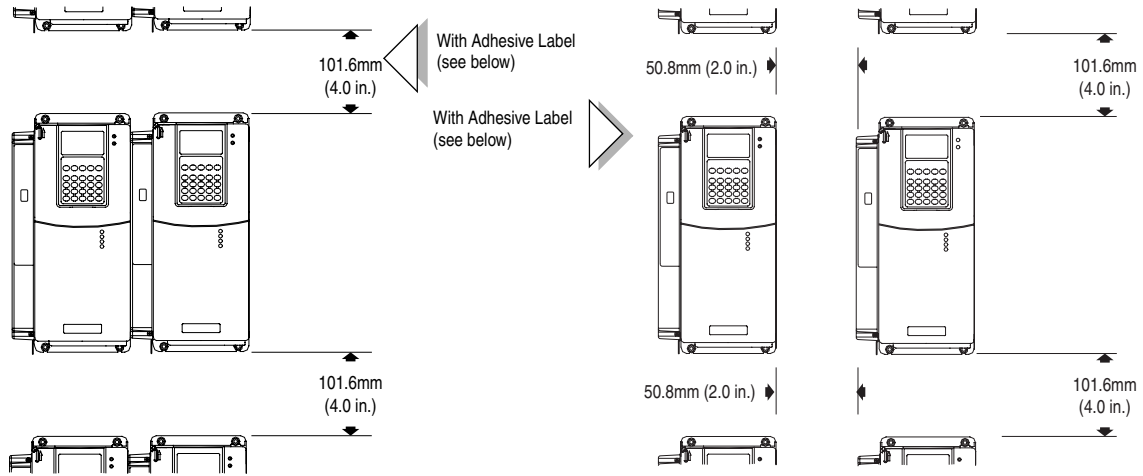

Frame 9

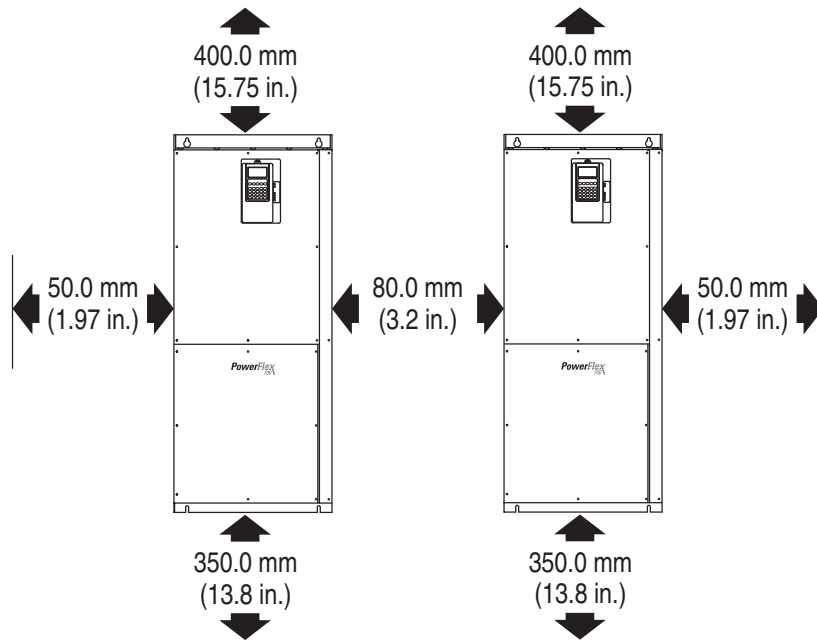

Minimum Mounting Clearances, Cont.

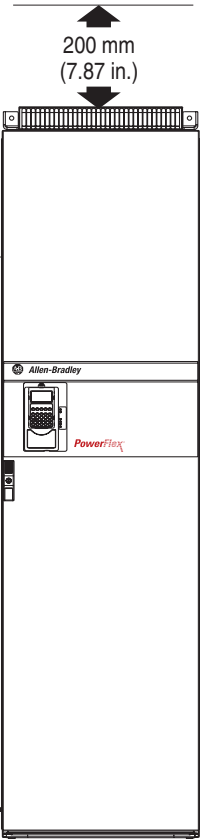

Frames 10 - 13
(Frame 10 shown)

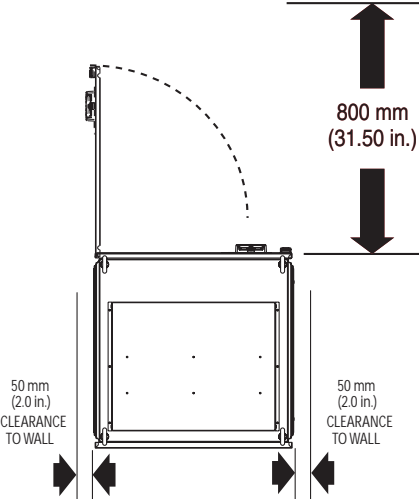

Frame to AC Drive Rating Cross Reference

Frame	208		240		400V		480V		600V		690V	
	ND kW	HD kW	ND HP	HD HP	ND kW	HD kW	ND HP	HD HP	ND HP	HD HP	ND kW	HD kW
1	0.75	0.55	1.0	0.75	0.75	0.55	1	0.75	1	0.75	-	-
	1.5	1.1	2.0	1.5	1.5	1.1	2	1.5	2	1.5	-	-
	2.2	1.5	3.0	2.0	2.2	1.5	3	2	3	2	-	-
	4.0	3.0	5.0	3.0	4.0	3.0	5	3	5	3	-	-
	5.5	4.0	7.5	5.0	5.5	4.0	7.5	5	7.5	5	-	-
	-	-	-	-	7.5	5.5	10	7.5	10	7.5	-	-
2	-	-	-	-	11	7.5	15	10	15	10	-	-
	7.5	5.5	10	7.5	15	11	20	15	20	15	-	-
3	-	-	-	-	18.5	15	25	20	25	20	-	-
	11	7.5	15	10	22	18.5	30	25	30	25	-	-
	15	11	20	15	30	22	40	30	40	30	-	-
4	-	-	-	-	37	30	50	40	50	40	-	-
	18.5	15	25	20	45	37	60	50	60	50	-	-
5	22	18.5	30	25	-	-	-	-	-	-	-	-
	30	22	40	30	55	45	75	60	75	60	45	37.5
	37	30	50	40	55	45	100	75	100	75	55	45
	-	-	-	-	-	-	-	-	-	-	75	55
6	-	-	-	-	-	-	-	-	-	-	90	75
	45	37	60	50	75	55	125	100	125	100	110	90
	55	45	75	60	90	75	150	125	150	125	132	110
	66	55	100	75	110	90	200	150	-	-	-	-
9	-	-	-	-	132	110	-	-	-	-	-	-
	-	-	-	-	160	132	250	200	200	150	160	132
10	-	-	-	-	160	132	250	200	200	150	200	160
	-	-	-	-	200	160	300	250	250	200	250	200
	-	-	-	-	250	200	350	300	350	250	315	250
	-	-	-	-	250	250	450	350	400	350	355	315
11	-	-	-	-	-	-	-	-	450	350	400	315
	-	-	-	-	315	250	500	450	500	400	450	355
	-	-	-	-	355	315	500	500	500	500	500	400
12	-	-	-	-	400	355	600	500	600	500	560	500
	-	-	-	-	450	400	700	600	700	650	630	560
	-	-	-	-	500	450	800	700	800	700	710	630
13	-	-	-	-	560	500	900	800	900	700	800	630
	-	-	-	-	630	560	1000	900	1000	900	900	800
	-	-	-	-	710	630	1200	1000	1100	1000	1000	900
	-	-	-	-	800	710	1250	1000	1300	1100	1100	1000

Frame to DC Drive Rating Cross Reference

Frame	325V		540V		650V		810V		932V	
	ND HP	HD HP	ND kW	HD kW	ND HP	HD HP	ND HP	HD HP	ND kW	HD kW
1	5.0	3.0	1.5	1.1	1.0	0.75	1.0	0.75	–	–
	7.5	5.0	2.2	1.5	2.0	1.5	2.0	1.5	–	–
	–	–	4.0	3.0	3.0	2.0	3.0	2.0	–	–
	–	–	5.5	4.0	5.0	3.0	5.0	3.0	–	–
	–	–	7.5	5.5	7.5	5.0	7.5	5.0	–	–
	–	–	11.0	7.5	10.0	7.5	10.0	7.5	–	–
	–	–	–	–	15	10	15	10	–	–
2	10	7.5	15	11	20	15	20	15	–	–
	–	–	18.5	15	25	20	25	20	–	–
3	15	10	22	18.5	30	25	30	25	–	–
	20	15	20	22	40	30	40	30	–	–
	–	–	37	30	50	40	50	40	–	–
4	25	20	45	37	60	50	60	50	–	–
	30	25	–	–	–	–	–	–	–	–
5	40	30	55	45	75	60	100	75	90	75
	50	40	55	45	100	75	–	–	–	–
	–	–	75	55	100	75	–	–	–	–
6	60	50	90	75	125	100	150	125	132	110
	75	60	110	90	150	125	–	–	–	–
	100	75	132	110	200	150	–	–	–	–
9	–	–	132	110	200	150	150	150	160	132
	–	–	160	132	250	200	200	150	200	160
10	–	–	200	160	300	250	250	200	250	200
	–	–	250	200	350	300	350	250	315	250
	–	–	250	250	450	350	400	350	355	315
	–	–	–	–	–	–	450	350	400	315
11	–	–	315	250	500	450	500	400	450	355
	–	–	355	315	500	500	500	500	500	400
	–	–	400	355	600	500	600	500	560	500
12	–	–	450	400	700	600	700	650	630	560
	–	–	500	450	800	700	800	700	710	630
	–	–	560	500	900	800	900	700	800	630
13	–	–	630	560	1000	900	1000	900	1000	900
	–	–	710	630	1200	1000	1100	1000	1100	1000
	–	–	800	710	1250	1000	1300	1100	1300	1100

Approximate Dimensions

PowerFlex 700S Frame 1-3 Dimensions (Frame 1 Shown)

Dimensions are in millimeters and (inches)

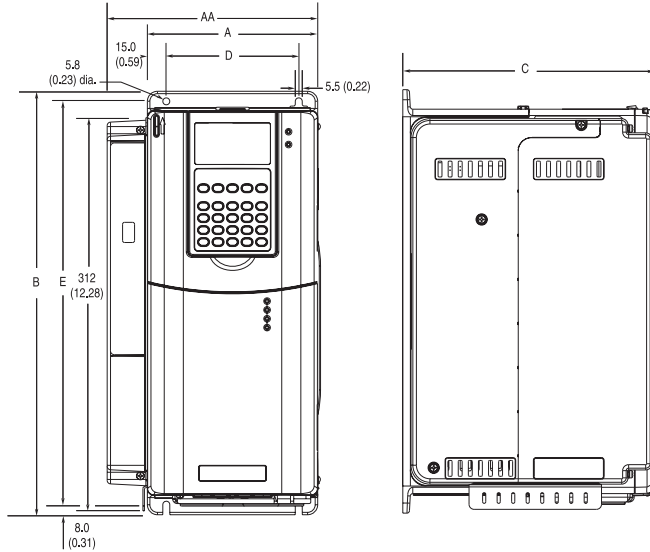

Frame 2 (Bottom View)

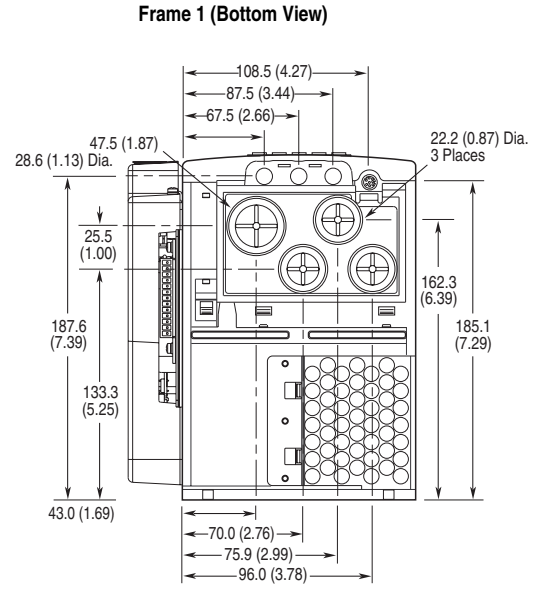

Frame 1 (Bottom View)

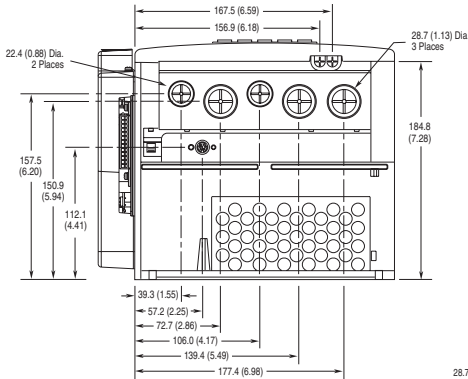

Frame 2 (Bottom View)

Frame 3 - All Drives except 50 HP, 480V (37 kW, 400V)

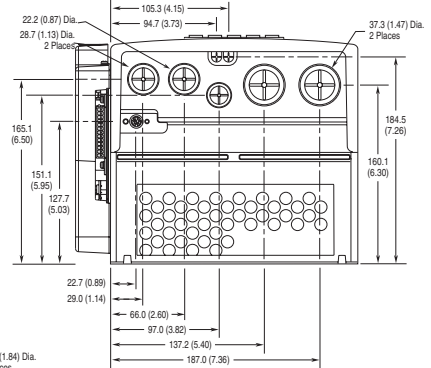

Frame 3 - 50 HP, 480V (37 kW, 400V) Normal Duty Drive

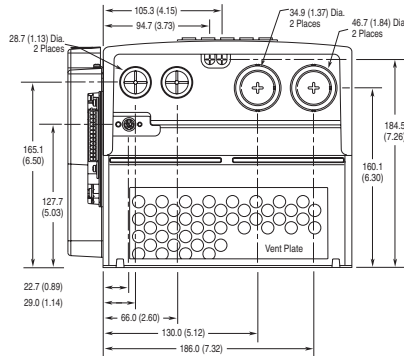

Frame ⁽¹⁾	Slim	Expanded	B	C (Max.)	D	E	Weight ⁽²⁾ kg (lbs.)	
	A (Max.)	AA					Drive	Drive & Packaging
1	135.0 (5.31)	166.9 (6.57)	336.0 (13.23)	200.0 (7.87)	105.0 (4.13)	320.0 (12.60)	7.03 (15.5)	9.98 (22)
2	222.0 (8.74)	253.9 (9.99)	342.5 (13.48)	200.0 (7.87)	192.0 (7.56)	320.0 (12.60)	12.52 (27.6)	15.20 (33.5)
3	222.0 (8.74)	253.9 (9.99)	517.5 (20.37)	200.0 (7.87)	192.0 (7.56)	500.0 (19.69)	18.55 (40.9)	22.68 (50)

(1) Refer to the table on page 64 for frame information.

(2) Weights include HIM, DriveLogix controller with ControlNet daughtercard, Hi-Resolution Encoder Option, and 20-COMM-C ControlNet adapter.

Approximate Dimensions, Cont.

PowerFlex 700S Frame 4

Dimensions are in millimeters and (inches)

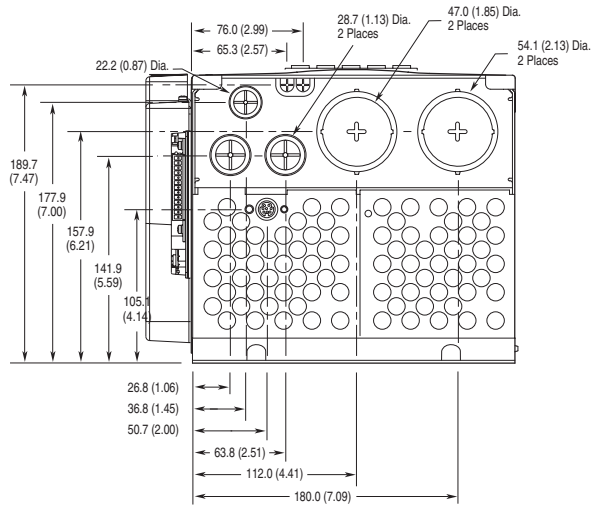
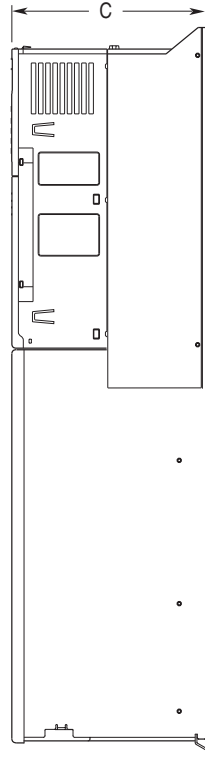
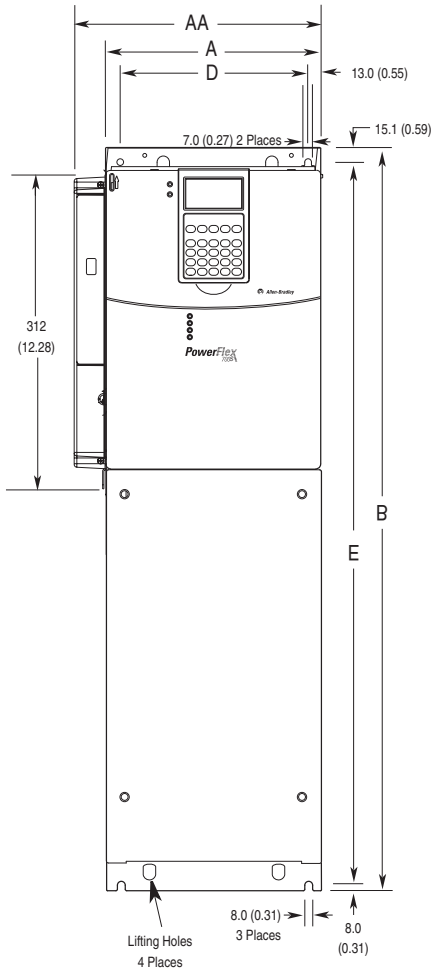

Frame (1)	Slim A (Max.)	Expanded AA	B	C (Max.)	D	E	Weight (2) kg (lbs.)	
							Drive	Drive & Packaging
4	220.0 (8.66)	251.9 (9.92)	758.8 (29.87)	201.7 (7.94)	192.0 (7.56)	738.2 (29.06)	24.49 (54.0)	29.03 (64.0)

(1) Refer to the table on page 64 for frame information.

(2) Weights include HIM, DriveLogix controller with ControlNet daughtercard, Hi-Resolution Encoder Option, and 20-COMM-C ControlNet adapter.

Approximate Dimensions, Cont.

PowerFlex 700S Frame 5

Dimensions are in millimeters and (inches)

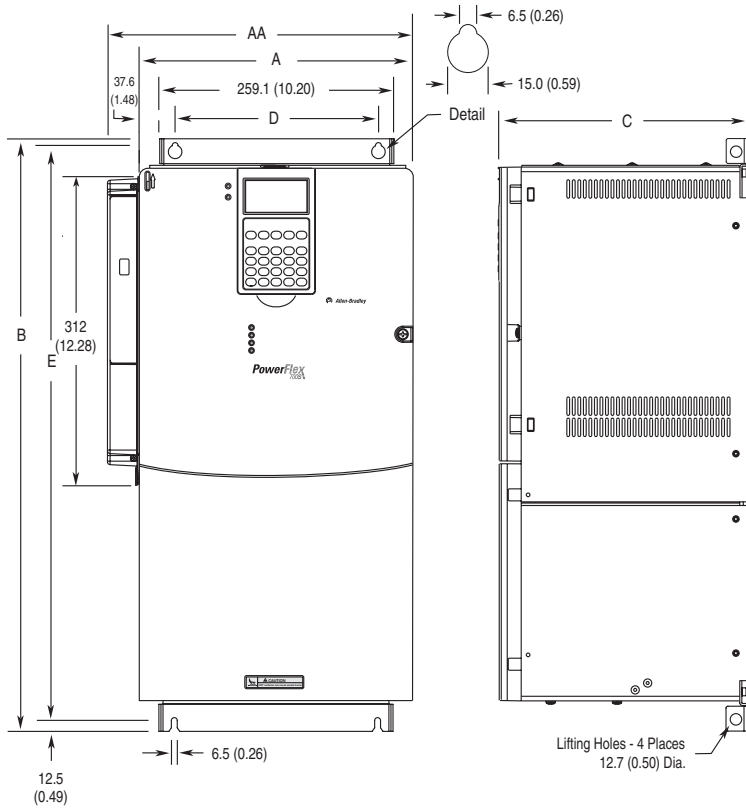

Frame 5 - 75 HP, 480V (55 kW, 400V) Normal Duty Drive

Frame 5 - 100 HP, 480V (55 kW, 400V) Normal Duty Drive

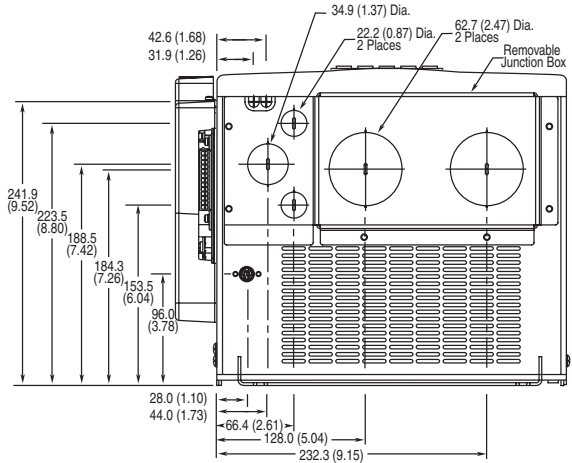
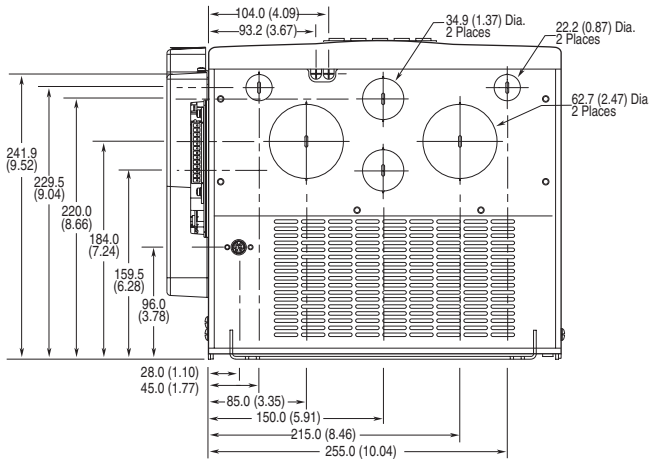

Frame (1)	Slim A (Max.)	Expanded AA	B	C (Max.)	D	E	Weight (2) kg (lbs.)	
							Drive	Drive & Packaging
5	308.0 (12.16)	339.9 (13.38)	644.5 (25.37) (3)	275.4 (10.84)	225.0 (8.86)	625.0 (24.61)	37.19 (82.0)	42.18 (93.0)

(1) Refer to the table on page 64 for frame information.

(2) Weights include HIM, DriveLogix controller with ControlNet daughtercard, Hi-Resolution Encoder Option, and 20-COMM-C ControlNet adapter.

(3) When using the supplied junction box (100 HP drives Only), add an additional 45.1 mm (1.78 in.) to this dimension.

Approximate Dimensions, Cont.

PowerFlex 700S Frame 6

Dimensions are in millimeters and (inches)

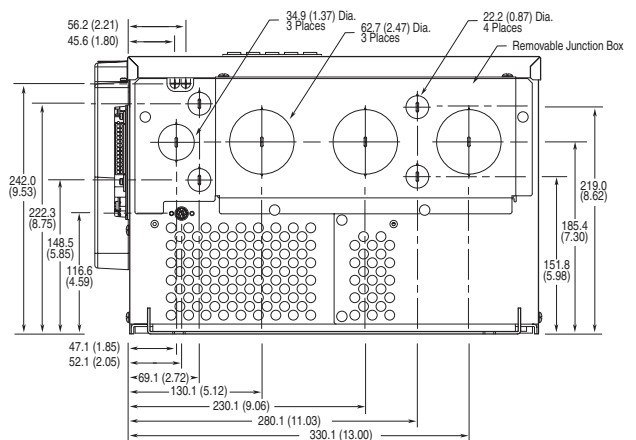
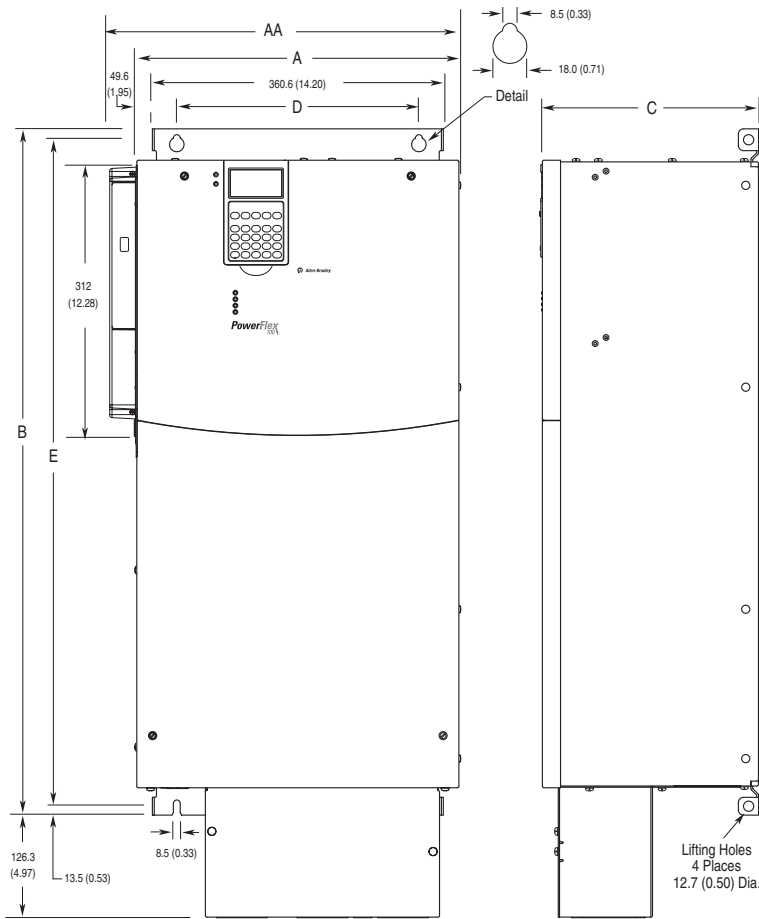

Frame (1)	Slim A (Max.)	Expanded AA	B	C (Max.)	D	E	Approx. Weight (2) kg (lbs.) Drive
6	403.9 (15.90)	435.8 (17.16)	850.0 (33.46)	275.5 (10.85)	300.0 (11.81)	825.0 (32.48)	71.44 (157.5) (3)

(1) Refer to the table on page 64 for frame information.
 (2) Weights include HIM and Standard I/O.
 (3) Add an additional 3.6 kg (8.00 lbs.) for 200 HP drives.

Approximate Dimensions, Cont.

PowerFlex 700S Frame 9 Dimensions

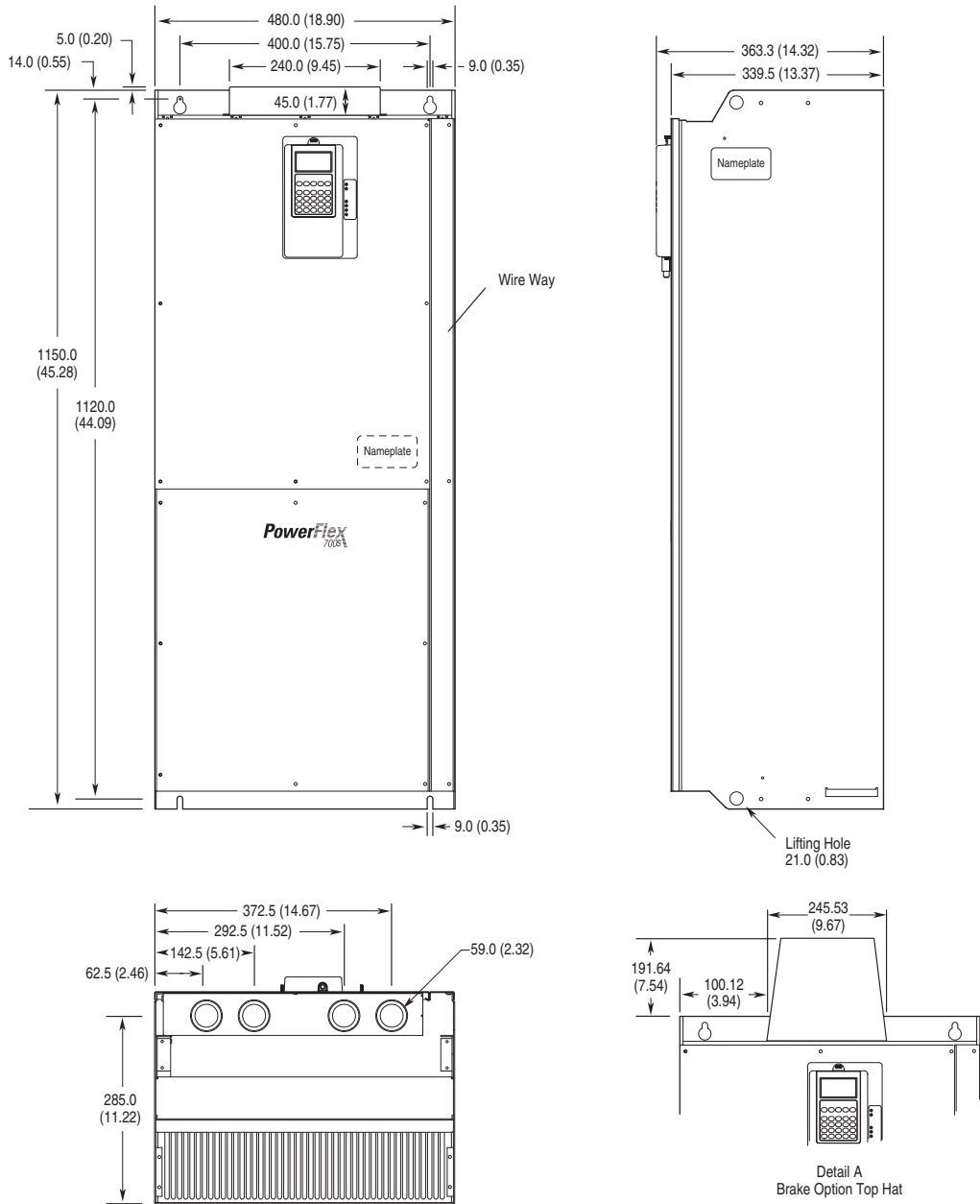

Dimensions are in millimeters and (inches).

Frame Size	Type	Weight kg (lbs.)
9	400V AC , 261 Amp Drive & Enclosure	143 (315)
	400V AC , 300 Amp Drive & Enclosure	151 (333)
	400V DC, 261 Amp Drive & Enclosure	109 (240)
	400V DC, 300 Amp Drive & Enclosure	117 (257)
	600V AC Drive & Enclosure	143 (315)
	600V DC Drive & Enclosure	109 (240)

Approximate Dimensions, Cont.

PowerFlex 700S Frame 10 Dimensions, NEMA 1 IP21, Enclosure Code "A"

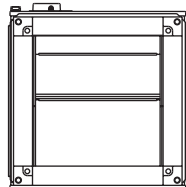
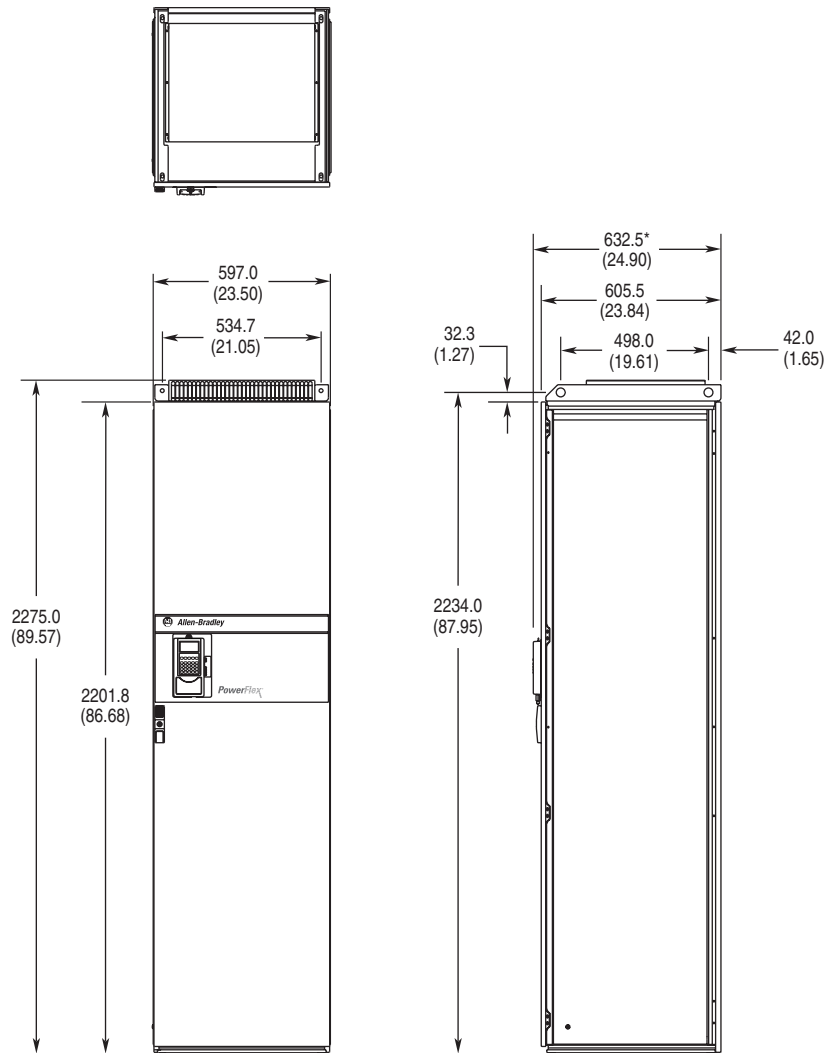

* This dimension is the depth for drives with the optional door-mounted HIM installed

Dimensions are in millimeters and (inches).

Frame Size	Voltage Class	Drive Rating Amps	Approx. Weight kg (lbs.) Drive & Enclosure (AC Input)	Approx. Weight kg (lbs.) Drive & Enclosure (DC Input)
10	400	385	432 (952)	317 (699)
		460	432 (952)	317 (699)
		520	432 (952)	317 (699)
	600	261	370 (816)	317 (699)
		325	401 (884)	317 (699)
		385	401 (884)	317 (699)
		416	401 (884)	317 (699)

Approximate Dimensions, Cont.

PowerFlex 700S Frame 11 Dimensions, NEMA 1 IP21, Enclosure Code "A"

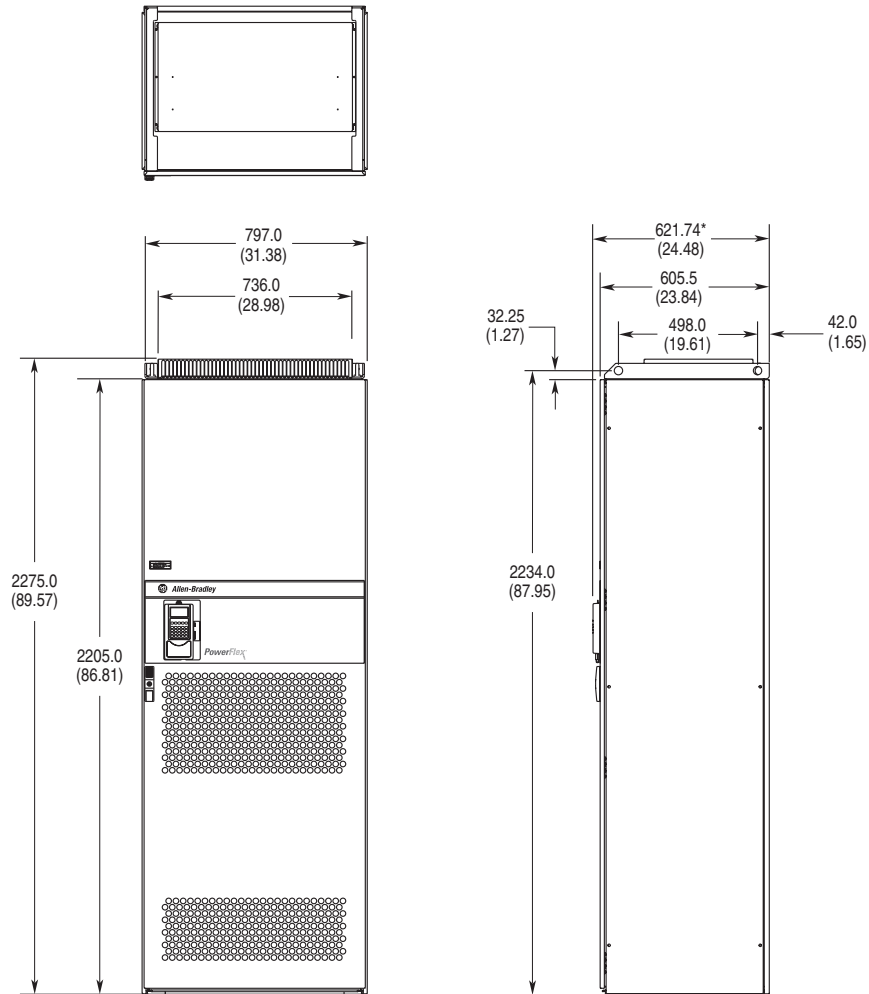

* This dimension is the depth for drives with the optional door-mounted HIM installed

Dimensions are in millimeters and (inches).

Frame Size	Voltage Class	Drive Rating Amps	Approx. Weight kg (lbs.) Drive & Enclosure (AC Input)	Approx. Weight kg (lbs.) Drive & Enclosure (DC Input)
11	400	590	614 (1354)	446 (983)
		650	614 (1354)	446 (983)
		730	614 (1354)	446 (983)
	600	460	561 (1237)	446 (983)
		502	561 (1237)	446 (983)
		590	676 (1490)	446 (983)

Approximate Dimensions, Cont.

PowerFlex 700S Frame 12 Dimensions, NEMA 1 IP21, Enclosure Code "A"

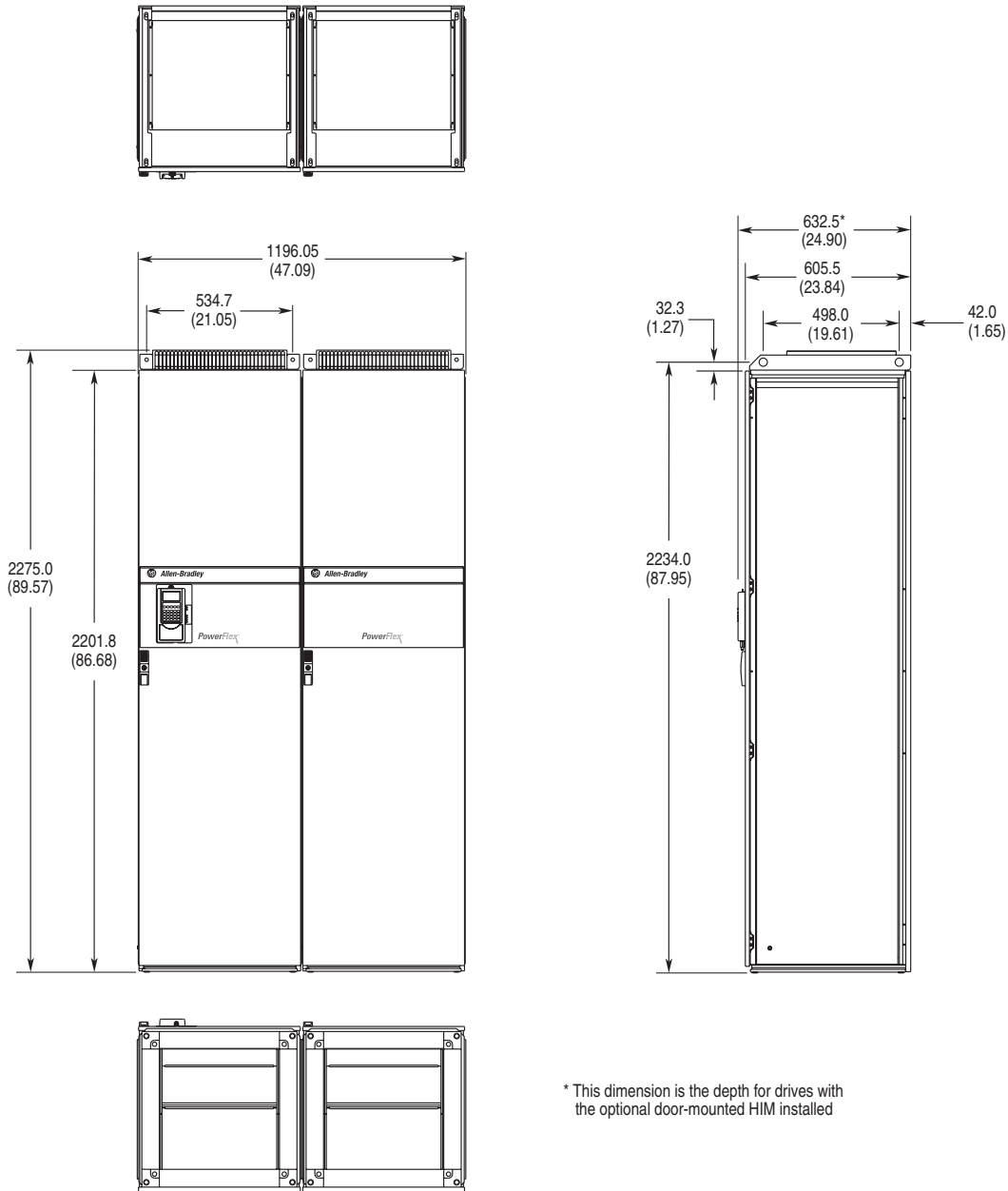

Dimensions are in millimeters and (inches).

Frame Size	Voltage Class	Drive Rating Amps	Approx. Weight kg (lbs.) Drive & Enclosure (AC Input)	Approx. Weight kg (lbs.) Drive & Enclosure (DC Input)
12	400	820	864 (1906)	634 (1398)
		920	864 (1906)	634 (1398)
		1030	864 (1906)	634 (1398)
	600	650	802 (1768)	634 (1398)
		750	802 (1768)	634 (1398)
		820	802 (1768)	634 (1398)

Approximate Dimensions, Cont.

PowerFlex 700S Frame 13 - Dimensions





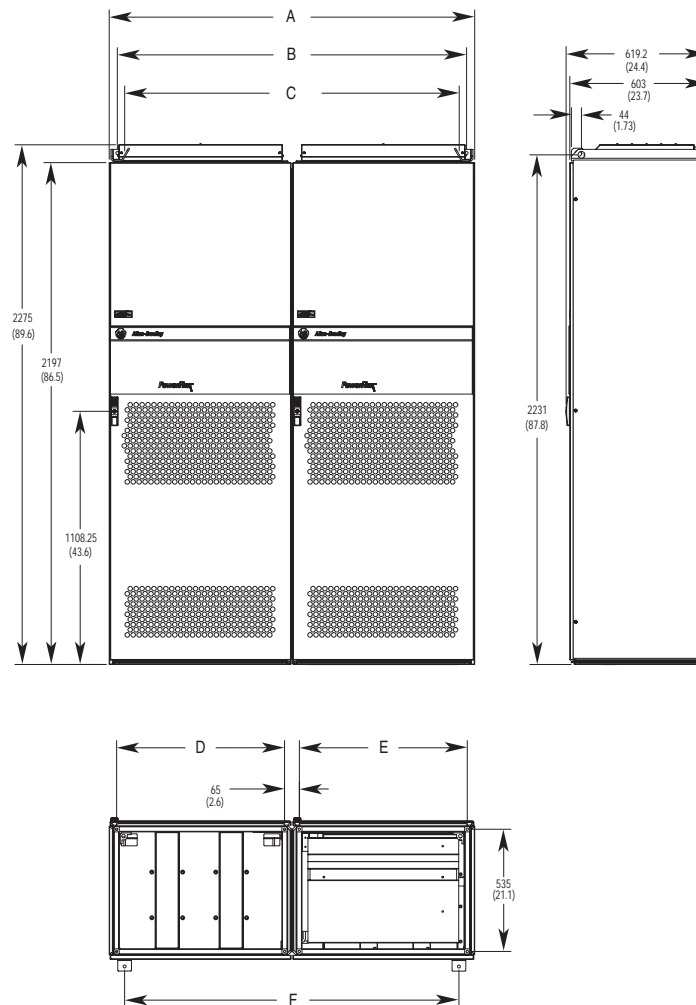





Voltage Class	Amps	A	B	C	D	E	F
400V	1150	1412 (56)	1329 (52)	1264 (50)	535 (21)	735 (29)	1264 (58)
	1300	1600 (63)	1529 (60)	1464 (58)	735 (29)	735 (29)	1464 (58)
	1450						
600V	920	1412 (56)	1329 (52)	1264 (50)	535 (21)	735 (29)	1264 (50)
	1030						
	1180						

Dimensions are in mm and (in.)



Frame Size	Voltage Class	Drive Rating Amps	Approx. Weight kg (lbs.) Drive & Enclosure (AC Input)	Approx. Weight kg (lbs.) Drive & Enclosure (DC Input)
13	400	1150	1248 (2751)	600 (1323)
		1300	1400 (3086)	600 (1323)
		1450	1400 (3086)	600 (1323)
	600	920	1248 (2751)	600 (1323)
		1030	1248 (2751)	600 (1323)
		1180	1248 (2751)	600 (1323)

Specifications

Category	Specification												
	Frames 1-6 (690V Drive frames 5 & 6 only)						Frames 9 & up						
Protection		200-208V	240V	380/400V	480V	600V (frames 0-4)	600V/ 690V (frames 5&6)	380/400V	480V	500V	600V	690V	
	AC Input Overvoltage Trip:	300VAC	300VAC	600VAC	600VAC	863VAC	863VAC	675VAC	675V AC	675V AC	889VAC	889VAC	
	Bus Overvoltage Trip:	405VDC	405VDC	810VDC	810VDC	1164VDC	1164VDC	911VDC	911VDC	911VDC	1200VDC	1200VDC	
	Bus Undervoltage Trip:	Adjustable						Adjustable					
	Nominal Bus Voltage:	281VDC	324VDC	540VDC	648VDC	810VDC	931VDC	540VDC	648VDC	645VDC	810VDC	931VDC	
	Heat Sink Thermistor:	Monitored by microprocessor overtemp trip						Monitored by microprocessor overtemp trip					
	Drive Overcurrent Trip	Calculated value, 105% of motor rated to 200% of drive rated						Calculated value, 105% of motor rated to 200% of drive rated					
	Software Current Limit:	105% of 3 sec. rating (158%-210%)						360% of rated Heavy Duty current (typical)					
	Hardware Current Limit:	143% of 3 sec rating (215%-287%)						—					
	Instantaneous Current Limit:	Up to 6000 volts peak per IEEE C62.41-1991						up to 6000 volts peak per IEEE C62.41-1991					
	Line Transients:	Showering arc transients up to 1500V peak						Showering arc transients up to 1500V peak					
	Control Logic Noise Immunity:	15 milliseconds at full load						15 milliseconds at full load					
	Power Ride-Thru:	0.25 sec., drive not running						0.25 seconds, drive not running					
Logic Control Ride-Thru	Phase-to-ground on drive output						Phase-to-ground on drive output						
Ground Fault Trip:	Phase-to-phase on drive output						Phase-to-phase on drive output						
Short Circuit Trip:	Phase-to-phase on drive output						Phase-to-phase on drive output						
Agency Certification	The drive is designed to meet applicable requirements of the following codes/standards: IEC 61800-2 Adjustable speed electrical power drive systems - General requirements IEC 61800-5-1 Adjustable speed electrical power drive systems - Safety requirements NFPA 70 – US National Electric Code NEMA 250 – Enclosures for Electrical Equipment						The drive is designed to meet applicable requirements of the following codes/standards: IEC 61800-2 Adjustable speed electrical power drive systems - General requirements IEC 61800-5-1 Adjustable speed electrical power drive systems - Safety requirements NFPA 70 - US National Electrical Code						
							UL and cUL Listed to UL508C and CAN/CSA - 22.2 No. 14-95						
							Marked for all applicable European Directives EMC Directive (89/336/EEC) Emissions EN 61800-3 Adjustable Speed electrical power drive systems Part 3 Immunity EN 61800-3 Second Environment, Restricted Distribution Low Voltage Directive (73/23/EEC) EN 50178 Electronic Equipment for use in Power Installations						
							NA						
							Certified to ATEX directive 94/9/EC. Group II Category (2) GD Applications with ATEX Approved Motors. Refer to publication 20D-UM006, <i>PowerFlex 700S Drives with Phase II Control User Manual</i> , for more information.						
     						TUV Rheinland (applies to frames 1 - 6, 200/400V, and frames 5 & 6, 690V only) TUV Functional Safety Report only for frames 1 - 4, 600V (no FS mark on the label)							

Specifications, Cont.

Category	Specification																																													
	Frames 1-6 (690V Drive - frames 5 & 6 only)	Frames 9 & up																																												
Environment	Altitude:	1000m (3300 ft.) max. without derating	1000m (3300 ft.) max. without derating																																											
	Surrounding Air Temperature without Derating:		Based on the drive rating. Refer to the <i>PowerFlex 700S/H High Power Drives Installation Frame 9-13</i> manual, publication PFLEX-IN006....																																											
	Open Type:	0 to 50° C (32 to 122° F)	Note: Frames 9 & 10 are rated 0 to 40° C (32 to 104° F) surrounding air.																																											
	IP20:	0 to 50° C (32 to 122° F)																																												
	NEMA Type 1:	0 to 40° C (32 to 104° F)																																												
	IP56, NEMA Type 4X:	0 to 40° C (32 to 104° F)																																												
	Storage Temperature (all const.):	-40 to 70° C (-40 to 158° F)	-40 to 70° C (-40 to 158° F)																																											
	Relative Humidity:	5 to 95% non-condensing	5 to 95% non-condensing																																											
	Shock:	10G peak for 11 ms duration (±1.0 ms)	15G peak for 11ms duration (±1.0 ms)																																											
	Vibration:	0.152 mm (0.006 in.) displacement, 1G peak, 5.5 Hz	2 mm (0.0787 in.) displacement, 1G peak EN50178 / EN60068-2-6																																											
Sound:	<table border="1"> <thead> <tr> <th>Frame</th> <th>Fan Speed</th> <th>Sound Level</th> <th rowspan="7">Note: Sound pressure level is measured at 2 meters.</th> </tr> </thead> <tbody> <tr> <td>1</td> <td>30 CFM</td> <td>59 dB</td> </tr> <tr> <td>2</td> <td>50 CFM</td> <td>57 dB</td> </tr> <tr> <td>3</td> <td>120 CFM</td> <td>61 dB</td> </tr> <tr> <td>4</td> <td>190 CFM</td> <td>59 dB</td> </tr> <tr> <td>5</td> <td>200 CFM</td> <td>71 dB</td> </tr> <tr> <td>6</td> <td>300 CFM</td> <td>72 dB</td> </tr> </tbody> </table>	Frame	Fan Speed	Sound Level	Note: Sound pressure level is measured at 2 meters.	1	30 CFM	59 dB	2	50 CFM	57 dB	3	120 CFM	61 dB	4	190 CFM	59 dB	5	200 CFM	71 dB	6	300 CFM	72 dB	<table border="1"> <thead> <tr> <th>Frame</th> <th>Sound Level</th> <th>Background Noise Level</th> <th rowspan="7">Note: Sound pressure level is measured at 1 meter. All devices measured are 400V IP21 and in power up mode.</th> </tr> </thead> <tbody> <tr> <td>9</td> <td>78</td> <td>49</td> </tr> <tr> <td>10</td> <td>77</td> <td>49</td> </tr> <tr> <td>13</td> <td>76</td> <td>46</td> </tr> <tr> <td></td> <td></td> <td></td> </tr> <tr> <td></td> <td></td> <td></td> </tr> <tr> <td></td> <td></td> <td></td> </tr> </tbody> </table>	Frame	Sound Level	Background Noise Level	Note: Sound pressure level is measured at 1 meter. All devices measured are 400V IP21 and in power up mode.	9	78	49	10	77	49	13	76	46									
Frame	Fan Speed	Sound Level	Note: Sound pressure level is measured at 2 meters.																																											
1	30 CFM	59 dB																																												
2	50 CFM	57 dB																																												
3	120 CFM	61 dB																																												
4	190 CFM	59 dB																																												
5	200 CFM	71 dB																																												
6	300 CFM	72 dB																																												
Frame	Sound Level	Background Noise Level	Note: Sound pressure level is measured at 1 meter. All devices measured are 400V IP21 and in power up mode.																																											
9	78	49																																												
10	77	49																																												
13	76	46																																												
Atmosphere:	Important: Drive must not be installed in an area where the ambient atmosphere contains volatile or corrosive gas, vapors or dust. If the drive is not going to be installed for a period of time, it must be stored in an area where it will not be exposed to a corrosive atmosphere.																																													
Electrical	AC Input Voltage Tolerance:	See Input Voltage Range/Tolerance on page -79 for Full Power and Operating Range	See Input Voltage Range/Tolerance on page -79 for Full Power and Operating Range																																											
	Frequency Tolerance:	47-63 Hz	47-63 Hz.																																											
	Input Phases:	Three-phase input provides full rating for all drives. Single-phase operation provides 50% of rated current.	Three-phase input provides full rating for all drives. Single-phase operation provides 50% of rated current.																																											
	DC Input Voltage Tolerance:	±10% of Nominal Bus Voltage (above)	±10% of Nominal Bus Voltage (above)																																											
	Displacement Power Factor:	0.98 across speed range	0.98 across speed range																																											
	Efficiency:	97.5% at rated amps, nominal line volts.	97.5% at rated amps, nominal line volts.																																											
	Max. Short Circuit Current Rating: Using Recommended Fuse or Circuit Breaker Type:	Maximum short circuit current rating to match specified fuse/circuit breaker capability. ≤ 200,000 Amps	≤ 200,000 Amps																																											
	Maximum Drive to Motor Power Ratio:	The drive to motor rating cannot exceed a 2:1 ratio	The drive to motor rating cannot exceed a 2:1 ratio																																											

Specifications, Cont.

Category	Specification	Frames 1-6 (690V Drive frames 5 & 6 only)		Frames 9 & up	
Control	Method Induction Motor: Brushless Motor:	Sine coded PWM with programmable carrier frequency, Indirect Self-Organized, Field-Oriented Control, Current-regulated. Ratings apply to all drives. Refer to the <i>PowerFlex 700S Phase II Control Reference Manual</i> , publication PFLEX-RM003..., for derating guidelines. The drive can be supplied as 6 pulse or 12 pulse in a configured package.			
	Carrier Frequency	Drive rating: 4 kHz Settings: 2, 4, 6, 8, 10 kHz (6 kHz is for V/Hz operation only)		Drive rating: 2 kHz Settings: 2, 4, 6, 8, 10 kHz (6 kHz is for V/Hz operation only)	
	Output Voltage Range:	0 to rated motor voltage		0 to rated motor voltage	
	Output Frequency Range:	0 – 400 Hz		0 – 400 Hz Note: For output frequencies above 320 - 400 Hz consult the factory.	
	Speed Control	Speed regulation - without feedback 0.1% of base speed across 120:1 speed range 120:1 operating range 50 rad/sec bandwidth		Speed regulation - without feedback 0.1% of base speed across 120:1 speed range 120:1 operating range 50 rad/sec bandwidth	
		Speed regulation - with feedback 0.001% of base speed across 120:1 speed range 1000:1 operating range 744 rad/sec bandwidth		Speed regulation - with feedback 0.001% of base speed across 120:1 speed range 1000:1 operating range 300 rad/sec bandwidth	
	Torque Regulation	Torque Regulation - without feedback ±5%, 600 rad/sec bandwidth		Torque Regulation - without feedback ±10%, 600 rad/sec bandwidth	
		Torque Regulation - with feedback ±2%, 2500 rad/sec bandwidth		Torque Regulation - with feedback ±5%, 2500 rad/sec bandwidth	
	Selectable Motor Control:	Field Oriented Control with and without a feedback device and permanent magnet motor control			
	Stop Modes:	Multiple programmable stop modes including – Ramp, Coast and Current Limit			
	Accel/Decel	Independently programmable accel and decel times adjustable from 0 to 6553.5 in 0.1 second increments.			
	S-Curve Time	Adjustable from 0.5 to 4.0 seconds			
	Intermittent Overload:	110% Overload capability for up to 1 minute 150% Overload capability for up to 3 seconds			
Current Limit Capability:	Independent Motoring and Regenerative Power Limits programmable to 800% of rated output current.				
Electronic Motor Overload Protection	Class 10 protection with speed sensitive response. Investigated by U.L. to comply with N.E.C. Article 430 U.L. File E59272, volume 12.				

Specifications, Cont.

Category	Specification	Frames 1-6 (690V Drive frames 5 & 6 only)		Frames 9 & up						
Feedback	Encoder Inputs (2):	Dual Channel Plus Marker, Isolated with differential transmitter Output (Line Drive) Incremental, Dual Channel Quadrature type								
	Encoder PPR Rating:	Encoder PPR ratings are limited to the values specified in the table below:								
		PPR Rating Values:								
		n =	2 ⁿ =	x	mod 75	mod 125	mod 225	mod 375	mod 625	mod1125
		0	1		75	125	225	375	625	1125
		1	2		150	250	450	750	1250	2250
		2	4		300	500	900	1500	2500	4500
		3	8		600	1000	1800	3000	5000	9000
		4	16		1200	2000	3600	6000	10000	18000
		5	32		2400	4000	7200	12000	20000	--
		6	64		--	--	--	--	--	--
		7	128		--	--	--	--	--	--
		8	256		--	--	--	--	--	--
		9	512		--	--	--	--	--	--
	10	1024		--	--	--	--	--	--	
	11	2048		--	--	--	--	--	--	
	12	4096		--	--	--	--	--	--	
	13	8192		--	--	--	--	--	--	
	14	16384		--	--	--	--	--	--	
	Encoder Voltage Supply:	5V DC or 12 V DC 320 mA/channel 5V DC minimum high state voltage of 3.0 VDC, maximum low voltage state of 0.4V DC. 12 V DC minimum high state voltage of 7.0V DC, maximum low state voltage of 0.4V DC				5V DC or 12 V DC 320 mA/channel 5V DC minimum high state voltage of 3.0 VDC, maximum low voltage state of 0.4V DC. 12 V DC minimum high state voltage of 7V DC, maximum low state voltage of 0.4V DC				
	Maximum Input Frequency:	400 kHz				500 kHz				
	Stegmann Option:									
	Encoder Voltage Supply:	11.5V DC @ 130 mA				11.5V DC @ 130 mA				
	Hi-Resolution Feedback:	Sine/Cosine 1V P-P Offset 2.5				Sine/Cosine 1V P-P Offset 2.5				
	Maximum Cable Length:	182 m (600 ft.)				182 m (600 ft.)				
	RS-485 Interface:	Hi-Resolution Feedback Option card obtains the following information via the Hiperface RS-485 interface shortly after power-up: Address, Command Number, Mode, Number of turns, Number of Sine/Cos cycles, Checksum				Hi-Resolution Feedback Option card obtains the following information via the Hiperface RS-485 interface shortly after power-up: Address, Command Number, Mode, Number of turns, Number of Sine/Cos cycles, Checksum				
	Customer-I/O Plug (P1) - Hi Res:	Allen-Bradley PN: S94262912 Weidmuller PN: BL3.50/90/12BK				Allen-Bradley PN: S94262912 Weidmuller PN: BL3.50/90/12BK				
	Resolver Option:									
	Excitation Frequency:	2400 Hz				2400 Hz				
	Excitation Voltage:	4.25-26 Vrms				4.25-26 Vrms				
	Operating Frequency Range:	1 - 10 kHz				1 - 10 kHz				
	Resolver Feedback Voltage:	2V ± 300 mV				2V ± 300 mV				
	Maximum Cable Length:	304.8 meters (1000 ft.)				304.8 meters (1000 ft.)				
DriveLogix	User Available MemoryBase:	1.5 megabytes (CompactFlash™ for non-volatile storage also available)				1.5 megabytes (CompactFlash™ for non-volatile storage also available)				
	Battery:	1769-BA 0.59g lithium				1769-BA 0.59g lithium				
	Serial Cable:	1761-CBLPM02 to 1761-NET-AIC 1761-CBLPA00 to 1761-NET-AIC 1756-CP3 directly to controller 1747-CP3 directly to controller category 3 (2)				1761-CBLPM02 to 1761-NET-AIC 1761-CBLPA00 to 1761-NET-AIC 1756-CP3 directly to controller 1747-CP3 directly to controller category 3 (2)				
	Compact I/O Connection:	Up to (16) modules				Up to (16) modules				
	Cable:	20D-DL2-CL3 20D-DL2-CR3				20D-DL2-CL3 20D-DL2-CR3				

Input Voltage Range/Tolerance

Drive Rating	Nominal Line Voltage	Nominal Motor Voltage	Drive Full Power Range	Drive Operating Range
200-240	200	200†	200-264	180-264
	208	208	208-264	
	240	230	230-264	
380-400	380	380†	380-528	342-528
	400	400	400-528	
	480	460	460-528	
500-600 (Frames 1-4 Only)	600	575†	575-660	432-660
500-690 (Frames 5 & 6 Only)	600	575†	575-660	475-759
	690	690	690-759	

Drive Full Power Range = Nominal Motor Voltage to Drive Rated Voltage + 10%.
Rated current is available across the entire Drive Full Power Range

Drive Operating Range = Lowest† Nominal Motor Voltage - 10% to Drive Rated Voltage + 10%.
Drive Output is linearly derated when Actual Line Voltage is less than the Nominal Motor Voltage

Example:

Calculate the maximum power of a 5 HP, 460V motor connected to a 480V rated drive supplied with 342V Actual Line Voltage input.

- $\text{Actual Line Voltage} / \text{Nominal Motor Voltage} = 74.3\%$
- $74.3\% \times 5 \text{ HP} = 3.7 \text{ HP}$
- $74.3\% \times 60 \text{ Hz} = 44.6 \text{ Hz}$

At 342V Actual Line Voltage, the maximum power the 5 HP, 460V motor can produce is 3.7 HP at 44.6 Hz.

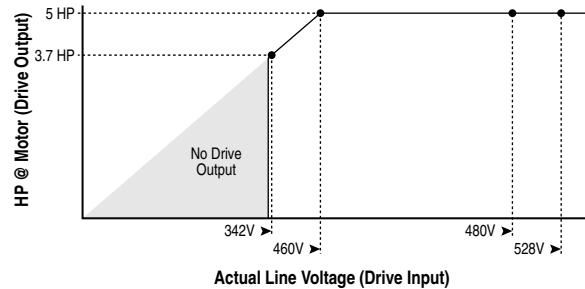
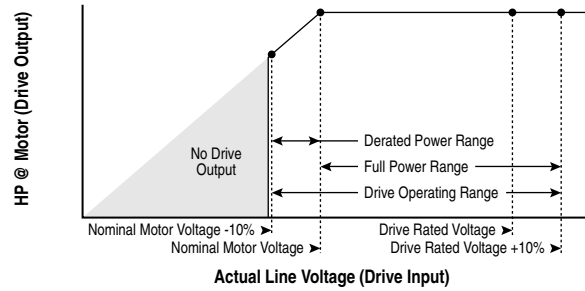

Altitude Derating

Frame	Type	Derate
All	Altitude	
	Efficiency (typical)	

Carrier Derating

Frame	Voltage	ND Rating	Enclosure	Frequency [●]	Derate
1	400V	11 kW	<ul style="list-style-type: none"> Open NEMA Type1 IP20 	6-10kHz	<p>Max. Surrounding Air Temp. °C vs. % of Output FLA. Curves for 6 kHz, 8 kHz, and 10 kHz.</p>
	460V	15 HP	<ul style="list-style-type: none"> Open NEMA Type1 IP20 	6-10kHz	<p>Max. Surrounding Air Temp. °C vs. % of Output FLA. Curves for 6 kHz, 8 kHz, and 10 kHz.</p>
2	400V	15kW	<ul style="list-style-type: none"> Open NEMA Type1 IP20 	8-10kHz	<p>Max. Surrounding Air Temp. °C vs. % of Output FLA. Curves for 8 kHz and 10 kHz.</p>
	460V	20 HP	<ul style="list-style-type: none"> Open NEMA Type1 IP20 	10 kHz	<p>Max. Surrounding Air Temp. °C vs. % of Output FLA. Curve for 10 kHz.</p>
		25 HP	<ul style="list-style-type: none"> Open NEMA Type1 IP20 	6-10 kHz	<p>Max. Surrounding Air Temp. °C vs. % of Output FLA. Curves for 6 kHz, 8 kHz, and 10 kHz.</p>

● Consult the factory for further derate information at other frequencies.

Carrier Derating, Cont'd

Frame	Voltage	ND Rating	Enclosure	Frequency [●]	Derate
3	400V	18.5 kW	<ul style="list-style-type: none"> Open NEMA Type1 IP20 	6-10 kHz	
		30 kW	<ul style="list-style-type: none"> Open NEMA Type1 IP20 	6-10 kHz	
		37 kW	<ul style="list-style-type: none"> Open NEMA Type1 IP20 	4-10 kHz	
3	460V	40 HP	<ul style="list-style-type: none"> Open NEMA Type1 IP20 	6-10 kHz	
		50 HP	<ul style="list-style-type: none"> Open NEMA Type1 IP20 	6-10 kHz	

●Consult the factory for further derate information at other frequencies.

Carrier Derating, Cont'd

Frame	Voltage	ND Rating	Enclosure	Frequency [Ⓞ]	Derate
5	460V	100 HP	<ul style="list-style-type: none"> • Open • NEMA Type1 • IP20 	6-8 kHz	

●Consult the factory for further derate information at other frequencies.

Frame	Ambient Temp.	Voltage	Frequency [Ⓞ]	Rated Amps	Derate	
9	40° C	400V	PWM	@300	@261	
			1.0 kHz	300	261	
			2.2 kHz	300	261	
			3.2 kHz	261	261	
			3.6 kHz	248	248	
			6.8 kHz	173	173	
			10.0 kHz	129	129	
		600V	PWM	@208	@170	
			1.0 kHz	208	170	
			1.5 kHz	208	170	
			1.9 kHz	208	170	
			2.7 kHz	170	170	
			3.0 kHz	158	158	
			3.6 kHz	140	140	
4.2 kHz	125	125				
4.5 kHz	117	117				
6.0 kHz	92	92				

●Consult the factory for further derate information at other frequencies.

Carrier Derating, Cont'd

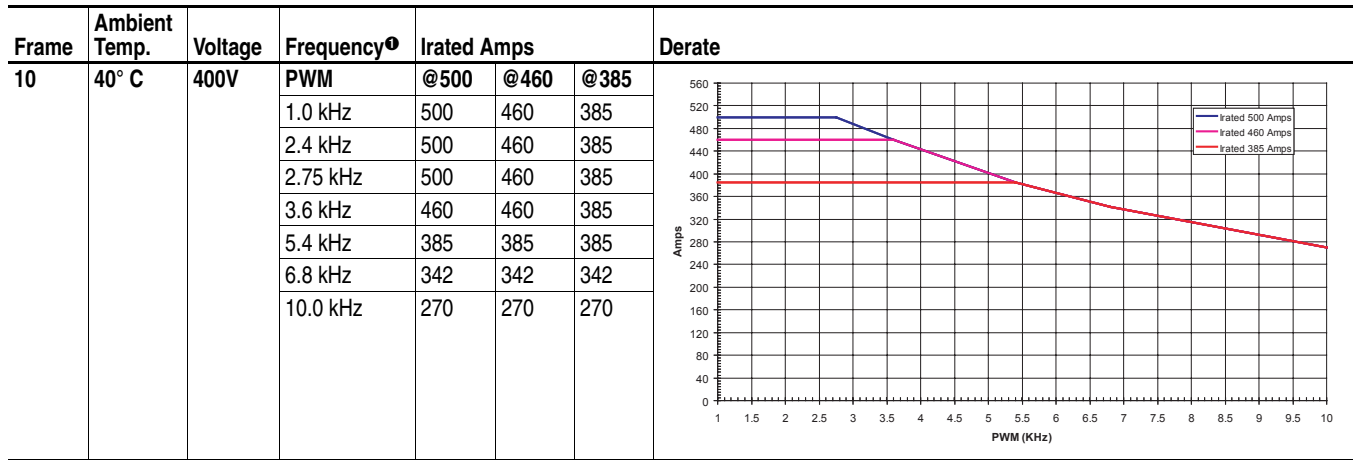

① Consult the factory for further derate information at other frequencies.

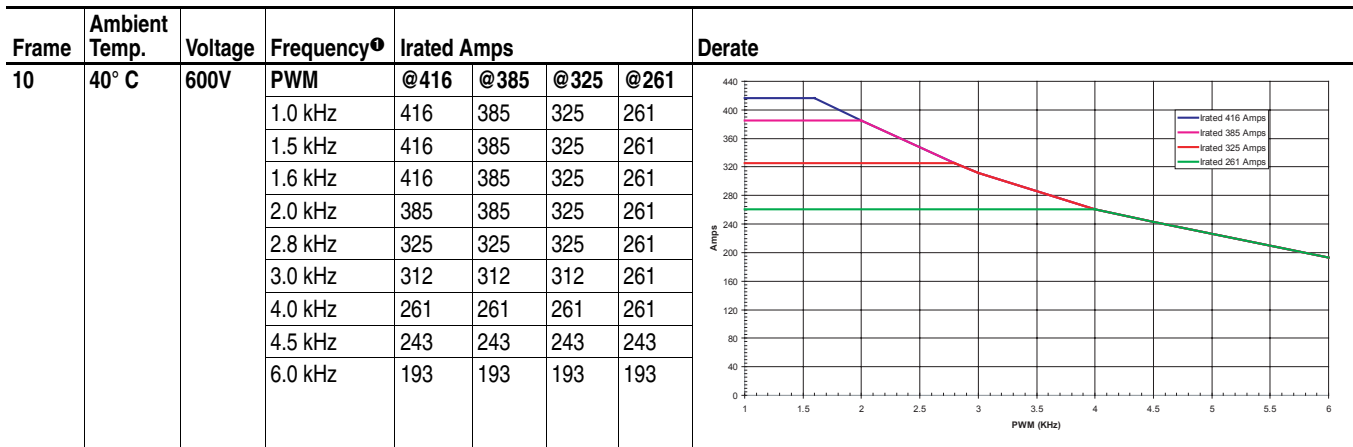

① Consult the factory for further derate information at other frequencies.

Carrier Derating, Cont'd

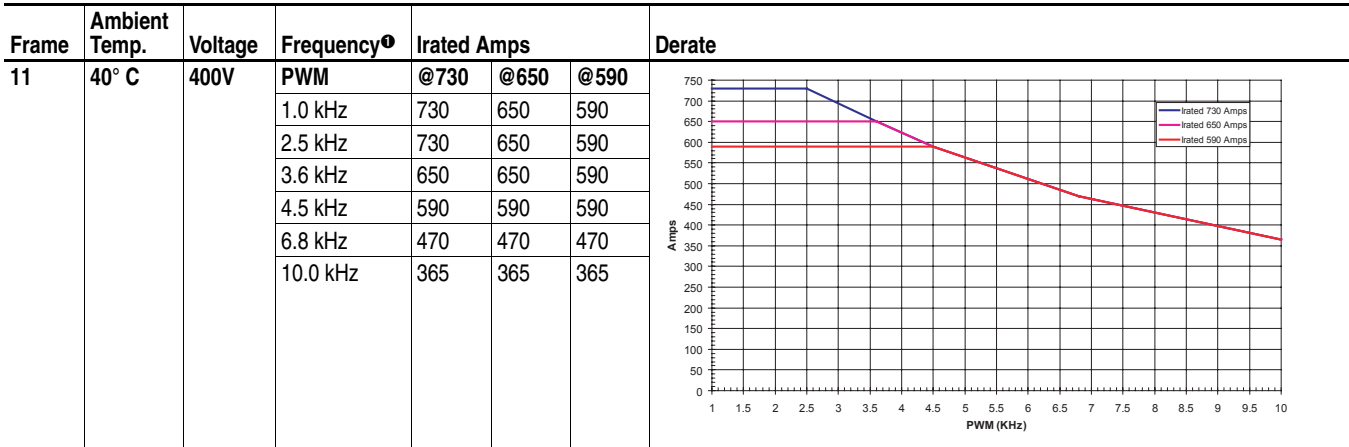

Ⓞ Consult the factory for further derate information at other frequencies.

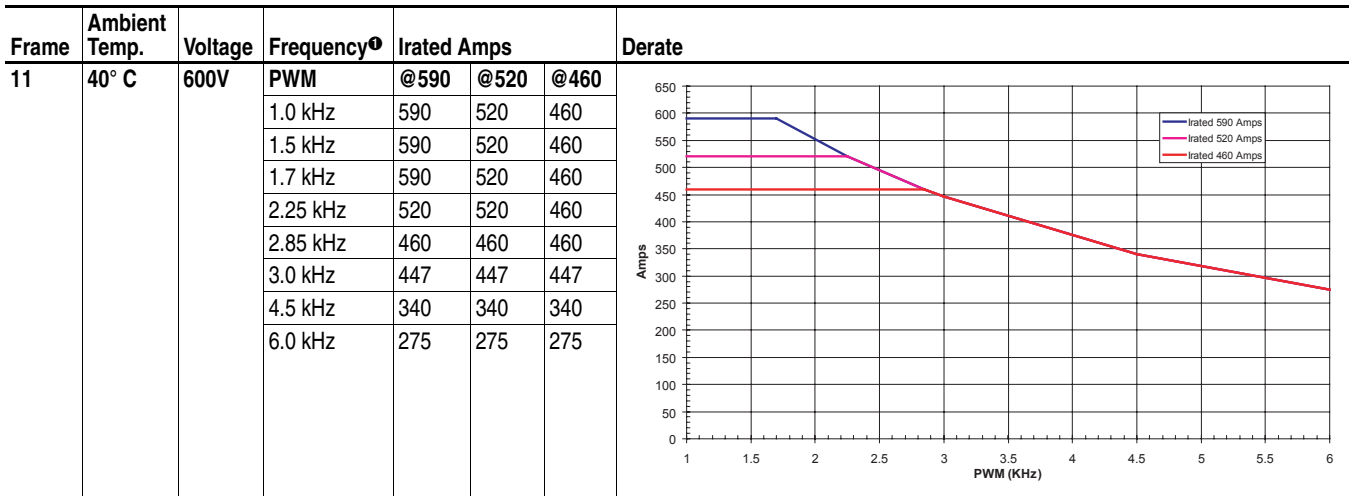

Ⓞ Consult the factory for further derate information at other frequencies.

Carrier Derating, Cont'd

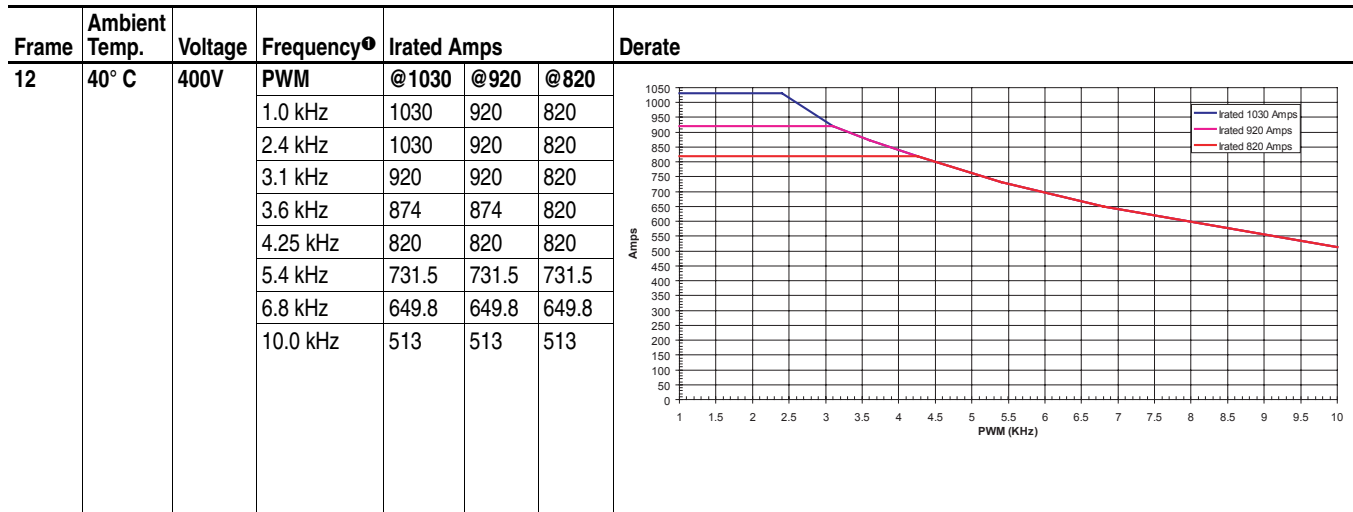

● Consult the factory for further derate information at other frequencies.

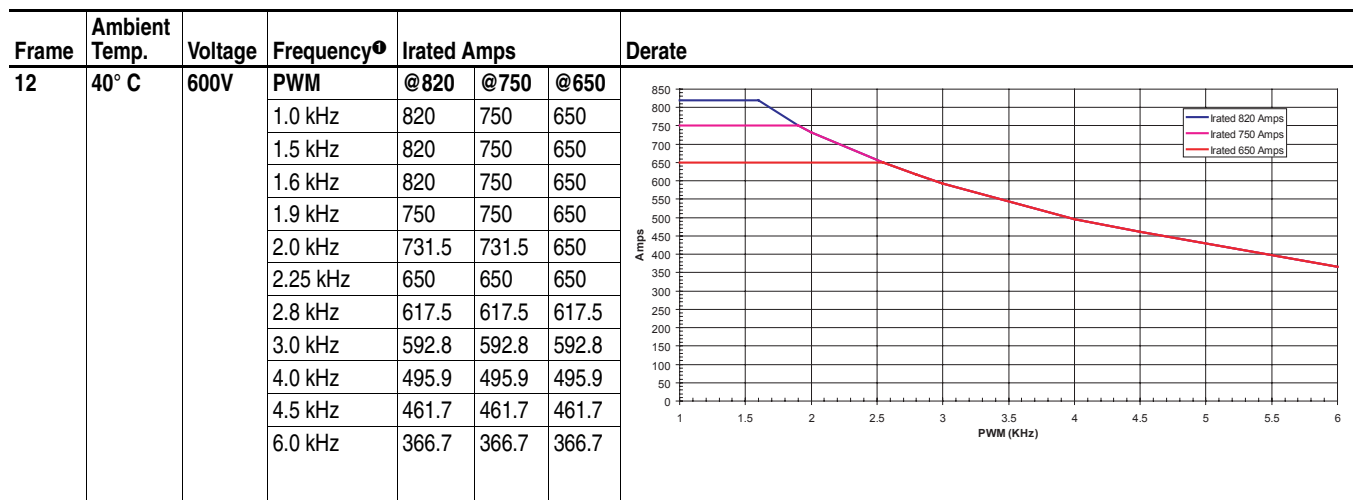

● Consult the factory for further derate information at other frequencies.

Carrier Derating, Cont'd

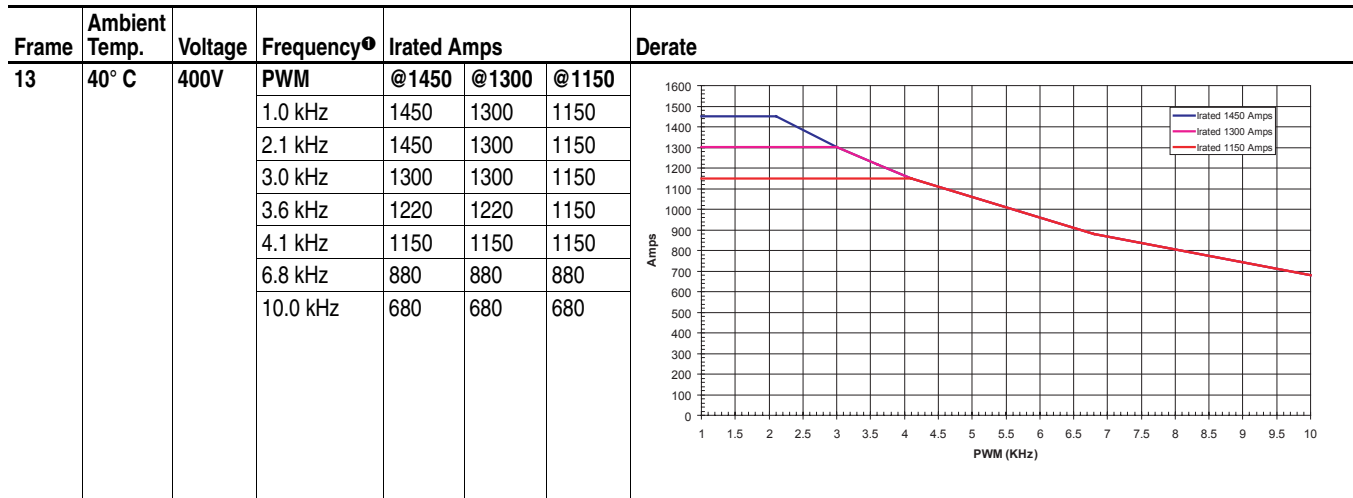

● Consult the factory for further derate information at other frequencies.

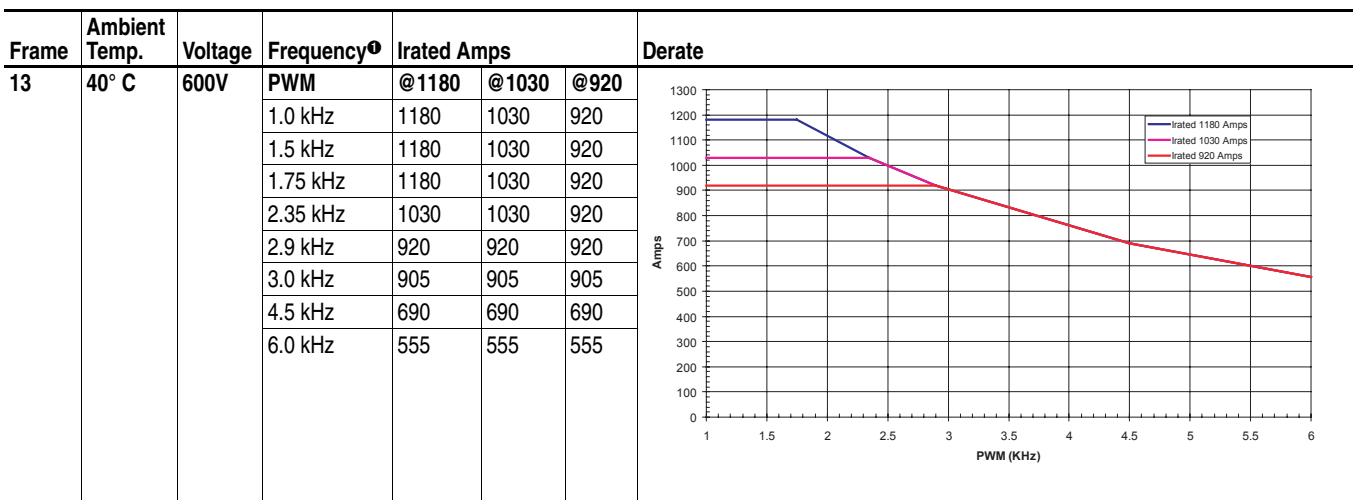

● Consult the factory for further derate information at other frequencies.

Watts Loss - Frames 10 - 13

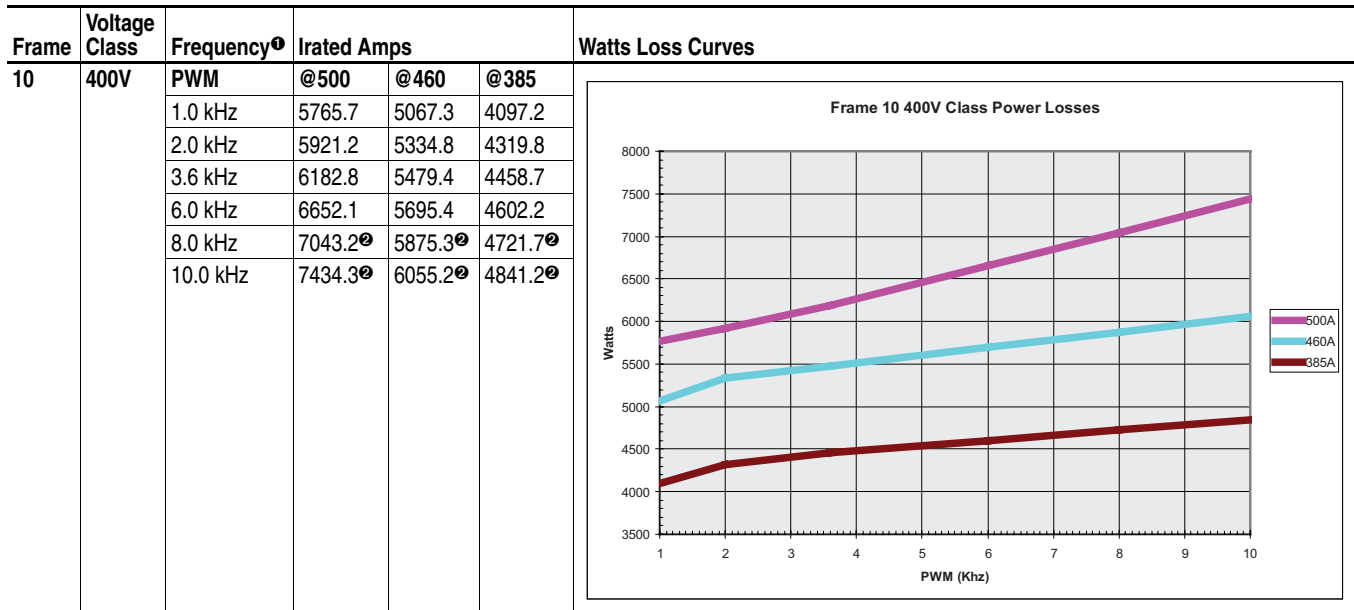

①Consult the factory for further derate information at other frequencies.
 ②Value calculated from slope.

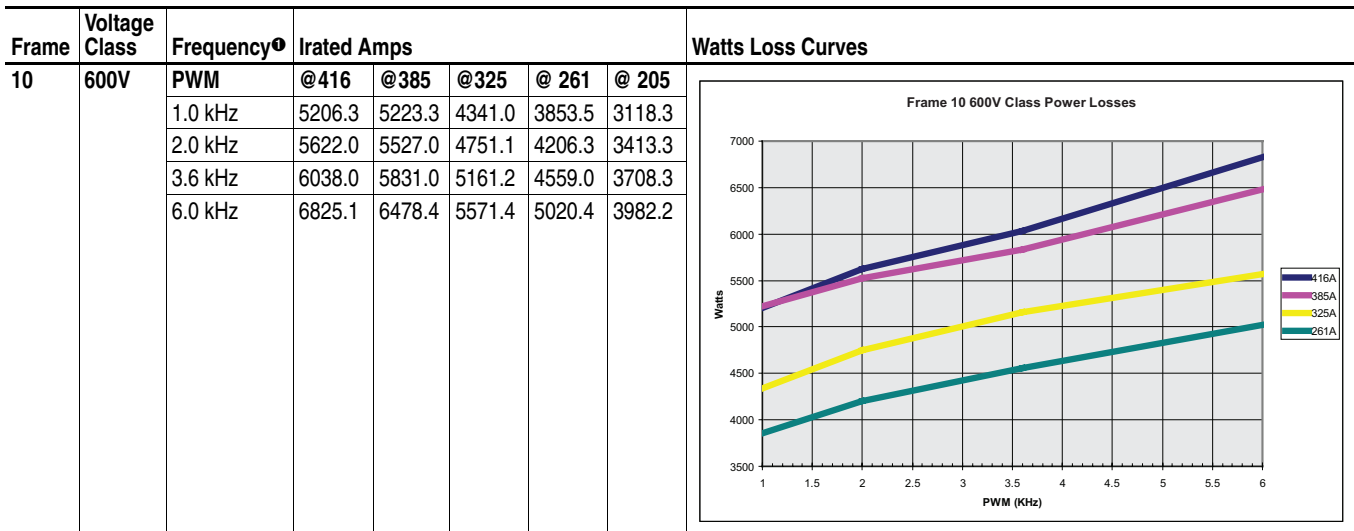

①Consult the factory for further derate information at other frequencies.

Watts Loss - Frames 10 - 13, Cont.

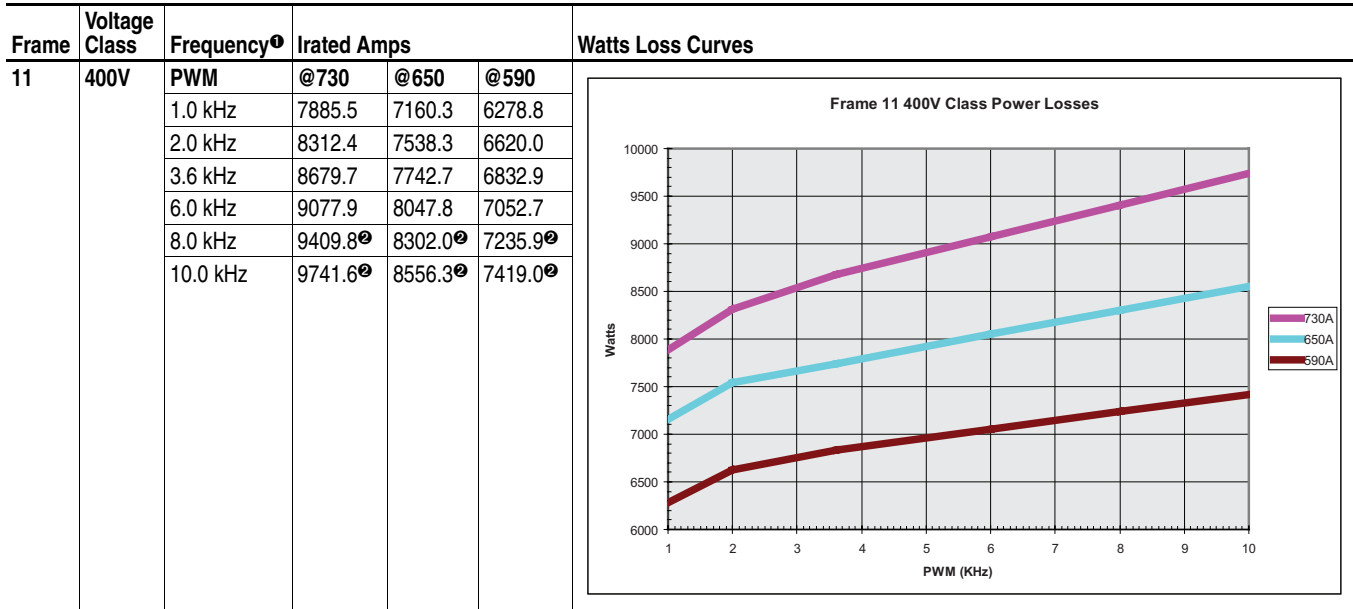

①Consult the factory for further derate information at other frequencies.

②Value calculated from slope.

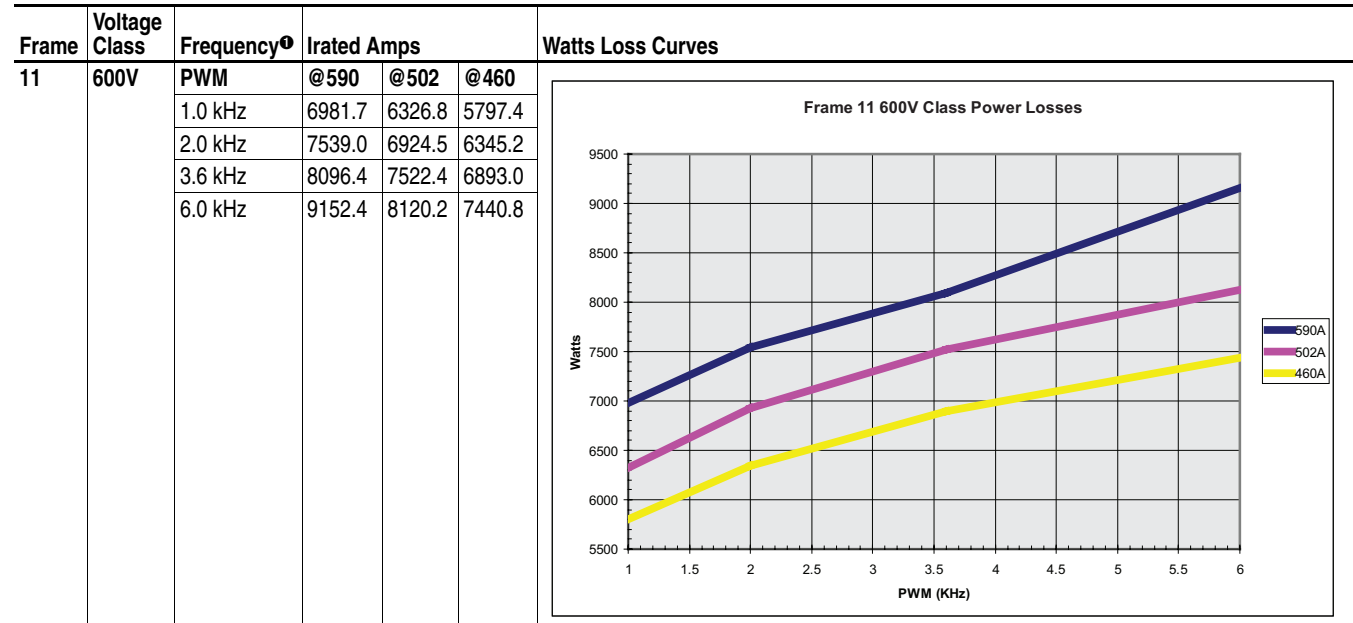

①Consult the factory for further derate information at other frequencies.

Watts Loss - Frames 10 - 13, Cont.

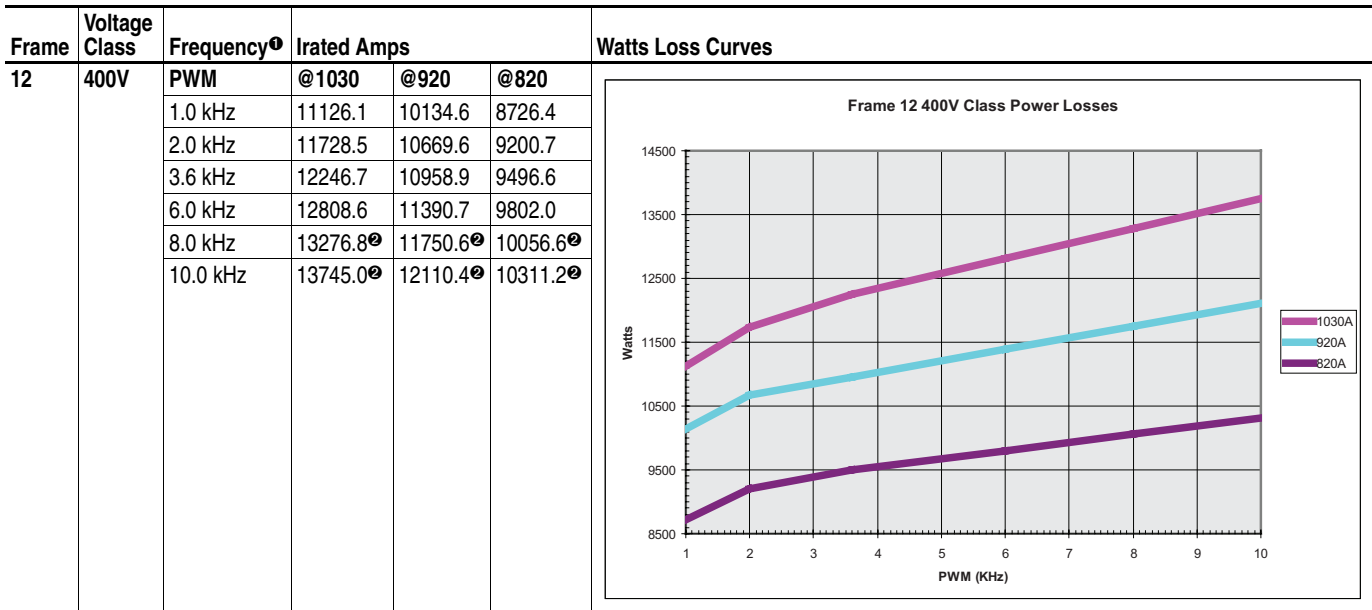

① Consult the factory for further derate information at other frequencies.

② Value calculated from slope.

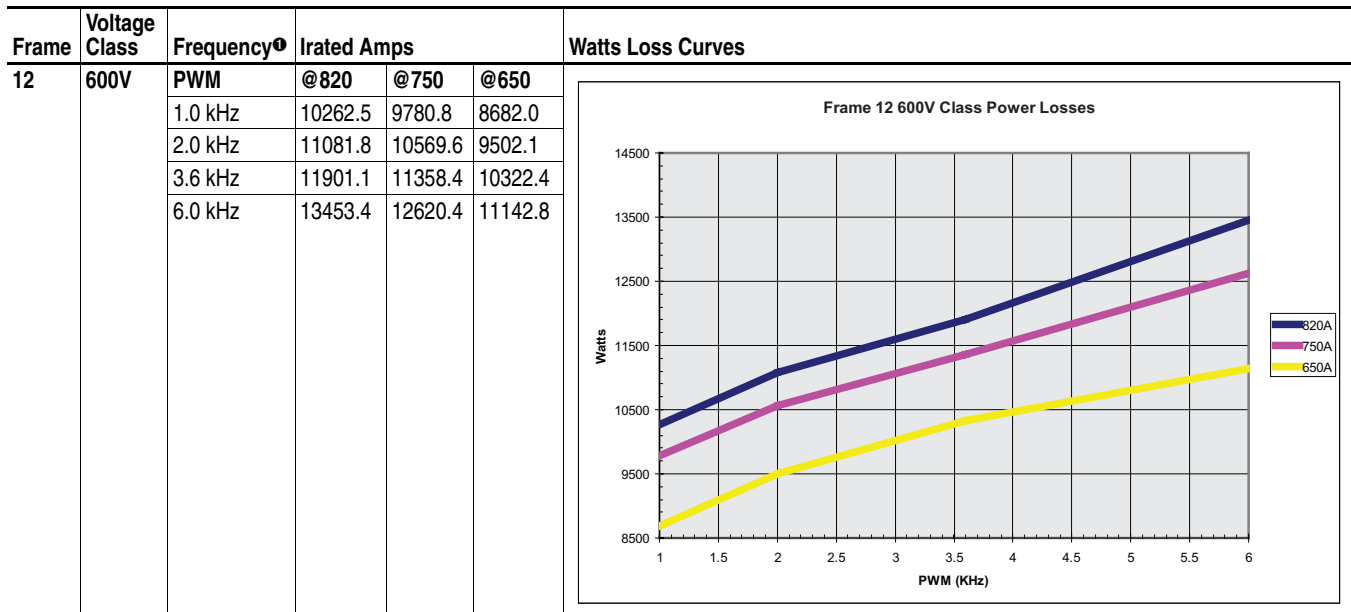

① Consult the factory for further derate information at other frequencies.

Watts Loss - Frames 10 - 13, Cont.

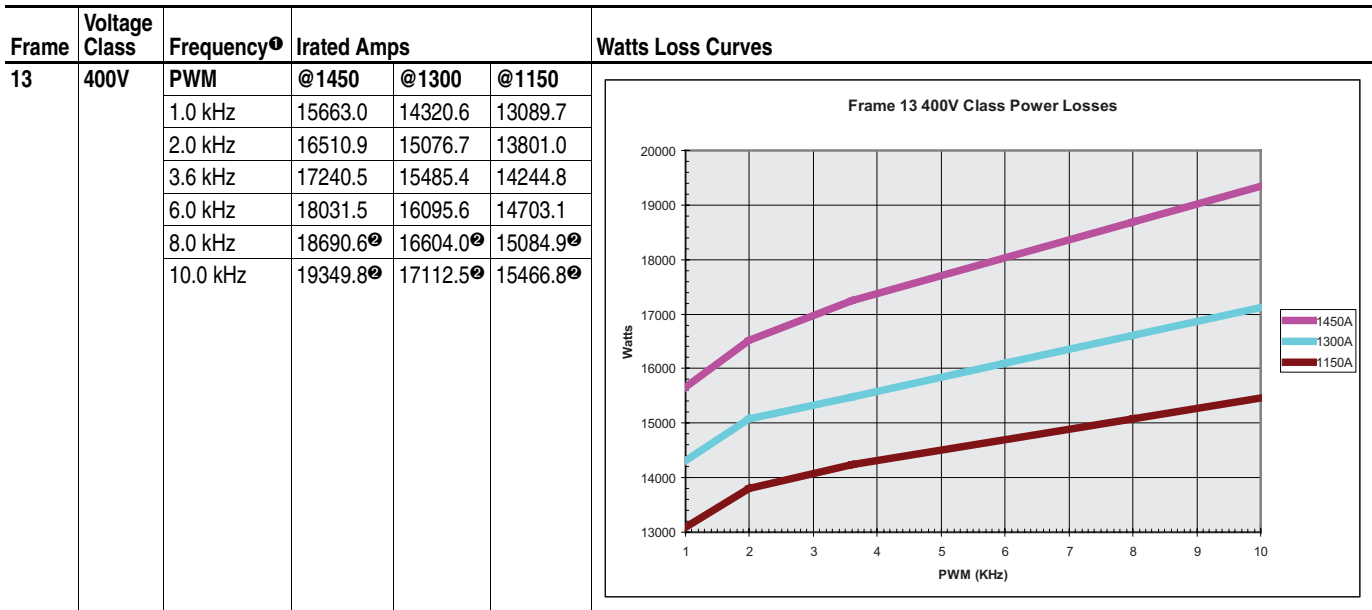

① Consult the factory for further derate information at other frequencies.

② Value calculated from slope.

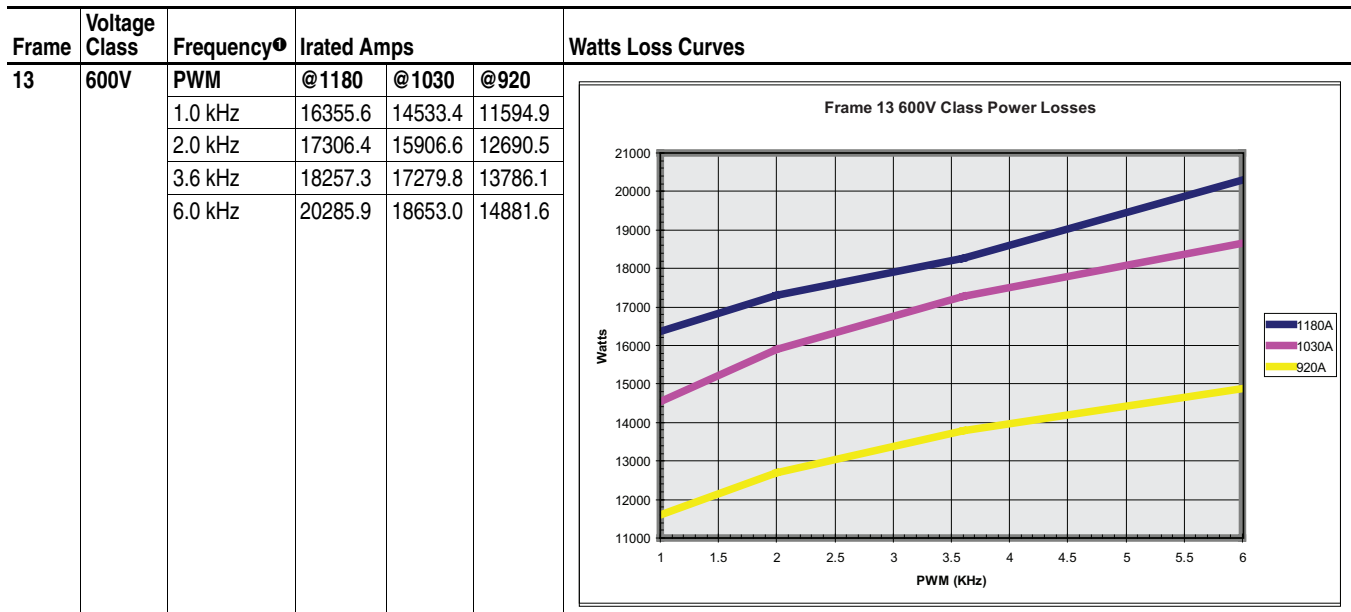

① Consult the factory for further derate information at other frequencies.

Reference Materials

The following publications provide general drive information.

Title	Publication	Available...
Wiring and Grounding for PWM AC Drives	DRIVES-IN001...	www.rockwellautomation.com/literature
Safety Guidelines for the Application, Installation and Maintenance of Solid State Control	SGI-1.1...	
A Global Reference Guide for Reading Schematic Diagrams	100-2.10...	
Guarding Against Electrostatic Damage	8000-4.5.2...	

The following publications provide detailed PowerFlex® 700S drive information:

Title	Publication	Available...
PowerFlex 700S Reference Manual, Phase II Control	PFLEX-RM003...	www.rockwellautomation.com/literature
PowerFlex 700S User Manual, Phase II Control	20D-UM006...	
PowerFlex 700S Quick Start, Phase II Control (Frames 1 - 6)	20D-QS002...	
PowerFlex 700S and 700H Installation Instructions (Frames 9 - 13)	PFLEX-IN006...	

The following publications provide necessary information when applying the DriveLogix Controller.:

Title	Publication	Available...
DriveLogix5730 Controller User Manual	20D-UM003...	www.rockwellautomation.com/literature
PowerFlex 700S Drive & DriveLogix Controller	20D-RN007...	
Logix5000 Controllers Common Procedures	1756-PM001...	
Logix5000 Controllers General Instructions	1756-RM003...	
Logix5000 Controllers Process Control and Drives Instructions	1756-RM006...	
RSLogix 5000 Getting Results	9399-RLD300GR...	
RSNetwork for ControlNet Getting Results	9398-CNETGR...	
RSLinx Getting Results Guide	9399-LINXGR...	

For Allen-Bradley Drives Technical Support:

Title	Online at...
Allen-Bradley Drives Technical Support	www.rockwellautomation.com/literature or call M-F, 7:00a.m. to 7:00p.m. Central STD time: 1.262.512.8176



PowerFlex, DriveLogix, Logix, CompactLogix, NetLinx, DriveExecutive, DriveObserver, DriveExpert, Force Technology, Zero Stacking, Flex I/O, FlexLogix, DriveTools, RSLogix 5000, SynchLink and SCANPort are trademarks of Rockwell Automation. ControlNet is a trademark of ControlNet International, Ltd. DeviceNet is a trademark of the Open DeviceNet Vendor Association. Trademarks not belonging to Rockwell Automation are property of their respective companies.

www.rockwellautomation.com

Power, Control and Information Solutions

Americas: Rockwell Automation, 1201 South Second Street, Milwaukee, WI 53204-2496 USA, Tel: (1) 414.382.2000, Fax: (1) 414.382.4444
Europe/Middle East/Africa: Rockwell Automation SA/NV, Vorstlaan/Boulevard du Souverain 36, 1170 Brussels, Belgium, Tel: (32) 2 663 0600, Fax: (32) 2 663 0640
Asia Pacific: Rockwell Automation, Level 14, Core F, Cyberport 3, 100 Cyberport Road, Hong Kong, Tel: (852) 2887 4788, Fax: (852) 2508 1846

Publication 20D-TD002F-EN-P - September 2006
Supersedes 20D-TD002E-EN-P - August 2006

Copyright © 2006 Rockwell Automation. All rights reserved. Printed in USA.