



## Shuttle DL20N Series Mini PC Intel Celeron User Guide

[Home](#) » [Shuttle](#) » Shuttle DL20N Series Mini PC Intel Celeron User Guide 

### Shuttle DL20N Series Mini PC Intel Celeron



#### Contents

- [1 Product Overview](#)
- [2 Hardware Installation](#)
  - [2.1 A. Begin Installation](#)
  - [2.2 B. Memory Module Installation](#)
  - [2.3 C. M.2 Device Installation](#)
  - [2.4 D. HDD or SSD Installation](#)
  - [2.5 E. Complete](#)
- [3 Safety Information](#)
- [4 Motherboard Illustration](#)
- [5 Jumper Settings](#)
- [6 CUSTOMER SERVICE](#)
- [7 Documents / Resources](#)
  - [7.1 References](#)

#### Product Overview

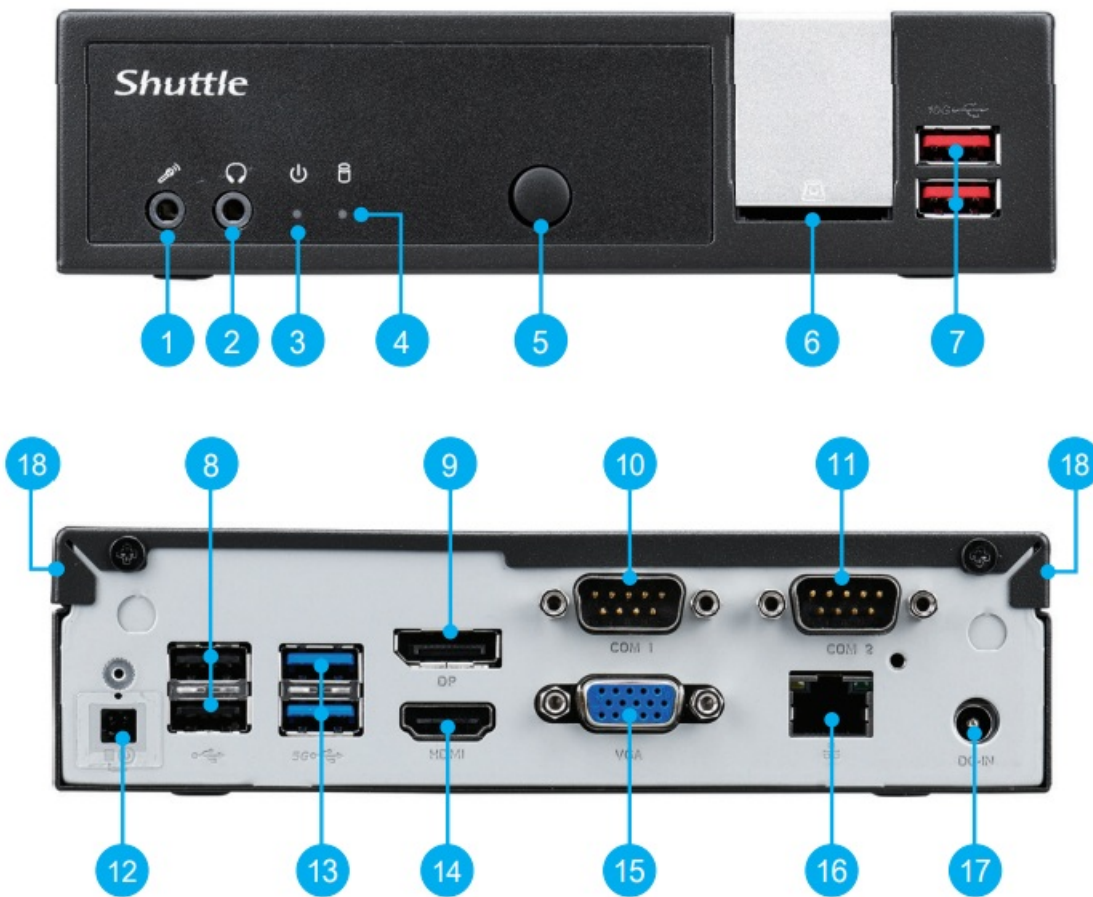

1. MIC-in
2. Headphones
3. Power LED
4. Hard Disk Drive LED
5. Power Button
6. SD Card Reader
7. USB 3.2 Gen 2 Ports
8. USB 2.0 Ports
9. DisplayPort
10. COM 1 Port (RS232/RS422/RS485)
11. COM 2 Port (RS232 only)
12. Clear CMOS & Power Button & +5V
13. USB 3.2 Gen 1 Ports
14. HDMI Port
15. D-Sub (VGA) Port
16. LAN Port
17. Power Jack (DC IN)
18. Kensington® Lock Hole

## Hardware Installation

### A. Begin Installation



For safety reasons, please ensure that the power cord is disconnected before opening the case.

1. Unscrew the two screws of the chassis cover.

Slide the cover backwards and upwards.

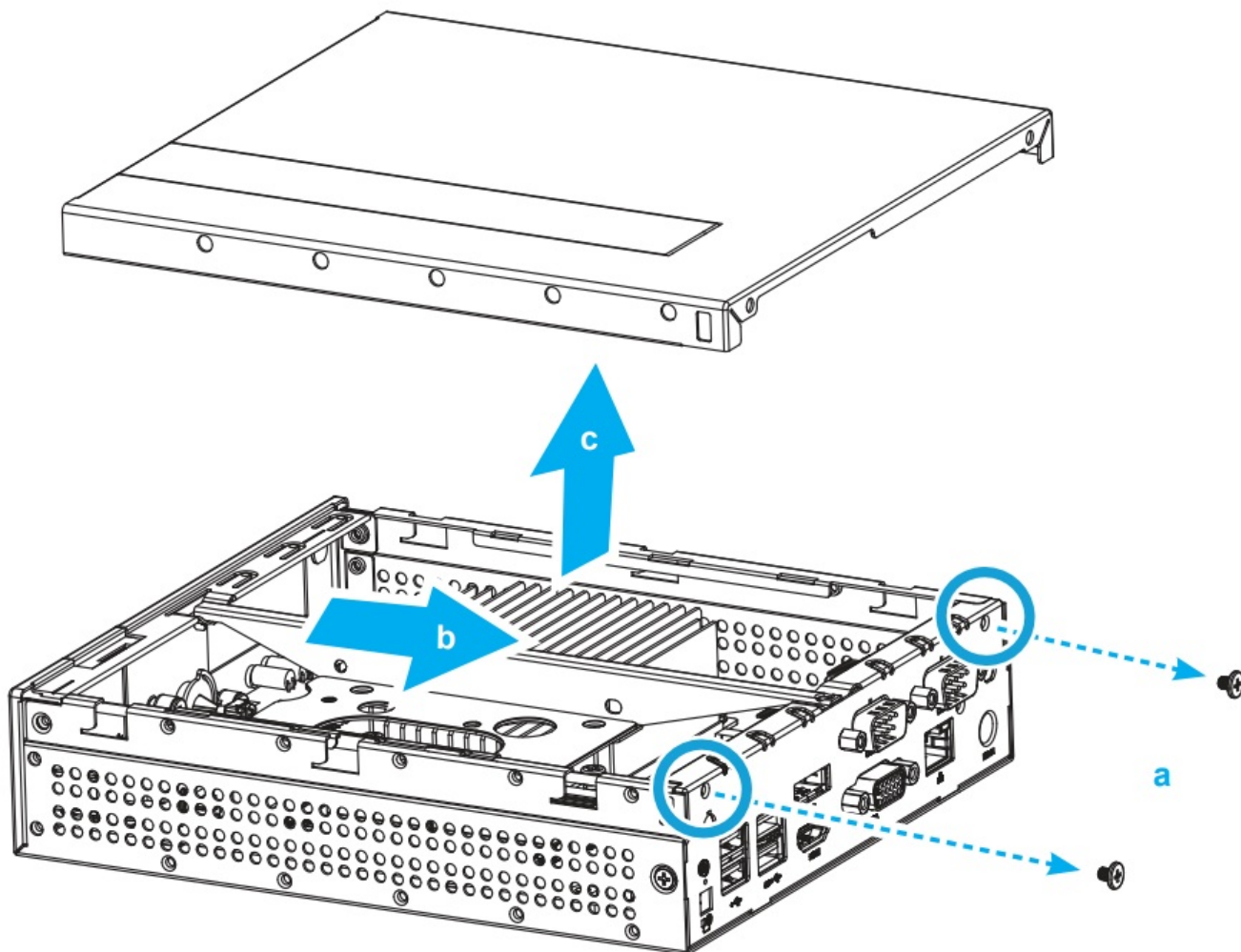

The product's colour and specifications may vary from the actually shipping product.

2. Unfasten the rack mount screw and remove the rack.

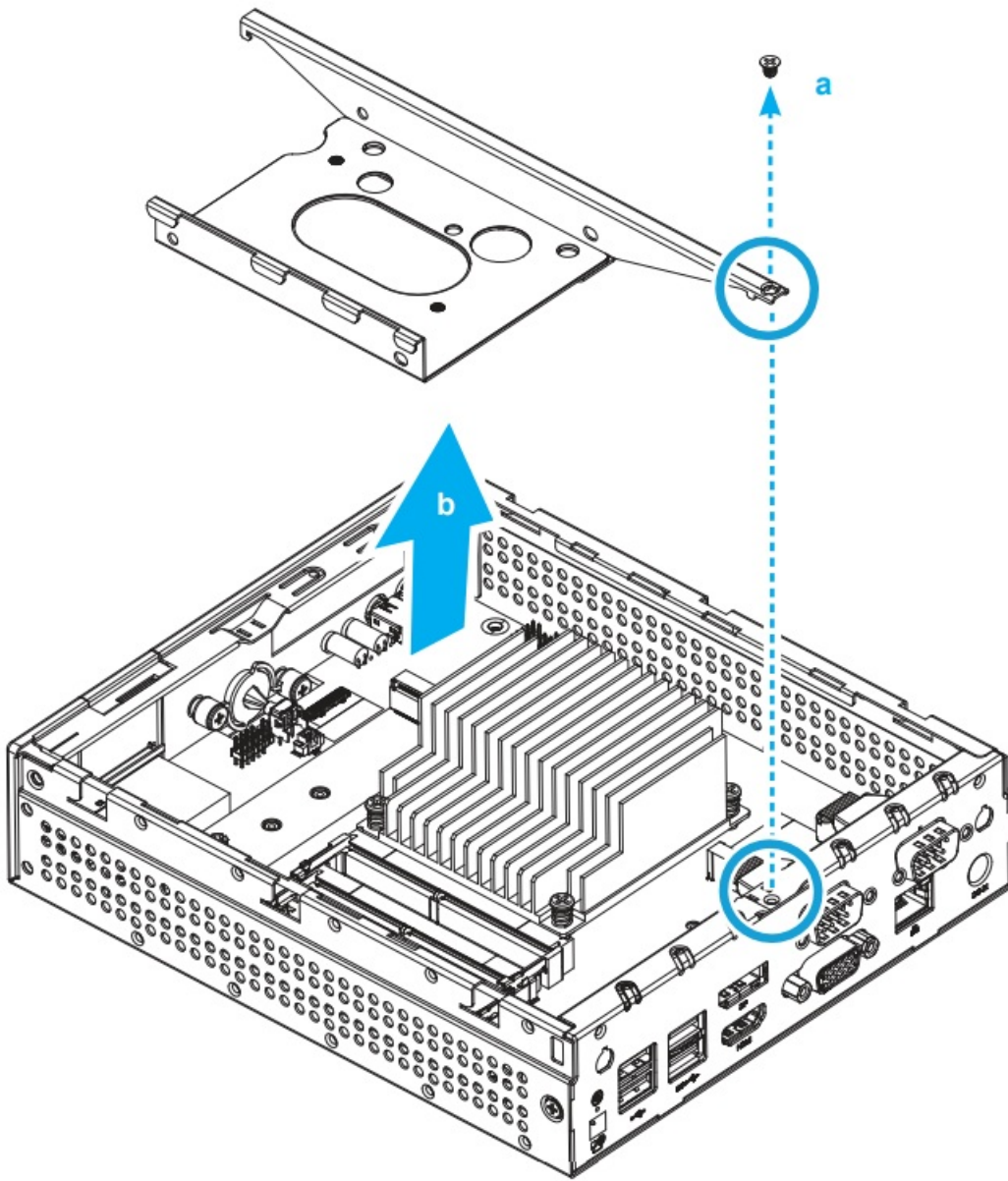

## B. Memory Module Installation



This motherboard does only support 1.2 V DDR4 SO-DIMM memory modules.

1. Locate the SO-DIMM slots on the motherboard.
2. Align the notch of the memory module with the one of the relevant memory slot.

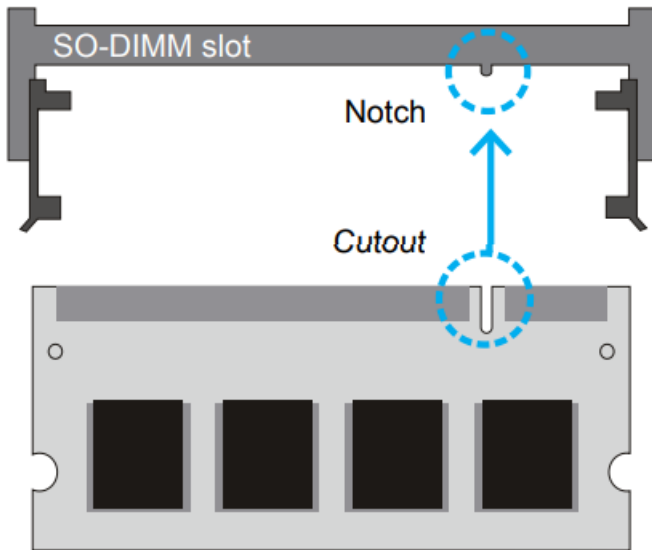

3. Gently insert the module into the slot in a 45-degree angle.
4. Carefully push down the memory module until it snaps into the locking mechanism.

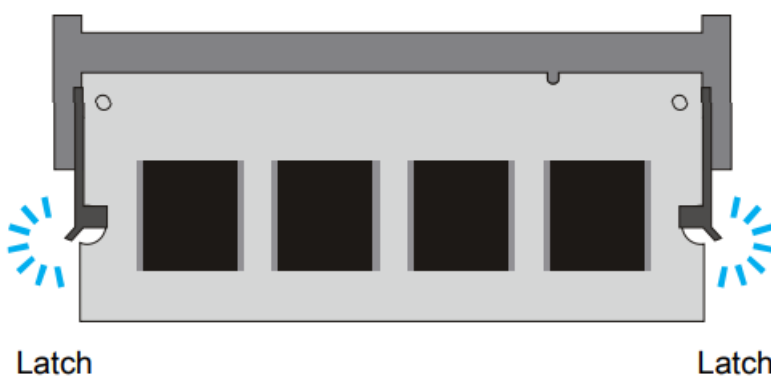
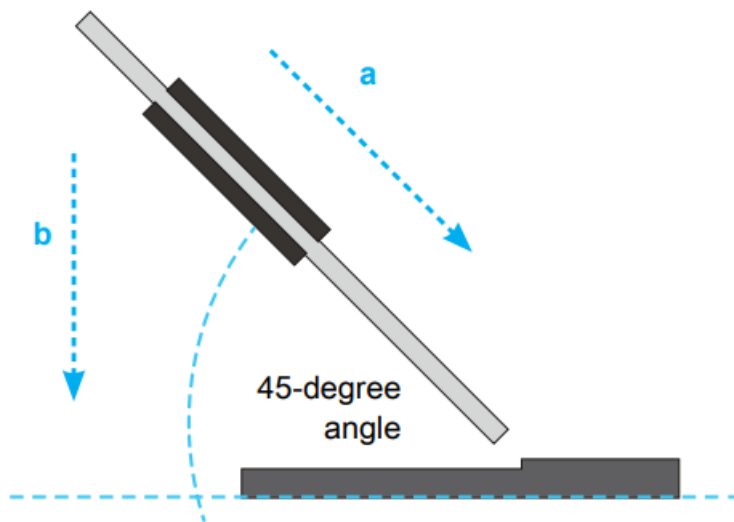

5. Repeat the above steps to install an additional memory module, if required.

### C. M.2 Device Installation

1. Locate the M.2 key slots on the motherboard.
2. Install the M.2 device into the M.2 slot and secure with the screw.

➤ M.2 2242/2260/2280 M key slot

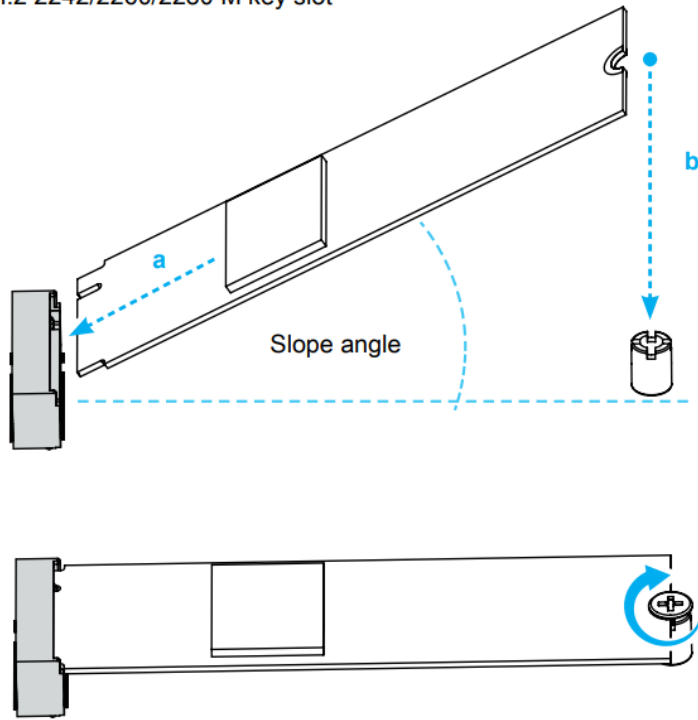

➤ M.2 2230 E Key slot

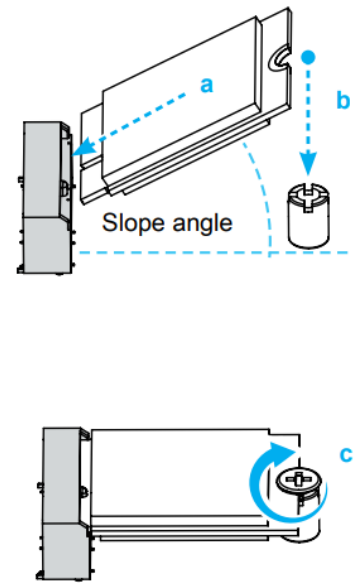

#### D. HDD or SSD Installation

1. Place an HDD or SSD in the rack and secure with the four screws from the sides.

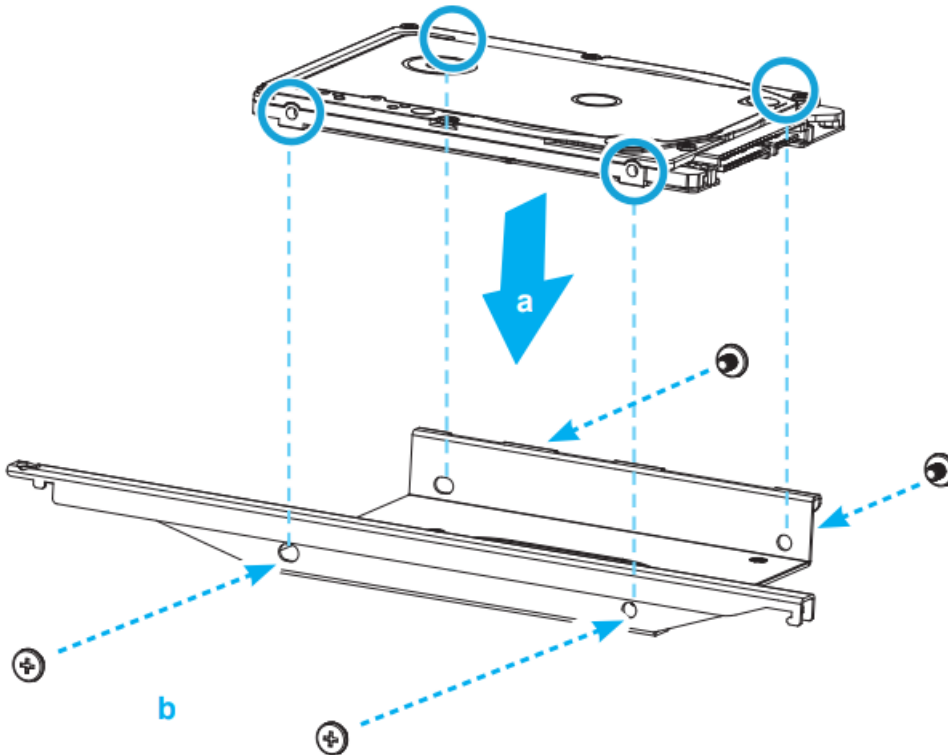

2. Slide the rack back into the chassis and refasten the screws. Connect the Serial ATA cable to the HDD or SSD.



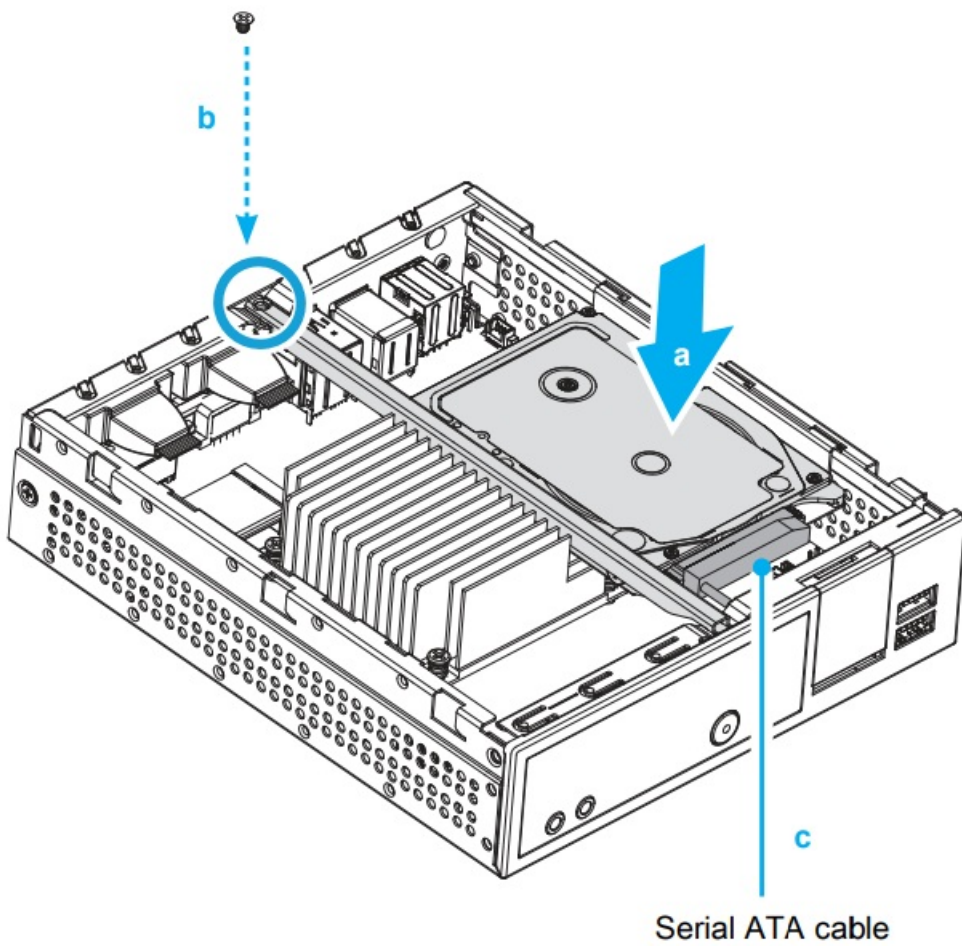

#### E. Complete

1. Please replace and affix the case cover with two screws, then connect the power cord.
2. Complete.

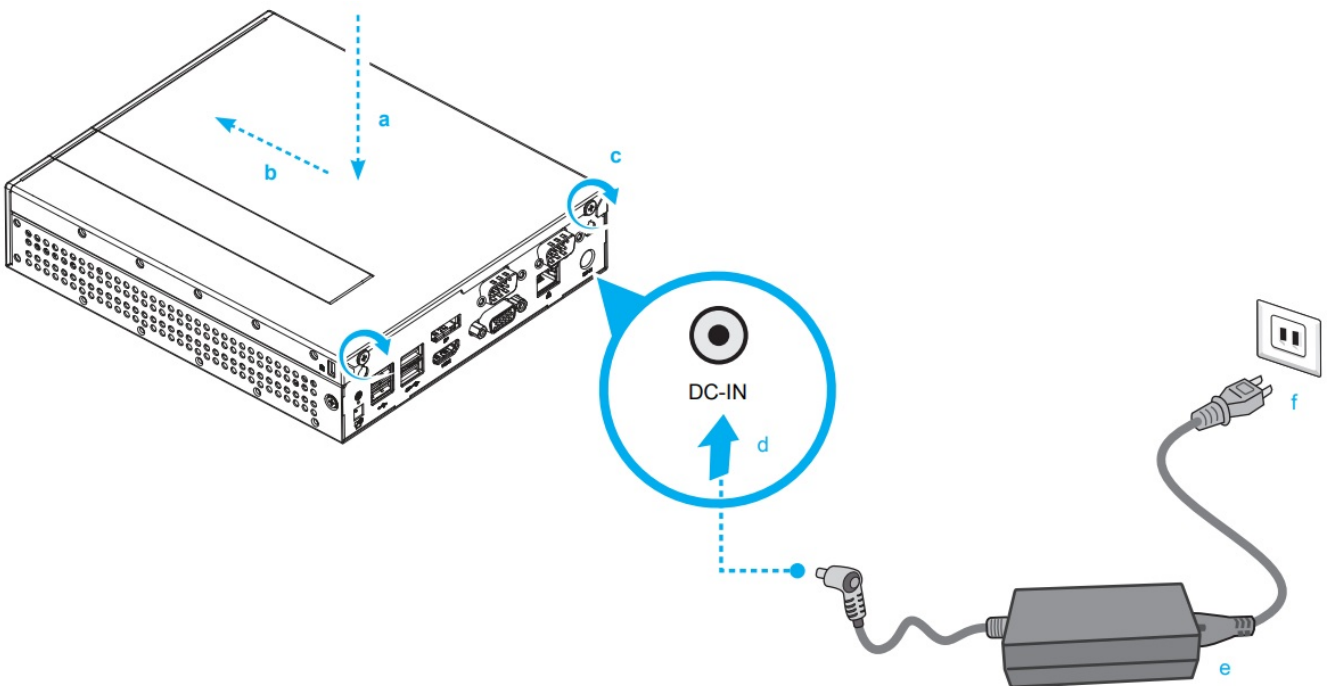

 Please press the “Del” key while booting to enter BIOS. Here, please load the optimised BIOS settings.

#### Safety Information



Incorrectly replacing the battery may damage this computer. Replace only with the same or equivalent as recommended by Shuttle. Dispose of used batteries according to the manufacturer's instructions.



All bundled parts, power cord included, shall not be used without this product.

This device complies with Part 15 of the FCC Rules. Operation is subject to the following two conditions: (1) this device may not cause harmful interference, and (2) this device must accept any interference received, including interference that may cause undesired operation.



This device meets the requirements for the EU conformity in accordance to the currently valid EU directives.

## **Motherboard Illustration**



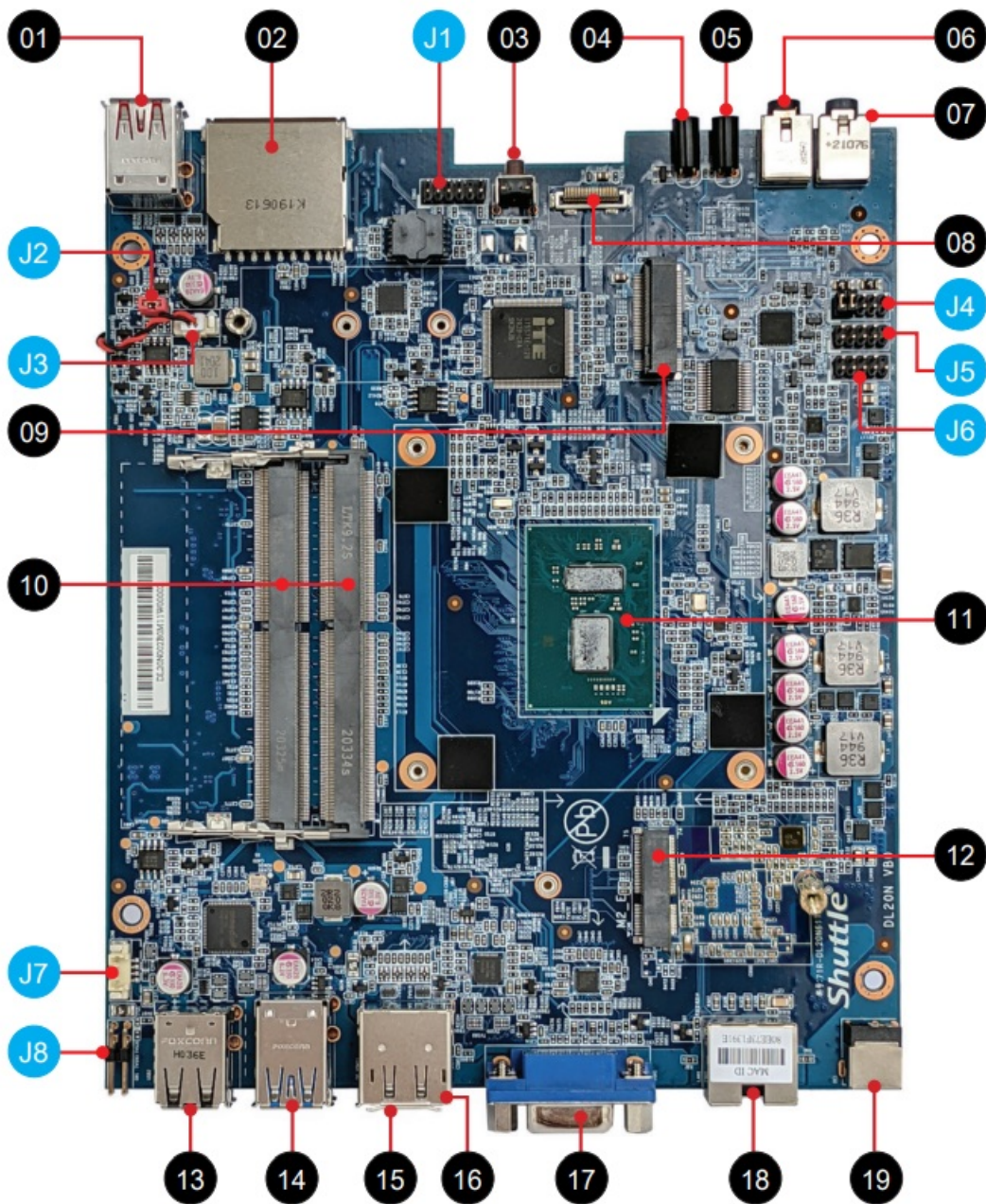

1. USB 3.2 Gen 2 Ports
2. SD Card Reader
3. Power Button
4. Hard Disk Drive LED
5. Power LED
6. Headphones
7. MIC-in
8. SATA Connector
9. M.2 2242/2260/2280 M key slot
10. DDR4 SO-DIMM Slot
11. Intel® Celeron® / Pentium processor
12. M.2 2230 E key slot
13. USB 2.0 Ports
14. USB 3.2 Gen 1 Ports
15. HDMI Port

- 16. DisplayPort
- 17. D-Sub (VGA) port
- 18. LAN Port
- 19. Power Jack (DC IN)

### Jumper Settings

- (J1) Debug Connector

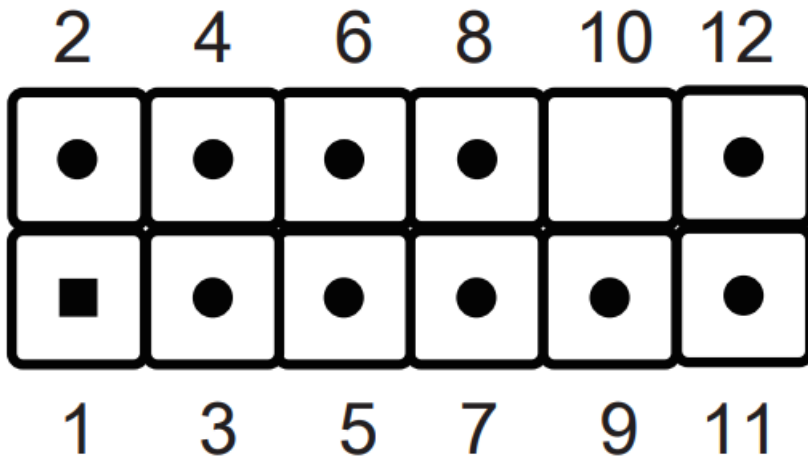

DBG1			
Pin	Signal Name	Pin	Signal Name
1	ESCK	2	EIO1
3	PCIE_RST_N	4	EIO0
5	ECS_N	6	+3.3VS
7	EIO3	8	GND
9	EIO2	10	
11	ALERT_N	12	ERST_N

- (J2) AC Back Auto Power ON

JP1	
Pin	Signal Name
1	Disable_N
2	GND

Default

Short (disabled)



Open (enabled)

2 1



- (J3) Battery Connector

CN9	
Pin	Signal Name
1	+VRTC_BAT
2	GND

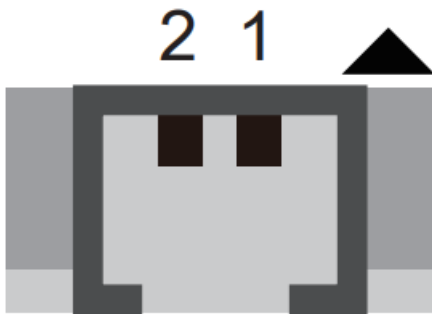

- (J4) COM 1 & COM 2 power switch

PORT Pin 9 "Ring Indicator" (RI) configuration:

Configure COM 1 with the first jumper:

- Short Pin 1-2: Pin 9 = RI (default)
- Short Pin 5-7: Pin 9 = +5V
- Short Pin 7-9: Pin 9 = +12V

Configure COM 2 with the second jumper:

- Short Pin 3-4: Pin 9 = RI (default)
- Short Pin 6-8: Pin 9 = +5V
- Short Pin 8-10: Pin 9 = +12V

- (J5) COM Port

- (J6)

2      4      6      8      10

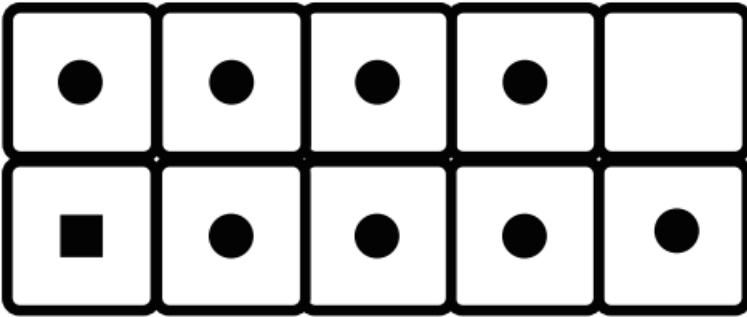

1      3      5      7      9

COM2			
Pin	Signal Name	Pin	Signal Name
1	DCD-	2	RXD
3	TXD	4	DTR-
5	GND	6	DSR-
7	RTS-	8	CTS-
9	RI-		

COM1							
Pin	Signal Name			Pin	Signal Name		
	RS232	RS422	RS485		RS232	RS422	RS485
1	DCD-	TXD-	DATA-	2	RXD	TXD+	DATA+
3	TXD	RXD+		4	DTR-	RXD-	
5	GND	GND	GND	6	DSR-		
7	RTS-			8	CTS-		
9	RI-						

- (J7) USB2.0 connector

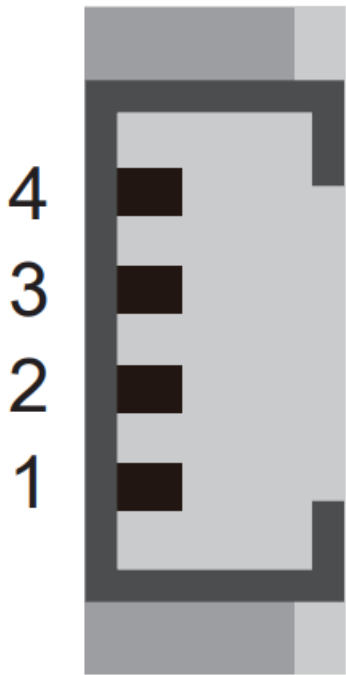

- (J8) Clear CMOS & power button & +5V

SW1	
Pin	Signal Name
1	RTCRST-
2	+5V
3	GND
4	PWRSW-

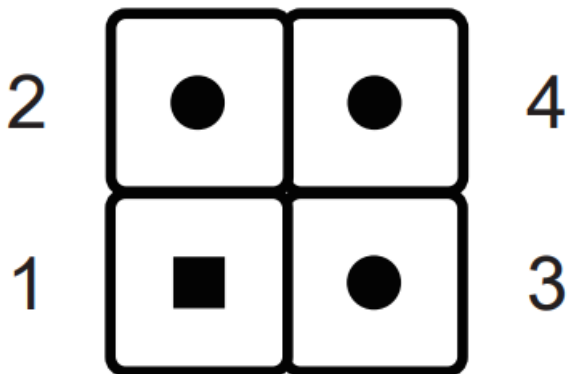

JP2			
Pin	Signal Name	Pin	Signal Name
1	RI1-	2	COM_RI1-
3	RI2-	4	COM_RI2-
5	+5V	6	+5V
7	RI1_PWR	8	RI2_PWR
9	+12V	10	+12V

2 4 6 8 10

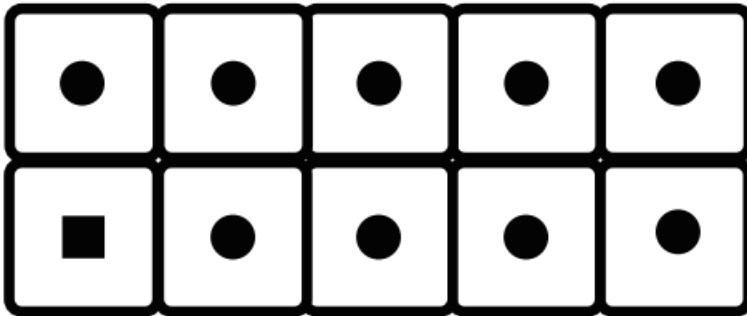

1 3 5 7 9

## CUSTOMER SERVICE

More information on this product can be found at: <http://bit.ly/DL20N>

## Documents / Resources

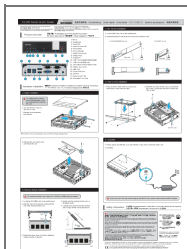

[Shuttle DL20N Series Mini PC Intel Celeron](#) [pdf] User Guide  
DL20N Series Mini PC Intel Celeron, DL20N Series, Mini PC Intel Celeron, Intel Celeron, Celeron

## References

- [Shuttle Global - DL20N SERIES](#)