

ABB drives in metals

Medium voltage drives for improved product quality and process control

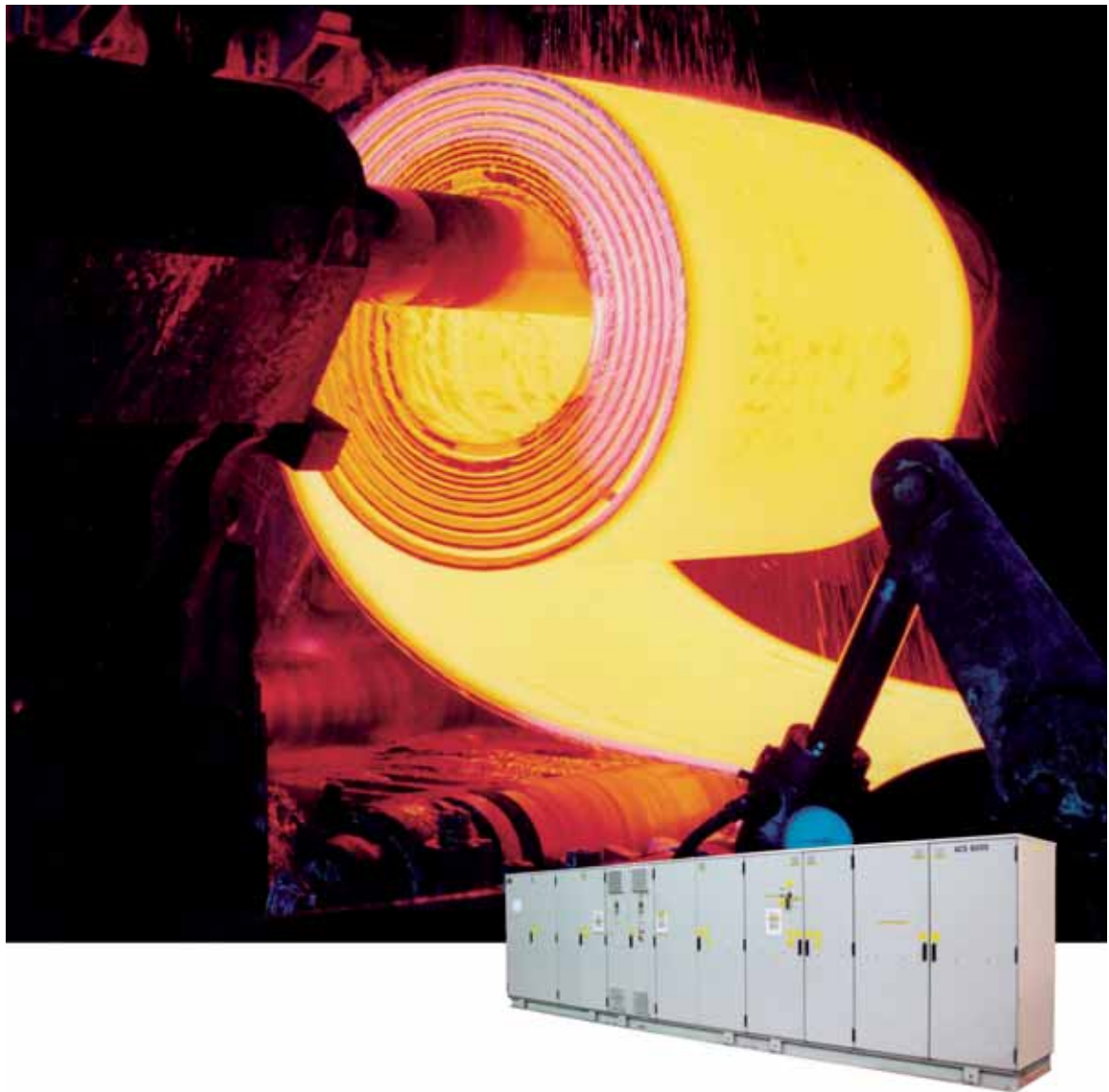

ABB



ABB – the world’s leading supplier of variable speed drives for the metals industry

ABB’s extensive experience and history of innovation helps metals and foundry customers around the world to minimize downtime, enhance production safety and increase productivity.

Leading-edge drive technology for metals applications

For more than 100 years ABB has provided drive products and systems to its customers in different industries. ABB’s unmatched experience in AC drive technology, combined with its long experience in the metals industry, results in innovative drive solutions with superior performance and reliability.

ABB’s reliable drive products and systems operate and integrate seamlessly into the customer’s automation world to maximize total plant performance.

ABB drives for metals applications

ABB’s medium voltage drives are designed for rapid torque variation, load cycling and fast alternation between driving and braking.

ABB supplies drive products and systems for various kinds of applications in the metals industry:

- Profile rolling mills
- Hot flat rolling mills
- Cold rolling mills
- Blast furnace blowers
- Fans
- Pumps

Controlling processes with variable speed drives results in the following benefits:

- Optimized production quality
- Optimized production output
- Minimized scrap
- Increased process reliability
- Reduced CO₂ emissions
- Minimized wear and tear of equipment



Variable speed drives for metals applications

The investment in highly efficient and highly reliable variable speed drives improves product quality and process control while reducing energy costs.

Drives for rolling mills

Rolling mill applications demand high precision and high overloadability. They are characterized by quickly changing loads, rapid alternation between driving and braking actions, constant torque in a wide speed range and large torque steps.

ABB medium voltage drives are the perfect answer for the requirements of the metals industry. By accurately controlling the rolling mill process with ABB drives, customers in the metals industry are able to optimize

production, minimize wear, enhance reliability and ensure the quality of the end product. ABB has a dedicated team specialized in providing optimized drive packages for demanding rolling mill applications.

A rolling mill drive package includes:

- Medium voltage converters
- Motors
- Transformers
- Services such as training, commissioning and spare parts

Cold rolling and non-ferrous mills

High dimension accuracy, better surface quality and better steel strength are achieved with ABB's state-of-the-art medium voltage drives for all rolling mills, including

- Foil mills
- Skin-pass mills
- Two-stand mills
- Tandem mills (TCM)
- Break-down mills
- Reversing cold mills (RCM, Z-mill)
- Two-stand reversing mills (e.g. CCM)

Hot rolling mills

ABB's innovative and highly dynamic drive solutions have contributed to unique production process improvements, high uptime and optimized product quality.

- Rod and bar mills
- Wire rod mills
- Section mills
- Tube mills
- Conventional hot strip mills
- Compact mills based on thin slab in line production (CSP and ISP)
- Steckel mills
- Plate mills



Drives for auxiliary processes

Not only the main rolling mill processes benefit from state-of-the-art medium voltage drives. High voltage auxiliary motors, controlled by variable speed drives, will consume significantly less energy than fixed-speed motors.

Medium voltage auxiliary applications:

- Descaling pumps
- ID/FD fans

Benefits of ABB drives for metals applications

Control of torque and speed

Fast and accurate control of torque and speed under all operating conditions is an important pre-requisite within a rolling mill for the successful control of material thickness, flatness and tension.

ABB's award-winning control platform, Direct Torque Control (DTC), results in the highest torque and speed performance ever achieved in medium voltage drives. Control of the drive is immediate and smooth under all conditions.

Network friendly

The influence of the industrial production on the power supply system is often underestimated. Difficult conditions exist in metal processes where big load changes and large speed-controlled drives can cause voltage deviations and harmonics. Optimized drive selections can minimize the disturbances as well as compensate the need for reactive power.

Flow and pressure control

Air and water consumption vary greatly during a day. Consequently, pumps and fans often run at partial load. By controlling the flow and pressure with variable speed drives, the pumps and fans will operate at maximum efficiency under a variety of flow conditions, considering the actual need.

A fan or pump, which is controlled by a variable speed drive and running at half speed, consumes only about one-eighth of the energy compared to one running at full speed.

Soft starting

Variable speed drives also act as soft starters reducing the stress on network, motors, pumps and fans. During the starting process, the variable speed drive progressively increases the motor speed and smoothly accelerates the load to its rated speed.

Soft starters eliminate high starting currents and voltage dips which can cause process trips. With soft starters, maintenance costs will be reduced and the lifetime of the equipment extended.

Benefits

- Fast and precise torque and speed control under all conditions through DTC
- Full 4 quadrant operation
- Several motors can be linked to one multidrive
- Minimized system energy consumption
- Control compatibility with other ABB drives
- Easy interfacing with upper level automation systems
- Optimal power factor throughout the speed range
- Minimized harmonic content with optimized pulse pattern

Medium voltage drives

The heart of the medium voltage drive system is the variable speed drive converter. ABB offers the entire range of drives and soft starters for medium voltage applications in the power range of 315 kW to more than 100 MW.

ACS 6000 rolling mill drive

ABB's ACS 6000 is a modular drive designed for the most demanding single-motor and multi-motor applications in the metals industry. It is available with four sizes of inverter modules (3, 5, 7 and 9 MVA). The optimum configuration for specific applications can be reached by combining the modules with minimum engineering effort.

Several motors can be linked to the ACS 6000 via a common DC bus, enabling multi-motor operation with only one multidrive converter. A multidrive, common DC-bus converter offers a solution with optimum efficiency. This configuration allows motoring and generating power flow between the inverters through the DC link.



ACS 1000, 315 kW – 5 MW

ACS 5000, 2 – 22 MW

ACS 6000, 3 – 27 MW

MEGADRIVE-LCI, 2 – 72 MW
(higher on request)

ACS 1000

The ACS 1000 product family of medium voltage drives is an unbeatable solution for auxiliary processes in the metals industry. Due to its unique output sine filter, which eliminates voltage reflections and common mode voltages, the ACS 1000 is suitable for standard motors and retrofit applications.

The ACS 1000i is a fully integrated drive including input transformer and input contactor.

MEGADRIVE-LCI

ABB's MEGADRIVE-LCI converter is an optimal solution for high voltage and high power fan applications. Standard designs are available for ratings up to 72 MW, engineered designs for more than 100 MW. These converters are mainly used as soft starters or drives for blast furnace blowers or ID/FD fans.

ACS 5000

The ACS 5000 can be applied to standard industrial motors (induction and synchronous) up to 6.9 kV. It is ideal for applications such as blast furnace blowers, fans and pumps. Retrofitting these high-powered applications with the ACS 5000 will result in significant improvements in efficiency and reliability.

Drives for low voltage applications

ABB also offers drives for low voltage metals applications. The ACS 800 multidrive, based on the common ABB drive platform including DTC, is a highly flexible AC drive that can be customized to meet the precise needs of demanding applications.

Technology highlights

Reliability is the main guiding principle of ABB's research and development activities for medium voltage drives.

Parts count

The fewer the parts the higher the reliability. ABB uses high power semiconductor switching devices and a topology that brings down the part count to a minimum.

Fuseless design

All ABB medium voltage drives are designed to operate safely without fuses. This results in less spare parts and fast re-starting after an overcurrent trip.

Encoderless

Encoders are known to cause failures. They have an exposed position on the motor. ABB's medium voltage drives for auxiliary processes can operate without an encoder.

Semiconductor switching devices

ABB has developed a high power switch called IGCT (Integrated Gate Commutated Thyristor) to allow the use of modern control algorithms, which can eliminate harmonics, improve dynamic response time and maintain or even control the power factor. This results in a reliable, compact and service-friendly drive.

Low losses

The inherently low total losses of the IGCT require low cooling capacity and small cooling equipment.

High power density

The use of a minimum number of high power switching components ensures high reliability.

The diode and line commutated thyristors still hold the top position for very high power, lowest losses and highest reliability but they do not allow the use of modern control algorithms.

Control

ABB's award-winning control platform, Direct Torque Control (DTC), results in the highest torque and speed performance ever achieved in medium voltage drives. Control of the drive is immediate and smooth under all conditions.



DriveWare, the tools to increase availability

The ACS platform incorporates a set of user-friendly tools.

DriveWindow is an advanced, easy-to-use tool for commissioning, maintenance and remote diagnostics and monitoring of ABB drive systems.

DriveSupport is a simple, clear and concise multimedia-based service tool, which provides clear instructions for troubleshooting and servicing drives.

Drive Performance Optimization tool (DPO)

The tool calculates mechanical system natural frequencies maximizing drive dynamic performance and minimizing wear and tear. Actual application software is used to simulate real torque and speed control features.

Rolling mill drive control

Enhanced Dynamic Features (EDF) control is a set of functions designed to increase the performance of rolling mill drive trains and to handle speed control related problems such as torsional vibrations and backlash.

Configuration concepts

The examples illustrate how the modular platform of the ACS 6000 is applied to provide the optimum converter configuration for any specific rolling mill.

Reversing cold mill

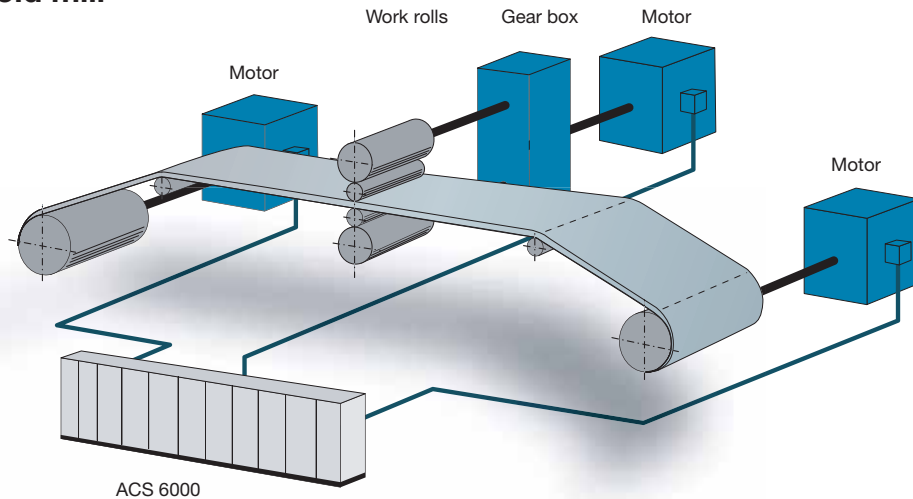

Reversing cold mill

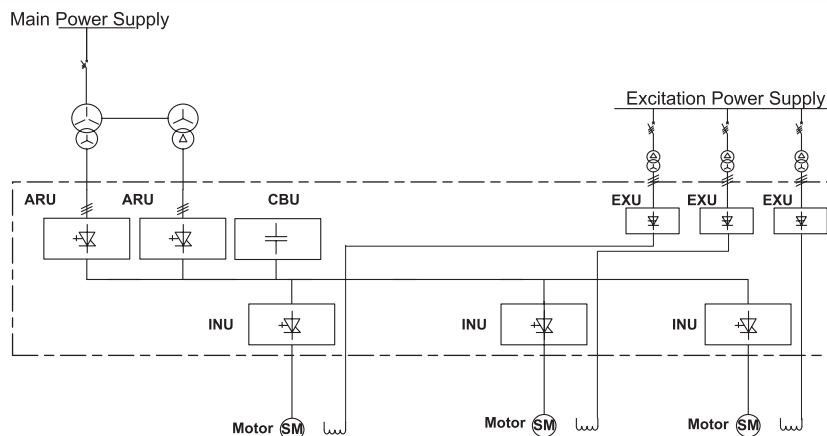

Converter configuration

Reversing cold mill features

- The mill consists of one or two mill stands and two or three reels; the material may be recoiled several times
- High torque and speed accuracy and reliability is required
- A wide range of final products is produced in one mill
- One of the reel motors is always regenerating
- Reel motors have a very long field-weakening range
- Wide speed and load variations can cause disturbances in the network

Benefits of ABB medium voltage drives

- A modular and proven solution minimizes the system complexity, installation and commissioning time
- Direct Torque Control (DTC) ensures highest product quality
- A wide tension control range can increase the product mix with full flexibility
- The common DC bus reduces energy consumption
- Optimized motors and inverters from the same supplier ensure best performance and lowest losses
- Active elimination of harmonics and a unity power factor are essential features of ABB drives

Hot rolling mill

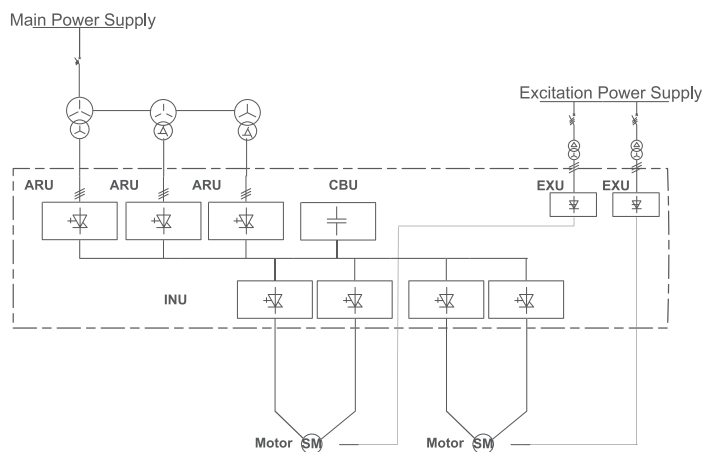
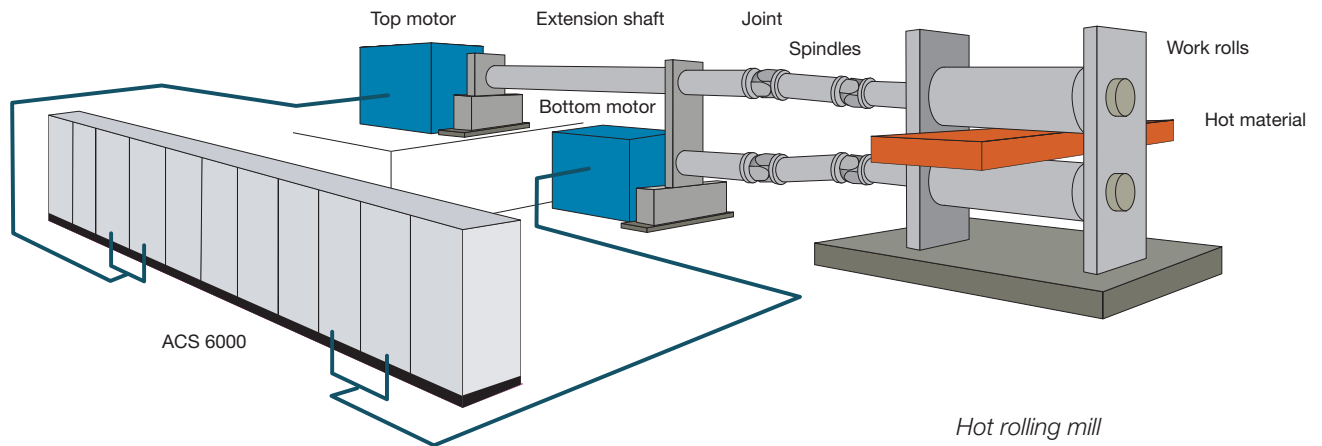

Hot rolling mill features

- Typically very high torques and overloads are required
- The rolling mill stand is fed by one motor or by two motors in twin-drive configuration
- One or several stands in one process; reversing or continuous multi-stand operation is required
- High powers and rapid load changes pose a challenge to the supply network design

Benefits of ABB medium voltage drives

- Direct Torque Control (DTC) ensures highest quality of the torque over the full speed range
- ABB offers reliable technology with full flexibility in single and multi-motor configurations
- The common DC bus ensures optimized energy consumption
- ABB medium voltage drives minimize voltage fluctuations towards the network and suppress harmonic currents; also in weak networks

Motors and transformers

ABB drive packages include medium voltage converters as well as motors and transformers.

Converter motors

ABB's converter motors have earned an excellent reputation for performance and reliability. ABB's product range includes induction as well as synchronous motors.

Synchronous motors are typically considered for high power and wide speed range (e.g. rolling mills: rated torque up to 2400 kNm, rated power up to 20 MW and top speed up to 1800 rpm). In addition to their high power capabilities, synchronous motors offer the benefits of high efficiency and high performance through the utilization of different rotor designs.

Squirrel cage induction motors are the work-horses of the industry due to their versatility, reliability and simplicity. Typical applications are rolling mills, coilers, pumps and fans. They are available up to 18 MW.

Converter transformers

Converter transformers are especially designed for operation with variable speed drives. They adapt the converter to the supply network and provide a galvanic isolation between drive and supply network.

Converter transformers are available for nearly all ratings. Secondary voltages are optimized to match the converter and motor voltage. Oil or dry types for indoor or outdoor mounting are available. Busbar connections can also be provided.



Rolling mill synchronous motor



Converter transformer

Testing, service and support

ABB drives are backed by unrivalled service and support from the customer's initial inquiry throughout the entire life cycle of the drive system.

Testing

ABB is committed to ensuring the reliability of every drive it delivers. To verify that quality standards and customer requirements are fully met every component of a drive is subjected to thorough testing in ABB's modern test facilities.

Routine tests and functional tests form an integral part of the scope of supply of ABB's medium voltage drives. They are performed in accordance with international standards and ABB quality assurance procedures.

Installation and commissioning

Substantial benefits can be gained from proper installation and commissioning of the equipment. Predictive testing and inspection, in addition to traditional operational parameter setting, done by ABB's qualified and certified commissioning engineers, will reduce start-up time, increase safety and reliability and decrease life-cycle costs. In addition, operators can be given practical training by experienced specialists on site.

Training

Extensive training for ABB's medium voltage drives can be provided at the ABB University. A range of training programs is offered from basic tutorials to programs tailored to the customer's specific needs. -> www.abb.com/abbuniversity

Life-cycle management

ABB's drive life-cycle management model provides customers with the maximum profit for their purchased assets by maintaining high availability, eliminating unplanned repair costs and extending the lifetime of the drive. Life-cycle management maximizes the value of the equipment and maintenance investment by:

- providing spare parts and expertise throughout the life cycle
- providing efficient product support and maintenance for improved reliability
- adding functionality to the initial product by following the upgrade path
- providing a smooth transition to a new technology at the end of the life cycle

Global network, local presence

After sales service is an integral part of providing the customer with a reliable and efficient drive system. The ABB Group of companies operates in more than 100 countries and has a worldwide network of service operations. Wherever you are, ABB is there for you.

Services for ABB's medium voltage drives

- Supervision of installation and commissioning
- Training
- Remote diagnostics
- Customized maintenance contracts
- Local support
- 24 x 365 support line
- Spare parts and logistics network
- Worldwide service network



ABB Switzerland Ltd
Medium Voltage Drives
CH-5300 Turgi / Switzerland
Tel +41 58 589 27 95
Fax +41 58 589 29 84
Email mvdrives@ch.abb.com

www.abb.com/motors&drives

ABB Oy
P.O. Box 94
FIN-00381 Helsinki / Finland
Tel +358 10 22 2000
Fax +358 10 22 22933
Email drive.packages@fi.abb.com

www.abb.com/motors&drives