

ABB WIND TURBINE CONVERTERS

ACS880-87LC-4000A/4021A-7 and ACS880-87LC-4000A/4132A-7 wind turbine converters

Hardware manual



List of related documents

General manuals

	Code (English)
Drive/converter/inverter safety instructions	3AXD50000037978
ACS880-77LC/-87LC wind turbine converters system description	3AXD50000022022
ACS880-87LC-4000A/4021A-7 and ACS880-87LC-4000A/4132A-7 wind turbine converters hardware manual	3AUA0000120723
ACS880-77LC/-87LC wind turbine converters start-up guide	3AXD50000033775
ACS880-77LC/-87LC wind turbine converters firmware manual	3AUA0000130879
Emergency stop, stop category 0 (option +Q951) for ACS880-77LC/-87LC wind turbine converters user's manual	3AXD50000040787
Drive composer Start-up and maintenance PC tool user's manual	3AUA0000094606
Manuals for I/O extension modules, fieldbus adapters, etc.	

Other documents

Circuit diagrams set
Fieldbus interface description
Firmware release note with the download instructions

For manuals, contact your local ABB representative.

Hardware manual

ACS880-87LC-4000A/4021A-7 and
ACS880-87LC-4000A/4132A-7 wind turbine converters

Table of contents



1. Safety instructions



4. Mechanical installation



6. Electrical installation



Table of contents

1. Safety instructions

Contents of this chapter	11
Use of warnings and notes	11
General safety in installation, start-up and maintenance	12
Electrical safety in installation, start-up and maintenance	13
Precautions before electrical work	13
Additional instructions and notes	14
Fiber optic cables	15
Opening and disconnecting the main circuit breaker	16
Disconnecting the charging circuit from the main circuit	19
Disconnecting the external auxiliary power supply	20
Disconnecting the internal 230 V and 400 V auxiliary power supply (terminal X1)	20
Grounding	21
Work on the liquid cooling system	22

2. Introduction to the manual

Contents of this chapter	23
Target audience	23
Purpose of the manual	23
Contents of the manual	24
Related documents	24
Categorization by frame size and option code	24
Quick installation, commissioning and operation flowchart	25
Terms and abbreviations	26

3. Operation principle and hardware description

Contents of this chapter	29
Operation principle	29
Generator control	30
Overview diagram of the wind turbine converter	31
Layout drawing	32
Overview of power and control connections	36
Circuit boards	37
BAMU board	38
Type designation labels	39
Type designation key	40
Basic code	41
Option codes (plus codes)	41

4. Mechanical installation

Contents of this chapter	43
Safety instructions	43
Checklist before mechanical installation	44
Moving the converter package	45
Moving the converter package by fork-lift	45



Lifting the converter package	46
Moving the converter on rollers	46
Unpacking	46
Lifting the converter – ABB lift adapter bars (customer variant) are in use	47
Lifting the converter	48
Placing the converter	49
Fastening the cabinet to the floor	50
Internal cooling circuit	50
Lifting the door	51
Miscellaneous	51
Cable duct in the floor below the cabinet	51
Electric welding	51

5. Planning the electrical installation

Contents of this chapter	53
Selecting the grid disconnecting device	53
Checking the compatibility of the generator and the converter	54
Protecting the generator insulation and bearings	54
Selecting the power cables	55
General rules	55
Sufficient conductivity of the protective conductor	55
Typical power cable sizes	57
CE cables	57
UL cables	57
Alternative power cable types	57
Power cable types for limited use	57
Not allowed power cable types	58
Generator cable shield	58
Single core vs multicore cables in grid cabling	59
Additional US and Canada requirements	59
Conduit	59
Armored cable / shielded power cable	59
Selecting the DC resistors	60
Selecting the control cables	60
General rules	60
Relay cable	60
Routing the cables	61
Control cable ducts	61
Protecting the converter installation	62
Protecting the grid cable in short-circuit situations	62
Protecting the generator and generator cable in short-circuit situations	62
Protecting the converter, generator cable and grid cable against thermal overload	62
Protecting the converter against ground faults in the generator or generator cable	62
Protecting the converter against ground faults in the converter or grid cable	62
Implementing the emergency stop function	63
Implementing the grid fault ride-through function	63
Supplying power for the auxiliary circuits	63
Using a safety switch between the converter and generator	64
Using a contactor between the converter and generator (option +F269)	64
Protecting the contacts of relay outputs	64



6. Electrical installation

Contents of this chapter	67
Checking the insulation of the assembly	67
Converter	67
Grid cable	68
Generator stator and generator cable	68
Integrated DC chopper and DC resistor (option +D150+D151)	68
Connecting the grid cables/busbars	68
Connection diagram	68
Connection procedure	69
Connecting the generator cables	70
Connection diagram	70
Connection procedure	70
Connecting the external power supply cable for the auxiliary circuit	72
Connecting the control cables	73
Default I/O connection diagrams	76
Connecting a PC	76

7. Installation checklist

Contents of this chapter	77
Before you start	77
Checklist	78

8. Maintenance

Contents of this chapter	79
Maintenance intervals	80
Maintenance timers and counters	81
Cabinet	82
Replacing inlet (door) filter (IP54, customer variant)	82
Power connections	83
Tightening	83
Fans	83
Replacing the cooling fan of the converter module	84
Replacing the fan of the main breaker cubicle	86
Replacing the cooling fan of the auxiliary control cubicle	89
Replacing the upper cooling fan of the LCL filter cubicle	91
Replacing the lower cooling fan of the LCL filter cubicle	93
Fuses	95
Replacing the DC fuses	95
Replacing the AC fuses	96
Converter module	97
Replacing the converter module	97
Capacitors	103
BCU control unit	104
Replacing the memory unit	104
Replacing the real-time clock battery	104
Replacing the SD/SDHC memory card	104
Replacement illustration	105
Main circuit breaker	105



9. Technical data

Contents of this chapter	107
Ratings	107
Definitions	108
Derating	108
Temperature derating	108
Altitude derating	108
Type equivalence table	108
Fuses	109
Main circuit AC fuses	109
Main circuit DC fuses	109
Fuses for the voltage measurement board BAMU	109
Dimensions, weights and free space requirements	109
Losses, cooling data and noise	110
Internal cooling circuit data	110
Terminal and lead-through data for the grid connection	110
Tightening torques	110
Terminal and lead-through data for the generator cable	111
Grid specification	111
Requirements for the grid connection	111
Generator connection data	112
BCU control unit	112
Efficiency	112
Degree of protection	112
Environmental and corrosion classification	112
Ambient conditions	113
Materials	114
Auxiliary circuit current consumption	114
ACS880-87LC-4000A/4021A-7 and ACS880-87LC-4000A/4132A-7	114
UPS supply	114
Non-UPS supply	114
Applicable standards	115
CE marking	115
Compliance with the European Low Voltage Directive	115
Compliance with the European EMC Directive	115
Compliance with the European Machinery Directive	115
Regulatory Compliance Mark (RCM)	116
EAC marking	116
Compliance with EN 61800-3:2004/A1:2012	116
Definitions	116
Category C4	117
ETL marking	117
DNV-GL Renewable Certification marking	117
WEEE marking	118
Disclaimers	118
Generic disclaimer	118
Cybersecurity disclaimer	118

10. Control units of the converter

Contents of this chapter	119
General	119
BCU control unit	119



Layout and connections	120
BCU layout and connections	120
Control unit connector data	122

11. Dimension drawings

Contents of this chapter	125
--------------------------------	-----

12. Cooling and heating

Contents of this chapter	129
Hardware description	129
General	129
Diagram of the internal cooling and heating circuit	129
Planning the cooling system	131
Connection to a customer cooling unit	131
General requirements	131
Coolant temperature control	131
Mechanical installation	132
Connecting the internal cooling circuit to a customer cooling unit	132
Connecting the liquid pipes	132
Filling up and bleeding the internal cooling circuit	133
Converters with a customer cooling unit	133
Draining the internal cooling circuit	134
Cooling station control	134
Specifications	136
Temperature limits	136
Pressure limits	136
Water quality	137
Freeze protection and corrosion inhibition	137
Coolant concentration	137
Liquid mixture quality	137
Approved coolants	138
Materials	138
Heating	139
Cold start (-30 °C ... +10 °C)	139
Normal start (-30 °C ... +10 °C)	139
Circuit diagram	141

Further information

Product and service inquiries	143
Product training	143
Providing feedback on ABB Drives manuals	143





1

Safety instructions



Contents of this chapter

This chapter contains the safety instructions which you must obey when you install and operate the converter, and do maintenance on the converter. If you ignore the safety instructions, injury, death or damage can occur to the converter, the generator or other adjoining equipment. Read the safety instructions before you work on the unit.

Use of warnings and notes

Warnings tell you about conditions which can cause injury or death, or damage to the equipment. They also tell you how to prevent the danger. Notes draw attention to a particular condition or fact, or give information on a subject.

The manual uses these warning symbols:



Electricity warning tells about hazards from electricity which can cause injury or death, or damage to the equipment.



General warning tells about conditions, other than those caused by electricity, which can cause injury or death, or damage to the equipment.



Electrostatic sensitive devices warning tells you about the risk of electrostatic discharge which can cause damage to the equipment.

General safety in installation, start-up and maintenance

These instructions are for all personnel that install the converter and do maintenance work on it.



WARNING! Obey these instructions. If you ignore them, injury or death, or damage to the equipment can occur.

- Use safety shoes with a metal toe cap. Use protective gloves.
- Handle the converter modules carefully:
 - Lift the module with a lifting device only. Use the designated lifting points. See the converter hardware manual.
 - Do not tilt the module. It will overturn very easily because it is heavy and its center of gravity is high.
 - Modules running on wheels: Make sure that the module does not topple over when you move it on the floor: Whenever possible secure the module also with chains. Do not leave the module unattended on a sloping floor.
- Beware of hot surfaces. Some parts, such as heatsinks of power semiconductors, remain hot for a while after disconnection of the electrical supply.
- Keep the converter in its package or protect it otherwise from dust and burr from drilling and grinding until you install it. Protect also the installed converter against dust and burr. Electrically conductive debris inside the drive can cause damage or malfunction.
- Vacuum clean the area below the converter before the start-up to prevent the converter cooling fans from drawing the dust inside the converter.
- Do not cover the air inlet and outlet when the converter is running.
- Make sure that there is sufficient cooling. Before power switch-on, make sure that the liquid cooling circuit is filled up with coolant. Running the external cooling pump dry will damage it. Also the converter will not cool down. See the converter hardware manual.
- Before you connect voltage to the converter, make sure that the cabinet doors are closed. Keep the doors closed during operation.
- Before you adjust the converter operation limits, make sure that the generator and all driven equipment can operate throughout the set operation limits.
- The maximum number of converter power-ups is five in ten minutes. Too frequent power-ups can damage the charging circuit of the DC capacitors.
- Make sure that safety circuits (for example, emergency stop, if any) are validated at start-up.
- Beware of the cooling fan blades. The fans can continue to rotate for a while after the disconnection of the electrical supply.
- Service the main contactor once a year. If not serviced, damage can occur to the wind turbine.



Note:

- Only authorized persons are allowed to repair a malfunctioning converter.

Electrical safety in installation, start-up and maintenance

■ Precautions before electrical work

These instructions are for the qualified electricians who do work on the converter, generator cable or generator.



WARNING! Perform the electrical safety precautions below before starting any work on the installation. If you ignore the precautions, physical injury or death, or damage to the equipment can occur. If you are not a qualified electrician, do not proceed or do any installation or maintenance work.

1. Clearly identify the work location.
2. Disconnect all possible voltage sources.
 - Open the main circuit breaker (Q1), disconnect, lock and attach a warning notice to it. See section [Opening and disconnecting the main circuit breaker](#) on page 16.
 - Open the charging circuit switch-disconnector (Q10). See section [Disconnecting the charging circuit from the main circuit](#) on page 19.
 - Open and lock out the auxiliary voltage switch-disconnectors (Q2 and Q3). See section [Disconnecting the external auxiliary power supply](#) on page 20.
 - Disconnect any external dangerous voltages from the control circuits (such as relay outputs).
 - Open, disconnect and lock out the breaker of the grid transformer as the main circuit breaker of the converter does not remove the voltage from the grid cable busbars and some auxiliary circuits. Attach a warning notice to the disconnector.
 - Lock the turbine rotor (and generator shaft).
 - Open the safety switch between the generator-side converter and the generator (if any).
 - After you disconnect the converter, always wait for five minutes to let the intermediate circuit capacitors discharge before you continue.
3. Protect any other energized parts in the work location against contact.
4. Take special precautions when close to bare conductors.
5. Measure that the installation is de-energized.
 - Use a multimeter with an impedance of at least 1 Mohm.
 - Make sure that the voltage between the converter grid cable terminals (L1, L2, L3) and the grounding (PE) busbar is close to 0 V.
 - Make sure that the voltage between the generator cable terminals (U2, V2, W2) and the grounding (PE) busbar is close to 0 V.
 - Make sure that the voltage between the DC bus and the grounding (PE) busbar is close to 0 V.





WARNING! If the measurement requires removal or disassembly of shrouding or other cabinet structures, obey the local laws and regulations applicable to live working (including – but not limited to – electric shock and arc protection).

6. Install temporary grounding as required by the local regulations.
 7. Ask the person in control of the electrical installation work for a permit to work.
-

■ Additional instructions and notes



WARNING! Obey these instructions. If you ignore them, injury or death, or damage to the equipment can occur.

- If you are not a qualified electrician, do not do electrical installation or maintenance work.
- We do not recommend that you secure the cabinet by arc welding. If you have to, obey the instructions in the converter hardware manual.
- Do not do insulation or voltage withstand tests on the converter or converter modules.
- Control boards of the converter unit may be at the main circuit potential. Dangerous voltages can be present between the control boards and the frame of the converter unit when the main circuit voltage is on. It is critical that the measuring instruments, such as an oscilloscope, are used with caution and safety always as a priority. The fault tracing instructions give special mention of cases in which measurements may be performed on the control boards, also indicating the measuring method to be used.

Note:

- The generator cable terminals on the converter are at a dangerously high voltage when the converter is connected to the grid, regardless of whether the generator is running or not.
 - The converter DC bus carries a dangerous voltage (over 500 V) when the converter is connected to the grid or when the generator shaft is rotating.
 - External wiring can supply dangerous voltages to the terminals of relay outputs.
-



WARNING! Use a grounding wrist band when you handle the printed circuit boards. Do not touch the boards unnecessarily. The boards contain components sensitive to electrostatic discharge.

■ Fiber optic cables



WARNING! Obey these instructions. If you ignore them, equipment malfunction and damage to the fiber optic cables can occur.

- Handle the fiber optic cables with care.
 - When you unplug the cables, always hold the connector, not the cable itself.
 - Do not touch the ends of the fibers with bare hands as the ends are extremely sensitive to dirt.
 - Do not bend the fiber optic cables too tightly. The minimum allowed bend radius is 35 mm (1.4 in).
-



■ Opening and disconnecting the main circuit breaker

These instructions are for the qualified electricians who do work on the converter, generator cable or generator.



WARNING! If you are not a qualified electrician, do not proceed or do any installation or maintenance work.

1. Undo the two fastening screws of the main circuit breaker (Q1) cover.
2. Open the cover and put the key into its place.
3. To access the crank, turn the lower key and
4. press down the button next to the lower key.
5. Pull out the crank.
6. Insert the crank into the hole next to the lower key and turn the crank until it stops.
7. Make sure that the rotating switch to the right of the crank is in the DISCONNECTED position.
8. Lock the Push OFF switch to the Push OFF position with the key on the right. Put the key(s) in a safe place. Make sure that the OPEN/CLOSED indicator shows OPEN.
9. Write your name, phone number and the date to the “Do not switch on. Men at work” warning sign and hang the warning sign on the main circuit breaker.



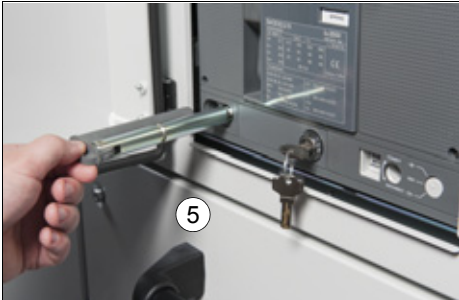

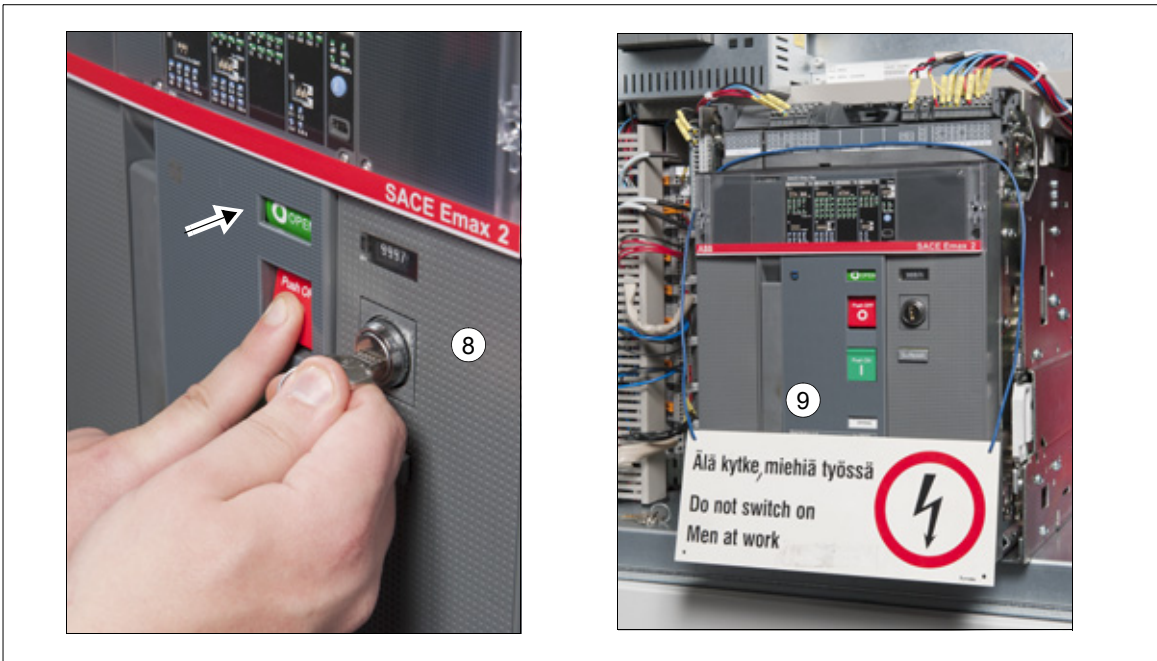

■ Disconnecting the charging circuit from the main circuit



WARNING! If you are not a qualified electrician, do not proceed.

1. Make sure that you have opened the main circuit breaker (Q1). See section [Opening and disconnecting the main circuit breaker](#) on page 16.
2. In the charging cubicle, turn the charging circuit switch (Q10) from ON position (a) to the OFF position (b).
3. Lock the charging circuit switch to the OFF position with a padlock. Stow the key(s) in a safe place.
4. Write your name, phone number and the date to the “Do not switch on. Men at work” warning sign and hang the warning sign to the charging circuit switch.

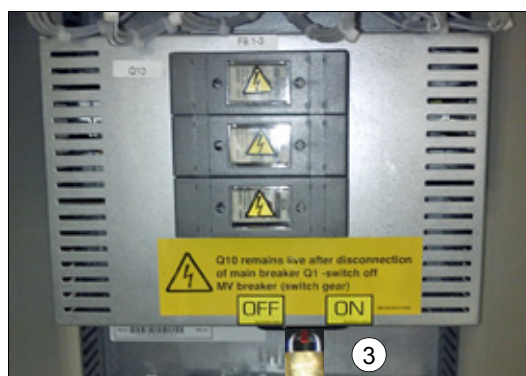
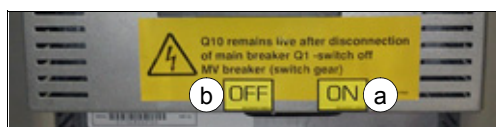

■ Disconnecting the external auxiliary power supply



WARNING! If you are not a qualified electrician, do not proceed.

1. Make sure that you have opened the main circuit breaker (Q1). See section [Opening and disconnecting the main circuit breaker](#) on page 16.
2. In the charging cubicle, turn the Q2 and Q3 disconnectors to the OFF position.
3. Lock the Q2 and Q3 disconnectors to the OFF position with the locking plate and hang a padlock to the plate.

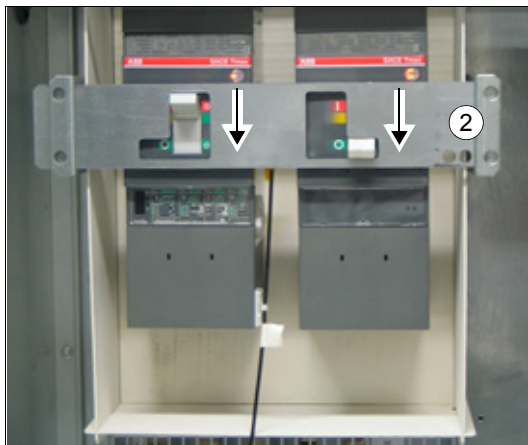

Example photos of Q2 and Q3

Disconnecting the internal 230 V and 400 V auxiliary power supply (terminal X1)

4. In the auxiliary control cubicle, disconnect the cables on the terminal X1.

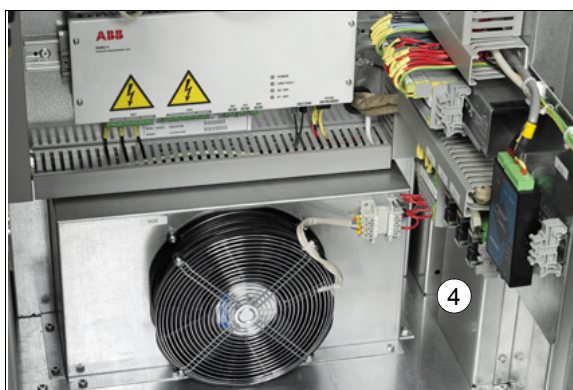

Example photo of X1

■ Grounding

These instructions are intended for all who are responsible for the grounding of the converter.



WARNING! Obey these instructions. If you ignore them, injury or death, or damage to the equipment can occur, and electromagnetic interference can increase.

- If you are not a qualified electrician, do not do electrical installation or maintenance work.
- Always ground the converter, the generator and adjoining equipment to ensure personnel safety in all circumstances, and to reduce electromagnetic emission and interference.
- Make sure that the conductivity of the grounding conductors is sufficient. See the converter hardware manual. Obey the local regulations.
- In a multiple-converter installation, connect each converter separately to protective earth (PE).

Note:

- You can use power cable shields as grounding conductors only when their conductivity is sufficient.
 - As the normal touch current of the converter is higher than 3.5 mA AC or 10 mA DC, you must use a fixed protective earth connection. See EN 61800-5-1, 4.3.5.5.2.
-



Work on the liquid cooling system

These instructions are intended for all who are responsible for installation and maintenance work of the liquid cooling system of the converter.



WARNING! Obey these instructions. If you ignore them, injury or damage to the equipment can occur.

- Beware of hot liquid. Do not work on the liquid cooling system until the pressure is lowered down by stopping the pumps. High-pressure hot coolant (600 kPa, over 50 °C/122 °F) is present in the internal cooling circuit when the converter is in operation.
- Before power switch-on, make sure that the internal cooling circuit is filled up with coolant. Running the external cooling pump dry will damage it. Also the converter will not cool down.
- Avoid skin contact with coolant, especially antifreeze. Do not syphon them by mouth. If such substance is swallowed or gets into the eyes, seek medical advice.
- To avoid breaking the coolant pipes, do not overtighten the nuts of the unions.

- Blue connectors: Leave 2...3 millimeters of thread visible.

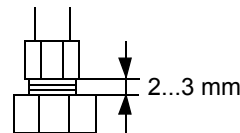

- Black connectors: Tightening torque is 10 N·m (7.4 lbf·ft) in room temperature (around +20 °C/68 °F).
- If the ambient temperature is below +5 °C (41 °F), add antifreeze and corrosion inhibitors to the cooling liquid.
- Drain the system before storing in temperatures below 0 °C (0 °F). Freezing of the liquid cooling system is not allowed. Operation at liquid temperatures below zero is not permitted, not even with antifreeze.



Introduction to the manual

Contents of this chapter

This chapter describes the intended audience and contents of the manual. It also contains a flowchart of steps in checking the delivery, installing and commissioning the wind turbine converter. The flowchart refers to chapters/sections in this manual and other manuals.

Target audience

This manual is intended for people who plan the installation, install, commission, use and service the converter. Read the manual before working on the converter. The reader is expected to know the fundamentals of electricity, wiring, electrical components and electrical schematic symbols.

The manual is written for readers worldwide.

Purpose of the manual

This manual helps in planning the installation, installing, using and servicing the converter.

Contents of the manual

- [Safety instructions](#)
- [Operation principle and hardware description](#)
- [Mechanical installation](#)
- [Planning the electrical installation](#)
- [Electrical installation](#)
- [Installation checklist](#)
- [Maintenance](#)
- [Technical data](#)
- [Control units of the converter](#)
- [Dimension drawings](#)
- [Cooling and heating](#)

Related documents

See [List of related documents](#) on the inside of the front cover.

Categorization by frame size and option code

This manual deals with the wind turbine converters made of the modules of the frame size R9iLC. The frame size of each converter type is indicated in section [Type equivalence table](#) on page [108](#).

The instructions, technical data and dimensional drawings which concern only certain optional selections are marked with + codes. The options included in the converter can be identified from the + codes visible on the type designation label. The + code selections are listed in chapter [Operation principle and hardware description](#) under [Type designation key](#).

Quick installation, commissioning and operation flowchart

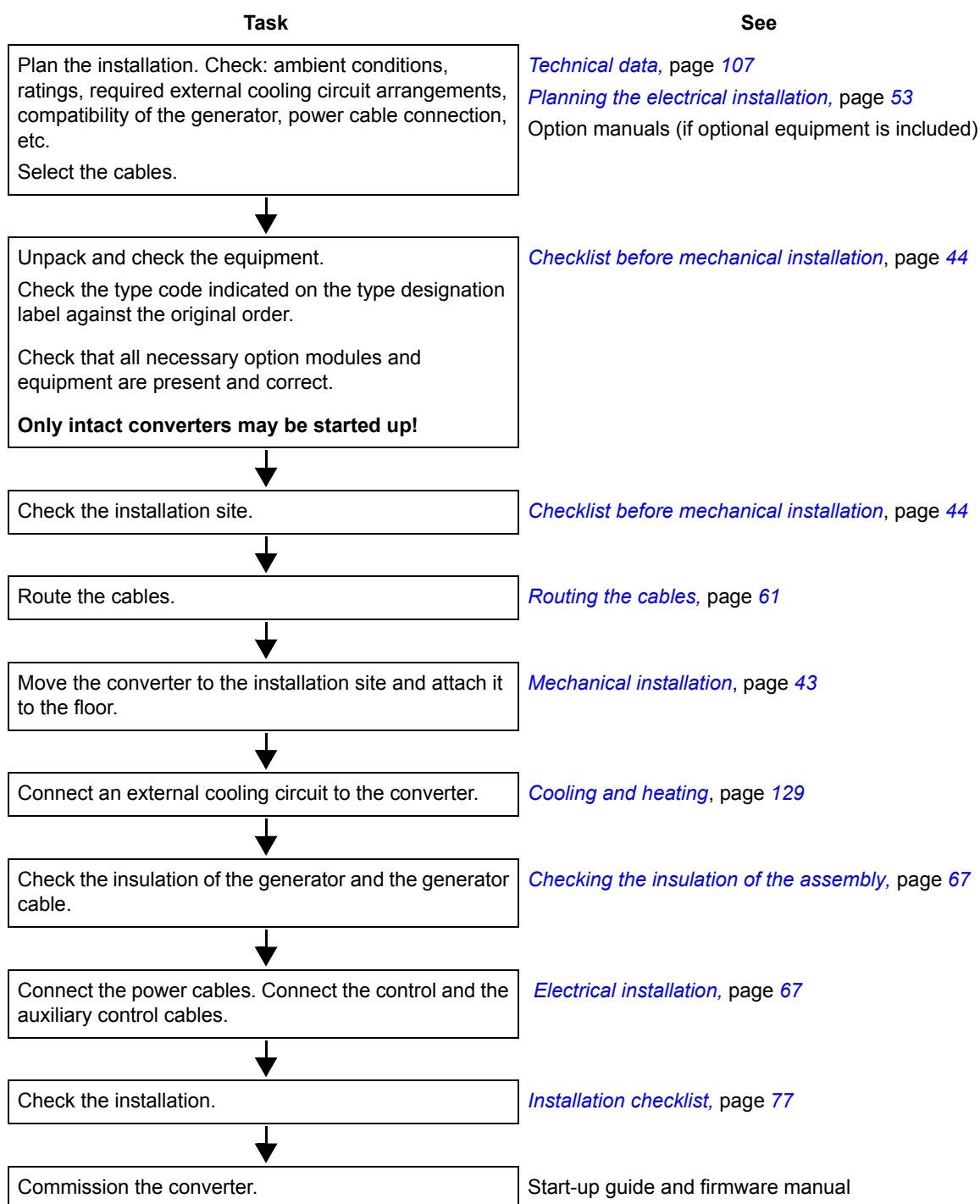

Terms and abbreviations

Term/abbreviation	Explanation
Auxiliary voltage switch	Main switch for the auxiliary voltage
Auxiliary control cubicle (ACU)	The cubicle with auxiliary devices such as auxiliary voltage circuit breakers, control electronics, measurement boards, etc.
BAMU	Main voltage measurement board
BCON	Type of control board
BCU	Type of control unit, a BCON board in a metal housing. See BCON .
DC chopper	Protects the converter by cutting down a peak overvoltage in the converter DC link: conducts the surplus energy from the intermediate circuit of the wind turbine converter to the DC resistor when necessary. The chopper operates when the DC link voltage exceeds a maximum limit. A sudden disturbance in turbine operation or grid can cause the DC voltage rise.
DC resistor	Dissipates the surplus energy conducted by the DC chopper to heat. Essential part of the chopper circuit. See DC chopper .
CCU	Control cubicle
Control board	Circuit board in which the control program runs. See BCON .
Control unit	Control board built in a rail-mountable housing. See BCU .
Converter	Converts direct current and voltage to alternating current and voltage, or vice versa.
Converter module	Grid-side converter or generator-side converter module
Cubicle	One section of a cabinet-installed wind turbine converter. A cubicle is typically behind a door of its own.
DC link	DC circuit between grid-side converter and generator-side converter
DC link capacitors	Energy storage which stabilizes the intermediate circuit DC voltage.
DDCS	Distributed drives communication system; a protocol used in optical fiber communication
DTC	Direct torque control; a generator control method by ABB.
EMC	Electromagnetic compatibility
FCAN	Optional CANopen® adapter module
FCNA	Optional ControlNet™ adapter module
FDNA	Optional DeviceNet™ adapter module
FEA	Optional extension adapter module
FECA	Optional EtherCAT® adapter module
FEN-31	Optional HTL incremental encoder interface module
FENA	Optional Ethernet adapter module for EtherNet/IP™, Modbus TCP® and PROFINET IO® protocols
FIO-01	Optional digital I/O extension module
FIO-11	Optional analog I/O extension module
FPBA	Optional PROFIBUS DP® adapter module

Term/abbreviation	Explanation
Frame (size)	Refers to converter modules that share a similar mechanical construction, for example: <ul style="list-style-type: none"> • frame 5×R9iLC + 6×R9iLC includes five R9iLC generator-side converter modules and six R9iLC grid-side converter modules.
Generator-side converter	The converter part that is connected to the generator stator and controls the generator operation. It converts the AC power from the generator to the converter DC bus.
Grid-side converter	A converter that is connected to the grid and is capable of transferring energy from the converter DC link to the grid and vice versa.
I/O	Input/Output
IGBT	Insulated gate bipolar transistor; a voltage-controlled semiconductor type widely used in various converters because of their easy controllability and high switching frequency.
Intermediate circuit	See DC link .
LCL filter	Inductor-capacitor-inductor filter at AC side of the grid-side converter. Attenuates harmonics.
Main circuit breaker	Electrically-controlled main switching and protecting device. A withdrawable breaker can also be used as the main disconnecter.
MBC	Main breaker cubicle containing main switching and disconnecting devices, power terminals, etc.
NETA-21	Remote monitoring tool
Parameter	User-adjustable operation instruction to the converter, or signal measured or calculated by the converter.
PE	Protective Earth
PLC	Programmable logic controller
PSL	Power stage link
PROFIBUS®, PROFIBUS DP, PROFINET IO	Registered trademarks of PI - PROFIBUS & PROFINET International
R9iLC	Converter module size, see Frame (size) .
UPS	Uninterruptible power supply
Wind turbine converter	A converter for controlling AC generators in wind turbine applications.
Wind turbine system	Wind turbine system consists of the wind turbine, wind turbine converter, generator etc.
WTC	Wind turbine controller. The wind turbine controller controls the whole wind turbine system.
ZMU	Memory unit attached to the BCU control unit connector X205 MEMORY UNIT.



3

Operation principle and hardware description

Contents of this chapter

This chapter describes the operation principle and the construction of the wind turbine converter.

Operation principle

The ACS880-87LC is a four-quadrant, cabinet-mounted liquid-cooled converter intended for full power conversion turbines with an induction generator or a permanent magnet generator. The converter is connected between the generator stator and the grid. The converter can be installed up in the nacelle or down on the ground level.

The converter consists of back-to-back connected cubicles that contain the grid-side converter modules, generator-side converter modules, LCL filter, terminals or grid busbars for grid cables and generator cables, internal control circuits, external control cable terminals, auxiliary circuits and external auxiliary power supply terminals.

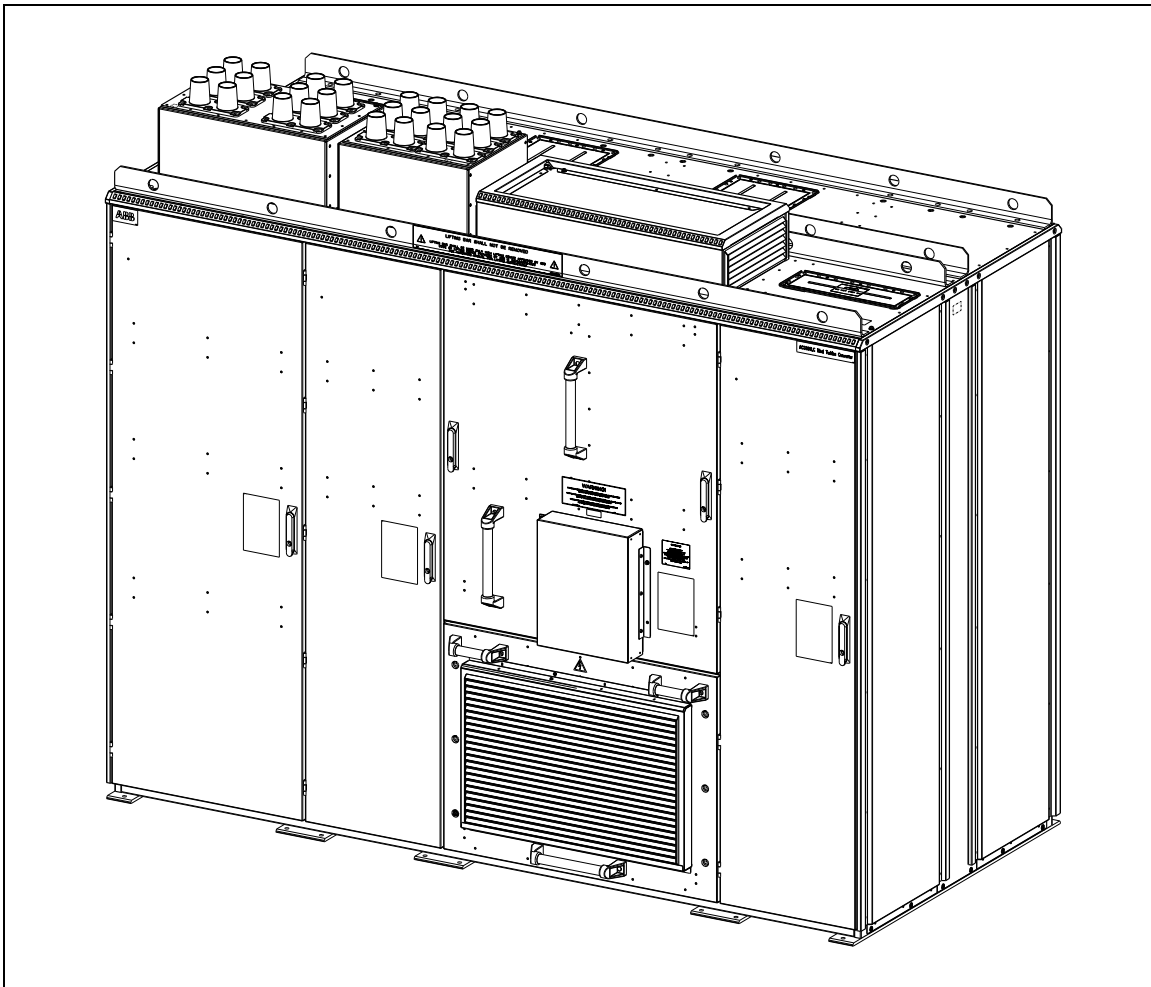

Generator control

The generator power flows through the generator-side converter to the converter intermediate DC circuit.

The generator control is based on the Direct torque control (DTC) method. Two phase currents and intermediate DC circuit voltage are measured and used for the control. The third phase current is measured for ground fault protection.

Overview diagram of the wind turbine converter

An example single-line diagram of the wind turbine converter is shown below.

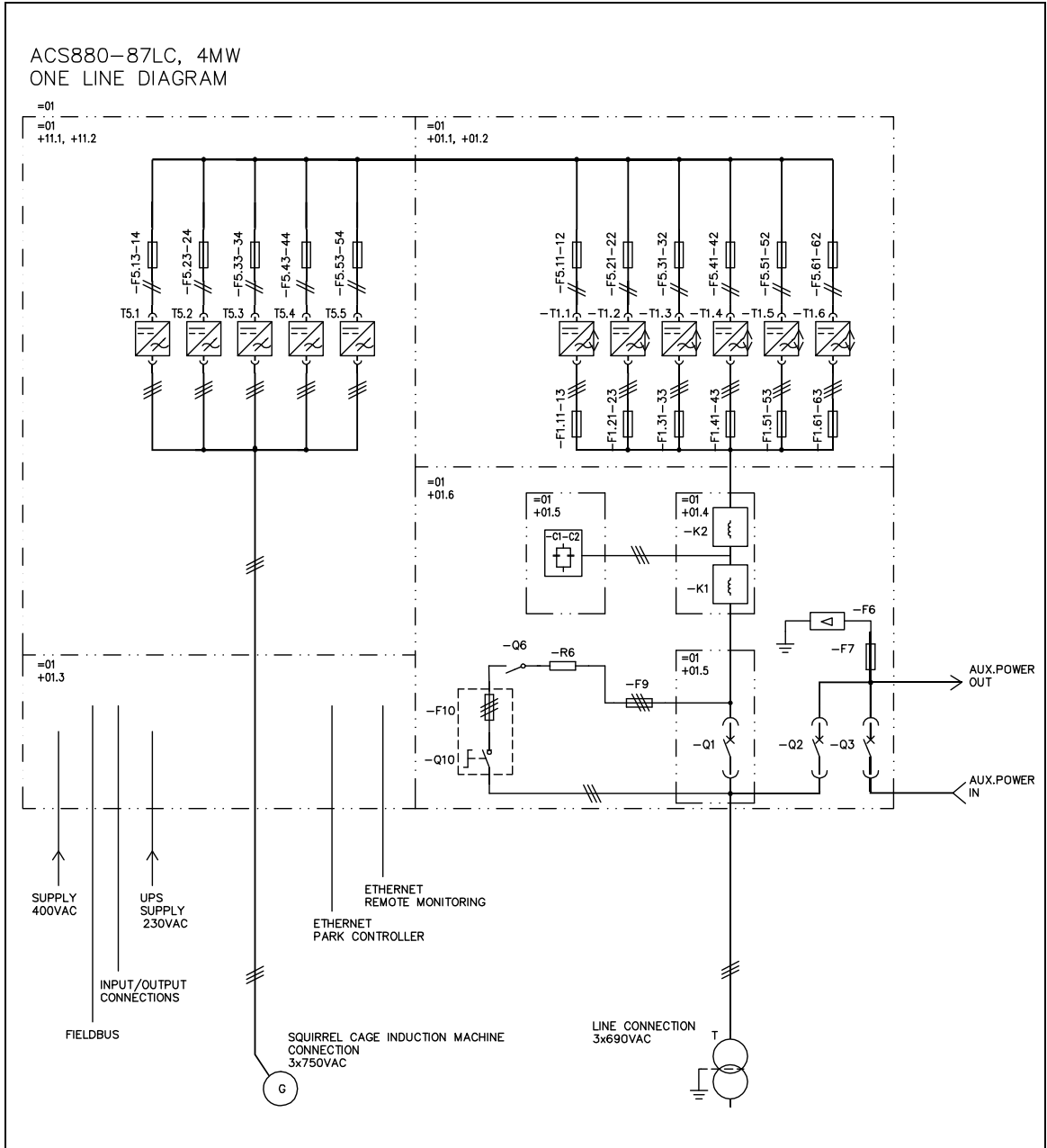

Layout drawing

Layout of the wind turbine converter is shown below.

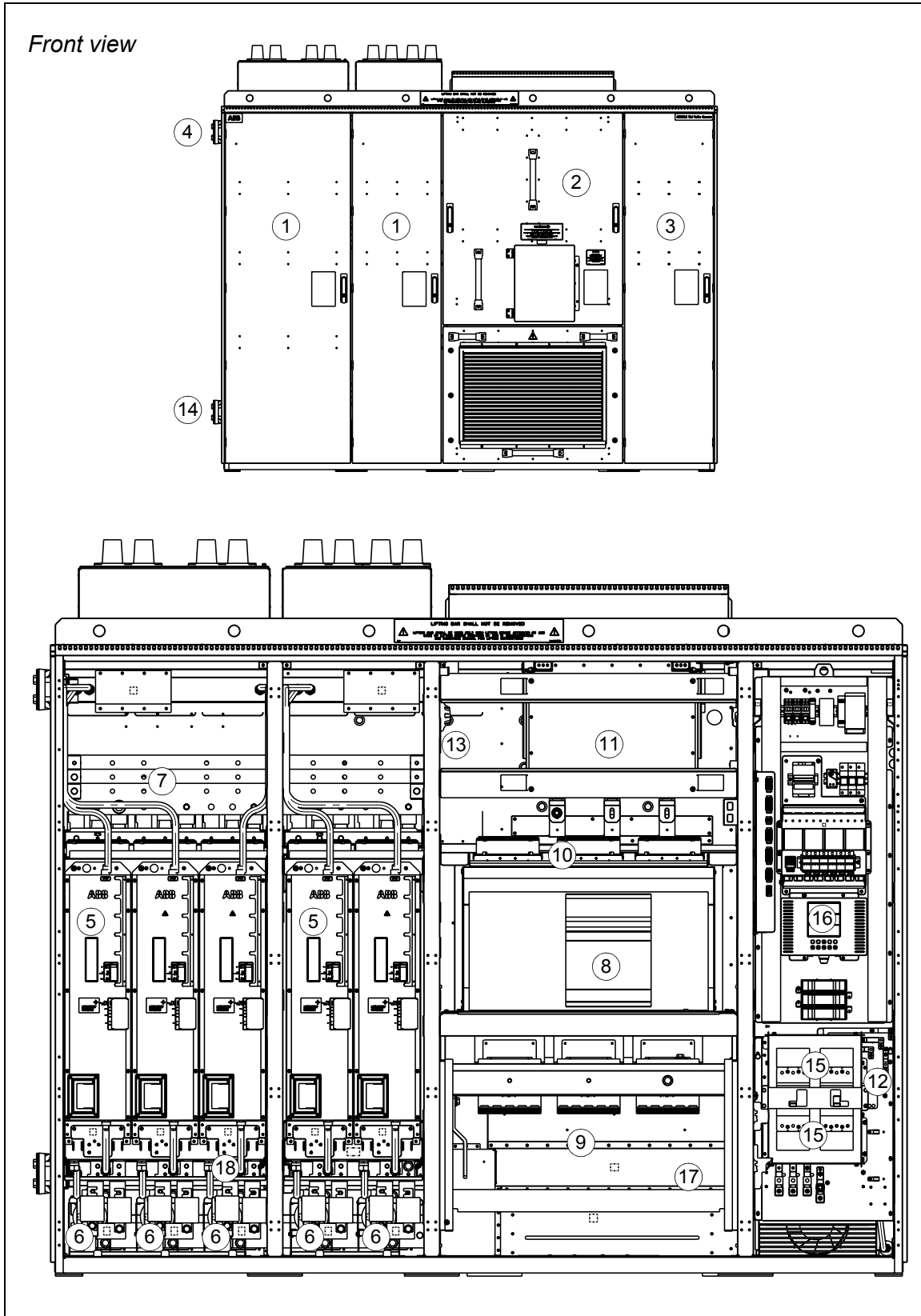

No.	Description
1	Generator-side converter cubicles [+11.1, +11.2]
2	Main breaker cubicle [+01.6]
3	Charging cubicle [+01.6]
4	Coolant out (option +C144 cooling connectors left)
5	Generator-side converter modules [T5]
6	DC fuses [F5]
7	Generator cable terminals [U2, V2, W2]
8	Main circuit breaker [Q1]
9	Grid cable/busbar terminals [L1, L2, L3]
10	Cooling fans of the main breaker cubicle [M16, M17, M18]
11	Capacitors of the LCL filter [C1, C2]
12	Terminals for the auxiliary power [+01.6]
13	Smoke detector (customer variant, [A2])
14	Coolant in (option +C144 cooling connectors left)
15	Auxiliary power disconnectors [Q2, X11; Q3, X12]
16	Charging circuit switch [Q10]
17	Grounding point for grid connection [01.5, WE1]
18	Grounding point for generator connection [+11.1, +11.2, WE1]

Back view

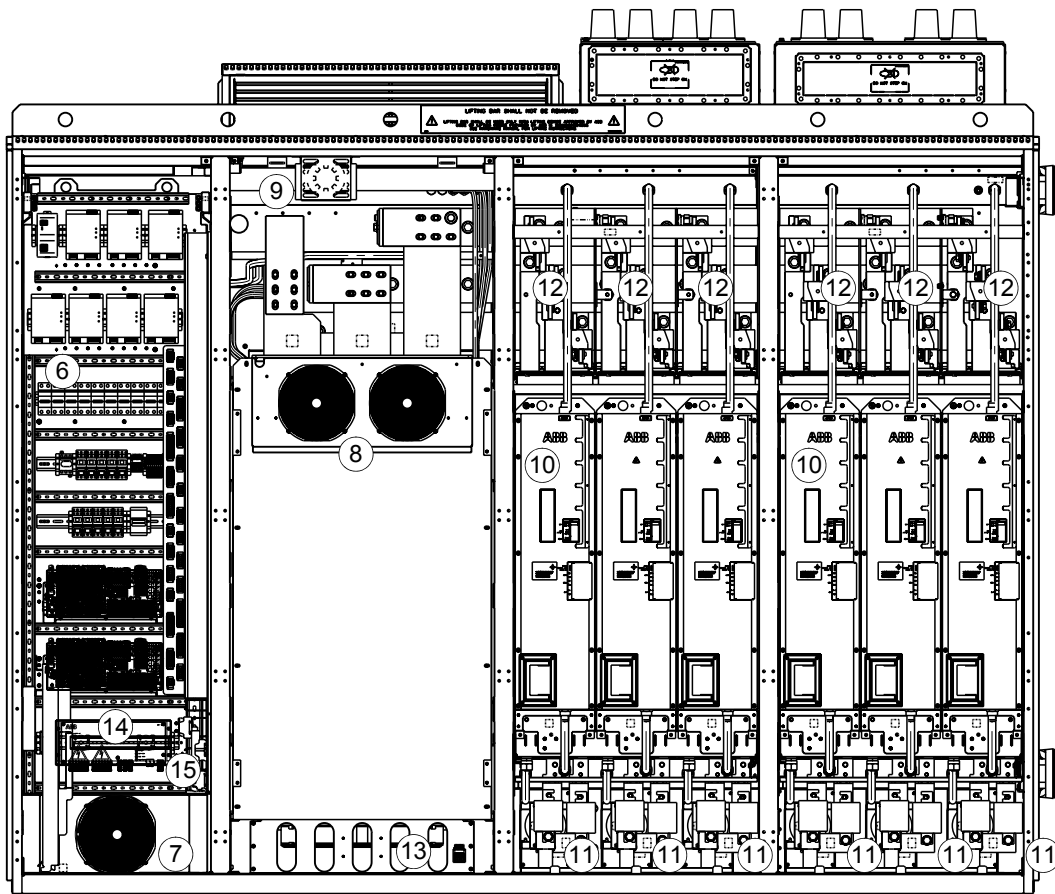
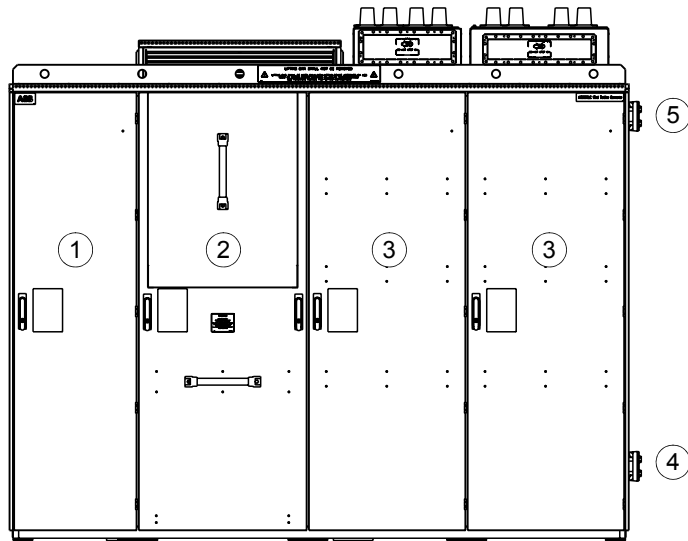

No.	Description
1	Auxiliary control cubicle [+01.3]
2	LCL filter cubicle [+01.6]
3	Grid-side converter cubicle [+01.1, +01.2]
4	Coolant in (option +C144 cooling connectors left)
5	Coolant out (option +C144 cooling connectors left)
6	Control electronics
7	Cooling fan of the auxiliary control cubicle [M29]
8	Upper cooling fans of the LCL filter cubicle [M33, M34]
9	Smoke detector (customer variant, [A3])
10	Grid-side converter modules [T1]. Note: ACS880-87LC-4000A/4021A-7 contains five grid-side converter modules.
11	Grid-side converter DC fuses [F5]
12	Grid-side converter AC fuses [F1]
13	Lower cooling fans of the LCL filter cubicle [M20, M21, M22]
14	BCU control units, own for both grid-side converter modules and generator-side converter modules [K11 (BCU of the grid-side converter), K51 (BCU of the generator-side converter)]
15	Control cable terminals for customer connections [X5, X8]

Overview of power and control connections

The diagram shows the power connections and internal control interfaces of the wind turbine converter. See also section [Circuit boards](#) (page 37). The option module slots on the control unit are reserved for internal use and communication.

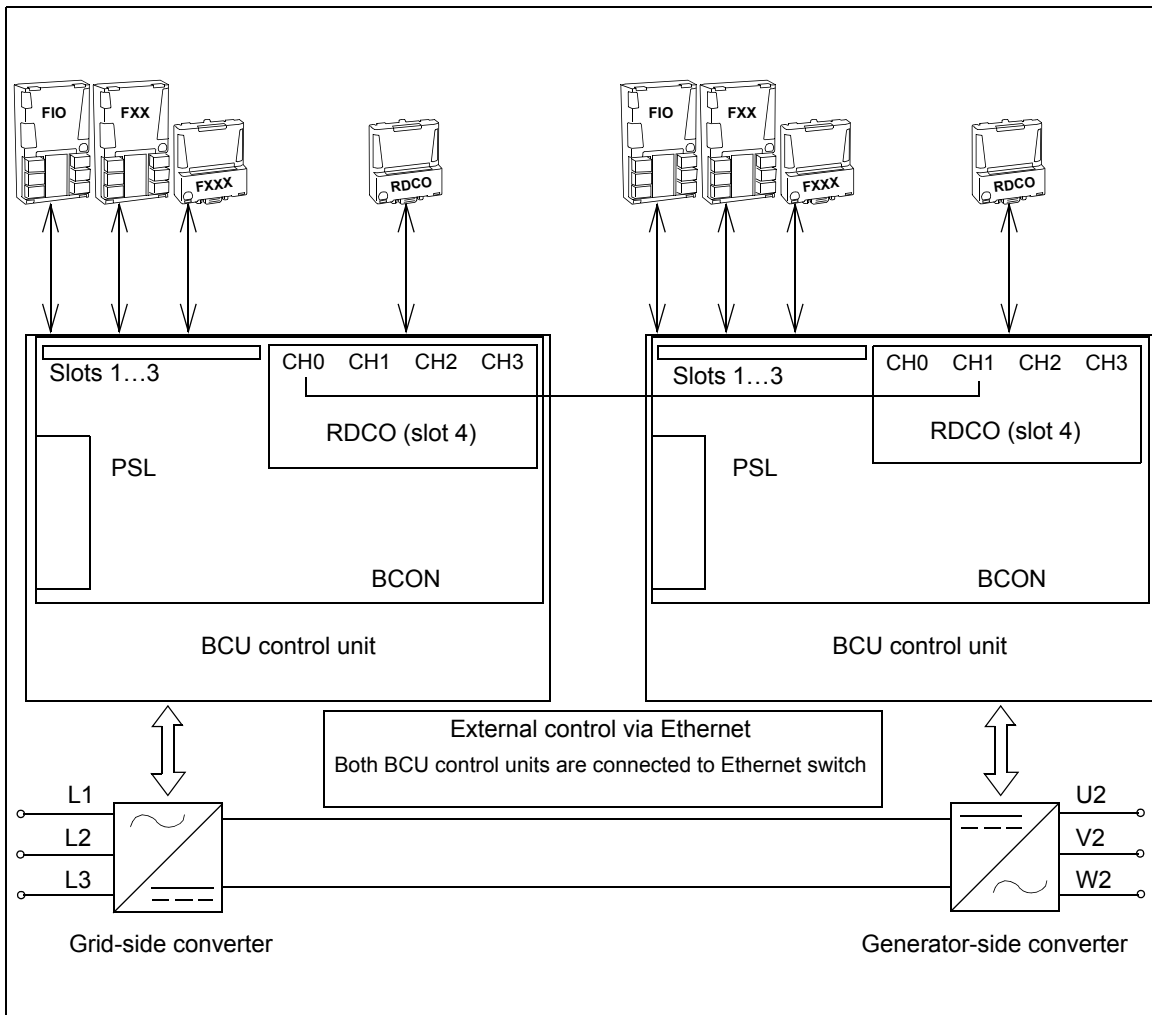

Circuit boards

This example diagram shows the interconnections between the control boards of the converter.

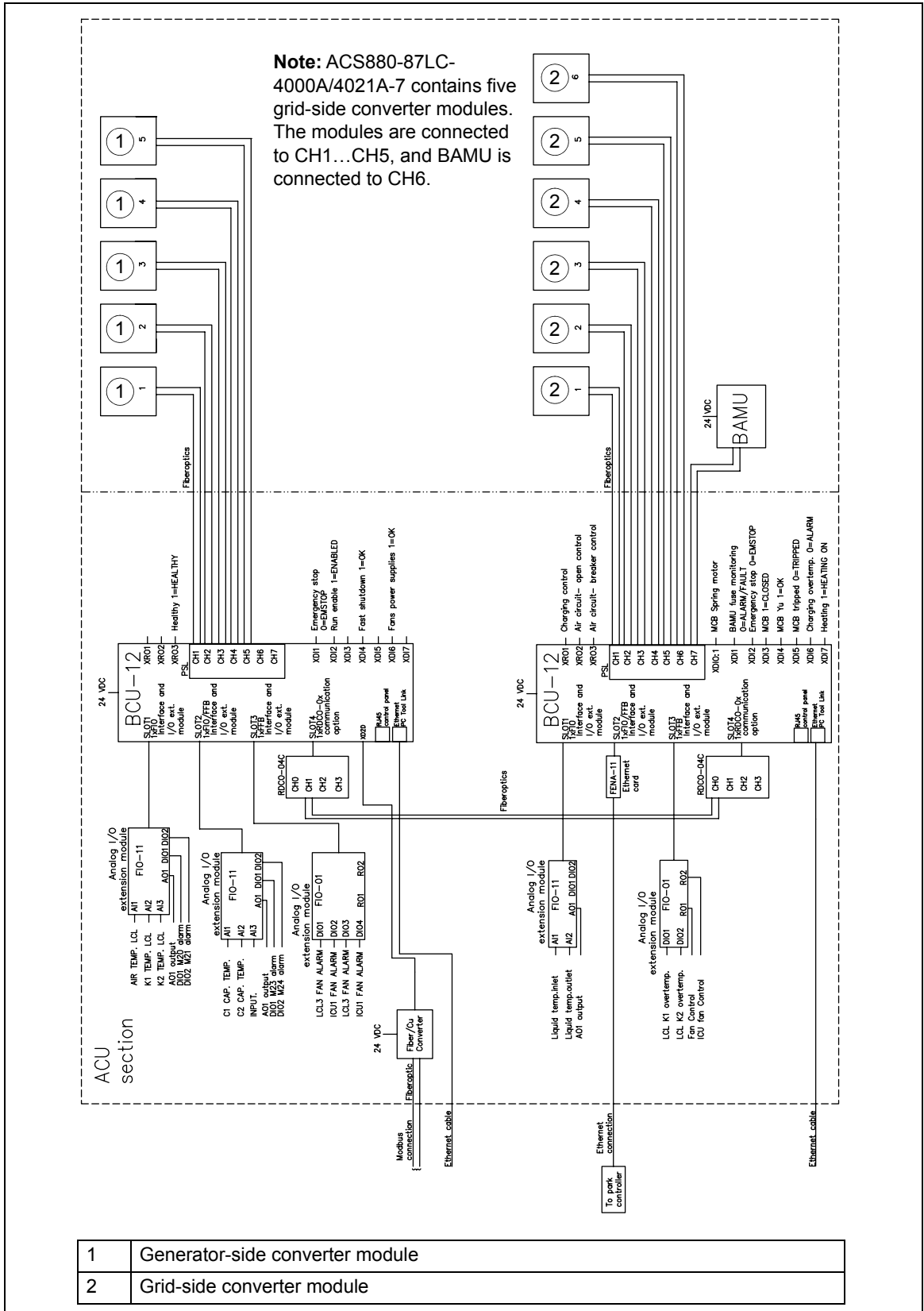

For information on the BCU control units, see chapter [Control units of the converter](#).

BAMU board

The BAMU board is a multipurpose measurement unit for voltage and current measurement. It has two three-phase voltage inputs and three current inputs.

When the option +F276 (grid fault ride-through) is selected, the BAMU board is included in the delivery for measuring three grid voltages.



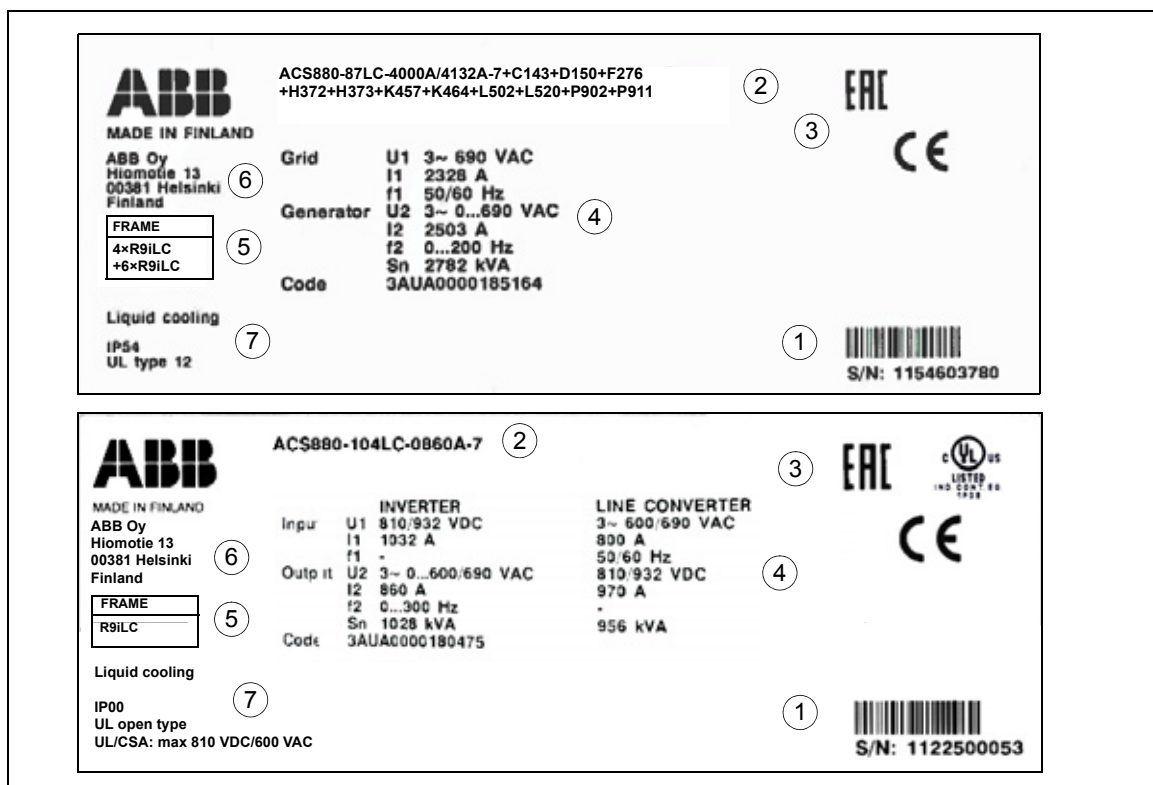

Type designation labels

The type designation label of the wind turbine converter is attached inside the cabinet door. The type designation label includes ratings, valid markings, type code and serial number of the converter. Each converter module is also individually labeled.

Typical labels are shown below.



No.	Description
1	Serial number. The first digit of the serial number refers to the manufacturing plant. The next four digits refer to the converter's manufacturing year and week, respectively. The remaining digits complete the serial number so that there are no two converters with the same number.
2	Type code. See section Type designation key . If the delivery contains a DC chopper, option code +D150 is marked in the converter label.

No.	Description
3	<p>Valid markings. Possible markings are, for example:</p> <ul style="list-style-type: none"> • CE marking  • EAC marking  • UL marking  • RCM marking  • WEEE marking  <p>See chapter Technical data.</p>
4	Ratings of the converter
5	<p>Number and frame size of the converter modules.</p> <p>In the upper label for the ACS880-87LC converter, there are four generator-side converter modules, six grid-side converter modules, and the frame size is R9iLC.</p> <p>In the lower label for converter module, the frame size of the module is R9iLC.</p>
6	Manufacturing location
7	Information about cooling, IP class etc.

Type designation key

The type code of the wind turbine converter contains information on the specifications and configuration.

- The first 23 digits form the basic code. It describes the basic construction of the wind turbine converter. The fields in the basic code are separated with hyphens.
- The option codes follow the basic code. Each option code starts with an identifying letter (common for the whole product series), followed by descriptive digits. The option codes are separated by plus signs.

The selections are listed below. For more information, contact your local ABB representative.

■ Basic code

Digit no.	Name/Description	Alternatives	Description
1...6	Product series	ACS880	ACS880 product series
8...11	Construction	87LC	Cabinet mounted liquid-cooled wind turbine converter
13...23	Size	See section Ratings on page 107 .	Generator-side converter current rating / Grid-side converter current rating
25	Voltage rating	7	7 – Voltage range 525...690 V. This is indicated in the type designation label as a typical input voltage level (3~ 690 V AC).

■ Option codes (plus codes)

Code	Description
I/O options	
L500	FIO-11 analog I/O extension module (included as standard)
L501	FIO-01 digital I/O extension module
L502	FEN-31 HTL incremental encoder interface module
Fieldbus	
K451	FDNA-01 DeviceNet adapter module
K454	FPBA-01 PROFIBUS DP adapter module
K457	FCAN-01 CANopen adapter module
K462	FCNA-01 ControlNet adapter module
K466	Ethernet (Modbus TCP, EtherNet/IP) adapter
K467	Ethernet (Modbus TCP, PROFINET IO) adapter
K469	FECA-01 EtherCAT adapter module
K473	FENA-11 Ethernet adapter module (EtherNet/IP, Modbus TCP, PROFINET)
Ethernet	
K464	NETA-21 remote monitoring tool (EIP, MB/TCP)
Construction	
C129	UL design
C143	Cooling connections right (when looking the converter from the main breaker cubicle side)
C144	Cooling connections left (when looking the converter from the main breaker cubicle side)
C145	Pipe connections with ANSI flange
H370	Cable conduit entry for 3-phase cabling - generator cable
H371	Cable conduit entry for 3-phase cabling - grid cable
H372	Cable conduit entry for 1-phase cabling - generator cable
H373	Cable conduit entry for 1-phase cabling - grid cable
L520	Fast connector plugs for I/O terminals
C161	Removable doors
Grid control options	
F276	Grid fault ride-through
D150+F276	Grid fault ride-through with energy absorber
D151	DC resistor
Output contactor	
F269	Output contactor
Auxiliary controls	
G407	Control of external contactor(s) of the generator
G408	Control of external air circuit breaker of the generator

42 Operation principle and hardware description

Code	Description
Cabinet options	
G335	Current transformers for grid current measurement
G396	Auxiliary 3-phase power output - 125 A (included as standard)
G397	Auxiliary 3-phase power output - 100 A (included as standard)
G398	Auxiliary 3-phase power output - 80 A (included as standard)
G399	Auxiliary 3-phase power output - 63 A (included as standard)
G422	Bleeding valve
Specialities	
P902	Customized (described in Technical Appendix)
P911	Extended warranty
Safety options	
Q951	Emergency stop, stop category 0
Documentation language (delivered set may include documents in English)	
R701	German
R707	French

4

Mechanical installation

Contents of this chapter

This chapter describes the mechanical installation procedure of the wind turbine converter.

Safety instructions

See chapter [Safety instructions](#).



Checklist before mechanical installation

	<input checked="" type="checkbox"/>
<p>The installation site</p> <p>Check the installation site. See section <i>Ambient conditions</i> on page 113 for the allowed operating conditions, and section <i>Dimensions, weights and free space requirements</i> on page 109 for the requirements for free space around the converter.</p> <p>Check that the floor that the converter is installed on is of non-flammable material, as smooth as possible, and strong enough to support the weight of the converter.</p> <p>Check the floor flatness with a spirit level. The maximum allowed deviation from the surface level is 5 mm (0.2 in) in every 3 meters (9.8 ft).</p> <p>If necessary, level the installation site, as the cabinet is not equipped with adjustable feet.</p> <p>Check that the wall behind the converter is of non-flammable material.</p>	<input type="checkbox"/>
<p>Required tools</p> <p>Check that you have following tools for moving the converter to its final position, fastening it to the floor and tightening the connections:</p> <ul style="list-style-type: none"> • crane or fork-lift (check the load capacity); iron bar and piece of planked wood • Pozidriv and Torx (2.5 ... 6 mm, 0.98 ... 0.2 in) screwdrivers for the tightening of the frame screws (Screws needed for fastening the cabling boxes and other accessories delivered by ABB are included in the delivery. They are inside the cabinet. The delivery does not contain screws or tools to install the cabinet to the floor.) • torque wrench • set of wrenches and sockets. 	<input type="checkbox"/>
<p>The delivery</p> <p>For unpacking the delivery, see page 46.</p> <p>Check that the delivery contains:</p> <ul style="list-style-type: none"> • converter cabinet • cabling boxes for the grid-side converter and generator-side converter (optional) • option modules (installed at the factory) • DC chopper(s) and DC resistor(s) (optional) • appropriate wind turbine converter manual(s) and option module manual(s) • delivery documents (dimension drawings, circuit diagrams, etc.). <p>The manual(s) and other loose parts are delivered inside the converter.</p> <p>Check that there are no signs of damage.</p> <p>Check the information on the type designation label of the converter to verify that the delivery is of correct type.</p>	<input type="checkbox"/>



Moving the converter package

■ Moving the converter package by fork-lift



WARNING! Only use a heavy duty forklift that can carry the weight of the converter.

- Make sure that the reach of the fork lift is long enough. The package is wide and the center of gravity is far from the edges.
- Do not tilt. The center of gravity is high.
- Move only in the upright position.

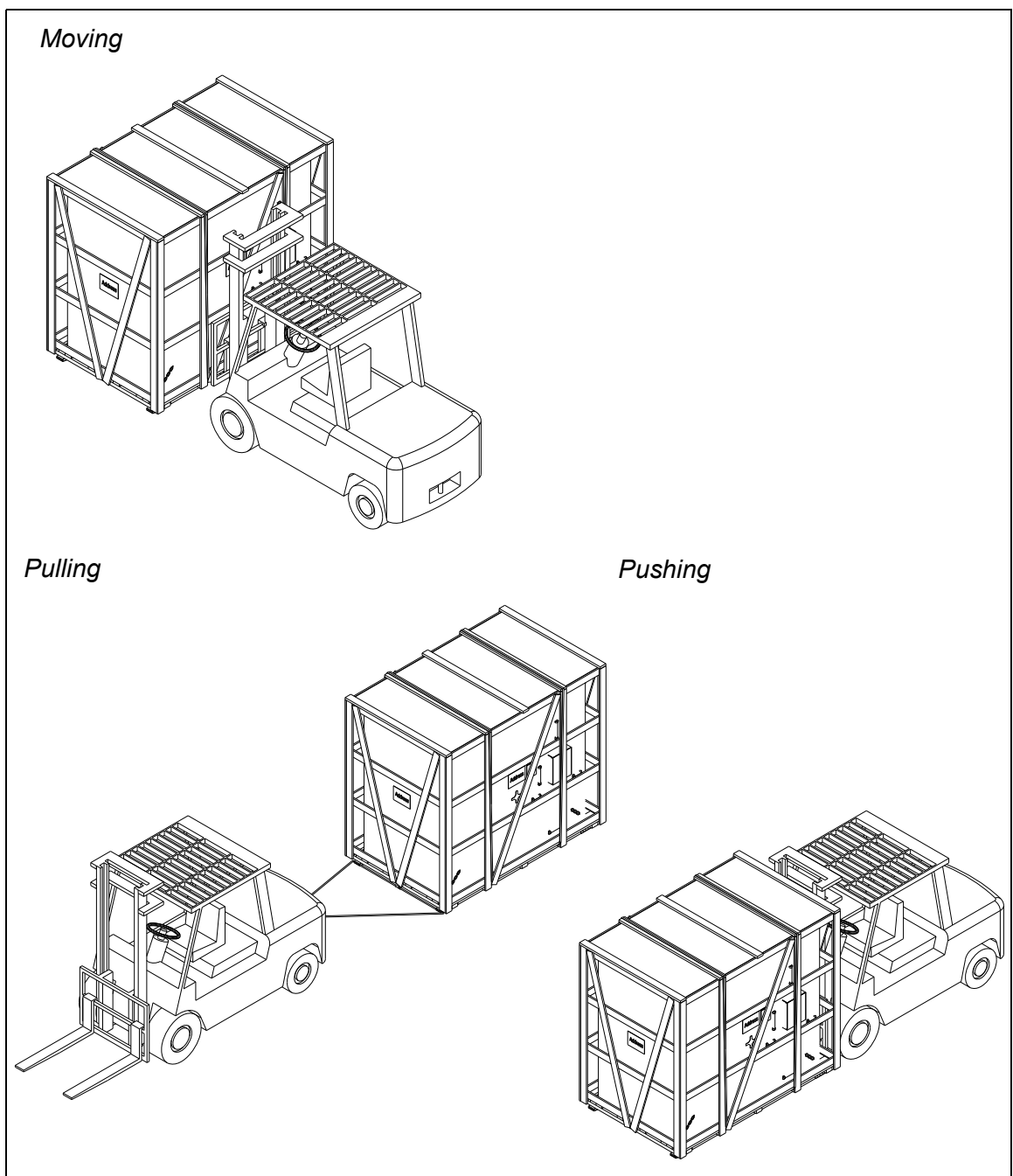

■ Lifting the converter package

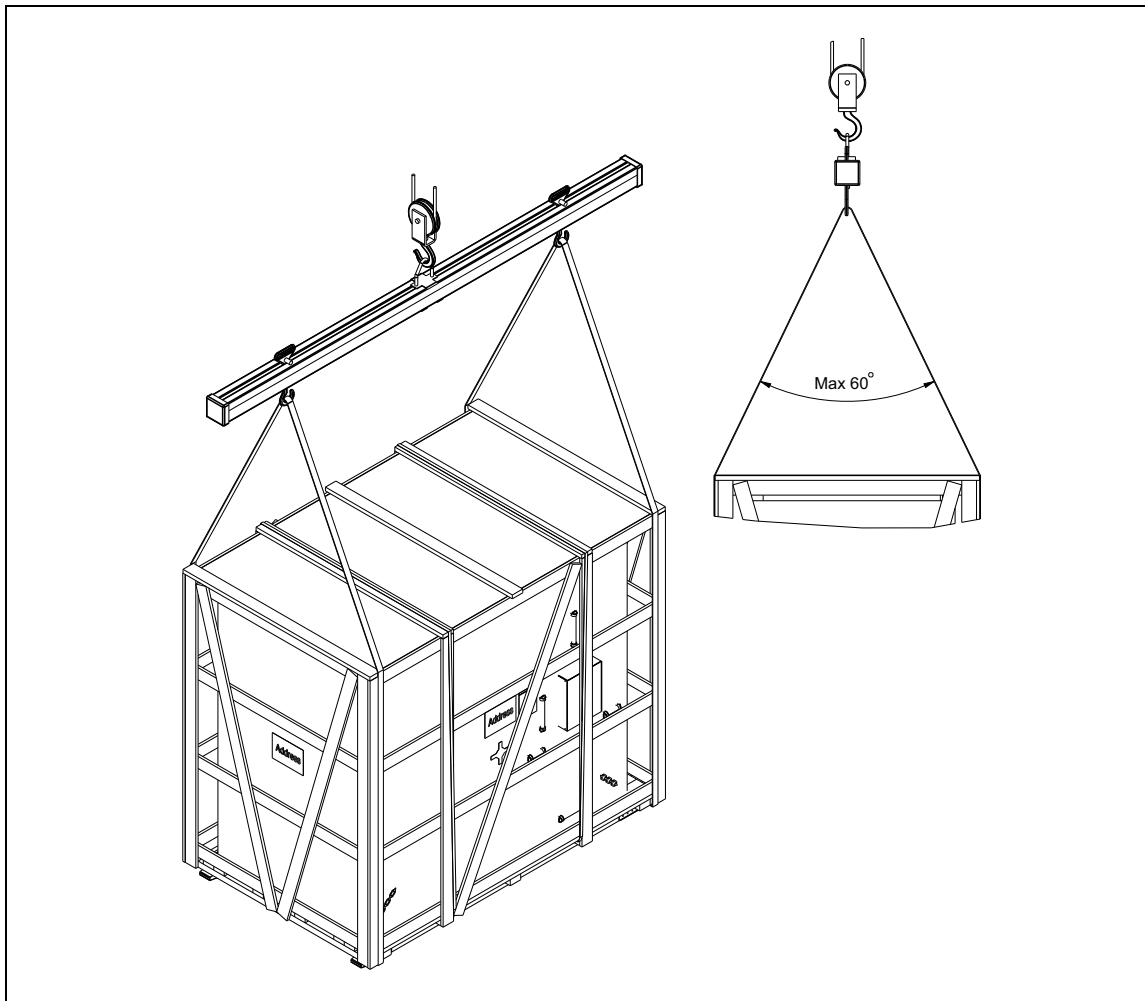

■ Moving the converter on rollers

Do not move the converter on rollers.

Unpacking

Unpack the wind turbine converter when you have moved the converter to its final installation location, or near it.

1. Cut the attachment clamps with side cutters and pull them away.
2. Remove the fastening screws/nails/rivets and unpack the converter from the wooden package.
3. Cut the plastic covering the converter with a carpet knife and remove it.
4. Detach the converter from its platform, lift the converter and remove the platform.

Lifting the converter – ABB lift adapter bars (customer variant) are in use

The ordering code for ABB lift adapter bars is 3AUA0000154605.

1. Attach the ABB lift adapter to the lifting bars on the roof.
2. Attach the lifting sling to the ABB lift adapter lifting point.
3. Lift steadily.
4. Position the converter as near its final position as possible.
5. Remove the ABB lift adapter and store it for later use.



Lifting the converter

Obey these instructions when there are no ABB lift adapter bars in use:

1. Attach the lifting slings to holes of the lifting bars (a). Use long enough slings. See the minimum lifting angle in the figure below.



WARNING! Divide the weight to all lifting bars and all holes. If you do not divide the load evenly, the lifting bars can not carry the weight of the converter.

2. Tighten the slings steadily and make sure that the load is evenly divided.
3. Lift steadily.
4. Position the converter as near its final position as possible.
5. Remove the lifting bars and refasten the roof bolts to retain the degree of protection of the cabinet. Store the loose lifting bars for later use.

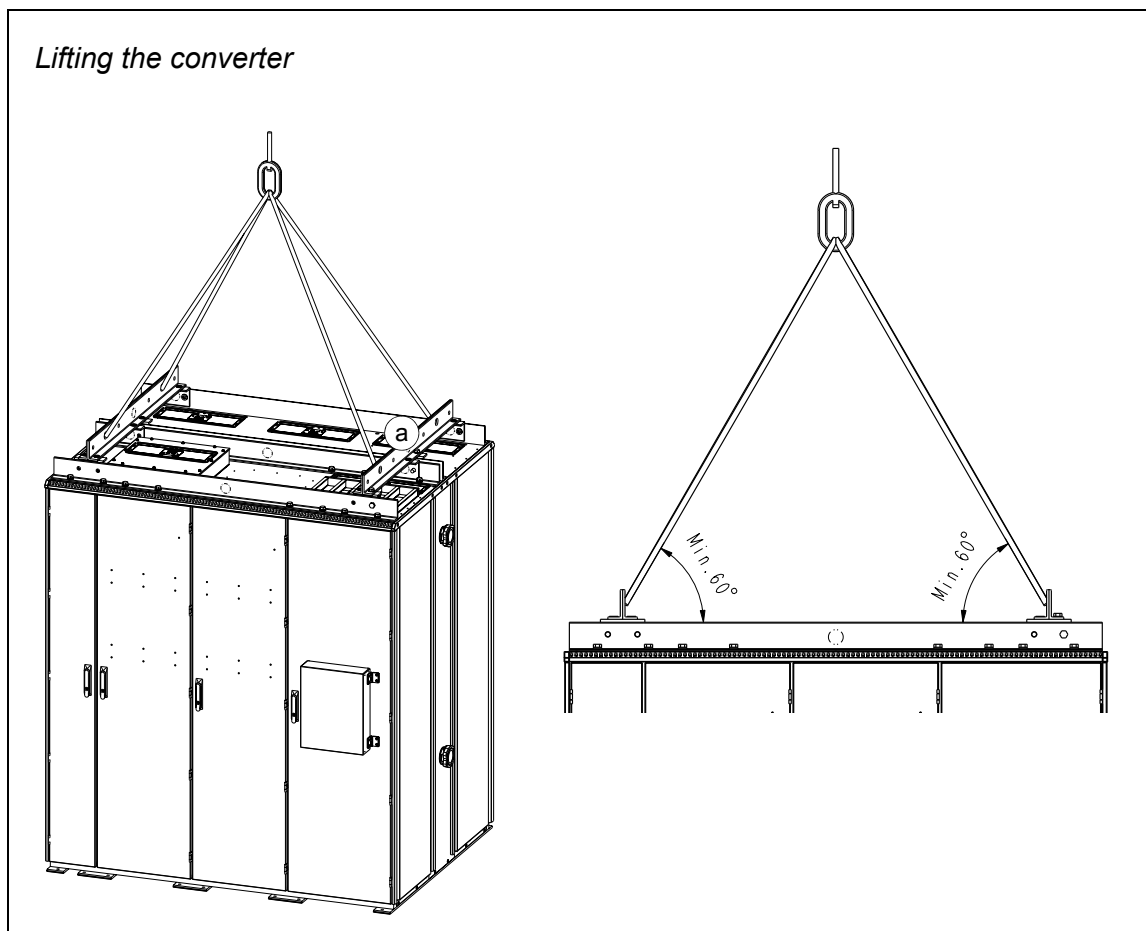

Placing the converter

The cabinet can be placed into its final position with an iron bar and a wooden piece at the bottom edge of the cabinet. Place the wooden piece carefully to avoid damage to the cabinet frame.



The cabinet has a back-to-back design, and thus you cannot install it with a longer side against a wall.

The converter must be installed in an upright vertical position.

Notes:

- Leave a 400 mm (16 in) clearance above the converter cabinet to allow pressure release lids to open in an arc fault situation.
- Leave space at the side for the coolant pipes.
- You can adjust the height, for example, if the floor is uneven by using metal shims between the cabinet frame and floor.

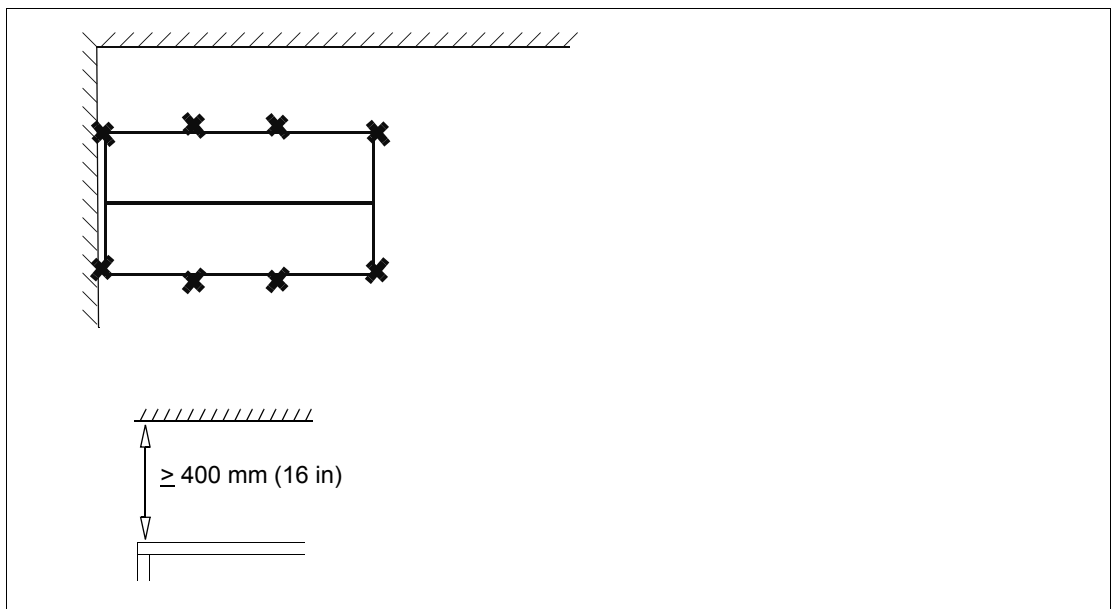

Fastening the cabinet to the floor

Bolt the converter to the floor through the holes in each flat bar at the base of the cabinet using M12 screws.

We do not recommend welding (see section [Electric welding](#) on page 51).

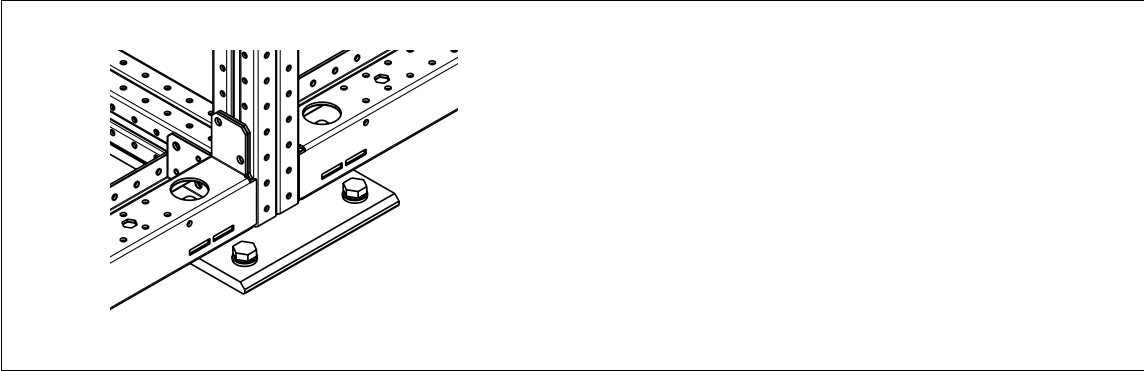

Internal cooling circuit

For installations related to cooling, see chapter [Cooling and heating](#) on page 132.



Lifting the door

1. Open the handles.
2. Detach the upper part of the door.
3. Lift the door upwards.

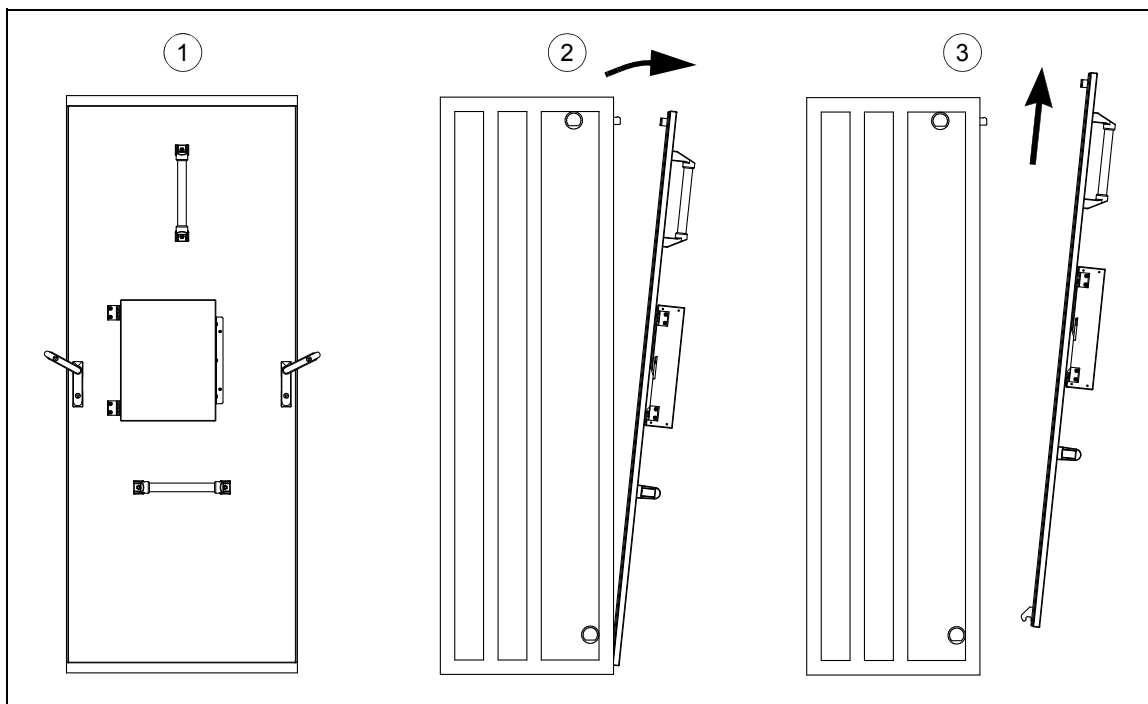

Miscellaneous

■ Cable duct in the floor below the cabinet

You can construct cable ducts below the cabinet. The duct width must not exceed 450 mm (18 in). The cabinet weight lies on the 100 mm (4 in) wide sections in front, middle and back which the floor must carry.

Prevent the cooling air flow from the cable duct to the cabinet by bottom plates. To ensure the degree of protection for the cabinet use the original bottom plates delivered with the converter. With user-defined cable entries, take care of the degree of protection, fire protection and EMC compliance.

■ Electric welding

It is not recommended to fasten the cabinet by welding. If you must do it for some reason:

- Weld only the flat bar under the cabinet, never the cabinet frame itself.
- Clamp the welding electrode onto the flat bar about to be welded or to the next flat bar of the cabinet (within 0.5 meters of the welding point).



WARNING! If the welding return wire is connected improperly, the welding circuit may damage electronic circuits in the cabinet. The thickness of the zinc coating of the cabinet frame is 100 ... 200 micrometers; on the flat bars the coating is approximately 20 micrometers. Ensure that the welding fumes are not inhaled.



5

Planning the electrical installation

Contents of this chapter

This chapter contains the instructions that you must follow when selecting the generator, cables, protections, cable routing and way of operation for the converter system.

Note: The installation must always be designed and made according to applicable local laws and regulations. ABB does not assume any liability whatsoever for any installation which breaches the local laws and/or other regulations. Furthermore, if the recommendations given by ABB are not followed, the converter may experience problems that the warranty does not cover.

Selecting the grid disconnecting device

The converter is equipped with a main circuit breaker as standard. The breaker is withdrawable: when withdrawn (cranked out), the breaker operates as a main disconnect for the converter. However, the withdrawn main circuit breaker does not isolate the grid cable terminals of the converter from the grid. Equip the installation with another disconnecting device placed in between the power grid and the grid cable terminals of the converter. For example, the main circuit breaker of the grid transformer could also be used as the extra disconnecting device if it meets the requirements for a disconnecting device.

Checking the compatibility of the generator and the converter

The converter is compatible with induction generators and permanent magnet generators.

1. Select the generator according to the ratings table in chapter [Technical data](#) on page 107.
2. Check that the generator and the converter have the same voltage rating. Check also that the voltage ratings match the voltage to be connected to the grid-side converter.

Note: You can rise the converter DC link voltage 10% of its natural level (by a parameter setting). The effect is equivalent to a 10% voltage rise at the generator terminals. Before you use this feature, make sure that the generator insulation can withstand the higher voltage level.

When	the generator voltage rating should be
DC bus voltage is not increased from nominal (default)	U_N
DC bus voltage is increased from nominal by parameter setting	U_{ACeq}
U_N $\hat{=}$ rated grid-side voltage of the converter U_{ACeq} $\hat{=}$ equivalent grid-side voltage of the converter in V AC, $U_{ACeq} = U_{DC} / 1.41$ U_{DC} $\hat{=}$ maximum DC bus voltage of the converter in V DC. You can set the voltage reference with parameter in grid-side converter control program for $1.1 \cdot 1.41 \cdot U_N$ at maximum. You can set the reference to a lower value but the program restricts it to a value of at least $1.41 \cdot U_N$.	

3. Make sure that the generator is suitable for the converter use, ie, it can withstand the voltage peaks at of the converter:
 - Use insulated N end (non-driven end) bearing in the generator.
 - Make sure that the generator insulation meets the requirements in the table below.
 - Select the cables according to the instruction in this manual.
 - Install the converter and its cabling as instructed in this manual.

■ Protecting the generator insulation and bearings

The generator-side converter output of the wind turbine converter comprises – regardless of output frequency – pulses of approximately the converter DC bus voltage with a very short rise time. This is the case with all converters employing modern IGBT technology.

The voltage of the pulses can be almost double at the generator terminals, depending on the attenuation and reflection properties of the generator cable and the terminals. This in turn can cause additional stress on the generator and generator cable insulation.

Modern variable speed converters with their fast rising voltage pulses and high switching frequencies can cause current pulses that flow through the generator bearings, which can gradually erode the bearing races and rolling elements.

You can avoid the stress on generator insulation by using ABB du/dt filters. du/dt filters also reduce bearing currents. The converter is equipped with the following output filters:

- du/dt filter protects generator insulation system and reduces bearing currents
- common mode filter mainly reduces bearing currents.

To avoid damage to generator bearings, the cables must be selected and installed according to the instructions given in this manual. In addition, insulated N-end (non-converter end) bearings must be used.

Selecting the power cables

■ General rules

Dimension the grid cable or busbar and generator cable **according to local regulations**:

- The cable must be able to carry the converter load current. See chapter [Technical data](#) on page [107](#) for the rated currents.
- The cable must be rated for at least 90 °C (194 °F) maximum permissible temperature of conductor in continuous use. See also section [Additional US and Canada requirements](#) on page [59](#).
- The inductance and impedance of the PE conductor/cable (grounding wire) must be rated according to permissible touch voltage appearing under fault conditions (so that the fault point voltage will not rise excessively when a ground fault occurs).
- The rated voltage between the conductors of the cable should be minimum 1 kV.

For generators, the symmetrical shielded generator cable is highly recommended. See section [Alternative power cable types](#) on page [57](#).

Note: When continuous conduit is employed, shielded cable is not required.

Note: When using a four-conductor system, consult the generator manufacturer regarding bearing and disturbance shielding.

In a non-symmetrical four-conductor system, voltage can be induced to the separate PE conductor, which rises generator frame potential and causes current to ground through the generator bearings and shaft. This causes extra wear. Whereas, in a symmetrical shielded cable, the high capacitance between the PE conductor and the phase conductors forms an LC filter reducing bearing currents and voltage changes.

A four-conductor system is allowed for grid cabling, but shielded symmetrical cable is highly recommended.

■ Sufficient conductivity of the protective conductor

The protective conductor must always have an adequate conductivity.

Unless local wiring regulations state otherwise, the cross-sectional area of the protective conductor must agree with the conditions that require automatic disconnection of the supply required in 411.3.2. of IEC 60364-4-41:2005 and be capable of withstanding the prospective fault current during the disconnection time of the protective device.

The cross-sectional area of the protective conductor can either be selected from the table below or calculated according to 543.1 of IEC 60364-5-54.

This table shows the minimum cross-sectional area related to the phase conductor size according to IEC 61800-5-1 when the phase conductor and the protective conductor are made of the same metal. If this is not so, the cross-sectional area of the protective earthing conductor shall be determined in a manner which produces a conductance equivalent to that which results from the application of this table.

Cross-sectional area of the phase conductors S (mm²)	Minimum cross-sectional area of the corresponding protective conductor S_p (mm²)
S ≤ 16	S
16 < S ≤ 35	16
35 < S ≤ 400	S/2
400 < S ≤ 800	200
800 < S	S/4

Compared to a four-conductor system, the use of symmetrical shielded cable reduces electromagnetic emission of the whole converter system as well as generator bearing currents and wear.

The generator cable and its PE pigtail (twisted screen) should be kept as short as possible in order to reduce electromagnetic emission as well as capacitive current.

■ Typical power cable sizes

CE cables

Generator cables						
Converter type	Cable type	Conductor type	Total quantity of parallel cables			
			240 mm ²	185 mm ²	120 mm ²	95 mm ²
ACS880-87LC-4000A/4021A-7	EPR	Copper	9	10	13	15
4000A/4132A-7	EPR	Copper	9	10	13	15

Grid cables						
Converter type	Cable type	Conductor type	Total quantity of parallel cables			
			240 mm ²	185 mm ²	120 mm ²	95 mm ²
ACS880-87LC-4000A/4021A-7	EPR	Copper	9	11	14	16
4000A/4132A-7	EPR	Copper	9	11	14	16

UL cables

Generator cables							
Converter type	Cable type	Conductor type	Total quantity of parallel cables				
			500 kcmil	400 kcmil	350 kcmil	300 kcmil	250 kcmil
ACS880-87LC-4000A/4021A-7	EPR	Copper	20	22	24	26	29
4000A/4132A-7	EPR	Copper	20	22	24	26	29

Grid cables							
Converter type	Cable type	Conductor type	Total quantity of parallel cables				
			500 kcmil	400 kcmil	350 kcmil	300 kcmil	250 kcmil
ACS880-87LC-4000A/4021A-7	EPR	Copper	21	24	26	29	32
4000A/4132A-7	EPR	Copper	21	24	26	29	32

■ Alternative power cable types

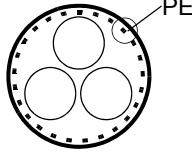
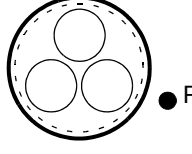
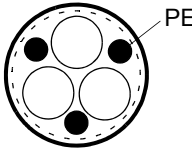

The power cable types that you can use with the converter are shown below.

	<p>Symmetrical shielded cable with three phase conductors and a concentric PE conductor as shield. The shield must meet the requirements of IEC 61800-5-1. Check with local / state / country electrical codes for allowance.</p>
	<p>Symmetrical shielded cable with three phase conductors and a concentric PE conductor as shield. A separate PE conductor is required if the shield does not meet the requirements of IEC 61800-5-1.</p>
	<p>Symmetrical shielded cable with three phase conductors and symmetrically constructed PE conductor, and a shield. The PE conductor must meet the requirements of IEC 61800-5-1.</p>

Power cable types for limited use

	<p>A four-conductor system (three phase conductors and a protective conductor on a cable tray) is not recommended for cabling.</p>
---	--

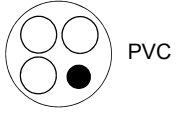
Not allowed power cable types

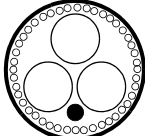
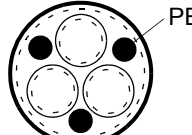
	<p>A four-conductor system (three phase conductors and a PE conductor in a PVC conduit)</p>
	<p>Corrugated cable with three phase conductors and a protective conductor or cable in EMT conduit</p>
	<p>A well-shielded (Al/Cu shield) four-conductor system (three phase conductors and a PE conductor or four conductors)</p>
	<p>Symmetrical shielded cable with individual shields for each phase conductor is not allowed on any cable size for grid and generator cabling.</p>

Generator cable shield

If the generator cable shield is used as the sole protective earth conductor of the generator, make sure that the conductivity of the shield is sufficient. See subsection [General rules](#) above, or IEC 61800-5-1.

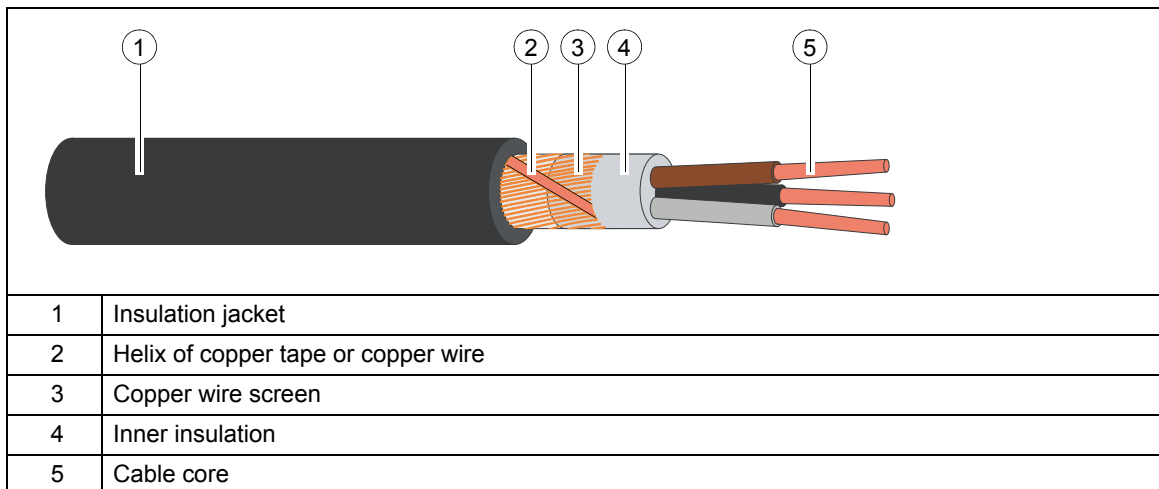

To effectively suppress radiated and conducted radio-frequency emissions, the cable shield conductivity must be at least 1/10 of the phase conductor conductivity. The requirements are easily met with a copper or aluminum shield. The minimum requirement of the generator cable shield of the converter is shown below. It consists of a concentric layer of copper wires with an open helix of copper tape or copper wire. The better and tighter the shield, the lower the emission level and bearing currents.



■ Single core vs multicore cables in grid cabling

Use symmetrical grid cabling. Asymmetry leads to unequal current distribution between the conductors which may cause disturbances and fault trips. To avoid asymmetry, use symmetrical multicore (three-phase) cables where possible. Single core cabling is also allowed if the cables are grouped symmetrically.

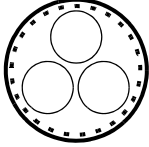
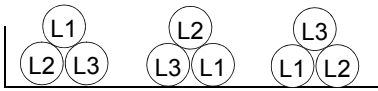
The table below shows three possible cabling options.

No.	Layout	Description
1		Multicore cabling (recommended). See subsection Alternative power cable types for the possible constructions of the PE (protective earth/ground).
2		Single core cables in trefoil (preferable single core cabling option).
3		Single core cables laid flat.

■ Additional US and Canada requirements

Use copper, copper-clad aluminum or aluminum conductors. Use conductors rated for 75 °C (167 °F) only.

Run the cabling in metallic conduits, or use type MC continuous corrugated aluminum armor cable with symmetrical grounds or shielded power cable for the generator cables if metallic conduit is not used.

Conduit

Bridge the joints of the conduits with a ground conductor bonded to the conduit on each side of the joint. Bond the conduits also to the converter enclosure. Use separate conduits for grid, generator, DC resistors, and control wiring. A dedicated ground cable is always required.

Note: Do not run generator wiring from more than one converter in the same conduit.

Armored cable / shielded power cable

6-conductor (3 phases and 3 ground) type MC continuous corrugated aluminum armor cable with symmetrical grounds is available from the following suppliers (trade names in parentheses):

- Anixter Wire & Cable (Philsheath)
- BICC General Corp (Philsheath)
- Rockbestos Co. (Gardex)
- Oaknite (CLX).

Shielded power cables are available from Belden, Lapp Kabel (ÖLFLEX) and Pirelli, among others.

Selecting the DC resistors

For further information, contact your local ABB representative.

Selecting the control cables

■ General rules

All control cables must be shielded.

As a general rule, the control signal cable shield should be grounded directly in the wind turbine converter. The other end of the shield should be left unconnected or grounded indirectly via a high frequency, high voltage capacitor of a few nanofarads. The screen can also be grounded directly at both ends if they are in the same earth line with no significant voltage drop between the end points.

Use a double shielded twisted pair cable (see figure a) for analog signals. This type of cable is recommended for the pulse encoder signals as well. Employ one individually shielded pair for each signal. Do not use common return for different analog signals.

A double shielded cable is the best alternative for low voltage digital signals but single shielded twisted multipair cable (figure b) is also acceptable.

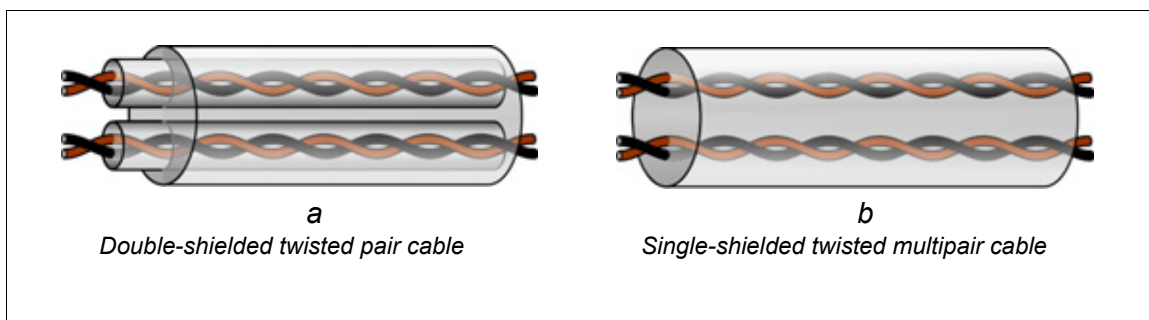

Run analog and digital signals in separate, shielded cables.

Relay-controlled signals, providing their voltage does not exceed 48 V, can be run in the same cables as digital input signals. It is recommended to run the relay-controlled signals as twisted pairs.

Never mix 24 V DC and 115 / 230 V AC signals in the same cable.

■ Relay cable

The cable type with braided metallic screen (for example, ÖLFLEX from Lapp Kabel, Germany) has been tested and approved by ABB.

Routing the cables

Route the generator cable away from other cable routes. It is recommended that the generator cable, grid cable and control cables are installed on separate trays. Avoid long parallel runs of generator cables with other cables in order to decrease electromagnetic interference caused by the rapid changes in the converter output voltage.

Where control cables must cross power cables make sure they are arranged at an angle as near to 90° as possible. Do not run extra cables through the converter.

The cable trays must have good electrical bonding to each other and to the grounding electrodes. You can use aluminum tray systems to improve local equalizing of potential.

A diagram of the cable routing is below.

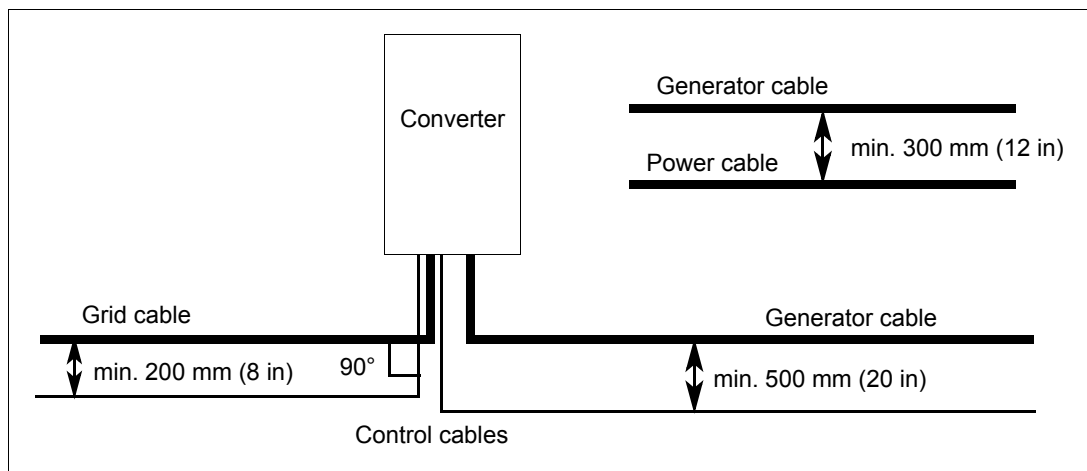

■ Control cable ducts

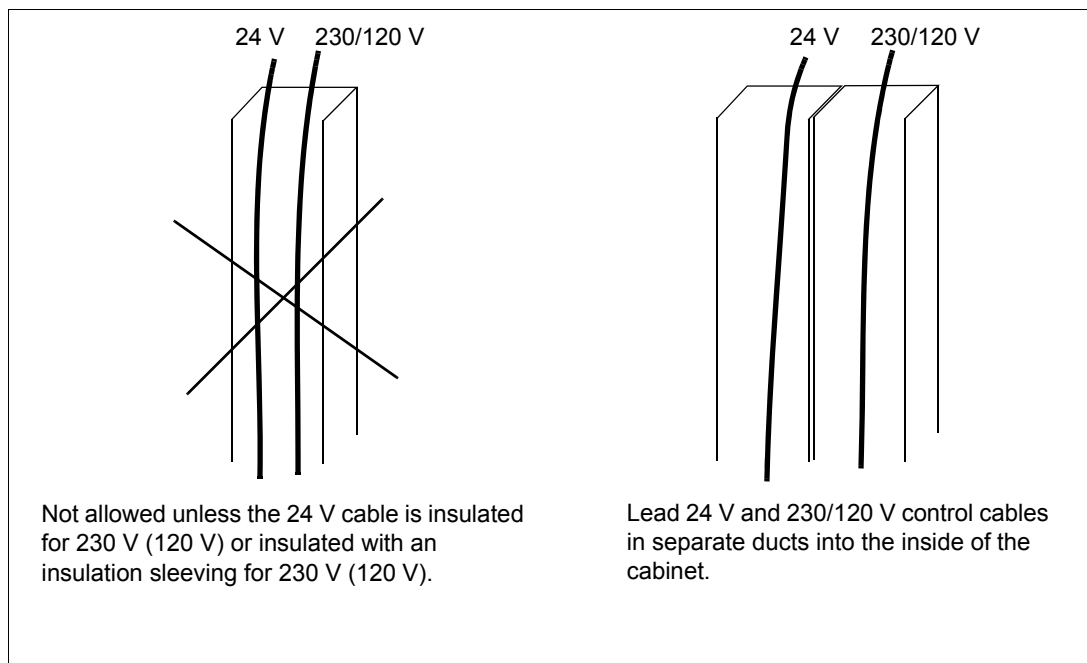

Protecting the converter installation

■ **Protecting the grid cable in short-circuit situations**

Equip the cable with fuses. Size the fuses according to local safety regulations, appropriate voltage and the rated current of the converter.

■ **Protecting the generator and generator cable in short-circuit situations**

The converter protects the generator cable and the generator in a short-circuit situation when the generator cable is sized according to the nominal current of the converter. No additional protection devices are needed.

■ **Protecting the converter, generator cable and grid cable against thermal overload**

The converter protects itself, the grid cables and generator cables against thermal overload when the cables are sized according to the nominal current of the converter and ambient conditions are within the limits specified under *Ambient conditions* on page 113. No additional thermal protection devices are needed.

■ **Protecting the converter against ground faults in the generator or generator cable**

Both the grid-side converter and generator-side converter are equipped with an internal ground fault protective function to protect them against ground faults in the converter itself, the generator and generator cable. (This is not a personal safety or a fire protection feature.) You can disable both ground fault protective functions (not recommended); refer to the firmware manual.

■ **Protecting the converter against ground faults in the converter or grid cable**

Both the grid-side converter and generator-side converter are equipped with an internal ground fault protective function to protect them against ground faults in the converter itself and grid cable. (This is not a personal safety or a fire protection feature.) You can disable both ground fault protective functions (not recommended); refer to the firmware manual.

Implementing the emergency stop function

The converter can be equipped with an emergency stop circuit which can be used to implement the emergency stop function.

Converters with the option +Q951, see *Emergency stop, stop category 0 (option +Q951) for ACS880-77LC/87LC wind turbine converters user's manual* (3AXD50000040787 [English]).

Implementing the grid fault ride-through function

See the firmware manual.

Supplying power for the auxiliary circuits

The converter is not equipped with an auxiliary voltage transformer. Always connect an external auxiliary power supply. For the power rating, see section [Auxiliary circuit current consumption](#) on page [114](#).

As standard, the converter auxiliary circuit is to be supplied from the electrical power network through an external transformer.

The converter is equipped with connectors for 3-phase 400 V AC non-uninterruptible power supply, and 230 V AC uninterruptible power supply. The customer has to supply uninterruptible power from an external on-line power supply.

Using a safety switch between the converter and generator

To minimize the emission level when safety switches are installed in the generator cable between the converter and the generator:

- Install the equipment in a metal enclosure in a way that the conduit or generator cable shielding runs consistently without breaks from the converter to the generator.

Using a contactor between the converter and generator (option +F269)

Note: Select this option selected if you use the wind turbine converter with a permanent magnet generator.

If you install a contactor between the converter and generator:

- install the contactor inside a metal enclosure
- keep the shield and any protective ground (PE) conductors continuous (connect the incoming and outgoing shields / PE conductors)
- when the DTC generator control mode is in use: make sure that it is not possible to open the contactor while the converter is in operation. The contactor may be opened only after a stop command is given to the generator-side converter. Otherwise the contactor may be damaged.

Protecting the contacts of relay outputs

Inductive loads (such as relays, contactors and generators) cause voltage transients when switched off.

The relay contacts of the control board are protected with varistors (250 V) against overvoltage peaks. In spite of this, it is highly recommended to equip inductive loads with noise attenuating circuits (varistors, RC filters [AC] or diodes [DC]) in order to minimize the EMC emission at switch-off. If not suppressed, the disturbances may connect capacitively or inductively to other conductors in the control cable and form a risk of malfunction in other parts of the system.

Install the protective component as close to the inductive load as possible. Do not install the protective components at the terminal block.

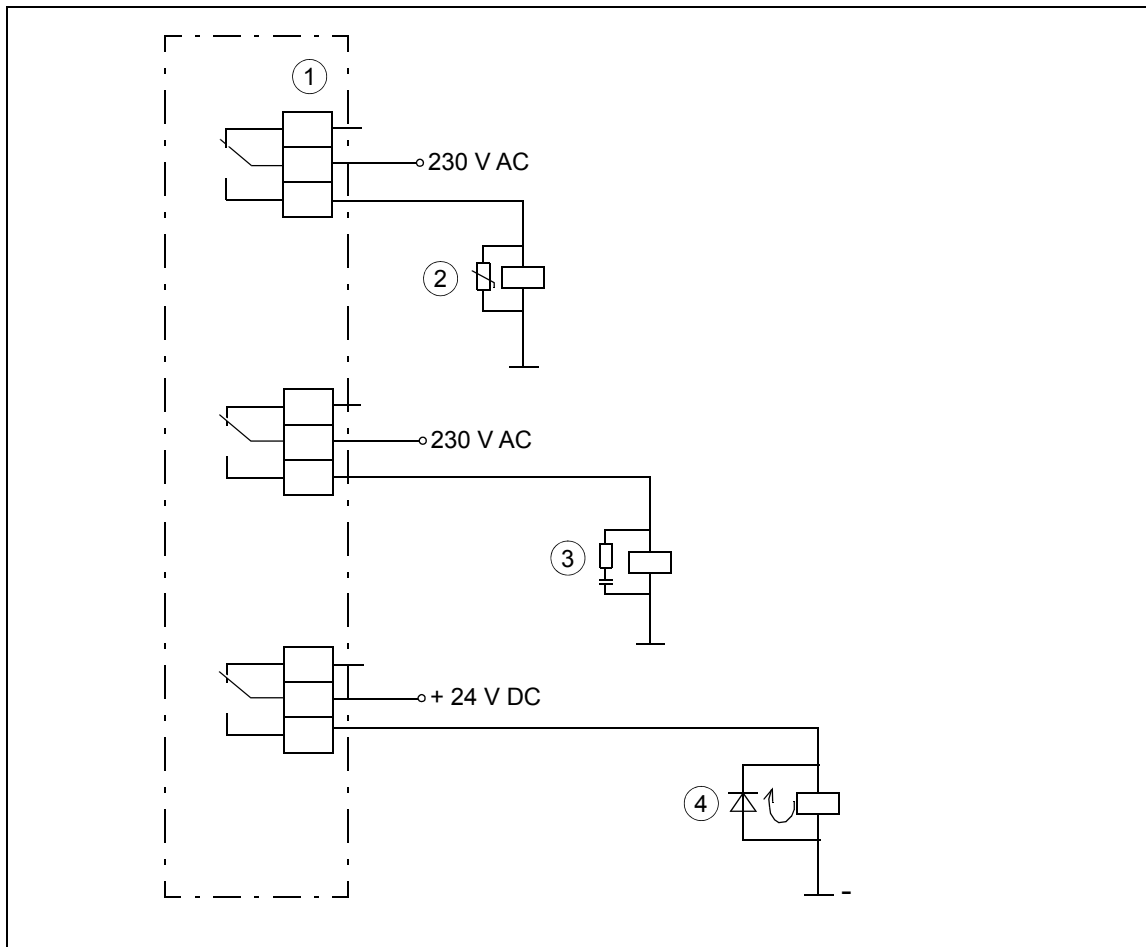

1) Relay outputs; 2) Varistor; 3) RC filter; 4) diode

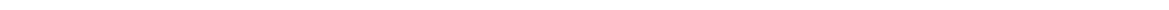

6

Electrical installation

Contents of this chapter

This chapter describes the electrical installation procedure of the wind turbine converter.



WARNING! Only qualified electricians are allowed to carry out the work described in this chapter. Read the complete safety instructions of the converter. If you ignore them, injury or death, or damage to the equipment can occur.

See the circuit diagrams delivered with the converter. The diagrams of this chapter do not necessarily match the installation-specific circuit diagrams of a tailor-made wind turbine converter.

Checking the insulation of the assembly



WARNING! See and obey the safety instructions of the converter. If you ignore them, injury or death, or damage to the equipment can occur.

■ Converter

Do not make any voltage tolerance or insulation resistance tests (for example, hi-pot or megger) on any part of the converter as testing may damage the converter. Every converter has been tested for insulation between the main circuit and the chassis at the factory. Also, there are voltage-limiting circuits inside the converter which cut down the testing voltage automatically.



Grid cable

Check the insulation of the grid cable according to local regulations before connecting it to the converter.

Generator stator and generator cable

Check the insulation of the generator stator and cable as follows:

- Check that all cables are disconnected from the converter output terminals U2, V2 and W2.
- Measure the insulation resistance between each phase conductor and the protective ground conductor using a measuring voltage of 1000 V DC. The insulation resistance of an ABB generator must exceed 100 Mohm (reference value at 25 °C or 77 °F). For the insulation resistance of other generators, please consult the manufacturer’s instructions.
- **Note:** Make sure that there is no condensed moisture inside the generator casing. If you suspect that there is moisture, dry the generator before measurement.
- **Note:** When using permanent magnet generator, it must be stable at the time of the measurement.

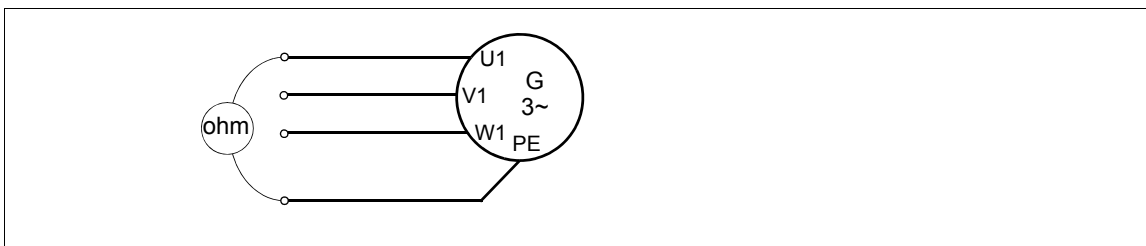

Integrated DC chopper and DC resistor (option +D150+D151)

Every converter equipped with integrated DC chopper and DC resistor is tested for insulation between the main circuit and the chassis at the factory (2700 V rms 50 Hz for 1 second). Do not make any voltage tolerance or insulation resistance tests.

Connecting the grid cables/busbars

Connection diagram

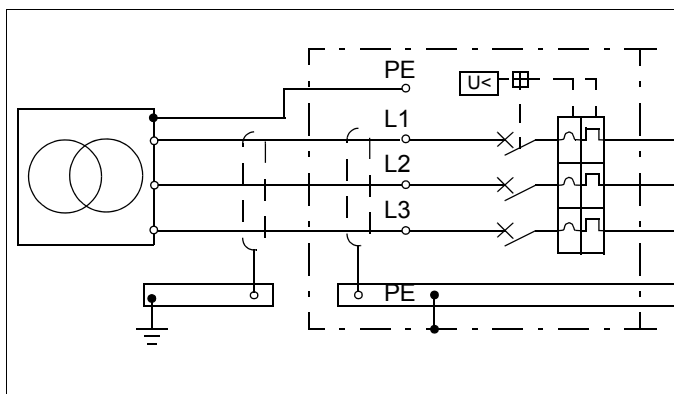

■ Connection procedure



WARNING! See and obey the safety instructions of the converter. If you ignore them, injury or death, or damage to the equipment can occur.



WARNING! Apply grease to stripped aluminum conductors before attaching them to non-coated aluminum cable lugs. Obey the grease manufacturer's instructions. Aluminum-aluminum contact can cause oxidation in the contact surfaces.

1. Open the door of the main breaker cubicle. Unlock the handle, release it from the holder and turn upwards to release the door locking mechanism.
2. Remove the shroud that protects the grid cable/busbar terminals.
3. Lead the grid cables/busbars into the inside of the cubicle.
4. Fasten the grid cables/busbars to the grid connection terminals. Connect the phase conductors to terminals L1, L2 and L3. Tighten the conductors to 70 N·m (52 lbf·ft). Tightening torques are also given in chapter [Technical data](#).
5. Connect ground conductors or cables to the cabinet PEN (ground) busbar.
6. Provide support for the connections whenever necessary.
7. Refit all shrouds removed earlier.
8. Close the door.

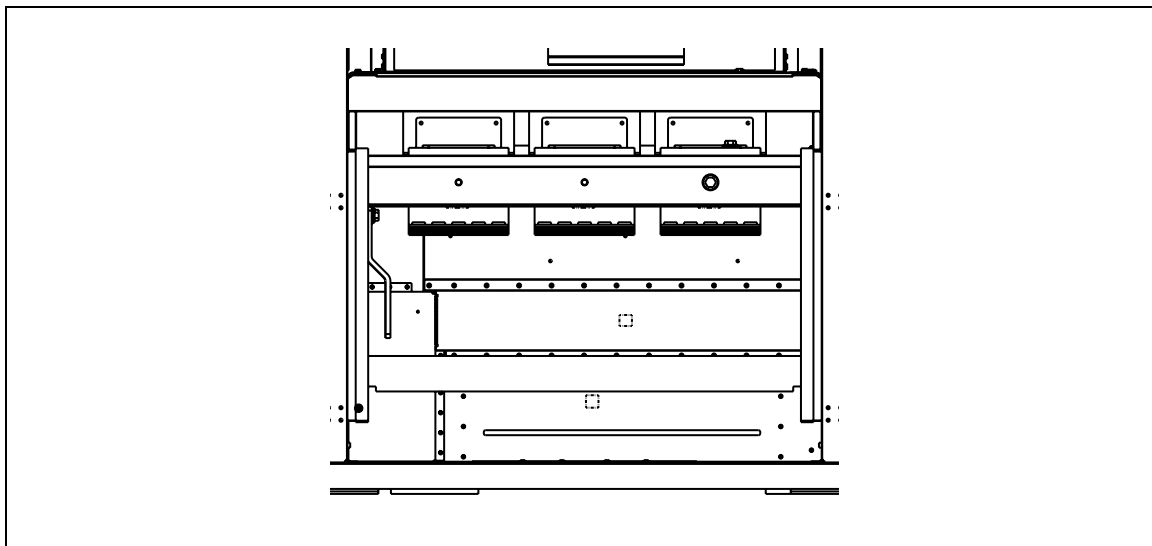

Connecting the generator cables

■ Connection diagram

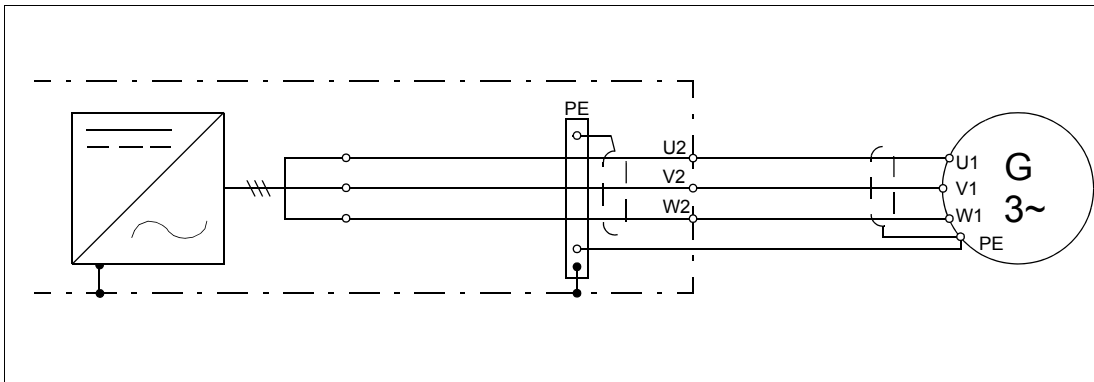

■ Connection procedure



WARNING! See and obey the safety instructions of the converter. If you ignore them, injury or death, or damage to the equipment can occur.



WARNING! Apply grease to stripped aluminum conductors before attaching them to non-coated aluminum cable lugs. Obey the grease manufacturer's instructions. Aluminum-aluminum contact can cause oxidation in the contact surfaces.

1. Open the door of the generator cable connection cubicle (see figures on the next page).
2. Remove the shroud that protects the generator cable connection busbars and cable entries.
3. Ensure that foreign objects (screws, etc.) cannot fall inside the converter module. During installation, cover the top of the module with plastic, fabric etc.



WARNING! Foreign objects inside the converter module can cause eg, short-circuit. Injury or death, or damage to the equipment can occur.

4. When shielded cable is used:

- Lead the cables into the inside of the cubicle. Ground a shielded cable 360° at the lead-through with an EMC cable gland (to be supplied by the customer).
- Connect the cables as follows:
- Cut the cables to suitable length. Strip the cables and conductors. Fasten the cable lugs to the conductor ends.
- Twist the cable shields into bundles and connect to the cabinet PE (ground) busbar. Connect any separate ground conductors or cables to the cabinet PE (ground) busbar.
- Connect the phase conductors to terminals U2, V2 and W2. See the appropriate connection diagram above. Tighten the phase conductors and PE to a 120 N·m (89 lbf·ft) torque.

When single-core cables without metal shield are used:

- Lead the cables into the inside of the cubicle through the IP sealing glands.
 - Connect the phase conductors to terminals U2, V2 and W2, and the PE conductors to the PE terminal. Tighten the phase and PE conductors (see page 110).
5. Provide support for the cables whenever necessary.
 6. Remove the cover on top of the converter module.



WARNING! The cover on top of the converter module can cause overheating. Injury or death, or damage to the equipment can occur.

7. Refit the shroud removed earlier and close the door.
8. Connect the generator end of the cable. For minimum radio frequency interference and generator bearing current, ground the cable shield 360° at the lead-through of the generator terminal box. For the generator specific instructions, see the manufacturer's user manual.

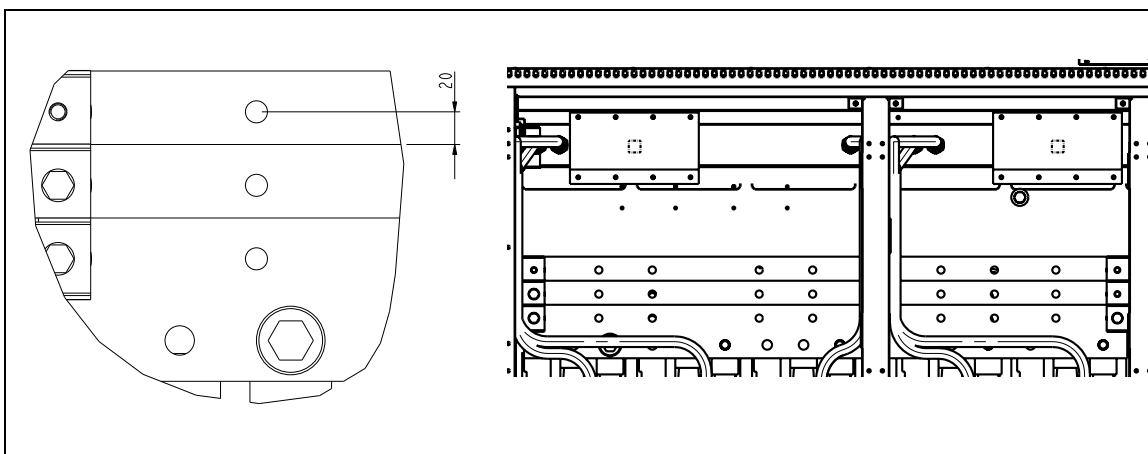
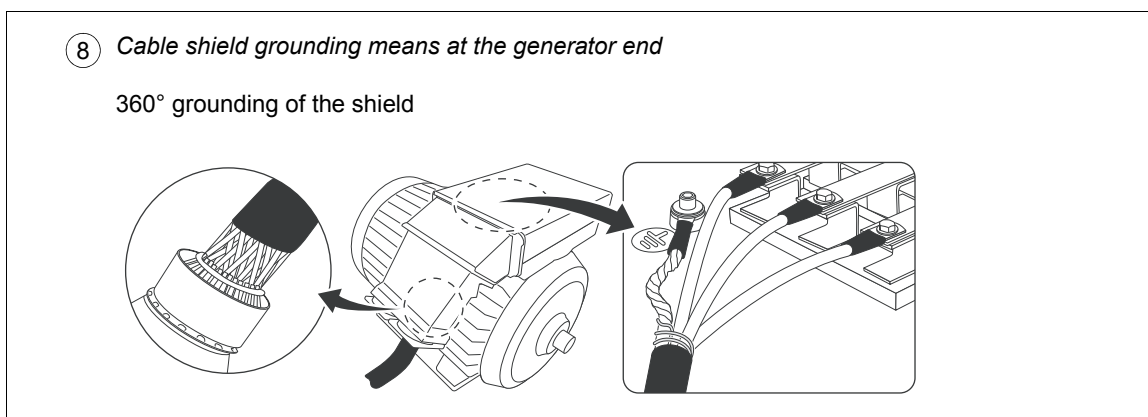

Connecting the external power supply cable for the auxiliary circuit

Power supply terminals for the auxiliary circuit are located in the lower part of the charging cubicle. See the connection diagrams below, and section [Auxiliary circuit current consumption](#) on page 114.

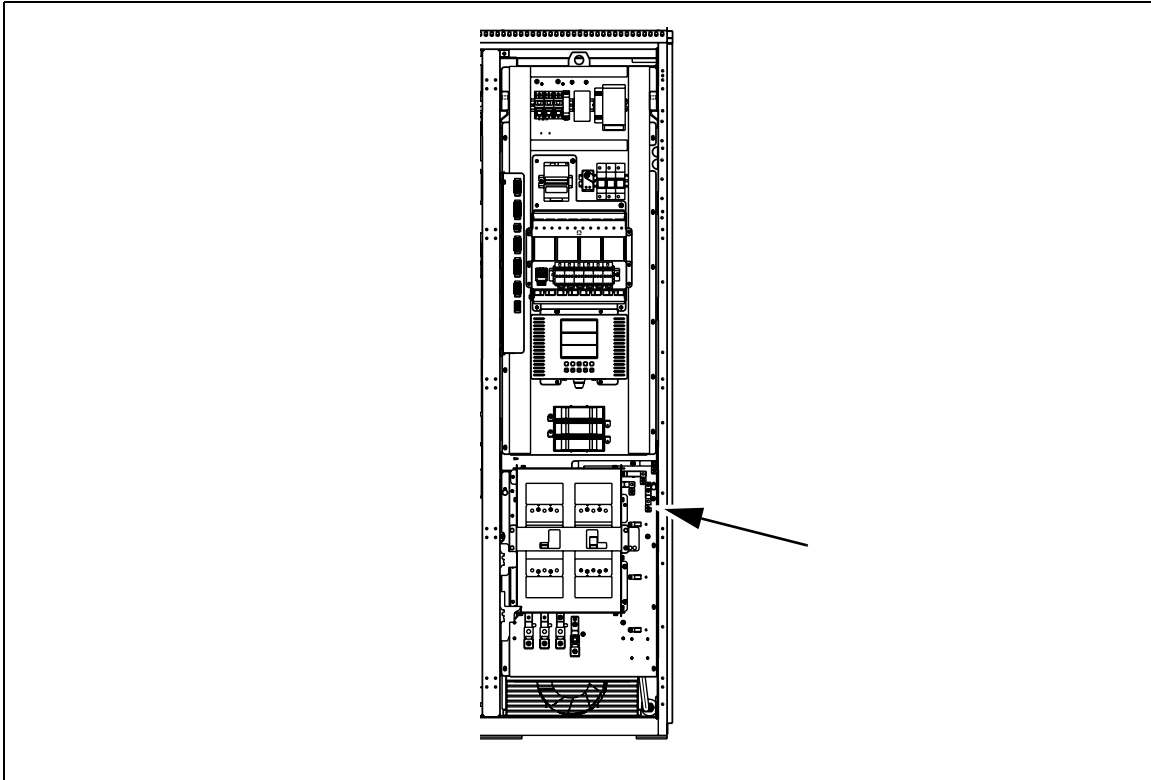

Connecting the control cables

Control cable connectors are located in the lower part of the auxiliary control cubicle (see section [Layout drawing](#) on page 32). See the connection diagrams below and the circuit diagrams delivered with the converter.

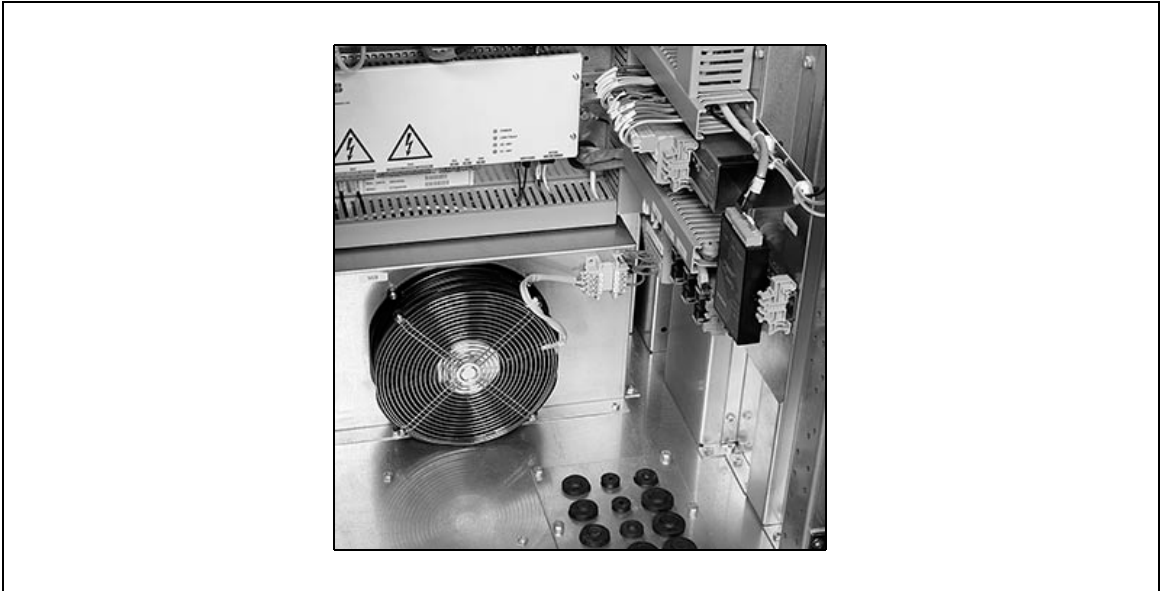

74 Electrical installation

Diagrams for the customer connections are presented below.

CONVERTER UNIT

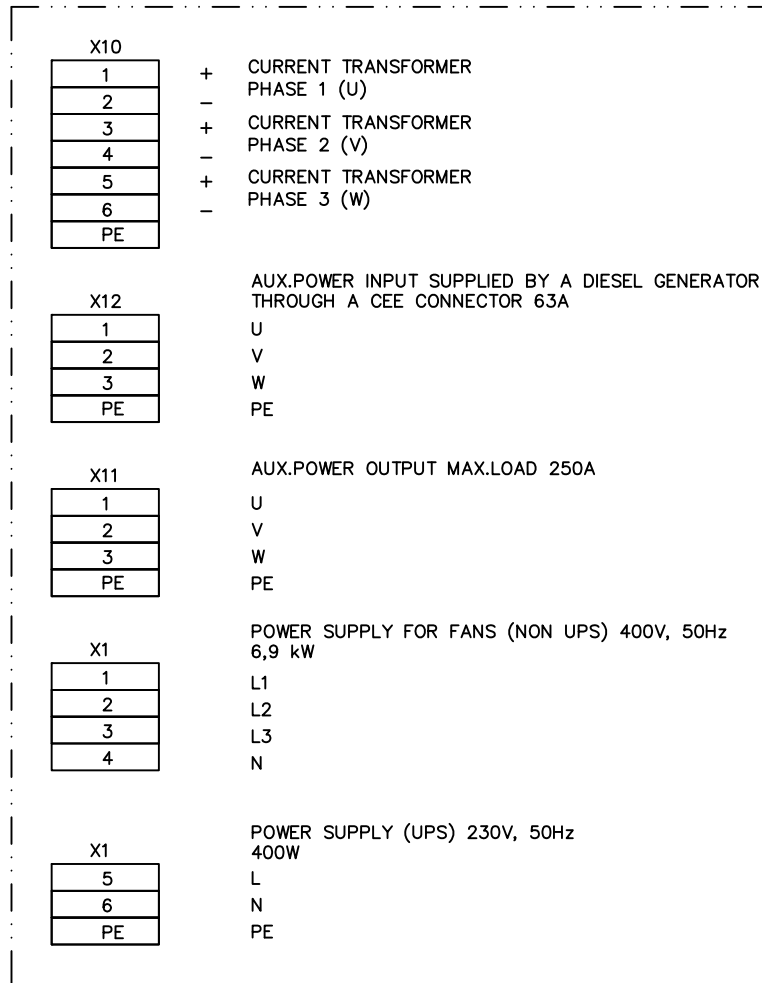

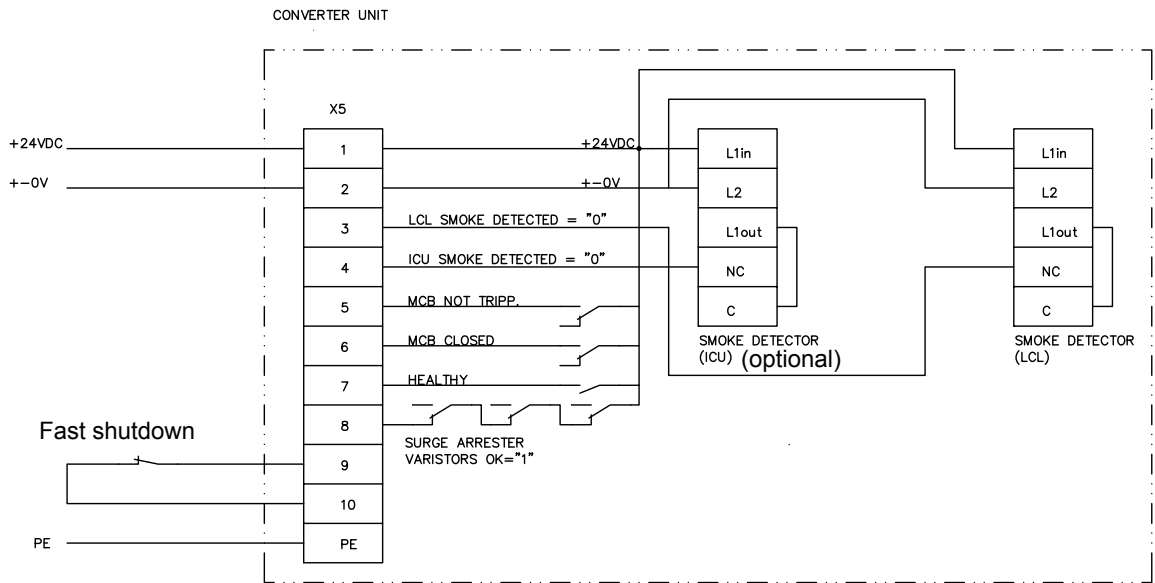

CONVERTER UNIT

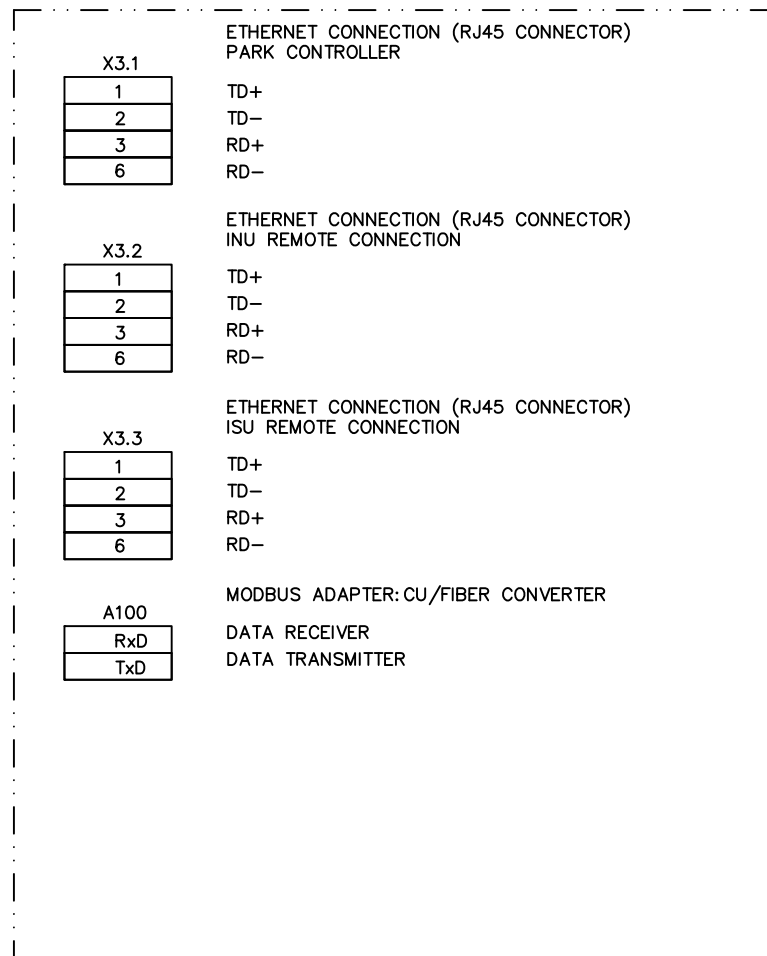

■ **Default I/O connection diagrams**

See the circuit diagrams delivered with the converter.

Connecting a PC

See the start-up guide.



7

Installation checklist

Contents of this chapter

This chapter contains instructions for checking the installation of the wind turbine converter.

Before you start

Check the mechanical and electrical installation of the converter before start-up. Go through the checklist together with another person.



WARNING! Only qualified electricians are allowed to carry out the work described below. Do the tasks described in the safety instructions of the converter. If you ignore them, injury or death, or damage to the equipment can occur.

1. Open the main disconnecter of the converter and lock it to open position.
 2. Ensure by measuring that the converter is not powered.
-

Checklist

Make sure that ...	<input checked="" type="checkbox"/>
The ambient operating conditions meet the specifications given in chapter <i>Technical data</i> .	<input type="checkbox"/>
The converter has been fixed properly on an even, horizontal and non-flammable floor and if necessary due to vibration etc, also from top to the wall or roof.	<input type="checkbox"/>
The cooling circuit joints are tight.	<input type="checkbox"/>
All bleed and drain valves have been closed.	<input type="checkbox"/>
The internal cooling circuit has been filled with coolant that meets the specification. See section <i>Specifications</i> on page 136.	<input type="checkbox"/>
The internal cooling circuit has been bled. See section <i>Filling up and bleeding the internal cooling circuit</i> on page 133.	<input type="checkbox"/>
There is an adequately sized protective earth (ground) conductor between the converter and the main grounding busbar of the wind turbine.	<input type="checkbox"/>
The generator is properly grounded.	<input type="checkbox"/>
All protective earth (ground) conductors have been connected to the appropriate terminals and the terminals have been tightened (pull the conductors to check).	<input type="checkbox"/>
The voltage of the grid transformer matches the nominal voltage of the grid-side converter. Check the type designation label.	<input type="checkbox"/>
The grid cable or grid busbars have been connected to the appropriate terminals, the phase order is right, and the terminals have been tightened. (Pull the conductors to check.) For tightening torques, see section <i>Tightening torques</i> on page 110.	<input type="checkbox"/>
The generator cable has been connected to the appropriate terminals, the phase order is right, and the terminals have been tightened. (Pull the conductors to check.) For tightening torques, see section <i>Tightening torques</i> on page 110.	<input type="checkbox"/>
The generator cable (and DC resistor cable, if present) has been routed away from other cables.	<input type="checkbox"/>
<u>Converters which have a DC chopper (option +D150) with a customer-acquired and installed DC resistor:</u> The DC resistor has been installed, connected to the appropriate terminals, and the terminals have been tightened. (Pull the conductors to check.) Test the DC resistor installation by measuring. Measure the resistance of each DC resistor from the cabinet DC resistor connectors. Ensure that the resistance value is within the allowed minimum and maximum values defined for the chopper circuit.	<input type="checkbox"/>
The control cables have been connected to the appropriate terminals, and the connections are tight. (Pull the conductors to check.)	<input type="checkbox"/>
The capacitor unit of the LCL filter has been connected to the appropriate terminals, and the terminals have been tightened. (Pull the conductors to check.) For tightening torques, see section <i>Tightening torques</i> on page 110. Test the LCL filter installation by measuring. Measure the LCL filter capacitance symmetrically in each phase in the grid-side converter cubicle.	<input type="checkbox"/>
There are no tools, foreign objects or dust from drilling inside the converter.	<input type="checkbox"/>
All shrouds and cover of the generator connection box are in place. Cabinet doors have been closed.	<input type="checkbox"/>
The converter is ready for start-up.	<input type="checkbox"/>



Maintenance

Contents of this chapter

This chapter contains preventive maintenance intervals and instructions.

Maintenance intervals

The table below shows the maintenance tasks which can be done by the end user. For more information, contact your local ABB Service representative (www.abb.com/searchchannels).

Maintenance task/object	Years from start-up													...
	0	1	2	3	4	5	6	7	8	9	10	11	12	
Replacement														
Cooling fans						R					R			
Cooling fan power supply											R			
Water-glycol coolant with inhibitor (see Note 1 below)			I		I		R		I		I		R	
ABB-SACE main circuit breaker maintenance (see Note 2 below)		P	P	P	P	P	P	P	P	P	P/R	P	P	
Inspection and/or performance														
Adding coolant corrosion inhibitor (if coolant with separate inhibitor is used) (see Note 1 below)		I	P	I	P	I	P	I	P	I	P	I	P	
Cabinet door air filter (customer variant), change interval depends on cleanliness of ambient air		I/R	I/R	I/R	I/R	I/R	I/R	I/R	I/R	I/R	I/R	I/R	I/R	
Checking cooling liquid pipe connections		I	I	I	I	I	I	I	I	I	I	I	I	
Checking the connections of fiber optic cables				I			I			I			I	
Checking tightness of cable and busbar terminals. Tightening if needed.				P			P			P			P	
Checking the quick connector of the converter module				I			I			I			I	
Checking the condition of contactors		I	I	I	I	I	I	I	I	I	I	I	I	
Checking the condition of the main contactors (maintenance according to the manufacturer's instructions)		I	I	I	I	I	I	I	I	I	I	I	I	
Checking ambient conditions (dustiness, corrosion, temperature)		I	I	I	I	I	I	I	I	I	I	I	I	
Checking the quality of auxiliary voltage		I	I	I	I	I	I	I	I	I	I	I	I	
Improvements														
Firmware and hardware upgrade based on product notes		I	I	I	I	I	I	I	I	I	I	I	I	
Measurements and tests														
Functional test with net voltage		P	P	P	P	P	P	P	P	P	P	P	P	
Basic measurements with supply voltage		P	P	P	P	P	P	P	P	P	P	P	P	
Spare parts														
Spare part stock		I	P	I	P	I	P	I	P	I	P	I	P	

3AXD10000258568

Symbols

I Inspection (visual inspection and maintenance action if needed)

P Performance of on/off-site work (commissioning, tests, measurements or other work)

R Replacement

Maintenance and component replacement intervals are based on the assumption that the equipment is operated within the specified ratings and ambient conditions. ABB recommends annual inspections to ensure the highest reliability and optimum performance.

Long term operation near the specified maximum ratings or ambient conditions may require shorter maintenance intervals for certain components. Contact your local ABB Service representative for additional maintenance recommendations.

Note 1: Cooling liquid to be used is BASF Glysantin® G30® or Valvoline Zerex G30 mixed with tapwater. For more details, see chapter [Cooling and heating](#). In case practical examples or specific tests carried with the above mentioned cooling mixture together with the cooling system materials the maintenance interval can be revised.

Note 2: The maintenance schedule of the main circuit breaker is according to maximum 1,000 operations of the breaker per each year. Replacement after 6000 operations. For more information, refer to the maintenance manual of the ABB SACE breaker.

Maintenance timers and counters

The control program has maintenance timers or counters that can be configured to generate a warning when a pre-defined limit is reached. Each timer/counter can be set to monitor any parameter. This feature is especially useful as a service reminder. For more information, see the firmware manual.

Cabinet

■ Replacing inlet (door) filter (IP54, customer variant)

1. Remove all the fasteners (8 pcs) from the upper support plate (a) and the fasteners (4 pcs) attaching the lower support plate (b) to the door plate.
2. Remove the upper support plate (a).
3. Lift the grating and pull it away from the door.
4. Remove the air filter mat.
5. Place the new filter mat in the grating the metal wire side facing the door.
6. Reinstall the grating in reverse order.

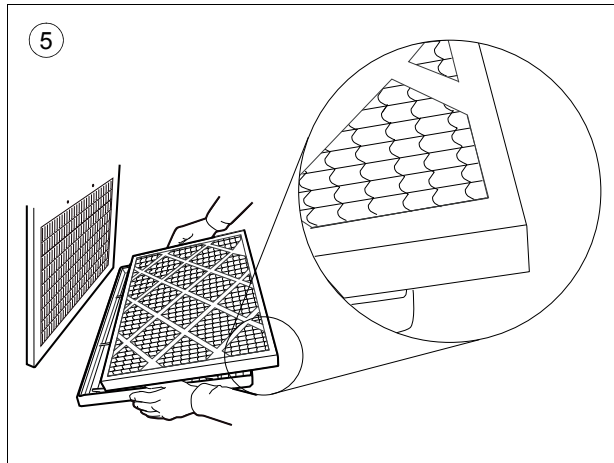
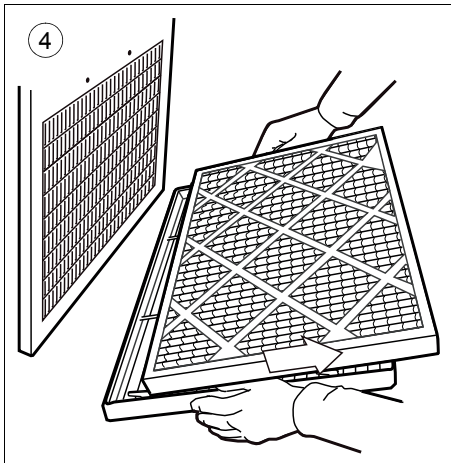
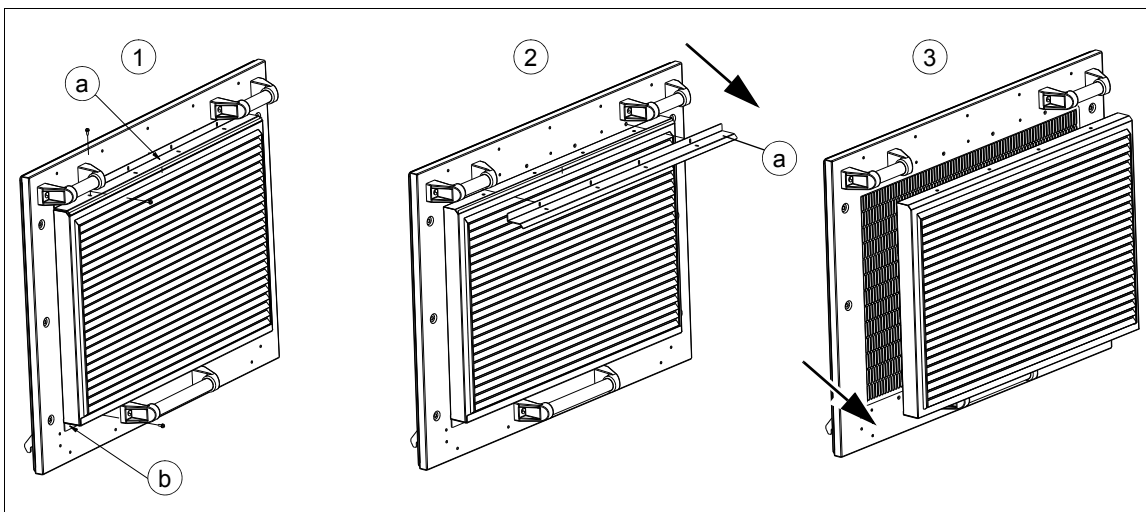

Power connections

■ Tightening



WARNING! Only qualified electricians are allowed to do this work. Read the complete safety instructions of the converter. If you ignore the instructions, physical injury, death, or damage to the equipment can occur.

1. Disconnect the converter from the all power sources and make sure it is safe to start the work. See the safety instructions.
2. Check the tightness of the cable connections. Use the tightening torques given in chapter [Technical data](#).

Fans

The lifespan of the cooling fans of the converter depend on the running time of the fan, ambient temperature and dust concentration. See the firmware manual for the parameter or actual value which indicates the running time of the cooling fan of the converter modules. For resetting the running time after a fan replacement, contact ABB.

Replacement fans are available from ABB. Do not use other than ABB specified spare parts.

All the fans in the converter are of the same type.

■ Replacing the cooling fan of the converter module



WARNING! Only qualified electricians are allowed to do this work. Read the complete safety instructions of the converter. If you ignore the instructions, physical injury, death, or damage to the equipment can occur.

1. Disconnect the converter from the all power sources and make sure it is safe to start the work. See the safety instructions.
 2. Cooling fan of the converter module (a) is located on top of the module. Open the door of the converter module cubicle and remove the shroud in front of the fan.
 3. Disconnect the wiring plug of the fan (b).
 4. Remove the fastening screws (c) of the fan support.
 5. Lift the fan unit out of the cabinet.
 6. Detach the fan from the support plate by loosening the fastening screws of the fan. The fan grille is detached then too.
 7. Install a new fan in reverse order. Check that the air flow direction is correct (an arrow indicating the direction is marked on the side of the fan). Remember to install the fan grille before lifting the fan into the cabinet.
-

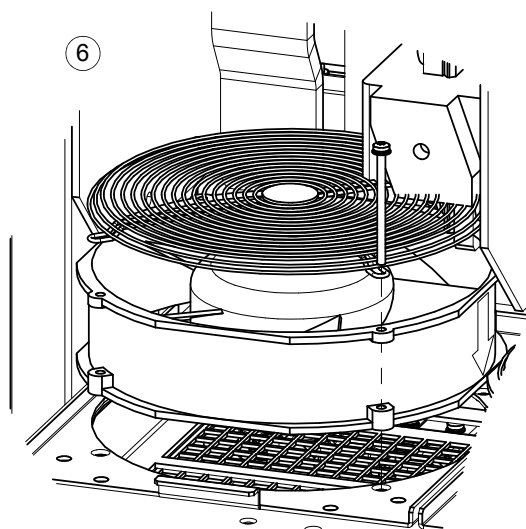
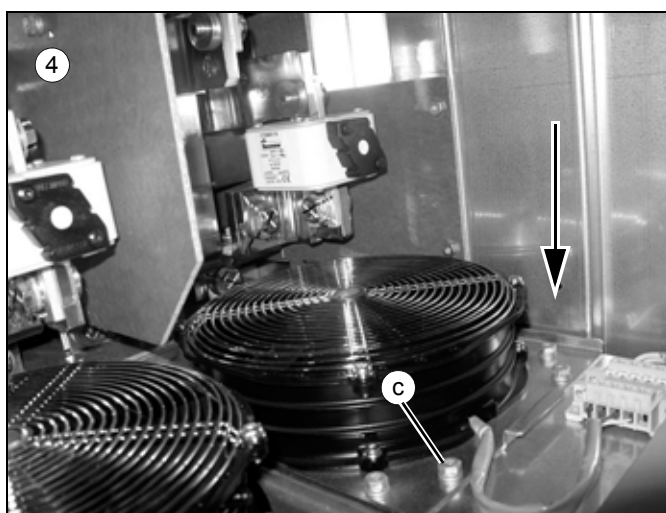
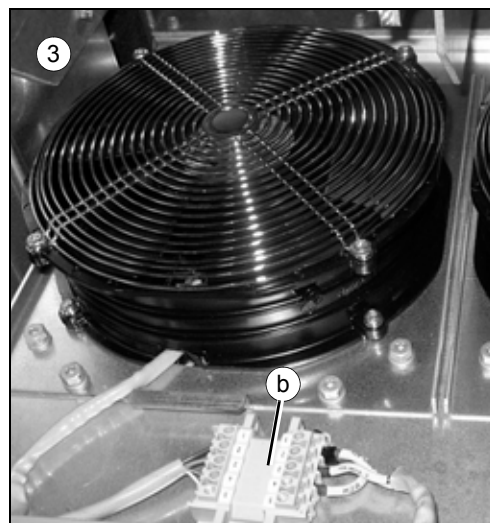
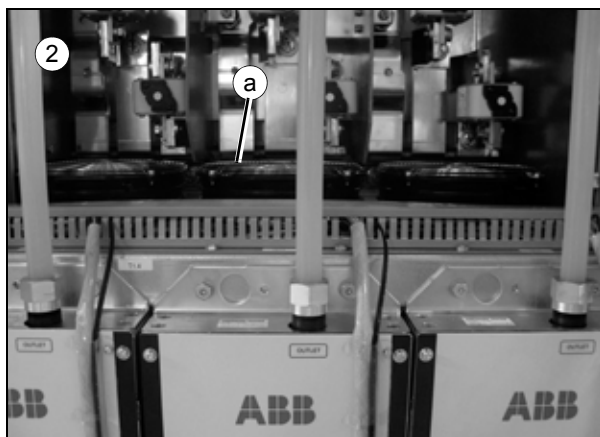

■ Replacing the fan of the main breaker cubicle



WARNING! Only qualified electricians are allowed to do this work. Read the complete safety instructions of the converter. If you ignore the instructions, physical injury, death, or damage to the equipment can occur.

1. Disconnect the converter from the all power sources and make sure it is safe to start the work. See the safety instructions.
 2. Detach the shroud in front of the fan of the main breaker cubicle.
 3. Pull the shroud carefully out of the cabinet. Observe the cable rail on top of the main circuit breaker when removing the shroud.
 4. Disconnect the wiring plug of the fan.
 5. Remove the fastening screws of the plate in front of the fans and remove the plate.
 6. Remove the fastening screws of the fan support plate and pull the support plate and the fan out.
 7. Remove the fastening screws of the fan grille (M5×10, 4 pcs) and detach the fan grille.
 8. Remove the fastening screws of the fan (M4, 4 pcs).
 9. Replace the fan.
 10. Install a new fan in reverse order. Check that the air flow direction is correct (an arrow indicating the direction is marked on the side of the fan).
-

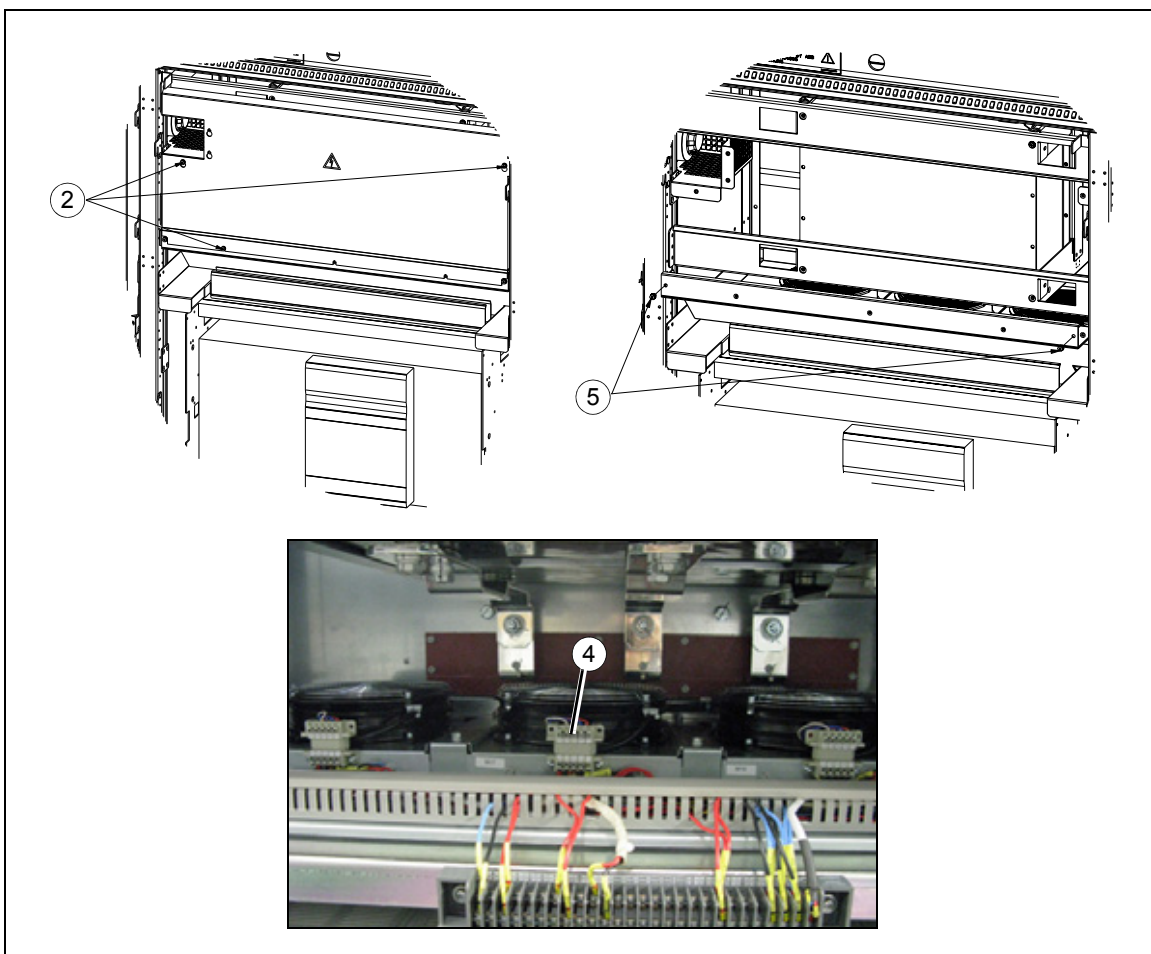

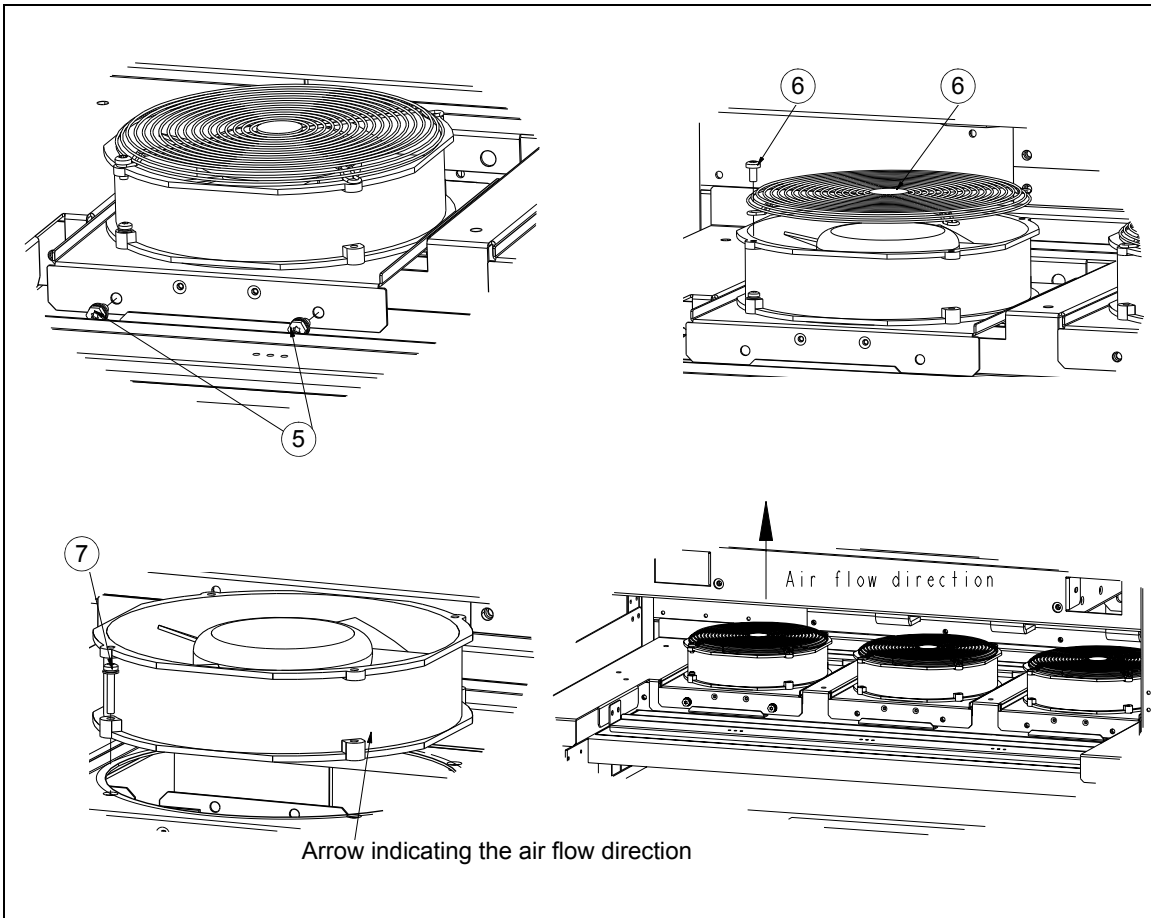

■ Replacing the cooling fan of the auxiliary control cubicle



WARNING! Only qualified electricians are allowed to do this work. Read the complete safety instructions of the converter. If you ignore the instructions, physical injury, death, or damage to the equipment can occur.

1. Disconnect the converter from the all power sources and make sure it is safe to start the work. See the safety instructions.
 2. The cooling fan of the auxiliary control cubicle is located in the lower part of the cubicle. Open the door of the auxiliary control cubicle.
 3. Disconnect the wiring plug of the fan.
 4. Undo the four fastening screws of the fan.
 5. Pull the fan out.
 6. Install a new fan in reverse order. Check that the air flow direction is correct (an arrow indicating the direction is marked on the side of the fan). For the correct air flow circulation, see the picture below.
-

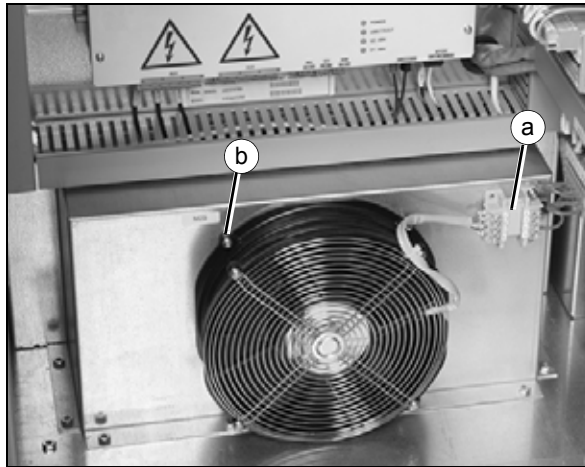

Air flow circulation

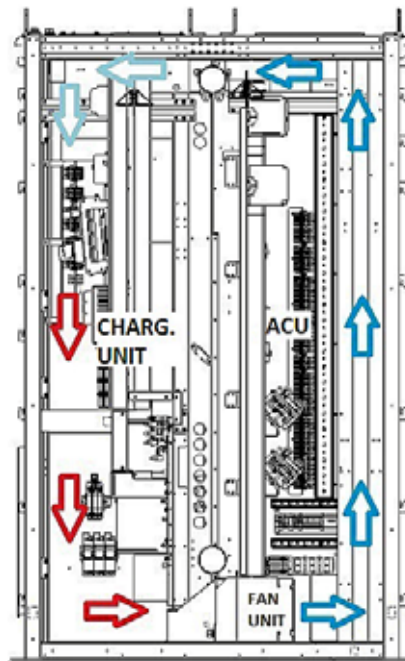

■ Replacing the upper cooling fan of the LCL filter cubicle



WARNING! Only qualified electricians are allowed to do this work. Read the complete safety instructions of the converter. If you ignore the instructions, physical injury, death, or damage to the equipment can occur.

1. Disconnect the converter from the all power sources and make sure it is safe to start the work. See the safety instructions.
 2. Open the door of the LCL filter cubicle. The upper cooling fans of the LCL filter cubicle are attached to the metal plate.
 3. Disconnect the wiring plug of the fan (a).
 4. Undo the fastening screws of the fan (b).
 5. Pull the fan out.
 6. Install a new fan in reverse order. Check that the air flow direction is correct (an arrow indicating the direction is marked on the side of the fan). In this case, the air flow direction is towards the inner part of the cabinet.
-

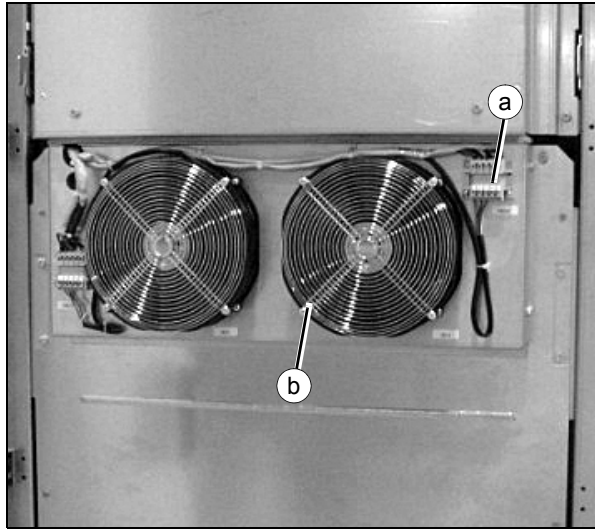

Air flow direction, side view of the cubicle

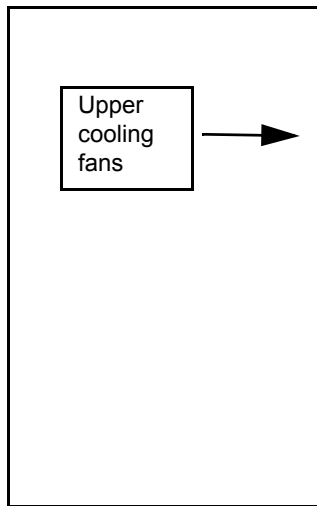

Door of the LCL filter cubicle

■ Replacing the lower cooling fan of the LCL filter cubicle



WARNING! Only qualified electricians are allowed to do this work. Read the complete safety instructions of the converter. If you ignore the instructions, physical injury, death, or damage to the equipment can occur.

1. Disconnect the converter from the all power sources and make sure it is safe to start the work. See the safety instructions.
2. Open the door of the LCL filter cubicle. There are three cooling fans in the lower part of the cubicle.
3. Disconnect the wiring plugs (3 pcs, a) of the fans and detach the thermostat (B27, b).
4. Remove the fastening screws (M6, 6 pcs, c) and pull the fan cassette out.

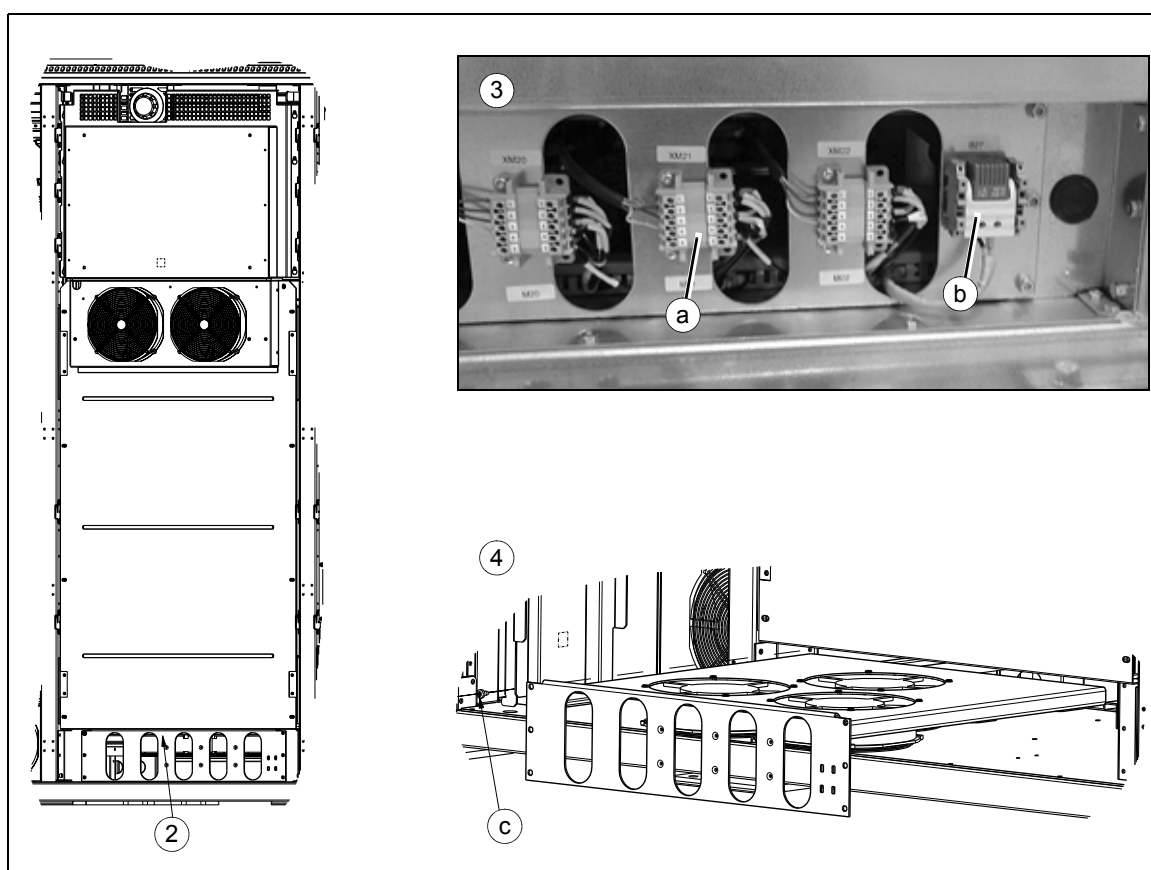

94 Maintenance

5. Remove the fastening screws of the fan (M4 × 60 mm, 4 pcs, d)
6. Replace the fan.
7. Install a new fan in reverse order. Check that the air flow direction is correct (an arrow indicating the direction is marked on the side of the fan). In this case, the air flow direction is upwards.

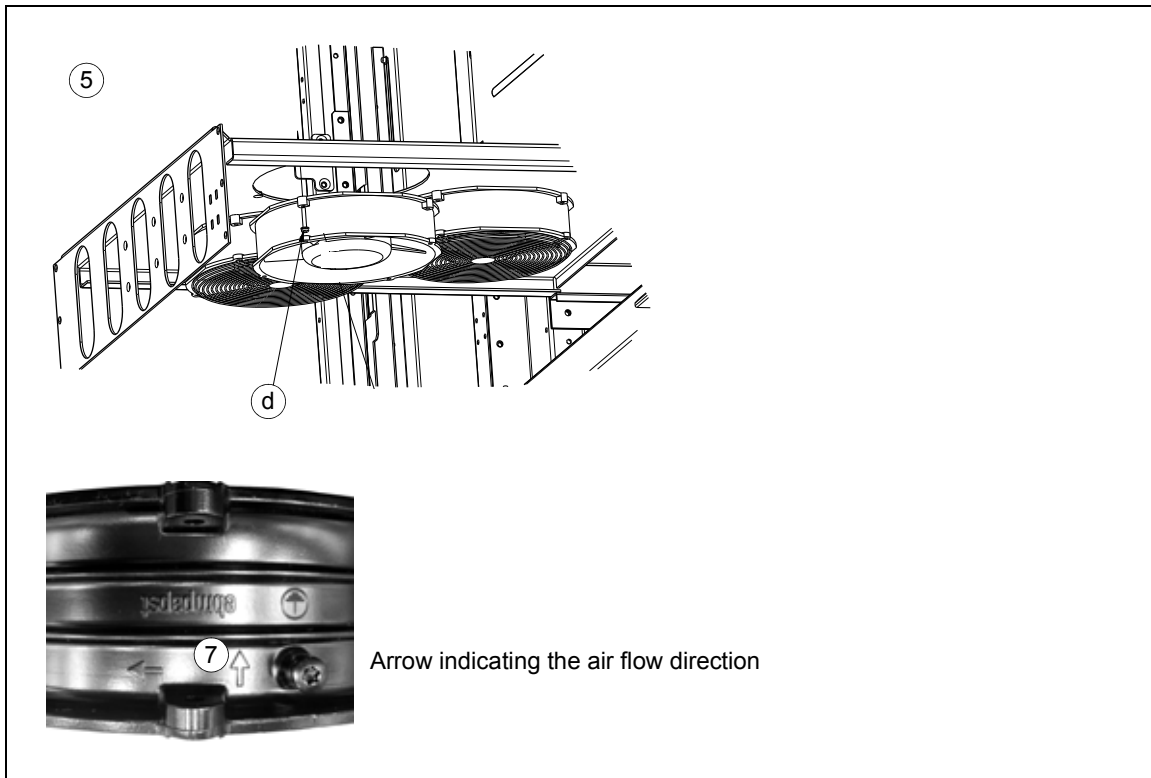

Fuses

■ Replacing the DC fuses



WARNING! Only qualified electricians are allowed to do this work. Read the complete safety instructions of the converter. If you ignore the instructions, physical injury, death, or damage to the equipment can occur.

1. Disconnect the converter from the all power sources and make sure it is safe to start the work. See the safety instructions.
2. Remove the shrouds in front of the fuses.
3. Open the M10 screws and remove the fuses.
4. Insert new fuses.
5. Re-assemble the parts in reverse order. The tightening torque for the M10 screws is 42 N·m (31 lbf·ft).

This figure is shown as an example.

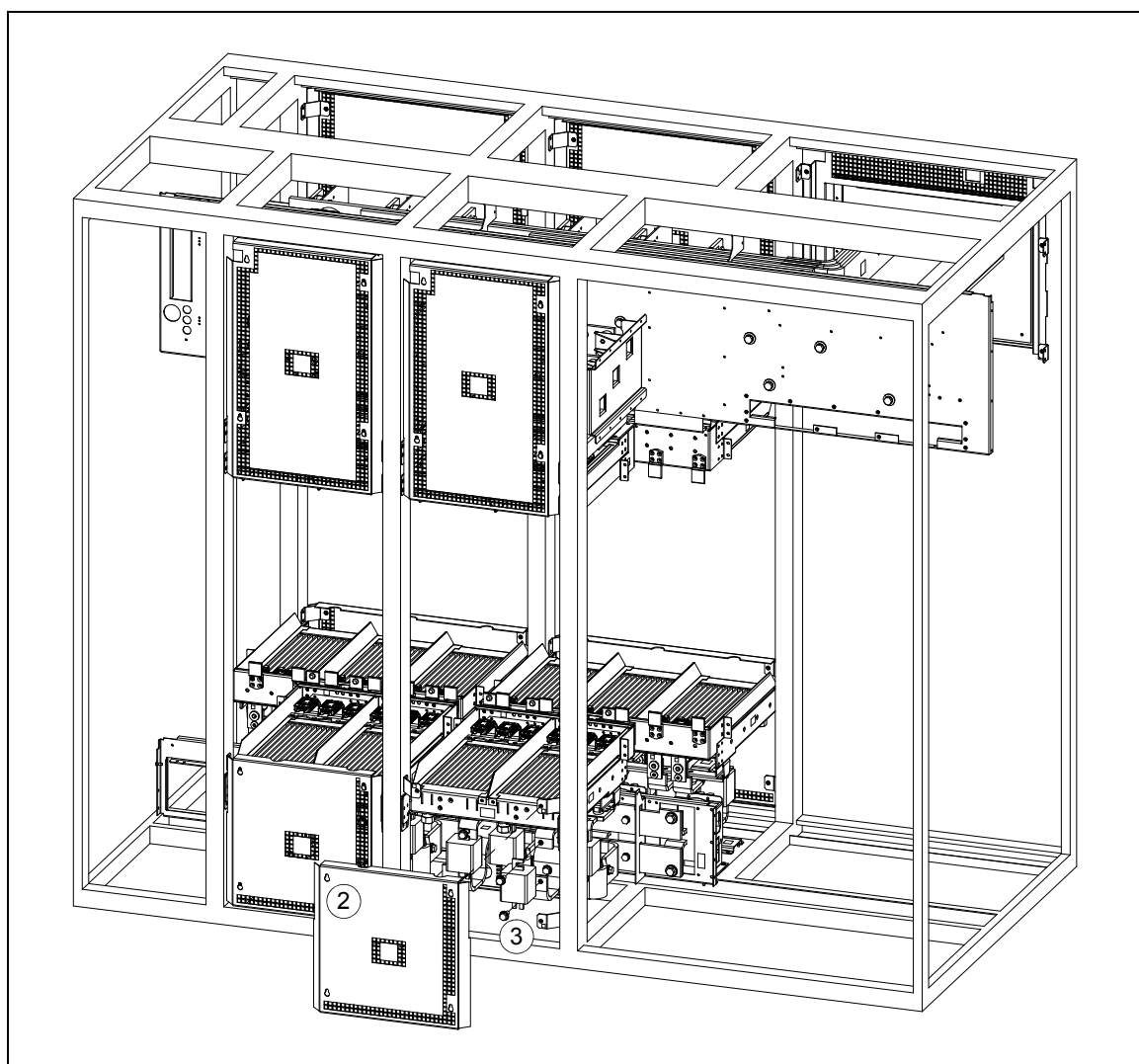

■ Replacing the AC fuses



WARNING! Only qualified electricians are allowed to do this work. Read the complete safety instructions of the converter. If you ignore the instructions, physical injury, death, or damage to the equipment can occur.

1. Disconnect the converter from the all power sources and make sure it is safe to start the work. See the safety instructions.
2. Remove the shrouds in front of the fuses.
3. Open the M10 screws and remove the fuses.
4. Insert new fuses.
5. Re-assemble the parts in reverse order. The tightening torque for the M10 screws is 42 N·m (31 lbf·ft).

This figure is shown as an example.

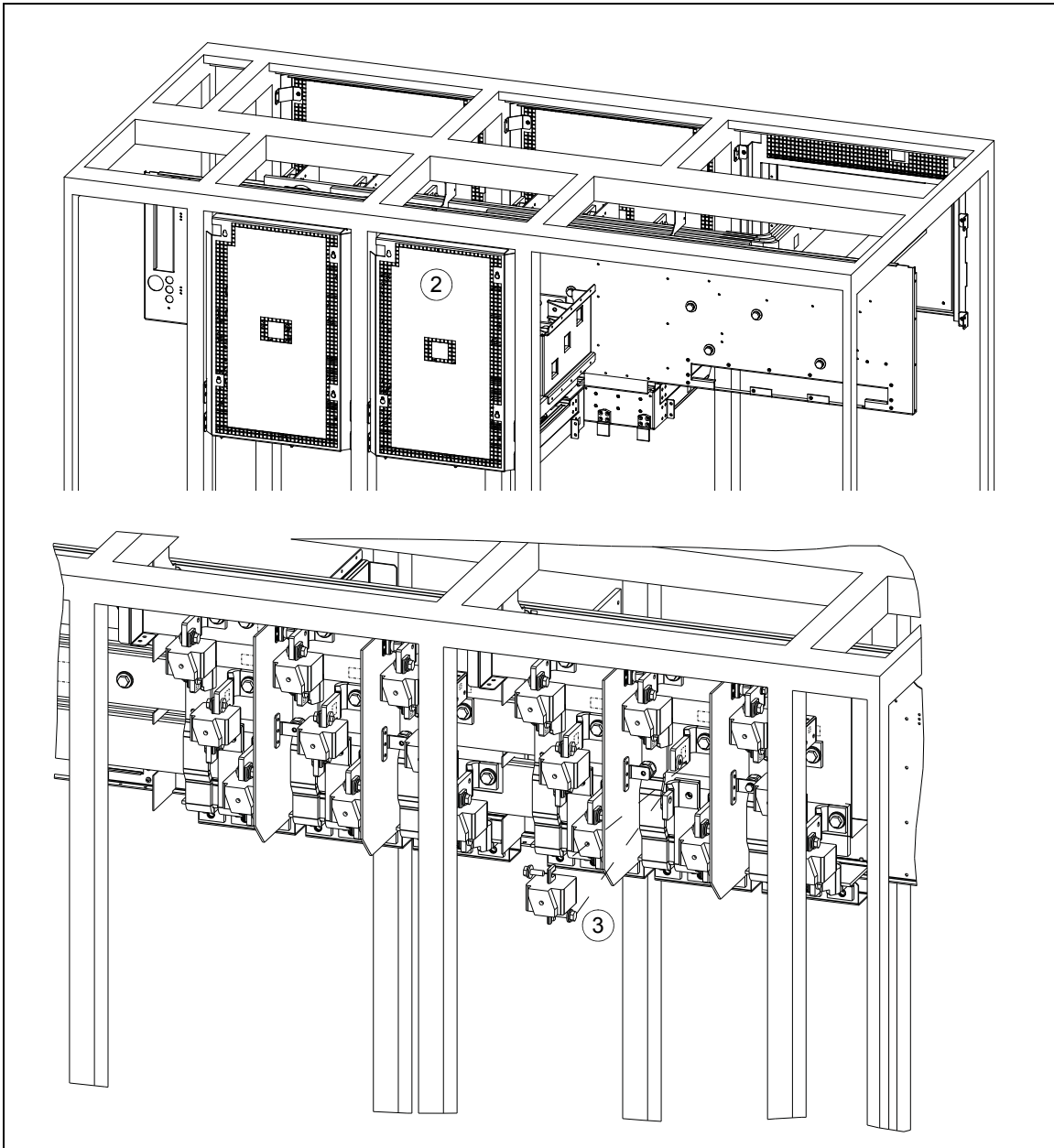

Converter module

■ Replacing the converter module



WARNING! Only qualified electricians are allowed to do this work. Read the complete safety instructions of the converter. If you ignore the instructions, physical injury, death, or damage to the equipment can occur.



WARNING! If you ignore the following instructions, physical injury, death, or damage to the equipment can occur:

- The modules are heavy and have a high center of gravity. They topple over easily if handled carelessly.
 - When removing a module, pull the module carefully out of the cubicle along the installation stand. Prevent the module from falling.
 - Keep your fingers away from the edge of the module front plate to avoid pinching them between the module and the cubicle.
 - Use protective gloves! The edges of the module are sharp!
 - Beware not to drop the screws inside the module!
 - Do not tilt the module. Do not leave the module unattended on a sloping floor.
-
1. Disconnect the converter from the all power sources and make sure it is safe to start the work. See the safety instructions. Secure the main circuit breaker [Q1] to the disconnected (racked out) position. If the disconnecting equipment is located outside the cabinet, make sure that it is in the disconnected position. Close the inlet and outlet valves of the liquid cooling unit, and drain the cooling circuit. See section [Draining the internal cooling circuit](#) on page 134.
 2. Open the door of the module cubicle.
-

3. Remove the shrouds on top and bottom of module cubicle.
4. Remove the shroud supports.
5. Remove the plastic covers in front of the fiber optic cables.
6. Unplug the fiber optic cables and X50 connectors. Carefully place the cables on top of the fan.

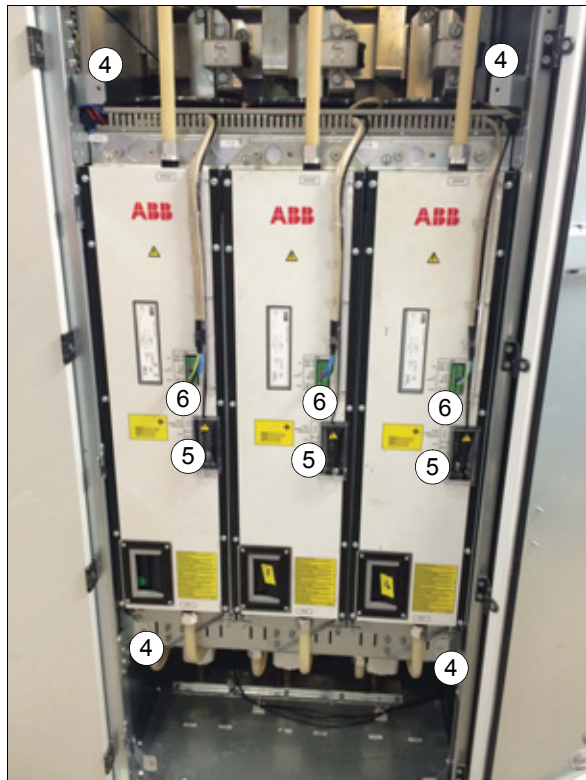

7. Remove the pipe clamps from top tubes.

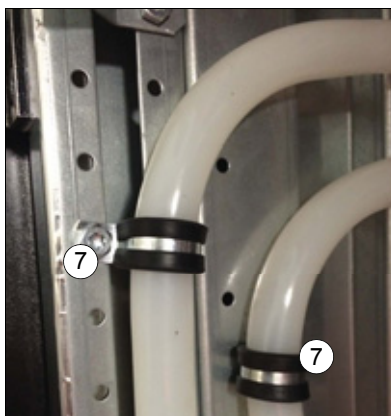

8. Open top liquid connection nut with 30 mm wrench. Pull the pipe upwards to release it.
9. Open two module support bolts from top.

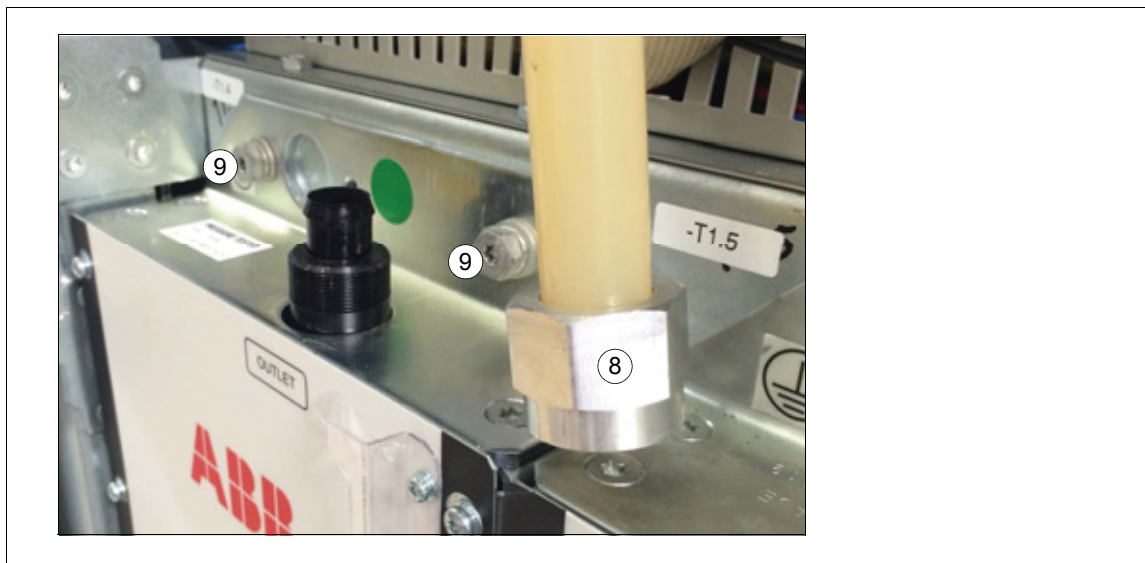

10. Open bottom liquid connection with 30 mm wrench. Pull the pipe downwards to release it.
11. Remove the module bottom support by opening 3 pcs of M6 screws and 2 pcs of M8 screws.
12. Open 2 pcs of Taptite® M6 screws.

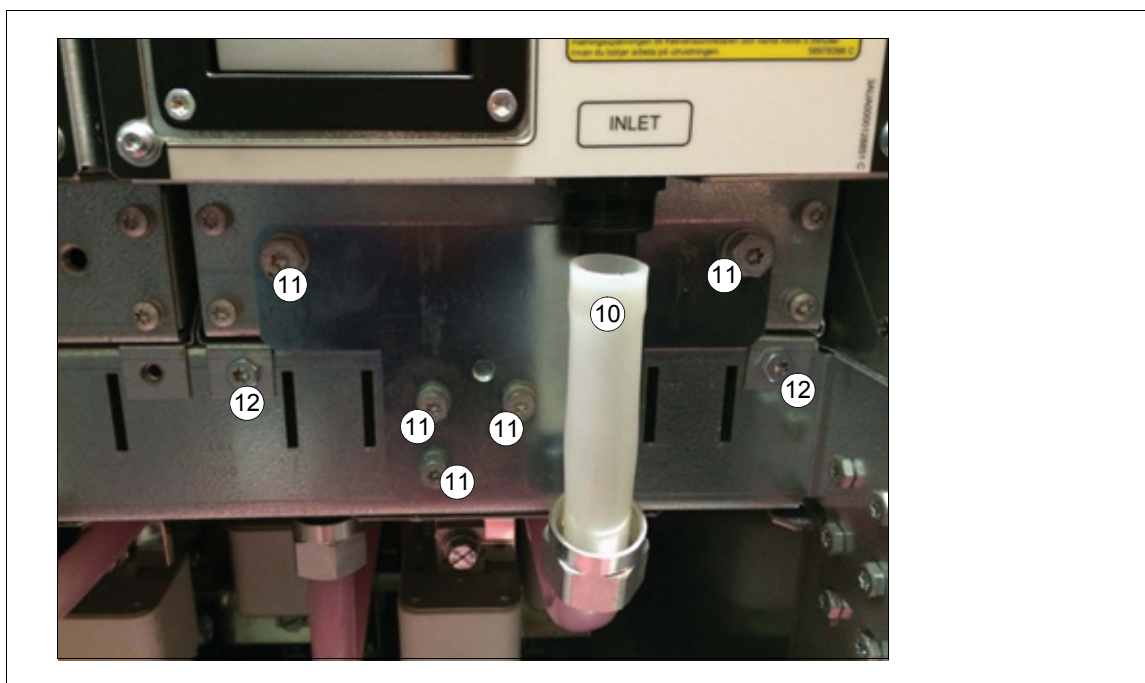

13. Open Taptite® M6 screw on the floor.

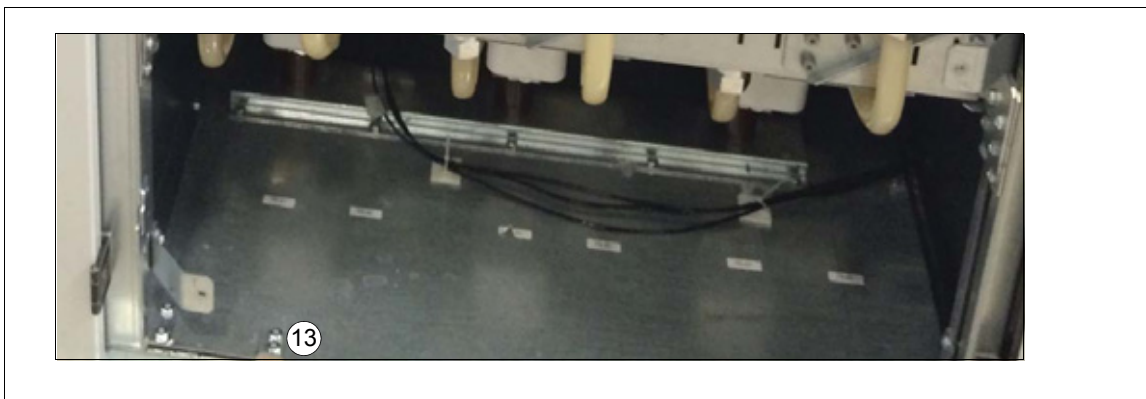

14. Open the installation stand (optional) and place it in front of the module.



- 15. Install 3 pcs of M6 Taptite® screws (removed earlier) to secure the installation stand. Tightening torque is 5 N·m (3.7 lbf·ft).

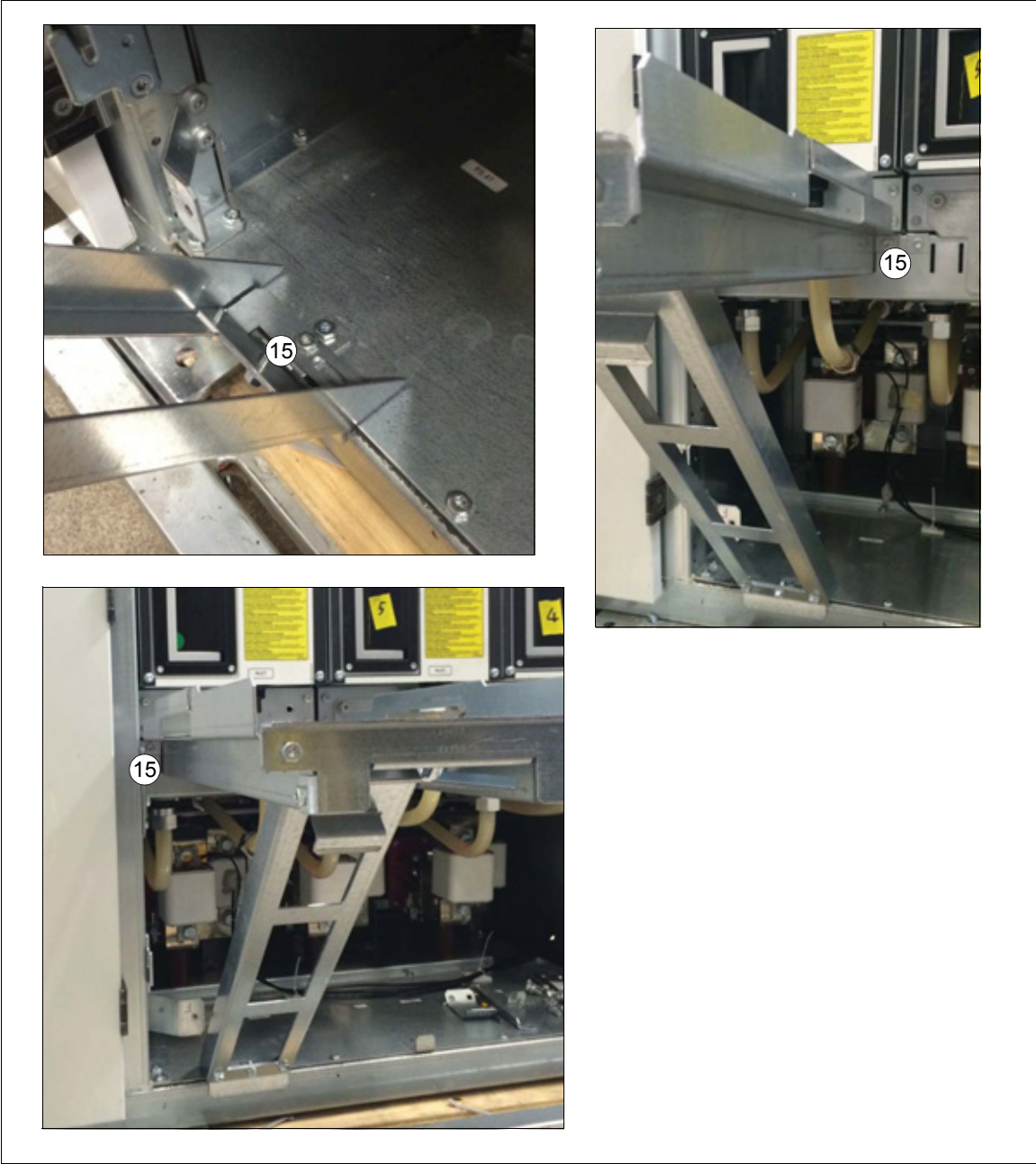

16. Insert M8 bolt to the hole on the top part of the module and turn it clockwise. This will help in pushing the module out. It also helps in pulling simultaneously from the handle while turning the screw.

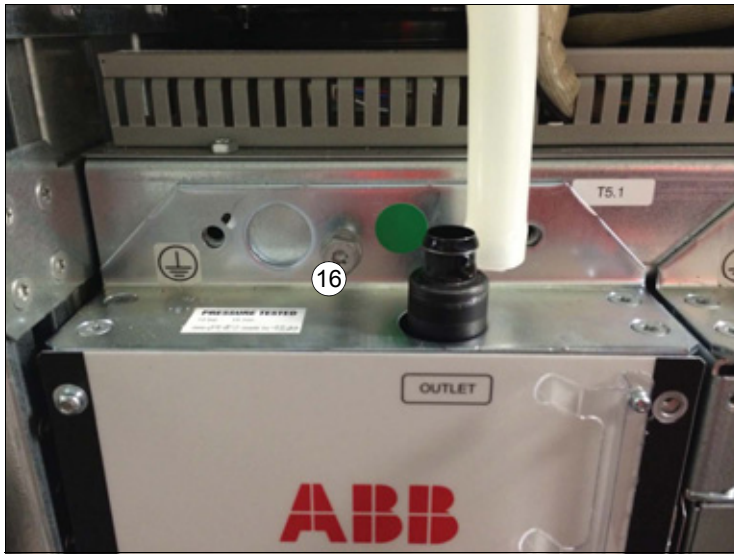

17. Pull the module out a bit (5 cm [20 in]) and install the lifting hook to the lifting hole.



18. Pull the whole module onto the installation stand. Keep the pipes and wires away from the sharp edges and be careful not to damage the coolant connections.
19. Lift the module onto a pallet or other platform for transportation.
20. Install a new module in reverse order. Tightening torque for cooling connectors is 10 N·m (7.4 lbf·ft) in room temperature (around +20 °C [68 °F]).

Capacitors

The converter intermediate circuit employs film capacitors. Their lifespan depends on the operating time of the converter, loading and ambient temperature. Capacitor life can be prolonged by lowering the ambient temperature.

Capacitor failure is usually followed by the converter module and module fuse failure, or a fault trip. Contact ABB if capacitor failure is suspected. Replacements are available from ABB. Do not use other than ABB specified spare parts.

BCU control unit



WARNING! Only qualified electricians are allowed to do this work. Do not remove or insert a memory unit when the converter is powered or the control unit is powered from an external power source.

Read the complete safety instructions of the converter. If you ignore the instructions, physical injury, death, or damage to the equipment can occur.

Disconnect the converter from the all power sources and make sure it is safe to start the work. See the safety instructions.

■ Replacing the memory unit

The memory unit is located on the BCU control unit.



WARNING! Do not remove or insert the memory unit when the control unit is powered.

See b in figure [Replacement illustration](#) on page 105.

1. To remove the memory unit, undo the fastening screw and pull the memory unit out.
2. Insert the new memory unit and fasten the screw.

■ Replacing the real-time clock battery

Replace the real-time clock battery if the BATT LED is not illuminated when the control unit is powered.

See a in figure [Replacement illustration](#) on page 105.

1. Undo the fastening screw and remove the battery.
2. Insert the new battery according to figure [Replacement illustration](#).
3. Dispose the old battery according to local disposal rules or applicable laws.
4. Set the real-time clock.

■ Replacing the SD/SDHC memory card

Note: Do not remove the SD card while the yellow WRITE LED is lit. Writing to the SD card is in progress.

See c in figure [Replacement illustration](#) on page 105.

1. Undo the fastening screw (Torx T10) of the clip covering the memory card and press the card to remove it. For the card location, see the following figure.
 2. Insert the new card in reverse order. Tightening torque for fastening screw is 0.7 N·m (0.5 lbf·ft). Repeat the replacement procedure for other BCU control unit if needed.
-

■ Replacement illustration

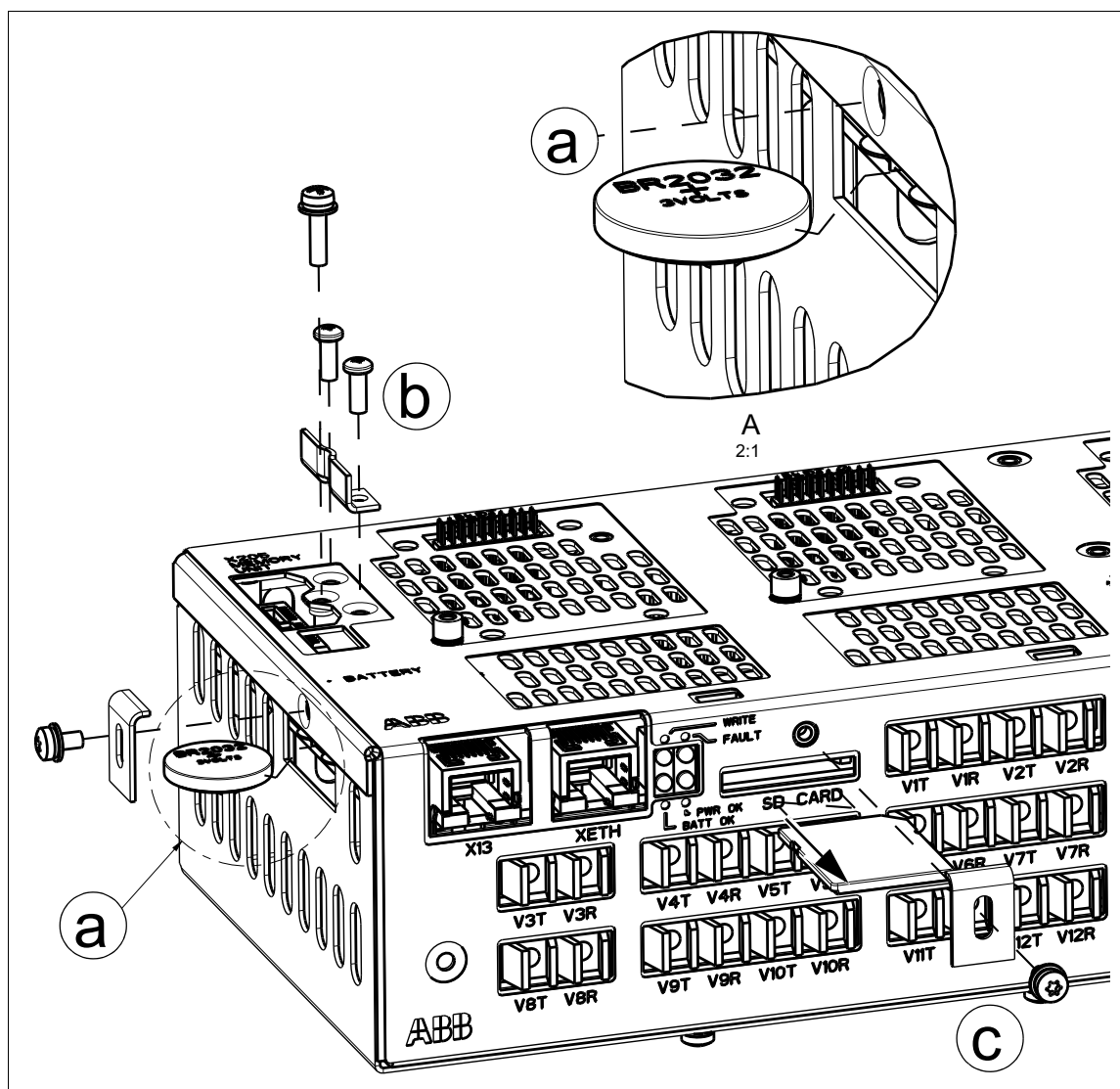

See also chapter [Control units of the converter](#).

Main circuit breaker

For ABB-SACE main circuit breaker maintenance, refer to the manufacturer's instructions (1SDH001000R0002).

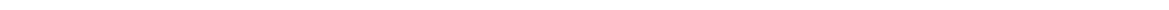

9

Technical data

Contents of this chapter

This chapter contains the technical data of the ACS880-87LC-4000A/4021A-7 and ACS880-87LC-4000A/4132A-7.

Ratings

Converter type ACS880-87LC-	Generator-side converter ratings		Grid-side converter ratings			Cos phi
	P_{gen}	I_2	P_{grid}	I_1	S_n	
	kW	A	kW	A	kVA	
$U_N = 690\text{ V}$						
4000A/4021A-7	4302	4000	4325	4021	4806	0.9
4000A/4132A-7	4302	4000	4445	4132	4939	0.9

3AXD10000011539

Definitions

Generator-side converter ratings

U_N Nominal voltage (see also section [Grid specification](#) on page 111)

P_{gen} Typical generator power. The power ratings apply at nominal voltage 690 V.

I_2 Continuous rms current of the generator-side converter

Grid-side converter ratings

P_{grid} Rated grid-side converter power. The power ratings apply at nominal voltage 690 V.

I_1 Continuous rms current of the grid-side converter

S_n Apparent power

Cos phi Controllable cos phi with full rated power capacity. Range: -value...+value.

Derating

The load capacity (current and power) decreases if the installation site altitude exceeds 1000 meters (3281 ft), or if the ambient temperature exceeds 45 °C (113 °F).

Temperature derating

In the temperature range +45 °C (+113 °F) ... +55 °C (+131 °F), the rated output current is decreased by 2.5 % for every additional 1 °C (1.8 °F). The output current is calculated by multiplying the current given in the rating table by the derating factor.

Example If the ambient temperature is 55 °C (+131 °F), the derating factor is

$100\% - 2.5 \frac{\%}{^{\circ}\text{C}} \cdot 10^{\circ}\text{C} = 75\%$ or 0.75. The output current is then $0.75 \cdot I_{gen}$.

Altitude derating

At altitudes from 1000 ... 2000 m (3281 ... 6562 ft) above sea level, the derating is 0.5% for every 100 m (328 ft). Derating is allowed only on maximum continuous current for grid and generator. If the installation site is situated higher than 2000 m (6562 ft) above sea level, contact ABB.

Alternatively the derating can be handled with cooling liquid temperature derating. 1 °C for every 100 m. This means that in eg, 2000 m installation, the maximum liquid temperature is 40 °C (instead of 50 °C) instead of 5% current derating.

Type equivalence table

Converter type ACS880-87LC-	Construction type	Basic module type (R9iLC)	
		Generator-side converter	Grid-side converter
	Generator-side converter modules + Grid-side converter modules+ LCL	ACS880-104LC-... (+E205)	ACS880-104LC-... (+E205)
$U_N = 690 \text{ V}$			
4000A/4021A-7	5×R9iLC + 5×R9iLC + 1×LCL	-0860A-7	-0800A-7
4000A/4132A-7	5×R9iLC + 6×R9iLC + 1×LCL	-0860A-7	-0800A-7

3AXD10000011539

Fuses

■ Main circuit AC fuses

Converter type ACS880-87LC-	AC fuses		
	Type	I_N A rms	Qty
$U_N = 690$ V			
4000A/4021A-7	Bussmann 170M6116	1250	15
4000A/4132A-7	Bussmann 170M6116	1250	18

3AXD10000011539

■ Main circuit DC fuses

Converter type ACS880-87LC-	DC fuses		
	Type	I_N A rms	Qty
$U_N = 690$ V			
4000A/4021A-7	Bussmann 170M6151	1400	20
4000A/4132A-7	Bussmann 170M6151	1400	22

3AXD10000011539

■ Fuses for the voltage measurement board BAMU

The fuse type is Mersen cartridge fuse 1021 CP URB 27x60/32, 32 A 1000 V AC (IEC/UL); 2 pcs

Dimensions, weights and free space requirements

See also chapter [Dimension drawings](#).

Converter type ACS880-87LC-	Dimensions			Weight
	Height	Depth	Width	
	mm (in)	mm (in)	mm (in)	kg (lb)
$U_N = 690$ V				
4000A/4021A-7	2000 (78.7)	1200 (47.2)	2700 (106.3)	4300 (9480)
4000A/4132A-7	2000 (78.7)	1200 (47.2)	2700 (106.3)	4500 (9921)

3AXD10000011539

For free space requirements, see chapter [Dimension drawings](#).

Losses, cooling data and noise

Converter type ACS880-87LC-	Losses		Cooling data			Noise
	Liquid	Air	Coolant quantity	Mass flow (tolerance -2%... +20%)	Pressure loss	
	kW	kW	l	l/min	kPa	dBA
$U_N = 690 \text{ V}$						
4000A/4021A-7	148	3	50	280	100	< 70
4000A/4132A-7	153	3	80	300	100	< 70

3AXD10000011539

Internal cooling circuit data

See chapter [Cooling and heating](#).

Terminal and lead-through data for the grid connection

Each busbar consists of two parts placed against each other. You can connect cable lugs to both sides of the connection busbar. Grid-side power connection enters the cabinet at the bottom of the cabinet.

Tightening torques

Screw size	Torque
M5	4 N·m (3 lbf·ft)
M6	9 N·m (6.6 lbf·ft)
M8	22 N·m (16.2 lbf·ft)
M10	42 N·m (31 lbf·ft)
M12	70 N·m (52 lbf·ft)
M16	120 N·m (89 lbf·ft)

For the drawings and dimensions of the grid cable terminals, see chapter [Dimension drawings](#).

Terminal and lead-through data for the generator cable

You can connect cable lugs to both sides of the connection busbar. The lead-throughs are acquired separately by the customer. Generator cables enter the cabinet at the top of the cabinet.

Generator cable connection busbars are presented below. See also chapter [Dimension drawings](#).

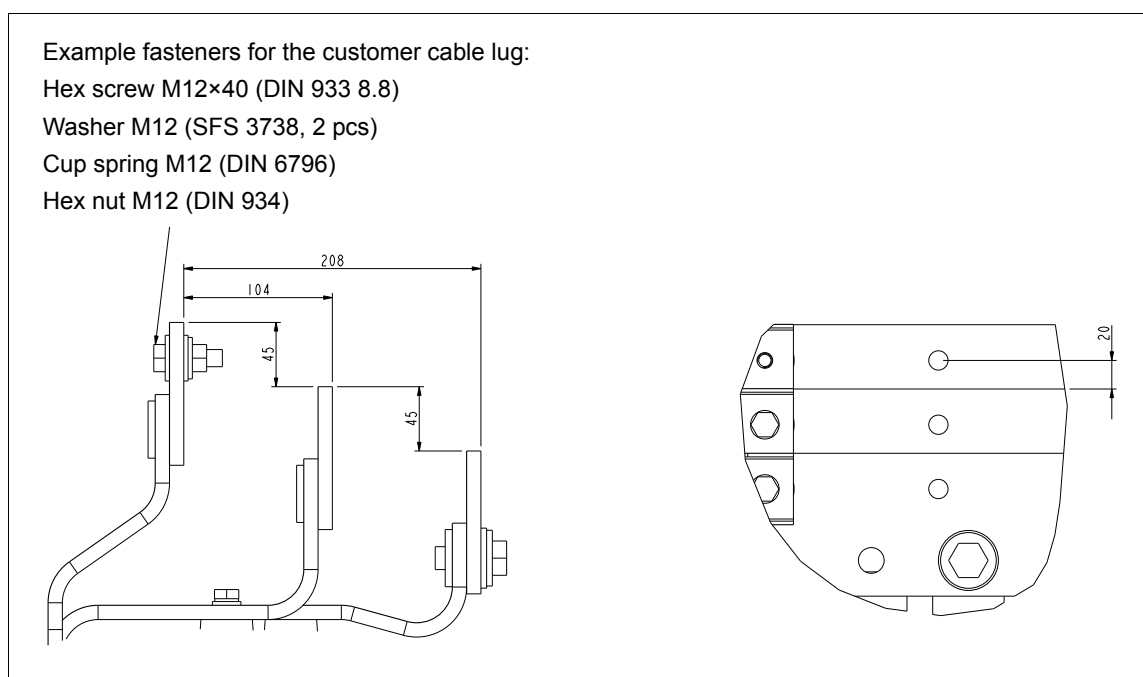

Grid specification

Voltage (U_1)	525/550/575/600/660/690 V AC 3-phase for 690 V AC converters. This is indicated in type designation label as typical input voltage level (3~ 690 V AC). ±10% variation from the converter nominal voltage is allowed as default.
Frequency (f_1)	50 ± 5 Hz or 60 ± 5 Hz. Maximum rate of change 17%/s.
Maximum allowable prospective short-circuit current (IEC 60439-1, UL 508 C)	75 kA when protected by fuses given under Fuses . According to UL 508C, the converter is not rated for short-circuits with a power factor less than 1.
Power factor	-1...0...1
Harmonic distortion	Total harmonic current distortion ($n = 2...40$) < 5%. Total harmonic voltage distortion ($n = 2...40$) < 5%, when $R_{sc} \geq 7$.

Requirements for the grid connection

For applicable grid codes, contact your local ABB representative.

Generator connection data

Generator types	AC induction generators, permanent magnet generators
Voltage (U_2)	0 ... 110% U_1 , 3-phase symmetrical, U_{\max} 750 V
Output frequency (f_2)	8...200 Hz
Switching frequency	2 kHz (average)
Frequency resolution	0.01 Hz
Current	See section Ratings on page 107.
Field weakening point	8 ... 300 Hz

BCU control unit

See chapter [Control units of the converter](#).

Efficiency

96.5% at nominal load with power factor 1.0 at 690 V.

Degree of protection

The converter is labeled as IP54, IP2x with cubicle doors open.

Some customer variants may be different, eg, the LCL filter cubicle, converter module cubicles and auxiliary control cubicle: IP54. Main breaker cubicle: IP21. In this case, the converter is labeled as IP21.

Environmental and corrosion classification

The expected lifetime for the converter cabinet enclosure is considered to be at least 20 years under the following environmental classifications and corrosion class.

Environmental classifications in accordance with IEC60721-3-3

- Climatic conditions 3K5 ¹⁾
- Special climatic conditions 3Z11 ²⁾
- Chemically active substances 3C2
- Mechanically active substances 3S2
- Mechanical conditions 3M1

Corrosion class in accordance with 12944-1

- Corrosion class for the cabinet enclosure (painted surfaces, pre-treatment FeP, polyester powder paint thickness 80 μm) C3L ³⁾

Notes:

¹⁾ Condensation and/or formation of ice inside the converter cabinet is not allowed in any operational circumstances.

²⁾ ABB additional extension to ambient surrounding temperature, outside the cabinet, -30 °C ... 55 °C (-22 °F ... 131 °F). See also section [Temperature derating](#) on page 108.

³⁾ L denotes service life >15 years.

Disclaimer

The customer shall ensure that the environmental conditions inside the wind turbine is maintained in order to fulfill the environmental classifications and/or corrosion class, as herein stated. If the operational condition is out of any environmental classifications and/or corrosion class, the expected lifetime of the converter may be

risked and the ABB converter warranty is terminated. If the customer is unsure about the environmental conditions and/or corrosion class inside the wind turbine, the customer is responsible for contacting ABB before the converter installation, and get an approval from ABB to use the converter in such an environmental condition and/or corrosive class.

Ambient conditions

Environmental limits for the converter are given below. The converter must be used in a heated, indoor controlled environment.

	Operation installed for stationary use	Storage in the protective package	Transportation in the protective package
Installation site altitude	0 ... 1000 m (3281 ft) above sea level. Above 1000 m (3281 ft), see section Derating on page 108.	-	-
Air temperature	-30 ... +45 °C (-22 ... +113 °F) (with heating procedure below +5 °C before start-up) Freezing of coolant is not allowed. Above +45 °C (+113 °F), see section Derating on page 108.	-40 ... +70 °C (-40 ... +158 °F)	-40 ... +70 °C (-40 ... +158 °F)
Relative humidity	0 ... 95%	0 ... 95%	0 ... 95%
	No condensation allowed. Maximum allowed relative humidity is 60% in the presence of corrosive gases.		
Contamination levels (IEC 60721-3-3, IEC 60721-3-2, IEC 60721-3-1)	No conductive dust allowed.		
	Boards with coating: Chemical gases: Class 3C2 Solid particles: Class 3S2	Boards with coating: Chemical gases: Class 1C2 Solid particles: Class 1S3	Boards with coating: Chemical gases: Class 2C2 Solid particles: Class 2S2
Atmospheric pressure	70 ... 106 kPa 0.7 ... 1.05 atmospheres	70 ... 106 kPa 0.7 ... 1.05 atmospheres	60 ... 106 kPa 0.6 ... 1.05 atmospheres
Vibration (IEC 60068-2-6)	10...58 Hz, max. 0.075 mm displacement amplitude 58...150 Hz 10 m/s ²	10...58 Hz, max. 0.075 mm displacement amplitude 58...150 Hz 10 m/s ²	Max. 3.5 mm (0.14 in.) (2 ... 9 Hz), max. 15 m/s ² (49 ft/s ²) (9 ... 200 Hz) sinusoidal
Shock (IEC 60068-2-27)	Not allowed	Max. 100 m/s ² (330 ft/s ²), 11 ms	Max. 100 m/s ² (330 ft/s ²), 11 ms
Free fall	Not allowed	100 mm (4 in.)	100 mm (4 in.)

Materials

Cabinet	Hot-dip zinc-coated (thickness approx. 20 µm) steel sheet (thickness 1.5 mm) with polyester thermosetting powder coating (thickness approx. 80 µm) on visible surfaces. Color: RAL 7035 (light beige, semi-gloss). Color of the side panels: RAL 9017 (black, semi-gloss)
Busbars	Tin- or silver-plated copper or aluminum
Internal cooling circuit piping	Aluminum, acid-fast stainless steel, PA pipes
Fire safety of materials (IEC 60332-1)	Insulating materials and non-metallic items: Mostly self-extinctive
Packaging	Frame: Wood or plywood. Plastic wrapping: PE-LD. Bands: PP or steel.
Disposal	The main parts of the converter can be recycled to preserve natural resources and energy. Product parts and materials should be dismantled and separated. Generally all metals, such as steel, aluminum, copper and its alloys, and precious metals can be recycled as material. Plastics, rubber, cardboard and other packaging material can be used in energy recovery. Printed circuit boards and large electrolytic capacitors need selective treatment according to IEC 62635 guidelines. To aid recycling, plastic parts are marked with an appropriate identification code. Please contact your local ABB distributor for further information on environmental aspects and recycling instructions for professional recyclers. End of life treatment must follow international and local regulations.

Auxiliary circuit current consumption

Auxiliary circuit current consumption varies depending on the size of the converter and selected options. For detailed information, contact your local ABB representative.

■ ACS880-87LC-4000A/4021A-7 and ACS880-87LC-4000A/4132A-7

UPS supply

Voltage 230 V AC ± 5%, frequency 50 Hz or 60 Hz, typical power consumption 500 W, maximum power and current consumption 12700 W / RMS 10 ms and 55 A / RMS 10 ms at power on, maximum power and current consumption 2000 W / RMS 20 ms and 10 A / RMS 20 ms at start-up.

Non-UPS supply

Voltage 400 V AC ± 5%, frequency 50 Hz or 60 Hz, typical continuous power consumption < 4500 W, maximum peak power and current consumption < 28000 W / RMS 20 ms, maximum $I_{\text{peak}} = 45$ A at start-up.

Applicable standards

	The converter complies with the standards below. The compliance with the European Low Voltage Directive is verified according to standards EN 61800-5-1.
• EN 60204-1: 2006 + A1:2009 + AC:2010	Safety of machinery. Electrical equipment of machines. Part 1: General requirements. <i>Provisions for compliance:</i> The final assembler of the machine is responsible for installing - an emergency-stop device.
• EN 60529:1991	Degrees of protection provided by enclosures (IP code)
• EN/IEC 61439:2011	Low-voltage switchgear and controlgear assemblies
• EN/IEC 60146	Semiconductor converters - General requirements and line commutated converters
• EN/IEC 50178	Electronic equipment for use in power installations
• IEC 60664-1:2007	Insulation coordination for equipment within low-voltage systems. Part 1: Principles, requirements and tests.
• IEC 61400-1:2005	Wind turbines. Part 1: Design requirements
• IEC 61800-3:2017	Adjustable speed electrical power drive systems. Part 3: EMC requirements and specific test methods
• EN 61800-5-1:2007	Adjustable speed electrical power drive systems. Part 5-1: Safety requirements – electrical, thermal and energy.
• BS7671	Requirements for electrical installations
• NEMA 250:2003	Enclosures for Electrical Equipment (1000 Volts Maximum)
• UL 61800-5-1	Adjustable Speed Electrical Power Drive Systems - Part 5-1: Safety Requirements - Electrical, Thermal and Energy. See ETL marking on page 117.
• GL-IV-1:2010	Guideline for Certification of Wind Turbines

CE marking

A CE mark is attached to the converter to verify that the converter follows the provisions of the European Low Voltage Directive 2014/35/EU (previously 2006/95/EC) and EMC Directive 2014/30/EU (previously 2004/108/EC).

■ Compliance with the European Low Voltage Directive

The compliance with the European Low Voltage Directive has been verified according to standard EN 61800-5-1.

■ Compliance with the European EMC Directive

See section [Compliance with EN 61800-3:2004/A1:2012](#).

Compliance with the European Machinery Directive

Note: In standard texts, the term 'drive' stands for 'converter' in case of wind turbine applications.

The drive is an electronic product which is covered by the European Low Voltage Directive. The drive is equipped with a main circuit breaker which can be used in safety functions for machinery. These safety functions are in the scope of the Machinery Directive as safety components, and appropriate harmonized standards (EN ISO 13849 or EN 62061) shall be applied.

Converters with the option +Q951, see *Emergency stop, stop category 0 (option +Q951) for ACS880-77LC/87LC wind turbine converters user's manual (3AXD50000040787 [English])*.

Regulatory Compliance Mark (RCM)

RCM marking is pending. Applies as Compliance with EN 61800-3:2004.

EAC marking

The converter has EAC certification. EAC marking is required in Russia, Belarus and Kazakhstan.

Compliance with EN 61800-3:2004/A1:2012

■ Definitions

EMC stands for Electromagnetic Compatibility. It is the ability of electrical/electronic equipment to operate without problems within an electromagnetic environment. Likewise, the equipment must not disturb or interfere with any other product or system within its locality.

First environment includes establishments connected to a low-voltage network which supplies buildings used for domestic purposes.

Second environment includes establishments connected to a network not supplying domestic premises.

Drive of category C4: drive of rated voltage equal to or above 1000 V, or rated current equal to or above 400 A, or intended for use in complex systems in the second environment.

■ Category C4

The requirements of the standard can be met as follows:

1. It is ensured that no excessive emission is propagated to neighbouring low-voltage networks. In some cases, the natural suppression in transformers and cables is sufficient. If in doubt, the supply transformer with static screening between the primary and secondary windings can be used.

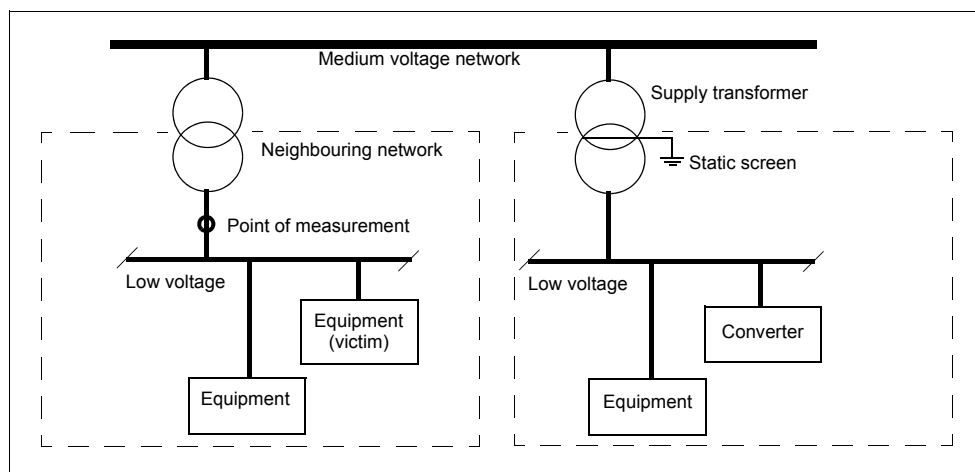

2. An EMC plan for preventing disturbances is drawn up for the installation. A template is available from the local ABB representative.
3. The generator and control cables are selected as specified in the hardware manual.
4. The converter is installed according to the instructions given in the hardware manual.

WARNING! A drive of category C4 is not intended to be used on a low-voltage public network which supplies domestic premises. Radio frequency interference is expected if the converter is used on such a network.

ETL marking

cETLus (according to UL) marking is pending.

The converters are ETL certified in accordance with UL 61800-5-1 *Adjustable Speed Electrical Power Drive Systems First Edition*.

The converter provides overload protection in accordance with the National Electrical Code (US) and Canadian Electrical Code (Canada). See the firmware manual for setting. Default setting is off; the setting must be activated at start-up.

The converters are to be used in a heated indoor controlled environment. See section [Ambient conditions](#) for specific limits.

DNV-GL Renewable Certification marking

This converter type is GL2010 Component Certified according to *GL-IV-1:2010 Guideline for Certification of Wind Turbines* by DNV-GL, and is allowed to bear the DNV-GL Renewable Certification mark (Certificate No. CC-GL-IV-1-00282-1):

- ACS880-87LC-4000A/4132A-7.

WEEE marking

The converter is marked with the wheelie bin symbol. It indicates that at the end of life the converter should enter the recycling system at an appropriate collection point and not placed in the normal waste stream. See section [Materials](#) on page [114](#).

Disclaimers

■ Generic disclaimer

The manufacturer shall have no obligation with respect to any product which (i) has been improperly repaired or altered; (ii) has been subjected to misuse, negligence or accident; (iii) has been used in a manner contrary to the manufacturer's instructions; or (iv) has failed as a result of ordinary wear and tear.

■ Cybersecurity disclaimer

This product is designed to be connected to and to communicate information and data via a network interface. It is Customer's sole responsibility to provide and continuously ensure a secure connection between the product and Customer network or any other network (as the case may be). Customer shall establish and maintain any appropriate measures (such as but not limited to the installation of firewalls, application of authentication measures, encryption of data, installation of anti-virus programs, etc) to protect the product, the network, its system and the interface against any kind of security breaches, unauthorized access, interference, intrusion, leakage and/or theft of data or information. ABB and its affiliates are not liable for damages and/or losses related to such security breaches, any unauthorized access, interference, intrusion, leakage and/or theft of data or information.

10

Control units of the converter

Contents of this chapter

This chapter describes the layout and connections of the control units and contains the specifications of the inputs and outputs of the control units.

For the actual connections of the control units used in the ACS880-87LC converter, see the circuit diagrams delivered with the converter.

General

■ BCU control unit

The BCU control unit consists of a BCON control board (and a BIOC I/O and power supply board) built in a metal housing. The BCU is mounted separately from the converter module(s), and connected to the module(s) by fiber optic cables. In this manual, the name “BCU” represents the control unit type BCU-12.

Layout and connections

BCU layout and connections

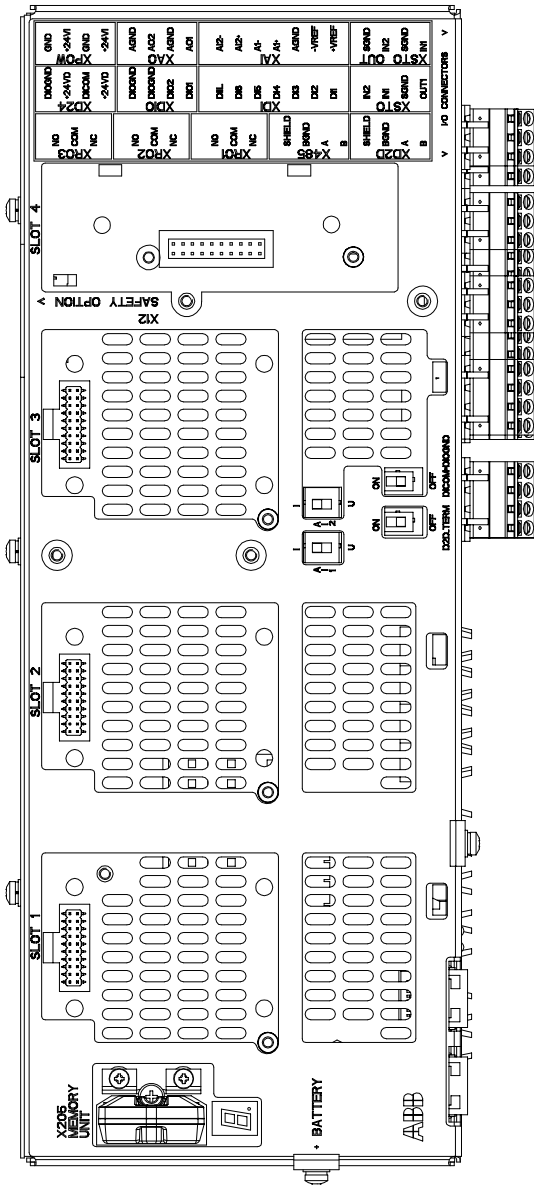

	Description
I/O	I/O terminals (see the following diagram)
SLOT 1	I/O extension, encoder interface or fieldbus adapter module connection. (This is the sole location for an FDPI-02 diagnostics and panel interface.)
SLOT 2	I/O extension, encoder interface or fieldbus adapter module connection
SLOT 3	I/O extension, encoder interface, fieldbus adapter connection
SLOT 4	RDCO-0x DDCS communication option module connection
X205	Memory unit connection
BATTERY	Holder for real-time clock battery
AI1	Mode selector for analog input AI1 (I = current, U = voltage)
AI2	Mode selector for analog input AI2 (I = current, U = voltage)
D2D TERM	Termination switch for drive-to-drive link (D2D)
DICOM= DIOGND	Ground selection. Determines whether DICOM is separated from DIOGND (ie, the common reference for the digital inputs floats).
7-segment display Multicharacter indications are displayed as repeated sequences of characters	
	("U" is indicated briefly before "o".) Control program startup in progress
	(Flashing) Firmware cannot be started. Memory unit missing or corrupted
	Firmware download from PC to control unit in progress
	At power-up, the display may show short indications of eg. "1", "2", "b" or "U". These are normal indications immediately after power-up. If the display ends up showing any other value than those described, it indicates a hardware failure.

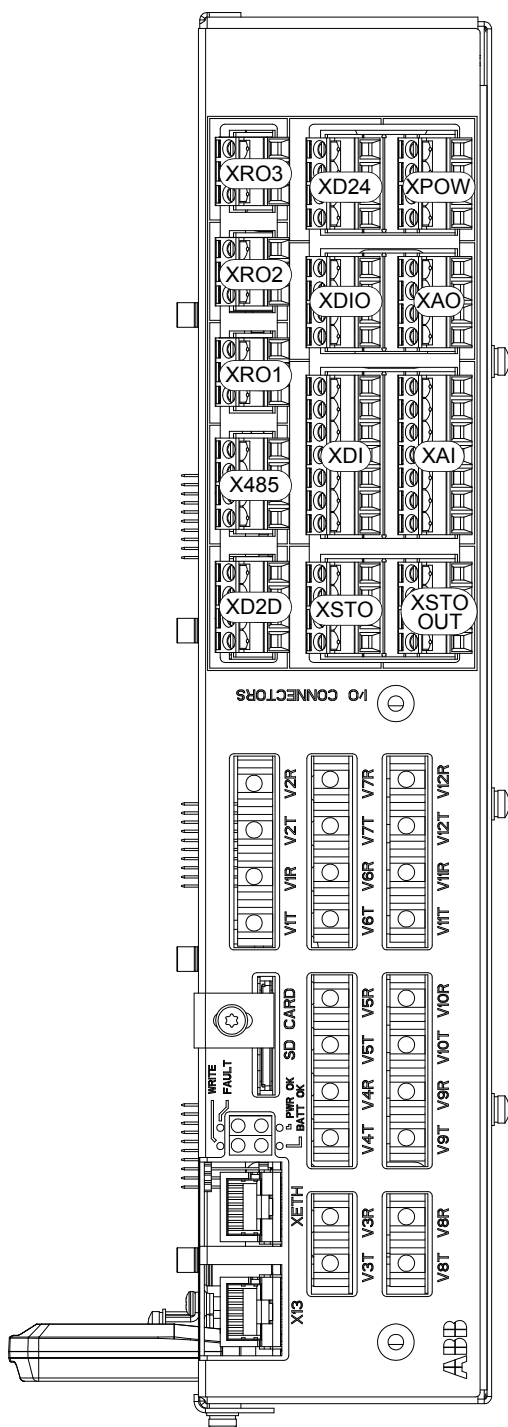

	Description
XAI	Analog inputs
XAO	Analog outputs
XDI	Digital inputs, Digital input interlock (DIIL)
XDIO	Digital input/outputs
XD2D	Drive-to-drive link
XD24	+24 V output (for digital inputs)
XETH	Ethernet port
XPOW	External power input
XRO1	Relay output RO1
XRO2	Relay output RO2
XRO3	Relay output RO3
XSTO	Not in use in wind turbine converters.
XSTO OUT	Not in use in wind turbine converters.
X12	Not in use in wind turbine converters.
X13	Control panel connection
X485	Not in use

V1T/V1R, V2T/V2R	Fiber optic connection to converter modules 1 and 2 (VxT = transmitter, VxR = receiver)
V3T/V3R ... V7T/V7R	Fiber optic connection to converter modules 3...7 (BCU-12/22 only) (VxT = transmitter, VxR = receiver)
V8T/V8R ... V12T/V12R	Fiber optic connection to converter modules 8...12 (BCU-22 only) (VxT = transmitter, VxR = receiver)

SD CARD	Data logger memory card for converter module communication
---------	--

BATT OK	Real-time clock battery voltage is higher than 2.8 V. If the LED is off when the control unit is powered, replace the battery.
FAULT	The control program has generated a fault. See the firmware manual.
PWR OK	Internal voltage supply is OK
WRITE	Writing to memory card in progress. Do not remove the memory card.

Control unit connector data

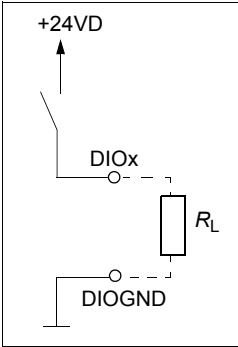
Power supply (XPOW)	<p>Connector pitch 5 mm, wire size 2.5 mm² 24 V (±10%) DC, 2 A External power input. Two supplies can be connected to BCU for redundancy.</p>
Relay outputs RO1...RO3 (XRO1...XRO3)	<p>Connector pitch 5 mm, wire size 2.5 mm² 250 V AC / 30 V DC, 2 A Protected by varistors</p>
+24 V output (XD24:2 and XD24:4)	<p>Connector pitch 5 mm, wire size 2.5 mm² Total load capacity of these outputs is 4.8 W (200 mA / 24 V) minus the power taken by DIO1 and DIO2.</p>
Digital inputs DI1...DI6 (XDI:1...XDI:6)	<p>Connector pitch 5 mm, wire size 2.5 mm² 24 V logic levels: "0" < 5 V, "1" > 15 V R_{in}: 2.0 kohm Input type: NPN/PNP (DI1...DI5), NPN (DI6) Hardware filtering: 0.04 ms, digital filtering up to 8 ms DI6 (XDI:6) can alternatively be used as an input for a PTC thermistor. "0" > 4 kohm, "1" < 1.5 kohm I_{max}: 15 mA (DI1...DI5), 5 mA (DI6)</p>
Start interlock input DIIL (XDI:7)	<p>Connector pitch 5 mm, wire size 2.5 mm² 24 V logic levels: "0" < 5 V, "1" > 15 V R_{in}: 2.0 kohm Input type: NPN/PNP Hardware filtering: 0.04 ms, digital filtering up to 8 ms</p>
Digital inputs/outputs DIO1 and DIO2 (XDIO:1 and XDIO:2)	<p>Connector pitch 5 mm, wire size 2.5 mm² <u>As inputs:</u> 24 V logic levels: "0" < 5 V, "1" > 15 V R_{in}: 2.0 kohm Filtering: 1 ms <u>As outputs:</u> Total output current from +24VD is limited to 200 mA</p>
<p>Input/output mode selection by parameters. DIO1 can be configured as a frequency input (0...16 kHz with hardware filtering of 4 microseconds) for 24 V level square wave signal (sinusoidal or other wave form cannot be used). DIO2 can be configured as a 24 V level square wave frequency output. See the firmware manual, parameter group 11/111.</p>	
Reference voltage for analog inputs +VREF and -VREF (XAI:1 and XAI:2)	<p>Connector pitch 5 mm, wire size 2.5 mm² 10 V ±1% and -10 V ±1%, R_{load} 1...10 kohm Maximum output current: 10 mA</p>
Analog inputs AI1 and AI2 (XAI:4 ... XAI:7)	<p>Connector pitch 5 mm, wire size 2.5 mm² Current input: -20...20 mA, R_{in} = 100 ohm Voltage input: -10...10 V, R_{in} > 200 kohm Differential inputs, common mode range ±30 V Sampling interval per channel: 0.25 ms Hardware filtering: 0.25 ms, adjustable digital filtering up to 8 ms Resolution: 11 bit + sign bit Inaccuracy: 1% of full scale range</p>

Analog outputs AO1 and AO2 (XAO)	Connector pitch 5 mm, wire size 2.5 mm ² 0...20 mA, $R_{load} < 500 \text{ ohm}$ Frequency range: 0...500 Hz Resolution: 11 bit + sign bit Inaccuracy: 2% of full scale range
Drive-to-drive link (XD2D)	Connector pitch 5 mm, wire size 2.5 mm ² Physical layer: RS-485 Termination by switch
RS-485 connection (X485)	Connector pitch 5 mm, wire size 2.5 mm ² Physical layer: RS-485
Safe torque off connection (XSTO)	Connector pitch 5 mm, wire size 2.5 mm ² Input voltage range: -3...30 V DC Logic levels: "0" < 5 V, "1" > 17 V For the converter to start, both connections must be "1" EMC (immunity) according to IEC 61326-3-1
Safe torque off output (XSTO OUT)	Connector pitch 5 mm, wire size 2.5 mm ²
Control panel connection (X13)	Connector: RJ-45 Cable length < 3 m
Ethernet connection (XETH)	Connector: RJ-45
SDHC memory card slot (SD CARD)	Memory card type: SDHC Maximum memory size: 4 GB

The terminals of the control unit fulfill the Protective Extra Low Voltage (PELV) requirements. The PELV requirements of a relay output are not fulfilled if a voltage higher than 48 V is connected to the relay output.

A large green square with rounded corners containing the number 11 in a bold, black, sans-serif font.

Dimension drawings

Contents of this chapter

This chapter contains dimension drawings of the wind turbine converter. See also the dimension drawings delivered with the converter.

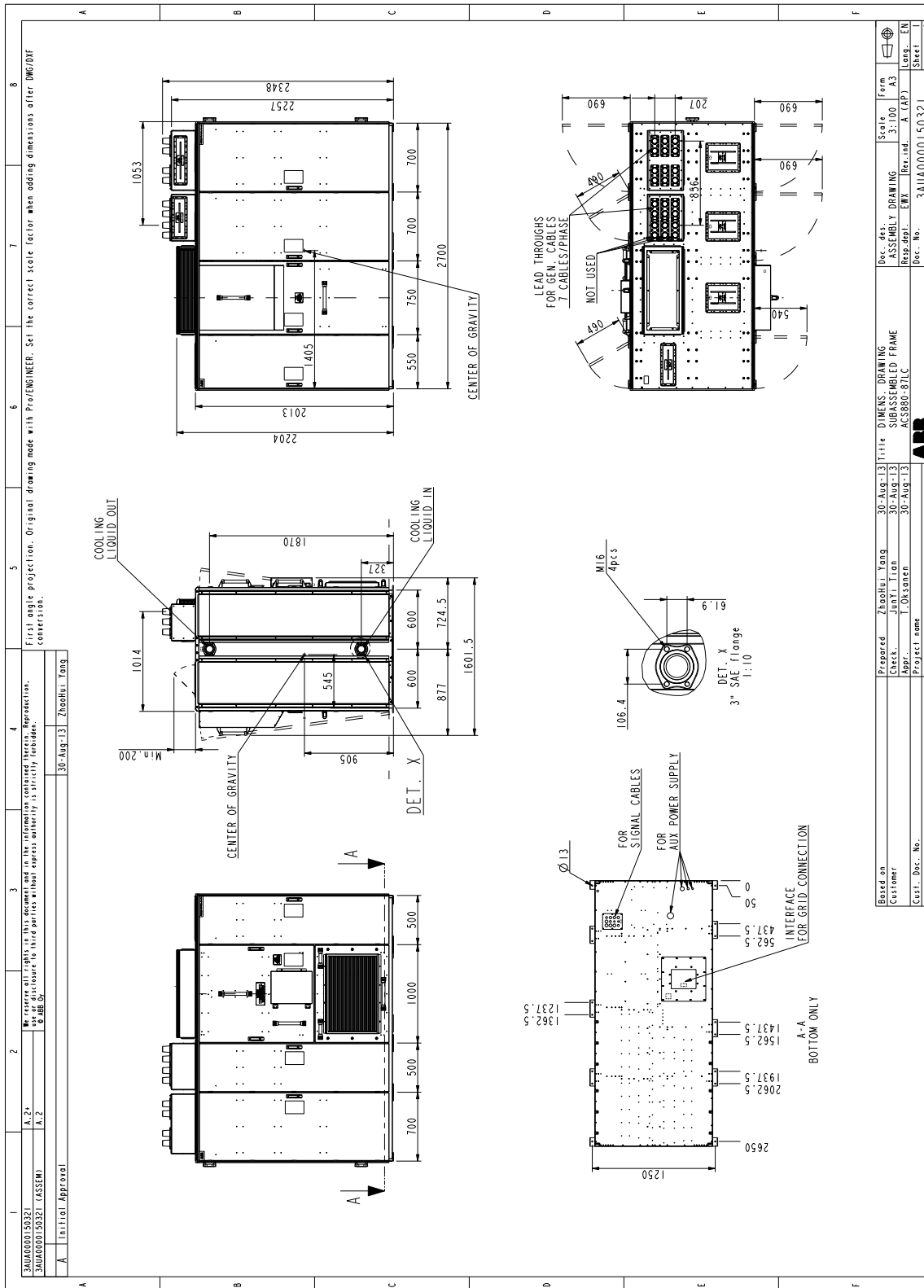

1	2	3	4	5	6	7	8
3AU00001503Z1	3AU00001503Z1	3AU00001503Z1	3AU00001503Z1	3AU00001503Z1	3AU00001503Z1	3AU00001503Z1	3AU00001503Z1
Initial Approval							

30-Aug-13 Zhaohui Yang
 30-Aug-13 Junli Tian
 30-Aug-13 T. Ohtsuka
 30-Aug-13

Based on	Prepared	Zhaohui Yang	30-Aug-13	Title	DIMENS. DRAWING	Scale	Form
Customer	Checked	Junli Tian	30-Aug-13	Customer	ASSEMBLED FRAME	3:100	A3
Cust. Doc. No.	Project name	T. Ohtsuka	30-Aug-13	Project name	ASSEMBLED FRAME	3:100	A3
ABB Ref. No.	Weight kg	3AU00001503Z1		Doc. No.	3AU00001503Z1		

First angle projection. Original drawing made with Pro/ENGINEER. Set the correct scale factor when adding dimensions after DWG/DXF conversion.

We reserve all rights in this document and in the information contained therein. Reproduction, use or disclosure to third parties without express authority is strictly forbidden.

30-Aug-13 Zhaohui Yang
 30-Aug-13 Junli Tian
 30-Aug-13 T. Ohtsuka
 30-Aug-13

30-Aug-13

30-Aug-13

30-Aug-13

30-Aug-13

30-Aug-13

30-Aug-13

30-Aug-13

30-Aug-13

30-Aug-13

30-Aug-13

30-Aug-13

30-Aug-13

30-Aug-13

30-Aug-13

30-Aug-13

30-Aug-13

30-Aug-13

30-Aug-13

30-Aug-13

30-Aug-13

30-Aug-13

30-Aug-13

30-Aug-13

30-Aug-13

30-Aug-13

30-Aug-13

30-Aug-13

30-Aug-13

30-Aug-13

30-Aug-13

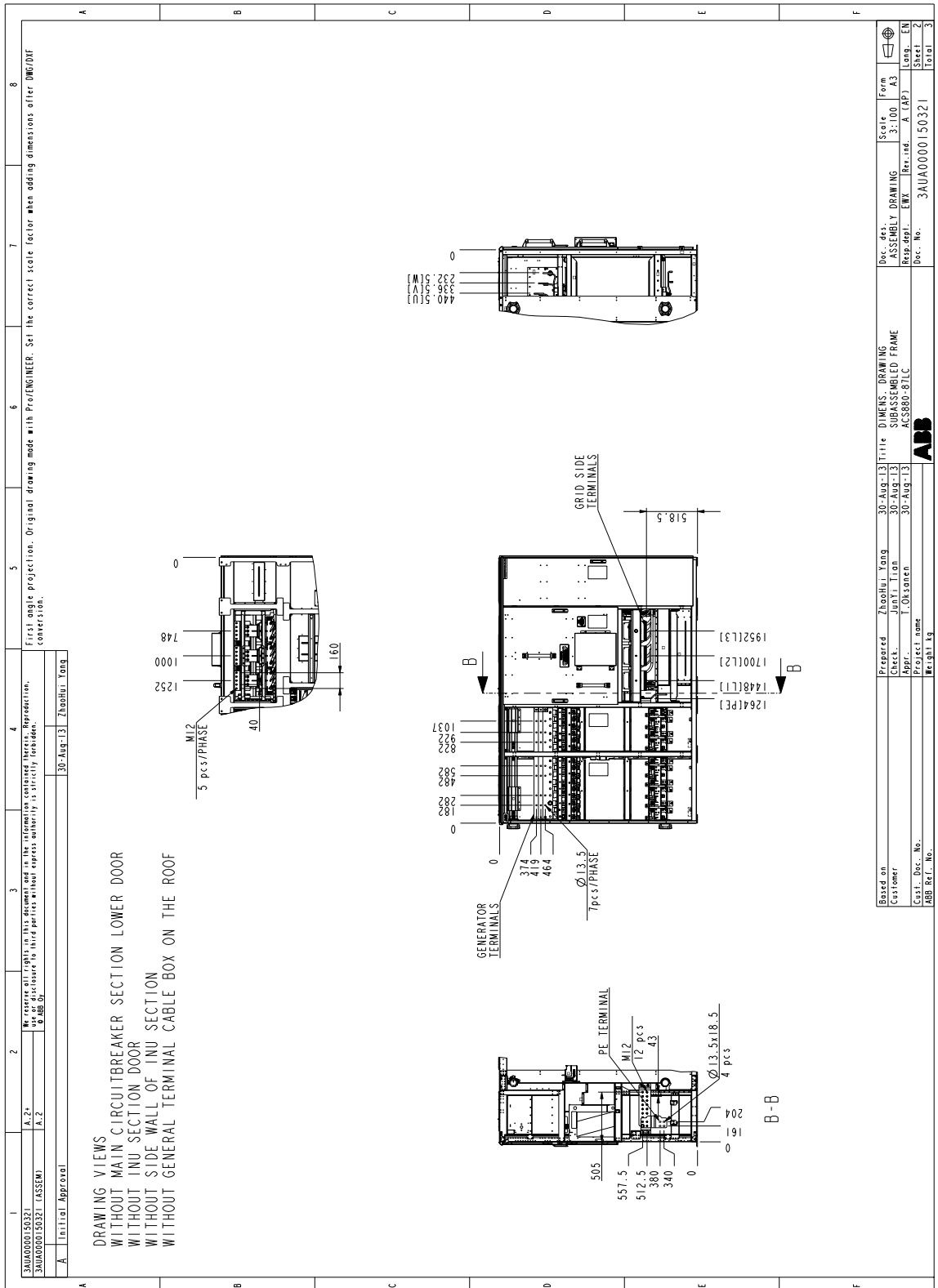

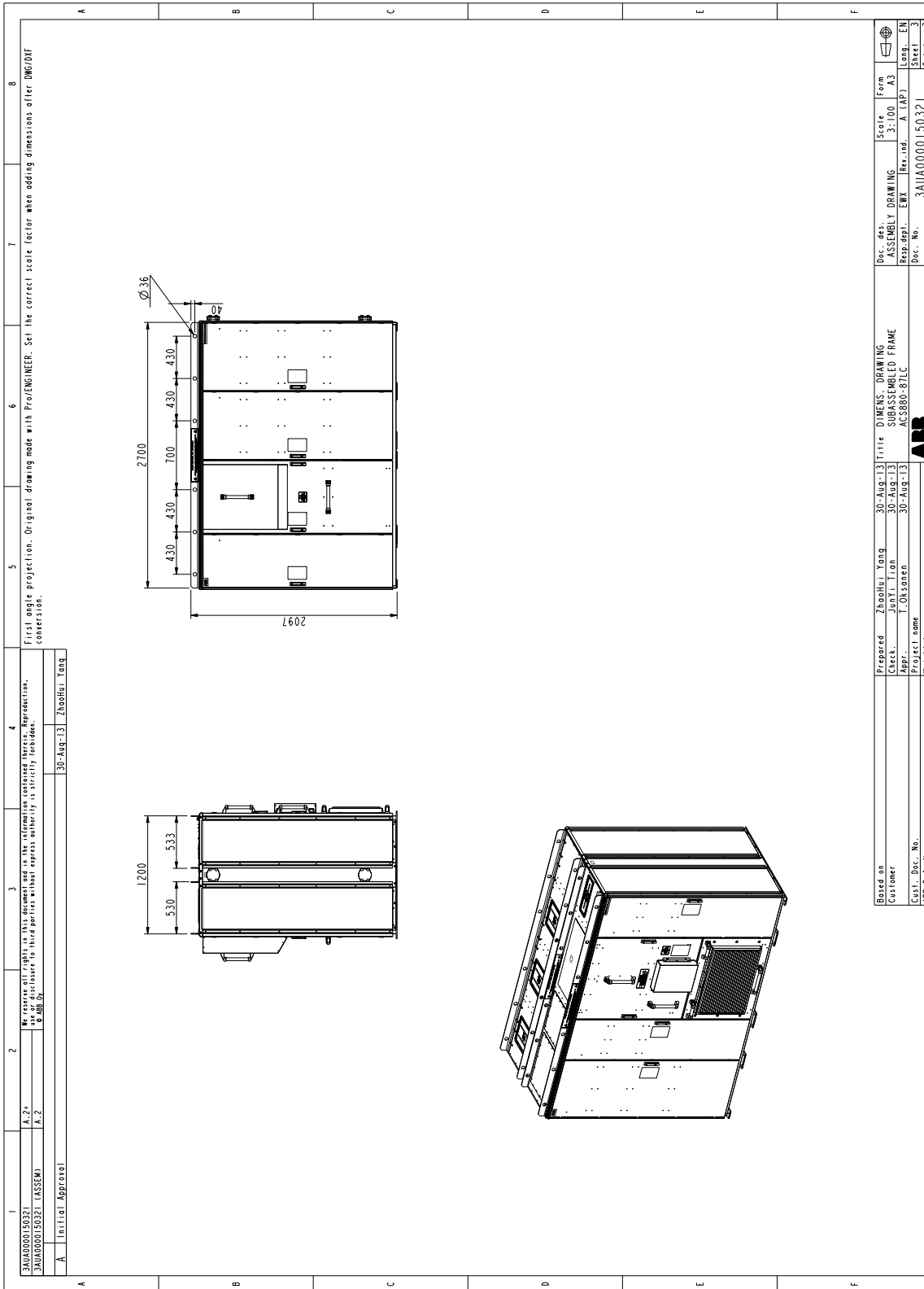

Based on	Prepared	Zhaohui Yang	30-Aug-13	Title	DIMENS. DRAWING	Scale	1:100	Form	
Customer	Checked	Leon	30-Aug-13	Subassembly FRAME	ASSEMBLY DRAWING	Sheet	100	EN	
	Approved	T. Oksteden	30-Aug-13	ACS880-87LC	Project name	Doc. No.	3UAU00001503Z1	Sheet	3
					Weight kg			Total	3



12

Cooling and heating

Contents of this chapter

This chapter deals with the internal cooling circuit.

Hardware description

■ General

The internal cooling circuit covers the heat-generating electrical components and transfers the heat to the external cooling circuit that is usually part of a larger external cooling system.

■ Diagram of the internal cooling and heating circuit

The following example diagram shows how coolant circulates in the auxiliary control, grid-side converter, LCL filter, main breaker and generator-side converter cubicles of the wind turbine converter.

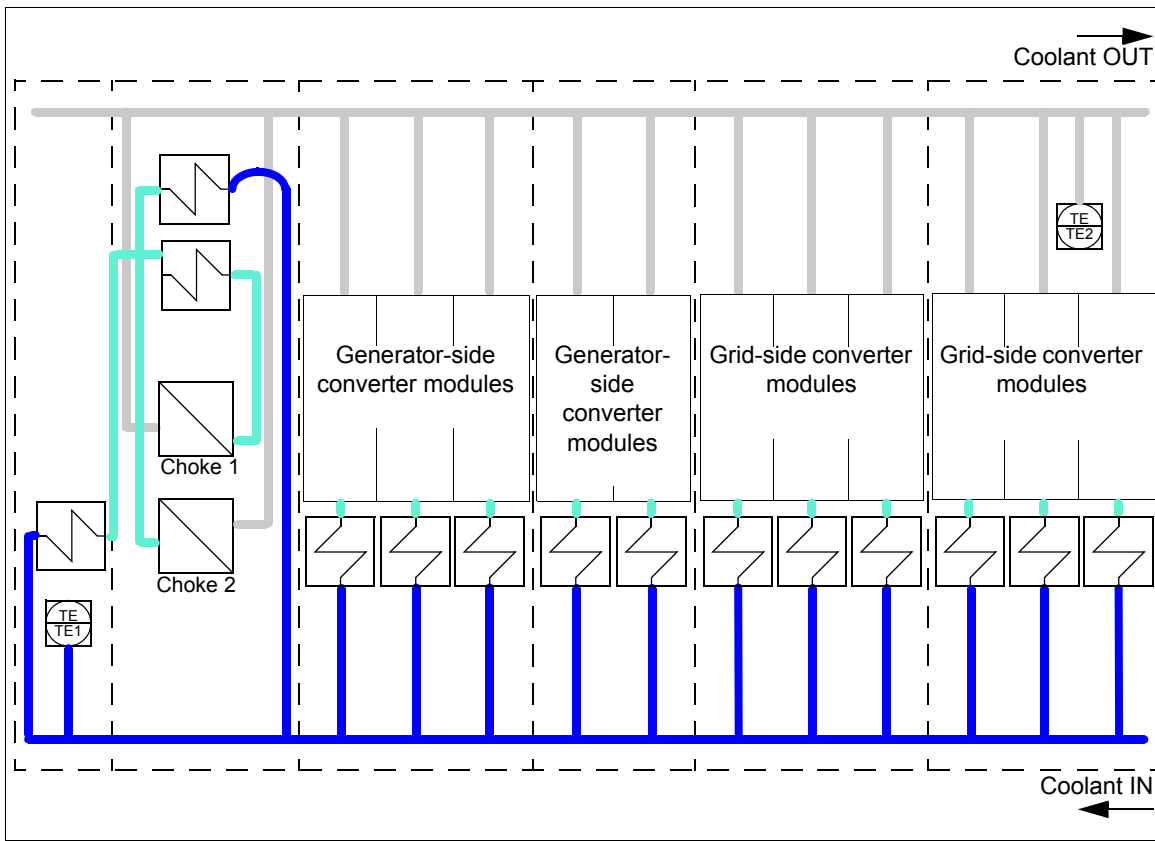

Planning the cooling system

■ Connection to a customer cooling unit

General requirements

Equip the system with an expansion tank to damp pressure rise due to volume changes when the temperature varies. Keep the pressure within the limits specified in [Specifications](#) below. Install a pressure regulator to ensure that the maximum permissible operating pressure is not exceeded.

Install a bleeding valve at the highest point of the cooling circuit. Bleeding valve is not included in the ABB converter delivery as standard. It can be ordered as an option (+G422).

The materials used in the cooling system are listed in [Specifications](#) on page 136.

Coolant temperature control

The temperature of the coolant in the internal cooling circuit must be kept within the limits specified in [Specifications](#) on page 136. Note that the minimum temperature depends on ambient temperature and relative humidity.

The following diagram shows an example of coolant temperature control using the three-way valve in the external cooling circuit. Part of the infeed coolant flow is directed into the return pipe through a three-way valve without letting it circulate in the internal cooling circuit if the coolant in the internal circuit is too cold.

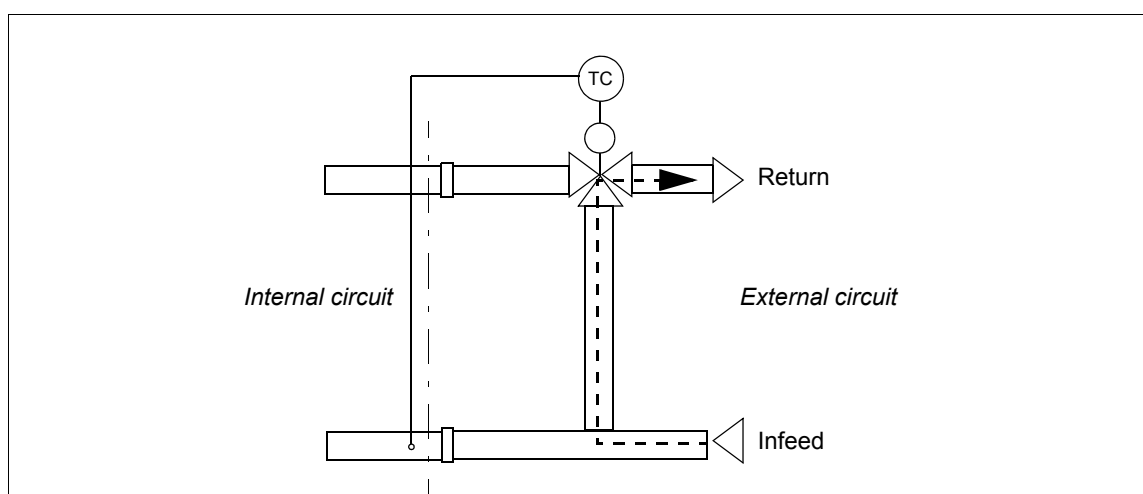

Mechanical installation

■ Connecting the internal cooling circuit to a customer cooling unit

The converter delivery does not include the liquid cooling unit that is to be connected to the converter cabinet.

Connecting the liquid pipes

Note: It is recommended to use closing valves in the pipe connections of the cooling circuit.

1. Ensure that there is sufficient space and free access to make proper cooling pipe connections between the liquid cooling unit and the converter. It is not allowed to use inflexible and fixed cooling pipe connections between two separate units (eg, liquid cooling unit and the converter connection). Always use a flexible connector that can reduce possible stress caused by eg, vibration.
 2. Check visually that the converter liquid pipes are not damaged (threads and flange joint not damaged).
 3. Connect the external cooling circuit directly to the coupling pipes on the side of the converter. Lay liquid piping with extreme care. Secure the pipes properly mechanically and check for leaks. See chapter [Technical data](#) for the pipe materials.
 4. Position the liquid pipe ends against each other.
 5. Centre the connector onto the pipe ends.
 6. Tighten the
 - threaded connector carefully and ensure that it is slid on the pipe ends. The use of appropriate sealant is recommended.
 - flange bolts to a minimum torque of 70 N·m (52 lbf·ft).
 7. Make sure that the liquid pipes are securely connected.
-

Filling up and bleeding the internal cooling circuit

Both the converter and coolant must be at room temperature before filling in the cooling circuit.



WARNING! Obey these instructions. If you ignore them, injury or death, or damage to the equipment can occur.

- Make sure that the maximum permissible operating pressure is not exceeded. When necessary control the pressure to appropriate level by draining excess coolant out of the system.
 - Do not drain propylene glycol into the sewer system.
 - Be careful when you bleed the cooling circuit. Air bubbles in the circuit may reduce or completely block coolant flow and cause overheating. Fill up and bleed the pumps in the cooling circuit carefully as they can get damaged when run dry. Obey the instructions of the external the cooling unit.
-

■ Converters with a customer cooling unit

Notes:

- The bleed valves in the converter are used only to vent the air from the circuit so that it can be displaced by the coolant. The actual bleeding of the circuit must be done via an external bleed valve installed at the highest point of the cooling circuit. The most practical location for the valve is usually near or at the cooling unit. Bleeding and draining valves are not included in the standard delivery of the ABB converter (bleeding valve is option +G422).
 - Observe the instructions given by the manufacturer of the cooling unit. Pay special attention to filling up and bleeding the pumps properly as they may be damaged if operated when dry.
 - Draining propylene glycol into the sewer system is not allowed.
1. Open the bleed valve at the cooling unit.
 2. Lead the bleed hoses into buckets or other suitable containers. Extend the standard hoses if necessary.
 3. Fill the circuit with coolant. For coolant specification, see below.
 4. After the converter is filled up, coolant will start flowing from the bleed hose of the converter. Let some coolant flow out before closing the bleed valve.
 5. Let any air remaining in the system out through the bleed valve at the cooling unit.
 6. Close the bleed valve at the cooling unit.
 7. Continue to fill in coolant until a base pressure of 100...150 kPa is achieved.
 8. Open the bleed valve of the pump to allow any air out.
 9. Re-check the pressure and add coolant if necessary.
 10. Start the coolant pump. Let any air remaining in the system out through the bleed valve at the cooling unit.
 11. After one to two minutes, stop the pump or block the coolant flow with a valve.
 12. Re-check the pressure and add coolant if necessary.
-

- Repeat steps 10...12 a few times until all air is let out of the cooling circuit. Listen for a humming sound and/or feel the piping for vibration to find out if there is still air left in the circuit.

Adjustments

- Set the base pressure to 100...150 kPa by draining coolant from the fill/drain coupling.
- Control the coolant temperature so that it stays between the limits stated in [Specifications](#) on page 136.

Draining the internal cooling circuit

You can drain the internal cooling circuit through the cooling unit as follows:

Note: Draining coolant into the sewer system is not allowed.



WARNING! High-pressure hot coolant may be present in the internal cooling circuit. No work on the cooling circuit is allowed until the pressure is lowered down by stopping the pumps and draining coolant.

- Lead the bleed hose into a bucket or other suitable container. Extend the standard hoses when necessary.
- Open the bleed valve to let air displace the liquid.
- If required, dry the piping with compressed oil-free air of less than 6 bar (600 kPa).
- If the converter is to be stored in temperatures below 0 °C (32 °F),
 - dry the cooling circuit with air
 - fill the cooling circuit with a mixture of water and coolant according to section [Freeze protection and corrosion inhibition](#) on page 137
 - drain the cooling circuit again.

Cooling station control

Instructions for liquid cooling control:

- After the transportation package is opened
 - The converter must be stored in non-condensing environment.
 - During turbine installation - before converter hot-commissioning (no electrical running performed yet). The converter must be protected against direct climate changes, such as rain and sunlight (temperature cover).
 - Remove the temperature cover.
 - Visual inspection - no condensation water inside the converter can be found. The converter doors must be closed after visual inspection.
 - Start cooling liquid circulation. Forced heating must be enabled in all conditions. Set the cooling system target temperature to +45 °C...50 °C (+113 °F...122 °F). Enable 230 V AC supply to the converter.
 - Run the converter for a minimum of 24 hours.
 - After turbine installation - during converter hot-commissioning
 - Follow the product-specific start-up guide.
 - During normal operation
 - Cold start - heating request according to the converter heating demands.
-

- b. Humidity control - set cooling liquid temperature at least +10 °C (+50 °F) above converter outside air. The cooling liquid temperature: minimum +25 °C (+77 °F) and maximum +50 °C (+122 °F).
5. During normal operation - long period of time lack of electricity
- a. Option 1: Back up power source to maintain 230 V AC for cooling unit and converter
 - b. Option 2: Follow points 2.c. and 2.d.
-

Specifications

Temperature limits

Ambient temperature: See chapter [Technical data](#) on page 107.

Minimum coolant inlet temperature: Condensation or frost is not allowed. The minimum coolant temperature to avoid condensation (at an atmospheric pressure of 1 bar / 100 kPa) is shown below as a function of the relative humidity (ϕ) and the ambient temperature (T_{air}). To avoid all kind of condensation inside the converter: ABB highly recommends to maintain / heat up the cooling liquid +10 °C (+50 °F) above the ambient temperature (ie, air temperature outside the converter), within the limits that the cooling liquid minimum temperature is +5 °C (41 °F) and maximum temperature is +50 °C (122 °F).

T_{air} (°C)	Min. T_{coolant} (°C)				
	$\phi = 95\%$	$\phi = 80\%$	$\phi = 65\%$	$\phi = 50\%$	$\phi = 40\%$
5	4.3	1.9	-0.9	-4.5	-7.4
10	9.2	6.7	3.7	-0.1	-3.0
15	14.2	11.5	8.4	4.6	1.5
20	19.2	16.5	13.2	9.4	6.0
25	24.1	21.4	17.9	13.8	10.5
30	29.1	26.2	22.7	18.4	15.0
35	34.1	31.1	27.4	23.0	19.4
40	39.0	35.9	32.2	27.6	23.8
45	44.0	40.8	36.8	32.1	28.2
50	49.0	45.6	41.6	36.7	32.8
55	53.9	50.4	46.3	42.2	37.1

Not allowed as standard but the coolant temperature must be 5 °C (41 °F) or above. Consult an ABB representative if operation below coolant temperature 5 °C (41 °F) is required.

Example: At an air temperature of 45 °C (113 °F) and relative humidity of 65% the coolant temperature may not be below +36.8 °C (98.2 °F).

Maximum coolant inlet temperature: 50 °C (122 °F) without derating of the converter output capacity. Range above 50 °C (122 °F) is allowed as follows:

Range	Converter output current derating
50 ... 55 °C (122 ... 131 °F)	2.5% per 1 °C (1.8 °F) temperature increase

Maximum temperature rise: 13 °C (55.4 °F); depends on mass flow.

Pressure limits

Base pressure: 100...150 kPa (recommended); 200 kPa (maximum). Base pressure denotes the pressure of the system compared with the atmospheric pressure when the cooling circuit is filled with coolant.

Maximum design pressure: 500 kPa

Recommended design maximum pressure: 380 kPa. **Note:** Contact ABB if you need to rise the pressure over this limit. The pressure difference must be within given limits to avoid malfunction due to excessive coolant flow.

Nominal pressure difference: 110 kPa / 120 kPa (hydrostatic)

Maximum pressure difference: 170 kPa / 180 kPa (hydrostatic)

■ Water quality

Tap water	
The use of drinking water without gas/bubbles is allowed as follows:	
<ul style="list-style-type: none"> The water must fulfill the requirements of the Council Directive 98/83/EC of 3/11/98 on the quality of water intended for human consumption. 	
Note: The following requirements apply to the water to be used in the coolant, not the water-glycol-inhibitor mixture.	
pH value	6.0...8.0
Chloride	< 50 mg/l
Fluoride	< 50 mg/l
Sulphate	< 100 mg/l
Total dissolved solids	< 200 mg/l, no deposits are allowed at the temperature of +57 °C (153 °F)
Total hardness as CaCO ₃	< 250 mg/l
Conductivity	< 400 µS/cm (this equals the resistance of > 2500 ohm/cm)
The water must be clean of solid matter.	The use of purified water which is not intended for human consumption is forbidden.

■ Freeze protection and corrosion inhibition



WARNING! Pay special attention to the composition of the coolant. Use the water-coolant mixture specified by ABB in the internal cooling circuit. Adding any other ingredient to the coolant may cause corrosion or dissolution of gaskets or adhesives used in couplings. It may also affect the viscosity of the coolant and degrade the cooling capacity of the cooling circuit and thus the load capacity of the drive. THE WARRANTY DOES NOT COVER DAMAGE OCCURRING FROM USE OF IMPROPER COOLANT.

Coolant concentration

ABB recommends diluting coolant 50:50 with water. Note that the concentration of coolant should not be less than 33% and not more than 60%. Following table shows how the diluting portion effects to frost protection.

Frost protection down to	Coolant concentration	Water concentration
-20 °C (-4 °F)	33%	66%
-27 °C (-16.6 °F)	40%	60%
-38 °C (-36.4 °F)	50%	50%
-54 °C (-65.2 °F)	60%	40%



WARNING! Operation at liquid temperatures below 0 °C (32 °F) is not permitted even with antifreeze.

Liquid mixture quality

The pH level of the coolant **must not** be manipulated by adding chemicals not specified in this document. This may build up sediment in the liquid.

Approved coolants

- BASF Glysantin G30® or Valvoline Zerex G30. For other coolants, contact your local ABB representative.



WARNING! Do not mix different approved coolants in any conditions! Replace the cooling liquid always with same cooling liquid! Mixing different coolant types is a risk for cooling system corrosion.

■ Materials

Materials used in the internal cooling circuit are:

- stainless steel AISI 316L (UNS 31603)
 - heavy gauge aluminum
 - plastic materials such as PA, PEX and PTFE
- Note:** PVC hoses are not suitable for use with antifreeze.
- rubber gasket NBR (nitrile rubber).

Use only these materials in the external cooling circuit, too.



WARNING! When connecting external piping to the internal cooling circuit, use only materials that are specified above. Copper and brass must not be used under any circumstances. Even minor dissolution of copper can cause copper precipitation on aluminum and subsequent galvanic corrosion. The liquid cooling system may not contain any zinc (for example, galvanized pipes) at all since zinc would react with the inhibitor.

Heating

The converter is not equipped with a heating element. Thus, it must be heated using the coolant circuit. The external liquid cooling unit must be equipped with a heater capable of heating the converter up within reasonable time. Temperatures in each converter cubicle are monitored separately by using thermostats with a fixed set point of 10 ± 5 °C. There is no specific heating request signal in the converter cabinet for the customer. You can check the heating request signal on the terminal XDI:7 on the BCU control unit of the grid-side converter. For more information, see *Hardware manual* and the circuit diagrams delivered with the converter.

Note: The cooling unit must always be equipped with a proper overtemperature protection device(s).

The operation of the converter temperature control logic is described in the following sections in two different circumstances: cold start and normal start.

■ Cold start (-30 °C ... +10 °C)

The auxiliary 230 V AC and 400 V AC power is connected to terminal block X1 on the converter. At first, the auxiliary power is not switched on and the printed circuit boards are not energized.

1. Switch on the external cooling unit and heating of the cooling liquid. Make sure that the coolant circulates in the converter cooling circuit (all cubicles).
2. Switch on the auxiliary voltages. Connect input voltage to the terminal X1: 230 V AC (UPS) and 400V AC (non-UPS).
3. Wait for the converter cabinet to warm up.
4. If the temperature of the auxiliary control cubicle is ≤ -10 °C, the fans inside the converter cabinet start and speed up the warming process.
5. Wait until the fans stop. The temperature has risen enough in all parts of the converter cabinet.
6. When the temperature is high enough and the fans stop, a control relay switches on the energizes the control boards automatically. The converter is ready for the normal power up.

Temperature sensors control relays K12.1, K18.1, K18.2 and K18.3. When the converter is heated up properly ($T > 10$ °C), auxiliary power to the printed circuit boards is switched on by relay K18.3. The relay stays energized unless auxiliary power is switched off with circuit breaker [F11]. The heating requests to the cooling unit change automatically from on to off when heating is not needed any more and vice versa. The converter also switches off the cooling pump start request if the converter is not powered up yet (does not need any cooling).

■ Normal start (-30 °C ... +10 °C)

When the temperature in all converter cubicles is above 10 °C, no heating is needed. You can start without any pre-heating:

1. Switch on the external liquid cooling unit and the pump that circulates coolant in the converter.
 2. Switch on the auxiliary power. The converter is ready for the power up.
-

Note: If the converter temperature goes again below 10 °C inside any converter cubicle, the converter restarts the heating procedure again and the normal start can continue only after the temperature is on sufficient level. See section [Cold start \(-30 °C ... +10 °C\)](#) on page [139](#).

When relay K18.3 has been energized in the cold start procedure described above, the converter gives the heating and starting the pump requests to the liquid cooling unit when the cubicle temperature decreases below 10 °C. Heating request of the converter cabinet is wired to XDI:7 on the BCU control unit of the grid-side converter. If XDI:7 becomes "1", some parts of the converter cabinet are not warm enough. In this case the customer needs to switch on the warming of the cooling liquid and the pump of the external liquid cooling unit. When the temperature rises above 10 °C, the converter disconnects the heating request.

■ Circuit diagram

The following diagrams show the heating control logic of the converter. **Note:** This is an overview diagram to help in understanding the description of the heating above. See the delivery-specific circuit diagrams for the actual wiring for each converter.

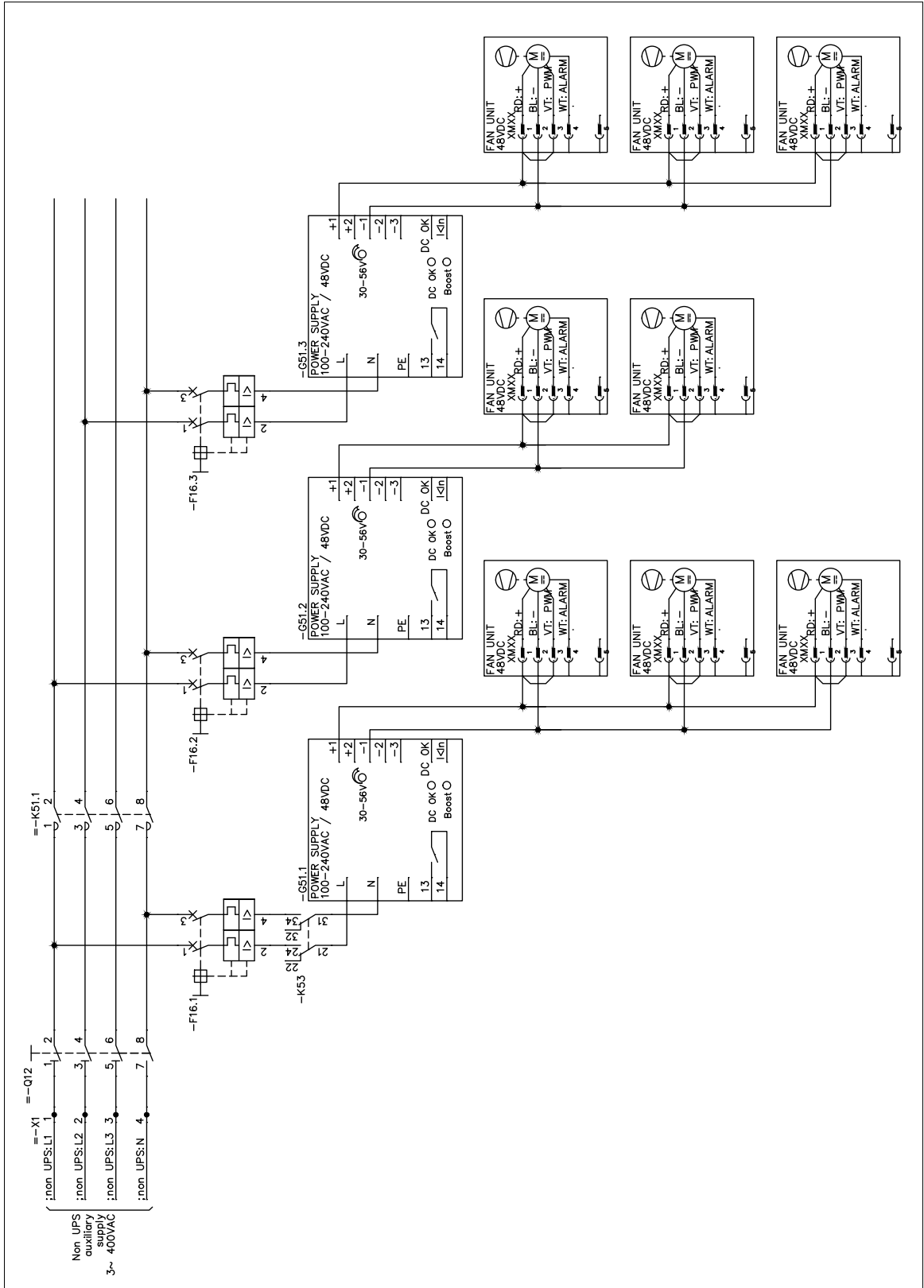

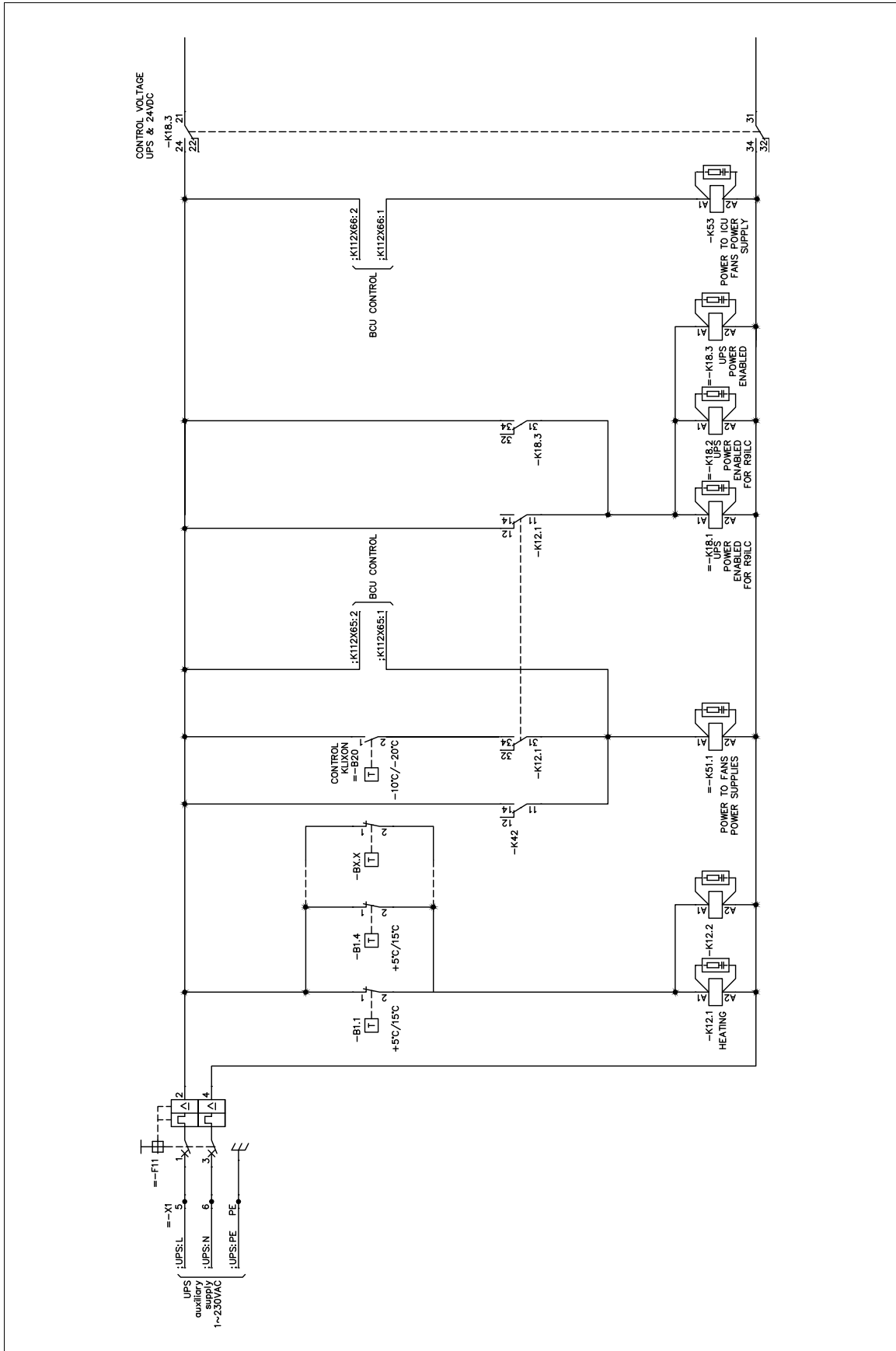

Further information

Product and service inquiries

Address any inquiries about the product to your local ABB representative, quoting the type designation and serial number of the unit in question. A listing of ABB sales, support and service contacts can be found by navigating to abb.com/searchchannels.

Product training

For information on ABB product training, navigate to new.abb.com/service/training.

Providing feedback on ABB Drives manuals

Your comments on our manuals are welcome. Navigate to new.abb.com/drives/manuals-feedback-form.



abb.com/windconverters