

# ACS800

Hardware manual  
ACS800-07 (+V992) drives (500 to 2800 kW)



# List of related manuals

## Hardware manual

---

*ACS800-07 (+V992) Drives (500 to 2800 kW) Hardware Manual* [3AUA0000068936](#)

## Supply unit firmware manual

---

*ACS800 Diode Supply Control Program Firmware Manual* [3AUA0000068937](#)

## Inverter unit firmware manuals (Drive control program firmware manuals)

---

*ACS800 System Control Program Firmware Manual and* [3AFE64670646](#)

*Adaptive Program Application Guide* [3AFE68420075](#)

*ACS800 Standard Control Program Firmware Manual and* [3AFE64527592](#)

*Adaptive Program Application Guide* [3AFE64527274](#)

*ACS800 Master/Follower Application Guide* [3AFE64590430](#)

*ACS800 Pump Control Application Program Firmware Manual* [3AFE68478952](#)

*ACS800 Extruder Control Program Supplement* [3AFE64648543](#)

*ACS800 Centrifuge Control Program Supplement* [3AFE64667246](#)

*ACS800 Traverse Control Program Supplement* [3AFE64618334](#)

etc.

## Option manuals

---

*Safety options for ACS800 cabinet-installed drives (+Q950, +Q951, +Q952, +Q963, +Q964, +Q967 and +Q968), Wiring, start-up and operation instructions* [3AUA0000026238](#)

*RDCO-01/02/03 DDCS Communication Option Modules* [3AFE64492209](#)

*Manuals and quick guides for I/O extension modules, fieldbus adapters, etc*

You can find manuals and other product documents in PDF format on the Internet. See section [Document library on the Internet](#) on the inside of the back cover. For manuals not available in the Document library, contact your local ABB representative.



[ACS800-07 manuals](#)

ACS800-07 (+V992) drives  
500 to 2800 kW

## **Hardware manual**

3AUA0000068936 REV C  
EN  
EFFECTIVE: 2013-02-07



# Safety instructions

---

## What this chapter contains

This chapter contains safety instructions you must follow when installing, operating and servicing the drive. If ignored, physical injury or death may follow, or damage may occur to the drive, the motor or driven equipment. Read the safety instructions before you work on the unit.

## Usage of warnings and notes

There are two types of safety instructions throughout this manual: warnings and notes. Warnings caution you about conditions which can result in serious injury or death and/or damage to the equipment, and advise on how to avoid the danger. Notes draw attention to a particular condition or fact, or give information on a subject. The warning symbols are used as follows:



**Dangerous voltage warning** warns of high voltages which can cause physical injury and/or damage to the equipment.



**General warning** warns about conditions, other than those caused by electricity, which can result in physical injury and/or damage to the equipment.



**Electrostatic discharge warning** warns of electrostatic discharge which can damage the equipment.

## Installation and maintenance work

These warnings are intended for all who work on the drive, motor cable or motor. Ignoring the instructions can cause physical injury or death, or damage the equipment.

---

### WARNING!



- Only qualified electricians are allowed to install and maintain the drive.
- Before starting the work on any part of the drive, isolate it from the power line with the main disconnecting device (main breaker or main switch-disconnector). The main switch-disconnector or main breaker does not remove the voltage from the input busbars of the drive.
- Never work on the drive, the motor cable or the motor when main power is applied. After switching off the input power, always wait for 5 minutes to let the intermediate circuit capacitors discharge before you start working on the drive, the motor or the motor cable. Measure the voltage between terminals UDC+ and UDC- (L+ and L-) with a multimeter (impedance at least 1 Mohm) to ensure that the drive is discharged before beginning work.
- Before working on any part of the drive, isolate its auxiliary circuits from the power supply with the auxiliary voltage switch [Q10].
- Apply temporary grounding before working on the unit.
- Do not work on the control cables when power is applied to the drive or to the external control circuits. Externally supplied control circuits may cause dangerous voltages to exist inside the drive even when the main power of the drive is switched off.
- Do not make any insulation or voltage withstand tests on the drive or drive modules.
- When reconnecting the motor cable, always check that the phase order is correct.
- When joining shipping splits (if any), check the cable connections at the joints before switching on the supply voltage.
- Live parts on the inside of the doors are protected against direct contact. Special attention shall be paid when handling metallic shrouds.
- After maintaining or modifying a drive safety circuit or changing circuit boards inside the module, retest the functioning of the safety circuit according to the start-up instructions.
- Do not change the electrical installations of the drive except for the essential control and power connections. Changes may affect the safety performance or operation of the drive unexpectedly. All customer-made changes are on the customer's responsibility.

**Note:**

- The main disconnecting device (main breaker or main switch-disconnector) does not switch off the voltage from the auxiliary circuits or the input busbars.
- The motor cable terminals on the drive are at a dangerously high voltage when the input power is on, regardless of whether the motor is running or not.
- The brake control terminals (UDC+, UDC-, R+ and R- terminals) carry a dangerous DC voltage (over 500 V).
- Depending on the external wiring, dangerous voltages (115 V, 220 V or 230 V) may be present on the relay outputs of the drive system.
- The Prevention of unexpected start-up function (option +Q950) does not remove the voltage from the main and auxiliary circuits.
- The Safe torque off function (option +Q968) does not remove the voltage from the main and auxiliary circuits.

**WARNING!**

- During the installation procedure, the inverter modules may have to be temporarily extracted from the cabinet. The modules have a high center of gravity. In order to minimise the danger of toppling over, keep the support legs of the modules extended whenever manoeuvring the modules outside the cabinet.
- Use extreme caution when manoeuvring a module that runs on wheels. The modules are heavy and have a high centre of gravity. They topple over easily if handled carelessly.
- Do not use the ramp with plinth heights over 50 mm (2.0 in). The ramp supplied with the drive system is designed for a plinth height of 50 mm (2.0 in) (the standard plinth height of ABB cabinets).
- When removing a module which is equipped with wheels, pull the module carefully out of the cubicle along the ramp. Make sure that the wires do not catch. While pulling on the handle, keep a constant pressure with one foot on the base of the module to prevent the module from falling on its back.
- When replacing a module which is equipped with wheels, push the module up the ramp and back into the cubicle. Keep your fingers away from the edge of the module front plate to avoid pinching them between the module and the cubicle. Also, keep a constant pressure with one foot on the base of the module to prevent the module from falling on its back.
- Electrically conductive dust inside the unit may cause damage or lead to malfunction. Make sure that dust from drilling does not enter the drive when installing

- Fastening the cabinet by riveting or welding is not recommended. However, if welding is necessary, ensure the return wire is properly connected in order not to damage the electronic equipment in the cabinet. Also ensure that welding fumes are not inhaled.
  - Ensure sufficient cooling of the unit.
  - Cooling fans may continue to rotate for a while after the disconnection of the electrical supply.
  - Some parts inside the drive cabinet, such as heatsinks of power semiconductors, remain hot for a while after the disconnection of the electrical supply.
- 

**WARNING!**

- The printed circuit boards contain components sensitive to electrostatic discharge. Wear a grounding wrist band when handling the boards. Do not touch the boards unnecessarily.
-



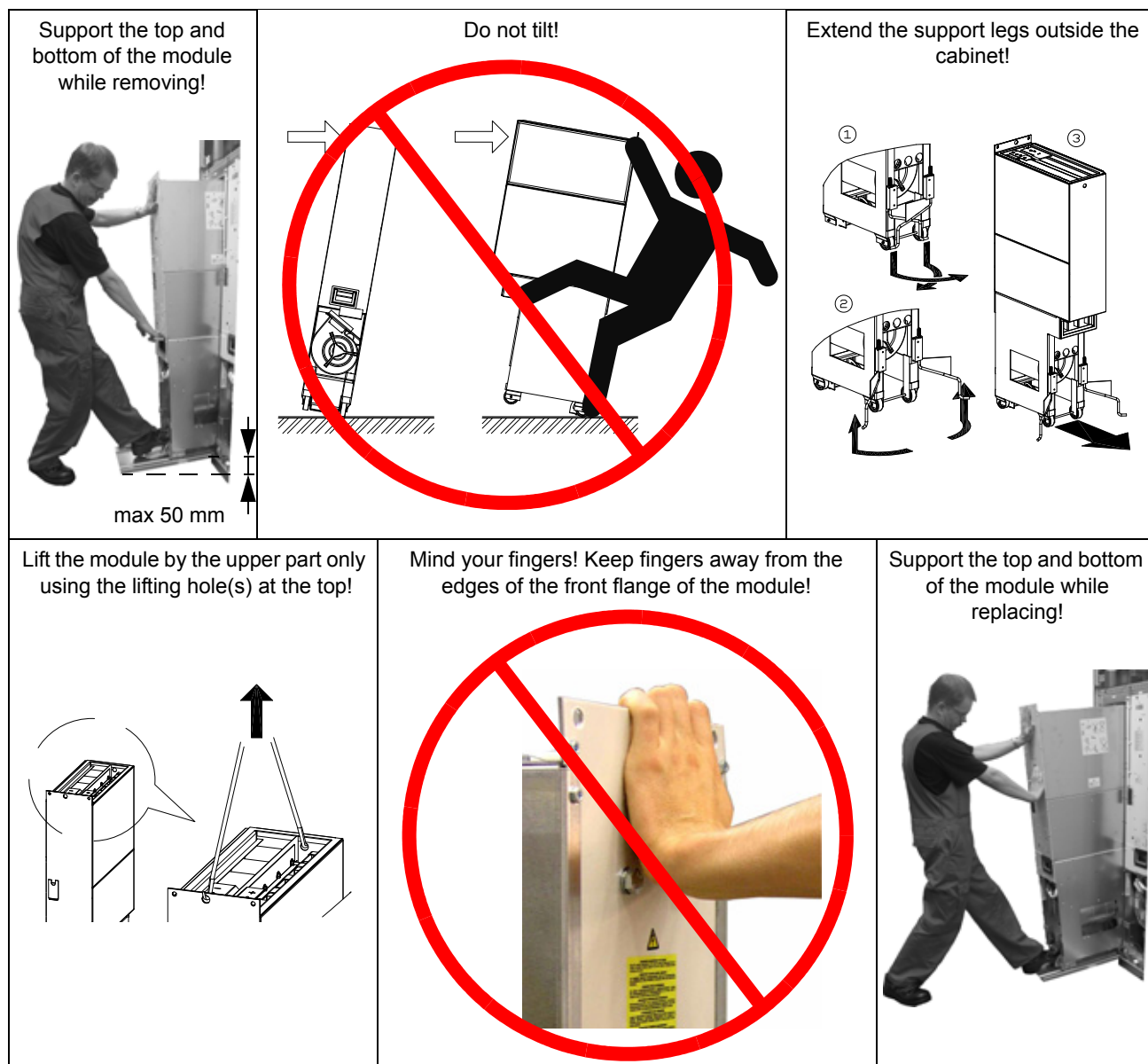

## Grounding

These instructions are intended for all who are responsible for the grounding of the drive. Incorrect grounding can cause physical injury, death or equipment malfunction and increase electromagnetic interference.

---

### WARNING!



- Ground the drive, motor and adjoining equipment to ensure personnel safety in all circumstances, and to reduce electromagnetic emission and pick-up.
- Make sure that grounding conductors are adequately sized as required by safety regulations.
- In a multiple-drive installation, connect each drive separately to protective earth (PE).
- Do not install a drive equipped with an EMC (line) filter to an ungrounded power system or a high resistance -grounded (over 30 ohms) power system.

### Note:

- Power cable shields are suitable for equipment grounding conductors only when adequately sized to meet safety regulations.
- As the normal leakage current of the drive is higher than 3.5 mA AC or 10 mA DC, a fixed protective earth connection is required by EN 61800-5-1, 4.3.5.5.2. The cross-section of the protective earthing conductor must be at least 10 mm<sup>2</sup> Cu or 16 mm<sup>2</sup> Al.

---

## Fibre optic cables

---

### WARNING!



- Handle the fibre optic cables with care. When unplugging optic cables, always grab the connector, not the cable itself. Do not touch the ends of the fibres with bare hands as the fibre is extremely sensitive to dirt. The minimum allowed bend radius is 35 mm (1.4”).
-

## Operation

These warnings are intended for all who plan the operation of the drive or operate the drive. Ignoring the instructions can cause physical injury or death or damage the equipment.

---

### WARNING!





- If the drive is equipped with an optional brake unit, make sure there are inverters connected to the intermediate circuit before start. As a rule of thumb, the sum capacitance of the inverters connected must be at least 30% of the sum capacitance of all inverters.
- Close the switch fuses of all parallel-connected inverters before start.
- Do not open the DC switch fuse of an inverter when the inverter is running.
- The Safe torque off function (option +Q967 or +Q968) can be used for stopping the drive in emergency stop situations. In the normal operating mode, use the Stop command instead.

---

### WARNING!



- Before adjusting the drive and putting it into service, make sure that the motor and all driven equipment are suitable for operation throughout the speed range provided by the drive. The drive can be adjusted to operate the motor at speeds above and below the speed provided by connecting the motor directly to the power line.
- Do not activate automatic fault reset functions of the drive control program if dangerous situations can occur. When activated, these functions will reset the drive and resume operation after a fault.
- Do not control the motor with the disconnecting device (means); instead, use the control panel keys  and , or commands via the I/O board of the drive. The maximum allowed number of charging cycles of the DC capacitors (ie, power-ups by applying power) is five in ten minutes.
- Do not use the Prevention of unexpected start-up function (option +Q950) for stopping the drive when the inverter unit(s) is running. Give a Stop command instead.

### Note:

- If an external source for start command is selected and it is ON, the drive will start immediately after fault reset unless the drive is configured for 3-wire (a pulse) start/stop.
  - When the control location is not set to Local (L not shown in the status row of the display), the stop key on the control panel will not stop the drive. To stop the drive using the control panel, press the LOC/REM key and then the stop key .
-

## Permanent magnet motor drives

These are additional warnings concerning permanent magnet motor drives.

---



**WARNING!** Do not work on the drive when the permanent magnet motor is rotating. Also when the supply power is switched off, a rotating permanent magnet motor feeds power to the intermediate circuit of the drive and also the supply connections become live (even when the inverter is stopped!).

---

### Installation and maintenance work

- Disconnect the motor from the drive with a safety switch and additionally, if possible,
- Lock the motor shaft and ground the motor connection terminals temporarily by connecting them together as well as to the PE.

### Operation

Do not run the motor above the rated speed. Motor overspeed leads to overvoltage which may result in explosion of the capacitors in the intermediate circuit of the drive.

### Control program

To control a permanent magnet motor, only use the ACS800 permanent magnet synchronous motor drive control program.

# Table of contents

---

List of related manuals . . . . .	2
-----------------------------------	---

## ***Safety instructions***

What this chapter contains . . . . .	5
Usage of warnings and notes . . . . .	5
Installation and maintenance work . . . . .	6
Grounding . . . . .	10
Fibre optic cables . . . . .	10
Operation . . . . .	11
Permanent magnet motor drives . . . . .	12
Installation and maintenance work . . . . .	12
Operation . . . . .	12
Control program . . . . .	12

## ***Table of contents***

### ***Introduction to this manual***

What this chapter contains . . . . .	21
Target audience . . . . .	21
Categorization according to the frame size . . . . .	21
Contents . . . . .	22
Installation and commissioning flowchart . . . . .	23
Terms and abbreviations . . . . .	24

### ***Hardware description***

What this chapter contains . . . . .	27
ACS800-07 (+V992) . . . . .	27
Cabinet line-up . . . . .	27
Single-line circuit diagram of the drive, example 1 . . . . .	28
Single-line circuit diagram of the drive, example 2 . . . . .	29
Layout drawing, example 1 . . . . .	30
Layout drawing, example 2 . . . . .	31
Swing-out frame . . . . .	33
Power connections and control interfaces of the drive . . . . .	34
Control panel CDP 312R . . . . .	35
To control the supply unit... . . . .	35
To control the inverter unit... . . . .	36
Controls of the inverter unit (and motor) . . . . .	36
Control panel . . . . .	36
Analog and digital I/O signals . . . . .	36
Fieldbus . . . . .	36
Controls of the supply unit . . . . .	37

Main disconnecting device	37
Auxiliary voltage switch	37
Grounding switch	37
Other operating switches	38
Control panel	38
Analog and digital I/O signals	38
Fieldbus	40
Power loss ride-through function	40
Ground fault monitoring	40
Reduced run function	40
Type designation	41

### ***Mechanical installation***

What this chapter contains	45
General	45
Required tools	45
Moving the unit	46
...by crane	46
...by fork-lift or pallet truck	47
...on rollers	47
Laying the unit on its back	47
Final placement of the unit	48
Before installation	49
Delivery check	49
Installation procedure	50
Fastening the cabinet to the floor (Non-marine units)	51
Clamping	51
Holes inside the cabinet	52
Fastening the unit to the floor and wall (Marine units)	53
Joining the shipping splits	54
Procedure	54
Connecting the DC busbars and the PE busbar	55
DC busbars	56
PE busbar	56
Miscellaneous	57
Cable duct in the floor below the cabinet	57
Cooling air intake through bottom of cabinet	58
Example	58
Electric welding	59

### ***Planning the electrical installation***

What this chapter contains	61
Motor selection and compatibility	61
Selecting the motor	61
Protecting the motor insulation and bearings	62
Requirements table	62
Additional requirements for explosion-safe (EX) motors	64
Additional requirements for HXR and AMA motors	64

Additional requirements for ABB motors of types other than M2_, M3_, M4_, HX_ and AM_ . . . . .	64
Additional requirements for the braking applications . . . . .	64
Additional requirements for ABB high-output motors and IP23 motors . . . . .	65
Additional requirements for non-ABB high-output and IP23 motors . . . . .	66
Additional data for calculating the rise time and the peak line-to-line voltage . . . . .	67
Additional note for sine filters . . . . .	67
Permanent magnet motor. . . . .	67
Thermal overload and short-circuit protection . . . . .	68
Thermal overload protection of the drive and the input and motor cables . . . . .	68
Thermal overload protection of the motor . . . . .	68
Protection against short-circuit in the motor cable . . . . .	68
Protection against short-circuit inside the drive or in the supply cable . . . . .	68
Ground fault protection. . . . .	69
Emergency stop devices . . . . .	69
Restarting after an emergency stop . . . . .	69
Prevention of unexpected start-up (option +Q950) . . . . .	70
Safe torque off (option +Q968). . . . .	71
Selecting the power cables . . . . .	72
General rules . . . . .	72
Alternative power cable types . . . . .	73
Power cable types that can be used with the drive are represented below. . . . .	73
Recommended power cable types . . . . .	73
Power cable types for restricted use . . . . .	73
Not allowed power cable types . . . . .	73
Motor cable shield . . . . .	74
Additional US requirements . . . . .	74
Conduit . . . . .	74
Armored cable / shielded power cable . . . . .	74
Power factor compensation capacitors . . . . .	75
Equipment connected to the motor cable. . . . .	75
Installation of safety switches, contactors, connection boxes, etc . . . . .	75
Bypass connection . . . . .	75
Before opening an output contactor (in the DTC motor control mode) . . . . .	76
Relay output contacts and inductive loads. . . . .	76
Selecting the control cables . . . . .	77
Relay cable . . . . .	77
Control panel cable . . . . .	77
Coaxial cable (for use with Advant Controllers AC 80/AC 800) . . . . .	77
Connection of a motor temperature sensor to the drive I/O . . . . .	78
Installation sites above 2000 metres (6562 feet) . . . . .	78
Routing the cables . . . . .	79
Control cable ducts . . . . .	79

### **Electrical installation**

What this chapter contains . . . . .	81
Before installation. . . . .	81
Checking the insulation of the assembly . . . . .	81
Drive . . . . .	81

Supply cable	81
Motor and motor cable	82
IT (ungrounded) systems	82
External earth fault in IT (ungrounded) systems	82
Input power connection – Units without main switch-disconnector or main breaker (no option +F253 or +F255)	83
Connection diagrams	83
Six-pulse connection, two DSU modules in parallel	83
Twelve-pulse connection, two DSU modules in parallel	84
Connection procedure	84
Phase 1 – Removing the module	85
Phase 2 – Installing the cables	88
Phase 3 – Replacing the module	89
Use of the dual-cable screw lug connector	90
Removal of the dual-cable screw lug connector	90
Input power connection – Units with main switch-disconnector or main breaker (option +F253 or +F255)	91
Connection diagrams	91
Six-pulse connection, two DSU modules in parallel	91
Twelve-pulse connection, two DSU modules in parallel	92
Connection procedure	93
Motor connection – Units without common motor terminal cubicle (no option +H359)	94
Connection diagram	94
Connection procedure	95
	96
Motor connection – Units with common motor terminal cubicle (option +H359)	98
Connection diagram	98
Connection procedure	98
Control connections	99
Drive/inverter control connections	99
Supply unit control connections	99
Connection procedure	100
Installation of optional modules and PC	101
PC connection	101
Optional modules	102
Cabling of I/O and fieldbus modules	102
Cabling of pulse encoder interface module	102
Fibre optic link	102
Connections and tap settings of the auxiliary voltage transformer of the drive	103
Switching on and selecting the supply voltage of the auxiliary voltage transformer of the DSU module	104
Installation of brake resistors	104

### **Motor control and I/O board (RMIO)**

What this chapter contains	105
Note on cabinet-installed ACS800 drives	105
Note on the terminal labelling	105
External control connections (non-US)	106
External control connections (US)	107



RMIO board specifications . . . . .	108
Analogue inputs . . . . .	108
Constant voltage output . . . . .	108
Auxiliary power output . . . . .	108
Analogue outputs . . . . .	108
Digital inputs . . . . .	108
Relay outputs . . . . .	109
DDCS fibre optic link . . . . .	109
24 VDC power input . . . . .	109

### **Installation checklist and start-up**

What this chapter contains . . . . .	111
Installation checklist . . . . .	111
Start-up procedure . . . . .	112
Basic checks with no voltage connected . . . . .	112
Connecting voltage to input terminals and auxiliary circuit . . . . .	113
Starting the supply unit . . . . .	113
Setting up the supply unit control program . . . . .	114
Setting up the drive control program . . . . .	114
On-load checks . . . . .	114

### **Maintenance**

What this chapter contains . . . . .	117
Maintenance intervals . . . . .	117
Redundancy (Reduced run capability) . . . . .	118
Removing a DSU module and selecting the Reduced run feature . . . . .	118
Removing an inverter module and selecting the Reduced run feature . . . . .	120
Replacing the PPCS branching unit (APBU-xx) memory backup battery . . . . .	121
Cleaning the cabinet, checking and replacing the air filters . . . . .	122
Checking the connections of the power cables and the quick connectors of the modules . . . . .	122
Cooling fans . . . . .	123
Supply, inverter and brake module cooling fans . . . . .	123
Replacing the fan of the supply module . . . . .	123
Replacing the fan of the inverter and brake module . . . . .	124
Replacing the fans in the auxiliary control cubicle . . . . .	125
Replacing the fan in the incoming cubicle with the main breaker (option +F255) . . . . .	126
Replacing the additional fans in the IP54 / UL type 12 drives (+B055 and +B059) . . . . .	127
Heatsinks . . . . .	129
Cleaning the heatsink . . . . .	129
Capacitors . . . . .	129
Reforming the electrolytic capacitors . . . . .	129
Capacitor replacement . . . . .	129
Safety function checks in the maintenance routine . . . . .	130
Other maintenance actions . . . . .	130
Replacement of a supply inverter or brake modules . . . . .	130

**Fault tracing**

What this chapter contains .....	131
Faults and warnings displayed by the CDP 312R control panel .....	131
Conflicting ID numbers .....	131
Supply module LED .....	132
Other LEDs of the drive .....	132

**Technical data**

What this chapter contains .....	133
Ratings .....	133
Symbols .....	134
Derating .....	134
Temperature derating .....	134
Altitude derating .....	134
ACS800-07 (+V992) frame sizes and power module types .....	135
AC fuses .....	136
DC fuses at inverter module input .....	137
Fuses for main circuit voltage measurement for the BAMU board .....	137
Fuses on the CVAR board .....	137
DC fuses for the DSU module .....	137
Input power connection .....	138
Motor connection .....	140
Efficiency .....	141
Cooling .....	142
Degrees of protection .....	142
Ambient conditions .....	142
Materials .....	143
Tightening torques for power connections .....	143
Applicable standards .....	144
CE marking .....	145
Compliance with the European Low Voltage Directive .....	145
Compliance with the European EMC Directive .....	145
Compliance with the European Machinery Directive .....	145
Compliance with EN 61800-3:2004 .....	145
Definitions .....	145
First environment (PDS of category C2) .....	145
Second environment (PDS of category C3) .....	146
Second environment (PDS of category C4) .....	146
“C-tick” marking .....	146
GOST R certificate of conformity .....	146

**Dimensions**

What this chapter contains .....	149
Cabinet line-ups .....	149
1×D4 + 2×R8i .....	150
2×D4 + 2×R8i .....	151
2×D4 + 4×R8i .....	152

3×D4 + 3×R8i	152
3×D4 + 4×R8i	152
2×D4 + 3×R8i	152
3×D4 + 6×R8i	153
4×D4 + 6×R8i	153
3×D4 + 5×R8i	153
Frame size 1×D4 + 2×R8i	154
Frame size 1×D4 + 2×R8i (with a main switch-disconnector +F253)	157
Frame size 1×D4 + 2×R8i (with top entry/exit)	163
Frame size 2×D4 + 2×R8i	166
Frame size 2×D4 + 2×R8i (with a main switch-disconnector +F253)	169
Frame size 2×D4 + 3×R8i	172
Frame size 2×D4 + 3×R8i (with a main switch-disconnector +F253)	175
Frame size 2×D4 + 3×R8i (with a main breaker +F255)	179
Frame size 3×D4 + 4×R8i (with a main switch-disconnector +F253)	183
Frame size 3×D4 + 4×R8i (with a main breaker +F255)	187
Common motor terminal cubicle	191

### **Resistor braking**

What this chapter contains	195
Resistor braking options	195
Chopper/Resistor combinations – Technical data	196
Brake resistors – Technical data	196
Verifying the capacity of the braking equipment	197
Custom resistors	197
Calculating the maximum braking power ( $P_{br}$ )	198
Example 1	198
Example 2	198
Example 3	199
Custom resistor installation and wiring	200
Brake circuit commissioning	201

### **Further information**

Product and service inquiries	203
Product training	203
Providing feedback on ABB Drives manuals	203
Document library on the Internet	203



# Introduction to this manual

---

## What this chapter contains

This chapter describes the intended audience and contents of the manual. It contains a flowchart of steps in checking the delivery, installing and commissioning the drive. The flowchart refers to chapters/sections in this manual and other manuals.

## Target audience

This manual is intended for people who plan the installation, install, commission, use and service the drive. Read the manual before working on the drive. The reader is expected to know the fundamentals of electricity, wiring, electrical components and electrical schematic symbols.

The manual is written for readers worldwide. Both SI and imperial units are shown. Special US instructions for installations within the United States that must be installed per the National Electrical Code and local codes are marked with (US).

## Categorization according to the frame size

Some instructions, technical data and dimensional drawings which concern only certain drive frame sizes are marked with the symbol of the frame size (such as “1×D4 + 2×R8i”, etc). The frame size is not marked on the drive designation label. To identify the frame size of your drive, see the rating tables in chapter [Technical data](#).

## Contents

The chapters of this manual are briefly described below.

*Safety instructions* gives safety instructions for the installation, commissioning, operation and maintenance of the drive.

*Introduction to this manual* introduces this manual.

*Hardware description* describes the drive.

*Mechanical installation* instructs how to move, place and mount the drive.

*Planning the electrical installation* provides advice on motor and cable selection, the protective functions of the drive, and cable routing.

*Electrical installation* describes the cabling and wiring of the drive.

*Motor control and I/O board (RMIO)* shows external control connections to the motor control and I/O board and its specifications.

*Installation checklist and start-up* helps in checking the mechanical and electrical installation of the drive.

*Maintenance* contains preventive maintenance instructions.

*Fault tracing* contains troubleshooting instructions.

*Technical data* contains the technical specifications of the drive, eg, ratings, frame sizes and technical requirements, provisions for fulfilling the requirements for CE and other markings and warranty policy.

*Dimensions* contains information on the dimensions of the drive.

*Resistor braking* describes how to select, protect and wire optional brake choppers and resistors.

## Installation and commissioning flowchart

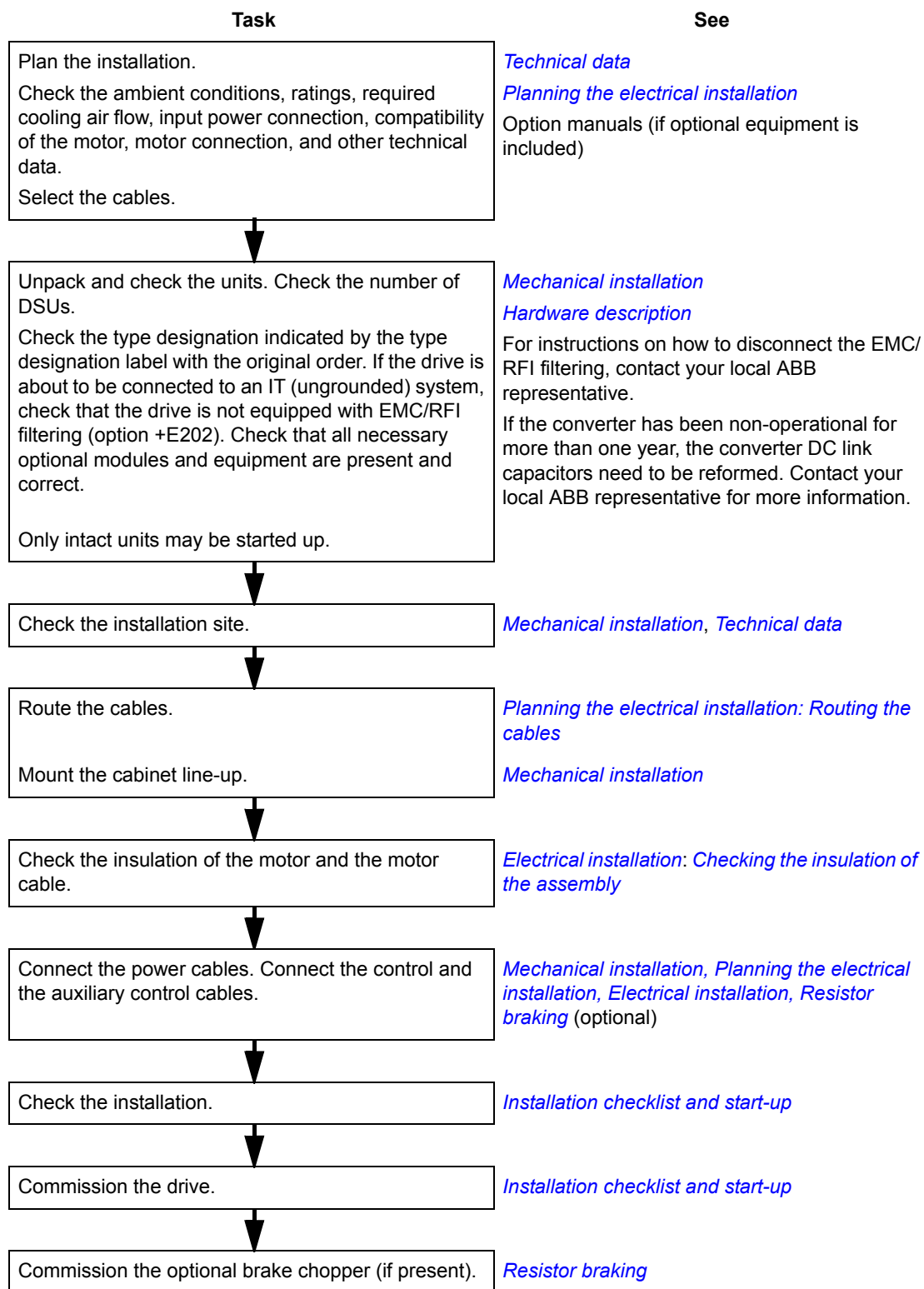

## Terms and abbreviations

Term/Abbreviation	Explanation
ADPI	Control panel interface board
AINT	Main circuit interface board
APBU	Branching unit used for making parallel connections for both supply units and inverter modules
BAMU	Main voltage measurement board
CDP 312R	Control panel type
CINT	Module interface board
CMF	Common mode filtering
CMIB	Interface board to the main circuit thyristors and current measurements
CVAR	Varistor board
DDCS	Distributed drives communication system; a protocol used in optical fiber communication
Diode supply module	See supply module. The rectifier consists of diodes (or diodes and thyristors).
Diode supply unit	See supply unit and diode supply module.
DSU module	Diode supply module
DTC	Direct torque control; a motor control method that provides accurate speed and torque control even without a speed feedback device. Further information is available from <i>ABB Technical guide No. 1: Direct torque control - the world's most advanced AC drive technology</i> (3AFE58056685 [English]).  DTC is also applied to products that feed energy into the power supply network.
EMC	Electromagnetic compatibility
Frame (size)	Relates to the construction type of the component in question For example, several drive types with different power ratings may have the same basic construction, and this term is used in reference to all those drive types.  With the ACS800-07 (+V992) (> 500 kW), the frame size of the drive indicates the quantity and frame size of the supply modules, plus the quantity and frame size of the inverter modules, eg, "2×D4 + 4×R8i".  To determine the frame size of a drive type, see the rating tables in chapter <a href="#">Technical data</a> .
IGBT	Insulated gate bipolar transistor
Inverter	Converter which converts direct current (DC) and voltage into alternating current (AC) and voltage
Inverter module	Inverter and related auxiliary devices enclosed inside a metal frame or enclosure  The inverter module is one of the major building blocks in a cabinet-installed drive.



<b>Term/Abbreviation</b>	<b>Explanation</b>
Inverter unit	Inverter module(s) under control of one control board, and the related auxiliary devices Typically, one inverter unit controls one motor. There is one inverter unit in a single drive (such as ACS800-07) and several in a multidrive installation.
IT network	Type of supply network that has no (low-impedance) connection to ground/earth.
Multidrive	Drive for the control of several motors which are typically coupled to the same machinery There are one supply unit and several inverter units in a multidrive.
PDS	Power drive system
PPCS	Power plate communication system; a protocol used in the optical fiber link that controls the output semiconductors of an inverter module.
RDCO	Satellite board that can be snapped on the RMIO board to add the number of fibre optic channels available
RDCU	Drive control unit The RDCU consists of a control board (RMIO) enclosed inside a plastic casing for an easy snap-on installation. There are two RDCUs in a large single drive: one for the supply unit (supply unit control board) and the other for the inverter unit (inverter unit control board).
Rectifier	Converts alternating current (AC) and voltage into direct current (DC) and voltage
RFI	Radio-frequency interference
RMIO	Motor control and I/O board The RMIO board is a versatile control board and an I/O interface. Its use is determined by the control program loaded into the board. The RMIO board is widely used in the ACS800 product series. It is used for controlling drive modules, inverter units, supply units, cooling units, brake units, etc. See also RDCU.
Single drive	Drive for the control of one motor
Supply module	Rectifier and related auxiliary devices enclosed inside a metal frame or enclosure The supply module is one of the major building blocks of a cabinet-installed drive.
Supply unit	Supply module(s) under control of one control board, and the related auxiliary devices There is one supply unit in a drive.
TN network	Type of supply network that provides a direct connection to ground (earth).
UPS	Uninterruptible power supply



# Hardware description

---

## What this chapter contains

This chapter describes the construction of the drive in short.

## ACS800-07 (+V992)

ACS800-07 (+V992) is a cabinet-mounted drive for controlling AC motors.

### Cabinet line-up

The drive consists of several cubicles that contain the supply and motor terminals, 1 to 4 diode supply module(s), 2 to 6 inverter modules, and optional equipment. The actual arrangement of the cubicles vary from type to type and the selected options. See chapter [Dimensions](#) for the different line-up variations.

### Single-line circuit diagram of the drive, example 1

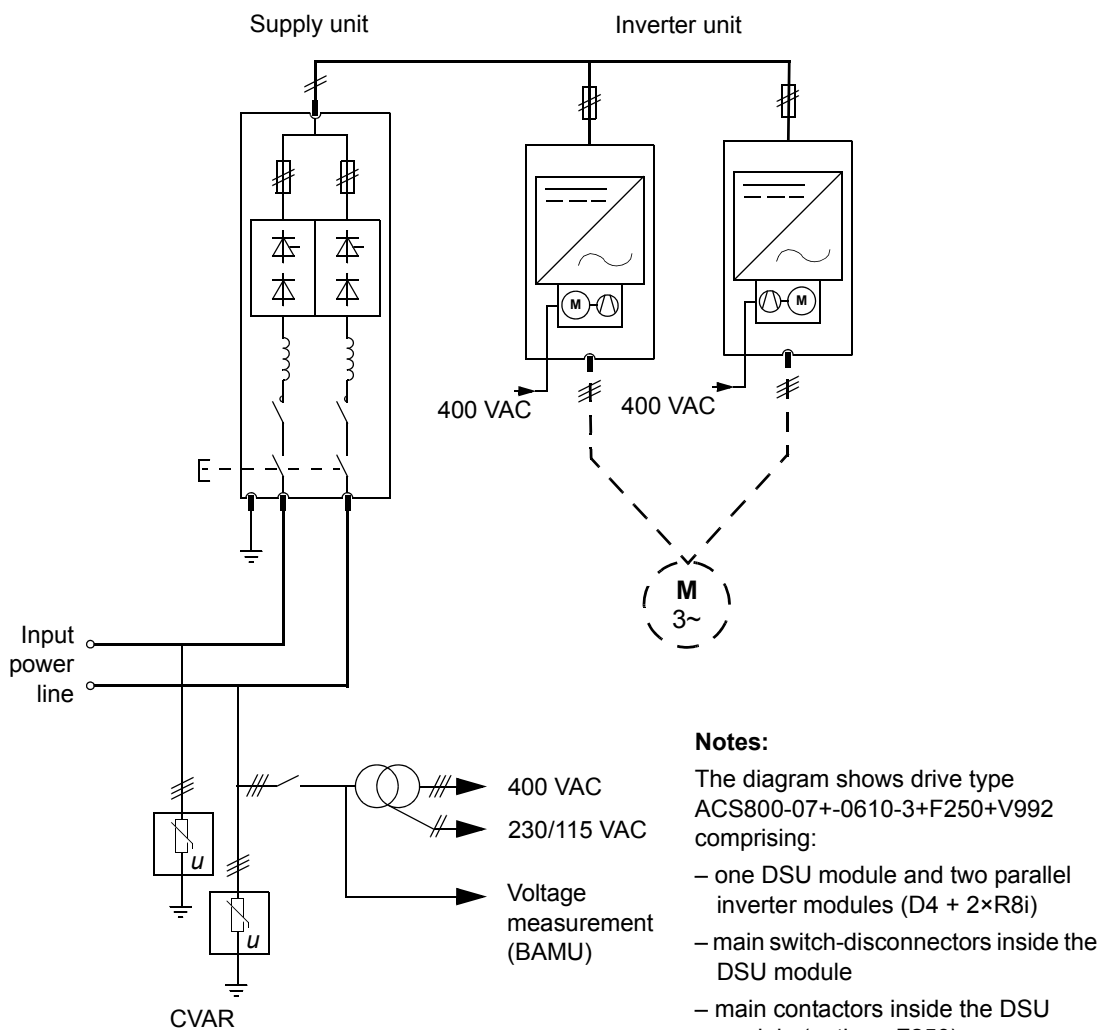

## Single-line circuit diagram of the drive, example 2

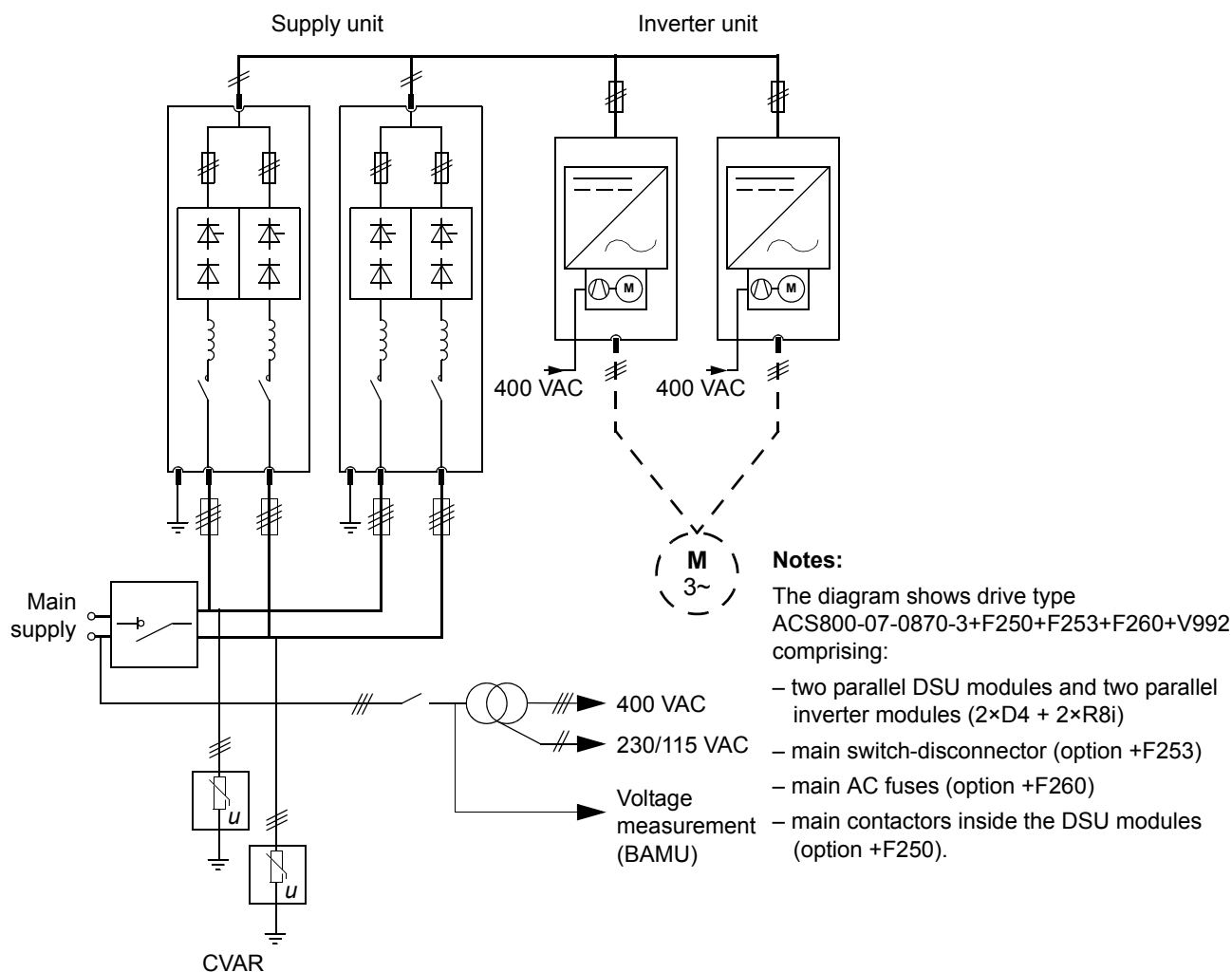

## Layout drawing, example 1

The following drawing shows an ACS800-07-0610-3+F250+V992 drive type comprising:

- one DSU module and two parallel inverter modules (1×D4 + 2×R8i)
- main switch-disconnector inside the DSU module (internal main switch-disconnectors)
- main contactors (option +F250) inside the DSU module.

Auxiliary control cubicle      Supply module cubicle      Inverter module cubicle

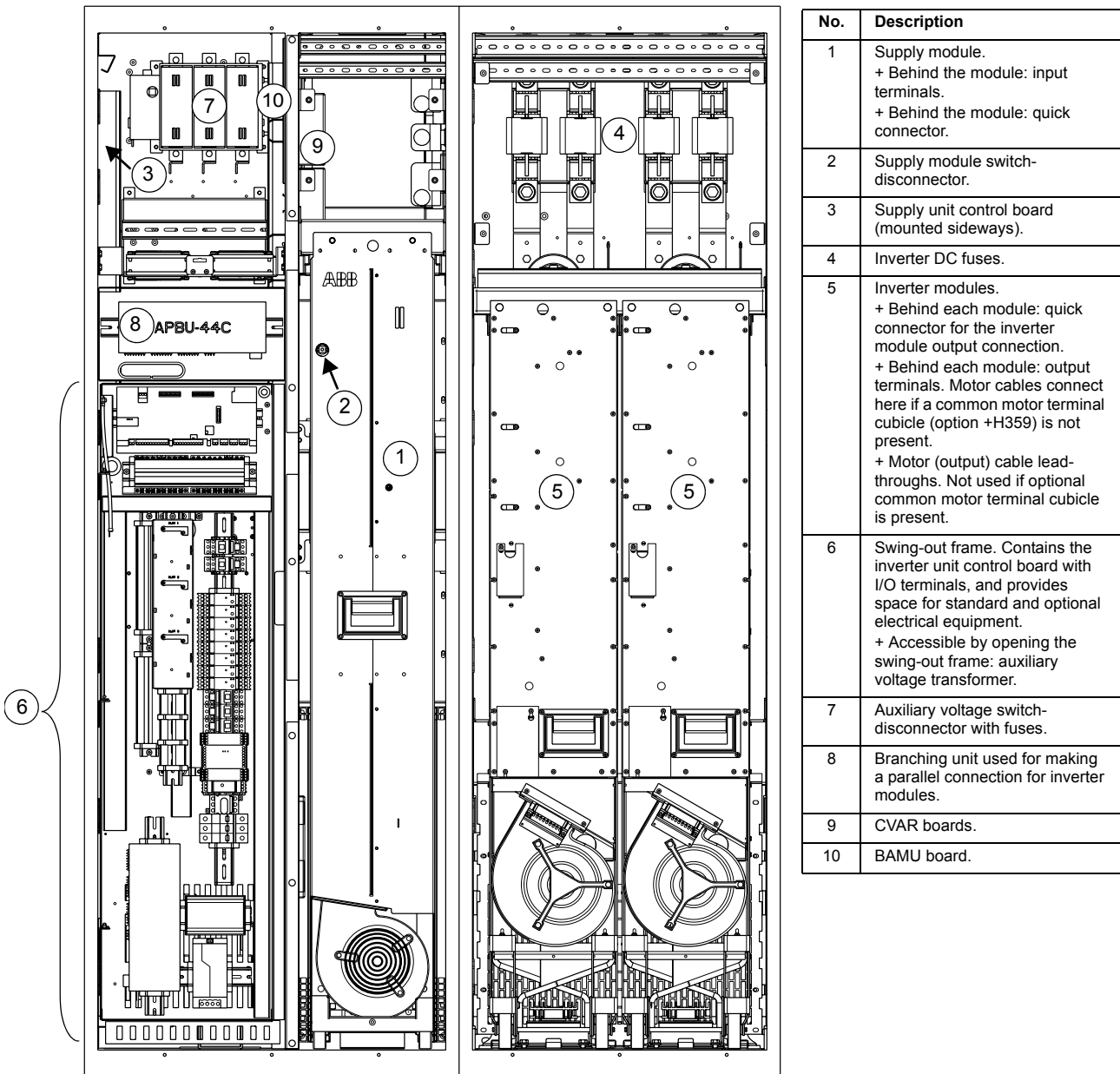

## Layout drawing, example 2

The following drawing shows drive type  
ACS800-07-0870-3+F253+F259+F260+V992 comprising:

- two parallel DSU modules and two parallel inverter modules (2×D4 + 2×R8i)
- optional main switch-disconnector (option +F253) and grounding switch (option +F259)
- main AC fuses (option +F260)
- main contactors (option +F250) inside the DSU modules.

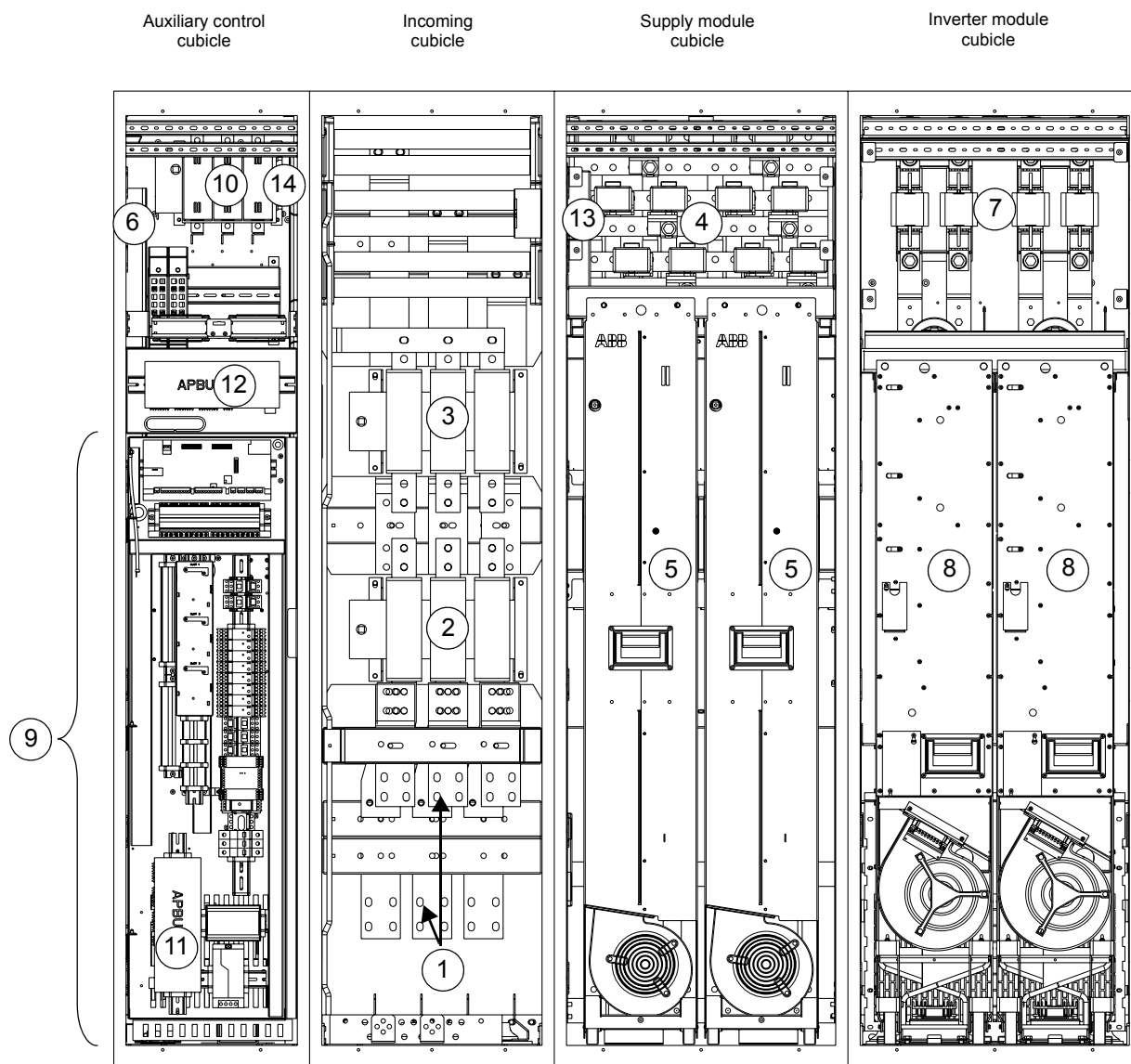

See the legend on the following page.

No.	Description
1	Input busbars.
2	Main switch-disconnector (option +F253) in a dedicated cubicle.
3	Grounding switch (option +F259).
4	AC fuses. Only present if the drive is equipped with a main switch-disconnector or main breaker.
5	Supply modules. + Behind each module: quick connector.
6	Supply unit control board (mounted sideways).
7	Inverter DC fuses.
8	Inverter modules. + Behind each module: quick connector for the inverter module output connection. + Behind each module: output terminals. Motor cables connect here if a common motor terminal cubicle (option +H359) is not present. + Motor (output) cable lead-throughs.
9	Swing-out frame. Contains the inverter unit control board with I/O terminals, and provides space for standard and optional electrical equipment. + Accessible by opening the swing-out frame: auxiliary voltage transformer.
10	Auxiliary voltage switch-disconnector.
11	APBU board for communication between the DSU control board and the parallel-connected DSU modules.
12	APBU board for communication between the inverter unit control board and the parallel-connected inverter modules.
13	CVAR boards.
14	BAMU board.



## Swing-out frame

The swing-out frame inside the auxiliary control cubicle provides space for the inverter unit control board, control electronics of the drive, I/O terminal blocks, and optional electrical equipment. The lead-throughs for I/O cables, the auxiliary voltage transformer, and further space for additional equipment are available behind the frame. The frame can be opened by removing the two locking screws and moving the swing-out frame aside. (Depending on selected options, actual equipment of the drive may differ from what is depicted below.)

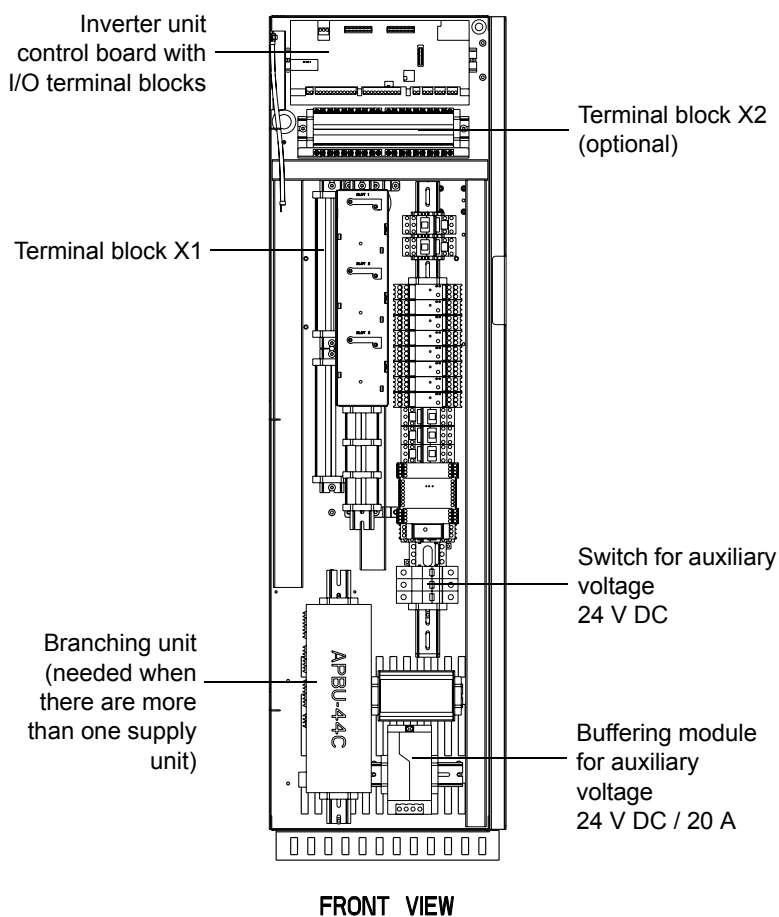

## Power connections and control interfaces of the drive

The following diagram illustrates the power connections and control interfaces of the drive. The table below gives some additional information on the numbered items.

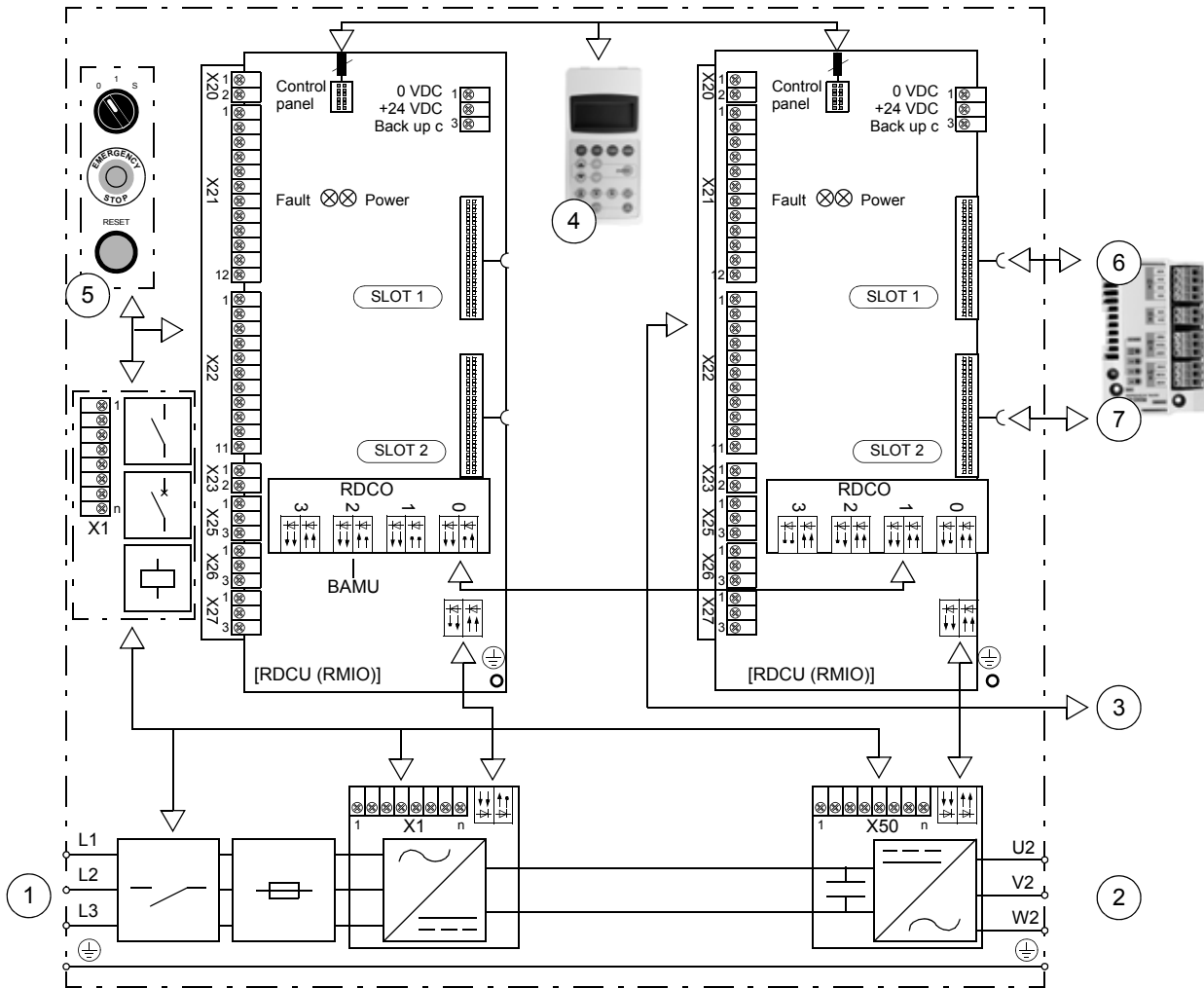

No.	Description	See also page
1	Input power and PE connection terminals	<a href="#">55, 56, 81</a>
2	Motor connection terminals	<a href="#">94, 98, 140</a>
3	Terminal block on the inverter control unit for the user-defined digital and analogue control signals	<a href="#">36</a>
4	Control panel	<a href="#">35</a>
5	Operation switches: main contactor/breaker control and supply unit start, emergency stop, reset etc. Composition vary depending on the options in use.	<a href="#">38</a>
6	Slot 1 on the inverter control unit for an optional I/O extension module (RAIO, RDIO), pulse encoder interface module (RTAC), or fieldbus adapter module (eg, RMBA, RDNA, RPBA)	<a href="#">101</a>
7	Slot 2 on the inverter control unit for an optional I/O extension module (RAIO, RDIO) or pulse encoder interface module (RTAC)	<a href="#">101</a>

## Control panel CDP 312R

A control panel (type CDP 312R) is installed on the door of the drive. The CDP 312R is the user interface of the supply unit and the inverter unit of the drive, providing the essential controls such as Start/Stop/Direction/Reset/Reference, and the parameter settings for the units' control programs. More information on using the panel can be found in the *Firmware Manual* delivered with the drive.

The control panel is wired to both the supply unit and the inverter unit. By default, the panel is set to control the inverter unit. The unit that is currently being controlled is indicated by the ID number. The ID number can be seen in the Drive Selection Mode of the panel. By default, one (1) denotes the inverter unit and two (2) denotes the supply unit.

The control panel can communicate with and control only one of the units at a time, and it displays the Warning and Fault messages of the unit it controls. In addition, the panel indicates the active warnings and faults in the unit that is not currently being controlled (for more information, see chapter [Fault tracing](#)).





**WARNING!** Switch the control panel from the inverter unit to the supply unit only when the motor is stopped and you do not need the panel for stopping the motor. You cannot stop the motor using the control panel when the panel is controlling the supply unit.

The control is switched between the units as follows:

*To control the supply unit...*

Step	Action	Press...	Display (example)
1.	To enter the Drive Selection Mode <b>Note:</b> In local control mode, the inverter unit trips if parameter 30.02 PANEL LOSS is set to FAULT. Refer to the appropriate control program firmware manual.		ACS 800 610_3Sx ASXR7xxx ID-NUMBER 1
2.	To scroll to ID number 2		ACS 800 0910_7NR IXXR7xxx ID-NUMBER 2
3.	To verify the change to the supply unit and display the warning or fault text		2 -> 380.0 V ACS 800 0910_7NR *** FAULT *** DC OVERVOLT (3220)

To control the inverter unit...

Step	Action	Press...	Display (example)
1.	To enter the Drive Section Mode		ACS 800 0910_3LR IXXR7xxx ID-NUMBER 2
2.	To scroll to ID number 1		ACS 800 0910_3Sx ASXR7xxx ID-NUMBER 1
3.	To verify the change to the inverter unit		1 L -> 0.0 rpm I FREQ 0.00 Hz CURRENT 0.00 A POWER 0.00 %

## Controls of the inverter unit (and motor)

The inverter control program runs in the RDCU control unit located in the swing-out frame. The RDCU is connected to the inverter modules by a fibre optic link, distributed through an optical branching unit. In the inverter modules, the optic link connects to the AINT board, the terminals of which are accessible through a hole on the front panel of the module.

The user controls the inverter unit (and motor) with the control panel, the I/O interface on the control board or through the fieldbus interface.

### Control panel

A control panel is installed on the door of the drive. The panel is the user interface of the inverters of the drive, providing the essential controls such as Start/Stop/Direction/Reset/Reference, and the parameter settings for the drive control program. The panel can also be used for the set-up and monitoring of the supply unit (see section [Control panel CDP 312R](#) on page 35). See the *Firmware manual of the drive control program* and *ACS800 diode supply control program firmware manual* (3AUA0000068937[English]) for further information.

### Analog and digital I/O signals

For the default I/O diagram, see [External control connections \(non-US\)](#) and [External control connections \(US\)](#).

### Fieldbus

See the appropriate *Firmware manual* of the drive control program.

## Controls of the supply unit

The supply unit control program runs in the RDCU control unit located in the swing-out frame. The RDCU is connected to the supply modules by a fibre optic link, and a separate wire set. If there are parallel supply modules, the controls from the RDCU are distributed to the modules with an optical branching unit (APBU board). The RDCU is also connected to the inverter unit with a fibre optic link and to the panel through the panel link.

Typically, the user controls the supply unit with the control devices mounted on the cabinet door. The use of these control devices is described in the following subsections. No additional control devices or connections are needed. However, it is also possible to control the unit with the control panel and through the fieldbus.

### Main disconnecting device

The drive is always equipped with a main disconnecting device. The device is either the main switch-disconnector inside the module (no option +F253 or +F255), the main switch-disconnector outside the module (option +F253), or the main breaker outside the module (option +F255).

The user operates the main switch-disconnector(s) with a handle on the cabinet door. The breaker is withdrawable; its must be racked out when disconnection is needed.



**WARNING!** The main disconnecting device does not switch off the auxiliary voltages inside the cabinet.

---

### Auxiliary voltage switch

The auxiliary voltage switch controls the voltage supply for the auxiliary circuits.

**Note:** If the drive is equipped with an uninterruptible power supply (option +G307) there is also an additional switch-disconnector inside the cabinet for the UPS circuit.

### Grounding switch

A grounding switch for the temporary grounding is an option (+F259). The user operates the switch from a handle on the cabinet door.

## Other operating switches

Depending on the drive options, the switches shown in the drawing below may be mounted on the door of the cabinet.

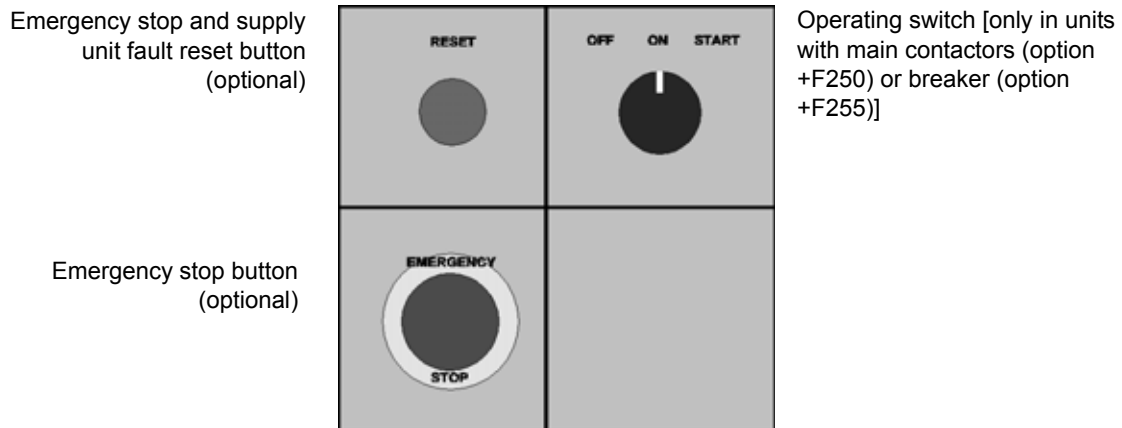

**Note:** On units without the line contactor option (+F250), main breaker option (+F255) or the main switch-disconnector option (+F253), the supply unit will start rectifying as soon as the user closes the switch-disconnector(s) of the supply module(s). There is no separate operating switch for the start on the cabinet door.

## Control panel

There is one panel on the cabinet door which communicates with the inverter unit by default. However, the panel link is also wired to the control board of the supply unit. You can change the communication from the inverter unit to the supply unit (see section [Control panel CDP 312R](#) on page 35), after which it is possible to:

- view and reset fault and warning messages, and view the fault history
- view actual signals
- change parameter settings
- change between the local and external control and, in the local control, start and stop the supply unit.

For the instructions on the use of the panel, see the appropriate *Firmware manual of the drive control program*. For details on the supply unit control program, see *ACS800 diode supply control program firmware manual* (3AUA0000068937[English]).

## Analog and digital I/O signals

The diagram below shows the I/O signal connections of a standard diode supply unit.

**Note:** The I/O setting is reserved for the internal use. Do not change the wiring.

**Note:** The I/O connections of the delivery may vary somewhat from what is represented depending on which options are in use. Always refer to the circuit diagram set delivered with the drive if in doubt of the applicability.

The default cable connections to the RMIO board of the DSU are shown below.

**Terminal block size:**

cables 0.3 to 3.3 mm<sup>2</sup> (22 to 12 AWG)

**Tightening torque:**

0.2 to 0.4 Nm (2 to 4 lbf in.)

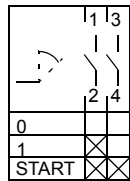

\* Three-position operating switch

- 1) Non-programmable I/O
- 2) External alarm/fault indication via digital input DI4: See parameter 30.04 DI4 EXT EVENT.
- 3) External alarm/fault indication via digital input DI5: See parameter 30.05 DI5 EXT EVENT.
- 4) Acknowledgement from the main breaker (if in use). If there is no main breaker but the module-in-built contactors are in use, the contactors are monitored by the CMIB board.

X20

1	VREF-	Reference voltage -10 VDC,
2	GND	$1 \text{ kohm} \leq R_L \leq 10 \text{ kohm}$

X21

1	VREF+	Reference voltage 10 VDC,
2	GND	$1 \text{ kohm} \leq R_L \leq 10 \text{ kohm}$
3	AI1+	By default, not in use. 0(2) ... 10 V, $R_{in} > 200 \text{ kohm}$
4	AI1-	
5	AI2+	By default, not in use. 0(4) ... 20 mA, $R_{in} = 100 \text{ ohm}$
6	AI2-	
7	AI3+	By default, not in use. 0(4) ... 20 mA, $R_{in} = 100 \text{ ohm}$
8	AI3-	
9	AO1+	By default, not in use. 0(4) ... 20 mA, $R_L \leq 700 \text{ ohm}$
10	AO1-	
11	AO2+	By default, not in use. 0(4) ... 20 mA, $R_L \leq 700 \text{ ohm}$
12	AO2-	

X22

1	DI1	Overtemperature supervision <sup>1)</sup>
2	DI2	On / Off <sup>1)</sup>
3	DI3	Start (  rising edge start <sup>1)</sup>
4	DI4	By default, not in use. <sup>2)</sup>
5	DI5	Fault (0) <sup>3)</sup>
6	DI6	Reset <sup>1)</sup>
7	+24V	+24 VDC max. 100 mA
8	+24V	
9	DGND	Digital ground
10	DGND	Digital ground
11	DI7(DIIL)	By default, not in use. <sup>4)</sup>

X23

1	+24V	Auxiliary voltage output, non-isolated, 24 VDC 250 mA
2	GND	

X25

1	RO11	Relay output 1: Running
2	RO12	
3	RO13	

X26

1	RO21	Relay output 2: Fault (-1)
2	RO22	
3	RO23	

X27

1	RO31	Relay output 3: Main contactor/ breaker control <sup>1)</sup>
2	RO32	
3	RO33	

24 V DC / 115 V AC / 230 V AC →  
Contactor or breaker on/off ←

## Fieldbus

For more information on the fieldbus communication, see *ACS800 diode supply control program firmware manual* (3AUA0000068937[English]).

## Power loss ride-through function

The power loss ride-through function keeps the supply unit operative over an unexpected input power break. You can activate the function and define the delay time in the DSU control program. For more information, see *ACS800 diode supply control program firmware manual* (3AUA0000068937 [English]).

**Note:** Supply units equipped with a main breaker (option +F255) have the ride-through function available only when a terminal for external control voltage (option +G307) is used and supplied with UPS. With a main switch-disconnector (option +F253) the ride-through function is available as standard also without the UPS.

## Ground fault monitoring

Ground fault current monitoring is available on the inverter side for TN networks.

The DSU does not monitor ground current in an IT (ungrounded) network. However, the unit can be equipped with an optional insulation monitoring device (option +Q954). The device detects ground faults by monitoring the insulation resistance between the power line and ground. When the resistance value goes below the user-defined limit, the device evokes the DSU ground fault monitoring through a digital input. You can define the DSU operation in an ground fault with the DSU parameters. For more information, see the documentation of the monitoring device delivered with the drive, and parameter group 30 in *ACS800 diode supply control program firmware manual* (3AUA0000068937[English]).

## Reduced run function

If one of the parallel-connected supply or inverter modules must be taken out of the cabinet for service, it is possible to continue operation using the remaining modules at reduced power. See [Redundancy \(Reduced run capability\)](#).



## Type designation

The type code of the drive is indicated on the type designation label, attached on a door of the supply unit. The type code contains information on the specifications and configuration of the drive. The first digits from left express the basic configuration (for example, ACS800-07-0610-3+V992). The optional selections are given thereafter, separated by + signs (for example, +E202). The main selections are described below.

**Note:** The information below is for quick reference only and does not contain all conditions and details. For more information, refer to *ACS800 Ordering Information* (3AFY64556568), available through ABB representatives.

Selection	Alternatives
<b>Product series</b>	ACS800 product series
<b>Type</b>	<b>07</b> = cabinet-mounted When no options are selected: IP21 (UL Type 1), main switch/disconnector(s), 230 V auxiliary voltage, <i>du/dt</i> filtering (+E205), common mode filtering (CMF) (+E208), EMC/RFI filtering for second environment (+E210), drive control program, bottom entry/exit of cables, coated circuit boards, set of English manuals.
<b>Size</b>	Refer to <i>Technical data: Ratings</i> .
<b>Voltage range</b> (nominal rating in <b>bold</b> )	<b>3</b> = 380/ <b>400</b> /415 VAC <b>5</b> = 380/400/415/440/460/480/ <b>500</b> VAC <b>7</b> = 525/575/600/ <b>690</b> VAC
+ options	
<b>I/O options</b>	Refer to <i>ACS800 Ordering Information</i> (3AFY64556568 [English]).
<b>Fieldbus adapter</b>	
<b>Control program</b>	
<b>Degree of protection</b>	<b>B053</b> = IP22 (UL Type 1) <b>B054</b> = IP42 (UL Type 1) <b>B055</b> = IP54 (UL Type 12) (Not available with +C134) <b>B059</b> = IP54R (with connection to air outlet duct)
<b>Construction</b>	<b>C121</b> = Marine construction (reinforced mechanical parts and fastening, marking of conductors [A1], door handles, self-extinctive materials) <b>C129</b> = UL Listed (115 V AC auxiliary voltage, cable conduit entries, all components UL listed/recognized, max. supply voltage 600 V; +F253, +F260 and top entry of cables are standard) <b>C134</b> = CSA Approved (as +C129, with CSA approved components)
<b>Filters</b>	<b>E202</b> = EMC/RFI filtering for first environment TN (grounded) system, restricted (A-limits). Only for 6-pulse ACS800-07-0610-3 and -0760-5. Requires +F253 and +F260. <b>E206</b> = Sine output filters (Not available with +C121, +C129 or +C134) <b>Note:</b> <i>du/dt</i> filtering (+E205), common mode filtering (CMF) (+E208), and EMC/RFI filtering for second environment (+E210) are standard equipment.
<b>Resistor braking</b>	<b>D150</b> = brake choppers <b>D151</b> = brake resistors (not available in IP54 or IP54R)

Selection	Alternatives
<b>Line options</b>	<p><b>F250</b> = main contactors inside the DSU modules</p> <p><b>F253+F260</b> = aR AC fuses + main switch-disconnector (6-pulse) (Main switch-disconnectors in DSU modules removed)</p> <p><b>A004+F253+F260</b> = aR AC fuses + main switch-disconnector (12-pulse) (Main switch-disconnectors in supply modules removed) (with +C129 and +C134, second cubicle for main switch-disconnector added)</p> <p><b>F255+F260</b> = main breaker (6-pulse only) (Not available with frame 1×D4 + n×R8i) (Main switch-disconnectors and main contactors in supply modules removed)</p> <p><b>F259</b> = grounding switch (only with +F253 or +F255) (Not available with +C129 or +C134)</p>
<b>Version</b>	<b>V992</b> = DSU version 2 not backward compatible with those diode supply units that are not marked with the +V992 code
<b>Cabling</b>	<p><b>H351</b> = top entry (IP54 and IP54R require +F253 or +F255)</p> <p><b>H353</b> = top exit</p> <p><b>H350</b> = Bottom entry (only with +C129)</p> <p><b>H352</b> = Bottom exit (only with +C129)</p> <p><b>H358</b> = US/UK gland/conduit plate (standard with +C129 and +C134)</p> <p><b>H359</b> = common motor terminal cubicle</p>
<b>Auxiliary voltage</b>	<b>G304</b> = 115 VAC auxiliary voltage (standard with +C129 and +C134)
<b>Cabinet options</b>	<p><b>G300</b> = cabinet heaters (external supply) (Not available with option +C129 or +C134)</p> <p><b>G313</b> = motor heater output (external supply)</p> <p><b>G307</b> = terminals for external control voltage (UPS)</p> <p><b>G317</b> = busbar supply conductors (6-pulse only) (Requires option +F253 or +F255)</p> <p><b>G330</b> = halogen-free wiring and materials (Not available with option +C129 or +C134)</p> <p><b>G338</b> = additional wire markings (Equipment pin numbers are printed on wires between modules and on wires connected to equipment.)</p> <p><b>G339</b> = additional wire markings (Equipment and terminal block pin numbers are printed on wires between modules and on wires connected to equipment and terminal blocks. Main circuit conductors are marked.)</p> <p><b>G340</b> = additional wire markings (Equipment pin numbers are marked with rings on wires between modules and on wires connected to equipment, terminal blocks and detachable screw terminals. Main circuit conductors are marked.)</p> <p><b>G341</b> = additional wire markings (Equipment identifications and terminal block pin numbers are marked by rings on optical fibres, on wires between modules, and on wires connected to equipment, terminal blocks and detachable screw terminals. Main circuit conductors and also short and obvious connections are marked.)</p> <p><b>G342</b> = additional wire markings (Equipment identifications and terminal block pin numbers and remote addresses are marked by rings on optical fibres, on wires between modules, and on wires connected to equipment, terminal blocks and detachable screw terminals. Main circuit conductors and also short and obvious connections are marked.)</p>
<b>Language of manuals</b>	<p><b>Rxxx</b></p> <p>Refer to <i>ACS800 Ordering Information</i> (3AFY64556568 [English]).</p>
<b>Starter of auxiliary motor fan</b>	<p><b>M602</b> = 2.5 ... 4 A (1, 2 or 4 pcs)</p> <p><b>M603</b> = 4 ... 6.3 A (1, 2 or 4 pcs)</p> <p><b>M604</b> = 6.3 ... 10 A (1, 2 or 4 pcs)</p> <p><b>M605</b> = 10 ... 16 A (1 or 2 pcs)</p> <p><b>M606</b> = 16 ... 25 A (1 pc)</p>

Selection	Alternatives
<b>Safety features</b>	<p><b>Q950</b> = Prevention of unexpected start-up (Category 3) (not with +Q968, +Q963, +Q964, +Q971)</p> <p><b>Q951</b> = Emergency stop, stop category 0 with opening the main contactor/breaker</p> <p><b>Q952</b> = Emergency stop, stop category 1 with opening the main contactor/breaker</p> <p><b>Q954</b> = Ground fault monitoring (IT [ungrounded] system)</p> <p><b>Q959</b> = Red-coloured trip push button for external breaker</p> <p><b>Q963</b> = Emergency stop, stop category 0 without opening the main contactor/breaker</p> <p><b>Q964</b> = Emergency stop, stop category 1 without opening the main contactor/breaker SS1</p> <p><b>Q968</b> = Safe torque off with a safety relay</p> <p><b>Q971</b> = ATEX certified safety function (only with +L513 and +L514, not with +Q950)</p>
<b>Special</b>	<p><b>P902</b> = customised (described in Technical appendix on ordering)</p> <p><b>P904</b> = extended warranty</p> <p><b>P913</b> = special colour</p>



# Mechanical installation

---

## What this chapter contains

This chapter describes the mechanical installation procedure of the drive.

## General

See chapter [Technical data](#) for allowable operating conditions and requirements for free space around the unit.

The unit should be installed in an upright vertical position.

**The floor** that the unit is installed on should be of non-flammable material, as smooth as possible, and strong enough to support the weight of the unit. The floor flatness must be checked with a spirit level before the installation of the cabinets into their final position. The maximum allowed deviation from the surface level is 5 mm in every 3 metres. The installation site should be levelled, if necessary, as the cabinet is not equipped with adjustable feet.

**The wall** behind the unit should be of non-flammable material.

Provide the drive with the amount of fresh **cooling air** given in [Installation procedure](#).

**Note:** Very wide cabinet line-ups are delivered as “shipping splits”.

## Required tools

The tools required for moving the unit to its final position, fastening it to the floor and tightening the connections are listed below:

- crane, fork-lift or pallet truck (check load capacity!); iron bar, jack and rollers
- Pozidrive and Torx (2.5–6 mm) screwdrivers for the tightening of the frame screws
- torque wrench
- set of wrenches or sockets for joining shipping splits.

## Moving the unit

...by crane

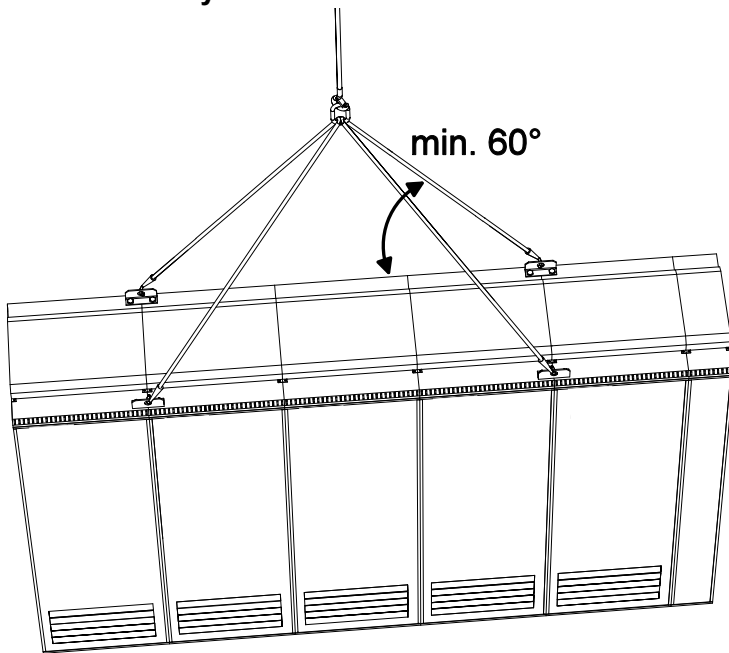

Use the steel lifting lugs attached to the top of the cabinet. Insert the lifting ropes or slings into the holes of the lifting lugs.

The lifting lugs can be removed (not mandatory) once the cabinet is in its final position. **If the lifting lugs are removed, the bolts must be refastened to retain the degree of protection of the cabinet.**

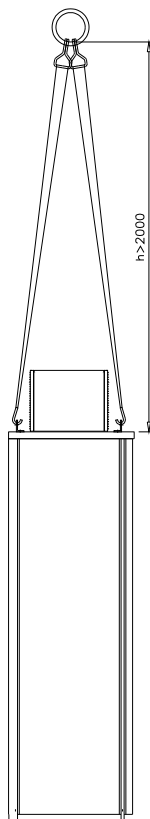

### IP54 units

Allowed minimum height of lifting ropes or slings for IP54 units is 2 metres (6.6 feet).

### ...by fork-lift or pallet truck

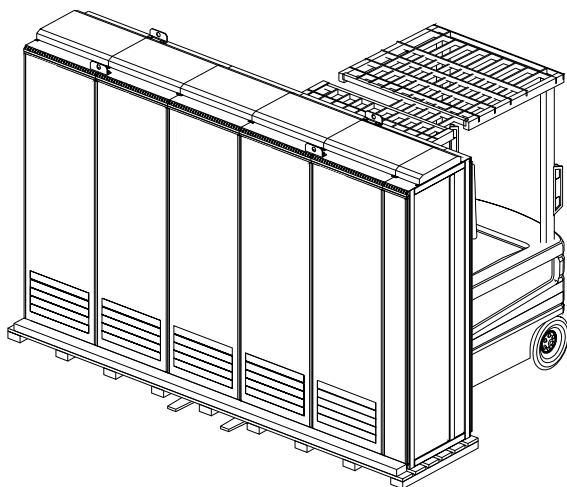

The center of gravity may be quite high. Be therefore careful when transporting the unit. Tilting the cabinets must be avoided.

The units are to be moved only in the upright position.

If using a pallet truck, check its load capacity before attempting to move the unit.

### ...on rollers

(Not allowed with Marine versions)

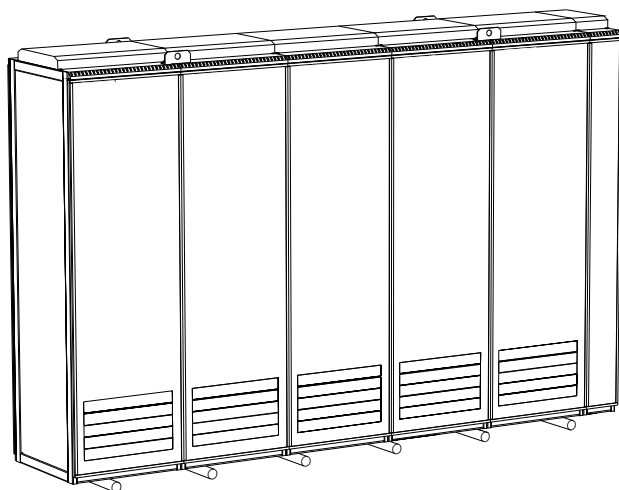

Remove the wooden bottom frame which is part of the shipment.

Lay the unit on the rollers and move it carefully until close to its final location.

Remove the rollers by lifting the unit with a crane, fork-lift, pallet truck or jack as described above.

### Laying the unit on its back

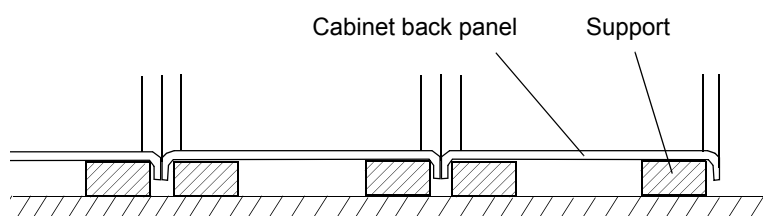

If the cabinet needs to be laid on its back, it must be supported from below beside the cubicle seams as shown.

#### Notes:

- Transportation of a unit on its back is only allowed if the unit is equipped for such transportation at the factory.
- Never lay or transport a unit with sine filters (ie, with option code +E206) on its back.

### Final placement of the unit

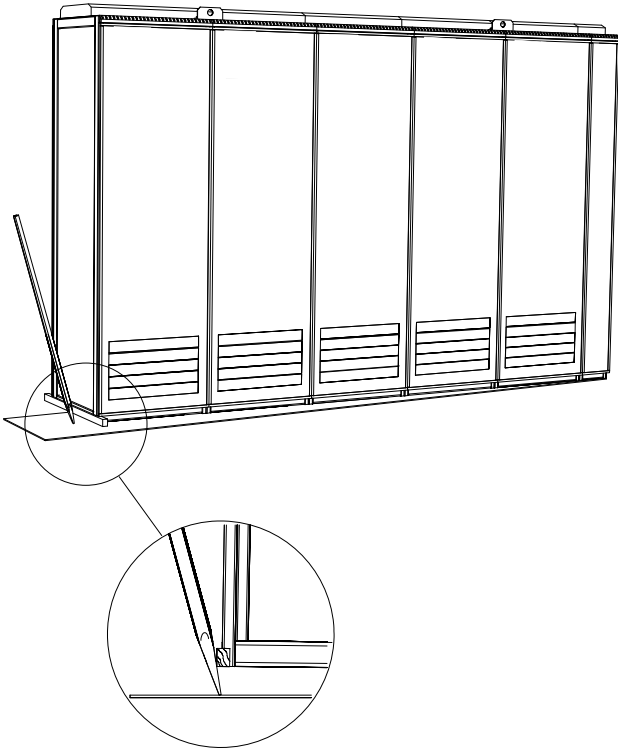

The cabinet can be moved into its final position with an iron bar and a wooden piece at the bottom edge of the cabinet. Care is to be taken to properly place the wooden piece so as not to damage the cabinet frame.



## Before installation

### Delivery check

The drive delivery contains:

- drive cabinet line-up
- optional modules (if ordered) installed into the control rack at the factory
- ramp for extracting supply and inverter modules from the cabinet
- hardware manual
- appropriate firmware manuals and guides
- optional module manuals
- delivery documents.

Check that there are no signs of damage. Before attempting installation and operation, check the information on the type designation label of the drive to verify that the unit is of the correct type. The label includes an IEC and NEMA rating, C-UL US, and CSA markings, a type designation and a serial number, which allow individual recognition of each unit. The first digit of the serial number refers to the manufacturing plant. The next four digits refer to the unit's manufacturing year and week respectively. The remaining digits complete the serial number so that there are no two units with the same serial number.

The following type designation label is located on the supply unit door.

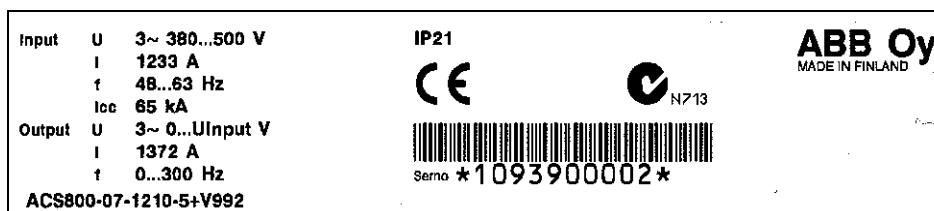

In addition to the actual type designation label, there are the following two labels attached elsewhere on the drive.

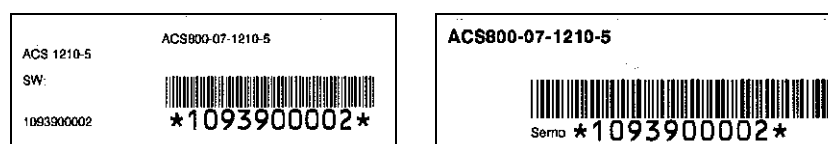

Each power module (ie, supply and inverter module) is also individually labelled.

## Installation procedure

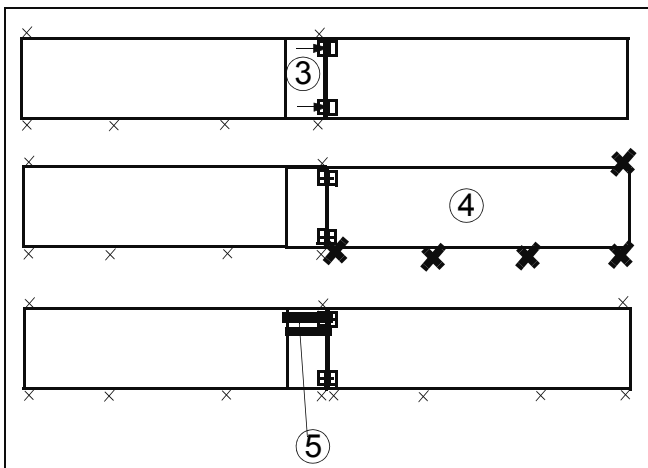
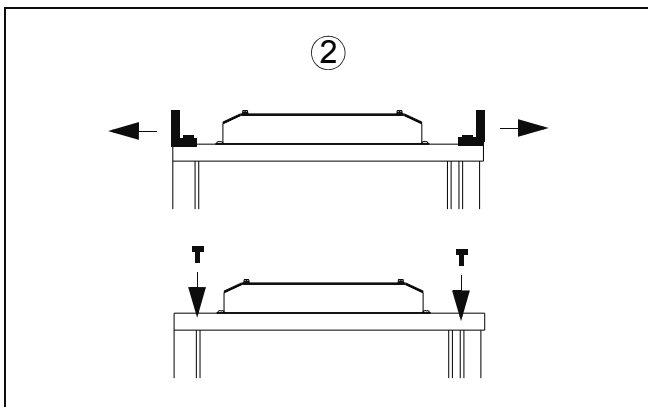
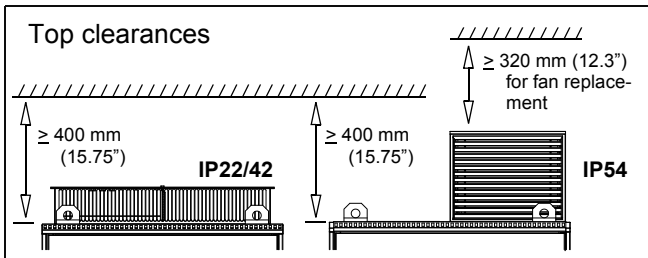
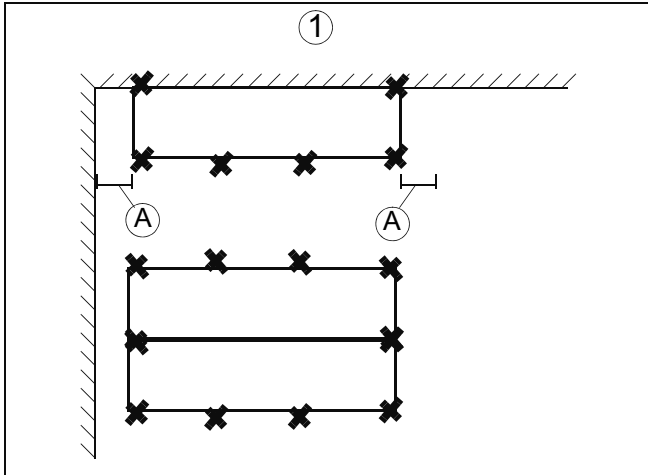

See detailed instructions in the following few pages.

(1) The cabinet can be installed with its back against a wall, or back-to-back with another unit. Fasten the unit (or first shipping split) to the floor with fastening clamps or through the holes inside the cabinet. See section *Fastening the cabinet to the floor (Non-marine units)*.

With marine versions, fasten the unit (or first shipping split) to the floor and wall/roof as described in section *Fastening the unit to the floor and wall (Marine units)*.

**Note:** A clearance of 400 mm (15.75") minimum above the basic roof level of the cabinet (see inset on left) is required for cooling.

**Note:** Leave some space at the left-hand and right-hand sides of the line-up (A) to allow the doors to open sufficiently.

**Note:** Any height adjustment must be done before fastening the units or shipping splits together. Height adjustment can be done by using metal shims between the bottom frame and floor.

(2) Remove the lifting bars (if present). In marine units, also replace the lifting lugs with L-profiles (see below). Use the original bolts to block any unused holes.

(3) If the line-up consists of shipping splits, fasten the first split to the second. Each shipping split includes a joining cubicle where the busbars connect to the next split.

(4) Fasten the second shipping split to the floor.

(5) Join the DC busbars and the PE busbars.

(6) Repeat steps (2) to (5) for the remaining shipping splits.

## Fastening the cabinet to the floor (Non-marine units)

The cabinet is to be fastened to the floor by using clamps along the edge of the cabinet bottom, or by bolting the cabinet to the floor through the holes inside.

### Clamping

Insert the clamps into the twin slots along the front and rear edges of the cabinet frame body and fasten them to the floor with a bolt. The recommended maximum distance between the clamps is 800 mm (31.5”).

If there is not enough working space behind the cabinet for mounting, replace the lifting lugs at the top with L-brackets (not included) and fasten the top of the cabinet to the wall.

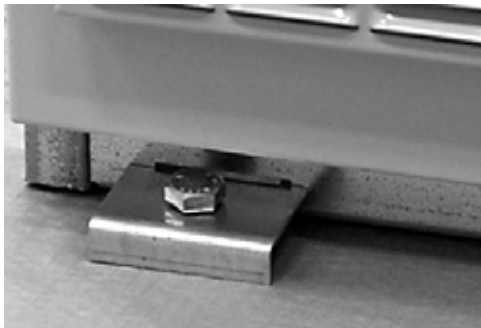

Slot detail, front view  
(dimensions in millimetres)

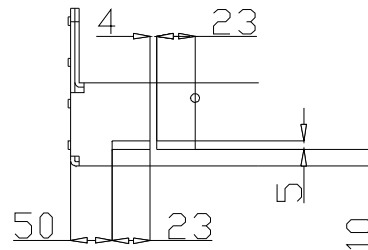

Clamp dimensions (in millimetres)

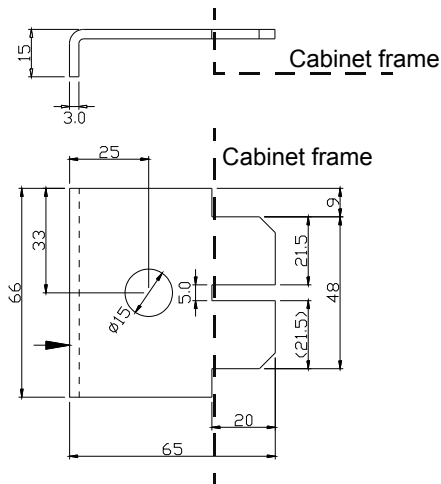

Distances between slots

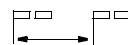
Cubicle Width (mm)	Distance in millimetres and (inches)
	
300	150 (5.9")
400	250 (9.85")
600	450 (17.7")
700	550 (21.65")
800	650 (25.6")

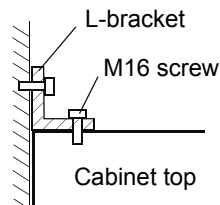

Fastening the cabinet at the top with L-brackets (side view)

**Holes inside the cabinet**

The cabinet can be fastened to the floor using the fastening holes inside the cabinet, if they are accessible. The recommended maximum distance between the fastening points is 800 mm (31.5”).

If there is not enough working space behind the cabinet for mounting, replace the lifting lugs at the top with L-brackets (not included) and fasten the top of the cabinet to the wall.

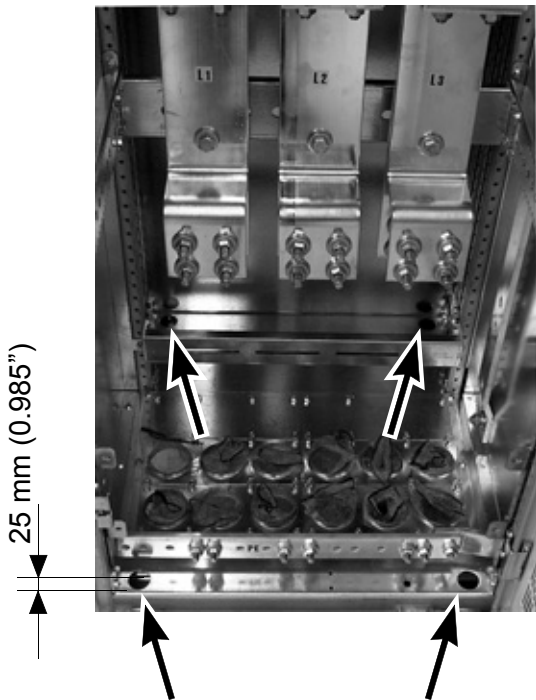

Fastening holes inside the cabinet (marked with arrows)

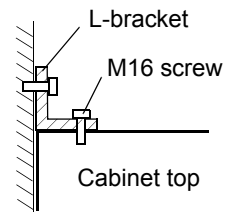

Fastening the cabinet at the top with L-brackets (side view)

Distances between fastening holes  
Bolt size: M10 to M12 (3/8” to 1/2”).

Cubicle Width	Distance between holes	
		Outer Ø31 mm (1.22”)
300		150 mm (5.9”)
400		250 (9.85”)
600		450 (17.7”)
700		550 (21.65”)
800		650 (25.6”)

**Added width:**

Side panels of the cabinet: 15 mm (0.6”)  
Back panel of the cabinet: 10 mm (0.4”)  
Gap between cubicles (mm):

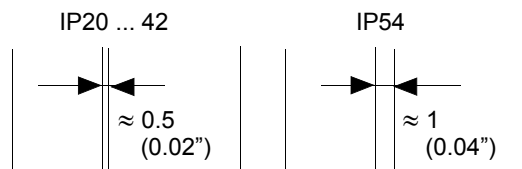

## Fastening the unit to the floor and wall (Marine units)

The unit must be fastened to the floor and roof (wall) as follows:

- ① Bolt the unit to the floor through the holes in each flat bar at the base of the cabinet using M10 or M12 screws.
- ② If there is not enough room behind the cabinet for installation, clamp the rear ends of the flat bars as shown in figure (2).
- ③ Fasten the top of the cabinet to the rear wall and/or roof using brackets.

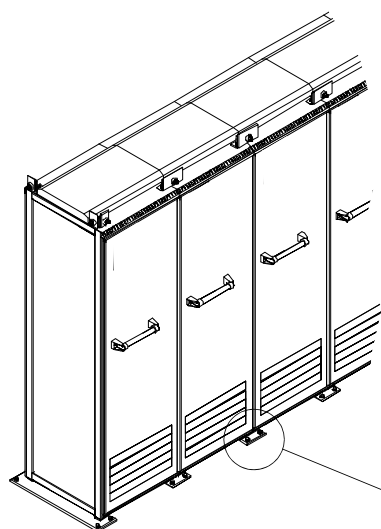

1

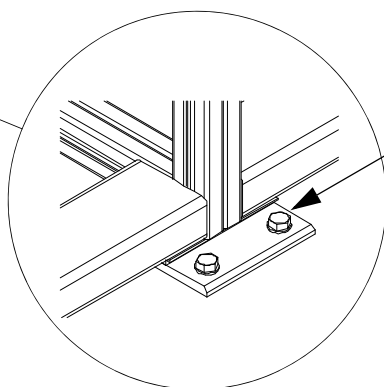

Use M10 or M12 screws; welding is not recommended (see section [Electric welding](#) below).

2

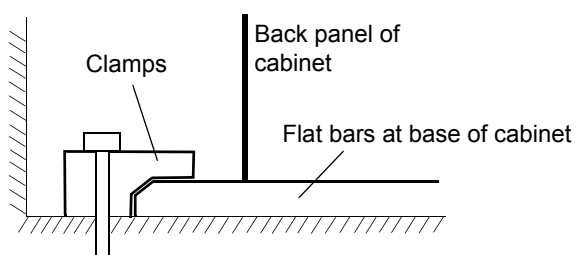

*Clamping the cabinet to the floor at the back*

3

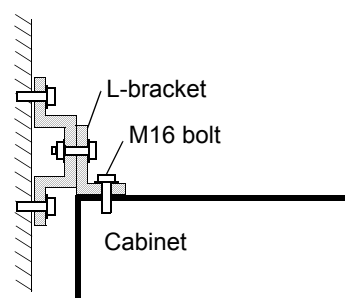

*Fastening the cabinet at the top with brackets (side view)*

## Joining the shipping splits

The busbar systems and wiring harnesses of two shipping splits are joined in the common motor terminal cubicle (if present) or a busbar joining cubicle. Special M6 screws for fastening the shipping splits together are enclosed in a plastic bag inside the rightmost cubicle of the first shipping split. The threaded bushings are already mounted on the post.

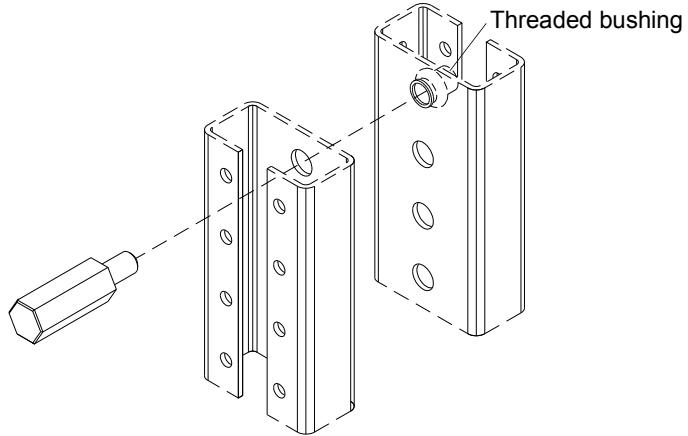

### Procedure

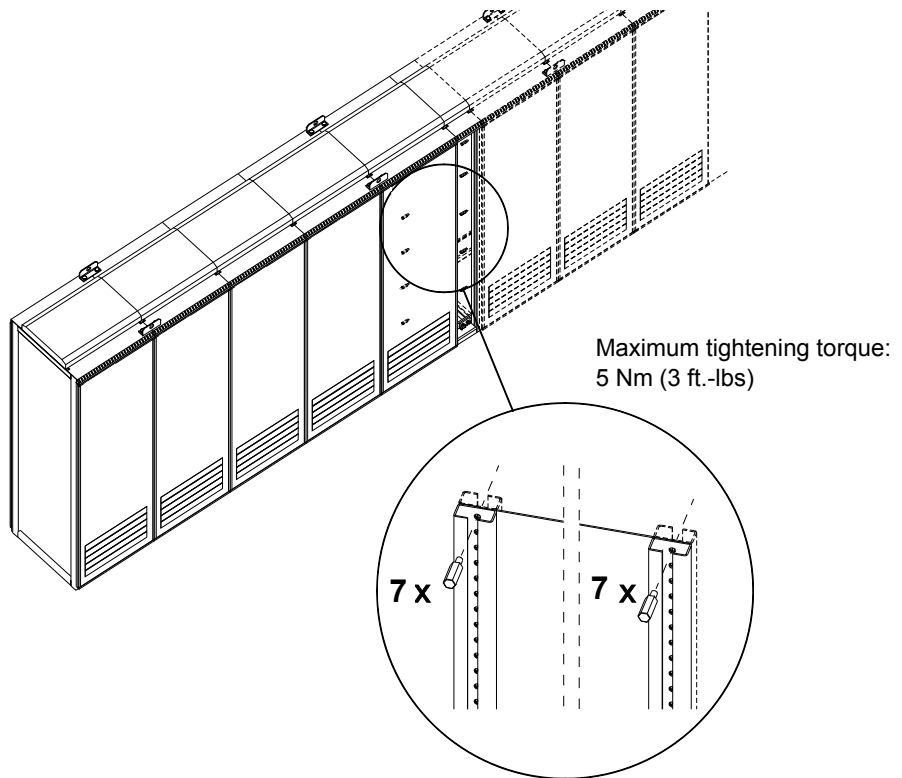

- Fasten the front post of the joining section with 7 screws to the front frame post of the next cubicle.

- Remove any intermediate or partitioning plates covering the rear posts of the joining cubicle.

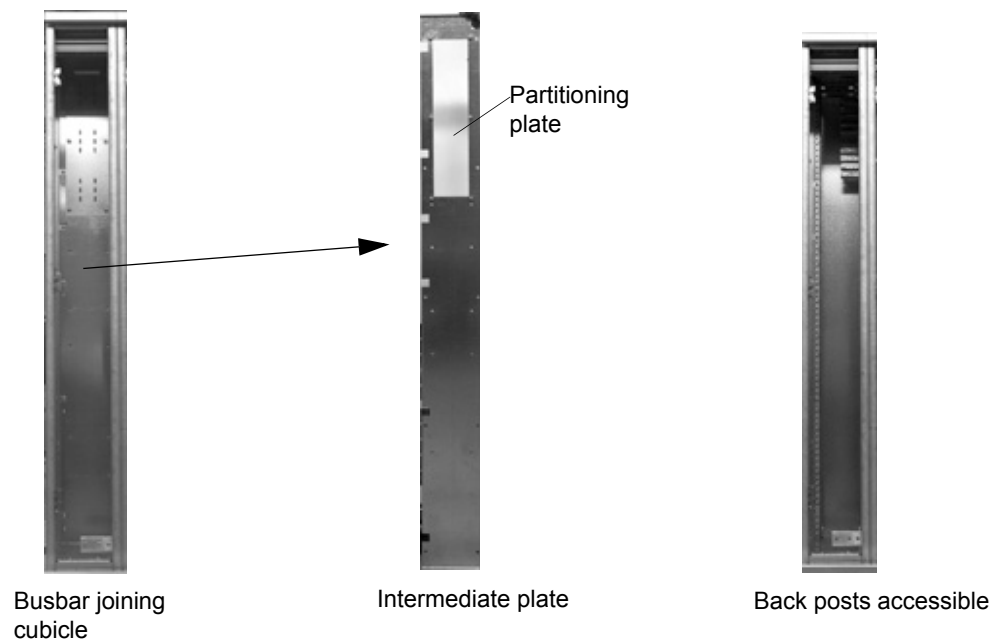

- Fasten the rear post of the joining section with seven screws (below the busbar joining part) to the rear post of the next cubicle.
- Replace all partitioning plates in the upper part of it after connecting the DC busbars (see section [Connecting the DC busbars and the PE busbar](#)).

### Connecting the DC busbars and the PE busbar

Horizontal main DC busbars and the PE busbar are connected from the front of the joining cubicle. All necessary materials are located in the joining cubicle.

- Remove the front metal partitioning plate located in the busbar joining cubicle.
- Unscrew the bolts of the joint pieces.
- Connect the busbars with the joint pieces (see figure below). For aluminium busbars, suitable anti-oxidant joint compound must be used to avoid corrosion and to ensure good electrical connection. The oxide layer must be scrubbed off from the joints before applying the compound.
- Refit all shrouds for safety of personnel.

*DC busbars*

The DC busbar connection is shown below.

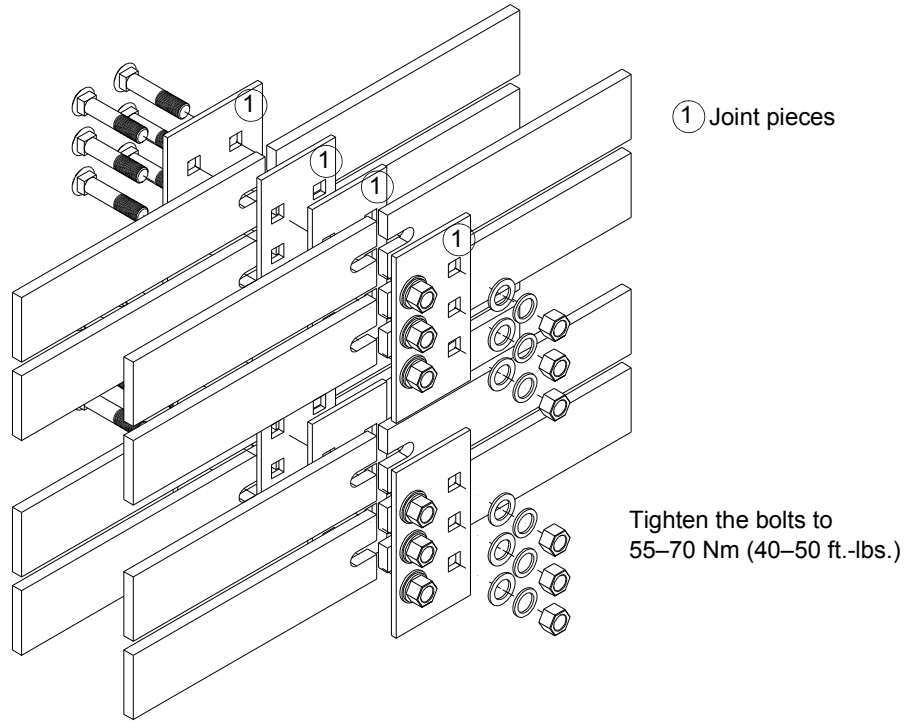

*Side view of single busbar connection*

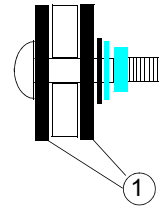

*PE busbar*

The PE busbar runs continuously through the line-up near the floor at the back. The connection is shown below. No separate nuts are needed.

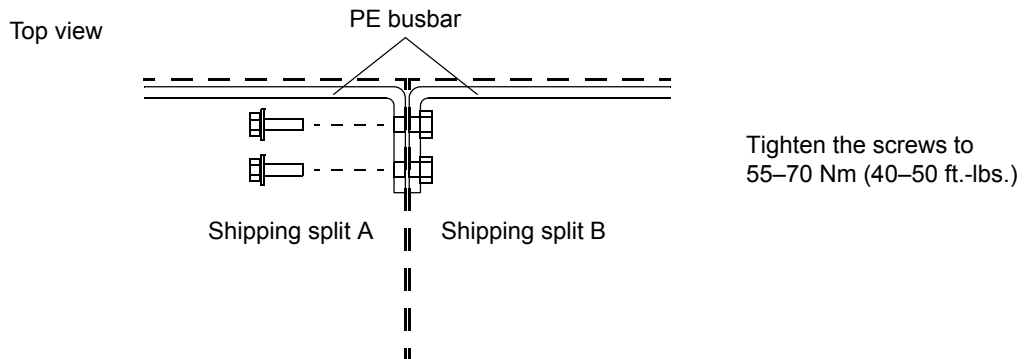



## Miscellaneous

### Cable duct in the floor below the cabinet

A cable duct can be constructed below the 400 mm (15.75") wide middle part of the cabinet. The cabinet weight lies on the two 100 mm (3.94") wide transverse sections which the floor must carry.

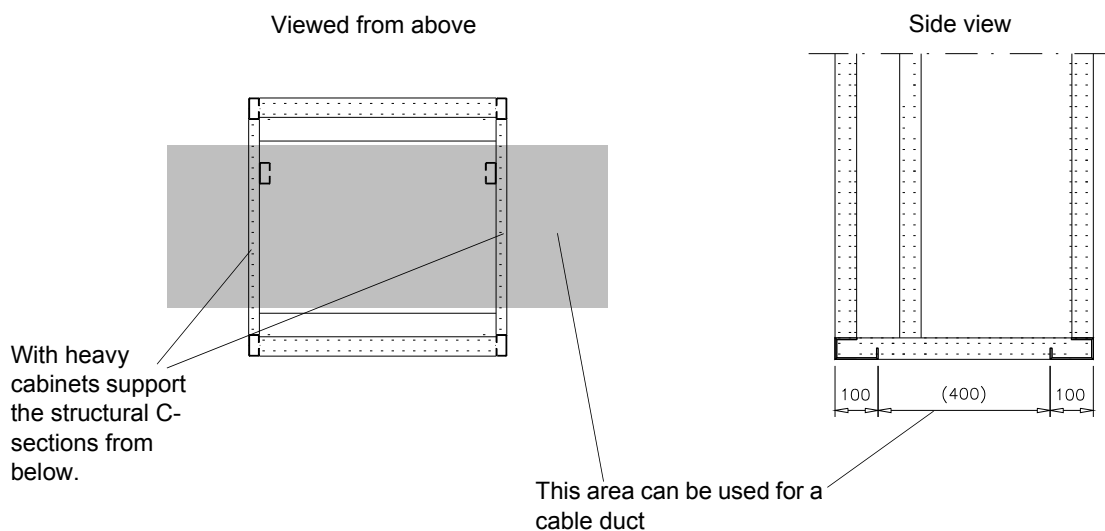

Prevent the cooling air flow from the cable duct to the cabinet by bottom plates. To ensure the degree of protection for the cabinet use the original bottom plates delivered with the unit. With user-defined cable entries, take care of the degree of protection, fire protection and EMC compliance.

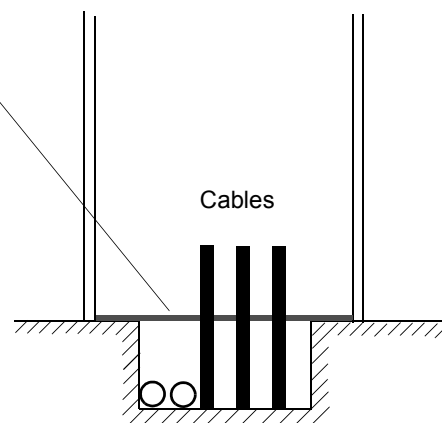

### Cooling air intake through bottom of cabinet

Units with air intake through the bottom of the cabinet (optional feature) are intended for installation on an air duct in the floor. The required air inlets in the floor are as listed below. Refer also to the dimensional drawings delivered with the unit.

- for Supply module cubicles:  $w \times 505$  mm (21.65"), where  $w$  equals cubicle width – 50 mm (1.97")
- for Inverter module cubicles, Auxiliary control cubicles, Incoming cubicles:  $w \times 400$  mm (21.65"), where  $w$  equals cubicle width – 50 mm (1.97")
- $w \times 130$  mm (5.12") at the back of the cabinet line-up, where  $w$  equals the total width of adjacent cubicles with air inlets. This area may or may not be consistent through the width of the whole line-up.

#### Example

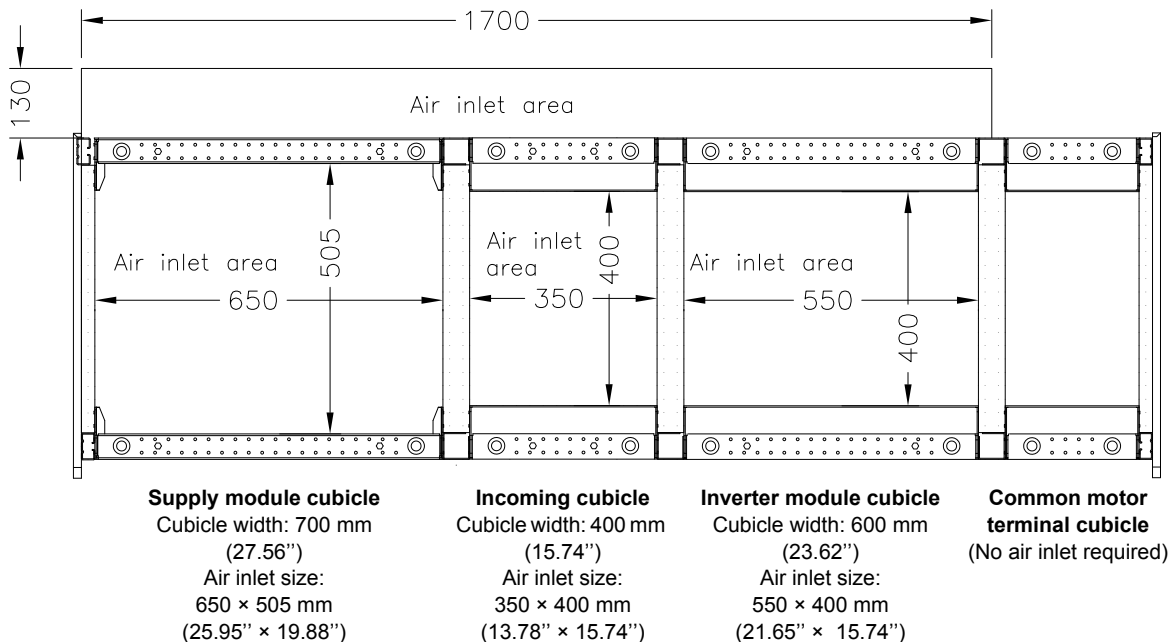

#### Notes:

- The plinth of the cabinet must be supported all round.
- The air duct must be able to supply a sufficient volume of cooling air. The minimum air flow values are given in chapter [Technical data](#).
- The cubicles of diode supply units require a larger air inlet area than other cubicles.
- Some cubicles (mainly those without active, heat-generating components) require no air inlet.

## Electric welding

It is not recommended to fasten the cabinet by welding.

### Cabinets without flat bars at the base

- Connect the return conductor of the welding equipment to the cabinet frame at the bottom within 0.5 metres (19.68") of the welding point.

### Cabinets with flat bars at the base

- Weld only the flat bar under the cabinet, never the cabinet frame itself.
- Clamp the welding electrode onto the flat bar about to be welded or onto the floor within 0.5 metres (19.68") of the welding point.



**WARNING!** If the welding return wire is connected improperly, the welding circuit may damage electronic circuits in the cabinet. The thickness of the zinc coating of the cabinet frame is 100 to 200 micrometers; on the flat bars the coating is approximately 20 micrometers. Ensure that the welding fumes are not inhaled.

---



# Planning the electrical installation

---

## What this chapter contains

This chapter contains the instructions that you must follow when selecting the motor, cables, protections, cable routing and way of operation for the drive system.

**Note:** The installation must always be designed and made according to applicable local laws and regulations. ABB does not assume any liability whatsoever for any installation which breaches the local laws and/or other regulations. Furthermore, if the recommendations given by ABB are not followed, the drive may experience problems that the warranty does not cover.

## Motor selection and compatibility

### Selecting the motor

1. Select the motor according to the rating tables in chapter [Technical data](#). Use the DriveSize PC tool if the default load cycles are not applicable.
2. Check that the motor ratings lie within the allowed ranges of the drive control program:
  - motor nominal voltage is  $1/2 \dots 2 \cdot U_N$  of the drive
  - motor nominal current is  $1/6 \dots 2 \cdot I_{2hd}$  of the drive in DTC control and  $0 \dots 2 \cdot I_{2hd}$  in scalar control. The control mode is selected by a drive parameter.
3. Check that the motor voltage rating meets the application requirements:
  - The motor voltage is selected according to the AC voltage feeding the drive when the drive is equipped with a diode input bridge (a non-regenerative drive) and will operate in the motor mode (ie, no braking).
  - The motor nominal voltage is selected according to “the equivalent AC power source voltage of the drive” if the intermediate DC circuit voltage of the drive is increased from the nominal level by resistor braking or by the control program of a regenerative IGBT line side converter (parameter selectable function).

The equivalent AC power source voltage for the drive is calculated as follows:

$$U_{ACeq} = U_{DCmax}/1.35$$

where

$U_{ACeq}$  = equivalent AC power source voltage of the drive

$U_{DCmax}$  = maximum intermediate DC circuit voltage of the drive

See section [Additional requirements for the braking applications](#) below the [Requirements table](#).

4. Consult the motor manufacturer before using a motor in a drive system where the motor nominal voltage differs from the AC power source voltage.
5. Ensure that the motor insulation system withstands the maximum peak voltage in the motor terminals. See the [Requirements table](#) below for the required motor insulation system and drive filtering.

**Example:** When the supply voltage is 440 V and the drive is operating in the motor mode only, the maximum peak voltage in the motor terminals can be approximated as follows:  $440 \text{ V} \cdot 1.35 \cdot 2 = 1190 \text{ V}$ . Check that the motor insulation system withstands this voltage.

### Protecting the motor insulation and bearings

The output of the drive comprises – regardless of output frequency – pulses of approximately 1.35 times the equivalent mains network voltage with a very short rise time. This is the case with all drives employing modern IGBT inverter technology.

The voltage of the pulses can be almost double at the motor terminals, depending on the attenuation and reflection properties of the motor cable and the terminals. This in turn can cause additional stress on the motor and motor cable insulation.

Modern variable speed drives with their fast rising voltage pulses and high switching frequencies can cause current pulses that flow through the motor bearings, which can gradually erode the bearing races and rolling elements.

The stress on motor insulation can be avoided by using optional ABB  $du/dt$  filters.  $du/dt$  filters also reduce bearing currents.

To avoid damage to motor bearings, the cables must be selected and installed according to the instructions given in this manual. In addition, insulated N-end (non-driven end) bearings and output filters from ABB must be used according to the following table. Two types of filters are used individually or in combinations:

- $du/dt$  filtering (protects motor insulation system and reduces bearing currents).
- common mode filtering (CMF) (mainly reduces bearing currents).

### Requirements table

The following table shows how to select the motor insulation system and when an optional drive  $du/dt$  and common mode filters and insulated N-end (non-drive end) motor bearings are required. Ignoring the requirements or improper installation may shorten motor life or damage the motor bearings and voids the warranty.

Manufacturer	Motor type	Nominal mains voltage (AC line voltage)	Motor insulation system	Requirement for		
				ABB du/dt filter, insulated N-end bearing and ABB common mode filter		
				$P_N < 100$ kW and frame size < IEC 315	$100$ kW $\leq P_N < 350$ kW or frame size $\geq$ IEC 315	$P_N \geq 350$ kW or frame size $\geq$ IEC 400
			$P_N < 134$ hp and frame size < NEMA 500	$134$ hp $\leq P_N < 469$ hp or frame size $\geq$ NEMA 500	$P_N \geq 469$ hp or frame size > NEMA 580	
A B B	Random-wound M2_, M3_ and M4_	$U_N \leq 500$ V	Standard	-	+ N	+ N + CMF
		$500$ V $< U_N \leq 600$ V	Standard	+ du/dt	+ du/dt + N	+ du/dt + N + CMF
			or	Reinforced	-	+ N
		$600$ V $< U_N \leq 690$ V (cable length $\leq 150$ m)	Reinforced	+ du/dt	+ du/dt + N	+ du/dt + N + CMF
		$600$ V $< U_N \leq 690$ V (cable length > 150 m)	Reinforced	-	+ N	+ N + CMF
	Form-wound HX_ and AM_	$380$ V $< U_N \leq 690$ V	Standard	n.a.	+ N + CMF	$P_N < 500$ kW: + N + CMF $P_N \geq 500$ kW: + N + CMF + du/dt
	Old* form-wound HX_ and modular	$380$ V $< U_N \leq 690$ V	Check with the motor manufacturer.	+ du/dt with voltages over 500 V + N + CMF		
	Random-wound HX_ and AM_**	$0$ V $< U_N \leq 500$ V	Enamelled wire with fibre glass taping	+ N + CMF		
		$500$ V $< U_N \leq 690$ V		+ du/dt + N + CMF		
	HDP	Consult the motor manufacturer.				
N O N - A B B	Random-wound and form-wound	$U_N \leq 420$ V	Standard: $\hat{U}_{LL} = 1300$ V	-	+ N or CMF	+ N + CMF
		$420$ V $< U_N \leq 500$ V	Standard: $\hat{U}_{LL} = 1300$ V	+ du/dt	+ du/dt + N	+ du/dt + N + CMF
				or	+ du/dt + CMF	
				or	Reinforced: $\hat{U}_{LL} = 1600$ V, 0.2 microsecond rise time	-
		$500$ V $< U_N \leq 600$ V	Reinforced: $\hat{U}_{LL} = 1600$ V	+ du/dt	+ du/dt + N	+ du/dt + N + CMF
				or	+ du/dt + CMF	
				or	Reinforced: $\hat{U}_{LL} = 1800$ V	-
		$600$ V $< U_N \leq 690$ V	Reinforced: $\hat{U}_{LL} = 1800$ V	+ du/dt	+ du/dt + N	+ du/dt + N + CMF
			Reinforced: $\hat{U}_{LL} = 2000$ V, 0.3 microsecond rise time ***	-	N + CMF	N + CMF

- \* manufactured before 1.1.1998
- \*\* For motors manufactured before 1.1.1998, check for additional instructions with the motor manufacturer.
- \*\*\* If the intermediate DC circuit voltage of the drive will be increased from the nominal level by resistor braking or by the IGBT supply unit control program (parameter selectable function), check with the motor manufacturer if additional output filters are needed in the applied drive operation range.

The abbreviations used in the table are defined below.

Abbreviation	Definition
$U_N$	nominal voltage of the supply network
$\hat{U}_{LL}$	peak line-to-line voltage at motor terminals which the motor insulation must withstand
$P_N$	motor nominal power
$du/dt$	$du/dt$ filtering at the output of the drive (option +E205)
CMF	common mode filtering (option +E208)
N	N-end bearing: insulated motor non-driven end bearing
n.a.	Motors of this power range are not available as standard units. Consult the motor manufacturer.

#### *Additional requirements for explosion-safe (EX) motors*

If you will use an explosion-safe (EX) motor, follow the rules in the requirements table above. In addition, consult the motor manufacturer for any further requirements.

#### *Additional requirements for HXR and AMA motors*

All AMA machines (manufactured in Helsinki) for drive systems have form-wound windings. All HXR machines manufactured in Helsinki starting 1.1.1998 have form-wound windings.

#### *Additional requirements for ABB motors of types other than M2\_, M3\_, M4\_, HX\_ and AM\_*

Use the selection criteria given for non-ABB motors.

#### *Additional requirements for the braking applications*

When the motor brakes the machinery, the intermediate circuit DC voltage of the drive increases, the effect being similar to increasing the motor supply voltage by up to 20 percent. Consider this voltage increase when specifying the motor insulation requirements if the motor will be braking a large part of its operation time.

Example: Motor insulation requirement for a 400 V drive must be selected as if the motor were supplied with 480 V.



*Additional requirements for ABB high-output motors and IP23 motors*

The rated output power of high output motors is higher than what is stated for the particular frame size in EN 50347:2001. This table shows the requirements for ABB random-wound motor series (for example, M3AA, M3AP and M3BP).

Nominal AC supply voltage	Motor insulation system	Requirement for		
		ABB $du/dt$ and common mode filters, insulated N-end motor bearings		
		$P_N < 100 \text{ kW}$	$100 \text{ kW} \leq P_N < 200 \text{ kW}$	$P_N \geq 200 \text{ kW}$
		$P_N < 140 \text{ hp}$	$140 \text{ hp} \leq P_N < 268 \text{ hp}$	$P_N \geq 268 \text{ hp}$
$U_N \leq 500 \text{ V}$	Standard	-	+ N	+ N + CMF
$500 \text{ V} < U_N \leq 600 \text{ V}$	Standard	+ $du/dt$	+ N + $du/dt$	+ N + $du/dt$ + CMF
	or			
	Reinforced	-	+ N	+ N + CMF
$600 \text{ V} < U_N \leq 690 \text{ V}$	Reinforced	+ $du/dt$	+ N + $du/dt$	+ N + $du/dt$ + CMF

*Additional requirements for non-ABB high-output and IP23 motors*

The rated output power of high output motors is higher than what is stated for the particular frame size in EN 50347:2001. The table below shows the requirements for random-wound and form-wound non-ABB motors with nominal power smaller than 350 kW. For bigger motors, consult the motor manufacturer.

Nominal AC supply voltage	Requirement for		
	Motor insulation system	ABB du/dt filter, insulated N-end bearing and ABB common mode filter	
		$P_N < 100 \text{ kW}$ or frame size $< \text{IEC 315}$	$100 \text{ kW} \leq P_N < 350 \text{ kW}$ or $\text{IEC 315} \leq \text{frame size} < \text{IEC 400}$
	$P_N < 134 \text{ hp}$ or frame size $< \text{NEMA 500}$	$134 \text{ hp} \leq P_N < 469 \text{ hp}$ or $\text{NEMA 500} \leq \text{frame size} \leq \text{NEMA 580}$	
$U_N \leq 420 \text{ V}$	Standard: $\hat{U}_{LL} = 1300 \text{ V}$	+ N or CMF	+ N + CMF
$420 \text{ V} < U_N \leq 500 \text{ V}$	Standard: $\hat{U}_{LL} = 1300 \text{ V}$	+ du/dt + (N or CMF)	+ N + du/dt + CMF
	or Reinforced: $\hat{U}_{LL} = 1600 \text{ V}$ , 0.2 microsecond rise time	+ N or CMF	+ N + CMF
$500 \text{ V} < U_N \leq 600 \text{ V}$	Reinforced: $\hat{U}_{LL} = 1600 \text{ V}$	+ du/dt + (N or CMF)	+ du/dt + N + CMF
	or Reinforced: $\hat{U}_{LL} = 1800 \text{ V}$	+ N or CMF	+ N + CMF
$600 \text{ V} < U_N \leq 690 \text{ V}$	Reinforced: $\hat{U}_{LL} = 1800 \text{ V}$	+ N + du/dt	+ N + du/dt + CMF
	Reinforced: $\hat{U}_{LL} = 2000 \text{ V}$ , 0.3 microsecond rise time ***	N + CMF	N + CMF

\*\*\* If the intermediate DC circuit voltage of the drive is increased from the nominal level by resistor braking, check with the motor manufacturer if additional output filters are needed in the applied drive operation range.

### Additional data for calculating the rise time and the peak line-to-line voltage

If you need to calculate the actual peak voltage and voltage rise time considering the actual cable length, proceed as follows:

- Peak line-to line voltage: Read the relative  $\hat{U}_{LL}/U_N$  value from the appropriate diagram below and multiply it by the nominal supply voltage ( $U_N$ ).
- Voltage rise time: Read the relative values  $\hat{U}_{LL}/U_N$  and  $(du/dt)/U_N$  from the appropriate diagram below. Multiply the values by the nominal supply voltage ( $U_N$ ) and substitute into equation  $t = 0.8 \cdot \hat{U}_{LL}/(du/dt)$ .

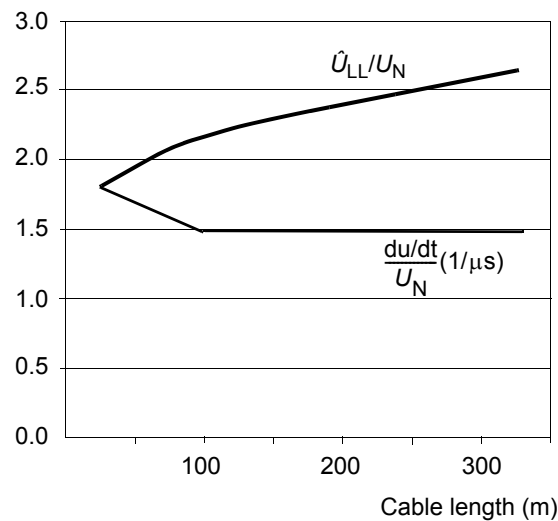

With du/dt Filter

### Additional note for sine filters

Sine filters protect the motor insulation system. A factory-installed sine filter is available for the cabinet-installed units. The peak phase-to-phase voltage with the sine filter is approximately  $1.5 \times U_N$ .

## Permanent magnet motor

Only one permanent magnet motor can be connected to the inverter output.

It is recommended to install a safety switch between a permanent magnet motor and the motor cable. The switch is needed to isolate the motor during any maintenance work on the drive.

## Thermal overload and short-circuit protection

### Thermal overload protection of the drive and the input and motor cables

The drive protects itself and the input and motor cables against thermal overload when the cables are dimensioned according to the nominal current of the drive. No additional thermal protection devices are needed.



**WARNING!** If the drive is connected to multiple motors, a separate thermal overload switch or a circuit breaker must be used for protecting each cable and motor. These devices may require a separate fuse to cut off the short-circuit current.

---

### Thermal overload protection of the motor

According to regulations, the motor must be protected against thermal overload and the current must be switched off when overload is detected. The drive includes a motor thermal protection function that protects the motor and switches off the current when necessary. Depending on a drive parameter value, the function either monitors a calculated temperature value (based on a motor thermal model) or an actual temperature indication given by motor temperature sensors. The user can tune the thermal model further by feeding in additional motor and load data.

See the *Firmware manual* of the drive control program for more information on the motor thermal protection, and the connection and use of the temperature sensors.

### Protection against short-circuit in the motor cable

The drive protects the motor cable and the motor in a short-circuit situation when the motor cable is dimensioned according to the nominal current of the drive. No additional protection devices are needed.

### Protection against short-circuit inside the drive or in the supply cable

- If the drive is equipped with internal AC fuses (option code +F260), install external protection (such as fuses) at the supply to protect the input cable.
- If the drive is not equipped with AC input fuses, install external fuses at the supply to protect the input cable and the drive. Use the AC fuse types listed in chapter [Technical data](#) on page 136, or equivalent fuses. Six fuses are needed for each DSU module.



**WARNING!** Circuit breakers are not capable of providing sufficient protection because they are inherently slower than fuses. Always use fuses with circuit breakers.

---

## Ground fault protection

The inverter unit is equipped with an internal ground fault protective function to protect the drive against ground faults in the drive, motor and motor cable (This is not a personal safety or a fire protection feature). The ground fault protective function can be disabled; refer to the *Firmware Manual* of the drive control program.

See the *ACS800 Ordering Information* (3AFY64556568 [English], available on request) for other available ground fault protection options.

The EMC filter (if present) includes capacitors connected between the main circuit and the frame. These capacitors and long motor cables increase the ground leakage current and may cause fault current circuit breakers to function.

## Emergency stop devices

For safety reasons, install the emergency stop devices at each operator control station and at other operating stations where emergency stop may be needed. Pressing the stop key (⏹) on the control panel of the drive, or turning the operating switch of the drive from position “1” to “0” does not generate an emergency stop of the motor or separate the drive from dangerous potential.

An emergency stop function is optionally available for stopping and switching off the whole drive. Two modes are available: immediate removal of power (Category 0) and controlled emergency stop (Category 1).

**Note:** If you add or modify the wiring in the drive safety circuits, ensure that the appropriate standards (eg, IEC 61800-5-1, EN 62061, EN/ISO 13849-1 and -2) and the ABB guidelines are met.

### Restarting after an emergency stop

After an emergency stop, the emergency stop button must be released and a reset performed before the main contactor (or main breaker) can be closed and the drive started.

## Prevention of unexpected start-up (option +Q950)

The drive can be equipped with an optional Prevention of unexpected start-up function according to standards IEC/EN 60204-1:1997; ISO/DIS 14118:2000 and EN 1037:1996. The circuit conforms to EN 954-1, Category 3.

The function is achieved by disconnecting the control voltage to the power semiconductors of the inverters of the drive. Thus it is not possible for the power semiconductors to switch and generate the AC voltage needed to rotate the motor. In case of faulty main circuit components, the DC voltage from the busbars can be conducted to the motor but an AC motor cannot rotate without the field generated by an AC voltage.

The operator activates the Prevention of unexpected start-up function using a switch mounted on a control desk. When the function is activated, the switch is opened, and an indicator lamp will light.



**WARNING!** The Prevention of unexpected start-up function does not disconnect the voltage of the main and auxiliary circuits from the drive. Therefore maintenance work on electrical parts of the drive can only be carried out after isolating the drive system from the main supply.

---

**Note:** If a running drive is stopped by using the Prevention of unexpected start-up function, the drive will cut off the motor supply voltage and the motor will coast to stop.

For more information, see *Safety options for ACS800 cabinet-installed drives (+Q950, +Q951, +Q952, +Q963, +Q964, +Q967 and +Q968), Wiring, start-up and operation instructions* (3AUA0000026238 [English]).

## Safe torque off (option +Q968)

The drive supports the Safe torque off (STO) function according to standards EN 61800-5-2:2007; EN 62061:2005/AC:2010; EN/ISO 13849-1:2008/AC:2009, EN/ISO 13849-2:2008, EN 60204-1:2006/AC:2010 and IEC 61508 ed.1. The function also corresponds to Prevention of unexpected start-up of EN 1037.

The Safe torque off function disables the control voltage of the power semiconductors of the drive output stage, thus preventing the inverter from generating the voltage required to rotate the motor (see the diagram below). By using this function, short-time operations (like cleaning) and/or maintenance work on non-electrical parts of the machinery can be performed without switching off the power supply to the drive.

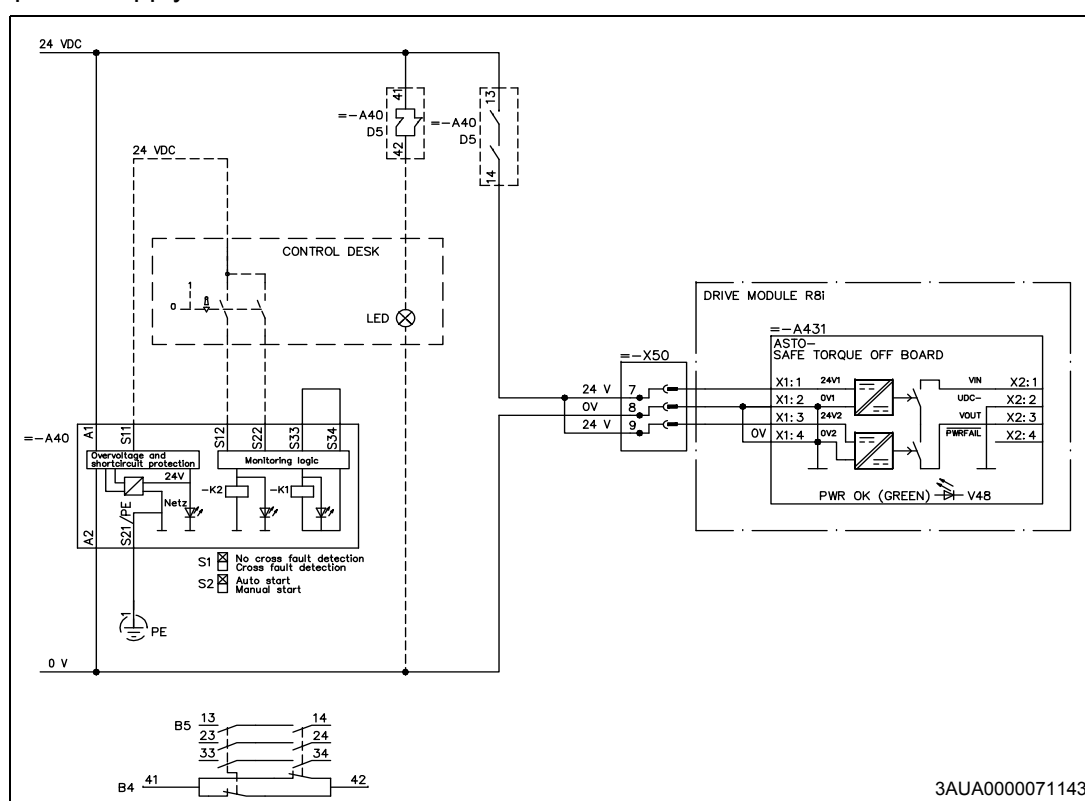

**WARNING!** The Safe torque off function does not disconnect the voltage of the main and auxiliary circuits from the drive. Therefore maintenance work on electrical parts of the drive or the motor can only be carried out after isolating the drive system from the main supply.

**Note:** If a running drive is stopped by using the Safe torque off function, the drive will cut off the motor supply voltage and the motor will coast to a stop.

**Note:** If you add or modify the wiring in the drive safety circuits, ensure that the appropriate standards (eg, IEC 61800-5-1, EN 62061, EN/ISO 13849-1 and -2) and the ABB guidelines are met.

For more information, see *Safety options for ACS800 cabinet-installed drives (+Q950, +Q951, +Q952, +Q963, +Q964, +Q967 and +Q968), Wiring, start-up and operation instructions* (3AUA0000026238 [English]).

## Selecting the power cables

### General rules

Dimension the supply (input power) and motor cables **according to local regulations**:

- The cable must be able to carry the drive load current. See chapter [Technical data](#) for the rated currents.
- The cable must be rated for at least 70 °C (158 °F) maximum permissible temperature of conductor in continuous use. For US, see [Additional US requirements](#).
- The inductance and impedance of the PE conductor/cable (grounding wire) must be rated according to permissible touch voltage appearing under fault conditions (so that the fault point voltage will not rise excessively when an ground fault occurs).
- 600 VAC cable is accepted for up to 500 VAC. For 690 VAC rated equipment, the rated voltage between the conductors of the cable should be minimum 1 kV.

For drive frame size R5 and larger, or motors larger than 30 kW, symmetrical shielded motor cable must be used (figure below). A four-conductor system can be used up to frame size R4 with up to 30 kW motors, but shielded symmetrical motor cable is recommended.

**Note:** When continuous conduit is employed, shielded cable is not required.

A four-conductor system is allowed for input cabling, but shielded symmetrical cable is recommended. To operate as a protective conductor, the shield conductivity must be as follows when the protective conductor is made of the same metal as the phase conductors:

Cross-sectional area of the phase conductors $S$ (mm <sup>2</sup> )	Minimum cross-sectional area of the corresponding protective conductor $S_p$ (mm <sup>2</sup> )
$S \leq 16$	$S$
$16 < S \leq 35$	16
$35 < S$	$S/2$

Compared to a four-conductor system, the use of symmetrical shielded cable reduces electromagnetic emission of the whole drive system as well as motor bearing currents and wear.

**Note:** The cabinet configuration of the drive may require multiple supply and/or motor cabling. Refer to the connection diagrams in [Electrical installation](#).

The motor cable and its PE pigtail (twisted screen) should be kept as short as possible in order to reduce electromagnetic emission as well as capacitive current.





### Alternative power cable types

Power cable types that can be used with the drive are represented below.

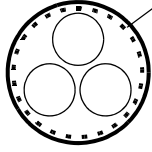
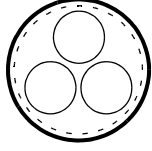
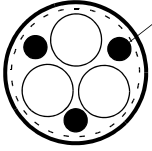
#### Recommended power cable types

	<p>Symmetrical shielded cable with three phase conductors and a concentric PE conductor as shield. The shield must meet the requirements of IEC 61439-1. Check with local / state / country electrical codes for allowance.</p>
	<p>Symmetrical shielded cable with three phase conductors and a concentric PE conductor as shield. A separate PE conductor is required if the shield does not meet the requirements of IEC 61439-1.</p>
	<p>Symmetrical shielded cable with three phase conductors and symmetrically constructed PE conductor, and a shield. The PE conductor must meet the requirements of IEC 61439-1.</p>

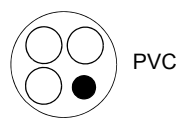
#### Power cable types for restricted use

	<p>A four-conductor system (three phase conductors and a protective conductor on a cable tray) is <b>not allowed for motor cabling</b> (it is allowed for input cabling).</p>
	<p>A four-conductor system (three phase conductors and a PE conductor in a PVC conduit) is <b>allowed for input and motor cabling with phase conductor cross-section less than 10 mm<sup>2</sup> (8 AWG) or motors ≤ 30 kW (40 hp)</b>. Not allowed in USA.</p>
	<p>Corrugated or EMT cable with three phase conductors and a protective conductor is allowed for motor cabling with phase conductor cross section less than 10 mm<sup>2</sup> (8 AWG) or motors ≤ 30 kW (40 hp).</p>

#### Not allowed power cable types

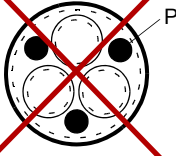
	<p>Symmetrical shielded cable with individual shields for each phase conductor is not allowed on any cable size for input and motor cabling.</p>
---	--

### Motor cable shield

If the motor cable shield is used as the sole protective earth conductor of the motor, ensure that the conductivity of the shield is sufficient. See subsection [General rules](#) above, or IEC 61439-1. To effectively suppress radiated and conducted radio-frequency emissions, the shield conductivity must be at least 1/10 of the phase conductor conductivity. The requirements are easily met with a copper or aluminium shield. The minimum requirement of the motor cable shield of the drive is shown below. It consists of a concentric layer of copper wires with an open helix of copper tape. The better and tighter the shield, the lower the emission level and the bearing currents.

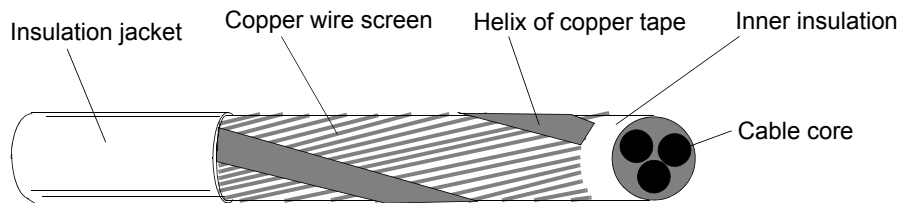

### Additional US requirements

Type MC continuous corrugated aluminum armor cable with symmetrical grounds or shielded power cable must be used for the motor cables if metallic conduit is not used. For the North American market, 600 VAC cable is accepted for up to 500 VAC. 1000 VAC cable is required above 500 VAC (below 600 VAC). For drives rated over 100 amperes, the power cables must be rated for 75 °C (167 °F).

#### Conduit

Where conduits must be coupled together, bridge the joint with a ground conductor bonded to the conduit on each side of the joint. Bond the conduits also to the drive enclosure. Use separate conduits for input power, motor, brake resistors, and control wiring. When conduit is employed, type MC continuous corrugated aluminum armor cable or shielded cable is not required. A dedicated ground cable is always required.



**WARNING!** Do not run motor wiring from more than one drive in the same conduit.

#### *Armored cable / shielded power cable*

The motor cables can be run in the same cable tray as other 460 V or 600 V power wiring. Control and signal cables must not be run in the same tray as power cables. Six conductor (3 phases and 3 ground) type MC continuous corrugated aluminum armor cable with symmetrical grounds is available from the following suppliers (trade names in parentheses):

- Anixter Wire & Cable (Philsheath)
- BICC General Corp (Philsheath)
- Rockbestos Co. (Gardex)
- Oaknite (CLX).

Shielded power cables are available from Belden, LAPPKABEL (ÖLFLEX) and Pirelli, among others.

## Power factor compensation capacitors

Power factor compensation is not needed with AC drives. However, if a drive is to be connected to a system with compensation capacitors already installed, note the following restrictions.



**WARNING!** Do not connect power factor compensation capacitors to the motor cables (between the drive and the motor). They are not meant to be used with AC drives and can cause permanent damage to the drive or themselves.

---

If there are power factor compensation capacitors in parallel with the three-phase input of the drive:

- Do not connect a high-power capacitor to the power line while the drive is connected. The connection will cause voltage transients that may trip or even damage the drive.
- If capacitor load is increased/decreased step by step when the AC drive is connected to the power line, ensure that the connection steps are low enough not to cause voltage transients that would trip the drive.
- Check that the power factor compensation unit is suitable for use in systems with AC drives, ie, harmonic-generating loads. In such systems, the compensation unit should typically be equipped with a blocking reactor or harmonic filter.

## Equipment connected to the motor cable

### Installation of safety switches, contactors, connection boxes, etc

To minimize the emission level when safety switches, contactors, connection boxes or similar equipment are installed in the motor cable between the drive and the motor:

- EU: Install the equipment in a metal enclosure with 360 degrees grounding for the shields of both the incoming and outgoing cables, or in another way connect the shields of the cables together.
- US: Install the equipment in a metal enclosure in a way that the conduit or motor cable shielding runs consistently without breaks from the drive to the motor.

### *Bypass connection*



**WARNING!** Never connect the supply power to the drive output terminals U2, V2 and W2. If frequent bypassing is required, employ mechanically connected switches or contactors. Mains (line) voltage applied to the output can result in permanent damage to the unit.

---

### Before opening an output contactor (in the DTC motor control mode)

Stop the drive and wait for the motor to stop before opening a contactor between the output of the drive and the motor when the DTC control mode is selected. (See the *Firmware Manual* of the drive control program for the required parameter settings.) Otherwise, the contactor will be damaged.

In scalar control, the contactor can be opened with the drive running.

### Relay output contacts and inductive loads

Inductive loads (such as relays, contactors, motors) cause voltage transients when switched off.

The relay contacts of the RMIO board are protected with varistors (250 V) against overvoltage peaks. In spite of this, it is highly recommended to equip inductive loads with noise attenuating circuits (varistors, RC filters [AC] or diodes [DC]) to minimize the EMC emission at switch-off. If not suppressed, the disturbances may connect capacitively or inductively to other conductors in the control cable and form a risk of malfunction in other parts of the system.

Install the protective component as close to the inductive load as possible. Do not install the protective components at the terminal block.

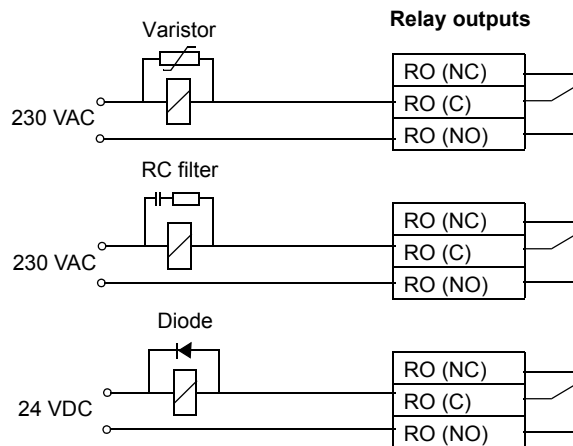

## Selecting the control cables

All control cables must be shielded.

Use a double-shielded twisted pair cable (see figure a) for analogue signals. This type of cable is recommended for the pulse encoder signals also. Employ one individually shielded pair for each signal. Do not use common return for different analogue signals.

A double-shielded cable is the best alternative for low-voltage digital signals but single-shielded twisted multipair cable (figure b) is also usable.

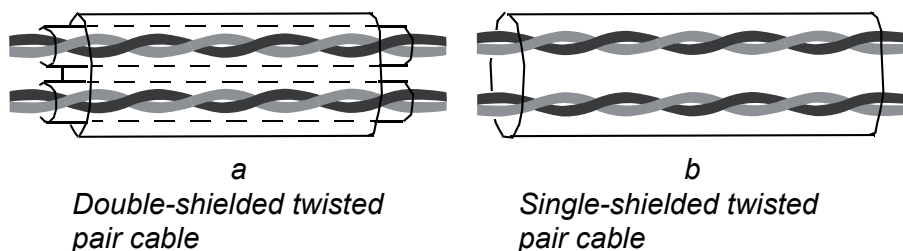

Run analogue and digital signals in separate, shielded cables.

Relay-controlled signals, providing their voltage does not exceed 48 V, can be run in the same cables as digital input signals. It is recommended that the relay-controlled signals be run as twisted pairs.

Never mix 24 VDC and 115 / 230 VAC signals in the same cable.

### Relay cable

The cable type with braided metallic screen (eg, ÖLFLEX LAPPKABEL, Germany) has been tested and approved by ABB.

### Control panel cable

In remote use, the cable connecting the control panel to the drive must not exceed 3 metres (10 ft). The cable type tested and approved by ABB is used in control panel option kits.

### Coaxial cable (for use with Advant Controllers AC 80/AC 800)

- 75 ohm
- RG59, diameter 7 mm or RG11, diameter 11 mm
- Maximum cable length: 300 m (1000 ft)

## Connection of a motor temperature sensor to the drive I/O

---



**WARNING!** IEC 60664 requires double or reinforced insulation between live parts and the surface of accessible parts of electrical equipment which are either non-conductive or conductive but not connected to the protective earth.

To fulfil this requirement, the connection of a thermistor (and other similar components) to the digital inputs of the drive can be implemented in three alternate ways:

1. There is double or reinforced insulation between the thermistor and live parts of the motor.
  2. Circuits connected to all digital and analogue inputs of the drive are protected against contact and insulated with basic insulation (the same voltage level as the drive main circuit) from other low voltage circuits.
  3. An external thermistor relay is used. The insulation of the relay must be rated for the same voltage level as the main circuit of the drive. For connection, see the *Firmware Manual of the drive control program*.
- 

## Installation sites above 2000 metres (6562 feet)

---



**WARNING!** Protect against direct contact when installing, operating and servicing the RMIO board wiring and optional modules attached to the board. The Protective Extra Low Voltage (PELV) requirements stated in EN 50178 are not fulfilled at altitudes above 2000 m (6562 ft).

---

## Routing the cables

Route the motor cable away from other cable routes. Motor cables of several drives can be run in parallel installed next to each other. It is recommended that the motor cable, input power cable and control cables be installed on separate trays. Avoid long parallel runs of motor cables with other cables in order to decrease electromagnetic interference caused by the rapid changes in the drive output voltage.

Where control cables must cross power cables make sure they are arranged at an angle as near to 90 degrees as possible. Do not run extra cables through the drive.

The cable trays must have good electrical bonding to each other and to the grounding electrodes. Aluminium tray systems can be used to improve local equalizing of potential.

A diagram of the cable routing is below.

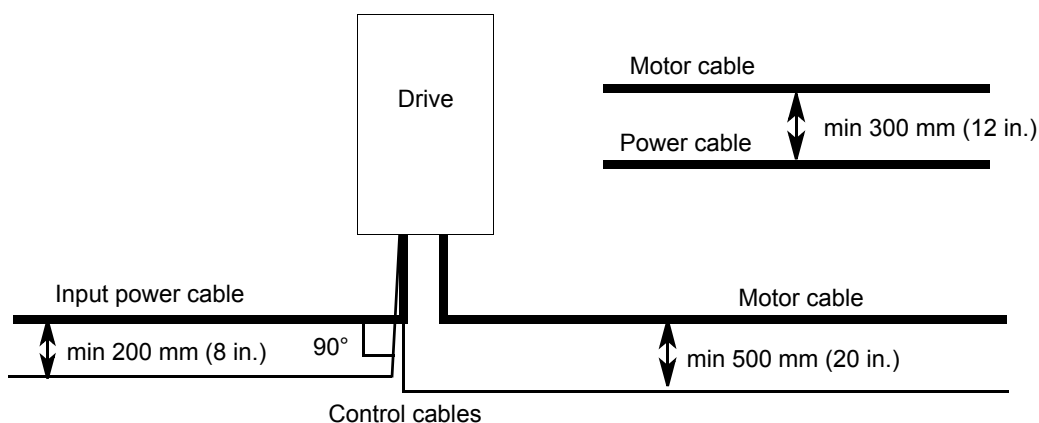

### Control cable ducts

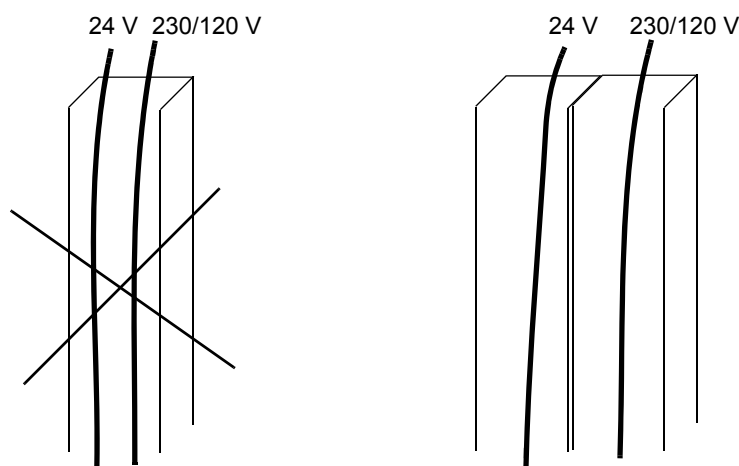

Not allowed unless the 24 V cable is insulated for 230/120 V or insulated with insulation sleeving for 230/120 V.

Lead 24 V and 230/120 V control cables in separate ducts inside the cabinet.





# Electrical installation

---

## What this chapter contains

This chapter describes the electrical installation procedure of the drive.



**WARNING!** Only qualified electricians are allowed to carry out the work described in this chapter. Follow the [Safety instructions](#) on the first pages of this manual. Ignoring the safety instructions can cause injury or death.

---



**WARNING!** During the installation procedure, the supply and inverter modules may have to be temporarily extracted from the cabinet. The modules are heavy, and have a high center of gravity. To minimize the danger of toppling over, keep the sheet metal support supplied with the drive attached to the modules whenever manoeuvring them outside the cabinet.

---

## Before installation

### Checking the insulation of the assembly

---



**WARNING!** Check the insulation before connecting the drive to the supply. Make sure that the drive is disconnected from the supply (input power).

---

#### *Drive*

Do not make any voltage tolerance or insulation resistance tests (eg, hi-pot or megger) on any part of the drive as testing can damage the drive. Every drive has been tested for insulation between the main circuit and the chassis at the factory. Also, there are voltage-limiting circuits inside the drive which cut down the testing voltage automatically.

#### *Supply cable*

Check the insulation of the supply (input) cable according to local regulations before connecting to the drive.

### Motor and motor cable

Check the insulation of the motor and motor cable as follows:

1. Check that the motor cable is connected to the motor, and disconnected from the drive output terminals U2, V2 and W2.
2. Measure the insulation resistance between each phase conductor and the protective earth conductor using a measuring voltage of 1000 V DC. The insulation resistance of an ABB motor must exceed 100 Mohm (reference value at 25 °C or 77 °F). For the insulation resistance of other motors, please consult the manufacturer's instructions.

**Note:** Moisture inside the motor casing will reduce the insulation resistance. If moisture is suspected, dry the motor and repeat the measurement.

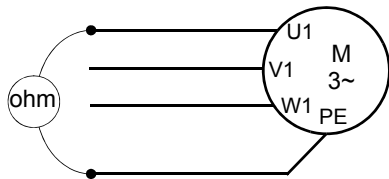

### IT (ungrounded) systems

An EMC filter (option +E202) is not suitable for use in an IT (ungrounded) system. If the drive is equipped with an EMC filter (option +E202), disconnect the filter before connecting the drive to the supply network. For detailed instructions on how to do this, please contact your local ABB representative.



**WARNING!** If a drive with an EMC filter (option +E202) is installed on an IT system [an ungrounded power system or a high resistance-grounded (over 30 ohms) power system], the system will be connected to ground potential through the EMC filter capacitors of the drive. This may cause danger or damage the unit.

### External earth fault in IT (ungrounded) systems

On ungrounded systems, an optional insulation monitoring device (Bender IRDH265 or IRDH275, option +Q954) is used. Refer to its documentation for set-up instructions.

## Input power connection – Units without main switch-disconnector or main breaker (no option +F253 or +F255)

### Connection diagrams

*Six-pulse connection, two DSU modules in parallel*

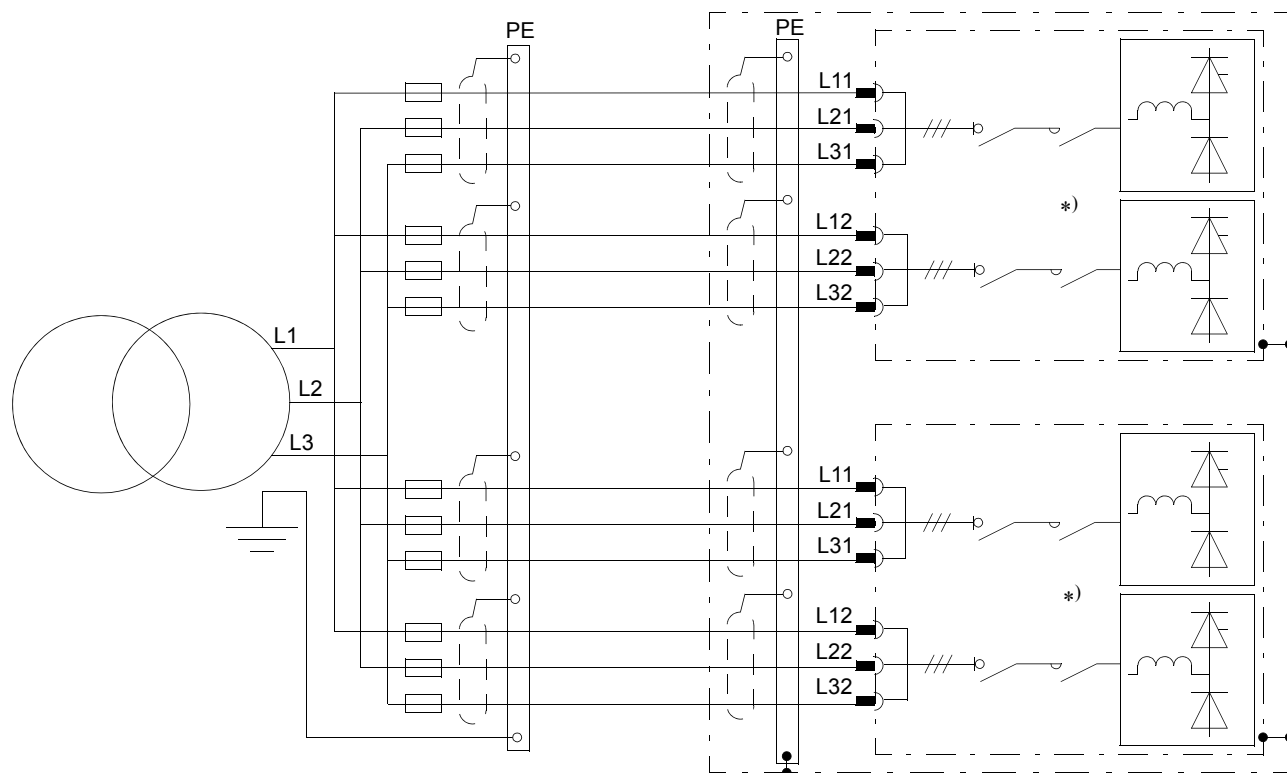

#### Notes:

- No parallel cabling is shown here.
- Each input terminal of the supply modules must be fed through a dedicated fuse. The fuses are specified in [Technical data](#).
- \*) Contactors are optional.

### Twelve-pulse connection, two DSU modules in parallel

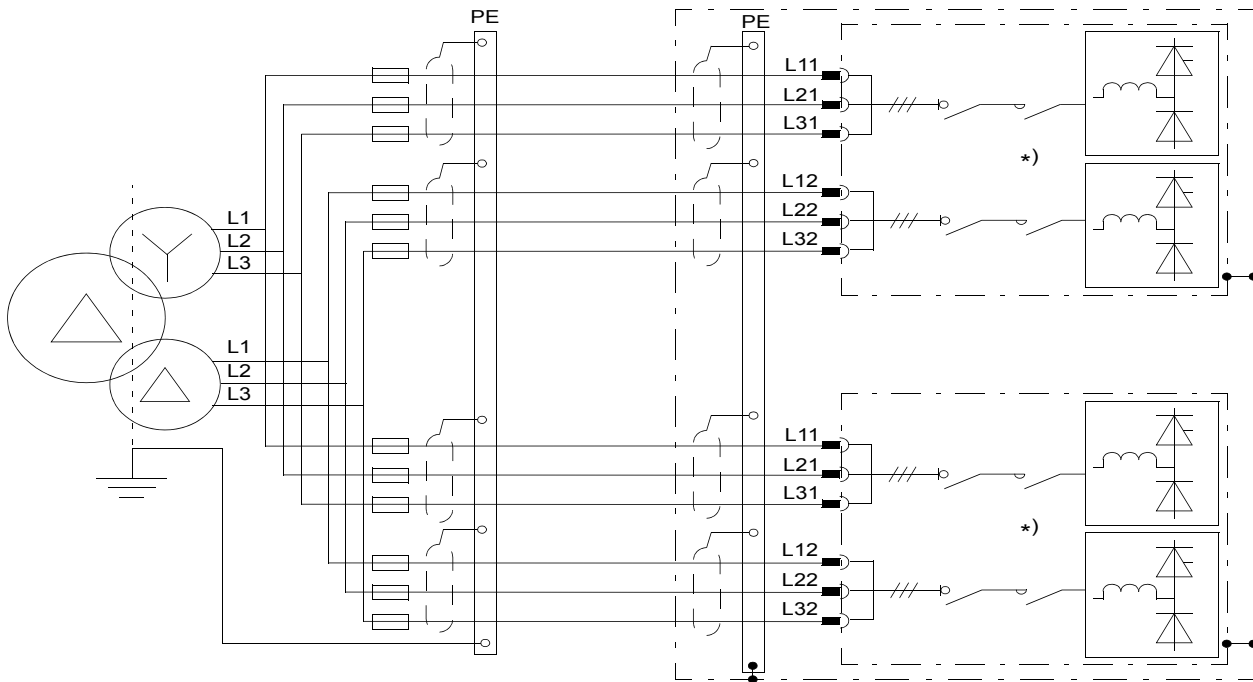

#### Notes:

- No parallel cabling (for each module) is shown here.  
It is also possible to connect all input power terminals of module 1 to the transformer Y-output and module 2 to the transformer D-output. Note, however, that then the two bridges inside a single module do not form a 12-pulse connection any more. This means that the benefits of the 12-pulse connection are not available during a temporary operation with one module out of use (eg, for maintenance).
- Each input terminal of the supply modules must be fed through a dedicated fuse. The fuses are specified in [Technical data](#).
- The secondaries of the transformer must not be grounded.
- When the same 12-pulse transformer is used to supply more than one module, connect the DC outputs of all modules to a common DC link. Separate links will cause current unbalance fault trips due to circulating currents between the modules.
- \*) Contactors are optional.

#### Connection procedure



**WARNING!** Read and follow the instructions given in [Safety instructions](#). Ignoring the instructions can cause physical injury or death, or damage to the equipment.

Phase I – Removing the module

**WARNING!** Ignoring the following instructions can cause physical injury or death, or damage to the equipment.



- Use extreme caution when manoeuvring a module that runs on wheels. The modules are heavy and have a high centre of gravity. They topple over easily if handled carelessly.
- Do not use the ramp which is supplied with the drive with heights over 50 mm (2.0 in). The ramp is designed for a plinth height of 50 mm (2.0 in) (the standard plinth height of ABB cabinets).

<p>Support the top and bottom of the module while removing!</p> <p>max 50 mm</p>	<p>Do not tilt!</p>	<p>Extend the support legs outside the cabinet!</p>
<p>Lift the module by the upper part only using the lifting hole(s) at the top!</p>	<p>Mind your fingers! Keep fingers away from the edges of the front flange of the module!</p>	<p>Support the top and bottom of the module while replacing!</p>

To remove the module, follow the steps below:

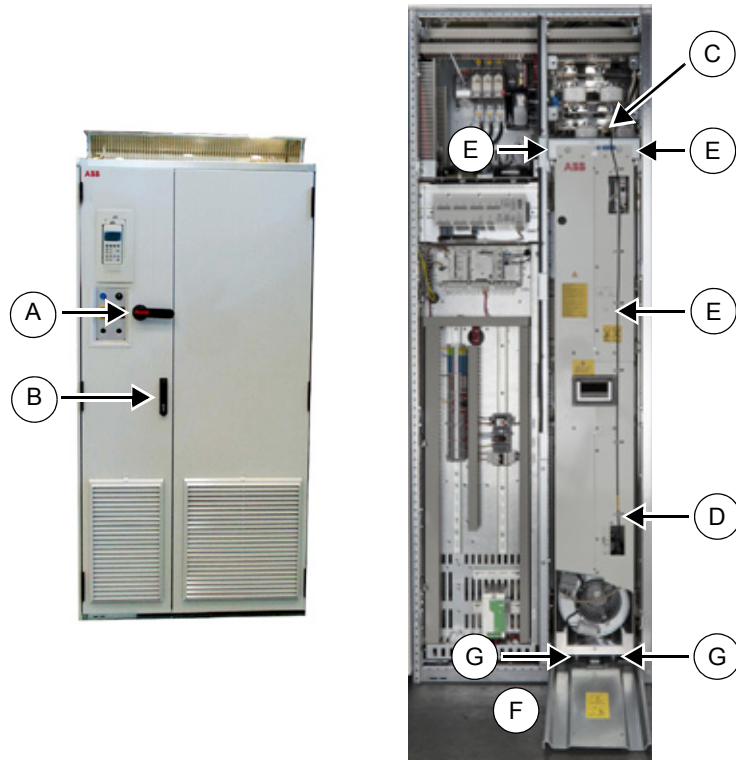

1. Turn the main switch-disconnector to the open position. (A)
2. Release the door handle and open the doors. (B)
3. Disconnect the module signal wire set. (C) The counterpart must be used and connected to the wire set instead of the DSU module, when the module is removed from the cabinet.

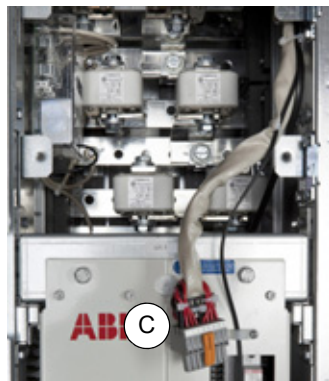

4. Unplug also the pair of fibre optic cables from its connectors on the front of the DSU module. Bind the fibre optic cables to a suitable support (away from the area you are working in) without twisting or coiling them. The cables must not be squeezed between any objects. (D)

5. Loosen the module fastening screws and the quick connector locking screw (5-mm hexagonal head). (E) If your drive has the marine construction (option +C121), remove the fan. For instructions, see [Replacing the fan of the supply module](#) on page 123. Then loosen also the two bolts that connect the bottom of the module to the installation plate at the back.
6. Place the module pull-out ramp firmly against the cabinet base. (F) Insert the module pull-out ramp under the two screws on the base of the cabinet and tighten. (G)
7. Pull the module carefully out of the cabinet along the ramp. (H)



**WARNING!** Make sure that the wires do not catch. While pulling on the handle, keep a constant pressure with one foot on the base of the module to prevent the module from falling on its back. Use safety shoes with metal toe cap to avoid foot injury.

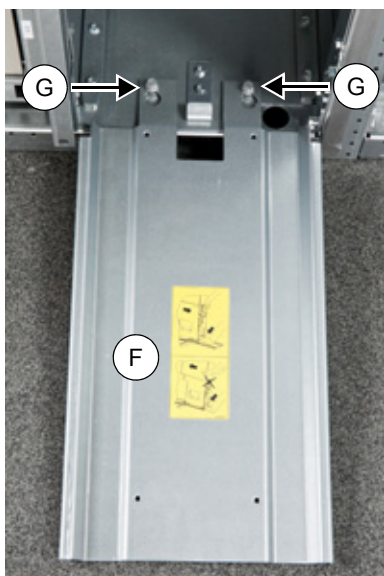

### Phase 2 – Installing the cables

1. Remove the plastic insulators covering the input power terminals.



2. Lead the cables into the inside of the cabinet. Make the 360° grounding arrangement at the cable entries as shown below.

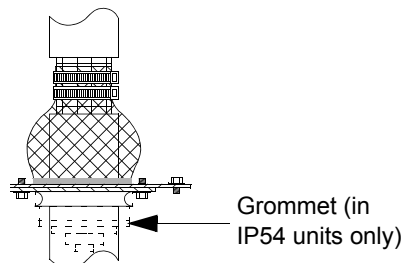

3. Connect the cables as follows:
  - Twist the cable shields to bundles and connect to the cabinet PE (ground) busbar. Connect the separate ground conductors/cables to the cabinet PE (ground) busbar.
  - Connect the phase conductors to the input power terminals (U1.1 ...). Depending on the cable size, use cable lugs or the dual-cable screw lug connectors which are installed to the busbars as standard. For details on the terminals and tightening torques, see [Technical data – Input power connection](#) on page 138, and section [Use of the dual-cable screw lug connector](#) below.
4. Refit the plastic insulators onto the input power terminals.



### *Phase 3 – Replacing the module*

1. Push the module back in and tighten the fastening screws.



**WARNING!** Keep your fingers away from the edge of the module front plate to avoid pinching them between the module and the cubicle. Also, keep a constant pressure with one foot on the base of the module to prevent the module from falling on its back.

---

2. Tighten the connector locking screw to 4 Nm (3 lbf.ft). Be careful not to break the locking screw. Note that the module can only mate with the quick connector when the switch-disconnector is in the open position.
3. Plug the module signal wire set to the module signal connector.
4. Plug the fibre optic cables back to their connectors.
5. Remove the module pull-out ramp and close the cabinet doors.

*Use of the dual-cable screw lug connector*

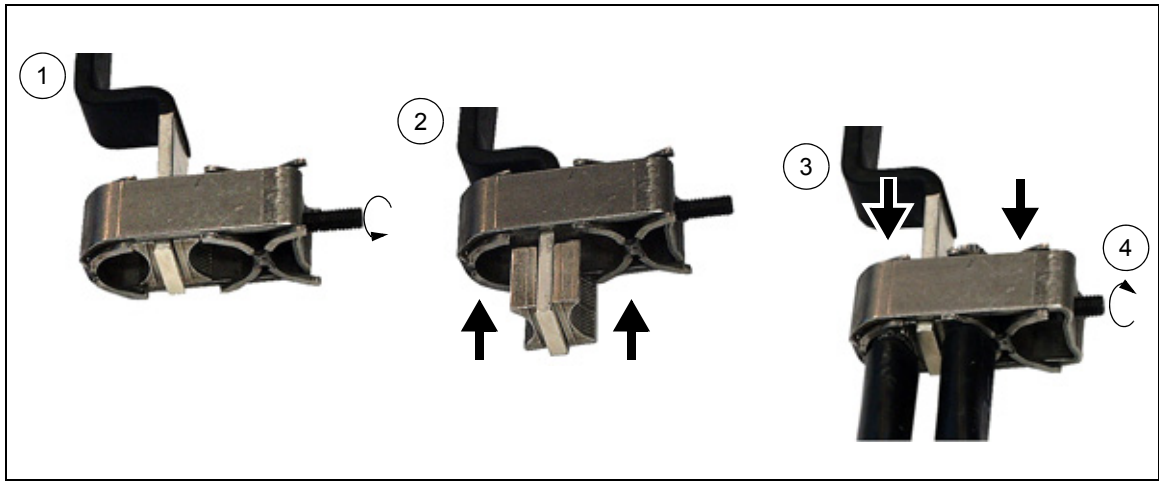

*Removal of the dual-cable screw lug connector*

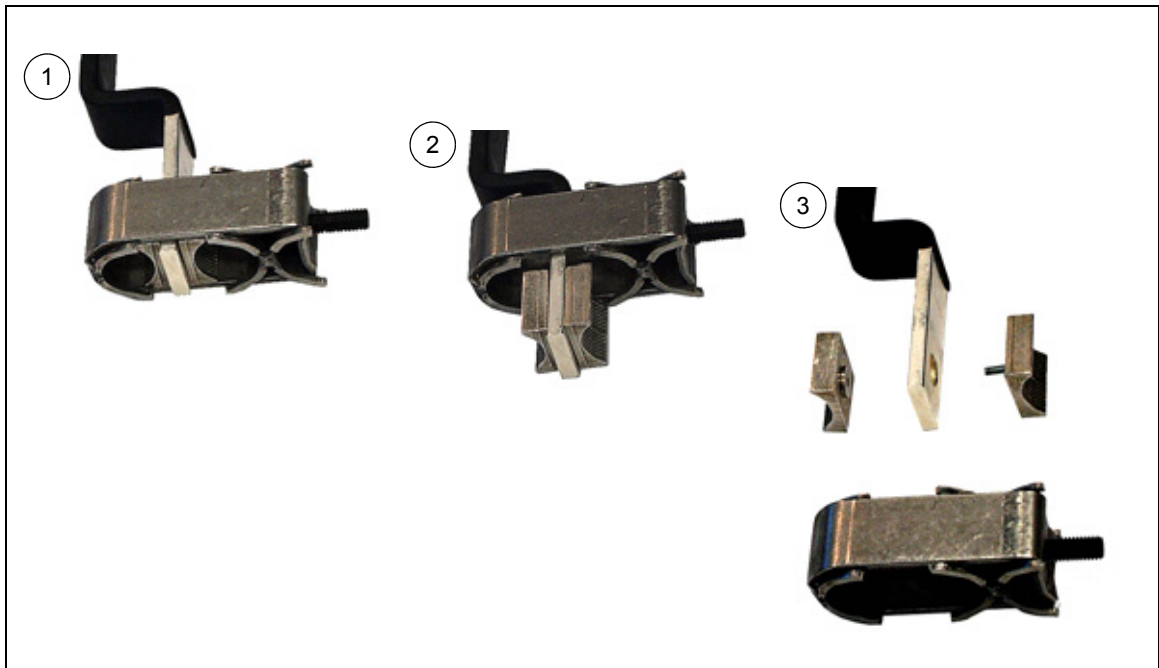

## Input power connection – Units with main switch-disconnector or main breaker (option +F253 or +F255)

### Connection diagrams

*Six-pulse connection, two DSU modules in parallel*

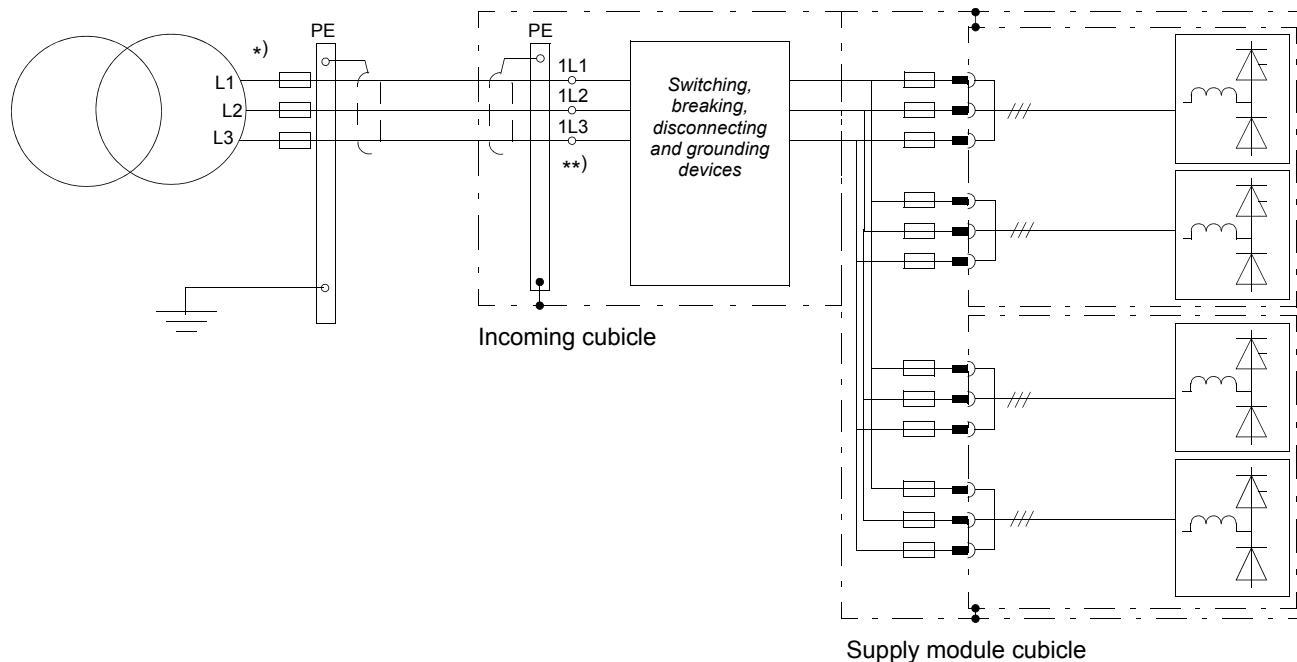

#### Notes:

\*)

Fuses are not required if the input power line is constructed of busbars that withstand the transformer short circuit current, or the input cables will be protected by some other means, eg, by a circuit breaker at the primary side of the transformer.

\*\*)

The cable lead-through details (number and size of holes), and cable connection details (number and dimensions of busbars, tightening torque) are given in chapter [Technical data](#), section [Input power connection](#).

*Twelve-pulse connection, two DSU modules in parallel*

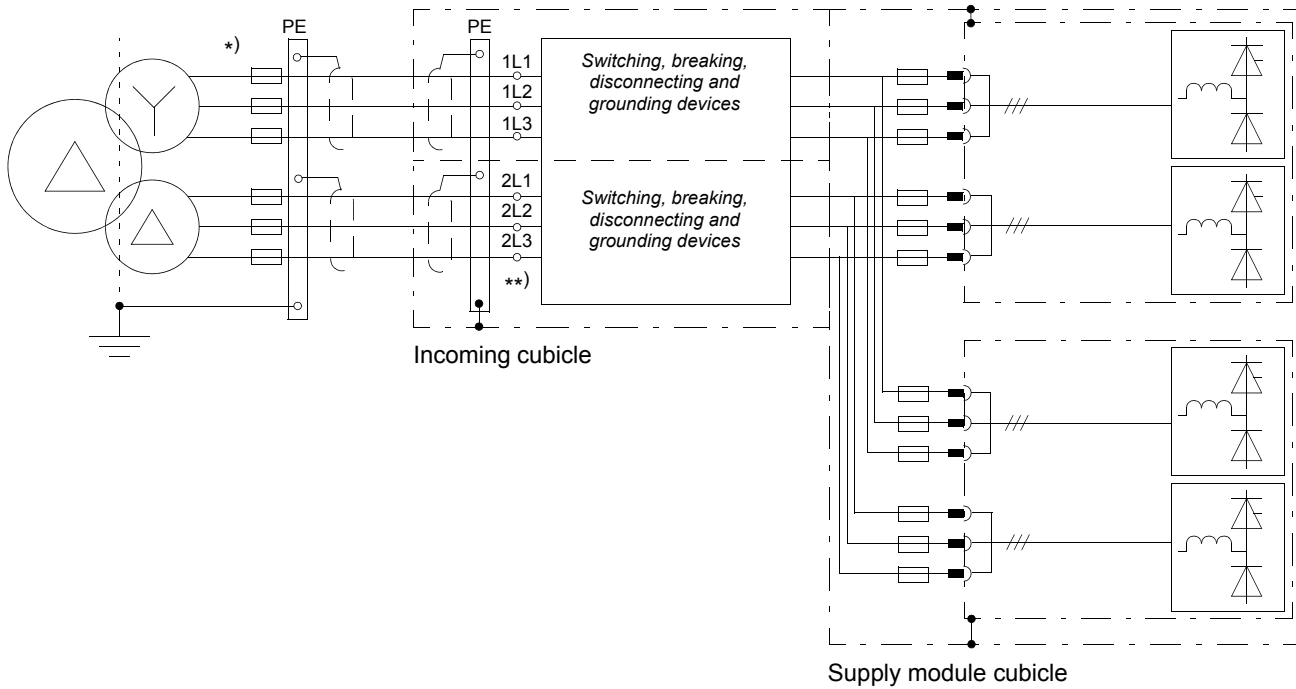

**Notes:**

When the same 12-pulse transformer is used to supply more than one module, connect the DC outputs of all modules to a common DC link. Separate links will cause current unbalance fault trips due to circulating currents between the modules.

\*) Fuses are not required if the input power line is constructed of busbars that withstand the transformer short circuit current, or the input cables will be protected by some other means, eg, by a circuit breaker at the primary side of the transformer.

\*\*\*) No bridging (connecting 1L1 to 2L1, 1L2 to 2L2, and 1L3 to 2L3) is allowed!

There are two separate incoming cubicles – one for terminals 1L1, 1L2 and 1L3, the other for 2L1, 2L2 and 2L3 – if **a)** the unit is equipped with main breakers, **b)** the drive is UL listed, or **c)** the incoming cubicle is designed for a busbar connection.

The cable lead-through details (number and size of holes), and cable connection details (number and dimensions of busbars, tightening torque) are given in chapter [Technical data](#), section [Input power connection](#).

## Connection procedure



**WARNING!** Read and follow the instructions given in [Safety instructions](#). Ignoring the instructions can cause physical injury or death, or damage to the equipment.

Open the door of the incoming (main switch-disconnector or main breaker) cubicle.

Remove any shrouds covering the input terminals and cable entries.

Lead the cables into the cubicle. Make the 360° grounding arrangement at the cable entries as shown below.

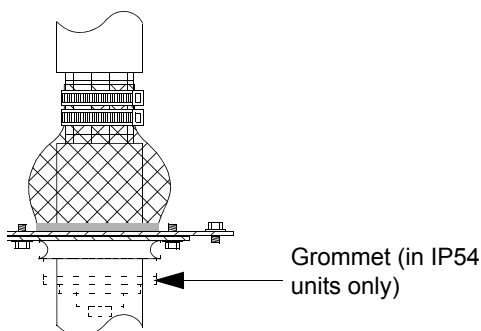

Cut the cables to suitable length.

Strip the cables and conductors.

Twist the cable screens into bundles and connect to the cabinet PE (ground) busbar.

Connect the separate ground conductors/cables to the cabinet PE (ground) busbar.

Connect the phase conductors to the input terminals using the torques given in chapter [Technical data](#), section [Input power connection](#).

Refit the shrouds removed earlier.

Close the door.

## Motor connection – Units without common motor terminal cubicle (no option +H359)

The motor cables are to be connected to the output busbars behind each inverter module. The location and dimensions of the busbars are visible in the dimensional drawings delivered with the drive, as well as the example drawings presented in chapter [Dimensions](#).

### Connection diagram

The diagram below shows a drive with a single inverter module. 360° grounding is to be used at cable entries.

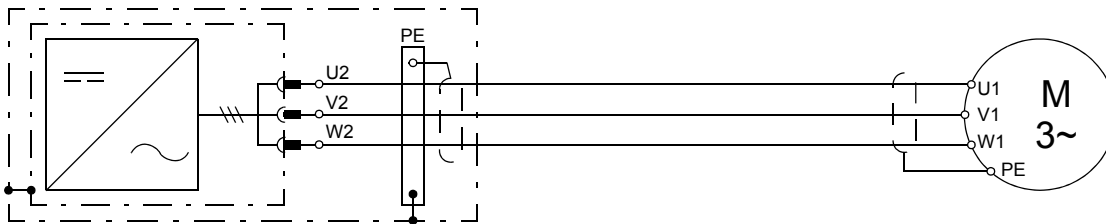

Inverter module cubicle

The recommended cable types are given in chapter [Planning the electrical installation](#).

Whenever the inverter unit consists of parallel-connected inverter modules, all the modules (two are shown below) are to be **cabled separately** to the motor.

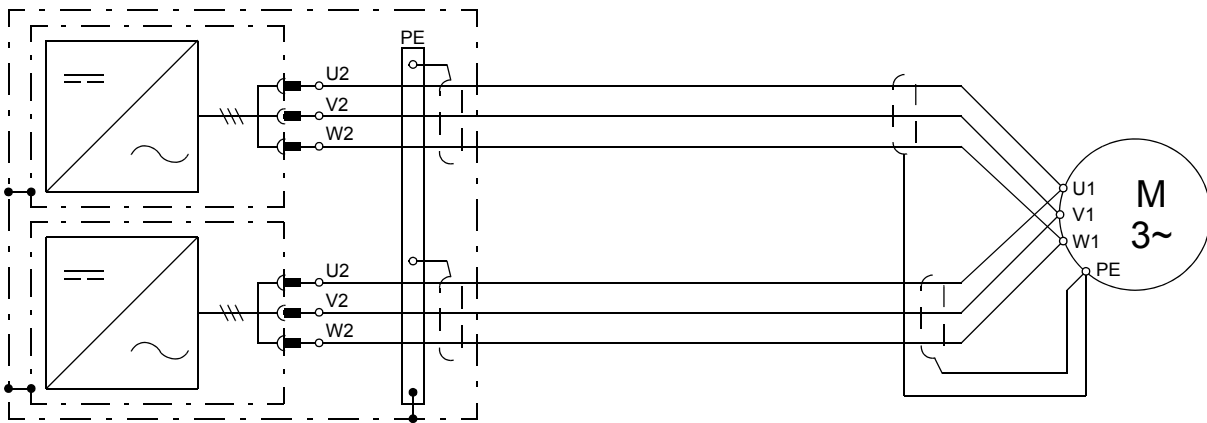

Inverter module cubicle

The recommended cable types are given in chapter [Planning the electrical installation](#).



**WARNING!** The cabling from all inverter modules to the motor must be physically identical considering cable type, cross-sectional area, and length.

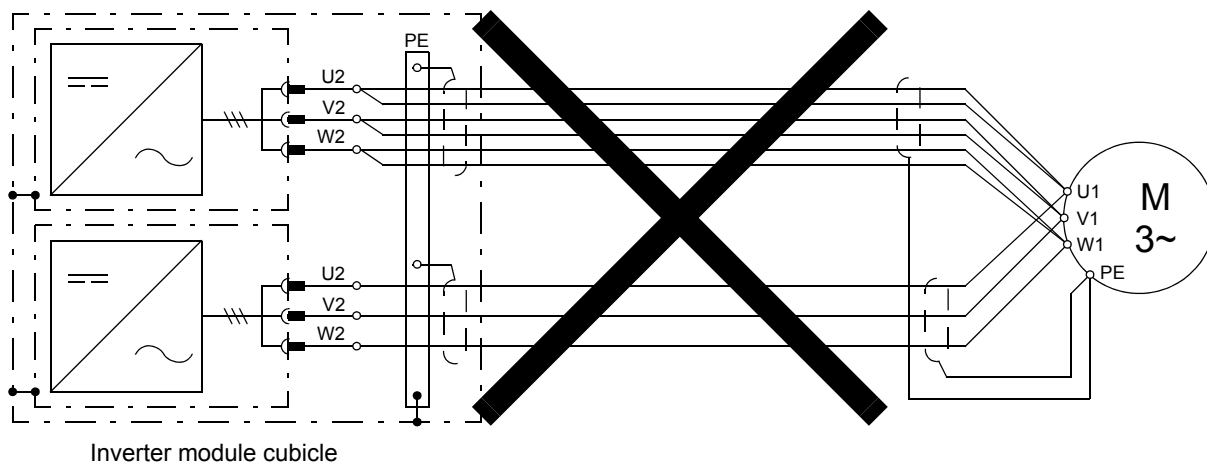

### Connection procedure



**WARNING!** Read and follow the instructions given in [Safety instructions](#). Ignoring the instructions can cause physical injury or death, or damage to the equipment.

**WARNING!** Ignoring the following instructions can cause physical injury or death, or damage to the equipment.



- Use extreme caution when manoeuvring a module that runs on wheels. The modules are heavy and have a high centre of gravity. They topple over easily if handled carelessly.
- Do not use the ramp which is supplied with the drive with heights over 50 mm (2.0 in). The ramp is designed for a plinth height of 50 mm (2.0 in) (the standard plinth height of ABB cabinets).

Extract each inverter module from the cubicle as follows:

- (1) Open the door of the inverter module cubicle.
- (2) Remove the shroud covering the upper part of the cubicle.
- (3) Open the transparent cover on the front of the inverter module and disconnect the fibre optic cables. Move the cables aside.
- (4) Remove the L-shaped DC busbars on top of the module.
- (5) Disconnect the terminal block (X50) next to the DC busbars.
- (6) Remove the two module fastening screws (6a) at the top. At the base of the module, loosen the two fastening screws (6b) but leave them in place; lift the bracket (6c) into the up position.
- (7) Insert the module pull-out ramp under the two screws at the base of the module and tighten.
- (8) Pull the module carefully out of the cubicle along the ramp.



**WARNING!** Make sure that the wires do not catch. While pulling on the handle, keep a constant pressure with one foot on the base of the module to prevent the module from falling on its back. Use safety shoes with metal toe cap to avoid foot injury.

- (9) Extend the support legs of the module. Keep the legs extended until the module is about to be inserted back into the cubicle.

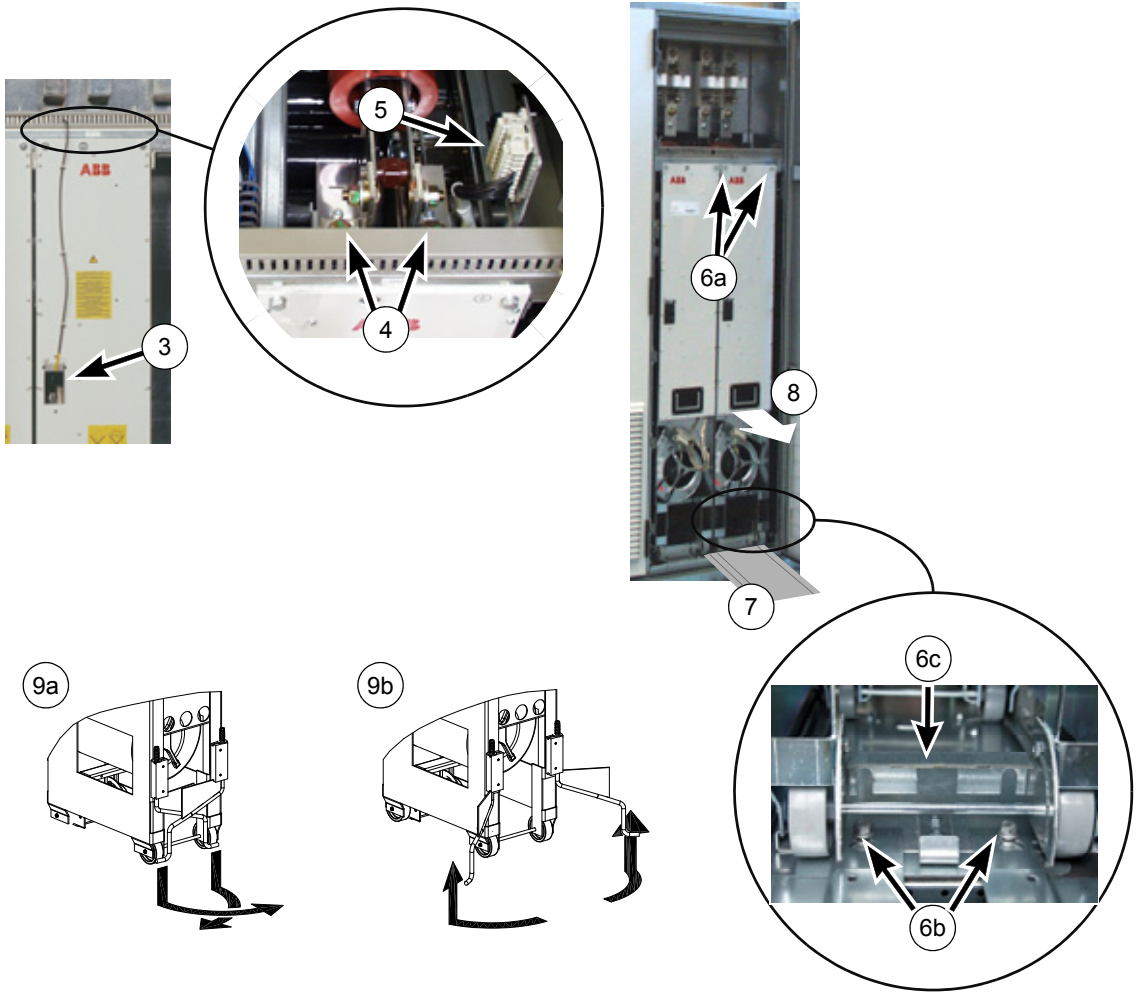



Lead the cables into the cabinet below each inverter module. Make the 360° grounding arrangement at the cable entry as shown.

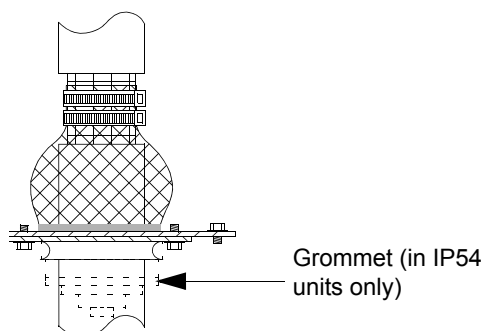

Cut the cables to a suitable length.

Strip the cables and conductors.

Twist the cable screens into bundles and connect to cabinet PE (ground) busbar.

Connect any separate ground conductors/cables to cabinet PE (ground) busbar.

Connect the phase conductors to the output terminals.

Use the tightening torques specified in [Technical data – Motor connection](#) on page 140.

Insert each inverter module into the cubicle as follows:

(1) Move the inverter module close to the ramp, then retract the support legs of the module.

(2) Push the module back into the cubicle – mind your fingers.



**WARNING!** Keep your fingers away from the edge of the module front plate to avoid pinching them between the module and the cubicle. Also, keep a constant pressure with one foot on the base of the module to prevent the module from falling on its back.

(3) Refasten the module fixing screws at the top, reconnect the DC busbars.

(4) Reconnect the cables (X50, fibre optic cables).

(5) Loosen the module fastening screws at the base of the module and remove the pull-out ramp. Flip the module fastening bracket into the down position and tighten the screws.

Close the doors.

At the motor, connect the cables according to instructions from the motor manufacturer. Pay special attention to the phase order.

For minimum radio frequency interference:

- ground the cable shield 360 degrees at the lead-through of the motor terminal box

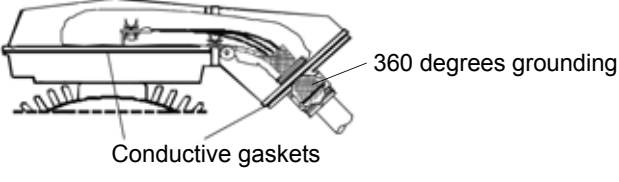

- or ground the cable by twisting the shield as follows: flattened width  $\geq 1/5 \times$  length.

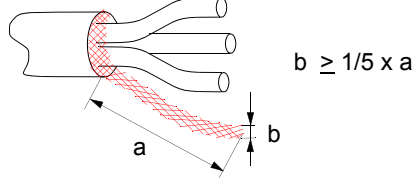

### Motor connection – Units with common motor terminal cubicle (option +H359)

#### Connection diagram

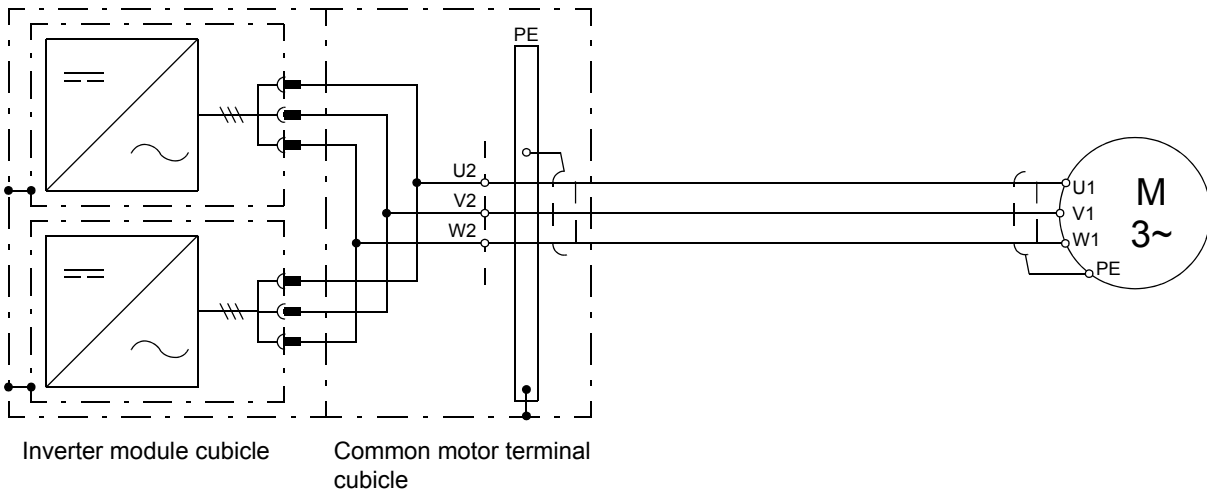

The recommended cable types are given in chapter [Planning the electrical installation](#).

#### Connection procedure

See the connection procedure on page [97](#).

## Control connections

### Drive/inverter control connections

The control connections are made on the terminal blocks provided in the swing-out frame in the auxiliary control cubicle of the drive. Refer to the circuit diagrams delivered with the drive, and to chapter *Motor control and I/O board (RMIO)*.

### Supply unit control connections

The supply unit is controlled using the local control devices mounted on the cabinet door. No external control connections by the user are needed. However, the user can connect certain external devices to the supply module. It is possible to:

- halt the supply unit by an external emergency stop button (if the unit is equipped with a local emergency stop button)
- read supply unit's status information through the relay outputs.

Refer to the circuit diagrams delivered with the drive for the connection terminals for the external control devices.

## Connection procedure

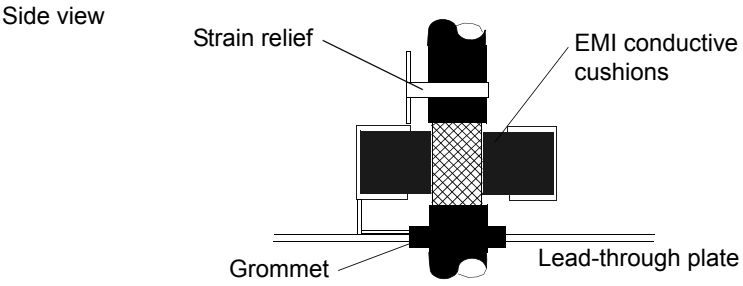
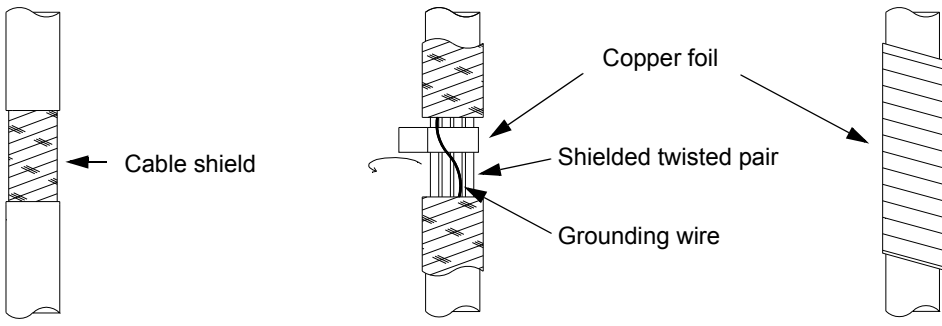
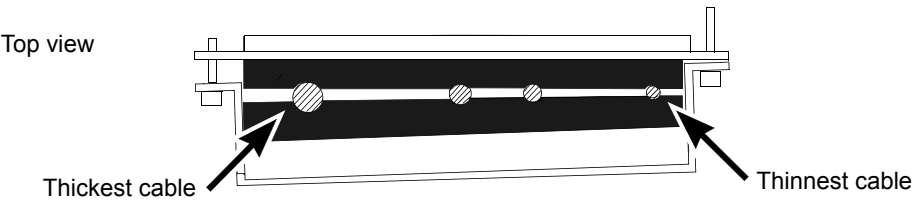
Turn the main switch-disconnector into open position (or rack the withdrawable main breaker out).
Release the door handle and open the door of the auxiliary control cubicle.
Remove the two locking screws at the edge of the swing-out frame and open the frame.
Run the cables into the inside of the cabinet through the grommets provided.
<i>Top entry units only:</i> If several cables need to be run through one grommet, use Loctite 5221 (cat. no. 25551) under the grommet to seal the cable entry.
Run the cables between the EMI conductive cushions as shown below. Strip the cable at this location to enable proper connection of the bare shield and the cushions. Tighten the cushions firmly onto the cable shields.
<p>Side view</p>  <p>The diagram shows a cable entering a cabinet through a grommet. A strain relief is attached to the cable. The cable passes between two EMI conductive cushions. The grommet is secured to a lead-through plate.</p>
If the outer surface of a cable shield is non-conductive, turn the shield inside out as shown below and apply copper foil to keep the shielding continuous. Do not cut the grounding wire (if present).
<p>Stripped cable                      Conductive surface of the shield exposed                      Stripped part covered with copper foil</p>  <p>The three diagrams illustrate the process of preparing a cable shield. The first shows a cable with a shielded section. The second shows the shield turned inside out, exposing the conductive surface of the shield, the shielded twisted pair, and the grounding wire. The third shows the exposed conductive surface covered with copper foil.</p>
On top entry units, sort the cables so that the thinnest and thickest cables are at opposite ends of the opening.
<p>Top view</p>  <p>The diagram shows a top view of a cable tray with several cables. The thickest cable is on the left and the thinnest cable is on the right, illustrating the sorting procedure.</p>

Run the cables to the swing-out frame as shown below. Wherever possible, use the existing cable trunking (1) in the cabinet. Use sleeving wherever the cables are laid against sharp edges. Leave some slack in the cable at the hinge (2) to allow the frame to open fully. Tie the cables to the braces (3) to provide strain relief.

Swing-out frame open



Cable routing example

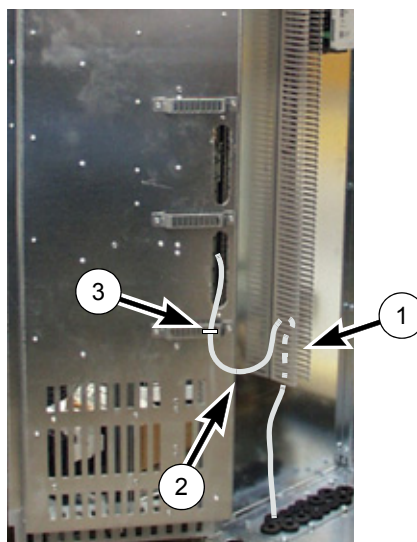

Cut the cables to a suitable length. Strip the cables and conductors.

Twist the cable shields into bundles and connect them to the ground terminal nearest to the terminal block. Keep the unshielded portion of the cables as short as possible.

Connect the conductors to appropriate terminals (see chapter [Motor control and I/O board \(RMIO\)](#) and the circuit diagrams delivered with the unit).

Close the swing-out frame, refasten, and close the doors.

## Installation of optional modules and PC



**WARNING!** Read and follow the safety instructions, given in *ACS800 Multidrive and Multidrive Modules Safety Instructions (3AFE64760432 [English])*. Ignoring the instructions can cause physical injury or death, or damage to the equipment.

### PC connection

Connect the PC to CH3 of the RDCO module via a fibre optic link. The RDCO is attached to an option slot of the RMIO board. See also [Fibre optic link](#) below.

**Optional modules**

Optional modules (such as fieldbus adapters, I/O extension modules and the pulse encoder interface modules) are inserted into the optional module slots of the inverter unit control board (RDCU) and fixed with two screws. See the appropriate optional module manual for further instructions.

*Cabling of I/O and fieldbus modules*

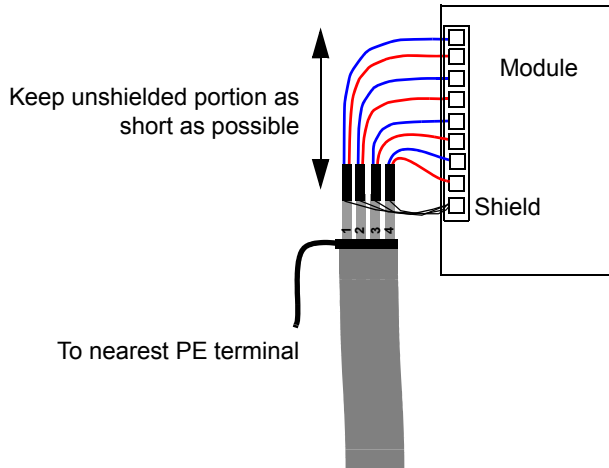

*Cabling of pulse encoder interface module*

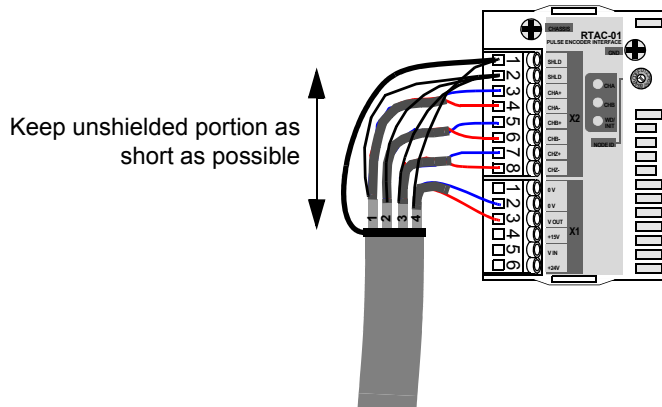

**Note 1:** If the encoder is of unisolated type, ground the encoder cable at the drive end only. If the encoder is galvanically isolated from the motor shaft and the stator frame, ground the encoder cable shield at the drive and the encoder end.

**Note 2:** Twist the pair cable wires.

**Fibre optic link**

A DDCS fibre optic link is provided via the RDCO module (optional) for PC tools, master/follower link, NDIO, NTAC, NAI0, AIMA I/O module adapter and fieldbus adapter modules of type Nxxx. See *RDCO-01/02/03 DDCS Communication Option Modules* [3AFE64492209 (English)] for the connections. Observe colour coding when installing fibre optic cables. Blue connectors go to blue terminals, and grey connectors to grey terminals.

When installing multiple modules on the same channel, connect them in a ring.

## Connections and tap settings of the auxiliary voltage transformer of the drive

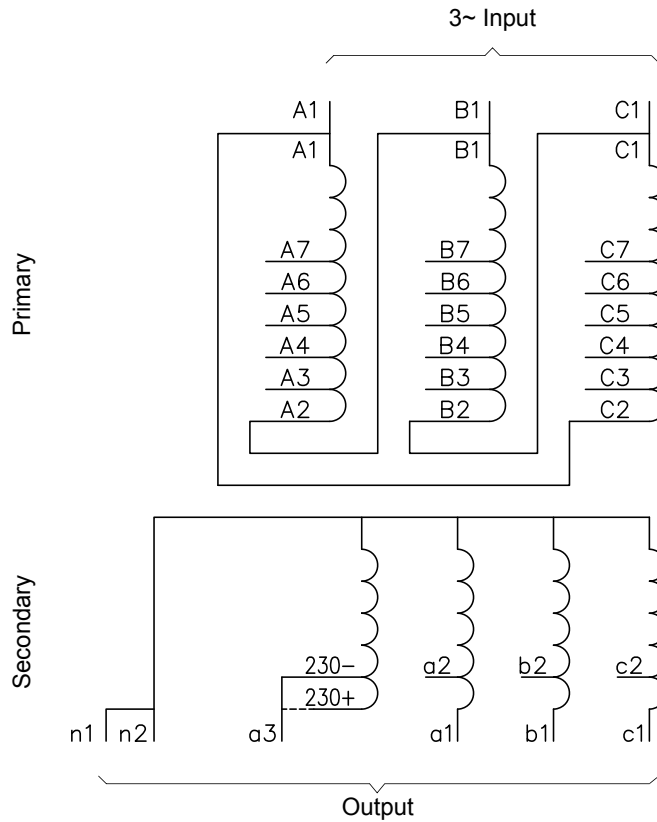

Supply voltage	3~ input			
	Terminals	Tap settings		
		A1 to...	B1 to...	C1 to...
690 V	A1, B1, C1	C2	A2	B2
660 V	A1, B1, C1	C2	A2	B2
600 V	A1, B1, C1	C3	A3	B3
575 V	A1, B1, C1	C3	A3	B3
525 V	A1, B1, C1	C4	A4	B4
500 V	A1, B1, C1	C4	A4	B4
480 V	A1, B1, C1	C5	A5	B5
460 V	A1, B1, C1	C5	A5	B5
440 V	A1, B1, C1	C6	A6	B6
415 V	A1, B1, C1	C6	A6	B6
400 V	A1, B1, C1	C7	A7	B7
380 V	A1, B1, C1	C7	A7	B7

Supply voltage	1~ output		3~ output	
	230 V		400 V (50 Hz)	320 V (60 Hz)
	Terminals	Tap setting	Terminals	Terminals
690 V	a3, n1	230-	a1, b1, c1	a2, b2, c2
660 V	a3, n1	230+	a1, b1, c1	a2, b2, c2
600 V	a3, n1	230-	a1, b1, c1	a2, b2, c2
575 V	a3, n1	230+	a1, b1, c1	a2, b2, c2
525 V	a3, n1	230-	a1, b1, c1	a2, b2, c2
500 V	a3, n1	230+	a1, b1, c1	a2, b2, c2
480 V	a3, n1	230-	a1, b1, c1	a2, b2, c2
460 V	a3, n1	230+	a1, b1, c1	a2, b2, c2
440 V	a3, n1	230-	a1, b1, c1	a2, b2, c2
415 V	a3, n1	230+	a1, b1, c1	a2, b2, c2
400 V	a3, n1	230-	a1, b1, c1	a2, b2, c2
380 V	a3, n1	230+	a1, b1, c1	a2, b2, c2

## Switching on and selecting the supply voltage of the auxiliary voltage transformer of the DSU module

1. Detach the lid which covers the switches and selector of the auxiliary voltage transformer of the DSU module. The lid is on the front cover of the module. In the figure below, the lid has been detached already.
2. Check that the secondary circuit is closed, that is, check that the grounding switch (A) is pressed down. See the figure below.
3. Close the protective circuit breaker (B) of the auxiliary voltage transformer, that is, set it to the ON position.
4. Select the primary side voltage of the transformer by attaching the plug (C) to the appropriate position.
5. Repeat this procedure with all diode supply modules.

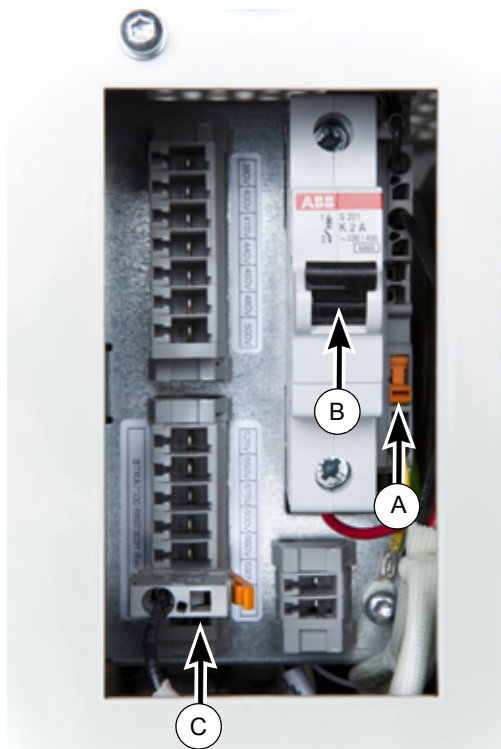

## Installation of brake resistors

A drive with option +D150 (brake copper) and option +D151 (brake resistor) has both the chopper and the brake resistor installed as standard. No installation by the customer is needed. However, if the drive is equipped with option +D150 only, the user must acquire and install the brake resistors according to the instructions in chapter [Resistor braking](#).



# Motor control and I/O board (RMIO)

---

## What this chapter contains

This chapter shows

- external control connections to the control board of the inverter unit with the ACS800 standard control program (Factory macro)
- specifications of the inputs and outputs of the board.

**Note:** This chapter describes the standard I/O connections of the RMIO board controlling the inverter unit. There is also another RMIO board which controls the supply unit. The supply unit I/O connections are reserved for internal use (no customer connections are possible or allowed). See chapter [Hardware description](#) for the description of the supply unit I/O interface.

## Note on cabinet-installed ACS800 drives

The terminals of the RMIO board are optionally wired to terminal block X2. The connections shown below apply also to terminal block X2 (the markings are identical to the ones on the RMIO board).

Terminals of X2 accept cables from 0.5 to 4.0 mm<sup>2</sup> (22 to 12 AWG). The tightening torque for screw terminals is 0.4 to 0.8 Nm (0.3 to 0.6 lbf.ft). For disconnecting wires from spring terminals, use a screwdriver with a blade thickness of 0.6 mm (0.024") and width of 3.5 mm (0.138"), for example Phoenix Contact SZF 1-0,6X3,5.

## Note on the terminal labelling

Optional modules (type Rxxx) may have terminal designations that coincide with those of the RMIO board.

## External control connections (non-US)

External control cable connections to the RMIO board for the ACS800 Standard Control Program (Factory macro) are shown below. For external control connections of other application macros and programs, see the appropriate *Firmware manual* of the drive control program.

**Terminal block size:**

cables 0.3 to 3.3 mm<sup>2</sup> (22 to 12 AWG)

**Tightening torque:**

0.2 to 0.4 Nm (0.2 to 0.3 lbf ft)

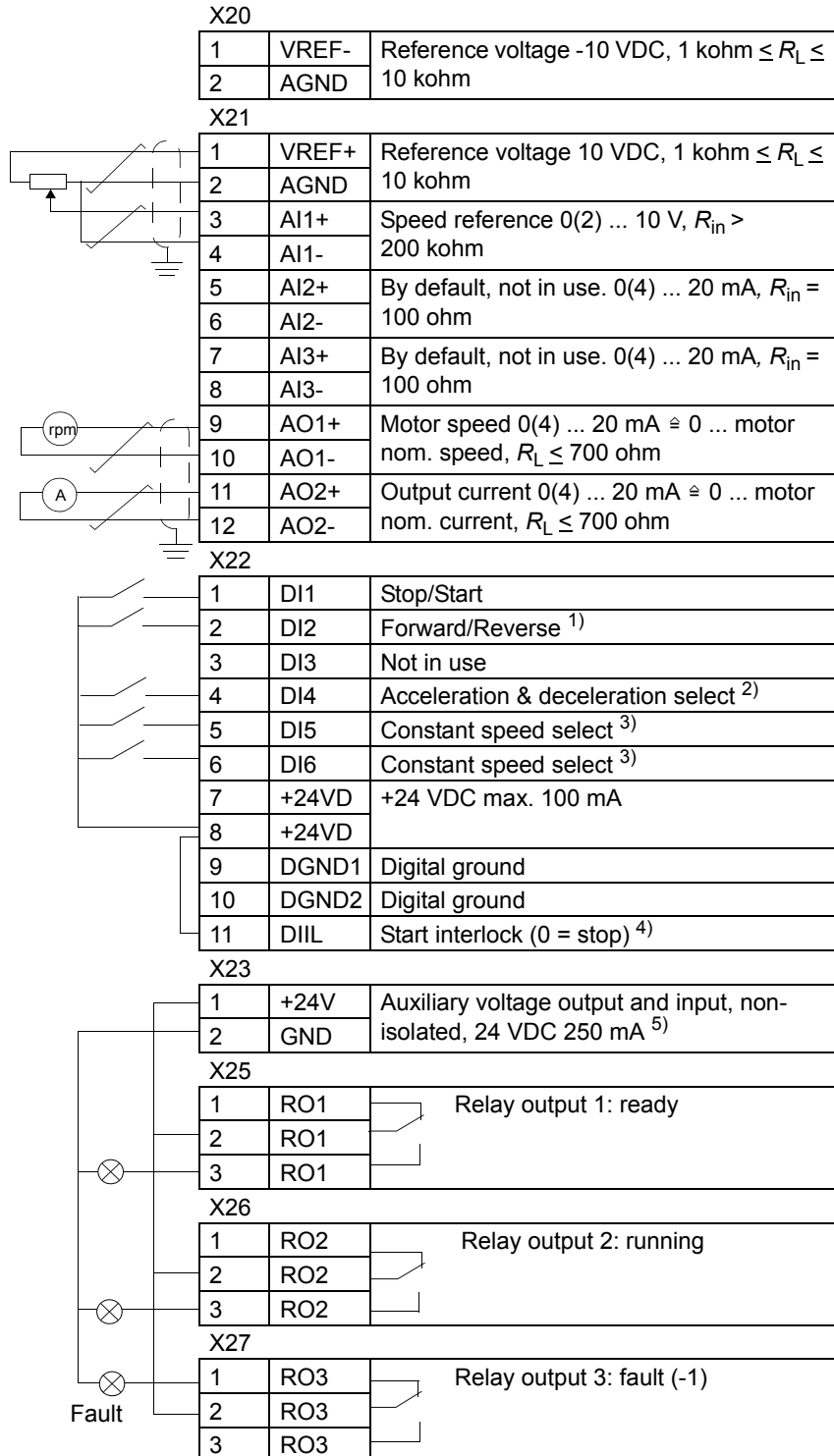

1) Only effective if par. 10.03 is set to REQUEST by the user.

2) 0 = open, 1 = closed

DI4	Ramp times according to
0	parameters 22.02 and 22.03
1	parameters 22.04 and 22.05

3) See par. group 12 CONSTANT SPEEDS.

DI5	DI6	Operation
0	0	Set speed through AI1
0	1	Constant speed 1
1	1	Constant speed 3

4) See parameter 21.09 START INTRL FUNC.

5) Total maximum current shared between this output and optional modules installed on the board.

## External control connections (US)

External control cable connections to the RMIO board for the ACS800 Standard Control Program (Factory macro US version) are shown below. For external control connections of other application macros and programs, see the appropriate *Firmware manual* of the drive control program.

**Terminal block size:**

cables 0.3 to 3.3 mm<sup>2</sup> (22 to 12 AWG)

**Tightening torque:**

0.2 to 0.4 Nm (0.2 to 0.3 lbf ft)

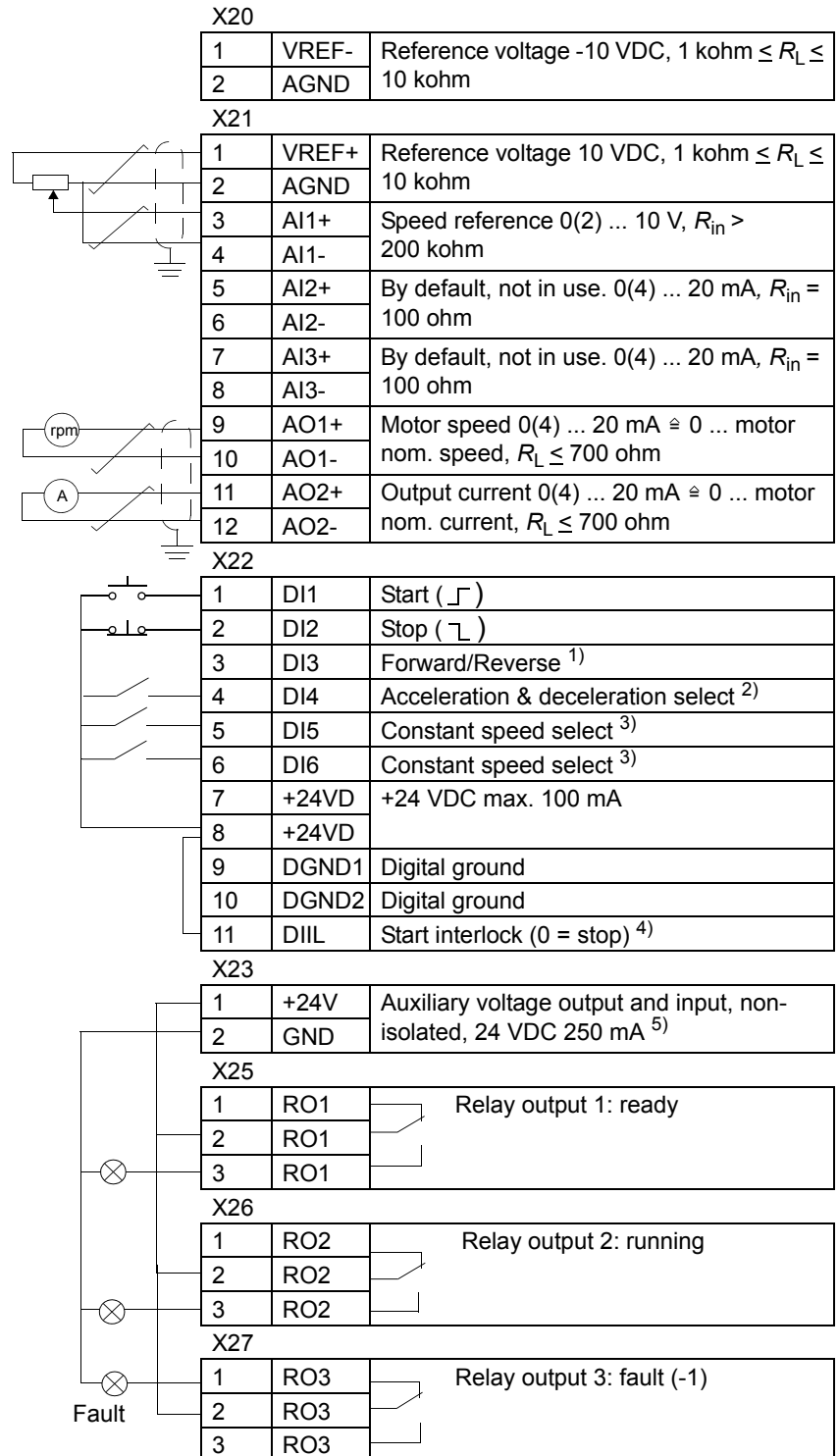

<sup>1)</sup> Only effective if par. 10.03 is set to REQUEST by the user.

<sup>2)</sup> 0 = open, 1 = closed

DI4	Ramp times according to
0	parameters 22.02 and 22.03
1	parameters 22.04 and 22.05

<sup>3)</sup> See par. group 12 CONSTANT SPEEDS.

DI5	DI6	Operation
0	0	Set speed through AI1
1	0	Constant speed 1
0	1	Constant speed 2
1	1	Constant speed 3

<sup>4)</sup> See parameter 21.09 START INTRL FUNC.

<sup>5)</sup> Total maximum current shared between this output and optional modules installed on the board.

## RMIO board specifications

### Analogue inputs

---

	Two programmable differential current inputs (0 mA / 4 mA ... 20 mA, $R_{in} = 100 \text{ ohm}$ ) and one programmable differential voltage input (-10 V / 0 V / 2 V ... +10 V, $R_{in} > 200 \text{ kohm}$ ).
	The analogue inputs are galvanically isolated as a group.
Isolation test voltage	500 VAC, 1 min
Max. common mode voltage between the channels	$\pm 15 \text{ VDC}$
Common mode rejection ratio	$\geq 60 \text{ dB}$ at 50 Hz
Resolution	0.025% (12 bit) for the -10 V ... +10 V input. 0.5% (11 bit) for the 0 ... +10 V and 0 ... 20 mA inputs.
Inaccuracy	$\pm 0.5\%$ (Full Scale Range) at 25 °C (77 °F). Temperature coefficient: $\pm 100 \text{ ppm/}^\circ\text{C}$ ( $\pm 56 \text{ ppm/}^\circ\text{F}$ ), max.

### Constant voltage output

---

Voltage	+10 VDC, 0, -10 VDC $\pm 0.5\%$ (Full Scale Range) at 25 °C (77 °F). Temperature coefficient: $\pm 100 \text{ ppm/}^\circ\text{C}$ ( $\pm 56 \text{ ppm/}^\circ\text{F}$ ) max.
Maximum load	10 mA
Applicable potentiometer	1 kohm to 10 kohm

### Auxiliary power output

---

Voltage	24 VDC $\pm 10\%$ , short circuit proof
Maximum current	250 mA (shared between this output and optional modules installed on the RMIO)

### Analogue outputs

---

	Two programmable current outputs: 0 (4) to 20 mA, $R_L \leq 700 \text{ ohm}$
Resolution	0.1% (10 bit)
Inaccuracy	$\pm 1\%$ (Full Scale Range) at 25 °C (77 °F). Temperature coefficient: $\pm 200 \text{ ppm/}^\circ\text{C}$ ( $\pm 111 \text{ ppm/}^\circ\text{F}$ ) max.

### Digital inputs

---

	Six programmable digital inputs (common ground: 24 VDC, -15% to +20%) and a start interlock input. Group isolated, can be divided in two isolated groups (see <a href="#">Isolation and grounding diagram</a> below).
	Thermistor input: 5 mA, $< 1.5 \text{ kohm} \hat{=} "1"$ (normal temperature), $> 4 \text{ kohm} \hat{=} "0"$ (high temperature), open circuit $\hat{=} "0"$ (high temperature).
	Internal supply for digital inputs (+24 VDC): short circuit proof. An external 24 VDC supply can be used instead of the internal supply.
Isolation test voltage	500 VAC, 1 min
Logical thresholds	$< 8 \text{ VDC} \hat{=} "0"$ , $> 12 \text{ VDC} \hat{=} "1"$
Input current	DI1 to DI 5: 10 mA, DI6: 5 mA
Filtering time constant	1 ms

### Relay outputs

---

	Three programmable relay outputs
Switching capacity	8 A at 24 VDC or 250 VAC, 0.4 A at 120 VDC
Minimum continuous current	5 mA rms at 24 VDC
Maximum continuous current	2 A rms
Isolation test voltage	4 kVAC, 1 minute

### DDCS fibre optic link

---

With optional communication adapter module RDCO. Protocol: DDCS (ABB Distributed Drives Communication System)

### 24 VDC power input

---

Voltage	24 VDC $\pm$ 10%
Typical current consumption (without optional modules)	250 mA
Maximum current consumption	1200 mA (with optional modules inserted)

The terminals on the RMIO board as well as on the optional modules attachable to the board fulfil the Protective Extra Low Voltage (PELV) requirements stated in EN 50178 provided that the external circuits connected to the terminals also fulfil the requirements and the installation site is below 2000 m (6562 ft). Above 2000 m (6562 ft), see page [78](#).

### Isolation and grounding diagram

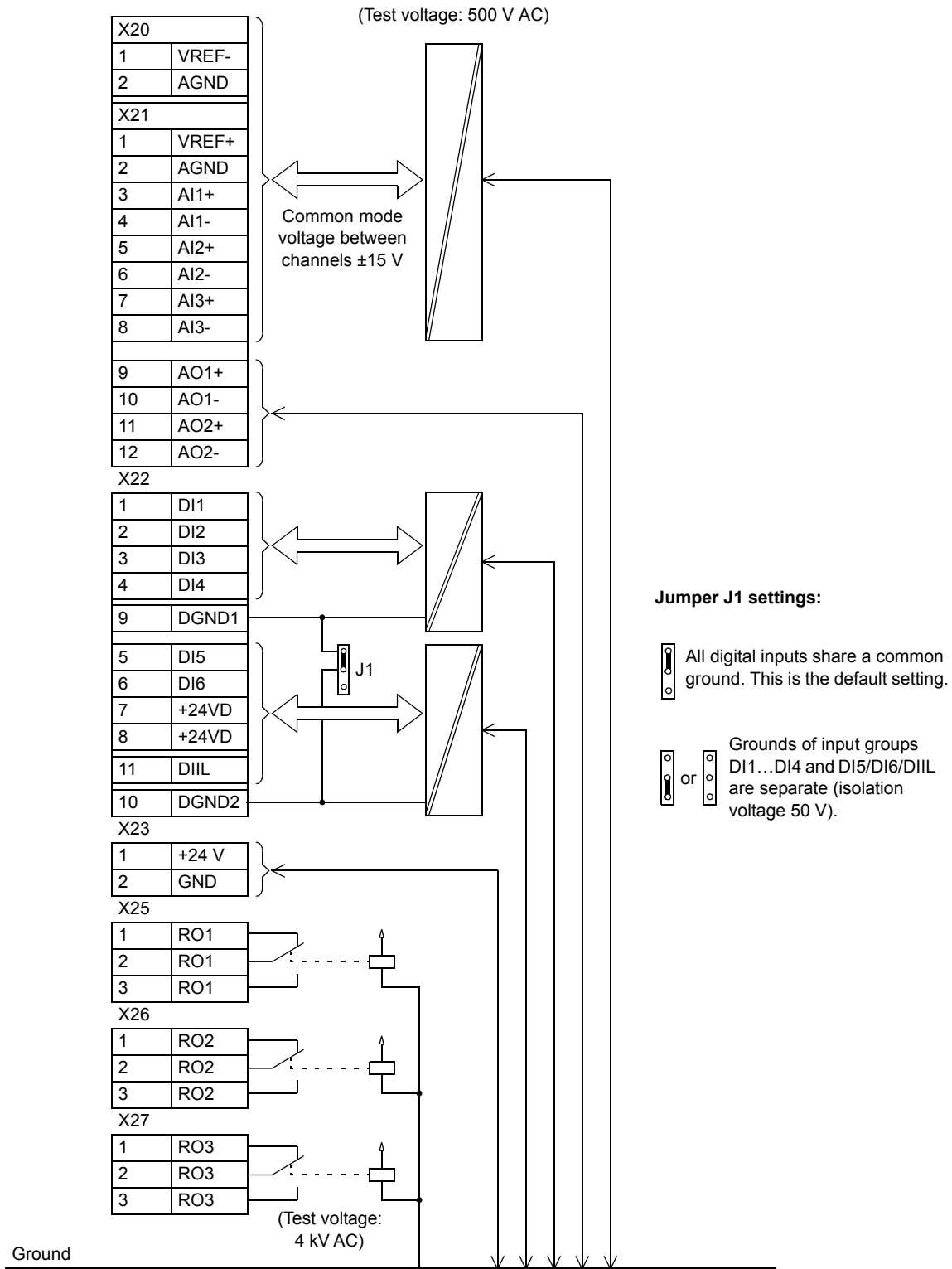

# Installation checklist and start-up

---

## What this chapter contains

This chapter contains a list for checking the mechanical and electrical installation of the drive, and gives basic instructions on how to start-up the ACS800-07 (+V992) drive.

## Installation checklist

Check the mechanical and electrical installation of the drive before start-up. Go through the checklist below together with another person. Read the [Safety instructions](#) on the first pages of this manual before you work on the unit.

Check that...	
<b>MECHANICAL INSTALLATION</b>	
<input type="checkbox"/>	The ambient operating conditions are allowed. See <a href="#">Electrical installation</a> , <i>Technical data: Ratings or Ambient conditions</i> .
<input type="checkbox"/>	The unit is fixed properly to floor. See <a href="#">Mechanical installation</a> .
<input type="checkbox"/>	The cooling air will flow freely.
<b>ELECTRICAL INSTALLATION</b> See <a href="#">Planning the electrical installation</a> , <a href="#">Electrical installation</a> .	
<input type="checkbox"/>	The motor and the driven equipment are ready for start.
<input type="checkbox"/>	The EMC filter (option +E202) is disconnected if the drive is connected to an IT (ungrounded) system.
<input type="checkbox"/>	The drive is grounded properly: <ol style="list-style-type: none"> <li>1) adequately sized PE conductor</li> <li>2) properly tightened PE conductor.</li> </ol>
<input type="checkbox"/>	The supply (input power) voltage matches the nominal input voltage of the drive.
<input type="checkbox"/>	The supply (input power) connection to the input terminals are OK and the phase order is correct.
<input type="checkbox"/>	Appropriate supply (input power) fuses are installed.
<input type="checkbox"/>	The motor connections at the output terminals are OK.
<input type="checkbox"/>	The motor cable is routed away from other cables.
<input type="checkbox"/>	Settings of the auxiliary voltage transformer of the drive.
<input type="checkbox"/>	Settings of the internal transformer in the DSU.
<input type="checkbox"/>	There are no power factor compensation capacitors in the motor cable.
<input type="checkbox"/>	The external control connections of the drive are OK.
<input type="checkbox"/>	There are no tools, foreign objects or dust from drilling inside the drive.
<input type="checkbox"/>	Supply (input power) voltage cannot be applied to the output of the drive (with a bypass connection).

**Check that...**

- For drives with Category 1 Emergency stop function (option +Q952 or +Q964): The time relay has been set to a suitable value (somewhat longer than the stop ramp of the inverter units).
- All shrouds are in place.

**Start-up procedure**



This section instructs how to start-up the ACS800-07 (+V992) drive. The instructions do not cover all possible tasks of all possible variants of the drive as the composition of the make-to-order drives vary. Always refer to the delivery-specific circuit diagrams when performing the drive start-up. The device designations in square brackets, for example [Q10], refer to the designations used in the circuit diagrams typically.



**WARNING!** Only qualified electricians are allowed to carry out the work described in this chapter. Read chapter [Safety instructions](#) before you start the work. Ignoring the safety instructions can cause injury or death.

Action	Additional information
 <p><b>WARNING!</b> Ensure that the disconnecter of the supply transformer is locked in the open position, ie, no voltage is, or cannot be connected to drive inadvertently. Check also by measuring that there is no voltage connected.</p> <ul style="list-style-type: none"> <li><input type="checkbox"/> Check that the main disconnecting device of the supply unit is open:           <ul style="list-style-type: none"> <li>- Drives with a main breaker [Q1] (option +F255): The breaker is in the withdrawn position (racked out).</li> <li>- Drives with a main switch-disconnector (option +F253): The switch is in the open position.</li> <li>- Other drives (no option +F253 or +F255): The main switch disconnecter is locked in the open position.</li> </ul> </li> </ul>	
<p><b>Basic checks with no voltage connected</b></p> <ul style="list-style-type: none"> <li><input type="checkbox"/> If the unit is equipped with a main breaker [Q1], set the current trip limits of the breaker. The trip limits have been preset to generic values by the breaker manufacturer. The generic limits do not correspond to the protection requirements of the application. For the limit rules, see below.           <p><i>General rule</i> Ensure that the selectivity condition is fulfilled, ie, the breaker trips at a lower current than the protection device of the supplying network, and that the limit is high enough not to cause unnecessary trips during the intermediate DC circuit load peak at start.</p> <p><i>Long-term current limit</i> As a rule of thumb, this should be set to the rated AC current of the module.</p> <p><i>Peak current limit</i> As a rule of thumb, this should be set to a value 3 - 4 times the rated AC current of the module.</p> </li> </ul>	<p>Optional device (+F255). See the delivery specific circuit diagrams and the manuals of the breaker.</p>



<p><b>Action</b></p> <ul style="list-style-type: none"> <li><input type="checkbox"/> Check the settings of any adjustable relays and breakers/switches in the auxiliary circuits.</li> <li><input type="checkbox"/> Disconnect any unfinished or unchecked 230/115-VAC cables that lead from the terminal blocks to the outside of the equipment.</li> <li><input type="checkbox"/> Locate the PPCS branching unit(s) (APBU-xx). Enable memory backup battery by setting actuator 6 of switch S3 to ON.</li> <li><input type="checkbox"/> Check the voltage setting of the auxiliary voltage transformer of the drive [T10].</li> <li><input type="checkbox"/> Check the voltage setting of the auxiliary voltage transformer in the DSU module.</li> </ul>	<p><b>Additional information</b></p> <p>Composition varies. See delivery specific circuit diagrams.</p> <p>As standard, memory backup is switched off to save the battery.</p> <p>See page <a href="#">103</a>.</p> <p>See page <a href="#">104</a>.</p>
<p><b>Connecting voltage to input terminals and auxiliary circuit</b></p> <p> <b>WARNING!</b> When voltage is connected to the input terminals, voltage may also be connected to the auxiliary circuits of the drive unit(s). Make sure that it is safe to apply voltage. Ensure that:</p> <ul style="list-style-type: none"> <li>• nobody is working on the unit or circuits that are wired from outside into the cabinets</li> <li>• covers of motor terminal boxes are in place.</li> </ul> <ul style="list-style-type: none"> <li><input type="checkbox"/> Close the circuit breaker which connects the 24 V DC supply voltage for the boards [F7].</li> <li><input type="checkbox"/> Close the circuit breaker which connects the supply voltage for the AC fans and 24 V DC power supply [F11].</li> <li><input type="checkbox"/> Close the circuit breaker which connects the supply voltage for the fan in the incoming cubicle [F101].</li> <li><input type="checkbox"/> Close the circuit breaker which connects the control voltage for the main breaker [F12].</li> <li><input type="checkbox"/> Close the circuit breaker which connects the control voltage for the optional emergency stop circuit [F21].</li> <li><input type="checkbox"/> Close the circuit breaker [F5] which connects the measuring board (BAMU) to the main circuit.</li> <li><input type="checkbox"/> Check the circuit diagrams and close any other breakers and switches in the auxiliary circuit. The composition vary depending on the options of the drive.</li> <li><input type="checkbox"/> Close the doors of the cabinets.</li> <li><input type="checkbox"/> Close the main breaker of the supply transformer.</li> <li><input type="checkbox"/> Close the auxiliary circuit switch [Q10].</li> </ul>	<p>Only with option +F253 or +F255.</p> <p>Only with option +F255.</p> <p>Only with options Q951, Q952, Q963 and Q964.</p> <p>Only with option +F253 or +F255.</p>
<p><b>Starting the supply unit</b></p> <p> <b>WARNING!</b> If the drive is equipped with a brake unit, make sure there are inverters connected to the intermediate circuit before start. As a rule of thumb, the sum capacitance of the inverters connected must be at least 30% of the sum capacitance of all inverters.</p>	<p>Optional unit +D150.</p> <p>If there is not enough capacitive load at start, the DC voltage will overshoot the controller voltage limit, causing immediate start of braking. An unloaded supply unit keeps the DC voltage high and the chopper remains conductive.</p>

<p><b>Action</b></p> <ul style="list-style-type: none"> <li><input type="checkbox"/> Open the grounding switch (if present) and close the drive main disconnecting device. <b>Note:</b> The grounding switch and the main disconnecting device are either mechanically coupled or electrically interlocked: The grounding switch can be closed only when the main disconnecting device is open. The disconnecter can be closed only when the grounding switch is open.</li> <li><input type="checkbox"/> Close the drive main disconnecting device: <u>Units with a main breaker (option +F255):</u> Unlock the withdrawn breaker and rack it in. <u>Units with a main switch-disconnector (option +F253):</u> Unlock the switch and turn it into the closed position.</li> <li><input type="checkbox"/> Close the main contactors (option +F250] or the main breaker [Q1] (option +F255), and start the DSU: Turn the three-position operating switch [S11] on the cabinet door from 0 to the START position for 2 s.</li> </ul>	<p><b>Additional information</b></p> <p>Optional device (option +F259). See delivery specific circuit diagrams.</p> <p>See delivery specific circuit diagrams.</p>
<p><b>Setting up the supply unit control program</b></p> <ul style="list-style-type: none"> <li><input type="checkbox"/> Check the settings of the supply unit control program.</li> </ul>	<p>See section Start-up in <i>ACS800 diode supply control program firmware manual</i> (3AUA0000068937[English]).</p>
<p><b>Setting up the drive control program</b></p> <ul style="list-style-type: none"> <li><input type="checkbox"/> Select the application macro and adjust the parameter settings of the drive control program to meet the application needs.</li> </ul>	<p>Appropriate <i>Firmware Manual</i> of the drive control program delivered with the drive.</p>
<p><b>On-load checks</b></p> <ul style="list-style-type: none"> <li><input type="checkbox"/> Check the correct operation of the emergency stop circuits from each operating location. If the drive is equipped with the category 1 emergency stop function (option +Q952 or +Q964), adjust the delay time of the emergency stop relay and the deceleration time of the drive emergency stop function. The factory default settings do not necessarily meet the application needs.</li> <li><input type="checkbox"/> Check that the Prevention of unexpected start-up function from each operating location.</li> <li><input type="checkbox"/> Check the correct operation of the Safe torque off function from each operating location.</li> <li><input type="checkbox"/> Activate and check the operation of the power loss ride-through function. if automatic restart is required/allowed after a short power supply break.</li> <li><input type="checkbox"/> If the earth fault monitoring is used, check its settings.</li> </ul>	<p>Optional device (options +Q951, +Q952, +Q963, +Q964). See delivery specific circuit diagrams and <i>Safety options instructions for ACS800 drives</i> (3AUA0000026238 [English]).</p> <p>Optional function (+Q950). See delivery specific circuit diagrams and <i>Safety options instructions for ACS800 drives</i> (3AUA0000026238 [English]).</p> <p>Optional function (options +Q967, +Q968). See delivery specific circuit diagrams and <i>Safety options instructions for ACS800 drives</i> (3AUA0000026238 [English]).</p> <p>See <i>ACS800 diode supply control program firmware manual</i> (3AUA0000068937[English]).</p> <p>Optional device (option +Q954). See the documentation of the monitoring device delivered with the drive or from <a href="http://www.bender.org">www.bender.org</a>.</p>

<b>Action</b>	<b>Additional information</b>
<input type="checkbox"/> Check that the cooling fans rotate freely in the right direction, and the air flows upwards.	Check visually that the fans rotate in the direction indicated by an arrow on the fan housing.
<input type="checkbox"/> Check the direction of rotation of the motor.	



# Maintenance

## What this chapter contains

This chapter contains preventive maintenance instructions.

## Maintenance intervals

This table lists the routine maintenance intervals recommended by ABB.

Interval	Maintenance action	Instructions
Every year of storage	Reforming the capacitors	See document <i>Capacitor reforming instructions</i> (3BFE64059629 [English]) and <i>Capacitors</i> .
Every year	Checking the dustiness, corrosion, air filters and temperature of the drive Cleaning the interior of the cabinet and replacing the air filters when necessary	See <i>Cleaning the cabinet, checking and replacing the air filters</i> .
Every year [IP22 and IP42 units (+B053 and +B054)]	Checking the air filters; replacing them if necessary	See <i>Cleaning the cabinet, checking and replacing the air filters</i> .
Every year [IP54 units (+B055 and +B059)]	Replacing the air filters	
Every 3 years	Checking and cleaning the connections of the power cables and the quick connectors of the supply and inverter modules	See <i>Checking the connections of the power cables and the quick connectors of the modules</i> .
Every 3 years	Replacing the cooling fans of the supply, inverter and brake modules (in a 60-Hz supply network)	See <i>Cooling fans</i> .
Every 6 years	Checking the tightness of the power connections	See <i>Tightening torques for power connections</i> .
Every 6 years	Replacing the cooling fans inside the cubicles	See <i>Cooling fans</i> .
Every 6 years	Replacing the cooling fans of the supply, inverter and brake modules (in a 50-Hz supply network)	See <i>Cooling fans</i> .
Every 6 years [IP54 units (+B055 and +B059)]	Replacing the cooling fan on the cabinet roof	See <i>Cooling fans</i> .
Every 6 years	Replacing the memory backup battery of the PPCS branching unit (APBU-xx)	Locate the APBU unit. See <i>Replacing the PPCS branching unit (APBU-xx) memory backup battery</i> .
Every 9 years (if the drive is subjected to high ambient temperature)	Replacing the capacitors	See <i>Capacitors</i> .
Every 9 years	Replacing the CINT board in the DSU module	Contact your local ABB Service representative.

Interval	Maintenance action	Instructions
Every 12 years (when the drive has been operating in normal ambient temperature)	Replacing the capacitors	See <a href="#">Capacitors</a> .

Consult your local ABB Service representative for more details on the maintenance. On the Internet, go to <http://www.abb.com/drivesservices>.

## Redundancy (Reduced run capability)

If one of the parallel-connected supply or inverter modules must be taken out of the cabinet for service, it is possible to continue operation using the remaining modules at reduced power.

### Removing a DSU module and selecting the Reduced run feature

**Note:** The maximum number of removed DSU modules is limited to 50% of the original number of parallel-connected modules.



**WARNING!** Read and follow the instructions in chapter [Safety instructions](#). Ignoring the instructions can cause physical injury or death, or damage to the equipment.

1. Switch off the power to the unit and open the main disconnecting device. Close the grounding switch (option +F259) if there is one.
2. Let the intermediate circuit DC capacitors discharge for five minutes. Ensure by measuring that the drive is not live before starting the work.
3. Extract the module to be serviced from the cabinet. Follow the directions given in section [Connection procedure](#) on page [84](#).

4. Fasten the air baffle(s) provided with the unit to the top module guide (A) to block airflow through the empty module bay (B). See the figures below.

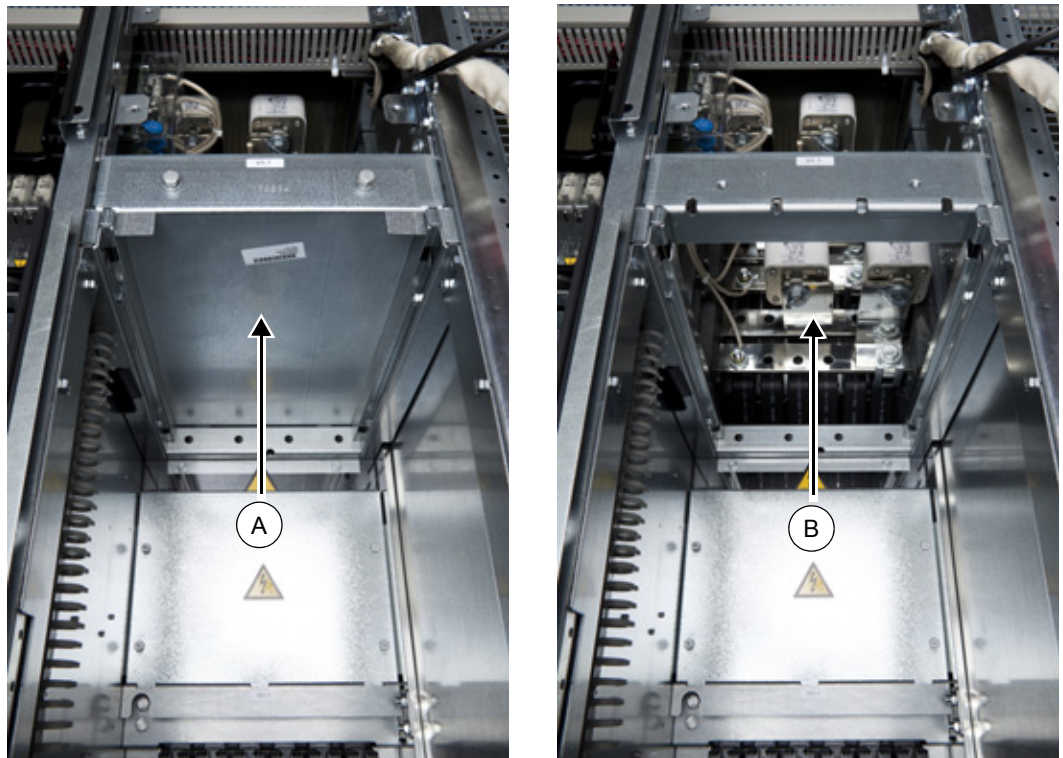

5. Close the cabinet doors.
6. Switch on the auxiliary control voltage of the drive.
7. Switch the panel from the inverter unit to the DSU. The supply and inverter units are connected to the same panel through a panel link. The panel communicates with either one at the time. The switching between the nodes online is instructed in section [Control panel CDP 312R](#) on page 35.
8. Make the necessary parameter adjustments in the drive firmware. Refer to the appropriate *Firmware manual* of the drive control program.
9. Set the number of the existing supply modules and activate the Reduced run function with parameter 16.10 INT CONFIG USER. For more information, refer to *ACS800 diode supply control program firmware manual* (3AUA0000068937 [English]).

## Removing an inverter module and selecting the Reduced run feature



---

**WARNING!** Read and follow the instructions in chapter [Safety instructions](#). Ignoring the instructions can cause physical injury or death, or damage to the equipment.

---

1. Switch off the power to the unit and open the main disconnecting device. Close the grounding switch (option +F259) if there is one.
2. Let the intermediate circuit DC capacitors discharge for five minutes. Ensure by measuring that the drive is not live before starting the work.
3. Extract the module to be serviced from the cabinet. Follow the directions given on page [95](#).
4. Fasten the air baffle provided with the unit to the top module guide to block airflow through the empty module bay. The installation principle is described on page [118](#).
5. Close the cabinet doors.
6. Switch on the auxiliary control voltage of the drive.
7. Switch the panel from DSU communication to inverter communication. The supply and inverter units are connected to the same panel through a panel link. The panel communicates with either one at the time. The switching is instructed in chapter *Control panel* in the *Firmware manual* of the drive control program.
8. Make the necessary parameter adjustments in the drive firmware. Refer to the appropriate *Firmware manual* of the drive control program. For example, if the ACS800 standard control program is in use, decrease the number of parallel inverter modules to the appropriate value by parameter 95.03 INT CONFIG.



## Replacing the PPCS branching unit (APBU-xx) memory backup battery



**WARNING!** Read and follow the instructions in chapter [Safety instructions](#). Ignoring the instructions can cause physical injury or death, or damage to the equipment.

1. Switch off the power to the unit and open the main disconnecting device. Close the grounding switch (option +F259) if there is one.
2. Let the intermediate circuit DC capacitors discharge for five minutes. Ensure by measuring that the drive is not live before starting the work.
3. Locate the branching units in the auxiliary control cubicle. Remove any shrouds.
4. Open the screws on the cover (3 pcs, indicated with arrows in the figure below).
5. Slide off the cover.
6. Remove the battery.
7. Insert the new CR 2032 battery and reattach the cover.

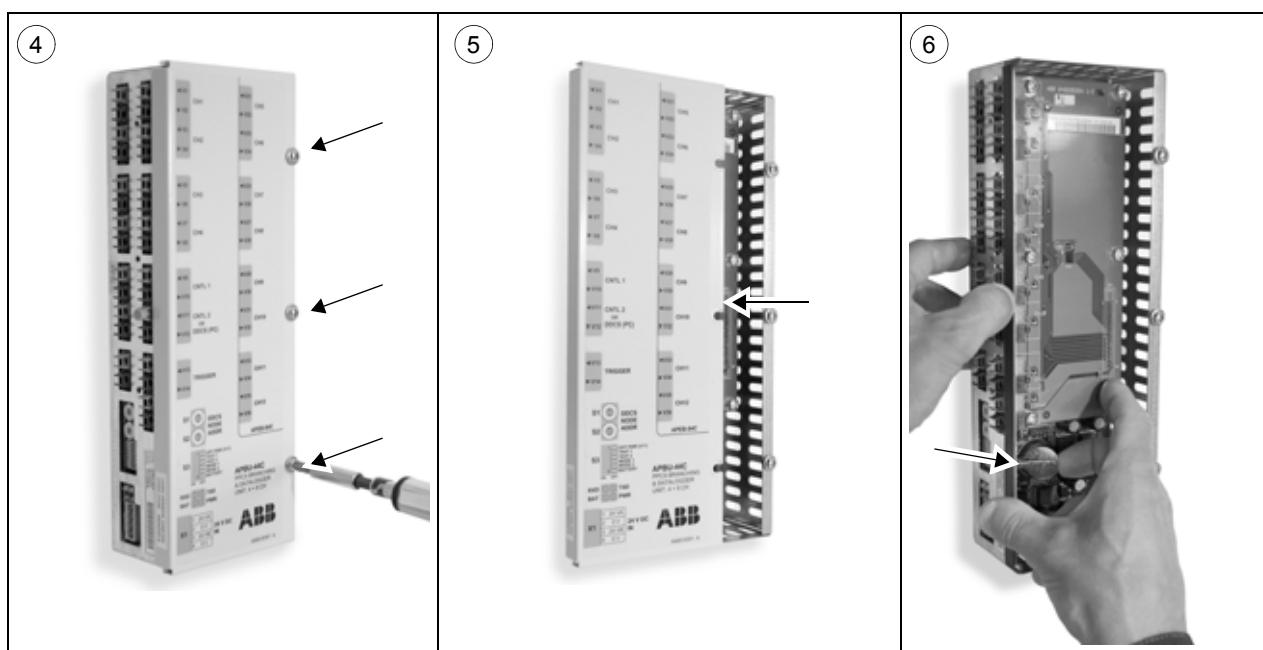

## Cleaning the cabinet, checking and replacing the air filters



**WARNING!** Read and follow the instructions in chapter [Safety instructions](#). Ignoring the instructions can cause physical injury or death, or damage to the equipment.

1. Switch off the power to the unit and open the main disconnecting device. Close the grounding switch (option +F259) if there is one.
2. Let the intermediate circuit DC capacitors discharge for five minutes. Ensure by measuring that the drive is not live before starting the work.
3. Open the cabinet doors.
4. Check the air filters and replace if necessary (see [Technical data](#) for the correct filter types). The inlet (door) filters can be accessed by removing the fastener(s) at the top of the grille, then lifting the grille and pulling it away from the door. The outlet (roof) filter in IP54 (+B055) units has a similar mechanism.
5. Check the cleanliness of the cabinet. Clean the interior of the cabinet if necessary using a soft brush and a vacuum cleaner.
6. Close the cabinet doors.

## Checking the connections of the power cables and the quick connectors of the modules



**WARNING!** Read and follow the instructions in chapter [Safety instructions](#). Ignoring the instructions can cause physical injury or death, or damage to the equipment.

1. Switch off the power to the unit and open the main disconnecting device. Close the grounding switch (option +F259) if there is one.
2. Let the intermediate circuit DC capacitors discharge for five minutes. Ensure by measuring that the drive is not live before starting the work.
3. Open the cabinet doors.
4. Extract one supply or inverter module from the cabinet as described in the connection procedures in chapter [Electrical installation](#).
5. Check the tightness of the cable connections at the quick connector. Use the tightening torque table in [Technical data](#).
6. Clean all contact surfaces of the quick connector and apply a layer of suitable joint compound (eg, Isoflex® Topas NB 52 from Klüber Lubrication) onto them.
7. Re-insert the supply/inverter module.
8. Repeat steps 4 to 7 for all remaining supply and inverter modules.

## Cooling fans

### Supply, inverter and brake module cooling fans

The actual lifespan of the fan depends on the running time of the fan, ambient temperature and dust concentration. Each supply and inverter module has its own cooling fan. Replacements are available from ABB. Do not use other than ABB specified spare parts.

The control program keeps track of the running time of the cooling fan of the **inverter** modules. See the *Firmware manual* of the drive control program for the actual signal which indicates the running time.

#### *Replacing the fan of the supply module*



**WARNING!** Read and follow the instructions in chapter [Safety instructions](#). Ignoring the instructions can cause physical injury or death, or damage to the equipment.

1. Switch off the power to the unit and open the main disconnecting device. Close the grounding switch (option +F259) if there is one.
2. Let the intermediate circuit DC capacitors discharge for five minutes. Ensure by measuring that the drive is not live before starting the work.
3. Open the supply module cubicle doors.
4. Loosen the locking screw (marked with letter A in the figure below).
5. Disconnect the fan wiring plug (B).
6. Pull out the fan (C).
7. Install a new fan in reverse order.

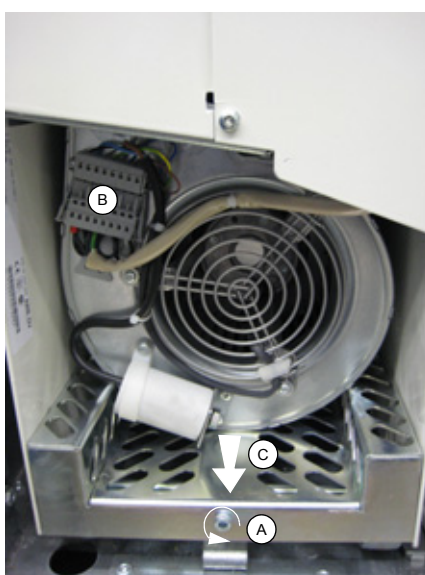

### Replacing the fan of the inverter and brake module



**WARNING!** Read and follow the instructions in chapter [Safety instructions](#). Ignoring the instructions can cause physical injury or death, or damage to the equipment.

1. Switch off the power to the unit and open the main disconnecting device. Close the grounding switch (option +F259) if there is one.
2. Let the intermediate circuit DC capacitors discharge for five minutes. Ensure by measuring that the drive is not live before starting the work.
3. Open the inverter module cubicle doors.
4. Disconnect the fan wiring plug (marked with letter A in the figure below).
5. Remove the locking screws (B).
6. Pull the fan out along its sliding rails (C).
7. Install a new fan in reverse order.

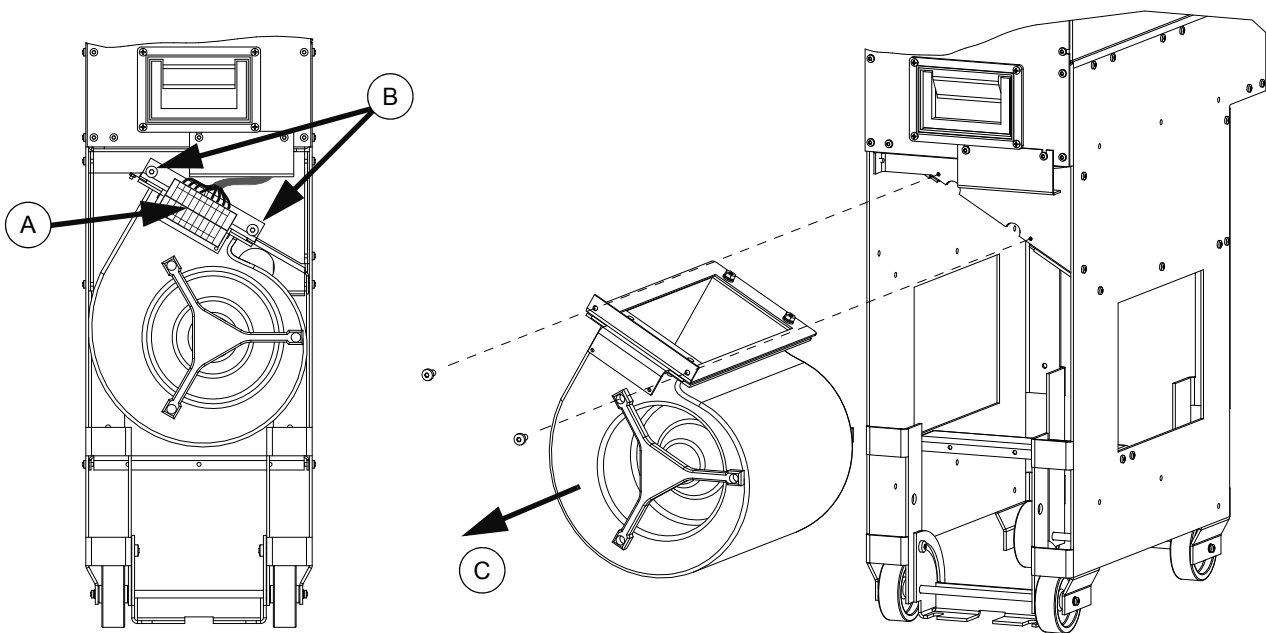

## Replacing the fans in the auxiliary control cubicle



**WARNING!** Read and follow the instructions in chapter [Safety instructions](#). Ignoring the instructions can cause physical injury or death, or damage to the equipment.

1. Switch off the power to the unit and open the main disconnecting device. Close the grounding switch (option +F259) if there is one.
2. Let the intermediate circuit DC capacitors discharge for five minutes. Ensure by measuring that the drive is not live before starting the work.
3. Open the door of the auxiliary control cubicle (or combined auxiliary control cubicle and supply cubicle).
4. Detach the wiring from each fan (AC plug and grounding wire).
5. Undo the four fastening screws of the fan assembly and pull the assembly outwards to gain access to the fan fastening screws.
6. Undo the fastening screws of the fans (there are four for each fan) from below. Remove the fans.
7. Install new fans in reverse order. Before fastening the fans, make sure the airflow arrow on both fans is pointed up.

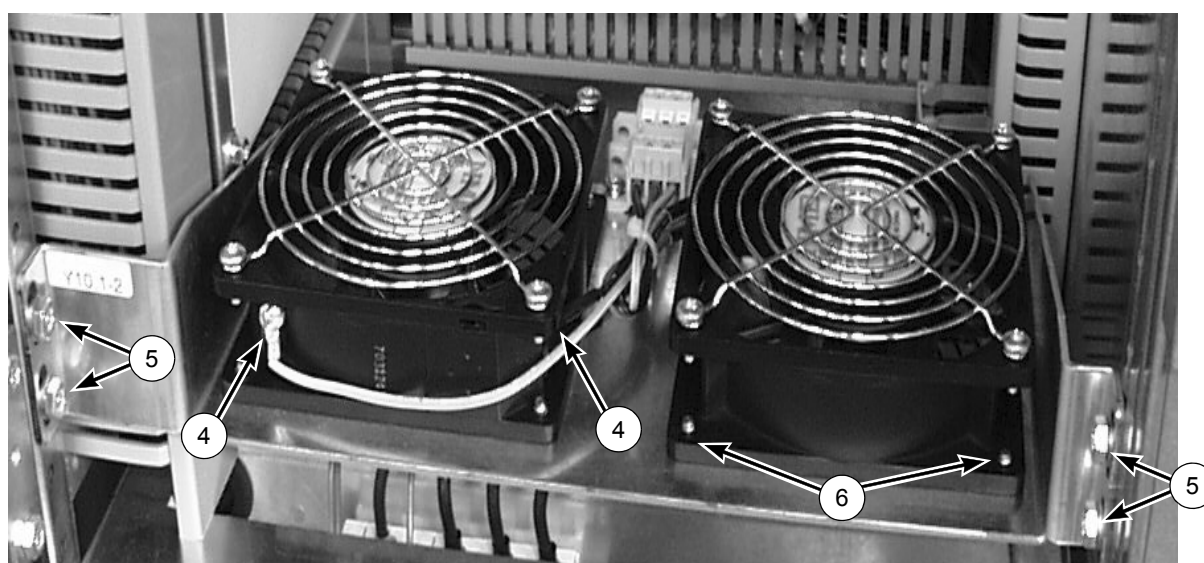

### Replacing the fan in the incoming cubicle with the main breaker (option +F255)

Certain IP2x/IP4x (+B053 and +B054) units with a main breaker are also fitted with two fans at the air outlet on the roof. Replace the fans as follows:



**WARNING!** Read and follow the instructions in chapter [Safety instructions](#). Ignoring the instructions can cause physical injury or death, or damage to the equipment.

1. Switch off the power to the unit and open the main disconnecting device. Close the grounding switch (option +F259) if there is one.
2. Let the intermediate circuit DC capacitors discharge for five minutes. Ensure by measuring that the drive is not live before starting the work.
3. Remove the grating (A) and the two fans by undoing the four screws (B).
4. If necessary, undo the four screws (C) to remove the airflow guide (D).

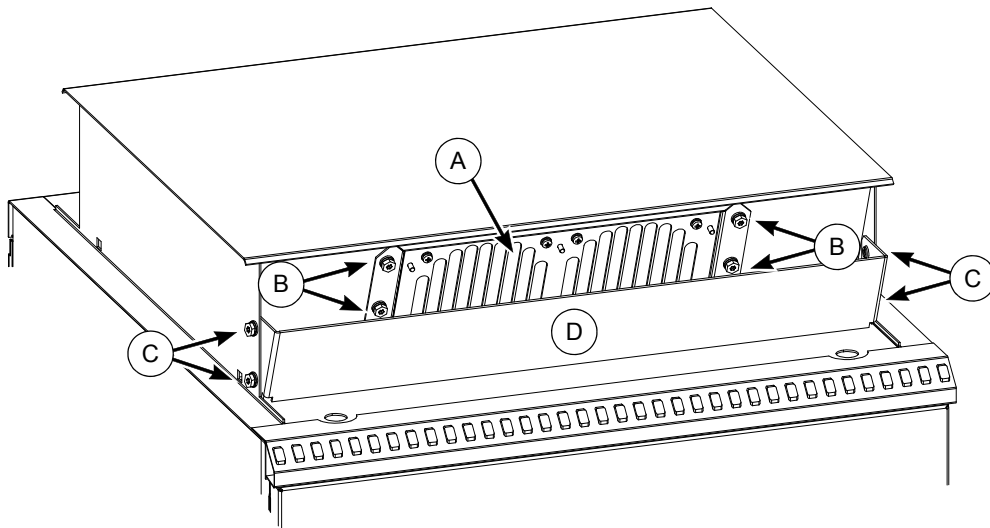

## Replacing the additional fans in the IP54 / UL type 12 drives (+B055 and +B059)

---



**WARNING!** Read and follow the instructions in chapter [Safety instructions](#). Ignoring the instructions can cause physical injury or death, or damage to the equipment.

---

1. Switch off the power to the unit and open the main disconnecting device. Close the grounding switch (option +F259) if there is one.
2. Let the intermediate circuit DC capacitors discharge for five minutes. Ensure by measuring that the drive is not live before starting the work.
3. Remove the front and back gratings of the fan compartment by lifting them upwards.
4. Remove the shrouds by undoing the fastening screws.
5. Undo the fastening screws of the side/top cover of the fan.
6. Lift the side/top cover of the fan off.
7. Disconnect the fan supply wire connector from the cabinet roof (on top and inside the cabinet).
8. Undo the fastening screws of the fan cassette at each corner.
9. Lift the fan cassette off.
10. Undo the cable ties on the top of the fan cassette.
11. Disconnect the cables (detachable terminals).
12. Remove the fan capacitor by undoing the fastening screw of the clamp.
13. Undo the fastening screws of the fan.
14. Pull the fan out.
15. Install the new fan and fan capacitor in reverse order to the above. Ensure that the fan is centered and rotates freely.

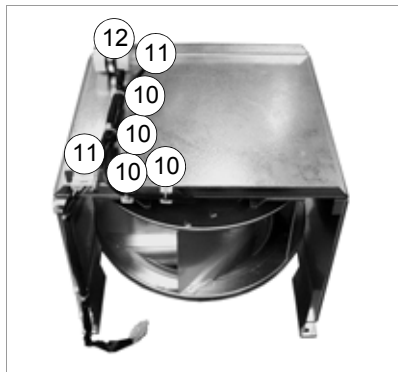
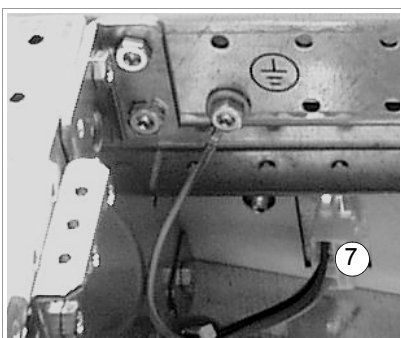
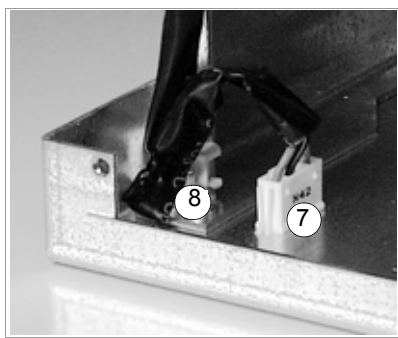
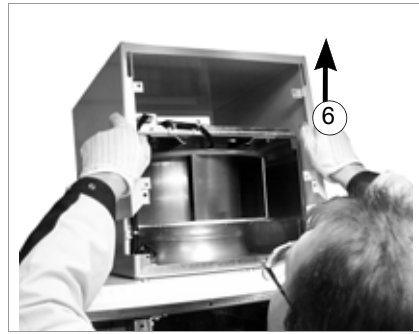
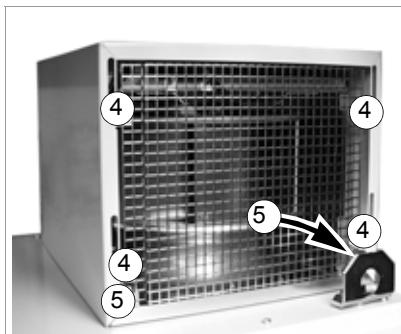
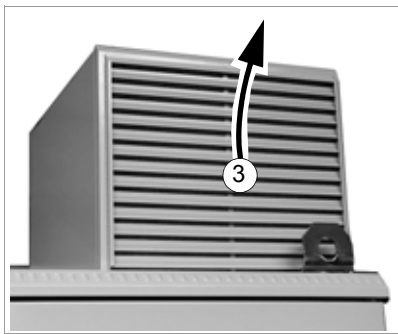



## Heatsinks

The heatsink fins of the power modules pick up dust from the cooling air. The module runs into overtemperature warnings and faults if the heatsinks are not clean. Clean the heatsink when necessary.

### Cleaning the heatsink



---

**WARNING!** Read and follow the instructions in chapter [Safety instructions](#). Ignoring the instructions can cause physical injury or death, or damage to the equipment.

---

1. Switch off the power to the unit and open the main disconnecting device. Close the grounding switch (option +F259) if there is one.
2. Let the intermediate circuit DC capacitors discharge for five minutes. Ensure by measuring that the drive is not live before starting the work.
3. Remove the cooling fan (see section [Cooling fans](#)).
4. Blow dry clean compressed air from bottom to top and simultaneously use a vacuum cleaner at the air outlet to trap the dust.

**Note:** Prevent the dust from entering adjoining equipment.

5. Refit the cooling fan.

## Capacitors

The inverter modules employ several electrolytic capacitors. The life of a capacitor can be prolonged by lowering the ambient temperature.

It is not possible to predict a capacitor failure. A capacitor failure is usually followed by damage to the unit and an input cable fuse failure, or a fault trip. Contact ABB if a capacitor failure is suspected.

### Reforming the electrolytic capacitors

Reform (re-age) spare part capacitors once a year according to *Capacitor reforming guide* (3BFE64059629 [English], available through your local ABB representative).

### Capacitor replacement

Contact an ABB service representative.

## Safety function checks in the maintenance routine

It is a good practice to check the operation of the optional safety functions at appropriate intervals.

If the drive is equipped with optional safety functions +Q950, +Q951, +Q952, +Q954, +Q963, +Q964 or Q968, include the safety function tests described in *Safety options instructions for ACS800 drives (3AUA0000026238 [English])* to the routine maintenance program of the machinery that the drive runs.

If you replace a circuit board or wire set inside the drive module, re-test the safety function.

If you detect any failure in safety functions, contact your local ABB representative.

## Other maintenance actions

### Replacement of a supply inverter or brake modules

To replace supply, inverter or three-phase brake modules, follow the instructions on the module removal and refitting given in chapter [Electrical installation](#). The brake modules are identical with the inverter modules.

# Fault tracing

---

## What this chapter contains

This chapter instructs in interpreting the LED indications of the ACS800-07 (+V992) drive.

## Faults and warnings displayed by the CDP 312R control panel

The control panel displays the Warning and Fault messages of the unit (that is, supply unit or inverter unit) the panel is currently controlling.

In addition, the panel indicates the active warnings and faults in the unit that is not currently being controlled. The information between the units is delivered through a separate serial communication channel.

An active warning or fault state in the supply unit (ID:2) is indicated by flashing messages WARNING, ID:2 or FAULT, ID:2 on the control panel display when the panel is controlling the inverter unit.

FAULT, ID:2	
FREQ	0.00 Hz
CURRENT	0.00 A
POWER	0.00 %

To display the warning or fault identification text, switch the control panel to view the supply unit as described in section [Control panel CDP 312R](#) on page 35.

Information on warnings and faults concerning the supply unit are contained within the *ACS800 Diode Supply Control Program Firmware Manual (3AUA0000068937 [English])*.

The warnings and faults concerning the inverter unit are dealt with in the control program (for example, Standard Control Program) *Firmware Manual*.

## Conflicting ID numbers

If the ID numbers of the supply and the inverter units are set equal, the control panel stops functioning. To clear the situation:

- Disconnect the panel cable from the RMIO board of the inverter unit.
- Set the ID number of the supply unit RMIO board to 2. For the setting procedure, see the control program (for example, Standard Control Program) *Firmware Manual*.
- Disconnect the panel cable from the supply unit RMIO board, and reconnect it to the inverter unit RMIO board.
- Set the ID number of the inverter unit to 1.
- Reconnect the panel cable to the RMIO board of the supply unit.

## Supply module LED

There is the following LED on the cover of the CINT board.

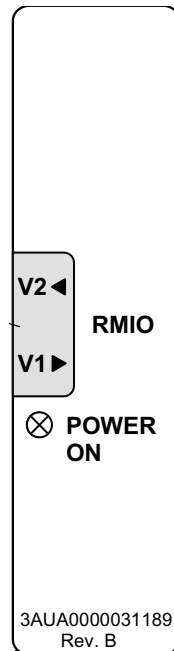

The circuit board is powered when the green LED is on.

## Other LEDs of the drive

Location	LED	Indication
RMIO board (RDCU control unit)	Red	Drive in the fault state.
	Green	Power supply on the board is OK.
Control panel mounting platform (with the control panel removed)	Red	Drive in the fault state.
	Green	Main + 24 V power supply for the control panel and the RMIO board is OK.
AINT board (visible through the transparent cover on the front of the inverter modules)	V204 (green)	+5 V voltage of the board is OK.
	V309 (red)	Prevention of unexpected start-up or Safe torque off is ON.
	V310 (green)	IGBT control signal transmission to the gate driver control boards is enabled.
APBU board	"RXD"	Data is being received from RDCU drive control unit.
	"TXD"	Data is being sent to RDCU drive control unit.
	"BAT"	Memory backup battery voltage is OK.
	"PWR"	5 V power to on-board logic is OK.

# Technical data

## What this chapter contains

This chapter contains the technical specifications of the drive, eg, ratings, frame sizes and technical requirements, provisions for fulfilling the requirements for CE and other markings.

## Ratings

The ratings for the ACS800-07 (+V992) with 50 Hz and 60 Hz supplies are given below. The symbols are described below the table.

ACS800-07 (+V992) type	Nominal ratings		No-over-load use	Light-overload use		Heavy-duty use		Heat dissipation kW	Air flow m <sup>3</sup> /h	Noise level dBA
	$I_{\text{cont.max}}$ A	$I_{\text{max}}$ A	$P_{\text{cont.max}}$ kW	$I_{2N}$ A	$P_N$ kW	$I_{2\text{hd}}$ A	$P_{\text{hd}}$ kW			
Three-phase supply voltage 380 V, <b>400 V</b> or 415 V										
ACS800-07-0610-3	879	1315	500	844	500	657	400	13.0	3120	73
ACS800-07-0770-3	1111	1521	630	1067	630	831	450	17.2	3840	74
ACS800-07-0870-3	1255	1877	710	1205	710	939	500	18.5	3840	74
ACS800-07-1030-3	1452	1988	800	1394	800	1086	630	23.9	3840	74
ACS800-07-1230-3	1770	2648	1000	1699	1000	1324	710	27.5	5040	75
ACS800-07-1540-3	2156	2951	1200	2070	1200	1613	900	35.4	5760	76
ACS800-07-1850-3	2663	3894	1450	2556	1450	1992	1120	42.7	6960	76
Three-phase supply voltage 380 V, 400 V, 415 V, 440 V, 460 V, 480 V or <b>500 V</b>										
ACS800-07-0760-5	883	1321	630	848	630	660	500	14.0	3120	73
ACS800-07-0910-5	1050	1524	710	1008	710	785	560	17.2	3840	74
ACS800-07-1090-5	1258	1882	900	1208	900	941	630	19.9	3840	74
ACS800-07-1210-5	1372	1991	1000	1317	1000	1026	710	23.8	3840	74
ACS800-07-1540-5	1775	2655	1250	1704	1200	1328	900	29.4	5040	75
ACS800-07-1820-5	2037	2956	1450	1956	1400	1524	1120	35.0	5760	76
ACS800-07-2310-5	2670	3901	1900	2563	1850	1997	1400	45.4	6960	76
Three-phase supply voltage 525 V, 550 V, 575 V, 600 V, 660 V, or <b>690 V</b>										
ACS800-07-0750-7	628	939	630	603	630	470	500	13.9	3120	73
ACS800-07-0870-7	729	1091	710	700	710	545	560	17.1	3120	73
ACS800-07-1060-7	885	1324	800	850	800	662	630	18.4	3120	73
ACS800-07-1160-7	953	1426	900	915	900	713	710	20.8	3840	74
ACS800-07-1500-7	1258	1882	1200	1208	1200	941	900	27.0	5040	75
ACS800-07-1740-7	1414	2115	1400	1357	1400	1058	1000	32.5	5040	75
ACS800-07-2120-7	1774	2654	1700	1703	1700	1327	1250	40.1	6240	76
ACS800-07-2320-7	1866	2792	1900	1791	1800	1396	1400	43.3	6960	76
ACS800-07-2900-7	2321	3472	2300	2228	2200	1736	1600	51.5	8160	77
ACS800-07-3190-7	2665	3987	2600	2558	2500	1993	1900	58.0	9360	78
ACS800-07-3490-7	2770	4144	2800	2659	2700	2072	2100	63.6	10080	78

PDM-184674-0.36

## Symbols

### Nominal ratings

$I_{\text{cont.max}}$  Continuous rms output current. No overloadability at 40 °C (104 °F).

$I_{\text{max}}$  Maximum output current. Allowable for 10 seconds at start, otherwise as long as allowed by drive temperature.

### Typical ratings for no-overload use

$P_{\text{cont.max}}$  Typical motor power. The power ratings apply to most IEC 60034 motors at nominal voltage (400, 500 or 690 V).

### Typical ratings for light-overload use (10% overloadability)

$I_{2N}$  Continuous rms current. 10% overload is allowed for 1 minute every 5 minutes.

$P_N$  Typical motor power. The power ratings apply to most IEC 60034 motors at nominal voltage (400, 500 or 690 V).

### Typical ratings for heavy-duty use (50% overloadability)

$I_{2hd}$  Continuous rms current. 50% overload is allowed for 1 minute every 5 minutes.

$P_{hd}$  Typical motor power. The power ratings apply to most IEC 60034 motors at nominal voltage (400, 500 or 690 V).

## Derating

The load capacity (current and power) decreases if the installation site altitude exceeds 1000 metres (3281 ft), or if the ambient temperature exceeds 40 °C (104 °F).

### Temperature derating

In the temperature range +40 °C (+104 °F) to +50 °C (+122 °F), the rated output current is decreased by 1% for every additional 1 °C (1.8 °F). The output current is calculated by multiplying the current given in the rating table by the derating factor.

Example If the ambient temperature is 50 °C (+122 °F), the derating factor is  $100\% - 1 \frac{\%}{\text{°C}} \cdot 10 \text{ °C} = 90\%$  or 0.90. The output current is then  $0.90 \times I_{2N}$  or  $0.90 \times I_{\text{cont.max}}$ .

### Altitude derating

At altitudes from 1000 to 4000 m (3281 to 13123 ft) above sea level, the derating is 1% for every 100 m (328 ft). For a more accurate derating, use the DriveSize PC tool. If the installation site is higher than 2000 m (6600 ft) above sea level, please contact your local ABB distributor or office for further information.

## ACS800-07 (+V992) frame sizes and power module types

ACS800-07 (+V992) type	Frame size (supply+inverter modules)	Supply module(s) used		Inverter modules used	
		Qty	Type	Qty	Type
Three-phase supply voltage 380 V, 400 V or 415 V					
ACS800-07-0610-3	1×D4 + 2×R8i	1	ACS800-704-0910-7	2	ACS800-104-0390-3
ACS800-07-0770-3	2×D4 + 2×R8i	2	ACS800-704-0640-7	2	ACS800-104-0390-3
ACS800-07-0870-3	2×D4 + 2×R8i	2	ACS800-704-0640-7	2	ACS800-104-0510-3
ACS800-07-1030-3	2×D4 + 2×R8i	2	ACS800-704-0910-7	2	ACS800-104-0510-3
ACS800-07-1230-3	2×D4 + 3×R8i	2	ACS800-704-0910-7	3	ACS800-104-0510-3
ACS800-07-1540-3	3×D4 + 3×R8i	3	ACS800-704-0910-7	3	ACS800-104-0510-3
ACS800-07-1850-3	3×D4 + 4×R8i	3	ACS800-704-0910-7	4	ACS800-104-0510-3
Three-phase supply voltage 380 V, 400 V, 415 V, 440 V, 460 V, 480 V or 500 V					
ACS800-07-0760-5	1×D4 + 2×R8i	1	ACS800-704-0910-7	2	ACS800-104-0460-5
ACS800-07-0910-5	2×D4 + 2×R8i	2	ACS800-704-0640-7	2	ACS800-104-0460-5
ACS800-07-1090-5	2×D4 + 2×R8i	2	ACS800-704-0640-7	2	ACS800-104-0610-5
ACS800-07-1210-5	2×D4 + 2×R8i	2	ACS800-704-0910-7	2	ACS800-104-0610-5
ACS800-07-1540-5	2×D4 + 3×R8i	2	ACS800-704-0910-7	3	ACS800-104-0610-5
ACS800-07-1820-5	3×D4 + 3×R8i	3	ACS800-704-0910-7	3	ACS800-104-0610-5
ACS800-07-2310-5	3×D4 + 4×R8i	3	ACS800-704-0910-7	4	ACS800-104-0610-5
Three-phase supply voltage 525 V, 550 V, 575 V, 600 V, 660 V, or 690 V					
ACS800-07-0750-7	1×D4 + 2×R8i	1	ACS800-704-0640-7	2	ACS800-104-0440-7
ACS800-07-0870-7	1×D4 + 2×R8i	1	ACS800-704-0910-7	2	ACS800-104-0440-7
ACS800-07-1060-7	1×D4 + 2×R8i	1	ACS800-704-0910-7	2	ACS800-104-0580-7
ACS800-07-1160-7	2×D4 + 2×R8i	2	ACS800-704-0640-7	2	ACS800-104-0580-7
ACS800-07-1500-7	2×D4 + 3×R8i	2	ACS800-704-0640-7	3	ACS800-104-0580-7
ACS800-07-1740-7	2×D4 + 3×R8i	2	ACS800-704-0910-7	3	ACS800-104-0580-7
ACS800-07-2120-7	2×D4 + 4×R8i	2	ACS800-704-0910-7	4	ACS800-104-0580-7
ACS800-07-2320-7	3×D4 + 4×R8i	3	ACS800-704-0910-7	4	ACS800-104-0580-7
ACS800-07-2900-7	3×D4 + 5×R8i	3	ACS800-704-0910-7	5	ACS800-104-0580-7
ACS800-07-3190-7	3×D4 + 6×R8i	3	ACS800-704-0910-7	6	ACS800-104-0580-7
ACS800-07-3490-7	4×D4 + 6×R8i	4	ACS800-704-0910-7	6	ACS800-104-0580-7

PDM-184674-0.32

## AC fuses

ACS800-07 (+V992) type	Input current (A)	Qty.	Type (IEC/UL/CSA)	Rated current (A rms)	Voltage (V)	$I^2t$ Pre-arc	$I^2t$ Clearing at 660V	$I^2t$ Clearing at 210000 [A2s]
$U_N = 400\text{ V}$ (Range 380-415 V)								
-0610-3	790	6	170M6410 Bussmann	630	690	31000	210000	210000
-0770-3	999	12						
-0870-3	1128	12						
-1030-3	1305	12						
-1230-3	1591	12						
-1540-3	1938	18						
-1850-3	2394	18						
$U_N = 500\text{ V}$ (Range 380-500 V)								
-0760-5	793	6	170M6410 Bussmann	630	690	31000	210000	210000
-0910-5	944	12						
-1090-5	1131	12						
-1210-5	1233	12						
-1540-5	1596	12						
-1820-5	1831	18						
-2310-5	2400	18						
$U_N = 690\text{ V}$ (Range 525-690 V)								
-0750-7	565	6	170M6410 Bussmann	630	690	31000	210000	210000
-0870-7	655	6						
-1060-7	795	6						
-1160-7	856	12						
-1500-7	1131	12						
-1740-7	1271	12						
-2120-7	1595	12						
-2320-7	1678	18						
-2900-7	2086	18						
-3190-7	2396	18						
-3490-7	2490	24						

\*If the drive is not equipped with internal AC fuses (option code +F260), install specified fuses externally at the AC supply. See the diagram on page 83 for the cabling arrangement at each supply module.



## DC fuses at inverter module input

ACS800-07 (+V922) type	Input current (A)	Qty.	Type (IEC)	Type (UL/CSA)	Rated current (A rms)	Voltage (V)
$U_N = 400 \text{ V}$ (Range 380-415 V)						
-0610-3	790	4	170M8547 Bussmann	170M6216 Bussmann	1250	690
-0770-3	999	4				
-0870-3	1128	4	170M8550 Bussmann	170M6219 Bussmann	1600	690
-1030-3	1305	4				
-1230-3	1591	6				
-1540-3	1938	6				
-1850-3	2394	8				
$U_N = 500 \text{ V}$ (Range 380-500 V)						
-0760-5	793	4	170M8547 Bussmann	170M6216 Bussmann	1250	690
-0910-5	944	4				
-1090-5	1131	4	170M8550 Bussmann	170M6219 Bussmann	1600	690
-1210-5	1233	4				
-1540-5	1596	6				
-1820-5	1831	6				
-2310-5	2400	8				
$U_N = 690 \text{ V}$ (Range 525-690 V)						
-0750-7	565	4	170M8647 Bussmann	170M8637 Bussmann	800	1000
-0870-7	655	4				
-1060-7	795	4	170M8650 Bussmann	170M8639 Bussmann	1000	1000
-1160-7	856	4				
-1500-7	1131	6				
-1740-7	1271	6				
-2120-7	1595	8				
-2320-7	1678	8				
-2900-7	2086	10				
-3190-7	2396	12				
-3490-7	2490	12				

## Fuses for main circuit voltage measurement for the BAMU board

The fuse type is Mersen A070GRC01T13, 1 A 700 V AC 160 kA.

## Fuses on the CVAR board

The fuse type is Mersen A070GRB10T13/G330010 10 A 700 V AC.

## DC fuses for the DSU module

Each D4 type DSU module uses four fuses. The fuses are located inside the DSU module. The DC fuse is Bussmann 170M4908 (with fuse indicators that are both IEC- and UL-recognized).

## Input power connection

---

<b>Voltage (<math>U_1</math>)</b>	380/400/415 VAC 3-phase $\pm 10\%$ for 400 VAC units 380/400/415/440/460/480/500 VAC 3-phase $\pm 10\%$ for 500 VAC units 525/550/575/600/660/690 VAC 3-phase $\pm 10\%$ for 690 VAC units	
<b>Short-circuit withstand strength (IEC 60439-1)</b>	<u>Drives without grounding switch (option +F259):</u> Maximum allowable prospective short-circuit current is 65 kA. The peak withstand current is 143 kA. <u>Drives with grounding switch (option +F259):</u> Maximum allowable prospective short-circuit current is 50 kA. The peak withstand current is 105 kA.	
<b>Short-circuit current protection (UL 508A)</b>	The drive is suitable for use on a circuit capable of delivering not more than 100,000 rms symmetrical amperes at 600 V maximum when protected by fuses given in the fuse tables.	
<b>Short-circuit current protection (CSA C22.2 No. 14-05)</b>	The drive is suitable for use on a circuit capable of delivering not more than 65 kA rms symmetrical amperes at 600 V maximum when protected by fuses given in the fuse tables.	
<b>Frequency</b>	48 to 63 Hz, maximum rate of change 17%/s	
<b>Imbalance</b>	Max. $\pm 3\%$ of nominal phase to phase input voltage	
<b>Fundamental power factor (<math>\cos \phi_1</math>)</b>	0.98 (at nominal load)	
<b>Transformer for 12-pulse supply</b>	Connection	Dy 11 d0 or Dyn 11 d0
	Phase shift between secondaries	30° electrical
	Voltage difference between secondaries	< 0.5%
	Short-circuit impedance of secondaries	> 5%
	Short-circuit impedance difference between secondaries	< 10% of short-circuit impedance
	Other	No grounding of the secondaries allowed. Static screen recommended
<b>Input power cable lead-throughs</b>	Units without main switch-disconnector or main breaker (no option +F253 or +F255): 4 $\times$ $\varnothing$ 60 mm (2.36") at each supply module Units with a main switch-disconnector (option +F253): 9 $\times$ $\varnothing$ 60 mm (2.36") (frame 1 $\times$ D4 + 2 $\times$ R8i) 12 $\times$ $\varnothing$ 60 mm (2.36") (frame 2 $\times$ D4 + n $\times$ R8i) 18 $\times$ $\varnothing$ 60 mm (2.36") (frame 3 $\times$ D4 + n $\times$ R8i and 4 $\times$ D4 + n $\times$ R8i) Units with a main breaker (option +F255): 18 $\times$ $\varnothing$ 60 mm (2.36")	

**Input terminals at each supply module** (units without main switch-disconnector or main breaker; no option +F253 or +F255)

Conductor size	Max. no. and size of cable lugs per phase	Lug hole	Bolt	Tightening torque
IEC Cabling				
$\leq 150 \text{ mm}^2$	$2 \times 150 \text{ mm}^2$	$1 \times 11$	M10	40 Nm
185 ... 240 $\text{mm}^2$	OL $2 \times 185\text{-}240 \text{ mm}^2$ (with dual-cable screw lug included with delivery)	–	–	15 Nm
US Cabling				
300 ... 350 MCM	$2 \times 350 \text{ MCM}$	$2 \times 1\frac{3}{4}"$	$7/16"$	30 lbf.ft

**Input terminals** (units with main switch-disconnector or main breaker; option +F253 or +F255)

Busbar dimensions	No. of busbars	Bolt size	Tightening torque
	See below	M12 or $\frac{1}{2}"$	70 Nm (50 lb.ft)

Number of input busbars (6-pulse units)			
No. of supply modules (nxD4)	No. of busbars per connection point		
	1L1	1L2	1L3
1	1	1	1
2	2	2	2
3	3	3	3
4	3	3	3

Number of input busbars (12-pulse units)						
No. of supply modules (nxD4)	No. of busbars per connection point					
	1L1	1L2	1L3	2L1	2L2	2L3
1	1	1	1	1	1	1
2	2	2	2	2	2	2
3	3	3	3	3	3	3
4	3	3	3	3	3	3

## Motor connection

---

<b>Voltage (<math>U_2</math>)</b>	0 to $U_1$ , 3-phase symmetrical, $U_{\max}$ at the field weakening point
<b>Frequency</b>	DTC mode: 0 to $3.2 \times f_{\text{FWP}}$ . Maximum frequency 300 Hz.  $f_{\text{FWP}} = \frac{U_{\text{Nmains}}}{U_{\text{Nmotor}}} \cdot f_{\text{Nmotor}}$ <p>where <math>f_{\text{FWP}}</math> = frequency at field weakening point; <math>U_{\text{Nmains}}</math> = mains (input power) voltage;  <math>U_{\text{Nmotor}}</math> = rated motor voltage; <math>f_{\text{Nmotor}}</math> = rated motor frequency</p>
<b>Frequency resolution</b>	0.01 Hz
<b>Current</b>	See section <a href="#">Ratings</a> .
<b>Power limit</b>	$2 \times P_{\text{hd}}$ . After approximately 2 minutes at $2 \times P_{\text{hd}}$ , the limit is set at $P_{\text{cont.max}}$ .
<b>Field weakening point</b>	8 to 300 Hz
<b>Switching frequency</b>	2 kHz (average)
<b>Motor cable lead-throughs</b>	$3 \times \text{Ø}60$ mm at each inverter module (units without common motor terminal cubicle, no option +H359) Units with common motor terminal cubicle (option +H359): See chapter <a href="#">Dimensions</a> .

**Output terminals at each R8i inverter module** (units without common motor terminal cubicle, no option +H359)

Bottom exit  
Side view  
Bolt size: M12 or ½"  
Tightening torque: 70 Nm (52 lbf.ft)

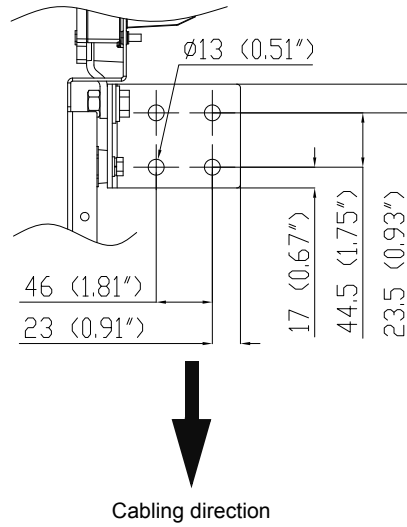

Top exit  
Side view  
Bolt size: M12 or ½"  
Tightening torque: 70 Nm (52 lbf.ft)

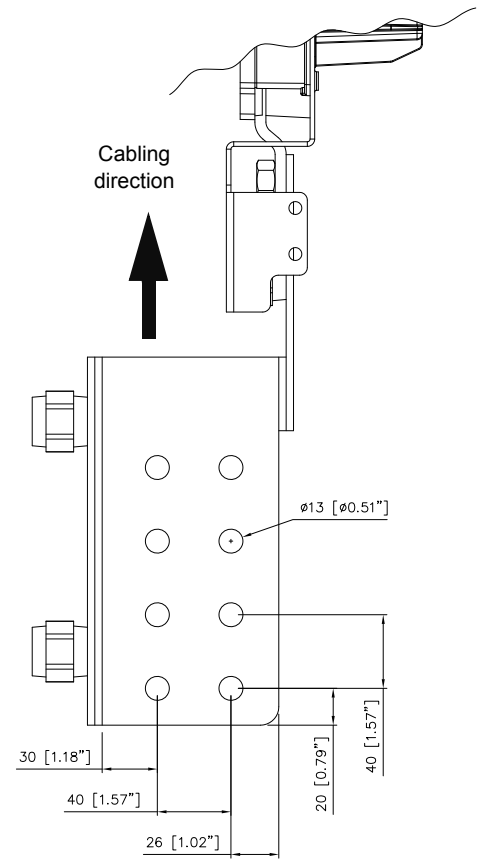

68265631-A0

cabinet\_400\_generic.asm

**Output terminals** (units with common motor terminal cubicle, option +H359) 8 × Ø13 mm per phase. See chapter [Dimensions](#).

**Maximum recommended motor cable length** 100 m (328 ft). Motor cables up to 500 m (1640 ft) long are allowed but EMC filtering within the specified limits will not be realised.

## Efficiency

Approximately 98% at nominal power level

## Cooling

**Method** Internal fans, flow direction from bottom to top

Filter material	Inlet (door)	Outlet (roof)
	<b>IP22/IP42 units</b> (+B053 and +B054)	Lufffilter airTex G150
<b>IP54 units</b> (+B055 and +B059)	Lufffilter airComp 300-50	Lufffilter airTex G150

**Free space around the unit** See chapter [Mechanical installation](#).

**Cooling air flow** See [Ratings](#).

## Degrees of protection

IP21; IP22; IP42; IP54, IP54R (with air outlet duct)

## Ambient conditions

Environmental limits for the drive are given below. The drive must be used in a heated, indoor controlled environment.

	<b>Operation</b> installed for stationary use	<b>Storage</b> in the protective package	<b>Transportation</b> in the protective package
<b>Installation site altitude</b>	<p><u>Supply voltage &lt; 600 V AC:</u> max. 4000 m, except drives with options +Q963, +Q964 and +Q968: max. 2000 m</p> <p><u>Supply voltage &gt; 600 V AC (max. 690 V AC):</u> - IT (ungrounded) and corner-grounded networks: max. 2000 m (6562 ft) - TN (grounded) networks: max. 4000, except drives with options +Q963, +Q964 and +Q968: max. 2000 m (6562 ft)</p> <p><b>Note:</b> Above 1000 m (3281 ft), see also section <a href="#">Derating</a>.</p>	-	-
<b>Air temperature</b>	-15 to +50 °C (5 to 122 °F), no frost allowed. See section <a href="#">Derating</a> .	-40 to +70 °C (-40 to +158 °F)	-40 to +70 °C (-40 to +158 °F)
<b>Relative humidity</b>	5 to 95%	Max. 95%	Max. 95%
No condensation allowed. Maximum allowed relative humidity is 60% in the presence of corrosive gases.			

<b>Contamination levels</b> (IEC 60721-3-3, IEC 60721-3-2, IEC 60721-3-1)	No conductive dust allowed.		
	<b>Boards without coating:</b> Chemical gases: Class 3C1 Solid particles: Class 3S2 <b>Boards with coating:</b> Chemical gases: Class 3C2 Solid particles: Class 3S2	<b>Boards without coating:</b> Chemical gases: Class 1C2 Solid particles: Class 1S3 <b>Boards with coating:</b> Chemical gases: Class 1C2 Solid particles: Class 1S3	<b>Boards without coating:</b> Chemical gases: Class 2C2 Solid particles: Class 2S2 <b>Boards with coating:</b> Chemical gases: Class 2C2 Solid particles: Class 2S2
<b>Atmospheric pressure</b>	70 to 106 kPa 0.7 to 1.05 atmospheres	70 to 106 kPa 0.7 to 1.05 atmospheres	60 to 106 kPa 0.6 to 1.05 atmospheres
<b>Vibration</b> (IEC 60068-2)	Max. 1 mm (0.04 in.) (5 to 13.2 Hz), max. 7 m/s <sup>2</sup> (23 ft/s <sup>2</sup> ) (13.2 to 100 Hz) sinusoidal	Max. 1 mm (0.04 in.) (5 to 13.2 Hz), max. 7 m/s <sup>2</sup> (23 ft/s <sup>2</sup> ) (13.2 to 100 Hz) sinusoidal	Max. 3.5 mm (0.14 in.) (2 to 9 Hz), max. 15 m/s <sup>2</sup> (49 ft/s <sup>2</sup> ) (9 to 200 Hz) sinusoidal
<b>Shock</b> (IEC 60068-2-27)	Not allowed	Max. 100 m/s <sup>2</sup> (330 ft./s <sup>2</sup> ), 11 ms	Max. 100 m/s <sup>2</sup> (330 ft./s <sup>2</sup> ), 11 ms
<b>Free fall</b>	Not allowed	100 mm (4 in.) for weight over 100 kg (220 lb)	100 mm (4 in.) for weight over 100 kg (220 lb)

## Materials

<b>Cabinet</b>	Hot-dip zinc-coated (thickness approx. 20 µm) steel sheet (thickness 1.5 mm) with polyester thermosetting powder coating (thickness approx. 80 µm) on visible surfaces except back panel. Colour: RAL 7035 (light beige, semigloss).
<b>Busbars</b>	Tin- or silver-plated copper
<b>Fire safety of materials</b> (IEC 60332-1)	Insulating materials and non-metallic items: Mostly self-extinctive
<b>Packaging</b>	Frame: Wood or plywood. Plastic wrapping: PE-LD. Bands: PP or steel.
<b>Disposal</b>	<p>The drive contains raw materials that should be recycled to preserve energy and natural resources. The package materials are environmentally compatible and recyclable. All metal parts can be recycled. The plastic parts can either be recycled or burned under controlled circumstances, according to local regulations. Most recyclable parts are marked with recycling marks.</p> <p>If recycling is not feasible, all parts excluding electrolytic capacitors and printed circuit boards can be landfilled. The DC capacitors (C1-1 to C1-x) contain electrolyte and the printed circuit boards contain lead, both of which are classified as hazardous waste within the EU. They must be removed and handled according to local regulations.</p> <p>For further information on environmental aspects and more detailed recycling instructions, please contact your local ABB distributor.</p>

## Tightening torques for power connections

Screw size	Torque
M5	3.5 Nm (2.6 lbf.ft)
M6	9 Nm (6.6 lbf.ft)
M8	20 Nm (14.8 lbf.ft)
M10	40 Nm (29.5 lbf.ft)
M12	70 Nm (52 lbf.ft)
M16	180 Nm (133 lbf.ft)

## Applicable standards

---

- The drive complies with the following standards.
- EN 50178:1997 *Electronic equipment for use in power installations.*
  - IEC/EN 61800-5-1:2007 *Power drive system product standard - Safety requirements*
  - EN 60204-1:2006 + A1:2009 *Safety of machinery. Electrical equipment of machines. Part 1: General requirements.*  
*Provisions for compliance:* The final assembler of the machine is responsible for installing  
 - an emergency-stop device  
 - a supply disconnecting device.
  - EN 60529:1991 *Degrees of protection provided by enclosures (IP code)*
  - IEC 60664-1:2007 *Insulation coordination for equipment within low-voltage systems. Part 1: Principles, requirements and tests*
  - EN 61800-3:2004 *EMC product standard including specific test methods*
  - UL 508C *UL Standard for Safety, Power Conversion Equipment*
  - UL 508A *Standard for Safety, Industrial Control Panels*
  - CSA C22.2 No. 14-10 *Industrial control equipment*
  - GOST R 51321-1:2007 *Low-voltage switchgear and control gear assemblies. Part 1 – Requirements for type-tested and partially type-tested assemblies – General technical requirements and methods of tests*



## CE marking

A CE mark is attached to the drive to verify that the unit follows the provisions of the European Low Voltage and EMC Directives. The CE marking also verifies that the drive, in regard to its safety functions (such as Safe torque off), conforms with the Machinery Directive as a safety component.

### Compliance with the European Low Voltage Directive

The compliance with the European Low Voltage Directive has been verified according to standards EN 60204-1 and EN 61800-5-1.

### Compliance with the European EMC Directive

The EMC Directive defines the requirements for immunity and emissions of electrical equipment used within the European Union. The EMC product standard (EN 61800-3:2004) covers requirements stated for drives. See section [Compliance with EN 61800-3:2004](#) below.

### Compliance with the European Machinery Directive

The drive is an electronic product which is covered by the European Low Voltage Directive. However, the drive can be equipped with the Safe torque off function and other safety functions for machinery which, as safety components, are in the scope of the Machinery Directive. These functions of the drive comply with European harmonized standards such as EN 61800-5-2. The declaration of conformity for each function is in the appropriate function-specific manual.

### Compliance with EN 61800-3:2004

#### Definitions

EMC stands for **E**lectromagnetic **C**ompatibility. It is the ability of electrical/electronic equipment to operate without problems within an electromagnetic environment. Likewise, the equipment must not disturb or interfere with any other product or system within its locality.

*First environment* includes establishments connected to a low-voltage network which supplies buildings used for domestic purposes.

*Second environment* includes establishments connected to a network not supplying domestic premises.

*PDS of category C1*: PDS of rated voltage less than 1000 V, intended for use in the first environment.

*PDS of category C2*: PDS of rated voltage less than 1000 V, which is neither a plug in device nor a movable device and, when used in the first environment, is intended to be installed and commissioned only by a professional.

*PDS of category C3*: PDS of rated voltage less than 1000 V, intended for use in the second environment and not intended for use in the first environment.

*PDS of category C4*: PDS of rated voltage equal to or above 1000 V, or rated current equal to or above 400 A, or intended for use in complex systems in the second environment.

#### First environment (PDS of category C2)

The requirements of the EMC Directive can be met as follows for restricted distribution:

1. The drive is equipped with EMC filter +E202.
2. The motor and control cables are selected as specified in the *Hardware Manual*.
3. The drive is installed according to the instructions given in the *Hardware Manual*.
4. Maximum cable length is 100 metres (328 ft).

**WARNING!** The drive may cause radio interference if used in a residential or domestic environment. The user is required to take measures to prevent interference, in addition to the requirements for CE compliance listed above, if necessary.

**Note:** It is not allowed to install a drive equipped with EMC filter +E202 on IT (unearthed) systems. The supply network becomes connected to earth potential through the EMC filter capacitors which may cause danger or damage the unit.

### Second environment (PDS of category C3)

The requirements of the EMC Directive can be met as follows:

1. The drive is equipped with EMC filter +E210. The filter is suitable for TN (earthed) and IT (unearthed) networks.
2. The motor and control cables are selected as specified in the drive manuals.
3. The drive is installed according to the instructions given in the drive manuals.
4. Maximum cable length is 100 metres (328 ft).

### Second environment (PDS of category C4)

If the above listed provisions cannot be met, the requirements of the EMC Directive can be met as follows for restricted distribution:

1. It is ensured that no excessive emission is propagated to neighbouring low-voltage networks. In some cases, the natural suppression in transformers and cables is sufficient. If in doubt, the supply transformer with static screening between the primary and secondary windings can be used.

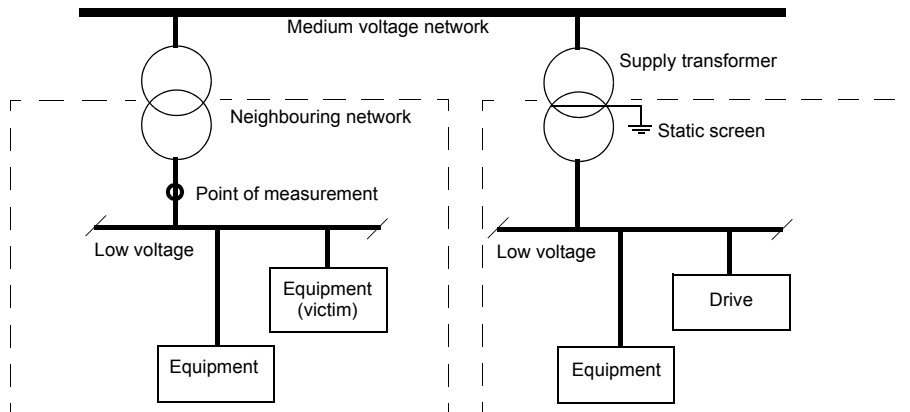

2. An EMC plan for preventing disturbances is drawn up for the installation. A template is available from the local ABB representative.
3. The motor and control cables are selected as specified in the drive manuals.
4. The drive is installed according to the instructions given in the drive manuals.

## “C-tick” marking

A “C-tick” mark is attached to each drive in order to verify compliance with the EMC product standard (EN 61800-3:2004), required under the Trans-Tasman Electromagnetic Compatibility Scheme for levels 1, 2 and 3 in Australia and New Zealand. See section [Compliance with EN 61800-3:2004](#).

## GOST R certificate of conformity

The drive has been given a GOST R certificate of conformity.





# Dimensions

---

## What this chapter contains

This chapter contains the composition of cabinet line-ups for each frame size and example dimension drawings of the ACS800-07 (+V992) drive.

## Cabinet line-ups

The drive consists of cubicles built into a cabinet line-up. The tables below show the composition of cabinet line-ups for each frame size and the standard combinations of options. The dimensions are in millimetres.

### Notes:

- The side panels increase the total line-up width by 30 millimetres (1.2”).
- The standard depth of the cabinet line-up is 650 mm (excluding door equipment such as switches and air inlet gratings). This is increased by 130 millimetres (5.1”) with top entry/exit models as well as units with cooling air intake through the bottom of the cabinet.
- The measurements given apply to 6-pulse-input, non-UL/CSA units. For dimensions of 12-pulse-input or UL/CSA units, contact your local ABB representative.

The tables are followed by example dimensional drawings.

1xD4 + 2xR8i														
Auxiliary control cubicle & supply module cubicle	EMC/RFI filter cubicle	Incoming cubicle (with +F253)	Inverter module cubicle	Joining cubicle	Common motor terminal cubicle	*Brake chopper 1	*Brake resistor 1	*Brake chopper 2	*Brake resistor 2	*Brake chopper 3	*Brake resistor 3	Shipping split widths	Line-up width	Net weight (kg approx.)
700			600									1300	1300	890
700	300	400	600									2000	2000	1490
700		400	600									1700	1700	1190
700			600		300							1600	1600	1060
700	300	400	600		300							2300	2300	1660
700		400	600		300							2000	2000	1360
700			600			400		400				2100	2100	1250
700	300	400	600			400		400				2800	2800	1850
700		400	600			400		400				2500	2500	1550
700			600		300	400		400				2400	2400	1420
700	300	400	600		300	400		400				3100	3100	2020
700		400	600		300	400		400				2800	2800	1720
700			600	200		400	800	400	800			1500 + 2400	3900	980 + 800
700	300	400	600	200		400	800	400	800			2200 + 2400	4600	1580 + 800
700		400	600	200		400	800	400	800			1900 + 2400	4300	1280 + 800
700			600		300	400	800	400	800			1600 + 2400	4000	1060 + 800
700	300	400	600		300	400	800	400	800			2300 + 2400	4700	1660 + 800
700		400	600		300	400	800	400	800			2000 + 2400	4400	1360 + 800
700			600			400		400		400		2500	2500	1430
700	300	400	600			400		400		400		3200	3200	2030
700		400	600			400		400		400		2900	2900	1730
700			600		300	400		400		400		2800	2800	1600
700	300	400	600		300	400		400		400		3500	3500	2200
700		400	600		300	400		400		400		3200	3200	1900
700			600	200		400	800	400	800	400	800	1500 + 3600	5100	980 + 1200
700	300	400	600	200		400	800	400	800	400	800	2200 + 3600	5800	1580 + 1200
700		400	600	200		400	800	400	800	400	800	1900 + 3600	5500	1280 + 1200
700			600		300	400	800	400	800	400	800	1600 + 3600	5200	1060 + 1200
700	300	400	600		300	400	800	400	800	400	800	2300 + 3600	5900	1660 + 1200
700		400	600		300	400	800	400	800	400	800	2000 + 3600	5600	1360 + 1200

\*The number of brake choppers depends on drive type. See chapter [Resistor braking](#).

2×D4 + 2×R8i															
Auxiliary control cubicle	Incoming cubicle (with +F253)	Incoming cubicle (with +F255)	Supply module cubicle	Inverter module cubicle	Joining cubicle	Common motor terminal cubicle	*Brake chopper 1	*Brake resistor 1	*Brake chopper 2	*Brake resistor 2	*Brake chopper 3	*Brake resistor 3	Shipping split widths	Line-up width	Net weight (kg approx.)
400			600	600									1600	1600	1200
400	500		600	600									2100	2100	1580
400		600	600	600									2200	2200	1900
400			600	600		300							1900	1900	1370
400	500		600	600		300							2400	2400	1750
400		600	600	600		300							2500	2500	2070
400			600	600			400		400				2400	2400	1560
400	500		600	600			400		400				2900	2900	1940
400		600	600	600			400		400				3000	3000	2260
400			600	600		300	400		400				2700	2700	1730
400	500		600	600		300	400		400				3200	3200	2110
400		600	600	600		300	400		400				3300	3300	2430
400			600	600	200		400	800	400	800			1800 + 2400	4200	1290 + 800
400	500		600	600	200		400	800	400	800			2300 + 2400	4700	1670 + 800
400		600	600	600	200		400	800	400	800			2400 + 2400	4800	1990 + 800
400			600	600		300	400	800	400	800			1900 + 2400	4300	1370 + 800
400	500		600	600		300	400	800	400	800			2400 + 2400	4800	1750 + 800
400		600	600	600		300	400	800	400	800			2500 + 2400	4900	2070 + 800
400			600	600			400		400		400		2800	2800	1740
400	500		600	600			400		400		400		3100	3100	2120
400		600	600	600			400		400		400		3400	3400	2440
400			600	600		300	400		400		400		3100	3100	1910
400	500		600	600		300	400		400		400		3600	3600	2290
400		600	600	600		300	400		400		400		3700	3700	2610
400			600	600	200		400	800	400	800	400	800	1800 + 3600	5400	1290 + 1200
400	500		600	600	200		400	800	400	800	400	800	2300 + 3600	5900	1670 + 1200
400		600	600	600	200		400	800	400	800	400	800	2400 + 3600	6000	1990 + 1200
400			600	600		300	400	800	400	800	400	800	1900 + 3600	5500	1370 + 1200
400	500		600	600		300	400	800	400	800	400	800	2400 + 3600	6000	1750 + 1200
400		600	600	600		300	400	800	400	800	400	800	2500 + 3600	6100	2070 + 1200

\*The number of brake choppers depends on drive type. See chapter [Resistor braking](#).

<b>2×D4 + 3×R8i</b>								
Auxiliary control cubicle	Incoming cubicle (with +F253)	Incoming cubicle (with +F255)	Supply module cubicle	Inverter module cubicle	Common motor terminal cubicle	Shipping split widths	Line-up width	Net weight (kg approx.)
400			600	800		1800	1800	1350
400	500		600	800		2300	2300	1730
400		600	600	800		2400	2400	2050
400			600	800	400	2200	2200	1540
400	500		600	800	400	2700	2700	1920
400		600	600	800	400	2800	2800	2240

<b>2×D4 + 4×R8i</b>									
Auxiliary control cubicle	Incoming cubicle (with +F253)	Incoming cubicle (with +F255)	Supply module cubicle	Inverter module cubicle 1	Common motor terminal cubicle	Inverter module cubicle 2	Shipping split widths	Line-up width	Net weight (kg approx.)
400			600	600		600	2200	2200	1680
400	500		600	600		600	2700	2700	2060
400		600	600	600		600	2800	2800	2380
400			600	600	400	600	2600	2600	1870
400	500		600	600	400	600	3100	3100	2250
400		600	600	600	400	600	3200	3200	2570

<b>3×D4 + 3×R8i</b>								
Auxiliary control cubicle	Incoming cubicle (with +F253)	Incoming cubicle (with +F255)	Supply module cubicle	Inverter module cubicle	Common motor terminal cubicle	Shipping split widths	Line-up width	Net weight (kg approx.)
400			800	800		2000	2000	1540
400	600		800	800		2600	2600	1940
400		600	800	800		2600	2600	2240
400			800	800	400	2400	2400	1730
400	600		800	800	400	3000	3000	2130
400		600	800	800	400	3000	3000	2430

<b>3×D4 + 4×R8i</b>									
Auxiliary control cubicle	Incoming cubicle (with +F253)	Incoming cubicle (with +F255)	Supply module cubicle	Inverter module cubicle 1	Common motor terminal cubicle	Inverter module cubicle 2	Shipping split widths	Line-up width	Net weight (kg approx.)
400			800	600		600	2400	2400	1870
400	600		800	600		600	3000	3000	2270
400		600	800	600		600	3000	3000	2570
400			800	600	400	600	2800	2800	2060
400	600		800	600	400	600	3400	3400	2460
400		600	800	600	400	600	3400	3400	2760



<b>3×D4 + 5×R8i</b>									
Auxiliary control cubicle	Incoming cubicle (with +F253)	Incoming cubicle (with +F255)	Supply module cubicle	Inverter module cubicle 1	Common motor terminal cubicle	Inverter module cubicle 2	Shipping split widths	Line-up width	Net weight (kg approx.)
400			800	800		600	2600	2600	2020
400	600		800	800		600	3200	3200	2420
400		600	800	800		600	3200	3200	2720
400			800	800	400	600	3000	3000	2210
400	600		800	800	400	600	3600	3600	2610
400		600	800	800	400	600	3600	3600	2910

<b>3×D4 + 6×R8i</b>									
Auxiliary control cubicle	Incoming cubicle (with +F253)	Incoming cubicle (with +F255)	Supply module cubicle	Inverter module cubicle 1	Common motor terminal cubicle	Inverter module cubicle 2	Shipping split widths	Line-up width	Net weight (kg approx.)
400			800	800		800	2800	2800	2170
400	600		800	800		800	3400	3400	2570
400		600	800	800		800	3400	3400	2870
400			800	800	600	800	3400	3400	2390
400	600		800	800	600	800	4000	4000	2790
400		600	800	800	600	800	4000	4000	3090

<b>4×D4 + 6×R8i</b>									
Auxiliary control cubicle	Incoming cubicle (with +F253)	Incoming cubicle (with +F255)	Supply module cubicle	Inverter module cubicle 1	Common motor terminal cubicle	Inverter module cubicle 2	Shipping split widths	Line-up width	Net weight (kg approx.)
400			600 + 600	800		800	3200	3200	2520
400	600		600 + 600	800		800	3800	3800	2920
400		600	600 + 600	800		800	3800	3800	3220
400			600 + 600	800	600	800	3800	3800	2740
400	600		600 + 600	800	600	800	4400	4400	3840
400		600	600 + 600	800	600	800	4400	4400	4140

# Frame size 1xD4 + 2xR8i

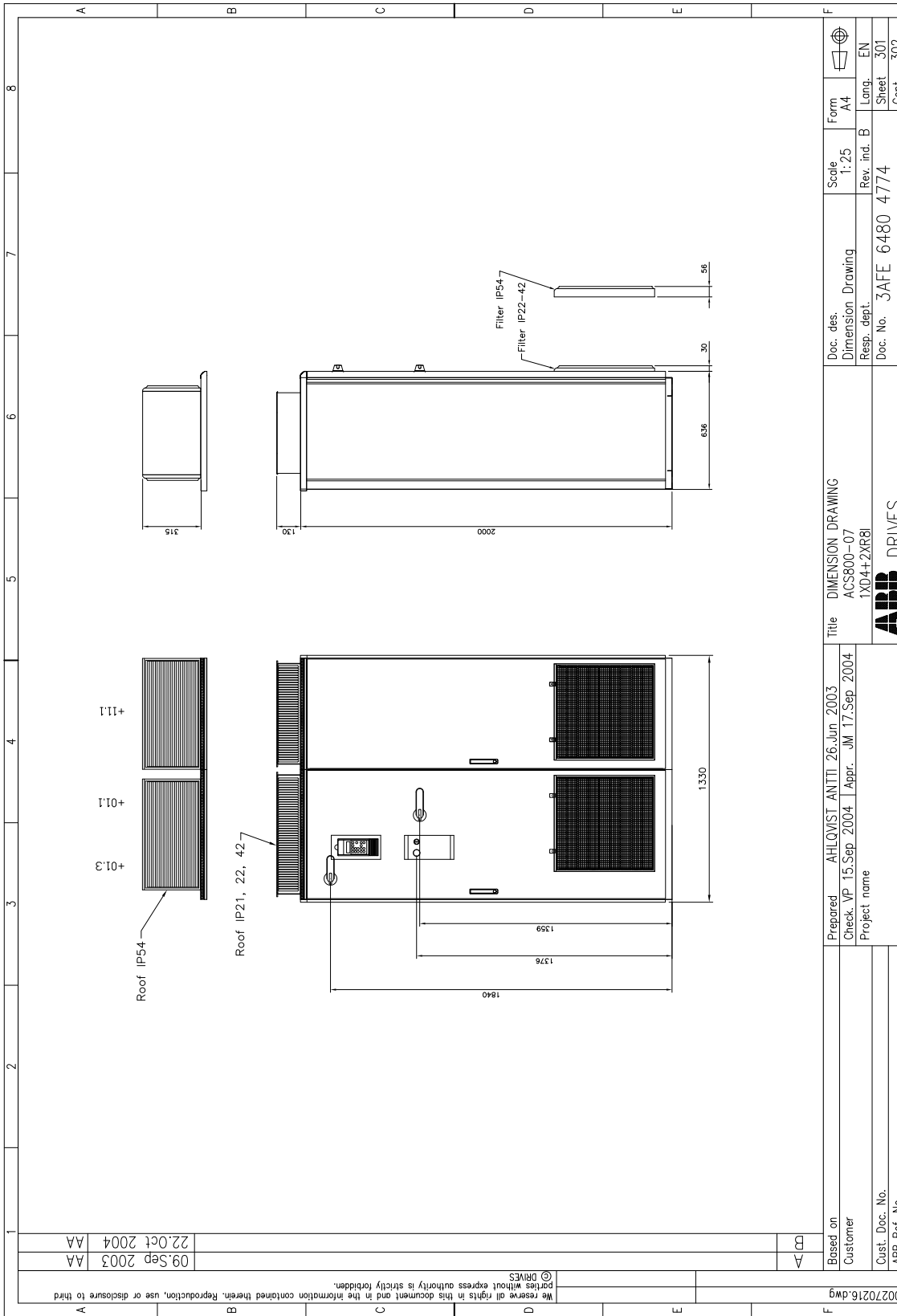

Frame size 1x4D + 2xR8i (continued)

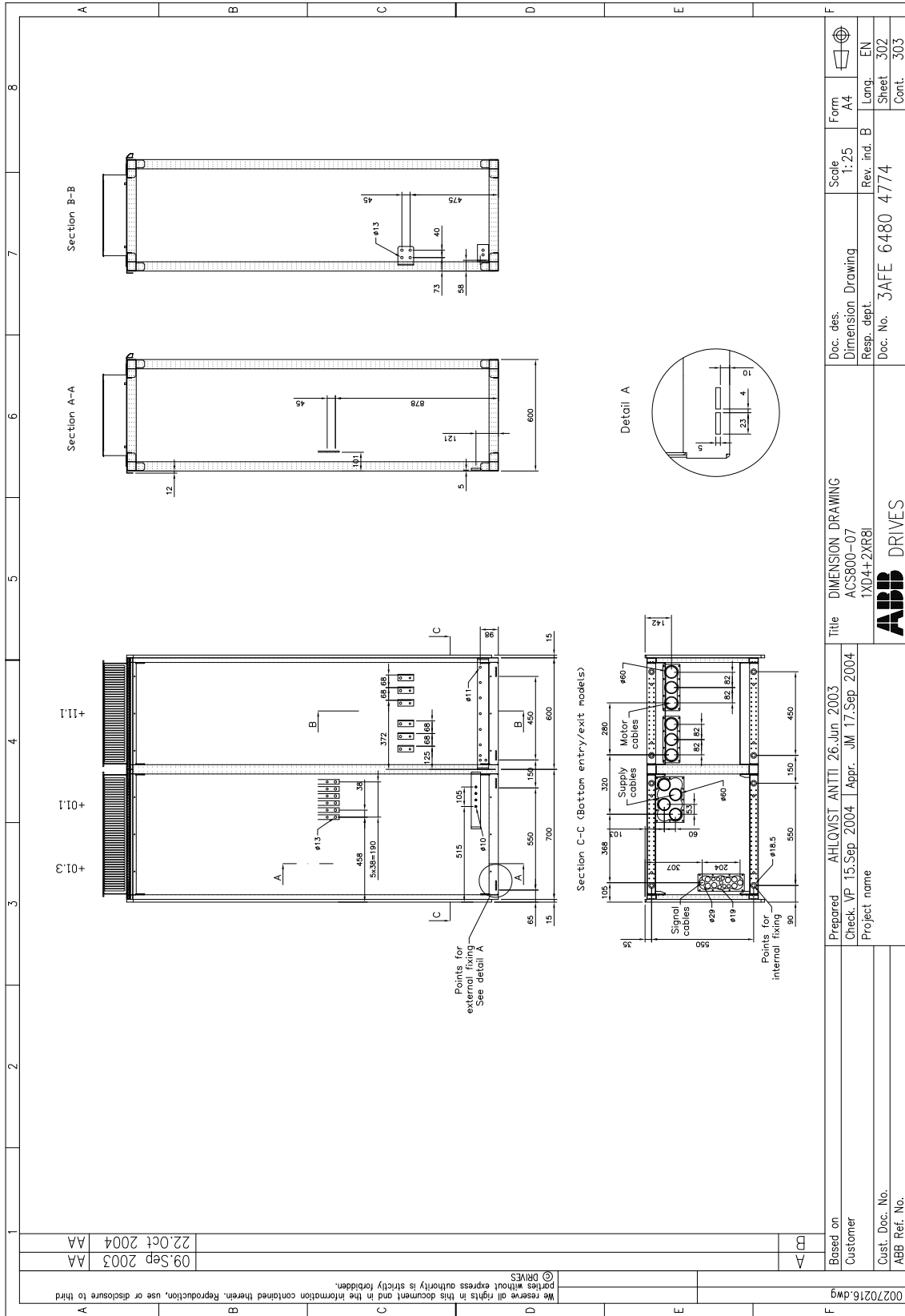

We reserve all rights in this document and the information contained therein. Reproduction, use or disclosure to third parties without express authority is strictly forbidden.

© DRIVES

09.Sep 2003	AA
22.Oct 2004	AA

Frame size 1×D4 + 2×R8i (continued)

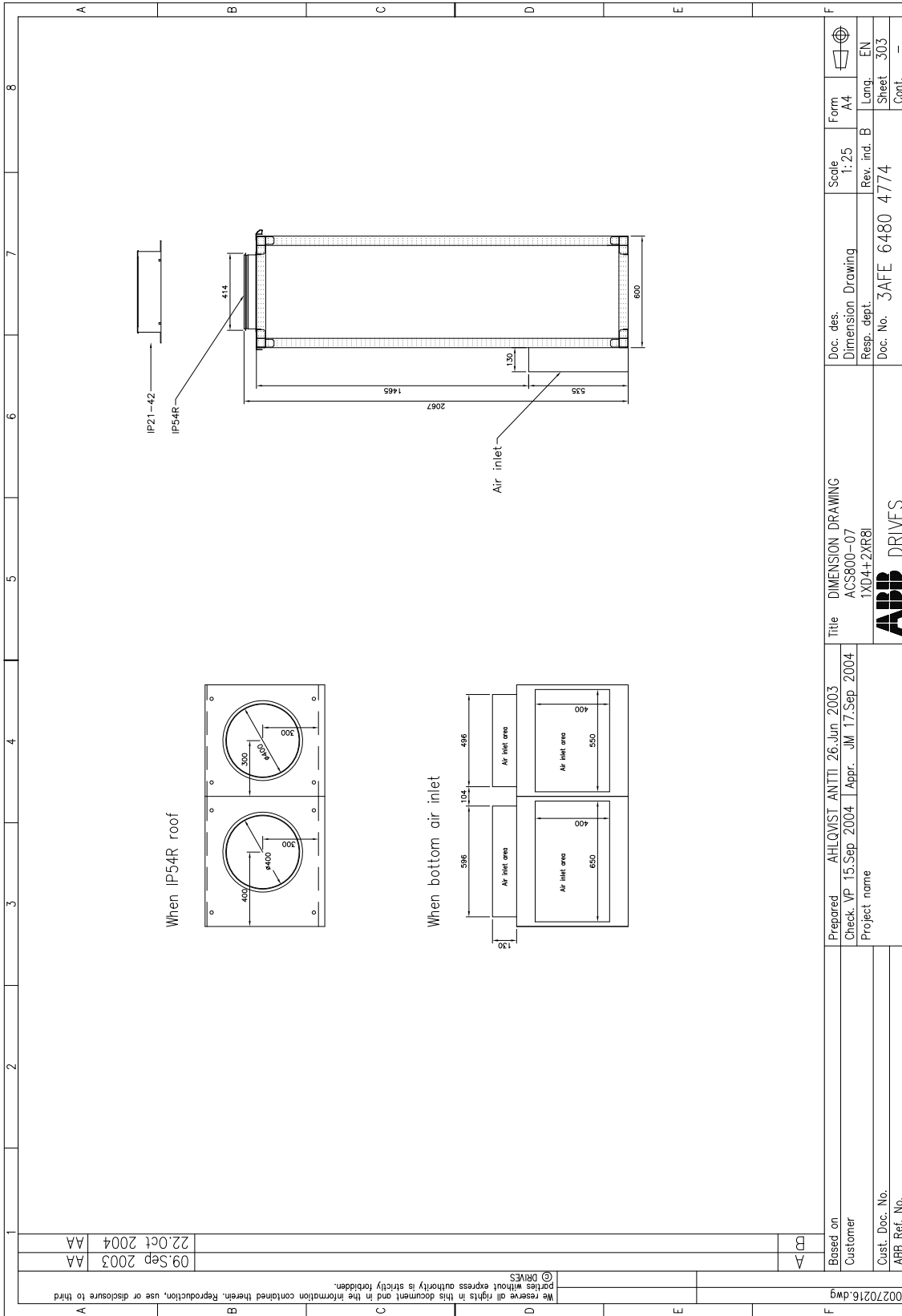

Frame size 1xD4 + 2xR8i (with a main switch-disconnector +F253)

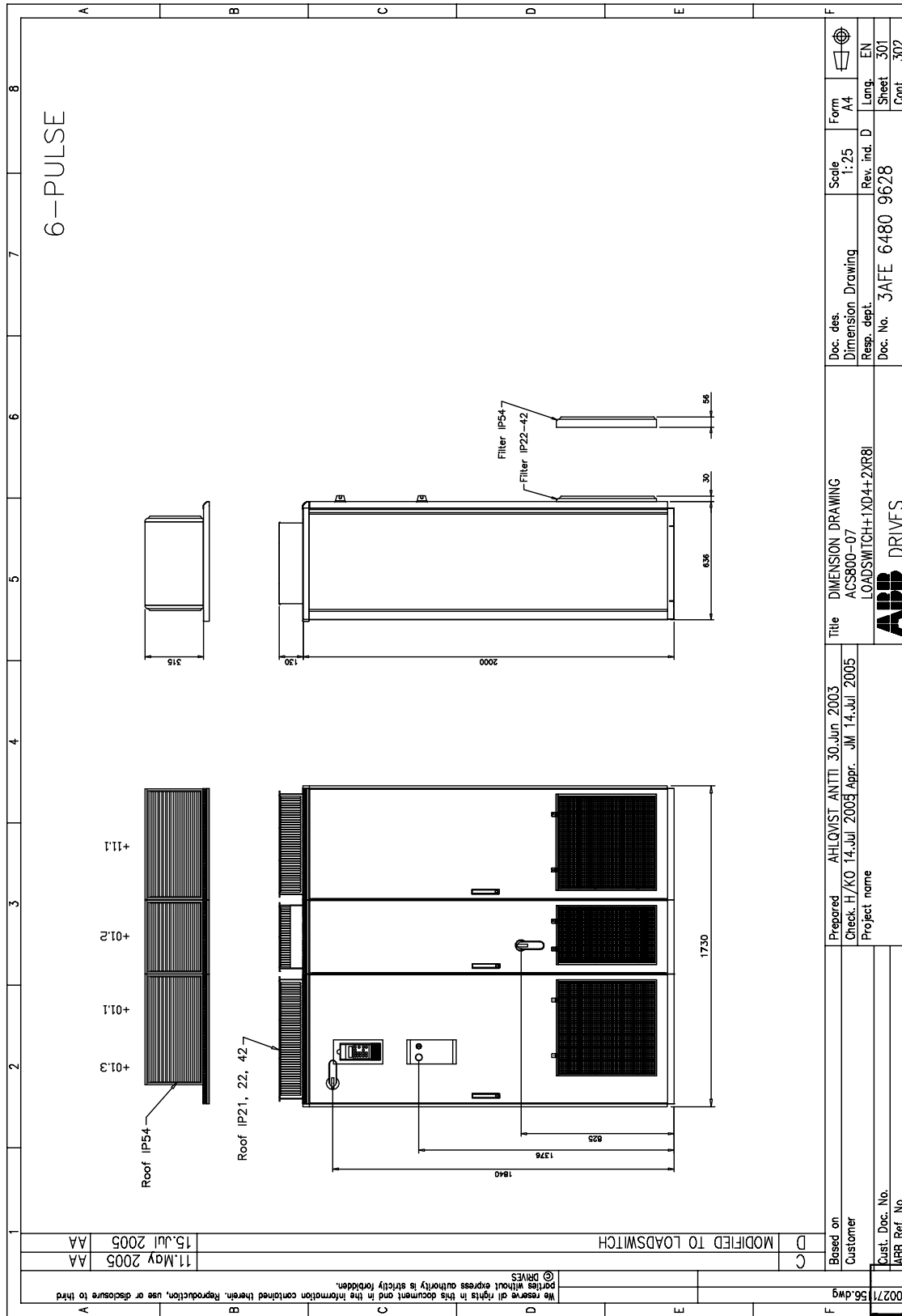

00271156.dwg  
 We reserve all rights in this document and in the information contained therein. Reproduction, use or disclosure to third parties without express authority is strictly forbidden.  
 © ABB DRIVES

11.May 2005 AA  
 15.Jul 2005 AA

MODIFIED TO LOADSWITCH

Based on Customer  
 Cust. Doc. No. ABB Ref. No.

Prepared AHLOVIST ANITI 30.Jun.2003  
 Check. H/KO 14.Jul 2005 Appr. JM 14.Jul. 2005  
 Project name

Title DIMENSION DRAWING  
 ACS800-07  
 LOADSWITCH+1XD4+2XR8i  
**ABB DRIVES**

Doc. des. Dimension Drawing  
 Resp. dept.  
 Doc. No. 3AFE 6480 9628  
 Scale 1:25  
 Rev. Ind. D  
 Form A4  
 Lang. EN  
 Sheet 301  
 Cont. 302

Frame size 1×D4 + 2×R8i (with +F253) (continued)

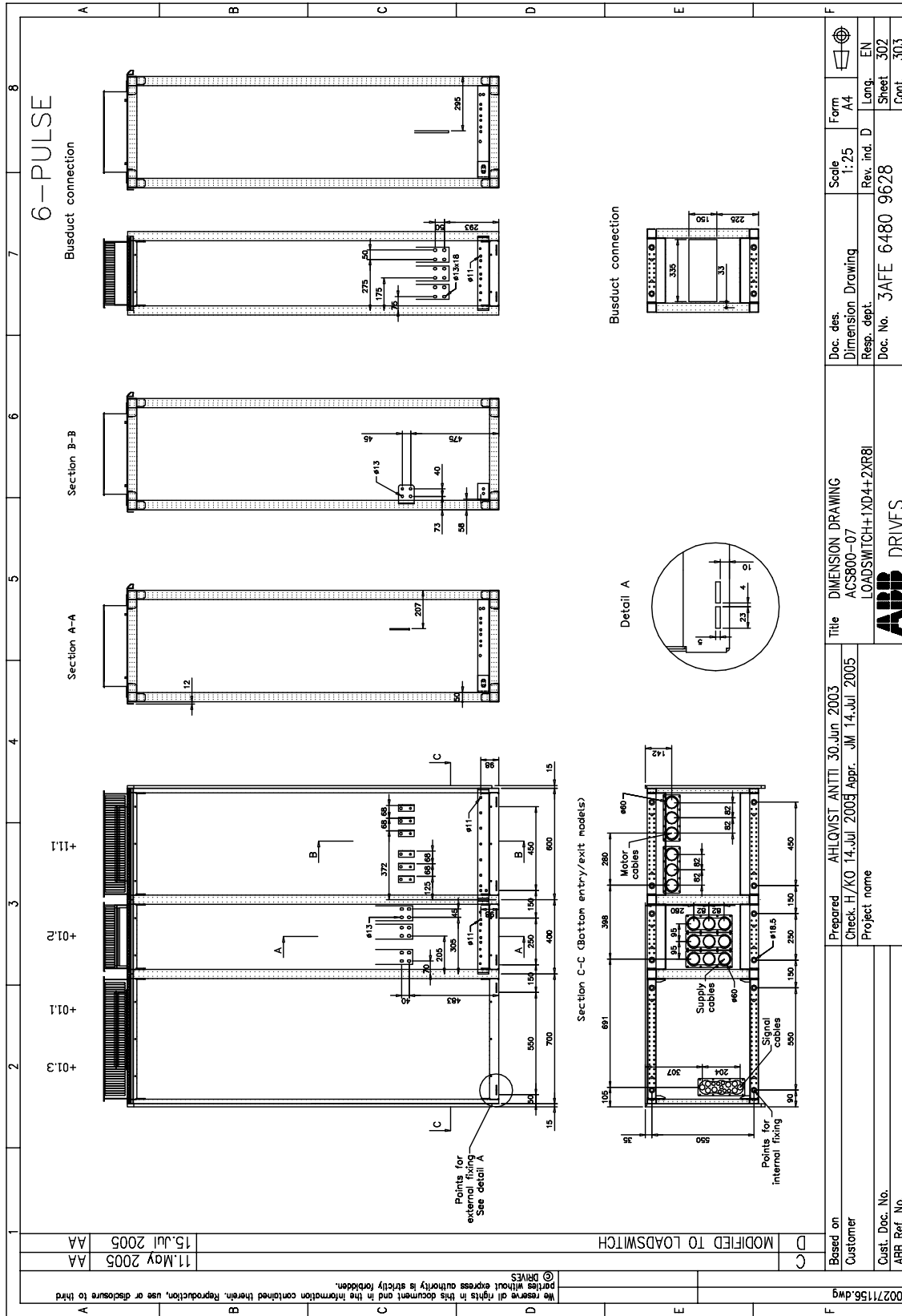

We reserve all rights in this document and in the information contained therein. Reproduction, use or disclosure to third parties without express authority is strictly forbidden.  
© ABB Drives

D	MODIFIED TO LOADSWITCH
C	Customer
B	11 May 2005
A	AA
A	15 Jul 2005
A	AA

00271156.dwg	Prepared	AHLQVIST ANITLI 30 Jun 2003	Title	DIMENSION DRAWING
	Customer	Check: H/KO 14 Jul 2005	Doc. des.	Dimension Drawing
	Project name	Appr.: JM 14 Jul 2005	Resp. dept.	Rev. ind. D
				Lang. EN
				Sheet 302
				Cont. 303
				Doc. No. 3AFE 6480 9628
				Scale 1:25
				Form A4

**ABB** DRIVES

Frame size 1x D4 + 2x R8i (with +F253) (continued)

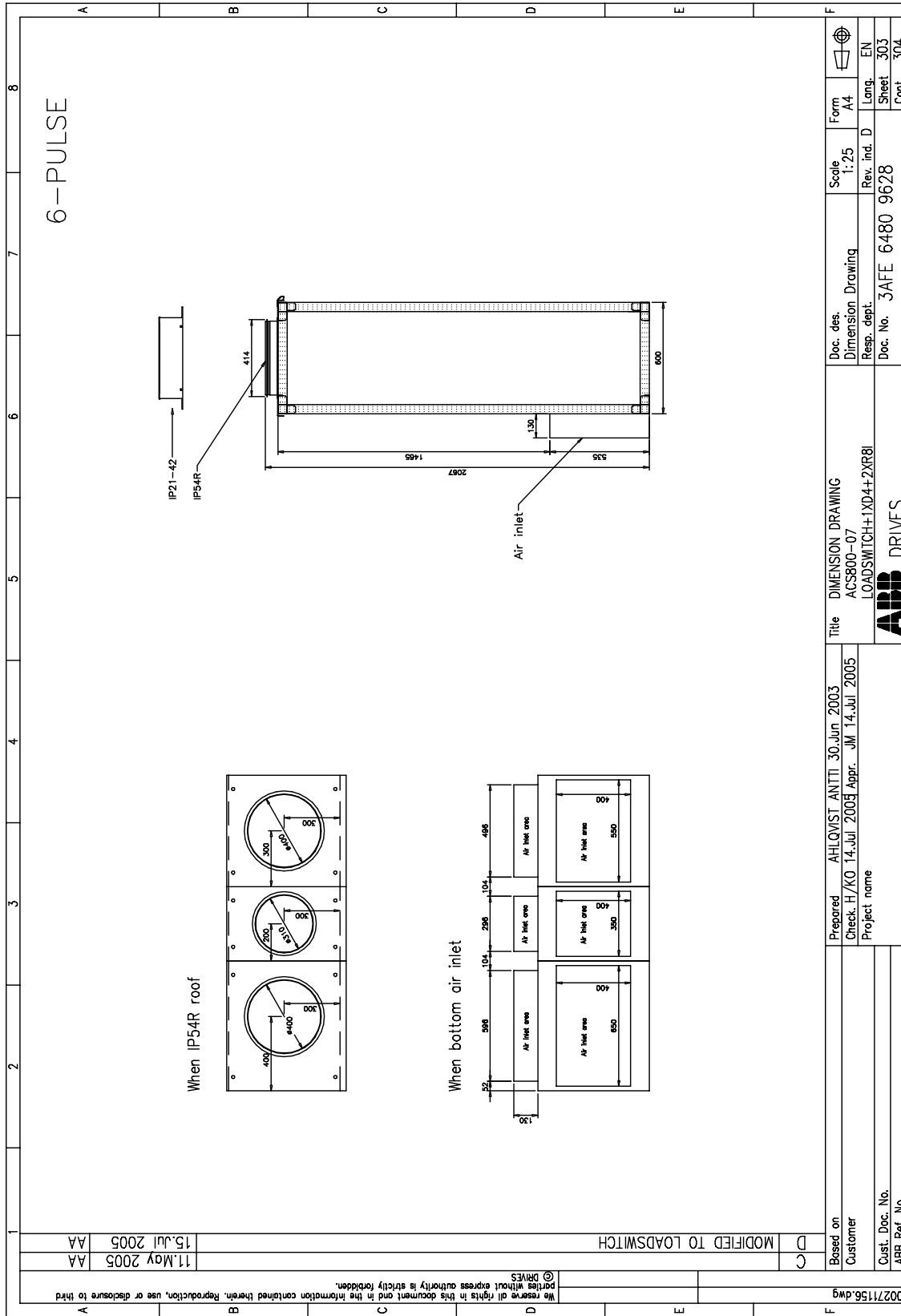

Frame size 1x D4 + 2x R8i (with +F253) (continued)

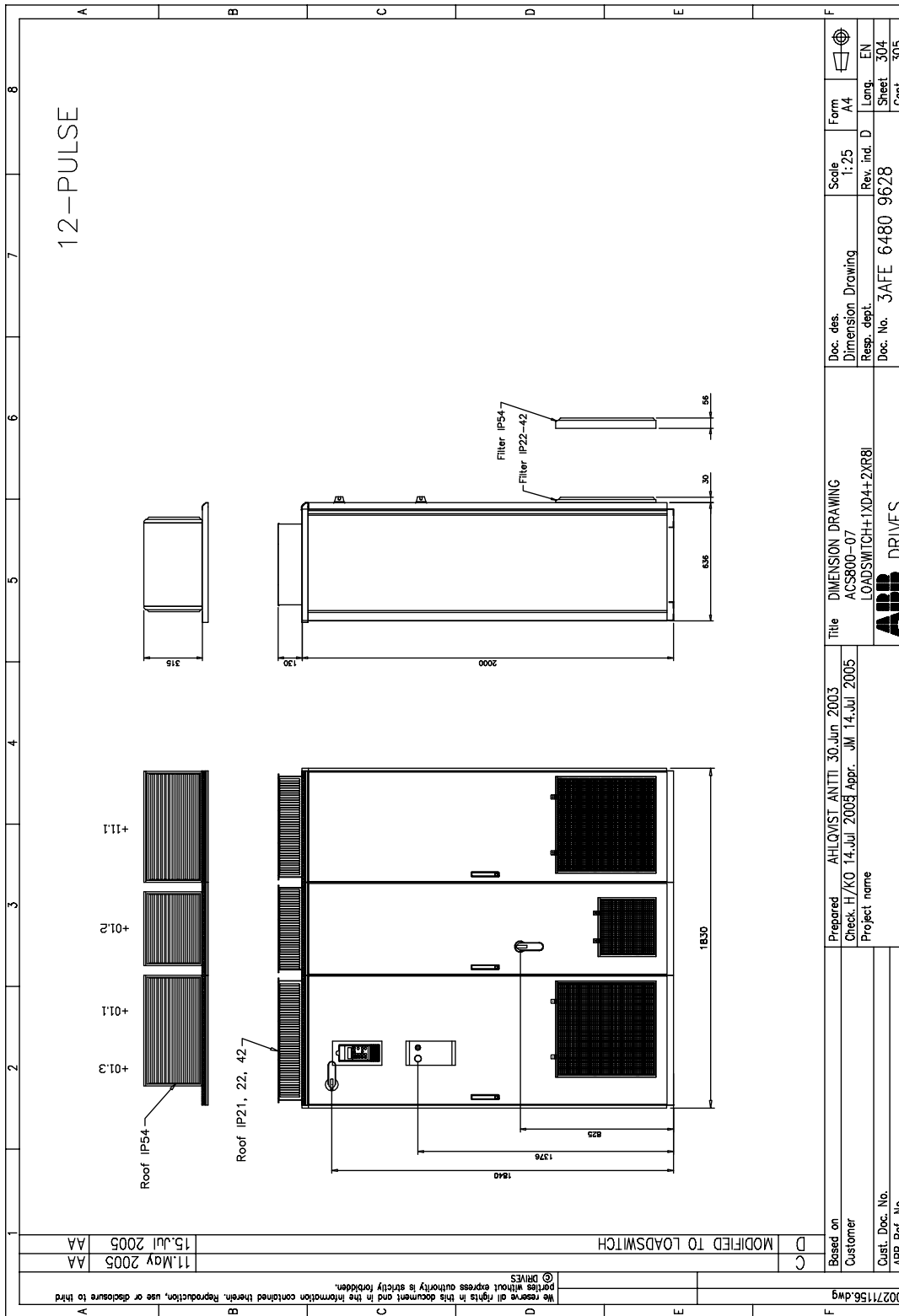



Frame size 1x D4 + 2x R8i (with +F253) (continued)

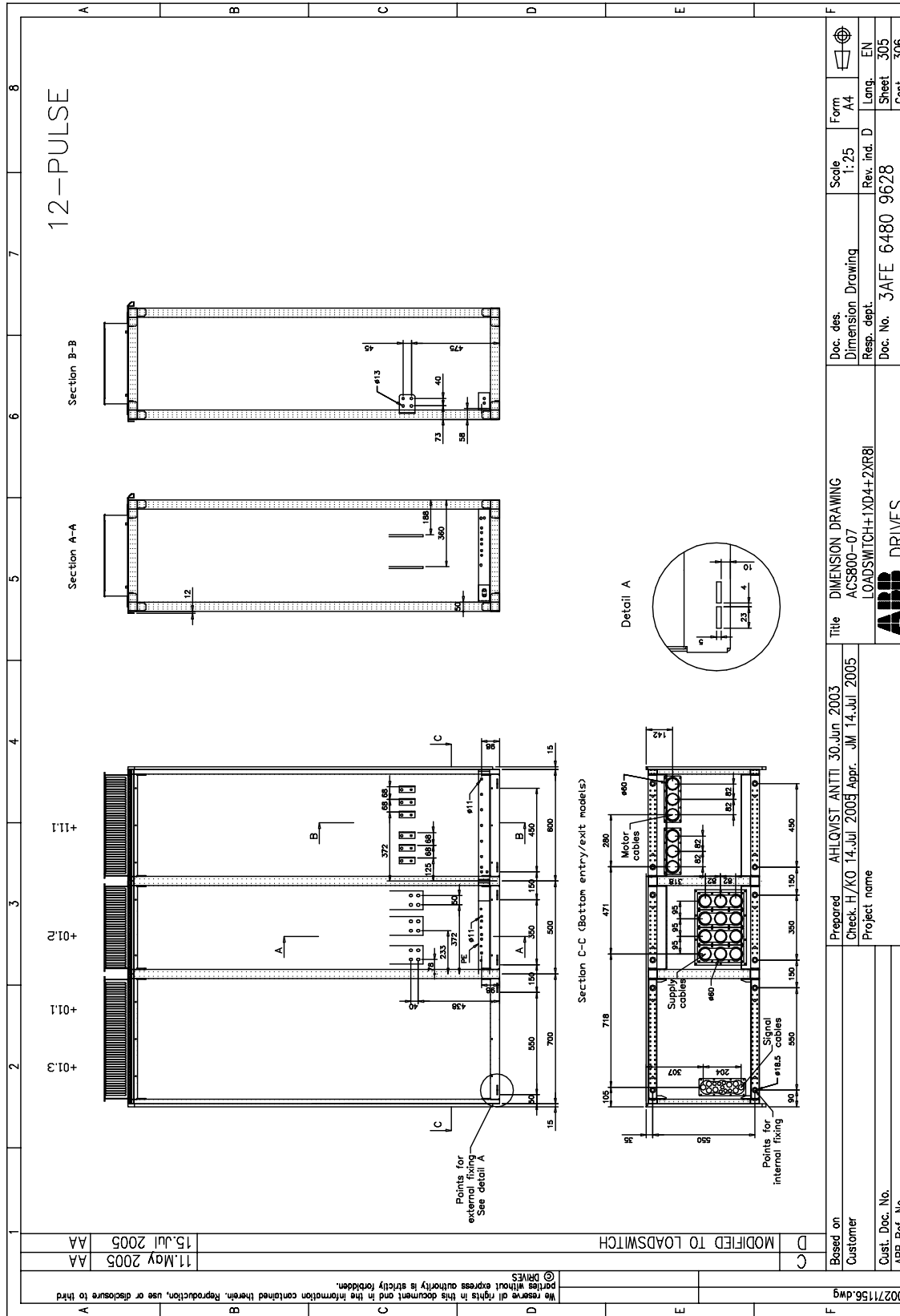

12-PULSE

Section B-B

Section A-A

Section C-C (Bottom entry/exit models)

Detail A

00271156.dwg	Based on Customer	Prepared AHLQVIST ANTTI 30.Jun 2003	Title DIMENSION DRAWING	Doc. des. Dimension Drawing	Scale 1:25	Form A4	 EN
11 May 2005 AA	Customer	Check. H/KO 14.Jul 2005 Appr. JM 14.Jul 2005	LOADSWITCH+1XD4+2XR8I	Resp. dept. LOADSWITCH+1XD4+2XR8I	Rev. ind. D	Lang. EN	
		Project name	<b>ABB</b> DRIVES	Doc. No. 3AFE 6480 9628		Sheet 305	Cont. 306
		ABB Ref. No.					

Frame size 1×D4 + 2×R8i (with +F253) (continued)

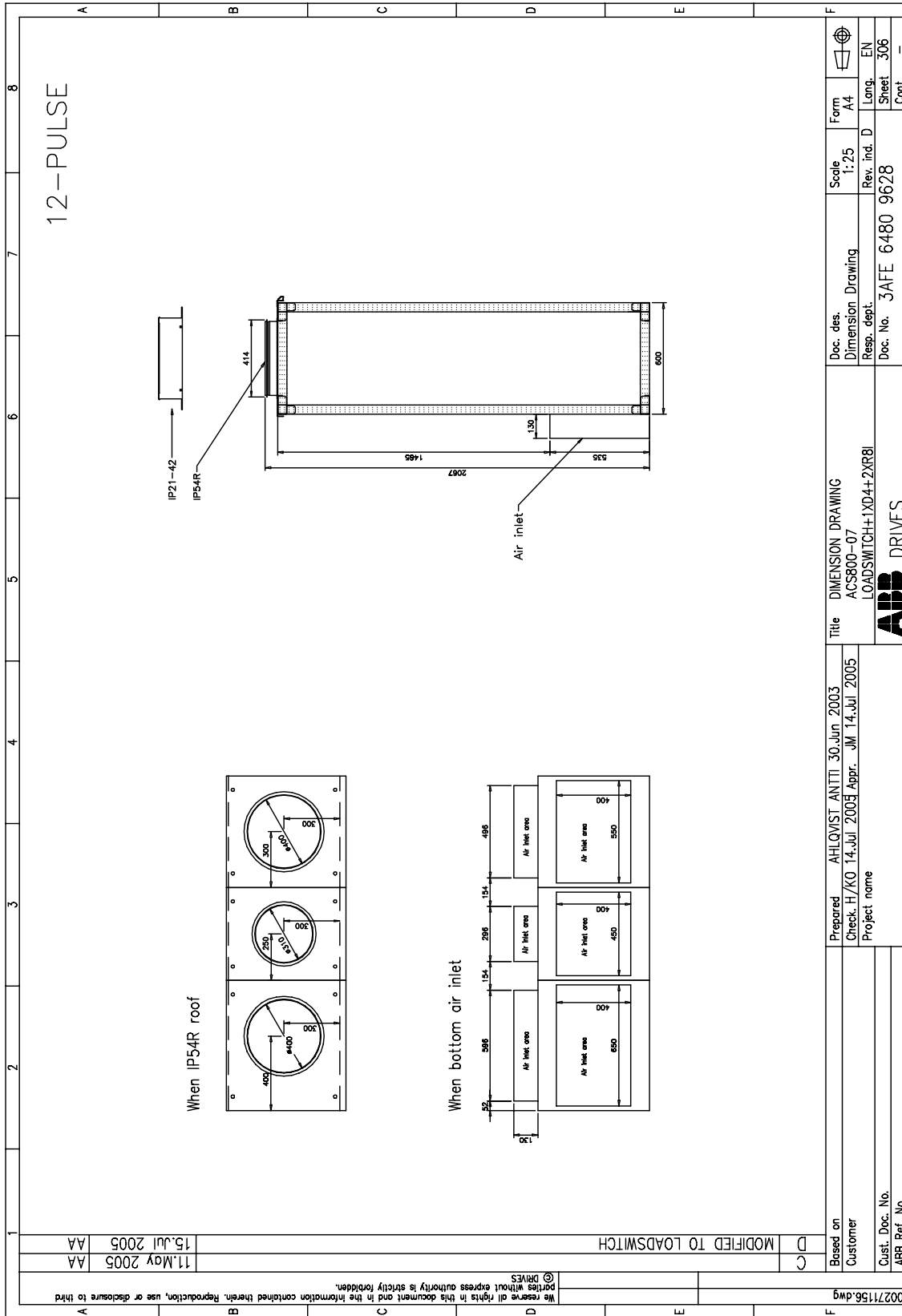

# Frame size 1xD4 + 2xR8i (with top entry/exit)

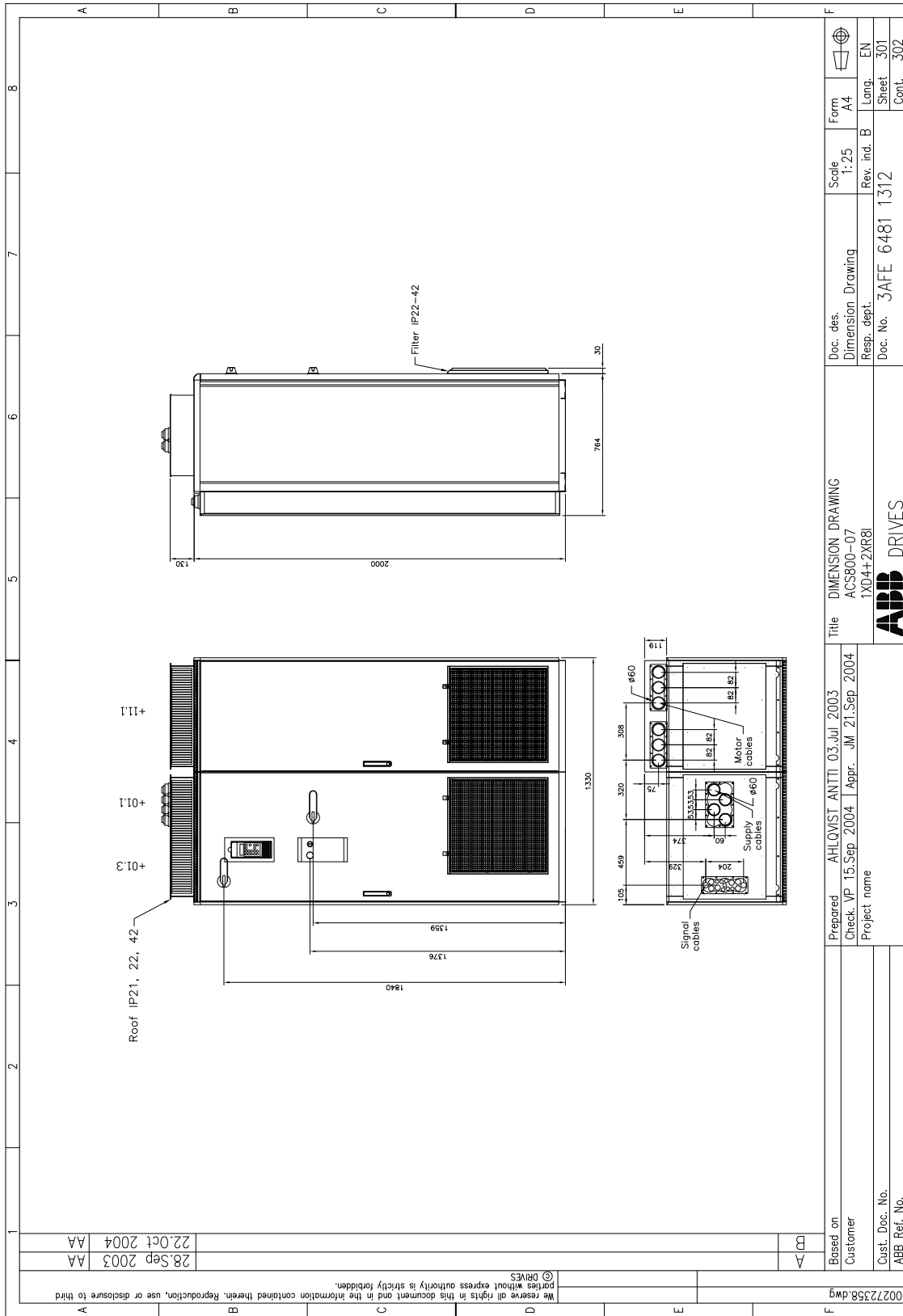

© DRIVES  
 We reserve all rights in this document and in the information contained therein. Reproduction, use or disclosure to third parties without express authority is strictly forbidden.

28.Sep 2003	AA
22.Oct 2004	AA

00272358.dwg
--------------

Based on  
 Customer  
 Cust. Doc. No.  
 ABB Ref. No.

Prepared AHLOVIST ANTTI 03.Jul 2003  
 Check. VP 15.Sep 2004 | Appr. JM 21.Sep 2004  
 Project name

Title  
 DIMENSION DRAWING  
 ACS800-07  
 1XD4+2XR8i

**ABB DRIVES**

Doc. des.  
 Dimension Drawing  
 Resp. dept.  
 Doc. No. 3AFE 6481 1312

Scale 1:25	Form A4
Rev. Ind. B	Lang. EN
Sheet 301	Cont. 302

A	B	C	D	E	F
---	---	---	---	---	---

1	2	3	4	5	6	7	8
---	---	---	---	---	---	---	---

Frame size 1x D4 + 2x R8i (with top entry/exit) (continued)

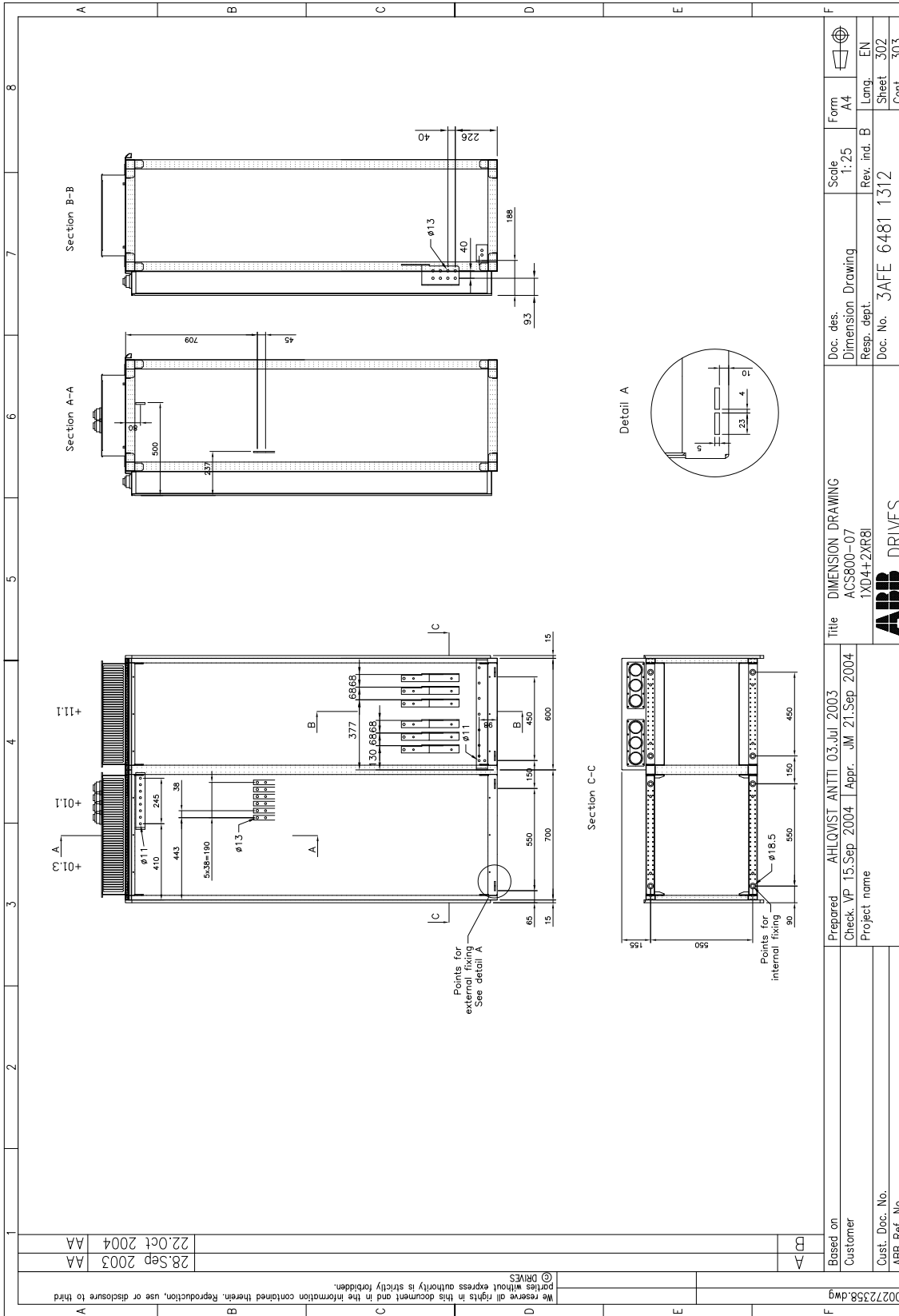

Frame size 1xD4 + 2xR8i (with top entry/exit) (continued)

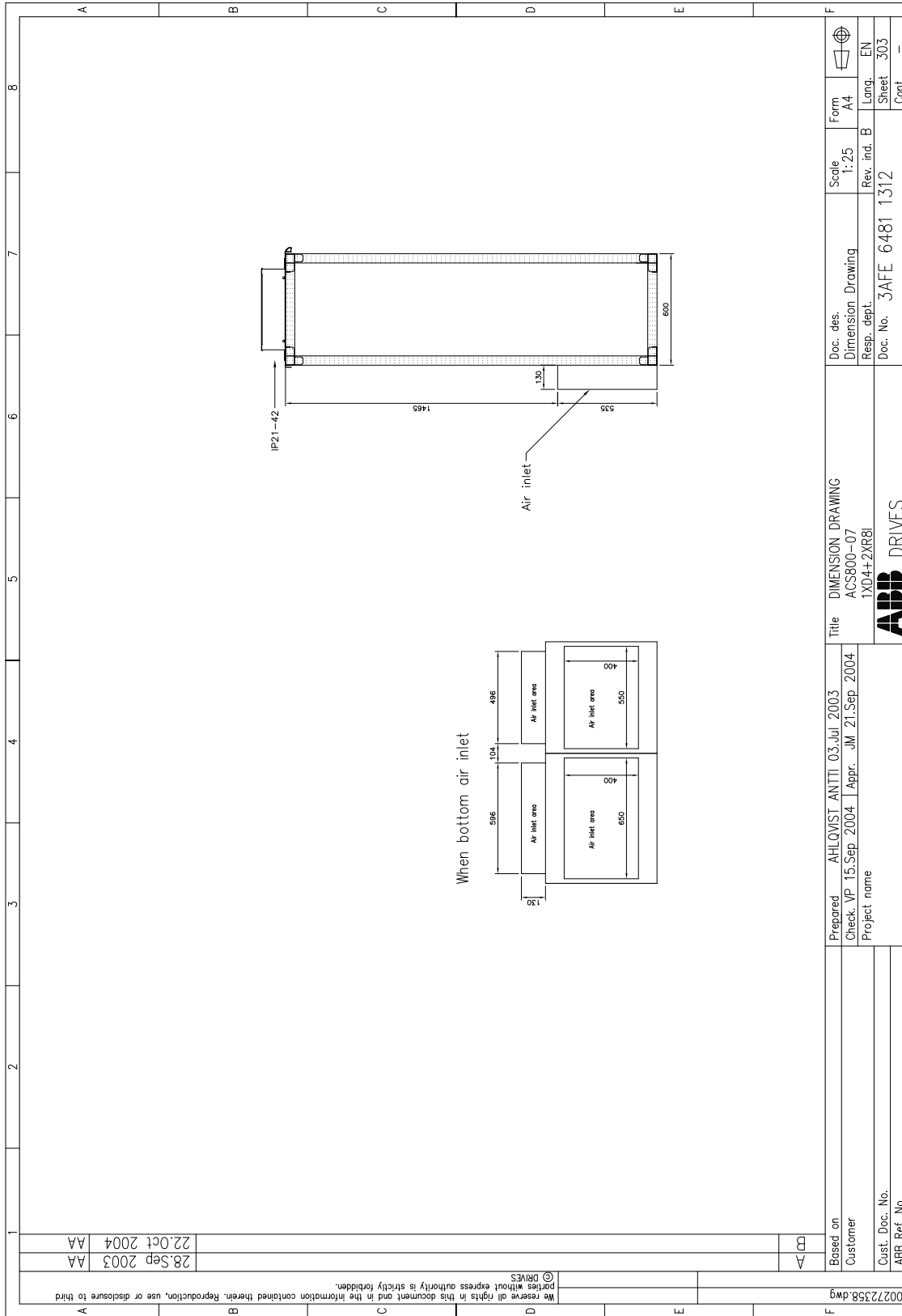

# Frame size 2xD4 + 2xR8i

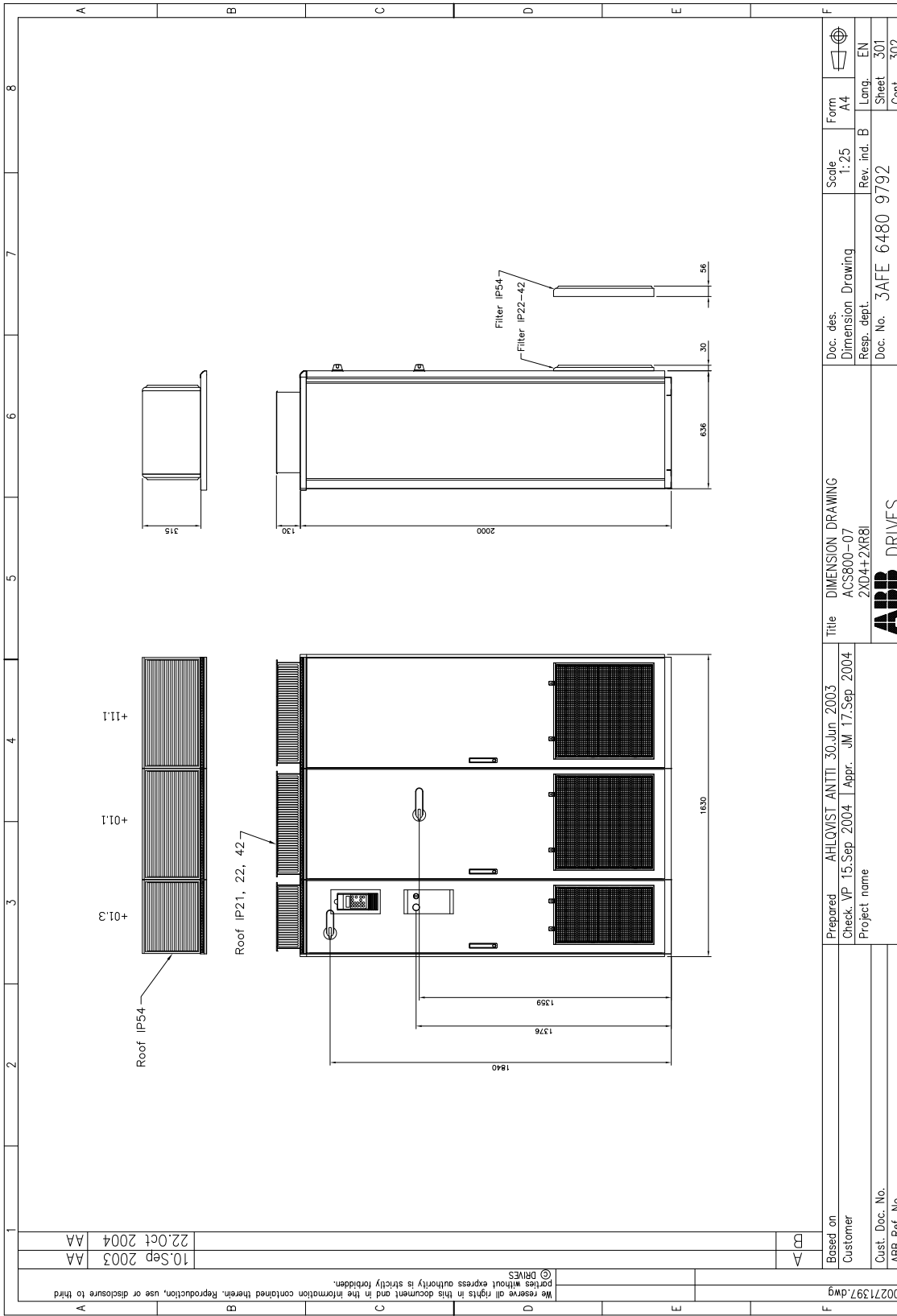

00271397.dwg	10.Sep 2003	AA
	22.Oct 2004	AA

We reserve all rights in this document and in the information contained therein. Reproduction, use or disclosure to third parties without express authority is strictly forbidden.  
© BRVES

Based on Customer	Prepared AHLQVIST ANTTI 30.Jun 2003	Title DIMENSION DRAWING	Doc. des. Dimension Drawing	Scale 1:25	Form A4
Cust. Doc. No. ABB Ref. No.	Check. VP 15.Sep 2004 Appr. JM 17.Sep 2004	ACS800-07 2XD4+2XR8i	Resp. dept. EN	Rev. ind. B 9792	Lana. EN
	Project name	<b>ABB</b> DRIVES	Doc. No. SAFE 6480 9792		Sheet 301
					Cont. 302

Frame size 2xD4 + 2xR8i (continued)

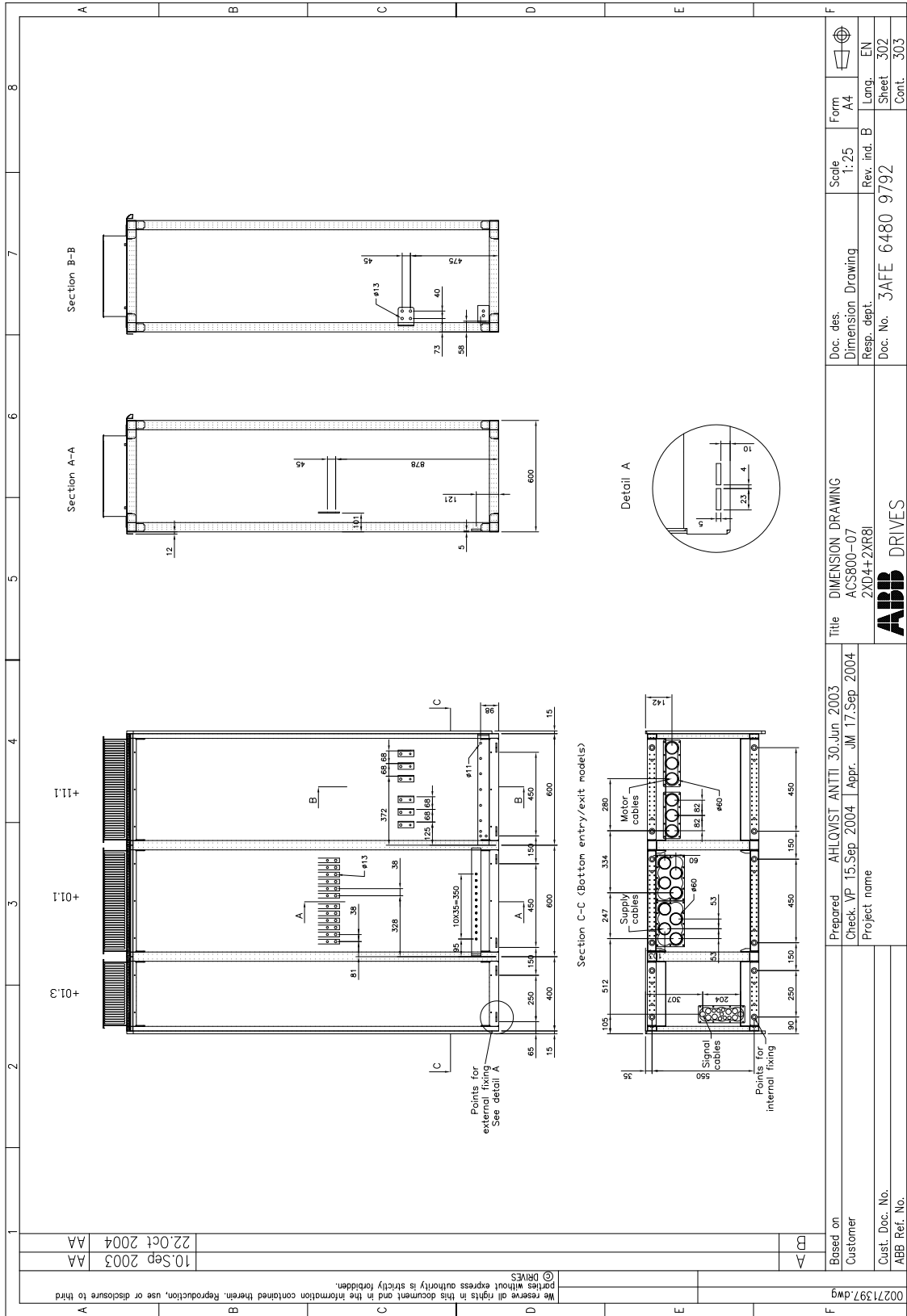

We reserve all rights in this document and in the information contained therein. Reproduction, use or disclosure to third parties without express authority is strictly forbidden.

© DRIVES

10.Sep 2003 AA  
22.Oct 2004 AA

00271397.dwg

Based on Customer

Cust. Doc. No. ABB Ref. No.

Prepared AHLOVIST ANITTI 30.Jun.2003  
Check.VP 15.Sep.2004 | Appr. J.M 17.Sep.2004  
Project name

Title DIMENSION DRAWING  
ACS800-07  
2XD4+2XR8i

**ABB** DRIVES

Doc. des. Dimension Drawing  
Resp. dept. Doc. No. 3AFE 6480 9792

Scale 1:25  
Rev. ind. B  
Form A4  
Lang. EN  
Sheet 302  
Cont. 303

Frame size 2×D4 + 2×R8i (continued)

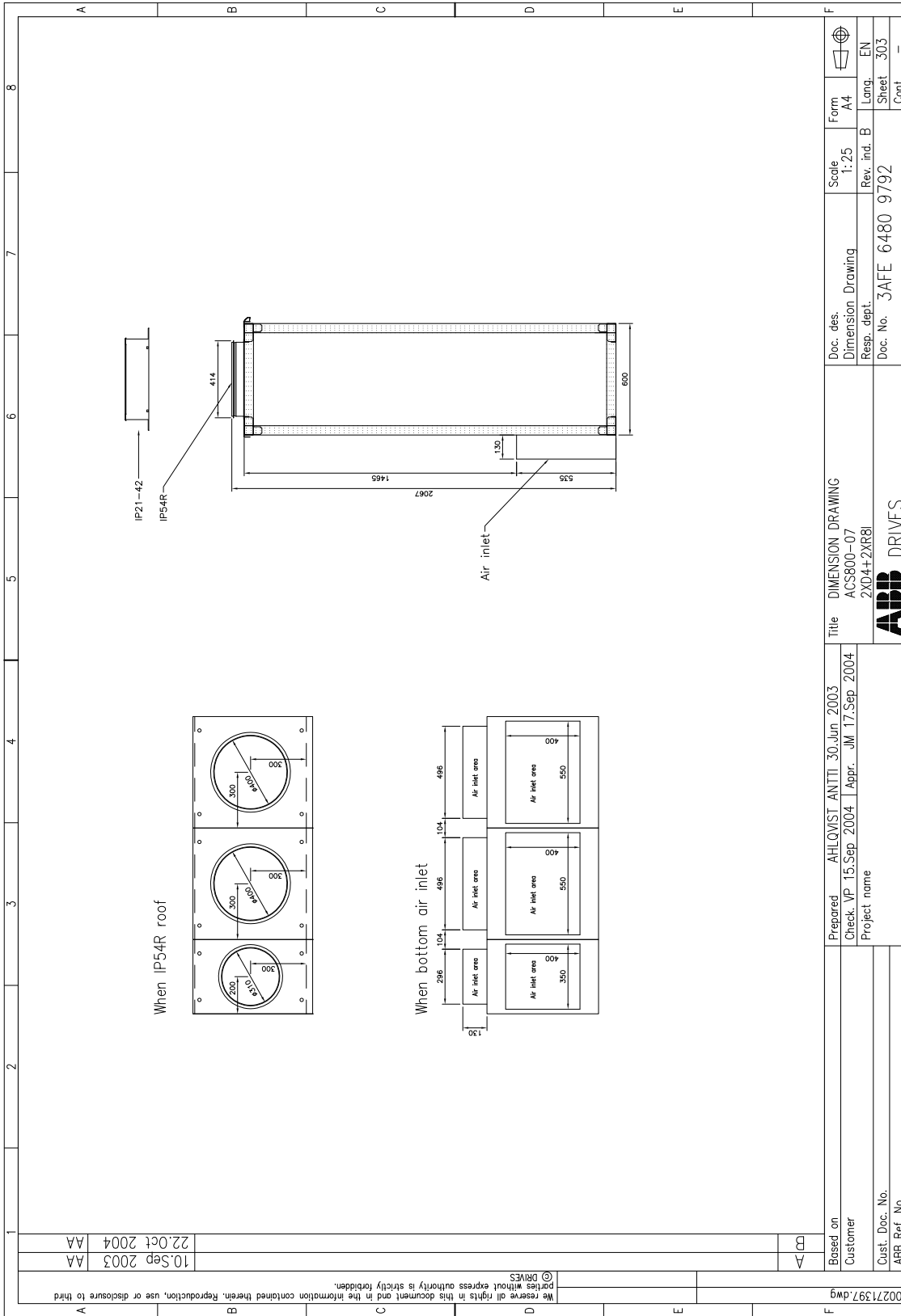



Frame size 2xD4 + 2xR8i (with a main switch-disconnector +F253)

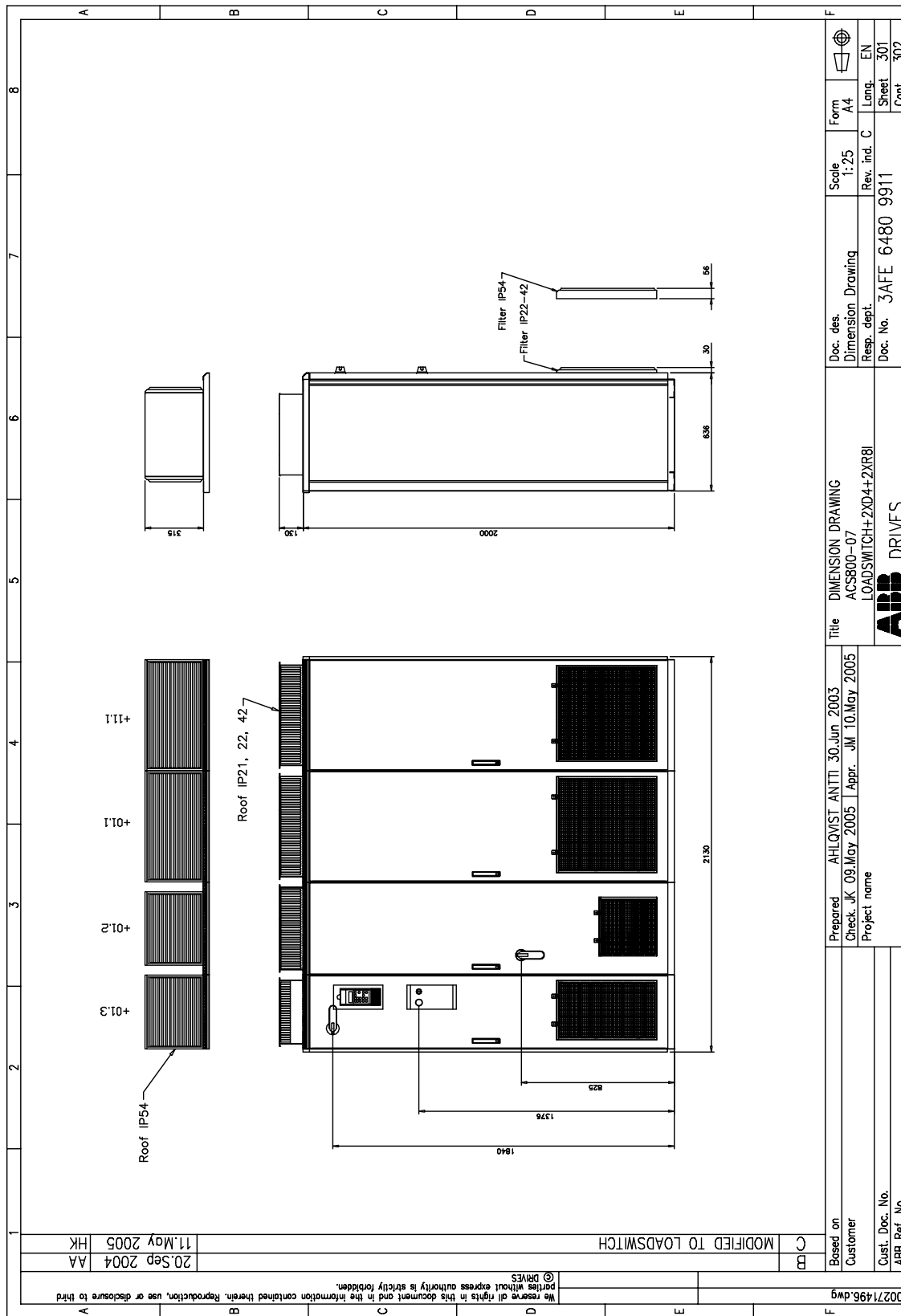

20.Sep.2004	AA
11.May.2005	HK

MODIFIED TO LOADSWITCH

00271496.dwg  
 We reserve all rights in this document and in the information contained therein. Reproduction, use or disclosure to third parties without express authority is strictly forbidden.  
 © ABB DRIVES

Based on	Customer	Doc. des. Dimension Drawing	Scale 1:25	Form A4
Cust. Doc. No. ABB Ref. No.	Project name	Resp. dept.	Rev. ind. C	Lang. EN
Prepared	AHLOVIST ANTTI 30.Jun.2003	Doc. No.	3AFE 6480 9911	Sheet 301
Check	JK 09.May.2005	Rev. ind.	9911	Cont. 302
Appr.	JM 10.May.2005	<b>ABB</b> DRIVES Title DIMENSION DRAWING ACS800-07 LOADSWITCH+2XD4+2XR8I		
Project name				

Frame size 2x D4 + 2x R8i (with +F253) (continued)

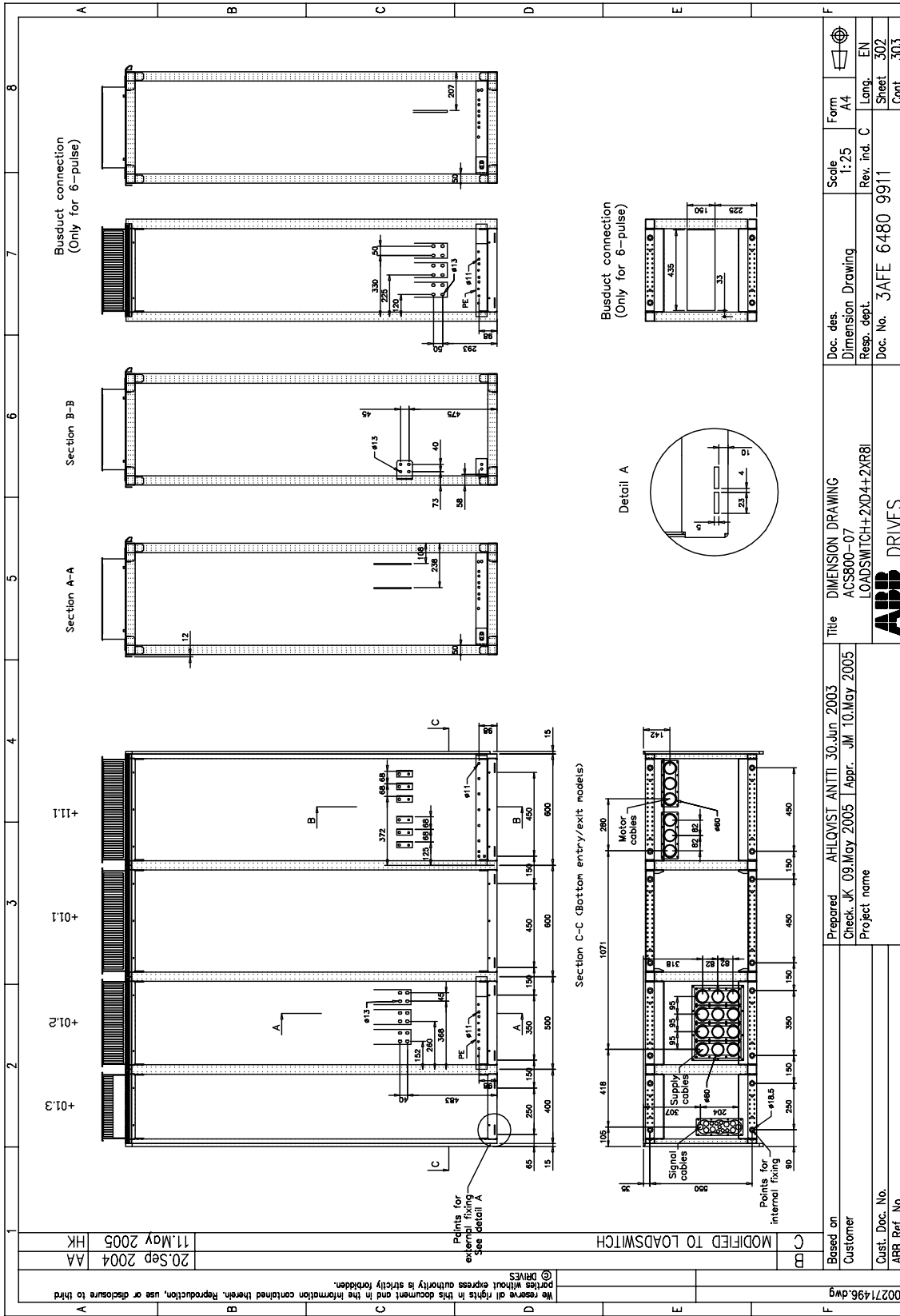

Frame size 2x D4 + 2x R8i (with +F253) (continued)

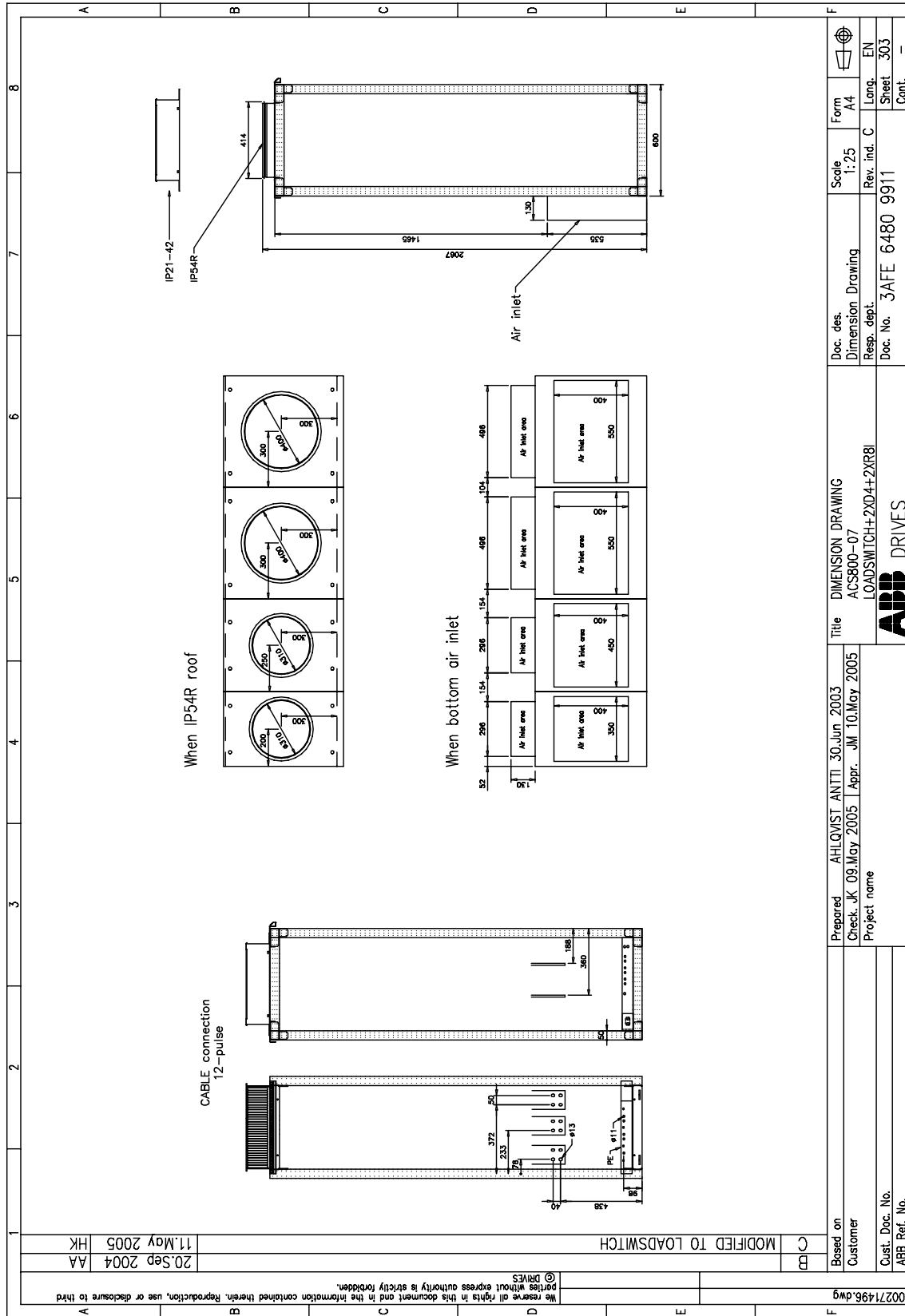

# Frame size 2x D4 + 3x R8i

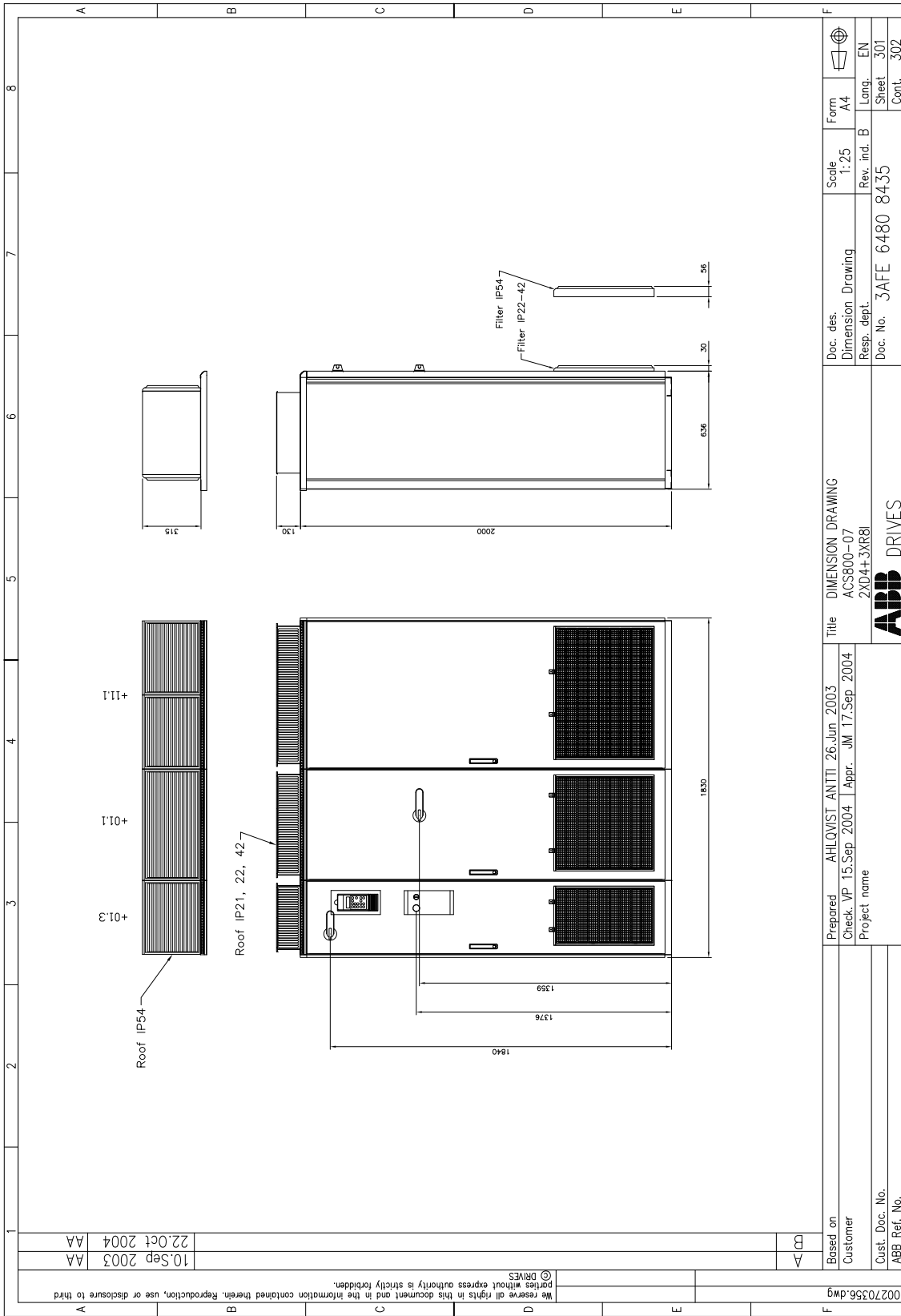

Frame size 2x D4 + 3x R8i (continued)

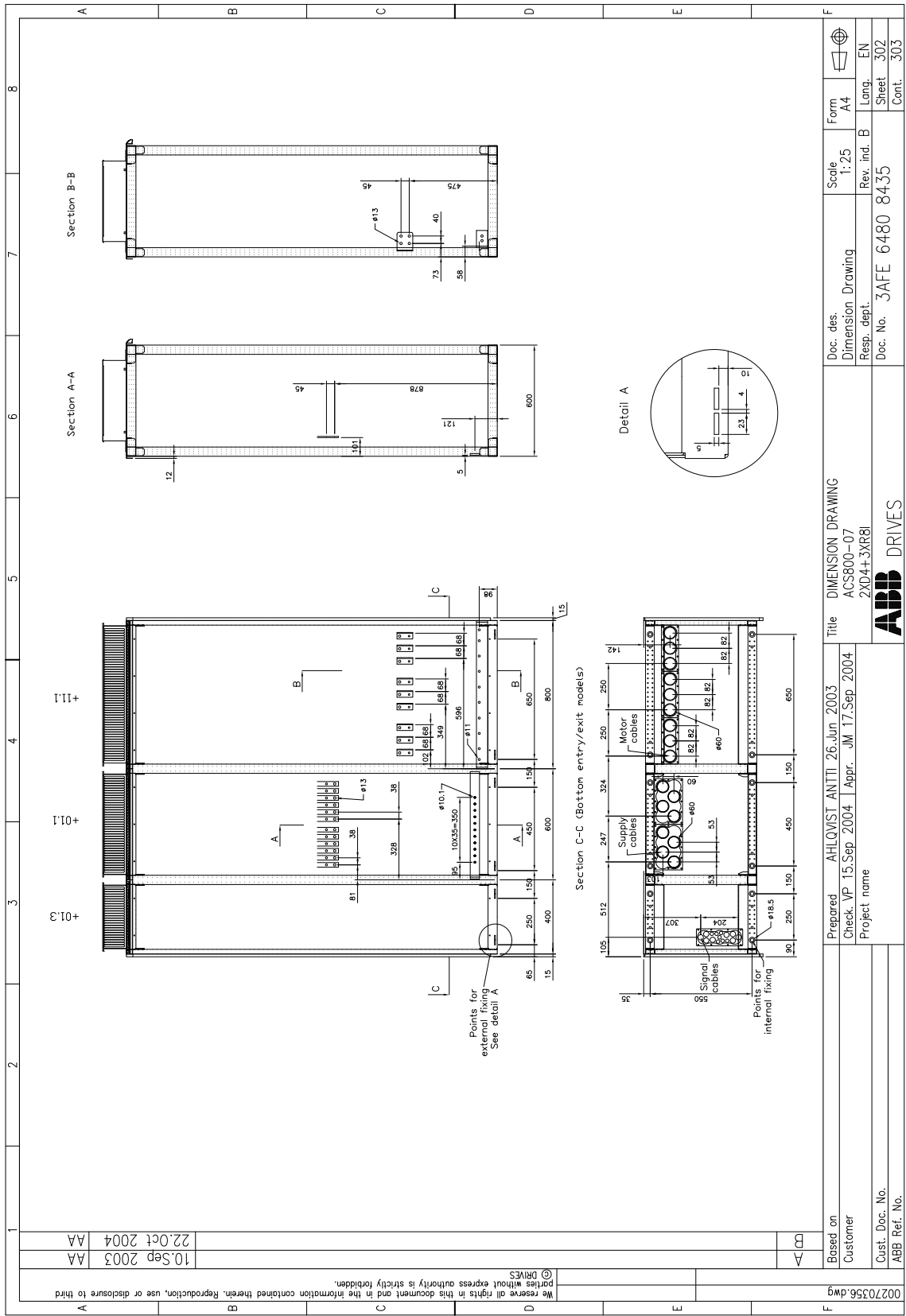

00270356.dwg  
 We reserve all rights in this document and in the information contained therein. Reproduction, use or disclosure to third parties without express authority is strictly forbidden.  
 © ABB DRIVES

Based on	Customer	Prepared	AHLQVIST ANTTI 26.Jun 2003	Title	DIMENSION DRAWING	Doc. des.	Dimension Drawing	Scale	1:25	Form	A4
Customer		Check	VP 15.Sep 2004	Appr.	JM 17.Sep 2004	Res. dept.	ACS800-07 2XD4+3XR8I	Rev. ind.	B	Lang.	EN
Cust. Doc. No.	ABB Ref. No.	Project name				Doc. No.	3AFE 6480 8435	Sheet	302	Cont.	303



Frame size 2×D4 + 3×R8i (continued)

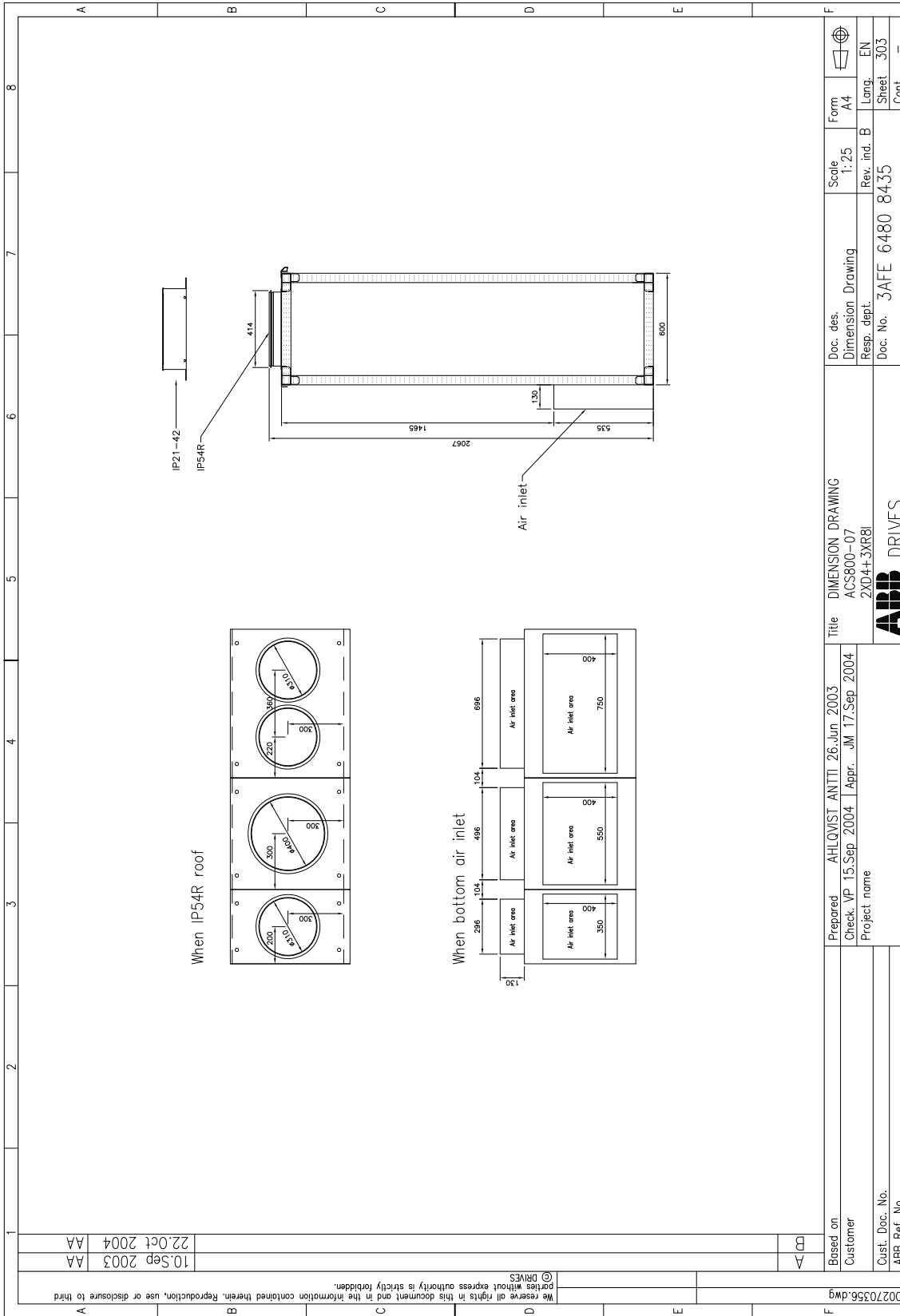

**Frame size 2xD4 + 3xR8i (with a main switch-disconnector +F253)**

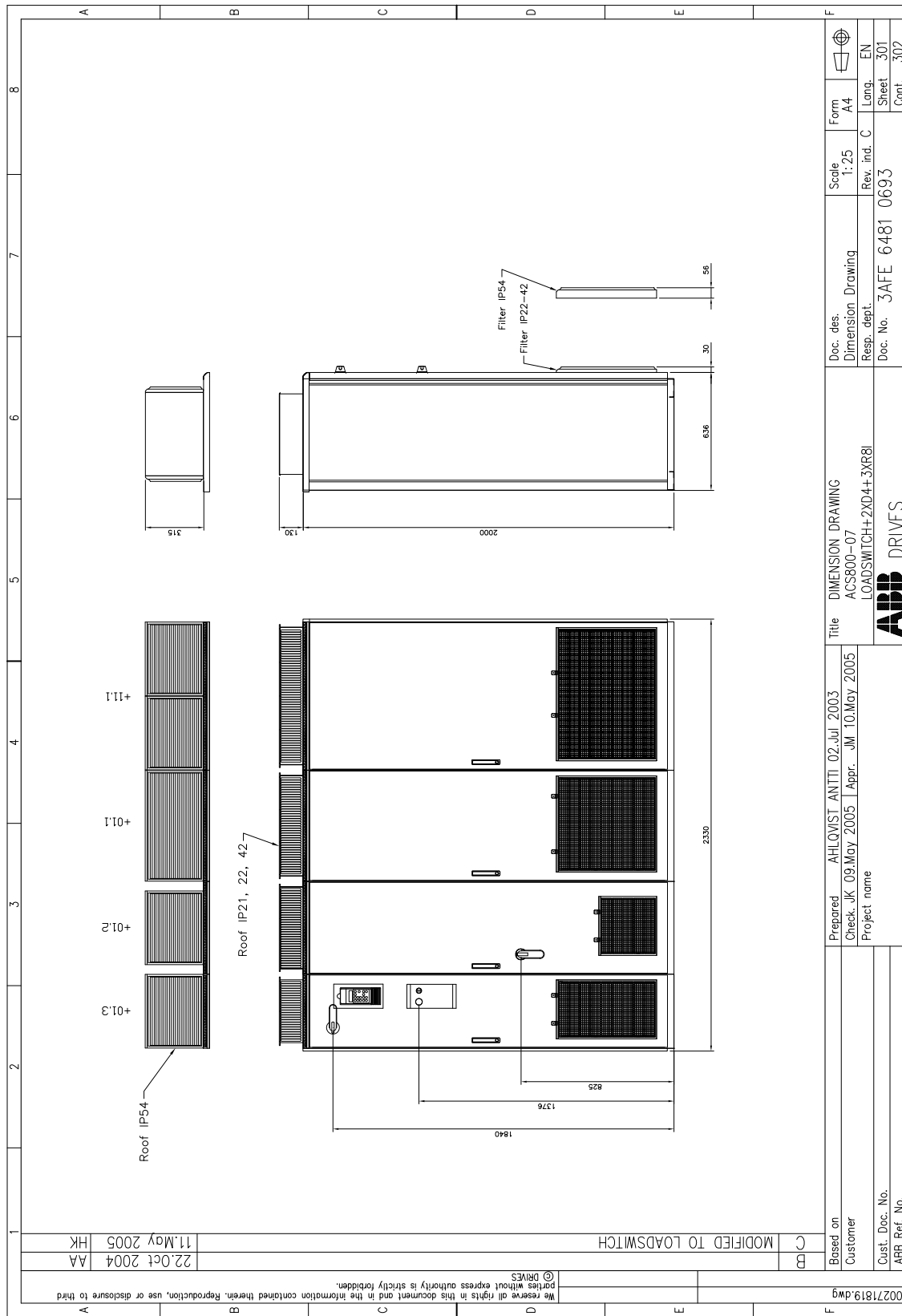

22.Oct.2004	AA
11.May.2005	HK

MODIFIED TO LOADSWITCH

00271819.dwg  
 We reserve all rights in this document and in the information contained therein. Reproduction, use or disclosure to third parties without express authority is strictly forbidden.  
 © DRIVES

Based on	Customer	Prepared	AHLQVIST ANITTI 02.Jul. 2003	Title	DIMENSION DRAWING	Doc. des.	Dimension Drawing	Scale	1:25	Form	A4
		Check	JK 09.May.2005	Appr.	JM 10.May.2005	Resp. dept.	LOADSWITCH+2XD4+3XR8i	Rev. ind.	C	Lana.	EN
Cust. Doc. No.		Project name				Doc. No.	SAFE 6481 0693			Sheet	301
ABB Ref. No.										Cont.	302



Frame size 2×D4 + 3×R8i (with +F253)

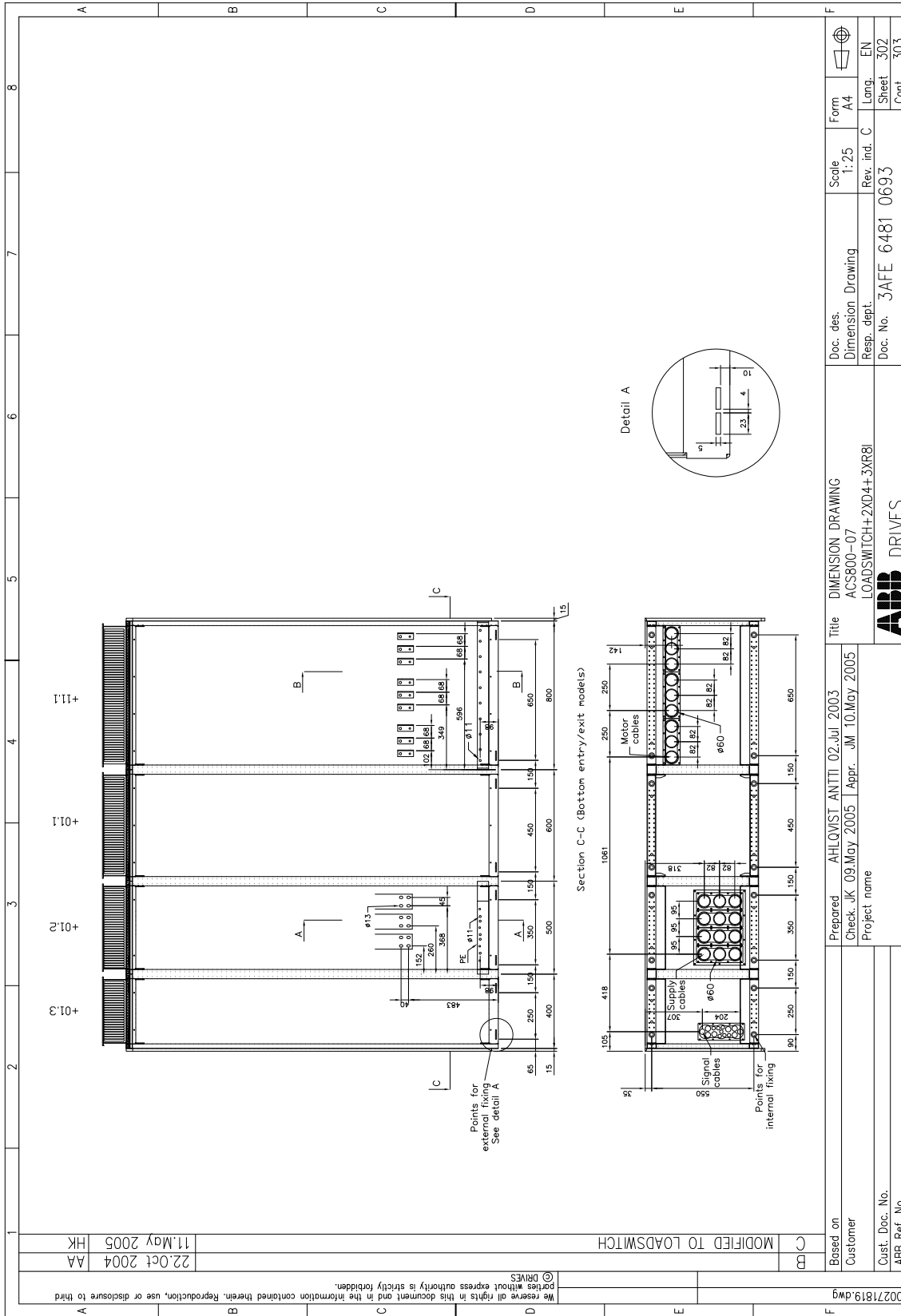



Frame size 2x D4 + 3x R8i (with +F253)

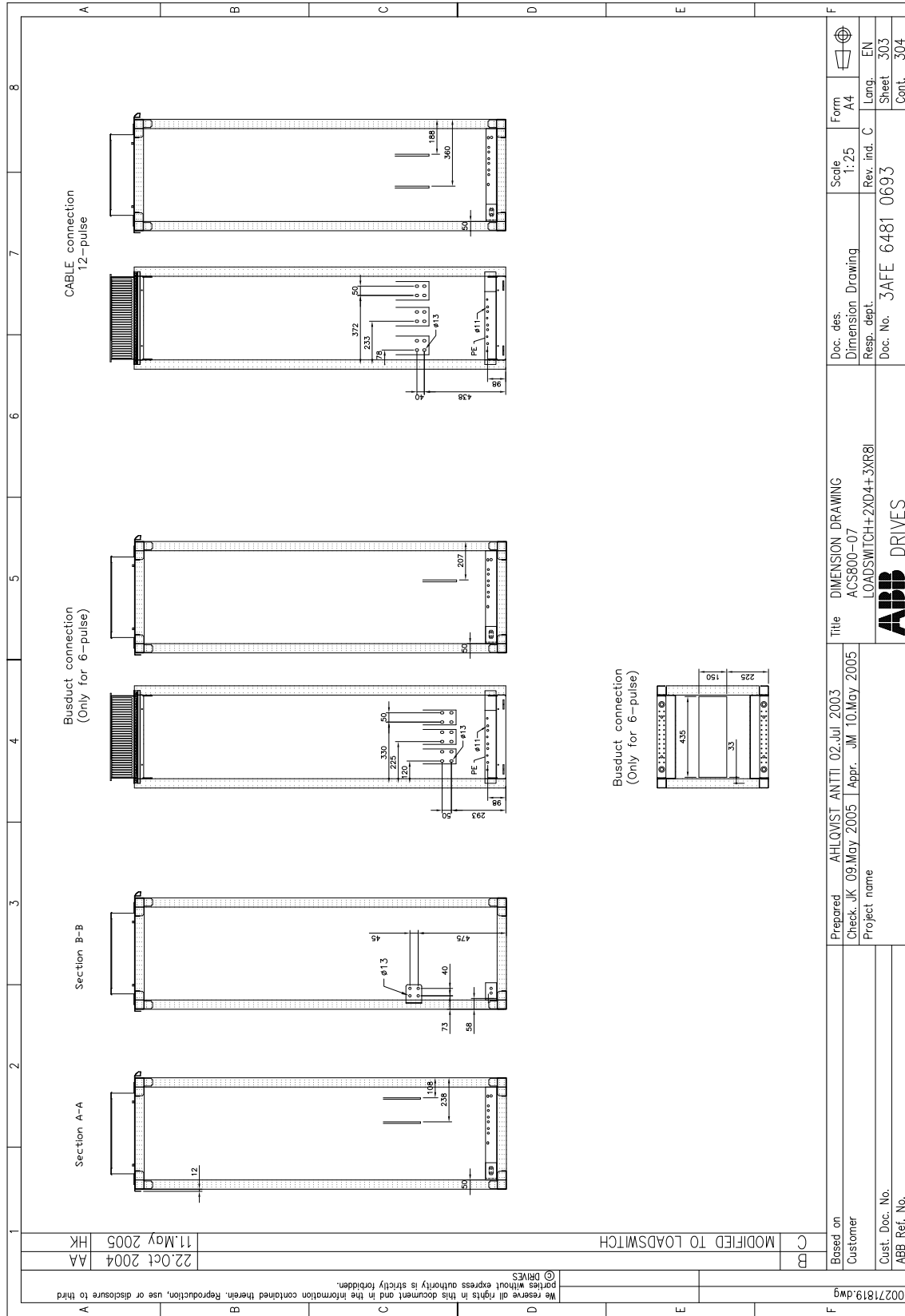

Frame size 2×D4 + 3×R8i (with +F253)

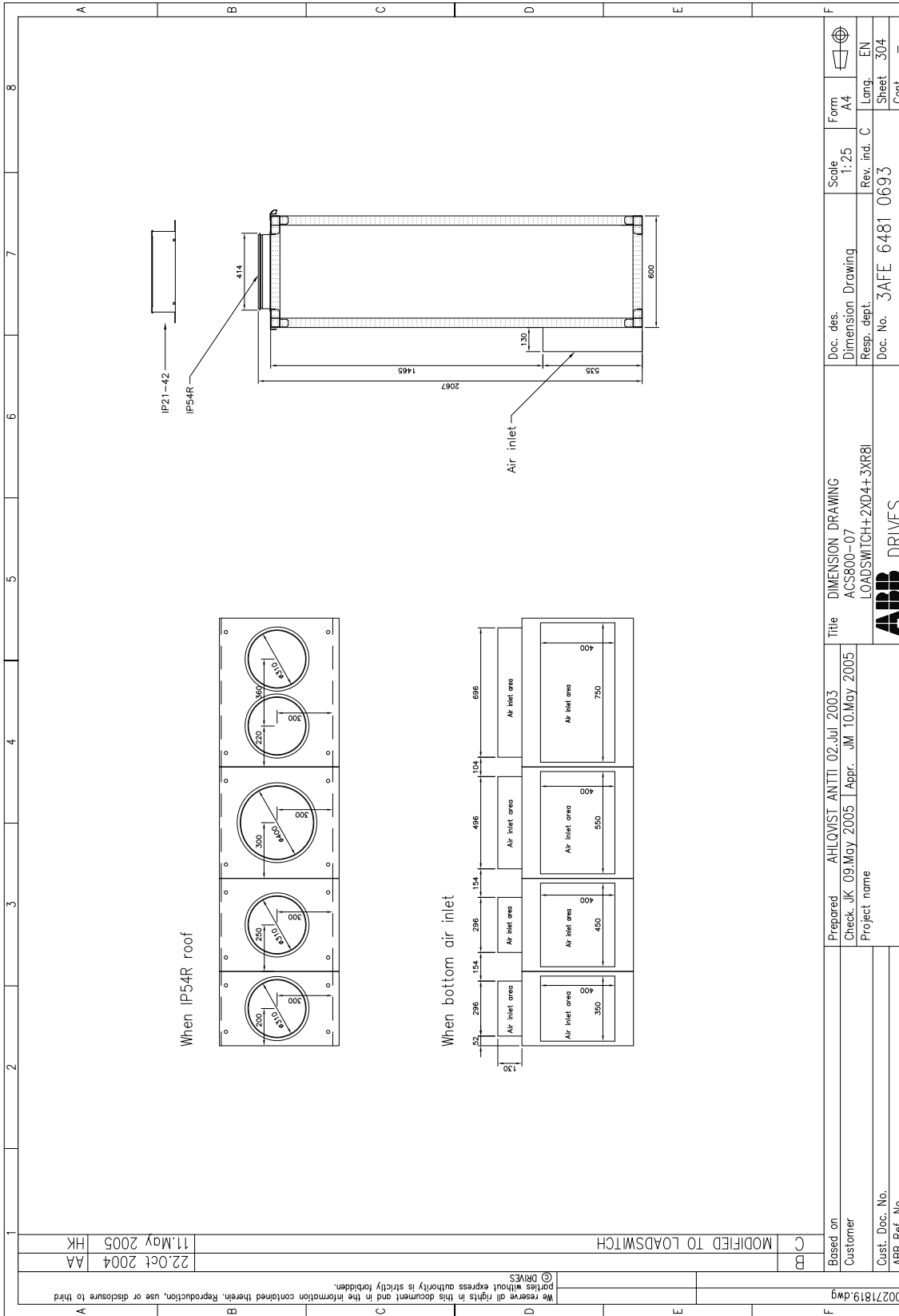

### Frame size 2xD4 + 3xR8i (with a main breaker +F255)

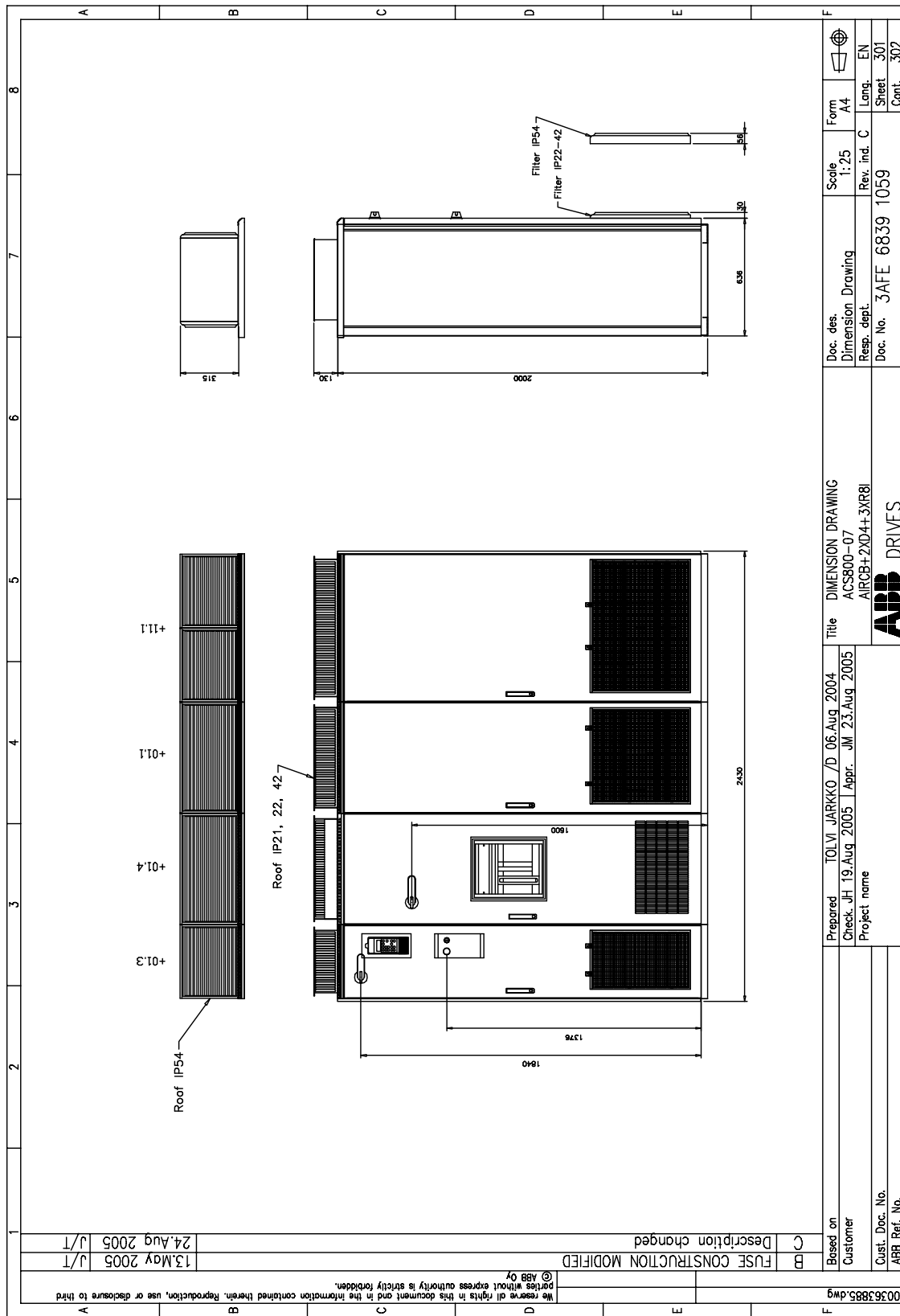

00363885.dwg	Based on	Prepared	Title		Doc. des.	Scale	Form	Sheet	Cont.
	Customer	TOLVI, JARKKO /D 06.Aug 2004	DIMENSION DRAWING		Dimension Drawing	1:25	A4	301	302
		Check: JH 19.Aug 2005   Appr.: JM 23.Aug 2005	ACS800-07 AIRCB+2XD4+3XR8I		Resp. dept.	Rev. ind. C	Lang. EN	301	302
		Project name	ABB DRIVES		Doc. No.	3AFE 6839 1059			
		Cust. Doc. No.							
		ABB Ref. No.							
<p>© ABB Oy We reserve all rights in this document and in the information contained therein. Reproduction, use or disclosure to third parties without express authority is strictly forbidden.</p>									
B	FUSE CONSTRUCTION MODIFIED								
C	Description changed								
		13.May 2005	J/T						
		24.Aug 2005	J/T						

Frame size 2x D4 + 3x R8i (with +F255) (continued)

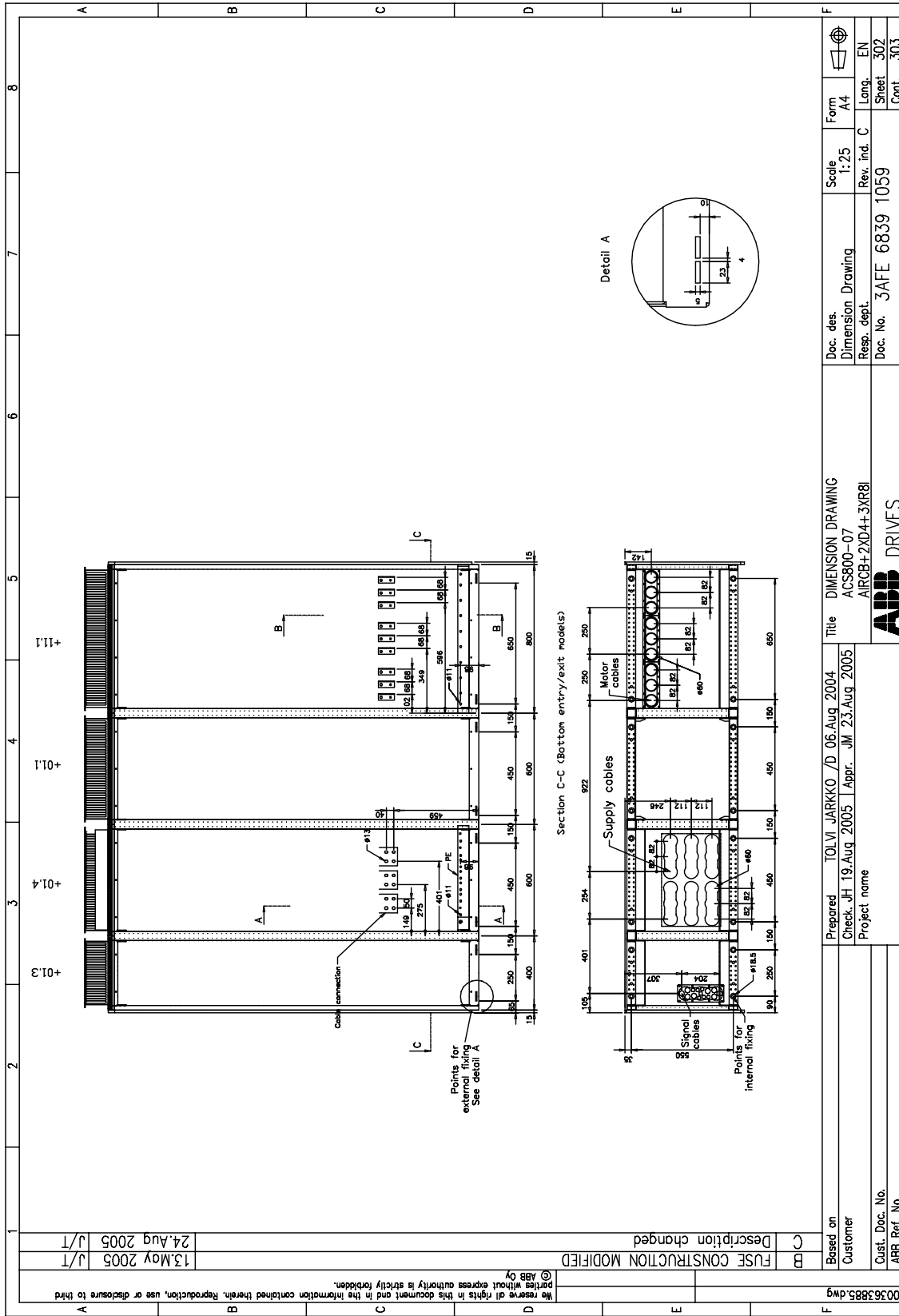

Frame size 2xD4 + 3xR8i (with +F255) (continued)

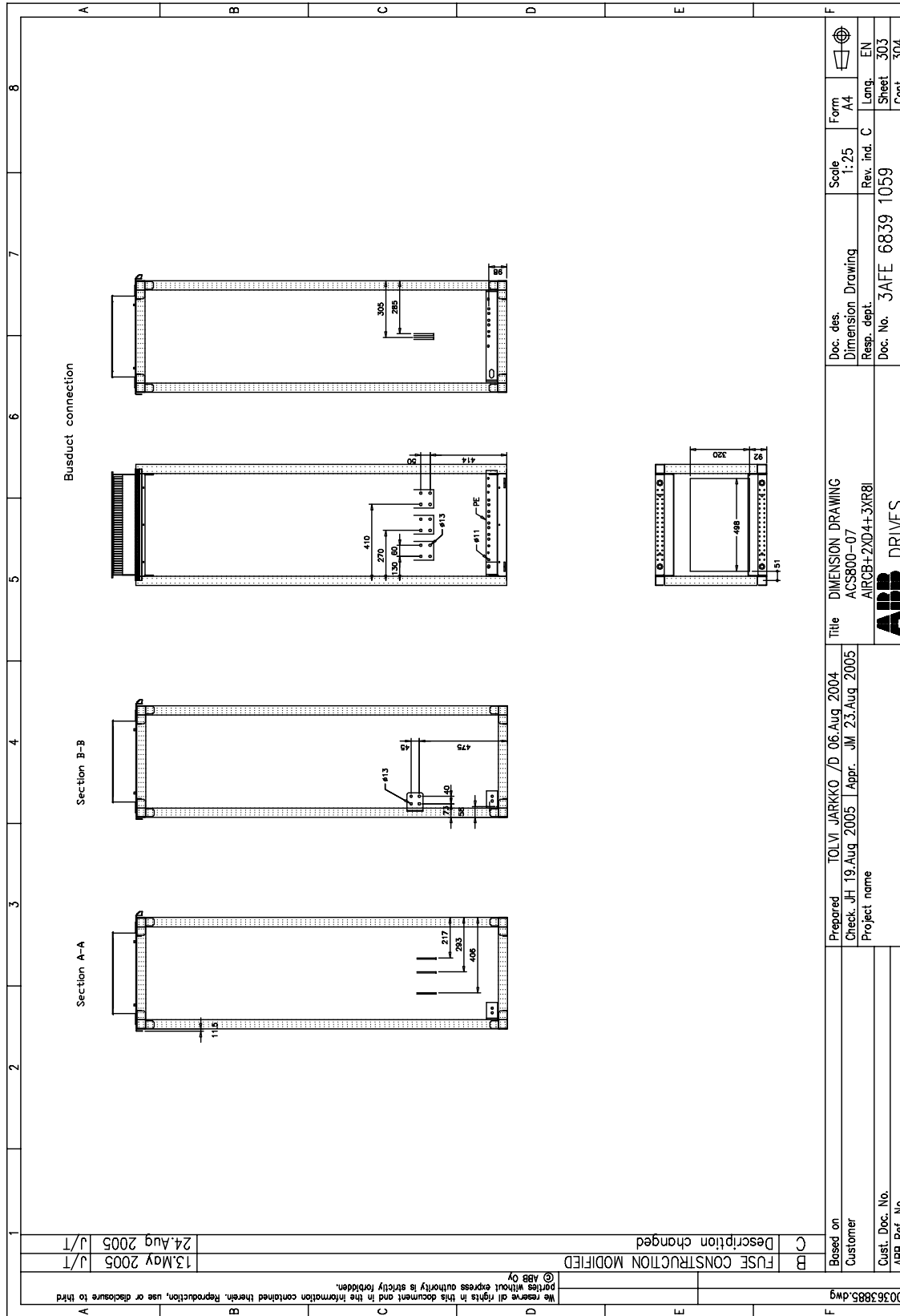

Frame size 2x D4 + 3x R8i (with +F255) (continued)

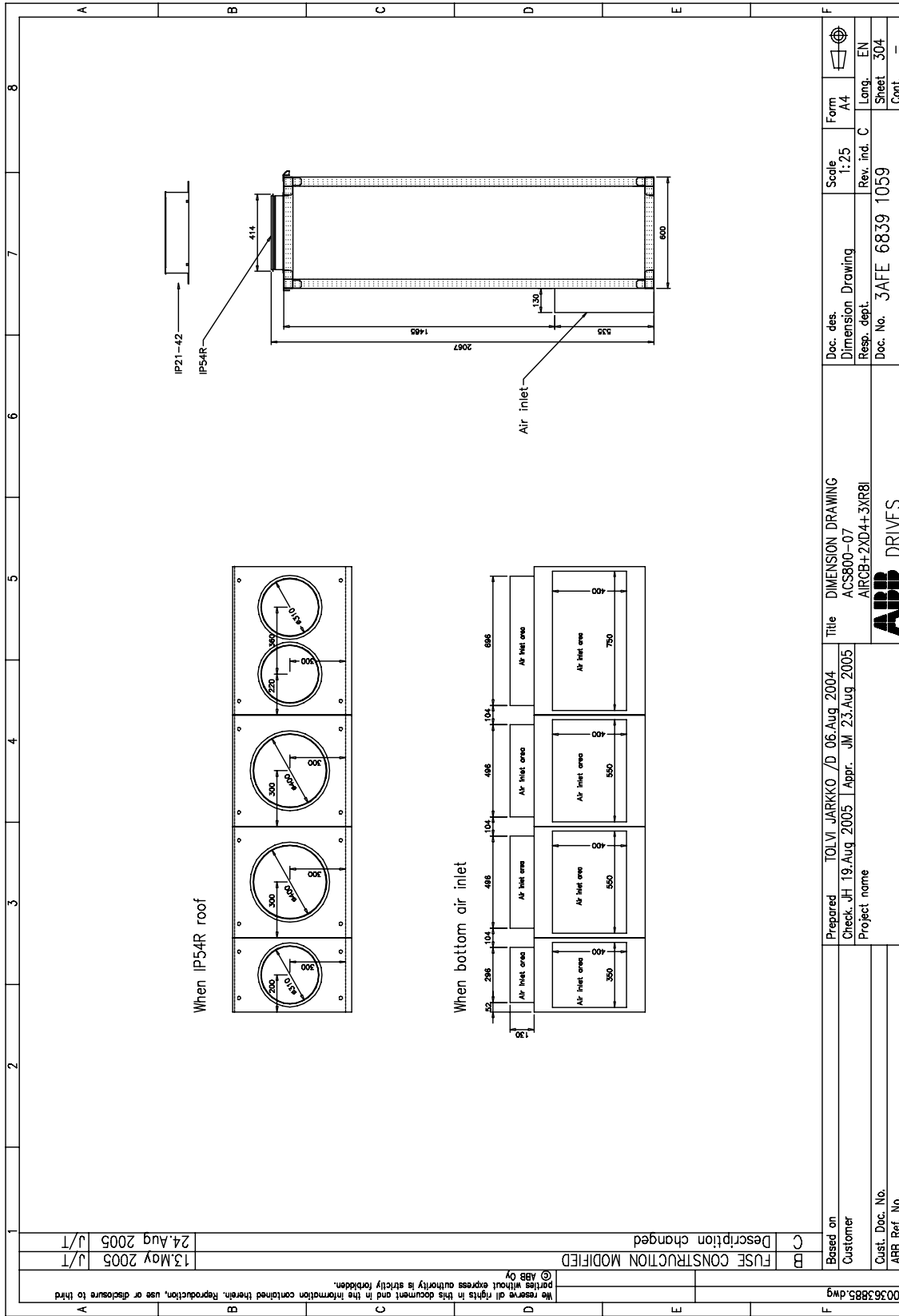

### Frame size 3xD4 + 4xR8i (with a main switch-disconnector +F253)

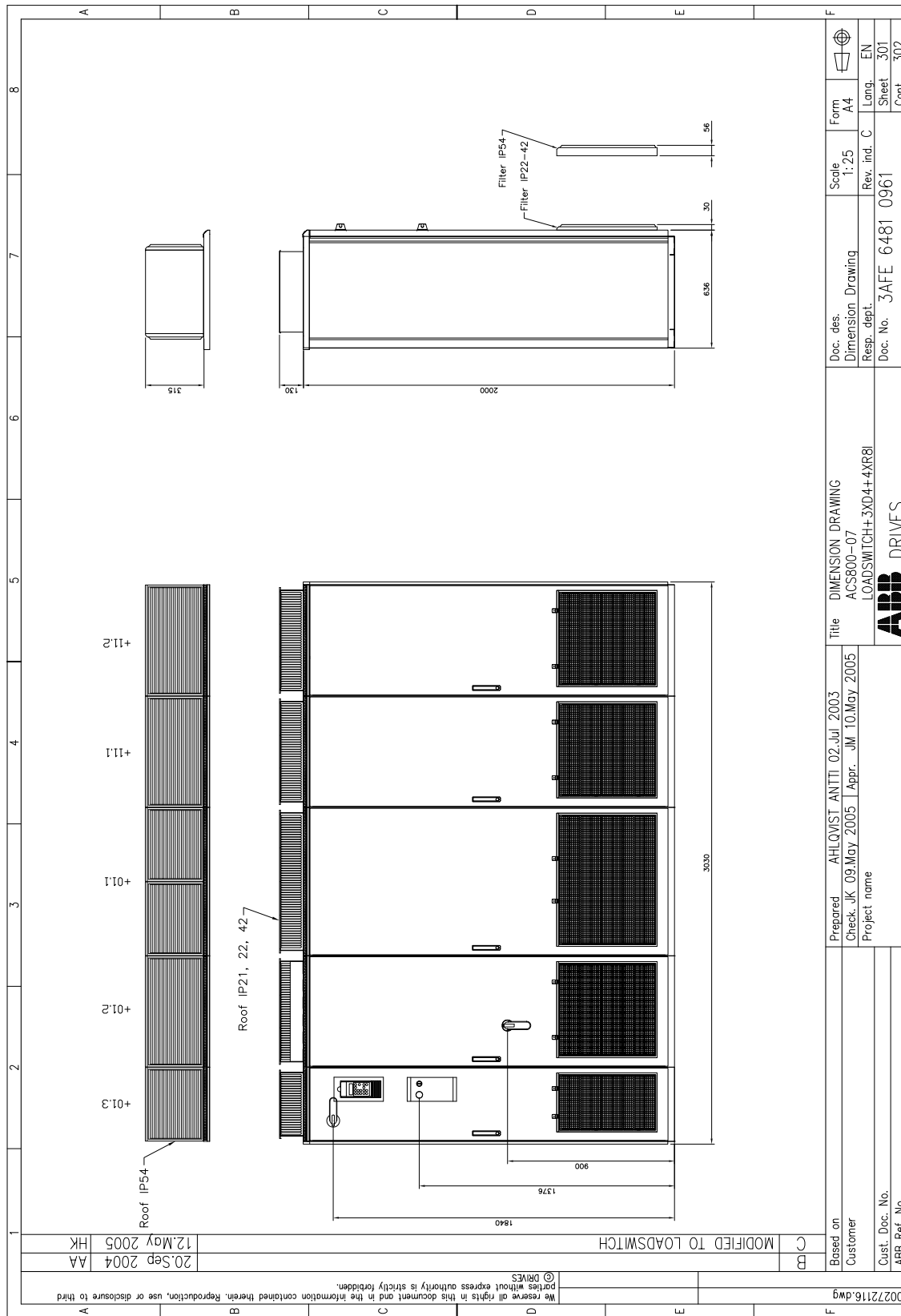

Frame size 3xD4 + 4xR8i (with +F253) (continued)

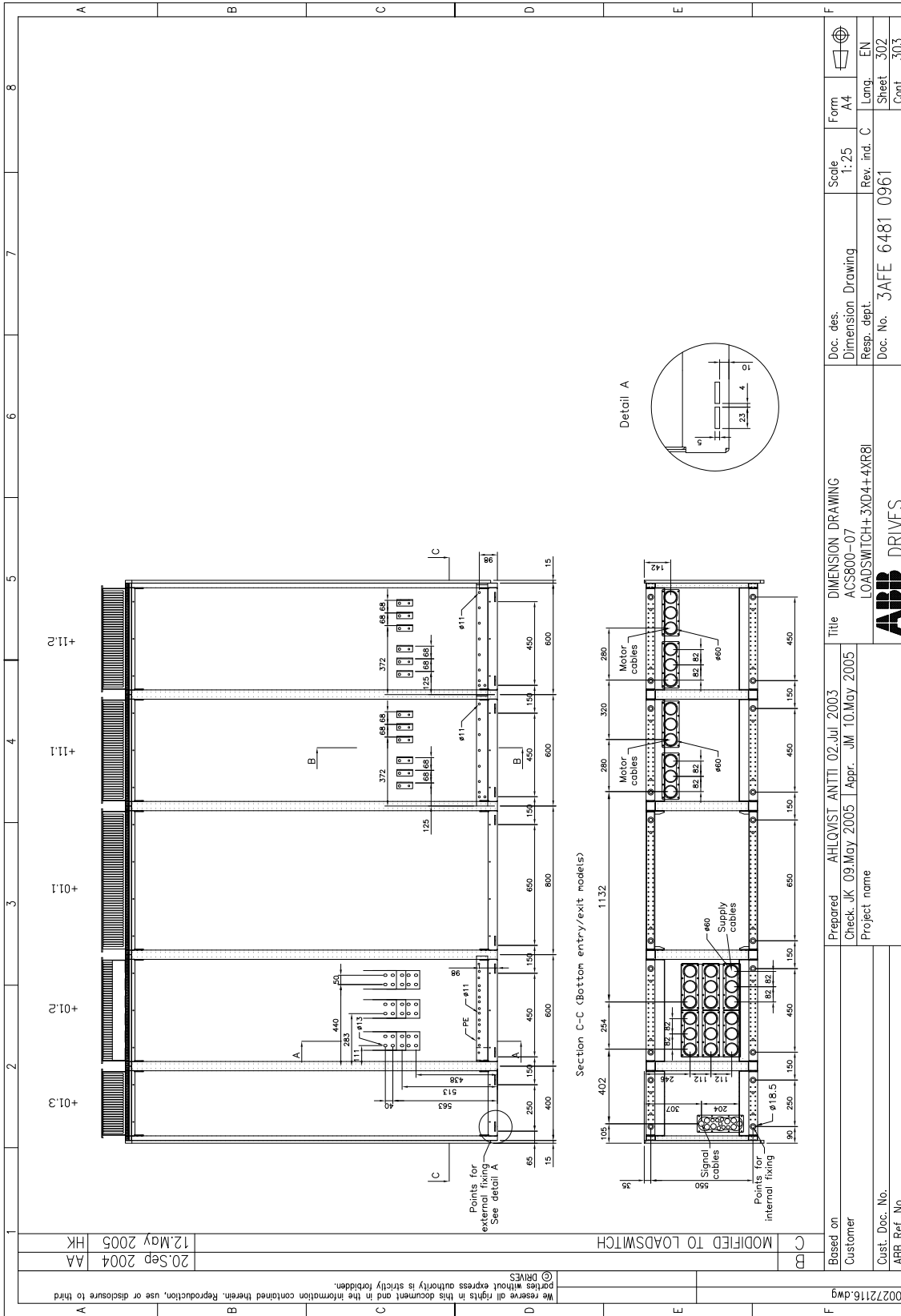



Frame size 3xD4 + 4xR8i (with +F253) (continued)

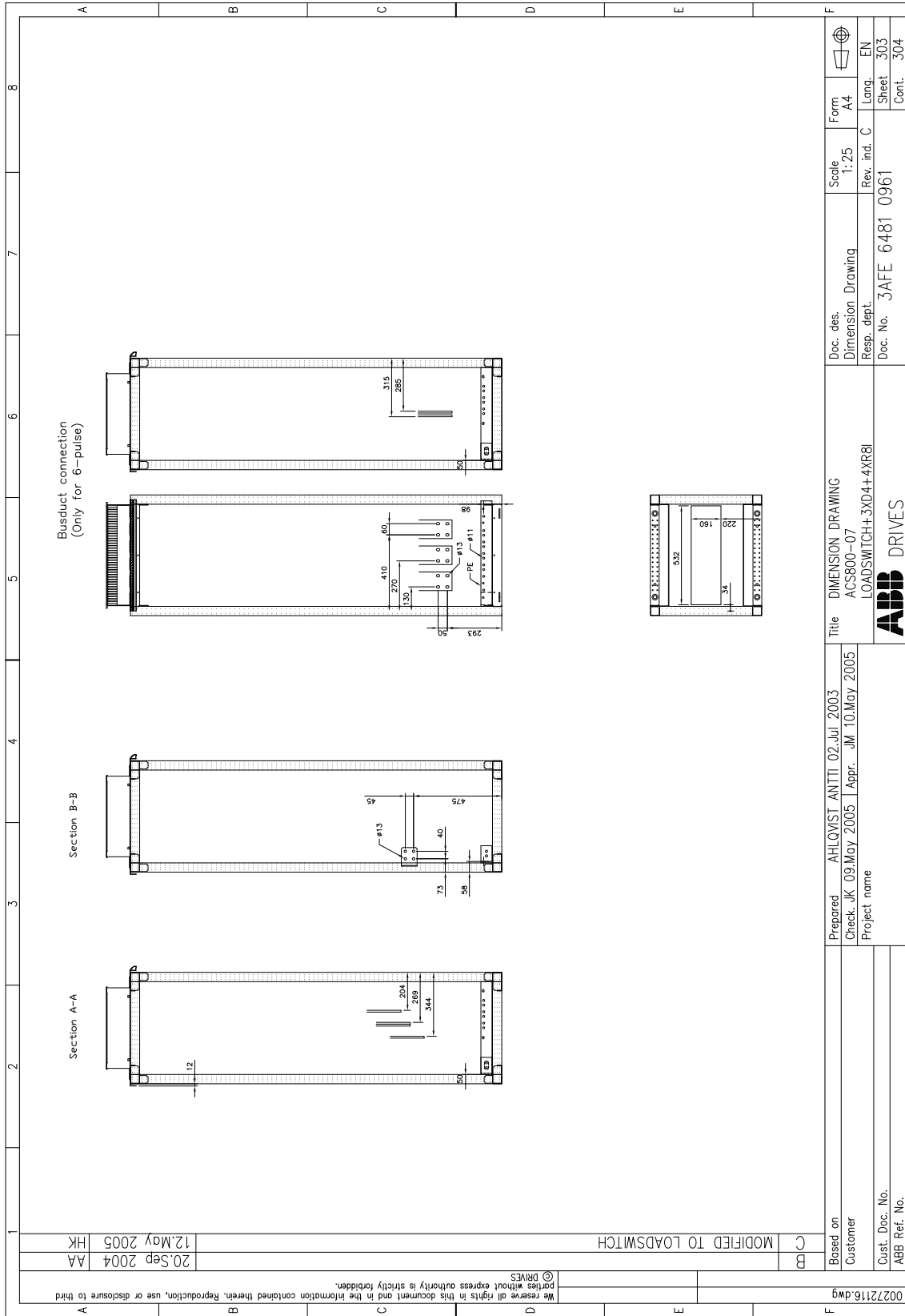

Frame size 3×D4 + 4×R8i (with +F253) (continued)

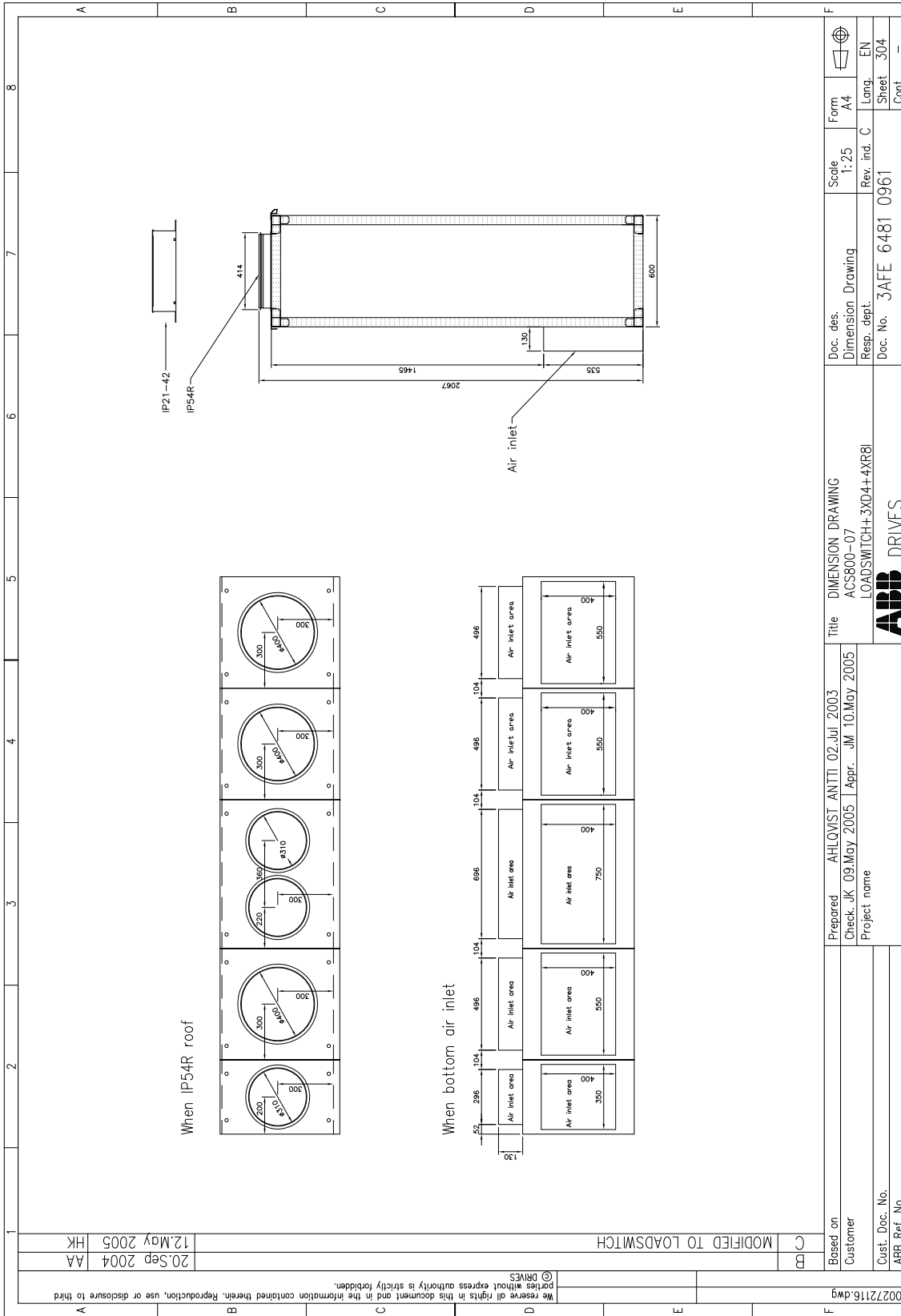

### Frame size 3xD4 + 4xR8i (with a main breaker +F255)

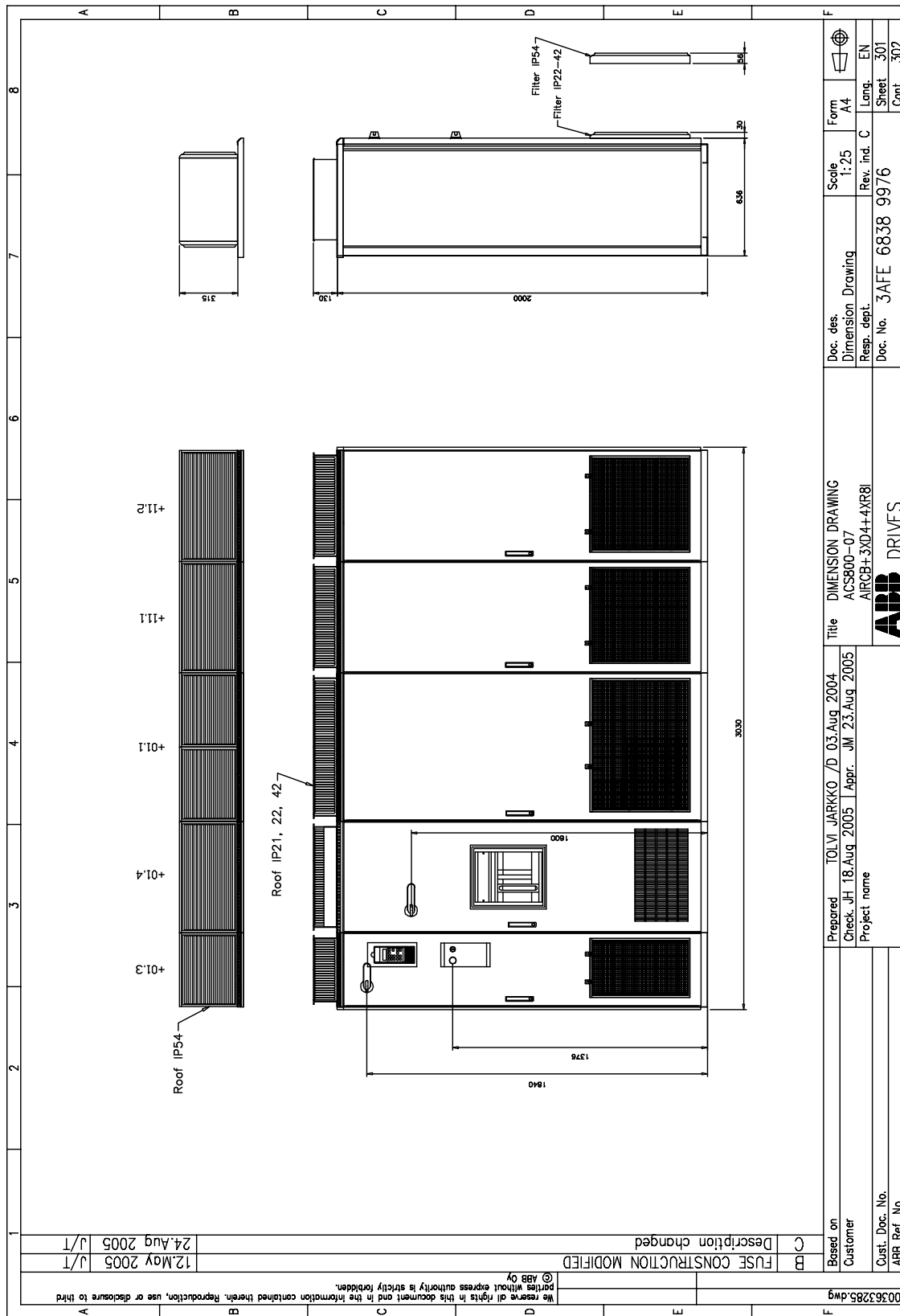

Frame size 3×D4 + 4×R8i (with +F255) (continued)

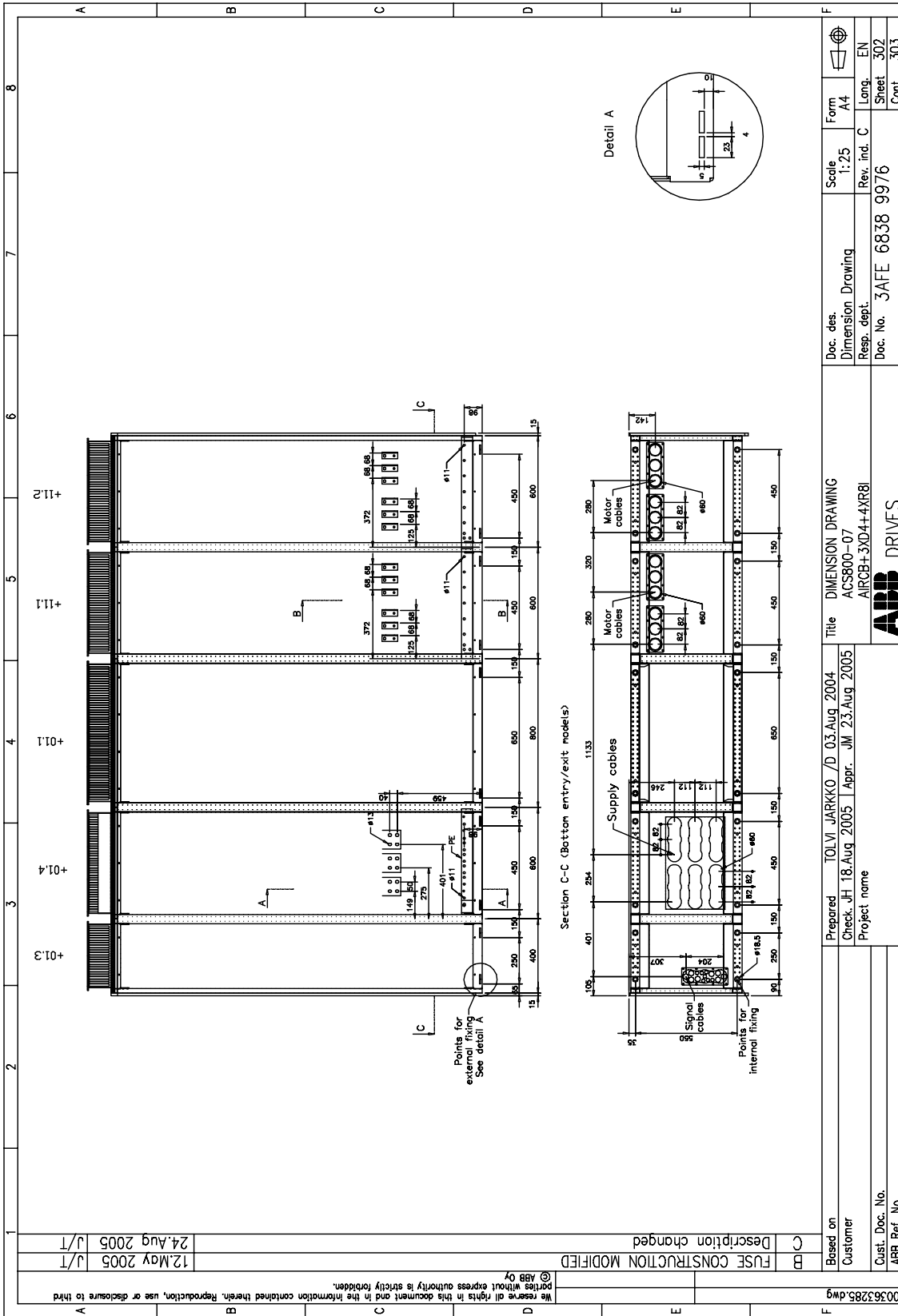

00363285.dwg		FUSE CONSTRUCTION MODIFIED		© ABB Oy		We reserve all rights in this document and in the information contained therein. Reproduction, use or disclosure to third parties without express authority is strictly forbidden.	
CD	Description changed	12.May 2005	J/T				
C		24.Aug 2005	J/T				
Based on Customer		Prepared TOLVI JARKKO /D 03.Aug 2004		Title DIMENSION DRAWING			
Cust. Doc. No. ABB Ref. No.		Check JH 18.Aug 2005		ACS800-07		Dimension Drawing	
		Apr. JM 23.Aug 2005		AIRCB+3XD4+4XR8I		Resp. dept.	
		Project name		ABB DRIVES		Doc. No. 3AFE 6838 9976	
				Scale 1:25		Form A4	
				Rev. ind. C		Lang. EN	
				Rev. ind. C		Sheet 302	
				Rev. ind. C		Cont. 303	

Frame size 3×D4 + 4×R8i (with +F255) (continued)

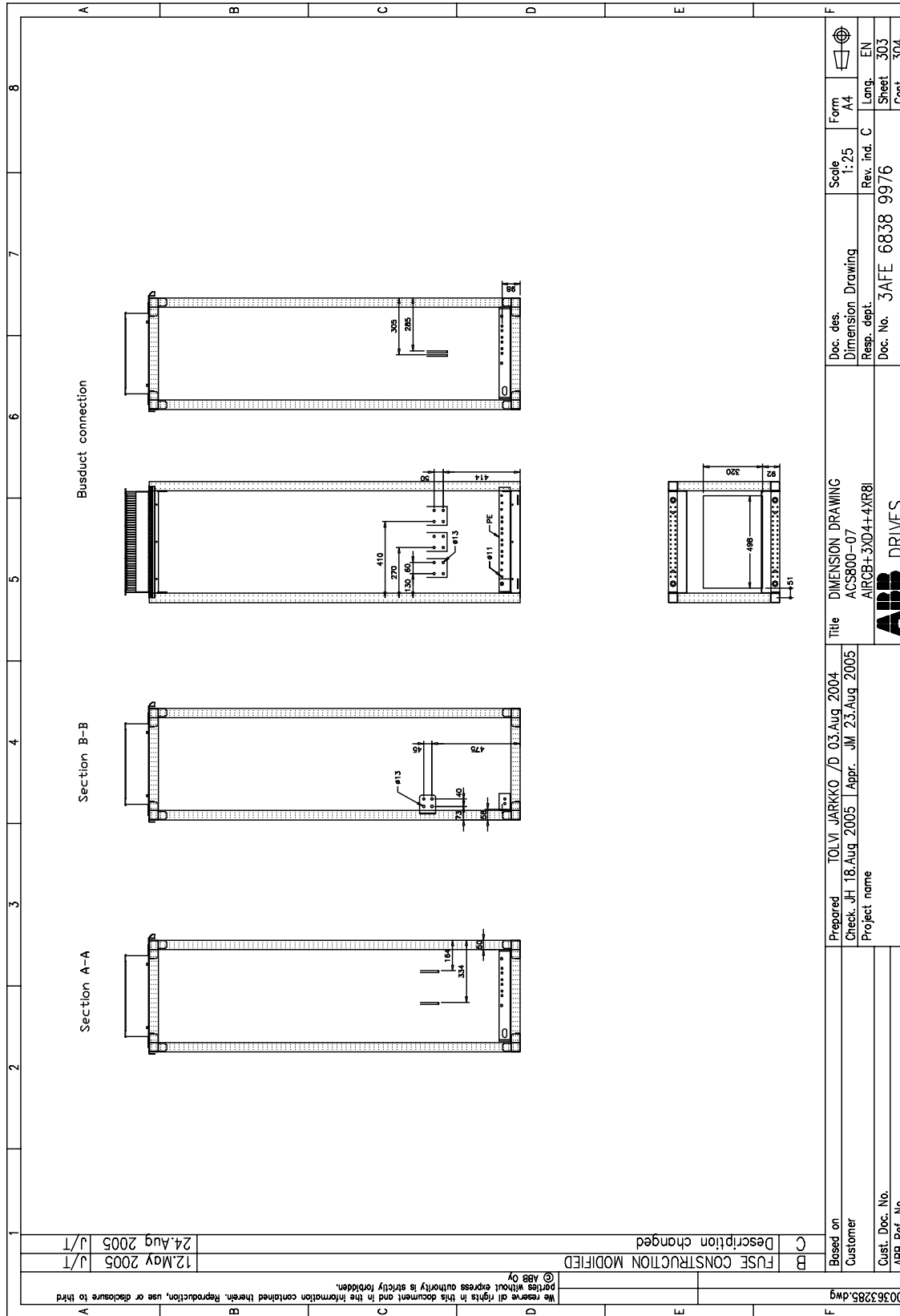

Frame size 3×D4 + 4×R8i (with +F255) (continued)

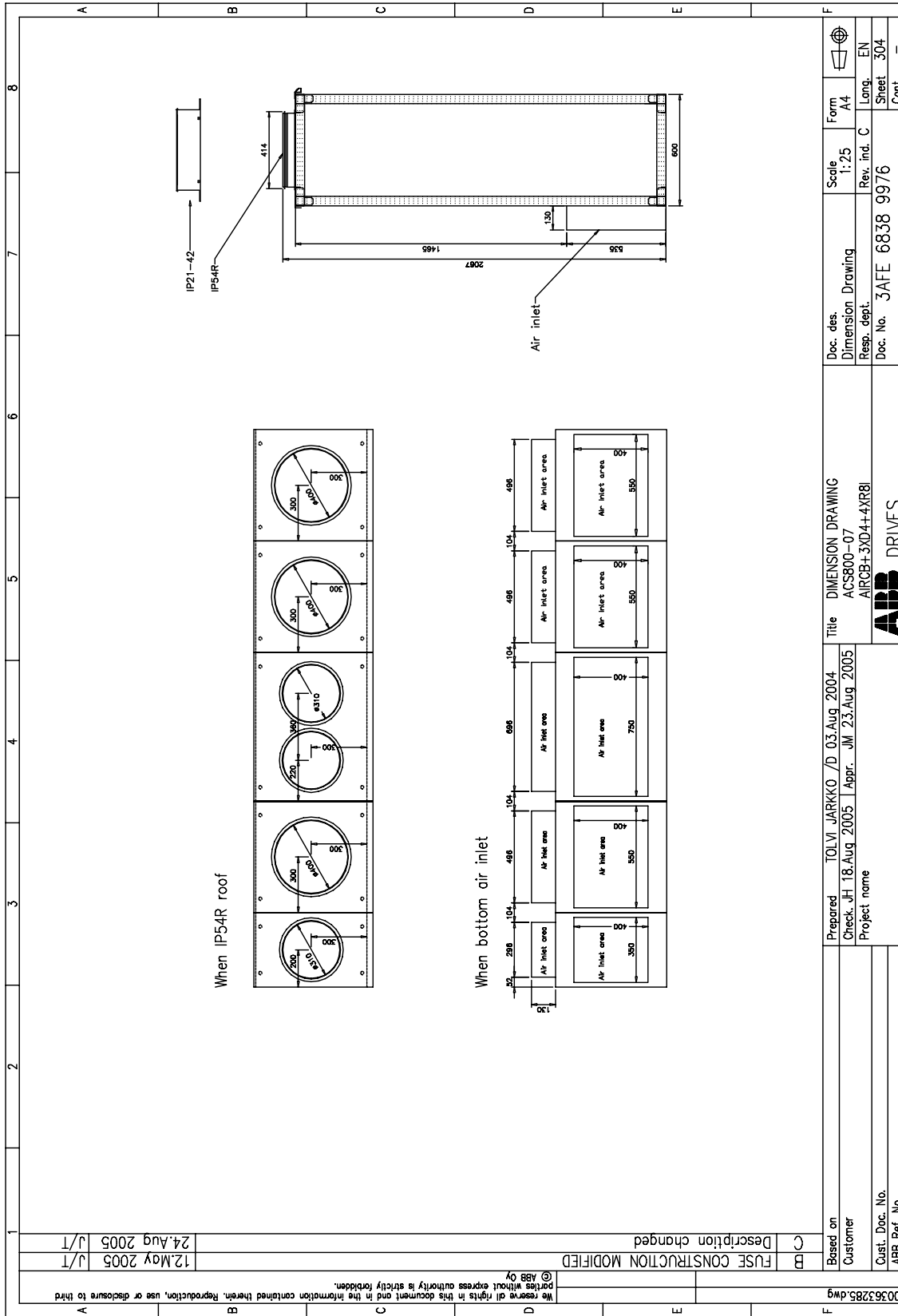

# Common motor terminal cubicle

Depending on the drive size, the common motor terminal cubicle is either 300, 400 or 600 mm wide. Refer to the cabinet line-up tables at the beginning of this chapter.  
300 mm

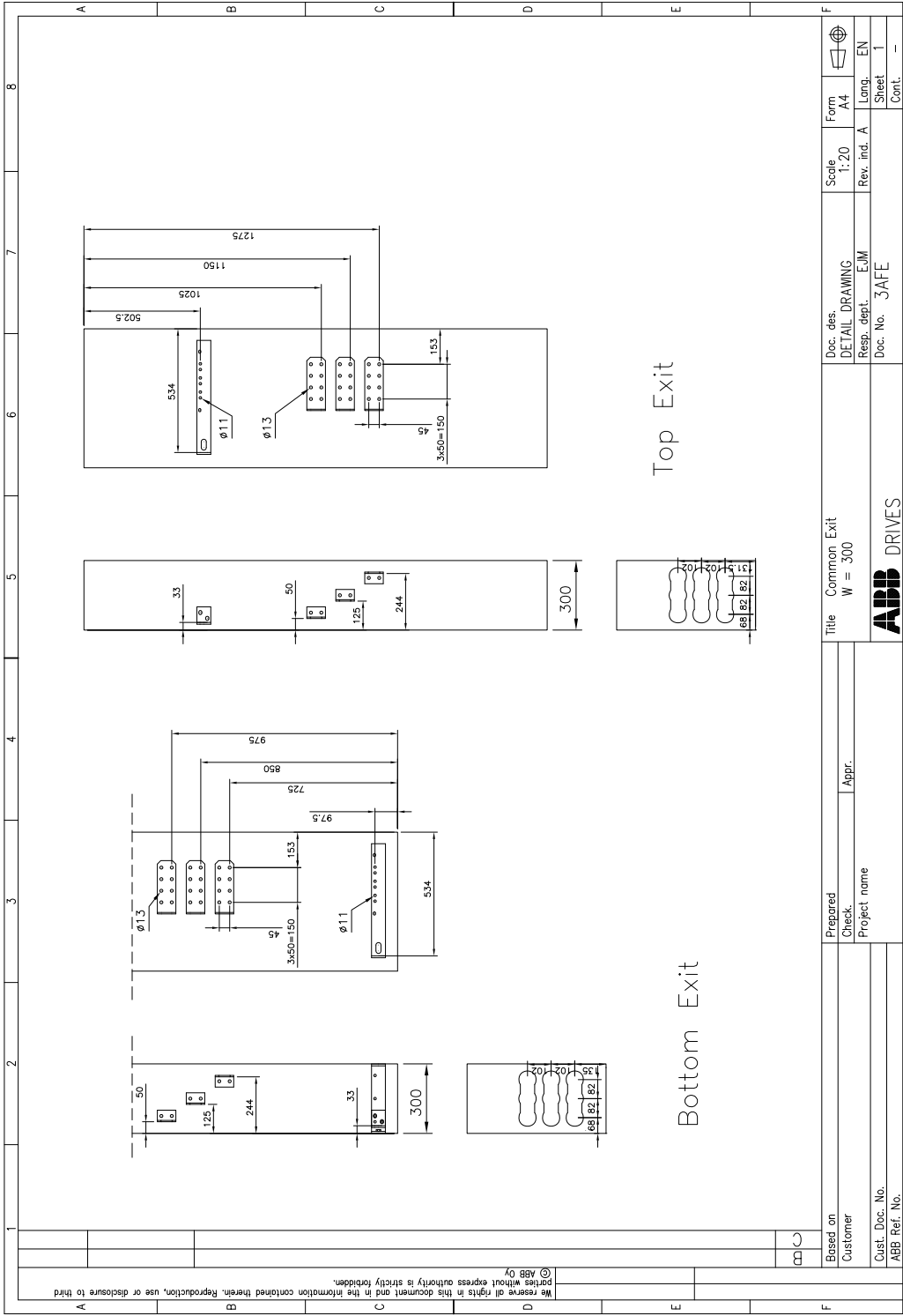

400 mm

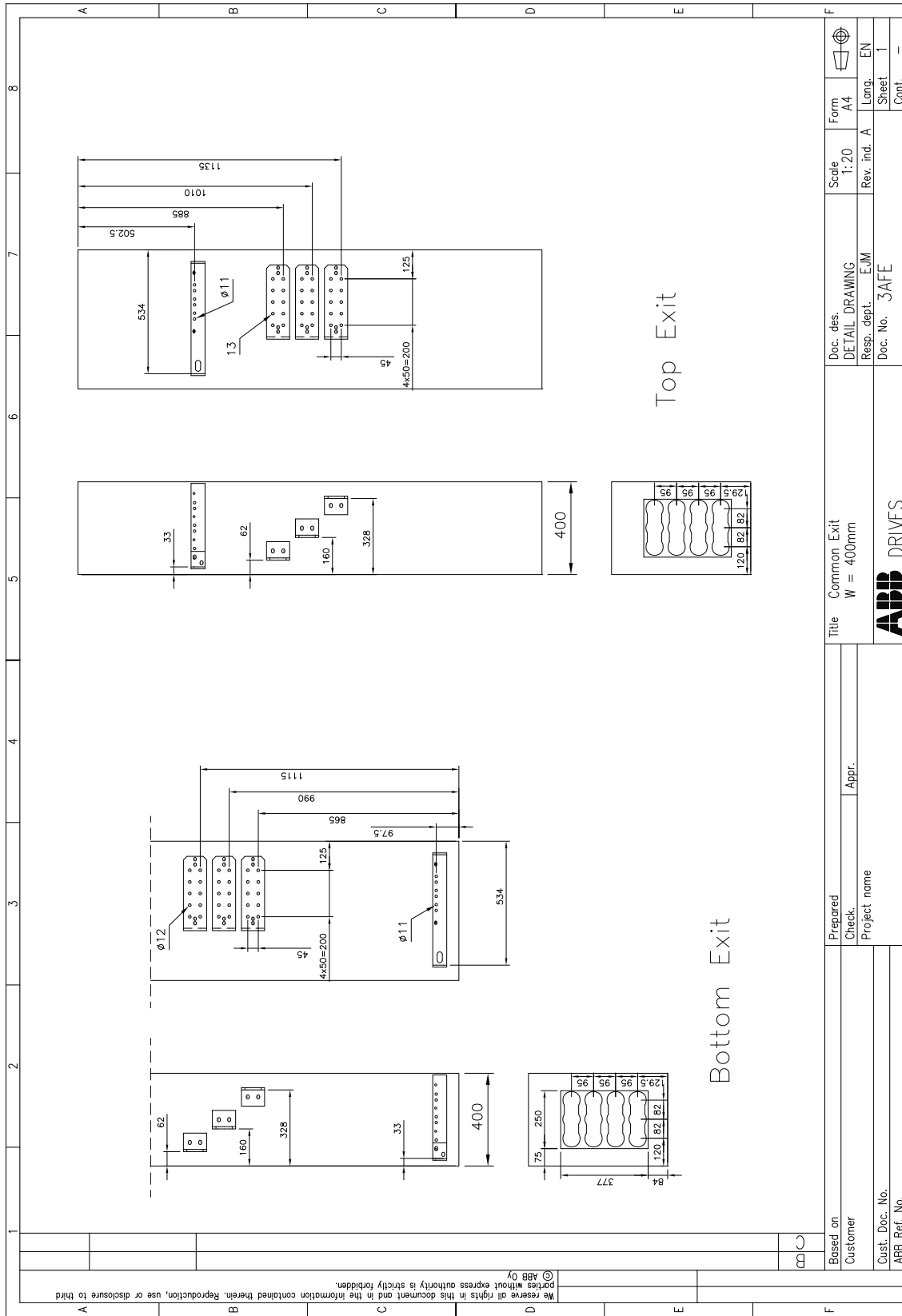

We reserve all rights in this document and in the information contained therein. Reproduction, use or disclosure to third parties without express authority is strictly forbidden.  
 © ABB Oy

Based on	Prepared	Title	Scale	Form
Customer	Check	Common Exit W = 400mm	1:20	A4
Cust. Doc. No.	Project name	Doc. des. DETAIL DRAWING	Rev. ind. A	Lang. EN
ABB Ref. No.	Appr.	Resp. dept. EJM	Doc. No. 3AFE	Sheet 1
		<b>ABB</b> DRIVES		Cont. —



600 mm

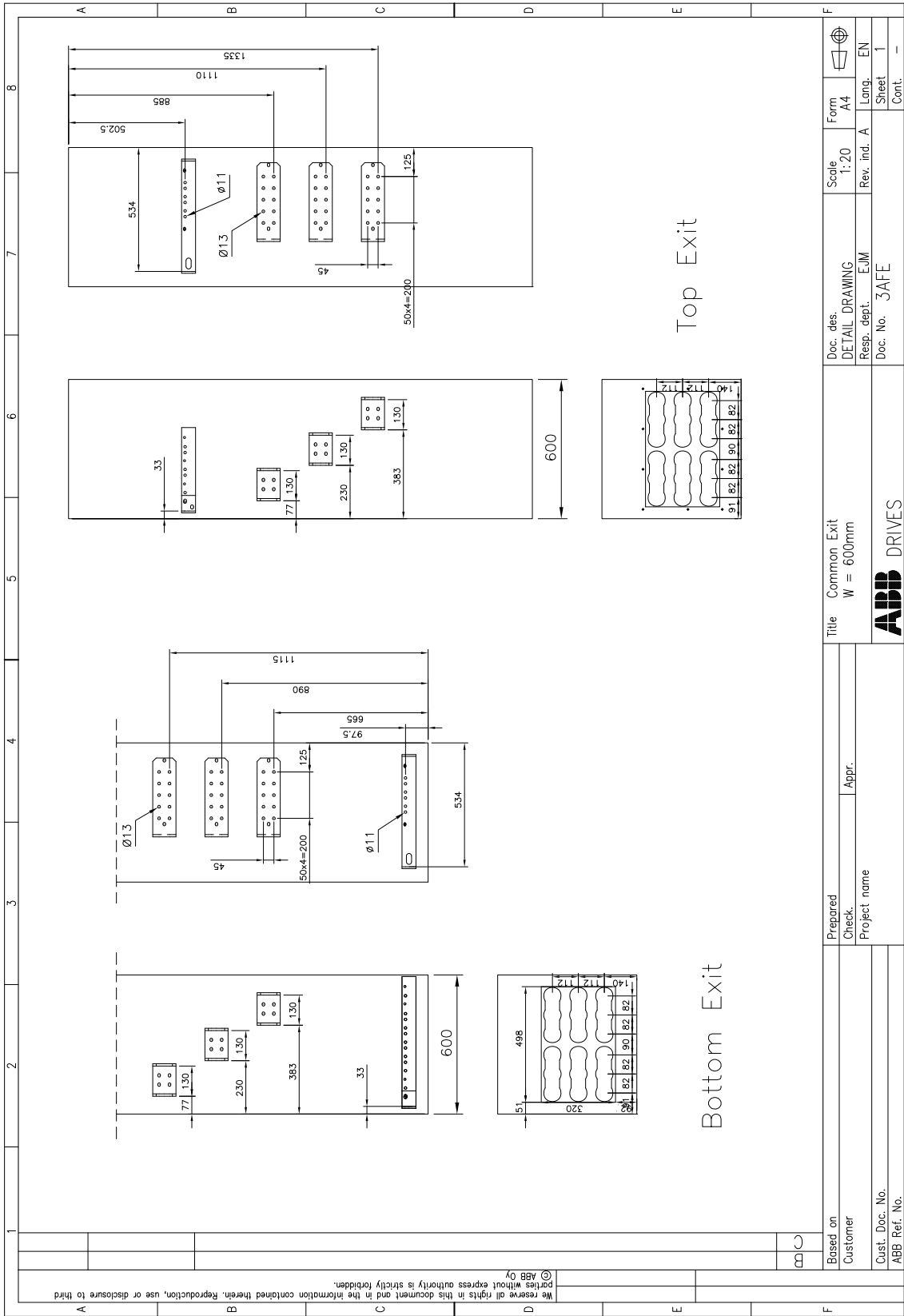

Based on Customer	Prepared Check	Title Common Exit W = 600mm		Doc. des DETAIL DRAWING	Scale 1:20	Form A4	Sheet 1
Cust. Doc. No. ABB Ref. No.	Project name	APPR.		Resp. dept. EJM	Rev. ind. A	Lang. EN	Cont.
		ABB DRIVES		Doc. No. 3AFE			

We reserve all rights in this document and in the information contained therein. Reproduction, use or disclosure to third parties without express authority is strictly forbidden.  
© ABB Oy



# Resistor braking

---

## What this chapter contains

This chapter describes the resistor braking options of the ACS800-07 (+V992).

## Resistor braking options

The following ACS800-07 (+V992) (>500 kW) drives are available with brake choppers and resistors.

$U_N$	ACS800-07 (+V992) type	Brake chopper type (+D150)	Brake resistor type (+D151)
400 V	ACS800-07-0610-3	2 × NBRA-659	2 × (2 × SAFUR180F460)
	ACS800-07-0770-3	2 × NBRA-659	2 × (2 × SAFUR180F460)
	ACS800-07-0870-3	3 × NBRA-659	3 × (2 × SAFUR180F460)
	ACS800-07-1030-3	3 × NBRA-659	3 × (2 × SAFUR180F460)
500 V	ACS800-07-0760-5	2 × NBRA-659	2 × (2 × SAFUR200F500)
	ACS800-07-0910-5	2 × NBRA-659	2 × (2 × SAFUR200F500)
	ACS800-07-1090-5	3 × NBRA-659	3 × (2 × SAFUR200F500)
	ACS800-07-1210-5	3 × NBRA-659	3 × (2 × SAFUR200F500)
690 V	ACS800-07-0750-7	2 × NBRA-669	2 × (2 × SAFUR200F500)
	ACS800-07-0870-7	2 × NBRA-669	2 × (2 × SAFUR200F500)
	ACS800-07-1060-7	3 × NBRA-669	3 × (2 × SAFUR200F500)
	ACS800-07-1160-7	3 × NBRA-669	3 × (2 × SAFUR200F500)

### Chopper/Resistor combinations – Technical data

The following table contains the technical data of some chopper/resistor combinations.

$U_N$	Chopper(s)	Resistors	$R$ (ohm)	$P_{brmax}$ (kW)	$P_{cont}$ (kW)	$I_{max}$ (A)	Duty Cycle (10/60 s)		Duty Cycle (1/5 min)	
							$P_{br}$ (kW)	$I_{rms}$ (A)	$P_{br}$ (kW)	$I_{rms}$ (A)
400 V	1 × NBRA-659	2 × SAFUR180F460	1.2	353	54	545	287	444	167	257
	2 × NBRA-659	2 × (2 × SAFUR180F460)	1.2	706	108	1090	575	888	333	514
	3 × NBRA-659	3 × (2 × SAFUR180F460)	1.2	1058	162	1635	862	1332	500	771
500 V	1 × NBRA-659	2 × SAFUR200F500	1.35	403	54	605	287	355	167	206
	2 × NBRA-659	2 × (2 × SAFUR200F500)	1.35	806	108	1210	575	710	333	412
	3 × NBRA-659	3 × (2 × SAFUR200F500)	1.35	1208	162	1815	862	1065	500	618
690 V	1 × NBRA-669	2 × SAFUR200F500	1.35	404	54	835	287	257	167	149
	2 × NBRA-669	2 × (2 × SAFUR200F500)	1.35	807	108	1670	575	514	333	298
	3 × NBRA-669	3 × (2 × SAFUR200F500)	1.35	1211	162	2505	862	771	500	447

$U_N$  = Nominal voltage

$R$  = Resistance of specified resistors (per chopper)

$P_{brmax}$  = Maximum short-term (1 min every 10 mins) braking power

$P_{cont}$  = Maximum continuous braking power

$I_{max}$  = Maximum peak current

$P_{br}$  = Braking power for the specified duty cycle

$I_{rms}$  = Corresponding rms current

### Brake resistors – Technical data

The following table contains the technical data for the resistors supplied by ABB.

Type	$U_N$ (V)	$R$ (ohm)	$E_R$ (kJ)	$P_{Rcont}$ (kW)
SAFUR125F500	500	4.0	3600	9.0
SAFUR210F575	575	3.4	4200	10.5
SAFUR200F500	500	2.7	5400	13.5
SAFUR180F460	460	2.4	6000	15.0

$U_N$  Nominal voltage

$R$  Resistance

$E_R$  Short energy pulse that the resistor assembly will withstand each 400 seconds

$P_{Rcont}$  Continuous power (heat) dissipation of the resistor when placed correctly. Energy  $E_R$  dissipates in 400 seconds.

## Verifying the capacity of the braking equipment

1. Calculate the maximum power ( $P_{\max}$ ) generated by the motor during braking.
2. Ensure the following condition is met:

$$P_{\text{brmax}} \geq P_{\max}$$

The  $P_{\text{brmax}}$  values specified in the technical data table above are for the reference braking cycle (1 minute of braking, 9 minutes of rest).

If the actual duty cycle does not correspond to the reference cycle, the maximum allowed braking power  $P_{\text{br}}$  must be used instead. In the technical data table,  $P_{\text{br}}$  is given for two additional braking cycles. See below for directions for calculating  $P_{\text{br}}$  for other braking cycles.

3. Check the resistors selection. The energy generated by the motor during a 400-second period must not exceed the heat dissipation capacity  $E_R$ .  
If the  $E_R$  value is not sufficient, it is possible to use a four-resistor assembly in which two standard resistors are connected in parallel, two in series. The  $E_R$  value of the four-resistor assembly is four times the value specified for the standard resistor.

### Custom resistors

Resistors other than the standard resistors can be used provided that:

- the resistance is not lower than with the standard resistors



**WARNING!** Never use a brake resistor with a resistance below the value specified for the particular drive / brake chopper / resistor combination. The drive and the chopper are not able to handle the overcurrent caused by the low resistance.

- the resistance does not restrict the braking capacity needed, ie,

$$P_{\max} < \frac{U_{\text{DC}}^2}{R}$$

where

$P_{\max}$	maximum power generated by the motor during braking
$U_{\text{DC}}$	voltage over the resistor during braking, for example, 1.35 · 1.2 · 415 VDC (when supply voltage is 380 to 415 VAC), 1.35 · 1.2 · 500 VDC. (when supply voltage is 440 to 500 VAC) or 1.35 · 1.2 · 690 VDC (when supply voltage is 525 to 690 VAC).
$R$	resistor resistance (ohm)

- the heat dissipation capacity ( $E_R$ ) of the resistors is sufficient for the application (see step 3 above).

### Calculating the maximum braking power ( $P_{br}$ )

- Braking energy transferred during any ten minute period must be less than or equal to the energy transferred during the reference braking cycle.
- The braking power must not exceed the rated maximum value  $P_{brmax}$ .

$$\underline{1.} \quad n \times P_{br} \times t_{br} \leq P_{brmax} \times 60 \text{ s}$$

$$\underline{2.} \quad P_{br} \leq P_{brmax}$$

$n$  = Number of braking pulses during a ten minute period

$P_{br}$  = Maximum allowed braking power (kW).

$t_{br}$  = Braking time (s)

$P_{brmax}$  = Maximum Braking Power for a reference cycle (kW)

#### Example 1

Duration of a braking cycle is 30 minutes. The braking time is 15 minutes.

**Result:** If the braking time exceeds 10 minutes, the braking is considered continuous. The allowed continuous braking power is 10% of the Maximum Braking Power ( $P_{brmax}$ ).

#### Example 2

Duration of a braking cycle is three minutes. The braking time is 40 seconds.

$$\underline{1.} \quad P_{br} \leq \frac{P_{brmax} \times 60 \text{ s}}{4 \times 40 \text{ s}} = 0.375 \times P_{brmax}$$

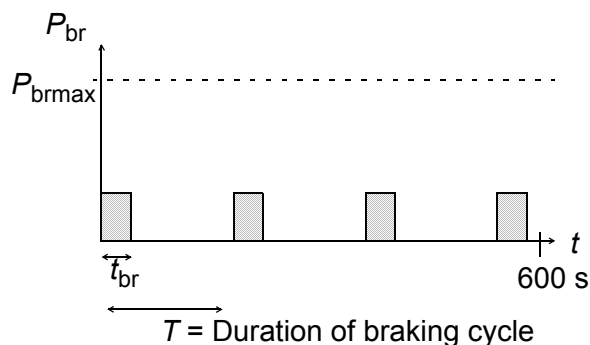

$$\underline{2.} \quad P_{br} < P_{brmax} \quad \text{O.K.}$$

**Result:** The maximum allowed braking power for the cycle is 37% of the rated value given for the reference cycle.

**Example 3**

Duration of a braking cycle is three minutes. The braking time is 10 seconds.

$$\underline{1.} \quad P_{br} \leq \frac{P_{brmax} \times 60 \text{ s}}{4 \times 10 \text{ s}} = 1.5 \cdot P_{brmax}$$

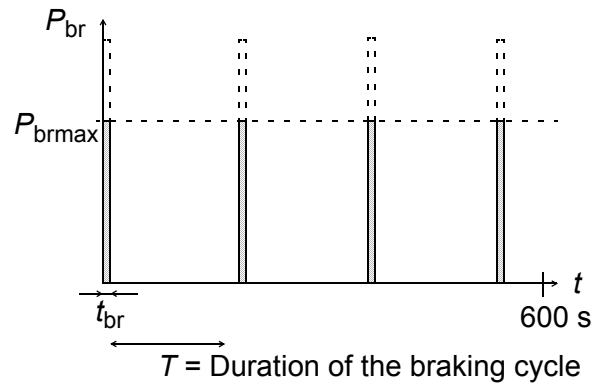

$$\underline{2.} \quad P_{br} > P_{brmax} \quad \text{Not allowed.}$$

**Result:** The maximum allowed braking power for the cycle is equal to the Maximum Braking Power ( $P_{brmax}$ ) given for the reference cycle.

## Custom resistor installation and wiring

Effective cooling of the resistors must be ensured.



**WARNING!** All materials near the brake resistors must be non-flammable. The surface temperature of the resistors is high. The temperature of the air rising from the resistors is hundreds of degrees Celsius. Protect the resistors against contact.

For a resistor cable, use a shielded cable. The maximum length of the resistor cable is 50 m (164 ft).

A recommended copper cable size for connecting the user-defined resistor to the brake unit is as follows:

- 400 V brake unit: 3 x 95 mm<sup>2</sup> + 50 mm<sup>2</sup>
- 500 V brake unit: 3 x 95 mm<sup>2</sup> + 50 mm<sup>2</sup>
- 690 V brake unit: 3 x 120 mm<sup>2</sup> + 70 mm<sup>2</sup>

For protection against overheating, resistors with thermal circuit breakers (standard in ABB resistors) should be used. The circuit breakers should be wired to the ENABLE inputs of the brake choppers.



**WARNING!** The ENABLE input terminal blocks of the choppers are at intermediate circuit potential when the supply unit of the ACS800-07 (+V992) drive is running. This voltage is extremely dangerous and may cause serious damage or injuries if the isolation level and protection conditions for the thermal circuit breakers are not sufficient. The normally-closed breakers should always be properly isolated (over 2.5 kV) and shrouded against contact.

**Note:** For the ENABLE input wiring, use a cable rated as follows:

- twisted pair (screened type recommended)
- rated operating voltage between a core and earth ( $U_0$ ):  $\geq 750$  V
- insulation test voltage  $> 2.5$  kV.



The following is a wiring diagram example of the resistor connection.

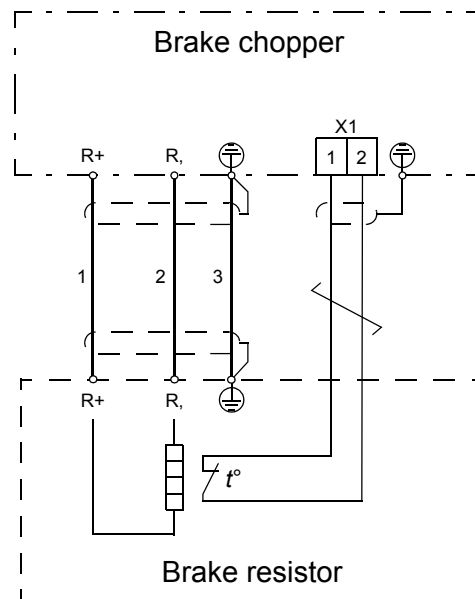

## Brake circuit commissioning

In the drive control program, overvoltage control of the drive must be disabled for correct operation of the brake chopper. Check the drive parameter setting at the start up.

**Note:** Some brake resistors are coated with oil film for protection. At the start-up, the coating burns off and produces a little bit of smoke. Ensure proper ventilation at the start-up.



## Further information

### Product and service inquiries

Address any inquiries about the product to your local ABB representative, quoting the type designation and serial number of the unit in question. A listing of ABB sales, support and service contacts can be found by navigating to [www.abb.com/drives](http://www.abb.com/drives) and selecting *Sales, Support and Service network*.

### Product training

For information on ABB product training, navigate to [www.abb.com/drives](http://www.abb.com/drives) and select *Training courses*.

### Providing feedback on ABB Drives manuals

Your comments on our manuals are welcome. Go to [www.abb.com/drives](http://www.abb.com/drives) and select *Document Library – Manuals feedback form (LV AC drives)*.

### Document library on the Internet

You can find manuals and other product documents in PDF format on the Internet. Go to [www.abb.com/drives](http://www.abb.com/drives) and select *Document Library*. You can browse the library or enter selection criteria, for example a document code, in the search field.

# Contact us

[www.abb.com/drives](http://www.abb.com/drives)

[www.abb.com/drivespartners](http://www.abb.com/drivespartners)

3AJUA0000068936 Rev C (EN) 2013-02-07