

**TPU2000//2000R MODBUS/MODBUS PLUS
AUTOMATION TECHNICAL GUIDE**

TG 7.11.1.7-61

Version 1.0

12/01

Contents

Section 1 – Introduction

Introduction 1

Section 2 – Communication Card Identification and Physical Port Characteristics

Communication Identification and Physical Port Characteristics..... 3
Communication Card Part Number Options 5
Unit Communication Card Verification 8

Section 3 – TPU2000 and TPU2000R Device Connectivity

TPU2000 and TPU2000R Device Connectivity 10
RS232 Interface Connectivity 10
Port Isolation 10
RS232 Handshaking Defined..... 11
RS232 Cable Connectivity 11
RS485 Device Connectivity with the TPU2000 and TPU2000R..... 13

Section 4 – TPU2000 and TPU2000R Device Parameterization

TPU2000 and TPU2000R Device Parameterization 17
COM 0 Port (Front Port Configuration) 17
COM Port 1 Option Settings (TPU2000R Only) [Catalog 588XXX00-XXX0 or 588XXX50-XXX0] 19
COM Port 2 Option Settings (TPU2000R Only) [Catalog 588XXX00-XXX0 or 588XXX6-XXX4] 20
COM Port 3 and AUX COM Configuration 21
Modbus Protocol Selection and Configuration for Port 3 and AUX COM 22
Modbus Plus Port Configuration [COM 3 on Selected Units] (TPU2000R Only)..... 24
IRIG B Configuration and Wiring..... 24
Hardware Configuration 27
Software Configuration..... 29

Section 5 – Modbus

Modbus Protocol..... 30
Modbus ASCII Emulation 30
Modbus RTU Emulation..... 32
Modbus Plus (Available on the TPU2000R Only) 33
Modbus Plus Theory of Operation..... 33
Modbus and Modbus Plus General Notes..... 37
Modbus/Modbus Plus Register Map..... 37
0X Discrete Coils..... 37
Function Code 1 (Read Coil Status) – Read Only Data..... 38
Modbus 0X Implementation Features 39
Logical Output Block (Single Bit Data) – 108 Discrete Coils (99 Elements Defined for 2 Winding TPU, 176 Elements Defined for 3 Winding TPU) 41
Physical Output Block (Single Bit Data) – 16 Discrete Coils (8 Elements Defined)..... 50
Logical Output Block (Two Bit Data with Momentary Change Detection)..... 50
Physical Output Block (Two Bit Data with Momentary Change Detection): Not available on TPU2000 54
1X Discrete Contact Inputs..... 55
Function Code 2 – Read Input Status (Read Only Data)..... 55
Logical Inputs (34 Elements Defined 2 Winding TPU2000/2000R – 80 Elements Defined 3 Winding TPU2000/2000R)..... 57
Physical Inputs (16 Elements Defined) 59
Momentary Change Detect Logical Inputs (68 Elements Defined 2 Winding TPU – 160 Elements Defined 3 Winding TPU)..... 59
Physical Input Momentary Change Detect (32 Elements Defined)..... 63
4X Register Read Capabilities 64

TPU2000/2000R Modbus/Modbus Plus Automation Guide

Function Code 03 – Read Holding Registers (Read Only)	66
Register Scaling and Re-Mapping and User Definable (UDR) Configuraton Process.....	66
TPU2000 and TPU2000R Internal Operation.....	67
ABB Data Type Definitions	68
Register Scaling Investigated	69
Scaling Option and Destination Register Length Options Explained	70
Destination Register Length Justification Options Explained	73
Source Register Address and Source Register Type Explained	73
Source Scale Range and Source Scale Type Selections Explained.....	73
TPU2000 and TPU2000R User Definable Register Defaults.....	75
Relay Status (1 Register Defined).....	78
Diagnostic Status (2 Registers Defined).....	79
Unit Information (15 Registers Defined).....	80
Read Quick Status (3 Registers Defined)	81
Power Fail Status Information (9 Registers Defined)	82
Fast Status (2 Registers Defined)	82
Communication Event Log (8 Registers Defined)	83
Metering Values (35 Registers Defined).....	84
Load Current and Angular Values (63 Registers Defined TPU 2 Winding– 66 Registers Defined TPU 3 Winding)	85
RMS Voltage/Angular/Real and Reactive Power/Energy Values Block (17 Registers Defined)	87
RMS Demand Current/Real and Reactive Power Values Block (24 Registers Defined).....	88
Minimum and Maximum Peak Demand (60 Registers Defined).....	89
Breaker Counters (11 Registers Defined) Modbus Function 03 Read Only	96
Discrete 4X Register Bit Data Reporting (26 Registers Defined).....	97
4X Register Write Capabilities	106
Function Code 16 Preset 4X Registers (Write Only).....	107
Function Code 23 Read/Write Register (Read/Write Concurrently).....	108
Fault Records	108
Differential Fault Record Reporting	110
Through Fault Buffers	114
Harmonic Restraint Fault Record	118
Event Records (11 Registers Defined).....	123
Providing Control Functionality in the TPU2000/2000R.....	126
Group I Control Features Explained.....	129
Scada Redi	130
Group II Control Features Explained.....	132
Group III Control Features Explained	136
Group IV Control Features Explained.....	139
Group V Control Features Explained.....	145
Group VI Control Features Explained.....	149
Oscillographic Data Storage (Version 1.5 and Greater TPU2000R Only).....	151
Oscillographic Configuration (12 Registers Defined).....	152
Oscillographic Data Retrieval.....	155
Data Retrieval Theory of Operation.....	155
Oscillographic Data Interpretation	164
6X Registers	165
Function Code 20 (Read General Reference) and 21 (Write General Reference).....	166
Programmable Input Configuration.....	167
Term Definitions	167
Methodology and Register Manipulation to Configure the Programmable Logical Input	168
Programmable Output Select Configuration.....	174
Programmable Output User Defined String Block.....	178
Settings	179
Configuration Settings.....	194
Counters	197
Alarm Settings	197
Real Time Clock (13 Registers Defined).....	199
ULO Connection Settings and User Names	199

TPU2000/2000R Modbus/Modbus Plus Automation Guide

ULI Connection Settings and User Names.....	201
Force Logical Input Allocation and Name Assignment	202
Modbus Plus Global Register Mapping (37 Registers Defined) TPU2000R Only	205
User Definable Register Configuration Block.....	209
Modbus ASCII Communication Test Example.....	225
Calculation of the LRC (Longitudinal Redundancy Code).....	226
Modbus CRC-16 Calculation	226
TPU2000/TPU2000R Modbus Exception Response Analysis	227
Modbus Troubleshooting Tips.....	228
TPU2000/TPU2000R Modbus ASCII Communication Timing Analysis	229
Modbus Baud Rate Analysis	230
TPU2000/TPU2000R Throughput Analysis.....	232
Final Throughput Calculation and Analysis.....	232
Modbus Plus Troubleshooting.....	234
Modbus Plus Throughput	235
Appendix A-TPU Standard 10 Byte Protocol Document.....	237
Appendix B-ASCII Conversion Table.....	328
Appendix C-Modbus Plus Communication Between an ABB Protective Relay and a Modicon PLC	331
Appendix D-Telebyte RS232/485 Converter Connection to ABB Protective Relays	338

The following are trademarks of AEG Schneider Automation Inc.

Modbus®, Modbus Plus®, Modicon®

IBM®, OS 2®, and IBM PC® are registered trademarks of International Business Machines Corporation.

The following are registered trademarks of the Microsoft Corporation:

Windows NT® Windows 3.1®

Windows 95® Windows 98®

Hyperterminal® MS-DOS®

Microsoft ®

USDATA ® is a registered trademark of the USDATA Corporation.

Tables

Section 1 – Introduction

Table 1-1. Protocol Capabilities Listed by Product Type	2
---	---

Section 2 – Communication Card Identification and Physical Port Characteristics

Table 2-1. TPU2000 Communication Options	6
Table 2-2. TPU2000 Communication Card Matrix for Unit 488MRXDZ-CSSSQ	7
Table 2-3. TPU2000R Communication Options	7
Table 2-4. TPU2000R Communication Card Matrix for Unit 588XXXYZ-XXXXQ	8
Table 2-5. TPU2000R Communication Card Matrix	8

Section 3 – TPU2000 and TPU2000R Device Connectivity

Table 3-1. Physical Interface Options	10
Table 3-2. TPU2000 AUX COM Signal Assignments	16

Section 4 – TPU2000 and TPU2000R Device Parameterization

Table 4-1. TPU2000 and TPU2000R COM Port 0 Front Panel Interface Parameters	17
Table 4-2. WinECP Communication Port Settings	19
Table 4-3. COM Port 1 and COM Port 2 WinECP Port Setting Options	19
Table 4-4. Valid Parameter Selection for Standard Ten Byte and Modbus Protocols	22

Section 5 – Modbus

Table 5-1. Logical Output Modbus Address Map Definition	41
Table 5-2. Physical Output Contact Mapping Defined	50
Table 5-3. Momentary Change Detect Data Definition	50
Table 5-4. Modbus Physical Output Momentary Change Detect Address Allocation	54
Table 5-5. Logical Input Modbus Address Map Definition	57
Table 5-6. Physical Input Modbus Address Map Definition	59
Table 5-7. Logical Input Status Momentary Change Detect Status	59
Table 5-8. Physical Input Momentary Change Detect Register Map	63
Table 5-9. Register Scaling Queries	69
Table 5-10. Minimum and Maximum Ranges for Scaled Numbers Depending Upon Scale Option and Bit Length Selected	71
Table 5-11. Default Scaling and Remapping Register Assignments	75
Table 5-12. Relay Status Modbus Address Map Definition	78
Table 5-13. Diagnostic Status Modbus Address Map Definition	80
Table 5-14. Unit Information Status Modbus Address Map Definition	81
Table 5-15. Quick Status Modbus Address Map Definition	82
Table 5-16. Power Fail Table Register Definition	82
Table 5-17. Fast Status Modbus Address Map Definition	83
Table 5-18. Communication Error Event Log	83
Table 5-19. TPU2000/TPU2000R Metering Values	84
Table 5-20. Demand Metering Modbus Address Map Definition	85
Table 5-21. TPU2000/TPU2000R Metering Values	87
Table 5-22. To Be Named	88
Table 5-23. Peak Demand Register Map for the TPU2000R and TPU2000	90
Table 5-24. Minimum Demand Register Map for the TPU2000R and TPU2000	93
Table 5-25. Breaker Counter Definition Table	96
Table 5-26. Logical Input Table (8 Registers 128 Elements)	97
Table 5-27. Logical Input Definition Table (8 Registers – 127 Elements)	100
Table 5-28. Physical Output Table (1 Register Defined)	102
Table 5-29. Physical Input Table (1 Register Defined)	102
Table 5-30. Force Table Mapping	103
Table 5-31. Three Winding Logical Output Points	105
Table 5-32. Fault Record Data Assignment	109

TPU2000/2000R Modbus/Modbus Plus Automation Guide

Table 5-33. Differential 2 Winding Fault Record Register Definition	110
Table 5-34. 2 Winding Differential Fault Record Address Table.....	113
Table 5-35. 2 Winding Through Fault Register Definition for the TPU2000/TPU2000R	115
Table 5-36. 3 Winding Through Fault Record Buffer Modbus Register Definition.....	117
Table 5-37. 2 Winding Harmonic Restraint Fault Record Buffer Modbus Register Assignment	119
Table 5-38. 3 Winding Harmonic Fault Register Definitions.....	121
Table 5-39. Operation Record Address Definition.....	124
Table 5-40. Event Record Definition Type.....	124
Table 5-41. Security Status Register Indicating Password Requirement	127
Table 5-42. Group I Control Registers	129
Table 5-43. Group II Bit Definitions for TPU2000R Control.....	133
Table 5-44. State Truth Chart for Physical Input Forcing Function	134
Table 5-45. TPU2000R Bit Control Function Definitions.....	136
Table 5-46. State Truth Chart for Physical Input Forcing Function	138
Table 5-47. ECP Default Correlation to Forced Logical Input Bit Map	140
Table 5-48. State Truth Chart for Physical Input Forcing Function	142
Table 5-49. TPU2000 and TPU2000R Bit Control Function Definitions	142
Table 5-50. State Truth Chart for Physical Input Forcing Function	145
Table 5-51. TPU2000 and TPU2000R Bit Control Function Definitions	145
Table 5-52. TPU2000 and TPU2000R Bit Control Function Definitions	150
Table 5-53. Oscillographic Resolution Capabilities	152
Table 5-54. Oscillographic Configuration Registers	153
Table 5-55. Oscillographic Data Format Retrieval Block	156
Table 5-56. Physical Logical Function Byte Configuration Codes for Register 60044 to 60058	169
Table 5-57. Relay Configuration Setting Definition	170
Table 5-58. Programmable Input “NEGATED” “AND” Input	171
Table 5-59. AND/OR Conditional Logic Table	172
Table 5-60. Physical Input Mapping Table	173
Table 5-61. Relay Configuration Setting Definition	174
Table 5-62. Physical Logical Function Byte Configuration Codes for Register 60044 to 60058	175
Table 5-63. Programmable Output AND/OR Select.....	178
Table 5-64. Programmable Output User Defined Strings	178
Table 5-65. To Be Named	179
Table 5-66. Primary Settings Register Definition Common to the 2 and 3 Winding Units.....	180
Table 5-67. 3 Winding Primary Settings Block	183
Table 5-68. ALT 1 Settings Register Definition.....	185
Table 5-69. Alternate 1 Settings for 3 Winding Block.....	188
Table 5-70. ALT 2 Settings Register Definition.....	190
Table 5-71. Alternate 2 Settings for 3 Winding Block.....	193
Table 5-72. TPU2000/2000R Configuration Settings Register Setting.....	194
Table 5-73. TPU2000/2000R Configuration Settings Register Setting.....	196
Table 5-74. Counter Register Assignment	197
Table 5-75. Alarm Setting Table.....	198
Table 5-76. 3 Winding Alarm Settings Block	198
Table 5-77. Real Time Clock Register Definition Assignment	199
Table 5-78. ULO Table Map for Character Name Assignment.....	199
Table 5-79. ULI Table Map for Character Name Assignment	201
Table 5-80. FLI Soft Bit Table Map and Character Name Assignment Register Map.....	202
Table 5-81. Modbus Plus Global Register Map Configuration Definition.....	207
Table 5-82. User Definable Register Configuration Table	210
Table 5-83. Modbus Standard Exception Codes	228
Table 5-84. TPU2000/TPU2000R Defined Exception Codes.....	228
Table 5-85. Character Transfer Time vs Baud Rate.....	231
Table 5-86. TPU2000/TPU2000R Modbus CommandThroughput (Average time in mS).....	232

Figures

Section 1 – Introduction

Figure 1-1. Distribution Protection Unit Product Family.....	1
--	---

Section 2 – Communication Card Identification and Physical Port Characteristics

Figure 2-1. COM 0 Port Location.....	3
Figure 2-2. Physical Optional Communication Card Port Locations	3
Figure 2-3. TPU2000 and TPU2000R Communication Cards.....	4
Figure 2-4. Physical Communication Card Location for the TPU2000	4
Figure 2-5. Physical Communication Card Location for the TPU2000R.....	5

Section 3 – TPU2000 and TPU2000R Device Connectivity

Figure 3-1. Point to Point Architecture Using RS232.....	11
Figure 3-2. Multi-Drop Topology Using RS232	11
Figure 3-3. 9 Pin RS232-DTE-DTE Connector	12
Figure 3-4. Connection of a DB25 Connector to a TPU2000 or TPU2000R.....	12
Figure 3-5. Location of RS485 Resistor Configuration Jumpers in the TPU2000R	14
Figure 3-6. RS485 Topology Configuration for the TPU2000R.....	14
Figure 3-7. Alternate External Resistor Placement for the TPU2000R	15
Figure 3-8. RS485 Communication Cabling (TPU2000R)	15
Figure 3-9. TPU2000 RS485 Wiring Diagram.....	16

Section 4 – TPU2000 and TPU2000R Device Parameterization

Figure 4-1. Initial WinECP Communication Configuration Screen.....	18
Figure 4-2. Communication Port Setup Screen	18
Figure 4-3. COM Port 1 WinECP Setting Screen.....	20
Figure 4-4. WinECP COM Port 2 Communication Screen.....	20
Figure 4-5. TPU2000R Communication Capability Chart	21
Figure 4-6. TPU2000 Communication Capability Chart.....	21
Figure 4-7. Modbus, DNP 3.0, SPACOM, and PG&E Port 3 Communication Screen.....	23
Figure 4-8. Typical IRIG B Architecture	25
Figure 4-9. IRIG B Frame Construction	26
Figure 4-10. DPU/TPU/GPU2000R and DPU1500R IRIG B Connector Placement	27
Figure 4-11. DPU/TPU2000 IRIG B Connector Placement.....	27
Figure 4-12. Load Impedance Calculation.....	28
Figure 4-13. Pin to Pin Illustration of ABB Protective Daisychain Link for IRIG B	29

Section 5 – Modbus

Figure 5-1. Modbus Polling Sequence.....	30
Figure 5-2. Modbus ASCII Transmitted and Received Frame Formats	31
Figure 5-3. Modbus ASCII Frame Format	31
Figure 5-4. Modbus ASCII Frame Analysis.....	31
Figure 5-5. Modbus RTU Format	32
Figure 5-6. RTU Frame Format.....	32
Figure 5-7. Modbus Plus Message Frame Structure.....	34
Figure 5-8. Modbus Plus Token Rotation Explanation	34
Figure 5-9. Modbus Plus Token Rotation Explanation	34
Figure 5-10. Modbus Plus Token Rotation Explanation.....	35
Figure 5-11. Modbus Plus Network Topology.....	35
Figure 5-12. Modbus Plus Path Designation.....	36
Figure 5-13. Modbus Plus Addressing Example.....	36
Figure 5-14. Modbus Protocol Function 01 Frame Format	38
Figure 5-15. Example Transaction Request for Eight Physical Output Coils	39
Figure 5-16. Example of Raw Data Decode	39

TPU2000/2000R Modbus/Modbus Plus Automation Guide

Figure 5-17. Momentary Change Detect Example	40
Figure 5-18. Latched Element Status Example	41
Figure 5-19. 1X Input Request Using Modbus Command 02.....	56
Figure 5-20. Momentary Change Detect Example	57
Figure 5-21. Momentary Change Detect Status Example.....	63
Figure 5-22. Decode of Raw Data Bits as seen on Data Scope Analyzer	63
Figure 5-23. Vendor Documentation Translation Example	65
Figure 5-24. 4X Data Read Frame Format.....	66
Figure 5-25. Register Scaling Methodology	67
Figure 5-26. Change Configuration Settings Menu Illustrating CT and VT Configuration.....	68
Figure 5-27. User Definable Register Configuration Screen.....	69
Figure 5-28. Popup Menu Configuration Screen for Data Type Register Selections	70
Figure 5-29. Relationship Between Scaled and Unscaled Formats for Offset Bipolar, Bipolar, Unipolar, and Negative Unipolar Scaling Selection in the TPU2000 and 2000R	72
Figure 5-30. Bit Justification Notation.....	73
Figure 5-31. Register Scaling Default Example	76
Figure 5-32. Scaling Example for Voltage Mapped Registers	77
Figure 5-33. Application Example: Fetch Relay Status from the TPU2000/2000R.....	79
Figure 5-34. Application Example: Returned Relay Response.....	79
Figure 5-35. Demand Current Calculation.....	89
Figure 5-36. Energy Demand Calculation	90
Figure 5-37. Modbus Write Command 16 (10 HEX) Allowing Writes to the TPU2000/2000R.....	107
Figure 5-38. Function 23 Read/Write Command Format	108
Figure 5-39. 2 Winding Differential Fault Buffer.....	109
Figure 5-40. 3 Winding Differential Fault Buffer.....	110
Figure 5-41. Event Record Access Illustration if Function 23 is Issued to TPU2000/2000R Device	115
Figure 5-42. To Be Named.....	119
Figure 5-43. Typical Control Features Available for the TPU2000 and TPU2000R.....	127
Figure 5-44. Reset Target LED's Via Modbus Network Control	130
Figure 5-45. Typical Modbus/Modbus Plus Register Definition	131
Figure 5-46. Scada Redi Memory Map Modification	131
Figure 5-47. Typical Commissioning System	132
Figure 5-48. Force Physical Input Example.....	134
Figure 5-49. Force Physical Input Example.....	134
Figure 5-50. Force Physical Input Example.....	135
Figure 5-51. Force Physical Output Example	138
Figure 5-52. Force Physical Output Example	139
Figure 5-53. Force Physical Output Example	139
Figure 5-54. ECP Default Logical Input List	140
Figure 5-55. Mapping Function Screen for Logical Inputs	141
Figure 5-56. Application Example Illustrating the Use of FLI Group IV Methodology	144
Figure 5-57. Reset Sequence for 46-1, 46-2, and 63 Latch Status Bits.....	149
Figure 5-58. Momentary Pulse Control Illustrated.....	151
Figure 5-59. Waveform Capture Buffer Options	151
Figure 5-60. Oscillographic Retrieval/Storage Parameterization Philosophy	154
Figure 5-61. Configuration Data Retrieval Example.....	155
Figure 5-62. Memory Map Philosophy for Oscillographic Waveform Retrieval	156
Figure 5-63. Data Interpretation	165
Figure 5-64. Function 20 Read 6X Register Frame Definition.....	166
Figure 5-65. Modbus Command 21-Write General Reference Format	166
Figure 5-66. Bit Input Mapping Definition for Registers	169
Figure 5-67. Low Bit Output Mapping Definition for Registers	175
Figure 5-68. High Bit Output Mapping Definition for Registers.....	175
Figure 5-69. Low Bit Output Mapping Definition for Registers	177
Figure 5-70. Setting Tab Display Screen with Modbus Plus Global Register Configuration Option.....	206
Figure 5-71. Global Register Configuration Option Screen.....	206
Figure 5-72. Global Register Configuration Screen.....	207
Figure 5-73. Exception Code Example for Holding Register Read	228
Figure 5-74. Diagnostic Function Code.....	229

TPU2000/2000R Modbus/Modbus Plus Automation Guide

Figure 5-75. Example Communication Timing Topology	230
Figure 5-76. Network Throughput Analysis at 1200 Baud	233
Figure 5-77. Network Throughput Analysis at 19200 Baud.....	233
Figure 5-78. Modbus Plus Network Throughput Example	235

Section 1 - Introduction

With the introduction of a microprocessor based protective relay, today's relay protection engineer must be familiar with topics outside of traditional relaying schemes. It is intended that the production of this manual will enable the relay engineer to understand the principles of a microprocessor-based relay's inclusion in a substation automation project.

Substation automation is heavily dependent upon integration of the appropriate components to allow reporting of metering and event data. The foundation of a successful automation solution is thorough engineering of a communication system. The Transmission Protection Unit (TPU) is the culmination of intensive design efforts and relaying experience, which combine protective relaying and communication capabilities at an economical price. Through the evolution of protective relays, it was decided that a special manual needed to serve today's power automation specialist.

This manual is intended to give the reader an in-depth explanation of the communication interfaces available with the Transmission Protection Unit. Successful integration of microprocessor based relays like the TPU depends on not just understanding the bits and bytes of a particular protocol. It is the inherent understanding and application of such esoteric topics as physical interfaces, real time control, manufacturer independent device integration, throughput vs. speed of communication, ... which influences the success of an automation project.

In many cases the individual performing the SCADA integration is not a relay protection engineer. This manual departs from the standard type of relay manual in that each data type is explained and each bit, byte and word meaning is explained. Several application examples are given within each section. A description of each protocol command is illustrated for the benefit of the user. Appendices are included detailing application notes, which augment the text. An explanation of the product's physical interfaces and the connectivity required is explored in depth. Explanations of register's uses to increase overall throughput are also explored. Throughput is always an issue when the system is commissioned. Understanding ways to improve the system data update is explained.

Several steps are required to permit successful communication between devices:

1. Identification of the hardware components (Section 2)
2. Correct physical connection between devices (Section 3).
3. Correct device configuration of port protocol and operation parameters (Section 4).
4. Generation and interpretation of the protocol command strings (Section 5).

The following sections shall explore the following procedures in depth when establishing a communication automation system, utilizing the TPU2000 and TPU2000R. An additional Section (Section 6) illustrates troubleshooting and commissioning of the Modbus/Modbus Plus Networks.

The TPU2000, and TPU2000R all have networking capabilities. Figure 1-1 shows the general look of the units as viewed from the front.

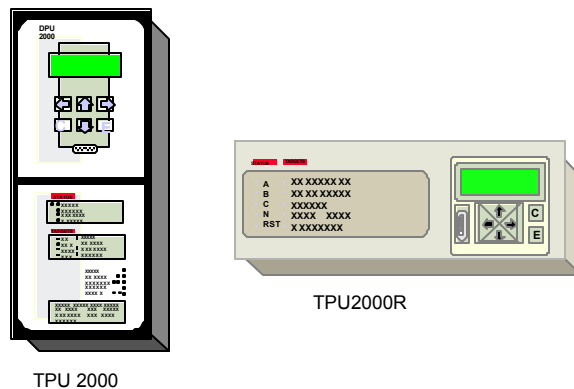

Figure 1-1. Distribution Protection Unit Product Family

TPU2000/2000R Modbus/Modbus Plus Automation Guide

The products differentiate themselves as listed in Table 1-1. Table 1-1 lists the available protocols within the relays. Standard Ten Byte is an ABB protocol which is within the TPU2000 and TPU2000R protective relays. Standard Ten Byte is an asynchronous byte oriented protocol. The programming software (ECP [DOS External Communication Program] and WINECP [Windows External Communication Program]) allows configuration of the relay through a port on the units. Standard Ten Byte is available through an RS232 or RS485 port on the TPU.

INCOM is an ABB protocol, which is a derivative of Standard Ten Byte. It is a modulated synchronous bit stream using the same commands as in the Standard Ten Byte protocol. INCOM is available as an option for the TPU2000 and TPU2000R relays as indicated within Table 1-1. Its physical interface is proprietary in that the TPU node expects a modulated signal.

Modbus is an industrial de-facto standard protocol, which has been widely embraced by the utility industry. Modbus has two emulation's, RTU, which is a synchronous protocol and ASCII which is an asynchronous protocol. Modbus uses only one command set, but two emulation's. Modbus strengths are that it uses a standard RS232 or RS485 interface to interconnect nodes on a network.

Modbus Plus is a hybrid protocol refinement of Modbus. Modbus Plus has a proprietary physical interface which is available to device manufacturers through a connectivity program with Groupe Schneider. The interface offers greater speed and communication features than Modbus.

DNP 3.0 is a protocol, which has its roots deep in the utility industry. It is an asynchronous protocol that allows connectivity through a standard RS232 or RS485 port. It includes such defined capabilities as file transfer, and timestamping as part of the protocol, which makes it desirable for a utility implementation.

Table 1-1. Protocol Capabilities Listed by Product Type

PRODUCT	PROTOCOL	NOTES
TPU2000	Standard Ten Byte	Addressable Front Com, Com 1 and Aux Com
	INCOM	2 Wire (and Shield) Current Injection Physical Interface
	Modbus	RS232 or RS485
	DNP 3.0	RS232 or RS485
TPU2000R	Standard Ten Byte	RS232 or RS485
	INCOM	2 Wire (and Shield) Current Injection Physical Interface
	Modbus	RS232 or RS485
	Modbus Plus	Proprietary Current Injection Physical Interface
	DNP 3.0	RS232 or RS485

Within this document, only **Modbus**, and **Modbus Plus** protocols shall be covered in depth. Standard 10 Byte, INCOM and DNP 3.0 shall be explained superficially. If one would need to reference the specific details of Standard Ten Byte or INCOM protocols, please reference the engineering specifications concerning these topics in Appendix A of this document.

Section 2 - Communication Card Identification and Physical Port Characteristics

The communication connector at the front of the unit (near the target LED's) communicates to the ECP or WINECP configuration program. This communication port is referred to as COM 0 and is common to both the TPU2000, and TPU2000R. The protocol emulated through this front port is an addressable emulation of STANDARD 10 BYTE PROTOCOL. With the addition of a communication card option, the unit emulates the protocols described in Table 1-1. The inclusion of optional communication boards enables the rear ports (as shown in Figure 2-2) of their respective units.

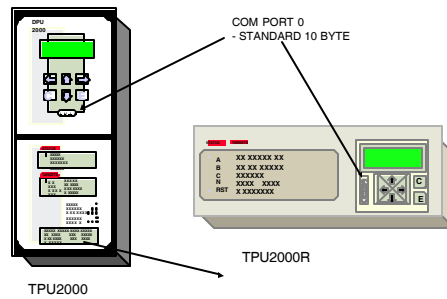

Figure 2-1. COM 0 Port Location

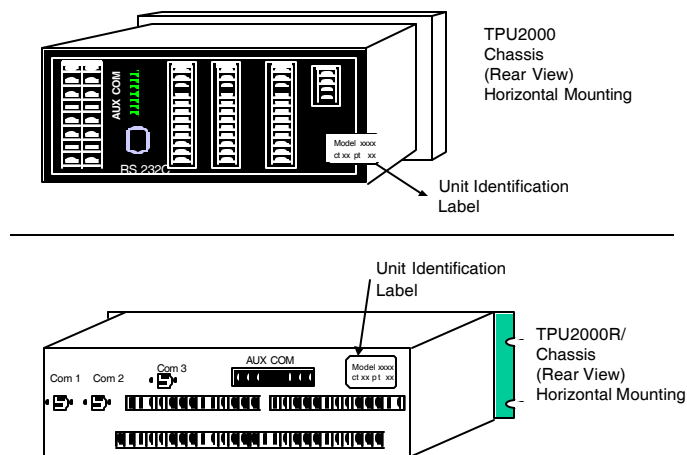

Figure 2-2. Physical Optional Communication Card Port Locations

The TPU2000 and TPU2000R differ in physical appearance. The communication cards inserted within the unit also differ in form, fit and construction. A typical TPU2000 and TPU2000R's communication card is illustrated in Figure 2-3 of this document. As shown, the TPU2000R has two physical interface connectors built onto the card. The form factor of these connectors are industry common DB 9 and "PHOENIX 10 POSITION" connectors. The "PHOENIX 10 POSITION" connector has a capacity to land two 18 wire gauge conductors at each position. The TPU2000 has the communication port connectors fixed as part of the chassis. The physical card slot for housing the communication card is marked on the chassis as "COM". The communication card mates with internal connectors allowing electrical and physical connections for the communication card and chassis mounted physical connectors.

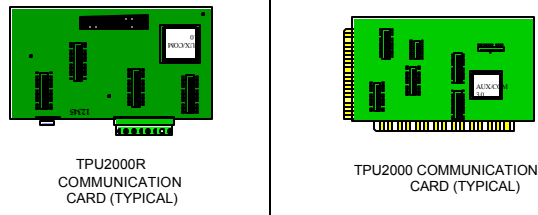

Figure 2-3. TPU2000 and TPU2000R Communication Cards

The TPU2000 Communication card is housed within a removable chassis. The communication card mates with edge card connectors located at the front and bottom of the removable chassis. Figure 2-3 illustrates the mounting location of the TPU2000 Communication card. Figure 2-4 illustrates the communication port locations of the TPU2000, which may be configured to communicate with the protocols described in Section 1 of this document.

The TPU2000R mates with the unit's main board to enable/disable Com Ports 1,2,3, and AUX COM. The communication cards physical interfaces protrude through the sheet metal back plate housing of the unit and allow for access to the physical connection ports. Figure 2-5 illustrates the location of the communication board assembly.

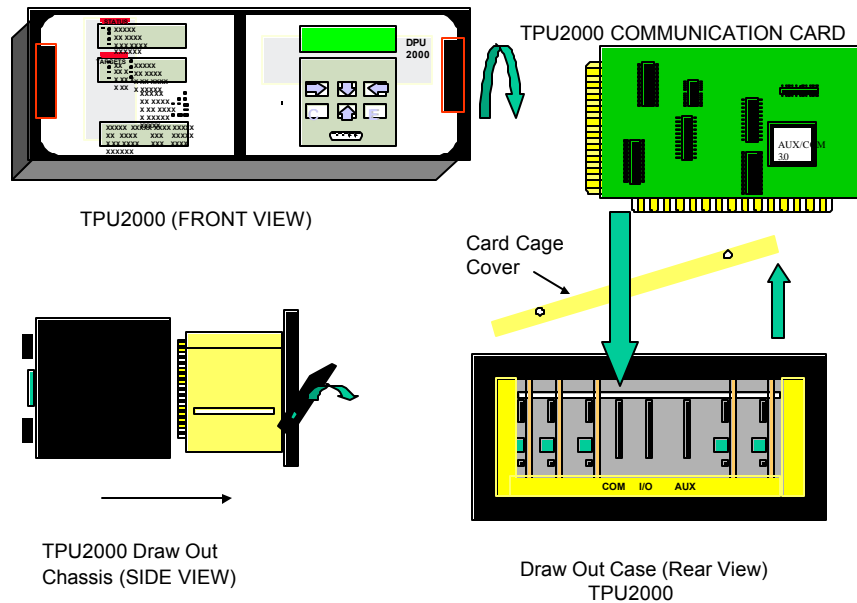

Figure 2-4. Physical Communication Card Location for the TPU2000

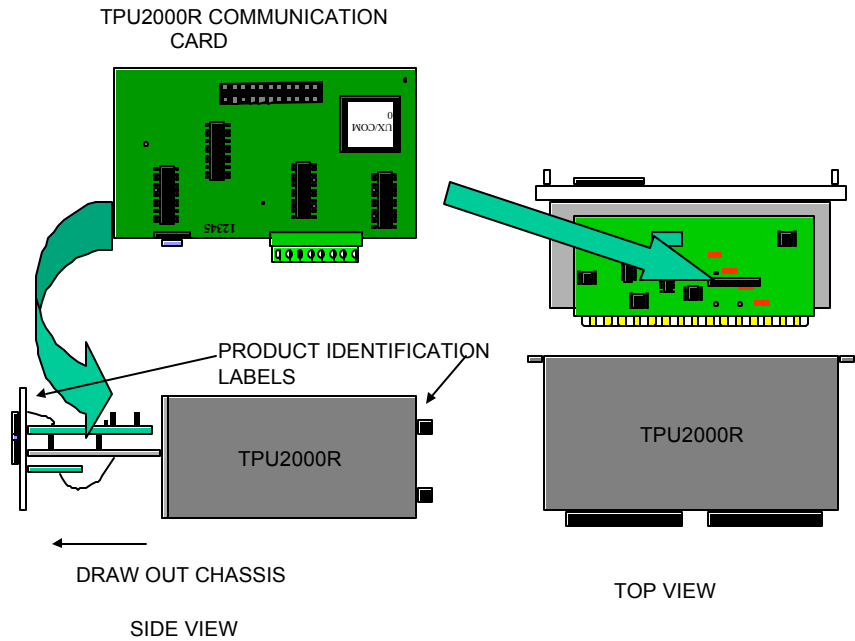

Figure 2-5. Physical Communication Card Location for the TPU2000R

CAUTION: REMOVAL OF THE DRAW OUT CHASSIS COMPONENTS WILL DE-ENERGIZE THE ELECTRONICS OF THE UNIT THEREBY PREVENTING SYSTEM PROTECTION. EXTREME CARE MUST BE TAKEN WHEN REMOVING THE ELECTRONIC DRAWER FROM THE CHASSIS SINCE ALL PROTECTIVE RELAY FUNCTIONALITY WILL BE TERMINATED.

CAUTION: IF THE UNIT IS UNDER POWER- THE CT's ARE SHORTED INTERNALLY THROUGH THE CHASSIS INTERNAL CONNECTORS. HOWEVER, EXTREME CAUTION MUST BE EXERCISED WHEN REMOVING THE DRAW OUT CASE FROM AN ENERGIZED UNIT. ABB TAKES NO RESPONSIBILITY FOR ACTIONS RESULTING FROM AVOIDANCE OF THIS WARNING AND CAUTION NOTICE.

CAUTION: Sensitive electronic components are contained within the TPU2000 and TPU2000R units. The individual removing the component boards from the fixed chassis must be grounded to the same potential as the unit. IF THE OPERATOR AND THE CASE ARE NOT CONNECTED TO THE SAME GROUND POTENTIAL, STATIC ELECTRICITY MAY BE CONDUCTED FROM THE OPERATOR TO THE INTERNAL COMPONENTS RESULTING IN DAMAGE TO THE UNIT.

Communication Card Part Number Options

The TPU2000 and TPU2000R may be ordered with a variety of communication options as listed in Table 2-1. The communication option card installed in the unit is identified by the part number located on the unit or identified through the ECP, WinECP or Front Panel (LCD) interfaces. The protocols available are:

- ❑ **STANDARD TEN BYTE®** – This is an ABB specific ASCII encoded (asynchronous) 10 byte communication protocol. It allows attainment of all relay parameters. It is the base unit protocol in which configuration programs such as ECP, and WinECP communicate to the TPU2000 or TPU2000R. It is the protocol standard for the COM 0 communication port of the TPU2000 and TPU2000R. Standard 10 Byte does not utilize a proprietary hardware physical interface. Appendix A includes the TPU2000 and TPU2000R Standard 10 Byte Protocol Document.
- ❑ **INCOM®** – This is an ABB Specific bit oriented (synchronous) protocol. INCOM uses the same commands as Standard Ten Byte, but its inherent bandwidth utilization is far greater than Standard Ten Byte is in that no data encoding is required. INCOM only defined two baud rates 9600 and 1200.

TPU2000/2000R Modbus/Modbus Plus Automation Guide

INCOM is a proprietary interface in that its physical presentation to the communication medium is dependent upon the baud rate selected. 1200 Baud uses current injection baseband signal presentation, whereas 9600-Baud implements a phase shift frequency in its representation of digital 1 and 0 values. Appendix A includes the TPU2000 and TPU2000R Standard Ten Byte Protocol document which describes INCOM in further detail.

- ❑ DNP 3.0® – This is a Utility industry standard protocol allowing communication between a host and slave devices. DNP 3.0 is a byte oriented (asynchronous) protocol which is physical interface device independent. The protocol allows for time synchronization, and unsolicited event reporting. It is a very popular protocol in utility installations. The discussion of DNP 3.0 protocol is included in this document.
- ❑ SPACOM® – This is an ABB Specific byte oriented (asynchronous) protocol common in Europe. It is a Master-Slave protocol which is implemented on a variety of physical interfaces. SPACOM protocol is not covered within this document.
- ❑ MODBUS® – This is an Industrial standard. The protocol allows a single master device to communicate with several slave devices. It has gained wide acceptance in that a great majority of utility devices incorporate Modbus protocol. Modbus Protocol is physical interface independent. Modbus Protocol has two emulation's RTU (a synchronous bit oriented emulation) and ASCII (an asynchronous byte oriented emulation). The TPU2000 and TPU2000R may be configured for both emulations. The discussion of Modbus protocol is included in this document. Please reference the TPU2000 and TPU2000R Modbus/Modbus Plus Automation Technical Guide TG 7.11.1.7-51 for a discussion of this protocol.
- ❑ MODBUS PLUS® – This protocol is also and industrial standard. Modbus Plus allows up to 64 devices to communicate on a single network using token passing techniques. 5 networks may be bridged (interconnected) to form a larger Modbus Plus network. The Modbus Plus protocol is fast (1 megabaud) and uses several advanced techniques to maximize bandwidth. The physical interface to Modbus Plus is proprietary and regulated by Groupe Schneider. Modbus Plus is the incorporation of Modbus commands on a HDLC®- like protocol using a current injection interface. The discussion of Modbus Plus protocol is included in this document. Only the TPU 2000R has the capability of communicating using the Modbus Plus protocol. Please reference the TPU2000 and TPU2000R Modbus/Modbus Plus Automation Technical Guide TG 7.11.1.7-51 for a discussion of this protocol. **(AVAILABLE ON THE TPU2000R ONLY).**

The device configuration for the TPU2000 is illustrated in Tables 2-1 and 2-2 illustrating the configuration options. The generic part number for the TPU2000 is 4 8 8 M R X D Z – C S S S Q. Deciphering the part numbers: found on the labels of the unit or obtained through ECP or the Front Panel LCD Interface, allows easy identification of the communication options found on the unit.

Table 2-1. TPU2000 Communication Options

IF PART NUMBER POSITION "Z" IS	THE TPU2000 HAS AN INSTALLED OPTION For unit 4 8 8 M R X D Z – C S S S Q (COMMUNICATION PHYSICAL INTERFACE OPTION)
1	RS232 (COM 3) Isolated Port Enabled
2	RS485 (AUX COM PORT) and RS232 (COM 3) Ports Enabled
3	INCOM (AUX COM PORT) Enabled
4	RS 485 AUX COM PORT and INCOM (AUX COM PORT) Enabled
5	RS485 (AUX COM PORT) Ports Enabled
IF PART NUMBER POSITION "Q" IS	THE TPU2000 HAS AN INSTALLED OPTION For unit 4 8 8 M R X D C – Z S S S Q (COMMUNICATION PHYSICAL INTERFACE OPTION)
0	STANDARD TEN BYTE
1	DNP 3.0
2	SPACOM
4	MODBUS

Table 2-2. TPU2000 Communication Card Matrix for Unit 4 8 8 M R X D Z – C S S S Q

“Z” Digit	“Q” Digit	COM 3	AUX COM RS485	INCOM	IRIG B
1	0	Standard 10 Byte RS232			
2	0	Standard 10 Byte RS232	Standard 10 Byte		Available
2	1	Standard 10 Byte <u>or</u> DNP 3.0 RS232	Standard 10 Byte <u>or</u> DNP 3.0		
2	2	Standard 10 Byte RS232	SPACOM		
2	4	Standard 10 Byte <u>or</u> Modbus RS232	Standard 10 Byte <u>or</u> Modbus		Available
3	0			Available	Available
4	0		Standard 10 Byte	Available	Available
4	1		DNP 3.0	Available	Available
4	2		SPACOM		
4	4		Modbus	Available	Available
5	0		Standard 10 Byte		

The device configuration for the TPU2000R is illustrated in Tables 2-3 and 2-4 illustrating the configuration options. The generic part number for the TPU2000 is 5 8 8 X X X Y Z – X X X X Q. Deciphering the part numbers: found on the labels of the unit or obtained through ECP or the Front Panel LCD Interface, allows easy identification of the communication options found on the unit.

Table 2-3. TPU2000R Communication Options

IF PART NUMBER POSITION “Y” IS	THE TPU2000R HAS AN INSTALLED OPTION For unit 5 8 8 X X X Y Z – X X X X Q (X = Don't Care) (FRONT PANEL INTERFACE OPTION)
0	Horizontal Unit Mounting – No front panel LCD interface.
1	Horizontal Unit Mounting – Front panel LCD interface is included.
5	Vertical Unit Mounting – No front panel LCD interface.
6	Vertical Unit Mounting – Front panel LCD interface is included.
IF PART NUMBER POSITION “Z” IS	THE TPU2000R HAS AN INSTALLED OPTION For unit 5 8 8 X X X Y Z – X X X X Q (X = Don't Care) (COMMUNICATION PHYSICAL INTERFACE OPTION)
0	RS232 (COM 1) Non-Isolated Port is active on the unit.
1	RS232 (COM 2) Isolated Port Only is active on the unit. (SEE NOTE)
2	RS485 (AUX COM PORT) and RS232 (COM 3) Ports on Option Card.
3	INCOM (AUX COM PORT) and RS485 (AUX COM PORT) Ports on Option Card.
4	INCOM (AUX COM PORT) and RS485 (AUX COM PORT) Ports on Option Card.
5	RS485 (AUX COM PORT) Port On Option Card.
6	Modbus Plus Port (COM 3) on the Option Card.
7	Modbus Plus (COM 3) and RS485 (AUX COM PORT) on the Option Card.
8	RS485 (COM 3) and RS485 (AUX COM PORT) Ports on the Option Card.
	NOTE: * = If the option denoted in part number position “Y” is a 0 or 5, the COM 2 port is enabled, if the option denoted in part number position “Y” is a 2 or 6 the COM 2 Port is disabled.
IF PART NUMBER POSITION “Q” IS	THE TPU2000R HAS AN INSTALLED OPTION For unit 5 8 8 X X X Y Z – X X X X Q (X = Don't Care) (COMMUNICATION PHYSICAL INTERFACE OPTION)
0	STANDARD TEN BYTE
1	DNP 3.0
4	Modbus/Modbus Plus (Depending on hardware interface selected in Position Z)

TPU2000/2000R Modbus/Modbus Plus Automation Guide

Table 2-4. TPU2000R Communication Card Matrix for Unit 5 8 8 X X X Y Z – X X X X Q

“Z” Digit	“Q” Digit	COM 1 RS232	COM 2 RS232	COM 3	AUX COM RS485	INCOM	IRIG B
0	0	Note 1	Standard 10 Byte				
1	0	Note 1		Standard 10 Byte RS232			
2	0	Note 1		Standard 10 Byte RS232	Standard 10 Byte		Available
2	1	Note 1		Standard 10 Byte <u>or</u> DNP 3.0 RS232	Standard 10 Byte <u>or</u> DNP 3.0		
2	4	Note 1		Standard 10 Byte <u>or</u> Modbus RS232	Standard 10 Byte <u>or</u> Modbus		Available
3	0	Note 1				Available	Available
4	0	Note 1			Standard 10 Byte	Available	Available
4	1	Note 1			DNP 3.0	Available	Available
4	4	Note 1			Modbus	Available	Available
5	0	Note 1			Standard 10 Byte		
6	4	Note 1	Standard 10 Byte	Modbus Plus			
7	4	Note 1		Modbus Plus	Standard 10 Byte		
8	0	Note 1		Standard 10 Byte RS485	Standard 10 Byte		Available
8	1	Note 1		Standard 10 Byte <u>or</u> DNP 3.0 RS485	Standard 10 Byte <u>or</u> DNP 3.0		
8	4	Note 1		Standard 10 Byte <u>or</u> Modbus RS485	Standard 10 Byte <u>or</u> Modbus		Available

NOTE 1- Available if Digit “Y” is 0 or 5. Front Panel Interface not included. Unavailable if Digit “Y” is 1 or 6.

The visual identification of a TPU2000R communication card is completed through visual inspection of the card component location and the part number of the base printed circuit board as illustrated in Table 2-5.

Table 2-5. TPU2000R Communication Card Matrix

“Z” Digit	Raw Circuit Board Part Number	Components To Look For
1	COMM 485 PCB 613709-005 REV0	Parts near black 9 pin 232 connector are populated
2	2000R AUX COM 613708-005 REV0	Parts in middle of board are not populated - 2 DC/DC Converters (U1 & U8)
3	AUX COM 613708-005 REV0	Only parts in middle of board - no DC/DC Converters, has Transformer T2
4	AUX COM 613708-005 REV0	Parts near black 9 pin 232 connector are not populated - only 1 DC/DC Converter (U1)
5	COMM 485 PCB 613709-005 REV0	Parts near green connector are populated
6	MODBUS COMM PCB 613720-002 REV1	RS485 option parts NOT populated (area inside dotted border)
7	MODBUS COMM PCB 613720-002 REV1	Fully populated
8	AUX & AUX 613755-002 REV0	Fully populated

Unit Communication Card Verification

There are several ways to identify the communication cards inserted in the TPU2000 or TPU2000R units. Some of the methods require the unit to be powered up. Other methods require the unit to be taken out of service.

To identify the unit part number of the present TPU2000 or TPU2000R, the following steps may be executed to facilitate unit identification.

1. With the unit energized, if the unit has a Front Panel LCD (Refer to Tables 2-1 through 2-4 inclusive for identification) Interface:
 1. Depress the “E” Key.
 2. Depress the Arrow Down Key “↓” once to highlight the SETTINGS field. Depress the “E” Key.
 3. Depress the Arrow Down Key “↓” twice to highlight the UNIT INFORMATION field. Depress the “E” key.
 4. The Serial Number and Catalog Number shall be displayed.

If the Unit does not have a Front Panel LCD Interface (Refer to Tables 2-1 through 2-4 inclusive for identification) and the user has DOS ECP or if the user wishes not to use the unit’s Front Panel LCD Interface:

1. Start ECP.
2. Select the appropriate communication parameters so that the personal computer attached to the TPU2000 or TPU2000R will communicate via the null modem cable connection. (See Figure 3-3 or Figure 3-4)
3. Depress enter to allow attachment of the unit.
4. The Serial Number and Catalog Number shall be displayed.

If the Unit does not have a Front Panel LCD Interface (Refer to Tables 2-1 through 2-4 inclusive for identification) and the user has WinECP or if the user wishes not to use the unit’s Front Panel Interface:

1. Start WinECP.
 2. Depress the “DIRECT ACCESS” selection button presented in the pop-up window.
 3. Depress the “CONNECT” option selection presented within the pop-up window.
 4. Select the “HELP” Menu option at the top right-hand section of the menu bar.
 5. Select the Drag-Down Menu item “UNIT INFORMATION”.
 6. A pop-up window shall appear with the Serial Number and Catalog Number.
2. At the back of the TPU2000 or the TPU2000R chassis, in the left-hand lower section of the unit, a label shall appear indicating the serial number and model number of the unit. It should match the data presented in the ECP, WinECP or Front Panel Interface (FPI) Menus. If it does not, please contact the factory.
 3. As a final check, if the TPU2000 or TPU2000R can be powered-down or if protection can be interrupted, loosen the front panel screws at the front of the unit. Remove the product component drawer from the chassis. Face the front panel interface, and rotate the board so that the semiconductor components are directly visible. On the backside of the metal panel supporting the Front Panel Interface, a label shall be available indicating the serial number and model number. These numbers should match those obtained in steps 1 and 2. If they do not, please contact the factory.

Section 3 - TPU2000 and TPU2000R Device Connectivity

Communication between devices is only possible through connectivity of the units through a physical media interface. There are two physical interface types on a TPU2000R and a TPU2000. Table 3-1 lists the characteristics for each of the port types. Those physical interfaces are:

- ❑ RS232 (isolated and non-isolated)
- ❑ RS485 (isolated)

Table 3-1. Physical Interface Options

	TPU2000R	TPU2000	Notes
COM 0	RS232 Non Isolated	RS232 Isolated	Front Port Standard 10 Byte
COM 1	RS232 Non Isolated		Standard 10 Byte Only
COM 2	RS232 Non Isolated		Standard 10 Byte Only
COM 3	RS232 Isolated/RS485 Isolated or Modbus Plus	RS232 Isolated (Modbus + NOT OFFERED)	TPU2000R – Communication Option Card Determines Physical Interface
AUX COM	RS485 (Isolated) and/or INCOM	RS485 (Isolated) and/or INCOM	Physical Interface Dependent on Communication Option Card Interface Selected

RS232 Interface Connectivity

RS232 is perhaps the most utilized and least understood communication interface in use. RS232 is sometimes misinterpreted to be a protocol; it is in fact a physical interface. A physical interface is the hardware and network physical media used to propagate a signal between devices. Examples of physical interfaces are RS232 serial link, printer parallel port, current loop, V. 24, IEEE Bus... Examples of network media are, twisted copper pair, coaxial cable, free air...

RS232 gained widespread acceptance due to its ability to connect to another RS232 device or modem. A modem is a device, which takes a communication signal and modulates it into another form. Common forms of modems include telephone, fiber optic, microwave, and radio frequency. Modem connectivity allows attachment of multiple devices on a communication network or allows extension of communication distances in a network with two nodes. Physical connection of two devices or more than two devices require differing approaches. Figure 3-1 illustrates a topology using two devices (point to point topology). Figure 3-2 illustrates a multi-drop topology between many nodes. RS232 was designed to allow two devices to communicate without using intermediate devices.

Port Isolation

Network installation within a substation requires special considerations. A substation environment is harsh in that high levels of electromagnetic interference are present. Additional ground currents are present in such installations. RS232 is an unbalanced network in that all signals are referenced to a common ground. On longer cable runs, the potential of the signals at the sending device can be significantly lower than at the receiving end due to electrical interference and induced ground current. This increases with long runs of cable and use of unshielded cable. ABB’s Substation Automation and Protection Division recommends the length of RS232 cable be less than 10 feet (3 meters) for an un-isolated port and that the cable be shielded. Internal to a typical device, the RS232 transceivers are referenced to the electronic components internal ground. Any electrical interference could be coupled through the chip set and fed back to the device. Typical isolation ratings of a non-isolated port could be as low as 1 volt. Such a port could allow electrical feedback of noise to the electronics for any signal interference over 1 volt.

Coms 0 through 2 on TPU/TPU/GPU units are non-isolated. However an RS232 implementation on Com 3 uses opto-isolation technology which increases electrical isolation from the port to the devices internal circuitry to 2.3 kV. It is highly desirable to utilize this port in connection to devices in longer cable runs and dedicated communication networks. RS232 isolated ports are limited in connection distance for a maximum of fifty feet.

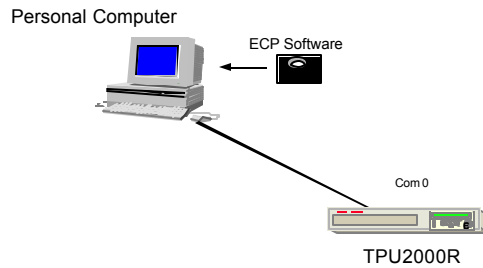

Figure 3-1. Point to Point Architecture Using RS232

RS232 Handshaking Defined

Handshaking is the ability of the device to control the flow of data between devices. There are two types of “handshaking”, hardware and software. Hardware handshaking involves the manipulation of the RTS (Request to Send) and CTS (Clear to Send) card control signal lines allowing data communication direction and data flow rates to be controlled by the DTE device. Also the flow is controlled by the DTR (Data Terminal Ready) signal which allows the DCE operation.

Software handshaking involves the data flow control by sending specific characters in the data streams. To enable transmission, the XON character is transmitted. To disable reception of data, the transmitting device sends an XOFF character. If the XOFF character is imbedded within the data stream as information, the receiving node automatically turns off. This is the main weakness of software handshaking, inadvertent operation due to control characters being imbedded within data streams. Software handshaking is usually used in printer control.

The TPU2000 and TPU2000R devices do not incorporate handshaking, therefore, the control lines may be ignored as illustrated in Figure 3-3. However, some PC software utilizes handshaking, thus the port on the personal computer may require a special hardware configuration of the cable to the port. Consult with the software vendor to determine RS232 control and buffering requirements and the need for signal jumpers required in RS232 cabling.

The ports on the TPU/TPU/GPU have been tested for operation up to a speed of 19,200 baud. 19,200 baud is the typical data rate applicable for the operation of an asynchronous communication connection over RS232 without the use of additional timing lines.

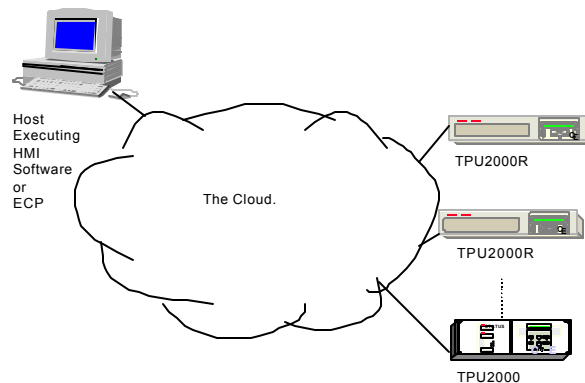

Figure 3-2. Multi-Drop Topology Using RS232

RS232 Cable Connectivity

A cable diagram is illustrated in Figure 3-3 and 3-4. Figure 3-3 shows the direction of communication signal transmission and the gender of the connectors used in constructing a communication cable.

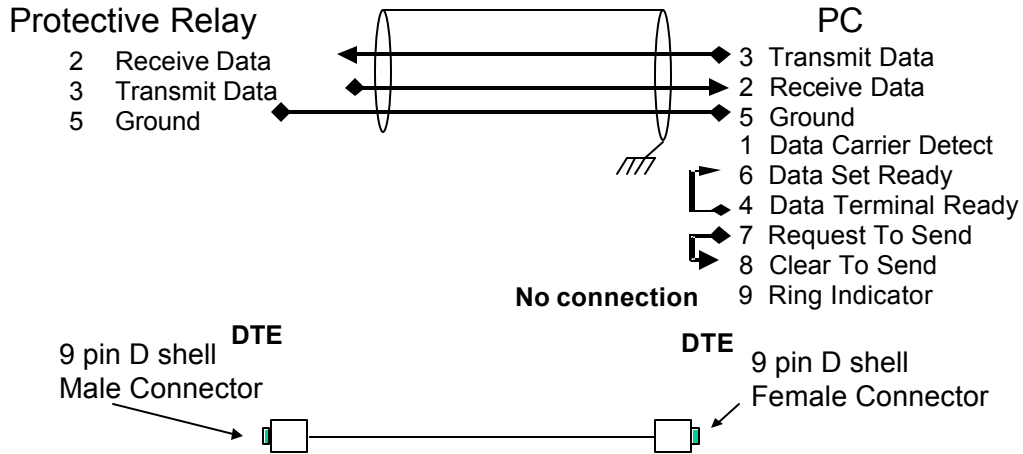

Figure 3-3. 9 Pin RS232-DTE-DTE Connector

An RS232 interface was designed to simplify the interconnection of devices. Definition of terms may demystify issues concerning RS232 interconnection. Two types of RS232 devices are available, DTE and DCE. DTE stands for **Data Terminal Equipment** whereas DCE stands for **Data Communication Equipment**. These definitions categorize whether the device originates/receives the data (DTE) or electrically modifies and transfers data from location to location (DCE). Personal Computers are generally DTE devices while line drivers/ modems/ converters are DCE devices. DPU/TPU/GPU devices have RS232 DTE implementation. Generally, with a few exceptions, a “straight through cable”(a cable with each pin being passed through the cable without jumpering or modification) will allow a DTE device to communicate to a DCE device.

Connection of a PC to a TPU2000 or TPU2000R requires cable modification since the interconnected devices are both DTE. The same cabling would be utilized if one would connect two DCE devices. The classifications of DTE/DCE devices allow the implementers to determine which device generates the signal and which device receives the signal. Studying Figure 3-3, Pins 2 and 3 are data signals, pin 5 is ground whereas pins 1,6,7,8,9 are control signals. The arrows illustrate signal direction in a DTE device. The TPU2000 and TPU2000R series of protective devices do not incorporate hardware or software “handshaking”.

If a host device has an RS232 physical interface with a DB 25 connector, reference Figure 3-5 for the correct wiring interconnection.

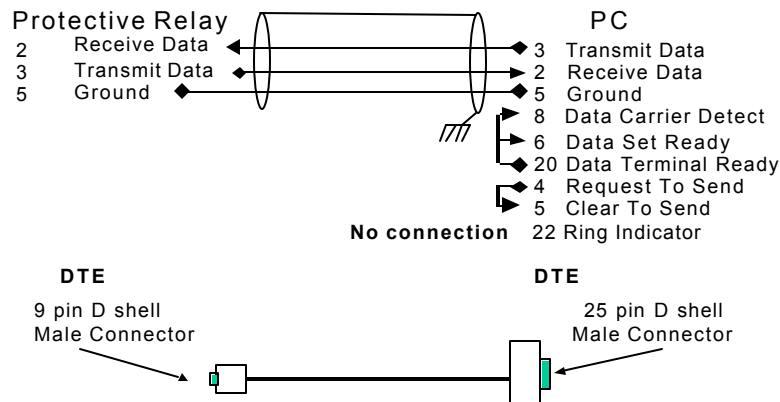

Figure 3-4. Connection of a DB 25 Connector to a TPU2000 or TPU2000R

RS485 Device Connectivity with the TPU2000 and TPU2000R

RS485 is one of the more popular physical interfaces in use today. It was developed as an enhancement of the RS422 physical interface. Its inherent strength is its ability to transmit a message over a twisted pair copper medium of 3000 feet in length. An RS485 interface is able to transmit and receive a message over such a distance because it is a balanced interface. That is, it does not reference the signal to the system's electrical ground, as is the case in an RS232 interface. RS485 references the communication voltage levels to a pair of wires isolated from system ground. Depending on the manufacturer's implementation, isolation may be optical or electronic. RS485 has two variants, two-wire and four-wire. In the two-wire format, communication occurs over one single wire pair. In four-wire format, communication occurs over two wire pairs, transmit and receive. The two-wire format is the most common in use. The TPU2000 and TPU2000R support half duplex two-wire format only. The RS485 port is also optically isolated to provide for 3000 V of isolation.

The RS485 network supported and recommended by ABB requires the use of three conductor shielded cable. Suggested RS485 cable and the respective manufacturer's wire numbers are:

- ALPHA 58902
- Belden 9729
- Belden 9829
- Carol 58902

ABB does not support deviations from the specified cables. The selected cable types listed are of the type which have the appropriate physical and electrical characteristics for installation in substation environments.

A multi-drop RS485 connection is illustrated in Figure 3-2. Three wires, Positive (Terminal 9), Negative (Terminal 8) and Ground (Terminal 10). RS485 requires a termination resistor at each end of the communication cable. The resistance shall be from 90 to 120 ohms. Additionally, depending upon the RS485 physical interface converter used, a pull-up and pull-down resistor may be added to bias the line to decrease the amount of induced noise coupled onto the line when no communications are occurring. Internal to the TPU2000 and TPU2000R are jumpers which when inserted in the proper position (as referenced in Figure 3-5), bias the line by inserting the proper pull-up, pull-down, and termination resistors. To configure the Jumpers J6, J7, and J8, execute the following procedure:

- ❑ Refer to Figures 2-4 or 2-5 depending upon the model of Distribution Protection Unit which is installed.
- ❑ Refer to Figure 3-6 illustrating the placement of J6, J7 and J8 (or J16, J17, or J 18 on a type 8 card enabling RS 485 for COM 3). J6 (or J16 for COM 3) inserts a 120 ohm resistor between transmit and receive lines. J7 or (J17 for COM 3) and J8 or (J18 for COM 3) inserts a pull-up and pull-down resistor. The IN position inserts the associated resistor in to the circuit. The OUT position removes the resistor from the circuit.
- ❑ Insert the TPU2000 and TPU2000R unit into the chassis as per the instructions associated with Figures 2-4 or 2-5.
- ❑ Tighten the knurled screws at the front of the unit.
- ❑ **IT IS advisable to place a sticker on the front of TPU2000 AND TPU2000R indicating that it is a terminated end of line unit.** This makes maintenance of installed units easier.

The following example illustrates an interconnection of the TPU2000 and TPU2000R with a host device through a UNICOM physical interface connection using a 3-wire connection method. It should be noted that the RS485 design on ABB relay products incorporates isolation. That is, the RS485 ground is electrically isolated from the internal circuitry thereby assuring minimal interference from the extreme noise environments found in a substation. Care should be used when installing an RS485 communication network. The recommended configuration must be followed as shown in Figure 3-5, 3-6, 3-7, and 3-8. Jumpers J6, J7, and J8 should be inserted to provide termination and pull-up at the TPU2000 and TPU2000R end. Although not shown, a 120 ohm resistor should be inserted between the TX/RX + and TX/RX- pairs to provide for termination at the transmission end.

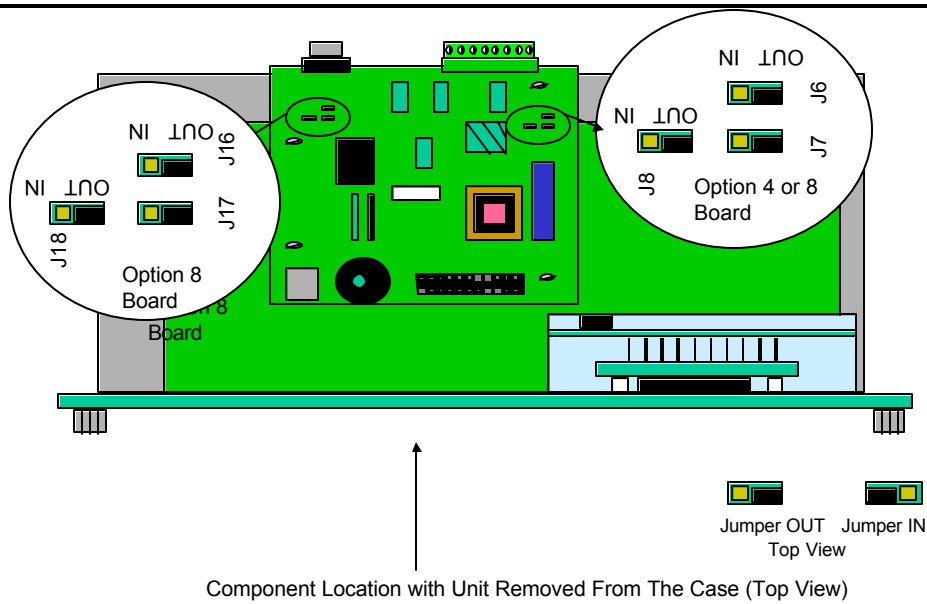

Figure 3-5. Location of RS485 Resistor Configuration Jumpers in the TPU2000R

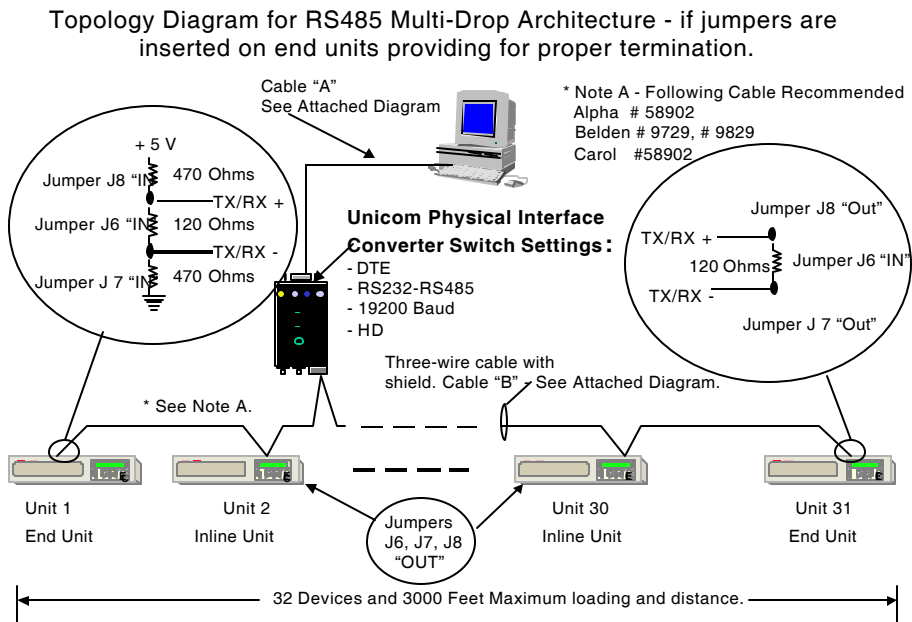

Figure 3-6. RS485 Topology Configuration for the TPU2000R

Topology Diagram for RS485 Multi-Drop Architecture - if external resistors are installed providing proper termination.

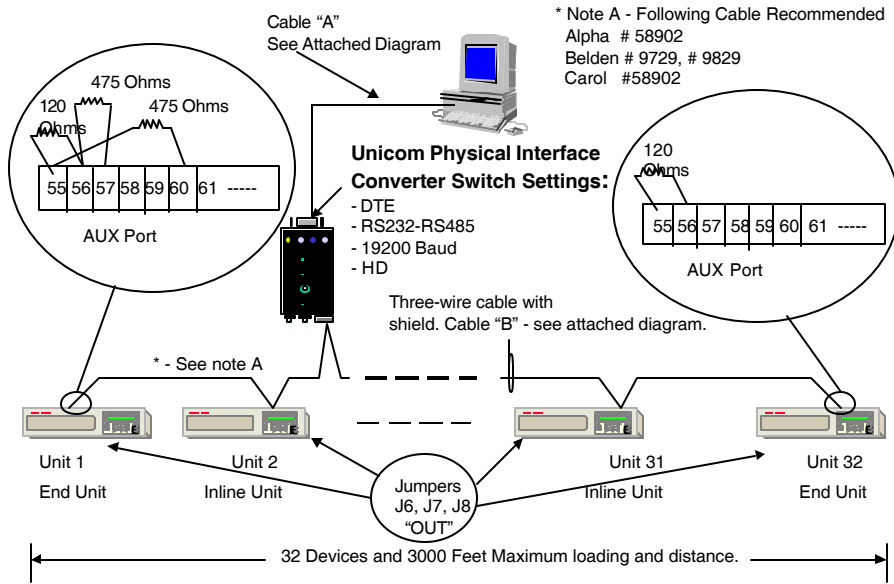

Figure 3-7. Alternate External Resistor Placement for the TPU2000R

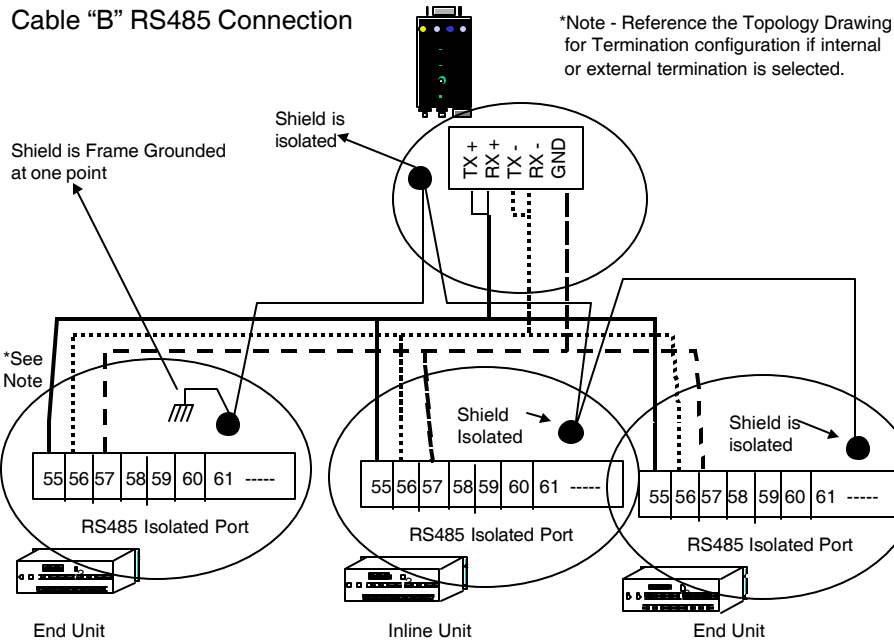

Figure 3-8. RS485 Communication Cabling (TPU2000R)

The TPU2000 has the two wire RS485 communication connectivity terminals located in a different position than that for the TPU2000R. Table 3-2 lists the AUX COM connector signal assignments for the TPU2000.

Table 3-2. TPU2000 AUX COM Signal Assignments

Pin Number	Pin Definition
65	IRIG B Minus
66	IRIG B Plus
67	INCOM
68	INCOM
69	+5 VDC (100 mA max)
70	RESERVED
71	RESERVED
72	RS485 Common /(Return)
73	RS485 Minus
74	RS485 Plus

Therefore, connection of several TPU2000 units on a communication network would yield the wiring as depicted in Figure 3-9. TPU2000 and TPU2000R units may be interconnected on the same network as long as this signal position difference is noted and signal polarity is followed.

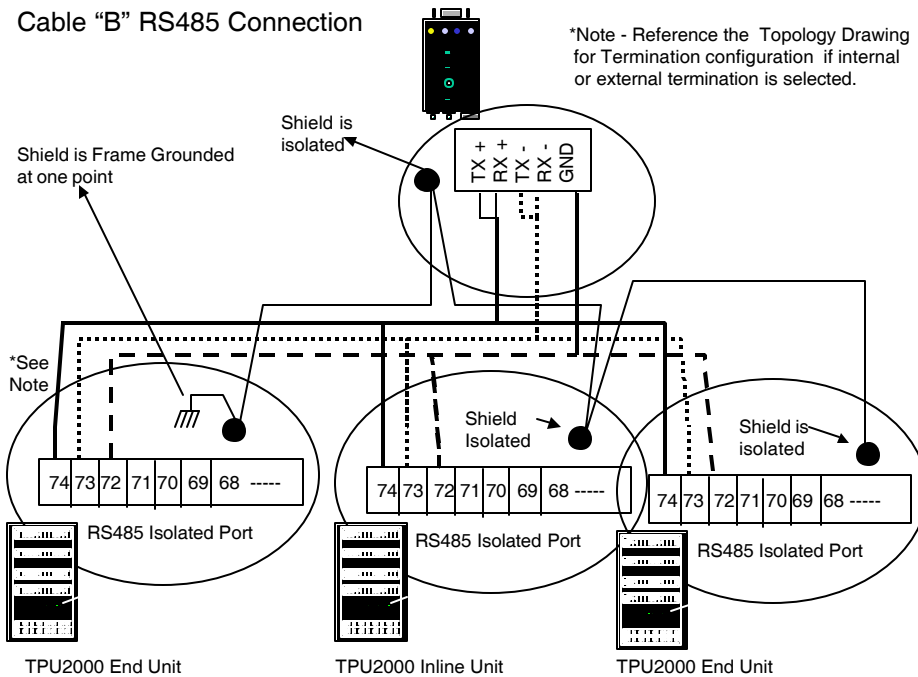

Figure 3-9. TPU2000 RS485 Wiring Diagram

Section 4 - TPU2000 and TPU2000R Device Parameterization

Establishing TPU2000 and TPU2000R communication depends upon correct parameterization of the communication menus within the unit. Parameterization may occur via the unit's front panel interface or through ECP (External Communication Program) or WinECP (Windows External Communication Program). Modbus, Modbus Plus and DNP require certain parameterizations. Even COM 0 requires certain parameterization to communication with the configuration program.

COM 0 Port (Front Port Configuration)

In order to attach a configuration program to the TPU2000 or TPU2000R, the correct parameters must be set up within the unit. The supported parameters are listed in Table 4-1 below. The protocol for the unit is addressable Standard 10 Byte. To view the communication port parameters it is advised that they should be viewed via the unit's front panel interface. If the TPU2000 or TPU2000R does not have a front panel interface, the parameters should be marked on the front panel sticker with the port's parameters.

The keystrokes required for visualizing the communication port parameters from the front panel interface are:

1. Depress the "E" pushbutton
2. Depress the "↓" key once to select the SETTINGS Menu and then depress the "E" pushbutton.
3. Depress the "E" pushbutton to select the SHOW SETTINGS Menu selection.
4. Depress the "↓" key six times to select the COMMUNICATIONS Menu and then depress the "E" pushbutton.
5. Under the SHOW COM SETTINGS MENU, the following shall be displayed for the Front Panel RS 232 port (FP).
 - Unit Node Address (Address displayed in HEX)
 - FP RS 232 Baud
 - FP RS 232 Frame

Other parameters shall be shown. The parameters listed shall vary in accordance with the communication card inserted within the unit. However, the FP displayed parameters must match with the parameters configured in the Standard Ten Byte Section of the ECP package.

One may change parameters via the front panel interface. The selections for each parameter required in Front Panel Port configuration is shown in Table 4-1.

Table 4-1. TPU2000 and TPU2000R COM Port 0 Front Panel Interface Parameters

Option	Selection	Notes
Unit Node Address	1 to FFF (1 = default setting)	1 to 2048 decimal node address
FP RS232 Baud	300	Selectable Baud Rates for the Standard Ten Byte Front Panel Port.
	1200	
	2400	
	4800	
	9600 (default setting)	
FP RS232 Frame	N – 8 – 1 (default setting)	No Parity 8 Data Bits 1 Stop Bit
	N – 8 – 2	No Parity 8 Data Bits 2 Stop Bits

Modification of the Front Panel Parameter settings is accomplished via the following keystrokes:

1. From the metering menu depress the "E" key.
2. Depress the "↓" key once to select the SETTINGS Menu and then depress the "E" pushbutton.
3. Depress the "↓" key once to select the SHOW SETTINGS Menu selection. Depress the "E" pushbutton.

TPU2000/2000R Modbus/Modbus Plus Automation Guide

4. Depress the “↓” key seven times to select the COMMUNICATIONS Menu and then depress the “E” pushbutton.
5. Enter the unit’s password, one digit at a time. The default password is four spaces. Depress the “E” pushbutton once.
6. The CHANGE COMMUNICATION SETTINGS Menu shall be displayed. With the cursor at the Unit Address field, depress “E”. The unit address can be modified. The address selected in this field will configure the address for the entire node. Use the “↓” and “↑” arrow keys to select the password digit entry. Use the “→” and “←” keys to select the digit to configure. Depress “E” to save the digits. Depress “C” to return to the Root Menu.
7. Once returned to the Main Menu, depress the “↓” key once to select the FRONT RS232 BAUD RATE Menu and then depress the “E” pushbutton. The selections for the menu are listed in Table 4-1. Use the “→” and “←” keys to select the baud rates for the port. Depress “E” to select the entry. Depress “C” to return to the Root Menu.
8. Once returned to the Main Menu, depress the “↓” key once to select the FRONT RS232 FRAME Menu and then depress the “E” pushbutton. The selections for the menu are listed in Table 4-1. Use the “→” and “←” keys to select the baud rates for the port. Depress “E” to select the entry. Depress “C” to return to the Root Menu.
9. To Save the selections configured in the previous steps depress the “C” pushbutton. A query will be presented to the operator “Enter YES to save settings <NO>”. Use the “→” and “←” keys to select the option YES and depress “E” to save the settings.

If the unit does not have a front panel interface, it is advisable that the communication port parameters be marked on the front of the unit. If the parameters are not known, please contact ABB Technical Support to obtain the procedure to determine the parameters or take the unit out of service and reset the port parameters.

Figure 4-1 illustrates the parameterization screen in WinECP which must be parameterized allowing communication between the configuration unit and the TPU2000 or TPU2000R.



Figure 4-1. Initial WinECP Communication Configuration Screen

A direct connect is selected in this instance allowing retrieval and configuration of the relay parameters. Once the OK button is depressed, the screen shown in Figure 4-2 is presented to the operator.

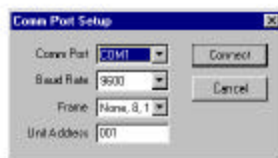

Figure 4-2. Communication Port Setup Screen

The selections in WinECP are illustrated in Table 4-2. The settings must agree with those configured in the TPU2000 and TPU2000R.

Table 4-2. WinECP Communication Port Settings

Option	Selection	Notes
COM PORT	COM 1	Personal Computer Port Selection for ECP to TPU2000 and TPU2000R connection.
	COM 2	
	COM 3	
	COM 4	
BAUD RATE	300	Baud Rates Offered for TPU 2000/2000R connection to the WinECP RS232 port connection.
	1200	
	2400	
	4800	
	9600 (default setting)	
	19200	
Frame	None – 8 – 1 (default setting)	No Parity 8 Data Bits 1 Stop Bit
	None – 8 – 2	No Parity 8 Data Bits 2 Stop Bits
	Even – 8 – 1	Even Parity 8 Data Bits 1 Stop Bit
	Odd – 8 – 1	Odd Parity 8 Data Bits 1 Stop Bit
	Even – 7 – 1	Even Parity 7 Data Bits 1 Stop Bit
	None – 7 – 2	Even Parity 7 Data Bits 2 Stop Bits
	Odd – 7 – 1	Odd Parity 7 Data Bits 1 Stop Bit
Unit Address	1 – FFF (1 = Default)	Unit Address in HEX
NOTE : Bold indicates Selections Supported by WinECP and TPU2000/TPU2000R		

COM Port 1 Option Settings (TPU2000R Only) [Catalog 588 XXX00-XXX0 or 588 XXX50-XXX0]

If the unit does not have a front panel interface, the rear port is on the TPU2000R is active. The Configuration screens through WinECP are shown in Figure 4-3 for reference. The communication options may not be configured via the front panel interface since this port is only active if the unit does not have a front panel communication port interface (see Section 3 of this document for further information). The communication protocol supported on this port is Standard Ten Byte Only.

Table 4-3 illustrates the port configuration options available for this COM Port 1. Figure 4-3 illustrates the WinECP screen used to configure Communication Port 1 in the TPU2000R.

Table 4-3. COM Port 1 and COM Port 2 WinECP Port Setting Options

Option	Selection	Notes
BAUD RATE	300	Com Port Baud Rate Selections Via WinECP or DOS ECP
	1200	
	2400	
	4800	
	9600 (default setting)	
	19200	
	38400	
Frame	None – 8 – 1 (default setting)	No Parity 8 Data Bits 1 Stop Bit
	None – 8 – 2	No Parity 8 Data Bits 2 Stop Bits
	Even – 8 – 1	Even Parity 8 Data Bits 1 Stop Bit
	Odd – 8 – 1	Odd Parity 8 Data Bits 1 Stop Bit
	Even – 7 – 1	Even Parity 7 Data Bits 1 Stop Bit
	None – 7 – 2	Even Parity 7 Data Bits 2 Stop Bits
	Odd – 7 – 1	Odd Parity 7 Data Bits 1 Stop Bit

TPU2000/2000R Modbus/Modbus Plus Automation Guide

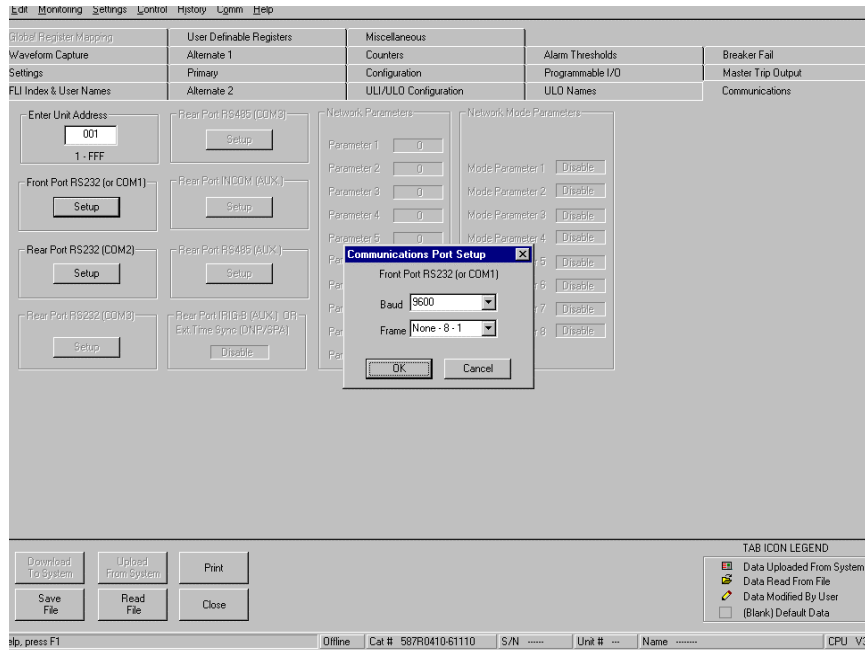

Figure 4-3. COM Port 1 WinECP Setting Screen

COM Port 2 Option Settings (TPU2000R Only) [Catalog 588 XXXX0-XXX0 or 588 XXXX6-XXX4]

There are two option boards, which enable communication port 2 for the TPU2000R. Figure 4-4 illustrates the configuration screen for the COM PORT 2 options when viewed on WinECP.

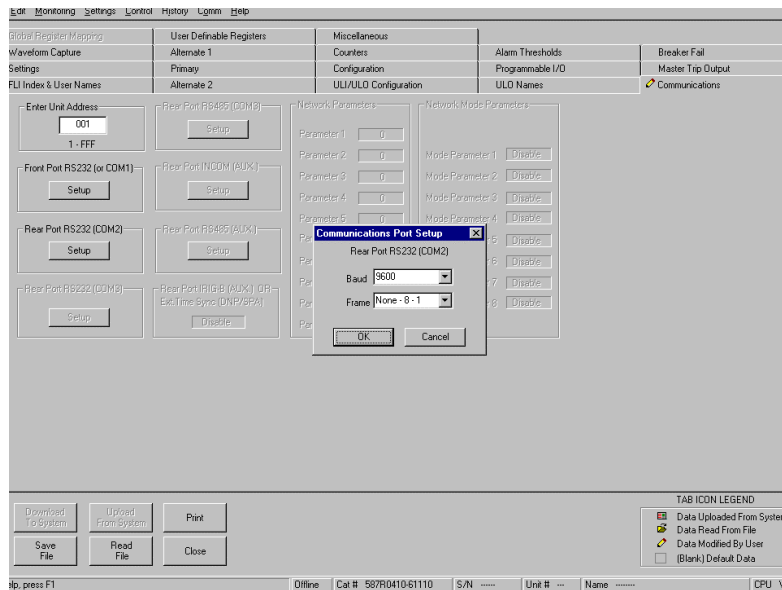

Figure 4-4. WinECP COM Port 2 Communication Screen

The options for configuration are listed in Table 4-3.

COM Port 3 and AUX COM Configuration

The TPU2000 and TPU2000R share the same commonality in that two rear ports may be available depending upon the hardware inserted in the units. The configuration techniques vary in that the configuration depends upon the protocol included on the board itself. Figure 4-5 lists the combinations for the TPU2000R. Figure 4-6 lists the communication option combinations for the TPU2000. IRIG B time synchronization is not covered in this guide since the DNP 3.0 boards do not support IRIG B time synchronization.

Catalog Number Select Option		REAR PORT ASSIGNMENTS					
		RS-232	RS-485	INCOM	IRIG-B		
0	0	ABB Trn Byte	ABB Trn Byte				
1	0	ABB Trn Byte	ABB Trn Byte	ABB Trn Byte			IRIG-B
2	1	ABB Trn Byte		DNP 3.0	ABB Trn Byte		
2	4	ABB Trn Byte	Modbus Trn ABB Trn Byte See Note #	Modbus Trn ABB Trn Byte See Note #			IRIG-B
3	0	ABB Trn Byte					INCOM IRIG-B
4	0	ABB Trn Byte		ABB Trn Byte			INCOM IRIG-B
4	1	ABB Trn Byte		DNP 3.0			INCOM
4	4	ABB Trn Byte		Modbus ID			INCOM IRIG-B
5	0	ABB Trn Byte		ABB Trn Byte			
6	4	ABB Trn Byte	ABB Trn Byte	Modbus Plus™			
7	4	ABB Trn Byte		Modbus Plus™	ABB Trn Byte		
8	0	ABB Trn Byte		ABB Trn Byte (RS-485)	ABB Trn Byte		DNP 3.0
8	1	ABB Trn Byte		ABB Trn Byte (RS-485)	DNP 3.0 (RS-485)		IRIG-B
8	4	ABB Trn Byte	Modbus ID / ABB Trn Byte (RS-485) See Note #	Modbus ID / ABB Trn Byte (RS-485) See Note #			IRIG-B

Figure 4-5. TPU2000R Communication Capability Chart

Catalog Number Select Option		REAR PORT ASSIGNMENTS					
		RS-232	RS-485	INCOM	IRIG-B		
0	0	Standard	Standard				
1	0	Standard		Standard			
2	0	Standard		Standard	Standard		IRIG-B
2	1	Standard		Standard	DNP 3.0		
2	2	Standard		Standard	Standard		
2	3	Standard		Standard	Standard		
2	4	Standard		Modbus® or Standard See Note #	Modbus® or Standard See Note #		IRIG-B
3	0	Standard					INCOM IRIG-B
4	0	Standard			Standard		INCOM IRIG-B
4	1	Standard			DNP 3.0		INCOM
4	2	Standard			Standard		INCOM
4	4	Standard			Modbus®		INCOM IRIG-B
5	0	Standard		Modbus or Standard RS-485	Modbus or Standard		IRIG-B

Figure 4-6. TPU2000 Communication Capability Chart

Modbus Protocol Selection and Configuration for Port 3 and AUX COM

Modbus requires parameterization above that of the unit number, baud rate, and frame selection. The philosophy is that (if the hardware is provided on the card) one or both ports may be configured with Standard Ten Byte or Modbus (ASCII or RTU). The parameterization requires entry of constants in the Parameter Section of the Communication configuration menu tab (Via WinECP) or Configuration Menu (via the Front Panel Interface). If as per the above tables, the Modbus card is to be configured via software (ECP or WinECP), the following must be configured via the front panel interface or via WinECP.

The following table represents Option 2 Communications Settings:

<u>Parameter 1</u>	<u>ModeParameter 1</u>	<u>Mode Parameter 2</u>	<u>(COM3)</u>	<u>RS485 (AUX)</u>
0	Disabled	Disabled	STD	STD
1	Disabled	Disabled	Modbus RTU	STD
1	Enabled	Disabled	Modbus ASCII	STD
2	Disabled	Disabled	STD	Modbus RTU
2	Disabled	Enabled	STD	Modbus ASCII
3	Disabled	Disabled	Modbus RTU	Modbus RTU
3	Enabled	Disabled	Modbus ASCII	Modbus RTU
3	Disabled	Enabled	Modbus RTU	Modbus ASCII
3	Enabled	Enabled	Modbus ASCII	Modbus ASCII

NOTE: STD is Standard Ten Byte Protocol Selected.

If a Modbus capable card is inserted into the unit, the configuration screen appears as shown in Figure 4-7. The Baud and Frame Options allowable for RTU and ASCII communication are shown in Table 4-4.

Table 4-4. Valid Parameter Selections for Standard Ten Byte and Modbus Protocols

PROTOCOL SELECTED	BAUD RATE SELECTIONS	FRAME SELECTIONS
Modbus ASCII	300,1200, 2400, 4800, 9600, 19200	<ul style="list-style-type: none"> • Odd Parity, 7 Data Bits, One Stop Bit • Odd Parity , 7 Data Bits, Two Stop Bits • Even Parity, 7 Data Bits, One Stop Bit • Even Parity, 7 Data Bits, Two Stop Bits
Modbus RTU	300,1200, 2400, 4800, 9600, 19200	<ul style="list-style-type: none"> • Even Parity, 8 Data Bits, One Stop Bit • No Parity, 8 Data Bits, One Stop Bit • Odd Parity, 8 Data Bits, One Stop Bit • No Parity, 8 Data Bits, Two Stop Bits
Standard Ten Byte	300,1200, 2400, 4800, 9600, 19200	<ul style="list-style-type: none"> • Odd Parity, 7 Data Bits, One Stop Bit • Odd Parity , 7 Data Bits, Two Stop Bits • Even Parity, 7 Data Bits, One Stop Bit • Even Parity, 7 Data Bits, Two Stop Bits • Even Parity, 8 Data Bits, One Stop Bit • No Parity, 8 Data Bits, One Stop Bit • Odd Parity, 8 Data Bits, One Stop Bit • No Parity, 8 Data Bits, Two Stop Bits

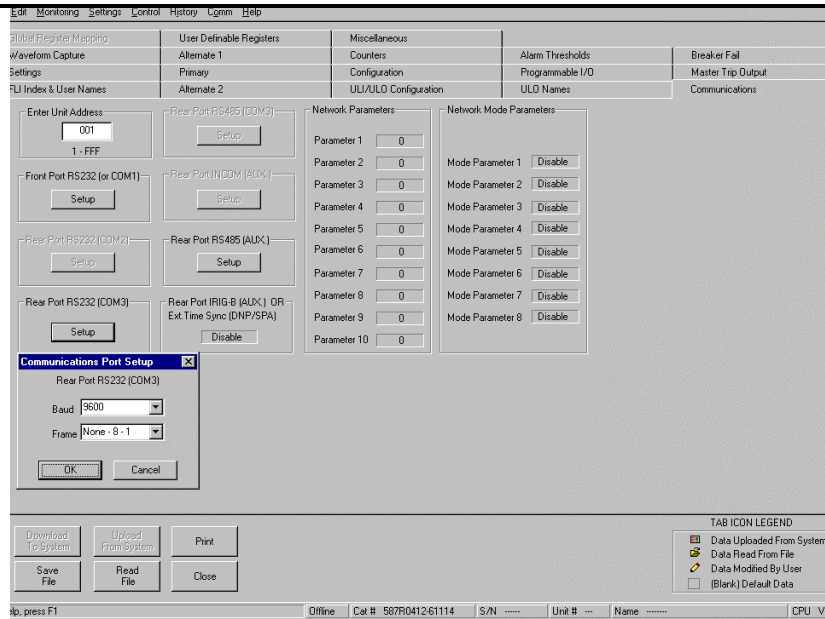

Figure 4-7. Modbus, DNP 3.0, SPACOM, and PG&E Port 3 Communication Screen

One should notice that the Parameter Section and the Mode Parameter Section is not greyed if the relay selection for Modbus is enabled (as discerned from the relay part number).

If the card is associated with Option Card 2 (the digit before the dash number in the part number), both the RS232 port and RS485 (AUX COM), the WINECP and Front Panel Interface will be represented in the query for configuration.

If the card is associated with Option Card 8 (COM 3 and AUX COM being RS485), the configuration software program and the front panel interface shall indicate that COM 3 is RS485 in that the query will indicate RP 485.

The Front Panel Interface configuration procedure is as follows:

Modification of the Front Panel Parameter settings is accomplished via the following keystrokes:

1. From the metering screen depress the “E” key.
2. Depress the “↓” key once to select the SETTINGS Menu and then depress the “E” pushbutton.
3. Depress the “↓” key once to select the CHANGE SETTINGS Menu selection. Depress the “E” pushbutton.
4. Depress the “↓” key seven times to select the COMMUNICATIONS Menu and then depress the “E” pushbutton.
5. Enter the unit’s password, one digit at a time. The default password is four spaces. Depress the “E” pushbutton once.
6. The CHANGE COMMUNICATION SETTINGS Menu shall be displayed. With the cursor at the Unit Address field, depress “E”. The unit address can be modified. The address selected in this field will configure the address for the entire node. Use the “↓” and “↑” arrow keys to select the password digit entry. Use the “→” and “←” keys to select the digit to configure. Depress “E” to save the digits. Depress “C” to return to the Root Menu.
7. Once returned to the Main Menu, depress the “↓” key four times to select the RP RS232 BAUD RATE (SEE NOTE 1) Menu and then depress the “E” pushbutton. The selections for the menu are listed in Table 4-1. Use the “→” and “←” keys to select the baud rates for the port. Depress “E” to select the entry. Depress “C” to return to the Root menu.

TPU2000/2000R Modbus/Modbus Plus Automation Guide

8. Once returned to the Main Menu, depress the “↓” key once to select the RP_RS232_FRAME (SEE NOTE 2) Menu and then depress the “E” pushbutton. The selections for the menu are listed in Table 4-1. Use the “→” and “←” keys to select the baud rates for the port. Depress “E” to select the entry. Depress “C” to return to the Root Menu.
9. Once returned to the Main Menu, depress the “↓” key once to select the RP_RS485_BAUD_RATE (SEE NOTE 3) menu and then depress the “E” pushbutton. The selections for the menu are listed in Table 4-1. Use the “→” and “←” keys to select the baud rates for the port. Depress “E” to select the entry. Depress “C” to return to the Root Menu.
10. Once returned to the main menu, depress the “↓” key once to select the RP_RS485_FRAME (SEE NOTE 4) menu and then depress the “E” pushbutton. The selections for the menu are listed in Table 4-1. Use the “→” and “←” keys to select the baud rates for the port. Depress “E” to select the entry. Depress “C” to return to the Root Menu.
11. Once returned to the Main Menu, depress the “↓” key once to select the RP_IRIG_B selection. Refer to Section 5 to determine the configuration for the IRIG B of the unit.
12. Once returned to the Main Menu, depress the “↓” key once to select the PARAMETER_1 Menu and then depress the “E” pushbutton. The selections for this field may range from 0 to 255. Use the “→” and “←” keys to select appropriate entry for Parameter 1 as described above. Depress “E” to select the entry. Depress “C” to return to the Root Menu.
13. Once returned to the Main Menu, depress the “↓” key twelve times to select the MODE_PARAMETER_1 Menu item and then depress the “E” pushbutton. The selections for this field are enable and disable. Use the “→” and “←” keys to select appropriate entry for MODE PARAMETER 1 as described above. Depress “E” to select the entry. Depress “C” to return to the Root Menu.
14. Once returned to the Main Menu, depress the “↓” key once to select the MODE_PARAMETER_2 Menu item and then depress the “E” pushbutton. The selections for this field are enable and disable. Use the “→” and “←” keys to select appropriate entry for MODE PARAMETER 1 as described above. Depress “E” to select the entry. Depress “C” to return to the Root Menu.
15. To Save the selections configured in the previous steps depress the “C” pushbutton. A query will be presented to the operator “Enter YES to save settings <NO>”. Use the “→” and “←” keys to select the option YES and depress “E” to save the settings.

NOTE 1: If the DUAL RS485 Board (Option 8) is selected, the query shall be modified as: RS485 – 1 Baud. If the hardware does not support COM 3, this query shall be omitted.

NOTE 2: If the DUAL RS485 Board (Option 8) is selected, the query shall be modified as RS485 – 1 Frame. If the hardware does not support COM 3, this query shall be omitted.

NOTE 3: If the DUAL RS485 Board (Option 8) is selected, the query shall be modified to RS485 – 2 Baud.

NOTE 4: If the DUAL RS485 Board (Option 8) is selected, the query shall be modified to RS485 – 2 Frame.

Modbus Plus Port Configuration [COM 3 on Selected Units] (TPU2000R Only)

Only the TPU2000R supports Modbus Plus. The TPU2000R recognizes if the communication card supports Modbus Plus. Only the Unit Address field within the communication port parameter screen is used via Modbus Plus. One should refer later sections in this manual for a further explanation of the Modbus Plus addressing scheme for accessing relay information.

IRIG B Configuration and Wiring

Although not a protocol, IRIG B time synchronization is included on the communication cards within the TPU2000 and TPU2000R. The following section describes the theory, connection and configuration options present within the TPU2000 and TPU2000R.

IRIG B is a time code, which allows devices across the world to synchronize with a common time source to a resolution of one millisecond. IRIG B allows each device to synchronize with the frame received by an IRIG B receiver. ABB's DPU/TPU/GPU2000/R relays (herein referred to as an IED) offer IRIG B time synchronization capabilities.

Figure 4-8 illustrates a typical IRIG B installation. An IRIG B time receiver accepts the RF signal and transforms it into a one second time synch frame. IEDs in the substation use the one second time synch frame to govern their internal clocks and event recorders.

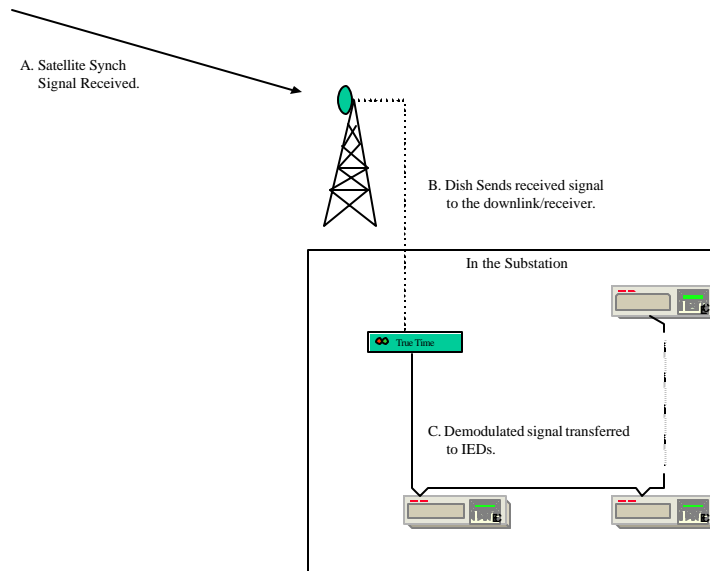

Figure 4-8. Typical IRIG B Architecture

IRIG B receivers/converters can format the IRIG B synchronization frames as a TTL-level pulse width, Manchester Encoded or Modulated Carrier Frequency signal. TTL-level signals are pulse DC with a voltage range of 0 to 5V. Modulated Carrier Frequency signals are pulse coded AM signals with modulation (tone bursts).

IRIG B is a general designation for time synchronization. There are many subsets to the IRIG B format. These were developed to provide functionality primarily for military applications dealing with missile and spacecraft tracking, telemetry systems, and data handling systems. IRIG B was embraced by the utility industry to answer a need to provide a sequence of events capability between a group of substations. Care must be exercised to match the device demodulating the signal from the satellite (downlink converter) with the IED's requiring specific IRIG B code formats.

DPU/TPU/GPU products support Pulse Width Code (X= 0), whereas, REL 3XX products having an IRIG B Poni Card support Pulse Width Code and Sine Wave Amplitude Modulated, and REL5XX products support Sine Wave Amplitude Modulated IRIG. If the IRIG signal supplied to the device is one in which the attached device cannot decode, the IED shall not synchronize with the signal and IED will not calculate time correctly.

The IRIG B time code has a one second time frame. Every frame contains 30 bits of Binary Coded Decimal time information representing seconds, minutes, hours, days and a second 17 bit straight binary time-of-day. The frame has internal time markers, which insure time-stamping accuracy to the millisecond. An eight millisecond frame reference marker appears during the first ten milliseconds of each frame. Another eight millisecond position identifier appears during the ninetieth millisecond of each one hundred millisecond period mark. The 30 bit Binary Coded Decimal time data occurs in the first one hundred millisecond of each 1 second frame. Optional control functions are sometimes encoded in the data stream. These functions control deletion commands and allow different data groupings within the synchronization strings. Decoding an IRIG B pulse is quite a complex undertaking. A typical 1 second time frame is illustrated in Figure 4-9. It is interesting to note that the year is not included within the IRIG B frame. If the Control Function frame (CF) or Straight Binary Time of Day frame (SBT) is not used, the bits defined within those fields are to be set as a string of zeroes and sent to the IED IRIG B receiver.

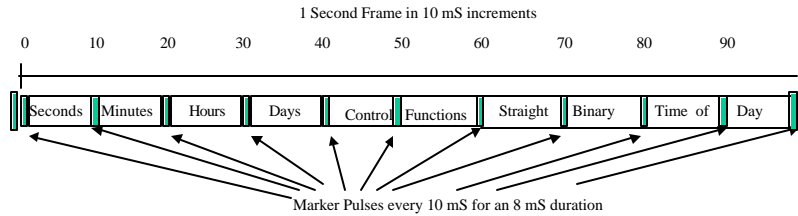

Figure 4-9. IRIG B Frame Construction

IRIG B is defined for code format sets identified by a three digit format number. Permissible format numbers for the IRIG B subsets are:

IRIG B XYZ Where:

The first field "X" identifies the encoding type of the IRIG B signal. DPU/TPU/GPU products support Pulse Width Code (X= 0), whereas, REL 3XX products having an IRIG B PONI Card support Pulse Width Code and Sine Wave Amplitude Modulated, and REL5XX products support Sine Wave Amplitude Modulated IRIG. Manchester Modulated code was added in IRIG Standard 200-98 Dated May 1998. It is not supported in the ABB protective relay products which are IRIG B capable.

The second field "Y" determines if a carrier is included within IRIG B Data format.

The third field "Z" determines if a combination of the BCD time/Control Function/Straight Binary Time is included within the IRIG B time frame. The inclusion or exclusion of any of the fields may cause errors in receivers not designed for the field's inclusion/ exclusion.

The following combinations may seem daunting, but only a subset of the listed formats are actually defined within the specification.

IF X =

- 0 = Pulse Width Code
- 1 = Sine Wave Amplitude Modulated
- 2 = Manchester Modulated Code

IF Y =

- 0 = No Carrier
- 2 = 1Khz , 1mS
- 3 = 10Khz, 0.1 mS
- 4 = 100 Khz, 10 mS
- 5 = 1Mhz, 1mS

IF Z=

- 0 =BCD Time,Control Function, Straight Binary Seconds
- 1 =Binary Coded Decimal Time, Control Function
- 2 =Binary Coded Decimal Time
- 3 =Binary Coded Decimal Time, Straight Binary Seconds

For the TPU/GPU/DPU2000/2000R products, IRIG B 000 and 002 formats are supported. Consult the IRIG B generator manufacturer so that the correct IRIG B code format is supplied to the receiving devices.

Hardware Configuration

IRIG B time synchronization is available for the products listed in Tables 4-6 and 4-7. Generally, three types of protective relays do not offer IRIG B, units without a communication card, units with Modbus Plus communication cards, and units with DNP 3.0 communication cards.

Each of these units uses the AUX COM port located at the rear of the relay to accept the TTL IRIG B signal. The DPU/TPU/GPU2000R use Pins 63 and 64 to accept the IRIG B negative polarity and IRIG B positive polarity signals respectively, as illustrated in Figure 4-10. The DPU/TPU2000(R) and use pins 65 and 66 as illustrated in Figure 4-11.

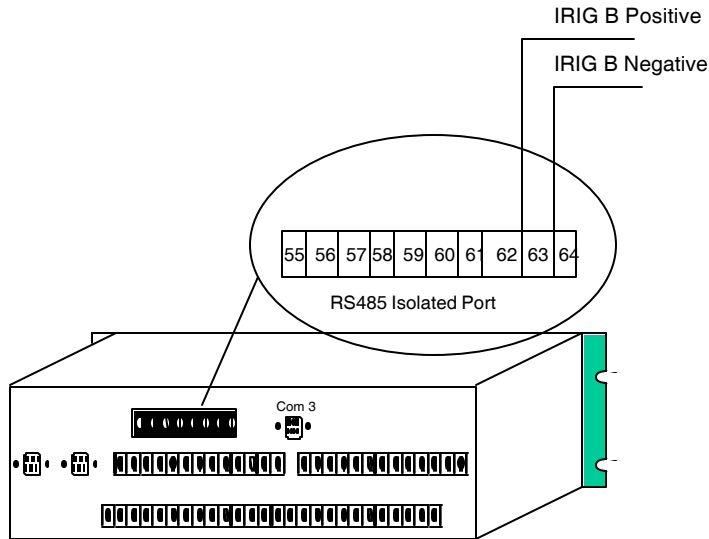

Figure 4-10. DPU/TPU/GPU2000R and DPU1500R IRIG B Connector Placement

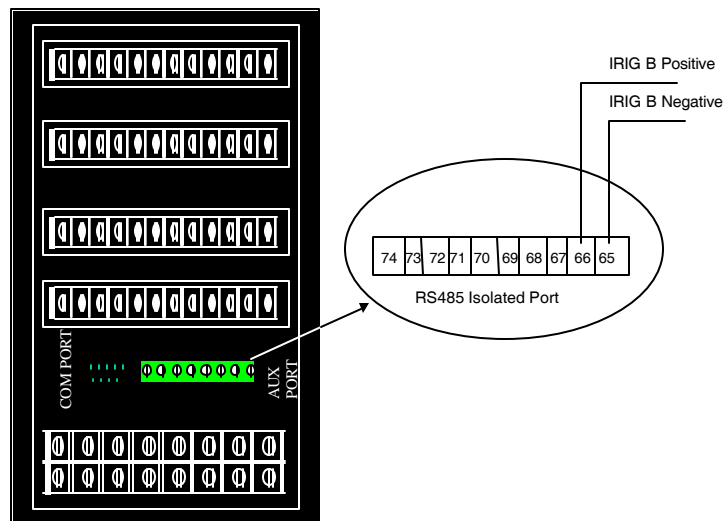

Figure 4-11. DPU/TPU2000 IRIG B Connector Placement

TPU2000/2000R Modbus/Modbus Plus Automation Guide

ABB's implementation of IRIG B requires that the signal be daisy-chained to each device. Each device in the IRIG B network presents a load to the IRIG B receiver/converter. Daisy-chained inputs are simple parallel circuits. A sample calculation is shown for the example illustrated in Figure 4-13.

If the input impedance of each DPU/TPU/GPU2000/R is measured at its IRIG B connection, the impedance would be 1000 ohms. Each IRIG B input requires less than one mA to drive it.

Calculating the load impedance presented to the IRIG B source generator is illustrated in Figure 4-12. Each IED load on the IRIG B link presents a parallel impedance to the source. The general equation for parallel impedance is:

$$\frac{1}{Z_{\text{Total}}} = \frac{1}{Z_1} + \frac{1}{Z_2} + \frac{1}{Z_3} + \dots$$

$$I_{\text{Total}} = I_1 + I_2 + I_3 + \dots$$

This impedance equation simplifies to the form in Figure 4-12 when all IED loads are identical. If the loads are not identical, the general equation listed above must be used to calculate the load.

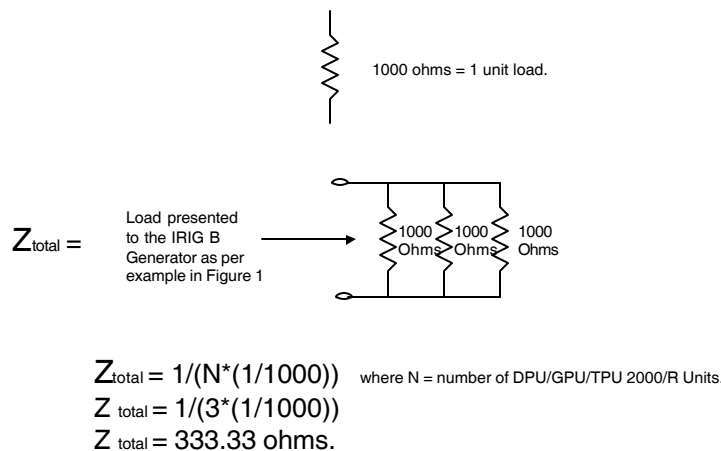

Thus the Source must be capable of driving a 333.33 ohm load.

Figure 4-12. Load Impedance Calculation

The calculated load impedance for the architecture presented in Figure 4-12 is 333.33 ohms. In this example the IRIG B receiver/converter must be capable of sending a three milli-amp TTL-level signal to a 333.33 ohm load. If the source is not matched with the load impedance, IRIG B will not operate correctly.

The cable recommended to connect the IRIG B devices shall have the following characteristics:

- Capacitance: less than 40 pF per foot line to shield
- Construction: 2-wire twisted pair shielded with PVC jacket The minimum current required for each TPU 2000R load is 4 mA at 5 V .

The maximum lead length of the entire relay is to be no more than 1000 feet. Cable types and vendors recommended and supported by ABB to interconnect the IRIG B devices are:

BELDEN 9841, BELDEN YM29560, or equivalent

An example of the terminal to terminal daisychain interconnection of three units is illustrated in Figure 4-13.

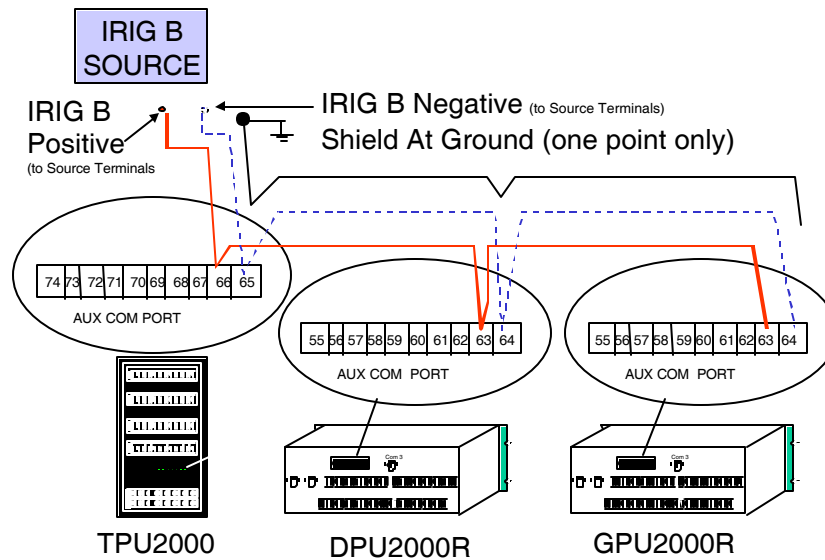

Figure 4-15. Pin to Pin Illustration of ABB Protective Daisychain link for IRIG B

Software Configuration

Physical interconnection of the devices is only one part of the procedure to allow IRIG B time stamp. The ABB protective relays must be configured to allow for IRIG B to be enabled. The procedure follows:

1. Start ECP from the DOS operating system for the appropriate device being configured.
2. Highlight the Change Settings Menu.
3. Highlight and Select the Communications Menu.
4. Scroll down to the field " IRIG B".
5. Depress the enter key and select the "ENABLE" selection. Two selections are displayed, ENABLE-mmm or ENABLE-cc. ENABLE-mmm will timestamp events and display the millisecond time as a number from 1 to 999. ENABLE-cc will timestamp events and display the millisecond time as a decimal fraction of a second from 1 to 99.
6. Return from the menu item.
7. Download the changed selections to the attached unit.

The unit is now synchronized to the IRIG B time source. All events shall be time stamped to the common IRIG B time source. The protective relays may also be configured for IRIG B timestamping from the front panel MMI of units which are equipped with a front panel interface.

Section 5 - Modbus

Modbus is available in two emulation's, Modbus RTU and Modbus ASCII. Modbus RTU is a bit oriented protocol (normally referred to as Synchronous), and Modbus ASCII is a byte oriented protocol (normally referred to as Asynchronous). Both emulations support the same command set. **Networked nodes cannot communicate unless the same emulation of the Modbus protocol is interpreted.** This is an extremely important issue. The TPU2000 and TPU2000R, support the Modbus ASCII and RTU protocol emulations.

Modbus Protocol

Modbus operates in the following fashion. A host device transmits a command, and one of the attached device(s) respond. Each device has a unique address assigned to it. Each device is configured for the same protocol emulation of Modbus. Figure 5-1 illustrates the polling sequence.

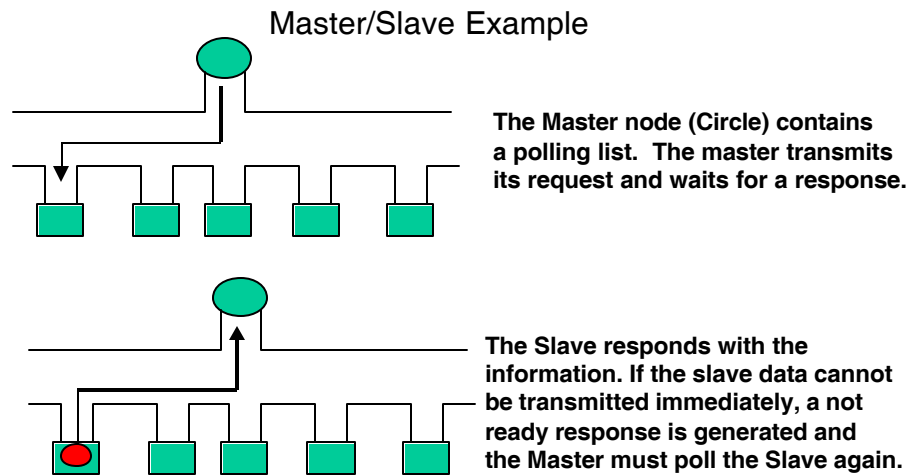

Figure 5-1. Modbus Polling Sequence

The TPU2000, and TPU2000R, are designed as Modbus slave emulation devices. That is, a device, a host, (illustrated in Figure 5-1) must be able to generate Master Requests in a Modbus format so that the slave, (TPU2000 or TPU2000R) is able to receive the commands.

Modbus ASCII Emulation

An ASCII character is defined as 7 data bits. A character is represented as a number from 00 HEX to 7F HEX. Appendix B contains an ASCII character conversion chart. If a 0 is transmitted, it must be decoded to an ASCII representation to be interpreted by the receiving device. 0 decimal is 30 hex for an ASCII representation. The frame format for Modbus is represented in Figure 5-2. The device address, function code and checksum is part of the transmitted frame. The Checksum is a Longitudinal Redundancy Check (LRC). Its calculation shall be described later in this guide.

The generic Modbus Frame is analyzed in Figure 5-3. The start of an ASCII frame is always a colon (: = 3A HEX) and a termination of the command is a line feed and carriage return (lf cr = 0D 0A). The format is the same for the host transmitting the frame and the slave node responding to the host's transmission. The device address is imbedded within the frame along with the Modbus command function code. A checksum is appended to the entire command. The checksum is a Longitudinal Redundancy Checksum. The LRC checksum combined with parity and internal field length detection determination, provides good security in detection of data packet errors. LRC is easily calculated by many devices which results in ASCII emulation's popularity.

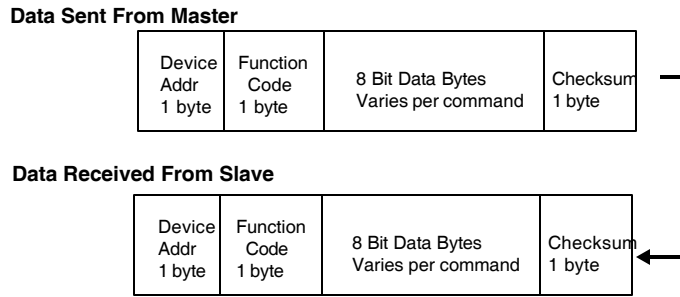

(Device Address = 0 (Null Command), 1 - 247, 255 (Broadcast))

Figure 5-2. Modbus ASCII Transmitted and Received Frame Formats

START	ADDRESS	FUNCTION	DATA	LRC	END
1 Char :	2 Chars	2 Chars	N Chars	2 Chars	2 Chars CR LF

Figure 5-3. Modbus ASCII Frame Format

The Modbus characters are encoded with a variety of frame sizes. An analysis of each frame is illustrated in Figure 5-4. When selecting a common frame size, (as explained in the configuration setup examples), parity, word length, and stop bits are selected to form a 10 bit data frame (1 start bit + 7 data bits + 1 stop bit + 1 Parity bit “OR” 1 start bit + 2 stop bits + 7 data bits + NO Parity = 10 bits per frame). It is important to note this distinction since if TPU2000, and TPU2000R, device attachment is to occur through a device, the device must support 10 bit asynchronous data framing.

Least Significant BitMost Significant Bit

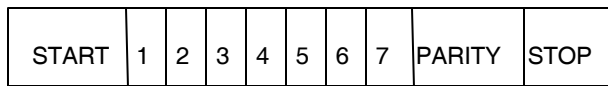

With Parity Checking

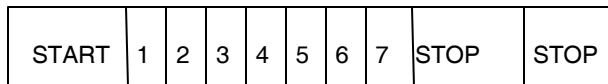

Without Parity Checking

Figure 5-4. Modbus ASCII Frame Analysis

The TPU2000 and TPU2000R offers a variety of frame sizes. If the frame size, 8N1 is selected (8 Data Bits, No Parity, 1 Stop Bit), then an additional stop bit is inserted. The frame format follows that of Figure 5-4 “Without Parity Checking”. However, when using ASCII protocol with many other devices, the data is limited to 7 bits. Selection of 8 bits for the data frame will automatically require that the device receive/transmit RTU mode. The ABB TPU2000 and TPU2000R, does not allow for this override, however several programmable logic controller manufacturers allow for this.

The receiving device determines that a frame is on the network by sensing the first character (: colon) and then determining that the message address is the same as that assigned to itself. If the Modbus device does not receive a carriage return line feed (lf cf 0A 0D) within an appreciable amount of time, the host will timeout. The length of characters in the message determines Timeout. Modbus ASCII will timeout is the time delay between each character exceeds 1 second delay between each character’s transmission. If 100 characters are required to

TPU2000/2000R Modbus/Modbus Plus Automation Guide

transmit a complete Modbus ASCII frame, then the timeout for the message could be in excess of 100 seconds for that specific exchange.

Modbus RTU Emulation

In contrast to the ASCII representation, Modbus allows for no encoding of the transmitted or received data message. If a data byte of 00 (zero zero) is sent to an IED from a Host, the data would be sent as a single byte of data (binary 0000 0000). If data would be sent as an ASCII data string the data would be composed of the encoded ASCII string 30 30 hex (binary 0011 0000 0011 0000). The Modbus RTU emulation is twice as efficient as Modbus ASCII mode.

START	ADDRESS	FUNCTION	DATA	LRC	END
4 Char Delays	8 Bits	8 Bits	N * 8 bits	16 Bits	4 Char Delays

Figure 5-5. Modbus RTU Format

RTU Framing

Least Significant BitMost Significant Bit

START	1	2	3	4	5	6	7	8	PARITY	STOP
-------	---	---	---	---	---	---	---	---	--------	------

With Parity Checking

START	1	2	3	4	5	6	7	8	STOP	STOP
-------	---	---	---	---	---	---	---	---	------	------

Without Parity Checking

Figure 5-6. RTU Frame Format

Figures 5-5 and 5-6 illustrate the format of the Modbus RTU emulation. An analysis of each frame is illustrated in Figure 5-6. When selecting a common frame size, (as explained in the configuration setup examples), parity, word length, and stop bits are selected to form a 11 bit data frame (1 start bit + 8 data bits + 1 stop bit + 1 Parity bit "OR" 1 start bit + 2 stop bits + 8 data bits + NO Parity = 11 bits per frame). It is important to note this distinction since if TPU2000, and TPU2000R, device attachment is to occur through a device, the device must support 11 bit asynchronous data framing.

Modbus ASCII protocol synchronizes host to IED messaging through monitoring the leading character (: colon). Modbus RTU synchronizes the host to IED messaging through time delays. Modbus RTU emulation. Modbus RTU timeout depends on the following rules.

- If delay between transmissions is < 3.5 Character Times, the message is received.
- If delay < 3.5 character times, receiving device appends characters to last message.
- If delay is sensed > 1.5 message times, receiving device flushes the buffer. Next character is new message.

The Modbus RTU emulation senses timeouts quicker than the Modbus ASCII emulation. The Modbus RTU emulation also uses a CRC -16 checksum in contrast to the Modbus ASCII using a LRC (Longitudinal

Redundancy Check). The CRC –16 is a much more robust checksum. With parity, internal protocol message length field checks and the CRC-16, the error detection is exceptional.

IMPLEMENTATION TIP-When commissioning a Modbus system, it is always advisable to connect a communication analyzer in-line with the host. It is always uncertain whether the host is sending the command correctly. Within the TPU2000 and TPU2000R, an incorrect address request will always generate an exception response from the relay. If an exception response is generated, many host devices will not display the Modbus exception response generated by the unit. A communication analyzer allows for rapid troubleshooting of a malfunctioning network connection.

Modbus Plus (Available on the TPU2000R Only)

Modbus capabilities were expanded in a significant way during the late 1980's. The base command set was not changed from the Modbus protocol, however, the protocol access method was modified. The limitations of Modbus exposed themselves in a few areas:

- ❑ The throughput was dependent upon the physical interface (RS232 and 485) which limited the speed of data transfer.
- ❑ The Modbus protocol did not efficiently manage its bandwidth. Exorbitant amounts of time could be spent waiting for the slave device to respond with data or timeout.
- ❑ The Modbus protocol only allowed connection of a single host (or multiple hosts with the addition of hardware multiplexers) to up to 247 IEDs.

The originator of the protocol Modicon AEG, had devised a way to use the Modbus protocol and present it to the attached nodes to eliminate the deficiencies found in large Modbus installations.

Modbus Plus was developed using a proprietary physical interface allowing communication over a twisted shielded pair medium. The baud rate of the network was fixed at 1 megabaud. If this had been the only change from Modbus to Modbus Plus, the network's introduction would not have been significant. The Modbus repackaging into a Modbus Plus format afforded the following significant benefits:

- ❑ Up to 34 simultaneous conversations may occur on a network.
- ❑ Each device on a Modbus network is capable of being a host.
- ❑ Each device may broadcast a data, which is received by all other nodes on the network.
- ❑ Node to node network throughput time may be deterministically calculated.

The Modbus Plus interface was afforded though the manufacturer entering into a "MODCONNECT AGREEMENT" allowing sharing of technology between the IED implementers and Modicon AEG. The IED implementers received Modbus Plus chipsets and technology allowing network implementation. Once the implementation was completed, a certification process ensued and upon the IED's successful test of the implementation, certification was bestowed upon the IED.

Modbus Plus Theory of Operation

Modbus Plus is a token passing network based upon an HDLC like protocol implementation. The frame structure of the protocol is illustrated in Figure 5-3. As illustrated, the Modbus command structure is imbedded in the Modbus Plus structure. Thus, all Modbus commands are used for Modbus Plus. The manufacturer of the protocol supplies drivers allowing DOS, Windows [3.1, 95 or 98] to communicate with the Modbus Plus hardware. The implicit understanding of Modbus Plus protocol frames is not needed by the operator. This discussion is meant to inform the reader of the commonality between Modbus and Modbus Plus.

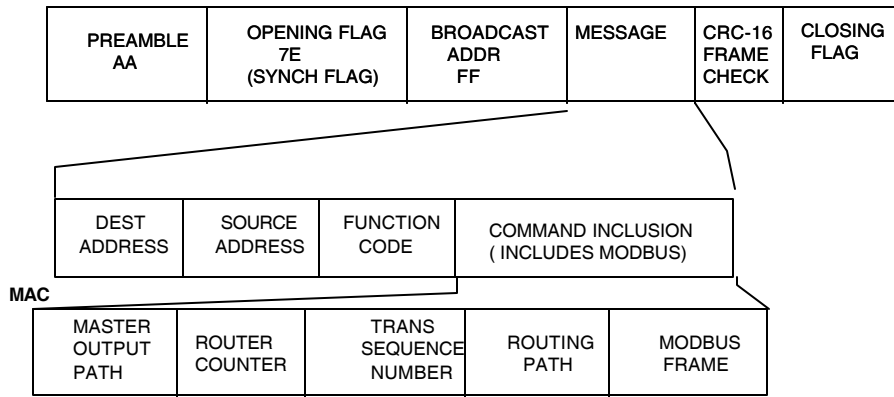

Figure 5-7. Modbus Plus Message Frame Structure

Modbus Plus is a “token passing” network in that upon startup, a token is generated. The node with the token acts as a host device. The node holds a token for a period of time and passes the token to the next node on the network. The token rotation scheme is described in Figures 5-8 through 5-10.

PEER TO PEER EXAMPLE

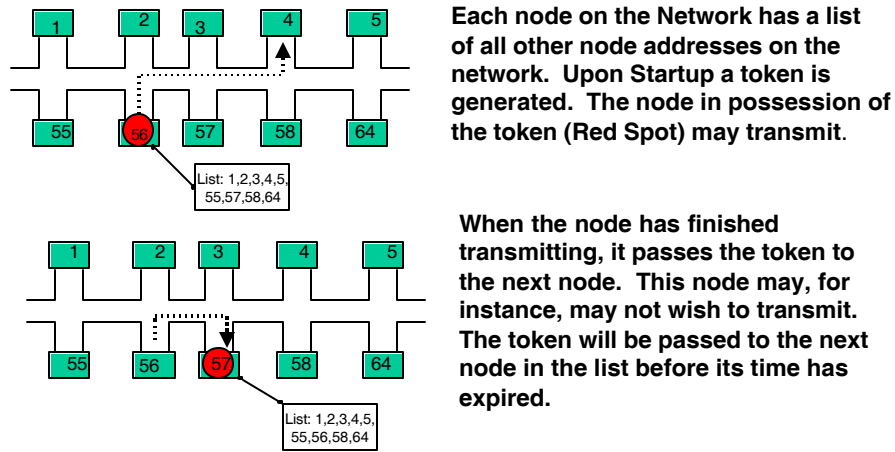

Figure 5-8. Modbus Plus Token Rotation Explanation

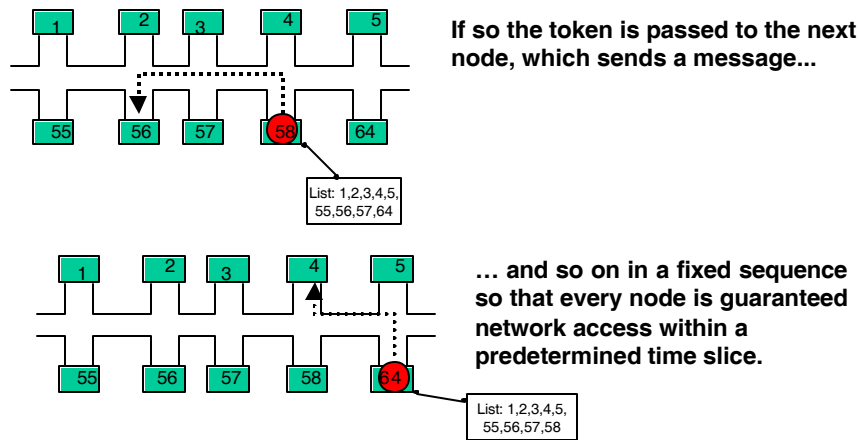

Figure 5-9. Modbus Plus Token Rotation Explanation

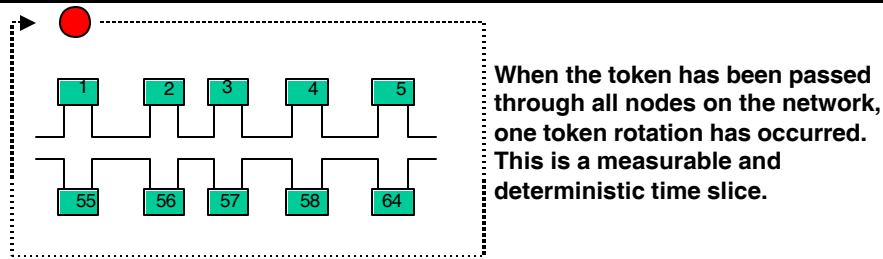

Figure 5-10. Modbus Plus Token Rotation Explanation

Modbus Plus allows interconnection of up to 5 networks of devices. Each Modbus Plus network may be comprised of up to 64 nodes of IED's distributed over 6000 feet of cable. Physical interface cabling is discussed in other sections of this document. Each network is interconnected with a bridge device. The Modbus Plus Bridge is obtainable through Schneider Electric or Square D Company. The Modbus Plus Bridge is an addressable device with each port being assigned an address particular to the network to which it is attached. Figure 5-11 illustrates the network configuration.

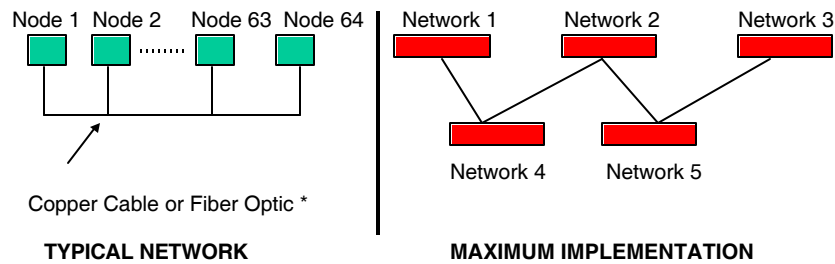

Figure 5-11. Modbus Plus Network Topology

Understanding the concept of Modbus Plus Paths is critical for assignment of a node address and calculating network throughput. Figure 5-12 illustrates the maximum path implementation for Modbus Plus. The maximum path implementation for a Modbus Plus Node is shown in Figure 5-12.

- ❑ 8 Program Master Paths (Programmable Logic Controller Only)
 - Used by Programmable Logic controllers to Transfer Master Data From Node to Node (Unavailable to Modconnect Partner IED's)
- ❑ 8 Program Slave Paths (Programmable Logic Controller Only)
 - Used by Programmable Logic controller to Receive Master Data From Node to Node (Unavailable to Modconnect Partner IED's)
- ❑ 8 Data Slave Paths
 - Used by Nodes to Receive Slave Data (Available to Modconnect Partner IED's)
- ❑ 8 Data Master Paths
 - Used by Slave Nodes to Transmit Slave Data to other Nodes (Available to Modconnect Partner IED's)
- ❑ 1 Global Input Data Path
 - Global Data Path to Receive Global Data from Other Modbus Plus Nodes (Available to Modconnect Partner IED's)
- ❑ 1 Global Output Data Path
 - Global Data Path to allow the node to Transmit Global Data to other Modbus Plus Nodes (Available to Modconnect Partner IED's)

Global Data is a Modbus Plus capability allowing each node to place up to 32 – 16 bit words of data on the network. Each word of Global Data is retrievable by any node on that segment of the Modbus Plus Network. GLOBAL DATA IS NOT RETRIEVABLE THROUGH A MODBUS PLUS BRIDGE OR BRIDGE MULTIPLEXER DEVICE.

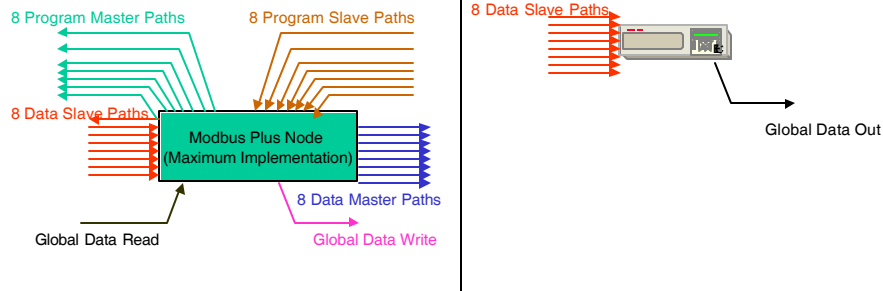

Figure 5-12. Modbus Plus Path Designation

The TPU2000R implementation of Modbus Plus shows the data path implementation. The TPU2000R Modbus Plus implementation allows:

- ❑ The TPU2000R to receive information requests from a device acting as a host along one of its 8 data slave paths.
- ❑ The TPU2000R to place up to 32 registers of data on the Global Out Data Path. The data sent on the Global Out Path is configurable through ECP or WinECP. The Configuration Method is described in Section 4.

The TPU2000R implements Modbus Plus as a HOST device. The Modbus Plus address assignment required depends upon the understanding of the path assignment discussion. Figure 5-13 illustrates the addressing required when a device (such as a programmable logic controller or a host device with a Modbus Plus SA 85 card) must access a TPU2000R via Modbus Plus. An application note is included in Appendix C describing the process for Programmable Logic Controller attachment with a TPU2000R. This application note can easily be applied in connecting a TPU2000R to a Programmable Logic Controller Network.

As per Figure 5-13, if a host device X is to request data from an ABB TPU2000R, the node address (configured via the front panel interface, ECP, or WinECP) is the first address node entry in the data path for the address Routing Path 1. In the case with the nodes sharing the same network, the Routing Path 2 entry is the slave path address communicated with. The Route address for the slave path is 1 through 8.

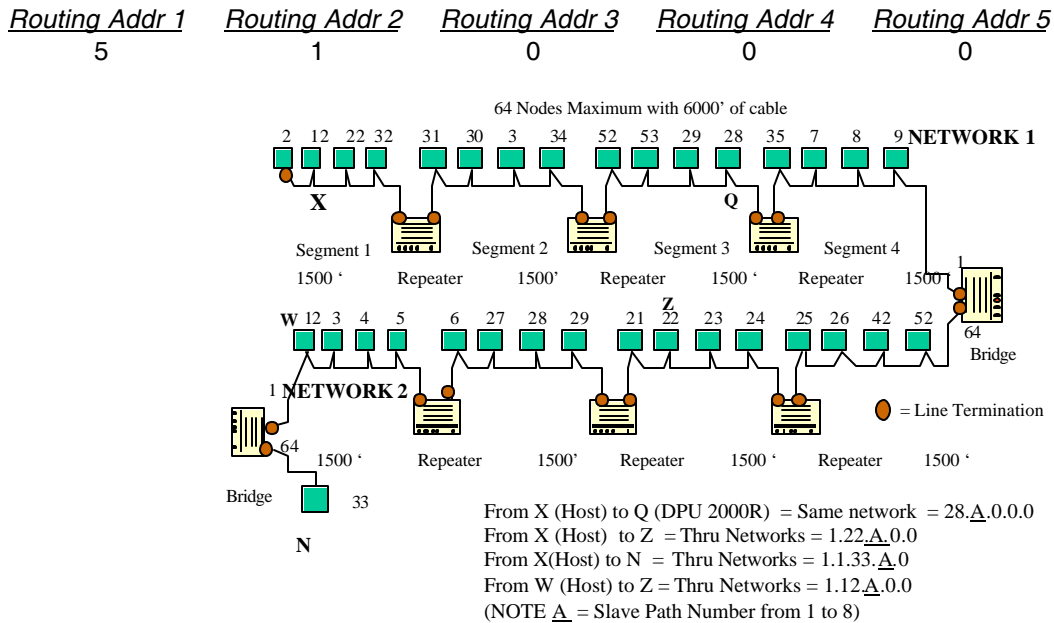

Figure 5-13. Modbus Plus Addressing Example

If a node had to cross a network boundary through a Bridge, the examples illustrate how node access addressing would be affected.

Modbus and Modbus Plus General Notes

Modbus is an exceptional protocol for bridging a majority of vendor devices to communicate to each other. The generation of each protocol, throughput, robust capabilities and troubleshooting techniques shall be covered in later sections. The understanding of each of these principles shall aid the implement in exploiting the capabilities within their own automation system.

Modbus ASCII, Modbus RTU, and Modbus Plus have the following capacities implemented within the TPU2000 and TPU2000R.

- ❑ 01 - Read 0X Coil Status
- ❑ 02 - Read 1X Contact Status
- ❑ 03 - Read 4X Holding Registers
- ❑ 16 - Write 4X Holding Registers
- ❑ 08 - Diagnostics
- ❑ 23 - Write 4X and Read 4X Holding Registers
- ❑ 20 - Read 6X Extended Registers
- ❑ 21 - Write 6X Extended Registers

The TPU2000 and TPU2000R emulates a slave device. Any other Modbus command sent to the TPU2000 and TPU2000R shall result in a Modbus exception code being sent to the transmitting device. The following sections will further describe the Modbus functionality within the TPU2000 and TPU2000R.

IMPLEMENTATION TIP-Although the TPU2000 and TPU2000R allows configuration of Modbus for a Frame of N-8-1, some implementations will interpret this emulation of Modbus to be RTU Mode. The TPU2000 and TPU2000R does not support this mode. It is advisable to contact the manufacturer of the host and host software to determine the interpretation of the command string. For example, the Modicon XMIT and COMM BLOCK allowing the PLC to emulate a host device only allows block frame size designation of 7 data bits.

Modbus/Modbus Plus Register Map

0X Discrete Coils

Discrete Modbus Coil status is available via a function 01 request via Modbus. Figure 5-14 illustrates a typical command sequence. The Host polls the TPU2000/TPU2000R for the Data. The TPU2000/2000R receives the request and responds with the expected data. The Host then interprets the command response, checks the checksum (LRC if ASCII, CRC 16 if RTU mode and then displays the interpreted data. Additional information is available in Modicon's protocol manual references listed at the beginning of this document.

Function 01 - Read Coil Status

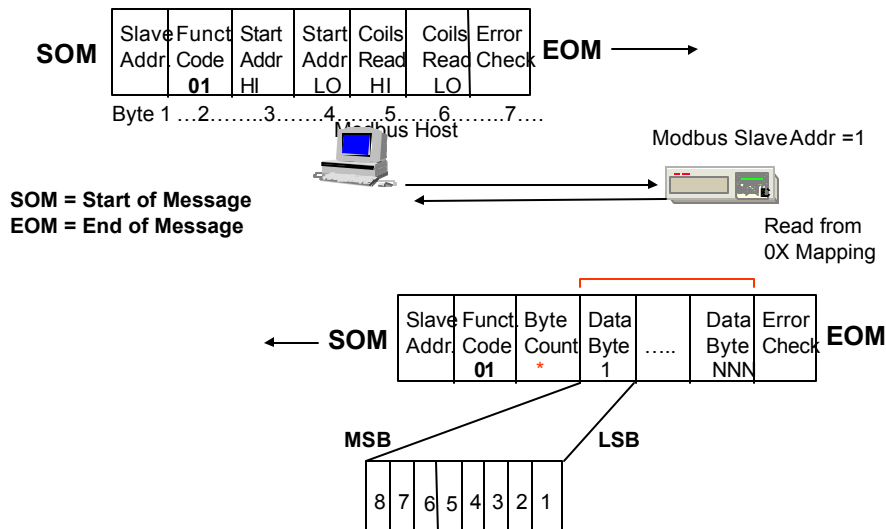

Figure 5-14. Modbus Protocol Function 01 Frame Format

Function Code 1 (Read Coil Status) – Read Only Data

The 0X read command allows for access of Logical and Physical Input data. The information listed in Tables 1, 2, and 3 is that which is reported in real time. In other words, if the bits are polled as per the table, the status of each data bit is reported at the time the data is requested. If the data is momentary in nature, then access of status is dependent upon reading the information at the time the function or signal is present.

Table 5-1 lists the Logical Output Single Bit Data. The data listed within the table includes real time status bits which may be briefly reported status bits. In other words, they follow the real time status of the point. Other points reported in the table are latched.

A Latched point (sometimes referred to as Sealed In Output Point). These points stay energized until they are reset by a group control function. The function is reset via the method described in the 4X control explanation and an example is shown in Figure 5-15.

Momentary data reporting is available at the present time. Some bit statuses are brief in reporting nature. Modbus and Modbus Plus do not have a method of timestamping events, nor is there a “protocol defined” method to ensure that an event is not lost. ABB incorporates a method called “Momentary Bit Status Reporting” allowing a host to poll a protective device at any time and ensure that a contact change notification occurs. The method shall be explained later in this document.

If data is requested from memory addresses not defined within this document, a Modbus Exception Code shall be generated.

Figures 5-15 and 5-16 illustrate a simple example of a host requesting data from a TPU2000R relay where Physical Relay Coil Status is requested of the TPU2000/TPU2000R. The example illustrates that data is requested in the Modbus ASCII frame format illustrated in Figure 5-15, raw data received by the host is decoded from ASCII to HEX. The host as illustrated in Figure 5-16 parses the individual status bits.

Example - Read Output 1-6

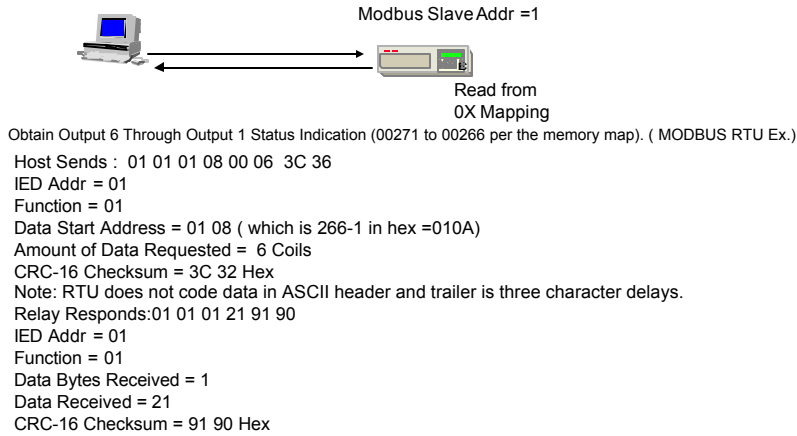
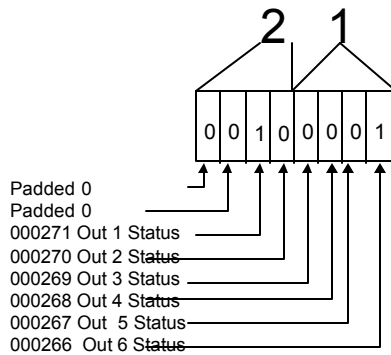

Figure 5-15. Example Transaction Request for Eight Physical Output Coils

Function 01- Read Coil Status

Example - Analysis of Data Received



RESULT : Output 1 and Output 6 are energized.

Figure 5-16. Example of Raw Data Decode

Modbus 0X Implementation Features

Modbus is a protocol often used in the industrial sector. The protocol was developed to operate between hosts and programmable logic controllers. The controlling device, in most cases was a PLC (Programmable Logic Controller), which had the capability of detecting and storing fast events and indicating to the polling device that an event had occurred. The change detect feature was not part of the protocol, but part of the monitoring device (namely the Modicon PLC).

Utility devices require that no event is to be missed in the field IED. ABB has incorporated two methods in which a device is notified that events have occurred in the field IED between host polls. The two methods employed for 0x data (Modbus Function Code 01) are:

- MOMENTARY CHANGE DETECT
- LATCHED ELEMENT RETENTION

MOMENTARY CHANGE DETECT and LATCHED ELEMENT RETENTION are independent of the protocol. These ABB innovations allow Modbus protocol to address and satisfy the concerns common to a utility

TPU2000/2000R Modbus/Modbus Plus Automation Guide

installation. The two functionality's are those in excess of the real time status access that Modbus function code 01 affords.

Momentary Change Detect status is incorporated using two bits to indicate present status and momentary indication status. The odd bit is the status bit and the even bit is the momentary bit. The status bit indicates the present state of the element accessed. The momentary bit indicates element transitioning more than once between IED reads. The momentary bit is set to a "1" if the element has transitioned more than once. The bit is reset upon a host access. Addresses 00513 through 01056 are allocated for momentary change bit detect status detection. **NOTE: MOMENTARY BITS MUST BE READ IN PAIRS.**

An example of momentary change detect is illustrated in Figure 5-17. Suppose a host device monitors TPU2000R physical output bit 1. Figure 5-17 illustrates the physical output transitions of output 1. At each output rising edge/falling edge transition, the status of the Modbus coil 0x addresses are listed. The dotted line arrows indicate the poll received by the TPU2000R and the state of both the status bit and the momentary indication bit. Note that the even bit (momentary change detect) resets itself to a zero state after a host read.

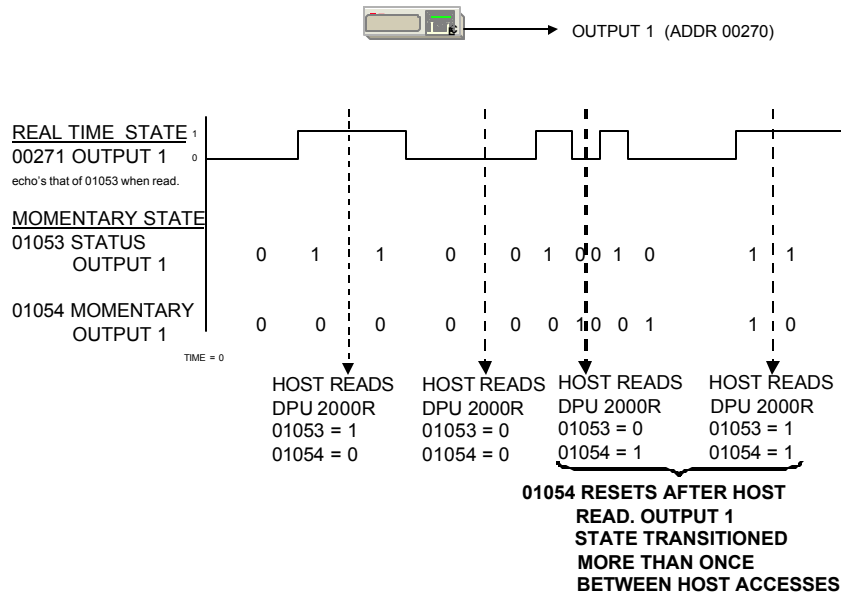

Figure 5-17. Momentary Change Detect Example

Latched Element Retention is a method by which when an element has transitions from a 0 (inactive), to a 1 (active) status, the element is set to "1". The element stays at a status of 1 until the operator executes a reset sequence. The reset of latched points may occur:

- ❑ The operator may depress the "SYSTEM RESET" pushbutton at the faceplate of the TPU2000R
- ❑ Depress the "C", "E", and "↑" (UP ARROW), keys simultaneously on the membrane keypad (TPU2000R and TPU2000)
- ❑ Initiate a supervisory bit reset sequence for the individual bits requiring reset. Reference Section 5 of this guide for a detailed explanation of the reset procedure.

Figure 5-18 illustrates the operation of a latched bit sequence. The LATCHED elements are denoted with the symbol (L) within the tables. Example latched elements are addresses 0050 through 0069 in Table 5-1 of this document.

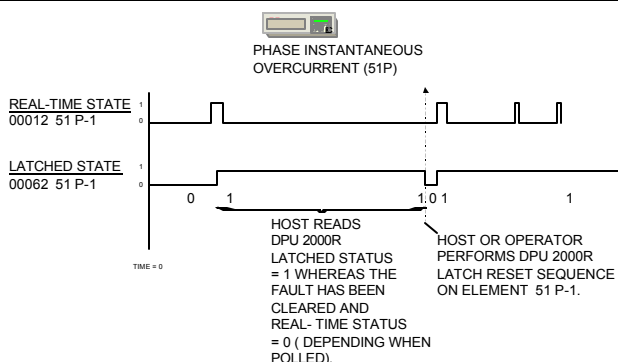

Figure 5-18. Latched Element Status Example

Logical Output Block (Single Bit Data) – 108 Discrete Coils (99 Elements Defined 2 Winding TPU, 176 Elements Defined for 3 Winding TPU)

Relay Element Status as described in Table 5-3. Additional coil status has been added in the latest version of TPU2000/TPU2000R executive firmware. Consult the symbol keys in the table for revision level feature inclusion.

The status information reported in Table 5-3 is reported as real time status bits. Additional Latched or Seal In bits are reported as status as illustrated in the following table.

Table 5-1. Logical Output Modbus Address Map Definition

Register Address	Item	Description
00513:	DIFF STATUS	Differential Trip Contact Energized (Status)
00514:	DIFF MOMENTARY	Differential Trip Contact Energized (Momentary)
00515:	SELFCHECK ALARM STATUS	Self Check Alarm Energized (Status)
00516:	SELFCHECK ALARM MOMENTARY	Self Check Alarm Energized (Momentary)
00517:	87T STATUS	Harmonic Restrained % Differential Trip Alarm Energized (Status)
00518:	87T MOMENTARY	Harmonic Restrained % Differential Trip Alarm Energized (Momentary)
00519:	87H STATUS	Unrestrained High Set Instantaneous Differential Trip Alarm Energized (Status)
00520:	87H MOMENTARY	Unrestrained High Set Instantaneous Differential Trip Alarm Energized (Momentary)
00521:	2HROA STATUS	2 nd Harmonic Restraint Alarm Energized (Status)
00522:	2HROA MOMENTARY	2 nd Harmonic Restraint Alarm Energized (Momentary)
00523:	5HROA STATUS	5 th Harmonic Restraint Alarm Energized (Status)
00524:	5HROA MOMENTARY	5 th Harmonic Restraint Alarm Energized (Momentary)
00525:	AHROA STATUS	All Harmonics Restraint Alarm (2 nd through 11th Harmonic) Energized (Status)
00526:	AHROA MOMENTARY	All Harmonics Restraint Alarm (2 nd through 11th Harmonic) Energized (Momentary)
00527:	TCFA STATUS	Trip Circuit is Open Fail Alarm Energized (Status)
00528:	TCFA MOMENTARY	Trip Circuit is Open Fail Alarm Energized (Momentary)
00529:	TFA STATUS	Trip Fail Alarm Energized (Status)
00530:	TFA MOMENTARY	Trip Fail Alarm Energized (Momentary)
00531:	51P-1 STATUS	Winding 1 Phase Time Overcurrent Alarm Energized (Status)
00532:	51P-1 MOMENTARY	Winding 1 Phase Time Overcurrent Alarm Energized (Momentary)
00533:	51P-2 STATUS	Winding 2 Phase Time Overcurrent Alarm Energized (Status)

TPU2000/2000R Modbus/Modbus Plus Automation Guide

Register Address	Item	Description
00534:	51P-2 MOMENTARY	Winding 2 Phase Time Overcurrent Alarm Energized (Momentary)
00535:	50P-1 STATUS	1 st Winding 1 Phase Instantaneous Overcurrent Trip Alarm Energized (Status)
00536:	50P-1 MOMENTARY	1 st Winding 1 Phase Instantaneous Overcurrent Trip Alarm Energized (Momentary)
00537:	150P-1 STATUS	2 nd Winding 1 Phase Instantaneous Overcurrent Trip Alarm Energized (Status)
00538:	150P-1 MOMENTARY	2 nd Winding 1 Phase Instantaneous Overcurrent Trip Alarm Energized (Momentary)
00539:	50P-2 STATUS	1 st Winding 2 Phase Instantaneous Overcurrent Trip Alarm Energized (Status)
00540:	50P-2 MOMENTARY	1 st Winding 2 Phase Instantaneous Overcurrent Trip Alarm Energized (Momentary)
00541:	150P-2 STATUS	2 nd Winding 2 Phase Instantaneous Overcurrent Trip Alarm Energized (Status)
00542:	150P-2 MOMENTARY	2 nd Winding 2 Phase Instantaneous Overcurrent Trip Alarm Energized (Momentary)
00543:	51N-1 STATUS	Winding 1 Neutral Time Overcurrent Trip Alarm Energized (Status)
00544:	51N-1 MOMENTARY	Winding 1 Neutral Time Overcurrent Trip Alarm Energized (Momentary)
00545:	51N-2 STATUS	Winding 1 Neutral Time Overcurrent Trip Alarm Energized (Status)
00546:	51N-2 MOMENTARY	Winding 1 Neutral Time Overcurrent Trip Alarm Energized (Momentary)
00547:	50N-1 STATUS	1 st Winding 1 Neutral Instantaneous Overcurrent Trip Alarm Energized (Status)
00548:	50N-1 MOMENTARY	1 st Winding 1 Neutral Instantaneous Overcurrent Trip Alarm Energized (Momentary)
00549:	150N-1 STATUS	2 nd Winding 1 Neutral Instantaneous Overcurrent Trip Alarm Energized (Status)
00550:	150N-1 MOMENTARY	2 nd Winding 1 Neutral Instantaneous Overcurrent Trip Alarm Energized (Momentary)
00551:	50N-2 STATUS	1 st Winding 2 Neutral Instantaneous Overcurrent Trip Alarm Energized (Status)
00552:	50N-2 MOMENTARY	1 st Winding 2 Neutral Instantaneous Overcurrent Trip Alarm Energized (Momentary)
00553:	150N-2 STATUS	2 nd Winding 2 Neutral Instantaneous Overcurrent Trip Alarm Energized (Status)
00554:	150N-2 MOMENTARY	2 nd Winding 2 Neutral Instantaneous Overcurrent Trip Alarm Energized (Momentary)
00555:	46-1 STATUS	Winding 1 Negative Sequence Time Overcurrent Trip Alarm Energized (Status)
00556:	46-1 MOMENTARY	Winding 1 Negative Sequence Time Overcurrent Trip Alarm Energized (Momentary)
00557:	46-2 STATUS	Winding 1 Negative Sequence Time Overcurrent Trip Alarm Energized (Status)
00558:	46-2 MOMENTARY	Winding 1 Negative Sequence Time Overcurrent Trip Alarm Energized (Momentary)
00559:	87T-D STATUS	Percentage Differential Disabled Alarm Energized (Status)
00560:	87T-D MOMENTARY	Percentage Differential Disabled Alarm Energized (Momentary)
00561:	87H-D STATUS	High Set Instantaneous Function Disabled Alarm Energized (Status)

TPU2000/2000R Modbus/Modbus Plus Automation Guide

Register Address	Item	Description
00562:	87H-D MOMENTARY	High Set Instantaneous Function Disabled Alarm Energized (Momentary)
00563:	51P-1D STATUS	Winding 1 Phase Time Overcurrent Function Disabled Alarm (Status)
00564:	51P-1D MOMENTARY	Winding 1 Phase Time Overcurrent Function Disabled Alarm (Momentary)
00565:	51P-2D STATUS	Winding 2 Phase Time Overcurrent Function Disabled Alarm (Status)
00566:	51P-2D MOMENTARY	Winding 2 Phase Time Overcurrent Function Disabled Alarm (Momentary)
00567:	51N-1D STATUS	Winding 1 Neutral Time Overcurrent Function Disabled Alarm (Status)
00568:	51N-1D MOMENTARY	Winding 1 Neutral Time Overcurrent Function Disabled Alarm (Momentary)
00569:	51N-2D STATUS	Winding 2 Neutral Time Overcurrent Function Disabled Alarm (Status)
00570:	51N-2D MOMENTARY	Winding 2 Neutral Time Overcurrent Function Disabled Alarm (Momentary)
00571:	50P-1D STATUS	1 st Winding 1 Phase Instantaneous Overcurrent Function Disabled Alarm (Status)
00572:	50P-1D MOMENTARY	1 st Winding 1 Phase Instantaneous Overcurrent Function Disabled Alarm (Momentary)
00573:	50P-2D STATUS	1 st Winding 2 Phase Instantaneous Overcurrent Function Disabled Alarm (Status)
00574:	50P-2D MOMENTARY	1 st Winding 2 Phase Instantaneous Overcurrent Function Disabled Alarm (Momentary)
00575:	50N-1D STATUS	1 st Winding 1 Neutral Instantaneous Overcurrent Function Disabled Alarm (Status)
00576:	50N-1D MOMENTARY	1 st Winding 1 Neutral Instantaneous Overcurrent Function Disabled Alarm (Momentary)
00577:	50N-2D STATUS	1 st Winding 2 Neutral Instantaneous Overcurrent Function Disabled Alarm (Status)
00578:	50N-2D MOMENTARY	1 st Winding 2 Neutral Instantaneous Overcurrent Function Disabled Alarm (Momentary)
00579:	150P-1D STATUS	2 nd Winding 1 Phase Instantaneous Overcurrent Function Disabled Alarm (Status)
00580:	150P-1D MOMENTARY	2 nd Winding 1 Phase Instantaneous Overcurrent Function Disabled Alarm (Momentary)
00581:	150P-2D STATUS	2 nd Winding 2 Phase Instantaneous Overcurrent Function Disabled Alarm (Status)
00582:	150P-2D MOMENTARY	2 nd Winding 2 Phase Instantaneous Overcurrent Function Disabled Alarm (Momentary)
00583:	150N-1D STATUS	2 nd Winding 1 Neutral Instantaneous Overcurrent Function Disabled Alarm (Status)
00584:	150N-1D MOMENTARY	2 nd Winding 1 Neutral Instantaneous Overcurrent Function Disabled Alarm (Momentary)
00585:	150N-2D STATUS	2 nd Winding 2 Neutral Instantaneous Overcurrent Function Disabled Alarm (Status)
00586:	150N-2D MOMENTARY	2 nd Winding 2 Neutral Instantaneous Overcurrent Function Disabled Alarm (Momentary)
00587:	46-1D STATUS	Winding 1 Negative Sequence Time Overcurrent Function Disabled Alarm (Status)
00588:	46-1D MOMENTARY	Winding 1 Negative Sequence Time Overcurrent Function Disabled Alarm (Momentary)
00589:	46-2D STATUS	Winding 1 Negative Sequence Time Overcurrent Function

TPU2000/2000R Modbus/Modbus Plus Automation Guide

	Register Address	Item	Description
			Disabled Alarm (Status)
	00590:	46-2D MOMENTARY	Winding 1 Negative Sequence Time Overcurrent Function Disabled Alarm (Momentary)
	00591:	PATA STATUS	Phase A Target Alarm Energized (Status)
	00592:	PATA MOMENTARY	Phase A Target Alarm Energized (Momentary)
	00593:	PBTA STATUS	Phase B Target Alarm Energized (Status)
	00594:	PBTA MOMENTARY	Phase B Target Alarm Energized (Momentary)
	00595:	PCTA STATUS	Phase C Target Alarm Energized (Status)
	00596:	PCTA MOMENTARY	Phase C Target Alarm Energized (Momentary)
	00597:	PUA STATUS	Pick Up Alarm Energized (Status)
	00598:	PUA MOMENTARY	Pick Up Alarm Energized (Momentary)
	00599:	63 STATUS	Sudden Pressure Input Alarm Energized (Status)
	00600:	63 MOMENTARY	Sudden Pressure Input Alarm Energized (Momentary)
	00601:	THRUFA STATUS	Through Fault Alarm Energized (Status)
	00602:	THRUFA MOMENTARY	Through Fault Alarm Energized (Momentary)
	00603:	TFCA STATUS	Through Fault Counter Alarm Energized (Status)
	00604:	TFCA MOMENTARY	Through Fault Counter Alarm Energized (Momentary)
	00605:	TFKA-2 STATUS	Through Fault KiloAmp Symmetrical Alarm Winding 2 Energized. (Status)
	00606:	TFKA-2 MOMENTARY	Through Fault KiloAmp Symmetrical Alarm Winding 2 Energized. (Momentary)
	00607:	TFSCA STATUS	Through Fault Summation Cycle Alarm Energized (Status)
	00608:	TFSCA MOMENTARY	Through Fault Summation Cycle Alarm Energized (Momentary)
	00609:	DTC STATUS	Differential Trip Current Alarm Energized (Status)
	00610:	DTC MOMENTARY	Differential Trip Current Alarm Energized (Momentary)
	00611:	OCTC STATUS	Overcurrent Trip Counter Alarm Energized (Status)
	00612:	OCTC MOMENTARY	Overcurrent Trip Counter Alarm Energized (Momentary)
	00613:	PDA STATUS	Phase Demand Current Alarm Energized (Status)
	00614:	PDA MOMENTARY	Phase Demand Current Alarm Energized (Momentary)
	00615:	NDA STATUS	Neutral Demand Current Alarm Energized (Status)
	00616:	NDA MOMENTARY	Neutral Demand Current Alarm Energized (Momentary)
	00617:	PRIM STATUS	Primary Settings Alarm Energized (Status)
	00618:	PRIM MOMENTARY	Primary Settings Alarm Energized (Momentary)
	00619:	ALT1 STATUS	Alternate 1 Settings Enabled (Status)
	00620:	ALT1 MOMENTARY	Alternate 1 Settings Enabled (Momentary)
	00621:	ALT2 STATUS	Alternate 2 Settings Enabled (Status)
	00622:	ALT2 MOMENTARY	Alternate 2 Settings Enabled (Momentary)
	00623:	STCA STATUS	Settings Table Changed Alarm Energized (Status)
	00624:	STCA MOMENTARY	Settings Table Changed Alarm Energized (Momentary)
(L)	00625:	87T STATUS	Harmonic Restrained % Differential Trip Alarm Energized (Status)
(L)	00626:	87T MOMENTARY	Harmonic Restrained % Differential Trip Alarm Energized (Momentary)
(L)	00627:	87H STATUS	Unrestrained High Set Instantaneous Differential Trip Alarm Energized (Status)
(L)	00628:	87H MOMENTARY	Unrestrained High Set Instantaneous Differential Trip Alarm Energized (Momentary)
(L)	00629:	2HROA STATUS	2 nd Harmonic Restraint Alarm Energized (Status)
(L)	00630:	2HROA MOMENTARY	2 nd Harmonic Restraint Alarm Energized (Momentary)
(L)	00631:	5HROA STATUS	5 th Harmonic Restraint Alarm Energized (Status)
(L)	00632:	5HROA MOMENTARY	5 th Harmonic Restraint Alarm Energized (Momentary)
(L)	00633:	AHROA STATUS	All Harmonics Restraint Alarm (2 nd through 11th Harmonic)

TPU2000/2000R Modbus/Modbus Plus Automation Guide

	Register Address	Item	Description
			Energized (Status)
(L)	00634:	AHROA MOMENTARY	All Harmonics Restraint Alarm (2 nd through 11th Harmonic) Energized (Momentary)
(L)	00635:	51P-1 STATUS	Winding 1 Phase Time Overcurrent Alarm Energized (Status)
(L)	00636:	51P-1 MOMENTARY	Winding 1 Phase Time Overcurrent Alarm Energized (Momentary)
(L)	00637:	51P-2 STATUS	Winding 2 Phase Time Overcurrent Alarm Energized (Status)
(L)	00638:	51P-2 MOMENTARY	Winding 2 Phase Time Overcurrent Alarm Energized (Momentary)
(L)	00639:	50P-1 STATUS	1 st Winding 1 Phase Instantaneous Overcurrent Trip Alarm Energized (Status)
(L)	00640:	50P-1 MOMENTARY	1 st Winding 1 Phase Instantaneous Overcurrent Trip Alarm Energized (Momentary)
(L)	00641:	150P-1 STATUS	2 nd Winding 1 Phase Instantaneous Overcurrent Trip Alarm Energized (Status)
(L)	00642:	150P-1 STATUS	2 nd Winding 1 Phase Instantaneous Overcurrent Trip Alarm Energized (Status)
(L)	00643:	50P-2	1 st Winding 2 Phase Instantaneous Overcurrent Trip Alarm Energized
(L)	00644:	50P-2	1 st Winding 2 Phase Instantaneous Overcurrent Trip Alarm Energized
(L)	00645:	150P-2	2 nd Winding 2 Phase Instantaneous Overcurrent Trip Alarm Energized
(L)	00646:	150P-2	2 nd Winding 2 Phase Instantaneous Overcurrent Trip Alarm Energized
(L)	00647:	51N-1	Winding 1 Neutral Time Overcurrent Trip Alarm Energized
(L)	00648:	51N-1	Winding 1 Neutral Time Overcurrent Trip Alarm Energized
(L)	00649:	51N-2	Winding 1 Neutral Time Overcurrent Trip Alarm Energized
(L)	00650:	51N-2	Winding 1 Neutral Time Overcurrent Trip Alarm Energized
(L)	00651:	50N-1	1 st Winding 1 Neutral Instantaneous Overcurrent Trip Alarm Energized
(L)	00652:	50N-1	1 st Winding 1 Neutral Instantaneous Overcurrent Trip Alarm Energized
(L)	00653:	150N-1	2 nd Winding 1 Neutral Instantaneous Overcurrent Trip Alarm Energized
(L)	00654:	150N-1	2 nd Winding 1 Neutral Instantaneous Overcurrent Trip Alarm Energized
(L)	00655:	50N-2	1 st Winding 2 Neutral Instantaneous Overcurrent Trip Alarm Energized
(L)	00656:	50N-2	1 st Winding 2 Neutral Instantaneous Overcurrent Trip Alarm Energized
(L)	00657:	150N-2	2 nd Winding 2 Neutral Instantaneous Overcurrent Trip Alarm Energized
(L)	00658:	150N-2	2 nd Winding 2 Neutral Instantaneous Overcurrent Trip Alarm Energized
(L)	00659:	46-1	Winding 1 Negative Sequence Time Overcurrent Trip Alarm Energized
(L)	00660:	46-1	Winding 1 Negative Sequence Time Overcurrent Trip Alarm Energized
(L)	00661:	46-2	Winding 1 Negative Sequence Time Overcurrent Trip Alarm Energized
(L)	00662:	46-2	Winding 1 Negative Sequence Time Overcurrent Trip Alarm Energized
(L)	00663:	63	Sudden Pressure Seal In Alarm Energized

TPU2000/2000R Modbus/Modbus Plus Automation Guide

	Register Address	Item	Description
(L)	00664:	63	Sudden Pressure Seal In Alarm Energized
	00665:	ULO 1	User Logical Output 1
	00666:	ULO 1	User Logical Output 1
	00667:	ULO 2	User Logical Output 2
	00668:	ULO 2	User Logical Output 2
	00669:	ULO 3	User Logical Output 3
	00670:	ULO 3	User Logical Output 3
	00671:	ULO 4	User Logical Output 4
	00672:	ULO 4	User Logical Output 4
	00673:	ULO 5	User Logical Output 5
	00674:	ULO 5	User Logical Output 5
	00675:	ULO 6	User Logical Output 6
	00676:	ULO 6	User Logical Output 6
	00677:	ULO 7	User Logical Output 7
	00678:	ULO 7	User Logical Output 7
	00679:	ULO 8	User Logical Output 8
	00680:	ULO 8	User Logical Output 8
	00681:	ULO 9	User Logical Output 9
	00682:	ULO 9	User Logical Output 9
	00683:	LOADA	Load Current Alarm Energized
	00684:	LOADA	Load Current Alarm Energized
	00685:	OCA-1	Winding 1 Overcurrent Alarm Energized
	00686:	OCA-1	Winding 1 Overcurrent Alarm Energized
	00687:	OCA-2	Winding 2 Overcurrent Alarm Energized
	00688:	OCA-2	Winding 2 Overcurrent Alarm Energized
	00689:	HLDA-1	Winding 1 High Level Detector Alarm
	00690:	HLDA-1	Winding 1 High Level Detector Alarm
	00691:	LLDA-1	Winding 1 Low Level Detector Alarm
	00692:	LLDA-1	Winding 1 Low Level Detector Alarm
	00693:	HLDA-2	Winding 2 High Level Detector Alarm
	00694:	HLDA-2	Winding 2 High Level Detector Alarm
	00695:	LLDA-1	Winding 1 Low Level Detector Alarm
	00696:	LLDA-1	Winding 1 Low Level Detector Alarm
	00697:	HPFA	High Power Factor Alarm Energized
	00698:	HPFA	High Power Factor Alarm Energized
	00699:	LPFA	Low Power Factor Alarm Energized
	00700:	LPFA	Low Power Factor Alarm Energized
	00701:	VarDA	3 Phase kVar Demand Alarm Energized
	00702:	VarDA	3 Phase kVar Demand Alarm Energized
	00703:	PVarA	Positive 3 Phase kVar Alarm Energized
	00704:	PVarA	Positive 3 Phase kVar Alarm Energized
	00705:	NVarA	Negative 3 Phase kVar Alarm Energized
	00706:	NVarA	Negative 3 Phase kVar Alarm Energized
	00707:	PWatt1	Pwinding 1 Positive 3 Phase kWatt Alarm Energized
	00708:	PWatt1	Pwinding 1 Positive 3 Phase kWatt Alarm Energized
	00709:	Pwatt2	Pwinding 2 Positive 3 Phase kWatt Alarm Energized
	00710:	Pwatt2	Pwinding 2 Positive 3 Phase kWatt Alarm Energized
3	00711:	Reserved	Reserved
3	00712:	Reserved	Reserved
3	00713:	Reserved	Reserved
3	00714:	Reserved	Reserved
3	00715:	Reserved	Reserved
3	00716:	Reserved	Reserved

TPU2000/2000R Modbus/Modbus Plus Automation Guide

	Register Address	Item	Description
3	00717:	Reserved	Reserved
3	00718:	Reserved	Reserved
3	00719:	Reserved	Reserved
3	00720:	Reserved	Reserved
3	00721:	Reserved	Reserved
3	00722:	Reserved	Reserved
3	00723:	Reserved	Reserved
3	00724:	Reserved	Reserved
3	00725:	Reserved	Reserved
3	00726:	Reserved	Reserved
3	00727:	Reserved	Reserved
3	00728:	Reserved	Reserved
3	00729:	Reserved	Reserved
3	00730:	Reserved	Reserved
3	00731:	Reserved	Reserved
3	00732:	Reserved	Reserved
3	00733:	Reserved	Reserved
3	00734:	Reserved	Reserved
3	00735:	Reserved	Reserved
3	00736:	Reserved	Reserved
3	00737:	Reserved	Reserved
3	00738:	Reserved	Reserved
3	00739:	Reserved	Reserved
3	00740:	Reserved	Reserved
3	00741:	Reserved	Reserved
3	00742:	Reserved	Reserved
3	00743:	Reserved	Reserved
3	00744:	Reserved	Reserved
3	00745:	Reserved	Reserved
3	00746:	Reserved	Reserved
3	00747:	Reserved	Reserved
3	00748:	Reserved	Reserved
3	00749:	Reserved	Reserved
3	00750:	Reserved	Reserved
3	00751:	Reserved	Reserved
3	00752:	Reserved	Reserved
3	00753:	Reserved	Reserved
3	00754:	Reserved	Reserved
3	00755:	Reserved	Reserved
3	00756:	Reserved	Reserved
3	00757:	Reserved	Reserved
3	00758:	Reserved	Reserved
3	00759:	Reserved	Reserved
3	00760:	Reserved	Reserved
3	00761:	Reserved	Reserved
3	00762:	Reserved	Reserved
3	00763:	Reserved	Reserved
3	00764:	Reserved	Reserved
3	00765:	Reserved	Reserved
3	00766:	Reserved	Reserved
3	00767:	Reserved	Reserved
3	00768:	Reserved	Reserved
3	00769:	51P-3	Winding 3 Phase Time Overcurrent Alarm Energized

TPU2000/2000R Modbus/Modbus Plus Automation Guide

	Register Address	Item	Description
3	00770:	51P-3	Winding 3 Phase Time Overcurrent Alarm Energized
3	00771:	50P-3	1 st Winding 3 Phase Instantaneous Overcurrent Trip Alarm Energized
3	00772:	50P-3	1 st Winding 3 Phase Instantaneous Overcurrent Trip Alarm Energized
3	00773:	150P-3	2 nd Winding 3 Phase Instantaneous Overcurrent Trip Alarm Energized
3	00774:	150P-3	2 nd Winding 3 Phase Instantaneous Overcurrent Trip Alarm Energized
3	00775:	51N-3	Winding 3 Neutral Time Overcurrent Alarm Energized
3	00776:	51N-3	Winding 3 Neutral Time Overcurrent Alarm Energized
3	00777:	50N-3	1 st Winding 3 Neutral Instantaneous Overcurrent Trip Alarm Energized
3	00778:	50N-3	1 st Winding 3 Neutral Instantaneous Overcurrent Trip Alarm Energized
3	00779:	150N-3	2 nd Winding 3 Neutral Instantaneous Overcurrent Trip Alarm Energized
3	00780:	150N-3	2 nd Winding 3 Neutral Instantaneous Overcurrent Trip Alarm Energized
3	00781:	46-3	Winding 1 Negative Sequence Time Overcurrent Trip Alarm Energized
3	00782:	46-3	Winding 1 Negative Sequence Time Overcurrent Trip Alarm Energized
3	00783:	51G	Ground Time Overcurrent Control Energized
3	00784:	51G	Ground Time Overcurrent Control Energized
3	00785:	50G	1 st Ground Time Instantaneous Overcurrent Control Energized
3	00786:	50G	1 st Ground Time Instantaneous Overcurrent Control Energized
3	00787:	150G	2 nd Ground Time Instantaneous Overcurrent Control Energized
3	00788:	150G	2 nd Ground Time Instantaneous Overcurrent Control Energized
3	00789:	51P-3D	Winding 3 Phase Time Overcurrent Function Disabled Alarm Energized
3	00790:	51P-3D	Winding 3 Phase Time Overcurrent Function Disabled Alarm Energized
3	00791:	50P-3D	1 st Winding 3 Phase Instantaneous Overcurrent Function Disabled Alarm Energized
3	00792:	50P-3D	1 st Winding 3 Phase Instantaneous Overcurrent Function Disabled Alarm Energized
3	00793:	150P-3D	2 nd Winding 3 Phase Instantaneous Overcurrent Disable Alarm Energized
3	00794:	150P-3D	2 nd Winding 3 Phase Instantaneous Overcurrent Disable Alarm Energized
3	00795:	51N-3D	Winding 3 Phase Time Overcurrent Function Disabled Alarm Energized
3	00796:	51N-3D	Winding 3 Phase Time Overcurrent Function Disabled Alarm Energized
3	00797:	50N-3D	1 st Winding 3 Neutral Instantaneous Overcurrent Function Disabled Alarm Energized
3	00798:	50N-3D	1 st Winding 3 Neutral Instantaneous Overcurrent Function Disabled Alarm Energized
3	00799:	150N-3D	2 nd Winding 3 Neutral Instantaneous Overcurrent Disable

TPU2000/2000R Modbus/Modbus Plus Automation Guide

	Register Address	Item	Description
			Alarm Energized
3	00800:	150N-3D	2 nd Winding 3 Neutral Instantaneous Overcurrent Disable Alarm Energized
3	00801:	46-3D	Winding 3 Negative Sequence Time Overcurrent Function Disabled Alarm Energized
3	00802:	46-3D	Winding 3 Negative Sequence Time Overcurrent Function Disabled Alarm Energized
3	00803:	51GD	Ground Time Overcurrent Trip Alarm
3	00804:	51GD	Ground Time Overcurrent Trip Alarm
3	00805:	50GD	1 st Winding 3 Ground Instantaneous Overcurrent Disable Alarm Energized
3	00806:	50GD	1 st Winding 3 Ground Instantaneous Overcurrent Disable Alarm Energized
3	00807:	150GD	2 nd Winding 3 Ground Instantaneous Overcurrent Disable Alarm Energized
3	00808:	150GD	2 nd Winding 3 Ground Instantaneous Overcurrent Disable Alarm Energized
(L) 3	00809:	51P-3*	Winding 3 Phase Time Overcurrent Alarm Energized Seal In
3	00810:	51P-3*	Winding 3 Phase Time Overcurrent Alarm Energized Seal In
(L) 3	00811:	50P-3*	1 st Winding 3 Phase Instantaneous Overcurrent Trip Alarm Energized Seal In
3	00812:	50P-3*	1 st Winding 3 Phase Instantaneous Overcurrent Trip Alarm Energized Seal In
(L) 3	00813:	150P-3*	2 nd Winding 3 Phase Instantaneous Overcurrent Trip Alarm Energized Seal In
3	00814:	150P-3*	2 nd Winding 3 Phase Instantaneous Overcurrent Trip Alarm Energized Seal In
(L) 3	00815:	51N-3*	Winding 3 Neutral Time Overcurrent Alarm Energized Seal In
3	00816:	51N-3*	Winding 3 Neutral Time Overcurrent Alarm Energized Seal In
(L) 3	00817:	50N-3*	1 st Winding 3 Neutral Instantaneous Overcurrent Trip Alarm Energized Seal In
3	00818:	50N-3*	1 st Winding 3 Neutral Instantaneous Overcurrent Trip Alarm Energized Seal In
(L) 3	00819:	150N-3*	2 nd Winding 3 Neutral Instantaneous Overcurrent Trip Alarm Energized Seal In
3	00820:	150N-3*	2 nd Winding 3 Neutral Instantaneous Overcurrent Trip Alarm Energized Seal In
(L) 3	00821:	46-3*	Winding 1 Negative Sequence Time Overcurrent Trip Alarm Energized Seal In
3	00822:	46-3*	Winding 1 Negative Sequence Time Overcurrent Trip Alarm Energized Seal In
(L) 3	00823:	51G*	Ground Time Overcurrent Control Energized Seal In
3	00824:	51G*	Ground Time Overcurrent Control Energized Seal In
(L) 3	00825:	50G*	1 st Ground Time Instantaneous Overcurrent Control Energized Seal In
3	00826:	50G*	1 st Ground Time Instantaneous Overcurrent Control Energized Seal In
(L) 3	00827:	150G*	2 nd Ground Time Instantaneous Overcurrent Control Energized Seal In
3	00828:	150G*	2 nd Ground Time Instantaneous Overcurrent Control Energized Seal In
3	00829:	TFKA-3	Through Fault KiloAmps Symmetrical Winding 3
3	00830:	TFKA-3	Through Fault KiloAmps Symmetrical Winding 3
3	00831:	HLDA-3	Winding 3 High Level Detector Alarm Energized

TPU2000/2000R Modbus/Modbus Plus Automation Guide

	Register Address	Item	Description
3	00832:	HLDA-3	Winding 3 High Level Detector Alarm Energized
3	00833:	LLDA-3	Winding 3 Low Level Detector Alarm Energized
3	00834:	LLDA-3	Winding 3 Low Level Detector Alarm Energized
3	00835:	OCA-3	Winding 3 Overcurrent Alarm Energized
3	00836:	OCA-3	Winding 3 Overcurrent Alarm Energized
3	00837:	PWatt3	Winding 3 Positive 3 Phase kWatt Alarm Energized
3	00838:	PWatt3	Winding 3 Positive 3 Phase kWatt Alarm Energized
3	00839:	OCA Gnd	Ground Overcurrent Alarm Energized
3	00840:	OCA Gnd	Ground Overcurrent Alarm Energized

Physical Output Block (Single Bit Data) – 16 Discrete Coils (8 Elements Defined)

Output status is described in Table 5-2. The state of the addresses 00257 through 00272 follow the state of the physical output hardware contacts located at the rear screw terminals of the relay. It should be noted that some of the Physical Output contact status information is not available in the TPU2000R. Table 5-2 notes the elements, which are undefined in the TPU2000R. The TPU2000R has six physical output contacts, which are map-able via ECP software. The TPU2000R has a single dedicated physical output contact defined as TRIP. The TPU2000 has seven map-able physical output contacts (1 through 7) and a dedicated TRIP contact. The status of the element mirrors that of the physical contact and that reported through the TPU2000/2000R front panel interface of through the ECP or WinECP configuration program.

Table 5-2. Physical Output Contact Mapping Defined

Discrete Address	Item	Description
00257:	Spare	Reserved
00258:	Spare	Reserved
00259:	Spare	Reserved
00260:	Spare	Reserved
00261:	Spare	Reserved
00262:	Spare	Reserved
00263:	Spare	Reserved
00264:	Spare	Reserved
00265:	OUT7	Physical Output Contact 7
00266:	OUT 6	Physical Output Contact 6
00267:	OUT5	Physical Output Contact 5
00268:	OUT4	Physical Output Contact 4
00269:	OUT3	Physical Output Contact 3
00270:	OUT2	Physical Output Contact 2
00271:	OUT1	Physical Output Contact 1
00272:	TRIP	Breaker Trip Physical Output Contact

Logical Output Block (Two Bit Data with Momentary Change Detection)

Modbus does not support features commonly required within the utility industry. However, the protocol may easily be adapted to support features required. It is most important that no event is to be missed by a polling host when a device is not accessed. To this end, a feature has been developed which ensures that the status of the data change is always reported. Table 5-3 lists the Momentary Logical Output Mapping.

Table 5-3. Momentary Change Detect Data Definition

Register Address	Item	Description
00001	DIFF	Differential Trip Contact Energized
00002	SELFCHK	Self Check Alarm Energized

TPU2000/2000R Modbus/Modbus Plus Automation Guide

Register Address	Item	Description
	ALARM	
00003	87T	Harmonic Restrained % Differential Trip Alarm Energized
00004	87H	Unrestrained High Set Instantaneous Differential Trip Alarm Energized
00005	2HROA	2 nd Harmonic Restraint Alarm Energized
00006	5HROA	5 th Harmonic Restraint Alarm Energized
00007	AHROA	All Harmonics Restraint Alarm (2 nd through 11th Harmonic) Energized
00008	TCFA	Trip Circuit is Open Fail Alarm Energized
00009	TFA	Trip Fail Alarm Energized
00010	51P-1	Winding 1 Phase Time Overcurrent Alarm Energized
00011	51P-2	Winding 2 Phase Time Overcurrent Alarm Energized
00012	50P-1	1 st Winding 1 Phase Instantaneous Overcurrent Trip Alarm Energized
00013	150P-1	2 nd Winding 1 Phase Instantaneous Overcurrent Trip Alarm Energized
00014	50P-2	1 st Winding 2 Phase Instantaneous Overcurrent Trip Alarm Energized
00015	150P-2	2 nd Winding 2 Phase Instantaneous Overcurrent Trip Alarm Energized
00016	51N-1	Winding 1 Neutral Time Overcurrent Trip Alarm Energized
00017	51N-2	Winding 1 Neutral Time Overcurrent Trip Alarm Energized
00018	50N-1	1 st Winding 1 Neutral Instantaneous Overcurrent Trip Alarm Energized
00019	150N-1	2 nd Winding 1 Neutral Instantaneous Overcurrent Trip Alarm Energized
00020	50N-2	1 st Winding 2 Neutral Instantaneous Overcurrent Trip Alarm Energized
00021	150N-2	2 nd Winding 2 Neutral Instantaneous Overcurrent Trip Alarm Energized
00022	46-1	Winding 1 Negative Sequence Time Overcurrent Trip Alarm Energized
00023	46-2	Winding 1 Negative Sequence Time Overcurrent Trip Alarm Energized
00024	87T-D	Percentage Differential Disabled Alarm Energized
00025	87H-D	High Set Instantaneous Function Disabled Alarm Energized
00026	51P-1D	Winding 1 Phase Time Overcurrent Function Disabled Alarm
00027	51P-2D	Winding 2 Phase Time Overcurrent Function Disabled Alarm
00028	51N-1D	Winding 1 Neutral Time Overcurrent Function Disabled Alarm
00029	51N-2D	Winding 2 Neutral Time Overcurrent Function Disabled Alarm
00030	50P-1D	1 st Winding 1 Phase Instantaneous Overcurrent Function Disabled Alarm
00031	50P-2D	1 st Winding 2 Phase Instantaneous Overcurrent Function Disabled Alarm
00032	50N-1D	1 st Winding 1 Neutral Instantaneous Overcurrent Function Disabled Alarm
00033	50N-2D	1 st Winding 2 Neutral Instantaneous Overcurrent Function Disabled Alarm
00034	150P-1D	2 nd Winding 1 Phase Instantaneous Overcurrent Function Disabled Alarm
00035	150P-2D	2 nd Winding 2 Phase Instantaneous Overcurrent Function Disabled Alarm
00036	150N-1D	2 nd Winding 1 Neutral Instantaneous Overcurrent Function Disabled Alarm
00037	150N-2D	2 nd Winding 2 Neutral Instantaneous Overcurrent Function Disabled Alarm
00038	46-1D	Winding 1 Negative Sequence Time Overcurrent Function Disabled Alarm
00039	46-2D	Winding 1 Negative Sequence Time Overcurrent Function Disabled Alarm
00040	PATA	Phase A Target Alarm Energized
00041	PBTA	Phase B Target Alarm Energized
00042	PCTA	Phase C Target Alarm Energized
00043	PUA	Pick Up Alarm Energized
00044	63	Sudden Pressure Input Alarm Energized
00045	THRUFA	Through Fault Alarm Energized
00046	TFCA	Through Fault Counter Alarm Energized
00047	TFKA-2	Through Fault KiloAmp Symmetrical Alarm Winding 2 Energized
00048	TFSCA	Through Fault Summation Cycle Alarm Energized
00049	DTC	Differential Trip Current Alarm Energized
00050	OCTC	Overcurrent Trip Counter Alarm Energized
00051	PDA	Phase Demand Current Alarm Energized
00052	NDA	Neutral Demand Current Alarm Energized
00053	PRIM	Primary Settings Alarm Energized
00054	ALT1	Alternate 1 Settings Enabled

TPU2000/2000R Modbus/Modbus Plus Automation Guide

	Register Address	Item	Description
	00055	ALT2	Alternate 2 Settings Enabled
	00056	STCA	Settings Table Changed Alarm Energized
(L)	00057	87T	Harmonic Restrained % Differential Trip Alarm Energized
(L)	00058	87H	Unrestrained High Set Instantaneous Differential Trip Alarm Energized
(L)	00059	2HROA	2 nd Harmonic Restraint Alarm Energized
(L)	00060	5HROA	5 th Harmonic Restraint Alarm Energized
(L)	00061	AHROA	All Harmonics Restraint Alarm (2 nd through 11th Harmonic) Energized
(L)	00062	51P-1	Winding 1 Phase Time Overcurrent Alarm Energized
(L)	00063	51P-2	Winding 2 Phase Time Overcurrent Alarm Energized
(L)	00064	50P-1	1 st Winding 1 Phase Instantaneous Overcurrent Trip Alarm Energized
(L)	00065	150P-1	2 nd Winding 1 Phase Instantaneous Overcurrent Trip Alarm Energized
(L)	00066	50P-2	1 st Winding 2 Phase Instantaneous Overcurrent Trip Alarm Energized
(L)	00067	150P-2	2 nd Winding 2 Phase Instantaneous Overcurrent Trip Alarm Energized
(L)	00068	51N-1	Winding 1 Neutral Time Overcurrent Trip Alarm Energized
(L)	00069	51N-2	Winding 1 Neutral Time Overcurrent Trip Alarm Energized
(L)	00070	50N-1	1 st Winding 1 Neutral Instantaneous Overcurrent Trip Alarm Energized
(L)	00071	150N-1	2 nd Winding 1 Neutral Instantaneous Overcurrent Trip Alarm Energized
(L)	00072	50N-2	1 st Winding 2 Neutral Instantaneous Overcurrent Trip Alarm Energized
(L)	00073	150N-2	2 nd Winding 2 Neutral Instantaneous Overcurrent Trip Alarm Energized
(L)	00074	46-1	Winding 1 Negative Sequence Time Overcurrent Trip Alarm Energized
(L)	00075	46-2	Winding 1 Negative Sequence Time Overcurrent Trip Alarm Energized
(L)	00076	63	Sudden Pressure Seal In Alarm Energized
	00077	ULO 1	User Logical Output 1
	00078	ULO 2	User Logical Output 2
	00079	ULO 3	User Logical Output 3
	00080	ULO 4	User Logical Output 4
	00081	ULO 5	User Logical Output 5
	00082	ULO 6	User Logical Output 6
	00083	ULO 7	User Logical Output 7
	00084	ULO 8	User Logical Output 8
	00085	ULO 9	User Logical Output 9
	00086	LOADA	Load Current Alarm Energized
	00087	OCA-1	Winding 1 Overcurrent Alarm Energized
	00088	OCA-2	Winding 2 Overcurrent Alarm Energized
	00089	HLDA-1	Winding 1 High Level Detector Alarm
	00090	LLDA-1	Winding 1 Low Level Detector Alarm
	00091	HLDA-2	Winding 2 High Level Detector Alarm
	00092	LLDA-1	Winding 1 Low Level Detector Alarm
	00093	HPFA	High Power Factor Alarm Energized
	00094	LPFA	Low Power Factor Alarm Energized
	00095	VarDA	3 Phase kVar Demand Alarm Energized
	00096	PVarA	Positive 3 Phase kVar Alarm Energized
	00097	NVarA	Negative 3 Phase kVar Alarm Energized
	00098	PWatt1	Pwinding 1 Positive 3 Phase kWatt Alarm Energized
	00099	Pwatt2	Pwinding 2 Positive 3 Phase kWatt Alarm Energized
3	00100	Reserved	Reserved
3	00101	Reserved	Reserved
3	00102	Reserved	Reserved
3	00103	Reserved	Reserved
3	00104	Reserved	Reserved
3	00105	Reserved	Reserved
3	00106	Reserved	Reserved
3	00107	Reserved	Reserved

TPU2000/2000R Modbus/Modbus Plus Automation Guide

	Register Address	Item	Description
	3	00108	Reserved
	3	00109	Reserved
	3	00110	Reserved
	3	00111	Reserved
	3	00112	Reserved
	3	00113	Reserved
	3	00114	Reserved
	3	00115	Reserved
	3	00116	Reserved
	3	00117	Reserved
	3	00118	Reserved
	3	00119	Reserved
	3	00120	Reserved
	3	00121	Reserved
	3	00122	Reserved
	3	00123	Reserved
	3	00124	Reserved
	3	00125	Reserved
	3	00126	Reserved
	3	00127	Reserved
	3	00128	Reserved
	3	00129	51P-3
	3	00130	50P-3
	3	00131	150P-3
	3	00132	51N-3
	3	00133	50N-3
	3	00134	150N-3
	3	00135	46-3
	3	00136	51G
	3	00137	50G
	3	00138	150G
	3	00139	51P-3D
	3	00140	50P-3D
	3	00141	150P-3D
	3	00142	51N-3D
	3	00143	50N-3D
	3	00144	150N-3D
	3	00145	46-3D
	3	00146	51GD
	3	00147	50GD
	3	00148	150GD
(L)	3	00149	51P-3*
(L)	3	00150	50P-3*
(L)	3	00151	150P-3*
(L)	3	00152	51N-3*
(L)	3	00153	50N-3*
(L)	3	00154	150N-3*

TPU2000/2000R Modbus/Modbus Plus Automation Guide

	Register Address	Item	Description
(L) 3	00155	46-3*	Winding 1 Negative Sequence Time Overcurrent Trip Alarm Energized Seal In
(L) 3	00156	51G*	Ground Time Overcurrent Control Energized Seal In
(L) 3	00157	50G*	1 st Ground Time Instantaneous Overcurrent Control Energized Seal In
(L) 3	00158	150G*	2 nd Ground Time Instantaneous Overcurrent Control Energized Seal In
3	00159	TFKA-3	Through Fault KiloAmps Symmetrical Winding 3
3	00160	HLDA-3	Winding 3 High Level Detector Alarm Energized
3	00161	LLDA-3	Winding 3 Low Level Detector Alarm Energized
3	00162	OCA-3	Winding 3 Overcurrent Alarm Energized
3	00163	PWatt3	Winding 3 Positive 3 Phase kWatt Alarm Energized
3	00164	OCA Gnd	Ground Overcurrent Alarm Energized
3	00165	Reserved	Reserved
3	00166	Reserved	Reserved
3	00167	Reserved	Reserved
3	00168	Reserved	Reserved
3	00169	Reserved	Reserved
3	00170	Reserved	Reserved
3	00171	Reserved	Reserved
3	00172	Reserved	Reserved
3	00173	Reserved	Reserved
3	00174	Reserved	Reserved
3	00175	Reserved	Reserved
3	00176	Reserved	Reserved
3= 3 Winding TPU Only (L)= Latched or Seal In Point			

Physical Output Block (Two Bit Data with Momentary Change Detection): Not available on TPU2000

The TPU2000R allows for momentary bit change detect for all physical outputs on the protective device. The physical output devices. The status bit will reflect the same status as that of 00257 through 00272. The momentary bit shall detect a status change between reads of the element's data. As always, the bits must be read in pairs for accurate reporting of the element status. Table 5-4 lists the definitions of each defined 0X address.

Table 5-4. Modbus Physical Output Momentary Change Detect Address Allocation

Discrete Address	Item	Description
01025	Spare Status	Reserved
01026	Spare Momentary	Reserved
01027	Spare Status	Reserved
01028	Spare Momentary	Reserved
01029	Spare Status	Reserved
01030	Spare Momentary	Reserved
01031	Spare Status	Reserved
01032	Spare Momentary	Reserved
01033	Spare Status	Reserved
01034	Spare Momentary	Reserved
01035	Spare Status	Reserved
01036	Spare Momentary	Reserved
01037	Spare Status	Reserved
01038	Spare Momentary	Reserved

TPU2000/2000R Modbus/Modbus Plus Automation Guide

Discrete Address	Item	Description
01039	Spare Status	Reserved
01040	Spare Momentary	Reserved
01041	OUT 7	Physical Output Contact 7
01042	OUT 7	Physical Output Contact 7 Change Detect Between Scans
01043	OUT 6	Physical Output Contact 6
01044	OUT 6	Physical Output Contact 6 Change Detect Between Scans
01045	OUT 5	Physical Output Contact 5
01046	OUT 5	Physical Output Contact 5 Change Detect Between Scans
01047	OUT 4	Physical Output Contact 4
01048	OUT 4	Physical Output Contact 4 Change Detect Between Scans
01049	OUT 3	Physical Output Contact 3
01050	OUT 3	Physical Output Contact 3 Change Detect Between Scans
01051	OUT 2	Physical Output Contact 2
01052	OUT 2	Physical Output Contact 2 Change Detect Between Scans
01053	OUT 1	Physical Output Contact 1
01054	OUT 1	Physical Output Contact 1 Change Detect Between Scans
01055	TRIP Status	Breaker Trip Physical Output Contact
01056	TRIP Momentary	Breaker Trip Physical Output Contact Change Detect Between Scans

1X Discrete Contact Inputs

Discrete physical input and relay element status are available via a function 02 request through Modbus and through a Modbus Plus Host. The TPU2000/2000R does not support the Modbus Plus feature of PEER COP thus 1X data cannot be obtained from a PLC (Programmable Logic Controller) supporting such a feature. Figure 5-19 illustrates a typical command sequence. The Host polls the TPU2000R for the Data. The TPU2000R receives the request and responds with the expected data. The Host then interprets the command response, checks the LRC checksum in ASCII mode and then displays the interpreted data. If the node is configured for RTU Modbus, the start of message character is three character delays, and the end of message consists of a CRC-16 checksum and three character delays. Additional information is available in Modicon's protocol manual references listed at the beginning of this document. The same information is available through a 4X register read command, which allows a host without 1X data accesses capabilities to obtain physical input and relay element information. Tables 5-5 through 5-9 list the 1X discrete contact memory map as defined for Modbus RTU and ASCII. Modbus Plus embeds the Modbus message in its structure. Please reference Section 5 of this document for a more complete discussion of Modbus Plus message structure.

Function Code 2 - Read Input Status (Read Only Data)

Figure 5-19 illustrates the command format required for execution of function code 2.

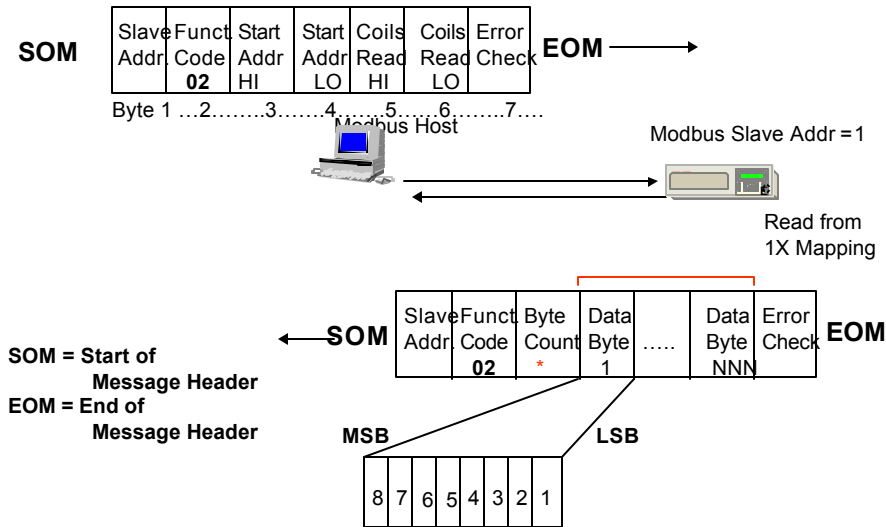

Figure 5-19. 1X Input Request Using Modbus Command 02

It should be noted that every TPU2000R allows real time status reporting when the unit is polled. If a status is momentary and is missed during the host poll, then the data is lost. Polling using the status Momentary Change Detect Feature insures that the host device does not miss the momentary change. It should also be noted that data requested from 1X data address ranges not defined within this document generates Modbus exception codes.

Utility devices require that no event is to be missed in the field IED. ABB has incorporated one method in which a device is notified that events have occurred in the field IED between host polls. The method employed for 1x data (Modbus Function Code 02) data collection of rapidly changing momentary signals is Momentary Change Detect.

MOMENTARY CHANGE DETECT is independent of the protocol. These ABB innovations allow Modbus protocol to address and satisfy the concerns common to a utility installation. The two functionality's are those in excess of the real time status access that Modbus function code 02 affords.

Momentary Change Detect status is incorporated using two bits to indicate present status and momentary indication status. The odd bit is the status bit and the even bit is the momentary bit. The status bit indicates the present state of the element accessed. The momentary bit indicates element transitioning more than once between IED reads. The momentary bit is set to a "1" if the element has transitioned more than once. The bit is reset upon a host access. Addresses 10513 through 11056 are allocated for momentary change bit detect status detection. NOTE: MOMENTARY BITS MUST BE READ IN PAIRS.

An example of momentary change detect is illustrated in Figure 5-20. Suppose a host device monitors TPU2000R physical input bit 1. Figure 5-20 illustrates the physical input transitions of input 1. At each field voltage rising edge/falling edge transition, the status of the Modbus contact 1x addresses are listed. The dotted line arrows indicate the poll received by the TPU2000R and the state of both the status bit and the momentary indication bit. Note that the even bit (momentary change detect) resets itself to a zero state after a host read.

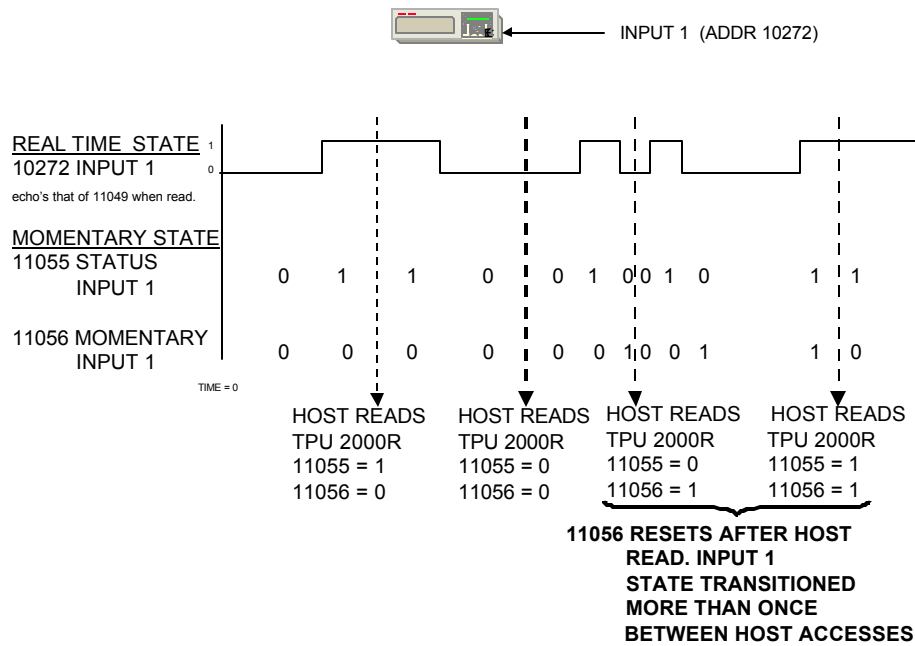

Figure 5-20. Momentary Change Detect Example

Logical Inputs (34 Elements Defined 2 Winding TPU2000/2000R - 80 Elements Defined 3 Winding TPU2000/2000R)

This section of relay information allows access of relay element data. Some of the status bit information reported in 1X discrete response is available as 0X-register definition table. All of the individual information is available in the 4X-register definition table (Modbus Function Code 03). Table 5-5 lists the discrete point address assignment for physical inputs and control elements within the TPU2000/2000R.

Table 5-5. Logical Input Modbus Address Map Definition

Note	Register Address	Item	Description
	10001:	87T	2 or 3 Winding 3- Phase % Differential Current Control
	10002:	87H	2 or 3 Winding 3 Phase % High Set Instantaneous Differential Current Control
	10003:	51P-1	Winding 1 Phase Time Overcurrent Control Enabled
	10004:	51P-2	Winding 2 Phase Time Overcurrent Control Enabled
	10005:	51N-1	Winding 1 Neutral Time Overcurrent Control Enabled
	10006:	51N-2	Winding 2 Neutral Time Overcurrent Control Enabled
	10007:	50P-1	1 st Winding 1 Phase Time Instantaneous Control Enabled
	10008:	50P-2	1 st Winding 2 Phase Time Instantaneous Control Enabled
	10009:	50N-1	1 st Winding 1 Neutral Time Instantaneous Control Enabled
	10010:	50N-2	1 st Winding 2 Neutral Time Instantaneous Control Enabled
	10011:	150P-1	2 nd Winding 1 Phase Time Instantaneous Control Enabled
	10012:	150P-2	2 nd Winding 2 Phase Time Instantaneous Control Enabled
	10013:	150N-1	2 nd Winding 1 Neutral Time Instantaneous Control Enabled
	10014:	150N-2	2 nd Winding 2 Neutral Time Instantaneous Control Enabled
	10015:	46-1	Winding 1 Negative Sequence Control Enabled
	10016:	46-2	Winding 2 Negative Sequence Control Enabled
	10017:	ALT1	Enable Alternate 1 Settings
	10018:	ALT2	Enable Alternate 2 Settings
	10019:	ECI1	Initiate Event Capture 1
	10020:	ECI2	Initiate Event Capture 2

TPU2000/2000R Modbus/Modbus Plus Automation Guide

Note	Register Address	Item	Description
	10021:	WCI	Waveform Capture Initiate
	10022:	TRIP	Differential Trip Output Initiated
	10023:	SPR	Sudden Pressure Relay Input Initiated
	10024:	TCM	Trip Coil Monitor
	10025:	ULI1	User Logical Input 1 Element Energized
	10026:	ULI2	User Logical Input 2 Element Energized
	10027:	ULI3	User Logical Input 3 Element Energized
	10028:	ULI4	User Logical Input 4 Element Energized
	10029:	ULI5	User Logical Input 5 Element Energized
	10030:	ULI6	User Logical Input 6 Element Energized
	10031:	ULI7	User Logical Input 7 Element Energized
	10032:	ULI8	User Logical Input 8 Element Energized
	10033:	ULI9	User Logical Input 9 Element Energized
	10034:	CRI	Reclose and Overcurrent Counters Cleared
3	10035:	Reserved	Reserved
3	10036:	Reserved	Reserved
3	10037:	Reserved	Reserved
3	10038:	Reserved	Reserved
3	10040:	Reserved	Reserved
3	10041:	Reserved	Reserved
3	10042:	Reserved	Reserved
3	10043:	Reserved	Reserved
3	10044:	Reserved	Reserved
3	10045:	Reserved	Reserved
3	10046:	Reserved	Reserved
3	10047:	Reserved	Reserved
3	10048:	Reserved	Reserved
3	10049:	Reserved	Reserved
3	10050:	Reserved	Reserved
3	10051:	Reserved	Reserved
3	10052:	Reserved	Reserved
3	10053:	Reserved	Reserved
3	10054:	Reserved	Reserved
3	10055:	Reserved	Reserved
3	10056:	Reserved	Reserved
3	10057:	Reserved	Reserved
3	10058:	Reserved	Reserved
3	10059:	Reserved	Reserved
3	10060:	Reserved	Reserved
3	10061:	Reserved	Reserved
3	10062:	Reserved	Reserved
3	10063:	Reserved	Reserved
3	10064:	Reserved	Reserved
3	10065:	51P-3	Winding 3 Phase Time Overcurrent Control Enabled
3	10066:	51N-3	Winding 3 Neutral Time Overcurrent Control Enabled
3	10067:	50P-3	1 st Winding 3 Phase Time Instantaneous Control Enabled
3	10068:	50N-3	1 st Winding 3 Neutral Time Instantaneous Control Enabled
3	10069:	150P-3	2 nd Winding 3 Phase Time Instantaneous Control Enabled
3	10070:	150N-3	2 nd Winding 3 Neutral Time Instantaneous Control Enabled
3	10071:	46-3	Winding 3 Negative Sequence Control Enabled
3	10072:	51G	Ground Time Overcurrent Control Enabled
3	10073:	50G	Ground Time Instantaneous Control Enabled
			3= 3 Winding TPU Only

Physical Inputs (16 Elements Defined)

Physical inputs are map-able for various functional inputs. Input status correlates to the state of the input seen at the physical terminals of the TPU2000/2000R their status is available at the following addresses as illustrated in Table 5-6.

Table 5-6. Physical Input Modbus Address Map Definition

Notes	Register Address	Item	Description
	10257:	Reserved	Reserved
	10258:	Reserved	Reserved
	10259:	Reserved	Reserved
	10260:	Reserved	Reserved
	10261:	Reserved	Reserved
	10262:	Reserved	Reserved
	10263	Reserved	Reserved
	10264	IN9	Physical Input 9
	10265:	IN8	Physical Input 8
	10266:	IN7	Physical Input 7
	10267:	IN6	Physical Input 6
	10268:	IN5	Physical Input 5
	10269:	IN4	Physical Input 4
	10270:	IN3	Physical Input 3
	10271:	IN2	Physical Input 2
	10272:	IN1	Physical Input 1

Momentary Change Detect Logical Inputs (68 Elements Defined 2 Winding TPU - 160 Elements Defined 3 Winding TPU)

Whereas the information presented in Tables 5-5 and 5-6 illustrate the real time status of the designated data points, the status in Table 5-7 lists the data in Momentary Change Detect status. The momentary change detect decoding follows the same philosophy as that presented in Section 5 for the 0X logical and physical data presentation.

Table 5-7. Logical Input Status Momentary Change Detect Status

Notes	Register Address	Item	Description
	10513	87T Status	2 or 3 Winding 3- Phase % Differential Current Control (Status)
	10514	87T Momentary	2 or 3 Winding 3- Phase % Differential Current Control (Momentary)
	10515	87H Status	2 or 3 Winding 3 Phase % High Set Instantaneous Differential Current Control (Status)
	10516	87H Momentary	2 or 3 Winding 3 Phase % High Set Instantaneous Differential Current Control (Momentary)
	10517	51P-1 Status	Winding 1 Phase Time Overcurrent Control Enabled (Status)
	10518	51P-1 Momentary	Winding 1 Phase Time Overcurrent Control Enabled (Momentary)
	10519	51P-2 Status	Winding 2 Phase Time Overcurrent Control Enabled (Status)
	10520	51P-2 Momentary	Winding 2 Phase Time Overcurrent Control Enabled (Momentary)
	10521	51N-1 Status	Winding 1 Neutral Time Overcurrent Control Enabled (Status)
	10522	51N-1 Momentary	Winding 1 Neutral Time Overcurrent Control Enabled (Momentary)
	10523	51N-2 Status	Winding 2 Neutral Time Overcurrent Control Enabled (Status)
	10524	51N-2 Momentary	Winding 2 Neutral Time Overcurrent Control Enabled (Momentary)
	10525	50P-1 Status	1 st Winding 1 Phase Time Instantaneous Control Enabled (Status)
	10526	50P-1 Momentary	1 st Winding 1 Phase Time Instantaneous Control Enabled (Momentary)

TPU2000/2000R Modbus/Modbus Plus Automation Guide

Notes	Register Address	Item	Description
	10527	50P-2 Status	1 st Winding 2 Phase Time Instantaneous Control Enabled (Status)
	10528	50P-2 Momentary	1 st Winding 2 Phase Time Instantaneous Control Enabled (Momentary)
	10529	50N-1 Status	1 st Winding 1 Neutral Time Instantaneous Control Enabled (Status)
	10530	50N-1 Momentary	1 st Winding 1 Neutral Time Instantaneous Control Enabled (Momentary)
	10531	50N-2 Status	1 st Winding 2 Neutral Time Instantaneous Control Enabled (Status)
	10532	50N-2 Momentary	1 st Winding 2 Neutral Time Instantaneous Control Enabled (Momentary)
	10533	150P-1 Status	2 nd Winding 1 Phase Time Instantaneous Control Enabled (Status)
	10534	150P-1 Momentary	2 nd Winding 1 Phase Time Instantaneous Control Enabled (Momentary)
	10535	150P-2 Status	2 nd Winding 2 Phase Time Instantaneous Control Enabled (Status)
	10536	150P-2 Momentary	2 nd Winding 2 Phase Time Instantaneous Control Enabled (Momentary)
	10537	150N-1 Status	2 nd Winding 1 Neutral Time Instantaneous Control Enabled (Status)
	10538	150N-1 Momentary	2 nd Winding 1 Neutral Time Instantaneous Control Enabled (Momentary)
	10539	150N-2 Status	2 nd Winding 2 Neutral Time Instantaneous Control Enabled (Status)
	10540	150N-2 Momentary	2 nd Winding 2 Neutral Time Instantaneous Control Enabled (Momentary)
	10541	46-1 Status	Winding 1 Negative Sequence Control Enabled (Status)
	10542	46-1 Momentary	Winding 1 Negative Sequence Control Enabled (Momentary)
	10543	46-2 Status	Winding 2 Negative Sequence Control Enabled (Status)
	10544	46-2 Momentary	Winding 2 Negative Sequence Control Enabled (Momentary)
	10545	ALT1 Status	Enable Alternate 1 Settings (Status)
	10546	ALT1 Momentary	Enable Alternate 1 Settings (Momentary)
	10547	ALT2 Status	Enable Alternate 2 Settings (Status)
	10548	ALT2 Momentary	Enable Alternate 2 Settings (Momentary)
	10549	ECI1 Status	Initiate Event Capture 1 (Status)
	10550	ECI1 Momentary	Initiate Event Capture 1 (Momentary)
	10551	ECI2 Status	Initiate Event Capture 2 (Status)
	10552	ECI2 Momentary	Initiate Event Capture 2 (Momentary)
	10553	WCI Status	Waveform Capture Initiate (Status)
	10554	WCI Momentary	Waveform Capture Initiate (Momentary)
	10555	TRIP Status	Differential Trip Output Initiated (Status)
	10556	TRIP Momentary	Differential Trip Output Initiated (Momentary)
	10557	SPR Status	Sudden Pressure Relay Input Initiated (Status)
	10558	SPR Momentary	Sudden Pressure Relay Input Initiated (Momentary)
	10559	TCM Status	Trip Coil Monitor (Status)
	10560	TCM Momentary	Trip Coil Monitor (Momentary)
	10561	ULI1 Status	User Logical Input 1 Element Energized (Status)
	10562	ULI1 Momentary	User Logical Input 1 Element Energized (Momentary)
	10563	ULI2 Status	User Logical Input 2 Element Energized (Status)
	10564	ULI2 Momentary	User Logical Input 2 Element Energized (Momentary)
	10565	ULI3 Status	User Logical Input 3 Element Energized (Status)
	10566	ULI3 Momentary	User Logical Input 3 Element Energized (Momentary)
	10567	ULI4 Status	User Logical Input 4 Element Energized (Status)
	10568	ULI4 Momentary	User Logical Input 4 Element Energized (Momentary)
	10569	ULI5 Status	User Logical Input 5 Element Energized (Status)
	10570	ULI5 Momentary	User Logical Input 5 Element Energized (Momentary)
	10571	ULI6 Status	User Logical Input 6 Element Energized (Status)
	10572	ULI6 Momentary	User Logical Input 6 Element Energized (Momentary)

TPU2000/2000R Modbus/Modbus Plus Automation Guide

Notes	Register Address	Item	Description
	10573	ULI7 Status	User Logical Input 7 Element Energized (Status)
	10574	ULI7 Momentary	User Logical Input 7 Element Energized (Momentary)
	10575	ULI8 Status	User Logical Input 8 Element Energized (Status)
	10576	ULI8 Momentary	User Logical Input 8 Element Energized (Momentary)
	10577	ULI9 Status	User Logical Input 9 Element Energized (Status)
	10578	ULI9 Momentary	User Logical Input 9 Element Energized (Momentary)
	10579	CRI Status	Reclose and Overcurrent Counters Cleared (Status)
	10580	CRI Momentary	Reclose and Overcurrent Counters Cleared (Momentary)
3	10581	Reserved	Reserved
3	10582	Reserved	Reserved
3	10583	Reserved	Reserved
3	10584	Reserved	Reserved
3	10585	Reserved	Reserved
3	10586	Reserved	Reserved
3	10587	Reserved	Reserved
3	10588	Reserved	Reserved
3	10589	Reserved	Reserved
3	10590	Reserved	Reserved
3	10591	Reserved	Reserved
3	10592	Reserved	Reserved
3	10593	Reserved	Reserved
3	10594	Reserved	Reserved
3	10595	Reserved	Reserved
3	10596	Reserved	Reserved
3	10597	Reserved	Reserved
3	10598	Reserved	Reserved
3	10599	Reserved	Reserved
3	10600	Reserved	Reserved
3	10601:	Reserved	Reserved
3	10602:	Reserved	Reserved
3	10603:	Reserved	Reserved
3	10604:	Reserved	Reserved
3	10605:	Reserved	Reserved
3	10606:	Reserved	Reserved
3	10607:	Reserved	Reserved
3	10608:	Reserved	Reserved
3	10609:	Reserved	Reserved
3	10610:	Reserved	Reserved
3	10611:	Reserved	Reserved
3	10612:	Reserved	Reserved
3	10613:	Reserved	Reserved
3	10614:	Reserved	Reserved
3	10615:	Reserved	Reserved
3	10616:	Reserved	Reserved
3	10617:	Reserved	Reserved
3	10618:	Reserved	Reserved
3	10619:	Reserved	Reserved
3	10620:	Reserved	Reserved
3	10621:	Reserved	Reserved
3	10622:	Reserved	Reserved
3	10623:	Reserved	Reserved
3	10624:	Reserved	Reserved
3	10625:	Reserved	Reserved

TPU2000/2000R Modbus/Modbus Plus Automation Guide

Notes	Register Address	Item	Description
3	10626:	Reserved	Reserved
3	10627:	Reserved	Reserved
3	10628:	Reserved	Reserved
3	10629:	Reserved	Reserved
3	10630:	Reserved	Reserved
3	10631:	Reserved	Reserved
3	10632:	Reserved	Reserved
3	10633:	Reserved	Reserved
3	10634:	Reserved	Reserved
3	10635:	Reserved	Reserved
3	10636:	Reserved	Reserved
3	10637:	Reserved	Reserved
3	10638:	Reserved	Reserved
3	10639:	Reserved	Reserved
3	10640:	Reserved	Reserved
3	10641:	51P-3 Status	Winding 3 Phase Time Overcurrent Control Enabled (Status)
3	10642:	51P-3 Momentary	Winding 3 Phase Time Overcurrent Control Enabled (Momentary)
3	10643:	51N-3 Status	Winding 3 Neutral Time Overcurrent Control Enabled (Status)
3	10644:	51N-3 Momentary	Winding 3 Neutral Time Overcurrent Control Enabled (Momentary)
3	10645:	50P-3 Status	1 st Winding 3 Phase Time Instantaneous Control Enabled (Status)
3	10646:	50P-3 Momentary	1 st Winding 3 Phase Time Instantaneous Control Enabled (Momentary)
3	10647:	50N-3 Status	1 st Winding 3 Neutral Time Instantaneous Control Enabled (Status)
3	10648:	50N-3 Momentary	1 st Winding 3 Neutral Time Instantaneous Control Enabled (Momentary)
3	10649:	150P-3 Status	2 nd Winding 3 Phase Time Instantaneous Control Enabled (Status)
3	10650:	150P-3 Momentary	2 nd Winding 3 Phase Time Instantaneous Control Enabled (Momentary)
3	10651:	150N-3 Status	2 nd Winding 3 Neutral Time Instantaneous Control Enabled (Status)
3	10652:	150N-3 Momentary	2 nd Winding 3 Neutral Time Instantaneous Control Enabled (Momentary)
3	10653:	46-3 Status	Winding 3 Negative Sequence Control Enabled (Status)
3	10654:	46-3 Momentary	Winding 3 Negative Sequence Control Enabled (Momentary)
3	10655:	51G Status	Ground Time Overcurrent Control Enabled (Status)
3	10656:	51G Momentary	Ground Time Overcurrent Control Enabled (Momentary)
3	10657:	50G Status	Ground Time Instantaneous Control Enabled (Status)
3	10658:	50G Momentary	Ground Time Instantaneous Control Enabled (Momentary)
3	10659:	150G Status	2 nd Ground Time Instantaneous Control Enabled (Status)
3	10660:	150G Momentary	2 nd Ground Time Instantaneous Control Enabled (Momentary)
3	10661:	ECI3 Status	Event Capture Initiate Enabled (Status)
3	10662:	ECI3 Momentary	Event Capture Initiate Enabled (Momentary)
3	10663:	Reserved	Reserved
3	10664:	Reserved	Reserved
3	10665:	Reserved	Reserved
3	10666:	Reserved	Reserved
3	10667:	Reserved	Reserved
3	10668:	Reserved	Reserved
3	10669:	Reserved	Reserved
3	10670:	Reserved	Reserved
3	10671:	Reserved	Reserved
3	10672:	Reserved	Reserved

3= Three Winding TPU Only

Application Example: Obtain Winding 1 Phase Time and Winding 2 Phase Time (51P-1 and 51P-2 Status). The relay status is available from inputs 10517 through 10520 using Momentary Change Detect Bits. Figures 5-21 and 5-22 illustrate the polling sequence and raw data returned over the network utilizing function code 02 using Momentary change detect notification.

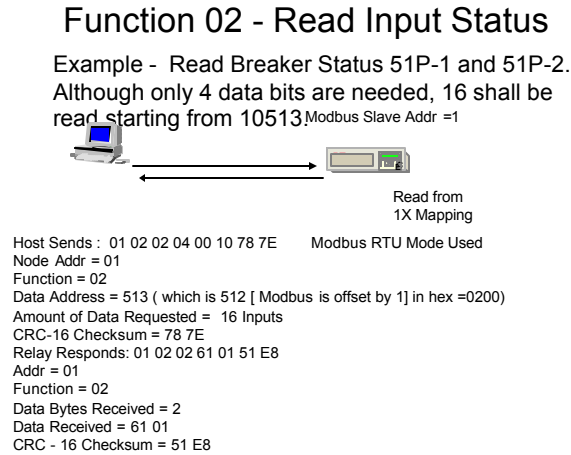

Figure 5-21. Momentary Change Detect Status Example

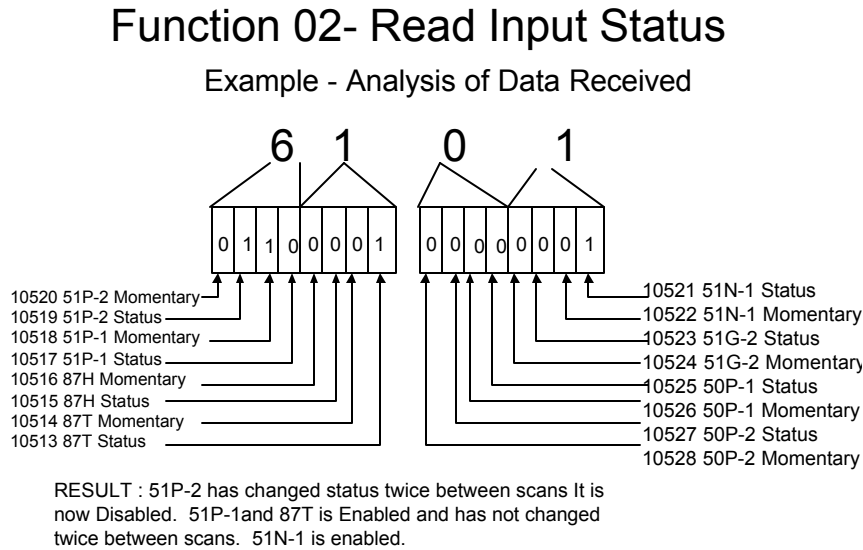

Figure 5-22. Decode of Raw Data Bits as Seen on Data Scope Analyzer

Physical Input Momentary Change Detect (32 Elements Defined)

Physical inputs are mappable for various functional inputs. Their status is available at the following addresses as illustrated in Table 5-8. The status information is similar to that presented in Table 5-7 above, however momentary status is provided in this block.

Table 5-8. Physical Input Momentary Change Detect Register Map

Notes	Address	Item	Description
	11025:	Reserved	Reserved
	11026:	Reserved	Reserved
	11027:	Reserved	Reserved
	11028:	Reserved	Reserved

TPU2000/2000R Modbus/Modbus Plus Automation Guide

Notes	Address	Item	Description
	11029:	Reserved	Reserved
	11030:	Reserved	Reserved
	11031:	Reserved	Reserved
	11032:	Reserved	Reserved
	11033:	Reserved	Reserved
	11034:	Reserved	Reserved
	11035:	Reserved	Reserved
	11036:	Reserved	Reserved
	11037:	Reserved	Reserved
	11038:	Reserved	Reserved
	11039:	Reserved	Reserved
	11040:	Reserved	Reserved
	11041:	IN8 Status	Physical Input 8 Status
	11042:	IN8 Momentary	Physical Input 8 (Momentary)
	11043:	IN7 Status	Physical Input 7 Status
	11044:	IN7 Momentary	Physical Input 7 (Momentary)
	11045:	IN6 Status	Physical Input 6 Status
	11046:	IN6 Momentary	Physical Input 6 Change Detect Between Host Scan
	11047:	IN5 Status	Physical Input 5 Status
	11048:	IN5 Momentary	Physical Input 5 Change Detect Between Host Scan
	11049:	IN4 Status	Physical Input 4 Status
	11050:	IN4 Momentary	Physical Input 4 Change Detect Between Host Scan
	11051:	IN3 Status	Physical Input 3 Status
	11052:	IN3 Momentary	Physical Input 3 Change Detect Between Host Scan
	11053:	IN2 Status	Physical Input 2 Status
	11054:	IN2 Momentary	Physical Input 2 Change Detect Between Host Scan
	11055:	IN1 Status	Physical Input 1 Status
	11056:	IN1 Momentary	Physical Input 1 Change Detect Between Host Scan

4X Register Read Capabilities

The TPU2000/2000R implementation of 4X registers allow for both status reads and in limited cases for control register writes. Many host devices do not allow the access of data from discrete data types (such as 0X and 1X discrete output and input function codes). The Modbus implementation within the TPU2000/2000R relay allows for Modbus commands 03, 16 (10 hex) and 23 (17 hex) register commands. Real time relay status is available for the following relay data types and functionality:

- Relay Status
- Diagnostic Status
- Unit Information
- CT and PT Information
- Physical Input Status
- Logical Input Status
- Physical Output Status
- Logical Output Status
- Load Metering Data
- Demand Metering Data
- Master Trip Functionality
- Fault Record Buffering (1- 32)
- Event Record Buffering (1- 128)
- Breaker Counter Operation Retrieval
- Force of Physical Outputs
- Breaker Control Functions over the network
- Reset of Counter, Event Buffer, Operational Buffer, Seal In and Target information.

Each function code and data type shall be explained in detail, within the following sections.

Modbus protocol allows a variety of information to be placed within the 4X register types. The interpretation of the returned data is key to data received in the request. Modbus protocol is predicated upon register information being returned. A register is 2 bytes, or 16 bits which translates into one word. Multiple words may be combined to form a longer word which allows a larger read to be obtained from the TPU2000/2000R. The TPU2000/2000R supports the following data return types for 4X formats:

- Unsigned - 16 bits - 2 bytes – Range 0 to + 65,535
- Signed - 16 bits – 2 bytes - Range –32,768 to 32,767
- Unsigned Long - 32 bits - 4 bytes - Range 0 to +4,294,967,295
- Signed Long - 32 bits - 4 bytes - Range -2,147,483,648 to +2,147,483,647
- ASCII - 16 bits – 2 bytes – 2 characters per register (Reference Appendix B)

The tables contained within this document reference the above definitions and give the cadence of bytes or words as:

- MSB Most Significant Byte
- LSB Least Significant Byte
- MSW Most Significant Word
- LSW Least Significant Word
- Msb Most significant bit
- Lsb Least significant bit

One must take particular note when interpreting the data bits returned from the IED. Different manufacturers input data from Modbus devices however, each manufacturer starts its address start addresses taking into account the zero offset whereas, other manufacturers do not. Some manufacturers number their data bit presentations in the registers differently. Figure 5-23 below illustrates the register decoding differences.

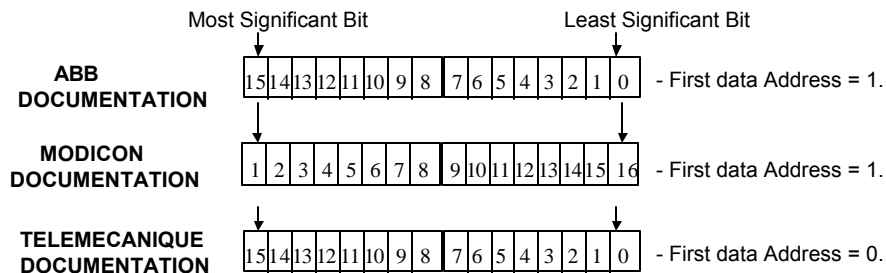

For Example: If a Telemecanique PLC was serving as a Modbus host, the ABB documentation for bit interpretation most significant bit = bit 15 leftmost bit, least significant bit = bit 0 rightmost bit. However, to access a register the host would need to subtract the value of 1 from the data address to obtain the correct data.

If a Modicon PLC was serving as a Modbus host, the ABB documentation would need to be transposed to acknowledge that any data analyzed by the host in the bit 16 position would reflect the status described as Bit 0 lsb nomenclature. No data address offset would need to be performed to obtain the correct information from the protective relay.

Figure 5-23. Vendor Documentation Translation Example

Function Code 03 – Read Holding Registers (Read Only)

The 4x frame sequence is illustrated in Figure 5-24 for Function 03 (Read Holding Registers). The Host sends the protocol request and the TPU2000/2000R responds. The host decodes the data requested dependent upon the definition of the register data. The reader should note that Modbus ASCII denotes a Colon (:) and Carriage Return/Line Feed combination for Start of Message and End Of Message designators. Modbus RTU designates

TPU2000/2000R Modbus/Modbus Plus Automation Guide

3 character delays for a Start of Message and End Of Message designator. Tables 5-9 through 5-19 list the register mapping for Modbus reads. Access of Momentary data access is not available through 4X reads.

Function 03 - Read Holding Registers

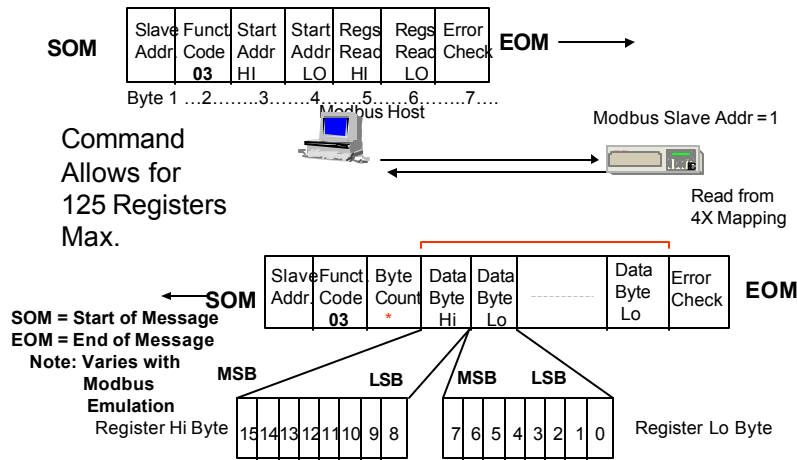

Figure 5-24. 4x Data Read Frame Format

Register Scaling and Re-Mapping and User Definable Register (UDR) Configuration Process

In the evolution of SCADA hosts, different capabilities have been implemented in conjunction with a protocol's implementation. Some SCADA manufacturers have limited the range of numbers accepted at the host level. Other SCADA manufacturers have reserved alternate definitions of most significant bit placement. Still, other SCADA manufacturers have restricted the amount of commands, which a host may send over a network.

ABB's implementation of Register Scaling and Re-Mapping is one method of dealing with certain restrictions or limitations of a SCADA host's protocol implementation. For example, if a host device only accepts numbers from a value of 0 to 4095 (12 bit unipolar) or -2047 to + 2048, how can that host device interpret the Van (Voltage a to neutral) in the TPU2000 which reports the value as a number from 0 to +4,294,967,295 (32 bit number)? The answer is that one of the devices must take the 32 bit data and scale it into a format usable by the other device. Many hosts share this limitation and are unable to undertake the mathematical machinations to scale the data value. The ABB TPU2000 and 2000R permits scaling of its own internal data. The procedure is straightforward in that a simple configuration screen is presented to the operator and menu of choices is selected to complete the configuration procedure.

Re-mapping is especially instrumental in increasing network throughput by allowing all information to be accessed via one network transaction. Within the TPU2000 and 2000R, multitudes of values are available for retrieval via a network connection. However, different protocols require that each group of information can only be accessed via a single network query. Thus if three different groups of information are required via the network, three network accesses must occur. However, if the information is re-mapped to a single memory area in the relay, only one network access need be undertaken to gather the data. Network throughput is increased. Register scaling and re-mapping is common to all ABB TPU2000 and 2000R relays. The Register Scaling and Re-Mapping procedure is the same for DNP/Modbus/Modbus Plus/Standard Ten Byte Protocols. Modbus uses this method to group data so that throughput may be improved by obtaining the data in one network scan.

TPU2000 and TPU2000R protective relays provide for scaling and re-mapping functionality. The TPU does not support this capability. Figure 5-25 illustrates the example of re-mapping Van to one of 32 possible Modbus register locations. The example table configuration entries are shown in the Figure. A definition of each configuration entry and mathematically derived configuration examples follow.

TPU2000 and 2000R Internal Operation

The TPU2000 and TPU2000R reads the raw analog values received from the CT and PT physical connections. The microprocessor-based relay then converts the analog values to a raw digital numeric value from the relay's internal Analog to Digital Converter (A/D) hardware platform. The conversion of the voltage and current readings is not complete. The TPU2000 and TPU2000R microprocessor then takes the raw converted value and performs a mathematical calculation providing a numeric value which is displayed on the relay's front panel MMI or through network accesses.

A protection engineer would recognize the terms as such:

PRIMARY VALUES – the metering values displayed on the protective relay's front panel interface.

SECONDARY VALUES – the current or voltage received by the CT or PT attached to the unit.

SCALED VALUES – the value received by the host device (or calculated by the IED and transmitted to the host) through the communication interface.

The mathematical calculations involved require the CT Phase, CT Neutral, and PT ratios in order to convert the raw A/D to an understandable value, displayed on the front panel MMI or available for access via a network connection. Thus, the information Van (Voltage A to Neutral), is displayed on the front panel MMI in converted format (not raw A/D readings), and the data received via the Modbus/Modbus Plus Registers (40265 and 40266) is reported in Volts in a 32 bit representation. The maximum value able to be physically metered by the relay is dependent upon the TPU2000/2000R and the ratio of the PT and CT's used. The CT and PT values are entered into the TPU through ECP/WinECP in the Configuration Settings Menu illustrated in Figure 5-14. However, life as we know it, is not perfect. Many SCADA hosts are unable to interpret the 32-bit value received over a network. What can be done? ABB's answer is to provide for a fill-in-the-blanks method of scaling. This method takes the interpreted value and provides for **DIVISOR SCALING** (taking the MMI/network register values and dividing by a constant) or a **RATIO SCALING** (taking the MMI values/network register values, PT Ratios, CT Ratios and Full SCALE Metered Readings) and transform it into a raw scaled value depending on the minimum/maximum value the SCADA system can interpret. The SCADA system must then receive the mathematical value and perform its own internal calculations so that the data may be displayed to the operator which mirrors that displayed on the relay's front panel.

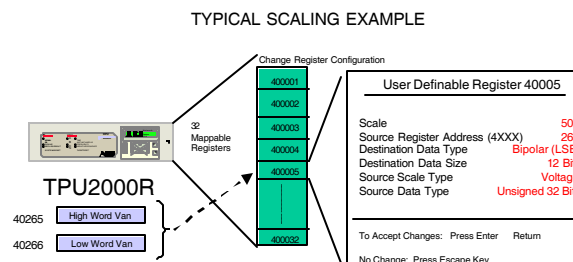

Figure 5-25. Register Scaling Methodology

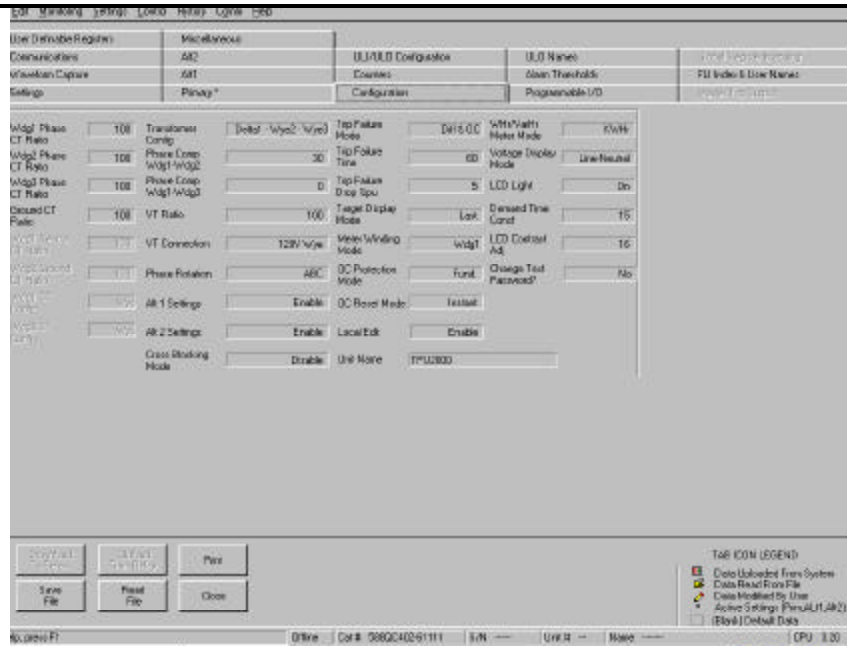
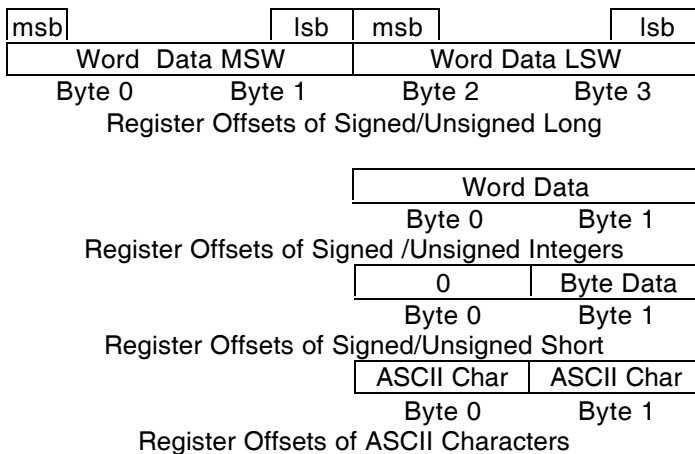

Figure 5-26. Change Configuration Settings Menu Illustrating CT and VT Configuration

ABB Data Type Definitions

All definitions within this manual shall be based upon bits or registers. The ABB concept of Register Scaling and Remapping is based upon the Modbus address map contained within this protocol document, it is essential to understand Modbus Protocol even when providing Register Scaling and Remapping for DNP, Modbus Plus or Standard Ten Byte Protocols.

For example, Modbus requires all register values to be reported in 16 bit portions (1 word). Two registers may be combined to form numeric representations for IEEE notations, long signed (a number from -2,147,483,648 to +2,147,483,647) or unsigned numbers (a number from 0 to +4,294,967,295). If a value is requested in the short form (a number from -128 to +127, or 0 to 255), 16 bits will be returned as a response to the host's request, but the number will be within the range of an 8 bit integer.



The TPU2000 and TPU2000R support the following data return types for 4X formats:

- Unsigned Short - 8 bits - 1 byte in 1 word - Range 0 to 255
- Signed Short - 8 bits - 1 byte in 1 word - Range -128 to +127
- Unsigned - 16 bits - 2 bytes in 1 word - Range 0 to + 65,535
- Signed - 16 bits - 2 bytes in 1 word - Range -32,768 to 32,767

- Unsigned Long - 32 bits - 4 bytes in 2 words - Range 0 to +4,294,967,295
- Signed Long - 32 bits - 4 bytes in 2 words - Range -2,147,483,648 to +2,147,483,647
- ASCII - 16 bits - 2 bytes in 1 word 2 characters per register (Reference Appendix B)

The tables contained within this document reference the above definitions and give the cadence of bytes or words as:

- MSB Most Significant Byte
- LSB Least Significant Byte
- MSW Most Significant Word
- LSW Least Significant Word
- msb Most Significant Bit
- lsb Least Significant Bit

Register Scaling Investigated

Within ECP and WinECP, the Change Settings Mode must be entered. A selection titled “Register Configuration” will appear to the operator. Within ECP, a screen as depicted in Figures 5-26 and 5-27 appears allowing configuration of any of the 32 available registers.

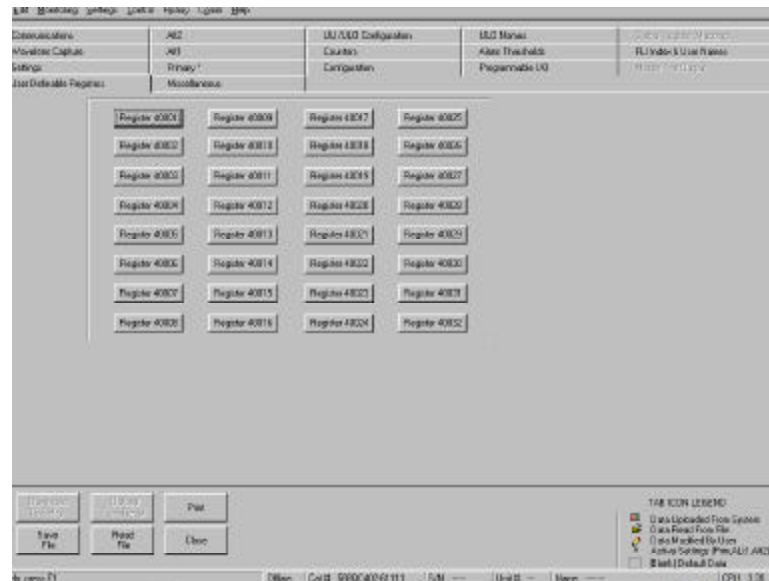

Figure 5-27. User Definable Register Configuration Screen

When using the ABB ECP Relay configuration program or the ABB WinECP Relay configuration program, the following menu items must be selected for each of the 32 mappable and scalable entries. The scaled register addresses are resident in Modbus addressing format from Register 40001 through 40032. The following fields must be configured to perform scaling correctly:

Table 5-9. Register Scaling Queries

WIN ECP/ ECP QUERY	QUERY SELECTIONS
SCALING METHOD	UNIPOLAR
	NEGATIVE UNIPOLAR
	BIPOLAR
	OFFSET BIPOLAR
DESTINATION REGISTER JUSTIFICATION (Selectable with Scaling Method)	LSB (Least Significant Bit)
	MSB (Most Significant Bit)

TPU2000/2000R Modbus/Modbus Plus Automation Guide

DESTINATION REGISTER SIZE	16 Bits
	12 Bits
	8 Bits
	4 Bits
	2 Bit
SOURCE REGISTER ADDRESS	257 – XXXX which is a valid 4X register listed within this document
SOURCE REGISTER TYPE	16 Bits Signed
	16 Bits Unsigned
	32 Bits Signed
	32 Bits Unsigned
SOURCE SCALE RANGE	1 – 65535
SOURCE SCALE TYPE	CURRENT
	VOLTAGE
	POWER
	NORMAL
	REMAINDER

Figure 5-27 illustrates the WIN ECP configuration, which appears before the operator upon configuration of each of the User Definable Registers (UDR). Using the computer's arrow keys to select the field, and depressing the space bar shall allow configuration of the fields within this popup menu screen.

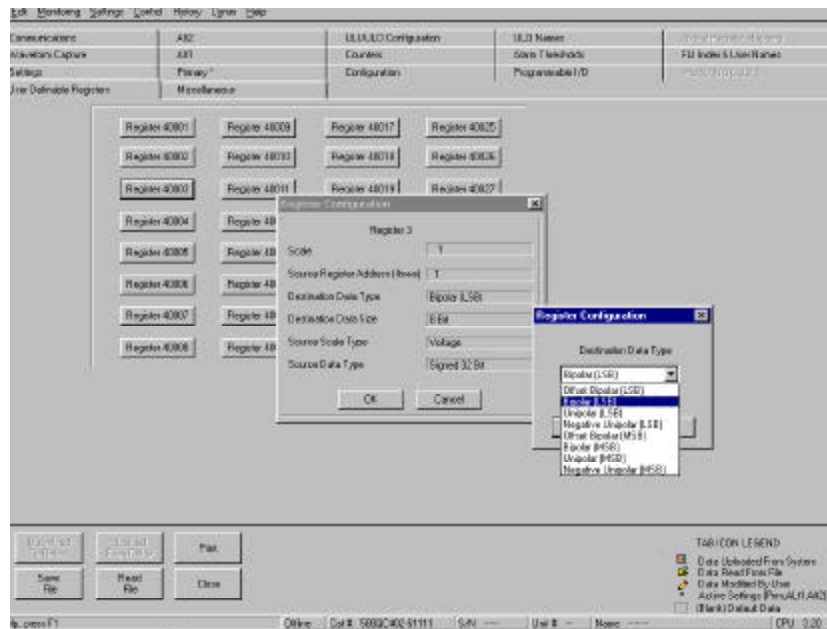

Figure 5-28. Popup Menu Configuration Screen for Data Type Register Selections

Scaling Option and Destination Register Length Options Explained

The source data may be scaled from a 32 bit or 16 bit value from the relay to a 16,12,8,4,or 2, bit scale of the value which is sent to a destination register. The scaling, minimum and maximum values sent to the destination register are listed in the table below.

Table 5-10. Minimum and Maximum Ranges for Scaled Numbers Depending Upon Scale Option and Bit Length Selected

SCALE OPTION	16 Bit Scale		12 Bit Scale		8 Bit Scale		4 Bit Scale		1 Bit Scale	
	min	max	min	max	min	max	min	max	min	max
Offset Bipolar	0	65535	0	4095	0	255	0	15	0	4
Bipolar	-32768	32767	-2048	2047	-128	127	-8	7	-1	2
Unipolar	0	65535	0	4095	0	255	0	15	0	4
Negative Unipolar	0	65535	0	4095	0	255	0	15	0	4

The above table lists the maximum and minimum values reported to a host in the scaled format. Table 5-10 illustrates the value correlation between the scale bit minimum and maximum numbers reported to the host versus the unscaled values generated by the TPU2000 and 2000R.

Within following discussions of scaling parameters, it should be remembered that the bit scale shall be referred to as the quantity “N” which is used extensively for the final scaled value calculation. N shall be a value of 16,12,8,4, or 2, which corresponds to the Bit Scale type referred to in Table 5-10 above.

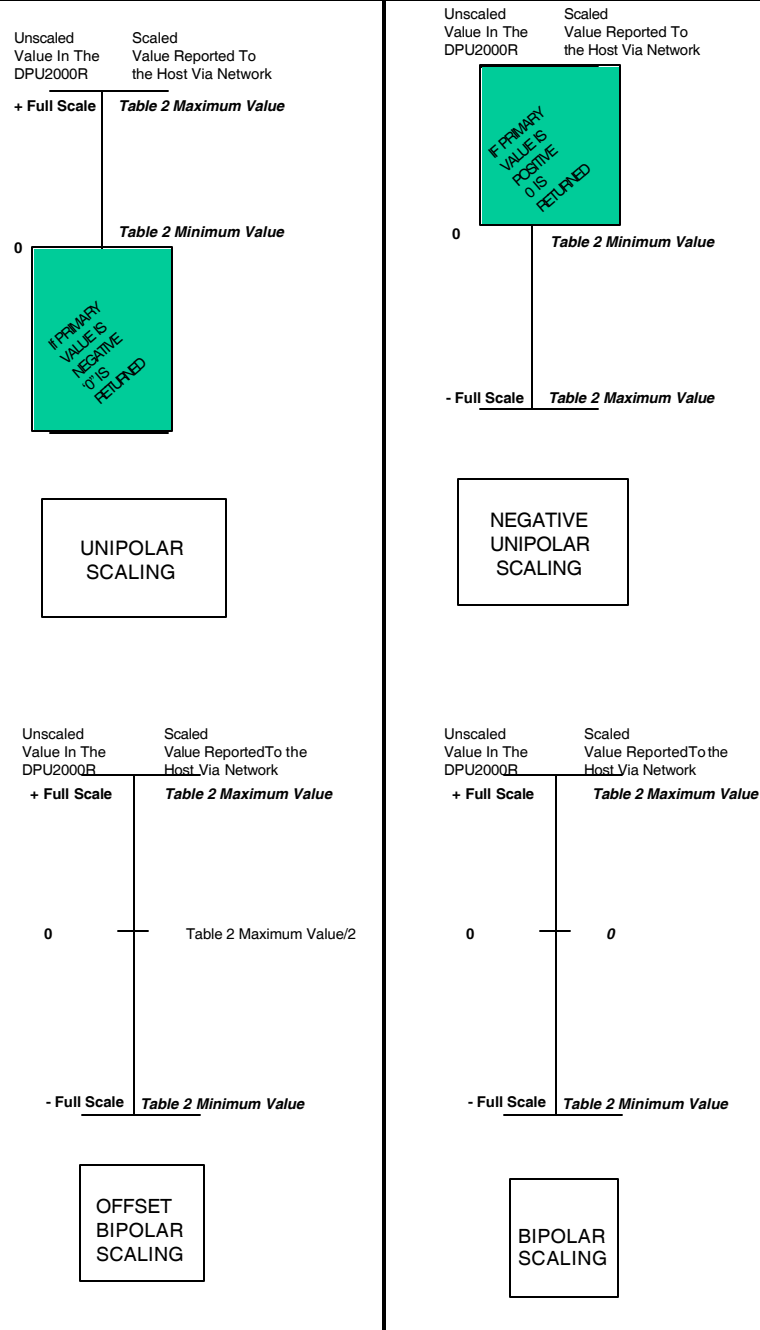

Figure 5-29. Relationship Between Scaled and Unscaled Formats for Offset Bipolar, Bipolar, Unipolar, and Negative Unipolar Scaling Selection in the TPU2000 and 2000R

If one were to mathematically compute the minimum and maximum values as described above in Table 5-10 and relate the values to the unscaled full scale + and full scale – values, the following equations would result from the analysis.

Data Type Definitions

EQUATION 1:

Offset Bipolar

EQUATION 2:

Bipolar

Value Ranges

$(0 \text{ to } +2^{N-1})$ where $0 = -FS$, $2^{N-1} - 1 = 0$ and $2^N - 1 = +FS$

$(-2^{N-1} \text{ to } +2^{N-1} - 1)$ where $-2^{N-1} = -FS$, $0 = 0$ and $2^{N-1} - 1 = +FS$

EQUATION 3:

Unipolar (0 to 2^N-1) where 0 = 0 and $2^N-1 = +FS$

EQUATION 4:

Negative Unipolar (0 to 2^N-1) where 0 = 0 and $2^N-1 = -FS$

NOTE: for the above equations “N” = the amount of bits selected for scaling (i.e. 16, 12, 8, 4, 2)

Destination Register Length Justification Options Explained

Modbus has one definition, but its definition has been interpreted differently by various protocol implementers. This presents a special challenge to the automation engineer. For example, some host device implementations count the first address as address zero whereas other implementers count the first address as address 1 and internally shift the address to offset it by 1 to account for the baseline format.

Another interpretation has been that of most significant bit and least significant bit justification. Two selections are possible for the query DESTINATION BIT JUSTIFICATION. Selections as per Table 5-10 and Figure 5-30 are MSB and LSB. Figure 5-30 illustrates the bit definition and bit padding for the DESTINATION BIT JUSTIFICATION field selection and DESTINATION REGISTER SIZE query.

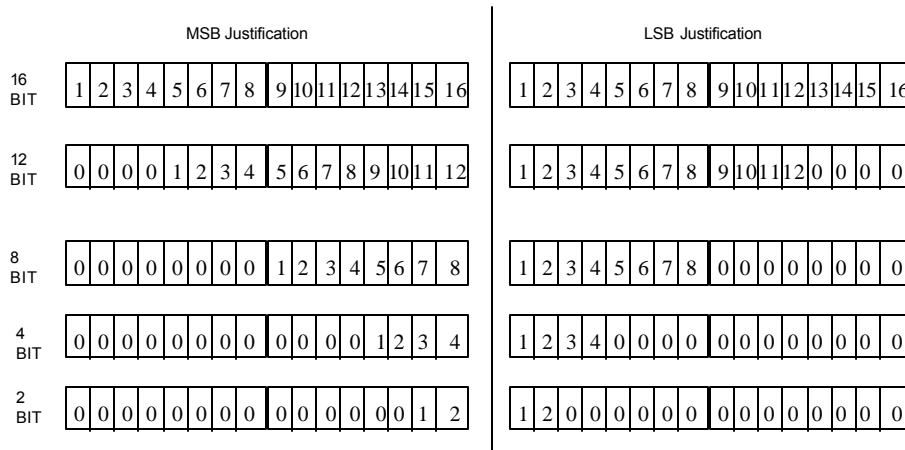

NOTE : Bit designated as a 1 is the words most significant bit whereas the highest bit number is the least significant bit. 0 indicates a padded bit.

Figure 5-30. Bit Justification Notation

An investigation of Figure 5-30 illustrates that register justification shifts the data to the left of the right of the register. If the reported data for example is to be reported as 1 after scaling, the internal Modbus presentation to the host shall be 0001 hex in 12 bit MSB justification format and 0010 in the 12 bit LSB justification format. In both cases Bit 12 is set to represent the number 1, however the reported data to the host is shifted accordingly depending upon the hosts interpretation of the Modbus data.

Source Register Address and Source Register Type Explained

Table 5-11 lists the source addresses of each of the TPU quantities which may be mapped to the User Definable Registers. The addresses are actually the MODBUS addresses from the TPU Modbus Address map. One may consult the TPU 2000/2000R Automation Guide for the exact addresses. For example, if one wished to map the Voltage a to neutral value from its Modbus address at Register 40265, the entry within the SOURCE REGISTER query would be 265. The leading 40 designation (or 4X as some refer to it as) is not required. However, for ease of configuration, the pointer addresses are given to the user in Table 5-11.

TPU2000/2000R Modbus/Modbus Plus Automation Guide

Within this Automation Technical Guide several designations are given for the source data type. Each value reported within a 4X Register has a separate designation. Example data type designations available for scaling and re-mapping are as follows:

Unsigned Long	Register 40385	Restraint Current A Winding 1	32 Bit Register Unsigned
Unsigned Short	Register 40260	Restraint Current A	16 Bit Register Signed
Unsigned Long	Registers 40513	Voltage Phase A	32 Bit Double Register Unsigned
Signed Long	Registers 40528	40528 kWatts Phase A	32 Bit Double Register Signed

The query field may contain any of the above four register types for data transfer.

Source Scale Range and Source Scale Type Selections Explained

Scaling is determined by a simple formula depending upon the SCALE TYPE, FULL SCALE/SCALE FACTOR, SCALING OPTION, and DESTINATION LENGTH, values.

Each of the 4X registers defined within the Modbus Protocol Document are classified by being a Current Value, Voltage Value, or Power Value. If one of these aforementioned scale types are selected, the value in the FULL SCALE/SCALE FACTOR field is designated as the maximum value of the unscaled source value. If the source value is above the configured FULL SCALE/SCALE FACTOR field value, the maximum value (as shown in [Table X](#)) will be reported as the destination register scaled value.

The values within the relay may be scaled by an integer factor if a normal or remainder scaling type is selected. If one of aforementioned selections are within the FULL SCALE/SCALE FACTOR selection field then the selection is automatically the scale factor.

The allowable values for the FULL SCALE/SCALE FACTOR field are from 1 to 65535. This is equivalent to the secondary quantities and the relationship to the primary quantities being scaled as per said formulas below. (which should be familiar to those of you who are "old" transducer engineers.)

If one of the voltage, current, or power SCALE TYPES are selected, then one or more of the following CT /PT ratio values must be known to compute the destination scaled value. The quantities which must be known to compute the equations for scaling are:

40158:	Unsigned Short	Phase CT (CT)
40159:	Unsigned Short	Neutral CT Ratio (CT)
40160:	Unsigned Short	PT Ratio (PT)

NOTE: If the quantity being scaled is a Phase Current then the Phase A CT value entered in WIN ECP is used in the following equations. If the quantity being scaled is a Neutral Current value, then the Neutral Current CT is used in the following scaling equations. The values may be viewed from the ECP/WinECP program as illustrated in Figure 5-16.

IF OFFSET BIPOLAR CURRENT IS SELECTED

EQUATION 5:

$$\text{Register Value} = (2^{N-1} \cdot \text{Source Value} / [\text{FS} \cdot \text{CT Ratio}]) + 2^{N-1} - 1$$

IF OFFSET BIPOLAR VOLTAGE IS SELECTED

EQUATION 6:

$$\text{Register Value} = (2^{N-1} \cdot \text{Source Value} / [\text{FS} \cdot \text{PT Ratio}]) + 2^{N-1} - 1$$

IF OFFSET BIPOLAR POWER IS SELECTED

EQUATION 7:

$$\text{Register Value} = (2^{N-1} \cdot \text{Source Value} / [\text{FS} \cdot \text{CT Ratio} \cdot \text{PT Ratio}]) + 2^{N-1} - 1$$

IF NORMAL SCALING IS SELECTED

EQUATION 8:

$$\text{Register Value} = \text{Source Value} / \text{Scale}$$

IF REMAINDER SCALING IS SELECTED

EQUATION 9:

Register Value = Remainder of [Source Value/Scale] (commonly referred to as the modulus function).

IF BIPOLAR CURRENT IS SELECTED

EQUATION 10:

$$\text{Register Value} = (2^{N-1} \cdot \text{Source Value} / [\text{FS} \cdot \text{CT Ratio}])$$

IF BIPOLAR VOLTAGE IS SELECTED

EQUATION 11:

$$\text{Register Value} = (2^{N-1} \cdot \text{Source Value} / [\text{FS} \cdot \text{PT Ratio}])$$

IF BIPOLAR POWER IS SELECTED

EQUATION 12:

$$\text{Register Value} = (2^{N-1} \cdot \text{Source Value} / [\text{FS} \cdot \text{CT Ratio} \cdot \text{PT Ratio}])$$

IF UNIPOLAR OR NEGATIVE UNIPOLAR EQUATIONS ARE USED, Then the BIPOLAR equations above are applicable with the note that,

FOR UNIPOLAR, if the result of the equation (10,11,or 12) is positive, then the register is filled with the value calculated, else the reported value is 0

FOR NEGATIVE UNIPOLAR, If the result of the equation (10,11, or 12) is negative, then the register is filled with the absolute value of the equation. If the calculated value is positive in sign, then the reported value is 0.

One should notice that if equations 5, 6, 7, 10, 11,or 12 are used, the SCALE entry shown in [Figure 5-12?](#), refers to the full scale value referenced in the equations. If equations 8 or 9 are used, the SCALE entry shown in [Figure 8-2](#) refers to the Scale divisor denominator as referenced.

TPU2000 and 2000R User Definable Register Defaults

The TPU2000 and 2000R contains User Definable Register default mappings as shown in Table 5-11 below. It should be noted that the register shall saturate at the maximum values computed and shown in Table 5-10 above. The maximum saturation value can be computed to be 2^{N-1} where N is the register size in bits.

Table 5-11. Default Scaling and Remapping Register Assignments

User Definable Register	Register Type (Bits)	Start Register (Bits/Type)	FS or Scale(Type)	Description
1: 40001	Unipolar (16)	40129 (16/Unsigned)	1(Normal)	Relay Status
2: 40002	Offset Bipolar (12)	40393 (16/Unsigned)	10 (Current)	Load Current A(Wdg 2)
3: 40003	Offset Bipolar (12)	40395 (16/Unsigned)	10 (Current)	Load Current B(Wdg 2)
4: 40004	Offset Bipolar (12)	40397 (16/Unsigned)	10 (Current)	Load Current C(Wdg 2)
5: 40005	Offset Bipolar (12)	40513 (32/Unsigned)	150 (Voltage)	Voltage VAN
6: 40006	Offset Bipolar (12)	40515 (32/Unsigned)	150 (Voltage)	Voltage VBN
7: 40007	Offset Bipolar (12)	40517 (32/Unsigned)	150 (Voltage)	Voltage VCN
8: 40008	Offset Bipolar (12)	40552 (32/Signed)	3000 (Power)	3 Phase Watts
9: 40009	Offset Bipolar (12)	40554 (32/Signed)	3000 (Power)	3 Phase VARs
10: 10010	Offset Bipolar (12)	40528 (32/Signed)	1000 (Power)	Phase A Watts
11: 40011	Offset Bipolar (12)	40530 (32/Signed)	1000 (Power)	Phase B Watts
12: 40012	Offset Bipolar (12)	40532 (32/Signed)	1000 (Power)	Phase C Watts
13: 40013	Offset Bipolar (12)	40534 (32/Signed)	1000 (Power)	Phase A VARs
14: 40014	Offset Bipolar (12)	40536 (32/Signed)	1000 (Power)	Phase B VARs

TPU2000/2000R Modbus/Modbus Plus Automation Guide

15: 40015	Offset Bipolar (12)	40538 (32/Signed)	1000 (Power)	Phase C VARs
16: 40016	Unipolar (16)	40158 (16/Unsigned)	1 (Normal)	Phase CT Ratio
17: 40017	Unipolar (16)	40159 (16/Unsigned)	1 (Normal)	PT Ratio
18: 40018	Offset Bipolar (12)	40399 (16/Unsigned)	10 (Current)	Load Current N
19: 40019	Unipolar (16)	40556 (32/Signed)	10000 (Normal)	Pos 3 Phase kWatthours (High)
20: 40020	Unipolar (16)	40556 (32/Signed)	10000 (Remainder)	Pos 3 Phase kWatthours (Low)
21: 40021	Neg Unipolar (16)	40556 (32/Signed)	10000 (Normal)	Neg 3 Phase kWatthours (High)
22: 40022	Neg Unipolar (16)	40556 (32/Signed)	10000 (Remainder)	Pos 3 Phase kWatthours (Low)
23: 40023	Unipolar (16)	40558 (32/Signed)	10000 (Normal)	Pos 3 Phase kVARhours (High)
24: 40024	Unipolar (16)	40558 (32/Signed)	10000 (Remainder)	Pos 3 Phase kVARhours (Low)
25: 40025	Neg Unipolar (16)	40558 (32/Signed)	10000 (Normal)	Neg 3 Phase kVARhours (High)
26: 40026	Neg Unipolar (16)	40558 (32/Signed)	10000 (Remainder)	Neg 3 Phase kVARhours (Low)
27: 40027	Unipolar (16)	40562 (16/Unsigned)	1 (Normal)	System Frequency
28: 40028	No Default	No Default	No Default	Spare
29: 40029	No Default	No Default	No Default	Spare
30: 40030	No Default	No Default	No Default	Spare
31: 40031	No Default	No Default	No Default	Spare
32: 40032	No Default	No Default	No Default	Spare

An explanation of some of the above default mappings are offered as a guide to understanding the scaling methodology implementation. Figure 5-31 illustrates the scaling procedure for remapped registers 40001 through 40032. Registers 257, 259, and 261 (as detailed in Table 5-11 above) contain the MMI reported current values to be remapped and re-scaled to 12 bit Offset Bipolar Values.

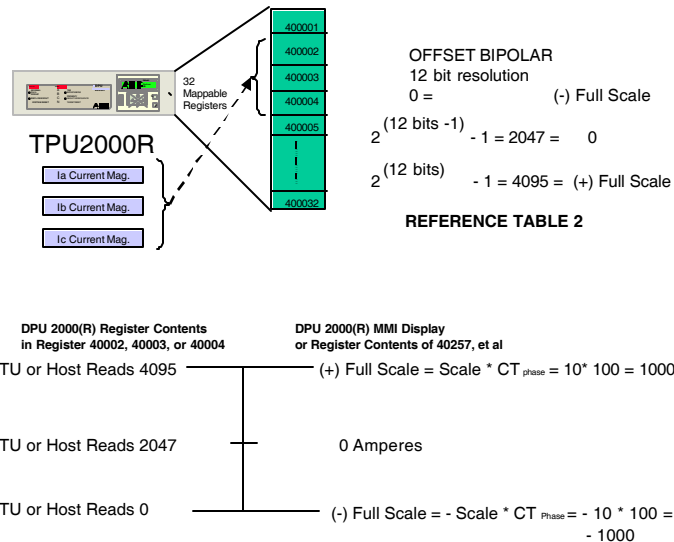

Figure 5-31. Register Scaling Default Example

The mathematics to determine the reported value to the host is illustrated in Figure 5-31 and using Equation 5 above.

Full Scale = **10 MAX VALUE ALLOWABLE ON FPI = 10 * CT ratio.**

CT Ratio (Current Calculation) = **100:1** (as per the default screen shown in **Figure 8-2**)

Source Value Location = **385 [16 Bit Value Signed]**

Calculate the 12 bit scaled reading when the TPU2000R indicates 5A for Ia.

$$\left(\left(2^{(12 \text{ bits} - 1)} * 5A \right) / (10 * 100) \right) + \left(2^{(12 \text{ bits} - 1)} - 1 \right) = 3071 \text{ counts.}$$

Thus Equation 7 illustrates that a current of 5A displayed on the MMI shall indicate a count of 3071 reported to the SCADA Host when register 40002 is read. The SCADA host shall then interpret it and display it on its host screen as 5 A.

Perhaps another example shall suffice. The TPU2000/2000R also meters voltages. The next example illustrates the scaling which occurs for the default registers, 40006, and 40007. **Figure 8-8** shows the scale algorithm application for scaling to an Offset Bipolar 12 bit number.

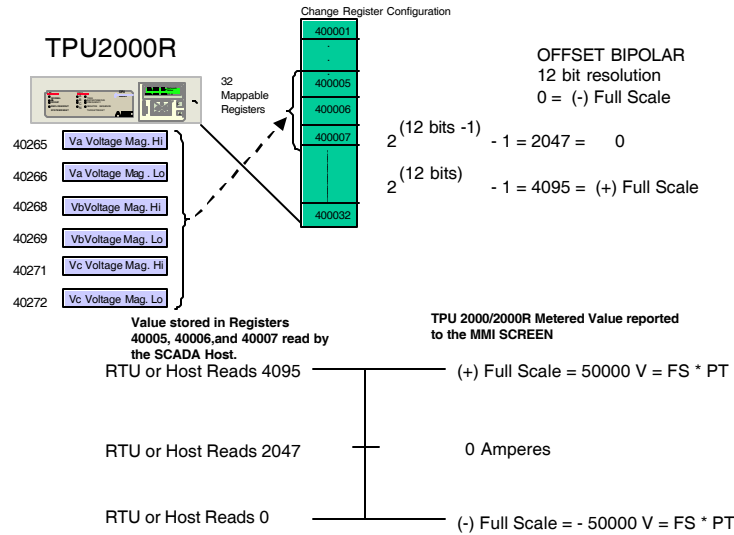

Figure 5-32. Scaling Example for Voltage Mapped Registers

The values used for this example are:

Full Scale = **500**

PT Ratio (Current Calculation) = **100:1**

Source Value Location = **513 [neglect the leading 4] 32 Bit Value Unsigned]**

Using Equation 6 the following results when calculating the numeric value reported to the SCADA host when register 40005, 40006 or 40007 is accessed.

$$\left(\left(2^{(12 \text{ bits} - 1)} * 11884 \right) / (500 * 100) \right) + \left(2^{(12 \text{ bits} - 1)} - 1 \right) = 3699.562 \text{ counts}$$

$$1622.562 + 2047 = 3699$$

When the front panel MMI reads 11884 V, a value of 3699 is reported to the SCADA host.

One final example is illustrated for transferring values from different areas in the protective relay to the default table. Such values as Relay status (located in register 40129 and transferred to 40001), Phase CT ratio (used by the SCADA host to provide for scale conversion located in Register 40158 and transferred to 40016), PT ratio (used by the SCADA host to provide for scale conversion in Register 40160 and transferred to 40017), and system frequency (located in Register 40027).

TPU2000/2000R Modbus/Modbus Plus Automation Guide

The transfer of registers to a block is accomplished by using equation 8 and providing a scale factor of 1. Thus the contents of the source register are divided by 1 and transferred to the User Definable Register Table. It is important that the scale type of 16 be used to ensure the transfer is not scaled.

Relay Status (1 Register Defined)

Bit 0 shall update if the unit has failed Self Test. Bits 1 (Lsb) through Bit 4, Bit 9 and 10, shall update to a 1 if any of the corresponding data to the bit group changes. The Bits shall reset when the register is polled by the host.

Bits 1, 2, 3, 4, 5, 6, 7, 8, 9, 10 and 11, update the status real time indicate the state of the bit defined TPU2000/2000R relay feature.

If Bit 2 is enabled, then 6X register parameterization data has been changed through the front panel of the TPU2000/2000R. In an automation application, a read of this register allows for quick determination of which data to access for immediate display. The Bits are reset when read by the host. Table 5-12 lists the bit mapping for the relay status register.

The Relay Status register is especially valuable in that if a TPU2000/2000R value has changed, it may be determined via a read of Register 40129. Once the Relay Status register has been accessed by the host, all bits in Register 40129 will be reset by the relay. The status shall then be refreshed by the TPU2000/2000R until the next host read of Register 40129. Once the status change has been detected by the host, specific registers further detailing the status change may be accessed by the host.

Table 5-12. Relay Status Modbus Address Map Definition

Register Address	Item	Description
40129	Relay Status	Unsigned 16 bit
	Bit 0 Self Test (Lsb)	Self Test In Progress
	Bit 1 Contact Input Changed	Input Transitioned
	Bit 2 Local Settings Changed	Settings Changed
	Bit 3 Remote Edit Disabled	Edit Via Network Enabled
	Bit 4 Alternate Settings 1 Active	Alternate Setting Group 1 Enabled
	Bit 5 Alternate Settings 2 Active	Alternate Setting Group 2 Enabled
	Bit 6 New Fault Record	New Fault Record In Buffer
	Bit 7 Control Power Cycled	Unit Power Cycled
	Bit 8 New Operation Recorded	New Operation Record in Buffer
	Bit 9 New Peak Demand Recorded	New Peak Demand In Buffer
	Bit 10 New Minimum Demand Value	New Minimum Demand In Buffer
	Bit 11 Reserved	
	Bit 12 Reserved	
	Bit 13 Reserved	
	Bit 14 Reserved	
	Bit 15 Reserved (Msb)	

Application Example. A Modbus Host is able to parse data in a bit format which it access through the network. The host is required to monitor a TPU2000/2000R for new fault and event records. What command should be sent to a TPU2000/2000R to gather the information.

Figures 5-33 and 5-34 illustrate data strings sent to the TPU2000/2000R to determine if a new event or operation record has been stored.

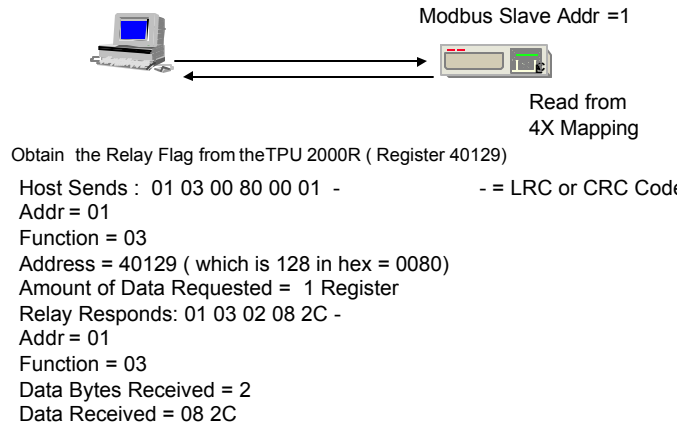

Figure 5-33. Application Example: Fetch Relay Status from the TPU2000/2000R

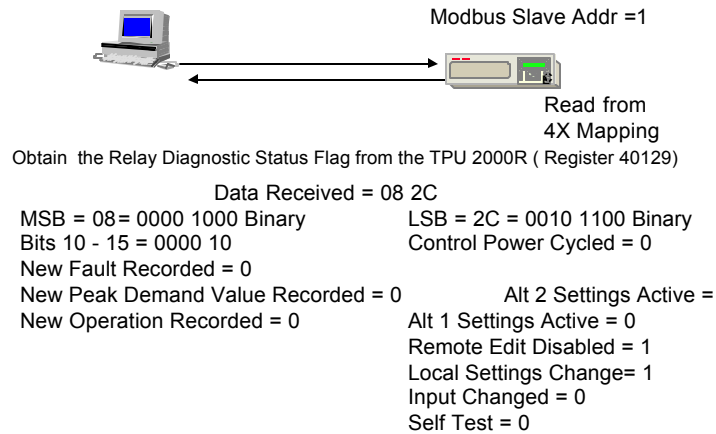

Figure 5-34. Application Example: Returned Relay Response

Since the last read of the status register, a new fault record and event record has been input within the TPU2000/2000R buffers.

Diagnostic Status (2 Registers Defined)

Bits 0, 1, or 2 are updated continuously. The TPU2000/2000R performs diagnostics:

- Upon power-up of the unit.
- Continuously thereafter on a periodic basis. A variety of TPU2000/2000R diagnostics are performed and completed in 20 minute intervals.

If a "SELF TEST" failure is reported in Register 40129 Bit 0 or discrete output 0007, access of Register 40129 shall enable the user to access the cause. Diagnostic Status is reported via MMI front panel or Network port access.

Bit 3 Reflects the OR'ing of all EEPROM Settings stored. (ie if one fails [bit 0, 1, or 2 is set to a 1]) this is set. Within the TPU2000/2000R are three relay parameter copies. Upon power-up, the copies are compared to each other. If there is a miscompute, a TPU2000/2000R PROM Failure is logged. Bit 3 is set when the unit failures to successfully read from all three copies of the Stored Parameters.

Bits 0 through 3 are cleared only at a unit Power On Reset, or a unit TPU2000/2000R reset through the front panel.

TPU2000/2000R Modbus/Modbus Plus Automation Guide

IMPLEMENTATION TIP- Front Panel Reset Is Accomplished By Pressing The “C”, “E”, And “Up Arrow Keys” Simultaneously On The Front MMI Panel Of The TPU2000/2000R.

The bit shall indicate 1 for diagnostic failure indication. These bits show the status.

Table 5-13. Diagnostic Status Modbus Address Map Definition

Register Address	Item	Description
40130	Main CPU Diag. Status	Unsigned 16 Bit
	Bit 15 DSP COP FAILURE (msb)	Digital Signal Processor Failure
	Bit 14 DSP +5V FAILURE	Digital Signal Process Pwr supply Fail
	Bit 13 DSP +/-15V FAILURE	Digital Signal Process Pwr supply Fail
	Bit 12 DSP +/-5V FAILURE	Digital Signal Process Pwr supply Fail
	Bit 11 DSP ADC FAILURE	Analog/Digital Converter Fail
	Bit 10 DSP EXT RAM FAILURE	Digital Signal Process Pipeline Fail
	Bit 9 DSP INT RAM FAILURE	Digital Signal Process RAM Fail
	Bit 8 DSP ROM FAILURE	Digital Signal Process ROM Fail
	Bit 7 Spare	Reserved
	Bit 6 Spare	Reserved
	Bit 5 Spare	Reserved
	Bit 4 Spare	Reserved
	Bit 3 CPU EEPROM FAILURE	EEPROM Checksum fail on Refresh
	Bit 2 CPU NVRAM FAILURE	Non-Volatile RAM Failure
	Bit 1 CPU EPROM FAILURE	Checksum Failure on EPROM
Bit 0 CPU RAM FAILURE (lsb)	Main CPU RAM FAILURE	
40131	Bit 0 Reserved (Lsb)	The upper byte of this word updates every second indicating that the unit is alive. A host may monitor this register to determine if the unit is online.
	Bit 1 Reserved	
	Bit 2 Reserved	
	Bit 3 Reserved	
	Bit 4 Reserved	
	Bit 5 Reserved	
	Bit 6 Reserved	
	Bit 7 Reserved	
	Bit 8 Heartbeat Low Bit	
	Bit 9 Heartbeat	
	Bit 10 Heartbeat	
	Bit 11 Heartbeat	
	Bit 12 Heartbeat	
	Bit 13 Heartbeat	
	Bit 14 Heartbeat	
	Bit 15 Heartbeat Hi Bit (Msb)	

Unit Information (15 Registers Defined)

Unit information status allows retrieval of TPU2000/2000R Executive firmware revision numbers, TPU2000/2000R Catalog numbers as well as TPU2000/2000R Unit Serial numbers. The TPU2000/2000R has the use of only one communication port, access of Register 40143 allows a remote host to determine which port is designated for use. Two of the registers within the unit information block are scaled, 40140 and 40141. The returned unsigned 16 bit data values when divided by 100 will mirror the revision numbers as seen on the front LCD panel within the Unit Information menu of the TPU2000/2000R. These are the only scaled registers within this block of 4X registers available for read. Table 5-14 further defines the Unit Information status block.

Table 5-14. Unit Information Status Modbus Address Map Definition

Register Address	Item	Description
40132	Relay Configuration Bit 0 Meter Winding Mode Bit 1 Meter Winding Mode Bit 2 PT Configuration Bit 3 Var/HR Unit Meas. Bit 4 Voltage Meas. Tech. Bit 5 Reserved Bit 6 Reserved Bit 7 Reserved Bit 8 Reserved Bit 9 Reserved Bit 10 Reserved Bit 11 Reserved Bit 12 Reserved Bit 13 Reserved Bit 14 Reserved Bit 15 Reserved (Msb)	Unsigned Integer 0,0 = Winding 1, 0,1 = Winding 2 1,0 = Winding 3 0 = Wye: 1 = Delta 0 = k Whr/k Varh, 1= M Whr/M Vhr 0 = Line to Neutral 1 = Line to Line Reserved Reserved Reserved Reserved Reserved Reserved Reserved Reserved Reserved Reserved Reserved
40133	Catalog Number (MSW)	ASCII – 2 Characters Leftmost Digits
40134	Catalog Number	ASCII – 2 Characters
40135	Catalog Number	ASCII – 2 Characters
40136	Catalog Number	ASCII – 2 Characters
40137	Catalog Number	ASCII – 2 Characters
40138	Catalog Number	ASCII – 2 Characters
40139	Catalog Number	ASCII – 2 Characters
40138	Catalog Number	ASCII – 2 Characters
40139	Catalog Number	ASCII – 2 Characters
40142	Catalog Number (LSW)	ASCII – 2 Characters Rightmost Digits
40143	Main CPU Sw Version Number	Unsigned 16 Bit – (Scale Factor 100)
40144	Analog DSP Sw Version Number	Unsigned 16 Bit – (Scale Factor 10)
40145	Front Panel Controller Sw Version Number	Unsigned 16 Bit – (Scale Factor 10)
40146	Communication Sw Version Number	Unsigned 16 Bit – (Scale Factor 10)
40147	Unit Serial Number (MSW)	Unsigned Long 32 Bit (Most Significant Word – 16 Bits)
40148	Unit Serial Number (LSW)	Unsigned Long 32 Bit (Least Significant Word – 16 Bits)
40149	Unit Name (Most Significant Digits)	ASCII – 2 Characters (Leftmost Digits)
40150	Unit Name	ASCII – 2 Characters
40151	Unit Name	ASCII – 2 Characters
40152	Unit Name	ASCII – 2 Characters
40153	Unit Name	ASCII – 2 Characters
40154	Unit Name	ASCII – 2 Characters
40155	Unit Name	ASCII – 2 Characters
40156	Unit Name	ASCII – 2 Characters
40157	Unit Name (Least Significant Digits)	ASCII – 2 Characters (Rightmost Digits)

Read Quick Status (3 Registers Defined)

CT and PT ratio configuration data is available. As standard, The CT ratio is to 1as is the Neutral and PT ratios are to 1. Quick status registers are illustrated in Table 5-15.

Table 5-15. Quick Status Modbus Address Map Definition

Register Address	Item	Description
40158	Phase CT Ratio	Unsigned 16 Bit
40159	Neutral Ratio	Unsigned 16 Bit
40160	PT Ratio	Unsigned 16 Bit

Power Fail Status Information (9 Registers Defined)

If the TPU2000 or TPU2000R loses power, the unit has the capability to sense power is being lost. During this shutdown time, the unit stores the timestamp of power fail occurrence. The storage format is shown in Table 5-16.

Table 5-16. Power Fail Table Register Definition

Address	Item	Description
40161	Power Fail Timestamp Year	Unsigned Integer 16 Bit 1900<=Range<= 2100
40162	Power Fail Timestamp Month	Unsigned Integer 16 Bit 1<=Range <=12
40163	Power Fail Timestamp Day	Unsigned Integer 16 Bit 1<=Range<=31
40164	Power Fail Timestamp Hours	Unsigned Integer 16 Bit 0<=Range<=23
40165	Power Fail Timestamp Minutes	Unsigned Integer 16 Bit 0<=Range<=59
40166	Power Fail Timestamp Seconds	Unsigned Integer 16 Bit 0<=Range<=59
40167	Power Fail Timestamp Hundreths of Seconds	Unsigned Integer 16 Bit 0<=Range<99
40168	Power Fail Timestamp Fail Type	Unsigned Integer 16 Bit 1 = DC
40169	Power Fail Timestamp Machine State	Unsigned Integer 16 Bit 0 = Circuit Breaker Closed 1 = Picked Up 2 = Circuit Breaker Tripping 3 = Circuit Breaker Failed to Open 4 = Circuit Breaker Open 6 = Circuit Breaker Open 7 = Circuit Breaker Failed to Open 8 = Control Switch Trip Fail 9 = Circuit Breaker State Unknown

Fast Status (2 Registers Defined)

Fast Status is available for an operator interface to determine the device queried. The Division Code for the TPU2000/2000R is 1A HEX. The product ID for the TPU2000/2000R is 0E HEX.

One should also notice that the reporting of a new operation record is reported here in word 40170 in bit position 9. The bit is reset whenever the word is accessed via a network read.

Table 5-17. Fast Status Modbus Address Map Definition

Register Address	Item	Description
40170	Fast Status Bit 0 - 5 Division Code (Lsb) Bit 6 Reserved Bit 7 Reserved Bit 8 Reserved Bit 9 Unreported Operation Record Bit 10 – 15 Reserved	Unsigned 16 Bit 00 0101 = 07 HEX) Reserved Reserved Reserved 1 = Unreported Record Reserved
40171	Fast Status Bit 0 - 5 Reserved (Lsb) Bit 6 Reserved Bit 7 Reserved Bit 8 Reserved Bit 9 Reserved Bit 10 – 15 Product ID (Msb)	Unsigned Integer 16 Bit Reserved Reserved Reserved Reserved Reserved 00 1110 = 0E HEX left justified

Communication Event Log (8 Registers Defined)

Whenever a communication error occurs, the TPU2000/TPU2000R generates an exception response to the rejected command. Registers 40172 through 40179 contains information on the last communication error experienced via the front communication port, rear INCOM port or the RS232/485 ports resident on the relay's communication card. Table 5-18 lists the register definition for the event log.

Table 5-18. Communication Error Event Log

Address	Item	Definition
40172	Last Comm Port Error	Unsigned Integer 0 = Modbus Plus (Type 6 or 7 Card Only TPU2000R) 1 = INCOM 2 = RS232 3 = RS485
40173	Last Comm Error Command	Unsigned Integer/ Word Byte Decode If Modbus or Modbus Plus, register contains Modbus Command. If INCOM or Standard Ten Byte, register contains Command + Subcommand in upper lower byte decode.
40174	Last Comm Error Register Request	Unsigned Integer Last Requested Address on Comm error read/write request.
40175	Last Comm Error Type	Unsigned Integer 1= Invalid Password 2 = Checksum Error 3 = Block/Register Range Invalid 4 = Block/Register attempted to be accessed invalid 5 = Range of data attempted to be accessed invalid 6 = Invalid Data 7 = Settings being edited elsewhere in unit or remote edit disabled 8 = A write to one setting group attempted while actively editing another. 9 = Breaker State Invalid 10 = Data entered is below minimum value 11 = Data entered is above maximum allowed 12 = Data entered is out of step 13 = Internal Software Error 32 = Reference Type or File Number Invalid 33 = Too many registers for Modbus Protocol

TPU2000/2000R Modbus/Modbus Plus Automation Guide

40176	Control Mask If Write Error	Unsigned Integer Control Mask 1 Write Mask (MSW)
40177	Control Mask If Write Error	Unsigned Integer Control Mask 1 Write Mask (LSW)
40178	Control Mask If Write Error	Unsigned Integer Control Mask 2 Write Mask (MSW)
40179	Control Mask If Write Error	Unsigned Integer Control Mask 2 Write Mask (LSW)

Metering Values (35 Registers Defined)

Metering Values are defined Table 5-19. Various data types are associated with each element. All metering values are reported in primary units and should reflect the status as shown on the TPU2000/2000R Front Panel Interface, ECP or WinECP metering screens. Many of the quantities are scaled, such as operating current to denote a decimal point when read. Operate Current 40257 should be divided by 800 to obtain the decimal point which is visible when viewing the value from the front panel.

Table 5-19. TPU2000/TPU2000R Metering Values Table

Register Address	Item	Scale Factor	Description
40257	Operate Current A	800	Unsigned 16 Bit
40258	Operate Current B	800	Unsigned 16 Bit
40259	Operate Current C	800	Unsigned 16 Bit
40260	Restraint Current A Winding 1	800	Unsigned 16 Bit
40261	Restraint Current B Winding 1	800	Unsigned 16 Bit
40262	Restraint Current C Winding 1	800	Unsigned 16 Bit
40263	Restraint Current A Winding 2	800	Unsigned 16 Bit
40264	Restraint Current-B Winding 2	800	Unsigned 16 Bit
40265	Restraint Current C Winding 2	800	Unsigned 16 Bit
40266	Restraint Current A Winding 3	800	Unsigned 16 Bit
40267	Restraint Current B Winding 3	800	Unsigned 16 Bit
40268	Restraint Current C Winding 3	800	Unsigned 16 Bit
40269	Restraint Angle-A Winding 1	1	Unsigned 16 Bit
40270	Restraint Angle-B Winding 1	1	Unsigned 16 Bit
40271	Restraint Angle-C Winding 1	1	Unsigned 16 Bit
40272	Restraint Angle-A Winding 2	1	Unsigned 16 Bit
40273	Restraint Angle-B Winding 2	1	Unsigned 16 Bit
40274	Restraint Angle-C Winding 2	1	Unsigned 16 Bit
40275	Restraint Angle-A Winding 3	1	Unsigned 16 Bit
40276	Restraint Angle-B Winding 3	1	Unsigned 16 Bit
40277	Restraint Angle-C Winding 3	1	Unsigned 16 Bit
40278	% Second Harmonic-A Winding 1	2	Unsigned High Order Byte LSB
40278	% Second Harmonic-B Winding 1	2	Unsigned Low Order Byte MSB
40279	% Second Harmonic-C Winding 1	2	Unsigned High Order Byte LSB
40279	% Fifth Harmonic-A Winding 1	2	Unsigned Low Order Byte MSB
40280	% Fifth Harmonic-B Winding 1	2	Unsigned High Order Byte LSB
40280	% Fifth Harmonic-C Winding 1	2	Unsigned Low Order Byte MSB
40281	% All Harmonic-A Winding 1	2	Unsigned High Order Byte LSB
40281	% All Harmonic-B Winding 1	2	Unsigned Low Order Byte MSB
40282	% All Harmonic-C Winding 1	2	Unsigned High Order Byte LSB
40282	% Second Harmonic-A Winding 2	2	Unsigned Low Order Byte MSB
40283	% Second Harmonic-B Winding 2	2	Unsigned High Order Byte LSB
40283	% Second Harmonic-C Winding 2	2	Unsigned Low Order Byte MSB
40284	% Fifth Harmonic-A Winding 2	2	Unsigned High Order Byte LSB

TPU2000/2000R Modbus/Modbus Plus Automation Guide

Register Address	Item	Scale Factor	Description
40284	% Fifth Harmonic-B Winding 2	2	Unsigned Low Order Byte MSB
40285	% Fifth Harmonic-C Winding 2	2	Unsigned High Order Byte LSB
40285	% All Harmonic-A Winding 2	2	Unsigned Low Order Byte MSB
40286	% All Harmonic-B Winding 2	2	Unsigned High Order Byte LSB
40286	% All Harmonic-C Winding 2	2	Unsigned Low Order Byte MSB
40287	% Second Harmonic-A Winding 3	2	Unsigned High Order Byte LSB
40287	% Second Harmonic-B Winding 3	2	Unsigned Low Order Byte MSB
40288	% Second Harmonic-C Winding 3	2	Unsigned High Order Byte LSB
40288	% Fifth Harmonic-A Winding 3	2	Unsigned Low Order Byte MSB
40289	% Fifth Harmonic-B Winding 3	2	Unsigned High Order Byte LSB
40289	% Fifth Harmonic-C Winding 3	2	Unsigned Low Order Byte MSB
40290	% All Harmonic-A Winding 3	2	Unsigned High Order Byte LSB
40290	% All Harmonic-B Winding 3	2	Unsigned Low Order Byte MSB
40291	% All Harmonic-C Winding 3	2	Unsigned High Order Byte LSB
40291	Current Tap Scale Winding 1	10	Unsigned Low Order Byte MSB
40292	Current Tap Scale Winding 2	10	Unsigned High Order Byte LSB
40292	Current Tap Scale Winding 3	10	Unsigned Low Order Byte MSB

Load Current and Angular Values (63 Registers Defined TPU 2 Winding – 66 Registers Defined TPU 3 Winding)

Load Currents for the windings are reported in Registers 40385 through 40447 for a Two Winding TPU2000/2000R. If the Modbus card is inserted in a 3 Winding Unit, the status is reported in 40385 through 40450. Ground Current Angles and Magnitudes were added in version X.XX flash executives and version 1.80 Modbus chipsets.

Table 5-20. Demand Metering Modbus Address Map Definition

Register Address	Item	Description
40385	Load Current A Winding 1	Unsigned 32 Bit High Order Word MSW
40386	Load Current A Winding 1	Unsigned 32 Bit Low Order Word LSW
40387	Load Current B Winding 1	Unsigned 32 Bit High Order Word MSW
40388	Load Current B Winding 1	Unsigned 32 Bit Low Order Word LSW
40389	Load Current C Winding 1	Unsigned 32 Bit High Order Word MSW
40390	Load Current C Winding 1	Unsigned 32 Bit Low Order Word LSW
40391	Load Current N Winding 1	Unsigned 32 Bit High Order Word MSW
40392	Load Current N Winding 1	Unsigned 32 Bit Low Order Word LSW
40393	Load Current A Winding 2	Unsigned 32 Bit High Order Word MSW
40394	Load Current A Winding 2	Unsigned 32 Bit Low Order Word LSW
40395	Load Current B Winding 2	Unsigned 32 Bit High Order Word MSW
40396	Load Current B Winding 2	Unsigned 32 Bit Low Order Word LSW
40397	Load Current C Winding 2	Unsigned 32 Bit High Order Word MSW
40398	Load Current C Winding 2	Unsigned 32 Bit Low Order Word LSW
40399	Load Current N Winding 2	Unsigned 32 Bit High Order Word MSW
40400	Load Current N Winding 2	Unsigned 32 Bit Low Order Word LSW
40401	Load Current A Winding 3	Unsigned 32 Bit High Order Word MSW
40402	Load Current A Winding 3	Unsigned 32 Bit Low Order Word LSW
40403	Load Current B Winding 3	Unsigned 32 Bit High Order Word MSW
40404	Load Current B Winding 3	Unsigned 32 Bit Low Order Word LSW
40405	Load Current C Winding 3	Unsigned 32 Bit High Order Word MSW
40406	Load Current C Winding 3	Unsigned 32 Bit Low Order Word LSW
40407	Load Current N Winding 3	Unsigned 32 Bit High Order Word MSW

TPU2000/2000R Modbus/Modbus Plus Automation Guide

Register Address	Item	Description
40408	Load Current N Winding 3	Unsigned 32 Bit Low Order Word LSW
40409	Load Current A Angle Winding 1	Unsigned 16 Bit
40410	Load Current B Angle Winding 1	Unsigned 16 Bit
40411	Load Current C Angle Winding 1	Unsigned 16 Bit
40412	Load Current N Angle Winding 1	Unsigned 16 Bit
40413	Load Current A Angle Winding 2	Unsigned 16 Bit
40414	Load Current B Angle Winding 2	Unsigned 16 Bit
40415	Load Current C Angle Winding 2	Unsigned 16 Bit
40416	Load Current N Angle Winding 2	Unsigned 16 Bit
40417	Load Current A Angle Winding 3	Unsigned 16 Bit
40418	Load Current B Angle Winding 3	Unsigned 16 Bit
40419	Load Current C Angle Winding 3	Unsigned 16 Bit
40420	Load Current N Angle Winding 3	Unsigned 16 Bit
40421	Load Current Zero Sequence Winding 1	Unsigned 32 Bit High Order Word MSW
40422	Load Current Zero Sequence Winding 1	Unsigned 32 Bit Low Order Word LSW
40423	Load Current Positive Sequence Winding 1	Unsigned 32 Bit High Order Word MSW
40424	Load Current Positive Sequence Winding 1	Unsigned 32 Bit Low Order Word LSW
40425	Load Current Negative Sequence Winding 1	Unsigned 32 Bit High Order Word MSW
40426	Load Current Negative Sequence Winding 1	Unsigned 32 Bit Low Order Word LSW
40427	Load Current Zero Sequence Winding 2	Unsigned 32 Bit High Order Word MSW
40428	Load Current Zero Sequence Winding 2	Unsigned 32 Bit Low Order Word LSW
40429	Load Current Positive Sequence Winding 2	Unsigned 32 Bit High Order Word MSW
40430	Load Current Positive Sequence Winding 2	Unsigned 32 Bit Low Order Word LSW
40431	Load Current Negative Sequence Winding 2	Unsigned 32 Bit High Order Word MSW
40432	Load Current Negative Sequence Winding 2	Unsigned 32 Bit Low Order Word LSW
40433	Load Current Zero Sequence Winding 3	Unsigned 32 Bit High Order Word MSW
40434	Load Current Zero Sequence Winding 3	Unsigned 32 Bit Low Order Word LSW
40435	Load Current Positive Sequence Winding 3	Unsigned 32 Bit High Order Word MSW
40436	Load Current Positive Sequence Winding 3	Unsigned 32 Bit Low Order Word LSW
40437	Load Current Negative Sequence Winding 3	Unsigned 32 Bit High Order Word MSW
40438	Load Current Negative Sequence Winding 3	Unsigned 32 Bit Low Order Word LSW
40439	Load Current Zero Sequence Angle Winding 1	Unsigned 16 Bit
40440	Load Current Positive Sequence Angle Winding 1	Unsigned 16 Bit
40441	Load Current Negative Sequence Angle Winding 1	Unsigned 16 Bit
40442	Load Current Zero Sequence Angle Winding 2	Unsigned 16 Bit
40443	Load Current Positive Sequence Angle Winding 2	Unsigned 16 Bit
40444	Load Current Negative Sequence Angle Winding 2	Unsigned 16 Bit
40445	Load Current Zero Sequence Angle Winding 3	Unsigned 16 Bit
40446	Load Current Positive Sequence Angle Winding 3	Unsigned 16 Bit
40447	Load Current Negative Sequence Angle Winding 3	Unsigned 16 Bit
40448	Ground Current Magnitude – Sensor 10 (See Note 1)	Unsigned 32 Bit High Order Word MSW
40449	Ground Current Magnitude – Sensor 10 (See Note 1)	Unsigned 32 Bit Low Order Word LSW
40450	Ground Current Angle – Sensor 10 (See Note 1)	Unsigned 16 Bit

NOTE 1: Version XXX TPU Executive and Version 1.80 Modbus or greater. 3 Winding Version only

RMS Voltage/Angular/Real and Reactive Power/Energy Values Block (17 Registers Defined)

In addition to the Current values, the Voltage and Power values are reported in the same format. One should notice that reporting of Power Factor and Signed Power Factor differ in register assignment with respect to whether the TPU is a 2 Winding Unit (Part Number 588R or 588V) or a 3 Winding Unit (588T or 588Q).

Table 5-21. TPU2000/TPU2000R Metering Values Table

Register Address	Item	Scale Factor	Description
40513	Voltage VA	1	Unsigned High Order Word LSW
40514	Voltage VA	1	Unsigned Low Order Word MSW
40515	Voltage VB	1	Unsigned High Order Word LSW
40516	Voltage VB	1	Unsigned Low Order Word MSW
40517	Voltage VC	1	Unsigned High Order Word LSW
40518	Voltage VC	1	Unsigned Low Order Word MSW
40519	Voltage VA Angle	1	Unsigned 16 Bit
40520	Voltage VB Angle	1	Unsigned 16 Bit
40521	Voltage VC Angle	1	Unsigned 16 Bit
40522	Voltage Positive Sequence	1	Unsigned High Order Word LSW
40523	Voltage Positive Sequence	1	Unsigned Low Order Word MSW
40524	Voltage Negative Sequence	1	Unsigned High Order Word LSW
40525	Voltage Negative Sequence	1	Unsigned Low Order Word MSW
40526	Voltage Positive Sequence Angle	1	Unsigned 16 Bit
40527	Voltage Negative Sequence Angle	1	Unsigned 16 Bit
40528	KWatts A	1	Unsigned High Order Word LSW
40529	KWatts A	1	Unsigned Low Order Word MSW
40530	KWatts B	1	Unsigned High Order Word LSW
40531	KWatts B	1	Unsigned Low Order Word MSW
40532	KWatts C	1	Unsigned High Order Word LSW
40533	KWatts C	1	Unsigned Low Order Word MSW
40534	KVars A	1	Unsigned High Order Word LSW
40535	KVars A	1	Unsigned Low Order Word MSW
40536	KVars B	1	Unsigned High Order Word LSW
40537	KVars B	1	Unsigned Low Order Word MSW
40538	KVars C	1	Unsigned High Order Word LSW
40539	KVars C	1	Unsigned Low Order Word MSW
40540	KWatt Hours A	1	Unsigned High Order Word LSW
40541	KWatt Hours A	1	Unsigned Low Order Word MSW
40542	KWatt Hours B	1	Unsigned High Order Word LSW
40543	KWatt Hours B	1	Unsigned Low Order Word MSW
40544	KWatt Hours C	1	Unsigned High Order Word LSW
40545	KWatt Hours C	1	Unsigned Low Order Word MSW
40546	KVar Hours A	1	Unsigned High Order Word LSW
40547	KVar Hours A	1	Unsigned Low Order Word MSW
40548	KVar Hours B	1	Unsigned High Order Word LSW
40549	KVar Hours B	1	Unsigned Low Order Word MSW
40550	KVar Hours C	1	Unsigned High Order Word LSW
40551	KVar Hours C	1	Unsigned Low Order Word MSW
40552	3 Phase KWatts	1	Unsigned High Order Word LSW
40553	3 Phase KWatts	1	Unsigned Low Order Word MSW
40554	3 Phase KVars	1	Unsigned High Order Word LSW
40555	3 Phase KVars	1	Unsigned Low Order Word MSW

TPU2000/2000R Modbus/Modbus Plus Automation Guide

Register Address	Item	Scale Factor	Description
40556	3 Phase Kwatt Hours	1	Unsigned High Order Word LSW
40557	3 Phase Kwatt Hours	1	Unsigned Low Order Word MSW
40558	3 Phase Kvar Hours	1	Unsigned High Order Word LSW
40559	3 Phase Kvar Hours	1	Unsigned Low Order Word MSW
40560	3 Phase KVA	1	Unsigned High Order Word LSW
40561	3 Phase KVA	1	Unsigned Low Order Word MSW
40562	System Frequency	100	Unsigned Byte – 8 bits represented in a 16 bit format
40563	Spare (2 Winding Unit) Power Factor (3 Winding Unit)	N/A	INTERPRETED WORD Bits 15 – 9 Not Used (mSW) Bit 8 Quantity Sign: 1 = Pos. 0 = Neg. Bit 7 Status: 0 = Leading 1 = Lagging Bit 0 – 6 Power Factor * 100 (ISW)
40564	Power Factor (2 Winding Unit) Spare (3 Winding Unit)	N/A	Bits 15 – 9 : Not Used (mSW) Bit 8: Quantity Sign: 1 = Pos. 0 = Neg. Bit 7: Status: 0 = Leading 1 = Lagging Bit 0 – 6 : Power Factor * 100 (ISW)
40565	Signed Power Factor	100	Signed 16 Bits
40566	Power Factor Status	1	0 = Leading 1 = Lagging

RMS Demand Current/Real and Reactive Power Values Block (24 Registers Defined)

Present RMS demand values are reported in Registers 40641 through 40664 for both the three and two winding TPU2000R and the two Winding TPU2000. The values are mapped as per the definitions listed in Table 5-22.

Table 5-22. To Be Named

Register	Definition	Description
40641	Demand Current Phase A	Unsigned 32 Bit High Order Word MSW
40642	Demand Current Phase A	Unsigned 32 Bit Low Order Word LSW
40643	Demand Current Phase B	Unsigned 32 Bit High Order Word MSW
40644	Demand Current Phase B	Unsigned 32 Bit Low Order Word LSW
40645	Demand Current Phase C	Unsigned 32 Bit High Order Word MSW
40646	Demand Current Phase C	Unsigned 32 Bit Low Order Word LSW
40647	Demand Current Neutral	Unsigned 32 Bit High Order Word MSW
40648	Demand Current Neutral	Unsigned 32 Bit Low Order Word LSW
40649	Demand kWatts Phase A	Unsigned 32 Bit High Order Word MSW
40650	Demand kWatts Phase A	Unsigned 32 Bit Low Order Word LSW
40651	Demand kWatts Phase B	Unsigned 32 Bit High Order Word MSW
40652	Demand kWatts Phase B	Unsigned 32 Bit Low Order Word LSW
40653	Demand kWatts Phase C	Unsigned 32 Bit High Order Word MSW
40654	Demand kWatts Phase C	Unsigned 32 Bit Low Order Word LSW
40655	Demand kVars Phase A	Unsigned 32 Bit High Order Word MSW
40656	Demand kVars Phase A	Unsigned 32 Bit Low Order Word LSW
40657	Demand kVars Phase B	Unsigned 32 Bit High Order Word MSW
40658	Demand kVars Phase B	Unsigned 32 Bit Low Order Word LSW
40659	Demand kVars Phase C	Unsigned 32 Bit High Order Word MSW
40660	Demand kVars Phase C	Unsigned 32 Bit Low Order Word LSW
40661	3 Phase Demand Watts	Unsigned 32 Bit High Order Word MSW
40662	3 Phase Demand Watts	Unsigned 32 Bit Low Order Word LSW
40663	3 Phase Demand Vars	Unsigned 32 Bit High Order Word MSW
40664	3 Phase Demand Vars	Unsigned 32 Bit Low Order Word LSW

Minimum and Maximum Peak Demand (60 Registers Defined)

Peak Demands are monitored and logged within the TPU2000 and TPU2000R. The demands are constantly logged by the IED until reset by the operator. The reset bit is located in register 41410 through 41415. Please reference Section 5 for the procedure to initiate Minimum and Maximum Peak Value reset. Each value is time-stamped and the peak value is stored. The values are compared every 2 seconds. If the new value is greater than the previous stored value (as is the case for the peak demand) or less than the previous stored value (as is the case for the minimum demand), the old value is discarded and the new value is reported. Peak Demand and Minimum Demand definitions are defined in Tables 5-22 and 5-23 The status of the update is reflected in Bits 9 and 10 of Register 40129. Please reference the 6X register configuration tables to configure energy demand parameterization.

Demand Metering is reported within Table 5-?. The accumulated magnitudes are reported in 16 bit unsigned and 32 bit unsigned numerical values as indicated in the following table. The demands are reset by writing a reset command to the 4X register, XXXX Bit X. Please reference Table 5-24 of this document for the control register group and bit designation to reset this group of registers. Refer to Table 6 Register 4129 bit 9 which will indicate that a new Peak Demand Value has been accumulated within this table.

Demand metering is calculated on a fixed demand window accumulation. The demands are based upon a time window of 15, 30, or 60-minute calculation intervals. Refer to Table 5-26 within this document to reference the procedure for setting the sliding demand window time base.

Demand Metering initiates at time = 0 which may be a unit power up, system reset via the front panel or through a demand metering reset via the network as described in Table 5-24 of this document. It is not dependent upon the time-of-day clock (TOD) within the unit. The TPU2000/2000R has an internal timer that is monitored to determine the end of the selected interval (15, 30, or 60 minutes) and the start of the new interval.

Current (Ia, Ib, Ic, and In) and power (KW and KVAR) are calculated and integrated within the demand calculation for that interval on a 32 cycle time period interval within the demand time window selected. The following figures illustrate the method of calculating and reporting the Demand Values depending upon reporting of current or energy.

Current Demand Metering

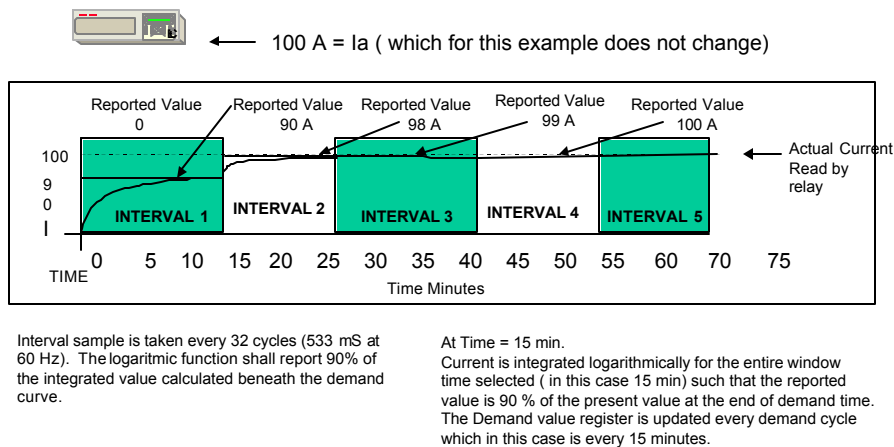

Figure 5-35. Demand Current Calculation

Energy Demand Metering

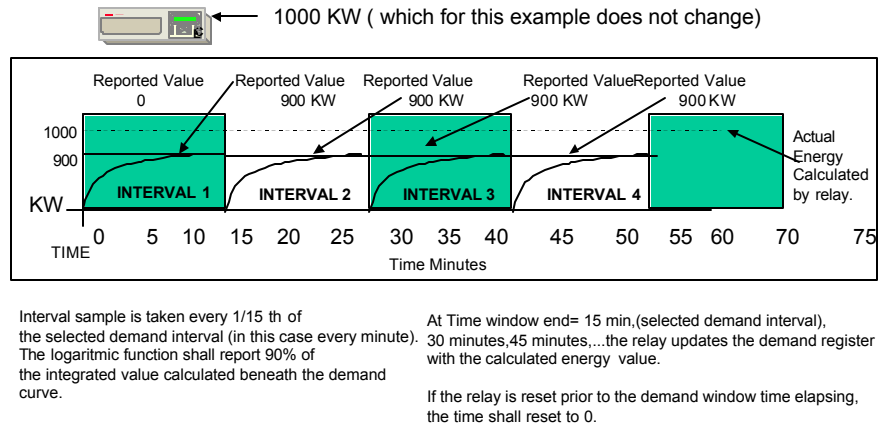

Figure 5-36. Energy Demand Calculation

Figures 5-35 and 5-36 illustrate the energy and current calculation methods and data reported when accessed via the network. To simplify the explanation, the current and energy has been kept constant. This example illustrates a calculation based upon a window size of 15 minute demand intervals.

Table 5-23. Peak Demand Register Map for the TPU2000R and TPU2000

Register Address	Item	Description
40769	Peak Demand Current Phase A	Unsigned 32 Bit High Order Word MSW
40770	Peak Demand Current Phase A	Unsigned 32 Bit Low Order Word LSW
40771	Peak Demand Current Phase A Year	Most Significant Byte 8 Bits 00<= Range <= 99
40771	Peak Demand Current Phase A Month	Least Significant Byte 8 Bits 00<= Range <= 12
40772	Peak Demand Current Phase A Day	Most Significant Byte 8 Bits 00<= Range<= 31
40772	Peak Demand Current Phase A Hour	Most Significant Byte 8 Bits 00<= Range <= 23
40773	Peak Demand Current Phase A Minute	Most Significant Byte 8 Bits 00<= Range <= 59
40773	Reserved Byte	Reserved
40774	Peak Demand Current Phase B	Unsigned 32 Bit High Order Word MSW
40775	Peak Demand Current Phase B	Unsigned 32 Bit Low Order Word LSW
40776	Peak Demand Current Phase B Year	Most Significant Byte 8 Bits 00<= Range <= 99
40776	Peak Demand Current Phase B Month	Least Significant Byte 8 Bits 00<= Range <= 12
40777	Peak Demand Current Phase B Day	Most Significant Byte 8 Bits 00<= Range<= 31
40777	Peak Demand Current Phase B Hour	Most Significant Byte 8 Bits 00<= Range <= 23
40778	Peak Demand Current Phase B Minute	Most Significant Byte 8 Bits 00<= Range <= 59
40778	Reserved Byte	Reserved
40779	Peak Demand Current Phase C	Unsigned 32 Bit High Order Word MSW
40780	Peak Demand Current Phase C	Unsigned 32 Bit Low Order Word LSW
40781	Peak Demand Current Phase C Year	Most Significant Byte 8 Bits

TPU2000/2000R Modbus/Modbus Plus Automation Guide

Register Address	Item	Description
		00<= Range <= 99
40781	Peak Demand Current Phase C Month	Least Significant Byte 8 Bits 00<= Range <= 12
40782	Peak Demand Current Phase C Day	Most Significant Byte 8 Bits 00<= Range<= 31
40782	Peak Demand Current Phase C Hour	Most Significant Byte 8 Bits 00<= Range <= 23
40783	Peak Demand Current Phase C Minute	Most Significant Byte 8 Bits 00<= Range <= 59
40783	Reserved Byte	Reserved
40784	Peak Demand Current Neutral	Unsigned 32 Bit High Order Word MSW
40785	Peak Demand Current Neutral	Unsigned 32 Bit Low Order Word LSW
40786	Peak Demand Current Neutral Year	Most Significant Byte 8 Bits 00<= Range <= 99
40786	Peak Demand Current Neutral Month	Least Significant Byte 8 Bits 00<= Range <= 12
40787	Peak Demand Current Neutral Day	Most Significant Byte 8 Bits 00<= Range<= 31
40787	Peak Demand Current Neutral Hour	Most Significant Byte 8 Bits 00<= Range <= 23
40788	Peak Demand Current Neutral Minute	Most Significant Byte 8 Bits 00<= Range <= 59
40788	Reserved Byte	Reserved
40789	Kwatt Hours (Phase A) Peak Demand	Signed 32 Bit High Order Word MSW
40790	Kwatt Hours (Phase A) Peak Demand	Signed 32 Bit Low Order Word LSW
40791	Peak Demand Kwatt Hours (Phase A) Year	Most Significant Byte 8 Bits 00<= Range <= 99
40791	Peak Demand Kwatt Hours (Phase A) Month	Least Significant Byte 8 Bits 00<= Range <= 12
40792	Peak Demand Kwatt Hours (Phase A) Day	Most Significant Byte 8 Bits 00<= Range<= 31
40792	Peak Demand Kwatt Hours (Phase A) Hour	Most Significant Byte 8 Bits 00<= Range <= 23
40793	Peak Demand Kwatt Hours (Phase A) Minute	Most Significant Byte 8 Bits 00<= Range <= 59
40793	Reserved Byte	Reserved
40794	Kwatt Hours (Phase B) Peak Demand	Signed 32 Bit High Order Word MSW
40795	Kwatt Hours (Phase B) Peak Demand	Signed 32 Bit Low Order Word LSW
40796	Peak Demand Kwatt Hours (Phase B) Year	Most Significant Byte 8 Bits 00<= Range <= 99
40796	Peak Demand Kwatt Hours (Phase B) Month	Least Significant Byte 8 Bits 00<= Range <= 12
40797	Peak Demand Kwatt Hours (Phase B) Day	Most Significant Byte 8 Bits 00<= Range<= 31
40797	Peak Demand Kwatt Hours (Phase B) Hour	Most Significant Byte 8 Bits 00<= Range <= 23
40798	Peak Demand Kwatt Hours (Phase B) Minute	Most Significant Byte 8 Bits 00<= Range <= 59
40798	Reserved Byte	Reserved
40799	Kwatt Hours (Phase C) Peak Demand	Signed 32 Bit High Order Word MSW
40800	Kwatt Hours (Phase C) Peak Demand	Signed 32 Bit Low Order Word LSW
40801	Peak Demand Kwatt Hours (Phase C) Year	Most Significant Byte 8 Bits 00<= Range <= 99
40801	Peak Demand Kwatt Hours (Phase C)	Least Significant Byte 8 Bits

TPU2000/2000R Modbus/Modbus Plus Automation Guide

Register Address	Item	Description
	Month	00<= Range <= 12
40802	Peak Demand Kwatt Hours (Phase C) Day	Most Significant Byte 8 Bits 00<= Range<= 31
40802	Peak Demand Kwatt Hours (Phase C) Hour	Most Significant Byte 8 Bits 00<= Range <= 23
40803	Peak Demand Kwatt Hours (Phase C) Minute	Most Significant Byte 8 Bits 00<= Range <= 59
40803	Reserved Byte	Reserved
40804	Kwatt Hours (3 Phase) Peak Demand	Signed 32 Bit High Order Word MSW
40805	Kwatt Hours (3 Phase) Peak Demand	Signed 32 Bit Low Order Word LSW
40806	Peak Demand Kwatt Hours (3 Phase) Year	Most Significant Byte 8 Bits 00<= Range <= 99
40806	Peak Demand Kwatt Hours (3 Phase) Month	Least Significant Byte 8 Bits 00<= Range <= 12
40807	Peak Demand Kwatt Hours (3 Phase) Day	Most Significant Byte 8 Bits 00<= Range<= 31
40807	Peak Demand Kwatt Hours (3 Phase) Hour	Most Significant Byte 8 Bits 00<= Range <= 23
40808	Peak Demand Kwatt Hours (3 Phase) Minute	Most Significant Byte 8 Bits 00<= Range <= 59
40808	Reserved Byte	Reserved
40809	KVAR Hours (Phase A) Peak Demand	Signed 32 Bit High Order Word MSW
40810	KVAR Hours (Phase A) Peak Demand	Signed 32 Bit Low Order Word LSW
40811	Peak Demand KVAR Hours (Phase A) Year	Most Significant Byte 8 Bits 00<= Range <= 99
40811	Peak Demand KVAR Hours (Phase A) Month	Least Significant Byte 8 Bits 00<= Range <= 12
40812	Peak Demand KVAR Hours (Phase A) Day	Most Significant Byte 8 Bits 00<= Range<= 31
40812	Peak Demand KVAR Hours (Phase A) Hour	Most Significant Byte 8 Bits 00<= Range <= 23
40813	Peak Demand KVAR Hours (Phase A) Minute	Most Significant Byte 8 Bits 00<= Range <= 59
40813	Reserved Byte	Reserved
40814	KVAR Hours (Phase B) Peak Demand	Signed 32 Bit High Order Word MSW
40815	KVAR Hours (Phase B) Peak Demand	Signed 32 Bit Low Order Word LSW
40816	Peak Demand KVAR Hours (Phase B) Year	Most Significant Byte 8 Bits 00<= Range <= 99
40816	Peak Demand KVAR Hours (Phase B) Month	Least Significant Byte 8 Bits 00<= Range <= 12
40817	Peak Demand KVAR Hours (Phase B) Day	Most Significant Byte 8 Bits 00<= Range<= 31
40817	Peak Demand KVAR Hours (Phase B) Hour	Most Significant Byte 8 Bits 00<= Range <= 23
40818	Peak Demand KVAR Hours (Phase B) Minute	Most Significant Byte 8 Bits 00<= Range <= 59
40818	Reserved Byte	Reserved
40819	KVAR Hours (Phase C) Peak Demand	Signed 32 Bit High Order Word MSW
40820	KVAR Hours (Phase C) Peak Demand	Signed 32 Bit Low Order Word LSW
40821	Peak Demand KVAR Hours (Phase C) Year	Most Significant Byte 8 Bits 00<= Range <= 99
40821	Peak Demand KVAR Hours (Phase C) Month	Least Significant Byte 8 Bits 00<= Range <= 12
40822	Peak Demand KVAR Hours (Phase C)	Most Significant Byte 8 Bits

TPU2000/2000R Modbus/Modbus Plus Automation Guide

Register Address	Item	Description
	Day	00<= Range<= 31
40822	Peak Demand KVAR Hours (Phase C) Hour	Most Significant Byte 8 Bits 00<= Range <= 23
40823	Peak Demand KVAR Hours (Phase C) Minute	Most Significant Byte 8 Bits 00<= Range <= 59
40823	Reserved Byte	Reserved
40824	KVAR Hours (3 Phase) Peak Demand	Signed 32 Bit High Order Word MSW
40825	KVAR Hours (3 Phase) Peak Demand	Signed 32 Bit Low Order Word LSW
40826	Peak Demand KVAR Hours (3 Phase) Year	Most Significant Byte 8 Bits 00<= Range <= 99
40826	Peak Demand KVAR Hours (3 Phase) Month	Least Significant Byte 8 Bits 00<= Range <= 12
40827	Peak Demand KVAR Hours (3 Phase) Day	Most Significant Byte 8 Bits 00<= Range<= 31
40827	Peak Demand KVAR Hours (3 Phase) Hour	Most Significant Byte 8 Bits 00<= Range <= 23
40828	Peak Demand KVAR Hours (3 Phase) Minute	Most Significant Byte 8 Bits 00<= Range <= 59
40828	Reserved Byte	Reserved

The minimum demand table is as follows:

Table 5-24. Minimum Demand Register Map for the TPU2000R and TPU2000

Register Address	Item	Description
40897	Minimum Demand Current Phase A	Unsigned 32 Bit High Order Word MSW
40898	Minimum Demand Current Phase A	Unsigned 32 Bit Low Order Word LSW
40899	Minimum Demand Current Phase A Year	Most Significant Byte 8 Bits 00<= Range <= 99
40899	Minimum Demand Current Phase A Month	Least Significant Byte 8 Bits 00<= Range <= 12
40900	Minimum Demand Current Phase A Day	Most Significant Byte 8 Bits 00<= Range<= 31
40900	Minimum Demand Current Phase A Hour	Most Significant Byte 8 Bits 00<= Range <= 23
40901	Minimum Demand Current Phase A Minute	Most Significant Byte 8 Bits 00<= Range <= 59
40901	Reserved Byte	Reserved
40902	Minimum Demand Current Phase B	Unsigned 32 Bit High Order Word MSW
40903	Minimum Demand Current Phase B	Unsigned 32 Bit Low Order Word LSW
40904	Minimum Demand Current Phase B Year	Most Significant Byte 8 Bits 00<= Range <= 99
40904	Minimum Demand Current Phase B Month	Least Significant Byte 8 Bits 00<= Range <= 12
40905	Minimum Demand Current Phase B Day	Most Significant Byte 8 Bits 00<= Range<= 31
40905	Minimum Demand Current Phase B Hour	Most Significant Byte 8 Bits 00<= Range <= 23
40906	Minimum Demand Current Phase B Minute	Most Significant Byte 8 Bits 00<= Range <= 59
40906	Reserved Byte	Reserved
40907	Minimum Demand Current Phase C	Unsigned 32 Bit High Order Word MSW
40908	Minimum Demand Current Phase C	Unsigned 32 Bit Low Order Word LSW

TPU2000/2000R Modbus/Modbus Plus Automation Guide

Register Address	Item	Description
40909	Minimum Demand Current Phase C Year	Most Significant Byte 8 Bits 00<= Range <= 99
40909	Minimum Demand Current Phase C Month	Least Significant Byte 8 Bits 00<= Range <= 12
40910	Minimum Demand Current Phase C Day	Most Significant Byte 8 Bits 00<= Range<= 31
40910	Minimum Demand Current Phase C Hour	Most Significant Byte 8 Bits 00<= Range <= 23
40911	Minimum Demand Current Phase C Minute	Most Significant Byte 8 Bits 00<= Range <= 59
40911	Reserved Byte	Reserved
40912	Minimum Demand Current Neutral	Unsigned 32 Bit High Order Word MSW
40913	Minimum Demand Current Neutral	Unsigned 32 Bit Low Order Word LSW
40914	Minimum Demand Current Neutral Year	Most Significant Byte 8 Bits 00<= Range <= 99
40914	Minimum Demand Current Neutral Month	Least Significant Byte 8 Bits 00<= Range <= 12
40915	Minimum Demand Current Neutral Day	Most Significant Byte 8 Bits 00<= Range<= 31
40915	Minimum Demand Current Neutral Hour	Most Significant Byte 8 Bits 00<= Range <= 23
40916	Minimum Demand Current Neutral Minute	Most Significant Byte 8 Bits 00<= Range <= 59
40916	Reserved Byte	Reserved
40917	Kwatt Hours (Phase A) Minimum Demand	Signed 32 Bit High Order Word MSW
40918	Kwatt Hours (Phase A) Minimum Demand	Signed 32 Bit Low Order Word LSW
40919	Minimum Demand Kwatt Hours (Phase A) Year	Most Significant Byte 8 Bits 00<= Range <= 99
40919	Minimum Demand Kwatt Hours (Phase A) Month	Least Significant Byte 8 Bits 00<= Range <= 12
40920	Minimum Demand Kwatt Hours (Phase A) Day	Most Significant Byte 8 Bits 00<= Range<= 31
40920	Minimum Demand Kwatt Hours (Phase A) Hour	Most Significant Byte 8 Bits 00<= Range <= 23
40921	Minimum Demand Kwatt Hours (Phase A) Minute	Most Significant Byte 8 Bits 00<= Range <= 59
40921	Reserved Byte	Reserved
40922	Kwatt Hours (Phase B) Minimum Demand	Signed 32 Bit High Order Word MSW
40923	Kwatt Hours (Phase B) Minimum Demand	Signed 32 Bit Low Order Word LSW
40924	Minimum Demand Kwatt Hours (Phase B) Year	Most Significant Byte 8 Bits 00<= Range <= 99
40924	Minimum Demand Kwatt Hours (Phase B) Month	Least Significant Byte 8 Bits 00<= Range <= 12
40925	Minimum Demand Kwatt Hours (Phase B) Day	Most Significant Byte 8 Bits 00<= Range<= 31
40925	Minimum Demand Kwatt Hours (Phase B) Hour	Most Significant Byte 8 Bits 00<= Range <= 23
40926	Minimum Demand Kwatt Hours (Phase B) Minute	Most Significant Byte 8 Bits 00<= Range <= 59
40926	Reserved Byte	Reserved
40927	Kwatt Hours (Phase C) Minimum Demand	Signed 32 Bit High Order Word MSW
40928	Kwatt Hours (Phase C) Minimum Demand	Signed 32 Bit Low Order Word LSW
40929	Minimum Demand Kwatt Hours (Phase C) Year	Most Significant Byte 8 Bits 00<= Range <= 99

TPU2000/2000R Modbus/Modbus Plus Automation Guide

Register Address	Item	Description
40929	Minimum Demand Kwatt Hours (Phase C) Month	Least Significant Byte 8 Bits 00<= Range <= 12
40930	Minimum Demand Kwatt Hours (Phase C) Day	Most Significant Byte 8 Bits 00<= Range<= 31
40930	Minimum Demand Kwatt Hours (Phase C) Hour	Most Significant Byte 8 Bits 00<= Range <= 23
40931	Minimum Demand Kwatt Hours (Phase C) Minute	Most Significant Byte 8 Bits 00<= Range <= 59
40931	Reserved Byte	Reserved
40932	Kwatt Hours (3 Phase) Minimum Demand	Signed 32 Bit High Order Word MSW
40933	Kwatt Hours (3 Phase) Minimum Demand	Signed 32 Bit Low Order Word LSW
40934	Minimum Demand Kwatt Hours (3 Phase) Year	Most Significant Byte 8 Bits 00<= Range <= 99
40934	Minimum Demand Kwatt Hours (3 Phase) Month	Least Significant Byte 8 Bits 00<= Range <= 12
40935	Minimum Demand Kwatt Hours (3 Phase) Day	Most Significant Byte 8 Bits 00<= Range<= 31
40935	Minimum Demand Kwatt Hours (3 Phase) Hour	Most Significant Byte 8 Bits 00<= Range <= 23
40936	Minimum Demand Kwatt Hours (3 Phase) Minute	Most Significant Byte 8 Bits 00<= Range <= 59
40936	Reserved Byte	Reserved
40937	KVAR Hours (Phase A) Minimum Demand	Signed 32 Bit High Order Word MSW
40938	KVAR Hours (Phase A) Minimum Demand	Signed 32 Bit Low Order Word LSW
40939	Minimum Demand KVAR Hours (Phase A) Year	Most Significant Byte 8 Bits 00<= Range <= 99
40939	Minimum Demand KVAR Hours (Phase A) Month	Least Significant Byte 8 Bits 00<= Range <= 12
40940	Minimum Demand KVAR Hours (Phase A) Day	Most Significant Byte 8 Bits 00<= Range<= 31
40940	Minimum Demand KVAR Hours (Phase A) Hour	Most Significant Byte 8 Bits 00<= Range <= 23
40941	Minimum Demand KVAR Hours (Phase A) Minute	Most Significant Byte 8 Bits 00<= Range <= 59
40941	Reserved Byte	Reserved
40942	KVAR Hours (Phase B) Minimum Demand	Signed 32 Bit High Order Word MSW
40943	KVAR Hours (Phase B) Minimum Demand	Signed 32 Bit Low Order Word LSW
40944	Minimum Demand KVAR Hours (Phase B) Year	Most Significant Byte 8 Bits 00<= Range <= 99
40944	Minimum Demand KVAR Hours (Phase B) Month	Least Significant Byte 8 Bits 00<= Range <= 12
40945	Minimum Demand KVAR Hours (Phase B) Day	Most Significant Byte 8 Bits 00<= Range<= 31
40945	Minimum Demand KVAR Hours (Phase B) Hour	Most Significant Byte 8 Bits 00<= Range <= 23
40946	Minimum Demand KVAR Hours (Phase B) Minute	Most Significant Byte 8 Bits 00<= Range <= 59
40946	Reserved Byte	Reserved
40947	KVAR Hours (Phase C) Minimum Demand	Signed 32 Bit High Order Word MSW
40948	KVAR Hours (Phase C) Minimum Demand	Signed 32 Bit Low Order Word LSW
40949	Minimum Demand KVAR Hours (Phase C) Year	Most Significant Byte 8 Bits 00<= Range <= 99
40949	Minimum Demand KVAR Hours (Phase C) Month	Least Significant Byte 8 Bits 00<= Range <= 12

TPU2000/2000R Modbus/Modbus Plus Automation Guide

Register Address	Item	Description
40950	Minimum Demand KVAR Hours (Phase C) Day	Most Significant Byte 8 Bits 00<= Range<= 31
40950	Minimum Demand KVAR Hours (Phase C) Hour	Most Significant Byte 8 Bits 00<= Range <= 23
40951	Minimum Demand KVAR Hours (Phase C) Minute	Most Significant Byte 8 Bits 00<= Range <= 59
40951	Reserved Byte	Reserved
40952	KVAR Hours (3 Phase) Minimum Demand	Signed 32 Bit High Order Word MSW
40953	KVAR Hours (3 Phase) Minimum Demand	Signed 32 Bit Low Order Word LSW
40954	Minimum Demand KVAR Hours (3 Phase) Year	Most Significant Byte 8 Bits 00<= Range <= 99
40954	Minimum Demand KVAR Hours (3 Phase) Month	Least Significant Byte 8 Bits 00<= Range <= 12
40955	Minimum Demand KVAR Hours (3 Phase) Day	Most Significant Byte 8 Bits 00<= Range<= 31
40955	Minimum Demand KVAR Hours (3 Phase) Hour	Most Significant Byte 8 Bits 00<= Range <= 23
40956	Minimum Demand KVAR Hours (3 Phase) Minute	Most Significant Byte 8 Bits 00<= Range <= 59
40956	Reserved Byte	Reserved

Breaker Counters (11 Registers Defined) Modbus Function 03 Read Only

Breaker Counters allow diagnostic evaluation of operations for maintenance purposes. The TPU2000/2000R allows selection of reclosure for up to 4 shots with the fifth event initiating lockout. The counter registers are reset via a write to registers 63713 through 63719 as defined in Table 5-25. Table 5-25 defines the register map for the Breaker Counter capabilities within the unit. Additionally, unreported fault record counts are available. This is especially helpful when accessing fault buffers (using the unreported records command) and knowing the amount of records yet to be accessed.

Table 5-25. Breaker Counter Definition Table

Register Address	Item	Description
41025	Unreported Differential Fault Record Counter	Unsigned Integer 16 Bits 0<=Range<=9999
41026	Unreported Through Fault Record Counter	Unsigned Integer 16 Bits 0<=Range<=9999
41027	Unreported Harmonic Restraint Record Fault Counter	Unsigned Integer 16 Bits 0<=Range<= 9999
41028	Unreported Operation Record Counter	Unsigned Integer 16 Bits 0<=Range<= 9999
41029	Through Fault Counter	Unsigned Integer 16 Bits
41030	Through Fault KSIA Kiloamps Symmetrical Ia – Current existing when breaker opened on Phase A.	Signed 32 Bit High Order Word MSW
41031	Through Fault KSIA Kiloamps Symmetrical Ia – Current existing when breaker opened on Phase A.	Signed 32 Bit Low Order Word LSW
41032	Through Fault KSIB Kiloamps Symmetrical Ib – Current existing when breaker opened on Phase B.	Signed 32 Bit High Order Word MSW
41033	Through Fault KSIB Kiloamps Symmetrical Ib – Current existing	Signed 32 Bit Low Order Word LSW

TPU2000/2000R Modbus/Modbus Plus Automation Guide

	when breaker opened on Phase B.	
41034	Through Fault KSIC Kiloamps Symmetrical I _c – Current existing when breaker opened on Phase C	Signed 32 Bit High Order Word MSW
41035	Through Fault KSIC Kiloamps Symmetrical I _c – Current existing when breaker opened on Phase C	Signed 32 Bit Low Order Word LSW
41036	Through Fault Cycle Summation Counter	Signed 32 Bit High Order Word MSW
41037	Through Fault Cycle Summation Counter	Signed 32 Bit Low Order Word LSW
41038	Overcurrent Trip Counter	Unsigned 16 Bit 0 – 9999
41039	Differential Trip Counter	Unsigned 16 Bit 0 – 9999

Discrete 4X Register Bit Data Reporting (26 Registers Defined)

The TPU2000 and TPU2000R offers bit status reporting via 0X and 1X Modbus/Modbus Plus command retrieval. Some hosts however do not offer the capability to read data via these data types. The data types have been structured to be reported in 4X data types. Reported data is of the following types:

- Logical Outputs
- Logical Inputs
- Physical Inputs
- Forced Physical Input State Reporting
- Forced Physical Output State Reporting
- Forced Logical Input State Reporting

The following registers only report the status of the elements. Some of the elements are latched and behave as do their 0X and 1X counterparts. The bits are reset depending upon the reset control via the 4X control registers (Reference Section 5).

It should be noted that for the following bits, the operational characteristics are included for reference:

TCFA – Trip Circuit Failure Alarm – This bit indicates that the Trip Circuit is Open. The Alarm remains continuously energized (value = 1) until circuit continuity is sensed.

TFA – Trip Failure Alarm – This bit indicates that a fault has not been cleared within the programmable Trip Failure Time setting of 5 to 60 Cycles. Use the Trip Failure Mode Setting (Differential, Overcurrent, or Differential and Overcurrent) to select the type of faults for which a trip failure alarm will be given. The Trip Failure Alarm clears when the current drops below the Trip Failure Drop-Off setting.

PUA - Pick Up Alarm: Differential and Overcurrent (87/51/50/150/46) Pickup Alarm. Indicates that an enabled protective function is picked up and can be used as a fault detector alarm. The Alarm Resets 500 mS after the “picked up” state has dropped out.

THRUFA – Through Fault Alarm – This alarm is actuated by the Disturbance pickup setting.

Table 5-26. Logical Input Table (8 Registers 128 Elements)

Address	Item	Description
41153	Logical Output Bit 15 = DIFF Bit 14 = SELF CHECK ALARM Bit 13 = 87T Bit 12 = 87H Bit 11 = 2HROA Bit 10 = 5HROA Bit 9 = AHROA	Unsigned Integer 16 Bits Differential Trip Alarm (msb leftmost bit) 0 = Fault, 1 = Normal Diagnostic Alarm Harmonic Restrained % Differential Trip Alarm Unrestrained High Set Instantaneous Differential Trip Alarm 2 nd Harmonic Restraint Alarm 5 th Harmonic Restraint Alarm All Harmonics Restraint Alarm

TPU2000/2000R Modbus/Modbus Plus Automation Guide

Address	Item	Description
	Bit 8 = TCFA Bit 7 = TFA Bit 6 = 51P1 Bit 5 = 51P2 Bit 4 = 50-P1 (Note 1) Bit 3 = 150P-1 (Note 1) Bit 2 = 50-P2 (Note 1) Bit 1 = 150P-2 (Note 1) Bit 0 = 51N-1 (Note 1) (lsb)	Trip Coil Failure Alarm (Trip Circuit Open =1) Trip Failure Alarm (Trip Not Cleared within Trip Fail Dropout Set) Winding 1 Phase Time Overcurrent Trip Alarm Winding 2 Phase Time Overcurrent Trip Alarm 1 st Winding Phase 1 Instantaneous Overcurrent Trip Alarm 2 nd Winding 1 Phase Instantaneous Overcurrent Trip Alarm 1 st Winding Phase 2 Instantaneous Overcurrent Trip Alarm 2 nd Winding 2 Phase Instantaneous Overcurrent Trip Alarm Winding 1 Neutral Time Overcurrent Trip Alarm (lsb rightmost bit)
41154	Logical Output Bit 15 = 51G-2 (Note 1) Bit 14 = 50N-1 (Note 1) Bit 13 = 150N-1 (Note 1) Bit 12 = 50G-2 (Note 1) Bit 11 = 150G-2 (Note 1) Bit 10 = 46-1 (Note 1) Bit 9 = 46-2 (Note 1) Bit 8 = 87T-D (Note 1) Bit 7 = 87H-D (Note 1) Bit 6 = 51P-1D (Note 1) Bit 5 = 51P-2D (Note 1) Bit 4 = 51N-1D (Note 1) Bit 3 = 51G-2D (Notes 1, 2) Bit 2 = 50P-1D (Note 1) Bit 1 = 50P-2D (Note 1) Bit 0 = 50N-1D (Note 1)	Unsigned Integer 16 Bits 1 st Winding 2 Ground Time Trip Alarm (msb leftmost bit) 1 st Winding 1 Neutral Instantaneous Trip Alarm 2 nd Winding 1 Neutral Instantaneous Overcurrent Trip Alarm 1 st Winding 2 Ground Instantaneous Trip Alarm 2 nd Winding 2 Ground Instantaneous Overcurrent Trip Alarm Winding 1 Negative Sequence Time Overcurrent Trip Alarm Winding 2 Negative Sequence Time Overcurrent Trip Alarm Percentage Differential Function Disabled Alarm High Set Instantaneous Function Disabled Alarm Winding 1 Phase Time Overcurrent Function Disabled Alarm Winding 1 Phase Time Overcurrent Function Disabled Alarm Winding 1 Neutral Time Overcurrent Function Disabled Alarm Winding 2 Ground Time Overcurrent Function Disabled Alarm 1 st Winding 1 Phase Instantaneous Overcurrent Function Disabled Alarm 1 st Winding 2 Phase Instantaneous Overcurrent Function Disabled Alarm 1 st Winding 1 Neutral Instantaneous Overcurrent Function Disabled Alarm (lsb rightmost bit)
41155	Logical Output Bit 15 = 50G-2D (Note 1,2) Bit 14 = 150P-1D Bit 13 = 150P-2D Bit 12 = 150N-1D Bit 11 = 150G-2D (Notes 1,2) Bit 10 = 46-1D Bit 9 = 46-2D Bit 8 = PATA Bit 7 = PBTA Bit 6 = PCTA Bit 5 = PUA Bit 4 = 63 Bit 3 = THRUFA Bit 2 = TFCA (Note 1) Bit 1 = TFKA (Note 1) Bit 0 = TFSCA (Note 1)	Unsigned Integer 16 Bit Winding 2 Ground Time Overcurrent Function Disabled Alarm (msb leftmost bit) 2 nd Winding 1 Phase Instantaneous Overcurrent Function Disabled Alarm 2 nd Winding 2 Phase Instantaneous Overcurrent Function Disabled Alarm 2 nd Winding 1 Neutral Instantaneous Overcurrent Function Disabled Alarm 2 nd Winding 2 Ground Instantaneous Overcurrent Function Disabled Alarm Winding 1 Negative Sequence Time Overcurrent Function Disabled Alarm Winding 2 Negative Sequence Time Overcurrent Function Disabled Alarm Phase A Target Alarm Phase B Target Alarm Phase C Target Alarm Pick Up Alarm Sudden Pressure Alarm Through Fault Alarm Through Fault Counter Alarm Through Fault Counter Alarm Through Fault Cycle Summation Alarm (lsb rightmost bit)
41156	Logical Output Bit 15 = DTC (Note 1) Bit 14 = OCTC Bit 13 = PDA	Unsigned Integer 16 Bit Differential Trip Counter Alarm (msb leftmost bit) Overcurrent Trip Counter Alarm Phase Demand Counter Alarm

TPU2000/2000R Modbus/Modbus Plus Automation Guide

Address	Item	Description
	Bit 12 = NDA Bit 11 = PRIM Bit 10 = ALT1 Bit 9 = ALT2 Bit 8 = STCA (L) Bit 7 = 87T (L) Bit 6 = 87H (L) Bit 5 = 2HROA (L) Bit 4 = 5HROA (L) Bit 3 = AHROA (L) Bit 2 = 50P-1D (L) Bit 1 = 50P-2D (L) Bit 0 = 50N-1D (L)	Neutral Demand Current Alarm Primary Settings Enabled Alarm Alternate 1 Settings Enabled Alarm Alternate 2 Setting Enabled Alarm Settings Table Changed Alarm Latched Harmonic Restrained % Differential Trip Alarm Latched Unrestrained High Set Instantaneous Differential Trip Alarm Latched 2 nd Harmonic Restraint Alarm Latched 5 th Harmonic Restraint Alarm Latched All Harmonics Restraint Alarm Latched 1 st Winding Phase 1 Instantaneous Overcurrent Trip Alarm Latched 2 nd Winding 1 Phase Instantaneous Overcurrent Trip Alarm Latched 1 st Winding Phase 2 Instantaneous Overcurrent Trip Alarm Latched (lsb rightmost bit)
41157	Logical Output Bit 15 = 150P-1 (L) Bit 14 = 50-P2 (L) Bit 13 = 150P-2 (L) Bit 12 = 51N-1 (L) Bit 11 = 51N-2 (L) (Note 3) Bit 10 = 50N-1 (L) Bit 9 = 150N-1 (L) Bit 8 = 50N-2 (L) (Note 3) Bit 7 = 150N-2 (L) (Note 3) Bit 6 = 46-1 (L) Bit 5 = 46-2 (L) Bit 4 = 63 (L) Bit 3 = ULO 1 Bit 2 = ULO 2 Bit 1 = ULO 3 Bit 0 = ULO 4	Unsigned Integer 16 Bit (msb leftmost bit) 2 nd Winding 1 Phase Instantaneous Overcurrent Trip Alarm Latched 1 st Winding Phase 2 Instantaneous Overcurrent Trip Alarm Latched 2 nd Winding 2 Phase Instantaneous Overcurrent Trip Alarm Latched Winding 1 Neutral Time Overcurrent Trip Alarm Latched Winding 2 Neutral Time Overcurrent Seal In Alarm Latched 1stWinding 1 Neutral Instantaneous Overcurrent Seal In Alarm Latched 2 nd Winding 1 Neutral Instantaneous Overcurrent Seal In Alarm Latched 1 st Winding 2 Neutral Instantaneous Overcurrent Seal In Alarm Latched 2 nd Winding 2 Neutral Instantaneous Overcurrent Seal In Alarm Latched Winding 1 Negative Sequence Time Overcurrent Seal In Alarm Winding 2 Negative Sequence Time Overcurrent Seal In Alarm Sudden Pressure Seal In Alarm User Logical Output 1 Energized User Logical Output 2 Energized User Logical Output 3 Energized User Logical Output 4 Energized (lsb rightmost bit)
41158	Logical Output Bit 15 = ULO 5 Bit 14 = ULO 6 Bit 13 = ULO 7 Bit 12 = ULO 8 Bit 11 = ULO 9 Bit 10 = LOADA Bit 9 = OCA -1 Bit 8 = OCA-2 Bit 7 = HLDA-1 Bit 6 = LLDA-1 Bit 5 = HLDA-2 Bit 4 = LLDA-2 Bit 3 = HPFA Bit 2 = LPFA Bit 1 = VarDA	Unsigned Integer 16 Bit User Logical Output 5 Energized (msb leftmost) User Logical Output 6 Energized User Logical Output 7 Energized User Logical Output 8 Energized User Logical Output 9 Energized Load Current Alarm Winding 1 Overcurrent Alarm Winding 2 Overcurrent Alarm Winding 1 High Level Detector Alarm Winding 1 Low Level Detector Alarm Winding 1 High Level Detector Alarm Winding 2 Low Level Detector Alarm High Power Factor Alarm Low Power Factor Alarm 3 Phase kVar Demand Alarm

TPU2000/2000R Modbus/Modbus Plus Automation Guide

	Bit 8 = 50P-2 Bit 7 = 50N-1 Bit 6 = 50G-2 (Note 2) 50N-2 (Note 3) Bit 5 = 150P-1 Bit 4 = 150P-2 Bit 3 = 150N-1 Bit 2 = 150G-2 Bit 1 = 46-1 Bit 0 = 46-2	Enabled 1 st Winding 2 Phase Instantaneous Overcurrent Control Enabled 1 st Winding 1 Neutral Instantaneous Overcurrent Control Enabled 1st Winding 2 Ground Instantaneous Overcurrent Control Enabled 1st Winding 2 Neutral Instantaneous Overcurrent Control Enabled 2 nd Winding 1 Phase Instantaneous Overcurrent Control Enabled 2 nd Winding 2 Phase Instantaneous Overcurrent Control Enabled 2 nd Winding 1 Neutral Instantaneous Overcurrent Control Enabled 2 nd Winding 2 Ground Instantaneous Overcurrent Control Enabled Winding 1 Negative Sequence Control Enabled Winding 1 Negative Sequence Control Enabled (lsb rightmost)
41162	Logical Input Bit 15 = ALT 1 Bit 14 = ALT 2 Bit 13 = ECI 1 Bit 12 = ECI 2 Bit 11 = WCI Bit 10 = TRIP Bit 9 = SPR Bit 8 = TCM Bit 7 = ULI 1 Bit 6 = ULI 2 Bit 5 = ULI 3 Bit 4 = ULI 4 Bit 3 = ULI 5 Bit 2 = ULI 6 Bit 1 = ULI 7 Bit 0 = ULI 8	Unsigned Integer 16 Bit Alternate 1 Settings Enabled (msb leftmost) Alternate 2 Settings Enabled Event Capture 1 Initiated Enabled Event Capture 2 Initiated Enabled Waveform Capture Initiated Initiate Differential Trip Output Contacts Sudden Pressure Input Sensed Trip Coil Monitor Input Sensed User Logical Input 1 Sensed User Logical Input 2 Sensed User Logical Input 3 Sensed User Logical Input 4 Sensed User Logical Input 5 Sensed User Logical Input 6 Sensed User Logical Input 7 Sensed User Logical Input 8 Sensed (lsb rightmost)
41163	Logical Input Bit 15 = ULI 9 Bit 14 = CRI Bit 13 = Reserved Bit 12 = Reserved Bit 11 = Reserved Bit 10 = Reserved Bit 9 = Reserved Bit 8 = Reserved Bit 7 = Reserved Bit 6 = Reserved Bit 5 = Reserved Bit 4 = Reserved Bit 3 = Reserved Bit 2 = Reserved Bit 1 = Reserved Bit 0 = Reserved	Unsigned Integer 16 Bits User Logical Input 8 Sensed (msb leftmost) Fault and Overcurrent Clear Through Counters Enabled Reserved Reserved Reserved Reserved Reserved Reserved Reserved Reserved Reserved Reserved Reserved Reserved Reserved Reserved Reserved Reserved (lsb rightmost)
41164	Logical Input Reserved	Unsigned Integer 16 Bits Reserved
41165	Logical Input Bit 15 = 51P-3 (Note 3)	Unsigned Integer 16 Bits Winding 3 Phase Instantaneous Overcurrent Control Enabled

	Bit 11 = Reserved Bit 10 = Reserved Bit 9 = Reserved Bit 8 = IN 9 Bit 7 = IN 8 Bit 6 = IN 7 Bit 5 = IN 6 Bit 4 = IN 5 Bit 3 = IN 4 Bit 2 = IN 3 Bit 1 = IN 2 Bit 0 = IN 1	(lsb rightmost bit)
--	--	---------------------

Table 5-30. Force Table Mapping

Register Address	Item	Description
41171	FORCE PHYS IN Bit 15 = Reserved Bit 14 = Reserved Bit 13 = Reserved Bit 12 = Reserved Bit 11 = Reserved Bit 10 = Reserved Bit 9 = Reserved Bit 8 = IN 9 Bit 7 = IN 8 Bit 6 = IN 7 Bit 5 = IN 6 Bit 4 = IN 5 Bit 3 = IN 4 Bit 2 = IN 3 Bit 1 = IN 2 Bit 0 = IN 1	Unsigned Integer 16 Bits – Physical Input Select Status Reserved (msb leftmost bit) Reserved Reserved Reserved Reserved Reserved Reserved 0 = Normal, 1 = Forced 0 = Normal, 1 = Forced 0 = Normal, 1 = Forced 0 = Normal, 1 = Forced 0 = Normal, 1 = Forced 0 = Normal, 1 = Forced 0 = Normal, 1 = Forced 0 = Normal, 1 = Forced 0 = Normal, 1 = Forced 0 = Normal, 1 = Forced (lsb rightmost bit)
41172	FORCE PHYS IN Bit 15 = Reserved Bit 14 = Reserved Bit 13 = Reserved Bit 12 = Reserved Bit 11 = Reserved Bit 10 = Reserved Bit 9 = Reserved Bit 8 = IN 9 Bit 7 = IN 8 Bit 6 = IN 7 Bit 5 = IN 6 Bit 4 = IN 5 Bit 3 = IN 4 Bit 2 = IN 3 Bit 1 = IN 2 Bit 0 = IN 1	Unsigned Integer 16 Bits – Physical Input Bit State Reserved (msb leftmost bit) Reserved Reserved Reserved Reserved Reserved Reserved 0 = Open, 1 = Closed 0 = Open, 1 = Closed 0 = Open, 1 = Closed 0 = Open, 1 = Closed 0 = Open, 1 = Closed 0 = Open, 1 = Closed 0 = Open, 1 = Closed 0 = Open, 1 = Closed 0 = Open, 1 = Closed 0 = Open, 1 = Closed (lsb rightmost bit)
41173	Phys Out Bit 15 = Reserved Bit 14 = Reserved Bit 13 = Reserved Bit 12 = Reserved Bit 11 = Reserved Bit 10 = Reserved	16 Bit Unsigned Integer Physical Output Select Status Reserved (msb leftmost bit) Reserved Reserved Reserved Reserved Reserved

TPU2000/2000R Modbus/Modbus Plus Automation Guide

	Bit 9 = Reserved Bit 8 = Reserved Bit 7 = OUT 7 Bit 6 = OUT 6 Bit 5 = OUT 5 Bit 4 = OUT 4 Bit 3 = OUT 3 Bit 2 = OUT 2 Bit 1 = OUT 1 Bit 0 = TRIP	Reserved Reserved 0 = Normal, 1 = Forced 0 = Normal, 1 = Forced 0 = Normal, 1 = Forced 0 = Normal, 1 = Forced 0 = Normal, 1 = Forced 0 = Normal, 1 = Forced 0 = Normal, 1 = Forced 0 = Normal, 1 = Forced 0 = Normal, 1 = Forced (lsb rightmost bit)
41174	Phys Out Bit 15 = Reserved Bit 14 = Reserved Bit 13 = Reserved Bit 12 = Reserved Bit 11 = Reserved Bit 10 = Reserved Bit 9 = Reserved Bit 8 = Reserved Bit 7 = OUT 7 Bit 6 = OUT 6 Bit 5 = OUT 5 Bit 4 = OUT 4 Bit 3 = OUT 3 Bit 2 = OUT 2 Bit 1 = OUT 1 Bit 0 = TRIP	16 Bit Unsigned Integer – Physical Output Select State Reserved (msb leftmost bit) Reserved Reserved Reserved Reserved Reserved Reserved 0 = Open, 1 = Closed 0 = Open, 1 = Closed 0 = Open, 1 = Closed 0 = Open, 1 = Closed 0 = Open, 1 = Closed 0 = Open, 1 = Closed 0 = Open, 1 = Closed 0 = Open, 1 = Closed 0 = Open, 1 = Closed 0 = Open, 1 = Closed 0 = Open, 1 = Closed 0 = Open, 1 = Closed (lsb rightmost bit)
41175	FORCED LOGICAL IN Bit 15 = FLI 17 Bit 14 = FLI 18 Bit 13 = FLI 19 Bit 12 = FLI 20 Bit 11 = FLI 21 Bit 10 = FLI 22 Bit 9 = FLI 23 Bit 8 = FLI 24 Bit 7 = FLI 25 Bit 6 = FLI 26 Bit 5 = FLI 27 Bit 4 = FLI 28 Bit 3 = FLI 29 Bit 2 = FLI 30 Bit 1 = FLI 31 Bit 0 = FLI 32	Unsigned Integer 16 Bits – FLI Select Status 0 = Normal, 1 = Forced (msb leftmost bit) 0 = Normal, 1 = Forced 0 = Normal, 1 = Forced 0 = Normal, 1 = Forced 0 = Normal, 1 = Forced 0 = Normal, 1 = Forced 0 = Normal, 1 = Forced 0 = Normal, 1 = Forced 0 = Normal, 1 = Forced 0 = Normal, 1 = Forced 0 = Normal, 1 = Forced 0 = Normal, 1 = Forced 0 = Normal, 1 = Forced 0 = Normal, 1 = Forced 0 = Normal, 1 = Forced 0 = Normal, 1 = Forced 0 = Normal, 1 = Forced 0 = Normal, 1 = Forced 0 = Normal, 1 = Forced (lsb rightmost bit)
41176	FORCED LOGICAL IN Bit 15 = FLI 1 Bit 14 = FLI 2 Bit 13 = FLI 3 Bit 12 = FLI 4 Bit 11 = FLI 5 Bit 10 = FLI 6 Bit 9 = FLI 7 Bit 8 = FLI 8 Bit 7 = FLI 9 Bit 6 = FLI 10 Bit 5 = FLI 11 Bit 4 = FLI 12 Bit 3 = FLI 13	Unsigned Integer 16 Bits – FLI Select Status 0 = Normal, 1 = Forced (msb leftmost bit) 0 = Normal, 1 = Forced 0 = Normal, 1 = Forced 0 = Normal, 1 = Forced 0 = Normal, 1 = Forced 0 = Normal, 1 = Forced 0 = Normal, 1 = Forced 0 = Normal, 1 = Forced 0 = Normal, 1 = Forced 0 = Normal, 1 = Forced 0 = Normal, 1 = Forced 0 = Normal, 1 = Forced 0 = Normal, 1 = Forced 0 = Normal, 1 = Forced 0 = Normal, 1 = Forced 0 = Normal, 1 = Forced 0 = Normal, 1 = Forced 0 = Normal, 1 = Forced

TPU2000/2000R Modbus/Modbus Plus Automation Guide

	Bit 2 = FLI 14 Bit 1 = FLI 15 Bit 0 = FLI 16	0 = Normal, 1 = Forced 0 = Normal, 1 = Forced 0 = Normal, 1 = Forced (lsb rightmost bit)
41177	FORCED LOGICAL IN Bit 15 = FLI 17 Bit 14 = FLI 18 Bit 13 = FLI 19 Bit 12 = FLI 20 Bit 11 = FLI 21 Bit 10 = FLI 22 Bit 9 = FLI 23 Bit 8 = FLI 24 Bit 7 = FLI 25 Bit 6 = FLI 26 Bit 5 = FLI 27 Bit 4 = FLI 28 Bit 3 = FLI 29 Bit 2 = FLI 30 Bit 1 = FLI 31 Bit 0 = FLI 32	Unsigned Integer 16 Bits FLI Point State 0 = De-energized, 1 = Energized (msb leftmost bit) 0 = De-energized, 1 = Energized 0 = De-energized, 1 = Energized 0 = De-energized, 1 = Energized 0 = De-energized, 1 = Energized 0 = De-energized, 1 = Energized 0 = De-energized, 1 = Energized 0 = De-energized, 1 = Energized 0 = De-energized, 1 = Energized 0 = De-energized, 1 = Energized 0 = De-energized, 1 = Energized 0 = De-energized, 1 = Energized 0 = De-energized, 1 = Energized 0 = De-energized, 1 = Energized 0 = De-energized, 1 = Energized 0 = De-energized, 1 = Energized (lsb rightmost bit)
41178	FORCED LOGICAL IN Bit 15 = FLI 1 Bit 14 = FLI 2 Bit 13 = FLI 3 Bit 12 = FLI 4 Bit 11 = FLI 5 Bit 10 = FLI 6 Bit 9 = FLI 7 Bit 8 = FLI 8 Bit 7 = FLI 9 Bit 6 = FLI 10 Bit 5 = FLI 11 Bit 4 = FLI 12 Bit 3 = FLI 13 Bit 2 = FLI 14 Bit 1 = FLI 15 Bit 0 = FLI 16	Unsigned Integer 16 Bits 0 = De-energized, 1 = Energized (msb leftmost bit) 0 = De-energized, 1 = Energized 0 = De-energized, 1 = Energized 0 = De-energized, 1 = Energized 0 = De-energized, 1 = Energized 0 = De-energized, 1 = Energized 0 = De-energized, 1 = Energized 0 = De-energized, 1 = Energized 0 = De-energized, 1 = Energized 0 = De-energized, 1 = Energized 0 = De-energized, 1 = Energized 0 = De-energized, 1 = Energized 0 = De-energized, 1 = Energized 0 = De-energized, 1 = Energized 0 = De-energized, 1 = Energized 0 = De-energized, 1 = Energized (lsb rightmost bit)

Table 5-31. Three Winding Logical Output Points

Register Address	Item	Description
41179	Phys Out Bit 15 = 51P-3 Bit 14 = 50P-3 Bit 13 = 150P-3 Bit 12 = 51N-3 Bit 11 = 50N-3 Bit 10 = 150N-3 Bit 9 = 46-3 Bit 8 = 51G Bit 7 = 50 G Bit 6 = 150G Bit 5 = 51P-3D Bit 4 = 51N-3D Bit 3 = 50P-3D Bit 2 = 50N-3D Bit 1 = 150P-3D	16 Bit Unsigned Integer Physical Output Select Status Winding 3 Phase Time Overcurrent Alarm (msb leftmost bit) 1 st Winding 3 Phase Instantaneous Overcurrent Alarm 2 nd Winding 3 Phase Instantaneous Overcurrent Alarm Winding 3 Neutral Time Overcurrent Alarm 1 st Winding 3 Neutral Instantaneous Overcurrent Alarm 2 nd Winding 3 Neutral Instantaneous Overcurrent Alarm Winding 3 Negative Sequence Time Overcurrent Alarm 1 st Ground Instantaneous Overcurrent Alarm Ground Time Overcurrent Alarm 2 nd Ground Instantaneous Overcurrent Alarm Winding 3 Phase Instantaneous Overcurrent Function Disabled Alarm Winding 3 Neutral Instantaneous Overcurrent Function Disabled Alarm 1 st Winding 3 Phase Time Overcurrent Function Disabled Alarm Winding 3 Neutral Time Overcurrent Function Disabled Alarm 2 nd Winding 3 Phase Time Overcurrent Function Disabled Alarm

TPU2000/2000R Modbus/Modbus Plus Automation Guide

	Bit 0 = 150N-3D	2 nd Winding 3 Neutral Time Overcurrent Function Disabled Alarm (lsb rightmost bit)
41180	Phys Out Bit 15 = 46-3 Bit 14 = 51GD Bit 13 = 50GD Bit 12 = 150GD Bit 11 = 51P-3(L) Bit 10 = 50P-3 (L) Bit 9 = 150P-3 (L) Bit 8 = 51N-3 (L) Bit 7 = 50N-3 (L) Bit 6 = 150N-3 (L) Bit 5 = 46-3 (L) Bit 4 = 51G (L) Bit 3 = 50G (L) Bit 2 = 150G (L) Bit 1 = TFKA-3 (Note 1) Bit 0 = HLDA-3	16 Bit Unsigned Integer Winding 3 Negative Sequence Time Overcurrent Alarm (msb leftmost bit) 1 st Ground Instantaneous Overcurrent Function Disabled Alarm 1 st Winding 3 Ground Instantaneous Overcurrent Function Disabled 2 nd Winding 3 Ground Instantaneous Overcurrent Function Disabled Winding 3 Phase Time Overcurrent Alarm Latched 1 st Winding 3 Phase Instantaneous Overcurrent Alarm Latched 2 nd Winding 3 Phase Instantaneous Overcurrent Alarm Latched Winding 3 Neutral Time Overcurrent Alarm Latched 1 st Winding 3 Neutral Instantaneous Overcurrent Alarm Latched 2 nd Winding 3 Neutral Instantaneous Overcurrent Alarm Latched Winding 3 Negative Sequence Time Overcurrent Alarm Latched 1 st Ground Instantaneous Overcurrent Alarm Latched Ground Time Overcurrent Alarm Latched 2 nd Ground Instantaneous Overcurrent Alarm Latched Through Fault Counter Alarm Winding 3 High Level Detector Alarm (lsb rightmost bit)
41181	Phys Out Bit 15 = LLDA -3 Bit 14 = OCA-3 Bit 13 = Pwatt3 Bit 12 = OCA Gnd Bit 11 = Reserved Bit 10 = Reserved Bit 9 = Reserved Bit 8 = Reserved Bit 7 = Reserved Bit 6 = Reserved Bit 5 = Reserved Bit 4 = Reserved Bit 3 = Reserved Bit 2 = Reserved Bit 1 = Reserved Bit 0 = Reserved	16 Bit Unsigned Integer Physical Output Select Status Winding 3 Low Level Detector Alarm (msb leftmost bit) Winding 3 Overcurrent Alarm Winding 3 Positive 3 Phase Watt Alarm Ground Overcurrent Alarm Reserved Reserved Reserved Reserved Reserved Reserved Reserved Reserved Reserved Reserved Reserved Reserved Reserved (lsb rightmost bit)
41182	Phys Out Reserved	16 Bit Unsigned Integer Physical Output Select Status Reserved

4X Register Write Capabilities

All of the Modbus status retrieval have involved 03 register read commands only. Modbus allows for two types of commands involving control writes to obtain read data. One Modbus command allows register writes. Another Modbus command allows for register writes and reads with one command. The type of functionality performed with relay writes is as such:

- Access of Differential Fault Records (2 Winding and 3 Winding Values)
- Access of Through Fault Records (2 Winding and 3 Winding Values)
- Access of Harmonic Restraint Fault Records (2 Winding and 3 Winding Values)
- Access of Operation Records
- Trip Initiation
- Enable/Disable of Protective Functions
- Clearing of Event Counters
- Enable/Disable of Supervisory Functions
- Reset of Targets
- Clear of Seal In's

Function Code 16 Preset 4X Registers (Write Only)

Figure 5-37 illustrates the Modbus command structure writing multiple registers.

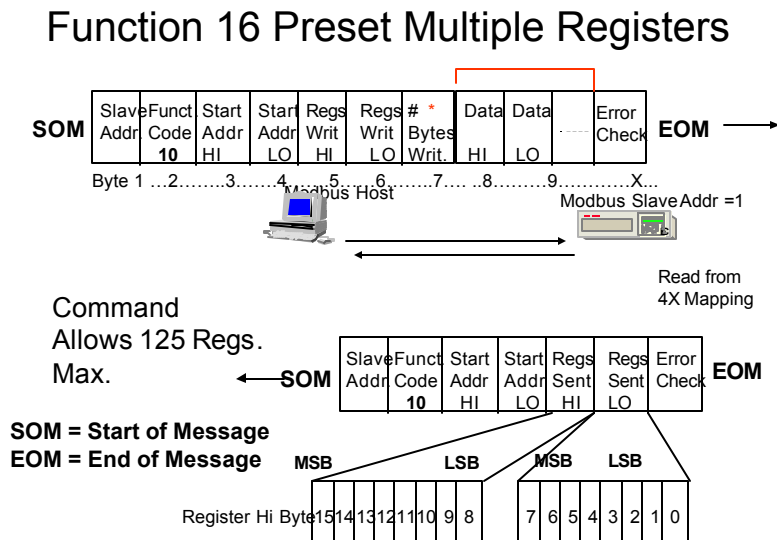

Figure 5-37. Modbus Write Command 16 (10 Hex) Allowing Writes to the TPU2000/2000R

The write multiple register command is convenient for writing the following control blocks:

Control Block 1 allows for:

- Initiation of Relay Trip
- Initiation of Input Functions

Control Block 2 allows for:

- Forcing of Physical Input Logical Statuses

Control Block 3 allows for:

- Force of Physical Output Points

Control Block 4 allows for:

- Force Logical Input Bits 1 to 32

Control Block 5 allows for:

- Setting and Resetting of Protective Functions and Resetting of Alarms

Control Block 6 allows for:

- Forcing of Physical Output Points for a limited duration of time

Whenever a write occurs to the TPU2000/2000R:

- The TPU2000/2000R receives the command:
- Command Interpreted in 1 quarter cycle.
- Relay Protection Occurs.
- Command acts on the device.
- The command response is generated to the Host from the TPU2000/2000R after the action is completed.

The defined control blocks 1 and 2 are write capable and are well suited for access control via the Modbus command 16 (10 HEX).

Function 23 Read/Write Register (Read/Write Concurrently)

Another format command which allows for a simultaneous read/write is command 23 (17HEX). Figure 5-38 illustrates the Read/Write 4X Register command format. The 23 command is used when the user wishes to write a register for control buffer access and read a group of registers which was accessed via the read.

Control Blocks 1 and 2 allows for access of protective device function state. If a user wished to read the status of each function within the relay, a Function Read/Write Register Command would be the most desirable command to be issued. Read/Write register data commands are also useful in accessing the Operation, Differential Fault, Through Fault and Harmonic Restraint Fault record blocks.

Review of the Modbus 23 command allows for write and read of data if the total amount of read and write registers do not exceed over 125 words. An advantage of using a combined read/write command is that of speed. If conventional commands were to be used, a 16 Write 4X Register Command would be issued and thereafter, within 10 seconds, a 03 Modbus (Read 4X Register Command) would then be issued to extract the data from the relay. Using Modbus command 23 allows for decreasing of the overhead associated with multiple register reads and writes.

Function 23 Read/Write 4X Registers

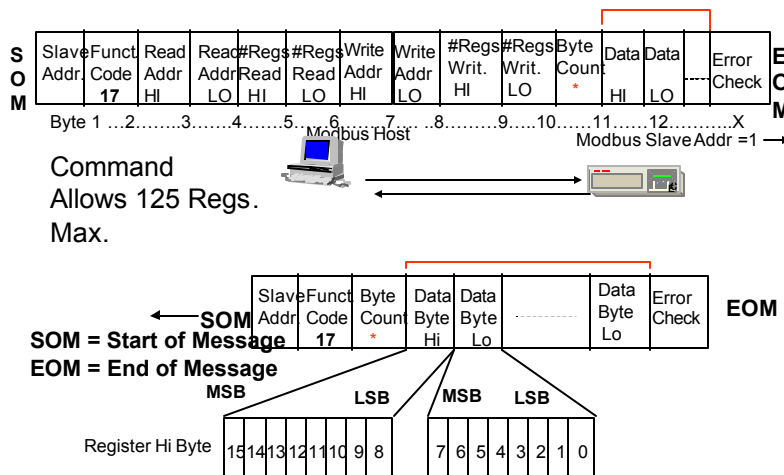

Figure 5-38. Function 23 Read/Write Command Format

Fault Records

Fault records are stored in the TPU2000/2000R according to the following format. Figure 5-39 illustrates the method of accessing the Fault Record Data via the TPU2000/2000R. The TPU2000/2000R has an internal circular buffer, which stores a maximum of 32 faults. These faults are stored internally to the TPU2000/2000R's fault stack as indicated in the figure. Each fault is defined as a block of registers. The first defined register in the table is the fault record control register. Fault records are viewed by writing a data word to the first register in the data stack as defined for each Fault Record stack and reading the block of consecutive registers for that stack. Table 5-32 lists the type of Fault Record available in the TPU2000R, the Modbus Control Register Address and the Data Stack Address to retrieve the fault information.

Table 5-32. Fault Record Data Assignment

Description	Control Register Address	Buffer Start Address	Buffer End Address	Buffer Register Size	Notes
Differential Fault Records	41665	41666	41745	80	2 Winding Records Only
Through Fault Records	41793	41794	41830	37	2 Winding Records Only
Harmonic Restraint Records	41921	41922	42009	88	2 Winding Records Only
Differential Fault Records	42305	42306	42352	47	3 Winding Records Only
Through Fault Records	42433	42434	42466	33	3 Winding Records Only
Differential Fault Records	42561	42562	42601	40	3 Winding Records Only

If the number of faults exceed 32, then the buffer overwrites the oldest record contained within its internal stack. Access and control can be accomplished over Modbus in one of two methods.

If no data accumulated within the fault record, values of 0 shall be returned in the buffer. A new fault record entry is indicated via Bit 6 of Register 40129 being set to a 1. Reference Table 5-9 of this document for a more detailed explanation of the registers bit map.

The Fault Record number can be a number from 1 to 999. ONLY THE PREVIOUS 32 RECORDS ARE KEPT IN THE FAULT RECORD BUFFER. Fault Records are sequentially numbered from 1 to 999. If the fault number is presently at 999, and an additional fault is recorded, the fault number shall rollover to 1. The Record number and fault buffer cannot be cleared and reset through a keypad or unit reset procedure or a reset via the network as explained in Section 3 as a note.

METHOD 1:

The host writes a Modbus 23 Command (Modbus 4X Register Read/Write) in which a control code (1, 2, or 3) is written to The Fault Control Register Address as defined in Table 1 and the buffer is filled with fault data from the Fault Buffer Start until the Buffer End address. A command of 1 = Points to the First Record in the Fault Table. A command of 2 Points to the next fault in the fault table. A command of 3 points to the last unreported fault in the fault table. Figure 5-39 graphically illustrates the write/read process for access of fault or operation records.

METHOD 2:

The host writes a Modbus Command 16 (Modbus 4X Register Write Command) in which a control code (1, 2, or 3) is written to the Fault Control Register Address as defined in Table 5-32 and the buffer is filled with fault data in the addresses defined for the Fault Buffer (reference Table 5-32). Within 10 seconds after the 16 command is issued, the host issues a Modbus 03 command (Modbus 4X Register Read command) in which the fault data is retrieved from the Fault Buffer as defined for the retrieved fault.

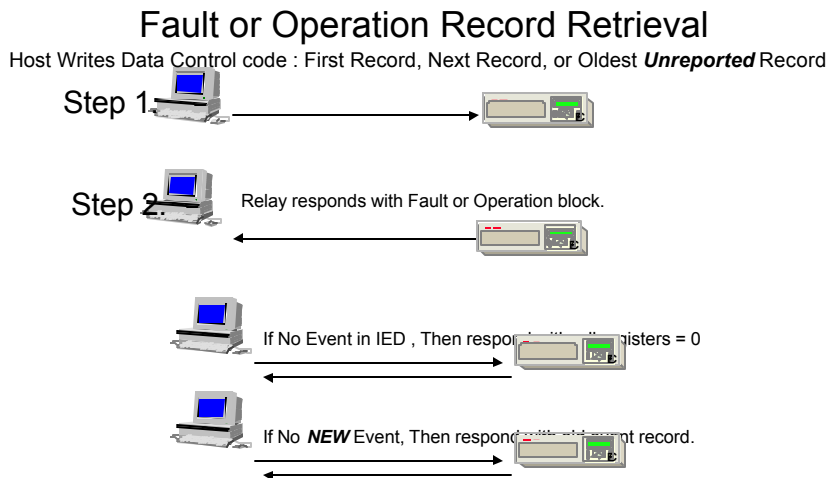

Figure 5-39. 2 Winding Differential Fault Buffer

Differential Fault Record Reporting

There are two Differential Fault Record Buffers contained within the TPU2000R Modbus Register mapping. They are 2 Winding Differential Fault Buffer information for the TPU2000 and TPU2000R and a 3 Winding Differential Fault Buffer which is only available for the TPU2000R 3 Winding Unit.

Table 5-33 lists the register map for the 2 Winding buffer and Table 5-34 lists that for the 3 Winding unit.

Differential Fault Record Layout (TPU2000/TPU 2000R)

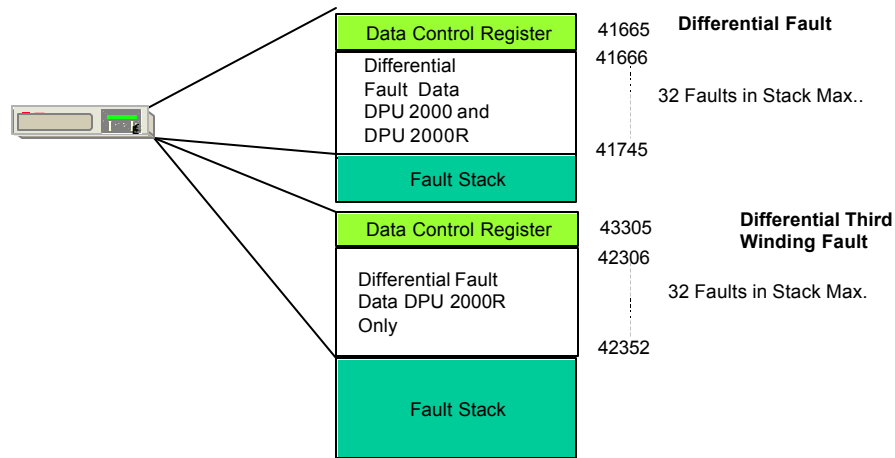

Figure 5-40. 3 Winding Differential Fault Buffer

Table 5-33. Differential 2 Winding Fault Record Register Definition

Register Address	Item	Description (Multiplier if any)
41665	Differential 2 Winding Fault Control Register 1 = First Record 2 = Next Record 3 = Oldest Unreported Record	Fault Record Control Register Unsigned 16 Bit 1 = Fill 41666 through 41745 with First Record in Data Buffer. 2 = Fill 41666 through 41745 with next Record Data pointed to in buffer. 3 = Fill 41666 through 41745 with the last (oldest unreported) record of data.
41666	Parameter Flag	Unsigned Integer 16 Bit
41667	Fault Type Element	Unsigned 16 Bit 00 = 87T – % Differential Alarm 01 = 87H – High Set Inst. Differential Alarm 02 = 51P-1 – Winding 1 Phase Time Overcurrent 03 = 51P-2 – Winding 2 Phase Time Overcurrent 04 = 50P-1 – 1 st Winding 1 Phase Inst. Overcurrent 05 = 50N-1 – 1 st Winding 1 Neutral Inst. Overcurrent 06 = 150P-1 – 2 nd Winding 1 Phase Inst. Overcurrent 07 = 150N-1 – 2 nd Winding 1 Neutral Inst. Overcurrent 08 = 46-1 – Neg. Sequence 1 Inst. Time Overcurrent 09 = 51P-2 – Winding 2 Phase Time Overcurrent 10 = 51G-2 – Winding 2 Ground Time Overcurrent 11 = 50P-2 – 1 st Winding 2 Phase Inst. Overcurrent 12 = 50G-2 – 1 st Winding 2 Ground Inst. Overcurrent 13 = 150P-2 – 2 nd Winding 2 Phase Inst. Overcurrent

TPU2000/2000R Modbus/Modbus Plus Automation Guide

Register Address	Item	Description (Multiplier if any)
		14 = 150G-2 – 2 nd Winding 2 Ground Inst. Overcurrent 15 = 46-2 – Neg. Sequence 2 Inst. Time Overcurrent 16 = ECI-1 – Event Capture Initiate 1 17 = ECI-2 – Event Capture Initiate 2 18 = Through Fault 19 = Harmonic Restraint
41668	Setting At Fault Event	Unsigned 16 Bit 01 = Primary Settings 02 = Alternate 1 Settings 03 = Alternate 2 Settings
41669	Fault Record Number	Unsigned 16 Bit (1 – 999, only last 32 kept)
41670	Year 2 digit 00 -99	Unsigned 16 Bit Year of Fault
41671	Month 1 - 12	Unsigned 16 Bit Month of Fault
41672	Day 1 - 31	Unsigned 16 Bit Day of Fault
41673	Hour 00 - 23	Unsigned 16 Bit Hour of Fault
41674	Minute 00 - 59	Unsigned 16 Bit Minute of Fault
41675	Second 00 - 59	Unsigned 16 Bit Second of Fault
41676	Hundredths of Seconds 0 - 99	Unsigned 16 Bit Hundredth Second of Fault Time
41677	Clear Time	Unsigned 16 Bit (X 1000) seconds
41678	Winding1 Tap	Unsigned 16 Bit (X 500)
41679	Winding2 Tap	Unsigned 16 Bit (X 800)
41680	I operate Phase A	Unsigned 16 Bit (X 800)
41681	I operate Phase B	Unsigned 16 Bit (X 800)
41682	I operate Phase C	Unsigned 16 Bit (X 800)
41683	I restraint Phase A-Winding 1	Unsigned 16 Bit (X 800)
41684	I restraint Phase B-Winding 1	Unsigned 16 Bit (X 800)
41685	I restraint Phase C-Winding 1	Unsigned 16 Bit (X 800)
41686	I restraint Phase A-Winding 2	Unsigned 16 Bit (X 800)
41687	I restraint Phase B-Winding 2	Unsigned 16 Bit (X 800)
41688	I restraint Phase C-Winding 2	Unsigned 16 Bit (X 800)
41689	2nd Harmonic Phase A-Winding 1	Unsigned 16 Bit (X 2)
41690	5th Harmonic Phase A-Winding 1	Unsigned 16 Bit (X 2)
41691	All Harmonic Phase A-Winding 1	Unsigned 16 Bit (X 2)
41692	2nd Harmonic Phase B-Winding 1	Unsigned 16 Bit (X 2)
41693	5th Harmonic Phase B-Winding 1	Unsigned 16 Bit (X 2)
41694	All Harmonic Phase B-Winding 1	Unsigned 16 Bit (X 2)
41695	2nd Harmonic Phase C-Winding 1	Unsigned 16 Bit (X 2)
41696	5th Harmonic Phase C-Winding 1	Unsigned 16 Bit (X 2)
41697	All Harmonic Phase C-Winding 1	Unsigned 16 Bit (X 2)
41698	2nd Harmonic Phase A-Winding 2	Unsigned 16 Bit (X 2)
41699	5th Harmonic Phase A-Winding 2	Unsigned 16 Bit (X 2)
41700	All Harmonic Phase A-Winding 2	Unsigned 16 Bit (X 2)
41701	2nd Harmonic Phase B-Winding 2	Unsigned 16 Bit (X 2)
41702	5th Harmonic Phase B-Winding 2	Unsigned 16 Bit (X 2)
41703	All Harmonic Phase B-Winding 2	Unsigned 16 Bit (X 2)
41704	2nd Harmonic Phase C-Winding 2	Unsigned 16 Bit (X 2)
41705	5th Harmonic Phase C-Winding 2	Unsigned 16 Bit (X 2)
41706	All Harmonic Phase C-Winding 2	Unsigned 16 Bit (X 2)
41707	I restraint Phase A-Winding 1 (Ang)	Unsigned 16 Bit
41708	I restraint Phase B-Winding 1 (Ang)	Unsigned 16 Bit
41709	I restraint Phase C-Winding 1 (Ang)	Unsigned 16 Bit
41710	I restraint Phase A-Winding 2 (Ang)	Unsigned 16 Bit
41711	I restraint Phase B-Winding 2 (Ang)	Unsigned 16 Bit

TPU2000/2000R Modbus/Modbus Plus Automation Guide

Register Address	Item	Description (Multiplier if any)
41712	I restraint Phase C-Winding 2 (Ang)	Unsigned 16 Bit
41713	I Phase A-Winding 1	Unsigned 16 Bit (X 800)
41714	I PhaseB-Winding 1	Unsigned 16 Bit (X 800)
41715	I Phase C-Winding 1	Unsigned 16 Bit (X 800)
41716	I Neutral-Winding 1	Unsigned 16 Bit (X 800)
41717	I Phase A-Winding 2	Unsigned 16 Bit (X 800)
41718	I Phase B-Winding 2	Unsigned 16 Bit (X 800)
41719	I Phase C-Winding 2	Unsigned 16 Bit (X 800)
41720	I Neutral-Winding 2	Unsigned 16 Bit (X 800)
41721	Spare	Unsigned 16 Bit
41722	I Phase A-Winding 1 (Ang)	Unsigned 16 Bit
41723	I Phase B-Winding 1 (Ang)	Unsigned 16 Bit
41724	I Phase C-Winding 1 (Ang)	Unsigned 16 Bit
41725	I Neutral-Winding 1 (Ang)	Unsigned 16 Bit
41726	I Phase A-Winding 2 (Ang)	Unsigned 16 Bit
41727	I Phase B-Winding 2 (Ang)	Unsigned 16 Bit
41728	I Phase C-Winding 2 (Ang)	Unsigned 16 Bit
41729	I Neutral-Winding 2 (Ang)	Unsigned 16 Bit
41730	I 0-1 – Zero Sequence Current Winding 1	Unsigned 16 Bit (X 800)
41731	I 1-1 – Positive Sequence Current Winding 1	Unsigned 16 Bit (X 800)
41732	I 2-1 – Negative Sequence Current Winding 1	Unsigned 16 Bit (X 800)
41733	I 0-2 – Zero Sequence Current Winding 2	Unsigned 16 Bit (X 800)
41734	I 1-2 – Positive Sequence Current Winding 2	Unsigned 16 Bit (X 800)
41735	I 2-2 – Negative Sequence Current Winding 2	Unsigned 16 Bit (X 800)
41736	I 0-1 (Ang) – Zero Sequence Angle Winding 1	Unsigned 16 Bit
41737	I 1-1 (Ang) – Positive Sequence Angle Winding 1	Unsigned 16 Bit
41738	I 2-1 (Ang) – Negative Sequence Angle Winding 1	Unsigned 16 Bit
41739	I 0-2 (Ang) – Zero Sequence Angle Winding 2	Unsigned 16 Bit
41740	I 1-2 (Ang) – Positive Sequence Angle Winding 2	Unsigned 16 Bit
41741	I 2-2 (Ang) – Negative Sequence Angle Winding 2	Unsigned 16 Bit
41742	Scale - Phase Wdg 1	Unsigned 16 Bit
41743	Scale - Phase Wdg 2	Unsigned 16 Bit
41744	Scale - Neutral Wdg 1	Unsigned 16 Bit
41745	Scale - Neutral Wdg 2	Unsigned 16 Bit

The 3 Winding Differential Fault Register Definition Table follows.

Table 5-34. 3 Winding Differential Fault Record Address Table

Register Address	Item	Description (Multiplier if any)
42305	Differential 3 Winding Fault Control Register 1 = First Record 2 = Next Record 3 = Oldest Unreported Record	Fault Record Control Register Unsigned 16 Bit 1 = Fill 42306 through 42352 with First Record in Data Buffer. 2 = Fill 42306 through 42352 with next Record Data pointed to in buffer. 3 = Fill 42306 through 42352 with the last (oldest unreported) record of data.
42306	Parameter Flag	Unsigned Integer 16 Bit
42307	Fault Type Element	Unsigned 16 Bit 00 = 87T – % Differential Alarm 01 = 87H – High Set Inst. Differential Alarm 02 = 51P-1 – Winding 1 Phase Time Overcurrent 03 = 51P-2 – Winding 2 Phase Time Overcurrent 04 = 50P-1 – 1 st Winding 1 Phase Inst. Overcurrent 05 = 50N-1 – 1 st Winding 1 Neutral Inst. Overcurrent 06 = 150P-1 – 2 nd Winding 1 Phase Inst. Overcurrent 07 = 150N-1 – 2 nd Winding 1 Neutral Inst. Overcurrent 08 = 46-1 – Neg. Sequence 1 Inst. Time Overcurrent 09 = 51P-2 – Winding 2 Phase Time Overcurrent 10 = 51G-2 – Winding 2 Ground Time Overcurrent 11 = 50P-2 – 1 st Winding 2 Phase Inst. Overcurrent 12 = 50G-2 – 1 st Winding 2 Ground Inst. Overcurrent 13 = 150P-2 – 2 nd Winding 2 Phase Inst. Overcurrent 14 = 150G-2 – 2 nd Winding 2 Ground Inst. Overcurrent 15 = 46-2 – Neg. Sequence 2 Inst. Time Overcurrent 16 = ECI-1 – Event Capture Initiate 1 17 = ECI-2 – Event Capture Initiate 2 18 = Through Fault 19 = Harmonic Restraint
42308	Setting At Fault Event	Unsigned 16 Bit 01 = Primary Settings 02 = Alternate 1 Settings 03 = Alternate 2 Settings
42309	Fault Record Number	Unsigned 16 Bit (1 – 999, only last 32 kept)
42310	Year 2 digit 00 -99	Unsigned 16 Bit Year of Fault
42311	Month 1 - 12	Unsigned 16 Bit Month of Fault
42312	Day 1 - 31	Unsigned 16 Bit Day of Fault
42313	Hour 00 - 23	Unsigned 16 Bit Hour of Fault
42314	Minute 00 - 59	Unsigned 16 Bit Minute of Fault
42315	Second 00 - 59	Unsigned 16 Bit Second of Fault
42316	Hundredths of Seconds 0 - 99	Unsigned 16 Bit Hundredth Second of Fault Time
42317	Clear Time	Unsigned 16 Bit (X 1000) seconds
42318	Winding 3 Tap	Unsigned 16 Bit (X 500)
42319	I restraint Phase A-Winding 3	Unsigned 16 Bit (X 800)
42320	I restraint Phase B-Winding 3	Unsigned 16 Bit (X 800)
42321	I restraint Phase C-Winding 3	Unsigned 16 Bit (X 800)
42322	2nd Harmonic Phase A-Winding 3	Unsigned 16 Bit (X 2)
42323	5th Harmonic Phase A-Winding 3	Unsigned 16 Bit (X 2)
42324	All Harmonic Phase A-Winding 3	Unsigned 16 Bit (X 2)
42325	2nd Harmonic Phase B-Winding 3	Unsigned 16 Bit (X 2)

TPU2000/2000R Modbus/Modbus Plus Automation Guide

Register Address	Item	Description (Multiplier if any)
42326	5th Harmonic Phase B-Winding 3	Unsigned 16 Bit (X 2)
42327	All Harmonic Phase B-Winding 3	Unsigned 16 Bit (X 2)
42328	2nd Harmonic Phase C-Winding 3	Unsigned 16 Bit (X 2)
42329	5th Harmonic Phase C-Winding 3	Unsigned 16 Bit (X 2)
42330	All Harmonic Phase C-Winding 3	Unsigned 16 Bit (X 2)
42331	I restraint Phase A-Winding 3 (Ang)	Unsigned 16 Bit
42332	I restraint Phase B-Winding 3 (Ang)	Unsigned 16 Bit
42333	I restraint Phase C-Winding 3 (Ang)	Unsigned 16 Bit
42334	I Phase A-Winding 3	Unsigned 16 Bit (X 800)
42335	I PhaseB-Winding 3	Unsigned 16 Bit (X 800)
42336	I Phase C-Winding 3	Unsigned 16 Bit (X 800)
42337	I Neutral-Winding 3	Unsigned 16 Bit (X 800)
42338	I Ground	Unsigned 16 Bit (X 800)
42339	I Phase A-Winding 3 (Angle)	Unsigned 16 Bit
42340	I Phase B-Winding 3 (Angle)	Unsigned 16 Bit
42341	I Phase C-Winding 3 (Angle)	Unsigned 16 Bit
42342	I Neutral-Winding 3(Angle)	Unsigned 16 Bit
42343	I Ground (Angle)	Unsigned 16 Bit
42344	I 0-2 – Zero Sequence Current Winding 3	Unsigned 16 Bit
42345	I 1-2 – Positive Sequence Current Winding 3	Unsigned 16 Bit
42346	I 2-2 – Negative Sequence Current Winding 3	Unsigned 16 Bit
42347	I 0-3 (Ang) – Zero Sequence Angle Winding 2	Unsigned 16 Bit
42348	I 1-3 (Ang) – Positive Sequence Angle Winding 3	Unsigned 16 Bit
42349	I 2-3 (Ang) – Negative Sequence Angle Winding 3	Unsigned 16 Bit
42350	Scale – Phase Wdg 3	Unsigned 16 Bit
42351	Scale – Neutral Wdg 3	Unsigned 16 Bit
42352	Scale – Ground Wdg 3	Unsigned 16 Bit

Through Fault Buffers

Thirty two through faults are stored within the TPU2000/2000R. A through-fault is stored on any overcurrent trip output or whenever the Disturbance-2 pickup setting is exceeded. Within the TPU2000 and TPU2000R the two Winding Through Fault buffer described in Table 5-35 allows the user to obtain the fault information. In a TPU2000R Three Winding Unit, additional fault information may be retrieved describing the fault conditions for the third winding.

Through Fault Record Layout (TPU2000/TPU2000R)

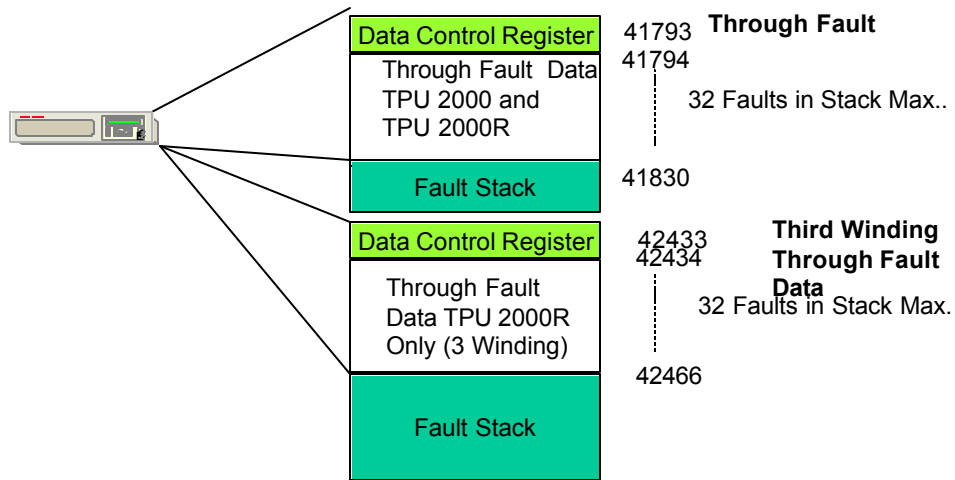

Figure 5-41. Event Record Access Illustration of Function 23 is Issued to a TPU2000/2000R Device

Table 5-35. 2 Winding Through Fault Register Definition for the TPU2000/TPU2000R

Register Address	Item	Description (Multiplier if any)
41793	2 Winding Through Fault Control Register 1 = First Record 2 = Next Record 3 = Oldest Unreported Record	Fault Record Control Register Unsigned 16 Bit 1 = Fill 41794 through 41830 with First Record in Data Buffer. 2 = Fill 41794 through 41830 with next Record Data pointed to in buffer. 3 = Fill 41794 through 41830 with the last (oldest unreported) record of data.
41794	Parameter Flag	Unsigned Integer 16 Bit
41795	Fault Type Element	Unsigned 16 Bit 00 = 87T – % Differential Alarm 01 = 87H – High Set Inst. Differential Alarm 02 = 51P-1 – Winding 1 Phase Time Overcurrent 03 = 51P-2 – Winding 2 Phase Time Overcurrent 04 = 50P-1 – 1 st Winding 1 Phase Inst. Overcurrent 05 = 50N-1 – 1 st Winding 1 Neutral Inst. Overcurrent 06 = 150P-1 – 2 nd Winding 1 Phase Inst. Overcurrent 07 = 150N-1 – 2 nd Winding 1 Neutral Inst. Overcurrent 08 = 46-1 – Neg. Sequence 1 Inst. Time Overcurrent 09 = 51P-2 – Winding 2 Phase Time Overcurrent 10 = 51G-2 – Winding 2 Ground Time Overcurrent 11 = 50P-2 – 1 st Winding 2 Phase Inst. Overcurrent 12 = 50G-2 – 1 st Winding 2 Ground Inst. Overcurrent 13 = 150P-2 – 2 nd Winding 2 Phase Inst. Overcurrent 14 = 150G-2 – 2 nd Winding 2 Ground Inst. Overcurrent 15 = 46-2 – Neg. Sequence 2 Inst. Time Overcurrent 16 = ECI-1 – Event Capture Initiate 1 17 = ECI-2 – Event Capture Initiate 2 18 = Through Fault 19 = Harmonic Restraint
41796	Setting At Fault Event	Unsigned 16 Bit 01 = Primary Settings

TPU2000/2000R Modbus/Modbus Plus Automation Guide

Register Address	Item	Description (Multiplier if any)
		02 = Alternate 1 Settings 03 = Alternate 2 Settings
41797	Fault Record Number	Unsigned 16 Bit (1 – 999, only last 32 kept)
41798	Year 2 digit 00 -99	Unsigned 16 Bit Year of Fault
41799	Month 1 - 12	Unsigned 16 Bit Month of Fault
41800	Day 1 - 31	Unsigned 16 Bit Day of Fault
41801	Hour 00 - 23	Unsigned 16 Bit Hour of Fault
41802	Minute 00 - 59	Unsigned 16 Bit Minute of Fault
41803	Second 00 - 59	Unsigned 16 Bit Second of Fault
41804	Hundredths of Seconds 0 - 99	Unsigned 16 Bit Hundredth Second of Fault Time
41805	Clear Time	Unsigned 16 Bit (X 1000) seconds
41806	Relay Time (MSW)	Most Significant Word Unsigned 16 Bit (X 1000)
41807	Relay Time (LSW)	Least Significant Word Unsigned 16 Bit (X 1000)
41808	I Phase A-Winding 1	Unsigned 16 Bit (X 800)
41809	I PhaseB-Winding 1	Unsigned 16 Bit (X 800)
41810	I Phase C-Winding 1	Unsigned 16 Bit (X 800)
41811	I Neutral-Winding 1	Unsigned 16 Bit (X 800)
41812	I Phase A-Winding 2	Unsigned 16 Bit (X 800)
41813	I Phase B-Winding 2	Unsigned 16 Bit (X 800)
41814	I Phase C-Winding 2	Unsigned 16 Bit (X 800)
41815	I Neutral –Winding 2	Unsigned 16 Bit (X 800)
41816	Spare	Unsigned 16 Bit
41817	I Phase A-Winding 1 (Ang)	Unsigned 16 Bit
41818	I Phase B-Winding 1 (Ang)	Unsigned 16 Bit
41819	I Phase C-Winding 1 (Ang)	Unsigned 16 Bit
41820	I Neutral-Winding 1 (Ang)	Unsigned 16 Bit
41821	I Phase A-Winding 2 (Ang)	Unsigned 16 Bit
41822	I Phase B-Winding 2 (Ang)	Unsigned 16 Bit
41823	I Phase C-Winding 2 (Ang)	Unsigned 16 Bit
41824	I Neutral-Winding 2 (Ang)	Unsigned 16 Bit
41825	I 0-1 – Zero Sequence Current Winding 1	Unsigned 16 Bit (X 800)
41826	I 1-1 – Positive Sequence Current Winding 1	Unsigned 16 Bit (X 800)
41827	I 2-1 – Negative Sequence Current Winding 1	Unsigned 16 Bit (X 800)
41828	I 0-2 – Zero Sequence Current Winding 2	Unsigned 16 Bit (X 800)
41829	I 1-2 – Positive Sequence Current Winding 2	Unsigned 16 Bit (X 800)
41830	I 2-2 – Negative Sequence Current Winding 2	Unsigned 16 Bit (X 800)
41831	I 0-1 (Ang) – Zero Sequence Angle Winding 1	Unsigned 16 Bit
41832	I 1-1 (Ang) – Positive Sequence Angle Winding 1	Unsigned 16 Bit
41833	I 2-1 (Ang) – Negative Sequence Angle Winding 1	Unsigned 16 Bit
41834	I 0-2 (Ang) – Zero Sequence Angle Winding 2	Unsigned 16 Bit
41835	I 1-2 (Ang) – Positive Sequence Angle Winding 2	Unsigned 16 Bit
41836	I 2-2 (Ang) – Negative	Unsigned 16 Bit

TPU2000/2000R Modbus/Modbus Plus Automation Guide

Register Address	Item	Description (Multiplier if any)
	Sequence Angle Winding 2	
41837	Scale - Phase Wdg 1	Unsigned 16 Bit
41838	Scale - Phase Wdg 2	Unsigned 16 Bit
41839	Scale - Neutral Wdg 1	Unsigned 16 Bit
41840	Scale - Neutral Wdg 2	Unsigned 16 Bit

The 3 Winding Through Fault Register Definition Table follows.

Table 5-36. 3 Winding Through Fault Record Buffer Modbus Register Definition

Register Address	Item	Description (Multiplier if any)
42433	3 Winding Through Fault Control Register 1 = First Record 2 = Next Record 3 = Oldest Unreported Record	Fault Record Control Register Unsigned 16 Bit 1 = Fill Register 42434 through 42466 with First Record in Data Buffer. 2 = Fill Register 42434 through 42466 with with next Record Data pointed to in buffer. 3 = Fill Register 42434 through 42466 with with the last (oldest unreported) record of data.
42434	Parameter Flag	Unsigned Integer 16 Bit
42435	Fault Type Element	Unsigned 16 Bit 00 = 87T – % Differential Alarm 01 = 87H – High Set Inst. Differential Alarm 02 = 51P-1 – Winding 1 Phase Time Overcurrent 03= 51P-2 – Winding 2 Phase Time Overcurrent 04 = 50P-1 – 1 st Winding 1 Phase Inst. Overcurrent 05 = 50N-1 – 1 st Winding 1 Neutral Inst. Overcurrent 06 = 150P-1 – 2 nd Winding 1 Phase Inst. Overcurrent 07 =150N-1 – 2 nd Winding 1 Neutral Inst. Overcurrent 08 = 46-1 – Neg. Sequence 1 Inst. Time Overcurrent 09 = 51P-2 – Winding 2 Phase Time Overcurrent 10 = 51G-2 – Winding 2 Ground Time Overcurrent 11 = 50P-2 – 1 st Winding 2 Phase Inst. Overcurrent 12 =50G-2 – 1 st Winding 2 Ground Inst. Overcurrent 13 = 150P-2- 2 nd Winding 2 Phase Inst.Overcurrent 14 = 150G-2- 2 nd Winding 2 Ground Inst Overcurrent 15 = 46-2- Neg Sequence 2 Inst. Time Overcurrent 16 = ECI-1 – Event Capture Initiate 1 17 = ECI-2 – Event Capture Initiate 2 18 = Through Fault 19 = Harmonic Restraint
42436	Setting At Fault Event	Unsigned 16 Bit 01 = Primary Settings 02 = Alternate 1 Settings 04 = Alternate 2 Settings
42437	Fault Record Number	Unsigned 16 Bit (1 – 999, only last 32 kept)
42438	Year 2 digit 00 -99	Unsigned 16 Bit Year of Fault
42439	Month 1 - 12	Unsigned 16 Bit Month of Fault
42440	Day 1 - 31	Unsigned 16 Bit Day of Fault
42441	Hour 00 - 23	Unsigned 16 Bit Hour of Fault
42442	Minute 00 - 59	Unsigned 16 Bit Minute of Fault
42443	Second 00 - 59	Unsigned 16 Bit Second of Fault
42444	Hundredths of Seconds 0 - 99	Unsigned 16 Bit Hundredth Second of Fault Time

TPU2000/2000R Modbus/Modbus Plus Automation Guide

Register Address	Item	Description (Multiplier if any)
42445	Clear Time	Unsigned 16 Bit (X 1000) seconds
42446	Relay Time (MSW)	Most Significant Word Unsigned 16 Bit (X 1000)
42447	Relay Time (LSW)	Least Significant Word Unsigned 16 Bit (X 1000)
42448	I Phase A-Winding 3	Unsigned 16 Bit (X 800)
42449	I Phase B-Winding 3	Unsigned 16 Bit (X 800)
42450	I Phase C-Winding 3	Unsigned 16 Bit (X 800)
42451	I Neutral-Winding 3	Unsigned 16 Bit (X 800)
42452	I Ground	Unsigned 16 Bit (X 800)
42453	I Phase A-Winding 3 (Angle)	Unsigned 16 Bit
42454	I Phase B-Winding 3 (Angle)	Unsigned 16 Bit
42455	I Phase C-Winding 3 (Angle)	Unsigned 16 Bit
42456	I Neutral-Winding 3(Angle)	Unsigned 16 Bit
42457	I Ground (Angle)	Unsigned 16 Bit
42458	I 0-2 – Zero Sequence Current Winding 3	Unsigned 16 Bit
42459	I 1-2 – Positive Sequence Current Winding 3	Unsigned 16 Bit
42460	I 2-2 – Negative Sequence Current Winding 3	Unsigned 16 Bit
42461	I 0-3 (Ang) – Zero Sequence Angle Winding 3	Unsigned 16 Bit
42462	I 1-3 (Ang) – Positive Sequence Angle Winding 3	Unsigned 16 Bit
42463	I 2-3 (Ang) – Negative Sequence Angle Winding 3	Unsigned 16 Bit
42464	Scale - Phase Wdg 3	Unsigned 16 Bit
42465	Scale – Neutral Wdg 3	Unsigned 16 Bit
42466	Scale – Ground Wdg 3	Unsigned 16 Bit

Harmonic Restraint Fault Record

The Harmonic Restraint Record Fault Buffer contains the last 32 Harmonic Restraint Faults. Each record displays one harmonic restraint operation at a time and includes the information defined in Tables 5-37 and 5-38. As with the previous fault buffers, one buffer is available detailing the data for a Two Winding TPU2000/TPU2000R. If one has a Three Winding TPU2000R, then the Three Winding Harmonic Restraint Buffer is updated as per the definitions shown in Table 5-37. Figure 5-42 illustrates the register mapping and control access for the Harmonic Restraint Fault Record Buffer.

Harmonic Restraint Fault Record Layout (TPU 2000/TPU 2000R)

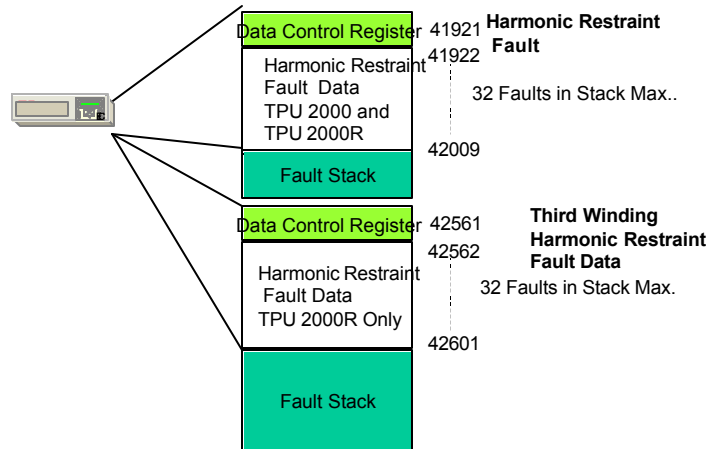

Figure 5-42.

Table 5-37. 2 Winding Harmonic Restraint Fault Record Buffer Modbus Address Assignment

Register Address	Item	Description (Multiplier if any)
41921	Harmonic 2 Winding Fault Control Register 1 = First Record 2 = Next Record 3 = Oldest Unreported Record	Fault Record Control Register Unsigned 16 Bit 1 = Fill 41922 through 42009 with First Record in Data Buffer. 2 = Fill 41922 through 42009 with next Record Data pointed to in buffer. 3 = Fill 41922 through 42009 with the last (oldest unreported) record of data.
41922	Parameter Flag	Unsigned Integer 16 Bit
41923	Fault Type Element	Unsigned 16 Bit 00 = 87T – % Differential Alarm 01 = 87H – High Set Inst. Differential Alarm 02 = 51P-1 – Winding 1 Phase Time Overcurrent 03 = 51P-2 – Winding 2 Phase Time Overcurrent 04 = 50P-1 – 1 st Winding 1 Phase Inst. Overcurrent 05 = 50N-1 – 1 st Winding 1 Neutral Inst. Overcurrent 06 = 150P-1 – 2 nd Winding 1 Phase Inst. Overcurrent 07 = 150N-1 – 2 nd Winding 1 Neutral Inst. Overcurrent 08 = 46-1 – Neg. Sequence 1 Inst. Time Overcurrent 09 = 51P-2 – Winding 2 Phase Time Overcurrent 10 = 51G-2 – Winding 2 Ground Time Overcurrent 11 = 50P-2 – 1 st Winding 2 Phase Inst. Overcurrent 12 = 50G-2 – 1 st Winding 2 Ground Inst. Overcurrent 13 = 150P-2 – 2 nd Winding 2 Phase Inst. Overcurrent 14 = 150G-2 – 2 nd Winding 2 Ground Inst. Overcurrent 15 = 46-2 – Neg. Sequence 2 Inst. Time Overcurrent 16 = ECI-1 – Event Capture Initiate 1 17 = ECI-2 – Event Capture Initiate 2 18 = Through Fault 19 = Harmonic Restraint
41924	Setting At Fault Event	Unsigned 16 Bit 01 = Primary Settings

TPU2000/2000R Modbus/Modbus Plus Automation Guide

Register Address	Item	Description (Multiplier if any)
		02 = Alternate 1 Settings 03 = Alternate 2 Settings
41925	Fault Record Number	Unsigned 16 Bit (1 – 999, only last 32 kept)
41926	Year 2 digit 00 -99	Unsigned 16 Bit Year of Fault
41927	Month 1 - 12	Unsigned 16 Bit Month of Fault
41928	Day 1 - 31	Unsigned 16 Bit Day of Fault
41929	Hour 00 - 23	Unsigned 16 Bit Hour of Fault
41930	Minute 00 - 59	Unsigned 16 Bit Minute of Fault
41931	Second 00 - 59	Unsigned 16 Bit Second of Fault
41932	Hundredths of Seconds 0 - 99	Unsigned 16 Bit Hundredth Second of Fault Time
41933	Winding1 Tap	Unsigned 16 Bit (X 10)
41934	Winding2 Tap	Unsigned 16 Bit (X 10)
41935	I operate Phase A	Unsigned 16 Bit (X 800)
41936	I operate Phase B	Unsigned 16 Bit (X 800)
41937	I operate Phase C	Unsigned 16 Bit (X 800)
41938	I restraint Phase A-Winding 1	Unsigned 16 Bit (X 800)
41939	I restraint Phase B-Winding 1	Unsigned 16 Bit (X 800)
41940	I restraint Phase C-Winding 1	Unsigned 16 Bit (X 800)
41941	I restraint Phase A-Winding 2	Unsigned 16 Bit (X 800)
41942	I restraint Phase B-Winding 2	Unsigned 16 Bit (X 800)
41943	I restraint Phase C-Winding 2	Unsigned 16 Bit (X 800)
41944	2nd Harmonic Phase A-Winding 1	Unsigned 16 Bit (X 2)
41945	5th Harmonic Phase A-Winding 1	Unsigned 16 Bit (X 2)
41946	All Harmonic Phase A-Winding 1	Unsigned 16 Bit (X 2)
41947	2nd Harmonic Phase B-Winding 1	Unsigned 16 Bit (X 2)
41948	5th Harmonic Phase B-Winding 1	Unsigned 16 Bit (X 2)
41949	All Harmonic Phase B-Winding 1	Unsigned 16 Bit (X 2)
41950	2nd Harmonic Phase C-Winding 1	Unsigned 16 Bit (X 2)
41951	5th Harmonic Phase C-Winding 1	Unsigned 16 Bit (X 2)
41952	All Harmonic Phase C-Winding 1	Unsigned 16 Bit (X 2)
41953	2nd Harmonic Phase A-Winding 2	Unsigned 16 Bit (X 2)
41954	5th Harmonic Phase A-Winding 2	Unsigned 16 Bit (X 2)
41955	All Harmonic Phase A-Winding 2	Unsigned 16 Bit (X 2)
41956	2nd Harmonic Phase B-Winding 2	Unsigned 16 Bit (X 2)
41957	5th Harmonic Phase B-Winding 2	Unsigned 16 Bit (X 2)
41958	All Harmonic Phase B-Winding 2	Unsigned 16 Bit (X 2)
41959	2nd Harmonic Phase C-Winding 2	Unsigned 16 Bit (X 2)
41960	5th Harmonic Phase C-Winding 2	Unsigned 16 Bit (X 2)
41961	All Harmonic Phase C-Winding 2	Unsigned 16 Bit (X 2)
41962	I restraint Phase A-Winding 1 (Ang)	Unsigned 16 Bit
41963	I restraint Phase B-Winding 1 (Ang)	Unsigned 16 Bit
41964	I restraint Phase C-Winding 1 (Ang)	Unsigned 16 Bit
41965	I restraint Phase A-Winding 2 (Ang)	Unsigned 16 Bit
41966	I restraint Phase B-Winding 2 (Ang)	Unsigned 16 Bit
41967	I restraint Phase C-Winding 2 (Ang)	Unsigned 16 Bit
41968	Winding 1 Tap	Unsigned 16 Bit (X 10)
41969	Winding 2 Tap	Unsigned 16 Bit (X 10)
41970	I Operate Phase A	Unsigned 16 Bit (X 800)
41971	I Operate Phase B	Unsigned 16 Bit (X 800)
41972	I Operate Phase C	Unsigned 16 Bit (X 800)
41973	I Restraint Phase A-Winding 1	Unsigned 16 Bit (X 800)
41974	I Restraint Phase B-Winding 1	Unsigned 16 Bit (X 800)

TPU2000/2000R Modbus/Modbus Plus Automation Guide

Register Address	Item	Description (Multiplier if any)
41975	I Restraint Phase C-Winding 1	Unsigned 16 Bit (X 800)
41976	I Restraint Phase A-Winding 2	Unsigned 16 Bit (X 800)
41977	I Restraint Phase B-Winding 2	Unsigned 16 Bit (X 800)
41978	I Restraint Phase C-Winding 2	Unsigned 16 Bit (X 800)
41979	2nd Harmonic Phase A-Winding 1	Unsigned 16 Bit (X 2)
41980	5th Harmonic Phase A-Winding 1	Unsigned 16 Bit (X 2)
41981	All Harmonic Phase A-Winding 1	Unsigned 16 Bit (X 2)
41982	2nd Harmonic Phase B-Winding 1	Unsigned 16 Bit (X 2)
41983	5th Harmonic Phase B-Winding 1	Unsigned 16 Bit (X 2)
41984	All Harmonic Phase B-Winding 1	Unsigned 16 Bit (X 2)
41985	2nd Harmonic Phase C-Winding 1	Unsigned 16 Bit (X 2)
41986	5th Harmonic Phase C-Winding 1	Unsigned 16 Bit (X 2)
41987	5th Harmonic Phase C-Winding 1	Unsigned 16 Bit (X 2)
41988	5th Harmonic Phase C-Winding 1	Unsigned 16 Bit (X 2)
41989	5th Harmonic Phase C-Winding 1	Unsigned 16 Bit (X 2)
41990	5th Harmonic Phase C-Winding 1	Unsigned 16 Bit (X 2)
41991	5th Harmonic Phase C-Winding 1	Unsigned 16 Bit (X 2)
41992	5th Harmonic Phase C-Winding 1	Unsigned 16 Bit (X 2)
41993	5th Harmonic Phase C-Winding 1	Unsigned 16 Bit (X 2)
41994	All Harmonic Phase C-Winding 1	Unsigned 16 Bit (X 2)
41995	2nd Harmonic Phase A-Winding 2	Unsigned 16 Bit (X 2)
41996	5th Harmonic Phase A-Winding 2	Unsigned 16 Bit (X 2)
41997	All Harmonic Phase A-Winding 2	Unsigned 16 Bit (X 2)
41998	2nd Harmonic Phase B-Winding 2	Unsigned 16 Bit (X 2)
41999	5th Harmonic Phase B-Winding 2	Unsigned 16 Bit (X 2)
42000	All Harmonic Phase B-Winding 2	Unsigned 16 Bit (X 2)
42001	2nd Harmonic Phase C-Winding 2	Unsigned 16 Bit (X 2)
42002	5th Harmonic Phase C-Winding 2	Unsigned 16 Bit (X 2)
42003	All Harmonic Phase C-Winding 2	Unsigned 16 Bit (X 2)
42004	I restraint Phase A-Winding 1 (Ang)	Unsigned 16 Bit
42005	I restraint Phase B-Winding 1 (Ang)	Unsigned 16 Bit
42006	I restraint Phase C-Winding 1 (Ang)	Unsigned 16 Bit
42007	I restraint Phase A-Winding 2 (Ang)	Unsigned 16 Bit
42008	I restraint Phase B-Winding 2 (Ang)	Unsigned 16 Bit
42009	I restraint Phase C-Winding 2 (Ang)	Unsigned 16 Bit

The 3 Winding Harmonic Fault Register Definition Table follows.

Table 5-38. 3 Winding Harmonic Fault Register Definitions

Register Address	Item	Description (Multiplier if any)
42561	Harmonic 3 Winding Fault Control Register 1 = First Record 2 = Next Record 3 = Oldest Unreported Record	Fault Record Control Register Unsigned 16 Bit 1 = Fill 42562 through 42604 with First Record in Data Buffer. 2 = Fill 42562 through 42604 with next Record Data pointed to in buffer. 3 = Fill 42562 through 42604 with the last (oldest unreported) record of data.
42562	Parameter Flag	Unsigned Integer 16 Bit
42563	Fault Type Element	Unsigned 16 Bit 00 = 87T – % Differential Alarm 01 = 87H – High Set Inst. Differential Alarm

TPU2000/2000R Modbus/Modbus Plus Automation Guide

Register Address	Item	Description (Multiplier if any)
		02 = 51P-1 – Winding 1 Phase Time Overcurrent 03= 51P-2 – Winding 2 Phase Time Overcurrent 04 = 50P-1 – 1 st Winding 1 Phase Inst. Overcurrent 05 = 50N-1 – 1 st Winding 1 Neutral Inst. Overcurrent 06 = 150P-1 – 2 nd Winding 1 Phase Inst. Overcurrent 07 =150N-1– 2 nd Winding 1 Neutral Inst. Overcurrent 08 = 46-1 – Neg. Sequence 1 Inst. Time Overcurrent 09 = 51P-2 – Winding 2 Phase Time Overcurrent 10 = 51G-2 – Winding 2 Ground Time Overcurrent 11 = 50P-2– 1 st Winding 2 Phase Inst. Overcurrent 12 =50G-2 – 1 st Winding 2 Ground Inst. Overcurrent 13 = 150P-2 – 2 nd Winding 2 Phase Inst. Overcurrent 14 = 150G-2 – 2 nd Winding 2 Ground Inst. Overcurrent 15 = 46-2 – Neg. Sequence 2 Inst. Time Overcurrent 16 = ECI-1 – Event Capture Initiate 1 17 = ECI-2 – Event Capture Initiate 2 18 = Through Fault 19 = Harmonic Restraint
42564	Setting At Fault Event	Unsigned 16 Bit 01 = Primary Settings 02 = Alternate 1 Settings 03 = Alternate 2 Settings
42565	Fault Record Number	Unsigned 16 Bit (1 – 999, only last 32 kept)
42566	Year 2 digit 00 -99	Unsigned 16 Bit Year of Fault
42567	Month 1 - 12	Unsigned 16 Bit Month of Fault
42568	Day 1 - 31	Unsigned 16 Bit Day of Fault
42569	Hour 00 - 23	Unsigned 16 Bit Hour of Fault
42570	Minute 00 - 59	Unsigned 16 Bit Minute of Fault
42571	Second 00 - 59	Unsigned 16 Bit Second of Fault
42572	Hundredths of Seconds 0 - 99	Unsigned 16 Bit Hundredth Second of Fault Time
42573	Winding3 Tap	Unsigned 16 Bit (X 10)
42574	I restraint Phase A-Winding 3	Unsigned 16 Bit (X 800)
42575	I restraint Phase B-Winding 3	Unsigned 16 Bit (X 800)
42576	I restraint Phase C-Winding 3	Unsigned 16 Bit (X 800)
42577	2nd Harmonic Phase A-Winding 3	Unsigned 16 Bit (X 2)
42578	5th Harmonic Phase A-Winding 3	Unsigned 16 Bit (X 2)
42579	All Harmonic Phase A-Winding 3	Unsigned 16 Bit (X 2)
42580	2nd Harmonic Phase B-Winding 3	Unsigned 16 Bit (X 2)
42581	5th Harmonic Phase B-Winding 3	Unsigned 16 Bit (X 2)
42582	All Harmonic Phase B-Winding 3	Unsigned 16 Bit (X 2)
42583	2nd Harmonic Phase C-Winding 3	Unsigned 16 Bit (X 2)
42584	5th Harmonic Phase C-Winding 3	Unsigned 16 Bit (X 2)
42585	All Harmonic Phase C-Winding 3	Unsigned 16 Bit (X 2)
42586	I restraint Phase A-Winding 3 (Ang)	Unsigned 16 Bit
42587	I restraint Phase B-Winding 3 (Ang)	Unsigned 16 Bit
42588	I restraint Phase C-Winding 3 (Ang)	Unsigned 16 Bit
42589	Winding 3 Tap	Unsigned 16 Bit (X 10)
42590	I restraint Phase A-Winding 3 (Ang)	Unsigned 16 Bit
42591	I restraint Phase B-Winding 3 (Ang)	Unsigned 16 Bit
42592	I restraint Phase C-Winding 3 (Ang)	Unsigned 16 Bit
42593	2nd Harmonic Phase A-Winding 3	Unsigned 16 Bit (X 2)
42594	5th Harmonic Phase A-Winding 3	Unsigned 16 Bit (X 2)
42595	All Harmonic Phase A-Winding 3	Unsigned 16 Bit (X 2)

TPU2000/2000R Modbus/Modbus Plus Automation Guide

Register Address	Item	Description (Multiplier if any)
42596	2nd Harmonic Phase B-Winding 3	Unsigned 16 Bit (X 2)
42597	5th Harmonic Phase B-Winding 3	Unsigned 16 Bit (X 2)
42598	All Harmonic Phase B-Winding 3	Unsigned 16 Bit (X 2)
42599	2nd Harmonic Phase B-Winding 3	Unsigned 16 Bit (X 2)
42600	5th Harmonic Phase B-Winding 3	Unsigned 16 Bit (X 2)
42601	All Harmonic Phase B-Winding 3	Unsigned 16 Bit (X 2)
42602	I restraint Phase A-Winding 3 (Ang)	Unsigned 16 Bit
42603	I restraint Phase B-Winding 3 (Ang)	Unsigned 16 Bit
42604	I restraint Phase C-Winding 3 (Ang)	Unsigned 16 Bit

Event Records (11 Registers Defined)

Event Record data is stored in the same manner as the Fault Record Data. Figure 24 illustrates the method of storage of the Event Record Data. As illustrated, 128 Groups of fault data is stored internal to the TPU2000/2000R. Each group is comprised of 11 registers of data as defined in Tables 23 and 24 below. The register for pointing to a group is defined in Register 42049. Fault records are viewed by writing a data word to 42049 as defined in the table below and reading the block of consecutive registers from 42050 through 42059.

If the number of Operation Records exceed 128, then the buffer overwrites the oldest record contained within its internal stack. Access and control can be accomplished over Modbus in one of two methods.

If 42049 has a value of 1 written to it, Registers 42050 through 42059 will fill with the FIRST Operation record within the 128 records stored in the unit. 42049 will then reset to a value of 0 when Registers 42050 through 42059 are read.

If 42049 has a value of 2 written to it, Registers 42050 through 42059 will contain the NEXT record of Operation Record data which was pointed after the write command executed. 42049 will reset to a value of 0 after the record has entered the buffer and is read by the host.

If 42049 has a value of 3 written to it, Registers 42050 through 42059 will fill with the LAST UNREPORTED record of Operation Record data in the 128 records of fault data stored in the unit. For example, if two records of data accumulated between reads, a read LAST UNREPORTED record command would point to the oldest unreported record of data accumulated in the buffer. The host could then send another value of 3 to the control register to obtain the newest value of the unreported record. A write of 3 to the fault record also would fill the buffer with a value of zero to indicate there are no other values to be retrieved from the buffer. The number of unreported operation records may be read from Modbus register XXXX.

If no data accumulated within the fault record, (such as after a system reset), values of 0 shall be returned in the buffer. A new fault record entry is indicated via Bit 8 of Register 40129 being set to a 1. Reference Table 5-9 of this document for a more detailed explanation of the registers bit map.

As with fault records, there are two methods of obtaining the information via the Modbus 23 (Write/Read) command or a combination of the Modbus 16 (Write Register) and 03 (Read Register) commands.

METHOD 1:

The host writes a Modbus 23 Command (Modbus 4X Register Read/Write) in which a control code (1, 2, or 3) is written to 42049 and the buffer is filled with fault data in Registers 42050 through 42059 to be returned in response to the command. A command of 1 = Points to the First Record in the Fault Table. A command of 2 Points to the next fault in the fault table. A command of 3 points to the last UNREPORTED fault in the fault table.

METHOD 2:

The host writes a Modbus Command 16 (Modbus 4X Register Write Command) in which a control code (1, 2, or 3) is written to 42049 and the buffer is filled with fault data in Registers 42050 through 42059. Within 10 seconds after the 16 command is issued, the host issues a Modbus 03 command (Modbus 4X Register Read command) in which the fault data is retrieved from the buffer in Register 42050 through 42059.

TPU2000/2000R Modbus/Modbus Plus Automation Guide

One should note the operation record event codes are arranged in groups to easily indicate the type of error dependent on the value of the operation record. Table 5-39 lists the Operation Record Event Codes.

Table 5-39. Operation Record Address Definition

Register Address	Item	Description
42049	EvtRecCtlReg 1 = First Record 2 = Next Record 3 = Last Unreported Record	Fault Record Control Register Unsigned 16 Bit 1 = Fill 42050 – 42059 with First Record Data. 2 = Fill 42050 – 42059 with next Record Data pointed to in buffer. 3 = Fill 42050 – 42059 with the last unreported record of data between the last data access
42050	Year (0-99)	Unsigned 16 Bit Year of Event
42051	Month	Unsigned 16 Bit Month of Event
42052	Day	Unsigned 16 Bit Day of Event
42053	Hour	Unsigned 16 Bit Hour of Event
42054	Minute	Unsigned 16 Bit Minute of Event
42055	Second	Unsigned 16 Bit Second of Event
42056	Hundredths of a Second	Unsigned 16 Bit Hundredth Second of Event Date
42057	Message Number	Unsigned Integer 16 Bits 0<=Range <=999
42058	VALUE ?	Who the hell knows?
42059	Operation Number	16 Bit Unsigned See Table XX

Table 5-40. Event Record Definition Type

Event Record Type (Register 42058 code definition)	
Operation Number	Definitions
00	87T Trip
01	87H Trip
02	51P-1 Trip
03	51N-1 Trip
04	50P-1 Trip
05	50N-1 Trip
06	150P-1 Trip
07	150N-1 Trip
08	46-1 Trip
09	51P-2 Trip
10	51G-2 Trip
11	50P-2 Alarm
12	50G-2 Alarm
13	150P-2 Block
14	150G-2 Trip
15	46-2 Restore
16	ECI-1
17	ECI-2
18	Through Fault
19	Harmonic Rest
31	Fault Clear Failed
32	Fault Cleared
33	Harmonic Restraint
34	Manual Trip
35	Manual Trip Failed
40	87T Enabled

TPU2000/2000R Modbus/Modbus Plus Automation Guide

Event Record Type (Register 42058 code definition)	
41	87H Enabled
42	51P-1 Enabled
43	51P-2 Enabled
44	51N-1 Enabled
45	51G-2 Enabled
46	50P-1 Enabled
47	50P-2 Enabled
48	50N-1 Enabled
49	50G-2 Enabled
50	150P-1 Enabled
51	150P-2 Enabled
52	150N-1 Enabled
53	150G-2 Enabled
54	46-1 Enabled
55	46-2 Enabled
56	ALT 1 Input Closed
57	ALT 2 Input Closed
58	Event Capture 1 Initiated
59	Event Capture 2 Initiated
60	Wave Capture Initiated
61	Trip Input Closed
62	SPR Input Closed
63	TCM Input Closed
64	Primary Set Active
65	Alt 1 Set Active
66	Alt 2 Set Active
70	Through Fault Counter Alarm
71	Through Fault kA Summation Alarm
72	Through Fault Cycle Alarm
73	OC Trip Counter Alarm
74	Differential Trip Counter Alarm
75	Phase Demand Alarm Disabled
76	Neutral Demand Alarm Disabled
77	Load Current Alarm
78	Trip Coil Failure
79	High Power Factor Alarm
80	Low Power Factor Alarm
81	k VAR Demand Alarm
82	Positive kVAR Alarm
83	Negative kVAR Alarm
84	Positive Watt Alarm 1
85	Positive Watt Alarm 2
90	Event Capture #1
91	Event Capture #2
92	Waveform Capture
93	High Level Detection Alarm Winding 1
94	Low Level Detection Alarm Winding 1
95	High Level Detection Alarm Winding 2
100	ROM Failure
101	RAM Failure
102	Self Test Failed
103	EEPROM Failure
104	BATRAM Failure
105	DSP Failure
106	Control Power Fail
107	Editor Access
120	87 T Disabled
121	87 H Disabled

TPU2000/2000R Modbus/Modbus Plus Automation Guide

Event Record Type (Register 42058 code definition)	
122	51P-1 Disabled
123	51P-2 Disabled
124	51N-1 Disabled
125	51G-2 Disabled
126	50P-1 Disabled
127	50P-2 Disabled
128	50N-1 Disabled
129	50G-2 Disabled
130	150P-1 Disabled
131	150P-2
132	150N-1
133	150G-2
134	46-1
135	46-2
136	ALT 1 Input Opened
137	ALT 2 Input Opened
138	Event Capture 1 Reset
139	Event Capture 2 Reset
140	Wave Capture Initiated Reset
141	Trip Input Opened
142	SPR Input Opened
143	TCM Input Opened
162	ULI1 Input Closed
163	ULI1 Input Opened
164	ULI2 Input Closed
165	ULI2 Input Opened
166	ULI3 Input Closed
167	ULI3 Input Opened
168	ULI4 Input Closed
169	ULI4 Input Opened
170	ULI5 Input Closed
171	ULI5 Input Opened
172	ULI6 Input Closed
173	ULI6 Input Opened
174	ULI7 Input Closed
175	ULI7 Input Opened
176	ULI8 Input Closed
177	ULI8 Input Opened
178	ULI9 Input Closed
179	ULI9 Input Opened
180	CRI Input Closed
181	CRI Input Opened

Providing Control Functionality in the TPU2000/TPU2000R

As described in the beginning of this section, six groups of control blocks are resident in the TPU2000/TPU2000R. Each group is comprised of 6 registers. The six control block groups are defined in Table 5-41. The first block within the set of registers determines whether or not the control block requires password control.

ABB relays are designed to operate with a variety of host products. Some host products cannot send a password with the control algorithm. With this in mind, the ABB TPU2000/TPU2000R allows control with or without password depending upon the setup performed in control register block 62560 through 62598. Security Mask Configuration Register 62598 contains a register as to when the corresponding bit is set, the control block associated with the bit disables password control. If the appropriate bit in Register 62598 is a value of "0", then password protection is required to actuate control functionality. Please refer to the 6X Register control section or ECP/WinECP help screens for additional information regarding configuration of these registers.

One 4X register at the beginning of the 4X control register groups is read only which feeds back the status of password control which was configured via Registers 62560 through 62598 (Security Mask Control Block) or via the Communications Configuration Screen accessible through ECP or WinECP. The register lists the six control blocks found in the TPU2000/TPU2000R. Table 5-41 lists the Security Mask register, which reports, which of the control blocks require password control. A status of 1 in the defined bit location allows any value to be placed in the password field (as shown in Table 5-42). The Security mask status of what was programmed through ECP, WinECP or Modbus Registers 62560 through 62598 may be obtained by reading Register 41409. A status of 0 in the defined field requires the correct password to be sent as part of the control process.

Figure 5-43 illustrates the Group Blocks within the TPU2000/TPU2000R and its associated typical control register mapping.

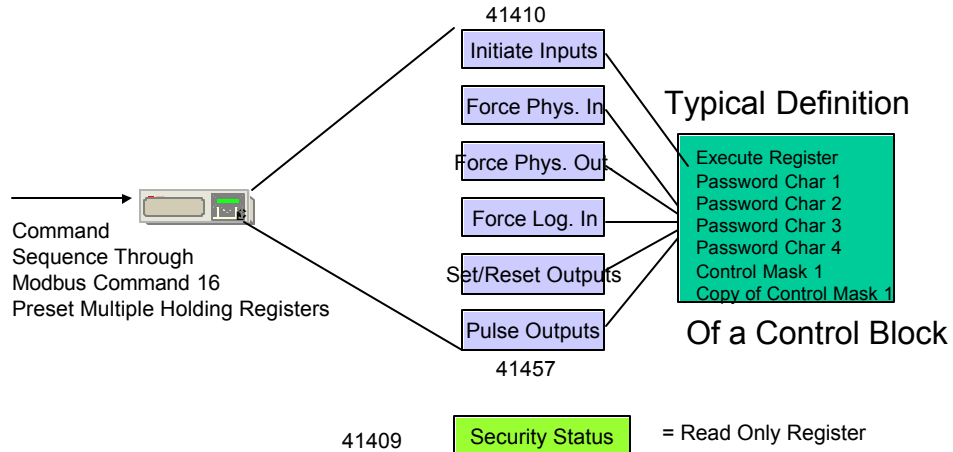

Figure 5-43. Typical Control Features Available for the TPU2000 and TPU2000R

Table 5-41. Security Status Register Indicating Password Requirement

Register	Item	Description
41409	16 Bit Unsigned	Security Mask (Read Only, See Register 0XXX for setup or refer to ECP or WinECP Configuration Program)
	Bit 0 (lsb)	Initiate Input (GROUP I) Password Required
	Bit 1	Force Physical Input (GROUP II) Password Required
	Bit 2	Force Physical Output (GROUP III) Password Required
	Bit 3	Force Logical Input (GROUP IV) Password Required
	Bit 4	Set/ Reset Outputs (GROUP V) Password Required
	Bit 5	Pulse Outputs (GROUP VI) Password Required
	Bit 6	Reserved
	Bit 7	Reserved
	Bit 8	Reserved
	Bit 9	Reserved
	Bit 10	Reserved
	Bit 11	Reserved
	Bit 12	Reserved
	Bit 13	Reserved
	Bit 14	Reserved
	Bit 15 (msb)	Reserved

One method to perform control through the Control Block is as follows:

- Write all registers other than the register associated with the “Execute Register”
- Write a “1” to execute the control command.

TPU2000/2000R Modbus/Modbus Plus Automation Guide

If an execute command is not written to the register block within 15 seconds after parameters have been configured in the block, the block will be reset and the entire configuration sequence must be re-initiated.

Another method to perform control through the Control Block is to write individual registers to the desired control Group block and then write “1” to the execute register within 15 seconds after all the writes have been completed.

Groups I through VI share commonality in that an operation type must be written to the Execute Register (Register 41410 in Group I [INITIATE INPUT], 41416 in Group II [FORCE PHYSICAL INPUT], 41423 in Group III [FORCE PHYSICAL OUTPUT], 41430 in Group IV [FORCE LOGICAL INPUT], 41440 in Group V [SET RESET OUTPUTS], and 41457 in Group VI [PULSE OUTPUTS]).

Writing a value of 0 to the execute register voids a control execution of the function. Writing a Value of 1 to the execute register allows the function to operate if the consecutive registers are parameterized correctly.

A correct Password may have to be written to the block for the desired function to execute (Registers 41411 and 41412 in Group I [INITIATE INPUT], 41417 and 41418 in Group II FORCE PHYSICAL INPUT], 41424 and 41425 in Group III [FORCE PHYSICAL OUTPUT], 41431 and 41432 in Group IV [FORCE LOGICAL INPUT], 41441 and 41442 in Group V [SET RESET OUTPUTS], and 41453 and 41454 in Group VI [PULSE OUTPUTS]). The ABB TPU2000/TPU2000R contains a default password of four spaces. If Appendix B is consulted, the ASCII code for a space is 20 (HEX). Thus the numerical value to be sent to the registers corresponding to the default password is 2020 (HEX) for password register 1 and 2020 (HEX) for password register 2.

IMPLEMENTATION TIP – if control does not occur after initiation through the network, verify that the local/remote control bit is not configured in the programmable logical inputs logic or that the local/remote control bit is in the remote state. If the local/remote control bit is configured, and the control switch is in the local position (indicating that control via the network is inhibited), if one of the control commands are sent via the network, a modbus exception response shall be sent to the host rejecting the command. If the local/ remote control bit is not configured, control may take place via the operator interface panel (MMI) or via the network contemporaneously. Additionally, modbus Registers 40172 through 40175, if read using modbus code “03” shall indicate the nature of the communication control errors of the last control function.

41452	Unsigned Short	Execute on Momentary Output Contact Registers (0=No Action,1=Execute)
41453	high byte	Relay or Test Password Character 1
	low byte	Relay or Test Password Character 2
41454	high byte	Relay or Test Password Character 3
	low byte	Relay or Test Password Character 4
41455	Unsigned Short	Spare
41456	Unsigned Short	Momentary Output Contact State Mask (bit state:0=No change, 1=Pulse Contact)
41457	Unsigned Short	Confirmation Momentary Output Contact State Mask (bit state:0=No change, 1=Pulse Contact)
		Momentary Output Contact State Mask
	Bit 15:	Spare
	Bit 14:	Spare
	Bit 13:	Spare
	Bit 12:	Spare
	Bit 11:	Spare
	Bit 10:	Spare
	Bit 09:	Spare
	Bit 08:	Spare
	Bit 07:	OUT7
	Bit 06:	OUT6
	Bit 05:	OUT5
	Bit 04:	OUT4
	Bit 03:	OUT3
	Bit 02:	OUT2
	Bit 01:	OUT1
	Bit 00:	TRIP

Note: This register group sets the appropriate physical output contact momentarily for the configured breaker failed to trip time.

Group I Control Features Explained

Group I provides the following functionality:

- Reset Energy Meters
- Reset Demands
- Reset Status
- Reset Targets
- Reset Alarm
- Toggle SCADA Ready

Group I control requires that the control bit be selected in Register 41414 and the same corresponding value should also be placed in 41415. If the values in the registers do not match, control shall not occur.

Table 5-42. Group I Control Registers

Notes	Register	Item	Description
	GROUP I		
	41410	Execute Register 0 = No Action 1 = Execute	Unsigned (16 Bits)
	41411	Password	ASCII – 2 Characters Leftmost Digits
	41412	Password	ASCII – 2 Characters Rightmost Digits
	41413	Spare	
	41414	Change Initiate Input Mask	Unsigned (16 Bits)
		Bit 0 Reserved (lsb)	
		Bit 1 Reserved	
		Bit 2 Reserved	
		Bit 3 Reserved	
		Bit 4 Reserved	
		Bit 5 Reserved	
		Bit 6 Reserved	
		Bit 7 Reserved	
		Bit 8 Reset Targets	1 = Control Bit State 0 = No Control
		Bit 9 Reset Alarms	1 = Control Bit State 0 = No Control
		Bit 10 Reset Min/Max demands	1 = Control Bit State 0 = No Control
		Bit 11 Reset Relay Status	1 = Control Bit State 0 = No Control
		Bit 12 Reset Energy Meters	1 = Control Bit State 0 = No Control
**		Bit 13 Toggle SCADA REDI	1 = Control Bit State 0 = No Control
		Bit 14 Reserved	
		Bit 15 Reserved (msb)	
	41415	Confirm Initiate Input Mask	Unsigned (16 Bits)
		Bit 0 Reserved	
		Bit 1 Reserved	
		Bit 2 Reserved	
		Bit 3 Reserved	
		Bit 4 Reserved	
		Bit 5 Reserved	
		Bit 6 Reserved	
		Bit 7 Reserved	
		Bit 8 Reset Targets	1 = Control Bit State 0 = No Control
		Bit 9 Reset Alarms	1 = Control Bit State 0 = No Control
		Bit 10 Reset Min/Max demands	1 = Control Bit State 0 = No Control
		Bit 11 Reset Relay Status	1 = Control Bit State 0 = No Control
		Bit 12 Reset Energy Meters	1 = Control Bit State 0 = No Control

TPU2000/2000R Modbus/Modbus Plus Automation Guide

**		Bit 13 Toggle SCADA REDI	1 = Control Bit State 0 = No Control
		Bit 14 Reserved	
		Bit 15 Reserved (msb)	
** = Version 4.10 TPU Flash Executive and Modbus Version 1.80 Firmware or Greater Required for this feature			

Figure 5-44 illustrates the command sequence for performing a Reset Target Alarms via the Modbus Network. Although the example illustrates that Registers 41410 through 41415 are written in one group, it is possible to send multiple registers in a group or single registers to completely configure this block. It is important that the execute command (data value = 1 in Register 41410) be sent last to initiate the Trip action on the breaker. Also all registers may be sent as one continuous block to effectuate control. Performing a write, read (to verify control action requested) and execute register write, allows the implementer to have check before operate control.

EXAMPLE 1 - Reset Targets via a Modbus Command Sequence.

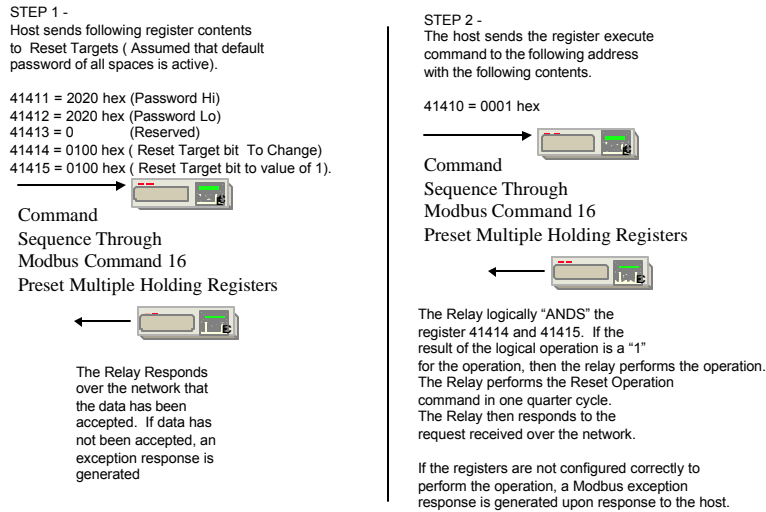

Figure 5-44. Reset Target LED's Via Modbus Network Control

SCADA REDI®

In any substation installation, commissioning the installation can be an exceptionally time-consuming procedure. This capability can consume up to 2 days per IED tested. ABB TPU2000 and TPU2000R relays have the capability to allow a read only 4X registers to be forced from a personal computer through the relay's communication port. Figure 5-45 illustrates the typical TPU2000 and TPU2000R memory map.

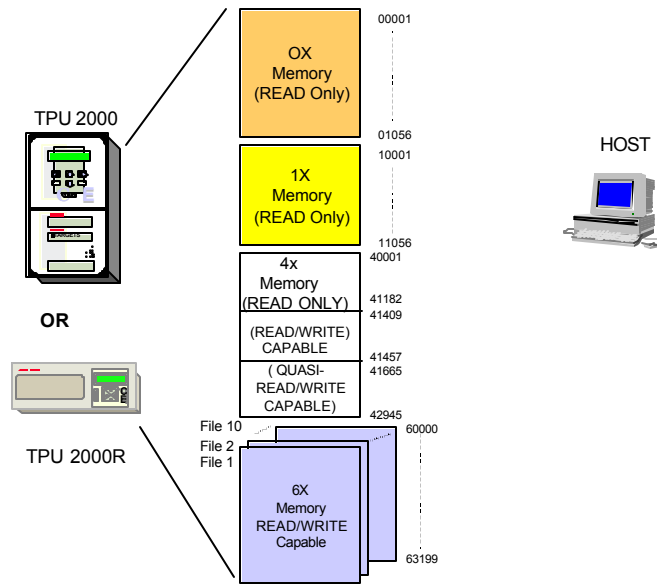

Figure 5-45. Typical Modbus/Modbus Plus Register Definition

During the commissioning process, it is required that the correct data is mapped from the relay to the host device. The conventional method is to have an individual with expensive test gear to apply individual voltages and currents to the relay terminals to simulate field conditions. The individual must be at the substation and a direct link must be made to the individual at the host device verifying the correct data is being received and interpreted correctly.

With 6X memory and some of the 4X memory, a host device can force the read/write capable 4X and 6X memory locations and verify data is sent and received to some memory location. The SCADA REDI® provides much more flexibility allowing streamlining of the commissioning process.

Within the TPU2000 and TPU2000R control register memory map a single bit (Bit 13 in Register 41415) may be set to allow READ, WRITE, and READ/WRITE Modbus/Modbus Plus commands to be sent to the previously READ ONLY memory locations. A typical scenario is illustrated in Figures 5-44 and 5-45.

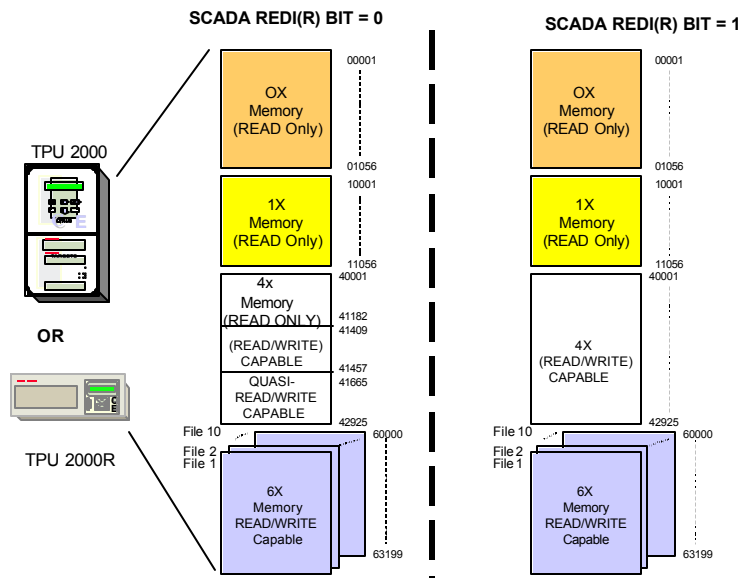

Figure 5-46. SCADA REDI® Memory Map Modification

TPU2000/2000R Modbus/Modbus Plus Automation Guide

As per Figure 5-45 all 4X memory is read/write capable. In other words, Modbus commands 03 – READ HOLDING REGISTERS, 16 – WRITE HOLDING REGISTERS, and 23 WRITE/READ HOLDING REGISTERS, may be used in communicating with the relay. **IT IS MOST IMPORTANT TO REALIZE THAT THE RELAY DISABLES LINK BETWEEN THE PROTECTIVE RELAY AND THE COMMUNICATION CARD (SIMILAR TO THE LOCAL REMOTE FEATURE). PROTECTIVE RELAY PROTECTION STILL OCCURS IF SCADA REDI® IS SET. ONLY THE COMMUNICATION IS DISABLED BETWEEN THE RELAY AND COMMUNICATION CARD.**

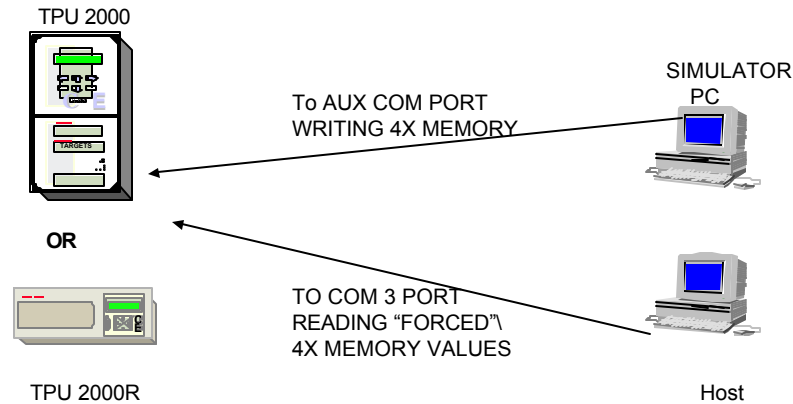

Figure 5-47. Typical Commissioning System

As shown in Figure 5-47, one system (a typical PC operating with a DDE utility and WINDOWS utility for example) could be forcing the registers and the second system, "the host" verifies that the data values are received correctly. Although the illustration shows a direct connect scenario, the Host and Simulator devices may be located offsite and connected to the substation via a modem or fiber optic connection.

Please refer to Section 5 to reference the method of toggling the SCADA REDI® bit Registers 41114 and 41115.

Group II Control Features Explained

Group II places each of the Physical Input statuses reported to the processor in the TPU2000R in to a logical state which is independent of the state of the contact input status present at the Physical Input of the TPU2000R. There are three modes which a Physical Input status may be placed in:

- **NORMAL** – The TPU2000R Physical Input Status reflects that of the voltage present at the Physical Input Terminal.
- **FORCED ON** – The TPU2000R Physical Input Status reported to the logic of the TPU2000R processor shall show a state of 1.
- **FORCED OFF** – The TPU2000R Physical Input Status reported to the logic of the TPU2000R processor shall show a state of 0.

The Force Physical Input State only affects the state reported to the central processor logic contained within the TPU2000R. Table 5-43 lists the definition of the control registers and maps each of the internal control bits. Seven Registers are required to perform control for Group II functions.

Table 5-43. Group II Bit Definitions for TPU2000R Control

Register	Item	Description
GROUP II		
41416	Execute Register 0 = No Action 1 = Execute	Unsigned (16 Bits)
41417	Password	ASCII – 2 Characters Leftmost Digits
41418	Password	ASCII – 2 Characters Rightmost Digits
41419	Spare	
41420	Force Physical Input Change Mask	Unsigned (16 Bits)
	Bit 0 Input 1 (Terminal 4) (lsb)	1 = Control Bit State 0 = No Control (lsb)
	Bit 1 Input 2 (Terminal 5)	1 = Control Bit State 0 = No Control
	Bit 2 Input 3 (Terminal 6)	1 = Control Bit State 0 = No Control
	Bit 3 Input 4 (Terminal 7)	1 = Control Bit State 0 = No Control
	Bit 4 Input 5 (Terminal 8)	1 = Control Bit State 0 = No Control
	Bit 5 Input 6 (Terminal 9)	1 = Control Bit State 0 = No Control
	Bit 6 Input 7 (Terminal 10)	1 = Control Bit State 0 = No Control
	Bit 7 Input 8 (Terminal 11)	1 = Control Bit State 0 = No Control
	Bit 8 Input 9 (Terminal 12)	1 = Control Bit State 0 = No Control
	Bit 9 Reserved	
	Bit 10 Reserved	
	Bit 11 Reserved	
	Bit 12 Reserved	
	Bit 13 Reserved	
	Bit 14 Reserved	
	Bit 15 Reserved (msb)	
41421	Force Physical Input Normal State Mask	Unsigned (16 Bits)
	Bit 0 Input 1 (Terminal 4) (lsb)	1 = Normal State Override 0 = Normal State
	Bit 1 Input 2 (Terminal 5)	1 = Normal State Override 0 = Normal State
	Bit 2 Input 3 (Terminal 6)	1 = Normal State Override 0 = Normal State
	Bit 3 Input 4 (Terminal 7)	1 = Normal State Override 0 = Normal State
	Bit 4 Input 5 (Terminal 8)	1 = Normal State Override 0 = Normal State
	Bit 5 Input 6 (Terminal 9)	1 = Normal State Override 0 = Normal State
	Bit 6 Input 7 (Terminal 10)	1 = Normal State Override 0 = Normal State
	Bit 7 Input 8 (Terminal 11)	1 = Normal State Override 0 = Normal State
	Bit 8 Input 9 (Terminal 12)	1 = Normal State Override 0 = Normal State
	Bit 9 Reserved	
	Bit 10 Reserved	
	Bit 11 Reserved	
	Bit 12 Reserved	
	Bit 13 Reserved	
	Bit 14 Reserved	
	Bit 15 Reserved (msb)	
41422	Force Physical Input Forcing State Mask	Unsigned (16 Bits)
	Bit 0 Input 1 (Terminal 4) (lsb)	1 = Force Set State 0 = Force Reset State
	Bit 1 Input 2 (Terminal 5)	1 = Force Set State 0 = Force Reset State
	Bit 2 Input 3 (Terminal 6)	1 = Force Set State 0 = Force Reset State
	Bit 3 Input 4 (Terminal 7)	1 = Force Set State 0 = Force Reset State
	Bit 4 Input 5 (Terminal 8)	1 = Force Set State 0 = Force Reset State
	Bit 5 Input 6 (Terminal 9)	1 = Force Set State 0 = Force Reset State
	Bit 6 Input 7 (Terminal 10)	1 = Force Set State 0 = Force Reset State
	Bit 7 Input 8 (Terminal 11)	1 = Force Set State 0 = Force Reset State

TPU2000/2000R Modbus/Modbus Plus Automation Guide

	Bit 8 Input 9 (Terminal 12)	1 = Force Set State 0 = Force Reset State
	Bit 9 Reserved	1 = Force Set State 0 = Force Reset State
	Bit 10 Reserved	1 = Force Set State 0 = Force Reset State
	Bit 11 Reserved	
	Bit 12 Reserved	
	Bit 13 Reserved	
	Bit 14 Reserved	
	Bit 15 Reserved (msb)	

Group II functions operate as follows:

Register 41420 = Force Physical Input Change Mask - Selects Control for the Function Specified.
 Register 41421 = Force Physical Input Normal State Mask - Places Bit in Normal or Force Mode.
 Register 41422 = Physical Input Forcing State Mask - If Bit is in Force Mode, Determines Force State.

A Truth Table for the aforementioned bits follows as illustrated in Table 5-44:

Table 5-44. State Truth Chart for Physical Input Forcing Function

Bit Value Change Mask Register 41420	Bit Value Normal/Forced Mask Register 41421	Bit Value Forced State Register 41422	Description
0	X	X	Normal - State follows Voltage at Term.
1	0	X	Normal - State follows Voltage at Term.
1	1	0	Input Forced – State = OFF
1	1	1	Input Forced – State = ON

Note: X = Don't Care State

Once an input is forced on or off, it must be “unforced” or returned to normal state for the point to resume normal operation and reflect the state present at the physical input terminals present at the rear of the relay. **It is important to emphasize that the forced states are stored in the TPU2000R's non-volatile RAM and will remain forced until unforced by the operator. A point may be “unforced” via the front panel MMI, DOS ECP, WinECP, or through the Modbus commands covered within this section.**

A simple example illustrates the Force/Normal control sequence via the Modbus command operations. Figures 5-48, 5-49, and 5-50 illustrate the word patterns which must be transmitted to the TPU2000R to complete a Force ON, Force Off and Return to Normal State Operation within the TPU2000R. As with the other control functions, the registers may be sent down individually, in blocks of data transferred, or as one block of data followed by an execute command as illustrated in Figures 5-48, 5-49, and 5-50.

EXAMPLE 2 - Force Input 4 to a State of 1 and Then to a Force State of 0, and Then to a Normal State.

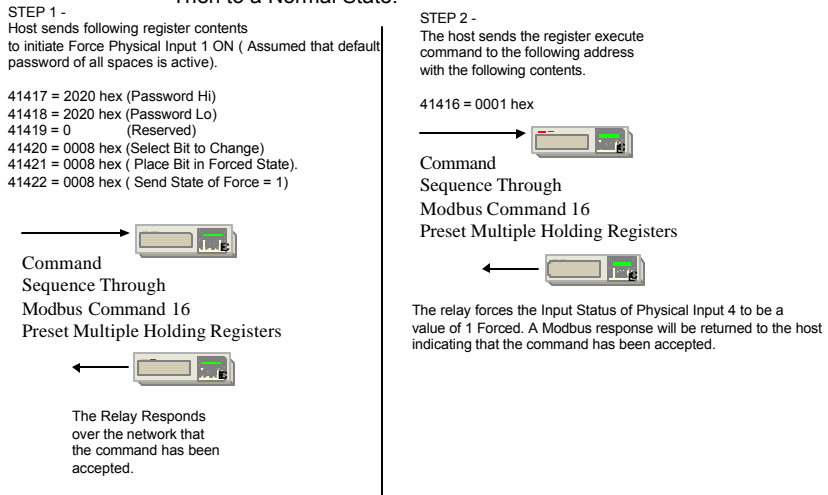

Figure 5-48. Force Physical Input Example

EXAMPLE 2 - Force Input 4 to a State of 1 and Then to a Force State of 0, and Then to a Normal State.

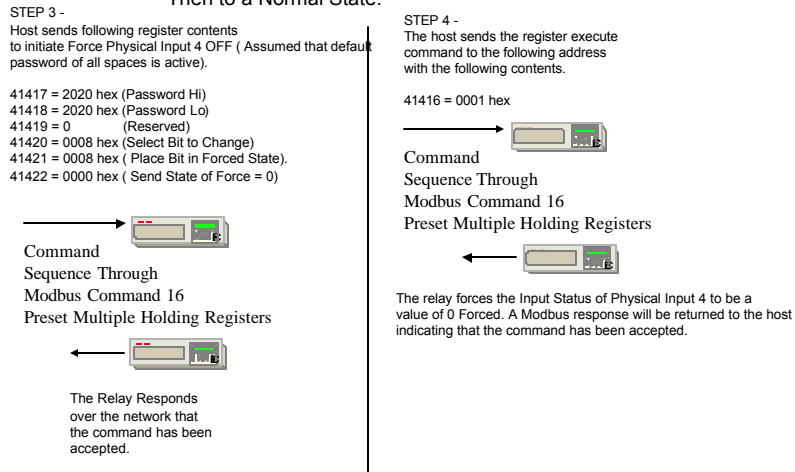

Figure 5-49. Force Physical Input Example (Continued)

EXAMPLE 2 - Force Input 4 to a State of 1 and Then to a Force State of 0, and Then to a Normal State.

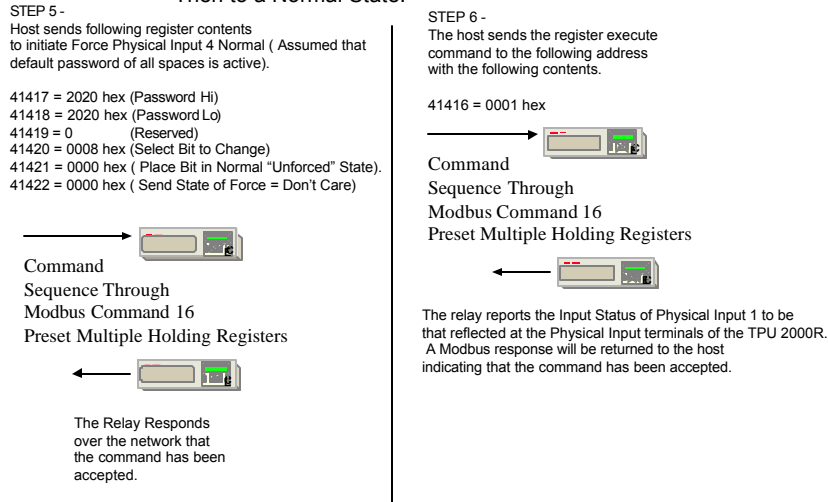

Figure 5-50. Force Physical Input Example (Continued)

IMPLEMENTATION TIP –As is common practice with any control, after a control task has been completed via the network, the host should query the device to assure that control has been executed.

Group III Control Features Explained

The complimentary control functions are available for forcing the Physical Output contacts located at the back of the relay. The Physical Output force functions follows that of the Physical Input Force Functionality. There are three modes which a Physical Output may be placed:

- **NORMAL** – The TPU2000R Physical Output reflects that of the logic configured within the protective relay
- **FORCED ON** – The TPU2000R Physical Output is energized. The Physical Output status is reported as a 1. If the point status is viewed via ECP or WinECP, the point will show a forced status
- **FORCED OFF** –TPU2000R Physical Output is de-energized. The Physical Output status is reported as a 0. If the point status is viewed via ECP or WinECP, the point will show a forced status.

Table 5-45 illustrates the mapping for Physical Output Forcing Capabilities.

Table 5-45. TPU2000R Bit Control Function Definitions

Register	Item	Description
GROUP III		
41423	Execute Register 0 = No Action 1 = Execute	Unsigned (16 Bits)
41424	Password	ASCII – 2 Characters Leftmost Digits
41425	Password	ASCII – 2 Characters Rightmost Digits
41426	Spare	
41427	Force Physical Output Change Mask	Unsigned (16 Bits)
	Bit 0 Trip (Terminal 29,30) (lsb)	1 = Control Bit State 0 = No Control
	Bit 1 Output 1 (Terminal 28,27)	1 = Control Bit State 0 = No Control
	Bit 2 Output 2 (Terminal 26,25)	1 = Control Bit State 0 = No Control
	Bit 3 Output 3 (Terminal 24,23)	1 = Control Bit State 0 = No Control
	Bit 4 Output 4 (Terminal 22 21)	1 = Control Bit State 0 = No Control
	Bit 5 Output 5 (Terminal 19,20)	1 = Control Bit State 0 = No Control

TPU2000/2000R Modbus/Modbus Plus Automation Guide

	Bit 6 Output 6 (Terminal 17,18)	1 = Control Bit State 0 = No Control
	Bit 7 Output 7	1 = Control Bit State 0 = No Control
	Bit 8 Reserved	
	Bit 9 Reserved	
	Bit 10 Reserved	
	Bit 11 Reserved	
	Bit 12 Reserved	
	Bit 13 Reserved	
	Bit 14 Reserved	
41428	Force Physical Output Normal State Mask	Unsigned (16 Bits)
	Bit 0 Trip (Terminal 29,30) (lsb)	1 = Normal State Override 0 = Normal State
	Bit 1 Output 1 (Terminal 28,27)	1 = Normal State Override 0 = Normal State
	Bit 2 Output 2 (Terminal 26,25)	1 = Normal State Override 0 = Normal State
	Bit 3 Output 3 (Terminal 24,23)	1 = Normal State Override 0 = Normal State
	Bit 4 Output 4 (Terminal 22 21)	1 = Normal State Override 0 = Normal State
	Bit 5 Output 5 (Terminal 19,20)	1 = Normal State Override 0 = Normal State
	Bit 6 Output 6 (Terminal 17,18)	1 = Normal State Override 0 = Normal State
	Bit 7 Output 7	1 = Normal State Override 0 = Normal State
	Bit 8 Reserved	
	Bit 9 Reserved	
	Bit 10 Reserved	
	Bit 11 Reserved	
	Bit 12 Reserved	
	Bit 13 Reserved	
	Bit 14 Reserved	
	Bit 15 Reserved (msb)	
41429	Force Physical Input Forcing State Mask	Unsigned (16 Bits)
	Bit 0 Trip (Terminal 29,30) (lsb)	1 = Force Set State 0 = Force Reset State
	Bit 1 Output 1 (Terminal 28,27)	1 = Force Set State 0 = Force Reset State
	Bit 2 Output 2 (Terminal 26,25)	1 = Force Set State 0 = Force Reset State
	Bit 3 Output 3 (Terminal 24,23)	1 = Force Set State 0 = Force Reset State
	Bit 4 Output 4 (Terminal 22 21)	1 = Force Set State 0 = Force Reset State
	Bit 5 Output 5 (Terminal 19,20)	1 = Force Set State 0 = Force Reset State
	Bit 6 Output 6 (Terminal 17,18)	1 = Force Set State 0 = Force Reset State
	Bit 7 Output 7	1 = Force Set State 0 = Force Reset State
	Bit 8 Reserved	
	Bit 9 Reserved	
	Bit 10 Reserved	
	Bit 11 Reserved	
	Bit 12 Reserved	
	Bit 13 Reserved	
	Bit 14 Reserved	
	Bit 15 Reserved (msb)	

Group III functions operate as follows:

Register 41427 = Force Physical Output Change Mask - Selects Control for the Function Specified

Register 41428 = Force Physical Output Normal State Mask - Places Bit in Normal or Force Mode.

Register 41429 = Physical Output Forcing State Mask – If Bit is in Force Mode, Determines Force State (State 1 = energized State 0 = de-energized).

A Truth Table for the aforementioned bits follows as illustrated in Table 5-46:

Table 5-46. State Truth Chart for Physical Input Forcing Function

Bit Value Change Mask Register 41427	Bit Value Normal/Forced Mask Register 41428	Bit Value Forced State Register 41429	Description
0	X	X	Normal - State follows Voltage at Term.
1	0	X	Normal - State follows Voltage at Term.
1	1	0	Output Forced – State = OFF
1	1	1	Output Forced – State = ON

Note: X = Don't Care State

Once an Output is forced on or off, it must be “unforced” or returned to normal state for the point to resume normal operation and reflect the state present at the physical Output terminals present at the rear of the relay. **It is important to emphasize that the forced states are stored in the TPU2000R’s non-volatile RAM and will remain forced until unforced by the operator. A point may be “unforced” via the front panel MMI, DOS ECP, WinECP, or through the Modbus commands covered within this section.**

A simple example shall illustrate the Force/Normal control sequence via the Modbus command operations. Figures 5-51, 5-52, and 5-53 illustrate the word patterns which must be transmitted to the TPU2000R to complete a Force On, Force Off and Return to Normal State Operation within the TPU2000R. As with the other control functions, the registers may be sent down individually, in blocks of data transferred, or as one block of data followed by an execute command as illustrated in Figures 5-51, 5-52, and 5-53.

EXAMPLE 3 - Force Output 6 to a State of 1 and Then to a Force State of 0, and Then to a Normal State.

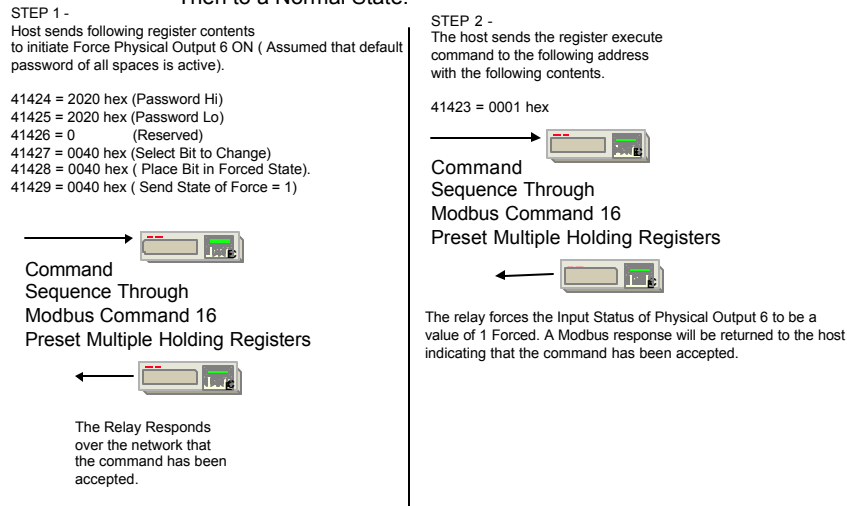

Figure 5-51. Force Physical Output Example

EXAMPLE 3 - Force Output 6 to a State of 1 and Then to a Force State of 0, and Then to a Normal State.

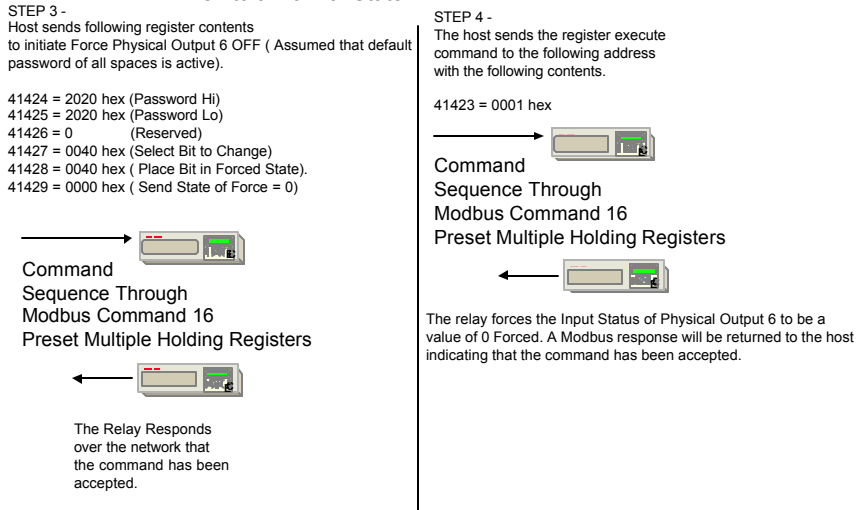

Figure 5-52. Force Physical Output Example (Continued)

EXAMPLE 3 - Force Output 6 to a State of 1 and Then to a Force State of 0, and Then to a Normal State.

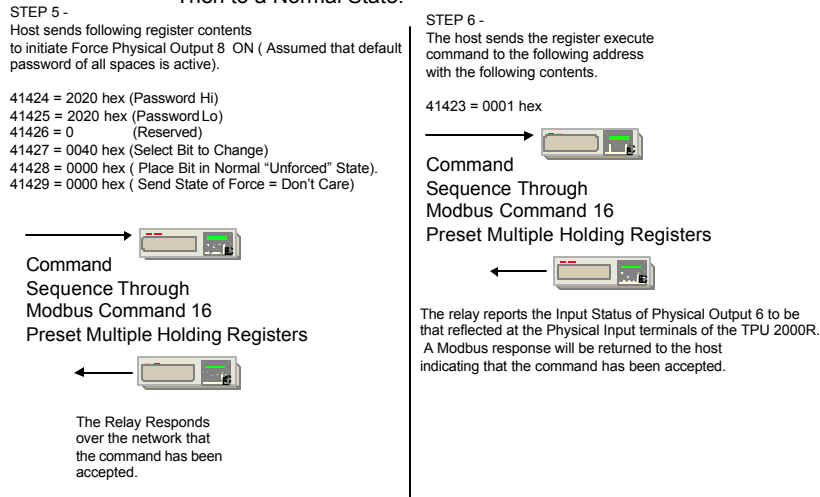

Figure 5-53. Force Physical Output Example (Continued)

IMPLEMENTATION TIP – As is common practice with any control, after a control task has been completed via the network, the host should query the device to assure that control has been executed.

Group IV Control Features Explained

The TPU2000 and TPU2000R have the capability of automation configuration to a generic Logical Input bit. These bits are generic in nature and can be mapped via ECP (External Communication Program) or WinECP (WINDOWS External Communication Program). Mapping of the values occurs as such:

1. From ECP or WinECP select the menu item “FLI Index and User Name” selection.
2. A list of default mappings are shown as in Figure 5-54 (ECP Screen) In this case the user is viewing the screen in ECP as shown in the CHANGE SETTINGS Screen.

TPU2000/2000R Modbus/Modbus Plus Automation Guide

3. The default list corresponds to the Logical Input mapping of Logical Inputs (hereto referred as LI) as illustrated in Table 5-47.
4. If one would wish to change the relay protective function element mapped to the specific LI, depress the “ENTER” key. The display in Figure 5-55 shall result.
5. The user would then scroll down the list and highlight the element desired to be mapped to the specific LI within the edited list.
6. Depress the “ENTER” key to map the selected element into the table.

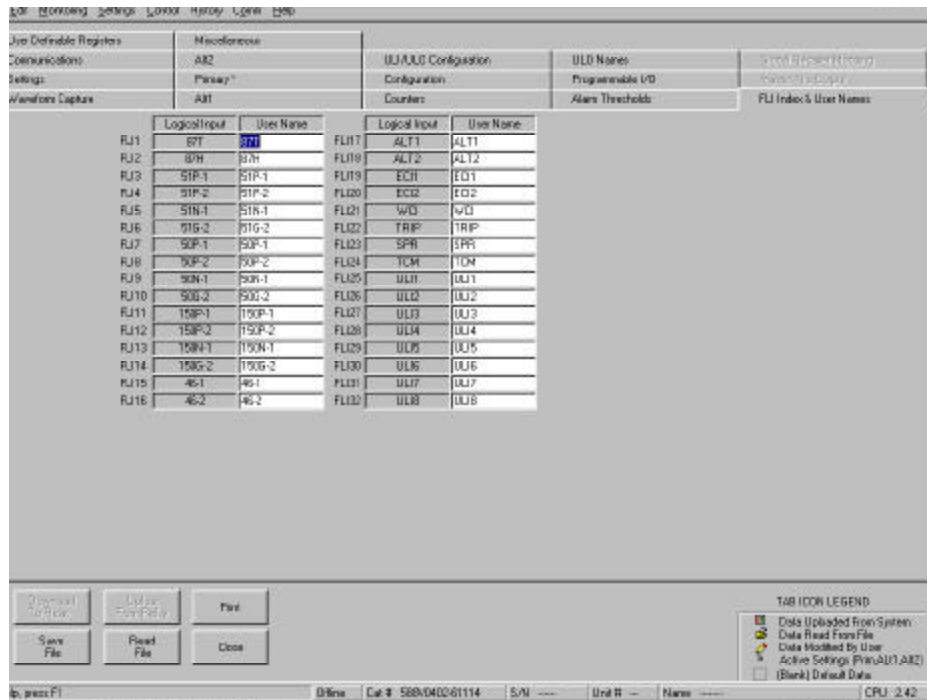

Figure 5-54. ECP Default Logical Input List

Table 5-47. ECP Default Correlation to Forced Logical Input Bit Map

FLI Number	Description	User Name	FLI Number	Description	User Name
FLI 01	3 Phase % Diff. Current Control	87 T	FLI 17	Alternate Settings 1 Enable	ALT 1
FLI 02	3 Phase Inst. Differential Current Control	87H	FLI 18	Alternate Settings 2 Enable	ALT 2
FLI 03	Winding 1 Phase Time Overcurrent Control	51P-1	FLI 19	Event Capture Initiate 1	ECI 1
FLI 04	Winding 2 Phase Time Overcurrent Control	51P-2	FLI 20	Event Capture Initiate 2	ECI 2
FLI 05	Winding 1 Neutral Time Overcurrent Control	51N-1	FLI 21	Waveform Capture Initiate	WCI
FLI 06	Winding 2 Ground Time Overcurrent Control Winding 2	51G-2	FLI 22	Differential Trip Output Contact Enable	TRIP
FLI 07	Phase Instantaneous Level 1 Enable Winding 1	50P-1	FLI 23	Sudden Pressure	SPR
FLI 08	Phase Instantaneous Level 1 Enable Winding 2	50P-2	FLI 24	Trip Coil Monitor Enable	TCM
FLI 09	Neutral Instantaneous Level 1 Enable Winding 1	50N-1	FLI 25	User Logical Input 1	ULI 1
FLI 10	Ground Instantaneous Level 1	50G-2	FLI 26	User Logical Input 2	ULI 2

TPU2000/2000R Modbus/Modbus Plus Automation Guide

	Enable Winding 2				
FLI 11	Phase Instantaneous Level 2 Enable Winding 1	150P-1	FLI 27	User Logical Input 3	ULI 3
FLI 12	Phase Instantaneous Level 2 Enable Winding 2	150P-2	FLI 28	User Logical Input 4	ULI 4
FLI 13	Neutral Instantaneous Level 2 Enable Winding 1	150N-1	FLI 29	User Logical Input 5	ULI 5
FLI 14	Ground Instantaneous Level 2 Enable Winding 2	150G-2	FLI 30	User Logical Input 6	ULI 6
FLI 15	Winding 1 Negative Sequence Control	46-1	FLI 31	User Logical Input 7	ULI 7
FLI 16	Winding 2 Negative Sequence Control	46-2	FLI 32	User Logical Input 8	ULI 8

The usefulness of this feature cannot be understated. Each one of these functions can be forced via a network control. Programming need not be done to allow for function control via a network. If the relaying feature “Waveform Capture Initiate” were to be enabled, the bit FLI 21 could be forced to an “ON” condition via the network control. If a desired control function were to be controlled via the network, then ECP mapping would have to be configured as per Figure 5-55. The method employed to force the state of the function is similar to that of the Group II and III functions. As illustrated in Table 5-48, the mapping of each of the FLI’s is illustrated. Registers 41430 through 41439 allow forcing of the desired feature.

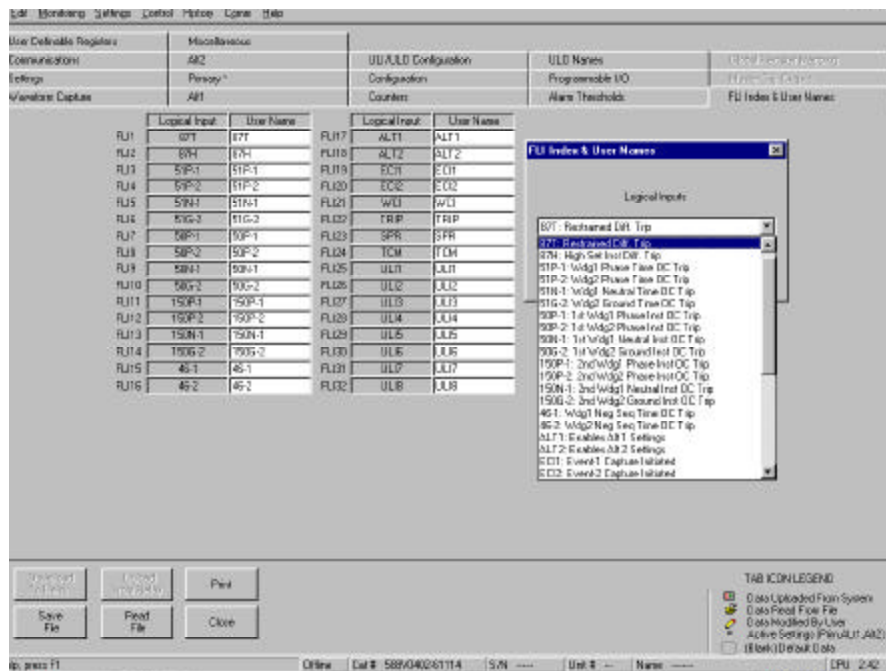

Figure 5-55. Mapping Function Screen for Logical Inputs

Group IV functions operate as follows:

- Register 41434 = Force Physical Output Change Mask - Selects Control for FLI 17 – FLI 32
- Register 41435 = Force Physical Output Change Mask - Selects Control for FLI 01 – FLI 16
- Register 41436 = Force Physical Output Normal State Mask - Places FLI 17 – FLI 32 in Normal or Force Mode
- Register 41437 = Force Physical Output Normal State Mask - Places FLI 01 – FLI 16 in Normal or Force Mode
- Register 41438 = Physical Output Forcing State Mask – If Bit is in Force Mode, Determines Force State FLI 17 to FLI 32 (State 1 = energized State 0 = de-energized)
- Register 41439 = Physical Output Forcing State Mask – If Bit is in Force Mode, Determines Force State FLI 01 to FLI 16 (State 1 = energized State 0 = de-energized)

TPU2000/2000R Modbus/Modbus Plus Automation Guide

A Truth Table for the aforementioned bits follows as illustrated in Table 5-48:

Table 5-48. State Truth Chart for Physical Input Forcing Function

Bit Value Change Mask Register 41434 and 41435	Bit Value Normal/Forced Mask Register 41436 and 41437	Bit Value Forced State Register 41438 and 41439	Description
0	X	X	Normal - State Unforced
1	0	X	Normal - State Unforced
1	1	0	Logical Input Forced – State = OFF
1	1	1	Logical Input Forced – State = ON

Note: X = Don't Care State

. There are three modes which a Physical Output may be placed:

- UNFORCED – The TPU2000/TPU2000R Logical Input is not forced to any state.
- FORCED ON – The TPU2000/TPU2000R Logical Input is energized and associated mapped function is enabled. The Logical Input status is reported as a 1. If the point status is viewed via ECP or WinECP, the Logical point will show a forced status with a logical state of 1.
- FORCED OFF – The TPU2000/TPU2000R Logical Input is de-energized. The Logical Input status is reported as a 0. If the point status is viewed via ECP or WinECP, the point will show a forced status with a logical state of 0.

Table 5-49. TPU2000 and TPU2000R Bit Control Function Definitions

Register	Item	Description
GROUP IV		
41430	Execute Register 0 = No Action 1 = Execute	Unsigned (16 Bits)
41431	Password	ASCII – 2 Characters Leftmost Digits
41432	Password	ASCII – 2 Characters Rightmost Digits
41433	Spare	
41434	Force Logical Input Change Mask FLI 17 to FLI 32	Unsigned (16 Bits) 1 = Control Bit State 0 = No Control
	Bit 0 FLI 17(lsb)	1 = Control Bit State 0 = No Control
	Bit 1 FLI 18	1 = Control Bit State 0 = No Control
	Bit 2 FLI 19	1 = Control Bit State 0 = No Control
	Bit 3 FLI 20	1 = Control Bit State 0 = No Control
	Bit 4 FLI 21	1 = Control Bit State 0 = No Control
	Bit 5 FLI 22	1 = Control Bit State 0 = No Control
	Bit 6 FLI 23	1 = Control Bit State 0 = No Control
	Bit 7 FLI 24	1 = Control Bit State 0 = No Control
	Bit 8 FLI 25	1 = Control Bit State 0 = No Control
	Bit 9 FLI 26	1 = Control Bit State 0 = No Control
	Bit 10 FLI 27	1 = Control Bit State 0 = No Control
	Bit 11 FLI 28	1 = Control Bit State 0 = No Control
	Bit 12 FLI 29	1 = Control Bit State 0 = No Control
	Bit 13 FLI 30	1 = Control Bit State 0 = No Control
	Bit 14 FLI 31	1 = Control Bit State 0 = No Control
	Bit 15 FLI 32 (msb)	1 = Control Bit State 0 = No Control
41435	Force Logical Input Change Mask FLI 01 to FLI 16	Unsigned (16 Bits) 1 = Control Bit State 0 = No Control

TPU2000/2000R Modbus/Modbus Plus Automation Guide

	Bit 0 FLI 01 (lsb)	1 = Control Bit State 0 = No Control
	Bit 1 FLI 02	1 = Control Bit State 0 = No Control
	Bit 2 FLI 03	1 = Control Bit State 0 = No Control
	Bit 3 FLI 04	1 = Control Bit State 0 = No Control
	Bit 4 FLI 05	1 = Control Bit State 0 = No Control
	Bit 5 FLI 06	1 = Control Bit State 0 = No Control
	Bit 6 FLI 07	1 = Control Bit State 0 = No Control
	Bit 7 FLI 08	1 = Control Bit State 0 = No Control
	Bit 8 FLI 09	1 = Control Bit State 0 = No Control
	Bit 9 FLI 10	1 = Control Bit State 0 = No Control
	Bit 10 FLI 11	1 = Control Bit State 0 = No Control
	Bit 11 FLI 12	1 = Control Bit State 0 = No Control
	Bit 12 FLI 13	1 = Control Bit State 0 = No Control
	Bit 13 FLI 14	1 = Control Bit State 0 = No Control
	Bit 14 FLI 15	1 = Control Bit State 0 = No Control
	Bit 15 FLI 16 (msb)	1 = Control Bit State 0 = No Control
41436	Force Logical Input Normal State Mask	Unsigned (16 Bits)
	Bit 0 FLI 17 (lsb)	1 = Force State 0 = Normal State
	Bit 1 FLI 18	1 = Force State 0 = Normal State
	Bit 2 FLI 19	1 = Force State 0 = Normal State
	Bit 3 FLI 20	1 = Force State 0 = Normal State
	Bit 4 FLI 21	1 = Force State 0 = Normal State
	Bit 5 FLI 22	1 = Force State 0 = Normal State
	Bit 6 FLI 23	1 = Force State 0 = Normal State
	Bit 7 FLI 24	1 = Force State 0 = Normal State
	Bit 8 FLI 25	1 = Force State 0 = Normal State
	Bit 9 FLI 26	1 = Force State 0 = Normal State
	Bit 10 FLI 27	1 = Force State 0 = Normal State
	Bit 11 FLI 28	1 = Force State 0 = Normal State
	Bit 12 FLI 29	1 = Force State 0 = Normal State
	Bit 13 FLI 30	1 = Force State 0 = Normal State
	Bit 14 FLI 31	1 = Force State 0 = Normal State
	Bit 15 FLI 32 (msb)	1 = Force State 0 = Normal State
41437	Force Logical Input Normal State Mask	Unsigned (16 Bits)
	Bit 0 FLI 01 (lsb)	1 = Force State 0 = Normal State
	Bit 1 FLI 02	1 = Force State 0 = Normal State
	Bit 2 FLI 03	1 = Force State 0 = Normal State
	Bit 3 FLI 04	1 = Force State 0 = Normal State
	Bit 4 FLI 05	1 = Force State 0 = Normal State
	Bit 5 FLI 06	1 = Force State 0 = Normal State
	Bit 6 FLI 07	1 = Force State 0 = Normal State
	Bit 7 FLI 08	1 = Force State 0 = Normal State
	Bit 8 FLI 09	1 = Force State 0 = Normal State
	Bit 9 FLI 10	1 = Force State 0 = Normal State
	Bit 10 FLI 11	1 = Force State 0 = Normal State
	Bit 11 FLI 12	1 = Force State 0 = Normal State
	Bit 12 FLI 13	1 = Force State 0 = Normal State
	Bit 13 FLI 14	1 = Force State 0 = Normal State
	Bit 14 FLI 15	1 = Force State 0 = Normal State
	Bit 15 FLI 16 (msb)	1 = Force State 0 = Normal State
41438	Force Logical Input State Mask FLI 17 – FLI 32	Unsigned (16 Bits)
	Bit 0 FLI 17 (lsb)	1 = Force State 0 = Normal State
	Bit 1 FLI 18	1 = Force State 0 = Normal State
	Bit 2 FLI 19	1 = Force State 0 = Normal State

TPU2000/2000R Modbus/Modbus Plus Automation Guide

	Bit 3 FLI 20	1 = Force State 0 = Normal State
	Bit 4 FLI 21	1 = Force State 0 = Normal State
	Bit 5 FLI 22	1 = Force State 0 = Normal State
	Bit 6 FLI 23	1 = Force State 0 = Normal State
	Bit 7 FLI 24	1 = Force State 0 = Normal State
	Bit 8 FLI 25	1 = Force State 0 = Normal State
	Bit 9 FLI 26	1 = Force State 0 = Normal State
	Bit 10 FLI 27	1 = Force State 0 = Normal State
	Bit 11 FLI 28	1 = Force State 0 = Normal State
	Bit 12 FLI 29	1 = Force State 0 = Normal State
	Bit 13 FLI 30	1 = Force State 0 = Normal State
	Bit 14 FLI 31	1 = Force State 0 = Normal State
	Bit 15 FLI 32 (msb)	1 = Force State 0 = Normal State
41439	Force Logical Input State Mask FLI 01 – FLI 16	Unsigned (16 Bits)
	Bit 0 FLI 01 (lsb)	1 = Force Set State 0 = Force Reset State
	Bit 1 FLI 02	1 = Force Set State 0 = Force Reset State
	Bit 2 FLI 03	1 = Force Set State 0 = Force Reset State
	Bit 3 FLI 04	1 = Force Set State 0 = Force Reset State
	Bit 4 FLI 05	1 = Force Set State 0 = Force Reset State
	Bit 5 FLI 06	1 = Force Set State 0 = Force Reset State
	Bit 6 FLI 07	1 = Force Set State 0 = Force Reset State
	Bit 7 FLI 08	1 = Force Set State 0 = Force Reset State
	Bit 8 FLI 09	1 = Force Set State 0 = Force Reset State
	Bit 9 FLI 10	1 = Force Set State 0 = Force Reset State
	Bit 10 FLI 11	1 = Force Set State 0 = Force Reset State
	Bit 11 FLI 12	1 = Force Set State 0 = Force Reset State
	Bit 12 FLI 13	1 = Force Set State 0 = Force Reset State
	Bit 13 FLI 14	1 = Force Set State 0 = Force Reset State
	Bit 14 FLI 15	1 = Force Set State 0 = Force Reset State
	Bit 15 FLI 16 (msb)	1 = Force Set State 0 = Force Reset State

A simple application example in Figure 5-56 follows, illustrating the method to force TPU2000 or TPU2000R functions via the Group IV mapping.

EXAMPLE 4 - Enable 150P- 2Control and UL1 1 which is mapped to a Physical Output via the ECP PHYSICAL OUTPUT MAP.

STEP 1 -
Host sends following register contents to initiate FLI 12 (Mapped To ZSC) and FLI 25 (Mapped to UL02) (Assumed that default password of all spaces is active).

41431 = 2020 hex (Password Hi)
41432 = 2020 hex (Password Lo)
41433 = 0 (Reserved)
41434 = 0200 hex (Select FLI 25 Bit to Change)
41435 = 0800 hex (Select FLI 12 Bit to Change).
41436 = 0200 hex (Select FLI 25 Force State)
41437 = 0800 hex (Select FLI 12 Force State)
41438 = 0200 hex (Set FLI 25 Bit to State of 1)
41439 = 0800 hex (Set FLI 12 Bit to State of 1)

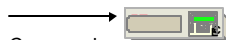

Command
Sequence Through
Modbus Command 16
Preset Multiple Holding Registers



The Relay Responds over the network that the command has been accepted.

STEP 2 -
The host sends the register execute command to the following address with the following contents.

41430 = 0001 hex

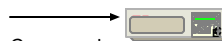

Command
Sequence Through
Modbus Command 16
Preset Multiple Holding Registers



The relay forces FLI 25 and FLI 12 to be a value of 1 Forced.
The TPU 2000R is mapped via the Change Logical Input Screen.
A Modbus response will be returned to the host indicating that the command has been accepted.

Figure 5-56. Application Example Illustrating the Use of FLI Group IV Methodology

Group V Control Features Explained

Group V control functions allow the resetting of specific alarms and/or the setting AND resetting of ULO states. Group 1 allows certain reset of alarms, targets, as well as other features. Group V allows reset of individual TPU2000 and TPU2000R alarm status bits. Within Tables 5-50 and 5-51, the mapping is described for controlled reset of the specific elements. Table 5-52 contains a mapping of which bits only are controlled by reset commands.

Group IV functions operate as follows:

- Register 41444 = Set/Reset Change Mask - Features 1
- Register 41445 = Set/Reset Change Mask - Features 2
- Register 41446 = Set/Reset Change Mask - Features 3
- Register 41447 = Set/Reset Change Mask - Features 4
- Register 41448 = Set/Reset State Change - Features 1
- Register 41449 = Set/Reset State Change - Features 2
- Register 41450 = Set/Reset State Change - Features 3
- Register 41451 = Set/Reset State Change - Features 4

A Truth Table for the aforementioned bits follows as illustrated in Table 5-50:

Table 5-50. State Truth Chart for Physical Input Forcing Function

Bit Value Change Mask Register 41444 through 41447	Bit Value Normal/Forced Mask Register 41448 through 41451	Description
0	X	Normal - State Unforced
1	0	Logical Input Forced – State = OFF
1	1	Logical Input Forced – State = ON

There are three modes which a Physical Output may be placed:

- UNFORCED – The TPU2000/TPU2000R Logical Input is not forced to any state.
- SET – The TPU2000/TPU2000R bit is set to a value of 1.
- RESET -The TPU2000/TPU2000R is set to a value of 0.

It should be noted that certain bits within the table can only be reset when selected. Other bits may be set or reset at will. Once a bit is forced, the NORMAL LED (located at the faceplate of the TPU2000 and 2000R) shall flash. The Normal LED is green in color.

Table 5-51. TPU2000 and TPU2000R Bit Control Function Definitions

Notes	Register	Item	Description
		GROUP V	
	41440	Execute Register 0 = No Action 1 = Execute	Unsigned (16 Bits)
	41441	Password	ASCII – 2 Characters Leftmost Digits
	41442	Password	ASCII – 2 Characters Rightmost Digits
	41443	Spare	
	41444	Change Mask Register 1	
R		Bit 15: 87T - 3 % Phase Differential Current Alarm	1 = Select bit 0 = Normal (msb)
R		Bit 14: 87H - 3 Instantaneous Phase Differential Current Alarm	1 = Select bit 0 = Normal
R		Bit 13: 2HROA - Second Harmonic	1 = Select bit 0 = Normal

TPU2000/2000R Modbus/Modbus Plus Automation Guide

		Restraint Alarm	
R		Bit 12: 5HROA - 5 th Harmonic Restraining Alarm	1 = Select bit 0 = Normal
R		Bit 11: AHROA - All Harmonics Restraint Alarm	1 = Select bit 0 = Normal
R		Bit 10: 51P-1 - Winding 1 Phase Time Overcurrent Trip Alarm	1 = Select bit 0 = Normal
R		Bit 9: 51P-2 - Winding 2 Phase Time Overcurrent Trip Alarm	1 = Select bit 0 = Normal
R		Bit 8: 50P-1 - 1 st Winding 1 Phase Instantaneous Overcurrent Trip Alarm	1 = Select bit 0 = Normal
R		Bit 7: 150P-1 - 2 nd Winding 1 Phase Instantaneous Overcurrent Trip Alarm	1 = Select bit 0 = Normal
R		Bit 6: 50P-2 - 1 st Winding 2 Phase Instantaneous Overcurrent Trip Alarm	1 = Select bit 0 = Normal
R		Bit 5: 150P-2 - 2 nd Winding 1 Phase Instantaneous Overcurrent Trip Alarm	1 = Select bit 0 = Normal
R		Bit 4: 51N-1 - Winding 1 Neutral Instantaneous Overcurrent Trip Alarm	1 = Select bit 0 = Normal
R		Bit 3: 51N-2 - Winding 2 Neutral Instantaneous Overcurrent Trip Alarm	1 = Select bit 0 = Normal
R		Bit 2: 50N-1 - 1 st Winding 1 Neutral Time Overcurrent Trip Alarm	1 = Select bit 0 = Normal
R		Bit 1: 150N-1 - 2 nd Winding 1 Neutral Time Overcurrent Trip Alarm	1 = Select bit 0 = Normal
R		Bit 0: 50N-2 - 1 st Winding 2 Neutral Time Overcurrent Trip Alarm	1 = Select bit 0 = Normal (lsb)
	41445	Change Mask Register 2	
R		Bit 15: 150N-2 - 2 nd Winding 2 Neutral Time Overcurrent Trip Alarm	1 = Select bit 0 = Normal (msb)
R		Bit 14: 46-1 - Winding 1 Negative Sequence Time Overcurrent Alarm	1 = Select bit 0 = Normal
R		Bit 13: 46-2 - Winding 2 Negative Sequence Time Overcurrent Alarm	1 = Select bit 0 = Normal
		Bit 12: 63 - Sudden Pressure Input Alarm	1 = Select bit 0 = Normal
		Bit 11: User Logical Output 1 – ULO 1	1 = Select bit 0 = Normal
		Bit 10: User Logical Output 2 – ULO 2	1 = Select bit 0 = Normal
		Bit 9: User Logical Output 3 – ULO 3	1 = Select bit 0 = Normal
		Bit 8: User Logical Output 4 – ULO 4	1 = Select bit 0 = Normal
		Bit 7: User Logical Output 5 – ULO 5	1 = Select bit 0 = Normal
		Bit 6: User Logical Output 6 – ULO 6	1 = Select bit 0 = Normal
		Bit 5: User Logical Output 7 – ULO 7	1 = Select bit 0 = Normal
		Bit 4: User Logical Output 8 – ULO 8	1 = Select bit 0 = Normal
		Bit 3: User Logical Output 9 – ULO 9	1 = Select bit 0 = Normal
		Bit 2: Reserved	
		Bit 1: Reserved	
		Bit 0: Reserved	
	41446	Change Mask Register 3	
R		Bit 15: 51P-3 - Winding 3 Phase Instantaneous Overcurrent Alarm	1 = Select bit 0 = Normal (msb)
R		Bit 14: 50P-3 - 1 st Winding 3 Phase Time Overcurrent Alarm	1 = Select bit 0 = Normal
R		Bit 13: 150P-3 - 2 nd Winding 3 Phase Time Overcurrent Alarm	1 = Select bit 0 = Normal
R		Bit 12: 51N-3 - Winding 3 Neutral Instantaneous Overcurrent Alarm	1 = Select bit 0 = Normal

TPU2000/2000R Modbus/Modbus Plus Automation Guide

R		Bit 11: 50N-3 - 1 st Winding 3 Neutral Time Overcurrent Alarm	1 = Select bit 0 = Normal
R		Bit 10: 150N-3 - 2 nd Winding 3 Neutral Time Overcurrent Alarm	1 = Select bit 0 = Normal
R		Bit 9: 46-3 - Winding 3 Negative Sequence Time Overcurrent Alarm	1 = Select bit 0 = Normal
R		Bit 8: 51G - Ground Instantaneous Overcurrent Alarm	1 = Select bit 0 = Normal
R		Bit 7: 50G - 1 st Ground Time Overcurrent Alarm	1 = Select bit 0 = Normal
R		Bit 6: 150G - 2 nd Ground Time Overcurrent Alarm	1 = Select bit 0 = Normal
		Bit 5: Reserved	
		Bit 4: Reserved	
		Bit 3: Reserved	
		Bit 2: Reserved	
		Bit 1: Reserved	
		Bit 0: Reserved	(lsb)
	41447	Change Mask Word 4	
		Bit 15: Reserved	(msb)
		Bit 14: Reserved	
		Bit 13: Reserved	
		Bit 12: Reserved	
		Bit 11: Reserved	
		Bit 10: Reserved	
		Bit 9: Reserved	
		Bit 8: Reserved	
		Bit 7: Reserved	
		Bit 6: Reserved	
		Bit 5: Reserved	
		Bit 4: Reserved	
		Bit 3: Reserved	
		Bit 2: Reserved	
		Bit 1: Reserved	
		Bit 0: Reserved	(lsb)
	41448	Set/Reset Mask Register 1	
R		Bit 15: 87T - 3 % Phase Differential Current Alarm	0 = Reset (msb)
R		Bit 14: 87H - 3 Instantaneous Phase Differential Current Alarm	0 = Reset
R		Bit 13: 2HROA - Second Harmonic Restraint Alarm	0 = Reset
R		Bit 12: 5HROA - 5 th Harmonic Restraining Alarm	0 = Reset
R		Bit 11: AHROA - All Harmonics Restraint Alarm	0 = Reset
R		Bit 10: 51P-1 - Winding 1 Phase Time Overcurrent Trip Alarm	0 = Reset
R		Bit 9: 51P-2 - Winding 2 Phase Time Overcurrent Trip Alarm	0 = Reset
R		Bit 8: 50P-1 - 1 st Winding 1 Phase Instantaneous Overcurrent Trip Alarm	0 = Reset
R		Bit 7: 150P-1 - 2 nd Winding 1 Phase Instantaneous Overcurrent Trip Alarm	0 = Reset
R		Bit 6: 50P-2 - 1 st Winding 2 Phase Instantaneous Overcurrent Trip Alarm	0 = Reset

TPU2000/2000R Modbus/Modbus Plus Automation Guide

R		Bit 5: 150P-2 - 2 nd Winding 1 Phase Instantaneous Overcurrent Trip Alarm	0 = Reset
R		Bit 4: 51N-1 - Winding 1 Neutral Instantaneous Overcurrent Trip Alarm	0 = Reset
R		Bit 3: 51N-2 - Winding 2 Neutral Instantaneous Overcurrent Trip Alarm	0 = Reset
R		Bit 2: 50N-1 - 1 st Winding 1 Neutral Time Overcurrent Trip Alarm	0 = Reset
R		Bit 1: 150N-1 - 2 nd Winding 1 Neutral Time Overcurrent Trip Alarm	0 = Reset
R		Bit 0: 50N-2 - 1 st Winding 2 Neutral Time Overcurrent Trip Alarm	0 = Reset
	41449	Set/Reset Mask Register 2	
R		Bit 15: 150N-2 - 2 nd Winding 2 Neutral Time Overcurrent Trip Alarm	0 = Reset
R		Bit 14: 46-1 - Winding 1 Negative Sequence Time Overcurrent Alarm	0 = Reset
R		Bit 13: 46-2 - Winding 2 Negative Sequence Time Overcurrent Alarm	0 = Reset
		Bit 12: 63 - Sudden Pressure Input Alarm	1 = Set 0 = Reset
		Bit 11: User Logical Output 1 – ULO 1	1 = Set 0 = Reset
		Bit 10: User Logical Output 2 – ULO 2	1 = Set 0 = Reset
		Bit 9: User Logical Output 3 – ULO 3	1 = Set 0 = Reset
		Bit 8: User Logical Output 4 – ULO 4	1 = Set 0 = Reset
		Bit 7: User Logical Output 5 – ULO 5	1 = Set 0 = Reset
		Bit 6: User Logical Output 6 – ULO 6	1 = Set 0 = Reset
		Bit 5: User Logical Output 7 – ULO 7	1 = Set 0 = Reset
		Bit 4: User Logical Output 8 – ULO 8	1 = Set 0 = Reset
		Bit 3: User Logical Output 9 – ULO 9	1 = Set 0 = Reset
		Bit 2: Reserved	
		Bit 1: Reserved	
		Bit 0: Reserved	
	41450	Set/Reset Mask Register 3	
R		Bit 15: 51P-3 - Winding 3 Phase Instantaneous Overcurrent Alarm	0 = Reset (msb)
R		Bit 14: 50P-3 - 1 st Winding 3 Phase Time Overcurrent Alarm	0 = Reset
R		Bit 13: 150P-3 - 2 nd Winding 3 Phase Time Overcurrent Alarm	0 = Reset
R		Bit 12: 51N-3 - Winding 3 Neutral Instantaneous Overcurrent Alarm	0 = Reset
R		Bit 11: 50N-3 - 1 st Winding 3 Neutral Time Overcurrent Alarm	0 = Reset
R		Bit 10: 150N-3 - 2 nd Winding 3 Neutral Time Overcurrent Alarm	0 = Reset
R		Bit 9: 46-3 - Winding 3 Negative Sequence Time Overcurrent Alarm	0 = Reset
R		Bit 8: 51G - Ground Instantaneous Overcurrent Alarm	0 = Reset
R		Bit 7: 50G - 1 st Ground Time Overcurrent Alarm	0 = Reset
R		Bit 6: 150G - 2 nd Ground Time Overcurrent Alarm	0 = Reset
		Bit 5: Reserved	
		Bit 4: Reserved	
		Bit 3: Reserved	

	Bit 2: Reserved	
	Bit 1: Reserved	
	Bit 0: Reserved	(lsb)
41451	Set Reset Mask Word 4	
	Bit 15: Reserved	(msb)
	Bit 14: Reserved	
	Bit 13: Reserved	
	Bit 12: Reserved	
	Bit 11: Reserved	
	Bit 10: Reserved	
	Bit 9: Reserved	
	Bit 8: Reserved	
	Bit 7: Reserved	
	Bit 6: Reserved	
	Bit 5: Reserved	
	Bit 4: Reserved	
	Bit 3: Reserved	
	Bit 2: Reserved	
	Bit 1: Reserved	
	Bit 0: Reserved	(lsb)
NOTE: R = A reset is only possible with these designated outputs. Attempting to set these will have no effect on the state of sealed alarms.		

A simple example illustrates the methodology for resetting of the trip contact alarms within the TPU2000 TPU2000R. Figure 5-57 details the control step procedure for a unit with the default password setting.

EXAMPLE 5 -Reset 46-1, 46-2 and 63 Alarm Status Bits.

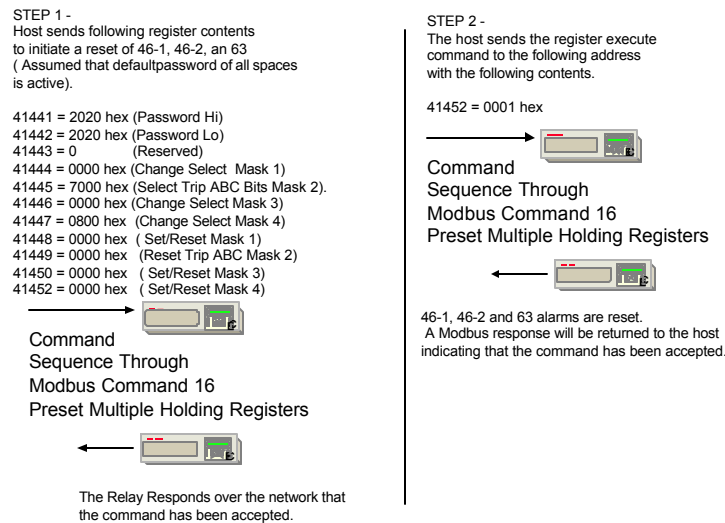

Figure 5-57. Reset Sequence for 46-1, 46-2 and 63 Latch Status Bits

Group VI Control Features Explained

Group VI is similar to the control provided in Group III. However, the control is not of the nature of a latched command control. The control type is of a momentary nature. The selected Physical Output is pulsed for a time duration set in the Breaker Failed To Trip Time Register. This register may be set to a value via ECP (External Communication Program) WinECP (Windows External Communications Program) or Register 61424.

As noted in Table 5-52, momentary pulse of a Physical Output is available on the TPU2000 and the TPU2000R.

TPU2000/2000R Modbus/Modbus Plus Automation Guide

The Breaker Failed to Trip time register is configured a number representing the number of cycles which the breaker shall trip. The range is a number from 5 to 60. The amount of time for breaker failed to trip is, of course dependent upon whether the relay is a 50 or 60 Hz model.

Table 5-52. TPU2000/TPU2000R Bit Control Function Definitions

Register	Item	Description
GROUP VI		
41452	Execute Register 0 = No Action 1 = Execute	Unsigned (16 Bits)
41453	Password	ASCII – 2 Characters Leftmost Digits
41454	Password	ASCII – 2 Characters Rightmost Digits
41455	Spare	
41456	Pulse Physical Output Change Mask	Unsigned (16 Bits)
	Bit 0 Trip(lsb)	1 = Pulse Output 0 = No Control
	Bit 1 Output 1 (Terminals 28,27)	1 = Pulse Output 0 = No Control
	Bit 2 Output 2 (Terminal 26,25)	1 = Pulse Output 0 = No Control
	Bit 3 Output 3 (Terminal 24,23)	1 = Pulse Output 0 = No Control
	Bit 4 Output 4 (Terminal 22,21)	1 = Pulse Output 0 = No Control
	Bit 5 Output 5 (Terminal 19,20)	1 = Pulse Output 0 = No Control
	Bit 6 Output 6 (Terminals 17,18)	1 = Pulse Output 0 = No Control
	Bit 7 Output 7 (TPU2000 ONLY)	1 = Pulse Output 0 = No Control
	Bit 8 Reserved	
	Bit 9 Reserved	
	Bit 10 Reserved	
	Bit 11 Reserved	
	Bit 12 Reserved	
	Bit 13 Reserved	
	Bit 14 Reserved	
	Bit 15 Reserved (msb)	
41457	Pulse Physical Output Change Mask	Unsigned (16 Bits)
	Bit 0 Trip(lsb)	1 = Pulse Output 0 = No Control
	Bit 1 Output 1 (Terminals 28,27)	1 = Pulse Output 0 = No Control
	Bit 2 Output 2 (Terminal 26,25)	1 = Pulse Output 0 = No Control
	Bit 3 Output 3 (Terminal 24,23)	1 = Pulse Output 0 = No Control
	Bit 4 Output 4 (Terminal 22 21)	1 = Pulse Output 0 = No Control
	Bit 5 Output 5 (Terminal 19,20)	1 = Pulse Output 0 = No Control
	Bit 6 Output 6 (Terminal 17,18)	1 = Pulse Output 0 = No Control
	Bit 7 Output 7 (TPU2000 ONLY)	1 = Pulse Output 0 = No Control
	Bit 8 Reserved	
	Bit 9 Reserved	
	Bit 10 Reserved	
	Bit 11 Reserved	
	Bit 12 Reserved	
	Bit 13 Reserved	
	Bit 14 Reserved	
	Bit 15 Reserved (msb)	

Group IV functions operate as follows and detailed in Example 6:

Register 41456 = Pulse Physical Output Mask - Selects Control for the Function Specified.

Register 41457 = Confirm Pulse Physical Output Mask (Copy of Register 41456).

Control is processed in that Registers 41456 and 41457 are “ANDED” together. If the resultant logical operation is completed with the result being a “1” in that bit location, the control function is executed. The TPU2000/TPU2000R offers immediate control. No buffering of commands is attempted.

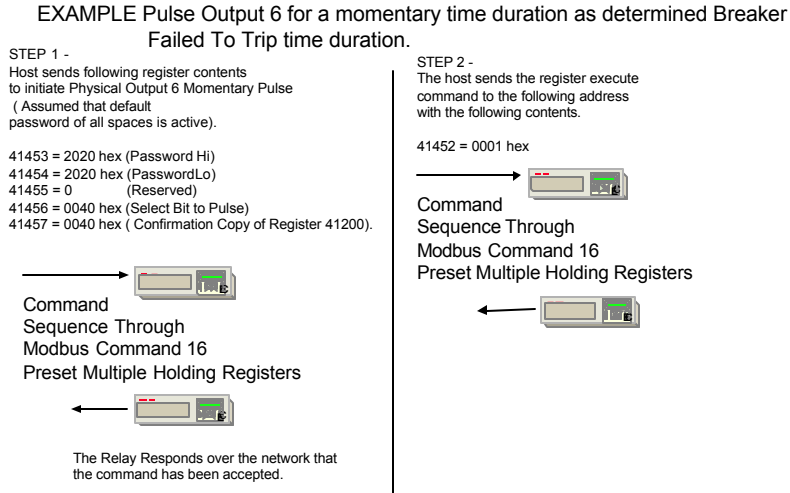

Figure 5-58. Momentary Pulse Control Illustrated

Oscillographic Data Storage (Version 1.5 and Greater TPU2000R Only)

The TPU2000R has the capability of accepting an option of OSCILLOGRAPHICS (Part Number 588 XXXXX – X1XXX [X = Don't Care]). The total storage buffer capacity for the TPU2000R is 64 cycles of waveform data, which consists of four input currents (one per phase and neutral), and three input voltages. A user may configure the TPU2000R to capture a single or multiple events of waveform capture. One may think of the waveform capture buffer as depicted in Figure 5-59.

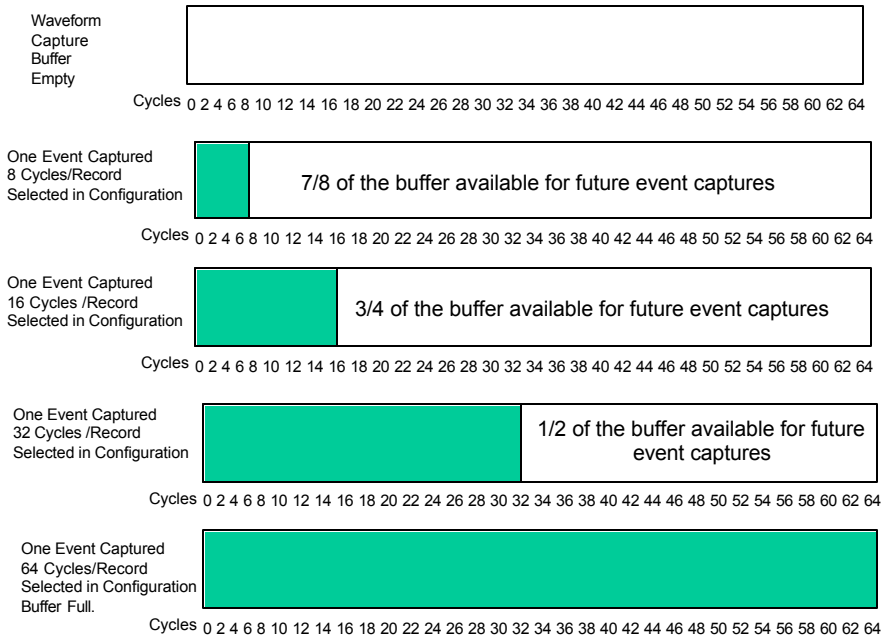

Figure 5-59. Waveform Capture Buffer Options

TPU2000/2000R Modbus/Modbus Plus Automation Guide

The TPU2000R may be configured to capture eight, four, two or one record(s) containing 8, 16, 32, or 64 cycles of data. Several data elements are stored in each waveform record. Such information as the individual quantity for each of the voltage/current phases, breaker 52a/b state, time-stamping information, and state of the protective function is retrievable via Modbus and Modbus Plus.

OSCILLOGRAPHIC data contains two elements of particular interest to the Automation Specialist. One element is the configuration of the oscillographic component as to when to acquire the data. The other element is retrieval of the wave form functions and the understanding of how to interpret the data for display purposes.

Oscillographic Configuration (12 Registers Defined)

One can configure the TPU2000R to capture pre-fault and post fault snapshots of data. The trigger to capture the data may be of the master trip element, breaker position, hard wired contact (Waveform Capture Initiate Element) or if any of the 20 defined protective elements are energized. The control and status block is defined in 6X Registers 63968 through 63199. The 6X file number for storage/retrieval of this data is in FILE 1 of the protocol.

Figure 5-60 illustrates the method to configure the oscillographics over Modbus or Modbus Plus. The host may retrieve the data via the 6X memory read command by first writing a value of "2" to the first memory location of the Oscillographic data block. The control register is defined as 63968. The registers from 63969 and 63970 should also be written with the appropriate unit password to effectuate the transfer of data from the TPU2000R to the Modbus Memory Map. The configuration data will then be transferred from the TPU2000R to the 6X registers reflecting the state of the Oscillographic configuration.

It should be remembered that some hosts are not capable of 6X register access. Parameterization of the Oscillographic Data Capture may be accomplished from the WinECP (WINdows External Communication Program) utility.

The definition of several key parameters must be understood in order to configure the waveform capture (Oscillographic) capabilities of the relay. The relay must not be parameterized (or re-parameterized) while the relay is monitoring the waveform for capture. Register 63972 controls the start/stop capabilities of this feature.

Register 63973 controls the storage capacity within the waveform capture buffer as shown in Figure 5-59. For example, if a value of 0 is selected, Eight records of data can be captured and stored by the TPU2000R upon the trigger action as defined in Registers 63975 through 63979. If the value of 3 is selected, a single record of data is captured, filling the entire buffer. The data captured for each channel consists of 8 samples per quarter cycle per channel (each of the eight channels are Ia, Ib, Ic, In, Va, Vb, and Vc). Table 5-53 explains the resolution of the capture. The 6X register Definition is included in Table 5-51.

Register 63974 configures the TPU2000R Trigger Mode. If Normal Mode (Value = 0) is selected, the trigger will allow waveform capture until capture is terminated by the host. If the buffer is full, the waveform will roll over and overwrite the first record in the buffer. If Single Shot (Value = 1) is selected, oscillographic capture monitoring will be terminated upon recording of the single event record.

Append Mode is a mode in which each individual bit of the Trigger Register 63975 – 63979 is evaluated. If one of the programmed trigger bits is active, the oscillographic data is stored. If during that time a second trigger bit is active, a second record shall be recorded and stored. If the Normal/Append (Value =3) Mode function is selected, the oscillographic function will continue at the end of waveform capture. If the buffer is full, then the next record will overwrite that record at the beginning of the buffer. If the Single Shot/Append Mode is selected, then the oscillographic function will terminate at the end of recording for that record.

Table 5-53. Oscillographic Resolution Capabilities

Register 63077 Selection	Description
0 = 8 Cycles per record – 8 Records	8 Records of Data Capture possible with <u>8 Cycles of Waveform Captured</u> @ 32 Samples per cycle per channel.
1 = 16 Cycles per record – 4 Records	4 Records of Data Capture possible with <u>16 Cycles of Waveform Captured</u> @ 32 Samples per cycle per channel.
2 = 32 Cycles per record – 2 Records	2 Records of Data Capture possible with <u>32 Cycles of Waveform Captured</u> @ 32 Samples per cycle per channel.
3 = 64 Cycles per record – 1 Record	1 Record of Data available possible with <u>64 Cycles of Waveform Captured</u> @ 32 Samples per cycle per channel.

Table 5-54. Oscillographic Configuration Registers

Register	Item	Description
63968	Execute Register	Unsigned Integer 16 Bits 0 = No Action 1 = Transfer Settings 2 = Retrieve Settings
63969	Access Password	2 Leftmost Digits ASCII
63970	Access Password	2 Rightmost Digits ASCII
63971	Reserved	Reserved
63972	Start/Stop Accumulation	Unsigned Integer 16 Bits 0 = Stop 1 = Start
63973	Acquisition Format	Unsigned Integer 16 Bits 0 = 8 Records Max Storage/8 Cycles/Record 1 = 4 Records Max Storage/16 Cycles/Record 2 = 2 Records Max Storage/32 Cycles/Record 3 = 1 Record Stored/64 Cycles/Record
63974	Trigger Mode	Unsigned Integer 16 Bits 0 = Normal 1 = Single Shot 2 = Normal/Append Mode 3 = Single Shot/Append Mode
63975	Trigger Position	Unsigned Integer 16 Bits Number of quarter cycles to capture pre-fault. If 63077 = 0 : 0 <= Trigger <= 32 If 63077 = 1 : 0 <= Trigger <= 64 If 63077 = 2 : 0 <= Trigger <= 128 If 63077 = 3 : 0 <= Trigger <= 256
63976	Trigger Flag Reserved	Unsigned Integer 16 Bits Set to zero
63977	Trigger Flag Reserved	Unsigned Integer 16 Bits Set to 0
63978	Trigger Flag Bit 0 = Master Trip (lsb) Bit 1 = Breaker Open Bit 2 = WCI Bit 3 = Reserved Bit 4 = Reserved Bit 5 = Reserved Bit 6 = Reserved Bit 7 = Reserved Bit 8 = Reserved Bit 9 = Reserved Bit 10 = Reserved Bit 11 = Reserved Bit 12 = Reserved Bit 13 = Reserved Bit 14 = Reserved Bit 15 = Reserved	Unsigned Integer 16 Bits Start Capture on Master Trip State Start Capture on Breaker Open Start Capture on Waveform Capture Initiate Reserved Reserved Reserved Reserved Reserved Reserved Reserved Reserved Reserved Reserved Reserved Reserved Reserved Reserved
63979	Trigger Flag Bit 0 = 87T (lsb) Bit 1 = 87H Bit 2 = 51P-1 Bit 3 = 51N-1 Bit 4 = 50P-1 Bit 5 = 50N-1	Unsigned Integer 16 Bits Start Capture on: 3 Phase % Differential Current Control 3 Phase Instantaneous Differential Current Control Winding 1 Phase Time Overcurrent Control Winding 1 Neutral Time Overcurrent Control Winding 1 Phase Instantaneous Overcurrent Control 1 st Winding 1 Neutral Instantaneous Overcurrent Control

TPU2000/2000R Modbus/Modbus Plus Automation Guide

Register	Item	Description
	Bit 6 = 150P-1 Bit 7 = 150N-1 Bit 8 = 46-1 Bit 9 = 51P-2 Bit10 = 51G (3 Winding) 51G-2 (2 Winding) Bit 11 = 50P-2 Bit 12 = 50G (3 Winding) 50G-2 (2 Winding) Bit 13 = 150P-2 Bit 14 = 150G (3 Winding) 150N-2 (2 Winding) Bit 15 = 46-2 (msb)	2 nd Winding 1 Phase Instantaneous Overcurrent Control 2 nd Winding 1 Neutral Instantaneous Overcurrent Control Winding 1 Negative Sequence Control Winding 2 Phase Instantaneous Overcurrent Control Ground Time Overcurrent Control Winding 2 Ground Time Overcurrent Control Winding 2 Phase Instantaneous Overcurrent Control 1 st Ground Time Overcurrent Control 1 st Winding 2 Ground Time Overcurrent Control 2 nd Winding 2 Phase Time Overcurrent Control 2 nd Ground Instantaneous Control 2 nd Winding 2 Neutral Phase Instantaneous Control Winding 2 Negative Sequence Control
63980	Bit 0 = Thru Fault (lsb) Bit 1 = Harmonic Restraint Bit 2 = External Input Bit 3 = 51P-3 (3 Winding Only) Bit 4 = 51N-3 (3 Winding Only) Bit 5 = 50P-3 (3 Winding Only) Bit 6 = 50N-3 (3 Winding Only) Bit 7 = 150P-3 (3 Winding Only) Bit 8 = 150N-3 (3 Winding Only) Bit 9 = 46-3 (3 Winding Only) Bit 10 = 51N-2 (3 Winding Only) Bit 11 = 50N-2 (3 Winding Only) Bit 12 = 150N-2 (3 Winding Only) Bit 13 = Reserved Bit 14 = Reserved Bit 15 = Reserved (msb)	Through Fault Control Harmonic Restraint Control External Input Control Winding 3 Phase Time Overcurrent Control Winding 3 Neutral Time Overcurrent Control 1 st Winding 3 Phase Instantaneous Overcurrent Control 1 st Winding 3 Neutral Inst. Overcurrent Control 2 nd Winding 3 Phase Instantaneous Overcurrent Control 2 nd Winding 3 Neutral Instantaneous Overcurrent Control Winding 3 Negative Sequence Control Winding 3 Neutral Time Overcurrent Control 1 st Winding 3 Neutral Inst. Overcurrent Control 2 nd Winding 3 Neutral Inst. Overcurrent Control
63084	Reserved	Reserved
63085-63199	Reserved	Reserved

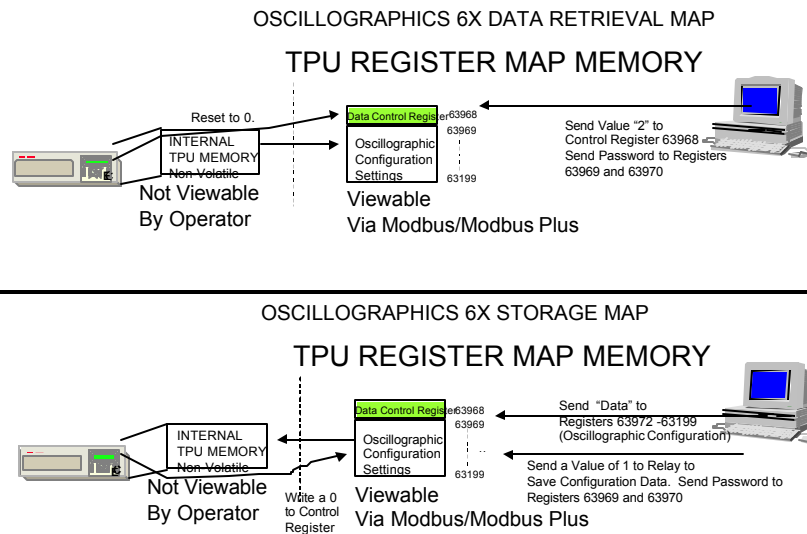

Figure 5-60. Oscillographics Retrieval/Storage Parameterization Philosophy

Whenever the relay is in the capture mode, the capture mode must be stopped to change setting information. Therefore, the following must be performed before changing settings:

1. Register 63072 should be written with a value of “2” to fill registers with the present configuration data within the TPU2000R. Registers 63073 and 63074 should contain the correct password to effectuate the “REFRESH REGISTER” command.
2. The oscillographic accumulation must be stopped to effectuate re-parameterization of the unit. A value of 0 must be written to Register 63076 to pause oscillographic monitoring.
3. The oscillographic data in the configuration block can be modified. To change the parameters, one would write the changed parameters to the appropriate registers as defined in Table 5-53.
4. The host would then write a value of “1” (Start Oscillographic Accumulation) to Register 63076.
5. The host would then write a value of “1” (Transfer Settings) to register 63072 along with the appropriate password (Registers 63073 and 63074). The data would then be transferred from the Modbus volatile register memory to the TPU2000R’s non-volatile configuration memory. This procedure is shown in Figure 5-60 above.

Oscillographic Data Retrieval

The TPU2000R has two steps which must be accomplished for Oscillographic Data Retrieval. Step 1 is that the Channel Data Parameters must be read from the TPU2000R. These parameters display the number of records in the Oscillographics buffer, Trigger Information, sample time stamps and point scaling information. The data is stored in a format in which the information is easily translated to a COMTRADE format.

The second step is the actual retrieval of the data point information used to construct the waveform. If one wishes to retrieve oscillographics from a 3 Winding Unit, the mapping is shown in Table 5-55. If one wishes to retrieve oscillographics from a 2 Winding Unit, the Modbus register map definition is given in [Table YY](#).

Data Retrieval Theory of Operation (3 Winding Units)

There are two sets of write registers required to obtain the captured waveforms, 42690 and 42817/42818.

Register 42690 controls the data constant retrieval for interpreting the point information of the individual points along the waveform curve. The registers in this define the parameters for the selected record. The method for access is described in Figure 5-61.

EXAMPLE 1 -OSCILLOGRAPHIC CONFIGURATION DATA RETRIEVAL (STEP 1)

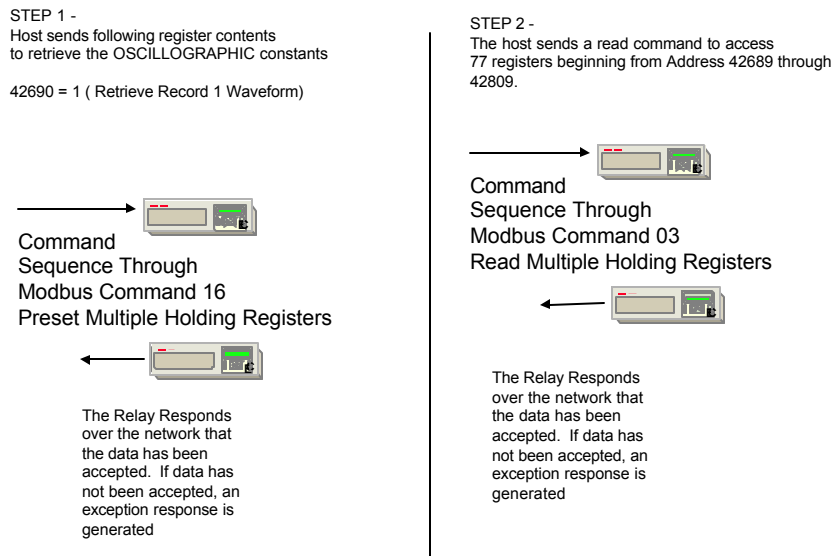

Figure 5-61. Configuration Data Retrieval Example

TPU2000/2000R Modbus/Modbus Plus Automation Guide

Register 42817 and 42818 control the method to obtain the individual points to construct the curve.

Each waveform consists of 32 points. The TPU2000R stores the waveform and transfers the data to the host in quarter cycle blocks. Thus, if 8 cycles are stored for a waveform Record, 32 blocks of data must be retrieved by the host to display the selected waveform record. Waveform data is to be read eight points per channel with eight channels per block.

The steps required to read the data are as such:

- ❑ Write the record number and quarter cycle block to access (Register 42818 = 1 for read first Quarter Cycle Block of Data). The TPU2000R shall reset the control register to 0.
- ❑ Read the block of point data.
- ❑ Write the Record Number and quarter cycle block to access (Register 42818 = 2 for read next Quarter Cycle Block of Data). The TPU2000R shall reset the control register to 0.
- ❑ Read the Block of point data.
- ❑ If Register 42820 is not equal to 0, repeat the previous two steps.

The process is illustrated pictorially in Figure 5-62.

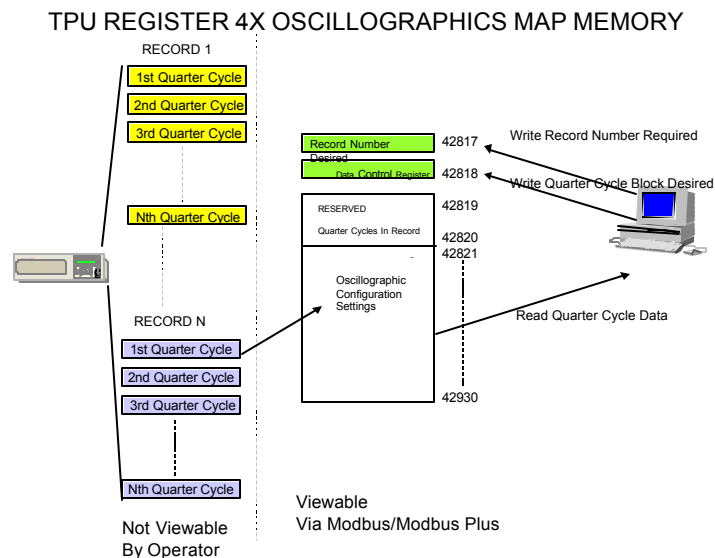

Figure 5-62. Memory Map Philosophy for Oscillographics Waveform Retrieval

Table 5-55. Oscillographic Data Format Retrieval Block

Register Address 3 Winding	Item	Description
CHANNEL DATA		
42689	<u>READ DATA</u> – Number of Records Stored	Unsigned Integer (16 Bits) Amount of Data Records in Buffer (Value = 0- 8)
42690	<u>WRITE DATA</u> – Record Desired to Retrieve	Unsigned Integer (16 Bits) (Value = 0 to 8)
42691	<u>READ DATA</u> –Trigger Flag Word 1 RESERVED	Unsigned Integer (16 Bits) RESERVED
42692	<u>READ DATA</u> – Trigger Flag Word 2 RESERVED	Unsigned Integer (16 Bits) RESERVED
42693	<u>READ DATA</u> – Trigger Flag Word 3 Bit 0 = Master Trip (Isb) Bit 1 = Breaker Open	Unsigned Integer (16 Bits) Start Capture on Master Trip State Start Capture on Breaker Open

TPU2000/2000R Modbus/Modbus Plus Automation Guide

Register Address 3 Winding	Item	Description
	Bit 2 = WCI Bit 3 = Reserved Bit 4 = Reserved Bit 5 = Reserved Bit 6 = Reserved Bit 7 = Reserved Bit 8 = Reserved Bit 9 = Reserved Bit 10 = Reserved Bit 11 = Reserved Bit 12 = Reserved Bit 13 = Reserved Bit 14 = Reserved Bit 15 = Reserved (msb)	Start Capture on Waveform Capture Initiate Reserved Reserved Reserved Reserved Reserved Reserved Reserved Reserved Reserved Reserved Reserved Reserved Reserved Reserved
42694	READ DATA – Trigger Flag Word 4 Bit 0 = 50N-1 (lsb) Bit 1 = 50N-2 Bit 2 = 50N-3 Bit 3 = 51N Bit 4 = 50P-1 Bit 5 = 50P-2 Bit 6 = 50P-3 Bit 7 = 51P Bit 8 = 67P Bit 9 = 67N Bit10 = 46 Bit 11 = 27 Bit 12 = 59 Bit 13 = 79V Bit 14 = 81S-1 Bit 15 = 81R –1 (msb)	Unsigned Integer (16 Bits) Neutral. Instantaneous Overcurrent Trip Neutral. Instantaneous Overcurrent Trip Neutral. Instantaneous Overcurrent Trip Neutral Time Overcurrent Trip Phase Instantaneous Overcurrent Trip Phase Instantaneous Overcurrent Trip Phase Instantaneous Overcurrent Trip Phase Time Overcurrent Trip Direct Overcurrent Trip Positive Sequence Direct Overcurrent Trip Negative Sequence Negative Sequence Overcurrent Trip Undervoltage Trip Overcurrent Trip Recloser Lockout Frequency Shed (First Stage) Frequency Restore (First Stage)
DATE/TIMESTAMPS OF TRIGGER POINT		
42695	Year	Unsigned Integer 16 Bits 0-99
42696	Month	Unsigned Integer 16 Bits 1- 12
42697	Day	Unsigned Integer 16 bits 1-31
42698	Hour	Unsigned Integer 16 Bits 0-23
42699	Minute	Unsigned Integer 16 Bits 0-59
42700	Second	Unsigned Integer 16 Bits 0-59
42701	Hundredths of Seconds	Unsigned Integer 16 Bits 0 – 99
42702	Quarter Cycle Trigger Point	Unsigned Integer 16 Bits Number of 1/4 Cycle of Trigger Point 0-255 (Dependent on 6X Register Config)
42703	Total Number of Channels	Unsigned Integer 16 Bits Default as 7
42704	Total Analog Data Channels	Unsigned Integer 16 Bits FIXED at 7
42705	Total Digital Data Channels	Unsigned Integer 16 Bits 0 <=Range <= 64

TPU2000/2000R Modbus/Modbus Plus Automation Guide

Register Address	Item	Description
3 Winding		
LINE FREQUENCY OF WAVEFORM		
42706	Line Frequency	Unsigned Integer 16 Bits 50 or 60 Hz
SAMPLE RATE INFORMATION		
42707	Reserved	Reserved
42708	Reserved	Reserved
42709	Reserved	Reserved
CHANNEL NAMES, UNITS, AND CONVERSIONS		
42710	CHANNEL 1 – Channel Number	Unsigned Integer 16 Bits See Note 1
42711	CHANNEL 1 – Channel Name	2 Digits ASCII
42712	CHANNEL 1 – Channel Phase Identification	Unsigned Integer 16 Bits See Note 1
42713	CHANNEL 1 – Channel Units	Unsigned Integer 16 Bits 1 = Amps 2 = Volts
42714	CHANNEL 1 – Scale Factor Numerator	Unsigned 32 Bit High Order Word (MSW)
42715	CHANNEL 1 – Scale Factor Numerator	Unsigned 32 Bit Low Order Word (LSW)
42716	CHANNEL 1 – Scale Factor Denominator	Unsigned 32 Bit High Order Word (MSW)
42717	CHANNEL 1 – Scale Factor Denominator	Unsigned 32 Bit Low Order Word (MSW)
42718	CHANNEL 2 – Channel Number	Unsigned Integer 16 Bits See Note 1
42719	CHANNEL 2 – Channel Name	2 Digits ASCII
42720	CHANNEL 2 – Channel Phase Identification	Unsigned Integer 16 Bits See Note 1
42721	CHANNEL 2 – Channel Units	Unsigned Integer 16 Bits 1 = Amps 2 = Volts
42722	CHANNEL 2 – Scale Factor Numerator	Unsigned 32 Bit High Order Word (MSW)
42723	CHANNEL 2 – Scale Factor Numerator	Unsigned 32 Bit Low Order Word (LSW)
42724	CHANNEL 2 – Scale Factor Denominator	Unsigned 32 Bit High Order Word (MSW)
42725	CHANNEL 2 – Scale Factor Denominator	Unsigned 32 Bit Low Order Word (MSW)
42726	CHANNEL 3 – Channel Number	Unsigned Integer 16 Bits See Note 1
42727	CHANNEL 3 – Channel Name	2 Digits ASCII
42728	CHANNEL 3 – Channel Phase Identification	Unsigned Integer 16 Bits See Note 1
42729	CHANNEL 3 – Channel Units	Unsigned Integer 16 Bits 1 = Amps 2 = Volts
42730	CHANNEL 3 – Scale Factor Numerator	Unsigned 32 Bit High Order Word (MSW)
42731	CHANNEL 3 – Scale Factor Numerator	Unsigned 32 Bit Low Order Word (LSW)
42732	CHANNEL 3 – Scale Factor Denominator	Unsigned 32 Bit High Order Word (MSW)
42733	CHANNEL 3 – Scale Factor Denominator	Unsigned 32 Bit Low Order Word (MSW)
42734	CHANNEL 4 – Channel Number	Unsigned Integer 16 Bits See Note 1
42735	CHANNEL 4 – Channel Name	2 Digits ASCII
42736	CHANNEL 4 – Channel Phase Identification	Unsigned Integer 16 Bits See Note 1
42737	CHANNEL 4 – Channel Units	Unsigned Integer 16 Bits 1 = Amps 2 = Volts
42738	CHANNEL 4 – Scale Factor Numerator	Unsigned 32 Bit High Order Word (MSW)

TPU2000/2000R Modbus/Modbus Plus Automation Guide

Register Address 3 Winding	Item	Description
42739	CHANNEL 4 – Scale Factor Numerator	Unsigned 32 Bit Low Order Word (LSW)
42740	CHANNEL 4 – Scale Factor Denominator	Unsigned 32 Bit High Order Word (MSW)
42741	CHANNEL 4 – Scale Factor Denominator	Unsigned 32 Bit Low Order Word (MSW)
42742	CHANNEL 5 – Channel Number	Unsigned Integer 16 Bits See Note 1
42743	CHANNEL 5 – Channel Name	2 Digits ASCII
42744	CHANNEL 5 – Channel Phase Identification	Unsigned Integer 16 Bits See Note 1
42745	CHANNEL 5 – Channel Units	Unsigned Integer 16 Bits 1 = Amps 2 = Volts
42746	CHANNEL 5 – Scale Factor Numerator	Unsigned 32 Bit High Order Word (MSW)
42747	CHANNEL 5 – Scale Factor Numerator	Unsigned 32 Bit Low Order Word (LSW)
42748	CHANNEL 5 – Scale Factor Denominator	Unsigned 32 Bit High Order Word (MSW)
42749	CHANNEL 5 – Scale Factor Denominator	Unsigned 32 Bit Low Order Word (MSW)
42750	CHANNEL 6 – Channel Number	Unsigned Integer 16 Bits See Note 1
42751	CHANNEL 6 – Channel Name	2 Digits ASCII
42752	CHANNEL 6 – Channel Phase Identification	Unsigned Integer 16 Bits See Note 1
42753	CHANNEL 6 – Channel Units	Unsigned Integer 16 Bits 1 = Amps 2 = Volts
42754	CHANNEL 6 – Scale Factor Numerator	Unsigned 32 Bit High Order Word (MSW)
42755	CHANNEL 6 – Scale Factor Numerator	Unsigned 32 Bit Low Order Word (LSW)
42756	CHANNEL 6 – Scale Factor Denominator	Unsigned 32 Bit High Order Word (MSW)
42757	CHANNEL 6 – Scale Factor Denominator	Unsigned 32 Bit Low Order Word (MSW)
42758	CHANNEL 7 – Channel Number	Unsigned Integer 16 Bits See Note 1
42759	CHANNEL 7 – Channel Name	2 Digits ASCII
42760	CHANNEL 7 – Channel Phase Identification	Unsigned Integer 16 Bits See Note 1
42761	CHANNEL 7 – Channel Units	Unsigned Integer 16 Bits 1 = Amps 2 = Volts
42762	CHANNEL 7 – Scale Factor Numerator	Unsigned 32 Bit High Order Word (MSW)
42763	CHANNEL 7 – Scale Factor Numerator	Unsigned 32 Bit Low Order Word (LSW)
42764	CHANNEL 7 – Scale Factor Denominator	Unsigned 32 Bit High Order Word (MSW)
42765	CHANNEL 7 – Scale Factor Denominator	Unsigned 32 Bit Low Order Word (MSW)
42766	CHANNEL 7 – Channel Number	Unsigned Integer 16 Bits See Note 1
42767	CHANNEL 8 – Channel Name	2 Digits ASCII
42768	CHANNEL 8 – Channel Phase Identification	Unsigned Integer 16 Bits See Note 1
42769	CHANNEL 8 – Channel Units	Unsigned Integer 16 Bits 1 = Amps 2 = Volts
42770	CHANNEL 8 – Scale Factor Numerator	Unsigned 32 Bit High Order Word (MSW)
42771	CHANNEL 8 – Scale Factor Numerator	Unsigned 32 Bit Low Order Word (LSW)
42772	CHANNEL 8 – Scale Factor Denominator	Unsigned 32 Bit High Order Word (MSW)
42773	CHANNEL 8 – Scale Factor Denominator	Unsigned 32 Bit Low Order Word (MSW)
42774	CHANNEL 9 – Channel Number	Unsigned Integer 16 Bits See Note 1

TPU2000/2000R Modbus/Modbus Plus Automation Guide

Register Address 3 Winding	Item	Description
42775	CHANNEL 9 – Channel Name	2 Digits ASCII
42776	CHANNEL 9 – Channel Phase Identification	Unsigned Integer 16 Bits See Note 1
42777	CHANNEL 9 – Channel Units	Unsigned Integer 16 Bits 1 = Amps 2 = Volts
42778	CHANNEL 9 – Scale Factor Numerator	Unsigned 32 Bit High Order Word (MSW)
42779	CHANNEL 9 – Scale Factor Numerator	Unsigned 32 Bit Low Order Word (LSW)
42780	CHANNEL 9 – Scale Factor Denominator	Unsigned 32 Bit High Order Word (MSW)
42781	CHANNEL 9 – Scale Factor Denominator	Unsigned 32 Bit Low Order Word (MSW)
42782	CHANNEL 10 – Channel Number	Unsigned Integer 16 Bits See Note 1
42783	CHANNEL 10 – Channel Name	2 Digits ASCII
42784	CHANNEL 10 – Channel Phase Identification	Unsigned Integer 16 Bits See Note 1
42785	CHANNEL 10 – Channel Units	Unsigned Integer 16 Bits 1 = Amps 2 = Volts
42786	CHANNEL 10 – Scale Factor Numerator	Unsigned 32 Bit High Order Word (MSW)
42787	CHANNEL 10 – Scale Factor Numerator	Unsigned 32 Bit Low Order Word (LSW)
42788	CHANNEL 10 – Scale Factor Denominator	Unsigned 32 Bit High Order Word (MSW)
42789	CHANNEL 10 – Scale Factor Denominator	Unsigned 32 Bit Low Order Word (MSW)
42790	CHANNEL 11 – Channel Number	Unsigned Integer 16 Bits See Note 1
42791	CHANNEL 11 – Channel Name	2 Digits ASCII
42792	CHANNEL 11 – Channel Phase Identification	Unsigned Integer 16 Bits See Note 1
42793	CHANNEL 11 – Channel Units	Unsigned Integer 16 Bits 1 = Amps 2 = Volts
42794	CHANNEL 11 – Scale Factor Numerator	Unsigned 32 Bit High Order Word (MSW)
42795	CHANNEL 11 – Scale Factor Numerator	Unsigned 32 Bit Low Order Word (LSW)
42796	CHANNEL 11 – Scale Factor Denominator	Unsigned 32 Bit High Order Word (MSW)
42797	CHANNEL 11 – Scale Factor Denominator	Unsigned 32 Bit Low Order Word (MSW)
42798	CHANNEL 12 – Channel Number	Unsigned Integer 16 Bits See Note 1
42799	CHANNEL 12 – Channel Name	2 Digits ASCII
42800	CHANNEL 12 – Channel Phase Identification	Unsigned Integer 16 Bits See Note 1
42801	CHANNEL 12 – Channel Units	Unsigned Integer 16 Bits 1 = Amps 2 = Volts
42802	CHANNEL 12 – Scale Factor Numerator	Unsigned 32 Bit High Order Word (MSW)
42803	CHANNEL 12 – Scale Factor Numerator	Unsigned 32 Bit Low Order Word (LSW)
42804	CHANNEL 12 – Scale Factor Denominator	Unsigned 32 Bit High Order Word (MSW)
42805	CHANNEL 12 – Scale Factor Denominator	Unsigned 32 Bit Low Order Word (MSW)
42806	CHANNEL 7 – Channel Number	Unsigned Integer 16 Bits See Note 1
42807	CHANNEL 7 – Channel Name	2 Digits ASCII
42808	CHANNEL 7 – Channel Phase Identification	Unsigned Integer 16 Bits See Note 1
42809	CHANNEL 7 – Channel Units	Unsigned Integer 16 Bits 1 = Amps

TPU2000/2000R Modbus/Modbus Plus Automation Guide

Register Address 3 Winding	Item	Description
		2 = Volts
42810	CHANNEL 7 – Scale Factor Numerator	Unsigned 32 Bit High Order Word (MSW)
42811	CHANNEL 7 – Scale Factor Numerator	Unsigned 32 Bit Low Order Word (LSW)
42812	CHANNEL 7 – Scale Factor Denominator	Unsigned 32 Bit High Order Word (MSW)
42813	CHANNEL 7 – Scale Factor Denominator	Unsigned 32 Bit Low Order Word (MSW)
42814 THROUGH 42816 RESERVED FOR FUTURE USE.		
NOTE 1:THE CODE FOR CHANNEL NUMBERS/CHANNEL PHASE ID ARE AS FOLLOWS – 1 = Ia 2 = Ib 3 = Ic 4 = In 5 = Va 6 = Vb 7 = Vc		
OSCILLOGRAPHIC QUARTER CYCLE DATA POINTS		
42817	<u>WRITE DATA</u> – Record Number Desired	Unsigned Integer 16 Bit 0<=Range <= 8 depending sample size
42818	<u>WRITE DATA</u> – Control Register	Unsigned Integer 16 Bit 1 = First Quarter Cycle of Data 2 = Next Quarter Cycle of Data 3 = Previous Quarter Cycle of Data
42819	Reserved	Reserved
42820	Quarter Cycle Blocks Remaining to be read	Unsigned Integer 16 Bit 0 = None <= Range<= 255
42821	Quarter Cycle Fault Type Word 1 Reserved	Unsigned Integer 16 Bit Reserved
42822	Quarter Cycle Fault Type Word 2 Bit 0 = 50N-1 (lsb) Bit 1 = 50N-2 Bit 2 = 50N-3 Bit 3 = 51N Bit 4 = 50P-1 Bit 5 = 50P-2 Bit 6 = 50P-3 Bit 7 = 51P Bit 8 = 67P Bit 9 = 67N Bit10 = 46 Bit 11 = 27 Bit 12 = 59 Bit 13 = 79V Bit 14 = 81S-1 Bit 15 = 81R –1 (msb)	Unsigned Integer 16 Bit Neutral. Instantaneous Overcurrent Trip Neutral. Instantaneous Overcurrent Trip Neutral. Instantaneous Overcurrent Trip Neutral Time Overcurrent Trip Phase Instantaneous Overcurrent Trip Phase Instantaneous Overcurrent Trip Phase Instantaneous Overcurrent Trip Phase Time Overcurrent Trip Direct Overcurrent Trip Positive Sequence Direct Overcurrent Trip Negative Sequence Negative Sequence Overcurrent Trip Undervoltage Trip Overcurrent Trip Recloser Lockout Frequency Shed (First Stage) Frequency Restore (First Stage)
42823	Quarter Cycle Pickup Type Word 1 Reserved	Unsigned Integer 16 Bit Reserved
42824	Quarter Cycle Pickup Type Word 2 Bit 0 = 50N-1 (lsb) Bit 1 = 50N-2 Bit 2 = 50N-3 Bit 3 = 51N Bit 4 = 50P-1 Bit 5 = 50P-2 Bit 6 = 50P-3 Bit 7 = 51P Bit 8 = 67P	Unsigned Integer 16 Bits Neutral. Instantaneous Overcurrent Trip Neutral. Instantaneous Overcurrent Trip Neutral. Instantaneous Overcurrent Trip Neutral Time Overcurrent Trip Phase Instantaneous Overcurrent Trip Phase Instantaneous Overcurrent Trip Phase Instantaneous Overcurrent Trip Phase Time Overcurrent Trip Direct Overcurrent Trip Positive Sequence

TPU2000/2000R Modbus/Modbus Plus Automation Guide

Register Address 3 Winding	Item	Description
	Bit 9 = 67N Bit10 = 46 Bit 11 = 27 Bit 12 = 59 Bit 13 = 79V Bit 14 = 81S-1 Bit 15 = 81R -1 (msb)	Direct Overcurrent Trip Negative Sequence Negative Sequence Overcurrent Trip Undervoltage Trip Overcurrent Trip Recloser Lockout Frequency Shed (First Stage) Frequency Restore (First Stage)
42825	Quarter Cycle Miscellaneous Data Word 1 Reserved	Unsigned Integer 16 Bits Reserved
42826	Quarter Cycle Miscellaneous Data Word 2 Bit 0 = Master Trip(Isb) Bit 1 = 52 a Bit 2 = BFA Bit 3 = Reserved Bit 4 = Reserved Bit 5 = Reserved Bit 6 = Reserved Bit 7 = Reserved Bit 8 = Reserved Bit 9 = Reserved Bit10 = Reserved Bit 11 = Reserved Bit 12 = Reserved Bit 13 = Reserved Bit 14 = Reserved Bit 15 = Reserved (msb)	Unsigned Integer 16 Bits Master Trip Status Breaker Status (1 = Open, 0 = Closed) Breaker Fail Alarm Reserved Reserved Reserved Reserved Reserved Reserved Reserved Reserved Reserved Reserved Reserved Reserved Reserved Reserved
OSCILLOGRAPHIC DATA POINTS		
42827	CHANNEL 1 POINT 1	Signed Integer 16 Bits
42828	CHANNEL 2 POINT 1	Signed Integer 16 Bits
42829	CHANNEL 3 POINT 1	Signed Integer 16 Bits
42830	CHANNEL 4 POINT 1	Signed Integer 16 Bits
42831	CHANNEL 5 POINT 1	Signed Integer 16 Bits
42832	CHANNEL 6 POINT 1	Signed Integer 16 Bits
42833	CHANNEL 7 POINT 1	Signed Integer 16 Bits
42834	CHANNEL 1 POINT 2	Signed Integer 16 Bits
42835	CHANNEL 2 POINT 2	Signed Integer 16 Bits
42836	CHANNEL 3 POINT 2	Signed Integer 16 Bits
42837	CHANNEL 4 POINT 2	Signed Integer 16 Bits
42838	CHANNEL 5 POINT 2	Signed Integer 16 Bits
42839	CHANNEL 6 POINT 2	Signed Integer 16 Bits
42840	CHANNEL 7 POINT 2	Signed Integer 16 Bits
42841	CHANNEL 1 POINT 3	Signed Integer 16 Bits
42842	CHANNEL 2 POINT 3	Signed Integer 16 Bits
42843	CHANNEL 3 POINT 3	Signed Integer 16 Bits
42844	CHANNEL 4 POINT 3	Signed Integer 16 Bits
42845	CHANNEL 5 POINT 3	Signed Integer 16 Bits
42846	CHANNEL 6 POINT 3	Signed Integer 16 Bits
42847	CHANNEL 7 POINT 3	Signed Integer 16 Bits
42848	CHANNEL 1 POINT 4	Signed Integer 16 Bits
42849	CHANNEL 2 POINT 4	Signed Integer 16 Bits
42850	CHANNEL 3 POINT 4	Signed Integer 16 Bits
42851	CHANNEL 4 POINT 4	Signed Integer 16 Bits
42852	CHANNEL 5 POINT 4	Signed Integer 16 Bits

TPU2000/2000R Modbus/Modbus Plus Automation Guide

Register Address	Item	Description
42853	CHANNEL 6 POINT 4	Signed Integer 16 Bits
42854	CHANNEL 7 POINT 4	Signed Integer 16 Bits
42855	CHANNEL 1 POINT 5	Signed Integer 16 Bits
42856	CHANNEL 2 POINT 5	Signed Integer 16 Bits
42857	CHANNEL 3 POINT 5	Signed Integer 16 Bits
42858	CHANNEL 4 POINT 5	Signed Integer 16 Bits
42859	CHANNEL 5 POINT 5	Signed Integer 16 Bits
42860	CHANNEL 6 POINT 5	Signed Integer 16 Bits
42861	CHANNEL 7 POINT 5	Signed Integer 16 Bits
42862	CHANNEL 1 POINT 6	Signed Integer 16 Bits
42863	CHANNEL 2 POINT 6	Signed Integer 16 Bits
42864	CHANNEL 3 POINT 6	Signed Integer 16 Bits
42865	CHANNEL 4 POINT 6	Signed Integer 16 Bits
42866	CHANNEL 5 POINT 6	Signed Integer 16 Bits
42867	CHANNEL 6 POINT 6	Signed Integer 16 Bits
42868	CHANNEL 7 POINT 6	Signed Integer 16 Bits
42869	CHANNEL 1 POINT 7	Signed Integer 16 Bits
42870	CHANNEL 2 POINT 7	Signed Integer 16 Bits
42871	CHANNEL 3 POINT 7	Signed Integer 16 Bits
42872	CHANNEL 4 POINT 7	Signed Integer 16 Bits
42873	CHANNEL 5 POINT 7	Signed Integer 16 Bits
42874	CHANNEL 6 POINT 7	Signed Integer 16 Bits
42875	CHANNEL 7 POINT 7	Signed Integer 16 Bits
42876	CHANNEL 1 POINT 8	Signed Integer 16 Bits
42877	CHANNEL 2 POINT 8	Signed Integer 16 Bits
42878	CHANNEL 3 POINT 8	Signed Integer 16 Bits
42879	CHANNEL 4 POINT 8	Signed Integer 16 Bits
42880	CHANNEL 5 POINT 8	Signed Integer 16 Bits
42881	CHANNEL 6 POINT 8	Signed Integer 16 Bits
42882	CHANNEL 7 POINT 8	Signed Integer 16 Bits
42883	CHANNEL 1 POINT 9	Signed Integer 16 Bits
42884	CHANNEL 2 POINT 9	Signed Integer 16 Bits
42885	CHANNEL 3 POINT 9	Signed Integer 16 Bits
42886	CHANNEL 4 POINT 9	Signed Integer 16 Bits
42887	CHANNEL 5 POINT 9	Signed Integer 16 Bits
42888	CHANNEL 6 POINT 9	Signed Integer 16 Bits
42889	CHANNEL 7 POINT 9	Signed Integer 16 Bits
42890	CHANNEL 1 POINT 10	Signed Integer 16 Bits
42891	CHANNEL 2 POINT 10	Signed Integer 16 Bits
42892	CHANNEL 3 POINT 10	Signed Integer 16 Bits
42893	CHANNEL 4 POINT 10	Signed Integer 16 Bits
42894	CHANNEL 5 POINT 10	Signed Integer 16 Bits
42895	CHANNEL 6 POINT 10	Signed Integer 16 Bits
42896	CHANNEL 7 POINT 10	Signed Integer 16 Bits
42897		
42898		
42899		
42900		
42901		
42902		
42903		
42904		

TPU2000/2000R Modbus/Modbus Plus Automation Guide

Register Address 3 Winding	Item	Description
42905		
42906		
42907		
42908		
42909		
42910		
42911		
42912		
42913		
42914		
42915		
42916		
42917		
42918		
42919		
42920		
42921		
42922		
42923		
42924		
42925		
42926		
42927		
42928		
42929		
42930		
42931		
42932		
42933		
42934		
42935		
42936		
42937		
42938		

Oscillographic Data Interpretation

Once the point and configuration data is obtained from the relay, constructing the waveform curve is fairly straightforward as illustrated in Figure 5-63. The mathematics required for obtaining point data follows:

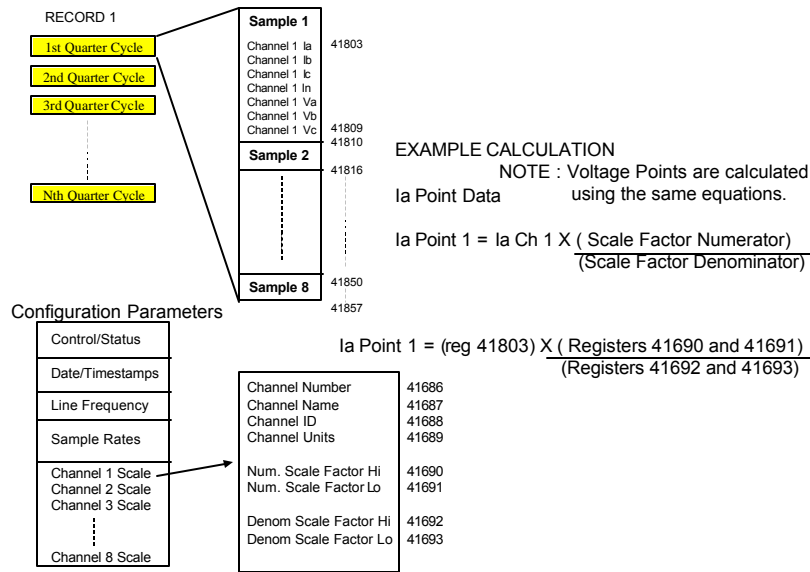

Figure 5-63. Data Interpretation

6X Registers

General Relay settings are available for viewing via the TPU2000/TPU2000R front panel interface. All parameters accessible through the front panel, ECP or WinECP are accessible through the Modbus 6X registers.

A protective relay may have thousands of parameters stored in its configuration. The Modbus/Modbus Plus capable 984-680 programmable logic controllers (and earlier models) have historically only defined up to 1890 or 1920 registers for access within its products. Later definitions of the Modbus/Modbus Plus Protocol and programmable logic controllers allowed defined up to 10,000 4X registers. Even with this improvement, this amount of registers was still too limited to store the vast amount of information available for retrieval and storage within a Modbus node (or protective relay for that matter).

Modbus protocol included a standard 6X register type. The protocol defines this memory as extended memory. Modbus 6X memory is available in groups of 10,000 registers. Up to 10 groups may be defined within a node. Each group is referenced in the Modbus protocol as a file.

It is a standard ABB practice to store any configuration settings in 6X register memory. The TPU2000/TPU2000R has all its parameters stored in File 0 of the 6X memory definition (Files being defined from 0 through 9).

Generally, all configurable functions available through ECP or WinECP configuration package may be configured via the 6X Modbus registers. However, ECP or WinECP configures the IED through the Standard Ten Byte protocol. ECP or WinECP configuration through the Modbus or Modbus Plus network is not possible at this time. The available configuration parameter functions via the 6X registers are:

- Programmable Logic Input Configuration
- Programmable Logic Output Configuration
- Primary Relay Settings
- Alt 1 Relay Settings
- Alt 2 Relay Settings
- Relay Configuration Settings
- Counter Settings
- Alarm Settings
- Real Time Clock Configuration
- ULO Connection Settings and Name Assignment
- Forced Logical Input Configuration and Name Assignment
- Modbus Plus Global Data Configuration
- User Definable Register Configuration

TPU2000/2000R Modbus/Modbus Plus Automation Guide

- ❑ Password Security Mask Control Configuration
- ❑ Oscilloscopes Control and Status

Each topic is covered in the sections following this discussion.

Function Code 20 (Read General Reference) and 21 (Write General Reference)

Modbus Protocol defines two commands 20 and 21 to read and write the registers within the 6X register groups (or blocks). Figure 5-64 illustrates the frame sequence of Function 20 and Figure 5-65 illustrates the frame sequence of Function 21.

Function 20 Read Gen.Ref.

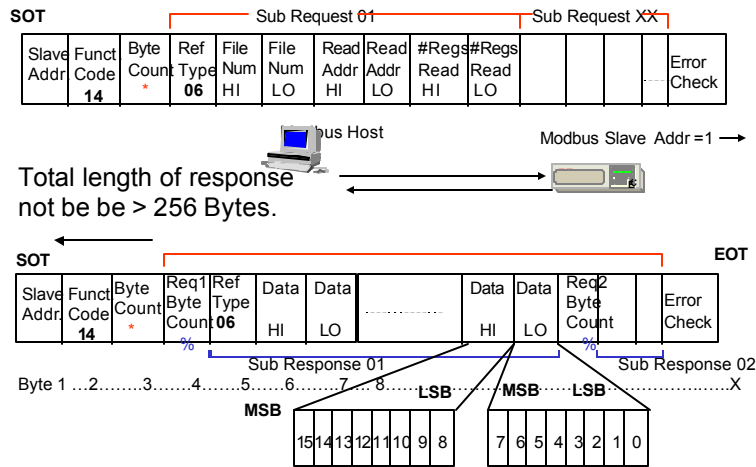

Figure 5-64. Function 20 Read 6x Register Frame Definition

Function 21 Read Gen.Ref.

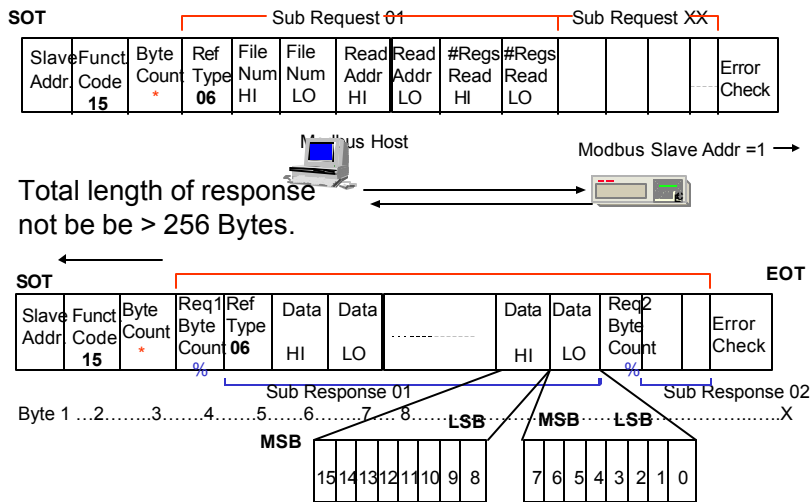

Figure 5-65. Modbus Command 21 - Write General Reference Format

IMPLEMENTATION TIP- When 6x Registers Are Written, A 10 Minute Execute Timer Is Initiated Upon The First Write To A 6x Block. If The Execute Register Is Not Written With A Value Of 1 Within The 10 Minutes Of The Initial Write, The 6x Veivable Register Segment Will Be Restored To The Original Values From The "TPU2000/TPU2000R's" Internal Flash Ram Memory.

Programmable Input Configuration

The TPU2000/TPU2000R allows for query or changing of Relay Configuration Data via the Modbus ASCII protocol. [Table 23](#) further describes the register assignment for viewing or changing the TPU2000/TPU2000R parameters.

Term Definitions

The parameterization may be configured via ECP or WinECP. However changing the Programmable Input Configuration is slightly more involved through Modbus Plus or Modbus. A few terms must be understood before discussing the procedure for changing the 6X memory Programmable Input parameters.

Physical Input: The opto-isolated binary input that allows external control by physically wiring the input terminals of the TPU2000R. Physical inputs are labeled (IN1, IN2, IN3, ..., 52A, 52B).

Logical Input: An input equated by the boolean combination of the physical inputs. These inputs are used by the TPU2000R's state machine and control subroutines. Logical Inputs are labeled (WCI, TCM, ...). See later in this paragraph for additional labels.

Active Open: This defines the type of connection from the physical input or inputs and means the physical state of the opto-isolator's logic is inverted. Example: if the voltage across IN1's terminals equals zero, then the boolean equation will evaluate this term as a logical one. Likewise, when a voltage is applied to IN1, the boolean equation will evaluate this term as a logical zero.

Active Closed: This defines the type of connection from the physical input or inputs and means that the physical state of the opto-isolator's logic is the non-inverted. Example: if a voltage is applied across IN1's terminals, then the boolean equation will evaluate this term as a logical one. Likewise, when a voltage is applied to IN1, the boolean equation will evaluate this term as a logical zero.

Boolean Logic Input Equation:

Logical
50P-1 = ORed Physical
IN1 + IN2 + IN3

Logical
WCI = ANDed Physical
IN1 * IN2 * IN3

Input Select:

The physical inputs are associated with a bit mask to determine which inputs are used when resolving the logical input's boolean equation. If the appropriate bit is set, the term will be included as part of the equation. Likewise, a cleared bit indicates that the physical input term will be ignored.

Negated AND Input:

This is a bit mask that indicates if a selected input is inverted based on the active open or closed state. The bit mask uses the same associated physical inputs pattern as in the Input Select data.

AND/OR Select:

The combination of the physical inputs' state used to resolve the boolean equation allows for the algebraic ANDing or ORing of all of the selected physical inputs.

User Definable Names:

Physical inputs, IN1 - IN13, have memory allocated for an eight character (NULL is implied in character 9) user definable strings.

Methodology and Register Manipulation to Configure the Programmable Logical Input

Four protocol commands are required to view or change the TPU2000R's programmable input setting tables. The command order for viewing these tables can be retrieved in any sequence, but when the settings are sent to the TPU2000, the commands must be sent in the following sequence:

- Receive Programmable Input Select and Index data.
- Receive Programmable Negated AND Input data.
- Receive Programmable Input AND/OR Select data.
- Receive Programmable Input User Defined Name data.

Up to 29 logical inputs may be selected at any one time. The protocol document refers to these generic logical inputs as INPUT1 - INPUT29. The bit assignment mask for the physical inputs are as follows:

0 = IN3, 1 = IN4, 2 = IN9, 3 = IN2, 4 = IN10, 5 = 43A, 6 = 52B, 7 = 52A, 8 = IN1, 9 = IN11, 10 = IN8, 11 = IN7, 12 = IN6, 13 = IN5, 14 = IN13, 15 = IN12

Tables 5-? through 5-? are used to configure the boolean algebraic equations for the desired configuration:

An example illustrating the configuration technique shall suffice:

EXAMPLE:

PH3 logical input is to be the combination of the physical inputs IN4 AND NOT IN3
ALT1 is to be selected through the logical input combination of the physical inputs IN1 OR IN3 OR NOT IN5.

The boolean logic representation of the above is derived to the following equations.

Equation XX -1 PH3 = IN4 * !IN3

Equation XX - 2 ALT1 = IN1 + IN3 + !IN5

PH3 is desired to be mapped to physical input 3. Alternate 1 selection is desired to be mapped to physical input 8.

SOLUTION:

First, generic inputs must be selected to setup the logic equation and for this case INPUT3 is used for PH3 and INPUT8 is used for ALT1. Note, any inputs 1-29 could be valid selections. The data values required for these selections use the INDEX table defined in the protocol document.

<u>Register</u>	<u>HexData</u>	<u>Comment</u>
60007	0XFF9F	Selects IN3 and IN4 bits for INPUT3 Input Select low byte. Reference Figure 5-66 for the mapping of the input selection table (Bit 0 = lsb [rightmost bit] Bit 15 = msb [leftmost bit]). (Reference Table 5-57)
Input xxxxxx		
60045	0x0300	Assigning PH3 offset to INPUT3 for Input Index high byte
The Physical Input 3 is to be mapped to the logical function PH3. The Logical Input function code definitions are given in Table 5-56 The codes are used to assign the logical function bytes listed in Table 5-57 registers 60044 through 60058.		
60012	0xDEFE	Selects IN1 and IN5 bits for INPUT8 Input Select high byte Selects IN3 bit for INPUT8 Input Select low byte
Reference Figure 5-66 for the mapping of the input selection table (Bit 0 = lsb [rightmost bit] Bit 15 = msb [leftmost bit]). (Reference Table 5-54)		
60047	0x000C	Assigning ALT1 offset to INPUT8 for Input Index low byte
Reference Figure 5-66 for the mapping of the input selection table (Bit 0 = lsb [rightmost bit] Bit 15 = msb [leftmost bit]). (Reference Table 5-57 and Figure 5-66).		
60066	0xFFFE	This step inverts IN3's logical state for INPUT3 Negated AND Input low byte. (Reference Table 5-58 and Figure 5-66)

60071	0xDFFF	Inverts IN5's logical state for INPUT8 Negated AND Input high byte. . (Reference Table 5-58 and Figure 5-66)
60128	0x0000	Boolean combination of INPUT3 selected physical logic are ANDed, all other (Reference Table 5-59)
60129	0x0004	INPUT1,2,4-29 are ORed together (Reference Table 5-59)

Table 5-56 lists the programmable Input Select and Index Bytes required for selecting the INPUT required as per Figure 5-66. (Note the table is inverted in that Bit 15 is the left most bit and bit 0 is actually the right most bit)

Bit Position:	15	14	13	12	11	10	9	8	7	6	5	4	3	2	1	0
TPU2000:	FB8	FB7	FB6	FB5	FB4	FB3	FB2	IN1	IN5	IN4	IN3	FB1	IN2	IN8	IN7	IN6

Figure 5-66. Bit Input Mapping Definition for Registers

Function Index Table and Definition

Table 5-56. Physical Logical Function Byte Configuration Codes for Registers 60044 to 60058

Index (decimal)	Input	Definition
00	52A	Breaker Position - Closed/Opened
01	52B	Breaker Position - Opened/Closed
02	43A	Reclose Function Enabled/Disabled
03	PH3	Phase Torque Control
04	GRD	Ground Torque Control
05	SCC	Spring Charging Contact
06	79S	Single Shot Reclosing
07	79M	Multi Shot Reclosing
08	TCM	Trip Coil Monitoring
09	50-1	Instantaneous 50P-1 50N-1
10	50-2	Instantaneous 50P-2 50N-2
11	50-3	Instantaneous 50P-3 50N-3
12	ALT1	Enables ALT1 settings table
13	ALT2	Enables ALT2 settings table
14	ECI1	Event Capture Initiated data in fault record
15	ECI2	Event Capture Initiated data in fault record
16	WCI	Waveform Capture Initiated
17	ZSC	Zone Sequence Coordination
18	Open	Trip initiated
19	Close	Close Initiated
20	46	Enables 46 Function
21	67P	Enables 67P Function (TPU2000/R)
22	67N	Enables 67N Function (TPU2000/R)
23	ULI1	User Logical Input Asserts ULO1 (TPU2000/R)
24	ULI2	User Logical Input Asserts ULO2 (TPU2000/R)
25	ULI3	User Logical Input Asserts ULO3 (TPU2000/R)
26	ULI4	User Logical Input Asserts ULO4 (TPU2000/R)
27	ULI5	User Logical Input Asserts ULO5 (TPU2000/R)
28	ULI6	User Logical Input Asserts ULO6 (TPU2000/R)
29	ULI7	User Logical Input Asserts ULO7 (TPU2000/R)
30	ULI8	User Logical Input Asserts ULO8 (TPU2000/R)
31	ULI9	User Logical Input Asserts ULO9 (TPU2000/R)
32	CRI	Resets Overcurrent Trip And all Recloser Counters
33	ARCI	Timed Reclose Block
34	TARC	Initiate Trip and Automatic Reclose
35	SEF	Sensitive Earth Fault Enable
36	Ext BFI	External Started Input (TPU2000/R)
37	BFI	Breaker Fail Initiate (TPU2000/R)
38	UDI	User-defined Display Input

TPU2000/2000R Modbus/Modbus Plus Automation Guide

39	25	Synchronism Check (TPU2000/R)
40	25	Bypass Synchronism Bypass (TPU2000/R)
41	Local	Local Enable

Table 5-57. Relay Configuration Setting Definition

Register Address	Item	Description
60000	SPARE_1	
60001	Execute Register 0 = No Action 1 = Update Registers 2 = Refresh Registers	Unsigned 16 Bit Range 0-2
60002	Access Password	ASCII – 2 Characters Leftmost Digits
60003	Access Password	ASCII – 2 Characters Rightmost Digits
60004	SPARE_2	
60005	INPUT 1 SELECT MASK	Unsigned Integer 16 Bits
60006	INPUT 2 SELECT MASK	Unsigned Integer 16 Bits
60007	INPUT 3 SELECT MASK	Unsigned Integer 16 Bits
60008	INPUT 4 SELECT MASK	Unsigned Integer 16 Bits
60009	INPUT 5 SELECT MASK	Unsigned Integer 16 Bits
60010	INPUT 6 SELECT MASK	Unsigned Integer 16 Bits
60011	INPUT 7 SELECT MASK	Unsigned Integer 16 Bits
60012	INPUT 8 SELECT MASK	Unsigned Integer 16 Bits
60013	INPUT 9 SELECT MASK	Unsigned Integer 16 Bits
60014	INPUT 10 SELECT MASK	Unsigned Integer 16 Bits
60015	INPUT 11 SELECT MASK	Unsigned Integer 16 Bits
60016	INPUT 12 SELECT MASK	Unsigned Integer 16 Bits
60017	INPUT 13 SELECT MASK	Unsigned Integer 16 Bits
60018	INPUT 14 SELECT MASK	Unsigned Integer 16 Bits
60019	INPUT 15 SELECT MASK	Unsigned Integer 16 Bits
60020	INPUT 16 SELECT MASK	Unsigned Integer 16 Bits
60021	INPUT 17 SELECT MASK	Unsigned Integer 16 Bits
60022	INPUT 18 SELECT MASK	Unsigned Integer 16 Bits
60023	INPUT 19 SELECT MASK	Unsigned Integer 16 Bits
60024	INPUT 20 SELECT MASK	Unsigned Integer 16 Bits
60025	INPUT 21 SELECT MASK	Unsigned Integer 16 Bits
60026	INPUT 22 SELECT MASK	Unsigned Integer 16 Bits
60027	INPUT 23 SELECT MASK	Unsigned Integer 16 Bits
60028	INPUT 24 SELECT MASK	Unsigned Integer 16 Bits
60029	INPUT 25 SELECT MASK	Unsigned Integer 16 Bits
60030	INPUT 26 SELECT MASK	Unsigned Integer 16 Bits
60031	INPUT 27 SELECT MASK	Unsigned Integer 16 Bits
60032	INPUT 28 SELECT MASK	Unsigned Integer 16 Bits
60033	INPUT 29 SELECT MASK	Unsigned Integer 16 Bits
60034	Reserved (WRITABLE)	Unsigned Integer 16 Bits
60035	Reserved (WRITABLE)	Unsigned Integer 16 Bits
60036	Reserved (WRITABLE)	Unsigned Integer 16 Bits
60037	Reserved (WRITABLE)	Unsigned Integer 16 Bits
60038	Reserved (WRITABLE)	Unsigned Integer 16 Bits
60039	Reserved (WRITABLE)	Unsigned Integer 16 Bits
60040	Reserved (WRITABLE)	Unsigned Integer 16 Bits
60041	Reserved (WRITABLE)	Unsigned Integer 16 Bits
60042	Reserved (WRITABLE)	Unsigned Integer 16 Bits
60043	Reserved (WRITABLE)	Unsigned Integer 16 Bits

TPU2000/2000R Modbus/Modbus Plus Automation Guide

60044	INPUT 1 INDEX Byte	Unsigned Integer Hi byte 8 leftmost bits
	INPUT 2 INDEX Byte	Unsigned Integer Lo byte 8 rightmost bits
60045	INPUT 3 INDEX Byte	Unsigned Integer Hi byte 8 leftmost bits
	INPUT 4 INDEX Byte	Unsigned Integer Lo byte 8 rightmost bits
60046	INPUT 5 INDEX Byte	Unsigned Integer Hi byte 8 leftmost bits
	INPUT 6 INDEX Byte	Unsigned Integer Lo byte 8 rightmost bits
60047	INPUT 7 INDEX Byte	Unsigned Integer Hi byte 8 leftmost bits
	INPUT 8 INDEX Byte	Unsigned Integer Lo byte 8 rightmost bits
60048	INPUT 9 INDEX Byte	Unsigned Integer Hi byte 8 leftmost bits
	INPUT 10 INDEX Byte	Unsigned Integer Lo byte 8 rightmost bits
60049	INPUT 11 INDEX Byte	Unsigned Integer Hi byte 8 leftmost bits
	INPUT 12 INDEX Byte	Unsigned Integer Lo byte 8 rightmost bits
60050	INPUT 13 INDEX Byte	Unsigned Integer Hi byte 8 leftmost bits
	INPUT 14 INDEX Byte	Unsigned Integer Lo byte 8 rightmost bits
60051	INPUT 15 INDEX Byte	Unsigned Integer Hi byte 8 leftmost bits
	INPUT 16 INDEX Byte	Unsigned Integer Lo byte 8 rightmost bits
60052	INPUT 17 INDEX Byte	Unsigned Integer Hi byte 8 leftmost bits
	INPUT 18 INDEX Byte	Unsigned Integer Lo byte 8 rightmost bits
60053	INPUT 19 INDEX Byte	Unsigned Integer Hi byte 8 leftmost bits
	INPUT 20 INDEX Byte	Unsigned Integer Lo byte 8 rightmost bits
60054	INPUT 21 INDEX Byte	Unsigned Integer Hi byte 8 leftmost bits
	INPUT 22 INDEX Byte	Unsigned Integer Lo byte 8 rightmost bits
60055	INPUT 23 INDEX Byte	Unsigned Integer Hi byte 8 leftmost bits
	INPUT 24 INDEX Byte	Unsigned Integer Lo byte 8 rightmost bits
60056	INPUT 25 INDEX Byte	Unsigned Integer Hi byte 8 leftmost bits
	INPUT 26 INDEX Byte	Unsigned Integer Lo byte 8 rightmost bits
60057	INPUT 27 INDEX Byte	Unsigned Integer Hi byte 8 leftmost bits
	INPUT 28 INDEX Byte	Unsigned Integer Lo byte 8 rightmost bits
60058	INPUT 29 INDEX Byte	Unsigned Integer Hi byte 8 leftmost bits
	INPUT 30 INDEX Byte	Unsigned Integer Lo byte 8 rightmost bits
60059	INPUT 31 INDEX Byte	Unsigned Integer Hi byte 8 leftmost bits
	INPUT 32 INDEX Byte	Unsigned Integer Lo byte 8 rightmost bits

The inputs may be logically ANDED or logically NEGATED. The selection of these functions are configured through Registers 60064 to 60095. The configuration word designation is shown in Figure 5-66.

Table 5-58. Programmable Input “NEGATED” “AND” Input

Address	Item	Description
60064	INPUT 1 AND/NEGATE MASK	Unsigned Integer 16 Bits
60065	INPUT 2 AND/NEGATE MASK	Unsigned Integer 16 Bits
60066	INPUT 3 AND/NEGATE MASK	Unsigned Integer 16 Bits
60067	INPUT 4 AND/NEGATE MASK	Unsigned Integer 16 Bits
60068	INPUT 5 AND/NEGATE MASK	Unsigned Integer 16 Bits
60069	INPUT 6 AND/NEGATE MASK	Unsigned Integer 16 Bits
60070	INPUT 7 AND/NEGATE MASK	Unsigned Integer 16 Bits
60071	INPUT 8 AND/NEGATE MASK	Unsigned Integer 16 Bits
60072	INPUT 9 AND/NEGATE MASK	Unsigned Integer 16 Bits
60073	INPUT 10 AND/NEGATE MASK	Unsigned Integer 16 Bits
60074	INPUT 11 AND/NEGATE MASK	Unsigned Integer 16 Bits
60075	INPUT 12 AND/NEGATE MASK	Unsigned Integer 16 Bits
60076	INPUT 13 AND/NEGATE MASK	Unsigned Integer 16 Bits
60077	INPUT 14 AND/NEGATE MASK	Unsigned Integer 16 Bits
60078	INPUT 15 AND/NEGATE MASK	Unsigned Integer 16 Bits
60079	INPUT 16 AND/NEGATE MASK	Unsigned Integer 16 Bits
60080	INPUT 17 AND/NEGATE MASK	Unsigned Integer 16 Bits

TPU2000/2000R Modbus/Modbus Plus Automation Guide

60081	INPUT 18 AND/NEGATE MASK	Unsigned Integer 16 Bits
60082	INPUT 19 AND/NEGATE MASK	Unsigned Integer 16 Bits
60083	INPUT 20 AND/NEGATE MASK	Unsigned Integer 16 Bits
60084	INPUT 21 AND/NEGATE MASK	Unsigned Integer 16 Bits
60085	INPUT 22 AND/NEGATE MASK	Unsigned Integer 16 Bits
60086	INPUT 23 AND/NEGATE MASK	Unsigned Integer 16 Bits
60087	INPUT 24 AND/NEGATE MASK	Unsigned Integer 16 Bits
60088	INPUT 25 AND/NEGATE MASK	Unsigned Integer 16 Bits
60089	INPUT 26 AND/NEGATE MASK	Unsigned Integer 16 Bits
60090	INPUT 27 AND/NEGATE MASK	Unsigned Integer 16 Bits
60091	INPUT 28 AND/NEGATE MASK	Unsigned Integer 16 Bits
60092	INPUT 29 AND/NEGATE MASK	Unsigned Integer 16 Bits
60093	INPUT 30 AND/NEGATE MASK	Unsigned Integer 16 Bits
60094	INPUT 31 AND/NEGATE MASK	Unsigned Integer 16 Bits
60095	INPUT 32 AND/NEGATE MASK	Unsigned Integer 16 Bits

If the combination logic is to be logically ANDed or ORed, then the following two registers must be configured indicating the resultant logic combination.

Table 5-59. AND/OR Conditional Logic Table

Address	Item	Description
60128	Programmable Input AND/OR Select Bit 0 = INPUT 17 AND/OR (lsb rightmost) Bit 1 = INPUT 18 AND/OR Bit 2 = INPUT 19 AND/OR Bit 3 = INPUT 20 AND/OR Bit 4 = INPUT 21 AND/OR Bit 5 = INPUT 22 AND/OR Bit 6 = INPUT 23 AND/OR Bit 7 = INPUT 24 AND/OR Bit 8 = INPUT 25 AND/OR Bit 9 = INPUT 26 AND/OR Bit 10 = INPUT 27 AND/OR Bit 11 = INPUT 28 AND/OR Bit 12 = INPUT 29 AND/OR Bit 13 = INPUT 30 AND/OR Bit 14 = INPUT 31 AND/OR Bit 15 = INPUT 32 AND/OR (msb leftmost)	Unsigned Integer 16 Bits 0 = Bits ANDed 1 = Bits ORed 0 = Bits ANDed 1 = Bits ORed 0 = Bits ANDed 1 = Bits ORed 0 = Bits ANDed 1 = Bits ORed 0 = Bits ANDed 1 = Bits ORed 0 = Bits ANDed 1 = Bits ORed 0 = Bits ANDed 1 = Bits ORed 0 = Bits ANDed 1 = Bits ORed 0 = Bits ANDed 1 = Bits ORed 0 = Bits ANDed 1 = Bits ORed 0 = Bits ANDed 1 = Bits ORed 0 = Bits ANDed 1 = Bits ORed 0 = Bits ANDed 1 = Bits ORed 0 = Bits ANDed 1 = Bits ORed 0 = Bits ANDed 1 = Bits ORed
60129	Programmable Input AND/OR Select Bit 0 = INPUT 1 AND/OR (lsb rightmost) Bit 1 = INPUT 2 AND/OR Bit 2 = INPUT 3 AND/OR Bit 3 = INPUT 4 AND/OR Bit 4 = INPUT 5 AND/OR Bit 5 = INPUT 6 AND/OR Bit 6 = INPUT 7 AND/OR Bit 7 = INPUT 8 AND/OR Bit 8 = INPUT 9 AND/OR Bit 9 = INPUT 10 AND/OR Bit 10 = INPUT 11 AND/OR Bit 11 = INPUT 12 AND/OR Bit 12 = INPUT 13 AND/OR Bit 13 = INPUT 14 AND/OR Bit 14 = INPUT 15 AND/OR Bit 15 = INPUT 16 AND/OR (msb leftmost)	Unsigned Integer 16 Bits 0 = Bits ANDed 1 = Bits ORed 0 = Bits ANDed 1 = Bits ORed 0 = Bits ANDed 1 = Bits ORed 0 = Bits ANDed 1 = Bits ORed 0 = Bits ANDed 1 = Bits ORed 0 = Bits ANDed 1 = Bits ORed 0 = Bits ANDed 1 = Bits ORed 0 = Bits ANDed 1 = Bits ORed 0 = Bits ANDed 1 = Bits ORed 0 = Bits ANDed 1 = Bits ORed 0 = Bits ANDed 1 = Bits ORed 0 = Bits ANDed 1 = Bits ORed 0 = Bits ANDed 1 = Bits ORed 0 = Bits ANDed 1 = Bits ORed 0 = Bits ANDed 1 = Bits ORed

Each programmable INPUT may be assigned a label of up to 8 characters Table 5-60 lists the register definition table which may be configured for each of the each characters. Please reference Appendix B for the ASCII conversion chart to aid in the configuration of these registers.

Table 5-60. Physical Input Mapping Table

Address	Item	Description
60256	INPUT 1 Rightmost 2 Characters	2 Digit ASCII Characters
60257	INPUT 1 Characters	2 Digit ASCII Characters
60258	INPUT 1 Characters	2 Digit ASCII Characters
60259	INPUT 1 Leftmost 2 Characters	2 Digit ASCII Characters
60260	INPUT 2 Rightmost 2 Characters	2 Digit ASCII Characters
60261	INPUT 2 Characters	2 Digit ASCII Characters
60262	INPUT 2 Characters	2 Digit ASCII Characters
60263	INPUT 2 Leftmost 2 Characters	2 Digit ASCII Characters
60264	INPUT 3 Rightmost 2 Characters	2 Digit ASCII Characters
60265	INPUT 3 Characters	2 Digit ASCII Characters
60266	INPUT 3 Characters	2 Digit ASCII Characters
60267	INPUT 3 Leftmost 2 Characters	2 Digit ASCII Characters
60268	INPUT 4 Rightmost 2 Characters	2 Digit ASCII Characters
60269	INPUT 4 Characters	2 Digit ASCII Characters
60270	INPUT 4 Characters	2 Digit ASCII Characters
60271	INPUT 4 Leftmost 2 Characters	2 Digit ASCII Characters
60272	INPUT 5 Rightmost 2 Characters	2 Digit ASCII Characters
60273	INPUT 5 Characters	2 Digit ASCII Characters
60274	INPUT 5 Characters	2 Digit ASCII Characters
60275	INPUT 5 Leftmost 2 Characters	2 Digit ASCII Characters
60276	INPUT 6 Rightmost 2 Characters	2 Digit ASCII Characters
60277	INPUT 6 Characters	2 Digit ASCII Characters
60278	INPUT 6 Characters	2 Digit ASCII Characters
60279	INPUT 6 Leftmost 2 Characters	2 Digit ASCII Characters
60280	INPUT 7 Rightmost 2 Characters	2 Digit ASCII Characters
60281	INPUT 7 Characters	2 Digit ASCII Characters
60282	INPUT 7 Characters	2 Digit ASCII Characters
60283	INPUT 7 Leftmost 2 Characters	2 Digit ASCII Characters
60284	INPUT 8 Rightmost 2 Characters	2 Digit ASCII Characters
60285	INPUT 8 Characters	2 Digit ASCII Characters
60286	INPUT 8 Characters	2 Digit ASCII Characters
60287	INPUT 8 Leftmost 2 Characters	2 Digit ASCII Characters
60288	INPUT 9 Rightmost 2 Characters	2 Digit ASCII Characters
60289	INPUT 9 Characters	2 Digit ASCII Characters
60290	INPUT 9 Characters	2 Digit ASCII Characters
60291	INPUT 9 Leftmost 2 Characters	2 Digit ASCII Characters
60292	Reserved	
60293	Reserved	
60294	Reserved	
60295	Reserved	
60296	Reserved	
60297	Reserved	
60298	Reserved	
60299	Reserved	
60300	Reserved	
60301	Reserved	
60302	Reserved	
60303	Reserved	

TPU2000/2000R Modbus/Modbus Plus Automation Guide

Address	Item	Description
60304	Reserved	
60305	Reserved	
60306	Reserved	
60307	Reserved	

Programmable Output Select Configuration

The configuration of the TPU2000R Output contacts follow the same philosophy as is the case with the programmable user inputs. Figures 5-67 and 5-68 list the mask bit designation for each of the bits for the mask.

Table 5-61. Relay Configuration Setting Definition

Register Address	Item	Description
60512	SPARE_1	
60513	Execute Register 0 = No Action 1 = Update Registers 2 = Refresh Registers	Unsigned 16 Bit Range 0-2
60514	Access Password	ASCII – 2 Characters Leftmost Digits
60515	Access Password	ASCII – 2 Characters Rightmost Digits
60516	SPARE_2	
60517	OUTPUT 5 SELECT MASK HI	Unsigned Integer 16 Bits Hi Bit Mask
60518	OUTPUT 5 SELECT MASK LO	Unsigned Integer 16 Bits Lo Bit Mask
60519	FEEDBACK 1 SELECT MASK HI	Unsigned Integer 16 Bits Hi Bit Mask
60520	FEEDBACK 1 SELECT MASK LO	Unsigned Integer 16 Bits Lo Bit Mask
60521	OUTPUT 4 SELECT MASK HI	Unsigned Integer 16 Bits Hi Bit Mask
60522	OUTPUT 4 SELECT MASK LO	Unsigned Integer 16 Bits Lo Bit Mask
60523	OUTPUT 6 SELECT MASK HI	Unsigned Integer 16 Bits Hi Bit Mask
60524	OUTPUT 6 SELECT MASK LO	Unsigned Integer 16 Bits Lo Bit Mask
60525	OUTPUT 3 SELECT MASK HI	Unsigned Integer 16 Bits Hi Bit Mask
60526	OUTPUT 3 SELECT MASK LO	Unsigned Integer 16 Bits Lo Bit Mask
60527	OUTPUT 2 SELECT MASK HI	Unsigned Integer 16 Bits Hi Bit Mask
60528	OUTPUT 2 SELECT MASK LO	Unsigned Integer 16 Bits Lo Bit Mask
60529	OUTPUT 1 SELECT MASK HI	Unsigned Integer 16 Bits Hi Bit Mask
60530	OUTPUT 1 SELECT MASK LO	Unsigned Integer 16 Bits Lo Bit Mask
60531	FEEDBACK 2 SELECT MASK HI	Unsigned Integer 16 Bits Hi Bit Mask
60532	FEEDBACK 2 SELECT MASK LO	Unsigned Integer 16 Bits Lo Bit Mask
60533	FEEDBACK 3 SELECT MASK	Unsigned Integer 16 Bits

TPU2000/2000R Modbus/Modbus Plus Automation Guide

	HI	Hi Bit Mask
60534	FEEDBACK 3 SELECT MASK LO	Unsigned Integer 16 Bits Lo Bit Mask
60535	FEEDBACK 4 SELECT MASK HI	Unsigned Integer 16 Bits Hi Bit Mask
60536	FEEDBACK 4 SELECT MASK LO	Unsigned Integer 16 Bits Lo Bit Mask
60537	FEEDBACK 5 SELECT MASK HI	Unsigned Integer 16 Bits Hi Bit Mask
60538	FEEDBACK 5 SELECT MASK LO	Unsigned Integer 16 Bits Lo Bit Mask
60539	FEEDBACK 6 SELECT MASK HI	Unsigned Integer 16 Bits Hi Bit Mask
60540	FEEDBACK 6 SELECT MASK LO	Unsigned Integer 16 Bits Lo Bit Mask
60541	FEEDBACK 7 SELECT MASK HI	Unsigned Integer 16 Bits Hi Bit Mask
60542	FEEDBACK 7 SELECT MASK LO	Unsigned Integer 16 Bits Lo Bit Mask
60543	FEEDBACK 8 SELECT MASK HI	Unsigned Integer 16 Bits Hi Bit Mask
60544	FEEDBACK 8 SELECT MASK LO	Unsigned Integer 16 Bits Lo Bit Mask

Table 5-63 lists the programmable Output Select and Index Bytes required for selecting the Output required as per Figure 5-68. Note a bit value of 1 means the bit is de-selected, a bit value of 0 means the bit is selected.

Bit Position:	15	14	13	12	11	10	9	8	7	6	5	4	3	2	1	0
TPU2000(R):	OT15	OT14	OT13	OT12	OT11	OT10	OT9	OT8	OT7	OT6	OT5	OT4	OT3	OT2	OT1	N/A

Figure 5-67. Low Bit Mask Output Mapping Definition for Registers

Bit Position:	15	14	13	12	11	10	9	8	7	6	5	4	3	2	1	0
TPU2000(R):	OT 31	OT 30	OT 29	OT 28	OT 27	OT 26	OT 25	OT 24	OT 23	OT 22	OT 21	OT 20	OT 19	OT 18	OT 17	OT 16

Figure 5-68. High Bit Mask Output Mapping Definition for Registers

Function Index Table and Definition

Table 5-62. Physical Logical Function Byte Configuration Codes for Registers 60044 to 60058

Index (decimal)	Input	Definition
00	TRIP	Fixed Trip
01	CLOSE	Fixed Close
02	ALARM	Self Check Alarm
03	27-1P	Single Phase Under Voltage
04	46	Negative Sequence Overcurrent
05	50P-1	Phase Inst. Overcurrent
06	50N-1	Neutral Inst. Overcurrent
07	50P-2	Phase Inst. Overcurrent
08	50N-2	Neutral Inst. Overcurrent
09	50P-3	Phase Inst. Overcurrent
10	50N-3	Neutral Inst. Overcurrent
11	51P	Phase Inst. Overcurrent
12	51N	Neutral Inst. Overcurrent
13	59	Over Voltage

TPU2000/2000R Modbus/Modbus Plus Automation Guide

Index (decimal)	Input	Definition
14	67P	Directional Overcurrent (pos seq)
15	67N	Directional Overcurrent (neg seq)
16	81S-1	Frequency Shed (First stage)
17	81R-1	Frequency Restore (First stage)
18	PATA	Phase A Target
19	PBTA	Phase B Target
20	PCTA	Phase C Target
21	TCFA	Trip Circuit Fail
22	TCC	Tap Changer Cutout
23	79DA	Recloser Disable
24	PUA	Pickup
25	79LOA	Recloser Lockout
26	BFA	Breaker Fail
27	PDA	Phase Peak Demand
28	NDA	Neutral Peak Demand
29	BFUA	Blown Fuse
30	KSI	KiloAmp Summation
31	79CA-1	Reclose Counter1
32	HPFA	High Power Factor
33	LPFA	Low Power Factor
34	OCTC	Overcurrent Trip Counter
35	50-1D	50-1 Element Disable
36	50-2D	50-2 Element Disable
37	STCA	Setting Table Change
38	ZSC	Zone Sequence
39	PH3-D	Phase Torque Control Disable
40	GRD-D	Neutral Torque Control Disable
42	32PA	Directional Pickup (pos seq)
43	32NA	Directional Pickup (neg seq)
44	27-3P	Phase Under Voltage
45	VarDA	Var Demand
46	79CA-2	Reclose Counter2
47	TRIPA	Single Pole Trip Phase A
48	TRIPB	Single Pole Trip Phase B
49	TRIPC	Single Pole Trip Phase C
50	27-1P*	Single Phase Under Voltage (LATCHED)
51	46*	Negative Sequence Overcurrent (LATCHED)
52	50P-1*	Phase Inst. Overcurrent (LATCHED)
53	50N-1*	Neutral Inst. Overcurrent (LATCHED)
54	50P-2*	Phase Inst. Overcurrent (LATCHED)
55	50N-2*	Neutral Inst. Overcurrent (LATCHED)
56	50P-3*	Phase Inst. Overcurrent (LATCHED)
57	50N-3*	Neutral Inst. Overcurrent (LATCHED)
58	51P*	Phase Time Overcurrent (LATCHED)
59	51N*	Neutral Time Overcurrent (LATCHED)
60	59*	Over Voltage (LATCHED)
61	67P*	Directional Overcurrent (pos seq) (LATCHED)
62	67N*	Directional Overcurrent (neg seq) (LATCHED)
63	81S-1*	Frequency Shed (First stage) (LATCHED)
64	81R-1*	Frequency Restore (First stage) (LATCHED)
65	81O-1*	Over Frequency (First stage) (LATCHED)
66	27-3P*	Phase Under Voltage (LATCHED)
67	TRIPA*	Single Pole Trip Phase A (LATCHED)
68	TRIPB*	Single Pole Trip Phase B (LATCHED)
69	TRIPC*	Single Pole Trip Phase C (LATCHED)
70	ULO1	User Logical Output 1

TPU2000/2000R Modbus/Modbus Plus Automation Guide

Index (decimal)	Input	Definition
71	ULO2	User Logical Output 2
72	ULO3	User Logical Output 3
73	ULO4	User Logical Output 4
74	ULO5	User Logical Output 5
75	ULO6	User Logical Output 6
76	ULO7	User Logical Output 7
77	ULO8	User Logical Output 8
78	ULO9	User Logical Output 9
79	PVArA	Positive Var
80	NVArA	Negative Var
81	LOADA	Load Current
82	81O-1	Over Frequency (First Stage)
83	81O-2	Over Frequency (2nd Stage)
84	81S-2	Frequency Shed (2nd Stage)
85	81R-2	Frequency Restore (2nd Stage)
86	81O-2*	Over Frequency (2nd Stage) (LATCHED)
87	81S-2*	Frequency Shed (2nd Stage) (LATCHED)
88	81R-2*	Frequency Restore (2nd Stage) (LATCHED)
89	CLTA	Cold Load Timer
90	PWatt1	Positive Watt Alarm 1
91	PWatt2	Positive Watt Alarm 2
92	79CA1*	Recloser Counter 1 Alarm (LATCHED)
93	79CA2*	Recloser Counter 2 Alarm (LATCHED)
94	SEF*	Sensitive Earth Fault Trip (LATCHED)
95	SEF	Sensitive Earth Fault Trip
86	BZA	Bus Zone Alarm
97	BF Trip	Breaker Fail Trip
98	BF Retrip	Breaker Fail Re-Trip
99	BF Trip*	Breaker Fail Trip (LATCHED)
100	BF Retrip*	Breaker Fail Re-Trip (LATCHED)
101	32P	Phase Directionality Alarm
102	32N	Neutral Directionality Alarm
103	32P*	Phase Directionality Alarm (LATCHED)
104	32N*	Neutral Directionality Alarm (LATCHED)
105	BFA*	Breaker Failure Alarm (LATCHED)
106	25*	In Synchronism (LATCHED)
107	25	In Synchronism
	SBA	Slow Breaker Alarm

The Outputs may be ANDed/Ored with a selection function placed in the index byte. The bits to be anded/ored are designated by the following axiom. If the selected bit in the pattern designated in Figure 5-69 is a 0, then the bit is OR'ed. If the selected bit is a 1 then the bits are AND'ed together. The Table Position for the Physical contact select is as per Table 5-65.

Bit Position:	7	6	5	4	3	2	1	0
TPU2000(R):	OT1	OT2	OT3	OT6	OT4	OT7	OT5	N/A

Figure 5-69. Low Bit Mask Output Mapping Definition for Registers

Table 5-63. Programmable Output AND/OR Select

Address	Item	Description
60576	Reserved	Unsigned Integer 16 Bits
60577	AND/OR Selection Bits	Unsigned Integer 16 Bits (See Figure 5-57 for Designation)
60578	OUTPUT 1 INDEX Byte	Unsigned Integer Hi byte 8 leftmost bits
	OUTPUT 2 INDEX Byte	Unsigned Integer Lo byte 8 rightmost bits
60579	OUTPUT 3 INDEX Byte	Unsigned Integer Hi byte 8 leftmost bits
	OUTPUT 4 INDEX Byte	Unsigned Integer Lo byte 8 rightmost bits
60580	OUTPUT 5 INDEX Byte	Unsigned Integer Hi byte 8 leftmost bits
	OUTPUT 6 INDEX Byte	Unsigned Integer Lo byte 8 rightmost bits
60581	OUTPUT 7 INDEX Byte	Unsigned Integer Hi byte 8 leftmost bits
	OUTPUT 8 INDEX Byte	Unsigned Integer Lo byte 8 rightmost bits
60582	OUTPUT 9 INDEX Byte	Unsigned Integer Hi byte 8 leftmost bits
	OUTPUT 10 INDEX Byte	Unsigned Integer Lo byte 8 rightmost bits
60583	OUTPUT 11 INDEX Byte	Unsigned Integer Hi byte 8 leftmost bits
	OUTPUT 12 INDEX Byte	Unsigned Integer Lo byte 8 rightmost bits
60584	OUTPUT 13 INDEX Byte	Unsigned Integer Hi byte 8 leftmost bits
	OUTPUT 14 INDEX Byte	Unsigned Integer Lo byte 8 rightmost bits
60585	OUTPUT 15 INDEX Byte	Unsigned Integer Hi byte 8 leftmost bits
	OUTPUT 16 INDEX Byte	Unsigned Integer Lo byte 8 rightmost bits
60586	OUTPUT 17 INDEX Byte	Unsigned Integer Hi byte 8 leftmost bits
	OUTPUT 18 INDEX Byte	Unsigned Integer Lo byte 8 rightmost bits
60587	OUTPUT 19 INDEX Byte	Unsigned Integer Hi byte 8 leftmost bits
	OUTPUT 20 INDEX Byte	Unsigned Integer Lo byte 8 rightmost bits
60588	OUTPUT 21 INDEX Byte	Unsigned Integer Hi byte 8 leftmost bits
	OUTPUT 22 INDEX Byte	Unsigned Integer Lo byte 8 rightmost bits
60589	OUTPUT 23 INDEX Byte	Unsigned Integer Hi byte 8 leftmost bits
	OUTPUT 24 INDEX Byte	Unsigned Integer Lo byte 8 rightmost bits
60590	OUTPUT 25 INDEX Byte	Unsigned Integer Hi byte 8 leftmost bits
	OUTPUT 26 INDEX Byte	Unsigned Integer Lo byte 8 rightmost bits
60591	OUTPUT 27 INDEX Byte	Unsigned Integer Hi byte 8 leftmost bits
	OUTPUT 28 INDEX Byte	Unsigned Integer Lo byte 8 rightmost bits
60592	OUTPUT 29 INDEX Byte	Unsigned Integer Hi byte 8 leftmost bits
	OUTPUT 30 INDEX Byte	Unsigned Integer Lo byte 8 rightmost bits
60592	OUTPUT 31 INDEX Byte	Unsigned Integer Hi byte 8 leftmost bits
	OUTPUT 32 INDEX Byte	Unsigned Integer Lo byte 8 rightmost bits

Programmable Output User Defined String Block

Each one of the Output contacts may be assigned an eight character name. The registers for configuration of the text name are Registers 60640 through 60695. The name is programmed similarly to the Input name designation. Table 5-64 lists the address assignment for the Programmable Output User Defined Strings.

Table 5-64. Programmable Output User Defined Strings

Address	Item	Description
60640	OUTPUT 1 Rightmost 2 Characters	2 Digit ASCII Characters
60641	OUTPUT 1 Characters	2 Digit ASCII Characters
60642	OUTPUT 1 Characters	2 Digit ASCII Characters
60643	OUTPUT 1 Leftmost 2 Characters	2 Digit ASCII Characters
60644	OUTPUT 2 Rightmost 2 Characters	2 Digit ASCII Characters
60645	OUTPUT 2 Characters	2 Digit ASCII Characters
60646	OUTPUT 2 Characters	2 Digit ASCII Characters

TPU2000/2000R Modbus/Modbus Plus Automation Guide

Address	Item	Description
60647	OUTPUT 2 Leftmost 2 Characters	2 Digit ASCII Characters
60648	OUTPUT 3 Rightmost 2 Characters	2 Digit ASCII Characters
60649	OUTPUT 3 Characters	2 Digit ASCII Characters
60650	OUTPUT 3 Characters	2 Digit ASCII Characters
60651	OUTPUT 3 Leftmost 2 Characters	2 Digit ASCII Characters
60652	OUTPUT 4 Rightmost 2 Characters	2 Digit ASCII Characters
60653	OUTPUT 4 Characters	2 Digit ASCII Characters
60654	OUTPUT 4 Characters	2 Digit ASCII Characters
60655	OUTPUT 4 Leftmost 2 Characters	2 Digit ASCII Characters
60656	OUTPUT 5 Rightmost 2 Characters	2 Digit ASCII Characters
60657	OUTPUT 5 Characters	2 Digit ASCII Characters
60658	OUTPUT 5 Characters	2 Digit ASCII Characters
60659	OUTPUT 5 Leftmost 2 Characters	2 Digit ASCII Characters
60660	OUTPUT 6 Rightmost 2 Characters	2 Digit ASCII Characters
60661	OUTPUT 6 Characters	2 Digit ASCII Characters
60662	OUTPUT 6 Characters	2 Digit ASCII Characters
60663	OUTPUT 6 Leftmost 2 Characters	2 Digit ASCII Characters
60664	OUTPUT 7 Rightmost 2 Characters	2 Digit ASCII Characters
60665	OUTPUT 7 Characters	2 Digit ASCII Characters
60666	OUTPUT 7 Characters	2 Digit ASCII Characters
60667	OUTPUT 7 Leftmost 2 Characters	2 Digit ASCII Characters
60668	Reserved	
60669	Reserved	
60670	Reserved	
60671	Reserved	

Each of the Programmable Output's may be delayed to operate on a time setting. The timer configuration settings are configured by the settings transferred to Registers 60768 through 60775.

Table 5-65. To Be Named

Address	Item	Description
60768	OUT 5 delay in 0.01 sec inc	Unsigned Integer 16 Bits (See Note 1)
60769	OUT 7 delay in 0.01 sec inc	Unsigned Integer 16 Bits (See Note 1)
60770	OUT 4 delay in 0.01 sec inc	Unsigned Integer 16 Bits (See Note 1)
60771	OUT 6 delay in 0.01 sec inc	Unsigned Integer 16 Bits (See Note 1)
60772	OUT 3 delay in 0.01 sec inc	Unsigned Integer 16 Bits (See Note 1)
60773	OUT 2 delay in 0.01 sec inc	Unsigned Integer 16 Bits (See Note 1)
60774	OUT 1 delay in 0.01 sec inc	Unsigned Integer 16 Bits (See Note 1)

Note 1: Range is as Such $0.00 \leq \text{Range} \leq 60 * 100$

Settings

There are three setting groups (PRIMARY, ALT 1 and ALT 2) possible in the TPU2000 and TPU2000R. However, the number of defined registers to read or transmit for the configuration process may vary depending upon the TPU model number one would purchase. If one has a 3 Winding TPU2000R, additional blocks of registers must be read for the following 3 Winding Configuration Data:

- Primary Settings
- Alternate 1 Settings
- Alternate 2 Settings
- Configuration Settings
- Counter Settings
- Alarm Settings

TPU2000/2000R Modbus/Modbus Plus Automation Guide

The selections are determined by the control bits set for group selection (Reference Section 5). The relay settings are configured via a selected CURVE SELECTION TYPE. These are based on different functions such as:

- ❑ CURVE SELECTIONS
- ❑ MODE SELECTIONS

The curve selection types are based upon whether the relay is an ANSI or IEC type. The following is the description of the codes to select the curve and recloser curves.

High byte consists of bits 15 through 8.

Low byte consists of bits 7 through 0.

(Note Bit 0 is the right most bit whereas bit 15 is the left most bit)

ANSI Curve Selection Type I

- 0 = Extremely Inverse
- 1 = Very Inverse
- 2 = Inverse
- 3 = Short Time Inverse
- 4 = Definite Time
- 5 = Long Time Extremely Inverse
- 6 = Long Time Very Inverse
- 7 = Long Time Inverse
- 8 = Recloser Curve
- 9 = Disabled
- 10 = User Curve 1
- 11 = User Curve 2
- 12 = User Curve 3

ANSI Curve Type II

- 0 = Disable
- 1 = Standard
- 2 = Inverse
- 3 = Definite Time
- 4 = Short Time Inverse
- 5 = Short Time Extremely Inverse
- 6 = User Curve 1
- 7 = User Curve 2
- 8 = User Curve 3

ANSI Curve Selection 87T

- 0 = Disable
- 1 = Percent Slope
- 2 = HU 30%
- 3 = HU 35%
- 4 = Percent 15% Tap
- 5 = Percent 25% Tap
- 6 = Percent 40% Tap
- 7 = User Curve 1
- 8 = User Curve 2
- 9 = User Curve 3

Mode Selection Type 87T

- 0 = Disabled
- 1 = 2nd Harmonics
- 2 = 2nd and 5th Harmonics
- 3 = All Harmonics

Table 5-66 lists the register assignments for the 6X registers for the Primary Settings Group Functions.

Table 5-66. Primary Settings Register Definition Common to the 2 and 3 Winding Units

Register Address	Item	Description
61024	SPARE_1	
61025	Execute Register 0 = No Action 1 = Update Registers 2 = Refresh Registers	Unsigned 16 Bits
61026	Access Password	ASCII – 2 Characters Leftmost Digits
61027	Access Password	ASCII – 2 Characters Rightmost Digits
61028	SPARE_2	
61029	87T Curve Type	Unsigned Integer 16 Bits
61030	87T Minimum I Operate	Unsigned 16 Bits

TPU2000/2000R Modbus/Modbus Plus Automation Guide

Register Address	Item	Description
		0.2 <=Range <=1.0 (X10)
61031	87T Percent Restraint	15<=Range<=60
61032	87T Restraint Mode	Unsigned Integer 16 Bits Refer to Mode Selection Table
61033	87T 2 nd Harmonic Restraint	Unsigned Integer 16 Bits 7.5<=Range<=25 (X10)
61034	87T 5 th Harmonic Restraint	Unsigned Integer 16 Bits 15<=Range<=40 (X10)
61035	87T All Harmonic Restraint	Unsigned Integer 16 Bits 15<=Range<=40 (X10)
61036	87H Tap X Byte	Unsigned Integer 16 Bits 6 <=Range<=20 (X10)
61037	87T-1 Amp	Unsigned Integer 16 Bits 2<=Range<=9 (X10) 0.4<=Range<=1.8 (X50)
61038	51P-1 Curve Select (TYPE I)	Unsigned 16 Bits Range 0-12 (See Text Above)
61039	51P-1 Pickup Amps	Unsigned 16 Bits 1<=Range<= 12 *10 0.2<=Range<=2.4 Amp * 50 (See Note)
61040	51P-1 Time Dial/Time Delay	Unsigned 16 Bits 1<=Range <=10 (X20) Time Dial 0<=Range<=10 (X20) Time Delay
61041	50P-1 Curve Select Byte (TYPE II)	Unsigned Integer 16 bits 0<=Range<=12 (See Text Above)
61042	50P-1 Pickup Amps	Unsigned 16 Bits 0.5<=Range<= 20 *10
61043	50P-1 Time Dial/Time Delay	Unsigned 16 Bits Dial *10 Delay * 100
61044	150P-1 Curve Select	Unsigned Integer 16 bits See Table Above
61045	150P-1 Pickup Amps	Unsigned 16 Bits 0.5<=Range<= 20 *10
61046	150P-1 Time Dial	Unsigned 16 Bits 0<=Range<=9.99 * 100
61047	46-1 Curve Select Byte	Unsigned Integer 16 bits See Table Above
61048	46-1 Pickup Amps	Unsigned 16 Bits 1<=Range<= 12 *10 0.2<=Range<=2.4 Amp * 50 (See Note)
61049	46-1 Time Dial/ Time Delay	Unsigned 16 Bits 1<=Range<=12 * 10 0.2<=Range<= 0.4 *50
61050	51N-1 Curve Select (TYPE II)	Unsigned 16 Bits Range 0-12 (See Text Above)
61051	51N-1 Pickup Amps	Unsigned 16 Bits 1<=Range<= 12 *10 0.2<=Range<=2.4 Amp * 50 (See Note)
61052	51N-1 Time Dial	Unsigned 16 Bits 1<=Range <=20 /Delay Byte 0<=Range<=10 * 20 51N Time Multiplier
61053	50N-1 Curve Select Byte (TYPE II)	Unsigned Integer 16 bits 0<=Range<=12 (See Text Above)
61054	51N-1 Pickup Amps	Unsigned 16 Bits

TPU2000/2000R Modbus/Modbus Plus Automation Guide

Register Address	Item	Description
		0.5<=Range<= 20 *10
61055	51N-1 Time Dial/Delay Setting	Unsigned 16 Bits Time Dial * 10 Delay * 100
61056	150N-1 Curve Select (TYPE II)	Unsigned Integer 16 bits See Table Above
61057	150N-1 Pickup Amps	Unsigned 16 Bits 0.5<=Range<= 20 *10
61058	150N-1 Time Delay	Unsigned 16 Bits 0<=Range<=9.99 * 100
61059	87T-2 Tap Amp Setting	Unsigned 16 Bits 2<=Range<=9 Amperes * 10 0.4<=Range <=1.8 * 50
61060	51P-2 Curve Select Byte (TYPE I)	Unsigned 16 Bits (See Text Above)
61061	51P-2 Pickup Amp/OA	Unsigned 16 Bits 1<=Range<=12 *10 0.2<=Range<=2.4 * 50
61062	51P-2 Time Dial /Delay Setting	Unsigned 16 Bits Dial : 1<=Range<=10 *20 Delay : 0<=Range<=10 * 20
61063	51P-2 Curve Select (TYPE I)	Unsigned 16 Bits Range 0-12 (See Text Above)
61064	51P-2 Pickup Amps	Unsigned 16 Bits 1<=Range<= 12 *10 0.2<=Range<=2.4 Amp * 50 (See Note)
61065	51P-2 Time Dial/Time Delay	Unsigned 16 Bits 1<=Range <=10 (X20) Time Dial 0<=Range<=10 (X20) Time Delay
61066	51P-2 Curve Select (TYPE II)	Unsigned 16 Bits Range 0-12 (See Text Above)
61067	51P-2 Pickup X Amps	Unsigned 16 Bits 0.5<=Range<=20 Amp * 10 (See Note)
61068	51P-2 Time Dial/Time Delay	Unsigned 16 Bits Time Dial * 10 Time Delay * 20
61069	46-2 Curve Select (TYPE I)	Unsigned Integer 16 bits See Table Above
61070	46-2 Pickup Amps	Unsigned 16 Bits 1<=Range<= 12 *10 0.2<=Range<=2.4 Amp * 50 (See Note)
61071	46-2 Time Dial/ Time Delay	Unsigned 16 Bits 1<=Range<=10 * 20 0<=Range<= 10 *20
61072	51G-2 Curve Select (TYPE II)	Unsigned 16 Bits Range 0-12 (See Text Above)
61073	51G-2 Pickup Amps	Unsigned 16 Bits 1<=Range<= 12 *10 0.2<=Range<=2.4 Amp * 50 (See Note)
61074	51G-2 Time Dial/Time Delay	Unsigned 16 Bits 1<=Range <=10 * 20 : Time Dial 0<=Range<=10 * 20 : Time Delay
61075	50G-2 Curve Select Byte (TYPE II)	Unsigned Integer 16 bits 0<=Range<=12 (See Text Above)
61076	51G-2 Pickup Amps	Unsigned 16 Bits 0.5<=Range<= 20 *10

TPU2000/2000R Modbus/Modbus Plus Automation Guide

Register Address	Item	Description
61077	51G-2 Time Dial/Delay Setting	Unsigned 16 Bits Time Dial * 10 Delay * 100
61078	150G-2 Curve Select (TYPE II)	Unsigned Integer 16 bits See Table Above
61079	150G-2 Pickup Amps	Unsigned 16 Bits $0.5 \leq \text{Range} \leq 20 * 10$
61080	150G-2 Time Delay	Unsigned 16 Bits $0 \leq \text{Range} \leq 9.99 * 100$
61081	Disturb 2 Pickup X	Unsigned Integer 16 Bits $0.5 \leq \text{Range} \leq 5 * 10$
61082	Level Detector-1 Pickup X	Unsigned Integer 16 Bits $0.5 \leq \text{Range} \leq 20 * 10$, 201 = Disable
61083	Level Detector-1 Pickup X	Unsigned Integer 16 Bits $0.5 \leq \text{Range} \leq 20 * 10$, 201 = Disable
61084	Unit Configuration Byte	Unsigned Integer 16 Bits (rightmost bit) Bit 0: Neutral Tap Range Wdg1 (lsb) (0 = 1-12 A, 1 = 0.2-2.4A) Bit 1: Neutral Tap Range Wdg1 (0 = 1-12 A, 1 = 0.2-2.4A) Bit 2: Neutral Tap Range Wdg1 (0 = 1-12 A, 1 = 0.2-2.4A) Bit 3: Neutral Tap Range Wdg1 (0 = 1-12 A, 1 = 0.2-2.4A) Bit 4: User Definable Curves Bit 5: Reserved Bit 6: Neutral Tap Range Wdg 3 (0 = 1-12 A, 1 = 0.2-2.4A) Bit 7: Phase Tap Range Wdg3 (0 = 1-12 A, 1 = 0.2-2.4A) Bit 8: MOCT's on Wdg1 (1= None 0= MOCT Present) Bit 9: MOCT's on Wdg1 (1= None 0= MOCT Present) Bit 10: Reserved Bit 11: Reserved Bit 12: Reserved Bit 13: Reserved Bit 14: Reserved Bit 15: Reserved (msb) (leftmost bit)

If the Alternate Settings 1 command is selected (as per Section 5 in this document), the settings are configured as follows in Table 5-67).

Table 5-67. 3 Winding Primary Settings Block

Register Address	Item	Description
63200	SPARE_1	
63201	Execute Register 0 = No Action 1 = Update Registers 2 = Refresh Registers	Unsigned 16 Bits
63202	Access Password	ASCII – 2 Characters Leftmost Digits
63203	Access Password	ASCII – 2 Characters Rightmost Digits
63204	SPARE_2	

TPU2000/2000R Modbus/Modbus Plus Automation Guide

Register Address	Item	Description
63205	87T-3 Amp	Unsigned Integer 16 Bits 2<=Range<=9 (X10) 0.4<=Range<=1.8 (X50)
63206	51P-3 Curve Select (TYPE I)	Unsigned 16 Bits Range 0-12 (See Text Above)
63207	51P-3 Pickup Amps	Unsigned 16 Bits 1<=Range<= 12 *10 0.2<=Range<=2.4 Amp * 50 (See Note)
63208	51P-3 Time Dial/Time Delay	Unsigned 16 Bits 1<=Range <=10 (X20) Time Dial 0<=Range<=10 (X20) Time Delay
63209	50P-3 Curve Select Byte (TYPE II)	Unsigned Integer 16 bits 0<=Range<=12 (See Text Above)
63210	50P-3 Pickup Amps	Unsigned 16 Bits 0.5<=Range<= 20 *10
63211	50P-3 Time Dial/Time Delay	Unsigned 16 Bits Dial *10 Delay * 100
63212	150P-3 Curve Select	Unsigned Integer 16 bits See Table Above
63213	150P-3 Pickup Amps	Unsigned 16 Bits 0.5<=Range<= 20 *10
63214	150P-3 Time Dial	Unsigned 16 Bits 0<=Range<=9.99 * 100
63215	46-3 Curve Select Byte	Unsigned Integer 16 bits See Table Above
63216	46-3 Pickup Amps	Unsigned 16 Bits 1<=Range<= 12 *10 0.2<=Range<=2.4 Amp * 50 (See Note)
63217	46-3 Time Dial/Time Delay	Unsigned 16 Bits 1<=Range<=12 * 10 0.2<=Range<= 0.4 *50
63218	51N-3 Curve Select (TYPE II)	Unsigned 16 Bits Range 0-12 (See Text Above)
63219	51N-3 Pickup Amps	Unsigned 16 Bits 1<=Range<= 12 *10 0.2<=Range<=2.4 Amp * 50 (See Note)
63220	51N-3 Time Dial	Unsigned 16 Bits 1<=Range <=20 /Delay Byte 0<=Range<=10 * 20 51N Time Multiplier
63221	50N-3 Curve Select Byte (TYPE II)	Unsigned Integer 16 bits 0<=Range<=12 (See Text Above)
63222	51N-3 Pickup Amps	Unsigned 16 Bits 0.5<=Range<= 20 *10
63223	51N-3 Time Dial/Delay Setting	Unsigned 16 Bits Time Dial * 10 Delay * 100
63224	150N-3 Curve Select (TYPE II)	Unsigned Integer 16 bits See Table Above
63225	150N-3 Pickup Amps	Unsigned 16 Bits 0.5<=Range<= 20 *10
63226	150N-3 Time Delay	Unsigned 16 Bits 0<=Range<=9.99 * 100
63227	51G-3 Curve Select (TYPE II)	Unsigned 16 Bits Range 0-12 (See Text Above)

TPU2000/2000R Modbus/Modbus Plus Automation Guide

Register Address	Item	Description
63228	51G-3 Pickup Amps	Unsigned 16 Bits 1<=Range<= 12 *10 0.2<=Range<=2.4 Amp * 50 (See Note)
63229	51G-3 Time Dial/Time Delay	Unsigned 16 Bits 1<=Range <=10 * 20 : Time Dial 0<=Range<=10 * 20 : Time Delay
63230	50G-3 Curve Select Byte (TYPE II)	Unsigned Integer 16 bits 0<=Range<=12 (See Text Above)
63231	51G-3 Pickup Amps	Unsigned 16 Bits 0.5<=Range<= 20 *10
63232	51G-3 Time Dial/Delay Setting	Unsigned 16 Bits Time Dial * 10 Delay * 100
63233	150G-3 Curve Select (TYPE II)	Unsigned Integer 16 bits See Table Above
63234	150G-3 Pickup Amps	Unsigned 16 Bits 0.5<=Range<= 20 *10
63235	150G-3 Time Delay	Unsigned 16 Bits 0<=Range<=9.99 * 100
63236	Disturb 3 Pickup X	Unsigned Integer 16 Bits 0.5<= Range<=5 *10
63237	Level Detector-1 Pickup X	Unsigned Integer 16 Bits 0.5<= Range<=20 *10 , 201 = Disable

Table 5-68. Alt 1 Settings Register Definition

Register Address	Item	Description
61152	SPARE_1	
61153	Execute Register 0 = No Action 1 = Update Registers 2 = Refresh Registers	Unsigned 16 Bits
61154	Access Password	ASCII – 2 Characters Leftmost Digits
61155	Access Password	ASCII – 2 Characters Rightmost Digits
61156	SPARE_2	
61157	87T Curve Type	Unsigned Integer 16 Bits
61158	87T Minimum I Operate	Unsigned 16 Bits 0.2 <=Range <=1.0 (X10)
61159	87T Percent Restraint	15<=Range<=60
61160	87T Restraint Mode	Unsigned Integer 16 Bits Refer to Mode Selection Table
61161	87T 2 nd Harmonic Restraint	Unsigned Integer 16 Bits 7.5<=Range<=25 (X10)
61162	87T 5 th Harmonic Restraint	Unsigned Integer 16 Bits 15<=Range<=40 (X10)
61163	87T All Harmonic Restraint	Unsigned Integer 16 Bits 15<=Range<=40 (X10)
61164	87H Tap X Byte	Unsigned Integer 16 Bits 6 <=Range<=20 (X10)
61165	87T-1 Amp	Unsigned Integer 16 Bits 2<=Range<=9 (X10) 0.4<=Range<=1.8 (X50)
61166	51P-1 Curve Select (TYPE I)	Unsigned 16 Bits Range 0-12 (See Text Above)

TPU2000/2000R Modbus/Modbus Plus Automation Guide

Register Address	Item	Description
61167	51P-1 Pickup Amps	Unsigned 16 Bits 1<=Range<= 12 *10 0.2<=Range<=2.4 Amp * 50 (See Note)
61168	51P-1 Time Dial/Time Delay	Unsigned 16 Bits 1<=Range <=10 (X20) Time Dial 0<=Range<=10 (X20) Time Delay
61169	50P-1 Curve Select Byte (TYPE II)	Unsigned Integer 16 bits 0<=Range<=12 (See Text Above)
61170	50P-1 Pickup Amps	Unsigned 16 Bits 0.5<=Range<= 20 *10
61171	50P-1 Time Dial/Time Delay	Unsigned 16 Bits Dial *10 Delay * 100
61172	150P-1 Curve Select	Unsigned Integer 16 bits See Table Above
61173	150P-1 Pickup Amps	Unsigned 16 Bits 0.5<=Range<= 20 *10
61174	150P-1 Time Dial	Unsigned 16 Bits 0<=Range<=9.99 * 100
61175	46-1 Curve Select Byte	Unsigned Integer 16 bits See Table Above
61176	46-1 Pickup Amps	Unsigned 16 Bits 1<=Range<= 12 *10 0.2<=Range<=2.4 Amp * 50 (See Note)
61177	46-1 Time Dial/ Time Delay	Unsigned 16 Bits 1<=Range<=12 * 10 0.2<=Range<= 0.4 *50
61178	51N-1 Curve Select (TYPE II)	Unsigned 16 Bits Range 0-12 (See Text Above)
61179	51N-1 Pickup Amps	Unsigned 16 Bits 1<=Range<= 12 *10 0.2<=Range<=2.4 Amp * 50 (See Note)
61180	51N-1 Time Dial	Unsigned 16 Bits 1<=Range <=20 /Delay Byte 0<=Range<=10 * 20 51N Time Multiplier
61181	50N-1 Curve Select Byte (TYPE II)	Unsigned Integer 16 bits 0<=Range<=12 (See Text Above)
61182	51N-1 Pickup Amps	Unsigned 16 Bits 0.5<=Range<= 20 *10
61183	51N-1 Time Dial/Delay Setting	Unsigned 16 Bits Time Dial * 10 Delay * 100
61184	150N-1 Curve Select (TYPE II)	Unsigned Integer 16 bits See Table Above
61185	150N-1 Pickup Amps	Unsigned 16 Bits 0.5<=Range<= 20 *10
61186	150N-1 Time Delay	Unsigned 16 Bits 0<=Range<=9.99 * 100
61187	87T-2 Tap Amp Setting	Unsigned 16 Bits 2<=Range<=9 Amperes * 10 0.4<=Range <=1.8 * 50
61188	51P-2 Curve Select Byte (TYPE I)	Unsigned 16 Bits (See Text Above)
61189	51P-2 Pickup Amp/OA	Unsigned 16 Bits 1<=Range<=12 *10 0.2<=Range<=2.4 * 50

TPU2000/2000R Modbus/Modbus Plus Automation Guide

Register Address	Item	Description
61190	51P-2 Time Dial/Delay Setting	Unsigned 16 Bits Dial : $1 \leq \text{Range} \leq 10 * 20$ Delay : $0 \leq \text{Range} \leq 10 * 20$
61191	51P-2 Curve Select (TYPE I)	Unsigned 16 Bits Range 0-12 (See Text Above)
61192	51P-2 Pickup Amps	Unsigned 16 Bits $1 \leq \text{Range} \leq 12 * 10$ $0.2 \leq \text{Range} \leq 2.4 \text{ Amp} * 50$ (See Note)
61193	51P-2 Time Dial/Time Delay	Unsigned 16 Bits $1 \leq \text{Range} \leq 10 (X20)$ Time Dial $0 \leq \text{Range} \leq 10 (X20)$ Time Delay
61194	51P-2 Curve Select (TYPE II)	Unsigned 16 Bits Range 0-12 (See Text Above)
61195	51P-2 Pickup X Amps	Unsigned 16 Bits $0.5 \leq \text{Range} \leq 20 \text{ Amp} * 10$ (See Note)
61196	51P-2 Time Dial/Time Delay	Unsigned 16 Bits Time Dial * 10 Time Delay * 20
61197	46-2 Curve Select (TYPE I)	Unsigned Integer 16 bits See Table Above
61198	46-2 Pickup Amps	Unsigned 16 Bits $1 \leq \text{Range} \leq 12 * 10$ $0.2 \leq \text{Range} \leq 2.4 \text{ Amp} * 50$ (See Note)
61199	46-2 Time Dial/Time Delay	Unsigned 16 Bits $1 \leq \text{Range} \leq 10 * 20$ $0 \leq \text{Range} \leq 10 * 20$
61200	51G-2 Curve Select (TYPE II)	Unsigned 16 Bits Range 0-12 (See Text Above)
61201	51G-2 Pickup Amps	Unsigned 16 Bits $1 \leq \text{Range} \leq 12 * 10$ $0.2 \leq \text{Range} \leq 2.4 \text{ Amp} * 50$ (See Note)
61202	51G-2 Time Dial/Time Delay	Unsigned 16 Bits $1 \leq \text{Range} \leq 10 * 20$: Time Dial $0 \leq \text{Range} \leq 10 * 20$: Time Delay
61203	50G-2 Curve Select Byte (TYPE II)	Unsigned Integer 16 bits $0 \leq \text{Range} \leq 12$ (See Text Above)
61204	51G-2 Pickup Amps	Unsigned 16 Bits $0.5 \leq \text{Range} \leq 20 * 10$
61205	51G-2 Time Dial/Delay Setting	Unsigned 16 Bits Time Dial * 10 Delay * 100
61206	150G-2 Curve Select (TYPE II)	Unsigned Integer 16 bits See Table Above
61207	150G-2 Pickup Amps	Unsigned 16 Bits $0.5 \leq \text{Range} \leq 20 * 10$
61208	150G-2 Time Delay	Unsigned 16 Bits $0 \leq \text{Range} \leq 9.99 * 100$
61209	Disturb 2 Pickup X	Unsigned Integer 16 Bits $0.5 \leq \text{Range} \leq 5 * 10$
61210	Level Detector-1 Pickup X	Unsigned Integer 16 Bits $0.5 \leq \text{Range} \leq 20 * 10$, 201 = Disable
61211	Level Detector-1 Pickup X	Unsigned Integer 16 Bits $0.5 \leq \text{Range} \leq 20 * 10$, 201 = Disable
61212	Unit Configuration Byte	Unsigned Integer 16 Bits (rightmost bit) Bit 0: Neutral Tap Range Wdg1 (lsb)

TPU2000/2000R Modbus/Modbus Plus Automation Guide

Register Address	Item	Description
		(0 = 1-12 A, 1 = 0.2-2.4A) Bit 1: Neutral Tap Range Wdg1 (0 = 1-12 A, 1 = 0.2-2.4A) Bit 2: Neutral Tap Range Wdg1 (0 = 1-12 A, 1 = 0.2-2.4A) Bit 3: Neutral Tap Range Wdg1 (0 = 1-12 A, 1 = 0.2-2.4A) Bit 4: User Definable Curves Bit 5: Reserved Bit 6: Neutral Tap Range Wdg 3 (0 = 1-12 A, 1 = 0.2-2.4A) Bit 7: Phase Tap Range Wdg3 (0 = 1-12 A, 1 = 0.2-2.4A) Bit 8: MOCT's on Wdg1 (1= None 0= MOCT Present) Bit 9: MOCT's on Wdg1 (1= None 0= MOCT Present) Bit 10: Reserved Bit 11: Reserved Bit 12: Reserved Bit 13: Reserved Bit 14: Reserved Bit 15: Reserved (msb) (leftmost bit)

If a 3 Winding Relay is used, Alternate Settings Table Definitions are given in Table 5-69 Below:

Table 5-69. Alternate 1 Settings For 3 Winding Block

Register Address	Item	Description
63328	SPARE_1	
63329	Execute Register 0 = No Action 1 = Update Registers 2 = Refresh Registers	Unsigned 16 Bits
63330	Access Password	ASCII – 2 Characters Leftmost Digits
63331	Access Password	ASCII – 2 Characters Rightmost Digits
63332	SPARE_2	
63333	87T-3 Amp	Unsigned Integer 16 Bits 2<=Range<=9 (X10) 0.4<=Range<=1.8 (X50)
63334	51P-3 Curve Select (TYPE I)	Unsigned 16 Bits Range 0-12 (See Text Above)
63335	51P-3 Pickup Amps	Unsigned 16 Bits 1<=Range<= 12 *10 0.2<=Range<=2.4 Amp * 50 (See Note)
63336	51P-3 Time Dial/Time Delay	Unsigned 16 Bits 1<=Range <=10 (X20) Time Dial 0<=Range<=10 (X20) Time Delay
63337	50P-3 Curve Select Byte (TYPE II)	Unsigned Integer 16 bits 0<=Range<=12 (See Text Above)
63338	50P-3 Pickup Amps	Unsigned 16 Bits 0.5<=Range<= 20 *10
63339	50P-3 Time Dial/Time Delay	Unsigned 16 Bits Dial *10

TPU2000/2000R Modbus/Modbus Plus Automation Guide

Register Address	Item	Description
		Delay * 100
63340	150P-3 Curve Select	Unsigned Integer 16 bits See Table Above
63341	150P-3 Pickup Amps	Unsigned 16 Bits $0.5 \leq \text{Range} \leq 20 * 10$
63342	150P-3 Time Dial	Unsigned 16 Bits $0 \leq \text{Range} \leq 9.99 * 100$
63343	46-3 Curve Select Byte	Unsigned Integer 16 bits See Table Above
63344	46-3 Pickup Amps	Unsigned 16 Bits $1 \leq \text{Range} \leq 12 * 10$ $0.2 \leq \text{Range} \leq 2.4 \text{ Amp} * 50$ (See Note)
63345	46-3 Time Dial/ Time Delay	Unsigned 16 Bits $1 \leq \text{Range} \leq 12 * 10$ $0.2 \leq \text{Range} \leq 0.4 * 50$
63346	51N-3 Curve Select (TYPE II)	Unsigned 16 Bits Range 0-12 (See Text Above)
63347	51N-3 Pickup Amps	Unsigned 16 Bits $1 \leq \text{Range} \leq 12 * 10$ $0.2 \leq \text{Range} \leq 2.4 \text{ Amp} * 50$ (See Note)
63348	51N-3 Time Dial	Unsigned 16 Bits $1 \leq \text{Range} \leq 20$ /Delay Byte $0 \leq \text{Range} \leq 10 * 20$ 51N Time Multiplier
63349	50N-3 Curve Select Byte (TYPE II)	Unsigned Integer 16 bits $0 \leq \text{Range} \leq 12$ (See Text Above)
63350	51N-3 Pickup Amps	Unsigned 16 Bits $0.5 \leq \text{Range} \leq 20 * 10$
63351	51N-3 Time Dial/Delay Setting	Unsigned 16 Bits Time Dial * 10 Delay * 100
63352	150N-3 Curve Select (TYPE II)	Unsigned Integer 16 bits See Table Above
63353	150N-3 Pickup Amps	Unsigned 16 Bits $0.5 \leq \text{Range} \leq 20 * 10$
63354	150N-3 Time Delay	Unsigned 16 Bits $0 \leq \text{Range} \leq 9.99 * 100$
63355	51G-3 Curve Select (TYPE II)	Unsigned 16 Bits Range 0-12 (See Text Above)
63356	51G-3 Pickup Amps	Unsigned 16 Bits $1 \leq \text{Range} \leq 12 * 10$ $0.2 \leq \text{Range} \leq 2.4 \text{ Amp} * 50$ (See Note)
63357	51G-3 Time Dial/Time Delay	Unsigned 16 Bits $1 \leq \text{Range} \leq 10 * 20$: Time Dial $0 \leq \text{Range} \leq 10 * 20$: Time Delay
63358	50G-3 Curve Select Byte (TYPE II)	Unsigned Integer 16 bits $0 \leq \text{Range} \leq 12$ (See Text Above)
63359	51G-3 Pickup Amps	Unsigned 16 Bits $0.5 \leq \text{Range} \leq 20 * 10$
63360	51G-3 Time Dial/Delay Setting	Unsigned 16 Bits Time Dial * 10 Delay * 100
63361	150G-3 Curve Select (TYPE II)	Unsigned Integer 16 bits See Table Above
63362	150G-3 Pickup Amps	Unsigned 16 Bits $0.5 \leq \text{Range} \leq 20 * 10$

TPU2000/2000R Modbus/Modbus Plus Automation Guide

Register Address	Item	Description
63363	150G-3 Time Delay	Unsigned 16 Bits 0<=Range<=9.99 * 100
63364	Disturb 3 Pickup X	Unsigned Integer 16 Bits 0.5<= Range<=5 *10
63365	Level Detector-1 Pickup X	Unsigned Integer 16 Bits 0.5<= Range<=20 *10 , 201 = Disable

If the Alternate Settings 2 command is selected (as per Section 5 in this document), the settings are configured as follows in Table 5-70).

Table 5-70. Alt 2 Settings Register Definition

Register Address	Item	Description
61280	SPARE_1	
61281	Execute Register 0 = No Action 1 = Update Registers 2 = Refresh Registers	Unsigned 16 Bits
61282	Access Password	ASCII – 2 Characters Leftmost Digits
61283	Access Password	ASCII – 2 Characters Rightmost Digits
61284	SPARE_2	
61285	87T Curve Type	Unsigned Integer 16 Bits
61286	87T Minimum I Operate	Unsigned 16 Bits 0.2 <=Range <=1.0 (X10)
61287	87T Percent Restraint	15<=Range<=60
61288	87T Restraint Mode	Unsigned Integer 16 Bits Refer to Mode Selection Table
61289	87T 2 nd Harmonic Restraint	Unsigned Integer 16 Bits 7.5<=Range<=25 (X10)
61290	87T 5 th Harmonic Restraint	Unsigned Integer 16 Bits 15<=Range<=40 (X10)
61291	87T All Harmonic Restraint	Unsigned Integer 16 Bits 15<=Range<=40 (X10)
61292	87H Tap X Byte	Unsigned Integer 16 Bits 6 <=Range<=20 (X10)
61293	87T-1 Amp	Unsigned Integer 16 Bits 2<=Range<=9 (X10) 0.4<=Range<=1.8 (X50)
61294	51P-1 Curve Select (TYPE I)	Unsigned 16 Bits Range 0-12 (See Text Above)
61295	51P-1 Pickup Amps	Unsigned 16 Bits 1<=Range<= 12 *10 0.2<=Range<=2.4 Amp * 50 (See Note)
61296	51P-1 Time Dial/Time Delay	Unsigned 16 Bits 1<=Range <=10 (X20) Time Dial 0<=Range<=10 (X20) Time Delay
61297	50P-1 Curve Select Byte (TYPE II)	Unsigned Integer 16 bits 0<=Range<=12 (See Text Above)
61298	50P-1 Pickup Amps	Unsigned 16 Bits 0.5<=Range<= 20 *10
61299	50P-1 Time Dial/Time Delay	Unsigned 16 Bits Dial *10 Delay * 100
61300	150P-1 Curve Select	Unsigned Integer 16 bits

TPU2000/2000R Modbus/Modbus Plus Automation Guide

Register Address	Item	Description
		See Table Above
61301	150P-1 Pickup Amps	Unsigned 16 Bits $0.5 \leq \text{Range} \leq 20 * 10$
61302	150P-1 Time Dial	Unsigned 16 Bits $0 \leq \text{Range} \leq 9.99 * 100$
61303	46-1 Curve Select Byte	Unsigned Integer 16 bits See Table Above
61304	46-1 Pickup Amps	Unsigned 16 Bits $1 \leq \text{Range} \leq 12 * 10$ $0.2 \leq \text{Range} \leq 2.4 \text{ Amp} * 50$ (See Note)
61305	46-1 Time Dial/Time Delay	Unsigned 16 Bits $1 \leq \text{Range} \leq 12 * 10$ $0.2 \leq \text{Range} \leq 0.4 * 50$
61306	51N-1 Curve Select (TYPE II)	Unsigned 16 Bits Range 0-12 (See Text Above)
61307	51N-1 Pickup Amps	Unsigned 16 Bits $1 \leq \text{Range} \leq 12 * 10$ $0.2 \leq \text{Range} \leq 2.4 \text{ Amp} * 50$ (See Note)
61308	51N-1 Time Dial	Unsigned 16 Bits $1 \leq \text{Range} \leq 20$ /Delay Byte $0 \leq \text{Range} \leq 10 * 20$ 51N Time Multiplier
61309	50N-1 Curve Select Byte (TYPE II)	Unsigned Integer 16 bits $0 \leq \text{Range} \leq 12$ (See Text Above)
61310	51N-1 Pickup Amps	Unsigned 16 Bits $0.5 \leq \text{Range} \leq 20 * 10$
61311	51N-1 Time Dial/Delay Setting	Unsigned 16 Bits Time Dial * 10 Delay * 100
61312	150N-1 Curve Select (TYPE II)	Unsigned Integer 16 bits See Table Above
61313	150N-1 Pickup Amps	Unsigned 16 Bits $0.5 \leq \text{Range} \leq 20 * 10$
61314	150N-1 Time Delay	Unsigned 16 Bits $0 \leq \text{Range} \leq 9.99 * 100$
61315	87T-2 Tap Amp Setting	Unsigned 16 Bits $2 \leq \text{Range} \leq 9 \text{ Amperes} * 10$ $0.4 \leq \text{Range} \leq 1.8 * 50$
61316	51P-2 Curve Select Byte (TYPE I)	Unsigned 16 Bits (See Text Above)
61317	51P-2 Pickup Amp/OA	Unsigned 16 Bits $1 \leq \text{Range} \leq 12 * 10$ $0.2 \leq \text{Range} \leq 2.4 * 50$
61318	51P-2 Time Dial/Delay Setting	Unsigned 16 Bits Dial : $1 \leq \text{Range} \leq 10 * 20$ Delay : $0 \leq \text{Range} \leq 10 * 20$
61319	51P-2 Curve Select (TYPE I)	Unsigned 16 Bits Range 0-12 (See Text Above)
61320	51P-2 Pickup Amps	Unsigned 16 Bits $1 \leq \text{Range} \leq 12 * 10$ $0.2 \leq \text{Range} \leq 2.4 \text{ Amp} * 50$ (See Note)
61321	51P-2 Time Dial/Time Delay	Unsigned 16 Bits $1 \leq \text{Range} \leq 10$ (X20) Time Dial $0 \leq \text{Range} \leq 10$ (X20) Time Delay
61322	51P-2 Curve Select (TYPE II)	Unsigned 16 Bits Range 0-12 (See Text Above)
61323	51P-2 Pickup X Amps	Unsigned 16 Bits

TPU2000/2000R Modbus/Modbus Plus Automation Guide

Register Address	Item	Description
		0.5<=Range<=20 Amp * 10 (See Note)
61324	51P-2 Time Dial/Time Delay	Unsigned 16 Bits Time Dial * 10 Time Delay * 20
61325	46-2 Curve Select (TYPE I)	Unsigned Integer 16 bits See Table Above
61326	46-2 Pickup Amps	Unsigned 16 Bits 1<=Range<= 12 *10 0.2<=Range<=2.4 Amp * 50 (See Note)
61327	46-2 Time Dial/ Time Delay	Unsigned 16 Bits 1<=Range<=10 * 20 0<=Range<= 10 *20
61328	51G-2 Curve Select (TYPE II)	Unsigned 16 Bits Range 0-12 (See Text Above)
61329	51G-2 Pickup Amps	Unsigned 16 Bits 1<=Range<= 12 *10 0.2<=Range<=2.4 Amp * 50 (See Note)
61330	51G-2 Time Dial/Time Delay	Unsigned 16 Bits 1<=Range <=10 * 20 : Time Dial 0<=Range<=10 * 20 : Time Delay
61331	50G-2 Curve Select Byte (TYPE II)	Unsigned Integer 16 bits 0<=Range<=12 (See Text Above)
61332	51G-2 Pickup Amps	Unsigned 16 Bits 0.5<=Range<= 20 *10
61333	51G-2 Time Dial/Delay Setting	Unsigned 16 Bits Time Dial * 10 Delay * 100
61334	150G-2 Curve Select (TYPE II)	Unsigned Integer 16 bits See Table Above
61335	150G-2 Pickup Amps	Unsigned 16 Bits 0.5<=Range<= 20 *10
61336	150G-2 Time Delay	Unsigned 16 Bits 0<=Range<=9.99 * 100
61337	Disturb 2 Pickup X	Unsigned Integer 16 Bits 0.5<= Range<=5 *10
61338	Level Detector-1 Pickup X	Unsigned Integer 16 Bits 0.5<= Range<=20 *10 , 201 = Disable
61339	Level Detector-1 Pickup X	Unsigned Integer 16 Bits 0.5<= Range<=20 *10 , 201 = Disable
61340	Unit Configuration Byte	Unsigned Integer 16 Bits (rightmost bit) Bit 0: Neutral Tap Range Wdg1 (lsb) (0 = 1-12 A, 1 = 0.2-2.4A) Bit 1: Neutral Tap Range Wdg1 (0 = 1-12 A, 1 = 0.2-2.4A) Bit 2: Neutral Tap Range Wdg1 (0 = 1-12 A, 1 = 0.2-2.4A) Bit 3: Neutral Tap Range Wdg1 (0 = 1-12 A, 1 = 0.2-2.4A) Bit 4: User Definable Curves Bit 5: Reserved Bit 6: Neutral Tap Range Wdg 3 (0 = 1-12 A, 1 = 0.2-2.4A) Bit 7: Phase Tap Range Wdg3 (0 = 1-12 A, 1 = 0.2-2.4A) Bit 8: MOCT's on Wdg1

TPU2000/2000R Modbus/Modbus Plus Automation Guide

Register Address	Item	Description
		(1= None 0= MOCT Present) Bit 9: MOCT's on Wdg1 (1= None 0= MOCT Present) Bit 10: Reserved Bit 11: Reserved Bit 12: Reserved Bit 13: Reserved Bit 14: Reserved Bit 15: Reserved (msb) (leftmost bit)

Table 5-71. Alternate 2 Settings for 3 Winding Block

Register Address	Item	Description
63456	SPARE_1	
63457	Execute Register 0 = No Action 1 = Update Registers 2 = Refresh Registers	Unsigned 16 Bits
63458	Access Password	ASCII – 2 Characters Leftmost Digits
63459	Access Password	ASCII – 2 Characters Rightmost Digits
63460	SPARE_2	
63461	87T-3 Amp	Unsigned Integer 16 Bits 2<=Range<=9 (X10) 0.4<=Range<=1.8 (X50)
63462	51P-3 Curve Select (TYPE I)	Unsigned 16 Bits Range 0-12 (See Text Above)
63463	51P-3 Pickup Amps	Unsigned 16 Bits 1<=Range<= 12 *10 0.2<=Range<=2.4 Amp * 50 (See Note)
63464	51P-3 Time Dial/Time Delay	Unsigned 16 Bits 1<=Range <=10 (X20) Time Dial 0<=Range<=10 (X20) Time Delay
63465	50P-3 Curve Select Byte (TYPE II)	Unsigned Integer 16 bits 0<=Range<=12 (See Text Above)
63466	50P-3 Pickup Amps	Unsigned 16 Bits 0.5<=Range<= 20 *10
63467	50P-3 Time Dial/Time Delay	Unsigned 16 Bits Dial *10 Delay * 100
63468	150P-3 Curve Select	Unsigned Integer 16 bits See Table Above
63469	150P-3 Pickup Amps	Unsigned 16 Bits 0.5<=Range<= 20 *10
63470	150P-3 Time Dial	Unsigned 16 Bits 0<=Range<=9.99 * 100
63471	46-3 Curve Select Byte	Unsigned Integer 16 bits See Table Above
63472	46-3 Pickup Amps	Unsigned 16 Bits 1<=Range<= 12 *10 0.2<=Range<=2.4 Amp * 50 (See Note)
63473	46-3 Time Dial/ Time Delay	Unsigned 16 Bits 1<=Range<=12 * 10 0.2<=Range<= 0.4 *50
63474	51N-3 Curve Select (TYPE II)	Unsigned 16 Bits

TPU2000/2000R Modbus/Modbus Plus Automation Guide

Register Address	Item	Description
		Range 0-12 (See Text Above)
63475	51N-3 Pickup Amps	Unsigned 16 Bits 1<=Range<= 12 *10 0.2<=Range<=2.4 Amp * 50 (See Note)
63476	51N-3 Time Dial	Unsigned 16 Bits 1<=Range <=20 /Delay Byte 0<=Range<=10 * 20 51N Time Multiplier
63477	50N-3 Curve Select Byte (TYPE II)	Unsigned Integer 16 bits 0<=Range<=12 (See Text Above)
63478	51N-3 Pickup Amps	Unsigned 16 Bits 0.5<=Range<= 20 *10
63479	51N-3 Time Dial/Delay Setting	Unsigned 16 Bits Time Dial * 10 Delay * 100
63480	150N-3 Curve Select (TYPE II)	Unsigned Integer 16 bits See Table Above
63481	150N-3 Pickup Amps	Unsigned 16 Bits 0.5<=Range<= 20 *10
63482	150N-3 Time Delay	Unsigned 16 Bits 0<=Range<=9.99 * 100
63483	51G-3 Curve Select (TYPE II)	Unsigned 16 Bits Range 0-12 (See Text Above)
63484	51G-3 Pickup Amps	Unsigned 16 Bits 1<=Range<= 12 *10 0.2<=Range<=2.4 Amp * 50 (See Note)
63485	51G-3 Time Dial/Time Delay	Unsigned 16 Bits 1<=Range <=10 * 20 : Time Dial 0<=Range<=10 * 20 : Time Delay
63486	50G-3 Curve Select Byte (TYPE II)	Unsigned Integer 16 bits 0<=Range<=12 (See Text Above)
63487	51G-3 Pickup Amps	Unsigned 16 Bits 0.5<=Range<= 20 *10
63488	51G-3 Time Dial/Delay Setting	Unsigned 16 Bits Time Dial * 10 Delay * 100
63489	150G-3 Curve Select (TYPE II)	Unsigned Integer 16 bits See Table Above
63490	150G-3 Pickup Amps	Unsigned 16 Bits 0.5<=Range<= 20 *10
63491	150G-3 Time Delay	Unsigned 16 Bits 0<=Range<=9.99 * 100
63492	Disturb 3 Pickup X	Unsigned Integer 16 Bits 0.5<= Range<=5 *10
63493	Level Detector-1 Pickup X	Unsigned Integer 16 Bits 0.5<= Range<=20 *10 , 201 = Disable

Configuration Settings

The TPU2000 and TPU2000R has configuration settings which may be set through the unit's Front Panel Interface (FPI), ECP (External Communication Program), WinECP (WINdows External Communication Program) or via Modbus/Modbus Plus via Registers 61458 through 61445. Table 5-72 is for the TPU2000 2 Winding units and the TPU2000R 2 and 3 Winding Units.

Table 5-72. TPU2000/2000R Configuration Setting Register Setting

Register Address	Item	Description
61408	SPARE_1	
61409	Execute Register 0 = No Action 1 = Update Registers 2 = Refresh Registers	Unsigned 16 Bit
61410	Access Password	ASCII – 2 Characters Leftmost Digits
61411	Access Password	ASCII – 2 Characters Rightmost Digits
61412	SPARE_2	
61413	Winding 1 Phase CT Ratio	Unsigned Integer 16 Bits 1<=Range<=4000
61414	Winding 1 Neutral CT Ratio	Unsigned Integer 16 Bits 1<=Range<=4000
61415	Winding 2 Phase CT Ratio	Unsigned Integer 16 Bits 1<=Range<=4000
61416	Winding 2 Neutral CT Ratio	Unsigned Integer 16 Bits 1<=Range<=4000
61417	Winding Phase Comp (Windings 1 and 2)	Unsigned Integer 16 Bits 0<=Range <=330 : /30
61418	Winding 1 CT Configuration	Unsigned Integer 16 Bits 0 = Wye
61419	Winding 1 CT Configuration	Unsigned Integer 16 Bits 0 = Wye
61420	Phase Rotation	Unsigned Integer 0 = ABC Rotation : 1 = ACB Rotation
61421	ALT 1 Setting Enable	Unsigned Integer 16 Bits 1 = Enabled : 0 = Disabled
61422	ALT 1 Setting Enable	Unsigned Integer 16 Bits 1 = Enabled : 0 = Disabled
61423	Trip Failure Mode	Unsigned Integer 16 Bits 0 = Differential Trip 1 = Overcurrent Alarm 2 = Differential and Overcurrent Trip Alarm
61424	Trip Failure Time	Unsigned Integer 5<=Range<=60 Seconds
61425	Trip Fail Dropout % Pickup	Unsigned Integer 5<=Range<=90
61426	Configuration Flag Bit 0 = OC Protect Mode Bit 1 = Reset Mode Bit 2 = Reserved Bit 3 =Target Display Mode Bit 4 = Local Edit Bit 5 = Remote Edit Bit 6 = Whr/VarHr Mtr Mode Bit 7 = LCD light Bit 8 = Cross Block Mode Bit 9 = Reserved Bit 10 = Reserved Bit 11 = Reserved Bit 12 = Reserved Bit 13 = Reserved Bit 14 = Reserved	Unsigned Integer 16 Bits 0 = Fundamental 1= RMS (lsb) Leftmost Bit 0 = Instant 1 = Delayed Reserved 0 = Last 1 = All 0 = Disabled 1 = Enabled 0 = Disabled 1 = Enabled 0 = Kwh 1 = MwHr 0 =Timer 1= On 0 = Disabled 1= Enabled Reserved Reserved Reserved Reserved Reserved Reserved

TPU2000/2000R Modbus/Modbus Plus Automation Guide

	Bit 15 = Reserved	Reserved (msb) Rightmost Bit
61427	Unit Name	ASCII – 2 Characters Leftmost Digits
61428	Unit Name	ASCII – 2 Characters Digits
61429	Unit Name	ASCII – 2 Characters Digits
61430	Unit Name	ASCII – 2 Characters Digits
61431	Unit Name	ASCII – 2 Characters Digits
61432	Unit Name	ASCII – 2 Characters Digits
61433	Unit Name	ASCII – 2 Characters Digits
61434	Unit Name	ASCII – 2 Characters Digits
61435	Unit Name	ASCII – 2 Characters Rightmost Digits
61436	Transformer Configuration	Unsigned Integer 16 Bits 0 = Y1-Y2-D3 1 = Y1-D2-Y3 2 = D1-Y2-Y3 3 = Y1-D2-D3 4 = D1-D2-Y3 5 = D1-Y2-D3 6 = D1-D2—D3 7 = Y1-Y2-Y3
61437	Time Demand Constant	Unsigned Integer 16 Bits 0 = 5 1 = 15 2 = 30 3 = 60
61438	LCD Contrast Adjust	Unsigned Integer 16 Bits 0<=Range <= 63
61439	Relay Password	ASCII – 2 Characters Leftmost Digits
61440	Relay Password	ASCII – 2 Characters Rightmost Digits
61441	Test Password	ASCII – 2 Characters Leftmost Digits
61442	Test Password	ASCII – 2 Characters Rightmost Digits
61443	Meter Winding Mode	Unsigned Integer 0 = Winding 1 1 = Winding 2 2 = Winding 3
61444	VT Configuration	Unsigned Integer 16 Bits 0 = 69 V Wye 1 = 120V Wye 2 = 120V Delta 3 = 208 V Delta
61445	VT Ratio	Unsigned Integer 16 Bits 1<=Range<=45000

The Configuration Files for the 3 Winding TPU2000R is as follows:

Table 5-73. TPU2000/2000R Configuration Setting Register Setting

Register Address	Item	Description
63584	SPARE_1	
63585	Execute Register 0 = No Action 1 = Update Registers 2 = Refresh Registers	Unsigned 16 Bit
63586	Access Password	ASCII – 2 Characters Leftmost Digits
63587	Access Password	ASCII – 2 Characters Rightmost Digits
63588	SPARE_2	
63589	Winding 3 Phase CT Ratio	Unsigned Integer 16 Bits

TPU2000/2000R Modbus/Modbus Plus Automation Guide

		1<=Range<=4000
63590	Winding 3 Neutral CT Ratio	Unsigned Integer 16 Bits 1<=Range<=4000
63591	Winding 3 Ground CT Ratio	Unsigned Integer 16 Bits 1<=Range<=4000
63592	Winding 3 CT Configuration	Unsigned Integer 16 Bits 0 = Wye 1 = Delta, IA-IC 2 = Delta, IA- IB
63593	Winding Phase Comp – Windings 1-3	Unsigned Integer 16 Bits 0<=Range <=330 / 30

Counters

TPU2000/TPU2000R has the ability to count breaker operations in a variety of modes. The same registers can be accessed via a Modbus Code 03 (Read Holding Registers). For 4X read access, refer to [Table 22](#). The same information can be read via the refresh register capability through Register 61922. To reset the Breaker Counters, write the value of 0 to Registers 61536 through 61547.

Table 5-74 is common to both the 2 Winding and 3 Winding TPU2000R and TPU2000 (available in 2 Winding Format Only). Table 5-74 is only available for configuration of the TPU2000R 3 Winding Relay.

Table 5-74. Counter Register Assignment

Register Address	Item	Description
63712	SPARE_1	
63713	Execute Register 0 = No Action 1 = Update Registers 2 = Refresh Registers	Unsigned 16 Bits
63714	Access Password	ASCII – 2 Characters Leftmost Digits
63715	Access Password	ASCII – 2 Characters Rightmost Digits
63716	SPARE_2	
63717	Through Fault Sum KSI Phase A – Winding 3	Unsigned 16 Bit 0 – 9999 Kiloamps Symmetrical – Current existing when breaker opened Phase A Winding 3
63718	Through Fault Sum KSI Phase B – Winding 3	Unsigned 16 Bit 0 – 9999 Kiloamps Symmetrical – Current existing when breaker opened Phase A Winding 3
63719	Through Fault Sum KSI Phase C – Winding 3	Unsigned 16 Bit 0 – 9999 Kiloamps Symmetrical – Current existing when breaker opened Phase A Winding 3

Alarm Settings

Counter and Metering settings may be set and configured via the registers from 61664 through 61682. Setting of the quantities is relatively straightforward. It should be noted that Positive Watt Alarm 1 and Positive Watt Alarm 2 units are displayed in either KWhr or MWhr according to bit 6 of Configuration Flag in the Configuration Settings Group. If bit is set to one, use MWhr, if bit is zero, use KWhr.

Table 5-75. Alarm Setting Table

Register Address	Item	Description
61664	SPARE_1	
61665	Execute Register 0 = No Action 1 = Update Registers 2 = Refresh Registers	Unsigned 16 Bits
61666	Access Password	ASCII – 2 Characters Leftmost Digits
61667	Access Password	ASCII – 2 Characters Rightmost Digits
61668	SPARE_2	
61669	Through Faults	Unsigned Integer 16 Bits 0<=Range <=9999
61670	Through Fault Summation KSI Alarm	Unsigned Integer 16 Bits 0<=Range <=9999
61671	Through Fault Summation Cycles	Unsigned Integer 16 Bits 0<=Range <=9999
61672	Overcurrent Trip Alarms	Unsigned Integer 16 Bits 0<=Range <=9999
61673	Differential Trip Alarms	Unsigned Integer 16 Bits 0<=Range <=9999
61674	Phase Demand	Unsigned Integer 0<=Range <=9999
61675	Neutral Demand	Unsigned Integer 0<=Range <=9999
61676	Load Current Alarms	Unsigned Integer 16 Bits 0<=Range <=9999
61677	3 Phase Demand Alarm	Unsigned Integer 16 Bits 10<=Range <=9999 , 10000 Disables
61678	Low PF Alarm	Unsigned Integer 16 Bits 0.5<=Range <=1.0 *100 , 101 Disables
61679	High PF Alarm	Unsigned Integer 16 Bits 0.5<=Range <=1.0 *100 , 101 Disables
61680	Positive KVAR Alarm	Unsigned Integer 16 Bits 10<=Range <=99990/10 , 10000 Disables
61681	Negative KVAR Alarm	Unsigned Integer 16 Bits 10<=Range <=99990/10 , 10000 Disables
61682	Positive Watt Alarm 1	Unsigned Integer 16 Bits 0<=Range <=9999 , 10000 Disables
62683	Positive Watt Alarm 2	Unsigned Integer 16 Bits 0<=Range <=9999 , 10000 Disables

Table 5-76. 3 Winding Alarm Settings Block

Register Address	Item	Description
63840	SPARE_1	
63841	Execute Register 0 = No Action 1 = Update Registers 2 = Refresh Registers	Unsigned 16 Bits
63842	Access Password	ASCII – 2 Characters Leftmost Digits
63843	Access Password	ASCII – 2 Characters Rightmost Digits
63844	SPARE_2	

TPU2000/2000R Modbus/Modbus Plus Automation Guide

63845	Positive Watt Alarm 2	Unsigned Integer 16 Bits 0<=Range <=9999 , 10000 Disables
63846	Through Fault Summation KSI Alarm – Winding 3.	Unsigned Integer 16 Bits 0<=Range <=9999

Real Time Clock (13 Registers Defined)

The real time clock data can be set via the network. This clock is the master which is used to time stamp operational records and event records in Registers 41029 through 41036 (as defined in Table 17) and Registers 41284 through 41291 (as defined in Table 20). It should be noted that the clock registers have been updated to reflect the four digit year required for Y2K compliance in time reporting.

If the month is set to 0, the real time clock is disabled. **The real time clock cannot be enabled or disabled via Modbus. The real time clock may only be disabled via TPU2000/TPU2000R Standard 10 Byte Protocol Attached hereto and referenced in Appendix A.**

Table 5-77 lists the register definition for Real Time Clock configuration.

Table 5-77. Real Time Clock Register Definition Assignment

Register Address	Item	Description
61792	SPARE_1	
61793	Execute Register 0 = No Action 1 = Update Registers 2 = Refresh Registers	Unsigned 16 Bits
61794	Access Password	ASCII – 2 Characters Leftmost Digits
61795	Access Password	ASCII – 2 Characters Rightmost Digits
61796	SPARE_2	
61797	Hour	Unsigned 16 Bit Hour Range 0-23
61798	Minute	Unsigned 16 Bit Minute Range 0-59
61799	Second	Unsigned 16 Bit Second Range 0-59
61800	Day	Unsigned 16 Bit Day Range 1-31
61801	Month	Unsigned 16 Bit Month Range 1-12
61802	Year	Unsigned 16 Bit Year Range 00-99

ULO Connection Settings and User Names

The TPU2000/TPU2000R has internal Soft Bits, which are used for logical boolean programming. Please reference the IL bulletin for a more detailed explanation of the use of these bits. One should also realize that Connected means that the ULO X is logically fed back through the appropriate FBX to the appropriate ULIX, where X is a number from 1 to 9.

Table 5-78 describes the register designation.

Registers 61924 designate whether the ULO is connected to the corresponding ULI. Registers 61926 through 61958 contain the 8 characters, which make up the ULO Name.

Table 5-78. ULO Table Map For Character Name Assignment

Address	Item	Description
61920	SPARE_1	
61921	Execute Register 0 = No Action 1 = Update Registers 2 = Refresh Registers	Unsigned 16 Bits

TPU2000/2000R Modbus/Modbus Plus Automation Guide

Address	Item	Description
61922	Access Password	ASCII – 2 Characters Leftmost Digits
61923	Access Password	ASCII – 2 Characters Rightmost Digits
61924	SPARE_2	
61925	ULO/ULI Connection Designation Bit 0 = ULO9 Bit 1 = ULO8 Bit 2 = ULO7 Bit 3 = ULO6 Bit 4 = ULO5 Bit 5 = ULO4 Bit 6 = ULO3 Bit 7 = ULO2 Bit 8 = ULO1 Bit 9 = Reserved Bit 10 = Reserved Bit 11 = Reserved Bit 12 = Reserved Bit 13 = Reserved Bit 14 = Reserved Bit 15 = Reserved	Unsigned Integer 16 Bit 0 = Connected 1 = Not Con. 0 = Connected 1 = Not Con. 0 = Connected 1 = Not Con. 0 = Connected 1 = Not Con. 0 = Connected 1 = Not Con. 0 = Connected 1 = Not Con. 0 = Connected 1 = Not Con. 0 = Connected 1 = Not Con. 0 = Connected 1 = Not Con. 0 = Connected 1 = Not Con. Reserved Reserved Reserved Reserved Reserved Reserved Reserved
61926	ULO 1 Rightmost 2 Characters	2 Digit ASCII Characters
61927	ULO 1 Characters	2 Digit ASCII Characters
61928	ULO 1 Characters	2 Digit ASCII Characters
61929	ULO 1 Leftmost 2 Characters	2 Digit ASCII Characters
61930	ULO 2 Rightmost 2 Characters	2 Digit ASCII Characters
61931	ULO 2 Characters	2 Digit ASCII Characters
61932	ULO 2 Characters	2 Digit ASCII Characters
61933	ULO 2 Leftmost 2 Characters	2 Digit ASCII Characters
61934	ULO 3 Rightmost 2 Characters	2 Digit ASCII Characters
61935	ULO 3 Characters	2 Digit ASCII Characters
61936	ULO 3 Characters	2 Digit ASCII Characters
61937	ULO 3 Leftmost 2 Characters	2 Digit ASCII Characters
61938	ULO 4 Rightmost 2 Characters	2 Digit ASCII Characters
61939	ULO 4 Characters	2 Digit ASCII Characters
61940	ULO 4 Characters	2 Digit ASCII Characters
61941	ULO 4 Leftmost 2 Characters	2 Digit ASCII Characters
61942	ULO 5 Rightmost 2 Characters	2 Digit ASCII Characters
61943	ULO 5 Characters	2 Digit ASCII Characters
61944	ULO 5 Characters	2 Digit ASCII Characters
61945	ULO 5 Leftmost 2 Characters	2 Digit ASCII Characters
61946	ULO 6 Rightmost 2 Characters	2 Digit ASCII Characters
61947	ULO 6 Characters	2 Digit ASCII Characters
61948	ULO 6 Characters	2 Digit ASCII Characters
61949	ULO 6 Leftmost 2 Characters	2 Digit ASCII Characters
61950	ULO 7 Rightmost 2 Characters	2 Digit ASCII Characters
61951	ULO 7 Characters	2 Digit ASCII Characters
61952	ULO 7 Characters	2 Digit ASCII Characters
61953	ULO 7 Leftmost 2 Characters	2 Digit ASCII Characters
61954	ULO 8 Rightmost 2 Characters	2 Digit ASCII Characters
61955	ULO 8 Characters	2 Digit ASCII Characters
61956	ULO 8 Characters	2 Digit ASCII Characters
61957	ULO 8 Leftmost 2 Characters	2 Digit ASCII Characters
61958	ULO 9 Rightmost 2 Characters	2 Digit ASCII Characters
61959	ULO 9 Characters	2 Digit ASCII Characters

TPU2000/2000R Modbus/Modbus Plus Automation Guide

Address	Item	Description
61960	ULO 9 Characters	2 Digit ASCII Characters
61961	ULO 9 Leftmost 2 Characters	2 Digit ASCII Characters

ULI Connection Settings and User Names

The TPU2000/TPU2000R has internal Soft Bits, which are used for logical boolean programming. Please reference the IL bulletin for a more detailed explanation of the use of these bits. Table 5-79 describes the register designation.

Registers 61926 through 61958 contain the 8 characters, which make up the ULO Name.

Table 5-79. ULI Table Map For Character Name Assignment

Address	Item	Description
62048	SPARE_1	
62049	Execute Register 0 = No Action 1 = Update Registers 2 = Refresh Registers	Unsigned 16 Bits
62050	Access Password	ASCII – 2 Characters Leftmost Digits
62051	Access Password	ASCII – 2 Characters Rightmost Digits
62052	SPARE_2	
62053	ULI 1 Rightmost 2 Characters	2 Digit ASCII Characters
62054	ULI 1 Characters	2 Digit ASCII Characters
62055	ULI 1 Characters	2 Digit ASCII Characters
62056	ULI 1 Leftmost 2 Characters	2 Digit ASCII Characters
62057	ULI 2 Rightmost 2 Characters	2 Digit ASCII Characters
62058	ULI 2 Characters	2 Digit ASCII Characters
62059	ULI 2 Characters	2 Digit ASCII Characters
62060	ULI 2 Leftmost 2 Characters	2 Digit ASCII Characters
62061	ULI 3 Rightmost 2 Characters	2 Digit ASCII Characters
62062	ULI 3 Characters	2 Digit ASCII Characters
62063	ULI 3 Characters	2 Digit ASCII Characters
62064	ULI 3 Leftmost 2 Characters	2 Digit ASCII Characters
62065	ULI 4 Rightmost 2 Characters	2 Digit ASCII Characters
62066	ULI 4 Characters	2 Digit ASCII Characters
62067	ULI 4 Characters	2 Digit ASCII Characters
62068	ULI 4 Leftmost 2 Characters	2 Digit ASCII Characters
62069	ULI 5 Rightmost 2 Characters	2 Digit ASCII Characters
62070	ULI 5 Characters	2 Digit ASCII Characters
62071	ULI 5 Characters	2 Digit ASCII Characters
62072	ULI 5 Leftmost 2 Characters	2 Digit ASCII Characters
62073	ULI 6 Rightmost 2 Characters	2 Digit ASCII Characters
62074	ULI 6 Characters	2 Digit ASCII Characters
62075	ULI 6 Characters	2 Digit ASCII Characters
62076	ULI 6 Leftmost 2 Characters	2 Digit ASCII Characters
62077	ULI 7 Rightmost 2 Characters	2 Digit ASCII Characters
62078	ULI 7 Characters	2 Digit ASCII Characters
62079	ULI 7 Characters	2 Digit ASCII Characters
62080	ULI 7 Leftmost 2 Characters	2 Digit ASCII Characters
62081	ULI 8 Rightmost 2 Characters	2 Digit ASCII Characters
62082	ULI 8 Characters	2 Digit ASCII Characters
62083	ULI 8 Characters	2 Digit ASCII Characters
62084	ULI 8 Leftmost 2 Characters	2 Digit ASCII Characters
62085	ULI 9 Rightmost 2 Characters	2 Digit ASCII Characters

TPU2000/2000R Modbus/Modbus Plus Automation Guide

Address	Item	Description
62086	ULI 9 Characters	2 Digit ASCII Characters
62087	ULI 9 Characters	2 Digit ASCII Characters
62088	ULI 9 Leftmost 2 Characters	2 Digit ASCII Characters

Force Logical Input Allocation and Name Assignment

The TPU2000/TPU2000R has the capability to assign input functions to “soft bits”. These “soft bits” are designated as Forced Logical Input Bit (FLI’s). The FLI bits may be forced through the network protocol as described in Section 5 of this document. However, the FLI’s must be mapped to a protective function to be controlled when the bit is set. Register addresses 62180 through 62196 allocate a byte containing a code thus mapping the desired function to the bit. Table 5-80 lists the logical inputs and their respective codes. Registers 62197 through 62321 lists the addresses assigned for the character string assignments to each of the “soft bit” FLI controls. The register lists are contained in Table 5-80 below.

Table 5-80. FLI Soft Bit Table Map and Character Name Assignment Register Map

Register Address	Item	Description
62176	SPARE_1	
62177	Execute Register 0 = No Action 1 = Update Registers 2 = Refresh Registers	Unsigned 16 Bits
62178	Access Password	ASCII – 2 Characters Leftmost Digits
62179	Access Password	ASCII – 2 Characters Rightmost Digits
62180	SPARE_2	
62181	FLI 1 INDEX Byte	Unsigned Integer Hi byte 8 leftmost bits
	FLI 2 INDEX Byte	Unsigned Integer Lo byte 8 rightmost bits
62182	FLI 3 INDEX Byte	Unsigned Integer Hi byte 8 leftmost bits
	FLI 4 INDEX Byte	Unsigned Integer Lo byte 8 rightmost bits
62183	FLI 5 INDEX Byte	Unsigned Integer Hi byte 8 leftmost bits
	FLI 6 INDEX Byte	Unsigned Integer Lo byte 8 rightmost bits
62184	FLI 7 INDEX Byte	Unsigned Integer Hi byte 8 leftmost bits
	FLI 8 INDEX Byte	Unsigned Integer Lo byte 8 rightmost bits
62185	FLI 9 INDEX Byte	Unsigned Integer Hi byte 8 leftmost bits
	FLI 10 INDEX Byte	Unsigned Integer Lo byte 8 rightmost bits
62186	FLI 11 INDEX Byte	Unsigned Integer Hi byte 8 leftmost bits
	FLI 12 INDEX Byte	Unsigned Integer Lo byte 8 rightmost bits
62187	FLI 13 INDEX Byte	Unsigned Integer Hi byte 8 leftmost bits
	FLI 14 INDEX Byte	Unsigned Integer Lo byte 8 rightmost bits
62188	FLI 15 INDEX Byte	Unsigned Integer Hi byte 8 leftmost bits
	FLI 16 INDEX Byte	Unsigned Integer Lo byte 8 rightmost bits
62189	FLI 17 INDEX Byte	Unsigned Integer Hi byte 8 leftmost bits
	FLI 18 INDEX Byte	Unsigned Integer Lo byte 8 rightmost bits
62190	FLI 19 INDEX Byte	Unsigned Integer Hi byte 8 leftmost bits
	FLI 20 INDEX Byte	Unsigned Integer Lo byte 8 rightmost bits
62191	FLI 21 INDEX Byte	Unsigned Integer Hi byte 8 leftmost bits
	FLI 22 INDEX Byte	Unsigned Integer Lo byte 8 rightmost bits
62192	FLI 23 INDEX Byte	Unsigned Integer Hi byte 8 leftmost bits
	FLI 24 INDEX Byte	Unsigned Integer Lo byte 8 rightmost bits
62193	FLI 25 INDEX Byte	Unsigned Integer Hi byte 8 leftmost bits
	FLI 26 INDEX Byte	Unsigned Integer Lo byte 8 rightmost bits
62194	FLI 27 INDEX Byte	Unsigned Integer Hi byte 8 leftmost bits
	FLI 28 INDEX Byte	Unsigned Integer Lo byte 8 rightmost bits
62195	FLI 29 INDEX Byte	Unsigned Integer Hi byte 8 leftmost bits

TPU2000/2000R Modbus/Modbus Plus Automation Guide

Register Address	Item	Description
	FLI 30 INDEX Byte	Unsigned Integer Lo byte 8 rightmost bits
62196	FLI 31 INDEX Byte	Unsigned Integer Hi byte 8 leftmost bits
	FLI 32 INDEX Byte	Unsigned Integer Lo byte 8 rightmost bits
62197	FLI 1 Rightmost 2 Characters	2 Digit ASCII Characters
62198	FLI 1 Characters	2 Digit ASCII Characters
62199	FLI 1 Characters	2 Digit ASCII Characters
62200	FLI 1 Leftmost 2 Characters	2 Digit ASCII Characters
62201	FLI 2 Rightmost 2 Characters	2 Digit ASCII Characters
62202	FLI 2 Characters	2 Digit ASCII Characters
62203	FLI 2 Characters	2 Digit ASCII Characters
62204	FLI 2 Leftmost 2 Characters	2 Digit ASCII Characters
62205	FLI 3 Rightmost 2 Characters	2 Digit ASCII Characters
62206	FLI 3 Characters	2 Digit ASCII Characters
62207	FLI 3 Characters	2 Digit ASCII Characters
62208	FLI 3 Leftmost 2 Characters	2 Digit ASCII Characters
62209	FLI 4 Rightmost 2 Characters	2 Digit ASCII Characters
62210	FLI 4 Characters	2 Digit ASCII Characters
62211	FLI 4 Characters	2 Digit ASCII Characters
62212	FLI 4 Leftmost 2 Characters	2 Digit ASCII Characters
62213	FLI 5 Rightmost 2 Characters	2 Digit ASCII Characters
62214	FLI 5 Characters	2 Digit ASCII Characters
62215	FLI 5 Characters	2 Digit ASCII Characters
62216	FLI 5 Leftmost 2 Characters	2 Digit ASCII Characters
62217	FLI 6 Rightmost 2 Characters	2 Digit ASCII Characters
62218	FLI 6 Characters	2 Digit ASCII Characters
62219	FLI 6 Characters	2 Digit ASCII Characters
62220	FLI 6 Leftmost 2 Characters	2 Digit ASCII Characters
62221	FLI 7 Rightmost 2 Characters	2 Digit ASCII Characters
62222	FLI 7 Characters	2 Digit ASCII Characters
62223	FLI 7 Characters	2 Digit ASCII Characters
62224	FLI 7 Leftmost 2 Characters	2 Digit ASCII Characters
62225	FLI 8 Rightmost 2 Characters	2 Digit ASCII Characters
62226	FLI 8 Characters	2 Digit ASCII Characters
62227	FLI 8 Characters	2 Digit ASCII Characters
62228	FLI 8 Leftmost 2 Characters	2 Digit ASCII Characters
62229	FLI 9 Rightmost 2 Characters	2 Digit ASCII Characters
62230	FLI 9 Characters	2 Digit ASCII Characters
62231	FLI 9 Characters	2 Digit ASCII Characters
62232	FLI 9 Leftmost 2 Characters	2 Digit ASCII Characters
62233	FLI 10 Rightmost 2 Characters	2 Digit ASCII Characters
62234	FLI 10 Characters	2 Digit ASCII Characters
62235	FLI 10 Characters	2 Digit ASCII Characters
62236	FLI 10 Leftmost 2 Characters	2 Digit ASCII Characters
62237	FLI 11 Rightmost 2 Characters	2 Digit ASCII Characters
62238	FLI 11 Characters	2 Digit ASCII Characters
62239	FLI 11 Characters	2 Digit ASCII Characters
62240	FLI 11 Leftmost 2 Characters	2 Digit ASCII Characters
62241	FLI 12 Rightmost 2 Characters	2 Digit ASCII Characters
62242	FLI 12 Characters	2 Digit ASCII Characters
62243	FLI 12 Characters	2 Digit ASCII Characters
62244	FLI 12 Leftmost 2 Characters	2 Digit ASCII Characters
62245	FLI 13 Rightmost 2 Characters	2 Digit ASCII Characters
62246	FLI 13 Characters	2 Digit ASCII Characters

TPU2000/2000R Modbus/Modbus Plus Automation Guide

Register Address	Item	Description
62247	FLI 13 Characters	2 Digit ASCII Characters
62248	FLI 13 Leftmost 2 Characters	2 Digit ASCII Characters
62249	FLI 14 Rightmost 2 Characters	2 Digit ASCII Characters
62250	FLI 14 Characters	2 Digit ASCII Characters
62251	FLI 14 Characters	2 Digit ASCII Characters
62252	FLI 14 Leftmost 2 Characters	2 Digit ASCII Characters
62253	FLI 15 Rightmost 2 Characters	2 Digit ASCII Characters
62254	FLI 15 Characters	2 Digit ASCII Characters
62255	FLI 15 Characters	2 Digit ASCII Characters
62256	FLI 15 Leftmost 2 Characters	2 Digit ASCII Characters
62257	FLI 16 Rightmost 2 Characters	2 Digit ASCII Characters
62258	FLI 16 Characters	2 Digit ASCII Characters
62259	FLI 16 Characters	2 Digit ASCII Characters
62260	FLI 16 Leftmost 2 Characters	2 Digit ASCII Characters
62261	FLI 17 Rightmost 2 Characters	2 Digit ASCII Characters
62262	FLI 17 Characters	2 Digit ASCII Characters
62263	FLI 17 Characters	2 Digit ASCII Characters
62264	FLI 17 Leftmost 2 Characters	2 Digit ASCII Characters
62265	FLI 18 Rightmost 2 Characters	2 Digit ASCII Characters
62266	FLI 18 Characters	2 Digit ASCII Characters
62267	FLI 18 Characters	2 Digit ASCII Characters
62268	FLI 18 Leftmost 2 Characters	2 Digit ASCII Characters
62269	FLI 19 Rightmost 2 Characters	2 Digit ASCII Characters
62270	FLI 19 Characters	2 Digit ASCII Characters
62271	FLI 19 Characters	2 Digit ASCII Characters
62272	FLI 19 Leftmost 2 Characters	2 Digit ASCII Characters
62273	FLI 20 Rightmost 2 Characters	2 Digit ASCII Characters
62274	FLI 20 Characters	2 Digit ASCII Characters
62275	FLI 20 Characters	2 Digit ASCII Characters
62276	FLI 20 Leftmost 2 Characters	2 Digit ASCII Characters
62277	FLI 21 Rightmost 2 Characters	2 Digit ASCII Characters
62278	FLI 21 Characters	2 Digit ASCII Characters
62279	FLI 21 Characters	2 Digit ASCII Characters
62280	FLI 21 Leftmost 2 Characters	2 Digit ASCII Characters
62281	FLI 22 Rightmost 2 Characters	2 Digit ASCII Characters
62282	FLI 22 Characters	2 Digit ASCII Characters
62283	FLI 22 Characters	2 Digit ASCII Characters
62284	FLI 22 Leftmost 2 Characters	2 Digit ASCII Characters
62285	FLI 23 Rightmost 2 Characters	2 Digit ASCII Characters
62286	FLI 23 Characters	2 Digit ASCII Characters
62287	FLI 23 Characters	2 Digit ASCII Characters
62288	FLI 23 Leftmost 2 Characters	2 Digit ASCII Characters
62289	FLI 24 Rightmost 2 Characters	2 Digit ASCII Characters
62290	FLI 24 Characters	2 Digit ASCII Characters
62291	FLI 24 Characters	2 Digit ASCII Characters
62292	FLI 24 Leftmost 2 Characters	2 Digit ASCII Characters
62293	FLI 25 Rightmost 2 Characters	2 Digit ASCII Characters
62294	FLI 25 Characters	2 Digit ASCII Characters
62295	FLI 25 Characters	2 Digit ASCII Characters
62296	FLI 25 Leftmost 2 Characters	2 Digit ASCII Characters
62297	FLI 26 Rightmost 2 Characters	2 Digit ASCII Characters
62298	FLI 26 Characters	2 Digit ASCII Characters
62299	FLI 26 Characters	2 Digit ASCII Characters

TPU2000/2000R Modbus/Modbus Plus Automation Guide

Register Address	Item	Description
62300	FLI 26 Leftmost 2 Characters	2 Digit ASCII Characters
62301	FLI 27 Rightmost 2 Characters	2 Digit ASCII Characters
62302	FLI 27 Characters	2 Digit ASCII Characters
62303	FLI 27 Characters	2 Digit ASCII Characters
62304	FLI 27 Leftmost 2 Characters	2 Digit ASCII Characters
62305	FLI 28 Rightmost 2 Characters	2 Digit ASCII Characters
62306	FLI 28 Characters	2 Digit ASCII Characters
62307	FLI 28 Characters	2 Digit ASCII Characters
62308	FLI 28 Leftmost 2 Characters	2 Digit ASCII Characters
62309	FLI 29 Rightmost 2 Characters	2 Digit ASCII Characters
62310	FLI 29 Characters	2 Digit ASCII Characters
62311	FLI 29 Characters	2 Digit ASCII Characters
62312	FLI 29 Leftmost 2 Characters	2 Digit ASCII Characters
62313	FLI 30 Rightmost 2 Characters	2 Digit ASCII Characters
62314	FLI 30 Characters	2 Digit ASCII Characters
62315	FLI 30 Characters	2 Digit ASCII Characters
62316	FLI 30 Leftmost 2 Characters	2 Digit ASCII Characters
62317	FLI 31 Rightmost 2 Characters	2 Digit ASCII Characters
62318	FLI 31 Characters	2 Digit ASCII Characters
62319	FLI 31 Characters	2 Digit ASCII Characters
62320	FLI 31 Leftmost 2 Characters	2 Digit ASCII Characters
62321	FLI 32 Leftmost 2 Characters	2 Digit ASCII Characters
62322	FLI 32 Characters	2 Digit ASCII Characters
62323	FLI 32 Characters	2 Digit ASCII Characters
62324	FLI 32 Rightmost 2 Characters	2 Digit ASCII Characters

Modbus Plus Global Register Mapping (37 Registers Defined) TPU2000R Only

Modbus Plus has the unique protocol characteristic that up to 32 registers of data may be attached to the token and seen by all the nodes on the Modbus Plus Network. The register configuration can be done through ECP or WinECP or via Modbus Plus. Global Mapping requires that the Modbus/Modbus Plus TPU2000 Register Address from 40001 Through 40921 (The read only defined registers) may be mapped to the GLOBAL REGISTER MAPPING TABLE. The leading 4X is deleted from the required register mapped to the block. An Example is shown in Figure 5-70. The register definitions for configuring Global Data are shown in Table 5-81 below.

Additionally, a security mask configuration register has been included within the configuration block. If the bit of Register 62598 assigned to the function is set to a 0. Then a password must be used when controlling a function in Groups 1 through Groups 6 as described in Section 5. The status of control being password protected/unprotected is indicated in Register 4XXXX. If a password section is unprotected, then the password requested in Groups 1 through 6 may be any arbitrary value corresponding to the bit state.

If one were to configure the global registers via ECP or WinECP, a configuration screen is available to parameterize each of the 32 global Modbus Plus registers. An example of the global register configuration screen is shown in Figures 5-70 below. If a Modbus Plus TPU2000R capable relay was configured (Model # 588 XXXX6- XXXX4 or 588 XXXX7-XXXX4), the following screen would be shown on WinECP. Note the Global Register Tab (accessed from the "SETTINGS" menu header) is visible and available as an option.

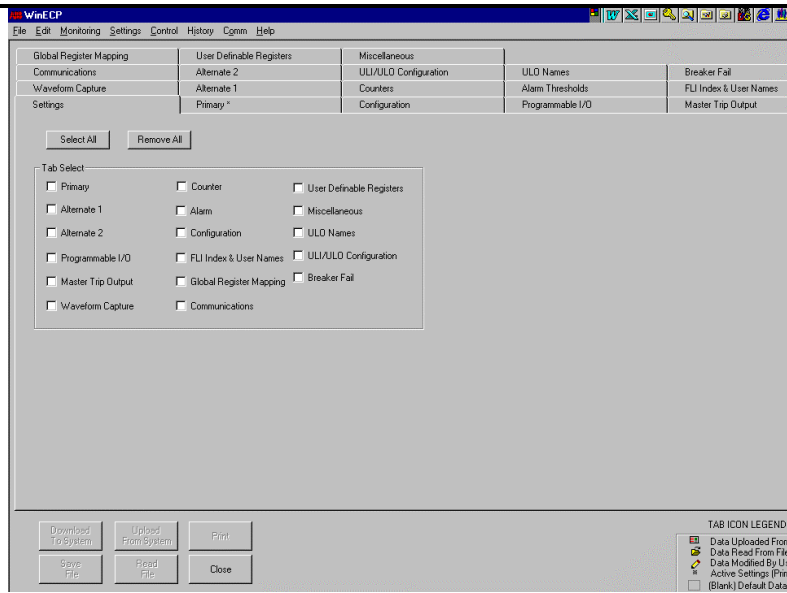

Figure 5-70. Setting Tab Display Screen with Modbus Plus Global Register Configuration Option

Depressing the Global Register Configuration tab allows the screen shown in Figure 5-71 to be visible. The Global Register Access screen and the Write Control Block (which is Register 4XXXX, reference the section TPU CONTROL FUNCTIONALITY for a complete description). Depress the SET GLOBAL REGISTERS pushbutton to access the register configuration screen.

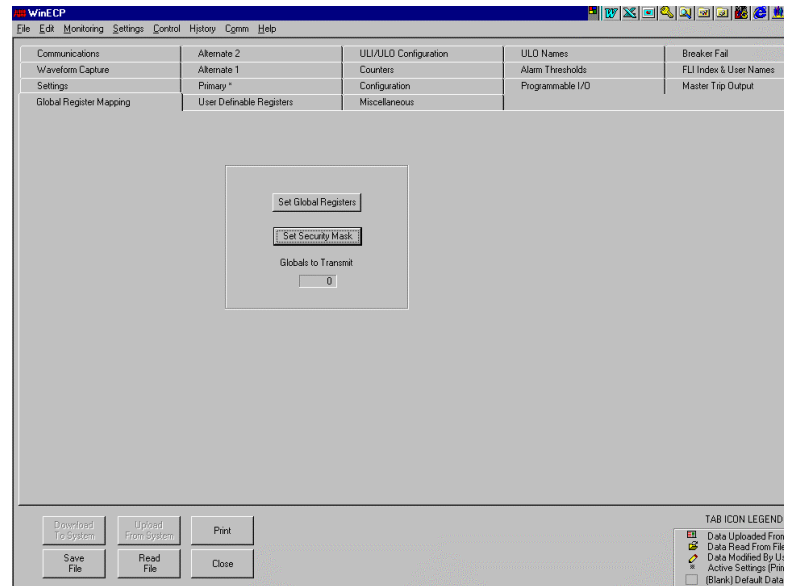

Figure 5-71. Global Register Configuration Option Screen

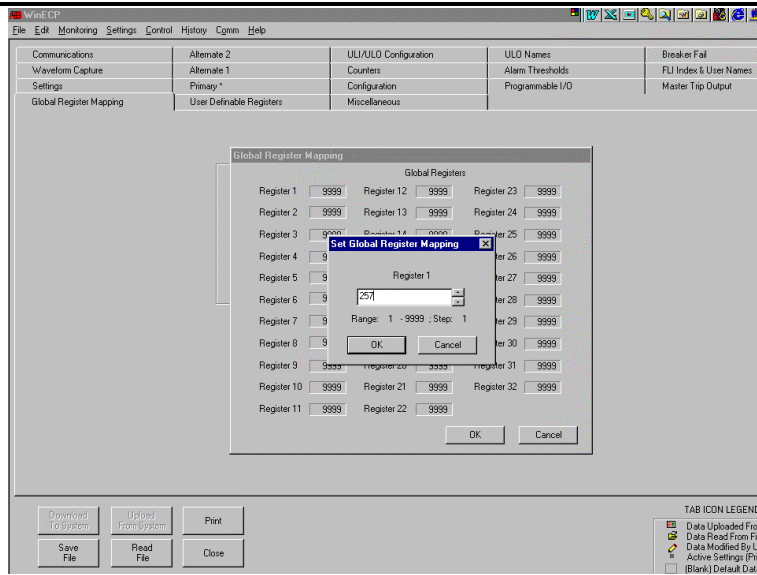

Figure 5-72. Global Register Configuration Screen

The screen shown in Figure 5-72 is visible once the Set Global Registers Screen is depressed. Double clicking the area over the register assignment field then allows the sub “window” to be visible. In this example, Ia (Phase A Current Register 257) is mapped to Global Register 1. The register address is found by referencing Table 5-81 of this document.

Table 5-81. Modbus Plus Global Register Map Configuration Definition

Register Address	Item	Description
62560	SPARE_1	
62561	Execute Register 0 = No Action 1 = Update Registers 2 = Refresh Registers	Unsigned 16 Bits
62562	Access Password	ASCII – 2 Characters Leftmost Digits
62563	Access Password	ASCII – 2 Characters Rightmost Digits
62564	SPARE_2	
62565	Number of Global Register To Transmit	Unsigned Integer 16 Bits 0<=Range<= 32
62566	Modbus Plus Global Register 1 Mapped Address	Unsigned Integer 16 Bits 1<=Range<=921
62567	Modbus Plus Global Register 2 Mapped Address	Unsigned Integer 16 Bits 1<=Range<=921
62568	Modbus Plus Global Register 3 Mapped Address	Unsigned Integer 16 Bits 1<=Range<=921
62569	Modbus Plus Global Register 4 Mapped Address	Unsigned Integer 16 Bits 1<=Range<=921
62570	Modbus Plus Global Register 5 Mapped Address	Unsigned Integer 16 Bits 1<=Range<=921
62571	Modbus Plus Global Register 6 Mapped Address	Unsigned Integer 16 Bits 1<=Range<=921
62572	Modbus Plus Global Register 7 Mapped Address	Unsigned Integer 16 Bits 1<=Range<=921
62573	Modbus Plus Global Register 8 Mapped Address	Unsigned Integer 16 Bits 1<=Range<=921
62574	Modbus Plus Global Register 9	Unsigned Integer 16 Bits

TPU2000/2000R Modbus/Modbus Plus Automation Guide

	Mapped Address	1<=Range<=921
62575	Modbus Plus Global Register 10 Mapped Address	Unsigned Integer 16 Bits 1<=Range<=921
62576	Modbus Plus Global Register 11 Mapped Address	Unsigned Integer 16 Bits 1<=Range<=921
62577	Modbus Plus Global Register 12 Mapped Address	Unsigned Integer 16 Bits 1<=Range<=921
62578	Modbus Plus Global Register 13 Mapped Address	Unsigned Integer 16 Bits 1<=Range<=921
62579	Modbus Plus Global Register 14 Mapped Address	Unsigned Integer 16 Bits 1<=Range<=921
62580	Modbus Plus Global Register 15 Mapped Address	Unsigned Integer 16 Bits 1<=Range<=921
62581	Modbus Plus Global Register 16 Mapped Address	Unsigned Integer 16 Bits 1<=Range<=921
62582	Modbus Plus Global Register 17 Mapped Address	Unsigned Integer 16 Bits 1<=Range<=921
62583	Modbus Plus Global Register 18 Mapped Address	Unsigned Integer 16 Bits 1<=Range<=921
62584	Modbus Plus Global Register 19 Mapped Address	Unsigned Integer 16 Bits 1<=Range<=921
62585	Modbus Plus Global Register 20 Mapped Address	Unsigned Integer 16 Bits 1<=Range<=921
62586	Modbus Plus Global Register 21 Mapped Address	Unsigned Integer 16 Bits 1<=Range<=921
62587	Modbus Plus Global Register 22 Mapped Address	Unsigned Integer 16 Bits 1<=Range<=921
62588	Modbus Plus Global Register 23 Mapped Address	Unsigned Integer 16 Bits 1<=Range<=921
62589	Modbus Plus Global Register 24 Mapped Address	Unsigned Integer 16 Bits 1<=Range<=921
62590	Modbus Plus Global Register 25 Mapped Address	Unsigned Integer 16 Bits 1<=Range<=921
62591	Modbus Plus Global Register 26 Mapped Address	Unsigned Integer 16 Bits 1<=Range<=921
62592	Modbus Plus Global Register 27 Mapped Address	Unsigned Integer 16 Bits 1<=Range<=921
62593	Modbus Plus Global Register 28 Mapped Address	Unsigned Integer 16 Bits 1<=Range<=921
62594	Modbus Plus Global Register 29 Mapped Address	Unsigned Integer 16 Bits 1<=Range<=921
62595	Modbus Plus Global Register 30 Mapped Address	Unsigned Integer 16 Bits 1<=Range<=921
62596	Modbus Plus Global Register 31 Mapped Address	Unsigned Integer 16 Bits 1<=Range<=921
62597	Modbus Plus Global Register 32 Mapped Address	Unsigned Integer 16 Bits 1<=Range<=921
62598	Security Mask For Control Block (See Section 5) Bit 0 (Right Bit) Initiate Input Bit 1 Force Physical Input Bit 2 Force Physical Output Bit 3 Force Logical Output Bit 4 Set/Reset Output Bit 5 Pulse Outputs Bit 6 Reserved Bit 7 Reserved	Unsigned Integer 16 Bits 1 = Control Unprotected 0 = Password Req. 1 = Control Unprotected 0 = Password Req. 1 = Control Unprotected 0 = Password Req. 1 = Control Unprotected 0 = Password Req. 1 = Control Unprotected 0 = Password Req. 1 = Control Unprotected 0 = Password Req. Reserved Reserved

Bit 8 Reserved	Reserved
Bit 9 Reserved	Reserved
Bit 10 Reserved	Reserved
Bit 11 Reserved	Reserved
Bit 12 Reserved	Reserved
Bit 13 Reserved	Reserved
Bit 14 Reserved	Reserved
Bit 15 Reserved	Reserved

User Definable Register Configuration Block

As described in Section 5 the TPU2000 and TPU2000R has the capability to scale and remap the Modbus registers within the unit. As shown in Table 5-82.

The following registers support modification and scaling of information contained in the Modbus user register set. The information in the 4xxxx registers can be tailored to the users needs with the following options:

1. Register: Register needed can be programmed.
2. Scalability: Data in the registers can be scaled.
3. Destination register data type: This supports multiple data types to match the destination systems needs.
4. Destination register data size: This supports multiple data sizes to match the destination systems needs.
5. MSB/LSB bit justification: This allows users to shift the bits contained in the 4xxxx register into the *Most* significant bits or the *Least* significant bits.

Here is an example of how to set up the modbus registers to exploit the above facilities. Consider a situation where the destination system is a SCADA. Suppose the user's SCADA system is setup to read the System Frequency on Register 40001 and requires the data be in the 12 Most significant bits. Also, let us suppose that the scale required on the system frequency is hex 0a (10 decimal) and the SCADA stores the value in a bipolar data type. The user would adopt the following procedure to setup register 40001 to meet the specifications of the destination system. Now write hex 0a (decimal 10) which is the scale we need into Register 62693. Next write hex 0232 (562 decimal) on Register 62694 which fetches the value from the Register 40562 (the source register for system frequency). Setting the data size (12), the data type (bipolar) and shifting data (into Most significant bits) is done as follows:

Register Size (12 bits)

Bit 7	Bit 6	Bit 5	Bit 4
0	0	1	1

MSB/LSB (Justified to the left i.e. data in the the Most Significant Bits)

Bit 3
1

Register Type (Bipolar)

Bit 2	Bit 1	Bit 0
0	0	1

So, write hex 039 (decimal 57) into Register 62695 and the registers should look like:

```

register 62692 hex 0000
register 62693 hex 000a
register 62694 hex 0232
register 62695 hex 0039
    
```

TPU2000/2000R Modbus/Modbus Plus Automation Guide

Now when the command is executed, the data is transferred to the TPU2000/2000R and subsequent data transmissions from register 40001 of the unit will be:

- 12 bit wide with the bits justified to the left (in the Most Significant Bits)
- The data type will be bipolar and compatible with the destination register type
- The value will be scaled by 10

Note: See the Register Scaling and Remapping Section 5 default Data type and size definitions

Table 5-82. User Definable Register Configuration Table

Register Address	Item	Description
62688	SPARE_1	
62689	Execute Register 0 = No Action 1 = Update Registers 2 = Refresh Registers	Unsigned 16 Bits
62690	Access Password	ASCII – 2 Characters Leftmost Digits
62691	Access Password	ASCII – 2 Characters Rightmost Digits
62692	SPARE_2	
62693	User Reg. 40001 Scale	Unsigned Integer 16 Bits 0<=Range<=65535
62694	User Reg. 40001 Source Register Address	Unsigned Integer 16 Bits 1<=Range<=922
62695	User Reg. 40001 Register Destination Type Rightmost Bits 2 – 1- 0 Destination Justification (Bit 3) Destination Scale Bit Size Bits 7 – 6- 5- 4	Unsigned Integer 16 Bits 0 0 0 = Offset Bipolar 0 0 1 = Bipolar 0 1 0 = Unipolar 0 1 1 = Negative Unipolar 1 = Least Significant Bit 0 = Most Significant Bit 0 0 0 0 = 2 Bits 0 0 0 1 = 4 Bits 0 0 1 0 = 8 Bits 0 1 0 0 = 12 Bits 1 0 0 0 = 16 Bits
62696	User Register 40001 Source Register Scale Type (Leftmost Byte) Data Type (Rightmost Byte)	Unsigned Integer 16 Bits 0 = Normal 1 = Remainder 2 = Phase Current 3 = Neutral Current 4 = Voltage 5 = Power 0 = Unsigned 16 Bits 1 = Unsigned 32 Bits 2 = Signed 16 Bits 3 = Signed 32 Bits
62697	User Reg. 40002 Scale	Unsigned Integer 16 Bits 0<=Range<=65535
62698	User Reg. 40002 Source Register Address	Unsigned Integer 16 Bits 1<=Range<=922
62699	User Reg. 40002 Register Destination Type Rightmost Bits 2 – 1- 0	Unsigned Integer 16 Bits 0 0 0 = Offset Bipolar 0 0 1 = Bipolar 0 1 0 = Unipolar 0 1 1 = Negative Unipolar

TPU2000/2000R Modbus/Modbus Plus Automation Guide

Register Address	Item	Description
	Destination Justification (Bit 3) Destination Scale Bit Size Bits 7 – 6- 5- 4	1 = Least Significant Bit 0 = Most Significant Bit 0 0 0 0 = 2 Bits 0 0 0 1 = 4 Bits 0 0 1 0 = 8 Bits 0 1 0 0 = 12 Bits 1 0 0 0 = 16 Bits
62700	User Register 40002 Source Register Scale Type (Leftmost Byte) Data Type (Rightmost Byte)	Unsigned Integer 16 Bits 0 = Normal 1 = Remainder 2 = Phase Current 3 = Neutral Current 4 = Voltage 5 = Power 0 = Unsigned 16 Bits 1 = Unsigned 32 Bits 2 = Signed 16 Bits 3 = Signed 32 Bits
62701	User Reg. 40003 Scale	Unsigned Integer 16 Bits 0<=Range<=65535
62702	User Reg. 40003 Source Register Address	Unsigned Integer 16 Bits 1<=Range<=922
62703	User Reg. 40003 Register Destination Type Rightmost Bits 2 – 1- 0 Destination Justification (Bit 3) Destination Scale Bit Size Bits 7 – 6- 5- 4	Unsigned Integer 16 Bits 0 0 0 = Offset Bipolar 0 0 1 = Bipolar 0 1 0 = Unipolar 0 1 1 = Negative Unipolar 1 = Least Significant Bit 0 = Most Significant Bit 0 0 0 0 = 2 Bits 0 0 0 1 = 4 Bits 0 0 1 0 = 8 Bits 0 1 0 0 = 12 Bits 1 0 0 0 = 16 Bits
62704	User Register 40003 Source Register Scale Type (Leftmost Byte) Data Type (Rightmost Byte)	Unsigned Integer 16 Bits 0 = Normal 1 = Remainder 2 = Phase Current 3 = Neutral Current 4 = Voltage 5 = Power 0 = Unsigned 16 Bits 1 = Unsigned 32 Bits 2 = Signed 16 Bits 3 = Signed 32 Bits
62705	User Reg. 40004 Scale	Unsigned Integer 16 Bits 0<=Range<=65535
62706	User Reg. 40004 Source Register Address	Unsigned Integer 16 Bits 1<=Range<=922
62707	User Reg. 40004 Register Destination Type Rightmost Bits 2 – 1- 0 Destination Justification (Bit 3) Destination Scale Bit Size Bits 7 – 6- 5- 4	Unsigned Integer 16 Bits 0 0 0 = Offset Bipolar 0 0 1 = Bipolar 0 1 0 = Unipolar 0 1 1 = Negative Unipolar 1 = Least Significant Bit 0 = Most Significant Bit 0 0 0 0 = 2 Bits 0 0 0 1 = 4 Bits

TPU2000/2000R Modbus/Modbus Plus Automation Guide

Register Address	Item	Description
		0 0 1 0 = 8 Bits 0 1 0 0 = 12 Bits 1 0 0 0 = 16 Bits
62708	User Register 40004 Source Register Scale Type (Leftmost Byte) Data Type (Rightmost Byte)	Unsigned Integer 16 Bits 0 = Normal 1 = Remainder 2 = Phase Current 3 = Neutral Current 4 = Voltage 5 = Power 0 = Unsigned 16 Bits 1 = Unsigned 32 Bits 2 = Signed 16 Bits 3 = Signed 32 Bits
62709	User Reg. 40005 Scale	Unsigned Integer 16 Bits 0<=Range<=65535
62710	User Reg. 40005 Source Register Address	Unsigned Integer 16 Bits 1<=Range<=922
62711	User Reg. 40005 Register Destination Type Rightmost Bits 2 – 1- 0 Destination Justification (Bit 3) Destination Scale Bit Size Bits 7 – 6- 5- 4	Unsigned Integer 16 Bits 0 0 0 = Offset Bipolar 0 0 1 = Bipolar 0 1 0 = Unipolar 0 1 1 = Negative Unipolar 1 = Least Significant Bit 0 = Most Significant Bit 0 0 0 0 = 2 Bits 0 0 0 1 = 4 Bits 0 0 1 0 = 8 Bits 0 1 0 0 = 12 Bits 1 0 0 0 = 16 Bits
62712	User Register 40005 Source Register Scale Type (Leftmost Byte) Data Type (Rightmost Byte)	Unsigned Integer 16 Bits 0 = Normal 1 = Remainder 2 = Phase Current 3 = Neutral Current 4 = Voltage 5 = Power 0 = Unsigned 16 Bits 1 = Unsigned 32 Bits 2 = Signed 16 Bits 3 = Signed 32 Bits
62713	User Reg. 40006 Scale	Unsigned Integer 16 Bits 0<=Range<=65535
62714	User Reg. 40006 Source Register Address	Unsigned Integer 16 Bits 1<=Range<=922
62715	User Reg. 40006 Register Destination Type Rightmost Bits 2 – 1- 0 Destination Justification (Bit 3) Destination Scale Bit Size Bits 7 – 6- 5- 4	Unsigned Integer 16 Bits 0 0 0 = Offset Bipolar 0 0 1 = Bipolar 0 1 0 = Unipolar 0 1 1 = Negative Unipolar 1 = Least Significant Bit 0 = Most Significant Bit 0 0 0 0 = 2 Bits 0 0 0 1 = 4 Bits 0 0 1 0 = 8 Bits 0 1 0 0 = 12 Bits 1 0 0 0 = 16 Bits

TPU2000/2000R Modbus/Modbus Plus Automation Guide

Register Address	Item	Description
62716	User Register 40006 Source Register Scale Type (Leftmost Byte) Data Type (Rightmost Byte)	Unsigned Integer 16 Bits 0 = Normal 1 = Remainder 2 = Phase Current 3 = Neutral Current 4 = Voltage 5 = Power 0 = Unsigned 16 Bits 1 = Unsigned 32 Bits 2 = Signed 16 Bits 3 = Signed 32 Bits
62717	User Reg. 40007 Scale	Unsigned Integer 16 Bits 0<=Range<=65535
62718	User Reg. 40007 Source Register Address	Unsigned Integer 16 Bits 1<=Range<=922
62719	User Reg. 40007 Register Destination Type Rightmost Bits 2 – 1- 0 Destination Justification (Bit 3) Destination Scale Bit Size Bits 7 – 6- 5- 4	Unsigned Integer 16 Bits 0 0 0 = Offset Bipolar 0 0 1 = Bipolar 0 1 0 = Unipolar 0 1 1 = Negative Unipolar 1 = Least Significant Bit 0 = Most Significant Bit 0 0 0 0 = 2 Bits 0 0 0 1 = 4 Bits 0 0 1 0 = 8 Bits 0 1 0 0 = 12 Bits 1 0 0 0 = 16 Bits
62720	User Register 40007 Source Register Scale Type (Leftmost Byte) Data Type (Rightmost Byte)	Unsigned Integer 16 Bits 0 = Normal 1 = Remainder 2 = Phase Current 3 = Neutral Current 4 = Voltage 5 = Power 0 = Unsigned 16 Bits 1 = Unsigned 32 Bits 2 = Signed 16 Bits 3 = Signed 32 Bits
62721	User Reg. 40008 Scale	Unsigned Integer 16 Bits 0<=Range<=65535
62722	User Reg. 40008 Source Register Address	Unsigned Integer 16 Bits 1<=Range<=922
62723	User Reg. 40008 Register Destination Type Rightmost Bits 2 – 1- 0 Destination Justification (Bit 3) Destination Scale Bit Size Bits 7 – 6- 5- 4	Unsigned Integer 16 Bits 0 0 0 = Offset Bipolar 0 0 1 = Bipolar 0 1 0 = Unipolar 0 1 1 = Negative Unipolar 1 = Least Significant Bit 0 = Most Significant Bit 0 0 0 0 = 2 Bits 0 0 0 1 = 4 Bits 0 0 1 0 = 8 Bits 0 1 0 0 = 12 Bits 1 0 0 0 = 16 Bits
62724	User Register 40008 Source Register Scale Type (Leftmost Byte)	Unsigned Integer 16 Bits 0 = Normal 1 = Remainder 2 = Phase Current

TPU2000/2000R Modbus/Modbus Plus Automation Guide

Register Address	Item	Description
	Data Type (Rightmost Byte)	3 = Neutral Current 4 = Voltage 5 = Power 0 = Unsigned 16 Bits 1 = Unsigned 32 Bits 2 = Signed 16 Bits 3 = Signed 32 Bits
62725	User Reg. 40009 Scale	Unsigned Integer 16 Bits 0<=Range<=65535
62726	User Reg. 40009 Source Register Address	Unsigned Integer 16 Bits 1<=Range<=922
62727	User Reg. 40009 Register Destination Type Rightmost Bits 2 – 1- 0 Destination Justification (Bit 3) Destination Scale Bit Size Bits 7 – 6- 5- 4	Unsigned Integer 16 Bits 0 0 0 = Offset Bipolar 0 0 1 = Bipolar 0 1 0 = Unipolar 0 1 1 = Negative Unipolar 1 = Least Significant Bit 0 = Most Significant Bit 0 0 0 0 = 2 Bits 0 0 0 1 = 4 Bits 0 0 1 0 = 8 Bits 0 1 0 0 = 12 Bits 1 0 0 0 = 16 Bits
62728	User Register 40009 Source Register Scale Type (Leftmost Byte) Data Type (Rightmost Byte)	Unsigned Integer 16 Bits 0 = Normal 1 = Remainder 2 = Phase Current 3 = Neutral Current 4 = Voltage 5 = Power 0 = Unsigned 16 Bits 1 = Unsigned 32 Bits 2 = Signed 16 Bits 3 = Signed 32 Bits
62729	User Reg. 40010 Scale	Unsigned Integer 16 Bits 0<=Range<=65535
62730	User Reg. 40010 Source Register Address	Unsigned Integer 16 Bits 1<=Range<=922
62731	User Reg. 40010 Register Destination Type Rightmost Bits 2 – 1- 0 Destination Justification (Bit 3) Destination Scale Bit Size Bits 7 – 6- 5- 4	Unsigned Integer 16 Bits 0 0 0 = Offset Bipolar 0 0 1 = Bipolar 0 1 0 = Unipolar 0 1 1 = Negative Unipolar 1 = Least Significant Bit 0 = Most Significant Bit 0 0 0 0 = 2 Bits 0 0 0 1 = 4 Bits 0 0 1 0 = 8 Bits 0 1 0 0 = 12 Bits 1 0 0 0 = 16 Bits
62732	User Register 40010 Source Register Scale Type (Leftmost Byte)	Unsigned Integer 16 Bits 0 = Normal 1 = Remainder 2 = Phase Current 3 = Neutral Current

TPU2000/2000R Modbus/Modbus Plus Automation Guide

Register Address	Item	Description
	Data Type (Rightmost Byte)	4 = Voltage 5 = Power 0 = Unsigned 16 Bits 1 = Unsigned 32 Bits 2 = Signed 16 Bits 3 = Signed 32 Bits
62733	User Reg. 40011 Scale	Unsigned Integer 16 Bits 0<=Range<=65535
62734	User Reg. 40011 Source Register Address	Unsigned Integer 16 Bits 1<=Range<=922
62735	User Reg. 40011 Register Destination Type Rightmost Bits 2 – 1- 0 Destination Justification (Bit 3) Destination Scale Bit Size Bits 7 – 6- 5- 4	Unsigned Integer 16 Bits 0 0 0 = Offset Bipolar 0 0 1 = Bipolar 0 1 0 = Unipolar 0 1 1 = Negative Unipolar 1 = Least Significant Bit 0 = Most Significant Bit 0 0 0 0 = 2 Bits 0 0 0 1 = 4 Bits 0 0 1 0 = 8 Bits 0 1 0 0 = 12 Bits 1 0 0 0 = 16 Bits
62736	User Register 40011 Source Register Scale Type (Leftmost Byte) Data Type (Rightmost Byte)	Unsigned Integer 16 Bits 0 = Normal 1 = Remainder 2 = Phase Current 3 = Neutral Current 4 = Voltage 5 = Power 0 = Unsigned 16 Bits 1 = Unsigned 32 Bits 2 = Signed 16 Bits 3 = Signed 32 Bits
62737	User Reg. 40012 Scale	Unsigned Integer 16 Bits 0<=Range<=65535
62738	User Reg. 40012 Source Register Address	Unsigned Integer 16 Bits 1<=Range<=922
62739	User Reg. 40012 Register Destination Type Rightmost Bits 2 – 1- 0 Destination Justification (Bit 3) Destination Scale Bit Size Bits 7 – 6- 5- 4	Unsigned Integer 16 Bits 0 0 0 = Offset Bipolar 0 0 1 = Bipolar 0 1 0 = Unipolar 0 1 1 = Negative Unipolar 1 = Least Significant Bit 0 = Most Significant Bit 0 0 0 0 = 2 Bits 0 0 0 1 = 4 Bits 0 0 1 0 = 8 Bits 0 1 0 0 = 12 Bits 1 0 0 0 = 16 Bits
62740	User Register 40012 Source Register Scale Type (Leftmost Byte) Data Type (Rightmost Byte)	Unsigned Integer 16 Bits 0 = Normal 1 = Remainder 2 = Phase Current 3 = Neutral Current 4 = Voltage 5 = Power 0 = Unsigned 16 Bits 1 = Unsigned 32 Bits

TPU2000/2000R Modbus/Modbus Plus Automation Guide

Register Address	Item	Description
		2 = Signed 16 Bits 3 = Signed 32 Bits
62741	User Reg. 40013 Scale	Unsigned Integer 16 Bits 0<=Range<=65535
62742	User Reg. 40013 Source Register Address	Unsigned Integer 16 Bits 1<=Range<=922
62743	User Reg. 40013 Register Destination Type Rightmost Bits 2 – 1- 0 Destination Justification (Bit 3) Destination Scale Bit Size Bits 7 – 6- 5- 4	Unsigned Integer 16 Bits 0 0 0 = Offset Bipolar 0 0 1 = Bipolar 0 1 0 = Unipolar 0 1 1 = Negative Unipolar 1 = Least Significant Bit 0 = Most Significant Bit 0 0 0 0 = 2 Bits 0 0 0 1 = 4 Bits 0 0 1 0 = 8 Bits 0 1 0 0 = 12 Bits 1 0 0 0 = 16 Bits
62744	User Register 40013 Source Register Scale Type (Leftmost Byte) Data Type (Rightmost Byte)	Unsigned Integer 16 Bits 0 = Normal 1 = Remainder 2 = Phase Current 3 = Neutral Current 4 = Voltage 5 = Power 0 = Unsigned 16 Bits 1 = Unsigned 32 Bits 2 = Signed 16 Bits 3 = Signed 32 Bits
62745	User Reg. 40014 Scale	Unsigned Integer 16 Bits 0<=Range<=65535
62746	User Reg. 40014 Source Register Address	Unsigned Integer 16 Bits 1<=Range<=922
62747	User Reg. 40014 Register Destination Type Rightmost Bits 2 – 1- 0 Destination Justification (Bit 3) Destination Scale Bit Size Bits 7 – 6- 5- 4	Unsigned Integer 16 Bits 0 0 0 = Offset Bipolar 0 0 1 = Bipolar 0 1 0 = Unipolar 0 1 1 = Negative Unipolar 1 = Least Significant Bit 0 = Most Significant Bit 0 0 0 0 = 2 Bits 0 0 0 1 = 4 Bits 0 0 1 0 = 8 Bits 0 1 0 0 = 12 Bits 1 0 0 0 = 16 Bits
62748	User Register 40014 Source Register Scale Type (Leftmost Byte) Data Type (Rightmost Byte)	Unsigned Integer 16 Bits 0 = Normal 1 = Remainder 2 = Phase Current 3 = Neutral Current 4 = Voltage 5 = Power 0 = Unsigned 16 Bits 1 = Unsigned 32 Bits 2 = Signed 16 Bits 3 = Signed 32 Bits
62749	User Reg. 40015 Scale	Unsigned Integer 16 Bits

TPU2000/2000R Modbus/Modbus Plus Automation Guide

Register Address	Item	Description
		0<=Range<=65535
62750	User Reg. 40015 Source Register Address	Unsigned Integer 16 Bits 1<=Range<=922
62751	User Reg. 40015 Register Destination Type Rightmost Bits 2 – 1- 0 Destination Justification (Bit 3) Destination Scale Bit Size Bits 7 – 6- 5- 4	Unsigned Integer 16 Bits 0 0 0 = Offset Bipolar 0 0 1 = Bipolar 0 1 0 = Unipolar 0 1 1 = Negative Unipolar 1 = Least Significant Bit 0 = Most Significant Bit 0 0 0 0 = 2 Bits 0 0 0 1 = 4 Bits 0 0 1 0 = 8 Bits 0 1 0 0 = 12 Bits 1 0 0 0 = 16 Bits
62752	User Register 40015 Source Register Scale Type (Leftmost Byte) Data Type (Rightmost Byte)	Unsigned Integer 16 Bits 0 = Normal 1 = Remainder 2 = Phase Current 3 = Neutral Current 4 = Voltage 5 = Power 0 = Unsigned 16 Bits 1 = Unsigned 32 Bits 2 = Signed 16 Bits 3 = Signed 32 Bits
62753	User Reg. 40016 Scale	Unsigned Integer 16 Bits 0<=Range<=65535
62754	User Reg. 40016 Source Register Address	Unsigned Integer 16 Bits 1<=Range<=922
62755	User Reg. 40016 Register Destination Type Rightmost Bits 2 – 1- 0 Destination Justification (Bit 3) Destination Scale Bit Size Bits 7 – 6- 5- 4	Unsigned Integer 16 Bits 0 0 0 = Offset Bipolar 0 0 1 = Bipolar 0 1 0 = Unipolar 0 1 1 = Negative Unipolar 1 = Least Significant Bit 0 = Most Significant Bit 0 0 0 0 = 2 Bits 0 0 0 1 =4 Bits 0 0 1 0 = 8 Bits 0 1 0 0 = 12 Bits 1 0 0 0 = 16 Bits
62756	User Register 40016 Source Register Scale Type (Leftmost Byte) Data Type (Rightmost Byte)	Unsigned Integer 16 Bits 0 = Normal 1 = Remainder 2 = Phase Current 3 = Neutral Current 4 = Voltage 5 = Power 0 = Unsigned 16 Bits 1 = Unsigned 32 Bits 2 = Signed 16 Bits 3 = Signed 32 Bits
62757	User Reg. 40017 Scale	Unsigned Integer 16 Bits 0<=Range<=65535
62758	User Reg. 40017 Source Register Address	Unsigned Integer 16 Bits 1<=Range<=922

TPU2000/2000R Modbus/Modbus Plus Automation Guide

Register Address	Item	Description
62759	User Reg. 40017 Register Destination Type Rightmost Bits 2 – 1- 0 Destination Justification (Bit 3) Destination Scale Bit Size Bits 7 – 6- 5- 4	Unsigned Integer 16 Bits 0 0 0 = Offset Bipolar 0 0 1 = Bipolar 0 1 0 = Unipolar 0 1 1 = Negative Unipolar 1 = Least Significant Bit 0 = Most Significant Bit 0 0 0 0 = 2 Bits 0 0 0 1 = 4 Bits 0 0 1 0 = 8 Bits 0 1 0 0 = 12 Bits 1 0 0 0 = 16 Bits
62760	User Register 40017 Source Register Scale Type (Leftmost Byte) Data Type (Rightmost Byte)	Unsigned Integer 16 Bits 0 = Normal 1 = Remainder 2 = Phase Current 3 = Neutral Current 4 = Voltage 5 = Power 0 = Unsigned 16 Bits 1 = Unsigned 32 Bits 2 = Signed 16 Bits 3 = Signed 32 Bits
62761	User Reg. 40018 Scale	Unsigned Integer 16 Bits 0<=Range<=65535
62762	User Reg. 40018 Source Register Address	Unsigned Integer 16 Bits 1<=Range<=922
62763	User Reg. 40018 Register Destination Type Rightmost Bits 2 – 1- 0 Destination Justification (Bit 3) Destination Scale Bit Size Bits 7 – 6- 5- 4	Unsigned Integer 16 Bits 0 0 0 = Offset Bipolar 0 0 1 = Bipolar 0 1 0 = Unipolar 0 1 1 = Negative Unipolar 1 = Least Significant Bit 0 = Most Significant Bit 0 0 0 0 = 2 Bits 0 0 0 1 = 4 Bits 0 0 1 0 = 8 Bits 0 1 0 0 = 12 Bits 1 0 0 0 = 16 Bits
62764	User Register 40018 Source Register Scale Type (Leftmost Byte) Data Type (Rightmost Byte)	Unsigned Integer 16 Bits 0 = Normal 1 = Remainder 2 = Phase Current 3 = Neutral Current 4 = Voltage 5 = Power 0 = Unsigned 16 Bits 1 = Unsigned 32 Bits 2 = Signed 16 Bits 3 = Signed 32 Bits
62765	User Reg. 40019 Scale	Unsigned Integer 16 Bits 0<=Range<=65535
62766	User Reg. 40019 Source Register Address	Unsigned Integer 16 Bits 1<=Range<=922
62767	User Reg. 40019 Register Destination Type Rightmost Bits 2 – 1- 0	Unsigned Integer 16 Bits 0 0 0 = Offset Bipolar 0 0 1 = Bipolar

TPU2000/2000R Modbus/Modbus Plus Automation Guide

Register Address	Item	Description
	Destination Justification (Bit 3) Destination Scale Bit Size Bits 7 – 6- 5- 4	0 1 0 = Unipolar 0 1 1 = Negative Unipolar 1 = Least Significant Bit 0 = Most Significant Bit 0 0 0 0 = 2 Bits 0 0 0 1 = 4 Bits 0 0 1 0 = 8 Bits 0 1 0 0 = 12 Bits 1 0 0 0 = 16 Bits
62768	User Register 40019 Source Register Scale Type (Leftmost Byte) Data Type (Rightmost Byte)	Unsigned Integer 16 Bits 0 = Normal 1 = Remainder 2 = Phase Current 3 = Neutral Current 4 = Voltage 5 = Power 0 = Unsigned 16 Bits 1 = Unsigned 32 Bits 2 = Signed 16 Bits 3 = Signed 32 Bits
62769	User Reg. 40020 Scale	Unsigned Integer 16 Bits 0<=Range<=65535
62770	User Reg. 40020 Source Register Address	Unsigned Integer 16 Bits 1<=Range<=922
62771	User Reg. 40020 Register Destination Type Rightmost Bits 2 – 1- 0 Destination Justification (Bit 3) Destination Scale Bit Size Bits 7 – 6- 5- 4	Unsigned Integer 16 Bits 0 0 0 = Offset Bipolar 0 0 1 = Bipolar 0 1 0 = Unipolar 0 1 1 = Negative Unipolar 1 = Least Significant Bit 0 = Most Significant Bit 0 0 0 0 = 2 Bits 0 0 0 1 = 4 Bits 0 0 1 0 = 8 Bits 0 1 0 0 = 12 Bits 1 0 0 0 = 16 Bits
62772	User Register 40020 Source Register Scale Type (Leftmost Byte) Data Type (Rightmost Byte)	Unsigned Integer 16 Bits 0 = Normal 1 = Remainder 2 = Phase Current 3 = Neutral Current 4 = Voltage 5 = Power 0 = Unsigned 16 Bits 1 = Unsigned 32 Bits 2 = Signed 16 Bits 3 = Signed 32 Bits
62773	User Reg. 40021 Scale	Unsigned Integer 16 Bits 0<=Range<=65535
62774	User Reg. 40021 Source Register Address	Unsigned Integer 16 Bits 1<=Range<=922
62775	User Reg. 40021 Register Destination Type Rightmost Bits 2 – 1- 0 Destination Justification (Bit 3)	Unsigned Integer 16 Bits 0 0 0 = Offset Bipolar 0 0 1 = Bipolar 0 1 0 = Unipolar 0 1 1 = Negative Unipolar 1 = Least Significant Bit 0 = Most Significant Bit 0 0 0 0 = 2 Bits

TPU2000/2000R Modbus/Modbus Plus Automation Guide

Register Address	Item	Description
	Destination Scale Bit Size Bits 7 – 6- 5- 4	0 0 0 1 = 4 Bits 0 0 1 0 = 8 Bits 0 1 0 0 = 12 Bits 1 0 0 0 = 16 Bits
62776	User Register 40021 Source Register Scale Type (Leftmost Byte) Data Type (Rightmost Byte)	Unsigned Integer 16 Bits 0 = Normal 1 = Remainder 2 = Phase Current 3 = Neutral Current 4 = Voltage 5 = Power 0 = Unsigned 16 Bits 1 = Unsigned 32 Bits 2 = Signed 16 Bits 3 = Signed 32 Bits
62777	User Reg. 40022 Scale	Unsigned Integer 16 Bits 0<=Range<=65535
62778	User Reg. 40022 Source Register Address	Unsigned Integer 16 Bits 1<=Range<=922
62779	User Reg. 40022 Register Destination Type Rightmost Bits 2 – 1- 0 Destination Justification (Bit 3) Destination Scale Bit Size Bits 7 – 6- 5- 4	Unsigned Integer 16 Bits 0 0 0 = Offset Bipolar 0 0 1 = Bipolar 0 1 0 = Unipolar 0 1 1 = Negative Unipolar 1 = Least Significant Bit 0 = Most Significant Bit 0 0 0 0 = 2 Bits 0 0 0 1 = 4 Bits 0 0 1 0 = 8 Bits 0 1 0 0 = 12 Bits 1 0 0 0 = 16 Bits
62780	User Register 40022 Source Register Scale Type (Leftmost Byte) Data Type (Rightmost Byte)	Unsigned Integer 16 Bits 0 = Normal 1 = Remainder 2 = Phase Current 3 = Neutral Current 4 = Voltage 5 = Power 0 = Unsigned 16 Bits 1 = Unsigned 32 Bits 2 = Signed 16 Bits 3 = Signed 32 Bits
62781	User Reg. 40023 Scale	Unsigned Integer 16 Bits 0<=Range<=65535
62782	User Reg. 40023 Source Register Address	Unsigned Integer 16 Bits 1<=Range<=922
62783	User Reg. 40023 Register Destination Type Rightmost Bits 2 – 1- 0 Destination Justification (Bit 3) Destination Scale Bit Size Bits 7 – 6- 5- 4	Unsigned Integer 16 Bits 0 0 0 = Offset Bipolar 0 0 1 = Bipolar 0 1 0 = Unipolar 0 1 1 = Negative Unipolar 1 = Least Significant Bit 0 = Most Significant Bit 0 0 0 0 = 2 Bits 0 0 0 1 = 4 Bits 0 0 1 0 = 8 Bits

TPU2000/2000R Modbus/Modbus Plus Automation Guide

Register Address	Item	Description
		0 1 0 0 = 12 Bits 1 0 0 0 = 16 Bits
62784	User Register 40023 Source Register Scale Type (Leftmost Byte) Data Type (Rightmost Byte)	Unsigned Integer 16 Bits 0 = Normal 1 = Remainder 2 = Phase Current 3 = Neutral Current 4 = Voltage 5 = Power 0 = Unsigned 16 Bits 1 = Unsigned 32 Bits 2 = Signed 16 Bits 3 = Signed 32 Bits
62785	User Reg. 40024 Scale	Unsigned Integer 16 Bits 0<=Range<=65535
62786	User Reg. 40024 Source Register Address	Unsigned Integer 16 Bits 1<=Range<=922
62787	User Reg. 40024 Register Destination Type Rightmost Bits 2 – 1- 0 Destination Justification (Bit 3) Destination Scale Bit Size Bits 7 – 6- 5- 4	Unsigned Integer 16 Bits 0 0 0 = Offset Bipolar 0 0 1 = Bipolar 0 1 0 = Unipolar 0 1 1 = Negative Unipolar 1 = Least Significant Bit 0 = Most Significant Bit 0 0 0 0 = 2 Bits 0 0 0 1 = 4 Bits 0 0 1 0 = 8 Bits 0 1 0 0 = 12 Bits 1 0 0 0 = 16 Bits
62788	User Register 40024 Source Register Scale Type (Leftmost Byte) Data Type (Rightmost Byte)	Unsigned Integer 16 Bits 0 = Normal 1 = Remainder 2 = Phase Current 3 = Neutral Current 4 = Voltage 5 = Power 0 = Unsigned 16 Bits 1 = Unsigned 32 Bits 2 = Signed 16 Bits 3 = Signed 32 Bits
62789	User Reg. 40025 Scale	Unsigned Integer 16 Bits 0<=Range<=65535
62790	User Reg. 40025 Source Register Address	Unsigned Integer 16 Bits 1<=Range<=922
62791	User Reg. 40025 Register Destination Type Rightmost Bits 2 – 1- 0 Destination Justification (Bit 3) Destination Scale Bit Size Bits 7 – 6- 5- 4	Unsigned Integer 16 Bits 0 0 0 = Offset Bipolar 0 0 1 = Bipolar 0 1 0 = Unipolar 0 1 1 = Negative Unipolar 1 = Least Significant Bit 0 = Most Significant Bit 0 0 0 0 = 2 Bits 0 0 0 1 = 4 Bits 0 0 1 0 = 8 Bits 0 1 0 0 = 12 Bits 1 0 0 0 = 16 Bits
62792	User Register 40025 Source Register	Unsigned Integer 16 Bits

TPU2000/2000R Modbus/Modbus Plus Automation Guide

Register Address	Item	Description
	Scale Type (Leftmost Byte) Data Type (Rightmost Byte)	0 = Normal 1 = Remainder 2 = Phase Current 3 = Neutral Current 4 = Voltage 5 = Power 0 = Unsigned 16 Bits 1 = Unsigned 32 Bits 2 = Signed 16 Bits 3 = Signed 32 Bits
62793	User Reg. 40026 Scale	Unsigned Integer 16 Bits 0<=Range<=65535
62794	User Reg. 40026 Source Register Address	Unsigned Integer 16 Bits 1<=Range<=922
62795	User Reg. 40026 Register Destination Type Rightmost Bits 2 – 1- 0 Destination Justification (Bit 3) Destination Scale Bit Size Bits 7 – 6- 5- 4	Unsigned Integer 16 Bits 0 0 0 = Offset Bipolar 0 0 1 = Bipolar 0 1 0 = Unipolar 0 1 1 = Negative Unipolar 1 = Least Significant Bit 0 = Most Significant Bit 0 0 0 0 = 2 Bits 0 0 0 1 = 4 Bits 0 0 1 0 = 8 Bits 0 1 0 0 = 12 Bits 1 0 0 0 = 16 Bits
62796	User Register 40026 Source Register Scale Type (Leftmost Byte) Data Type (Rightmost Byte)	Unsigned Integer 16 Bits 0 = Normal 1 = Remainder 2 = Phase Current 3 = Neutral Current 4= Voltage 5 = Power 0 = Unsigned 16 Bits 1 = Unsigned 32 Bits 2 = Signed 16 Bits 3 = Signed 32 Bits
62797	User Reg. 40027 Scale	Unsigned Integer 16 Bits 0<=Range<=65535
62798	User Reg. 40027 Source Register Address	Unsigned Integer 16 Bits 1<=Range<=922
62799	User Reg. 40027 Register Destination Type Rightmost Bits 2 – 1- 0 Destination Justification (Bit 3) Destination Scale Bit Size Bits 7 – 6- 5- 4	Unsigned Integer 16 Bits 0 0 0 = Offset Bipolar 0 0 1 = Bipolar 0 1 0 = Unipolar 0 1 1 = Negative Unipolar 1 = Least Significant Bit 0 = Most Significant Bit 0 0 0 0 = 2 Bits 0 0 0 1 = 4 Bits 0 0 1 0 = 8 Bits 0 1 0 0 = 12 Bits 1 0 0 0 = 16 Bits
62800	User Register 40027 Source Register Scale Type (Leftmost Byte)	Unsigned Integer 16 Bits 0 = Normal 1 = Remainder 2 = Phase Current

TPU2000/2000R Modbus/Modbus Plus Automation Guide

Register Address	Item	Description
	Data Type (Rightmost Byte)	3 = Neutral Current 4 = Voltage 5 = Power 0 = Unsigned 16 Bits 1 = Unsigned 32 Bits 2 = Signed 16 Bits 3 = Signed 32 Bits
62801	User Reg. 40028 Scale	Unsigned Integer 16 Bits 0<=Range<=65535
62802	User Reg. 40028 Source Register Address	Unsigned Integer 16 Bits 1<=Range<=922
62803	User Reg. 40028 Register Destination Type Rightmost Bits 2 – 1- 0 Destination Justification (Bit 3) Destination Scale Bit Size Bits 7 – 6- 5- 4	Unsigned Integer 16 Bits 0 0 0 = Offset Bipolar 0 0 1 = Bipolar 0 1 0 = Unipolar 0 1 1 = Negative Unipolar 1 = Least Significant Bit 0 = Most Significant Bit 0 0 0 0 = 2 Bits 0 0 0 1 = 4 Bits 0 0 1 0 = 8 Bits 0 1 0 0 = 12 Bits 1 0 0 0 = 16 Bits
62804	User Register 40028 Source Register Scale Type (Leftmost Byte) Data Type (Rightmost Byte)	Unsigned Integer 16 Bits 0 = Normal 1 = Remainder 2 = Phase Current 3 = Neutral Current 4 = Voltage 5 = Power 0 = Unsigned 16 Bits 1 = Unsigned 32 Bits 2 = Signed 16 Bits 3 = Signed 32 Bits
62805	User Reg. 40029 Scale	Unsigned Integer 16 Bits 0<=Range<=65535
62806	User Reg. 40029 Source Register Address	Unsigned Integer 16 Bits 1<=Range<=922
62807	User Reg. 40029 Register Destination Type Rightmost Bits 2 – 1- 0 Destination Justification (Bit 3) Destination Scale Bit Size Bits 7 – 6- 5- 4	Unsigned Integer 16 Bits 0 0 0 = Offset Bipolar 0 0 1 = Bipolar 0 1 0 = Unipolar 0 1 1 = Negative Unipolar 1 = Least Significant Bit 0 = Most Significant Bit 0 0 0 0 = 2 Bits 0 0 0 1 = 4 Bits 0 0 1 0 = 8 Bits 0 1 0 0 = 12 Bits 1 0 0 0 = 16 Bits
62808	User Register 40029 Source Register Scale Type (Leftmost Byte) Data Type (Rightmost Byte)	Unsigned Integer 16 Bits 0 = Normal 1 = Remainder 2 = Phase Current 3 = Neutral Current 4 = Voltage 5 = Power 0 = Unsigned 16 Bits

TPU2000/2000R Modbus/Modbus Plus Automation Guide

Register Address	Item	Description
		1 = Unsigned 32 Bits 2 = Signed 16 Bits 3 = Signed 32 Bits
62809	User Reg. 40030 Scale	Unsigned Integer 16 Bits 0<=Range<=65535
62810	User Reg. 40030 Source Register Address	Unsigned Integer 16 Bits 1<=Range<=922
62811	User Reg. 40030 Register Destination Type Rightmost Bits 2 – 1- 0 Destination Justification (Bit 3) Destination Scale Bit Size Bits 7 – 6- 5- 4	Unsigned Integer 16 Bits 0 0 0 = Offset Bipolar 0 0 1 = Bipolar 0 1 0 = Unipolar 0 1 1 = Negative Unipolar 1 = Least Significant Bit 0 = Most Significant Bit 0 0 0 0 = 2 Bits 0 0 0 1 = 4 Bits 0 0 1 0 = 8 Bits 0 1 0 0 = 12 Bits 1 0 0 0 = 16 Bits
62812	User Register 40030 Source Register Scale Type (Leftmost Byte) Data Type (Rightmost Byte)	Unsigned Integer 16 Bits 0 = Normal 1 = Remainder 2 = Phase Current 3 = Neutral Current 4 = Voltage 5 = Power 0 = Unsigned 16 Bits 1 = Unsigned 32 Bits 2 = Signed 16 Bits 3 = Signed 32 Bits
62813	User Reg. 40031 Scale	Unsigned Integer 16 Bits 0<=Range<=65535
62814	User Reg. 40031 Source Register Address	Unsigned Integer 16 Bits 1<=Range<=922
62815	User Reg. 40031 Register Destination Type Rightmost Bits 2 – 1- 0 Destination Justification (Bit 3) Destination Scale Bit Size Bits 7 – 6- 5- 4	Unsigned Integer 16 Bits 0 0 0 = Offset Bipolar 0 0 1 = Bipolar 0 1 0 = Unipolar 0 1 1 = Negative Unipolar 1 = Least Significant Bit 0 = Most Significant Bit 0 0 0 0 = 2 Bits 0 0 0 1 = 4 Bits 0 0 1 0 = 8 Bits 0 1 0 0 = 12 Bits 1 0 0 0 = 16 Bits
62816	User Register 40031 Source Register Scale Type (Leftmost Byte) Data Type (Rightmost Byte)	Unsigned Integer 16 Bits 0 = Normal 1 = Remainder 2 = Phase Current 3 = Neutral Current 4 = Voltage 5 = Power 0 = Unsigned 16 Bits 1 = Unsigned 32 Bits 2 = Signed 16 Bits 3 = Signed 32 Bits

TPU2000/2000R Modbus/Modbus Plus Automation Guide

Register Address	Item	Description
62817	User Reg. 40032 Scale	Unsigned Integer 16 Bits 0<=Range<=65535
62818	User Reg. 40032 Source Register Address	Unsigned Integer 16 Bits 1<=Range<=922
62819	User Reg. 40032 Register Destination Type Rightmost Bits 2 – 1- 0 Destination Justification (Bit 3) Destination Scale Bit Size Bits 7 – 6- 5- 4	Unsigned Integer 16 Bits 0 0 0 = Offset Bipolar 0 0 1 = Bipolar 0 1 0 = Unipolar 0 1 1 = Negative Unipolar 1 = Least Significant Bit 0 = Most Significant Bit 0 0 0 0 = 2 Bits 0 0 0 1 = 4 Bits 0 0 1 0 = 8 Bits 0 1 0 0 = 12 Bits 1 0 0 0 = 16 Bits
62820	User Register 40032 Source Register Scale Type (Leftmost Byte) Data Type (Rightmost Byte)	Unsigned Integer 16 Bits 0 = Normal 1 = Remainder 2 = Phase Current 3 = Neutral Current 4 = Voltage 5 = Power 0 = Unsigned 16 Bits 1 = Unsigned 32 Bits 2 = Signed 16 Bits 3 = Signed 32 Bits

Modbus ASCII Communication Test Example

The easiest method to initiate communications in the Modbus protocol is to read known discrete and register data. As per the TPU2000/TPU2000R Modbus register documentation, the unit catalog number is resident at Register 40133. A list of the register definitions of the TPU2000/TPU2000R is presented and explained in the next section. A Read Holding Register Modbus Command is explained. Documentation is available from Groupe Schneider further describing the Modbus ASCII emulation characteristics. The explanation contained within this document is intended to be a quick start guide to communication initiation.

The length of the catalog number is 12 characters or 6 registers. The following command string format, when sent will retrieve the catalog number from the unit.

: 01 03 00 83 00 06 73 lf cr

The above string in Modbus ASCII format should be sent:

3A 30 31 30 33 30 30 38 33 30 30 30 36 37 33 0D 0A

The string is translated as such:

Colon (in HEX), unit address = 01 (in HEX), Read Holding Registers (Code 3 in HEX), data memory desired address –1 = 132 decimal (0084 in HEX), number of registers read = 6 (0006 in HEX), message calculated LRC code 72 (37 32), and line feed (0D) and (0A).

A typical response shall include the following:

TPU2000/2000R Modbus/Modbus Plus Automation Guide

: Address number (01), Read Holding Registers Command (Code 3 in HEX), Byte Count Returned in decimal (0C in HEX 12 bytes in decimal) , Data Register 40133 = 3538 hex – 58 ASCII, Data Register 40134= 3743 hex , 7C ASCII , Data Register 40135 = 3034, 04 ASCII Data Register 40136 = 3132 hex, 32 ASCII Data Register 40137 = 3631 HEX, 61 ASCII Data Register 40138 = 3131HEX, 11 ASCII, and calculated LRC =79 (HEX) and line feed with carriage return (0D 0A).

The aforementioned response would be returned as such:

3A 30 31 30 33 30 43 35 38 37 43 30 34 31 32 36 31 31 31 37 39 0A 0D.

Calculation of the LRC (Longitudinal Redundancy Code)

Modbus ASCII protocol uses a Longitudinal Redundancy Code to verify correct reception of the command. This error check is used in addition to the parity option (used by the UART in the PC) and other data such as the byte count which verifies data returned. The process for calculation of the checksum is described as such:

1. Add all bytes in the message except for the colon, line feed, and carriage return. Exclude the LRC checksum which is included in the message structure.
2. Invert all bits in the word after the addition.
3. Add 1 to the inverted result. This is the checksum.

An example is as follows:

Command sent:

3A 30 31 30 33 30 30 38 33 30 30 30 36 37 33 0D 0A

Decode of the data from ASCII to HEX yields.

: 01 03 00 83 00 06 73 lf cr

The decoded LRC checksum is 73. The calculation of the checksum is as such:

1. Neglect the colon (3A) and the lf (Line Feed 0A) and cr (Carriage Return 0D). This decreases the string to
2. The LRC checksum 73 (37 33 in ASCII) should also be saved for comparison to the original data string. The string for LRC calculation is 01 03 00 83 00 06.
3. The byte data should be added thus $01 + 03 + 00 + 83 + 00 + 06 = 8D$ in HEX. Notice that the bytes have been decoded from ASCII before performing the addition.
4. A Two's complement must be performed on the number to determine the LRC Checksum. Inversion of the number 8D hex yields 72 hex.
5. To complete the Two's complement addition for accurate compilation of the checksum 1 hex must be added to the inverted bits to yield $72 + 1 = 73$ HEX. Thus the two calculated values agree.

Please reference the Modicon Modbus Documentation for additional command configuration on each data type (0X, 1X, 4X and 6X read write capabilities).

Modbus CRC-16 Calculation

The CRC – 16 error check is much more robust than that of the LRC error check. It is however, a more complex algorithm to compute. It's computation is started by setting a word of 16 bits to a value of FFFF hex. A byte of the message is logically OR'ed with the register word and then shifted in a predictable method. What follows is a reprint from the protocol manufacturer's manual MODICON MODBUS PROTOCOL REFERENCE GUIDE – PI-MBUS-300 Revision J Dated June 1996 published by Modicon Inc. Industrial Automation Systems, One High Street, North Andover, MA 01845.

“The Cyclical Redundancy Check (CRC) field is two bytes, containing a 16 –bit binary value. The CRC value is calculated by the transmitting device which appends the CRC to the message. The receiving device, recalculates a CRC during the receipt of the

message, and compares the calculated value to the value it received in the CRC field. If the two values are not equal, an error results.

The CRC is started by first preloading a 16 bit register to all 1's. Then a process begins of applying successive 8 – bit bytes of the message to the current contents of the register. Only the eight bits of data in each character are used for generating the CRC. Start and stop bits and the parity bit do not apply to the CRC.

During the generation of the CRC, each 8-bit character is exclusive ORed with the register contents. Then the result is shifted in the direction of the least significant bit (LSB), with a zero filled into the most significant bit (MSB) position. The LSB is extracted and examined. If the LSB was a 1, the register is then exclusive ORed with a preset, fixed value. If the LSB was a 0, no exclusive OR takes place.

The process is repeated until eight shifts have been performed. After the last eighth shift, the next 8-bit character is exclusive OR'ed with the register's current value and the process repeats for eight more shifts as described above. The final contents of the register, after all the characters of the message have been applied, is the CRC value.

1. A procedure for generating a CRC is
2. Load a 16 Bit Register with FFFF hex (all 1's) Call this the CRC register.
3. Exclusive OR the first 8-bit byte of the message with the two-order byte of the 16 –bit CRC register, putting the result in the CRC register.
4. Shift the CRC register one bit to the right (Toward the LSB), zero-filling the MSB. Extract and examine the LSB.
5. (If the LSB was 0): Repeat Step 3 (Another Shift)
6. (If the LSB was 1): Exclusive OR the CRC register with the polynomial value A001 hex (1010 0000 0000 0001)
7. Repeat Steps 3 and 4 until 8 shifts have been performed. When this is done, a complete 8-bit byte will have been processed
8. Repeat Steps 2 through 5 for the next 8 bit byte of the message. Continue doing this until all bytes have been processed.
9. The final contents of this CRC register is the CRC value.
10. When the CRC is placed into the message, its upper and lower bytes must be swapped as described below.”

The CRC- 16 message generation capability is best done by a hardware chip or using a software algorithm. Within the aforementioned manual, the protocol's inventor supplies a C language program to calculate the CRC-16 code. It is advised that the text be referenced for those wishing to calculate such a code.

TPU2000/TPU2000R Modbus Exception Response Analysis

If the TPU2000/TPU2000R does not understand the command sent to the device or if the command is sent in the wrong format, the TPU2000/TPU2000R shall generate an exception response. A Modbus exception response is in the format of that shown in Figure 5-73. As illustrated, the function code is “ANDed” with 80 HEX. Following the modified function code, an exception code byte will follow. The customary LRC and terminator of a Carriage Return and Line feed will terminate the communication string.

Table 5-83 shall list the standard Modbus Exception Codes and Table 5-84 lists the exception codes as the TPU2000/TPU2000R reports them. Notice that the TPU2000/TPU2000R does not report its exception codes as per the Modbus standard defined codes.

Table 5-83. Modbus Standard Exception Codes

Code	Name
01	ILLEGAL FUNCTION
02	ILLEGAL DATA ADDRESS
03	ILLEGAL DATA VALUE
05	ACKNOWLEDGE
06	SLAVE DEVICE BUSY
07	NEGATIVE ACKNOWLEDGE
08	MEMORY PARITY ERROR

Table 5-84. TPU2000/TPU2000R Defined Exception Codes

Code	Description
01	INVALID PASSWORD
04	INVALID REGISTER ADDRESS
05	INVALID RANGE ACCESSED
06	INVALID DATA
34	INVALID FUNCTION CODE
36	SUPERVISORY CONTROL DISABLED

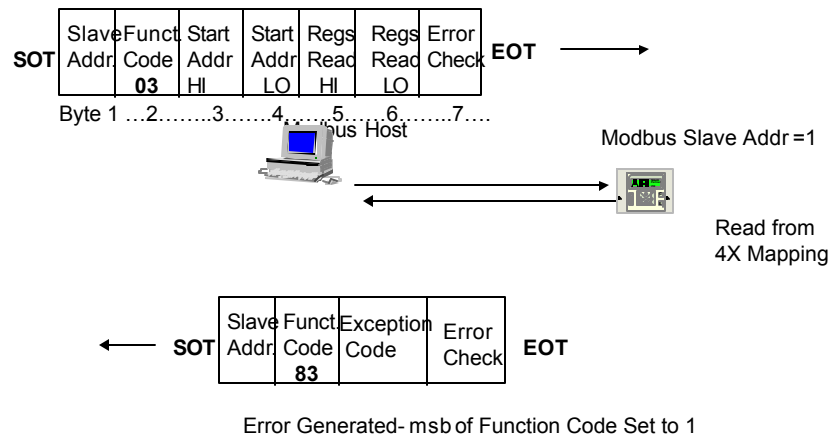

Figure 5-73. Exception Code Example for Holding Register Read

Modbus Troubleshooting Tips

The Modbus Protocol contains a set of commands intended to assist with network troubleshooting. Those commands are:

- 08 – Diagnostic Functions
- 0B –Fetch Communication Event Counter
- 0C- Fetch Communication Log

The TPU2000 and TPU2000R do support one sub function code of the Diagnostic Function 08. Modbus Commands 0B and 0C are not supported.

Figure 5-74 lists the 08 Diagnostic Function Format.

Function 08 - Diagnostic Function

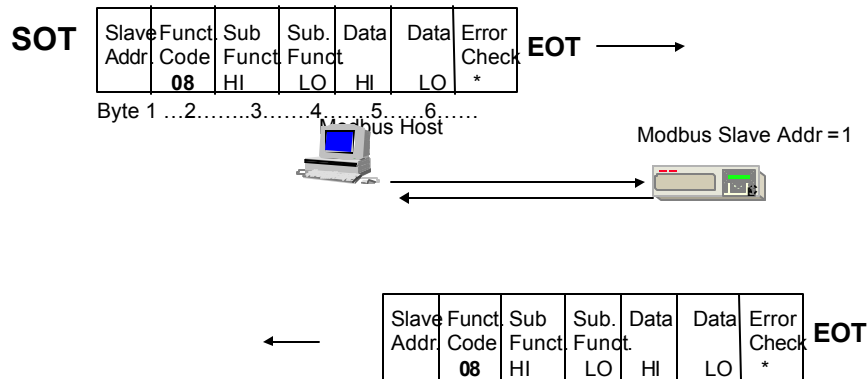

Figure 5-74. Diagnostic Function Code

Only Sub function 00 is supported. Sub function 00 is the loop-back function. If the sub function hi and lo bytes are 00 hex, whatever is placed in the data field by the host will be received by the TPU2000 or TPU2000R and returned or looped back to the host.

Another method to troubleshoot the TPU2000/TPU2000R is to use the 03 (Read Holding Register) command and access the communication status registers. The communication status registers reside at 4XXX through 4XXX. Section 5 of this document list the method to access and use these registers.

Finally, it is always advantageous to use a datascoper or a communication analyzer when troubleshooting a Modbus Network. Such devices allow the implementers to view the data strings between the host and IED. Modicon's parent company Schneider Electric has designed many utilities and products to assist the network professional with troubleshooting. Such tools are inexpensive when compared to the person-hours spent guessing as to what is sent between a host and IED. Such tools available are at a modest cost, such as Modlink, or at no cost MTS. Many of these tools are available on the website www.modicon.com.

TPU2000/TPU2000R Modbus ASCII Communication Timing Analysis

Perhaps the most common error in implementing a Modbus ASCII network is timing setup for communication. Modbus ASCII protocol operates according to the following timing rules:

- If the TPU2000/TPU2000R **receives** a command without a communication error (LRC, PARITY, FRAMING, OVERRUN ... errors), a normal response occurs.
- If the TPU2000/TPU2000R **does not receive** a command without a communication error (LRC, PARITY, FRAMING, OVERRUN, Errors), no response is returned. The host (master) device will sense a timeout according to its timeout parameter. The host could then send a new command or retry sending the original command.
- Modbus ASCII allows for internals up to 1 second between characters are acceptable gaps. The TPU2000/TPU2000R will not timeout. Character send gaps in excess of 1 second will result in TPU2000/TPU2000R Modbus port timeouts.

TPU2000/TPU2000R Modbus network implementers will usually notice communication errors in the form of excessive communication retries, errors, or non-responses. Understanding communication timing is a subject rarely covered in protocol manuals, but an important topic in network implementation.

Network timing is predicated upon the following factors:

Host Latency (How long does it take a host device to generate a command, receive the response and interpret the data).

TPU2000/2000R Modbus/Modbus Plus Automation Guide

Intermediate Device Latency (If a Modem, data concentrator or other device is between the end device required for data retrieval, how long does it take for each device to receive the command and process it downline to the next device).

TPU2000/TPU2000R Device Latency (How long does it take for a TPU2000/TPU2000R to receive a command, and return a response to the network).

Baud Rate (How fast is each data bit propagated on the medium. One cannot get around the laws of physics)

Protocol Efficiency [Network Bandwidth Utilization] (Does the protocol utilized allow for the issuance of another command before a response is received from an outstanding communication request).

The common question to a network system engineer is usually “ How fast can I get my relay alarm data to appear on the screen?”. An analysis of the amount of data and the above 5 areas is required.

Host latency varies widely by manufacturer or the PC or host computer. Software speed and port access varies widely. Most manufacturers of these hardware and software platforms have general benchmarks to supply to the users for processing time once the device acquires the data from the communication port.

Intermediate Device Latency also varies from the type of device used. Some modems have a device turnaround of 5 mS per transactions whereas, a radio modem may require hundreds of mS to obtain an open frequency from which to transmit.

This section shall illustrate and explain a simple network transaction based upon a simple point to point communication from a single TPU2000/TPU2000R to a host device as illustrated in Figure 5-75 of this document. **This example shall exclude SCADA Master host latency.**

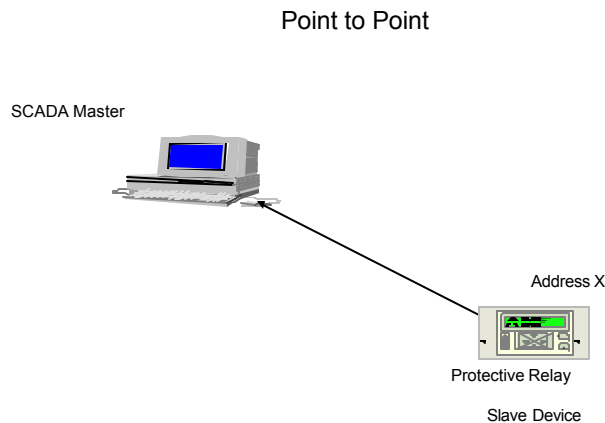

Figure 5-75. Example Communication Timing Topology

Modbus Baud Rate Analysis

If Modbus ASCII Protocol is re-examined, the Modbus frame is illustrated in Figure 5-4. The frame is a standard 10 bit frame. One character (7 data bits) is transmitted as 10 bits per frame.

The rate of the data transfer is determined by the selected baud rate. The faster the baud rate, the faster the communication. The TPU2000/TPU2000R supports baud rates of 1200, 2400, 4800, 9600 and 19200. The effect of transfer time is shown in Table 5-85. Each bit has specific transfer time which correlates to a specific character transfer time.

Table 5-85. Character Transfer Time vs Baud Rate

Baud Rate	Transfer Time Per Bit	Transfer Time Per Character
300	3.33 mS	3.33 mS
1200	0.833 mS	8.333 mS
2400	0.4167 mS	4.167 mS
4800	0.2083 mS	2.083 mS
9600	0.1041 mS	1.041 mS
19200	0.0521 mS	0.521 mS

These are fixed times determined by the laws of physics, and are standard for asynchronous bit stream transfers ASCII.

Each Modbus transfer varies in the amount of bytes transmitted and requested. Table 5-86 lists the amount of fixed data per some of the common Modbus Commands. For example, each data transmission contains the following characters as per Figure 5-3:

- Colon (:)[3A Hex]
- Slave Address (Two Characters)
- Function (Two Characters)
- Error Check (Two Characters)
- Line Feed (One Character)
- Carriage Return (One Character)

Each base transmitted and received command has at least 9 characters for transmission. The transmission time, depending upon baud rate can range from 74.97 mS (at 1200 baud) to 4.689 mS (at 19200 baud). For example Figure 5-14 illustrates the Function 01 Read Coil Status format. Figure 5-15 illustrates the transaction request for four coils. Analysis of the data transmitted and received yields the following:

Transmission Request:

Common characters 9 + 4 address characters + 4 data request characters
 Total characters for transmission request = 17 characters.

Returned Response

Common characters 9 + 2 data byte characters + 4 data returned characters.
 Total characters returned by TPU2000/TPU2000R = 15 characters.

Depending upon the baud rate the total time for the communication characters to propagate along the network could range from:

Transmission Request:

17 characters at 141.61. mS (1200 Baud) to 8.857 mS (19200 Baud)

Returned Response

15 characters at 124.95 mS (1200 Baud) to 7.815 (19200 Baud)

Total network transfer time via the physical medium can range from 265.56 mS at 1200 baud to 16.672 at 19,200 baud.

Baud rate is a major influence at 1200 baud and a lesser influence at 19200 baud. It must be realized that this is only one of three components analyzed for a complete throughput analysis. In this case the Host time to generate the command.

TPU2000/TPU2000R Throughput Analysis

Communication implementation within a protective relay is a demanding task. In other devices, communications may take first priority. Within an ABB protective relay **PROTECTION IS THE FIRST PRIORITY**. Communication shall not compromise protection capabilities. Thus communication throughput may vary depending upon the demands of the protection. Table 5-86 illustrates the TPU2000/TPU2000R average benchmark times for recognition of a Modbus command at the physical port and the time it takes to generate a reply to the respective port. The times listed in the table are average times and do not include the calculated values generated in Section 4.

Table 5-86. TPU2000/TPU2000R Modbus Command Throughput (Average Time in mS)

MODBUS Command	Register Start	Num. Refs.	Reading from TPU2000/TPU2000R		Write to TPU2000/TPU2000R	
			Min (ms)	Max (ms)	Min (ms)	Max (ms)
Real Logical Outs	00001	14	5.023	14.417		
Read Physical Outs	00129	4	1.497	10.688		
Read Physical Inputs	10129	2	1.381	13.726		
Load Metering	40513	27	21.270	30.184		
Configuration & Status	40129	22	18.848	26.324		
Event Records	41281	12	9.927	23.237		
Config Settings	60001	21	18.657	23.477	39.224	289.634
Primary Settings	60257	39	27.557	37.834	67.129	497.97
Master Trip Settings	61665	10	9.728	17.660	22.935	110.169
Test Setup:						
TPU2000/TPU2000R COMM Port Settings: 9600, E,7,2, through the FRONT RS-232 port						
MODLINK Setup: 500 ms Poll though COM1 on a 486DX100 Notebook Serial Port						
TPU2000/TPU2000R is "idle", No Current/Voltage applied.						
Write Min - Writing to update the Write Link side in ModLink						
Write Max - Time to Write 3 Sets of parameters to EEPROM and Return Response						
Write Max times ARE proportional to the size of the block being written, the larger the block, the longer the write time.						

For the example, the TPU2000/TPU2000R generation time for the sample example can range from 1.497 mS to 10.688 mS

Final Throughput Calculation and Analysis

A final calculation of our example throughput is warranted. For this example, the host update time shall now be assumed to be 250 mS. This 250 mS shall be an example estimation or time to generate a command, interpret the received command and update the screen. This is just for this example and varies according to:

- Speed of the host processor (hardware bus structure, # of processors, video card update, RAM memory, microprocessor speed.....)
- Operating system selected (LINUX, UNIX, OS2, WIN NT, WIN 3.1, WIN 98, WIN 95,)
- MMI Port Driver Efficiency (PRICOM, Power RICH, USDATA)

Two results will be calculated, operation at 1200 and 19200 baud. The example is described as per **Figure 11** within this document. The formula used to produce the typical response is:

System Throughput = Host Processing Time + String Transmit Time + TPU2000/TPU2000R Processing Time + String Reception Time

At 1200 Baud:

$$527.248 \text{ mS} = 250 \text{ mS} + 141.61 \text{ mS} + 10.688\text{mS (using worst case)} + 124.95 \text{ mS}$$

At 19200 Baud:

$$277.36 = 250 \text{ mS} + 8.857 \text{ mS} + 10.688 \text{ (using worst case) mS} + 7.815 \text{ mS}$$

Figures 5-76 and 5-77 illustrate the individual contributions from each of the components as a percentage of total transaction time.

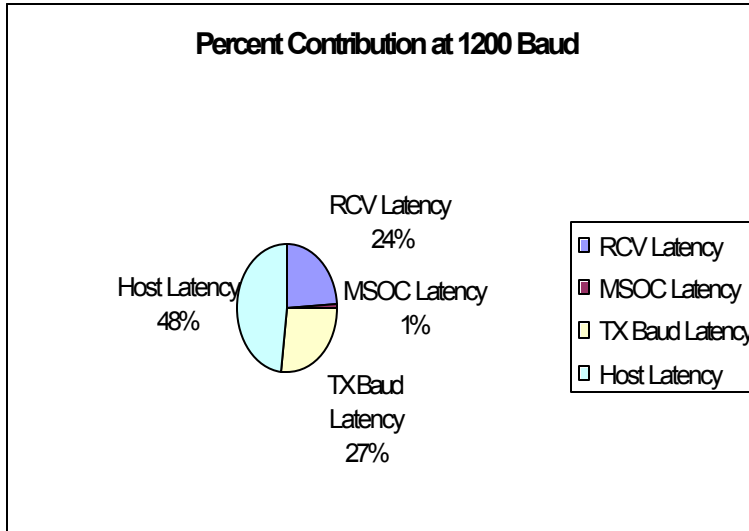

Figure 5-76. Network Throughput Analysis at 1200 Baud

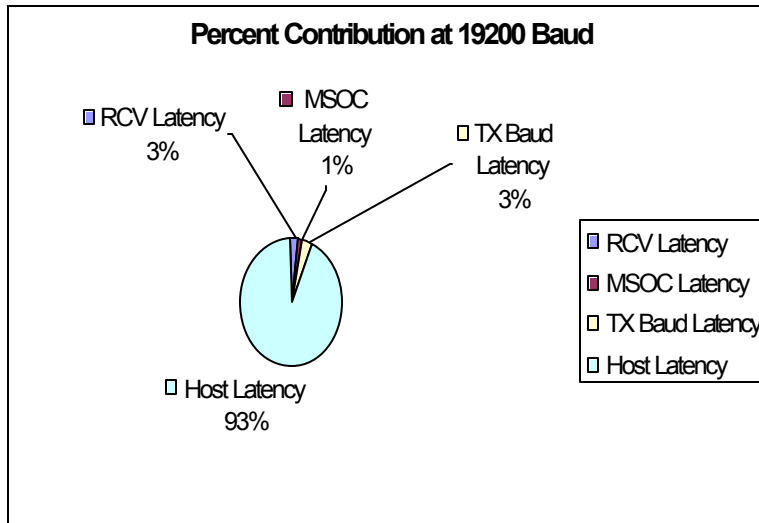

Figure 5-77. Network Throughput Analysis at 19200 Baud

Analysis of the simple example yields a few points to be considered when analyzing system throughput. Each element involved in communication timing contributes significantly to overall throughput. If the host executed and updated faster, overall throughput could be improved. If intermediate devices were inserted within the network, transaction time would increase proportionately. Baud rate is only one of many contributing factors in calculating system throughput. If one network access was required for retrieval of system data, overall network efficiency would be improved. If in a networked system, the protocol utilized would allow for additional data request commands while the slave device is processing a response, Network throughput time would be improved.

TPU2000/2000R Modbus/Modbus Plus Automation Guide

Virtual treatises have been written on improving system throughput and data updates. This simple example illustrates and allows the user to calculate system throughput times. This is especially critical so that the system user will not be surprised with overall system response.

ABB has implemented features within the protective relay to maintain system data integrity. Latched bit status, momentary change detect are a few features implemented within the various implementations of the Modbus protocol.

Modbus Plus Troubleshooting

Schneider Electric has designed Modbus Plus to be a very robust communication network. The publication 890 USE 100 00 Version 2.0 titled Modicon Modbus Plus Network Planning and Installation Guide Copyright 1995, AEG Schneider Automation, Inc. details the method for troubleshooting a Modbus Plus network.

There is no communication analyzer for Modbus Plus to view the communication commands occurring over the network. The SA 85 or PCMCIA Modbus Plus adapters have a software utility called MBP STAT which allows a personal computer to attach to the network allowing a network professional to troubleshoot a Modbus Plus anomaly. Please reference the MBP STAT documentation for use of this valuable troubleshooting tool.

Issues common to Modbus Plus communication errors arise from the following:

1. Improper Device Termination. The manufacturer's in-line and termination connectors must be used. Termination connectors must be used at the end of the lines for a string. The end of the string could be a repeater, bridge, repeater, or end device node.
2. Improper cable used. The manufacturer's cable should be used in that it is the correct impedance, capacitance and physical wire dimensions to physically mate with the connector.
3. Improper addressing is assumed. The TPU2000/2000R 's address is in HEX. The Modbus Plus host and MBP STAT uses decimal addressing. Additionally, it must be remembered that an additional byte must be appended to the end of the address signifying the path the host wishes to communicate.
4. Improper routing of the cable. The cable should be routed clear of high current devices and wires. Although, Modbus Plus is an industrial network, it is not recommended to route or wrap the cable around devices (such as bus bar) which emit EMI/RFI or high current spike devices. The network is a serial network, branches, or splits are not allowed in the cabling. If such configurations are necessary, please use fiber optics.
5. Improper grounding of the cable.

If proper care is not taken in the planning and installation of the network, the time saved on planning and installation is usually spent and exceeded in troubleshooting of the network. Since Modbus Plus is a serial network, any loose connection, impedance mismatch, or anomaly is usually difficult to find. Cable planning and installation errors are usually seen as communication errors or retries seen using the MBP STAT utility. The cable must be checked for continuity (in case of damage) and usually the cable must be disconnected and the cable sections checked.

A copy of the device troubleshooting section from the aforementioned Modbus Plus text is included for the benefit of the reader. The section covers cable continuity.

- ❑ Before checking continuity, disconnect all network cable connectors from the node devices-leave the drop cable ground lugs (ed. Note – if any since the tap and drop connectors have ground lugs whereas the dark and light grey connectors do not).to their site panel grounds.
- ❑ At any node device connector, measure the resistance between pins 2 and 3 (the signal pins), in the range of 60-.80 Ω , which include the cable wire resistance.
- ❑ At each node device connector, check for an open circuit between pin 2 (a signal pin) and pin 1 (the shield pin); then check between pin 3 (a signal pin) and pin 1 – an open circuit should exist for both checks.
- ❑ At each connector, check the continuity between pin 1 and the plant ground point on the local site panel or frame – direct continuity should be present.

If the above continuity checks are not consistent, break the network at various points, and it is recommended that a termination connector be selected at the break. Perform the above tests using MBP STAT and the continuity tests outlined above until the error rate is at a negligible level.

Also as with the Modbus test procedures, Modbus Plus has access to the communication status registers. Another method to troubleshoot the TPU2000/TPU2000R is to use Read 4X Holding Register command via a DDE editor or a PLC's MSTR instruction. The communication status registers may then be accessed. The communication status registers reside at 40712 through 40179. Section 5 of this document lists the method to access and use these registers.

Modbus Plus Throughput

The Manual Titled Modicon Modbus Plus Network Planning and Installation Guide Copyright 1995, AEG Schneider Automation, Inc., lists the methods to calculate Modbus Plus network throughput. It is recommended that the aforementioned text be consulted to perform a specific network throughput analysis.

The same principles for any protocol analysis apply to Modbus Plus Protocol analysis. Modbus Plus is a very efficient protocol since it's bandwidth is effectively utilized by using the hybrid features of an HDLC protocol with token passing. The ability of the network to carry out 32 individual conversations and 2 Global Data broadcast conversations is a very useful capability of the network. Combined with a high baud rate of over 1 megabaud, fast throughput is assured.

A typical Modbus Plus network is depicted in Figure 5-78. A Programmable Logic Controller is connected to a TPU2000R protective relay accessing data along one of its 8 data slave paths. A Personal Computer Host is not used as a device in this example since it is difficult to predict the latency of the host device. As seen from the example calculated with Modbus, host latency (in this case the PLC), network latency, and IED latency (TPU2000R) all must be evaluated in their contributions to overall network throughput. The PLC is using a Master instruction to access data on the network. The amount of logic in the PLC is 1K of ladder instructions operating with a combined scan rate of 4 mS per K of logic. A PLC physical input is assumed to be using in triggering the data for this example. The latency of the I/O module is assumed to be 1 mS (125 VDC Input Module).

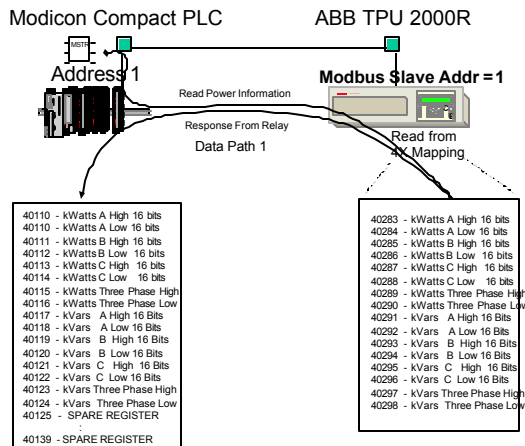

Figure 5-78. Modbus Plus Network Throughput Example

For a network with two nodes on a network as illustrated in Figure 5-78, the first step is to calculate the token rotation time using a master instruction.

Using the Token Rotation Time on Page 74 of the aforementioned Modbus Plus Manual, 890 USE 100 00 Version 2.0 where

TR = Token Rotation

DMW = Average number of words per Data Master Path used in the network (Maximum = 100)

DMP = the number of Data Master Paths used continuously in the network

GDW = the average number of global data words per message used in the network (Maximum = 32)

N = the number of nodes on the network.

TPU2000/2000R Modbus/Modbus Plus Automation Guide

Thus the token rotation is calculated according to the formula:

$$TR = (2.08 + 0.016 * DMW) * DMP + (0.19 + 0.016 * GDW) * GDN + 0.53 * N$$

In this example the PLC is continuously requesting 16 words of data. Only 1 path in this example (Path 1 is being utilized). For the sake of simplicity, no Global Data is being used on the network. The calculation for the token rotation time for the network in Figure 5-78 is:

$$TR = (2.08 + 0.016 * 16) * 1 + (0.19 + 0.016 * 0) * 0 + (0.53 * 2)$$

$$TR = 2.336 + 0 + 1.06$$

$$TR = 3.239 \text{ mS}$$

As per the suggestions in the manual, the worst case token rotation time is:

$$TR_{wk} = 1 * TR = 3.239 \text{ mS}$$

As per the suggestions in the manual, the best case token rotation time is:

$$TR_{bk} = 0.5 * TR = 1.620 \text{ mS}$$

Let us assume that a single read is triggered by a physical input on the PLC transitioning from a level 0 to a level 1 on the PLC processor.

A PLC throughput analysis of the host yields the following:

$$\text{PLC Input Delay} = 1 \text{ mS}$$

$$\text{PLC Scan} = 4 \text{ mS per K: } 2 \text{ scans of the PLC} = 8 \text{ mS} = 2 * 4 \text{ mS}$$

$$\text{PLC Scan and Delay} = 5 \text{ mS best case and } 9 \text{ mS worst Case}$$

It is interesting to note that 32 words of Global Data (if used in this calculation) were requested. An additional token rotation time of $(32 * 0.016) * 1 = 0.512 \text{ mS}$ would be added to a token rotation worst case (0.256 average contribution to the network otherwise). Thus with Global data, the average contribution for a single transaction would be 1.024 mS worst case for each network transaction.

Appendix A - TPU2000 Protocol Command Set

Revision 3.1

1 Revision History

Revision	Date	Author	Description
3.1	04/07/98	VAB	3-4-11: maximum CT ratio was 2000 for messages 2/1-4/2. Maximum VT ratio was 2000 for message 20/1-20/2.

TPU2000/2000R Modbus/Modbus Plus Automation Guide

The valid commands for the TPU2000 relay are listed below. The words transmit and receive in the command are with respect to the relay. The commands are spelt out in a 10 byte RS-232 protocol or a 3 byte INCOM protocol.

It will be easy to understand the commands in a 33 bit INCOM context and then translate the protocol to a 10 byte RS-232 protocol. The protocol messages are of two types - command and data.

Command Message (33 bit INCOM)

	S	S	C/D	Inst	Cmd	Subcmd	Address	BCH	S
Bit	1	2	3	4 to 7	8 to 11	12 to 15	16 to 27	28 to 32	33

Figure 3 - Command Message (INCOM)

Data Message (33 bit INCOM)

	S	S	C/D	Data 1	Data 2	Data 3	BCH	S
Bit	1	2	3	4 to 11	12 to 19	20 to 27	28 to 32	33

Figure 4 - Data Message (INCOM)

These INCOM message types can be represented in a 10 byte RS-232 protocol as follows:

Command Message (10 byte RS-232)

	STX	C/D	Inst	Cmd	SCmd	Addr Lo	Addr Mid	Addr Hi	CS Lo	CS Hi
Byte	1	2	3	4	5	6	7	8	9	10

Figure 5 - Command Message (10 byte RS 232)

The address bytes, Addr Lo, Addr Mid, and Addr Hi, are a 3 digit hex address. The checksum is 256 minus the sum of the ASCII characters in bytes 1 to 8. CS Lo is the low byte and CS Hi is the high byte of the checksum.

Example (3 4 1 command with a unit address of 001)

STX	=	hex 02	= use 2 -->Start of transmission
C/D	=	hex 31	= ascii 1 -->Command type of message
Inst	=	hex 33	= ascii 3 -->Instruction byte
Cmd	=	hex 34	= ascii 4 -->Command byte
SCmd	=	hex 31	= ascii 1 -->Subcommand byte
Addr Lo	=	hex 31	= ascii 1 -->Unit address low byte
Addr Mid	=	hex 30	= ascii 0 -->Unit address mid byte
Addr Hi	=	hex 30	= ascii 0 -->Unit address high byte
CS Lo	=	hex 34	= ascii 4 -->Checksum low byte
CS Hi	=	hex 46	= ascii F -->Checksum high byte

$$\text{Checksum} = 256 - (\text{STX} + \text{C/D} + \text{Inst} + \text{Cmd} + \text{SCmd} + \text{Addr Lo} + \text{Addr Mid} + \text{Addr Hi})$$

$$256 - (2 + 1 + 3 + 4 + 1 + 1 + 0 + 0) = \text{F4}$$

Data Message (10 byte RS-232)

	STX	C/D	D1 Lo	D1 Hi	D2 Lo	D2 Hi	D3 Lo	D3 Hi	CS Lo	CS Hi
Byte	1	2	3	4	5	6	7	8	9	10

Figure 6 - Data Message (10 byte RS 232)

Where D1 Lo is the low nibble of the first data byte and D1 Hi is the high nibble of the first data byte, D2 Lo is the low nibble of the second data byte and D2 Hi is the high nibble of the second data byte, and D3 Lo is the low nibble of the third data byte and D3 Hi is the high nibble of the third data byte.

The checksum is 256 minus the sum of the ASCII characters in bytes 1 to 8. CS Lo is the low byte and CS Hi is the high byte of the checksum.

Example (3 data bytes, ascii characters 4, 8, and 7)

STX	= hex 2	--> Start of transmission
C/D	= hex 0	--> Data type of message
D1 Lo	= hex 4	--> Data 1 low byte
D1 Hi	= hex 3	--> Data 1 high byte
D2 Lo	= hex 8	--> Data 2 low byte
D2 Hi	= hex 3	--> Data 2 high byte
D3 Lo	= hex 7	--> Data 3 low byte
D3 Hi	= hex 3	--> Data 3 high byte
CS Lo	= hex 2	--> Checksum low byte
CS Hi	= hex E	--> Checksum high byte

The three data bytes translate to:

Data 1 = 34 --> ascii 4
Data 2 = 38 --> ascii 8
Data 3 = 37 --> ascii 7

Checksum = 256 - (STX + C/D + D1L + D1H + D2L + D2H + D3L + D3H)
256 - (2 + 0 + 4 + 3 + 8 + 3 + 7 + 3) = E2

Transmission and reception convention

To acknowledge successful receipt of a message, an ACK is transmitted. The three byte message packet is 0x000013. For an unsuccessful reception, ie. a checksum error or an error in command processing, a NACK is transmitted. The three byte message packet is 0x100013.

The commands for the TPU2000 relay can be categorized into three basic types according to the response that is expected by the master. When a command or data is received, the TPU2000 must acknowledge if the reception was successful.

1-Simple Commands: A simple command directs the TPU2000 to perform specific actions. After the successful completion of these actions, the TPU2000 transmits an ACK as seen below.

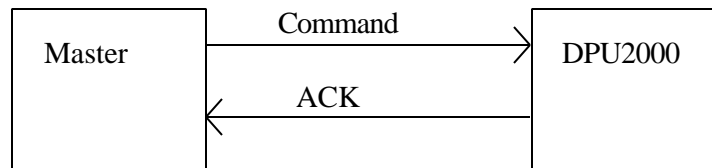

Figure 7 - Simple Command Communication Flow

2-Upload Data This type of command requests the TPU2000 to transmit specific data. The proper transmission of this data is the TPU2000 acknowledge of this type of command as seen below.

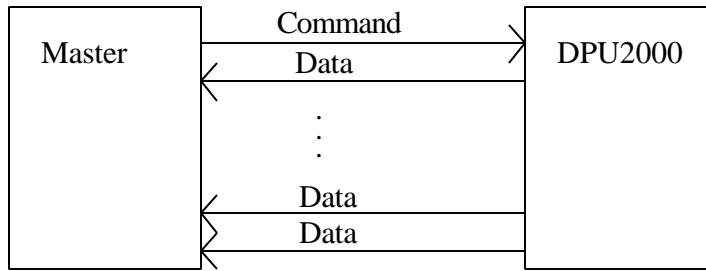

Figure 8 - Upload Data Communication Flow

3-Download Data: These commands edit the TPU2000 data. The TPU2000 responds with an ACK after the successful receipt of each data message packet. This can be seen in the figure below.

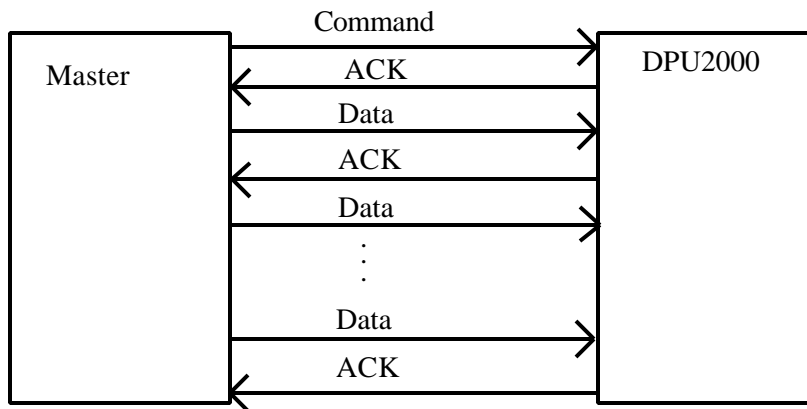

Figure 9 - Download Data Communication Flow

Message Packet Checksum: This checksum is different than the checksum associated with every incoming message packet. The value of the checksum is contained in a two byte integer and is the summation of all message bytes (1/1 + 1/2 + 1/3 + 2/1 + 2/2 + ...) for the command. The only exception is that the checksum message bytes are not included in the summation.

Example (3 3 1 command): (values are hex equivalent of the ASCII)

- | | |
|--------------|-------------------------------------|
| 1/1 = hex 05 | 3/1 = hex 44 |
| 1/2 = hex 31 | 3/2 = hex 00 |
| 1/3 = hex 04 | 3/3 = hex 00 |
| 2/1 = hex 00 | 4/1 = hex 00 |
| 2/2 = hex 01 | 4/2 = hex 00 <-- checksum high byte |
| 2/3 = hex 44 | 4/3 = hex C3 <-- checksum low byte |

Command Set Summary

<u>Inst</u>	<u>Cmd</u>	<u>Subcmd</u>	<u>Definition</u>
3	0	n	Status Commands
3	1	n	
3	2	n	
3	3	n	Transmit Settings Commands
3	4	n	Transmit Settings Commands
3	5	n	Transmit Meter/Record Commands
3	6	n	Load Profile/Record Commands
3	7	n	Transmit Meter Commands
3	8	n	
3	9	n	Relay Commands

TPU2000/2000R Modbus/Modbus Plus Automation Guide

3	10	n	Receive Edit Buffer Commands
3	11	n	Receive Edit Buffer Commands
3	12	n	
3	13	n	Programmable Curve Commands
3	14	n	Waveform Capture Commands
3	15	n	Reserved for Factory

0 Transmit Status "N" Commands (3 0 n)

<u>N</u>	<u>Definition</u>
0	Transmit Fast Status
1	Reserved
2	Unit Information
3	Reserved
4	Unreported Record Status
5	Reset Alarms/Target LEDs
6	Reset Max/Min Demand Currents
7	Show Logical I/O status

0.0 Transmit Fast Status (3 0 0)

This command will cause the relay to respond with one data message with the format shown below:

byte 3 | byte 2 | byte 1

ST2 ST1 L T4 T3 T2 T1 T0 | P5 P4 P3 P2 P1 P0 A3 A2 | A1 A0 D5 D4 D3 D2 D1 D0

D5 D4 D3 D2 D1 D0 => Division Code . RTD division code is 5(000101)

A3 A2 A1 A0 => A0 - One/More Unreported Operations

A1 - Reserved

A2,A3 - Reserved

P5 P4 P3 P2 P1 P0 => Product ID. (TPU2000 = 010011)

T2 T1 T0 => Reserved

T4 T3 => Reserved

L => Reserved for local operator interface action.

ST2 ST1 => Reserved for corporate standard status bits.

0.2 Unit Information (3 0 2)

This command will cause the relay to transmit data messages containing catalog number and the software version.

1/1-5/3	Catalog Number (18 characters)
6/1	CPU Software Version high byte (*100)
6/2	CPU Software Version low byte
6/3	DSP Software Version (*10)
7/1	Front Panel Software Version (*10)
7/2	Rear Communication Software version (*10)
7/3	Serial Number most significant low byte
8/1	Serial Number least significant high byte
8/2	Serial Number least significant low byte
8/3	Serial Number most significant high byte

0.3 RCVDALL (3 0 3)

- Reserved -

TPU2000/2000R Modbus/Modbus Plus Automation Guide

0.4 Unreported Record Status (3 0 4)

This command will respond with the number of unacknowledged operation and fault records.

To mark the record as being reported, a 3 6 12 command will retrieve the oldest unreported differential fault record and decrement the unreported differential fault record counter by one.

Likewise, a 3 6 13 command will retrieve the oldest unreported through fault record and decrement the unreported through fault record counter by one.

The 3 6 14 command will retrieve the oldest unreported harmonic restraint record and decrement the unreported harmonic restraint record counter by one.

The 3 6 15 command will retrieve the oldest unreported operations record and decrement the unreported operations record counter by one.

<u>Msg byte</u>	<u>Definition</u>
1/1	Relay Status (see command 4 1, msg 1/1)
1/2	Command + Subcommand = 0x04
1/3	Total Number of Messages = 4
2/1	Unreported Differential Fault Record Count byte
2/2	Unreported Through Fault Record Count byte
2/3	Unreported Harmonic Restraint Record Count byte
3/1	Unreported Operations Record Count byte
3/2	Spare
3/3	Spare
4/1	Spare
4/2	Spare
4/3	Spare

0.5 Reset Alarms/Target LEDs (3 0 5)

The targets, alarms and relay status flag (see command 3 4 1 msg 2/1) will be reset on the TPU. After the relay receives this command it will transmit an ACK/NACK based on the TPU completing the command.

0.6 Reset Max/Min Demand Currents (3 0 6)

This command will reset the maximum and minimum demand current values along with their time tags. After the relay receives this command it will transmit an ACK/NACK based on the TPU completing the command.

0.7 Show Logical Input/Output Status (3 0 7)

This command displays the binary value of the logical input and output table for the present state of the unit.

Bit = 0, Input Disabled/Output Not Energized

Bit = 1, Input Enabled/Output Energized

<u>Byte-Bit</u>	<u>Output</u>	<u>Input</u>	<u>Byte-Bit</u>	<u>Output</u>	<u>Input</u>
1-7	DIFF	87T	2-7	TFA	50N-1
1-6	ALARM	87H	2-6	51P-1	50G-2
1-5	87T	51P-1	2-5	51P-2	150P-1
1-4	87H	51P-2	2-4	50P-1	150P-2
1-3	2HROA	51N-1	2-3	150P-1	150N-1
1-2	5HROA	51G-2	2-2	50P-2	150G-2
1-1	AHROA	50P-1	2-1	150P-2	46-1
1-0	TCFA	50P-2	2-0	51N-1	46-2

TPU2000/2000R Modbus/Modbus Plus Automation Guide

<u>Byte-Bit</u>	<u>Output</u>	<u>Input</u>	<u>Byte-Bit</u>	<u>Output</u>	<u>Input</u>
3-7	51G-2	ALT1	4-7	87H-D	ULI1
3-6	50N-1	ALT2	4-6	51P-1D	ULI2
3-5	150N-1	ECI1	4-5	51P-2D	ULI3
3-4	50G-2	ECI2	4-4	51N-1D	ULI4
3-3	150G-2	WCI	4-3	51G-2D	ULI5
3-2	46-1	TRIP	4-2	50P-1D	ULI6
3-1	46-2	SPR	4-1	50P-2D	ULI7
3-0	87T-D	TCM	4-0	50N-1D	ULI8

<u>Byte-Bit</u>	<u>Output</u>	<u>Input</u>	<u>Byte-Bit</u>	<u>Output</u>	<u>Input</u>
5-7	50G-2D	ULI9	6-7	PBTA	
5-6	150P-1D	CRI	6-6	PCTA	
5-5	150P-2D		6-5	PUA	
5-4	150N-1D		6-4	63	
5-3	150G-2D		6-3	THRUFA	
5-2	46-1D		6-2	TFCA	
5-1	46-2D		6-1	TFKA	
5-0	PATA		6-0	TFSCA	

<u>Byte-Bit</u>	<u>Output</u>	<u>Input</u>	<u>Byte-Bit</u>	<u>Output</u>	<u>Input</u>
7-7	DTC		8-7	87T*	
7-6	OCTC		8-6	87H*	
7-5	PDA		8-5	2HROA*	
7-4	NDA		8-4	5HROA*	
7-3	PRIM		8-3	AHROA*	
7-2	ALT1		8-2	51P-1*	
7-1	ALT2		8-1	51P-2*	
7-0	STCA		8-0	50P-1*	

<u>Byte-Bit</u>	<u>Output</u>	<u>Input</u>	<u>Byte-Bit</u>	<u>Output</u>	<u>Input</u>
9-7	150P-1*		10-7	150G-2*	
9-6	50P-2*		10-6	46-1*	
9-5	150P-2*		10-5	46-2*	
9-4	51N-1*		10-4	63*	
9-3	51G-2*		10-3	ULO1	
9-2	50N-1*		10-2	ULO2	
9-1	150N-1*		10-1	ULO3	
9-0	50G-2*		10-0	ULO4	

<u>Byte-Bit</u>	<u>Output</u>	<u>Input</u>	<u>Byte-Bit</u>	<u>Output</u>	<u>Input</u>
11-7	ULO5		12-7	HLDA-1	
11-6	ULO6		12-6	LLDA-1	
11-5	ULO7		12-5	HLDA-2	
11-4	ULO8		12-4	LLDA-2	
11-3	ULO9		12-3	HPFA	
11-2	LOADA		12-2	LPFA	
11-1	OCA-1		12-1	VarDA	
11-0	OCA-2		12-0	PVArA	

<u>Byte-Bit</u>	<u>Output</u>	<u>Input</u>	<u>Byte-Bit</u>	<u>Output</u>	<u>Input</u>
13-7	NVArA		14-7	Spare	
13-6	PWatt1		14-6	Spare	
13-5	PWatt2		14-5	Spare	
13-4	Spare		14-4	Spare	
13-3	Spare		14-3	Spare	

TPU2000/2000R Modbus/Modbus Plus Automation Guide

13-2	Spare	14-2	Spare
13-1	Spare	14-1	Spare
13-0	Spare	14-0	Spare

<u>Msg byte</u>	<u>Definition</u>
1/1	Relay Status (see command 4 1, msg 1/1)
1/2	Command + Subcommand = 0x07
1/3	Total Number of Messages = 12
2/1	Logical Output byte 1
2/2	Logical Output byte 2
2/3	Logical Output byte 3
3/1	Logical Output byte 4
3/2	Logical Output byte 5
3/3	Logical Output byte 6
4/1	Logical Output byte 7
4/2	Logical Output byte 8
4/3	Logical Output byte 9
5/1	Logical Output byte 10
5/2	Logical Output byte 11
5/3	Logical Output byte 12
6/1	Logical Output byte 13
6/2	Logical Output byte 14
6/3	Logical Output byte 15
7/1	Logical Output byte 16
7/2	Logical Input byte 1
7/3	Logical Input byte 2
8/1	Logical Input byte 3
8/2	Logical Input byte 4
8/3	Logical Input byte 5
9/1	Logical Input byte 6
9/2	Logical Input byte 7
9/3	Logical Input byte 8
10/1	Logical Input byte 9
10/2	Logical Input byte 10
10/3	Logical Input byte 11
11/1	Logical Input byte 12
11/2	Logical Input byte 13
11/3	Logical Input byte 14
12/1	Logical Input byte 15
12/2	Logical Input byte 16
12/3	Spare
12/1	Spare
12/2	Checksum High byte
12/3	Checksum Low byte

1 Transmit Buffer "N" Commands (3 1 n)

<u>N</u>	<u>Definition</u>
0	Reserved for repeat 3 1 n
1	Register Based Communication Command

1.1 Transmit Register Based Data Set (3 1 1)

<u>Data Byte</u>	<u>Definition</u>
1/1	Block Number (0-255)
1/2	Offset Number (0-255)
1/3	Number of Bytes to Retrieve (NumBytes)(3-132) in multiples of 3

<u>Msg Byte</u>	<u>Definition</u>
1/1	Relay Status Byte Bit 7: Control Power Cycled Bit 6: New Fault Recorded Bit 5: Alternate 2 Settings Active Bit 4: Alternate 1 Settings Active Bit 3: Remote Edit Disable Bit 2: Local Settings Changed Bit 1: Contact Input Chnaged Bit 0: Selftest Status
1/2	Command + Subcommand = 0xXY
1/3	Total Number of Messages (TotalMsg = 1+(Num Bytes/3))
2/1	Data Byte Block Number, Offset Number
2/2	Data Byte Block Number, Offset Number + 1
2/3	Data Byte Block Number, Offset Number + 2
.	.
.	.
.	.
TotalMsg/1	Data Byte Block Number, Offset Number + NumBytes - 3
TotalMsg/2	Data Byte Block Number, Offset Number + NumBytes - 2
TotalMsg/3	Data Byte Block Number, Offset Number + NumBytes - 1

<u>Data Type Definitions</u>	<u>Value Ranges</u>
Unsigned Byte	(0 to 255)
Signed Byte	(-128 to 127)
Unsigned Short	(0 to 65535)
Signed Short	(-32,768 to 32767)
Unsigned Long	(0 to 4,294,967,295)
Signed Long	(-2,147,483,648 to 2,147,483,647)

Note: Data Byte Order follows the Low Address -High Byte, High Address - Low Byte Convention.

TPU2000/R Register Based Communication Definitions

BLK 0: SYSTEM STATUS/CONFIGURATION BLOCK

<u>Block Offset</u>	<u>Data Size</u>	<u>Scale</u>	<u>Description</u>
Offset 0:	Unsigned Word		Relay Status Bit 15-11: Spare Bit 10: New Minimum Demand Value Bit 9: New Peak Demand Value Bit 8: New Operation Recorded Bit 7: Control Power Cycled Bit 6: New Fault Recorded Bit 5: Alternate 2 Settings Active Bit 4: Alternate 1 Settings Active Bit 3: Remote Edit Disable Bit 2: Local Settings Changed Bit 1: Contact Input Changed Bit 0: Selftest Status
Offset 2:	Unsigned Long		Diagnostic Status Flag Bit 31-16: Spare Bit 15: DSP COP FAILURE Bit 14: DSP +5V FAILURE Bit 13: DSP +/-15V FAILURE Bit 12: DSP +/-5V FAILURE Bit 11: DSP ADC FAILURE Bit 10: DSP EXT RAM FAILURE

TPU2000/2000R Modbus/Modbus Plus Automation Guide

			Bit 9: DSP INT RAM FAILURE
			Bit 8: DSP ROM FAILURE
			Bit 7: Spare
			Bit 6: Spare
			Bit 5: Spare
			Bit 4: Spare
			Bit 3: CPU EEPROM FAILURE
			Bit 2: CPU NVRAM FAILURE
			Bit 1: CPU EPROM FAILURE
			Bit 0: CPU RAM FAILURE
Offset 6:	Unsigned Word		Relay Configuration
			Bit 15-4: Spare
			Bit 3: 0=kWhr/kVarhr, 1=MWhr/MVarhr
			Bit 2: 0= Wye PT, 1=Delta PT
			Bit 1,0: Meter Winding Mode (0=Winding 1, 1=Winding2, 2=Winding3)
Offset 8: 20	Char String(NULL Term)		Catalog Number
Offset 28:	Unsigned Short	100	CPU Software Version Number
Offset 30:	Unsigned Short	10	Analog/DSP Software Version Number
Offset 32:	Unsigned Short	10	Front Panel Controller Software Version Number
Offset 34:	Unsigned Short	10	Auxillary Communication Software Version Number
Offset 36:	Unsigned Long	1	Serial Number
Offset 40:	18 Char String (NULL Term)		Unit Name

BLK 1: DIFFERENTIAL CURRENT/ANGULAR/HARMONIC VALUES BLOCK

<u>Block Offset</u>	<u>Data Size</u>	<u>Scale</u>	<u>Description</u>
Offset 0:	Unsigned Word	800	Operate Current-A
Offset 2:	Unsigned Word	800	Operate Current-B
Offset 4:	Unsigned Word	800	Operate Current-C
Offset 6:	Unsigned Word	800	Restraint Current-A Winding 1
Offset 8:	Unsigned Word	800	Restraint Current-B Winding 1
Offset 10:	Unsigned Word	800	Restraint Current-C Winding 1
Offset 12:	Unsigned Word	800	Restraint Current-A Winding 2
Offset 14:	Unsigned Word	800	Restraint Current-B Winding 2
Offset 16:	Unsigned Word	800	Restraint Current-C Winding 2
Offset 18:	Unsigned Word	800	Restraint Current-A Winding 3
Offset 20:	Unsigned Word	800	Restraint Current-B Winding 3
Offset 22:	Unsigned Word	800	Restraint Current-C Winding 3
Offset 24:	Unsigned Word	1	Restraint Angle-A Winding 1
Offset 26:	Unsigned Word	1	Restraint Angle-B Winding 1
Offset 28:	Unsigned Word	1	Restraint Angle-C Winding 1
Offset 30:	Unsigned Word	1	Restraint Angle-A Winding 2
Offset 32:	Unsigned Word	1	Restraint Angle-B Winding 2
Offset 34:	Unsigned Word	1	Restraint Angle-C Winding 2
Offset 36:	Unsigned Word	1	Restraint Angle-A Winding 3
Offset 38:	Unsigned Word	1	Restraint Angle-B Winding 3
Offset 40:	Unsigned Word	1	Restraint Angle-C Winding 3
Offset 42:	Unsigned Word	1	Restraint Angle-B Winding 3
Offset 44:	Unsigned Byte	2	% Second Harmonic-A Winding 1
Offset 45:	Unsigned Byte	2	% Second Harmonic-B Winding 1
Offset 46:	Unsigned Byte	2	% Second Harmonic-C Winding 1
Offset 47:	Unsigned Byte	2	% Fifth Harmonic-A Winding 1
Offset 48:	Unsigned Byte	2	% Fifth Harmonic-B Winding 1
Offset 49:	Unsigned Byte	2	% Fifth Harmonic-C Winding 1
Offset 50:	Unsigned Byte	2	% All Harmonic-A Winding 1
Offset 51:	Unsigned Byte	2	% All Harmonic-B Winding 1
Offset 52:	Unsigned Byte	2	% All Harmonic-C Winding 1
Offset 53:	Unsigned Byte	2	% Second Harmonic-A Winding 2

TPU2000/2000R Modbus/Modbus Plus Automation Guide

Offset 54:	Unsigned Byte	2	% Second Harmonic-B Winding 2
Offset 55:	Unsigned Byte	2	% Second Harmonic-C Winding 2
Offset 56:	Unsigned Byte	2	% Fifth Harmonic-A Winding 2
Offset 57:	Unsigned Byte	2	% Fifth Harmonic-B Winding 2
Offset 58:	Unsigned Byte	2	% Fifth Harmonic-C Winding 2
Offset 59:	Unsigned Byte	2	% All Harmonic-A Winding 2
Offset 60:	Unsigned Byte	2	% All Harmonic-B Winding 2
Offset 61:	Unsigned Byte	2	% All Harmonic-C Winding 2
Offset 62:	Unsigned Byte	2	% Second Harmonic-A Winding 3
Offset 63:	Unsigned Byte	2	% Second Harmonic-B Winding 3
Offset 64:	Unsigned Byte	2	% Second Harmonic-C Winding 3
Offset 65:	Unsigned Byte	2	% Fifth Harmonic-A Winding 3
Offset 66:	Unsigned Byte	2	% Fifth Harmonic-B Winding 3
Offset 67:	Unsigned Byte	2	% Fifth Harmonic-C Winding 3
Offset 68:	Unsigned Byte	2	% All Harmonic-A Winding 3
Offset 69:	Unsigned Byte	2	% All Harmonic-B Winding 3
Offset 70:	Unsigned Byte	2	% All Harmonic-C Winding 3
Offset 71	Unsigned Byte	10	Current Tap Scale Winding 1
Offset 72	Unsigned Byte	10	Current Tap Scale Winding 2
Offset 73	Unsigned Byte	10	Current Tap Scale Winding 3

BLK 2: RMS LOAD CURRENT/ANGULAR VALUES BLOCK

<u>Block Offset</u>	<u>Data Size</u>	<u>Scale</u>	<u>Description</u>
Offset 0:	Unsigned Long	1	Load Current-A Winding 1
Offset 4:	Unsigned Long	1	Load Current-B Winding 1
Offset 8:	Unsigned Long	1	Load Current-C Winding 1
Offset 12:	Unsigned Long	1	Load Current-N Winding 1
Offset 16:	Unsigned Long	1	Load Current-A Winding 2
Offset 20:	Unsigned Long	1	Load Current-B Winding 2
Offset 24:	Unsigned Long	1	Load Current-C Winding 2
Offset 28:	Unsigned Long	1	Load Current-G Winding 2
Offset 32:	Unsigned Long	1	Load Current-A Winding 3
Offset 36:	Unsigned Long	1	Load Current-B Winding 3
Offset 40:	Unsigned Long	1	Load Current-C Winding 3
Offset 44:	Unsigned Long	1	Load Current-N Winding 3
Offset 48:	Unsigned Word	1	Load Current-A Angle Winding 1
Offset 50:	Unsigned Word	1	Load Current-B Angle Winding 1
Offset 52:	Unsigned Word	1	Load Current-C Angle Winding 1
Offset 54:	Unsigned Word	1	Load Current-N Angle Winding 1
Offset 56:	Unsigned Word	1	Load Current-A Angle Winding 2
Offset 58:	Unsigned Word	1	Load Current-B Angle Winding 2
Offset 60:	Unsigned Word	1	Load Current-C Angle Winding 2
Offset 62:	Unsigned Word	1	Load Current-G Angle Winding 2
Offset 64:	Unsigned Word	1	Load Current-A Angle Winding 3
Offset 66:	Unsigned Word	1	Load Current-B Angle Winding 3
Offset 68:	Unsigned Word	1	Load Current-C Angle Winding 3
Offset 70:	Unsigned Word	1	Load Current-N Angle Winding 3
Offset 72:	Unsigned Long	1	Load Current Zero Sequence Winding 1
Offset 76:	Unsigned Long	1	Load Current Positive Sequence Winding 1
Offset 80:	Unsigned Long	1	Load Current Negative Sequence Winding 1
Offset 84:	Unsigned Long	1	Load Current Zero Sequence Winding 2
Offset 88:	Unsigned Long	1	Load Current Positive Sequence Winding 2
Offset 92:	Unsigned Long	1	Load Current Negative Sequence Winding 2
Offset 96:	Unsigned Long	1	Load Current Zero Sequence Winding 3
Offset 100:	Unsigned Long	1	Load Current Positive Sequence Winding 3
Offset 104:	Unsigned Long	1	Load Current Negative Sequence Winding 3
Offset 108:	Unsigned Word	1	Load Current Zero Sequence Angle Winding 1
Offset 110:	Unsigned Word	1	Load Current Positive Sequence Angle Winding 1

TPU2000/2000R Modbus/Modbus Plus Automation Guide

Offset 112:	Unsigned Word	1	Load Current Negative Sequence Angle Winding 1
Offset 114:	Unsigned Word	1	Load Current Zero Sequence Angle Winding 2
Offset 116:	Unsigned Word	1	Load Current Positive Sequence Angle Winding 2
Offset 118:	Unsigned Word	1	Load Current Negative Sequence Angle Winding 2
Offset 120:	Unsigned Word	1	Load Current Zero Sequence Angle Winding 3
Offset 122:	Unsigned Word	1	Load Current Positive Sequence Angle Winding 3
Offset 124:	Unsigned Word	1	Load Current Negative Sequence Angle Winding 3

BLK 3: RMS VOLTAGE/ANGULAR/REAL and REACTIVE POWER/ENERGY VALUES BLOCK

<u>Block Offset</u>	<u>Data Size</u>	<u>Scale</u>	<u>Description</u>
Offset 0:	Unsigned Long	1	Voltage VA
Offset 4:	Unsigned Long	1	Voltage VB
Offset 8:	Unsigned Long	1	Voltage VC
Offset 12:	Unsigned Word	1	Voltage VA Angle
Offset 14:	Unsigned Word	1	Voltage VB Angle
Offset 16:	Unsigned Word	1	Voltage VC Angle
Offset 18:	Unsigned Long	1	Voltage Positive Sequence
Offset 22:	Unsigned Long	1	Voltage Negative Sequence
Offset 26:	Unsigned Word	1	Voltage Positive Sequence Angle
Offset 28:	Unsigned Word	1	Voltage Negative Sequence Angle
Offset 30:	Signed Long	1	kWatts A
Offset 34:	Signed Long	1	kWatts B
Offset 38:	Signed Long	1	kWatts C
Offset 42:	Signed Long	1	kVars A
Offset 46:	Signed Long	1	kVars B
Offset 50:	Signed Long	1	kVars C
Offset 54:	Signed Long	1	kWatt Hours A
Offset 58:	Signed Long	1	kWatt Hours B
Offset 62:	Signed Long	1	kWatt Hours C
Offset 66:	Signed Long	1	kVar Hours A
Offset 70:	Signed Long	1	kVar Hours B
Offset 74:	Signed Long	1	kVar Hours C
Offset 78:	Signed Long	1	3 Phase kWatts
Offset 82:	Signed Long	1	3 Phase kVars
Offset 86:	Signed Long	1	3 Phase kWatt Hours
Offset 90:	Signed Long	1	3 Phase kVar Hours
Offset 94:	Signed Long	1	3 Phase kVA
Offset 98:	Unsigned Short	100	System Frequency
Offset 100:	Unsigned Short		Power Factor

Bit 15-9: Not used
 Bit 8: 0=Positive, 1=Negative
 Bit 7: 0=Leading, 1=Lagging
 Bit 6-0: Power Factor Value (x100)

BLK 4: RMS DEMAND CURRENT/REAL and REACTIVE POWER VALUES BLOCK

<u>Block Offset</u>	<u>Data Size</u>	<u>Scale</u>	<u>Description</u>
Offset 0:	Signed Long	1	Demand Current-A
Offset 4:	Signed Long	1	Demand Current-B
Offset 8:	Signed Long	1	Demand Current-C
Offset 12:	Signed Long	1	Demand Current-N
Offset 16:	Signed Long	1	Demand kWatts-A
Offset 20:	Signed Long	1	Demand kWatts-B
Offset 24:	Signed Long	1	Demand kWatts-C
Offset 28:	Signed Long	1	Demand kVars-A
Offset 32:	Signed Long	1	Demand kVars-B
Offset 36:	Signed Long	1	Demand kVars-C
Offset 40:	Signed Long	1	3 Phase Demand Watts

TPU2000/2000R Modbus/Modbus Plus Automation Guide

Offset 44: Signed Long 1 3 Phase Demand Vars

BLK 5: RMS PEAK DEMAND CURRENT/REAL and REACTIVE POWER VALUES and TIME STAMPS BLOCK

<u>Block Offset</u>	<u>Data Size</u>	<u>Scale</u>	<u>Description</u>
Offset 0:	Signed Long	1	Peak Demand Current-A
Offset 4:	Unsigned Byte		Peak Demand Current-A Year
Offset 5:	Unsigned Byte		Peak Demand Current-A Month
Offset 6:	Unsigned Byte		Peak Demand Current-A Day
Offset 7:	Unsigned Byte		Peak Demand Current-A Hour
Offset 8:	Unsigned Byte		Peak Demand Current-A Minute
Offset 9:	Unsigned Byte		Spare
Offset10:	Signed Long	1	Peak Demand Current-B
Offset14:	Unsigned Byte		Peak Demand Current-B Year
Offset15:	Unsigned Byte		Peak Demand Current-B Month
Offset16:	Unsigned Byte		Peak Demand Current-B Day
Offset17:	Unsigned Byte		Peak Demand Current-B Hour
Offset18:	Unsigned Byte		Peak Demand Current-B Minute
Offset19:	Unsigned Byte		Spare
Offset 20:	Signed Long	1	Peak Demand Current-C
Offset 24:	Unsigned Byte		Peak Demand Current-C Year
Offset 25:	Unsigned Byte		Peak Demand Current-C Month
Offset 26:	Unsigned Byte		Peak Demand Current-C Day
Offset 27:	Unsigned Byte		Peak Demand Current-C Hour
Offset 28:	Unsigned Byte		Peak Demand Current-C Minute
Offset 29:	Unsigned Byte		Spare
Offset 30:	Signed Long	1	Peak Demand Current-N
Offset 34:	Unsigned Byte		Peak Demand Current-N Year
Offset 35:	Unsigned Byte		Peak Demand Current-N Month
Offset 36:	Unsigned Byte		Peak Demand Current-N Day
Offset 37:	Unsigned Byte		Peak Demand Current-N Hour
Offset 38:	Unsigned Byte		Peak Demand Current-N Minute
Offset 39:	Unsigned Byte		Spare
Offset 40:	Signed Long	1	Peak Demand KWatts-A
Offset 44:	Unsigned Byte		Peak Demand KWatts-A Year
Offset 45:	Unsigned Byte		Peak Demand KWatts-A Month
Offset 46:	Unsigned Byte		Peak Demand KWatts-A Day
Offset 47:	Unsigned Byte		Peak Demand KWatts-A Hour
Offset 48:	Unsigned Byte		Peak Demand KWatts-A Minute
Offset 49:	Unsigned Byte		Spare
Offset 50:	Signed Long	1	Peak Demand KWatts-B
Offset 54:	Unsigned Byte		Peak Demand KWatts-B Year
Offset 55:	Unsigned Byte		Peak Demand KWatts-B Month
Offset 56:	Unsigned Byte		Peak Demand KWatts-B Day
Offset 57:	Unsigned Byte		Peak Demand KWatts-B Hour
Offset 58:	Unsigned Byte		Peak Demand KWatts-B Minute
Offset 59:	Unsigned Byte		Spare
Offset 60:	Signed Long	1	Peak Demand KWatts-C
Offset 64:	Unsigned Byte		Peak Demand KWatts-C Year
Offset 65:	Unsigned Byte		Peak Demand KWatts-C Month
Offset 66:	Unsigned Byte		Peak Demand KWatts-C Day
Offset 67:	Unsigned Byte		Peak Demand KWatts-C Hour
Offset 68:	Unsigned Byte		Peak Demand KWatts-C Minute
Offset 69:	Unsigned Byte		Spare
Offset 70:	Signed Long	1	Peak Demand KVars-A
Offset 74:	Unsigned Byte		Peak Demand KVars-A Year
Offset 75:	Unsigned Byte		Peak Demand KVars-A Month
Offset 76:	Unsigned Byte		Peak Demand KVars-A Day

TPU2000/2000R Modbus/Modbus Plus Automation Guide

Offset 77:	Unsigned Byte		Peak Demand KVars-A Hour
Offset 78:	Unsigned Byte		Peak Demand KVars-A Minute
Offset 79:	Unsigned Byte		Spare
Offset 80:	Signed Long	1	Peak Demand KVars-B
Offset 84:	Unsigned Byte		Peak Demand KVars-B Year
Offset 85:	Unsigned Byte		Peak Demand KVars-B Month
Offset 86:	Unsigned Byte		Peak Demand KVars-B Day
Offset 87:	Unsigned Byte		Peak Demand KVars-B Hour
Offset 88:	Unsigned Byte		Peak Demand KVars-B Minute
Offset 89:	Unsigned Byte		Spare
Offset 90:	Signed Long	1	Peak Demand KVars-C
Offset 94:	Unsigned Byte		Peak Demand KVars-C Year
Offset 95:	Unsigned Byte		Peak Demand KVars-C Month
Offset 96:	Unsigned Byte		Peak Demand KVars-C Day
Offset 97:	Unsigned Byte		Peak Demand KVars-C Hour
Offset 98:	Unsigned Byte		Peak Demand KVars-C Minute
Offset 99:	Unsigned Byte		Spare
Offset 100:	Signed Long	1	3 Phase Peak Demand KWatts
Offset 104:	Unsigned Byte		3 Phase Peak Demand KWatts Year
Offset 105:	Unsigned Byte		3 Phase Peak Demand KWatts Month
Offset 106:	Unsigned Byte		3 Phase Peak Demand KWatts Day
Offset 107:	Unsigned Byte		3 Phase Peak Demand KWatts Hour
Offset 108:	Unsigned Byte		3 Phase Peak Demand KWatts Minute
Offset 109:	Unsigned Byte		Spare
Offset 110:	Signed Long	1	3 Phase Peak Demand KVars
Offset 114:	Unsigned Byte		3 Phase Peak Demand KVars Year
Offset 115:	Unsigned Byte		3 Phase Peak Demand KVars Month
Offset 116:	Unsigned Byte		3 Phase Peak Demand KVars Day
Offset 117:	Unsigned Byte		3 Phase Peak Demand KVars Hour
Offset 118:	Unsigned Byte		3 Phase Peak Demand KVars Minute
Offset 119:	Unsigned Byte		Spare

BLK 6: RMS MINIMUM DEMAND CURRENT/REAL and REACTIVE POWER VALUES and TIME STAMPS BLOCK

<u>Block Offset</u>	<u>Data Size</u>	<u>Scale</u>	<u>Description</u>
Offset 0:	Signed Long	1	Minimum Demand Current-A
Offset 4:	Unsigned Byte		Minimum Demand Current-A Year
Offset 5:	Unsigned Byte		Minimum Demand Current-A Month
Offset 6:	Unsigned Byte		Minimum Demand Current-A Day
Offset 7:	Unsigned Byte		Minimum Demand Current-A Hour
Offset 8:	Unsigned Byte		Minimum Demand Current-A Minute
Offset 9:	Unsigned Byte		Spare
Offset10:	Signed Long	1	Minimum Demand Current-B
Offset14:	Unsigned Byte		Minimum Demand Current-B Year
Offset15:	Unsigned Byte		Minimum Demand Current-B Month
Offset16:	Unsigned Byte		Minimum Demand Current-B Day
Offset17:	Unsigned Byte		Minimum Demand Current-B Hour
Offset18:	Unsigned Byte		Minimum Demand Current-B Minute
Offset19:	Unsigned Byte		Spare
Offset 20:	Signed Long	1	Minimum Demand Current-C
Offset 24:	Unsigned Byte		Minimum Demand Current-C Year
Offset 25:	Unsigned Byte		Minimum Demand Current-C Month
Offset 26:	Unsigned Byte		Minimum Demand Current-C Day
Offset 27:	Unsigned Byte		Minimum Demand Current-C Hour
Offset 28:	Unsigned Byte		Minimum Demand Current-C Minute
Offset 29:	Unsigned Byte		Spare
Offset 30:	Signed Long	1	Minimum Demand Current-N
Offset 34:	Unsigned Byte		Minimum Demand Current-N Year

TPU2000/2000R Modbus/Modbus Plus Automation Guide

Offset 35:	Unsigned Byte		Minimum Demand Current-N Month
Offset 36:	Unsigned Byte		Minimum Demand Current-N Day
Offset 37:	Unsigned Byte		Minimum Demand Current-N Hour
Offset 38:	Unsigned Byte		Minimum Demand Current-N Minute
Offset 39:	Unsigned Byte		Spare
Offset 40:	Signed Long	1	Minimum Demand KWatts-A
Offset 44:	Unsigned Byte		Minimum Demand KWatts-A Year
Offset 45:	Unsigned Byte		Minimum Demand KWatts-A Month
Offset 46:	Unsigned Byte		Minimum Demand KWatts-A Day
Offset 47:	Unsigned Byte		Minimum Demand KWatts-A Hour
Offset 48:	Unsigned Byte		Minimum Demand KWatts-A Minute
Offset 49:	Unsigned Byte		Spare
Offset 50:	Signed Long	1	Minimum Demand KWatts-B
Offset 54:	Unsigned Byte		Minimum Demand KWatts-B Year
Offset 55:	Unsigned Byte		Minimum Demand KWatts-B Month
Offset 56:	Unsigned Byte		Minimum Demand KWatts-B Day
Offset 57:	Unsigned Byte		Minimum Demand KWatts-B Hour
Offset 58:	Unsigned Byte		Minimum Demand KWatts-B Minute
Offset 59:	Unsigned Byte		Spare
Offset 60:	Signed Long	1	Minimum Demand KWatts-C
Offset 64:	Unsigned Byte		Minimum Demand KWatts-C Year
Offset 65:	Unsigned Byte		Minimum Demand KWatts-C Month
Offset 66:	Unsigned Byte		Minimum Demand KWatts-C Day
Offset 67:	Unsigned Byte		Minimum Demand KWatts-C Hour
Offset 68:	Unsigned Byte		Minimum Demand KWatts-C Minute
Offset 69:	Unsigned Byte		Spare
Offset 70:	Signed Long	1	Minimum Demand KVars-A
Offset 74:	Unsigned Byte		Minimum Demand KVars-A Year
Offset 75:	Unsigned Byte		Minimum Demand KVars-A Month
Offset 76:	Unsigned Byte		Minimum Demand KVars-A Day
Offset 77:	Unsigned Byte		Minimum Demand KVars-A Hour
Offset 78:	Unsigned Byte		Minimum Demand KVars-A Minute
Offset 79:	Unsigned Byte		Spare
Offset 80:	Signed Long	1	Minimum Demand KVars-B
Offset 84:	Unsigned Byte		Minimum Demand KVars-B Year
Offset 85:	Unsigned Byte		Minimum Demand KVars-B Month
Offset 86:	Unsigned Byte		Minimum Demand KVars-B Day
Offset 87:	Unsigned Byte		Minimum Demand KVars-B Hour
Offset 88:	Unsigned Byte		Minimum Demand KVars-B Minute
Offset 89:	Unsigned Byte		Spare
Offset 90:	Signed Long	1	Minimum Demand KVars-C
Offset 94:	Unsigned Byte		Minimum Demand KVars-C Year
Offset 95:	Unsigned Byte		Minimum Demand KVars-C Month
Offset 96:	Unsigned Byte		Minimum Demand KVars-C Day
Offset 97:	Unsigned Byte		Minimum Demand KVars-C Hour
Offset 98:	Unsigned Byte		Minimum Demand KVars-C Minute
Offset 99:	Unsigned Byte		Spare
Offset 100:	Signed Long	1	3 Phase Minimum Demand KWatts
Offset 104:	Unsigned Byte		3 Phase Minimum Demand KWatts Year
Offset 105:	Unsigned Byte		3 Phase Minimum Demand KWatts Month
Offset 106:	Unsigned Byte		3 Phase Minimum Demand KWatts Day
Offset 107:	Unsigned Byte		3 Phase Minimum Demand KWatts Hour
Offset 108:	Unsigned Byte		3 Phase Minimum Demand KWatts Minute
Offset 109:	Unsigned Byte		Spare
Offset 110:	Signed Long	1	3 Phase Minimum Demand KVars
Offset 114:	Unsigned Byte		3 Phase Minimum Demand KVars Year
Offset 115:	Unsigned Byte		3 Phase Minimum Demand KVars Month
Offset 116:	Unsigned Byte		3 Phase Minimum Demand KVars Day
Offset 117:	Unsigned Byte		3 Phase Minimum Demand KVars Hour

TPU2000/2000R Modbus/Modbus Plus Automation Guide

Offset 118:	Unsigned Byte	3 Phase Minimum Demand KVars Minute
Offset 119:	Unsigned Byte	Spare

BLK 7: COUNTERS BLOCK

<u>Block Offset</u>	<u>Data Size</u>	<u>Scale</u>	<u>Description</u>
Offset 0:	Unsigned Short	1	Unreported Differential Fault Record Counter
Offset 2:	Unsigned Short	1	Unreported Through Fault Record Counter
Offset 4:	Unsigned Short	1	Unreported Harmonic Restraint Record Counter
Offset 6:	Unsigned Short	1	Unreported Operation Record Counter
Offset 8:	Unsigned Short	1	Through Fault Counter
Offset 10:	Unsigned Long	1	Through Fault Summation kAmps-A Counter
Offset 14:	Unsigned Long	1	Through Fault Summation kAmps-B Counter
Offset 18:	Unsigned Long	1	Through Fault Summation kAmps-C Counter
Offset 22:	Unsigned Long	1	Through Fault Summation Cycles Counter
Offset 26:	Unsigned Short	1	Overcurrent Trip Counter
Offset 28:	Unsigned Short	1	Differential Trip Counter

BLK 8: PHYSICAL and LOGICAL INPUT/OUTPUT BLOCK

<u>Block Offset</u>	<u>Data Size</u>	<u>Description</u>
Offset 0:	Unsigned Long	Logical Output 0-31 Bit 31: DIFF Bit 15: 51G-2 Bit 30: ALARM Bit 14: 50N-1 Bit 29: 87T Bit 13: 150N-1 Bit 28: 87H Bit 12: 50G-2 Bit 27: 2HROA Bit 11: 150G-2 Bit 26: 5HROA Bit 10: 46-1 Bit 25: AHROA Bit 9: 46-2 Bit 24: TCFA Bit 8: 87T-D Bit 23: TFA Bit 7: 87H-D Bit 22: 51P-1 Bit 6: 51P-1D Bit 21: 51P-2 Bit 5: 51P-2D Bit 20: 50P-1 Bit 4: 51N-1D Bit 19: 150P-1 Bit 3: 51G-2D Bit 18: 50P-2 Bit 2: 50P-1D Bit 17: 150P-2 Bit 1: 50P-2D Bit 16: 51N-1 Bit 0: 50N-1D
Offset 4:	Unsigned Long	Logical Output 32-63 Bit 31: 50G-2D Bit 15: DTC Bit 30: 150P-1D Bit 14: OCTC Bit 29: 150P-2D Bit 13: PDA Bit 28: 150N-1D Bit 12: NDA Bit 27: 150G-2D Bit 11: PRIM Bit 26: 46-1D Bit 10: ALT1 Bit 25: 46-2D Bit 9: ALT2 Bit 24: PATA Bit 8: STCA Bit 23: PBTA Bit 7: 87T* Bit 22: PCTA Bit 6: 87H* Bit 21: PUA Bit 5: 2HROA* Bit 20: 63 Bit 4: 5HROA* Bit 19: THRUFA Bit 3: AHROA* Bit 18: TFCA Bit 2: 51P-1* Bit 17: TFKA Bit 1: 51P-2* Bit 16: TFSCA Bit 0: 50P-1*
Offset 8:	Unsigned Long	Logical Output 64-95 Bit 31: 150P-1* Bit 15: ULO5 Bit 30: 50P-2* Bit 14: ULO6 Bit 29: 150P-2* Bit 13: ULO7

TPU2000/2000R Modbus/Modbus Plus Automation Guide

		Bit 28: 51N-1*	Bit 12: ULO8
		Bit 27: 51G-2*	Bit 11: ULO9
		Bit 26: 50N-1*	Bit 10: LOADA
		Bit 25: 150N-1*	Bit 9: OCA-1
		Bit 24: 50G-2*	Bit 8: OCA-2
		Bit 23: 150G-2*	Bit 7: HLDA-1
		Bit 22: 46-1*	Bit 6: LLDA-1
		Bit 21: 46-2*	Bit 5: HLDA-2
		Bit 20: 63*	Bit 4: LLDA-1
		Bit 19: ULO1	Bit 3: HPFA
		Bit 18: ULO2	Bit 2: LPFA
		Bit 17: ULO3	Bit 1: VarDA
		Bit 16: ULO4	Bit 0: PVarA
Offset 12:	Unsigned Long	Logical Output 96-127	
		Bit 31: NVarA	Bit 15:
		Bit 30: PWatt1	Bit 14:
		Bit 29: PWatt2	Bit 13:
		Bit 28:	Bit 12:
		Bit 27:	Bit 11:
		Bit 26:	Bit 10:
		Bit 25:	Bit 9:
		Bit 24:	Bit 8:
		Bit 23:	Bit 7:
		Bit 22:	Bit 6:
		Bit 21:	Bit 5:
		Bit 20:	Bit 4:
		Bit 19:	Bit 3:
		Bit 18:	Bit 2:
		Bit 17:	Bit 1:
		Bit 16:	Bit 0:
Offset 16:	Unsigned Long	Logical Input 0-31	
		Bit 31: 87T	Bit 15: ALT1
		Bit 30: 87H	Bit 14: ALT2
		Bit 29: 51P-1	Bit 13: ECI1
		Bit 28: 51P-2	Bit 12: ECI2
		Bit 27: 51N-1	Bit 11: WCI
		Bit 26: 51G-2	Bit 10: TRIP
		Bit 25: 50P-1	Bit 9: SPR
		Bit 24: 50P-2	Bit 8: TCM
		Bit 23: 50N-1	Bit 7: ULI1
		Bit 22: 50G-2	Bit 6: ULI2
		Bit 21: 150P-1	Bit 5: ULI3
		Bit 20: 150P-2	Bit 4: ULI4
		Bit 19: 150N-1	Bit 3: ULI5
		Bit 18: 150G-2	Bit 2: ULI6
		Bit 17: 46-1	Bit 1: ULI7
		Bit 16: 46-2	Bit 0: ULI8
Offset 20:	Unsigned Long	Logical Input 32-63	
		Bit 31: ULI9	Bit 15:
		Bit 30: CRI	Bit 14:
		Bit 29:	Bit 13:
		Bit 28:	Bit 12:
		Bit 27:	Bit 11:
		Bit 26:	Bit 10:
		Bit 25:	Bit 9:
		Bit 24:	Bit 8:
		Bit 23:	Bit 7:
		Bit 22:	Bit 6:
		Bit 21:	Bit 5:

TPU2000/2000R Modbus/Modbus Plus Automation Guide

		Bit 20:	Bit 4:
		Bit 19:	Bit 3:
		Bit 18:	Bit 2:
		Bit 17:	Bit 1:
		Bit 16:	Bit 0:
Offset 24:	Unsigned Long	Logical Input 64-95 (Reserved)	
Offset 28:	Unsigned Long	Logical Input 96-127 (Reserved)	
Offset 32:	Unsigned Short	Physical Output	
		Bit 15: Spare	Bit 7: OUT7
		Bit 14: Spare	Bit 6: OUT6
		Bit 13: Spare	Bit 5: OUT5
		Bit 12: Spare	Bit 4: OUT4
		Bit 11: Spare	Bit 3: OUT3
		Bit 10: Spare	Bit 2: OUT2
		Bit 9: Spare	Bit 1: OUT1
		Bit 8: Spare	Bit 0: TRIP
Offset 34:	Unsigned Short	Physical Input	
		Bit 15: Spare	Bit 7: IN8
		Bit 14: Spare	Bit 6: IN7
		Bit 13: Spare	Bit 5: IN6
		Bit 12: Spare	Bit 4: IN5
		Bit 11: Spare	Bit 3: IN4
		Bit 10: Spare	Bit 2: IN3
		Bit 9: Spare	Bit 1: IN2
		Bit 8: IN9	Bit 0: IN1

3 Transmit Buffer "N" Commands (3 3 n)

<u>N</u>	<u>Definition</u>
0	Reserved for repeat 3 3 n
1	Communications Settings

3.1 Transmit Communications Settings (3 3 1)

Low byte consists of bits 0 through 7.
High byte consists of bits 8 through 15.

Port configuration byte

- bit0-3 = port baud rate where 0 = 300, 1 = 1200, 2 = 2400, 3 = 4800, 4 = 9600, 5 = 19200, 6 = 38400
- bit 4-5 = parity (0=None,1=Odd,2=Even)
- bit 6 = number of data bits (0=seven,1=eight)
- bit 7 = number of stop bits (0=one,1=two)

Valid Frame Combinations (EVEN 7 1, ODD 7 1, NONE 8 1, EVEN 8 1, ODD 8 1, NONE 8 2, NONE 7 2)

<u>Msg byte</u>	<u>Definition</u>
1/1	Relay Status (see command 3 4 1, msg 1/1)
1/2	Command + Subcommand = 0x31
1/3	Total Number of Messages = 9
2/1	Unit Address high byte
2/2	Unit Address low byte
2/3	Front Panel RS232 configuration byte
3/1	Rear Panel RS232 or INCOM configuration byte
3/2	Rear Panel RS485 configuration byte
3/3	Rear Panel IRIG byte 0=Disabled, 1=Enabled
4/1	Spare
4/2	Spare
4/3	Aux Port Parameter 1 byte (0-255)
5/1	Aux Port Parameter 2 byte (0-255)

5/2	Aux Port Parameter 3 byte (0-255)
5/3	Aux Port Parameter 4 byte (0-255)
6/1	Aux Port Parameter 5 byte (0-255)
6/2	Aux Port Parameter 6 byte (0-255)
6/3	Aux Port Parameter 7 byte (0-255)
7/1	Aux Port Parameter 8 byte (0-255)
7/2	Aux Port Parameter 9 byte (0-255)
7/3	Aux Port Parameter 10 byte (0-255)
8/1	Aux Port Parameter Mode byte
8/2	Spare
8/3	Spare
9/1	Spare
9/2	Checksum high byte
9/3	Checksum low byte

4 Transmit Buffer "N" Commands (3 4 n)

<u>N</u>	<u>Definition</u>
0	Reserved for repeat 3 4 n
1	Programmable Input Select and Index Tables
2	Programmable Input Negated AND Table
3	Programmable Input AND/OR Table
4	Programmable Input User Defined Input Names
5	Programmable Output Select Table
6	Programmable Output AND/OR Table
7	Programmable Output User Defined Output Strings
8	Primary Relay Settings
9	Alternate 1 Relay Settings
10	Alternate 2 Relay Settings
11	Configuration Settings
12	Counter Settings
13	Alarm Settings
14	Real Time Clock
15	Output Delays

4.1 Transmit Programmable Input Select and Index (3 4 1)

Bit = 0, Physical Input is selected.
 Bit = 1, Physical Input is not selected.
 Low byte consists of bits 0 through 7.
 High byte consists of bits 8 through 15.
 Index byte is the offset into the TPU's logical input structure.

<u>Offset</u>		<u>Definitions</u>
00	87T	Restrained Differential Trip
01	87H	High Set Inst Differential Trip
02	51P-1	Wdg1 Phase Time OC Trip
03	51P-2	Wdg2 Phase Time OC Trip
04	51N-1	Wdg1 Neutral Time OC Trip
05	51G-2	Wdg2 Ground Time OC Trip
06	50P-1	1st Wdg1 Phase Inst OC Trip
07	50P-2	1st Wdg2 Phase Inst OC Trip
08	50N-1	1st Wdg1 Neutral Inst OC Trip
09	50G-2	1st Wdg2 Ground Inst OC Trip
10	150P-1	2nd Wdg1 Phase Inst OC Trip
11	150P-2	2nd Wdg2 Phase Inst OC Trip
12	150N-1	2nd Wdg1 Neutral Inst OC Trip
13	150G-2	2nd Wdg2 Ground Inst OC Trip
14	46-1	Wdg1 Neg Seq Time OC Trip

TPU2000/2000R Modbus/Modbus Plus Automation Guide

15	46-2	Wdg2 Neg Seq Time OC Trip
16	ALT1	Enables Alt 1 Settings
17	ALT2	Enables Alt 2 Settings
18	ECI1	Event-1 Capture Initiated
19	ECI2	Event-2 Capture Initiated
20	WCI	Waveform Capture Initiated
21	Trip	Initiates Diff Trip Output
22	SPR	Sudden Pressure Input
23	TCM	Trip Coil Monitoring
24	ULI1	User Logical Input 1
25	ULI2	User Logical Input 2
26	ULI3	User Logical Input 3
27	ULI4	User Logical Input 4
28	ULI5	User Logical Input 5
29	ULI6	User Logical Input 6
30	ULI7	User Logical Input 7
31	ULI8	User Logical Input 8
32	ULI9	User Logical Input 9
33	CRI	Clears Through Fault and OC Counters

Example : if message 2/1 = hex 24
 2/2 = hex 11
 2/3 = hex 4

I/O word is 00100100 00010001 hex 2411

Note the Physical Inputs are translated using the physical input table below: In the example IN3, IN10, IN8 and IN5 are selected for GND.

The AND/OR selection and enable disable mapping is selected with commands 3 11 3 and 3 11 2

Bit	Physical Input
---	-----
0	IN6
1	IN7
2	IN8
3	IN2
4	IN9
5	IN3
6	IN4
7	IN5
8	IN1
9	Reserved
10	Reserved
11	Reserved
12	Reserved
13	Reserved
14	Reserved
15	Reserved

<u>Msg byte</u>	<u>Definition</u>
1/1	Relay Status Bit 0 : SelfTest Status Bit 1 : Contact Input Status changed Bit 2 : Local Settings Change Bit 3 : Remote Edit Disabled. Bit 4 : Alternate Settings Group 1 enabled. Bit 5 : Alternate Setting Group 2 enabled. Bit 6 : Fault Record Logged. Bit 7 : Power was Cycled

TPU2000/2000R Modbus/Modbus Plus Automation Guide

1/2	Command + Subcommand = 0x41		
1/3	Total Number of Messages = 34		
2/1	INPUT1 high byte		
2/2	INPUT1 low byte		
2/3	INPUT1 index byte		
3/1	INPUT2 high byte		
3/2	INPUT2 low byte		
3/3	INPUT2 index byte		
4/1	INPUT3 high byte		
4/2	INPUT3 low byte		
4/3	INPUT3 index byte		
5/1	INPUT4 high byte		
5/2	INPUT4 low byte	Bit	Physical Input
5/3	INPUT4 index byte	---	-----
6/1	INPUT5 high byte	0	IN6
6/2	INPUT5 low byte	1	IN7
6/3	INPUT5 index byte	2	IN8
7/1	INPUT6 high byte	3	IN2
7/2	INPUT6 low byte	4	IN9
7/3	INPUT6 index byte	5	IN3
8/1	INPUT7 high byte	6	IN4
8/2	INPUT7 low byte	7	IN5
8/3	INPUT7 index byte	8	IN1
9/1	INPUT8 high byte	9	Reserved
9/2	INPUT8 low byte	10	Reserved
9/3	INPUT8 index byte	11	Reserved
10/1	INPUT9 high byte	12	Reserved
10/2	INPUT9 low byte	13	Reserved
10/3	INPUT9 index byte	14	Reserved
11/1	INPUT10 high byte	15	Reserved
11/2	INPUT10 low byte		
11/3	INPUT10 index byte		
12/1	INPUT11 high byte		
12/2	INPUT11 low byte		
12/3	INPUT11 index byte		
13/1	INPUT12 high byte		
13/2	INPUT12 low byte		
13/3	INPUT12 index byte		
14/1	INPUT13 high byte		
14/2	INPUT13 low byte		
14/3	INPUT13 index byte		
15/1	INPUT14 high byte		
15/2	INPUT14 low byte		
15/3	INPUT14 index byte		
16/1	INPUT15 high byte		
16/2	INPUT15 low byte		
16/3	INPUT15 index byte		
17/1	INPUT16 high byte		
17/2	INPUT16 low byte		
17/3	INPUT16 index byte		
18/1	INPUT17 high byte		
18/2	INPUT17 low byte		
18/3	INPUT17 index byte		
19/1	INPUT18 high byte		
19/2	INPUT18 low byte		
19/3	INPUT18 index byte		
20/1	INPUT19 high byte		
20/2	INPUT19 low byte		
20/3	INPUT19 index byte		

TPU2000/2000R Modbus/Modbus Plus Automation Guide

21/1	INPUT20 low byte
21/3	INPUT20 index byte
22/1	INPUT21 high byte
22/2	INPUT21 low byte
22/3	INPUT21 index byte
23/1	INPUT22 high byte
23/2	INPUT22 low byte
23/3	INPUT22 index byte
24/1	INPUT23 high byte
24/2	INPUT23 low byte
24/3	INPUT23 index byte
25/1	INPUT24 high byte
25/2	INPUT24 low byte
25/3	INPUT24 index byte
26/1	INPUT25 high byte
26/2	INPUT25 low byte
26/3	INPUT25 index byte
27/1	INPUT26 high byte
27/2	INPUT26 low byte
27/3	INPUT26 index byte
28/1	INPUT27 high byte
28/2	INPUT27 low byte
28/3	INPUT27 index byte
29/1	INPUT28 high byte
29/2	INPUT28 low byte
29/3	INPUT28 index byte
30/1	INPUT29 high byte
30/2	INPUT29 low byte
30/3	INPUT29 index byte
31/1	INPUT30 high byte
31/2	INPUT30 low byte
31/3	INPUT30 index byte
32/1	INPUT31 high byte
32/2	INPUT31 low byte
32/3	INPUT31 index byte
33/1	INPUT32 high byte
33/2	INPUT32 low byte
33/3	INPUT32 index byte
34/1	spare
34/2	Checksum high byte
34/3	Checksum low byte

4.2 Transmit Programmable Input Negated AND Input (3 4 2)

From TPU Negated Programmable Input data transferred from TPU2 to PC. (3, 4, 2)

Bit = 0, Enabled when input is opened.

Bit = 1, Enabled when input is closed.

Low byte consists of bits 0 through 7.

High byte consists of bits 8 through 15.

<u>Msg byte</u>	<u>Definition</u>
1/1	Relay Status (see command 3 4 1, msg 1/1)
1/2	Command + Subcommand = 0x42
1/3	Total Number of Messages = 23
2/1	INPUT1 high byte
2/2	INPUT1 low byte
2/3	INPUT2 high byte
3/1	INPUT2 low byte

3/2	INPUT3 high byte		
3/3	INPUT3 low byte		
4/1	INPUT4 high byte		
4/2	INPUT4 low byte	Bit	Physical Input
4/3	INPUT5 high byte	---	-----
5/1	INPUT5 low byte	0	IN6
5/2	INPUT6 high byte	1	IN7
5/3	INPUT6 low byte	2	IN8
6/1	INPUT7 high byte	3	IN2
6/2	INPUT7 low byte	4	IN9
6/3	INPUT8 high byte	5	IN3
7/1	INPUT8 low byte	6	IN4
7/2	INPUT9 high byte	7	IN5
7/3	INPUT9 low byte	8	IN1
8/1	INPUT10 high byte	9	Reserved
8/2	INPUT10 low byte	10	Reserved
8/3	INPUT11 high byte	11	Reserved
9/1	INPUT11 low byte	12	Reserved
9/2	INPUT12 high byte	13	Reserved
9/3	INPUT12 low byte	14	Reserved
10/1	INPUT13 high byte	15	Reserved
10/2	INPUT13 low byte		
10/3	INPUT14 high byte		
11/1	INPUT14 low byte		
11/2	INPUT15 high byte		
11/3	INPUT15 low byte		
12/1	INPUT16 high byte		
12/2	INPUT16 low byte		
12/3	INPUT17 high byte		
13/1	INPUT17 low byte		
13/2	INPUT18 high byte		
13/3	INPUT18 low byte		
14/1	INPUT19 high byte		
14/2	INPUT19 low byte		
14/3	INPUT20 high byte		
15/1	INPUT20 low byte		
15/2	INPUT21 high byte		
15/3	INPUT21 low byte		
16/1	INPUT22 high byte		
16/2	INPUT22 low byte		
16/3	INPUT23 high byte		
17/1	INPUT23 low byte		
17/2	INPUT24 high byte		
17/3	INPUT24 low byte		
18/1	INPUT25 high byte		
18/2	INPUT25 low byte		
18/3	INPUT26 high byte		
19/1	INPUT26 low byte		
19/2	INPUT27 high byte		
19/3	INPUT27 low byte		
20/1	INPUT28 high byte		
20/2	INPUT28 low byte		
20/3	INPUT29 high byte		
21/1	INPUT29 low byte		
21/2	INPUT30 high byte		
21/3	INPUT30 low byte		
22/1	INPUT31 high byte		
22/2	INPUT31 low byte		
22/3	INPUT32 high byte		

TPU2000/2000R Modbus/Modbus Plus Automation Guide

23/1	INPUT32 low byte
23/2	Checksum high byte
23/3	Checksum low byte

4.3 Transmit Programmable Input AND/OR Select (3 4 3)

Bit = 0, Selected inputs are ORed together.

Bit = 1, Selected inputs are ANDED together.

<u>Msg byte</u>	<u>Definition</u>
1/1	Relay Status (see command 3 4 1, msg 1/1)
1/2	Command + Subcommand = 0x43
1/3	Total Number of Messages = 3
2/1	Programmable input AND/OR selection bits 24-31
2/2	Programmable input AND/OR selection bits 16-23
2/3	Programmable input AND/OR selection bits 8-15
3/1	Programmable input AND/OR selection bits 0-7
3/2	Checksum high byte
3/3	Checksum low byte

<u>Bit</u>	<u>Logical Input</u>
---	-----
0	INPUT1
1	INPUT2
.	.
.	.
.	.
27	INPUT28
28	INPUT29
29	INPUT30
30	INPUT31
31	INPUT32

4.4 Transmit Programmable User Defined Input Names (3 4 4)

User definable 8 char input strings. Byte 9 is an implied NULL.

<u>Msg byte</u>	<u>Definition</u>
1/1	Relay Status (see command 3 4 1, msg 1/1)
1/2	Command + Subcommand = 0x44
1/3	Total Number of Messages = 37
2/1-4/2	IN1 Character String 8 bytes
4/3-7/1	IN2 Character String 8 bytes
7/2-9/3	IN3 Character String 8 bytes
10/1-12/2	IN4 Character String 8 bytes
12/3-15/1	IN5 Character String 8 bytes
15/2-17/3	IN6 Character String 8 bytes
18/1-20/2	IN7 Character String 8 bytes
20/3-23/1	IN8 Character String 8 bytes
23/2-25/3	IN9 Character String 8 bytes
26/1-28/2	spare Character String 8 bytes
28/3-31/1	spare Character String 8 bytes
31/2-33/3	spare Character String 8 bytes
34/1-36/2	spare Character String 8 bytes
36/3-37/1	Spare
37/2	Checksum high byte
37/3	Checksum low byte

4.5 Transmit Programmable Output Select (3 4 5)

Bit = 0, Physical Output is selected.
 Bit = 1, Physical Output is not selected.
 Least significant low byte consists of bits 0 through 7.
 Least significant high byte consists of bits 8 through 15.
 Most significant low byte consists of bits 16 through 23.
 Most significant high byte consists of bits 24 through 31.

<u>Bit</u>	<u>Logical Output</u>
0	Not used, reserved for fixed Differential Trip
1	OUTPUT1
2	OUTPUT2
3	OUTPUT3
.	.
.	.
.	.
30	OUTPUT30
31	OUTPUT31

<u>Msg byte</u>	<u>Definition</u>
1/1	Relay Status (see command 3 4 1, msg 1/1)
1/2	Command + Subcommand = 0x45
1/3	Total Number of Messages = 21
2/1	Contact OUT5 most significant high byte
2/2	Contact OUT5 most significant low byte
2/3	Contact OUT5 least significant high byte
3/1	Contact OUT5 least significant low byte
3/2	Contact OUT7 most significant high byte
3/3	Contact OUT7 most significant low byte
4/1	Contact OUT7 least significant high byte
4/2	Contact OUT7 least significant low byte
4/3	Contact OUT4 most significant high byte
5/1	Contact OUT4 most significant low byte
5/2	Contact OUT4 least significant high byte
5/3	Contact OUT4 least significant low byte
6/1	Contact OUT6 most significant high byte
6/2	Contact OUT6 most significant low byte
6/3	Contact OUT6 least significant high byte
7/1	Contact OUT6 least significant low byte
7/2	Contact OUT3 most significant high byte
7/3	Contact OUT3 most significant low byte
8/1	Contact OUT3 least significant high byte
8/2	Contact OUT3 least significant low byte
8/3	Contact OUT2 most significant high byte
9/1	Contact OUT2 most significant low byte
9/2	Contact OUT2 least significant high byte
9/3	Contact OUT2 least significant low byte
10/1	Contact OUT1 most significant high byte
10/2	Contact OUT1 most significant low byte
10/3	Contact OUT1 least significant high byte
11/1	Contact OUT1 least significant low byte
11/2-21/1	Spare Outputs
21/2	Checksum high byte
21/3	Checksum low byte

TPU2000/2000R Modbus/Modbus Plus Automation Guide

4.6 Transmit Programmable Output AND/OR Select (3 4 6)

Bit = 0, Selected inputs are ORed together.

Bit = 1, Selected inputs are ANDed together.

Index byte is the offset into the TPU's logical output structure.

<u>Bit</u>	<u>Logical Output</u>
0	not used, reserved for fixed DIFF TRIP
1	Contact OUT5
2	Contact OUT7
3	Contact OUT4
4	Contact OUT6
5	Contact OUT3
6	Contact OUT2
7	Contact OUT1
8	spare
9	spare
10	spare
11	spare
12	spare
13	spare
14	spare
15	spare

<u>Index</u>	<u>Output</u>	<u>Definition</u>
00	DIFF	Fixed Diff Trip, 87T or 87H
01	ALARM	Fixed Self Check Alarm
02	87T	Percentage Differential Trip
03	87H	High Set Inst Diff Trip
04	2HROA	2nd Harm Restraint Output Alarm
05	5HROA	5th Harm Restraint Alarm
06	AHROA	All Harm Restraint Alarm
07	TCFA	Trip Circuit Failure Alarm
08	TFA	Trip Failure Alarm
09	51P-1	Wdg 1 Phase Time OC Trip
10	51P-2	Wdg 2 Phase Time OC Trip
11	50P-1	1st Wdg 1 Phase Inst OC Trip
12	150P-1	2nd Wdg 1 Phase Inst OC Trip
13	50P-2	1st Wdg 2 Phase Inst OC Trip
14	150P-2	2nd Wdg 2 Phase Inst OC Trip
15	51N-1	Wdg 1 Neutral Time OC Trip
16	51G-2	Wdg 2 Ground Time OC Trip
17	50N-1	1st Wdg 1 Neutral Inst OC Trip
18	150N-1	2nd Wdg 1 Neutral Inst OC Trip
19	50G-2	1st Wdg 2 Ground Inst OC Trip
20	150G-2	2nd Wdg 2 Ground Inst OC Trip
21	46-1	Wdg 1 Neg Sequence Time OC Trip
22	46-2	Wdg 2 Neg Sequence Time OC Trip
23	87T-D	Percentage Differential Disabled Alarm
24	87H-D	High Set Inst Diff Disabled Alarm
25	51P-1D	Wdg 1 Phase Time OC Disabled Alarm
26	51P-2D	Wdg 2 Phase Time OC Disabled Alarm
27	51N-1D	Wdg 1 Neutral Time OC Disabled Alarm
28	51G-2D	Wdg 2 Ground Time OC Disabled Alarm
29	50P-1D	1st Wdg 1 Phase Inst OC Disabled Alarm
30	50P-2D	1st Wdg 2 Phase Inst OC Disabled Alarm
31	50N-1D	1st Wdg 1 Neutral Inst OC Disabled Alarm
32	50G-2D	1st Wdg 2 Ground Inst OC Disabled Alarm

TPU2000/2000R Modbus/Modbus Plus Automation Guide

33	150P-1D	2nd Wdg 1 Phase Inst Disabled Alarm
34	150P-2D	2nd Wdg 2 Phase Inst Disabled Alarm
35	150N-1D	2nd Wdg 1 Neutral Inst Disabled Alarm
36	150G-2D	2nd Wdg 2 Ground Inst Disabled Alarm
37	46-1D	Wdg 1 Neg Sequence Time OC Disabled Alarm
38	46-2D	Wdg 2 Neg Sequence Time OC Disabled Alarm
39	PATA	Phase A LED Alarm
40	PBTA	Phase B LED Alarm
41	PCTA	Phase C LED Alarm
42	PUA	Pickup Alarm
43	63	Sudden Pressure Input Alarm
44	THRUFA	Through Fault Alarm
45	TFCA	Through Fault Counter Alarm
46	TFKA	Through Fault KAmplitude Summation Alarm
47	TFSCA	Through Fault Cycle Summation Alarm
48	DTC	Differential Trip Counter Alarm
49	OCTC	Overcurrent Trip Counter Alarm
50	PDA	Phase Current Demand Alarm
51	NDA	Neutral Current Demand Alarm
52	PRIM	Primary Set Enabled Alarm
53	ALT1	Alt1 Set Enabled Alarm
54	ALT2	Alt2 Set Enabled Alarm
55	STCA	Settings Table Changed Alarm
56	87T*	Percentage Diff Sealed In Alarm
57	87H*	High Set Inst Diff Sealed In Alarm
58	2HROA*	2nd Harmonic Restraint Sealed In Alarm
59	5HROA*	5th Harmonic Restraint Sealed In Alarm
60	AHROA*	All Harmonic Restraint Sealed In Alarm
61	51P-1*	Wdg 1 Phase Time OC Sealed In Alarm
62	51P-2*	Wdg 2 Phase Time OC Sealed In Alarm
63	50P-1*	1st Wdg1 Phase Inst OC Sealed In Alarm
64	150P-1*	2nd Wdg1 Phase Inst OC Sealed In Alarm
65	50P-2*	1st Wdg2 Phase Inst OC Sealed In Alarm
66	150P-2*	2nd Wdg2 Phase Inst OC Sealed In Alarm
67	51N-1*	Wdg1 Neutral Time OC Sealed In Alarm
68	51G-2*	Wdg2 Ground Time OC Sealed In Alarm
69	50N-1*	1st Wdg1 Neutral Inst OC Sealed In Alarm
70	150N-1*	2nd Wdg1 Neutral Inst OC Sealed In Alarm
71	50G-2*	1st Wdg2 Ground Inst OC Sealed In Alarm
72	150G-2*	2nd Wdg2 Ground Inst OC Sealed In Alarm
73	46-1*	Wdg1 Neg Sequence Time OC Sealed In Alarm
74	46-2*	Wdg2 Neg Sequence Time OC Sealed In Alarm
75	63*	Sudden Pressure Input Sealed In Alarm
76	ULO1	User Logical Output 1
77	ULO2	User Logical Output 2
78	ULO3	User Logical Output 3
79	ULO4	User Logical Output 4
80	ULO5	User Logical Output 5
81	ULO6	User Logical Output 6
82	ULO7	User Logical Output 7
83	ULO8	User Logical Output 8
84	ULO9	User Logical Output 9
85	LOADA	Load Current
86	OCA-1	Overcurrent Alarm, Winding 1
87	OCA-2	Overcurrent Alarm, Winding 2
88	HLDA-1	High Level Detection Alarm, Winding 1
89	LLDA-1	Low Level Detection Alarm, Winding 1
90	HLDA-2	High Level Detection Alarm, Winding 2
91	LLDA-2	Low Level Detection Alarm, Winding 2

TPU2000/2000R Modbus/Modbus Plus Automation Guide

92	HPFA	High Power Factor Alarm
93	LPFA	Low Power Factor Alarm
94	VarDA	Three Phase kVar Demand Alarm
95	PVArA	Positive 3 Phase kiloVAr Alarm
96	NVArA	Negative 3 Phase kiloVAr Alarm
97	PWatt1	Positive Watt Alarm 1
98	PWatt2	Positive Watt Alarm 2

<u>Msg byte</u>	<u>Definition</u>
1/1	Relay Status (see command 3 4 1, msg 1/1)
1/2	Command + Subcommand = 0x46
1/3	Total Number of Messages = 14
2/1	spare (bits 24-31)
2/2	spare (bits 16-23)
2/3	Programmable output AND/OR selection bits 8-15
3/1	Programmable output AND/OR selection bits 0-7
3/2	OUTPUT1 index byte
3/3	OUTPUT2 index byte
4/1	OUTPUT3 index byte
4/2	OUTPUT4 index byte
4/3	OUTPUT5 index byte
5/1	OUTPUT6 index byte
5/2	OUTPUT7 index byte
5/3	OUTPUT8 index byte
6/1	OUTPUT9 index byte
6/2	OUTPUT10 index byte
6/3	OUTPUT11 index byte
7/1	OUTPUT12 index byte
7/2	OUTPUT13 index byte
7/3	OUTPUT14 index byte
8/1	OUTPUT15 index byte
8/2	OUTPUT16 index byte
8/3	OUTPUT17 index byte
9/1	OUTPUT18 index byte
9/2	OUTPUT19 index byte
9/3	OUTPUT20 index byte
10/1	OUTPUT21 index byte
10/2	OUTPUT22 index byte
10/3	OUTPUT23 index byte
11/1	OUTPUT24 index byte
11/2	OUTPUT25 index byte
11/3	OUTPUT26 index byte
12/1	OUTPUT27 index byte
12/2	OUTPUT28 index byte
12/3	OUTPUT29 index byte
13/1	OUTPUT30 index byte
13/2	OUTPUT31 index byte
13/3	spare
14/1	spare
14/2	Checksum high byte
14/3	Checksum low byte

4.7 Transmit Programmable Output User Defined Strings (3 4 7)

User definable 8 char output strings. Byte 9 is an implied NULL

<u>Msg byte</u>	<u>Definition</u>
1/1	Relay Status (see command 3 4 1, msg 1/1)
1/2	Command + Subcommand = 0x47

1/3	Total Number of Messages = 39
2/1-4/2	OUT1 Character String 8 bytes
4/3-7/1	OUT2 Character String 8 bytes
7/2-9/3	OUT3 Character String 8 bytes
10/1-12/2	OUT4 Character String 8 bytes
12/3-15/1	OUT5 Character String 8 bytes
15/2-17/3	OUT6 Character String 8 bytes
18/1-20/2	OUT7 Character String 8 bytes
20/3-23/1	spare Character String 8 bytes
23/2-25/3	spare Character String 8 bytes
26/1-28/2	spare Character String 8 bytes
28/3-31/1	spare Character String 8 bytes
31/2-33/3	spare Character String 8 bytes
34/1-36/2	spare Character String 8 bytes
36/3-39/1	spare Character String 8 bytes
39/2	Checksum high byte
39/3	Checksum low byte

4.8,9,10 Transmit Relay Settings (3 4 X)

- (3 4 8) = Primary Settings
- (3 4 9) = Alternate 1 Settings
- (3 4 10) = Alternate 2 Settings

Low byte consists of bits 0 through 7.
High byte consists of bits 8 through 15.

Curve Selection Type I

- 0 = Extremely Inverse
- 1 = Very Inverse
- 2 = Inverse
- 3 = Short Time Inverse
- 4 = Definite Time
- 5 = Long Time Extremely Inverse
- 6 = Long Time Very Inverse
- 7 = Long Time Inverse
- 8 = Recloser Curve
- 9 = Disabled
- 10 = User Curve 1
- 11 = User Curve 2
- 12 = User Curve 3

Curve Selection Type II

- 0 = Disabled
- 1 = Standard
- 2 = Inverse
- 3 = Definite Time
- 4 = Short Time Inverse
- 5 = Short Time Extremely Inverse
- 6 = User Curve 1
- 7 = User Curve 2
- 8 = User Curve 3

Curve Selection Type 87T

- 0 = Disabled
- 1 = Percent Slope
- 2 = HU 30%
- 3 = HU 35%
- 4 = Percent 15 Tap

TPU2000/2000R Modbus/Modbus Plus Automation Guide

- 5 = Percent 25 Tap
- 6 = Percent 40 Tap
- 7 = User Curve 1
- 8 = User Curve 2
- 9 = User Curve 3

Mode Selection Type 87T

- 0 = Disabled
- 1 = 2nd Harmonics
- 2 = 2nd & 5th Harmonics
- 3 = All Harmonics

<u>Msg byte</u>	<u>Definition</u>
1/1	Relay Status (see command 3 4 1, msg 1/1)
1/2	Command + Subcommand = (Prim=0x48, Alt1=0x49, Alt2=0x4a)
1/3	Total Number of Messages = 25
2/1	87T Curve byte (Type 87T)
2/2	87T Minimum I Operate (0.2-1.0 *10)
2/3	87T Percent Restraint (15-60)
3/1	87T Restraint Mode (Mode Selection Type 87T)
3/2	87T 2nd Harmonic Restraint high byte(7.5-25 *10)
3/3	87T 2nd Harmonic Restraint low byte
4/1	87T 5th Harmonic Restraint high byte (15-40 *10)
4/2	87T 5th Harmonic Restraint low byte
4/3	87T All Harmonics Restraint high byte (15-40 *10)
5/1	87T All Harmonics Restraint low byte
5/2	87H Tap X byte (6-20 *10)
5/3	87T-1 Tap Amp (2-9 Amp *10, 0.4-1.8 Amp *50)
6/1	51P-1 Curve Select byte (Type I)
6/2	51P-1 Pickup Amp/OA (1-12 Amp *10, 0.2-2.4Amp *50)
6/3	51P-1 Timedial/delay (dial 1-10 *20, delay 0-10 *20)
7/1	50P-1 Curve Select byte (Type II)
7/2	50P-1 Pickup X byte (0.5-20.0, *10)
7/3	50P-1 Timedial/delay high byte (dial *10,delay *100)
8/1	50P-1 Timedial/delay low (dial 1-10, delay 0-9.99)
8/2	150P-1 Curve Select byte (Type II)
8/3	150P-1 Pickup X (0.5-20, *10)
9/1	150P-1 Timedial high byte (0-9.99, *100)
9/2	150P-1 Timedial low byte
9/3	46-1 Curve Select byte (Type I)
10/1	46-1 Pickup Amp byte (1-12 Amp *10, 0.2-2.4Amp *50)
10/2	46-1 Timedial/delay (dial 1-10 *20, delay 0-10 *20)
10/3	51N-1 Curve Select byte (Type I)
11/1	51N-1 Pickup Amp byte (1-12 Amp *10, 0.2-2.4Amp *50)
11/2	51N-1 Timedial/delay (dial 1-10 *20, delay 0-10 *20)
11/3	50N-1 Curve Select byte (Type II)
12/1	50N-1 Pickup X byte (0.5-20, *10)
12/2	50N-1 Timedial/delay high byte (dial *10,delay *100)
12/3	50N-1 Timedial/delay low (dial 1-10, delay 0-9.99)
13/1	150N-1 Curve Select byte (Type II)
13/2	150N-1 Pickup X byte (0.5-20, *10)
13/3	150N-1 Time Delay high byte (0-9.99, *100)
14/1	150N-1 Time Delay low byte
14/2	87T-2 Tap Amp byte (2-9 Amp *10, 0.4-1.8 Amp *50)
14/3	51P-2 Curve Select byte (Type I)
15/1	51P-2 Pickup Amp/OA (1-12 Amp *10, 0.2-2.4Amp *50)
15/2	51P-2 Timedial/delay (dial 1-10 *20, delay 0-10 *20)
15/3	50P-2 Curve Select byte (Type II)
16/1	50P-2 Pickup X byte (0.5-20, *10)

16/2	50P-2 Timedial/delay high byte (dial *10,delay *100)
16/3	50P-2 Timedial/delay low (dial 1-10, delay 0-9.99)
17/1	150P-2 Curve Select byte (Type II)
17/2	150P-2 Pickup X byte (0.5-20, *10)
17/3	150P-2 Time Delay high byte (0-9.99, *100)
18/1	150P-2 Time Delay low byte
18/2	46-2 Curve Select byte (Type I)
18/3	46-2 Pickup Amp byte (1-12 Amp *10, 0.2-2.4Amp *50)
19/1	46-2 Timedial/delay (dial 1-10 *20, delay 0-10 *20)
19/2	51G-2 Curve Select byte (Type I)
19/3	51G-2 Pickup Amp byte (1-12 Amp *10, 0.2-2.4Amp *50)
20/1	51G-2 Timedial/delay (dial 1-10 *20, delay 0-10 *20)
20/2	50G-2 Curve Select byte (Type II)
20/3	50G-2 PickupX (0.5-20, *10)
21/1	50G-2 Timedial/delay high byte (dial *10,delay *100)
21/2	50G-2 Timedial/delay low (dial 1-10, delay 0-9.99)
21/3	150G-2 Curve Select byte (Type II)
22/1	150G-2 Pickup X byte (0.5-20, *10)
22/2	150G-2 Time Delay high byte (0-9.99, *100)
22/3	150G-2 Time Delay low byte
23/1	Disturb-2 Pickup X byte (0.5-5, *10)
23/2	Level Detector-1 PickupX (0.5-20, *10, 201=Disable)
23/3	Level Detector-2 PickupX (0.5-20, *10, 201=Disable)
24/1	spare
24/2	spare
24/3	spare
25/1	Unit Configuration byte bit 0 : neutral tap range Wdg1 (0=1-12A, 1=0.2-2.4A) bit 1 : phase tap range Wdg1 (0=1-12A, 1=0.2-2.4A) bit 2 : neutral tap range Wdg2 (0=1-12A, 1=0.2-2.4A) bit 3 : phase tap range Wdg2 (0=1-12A, 1=0.2-2.4A) bit 4 : user definable curves bit 5 : Reserved for frequency bit 6 : neutral tap range Wdg3 (0=1-12A, 1=0.2-2.4A) bit 7 : phase tap range Wdg3 (0=1-12A, 1=0.2-2.4A)
25/2	Checksum high byte
25/3	Checksum low byte

4.11 Transmit Configuration Settings (3 4 11)

Low byte consists of bits 0 through 7.
High byte consists of bits 8 through 15.

Mode Selection Type Trip Failure

- 0 = Differential Trip
- 1 = OC Alarm
- 2 = Differential and OC Alarm

Mode Selection Type Demand Time Constant

- 0 = 5
- 1 = 15
- 2 = 30
- 3 = 60

Msg byte

Definition

- 1/1 Relay Status (see command 3 4 1, msg 1/1)
- 1/2 Command + Subcommand = 0x4b
- 1/3 Total Number of Messages = 21
- 2/1 Wdg1 P CT Ratio high byte (1-4000)

TPU2000/2000R Modbus/Modbus Plus Automation Guide

2/2	Wdg1 P CT Ratio low byte
2/3	Wdg1 N CT Ratio high byte (1-4000)
3/1	Wdg1 N CT Ratio low byte
3/2	Wdg2 P CT Ratio high byte (1-4000)
3/3	Wdg2 P CT Ratio low byte
4/1	Wdg2 G CT Ratio high byte (1-4000)
4/2	Wdg2 G CT Ratio low byte
4/3	Winding Phase Comp high byte (0-330, /30)
5/1	Winding Phase Comp low byte
5/2	Wind 1 CT Config high byte (0=Wye; 1=Delta, IA-IC; 2=Delta, IA-IB)
5/3	Wind 1 CT Config low byte
6/1	Wind 2 CT Config high byte (0=Wye; 1=Delta, IA-IC; 2=Delta, IA-IB)
6/2	Wind 2 CT Config low byte
6/3	Phase Rotation high byte (0=ABC, 1=ACB)
7/1	Phase Rotation low byte
7/2	Alt 1 Settings high byte (0=Disable, 1=Enable)
7/3	Alt 1 Settings low byte
8/1	Alt 2 Settings high byte (0=Disable, 1=Enable)
8/2	Alt 2 Settings low byte
8/3	Trip Failure Mode high byte (Type Trip Failure)
9/1	Trip Failure Mode low byte
9/2	Trip Failure Time high byte (5-60)
9/3	Trip Failure Time low byte
10/1	Trip Fail Dropout % PU high byte (5-90)
10/2	Trip Fail Dropout % PU low byte
10/3	Configuration Flag high byte bit 8 : Cross Block Mode (0=Disable, 1=Enable) bit 9 : SPARE bit 10 : SPARE bit 11 : SPARE bit 12 : SPARE bit 13 : SPARE bit 14 : SPARE bit 15 : SPARE
11/1	Configuration Flag low byte bit 0 : OC Protect Mode (0=Fund, 1=RMS) bit 1 : Reset Mode (0=Instant 1=Delayed) bit 2 : Spare bit 3 : Target Display Mode (0=Last, 1=All) bit 4 : Local Edit (0=Disable, 1=Enable) bit 5 : Remote Edit (0=Disable, 1=Enable) bit 6 : WHr/VARHr Meter Mode (0=KWHr, 1=MWHr) bit 7 : LCD Light (0=Timer, 1=On)
11/2-16/1	Unit Name character 1-15
16/2	Transformer Configuration Byte (0=Wye1-Wye2, 1=Wye1-Delta2, 2=Delta1-Wye2, 3=Delta1-Delta2)
16/3	Demand Time Const high byte (Type Demand Time)
17/1	Demand Time Const low byte
17/2	LCD Contrast Adj high byte (0-63)
17/3	LCD Contrast Adj low byte
18/1	Relay Password character 1
18/2	Relay Password character 2
18/3	Relay Password character 3
19/1	Relay Password character 4
19/2	Meter Winding Mode (0=Wdg1, 1=Wdg2, 2=Wdg3)
19/3	VT Configuration (0=69VWye, 1=120VWye, 2=120V Delta, 3=208V Delta)
20/1	VT Ratio high byte (1-4500)
20/2	VT Ratio low byte
20/3	Spare

21/1	Spare
21/2	Checksum high byte
21/3	Checksum low byte

4.12 Transmit Counter Settings (3 4 12)

Low byte consists of bits 0 through 7.
High byte consists of bits 8 through 15.

<u>Msg byte</u>	<u>Definition</u>
1/1	Relay Status (see command 3 4 1, msg 1/1)
1/2	Command + Subcommand = 0x4c
1/3	Total Number of Messages = 7
2/1	Through Faults high byte (0-9999)
2/2	Through Faults low byte
2/3	Through Fault Sum kAmp A high byte (0-9999)
3/1	Through Fault Sum kAmp A low byte
3/2	Through Fault kAmp B high byte (0-9999)
3/3	Through Fault kAmp B low byte
4/1	Through Fault kAmp C high byte (0-9999)
4/2	Through Fault kAmp C low byte
4/3	Thr Fault Sum Cyc high byte (0-99990)
5/1	Thr Fault Sum Cyc low byte
5/2	Overcurrent Trips high byte (0-9999)
5/3	Overcurrent Trips low byte
6/1	Differential Trips high byte (0-9999)
6/2	Differential Trips low byte
6/3	Spare
7/1	Spare
7/2	Checksum high byte
7/3	Checksum low byte

4.13 Transmit Alarm Settings (3 4 13)

Low byte consists of bits 0 through 7.
High byte consists of bits 8 through 15.

<u>Msg byte</u>	<u>Definition</u>
1/1	Relay Status (see command 3 4 1, msg 1/1)
1/2	Command + Subcommand = 0x4d
1/3	Total Number of Messages = 17
2/1	Through Faults high byte (0-9999)
2/2	Through Faults low byte
2/3	Through Fault Sum kAmp high byte (0-9999)
3/1	Through Fault Sum kAmp low byte
3/2	Through Fault Sum Cyc high byte (0-99990)
3/3	Through Fault Sum Cyc low byte
4/1	Overcurrent Trips high byte (0-9999)
4/2	Overcurrent Trips low byte
4/3	Differential Trips high byte (0-9999)
5/1	Differential Trips low byte
5/2	Phase Demand high byte (1-9999)
5/3	Phase Demand low byte
6/1	Neutral Demand high byte (1-9999)
6/2	Neutral Demand low byte
6/3	Load Current Alarm high byte (1 to 9999)
7/1	Load Current Alarm low byte
7/2	Phase Demand Alarm high byte (1-9999,10000=Disables)
7/3	Phase Demand Alarm low byte

TPU2000/2000R Modbus/Modbus Plus Automation Guide

8/1	Low PF Alarm high byte(0.5-1.0 *100, 101=Disables)
8/2	Low PF Alarm low byte
8/3	High PF Alarm high byte(0.5-1.0 *100, 101=Disables)
9/1	High Pf Alarm low byte
9/2	Positive kVAR Alarm high byte (10-99990 / 10,10000=Disable)
9/3	Positive kVAR Alarm low byte
10/1	Negative kVAR Alarm high byte (10-99990 /10,10000=Disable)
10/2	Negative kVAR Alarm high byte
10/3	Pos Watt Alarm 1 high byte (1-9999, 10000=Disable)
11/1	Pos Watt Alarm 1 low byte
11/2	Pos Watt Alarm 2 high byte (1-9999, 10000=Disable)
11/3	Pos Watt Alarm 2 low byte
12/1	Spare
12/2	Spare
12/3	Spare
13/1	Spare
13/2	Spare
13/3	Spare
14/1	Spare
14/2	Spare
14/3	Spare
15/1	Spare
15/2	Spare
15/3	Spare
16/1	Spare
16/2	Spare
16/3	Spare
17/1	Spare
17/2	Checksum high byte
17/3	Checksum low byte

4.14 Transmit Real Time Clock (3 4 14)

<u>Msg byte</u>	<u>Definition</u>
1/1	Relay Status (see command 3 4 1, msg 1/1)
1/2	Command + Subcommand = 0x4e
1/3	Total Number of Messages = 4
2/1	Hours byte (0-23)
2/2	Minutes byte (0-59)
2/3	Seconds byte (0-59)
3/1	Day byte (0-31), (0=Shutdown Clock)
3/2	Month byte (1-12)
3/3	Year byte (0-99)
4/1	Spare
4/2	Checksum high byte
4/3	Checksum low byte

4.15 Transmit Programmable Output Delays (3 4 15)

<u>Msg Byte</u>	<u>Definition</u>
1/1	Relay Status (see command 3 4 1, msg 1/1)
1/2	Command + Subcommand = 0x4f
1/3	Total Number of Messages = 8
2/1	OUT 5 delay high byte (0.00-60, *100)
2/2	OUT 5 delay low byte
2/3	OUT 7 delay high byte (0.00-60, *100)
3/1	OUT 7 delay low byte
3/2	OUT 4 delay high byte (0.00-60, *100)
3/3	OUT 4 delay low byte

4/1	OUT 6 delay high byte (0.00-60, *100)
4/2	OUT 6 delay low byte
4/3	OUT 3 delay high byte (0.00-60, *100)
5/1	OUT 3 delay low byte
5/2	OUT 2 delay high byte (0.00-60, *100)
5/3	OUT 2 delay low byte
6/1	OUT 1 delay high byte (0.00-60, *100)
6/2	OUT 1 delay low byte
6/3	Spare
7/1	Spare
7/2	Spare
7/3	Spare
8/1	Spare
8/2	Checksum high byte
8/3	Checksum low byte

5 Transmit Buffer "N" Commands (3 5 n)

When n=0 then the previous Receive Number command would define the number "N". Otherwise this command would take the number "N" defined by the subcmd field (1 - 15).

<u>N</u>	<u>Definition</u>
0	Reserved for repeat 3 5 n
1	Show Wdg 1 & 2 Load Metered Data
2	Show Demand Currents Data
3	Show Max Demand Currents Data
4	Show Min Demand Currents Data
5	Show Magnitudes Load Meter Data
6	Show Average Load Current
7	Show Wdg 1 & 2 Differential Meter Data
8	Send First Fault Record
9	Send Next Fault Record
10	Not used
11	Not used
12	Send First Operation Record
13	Send Next Operation Record
14	Breaker Status (including contact inputs)
15	Power Fail Data

5.1 Show Wdg 1 & 2 Load Metered Data (3 5 1)

<u>Msg byte</u>	<u>Definition</u>
1/1	Relay Status (see command 3 4 1, msg 1/1)
1/2	Command + Subcommand = 0x51
1/3	Total Number of Messages = 29
2/1	Aux. Status byte (Meter Mode) Bits 0 & 1 : 0=Winding1; 1=Winding2; 2=Winding3 Bit 2 : 0 = Wye PTs; 1 = Delta PTs Bit 3 : 0 = kWhr; 1 = MWhr
2/2	IA-1 Hi byte (Load Currents)
2/3	IA-1 Mid byte
3/1	IA-1 Lo byte
3/2	IA-1 Angle Hi byte
3/3	IA-1 Angle Lo byte
4/1	IB-1 Hi byte
4/2	IB-1 Mid byte
4/3	IB-1 Lo byte
5/1	IB-1 Angle Hi byte
5/2	IB-1 Angle Lo byte

TPU2000/2000R Modbus/Modbus Plus Automation Guide

5/3	IC-1 Hi byte
6/1	IC-1 Mid byte
6/2	IC-1 Lo byte
6/3	IC-1 Angle Hi byte
7/1	IC-1 Angle Lo byte
7/2	IN-1 Hi byte
7/3	IN-1 Mid byte
8/1	IN-1 Lo byte
8/2	IN-1 Angle Hi byte
8/3	IN-1 Angle Lo byte
9/1	I0-1 (Mag) Hi byte
9/2	I0-1 (Mag) Mid byte
9/3	I0-1 (Mag) Lo byte
10/1	I0-1 Angle Hi byte
10/2	I0-1 Angle Lo byte
10/3	I1-1 (Mag) Hi byte
11/1	I1-1 (Mag) Mid byte
11/2	I1-1 (Mag) Lo byte
11/3	I1-1 Angle Hi byte
12/1	I1-1 Angle Lo byte
12/2	I2-1 (Mag) Hi byte
12/3	I2-1 (Mag) Mid byte
13/1	I2-1 (Mag) Lo byte
13/2	I2-1 Angle Hi byte
13/3	I2-1 Angle Lo byte
14/1	IA-2 Hi byte
14/2	IA-2 Mid byte
14/3	IA-2 Lo byte
15/1	IA-2 Angle Hi byte
15/2	IA-2 Angle Hi byte
15/3	IB-2 Hi byte
16/1	IB-2 Mid byte
16/2	IB-2 Lo byte
16/3	IB-2 Angle Hi byte
17/1	IB-2 Angle Lo byte
17/2	IC-2 Hi byte
17/3	IC-2 Mid byte
18/1	IC-2 Lo byte
18/2	IC-2 Angle Hi byte
18/3	IC-2 Angle Lo byte
19/1	IG-2 Hi byte
19/2	IG-2 Mid byte
19/3	IG-2 Lo byte
20/1	IG-2 Angle Hi byte
20/2	IG-2 Angle Lo byte
20/3	I0-2 (Mag) Hi byte
21/1	I0-2 (Mag) Mid byte
21/2	I0-2 (Mag) Lo byte
21/3	I0-2 Angle Hi byte
22/1	I0-2 Angle Lo byte
22/2	I1-2 (Mag) Hi byte
22/3	I1-2 (Mag) Mid byte
23/1	I1-2 (Mag) Lo byte
23/2	I1-2 Angle Hi byte
23/3	I1-2 Angle Lo byte
24/1	I2-2 (Mag) Hi byte
24/2	I2-2 (Mag) Mid byte
24/3	I2-2 (Mag) Lo byte
25/1	I2-2 Angle Hi byte

25/2	I2-2 Angle Lo byte
25/3	Spare
26/1-29/3	Reserved for Tap Changer Position

5.2 Show Demand Currents Data (3 5 2)

<u>Msg byte</u>	<u>Definition</u>
1/1	Relay Status (see command 3 4 1, msg 1/1)
1/2	Command + Subcommand = 0x52
1/3	Total Number of Messages = 6
2/1	Aux. Status byte (see command 3 5 1, msg 2/1)
2/2	Demand Ia Hi byte (Load Currents)
2/3	Demand Ia Mid byte
3/1	Demand Ia Lo byte
3/2	Demand Ib Hi byte
3/3	Demand Ib Mid byte
4/1	Demand Ib Lo byte
4/2	Demand Ic Hi byte
4/3	Demand Ic Mid byte
5/1	Demand Ic Lo byte
5/2	Demand In/Ig Hi byte
5/3	Demand In/Ig Mid byte
6/1	Demand In/Ig Lo byte
6/2	Spare
6/3	Spare

5.3 Show Maximum Demand Currents Data (3 5 3)

<u>Msg byte</u>	<u>Definition</u>
1/1	Relay Status (see command 3 4 1, msg 1/1)
1/2	Command + Subcommand = 0x53
1/3	Total Number of Messages = 12
2/1	Aux. Status byte (see command 3 5 1, msg 2/1)
2/2	Max Dem Ia Hi byte (Load Currents)
2/3	Max Dem Ia Mid byte
3/1	Max Dem Ia Lo byte
3/2	Max Dem Ia time yy
3/3	Max Dem Ia time mn
4/1	Max Dem Ia time dd
4/2	Max Dem Ia time hh
4/3	Max Dem Ia time mm
5/1	Max Dem Ib Hi byte
5/2	Max Dem Ib Mid byte
5/3	Max Dem Ib Lo byte
6/1	Max Dem Ib time yy
6/2	Max Dem Ib time mn
6/3	Max Dem Ib time dd
7/1	Max Dem Ib time hh
7/2	Max Dem Ib time mm
7/3	Max Dem Ic Hi byte
8/1	Max Dem Ic Mid byte
8/2	Max Dem Ic Lo byte
8/3	Max Dem Ic time yy
9/1	Max Dem Ic time mn
9/2	Max Dem Ic time dd
9/3	Max Dem Ic time hh
10/1	Max Dem Ic time mm
10/2	Max Dem In/Ig Hi byte
10/3	Max Dem In/Ig Mid byte

TPU2000/2000R Modbus/Modbus Plus Automation Guide

11/1	Max Dem In/Ig Lo byte
11/2	Max Dem In/Ig time yy
11/3	Max Dem In/Ig time mn
12/1	Max Dem In/Ig time dd
12/2	Max Dem In/Ig time hh
12/3	Max Dem In/Ig time mm

5.4 Show Minimum Demand Currents Data (3 5 4)

<u>Msg byte</u>	<u>Definition</u>
1/1	Relay Status (see command 3 4 1, msg 1/1)
1/2	Command + Subcommand = 0x53
1/3	Total Number of Messages = 12
2/1	Aux. Status byte (see command 3 5 1, msg 2/1)
2/2	Min Dem Ia Hi byte (Load Currents)
2/3	Min Dem Ia Mid byte
3/1	Min Dem Ia Lo byte
3/2	Min Dem Ia time yy
3/3	Min Dem Ia time mn
4/1	Min Dem Ia time dd
4/2	Min Dem Ia time hh
4/3	Min Dem Ia time mm
5/1	Min Dem Ib Hi byte
5/2	Min Dem Ib Mid byte
5/3	Min Dem Ib Lo byte
6/1	Min Dem Ib time yy
6/2	Min Dem Ib time mn
6/3	Min Dem Ib time dd
7/1	Min Dem Ib time hh
7/2	Min Dem Ib time mm
7/3	Min Dem Ic Hi byte
8/1	Min Dem Ic Mid byte
8/2	Min Dem Ic Lo byte
8/3	Min Dem Ic time yy
9/1	Min Dem Ic time mn
9/2	Min Dem Ic time dd
9/3	Min Dem Ic time hh
10/1	Min Dem Ic time mm
10/2	Min Dem In/Ig Hi byte
10/3	Min Dem In/Ig Mid byte
11/1	Min Dem In/Ig Lo byte
11/2	Min Dem In/Ig time yy
11/3	Min Dem In/Ig time mn
12/1	Min Dem In/Ig time dd
12/2	Min Dem In/Ig time hh
12/3	Min Dem In/Ig time mm

5.5 Show Magnitudes Load Metered Data (3 5 5)

<u>Msg byte</u>	<u>Definition</u>
1/1	Relay Status (see command 3 4 1, msg 1/1)
1/2	Command + Subcommand = 0x55
1/3	Total Number of Messages = 6
2/1	Aux. Status byte (see command 3 5 1, msg 2/1)
2/2	Ia high byte (Load Currents)
2/3	Ia (mid byte)
3/1	Ia (low byte)
3/2	Ib (high byte)
3/3	Ib (mid byte)

4/1	Ib (low byte)
4/2	Ic (high byte)
4/3	Ic (mid byte)
5/1	Ic (low byte)
5/2	In/Ig (high byte)
5/3	In/Ig (mid byte)
6/1	In/Ig (low byte)
6/2	Spare
6/3	Spare

5.6 Show Average Load Current (3 5 6)

<u>Msg byte</u>	<u>Definition</u>
1/1	Relay Status (see command 3 4 1, msg 1/1)
1/2	Command + Subcommand = 0x56
1/3	Total Number of Messages = 3
2/1	Aux. Status byte (see command 3 5 1, msg 2/1)
2/2	Iavg (high byte)
2/3	Iavg (mid byte)
3/1	Iavg (low byte)
3/2	Spare
3/3	Spare

5.7 Show Wdg 1 & 2 Differential Metering (3 5 7)

<u>Msg byte</u>	<u>Definition</u>
1/1	Relay Status (see command 3 4 1, msg 1/1)
1/2	Command + Subcommand = 0x57
1/3	Total Number of Messages = 18
2/1	Aux. Status (see command 3 5 1, msg 2/1)
2/2	Iop A high byte (*800)
2/3	Iop A low byte
3/1	Iop B high byte (*800)
3/2	Iop B low byte
3/3	Iop C high byte (*800)
4/1	Iop C low byte
4/2	IresA-1 high byte (*800)
4/3	IresA-1 low byte
5/1	IresA-1 Angle high byte
5/2	IresA-1 Angle low byte
5/3	IresB-1 high byte (*800)
6/1	IresB-1 low byte
6/2	IresB-1 Angle high byte
6/3	IresB-1 Angle low byte
7/1	IresC-1 high byte (*800)
7/2	IresC-1 low byte
7/3	IresC-1 Angle high byte
8/1	IresC-1 Angle low byte
8/2	IresA-2 high byte (*800)
8/3	IresA-2 low byte
9/1	IresA-2 Angle high byte
9/2	IresA-2 Angle low byte
9/3	IresB-2 high byte (*800)
10/1	IresB-2 low byte
10/2	IresB-2 Angle high byte
10/3	IresB-2 Angle low byte
11/1	IresC-2 high byte (*800)
11/2	IresC-2 low byte
11/3	IresC-2 Angle high byte

TPU2000/2000R Modbus/Modbus Plus Automation Guide

12/1	IresC-2 Angle low byte
12/2	2nd Harmonic % A-1 byte (*2)
12/3	2nd Harmonic % B-1 byte (*2)
13/1	2nd Harmonic % C-1 byte (*2)
13/2	2nd Harmonic % A-2 byte (*2)
13/3	2nd Harmonic % B-2 byte (*2)
14/1	2nd Harmonic % C-2 byte (*2)
14/2	5th Harmonic % A-1 byte (*2)
14/3	5th Harmonic % B-1 byte (*2)
15/1	5th Harmonic % C-1 byte (*2)
15/2	5th Harmonic % A-2 byte (*2)
15/3	5th Harmonic % B-2 byte (*2)
16/1	5th Harmonic % C-2 byte (*2)
16/2	All Harmonics % A-1 byte (*2)
16/3	All Harmonics % B-1 byte (*2)
17/1	All Harmonics % C-1 byte (*2)
17/2	All Harmonics % A-2 byte (*2)
17/3	All Harmonics % B-2 byte (*2)
18/1	All Harmonics % C-2 byte (*2)
18/2	Winding 1 Tap (*10)
18/3	Winding 2 Tap (*10)

5.8 Send First Differential Fault Record (3 5 8)

The Differential Fault Record command returns data in two parts. This command requires a data byte message to indicate which part of the record is to be returned. If the data message 1/2 = 0, part 1 of the record is returned. If the data message 1/2 = 1, part 2 of the record is returned.

<u>Fault Type</u>	<u>Definitions</u>
00	87T
01	87H
02	51P-1
03	51N-1
04	50P-1
05	50N-1
06	150P-1
07	150N-1
08	46-1
09	51P-2
10	51G-2
11	50P-2
12	50G-2
13	150P-2
14	150G-2
15	46-2
16	ECI-1
17	ECI-2
18	Thru Flt
19	Harm Rest

Data byte

1/1	0 = Reserved for Unreported Records
1/2	0 = Send part 1 of Record, 1 = Send part 2 of Record
1/3	Checksum 1/1 + 1/2

Msg byte

Definition-Part 1 of Record

1/1	Relay Status (see command 3 4 1, msg 1/1)
1/2	Command + Subcommand = 0x58
1/3	Total Number of Messages = 28

2/1	Param Flag high byte
2/2	Param Flag low byte
2/3	Fault Type (element)
3/1	Setting
3/2	Fault Number (high byte)
3/3	Fault Number (low byte)
4/1	Year
4/2	Month
4/3	Day
5/1	Hours
5/2	Minutes
5/3	Seconds
6/1	Hundredths of seconds
6/2	Clear Time Hi byte (*1000)
6/3	Clear Time Lo byte
7/1	Winding1 Tap Hi byte (*10)
7/2	Winding1 Tap Lo byte
7/3	Winding2 Tap Hi byte (*10)
8/1	Winding2 Tap Lo byte
8/2	I operate A Hi byte (*800)
8/3	I operate A Lo byte
9/1	I operate B Hi byte (*800)
9/2	I operate B Lo byte
9/3	I operate C Hi byte (*800)
10/1	I operate C Lo byte
10/2	I restraint A-1 Hi byte (*800)
10/3	I restraint A-1 Lo byte
11/1	I restraint B-1 Hi byte (*800)
11/2	I restraint B-1 Lo byte
11/3	I restraint C-1 Hi byte (*800)
12/1	I restraint C-1 Lo byte
12/2	I restraint A-2 Hi byte (*800)
12/3	I restraint A-2 Lo byte
13/1	I restraint B-2 Hi byte (*800)
13/2	I restraint B-2 Lo byte
13/3	I restraint C-2 Hi byte (*800)
14/1	I restraint C-2 Lo byte
14/2	2nd Harmonic A-1 (*2)
14/3	5th Harmonic A-1 (*2)
15/1	All Harmonics A-1 (*2)
15/2	2nd Harmonic B-1 (*2)
15/3	5th Harmonic B-1 (*2)
16/1	All Harmonics B-1 (*2)
16/2	2nd Harmonic C-1 (*2)
16/3	5th Harmonic C-1 (*2)
17/1	All Harmonics C-1 (*2)
17/2	2nd Harmonic A-2 (*2)
17/3	5th Harmonic A-2 (*2)
18/1	All Harmonics A-2 (*2)
18/2	2nd Harmonic B-2 (*2)
18/3	5th Harmonic B-2 (*2)
19/1	All Harmonic B-2 (*2)
19/2	2nd Harmonic C-2 (*2)
19/3	5th Harmonic C-2 (*2)
20/1	All Harmonic C-2 (*2)
20/2	I restraint A-1 (Ang) Hi byte
20/3	I restraint A-1 (Ang) Lo byte
21/1	I restraint B-1 (Ang) Hi byte
21/2	I restraint B-1 (Ang) Lo byte

TPU2000/2000R Modbus/Modbus Plus Automation Guide

21/3	I restraint C-1 (Ang) Hi byte
22/1	I restraint C-1 (Ang) Lo byte
22/2	I restraint A-2 (Ang) Hi byte
22/3	I restraint A-2 (Ang) Lo byte
23/1	I restraint B-2 (Ang) Hi byte
23/2	I restraint B-2 (Ang) Lo byte
23/3	I restraint C-2 (Ang) Hi byte
24/1	I restraint C-2 (Ang) Lo byte
24/2	Spare
24/3	Spare
25/1	Spare
25/2	Spare
25/3	Spare
26/1	Spare
26/2	Spare
26/3	Spare
27/1	Spare
27/2	Spare
27/3	Spare
28/1	Spare
28/2	Spare
28/3	Spare

Data byte

See previous

Msg byte

Definition-Part 2 of Record

1/1	Relay Status (see command 3 4 1, msg 1/1)
1/2	Command + Subcommand = 0x58
1/3	Total Number of Messages = 28
2/1	Param Flag high byte
2/2	Param Flag low byte
2/3	Fault Type (element)
3/1	Setting
3/2	Fault Number (high byte)
3/3	Fault Number (low byte)
4/1	Year
4/2	Month
4/3	Day
5/1	Hours
5/2	Minutes
5/3	Seconds
6/1	Hundredths of seconds
6/2	Clear Time Hi byte (*1000)
6/3	Clear Time Lo byte
7/1	I A-1 high byte (*800 / Phase Wdg1 Scale)
7/2	I A-1 low byte
7/3	I B-1 high byte (*800 / Phase Wdg1 Scale)
8/1	I B-1 low byte
8/2	I C-1 high byte (*800 / Phase Wdg1 Scale)
8/3	I C-1 low byte
9/1	I N-1 high byte (*800 / Neutral Wdg1 Scale)
9/2	I N-1 low byte
9/3	I A-2 high byte (*800 / Phase Wdg2 Scale)
10/1	I A-2 low byte
10/2	I B-2 high byte (*800 / Phase Wdg2 Scale)
10/3	I B-2 low byte
11/1	I C-2 high byte (*800 / Phase Wdg2 Scale)
11/2	I C-2 low byte

11/3	I G-2 high byte (*800 / Ground Wdg2 Scale)
12/1	I G-2 low byte
12/2	Spare
12/3	I A-1 (ang) high byte
13/1	I A-1 (ang) low byte
13/2	I B-1 (ang) high byte
13/3	I B-1 (ang) low byte
14/1	I C-1 (ang) high byte
14/2	I C-1 (ang) low byte
14/3	I N-1 (ang) high byte
15/1	I N-1 (ang) low byte
15/2	I A-2 (ang) high byte
15/3	I A-2 (ang) low byte
16/1	I B-2 (ang) high byte
16/2	I B-2 (ang) low byte
16/3	I C-2 (ang) high byte
17/1	I C-2 (ang) low byte
17/2	I G-2 (ang) high byte
17/3	I G-2 (ang) low byte
18/1	I 0-1 high byte (*800 / Phase Wdg1 Scale)
18/2	I 0-1 low byte
18/3	I 1-1 high byte (*800 / Phase Wdg1 Scale)
19/1	I 1-1 low byte
19/2	I 2-1 high byte (*800 / Phase Wdg1 Scale)
19/3	I 2-1 low byte
20/1	I 0-2 high byte (*800 / Phase Wdg2 Scale)
20/2	I 0-2 low byte
20/3	I 1-2 high byte (*800 / Phase Wdg2 Scale)
21/1	I 1-2 low byte
21/2	I 2-2 high byte (*800 / Phase Wdg2 Scale)
21/3	I 2-2 low byte
22/1	I 0-1 (ang) high byte
22/2	I 0-1 (ang) low byte
22/3	I 1-1 (ang) high byte
23/1	I 1-1 (ang) low byte
23/2	I 2-1 (ang) high byte
23/3	I 2-1 (ang) low byte
24/1	I 0-2 (ang) high byte
24/2	I 0-2 (ang) low byte
24/3	I 1-2 (ang) high byte
25/1	I 1-2 (ang) low byte
25/2	I 2-2 (ang) high byte
25/3	I 2-2 (ang) low byte
26/1	Scale - Phase Wdg 1 high byte
26/2	Scale - Phase Wdg 1 low byte
26/3	Scale - Phase Wdg 2 high byte
27/1	Scale - Phase Wdg 2 low byte
27/2	Scale - Neutral Wdg 1 high byte
27/3	Scale - Neutral Wdg 1 low byte
28/1	Scale - Ground Wdg 2 high byte
28/2	Scale - Ground Wdg 2 low byte
28/3	Spare

If no fault data entry is present then send all 0s for 2/1 through 27/3.

5.9 Send Next Differential Fault Record (3 5 9)

Same format as (3 5 8) except Msg 1/2 = 0x59.

5.12 Send First Operations Record (3 5 12)

<u>Message Number</u>	<u>Definitions</u>
00	87T Trip
01	87H Trip
02	51P-1 Trip
03	51N-1 Trip
04	50P-1 Trip
05	50N-1 Trip
06	150P-1 Trip
07	150N-1 Trip
08	46-1 Trip
09	51P-2 Trip
10	51G-2 Trip
11	50P-2 Trip
12	50G-2 Trip
13	150P-2 Trip
14	150G-2 Trip
15	46-2 Trip
16	ECI-1
17	ECI-2
18	Thru Flt
19	Harm Rest
31	Fault Clear Failed
32	Fault Cleared
33	Harmonic Restraint
34	Manual Trip
35	Manual Trip Failed
40	87T Enabled
41	87H Enabled
42	51P-1 Enabled
43	51P-2 Enabled
44	51N-1 Enabled
45	51G-2 Enabled
46	50P-1 Enabled
47	50P-2 Enabled
48	50N-1 Enabled
49	50G-2 Enabled
50	150P-1 Enabled
51	150P-2 Enabled
52	150N-1 Enabled
53	150G-2 Enabled
54	46-1 Enabled
55	46-2 Enabled
56	ALT1 Input Closed
57	ALT2 Input Closed
58	Event Cap1 Init
59	Event Cap2 Init
60	Wave Cap. Init
61	Trip Input Closed
62	SPR Input Closed
63	TCM Input Closed
64	Primary Set Active
65	Alt1 Set Active
66	Alt2 Set Active
70	Thru Flt Cntr Alm
71	Thru Flt kASum Alm
72	Thru Flt Cycle Alm

73	OC Trip Cntr Alarm
74	Diff Trip Cntr Alm
75	Phase Demand Alarm
76	Neutral Demand Alm
77	Load Current Alarm
78	Trip Coil Failure
79	High PF Alarm
80	Low PF Alarm
81	kVAR Demand Alarm
82	Pos. kVAR Alarm
83	Neg. kVAR Alarm
84	Pos. Watt Alarm 1
85	Pos. Watt Alarm 2
90	Event Capture #1
91	Event Capture #2
92	Waveform Capture
93	High Level Detection Alarm, Wdg 1
94	Low Level Detection Alarm, Wdg 1
95	High Level Detection Alarm, Wdg 2
96	Low Level Detection Alarm, Wdg 2
100	ROM Failure
101	RAM Failure
102	Self Test Failed
103	EEPROM Failure
104	BATRAM Failure
105	DSP Failure
106	Control Power Fail
107	Editor Access
120	87T Disabled
121	87H Disabled
122	51P-1 Disabled
123	51P-2 Disabled
124	51N-1 Disabled
125	51G-2 Disabled
126	50P-1 Disabled
127	50P-2 Disabled
128	50N-1 Disabled
129	50G-2 Disabled
130	150P-1 Disabled
131	150P-2 Disabled
132	150N-1 Disabled
133	150G-2 Disabled
134	46-1 Disabled
135	46-2 Disabled
136	ALT1 Input Opened
137	ALT2 Input Opened
138	Event Cap1 Reset
139	Event Cap2 Reset
140	Wave Cap. Reset
141	Trip Input Opened
142	SPR Input Opened
143	TCM Input Opened
162	ULI1 Input Closed
163	ULI1 Input Opened
164	ULI2 Input Closed
165	ULI2 Input Opened
166	ULI3 Input Closed
167	ULI3 Input Opened
168	ULI4 Input Closed

TPU2000/2000R Modbus/Modbus Plus Automation Guide

169	ULI4 Input Opened
170	ULI5 Input Closed
171	ULI5 Input Opened
172	ULI6 Input Closed
173	ULI6 Input Opened
174	ULI7 Input Closed
175	ULI7 Input Opened
176	ULI8 Input Closed
177	ULI8 Input Opened
178	ULI9 Input Closed
179	ULI9 Input Opened
180	CRI Input Closed
181	CRI Input Opened

<u>Msg byte</u>	<u>Definition</u>
1/1	Relay Status (see command 3 4 1, msg 1/1)
1/2	Command + Subcommand = 0x5c
1/3	Total Number of Messages = 5
2/1	Year
2/2	Month
2/3	Day
3/1	Hour
3/2	Minute
3/3	Second
4/1	Hundredths of second
4/2	Message Number
4/3	Value (if any) Hi byte
5/1	Value (if any) Lo byte
5/2	Operation Number (high byte)
5/3	Operation Number (low byte)

If the operation entry doesn't exist then send 0's in all the bytes 2/1 through 5/3.

5.13 Send Next Operations Record (3 5 13)

Same format as (3 5 12) except Msg 1/2 = 0x5d.

5.14 Breaker Status (Including I/O Status) (3 5 14)

Input status bit 0=opened, 1=closed.

Output status bit 0=de-energized, 1=energized.

<u>Msg byte</u>	<u>Definition</u>
1/1	Relay Status (see command 3 4 1, msg 1/1)
1/2	Command + Subcommand = 0x5e
1/3	Total Number of Messages = 3
2/1	Contact Input Status (high byte) Bit 0 - Input 9 Bit 1 - Spare Bit 2 - Spare Bit 3 - Spare Bit 4 - Spare Bit 5 - Spare Bit 6 - Spare Bit 7 - Spare
2/2	Contact Input Status (low byte) Bit 0 - Input 1 Bit 1 - Input 2 Bit 2 - Input 3

	Bit 3 - Input 4
	Bit 4 - Input 5
	Bit 5 - Input 6
	Bit 6 - Input 7
	Bit 7 - Input 8
2/3	Self Test Status (high byte)
	Bit 0 - DSP ROM
	Bit 1 - DSP Internal RAM
	Bit 2 - DSP External RAM
	Bit 3 - ADC Failure
	Bit 4 - DSP +/-5V
	Bit 5 - DSP +/-15V
	Bit 6 - DSP +5V
	Bit 7 - DSP Comm. Failure
3/1	Self Test Status (low byte)
	Bit 0 - CPU RAM
	Bit 1 - CPU EPROM
	Bit 2 - CPU NVRAM
	Bit 3 - CPU EEPROM
	Bit 4 -
	Bit 5 -
	Bit 6 -
	Bit 7 -
3/2	Output Contact Status (high byte)
	Bit 0 - Spare
	Bit 1 - Spare
	Bit 2 - Spare
	Bit 3 - Spare
	Bit 4 - Spare
	Bit 5 - Spare
	Bit 6 - Spare
	Bit 7 - Spare
3/3	Output Contact Status (low byte)
	Bit 0 - Trip
	Bit 1 - Output 1
	Bit 2 - Output 2
	Bit 3 - Output 3
	Bit 4 - Output 4
	Bit 5 - Output 5
	Bit 6 - Output 6
	Bit 7 - Output 7

5.15 Power Fail Data (3 5 15)

<u>Msg byte</u>	<u>Definition</u>
1/1	Relay Status (see command 3 4 1, msg 1/1)
1/2	Command + Subcommand = 0x5f
1/3	Total Number of Messages = 4
2/1	Year
2/2	Month
2/3	Day
3/1	Hour
3/2	Minute
3/3	Second
4/1	Hundredths of second
4/2	Power Fail Type
	Bit 0: DC Control
	Bit 1: +5/+15V
4/3	Breaker Status (state)

TPU2000/2000R Modbus/Modbus Plus Automation Guide

6 Load Profile Commands & Records (3 6 n)

<u>N</u>	<u>Definition</u>
0	Define Load Profile Settings
1	Start Load Profile Data Accumulation
2	Freeze Load Profile Data
3	Report Load Profile Header-All
4	Report Next Load Profile Data Block
5	Retransmit Last Load Profile Data Block
6	Report Load Profile Header-Last
7	Not in use
8	Fault Record-First
9	Fault Record-Next
10	Restraint Record-First
11	Restraint Record-Next
12	Oldest Unreported Differential Record
13	Oldest Unreported Through Fault Record
14	Oldest Unreported Harmonic Restraint Record
15	Oldest Unreported Operations Record

6.0 Load Profile Settings (3 6 0)

Reserved for user configuration.

6.1 Accumulate Load Profile Data (3 6 1)

6.2 Freeze Load Profile Data (3 6 2)

6.3 Report Load Profile Data Header(All Data) (3 6 3)

This command is used to initialize the unit to report the entire contents of the accumulated load profile.

<u>Msg byte</u>	<u>Definition</u>
1/1	Relay Status (see command 3 4 1, msg 1/1)
1/2-4/1	Report Column (1-9) Attribute Number
4/2	spare
4/3-9/3	Unit Id Name (16 chars)
10/1-11/2	Time Tag of the first Block reporting (5 bytes :yy,mn,dd,hh,mm in order)
11/3	spare
12/1-12/2	Report Column 1 Attribute Scale(high, low byte)
12/3-17/3	Report Column (2-9) Attribute Scale

<u>Attr#</u>	<u>Description</u>	<u>Dynamic Scale</u>
0	Demand Ia	1
1	Demand Ib	1
2	Demand Ic	1
3	Demand In	1

6.4 Report Next Load Profile Data Block (3 6 4)

<u>Msg byte</u>	<u>Definition</u>
1/1	Demand Interval (5/15/30/60 Mins)
1/2-1/3	Record # (a number starting from 1 to #of blocks)
2/1	Total Number Data Bytes (1 through 126)
2/2-3/3	Time Tag of the first Block (5 bytes : hh, mm, dd, mn, yy in order) NOTE: Different order from command 3 6 3 time stamp.
4/1-45/3	Data Blocks (up to 126 bytes of data)

Each data block is a two byte word that has the following bit configuration:

- bit 0-13 : data values
- bit 14 : sign bit (1=multiply bits 0-13 by -1)
- bit 15 : scale bit (0=multiply bits 0-13 by 1, 1=multiply bits 0-13 by attribute scale)

Example: Report column 1 is profiling attribute #0 (Demand kW-A) and has a dynamic scale = 122

Data word	Binary pattern	Scale	Reported value
8,000	0001111101000000	1	8,000 kW
24,384	0101111101000000	-1	-8,000 kW
16,776	0100000011000100	122	23,912 kW
49,384	1100000011000100	-122	-23,912 kW

To obtain the reported value column from the data word, a listing for a c routine should look as follows:

```

long int ConvertData( unsigned short ,unsigned short );
long int  report_value;
unsigned short intdata_word;

report_value = ConvertData( data_word ,attribute_scale);
{
    int scale=1;

    if ( data_word & 0x4000 ) /* is sign bit set ? */
    {
        scale = -1;
    }

    if ( data_word & 0x8000 ) /* is scale bit set ? */
    {
        scale *= attribute_scale;
    }

    return( (data_word & 0x3fff) * scale );
}

```

6.5 Retransmit the Last Load Profile Data Block (3 6 5)

Same as Report Next Load Profile Data Block except its the previous data sent!

6.6 Report Load Profile Data Header(Last Data) (3 6 6)

This command is used to initialize the unit to report the entire contents of the accumulated load profile.

6.8 Send First Through Fault Record (3 6 8)

<u>Msg byte</u>	<u>Definition</u>
1/1	Relay Status (see command 3 4 1, msg 1/1)
1/2	Command + Subcommand = 0x68
1/3	Total Number of Messages = 30
2/1	Param Flag (high byte)
2/2	Param Flag (low byte)
2/3	Fault Type (element) (See Send First Differential Fault Record, command 3 5 8 for Fault Type Definitions)
3/1	Setting
3/2	Fault Number (high byte)
3/3	Fault Number (low byte)
4/1	Year

TPU2000/2000R Modbus/Modbus Plus Automation Guide

4/2	Month
4/3	Day
5/1	Hours
5/2	Minutes
5/3	Seconds
6/1	Hundredths of seconds
6/2	Clear Time High byte (*1000)
6/3	Clear Time Low byte
7/1	Relay Time Most Significant Hi byte (*1000)
7/2	Relay Time Most Significant Lo byte
7/3	Relay Time Least Significant Hi byte
8/1	Relay Time Least Significant Lo byte
8/2	I A-1 Hi byte (*800 / Phase Wdg1 Scale)
8/3	I A-1 Lo byte
9/1	I B-1 Hi byte (*800 / Phase Wdg1 Scale)
9/2	I B-1 Lo byte
9/3	I C-1 Hi byte (*800 / Phase Wdg1 Scale)
10/1	I C-1 Lo byte
10/2	I N-1 Hi byte (*800 / Neutral Wdg1 Scale)
10/3	I N-1 Lo byte
11/1	I A-2 Hi byte (*800 / Phase Wdg2 Scale)
11/2	I A-2 Lo byte
11/3	I B-2 Hi byte (*800 / Phase Wdg2 Scale)
12/1	I B-2 Lo byte
12/2	I C-2 Hi byte (*800 / Phase Wdg2 Scale)
12/3	I C-2 Lo byte
13/1	I G-2 Hi byte (*800 / Ground Wdg2 Scale)
13/2	I G-2 Lo byte
13/3	Spare
14/1	I A-1 (ang) Hi byte
14/2	I A-1 (ang) Lo byte
14/3	I B-1 (ang) Hi byte
15/1	I B-1 (ang) Lo byte
15/2	I C-1 (ang) Hi byte
15/3	I C-1 (ang) Lo byte
16/1	I N-1 (ang) Hi byte
16/2	I N-1 (ang) Lo byte
16/3	I A-2 (ang) Hi byte
17/1	I A-2 (ang) Lo byte
17/2	I B-2 (ang) Hi byte
17/3	I B-2 (ang) Lo byte
18/1	I C-2 (ang) Hi byte
18/2	I C-2 (ang) Lo byte
18/3	I G-2 (ang) Hi byte
19/1	I G-2 (ang) Lo byte
19/2	I 0-1 Hi byte (*800 / Phase Wdg1 Scale)
19/3	I 0-1 Lo byte
20/1	I 1-1 Hi byte (*800 / Phase Wdg1 Scale)
20/2	I 1-1 Lo byte
20/3	I 2-1 Hi byte (*800 / Phase Wdg1 Scale)
21/1	I 2-1 Lo byte
21/2	I 0-2 Hi byte (*800 / Phase Wdg2 Scale)
21/3	I 0-2 Lo byte
22/1	I 1-2 Hi byte (*800 / Phase Wdg2 Scale)
22/2	I 1-2 Lo byte
22/3	I 2-2 Hi byte (*800 / Phase Wdg2 Scale)
23/1	I 2-2 Lo byte
23/2	I 0-1 (ang) Hi byte
23/3	I 0-1 (ang) Lo byte

24/1	I 1-1 (ang) Hi byte
24/2	I 1-1 (ang) Lo byte
24/3	I 2-1 (ang) Hi byte
25/1	I 2-1 (ang) Lo byte
25/2	I 0-2 (ang) Hi byte
25/3	I 0-2 (ang) Lo byte
26/1	I 1-2 (ang) Hi byte
26/2	I 1-2 (ang) Lo byte
26/3	I 2-2 (ang) Hi byte
27/1	I 2-2 (ang) Lo byte
27/2	Scale - Phase Wdg 1 high byte
27/3	Scale - Phase Wdg 1 low byte
28/1	Scale - Phase Wdg 2 high byte
28/2	Scale - Phase Wdg 2 low byte
28/3	Scale - Neutral Wdg 1 high byte
29/1	Scale - Neutral Wdg 1 low byte
29/2	Scale - Ground Wdg 2 high byte
29/3	Scale - Ground Wdg 2 low byte
30/1	Spare
30/2	Spare
30/3	Spare

If no fault data entry is present then send all 0s for 2/1 through 30/3.

6.9 Send Next Through Fault Record (3 6 9)

Same format as (3 6 8) except Msg 1/2 = 0x69.

6.10 Send First Harmonic Restraint Record (3 6 10)

<u>Msg byte</u>	<u>Definition</u>
1/1	Relay Status (see command 3 4 1, msg 1/1)
1/2	Command + Subcommand = 0x6a
1/3	Total Number of Messages = 42
2/1	Param Flag (high byte)
2/2	Param Flag (low byte)
2/3	Fault Type (element) (See Send First Differential Fault Record, command 3 5 8 for Fault Type Definitions)
3/1	Setting
3/2	Fault Number (high byte)
3/3	Fault Number (low byte)
4/1	Year
4/2	Month
4/3	Day
5/1	Hours
5/2	Minutes
5/3	Seconds
6/1	Hundredths of seconds

Values at Start

6/2	Winding 1 Tap Hi byte (*10)
6/3	Winding 1 Tap Lo byte
7/1	Winding 2 Tap Hi byte (*10)
7/2	Winding 2 Tap Lo byte
7/3	I operate A hi byte (*800)
8/1	I operate A lo byte
8/2	I operate B hi byte (*800)
8/3	I operate B lo byte
9/1	I operate C hi byte (*800)
9/2	I operate C lo byte

TPU2000/2000R Modbus/Modbus Plus Automation Guide

9/3	I restraint A-1 Hi byte (*800)
10/1	I restraint A-1 Lo byte
10/2	I restraint B-1 Hi byte (*800)
10/3	I restraint B-1 Lo byte
11/1	I restraint C-1 Hi byte (*800)
11/2	I restraint C-1 Lo byte
11/3	I restraint A-2 Hi byte (*800)
12/1	I restraint A-2 Lo byte
12/2	I restraint B-2 Hi byte (*800)
12/3	I restraint B-2 Lo byte
13/1	I restraint C-2 Hi byte (*800)
13/2	I restraint C-2 Lo byte
13/3	2nd Harmonic A-1 byte (*2)
14/1	5th Harmonic A-1 byte (*2)
14/2	All Harmonics A-1 byte (*2)
14/3	2nd Harmonic B-1 byte (*2)
15/1	5th Harmonic B-1 byte (*2)
15/2	All Harmonics B-1 byte (*2)
15/3	2nd Harmonic C-1 byte (*2)
16/1	5th Harmonic C-1 byte (*2)
16/2	All Harmonics C-1 byte (*2)
16/3	2nd Harmonic A-2 byte (*2)
17/1	5th Harmonic A-2 byte (*2)
17/2	All Harmonics A-2 byte (*2)
17/3	2nd Harmonic B-2 byte (*2)
18/1	5th Harmonic B-2 byte (*2)
18/2	All Harmonics B-2 byte (*2)
18/3	2nd Harmonic C-2 byte (*2)
19/1	5th Harmonic C-2 byte (*2)
19/2	All Harmonics C-2 byte (*2)
19/3	I Restraint A-1 (ang) Hi byte
20/1	I Restraint A-1 (ang) Lo byte
20/2	I Restraint B-1 (ang) Hi byte
20/3	I Restraint B-1 (ang) Lo byte
21/1	I Restraint C-1 (ang) Hi byte
21/2	I Restraint C-1 (ang) Lo byte
21/3	I Restraint A-2 (ang) Hi byte
22/1	I Restraint A-2 (ang) Lo byte
22/2	I Restraint B-2 (ang) Hi byte
22/3	I Restraint B-2 (ang) Lo byte
23/1	I Restraint C-2 (ang) Hi byte
23/2	I Restraint C-2 (ang) Lo byte

Values at End

23/3	Winding 1 Tap Hi byte (*10)
24/1	Winding 1 Tap Lo byte
24/2	Winding 2 Tap Hi byte (*10)
24/3	Winding 2 Tap Lo byte
25/1	I operate A hi byte (*800)
25/2	I operate A lo byte
25/3	I operate B hi byte (*800)
26/1	I operate B lo byte
26/2	I operate C hi byte (*800)
26/3	I operate C lo byte
27/1	I restraint A-1 Hi byte (*800)
27/2	I restraint A-1 Lo byte
27/3	I restraint B-1 Hi byte (*800)
28/1	I restraint B-1 Lo byte
28/2	I restraint C-1 Hi byte (*800)

28/3	I restraint C-1 Lo byte
29/1	I restraint A-2 Hi byte (*800)
29/2	I restraint A-2 Lo byte
29/3	I restraint B-2 Hi byte (*800)
30/1	I restraint B-2 Lo byte
30/2	I restraint C-2 Hi byte (*800)
30/3	I restraint C-2 Lo byte
31/1	2nd Harmonic A-1 byte (*2)
31/2	5th Harmonic A-1 byte (*2)
31/3	All Harmonics A-1 byte (*2)
32/1	2nd Harmonic B-1 byte (*2)
32/2	5th Harmonic B-1 byte (*2)
32/3	All Harmonics B-1 byte (*2)
33/1	2nd Harmonic C-1 byte (*2)
33/2	5th Harmonic C-1 byte (*2)
33/3	All Harmonics C-1 byte (*2)
34/1	2nd Harmonic A-2 byte (*2)
34/2	5th Harmonic A-2 byte (*2)
34/3	All Harmonics A-2 byte (*2)
35/1	2nd Harmonic B-2 byte (*2)
35/2	5th Harmonic B-2 byte (*2)
35/3	All Harmonics B-2 byte (*2)
36/1	2nd Harmonic C-2 byte (*2)
36/2	5th Harmonic C-2 byte (*2)
36/3	All Harmonics C-2 byte (*2)
37/1	I Restraint A-1 (ang) Hi byte
37/2	I Restraint A-1 (ang) Lo byte
37/3	I Restraint B-1 (ang) Hi byte
38/1	I Restraint B-1 (ang) Lo byte
38/2	I Restraint C-1 (ang) Hi byte
38/3	I Restraint C-1 (ang) Lo byte
39/1	I Restraint A-2 (ang) Hi byte
39/2	I Restraint A-2 (ang) Lo byte
39/3	I Restraint B-2 (ang) Hi Lo byte
40/1	I Restraint B-2 (ang) Lo Hi byte
40/2	I Restraint C-2 (ang) Hi byte
40/3	I Restraint C-2 (ang) Lo byte
41/1	Duration Most Significant Hi byte (*1000)
41/2	Duration Most Significant Lo byte
41/3	Duration Least Significant Hi byte
42/1	Duration Least Significant Lo byte
42/2	Spare
42/3	Spare

If no harmonic restraint data entry is present then send all 0s for 2/1 through 27/3.

6.11 Send Next Harmonic Restraint Record (3 6 11)

Same format as (3 6 10) except Msg 1/2 = 0x6b.

6.12 Oldest Unreported Differential Fault Record (3 6 12)

This command will report the oldest unreported differential fault record. The 3 0 4 command can be issued to determine the number of unreported records that exist in the unit's queue. The issuance of the 3 6 12 command will decrement the unit's counter by one record.

Unreported Command Byte

0 = Get Oldest Unreported, 1 = Repeat last command

<u>Data Byte</u>	<u>Definition</u>
1/1	Unreported Command Byte
1/2	Record Part Byte (0=Part 1, 1=Part 2)
1/3	Checksum 1/1 + 1/2

Msg Byte Definition
Same format as (3 5 8) except Msg 1/2 = 0x6c.

6.13 Oldest Unreported Through Fault Record (3 6 13)

This command will report the oldest unreported through fault record. The 3 0 4 command can be issued to determine the number of unreported records that exist in the unit's queue. The issuance of the 3 6 13 command will decrement the unit's counter by one record.

Unreported Command Byte
0 = Get Oldest Unreported, 1 = Repeat last command

<u>Data Byte</u>	<u>Definition</u>
1/1	Unreported Command Byte
1/2	Reserved for Differential Record Part
1/3	Checksum 1/1 + 1/2

Msg Byte Definition
Same format as (3 6 8) except Msg 1/2 = 0x6d.

6.14 Oldest Unreported Harmonic Restraint Record (3 6 14)

This command will report the oldest unreported harmonic restraint record. The 3 0 4 command can be issued to determine the number of unreported records that exist in the unit's queue. The issuance of the 3 6 14 command will decrement the unit's counter by one record.

Unreported Command Byte
0 = Get Oldest Unreported, 1 = Repeat last command

<u>Data Byte</u>	<u>Definition</u>
1/1	Unreported Command Byte
1/2	Reserved for Differential Record Part
1/3	Checksum 1/1 + 1/2

Msg Byte Definition
Same format as (3 6 10) except Msg 1/2 = 0x6e.

6.15 Oldest Unreported Operations Record (3 6 15)

This command will report the oldest unreported operations record. The 3 0 4 command can be issued to determine the number of unreported records that exist in the unit's queue. The issuance of the 3 6 15 command will decrement the unit's counter by one record.

Unreported Command Byte
0 = Get Oldest Unreported, 1 = Repeat last command

<u>Data Byte</u>	<u>Definition</u>
1/1	Unreported Command Byte
1/2	Reserved for Differential Record Part
1/3	Checksum 1/1 + 1/2

Msg Byte Definition
Same format as (3 5 12) except Msg 1/2 = 0x6f.

9 Trip and Energize Commands (3 9 n)

<u>N</u>	<u>Definition</u>
0	Trip Command
2	Energize Output Contact Command
3	Set/Reset Outputs Command

9.0 Trip Command (3 9 0)

The TRIP command will be issued to the TPU. This command has a data message that contains the Password and a command verification code for trip.

<u>Msg byte</u>	<u>Definition</u>
1/1	Most significant high byte of password
1/2	Most significant low byte of password
1/3	Least significant high byte of password
2/1	Least significant low byte of password
2/2	spare
2/3	Command + Subcommand = 0x90

9.2 Energize Output Contact Command (3 9 2)

The test output contact command will be issued to the TPU. This command has a data message that contains the Password and a command verification code and a 16 bit word indicating which contacts should be closed.

The output contact will be a momentary closure for the time period specified in the configuration menu for trip failure time.

<u>Msg byte</u>	<u>Definition</u>
1/1	Most significant high byte of password
1/2	Most significant low byte of password
1/3	Least significant high byte of password
2/1	Least significant low byte of password
2/2	spare
2/3	Command + Subcommand = 0x92
3/1	Output Contact State Bit 0-7 - Spare
3/2	Output Contact State Bit 0 - TRIP Bit 1 - OUT1 Bit 2 - OUT2 Bit 3 - OUT3 Bit 4 - OUT4 Bit 5 - OUT5 Bit 6 - OUT6 Bit 7 - OUT7
3/3	Output Contact State Confirmation Bit 0-7 - Spare
4/1	Output Contact State Confirmation Bit 0 - TRIP Bit 1 - OUT1 Bit 2 - OUT2 Bit 3 - OUT3 Bit 4 - OUT4 Bit 5 - OUT5 Bit 6 - OUT6 Bit 7 - OUT7
4/2	Checksum high byte
4/3	Checksum low byte

TPU2000/2000R Modbus/Modbus Plus Automation Guide

9.3 Set/Reset Output Contacts Command (3 9 3)

This command allows for the assertion/deassertion of the ULO1 to ULO9 logical outputs. It also provides the means to reset the sealed in logical output contacts. Outputs denoted with an '*' are sealed in and can only be reset.

Bit = 0, Output Not Energized/No Change in Status.

Bit = 1, Output Energized/Change in Status.

<u>Bit</u>	<u>Output Byte1</u>	<u>Output Byte2</u>	<u>Output Byte3</u>
7	87T*	150P-1*	150G-2*
6	87H*	50P-2*	46-1*
5	2HROA*	150P-2*	46-2*
4	5HROA*	51N-1*	63*
3	AHROA*	51G-2*	ULO1
2	51P-1*	50N-1*	ULO2
1	51P-2*	150N-1*	ULO3
0	50P-1*	50G-2*	ULO4

<u>Bit</u>	<u>Output Byte4</u>	<u>Output Bytes5-8</u>
7	ULO5	SPARE
6	ULO6	SPARE
5	ULO7	SPARE
4	ULO8	SPARE
3	ULO9	SPARE
2	SPARE	SPARE
1	SPARE	SPARE
0	SPARE	SPARE

Example: To send a command to clear 150G-2* and set ULO4, the following command bytes should be issued.

Set/Reset Output Byte3 = 01 hex

Status Change Output Byte3 = 81 hex

This allows a change to occur for outputs in bit position 7 and 0. Note that you can only clear '*' (sealed in) outputs.

<u>Msg byte</u>	<u>Definition</u>
1/1	Most significant high byte of password
1/2	Most significant low byte of password
1/3	Least significant high byte of password
2/1	Least significant low byte of password
2/2	spare
2/3	Command + Subcommand = 0x93
3/1	Set/Reset Output Byte1
3/2	Set/Reset Output Byte2
3/3	Set/Reset Output Byte3
4/1	Set/Reset Output Byte4
4/2	Set/Reset Output Byte5
4/3	Set/Reset Output Byte6
5/1	Set/Reset Output Byte7
5/2	Set/Reset Output Byte8
5/3	Spare
6/1	Spare
6/2	Spare
6/3	Spare
7/1	Status Change Output Byte1
7/2	Status Change Output Byte2
7/3	Status Change Output Byte3
8/1	Status Change Output Byte4
8/2	Status Change Output Byte5
8/3	Status Change Output Byte6

9/1	Status Change Output Byte7
9/2	Status Change Output Byte8
9/3	Spare
10/1	Spare
10/2	Spare
10/3	Spare
11/1	Spare
11/2	Checksum high byte
11/3	Checksum low byte

10 Receive Buffer "N" Commands (3 10 n)

<u>N</u>	<u>Definition</u>
0	Reserved for repeat 3 10 n
1	Communications Settings

10.1 Receive Communications Settings (3 10 1)

Low byte consists of bits 0 through 7.
High byte consists of bits 8 through 15.

Port configuration byte

- bit 0-3 = port baud rate (0=300,1=1200,2=2400,3=4800, 4=9600,5=19200,6=38400)
- bit 4-5 = parity (0=None,1=Odd,2=Even)
- bit 6 = number of data bits (0=seven,1=eight)
- bit 7 = number of stop bits (0=one,1=two)

<u>Msg byte</u>	<u>Definition</u>
1/1	Most significant high byte of password
1/2	Most significant low byte of password
1/3	Least significant high byte of password
2/1	Least significant low byte of password
2/2	Spare
2/3	Command + Subcommand = 0xa1
3/1	Unit Address high byte
3/2	Unit Address low byte
3/3	Front Panel RS232 configuration byte
4/1	Rear Panel RS232 or INCOM configuration byte
4/2	Rear Panel RS485 configuration byte
4/3	Rear Panel IRIG byte 0=Disabled, 1=Enabled
5/1	Spare
5/2	Spare
5/3	Aux Port Parameter 1 byte (0-255)
6/1	Aux Port Parameter 2 byte (0-255)
6/2	Aux Port Parameter 3 byte (0-255)
6/3	Aux Port Parameter 4 byte (0-255)
7/1	Aux Port Parameter 5 byte (0-255)
7/2	Aux Port Parameter 6 byte (0-255)
7/3	Aux Port Parameter 7 byte (0-255)
8/1	Aux Port Parameter 8 byte (0-255)
8/2	Aux Port Parameter 9 byte (0-255)
8/3	Aux Port Parameter 10 byte (0-255)
9/1	Aux Port Parameter Mode byte
9/2	Spare
9/3	Spare
10/1	Spare
10/2	Checksum high byte
10/3	Checksum low byte

11 Receive Edit Buffer "N" Commands (3 11 n)

<u>N</u>	<u>Definition</u>
0	Reserved for repeat 3 11 n
1	Programmable Input Select and Index Tables
2	Programmable Input Negated AND Table
3	Programmable Input AND/OR Table
4	Programmable Input User Defined Input Names
5	Programmable Output Select Table
6	Programmable Output AND/OR Table
7	Programmable Output User Defined Output Names
8	Primary Relay Settings
9	Alternate 1 Relay Settings
10	Alternate 2 Relay Settings
11	Configuration Settings
12	Counter Settings
13	Alarm Settings
14	Real Time Clock
15	Output Delays

11.1 Receive Programmable Input Select and Index (3 11 1)

Bit = 0, Physical Input is selected.

Bit = 1, Physical Input is not selected.

Low byte consists of bits 0 through 7.

High byte consists of bits 8 through 15.

Index byte is the offset into the TPU's logical input structure.

<u>Offset</u>	<u>Definitions</u>
00	87T Restrained Differential Trip
01	87H High Set Inst Differential Trip
02	51P-1 Wdg1 Phase Time OC Trip
03	51P-2 Wdg2 Phase Time OC Trip
04	51N-1 Wdg1 Neutral Time OC Trip
05	51G-2 Wdg2 Ground Time OC Trip
06	50P-1 1st Wdg1 Phase Inst OC Trip
07	50P-2 1st Wdg2 Phase Inst OC Trip
08	50N-1 1st Wdg1 Neutral Inst OC Trip
09	50G-2 1st Wdg2 Ground Inst OC Trip
10	150P-1 2nd Wdg1 Phase Inst OC Trip
11	150P-2 2nd Wdg2 Phase Inst OC Trip
12	150N-1 2nd Wdg1 Neutral Inst OC Trip
13	150G-2 2nd Wdg2 Ground Inst OC Trip
14	46-1 Wdg1 Neg Seq Time OC Trip
15	46-2 Wdg2 Neg Seq Time OC Trip
16	ALT1 Enables Alt 1 Settings
17	ALT2 Enables Alt 2 Settings
18	ECI1 Event-1 Capture Initiated
19	ECI2 Event-2 Capture Initiated
20	WCI Waveform Capture Initiated
21	Trip Initiates Diff Trip Output
22	SPR Sudden Pressure Input
23	TCM Trip Coil Monitoring
24	ULI1 User Logical Input 1
25	ULI2 User Logical Input 2
26	ULI3 User Logical Input 3
27	ULI4 User Logical Input 4
28	ULI5 User Logical Input 5

29	ULI6	User Logical Input 6
30	ULI7	User Logical Input 7
31	ULI8	User Logical Input 8
32	ULI9	User Logical Input 9
33	CRI	Resets OC Trip and all Recloser Counters

<u>Msg byte</u>	<u>Definition</u>		
1/1	Most significant high byte of password		
1/2	Most significant low byte of password		
1/3	Least significant high byte of password		
2/1	Least significant low byte of password		
2/2	Spare		
2/3	Command + Subcommand = 0xb1		
3/1	INPUT1 high byte		
3/2	INPUT1 low byte		
3/3	INPUT1 index byte		
4/1	INPUT2 high byte		
4/2	INPUT2 low byte		
4/3	INPUT2 index byte		
5/1	INPUT3 high byte		
5/2	INPUT3 low byte		
5/3	INPUT3 index byte		
6/1	INPUT4 high byte	Bit	Physical Input
6/2	INPUT4 low byte		
6/3	INPUT4 index byte	---	-----
7/1	INPUT5 high byte	0	IN6
7/2	INPUT5 low byte	1	IN7
7/3	INPUT5 index byte	2	IN8
8/1	INPUT6 high byte	3	IN2
8/2	INPUT6 low byte	4	IN9
8/3	INPUT6 index byte	5	IN3
9/1	INPUT7 high byte	6	IN4
9/2	INPUT7 low byte	7	IN5
9/3	INPUT7 index byte	8	IN1
10/1	INPUT8 high byte	9	Reserved
10/2	INPUT8 low byte	10	Reserved
10/3	INPUT8 index byte	11	Reserved
11/1	INPUT9 high byte	12	Reserved
11/2	INPUT9 low byte	13	Reserved
11/3	INPUT9 index byte	14	Reserved
12/1	INPUT10 high byte	15	Reserved
12/2	INPUT10 low byte		
12/3	INPUT10 index byte		
13/1	INPUT11 high byte		
13/2	INPUT11 low byte		
13/3	INPUT11 index byte		
14/1	INPUT12 high byte		
14/2	INPUT12 low byte		
14/3	INPUT12 index byte		
15/1	INPUT13 high byte		
15/2	INPUT13 low byte		
15/3	INPUT13 index byte		
16/1	INPUT14 high byte		
16/2	INPUT14 low byte		
16/3	INPUT14 index byte		
17/1	INPUT15 high byte		
17/2	INPUT15 low byte		
17/3	INPUT15 index byte		
18/1	INPUT16 high byte		

TPU2000/2000R Modbus/Modbus Plus Automation Guide

18/2	INPUT16 low byte
18/3	INPUT16 index byte
19/1	INPUT17 high byte
19/2	INPUT17 low byte
19/3	INPUT17 index byte
20/1	INPUT18 high byte
20/2	INPUT18 low byte
20/3	INPUT18 index byte
21/1	INPUT19 high byte
21/2	INPUT19 low byte
21/3	INPUT19 index byte
22/1	INPUT20 high byte
22/2	INPUT20 low byte
22/3	INPUT20 index byte
23/1	INPUT21 high byte
23/2	INPUT21 low byte
23/3	INPUT21 index byte
24/1	INPUT22 high byte
24/2	INPUT22 low byte
24/3	INPUT22 index byte
25/1	INPUT23 high byte
25/2	INPUT23 low byte
25/3	INPUT23 index byte
26/1	INPUT24 high byte
26/2	INPUT24 low byte
26/3	INPUT24 index byte
27/1	INPUT25 high byte
27/2	INPUT25 low byte
27/3	INPUT25 index byte
28/1	INPUT26 high byte
28/2	INPUT26 low byte
28/3	INPUT26 index byte
29/1	INPUT27 high byte
29/2	INPUT27 low byte
29/3	INPUT27 index byte
30/1	INPUT28 high byte
30/2	INPUT28 low byte
30/3	INPUT28 index byte
31/1	INPUT29 high byte
31/2	INPUT29 low byte
31/3	INPUT29 index byte
32/1	INPUT30 high byte
32/2	INPUT30 low byte
32/3	INPUT30 index byte
33/1	INPUT31 high byte
33/2	INPUT31 low byte
33/3	INPUT31 index byte
34/1	INPUT32 high byte
34/2	INPUT32 low byte
34/3	INPUT32 index byte
35/1	Spare
35/2	Checksum high byte
35/3	Checksum low byte

11.2 Receive Programmable Input Negated AND (3 11 2)

Bit = 0, Enabled when input is opened.

Bit = 1, Enabled when input is closed.

Low byte consists of bits 0 through 7.

High byte consists of bits 8 through 15.

<u>Msg byte</u>	<u>Definition</u>		
1/1	Most significant high byte of password		
1/2	Most significant low byte of password		
1/3	Least significant high byte of password		
2/1	Least significant low byte of password		
2/2	spare		
2/3	Command + Subcommand = 0xb2		
3/1	INPUT1 high byte		
3/2	INPUT1 low byte		
3/3	INPUT2 high byte		
4/1	INPUT2 low byte		
4/2	INPUT3 high byte		
4/3	INPUT3 low byte		
5/1	INPUT4 high byte		
5/2	INPUT4 low byte		
5/3	INPUT5 high byte	Bit	Physical Input
6/1	INPUT5 low byte---		-----
6/2	INPUT6 high byte	0	IN6
6/3	INPUT6 low byte	1	IN7
7/1	INPUT7 high byte	2	IN8
7/2	INPUT7 low byte	3	IN2
7/3	INPUT8 high byte	4	IN9
8/1	INPUT8 low byte	5	IN3
8/2	INPUT9 high byte	6	IN4
8/3	INPUT9 low byte	7	IN5
9/1	INPUT10 high byte	8	IN1
9/2	INPUT10 low byte	9	Reserved
9/3	INPUT11 high byte	10	Reserved
10/1	INPUT11 low byte	11	Reserved
10/2	INPUT12 high byte	12	Reserved
10/3	INPUT12 low byte	13	Reserved
11/1	INPUT13 high byte	14	Reserved
11/2	INPUT13 low byte	15	Reserved
11/3	INPUT14 high byte		
12/1	INPUT14 low byte		
12/2	INPUT15 high byte		
12/3	INPUT15 low byte		
13/1	INPUT16 high byte		
13/2	INPUT16 low byte		
13/3	INPUT17 high byte		
14/1	INPUT17 low byte		
14/2	INPUT18 high byte		
14/3	INPUT18 low byte		
15/1	INPUT19 high byte		
15/2	INPUT19 low byte		
15/3	INPUT20 high byte		
16/1	INPUT20 low byte		
16/2	INPUT21 high byte		
16/3	INPUT21 low byte		
17/1	INPUT22 high byte		
17/2	INPUT22 low byte		
17/3	INPUT23 high byte		
18/1	INPUT23 low byte		
18/2	INPUT24 high byte		
18/3	INPUT24 low byte		
19/1	INPUT25 high byte		
19/2	INPUT25 low byte		

TPU2000/2000R Modbus/Modbus Plus Automation Guide

19/3	INPUT26 high byte
20/1	INPUT26 low byte
20/2	INPUT27 high byte
20/3	INPUT27 low byte
21/1	INPUT28 high byte
21/2	INPUT28 low byte
21/3	INPUT29 high byte
22/1	INPUT29 low byte
22/2	INPUT30 high byte
22/3	INPUT30 low byte
23/1	INPUT31 high byte
23/2	INPUT31 low byte
23/3	INPUT32 high byte
24/1	INPUT32 low byte
24/2	Checksum high byte
24/3	Checksum low byte

11.3 Receive Programmable Input AND/OR Select (3 11 3)

Bit = 0, Selected inputs are ORed together.
Bit = 1, Selected inputs are ANDed together.

<u>Msg byte</u>	<u>Definition</u>
1/1	Most significant high byte of password
1/2	Most significant low byte of password
1/3	Least significant high byte of password
2/1	Least significant low byte of password
2/2	spare
2/3	Command + Subcommand = 0xb3
3/1	Programmable input AND/OR selection bits 24-31
3/2	Programmable input AND/OR selection bits 16-23
3/3	Programmable input AND/OR selection bits 8-15
4/1	Programmable input AND/OR selection bits 0-7
4/2	Checksum high byte
4/3	Checksum low byte

<u>Bit</u>	<u>Logical Input</u>
---	-----
0	INPUT1
1	INPUT2
.	.
.	.
.	.
27	INPUT28
28	INPUT29
29	INPUT30
30	INPUT31
31	INPUT32

11.4 Receive Programmable Input User Defined Strings (3 11 4)

User definable 8 char input strings. Byte 9 is an implied NULL

<u>Msg byte</u>	<u>Definition</u>
1/1	Most significant high byte of password
1/2	Most significant low byte of password
1/3	Least significant high byte of password
2/1	Least significant low byte of password
2/2	spare

2/3	Command + Subcommand = 0xb4
3/1-5/2	IN1 Character String 8 bytes
5/3-8/1	IN2 Character String 8 bytes
8/2-10/3	IN3 Character String 8 bytes
11/1-13/2	IN4 Character String 8 bytes
13/3-16/1	IN5 Character String 8 bytes
16/2-18/3	IN6 Character String 8 bytes
19/1-21/2	IN7 Character String 8 bytes
21/3-24/1	IN8 Character String 8 bytes
24/2-26/3	IN9 Character String 8 bytes
27/1-29/2	spare Character String 8 bytes
29/3-32/1	spare Character String 8 bytes
32/2-34/3	spare Character String 8 bytes
35/1-37/2	spare Character String 8 bytes
37/3-38/1	spares
38/2	Checksum high byte
38/3	Checksum low byte

11.5 Receive Programmable Output Select (3 11 5)

Programmable Output data transferred from PC to TPU2000.

- Bit = 0, Physical Output is selected.
- Bit = 1, Physical Output is not selected.
- Least significant low byte consists of bits 0 through 7.
- Least significant high byte consists of bits 8 through 15.
- Most significant low byte consists of bits 16 through 23.
- Most significant high byte consists of bits 24 through 31.

Msg byte	Definition
1/1	Most significant high byte of password
1/2	Most significant low byte of password
1/3	Least significant high byte of password
2/1	Least significant low byte of password
2/2	spare
2/3	Command + Subcommand = 0xb5
3/1	Contact OUT5 most significant high byte
3/2	Contact OUT5 most significant low byte
3/3	Contact OUT5 least significant high byte
4/1	Contact OUT5 least significant low byte
4/2	Contact OUT7 most significant high byte
4/3	Contact OUT7 most significant low byte
5/1	Contact OUT7 least significant high byte
5/2	Contact OUT7 least significant low byte
5/3	Contact OUT4 most significant high byte
6/1	Contact OUT4 most significant low byte
6/2	Contact OUT4 least significant high byte
6/3	Contact OUT4 least significant low byte
7/1	Contact OUT6 most significant high byte
7/2	Contact OUT6 most significant low byte
7/3	Contact OUT6 least significant high byte
8/1	Contact OUT6 least significant low byte
8/2	Contact OUT3 most significant high byte
8/3	Contact OUT3 most significant low byte
9/1	Contact OUT3 least significant high byte
9/2	Contact OUT3 least significant low byte
9/3	Contact OUT2 most significant high byte
10/1	Contact OUT2 most significant low byte
10/2	Contact OUT2 least significant high byte

TPU2000/2000R Modbus/Modbus Plus Automation Guide

10/3	Contact OUT2 least significant low byte
11/1	Contact OUT1 most significant high byte
11/2	Contact OUT1 most significant low byte
11/3	Contact OUT1 least significant high byte
12/1	Contact OUT1 least significant low byte
12/2-22/1	spare
22/2	Checksum high byte
22/3	Checksum low byte

Bit	Logical Output
---	-----
0	TRIP
1	OUTPUT1
2	OUTPUT2
3	OUTPUT3
	.
	.
	.
30	OUTPUT29
31	OUTPUT30

11.6 Receive Programmable Output AND/OR Index (3 11 6)

Bit = 0, Selected outputs are ORed together.

Bit = 1, Selected outputs are ANDed together.

Index byte is the offset into the TPU's logical output structure.

<u>Index</u>	<u>Output</u>	<u>Definition</u>
00	DIFF	Fixed Diff Trip, 87T or 87H
01	ALARM	Fixed Self Check Alarm
02	87T	Percentage Differential Trip
03	87H	High Set Inst Diff Trip
04	2HROA	2nd Harm Restraint Output Alarm
05	5HROA	5th Harm Restraint Alarm
06	AHROA	All Harm Restraint Alarm
07	TCFA	Trip Circuit Failure Alarm
08	TFA	Trip Failure Alarm
09	51P-1	Wdg 1 Phase Time OC Trip
10	51P-2	Wdg 2 Phase Time OC Trip
11	50P-1	1st Wdg 1 Phase Inst OC Trip
12	150P-1	2nd Wdg 1 Phase Inst OC Trip
13	50P-2	1st Wdg 2 Phase Inst OC Trip
14	150P-2	2nd Wdg 2 Phase Inst OC Trip
15	51N-1	Wdg 1 Neutral Time OC Trip
16	51G-2	Wdg 2 Ground Time OC Trip
17	50N-1	1st Wdg 1 Neutral Inst OC Trip
18	150N-1	2nd Wdg 1 Neutral Inst OC Trip
19	50G-2	1st Wdg 2 Ground Inst OC Trip
20	150G-2	2nd Wdg 2 Ground Inst OC Trip
21	46-1	Wdg 1 Neg Sequence Time OC Trip
22	46-2	Wdg 2 Neg Sequence Time OC Trip
23	87T-D	Percentage Differential Disabled Alarm
24	87H-D	High Set Inst Diff Disabled Alarm
25	51P-1D	Wdg 1 Phase Time OC Disabled Alarm
26	51P-2D	Wdg 2 Phase Time OC Disabled Alarm
27	51N-1D	Wdg 1 Neutral Time OC Disabled Alarm
28	51G-2D	Wdg 2 Ground Time OC Disabled Alarm
29	50P-1D	1st Wdg 1 Phase Inst OC Disabled Alarm
30	50P-2D	1st Wdg 2 Phase Inst OC Disabled Alarm

TPU2000/2000R Modbus/Modbus Plus Automation Guide

31	50N-1D	1st Wdg 1 Neutral Inst OC Disabled Alarm
32	50G-2D	1st Wdg 2 Ground Inst OC Disabled Alarm
33	150P-1D	2nd Wdg 1 Phase Inst Disabled Alarm
34	150P-2D	2nd Wdg 2 Phase Inst Disabled Alarm
35	150N-1D	2nd Wdg 1 Neutral Inst Disabled Alarm
36	150G-2D	2nd Wdg 2 Ground Inst Disabled Alarm
37	46-1D	Wdg 1 Neg Seq Time OC Disabled Alarm
38	46-2D	Wdg 2 Neg Seq Time OC Disabled Alarm
39	PATA	Phase A LED Alarm
40	PBTA	Phase B LED Alarm
41	PCTA	Phase C LED Alarm
42	PUA	Pickup Alarm
43	63	Sudden Pressure Input Alarm
44	THRUFA	Through Fault Alarm
45	TFCA	Through Fault Counter Alarm
46	TFKA	Through Fault K Amp Summation Alarm
47	TFSCA	Through Fault Cycle Summation Alarm
48	DTC	Differential Trip Counter Alarm
49	OCTC	Overcurrent Trip Counter Alarm
50	PDA	Phase Current Demand Alarm
51	NDA	Neutral Current Demand Alarm
52	PRIM	Primary Set Enabled Alarm
53	ALT1	Alt1 Set Enabled Alarm
54	ALT2	Alt2 Set Enabled Alarm
55	STCA	Settings Table Changed Alarm
56	87T*	Percentage Diff Sealed In Alarm
57	87H*	High Set Inst Diff Sealed In Alarm
58	2HROA*	2nd Harmonic Restraint Sealed In Alarm
59	5HROA*	5th Harmonic Restraint Sealed In Alarm
60	AHROA*	All Harmonic Restraint Sealed In Alarm
61	51P-1*	Wdg 1 Phase Time OC Sealed In Alarm
62	51P-2*	Wdg 2 Phase Time OC Sealed In Alarm
63	50P-1*	1st Wdg1 Phase Inst OC Sealed In Alarm
64	150P-1*	2nd Wdg1 Phase Inst OC Sealed In Alarm
65	50P-2*	1st Wdg2 Phase Inst OC Sealed In Alarm
66	150P-2*	2nd Wdg2 Phase Inst OC Sealed In Alarm
67	51N-1*	Wdg1 Neutral Time OC Sealed In Alarm
68	51G-2*	Wdg2 Ground Time OC Sealed In Alarm
69	50N-1*	1st Wdg1 Neutral Inst OC Sealed In Alarm
70	150N-1*	2nd Wdg1 Neutral Inst OC Sealed In Alarm
71	50G-2*	1st Wdg2 Ground Inst OC Sealed In Alarm
72	150G-2*	2nd Wdg2 Ground Inst OC Sealed In Alarm
73	46-1*	Wdg1 Neg Seq Time OC Sealed In Alarm
74	46-2*	Wdg2 Neg Seq Time OC Sealed In Alarm
75	63*	Sudden Pressure Input Sealed In Alarm
76	ULO1	User Logical Output 1
77	ULO2	User Logical Output 2
78	ULO3	User Logical Output 3
79	ULO4	User Logical Output 4
80	ULO5	User Logical Output 5
81	ULO6	User Logical Output 6
82	ULO7	User Logical Output 7
83	ULO8	User Logical Output 8
84	ULO9	User Logical Output 9
85	LOADA	Load Current
86	OCA-1	Overcurrent Alarm Winding 1
87	OCA-2	Overcurrent Alarm Winding 2
88	HLDA-1	High Level Detection Alarm Winding 1
89	LLDA-1	Low Level Detection Alarm Winding 1

TPU2000/2000R Modbus/Modbus Plus Automation Guide

90	HLDA-2	High Level Detection Alarm Winding 2
91	LLDA-2	Low Level Detection Alarm Winding 2
92	HPFA	High Power Factor Alarm
93	LPFA	Low Power Factor Alarm
94	VarDA	Three Phase kVar Demand Alarm
95	PVArA	Positive 3 Phase kiloVAr Alarm
96	NVArA	Negative 3 Phase kiloVAr Alarm
97	PWatt1	Positive Watt Alarm 1
98	PWatt2	Positive Watt Alarm 2

<u>Msg byte</u>	<u>Definition</u>
1/1	Most significant high byte of password
1/2	Most significant low byte of password
1/3	Least significant high byte of password
2/1	Least significant low byte of password
2/2	spare
2/3	Command + Subcommand = 0xb6
3/1	spare (bits 24-31)
3/2	spare (bits 16-23)
3/3	Programmable output AND/OR selection bits 8-15
4/1	Programmable output AND/OR selection bits 0-7
4/2	OUTPUT1 index byte
4/3	OUTPUT2 index byte
5/1	OUTPUT3 index byte
5/2	OUTPUT4 index byte
5/3	OUTPUT5 index byte
6/1	OUTPUT6 index byte
6/2	OUTPUT7 index byte
6/3	OUTPUT8 index byte
7/1	OUTPUT9 index byte
7/2	OUTPUT10 index byte
7/3	OUTPUT11 index byte
8/1	OUTPUT12 index byte
8/2	OUTPUT13 index byte
8/3	OUTPUT14 index byte
9/1	OUTPUT15 index byte
9/2	OUTPUT16 index byte
9/3	OUTPUT17 index byte
10/1	OUTPUT18 index byte
10/2	OUTPUT19 index byte
10/3	OUTPUT20 index byte
11/1	OUTPUT21 index byte
11/2	OUTPUT22 index byte
11/3	OUTPUT23 index byte
12/1	OUTPUT24 index byte
12/2	OUTPUT25 index byte
12/3	OUTPUT26 index byte
13/1	OUTPUT27 index byte
13/2	OUTPUT28 index byte
13/3	OUTPUT29 index byte
14/1	OUTPUT30 index byte
14/2	OUTPUT31 index byte
14/3	spare
15/1	spare
15/2	Checksum high byte
15/3	Checksum low byte

Bit Physical Output

--- -----

0	not used reserved for fixed DIFF TRIP
1	Contact OUT5
2	Contact OUT7
3	Contact OUT4
4	Contact OUT6
5	Contact OUT3
6	Contact OUT2
7	Contact OUT1
8	spare
9	spare
10	spare
11	spare
12	spare
13	spare
14	spare
15	spare

11.7 Receive Programmable Output User Defined Names (3 11 7)

User definable 8 char output strings. Byte 9 is an implied NULL.

<u>Msg byte</u>	<u>Definition</u>
1/1	Most significant high byte of password
1/2	Most significant low byte of password
1/3	Least significant high byte of password
2/1	Least significant low byte of password
2/2	spare
2/3	Command + Subcommand = 0xb7
3/1-5/2	OUT1 Character String 8 bytes
5/3-8/1	OUT2 Character String 8 bytes
8/2-10/3	OUT3 Character String 8 bytes
11/1-13/2	OUT4 Character String 8 bytes
13/3-16/1	OUT5 Character String 8 bytes
16/2-18/3	OUT6 Character String 8 bytes
19/1-21/2	OUT7 Character String 8 bytes
21/3-24/1	spare Character String 8 bytes
24/2-26/3	spare Character String 8 bytes
27/1-29/2	spare Character String 8 bytes
29/3-32/1	spare Character String 8 bytes
32/2-34/3	spare Character String 8 bytes
35/1-37/2	spare Character String 8 bytes
37/3-40/1	spare Character String 8 bytes
40/2	Checksum high byte
40/3	Checksum low byte

11.8,9,10 Receive Relay Settings (3 11 X)

- (3 11 8) = Primary Settings
- (3 11 9) = Alternate 1 Settings
- (3 11 10) = Alternate 2 Settings

Low byte consists of bits 0 through 7.
High byte consists of bits 8 through 15.

Curve Selection Type I

- 0 = Extremely Inverse
- 1 = Very Inverse
- 2 = Inverse
- 3 = Short Time Inverse

TPU2000/2000R Modbus/Modbus Plus Automation Guide

- 4 = Definite Time
- 5 = Long Time Extremely Inverse
- 6 = Long Time Very Inverse
- 7 = Long Time Inverse
- 8 = Recloser Curve
- 9 = Disabled
- 10 = User Curve 1
- 11 = User Curve 2
- 12 = User Curve 3

Curve Selection Type II

- 0 = Disabled
- 1 = Standard
- 2 = Inverse
- 3 = Definite Time
- 4 = Short Time Inverse
- 5 = Short Time Extremely Inverse
- 6 = User Curve 1
- 7 = User Curve 2
- 8 = User Curve 3

Curve Selection Type 87T

- 0 = Disabled
- 1 = Percent Slope
- 2 = HU 30%
- 3 = HU 35%
- 4 = Percent 15 Tap
- 5 = Percent 25 Tap
- 6 = Percent 40 Tap
- 7 = User Curve 1
- 8 = User Curve 2
- 9 = User Curve 3

Mode Selection Type 87T

- 0 = Disabled
- 1 = 2nd Harmonics
- 2 = 2nd & 5th Harmonics
- 3 = All Harmonics

<u>Msg byte</u>	<u>Definition</u>
1/1	Most significant high byte of password
1/2	Most significant low byte of password
1/3	Least significant high byte of password
2/1	Least significant low byte of password
2/2	spare
2/3	Command + Subcommand = (Prim=0xb8, Alt1=0xb9, Alt2=0xba)
3/1	87T Curve Select byte (Type 87T)
3/2	87T Min I Operate byte (0.2-1.0 *10)
3/3	87T Percent Restraint byte (15-60)
4/1	87T Restraint Mode byte (Mode Selection Type 87T)
4/2	87T 2nd Harmonic Restraint high byte (7.5-25 *10)
4/3	87T 2nd Harmonic Restraint low byte
5/1	87T 5th Harmonic Restraint high byte (15-40 *10)
5/2	87T 5th Harmonic Restraint low byte
5/3	87T All Harmonics Restraint high byte (15-40 *10)
6/1	87T All Harmonics Restraint low byte
6/2	87H Tap X byte (6-20 *10)
6/3	87T-1 Tap Amp byte (2-9 Amp *10, 0.4-1.8 Amp *50)
7/1	51P-1 Curve Select byte (Type I)

TPU2000/2000R Modbus/Modbus Plus Automation Guide

7/2	51P-1 Pickup Amp/OA (1-12A *10, 0.2-2.4A *50)
7/3	51P-1 Timedial/delay (dial 1-10, delay 0-10, *20)
8/1	50P-1 Curve Select byte (Type II)
8/2	50P-1 Pickup X byte (0.5-20, *10)
8/3	50P-1 Timedial/delay high (dial *10,delay *100)
9/1	50P-1 Timedial/delay low (dial 1-10, delay 0-9.99)
9/2	150P-1 Curve Select byte (Type II)
9/3	150P-1 Pickup X byte (0.5-20, *10)
10/1	150P-1 Time Delay high byte (0-9.99, *100)
10/2	150P-1 Time Delay low byte
10/3	46-1 Curve Select byte (Type I)
11/1	46-1 Pickup Amp byte (1-12A *10, 0.2-2.4A *50)
11/2	46-1 Timedial/delay (dial 1-10, delay 0-10,*20)
11/3	51N-1 Curve Select byte (Type I)
12/1	51N-1 Pickup Amp byte (1-12A *10, 0.2-2.4A *50)
12/2	51N-1 Timedial/delay (dial 1-10, delay 0-10,*20)
12/3	50N-1 Curve Select byte (Type II)
13/1	50N-1 Pickup X byte (0.5-20, *10)
13/2	50N-1 Timedial/delay high (dial *10,delay *100)
13/3	50N-1 Timedial/delay low (dial 1-10, delay 0-9.99)
14/1	150N-1 Curve Select byte (Type II)
14/2	150N-1 Pickup X byte (0.5-20, *10)
14/3	150N-1 Time Delay high byte (0-9.99, *100)
15/1	150N-1 Time Delay low byte
15/2	87T-2 Tap Amp byte (2-9 Amp *10, 0.4-1.8 Amp *50)
15/3	51P-2 Curve Select byte (Type I)
16/1	51P-2 Pickup Amp/OA (1-12 Amp *10, 0.2-2.4Amp *50)
16/2	51P-2 Timedial/delay (dial 1-10, delay 0-10, *20)
16/3	50P-2 Curve Select byte (Type II)
17/1	50P-2 Pickup X byte (0.5-20, *10)
17/2	50P-2 Timedial/delay high (dial *10,delay *100)
17/3	50P-2 Timedial/delay low (dial 1-10, delay 0-9.99)
18/1	150P-2 Curve Select byte (Type II)
18/2	150P-2 Pickup X byte (0.5-20, *10)
18/3	150P-2 Time Delay high byte (0-9.99, *100)
19/1	150P-2 Time Delay low byte
19/2	46-2 Curve Select byte (Type I)
19/3	46-2 Pickup Amp byte (1-12A *10, 0.2-2.4A *50)
20/1	46-2 Timedial/delay byte (dial 1-10, delay 0-10, *20)
20/2	51G-2 Curve Select byte (Type I)
20/3	51G-2 Pickup Amp byte (1-12A *10, 0.2-2.4A *50)
21/1	51G-2 Timedial/delay byte (dial 1-10, delay 0-10, *20)
21/2	50G-2 Curve Select byte (Type II)
21/3	50G-2 Pickup X byte (0.5-20, *10)
22/1	50G-2 Timedial/delay high (dial *10,delay *100)
22/2	50G-2 Timedial/delay low (dial 1-10, delay 0-9.99)
22/3	150G-2 Curve Select byte (Type II)
23/1	150G-2 Pickup X byte (0.5-20, *10)
23/2	150G-2 Time Delay high byte (0-9.99, *100)
23/3	150G-2 Time Delay low byte
24/1	Disturb-2 Pickup X byte (0.5-5, *10)
24/2	Level Detector-1 PickupX (0.5-20, *10, 201=Disable)
24/3	Level Detector-2 PickupX (0.5-20, *10, 201=Disable)
25/1	spare
25/2	spare
25/3	spare
26/1	Unit Configuration byte bit 0 : neutral tap range Wdg1 (0=1-12A, 1=0.2-2.4A) bit 1 : phase tap range Wdg1 (0=1-12A, 1=0.2-2.4A)

TPU2000/2000R Modbus/Modbus Plus Automation Guide

	bit 2 : neutral tap range Wdg2 (0=1-12A, 1=0.2-2.4A)
	bit 3 : phase tap range Wdg2 (0=1-12A, 1=0.2-2.4A)
	bit 4 : user definable curves
	bit 5 : Reserved for frequency
	bit 6 : neutral tap range Wdg3 (0=1-12A, 1=0.2-2.4A)
	bit 7 : phase tap range Wdg3 (0=1-12A, 1=0.2-2.4A)
26/2	Checksum high byte
26/3	Checksum low byte

11.11 Receive Configuration Settings (3 11 11)

Low byte consists of bits 0 through 7.

High byte consists of bits 8 through 15.

Mode Selection Type Trip Failure

0 = Differential Trip

1 = OC Alarm

2 = Differential and OC Alarm

Mode Selection Type Demand Time Constant

0 = 5

1 = 15

2 = 30

3 = 60

Msg byte

Definition

1/1	Most significant high byte of password
1/2	Most significant low byte of password
1/3	Least significant high byte of password
2/1	Least significant low byte of password
2/2	spare
2/3	Command + Subcommand = 0xbb
3/1	Wdg1 P CT Ratio high byte (1-2000)
3/2	Wdg1 P CT Ratio low byte
3/3	Wdg1 N CT Ratio high byte (1-2000)
4/1	Wdg1 N CT Ratio low byte
4/2	Wdg2 P CT Ratio high byte (1-2000)
4/3	Wdg2 P CT Ratio low byte
5/1	Wdg2 G CT Ratio high byte (1-2000)
5/2	Wdg2 G CT Ratio low byte
5/3	Winding Phase Comp high byte (0-330, /30)
6/1	Winding Phase Comp low byte
6/2	Wind1 CT Config high byte (0=Wye; 1=Delta, IA-IC; 2=Delta, IA-IB)
6/3	Wind1 CT Config low byte
7/1	Wind2 CT Config high byte (0=Wye; 1=Delta, IA-IC; 2=Delta, IA-IB)
7/2	Wind2 CT Config low byte
7/3	Phase Rotation high byte (0=ABC, 1=ACB)
8/1	Phase Rotation low byte
8/2	Alt 1 Settings high byte (0=Disable, 1=Enable)
8/3	Alt 1 Settings low byte
9/1	Alt 2 Settings high byte (0=Disable, 1=Enable)
9/2	Alt 2 Settings low byte
9/3	Trip Failure Mode high byte (Type Trip Failure)
10/1	Trip Failure Mode low byte
10/2	Trip Failure Time high byte (5-60)
10/3	Trip Failure Time low byte
11/1	Trip Fail Dropout % PU high byte (5-90)
11/2	Trip Fail Dropout % PU low byte
11/3	Configuration Flag high byte

	bit 8 : Cross Block Mode (0=Disable, 1=Enable)
	bit 9 : SPARE
	bit 10 : SPARE
	bit 11 : SPARE
	bit 12 : SPARE
	bit 13 : SPARE
	bit 14 : SPARE
	bit 15 : SPARE
12/1	Configuration Flag low byte
	bit 0 : OC Protect Mode (0=Fund, 1=RMS)
	bit 1 : Reset Mode (0=Instant 1=Delayed)
	bit 2 : Spare
	bit 3 : Target Display Mode (0=Last, 1=All)
	bit 4 : Local Edit (0=Disable, 1=Enable)
	bit 5 : Remote Edit (0=Disable, 1=Enable)
	bit 6 : WHr/VARHr Meter Mode (0=KWHr, 1=MWHr)
	bit 7 : LCD Light (0=Timer, 1=On)
12/2	Unit Name character 1
12/3	Unit Name character 2
13/1	Unit Name character 3
13/2	Unit Name character 4
13/3	Unit Name character 5
14/1	Unit Name character 6
14/2	Unit Name character 7
14/3	Unit Name character 8
15/1	Unit Name character 9
15/2	Unit Name character 10
15/3	Unit Name character 11
16/1	Unit Name character 12
16/2	Unit Name character 13
16/3	Unit Name character 14
17/1	Unit Name character 15
17/2	Transformer Configuration Byte (0=Wye1-Wye2, 1=Wye1-Delta2, 2=Delta1-Wye2, 3=Delta1-Delta2)
17/3	Demand Time Const high byte (Type Demand Time)
18/1	Demand Time Const low byte
18/2	LCD Contrast Adjustment high byte (0-63)
18/3	LCD Contrast Adjustment low byte
19/1	Relay Password character 1
19/2	Relay Password character 2
19/3	Relay Password character 3
20/1	Relay Password character 4
20/2	Meter Winding Mode (0=Wdg1, 1=Wdg2, 2=Wdg3)
20/3	VT Configuration (0=69VWye, 1=120VWye, 2=120V Delta, 3=208V Delta)
21/1	VT Ratio high byte (1-2000)
21/2	VT Ratio low byte
21/3	spare
22/1	spare
22/2	Checksum high byte
22/3	Checksum low byte

11.12 Receive Counter Settings (3 11 12)

Low byte consists of bits 0 through 7.
 High byte consists of bits 8 through 15.

<u>Msg byte</u>	<u>Definition</u>
1/1	Most significant high byte of password
1/2	Most significant low byte of password
1/3	Least significant high byte of password

TPU2000/2000R Modbus/Modbus Plus Automation Guide

2/1	Least significant low byte of password
2/2	spare
2/3	Command + Subcommand = 0xbc
3/1	Through Faults Counter high byte (0-9999)
3/2	Through Faults Counter low byte
3/3	Thr Fault Sum kAmp A Counter high byte (0-9999)
4/1	Thr Fault Sum kAmp A Counter low byte
4/2	Through Fault Sum Cyc Counter high byte (0-99990)
4/3	Through Fault Sum Cyc Counter low byte
5/1	Overcurrent Trips Counter high byte (0-9999)
5/2	Overcurrent Trips Counter low byte
5/3	Differential Trips Counter high byte (0-9999)
6/1	Differential Trips Counter low byte
6/2	Thr Fault Sum kAmp B Counter high byte (0-9999)
6/3	Thr Fault Sum kAmp B Counter low byte
7/1	Thr Fault Sum kAmp C Counter high byte (0-9999)
7/2	Thr Fault Sum kAmp C Counter low byte
7/3	Spare
8/1	Spare
8/2	Checksum high byte
8/3	Checksum low byte

11.13 Receive Alarm Settings (3 11 13)

Low byte consists of bits 0 through 7.

High byte consists of bits 8 through 15.

<u>Msg byte</u>	<u>Definition</u>
1/1	Most significant high byte of password
1/2	Most significant low byte of password
1/3	Least significant high byte of password
2/1	Least significant low byte of password
2/2	spare
2/3	Command + Subcommand = 0xbd
3/1	Through Faults Alarm Threshold high byte (0-9999)
3/2	Through Faults Alarm Threshold low byte
3/2	Through Fault Sum kAmp Alarm Thres high (0-9999)
4/1	Through Fault Sum kAmp Alarm Threshold low byte
4/2	Through Fault Sum Cyc Alarm high (0-99990, /10)
4/3	Through Fault Sum Cyc Alarm Threshold low byte
5/1	Overcurrent Trips Alarm high byte (0-9999)
5/2	Overcurrent Trips Alarm low byte
5/3	Differential Trips Alarm high byte (0-9999)
6/1	Differential Trips Alarm low byte
6/2	Phase Demand Alarm high byte (1-9999)
6/3	Phase Demand Alarm low byte
7/1	Neutral Demand Alarm high byte (1-9999)
7/2	Neutral Demand Alarm low byte
7/3	Load Alarm high byte (1-9999)
8/1	Load Alarm low byte
8/2	Phase Demand Alarm high byte (1-9999,10000=Disables)
8/3	Phase Demand Alarm low byte
9/1	Low PF Alarm high byte(0.5-1.0 *100, 101=Disables)
9/2	Low PF Alarm low byte
9/3	High PF Alarm high byte(0.5-1.0 *100, 101=Disables)
10/1	High Pf Alarm low byte
10/2	Positive kVAR Alarm high byte (10-99990 / 10,10000=Disable)
10/3	Positive kVAR Alarm low byte
11/1	Negative kVAR Alarm high byte (10-99990 /10,10000=Disable)

11/2	Negative kVAR Alarm high byte
11/3	Pos Watt Alarm 1 high byte (1-9999, 10000=Disable)
12/1	Pos Watt Alarm 1 low byte
12/2	Pos Watt Alarm 2 high byte (1-9999, 10000=Disable)
12/3	Pos Watt Alarm 2 low byte
13/1	Spare
13/2	Spare
13/3	Spare
14/1	Spare
14/2	Spare
14/3	Spare
15/1	Spare
15/2	Spare
15/3	Spare
16/1	Spare
16/2	Spare
16/3	Spare
17/1	Spare
17/2	Spare
17/3	Spare
18/1	Spare
18/2	Checksum high byte
18/3	Checksum low byte

11.14 Receive Real Time Clock (3 11 14)

<u>Msg byte</u>	<u>Definition</u>
1/1	Most significant high byte of password
1/2	Most significant low byte of password
1/3	Least significant high byte of password
2/1	Least significant low byte of password
2/2	spare
2/3	Command + Subcommand = 0xbe
3/1	Hours byte (0-23)
3/2	Minutes byte (0-59)
3/3	Seconds byte (0-59)
4/1	Day byte (0-31), (0=Shutdown Clock)
4/2	Month byte (1-12)
4/3	Year byte (0-99)
5/1	spare
5/2	Checksum high byte
5/3	Checksum low byte

11.15 Receive Programmable Output Delays (3 11 15)

<u>Msg Byte</u>	<u>Definition</u>
1/1	Most significant high byte of password
1/2	Most significant low byte of password
1/3	Least significant high byte of password
2/1	Least significant low byte of password
2/2	Spare
2/3	Command + Subcommand = 0xbf
3/1	OUT 5 delay high byte (0.00-60, *100)
3/2	OUT 5 delay low byte
3/3	OUT 7 delay high byte (0.00-60, *100)
4/1	OUT 7 delay low byte
4/2	OUT 4 delay high byte (0.00-60, *100)
4/3	OUT 4 delay low byte
5/1	OUT 6 delay high byte (0.00-60, *100)

TPU2000/2000R Modbus/Modbus Plus Automation Guide

5/2	OUT 6 delay low byte
5/3	OUT 3 delay high byte (0.00-60, *100)
6/1	OUT 3 delay low byte
6/2	OUT 2 delay high byte (0.00-60, *100)
6/3	OUT 2 delay low byte
7/1	OUT 1 delay high byte (0.00-60, *100)
7/2	OUT 1 delay low byte
7/3	Spare
8/1	Spare
8/2	Spare
8/3	Spare
9/1	Spare
9/2	Checksum high byte
9/3	Checksum low byte

13 Programmable Curve Commands (3 13 n)

<u>N</u>	<u>Definition</u>
0	Reserved for repeat 3 13 n
1	Receive Overcurrent Curve Parameters
2	Receive First Overcurrent Curve Data Set
3	Receive Next Overcurrent Curve Data Set
4	Receive Overcurrent Curve Pointer Table
5	Send Overcurrent Curve Parameters
6	Send Overcurrent Curve Data Set
7	Send Overcurrent Curve Pointer Table
8	Receive Differential Curve Parameters
9	Receive First Differential Curve Data Set
10	Receive Next Differential Curve Data Set
11	Send Differential Curve Parameters
12	Send Differential Curve Data Set

13.1 Receive Overcurrent Curve Parameters (3 13 1)

For the unit to receive the overcurrent curve data, the following sequence of commands must be issued:

3 13 1 (Curve Parameters)
3 13 2 (8 Alpha-Beta segments) Block 0
3 13 3 (8 Alpha-Beta segments) Block 1
3 13 3 (8 Alpha-Beta segments) Block 2
3 13 3 (8 Alpha-Beta segments) Block 3
3 13 3 (8 Alpha-Beta segments) Block 4
3 13 3 (8 Alpha-Beta segments) Block 5
3 13 3 (8 Alpha-Beta segments) Block 6
3 13 4 (60 Pointer Offsets)

<u>Data Byte</u>	<u>Definition</u>
1/1	Most significant high byte of password
1/2	Most significant low byte of password
1/3	Least significant high byte of password
2/1	Least significant low byte of password
2/2	Spare
2/3	Command + Subcommand = 0xd1
3/1	Programmable curve number User Programmable Curve number: 1=User 1; 2=User 2; 3=User 3
3/2	Coefficient A (high high byte)
3/3	Coefficient A
4/1	Coefficient A
4/2	Coefficient A (low low byte)

4/3	Coefficient B (high byte)
5/1	Coefficient B
5/2	Coefficient B
5/3	Coefficient B (low byte)
6/1	Coefficient C (high byte)
6/2	Coefficient C
6/3	Coefficient C
7/1	Coefficient C (low byte)
7/2	Coefficient P (high byte)
7/3	Coefficient P
8/1	Coefficient P
8/2	Coefficient P (low byte)
8/3	Spare
9/1	Spare
9/2	Checksum (high byte)
9/3	Checksum (low byte)

13.2 Receive First Overcurrent Curve Data Set (3 13 2)

Data Byte	Definition
1/1	Most significant high byte of password
1/2	Most significant low byte of password
1/3	Least significant high byte of password
2/1	Least significant low byte of password
2/2	Spare
2/3	Command + Subcommand = 0xd2
3/1	Programmable curve number User Programmable Curve number: 1=User 1; 2=User 2; 3=User 3
3/2	Segment 0: Endrange (high byte)
3/3	Segment 0: Endrange (low byte)
4/1	Segment 0: Alpha (high byte)
4/2	Segment 0: Alpha
4/3	Segment 0: Alpha
5/1	Segment 0: Alpha (low byte)
5/2	Segment 0: Beta (high byte)
5/3	Segment 0: Beta
6/1	Segment 0: Beta
6/2	Segment 0: Beta (low byte)
6/3-9/3	Segment 1 (same as segment 0)
10/1-14/1	Segment 2 (same as segment 0)
14/2-18/2	Segment 3 (same as segment 0)
18/3-22/3	Segment 4 (same as segment 0)
23/1-27/1	Segment 5 (same as segment 0)
27/2-31/2	Segment 6 (same as segment 0)
31/3-35/3	Segment 7 (same as segment 0)
36/1	Spare
36/2	Checksum (high byte)
36/3	Checksum (low byte)

13.3 Receive Next Overcurrent Curve Data Set (3 13 3)

Same format as (3 13 2).

13.4 Receive Overcurrent Curve Pointer Table (3 13 4)

Data Byte	Definition
1/1	Most significant high byte of password
1/2	Most significant low byte of password
1/3	Least significant high byte of password

TPU2000/2000R Modbus/Modbus Plus Automation Guide

2/1	Least significant low byte of password
2/2	Spare
2/3	Command + Subcommand = 0xd4
3/1	Programmable curve number User Programmable Curve number: 1=User 1; 2=User 2; 3=User 3
3/2	Pointer offset 0
3/3	Pointer offset 1
4/1	Pointer offset 2
4/2	Pointer offset 3
4/3	Pointer offset 4
5/1	Pointer offset 5
5/2	Pointer offset 6
5/3	Pointer offset 7
6/1	Pointer offset 8
6/2	Pointer offset 9
6/3	Pointer offset 10
7/1	Pointer offset 11
7/2	Pointer offset 12
7/3	Pointer offset 13
8/1	Pointer offset 14
8/2	Pointer offset 15
8/3	Pointer offset 16
9/1	Pointer offset 17
9/2	Pointer offset 18
9/3	Pointer offset 19
10/1	Pointer offset 20
10/2	Pointer offset 21
10/3	Pointer offset 22
11/1	Pointer offset 23
11/2	Pointer offset 24
11/3	Pointer offset 25
12/1	Pointer offset 26
12/2	Pointer offset 27
12/3	Pointer offset 28
13/1	Pointer offset 29
13/2	Pointer offset 30
13/3	Pointer offset 31
14/1	Pointer offset 32
14/2	Pointer offset 33
14/3	Pointer offset 34
15/1	Pointer offset 35
15/2	Pointer offset 36
15/3	Pointer offset 37
16/1	Pointer offset 38
16/2	Pointer offset 39
16/3	Pointer offset 40
17/1	Pointer offset 41
17/2	Pointer offset 42
17/3	Pointer offset 43
18/1	Pointer offset 44
18/2	Pointer offset 45
18/3	Pointer offset 46
19/1	Pointer offset 47
19/2	Pointer offset 48
19/3	Pointer offset 49
20/1	Pointer offset 50
20/2	Pointer offset 51
20/3	Pointer offset 52
21/1	Pointer offset 53

21/2	Pointer offset 54
21/3	Pointer offset 55
22/1	Pointer offset 56
22/2	Pointer offset 57
22/3	Pointer offset 58
23/1	Pointer offset 59
23/2	Spare
23/3	Spare
24/1	Spare
24/2	Spare
24/3	Spare
25/1	Spare
25/2	Spare
25/3	Spare
26/1	Spare
26/2	Checksum (high byte)
26/3	Checksum (low byte)

13.5 Send Overcurrent Curve Parameters (3 13 5)

For the unit to receive the overcurrent curve data, the following sequence of commands must be issued.

- 3 13 5 (Curve Parameters)
- 3 13 6 (8 Alpha-Beta segments) Block 0
- 3 13 6 (8 Alpha-Beta segments) Block 1
- 3 13 6 (8 Alpha-Beta segments) Block 2
- 3 13 6 (8 Alpha-Beta segments) Block 3
- 3 13 6 (8 Alpha-Beta segments) Block 4
- 3 13 6 (8 Alpha-Beta segments) Block 5
- 3 13 6 (8 Alpha-Beta segments) Block 6
- 3 13 7 (60 Pointer Offsets)

<u>Data Byte</u>	<u>Definition</u>
1/1	Programmable Curve Number User Programmable Curve number: 1=User 1; 2=User 2; 3=User 3
1/2	Programmable Curve Number
1/3	Programmable Curve Number

<u>Msg Byte</u>	<u>Definition</u>
1/1	Relay Status (see command 3 4 1, msg 1/1)
1/2	Command + Subcommand = 0xd5
1/3	Total Number of Messages = 8
2/1	Coefficient A (high byte)
2/2	Coefficient A
2/3	Coefficient A
3/1	Coefficient A (low byte)
3/2	Coefficient B (high byte)
3/3	Coefficient B
4/1	Coefficient B
4/2	Coefficient B (low byte)
4/3	Coefficient C (high byte)
5/1	Coefficient C
5/2	Coefficient C
5/3	Coefficient C (low byte)
6/1	Coefficient P (high byte)
6/2	Coefficient P
6/3	Coefficient P
7/1	Coefficient P (low byte)
7/2	Spare

TPU2000/2000R Modbus/Modbus Plus Automation Guide

7/3	Spare
8/1	Spare
8/2	Checksum (high byte)
8/3	Checksum low byte)

13.6 Send Overcurrent Curve Data Set (3 13 6)

<u>Data Byte</u>	<u>Definition</u>
1/1	User Programmable Curve number: 1=User 1; 2=User 2; 3=User 3
1/2	Block number
1/3	Programmable curve number + Block number
<u>Msg Byte</u>	<u>Definition</u>
1/1	Relay Status (see command 3 4 1, msg 1/1)
1/2	Command + Subcommand = 0xd6
1/3	Total Number of Messages = 29
2/1	Programmable curve number User Programmable Curve number: 1=User 1; 2=User 2; 3=User 3
2/2	Block number
2/3	Segment 0: Endrange (high byte)
3/1	Segment 0: Endrange (low byte)
3/2	Segment 0: Alpha (high byte)
3/3	Segment 0: Alpha
4/1	Segment 0: Alpha
4/2	Segment 0: Alpha (low byte)
4/3	Segment 0: Beta (high byte)
5/1	Segment 0: Beta
5/2	Segment 0: Beta
5/3	Segment 0: Beta (low byte)
6/1-9/1	Segment 1 (same as segment 0)
9/2-12/2	Segment 2 (same as segment 0)
12/3-15/3	Segment 3 (same as segment 0)
16/1-19/1	Segment 4 (same as segment 0)
19/2-22/2	Segment 5 (same as segment 0)
22/3-25/3	Segment 6 (same as segment 0)
26/1-29/1	Segment 7 (same as segment 0)
29/2	Checksum (high byte)
29/3	Checksum (low byte)

13.7 Send Overcurrent Curve Pointer Table (3 13 7)

<u>Data Byte</u>	<u>Definition</u>
1/1	Programmable curve number User Programmable Curve number: 1=User 1; 2=User 2; 3=User 3
1/2	Programmable curve number
1/3	Programmable curve number
<u>Msg Byte</u>	<u>Definition</u>
1/1	Relay Status (see command 3 4 1, msg 1/1)
1/2	Command + Subcommand = 0xd7
1/3	Total Number of Messages = 25
2/1	Programmable curve number User Programmable Curve number: 1=User 1; 2=User 2; 3=User 3
2/2	Pointer offset 0
2/3	Pointer offset 1
3/1	Pointer offset 2
3/2	Pointer offset 3
3/3	Pointer offset 4
4/1	Pointer offset 5

4/2	Pointer offset 6
4/3	Pointer offset 7
5/1	Pointer offset 8
5/2	Pointer offset 9
5/3	Pointer offset 10
6/1	Pointer offset 11
6/2	Pointer offset 12
6/3	Pointer offset 13
7/1	Pointer offset 14
7/2	Pointer offset 15
7/3	Pointer offset 16
8/1	Pointer offset 17
8/2	Pointer offset 18
8/3	Pointer offset 19
9/1	Pointer offset 20
9/2	Pointer offset 21
9/3	Pointer offset 22
10/1	Pointer offset 23
10/2	Pointer offset 24
10/3	Pointer offset 25
11/1	Pointer offset 26
11/2	Pointer offset 27
11/3	Pointer offset 28
12/1	Pointer offset 29
12/2	Pointer offset 30
12/3	Pointer offset 31
13/1	Pointer offset 32
13/2	Pointer offset 33
13/3	Pointer offset 34
14/1	Pointer offset 35
14/2	Pointer offset 36
14/3	Pointer offset 37
15/1	Pointer offset 38
15/2	Pointer offset 39
15/3	Pointer offset 40
16/1	Pointer offset 41
16/2	Pointer offset 42
16/3	Pointer offset 43
17/1	Pointer offset 44
17/2	Pointer offset 45
17/3	Pointer offset 46
18/1	Pointer offset 47
18/2	Pointer offset 48
18/3	Pointer offset 49
19/1	Pointer offset 50
19/2	Pointer offset 51
19/3	Pointer offset 52
20/1	Pointer offset 53
20/2	Pointer offset 54
20/3	Pointer offset 55
21/1	Pointer offset 56
21/2	Pointer offset 57
21/3	Pointer offset 58
22/1	Pointer offset 59
22/2	Spare
22/3	Spare
23/1	Spare
23/2	Spare
23/3	Spare

TPU2000/2000R Modbus/Modbus Plus Automation Guide

24/1	Spare
24/2	Spare
24/3	Spare
25/1	Spare
25/2	Checksum (high byte)
25/2	Checksum (low byte)

13.8 Receive Differential Curve Parameters (3 13 8)

For the unit to receive the differential curve data, the following sequence of commands must be issued:

- 3 13 8 (Differential Curve Parameters)
- 3 13 9 (Operate Threshold Data Points) Block 0
- 3 13 10 (Operate Threshold Data Points) Block 1
- 3 13 10 (Operate Threshold Data Points) Block 2

<u>Data Byte</u>	<u>Definition</u>
1/1	Most significant high byte of password
1/2	Most significant low byte of password
1/3	Least significant high byte of password
2/1	Least significant low byte of password
2/2	Spare
2/3	Command + Subcommand = 0xd8
3/1	Programmable curve number (1, 2, or 3)
3/2	Coefficient A (high high byte)
3/3	Coefficient A
4/1	Coefficient A
4/2	Coefficient A (low low byte)
4/3	Coefficient B (high byte)
5/1	Coefficient B
5/2	Coefficient B
5/3	Coefficient B (low byte)
6/1	Coefficient C (high byte)
6/2	Coefficient C
6/3	Coefficient C
7/1	Coefficient C (low byte)
7/2	Spare
7/3	Spare
8/1	Spare
8/2	Spare
8/3	Spare
9/1	Spare
9/2	Checksum (high byte)
9/3	Checksum (low byte)

13.9 Receive First Differential Curve Data Set (3 13 9)

<u>Data Byte</u>	<u>Definition</u>
1/1	Most significant high byte of password
1/2	Most significant low byte of password
1/3	Least significant high byte of password
2/1	Least significant low byte of password
2/2	Spare
2/3	Command + Subcommand = 0xd9
3/1	Programmable curve number (1, 2, or 3)
3/2	Data Point 0: Operate Threshold (high byte)
3/3	Data Point 0: Operate Threshold (low byte)
4/1	Data Point 1: (same as Data Point 0)
4/2	Data Point 1: (same as Data Point 0)

TPU2000/2000R Modbus/Modbus Plus Automation Guide

4/3	Data Point 2: (same as Data Point 0)
5/1	Data Point 2: (same as Data Point 0)
5/2	Data Point 3: (same as Data Point 0)
5/3	Data Point 3: (same as Data Point 0)
6/1	Data Point 4: (same as Data Point 0)
6/2	Data Point 4: (same as Data Point 0)
6/3	Data Point 5: (same as Data Point 0)
7/1	Data Point 5: (same as Data Point 0)
7/2	Data Point 6: (same as Data Point 0)
7/3	Data Point 6: (same as Data Point 0)
8/1	Data Point 7: (same as Data Point 0)
8/2	Data Point 7: (same as Data Point 0)
8/3	Data Point 8: (same as Data Point 0)
9/1	Data Point 8: (same as Data Point 0)
9/2	Data Point 9: (same as Data Point 0)
9/3	Data Point 9: (same as Data Point 0)
10/1	Data Point 10: (same as Data Point 0)
10/2	Data Point 10: (same as Data Point 0)
10/3	Data Point 11: (same as Data Point 0)
11/1	Data Point 11: (same as Data Point 0)
11/2	Data Point 12: (same as Data Point 0)
11/3	Data Point 12: (same as Data Point 0)
12/1	Data Point 13: (same as Data Point 0)
12/2	Data Point 13: (same as Data Point 0)
12/3	Data Point 14: (same as Data Point 0)
13/1	Data Point 14: (same as Data Point 0)
13/2	Data Point 15: (same as Data Point 0)
13/3	Data Point 15: (same as Data Point 0)
14/1	Data Point 16: (same as Data Point 0)
14/2	Data Point 16: (same as Data Point 0)
14/3	Data Point 17: (same as Data Point 0)
15/1	Data Point 17: (same as Data Point 0)
15/2	Data Point 18: (same as Data Point 0)
15/3	Data Point 18: (same as Data Point 0)
16/1	Data Point 19: (same as Data Point 0)
16/2	Data Point 19: (same as Data Point 0)
16/3	Data Point 20: (same as Data Point 0)
17/1	Data Point 20: (same as Data Point 0)
17/2	Data Point 21: (same as Data Point 0)
17/3	Data Point 21: (same as Data Point 0)
18/1	Data Point 22: (same as Data Point 0)
18/2	Data Point 22: (same as Data Point 0)
18/3	Data Point 23: (same as Data Point 0)
19/1	Data Point 23: (same as Data Point 0)
19/2	Data Point 24: (same as Data Point 0)
19/3	Data Point 24: (same as Data Point 0)
20/1	Data Point 25: (same as Data Point 0)
20/2	Data Point 25: (same as Data Point 0)
20/3	Data Point 26: (same as Data Point 0)
21/1	Data Point 26: (same as Data Point 0)
21/2	Data Point 27: (same as Data Point 0)
21/3	Data Point 27: (same as Data Point 0)
22/1	Data Point 28: (same as Data Point 0)
22/2	Data Point 28: (same as Data Point 0)
22/3	Data Point 29: (same as Data Point 0)
23/1	Data Point 29: (same as Data Point 0)
23/2	Data Point 30: (same as Data Point 0)
23/3	Data Point 30: (same as Data Point 0)
24/1	Data Point 31: (same as Data Point 0)

TPU2000/2000R Modbus/Modbus Plus Automation Guide

24/2	Data Point 31: (same as Data Point 0)
24/3	Data Point 32: (same as Data Point 0)
25/1	Data Point 32: (same as Data Point 0)
25/2	Data Point 33: (same as Data Point 0)
25/3	Data Point 33: (same as Data Point 0)
26/1	Data Point 34: (same as Data Point 0)
26/2	Data Point 34: (same as Data Point 0)
26/3	Data Point 35: (same as Data Point 0)
27/1	Data Point 35: (same as Data Point 0)
27/2	Data Point 36: (same as Data Point 0)
27/3	Data Point 36: (same as Data Point 0)
28/1	Data Point 37: (same as Data Point 0)
28/2	Data Point 37: (same as Data Point 0)
28/3	Data Point 38: (same as Data Point 0)
29/1	Data Point 38: (same as Data Point 0)
29/2	Data Point 39: (same as Data Point 0)
29/3	Data Point 39: (same as Data Point 0)
30/1	Data Point 40: (same as Data Point 0)
30/2	Data Point 40: (same as Data Point 0)
30/3	Data Point 41: (same as Data Point 0)
31/1	Data Point 41: (same as Data Point 0)
31/2	Data Point 42: (same as Data Point 0)
31/3	Data Point 42: (same as Data Point 0)
32/1	Data Point 43: (same as Data Point 0)
32/2	Data Point 43: (same as Data Point 0)
32/3	Data Point 44: (same as Data Point 0)
33/1	Data Point 44: (same as Data Point 0)
33/2	Data Point 45: (same as Data Point 0)
33/3	Data Point 45: (same as Data Point 0)
34/1	Data Point 46: (same as Data Point 0)
34/2	Data Point 46: (same as Data Point 0)
34/3	Data Point 47: (same as Data Point 0)
35/1	Data Point 47: (same as Data Point 0)
35/2	Data Point 48: (same as Data Point 0)
35/3	Data Point 48: (same as Data Point 0)
36/1	Data Point 49: (same as Data Point 0)
36/2	Data Point 49: (same as Data Point 0)
36/3	Data Point 50: (same as Data Point 0)
37/1	Data Point 50: (same as Data Point 0)
37/2	Data Point 51: (same as Data Point 0)
37/3	Data Point 51: (same as Data Point 0)
38/1	Data Point 52: (same as Data Point 0)
38/2	Data Point 52: (same as Data Point 0)
38/3	Spare
39/1	Spare
39/2	Checksum (high byte)
39/3	Checksum (low byte)

13.10 Receive Next Differential Curve Data Set (3 13 10)

Same format as (3 13 9).

13.11 Send Differential Curve Parameters (3 13 11)

For the unit to receive the Differential curve data, the following sequence of commands must be issued.

- 3 13 11 (Differential Curve Parameters)
- 3 13 12 (Operate Threshold Data Points) Block 0
- 3 13 12 (Operate Threshold Data Points) Block 1

3 13 12 (Operate Threshold Data Points) Block 2

<u>Data Byte</u>	<u>Definition</u>
1/1	Programmable Curve Number (1, 2, or 3)
1/2	Programmable Curve Number (1, 2, or 3)
1/3	Programmable Curve Number (1, 2, or 3)
<u>Msg Byte</u>	<u>Definition</u>
1/1	Relay Status (see command 3 4 1, msg 1/1)
1/2	Command + Subcommand = 0xdb
1/3	Total Number of Messages = 8
2/1	Coefficient A (high byte)
2/2	Coefficient A
2/3	Coefficient A
3/1	Coefficient A (low byte)
3/2	Coefficient B (high byte)
3/3	Coefficient B
4/1	Coefficient B
4/2	Coefficient B (low byte)
4/3	Coefficient C (high byte)
5/1	Coefficient C
5/2	Coefficient C
5/3	Coefficient C (low byte)
6/1	Spare
6/2	Spare
6/3	Spare
7/1	Spare
7/2	Spare
7/3	Spare
8/1	Spare
8/2	Checksum (high byte)
8/3	Checksum low byte)

13.12 Send Differential Curve Data Set (3 13 12)

<u>Data Byte</u>	<u>Definition</u>
1/1	Programmable curve number (1, 2, or 3)
1/2	Block number
1/3	Programmable curve number + Block number
<u>Msg Byte</u>	<u>Definition</u>
1/1	Relay Status (see command 3 4 1, msg 1/1)
1/2	Command + Subcommand = 0xdc
1/3	Total Number of Messages = 38
2/1	Programmable curve number (1, 2, or 3)
2/2	Block number
2/3	Data Point 0: Operate Threshold (high byte)
3/1	Data Point 0: Operate Threshold (low byte)
3/2	Data Point 1: (same as Data Point 0)
3/3	Data Point 1: (same as Data Point 0)
4/1	Data Point 2: (same as Data Point 0)
4/2	Data Point 2: (same as Data Point 0)
4/3	Data Point 3: (same as Data Point 0)
5/1	Data Point 3: (same as Data Point 0)
5/2	Data Point 4: (same as Data Point 0)
5/3	Data Point 4: (same as Data Point 0)
6/1	Data Point 5: (same as Data Point 0)
6/2	Data Point 5: (same as Data Point 0)
6/3	Data Point 6: (same as Data Point 0)

TPU2000/2000R Modbus/Modbus Plus Automation Guide

7/1	Data Point 6: (same as Data Point 0)
7/2	Data Point 7: (same as Data Point 0)
7/3	Data Point 7: (same as Data Point 0)
8/1	Data Point 8: (same as Data Point 0)
8/2	Data Point 8: (same as Data Point 0)
8/3	Data Point 9: (same as Data Point 0)
9/1	Data Point 9: (same as Data Point 0)
9/2	Data Point 10: (same as Data Point 0)
9/3	Data Point 10: (same as Data Point 0)
10/1	Data Point 11: (same as Data Point 0)
10/2	Data Point 11: (same as Data Point 0)
10/3	Data Point 12: (same as Data Point 0)
11/1	Data Point 12: (same as Data Point 0)
11/2	Data Point 13: (same as Data Point 0)
11/3	Data Point 13: (same as Data Point 0)
12/1	Data Point 14: (same as Data Point 0)
12/2	Data Point 14: (same as Data Point 0)
12/3	Data Point 15: (same as Data Point 0)
13/1	Data Point 15: (same as Data Point 0)
13/2	Data Point 16: (same as Data Point 0)
13/3	Data Point 16: (same as Data Point 0)
14/1	Data Point 17: (same as Data Point 0)
14/2	Data Point 17: (same as Data Point 0)
14/3	Data Point 18: (same as Data Point 0)
15/1	Data Point 18: (same as Data Point 0)
15/2	Data Point 19: (same as Data Point 0)
15/3	Data Point 19: (same as Data Point 0)
16/1	Data Point 20: (same as Data Point 0)
16/2	Data Point 20: (same as Data Point 0)
16/3	Data Point 21: (same as Data Point 0)
17/1	Data Point 21: (same as Data Point 0)
17/2	Data Point 22: (same as Data Point 0)
17/3	Data Point 22: (same as Data Point 0)
18/1	Data Point 23: (same as Data Point 0)
18/2	Data Point 23: (same as Data Point 0)
18/3	Data Point 24: (same as Data Point 0)
19/1	Data Point 24: (same as Data Point 0)
19/2	Data Point 25: (same as Data Point 0)
19/3	Data Point 25: (same as Data Point 0)
20/1	Data Point 26: (same as Data Point 0)
20/2	Data Point 26: (same as Data Point 0)
20/3	Data Point 27: (same as Data Point 0)
21/1	Data Point 27: (same as Data Point 0)
21/2	Data Point 28: (same as Data Point 0)
21/3	Data Point 28: (same as Data Point 0)
22/1	Data Point 29: (same as Data Point 0)
22/2	Data Point 29: (same as Data Point 0)
22/3	Data Point 30: (same as Data Point 0)
23/1	Data Point 30: (same as Data Point 0)
23/2	Data Point 31: (same as Data Point 0)
23/3	Data Point 31: (same as Data Point 0)
24/1	Data Point 32: (same as Data Point 0)
24/2	Data Point 32: (same as Data Point 0)
24/3	Data Point 33: (same as Data Point 0)
25/1	Data Point 33: (same as Data Point 0)
25/2	Data Point 34: (same as Data Point 0)
25/3	Data Point 34: (same as Data Point 0)
26/1	Data Point 35: (same as Data Point 0)
26/2	Data Point 35: (same as Data Point 0)

26/3	Data Point 36: (same as Data Point 0)
27/1	Data Point 36: (same as Data Point 0)
27/2	Data Point 37: (same as Data Point 0)
27/3	Data Point 37: (same as Data Point 0)
28/1	Data Point 38: (same as Data Point 0)
28/2	Data Point 38: (same as Data Point 0)
28/3	Data Point 39: (same as Data Point 0)
29/1	Data Point 39: (same as Data Point 0)
29/2	Data Point 40: (same as Data Point 0)
29/3	Data Point 40: (same as Data Point 0)
30/1	Data Point 41: (same as Data Point 0)
30/2	Data Point 41: (same as Data Point 0)
30/3	Data Point 42: (same as Data Point 0)
31/1	Data Point 42: (same as Data Point 0)
31/2	Data Point 43: (same as Data Point 0)
31/3	Data Point 43: (same as Data Point 0)
32/1	Data Point 44: (same as Data Point 0)
32/2	Data Point 44: (same as Data Point 0)
32/3	Data Point 45: (same as Data Point 0)
33/1	Data Point 45: (same as Data Point 0)
33/2	Data Point 46: (same as Data Point 0)
33/3	Data Point 46: (same as Data Point 0)
34/1	Data Point 47: (same as Data Point 0)
34/2	Data Point 47: (same as Data Point 0)
34/3	Data Point 48: (same as Data Point 0)
35/1	Data Point 48: (same as Data Point 0)
35/2	Data Point 49: (same as Data Point 0)
35/3	Data Point 49: (same as Data Point 0)
36/1	Data Point 50: (same as Data Point 0)
36/2	Data Point 50: (same as Data Point 0)
36/3	Data Point 51: (same as Data Point 0)
37/1	Data Point 51: (same as Data Point 0)
37/2	Data Point 52: (same as Data Point 0)
37/3	Data Point 52: (same as Data Point 0)
38/1	Spare
38/2	Checksum (high byte)
38/3	Checksum (low byte)

14 Waveform Capture Commands (3 14 n)

<u>N</u>	<u>Definition</u>
0	Define waveform capture settings
1	Show waveform capture settings
2	Start waveform data accumulation
3	Stop waveform data accumulation
4	Report waveform record data headers
5	Fetch first block of a record (Part A)
6	Fetch next block of a record (Part A)
7	Retransmit last block of a record (Part A)
8	Fetch first block of a record (Part B)
9	Fetch next block of a record (Part B)
10	Retransmit last block of a record (Part B)
11	Fetch Acquisition Status

14.0 Define Waveform Capture Settings (3 14 0)

Note the trigger sources are OR'ed together.

Example: if 3/1 is Hex 07 ;trigger on 87T or 87H or 51P-1 pickup. The capture is 8 cycles of waveform with 32 samples per

TPU2000/2000R Modbus/Modbus Plus Automation Guide

cycle. We then have 8 inputs each of 8 cycles captured. The inputs are Ia-1,Ib-1,Ic-1,In-1, Ia-2 Ib-2 Ic-2 and Ig-2 . The data is sent from the TPU in quarter cycle records, that is 32/4 samples per analog variable.

<u>Data Byte</u>	<u>Definition</u>
1/1	Most significant high byte of password
1/2	Most significant low byte of password
1/3	Least significant high byte of password
2/1	Least significant low byte of password
2/2	Spare
2/3	Command + Subcommand = 0xe0
3/1	Trigger source (byte 1) Bit 0: 87T Bit 1: 87H Bit 2: 51P-1 Bit 3: 51N-1 Bit 4: 50P-1 Bit 5: 50N-1 Bit 6: 150P-1 Bit 7: 150N-1
3/2	Trigger source (byte 2) Bit 0: 46-1 Bit 1: 51P-2 Bit 2: 51G-2 Bit 3: 50P-2 Bit 4: 50G-2 Bit 5: 150P-2 Bit 6: 150G-2 Bit 7: 46-2
3/3	Trigger source : (byte 3) Bit 0: Through Fault Bit 1: Harmonic Restraint Bit 2: External (WCI)
4/1	Trigger source:reserved (byte 4)
4/2	Trigger position quarter cycle: 0 to 255 (for 64 qtr cycle record) 0 to 128 (for 32 qtr cycle record) 0 to 64 (for 16 qtr cycle record) 0 to 32 (for 8 qtr cycle record)
4/3	Mode/Record Size bit 0, 1: 00 = 8 rec of 8 qtr cycle record 01 = 4 rec of 16 qtr cycle record 10 = 2 rec of 32 qtr cycle record 11 = 1 rec of 64 qtr cycle record bit 6: Single Shot Mode (0=Off, 1=On) bit 7: Append Record Mode (0=Off, 1=On)
5/1	Spare
5/2	Checksum high byte
5/3	Checksum low byte

14.1 Report Waveform Capture Settings (3 14 1)

<u>Data Byte</u>	<u>Definition</u>
1/1	Relay Status (see command 3 4 1, msg 1/1)
1/2	Command + Subcommand = 0xe1
1/3	Total Number of Messages = 9
2/1 - 6/3	Unit ID Name (15 characters)
7/1	Trigger source (byte 1) Bit 0: 87T Bit 1: 87H

	Bit 2: 51P-1
	Bit 3: 51N-1
	Bit 4: 50P-1
	Bit 5: 50N-1
	Bit 6: 150P-1
	Bit 7: 150N-1
7/2	Trigger source (byte 2)
	Bit 0: 46-1
	Bit 1: 51P-2
	Bit 2: 51G-2
	Bit 3: 50P-2
	Bit 4: 50G-2
	Bit 5: 150P-2
	Bit 6: 150G-2
	Bit 7: 46-2
7/3	Trigger source (byte 3)
	Bit 0: Through Fault
	Bit 1: Harmonic Restraint
	Bit 2: External (WCI)
8/1	Trigger source (byte 4)
8/2	Trigger position quarter cycle:
	0 to 255 (for 64 qtr cycle record)
	0 to 128 (for 32 qtr cycle record)
	0 to 64 (for 16 qtr cycle record)
	0 to 32 (for 8 qtr cycle record)
8/3	Mode/Record Size

TPU2000/2000R Modbus/Modbus Plus Automation Guide

	bit 0, 1: 00 = 8 rec of 8 qtr cycle record
	01 = 4 rec of 16 qtr cycle record
	10 = 2 rec of 32 qtr cycle record
	11 = 1 rec of 64 qtr cycle record
	bit 6: Single Shot Mode (0=Off, 1=On)
	bit 7: Append Record Mode (0=Off, 1=On)
9/1	Spare
9/2	Checksum (high byte)
9/3	Checksum (low byte)

14.2 Arm Waveform Data Accumulation (3 14 2)

14.3 Disarm Waveform Data Accumulation (3 14 3)

14.4 Report Waveform Record Data Headers (3 14 4)

<u>Msg Byte</u>	<u>Definition</u>
1/1	Relay Status (see command 3 4 1, msg 1/1)
1/2	Command + Subcommand = 0xe4
1/3	Total Number of Messages = 38
2/1 - 6/3	Unit ID Name (15 characters)
7/1	Record 0: Trigger position
7/2	Record 0: Year
7/3	Record 0: Month
8/1	Record 0: Date
8/2	Record 0: Hour
8/3	Record 0: Minute
9/1	Record 0: Second
9/2	Record 0: Hundredth of second
9/3	Record 0: Spare
10/1	Record 0: Spare
10/2	Record 0: Mode/Record Size
	bit 0, 1: 00 = 8 rec of 8 qtr cycle record
	01 = 4 rec of 16 qtr cycle record
	10 = 2 rec of 32 qtr cycle record
	11 = 1 rec of 64 qtr cycle record
	bit 6: Single Shot Mode (0=Off, 1=On)
	bit 7: Append Record Mode (0=Off, 1=On)
10/3	Record 0: Spare
11/1 - 14/3	Record 1 (same as record 0)
15/1 - 18/3	Record 2 (")
19/1 - 22/3	Record 3 (")
23/1 - 26/3	Record 4 (")
27/1 - 30/3	Record 5 (")
31/1 - 34/3	Record 6 (")
35/1 - 38/3	Record 7 (")

14.5 Fetch First Block of a Record-Part A (3 14 5)

<u>Data Byte</u>	<u>Definition</u>
1/1	Record number (0 to 7)
1/2	Record number (0 to 7)-Duplicate
1/3	Record number (0 to 7)-TriPLICATE

<u>Msg Byte</u>	<u>Definition</u>
1/1	Relay status (see command 3 4 1, msg 1/1)
1/2	Command + Subcommand = 0xe5
1/3	Total Number of Messages = 45
2/1	Record number

2/2	Block number
2/3	Sample 0: Ia-1 (high byte)
3/1	Sample 0: Ia-1 (low byte)
3/2	Sample 0: Ib-1 (high byte)
3/3	Sample 0: Ib-1 (low byte)
4/1	Sample 0: Ic-1 (high byte)
4/2	Sample 0: Ic-1 (low byte)
4/3	Sample 0: In-1 (high byte)
5/1	Sample 0: In-1 (low byte)
5/2	Sample 0: Ia-2 (high byte)
5/3	Sample 0: Ia-2 (low byte)
6/1	Sample 0: Ib-2 (high byte)
6/2	Sample 0: Ib-2 (low byte)
6/3	Sample 0: Ic-2 (high byte)
7/1	Sample 0: Ic-2 (low byte)
7/2	Sample 0: Ig-2 (high byte)
7/3	Sample 0: Ig-2 (low byte)
8/1 - 13/1	Sample 1 data
13/2 - 18/2	Sample 2 data
18/3 - 23/3	Sample 3 data
24/1 - 29/1	Sample 4 data
29/2 - 34/2	Sample 5 data
34/3 - 39/3	Sample 6 data
40/1 - 45/1	Sample 7 data
45/2	Spare
45/3	Spare

14.6 Fetch Next Block of a Record-Part A (3 14 6)

Same message format as (3 14 5)

14.7 Retransmit Last Block of a Record-Part A (3 14 7)

Same message format as (3 14 5)

14.8 Fetch First Block of a Record-Part B (3 14 8)

<u>Msg Byte</u>	<u>Definition</u>
1/1	Relay status (see command 3 4 1, msg 1/1)
1/2	Command + Subcommand = 0xe8
1/3	Total Number of Messages = 9
2/1	Record number
2/2	Block number
2/3	Phase scale Wdg 1 (high byte)
3/1	Phase scale Wdg 1 (low byte)
3/2	Neutral scale Wdg 1 (high byte)
3/3	Neutral scale Wdg 1 (low byte)
4/1	Phase scale Wdg 2 (high byte)
4/2	Phase scale Wdg 2 (low byte)
4/3	Ground scale Wdg 2 (high byte)
5/1	Ground scale Wdg 2 (low byte)
5/2	Input status (high byte)
5/3	Input status (low byte)
6/1	Output status (high byte)
6/2	Output status (low byte)
	Bit 0: Differential Trip
	Bit 1: Trip failure
	Bit 2: Through Fault
	Bit 3: 2nd Harmonic Restraint

TPU2000/2000R Modbus/Modbus Plus Automation Guide

	Bit 4: 5th Harmonic Restraint
	Bit 5: All Harmonic Restraint
6/3	Pickup status (High high byte)
7/1	Pickup status (High low byte)
7/2	Pickup status (Low high byte)
	Bit 0: 46-1
	Bit 1: 51P-2
	Bit 2: 51G-2
	Bit 3: 50P-2
	Bit 4: 50G-2
	Bit 5: 150P-2
	Bit 6: 150G-2
	Bit 7: 46-2
7/3	Pickup status (Low low byte)
	Bit 0: 87T
	Bit 1: 87H
	Bit 2: 51P-1
	Bit 3: 51N-1
	Bit 4: 50P-1
	Bit 5: 50N-1
	Bit 6: 150P-1
	Bit 7: 150N-1
8/1	Fault status (High high byte)
8/2	Fault status (High low byte)
8/3	Fault status (Low high byte)
	Bit 0: 46-1
	Bit 1: 51P-2
	Bit 2: 51G-2
	Bit 3: 50P-2
	Bit 4: 50G-2
	Bit 5: 150P-2
	Bit 6: 150G-2
	Bit 7: 46-2
9/1	Fault status (Low low byte)
	Bit 0: 87T
	Bit 1: 87H
	Bit 2: 51P-1
	Bit 3: 51N-1
	Bit 4: 50P-1
	Bit 5: 50N-1
	Bit 6: 150P-1
	Bit 7: 150N-1
9/2	Spare
9/3	Spare

14.9 Fetch Next Block of a Record-Part B (3 14 9)

Same message format as (3 14 8)

14.10 Retransmit Last Block of a Record-Part B (3 14 10)

Same message format as (3 14 8)

14.11 Fetch Acquisition Status (3 14 11)

<u>Msg Byte</u>	<u>Definition</u>
1/1	Relay status (see command 3 4 1, msg 1/1)
1/2	Command + Subcommand = 0xeb
1/3	Total Number of Messages = 2

TPU2000/2000R Modbus/Modbus Plus Automation Guide

2/1	Mode/Record Size bit 0, 1: 00 = 8 rec of 8 qtr cycle record 01 = 4 rec of 16 qtr cycle record 10 = 2 rec of 32 qtr cycle record 11 = 1 rec of 64 qtr cycle record bit 6: Single Shot Mode (0=Off, 1=On) bit 7: Append Record Mode (0=Off, 1=On)
2/2	Records Remaining (Single Shot Mode Only)
2/3	State of Accumulation (0=Running, 1=Stopped)

Appendix B - ASCII CODE

Decimal Value	Hexadecimal Value	Control Character	Character
0	00	NUL (CTRL @)	Null
1	01	SOH (CTRL A)	
2	02	STX (CTRL B)	
3	03	ETX (CTRL C)	
4	04	EOT (CTRL D)	
5	05	ENQ (CTRL E)	
6	06	ACK(CTRL F)	
7	07	BEL (CTRL G)	Beep
8	08	BS (CTRL H)	Backspace
9	09	HT (CTRL I)	Tab
10	0A	LF (CTRL J)	Line-feed
11	0B	VT (CTRL K)	Cursor home
12	0C	FF (CTRL M)	Form-feed
13	0D	CR (CTRL N)	Carriage Return (Enter)
14	0E	SO (CTRL O)	Shift Out
15	0F	SI (CTRL P)	Shift In
16	10	DLE	Data Link Escape
17	11	DC1	
18	12	DC2	
19	13	DC3	
20	14	DC4	
21	15	NAK	
22	16	SYN	
23	17	ETB	
24	18	CAN	
25	19	EM	
26	1A	SUB	
27	1B	ESC	
28	1C		Cursor right
29	1D		Cursor left
30	1E		Cursor up
31	1F		Cursor down
32	20		Space
33	21		!
34	22		"
35	23		#
36	24		\$
37	25		%
38	26		&
39	27		'
40	28		(
41	29		(
42	2A		*
43	2B		+
44	2C		,
45	2D		-
46	2E		.
47	2F		/
48	30		0
49	31		1
50	32		2
51	33		3

TPU2000/2000R Modbus/Modbus Plus Automation Guide

52	34	4
53	35	5
54	36	6
55	37	7
56	38	8
57	39	9
58	3A	
59	3B	
60	3C	<
61	3D	
62	3E	>
63	3F	?
64	40	@
65	41	A
66	42	B
67	43	C
68	44	D
69	45	E
70	46	F
71	47	G
72	48	H
73	49	I
74	4A	J
75	4B	K
76	4C	L
77	4D	M
78	4E	N
79	4F	O
80	50	P
81	51	Q
82	52	R
83	53	S
84	54	T
85	55	U
86	56	V
87	57	W
88	58	X
89	59	Y
90	5A	Z
91	5B	[
92	5C	\
93	5D]
94	5E	^
95	5F	~
96	60	
97	61	a
98	62	b
99	63	c
100	64	d
101	65	e
102	66	f
103	67	g
104	68	h
105	69	i
106	6A	j
107	6B	k
108	6C	l
109	6D	m
110	6E	n

TPU2000/2000R Modbus/Modbus Plus Automation Guide

111	6F	o
112	70	p
113	71	q
114	72	r
115	73	s
116	74	t
117	75	u
118	76	v
119	77	w
120	78	x
121	79	y
122	7A	z
123	7B	{
124	7C	
125	7D	}
126	7E	~
127	7F	DEL

Appendix C - Modbus Plus Communication Between an ABB Protective Relay and a Modicon PLC

ABSTRACT: Modbus Plus Capable devices are continuously being introduced into the utility environment. This Application Note is intended to educate the user with the method to use the protective relay and PLC's Modbus Plus capabilities to allow for data access and control capabilities. A simple communication example is intended to give the reader a simple method to establish communication between devices using PLC Ladder Logic. This Application Note relies upon the reader's understanding of Ladder Logic programming of a Modicon PLC and Modbus Plus application.

Modbus Plus General Information

Modbus Plus is a communication protocol, which encompasses the physical layer, data link, transport and application link layer definition within the ISO model representation. The physical layer is a hybrid-defined interface, which allows up to 64 devices to be multi-dropped along a serial interconnection. The interface also allows devices to communicate to each other with a data rate (baud rate) of 1 megabaud. The combination of protocol implementation and baud rate selection make Modbus Plus an excellent high performance protocol desirable for the substation environment.

However, Modbus Plus has been given additional capabilities, which exceed the benefits of a fast baud rate. Modbus Plus is based upon a hybrid implementation of HDLC (High-level Data Link Control) protocol. This implementation allows multiple devices to communicate along a single cable interface. Modbus Plus allows up to 32 (or 64 with the addition of repeaters) devices to communicate along a network connection. Additionally, each device can be capable of transmitting/receiving data of a length of 32 data words, which can be seen by all nodes, attached to the network. Modbus Plus has the Modbus Protocol imbedded within its data transport structure.

Modbus Plus is a deterministic network in that the response time to a command can be reasonably calculated. The method of determinism employed is referred to as "Token Passing". Please refer to both ABB and Schneider Electric documentation referencing network throughput calculation. Each node attached to the network can read/write information in a calculated amount of time which is determined by data transferred along the network and the amount of nodes along the network receiving the token. The amount of time in which to transfer the token to each network is referred to as "Token Rotation Time".

Modbus Plus Communication Between Devices

Modicon Programmable Logic Controllers (PLC's) can communicate with Modbus Plus Capable devices using two methods: Method 1 is using Peer Cop,. Method 2 is using a Master Block.

Peer Cop is a capability used only to allow devices by Schneider Electric to communicate with each other. It enables one device to be configured to read or write from/to each other along a Modbus Plus connection path. It's throughput is dependent upon the Modbus Plus token rotation time.

A Master Block is the PLC's method of using an instruction, which is inserted within the PLC's Ladder Logic scan to access data from another Modbus Plus capable device. A Master Block performs the following data access tasks:

- Write 4X Data to other devices
- Read 4X Data from other devices
- Get Local Modbus Plus Network Statistics
- Clear Local Modbus Plus Network Statistics
- Write Global Database
- Read Global Database
- Get Remote Modbus Plus Network Statistics
- Clear Remote Modbus Plus Network Statistics
- Obtain Node Peer Cop Health Statistics

TPU2000/2000R Modbus/Modbus Plus Automation Guide

Data transfer (read or write) is explained later in this document. Network Statistics is a count of each of the node's good / bad transmission counts. If a bad transmission occurs, the nature of the failure is tallied on a table. Local statistics are those from nodes on the same Modbus Plus network, Remote Statistics are those gathered from nodes on other interconnected Modbus Plus networks.

An ABB protective relay has Modbus Plus "HOST" addressing implementation. An additional path entry is required for address assignment for devices which are designed with Modbus Plus "HOST" implementation. An ABB protective relay has the following Modbus Plus features available:

- Place 32 Registers of Data in the Global Database for access by other devices.
- Reply to 4X Read Data Requests from a Host or PLC Device.
- Perform Operations when 4X Write Data Requests are sent by a Host Device.
- Respond to Local and Remote Network Statistics Requests.
- Respond to Clear Local and Remote Local Statistics Requests.

In summary, the ABB protective relay responds to commands from a Modicon PLC as well as place data into the Global Register buffer for retrieval from a host device.

Modbus Plus Node Addressing and Path Designation

Modbus Plus Node addressing for a Modicon PLC is determined by a thumbwheel switch or dipswitch configuration on the appropriate PLC. Please reference the appropriate Schneider Electric Product Manual for further information.

Figure 1 illustrates the Modicon PLC's resident data paths. The PLC has four data slave paths resident in its device. An Additional Global Data Read Data Slave Path is available. It is through these paths that the PLC shall obtain the relay information.

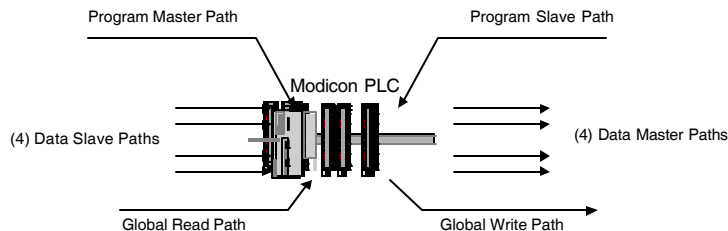

Figure 10. Typical Modicon PLC Modbus Plus Path Definition

The ABB Relay implementation host paths are shown in Figure 2. A comparison of the data paths shows the similarities and differences between the PLC and ABB Relay implementation.

The ABB Relay however, requires an additional path added to its base address to complete the full Modbus Plus address. As per the Figure 2 implementation, 8 data slave paths are incorporated within the relay. For a PLC to access the data within the relay, a base address of the node and one of the eight path addresses must be given for the address.

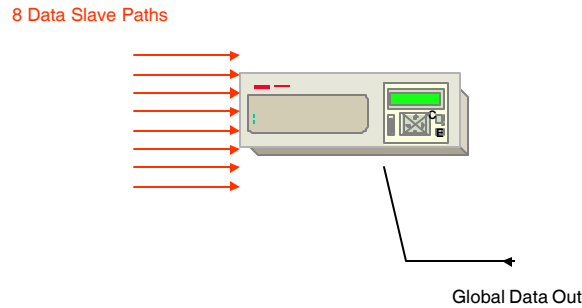

Figure 2. ABB Protective Relay Path Implementation

Setting the address, of the ABB protective relay is accomplished via the front panel interface or via the ECP programming software accessible via the programming port. The address is in HEX encoding.

For example, if the PLC in Figure 1 was configured for address 1 and the ABB Protective Relay was configured for address 10 decimal (or configured as ADDRESS "A" hex through the front panel or ECP), the PLC would address the relay through one of any of the following addresses:

- 10.1.0.0.0 - Address 10 Path 1
- 10.2.0.0.0 - Address 10 Path 2
- 10.3.0.0.0 - Address 10 Path 3
- 10.4.0.0.0 - Address 10 Path 4
- 10.5.0.0.0 - Address 10 Path 5
- 10.6.0.0.0 - Address 10 Path 6
- 10.7.0.0.0 - Address 10 Path 7
- 10.8.0.0.0 - Address 10 Path 8

The Master Block Explained

The Modicon PLC allows for 4X data retrieval via Modbus Plus. The PLC scans ladder logic as such: Read PLC INPUTS → Execute LADDER LOGIC → Write PLC Outputs. The PLC scan is illustrated in Figure 3. The PLC reads the physical inputs wired into the unit, executes the program written in the PLC's native language (icon based Ladder Logic), and writes the status to the physical Output modules to control the hardwired components.

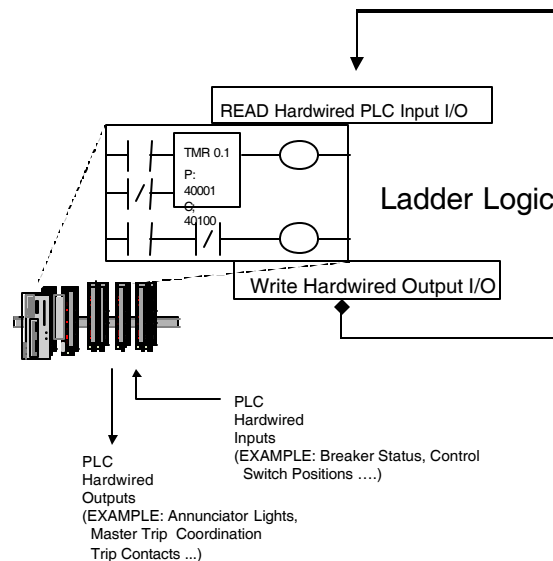

Figure 3. Typical PLC Logic Execution

TPU2000/2000R Modbus/Modbus Plus Automation Guide

Within the PLC, a Master Instruction should be programmed within the unit which when scanned and executed, the PLC will transmit/receive data over the Modbus Plus Network. It may take more than one PLC scan to obtain the data over the network. The PLC scan is never stopped to wait for the data. The PLC will continue with its logic execution and upon a new ladder logic scan, a determination will be made by the instruction as to whether it received the information in the appropriate amount of time. The throughput of the data acquisition is determined by a variety of factors:

- Ladder Logic Execution Speed.
- Token Rotation Speed of Modbus Plus.
- Amount of data travelling over the network at the time of the request.
- Latency of the receiving device to respond to the request when received.

The MSTR (Master) Block is illustrated in Figure 4. A single PLC may have up to four Master Blocks active at any one time accessing data from the ABB protective relay. The amount of data, which may be requested by a PLC, is determined by the amount of free data paths available on the PLC. The ABB protective relay has up to 8 data paths, which may be accessed and busy at one time. The MSTR instruction block is parameterized via the PLC's Ladder Logic to perform the intended functions as illustrated via the function codes. If one was to obtain data from the GLOBAL data path, the amount of active MSTR instructions could be in a number greater than four.

The MSTR instruction is executed whenever the ENABLE instruction leg is energized. If the instruction is enabled, the ACTIVE output at the right side of the instruction shall energize. When the instruction has executed correctly, the COMPLETE instruction leg shall energize and the ACTIVE leg shall de-energize. If an error occurs within parameterization or timeout of the network without a response, the ERROR leg shall energize and the ACTIVE leg shall de-energize. The parameterization shall occur through configuration of the correct 4XXXX registers via the table provided for the instruction. If an error occurs, register 4XXXX +1 shall contain a number other than 0 indicating the failure. If a successful communication occurs, the data will be transferred into register block 4YYYY to 4YYYY + NNN (if a read operation or network statistics read operation) or data transferred from the PLC block 4YYY to 4YYY + NNN if the MSTR operation is a write.

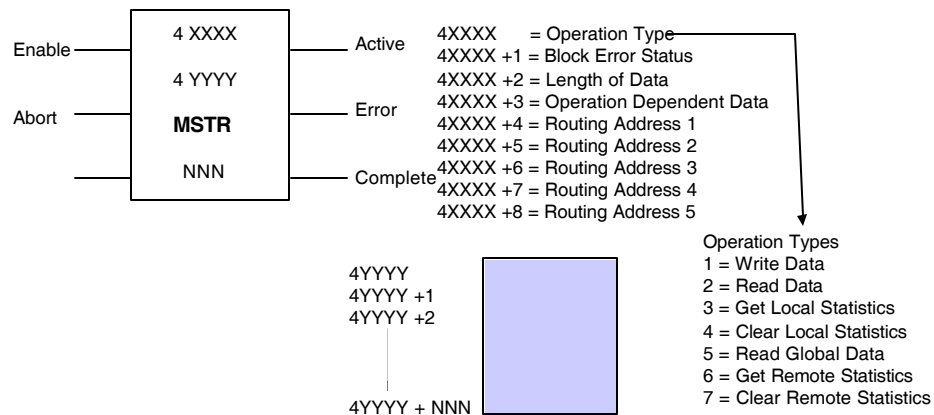

Figure 4. Modbus Plus Master Instruction

Meter Data Access To a PLC Host From an ABB Relay

Figure 5 illustrates a typical installation in which a PLC is to access data from an ABB DPU2000R using a Master Instruction.

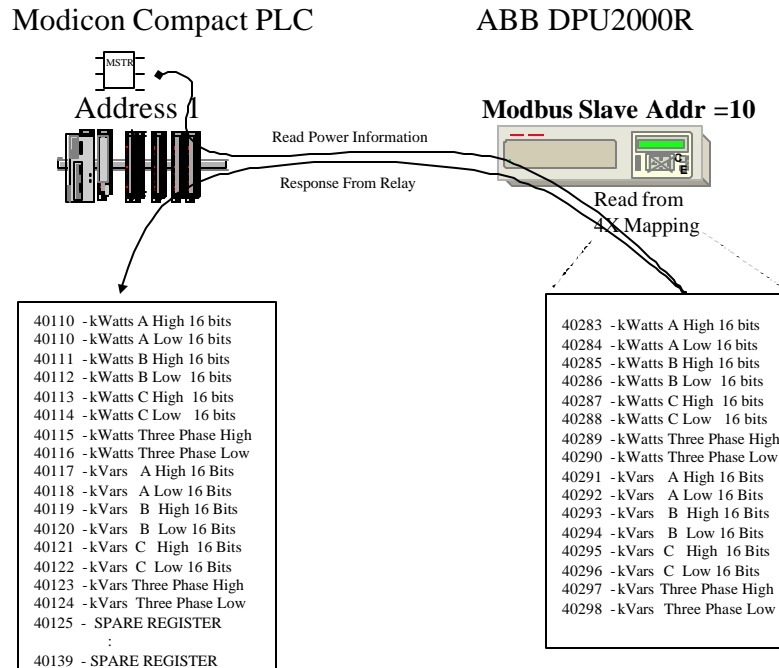

Figure 5. Modbus Plus Network Topology MSTR Read Instruction Example

A sample Ladder Logic Instruction network is given in Figure 6. The ladder logic is included for instruction purposes only. The MSTR instruction is energized by internal coil 00107. If the instruction is active, coil 00102 energizes to request the information from the ABB protective relay. If the block is parameterized incorrectly, coil 00103 will energize and register 400101 will contain a non-zero number indicating the fault type. If the Ladder Logic instruction obtains the information from the relay, output coil 00104 shall energize indicating completion of the network access. Also within this network example, an counter will increment each time a successful network communication occurs. This count, contained in the PLC memory 400109 can serve as a heartbeat counter to monitor continuous and successful communications.

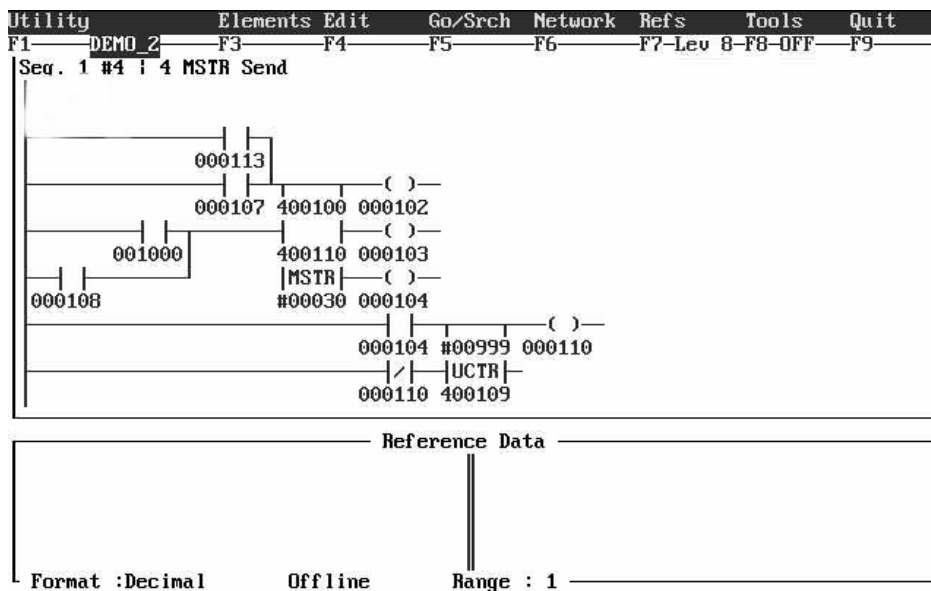

Figure 6. MSTR Ladder Logic Network Example

TPU2000/2000R Modbus/Modbus Plus Automation Guide

The MSTR is intended to access data from the ABB Protective relay. Figure 7 illustrates the Registers 400100 through 400108 which must be parameterized in order to obtain relay data. Figure 7 shows the MSTR configuration screen containing the parameters required for the Ladder Logic to operate correctly.

```

Utility      Hex      Dec      Bin      Goto      Quit
F1 DEMO_2    F3      F4      DX Zoom Editor      F7-Lev 8-F8-OFF  F9
MSTR: Modbus Plus Network Node Transaction      Page 1 / 4
Use page 2 for TCP/IP; page 3 for SV/MAX; page 4 for MMSE

MSTR Operation Function Code:      400100 UINT = 2      DEC
Error Status:                      400101 UINT = 0000  HEX
Number of Registers Transferred:    400102 UINT = 16     DEC
Function-dependent Information:      400103 UINT = 283   DEC
Routing 1, Destination Device Address: 400104 UINT = 10    DEC
Routing 2, Destination Device Address: 400105 UINT = 1      DEC
Routing 3, Destination Device Address: 400106 UINT = 0      DEC
Routing 4, Destination Device Address: 400107 UINT = 0      DEC
Routing 5, Destination Device Address: 400108 UINT = 0      DEC

Function Codes:
1 -> WRITE DATA      2 -> READ DATA
3 -> GET LOCAL STATISTICS  4 -> CLEAR LOCAL STATISTICS
5 -> WRITE GLOBAL DATABASE 6 -> READ GLOBAL DATABASE
7 -> GET REMOTE STATISTICS 8 -> CLEAR REMOTE STATISTICS
9 -> PEER COP HEALTH

End of Modbus Plus Section
    
```

Figure 7. MSTR Configuration Parameters

This example illustrates the configuration of Reading (PLC Register 400100 = 2) sixteen registers (PLC Register 400102 = 16) representing KW phase A,B,C, Total KW, KVARs phase A,B,C, and Total KVARs (Function Dependent Information from ABB DPU2000R Modbus Address 40283), at Node number 10 (DPU2000R = Node 10 [Address = 00A HEX]). Note the RELAY address is specified as the configured address via the relay front panel (Register 400104 = 10) and the Modbus Plus Data Slave path (in this case Data Slave Path 1 as designated in Register 400105 = 1).

Each time the MSTR instruction is executed, the data as designated in the parameterization block of 400100 to 400108 shall be transferred from the DPU 2000R's address to the PLC's data buffer which in this case resides in addresses 400110 through 400139 (as designated by the length of 30 at the bottom of the MSTR instruction). As illustrated in Figure 5, the data is transferred from the ABB DPU2000R's register map to the PLC's registers as illustrated.

Ladder logic may be written to change the parameters within the MSTR block so additional values may be obtained from the ABB DPU2000R. A sample ladder logic construct is included in Figure 8 which energizes the MSTR instruction when its operation has terminated.

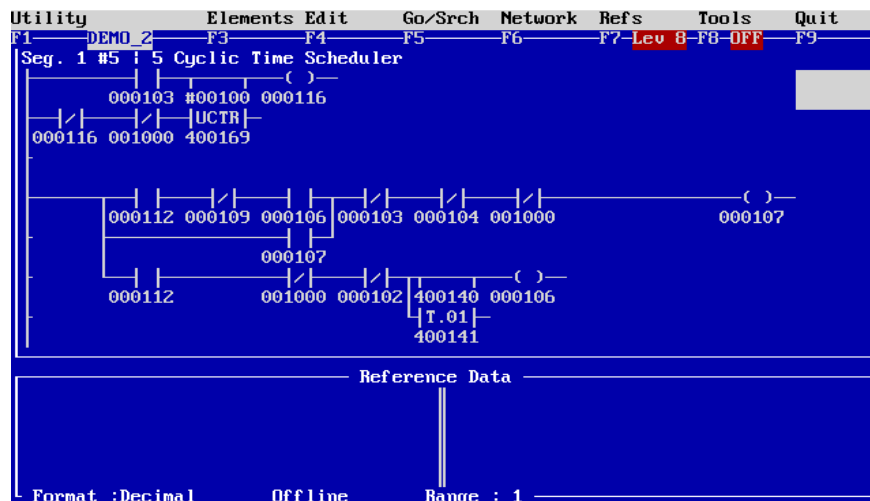

Figure 8. MSTR Cyclic Timer Ladder Logic

Figure 8 ladder constructs are as such:

01000 is a system reset contact which when energized resets the MSTR and counters.

00112 is a system start contact which when energized allows the MSTR to read network data over Modbus Plus.

If the network MSTR is idle (coil 00102 is de-energized or at a state of 0) then the timer energizes for the time indicated in Register 400140. Upon timeout, 00106 energizes and latches in 00107 which starts the MSTR instruction. Coil 00107 will be reset (or unlatched) when the MSTR terminates operation normally or through error. Upon reset, the MSTR instruction will not execute. The timer shall reset and when it times out, the entire sequence shall begin again.

The UCTR instruction contained in this logic counts the amount of Modbus Plus errors encountered when communicating to the relay. Its count is kept in Register 400169.

Additional ladder logic can be written to transfer different pointers to obtain additional information from the DPU2000R. The data would have to be transferred to Registers 400100 to 400108. The logic is relatively straightforward.

Conclusion

The ABB series of Protective relays have been designed and certified to operate seamlessly with Modicon Programmable Logic Controllers. The Ladder Logic is straightforward and easily implemented. Metering data, element status, fault/operation records, device settings, and other important and time-critical information is easily obtained from the relay using a programmable logic controller with Modbus Plus capability.

Reference Text

DPU/DPU2000R Modbus/Modbus Plus Implementation and Protocol Guide, Revision 1.5, August 18, 1998. ABB Company

INSTRUCTIONS – DPU2000R Distribution Protection Unit 1MRA587219-MIB (IB 7.11.1.7-4), REF 544, Issue B, October 1997, ABB Company

MODICON LADDER LOGIC BLOCK LIBRARY USERS GUIDE 840 USE 101 00, Version 1.1, July 1995, AEG Schneider Automation

MODICON MODSOFT Programmer Software User Guide, 840 USE 115 00, Version 1.1, June 1996, AEG Schneider Automation

MODBUS PLUS and SUBSTATION AUTOMATION, 8000BR9606R 11/97, REV C, Groupe Schneider

Appendix D- TELEBYTE RS 232/485 Converter Connection To ABB Protective Relays

ABSTRACT: There are many RS 232 to RS 485 converters on the market. Although ABB cannot and does not endorse a particular manufacturer of product, it does document several manufacturers' products with their use in systems using ABB protective relays. This application note illustrates the setup and connection of the TELEBYTE Model 245 optically isolated RS 232 to RS485 (2-wire/4wire) physical interface converter.

Typical Installation

The ABB protective relay is designed with a variety of physical communication interfaces. The ABB distribution relays such as the MSOC, GPU 2000R, TPU 2000R, DPU 2000R, DPU 2000, DPU 2000 and DPU 1500R are available with an RS 232, and/or RS 485 port(s).

Other devices such as the PONI M card for the REL 356 have only an RS 485 port.

Many host devices only have an RS 232 port(s). A method to connect such a device is required. Several converters are available to transform the physical interface on a device from RS 232 to RS 485. The advantages of RS 485 are that many devices may be attached to a single host in a multi-drop topology. RS 485 may communicate with up to 32 devices with an addressable protocol. An advantage of the Telebyte 245 converter is that, like the ABB protective relay, it is an isolated device.

General Information

Figure 1 illustrates the packaging of the Telebyte converter. The Telebyte Converter has two sets of red LED's indicating transmission and reception of information on its ports. One set of LED's indicates transmission/reception of data on its RS 232 port. The second set of LED's indicates transmission/reception of data on its RS 232/RS 485 port. These LED's are invaluable in visual troubleshooting of communications.

The Telebyte converter has two sets of DB 25 connectors. One connector is a standard RS 232 interface whereas the other connector is the RS 485/RS 422 interface. Switches 1 and 2 configure the RS 485 interface. A DTE/DCE (Data Terminal Emulation / Data Communication Emulation) switch configures the RS 232 pins determining where the data is expected (DTE = Data is Transmitted on Pin 2 and Data is Receive on Pin 3| DCE = Data is Transmitted on Pin 3 and Data is Received on Pin 2) on the RS 232 interface. Furthermore, Switch 2 configures the RS 485-control mode from the RS 232 port. In two-wire emulation, data control may occur from the RS 232 port's RTS (Request To Send) line or whether the data on the TD (Transmitted Data) pin is sensed. If the ABB device is a MSOC, GPU 2000R, TPU 2000R, DPU 2000R, DPU 2000, DPU 2000 and DPU 1500R, no data handshaking is permitted, thus the RS 232/485 converter must be configured for TD (Transmitted Data) mode. However, if the device attaching to the RS 232 port is a host which utilizes RTS/CTS (Request To Send/ Clear To Send) handshaking, the unit must be configured using the RTS dipswitch settings as illustrated in Figure 1. Additional information on the TELEBYTE 245 Optically Isolated converter is available on their website at www.telebyteusa.com.

There are several steps required to successfully install a communication network using a physical interface converter. They are:

1. Knowledge of the RS 232 interfaces. (What type of handshaking is employed?, Is the port DCE or DTE emulation?, Does the program executing on the attached device require certain signals such as CTS [Clear To Send], RTS [Request To Send], CD [Carrier Detect], DTR [Data Terminal Ready])? , What is the voltage of the RS 232 interface signals?)
2. Knowledge of the available power required. (If the converter requires external power, what is the voltage required?)
3. Knowledge of the RS 485 devices connected (2 Wire or 4 Wire?, Biasing Required?, Length of network?, Number of Devices Attached? Are the devices isolated?)
4. Proper installation of bias resistors.

5. Proper installation of termination resistors.
6. Proper selection and installation of the physical cable medium.
7. Proper configuration of the RS 232/485 physical interface switches and dipswitches.

TELEBYTE 245 OPTICAL ISOLATOR CONVERTER
RS 232 RS485/RS422

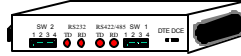

The 245 uses Pin 2 (TX/RX -) & Pin 14 (TX/RX +), Pin 7 is Ground for its connections to the Two Wire RS-485 Relay.

RS 485 SWITCH MODE (2 wire)	SW 1				SW 2			
	1	2	3	4	1	2	3	4
TRANSMIT DATA CONTROL	UP	DOWN	UP	DOWN	X	DOWN	UP	Y
RTS DATA CONTROL	UP	UP	DOWN	UP	X	DOWN	UP	Y
X = TERMINATION RESISTOR, UP = INSERTED, DOWN = OUT					Y = DON'T CARE			

Figure 1 – Telebyte Dipswitch Settings

RS232 Configuration And Cabling

The Telebyte RS 232 section of the converter uses the following pins:

- Pin 2 – Transmit Data
- Pin 3 - Receive Data
- Pin 7 - Ground

The RS 232 connector on the converter is a DB 25 male connector.

Depending upon the dipswitch settings, the following pins are used for transmit data control.

- Pin 4 – Request To Send
- Pin 5 – Clear To Send.

Although the TELEBYTE converter does use handshaking and control of the DTR signal (Pin 20), its use is not covered in this application note.

The Telebyte converter is an actively powered device requiring attachment to a supplied power transformer. This transformer supplies power to both ports on the unit. No additional power supplies are required for this converter to operate.

The TELEBYTE converter has an additional dipswitch configuring the RS 232 port for DCE or DTE configuration. Figures 2 and 3 illustrate cable pinouts to connect a PC or ABB to connect to a device. If the converter is attached to a PC Host device or an ABB IED, a straight through cable may be used (or a 9 pin to 25 pin cable) to attach the devices. The DTE/DCE switch must be placed in the DCE position due to the nature of RS 232 connections. If additional discussions of RS 232 are required, please consult the ABB Faxback System (610-877-0721) or the ABB website (www.abb.com/substationautomation). Several documents are available explaining RS 232 communication. The TELEBYTE converter has a DB 25 connector whereas the ABB IED's and most personal computers have DB 9 connectors. Figures 2 and 3 illustrate the cable connections are handshaking is used (RTS/CTS) control or if no handshaking (data control using the Transmitted Data line) is employed. Configuration of the data control handshaking mode is performed via the dipswitches located at the side of the converter. Refer to Figure 1 of this document for dipswitch configuration.

Cable "A"- RS 232 Cable for Connection from a NODE (DTE OR DCE) and the TELEBYTE converter configured correctly (DTE DEVICE AND TELEBYTE SWITCH IN DCE MODE --OR-- DCE DEVICE AND TELEBYTE SWITCH IN DTE MODE). DATA CONTROL RTS/CTS HANDSHAKING EMPLOYED.

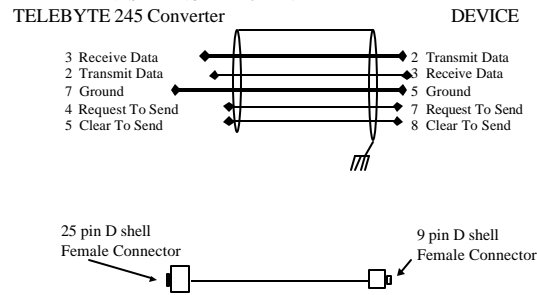

Figure 2 – RS 232 Cable Pinout With Handshaking Incorporated (See Figure 1 For Dipswitch Settings)

Cable "A"- RS 232 Cable for Connection from a NODE (DTE OR DCE) and the TELEBYTE converter configured correctly (DTE DEVICE AND TELEBYTE SWITCH IN DCE MODE --OR-- DCE DEVICE AND TELEBYTE SWITCH IN DTE MODE). NO HANDSHAKING Data Control via the Transmitted Data (TD) line.

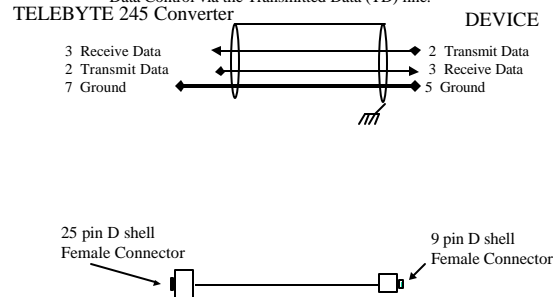

Figure 3 – RS 232 Cable Connections When No Handshaking Is Used. (See Figure 1 For Dipswitch Setting)

Power Requirements

The TELEBYTE converter is available using a variety of power supply options. The converter is supplied with a power converter, which attaches to which attaches to the device. For current options, please consult the TELEBYTE website.

RS485 Configuration And Cabling

The TELEBYTE converter supports RS 422, 4 Wire RS 485 and 2 Wire RS 485 connectivity. The ABB line of protective relays supports 2 Wire RS 485 connectivity. The dipswitch settings in Figure 1 are given only for the RS 485 two wire options. If additional configuration information is desired for RS 485 4 wire or RS 422 configuration please consult the TELEBYTE website.

The attractive feature of the TELEBYTE converter is the isolation of the RS 232 and RS 485/422 ports from external power supplies. This feature is important especially in utility applications where external noise is an issue.

RS 485 cabling is usually the source of most communication issues. Several issues must be remembered when installing such a cable:

1. In attachment to ABB relays in a Utility installation, one must remember to use a cable with 3 wires and a shield. Refer to Figures 4 through 7 for ABB recommended cables.
2. Termination must be attached to the extreme ends of the cable. If ABB relays are at the extreme ends of the cable, internal termination resistors are available to provide termination. If the TELEBYTE converter is inserted at the end of the cable, Switch Bank 2, Dipswitch position 1 inserts or removes a 120 ohm resistor in the circuit.
3. The cable attaching the nodes must be daisy- chained. Drops, Taps and stubs of cables are not supported. The addition of terminals, drops, taps, and cable stubs increase the signal reflections thus increasing the possibility of communication errors.
4. The CABLE SHIELD is grounded at one place only. The cable shield is continuous through all nodes, but it is isolated from the ground potential at each device.
5. The ABB protective device RS 485 ports are optically isolated, the ground wire must be attached to the shield ground at one place only. This is required to reference the field side of the device interface to a common reference.

RS485 Line Termination

RS 485 2 Wire connection diagrams are referenced in Figures 4 through 7. Figures 4 and 5 use the internal resistors within the DPU, GPU, TPU and MSOC units. Figures 6 and 7 illustrate an alternate method of using external resistors to provide biasing and line termination.

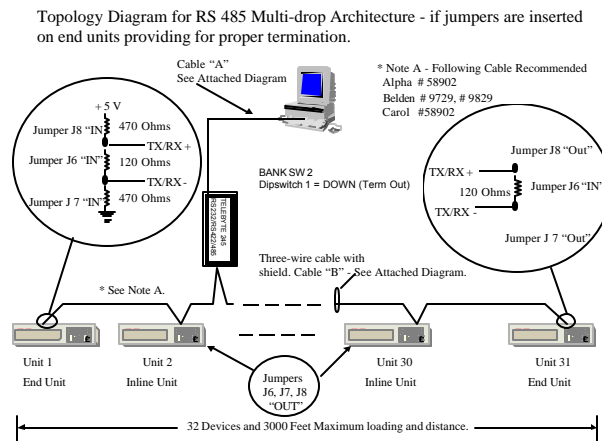

Figure 4 – RS 485 2 WIRE TERMINATION WITH THE RS 232/485 Converter INLINE and ABB Protective Relays At End Of Line Locations

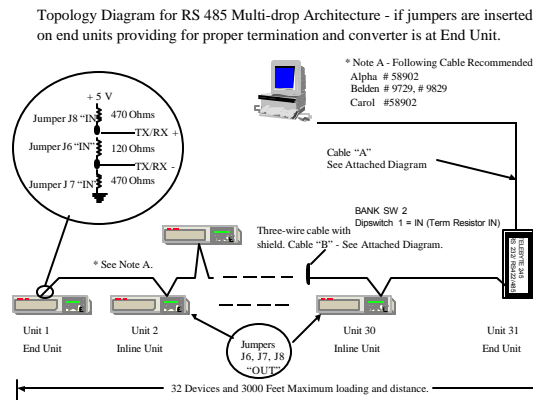

Figure 5 – Termination Using Internal Jumpers And Converter As An End Unit

TPU2000/2000R Modbus/Modbus Plus Automation Guide

One should recognize that termination is at both extreme ends of the cable. Also Figures 4 and 5 have the cable daisy-chained, thus minimizing communication signal reflections.

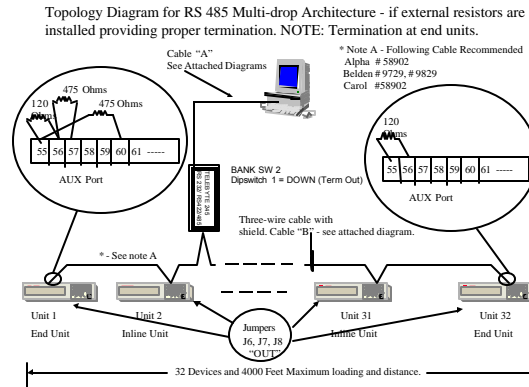

Figure 6 – Termination Using External Resistors And The Telebyte Converter Being An “In-Line” Unit

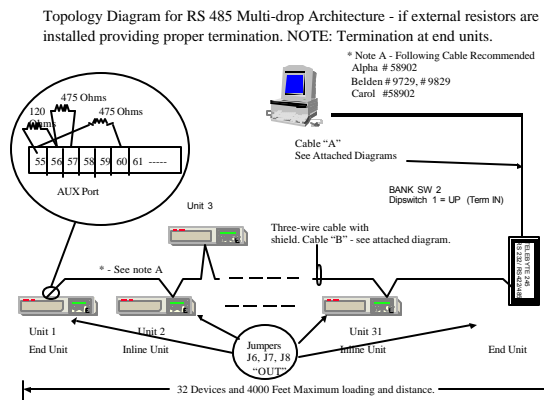

Figure 7 - Termination Using External Resistors On The IED’s And Using The Telebyte Converter As An End Unit

RS485 Biasing

Figures 4 through 7 illustrate the addition of resistors between the TX/RX (+) line and +V, and TX/RX (-) line and ground. These resistors are called bias resistors. Bias resistors are inserted at one node only, preferably at one extreme end of the network.

The TELEBYTE 245 is a “passive bias” unit in that when no device is communicating on the network, the data lines float. With the addition of the Pull-Up and Pull-Down resistors, the line is biased when no device is driving the lines. Biasing reduces the communication lines from being saturated with RFI or EMI induced noise from being coupled on the line. Addition of biasing on the network reduces the induced noise on the line.

The typical utility installation is an electrically noisy environment. Addition of data line biasing is recommended.

RS485 Conductor Connectivity

The TELEBYTE unit uses the following pins for RS 485 communication:

- PIN 2 - TX/RX (A) or TX/RX (-) or A
- PIN 14- TX/RX (B) or TX/RX (+) or B
- PIN 7 – GROUND

The TELEBYTE interface is a DB 25 FEMALE interface.

Figures 8 and 9 illustrate the individual conductor connectivity for attaching the ABB protective relays in the DPU/TPU/2000 and the DPU/TPU/GPU 2000R. It is important to note that Figures 8 and 9 illustrate only the attachment of each device terminal. EACH NODE MUST BE DAISY-CHAINED AS ILLUSTRATED IN FIGURES 4 THROUGH 7.

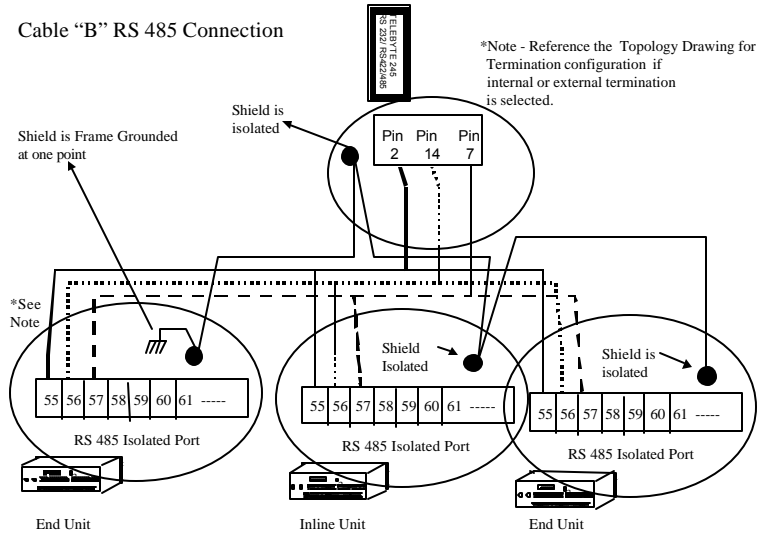

Figure 8 – Conductor Connectivity Diagram For The 2000R Products And The Telebyte Converter “Inline”

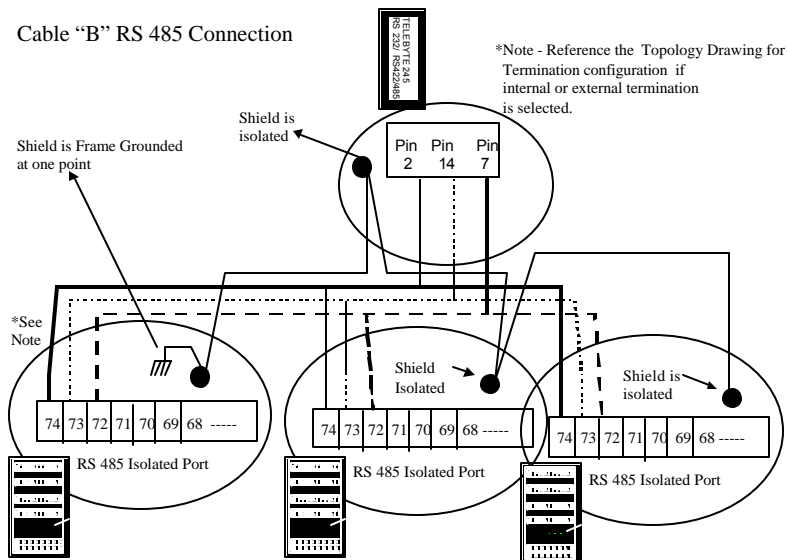

Figure 9 - Conductor Connectivity Diagram For The DPU/TPU 2000 Products

If an ABB relay uses a TYPE 8 card, COM PORT 3 is actually an RS 485 port presented in a DB 9 format. The Pin designation is presented in Table 1 and lists the cross listing for the AUX COM connector present on the 2000R product and 2000-product line. As illustrated in Figures 7 and 8, the AUX COM PORT connections are given. If one is installing RS 485 on a TYPE 8 card, both the AUX COM PORT and COM 3 have RS 485 connectivity available.

Table 1 - RS485 Communication Card RS485 Cross-Reference List

PIN DESIGNATION	COM 3 TYPE 8 COM PORT (2000R Family)	AUX COM PORT (2000R Family)	AUX COM PORT (2000 Family)
+ 5 VDC	8	60	77
RS485 Common	7	57	74
RS-485 (-)	2	56	73
RS-485 (+)	1	55	72

Wire attachment on an RS 485 TYPE 8 card's COM 3 DB 9 port can be tricky in an in-line installation. ABB has a special connector, which changes the female DB 9 port into a PHOENIX contact 9-pin connector (similar in format to the AUX COM PORT). The ABB part number of this 9 Pin male to Phoenix Card Connector is ABB part 602133-009. The same part is also available from Phoenix Contact and the part number is 27 61 50 9.

Troubleshooting

The TELEBYTE RS 232/RS485 converter Model Number 245 has the advantage of four LED's present at the side of the unit (as indicated in Figure 1) indicating RS232 port transmit data, RS232 port receive data, RS 485 port transmit data and RS 485 port receive data. Visual indication of these LED's should allow the implementor to troubleshoot a unit, which does not communicate at all.

If communication messages do not appear to be transferred from the RS 232 port to the RS 485 port, one should investigate wiring, DTE/DCE emulation switches, and the wiring on the RS 232 and RS 485 ports.

If the error rate of communication message transmission and reception is high, investigate wiring in the areas of:

1. Biasing of the cable in only one location.
2. Installation of termination resistors at two nodes only (at both remote ends).
3. Cable installation with three wires AND A SHIELD. REMEMBER SHIELD IS NOT GROUND.
4. DAISY- CHAINING the RS 485 wiring so no in-line stubs, taps, and junction strips are inserted in the unit.
5. Incorrect installation of the Shield (connected at in line nodes and isolated at ground).
6. Incorrect lengths of RS 485 or RS 232 cables (3000 feet = RS 485 or 50 feet = RS 232).
7. Incorrect selection of "handshake control" for operation with the IED or Host (ABB IED's do not employ handshaking. Some hosts require RTS/CTS handshaking or the CD and DTR signal must be looped back in the cable.)

Conclusion

There are many converters available on the market. Successful communication can result in using many manufacturers' physical interface converters. Success in implementing a physical interface relies on the implementor's knowledge of the software control of the physical interface, IED physical interface operation and knowledge of the particular brand of converter.

Contributed by:

John Popiak

Revision 0, 03/01

