

# LeddarTech<sup>®</sup>



## Leddar<sup>™</sup> M16 LED 16-Segment Solid-State LiDAR Sensor Module

### USER GUIDE

TF ID 013715

This page intentionally left blank

© 2021 LeddarTech Inc. All rights reserved.

The information contained herein is the property of the Company and shall not be reproduced in whole or in part without the prior written approval of the Company.

Leddar, LeddarTech, LeddarSteer, LeddarEngine, LeddarVision, LeddarSP, LeddarCore, VAYADrive, VayaVision, and related logos are trademarks or registered trademarks of LeddarTech Inc. All other brands, product names, and marks are or may be trademarks or registered trademarks used to identify products or services of their respective owners.

Please contact a LeddarTech sales representative if you have any questions regarding the information contained in this document or regarding LeddarTech products. For the most recent version of this document, visit LeddarTech's website. We also highly recommend that you read our Standard Sales Terms and Conditions, Product Warranty, and End-User License Agreement carefully. Documentation available at [www.leddartech.com](http://www.leddartech.com), section "Resources."

Leddar™ Configurator software: this software is based in part on the work of the Independent JPEG Group.

Keep this User Guide for future reference.

## DISCLAIMER

LeddarTech® shall not be liable for any errors or omissions herein or for any damages arising out of or related to this document or the information contained herein, even if LeddarTech has been advised of the possibility of such damages.

Descriptions of products, including, but not limited to, specifications and drawings, and other related information contained in this document, are provided only to illustrate their operation and application examples. The illustrations shown, including screen captures, may differ from the appearance of the actual product.

LeddarTech has made every effort to ensure that the information contained in the documentation accompanying its products, including, without limitation, its Specification Sheet, is accurate. However, LeddarTech will not be liable for any errors or omissions therein and reserves the right to modify the design and characteristics of products at any time without notice. For the most recent version of any product documentation, visit LeddarTech's website at [www.leddartech.com](http://www.leddartech.com). In case of discrepancy, the web version takes precedence over any printed literature.

LeddarTech may expressly designate certain products as completing a particular qualification (e.g., AEC-Q100). Customer agrees that it has the necessary expertise to select the product with the appropriate qualification designation for its applications and that proper product selection is at customer's own risk. The customer is solely responsible for compliance with all legal and regulatory requirements in connection with such selection.

LeddarTech does not control the installation and use of its products and shall have no liability if a product is used for an application for which it is not suited. LeddarTech's products are not recommended or authorized for safety, life support, medical applications, applications involving hazardous, corrosive, or radioactive substances, or for any use or application in which the failure of a component could cause personal injury, loss of life, or substantial harm to the environment or property. Where LeddarTech specifically promotes products as facilitating functional safety or as compliant with functional safety standards, such products are intended to help enable customers to design and create their own applications that meet applicable functional safety standards and requirements. Using products in an application does not by itself establish any safety features in the application.

Any technical advice provided by LeddarTech with reference to the use of its products is given without assumption by LeddarTech of any liability, and LeddarTech assumes no obligation or liability for the advice given or results obtained, all such advice being given and accepted at customer's sole risk.

LeddarTech reserves the right to modify its products at any time, without notice, at its sole discretion. The products' performance specifications and operating parameters are determined in an independent state and are not guaranteed to perform the same way if installed in a customer product.

## Table of Contents

<b>1.</b>	<b>INTRODUCTION .....</b>	<b>16</b>
1.1.	DESCRIPTION.....	16
1.2.	UNDERLYING PRINCIPLES.....	23
<b>2.</b>	<b>GETTING STARTED .....</b>	<b>24</b>
2.1.	SETUP.....	24
2.2.	CONNECTING TO THE MODULE.....	27
<b>3.</b>	<b>MEASUREMENTS AND SETTINGS .....</b>	<b>29</b>
3.1.	DISTANCE MEASUREMENT.....	29
3.2.	DATA DESCRIPTION.....	29
3.3.	ACQUISITION SETTINGS.....	31
3.3.1.	<i>General Settings</i> .....	31
3.3.2.	<i>Enabling and Disabling Segments</i> .....	36
3.3.3.	<i>Static Threshold</i> .....	37
3.4.	MEASUREMENT RATE.....	37
3.5.	CPU LOAD .....	38
3.6.	SERIAL PORT SETTINGS .....	39
3.7.	CAN PORT SETTINGS .....	40
<b>4.</b>	<b>COMMUNICATION.....</b>	<b>42</b>
4.1.	SERIAL PORT.....	42
4.2.	CAN BUS .....	48
<b>5.</b>	<b>LEDDAR CONFIGURATOR .....</b>	<b>56</b>
5.1.	INTRODUCTION.....	56
5.2.	CONNECTION WINDOW.....	56
5.3.	LEDDAR CONFIGURATOR MAIN WINDOW .....	57
5.3.1.	<i>Toolbar Display Controls</i> .....	57
5.3.2.	<i>Fit to Window</i> .....	58
5.3.3.	<i>Force Equal Horizontal and Vertical Scales</i> .....	58
5.3.4.	<i>Zoom In</i> .....	58
5.3.5.	<i>Zoom Out</i> .....	58
5.3.6.	<i>Scale</i> .....	58
5.3.7.	<i>Panning and Zooming</i> .....	58
5.3.8.	<i>Changing the Module Origin</i> .....	60
5.3.9.	<i>Changing the Module Orientation</i> .....	61
5.4.	SETTINGS.....	62
5.4.1.	<i>Device Name</i> .....	62

5.4.2.	<i>Acquisition Settings</i> .....	63
5.4.3.	<i>Module Position</i> .....	63
5.4.4.	<i>Advanced Detection Zones</i> .....	64
5.4.5.	<i>General</i> .....	64
5.4.6.	<i>Serial Ports</i> .....	66
5.4.7.	<i>CAN Ports</i> .....	67
5.5.	SAVING AND LOADING A CONFIGURATION .....	69
5.6.	CONFIGURING DETECTION RECORDS .....	69
5.7.	USING DETECTION RECORDS .....	71
5.8.	DATA LOGGING .....	72
5.9.	DEVICE STATE .....	74
5.10.	PREFERENCES .....	75
5.11.	RAW DETECTIONS .....	76
5.12.	VIEW SERIAL PORT DATA .....	78
<b>6.</b>	<b>SPECIFICATIONS</b> .....	<b>80</b>
6.1.	GENERAL .....	80
6.2.	ENVIRONMENTAL .....	80
6.3.	REGULATORY COMPLIANCE .....	80
6.4.	MECHANICAL .....	80
6.5.	ELECTRICAL .....	81
6.6.	OPTICAL .....	81
6.6.1.	<i>99° x 8° Module (M16D-75B0008)</i> .....	82
6.6.2.	<i>48° x 6° Module (M16D-75B0005)</i> .....	83
6.6.3.	<i>36° x 5° Module (M16D-75B0010)</i> .....	84
6.6.4.	<i>25° x 4° Module (M16D-75B0009)</i> .....	85
6.6.5.	<i>19° x 3° Module (M16D-75B0007)</i> .....	86
6.6.6.	<i>10° x 1.6° Module (M16D-75B0006)</i> .....	87
6.7.	PERFORMANCE .....	88
6.8.	DIMENSIONS .....	92
6.8.1.	<i>99° x 8° Module (M16D-75B0008)</i> .....	92
6.8.2.	<i>48° x 6° Module (M16D-75B0005)</i> .....	93
6.8.3.	<i>36° x 5° Module (M16D-75B0010)</i> .....	94
6.8.4.	<i>25° x 4° Module (M16D-75B0009)</i> .....	95
6.8.5.	<i>19° x 3° Module (M16D-75B0007)</i> .....	96
6.8.6.	<i>10° x 1.6° Module (M16D-75B0006)</i> .....	97
<b>7.</b>	<b>TROUBLESHOOTING</b> .....	<b>98</b>
<b>8.</b>	<b>MAINTENANCE</b> .....	<b>98</b>

9. DISPOSAL..... 98

10. TECHNICAL SUPPORT..... 98

APPENDIX A. EXAMPLE OF A 0X41 MODBUS FUNCTION ..... 99

APPENDIX B. EXAMPLE OF A 0X04 MODBUS..... 101

APPENDIX C. EXAMPLE OF A CAN BUS DETECTION REQUEST ..... 103

## Table of Figures

Fig. 1: Perspective front view (48° optics).....	17
Fig. 2: Top view with a terminal block connector .....	17
Fig. 3: Jumper configurations for 24 V and 12 V power supply .....	19
Fig. 4: M16 LED working diagram.....	20
Fig. 5: Expansion connector.....	21
Fig. 6: Illumination area and detection zone .....	23
Fig. 7: Welcome dialog box.....	24
Fig. 8: End-User License Agreement dialog box .....	25
Fig. 9: Product Types dialog box .....	25
Fig. 10: Destination Folder dialog box .....	26
Fig. 11: Installation dialog box .....	26
Fig. 12: Completing the installation .....	26
Fig. 13: Connecting to a module .....	27
Fig. 14: Connection dialog box.....	27
Fig. 15: Main window .....	28
Fig. 16: Distance measurement .....	29
Fig. 17: Raw Detections dialog box .....	29
Fig. 18: General tab – Acquisition Settings dialog box .....	31
Fig. 19: Detection thresholds .....	33
Fig. 20: Measurement smoothing example .....	35
Fig. 21: Segments tab – Acquisition Settings dialog box.....	36
Fig. 22: Disabled segments example.....	36
Fig. 23: Static Threshold tab – Acquisition Settings dialog box.....	37
Fig. 24: Device State window.....	39
Fig. 25: Raw Detections dialog box docked on the side of the main window .....	56
Fig. 26: Connection dialog box.....	56
Fig. 27: Leddar Configurator main window .....	57
Fig. 28: Zooming in (left) and out (right) horizontally .....	59
Fig. 29: Zooming in (left) and out (right) vertically.....	59
Fig. 30: Detection point coordinates .....	60
Fig. 31: Dot indicator to modify the module origin .....	60
Fig. 32: Module position display.....	61
Fig. 33: Red bar to rotate the module position.....	61
Fig. 34: Device menu – Configuration menu items.....	62
Fig. 35: Device Name dialog box .....	62



Fig. 36: Acquisition Settings dialog boxes .....	63
Fig. 37: Device menu – Sensor Position dialog box .....	63
Fig. 38: Device menu – Configuration and Advanced Detection Zones menu items .....	64
Fig. 39: Advanced Detection Zones dialog box .....	64
Fig. 40: Device menu – Configuration and Communication menu items.....	65
Fig. 41: General Settings dialog box.....	65
Fig. 42: LeddarHost dialog box .....	65
Fig. 43: Device menu – Configuration and Communication menu items.....	66
Fig. 44: Serial Ports Settings dialog box .....	66
Fig. 45: Device menu – Configuration and Communication menu items.....	67
Fig. 46: CAN Port Settings dialog box .....	68
Fig. 47: File menu .....	69
Fig. 48: Settings menu .....	69
Fig. 49: Preferences dialog box .....	70
Fig. 50: File menu to start a recording .....	70
Fig. 51: File menu to stop a recording .....	71
Fig. 52: File menu to open a recording .....	72
Fig. 53: Record Replay dialog box.....	72
Fig. 54: Settings menu .....	73
Fig. 55: Preferences dialog box for logging data .....	73
Fig. 56: File menu to start data recording .....	73
Fig. 57: File menu to stop data recording .....	74
Fig. 58: View menu .....	74
Fig. 59: Device State window.....	74
Fig. 60: Settings Menu – Preferences dialog box .....	75
Fig. 61: View menu – Raw Detections dialog box .....	76
Fig. 62: Example of detection filtering in the Raw Detections dialog box .....	77
Fig. 63: View menu .....	79
Fig. 64: Serial Port Viewer dialog box.....	79
Fig. 65: Serial port measurement.....	79
Fig. 66: Horizontal field of view (HFoV) and vertical field of view (VFoV) .....	81
Fig. 67: Detection efficiency (HFoV by segment), 99° x 8° module.....	82
Fig. 68: Detection efficiency (VFoV), 99° x 8° module.....	82
Fig. 69: Detection efficiency (HFoV by segment), 48° x 6° module.....	83
Fig. 70: Detection efficiency (VFoV), 48° x 6° module.....	83
Fig. 71: Detection efficiency (HFoV by segment), 36° x 5° module.....	84
Fig. 72: Detection efficiency (VFoV), 36° x 5° module.....	84

<i>Fig. 73: Detection efficiency (HFoV by segment), 25° x 4° module</i>	85
<i>Fig. 74: Detection efficiency (V FoV), 25° x 4° module</i>	85
<i>Fig. 75: Detection efficiency (HFoV by segment), 19° x 3° module</i>	86
<i>Fig. 76: Detection efficiency (V FoV), 19° x 3° module</i>	86
<i>Fig. 77: Detection efficiency (HFoV by segment), 10° x 1.6° module</i>	87
<i>Fig. 78: Detection efficiency (V FoV), 10° x 1.6° module</i>	87
<i>Fig. 79: Accuracy vs. distance</i>	88
<i>Fig. 80: Precision vs. amplitude</i>	88
<i>Fig. 81: 99° x 8° module amplitude vs. range</i>	89
<i>Fig. 82: 48° x 6° module amplitude vs. range</i>	89
<i>Fig. 83: 36° x 5° module amplitude vs. range</i>	90
<i>Fig. 84: 25° x 4° module amplitude vs. range</i>	90
<i>Fig. 85: 19° x 3° module amplitude vs. range</i>	91
<i>Fig. 86: 10° x 1.6° module amplitude vs. range</i>	91
<i>Fig. 87: 99° x 8° module dimensions</i>	92
<i>Fig. 88: 48° x 6° module dimensions</i>	93
<i>Fig. 89: 36° x 5° module dimensions</i>	94
<i>Fig. 90: 25° x 4° module dimensions</i>	95
<i>Fig. 91: 19° x 3° module dimensions</i>	96
<i>Fig. 92: 10° x 1.6° module dimensions</i>	97

## List of Tables

Table 1: Terminal block connector pin definition.....	18
Table 2: Jumper configuration .....	18
Table 3: RS-485 pin definition.....	20
Table 4: Expansion connector pin definition .....	21
Table 5: UART pin definition (TTL 3.3 V).....	22
Table 6: CAN pin definition .....	22
Table 7: SPI pin definition .....	22
Table 8: Distances per segment (channel) .....	23
Table 9: Raw Detection field description.....	30
Table 10: Flag value description .....	30
Table 11: Status value description.....	30
Table 12: Acquisition settings description.....	31
Table 13: Theoretical measurement rate .....	38
Table 14: Serial port settings description.....	39
Table 15: Maximum detections per baud rate / Measurement rate settings.....	40
Table 16: CAN port settings.....	40
Table 17: Report server ID message .....	42
Table 18: Get detection message (detection fields) .....	43
Table 19: Get detection message (trailing fields).....	43
Table 20: Get detection message (detection fields) .....	44
Table 21: Get detection message (trailing fields).....	44
Table 22: Read input register message .....	44
Table 23: Read holding register message definition.....	46
Table 24: CAN bus request message .....	48
Table 25: CAN bus request message (GET input data) .....	49
Table 26: CAN bus request message (GET holding data) .....	49
Table 27: CAN bus request message (SET holding data).....	50
Table 28: CAN bus answer message .....	52
Table 29: CAN bus number of detection message .....	53
Table 30: CAN bus answer message (GET input data).....	53
Table 31: Standard CAN bus detection message.....	55
Table 32: Flag information of measurement .....	55
Table 33: CAN bus detection message definition with flag information.....	55
Table 34: Serial port settings description.....	66
Table 35: CAN port settings description .....	68

<i>Table 36: Field description of the log text file.....</i>	<i>72</i>
<i>Table 37: Flag value description .....</i>	<i>78</i>
<i>Table 38: Status value description .....</i>	<i>78</i>
<i>Table 39: General specifications.....</i>	<i>80</i>
<i>Table 40: Environmental specifications .....</i>	<i>80</i>
<i>Table 41: Mechanical specifications .....</i>	<i>80</i>
<i>Table 42: Electrical specifications .....</i>	<i>81</i>
<i>Table 43: Optical specifications .....</i>	<i>81</i>
<i>Table 44: Horizontal FoV and Vertical FoV.....</i>	<i>81</i>
<i>Table 45: Module performances .....</i>	<i>88</i>

## Version History



Version	Description	Date (YYYY-MM-DD)
54A0020_V18.0_EN	<ul style="list-style-type: none"> <li>• Added Disclaimer information</li> <li>• Various updates throughout the document</li> </ul>	2019-01-11
54A0020_V19.0_EN	<ul style="list-style-type: none"> <li>• Updated Disclaimer</li> <li>• Updated as per NC #50079 &amp; NC #50080</li> </ul>	2021-04-16
54A0020_V20.0_EN	<ul style="list-style-type: none"> <li>• Updated to new User Guide template with minor corrections throughout the text, including for consistency</li> <li>• Deleted all occurrences of fail-safe option</li> <li>• Specified limited availability of demerging function throughout the document</li> <li>• Section 1.1: added Fig. 5 + connector information</li> <li>• Section 2.1: updated installation screenshots</li> <li>• Section 3.6: changed Port Number value in Table 14</li> <li>• Section 3.7: added 1<sup>st</sup> sentence of paragraph</li> <li>• Section 3.3.1: described power control modes</li> <li>• Section 5.3.2: updated text</li> <li>• Section 5.4.4: explained debouncing feature</li> <li>• Section 5.4.6: deleted expansion connector selection in Table 34</li> <li>• Section 8: updated optical surface cleaning procedure</li> </ul>	2021-06-11

## Contact Information

LeddarTech Inc.		
	Head Office	Production & Shipping
<b>Address</b>	4535, boulevard Wilfrid-Hamel, <b>Suite 240</b> Québec (Québec) G1P 2J7, Canada	4535, boulevard Wilfrid-Hamel, <b>Suite 140</b> Québec (Québec) G1P 2J7, Canada
<b>Phone</b>	+ 1-418-653-9000 1-855-865-9900 8:30 a.m. – 5:00 p.m. EST	
<b>Fax</b>	+ 1-418-653-9099	
<b>Support</b>	<a href="mailto:support@leddartech.com">support@leddartech.com</a>	
<b>Website</b>	<a href="http://www.leddartech.com">www.leddartech.com</a>	

## Document Conventions

This document uses the following conventions:

<b>Name of menu &gt; name of the window</b>	Shows the access path to menus under each section of the Leddar™ Configurator.
<b>Arial bold</b>	The names of buttons, menus, dialog boxes, and the elements of the interface are in <b>bold type</b> .
	<b>Note:</b> Contains helpful suggestions and references to information included within this User Guide.
	<b>Warning:</b> Refers to a warning or important information to follow.

This document uses the metric system (SI).

## 1. Introduction

The Leddar™ M16 module or M16 LED enables developers and integrators to make the most of Leddar™ technology through integration in detection and ranging systems. The purpose of the M16 LED module is to be easily and rapidly integrated into various applications.

The M16 LED can be configured for elementary applications or perform more complex tasks depending on the hardware and software settings.

### 1.1. Description

The M16 LED contains the following:

- Receiver assembly
- Source and control assembly

The M16 LED offers the following features:

- Horizontal field of view (FoV): 10°, 19°, 25°, 36°, 48°, and 99°
- 16 detection segments
- Real-time data acquisition and display (through USB)
- RS-485 port for measurement acquisition
- CAN bus for measurement acquisition

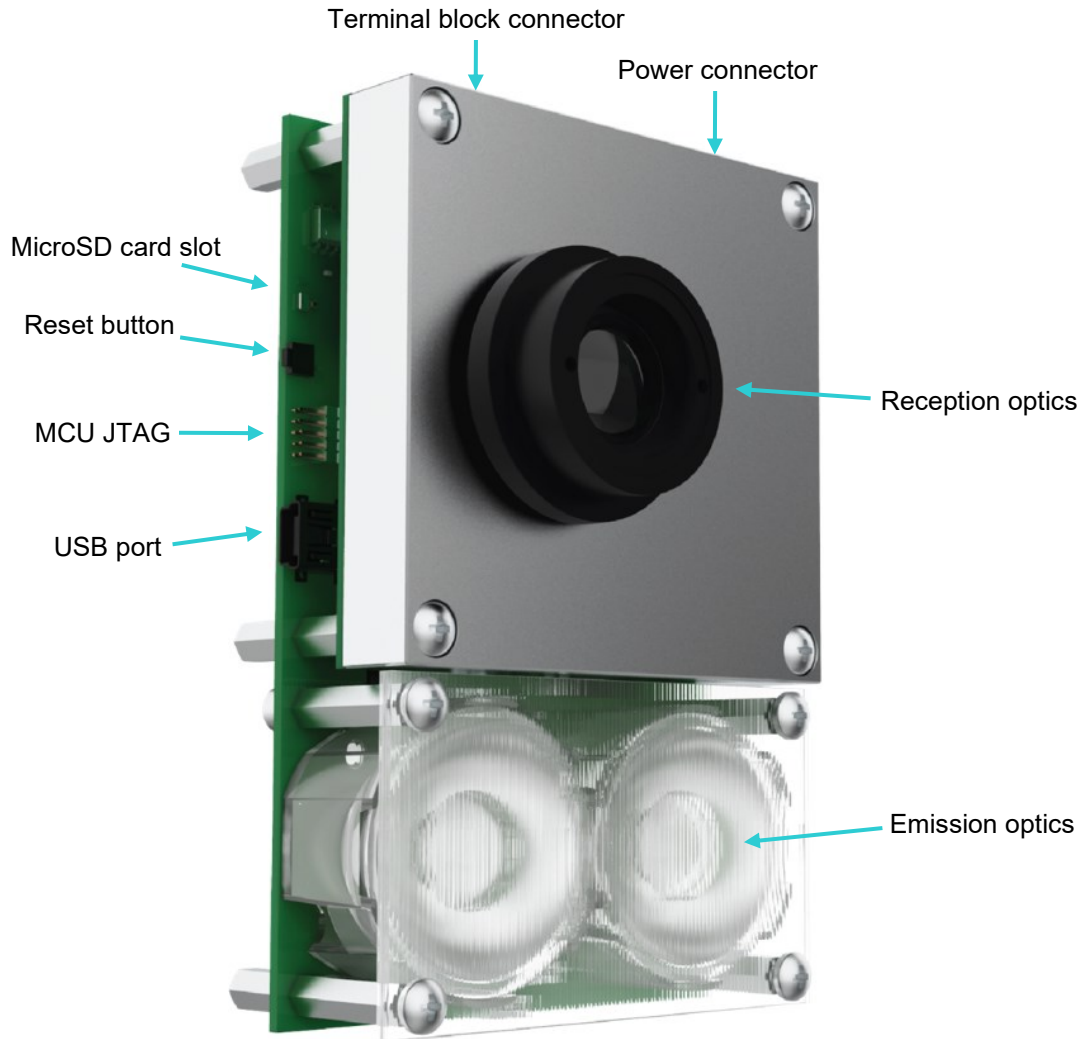
Interfaces available for custom application development:

- RS-485
- CAN bus
- DIP switches<sup>1</sup> (4 x)
- MicroSD card slot<sup>1</sup>
- Expansion connector (UART, CAN, SPI<sup>1</sup>, GPIO<sup>1</sup>, DAC<sup>1</sup>)

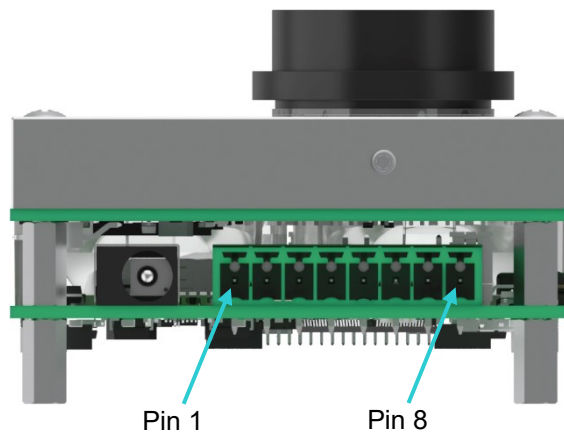
---

<sup>1</sup> Not implemented in the current MCU firmware.





**Fig. 1: Perspective front view (48° optics)**



**Fig. 2: Top view with a terminal block connector**

## Terminal block

The terminal block is an 8-pin connector at the top of the module. It provides CAN, RS-485, and power connectivity.

**Table 1: Terminal block connector pin definition**

Pin	1	2	3	4	5	6	7	8
Function	GND	DCIN	GND	RS-485+	RS-485-	GND	CAN-H	CAN-L

Pin 2 allows you to power the device directly through the terminal block instead of the DC connector. The ground is connected via pins 1, 3, and 6. The same conditions on jumpers P11, P13, and P15 as described in “Power connector” below apply to power the device using 12 V or 24 V.

## MicroSD card slot

The source and control assembly is equipped with a MicroSD card reader/writer. The slot is provided for custom application development and is not implemented in the current MCU firmware. Contact LeddarTech for future enhancements of the firmware.

## Reset button

The Reset button, located on the left side of the module, allows you to restart the module. This action can be used as an alternative to cycling the power.

## MCU JTAG


Application developers can use the JTAG port to load and debug MCU firmware.

## USB port

The USB port is a standard 2.0, 12-MBit/s port. This communication link is used by the Leddar™ Configurator software and provides a link for prototyping new applications (contact LeddarTech for the SDK).

## Power connector

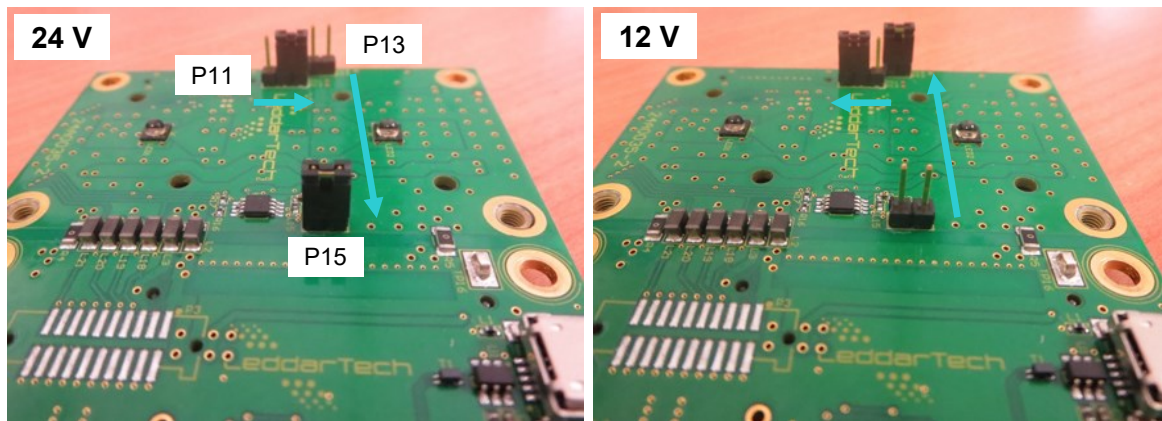
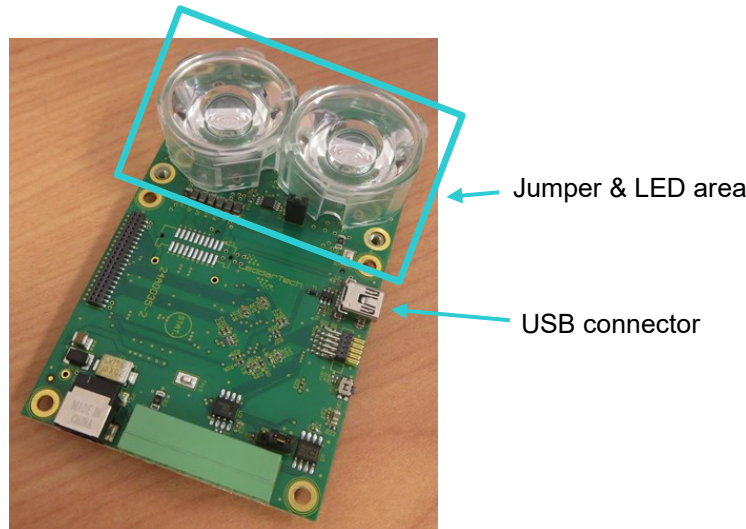
The power connector provides the module with a 24 V power source. However, using a 12 V source is also possible, provided the jumper configuration is changed. By default, jumper P11 connects its pins 1 and 2 for the 24 V. In this case, jumper P13 is disconnected, and P15 is connected. In 12 V supply mode, connect jumper P11 to pins 2 and 3, then disconnect P15 to connect P13 instead.

	<p><i>Using the included 24 V power source while in 12 V configuration may damage the module.</i></p>
---	---

**Table 2: Jumper configuration**

	P11	P13	P15
<b>24 V</b>	Pins 1 and 2	Disconnected	Connected
<b>12 V</b>	Pins 2 and 3	Connected	Disconnected

The figure below shows the MCU board with the two LEDs and the jumpers (top) and the 24 V and 12 V configurations (below). The two LED lenses and the receiver board have been removed for convenience in the two pictures, but the jumpers need not be configured.




**Fig. 3: Jumper configurations for 24 V and 12 V power supply**

### Receiver assembly

The receiver assembly contains the photodetector array (16 elements) and the controller for LED pulsing and data acquisition. Data acquisition is performed at a sampling frequency of 62.5 MHz. Oversampling and accumulation are also performed on this module assembly.

The module assembly generates a full waveform per segment at the module measurement rate.

	<p><i>The module measurement rate varies according to the oversampling and accumulation settings and the pulse rate according to FoV configuration.</i></p> <p><i>Lens coating color for 48° configuration may change between samples from greenish to bluish, but the inherent properties of the lens are not affected in the field of application of this product.</i></p>
---	--

### Source and control assembly

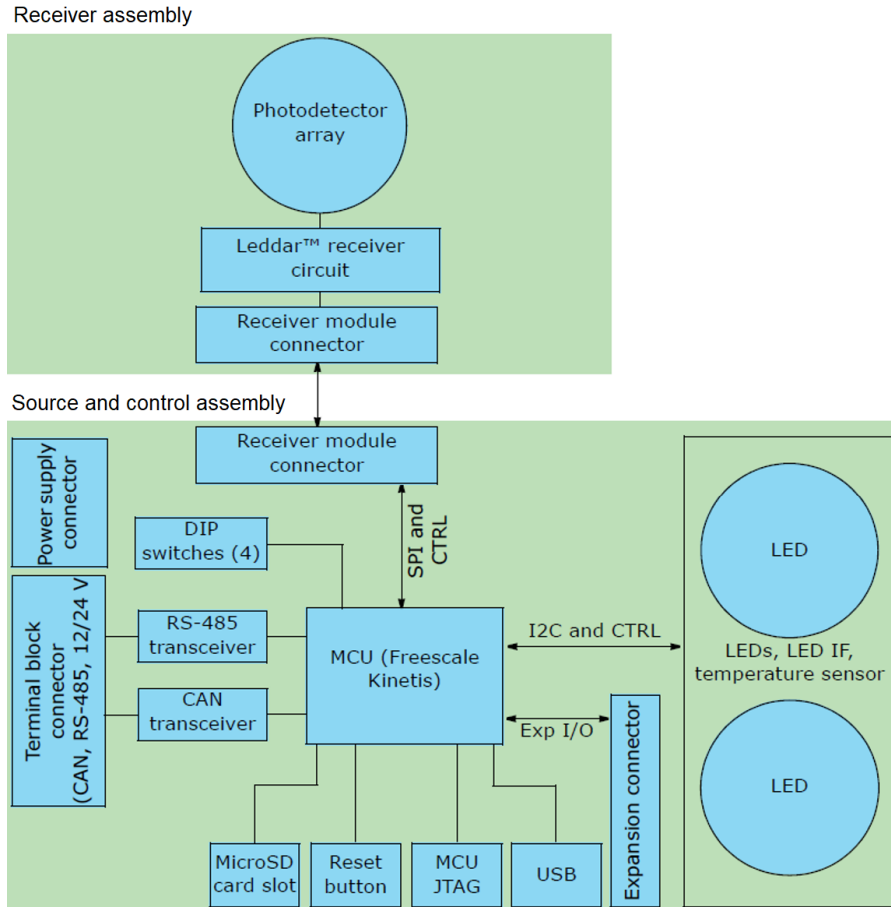
The source and control assembly includes the LEDs, the LED drivers, the MCU, the terminal block, and the external interfaces, while the receiver assembly includes the reception and emission optics.

The receiver assembly controls the LED pulsing since the receiver data acquisition must be synchronized with the LED pulses. A temperature module located near the LEDs is used to implement temperature compensation on the ranging results.

The MCU recovers the waveforms generated by the receiver assembly, performs full-waveform analysis, and generates detection and ranging data. The data can be displayed in software after a connection has been established through the USB link.

The source and control assembly offers several external interfaces, but most are provided for custom application development and are not implemented in the current MCU firmware. Contact LeddarTech for future enhancements of the firmware.

The following diagram illustrates how the components of the module interact with one another.



**Fig. 4: M16 LED working diagram**

### DIP switches

The source and control assembly is equipped with four DIP switches which are unused by the current design and are available as additional options for developing custom applications.

### RS-485 port

The RS-485 (ANSI/TIA/IEA-485) is a two-wire, half-duplex differential serial communication port often used in electrically noisy environments. The following table provides the pin definitions compliant with RS-485 standards.

**Table 3: RS-485 pin definition**


Pin 4	B	Non-inverting	+DATA
Pin 5	A	Inverting	-DATA

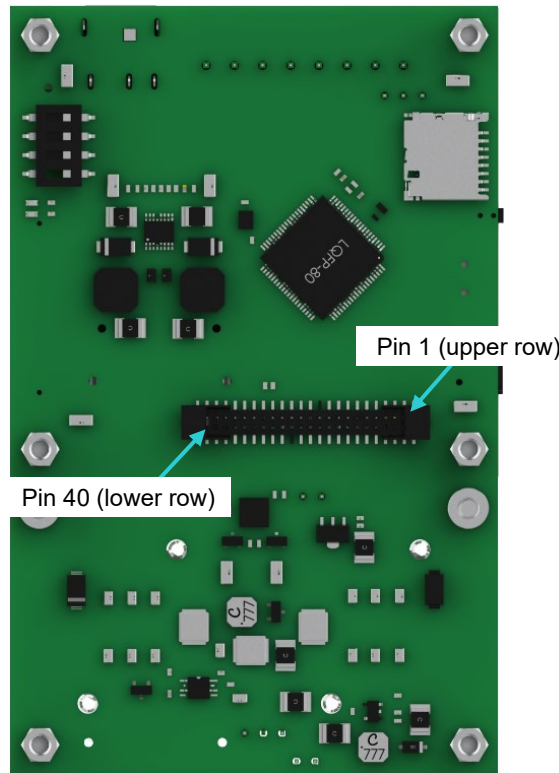
**CAN bus**

The CAN bus is implemented via a differential pair. Pin 7 connects to CAN-High (CAN+) and pin 8 to CAN-Low (CAN-). Jumper P9-P10 connects the 120 Ω CAN bus termination resistor when set in positions 1-2. The resistor is disconnected when in positions 2-3. The ISO 11898 standard describes the CAN technology.

**Expansion connector**

The expansion connector is another connectivity option that can be used for custom application development.

	<p><i>The UART link is the only option implemented in the current MCU firmware.</i></p>
---	---



**Fig. 5: Expansion connector**

Connector type: Samtec® FTS-120-02-F-DV-SA-P-TR, 50 mil pitch

Recommended mating connector type: Samtec® CLP-120-02-F-D-A

All even-numbered pins connect to the ground, while odd-numbered pins are described below.

**Table 4: Expansion connector pin definition**

	UART				CAN		GPIO/SPI/...							DAC	+3.3 V		+5.4 V		DC	
Pin	1	3	5	7	9	11	13	15	17	19	21	23	25	27	29	31	33	35	37	39
	2	4	6	8	10	12	14	16	18	20	22	24	26	28	30	32	34	36	38	40
GND																				

- UART

Pins 1, 3, 5, and 7 connect to UART2 from the MCU.

**Table 5: UART pin definition (TTL 3.3 V)**

Pin	Function
1	Tx
3	Rx
5	CTS
7	RTS

- CAN

Another CAN bus connector is available. Unlike the one on the terminal block, you are responsible for converting the receiver/transmitter signals to the CAN standard (CAN-High and CAN-Low).

**Table 6: CAN pin definition**

Pin	Function
9	Tx
11	Rx

- GPIO

General-purpose inputs/outputs are available through pins 13, 15, 17, 19, 21, 23, 25, and 27.

- SPI

The generic serial port interface functionality is available through pins 19, 21, 23, and 25.

**Table 7: SPI pin definition**

Pin	Function
19	MOSI
21	MISO
23	SCLK
25	CS

- DAC

Pin 29 is a digital-to-analog output. The reference voltage is 3.3 V.

## Status LEDs

There are two LEDs on this unit. One shows the activity of the microcontroller (blinking LED D6), and the other shows the USB connection status (LED D5).

## 1.2. Underlying Principles

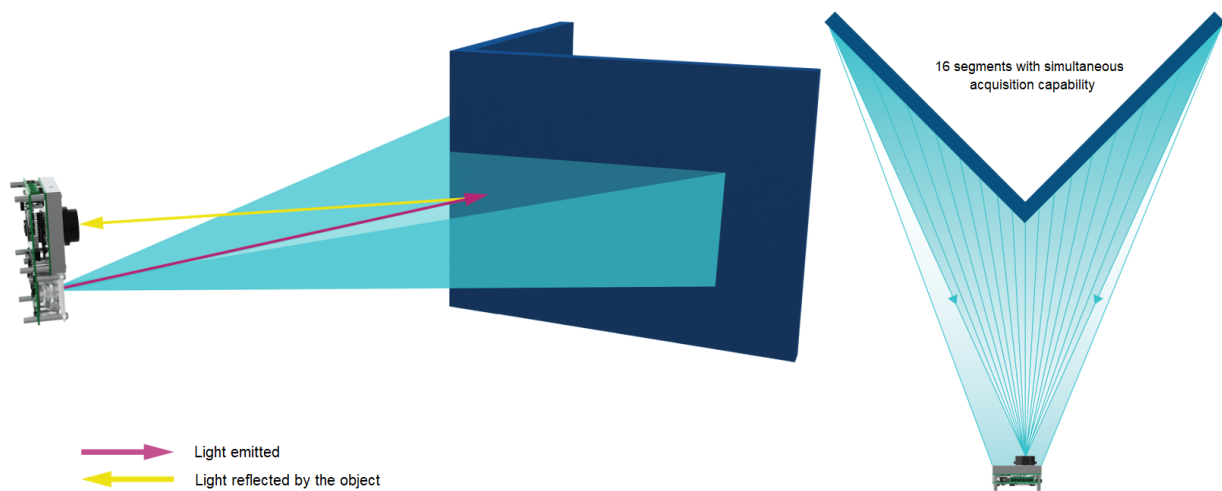
Created by LeddarTech, Leddar™ (light-emitting diode detection and ranging) is a unique sensing technology based on the LED illumination (infrared spectrum) and the time-of-flight of light principle. The LED emitters illuminate the area of interest (pulsed typically at 100 kHz). The multichannel module receiver collects the backscatter of the emitted light and measures the time taken for the emitted light to return to the module.

A 16-segment photodetector array is used and provides multiple detections and ranging segments. The full-waveform analysis enables detection and distance measurement of multiple objects in each segment, provided foreground objects do not fully obscure objects behind them. Oversampling and accumulation techniques are used to provide extended resolution and range.

Fig. 6 illustrates the illumination area and detection segments. The 16 segments provide a profile of the object in the beam. In other installations, the 16 segments can locate and track one or multiple objects in the beam.

**Table 8: Distances per segment (channel)**

Segment	1	2	3	4	5	6	7	8	9	10	11	12	13	14	15	16
Distance (m)	9.71	8.52	7.55	6.79	6.18	5.68	5.26	4.91	4.61	4.82	5.18	5.62	6.18	6.88	7.80	8.97



**Fig. 6: Illumination area and detection zone**

The core of Leddar sensing is the pulsing of diffused light, collection of reflected light, and full-waveform analysis (including oversampling and accumulation). The light source type, the number of light sources, and the illumination and reception beam can all be tailored to fit specific application requirements such as detection range, beam, and spatial resolution.



## 2. Getting Started

This chapter presents the steps to install Leddar™ Configurator and start using the M16 LED.

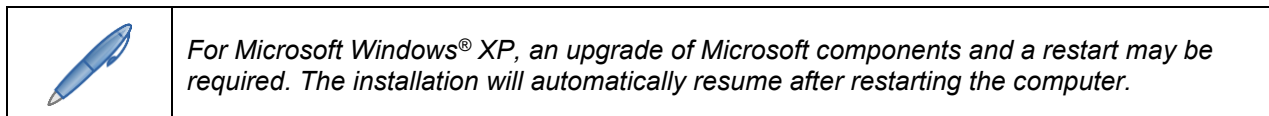
### 2.1. Setup

This section explains the Leddar™ Configurator installation and the procedure to set up the M16 LED. All software operations are described in section “5. Leddar Configurator.”

#### To install Leddar Configurator:

Download the LeddarInstaller.exe file from our website at: [www.leddartech.com/resources/#product-download/](http://www.leddartech.com/resources/#product-download/).

In the **Product Download** section, select **Leddar Configurator Software**, then click **LeddarInstaller.exe**. Double-click the file to start the installation.




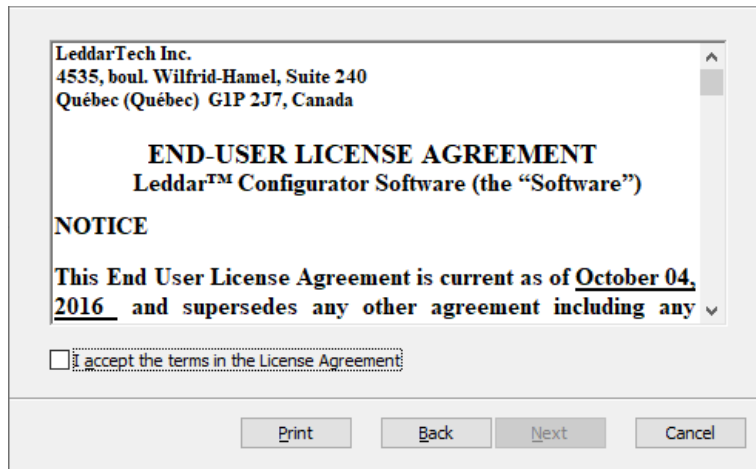
1. On the computer desktop, double-click the  **Leddar™ Configurator** icon.
2. In the **Welcome to the Leddar Configurator Setup Wizard** dialog box, click **Next**.



Fig. 7: Welcome dialog box


3. In the **End-User License Agreement** dialog box, read the terms of the agreement, select the **I accept the terms in the License Agreement** check box, and click **Next**.

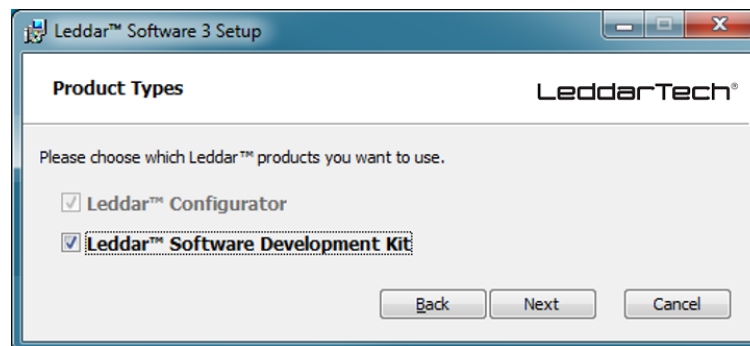




**Fig. 8: End-User License Agreement dialog box**

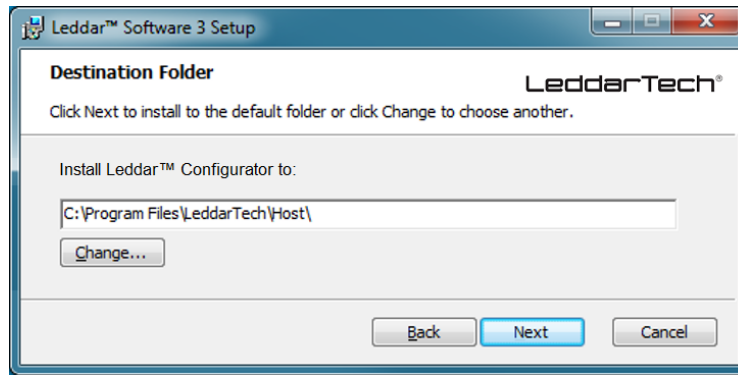
4. In the **Product Types** dialog box, the **Leddar™ Software Development Kit** check box is selected by default.

	<p><i>If you do not want to install the development kit, clear the check box.</i></p>
---	---



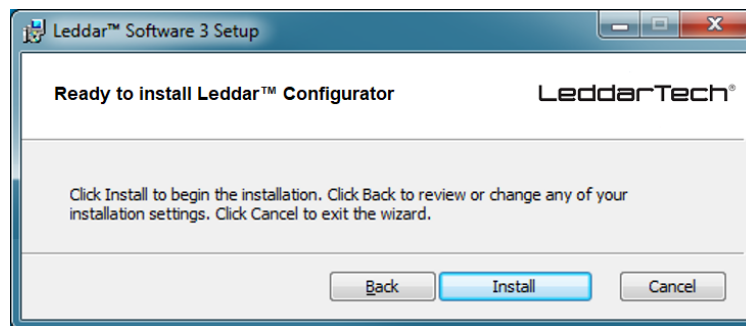
**Fig. 9: Product Types dialog box**

5. Click **Next**.
6. In the **Destination Folder** dialog box, click **Next** to select the default destination folder.  
OR  
Click the **Change** button to choose a destination folder.



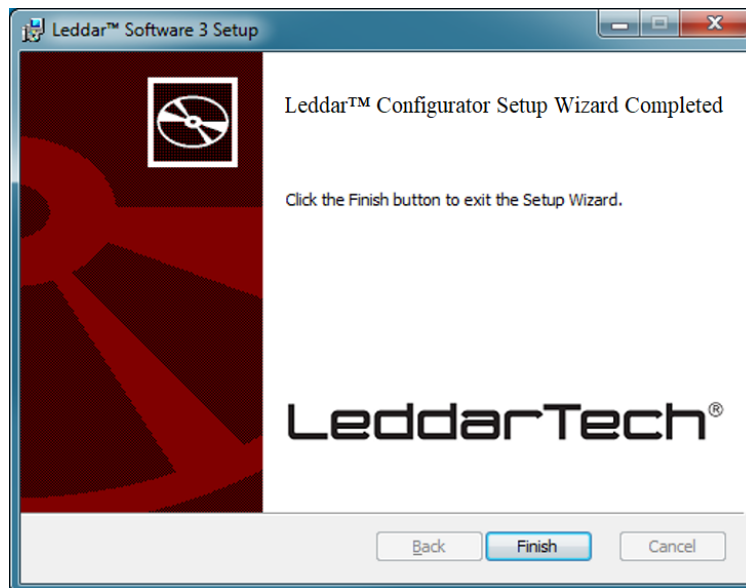
**Fig. 10: Destination Folder dialog box**

7. In the **Ready to Install Leddar™ Configurator** dialog box, click the **Install** button.



**Fig. 11: Installation dialog box**

8. In the **Leddar™ Configurator Setup Wizard Completed** dialog box, click **Finish**.



**Fig. 12: Completing the installation**


Leddar Configurator creates an icon on the computer desktop.

## 2.2. Connecting to the Module

The first time the module is connected to a computer, a few seconds are required for Windows™ to detect it and complete the installation.

Once the installation is completed, you can connect to the module.

### To connect to the module:

1. Connect the power cord to the module and to a power outlet.
2. Connect the USB cable to the module and to the computer.
3. On the computer desktop, double-click the **Leddar™ Configurator** icon.
4. In Leddar™ Configurator, click the  **Connect** button.

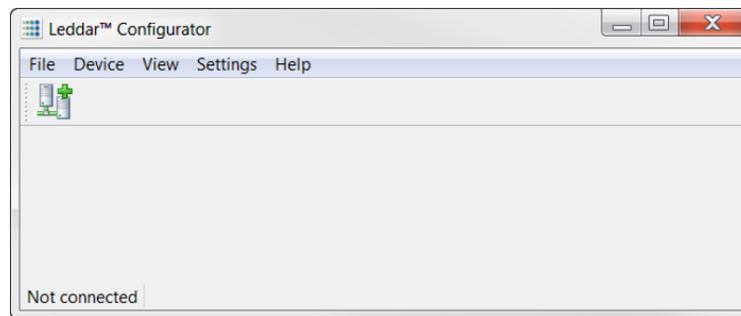


Fig. 13: Connecting to a module

5. In the **Select a connection type** list of the **Connection** dialog box, select the **IS16/M16/Evaluation Kit USB/Leddar Sight** option.

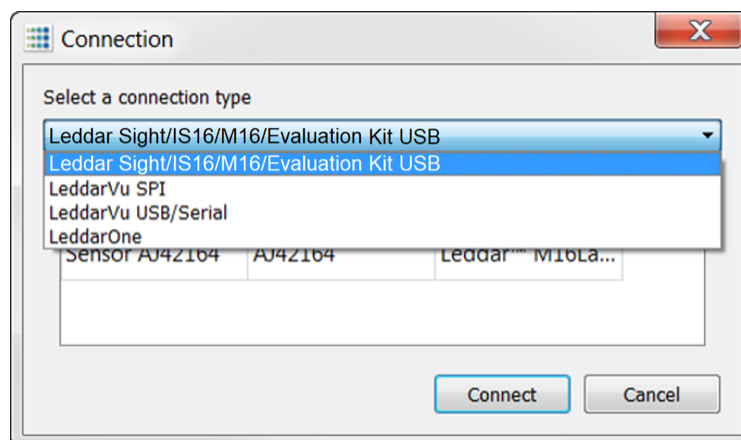

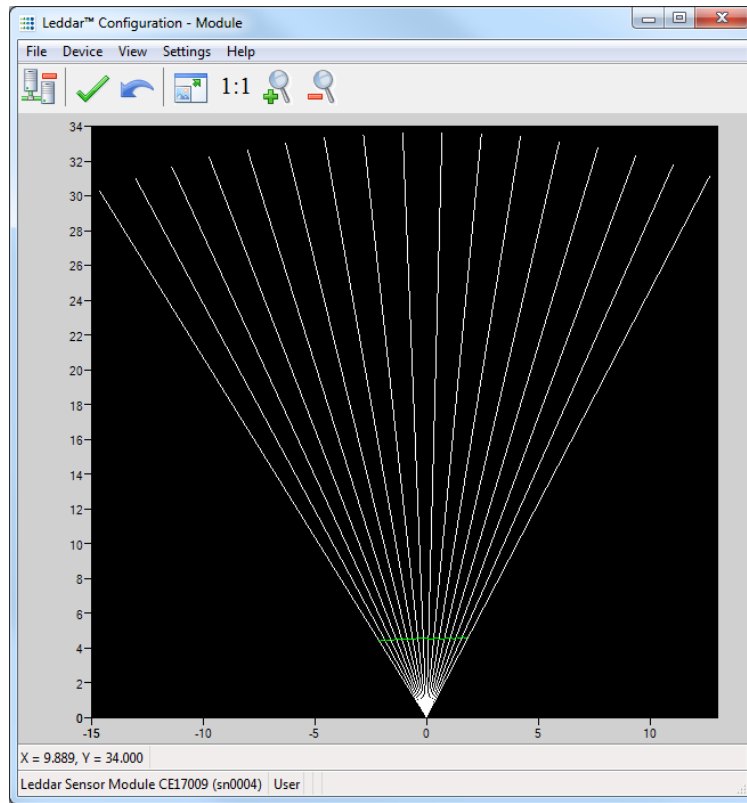


Fig. 14: Connection dialog box

6. In the product list, select the product and click the  **Connect** button.  
The main window displays the detections (green lines) in the segments (white lines).



**Fig. 15: Main window**

A complete description of Leddar Configurator features and parameters for the M16 LED can be found in section "5. Leddar Configurator."

### 3. Measurements and Settings

This chapter presents measurements, settings, and zone definition for the M16 LED.

#### 3.1. Distance Measurement

Distance is measured from the base of the standoffs for the M16 LED.

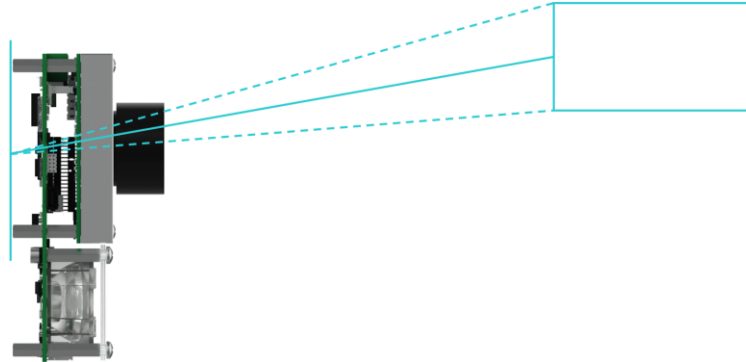


Fig. 16: Distance measurement

The dashed lines illustrate 1 of the 16 segments and the solid line indicates the distance measured by the module in that segment.

#### 3.2. Data Description

Data displayed in the **Raw Detections** dialog box allow you to precisely define the desired detection parameters (**View** menu > **Raw Detections**).

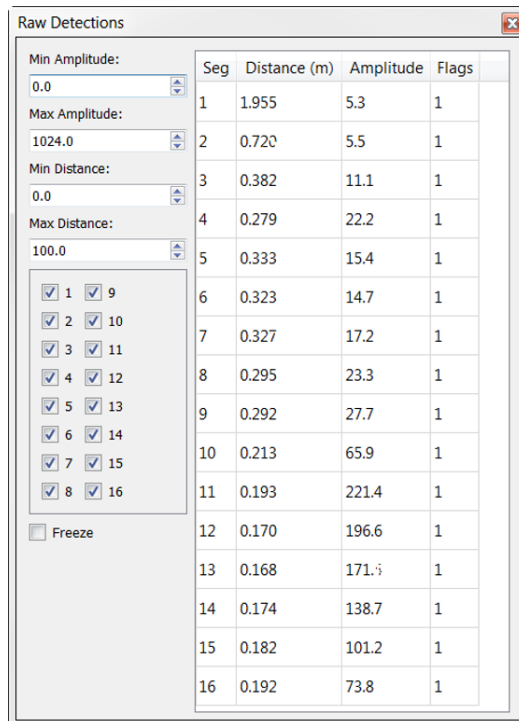


Fig. 17: Raw Detections dialog box

An object crossing the beam of the module is detected and measured. It is qualified by its distance, segment position, and amplitude. The quantity of light reflected to the module by the object generates the amplitude. The bigger the reflection, the higher the amplitude will be.

The amplitude is expressed in counts. A count is the unit value of the used ADC in the receiver. The fractional of counts is caused by the accumulation to achieve more precision.

**Table 9: Raw Detection field description**

Field	Description
<b>Segment (Seg)</b>	Beam segment in which the object is detected
<b>Distance</b>	Position of the detected object
<b>Amplitude</b>	Quantity of light reflected by the object and measured by the module
<b>Flags</b>	8-bit status (bit field). See Table 10.

The **Flag** parameter provides the status information that indicates the measurement type.

**Table 10: Flag value description**

Bit Position	Bit = 0	Bit = 1
<b>0</b>	Invalid measurement	Valid measurement
<b>1</b>	Normal measurement	Measurement is the result of demerging <sup>2</sup> processing.
<b>2</b>	Normal measurement	Interference was detected in the current frame.
<b>3</b>	Normal measurement	Received signal is above the saturation level. Measurements are valid (VALID is set) but have lower accuracy and precision. Consider decreasing the LED Intensity value.
<b>4</b>	Reserved	Reserved
<b>5</b>	Reserved	Reserved
<b>6</b>	Normal measurement	Detection is within the crosstalk zone.
<b>7</b>	Reserved	Reserved

The **Flag** field provisions for 8 bits encoded as a bit field. Three bits are currently used. The following table lists the implemented decimal values of the status bit field.

**Table 11: Status value description**

Status Value (Decimal)	Status Value (Binary)	Description
<b>1</b>	00000001	Normal measurement (valid)
<b>9</b>	00001001	Saturated signal (valid)

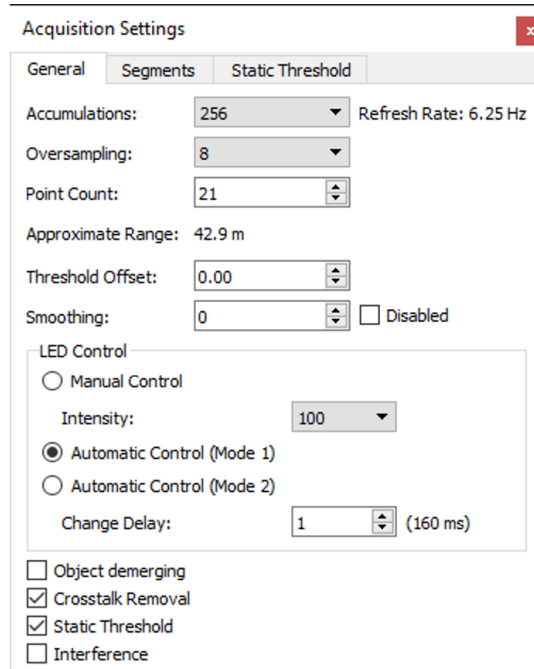
<sup>2</sup> Demerging available for M16 LED firmware version 53A0023-22 and previous.

### 3.3. Acquisition Settings


Acquisition settings allow you to define parameters to use for detection.

To open the **Acquisition Settings** dialog box, select **Device > Configuration > Acquisition**.

#### 3.3.1. General Settings



**Fig. 18: General tab – Acquisition Settings dialog box**

To apply new acquisition settings, click the  **Apply** button in the main window.

**Table 12: Acquisition settings description**

Parameter	Description	Range
<b>Accumulations</b>	Number of accumulations Higher values enhance range and reduce measurement rate and noise.	1
		2
		4
		8
		16
		32
		64
		128
		256
		512
		1 024
<b>Oversampling<sup>3</sup></b>	Number of oversampling cycles	1

<sup>3</sup> Oversampling of 1 and 2 might lead to accuracy below specification.

Parameter	Description	Range
	Higher values enhance accuracy/range and reduce the measurement rate.	2 4 8
<b>Point Count</b>	Number of base sample points Allows you to set the maximum detection range.	2 to 64
<b>Approximate Range</b>	Set the <b>Point Count</b> value using the up and down arrows to view the approximate range in meters or feet.	Varies
<b>Refresh Rate</b>	The theoretical measurement rate indicated in Hz The real measurement rate is shown in the <b>Device State</b> window under <b>View &gt; State</b> . Refer to section “3.4 Measurement Rate” on page 37 for more details.	Varies
<b>Threshold Offset</b>	Modification to the amplitude threshold Higher values decrease sensitivity and reduce range.	-5 to 100.00
<b>Smoothing</b>	Object smoothing algorithm Used to smooth the module measurements. The behavior of the smoothing algorithm can be adjusted by a value ranging from -16 to 16. Higher values enhance the module precision but reduce the module reactivity. The smoothing algorithm can be deactivated by selecting the <b>Disabled</b> check box or by entering <b>-17</b> in the <b>Smoothing</b> field. The measurement smoothing algorithm is advised for applications that need to measure slowly moving objects with high precision. For applications requiring to quickly track moving objects, the smoothing should be configured with a value lower than 0 or simply deactivated.	-16 to 16 Disabled at -17
<b>LED Control</b>	LED power control options Allow you to select between Manual and Automatic power control. In Automatic mode, the LED power is adjusted according to incoming detection amplitudes. The current LED power level is visible in the <b>View &gt; State &gt; Device State</b> window.	100% 90% 80% 65% 50% 35% 20% 10%
<b>Change Delay</b>	Minimum frame delay between power changes Smaller numbers speed up the response time of the LED power adjustment.	Varies
<b>Object Demerging<sup>4</sup></b>	Near-object discrimination Allows you to ease the discrimination of multiple objects in the same segment. Object Demerging is only available for a minimum of 8 oversamplings and a minimum of 256 accumulations. The number of merged pulses that can be processed for each frame is also limited. A status field is	N/A

<sup>4</sup> Demerging available for M16 LED firmware version 53A0023-22 and previous.



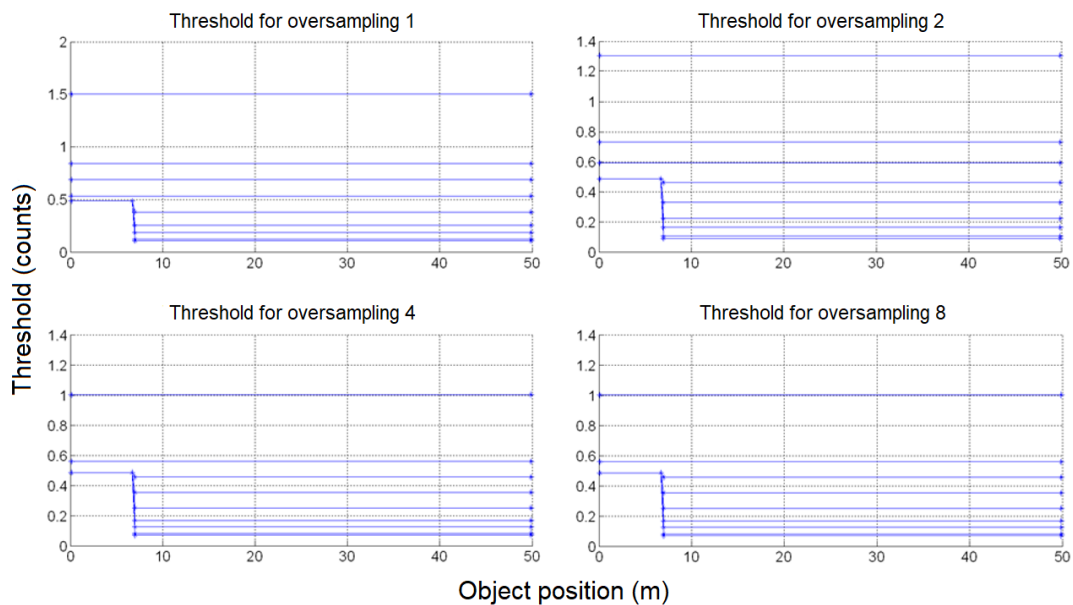
Parameter	Description	Range
	available in the device states window (Leddar Configurator), indicating if the module processes all merged pulses. The measurement precision of demerged objects tends to be of lower quality than on usual detections.	
<b>Crosstalk Removal</b>	Inter-channel interference noise mitigation Crosstalk is a phenomenon inherent to all multiple segments time-of-flight modules. It causes a degradation of the distance measurement accuracy of an object when one or more objects with significantly higher reflectivity are detected in other segments at a similar distance. This option enables an algorithm to compensate for the degradation due to crosstalk. This algorithm increases the computational load of the module microcontroller. It is recommended to disable the <b>Crosstalk Removal</b> option if the module is configured to run at a rate higher than 50 Hz.	N/A
<b>Static Threshold</b>	Default amplitude value (based on distance) under which detections are discarded to mitigate noise. It can be deactivated to gain more sensitivity.	Enabled Disabled
<b>Interference</b>	When enabled, this setting allows you to compare the previous and current frames to detect false positive detections and discard them.	Enabled Disabled

### Threshold Offset

The Threshold Offset is a value that allows you to modify the detection amplitude threshold.

A default detection threshold table was determined to provide robust detection and minimize false detections caused by noise in the input signal.

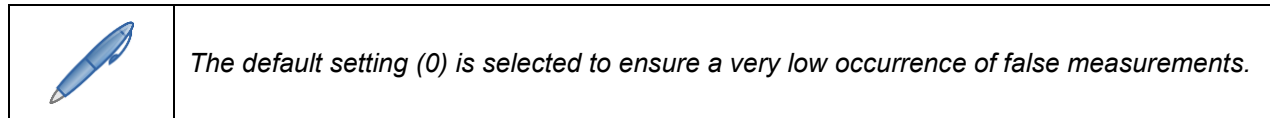
Fig. 19 presents the threshold table for a LED Intensity of 16. This table is effective when the Threshold Offset value is 0.



**Fig. 19: Detection thresholds**

The multiple lines in each graph show the thresholds for a few accumulations of 1 (top curve), 2, 4, 8, 16, 32, 64, 128, and 256 (bottom curve). Accumulations of 512 and 1024 are also available, although not shown (provide the lowest thresholds).

The **Threshold Offset** parameter has the effect of offsetting each value in the threshold table by the selected value. This provides a means of reducing (positive value) or increasing (negative value) the module's sensitivity. Increasing the Threshold Offset value allows ignoring (will not result in a measurement) signals with an amplitude higher than the default threshold. Decreasing the value of the Threshold Offset allows measurements of amplitude signals lower than the default threshold.



False measurements are likely to occur when reducing the Threshold Offset (negative values). These false measurements are very random in occurrence, while true measurements are repeatable. For this reason, it may be useful in some applications to use a higher sensitivity and filter out the false measurements at the application level. For example, this can be useful in applications that require long detection ranges or detection of small or low reflectivity targets.

## LED Intensity

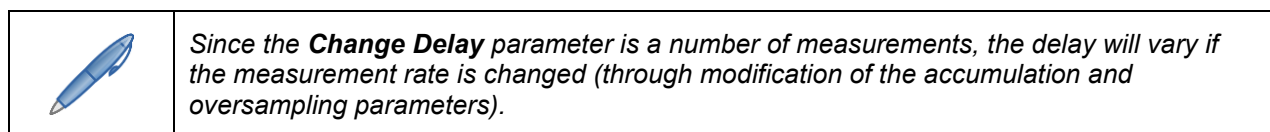
There are a total of 8 supported LED power levels. Their approximate relative power is as follows: 10%, 20%, 35%, 50%, 65%, 80%, 90%, and 100%.

There are three power control modes:

- Manual
- Automatic mode 1
- Automatic mode 2

With the Manual mode, the light power source of the module is set to a fixed value. This mode can be used in a controlled environment of module FoV.

For Automatic mode, the **Change Delay** parameter allows you to define the number of measurements required before allowing the module to increase or decrease the light source power level by one. For example, with the same **Change Delay**, the maximum rate of changes (per second) of the light source power will be twice higher at 12.5 Hz than at 6.25 Hz. The **Change Delay** can be set by the number of detection frames and the number of saturated segments that can be tolerated (Automatic mode 1 only).



Keeping the module in Automatic LED power mode (default setting) ensures it adapts to varying environments. Close range objects may reflect so much light that they can saturate the module, reducing the quality of the measurements. This mode will adapt the light output within the Change Delay setting to reach the optimal amplitude. On the other hand, low amplitudes provide lower accuracy and precision. The Automatic LED power mode will select a LED Intensity that provides the highest intensity to avoid the saturation condition.

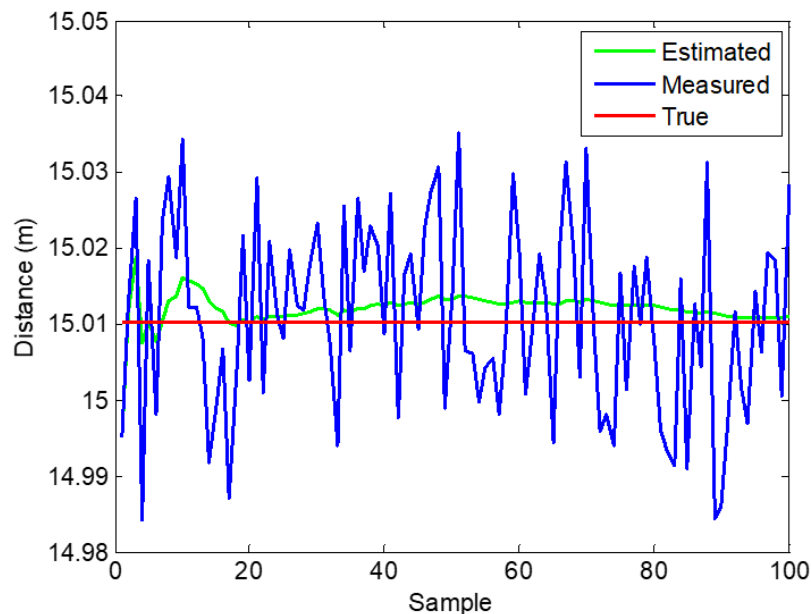
This automatic light source power mode will select a light source intensity that provides the highest intensity that avoids the saturation condition. Automatic mode 2 will adapt the light output within the Change Delay (frame parameter only) to reach at least one or more segments in saturation condition to provide the highest detection range. This mode is useful to keep the highest detection range into non-saturated segments when a strongly reflective object is detected.



*When a strongly reflective or nearby object is present in the field of view while monitoring farther distances, the automatic adjustment will reduce the effective range of the module (reduced LED Intensity value) and may prevent detection of long-range or low-reflectivity objects. For these applications, Manual mode with LED power set to 100% may be a better setting.*

## Smoothing

The smoothing algorithm increases the precision of the measurement at the cost of the module reactivity. The algorithm works by averaging consecutive measurements over a given time history. The history length of the filter is defined as a function of the measurement noise level. It also changes according to the oversampling and accumulation settings. The history length of the averaging filter can also be adjusted by a parameter ranging from  $-16$  to  $16$ . Select the **Disabled** check box or set the value to  $-17$  to disable smoothing. Higher values increase the module precision but reduce the module reactivity. An example of the behavior of the measurement smoothing algorithm is shown in Fig. 20 below.



**Fig. 20: Measurement smoothing example**

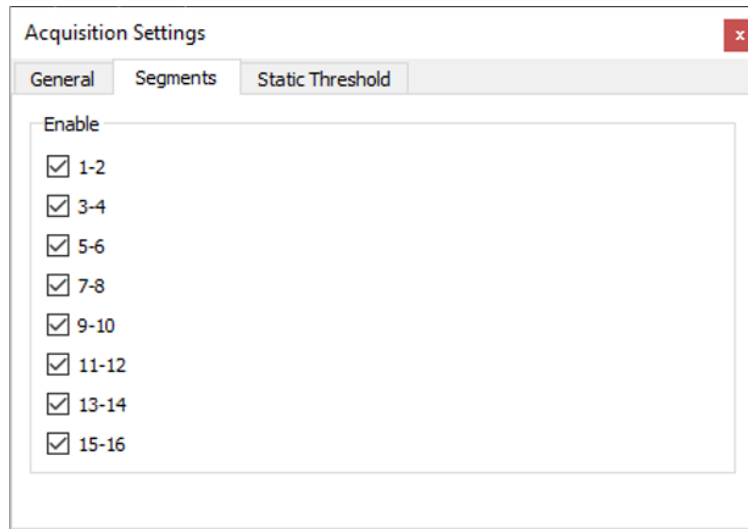
The red line represents the true target distance; the blue curve corresponds to the target distance measured by the module without smoothing, while the green curve is the smoothed measurements. Noteworthy is that the smoothing algorithm dramatically improves the measurement precision (standard deviation).



*The smoothing algorithm is recommended for applications that require highly precise measurements of slowly moving objects. For applications that track quickly moving objects, it is advised to decrease the **Smoothing** parameter's value or disable the smoothing algorithm. Select the **Disabled** check box or set the value to  $-17$  to disable smoothing.*

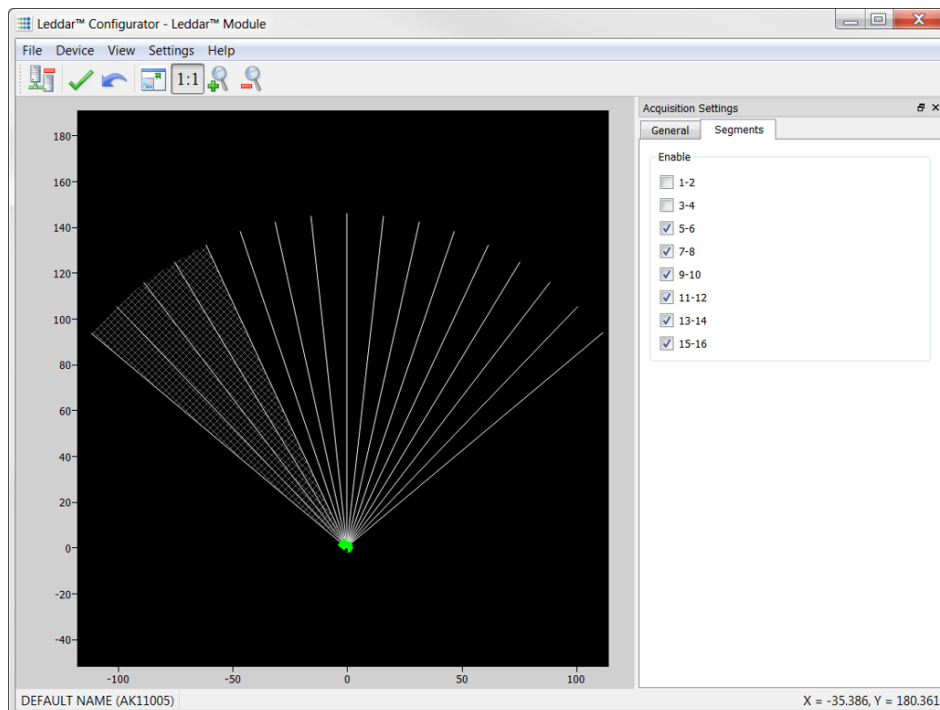
## 3.3.2. Enabling and Disabling Segments

To open the **Acquisition Settings** dialog box, select **Device > Configuration > Acquisition**. Segments are enabled by default.




**Fig. 21: Segments tab – Acquisition Settings dialog box**

The corresponding segments will appear with gray square lines in the main window when you deselect segments, as shown below.



**Fig. 22: Disabled segments example**

To apply new acquisition settings, click the  **Apply** button in the main window.

### 3.3.3. Static Threshold

The **Static Threshold** tab displays the current threshold applied in accordance with the acquisition settings.

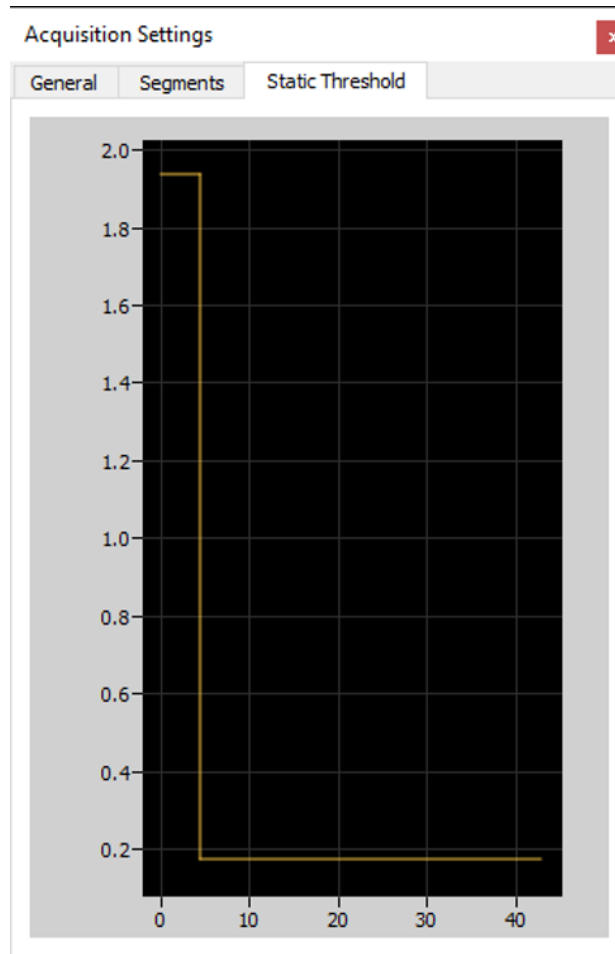


Fig. 23: Static Threshold tab – Acquisition Settings dialog box

The **Static Threshold** can be disabled in the **General Acquisition Settings** tab.

### 3.4. Measurement Rate

The module acquires an input waveform for each segment at a fixed rate of 12.8 kHz. Multiple acquisitions are used to perform accumulations and oversamplings and generate a final waveform that is then processed to detect the presence of objects and measure their position.

The theoretical measurement rate is, therefore:

$$\text{Measurement rate} = \frac{\text{Base rate}}{\text{Accumulations} * \text{oversamplings}} * \frac{8}{\text{Enabled segment pair}}$$

For example, with 256 accumulations and an oversampling value of 8 with all segment pairs enabled:

$$\text{Measurement rate} = \frac{12800}{256 * 8} * \frac{8}{8} = 6.25 \text{ Hz}$$

Refer to section “3.3.2 Enabling and Disabling Segments” on page 36 for more details.

The data processing time is not taken into account in this calculation. Hence, the actual measurement will almost always be lower than the theoretical value. The actual measurement rate depends on the complexity of the scene, and the algorithms enabled.

Table 13 presents the measurement rate for typical values of accumulations and oversampling.

**Table 13: Theoretical measurement rate**

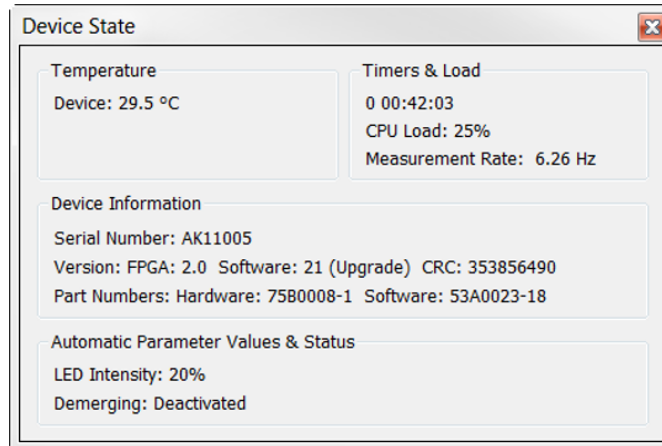
Accumulation	Oversampling	Measurement Rate (Hz)
1 024	8	1.56
512	8	3.13
256	8	6.25
128	8	12.5
64	8	25
32	8	50
1 024	4	3.13
512	4	6.25
256	4	12.5
128	4	25
64	4	50
32	4	100

### 3.5. CPU Load

The measurement rate varies with the accumulations and oversampling settings. The higher the rate, the higher the processing load is on the source and control assembly microcontroller. The **Point Count** parameter also impacts the processing load since it affects the number of sample points to process for each segment.

Given the high flexibility of parameter settings, it is possible to create a processing load that exceeds the capacity of the microcontroller. When the microcontroller load is exceeded, the theoretical measurement rate will not be obtained.

The load (**CPU Load**) is displayed in the **Device State** window (**View** menu > **State**). It is recommended to verify the load when modifying the **Accumulations**, **Oversampling**, and **Point Count** parameters. The measurement rate will be lower than the calculated rate, and the measurement period may be irregular when the load nears or reaches 100%.



**Fig. 24: Device State window**

### 3.6. Serial Port Settings

Several serial port settings are available to adjust data acquisition through the RS-485 link. Typical serial port settings such as baud rate and start/stop bit can be configured to the desired values.

A baud rate of 115 200 bps is recommended to provide the best data transfer rate and measurement rate up to 50 Hz. The following serial port settings are configurable:

**Table 14: Serial port settings description**

Parameter	Value
Port Number	1
Baud Rate (bps)	9 600 19 200 38 400 57 600 115 200 230 400 <sup>5</sup> 460 800 <sup>5</sup> 921 600 <sup>5</sup>
Parity	None Odd Even
Stop Bits	1 2
Address	1 to 247
Detections <sup>6</sup>	0 to 48

<sup>5</sup> To avoid errors, it is recommended not to select these rates. Availability according to selected serial port.

<sup>6</sup> This parameter can be limited to 40 if used with a 0x6A Modbus function.

The **Detections** parameter is the maximum number of detections to output in Modbus data transfers (Get Detections – function code 0x41). This information can be used to match the data transfer rate to the module measurement rate (the module will drop measurements if the measurement rate exceeds the data transfer rate).

To give an “equal chance” to each segment, the module parses all segments to output their nearest measurement. It then passes to the second nearest, etc., until either there are no more detections to output or the configured number of detections is reached.

The following table lists the theoretical maximum number of detections that can be transferred for different baud rates and measurement rates. This assumes the host can sustain the resulting data transfer rate.

**Table 15: Maximum detections per baud rate / Measurement rate settings**

Baud Rate (bps)	Measurement Rate (Hz)					
	1.5625	3.125	6.25	12.5	25	50
<b>921 600<sup>7</sup></b>	48	48	48	48	48	48
<b>460 800<sup>7</sup></b>	48	48	48	48	48	48
<b>230 400<sup>7</sup></b>	48	48	48	48	48	48
<b>115 200</b>	48	48	48	48	48	32
<b>57 600</b>	48	48	48	32	32	14
<b>38 400</b>	48	48	48	44	20	8
<b>19 200</b>	48	48	44	20	8	2
<b>9 600</b>	48	44	20	8	2	2

## 3.7. CAN Port Settings

The CAN port settings are available to adjust data acquisition through the CAN link. Typical CAN port settings such as baud rate, Tx and Rx ID, frame format, inter-message and inter-cycle delay, flag information, the maximum number of detections to output, and the message mode can be configured. The following CAN port settings are available:

**Table 16: CAN port settings**

Parameter	Value
<b>Port Number</b>	1
<b>Baud Rate (kbps)</b>	10
	20
	50
	100
	125
	250
	500
	1 000

<sup>7</sup> To avoid errors, it is recommended not to select these rates. Availability according to selected serial port.



Parameter	Value
<b>Base Tx ID</b>	The CAN arbitration ID used for data messages from the module containing the detections. The arbitration ID of the messages containing the number of detections will be this value plus one (see the protocol documentation).
<b>Base Rx ID</b>	The CAN arbitration ID used for data messages to the evaluation kit (see the protocol documentation).
<b>Frame Format</b>	Standard Extended
<b>Inter-Message Delay</b>	0 to 65 535 milliseconds
<b>Inter-Cycle Delay</b>	0 to 65 535 milliseconds
<b>Flag Information</b>	Enabled (see Table 31 on page 55) Disabled (see Table 33 on page 55)
<b>Detection</b>	1 to 96
<b>Message Mode</b>	Single Multiple

The CAN port supports two frame format standards: the standard 11 identifier bits and the extended 29 identifier bits.

For a CAN host device that uses limited resources, it is possible to slow down the CAN data transmission by adding configurable delays from 0 to 65 535 milliseconds:

- The **Inter-Message Delay** parameter is a delay to add between two CAN messages.
- The **Inter-Cycle Delay** parameter is a delay to add between two acquisition cycle message blocks. It is primarily used to send detection in continuous mode.

The **Flag Information** parameter, when activated, gives an 8-bit field additional information of measurement.

The **Detection** parameter is the maximum number of detections to output in the CAN bus. This can be used to limit the range of message IDs used in multiple message mode. In order to give an equal chance to each segment, the module parses all segments to output their nearest measurement and then moves to the next nearest, and so on until either there are no more detections to output or the configured number of detections is reached.

The **Message Mode** parameter is the type of transmission data on the CAN link. Two message modes are available. Refer to section “4.2 CAN Bus” on page 48 for more details.

## 4. Communication

### 4.1. Serial Port

The RS-485 port on the module uses the Modbus protocol using RTU transmission mode only. This section describes the commands that are implemented.

For more information on the Modbus protocol, visit [www.modbus.org](http://www.modbus.org).

#### Report server ID (function code 0x11)

This function returns information on the module in the following format:


**Table 17: Report server ID message**

Offset	Length	Description
0	1	Number of bytes of information (excluding this one). Currently, 0x95 since the size of the information returned is fixed.
1	32	Serial number as an ASCII string
33	1	Run status 0: OFF, 0xFF: ON. Should always return 0xFF; otherwise, the module is defective.
34	64	The device name as a Unicode string
98	16	The software part number as an ASCII string
114	16	The hardware part number as an ASCII string
130	8	The full firmware version as 4 16-bit values
138	4	The firmware 32-bit CRC
142	2	The firmware type (LeddarTech internal use)
144	2	The FPGA version
146	4	Device option flags (LeddarTech internal use)
150	2	Device identification code (9 for M16 LED)

#### Get detections (function code 0x41)

This function returns the detections/measurements in the following format:

The first byte is the number of detections in the message. Because of the limitation on a Modbus message length, a maximum of 48 detections will be returned. This is not a problem as you are very unlikely to have more than 48 detections in a real-world application.

	<p><i>This maximum can be configured to a lower value using the Leddar Configurator software (serial port configuration) or the Write Register command described below.</i></p>
---	---

Following the first byte, each detection has five bytes:

**Table 18: Get detection message (detection fields)**

Offset	Length	Description
0	2	Denotes the distance in centimeters (little-endian). Distance unit is defined by holding register 14.
2	2	The amplitude times 64 (that is, amplitude = this field / 64) (little-endian)
4	1	Low 4 bits are flags describing the measurement: Bit 0: Detection is valid (will always be set). Bit 1: Detection was the result of object demerging <sup>8</sup> . Bit 2: Interference was detected in the current frame. Bit 3: Detection is saturated. High 4 bits are the segment number.

Three more data fields follow the detection list:

**Table 19: Get detection message (trailing fields)**


Offset	Length	Description
0	4	Timestamp of the acquisition (little-endian), expressed as the number of milliseconds since the device was started.
4	1	Current LED power as a percentage of maximum
5	1	Current acquisition statuses. This is an 8-bit field with 1 bit currently defined (all others are reserved): Bit 1: Object demerging <sup>8</sup> is completed if set to 1 when this function is activated.

For an example of a 0x41 Modbus function (user-defined), refer to Appendix A.

### Get detections and flags info (function code 0x6A)

This function returns the detections/measurements in the following format:

The first byte is the number of detections in the message. Because of the limitation on a Modbus message length, a maximum of 40 detections will be returned.

	<i>This maximum can be configured to a lower value using the Leddar Configurator software (serial port configuration) or the Write Register command described below. This configuration parameter is the same as the original "Get detection" (0x41) function, but if it is over 40 detections, it will be internally overriding to a maximum of 40 detections for this "Get detection and flags info" (0x6A) function.</i>
---	---

<sup>8</sup> Demerging available for M16 LED firmware version 53A0023-22 and previous.

Following the first byte, each detection has six bytes:

**Table 20: Get detection message (detection fields)**

Offset	Length	Description
0	2	The distance in centimeters (little-endian). Distance unit is defined by holding register 14.
2	2	The amplitude times 64 (that is, amplitude = this field / 64) (little-endian)
4	1	4 bits are flags describing the measurement (all others are reserved): Bit 0: Detection is valid (will always be set). Bit 1: Detection is the result of object demerging <sup>9</sup> . Bit 2: Interference was detected in the current frame. Bit 3: Detection is saturated. Bit 6: Detection is within the crosstalk zone.
5	1	Segment number

Three more data fields follow the detection list:

**Table 21: Get detection message (trailing fields)**

Offset	Length	Description
0	4	Timestamp of the acquisition (little-endian). Expressed as the number of milliseconds since the device was started.
4	1	Current LED power as a percentage of maximum
5	1	Current acquisition statuses. This is an 8-bit field: Bit 0: Reserved Bit 1: Object demerging <sup>9</sup> is completed if set to 1 when this function is activated. Bit 2: Reserved

## Read input register (function code 0x4)

Table 22 lists the registers implemented for this command.


**Table 22: Read input register message**

Address	Description
0	Module temperature in degrees Celsius. Fixed point value with an 8-bit fractional part (that is, the temperature is the register value divided by 256).
1	Detection status for polling mode: 0: Detections not ready 1: Detections ready: this register is reset to 0 on reading input registers from addresses 13 to 207 or on execution of "get detections" function (code 0x41 or 0x6A).
2	Detection zone outputs bit field (1 zone per bit) Bit 0: Object in advanced detection zone (0 = no detection in advanced detection zone, 1 = detection in advanced detection zone). Only this zone is currently available.

<sup>9</sup> Demerging available for M16 LED firmware version 53A0023-22 and previous.

Address	Description
13	The least significant byte is the current LED power as a percentage of maximum. Most significant byte is acquisition statuses. This is an 8-bit field: Bit 0: Reserved Bit 1: Object demerging <sup>10</sup> is completed if set to 1 when this function is activated. Bit 2: Reserved
14	Low 16 bits of timestamp (number of milliseconds since the module was started)
15	High 16 bits of timestamp
16-31	Distance in centimeters of first detection for each segment, zero if no detection in a segment. Distance unit is defined by holding register 14.
32-47	Amplitude of first detection for each segment times 64 (that is, amplitude = this register / 64), zero if no detection in a segment
48-63	Distance of second detection for each segment
64-79	Amplitude of second detection for each segment
80-95	Distance of third detection
96-111	Amplitude of third detection
112-127	Distance of fourth detection
128-143	Amplitude of fourth detection
208	The least significant byte is the current LED power as a percentage of maximum. Most significant byte is acquisition statuses. This is an 8-bit field: Bit 0: Reserved Bit 1: Object demerging <sup>10</sup> is completed if set to 1 when this function is activated. Bit 2: Reserved
209	Low 16 bits of timestamp (number of milliseconds since the module was started). This register content is same as input register 14.
210	High 16 bits of timestamp. This register content is same as input register 15.
211-226	Distance in centimeters of first detection for each segment, zero if no detection in a segment. Distance unit is defined by holding register 14.
227-242	Amplitude of first detection for each segment times 64 (that is, amplitude = this register / 64), zero if no detection in a segment
243-258	Flags of first detection for each segment. Refer to Table 4 and Table 37.
259-274	Distance of second detection for each segment
275-290	Amplitude of second detection for each segment
291-306	Flags of second detection for each segment
307-322	Distance of third detection
323-338	Amplitude of third detection
339-354	Flags of third detection
355-370	Distance of fourth detection
371-386	Amplitude of fourth detection
387-402	Flags of fourth detection

<sup>10</sup> Demerging available for M16 LED firmware version 53A0023-22 and previous.

	<i>As per the Modbus protocol, register values are returned in big-endian format.</i>
---	---

For an example of a 0x04 Modbus function (read input register), refer to Appendix B.

**Read holding register (function code 0x3), write register (function code 0x6), and write multiple register (function code 0x10)**

Table 23 lists the registers implemented for these commands (see section 3.3 for a more detailed description of parameters).

**Table 23: Read holding register message definition**

Address	Description
<b>0</b>	Exponent for the number of accumulations (that is, if the content of this register is n, 2 <sup>n</sup> accumulations are performed)
<b>1</b>	Exponent for the number of oversamplings (that is, if the content of this register is n, 2 <sup>n</sup> oversamplings are performed)
<b>2</b>	Number of base samples
<b>3</b>	Reserved
<b>4</b>	Detection threshold as a fixed-point value with an 8-bit fractional part (that is, threshold value is this register divided by 256). The range is limited to a maximum of 100.0 and to a variable minimum determined by the accumulation and oversampling settings (read back the register to know the actual value set).
<b>5</b>	LED power as a percentage of maximum. A value above 100 is an error. Only the LED Intensity values defined in section 3.3.1 should be used. If a value is specified that is not one of the predefined values, the closest predefined value will be used. The register can be read back to know the actual value set.
<b>6</b>	Bit field of acquisition options with 6 bits currently defined (all others are reserved): Bit 0: Automatic LED Intensity enabled Bit 2: Object Demerging <sup>11</sup> enabled Bit 3: Crosstalk Removal disabled (disabled if set to 1) Bit 8: Automatic LED intensity mode: 0 = Mode 1 1 = Mode 2 Bit 9: Static detection threshold table usage disabled Bit 10: Interference algorithm enabled
<b>7</b>	Change delay in the number of measurements
<b>8</b>	Maximum number of detections (measurements) returned by functions 0x41 and 0x6A <sup>12</sup>
<b>9 and 10</b>	Reserved


<sup>11</sup> Demerging available for M16 LED firmware version 53A0023-22 and previous.

<sup>12</sup> Can be limited to 40 if used with a 0x6A Modbus function.

Address	Description
11	Smoothing: stabilizes the module measurements. The behavior of the smoothing algorithm can be adjusted by a value ranging from –16 to 16. Select the <b>Disabled</b> check box or set the value to –17 to disable smoothing.
12 and 13	Reserved
14	Distance units: mm = 1 000 cm = 100 dm = 10 m = 1
15	Communication segment activation: bit field of the selected segment to activate.
16	Reserved
17	Reserved
18	Acquisition segment pair activation: bit field of selected segment pair to activate.
19 to 26	Reserved
27	Port configuration stop bits: set to 1 or 2
28	Port configuration parity: 0 = None 1 = Odd 2 = Even
29	Port configuration baud rate (bps): 0 = 9 600 1 = 19 200 2 = 38 400 3 = 57 600 4 = 115 200 5 = 230 400 <sup>13</sup> 6 = 460 800 <sup>13</sup> 7 = 921 600 <sup>13</sup>
30	Port configuration Modbus module address: set from 1 to 247.

To set up the port configuration, it is recommended to do a Read Holding Register and a Write Multiple Register command for the entire range of Modbus holding register address from 27 to 30 inclusively.

The Write Register and Write Multiple Register command execution will fail if this module is USB connected to a host device; error code “4” will be returned.

	<i>As per the Modbus protocol, register values are returned in big-endian format.</i>
---	---

<sup>13</sup> To avoid errors, it is recommended not to select these rates. Availability according to selected serial port.

A request for a register that does not exist will return the error code “2.” Trying to set up a register to an invalid value will return error code “3.” If an error occurs while trying to execute the function, error code “4” will be returned.

## 4.2. CAN Bus

The CAN bus in single message mode uses the 1872 (0x750) base ID to send all detection messages. When sending detection, one 0x751 message will be sent, followed by as many 1872 (0x750) base ID messages as needed.

The CAN port in multiple message mode uses a maximum range from 1874 (0x752) ID to 1922 (0x782) of standard message or a maximum range from 1874 (0x752) ID to 1970 (0x7B2) of the message with detection flag information. When sending detection, one 0x751 message will be sent, followed by messages on ID range from 1874 (0x752) to as needed in multiple message mode.

Four message IDs are available (these IDs can be modified with the Leddar Configurator software).

### 1856 (0x740) (Rx base ID)


This is an 8-byte message length for command request that the module listens to: the first byte (byte 0) describes the main function, and the rest of the message bytes are used as arguments. Undescribed bytes are reserved and must be set to 0.

**Table 24: CAN bus request message**

Function Request (Byte 0)	Function Request Description	Function Argument (Byte 1)
1	Legacy: send detections once	--
2	Legacy: start sending detections continuously (the module will send a new set of detections each time they are ready without waiting for a request).	--
3	Stop sending detections continuously.	--
4	Send detection once.	Bit field of operation mode (this overrides the CAN operation mode field in CAN port configuration 3): Bit 0: 0 = return detection in single message mode, 1 = return detection in multiple message mode Bit 1: Reserved Bit 2: Reserved Bit 3: Detection flag message activation
5	Start sending detections continuously (that is, the module will send a new set of detections each time they are ready without waiting for a request).	Bit field of operation mode (this overrides the CAN operation mode field in CAN port configuration 3): Bit 0: 0 = return detection in single message mode, 1 = return detection in multiple message mode Bit 1: Reserved Bit 2: Reserved Bit 3: Detection flag message activation



Function Request (Byte 0)	Function Request Description	Function Argument (Byte 1)
6	GET input data (read-only)	See Table 25.
7	GET holding data	See Table 26.
8	SET holding data	See Table 27.

	<i>The GET and SET function messages always return an answer message on the 1873 (0x751) base ID. See the section below.</i>
---	--

**Table 25: CAN bus request message (GET input data)**

Input Data Type (Byte 1)	Input Data Description
0	Temperature
1	Device identification and option
2	Firmware version
3	FPGA version
4 to 9	Serial number
10 to 20	Device name
21 to 23	Software part number
24 to 26	Hardware part number
27	Detection zone

**Table 26: CAN bus request message (GET holding data)**

Holding Data Type (Byte 1)	Holding Data Description
0	Acquisition configuration
1	Reserved
2	Detection threshold
3	LED power percent (%)
4	Acquisition option
5	Auto-acquisition average frames
6	Smoothing
7	Distance resolution
8	Communication segment enabled
9	CAN port configuration 1
10	CAN port configuration 2

Holding Data Type (Byte 1)	Holding Data Description
11	CAN port configuration 3
12	Test mode
13	Reserved
14	Acquisition segment pair enabled


**Table 27: CAN bus request message (SET holding data)**

Holding Data Type (Byte 1)	Holding Data Description	Argument	Argument Description
0	Acquisition configuration	Byte 2	Exponent for the number of accumulations (that is, if the content of this register is n, 2 <sup>n</sup> accumulations are performed)
		Byte 3	Exponent for the number of oversamplings (that is, if the content of this register is n, 2 <sup>n</sup> oversamplings are performed)
		Byte 4	Number of base samples
1	Reserved	--	--
2	Detection threshold	Byte 4	Detection threshold as a fixed-point value with a 19-bit fractional part (that is, the threshold value is this register divided by 524 288) The range is limited to a maximum of 100.0 and to a variable minimum determined by the accumulations and oversamplings (read back the register to know the actual value).
		Byte 5	
		Byte 6	
		Byte 7	
3	LED power percent (%)	Byte 2	LED power as a percentage of maximum A value above 100 is an error. Only the LED Intensity values defined in section 3.3.1 should be used. If a value is specified that is not one of the predefined values, the closest predefined value will be used. The register can be read back to know the actual value set. Note that this value is ignored if the Automatic LED Intensity is enabled.
4	Acquisition option	Byte 2	Bit field of acquisition options with 6 bits currently defined (all others are reserved): Bit 0: Automatic LED Intensity enabled Bit 2: Object Demerging <sup>14</sup> enabled

<sup>14</sup> Demerging available for M16 LED firmware version 53A0023-22 and previous.

Holding Data Type (Byte 1)	Holding Data Description	Argument	Argument Description
		Byte 3	Bit 3: Crosstalk Removal disabled (disabled if set to 1) Bit 8: Automatic LED intensity mode: 0 = Mode 1 1 = Mode 2 Bit 9: Static detection threshold table usage disabled Bit 10: Interference algorithm enabled
5	Auto-acquisition average frames	Byte 2	Change delay in the number of measurements
		Byte 3	
6	Smoothing	Byte 2	Smoothing: used to stabilize the module measurements. The behavior of the smoothing algorithm can be adjusted by a value ranging from -16 to 16. Select the <b>Disabled</b> check box or set the value to -17 to disable smoothing.
7	Distance units	Byte 2	Distance units: mm = 1 000 cm = 100 dm = 10 m = 1
		Byte 3	
8	Communication segment enabled	Byte 2	Bit field of the activated segment for communication
		Byte 3	
9	CAN port configuration 1	Byte 2	Baud rate (kbps): 0 = 1 000 1 = 500 2 = 250 3 = 125 4 = 100 5 = 50 6 = 20 7 = 10
		Byte 3	Frame format: 0 = Standard 11 bits 1 = Extended 29 bits
		Byte 4	Tx base ID
		Byte 5	
		Byte 6	
10	CAN port configuration 2	Byte 4	Rx base ID

Holding Data Type (Byte 1)	Holding Data Description	Argument	Argument Description
		Byte 5	
		Byte 6	
		Byte 7	
11	CAN port configuration 3	Byte 2	CAN operation mode bit field: Bit 0: 0 = return detection in single message mode, 1 = return detection in multiple message mode Bit 1: Inter-message delay activation Bit 2: Inter-cycle delay activation Bit 3: Detection flag message activation
		Byte 3	Maximum number of detections (measurements) returned per CAN detection message transaction: 1 to 96
		Byte 4	Inter-message delay, 0 to 65 535 milliseconds
		Byte 5	
		Byte 6	Inter-cycle delay, 0 to 65 535 milliseconds
Byte 7			
12	Reserved	--	--
13	Reserved	--	--
14	Acquisition segment pair enabled	Byte 2	Bit field of segment pair enabled for acquisition
		Byte 3	

	<p><i>The SET command execution will fail if this module is USB connected to a host device; an error answer message will be returned.</i></p>
---	---

**1873 (0x751) (Tx Base ID + 1)**

This is an 8-byte message that indicates the number of detections that will be sent or the answer to the GET and SET command requests.

**Table 28: CAN bus answer message**

Answer Data (Byte 0)	Answer Data Description	Additional Answer Data (Byte 1 to Byte 7)
<b>Equal to or less than 96</b>	Number of detections	See Table 29.
<b>128 + 6</b>	Answer to GET input data request	Success: see the format in Table 30. Fail: byte 2 to byte 7 are set to 0xFF.
<b>128 + 7</b>	Answer to GET holding data request	Success: see the format in Table 27. Fail: byte 2 to byte 7 are set to 0xFF.

Answer Data (Byte 0)	Answer Data Description	Additional Answer Data (Byte 1 to Byte 7)
128 + 8	Answer to SET holding data request	Success: return echo of the SET command request. Fail: byte 2 to byte 7 are set to 0xFF.

Table 29: CAN bus number of detection message

Data	Data Return Description
Byte 0	Number of detections
Byte 1	Reserved
Byte 2	Current LED power as a percentage of maximum
Byte 3	Current acquisition statuses. This is an 8-bit field: Bit 0: Reserved Bit 1: Object demerging <sup>15</sup> is completed if set to 1 when this function is activated. Bit 2: Reserved
Byte 4	Timestamp of the acquisition. The timestamp is expressed as the number of milliseconds since the module was started.
Byte 5	
Byte 6	
Byte 7	

Table 30: CAN bus answer message (GET input data)

Input Data Type (Byte 1)	Input Data Description	Argument	Argument Description
0	Temperature	Byte 4	Temperature as a fixed-point value with a 16-bit fractional part (that is, the temperature value is this register divided by 65 536)
		Byte 5	
		Byte 6	
		Byte 7	
1	Device identification and options	Byte 2	Device identification code (9 for M16 LED module)
		Byte 3	Device option flags (LeddarTech internal use)
		Byte 4	
		Byte 5	
		Byte 6	
2	Firmware version	Byte 2	The firmware build version
		Byte 3	
		Byte 4	The firmware 32-bit CRC
		Byte 5	

<sup>15</sup> Demerging available for M16 LED firmware version 53A0023-22 and previous.

Input Data Type (Byte 1)	Input Data Description	Argument	Argument Description
		Byte 6	
		Byte 7	
3	FPGA version	Byte 2	The FPGA version
		Byte 3	
		Byte 4	The firmware type (LeddarTech internal use)
		Byte 5	
		Byte 6	Run status 0: OFF, 0xFF: ON. Should always return 0xFF; otherwise, the module is defective.
4 to 9	Serial number	Byte 2 to byte 7	Serial number as an ASCII string (max. 32 bytes)
10 to 20	Device name	Byte 2 to byte 7	The device name as a Unicode string (max. 64 bytes)
21 to 23	Software part number	Byte 2 to byte 7	The software part number as an ASCII string (max. 16 bytes)
24 to 26	Hardware part number	Byte 2 to byte 7	The hardware part number as an ASCII string (max. 16 bytes)
27	Detection zone	Byte 2	Detection zone outputs bit field (1 zone per bit) Bit 0: object in advanced detection zone (0 = no detection in advanced detection zone, 1 = detection in advanced detection zone). Only this zone is currently available.
		Byte 3	
		Byte 4	Reserved
		Byte 5	
		Byte 6	
		Byte 7	

**1872 (0x750) (Tx base ID)**

This is an 8-byte message containing detection use in single message mode. Two types of messages are supported: standard detection message and detection message with flag information.

The standard detection message contains two detections: if the number of detections is odd, the last message will be 0 filled in the last 4 bytes. The message is separated into two parts with the same format:

- Data bytes 0 and 1 contain the distance in units defined by “distance units” holding data.
- Data byte 2 and the 4 LSBs of byte 3 contain the amplitude as a 12-bit value. This value must be divided by 4 to provide the amplitude (that is, 2 bits for the fractional part).

The 4 MSBs of byte 3 contain the segment number.

**Table 31: Standard CAN bus detection message**

Byte 7	Byte 6	Byte 5	Byte 4	Byte 3	Byte 2	Byte 1	Byte 0
Segment (n+1)	Amplitude (n+1)	Distance (n+1)		Segment (n)	Amplitude (n)	Distance (n)	

The detection message with flag information contains only one detection, and the format is as follows:

- Data bytes 0 and 1 contain the distance in units defined by “distance units” holding data.
- Data bytes 2 and 3 contain the amplitude. This value must be divided by 64 to provide the amplitude (6 bits for the fractional part).
- Byte 4 contains the flag information, as described in Table 32 below.

**Table 32: Flag information of measurement**

<b>Bit 0</b>	Detection is valid (will always be set).
<b>Bit 1</b>	Detection was the result of object demerging <sup>16</sup> .
<b>Bit 2</b>	Interference was detected in the current frame.
<b>Bit 3</b>	Detection is saturated.
<b>Bit 4</b>	Reserved
<b>Bit 5</b>	Reserved
<b>Bit 6</b>	Detection is within the crosstalk zone.
<b>Bit 7</b>	Reserved

Byte 5 contains the segment number. Data bytes 6 and 7 are reserved.

**Table 33: CAN bus detection message definition with flag information**

Byte 7	Byte 6	Byte 5	Byte 4	Byte 3	Byte 2	Byte 1	Byte 0
--	--	Segment (n)	Flag (n)	Amplitude (n)		Distance (n)	

**1874 (0x752) (Tx base ID + 2)**

This is an 8-byte message for multiple message mode using the same format as 0x750 message (see above). Detections are sent on a message ID range from 1874 to [1874 + (number of detections / 2) + (number of detections modulo)] in standard detection message and sent on a message ID range from 1874 to [1874 + number of detections] in detection message with flag information. The range of message IDs can be limited by the maximum number of detections to CAN port output.

Example: Module with 1874 base ID: 19 detections are sent.

- From 1874 to 1884, message ID in standard detection message
- From 1874 to 1882, message ID in standard detection message on a module setup of 16 maximum amount of detections
- From 1874 to 1893, message ID in detection message with flag information
- From 1874 to 1890, message ID in detection message with flag information on a module setup of 16 maximum amount of detections

<sup>16</sup> Demerging available for M16 LED firmware version 53A0023-22 and previous.

For an example of a CAN bus detection request, refer to Appendix C.

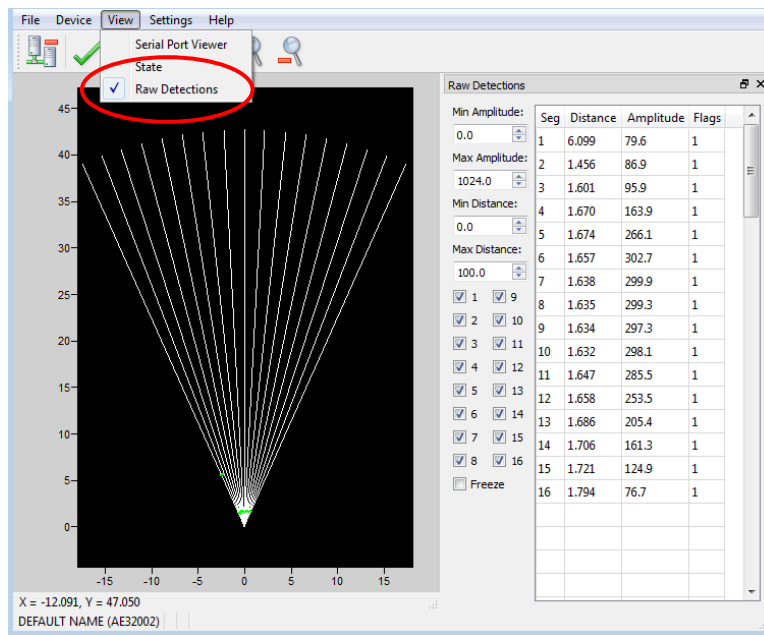
## 5. Leddar Configurator

The Leddar™ Configurator provides configuration parameters and operation functionalities for Leddar™ products.

### 5.1. Introduction

The Configurator interface can be resized manually or set to full-screen view.

All dialog boxes that do not include a selection of action buttons at the bottom, such as **Connect**, **OK**, **Cancel**, etc., are dockable at the top, the bottom, or on the right side of the main window.

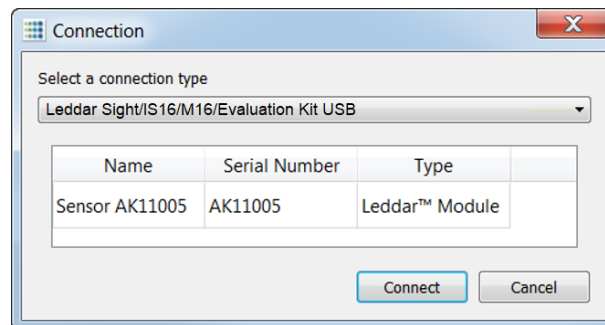


**Fig. 25: Raw Detections dialog box docked on the side of the main window**

When a dialog box or a window is already open, a check mark appears next to the command on the menu.

### 5.2. Connection Window

The following is a description of the information shown in the **Connection** dialog box.



**Fig. 26: Connection dialog box**



**Select a connection type**

The connection type being used.

The device list, in the center of the **Connection** dialog box, displays the devices currently detected.

**Name**

The device name can be modified (see section 5.4.1).

**Serial Number**

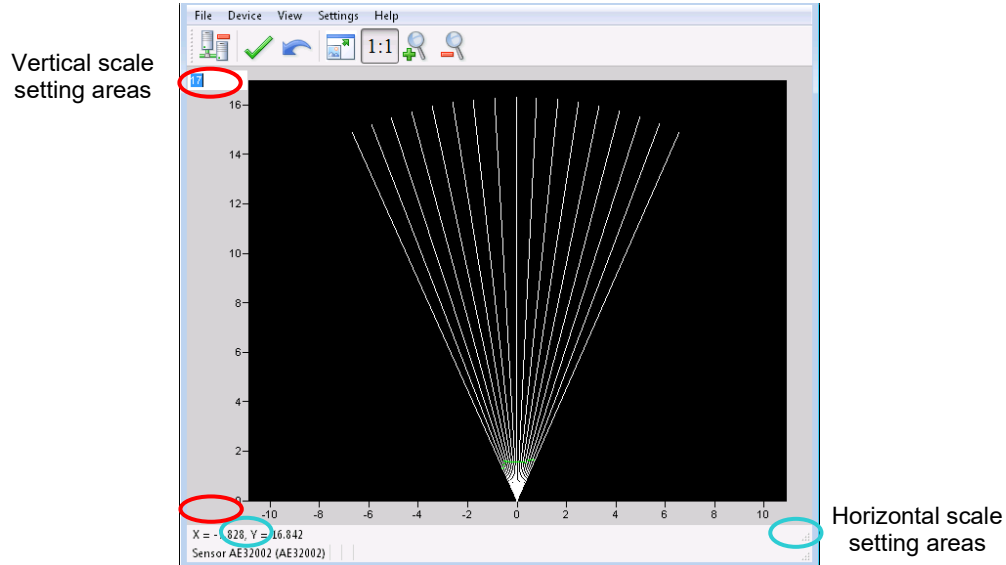
The serial number of the device as assigned by LeddarTech.

**Type**

The product name.

## 5.3. Leddar Configurator Main Window

After connecting to the device, the main window opens.



**Fig. 27: Leddar Configurator main window**


The measurements are plotted in a symbolic graph containing the 16 segments (white lines) originating from the module. Detections are drawn as arcs in their corresponding segments. Only valid measurements are displayed. A more detailed description of the measurements can be obtained in the **Raw Detections** dialog box (see section 5.11 on page 76).

The numbers X and Y displayed at the bottom are the mouse cursor position coordinates.


### 5.3.1. Toolbar Display Controls

The toolbar includes several buttons for adjusting the view of the main window display.


## 5.3.2. Fit to Window

The  **Fit to Window** button allows you to expand the display to fit the dimensions of the computer screen.


## 5.3.3. Force Equal Horizontal and Vertical Scales

When the  **Equal Scaling** button is selected (button highlighted), the original ratio of the display is kept or restored. The horizontal and vertical scales will be set to the same values, and the beam will be displayed in accordance with the beam properties (for example, the display will show a 48° beam for a 48° module).

Click the button again to change the vertical and horizontal scales independently.

	<p><i>When in equal scaling mode, you cannot zoom the display horizontally or vertically. That is, holding the <b>&lt;Control&gt;</b> or <b>&lt;Shift&gt;</b> key down while zooming in or out will have no effect. The scales cannot then be modified by entering values in the fields shown in Fig. 26 above.</i></p>
---	---

## 5.3.4. Zoom In

Click the  **Zoom In** button to zoom in vertically and horizontally around the center of the display.

## 5.3.5. Zoom Out

Click the  **Zoom Out** button to zoom out vertically and horizontally around the center of the display.

## 5.3.6. Scale



The window opens with the default scale setting. The horizontal and vertical scales can be changed manually by entering new values in the fields accessible by clicking the areas shown in Fig. 26 above.

To apply the changes, click anywhere in the main window.



## 5.3.7. Panning and Zooming

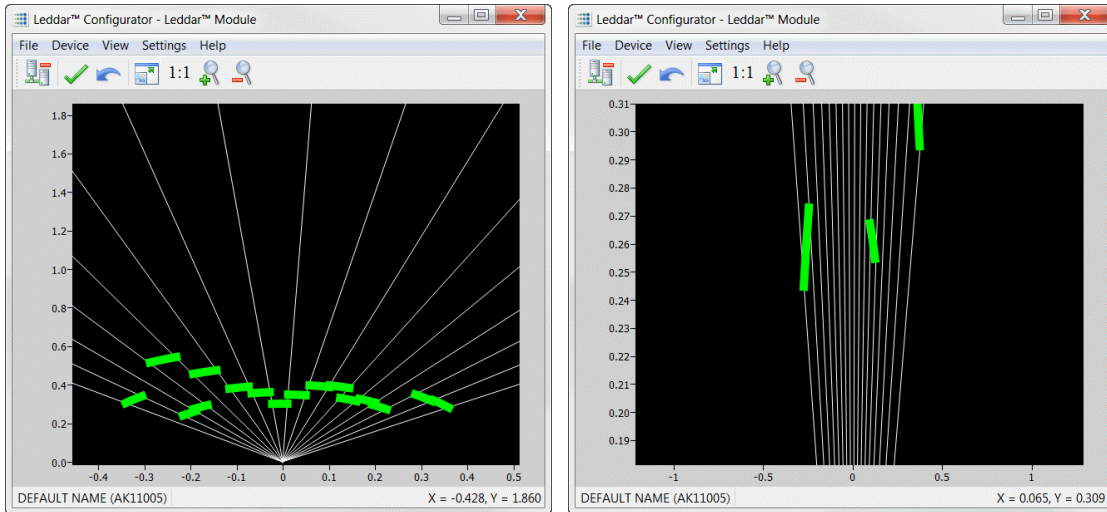
The display in the main window can be panned and zoomed in different ways. Panning and zooming is done relative to the mouse cursor position.

You can move up, down, and sideways by clicking and dragging the display.

To zoom the display in and out, use the mouse wheel alone. This has the same effect as clicking the  **Zoom In** or  **Zoom Out** button, respectively (see sections 5.3.4 and 5.3.5 above).


To zoom the display horizontally, hold the **<Control>** key of the computer keyboard down while using the mouse wheel.

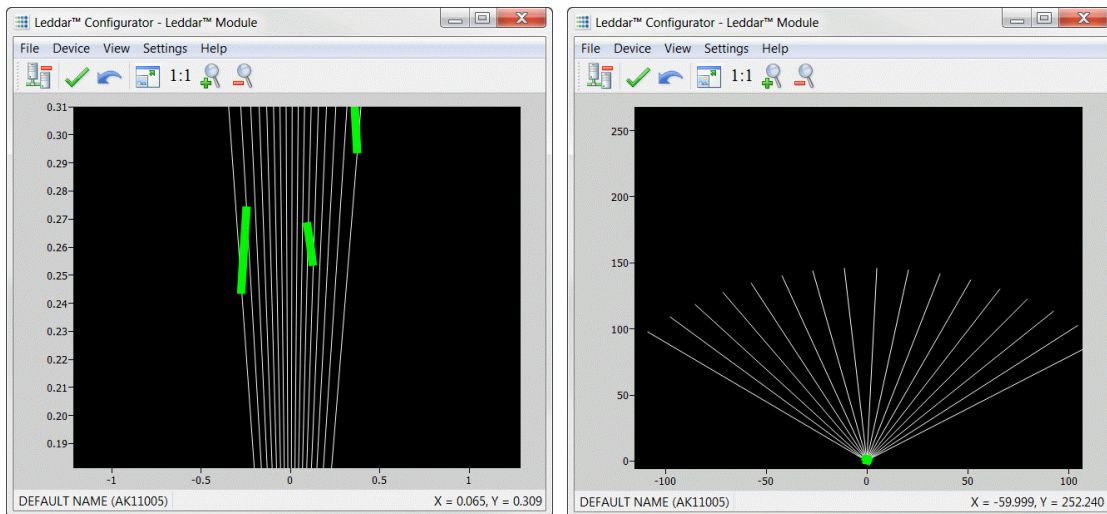
	<p>The  <b>Equal Scaling</b> button must not be selected (not highlighted).</p>
---	--



**Fig. 28: Zooming in (left) and out (right) horizontally**

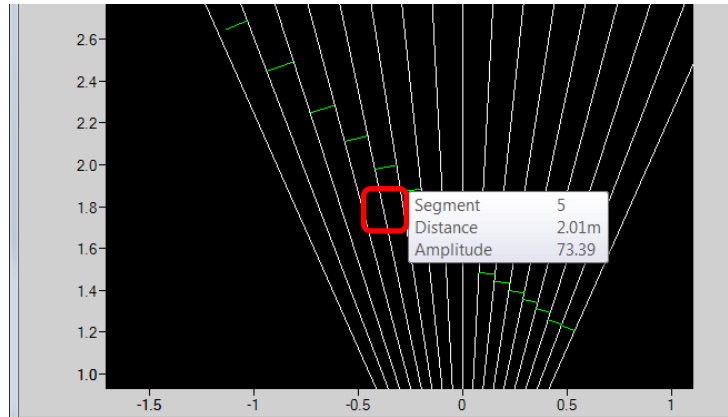
To zoom the display vertically, hold the **<Shift>** key down while using the mouse wheel.

	<p>The <b>1:1</b> <i>Equal Scaling</i> button must not be selected (not highlighted).</p>
---	---



**Fig. 29: Zooming in (left) and out (right) vertically**

The measurements of a detection point appear as a pop-up when you point to it with the mouse cursor for a more accurate assessment of the detection. Detection points are shown in green lines (arcs) in the main window for visibility reasons.

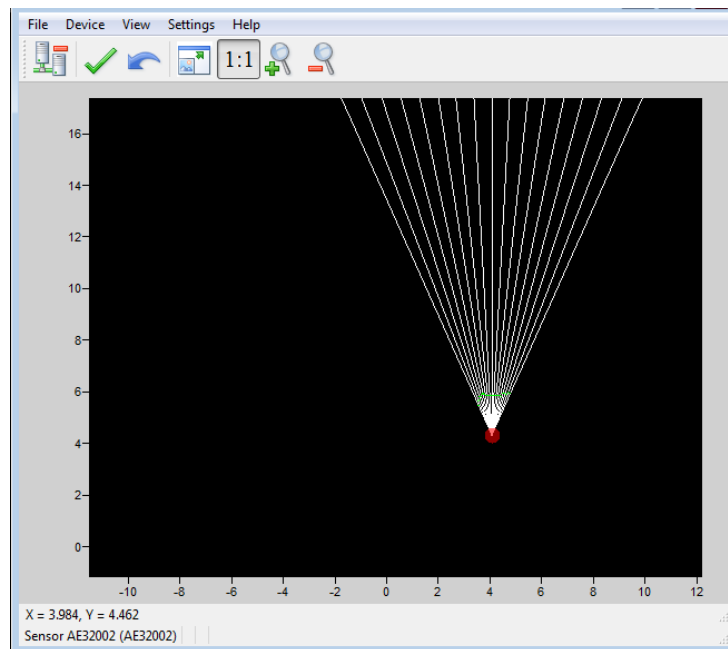


**Fig. 30: Detection point coordinates**

### 5.3.8. Changing the Module Origin

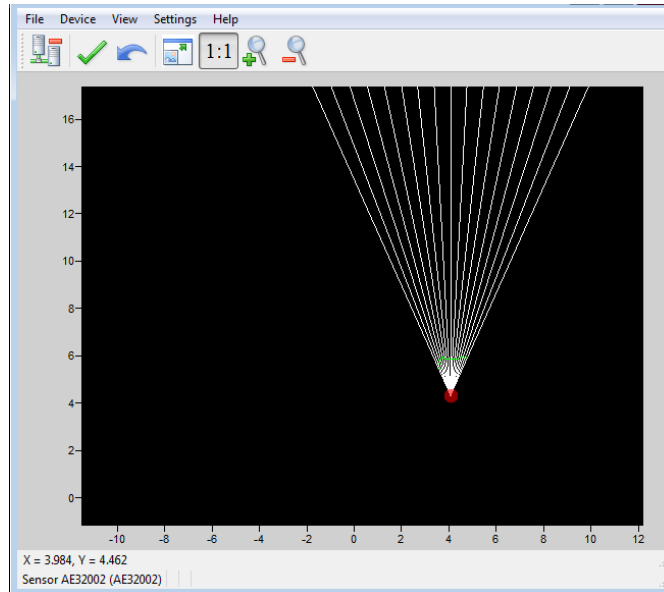
The module origin can be modified by clicking the module origin at the bottom of the segments.

To do so, use the mouse cursor to point to the bottom of the segments (a red dot appears), then click and drag it to the desired position.



**Fig. 31: Dot indicator to modify the module origin**

If you click and drag the module origin, the module position is displayed in the status bar, as shown in Fig. 32 below.



**Fig. 32: Module position display**

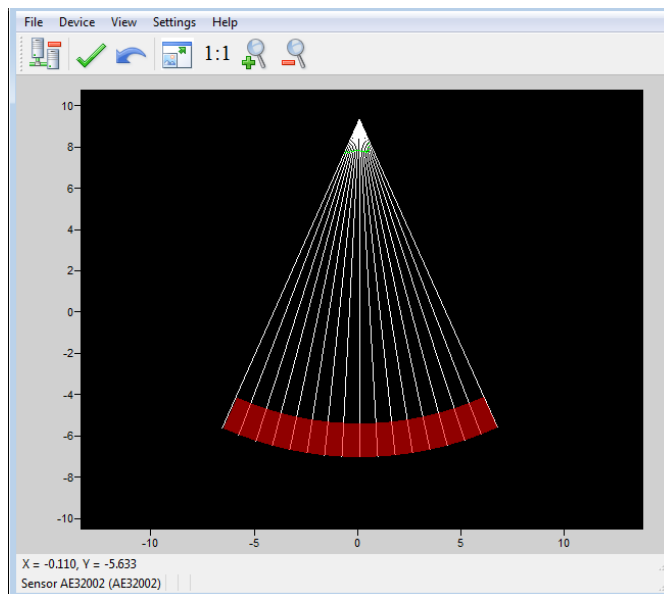
To apply the changes, click the  **Apply** button.

The module origin is saved in the module and can also be modified by editing the parameters in the module position settings window (see section “5.4.3 Module Position”).

### 5.3.9. Changing the Module Orientation

The module origin may be rotated to match the physical position of the module. If you do so, the main window display can better match the physical installation of the module. For example, if the module is installed above the ground, the module origin can be set to reflect its position.

Use the mouse cursor to point to the top of the segments (the top turns red), then click and drag it to the desired position.



**Fig. 33: Red bar to rotate the module position**

To apply the changes, click the  **Apply** button.

The module orientation is saved in the module and can also be modified by editing the parameters in the module position settings window (see section “5.4.3 Module Position”).

## 5.4. Settings

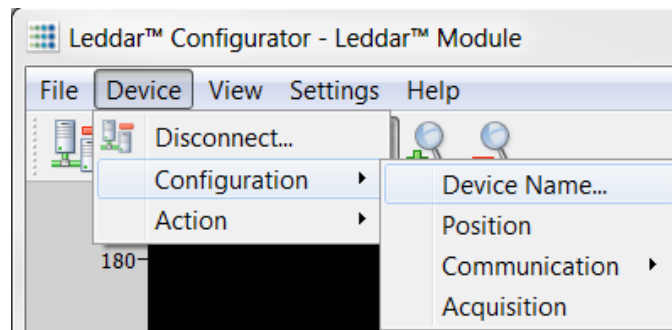
The module stores several settings. Once saved in the module, these parameters are effective at each power-up. The Leddar Configurator software loads these parameters upon each connection.

### 5.4.1. Device Name

When you connect to a module for the first time, it has a default name. You can change that name at any time.

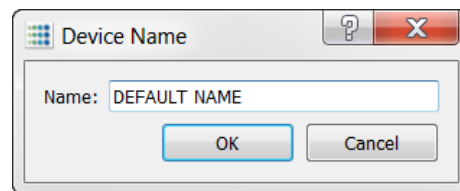
**To change the device name:**

1. Connect to a device.
2. In the **Device** menu, select **Configuration**, then click **Device Name....**




**Fig. 34: Device menu – Configuration menu items**

3. In the **Name** field of the **Device Name** dialog box, enter the new name of the device and click **OK**.



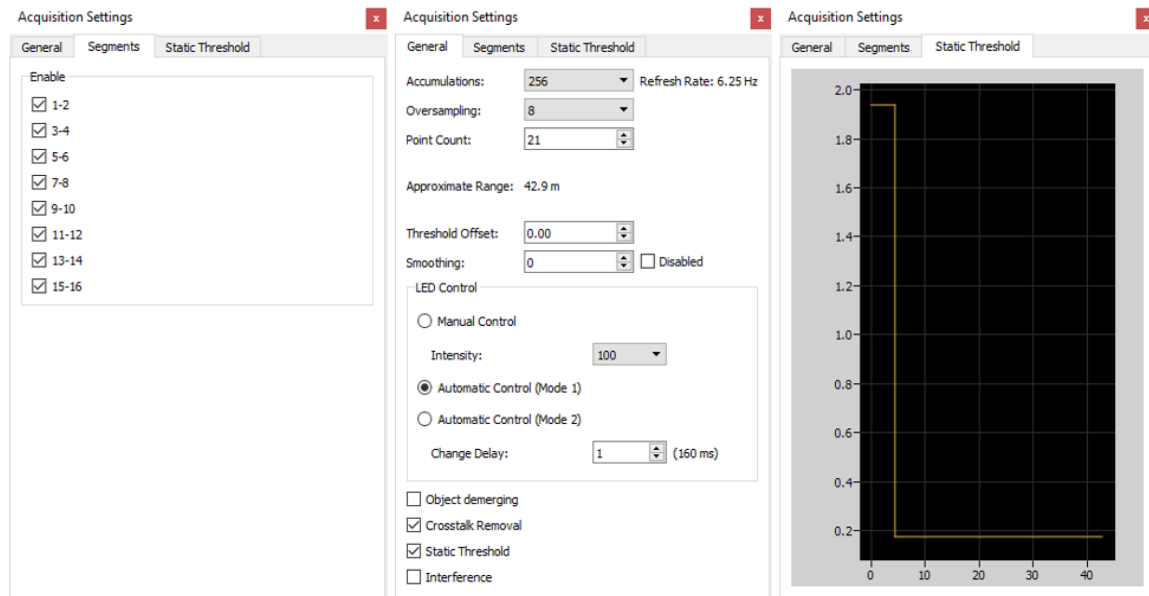
**Fig. 35: Device Name dialog box**

4. To apply the change, click the  **Apply** button in the Leddar Configurator main window.

### 5.4.2. Acquisition Settings

The Acquisition Settings function allows you to define parameters to use for detection and distance measurement.

To open the **Acquisition Settings** dialog box, select **Device**, then **Configuration**, then **Acquisition**.



**Fig. 36: Acquisition Settings dialog boxes**

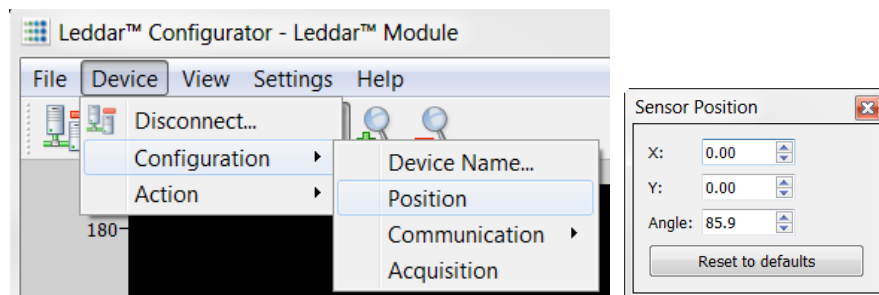
To apply the changes, click the  **Apply** button in the main window.

Refer to section 3.3 on page 31 for more details on all the parameters.

### 5.4.3. Module Position

The Module Position function allows you to define the module position with respect to the reference of the system it is used in. See sections 5.3.8 and 5.3.9 above for more details.

To open the **Module Position** dialog box, in the **Device** menu, select **Configuration**, then click **Position**.



**Fig. 37: Device menu – Sensor Position dialog box**

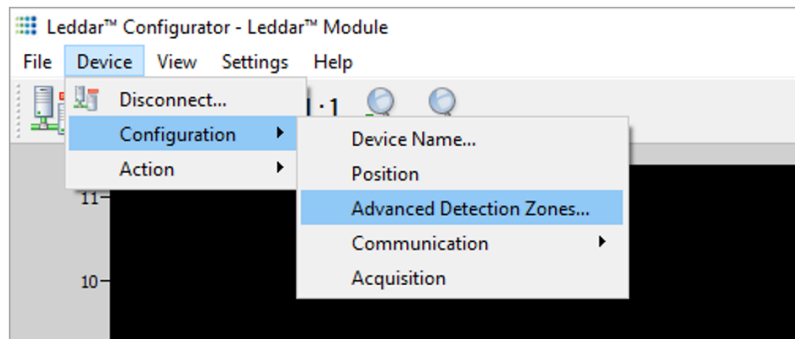
Change the numbers either using the arrows or by entering the value manually.

Click the **Reset to defaults** button to re-place the segments to their original manufacturing positions.

## 5.4.4. Advanced Detection Zones

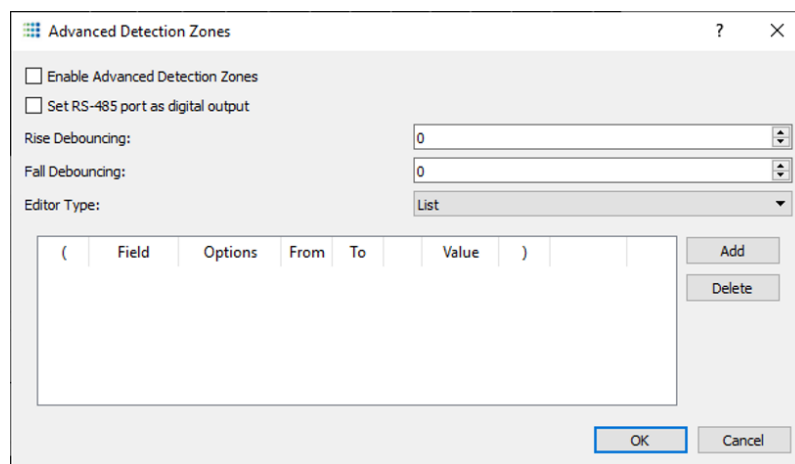
An Advanced Detection Zone is a configurable setting that allows you to display detections only if they are located in the specified zone.

To open the **Advanced Detection Zones** dialog box, in the **Device** menu, select **Configuration**, then click **Advanced Detection Zones...**



**Fig. 38: Device menu – Configuration and Advanced Detection Zones menu items**

In the **Advanced Detection Zones** dialog box, enter configuration lines to define the zone of interest.



**Fig. 39: Advanced Detection Zones dialog box**

### Rise Debouncing

Number of frames during which there is a detection in the detection zone necessary to output a bit of “presence.”

### Fall Debouncing

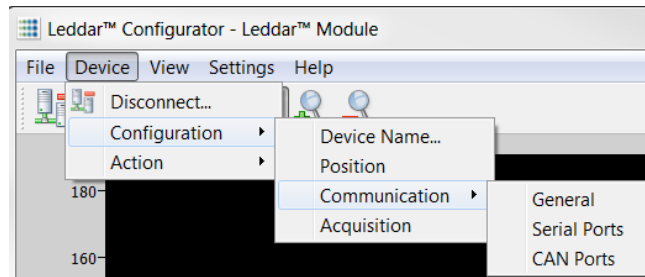
Number of frames during which there is no detection in the detection zone necessary to output a bit of “no presence.”

## 5.4.5. General

The module’s **General** communication settings are configurable.

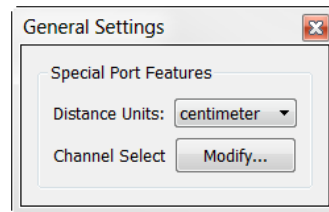
To open the **General Settings** dialog box, in the **Device** menu, select **Configuration**, then **Communication**, then click **General**.





**Fig. 40: Device menu – Configuration and Communication menu items**

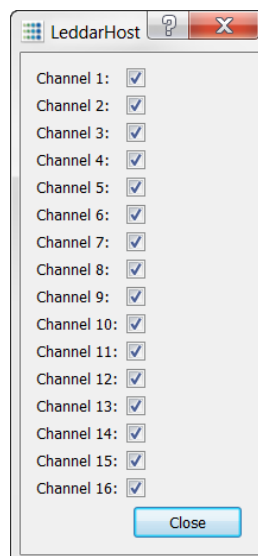
In the **General Settings** dialog box, in the **Distance Units** list, select the units with which you want to work.



**Fig. 41: General Settings dialog box**

The number of channels used is set to 16 by default, but you can remove some of them to suit your application through the **LeddarHost** dialog box. Next to **Channel Select**, click **Modify** and clear the desired check boxes.

In Modbus and CAN communications, you can either enable or disable one or more channels.

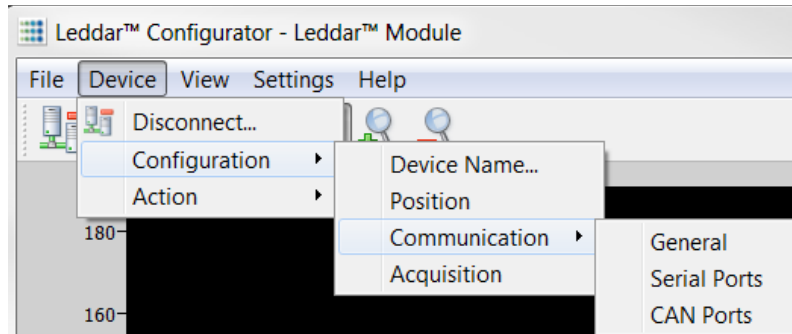


**Fig. 42: LeddarHost dialog box**

## 5.4.6. Serial Ports

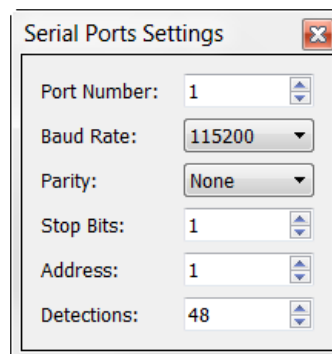
The module's serial port settings are configurable.

To open the **Serial Ports Settings** dialog box, in the **Device** menu, select **Configuration**, then **Communication**, then click **Serial Ports**.



**Fig. 43: Device menu – Configuration and Communication menu items**

In the **Serial Port Settings** dialog box, you can change the numbers using the arrows or by entering the value manually.



**Fig. 44: Serial Ports Settings dialog box**

*The **Detections** parameter can be limited to 40 if used with a 0x6A Modbus function.*

The following table describes the serial port settings.

**Table 34: Serial port settings description**

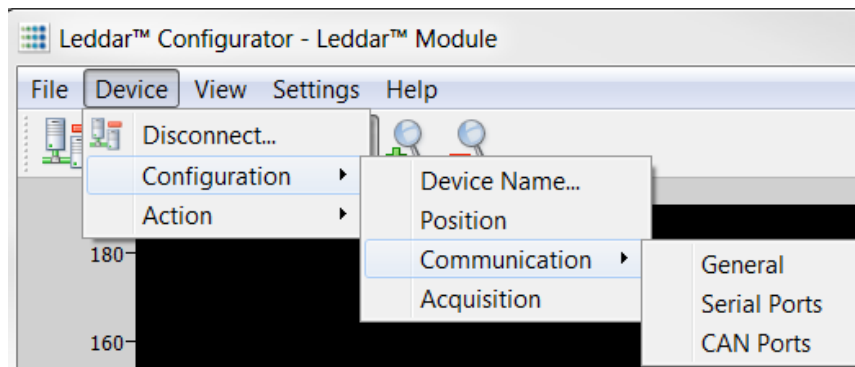
Parameter	Value
<b>Port Number</b>	Select <b>1</b> for the RS-485 port on the terminal block.
<b>Baud Rate (bps)</b>	9 600 19 200 38 400 57 600 115 200

Parameter	Value
	230 400 <sup>17</sup> 460 800 <sup>17</sup> 921 600 <sup>17</sup>
Parity	None Odd Even
Stop Bits	1 2
Address	1 to 247
Detections <sup>18</sup>	0 to 48

### 5.4.7. CAN Ports

The module CAN port settings are configurable.

To open the **CAN Port Settings** dialog box, in the **Device** menu, select **Configuration**, then **Communication**, then click **CAN Ports**.

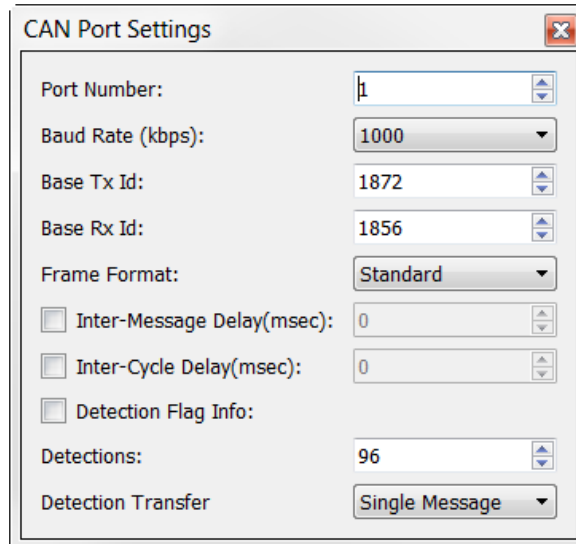


**Fig. 45: Device menu – Configuration and Communication menu items**

In the **CAN Port Settings** dialog box, you can change the numbers using the arrows or by entering the value manually.

<sup>17</sup> To avoid errors, it is recommended not to select these rates. Availability according to selected serial port.

<sup>18</sup> This parameter can be limited to 40 if used with a 0x6A Modbus function.



**Fig. 46: CAN Port Settings dialog box**

The following table describes the CAN port settings.

**Table 35: CAN port settings description**

Parameter	Value
<b>Port Number</b>	Select 1 for CAN communication.
<b>Baud Rate (kbps)</b>	10 20 50 100 125 250 500 1 000
<b>Base Tx ID</b>	The CAN arbitration ID used for data messages coming from the evaluation kit containing the detections. The arbitration ID of the messages containing the number of detections will be this value plus one (see the protocol documentation).
<b>Base Rx ID</b>	The CAN arbitration ID used for data messages sent to the evaluation kit (see the protocol documentation)
<b>Frame Format</b>	Standard Extended
<b>Inter-Message Delay</b>	0 to 65 535 milliseconds
<b>Inter-Cycle Delay</b>	0 to 65 535 milliseconds
<b>Detection Flag Info</b>	The information on the detection flag is displayed in the main window.
<b>Detections</b>	1 to 96
<b>Detection Transfer</b>	Single or multiple messages

## 5.5. Saving and Loading a Configuration

The software configuration for a device can be saved to a file. This enables you to back up settings and restore them in case of a system failure or in case you want to revert to earlier settings. You can also retrieve the configuration that was stored with a record file.

### To save a configuration:

In the **File** menu, click **Save Configuration...**

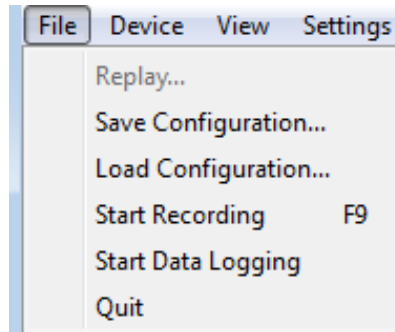


Fig. 47: File menu

### To load a configuration:

In the **File** menu, click **Load Configuration...**

## 5.6. Configuring Detection Records

Detection records provide playback of detections recorded by a device. This visual information can be useful for verification, troubleshooting, or training purposes. Detection records allow for a full data playback stored in a \*.lfl file that can later be reloaded and replayed.

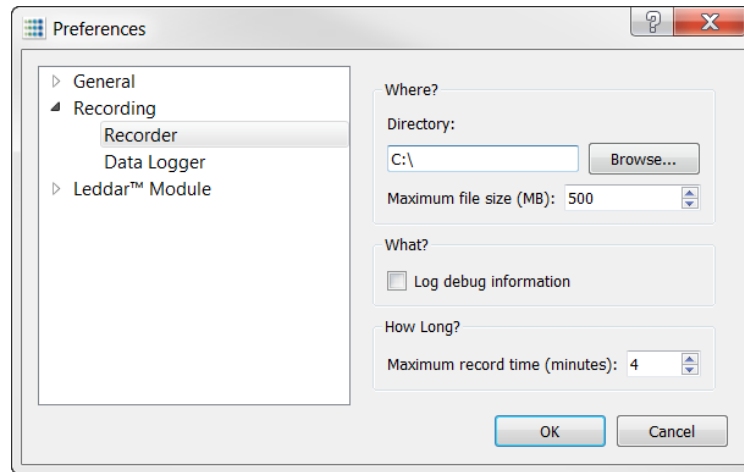
### To configure the detection record:

1. In Leddar Configurator, select the **Settings** menu, then click **Preferences...**



Fig. 48: Settings menu

2. In the **Preferences** dialog box, click **Recording**, then **Recorder**.



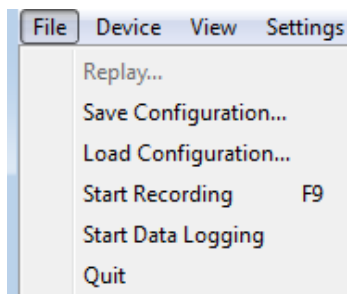
**Fig. 49: Preferences dialog box**

3. Under **Directory**, click the **Browse...** button to select the path to save the detection record file.
4. In the **Maximum file size (MB)** box, set the maximum file size using the arrows or by entering the value manually.
5. Under **What?** select the **Log debug information** check box.
6. Under **How Long?** next to **Maximum record time (minutes)**, set the length of time for recording using the arrows or by entering the value manually. At the end of that period, the recording will stop even if the file size has not reached its maximum.
7. Click **OK** to save the settings.

A complete description of the elements found in the recording **Preferences** dialog box follows the next two procedures.

### To start a recording:

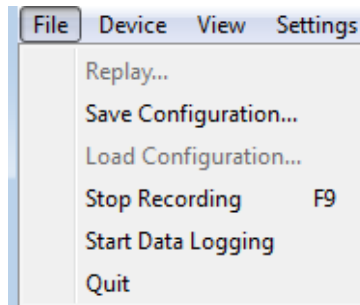
In the **File** menu, click **Start Recording**.



**Fig. 50: File menu to start a recording**

### To stop a recording manually:

In the **File** menu, click **Stop Recording**.



**Fig. 51: File menu to stop a recording**

The following is a description of the elements available in the recording **Preferences** dialog box.

### Record directory

The record directory is the folder in which all record files will be saved. These files are in a proprietary format, with the extension \*.lfl, and can only be opened and viewed with the Leddar Configurator software.

### Maximum file size

Record files can be quite large. Set the maximum file size as needed. The recording stops for the current file once it reaches the maximum file size and automatically switches the recording to another file. This is to keep record files of manageable sizes.

### Debug

These check boxes are reserved for the use of LeddarTech for debug purposes.

### Maximum record time

The value entered as the **Maximum record time** defines the length of the time for recording. At the end of that period, the recording will stop even if the file size has not reached its maximum.

## 5.7. Using Detection Records

Once you have completed a recording, you can review it and extract part of the recording.

The **Record Replay** dialog box offers the same functions as a regular video player: a stop button, a play button, and frame-by-frame forward and backward buttons are available.

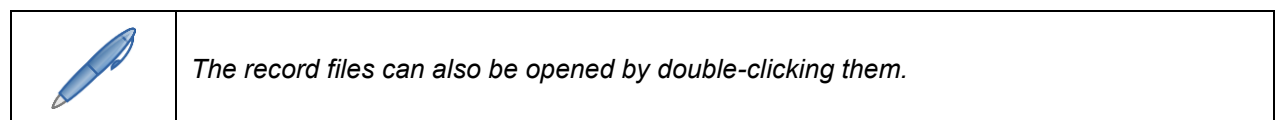
The **Position** slider lets you move directly to the desired position.

The **Playback Speed** slider lets you adjust the speed of the recording playback; faster is to the left.

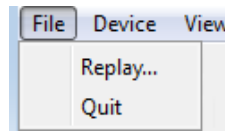
The **Start**, **End**, and **Extract** buttons allow you to select a portion of the recording and extract it for further reference or analysis.

### To play a record:

1. If you are connected to a device, disconnect from the device.  
Another option is to open another Leddar Configurator main window.

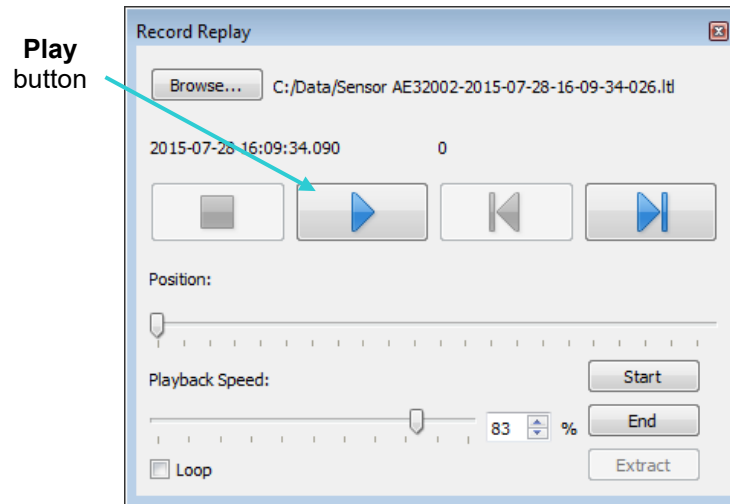


- In the **File** menu, click **Replay....**



**Fig. 52: File menu to open a recording**

- In the **Record Replay** dialog box, click the **Browse...** button to select a file.



**Fig. 53: Record Replay dialog box**

- Click the **Play** button to start the playback.

**To extract a record file segment:**

- Set the **Position** slider to the position where you want the file segment to start and click the **Start** button.
- Set the **Position** slider to the position where you want the file segment to stop and click the **End** button.  
OR  
Play the record and stop it at a position of interest, then click the **Start** button; restart playing the record, stop it again at a position of interest, and then click the **Stop** button.
- Click the **Extract** button to extract and save that file segment.

## 5.8. Data Logging

The Data Logging function is used to output the data to a .txt file. This file can be imported to a software application (such as Microsoft Excel) for offline analysis.

The duration of the record is indicated in the status bar.

Each line of the generated text file contains the information related to a single detection.

**Table 36: Field description of the log text file**

Time (msec)	Segment [0 15]	Amplitude [0 512]	Distance (m)	Status
12 735 204	7	0.9	33.61	1



In this table:

- **Time** indicates the timestamp of the detection from when the module was connected to the power supply.
- **Segment** refers to the location of the detection (line, column).
- **Amplitude** of the detection indicates the strength of the returned signal.
- **Distance** indicates the distance of the detection in meters or feet depending on the distance unit configured in the **Preferences** menu.
- **Status** corresponds to a flag value. Refer to section “5.11 Raw Detections” for more details.

To use the data logging function:

1. In the **Settings** menu of Leddar Configurator, click **Preferences...**



Fig. 54: Settings menu

2. In the **Preferences** dialog box, select **Recording**, then click **Data Logger**.

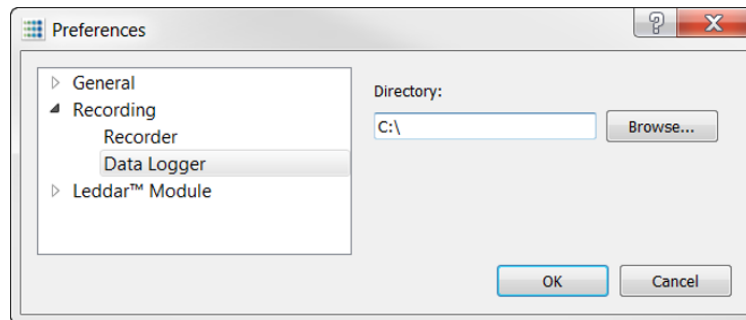


Fig. 55: Preferences dialog box for logging data

3. Under **Directory**, click the **Browse...** button to select the path where you want to save the log and click **OK**.
4. In the **File** menu, click **Start Data Logging**.

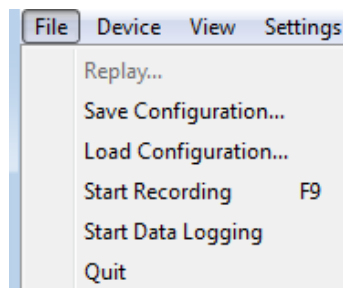
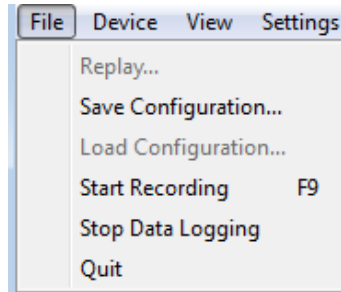


Fig. 56: File menu to start data recording

5. To stop recording, click **Stop Data Logging** in the **File** menu.

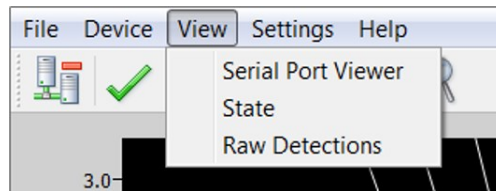


**Fig. 57: File menu to stop data recording**

A .txt file is saved in the selected directory.

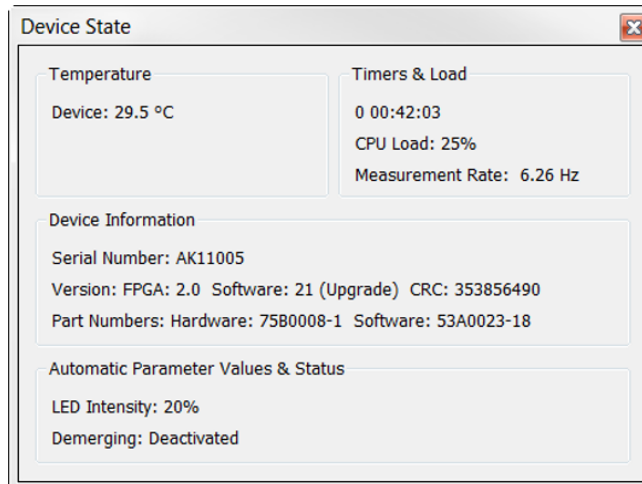
## 5.9. Device State

Information about a device is accessible when connecting to a device in the **Connection** window or by clicking the **State** command in the **View** menu.



**Fig. 58: View menu**

The **Device State** window opens.



**Fig. 59: Device State window**

### Temperature

This section indicates the temperature of the device.

### Timers & Load

This feature provides information on the time elapsed since the last module reset in days, hours, minutes, and seconds.

The **CPU Load** indicates how much of the module processor capacity is in use. When the load reaches nearly 100%, the processor may no longer be able to process all the data. The effective frame rate may be impacted.

The **Measurement Rate** indicates the rate at which the module measures the speed and dimension of static or moving surfaces.

### Device Information

The **Serial Number** is the number of the device as assigned by LeddarTech.

The **Version** includes the following:

- **FPGA:** The firmware version of the device.
- **Software:** The software version of the device.
- **CRC:** Indicates the firmware version to ensure that it is authentic.

The **Part Numbers** provide the hardware and software part numbers of a device as assigned by LeddarTech.

The **LED Intensity** is the current LED power in use by the module. It automatically adapts to too strong/too weak detections when properly activated in the **Acquisition settings** dialog box.

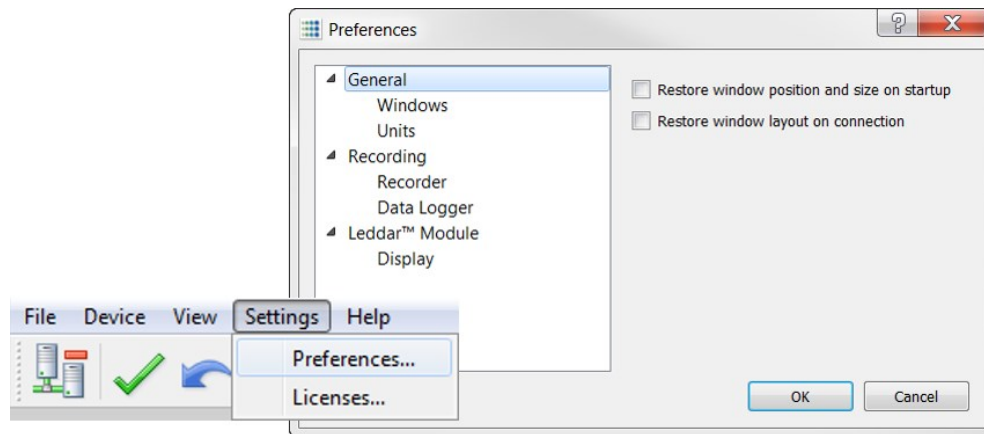
**Demerging**<sup>19</sup> indicates the current object demerging status when activated in the acquisition settings. It may be:

- **Partial:** When the demerge module did not process all pulses characteristic of merged objects.
- **Completed:** When the module processed all pulses characteristic of merged objects.

## 5.10. Preferences

Preferences are used to change various settings related to the display of Leddar Configurator.

Open the **Preferences** dialog box by clicking the **Preferences...** command in the **Settings** menu.



**Fig. 60: Settings Menu – Preferences dialog box**

### Windows

The following two options allow you to select how the content of the main window will be displayed in Leddar Configurator.

<sup>19</sup> Demerging available for M16 LED firmware version 53A0023-22 and previous.

- The **Restore window position and size on startup** option starts Leddar Configurator at the same place on the computer desktop and at the same size it was when it was closed.
- The **Restore window layout on connection** option connects to the evaluation kit at the same size it was and with all docked dialog boxes or windows that were displayed when it was closed.

## Units

The unit that is applied to distances displayed in Leddar Configurator.

The temperature is the unit used when displaying temperatures.

## Recording

The **Recorder** parameter lets you choose how data files are recorded.

The **Data Logger** parameter lets you select a directory to store logs.

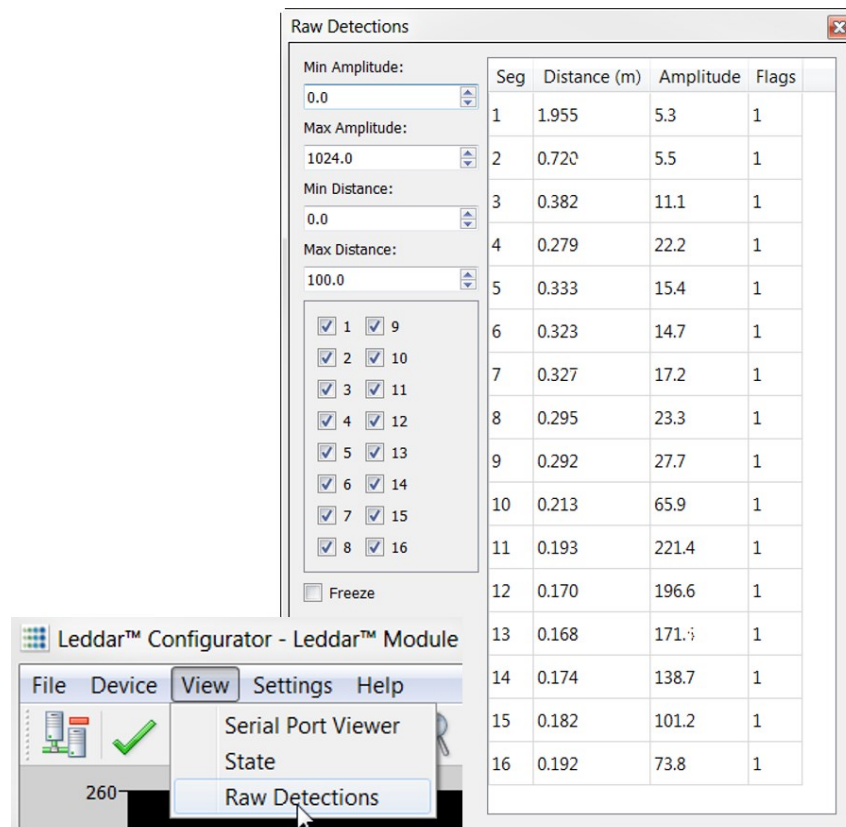
## Display

The **Detection Arc Thickness** parameter allows you to modify the pixel width of the displayed green detection arcs in the main window.

## 5.11. Raw Detections

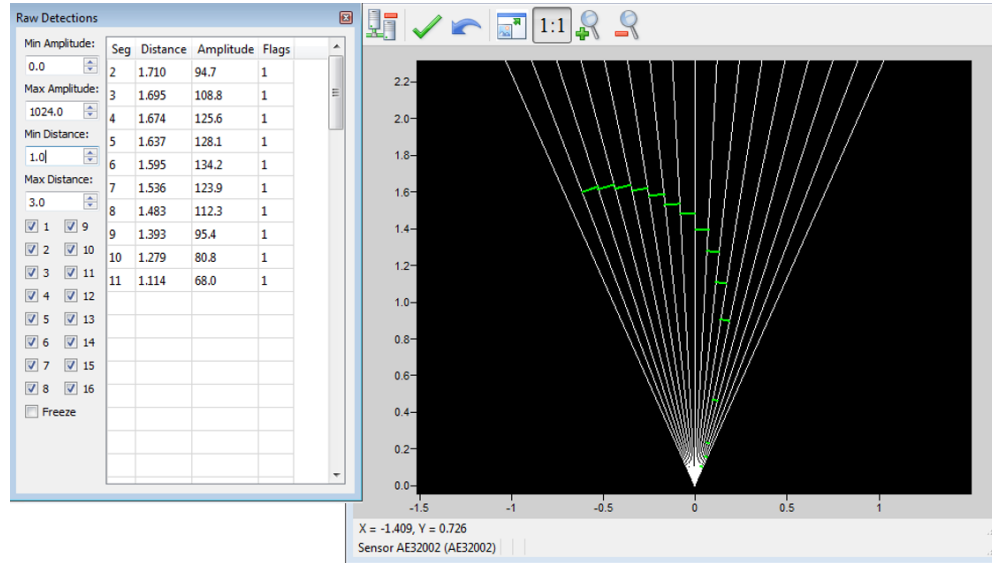
The **Raw Detections** dialog box allows you to view detection values in many ways. It provides filters to isolate segments and detection parameters.

To open the **Raw Detections** dialog box, click **Raw Detections** in the **View** menu.



**Fig. 61: View menu – Raw Detections dialog box**

Fig. 62 shows an example of raw detections. When there is no detection in some segments, only the segments where detection occurred appear in the list.



**Fig. 62: Example of detection filtering in the Raw Detections dialog box**

The following is a description of the parameters in the **Raw Detections** dialog box.

### Min and Max Amplitude

The value entered in the **Min Amplitude** field shows only detections of amplitude higher than or equal to that value in meters. For example, if the minimum amplitude is set to 5, only the detections of amplitude 5 and higher will be displayed.

The value entered in the **Max Amplitude** field will show only detections of amplitude lower than or equal to that value in meters. For example, if the maximum amplitude is set to 8, only the detections of amplitude 8 and lower will be displayed.

Setting a value in both fields will result in a range of amplitude to display.

### Min and Max Distance

The value entered in the **Min Distance** field will show only detections at a distance greater than or equal to that value. For example, if the minimum distance is set to 10, only the detections at a distance of 10 and more will be displayed.

The value entered in the **Max Distance** field will show only detections at a distance smaller than or equal to that value. For example, if the minimum distance is set to 20, only the detections at 20 and less will be displayed.

Setting a value in both fields will result in a range of distance to display.

### Check boxes 1 to 16

Check boxes 1 to 16 allow you to select which segments to display.

### Freeze

When selected, the **Freeze** parameter allows you to freeze the values displayed in the **Raw Detections** dialog box. To return to the live display, clear the check box.

## Seg

The **Seg** column lists the segment for which there is a detection according to the filters used. The segment numbers are read from left to right, starting at 1.

## Distance and Amplitude

The **Distance** column displays the distance of the detection, and the **Amplitude** column displays its amplitude.

## Flag

The **Flag** column displays a number that represents a detection type. See Table 37.

**Table 37: Flag value description**

Bit position	Bit 0	Bit 1
0	Invalid measurement	Valid measurement
1	Reserved	Reserved
2	Normal measurement	Interference was detected in the current frame.
3	Normal measurement	Received signal is above the saturation level. Measurements are valid (VALID is set) but have lower accuracy and precision. Consider decreasing the LED Intensity value.
4	Reserved	Reserved
5	Reserved	Reserved
6	Normal measurement	Detection is within the crosstalk zone.
7	Reserved	Reserved

The **Flag** field provisions for 8 bits encoded as a bit field. Three bits are currently used. The following table lists the implemented decimal values of the status bit field.

**Table 38: Status value description**

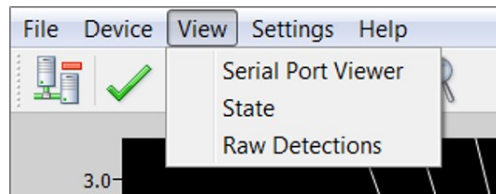
Status Value (Decimal)	Status Value (Binary)	Description
1	00000001	Normal measurement (valid)
9	00001001	Saturated signal (valid)

## 5.12. View Serial Port Data

When using a device through a serial port (for example, using an RS-485 to USB adapter cable), it is possible to establish a connection to the module and display the module measurements in Leddar Configurator.

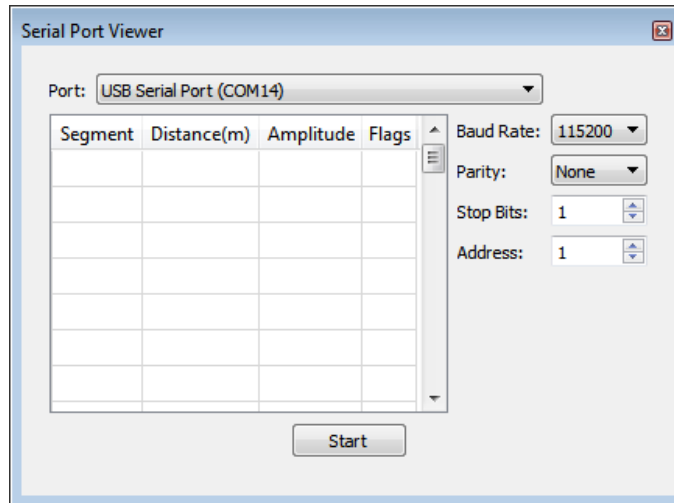
**To view the serial port data:**

1. In the **View** menu, click **Serial Port Viewer**.



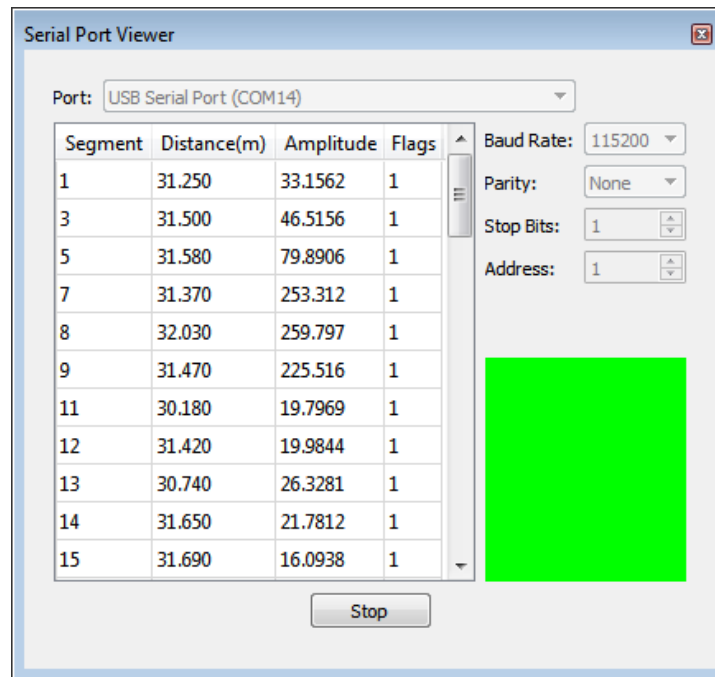
**Fig. 63: View menu**

2. In the **Port** list of the **Serial Port Viewer** dialog box, select the serial port of the connected module.



**Fig. 64: Serial Port Viewer dialog box**

3. Click the **Start** button to establish the connection and display the measurements.



**Fig. 65: Serial port measurement**

## 6. Specifications

### 6.1. General

**Table 39: General specifications**

<b>LED pulse rate</b>	102.4 kHz
<b>Photodetector array size</b>	1 x 16
<b>Photodetector acquisition rate</b>	62.5 MHz
<b>Measurement rate</b>	See Table 13 on page 38.
<b>USB</b>	2.0, 12 Mbits/s
<b>CAN</b>	10 to 1000 kbit/s, optional 120-Ω termination
<b>RS-485</b>	2-wire, half-duplex, 9 600 to 115 200 bps

### 6.2. Environmental

**Table 40: Environmental specifications**

<b>Operating temperature</b>	-40 °C to +85 °C
<b>Storage temperature</b>	-40 °C to +85 °C
<b>Relative humidity</b>	5% to 95%

### 6.3. Regulatory Compliance

The M16 LED module complies with the following standards:

- FCC Class B
- RoHS
- CE (EMC Class B or EN 60950)
- Eye safety: IEC 62471:2006 (exempt lamp classification)

### 6.4. Mechanical

**Table 41: Mechanical specifications**

<b>Model</b>	<b>Dimensions (mm, D x H x L)</b>	<b>Weight (g)</b>
<b>M16D-75B0006 (10° x 1.6°)</b>	87 x 104 x 66	295
<b>M16D-75B0007 (19° x 3°)</b>	71 x 104 x 66	255
<b>M16D-75B0009 (25° x 4°)</b>	60 x 104 x 66	205
<b>M16D-75B0010 (36° x 5°)</b>	52 x 104 x 66	200
<b>M16D-75B0005 (48° x 6°)</b>	47 x 104 x 66	175
<b>M16D-75B0008 (99° x 8°)</b>	63 x 104 x 84	210

See section “6.8 Dimensions” for dimensions including optics.



## 6.5. Electrical

**Table 42: Electrical specifications**

<b>Voltage</b>	24 VDC (or 12 VDC with alternate jumper settings)
<b>Power consumption (total)</b>	3.9 W

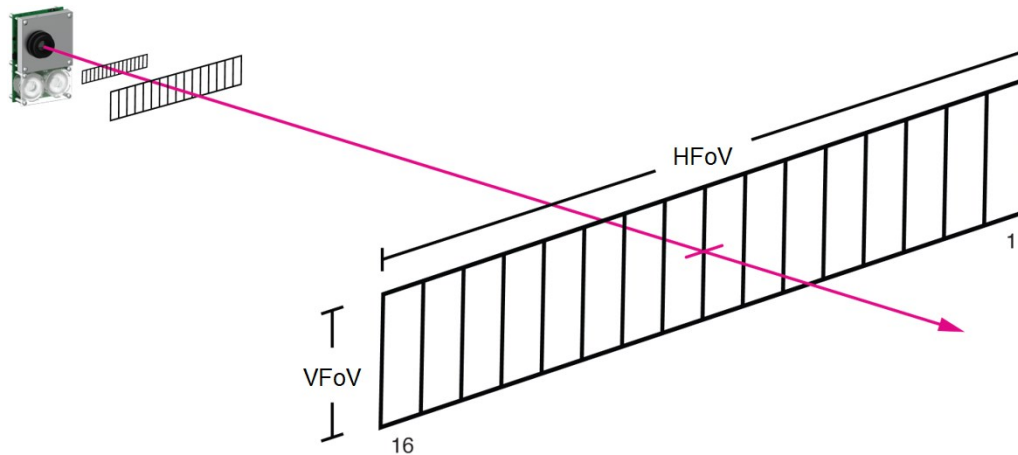
## 6.6. Optical

**Table 43: Optical specifications**

<b>Wavelength</b>	940 nm (infrared)
<b>LED risk group</b>	IEC 62471:2006 (exempt lamp classification)
<b>Horizontal FoV and Vertical FoV</b>	See Table 44 below.

**Table 44: Horizontal FoV and Vertical FoV**

<b>HFoV</b>	<b>VFoV</b>
$99^\circ \pm 2.5^\circ$	$8^\circ \pm 1.5^\circ$
$48^\circ \pm 1.5^\circ$	$6^\circ \pm 1^\circ$
$36^\circ \pm 1.5^\circ$	$5^\circ \pm 0.5^\circ$
$25^\circ \pm 1^\circ$	$4^\circ \pm 0.3^\circ$
$19^\circ \pm 1^\circ$	$3^\circ \pm 0.3^\circ$
$10^\circ \pm 1^\circ$	$1.6^\circ \pm 0.1^\circ$



**Fig. 66: Horizontal field of view (HFoV) and vertical field of view (VFoV)**

The following sections illustrate the sensitivity of the module across HFoV (segment amplitude efficiency) and VFoV (amplitude vs. tilt).

6.6.1. 99° x 8° Module (M16D-75B0008)

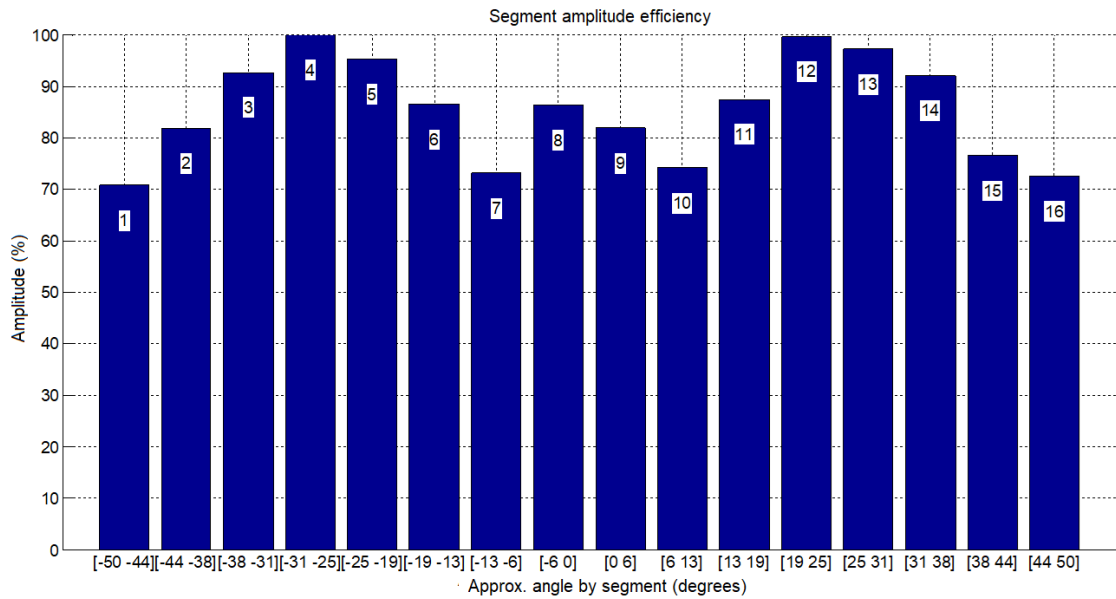


Fig. 67: Detection efficiency (HFOV by segment), 99° x 8° module

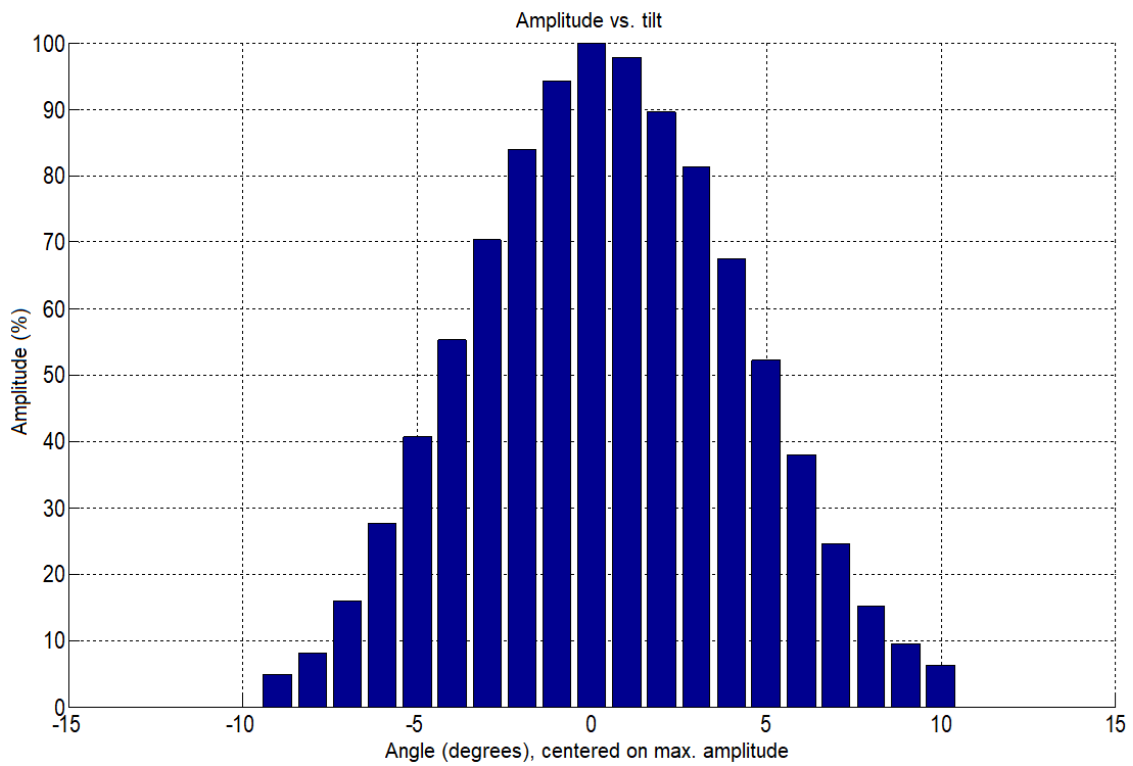


Fig. 68: Detection efficiency (VFOV), 99° x 8° module

6.6.2. 48° x 6° Module (M16D-75B0005)

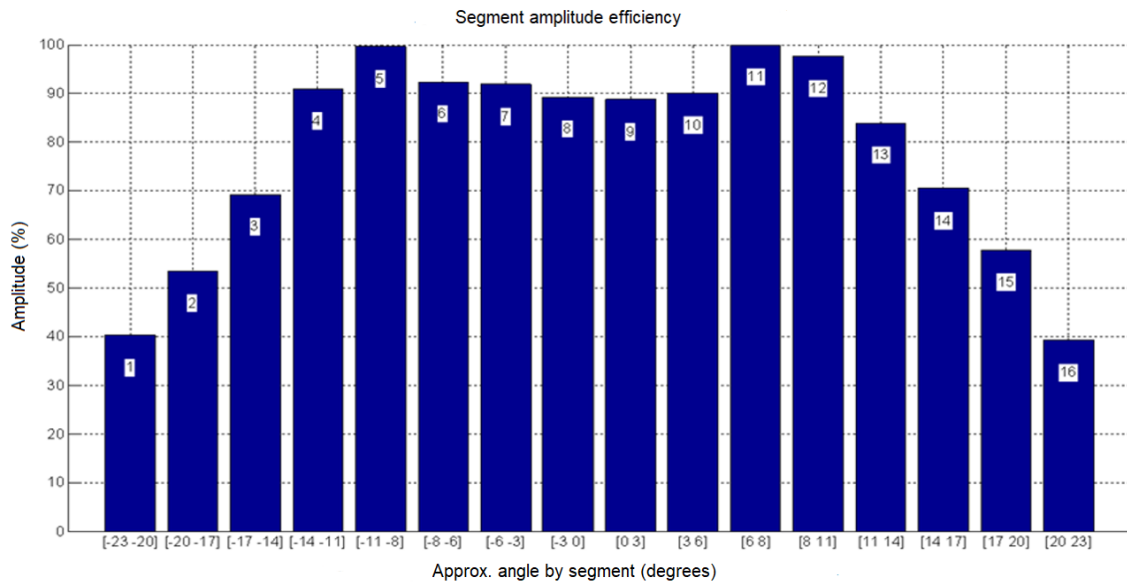


Fig. 69: Detection efficiency (HFoV by segment), 48° x 6° module

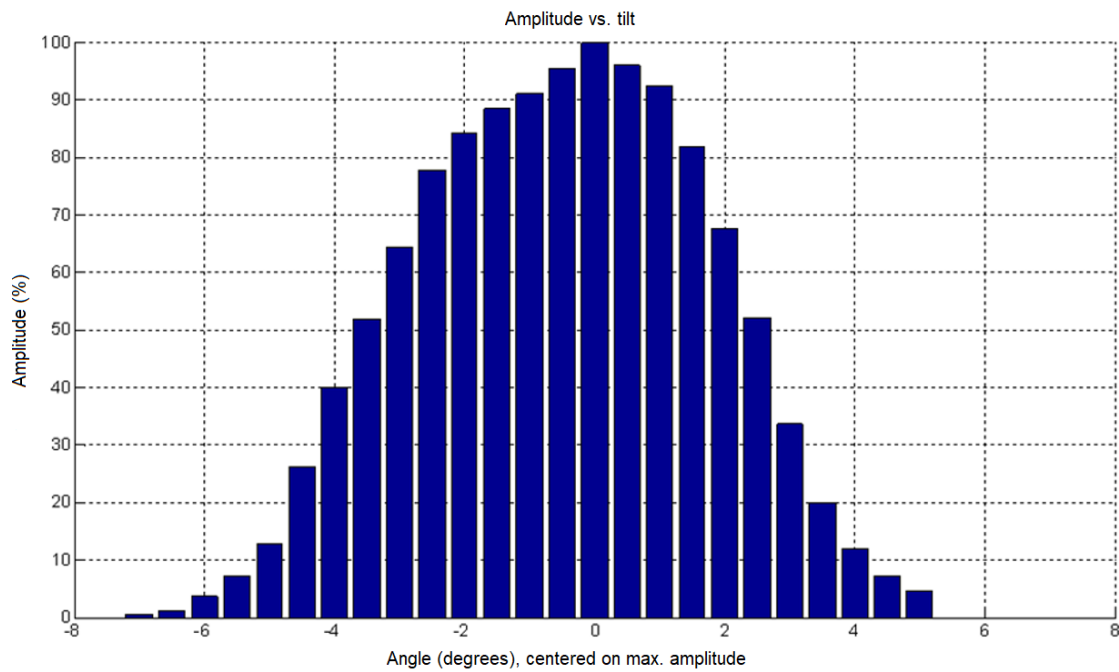


Fig. 70: Detection efficiency (VFoV), 48° x 6° module

6.6.3. 36° x 5° Module (M16D-75B0010)

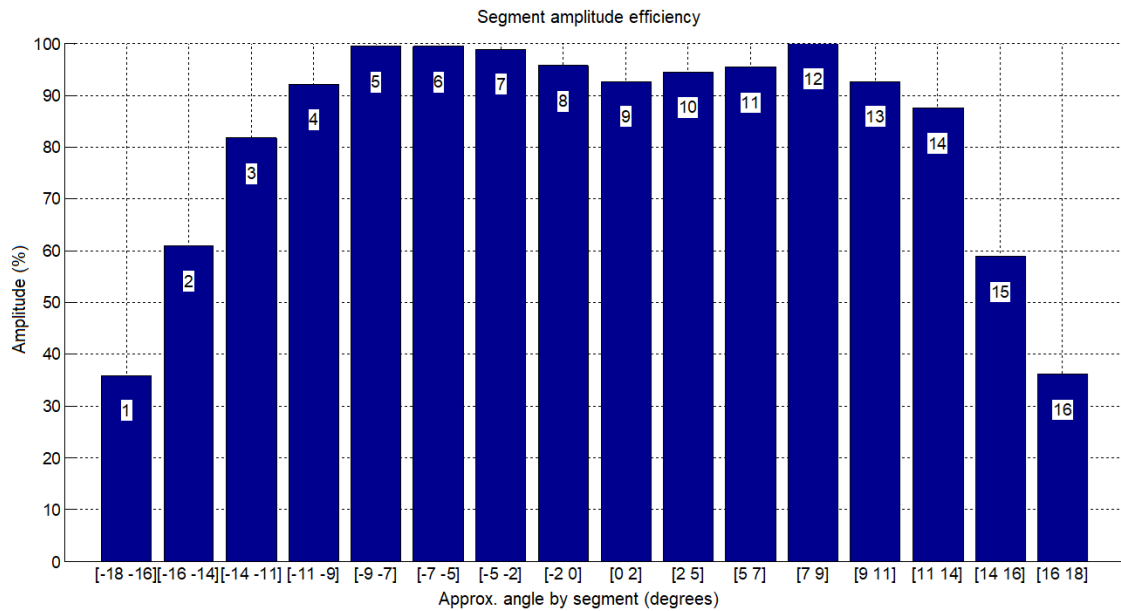


Fig. 71: Detection efficiency (HFOV by segment), 36° x 5° module

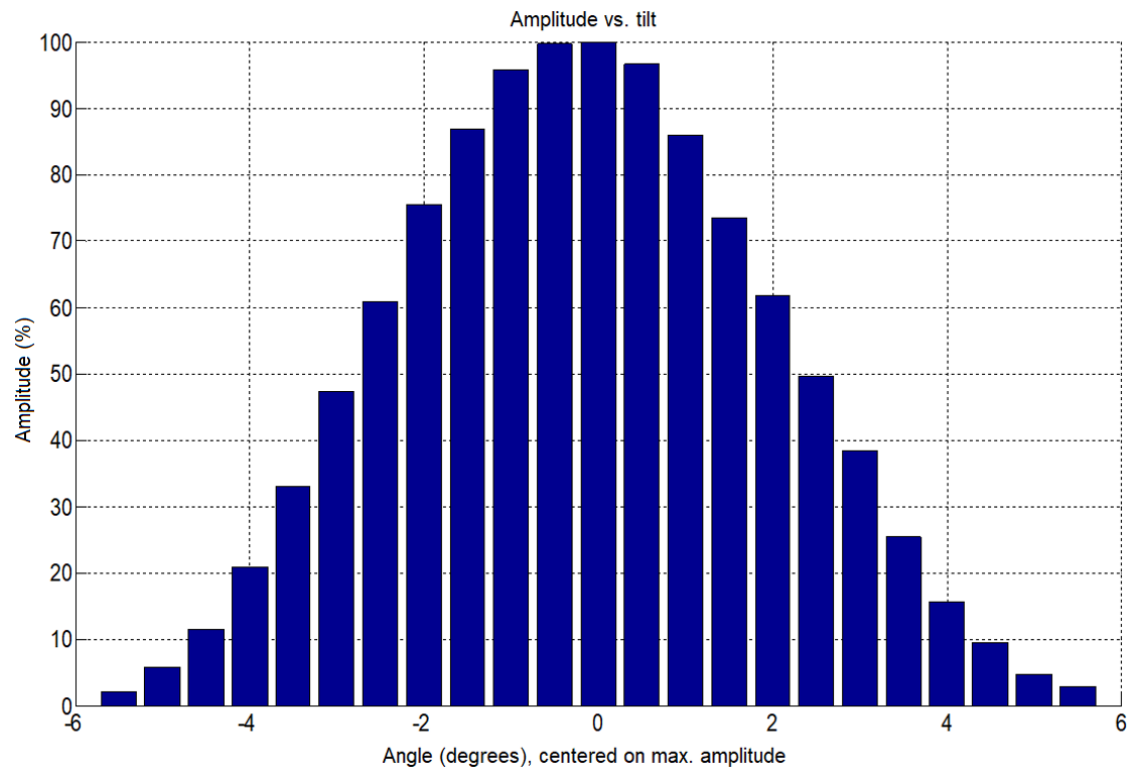


Fig. 72: Detection efficiency (VFOV), 36° x 5° module

6.6.4. 25° x 4° Module (M16D-75B0009)

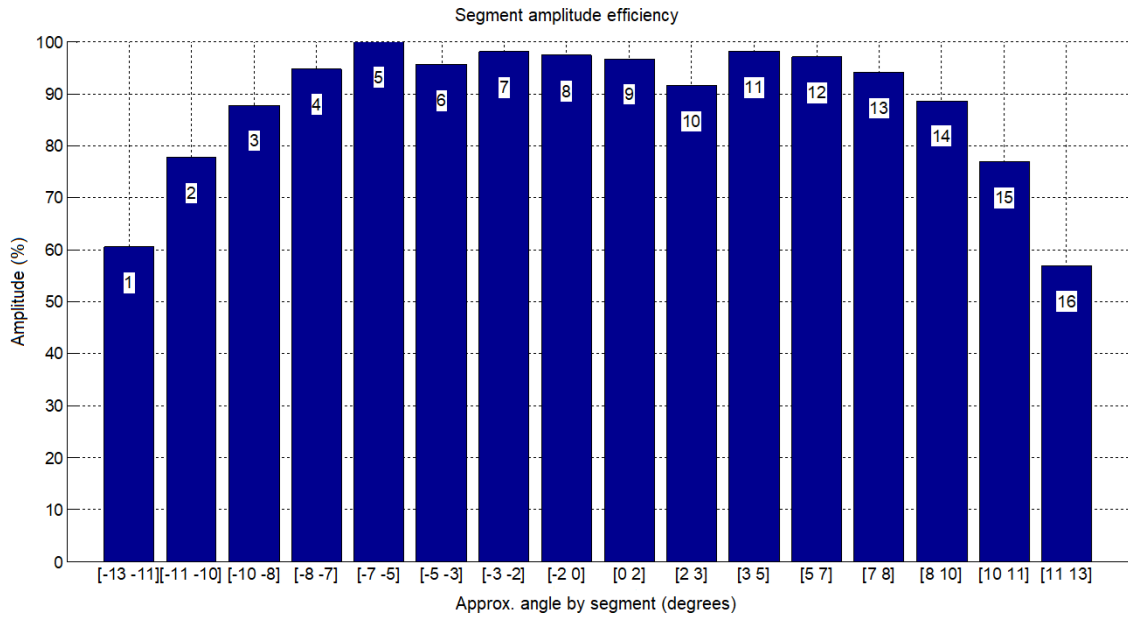


Fig. 73: Detection efficiency (HFoV by segment), 25° x 4° module

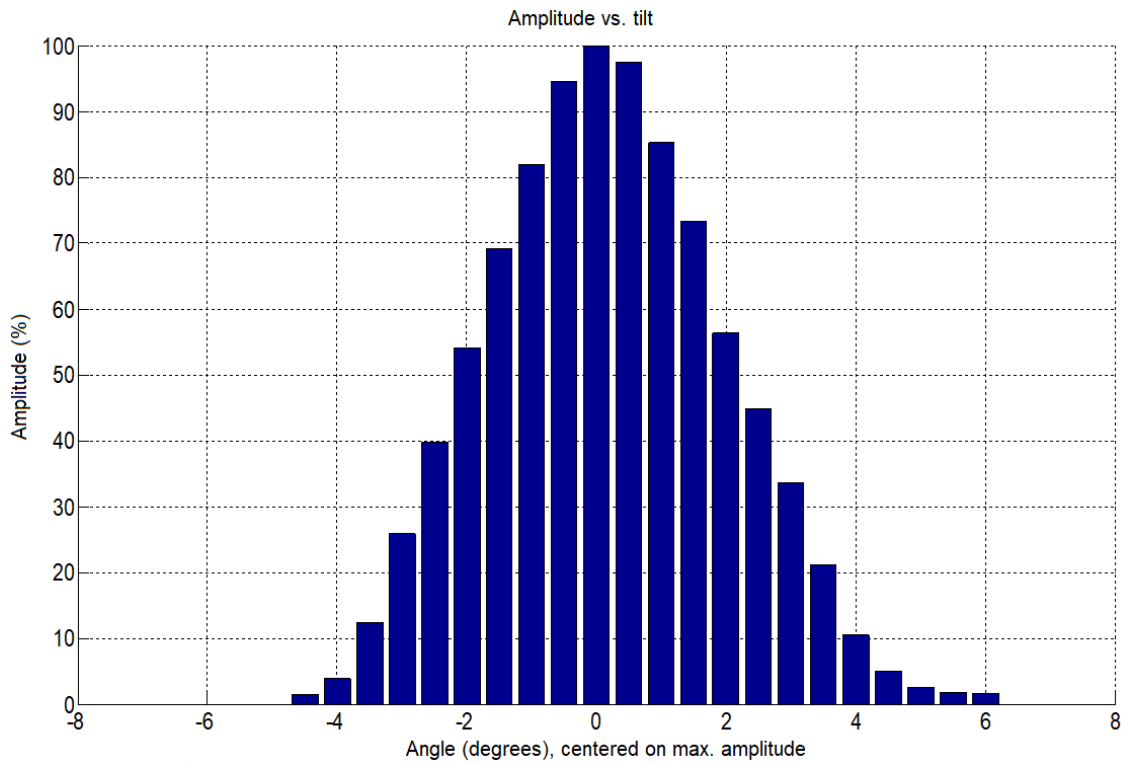


Fig. 74: Detection efficiency (VFoV), 25° x 4° module

6.6.5. 19° x 3° Module (M16D-75B0007)

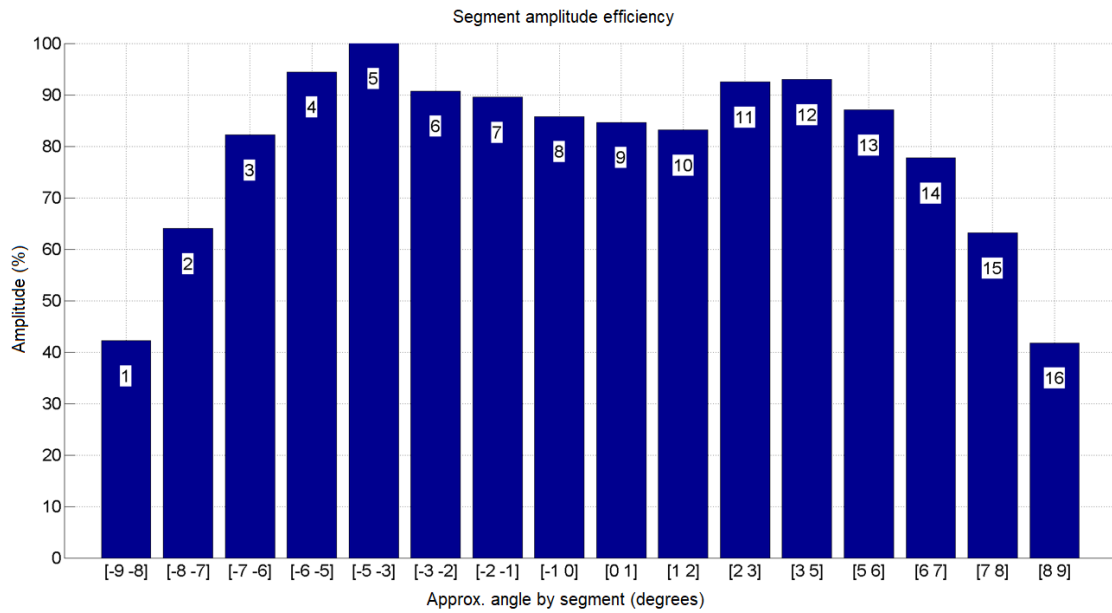


Fig. 75: Detection efficiency (HFoV by segment), 19° x 3° module

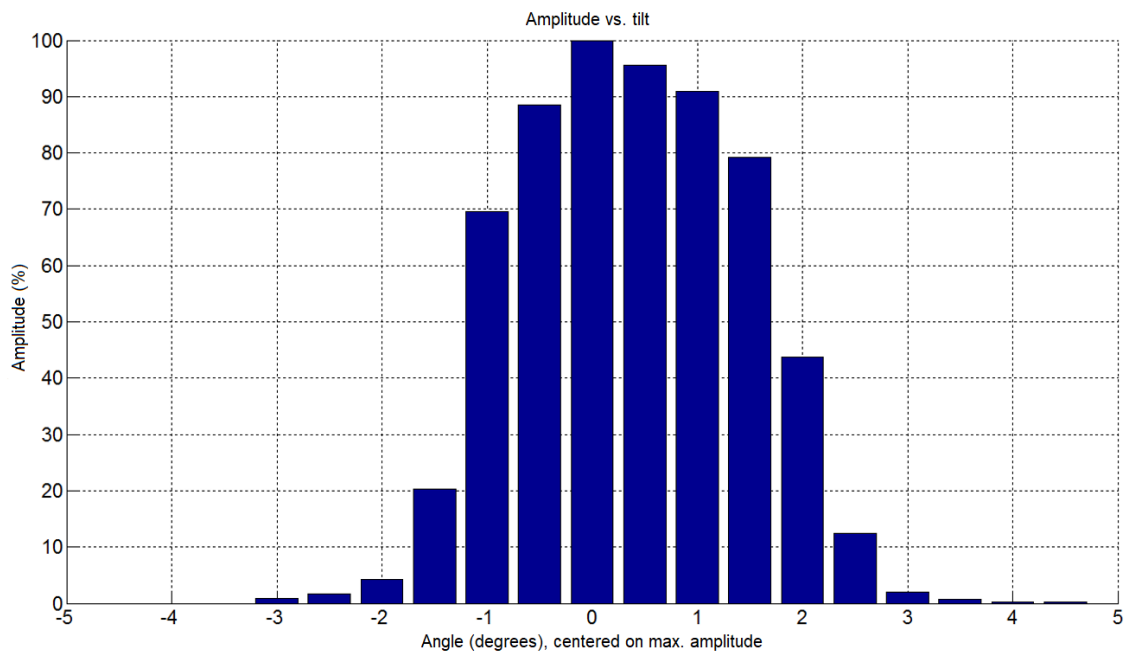


Fig. 76: Detection efficiency (VFoV), 19° x 3° module

6.6.6. 10° x 1.6° Module (M16D-75B0006)

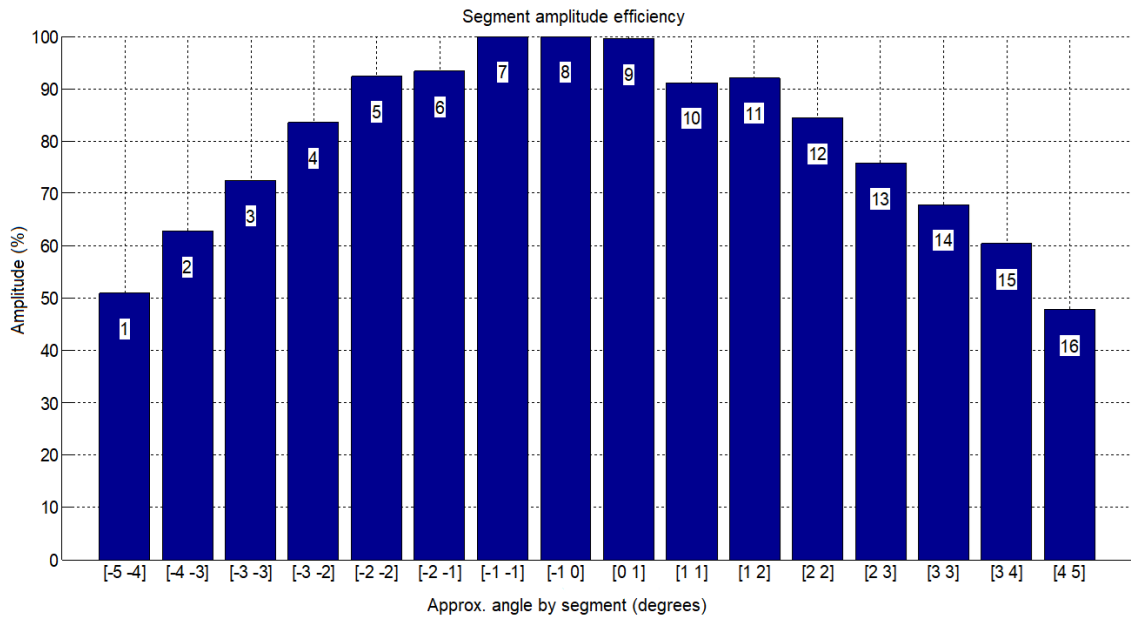


Fig. 77: Detection efficiency (HFOV by segment), 10° x 1.6° module

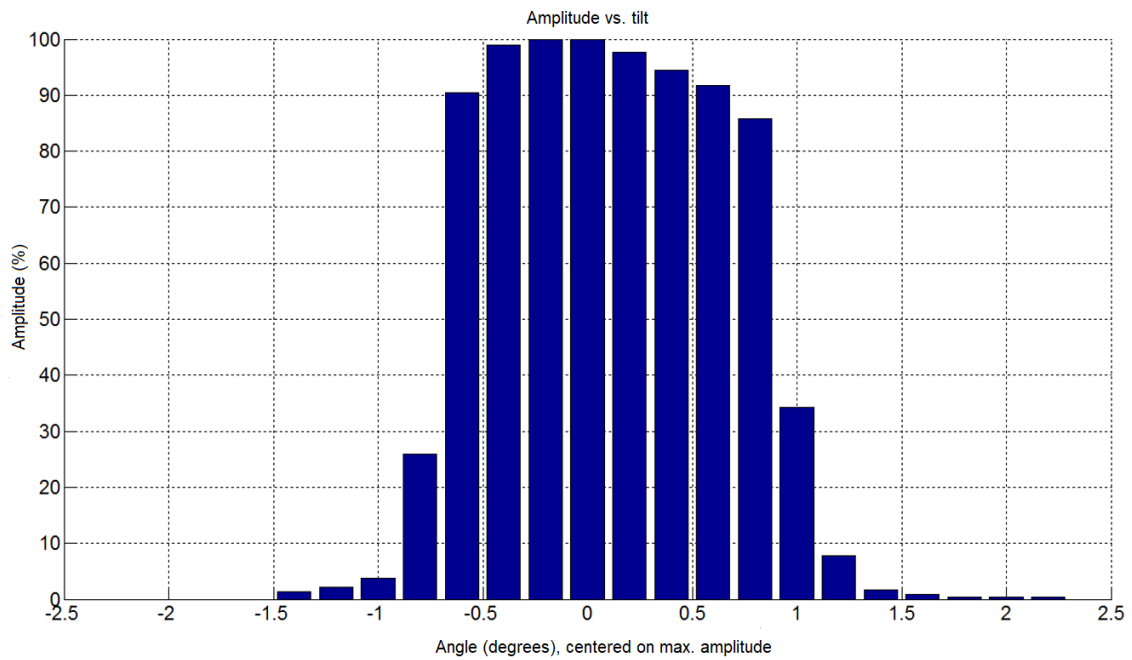


Fig. 78: Detection efficiency (VFOV), 10° x 1.6° module

## 6.7. Performance

Table 45: Module performances

Performance Metrics	Value
Measurement accuracy <sup>20</sup>	±5 cm
Measurement precision	6 mm (amplitude >15)
Resolution	1 cm
Range (maximum LED intensity)	Varies with beam optics and target properties (see amplitude vs. range figures below).

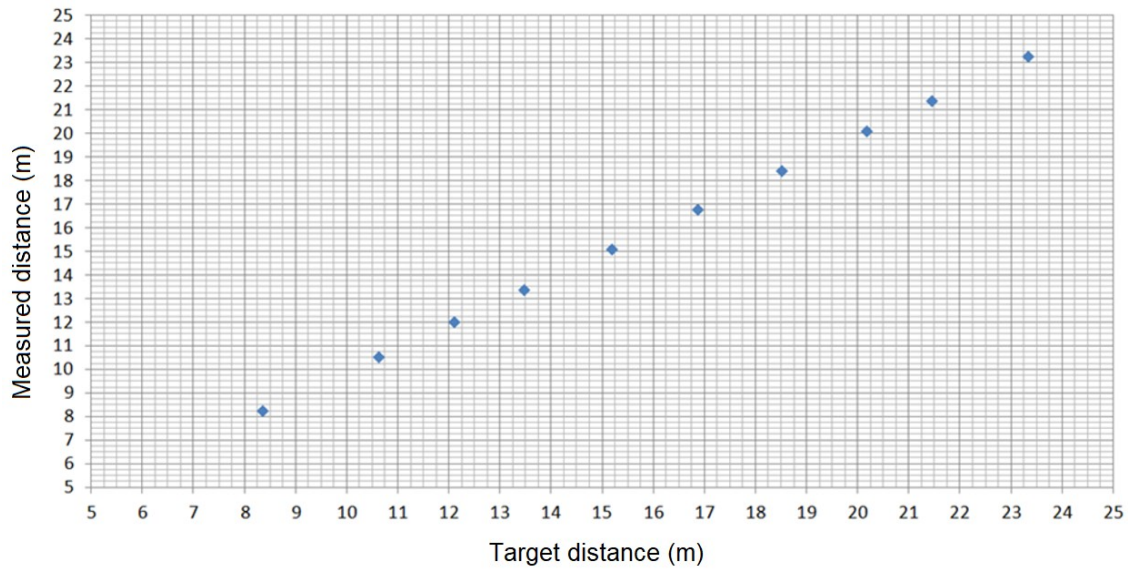


Fig. 79: Accuracy vs. distance

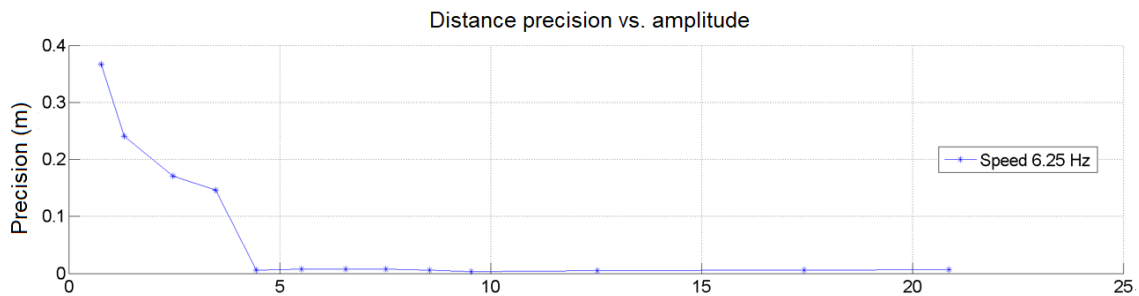
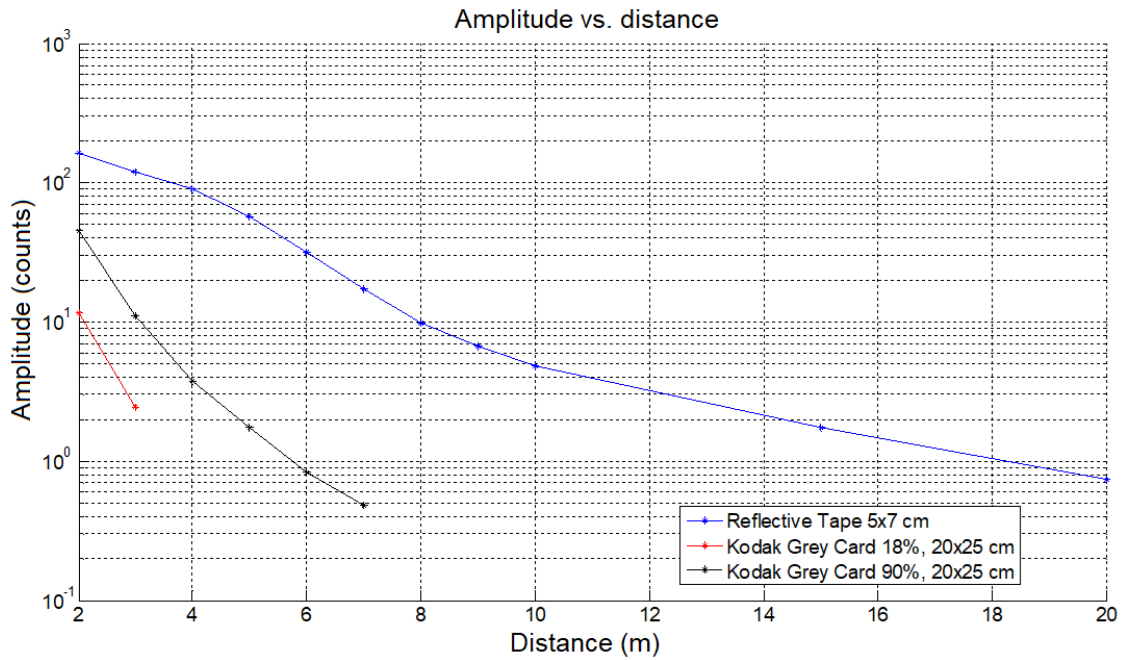


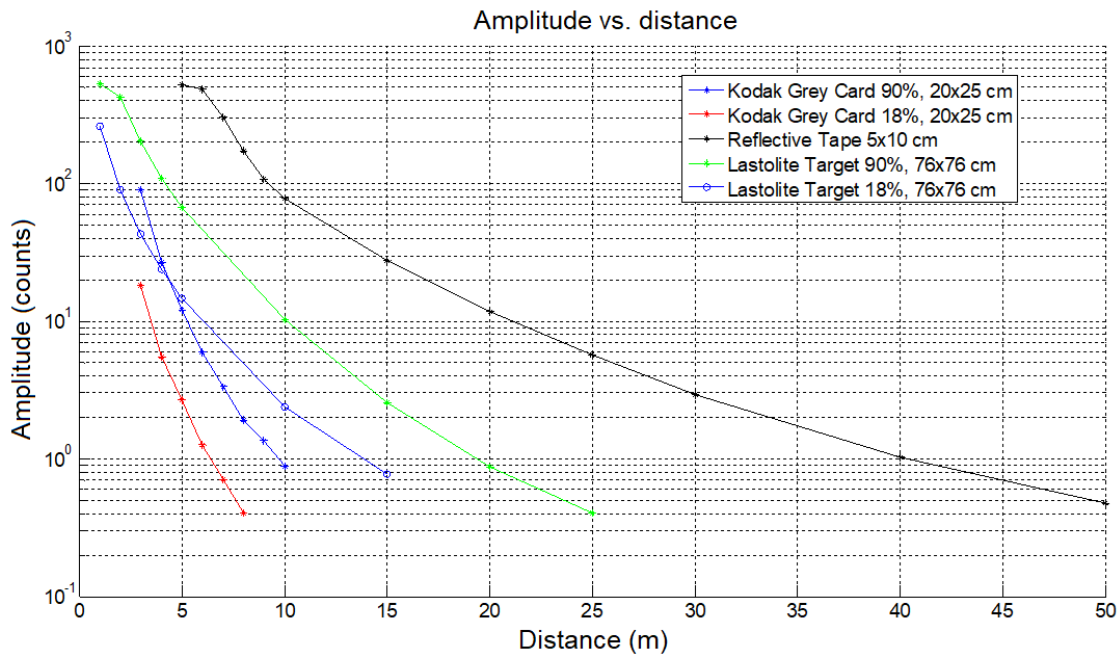
Fig. 80: Precision vs. amplitude  
(Accumulation: 256, oversampling: 8)

<sup>20</sup> For oversampling of 4 and more.

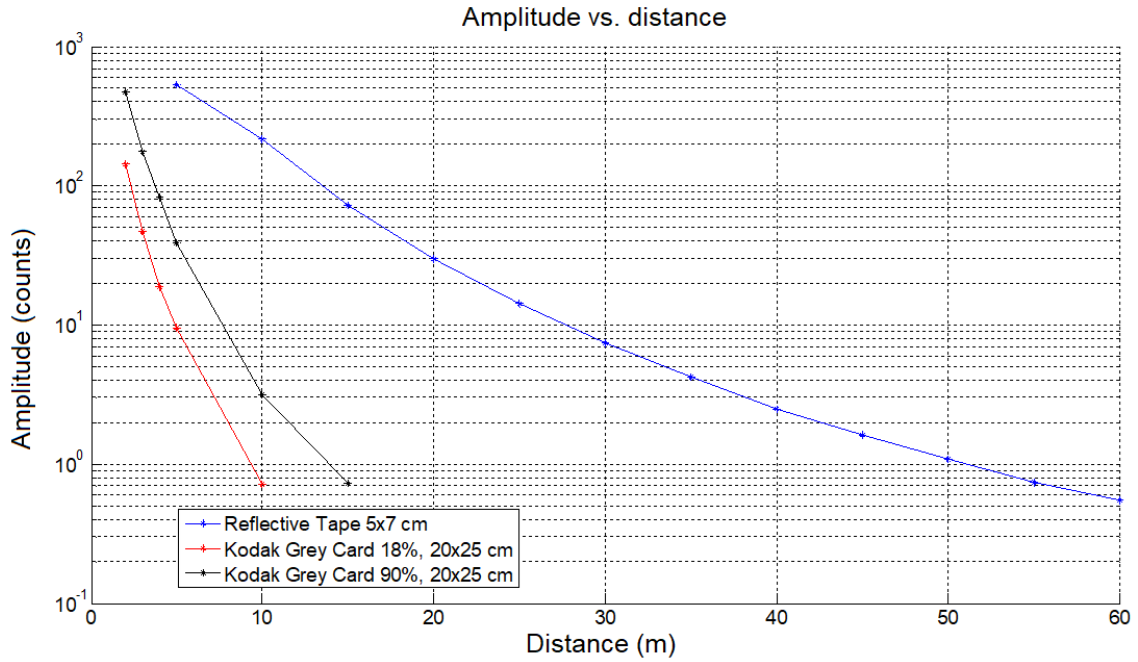




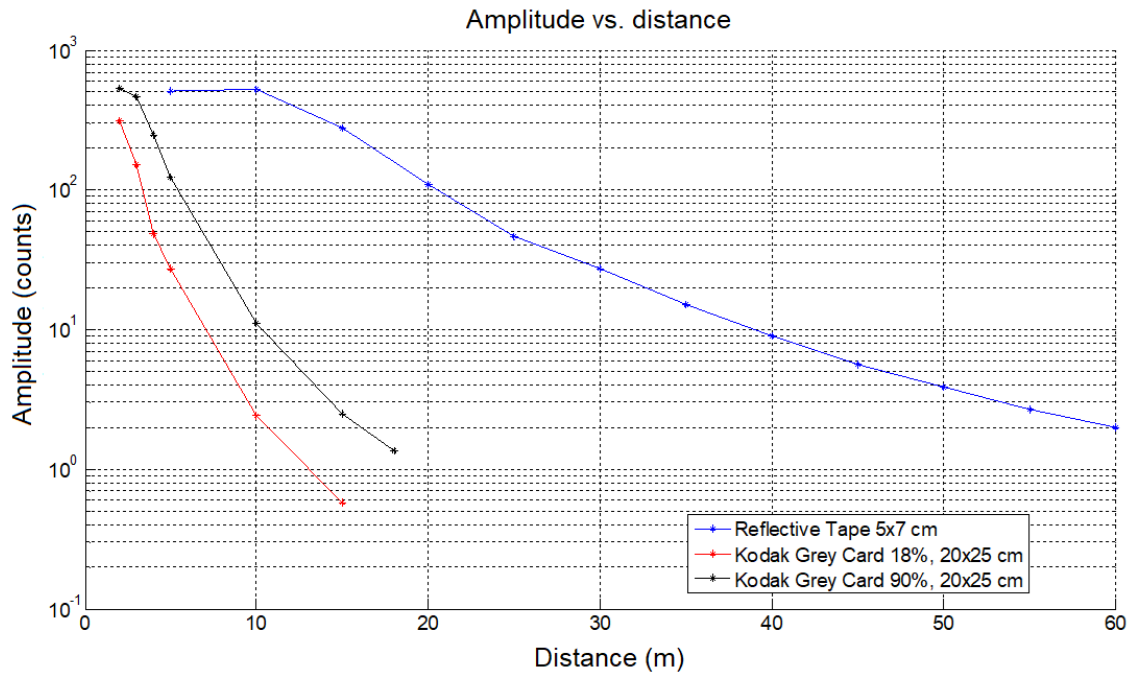
**Fig. 81: 99° x 8° module amplitude vs. range  
(Maximum LED intensity and 256 accumulations)**



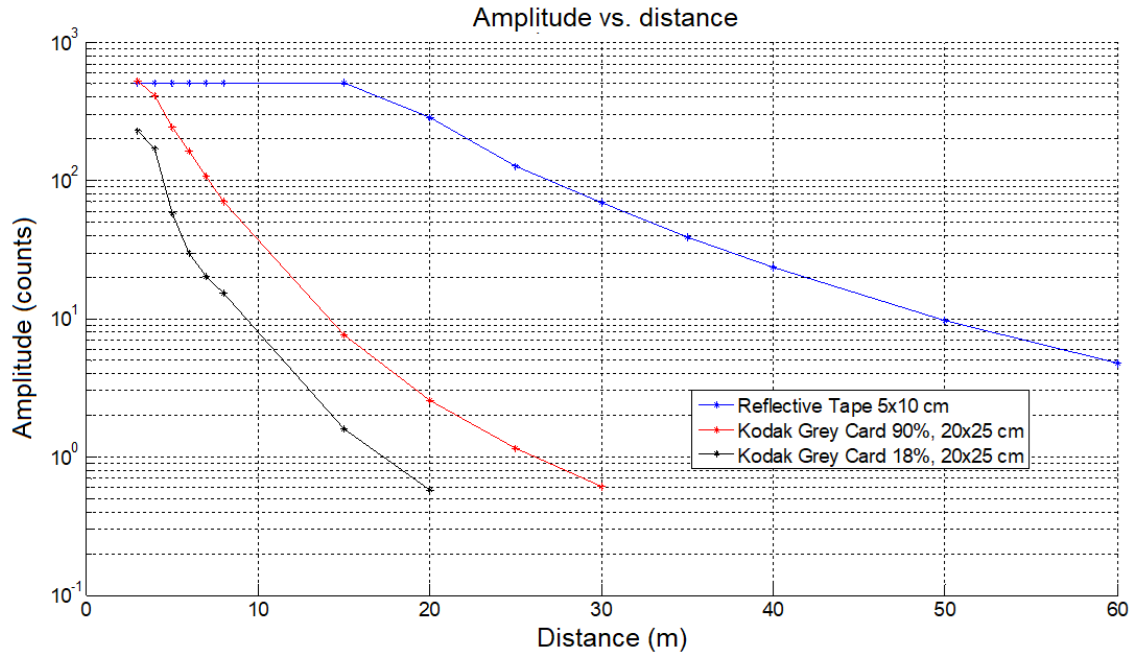
**Fig. 82: 48° x 6° module amplitude vs. range  
(Maximum LED intensity and 256 accumulations)**



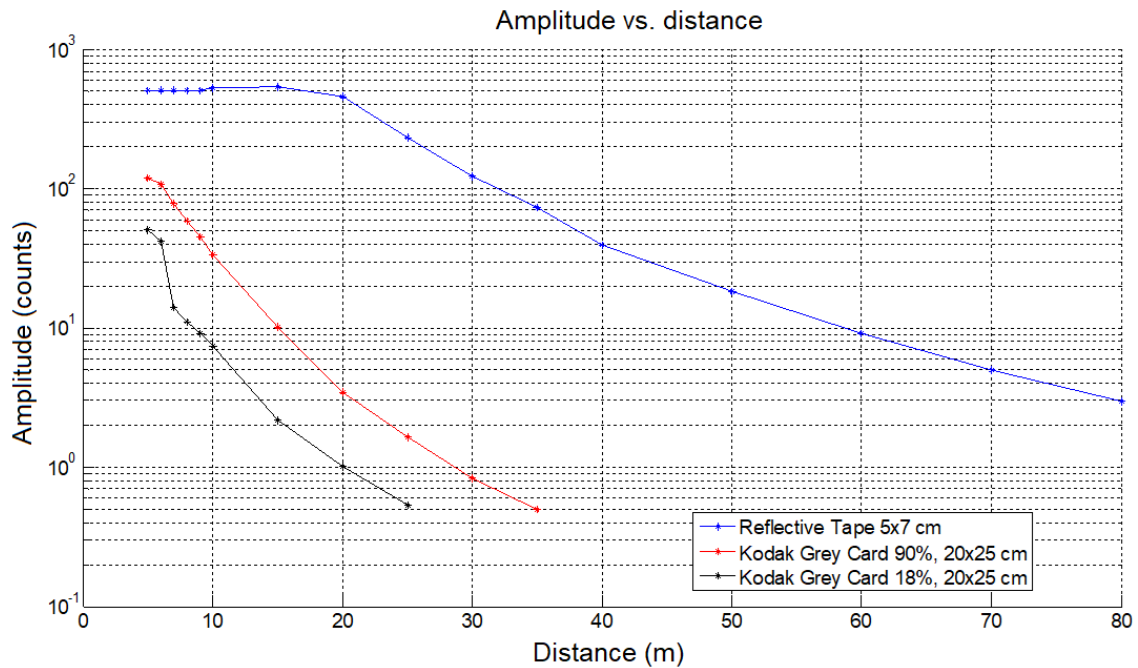
**Fig. 83: 36° x 5° module amplitude vs. range (Maximum LED intensity and 256 accumulations)**



**Fig. 84: 25° x 4° module amplitude vs. range (Maximum LED intensity and 256 accumulations)**



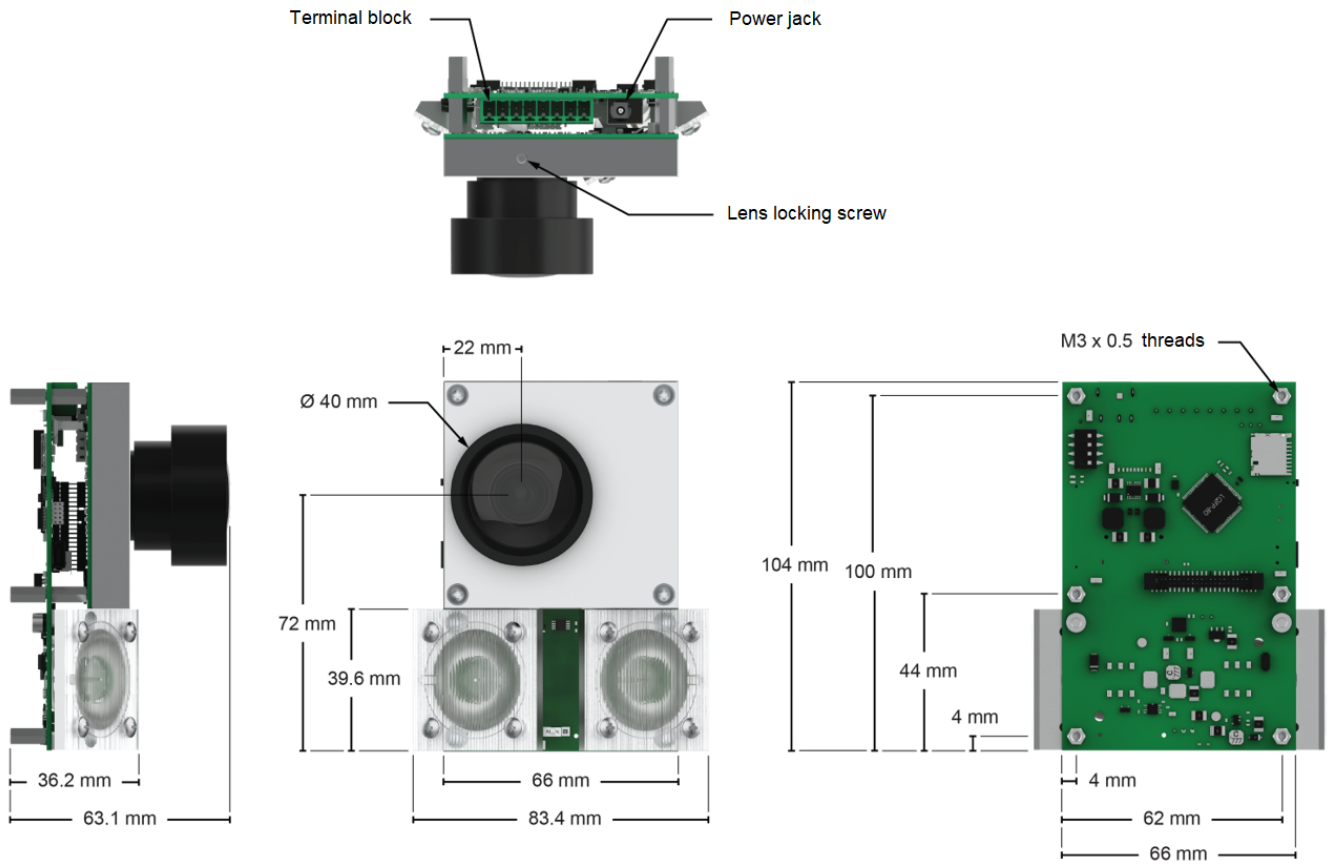
**Fig. 85: 19° x 3° module amplitude vs. range  
(Maximum LED intensity and 256 accumulations)**



**Fig. 86: 10° x 1.6° module amplitude vs. range  
(Maximum LED intensity and 256 accumulations)**

## 6.8. Dimensions

### 6.8.1. 99° x 8° Module (M16D-75B0008)



**Fig. 87: 99° x 8° module dimensions**

6.8.2. 48° x 6° Module (M16D-75B0005)

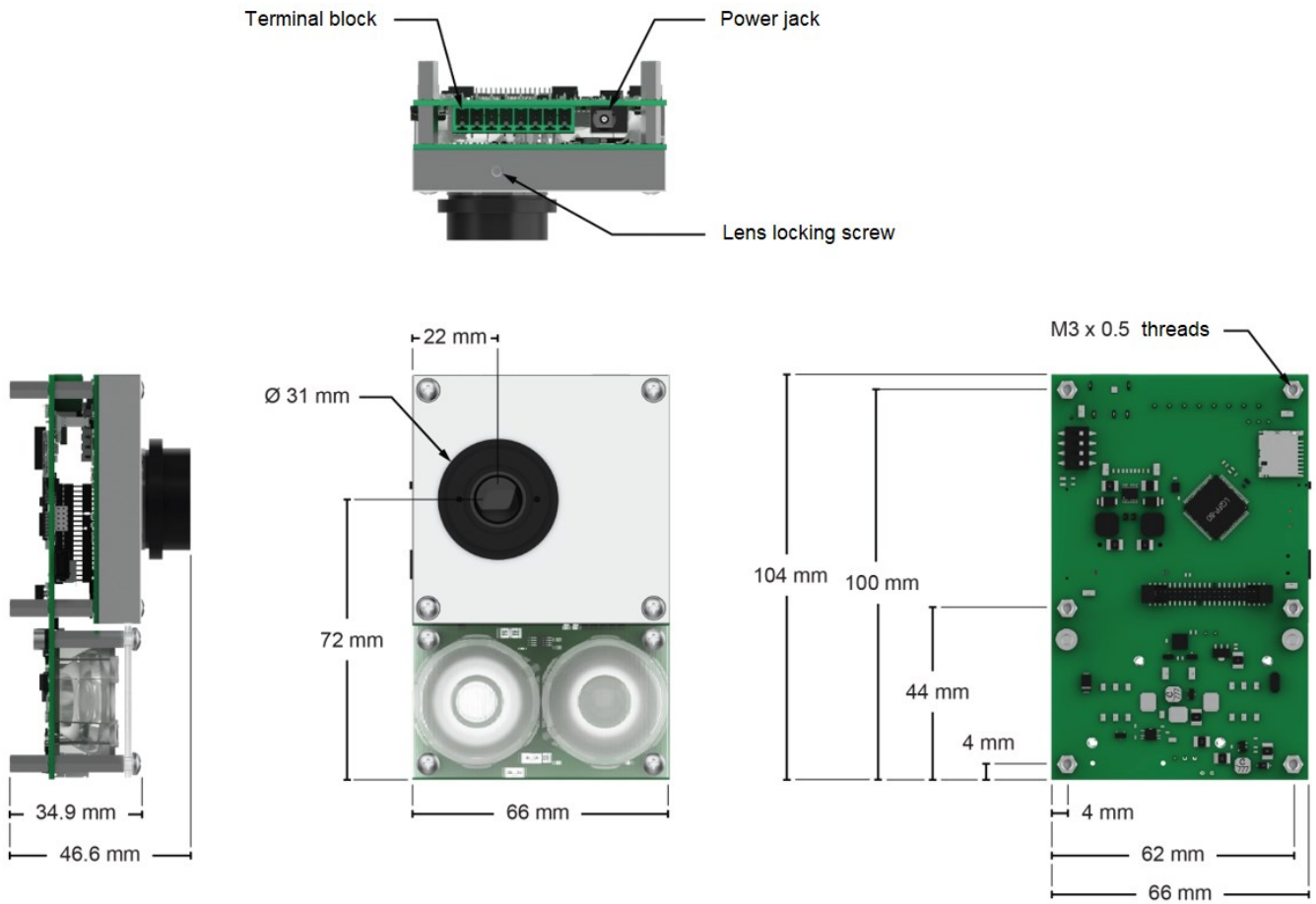


Fig. 88: 48° x 6° module dimensions

6.8.3. 36° x 5° Module (M16D-75B0010)

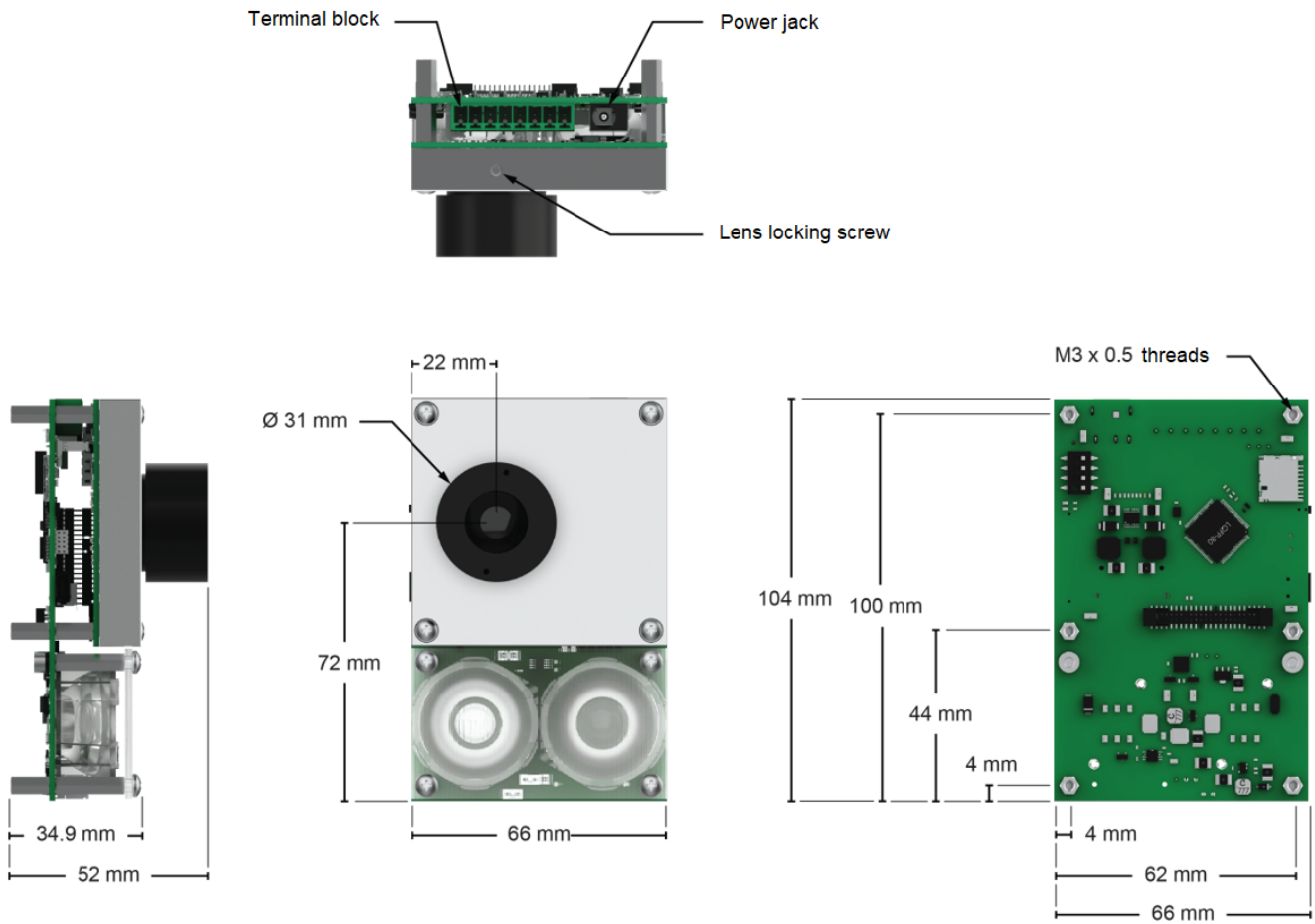


Fig. 89: 36° x 5° module dimensions

6.8.4. 25° x 4° Module (M16D-75B0009)

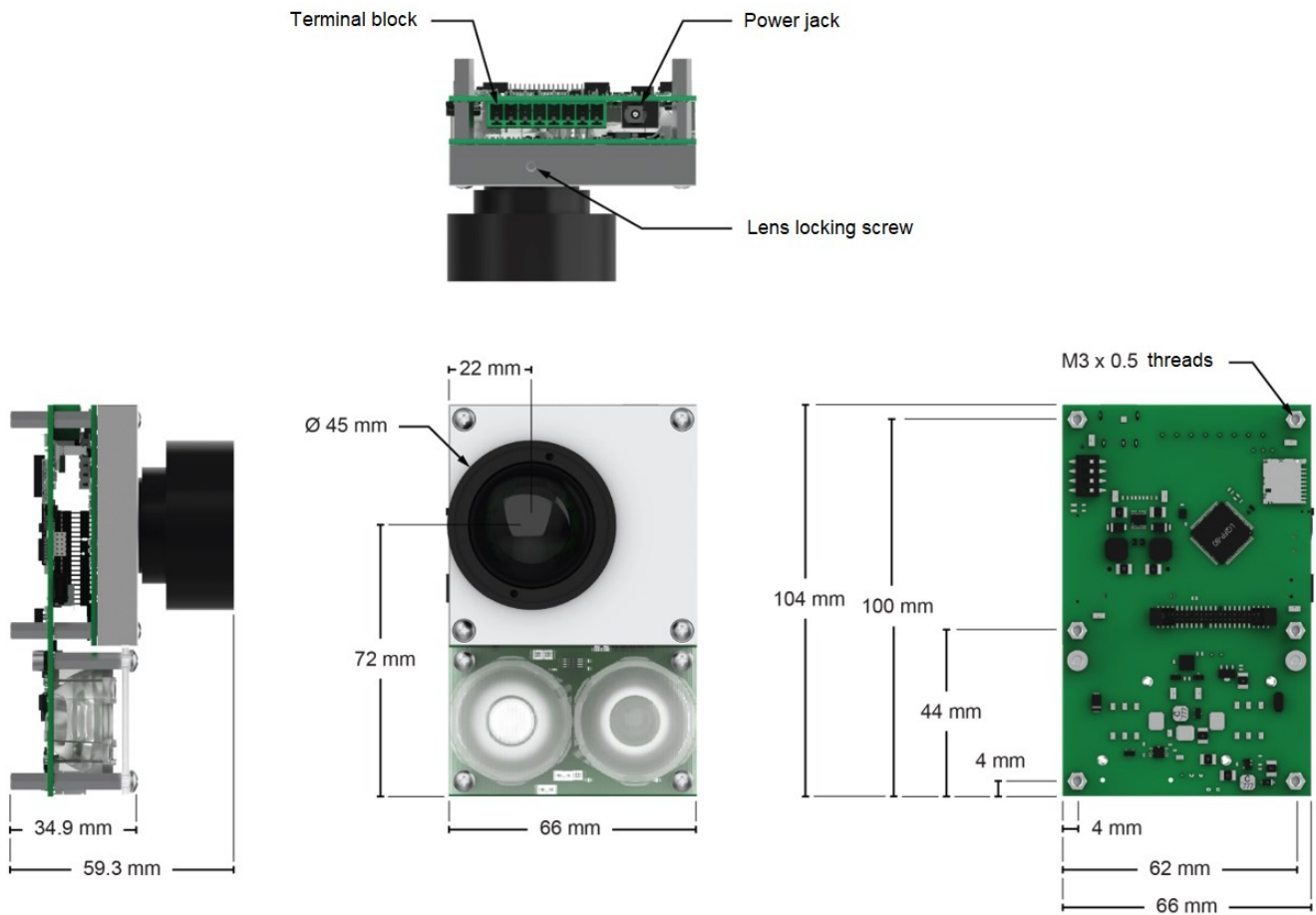


Fig. 90: 25° x 4° module dimensions

6.8.5. 19° x 3° Module (M16D-75B0007)

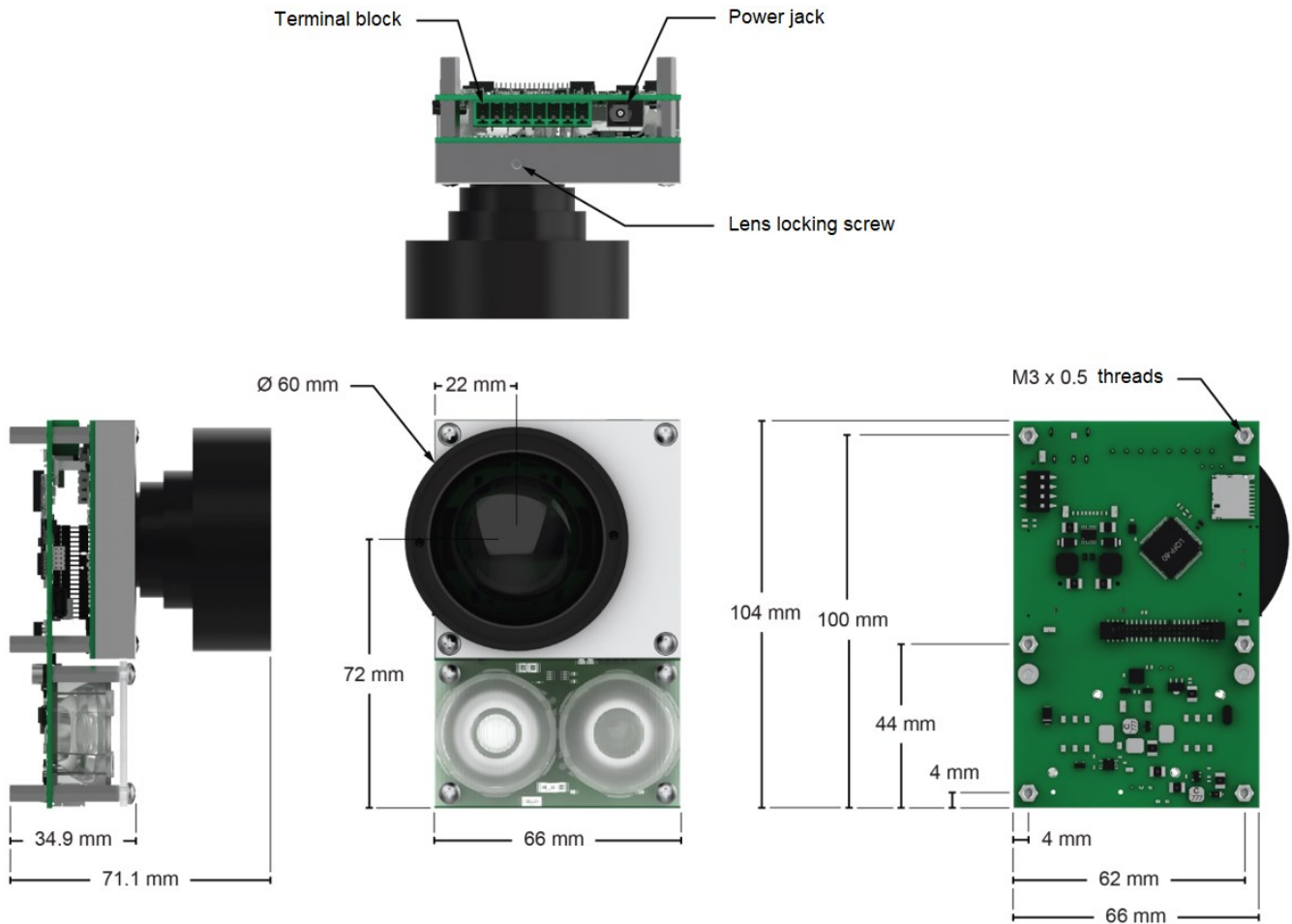


Fig. 91: 19° x 3° module dimensions



6.8.6. 10° x 1.6° Module (M16D-75B0006)

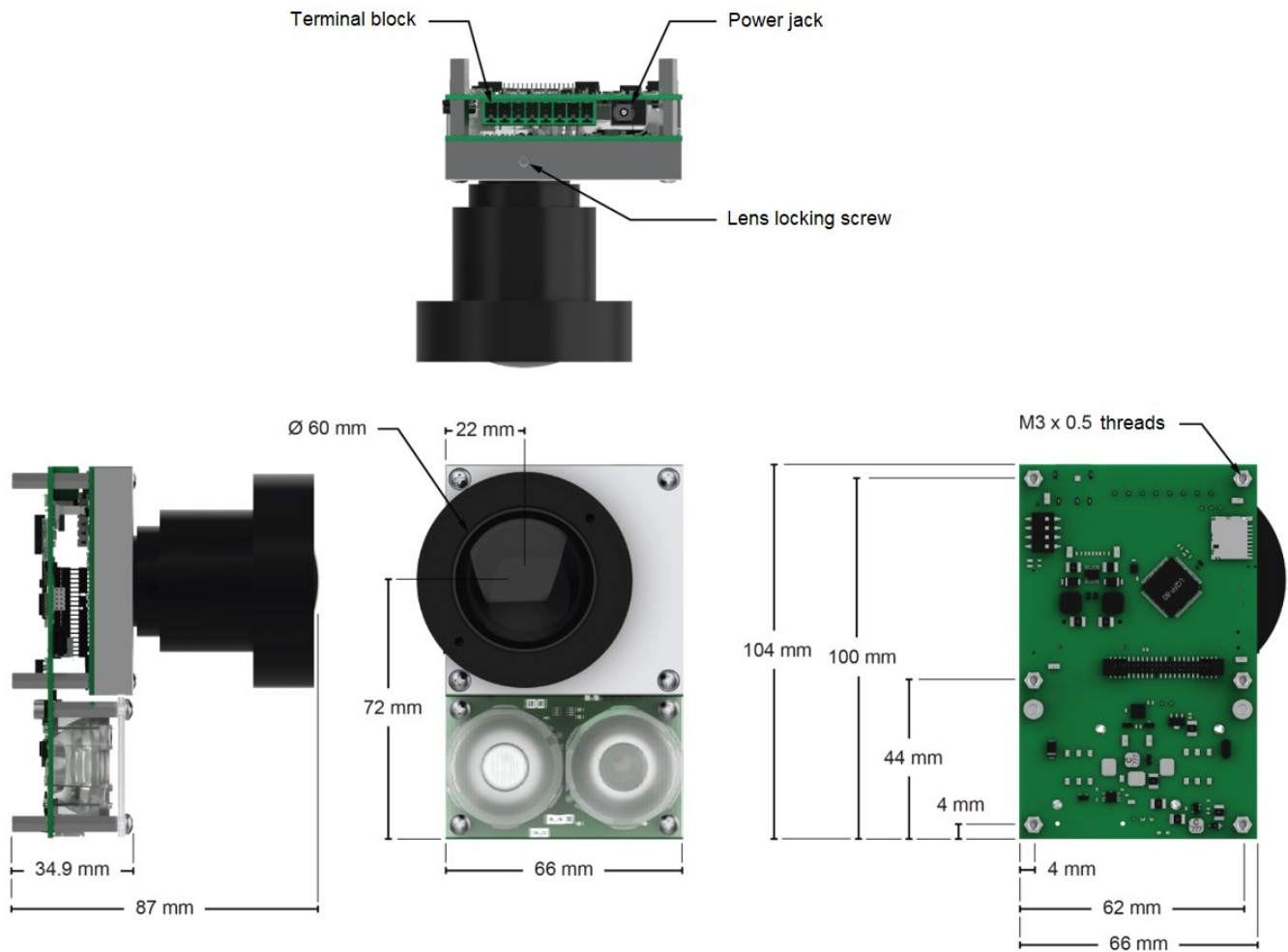




Fig. 92: 10° x 1.6° module dimensions

## 7. Troubleshooting

Contact LeddarTech for troubleshooting information concerning the M16 LED module.

## 8. Maintenance

<b>Manipulation</b>	 <i>Avoid touching the optical surfaces as fingerprints can permanently damage the optical coatings.</i>
<b>Cleaning the optical surfaces</b>	<ul style="list-style-type: none"><li>• Blow off dust using compressed air.</li><li>• Clean the optical surfaces with premium-grade optical tissues only.</li></ul>  <i>Do not use cotton-tipped applicators. If needed, clean the optical surfaces with isopropyl alcohol instead.</i>

For any questions or concerns on how to safely perform maintenance operations on the M16 LED sensor module, contact LeddarTech support at [support@leddartech.com](mailto:support@leddartech.com).

## 9. Disposal

Like any electronic equipment, the M16 LED sensor module contains environmentally unsustainable components. Dispose of in an environmentally responsible manner.

## 10. Technical Support

For technical enquiries, contact LeddarTech technical support at [support@leddartech.com](mailto:support@leddartech.com) to easily:

- follow up on your requests
- find quick answers to questions
- get valuable updates

Also, see the contact information at the end of this document.

Please have all relevant information such as part numbers, serial numbers, and pictures to facilitate support.

## Appendix A. Example of a 0x41 Modbus Function

Transmit data stream message

01 41 C0 10

Use the 0x41 command to read the Modbus address # 01, using the CRC C0 10.

Received data stream message

01 41 10 CA 01 58 04 01 DA 01 2F 04 11 C0 01 94 04 21 D0 01 2F 04 31 B6 01 BF 04  
41 C6 01 76 04 51 B3 01 D5 04 61 C7 01 7E 04 71 AE 01 EB 04 81 C2 01 93 04 91  
AD 01 F5 04 A1 C6 01 55 04 B1 B2 01 F1 04 C1 CC 01 48 04 D1 B0 01 DA 04 E1 D3  
01 2D 04 F1 CF 61 02 00 64 03 0F DB

Get detection messages (first byte)

Modbus address: 01 hex = 1 = address#1

Function code: 41 hex = 65 = function 0x41

Number of detections: 10 hex = 16 = 16 detections

Get detection messages (detection fields); refer to Table 17 on page 42.

(1) CA 01 58 04 01:

Distance (cm): 01 CA hex = 458 cm

Amplitude (count): 04 58 hex = 1112 / 64 = 17.375 counts

Segment/Flags #: 01 hex (segment #0, flag = valid)

(2) DA 01 2F 04 11:

Distance (cm): 01 DA hex = 474 cm

Amplitude (count): 04 2F hex = 1071 / 64 = 16.734 counts

Segment/Flags #: 11 hex (segment #1, flag = valid)

(3) C0 01 94 04 21:

Distance (cm): 01 C0 hex = 448 cm

Amplitude (count): 04 94 hex = 1172 / 64 = 18.313 counts

Segment/Flags #: 21 hex (segment #2, flag = valid)

(4) D0 01 2F 04 31:

Distance (cm): 01 D0 hex = 464 cm

Amplitude (count): 04 2F hex = 1071 / 64 = 16.734 counts

Segment/Flags #: 31 hex (segment #3, flag = valid)

(5) B6 01 BF 04 41:

Distance (cm): 01 B6 hex = 438 cm

Amplitude (count): 04 BF hex = 1215 / 64 = 18.984 counts

Segment/Flags #: 41 hex (segment #4, flag = valid)

(6) C6 01 76 04 51:

Distance (cm): 01 C6 hex = 454 cm

Amplitude (count): 04 76 hex = 1142 / 64 = 17.844 counts

Segment/Flags #: 51 hex (segment #5, flag = valid)

(7) B3 01 D5 04 61:

Distance (cm): 01 B3 hex = 435 cm

Amplitude (count): 04 D5 hex = 1117 / 64 = 17.453 counts

Segment/Flags #: 61 hex (segment #6, flag = valid)

(8) C7 01 7E 04 71:

Distance (cm): 01 C7 hex = 455 cm  
Amplitude (count): 04 7E hex =  $1150 / 64 = 17.969$  counts  
Segment/Flags #: 71 hex (segment #7, flag = valid)

(9) AE 01 EB 04 81:

Distance (cm): 01 AE hex = 430 cm  
Amplitude (count): 04 EB hex =  $1259 / 64 = 19.671$  counts  
Segment/Flags #: 81 hex (segment #8, flag = valid)

(10) C2 01 93 04 91:

Distance (cm): 01 C2 hex = 450 cm  
Amplitude (count): 04 93 hex =  $1171 / 64 = 18.267$  counts  
Segment/Flags #: 91 hex (segment #9, flag = valid)

(11) AD 01 F5 04 A1:

Distance (cm): 01 AD hex = 429 cm  
Amplitude (count): 04 F5 hex =  $1119 / 64 = 17.484$  counts  
Segment/Flags #: A1 hex (segment #10, flag = valid)

(12) C6 01 55 04 B1:

Distance (cm): 01 C6 hex = 454 cm  
Amplitude (count): 04 55 hex =  $1109 / 64 = 17.328$  counts  
Segment/Flags #: B1 hex (segment #11, flag = valid)

(13) B2 01 F1 04 C1:

Distance (cm): 01 B2 hex = 434 cm  
Amplitude (count): 04 F1 hex =  $1115 / 64 = 17.422$  counts  
Segment/Flags #: C1 hex (segment #12, flag = valid)

(14) CC 01 48 04 D1:

Distance (cm): 01 CC hex = 460 cm  
Amplitude (count): 04 48 hex =  $1096 / 64 = 17.125$  counts  
Segment/Flags #: D1 hex (segment #13, flag = valid)

(15) B0 01 DA 04 E1:

Distance (cm): 01 B0 hex = 432 cm  
Amplitude (count): 04 DA hex =  $1242 / 64 = 19.406$  counts  
Segment/Flags #: E1 hex (segment #14, flag = valid)

(16) D3 01 2D 04 F1:

Distance (cm): 01 D3 hex = 467 cm  
Amplitude (count): 04 2D hex =  $1069 / 64 = 16.703$  counts  
Segment/Flags #: F1 hex (segment #15, flag = valid)

Get detection messages (trailing fields); refer to Table 18 on page 43.

CF 61 02 00 64 03 0F DB:

TimeStamp (ms): 00 02 61 CF hex = 156111 ms = 156 s.

Light source POWER (%): 64 hex = 100 = 100%

Bit field acq. (reserved): 00 hex = 0

CRC (16-bits Modbus) = 0F DB



- (44) Segment #12 = 04 85 hex = 1157 / 64 = 18.078 counts
- (45) Segment #13 = 03 D8 hex = 984 / 64 = 15.375 counts
- (46) Segment #14 = 04 6E hex = 1134 / 64 = 17.719 counts
- (47) Segment #15 = 03 DD hex = 989 / 64 = 15.453 counts

## Appendix C. Example of a CAN Bus Detection Request

The controller sends the following:

ID	Data
0740	01

This message sends a request to receive the module detections only once.

The Leddar module answers the following:

ID	Data
0751	0F
0750	BD 00 85 00 C8 00 CA 10
0750	CE 00 AD 21 CB 00 3A 32
0750	C8 00 A1 42 C6 00 ED 52
0750	C4 00 FB 62 C5 00 2C 73
0750	C6 00 3A 85 C7 00 EC 92
0750	C6 00 7D A2 C9 00 0D B2
0750	CD 00 72 C1 CE 00 3F D1
0750	D1 00 5F E1 00 00 00 00

The following explains the first three lines of the answer:

ID: 0751      Data: 0F

0751 indicates that the data in this message will be the number of sent detections.

The number of sent detections is 0F hex = 15 detections; therefore, there are seven 0750 messages each containing two detections and one 0750 message containing only one detection.

ID: 0750      Data: BD 00 85 00 C8 00 CA 10

0750 = 8-byte message containing two detections.

Detection 1:

Distance is 00 BD hex = 189 cm

Amplitude is 085 hex/4 = 133/4 = 33.25

Channel is 0

Detection 2:

Distance is 00 C8 hex = 200 cm

Amplitude is 0 CA hex / 4 = 202/4 = 50.25

Channel is 1

ID: 0750      Data: CE 00 AD 21 CB 00 3A 32

0750 = 8-byte message containing two detections.

Detection 1:

Distance is 00 CE hex = 206 cm

Amplitude is 1 AD hex / 4 =  $429/4 = 107.25$

Channel is 2

Detection 2:

Distance is 00 CB hex = 203 cm

Amplitude is 2 3A hex / 4 =  $570/4 = 142.5$

Channel is 3





## LEDDARTECH INC.

[www.leddartech.com](http://www.leddartech.com)

### HEADQUARTERS

4535, boulevard Wilfrid-Hamel, Suite 240  
Québec (Québec) G1P 2J7, Canada

Phone: + 1-418-653-9000

Canada or USA (toll-free): 1-855-865-9900

[support@leddartech.com](mailto:support@leddartech.com)

[sales@leddartech.com](mailto:sales@leddartech.com)

**CANADA – USA – AUSTRIA – FRANCE – GERMANY – ITALY – ISRAEL – HONG KONG – CHINA**

More information on our offices worldwide can be found at: [leddartech.com/contact-us](http://leddartech.com/contact-us)

*Leddar, LeddarTech, LeddarSteer, LeddarEngine, LeddarVision, LeddarSP, LeddarCore, VAYADrive, VayaVision, and related logos are trademarks or registered trademarks of LeddarTech Inc. All other brands, product names, and marks are or may be trademarks or registered trademarks used to identify products or services of their respective owners.*

© 2021 LeddarTech Inc. Printed in Canada. All rights reserved.