

Keysight Model 66000A MPS Mainframe

Service Guide

NOTICE: This document contains references to Agilent Technologies. Agilent's former Test and Measurement business has become Keysight Technologies. For more information, go to www.keysight.com.



CERTIFICATION

Keysight Technologies certifies that this product met its published specifications at time of shipment from the factory. Keysight Technologies further certifies that its calibration measurements are traceable to the United States National Bureau of Standards, to the extent allowed by the Bureau's calibration facility, and to the calibration facilities of other International Standards Organization members.

WARRANTY

This Keysight Technologies hardware product is warranted against defects in material and workmanship for a period of three years from date of delivery. Keysight Technologies software and firmware products, which are designated by Keysight Technologies for use with a hardware product and when properly installed on that hardware product, are warranted not to fail to execute their programming instructions due to defects in material and workmanship for a period of 90 days from date of delivery. During the warranty period Keysight Technologies will, at its option, either repair or replace products which prove to be defective. Keysight Technologies does not warrant that the operation of the software, firmware, or hardware shall be uninterrupted or error free.

For warranty service, with the exception of warranty options, this product must be returned to a service facility designated by Keysight Technologies. Customer shall prepay shipping charges by (and shall pay all duty and taxes) for products returned to Keysight Technologies for warranty service. Except for products returned to Customer from another country, Keysight Technologies shall pay for return of products to Customer.

Warranty services outside the country of initial purchase are included in Keysight Technologies' product price, only if Customer pays Keysight Technologies international prices (defined as destination local currency price, or U.S. or Geneva Export price).

If Keysight Technologies is unable, within a reasonable time to repair or replace any product to condition as warranted, the Customer shall be entitled to a refund of the purchase price upon return of the product to Keysight Technologies.

LIMITATION OF WARRANTY

The foregoing warranty shall not apply to defects resulting from improper or inadequate maintenance by the Customer, Customer-supplied software or interfacing, unauthorized modification or misuse, operation outside of the environmental specifications for the product, or improper site preparation and maintenance. **NO OTHER WARRANTY IS EXPRESSED OR IMPLIED. KEYSIGHT TECHNOLOGIES SPECIFICALLY DISCLAIMS THE IMPLIED WARRANTIES OF MERCHANTABILITY AND FITNESS FOR A PARTICULAR PURPOSE.**

EXCLUSIVE REMEDIES

THE REMEDIES PROVIDED HEREIN ARE THE CUSTOMER'S SOLE AND EXCLUSIVE REMEDIES. KEYSIGHT TECHNOLOGIES SHALL NOT BE LIABLE FOR ANY DIRECT, INDIRECT, SPECIAL, INCIDENTAL, OR CONSEQUENTIAL DAMAGES, WHETHER BASED ON CONTRACT, TORT, OR ANY OTHER LEGAL THEORY.

ASSISTANCE

The above statements apply only to the standard product warranty. Warranty options, extended support contracts, product maintenance agreements and customer assistance agreements are also available. Contact your nearest Keysight Technologies. Sales and Service office for further information on Keysight Technologies' full line of Support Programs.

SAFETY SUMMARY

The following general safety precautions must be observed during all phases of operation of this mainframe. Failure to comply with these precautions or with specific warnings elsewhere in this guide violates safety standards of design, manufacture, and intended use of the mainframe. Keysight Technologies assumes no liability for the user's failure to comply with these requirements.

GROUND THE MAINFRAME.

This product is a Safety Class 1 instrument (provided with a protective earth terminal). To minimize shock hazard, the mainframe must be connected to an electrical ground. The mainframe must be connected to the ac power supply mains through a three-conductor power cable, with the third wire firmly connected to an electrical ground (safety ground) at the power outlet. Any interruption of the protective (grounding) conductor or disconnection of the protective earth terminal will cause a potential shock hazard that could result in personal injury.

DO NOT EXCEED INPUT RATINGS.

This mainframe is equipped with a power line filter to reduce electromagnetic interference and must be connected to a properly grounded receptacle to minimize electric shock hazard. Operation at line voltages or frequencies in excess of those stated on the line rating label may cause leakage currents in excess of 5.0 mA peak.

DO NOT OPERATE IN AN EXPLOSIVE ATMOSPHERE.

Do not operate the mainframe in the presence of flammable gases or fumes.

BEFORE APPLYING POWER.

Verify that the power cord is correctly connected to the mainframe.

SAFETY SYMBOLS.



Instruction manual symbol: the product will be marked with this symbol when it is necessary for the user to refer to the instruction manual (refer to Table of Contents) .



Indicates hazardous voltages.

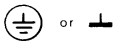

Indicate earth (ground) terminal.

WARNING

The WARNING sign denotes a hazard. It calls attention to a procedure, practice, or the like, which, if not correctly performed or adhered to, could result in personal injury. Do not proceed beyond a WARNING sign until the indicated conditions are fully understood and met.

CAUTION

The CAUTION sign denotes a hazard. It calls attention to an operating procedure, or the like, which, if not correctly performed or adhered to, could result in damage to or destruction of part or all of the product. Do not proceed beyond a CAUTION sign until the indicated conditions are fully understood and met.

Mainframes that appear damaged or defective should be made inoperative and secured against unintended operation until they can be repaired by qualified service personnel.

Printing History

The current edition of this guide is indicated below. Reprints of this guide containing minor corrections and updates may have the same printing date. New editions are identified by a new printing date and, in some cases, by a new part number. A new edition incorporates all new or corrected material since the previous edition. Changes to the guide occurring between editions are covered by change sheets shipped with this guide.

Edition 1 . . . November, 1992
Updated June, 2000
Updated April, 2001
Edition 2 . . . December, 2014

© Copyright 1992, 2000, 2014 Keysight Technologies

This document contains proprietary information protected by copyright. All rights are reserved. No part of this document may be photocopied, reproduced, or translated into another language without prior consent of Keysight Technologies. The information contained in this document is subject to change without notice.

Table of Contents

Overview.....	7
About This Manual	7
Related Documents	8
Revisions and Updates.....	8
Manual	8
Firmware.....	8
Safety Considerations	8
Electrostatic Discharge	9
Service Tools and Equipment	9
Verification.....	11
Preliminary Checkout	11
POWER-ON Checkout	12
Selftest Sequence	12
In Case of Trouble	12
Output Checkout	14
In Case of Trouble	14
Problem Not Identified	14
Disassembly	15
Disassembly Procedures	15
Removing the Modules and Module Connectors	15
Removing the Cover	15
Removing the Front Frame	15
Removing the Front Bezels and Keyboard Plug	16
Removing the Rear Subchassis	16
Removing the Pc Boards.....	16
Reassembly Procedures	17
Installing the Pc Boards	17
Assembling the Rear Subchassis.....	18
Assembling the Keyboard Plug and Front Bezels.....	18
Assembling the Front Frame	18
Assembling the Cover	19
Troubleshooting	21
Troubleshooting Sequence.....	21
Accessing the Flowcharts.....	21
If You Experienced a Selftest Failure	21
If You Experienced Other Problems With the Mainframe.....	22
Troubleshooting Flowcharts	22
Replacement Parts	33
Diagrams.....	39
Test Point and Component Location Diagram.....	39
Main Board Schematics	39
Sheet 1 Circuit Functions	39

Sheet 2 Circuit Functions	39
Sheet 3 Circuit Functions	40
Backplane Board Schematic	40
Exploded View Diagram.....	40
Schematic Notes	41
Manual Backdating	49
Index	51

Overview

About This Manual

This manual is a complete guide for servicing the Keysight 66000A Modular Power System (MPS) Mainframe. Troubleshooting information for the Keysight 661xxA MPS Power Modules is provided in the module service manual (see "Related Documents"), which should be used with this manual.

Note Troubleshooting the Keysight 66000A MPS Mainframe requires the use of one working Keysight 661xxA MPS Power Module.

This manual is organized into the following major sections:

- **Overview** discusses safety and equipment considerations to be aware of when troubleshooting. It also lists the tools and equipment required for troubleshooting.
- **Verification** consists of a series of tests that are used to help isolate a fault. It includes the selftest sequence that runs automatically at power-on and verifies the integrity of the microprocessor, the GPIB and serial interfaces, and the memory.
- **Disassembly** procedures are used to disassemble the instrument for repair.
- **Troubleshooting** procedures systematically verify selected circuits to isolate the cause of a problem. Suggestions for remedying the problem are also provided. Troubleshooting procedures are provided for the following circuits:
 - Bias Supplies.
 - Microprocessor.
 - RAM and ROM Memory.
 - GPIB and Serial Interfaces.
 - Discrete Fault Indicator/Remote Inhibit (DFI/RI) Circuitry.
 - Trigger Circuits.
 - Power Module Communication.
 - Keyboard Accessory Port.
- Replacement Parts lists part numbers for electrical components and miscellaneous chassis parts.
- Schematics and component location diagrams are provided as an aid in troubleshooting and repair.

Related Documents

The following documents are related to this manual:

Manual	Part Number	Description
Keysight 66000A MPS Mainframe Installation Guide	66000-90001	Provides product specifications, installation, and connection information.
Keysight Series 661xxA MPS Power Modules User's Guide	5959-3386	Describes the operation of the MPS Power Modules.
Keysight Series 661xxA MPS Power Modules Programming Guide	5959-3362	Describes SCPI programming commands, status reporting.
Keysight Series 661xxA MPS Power Modules Service Manual	5959-3364	Provides replaceable-parts lists, circuit diagrams, and verification procedures for the Keysight Series 661xxA MPS Power Modules.

Revisions and Updates

Manual

Keysight Technologies instruments are identified by a 10-digit serial number. The format is described as follows: first two letters indicate the country of manufacture. The next four digits are a code that identify either the date of manufacture or of a significant design change. The last four digits are a sequential number assigned to each instrument.

Item	Description
------	-------------

US	The first two letters indicates the country of manufacture, where US = USA; MY = Malaysia; SG = Singapore.
----	--

3648	This is a code that identifies either the date of manufacture or the date of a significant design change.
------	---

0101	The last four digits are a unique number assigned to each mainframe.
------	--

If changes have been made to your unit since the publication of this manual, a yellow Manual Change sheet may be supplied with the manual. It defines the differences between your unit and the unit described in this manual. The yellow change sheet may also contain information for correcting errors in the manual. Note that because not all changes to the product require changes to the manual, there may be no update information required for your unit.

Older serial number formats used with these instruments had a two-part serial number, i.e. 2701A-00101. This manual also applies to instruments with these older serial number formats. Refer to Manual Backdating for backdating information.

Firmware

This manual applies to mainframes that run on software revisions A.00.01 and up. The mainframe ROM chip has a label that specifies the firmware revision.

Safety Considerations

The Keysight 66000A MPS Mainframe is a Safety Class 1 instrument that has a protective earth terminal. Refer to the Safety Summary page at the beginning of this manual for general safety procedures and the meaning of safety symbols appearing in the manual and on the mainframe.

Electrostatic Discharge

CAUTION

The Modular Power System has components that can be damaged by ESD (electrostatic discharge). Failure to observe standard anti-static practices can result in serious degradation of performance even when complete failure does not occur.

When working on the Modular Power System, observe all anti-static work practices. This includes, but is not limited to:

- Working at a static-free station, such as a table covered with static-dissipative laminate or with a conductive table mat (Keysight P/N 9300-0797).
- Using a conductive wrist strap (Keysight P/N 9300-0969 or 9300-0970).
- Grounding all metal equipment at the station to a single, common ground.
- Connecting low-impedance test equipment to static sensitive components only when those components have power applied to them.
- Removing power from the Modular Power System before removing or installing printed circuit boards.

Service Tools and Equipment

The following tools are required to repair the Keysight 66000A MPS Mainframe:

- T15 and T25 TORX drivers.
- 10mm and 7mm HEX NUT drivers.
- #2 POZI driver.
- Slot-head screwdrivers - small and medium.
- DIP component removal tool.
- Soldering iron and solder.
- De-solder removal tool.
- Needle-nose pliers.
- Anti-static work mat and wrist strap.

The following equipment is required to troubleshoot the Keysight 66000A MPS Mainframe:

Table 1-1. Service Test Equipment

Instrument Required	Critical Specifications	Recommended Model	Use ¹
Power Cords (see Figure 1-1)	Option #831	P/N 8120-5573	V,T
	Option #833	P/N 8120-5568	
	Option #834	P/N 8120-5566	
	Option #841	P/N 8120-5572	
	Option #843	P/N 8120-5571	
	Option #845	P/N 8120-5570	
	Option #846	P/N 8120-5565	
	Option #847	P/N 8120-5567	
	Option #848	P/N 8120-5569	
	Test Cable	BNC (male) to BNC (male)	
Mini-Grappier clip leads	Wire Size: 24 AWG	P/N 8120-3326 or 8120-3327	V,T
DFI RI connector	Type: Terminal Block 4-pos. (supplied with mainframe)	P/N 1252-1488	V,T

Table 1-1. Service Test Equipment (continued)

Instrument Required	Critical Specifications	Recommended Model	Use¹
MPS Power Module DMM Logic Probe Oscilloscope MPS Keyboard ² Isolation transformer	Bandwidth: 100 MHz	Keysight 661xxA Series Keysight 34401A or equivalent Keysight 545A or equivalent Keysight 54504A or equivalent Keysight 66001A	V,T T T T V T

1 V = Verification; T = Troubleshooting.

2 Use of the keyboard is recommended for displaying selftest error messages.

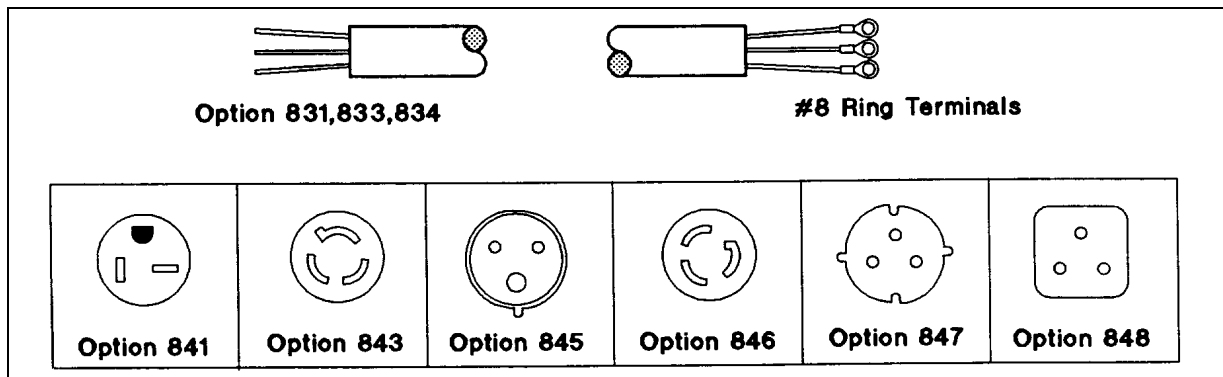

Figure 1-1. Power Cords

Verification

Operation verification of the Keysight 66000A MPS Mainframe consists of performing the procedure that is located in this section. This procedure verifies that the mainframe is performing properly without testing all specified parameters. The tests include a preliminary checkout, power-on selftest, and module communication.

Preliminary Checkout

1. Make sure that the front power switch is off **(0)**.
2. Look at the "Line Rating" chart on the rear of the mainframe.
 - a. Verify the modules are set to the appropriate line voltage setting. Line selector switches are located on the bottom of the modules.

Note At least one module is required to verify the operation of the mainframe.

- b. Remove the fuse and verify that the fuse is as specified on the label.
 - c. Install the module(s).
3. Make sure that the power cord is connected to the terminal block in accordance with the prevailing color code.

CAUTION

Connection of this instrument to an ac power source should be done only by qualified personnel.

Power Cord Wire Color Codes

Label	UL/CSA Cords	Harmonized Cordage
Line "L"	Black	Brown
Neutral "N"	White	Blue
Ground 	Green or Green with Yellow stripe	Green with Yellow stripe

4. Make sure that there is no load connected to the output connector by removing the output connector assembly.
5. Verify that the GPIB address switch is set to the desired address (0 - 31).

POWER-ON Checkout

1. Connect the instrument to the power source and turn the front power switch to ON (1).
2. Listen to confirm the modules' fans are on.

The power supply undergoes a selftest when you turn it on. The power-on selftest sequence tests the microprocessor, GPIB interface, and serial communications.

Selftest Sequence

3. All display digits and annunciators on the keyboard briefly turn on.
4. All front panel LEDs and annunciators on the modules briefly turn on.
5. The keyboard briefly displays the message:

```
Subaddr Instr
Frame 0, GPIB Addr 5

Shift          Unr Dis Prot Err Cal Rmt Lsn Tlk SRQ
```

6. The keyboard then displays the state of the addressed module.

```
Subaddr Instr
00      --      0.001V      0.000A      MODE:  --  --

Shift          Unr Dis Prot Err Cal Rmt Lsn Tlk SRQ
```

Note

The information displayed on the keyboard assumes:

- At least one power module is installed,
- Factory default state still stored in location 0,
- Frame mode switch on the back of the mainframe is set to **MAIN**,
- GPIB address of the mainframe is set to 5,
- Module configuration switches set to factory default states (all OPEN).

In Case of Trouble

Note

In case of a module failure, the front panel will display an Error Code -Uxx. Refer to the *Keysight Series 661xxA Service Manual* for information on troubleshooting the dc power modules.

A problem exists in the mainframe when one of these conditions is observed during selftest:

Table 2-1. Problem Symptoms

Symptoms	Probable Cause	Troubleshooting Procedure¹
Keyboard and modules remain turned off (fans not ON)	Input Line Voltage, check fuse F8	<i>Bias Troubleshooting</i>
Module fans turn ON, front displays remain blank (Turned OFF)	No bias voltages, check fuses F1 & F2	<i>Bias Troubleshooting</i>
Modules remain OFF, keyboard displays blinking cursor	Primary Microprocessor (U44) defective, check fuse F1	<i>ROM & Microprocessor Troubleshooting</i>
Keyboard displays Self-test Failed, ROM Checksum Test	ROM (U51) defective	<i>ROM & Microprocessor Troubleshooting</i>
Keyboard displays Self-test Failed, Internal RAM Test	Primary Microprocessor (U44) defective	<i>ROM & Microprocessor Troubleshooting</i>
Keyboard displays Self-test Failed, External RAM Test	RAM (U52) defective	<i>ROM & Microprocessor Troubleshooting</i>
Keyboard displays Self-test Failed, GPIB Test	GPIB Controller (U17) defective	<i>Overall Troubleshooting</i>
Keyboard displays Self-test Failed, Serial Comm Test	DUART (U91) defective	<i>Overall Troubleshooting</i>
Keyboard displays NO MODULES INSTALLED	Backplane power-up or communication defective	<i>Overall Troubleshooting²</i>
Keyboard displays MODULE NOT FUNCTIONING	Module defective or backplane communication defective	<i>Overall Troubleshooting</i>

¹ Refer to Chapter 4 of this manual for detailed troubleshooting procedures.

² Assumes that at least one module has been installed and is connected to the mainframe backplane.

Output Checkout

1. Make sure that there is no load connected to the output connector by removing the output connector assembly.
2. Check the basic voltage functions and module communications as shown in following table:

Action	Keyboard Display	Explanation
Press * R ▼ Enter	*RST	Resets the Modular Power System
Press 0 1 Enter	:OUTP ON	Enables the output
Press C ▼ 1 Enter	:CURR 1	Sets the output current to 1 A
Press V 5 Enter	:VOLT 5	Sets the output voltage to 5 V

3. The keyboard display should now be in meter mode indicating the voltage and status of the dc power module:

WARNING

Disable the output prior to connecting a load.

Press **0** **0** **Enter**

In Case of Trouble

If the keyboard and module displays do not read the correct voltage, check the operation of the module. Refer to the "Performance Measurement" section of the Keysight *Series 661xxA Power Modules Service Manual*.

Problem Not Identified

If after performing the checkout procedures you were unable to isolate the problem, refer to the "Overall Troubleshooting" procedure in Chapter 4. The overall troubleshooting procedure will verify whether the mainframe is at fault and will isolate the problem to a functional block.

Disassembly

This chapter provides disassembly and reassembly instructions for the Keysight 66000A MPS Mainframe. Refer to Chapter 6 for an exploded view diagram of the mainframe. Major mechanical components are identified with "MP" designations and are referenced in this section. Refer to Chapter 5 for the component descriptions. Refer to Chapter 1 for the tools required to disassemble and reassemble the unit.

Disassembly Procedures

WARNING

SHOCK HAZARD To avoid the possibility of personal injury, remove the mainframe from operation before removing the top cover. Turn off ac power and disconnect the line cord, GPIB cable, and load leads before attempting any disassembly.

When servicing the Main assembly and Backplane assembly, ac line voltages are present on the Main board and backplane connectors.

CAUTION

Most of the attaching hardware is metric. Use of other types of fasteners will damage threaded inserts.

Removing the Modules and Module Connectors

Before you can disassemble the mainframe, you must first remove all of the power supply modules as well as the module connectors on the back of the mainframe.

1. Use the slot-head screwdriver and release the pull tab at the front of each module.
2. Pull all of the modules out of the mainframe.
3. Use the Pozi driver and disconnect all of the module connectors from the back of the mainframe.

Removing the Cover

1. Use the T25 driver and remove the four screws that attach the handles (MP22) to the chassis .
2. Slide the cover (MP6) back, spread the sides slightly, and lift the cover up.
3. Lift the top tray (MP3) out of the chassis.

Removing the Front Frame

The cover must be removed from the unit before you can remove the front frame.

1. Use the T15 driver and remove the four screws that attach the front frame (MP18) to the chassis.
2. Slide the front frame forward about two inches.
3. Carefully unplug the cable (MP23) from the keyboard plug.

Removing the Front Bezels and Keyboard Plug

The front frame must be removed from the chassis before you can remove the bezel pieces (MP11-12).

Note	The keyboard plug (A3) can only be removed from the front frame after the bottom bezel (MP11) has been removed.
-------------	---

1. Insert the slot-head screwdriver into the notch at the bottom of each side bezel (MP12) to remove the bezels.
2. While applying upward pressure with the screwdriver to clear the latch, pull the side bezel away from the frame. When the latch clears the bottom bezel (MP11), the side bezel will come right out.
3. Repeat this procedure for the other side bezel.
4. When the side bezels have been removed, simply grasp the top (MP10) or bottom bezel (MP11) at either end and pull the bezels away from the frame. The bezels will snap out of the front frame.
5. Use the T15 driver to remove the two screws that attach the keyboard plug (A3).

Removing the Rear Subchassis

The cover must be removed from the unit before you can remove the rear subchassis (MP4).

1. Use the T15 driver and remove the six screws (three on each side) that attach the rear subchassis (MP4) to the chassis.
2. Slide the subchassis backward about three inches.
3. Carefully unplug the keyboard cable assembly (MP23) from the subchassis.
4. Grasp the on/off pushrod (MP13) firmly and unsnap it from the switch located inside the subchassis. Pull the pushrod straight back from the subchassis to unsnap it.
5. Remove the rear subchassis from the chassis.

Removing the PC Boards

The rear subchassis must be removed from the unit before you can remove the pc boards (A1, A2).

CAUTION	Observe all standard anti-static procedures when removing the pc boards from the subchassis (see Chapter 1).
----------------	--

1. Use the Pozi driver and remove the line cord from the unit. Note the color code and location of each wire on the terminal block before removing the cord.
2. Use the T15 driver and remove the four screws (two on the front and two on the back) that attach the backplane cover (MP5) to the subchassis (MP4).
3. Pull the bottom edge of the cover out slightly so that it clears the alignment pins and lift the cover straight up.
4. Grasp the Backplane board (A2) firmly and lift it straight out of its plug-in sockets.
5. Check to make sure that the FLT/INH connector is unplugged from the back of the unit.
6. Use the 7mm hex driver and remove the two nuts that connect the GPIB connector to the rear panel.
7. Use the 10mm hex driver and remove the nut that connects the ground wire to the rear panel.
8. Use the T15 driver and remove the three screws that attach the Main board (A1) to the subchassis (MP4).
9. Carefully lift up the pc board and remove it from the subchassis.

Reassembly Procedures

CAUTION

Most of the attaching hardware is metric. Use of other types of fasteners will damage threaded inserts.

Installing the PC Boards

1. Align the connectors on the Main board (A1) with the cutouts in the rear panel and carefully install the board in the subchassis (MP4).
2. Make sure the Main board is fully inserted in the notches along the edge of the subchassis.
3. Use the T15 driver and install the three screws that attach the Main board to the subchassis .
4. Use the 7mm hex driver and install the two flat washers, split washers, and nuts that fasten the GPIB connector to the rear panel.
5. Install the Backplane board (A2) into the connectors on the Main board.
6. Connect the ground hardware to the chassis in the following order:
 - a. lock washer.
 - b. ground wire.
 - c. lock washer.
 - d. nut.
7. Use the 10mm hex driver and tighten the grounding nut.
8. Align the slots in the backplane cover (MP5) with the notches on the Backplane board (A2) and snap the cover into place. Use the slot-head screwdriver to align the board in the slots.

9. Make sure that the pins on the bottom of the cover are in their holes and that the cover is flush against the subchassis.
10. Use the T15 driver and install the four screws (two on the front and two on the back) that attach the backplane cover to the subchassis.

Assembling the Rear Subchassis

1. Slide the rear subchassis (MP4) under the sides of the chassis but don't push it all the way in yet; leave about two inches of space.
2. Connect the keyboard cable (MP23) to the connector inside the subchassis.
3. Make sure that the on/off pushrod (MP13) and the chassis pins line up with the openings on the rear subchassis and slide the subchassis into place.
4. Use the T15 driver and install the six screws (three on each side) that attach the rear subchassis to the chassis. Don't tighten the screws until all six have been started.
5. Push the on/off pushrod (MP13) in from the front panel in until it snaps twice. The pushrod must snap twice to indicate that it is firmly connected to the switch inside the subchassis .

Assembling the Keyboard Plug and Front Bezels

1. Use the T15 driver to install the two screws that attach the keyboard plug (A3) in the second and third hole on the bottom right corner of the front frame (MP18) when viewed from the front. The bottom of the frame is thicker than the top.
2. Align the pins on the top and bottom bezels (MP10, MP11) with the corresponding holes on the frame and snap the bezels into place.
3. Check along the edges of the top and bottom bezels to make sure that they are snapped all the way into place.
4. Install the side bezels (MP 12) by inserting the top corner of each bezel first, then push the bottom corner toward the side of the frame until it snaps into place.

Assembling the Front Frame

1. Position the front frame (MP18) close to the front of the chassis. Insert the on/off pushrod (MP13) into its opening and connect the keyboard cable (MP23) to keyboard plug (A3).
2. Insert the sides of the chassis between the front frame (MP18) and the side bezels (MP12). Push the front frame onto the chassis as far it will go.
3. Use the T15 driver and install the four screws that attach the front frame to the chassis.
4. Look through the slots in the bottom tray and check that the keyboard cable (MP23) is positioned in the cable clamp. If not, insert the slot-head screwdriver through the slots in the bottom tray and slide the cable into the cable clamp. Don't force the tiwrap under the cable clamp; position the tiwrap in **front** of the cable clamp.

Assembling the Cover

1. Place the top tray (MP3) on the chassis with the vents toward the front of the unit.
2. Spread the sides of the cover (MP6) and slide it onto the chassis so that it fits into the slot behind the front panel assembly. Check that the cover is flush against the rear panel.
3. Use the T25 driver and install the four screws that attach the handles and the cover to the chassis.
4. Reattach the line cord if it has been removed from the unit using the Pozi driver. If necessary, refer to the *Mainframe Installation Guide* for more information.

Troubleshooting

This chapter provides troubleshooting and repair information for the Keysight 66000A MPS Mainframe. Before attempting to troubleshoot the mainframe, ensure that the problem is not with an external circuit or application, an MPS Power Module, the GPIB controller, the application program, or the input power line.

WARNING

SHOCK HAZARD Most of the troubleshooting procedures given in this chapter are performed with power applied and protective covers removed. Such maintenance should be performed only by service trained personnel who are aware of the hazards (for example, fire and electrical shock).

Troubleshooting Sequence

1. Verify that the Modular Power System mainframe is at fault.
2. Use the flowcharts to locate the mainframe functional block at fault.
3. Troubleshoot the functional block per flowchart instructions.

Troubleshooting tests built into firmware are provided to isolate a problem to one of the circuit boards or to a particular circuit on the board. Once a problem has been isolated to a particular circuit, suggestions are given as to what component may be at fault.

CAUTION

This instrument uses components that can be damaged or suffer serious performance degradation as a result of ESD (electrostatic discharge). Observe the standard anti-static precautions discussed in Chapter 1 to avoid damage to components.

Accessing the Flowcharts

If You Experienced a Selftest Failure

If you experienced a selftest failure as described in Chapter 2, Table 2-1, disassemble the pc boards and proceed directly to the flowchart indicated in the "Troubleshooting Procedure" columns of Table 2-1.

- Figure 4-1 - Overall Troubleshooting.
- Figure 4-2 - Bias Troubleshooting.
- Figure 4-3 - ROM & Microprocessor Troubleshooting.

If You Experienced Other Problems with the Mainframe

If you experienced problems other than a selftest failure with the mainframe, proceed directly to Figure 4-1- Overall Troubleshooting.

Troubleshooting Flowcharts

The following troubleshooting flowcharts are provided to help you identify and isolate a problem to a specific circuit on the Main (A1) board. Once a problem has been narrowed down to a specific circuit, suggestions are provided as to the components that may be responsible for the problem. Refer to the schematic diagrams for detailed information on circuit wiring and component function.

The overall troubleshooting flowchart (Figure 3-1) will identify most of the problems in the mainframe. The flowcharts of Figure 3-2 and Figure 3-3 will identify problems in the bias circuits and in the microprocessor circuits.

To aid in troubleshooting, the GPIB address switch (S7) can be set to run various test routines as described in the flowchart. Placing a jumper on test header J5 is also required to configure and run certain tests. You must provide jumper clips for test header J5.

Also, oscilloscope waveforms are provided on the flowchart along with the settings required to generate the waveforms.

WARNING

Connect the A1 board to ac mains through an isolation transformer when making measurements with an oscilloscope.

The Backplane (A2) board contains no active components. The schematic diagram provides point-to-point wiring information of the connectors on the Backplane board.

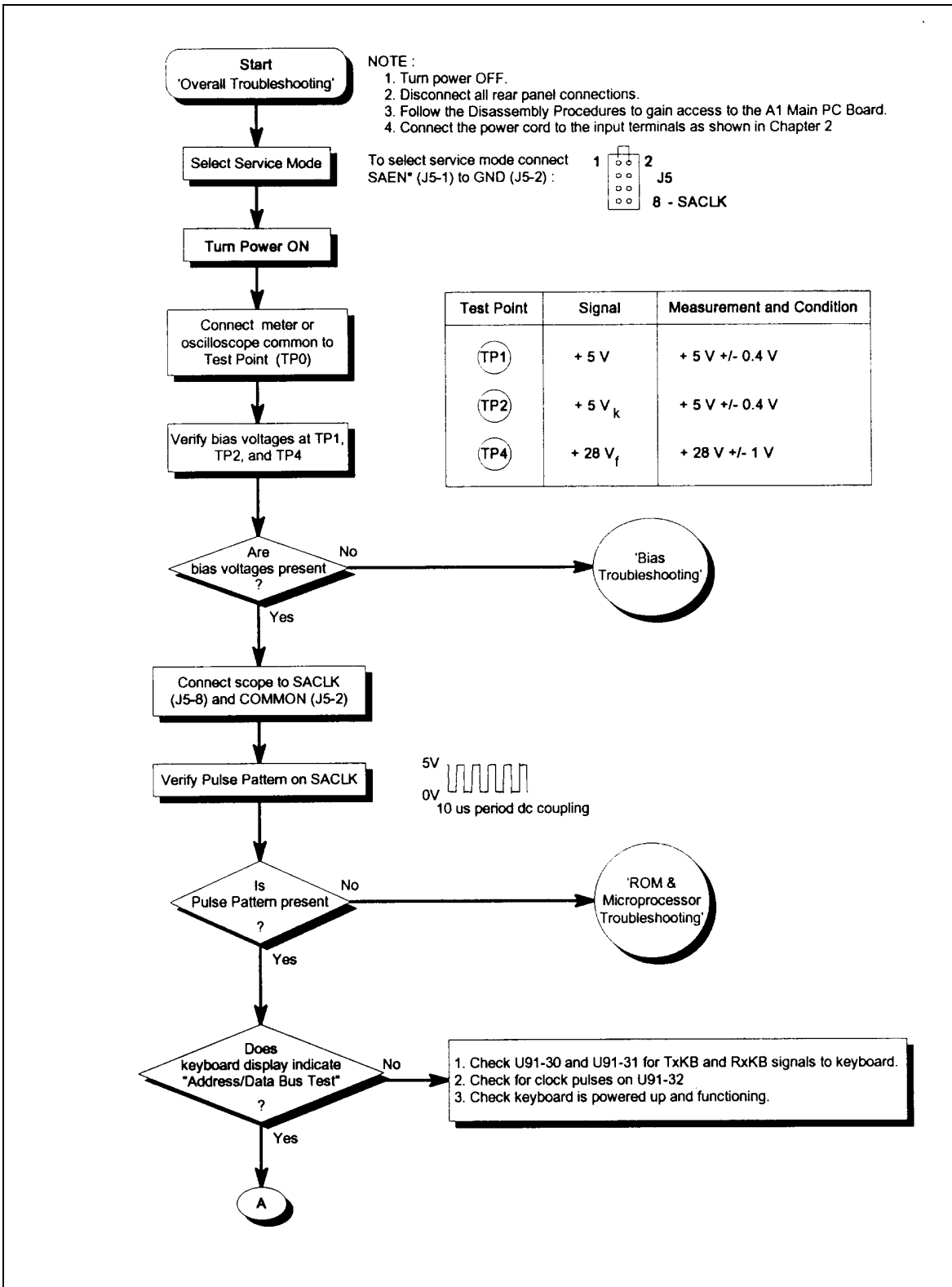

Figure 4-1. Overall Troubleshooting (Sheet 1 of 7)

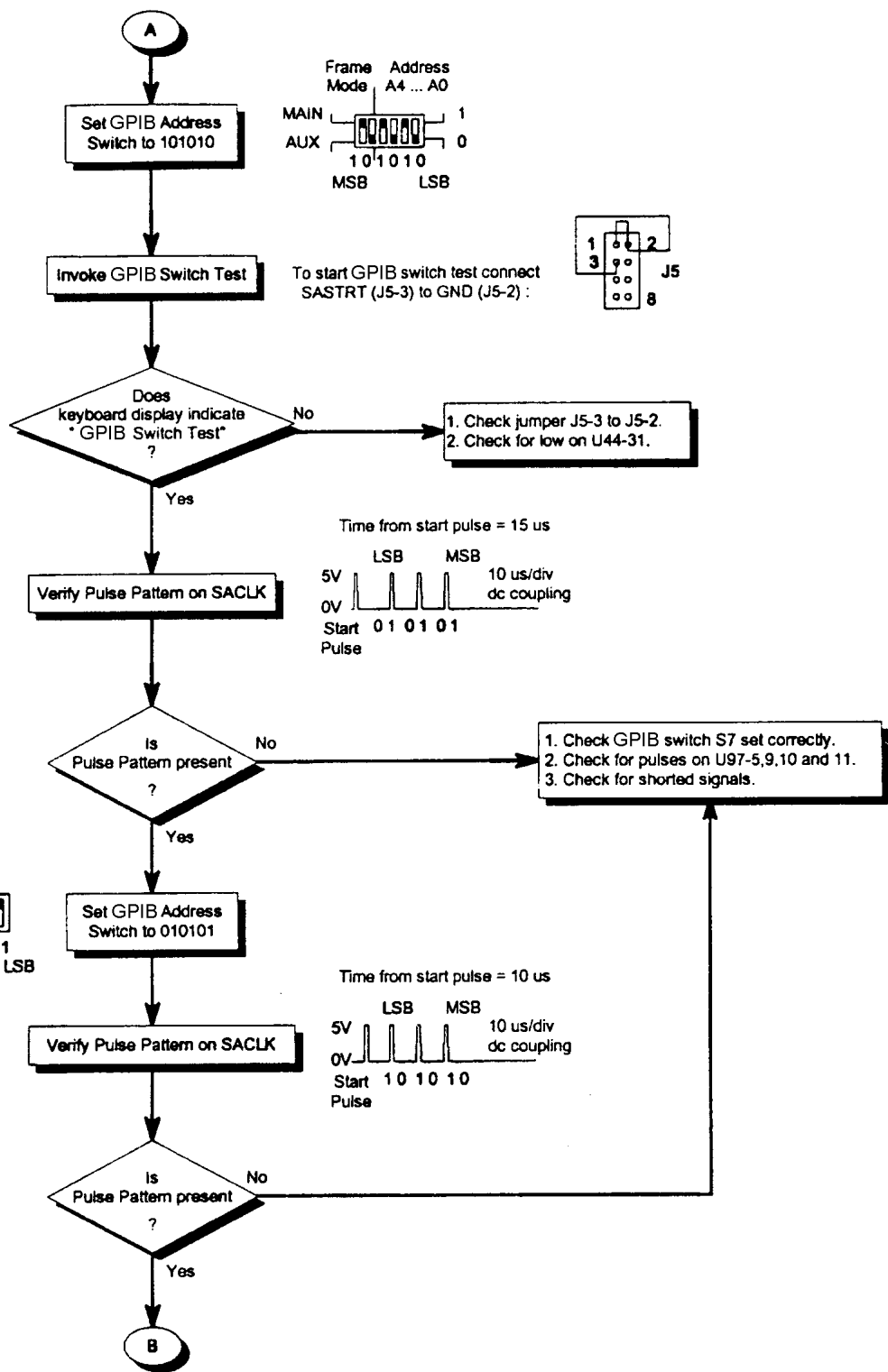

Figure 4-1. Overall Troubleshooting (Sheet 2 of 7)

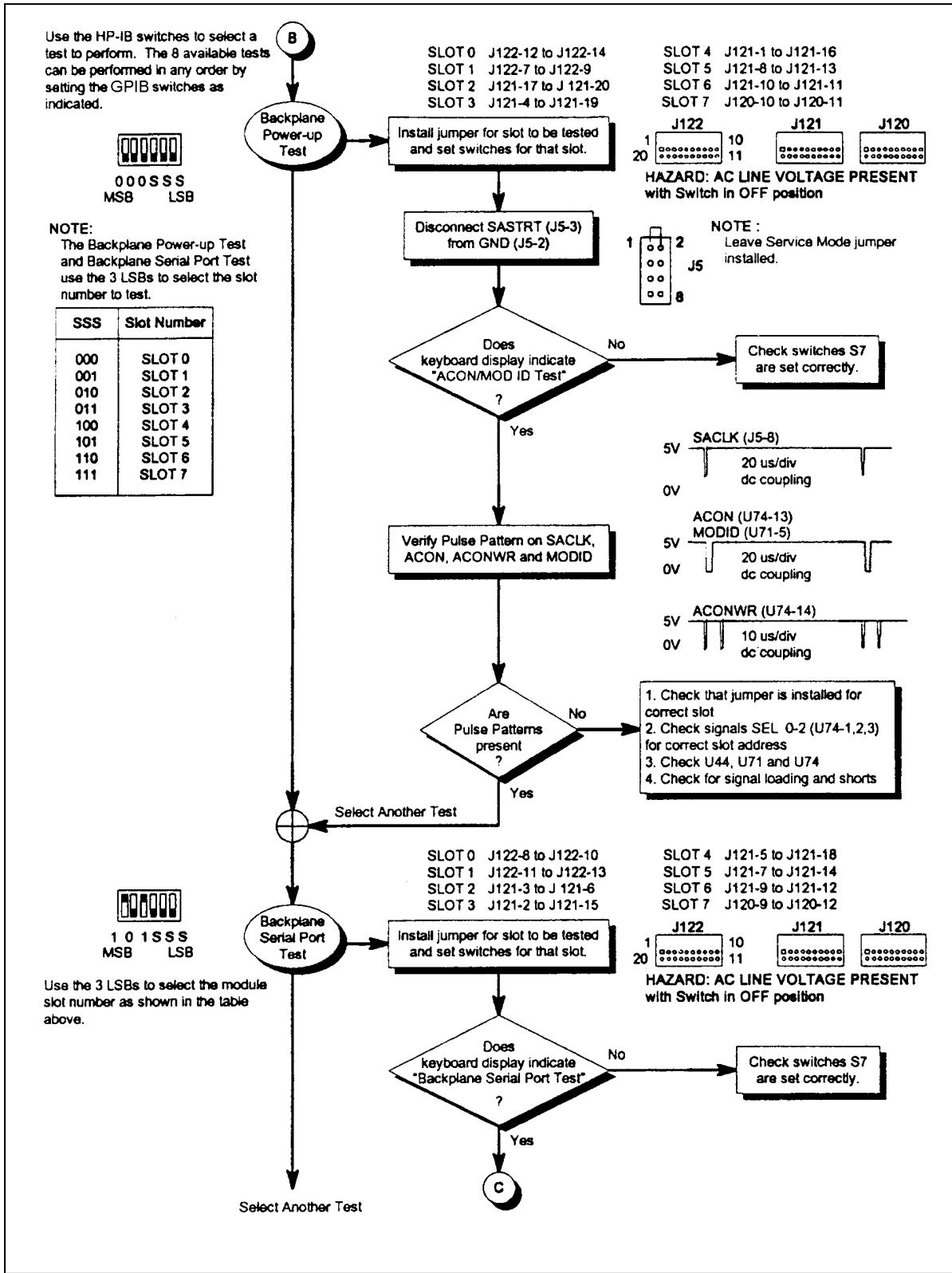

Figure 4-1. Overall Troubleshooting (Sheet 3 of 7)

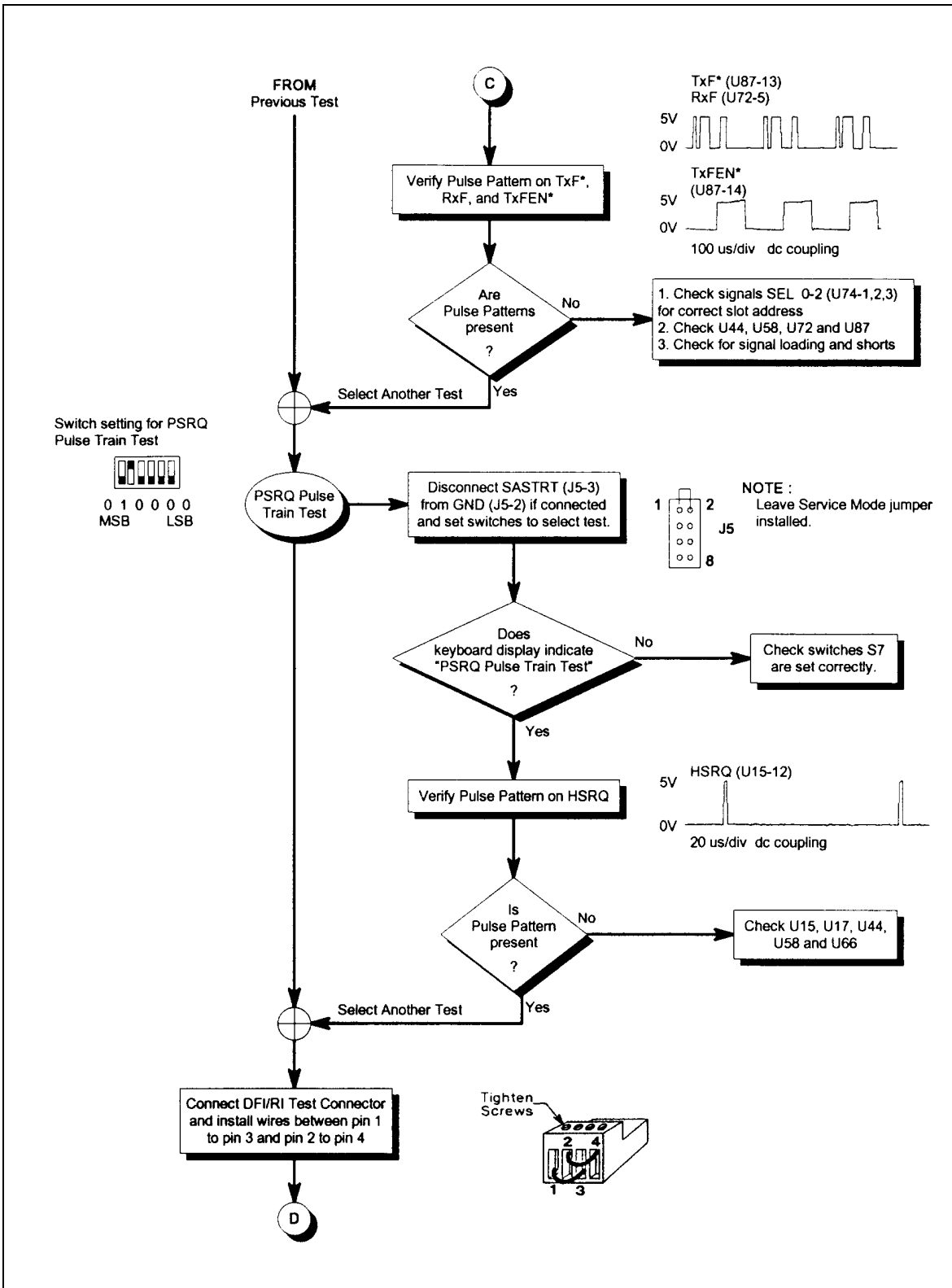

Figure 4-1. Overall Troubleshooting (Sheet 4 of 7)

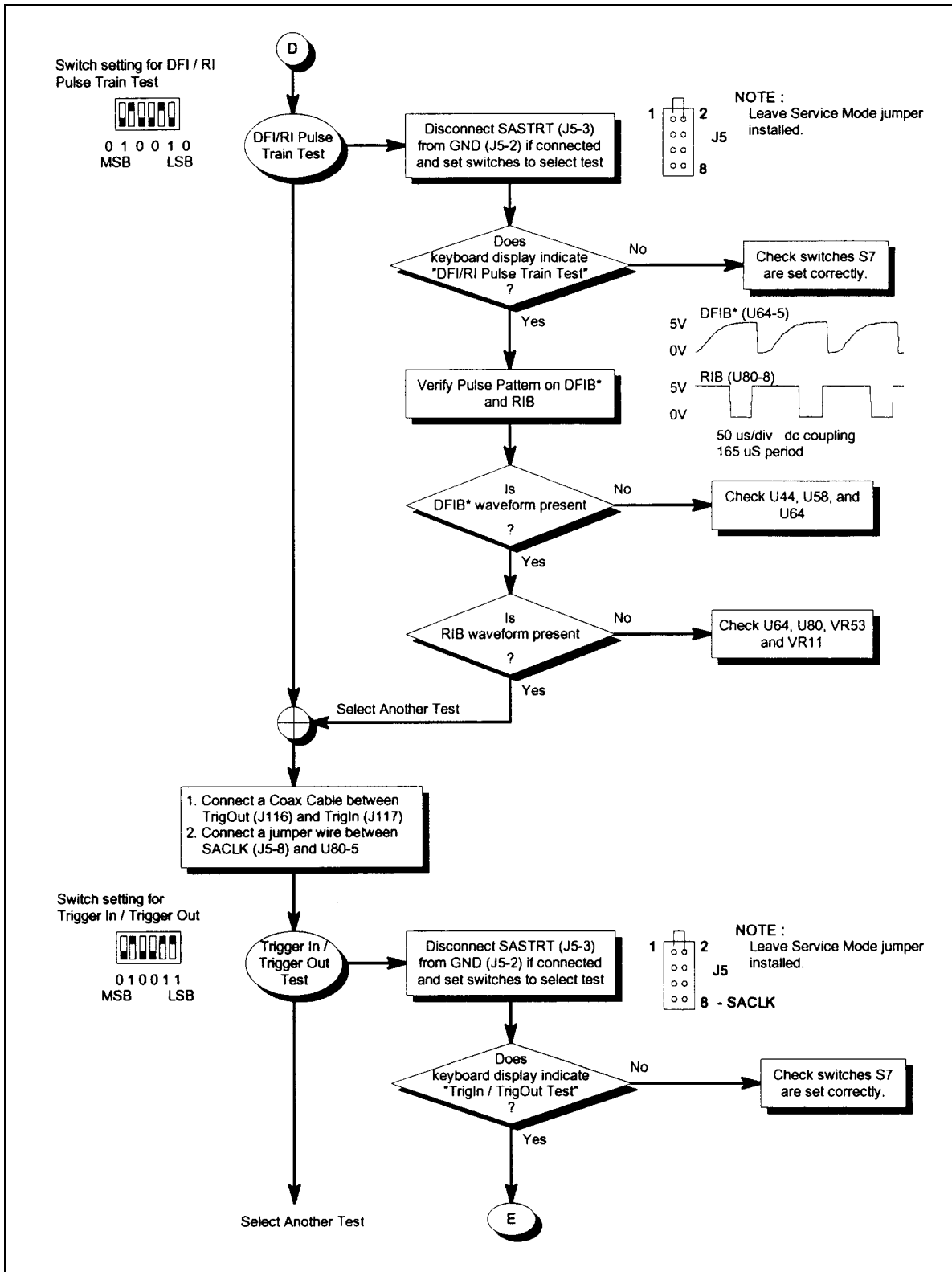

Figure 4-1. Overall Troubleshooting (Sheet 5 of 7)

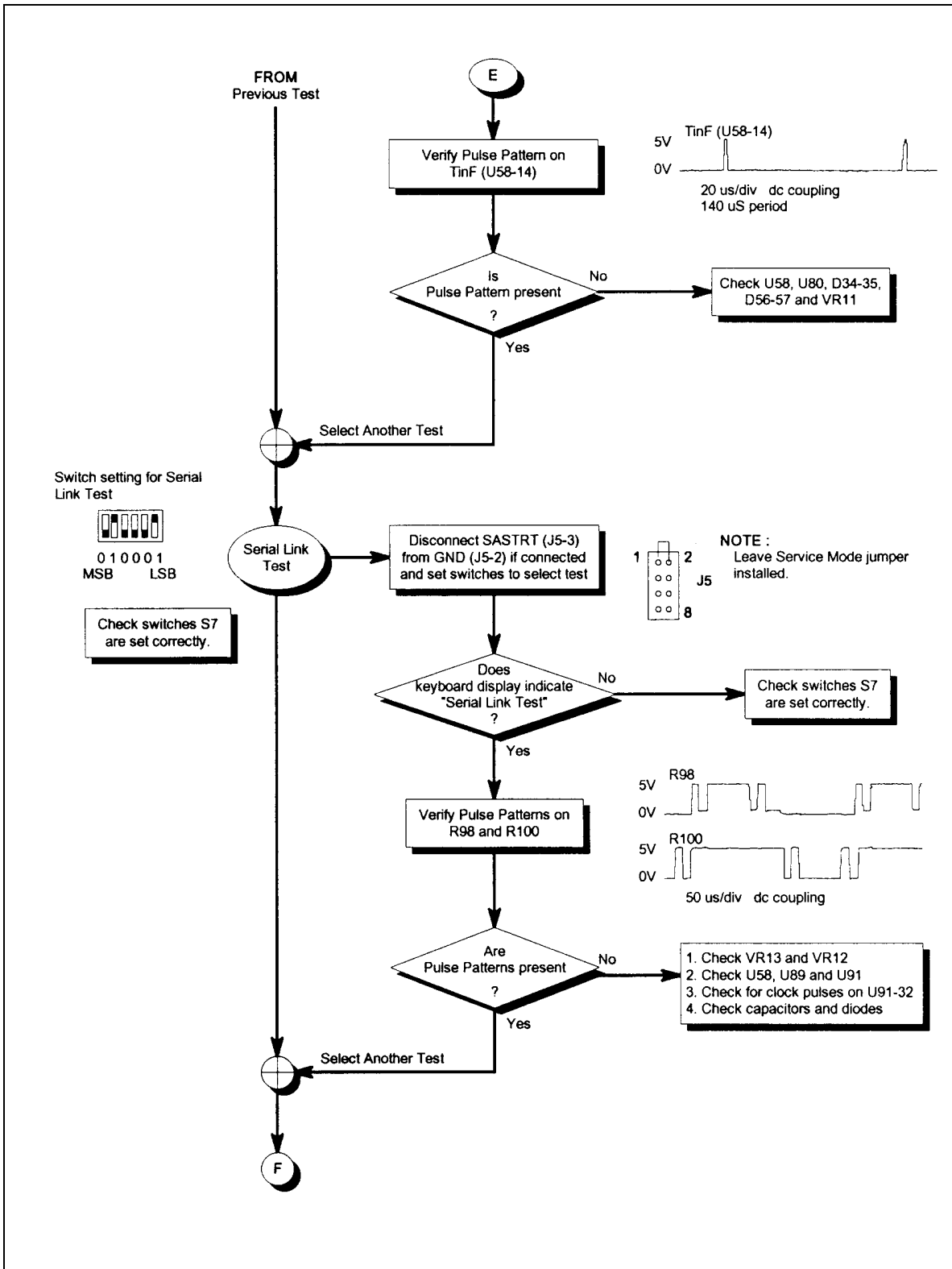

Figure 4-1. Overall Troubleshooting (Sheet 6 of 7)

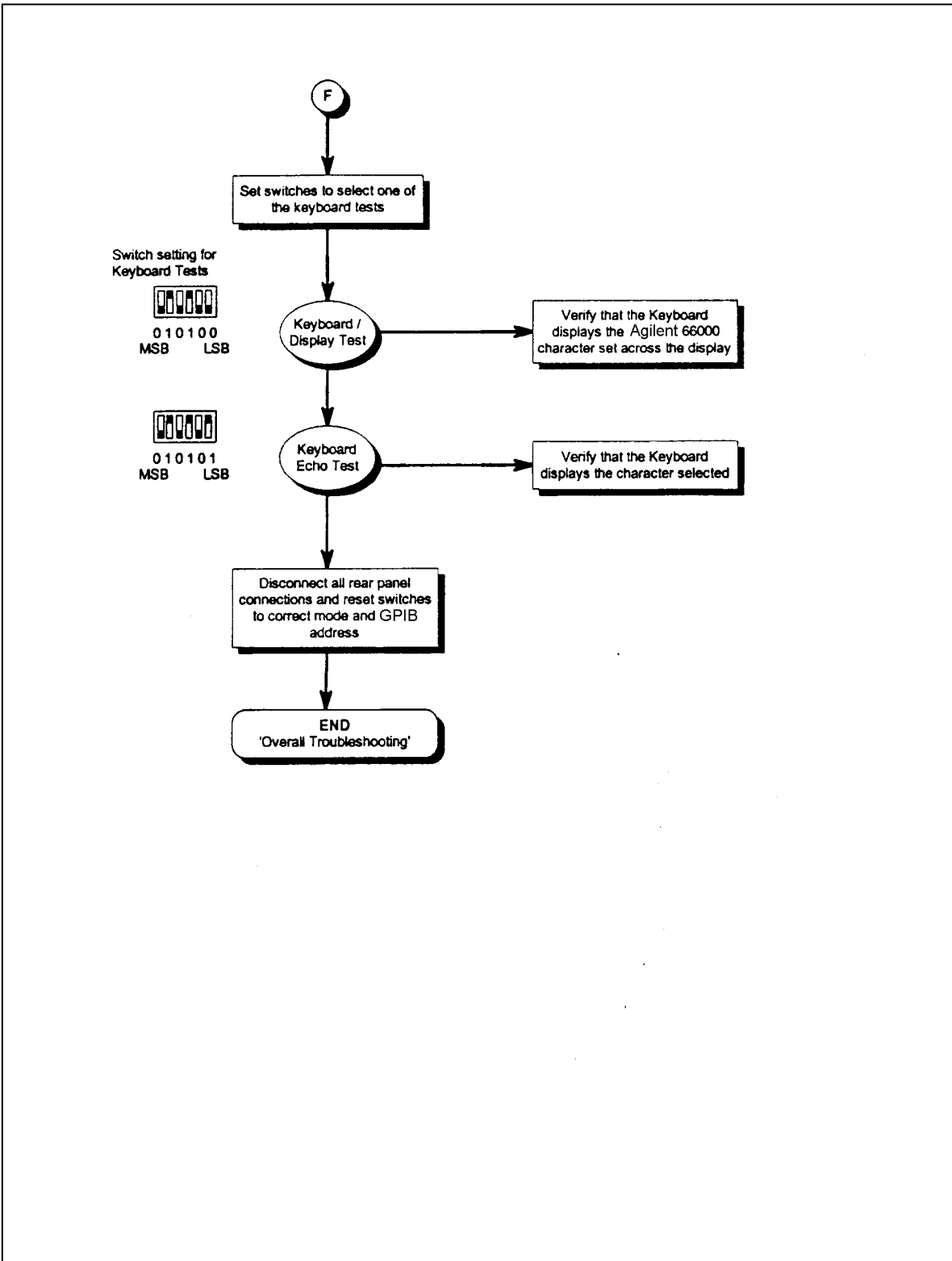

Figure 4-1. Overall Troubleshooting (Sheet 7 of 7)

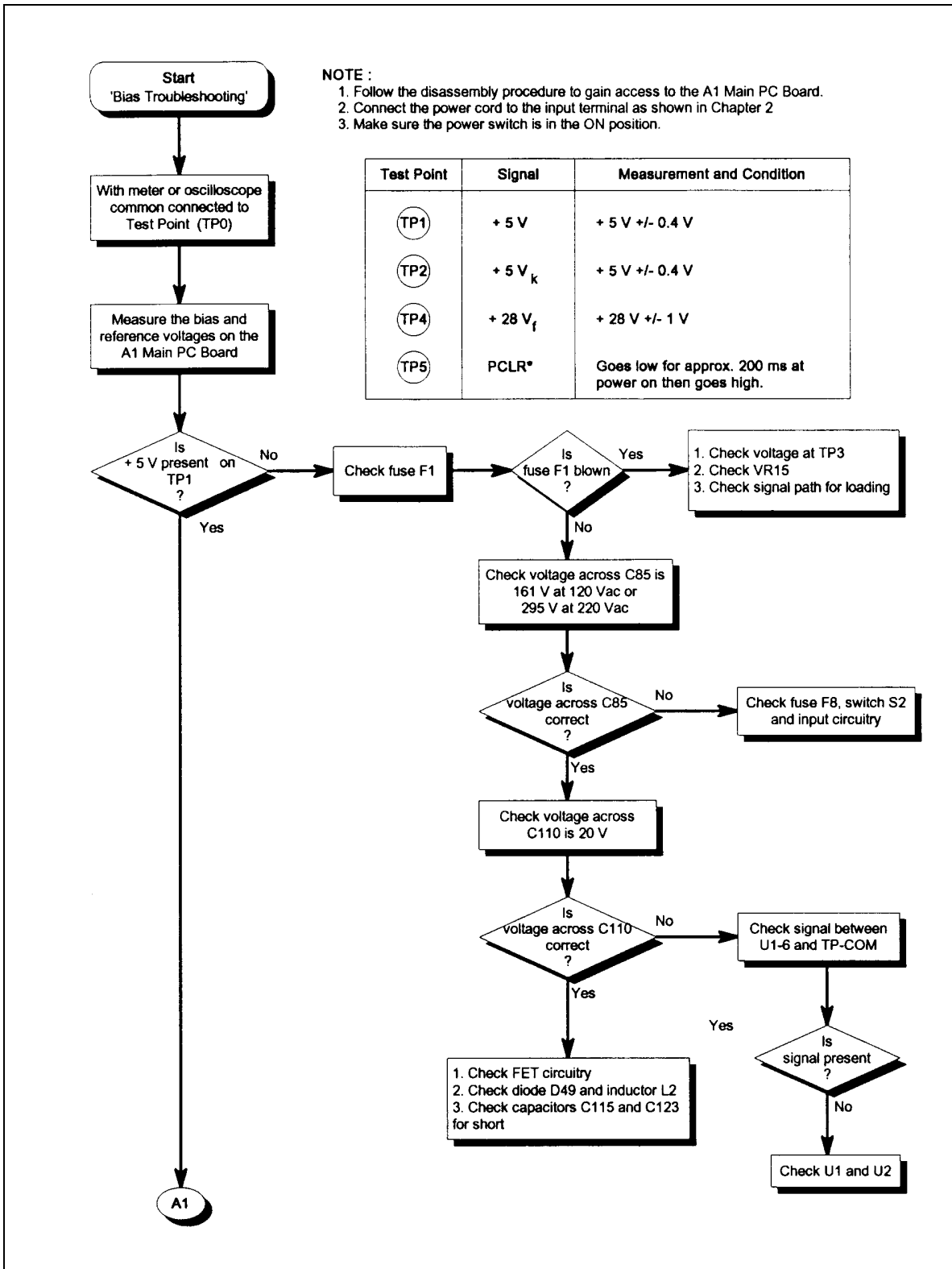

Figure 4-2. Bias Troubleshooting (Sheet 1 of 2)

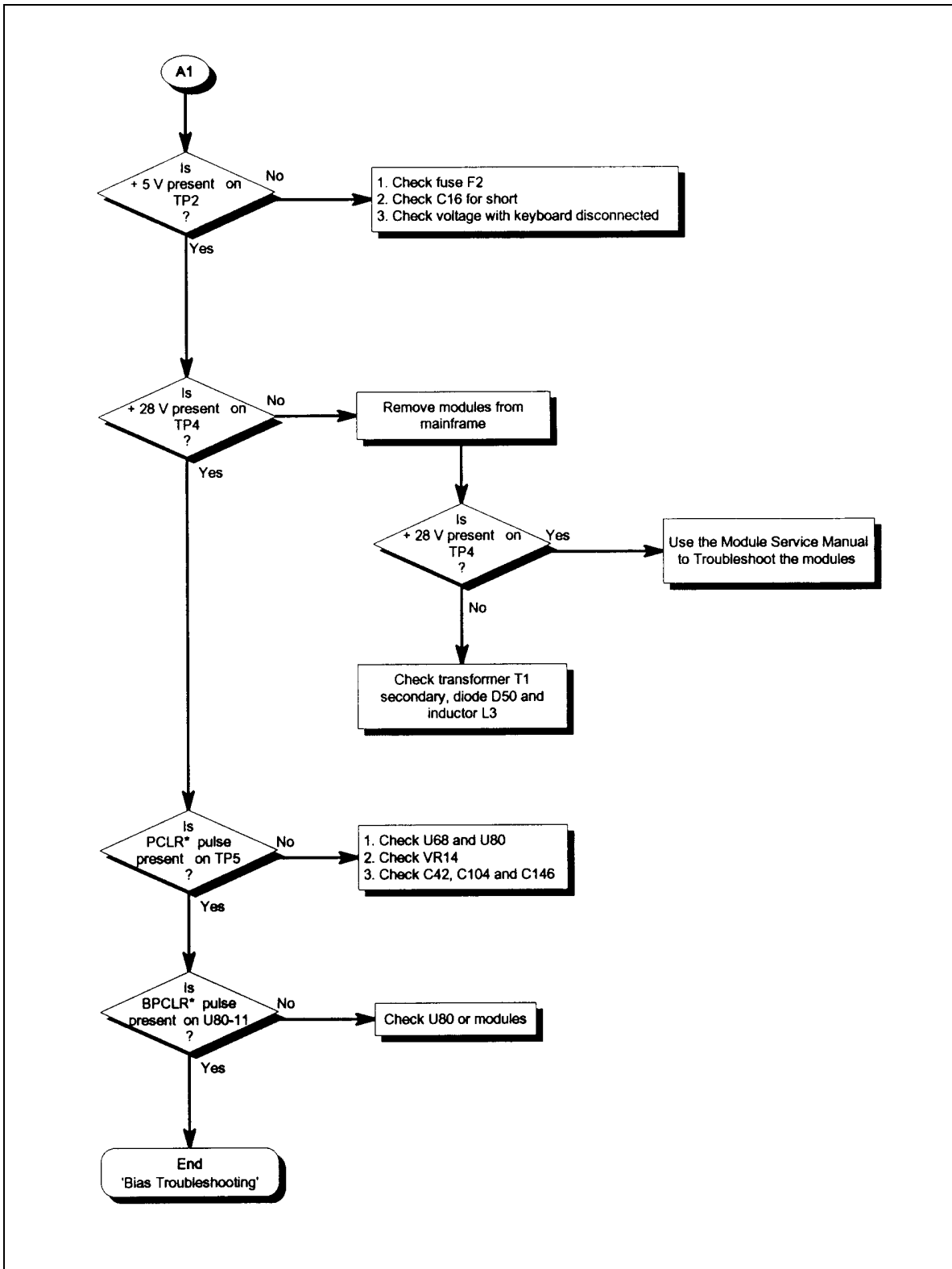

Figure 4-2. Bias Troubleshooting (Sheet 2 of 2)

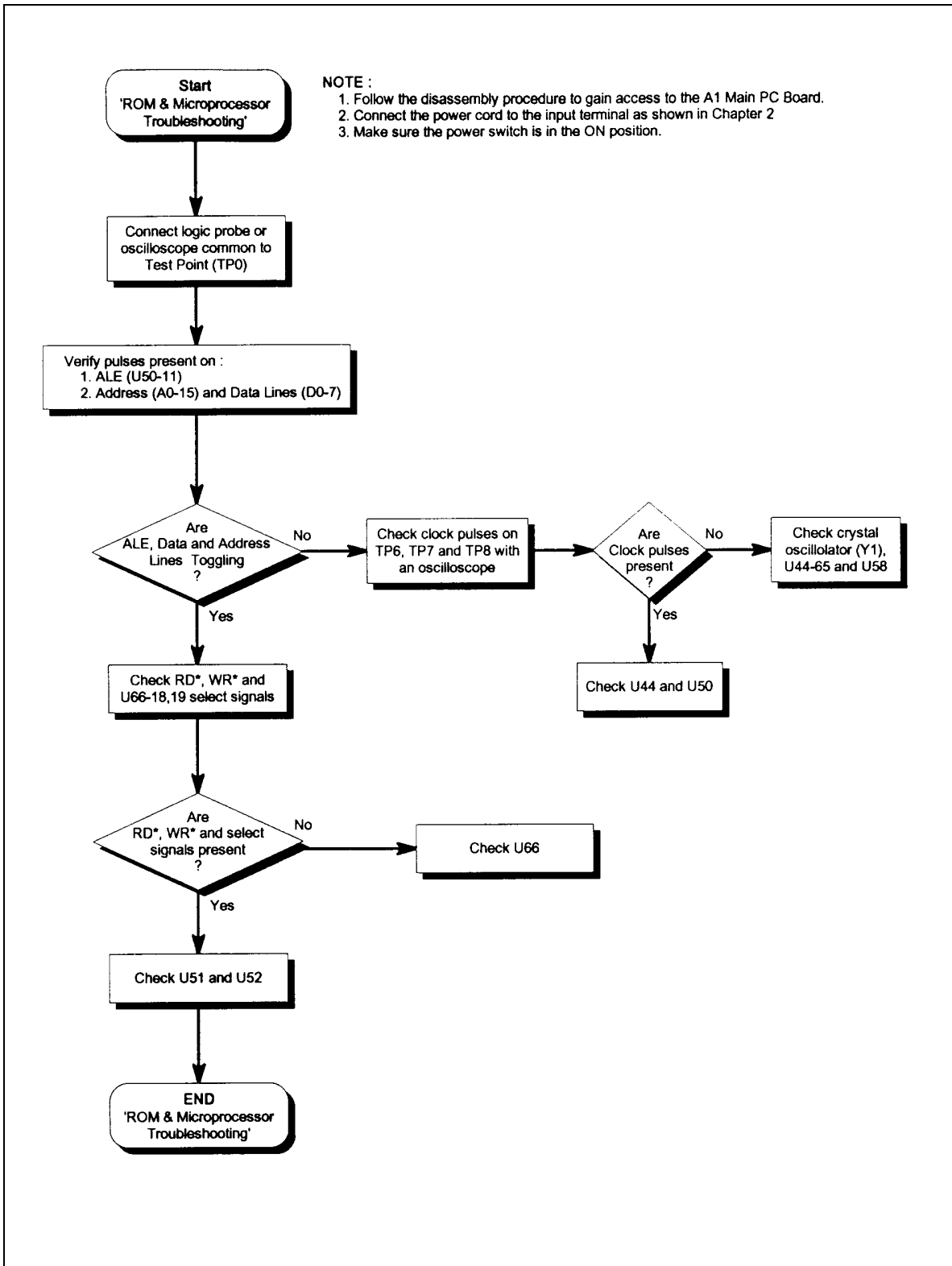

Figure 4-3. ROM & Microprocessor Troubleshooting

Replacement Parts

Table 5-1 lists the electrical components and Table 5-2 lists the mechanical components for the Keysight 66000A MPS Mainframe. These tables provide the following information:

- Reference designation.
- Keysight Technologies part number.
- Description of part.

You can order parts from your local Keysight Technologies sales office. A list of the regional sales offices is given at the back of this manual. When ordering parts, include the following information:

- Keysight Technologies part number.
- Description of the part.
- Quantity desired.
- MPS model number (Keysight 66000A).

The test point and locations diagram in Chapter 6 identifies the location of the electrical components on the Main board. The exploded view diagram in Chapter 6 identifies some of the major mechanical components of the mainframe and how they are assembled. Parts with "MP" designations identify components that are referenced in the parts list.

Table 5-1. Keysight 66000A MPS Mainframe Parts List - Electrical

Reference Designators	Part Number	Description
A1	66000-61020	ASSEMBLY-MAIN BOARD
C1,2	0160-2025	CAPACITOR-FXD 220pF ±5% 500V
C3	0160-4808	CAPACITOR-FXD 470pF ±5% 100V
C4	0160-4835	CAPACITOR-FXD 0.1uF ±10% 50V
C5	0160-5534	CAPACITOR-FXD 0.1uF ±10% 63V
C9-11	0160-4822	CAPACITOR-FXD 1000pF ±5% 100V
C12	0160-2025	CAPACITOR-FXD 220pF ±5% 500V
C14	0160-4787	CAPACITOR-FXD 22pF ±5% 100V
C15	0160-5422	CAPACITOR-FXD 0.047uF ±20% 50V
C16	0180-4136	CAPACITOR-FXD 10uF ±10% 20V
C17,18	0160-5422	CAPACITOR-FXD 0.047uF ±20% 50V
C20	0180-4405	CAPACITOR-FXD 470uF ±20% 50V
C42	0180-4136	CAPACITOR-FXD 10uF ±10% 20V
C50-53	0160-5422	CAPACITOR-FXD 0.047uF ±20% 50V
C56	0160-5422	CAPACITOR-FXD 0.047uF ±20% 50V
C64	0160-5422	CAPACITOR-FXD 0.047uF ±20% 50V
C65	0180-4136	CAPACITOR-FXD 10uF ±10% 20V
C68	0180-4136	CAPACITOR-FXD 10uF ±10% 20V
C85	0180-4396	CAPACITOR-FXD 390uF ±20% 400V
C87	0160-5422	CAPACITOR-FXD 0.047uF ±20% 50V
C88	0180-4136	CAPACITOR-FXD 10uF ±10% 20V
C89	0160-4807	CAPACITOR-FXD 33pF ±5% 100V
C90-92	0160-5422	CAPACITOR-FXD 0.047uF ±20% 50V
C96	0160-5422	CAPACITOR-FXD 0.047uF ±20% 50V
C98	0160-4807	CAPACITOR-FXD 33pF ±5% 100V
C100,101	0160-4822	CAPACITOR-FXD 1000pF ±5% 100V
C102,103	0160-4807	CAPACITOR-FXD 33pF ±5% 100V
C104	0160-4835	CAPACITOR-FXD 0.1uF ±10% 50V
C106	0160-5422	CAPACITOR-FXD 0.047uF ±20% 50V
C108	0160-4281	CAPACITOR-FXD 2200pF ±20% 250V
C110	0180-3805	CAPACITOR-FXD 10uF ±20% 50V
C115	0180-4394	CAPACITOR-FXD 1000uF ±20% 40V
C116	0160-4831	CAPACITOR-FXD 4700pF ±10% 100V
C118	0180-4395	CAPACITOR-FXD 470uF ±20% 50V
C123	0180-4405	CAPACITOR-FXD 470uF ±20% 50V
C124	0160-4830	CAPACITOR-FXD 2200pF ±10% 100V
C125	0160-5469	CAPACITOR-FXD 1uF ±10% 50V
C126,127	0160-5422	CAPACITOR-FXD 0.047uF ±20% 50V
C133	0160-7606	CAPACITOR-FXD 1uF ±20% 250V
C135,136	0160-4281	CAPACITOR-FXD 2200pF ±20% 250V
C137	0160-7606	CAPACITOR-FXD 1uF ±20% 250V
C138,139	0160-4183	CAPACITOR-FXD 1000pF ±20% 250V
C140-143	0160-4822	CAPACITOR-FXD 1000pF ±5% 100V
C146	0160-4835	CAPACITOR-FXD 0.1uF ±10% 50V
C150	0160-4830	CAPACITOR-FXD 2200pF ±10% 100V
C151	0160-4822	CAPACITOR-FXD 1000pF ±5% 100V
C160,161	0160-4439	CAPACITOR-FXD 4700pF ±20%

Table 5-1. Keysight 66000A MPS Mainframe Parts List - Electrical (continued)

Reference Designators	Part Number	Description
C162	0160-5422	CAPACITOR-FXD 0.047uF ±20% 50V
C163		NOT USED
D26	1901-1087	DIODE-POWER RECTIFIER 600V 3A 200ns
D30-32	1901-1087	DIODE-POWER RECTIFIER 600V 3A 200ns
D34-40	1901-1098	DIODE-SWITCHING IN4150 50V 200mA 4ns
D45	1901-1214	DIODE-POWER RECTIFIER 600V 1A 50ns
D46	1901-1128	DIODE-SCHOTTKY 40V 1A
D47,48	1901-1130	DIODE-GENERAL PURPOSE 600V 8A 50ns TO-220AC
D49,50	66000-60003	DIODE-WITH HEATSINK ASSEMBLY
D51,52	1901-1098	DIODE-SWITCHING IN4150 50V 200mA 4ns
D56-58	1901-1098	DIODE-SWITCHING IN4150 50V 200mA 4ns
F1	2110-0688	FUSE-SUBMINIATURE 3A 125V NTD AX UL CSA
F2	2110-0699	FUSE-SUBMINIATURE 5A 125V NTD AX UL CSA
F8	2110-0655	FUSE (METRIC) 3.15A 250V NTD FE IEC
J1	1252-0268	CONNECTOR-RECT MICRORBN 24-CKT 24-CONTACT
J3	1252-4307	CONNECTOR-UTIL P-&-SKT 4-CKT 4-CONTACT
J5	1251-4926	CONNECTOR-POST TYPE .100-PIN-SPCG 8-CONTACT
J114	1251-7330	MODULAR PHONE RECEPTACLE RIGHT ANGLE PC MOUNT
J116,117	1250-1842	CONNECTOR-RF BNC FEM PC-W-STANDOFFS 50-OHM
J119	1252-1014	CONNECTOR-RECT SDL 6-CKT 6-CONTACT
J120-122	1251-8667	CONNECTOR-POST TYPE .100-PIN-SPACING 20-CONTACT
J126	1251-8675	CONNECTOR-POST TYPE .100-PIN-SPACING 5-CONTACT
J200		NOT USED
L1	66000-80004	CHOKE - INPUT
L2,3	66000-80003	CHOKE- OUTPUT
L4	06024-80094	CHOKE - RFI
Q5,6	66000-60002	TRANSISTOR, FET WITH HEATSINK ASSEMBLY
Q7		NOT USED
R1,2	0699-3196	RESISTOR 150 ±5% 10W
R3	0698-3155	RESISTOR 4.64K ±1% .125W
R4	0698-3136	RESISTOR 17.8K ±1% .125W
R5	0757-0465	RESISTOR 100K ±1% .125W
R6	0757-0463	RESISTOR 82.5K ±1% .125W
R7	0757-0273	RESISTOR 3.01K ±1% .125W
R9,10	0698-6348	RESISTOR 3K ±0.1% .125W
R11	0698-3155	RESISTOR 4.64K ±1% .125W
R12	0757-0394	RESISTOR 51.1 ±1% .125W
R13	0757-0459	RESISTOR 56.2K ±1% .125W
R14	0757-0407	RESISTOR 200 ±1% .125W
R15	0757-0280	RESISTOR 1K ±1% .125W
R16	0699-3419	RESISTOR
R17	0699-3420	RESISTOR
R18	0698-3628	RESISTOR 220 ±5% 2W
R20,21	0698-3155	RESISTOR 4.64K ±1% .125W
R35	0698-8827	RESISTOR 1M ±1% .125W TF
R47	0698-3155	RESISTOR 4.64K ±1% .125W
R88	0698-7933	RESISTOR 3.83K ±0.1% .125W

Table 5-1. Keysight 66000A MPS Mainframe Parts List - Electrical (continued)

Reference Designators	Part Number	Description
R89	0698-6348	RESISTOR 3K \pm 0.1% .125W
R93	0698-3625	RESISTOR 160 \pm 5% 2W
R95	0698-3439	RESISTOR 178 \pm 1% .125W
R98	0698-4037	RESISTOR 46.4 \pm 1% .125W
R99	0698-3155	RESISTOR 4.64K \pm 1% .125W
R100	0698-4037	RESISTOR 46.4 \pm 1% .125W
R101	0698-3155	RESISTOR 4.64K \pm 1% .125W
R102,103	0698-4037	RESISTOR 46.4 \pm 1% .125W
R106	1810-0206	NETWORK-RESISTOR 8-SIP 10.0K OHM X 7
R107,108	0757-0442	RESISTOR 10K \pm 1% .125W
R109	0698-0082	RESISTOR 464 \pm 1% .125W
R110	0757-0442	RESISTOR 10K \pm 1% .125W
R113	0683-1015	RESISTOR 100 \pm 5% .25W
R114,115	1810-0305	NETWORK-RESISTOR 9-SIP 4.7K OHM X 8
R121	0757-0394	RESISTOR 51.1 \pm 1% .125W
R130	0698-3609	RESISTOR 22 \pm 5% 2W
R131-133	0757-0394	RESISTOR 51.1 \pm 1% .125W
R146	0757-0442	RESISTOR 10K \pm 1% .125W
R147	0698-0082	RESISTOR 464 \pm 1% .125W
R149	0757-0428	RESISTOR 1.62K \pm 1% .125W
R152-154	0683-1015	RESISTOR 100 \pm 5% .25W
R157	0698-3155	RESISTOR 4.64K \pm 1% .125W
R160-164	0698-8812	RESISTOR 1 \pm 1% .125W
R165	0757-0442	RESISTOR 10K \pm 1% .125W
R166,167	0698-3155	RESISTOR 4.64K \pm 1% .125W
R168,169	0811-1848	RESISTOR .5 \pm 10% 5W
R172	0698-8827	RESISTOR 1M \pm 1% .125W TF
R174-175	0757-0398	RESISTOR 75 \pm 1% .125W
R180,181	0698-3433	RESISTOR 28.7 \pm 1% .1 25W
R182	0686-2705	RESISTOR 27 \pm 5% 0.5W
R184	0698-3155	RESISTOR 4.64K \pm 1% .125W
R185	0698-0082	RESISTOR 464 \pm 1% .125W
R186,188		NOT USED
R187	0686-2705	RESISTOR 27 \pm 5% 0.5W
SCKT1	1200-1274	SOCKET-IC-CHIP-CARRIER 68-CONTACT (REF U44)
SCKT2	1200-0485	SOCKET-IC-DIP 14-CONTACT (REF S7)
SCKT3	1200-0567	SOCKET-IC-DIP 28-CONTACT (REF U51)
SCKT4	1200-0639	SOCKET-IC-DIP 20-CONTACT (REF U58,U66)
S2	3101-2808	SWITCH-PB DPST 4A 250Vac
S7	3101-2097	SWITCH-DIP SL 6-1A 0.1A 50Vdc
TB2	0360-2312	TERMINAL BLOCK 4-TERMINAL .039 IN SQUARE
TB5	0360-2421	TERMINAL BLOCK 3-TERMINAL RT-ANGLE 5-POSITION
T1	9100-4933	TRANSFORMER-FLYBACK FREQ: 100KHz
T2	66000-80001	TRANSFORMER-BIAS
T3	66000-80002	TRANSFORMER-DRIVER
U1	1826-2056	IC V REGULATOR-SWG 4.9/5.1V 8-DIP-P
U2	1990-1502	IC OPTO-ISOLATOR

Table 5-1. Keysight 66000A MPS Mainframe Parts List - Electrical (continued)

Reference Designators	Part Number	Description
U4	1826-1343	IC V REGULATOR-V-REFERENCE-ADJ 2.5/36V 8-DIP-P
U17	1821-1740	IC-GPIB TALKER/LISTENER
U44	1821-1479	IC-16-BIT MICROPROCESSOR, I/O, TIMER, TIMER, A/D
U50	1820-2724	IC LATCH TTL/ALS TRANSPARENT OCTL
U51	66000-80016	IC ROM GPIB - PROGRAMMED
U52	1818-4134	IC 64K SRAM 35-NS CMOS
U58	66000-80010	IC PROGRAMMABLE-LOGIC CMOS EEPLD - PROGRAMMED
U64	1990-0543	IC OPTO-ISOLATOR LED-PXSTR IF=150MA-MAX
U66	66000-80017	IC GAL DECODER - PROGRAMMED
U68	1826-2341	IC V REGULATOR-SWG 8-DIP-P
U71,72	1820-3176	IC MULTIPLEXER/DATA-SELECT CMOS/HC 8-TO-1-LINE
U74	1820-3206	IC LATCH CMOS/HC ADDRESSABLE POS-EDGE-TRIG
U80	1820-3097	IC GATE CMOS/HC AND QUAD 2-INPUT
U87	1820-3206	IC LATCH CMOS/HC ADDRESSABLE POS-EDGE-TRIG
U89	1820-6789	IC INTERFACE TRANSCEIVER
U91	1821-4383	IC DUAL UART, 68000 COMPATIBLE
U97	1820-3176	IC MULTIPLEXER/DATA-SELECT CMOS/HC 8-TO-1-LINE
U98	1820-6045	IC-GPIB TRANSCEIVER CHIP
U99	1820-6170	IC-GPIB TRANSCEIVER CHIP
VR4	1902-0244	DIODE-ZENER 30V 5% 1W
VR11,12	1902-0953	DIODE-ZENER 6.2V 5% DO-35 PD=.4W
VR13	1902-0959	DIODE-ZENER 11V 5% DO-35 PD=.4W
VR14,15	1902-0953	DIODE-ZENER 6.2V 5% DO-35 PD=.4W
VR16		NOT USED
VR17	1902-0244	DIODE-ZENER 30V 5%
VR53	1902-0766	DIODE-ZENER 18.2V 5% DO-35 PD=.4W
Y1	0410-2109	CRYSTAL-QUARTZ 12.00MHz
A2	66000-61021	ASSEMBLY-BACKPLANE BOARD
J1-8	1251-8414	CONNECTOR-POST TYPE .100-PIN-SPACING 48-CONTACT
J9-11	1251-8666	CONNECTOR-POST TYPE .100-PIN-SPACING 20-CONTACT
J12	1252-4306	CONNECTOR-UTIL P-&-SKT 4-CKT 4-CONTACT
A3	66000-61022	ASSEMBLY-KEYBOARD CONNECTOR BOARD
J301	1252-1014	CONNECTOR-RECT SDL 6-CKT 6-CONTACT
J302	1251-8608	CONNECTOR-POST TYPE .100-PIN-SPACING 5-CONTACT

Table 5-2. Keysight 66000A MPS Mainframe Parts List - Mechanical

Ref. Des	Qty	Part Number	Description
MP1	1	66000-00001	CHASSIS- MAIN
MP2	1	66000-00002	CHASSIS TRAY - BOTTOM
MP3	1	66000-00003	CHASSIS TRAY - TOP
MP4	1	5001-9840	SUBCHASSIS
MP6	1	66000-00007	COVER - UNIT
MP10	1	66000 40002	BEZEL - TOP
MP11	1	66000-40003	BEZEL- BOTTOM
MP12	2	66000-40004	BEZEL- SIDE
MP13	1	66000-40005	PUSHROD - ON/OFF
MP14	8	66000-40006	PANEL - FILLER
MP15	1	5041-8802	TRIM - TOP
MP16	2	5001-0540	TRIM - SIDE
MP17	1	66000-80007	NAMEPLATE
MP18	1	5021-8405	FRAME - FRONT
MP19	4	5041-8801	FOOT
MP20	2	5041-8819	CAP - STRAP HANDLE (FRONT)
MP21	2	5041-8820	CAP - STRAP HANDLE (REAR)
MP22	2	5062-3705	STRAP HANDLE
MP23	1	66000-80008	ASSEMBLY- KEYBOARD CABLE
MP24	1	8160-0728	RFI STRIP
MP25	1	5040-1676	AC INPUT SAFETY COVER (WITH HARDWARE)
(J1)	2	0380-0644	STANDOFF - HEX .255-IN-LG 6-32-THD
(J1)	2	2190-0034	WASHER - LOCK HLCL
(J1)	2	2190-0849	WASHER- FLAT MTLC
(J1)	2	0515-0406	SCREW - MACHINE M3 X 0.5 8MM-LG (J1 TO PC BOARD)
(L2,3)	2	0380-0625	STANDOFF - ROUND .687-IN-LG
(L4)	1	1480-0552	PIN - ESCUTCHEON .095-IN-DIA 2.09-IN-LG STL
(F8)	1	2110-0714	FUSEHOLDER
(TB2)	1	1252-1488	TERMINAL BLOCK 4-POSITION
(TB5)	2	0515-1146	SCREW - MACHINE M3 X 0.5 6MM-LG (TB5 TO PC BOARD)
	18	0515-0380	SCREW - MACHINE M4 X 0.7 10MM-LG (CHASSIS HARDWARE)
	4	0515-1384	SCREW - MACHINE M5 X 0.810MM-LG (HANDLE HARDWARE)
	2	0515-2086	SCREW - SPCL M4 X 0.7 7MM-LG (A3 TO FRONT FRAME)
		66000-60051	ASSEMBLY- SAFETY GROUND WIRE
		0535-0038	NUT - HEX DBL-CHAM M6 X 1.0 5.7MM-THK (SAFETY GROUND)
	2	2190-0084	WASHER - LOCK INTL T 1/4 IN .256 IN-ID (SAFETY GROUND)
	2	0403-0267	BUMPER FOOT-ADHESIVE MOUNTING
	2	1400-1195	CLAMP .38-DIA 1-WD NYLON (KEYBOARD CABLE)
		1400-0308	TIE WRAP (KEYBOARD CABLE)
		5080-2148	CABLE - SERIAL LINK (2 METER)
		66000-80006	LABEL - REAR PANEL
		66000-90001	MANUAL - MPS USER'S GUIDE
		66001-90001	MANUAL - QUICK REFERENCE GUIDE
		66001-90003	INSTRUCTION SHEET - KEYBOARD INSTALLATION
	2	5040-1697	BLOCK-TOP COVER

Diagrams

This chapter contains a test point and component location diagram and schematics for troubleshooting the Keysight 66000A MPS Mainframe. An exploded view diagram of the mechanical parts is also provided.

Test Point and Component Location Diagram

The test point and component location diagram identifies the location of the test points that are used in the troubleshooting procedures of Chapter 4, and are also shown on the schematic diagrams.

The test point and locations diagram also identifies all electrical components on the Main board. The diagram is divided into columns and rows designated "x coordinates" and "y coordinates". The accompanying table lists all of the components on the Main board and gives the coordinate location of each component. For example, resistor R154 is located at x coordinate 12.3 and y coordinate 3.3. Refer to Chapter 5 for the part number and description of each electrical part.

Main Board Schematics

WARNING

SHOCK HAZARD When servicing the Main assembly and Backplane assembly, ac line voltages are present on the Main board and backplane connectors.

Three foldout sheets comprise the Main board schematic diagrams. The circuit functions of each schematic sheet are given as follows:

Sheet 1 Circuit Functions

Among the circuit components included on Sheet 1 are: microprocessor U44, GPIB interface chips U15 and U17, ROM chip U51, RAM chip U52, keyboard input J119 and J126, serial link input/output J114, and address switch S7.

The GPIB interface is the link between the mainframe and the system controller. The keyboard input is the link between the mainframe and the Keysight 66001A keyboard. All communication between the mainframe and the controller or keyboard is processed by U44. Data communication between the modules and the controller is also directed through U44.

Switch S7 determines the address of the mainframe. It also indicates if the mainframe is directly connected to the GPIB, or linked to another mainframe. During troubleshooting, switch S7 is used to select diagnostic tests for troubleshooting. Pins on test header J5 must be jumpered to perform certain diagnostic tests.

Sheet 2 Circuit Functions

Among the circuits included on Sheet 1 are: rectifier diodes D26, D30-D32, filter capacitor C85, FET switches Q5 and Q6, power transformer T1, bias transformer F2, FET pulse control chip U1, and pulse transformer T3. Isolation between the ac input and the digital circuit is provided by T1 and opto-isolator U2.

Power to the mainframe is provided by a switching power supply. Energy is stored in the magnetic field of transformer T1 when current flows in the primary, and is transferred to the secondary side when the current flow in the primary is turned off. Primary current flow is controlled by FET switches, which are turned on and off at an 85KHz rate by U1.

Regulation is accomplished by controlling the on-time of the FET switches. U1 monitors the voltage at the secondary side of T1 through opto-isolator U2 and adjusts the on-time of the FETs accordingly. T2 provides bias power for U1.

Power at the secondary side of T1 is rectified and filtered to provide +5V power to the mainframe and +5V and +28V power to the turn-on circuits in the modules.

Sheet 3 Circuit Functions

Among the circuit components included on Sheet 1 are: multiplexers U71 and U72, demultiplexers U74 and U87, power-on chip U68, Trigger In/Out BNC connectors J116 and J117, and DFI/RI connector TB2.

The multiplexers and demultiplexers direct the digital signals from the microprocessor and distribute them among the eight module slot locations via J121 and J122. +5V and +28V bias power is distributed to the module slot locations via J120. U68 generates a power-on (power is available) signal to the module slot locations via J120.

Note J120 connects to J10 on the Backplane board, J121 connects to J9 on the Backplane board, and J122 connects to J11 on the Backplane board.

The Trig IN signal from J117 is distributed to the module slot locations via J120. The Trig OUT signal to J116 is directly received from the module slot locations via J120. The RI (remote inhibit) signal from TB2 is processed by U44. U44 also generates the DFI (discreet fault indicator), which is connected to TB2 via opto-isolator U64.

Backplane Board Schematic

WARNING

SHOCK HAZARD When servicing the Main assembly and Backplane assembly, ac line voltages are present on the Main board and backplane connectors.

The Backplane board schematic shows the distribution of the ac power and control signals from the Main board to the eight module connectors. There are no active components on the Backplane board.

Exploded View Diagram

The exploded view diagram at the end of this section documents how the major components of the Keysight 66000A MPS Mainframe are assembled. Parts with "MP" designations identify components that are referenced in the parts list. Refer to Chapter 5 for the part number and description of the mechanical parts.

Schematic Notes

Notes that apply to all schematic sheets are given as follows:

- All resistors are in ohms $\pm 1\%$, 1/8W, unless otherwise specified.
- All capacitors are in microfarads unless otherwise specified.
- An asterisk negates a signal name. For example, WR appears on the schematic as **WR***.
- Signal line destinations are given inside the parentheses at the end of the signal lines. For example, RDY (S01A5), indicates that the **RDY** signal continues on schematic sheet 01 at grid coordinates A, 5. Coordinates are labeled on the schematic border.
- Signal lines that are terminated by flags continue onto other sheets. Note that flags do NOT indicate signal flow direction.
- Signal lines without flags go to another location of the same schematic sheet.
- Test points on the schematic sheets (e.g. TP3) identify the location of the test points used in the troubleshooting procedures in Chapter 4.
- Voltages and waveforms shown on the schematics are obtained when following the troubleshooting procedures in Chapter 4.

Main Board Component Coordinates

	X	Y		X	Y		X	Y		X	Y		X	Y
C1	5.2	2.9	C124	5.4	0.4	F8	0.4	2.8	R47	14.1	2.4	R184	8.5	2.3
C2	6.7	3.5	C125	5.6	0.5	HS10	4.8	3.7	R88	12.7	2.4	R185	9.7	1.1
C3	3.8	3.4	C126	14.1	4.0	HS11	6.5	3.7	R89	12.8	1.9	R186	14.4	2.4
C4	4.0	3.9	C127	12.5	3.3	HS12	6.4	1.6	R93	13.1	4.1	R187	2.4	2.6
C5	5.0	4.1	C133	0.2	3.0	HS13	6.8	1.1	R95	11.3	3.3	R188	2.4	2.7
C9	3.9	3.9	C135	2.5	2.3	J1	8.6	4.2	R98	10.7	3.3	S2	1.0	1.5
C10	14.8	3.5	C136	2.3	1.8	J3	3.5	0.0	R99	10.6	3.8	S7	7.1	3.9
C11	14.3	3.5	C137	2.8	3.0	J5	14.3	1.7	R100	10.9	3.3	T1	4.8	1.0
C12	6.2	0.5	C138	1.6	4.2	J114	11.1	4.3	R101	10.8	3.3	T2	5.5	3.4
C14	3.3	3.9	C139	2.3	4.2	J116	12.6	3.9	R102	12.9	2.6	T3	5.5	4.3
C15	3.6	3.4	C140	10.8	1.8	J117	13.6	3.9	R103	13.0	3.1	TB2	12.0	4.3
C16	15.0	1.0	C141	14.3	1.2	J119	14.1	4.3	R106	7.1	3.8	TB5	1.4	4.3
C17	14.9	3.5	C142	11.0	0.9	J120	10.4	0.0	R107	12.4	3.3	U1	3.4	4.0
C18	14.8	1.0	C143	10.7	1.2	J121	8.5	0.0	R108	14.0	4.0	U15	8.3	3.2
C20	8.3	0.6	C146	12.9	2.4	J122	4.7	0.0	R109	13.9	3.8	U17	8.8	2.5
C42	13.7	2.4	C150	12.2	3.9	J126	15.0	0.3	R110	14.2	3.5	U2	3.9	0.5
C50	10.9	1.5	C151	10.4	3.8	J200	14.8	2.0	R113	12.7	3.3	U4	4.6	0.4
C51	11.1	0.9	C160	0.6	2.0	L1	1.5	3.1	R114	8.7	0.9	U44	13.6	0.7
C52	11.0	2.3	C161	0.6	1.8	L2	8.1	1.7	R115	8.6	1.5	U50	11.3	0.4
C53	13.8	3.1	C162	15.0	3.5	L3	7.4	1.5	R121	5.3	3.3	U51	11.2	2.5
C56	9.6	1.6	C163	14.8	2.5	L4	1.4	1.3	R130	6.2	2.0	U52	11.2	2.0
C64	11.0	3.0	D26	4.2	1.3	MC1	8.5	3.4	R131	6.3	3.9	U58	9.9	1.3
C65	11.1	1.5	D30	3.6	1.4	Q5	6.4	3.7	R132	6.8	3.9	U64	11.6	3.5
C68	10.9	3.0	D31	3.6	1.1	Q6	4.9	3.7	R133	5.2	3.3	U66	11.3	1.0
C85	3.5	2.2	D32	3.7	0.7	Q7	14.3	2.5	R146	11.4	3.3	U68	13.2	2.0
C87	14.4	0.7	D34	13.6	3.8	R1	4.5	2.4	R147	12.6	3.3	U71	8.7	1.0
C88	14.7	1.0	D35	12.9	3.8	R2	7.3	2.9	R149	5.8	0.4	U72	8.8	0.4
C89	12.7	0.5	D36	13.5	3.8	R3	13.9	2.4	R152	14.6	4.0	U74	9.9	0.9
C90	9.7	0.9	D37	12.8	3.1	R4	3.7	3.4	R153	14.5	4.0	U80	13.9	2.8
C91	8.6	3.1	D38	12.7	3.1	R5	3.4	3.9	R154	12.3	3.3	U87	9.9	0.4
C92	8.6	2.2	D39	13.2	3.1	R6	3.5	3.4	R157	14.7	2.7	U89	13.3	2.7
C96	8.1	3.8	D40	13.1	3.1	R7	4.0	3.4	R160	6.3	2.9	U91	8.8	1.7
C98	12.8	0.5	D45	4.5	3.9	R9	5.2	0.9	R161	6.4	2.9	U97	7.1	3.4
C100	10.5	3.3	D46	5.3	4.4	R10	5.1	0.4	R162	6.5	2.9	VR11	13.4	3.8
C101	11.0	3.3	D47	5.8	2.6	R11	10.9	0.4	R163	6.6	2.9	VR12	10.4	4.4
C102	10.3	4.4	D48	4.9	2.6	R12	4.5	0.9	R164	6.7	2.9	VR13	11.1	3.8
C103	11.2	3.8	D49	6.5	1.5	R13	4.6	3.9	R165	10.9	2.3	VR14	14.0	2.4
C104	13.0	2.4	D50	6.7	1.2	R14	3.9	3.4	R166	14.3	2.4	VR15	10.3	3.8
C106	13.3	3.8	D51	6.3	3.8	R15	5.2	4.4	R167	14.2	2.4	VR16	14.5	2.4
C108	2.7	2.3	D52	5.1	3.8	R16	7.1	1.2	R168	2.9	1.1	VR53	12.2	3.8
C110	4.2	4.4	D56	12.8	3.8	R17	3.6	3.1	R169	3.0	0.7	Y1	13.4	0.5
C115	7.4	2.2	D57	13.8	3.8	R18	6.7	0.7	R172	12.1	3.8			
C116	6.6	1.2	D58	13.7	3.8	R20	14.7	4.0	R180	1.1	2.0			
C118	7.5	0.7	F1	8.5	3.1	R21	14.4	4.0	R181	1.6	2.1			
C123	7.9	2.7	F2	14.8	2.7	R35	0.6	3.5	R182	2.4	2.8			

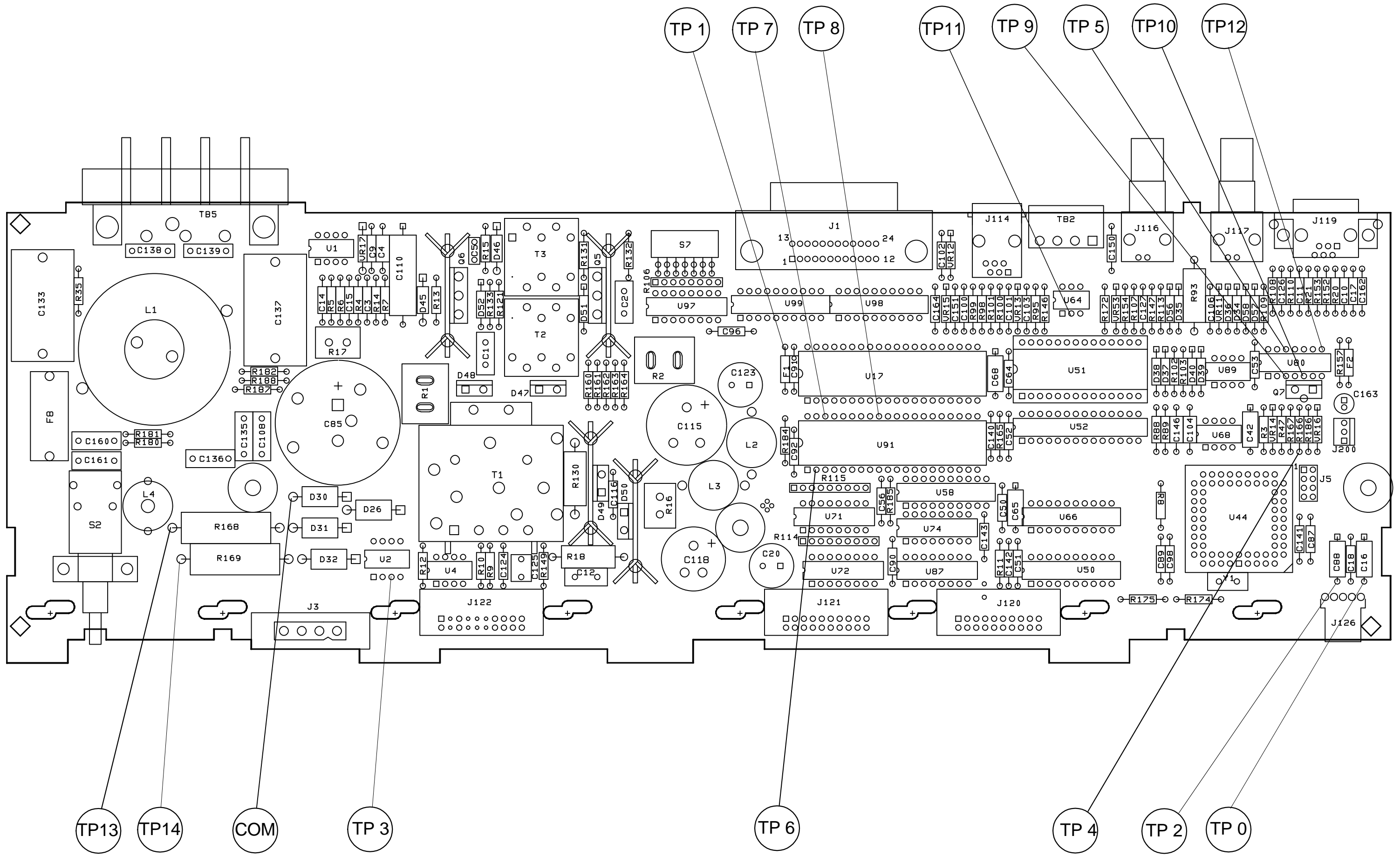

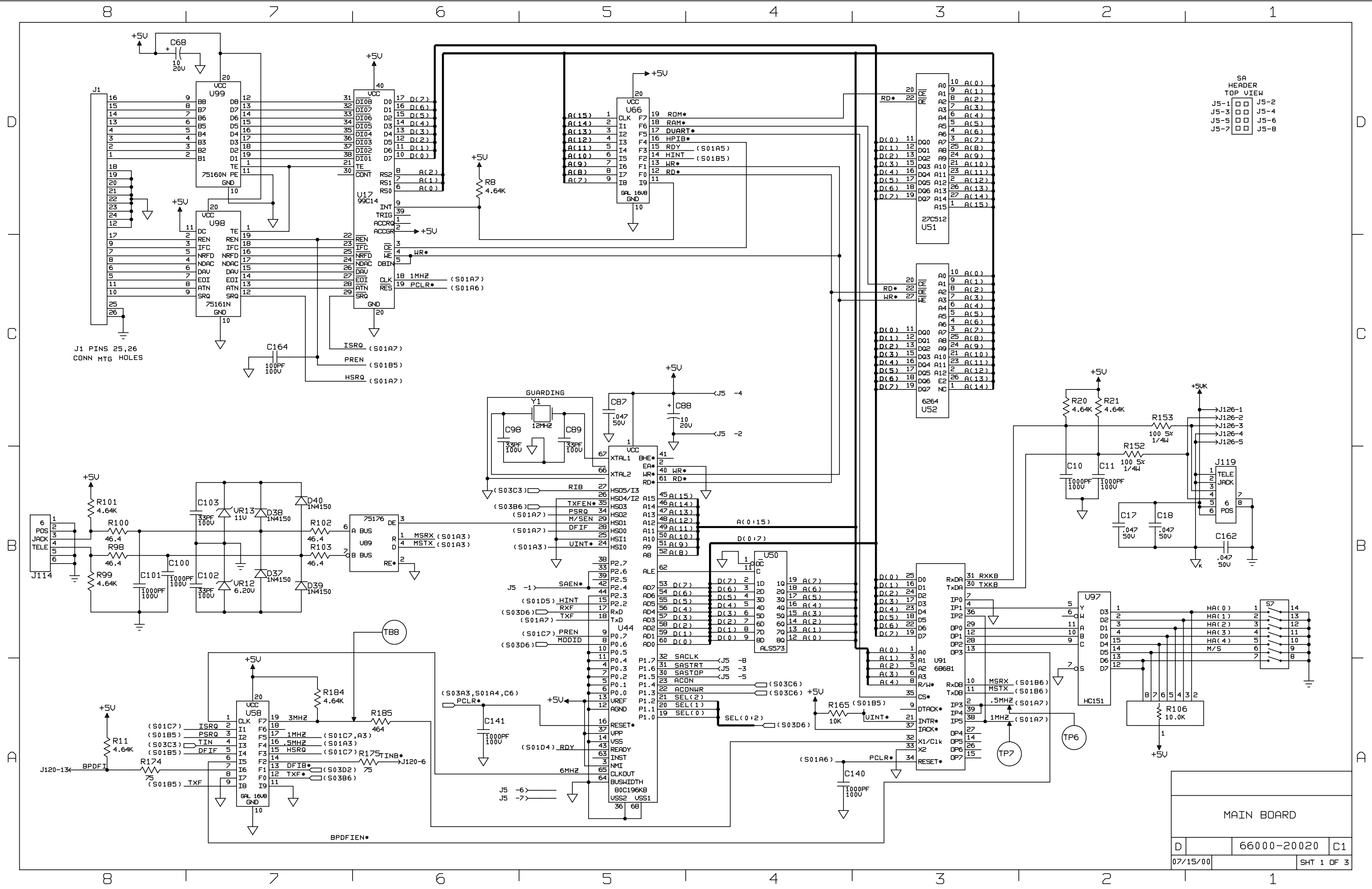

SA
HEADER
TOP VIEW

J5-1	J5-2
J5-3	J5-4
J5-5	J5-6
J5-7	J5-8

J1 PINS 25,26
CONN MTG HOLES

MAIN BOARD

66000-20020 C1
07/15/00 SHT 1 OF 3

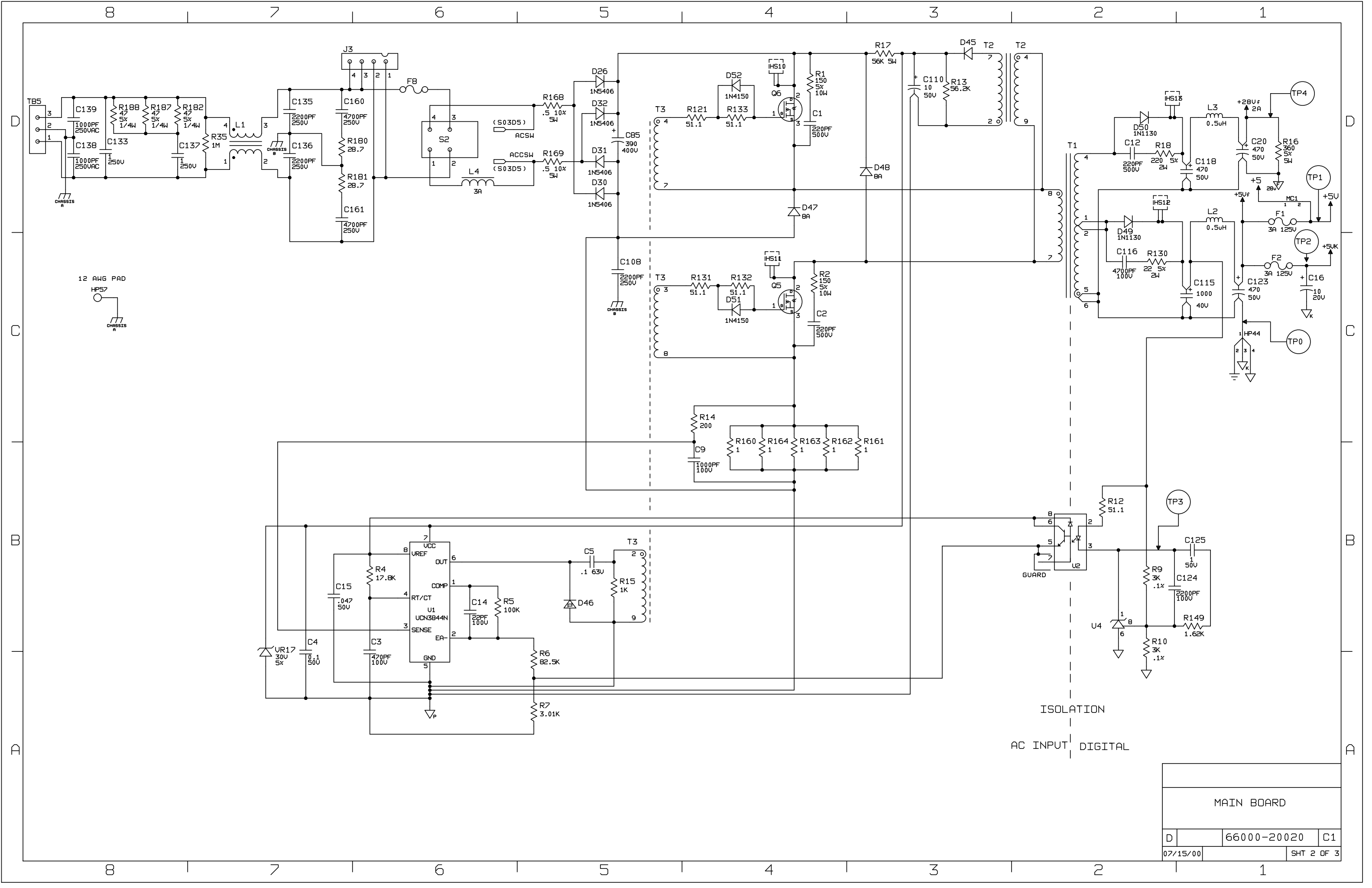

ISOLATION
AC INPUT | DIGITAL

MAIN BOARD		
D	66000-20020	C1
07/15/00		SHT 2 OF 3

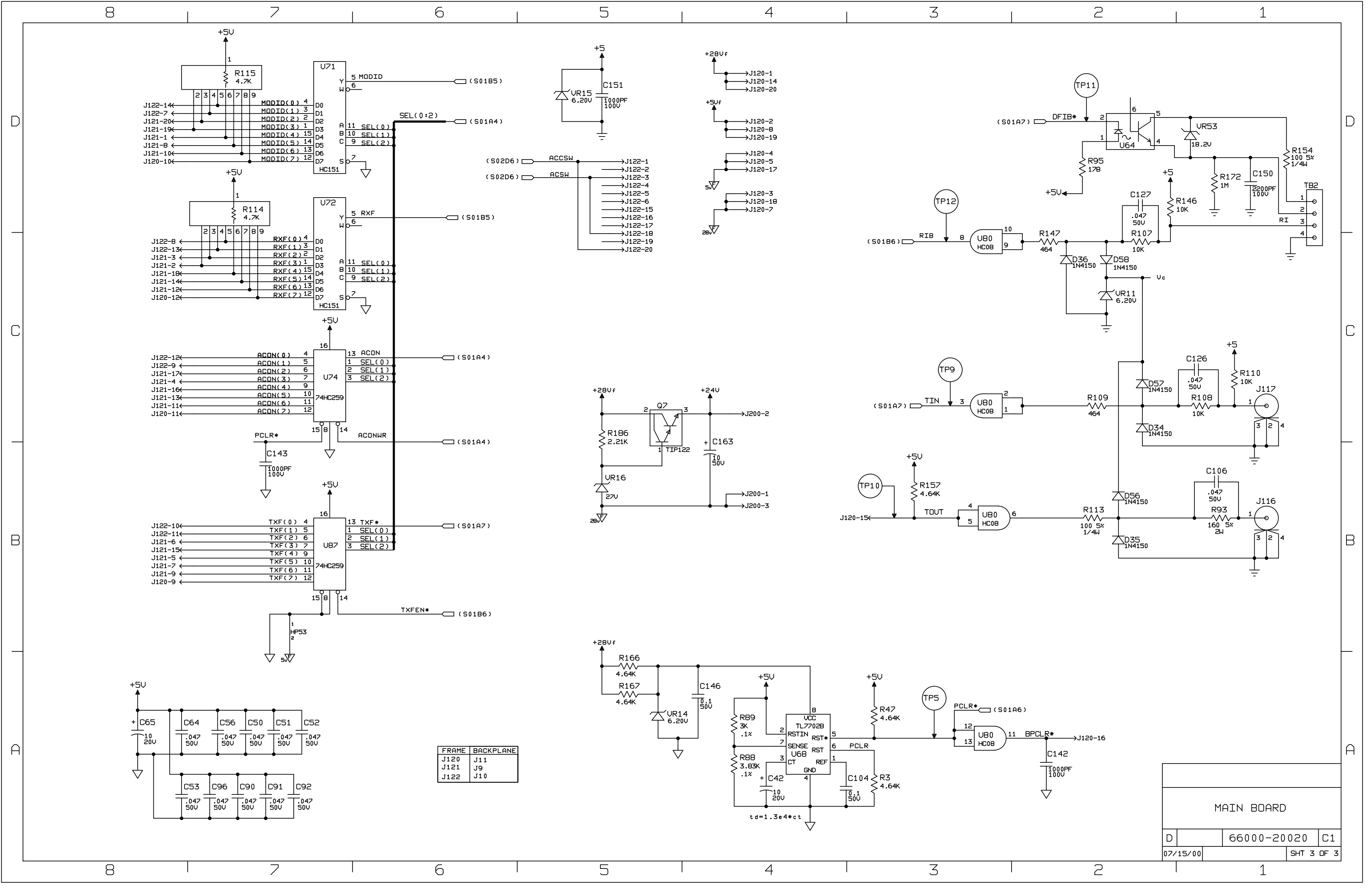

FRAME	BACKPLANE
J120	J11
J121	J9
J122	J10

MAIN BOARD		
D	66000-20020	C1
07/15/00		SHT 3 OF 3

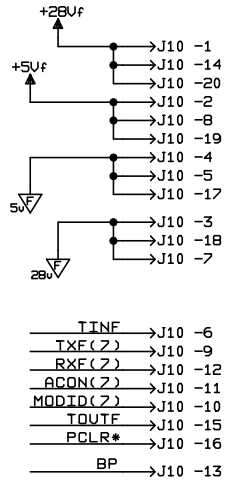
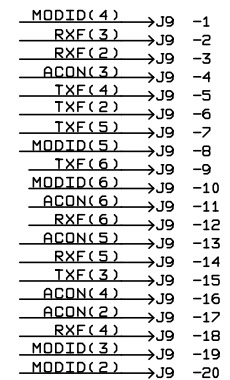
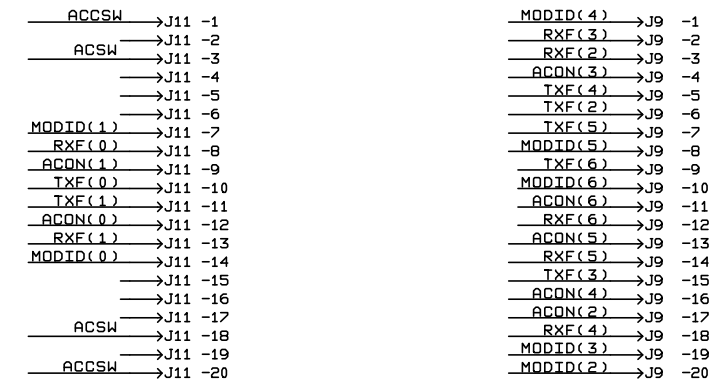
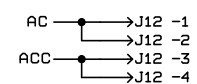
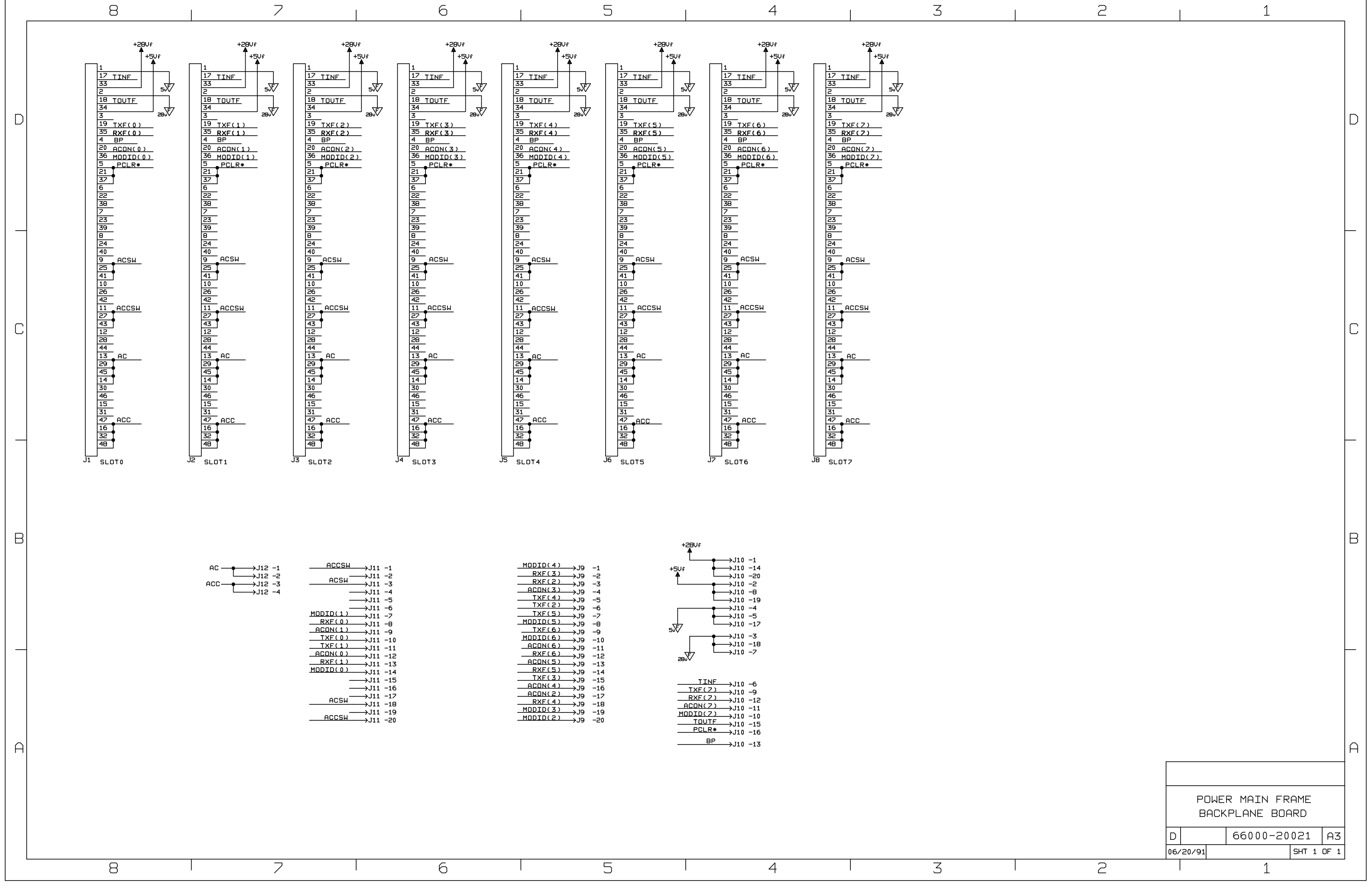

POWER MAIN FRAME BACKPLANE BOARD		
D	66000-20021	A3
06/20/91		SHT 1 OF 1

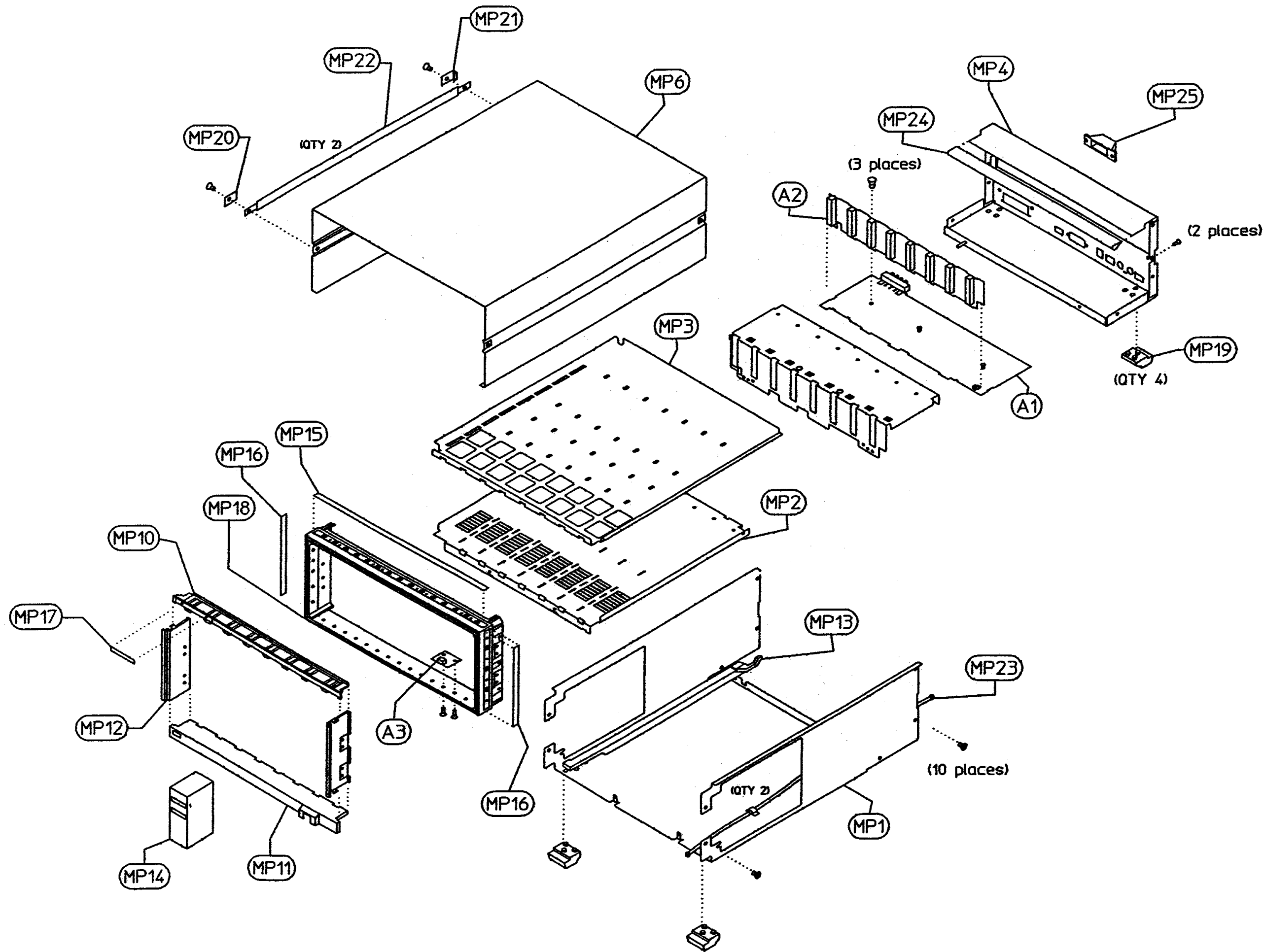

Manual Backdating

This section describes changes that must be made to the manual so that it applies to mainframes with older serial number formats. Look in the following table for the serial number of your instrument, and make only those changes listed for your instrument. Note that for some changes, you may be instructed to update the instrument if certain components are being replaced during repair.

Serial Prefix	<u>6600A</u> Serial Number	Changes
3302A	00101-00835	1 - 5
3350A	00836-00945	1 - 4
3445A	00946-01255	1 - 3
3445A	01256-01560	1, 2
3522A	01561-03295	1
	US35220101-MY400000306	1

Change 1

In Table 5-1 and on the schematic,
Delete: R174, R175, and VR17.
Change U17 to p/n 1820-2549.
Change U51 to p/n 66000-80009.
Change U66 to p/n 66000-80011.

Change 2

Make the following changes in Table 5-2:
Change: MP4 from a single subchassis (p/n 5001-9840)
to **two** subchassis parts: MP4 (p/n 66000-00004)
and MP5 (p/n 66000-00006).
Change: Screw (p/n 0515-0380) from qty 18 to qty 20
Delete: Cover block, p/n 5040-1697

Change 3

In Table 5-1 and on the schematic, delete VR4, p/n 1902-0244. In its place add C4, 0.1uF, 50V p/n 0160-4835.

Change 4

In Table 5-1 and on the schematic, delete U98 (1820-6045) and U99 (1820-0244). In their place add a single IC assembly, U15, p/n 1LH4-0001.

Change 5

In Table 5-1 and on the schematic change R182 and R187 to 42.2 ohms p/n 0757-0316. Add R188, 42.2 ohms p/n 0757-0316 in parallel with R182 and R187.

Index

	2	
+28V		31
	5	
+5V		30
	A	
ACON.....		25
"ACON/MOD ID Test"		25
ACONWR		25
"Address/Data Bus Test"		23
address lines		32
ALE		32
	B	
Backplane Power-up Test.....		25
"Backplane Serial Port Test"		25
bias voltages		23, 30
BPCLR*		31
	C	
checkout		11
	D	
data lines.....		32
DFIB*		27
"DFI/RI Pulse Train Test"		27
DFI/RI Test Connector.....		26
disassembly		
cover.....		15
front frame.....		15
modules		15
pc board.....		16
subchassis.....		16
documents - related.....		8
	E	
electrical parts		34
electrostatic discharge		9
equipment		9
error code		12

F

fuse	11
fuse F1	30
fuse F2	31

G

"GPIB Switch Test"	24
--------------------------	----

H

HSRQ	26
------------	----

K

keyboard	10, 12
Keyboard Display Test	29
Keyboard Echo Test	29

L

line voltage	11
--------------------	----

M

mechanical parts	38
microprocessor	32
MODID	25

O

output checkout	13
overall troubleshooting	23

P

PCLR*	31
power cord	10, 11
power module	7
"PSRQ Pulse Train Test"	26

R

RD	32
reassembly	17
revision number	8
RIB	27
ROM	32
RXF	26
RXKB	23

S

SACLK.....	23, 24, 25, 27
SASTRT.....	24, 25, 26, 27, 28
schematic	
notes.....	41
schematics.....	39
backplane board.....	40
main board.....	39
selftest.....	12
"Serial Link Test".....	28
serial number.....	8
service manual.....	8
shock hazard.....	21, 39

T

TINF.....	28
tools.....	9
TP0.....	23
TP1.....	23, 30
TP2.....	23, 30, 31
TP4.....	23, 30, 31
TP5.....	30, 31
TP6.....	32
TP7.....	32
TP8.....	32
"TrigIn/TrigOut Test".....	27
troubleshooting.....	21
flowcharts.....	22
TXF.....	26
TXFEN.....	26
TXKB.....	23

W

WR*.....	32
----------	----



This information is subject to change without notice.
© Keysight Technologies 1992, 2000, 2014
Edition 2, December 2014



66000-90003
www.keysight.com