

# interference<sup>ITEM™</sup> technology

THE INTERNATIONAL JOURNAL OF  
ELECTROMAGNETIC COMPATIBILITY™

# 2015

## EMC DIRECTORY & DESIGN GUIDE

# HARMONIC COMB GENERATORS ARE USEFUL TOOLS

### BACK COVER



### FEATURED TOPICS

- 10 EMC LIVE 2015
- 16 TEST INSTRUMENTATION
- 28 TESTING
- 45 CONDUCTED IMMUNITY
- 56 SHIELDING
- 66 DESIGN

### DIRECTORIES

- 86 CALENDAR OF EVENTS
- 87 CONSULTANT SERVICES
- 88 STANDARDS REVIEW
- 96 PROFESSIONAL SOCIETIES
- 100 GOVERNMENT DIRECTORY
- 108 EMC SUPPLIER QUICK GUIDE



# WHO SAYS YOU CAN'T HAVE IT ALL?

and with next-day, on-time delivery



**DRG Horns**  
170 MHz - 40 GHz  
6 Models



**Log Periodics**  
80 MHz - 7 GHz  
13 Models



**Preamplifiers**  
20 MHz - 40 GHz  
8 Models



**Low Loss Cables**  
DC - 40 GHz  
4 Models



**Biconicals**  
20 MHz - 330 MHz  
5 Models



**BiLogicals**  
25 MHz - 7 GHz  
8 Models



**Standard Gain Horns**  
1 GHz - 40 GHz  
9 Models



**All in one small package**



**H-Field Rods**  
100 Hz - 30 MHz  
4 Models



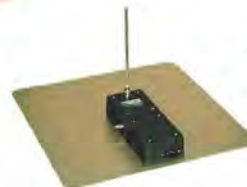
**Probes**  
20 Hz - 1 GHz  
16 Models



**Loops**  
20 Hz - 30 MHz  
7 Models



**Tripods and Accessories**



**Monopoles**  
100 Hz - 60 MHz  
5 Models

You Can Have It All when it comes to EMC/EMI testing. A.H. Systems is proud to bring you exciting new products, and many reliable favorites for your evaluation and compliance applications. Our antennas are unique and distinctive with broadband frequency ranges between 20 Hz up to 40 GHz. This enables us to specialize in various sales, rentals and, re-calibrations of test Antennas throughout the world. To view our products and get quick answers to your questions, access our comprehensive online catalog. Search for various information about product descriptions, typical AF plots, VSWR, power handling capabilities and links to product data sheets. Or simply request a catalog be sent to you. Not only have we been developing EMI Antennas for over 30 years, we also have organized worldwide sales representation. You can find your local knowledgeable representative in over 27 countries via our website. For quality products, excellent service and support with next-day, on-time delivery.

**Antennas...**

**And Kits too.**



**Innovation**

**Quality**

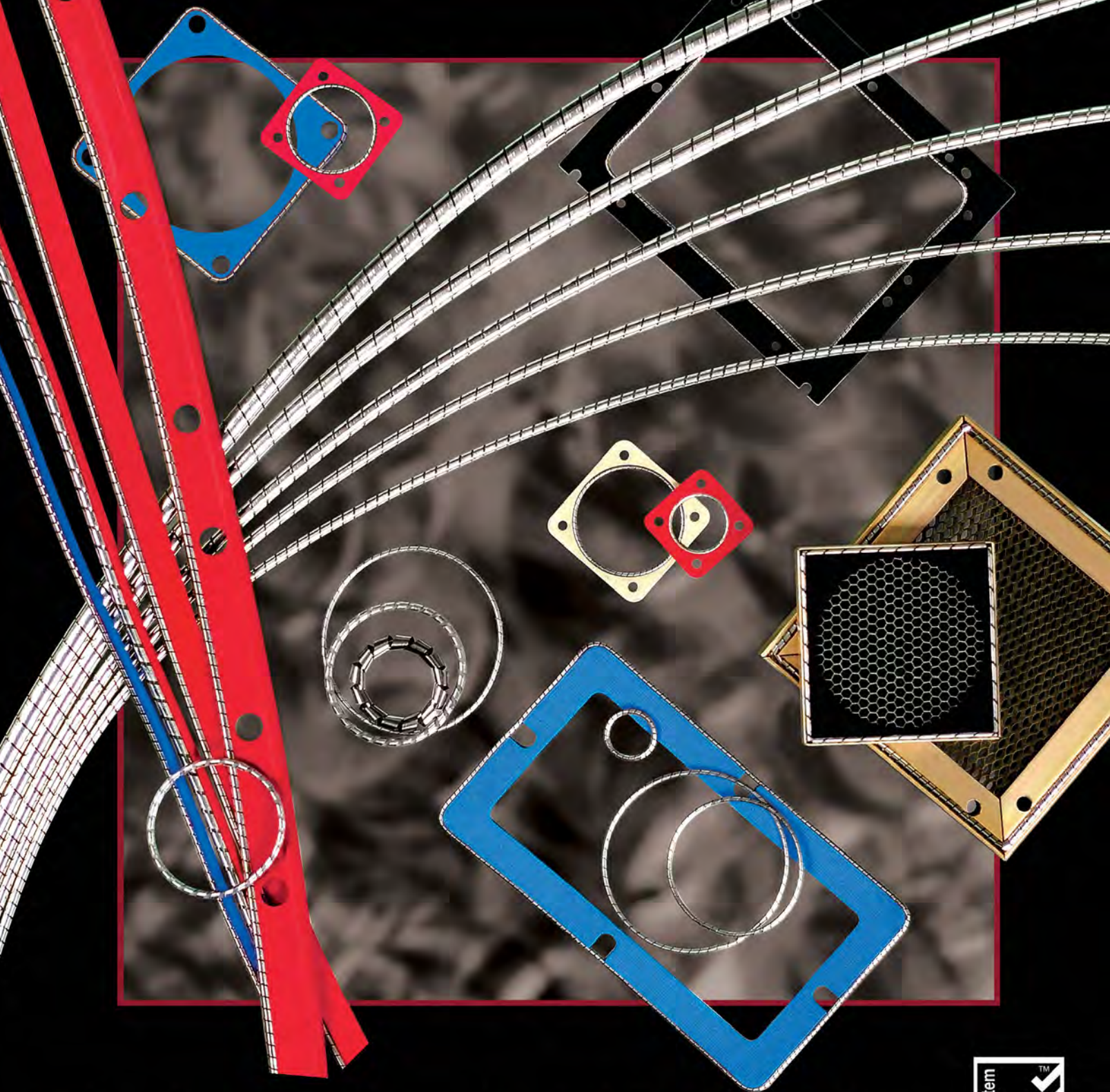
**Performance**

Phone: (818)998-0223 ♦ Fax (818)998-6892  
www.AHSystems.com?IT

**A.H. Systems**







# ***The Inspiration in EMI Shielding***

Visit our Website to request Free Samples, an EMI Educational DVD, Technical Assistance, & NEW EMI Shielding Catalog & Design Guide.

**[www.spira-emi.com](http://www.spira-emi.com)**

**(818) 764-8222 [info@spira-emi.com](mailto:info@spira-emi.com)**

**All Products Made in the USA**

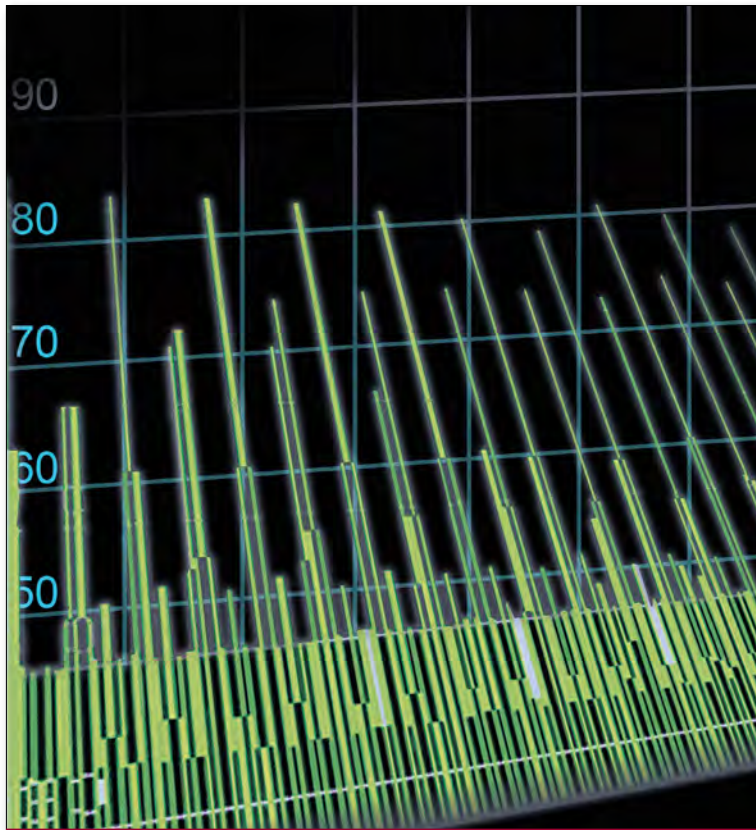


**ISO 9001  
AS9100**



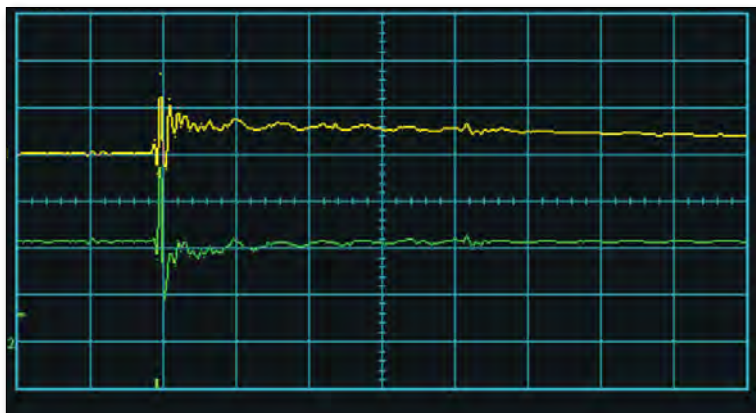


# Contents



**FEATURE - P.16**

Representative harmonics from the DIY comb generator. The lower harmonics are the even-order ones due to the oscillator deviating from a perfect 50% duty cycle. (From *Harmonic Comb Generators are Useful Tools* by Kenneth Wyatt)



**P.49**

Transient during ESD. (From *EMC War Stories: Letters From Home* by Candace Suriano)

**EDUCATION**

**10**  
**EMC LIVE**  
*ADVANCE PROGRAM*  
[www.emclive2015.com](http://www.emclive2015.com)

**TEST INSTRUMENTATION**

**16**  
**HARMONIC COMB GENERATORS ARE USEFUL TOOLS**  
*KENNETH WYATT*  
 WYATT TECHNICAL SERVICES

**TESTING**

**28**  
**CISPR NEWS: NEW REQUIREMENTS**  
*JAN SROKA*  
 UNIVERSITY OF WARSAW

**36**  
**FCC CHANGES CERTIFICATION PROCESS**  
*DAVID A. CASE*  
 CISCO SYSTEMS, INC.

**40**  
**RADIO EQUIPMENT DIRECTIVE: HISTORY OF REQUIREMENTS AND NEW CHANGES**  
*CHARLIE BLACKHAM*  
 SULIS CONSULTANTS LTD.

**AMPLIFIERS / ANTENNAS**

**46**  
**EMC WAR STORIES: LETTERS FROM HOME PART 2: IT'S HARD FOR MY COMPUTER TO SLEEP WHEN I'M DOING THE LAUNDRY**  
*CANDACE SURIANO*  
 SURIANO SOLUTIONS



# Our expertise takes you to the top. EMC solutions from Rohde & Schwarz.

We provide everything you need for development, precompliance and compliance measurements to ensure successful EMC certification.

- | Exceptionally fast EMI test receivers
- | Efficient diagnostic tools for detecting EMI
- | EMC software packages for interactive and fully automatic measurements
- | Wide range of accessories for performing EMI measurements
- | Compact and modular broadband amplifiers
- | RF shielded chambers
- | Complete EMC test systems

For more information, visit:  
[www.rohde-schwarz.com/ad/emc](http://www.rohde-schwarz.com/ad/emc)



# Contents

CONTENTS



P.62

Stripline. (From *Characterization of EMI Shielding Gaskets up to 40 GHz* by Christian Brull)



P.69

Trace clusters fanning out on a PCB: For example, in the baseband infrastructure of a handheld device. (From *EMI Across Randomly-Patterned Multiple Traces on a PCB of an Audio/Multimedia Infrastructure: Crosstalk Performance Vis-A-Vis Smart Handheld Devices* by Perambur S. Neelakanta & Aziz U. Noor)



P.84

Example of a high bandwidth (<150 ps) current sensor. (From *Seeding and Harvesting - Changing Design Requirements* by Mart Coenen)

## SHIELDING

**56**  
**CHARACTERIZATION OF EMI SHIELDING GASKETS UP TO 40 GHz**  
 CHRISTIAN BRULL  
 SCHLEGEL

## DESIGN

**66**  
**EMI ACROSS RANDOMLY-PATTERNED MULTIPLE TRACES ON A PCB OF AN AUDIO/MULTIMEDIA INFRA-STRUCTURE: CROSSTALK PERFORMANCE VIS-A-VIS SMART HANDHELD DEVICES**  
 PERAMBUR S. NEELAKANTA & AZIZ U. NOOR  
 FLORIDA ATLANTIC UNIVERSITY

**82**  
**SEEDING AND HARVESTING - CHANGING DESIGN REQUIREMENTS**  
 MART COENEN  
 EMC/MCC

## DEPARTMENTS & DIRECTORIES

- 8** EDITORIAL
- 10** EMC LIVE 2015
- 86** CALENDAR
- 87** CONSULTANT SERVICES
- 88** STANDARDS
- 96** SOCIETIES
- 100** GOVERNMENT DIRECTORY
- 108** 2015 EMC SUPPLIER QUICK GUIDE
- 112** INDEX OF ADVERTISERS



# The Total EMC Source For Your Automotive Needs



AR's EMC solutions make complicated test processes easier and more accurate. Everything is simplified – calibration, testing processes, DUT troubleshooting and generation of reports directly into convenient formats, such as Microsoft Word or Excel.

These products also have excellent speed, feature a modular design approach and allow their integrated components to be used in a variety of automotive test standards such as ISO, SAE, CISPR, and OEM requirements. These products have the flexibility to handle engineering development, mitigation and testing to numerous other standards such as: MIL-STD-461, RTCA DO-160, CISPR, EN, ETSI, FCC, ICES, AS/NZS, and VCCI.

The DER2018, with 140 MHz instantaneous bandwidth, is the One Receiver that catches short duration transient disturbances, and scans in seconds. By streamlining testing this CISPR 16 compliant EMI receiver will change the way you approach testing.

AR's AS4000 radiated immunity system gives you a turnkey package to perform susceptibility tests, in one self-contained unit up to 40 GHz. Our standard systems can also be customized to include testing to both radiated and conducted immunity and emissions requirements.

The Conducted Immunity (CI) platform offers flexibility to address any Bulk Current Injection (BCI) test method, as well as the ability to access components from the CI housing, such as the power meter and amplifier, to use in other test applications. With three Conducted Immunity Test Systems to choose from, you should never again have to perform laborious manual CI test procedures or worry about the accuracy of the results.

AR supplies a multitude of unique RF solutions to some of the best-known companies worldwide. Our products are backed by the strongest, most comprehensive warranty in the industry, and a global support network that's second to none. Call your local AR sales associate for a demonstration.

To learn more, visit [www.arworld.us/totalEMC](http://www.arworld.us/totalEMC) or call us at 215-723-8181.

ISO 9001:2008  
Certified



[www.arworld.us](http://www.arworld.us)



**rf/microwave instrumentation**

Other  divisions: modular rf • receiver systems • ar europe

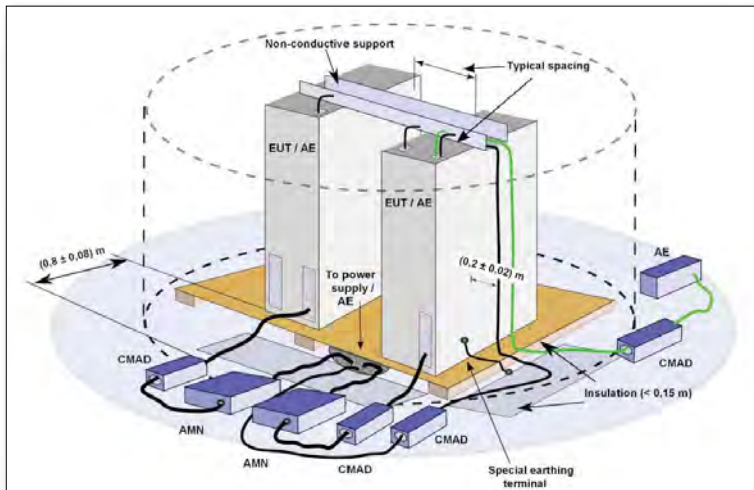
USA 215-723-8181. For an applications engineer, call 800-933-8181.

In Europe, call ar United Kingdom +44 1908 282766 • ar France +33147917530 • ar Deutschland +49 6101 802700 • ar Benelux +31 172 423000

Copyright © 2015 AR.  
The orange stripe on AR products is  
Reg. U.S. Pat. & TM. Off.

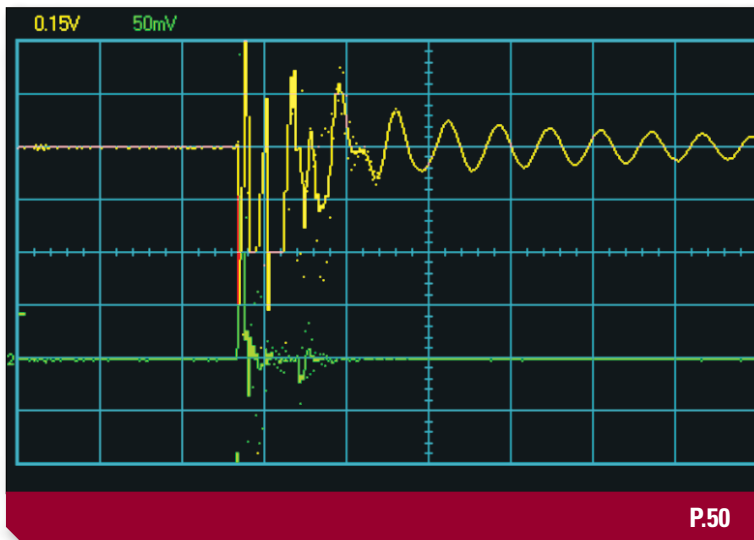


# Contents



P.32

Set-up for the floor standing equipment acc. to [4]. (From *CISPR News: New Requirements* by Jan Sroka)



P.50

Injected common mode current with  $0\Omega$  at gun but with common mode suppression on keyboard cable does not awaken computer. (From *EMC War Stories: Letters From Home* by Candace Suriano)

## EDITORIAL REVIEW BOARD

**KEITH ARMSTRONG**  
Cherry Clough Consultants

**STEPHEN CAINE**  
Alion Science & Technology

**DONALD HEIRMAN**  
Don Heirman Consultants, LLC

**DANIEL D. HOOLIHAN**  
Hoolihan EMC Consultants

**HERBERT MERTEL**  
Mertel Associates

**MARK MONTROSE**  
Montrose Compliance Services, Inc.

**MICHAEL OLIVER**  
MAJR Products

**HENRY W. OTT**  
Henry Ott Consultants

**KENNETH WYATT**  
Wyatt Technical Services LLC

*InterferenceTechnology—The EMC Directory & Design Guide, The EMC Symposium Guide, and The EMC Test & Design Guide* are distributed annually at no charge to qualified engineers and managers who are engaged in the application, selection, design, test, specification or procurement of electronic components, systems, materials, equipment, facilities or related fabrication services. To be placed on the subscriber list, complete the subscription qualification card or subscribe online at [InterferenceTechnology.com](http://InterferenceTechnology.com).

**ITEM Media** endeavors to offer accurate information, but assumes no liability for errors or omissions in its technical articles. Furthermore, the opinions contained herein do not necessarily reflect those of the publisher.

**ITEM™, InterferenceTechnology™—The EMC Directory & Design Guide™, and Interference Technology.com™** are trademarks of ITEM MEDIA and may not be used without express permission. *ITEM, InterferenceTechnology—The EMC Directory & Design Guide, The EMC Symposium Guide, The EMC Test & Design Guide* and *InterferenceTechnology.com*, are copyrighted publications of ITEM MEDIA. Contents may not be reproduced in any form without express permission.



# What?!

**Reliability**

**Quick Service**

**100% Mismatch Tolerance**

Deliver power into any load!

**Class A Solid-State**

**More Bandwidth**

**Upgradeable**

**& Value**



# Finally!

**There is no need to compromise quality and cost anymore**  
With **HV TECHNOLOGIES** and **Prâna** you can have it all

- Long proven history of Quality, Support and Value
- Coverage 10 kHz to 6 GHz, up to 12 kWatts
- Class A Design will work without Damage into any Mismatch/VSWR
- Ideally suited for EMC applications
- More Linear Power where it is needed
- Fully supported in North America by HV Technologies USA
- Expertise to help select the correct power level
- Upgradable, more Power when testing requirements change
- Customized Options
  - o Built in Bi-directional Couplers
  - o Digital Control and Interface
  - o RF Connector Locations
  - o Rack Systems

**HV TECHNOLOGIES, Inc.**  
emcsales@hvtechnologies.com  
703-365-2330



**PRÂNA**  
Broadband power amplifiers  
[www.prana-rd.com](http://www.prana-rd.com)

*Your Partner for EMC Solutions*

**HV**  
HV TECHNOLOGIES, Inc.  
[www.hvtechnologies.com](http://www.hvtechnologies.com)



# Signal Integrity and its Relationship to EMI



**C**ERTAIN DIGITAL DESIGNERS, to this day, still do not accept the fact that signal integrity and EMI are related. This comes from how they were taught in school or their particular area of interest within a narrow niche of electrical engineering. As long as digital circuits perform an intended function everything is good to go because SPICE says so. Why worry about EMI, as this is generally the job of someone else after the printed circuit board is built and sent out for testing.

The field of electrical engineering involves sending a signal from one location to another through a media. This media can be either free space or a metallic interconnect. Per James Clerk Maxwell, the only elements propagated in a transmission line are electric fields, magnetic fields and current. Voltage is not part of Maxwell's equations yet digital designers focus on voltage levels to ensure digital operation, therefore there is no relationship between signal integrity and electromagnetic theory, in their narrow of vision engineering design, which we know is wrong. Someone needs to go back to school!

A printed circuit board is a physical structure that supports transmission lines. Digital devices operate at a voltage potential, both logic high and logic low (DC analysis). It takes a finite time period to change logic states to create a somewhat looking square wave. If we round the digital edges significantly we end up with a sinewave. Doing a Fourier analysis on a digital pulse (time domain analysis) creates a spectral profile (frequency domain). Therefore, signal integrity and EMC are related. Now comes a question, do hard-core digital designer think about Fourier analysis when doing schematic capture with regard to fast edge rate clock signals?

Digital engineers who focus on signal integrity prefer to use an oscilloscope and SPICE, disregarding frequency domains aspects of signal propagation described by Fourier because it is easier to perform analysis in the time domain than frequency. Those doing EMC prefer to use a spectrum analyzer to determine total field strength at a distance in free space, but cannot determine the actual source of the undesired common-mode current using only a near-field probe.

Once the EMI problem area had been identified put away the spectrum analyzer. Switch to an oscilloscope and study the schematic and artwork. Examining signal integrity aspects of a digital pulse will identify where unwanted common-mode current is being generated.

The main point in this editorial is that signal integrity and EMI are related. One cannot perform engineering analysis by working in only one domain. Signal integrity engineers need to learn how to use a spectrum analyzer to see how much RF energy their high speed circuits generate, although an oscilloscope says the signal is fine with regard to digital logic operation. EMC engineers, once they determine the radiating location with a spectrum analyzer must now use an oscilloscope to analyze circuits in the time domain to find the source of common-mode current development. Remember signal integrity and EMI are exactly the same signal, just viewed and analyzed differently.

**Mark Montrose**

*Montrose Compliance Services  
Editorial Board Member  
Interference Technology*

**interference**<sup>ITEM™</sup>  
THE INTERNATIONAL JOURNAL OF  
ELECTROMAGNETIC COMPATIBILITY | **technology**

Editor

Belinda Stasiukiewicz

Editorial Assistant

Allison Titus

Graphic Designer

Erica Osting

Marketing Manager

Dawn Hoffman

Senior Marketing Specialist

Jacqueline Gentile

Senior Business Development Manager

Janet Ward

Business Development Managers

Blake Maclean

Katie Tolton

Administrative Manager

Eileen M. Ambler

Circulation Manager

Irene H. Nugent

President

Graham S. Kilshaw

Publisher Emeritus

Robert D. Goldblum



## USA

1000 Germantown Pike, F-2  
Plymouth Meeting, PA 19462

Phone: (484) 688-0300

Fax: (484) 688-0303

Email:

info@item-media.net

[www.item-media.net](http://www.item-media.net)

## CHINA, HONG KONG

ACT International

Mainland China - Linda Li, +86-21-62511200

Email: lindaL@actintl.com.hk

Hong Kong - Mark Mak, +85-22-8386298

Email: markm@actintl.com.hk

## JAPAN

e-OHTAMA, LTD.

Miho Toshima, +81-50-5538-2852

E-mail: item\_info@e-ohtama.jp

ITEM Media endeavors to offer accurate information, but assumes no liability for errors or omissions. Information published herein is based on the latest information available at the time of publication. Furthermore, the opinions contained herein do not necessarily reflect those of the publisher.

Copyright © 2015 • ITEM Media • ISSN 0190-0943

# DESIGN WITHOUT BARRIERS. PERFORMANCE WITHOUT LIMITS.

When designing components that travel at the speed of sound, precision is everything. Start to finish, from design assistance to prototype to delivery, Orbel delivers custom solutions faster than ever before—turning your specialized engineering needs into a high-performance reality.



AS9100C & ISO 9001 CERTIFIED

**ORBEL**  
ENGINEERED SOLUTIONS

ORBEL.com • 610-829-5000



# EMC LIVE 2015

April 28-30, 2015 - [www.emclive2015.com](http://www.emclive2015.com)

EMC Live 2015 is a unique 3-day online event, featuring live webinar presentations, with practical solutions to electromagnetic interference (EMI) challenges. Various electromagnetic compatibility (EMC) topics including shielding, grounding, filtering, standards, pre-compliance and testing will be covered. EMC Live is applicable to electronics, design and test engineers working in all industries.

## TECHNICAL PROGRAM

### DAY 1 - TUESDAY, APRIL 28

#### KEYNOTE PRESENTATION

10:00 a.m. – 10:30 a.m. (EDT)

#### WEBINAR

##### *Updates to MIL-STD-461-G*

11:00 a.m. – 11:45 a.m. (EDT)

#### OVERVIEW

MIL-STD-461 is the United States Military Standard that controls EMI characteristics of equipment and subsystems. A draft of MIL-STD-461G is presently out for industry review, with a goal of the revision being formally released later this year. Major changes will be discussed in this presentation, not only in terms of what the changes are but also the reasons and rationale behind them.

#### SPEAKER

**Ken Javor** has worked in the EMC industry for 30 years. He is a consultant to government and industry, runs a pre-compliance EMI test facility, and curates the Museum of EMC Antiquities, a collection of radios and instruments that were important in the development of the discipline, as well as a library of important documentation.

Presented by Platinum Sponsor:



### DAY 1 CONTINUED

#### WEBINAR

##### *Making Conducted and Radiated Emissions Measurements for EMI Pre-Compliance Test*

12:15 p.m. – 1:00 p.m. (EDT)

#### OVERVIEW

RF Analog and Digital hardware design engineers/technicians need to evaluate designs for EMI and EMC issues. Pre-compliance testing done before full compliance testing can help identify potential issues early in the design stage to reduce rework and lower cost. This webinar will discuss measurement techniques and tools used for EMI Pre-compliance measurements.

#### SPEAKER

**Ken Carolus** is a Business Development Manager working for HP/Agilent/Keysight Technologies for 30+ years. His roles have included Sales Support Engineer, Application Engineer, Product Planner, Project Manager and Business Development Engineer. During this time he has also developed training classes and seminars for a variety of wireless technologies and RF measurement applications.



Presented by Silver Sponsor:



[www.emclive2015.com](http://www.emclive2015.com)

## DAY 1 CONTINUED

### ROUNDTABLE

#### *Elephants in the Test Room – Part 2*

1:30 p.m. – 2:15 p.m. (EDT)

#### OVERVIEW

Elephant Discussion #1: Addressing Poor EMC Measurement Consistency  
There is a certain amount of irony in the fact that an EMC test facility is denied accreditation if the facility does not offer OATS testing. Yet it was confirmed during the last EMC Live event that there is an enormous disparity in inter-site OATS measurements. This begs the question as to why such reverence is given to the OATS test site, and why they are used as the basis of any type of reference at all.

*Can the ISO17025 department charged with covering EMC laboratories not work with the EMC industry to improve OATS measurement consistency?*

Elephant Discussion #2: The Search for a Golden 'Emissions Test Set-Up Proving' Emitter for use in 3-meter Chamber Tests\*

The use of a comb generator's output signature is a good method for checking all is well with an emissions test set-up, but in reality, simply proves the test system is consistent in providing the same wrong readings as before. Spot test-frequencies from signal generators overcome the arbitrary power levels and frequencies produced by comb generators.

*Is there a way to utilize existing calibrated test equipment and signal generator spot frequencies to calibrate the 3-meter chamber emissions test set-up?*



#### MODERATOR

**Tom Mullineaux** is an author and RF Engineer who has been in the EMC industry for 20 years, both as a supplier to the industry, and as a hands on program manager, achieving EMC compliance for new products.

#### PANELISTS

**Bruce Fagley** is the EMC technical manager for TUV Rheinland, with technical responsibility for all 5 of TUV's North American EMC facilities. He has more than 20 years' experience in EMC.

**Patrick G. André** received his physics degree in 1982 from Seattle University, with post graduate work in Electrical Engineering and Physics. He has worked in the Electromagnetic Compatibility (EMC) field over 30 years. He is a NARTE Certified Engineer in both EMC and ESD.

**Steve Koster** is a vice president at Washington Laboratories where he has dealt with EMC and Radio requirements for the last 21 years. Steve has tested or directly supervised thousands of projects over the years for FCC, MIL-STD, CE Mark, DO160 and REG Guide 1.180 and EPRI 102323.

**Joe DiBiase** graduated from Villanova University, in 1983 with a BS EE degree. Throughout his career he has been involved in EMC and he now is an engineer at AR RF/Microwave Instrumentation.

**\*EDITOR'S NOTE: TO READ MORE ABOUT HARMONIC COMB GENERATORS, CHECK OUT KEN WYATT'S ARTICLE ON PAGE 16!**

## DAY 1 CONTINUED

### WEBINAR

#### *The Future in Radiated Immunity Testing*

2:45 p.m. – 3:30 p.m. (EDT)

#### OVERVIEW

Traditional radiated immunity testing, such as IEC61000-4-3 for commercial products, requires 1% steps from 80 MHz to 1GHz. This can become time-consuming and costly. What if you could maintain compliance but test up to 10 times faster? Utilizing improved dwell time efficiency, a breakthrough technology is now available to support RI testing. Invest 30 minutes to see how this new technology allows you to test multiple tones simultaneously and get your product to market faster.

#### SPEAKER



**Carl Mueller** Carl Mueller is a Systems Engineer for AR RF/Microwave Instrumentation's Radiated and Conducted Immunity Systems, and test software. Carl is actively involved in product and system design, development, and testing as well as worldwide sales and customer support. With well over 20 years of experience in military systems integration and testing, Carl has worked as Principle System Engineer on radar warning receivers, communication jamming systems, and aircraft simulated training systems. His background includes extensive client contact, including on-site customer training. Mueller worked for AEL, Tracor, Marconi, BAE Systems, Cobham, and ACCU-SORT Systems prior to joining AR.

Presented by Gold Sponsor:



### WEBINAR

#### *Limitations of Active Rod Antennas in Emission Testing*

4:00 p.m. – 4:45 p.m. (EDT)

#### OVERVIEW

This webinar will discuss the general characteristics of rod antennas as used for emissions testing, and some of the intrinsic design limitations and drawbacks, such as impedance values. Some of the ways to overcome these drawbacks include using a fiber optic instead of a coax cable, and by connecting the antenna directly to an EMI receiver; this gains better control of the antenna behavior, and the receiver is able to measure the rod antenna's critical parameters continuously. By integrating the receiver with the antenna, the drawbacks of transferring the RF signal via fiber optic in analog mode are avoided. This webinar should be attended by all compliance and test engineers, especially those involved in military and automotive electronics, and any engineer involved in testing to CISPR 12, CISPR 16, CISPR 25, MIL-STD, and DO-160.

*(Limitations' webinar information continues on next page)*



## DAY 1 CONTINUED

(*Limitations' webinar information continued from previous page*)



## SPEAKER

**Roberto Grego** graduated in Electrotechnics in 1976 and served in the Army (Telecommunications). Since then, he has been involved in promoting high-profile T&M equipment since the early 80's in almost all applications fields from vibration analysis to RF, including EMC, and digital. From the 90s he has developed his career in international sales and marketing of diversified technical equipment.

Roberto joined Narda Safety Test Solutions (Italy) in 2005 as International Sales Manager for the EMC product line branded PMM, and is currently involved in the development of innovative solutions.

Presented by the new FR4003 Field Receiver by:



## DAY 2 - WEDNESDAY, APRIL 29

## WEBINAR

### *Improving EMI Compliance and Pre-compliance Testing Throughput with Time Domain Scanning*

11:00 a.m. – 11:45 a.m. (EDT)

## OVERVIEW

EMC compliance and pre-compliance testing can take a considerable amount of time, affecting test house revenue and product development time-to-market. This webinar discusses the time-reduction benefits that Time Domain scanning can bring to EMC testing.

The topics being presented are: What is Time Domain Scanning; Benefits of Time Domain Scanning for Commercial and MIL STD testing; Issues and concerns when using Time Domain Scanning; Using correct dwell times; Complying with CISPR requirements; and Receiver design vs.

Time Domain scanning speed tradeoffs – overload and sensitivity concerns.



## SPEAKER

**Mark Terrien** has over 20 years of product development experience with Hewlett Packard and Keysight (formerly Agilent) Technologies, with a focus on EMC receivers, spectrum analyzers and microwave test equipment. He holds an MBA from Golden Gate University in San Francisco and an MSEE in

Electromagnetic Wave Theory from the University of Wisconsin-Madison.

Presented by Silver Sponsor:



## DAY 2 CONTINUED

## WEBINAR

### *Early-Time HEMP Vs. IEMI Protection Measures: How are They Similar; Different*

12:15 p.m. – 1:00 p.m. (EDT)

## OVERVIEW

This webinar will focus on E1 HEMP (Early-Time High Altitude Electromagnetic Pulse) and IEMI (Intentional Electromagnetic Interference) High Frequency Protection Measures and the similarities and differences between the two. A variety of frequency specific point-of-entry systems can be incorporated in facility and equipment design when the frequencies of concern are properly identified. It is important to note that both narrowband and wideband EMP waveforms can be produced by non-lethal weapons using modern technology. The challenge is to accommodate numerous entry points for MEP and HVAC requirements while maintaining shield integrity and pulse. (continued...)



## SPEAKER

**Michael Caruso** is Director, Government & Specialty Business Development for ETS-Lindgren. He is a recognized leader in the RF Shielded Enclosure/ Anechoic Chamber Industry with 30-years' experience in account management, project management, technical applications, business development, marketing and sales planning. His operational experience in running

an EMC Laboratory adds to his depth of knowledge of real-world testing and leadership challenges.

Presented by:



## ROUNDTABLE

### *HEMP/IEMI and the Critical Infrastructures - Part 2*

1:30 p.m. – 2:15 p.m. (EDT)

## OVERVIEW

In this roundtable discussion, we will focus on the similarities and differences between the high-altitude electromagnetic pulse (HEMP) created by a nuclear detonation in space and intentional electromagnetic interference (IEMI) caused by electromagnetic weapons. Both the threats and protection methods will be reviewed. In addition the roundtable will include a discussion of misconceptions concerning HEMP/IEMI and their impacts on electronic systems.

## MODERATOR



**Bill Radasky** received his Ph.D. in Electrical Engineering from the University of California at Santa Barbara in 1981. He has worked on high power electromagnetic applications for more than 44 years and has published more than 400 reports and articles dealing with electromagnetic environments, effects and protection. In recent years, he has worked extensively in performing assessments for critical infrastructures to the threats of HEMP, IEMI and geomagnetic storms.

## DAY 2 CONTINUED

(HEMP roundtable information continued from previous page)

### PANELISTS

**George Baker** is emeritus professor of applied science at James Madison University. In addition to teaching graduate and undergraduate S&T courses, Baker directed the start-up and served as Technical Director of the university's Institute for Infrastructure and Information Assurance (IIIA). Much of his career was spent at the Defense Nuclear Agency (DNA) and the Defense Threat Reduction Agency (DTRA) directing national programs to protect strategic systems against EMP, including developing protection standards and guidelines.

**Michael Caruso** is a recognized leader in the RF Shielded Enclosure/Anechoic Chamber Industry with 30-years' experience in account management, project management, technical applications, business development, marketing and sales planning. Caruso chairs ETS-Lindgren's HEMP/EMP Product Team and has been involved in a sales, design, engineering and project management capacity for hundreds of projects involving high performance RF Shielding, both large and small over the years totaling over \$75MM.

### WEBINAR

#### *Electromagnetic Interference Testing (EMI) Basics – Part1: Capturing Pulsed/Intermittent Signals with Frequency Swept, Frequency Stepped, and Time Domain Scan Methodologies*

2:45 p.m. – 3:30 p.m. (EDT)

### OVERVIEW

Pulsed and/or intermittent signals are difficult to detect and even more difficult to properly characterize the amplitude across frequency. The ability to properly capture and characterize these intermittent signals is an important capability to the EMC engineer. There are several methods to perform the task and each has its own strengths and weaknesses. Thorough understanding of the method of measurement is necessary. During this technical session, we will compare three methodologies, namely Frequency Swept, Frequency Stepped and Time Domain Scan. We will demonstrate the details of each for a pulsed signal stimulus and provide insight for best measurement techniques for each method.

### SPEAKER



**Bill Wangard** is the EMI Receiver and Radio monitoring Product Manager at Rohde & Schwarz. He has 20+ years of RF and Receiver experience at Motorola and Rohde & Schwarz. Bill authored numerous patents at Motorola.

Presented by Platinum Sponsor:



## DAY 2 CONTINUED

### WEBINAR

#### *Choosing the Right Antenna for Today's Testing requirements*

4:00 p.m. – 4:45 p.m. (EDT)

### OVERVIEW

How to choose the correct EMC test antenna based upon the requirements of the standard. A simple guide to determining the correct choice of antenna to match the test required. RF veteran Tom Mullineaux in collaboration with the experts at AH Systems presents the basics and a framework for beginners, as well as more advanced topics for intermediate and advanced test engineers – such as antenna beamwidth and how to address it. All levels of EMI test engineers, technicians and managers will benefit from this presentation.



### SPEAKER

**Tom Mullineaux** is an author and RF Engineer who has been in the EMC industry for 20 years, both as a supplier to the industry, and as a hands on program manager, achieving EMC compliance for new products.

Presented by:



## DAY 3 - THURSDAY, APRIL 30

### WEBINAR

#### *Simulating Lightning and EMP Effects in Aerospace Applications*

11:00 a.m. – 11:45 a.m. (EDT)

### OVERVIEW

Aircraft designers are required to obtain certification for protection against lightning. Aircraft must be able to withstand the direct effects of high intensity lightning stroke currents flowing in the airframe and indirect effects of electromagnetic field coupling into electronics systems. Hardening aircraft to the effects of EMP is another important concern for aircraft designers.

Computational electromagnetics (CEM) analysis codes are increasingly used during the certification process to enhance and streamline expensive physical tests. CST STUDIO SUITE offers powerful CEM modeling and solver technology for simulating lightning and EMP effects. Special techniques are available for efficiently representing critical features such as composite airframe paneling, joints between panels and internal cable systems. CST's field solvers may be accelerated using high performance computing systems to minimize simulation times. This presentation will provide an overview of CST's modeling technology and approach for lightning and EMP simulation, along with several application examples.

(Simulating webinar information continued on next page)



## DAY 3 CONTINUED

(*'Simulating' webinar information continued from previous page*)



## SPEAKER

**David Johns** is VP of Engineering at CST of America. He received his PhD from Nottingham University UK in 1996 for developing a new 3D frequency-domain Transmission-Line Matrix (TLM) method. Dr. Johns has over 25 years of experience in developing and applying electromagnetic field simulation. He specializes in EMC, EMI and E3 applications.

**CST**



Presented by:

## WEBINAR

***Electromagnetic Interference Testing (EMI) Basics – Part 2: Looking Beyond Pass/Fail results with modern EMI Compliance Tests and Methodologies***

12:15 p.m. – 1:00 p.m. (EDT)

## OVERVIEW

Meeting EMC standards can be a daunting task, and it can become very expensive – especially when your design comes back from a test lab as 'failed'. Often there is little insight into why or where your design failed, let alone any hints to a possible root cause. But this is changing! More and more Labs and services offer debug information beyond the pass/fail results. Learn more about modern measurement techniques and instrumentation that enables proper debug and analysis for your EMI/EMS compliance tests.



## SPEAKER

**Bill Wangard** is the EMI Receiver and Radio monitoring Product Manager at Rohde & Schwarz. He has 20+ years of RF and Receiver experience at Motorola and Rohde & Schwarz.

Presented by Platinum Sponsor:



## ROUNDTABLE

***New Shielding Technologies: Issues and Solutions***

1:30 p.m. – 2:15 p.m. (EDT)

## OVERVIEW

This roundtable will focus on shielding, and the fields generated by new technologies like Near Field Communication, or Wireless Power Charging. These devices' technologies could possibly generate issues due to EMI and this roundtable will discuss them.

[www.emclive2015.com](http://www.emclive2015.com)

## DAY 3 CONTINUED

## WEBINAR

***EMC Testing Essentials***

2:45 p.m. – 3:30 p.m. (EDT)

## OVERVIEW

Demystify EMC testing and requirements for your whole team. This presentation covers: The top 8 reasons that companies fail EMC testing; The 8 traits, behaviours and mindsets of companies that pass first time; a top level overview of immunity testing, and how to create an emissions and immunity test plan for a specific product



## SPEAKER

**Andy Eadie** is the founder and CEO of EMC Fast Pass, an online training and education platform for engineers involved in EMC and RF pre-compliance testing, troubleshooting and certifications. Previously Andy worked as senior hardware design engineer for Panasonic and was the founder and Senior EMC Engineer of Island Labs, Canada which offered EMC testing and RF certification services.

Presented by:

**EMC FASTPASS**

## WEBINAR

***The Pat & Ken Show: '2015 EMC Product of the Year' Discussion***

4:00 p.m. – 4:45 p.m. (EDT)

## OVERVIEW

There has been a significant amount of innovation in the EMC market over the last 12 months, including breakthroughs in test instrumentation, new ideas in components, and advancements in materials. Join EMC consultants Patrick Andre and Ken Wyatt in some lively conversation as they look over the entries to the all-new 2015 EMC Product of the Year contest. Pat and Ken will review the innovations on display this year, and announce the winners, as chosen by EMC Live 2015 attendees.



To vote for the 2015 EMC Product of the Year, visit [www.emclive2015.com](http://www.emclive2015.com).

## SPEAKERS

**Kenneth Wyatt**, Sr. EMC Engr, Wyatt Technical Services, holds degrees in biology and electronic engineering and has worked as a product development engineer for 10 years. For over 20 years, he has worked as an EMC engineer and has been an independent EMC consultant since 2008.



**Patrick G. André** has worked in the Electromagnetic Compatibility (EMC) field over 30 years. He is a NARTE Certified Engineer in both EMC and ESD. He is president of André Consulting, Incorporated.

# CPI: Powering your world.



## Meet the new automotive and military EMC standards with CPI high-powered TWT amplifiers.

EMC facilities worldwide depend on CPI amplifiers for superior performance, reliability, and quality. CPI has a proven track record of consistent performance, service, and support. For EMC testing, CPI is the only manufacturer of both the TWT and the amplifier, ensuring quality designs and smooth operation. CW and pulsed amplifiers are available from 1 to 95 GHz, with power levels exceeding 2 kW over selected frequencies.

### TWTAs for EMC applications

1.0 -18.0 GHz up to 1000 W CW (10 kW available over select bands)

18.0-40.0 GHz up to 150 W (2.0 kW over select bands)

40.0 – 50.0 GHz up to 80 W

Full Pulsed Amplifier Suites to 8 kW  
(megawatts pulsed power capability)

### For more information please contact:

Communications & Power Industries Canada, Inc.  
45 River Drive, Georgetown, Ontario, Canada L7G 2J4

For Sales offices worldwide please e-mail: [marketing@cpi.cpii.com](mailto:marketing@cpi.cpii.com)  
Or look us up on the Web at: [www.cpii.com/emc](http://www.cpii.com/emc)



**satcom** division



# Harmonic Comb Generators Are Useful Tools

## KENNETH WYATT

Senior EMC Engineer  
Wyatt Technical Services

### INTRODUCTION

**ONE TOOL EVERY EMC** test lab should own is a harmonic comb generator. A comb generator is simply a device that will produce a set of harmonically related CW signals whose spacing is based on a fundamental oscillator frequency. For example, if we were to start with a 10 MHz clock oscillator and feed the digital output into a coax connector, we'd produce a series of CW higher-order harmonics spaced every 10 MHz apart. Generally, the harmonic amplitudes produced are fairly consistent, so they may be used as a frequency and amplitude calibrator. Comb generators are most often used for ensuring your semi-anechoic test chamber is reading correctly from day to day. Simply place the generator on the turntable and measure specific harmonics each day and record the trend data. I've occasionally found loose coax connectors or bad coax cables by comparing the current readings with past data. This would also fulfill the requirement for "equipment verification testing" as specified in ISO 17025. However, there are several other

interesting uses for these generators, especially if you build yourself a small one.

### COMB GENERATOR THEORY

We all know that fast digital signals produce a range of harmonics. A periodic square wave (Figure 1) may be represented by a series of more basic signals called "basis functions" (Figure 2). Assuming the rise and fall times of the square wave are straight up and down, an infinite number of harmonically-related basis functions, or sine waves are required. Digital circuitry today uses rise and fall times of sub-nanoseconds, which can generate harmonics ranging up to several hundreds to thousands of MHz.

If we take a simple crystal oscillator and capacitively couple the output to a coax connector, we've just created a pulse generator. The capacitor differentiates the square wave, allowing only the edges to pass as positive and negative-going spikes. These pulses result in a "comb" of harmonics spaced at half the fundamental frequency.

The better comb generators generally use a capacitively-coupled diode following the digital clock signal. These can be a standard signal diode, a Schottky diode, a step recovery diode (SRD) or even a high frequency (2-3 GHz) emitter-base junction. When these semiconductor junctions come out of reverse-bias, they "snap" on with a very fast edge – on the order of picoseconds for SRDs (Figure 3).



# for EMC

## R&K RF POWER AMPLIFIER

**New Design**

**A080M102 Series**

**Almost 1/3!!**



500W MODEL  
A080M102-5757R

1kW MODEL  
A080M102-6060R

1.5kW MODEL  
A080M102-6262R

**[RENEWAL!]**

### R&K RF Power Amplifier / 80MHz - 1GHz Series

- Downsizing!!
- High reliability!!
- High maintainability!!
- **After modified this building-block construction, gives you totally different RF power specs capability.**

#### · R&K Broadband RF POWER AMPLIFIERS LINE UP

Series	Frequency	Output Power
A009K251	9kHz ~ 250MHz	25W ~ 12kW
A009K401	9kHz ~ 400MHz	25W ~ 500W
A080M102	80MHz ~ 1GHz	10W ~ 4kW
A501M272	500MHz ~ 2.7GHz	5W ~ 120W
A801M202	800MHz ~ 2GHz	10W ~ 2kW
A801M402	800MHz ~ 4GHz	10W ~ 700W
GA102M252	1GHz ~ 2.5GHz	50W ~ 2kW
GA252M602	2.5GHz ~ 6GHz	10W ~ 250W



10kW MODEL  
A010K221-7070R

[www.rk-microwave.com](http://www.rk-microwave.com)



**R&K Company Limited**

721-1 Maeda, Fuji-City, Shizuoka-Pref. 416-8577 Japan  
TEL: +81-545-31-2600 FAX: +81-545-31-1600 E-mail: info@rkco.jp



## SIMPLE DIY COMB GENERATORS

Most simple comb generators simply utilize the fast edges from a crystal oscillator or oscillator module. Long time publisher, Gary Breed, devised a simple version using only a crystal and quad NAND gate (Reference 2). This is the lowest-cost design I've seen.

AMSAT-UK has a design that can easily go to 6 GHz (Figure 4). This may be purchased as a parts kit for about \$35. The unit uses a 96 MHz crystal, whose oscillator feeds a MAR-3 microwave amplifier and then into back-to-back SRD diodes. This design produces useful harmonics to 6 GHz (Figure 5).

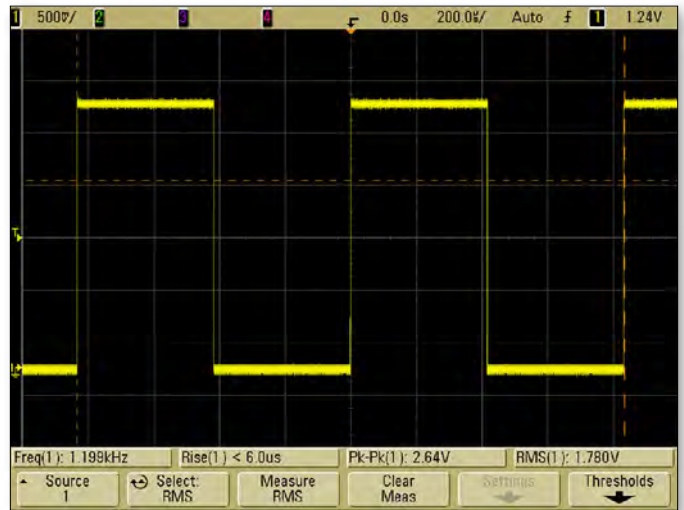
If a comb generator is needed quickly, simply start with a crystal oscillator module and couple the output through a small capacitor. The value matters very little and can range from 27 pF to 100 nF. This will generally produce nice harmonics up through 300 MHz, or more. For example, a 10 MHz oscillator will produce positive and negative spikes every 5 MHz, producing harmonics every 5 MHz. If the oscillator is near a 50% duty cycle (rare), the even-order harmonics will be suppressed to some degree. Adding a high-current driver will usually square up the edges better and create higher frequency harmonics. Adding a single diode or back-to-back diodes will also get you higher in frequency. The better comb generator designs will use Schottkey or SRD diodes. Because SRDs are mighty expensive and somewhat hard to find, you may also use the base-emitter junction on one of the high frequency (ft of 2-3 GHz) transistor.

Let's take a look at a simple circuit I use for some of my EMC seminar demos (Figure 6). This was developed by EMC consultant, David Eckhardt (Reference 4).

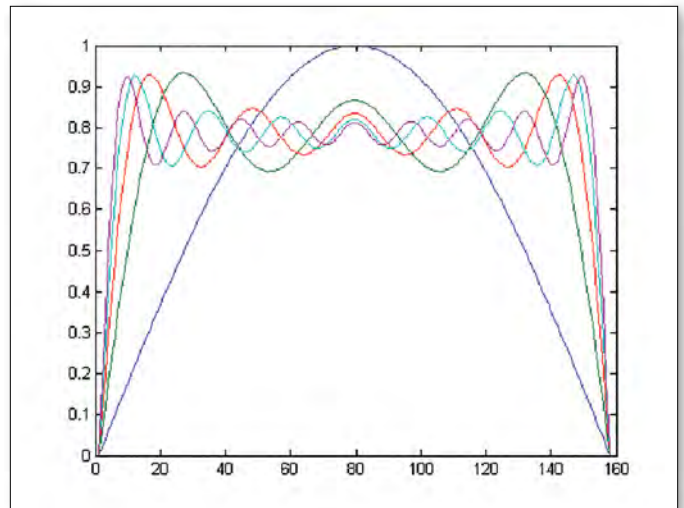
This was built on a small perf-board (Figure 7) and includes a 5V regulator, so it can be powered from a 9V battery. Figure 8 shows the waveform at the output. As you can see, the capacitor differentiates the rising and falling edges and the diode, when biased off, creates a very fast edge – on the order of 5 nanoseconds. Because the capacitor passes both the leading and falling edges, the harmonics generated will be 5 MHz apart (Figure 9). By utilizing a DIP socket, I can plug in different frequency oscillators, depending on my needs.

## COMMERCIAL COMB GENERATORS

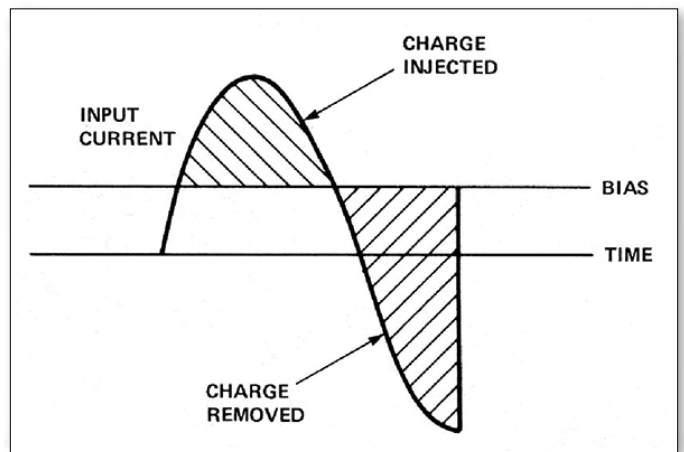
A number of companies make harmonic comb generators. I purchased a low-cost comb generator (Figure 10) from Applied Electromagnetic Technology (AET) for approximately \$350 (see references). These generators are available in various fundamental comb frequencies from 1.8 MHz up to 200 MHz and have useful harmonic frequencies well into the GHz. For general-purpose use, I purchased their 10 MHz model, which produces harmonics from 10 to over 1000 MHz. A small USB power supply from or USB port is used for power. The company also makes models specifically for measurement verification of semi-anechoic



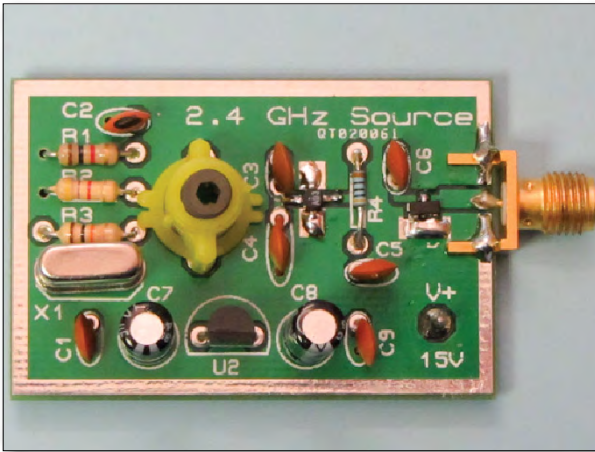
**FIGURE 1:** A periodic square wave digital signal. The rise and fall times determine the amount of harmonic content in the frequency domain.



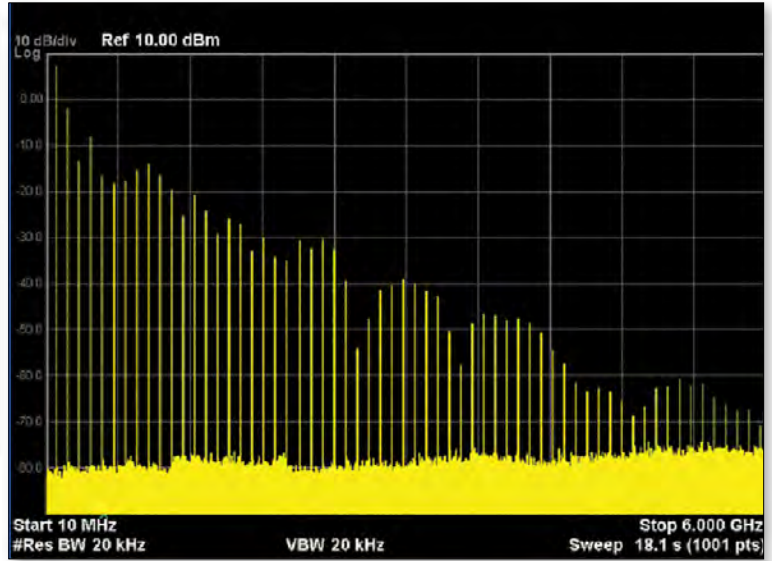
**FIGURE 2:** A representation of the square wave is comprised of a linear combination of basis functions, or sine waves. (Image courtesy of MathWorks)



**FIGURE 3:** An idealized waveform of the forward and reverse current through a step recovery diode (SRD), or equivalent high frequency diode. Note that the reverse current tends to “snap” off quickly, creating a very fast edge and corresponding high frequency harmonics.



**FIGURE 4:** The AMSAT-UK 2.4 GHz comb generator kit costs about \$35 and produces useful harmonics to 6 GHz.



**FIGURE 5:** The harmonic spectrum of the AMSAT-UK comb generator.

chambers. Their unique spherical dipole design may be turned to either the vertical or horizontal polarization. Read the full review of two of these generators in the Technical Articles section of my Web site (Reference 7).

Because the rise times of the AET generator are in the low ns range, the pulses create a wide range of harmonics.

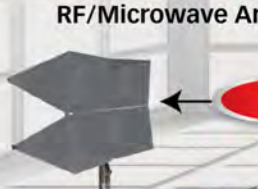
The 10 MHz model produces useful harmonics out beyond 1000 MHz. A sample voltage output from their 1.8 MHz AET generator is shown in Figure 11.

Using a comb generator as a standard source for verifying chambers will require an omnidirectional antenna. The antenna I used (Figure 12) is available through Evans




## YOUR COMPLETE SOLUTION FOR RADAR PULSE TESTING

**RF/Microwave Amplifiers**



**4 m**

**300 v/m & 600 v/m**  
1.2 GHz - 1.4 GHz  
2.7 GHz - 3.1 GHz



**1.75 m**  
**5.5 m**

**300 or 600 VOLTS per meter**




**0.5 kW - 8 kW+ Pulse Amps**

Model	Frequency Range	Power
S1412 - 500P	1.2 - 1.4 GHz	500 Watts Pulse
S1412 - 1 kWP	1.2 - 1.4 GHz	1 kW Pulse
S1412 - 2 kWP	1.2 - 1.4 GHz	2 kW Pulse
S1412 - 4 kWP	1.2 - 1.4 GHz	4 kW Pulse
S1412 - 8 kWP	1.2 - 1.4 GHz	8 kW Pulse
S1412 - XX kWP	1.2 - 1.4 GHz	XX kW Pulse
S3127 - 500P	2.7 - 3.1 GHz	500 Watts Pulse
S3127 - 1 kWP	2.7 - 3.1 GHz	1 kW Pulse
S3127 - 2 kWP	2.7 - 3.1 GHz	2 kW Pulse
S3127 - 4 kWP	2.7 - 3.1 GHz	4 kW Pulse
S3127 - 8 kWP	2.7 - 3.1 GHz	8 kW Pulse
S3127 - XX kWP	2.7 - 3.1 GHz	XX kW Pulse

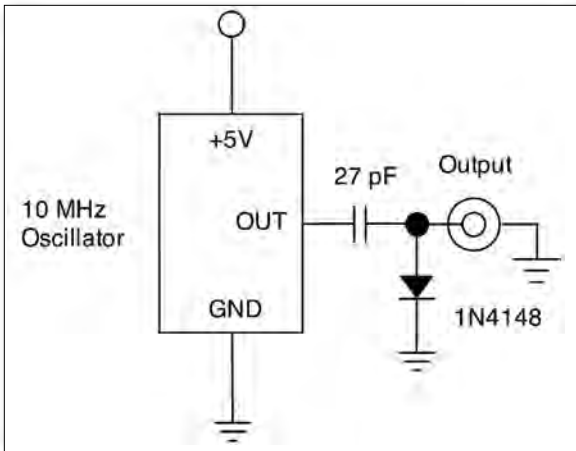
### INSTRUMENTS FOR INDUSTRY

903 South 2nd Street • Ronkonkoma, NY 11779  
Tel: 631-467-8400 • Fax: 631-467-8558 • sales@ifi.com • www.ifi.com

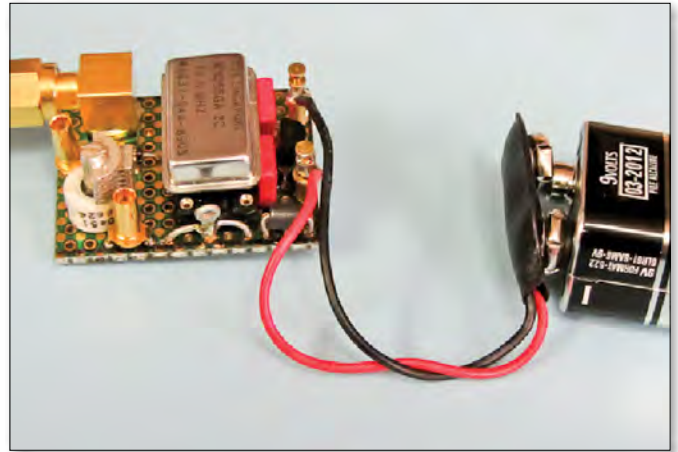


**COMPLIANCE TEST SOLUTIONS**





**FIGURE 6:** A simple comb generator using a 10 MHz oscillator, a capacitor (almost any value will work fine) and small signal diode. The harmonics start tapering off around 300 MHz.



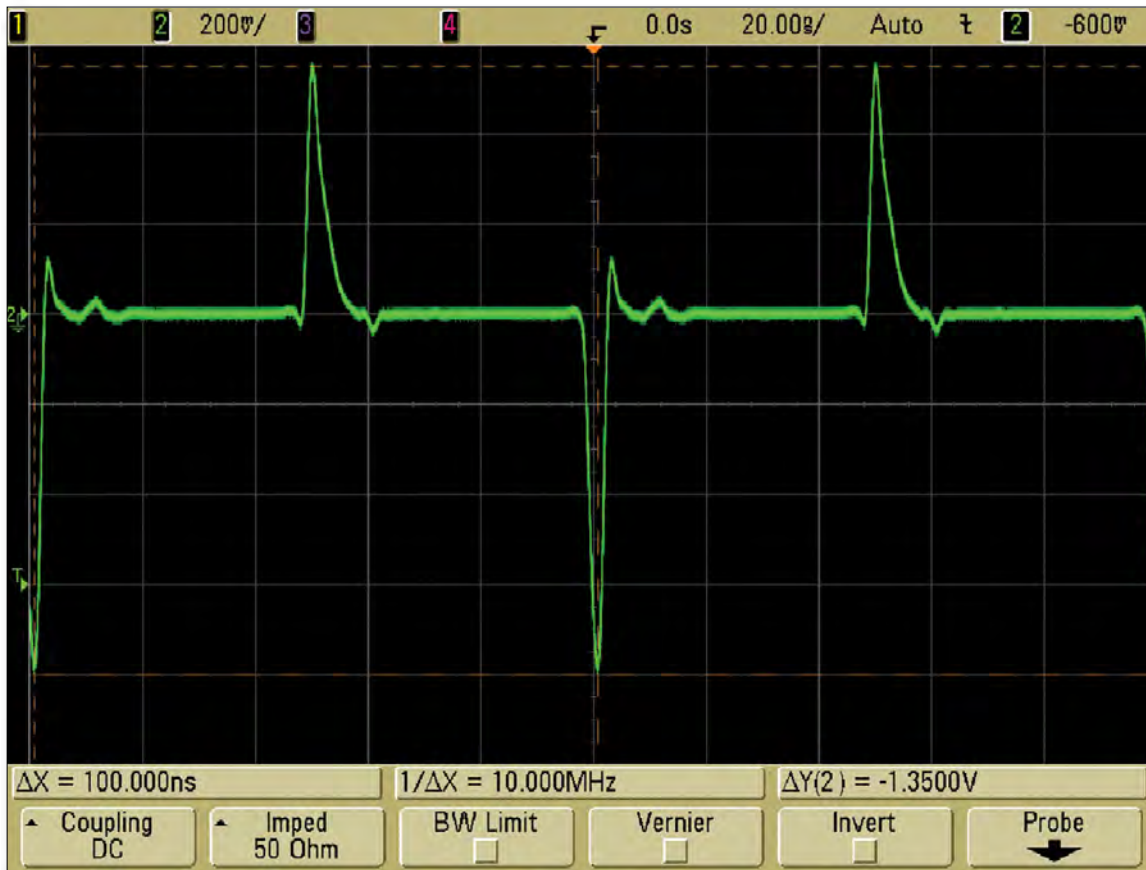
**FIGURE 7:** The simple DIY comb generator I use for demonstration purposes during my EMC seminars.

Engineering as their model EE-3 (Reference 12), but may be easily constructed from telescoping antennas or welding rod. As you can see (Figure 13), it appears to yield a good omnidirectional radiation pattern.

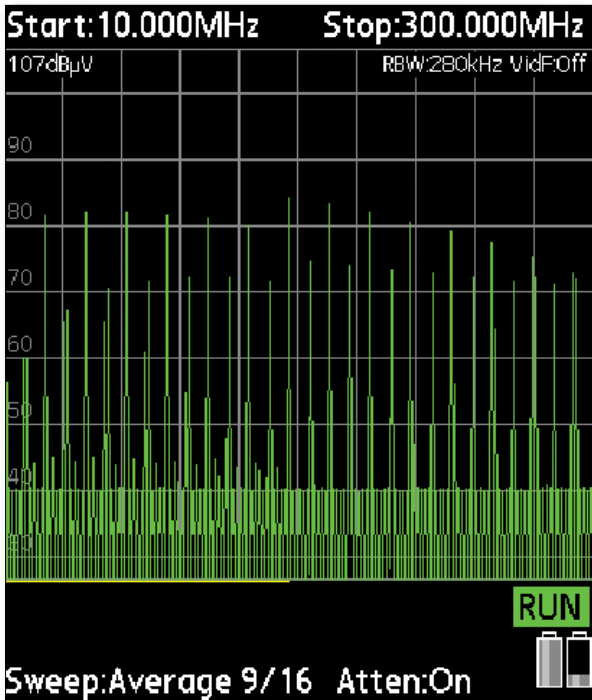
I purchased a small switch-mode USB power supply from Radio Shack to power the system. The generator is connected to the antenna with a short coaxial cable. During the chamber

test, it's best to use several ferrite chokes spaced evenly along the coax and power supply cable to reduce any effect of cable radiation by common-mode currents.

While the comb generator above is pretty versatile in general, it's not really designed to easily produce an omnidirectional signal for chamber measurements. For this, I'd recommend one of the many battery-powered comb genera-



**FIGURE 8:** Resulting waveform for the simple DIY comb generator. The series capacitor differentiates the square wave from the oscillator and the approximately 5 nanosecond pulses create the harmonic content.



**FIGURE 9:** Representative harmonics from the DIY comb generator. The lower harmonics are the even-order ones due to the oscillator deviating from a perfect 50% duty cycle.



**FIGURE 10:** Example of the AET comb generator. This \$350 unit is USB-powered and produces harmonics out past 1 GHz.



## TESEQ AUTOMOTIVE EMC – KEEP PACE WITH THE GLOBAL LEADER

Worldwide presence and local service: Teseq is peerless as the leader in Automotive EMC. Our pioneering work to establish EMC tests for motor vehicle electronics and our active involvement in the standardization committees satisfy automotive manufacturers and suppliers around the world. Teseq ensures that the latest advances are continuously incorporated in our test systems and our seven calibration centers guarantee a worldwide commitment to high quality standards and customer service.

**Teseq’s unique range of competencies and solutions:**

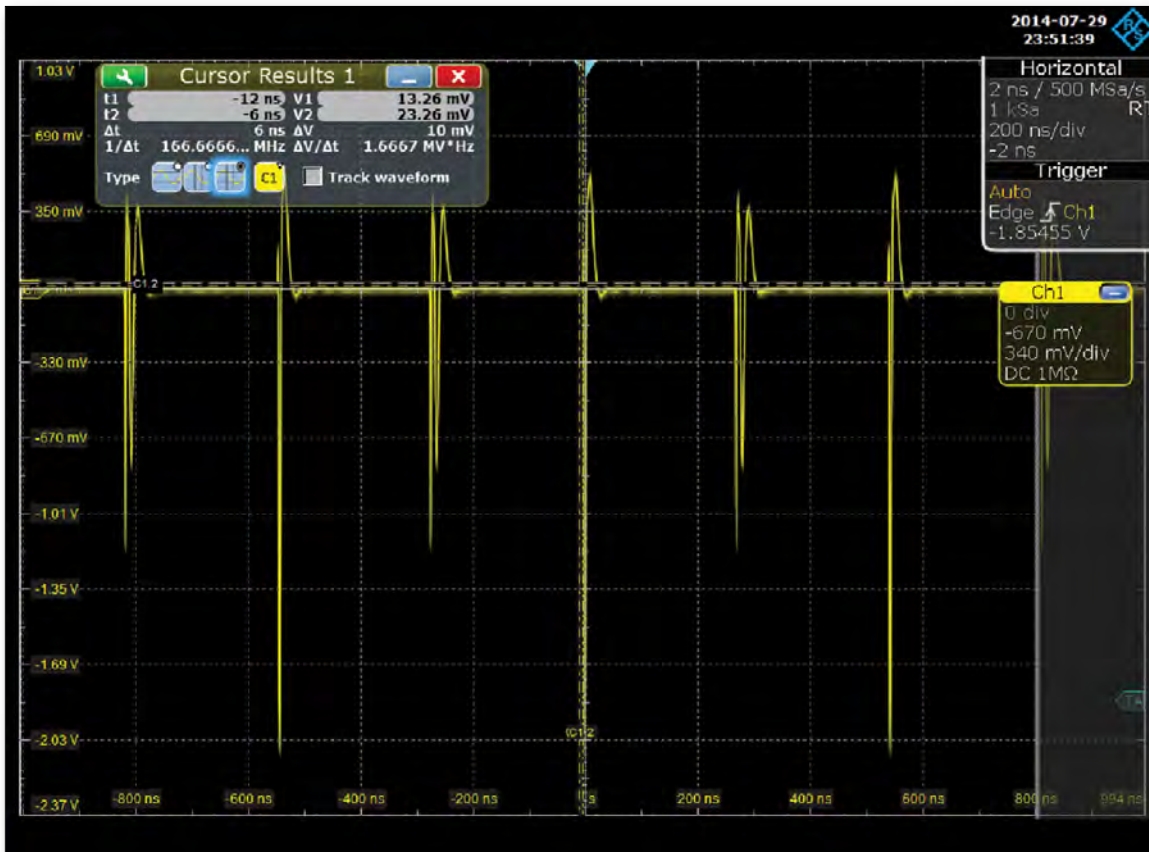
- Emissions
- Immunity
- BCI
- ESD 30 kV
- Transients
- Reverberation
- RF Solutions
- GTEM

Teseq Inc. Edison, NJ USA  
T +1 732 417 0501 F +1 732 417 0511  
usasales.cts@ametech.com www.tesequsa.com

**AMETEK®**  
COMPLIANCE TEST SOLUTIONS

**TESEQ**  
Advanced Test Solutions for EMC





**FIGURE 11:** The output pulses from the 1.8 MHz version of the AET generator. The rise time is about 2 ns.

tors designed for this purpose. The AET Model DRFS (Figure 14) is one of many examples. This generator may be adjusted with a recessed rotary switch, to 10, 64, 100 and 133 MHz comb frequencies. Harmonic frequencies are useful well into the GHz region. The company also makes spherical models, simulating a point source, specifically for verification of chambers and open area test ranges. These may be easily configured for both horizontal and vertical polarization.

While this model was designed to be attached to horn antennas, attaching a short vertical monopole makes it useful for verifying chamber measurements (in vertical polarization, only). Any short antenna (including DIY from stiff wire) should work satisfactorily. Ideally, it should resonate mid-band in the operational range of the generator.

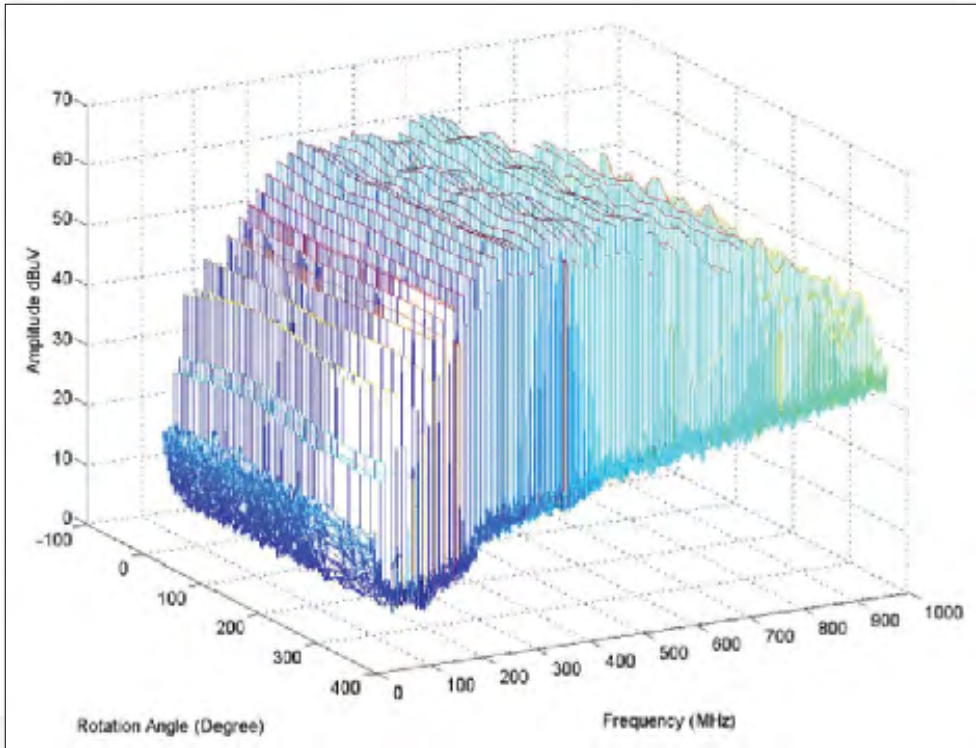
Many other companies make comb generators, including Com-Power ([www.com-power.com](http://www.com-power.com)) and York EMC Services (<http://www.yorkemc.co.uk>). Both companies sell a variety of models that produce useful harmonics up to 40 GHz. Com-Power (Figure 15) also makes one specifically designed to verify conducted emission test setups that covers the 150 kHz to 30 MHz range.



**FIGURE 12:** Reference antenna used for comb generator testing in a 3m chamber. The elements are telescoping, but I used it in the collapsed state to emulate a “point source” antenna.

## HOW TO USE COMB GENERATORS

Comb generators are certainly useful for characterizing chambers by measuring them as you would any normal product, but they are also useful for many other things. I’ve



**FIGURE 13:** 3D plot of frequency, amplitude and azimuth (rotation) from zero to 360 degrees. This plot shows the amplitude versus frequency of the system. The amplitude falls off at the low end due to inefficiencies in the antenna. You can also see that the omnidirectional antenna used becomes less so above about 700 MHz.

**THE BEST EMC-TEST-EQUIPMENT  
FOR ANY APPLICATION:**

**emtest**  
the benchmark for emc

Automotive + Telecom +  
Consumer Products + Military +  
Industrial + Medical + Avionics



Your **direct** line to AMETEK Compliance Test Solutions is **+1 732 4170501**

AMETEK Compliance Test Solutions › 52 Mayfield Ave. › Edison, NJ 08837, USA  
Tel.: +1 732 417 0501 › Fax: +1 732 417 0511  
usasales.cts@ametek.com › www.emtest.com

**AMETEK**  
COMPLIANCE TEST SOLUTIONS





**FIGURE 14:** AET model DRFS comb generator. This was designed to use as a calibration source for anechoic chambers.

used one to measure the shielding effectiveness of prototype enclosures and to determine the resonance of cables. I also use the small AET model as a pulse or harmonic generator for many of the experiments I demonstrate during my EMC seminars.



**FIGURE 15:** Radiated and conducted comb generators from Com-Power (Courtesy of Com-Power).

### RESONANCE MEASUREMENT

My colleague, Doug Smith, has recently developed a couple unique uses for small comb generators – measuring the resonant frequency of cables and the shielding effectiveness of cable shields. These papers are listed in References 5 and 6.

To measure cable or structural resonances, connect one probe to the comb generator and clamp it around the cable to be measured. This will inject harmonic currents into the cable. Connect the second current probe to the input of a spectrum analyzer. In my case, I used a Rohde & Schwarz RTE 1104 oscilloscope and used the FFT function to display a nice resonance spectrum (Figure 16).

Figure 17 shows a typical screen capture of the cable resonance. I found the 1.8 MHz comb generator best to use for this purpose, because the harmonics are much closer together, allowing better resolution of the resonant peak.

Interestingly, if you plug one end of the cable into the oscilloscope, such that the shield is connected to the instrument enclosure, the image of the 1m cable will reflect into the enclosure (plus line cord), effectively forming an electrical half-wave dipole at half the resonant frequency. I discussed this effect in Reference 11.

### SUMMARY

Use of a comb generator is very handy during times when you need a known characterized and stable source of signals. They

# RENT EMC TEST GEAR

**COMPLETE SYSTEMS**  
 MIL-STD-1275 • IEC 61000 • MIL-STD-461 • DO160 • Telcordia/Bellcore 1089  
 IEC60601-1-2 • ISO 7637 • HIRF • Lightning Strike • EFT/Burst • Ringwave  
 Dips & Interrupts • Radiated & Conducted • Emissions & Immunity  
 Harmonics & Flicker • Surge & more...

**RENT FROM THE LARGEST SUPPLIER OF EMC EQUIPMENT**  
 Teseq • Haefely • Keytek • Narda • Solar • IFI • NoiseKen  
 Montena ETS-Lindgren • Rohde & Schwarz • AE Technon  
 Com-Power • Agilent • EM Power • Amplifier Research • FCC  
 EM Test • EMC Partner & more...

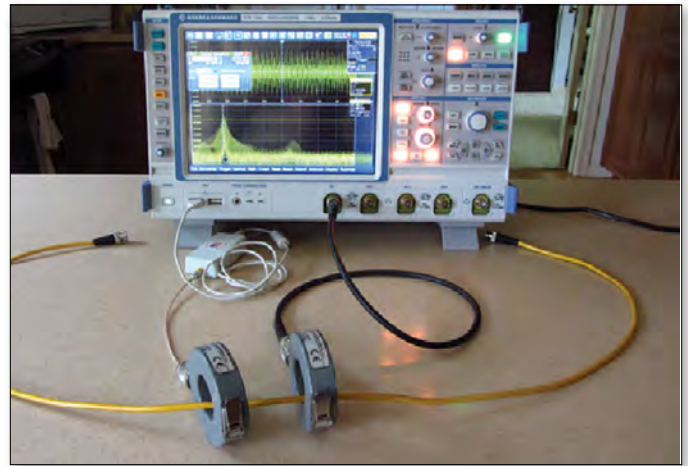
**ADVANCED TEST EQUIPMENT RENTALS**  
*The Knowledge. The Equipment. The Solution.*  
**Call Now 800-404-ATEC (2832)**

may be used to characterize anechoic chambers, measure shielding effectiveness, perform as a pulse generator or measure cable or metal structure resonance. The DIY versions are easy to make and are a useful tool to add to your test lab.

**ABOUT THE AUTHOR**

*Kenneth Wyatt, Sr. EMC Engineer, Wyatt Technical Services, LLC, holds degrees in biology and electronic engineering and has worked as a product development engineer for 10 years for various aerospace firms on projects ranging from DC-DC power converters to RF and microwave systems for shipboard and space platforms. For over 20 years, he worked as a senior EMC engineer for Hewlett-Packard and Agilent Technologies in Colorado Springs where he provided comprehensive EMC design and troubleshooting services. During that time, he developed and provided advanced EMC training and corporate leadership for EMC.*

*A prolific author and presenter, he has written or presented topics including RF amplifier design, RF network analysis software, EMC design and troubleshooting of products and use of harmonic comb generators for predicting shielding effectiveness. His specialty is EMI troubleshooting and is a co-author of the popular "EMC Pocket Guide". He recently coauthored the book with Patrick André, "EMI Troubleshooting Cookbook for Product Designers", with forward by Henry Ott. He has been*



**FIGURE 16:** Measuring the resonance of a 1m long cable using a couple of current probes and the AET 1.8 MHz comb generator.

*published in magazines such as, RF Design, Test & Measurement World, EMC Design & Test, Electronic Design, EDN, InCompliance, Interference Technology, Microwave Journal, HP Journal and several others. He currently authors The EMC Blog for EDN.com and manages the "EMC Troubleshooter's" group on LinkedIn.*

# MILMEGA

Introduces their range of Solid State Amplifier kits & modules

High reliability combined with compact size and low weight make the family ideal for use in commercial applications where space is at a premium and portability can be used to advantage.

- Available in a range of bandwidths from 800 MHz to 6 GHz with output power from 1 W to 230 W
- Class Leading Linearity and Noise Specifications
- Customised to suit your power needs
- Backed by the MILMEGA fully expensed warranty – no freight charges

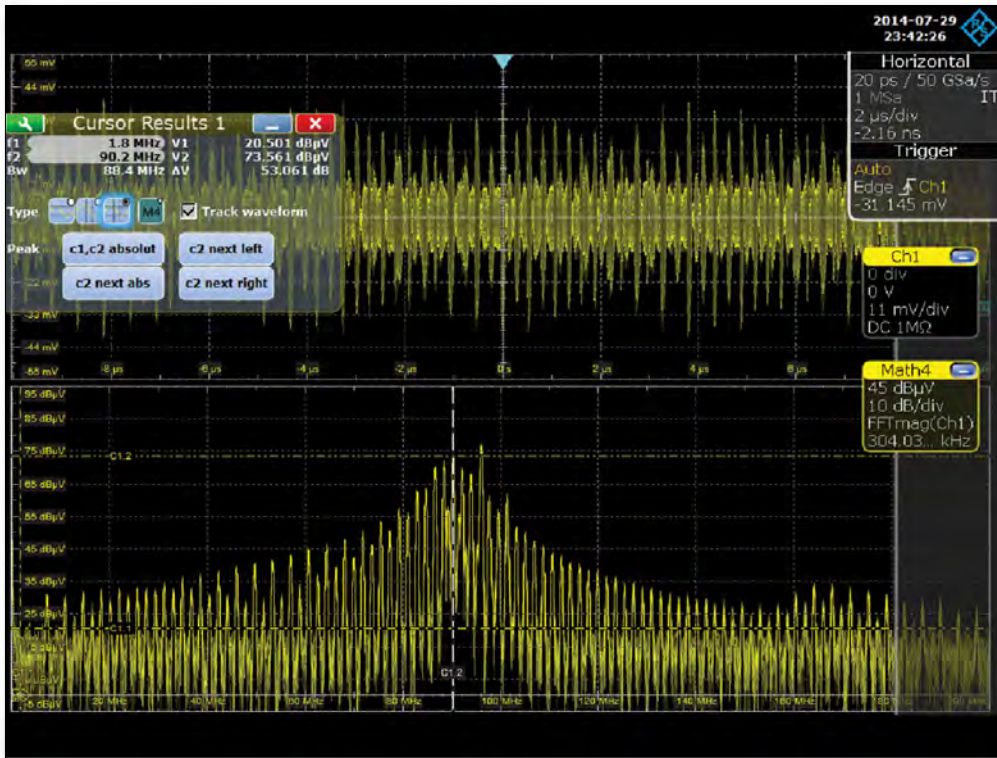
We promise only what we can deliver...then deliver more than we promise

Designers and Manufacturers  
of High Power Microwave  
and RF Amplifiers

MILMEGA is represented in US by  
AMETEK Compliance Test Solutions, Edison, NJ  
Tel. +1 732 417 0501 Fax +1 732 417 0511  
usasales.cts@ametek.com www.ametek-cts.com

MILMEGA Limited Park Road, Ryde, Isle of Wight  
PO33 2BE United Kingdom  
Tel. +44 1983 618004 Fax +44 1983 811521  
sales@milmega.co.uk www.milmega.co.uk





**FIGURE 17:** Received harmonic voltage from the current probe (upper trace) and the FFT of that voltage, showing the resonant peak at 88.4 MHz for the 1m long cable under test.

**OPHIR<sup>RF</sup>**  
THE ART OF WIRELESS

10 kHz - 40 GHz  
1W - 24kW

**High Power RF Systems**

[www.ophirRF.com](http://www.ophirRF.com)

**HAEFELY HIPOTRONICS**

**axos<sup>8</sup>**

**EMC IS ALL ABOUT STANDARDS.  
WE COVER THEM ALL IN ONE SINGLE BOX!**

- Compliance and pre-compliance testing of electrical products
- CE marking
- Product development and debugging
- Compliance testing of telecom and wireless devices

SURGE EFT / BURST VOLTAGE DIPS MAGNETIC FIELD RING WAVE TELECOM WAVE SERVICES

Designed by **HAEFELY TECHNOLOGY**

1650 Route 22 N | Brewster, NY 10509 | USA | 845 230 9242 | [www.haefelyemc.com](http://www.haefelyemc.com) | [emcsales@haefely.com](mailto:emcsales@haefely.com)

*Kenneth is a senior member of the IEEE and a long time member of the EMC Society where he served as their official photographer for 10 years. He has also served as a U.S. delegate to the International Electrotechnical Commission (IEC) for the international EMC standard, IEC 61326 (ISM products). He received a bachelor's degree in electronic engineering at California State University – Long Beach and completed additional coursework in physics at the University of California - Irvine.*

## REFERENCES

- [1] Applied Electromagnetic Technology, a maker of commercial comb generators, [www.appliedemtech.com](http://www.appliedemtech.com).
- [2] Gary Breed, A Simple One-Chip Comb Generator, High Frequency Electronics, Jan/Feb 1997, [k9ay@k9ay.net](mailto:k9ay@k9ay.net), [http://www.rfdh.com/ez/system/db/lib\\_jnl/upload/153/\[AMW9701\]\\_Design\\_Ideas\\_A\\_Simple\\_One-Chip\\_Comb\\_Generator.pdf](http://www.rfdh.com/ez/system/db/lib_jnl/upload/153/[AMW9701]_Design_Ideas_A_Simple_One-Chip_Comb_Generator.pdf)
- [3] David Bowman, A Low Cost Signal Source for 2.4 GHz, <http://g0mrf.com/source2.htm>. This is available as a kit of parts from AMSAT-UK (<http://www.uk.amsat.org/>)
- [4] Dave Eckhardt, Homebrew Comb Generator, private correspondence (January 2009).
- [5] Doug Smith, Using a Comb Generator to Demonstrate Impairment of Shielding Effectiveness of a Coaxial Cable, <http://emcesd.com/tt2009/tt100409.htm>.
- [6] Doug Smith, Using a Comb Generator with a Pair of Current Probes to Measure Cable Resonance, <http://emcesd.com/tt2009/tt110709.htm>.
- [7] Kenneth Wyatt, AET Comb Generator and AET DRFS Review, [http://www.emc-seminars.com/Technical\\_Articles/Technical\\_Articles.html](http://www.emc-seminars.com/Technical_Articles/Technical_Articles.html).
- [8] Kenneth Wyatt, EMC Design of the HP 54600 Series Oscilloscopes, HP Journal, February 1992, <http://www.hpl.hp.com/hpjournal/pdfs/IssuePDFs/1992-02.pdf>.
- [9] Kenneth Wyatt and Dean Chaney, RFI Measurements Using a Harmonic Comb Generator, RF Design Magazine, January 1991.
- [10] Alan Yates, Yet Another Comb Generator, <http://www.vk2zay.net/article/41>, this one was also designed to produce harmonics in the 2.4 GHz band, but can be modified for many other frequencies.
- [11] Kenneth Wyatt, Measuring resonance in cables, <http://www.edn.com/electronics-blogs/the-emc-blog/4423597/Measuring-resonance-in-cables>, October 2013.
- [12] Evans Engineering sells a low cost omnidirectional antenna for \$29.95, the model EE-3. Contact him at [beach\\_bob@msn.com](mailto:beach_bob@msn.com).

**interference**<sup>ITEM™</sup>  
THE INTERNATIONAL JOURNAL OF  
ELECTROMAGNETIC COMPATIBILITY | **technology**

**EMC**

**L I B R A R Y**

- Over 1,000 technical articles (spanning three decades) covering numerous EMC topics

- In-depth, practical, relevant information written by experts in the field

**SUBSCRIBE TODAY**  
[interferencetechnology.com](http://interferencetechnology.com)



# CISPR News: New Requirements

**JAN SROKA**

Professor  
University of Warsaw

## ABSTRACT

*There is still big improvement potential in reproducibility for EMC testing, and CISPR groups a constantly work on it. The document CISPR 11 + A1 act was issued in 2010. It is already in general maintenance revision, which will supersede the existing one in 2015. New regulations in this document include: Mandatory application of the common mode absorbing devices; precise definitions of the EUT volume and the small EUT, which will surely improve reproducibility of the radiated emission. The same concerns the treatment of the special earthing terminal by conducted emission - ambiguity, which is evidently an oversight, will be eliminated.*

## INTRODUCTION

**T**HE DOCUMENT CISPR 11 + A1 in act is issued in 2010. It is already in general maintenance revision which will supersede the existing one in 2015. Many regulations which improve reproducibility of the measurements are included in it. Among others there are:

- Mandatory usage of the Common Mode Absorbing Devices by radiated emission measurements up to 1GHz,

- Precise definition of the EUT volume,

- Bonding of the earthing terminal.

The reader should get familiar with these requirements in order to adopt them just on time.

After years of discussions on the CISPR meetings, the experts agreed that common mode impedances of the lines connected to the EUT have significant influence on the radiated emission below 1GHz. Specially it concerns the small table top equipments. Therefore it is required to mount the Common Mode Absorbing Device CMAD on all lines i.e.: power input and output as well communication and signal lines. CMADs should stabilize the common mode impedance, independently on the termination impedance of the line.

In the document [2] technical specification of the CMAD are established. Document [3] is the first one according to which the usage of the CMAD is mandatory.

The CMAD can, but may not decide about the EUT volume. Definition of the EUT volume changes also definition of the antenna – EUT distance.

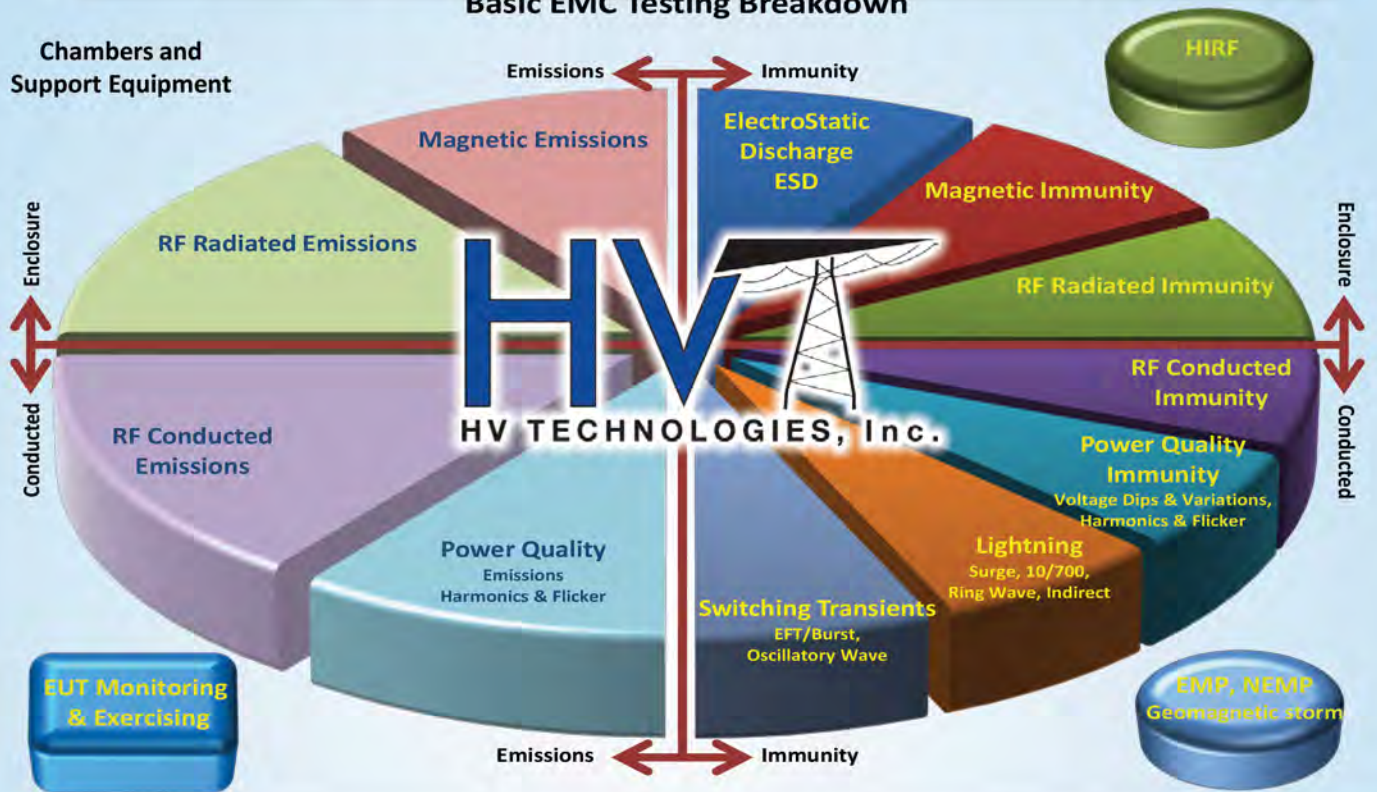
The term small EUT gives the decision criterion about ability of testing in the 3m distance. It is firstly introduced in the document [1]. However only precise definition of the EUT volume in document [4] eliminates interpretation ambiguity of this term.

In many cases the EUTs have additional earthing terminals, despite the PE

# Have Some HVT Pie

ONE SOURCE FOR THE HIGHEST QUALITY

## Basic EMC Testing Breakdown



RF Test Accessories



Your Partner for EMC Solutions

www.hvtechnologies.com  
emcsales@hvtechnologies.com  
Phone 703-365-2330





strain in the mains cable. It concerns mainly the EUTs with big dimensions and big rated power, intended for industrial applications. In the existing documents there were no regulations on how to treat them. In consequence there test hoses interpreted this in different ways. The document [4] terminates this arbitrator by radiated emission but there is still ambiguity by conducted emission.

**COMMON MODE ABSORBING DEVICE CMAD**

According to the document [2] reflection coefficient S11 of the CMAD must be within the following limit range (red lines in Fig. 1):

- upper limit 0,75 at 30MHz and 0,55 at 200MHz, decreasing linearly with the logarithm of the frequency (continuous line in Fig. 1),

- lower limit 0,6 at 30MHz and 0,4 at 200MHz, decreasing linearly with the logarithm of the frequency (dotted line in Fig. 1).

Transmission coefficient S21 must be less than 0,25 in the frequency range from 30MHz to 200MHz (blue line in Fig.1). These coefficients are referenced to the characteristic impedance ZC of the cylindrical wire with d diameter, placed in the height h over the metal reference. It can be expressed as follows

$$(1) Z_c = \frac{Z_0}{2 \cdot \pi} \operatorname{ar} \cosh \left( \frac{2 \cdot h}{d} \right)$$

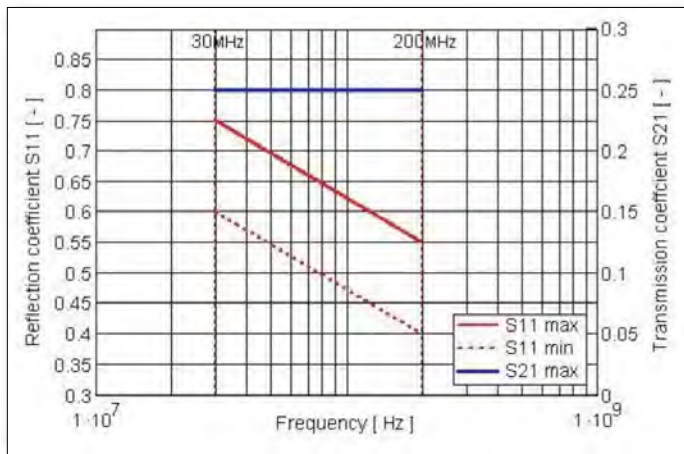
in which: Z0 – wave impedance of the vacuum.

Typical value of d is 4cm. The height h depends on the clamp construction. Characteristic impedances ZC for typical clamps are gathered in Table 1.

Asymmetric impedance of the line placed in the CMAD is as follows [5]

$$(2) Z_1 = \frac{(1+S_{11}\Gamma_L) \cdot (1-S_{22}\Gamma_L) + S_{12}\Gamma_L S_{21}}{(1-S_{11}\Gamma_L) \cdot (1-S_{22}\Gamma_L) - S_{12}\Gamma_L S_{21}} \cdot Z_c$$

by which:  $\Gamma_L$  – reflection coefficient, on the clamp port



**Figure 1:** Limit ranges of the CMAD scattering coefficients.

h = 30 mm	ZC = 204 Ω
h = 65 mm	ZC = 248 Ω
h = 90 mm	ZC = 270 Ω

**Table 1.** Typical reference impedances by CMAD characterization.

opposite to the EUT port. It is consequence of mismatching with ZC.

For negligible small coefficients S12 and S21 it is simplified to

$$(3) Z_1 = \frac{1+S_{11}\Gamma_L}{1-S_{11}\Gamma_L} \cdot Z_c$$

Analysis of Eq. (2) and (3) leads to the conclusion that both requirements imposed on the CMAD are necessary. Coefficient S11 ensures required impedance Z1 on the EUT port. Small coefficients S21 = S21 makes this impedance insensitive on the termination impedance of the line on the side opposite to the EUT.

Neither Secondary Absorbing Devices SADs, used by the measurement of the emission of power according to CISPR 16-1-3, nor decoupling clamps recommended by the standard EN 61000-4-6 do not fulfil the requirements of the CMAD. For testing houses it means the new purchase.

Set-up for the measurement of the radiated emission up to 1GHz

Document [4] requires the CMAD by emission measurement up to 1GHz. These measurements are performed on the turn floor. The EUT along with the cables builds by rotation the virtual cylindrical volume called in the document [4] the EUT volume. An example of the set-up, according to [4] for the table top equipment is shown in Fig. 2 and for the floor standing equipment in Fig. 3. It is visible in Fig. 3 that positioning of the CMAD decides about the outer surface of the EUT volume.

In the document [4] the precise definition of the distance antenna – EUT is given.

It is unambiguously defined between the reference point of the LogPer antenna (phase centre [5]) and the outer surface of the EUT volume (distance L in Fig. 4). It has following influence on the set-up:

- the term: 3m, or 10m measurement set-up is no more sufficient characterisation of the ability of the chamber. It must be accompanied with the information about the maximal volume of the EUT which can be measured. For this volume the Normalised Side Attenuation NSA [6] must be verified. Usually this volume is equal or less than the diameter of the turn floor.

- The place of the antenna in the chamber is not fixed any more. It changes depending on the diameter of the EUT volume.

# RADIATED IMMUNITY TESTING MORE FIELD, LESS POWER (LESS MONEY TOO)



**HOTN**  
**100** EDN 2014

**Some things in life seem unavoidable.** For an EMC engineer conducting IEC 61000-4-3 tests, its suffering with the complexity of RF immunity systems, buying bigger amps to compensate for reflected power loss from the load, and spending more money.

We're changing all that with the new EMfield™ Generator. It's everything you need to generate a 3 or 10 V/m at 3 m over 1 to 6 GHz in a sleek,

compact, configuration. Remarkably power efficient with minimal signal loss, it comes without the bulk, complexity, or cost of typical immunity systems.

It's a new revolution that's creating a smarter and less expensive way to do radiated immunity (RI) testing.

If you're ready to simplify your radiated immunity testing and save money too, get more information at [www.emfieldgenerator.com](http://www.emfieldgenerator.com).

 **ETS-LINDGREN**  
An ESCO Technologies Company

Offices Worldwide | [ets-lindgren.com](http://ets-lindgren.com)

3/15 RR ©2015 ETS-Lindgren Rev. B



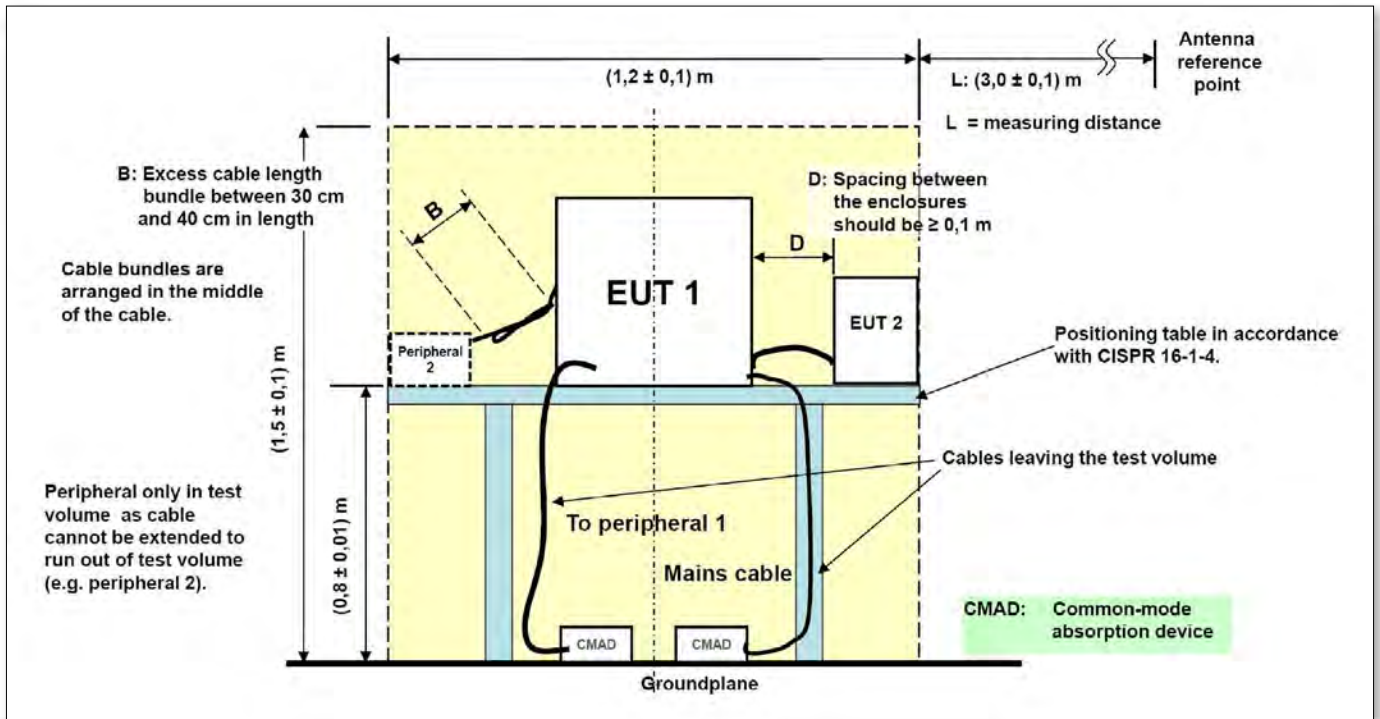


Figure 2: Set-up for the table top equipment acc. to [4].

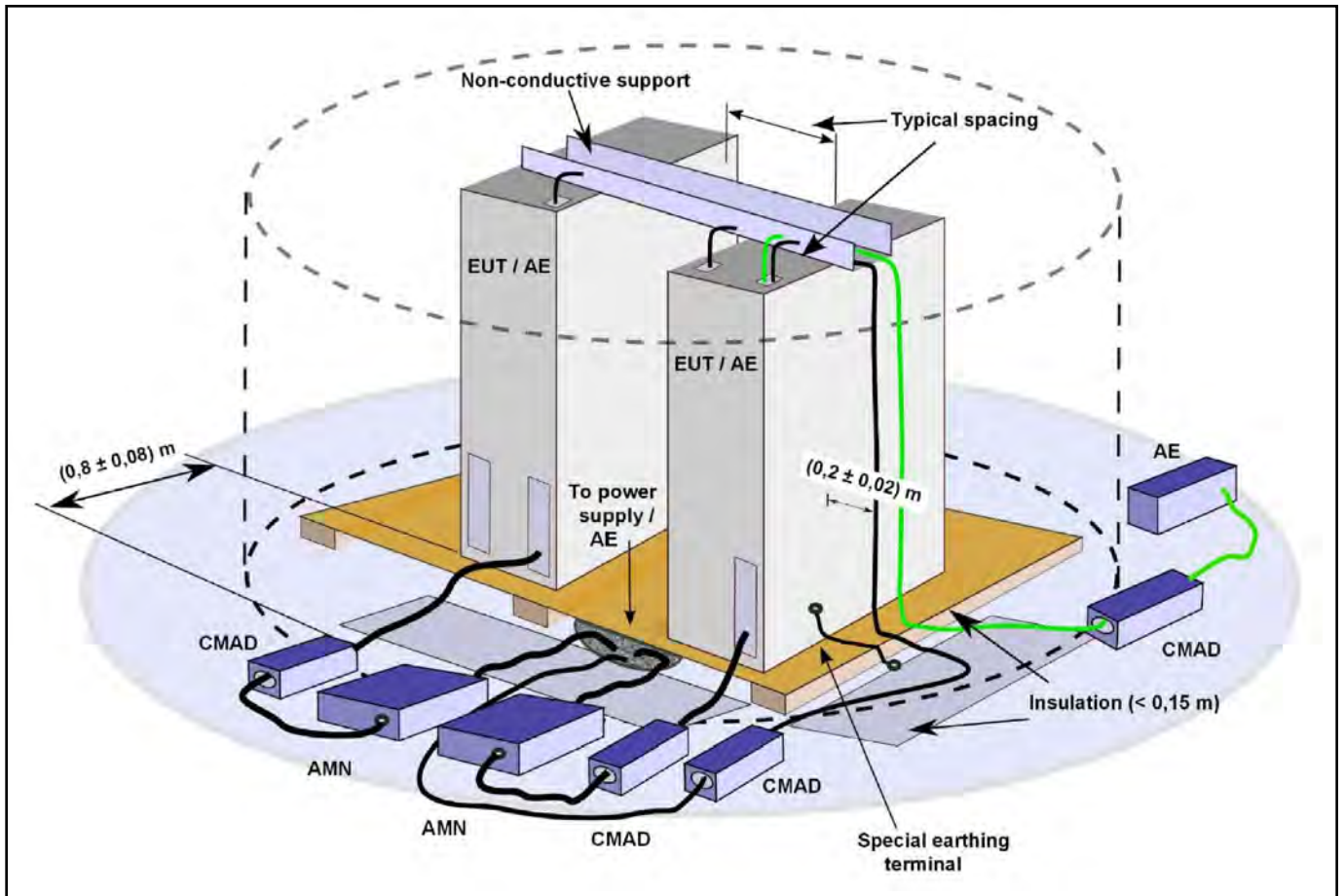


Figure 3: Set-up for the floor standing equipment acc. to [4].

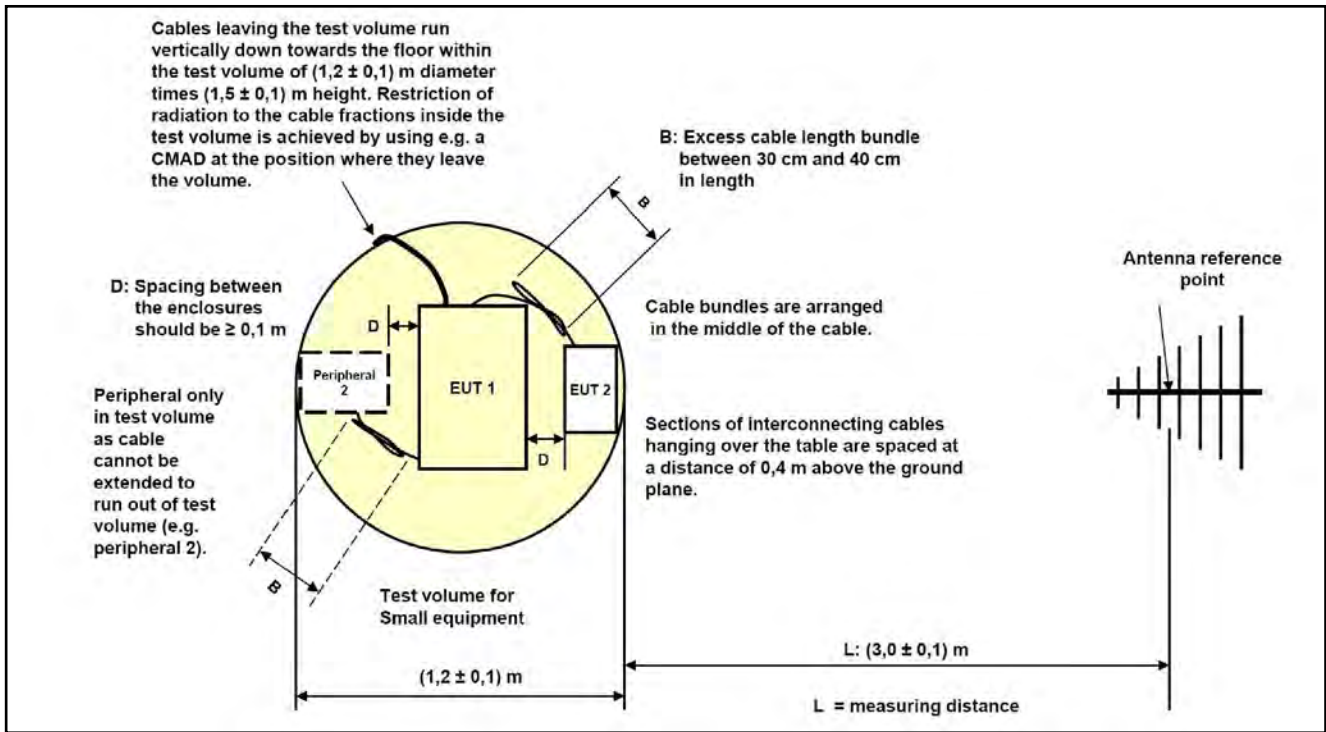


Figure 4: Measurement set-up along with the antenna acc. to [4].

**TAILOR MADE SOLUTIONS FOR YOUR UNIQUE APPLICATION**

**Advanced EMI/RFI Absorber Materials and Anechoic Chambers**

From the formulation of advanced materials in our laboratory to the design and construction of test facilities in the field, we are one of the world leaders in technology development pertaining to anechoic chambers, microwave and EMC absorbers, dielectrics and suppression materials.

**Cuming Microwave Corporation**  
 Pyramidal & Specialty Absorber Materials  
 T 508.521.6700  
 Avon, MA 02322  
 CumingMicrowave.com

**Cuming Lehman Chambers, Inc.**  
 Anechoic Chamber Design, Engineering and Construction  
 T 717.263.4101  
 Chambersburg, PA 17202  
 CumingLehman.com



## EUT EARTHING

In document [4] for the first time special earthing terminal (chapter 8.1, 8.2, Fig. 3) is introduced. If the EUT is fitted with special earthing terminal, despite the PE strain in the mains cord, then this must be connected to the ground reference during radiated and conducted emission measurements with an as short as possible uninductive lead. However in the same document in chapter 7.5.3.2 in which the set-up for the conducted emission measurement is defined, two other earthing terminals are defined, namely:

- earth connections for safety purposes,
- other earth connections (e.g. for EMC purposes).

These earth connections should be connected to the reference earth point of the Artificial Mains Network (AMN).

## CONCLUSIONS

The document [4] in preparation introduces several new requirements which precisely describes the test set-ups by radiated and conducted emission measurements. It surely improves reproducibility of the measurements.

The document [1] gives the criterion according to which the EUTs can be measured in the 3m set-up (small EUT). How-

ever only precise definition of the EUT volume in document [4] gives no doubts in interpretation of the small EUT. This definitively terminates misusing of the 3m chambers for the measurement of not small EUTs. Moreover the term of the EUT volume enables the differentiation of the 10m chambers due to the volume with verified NSA.

The document [4] shows two excluding ways of the treatment of the earth terminals by conducted emission measurements. It is evidently oversight which can have significant influence on the measurement results. Hopefully the national CISPR Committees will see it and will cause correction of this ambiguity.

## REFERENCES

- [1] CISPR 11 + A1: Industrial, scientific and medical equipment – Radio frequency disturbance characteristics – Limits and methods of measurement: 2010.
- [2] CISPR 16-1-4: Specification for radio disturbance and immunity measuring apparatus and methods - Part 1-4: Radio disturbance and immunity measuring apparatus - Antennas and test sites for radiated disturbance measurements. 2010.
- [3] CISPR 16-2-3: Specification for radio disturbance and immunity measuring apparatus and methods - Part 2-3: Methods of measurement of disturbances and immunity - Radiated disturbance measurements. 2010.
- [4] CISPR/B/598/CDV: Industrial, scientific and medical equipment – Radio frequency disturbance characteristics – Limits and methods of measurement: 2014.
- [5] Jan Sroka: Measurement Uncertainty in EMC tests, measurements of radio emission OWPW, Warsaw 2009.
- [6] Jan Sroka:  $|\Delta\text{NSASAC}| > 4\text{dB}$ . - co dalej? Przegląd Elektrotechniczny R. 90 NR 7/2014, pp. 14 -17, 2014.

## ABOUT THE AUTHOR

Prof. dr hab. inż. Jan Sroka is with the Warsaw University of Technology, IETiSIP, Koszykowa 75, 00-662 Warszawa.

He can be reached by email at [J.Sroka@iem.pw.edu.pl](mailto:J.Sroka@iem.pw.edu.pl) and with the EMC-Testcenter AG, Moosackerstr. 77, CH-8105 Regensdorf, Switzerland, e-mail: [jsroka@emc-testcenter.com](mailto:jsroka@emc-testcenter.com). He is also the EMC consultant by the company ASTAT Sp. z o. o. Poznań; visit [www.astat.com.pl](http://www.astat.com.pl).

**EMC COMPLIANCE CENTER**  
Specialists in solving a wave of EMI compliance problems.

- A2LA Accredited
- "CE" Mark Testing
- 200 Volts per meter
- NARTE certified EMI engineers
- Full service engineering support
- FULL VEHICLE ANECHOIC CHAMBER
- DOC, FDA, FCC, RTCA, MIL-STD, SAE testing

FC CE SAE A2LA AZDIE

**RADIOMETRICS**  
Midwest Corporation

(815)293-0772 [www.radiomet.com](http://www.radiomet.com)

### WANT TO KNOW MORE?

To learn more about this topic, attend our free three-day online event in April 2015! Visit [www.emc-clive2015.com](http://www.emc-clive2015.com) for more information.



# Got thermal problems? We've got solutions!

Visit us online at  
[Electronics-Cooling.com](http://Electronics-Cooling.com)

- Read the latest news, standards & product updates
- Find products & services with our Buyers' Guide
- Download the most recent issue of Electronics Cooling
- Share & comment on stories with colleagues

**Electronics**  
**COOLING**



# Stay in touch with the world of EMI/EMC news

Weekly Newsletter  
Subscribe today at [www.interferencetechnology.com](http://www.interferencetechnology.com)

**interference**<sup>ITEM™</sup>  
THE INTERNATIONAL JOURNAL OF ELECTROMAGNETIC COMPATIBILITY | **technology**



# FCC Changes Certification Process

## DAVID A. CASE

Senior Technical Leader Regulatory  
Cisco Systems Inc.

### ABSTRACT:

*The FCC Authorization and Evaluation Branch has been the forefront in regards to reviewing and issuing of FCC certification. With the adoption of the Telecommunications Certified Body (TCB) program, a number of these approvals were done via TCB reviewers with FCC oversight, though the FCC did reserve some specific applications for their review only. In April of 2014, the FCC Authorization Branch issued updated KDB (Knowledge Data Base) moving all current products on the exclusion list to TCB review. In December of 2014, the FCC adopted Report and Order 13-44, which moved the overall certification process over to the TCB's. Further a number of changes were adopted as well in regards to TCB audits, test site validations and technical standards.*

### BACKGROUND

**O**NE KEY ISSUE manufacturers face is time to market. The FCC review process could take from 65 to over 100 days at times. As every device had to go through FCC, the number of device reviews increased and so did the review time at the FCC, which as a result impacted time to market for manufacturers. To

accommodate industry the FCC acted.

In 1999, the FCC developed the Telecommunication Certified Body (TCB) certification program which offloaded some of the simpler review to Accredited 3rd party bodies.

Over the years the TCB reviewers went from approving 10% to over 90% of the products. As TCB's gained in expertise of reviewing, the use of TCB's reduced time to market for a number of products needing certification.

The FCC authorized them to perform reviews on more types of products including some new technologies that were restricted to the FCC, only, at one time. Some more difficult products were approved via the TCB Permit but Ask (PBA) process, which the TCB did the overall review but the FCC would review and in some case perform pre-grant audits on products before a TCB could issue a grant.

In response to petitions from the industry to further streamline the approval process and adopt the updated versions of the test standards, the Commission issued a Notice of Proposed Rulemaking (NPRM) in 2013.

In parallel to this April of 2014, the FCC removed authorized the TCB's to be allowed to review all items on the exclusion list under PBA process.

In December of 2014, the Commission adopted new streamlined rules for the Authorization and Evaluation Branch in regards to updating the overall approval process.



**u • nique** [yōō-nēk']

adjective

being the only one of its kind; unlike anything else:

[ *predic* ] (unique to) belonging or connected to  
(one particular person, group, place or thing)

## *Introducing The Only 4000 Watt CW, 80-1000 MHz Amplifier Of Its Kind*

Usually, we talk about all the features that make our amplifiers superior to all the other amps out there, but this time we can't. There simply is no other Class A 4000 watt amplifier that covers the 80-1000 MHz frequency range. Not only is AR's Model 4000W1000B in a class by itself, it's now approximately 1/3rd the size of our previous model.

When you specify this 4000 watt amplifier you're getting a tough, durable and completely reliable product that delivers all the power promised time after time. AR amplifiers perform beyond expectations, beyond the norm, and beyond the capabilities of ordinary amplifiers. As the industry leader for over 45 years, AR products are supported by a technical and customer support network that is second to none, and one you can rely upon to solve any problems or satisfy any requirements that you may encounter.

So when you buy an AR 4000 watt, 80-1000 MHz amplifier or any low power unit, you can't go wrong.

*To learn more, visit us at [www.arworld.us/4000W](http://www.arworld.us/4000W) or, for technical support, call 800-933-8181.*

ISO 9001:2008  
Certified



[www.arworld.us](http://www.arworld.us)



**rf/microwave instrumentation**

Other **ar** divisions: modular rf • receiver systems • ar europe

USA 215-723-8181. For an applications engineer, call 800-933-8181.

In Europe, call ar United Kingdom +44 1908 282766 • ar France +33147917530 • ar Deutschland +49 6101 802700 • ar Benelux +31 172 423000

Copyright © 2015 AR.  
The orange stripe on AR products is  
Reg. U.S. Pat. & TM. Off.



## UPDATED CERTIFICATION PROCESS

With the adoption of this order the Commission has designated that all products subject to certification are to be reviewed by the TCB's only. The FCC lab has been tasked with developing additional guidelines and procedures in regards to facilitating this change.

With this decision, the FCC is technically out of the certification business as far as product review other than to provide guidance and consultation to the TCB's. Obviously there will be pros and cons to this and time will point them out but overall, the concept is good.

The role of the FCC lab will then be focused on enforcement issues, interpretations, developing guidelines and test procedures. The FCC also would develop a list of products that the TCB's must consult with them on in regards to issuing certifications.

The FCC will also develop pre-grant audit program for the TCB's to address new technologies being approved such as for DFS (Dynamic Frequency Selection) testing.

The TCB training seminars will still be the focus for the FCC to bring TCB's up to speed on new requirements.

## TCB CHANGES

The order addresses additional requirements for TCB's including post-grant audit process changes. With these changes the program addresses some needed changes to better help facilitate the overall process.

The changes allow the FCC to dismiss an application or set aside a grant within 30 days via the E (equipment Authorization System). Until this change only the FCC could dismiss an application or remove a grant.

In regards to being accredited as a TCB, NIST has been appointed as the Designating Authority for US TCB's and outside the US Designated Authorities who have been recognized by the FCC in countries where MRA's exist.

The FCC will increase overall oversight of the TCB's themselves and TCB's that perform poorly may be suspended or removed from the overall program until deficiencies are addressed.

The Order also addresses the requirement for the need to perform the 5% audits and stipulates some requirements to insure the manufacturers provide actual production product versus the golden sample for audit. Further the FCC lab has retained the right to pick which samples or devices could be audited by a TCB. The FCC also limit the product audits a TCB can do to only products the TCB itself certified.

## TEST SITE AND STANDARD ISSUES

One major change is that the FCC will now require all test labs submitting test data for certification under any FCC rule part to be accredited and as such will be phasing out the listed lab list. This requirement not only applies to labs doing Part 15 and Part 18 testing but testing various licensed radio service devices.

After a specified date as set forth upon adoption of the rule change, test labs that are not accredited will no longer be able to submit test data unless accredited in accordance with ISO 17025.

In addition, any lab being subcontracted for testing by an accredited lab will also need to be accredited per the FCC regulations, even if only doing bench testing of the device.

Further in regards to recognition of accredited labs, the current proposal will be limited to countries where current Mutual Recognition Agreements exist. The FCC rules do include a mechanism for additional accreditation bodies to be recognizing as to allow non US labs in countries where there is an existing MRA to be recognized by OET.

For devices that require testing on an ANSI site, the test site must be compliant with the requirements of C 63.4 (2014) in regards to the site validation requirements. As such, the FCC R&O specifies the time period in which labs must be accredited to C63.4 (14).

Labs, which are listed on the FCC lab list, but not accredited, will also have a transition period in which to get accredited to allow acceptance of test data after the cutoff date.

The FCC adopted the latest versions of C63.4 (2014), which includes test site requirements for testing above 1GHz. This is a major change as until now, the site validation had to only be done to 1GHz.

In regards to radio testing, C63.10 (2013) has been adopted and replaces C63.10 (2009) that the FCC had authorized to be used via a Public Notice. One major change in regards to the test set up requires that the EUT antenna be mounted 1.5 meters above the ground plane for measurements above 1GHz. Further, the standard reflects most of the latest FCC changes in the various KDB's with a few exceptions. Note that one will still need to consult the KDB's in regard to some differences before performing some of the tests.

As such with the mandate for these standards, test labs will need to make changes in regards to their test sites and set ups.

It should be noted that Industry Canada RSS-Gen rev 4, which was adopted in November of 2014 also references these specific standards for use in testing similar devices, thus aligning the testing requirements for US and Canada.

## NEXT STEPS

The FCC also addressed a couple of obsolete requirements by removing them from the rules. The FCC also addressed the question on the measurement uncertainty in regards to RF Exposure testing with the withdrawal of OET65C.

Also OET can now has the allowance through updated Designated Authority to adopt later versions of Industry Standards without a formal rulemaking, thus allowing later versions that meet FCC review criteria to be authorized for use by FCC.

In regards to the various implementation times for the various parts, the clock will start running once the order is published in the Federal Register. For additional details see the Report and Order 13-44.



## Keep the test queue flowing.

Now you can detect EMI faster up to 44 GHz with the Keysight N9038A MXE EMI receiver. Speed up your EMC test queue with time domain scan. And get full CISPR 16-1-1:2010 and MIL-STD-461 compliance with easy upgradability for the future.

Learn how receiver technology improves EMC measurements and download app notes at:  
[www.keysight.com/find/testQ](http://www.keysight.com/find/testQ)

USA: 800 829 4444 CAN: 877 894 4414



Unlocking Measurement Insights

© Keysight Technologies, Inc. 2014

Agilent's Electronic Measurement Group has become **Keysight Technologies**.



# Radio Equipment Directive: History of Requirements and New Changes

## CHARLIE BLACKHAM

Principal Consultant and Director  
Sulis Consultants Ltd.

### ABSTRACT

*This article provides an introduction to the recently published Radio Equipment Directive (RED). It looks briefly at the history of the requirements, the changes in the product and regulatory landscape and looks at what it means to equipment manufacturers.*

### HISTORY

**T**HE CURRENT RADIO AND Telecommunications Terminal Equipment (R&TTE) Directive, 1999/5/EC entered into force over fourteen years ago on the 7th April 2000.

Before this “Telecommunications Terminal Equipment,” or TTE, had been covered by earlier Directive 98/12/EC which co-ordinated the requirements of the original 93/63/EEC and 93/97/EEC Directives. Radio equipment on the other hand was covered by a fragmented and non-aligned set of national approvals requirements.

The R&TTE Directive simplified the process and allowed manufacturers of radio equipment to place product on the Single European Market after demonstrating compliance with all Essential Requirements of EMC, Safety and Radio Spectrum Use.

Whilst the number of different radio devices placed on the Single European

Market since 2000 has not been directly tracked, the number could be considered to be similar to that placed on the US market which is tracked by the FCC<sup>1</sup>. This shows a near five-fold increase from 3000 in 1999 to nearly 15000 in 2012 and still growing at 12% p.a.

A number of issues that have arisen with the proliferation of radio devices have been addressed through updates to standards, but increased concerns over non-compliant products and other requirements from the “New Legislative Framework” (NLF) required the R&TTE Directive to be revised.

### DEVELOPMENT OF RED

Initial activity began back in 2007. Due to increasing concern regarding non-compliant equipment being placed on the market, a number of Market Surveillance Authorities (MSAs) were pushing for the implementation of a mandatory registration system of all equipment. This caused a great deal of discussion and contributed to the long gestation period.

Registration databases are common in other countries, such as USA and Canada, but they have one body responsible to one economic area – who would (be trusted to) run an EU wide scheme? Furthermore management of the data is non-trivial; the FCC database was 660 GB in 2009, and probably double that now.

The European Commission (EC) sent initial proposal to European Parliament in 2012. A second, non-sequential, draft

was created before a final “compromise” text was created in 2014.

This text was adopted at its first reading by the European Parliament on 13th March, by the EU council on 14th April and published as Directive 2014/53/EU on 22nd May 2014.

Whilst there are many similarities between the R&TTE Directive and RED, there are a number of differences, which are discussed further below. One of the differences is the removal of TTE, hence the shortened name “Radio Equipment Directive”.

## OBJECTIVES

The European Commission sees four main objectives in the development of the RED:

- To reinforce the obligations of ‘economic operators’ (see below), and to improve the legal tools available to Market Surveillance Authorities (MSAs) in order to improve their efficiency, in particular regarding traceability
- Note: ‘economic operators’ is a term from the NLF, and means manufacturers, authorised representatives, importers and distributors – everyone in a product’s supply chain.
- To clarify and simplify certain provisions - including the scope - in order to facilitate the application of the Directive
- To modify or suppress a number of administrative obligations which create burdens for economic operators without adding much value for them or MSAs.
- To insert certain requirements aiming at facilitating the use of radio equipment (e.g. the possibility of issuing delegated acts for interoperability, see later)

## SCOPE

The RED no longer applies to TTE, such as wired telephones, fax machines and ADSL modems which will now be covered by the EMC and LV Directives.

The scope of the RED has been widened to include:

- “Radio determination” equipment such as radars and RFID devices. These devices were considered to be within the scope of the R&TTE Directive as confirmed in the EU Commission’s formal interpretation<sup>ii</sup>, but the RED’s scope is much clearer making it more obvious that they are included and must comply.
- “Sound and TV broadcast receivers” – these were excluded under R&TTE, but will be covered for not only radio spectrum performance but possibly also subject to



**EMC/EMI TESTING & ENGINEERING LEADERSHIP ...**



**ON-SITE or IN-LAB...**

**We're ready, willing & able. Put us to the test.<sup>SM</sup>**

- Three state-of-the-art labs.
- Dedicated, highly trained staff.
- Full engineering support.
- Fully accredited: 300+ EMC test methods

**Trust Retlif...**for EMC and Lightning testing to national and international standards.

**Trust Retlif...**for shielded effectiveness testing, EMP, high level radiated susceptibility and low noise level emissions testing.

**Trust Retlif...**leading military, aerospace, maritime and rail organizations have, since 1978.



**RETLIF TESTING LABORATORIES**

*Put us to the test.<sup>SM</sup>*  
 795 Marconi Avenue • Ronkonkoma, NY 11779  
 TEL: (631) 737-1500 • FAX: (631) 737-1497 • [www.retelif.com](http://www.retelif.com)

Additional locations in New Hampshire, North Carolina, Pennsylvania & Washington D.C.



additional safety requirements as there is no low voltage level exclusion under R&TTE/RED (see below).

- Note: The Low voltage Directive exempts devices that operate below 50 V AC rms or 75 V DC, but there is no such “low voltage level” exclusion in the R&TTE or RED.
- “Receiver performance” – whilst this was covered in a number of ETSI product standards, its importance in an increasingly congested radio spectrum has made it part of the Directive.
- “Devices operating below 9 kHz” – the lower frequency limit of R&TTE was 9 kHz, but that has been removed. That will create some work for both ETSI to create standards and for European Communications Office (ECO) to define frequency allocations.

## ESSENTIAL REQUIREMENTS

Some new requirements of note:

- Article 3.2: Radio equipment shall be so constructed that it both effectively uses and supports the efficient use of radio spectrum in order to avoid harmful interference.
- Article 3.3: Radio equipment within certain categories or classes shall be so constructed that it complies with the following essential requirements:

- (a) radio equipment interworks with accessories, in particular with Common Chargers (see below);
- (b) radio equipment supports certain features in order to ensure that software can only be loaded into the radio equipment where the compliance of the combination of the radio equipment and software has been demonstrated.

Note: interworking is the ability of two or more items to be able to connect, communicate or exchange data, i.e. to be able to work with each other.

It should be noted that a number of Article 3.3’s requirements were in the R&TTE Directive, but there are only a handful of Harmonised Standards prescribing requirements and these are mostly for radios used to support safety of life at sea. Article 3.3 requirements are brought into being by the Commission through a “Delegated Act” in accordance with Article 44.

If one read the press release that accompanied the R&TTE Directive<sup>iii</sup> one might think that common chargers were the most important part of the Directive, but they are only a part.

It’s not currently clear what actual requirements will develop from these clauses in article 3.3 and they must first be made mandatory by a Delegated Act (a type of EC legal instrument discussed below).

Considering briefly what requirements there may be for the Common Charger, the actual requirements would be contained in a standard, but Industry and The Commission have already done an amount of work on this already, see [http://ec.europa.eu/enterprise/sectors/rtte/chargers/index\\_en.htm](http://ec.europa.eu/enterprise/sectors/rtte/chargers/index_en.htm), which may well be followed by those writing any future standard.

## ADDITIONAL REQUIREMENTS DUE TO NLF AND MARKET SURVEILLANCE

The NLF, comprising EU Decision 768/20080/EC and Regulation 765/2008/EC, came into force in 2010 to provide assistance with dealing with non-compliant products and to try and level the playing field for manufacturers of compliant products.

The requirements on all economic operators in the supply chain are those set out in Decision 768/2008/EC and are similar to those in the revised 2014 versions of the Low Voltage and EMC Directives. These are discussed in more detail in Articles 10 thru 13 of the RED.

The RED takes things a step further in Article 5 which contains a provision to require a registration scheme for products deemed to have a low level of compliance. It’s worth noting that the some countries voted against the inclusion of a registration scheme and no such scheme is currently being implemented – but that does not mean that there won’t be one at some point in the future.

Now defining, and determining, “low levels of compliance” could make a magazine article all of its own, as this covers a wide range of issues from otherwise compliant products having CE marks that are 0.25 mm too small through jammers which are illegal and non-compliant on multiple fronts.

# Need a Better Filter or Power Supply?



## Power Supplies and EMI Filters for your toughest compliance requirements

Curtis engineers specialize in standard and custom filter and power supply solutions for a variety of Class I and Class II applications:

- > Medical
- > Power Electronics
- > Appliance
- > Military



What can Curtis/Tri-Mag engineers do for you? Call us today.  
800-657-0853

Innovative  
Engineering  
Solutions



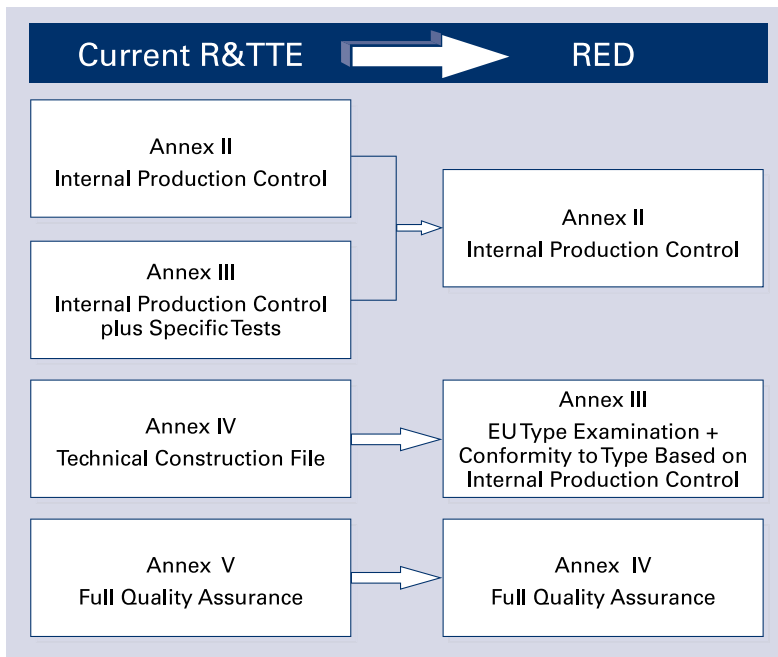
www.Tri-Mag.com

## SIMPLIFICATION OF MARKET ENTRY

- Whilst not currently permitted, the use of electronic labelling will be investigated and allowed where appropriate – for example on equipment with an integral screen such as a mobile phone.
- Class 2 devices which use non-harmonised frequency bands, or have other restrictions on being put into service, no longer require Notification to each member state before product is placed on the market. The alert mark (!) will also no longer need to be affixed.

## ROUTES TO COMPLIANCE

The conformity assessment process is revised under the RED:



## WHAT IS NEXT?

There's quite a lot to be done by member states, the EC and the relevant standards bodies, but little to be done at the moment for manufacturers of radio products currently under the R&TTE Directive. All products placed on the market before 12 June 2016 can continue to use the R&TTE until 2017 so, for many, consideration of compliance with the RED is unlikely to be required until 2016.

Notified Bodies need to be created for the RED. Discussions as to how this will be done are ongoing but one suggestion is that all existing NBs should be transferred "en masse" on a single date and then their competence against RED checked afterwards. This is to prevent market distortion and unfair advantage that could arise should NB changeover occur piecemeal. It should also be noted that whilst an NB can prepare an EU Type Examination Certificate before the RED comes into force, it cannot sign and issue it before 13 June 2016.

The RED also imposes additional requirements on information to be provided to the user such as labels and instructions,

but it's worth waiting to see whether more detailed guidance is provided in these areas before working on them.

## POSSIBLE DELEGATED & IMPLEMENTING ACTS

- Chargers: Delegated Act– Article 3(3)(a)
- SDR: Delegated Act– Article 3(3)(i)
- Access to Galileo: Delegated Act– Article 3(3)(g)

Note: Galileo is the EC's planned navigational satellite system, intended to complement the US Military's GPS system

- Information on restrictions: Implementing Act – Article 10(10)

Note: Delegated and Implementing Acts are the names given to two types of instrument the European Commission may adopt in order to ensure the implementation of EU law and are defined in the Lisbon Treaty. In summary:

- Delegated acts are dealt with by Article 290.2 and are defined as non-legislative acts of general application to supplement or amend certain non-essential elements of a legislative act.
- Implementing acts are dealt with by Article 291.3 and are to be used where uniform conditions for implementing legally binding Union acts are required.
- I don't wish to delve further into the legal subtleties, but would summarise by saying that none of these requirements are currently envisaged to be required when the RED enters into force, but may well become requirements in the future (subject to the required legislation coming into force).

## STANDARDS DEVELOPMENT

A certain amount of Standards development work is required by ETSI and CENELEC, though some of it is dependent on which Acts come into being.

- Scope: Article 2(1)(a)
- Receiver Performance: Article 3(2)
- Chargers: Article 3(3)(a)
- Software Defined Radio (SDR): Article 3(3)(i)
- Access to Galileo: Article 3(3)(g)

Work on standards for the first two of these items has started, but no draft standards have yet been produced. Manufacturers of Sound and TV receivers need to be aware that their products will be covered by the scope of the RED and will need to comply with new Radio Spectrum requirements, and possibly with safety requirements too. In the absence of a new product specific



Spectrum standard, which is likely to be developed, the standard that would most likely apply is ETSI EN 300 220-2 V2.4.1, which contains requirements for Receiver Spurious Emissions and Receiver Blocking.

Work on Article 3(3) standards will not start until the required legislation is in place, but it's currently thought that these parts of article 3(3) are likely to be addressed before others.

for over 20 years. After working for several manufacturers as Approvals Manager, Charlie set up Sulis Consultants in 2005 to offer advice and assistance to a wide range of clients. A former Notified Body technical expert, Charlie has helped clients CE mark a wide range of radio products operating from 1 MHz to 78 GHz and can be contacted at [charlie@sulisconsultants.com](mailto:charlie@sulisconsultants.com) or via [www.sulisconsultants.com](http://www.sulisconsultants.com)

### *Timescales and things to monitor :*

When	What
Now to 12 June 2016	Equipment must continue to be CE marked against R&TTE or LVD/EMC Directive as appropriate. The RED cannot be used before 13 June 2016.
March 2015 (Approximately)	<p>"Frequently Asked Questions on the transposition of the Directives" covering EMC, LVD and R&amp;TTE/RED to be published.</p> <p>2<sup>nd</sup> Commission workshop on RED.</p> <p>Start of activity to draw up Guidelines on the application of RED.</p>
13 June 2016	<p>All equipment within scope of RED placed on the market, or put into service, for the 1<sup>st</sup> time must comply with the RED. (see note)</p> <p>All equipment currently on the market may continue to be placed on the market in accordance with existing rules for R&amp;TTE or LVD+EMCD as appropriate.</p>
13 June 2017	<p>All equipment within scope of RED must now be declared compliant with RED.</p> <p>All equipment previously compliant with R&amp;TTE Directive, but not within the scope of the RED, must now be declared compliant with EMC Directive, and also with the LVD if it is applicable.</p>

**Note:** The transition period, from 13 June 2016 to 13 June 2017, is designed to be applied to products that were on the market before the RED came into force. However, a manufacturer may use previous legislation, such as R&TTE Directive, for new products, but would have to perform a reassessment to RED by 13 June 2017, and update all documentation, which would be cumbersome.

It's worth noting that you cannot declare compliance with both the R&TTE and RED on the same Declaration of Conformity (DoC), so there is going to be a certain amount of administrative work required during 2016-17 in updating DoCs and providing additional information in user manuals.

### **ABOUT THE AUTHOR**

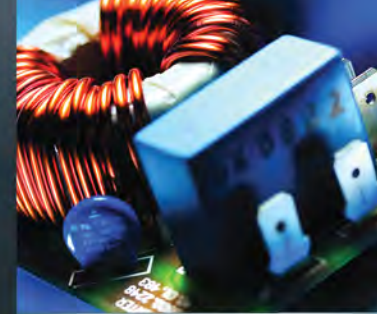
Sulis Consultants is an independent CE marking and Product Approvals consultancy based in Hampshire, England and specialising in helping manufacturers comply with the requirements of R&TTE, EMC, LV and RoHS Directives as well as radio certification for North America.

Charlie Blackham is a Chartered Engineer who has been working in the field of product approvals and CE marking

### **REFERENCES**

- [i] <http://transition.fcc.gov/bureaus/oet/ea/presentations/files/apr13/3a-Equipment-Authorization-Overview-041013-RD-.pdf>
- [ii] [http://ec.europa.eu/enterprise/sectors/rtte/documents/interpretation\\_en.htm](http://ec.europa.eu/enterprise/sectors/rtte/documents/interpretation_en.htm)
- [iii] [http://europa.eu/rapid/press-release\\_IP-14-261\\_en.htm](http://europa.eu/rapid/press-release_IP-14-261_en.htm)
- [iv] [http://eur-lex.europa.eu/legal-content/EN/ALL/;ELX\\_SESSIONID=JBBSJnJGfQyPdpX403YK9rkkT5rkK06J3tcV3lg9JSjxJhLBxn7L!847029099?uri=CELEX:32011R0182](http://eur-lex.europa.eu/legal-content/EN/ALL/;ELX_SESSIONID=JBBSJnJGfQyPdpX403YK9rkkT5rkK06J3tcV3lg9JSjxJhLBxn7L!847029099?uri=CELEX:32011R0182)

# SCHURTER EMC Solutions



SCHURTER's EMC filter assortment provides a variety of single and three phase line filters for both AC and DC applications. Choose from hundreds of power entry modules, block filters and related components to meet Industrial, IT and Medical compliance standards.

- Power line filters for 1- and 3-phase systems, single or double stage
- Power entry and block filters for use in AC and DC applications such as motor drives, motor controls, UPS systems, and inverters
- Power entry modules with current ratings up to 20 A @ 250 VAC; DC version up to 15 A @ 125 VDC
- Block filters with current ratings up to 2500 A @ 760 VAC; DC versions up to 2300 A @ 1200 VDC
- Block filters rated for higher ambient temperature up to +100°C, with corresponding deratings
- Custom designed block filters – attenuation, housing sizes, mounting and terminal styles
- UL and ENEC approved for use in equipment according to IEC 60601-1 and 60950



# EMC War Stories: Letters from Home

## Part 2: It's Hard for my Computer to Sleep When I'm Doing the Laundry

Editor's note: To read part 1, which was published in last year's Directory & Design Guide, visit [www.interferencetechnology.com](http://www.interferencetechnology.com) and click 'digital magazines.'

### CANDACE SURIANO

Consultant  
Suriano Solutions

### JOHN SURIANO

Nidec Automotive Motor Americas

*Dear John,*

*Once again it's a cold dry winter here and I have found that there is a great way to keep warm— by doing the laundry. I discovered something really strange, though: when I'm taking the laundry out of the dryer it sometimes wakes up the computer on the desk almost ten feet away! I knew I wasn't going stir-crazy during the long winter because I saw it several times. I figured the computer just couldn't get any sleep during the electrostatic lightning storms generated by the laundry. What a great opportunity to use some of our old EMC demo equipment with the kids to actually solve a problem...*

*As you know, the desktop computer in the laundry room is about ten feet away from the dryer. I found that when I removed some freshly dried fuzzy fabric from the dryer, the PC would suddenly wake up as shown in Figure 1. The fabric produces a particularly nasty electrostatic discharge (ESD). The discharge is actually a very fast conduction of charge through gas plasma between parts of the fabric having opposite charge polarity [1]. The duration of the arc is fractions of a microsecond [2] and so produces a very short pulse of radiation which propagates across the laundry room to the computer (Fig. 1).*

*This is, of course, a great opportunity for diagnostics and problem solving:*

1. *Use a reliable method for generating ESD*
2. *Find the responsible component for causing the problem*
3. *Define a repeatable test setup*
4. *Realize solutions*
5. *Explain the results*

### THE RELIABLE TEST METHOD

**E**SD IS SOMEWHAT random when it is generated by fabric. A more predictable result can be obtained using our home-made ESD gun shown in Figure 2. The gun uses a principle similar to that found in a mechanical car ignition. A trigger on a screw gun is used to interrupt DC current to the primary coil on a high voltage transformer from a TV. The secondary voltage is rectified and used to charge capacitors on the output. With one click of the trigger the gun can generate enough voltage for a spark at the output. Additional clicks make a bigger spark (Fig. 2).

### THE RESPONSIBLE COMPONENT

It was actually quite easy to find the component responsible for the computer malfunction. First, it was observed that making an arc with the ESD gun nearby to the computer could reliably awaken it from sleep mode. Since the keyboard is the normal user



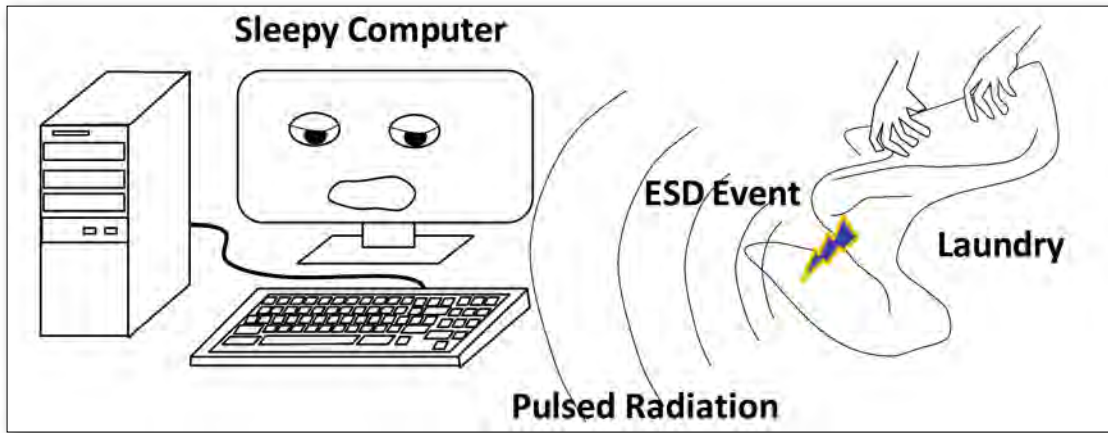
# High Performance EMI Filters

## Engineered To Perform, Built To Last

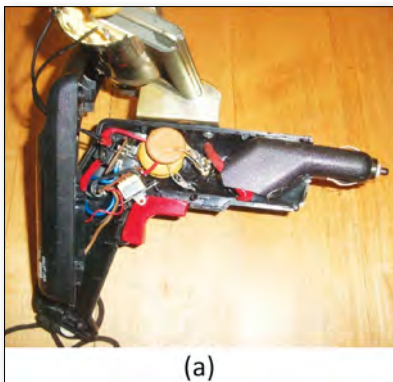
Delta's high performance EMI/EMC filter provides reliable and quick solutions to many of today's power condition requirements. With 35 years of experience and thousands of filter designs, Delta has a solution for your single or 3-phase power in both AC and DC applications.

- Over 1,000 standard part numbers
- Chassis mount filters rated up to 100A
- Medical grade filters with low leakage current
- 3-Phase filters rated up to 600A
- IEC filters rated up to 20A
- Worldwide safety approvals
- Highly customizable open frame design

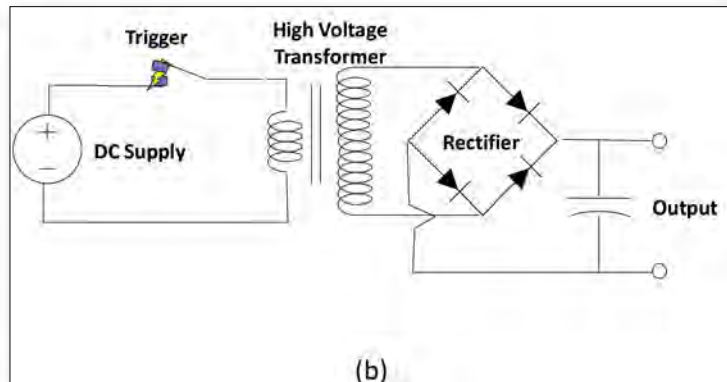




**FIGURE 1:** Pulsed radiation from an ESD event waking up a desktop PC



(a)



(b)

**FIGURE 2a-b:** Home-made ESD gun built after the car ignition principle

interface for this function it was the primary suspect. When unplugged it was found that the ESD gun could not wake up the computer unless it was nearly contacting the mouse.

The keyboard is a USB device. USB has differential data lines D+ and D- which transmit the information from the keyboard to the computer. The other two wires in the cable are positive and negative DC power. A USB jumper cable was placed between the keyboard and the computer. The jumper cable was opened up so that our PC oscilloscope could be used to examine the signals on these lines. Note that the measurements with the oscilloscope probes display 1/10 the actual voltage due to probe attenuation. Normal communications are shown in Figure 3(a) when the computer is awake. When the computer is asleep and a key is pressed there is a signal of almost 900mS from the keyboard as shown in Figure 3(b).

The same setup was used to see the signals during an ESD event. The oscilloscope trigger picked up the ESD event as shown in Figure 4(a). However, this transient voltage on D+ and D- is not what wakes up the computer. The computer is waiting for a 900mS pulse. By widening the time scale it is apparent that the ESD event causes the keyboard circuit to produce a normal wake pulse as shown in Figure 4(b). There

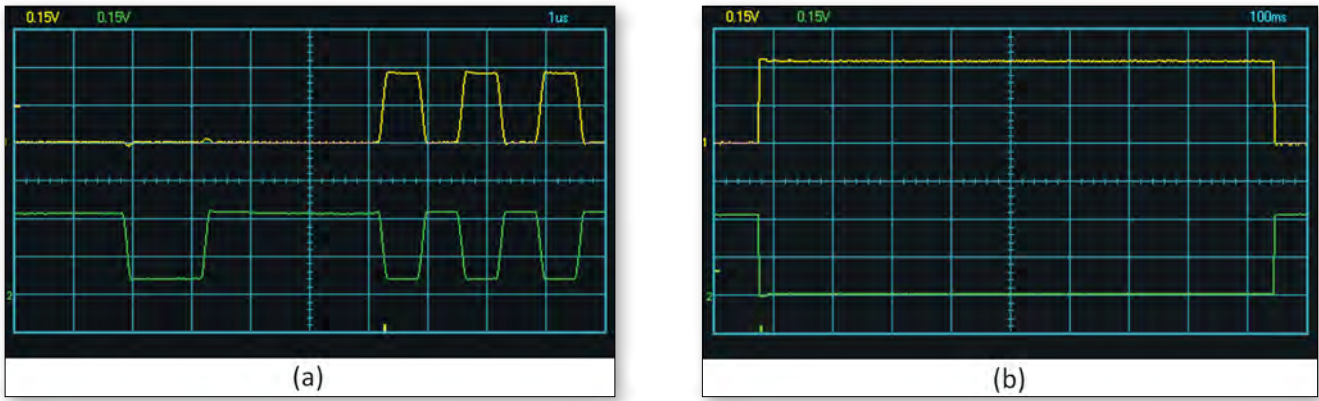
is more than 5mS between the ESD event and the response of the circuit which wakes up the computer. The ESD causes the computer to wake up, but the same ESD signal does not cause spurious characters when the computer is awake.

### THE REPEATABLE TEST SETUP

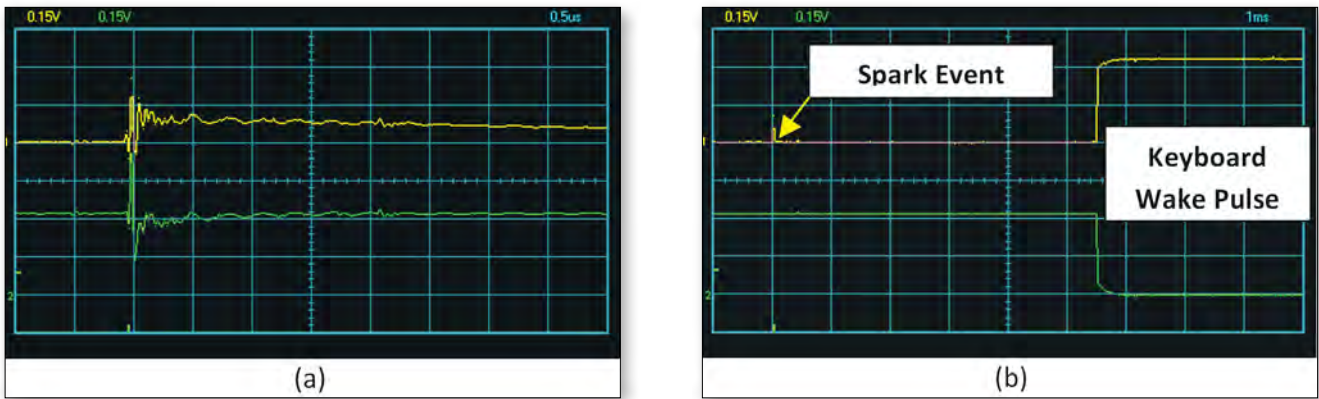
In order to have some confidence in the test results a repeatable setup of the computer and keyboard was constructed as shown in Figure 5(a). Guidelines showing the placement of the keyboard and the keyboard cable were drawn on the cardboard. The cardboard also helped protect our nice coffee table from the pursuit of scientific inquiry. A 1"X4" board was used as a guide to apply ESD discharges at known distance and orientation to the equipment as shown in Figure 5(b).

Instrumentation was also added. A loop antenna was made from the rim of a cottage cheese lid and some wire. That old Captain Nemo-like current probe we constructed from candlestick holders and Fari-rite p/n 5943003801 [3] also came in handy to measure the common mode current on the keyboard cable.

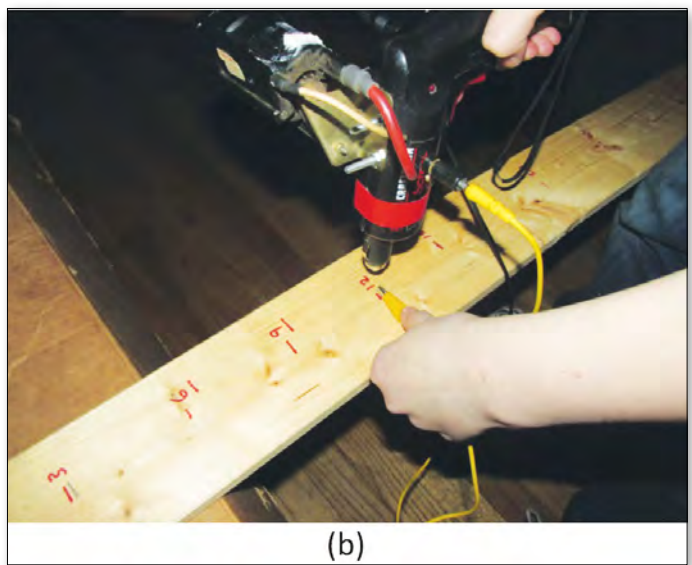
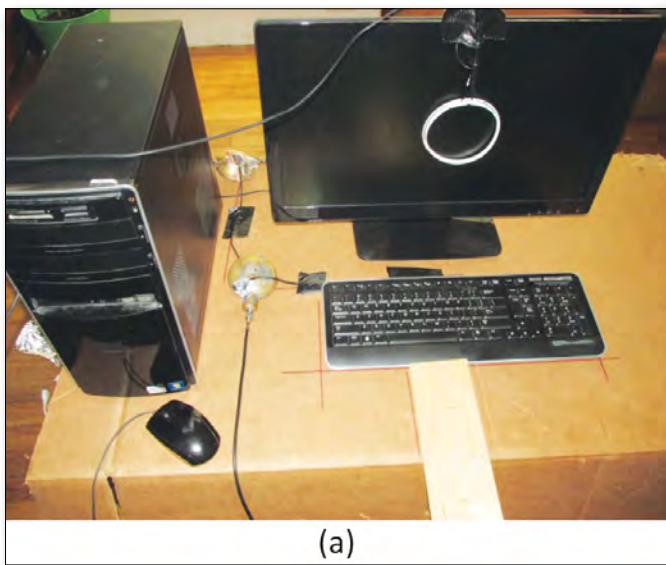
With this test setup the ESD gun has to be moved at least 18" away from the keyboard to prevent the computer from waking up on the lowest ESD setting (1 click of the trigger).



**FIGURE 3:** USB communication (a) normal awake data communication, (b) ~900mS pulse when awakening



**FIGURE 4:** (a) Transient during ESD, (b) Wake up pulse triggered more than 5mS after ESD



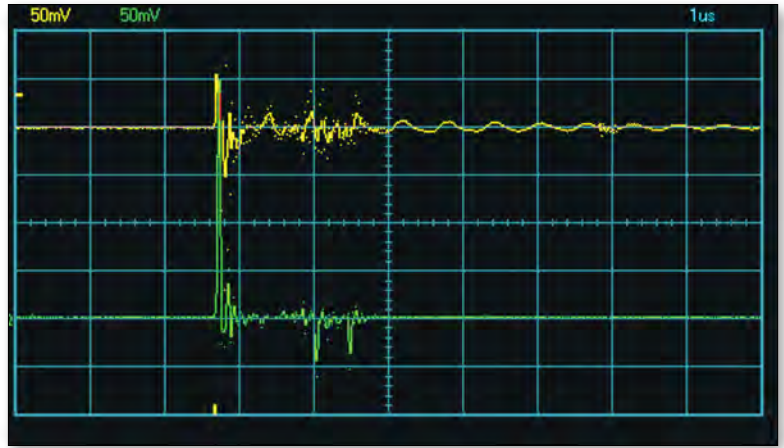
**FIGURE 5:** (a) repeatable test setup, (b) ESD gun positioning



The loop antenna measurement (in green) and current probe measurement (in yellow) for this condition are shown in Figure 6. The loop voltage, more than 2V (remembering that the scale for this is 1/10), is quite substantial.

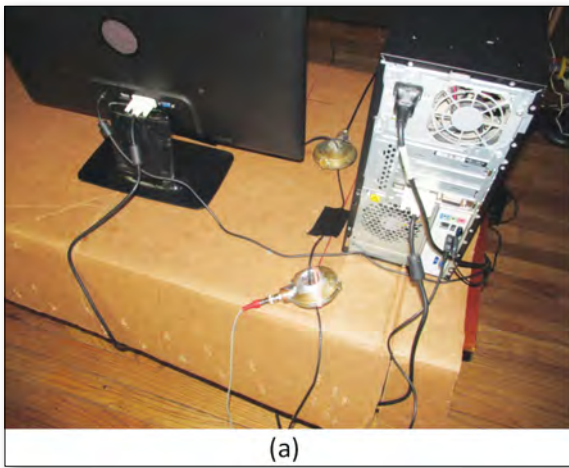
Since we made 2 of the candlestick current probes, one of them was used as a common mode injection probe as shown in Figure 7(a) after the manner of ISO 1152-4:2011 [4]. In the standard method the injected signal is from a signal generator. However in this implementation the signal source is the ESD gun as shown in Figure 7(b). In order to limit the injection current a resistor was used in the pulse return cable. Also it was discovered that the computer could be awakened by the probe even when the probe was not clamped around the keyboard cable due to common mode current on the probe feed cable. To fix this problem ferrite beads were added to the probe feed cable at the ESD gun injection point as shown in Figure 7(b).

The injection probe was able to easily turn on the computer even with about 1.5kΩ in series with the ESD gun return line. The measurement of the common mode current and

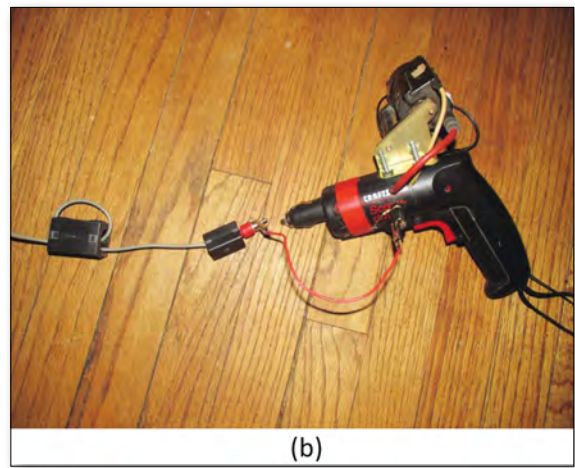


**FIGURE 6:** Measurements for loop antenna (green) and current probe (yellow) for ESD at 18"

the loop antenna voltage are shown in Figure 8(a). The loop antenna is either picking up signal from the common mode radiation off of the keyboard cable or is picking up the pulse from the gun as it injects.

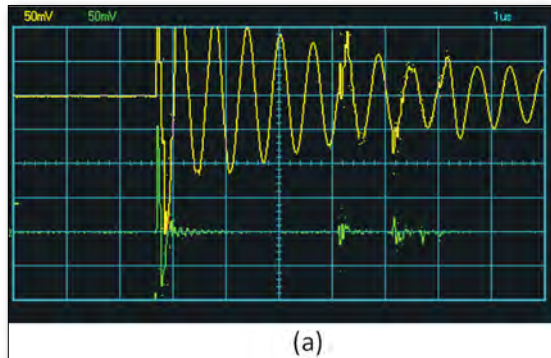


(a)

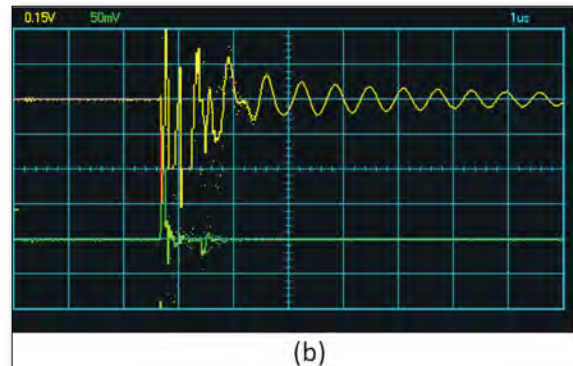


(b)

**FIGURE 7:** (a) Injection probe setup and (b) ESD gun injection showing beads on the probe cable

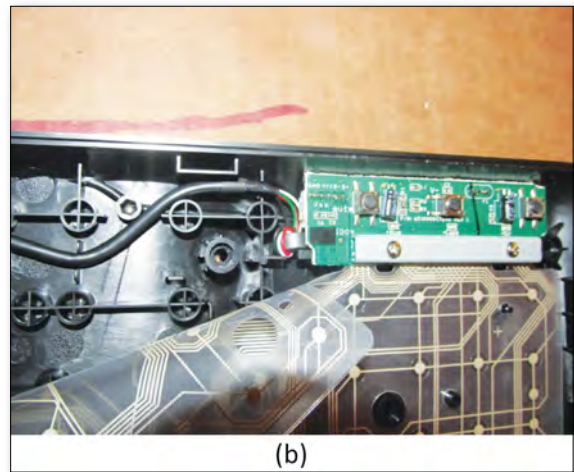
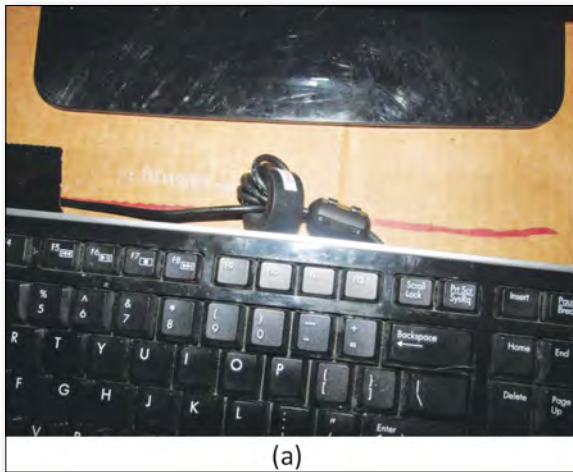


(a)



(b)

**FIGURE 8:** (a) Injected common mode current with 1.5kΩ at gun awakens computer, (b) With 0Ω at gun but with common mode suppression on keyboard cable does not awaken computer



**FIGURE 9:** (a) Common mode suppression added to the keyboard cable and (b) Common mode suppression found inside the keyboard on the cable

**THE REALIZED SOLUTIONS**

Since it is apparent that common mode current on the keyboard cable is able to turn on the computer, common mode suppression was added to the keyboard cable at the keyboard. With this suppression in place the common mode current is reduced and the computer is not awakened by the injection current from the ESD gun. Even with no resistance added

to the ESD gun return wire the computer is not booted. The reduced current is shown in Figure 8(b).

Common mode suppression used for the keyboard cable was comprised of a snap on bead from Radio Shack and a torroid with three turns of the cable as shown in Figure 9(a). The torroid is Fair-Rite part number 2643804502. It was found necessary to add the turns to the torroid for sufficient reduction of the common mode current.

**KNOCK OUT**  
LOW-FREQUENCY EMI

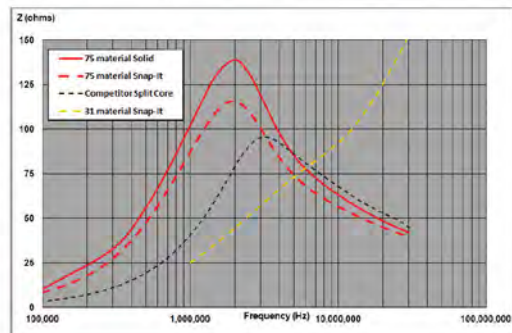


**75**  
MATERIAL

**Rachael Parker**  
Vice President  
Fair-Rite Products



Our new **75 Material** solves low-frequency EMI issues between 100 kHz and 5 MHz and suppresses common-mode noise up to 30 MHz! Only Fair-Rite offers this superior solution in its industry-leading Snap-It and corresponding solid cores.



**Fair-Rite Products Corp.**  
Your Signal Solution®

**Request A Free Sample Today!**  
888.324.7748 | Fair-Rite.com



Next the keyboard was disassembled to understand the path for common mode current and the means by which it causes the wake-up pulse. Surprise! When the keys were removed a common mode choke was discovered on the cable at the controller board as shown in Figure 9(b).

In addition to the beads, a shielding experiment was conducted. A sheet of aluminum foil was placed over the top of the keyboard. This foil was very effective in preventing ESD initiated wakeups. When the foil was placed underneath the keyboard as shown in Figure 10 similar results were observed.

The effectiveness of the solutions is judged by resistance to ESD voltage magnitude (the number of ESD trigger clicks) and the distance from its application. A summary of the effectiveness of the two solutions is given in Table 1. The most effective solution is the combination of beads and foil. The effect of the beads indicates a common mode susceptibility. Ordinarily it would be expected that the ungrounded foil would make the results worse due to an increase in capacitive coupling to the affected circuits. However, in this case the exact opposite is observed. These seemingly contradictory results can be explained by a detailed analysis of the keyboard circuitry.

**THE RESULTS EXPLAINED**

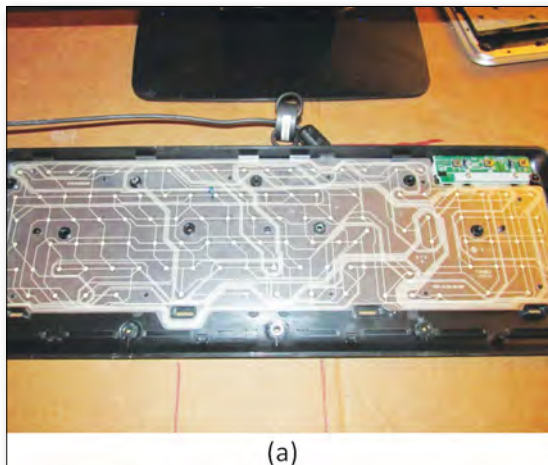
Inside the keyboard is a keyboard controller printed circuit board (PCB) attached to two plastic sheets with printed



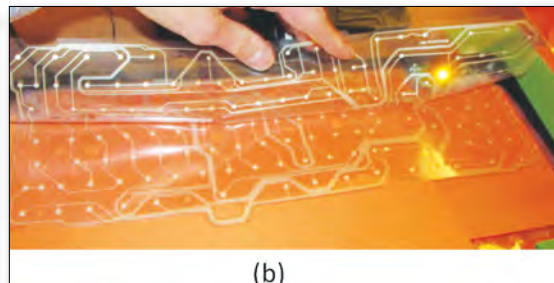
**FIGURE 10:** Foil placed under the keyboard—an effective solution

conductive traces as shown in Figure 11(a). The sheets overlay each other as shown in Figure 11(b). The sheets are “Row” or “Column” contacts based on the array method of ascertaining the connection of a given key. When a key is pressed a conductive dot on the top trace is made to contact a conductive dot on the bottom trace. These traces are the antennas for the ESD pulse radiation which create the common mode current.

Insight into the operation of a keyboard controller is found

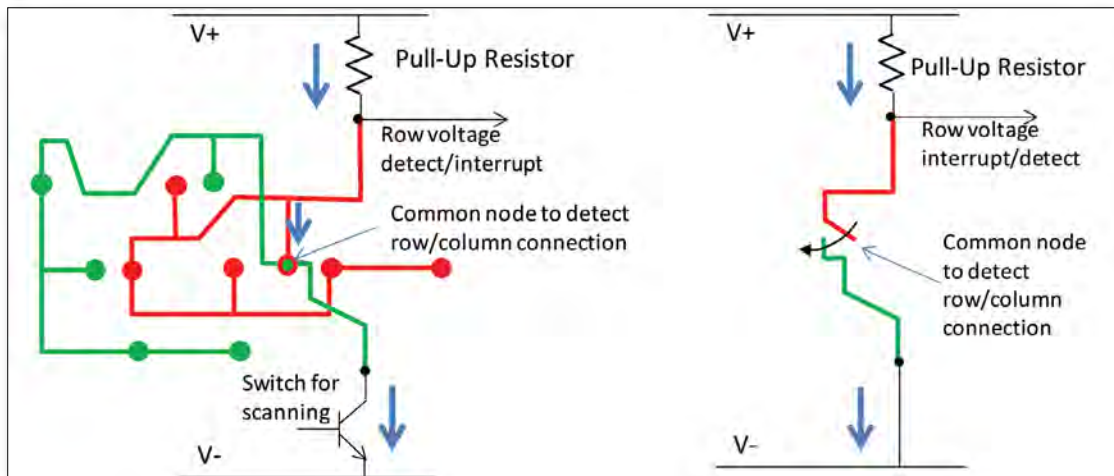


(a)



(b)

**FIGURE 11:** (a) Inside of the keyboard showing PCB and contact sheets and (b) Row and Column layers of contact sheets



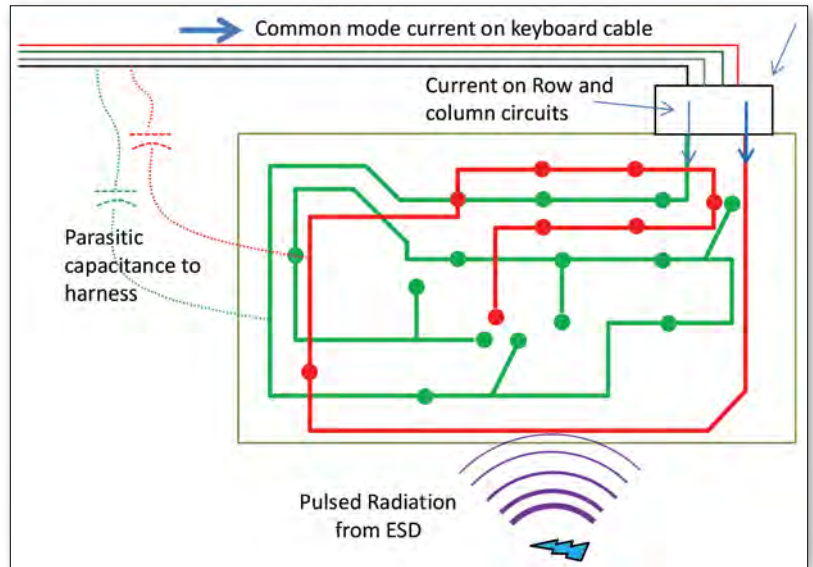
in datasheet [5] and the means of monitoring the signal during sleep mode is found in application note [6] for a keypad. One means of accomplishing this is shown in Figure 11. The keyboard has a set of contacts known as the “Row” contacts on the upper sheet and a second set of “Column” contacts on the lower sheet. Each trace on the, row sheet has a contact point which is coincident with one dot on one trace on the column sheet. Pressure from the key causes electrical contact between the two dots. During normal keyboard operation, the controller sequentially turns on the transistor on each column circuit during a scan operation. When the transistor is turned on for the column circuit for the depressed key, the voltage on the row circuit will drop low since it is connected to the minus voltage supply through the connected dots. If the controller finds a low voltage on the row circuit during the scan, it can identify the key responsible for the row/column connection. The circuit is simplified in Figure 11(b). In sleep mode the circuits are not scanned, but rather the transistors of all the column circuits are turned on simultaneously and a low voltage on any of the row circuits causes an interrupt of the controller resulting in the wake up of the computer.

An ESD event is very rapid compared to a normal keystroke. As mentioned, with the computer awake the ESD does not result in spurious characters. The controller de-bounces normal keystrokes during the scanning but this is not the case when asleep since the row voltages are directed to the controller interrupt.

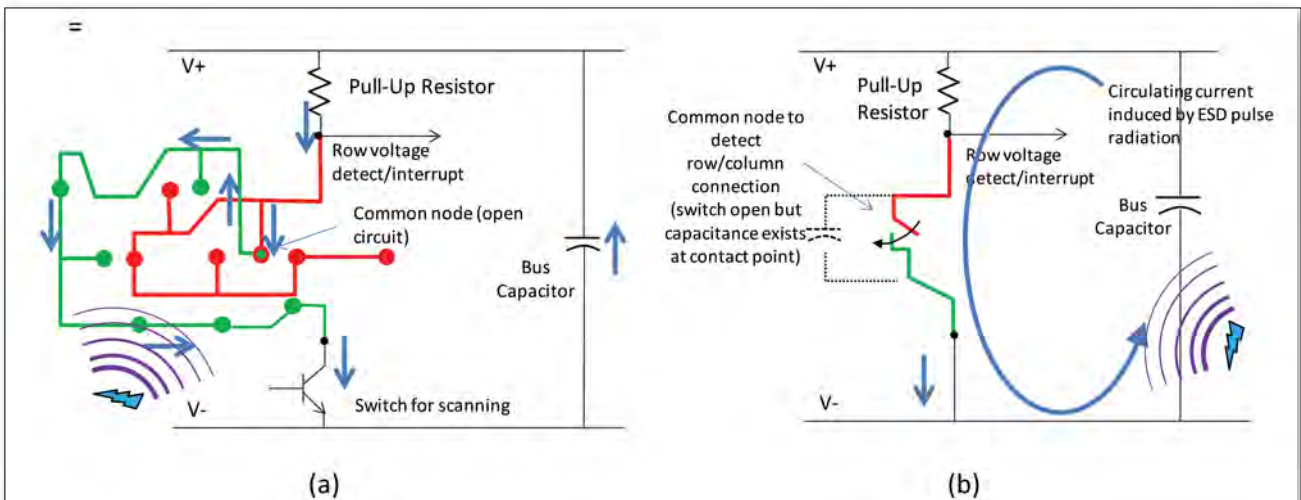
When common mode current is injected in the keyboard cable either by the injection probe or by the radiated ESD pulse from the gun, it passes into the keyboard onto the conductive

**TABLE 1:** Effectiveness of solutions

Number of ESD Trigger Clicks	Beads and Torroid on Keyboard Cable?	Foil Under Keyboard?	Foil Under Keyboard?
1	N	N	12" to 15"
1	Y	N	6" to 9"
1	N	Y	0 to 3"
3 to 5	Y	Y	<3"



**FIGURE 12:** Common Mode

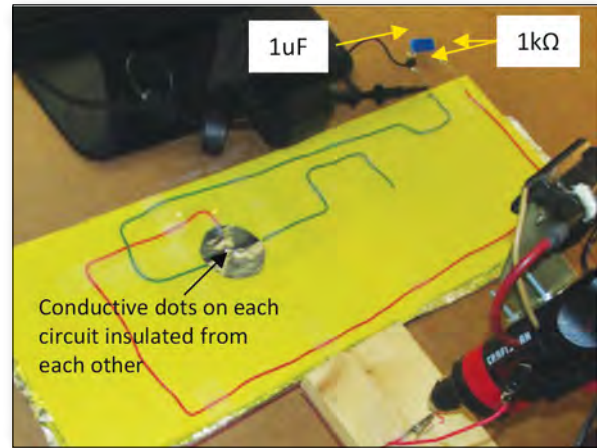


**FIGURE 13:** (a)Keyboard current loop through bus capacitance and (b)Simplified circuit

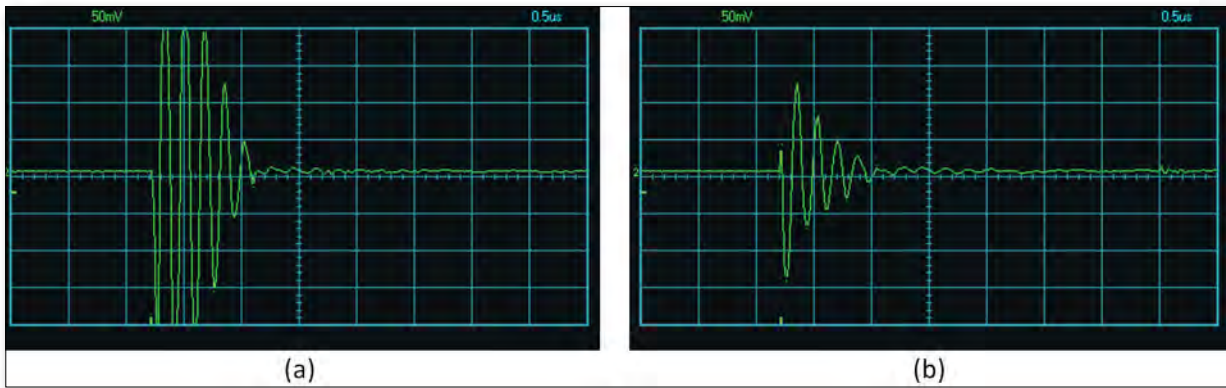


sheets. The sheets couple back to the cable and to ground by parasitic capacitance as shown in Figure 12. The current passing through the pull-up resistors results in a voltage drop that can be seen as low voltage on the row circuit even if no key is pressed. This triggers the controller interrupt and subsequently the wake-up pulse as in Figure 4(b). Placing beads and toroid on the cable reduce the common mode current and the susceptibility to the ESD.

This explanation, however, is not consistent with the effectiveness of the aluminum foil. The foil should improve the common mode coupling to the keyboard and make it more sensitive to the ESD pulses. A closer examination of the circuit leads to a reasonable explanation. In the circuit a bus capacitance across the supply voltage lines would result in a circuit loop with the row and column traces as shown in Figure 13(a). The circuit is connected not only by the bus capacitance but also by capacitance between the conductor dots at the common point of a given row and column trace



**FIGURE 14:** Simulated test artifact with bus capacitor, simulated Row and Column circuits



**FIGURE 15:** Measurement across circuit resistor (a)without foil, (b)with foil under artifact

as shown in the simplified circuit of Figure 13(b). When ESD pulse radiation passes through the loop it causes a voltage drop on the pull-up resistor.

Radiation from an ESD event also causes circulating currents in a piece of foil underneath the keyboard. The current is directed to produce a field which opposes the field hitting it from the ESD radiation. This reduces the field levels nearby to the foil surface and thus should reduce the circulating current in the keyboard. Since it was difficult to test this directly in the keyboard, a simulated keyboard artifact was constructed as shown in Figure 14. The artifact uses two wire segments to represent a pair of row and column circuits. At a common point overlaid conductive “dots” were made using conductive tape. A “dot” was placed on each circuit but the “dots” were insulated from one another. The “dots” were made larger than real life to aid in evaluation of the concept. Each circuit was connected by a 1kΩ resistor (for pull-up) to a 1uF “bus” capacitor.

Measurement of the voltage across one of the resistors confirms the theory. Figure 15(a) shows the voltage during an ESD pulse generated at 3” from the keyboard artifact

without foil underneath. Figure 15(b) shows a dramatic reduction in the voltage when foil is placed under the keyboard.

So now with some simple common mode chokes and a piece of foil I can safely fold the laundry and our computer can get a good night’s rest.

## REFERENCES

- [1] Henry W. Ott, *Noise Reduction Techniques in Electronic Systems*, 2nd Edition, John Wiley & Sons, U.S.A., 1988, pg. 203.
- [2] Henry W. Ott, *Electromagnetic Compatibility Engineering*, John Wiley & Sons, Inc., New Jersey, 2009, pg. 588.
- [3] Candace Suriano and John Suriano, “EMC means more than Everyone Must Comply,” *Conformity*, Vol. 10, No. 10, October 2005, pp. 12-21.
- [4] ISO 11452-4:2011 Road vehicles -- Component test methods for electrical disturbances from narrowband radiated electromagnetic energy -- Part 4: Harness excitation methods
- [5] Sprintek Corporation, SK5100/SK5101 FlexMatrix Keyboard Controller, Datasheet, Document No. DS0002 Ver. 1.05, October 2010.
- [6] Atmel Corp., AVR243: Matrix Keyboard Decoder, Application Note, Rev. 2532A-AVR-01/03, 2003.

# the world leader in emi filtering

Since 1968, the Spectrum Control line of electromagnetic products from API Technologies has delivered innovative solutions from standard and custom components to complex assemblies. With the industry's broadest line of standard products and world-class custom products, learn more about how we can help you address the mechanical, electrical and/or power requirements of your next design.



## coaxial emi filters

- Resin & hermetically sealed filters
- Motor-line feed-through filters (MLFT)
- High current/high voltage filters
- Miniature & solder-in filters
- 3 terminal chips & power surface mount filters



## emi filtered interconnects

- Ferrite, chip-cap & low profile D-sub
- High performance & hi-density D-sub
- USB filtered & ESD protected connectors
- Ribbon & datacom connectors
- Filter plates & terminal blocks



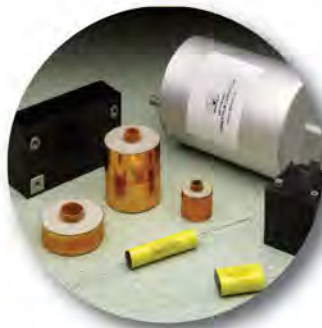
## emi power filters

- Single-line feed-through filters
- Power entry modules
- Power line filters & 3 phase power filters
- Military/aerospace multisection filters
- Custom filtered power solutions



## specialty connectors, cables & harnessing

- EMI filtered & unfiltered circular connectors
- Mini-MIL connectors
- Rapid mate connectors
- Audio connectors
- Hermetically sealed connectors
- Custom cable and harnessing



## power film capacitors

- Metalized polypropylene, polyester & polyphenylene sulfide film capacitors
- DC link capacitors
- Audio film capacitors
- Custom power film capacitors



## advanced ceramics

- Capacitor arrays
- SMPS modular capacitors
- Planar capacitors
- Discoidal & tubular capacitors

**GREAT Downloads!**



**Short Form Catalog & 332 Page Full Line Catalog**

[eis.apitech.com](http://eis.apitech.com) or call 888.267.1195



# Characterization of EMI Shielding Gaskets up to 40 GHz

## CHRISTIAN BRULL

EMC Engineer  
Schlegel

**E**MI GASKETS are conductive hardware's designed to conform to joint surface and provide a low impedance path. Compressed between two metal flanges, the gasket presents a complex impedance with resistive, inductive and capacitive properties. This will vary with frequency, materials, compression rate, geometry of the joint, etc. In the meantime, major differences are also observed between different type of gaskets. For instance conductive particle loaded silicones present important variations of efficiency with compression (large variations of electrical liaisons between conductive particles). The surface in contact is the main criteria for Fabric-over-Foam gaskets and for metal gaskets like fingerstocks made of beryllium Copper, variations occur mainly with frequency due to the slot pattern between fingers. As one can predict with all these variable parameters, the characterization of a gasket is rather a challenging exercise.

To understand what measurement techniques are currently available to

the gasket industry, reference should be made to IEEE Std 1302 released for the first time in 1998 and revised in 2008. It is a guidance document which gathers and compares most of the methods available (in 2008) for the characterization of EMI gaskets from DC up to 18 GHz. The document provides a basis for comparing the different techniques in use. It consists of three sections: Full standardized methods, alternative methods derived from standards and alternative non-standardized methods. Every method will not be discussed here (please refer to IEEE Std 1302) but probably the most popular one.

The standard most commonly used so far is without a doubt, Mil DTL 83528 C. This aperture attenuation method derived from the former Mil Std 285 (superseded by IEEE 299) characterizes the shielding effectiveness (SE) of the gasket from 20 MHz to 10 GHz (with possible extension to 18 GHz). The test set-up consist of a shielded room with an opening of 610/610 mm (24"/24") with one emitting antenna outside and a receiving antenna inside the room and two meters distance between antennas (Figs. 1 & 2)

A first measurement is made from one antenna to the other through the opening and a second is made when the opening is closed by means of a metal plate with the gasket to be tested mounted around

# EMI Shielding Solutions

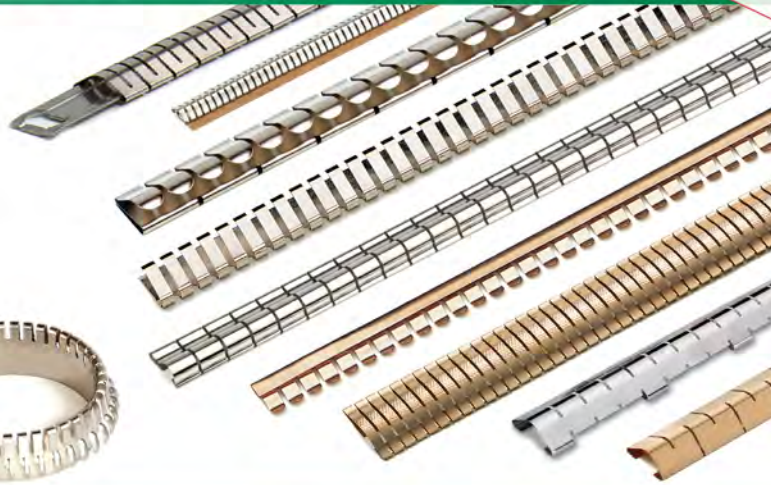
See us at:  
• Design2Part - Santa Clara  
• Design & Manufacturing NE - Boston

## Standard Spring Finger Gaskets

- Most complete line of standard BeCu shielding strips
- Strips range from 16 to 24 inches in length
- Continuous coils available up to 35 feet long
- Offered as single fingers or contact rings
- Choose from over 100 profiles with multiple plating options
- Clip-on, Stick-on, Snap-on or Track mounting
- In stock for immediate delivery



Download our 52-page Shielding Catalog.



## Standard Conductive Elastomers

- Mesh with and without elastomer core
- Conductive foam with X, Y & Z axis conductivity
- Metalized fabric standard profiles and gaskets
- Connector and waveguide die cut gaskets
- Conductive elastomers in sheets or die cut gaskets
- Elastomers for EMI shielding plus environmental seal



Download our 8-page EMI/RFI Shielding Guide.



## Custom Shielding

- Global supplier of custom EMI shielding products
- Commercial and military markets
- Shielded honeycomb vents and air filters
- Steel, copper alloys, brass and nickel silver
- Quick-turn, etching, forming and plating
- Board level shielding



Download our Capabilities Brochure.



# Tech-Etch

ISO 9001  
REGISTERED

[www.tech-etch.com](http://www.tech-etch.com)

TECH-ETCH, INC., 45 Aldrin Road, Plymouth, MA 02360 USA • TEL 508-747-0300 • FAX 508-746-9639 • sales@tech-etch.com



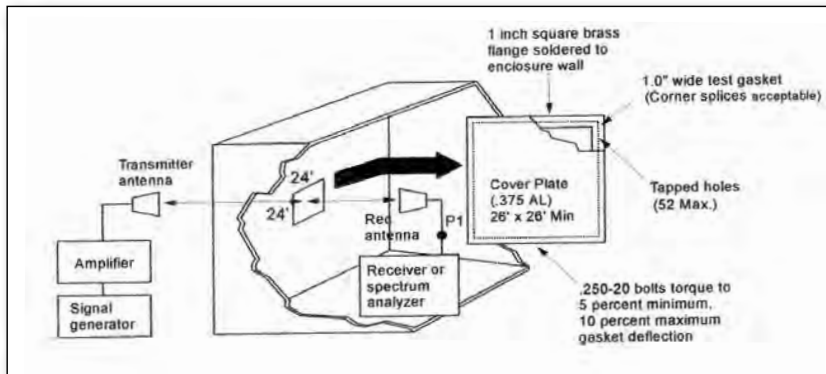


FIGURE 1: Mil-DTL 83528 C test set-up.

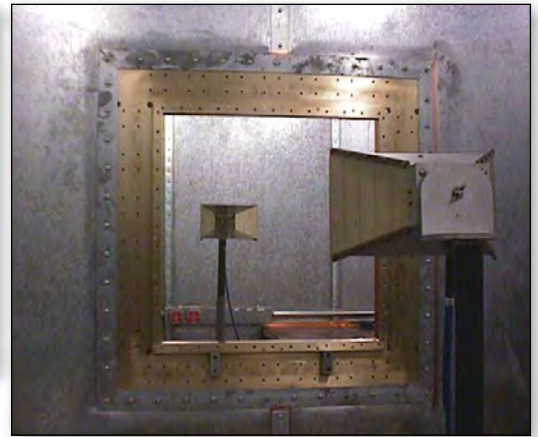


FIGURE 2: Mil-DTL 83528 C test set-up.

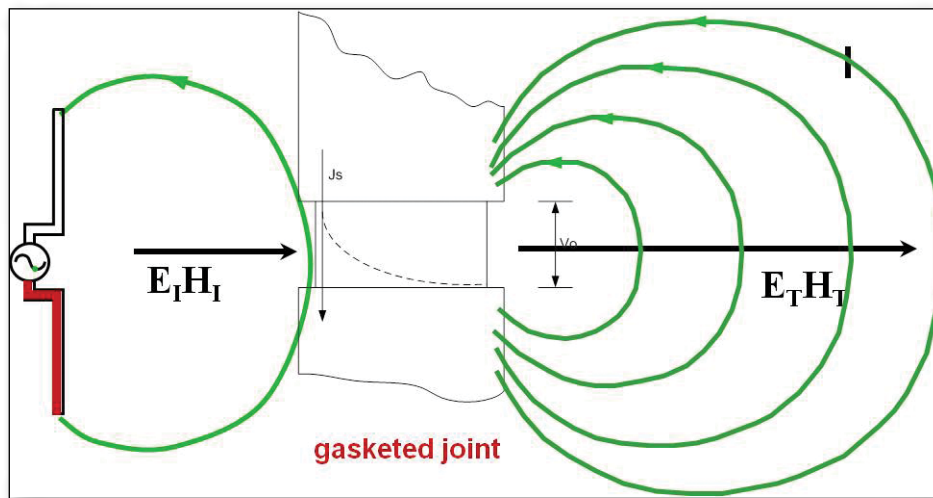


FIGURE 3: Principle transfer impedance.

and compressed. The method measures the field before and after the metal/gasket and the shielding effectiveness of the gasket is:  $20 \log E_1/E_2$  ( $H_1/H_2$ ) or the difference between both measurements in dB from 20 MHz to 10 GHz.

The method has a theoretical repeatability of  $\pm 6$ -10 dB. However, repeatability can deteriorate to  $\pm 20$  dB with small variations of the antenna position when half the wavelength is getting close to the characteristic dimension of the shielded room (change of antenna in the course of testing for each of the 3 decades). Another issue is the size of gaskets that can be tested by this method. The overlap of the heavy metal plate onto the shielded room wall induces capacitive coupling which effect the measurement when the gasket is small. There are other issues such as the size of the opening and its attenuation, the frequency limitation, the influence of the metallic screws (replaced sometimes by isolated clamps), etc. In practice, absolute values of SE should be taken very cautiously for the various reasons explained. It is observed that offset with actual values

obtained in applications, increases with the frequency. The main interest of the method is probably that it is a standard so that measurements according to Mil DTL 83528C can be compared and especially if testing was carried out by an independent Laboratory. The specification requires a minimum of 5 measurements per decade and very often, technical documentation on gaskets provides the average value of the 15 measurements.

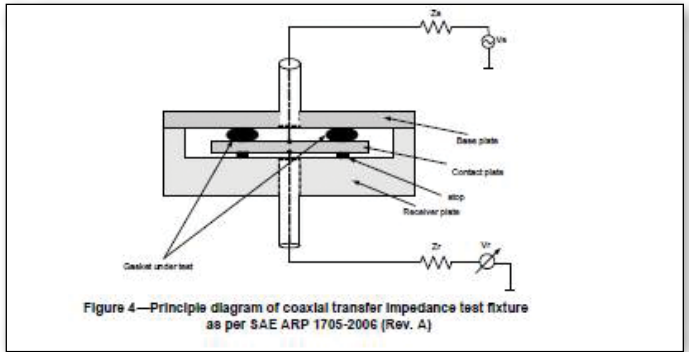
The other main standard is SAE ARP 1705, a current injection method measuring transfer impedance. When an electromagnetic field impinges onto a metal barrier, it induces a current which in turn creates a voltage across the seam which radiates (Fig. 3)

In the transfer impedance measuring technique, a current, supposedly resulting from the coupling with an electromagnetic field, is directly injected into the gasketed joint. The voltage across the seam is therefore measured. The ratio voltage over current reported in a 1 meter length defines the transfer impedance of the gasket expressed in dB Ohm/m. The current injection



**FIGURE 4:** Transfer impedance – SAE ARP 1705 rev. A.

method has a good repeatability of +/- 3-6 dB. SAE ARP 1705 Rev. A is limited to 1.5 GHz and a revision C is in progress which should extend the frequency range to 10 or 18 GHz. The measuring fixture can easily be modified to accommodate modules of different metals so that the degradation of contacts can be studied under different aging conditions. This method provides a direct indication of the conductivity of the gasketed joint but discussions are still ongoing into the relationship between transfer



**Figure 4—Principle diagram of coaxial transfer impedance test fixture as per SAE ARP 1705-2006 (Rev. A)**

**FIGURE 5:** Transfer impedance – principle diagram.

impedance and shielding effectiveness. In the Shelkunoff model, the overall attenuation into a material is the sum of reflection and absorption factors. The reflection factor is actually not considered in the transfer impedance (Figs. 4 & 5).

For the measurement of Shielding Effectiveness for small size gaskets, TEM-T and Ht Cells method is preferred. This is a non-standardized test method described in IEEE Std 1302 and used in R&D because of its good repeatability

## Astrodyne TDI...

### Your Ultimate Source for Military and Commercial EMI Filters

Count on Astrodyne TDI to meet all your EMC filter needs, including:

**COTS and Custom Military:** MIL-STD-461, MIL-STD-220A; full custom available

**Commercial Off-the-Shelf:** power line and power entry filters, industrial and medical; UL, CSA and VDE; RoHS compliant

**EMC Test and Design:** total in-house capability including self-certification for UL/EN in 4-6 weeks

For details on these and a full range of other filter solutions, call, email or visit us online.



**Astrodyne TDI**  
Now you have power.

Designers and Manufacturers of:

**RP** RADIUS POWER **LCR**

(800) 527-4362 • [emifiltersales@astrodyne.com](mailto:emifiltersales@astrodyne.com) • [www.astrodyne.com](http://www.astrodyne.com)





FIGURE 6: TEM-T.

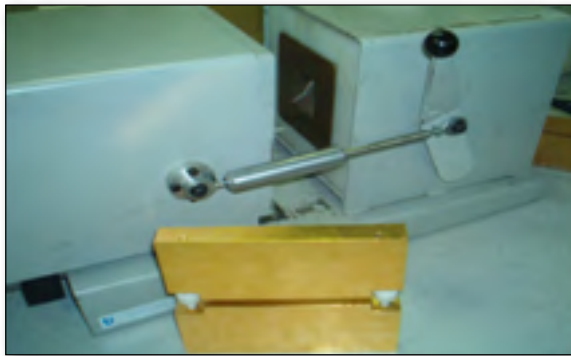
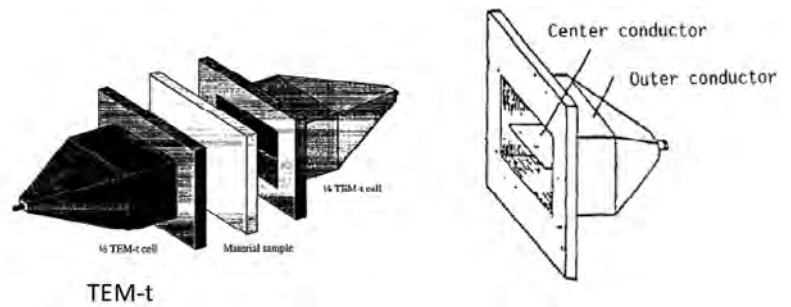
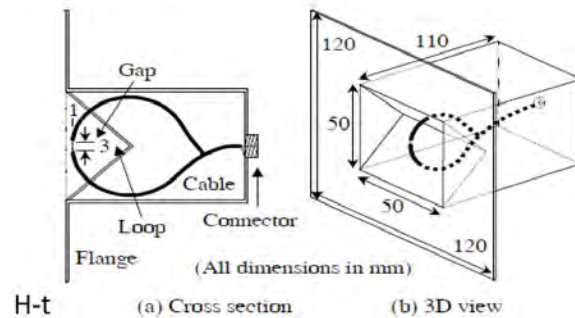


FIGURE 7: Ht.



H-t

(a) Cross section

(b) 3D view

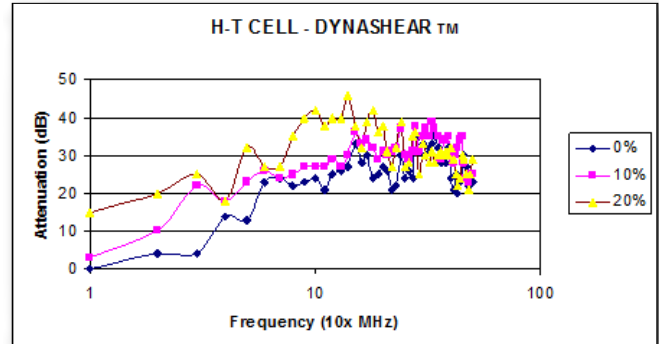
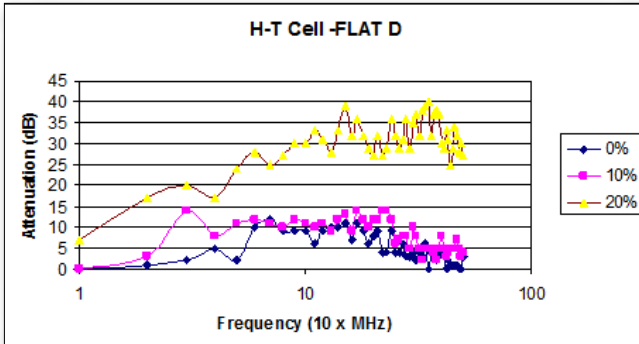
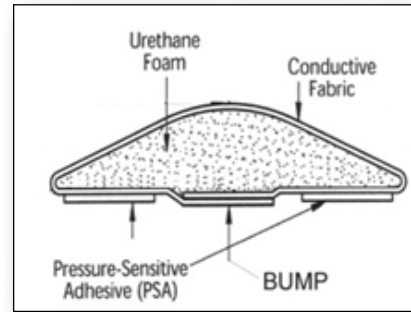
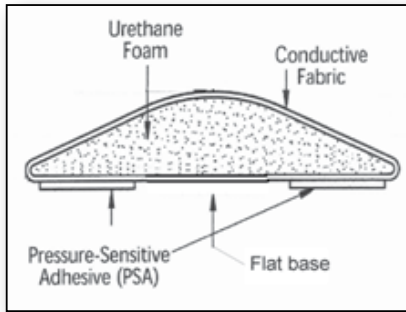
(1-3 dB). TEM-t is a TEM mode transmission line device simulating far field conditions. The square coaxial fixture of the TEM-t is cut in the middle so that a gasket holder compressing the gasket under test can be inserted between the two halves of the measuring equipment. The H-t cell is made by a set of two small loop antennas simulating the magnetic near field (Figs. 6 & 7).

In the following example, the Ht cell was used to evaluate the influence of a small deformation at the bottom (bump) of a Fabric-over-Foam D-shape gasket compared with a standard flat bottom one. The modification is intended to improve the efficiency at low compression in combination with non conductive pressure sensitive adhesive. SE measurement were taken at 0%-10%-20% compression (from the free height of the gasket). The gasket, SEM's DYNASHEAR EJ9, is 2.3 mm high so that 10 % compression represents a variation of only 0.23 mm in height. The results show that for a flat bottom gasket, a minimum compression of 20% must be applied to overcome the isolated layer of adhesive while with a small bump at the bottom, substantial SE is already obtained at low compression. H-t cell is an excellent method to characterize SE for such little variations of compression and for such a small size gasket. The absolute SE is not very high but it is mainly due to the short distance between the antenna and the gasket and therefore the low mismatch

between the characteristic impedance of the magnetic field and the intrinsic impedance of the gasketed joint. The frequency range is 100- 500 MHz (Figs. 8 & 9).

Most Electronic Equipments are working at higher speeds than in the past and with the latest technologies, systems take less and less space. Proximity creates new challenges with more cross-talk between circuits affecting the functions of equipment so that signal integrity has become more challenging, much more than just shielding for the compliance of equipment to a specific standard. In the US, for radiated measurements, FCC (Title 47 part 15.33) requires for systems with the highest frequency over 1GHz, to test to the 5th. harmonic or 40 GHz (whichever is the lowest). Testing Electronic equipment to 40 GHz starts to be very common in specific fields of Electronics. As one can see, there is a major gap between standards available to the gasket industry and the market requirements. For that reason a technical committee started to work on the revision and the extension of the IEEE Std 1302 from 18 GHz to 40 GHz. At the time of writing, there are not too many works in progress for the characterization of EMI gaskets up to 40 GHz. The major one is the stripline method (Fig. 10).

Schlegel Electronic Materials, in partnership with Prof. J. Catrysse and Prof. D. Pissort of the KULab REMI research group of the KULeuven (University of Leuven-



**FIGURE 8:** Flat bottom seal.

**FIGURE 9:** Seal with deformation.



Parker Chomerics is a global leader in supplying display windows, enhancements, EMI shielding components, thermal interface materials and plastics processing. Our window display products are designed to provide a variety of solutions for your display needs and are available in plastic or glass.

**Product Features**

- Display Protection
- Anti-Glare/Hard -Coated Finishes
- Anti-Reflection Coatings
- Hydrophobic & Olophobic Coatings
- EMI/RFI & ESD Protection
- Monolithic or Laminate Structures
- Embedded Custom Graphics
- Night Vision
- Circular or Linear Polarizers
- Privacy Filters (Directional Viewing)
- Optical Bonding

Call our Applications Engineering Department to discuss your display application and the various window and enhancement options that are available from Parker Chomerics.



781-935 4850  
chomailbox@parker.com

www.parker.com  
www.chomerics.com

**ENGINEERING YOUR SUCCESS.**



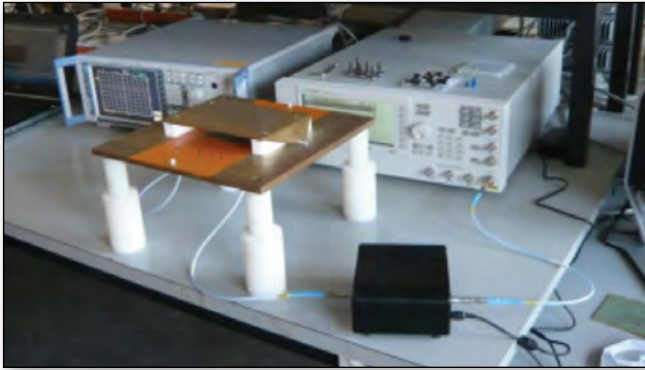


FIGURE 10: Stripline fixture.

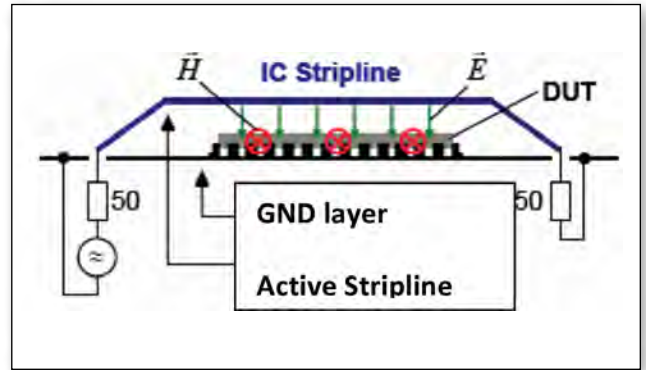


FIGURE 11: IEC 61967-8 / IEC 62132-8 -Principe.

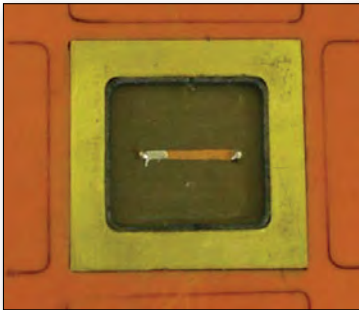


FIGURE 12:  $\mu$ -strip.

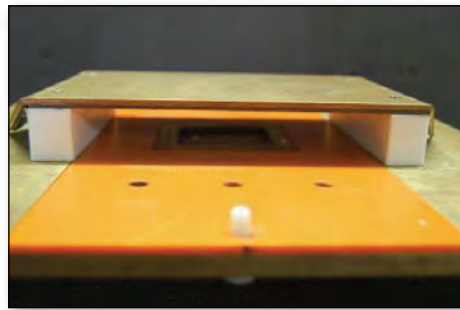


FIGURE 13: Stripline.



FIGURE 14: Metal plate attached to test

Belgium), developed a new testing fixture to characterize the Shielding effectiveness of conductive gaskets up to 40 GHz. The principle of this fixture is based on a method that was first introduced by Prof. B. Koerber to measure the radiated emission and susceptibility of Integrated Circuits (IEC 61967-8 and IEC 62132-8). The method utilizes a stripline antenna which closes over a PC-Board (Fig. 11).

In the new stripline fixture, the PC board with the IC under test is replaced by a small microstrip antenna embedded into a cavity within the ground plane. The cavity can be closed by means of a thick plate which compresses the gasket under test. A stripline antenna covers the set-up (Figs. 12-14).

The testing procedure, similar to IEEE 299 or Mil DTL 83528 C, is as follows :

- 1) a direct measurement from microstrip to stripline to establish a reference (measurement of the signal before the shield)
- 2) measurement of the closed cavity with the gasket under test (measurement of the signal after the shield)
- 3) Difference between both measurements in dB is the Shielding Effectiveness of the gasket .

Repeatability is excellent even if the signals are noisy. We can see on the hereafter graphs the SE obtained from 1 to 40 GHz for one Fabric- over- Foam gasket 3 by 9 mm, and one metal fingerstock D- shape of same dimension but with a slot of 0.45 mm and a finger width of 4.32 mm .Both were compressed to 50% from free height. The fabric-over-foam gasket has a pretty steady response while the metal gasket displays a continuous drop from 12 GHz because of the slot between the fingers. The attenuation will vary as a function of the slot pattern and the stripline fixture is an interesting mean to figure out its impact on SE at high frequency (Figs. 15 & 16).

Another example is the SE measurement of an I/O connector gasket made of conductive fabric over a non conductive foam core. The gasket is fabricated to the required width and then die-cut according to the dimensions of the connector shell. This type of solution worked fine in the past when most of the issues were in the 300 MHz region. The stripline method shows that this solution works up to 1 GHz. In fact with the frequency increase, openings created with the die-cut of non conductive foam core are leaking and sometimes the impedance of the return current path between flanges may even create antenna effect .The stripline method shows that by using a conductive fabric over a Z conductive

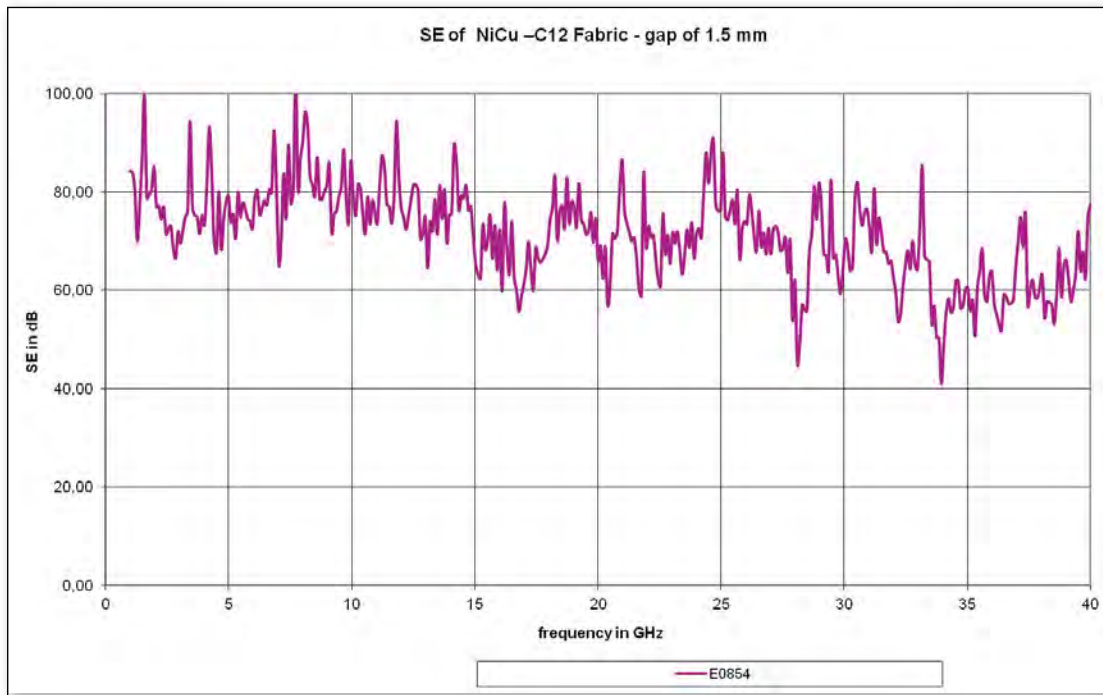


FIGURE 15: Fabric over foam.

**FOTOFAB** *A World Apart In a World of Parts!*

**Custom Shields and Metal Parts.**

Fotofab's process of photochemical etching offers speed, flexibility and precision unmatched by traditional manufacturing methods.

- Print to part in 1 day - yes we're that fast!
- Fotofab's technical staff will drive your project - even without a print.
- Complex features, non-standard sizes and company logos are free.
- Fotofab can form, plate and package your parts...

*Just tell us what you need!*

You'll see the difference as soon as you talk to us. Contact our sales staff today, or request your free shielding sample kit and design guide at [www.fotofab.com/shielding](http://www.fotofab.com/shielding)

**FOTOFAB** 773.463.6211 3758 W. Belmont Avenue  
 FAX.463.3387 Chicago, IL 60618  
 sales@fotofab.com USA



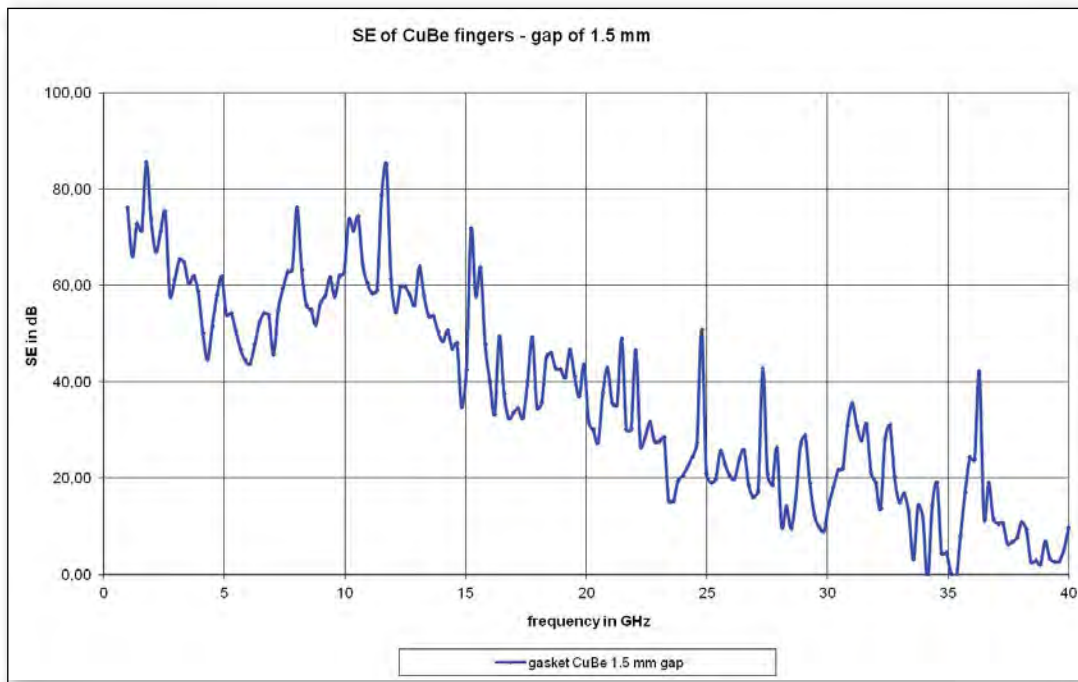


FIGURE 16: BeCu Fingerstocks.



**Expanding  
Technology™**

## Expanded Metal Foils For Shielding Effectiveness!

Using precision expanded metals can greatly enhance the electromagnetic shielding for your applications and meet EMI/RFI compliance.

However, shielding will react differently depending on its design, degrees of coverage and geometry. They determine how well your shielding attenuates electromagnetic fields.

Let our engineers help you decide on which expanded material best suits your needs and develop a configuration to provide effective shielding for your applications.

### Contact Dexmet Today!






**Shielding Material for**  
Aerospace • Electronics • Telecommunications • Industrial

[www.dexmetshielding.com](http://www.dexmetshielding.com) / (203) 294-4440

foam core, large improvements are obtained. At low frequency the fabric brings the major contribution and as the frequency rises, the Z conductive foam core ensures a higher shielding and a shorter return current path making this gasket construction a broadband solution [SEM Ref. ORS-II] (Figs. 17 & 18).

The stripline method features some other interesting characteristics. The microstrip antenna being a trace on a board, the PC board environment is reproduced so that the data obtained can be expected in a similar environment. For that reason, the method may be considered in the future for the characterization of PC-board shielded cans .

The test method will be soon supported by a standard from SAE (Society of Automotive and Aerospace Engineers) under the reference SAE ARP 6248.

#### ABOUT THE AUTHOR

Christian Brull has an Engineering degree in Electronics –HELMO Liege -Belgium. Brull started his EMC work in 1989 in application engineering and research and development in the field of EMI shielding. He is secretary of the IEEE PE 1302/ working group for the revision and the extension to 40 GHz of the IEEE Std 1302 Guide for the characterization of conductive gaskets in the frequency range of DC to 18 GHz. Member of the Society of Automotive and Aerospace Engineers SAE,AE-4/EMC Commitee. Currently he is Global Product Manager for Schlegel Electronic Materials

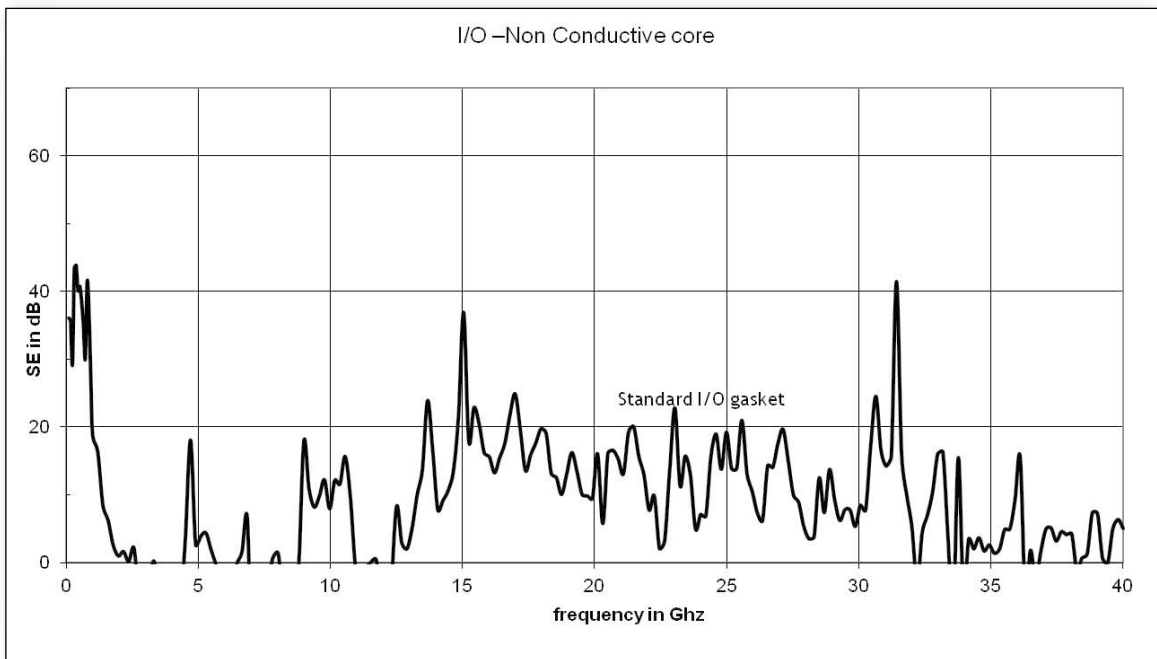


FIGURE 17: Fabric over non conductive core.

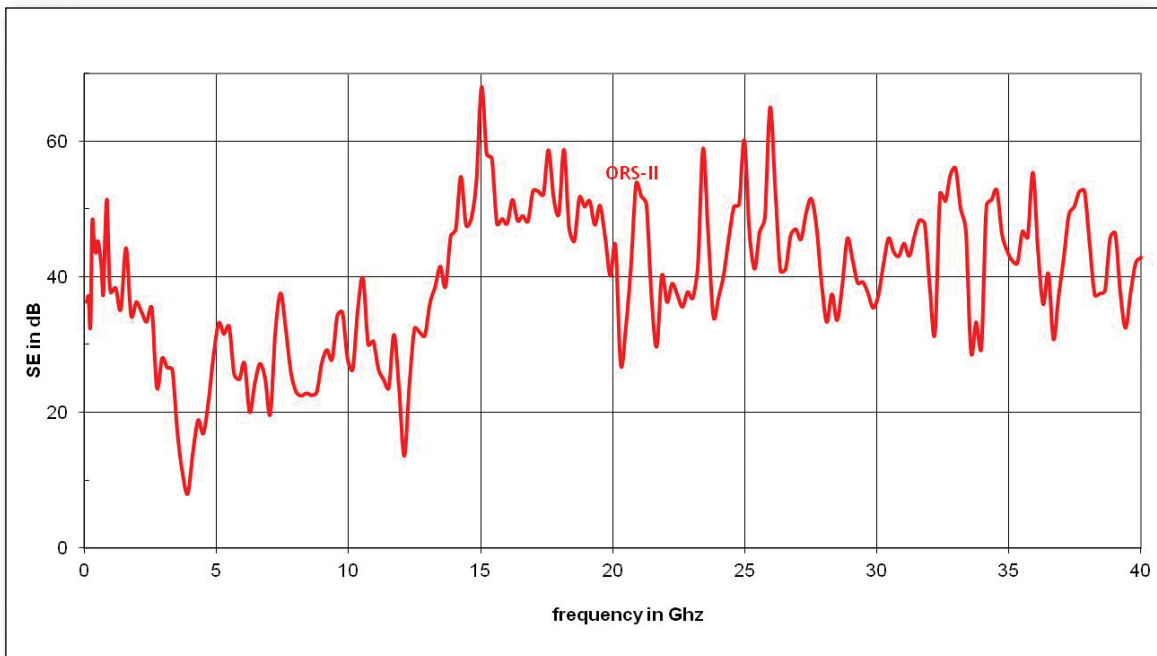


FIGURE 18: Fabric over Z conductive core.

## REFERENCES

- [1] IEEE Std 1302 –Rev. 2008 : IEEE Guide for the Electromagnetic Characterization of Conductive Gaskets in the Frequency Range of DC to 18 GHz
- [2] J. Catrysse, F. Vanhee, D. Pissoort, C. Brull, and G. Vandenbosch, “A new stripline measuring setup for the characterisation of conductive gaskets up to 18 GHz”, Proceedings of the IEEE International Conference on Electromagnetic Compatibility, Fort Lauderdale, Florida, USA, July 2010.
- [3] J. Catrysse, F. Vanhee, D. Pissoort, C. Brull, and P. Reynaert, “Expanding the Stripline Measuring Set-up for the Characterisation of Conductive Gaskets up to 40 GHz”, Proceedings of the IEEE International Conference on Electromagnetic Compatibility, Pittsburgh, Pennsylvania, USA, Aug. 2012
- [4] J. Catrysse, T. Grenson, F. Vanhee, D. Pissoort and C. Brull, “The importance of continuous and homogeneous Gasket Conductivity up to 40 GHz”, Proceedings of EMC Europe 2013 Brugge Symposium, Brugge, Sept. 2013
- [5] Schelkunoff, S. A., Electromagnetic Waves. New York: Van Nostrand, 1943.



# EMI Across Randomly-Patterned Multiple Traces on a PCB of an Audio/Multimedia Infrastructure: Crosstalk Performance Vis-à-Vis Smart Handheld Devices

PERAMBUR S. NEELAKANTA &  
AZIZ U. NOORI

Department of Computer and Electrical  
Engineering & Computer Science  
Florida Atlantic University

*appropriate for baseband sections supporting high-speed digital transports.*

*Results gathered from experimental studies are presented and corresponding theoretical estimates of NEXT and FEXT are cross-validated.*

## ABSTRACT

*In state-of-the-art wireless devices, accommodating a dense layout of copper traces on the associated printed-circuit boards (single and/or multi-layered), is inevitable. Relevantly, considering the baseband level of audio and/or multimedia sections in smart handheld devices, ad hoc routing of traces, patterned zigzag on the printed-circuit board (PCB) often prevails; hence, a unique modeling strategy is required to address the extent of crosstalk victimization of trace-lines located proximally to the aggressing signal paths.*

*The present study is devised to address and evaluate the performance integrity of a smart device with a PCB at the baseband section infested with a random cluster of traces; and, the associated high-speed digital transport on a trace (called aggressor) is assumed to induce unwanted crosstalk across victim traces in the vicinity. Relevant probabilistic attributes of randomly-dispersed trace patterns on the PCB invoking nondeterministic values of crosstalk are considered in this study; and, corresponding near- and far-end cross-talk (NEXT and FEXT) values are estimated. Such details can lead to compatible suggestions on crosstalk mitigation pursuits*

## INTRODUCTION

**T**HE SCOPE OF this paper is to devise a method to evaluate the performance integrity of a smart handheld device having a printed-circuit board (PCB) at its baseband section, infested with a random cluster of traces [1-17]. The associated transport of high-speed signals (audio and/or multimedia) on a specific trace (called, “the aggressor”) and the corresponding high-speed digital signal-processing (DSP) would invariably culminate in causing unwanted crosstalk across nearby traces (dubbed as “victims”) commensurate with the associated electromagnetic (EM) coupling between the lines.

The probabilistic attributes of such randomly-dispersed trace patterns on the PCB invoke nondeterministic values of near- and far-end crosstalk (NEXT and FEXT) values in the victim traces [2] [4] [7-9]. However, knowledge on such parameters would lead to compatible suggestions and possible design-reviews concerning mitigation pursuits at baseband sections of smart handheld wireless devices.

In the present study, experimental studies are performed on a test PCB

# CST EMC STUDIO 2015

## Design for EMC Compliance

Compliance with electromagnetic compatibility (EMC) regulations is a strict requirement for releasing products in many markets. CST develops simulation solutions that help identify potential compliance issues before the actual prototype is built, and to analyze products that fail compliance testing. This virtual prototyping can reduce design iterations and therefore reduce costs.

Engineers can study effects such as radiated or conducted emissions, susceptibility and environmental electromagnetic effects (E3). CST EMC STUDIO® directly addresses the unique requirements of this market by offering a palette of solvers based on mature, proven technology. These include specialized solvers for EMC-relevant structures such as enclosures, cable harnesses and PCBs.

CST EMC STUDIO – proven solver technology for EMC analysis.





as well as the theoretical estimates of NEXT and FEXT are made and cross-validated with measured values. The theoretical heuristics proposed, computational effort exercised and experimental results obtained thereof are cohesively presented to portray the efficacy of the study and its usefulness. The paper is organized as follows: In the following section (SECTION II), necessary background details are furnished as regard to modern wireless handheld devices vis-à-vis the digital-signal transport characteristics at their baseband sections supported on a cluster of PCB traces. In SECTION III, an overview on the electromagnetic interference (EMI) across the random cluster of PCB traces is presented. Furnished in SECTION IV is a statement on the theoretical heuristics pursued along with descriptions on crosstalk estimation under discussion. In SECTION V, the inter-trace coupling factor ( $F$ ) is defined and evaluated *via* EM field considerations. For analysis and computational study (and eventual experimental efforts), a test layout of PCB is described in SECTION VI. Presented in SECTION VII is the analytical framework pursued; and, lastly the measured and computed data are presented along with inferential details and suggestions on crosstalk mitigation in the context of the test PCB configurations.

## II. DIGITAL SIGNAL TRANSPORT AT BASEBAND SECTION OF WIRELESS HANDHELD DEVICES

In modern context, the gamut of modern wireless devices supports a variety of diverse data applications (DDA) with outputs culminating in audio, video and alphanumeric displays. Specifically, considering the smart handheld devices in vogue, the terminal phase of information in such devices invariably refers to an infrastructure of screen-display and/or audio output [17]. These displays/outputs normally stem from a host of baseband-signal processed and conveyed *via* a densely-packed set of copper-traces routed on rigid and/or flexible PCB frames (single or multilayered) to the terminal sections of a touch-pad screen, loudspeaker and microphone devices. Thus exists between signal-processing electronics and final display-sections in handheld wireless devices are scores of transmission-lines manifesting as copper-traces that connect the source nodes and terminal points as necessary; and, these traces often meander randomly (to and from the sending and receiving ends). Furthermore, they are mostly packed to a very close extent with a format of parallel and/or nonparallel fan-outs often seen as two-dimensional (2D) routing patterns. Also, such traces may prevail on a single-layer PCB and/or they could be stacked across multiple layers as necessary.

Considering, the plan of layout and topology of traces on a PCB as outlined above, they could in general, be classified into two types: (i) They may represent a simple pattern with each trace being parallel to others, but all traces being highly proximal to each other. (ii) Alternatively, such traces though non-crossing, may denote a complex pattern with traces

routed zigzag with no deterministic rule, but decided mostly on *ad hoc* based connectivity compatible for the required signal-flow. (In case, if some traces are required to cross each other, they would be kept separated layer-wise, by resorting to multi-layered PCBs).

Exclusive to baseband sections of handheld devices, the types of traces on a PCB described above are also required to support digital signal transports at very high bit rates. For example, with reference to state-of-the-art smartphones and other mobile/hand-held devices, the data bit-rates adopted at baseband levels could be significantly high ( $\sim 500$  Mbps); further, such streams of high-speed bits are often transferred between chips and/or various circuit nodes during baseband signal-processing, for example, between an image-sensor and an image sensor processor (ISP) [17]. To negotiate such transfers as mentioned earlier, an extensive count of copper-traces is envisaged at the board-level (formed either on a single surface or in multiple board/flex stacks). Further, these trace-lines could be of different lengths so as to accommodate the digital transits as necessary between the pins of any two devices placed at distinct locations on the board.

The physically transmitted baseband signal in essence represents a "digital-over-digital" transmission of pulse trains. In modern context of 3G through 4G considerations and associated LTE implications, the baseband data handled in the infrastructures of smartphones (as well as in similar devices) is relevant to specific versions of processors with chip-designs and/or system-on-chips (SoCs) that accommodate generous audio, and video digital signal-processing (DSP) schedules. Such processors are further required to meet multi-standard integration, reduced power dissipation and facilitate extra key-functions for the next-generation of smart, handheld devices. Relevantly, the associated baseband processors provide efficient operations with cost-effective, multimedia application-specific processing for the entry-level 3G as well as next-generation/evolving 4G systems.

In those complex baseband infrastructure and chip-specific operations mentioned above, the underlying applications invariably dictate the use of high-speed bit rates, which are placed on proximally located traces crowded and routed almost randomly as necessary. For example, considering video-processing support for 10/12 M-pixels imaging and 720p video-playback plus accelerated 2D/3D graphics, the operational needs push the processor speeds up to 1GHz or even higher. Concomitantly, related electrical transmissions of data point out the gravity of multiple high-speed transports on the limited-space circuit-board (and/or flexible-board) layouts. The underlying issue arising thereof can be summarized as follows: Together with the packaging designs of the components and chips placed on the board, the interconnections that support the said digital transports would invariably be in juxtapositions with close proximity; as well as, they could be routed and in transit unpredictably as necessary. Also, the transmission-lines (traces) deployed

would occupy significantly of high density (per unit area) on the PCB and of varying lengths.

The digital transports in PCB contexts of baseband infrastructure described above often culminate in posing unique crosstalk issues that call for effective mitigations [4,9,12,14-16]. That is, considering the PCB layouts with the disposition of two or more adjacent lines closely spaced, the proximity of such traces as indicated earlier would lead to a strong EM coupling between them. That is, the EM forces caused by the time-varying signal transport on the traces would interact across adjacent lines leading to EMI. It amounts to crosstalk meaning unintentional transfer of signal waveform signatures from one-line (named earlier as the aggressor and also known as the infector) to neighboring lines (designated earlier as victims). Such observed crosstalk effects are largely decided by the extent of induced electromagnetic forces decided by relative signal voltage,  $v(t)$  and current  $i(t)$  entities, transported on the traces. Further, the traces depict a set of transmission-lines with distributed resistive, inductive and capacitive characteristics; and, the lossy dielectric characteristics of the circuit-board material supporting the traces will also play a role in deciding the EM propagation characteristics of the signal transmission implicating signal attenuation, as well as dispersive capacitive and inductive effects on the signal transported.

### III. EMI ON THE CLUSTER OF PCB TRACES: AN OVERVIEW

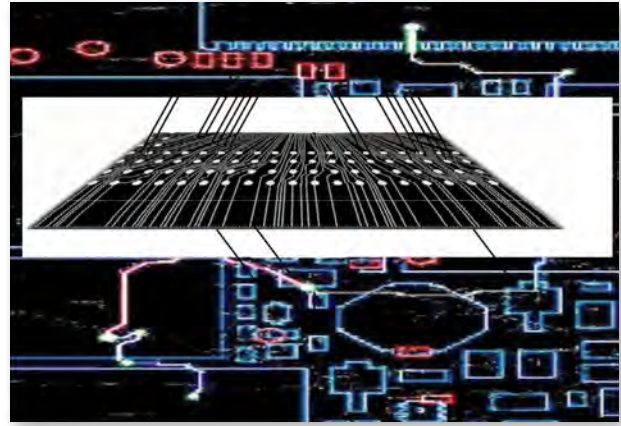
At system-level perspectives, a “trace” on a PCB refers to a transmission-line segment of an overall interconnection mostly comprised of a driver, the associated packages, one or two connectors plus vias etc. A typical wire-board package with traces fanning out is illustrated in Fig 1.

Predicting EMI proliferation on the PCB and the associated coupling behavior between the traces for the purpose of evaluating the resulting crosstalk is rather cumbersome especially, when the traces are arbitrarily off-set, laid non-parallel and randomly-spaced with respect to each other. Exact analytical solutions are not in general easy and mostly impractical. However, approximate modeling and deducing simulated results pertinent to simple, parallel topology of traces have been obtained in the past [10, 11].

Assessing crosstalk influence quantitatively becomes even more difficult when the signals traversing the traces correspond to high-speed digital waveforms with sharp rise-time characteristics. The corresponding inter-trace EM coupling and crosstalk may introduce time-interval-error (TIA) in pulsed waveforms due to spurious dispersion of EM energy, as indicated by the authors elsewhere in [17].

### IV. CROSSTALK ESTIMATION: STATEMENT OF THE PROBLEM AND DESCRIPTION

In view of the state-of-the-art aspects of crosstalk issues *vis-à-vis* PCBs exclusive to modern handheld wireless de-



**FIGURE 1:** Trace clusters fanning out on a PCB: For example, in the baseband infrastructure of a handheld device

vices, the present study is indicated to address such problems pertinent to densely-packed traces on PCBs, when the lines are either parallel and/or laid out in zigzag patterns with the lengths of line-segments being of random values; further, all the lines are assumed to be designed so as to support high-speed, sharp rise-time pulsed waveforms, which are likely to cause significant EM energy dispersions [ 12, 17 ] in the composite PCB structure with metallic traces laid on dielectric board; and, the resulting pervasive electromagnetic interference (EMI) on the board would manifest as crosstalk in victim traces. The generic layout of a pair of traces on a PCB that encounter crosstalk problems as relevant to this study is illustrated in Fig. 2. The aggressor-victim pair need not imply parallel traces. In general, such pairs can be non-parallel as illustrated in Fig.3.

Further, illustrated in Fig.4 is a more comprehensive illustration of multiple victim traces  $\{V_T\}$  infected by an aggressor,  $A_T$ . In general, all such traces, may pose statistically undulating paths and as such, each trace can be characterized by a root-mean squared (RMS) value of undulation geometry observed on the 2D-plane of the PCB. Hence, shown in Fig.4 is a value  $X_A$  of such RMS value for the aggressor,  $A_T$ ; and, the set  $\{X_V\}$  denotes corresponding values for the victim set  $\{V_T\}_{v=1,2,\dots}$  (Note: The victims are identified by the index,  $v = 1, 2, 3, \dots$ ).

Commensurate with the scope of the present study outlined above, the underlying objectives aim at deducing a coupling index that would measure implicitly the induced electric (**E**) and magnetic (**H**) field components in the victim traces as a result of high-speed signal transported on an aggressor line expressed in terms of the time-varying voltage,  $v(t)$  and current  $i(t)$  functions. If the values of **E**- and **H**-field components are estimated, it is proposed here that they would implicitly allow inferring the associated EMI and hence lead to deducing the relevant crosstalk coupling coefficient of interest.



The traditional EMI and crosstalk modeling in such ambient would involve determining the inductive (L) and capacitive (C) effects perceived on the traces on the basis of reactive (mutual) impedance considerations [6]. However, in such L- and C-based EMI evaluation (and in relevant crosstalk estimation), the underlying estimates may become computationally intensive, inasmuch as the associated inductive and capacitive effects have to be ascertained (mostly numerically) across the extensive framework of grids within which, the victim traces and the aggressor are situated. In other words, the underlying inter-trace coupling when viewed in terms of classical inductance and capacitance considerations implies reactive influence (that is, voltage-current relational phenomenon in Kirchoff's sense) experienced across a huge number of distributed set of nodes and loops modeled on a two-dimensional grid depicting the 2D-pattern of meshes, each with characteristics transmission-line features of the traces involved.

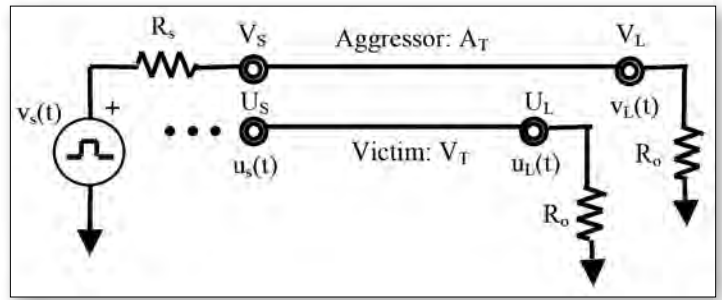
However, as mentioned earlier, it is proposed here that the coupling index (F) of interest can be alternatively defined (*in lieu* of L and C perspectives) *via* the assessments of **E** and **H** field components across the framework of victim traces due to time-varying signal voltage and current entities. Corresponding coupling index (F) can be expressed as follows [18]:

$$F = \sum_{k=1}^K |J(k)| \cdot \Delta A(k) \quad (1)$$

where  $|J(k)|$  denotes the magnitude of displacement current density (in A/m<sup>2</sup>) at the center of k<sup>th</sup> mesh of the matrix, K: [I × J] depicting the complete victim trace layout on the PCB. That is, considering the area wherein the victim traces reside on the PCB, it is divided into K meshes as shown in Fig.5; and,  $\Delta A(k)$  is the area (in m<sup>2</sup>) of the k<sup>th</sup> mesh with the coordinate (i, j) in question. Hence, F in equation (1) represents the gross influence of all displacement currents perceived as a result of **E**- and **H**- field forces on the PCB summed over the entire victim-trace layout.

It is shown in [18], such an approach towards deducing EMI effects *via* equation (1) is as good as 98% of the results obtained by traditional capacitance-inductance estimation method. But, the advantages of using the approach *via* equation (1) are as follows:

- It is independent of the position of victim traces across the layout surface
- It is computationally less complex; (and, traditional finite-difference, finite-element or moment method (FDM, FEM and MM methods) can be adopted to determine numerically the associated **E**- and **H**- components of the interference leading to the estimation of the coefficient, F
- It is highly suitable for the random pattern of the victims *versus* aggressor lines; and, details as regards



**FIGURE 2:** A parallel set of hypothetical victim traces  $\{V_v\}_{v=1,2,\dots}$  and an aggressor trace ( $A_T$ ) on a PCB. The terminal nodes of the aggressor and the victim are shown with the associated voltages,  $\{v_s, u_s\}$  and  $\{v_L, u_L\}$  respectively corresponding to source and load-ends

to exact dispositions of Kirchoff's nodes and loops deciding the [L] and [C] are not *per se*, required [19-21].

In view of the above, the present study is focused on deducing the coefficient (F) *via* **E**- and **H**-field components so as to specify the near- and far-end crosstalk (NEXT and FEXT) implications experienced in a typical complex trace-pattern, for example, as illustrated in Fig. 5. The notions of [18] and equation (1) are used, but significantly modified in this study specifically focused on PCB layouts of handheld wireless devices.

The crosstalk-induced coupled currents on the victim lines manifest as NEXT and FEXT. In a simple pair of parallel traces (with matched terminations), the aggressive (driven) line (1) would electromagnetically couple with the victim (un-driven) line (2), *via* two EM considerations namely, (i) the Columbic force field due to charges on the lines (traditionally implied as capacitive (C) effects); and, (ii) Faraday's induction force field due to time-varying magnetic coupling between the lines, commonly regarded as inductive (L) effects. A pair of inductance and capacitance (m × n) matrices is normally indicated to analyze the underlying EMI. For example, in the case of an aggressor-victim pair of lines (1 and 2), relevant L-C matrices can be written as follows [19-21]:

$$[L] = \begin{bmatrix} L_{11} & L_{12} \\ L_{21} & L_{22} \end{bmatrix} \text{ and } [C] = \begin{bmatrix} C_{11} & C_{12} \\ C_{21} & C_{22} \end{bmatrix} \quad (2)$$

where  $L_{11}$  or  $L_{22}$  implies the self-inductance (henry per unit length) of lines 1 or 2; and,  $L_{12}$  or  $L_{21}$  line denotes the mutual inductance (henry per unit length) between the lines, 1 and 2. Similarly,  $C_{11}$  or  $C_{22}$  depicts the self-capacitance (farad per unit length) of the lines 1 or 2 (measured with respect to ground) and  $C_{12}$  or  $C_{21}$  is the mutual capacitance (farad per unit length) between the lines 1 and 2 per unit length. Correspondingly, the near- and far-end crosstalk voltages induced can be written as follows:

$$v_{NEXT} = \frac{v_s}{4} \left[ \frac{L_{12}}{L_{11}} + \frac{C_{12}}{C_{11}} \right] \tag{3}$$

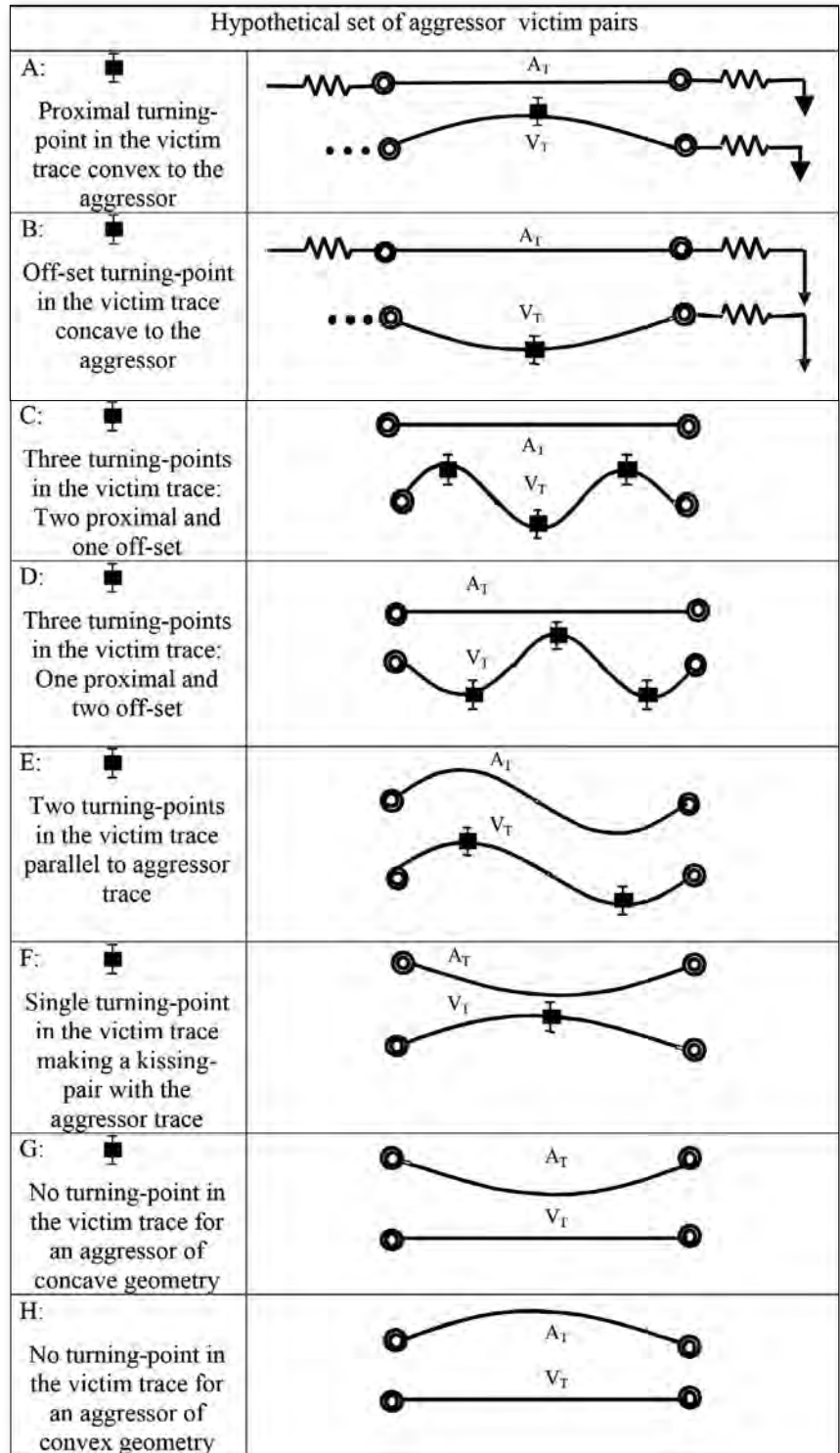
$$v_{FEXT} = \frac{v_s}{4} \left[ \frac{L_{12}}{L_{11}} + \frac{C_{12}}{C_{11}} \right] \times \left( \frac{\ell(L_{11}C_{11})^{1/2}}{2t_r} \right)$$

where  $v_s$  is the source voltage impressed on the aggressor line (Fig. 2); and,  $\ell$  is the length (in m) of the trace-lines; further  $t_r$  is the rise-time (in s) of the input signal,  $v_s(t)$ ; and,  $\ell(L_{11}C_{11})^{(1/2)}$  denotes the propagation delay (in s) encountered along the line of length,  $\ell$  meters.

**V. INTER-TRACE COUPLING FACTOR (F) ESTIMATION VIA EM FIELD CONSIDERATIONS**

In lieu of the traditional way of estimating the inter-trace coupling coefficient in terms of L and C considerations indicated above, as mentioned earlier the present study is devised to formulate an alternative approach based on EM field parameters to deduce the crosstalk related coupling across PCB traces. It is surmised that the proposed method is more appropriate for randomly patterned traces. Relevant underlying heuristics are as follows: Consider a PCB layout with a victim trace ( $V_T$ ) and a noise (aggressor) trace ( $A_T$ ) as illustrated earlier in Fig.2. The crosstalk coupling between  $V_T$  and  $A_T$  is decided by an EM emission map overlapping  $V_T$  and  $A_T$  across the domain in a layout on a two-dimensional plane layout.

The traces ( $V_T$  and  $A_T$ ) on the PCB in practice can be represented by segments joined up by a set of turning-points (Figs. 3 and 4). The number of such turning-points (N) and their locations on the PCB would depend on the electronic interconnections required as necessary. The coordinates of these turning-points are however, known a priori and therefore, deterministic. That is, they represent locales with defined coordinates on the 2D geometry of the PCB layout designed. Further, the terminal points (two for  $V_T$  and two for  $A_T$ ) of the traces are also deterministically specified at known (predefined) coordinates; and, in general, all traces are assumed to be of same width ( $w$  meters). Given the trace details as above, the study in hand has the following motives:



**FIGURE 3:** Set of possible layouts of aggressor ( $A_T$ ) and victim ( $V_T$ ) traces showing their relative, non-parallel geometrical dispositions on the PCB with one, more or zero turning-points seen on the victim traces



- a) To determine the **E**- and **H**-field components of the EMI on the trace domains of interest and knowing these components at the defined locations of turning-points
- b) To calculate the overall resulting coupling index, **F** for any specified victim trace with respect to an aggressor trace
- c) To assess the corresponding NEXT and FEXT levels at the terminal nodes
- d) To verify experimentally the theoretical heuristics proposed and computational assessments made
- e) To seek and suggest methods to mitigate (reduce) the crosstalk coupling involved

**VI. TEST PCB LAYOUT FOR ANALYSIS, COMPUTATIONAL AND EXPERIMENTAL STUDY**

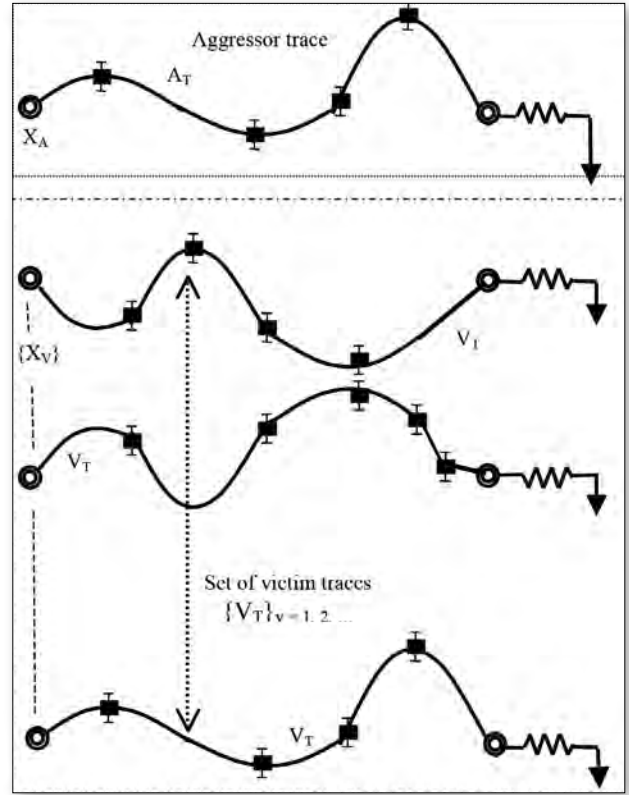
To illustrate the method of assessing the NEXT and FEXT for a random pattern of trace layout, the test PCB plus the overlaid traces on it considered is shown in Fig. 5. Suppose the traces as shown are such that the victim traces are laid to join fixed terminals  $\{P_1\}$ ,  $\{P_2\}$  and such traces are assumed to be confined within a certain rectangular area. The aggressor trace is sourced by  $v_s(t)$ , normally a high-speed pulsed voltage, that produces EM-field components extended into the vicinity and invades the entire domain of victim traces.

The objective of the study is as follows: (i) To analyze the associated electromagnetics and infer the **E**- and **H**-field components specifically at the turning-points of interest; (ii) to assess thereof, the NEXT and FEXT levels in any given victim trace; and (iii) hence, to realize eventually a layout of victim traces with minimized NEXT and FEXT levels as an EM compatible alternative to the original PCB design. In addition to a typical aggressor versus victim pair node-to-node EM coupling illustrated in Fig. 6, possible examples of victim traces positioned between start and end nodes,  $P_1$ - $P_2$  with varying number (**N**) of turning-points are shown in Fig.7.

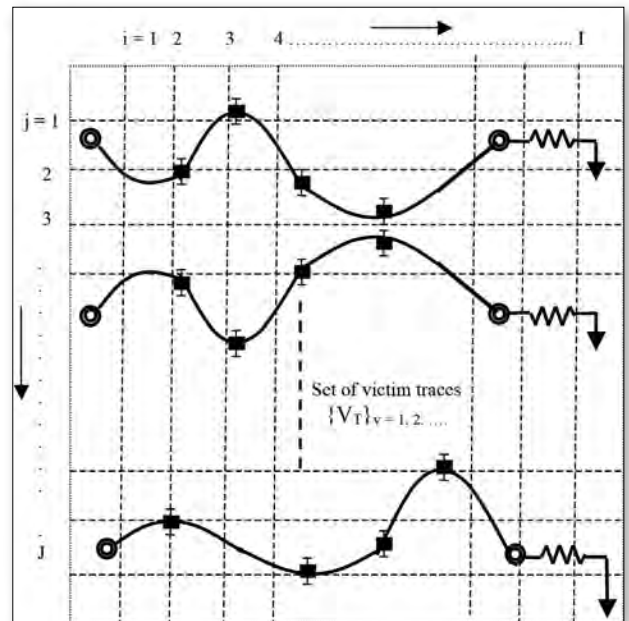
The layout (a) n Fig. 7, with the victim ( $P_1 - P_2$ ) having no turning-points is taken as the reference and assuming the standard case of parallel traces, the NEXT and FEXT can be deduced deterministically via coupling matrix relations of equations (2) and (3). That is, in terms of  $[L]$  and  $[C]$  of equation (2), the following EM-field relations can be written toward inductive (IC) and capacitive (CC) influences:

$$[v(t)]_{IC} = -[L] \times \frac{d[i(t)]_{IC}}{dt} \tag{4a}$$

$$[v(t)]_{CC} = \frac{1}{[C]} \int [i(t)]_{CC} dt \tag{4b}$$



**FIGURE 4:** Randomly-patterned set of victim traces  $\{V_T\}_{v=1,2,\dots}$  disposed with respect to an aggressor trace ( $A_T$ ) on the PCB. The entities  $X_A$  and  $\{X_v\}$  denote respectively, the RMS values of random geometrical undulations of the respective traces on the PCB 2D- plane



**FIGURE 5:** A matrix  $K: [I \times J]$  meshes conceived on the 2D-plane of the PCB layout infested with victim traces

where  $v_{IC}$  and  $v_{CC}$  are voltages induced on unit length of the victim due to inductive and capacitive effects respectively. Corresponding relations written in terms of magnetic ( $\mathbf{H}$ ) and electric ( $\mathbf{E}$ ) fields are given by:

$$v_{IC}(t) = -\mu[L] \times \frac{d[\mathbf{H}(t)]_{IC}}{dt} \tag{5a}$$

$$v_{CC}(t) = \frac{\epsilon}{[C]} \int \left[ \frac{d[\mathbf{E}(t)]_{CC}}{dt} \right] dt = \frac{\epsilon}{[C]} \mathbf{E}_{CC}(t) \tag{5b}$$

Hence, the net superimposed coupled EM-field relation is given by:

$$[v_{IC} + v_{CC}] = \left[ -\mu[L] \times \frac{d[\mathbf{H}(t)]_{IC}}{dt} \right]_{HC} + \left[ \frac{\epsilon}{[C]} \mathbf{E}_{CC}(t) \right]_{CC} \tag{6}$$

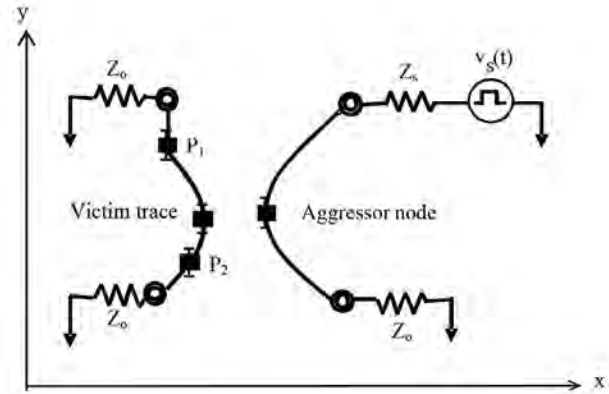
Suppose the turning-points (nodes) on the victim trace appear randomly located with respect to the aggressor trace so that, for a given set of  $[L]$  and  $[C]$ . The corresponding  $\mathbf{E}$ - and  $\mathbf{H}$ - components can then be specified as perturbed entities along the test traces. The fractional change in coupling influence thereof can be written as follows:

$$\frac{\Delta F}{F} = \frac{\partial}{\partial t} \left[ \frac{\Delta \mathbf{H}(t)}{[\mathbf{H}(t)]} \right] + \frac{\Delta \mathbf{E}(t)}{\mathbf{E}(t)} \tag{7}$$

**VII. ANALYSIS**

Consider the total space ( $\Omega$ ) of PCB layout wherein, as indicated earlier there could be a number of traces routed randomly on ad hoc basis, but placed proximal to each other. For example, a hypothetical layout on a given single layer is illustrated in Fig. 8 (where no physical crossings are assumed to be present).

Suppose AA' denotes the aggressor (infector or driven trace) supporting a trail of high-speed binary information along time-scale. Let YY' be a vertical line-of-separation on

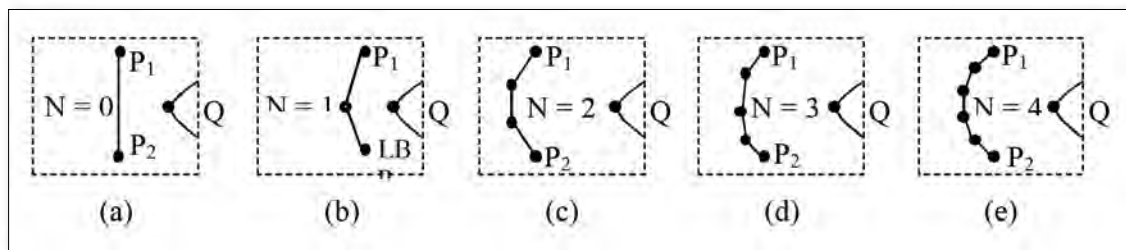


**FIGURE 6:** Victim and aggressor traces: Terminal nodes and turning-points

the PCB assumed to bifurcate the domain  $\Omega$  into two regions,  $\Omega_1$  and  $\Omega_2$  denoting the near- and far-end sides respectively as shown. With reference to the spaces  $\Omega_1$  and  $\Omega_2$ , and in terms of classical reactive coupling heuristics, each space has its own capacitive  $[C]$  and inductive  $[L]$  coupling matrices. These matrices can be alternatively viewed via electric ( $\mathbf{E}$ ) and magnetic field ( $\mathbf{H}$ ) components that emanate from the aggressor trace. These matrices can be alternatively viewed via electric ( $\mathbf{E}$ ) and magnetic field ( $\mathbf{H}$ ) components that emanate from the common aggressor line AA' and interfering on (or placing crosstalk into) the set of victim lines bb', cc', dd' etc. That is, relevant to  $\Omega_1$  and  $\Omega_2$ , the capacitive and inductive couplings can be implicitly specified in term of the associated  $\mathbf{E}$ - and  $\mathbf{H}$ -field components respectively by a set of matrices as follows:  $\Omega_1 \Rightarrow [\mathbf{E}]_1$  and  $[\mathbf{H}]_1$  and  $\Omega_2 \Rightarrow [\mathbf{E}]_2$  and  $[\mathbf{H}]_2$ .

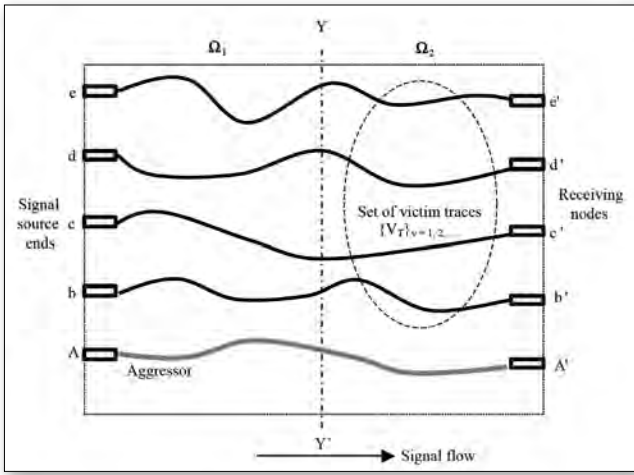
Correspondingly, each of  $\Omega_1$  and  $\Omega_2$  can be attributed with certain levels of susceptibility,  $S_1$  and  $S_2$  respectively to crosstalk on victims as a result of EM excitation stemming from the aggressor trace, AA'. In other words, the EM-field induced due to the signal-flow in AA' (aggressor) will cause a trail of susceptance to EMI point-by-point on the victims; and, relevant values can be denoted as  $\{S_j\}_1$  and  $\{S_j\}_2$  respectively in  $\Omega_1$  and  $\Omega_2$  as shown for example, in Fig.9, assuming an exclusive scenario of the victim bb' versus the aggressor AA'.

For the purpose of analysis, the domains  $\Omega_1$  and  $\Omega_2$  in Fig. 9 are further divided into grids (meshes) as illustrated in Figs.

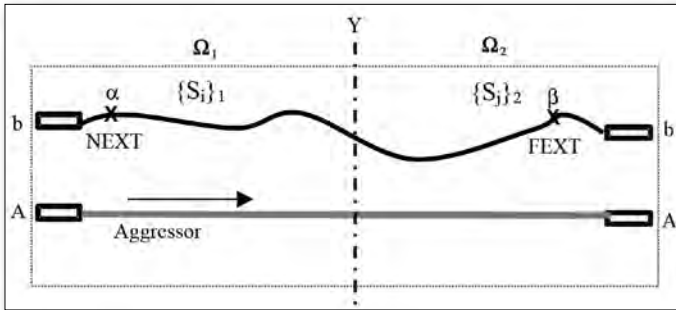


**FIGURE 7:** Set of victim ( $P_1 - P_2$ ) and aggressor (Q) trace-layouts each with varying number of turning points (N)





**FIGURE 8:** A hypothetical PCB layout with aggressor (AA') and a set of victim traces,  $\{V_v\}_{v=1,2,\dots}$ . (No crossing of traces is assumed). The regions  $\Omega_1$  and  $\Omega_2$  denote the near-end and far-end domains specified with respect to source and receiving ends

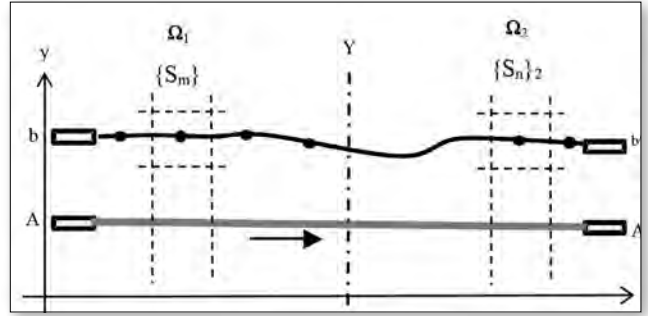


**FIGURE 9:** Illustration of bifurcated domains  $\Omega_1$  and  $\Omega_2$  with the set of susceptibility indices  $\{S_j\}_1$  and  $\{S_j\}_2$  respectively; and,  $\alpha$  and  $\beta$  denote NEXT and FEXT levels respectively on the victim trace

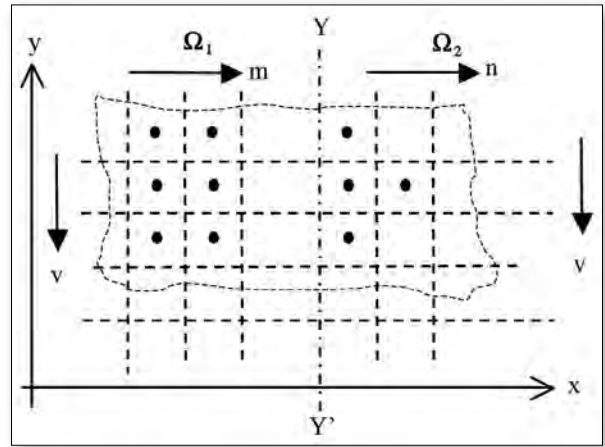
10 and 11. Further, specific to the domain  $\Omega_1$ , the coordinate of a mesh is  $(x_{m=1,2,\dots,M}, y_{v=1,2,\dots})$ . Likewise, for the domain  $\Omega_2$ , the coordinate of a mesh is specified as:  $(x_{n=1,2,\dots,N}, y_{v=1,2,\dots})$ . And, the interfering field vectors  $E$  and  $H$  are assumed to vary mesh-by-mesh along  $x$  and  $y$  directions, point-by-point. Therefore, considering, the nodes representing the grids in the matrices of  $\Omega_1$  and of  $\Omega_2$ , each node can be prescribed with a crosstalk susceptibility value  $(S_{m,1})$  and  $(S_{n,2})$  in  $\Omega_1$  and  $\Omega_2$  respectively. Further, the presence of  $\{S_{m,1}\}$  and  $\{S_{n,2}\}$  are denoted for example, as point-by-point values on the victim trace  $bb'$  in Fig. 10 with respect to the aggressor  $AA'$ .

Therefore, considering the nodes at the extremities of the victim  $bb'$ , when  $m = 1$  (in  $\Omega_1$ ),  $\{S_{m=1,1}\}$  denotes the NEXT; and, when  $n = N$  (in  $\Omega_2$ ),  $\{S_{n=N,2}\}$  refers to the FEXT. Further, the elements of  $\{S_m\}$  and  $\{S_n\}$  are taken as normalized values (between 0 to 1); and, the normalization is done with respect to the signal (or EM-field) level enforced (by the signal) at the sending-end of the aggressor line. In moving along the victim line (say  $bb'$ ), the step-by-step one-dimensional spatial progress of crosstalk influence (from mesh-to-mesh) can be

specified by the associated randomness of EM-field influence (interference) on the victim. Relevant heuristics are as follows:



**FIGURE 10:** Point-by-point representation of the susceptibility indices at nodes specified within each mesh of the matrix drawn on the 2D-plane of victim layout



**FIGURE 11:** Illustration of hypothetical sets  $\{m \times v\}$  and  $\{n \times v\}$  meshes prescribed for  $\Omega_1$  and  $\Omega_2$  respectively. (The victim traces are denoted by the index  $v$  both in  $\Omega_1$  and  $\Omega_2$  as identified in the text).

Considering the 2D framework of victim traces on the PCB, as indicated earlier, the media-line  $YY'$  divides the 2D domain into two sections,  $\Omega_1$  and  $\Omega_2$  corresponding to the NEXT and FEXT regions respectively. Further, these sections are divided into mesh sets of  $\{m \times v\}$  and  $\{n \times v\}$  meshes as illustrated in Fig.11.

Each node corresponds to a mesh, where the EMI-based  $E$ - and  $H$ -fields induced render the nodes susceptible for crosstalk. The EMI coupling influence across the traces and the resulting susceptibility at each node to crosstalk is specified by  $(S_{m,v,1})$  and  $(S_{n,v,2})$  for the domains  $\Omega_1$  and  $\Omega_2$  respectively.

Considering an  $m^{\text{th}}$  node in  $\Omega_1$  and an  $n^{\text{th}}$  in  $\Omega_2$ , the EMI coupling-influence proliferating (along such nodes in the row) conforms to a Poisson process; and as such, the dynamics of susceptibility values at  $(m + 1)^{\text{th}}$  and  $(n + 1)^{\text{th}}$  nodes can be written in terms of corresponding values at  $m^{\text{th}}$  and  $n^{\text{th}}$  nodes

can be expressed as step-by-step proliferation as follows:

$$(S_{m+1, v})_1 = \lambda [1 - \exp(-\lambda t)](S_{m, v})_1 \quad (8a)$$

$$(S_{n+1, v})_1 = \lambda [1 - \exp(-\lambda t)](S_{n, v})_2 \quad (8b)$$

where  $\lambda$  is a field-decay constant along the row (that is, x-direction and  $t$  is the instant of occurrence of the interference). Similarly, the progress of EMI coupling along the column of meshes (in the y-direction, that is along the meshes at  $(v = 1, 2, \dots)$ <sup>th</sup> locations can also be written in terms of a Poisson process dynamics. However, the x- and y-directed coupling events can be regarded as two independent spatiotemporal processes over the 2D-neighborhood in question. Hence, the dynamics of the susceptibility index ( $S$ ) assumed as a random variable can be written in terms of the following two independent stochastic, partial differential equations. With the coordinates of nodes designated as  $(x_m, y_v)$  and  $(x_n, y_v)$  for  $\Omega_1$  and  $\Omega_2$  respectively, relevant equations are as follows: Along the x-direction:

$$\frac{\partial S(t, x_m, y_v)}{\partial t} = S(t, x_m, y_v)[G - hS(t, x_{m+1}, y_v)] \quad (9a)$$

$$\frac{\partial S(t, x_n, y_v)}{\partial t} = S(t, x_n, y_v)[G - hS(t, x_{n+1}, y_v)] \quad (9b)$$

And, a similar pair of partial differential equations can be specified for y-direction also. In equation (9)  $G$  denotes the spatial proliferation rate of EMI and  $h$  is a local coefficient that weights the newly perceived EMI coupling of  $(m + 1)$ <sup>th</sup> or  $(n + 1)$ <sup>th</sup> node due to the dynamics of proliferation.

The aforesaid differential equations refer to logistics growth models for the spatiotemporal evolution of EMI-induced susceptibility levels at the nodes considered. Relevant solutions assume the sigmoid format. That is, the susceptibility levels implicitly denote corresponding probabilities of EMI prevailing at the nodes along the grid; and, they can be written as sigmoidal solutions of equation (9) as follows [17] [22, 23].

$$p(x_m, y_v)_{\Omega_1} = \frac{1}{2} \left[ 1 + \tanh \left( \frac{S_m^{\theta} + S_n^{(1-\theta)}}{2} \right) \right] \quad (10a)$$

$$q(x_n, y_v)_{\Omega_2} = \frac{1}{2} \left[ 1 + \tanh \left( \frac{S_m^{(1-\theta)} + S_n^{\theta}}{2} \right) \right] \quad (10b)$$

where  $\theta$  is the fraction equal to the ratio of the fractional node population in  $\Omega_1$  with respect to the total nodes across the entire framework of  $\Omega_1$  and  $\Omega_2$ ; that is,  $\theta = (\text{Number of nodes in } \Omega_1 / \text{Total number of nodes in } \Omega_1 \text{ and } \Omega_2)$ .

The aforesaid notions and results can be arrived at by following the probabilistic-theory of uncertainty applied to the random invasion of crosstalk proliferation in the domains of

interest. Relevant outline is as follows: Proportion of net EMI-induced influences in the regions  $\Omega_1$  and  $\Omega_2$  can be deduced on the basis of statistical uncertainty of the EM coupling involved across victim traces due to the signal transits of the aggressor line. Given that the finite number of total nodes in the entire framework of  $\Omega_1$  and  $\Omega_2$  is  $\mu_T$  and those victimized are  $(\mu_1, \mu_2, \mu_3 \dots \text{etc.})$  with distinct susceptibility levels 1, 2, 3, ... etc., the resulting statistical extent of uncertainty ( $\theta$ ) of EMI coupling in  $\Omega_1$  and  $\Omega_2$  can be written in terms of the associated entropy ( $\zeta$ ) considerations expressed in Bernoulli forms as follows [24]:

Referring to  $\Omega_1$ , corresponding  $\zeta_1$  along x-direction can be specified via entropy functional as follows:

For the region  $\Omega_1$ ,

$$\zeta_1 = \frac{1}{\mu_T} \ln \left[ \frac{\mu_T!}{\mu_1! \mu_2! \dots \mu_M!} \right] \quad (11a)$$

Likewise, for the region  $\Omega_2$ ,

$$\zeta_2 = \frac{1}{\mu_T} \ln \left[ \frac{\mu_T!}{\mu_1! \mu_2! \dots \mu_N!} \right] \quad (11b)$$

Therefore,  $\theta$  indicated above would correspond to the ratio  $\zeta_1/\zeta_2$  of relative uncertainty (of EMI influences) associated in the regions  $\Omega_1$  and  $\Omega_2$ ; and,  $\zeta_1/\zeta_2$  approximately reduces to,  $\theta = (\text{Number of nodes in } \Omega_1 / \text{Total number of nodes in } \Omega_1 \text{ and } \Omega_2)$ .

Correspondingly, relevant to the randomness of trace-layout, the following (normalized) coefficients (0 to 1),  $R_N$  and  $R_F$  can be attributed to NEXT and FEXT in the  $v$ <sup>th</sup> victim of  $\Omega_1$  and  $\Omega_2$  respectively consistent with the relations in equation (10):

$$(R_N)_v = \frac{1}{2} \left[ 1 + \tanh \left( \frac{S_{m=1}^{\theta} + \sum_n S_n^{(1-\theta)}}{2} \right) \right]_{\Omega_1} \quad (12a)$$

$$(R_F)_v = \frac{1}{2} \left[ 1 + \tanh \left( \frac{\sum_m S_m^{(1-\theta)} + S_{n=N}^{\theta}}{2} \right) \right]_{\Omega_2} \quad (12b)$$

The concept of deducing NEXT and FEXT specified by equation (12) via probabilistic attributes of crosstalk susceptibility at the nodes of interest implies the following: The logistic functional aspect of equation (12) suggests that the pervasion of crosstalk along the nodes of a victim trace would increase (or decrease) as the level of susceptibility of coupling due to **E**- and **H**-fields on the victim (emanating from the aggressor) increases or decreases. Further, the statistically-implied gross influence of susceptance in  $\Omega_1$  and  $\Omega_2$  results from the



superposition of such influences at the nodes {m} and {n} of  $\Omega_1$  and  $\Omega_2$  respectively.

As stated earlier, in classical perspectives of EMI estimation, the extent of overall EMI susceptibility is decided by EM coupling expressed via [C] and [L] deduced in a deterministic framework in terms of current-voltage based impedance relations (in Kirchoff's perspectives). In contrast, the present study follows the associated statistical attributes dictated by random perturbations of the values in the matrices  $[\Delta E]$  and  $[\Delta H]$  corresponding to the victim nodes of interest. As mentioned before, such randomness is largely imposed by the stochastic aspects of the geometrical layout due to random routing and/or geometrical spacing between the aggressor AA' and the victim bb' illustrated for example, in Fig.3. When the inter-trace coupling is viewed in terms of EM-field components, it can be quantified by the factor F deduced using **E** and **H** related entities and their relative perturbed values (caused by randomness) across the test area. That is, the invasion of **E**- and **H**- field components from the aggressor on the victims is assumed to cause corresponding random perturbations of coupling observed via differential values of  $[\Delta E]$  and  $[\Delta H]$  components; and, the result would be the crosstalk parameters manifesting as probabilistic values specified via equation (12).

Hence considering the transfer of signal across the traces (endorsing undesired crosstalk coupling), it can be viewed in terms of relative EM-field components (specified implicitly via F) line-to-line (starting from the aggressor line) along the set of victim traces,  $\{v = 1, 2, \dots\}$ . Further, in terms of **E** and **H** related entities, relevant F-values can be prescribed using the geometrical parameters depicted in Fig. 12.

With reference to the geometrical entities of Fig. 12, the induced EM-field coefficients (0 to 1) in the  $v^{\text{th}}$  victim trace would depend on the dimensions of the traces and the PCB. Further, the pervading field components (having three degrees of dimensional freedom) would decay with increasing distance of the victim trace from the aggressor. Correspondingly, the following EM field-dependent coefficients can be prescribed [9-13] respectively for NEXT and FEXT evaluations (Fig. 12):

$$(13a)$$

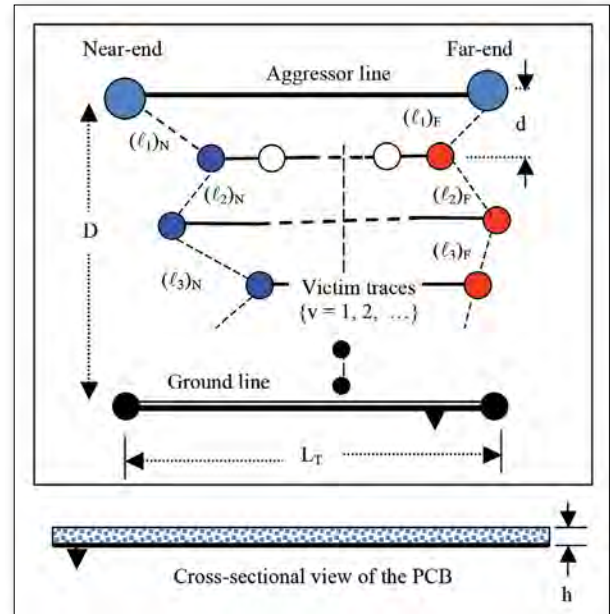
$$(F_N)_{v=1,2,\dots} = \left[ \frac{\{(\ell_v)_N/d\}^2 / \{1 + [(\ell_v)_N/h]^2\} \times (3/v)}{v_N \times (t_r/2t_s)} \right]$$

and

$$(13b)$$

$$(F_F)_{v=1,2,\dots} = \left[ \frac{\{(\ell_v)_F/d\}^2 / \{1 + [(\ell_v)_F/h]^2\} \times (3/v)}{v_N \times (t_r/2t_s)} \right]$$

where  $t_s$  denotes the settling-time of the pulsed signal. It is approximately equal to,  $(2 \text{ to } 3) \times$  (rise-time of the pulse,  $t_r$ ). Further,  $v_N$  represents a reference voltage equal to 1 volt and  $v_s$  is the applied signal level at the source-end of the aggressor trace.



**FIGURE 12:** Geometrical parameters of the traces and the associated distance values of node separation,  $(\ell_v = 1, 2, \dots)_N$  and  $(\ell_v = 1, 2, \dots)_F$  pertinent to the set of victims  $\{v = 1, 2, \dots\}$  experiencing the NEXT and FEXT respectively

In addition, the FEXT is also influenced by the propagation delay due to the finite distance from the source to the end-node along the aggressor line (of length  $L_T$  m). Corresponding weighting coefficient on the FEXT can be written as follows:

$$T_F = 1 / [1 + \{t_s (= 3t_r) \times v/L_T\}] \quad (14)$$

Further,  $\vartheta$  depicts the velocity of pulse transit on the trace and it can be specified via transmission-line concepts as nearly equal to,  $c/(\epsilon_r)^{1/2}$  where  $c (= 3 \times 10^8 \text{ m/s})$  represents the velocity of propagation of EM wave in free-space and  $\epsilon_r$  is the dielectric constant of the PCB substrate material. Hence, the final expressions for the NEXT and FEXT in the  $v^{\text{th}}$  victim are respectively as follows:

$$(NEXT)_v = (R_N)_v \times (F_N)_v \quad (15a)$$

and

$$(FEXT)_v = (R_F)_v \times (F_F)_v \times T_F \quad (15b)$$

## VIII. COMPUTED AND MEASURED RESULTS AND INFERRENTIAL REMARKS

In order to verify the efficacy of the analysis presented and predictive formulations derived for the NEXT and FEXT concerning the test PCB under discussion, a test PCB illustrated in Figs. 13a and 13b is used and the aggressor line marked is excited with pulsed signal at two test frequencies, namely, 40 MHz and 80 MHz. Both the aggressor and the victims are terminated with the impedance of  $R_o = 50 \text{ ohm}$ ; and, the source impedance ( $R_s$ ) is also equal to 50 ohm.

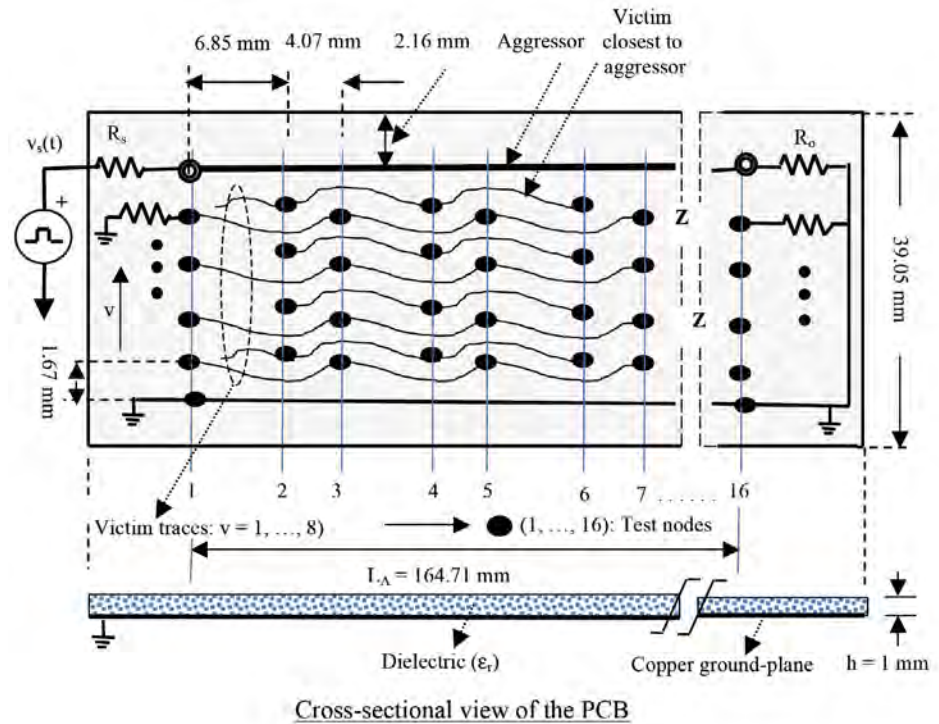
With a known signal voltage  $v_s(t)$  at 40 or 80 MHz applied at the aggressor source-node, the resulting (induced) near-end and far-end crosstalk voltages, namely,  $(u_{N,v})_v$  and  $(u_{F,v})_v$  respectively are measured using a broadband oscilloscope. Corresponding NEXT and FEXT values in the victims  $v = 1, 2, \dots, 8$  are determined respectively as:  $(u_{N,v})_v v_s$  and  $(u_{F,v})_v v_s$ .

Further, using the board and trace details of the test PCB, relevant computations on NEXT and FEXT values as given by equation (15) are performed. Presented in Table 1 are relevant measured values and computed data on NEXT and FEXT observed at the set of victim traces (indexed as  $v = 1, 2, \dots, 8$ ) and marked in Fig. 12. These details are also illustrated in Figs. 14a and 14b along with estimated statistical upper (UB) and lower (LB) bounds. These bounds denote the extrema that specify the error-bar on the estimated random entities (depicting the NEXT and FEXT values in question).

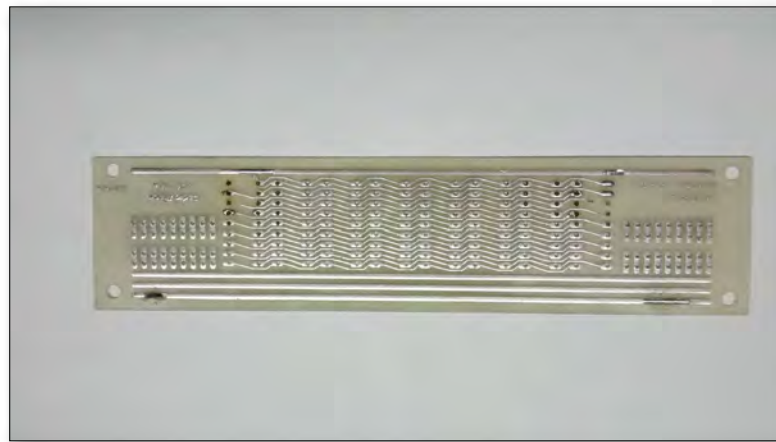
The UB and LB values are determined by replacing the  $\tanh(\cdot)$  function of equation (12) by  $L_q(\cdot)$  where  $L_q(\cdot)$  denotes the Langevin-Bernoulli function given explicitly by the following expression:  $L_q(z) = (1 + \frac{1}{2}q) \times \coth[(1 + \frac{1}{2}q)z] - (\frac{1}{2}q) \times \coth[(\frac{1}{2}q)z]$ . Here, the parameter  $q$  depicts the statistical disorder function [22]. That is, when  $q = 0.5$ , it refers to the condition of statistical disorder deciding the upper bound on the randomness of the estimates; and, when  $q = \infty$ , it denotes a state of total disorder prescribing the lower bound on the estimation. The concept of evaluating UB and LB values pertinent to the statistical estimates as above is described elsewhere in [23] by one of the authors.

From the results obtained, the following inferences can be made:

- In lieu of the traditional method of using LC parameters to assess NEXT and FEXT values in a PCB supporting multiple traces intended for the transport of high-speed pulses, proposed here is an alternative, implicit technique based on evaluating the inter-trace



**FIGURE 13a:** Test PCB with the aggressor plus a set of eight (8) victim traces. The traces are terminated with  $R_o = 50$  ohm impedance. The source impedance  $R_s$  is also 50 ohm. Each trace has sixteen nodes (including the NEXT and FEXT nodes located at near- and far-ends with reference to the source)



**FIGURE 13b:** The PCB used in the experimental studies

coupling caused by **E**- and **H**-field components of the EMI involved

- The proposed method is comprehensive to include the statistical aspects of high-density traces laid out with random routings on the PCB. Such configuration of traces are common in the baseband sections of modern  $h_a(x_{m=1,2,\dots,M}, y_{v=1,2,\dots})$  handheld wireless devices
- Considering three attributes of the associated EMI phenomenon, namely, (i) EM field, (ii) statistical aspects of the physical PCB constituents and (iii) the transit delay



$V_s$ volts (RMS)	f MHz	v	Measured values of crosstalk at the victim trace: Index - v		Computed data: Estimated crosstalk - UB and LB values at the victim trace: Index - v			
			NEXT	FEXT	$(NEXT)_v$		$(FEXT)_v$	
					UB	LB	UB	LB
2.161	40		Measured data at the trace: v = 1		Computed data at the trace: v = 1 taking $t_s \approx 2t_r$			
			$(u_N)_1/V_s$ = 0.073	$(u_F)_1/V_s$ = 0.090	0.09	0.08	0.09	0.07
			Normalized values of NEXT and FEXT with respect to measured data at v = 1					
		1	1.00	1.00	1.00	1.00	1.00	1.00
		2	0.65	0.61	0.47	0.48	0.47	0.48
		3	0.48	0.45	0.30	0.31	0.30	0.31
		4	0.32	0.38	0.22	0.23	0.22	0.23
		5	0.35	0.34	0.17	0.18	0.17	0.18
		6	0.22	0.24	0.14	0.15	0.34	
		7	0.32	0.24	0.12	0.13	0.12	
8	0.30	0.32	0.11	0.12	0.11	0.15		
1.007	80		Measured data at v = 1		Computed data at the trace: v = 1 taking $t_s \approx 2t_r$			
			$(u_N)_1/V_s$ = 0.314	$(u_N)_1/V_s$ = 0.321	0.25	0.19	0.24	0.18
			Normalized values of NEXT and FEXT with respect to measured data at v = 1					
		1	1.00	1.00	1.00	1.00	1.00	1.00
		2	0.55	0.43	0.46	0.46	0.46	0.46
		3	0.22	0.22	0.28	0.27	0.28	0.29
		4	0.19	0.19	0.20	0.21	0.21	0.21
		5	0.12	0.07	0.15	0.16	0.15	0.17
		6	0.72	0.05	0.12	0.13	0.12	0.13
		7	0.03	0.04	0.09	0.11	0.01	0.11
8	0.04	0.03	0.08	0.10	0.01	0.01		

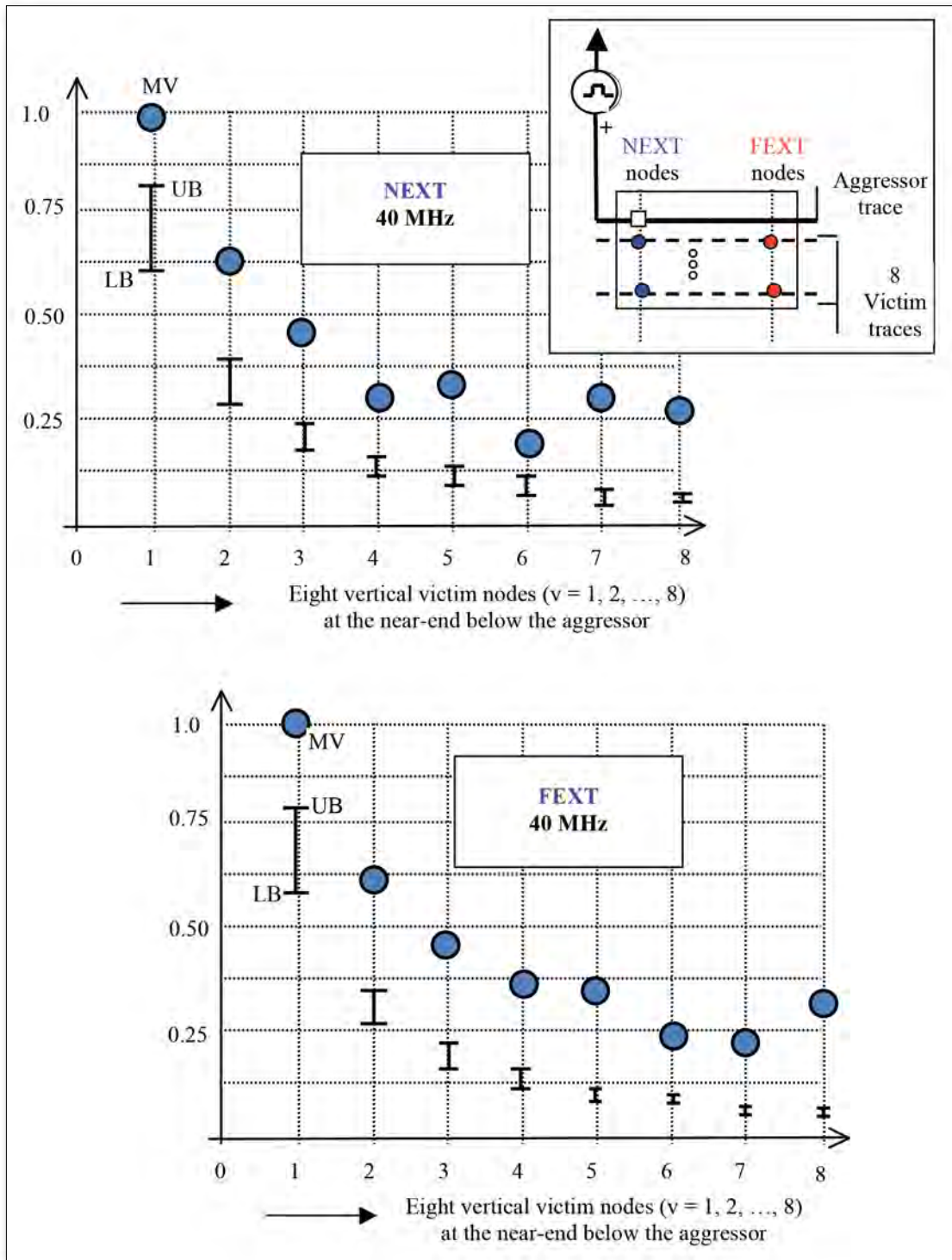
**TABLE 1:** Measured and computed data on NEXT and FEXT relevant to the test PCB illustrated in Fig. 13

issues of the signal pulse propagation on the traces, a pair of closed-form algorithms are derived (equations 15(a) and 15(b)) to deduce approximate values of the NEXT and the FEXT on a test PCB. Using the details and data as required, relevant computations of NEXT and FEXT can be done via simple computational effort. This is viably demonstrated with reference to a test PCB

- The efficacy of the algorithms developed is ascertained by cross-validating the computed details vis-à-vis mea-

sured data on a test PCB. The results presented in Table 1 and in Figs. 14(a) and 14(b) thereof indicate that the estimation procedure on NEXT and FEXT as advocated in this study favorably yields results (specified within the binding upper- and lower-limits) close to the measured data

- The proposal narrated here is a motivated effort to alleviate the non-prevailing status of a comprehensive method available to determine the NEXT and FEXT



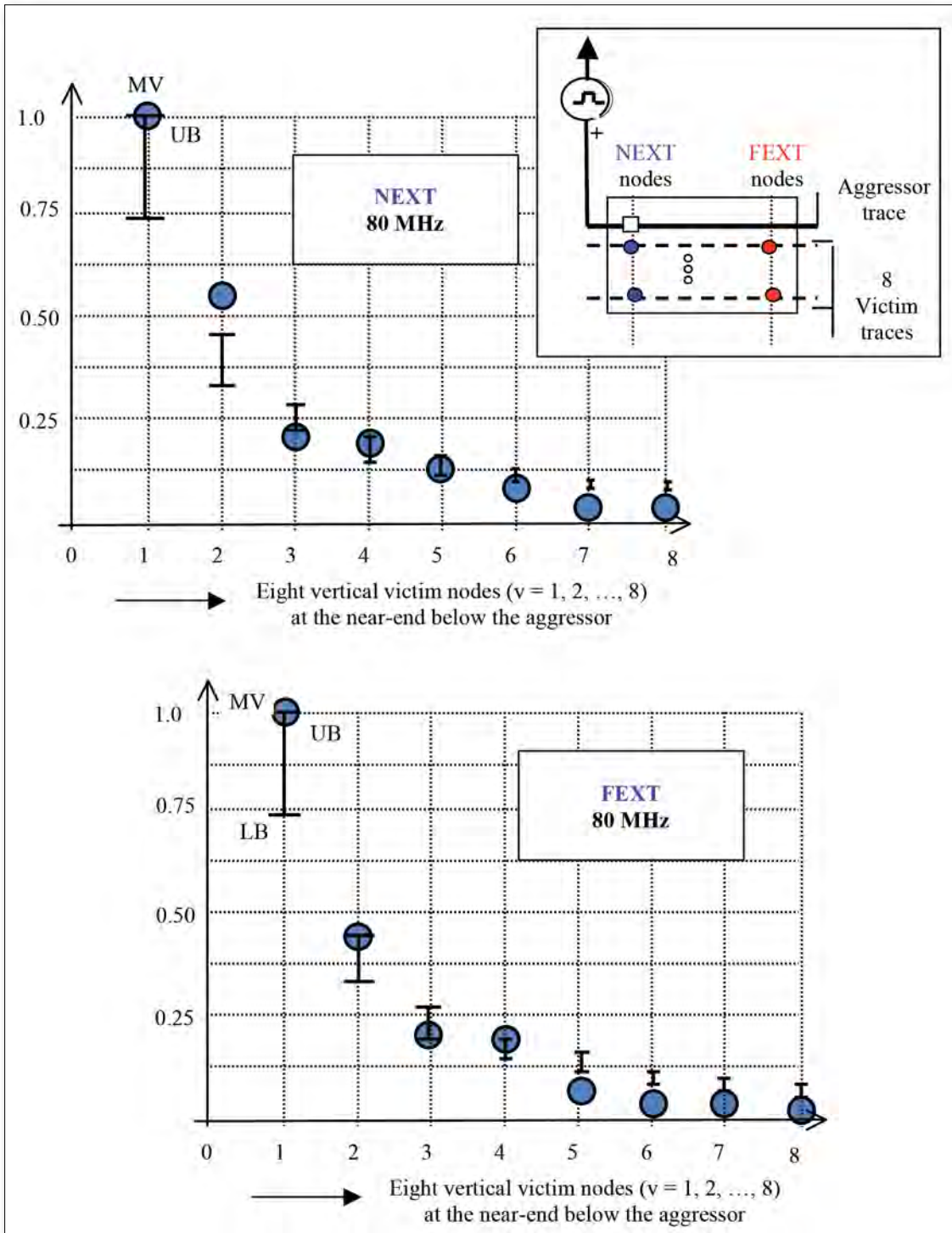
**FIGURE 14a:** Measured and computed values of NEXT and FEXT of the test PCB at 40 MHz. (MV: Measured values and UB and LB denote the upper and lower bounds respectively of the computed data)

coefficients pertinent to the test PCB described infested with a random layout of traces. That is, with the advent of PCBs required to possess a high-density of traces with random signal transit paths as well as supporting high-speed pulses of DDA category (as warranted in modern wireless handheld devices), estimating the associated inter-trace EMI coupling and crosstalk efforts is imminent; however, no straightforward theoretical

and/or computational strategy appears to be in vogue (to the best of authors' knowledge). As such, the present study is offered.

The study performed also provides some conclusive observations as regard to EMI and crosstalk infestation in the class test PCB described. Typically, the following may be noted;





**FIGURE 14b:** Measured and computed values of NEXT and FEXT of the test PCB at 80 MHz. (MV: Measured values and UB and LB denote the upper and lower bounds respectively of the computed data)

- The crosstalk values (NEXT and/or FEXT) are decided not only by the traditionally known mutual proximity of the victims (as well as with respect to the aggressor) but also implicated by the number of turning points on each trace. Such turning points depict discontinuities on the transmission-line with corresponding distorted **E-** and **H-** field distributions pervasively coupling onto the nearby lines.
- The victim trace closest to the aggressor may suffer crosstalk effects intensely
- Not only the geometry of trace routes, the mutual disposition of turning-points nodes in the adjacent traces would decide the NEXT and FEXT level ( Figs. 3 and 7)
- The net effect of crosstalk is decided by the following: (i) Pervasion of **E-** and **H-** fields across the random traces;

- (ii) randomness of the geometrical layout of traces and
- (iii) signal pulse characteristics.

Considering studies on the practical issues in high-speed PCB designs [2, 4], relevant objectives culminate in deducing tangible solution towards EMI suppression and formulating EM compatibility (EMC) considerations toward crosstalk minimization [6-9, 12, 15, 16, 25, 26].

Based on the observations in the present study concerning the crosstalk perceived in the test PCB (having a cluster of randomly displaced traces), the following are suggested toward possible crosstalk mitigation efforts:

- Design the PCB layout with optimally separated traces
- Minimize the number of turning-points nodes on the traces
- If a directional change is inevitable for a trace, possibly make the associated turn smooth, rather than being abrupt

Crosstalk mitigation efforts should also be done concurrently with minimizing the TIA considerations elaborated in [17].

## REFERENCES

- [1] C. R. Paul, Introduction to Electromagnetic Compatibility, John Wiley & Sons, Inc., New York, NY: 1992.
- [2] M. I. Montrose, EMC and the Printed Circuit Board: Design, Theory, and Layout Made Simple, IEEE Press, New York, NY: 1998.[3] S. J. Hall, and J. McCall, High Speed Digital Design: A Handbook of Interconnect Theory and Design Practice, John Wilson & Sons, New York, NY: 2000.
- [4] M.S. Sharawi: Practical issues in high speed PCB design, IEEE Potentials, vol. 23, (2), 2004, 24-27.
- [5] W. C. Bosshart, Printed Circuit Boards- Design and Technology, Tata-McGraw-Hill Publishing Co., New Delhi, India: 1984.
- [6] P. S. Neelakanta and D. De Groff: "Smart" shielding may modify performance to fit, EMC Technology, vol. 9(3), May/June 1990, 25-29.
- [7] P. S. Neelakanta and A. Preechayasomboon: EMI in high-speed digital transmission networks, Part I, Compliance Engineering, vol. XVI(7), November/December 1999, 36-47.
- [8] P. S. Neelakanta and J. Sivaraks: Mitigating EMI in high-speed digital transmission networks, Part II, Compliance Engineering, vol. XVII (2), March/April 2000, 34-47.
- [9] S. Searce et al: PCB Crosstalk Fundamentals and Strategy. Cisco White Paper- 2009 Available at: <http://www.pcbcarolina.com/images/sscearce-xtalk-ipc.pdf>
- [10] L. R Arnaut, C. S. Obiekezie, and D.W.P. Thomas: Empirical emission eigenmodes of printed circuit boards, IEEE Trans. on Electromag. Compat. vol. 56, (3), June 2014, 715-725.
- [11] P. Rajeswari, et al.: Comparative study of radiated emission in various microstripline structures on printed circuit boards, International Journal of Science and Research, vol. 2(4), April 2013, 2319-7064
- [12] High Speed PCB Layout Techniques, Texas Instruments Available at: <http://www.ti.com/lit/ml/slyp173/slyp173.pdf>
- [13] M.H. Pong, C.M. Lee and X. Wu: EMI due to electric field coupling on PCB, Proceeding of IEEE Annual Power Electronics Specialists Conference (PESC 98), (17-22 May 1998, Fukodo, Japan) vol. 2, 1998, pp.1125-1130.
- [14] Circuit Board Layout Techniques, Literature Number SLOA089: Excerpted from OP Amps for Everyone, Literature Number SLOD006A, Texas Instruments, 2008 Available at: <http://www.ti.com/lit/ml/sloa089/sloa089.pdf>
- [15] Design for EMI, Application Note AP-589, February 1999. Intel Available at: <http://www.intel.com/design/pentiumii/aplnots/24333402.pdf>
- [16] Z. Xu et al.: Crosstalk evaluation, suppression and modeling in 3D through-strata-via (TSV) network, Proceedings of 3D Systems Integration Conference (3DIC) IEEE International, (November 16-18, 2010, Munich, Germany), pp. 1-8.
- [17] P. S. Neelakanta and A. U. Noori: Mitigating time interval error (TIE) in high-speed baseband digital transports: Design for delay compensation at baseband infrastructure of smart-phones using fractal dispersive delay-lines, Circuit & Systems, vol.(5), May 2014, 115-123.
- [18] M. H. Pong, et al.: Reduction of crosstalk on Printed Circuit Board using Genetic Algorithm in Switching Power Supply, IEEE Trans. on Industrial Electronics vol. 48, (1), 2001, 235-238.
- [19] L. B. Gravelle and P. F. Wilson, "EMI/EMC in printed circuit board-A literature review," IEEE Trans. Electromag. Compt., vol. 34, May 1992, 109-116.
- [20] W. Xin, et al.: Reduction of EMI by electric field method, Proc. IEEE 14th Annual Applied Power Electronics Conference (APEC '99), (14-18 March 1999, Dallas, Texas), pp.135-138.
- [21] E. Bogatin, "Design rules for microstrip capacitance," IEEE Trans. Comp. Hybrids, Manufact., Technol., vol. 11, Sept. 1998, 253-259.
- [22] P.S. Neelakanta and D. De Groff: Neural Network Modeling: Statistical Mechanics and Cybernetic Perspectives, CRC Press, Boca Raton, FL: 1994.
- [23] P.S. Neelakanta and R. Yassin: Information-theoretic-based technoeconomic forecasting: Application to telecommunication service Industry, Netnomics, vol. 13, 2012, 45-78.
- [24] P.S. Neelakanta and Fong Ah Meng: Bioassay approach to prescribe safe-limits of exposure to nonionizing radiation in ecosystems", Biometric J. vol. 24(1), 1982, 69-86.
- [25] W. T. Huang, et al.: The optimal number and location of grounded vias to reduce crosstalk, Progress in Electromagnetics Research (PIER), vol. 95, 2009, 241- 266[26] P. W. Chiu, et al.: The impact of guard trace with open stub on time-domain waveform in high-speed digital circuits, Proc. IEEE Electrical Performance of Electronic Packaging and Systems Conference, (EPEPS 2009), (19-21 October 2009, Portland, Oregon, USA), pp. 219-222.



# Seeding and Harvesting: Changing ESD Design Requirements

**MART COENEN**

Owner  
EMCMCC

*For many years national and international norms and standards have been established to make device and product design and manufacturing life easier or at least defined within bounds. In most cases, there is even a life-cycle process for the norms and standards themselves. Old ones fade away and new ones flourish, but some remain everlasting though new insights have proven otherwise. The standardization processes are to create references and stability or to set long lasting trade barriers. Test equipment manufacturers, test houses and industry want an economic return on their investments with regard to international standard development, test equipment development, and the accompanying constraints all these requirements have on the products and devices that have to adhere these established norms and standards.*

## ABSTRACT

**C**HANGING DESIGN REQUIREMENTS has a huge impact on product and device developments in electronic industries. But what if standardization is lagging behind and the requirements posed are no longer suited for the problems occurring in the end-user's playing field. True, every requirement one changes or poses on product and device developments has an impact of the manufacturing processes chosen, the design effort, the verification method and all other requirements along the development chain up onto the end-users environment (which can hardly be changed and has to be taken as ultimate end-user requirement).

With System-Efficient ESD Design (SEED, see ESDA White Book 3), the ESD performance of nanoscale devices needs to be complemented by additional protection measures to meet the end-users environment. At the device level, the Human Body Model (HBM) or Charged Device Model (CDM) is used. The Machine Model (MM) has formally been abandoned. The Transmission-Line test Method (ANSI/ESD STM5.5.1-2008, IEC 60749-26TLM), typically 100 ns duration or even very fast Transmission-Line test Method (ANSI/ESD SP5.5.2-2007, vf-TLM), typically less

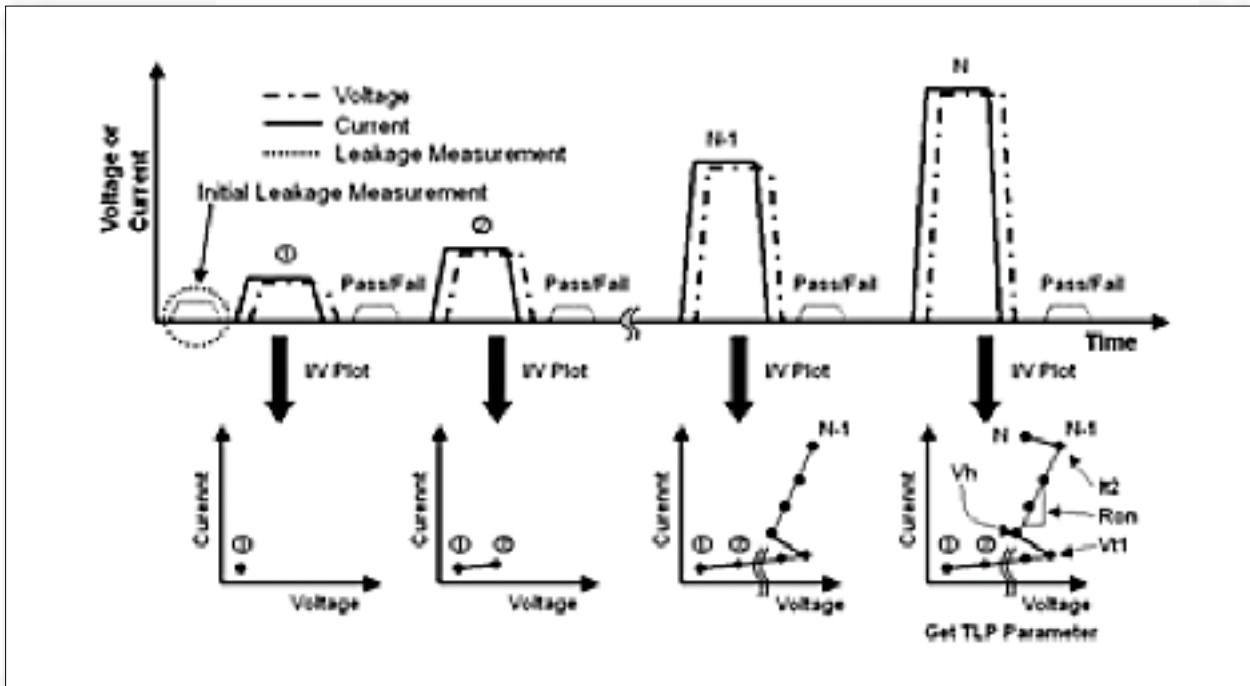


Figure 2: The I / V data after 70% of the TLP test pulse width with increasing voltage.

than 10 ns duration, is promoted heavily but no quantitative requirements have been posed similar to the HBM and CDM or end-user levels (IEC 61000-4-2).

Due to further miniaturization and thinner gate and insulation oxides with devices, the ESD requirements posed on these devices have to be reduced accordingly as physical limits with regard to peak current densities and peak field strength levels across insulating materials are exceeded into the hot electron effect region. As such, supplementary ESD protection requirements have to apply to the production, manufacturing, handling and assembly area as ESD Protected Area (EPA) requirements have to become tighter by two or more classes: IEC 61340-x-y or ANSI/ESD S20.20.

An integral approach is needed along the entire semiconductor device production chain, from wafer grinding to expose, dicing, bonding, assembly, testing, handling and storage to meet those new ESD protection demands which go beyond the ANSI/ESD S20.20. To verify these measures along the production chain up until the end-user environment, new requirements and environmental test methods have to be defined and new reference data bases with strong evidence have to be build (and that is where the harvesting (= less defects) can be started).

**INTRODUCTION**

The 'old' ESD test methods for devices stem from the 'old' Mil-Std 883 with multi-ns rise-times. The requirements were limited at those days by the measurement

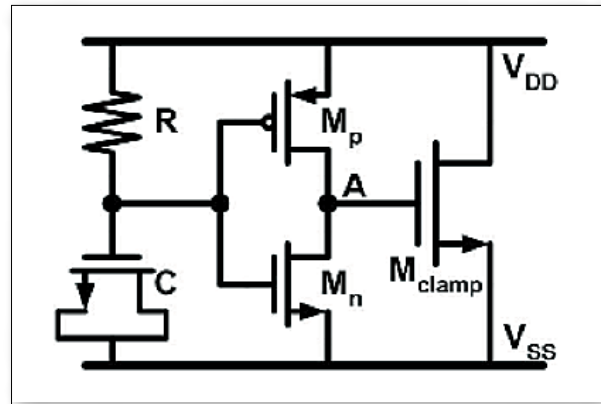
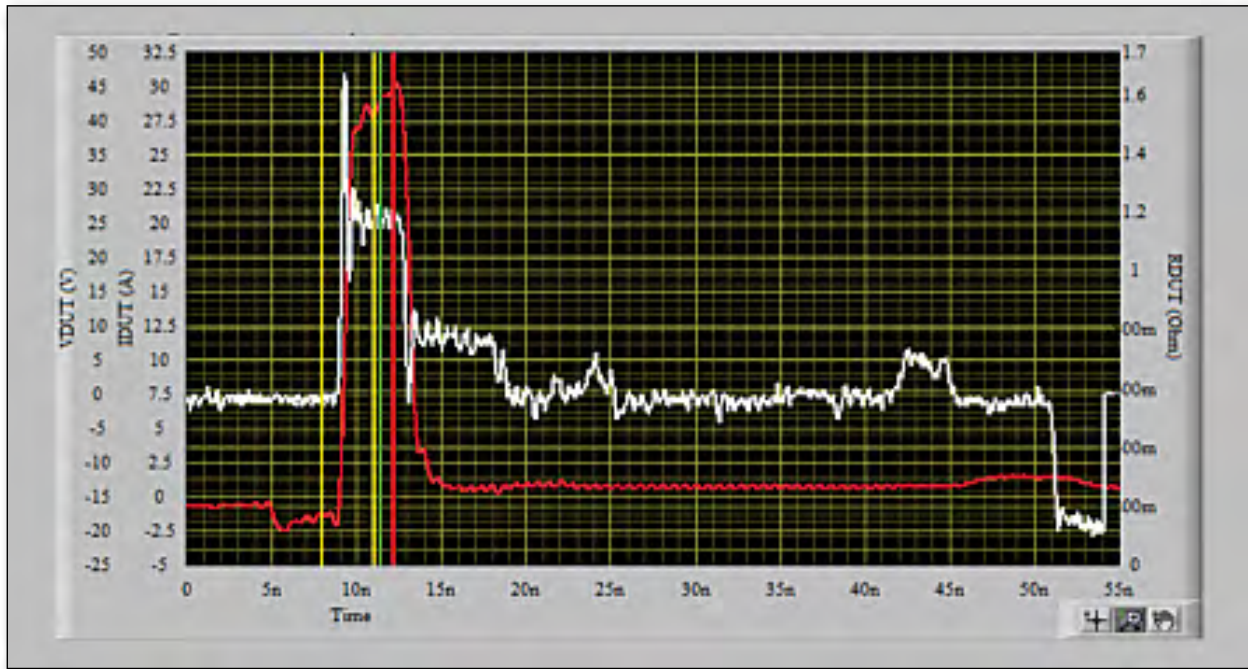


Figure 1: An example of a simplified pulse triggered ESD protection circuit.

bandwidth limitations of oscilloscopes and transient recorders, similar to the 'old' product requirements of the IEC 801-2 (1984). In the meanwhile, the end-user ESD requirements have been updated to the IEC 61000-4-2, 2008, representing the touch with a finger by a standing person. The rise time for end-user ESD pulses are in the sub-nanoseconds range: 0,7 – 1 ns followed by a more energetic lead pulse between 30 – 60 ns after initial touching. Further investigations are ongoing which show that metal-to-metal discharges will only be in the tens of picoseconds rise-time. Device level testing has been upgraded accordingly using the CDM test (dropping charged devices on a metal table), also with sub-nanoseconds rise time and short duration.





**Figure 3:** Full TLP I/V response waveform in a single pulse. Please note that the first span with respect to the 70% values.

TLP testing is introduced (1985) as a Panacea tool which can substitute all other ESD pulses up to the end-user requirements. Typically, the TLP method with some waveform shaping networks could do it but the measurement systems as they are commercially provided to the market typically can't. In particular the fact that the I/V-points are taken after 70% of the pulse width is a matter of 'seeding' concern.

#### SYSTEM-EFFICIENT ESD DESIGN (SEED)

As defined in the 3rd White Book of the ESDA, the intent is to build an integral ESD protection network in such a way that the ultimate functional circuit is being protected. In principle, this starts at the IC-level where the I/O or supply circuit is protected by the on-chip protection structures. Nowadays, the functional I/O and supply circuits are separately developed by different IP groups and ultimately joined with the pad protection at physical layout.

Most ESD protections are typically  $dV/dt$  or threshold/ breakdown voltage triggered, see Figure 1. But what if an only  $dV/dt$  triggered ESD protection device is used in parallel to a processor core supply circuitry with large equivalent supply decoupling capacitance? The ESD protection circuitry has been characterized separately before it is added to an IP library without considering further application. By the parallel capacitance of the core the  $dV/dt$  at the ESD protection circuit is reduced and as the  $dV/dt$  in application has become too dull, that  $dV/dt$  triggered protection is no longer

50  $\Omega$  Current Sensor Output  
(PORT 3)

50  $\Omega$  Pulse Input  
(PORT 1)



50  $\Omega$  Pulse Output  
(PORT 2)

**Figure 4:** Example of a high bandwidth (<150 ps) current sensor.

effective. As such the discharge current occurring with the ESD event charges up the internal core voltage until an overvoltage occurs.

If an external clamping circuit is used which is clamped to e.g. the +5 volt rail while the internal supply voltage of the circuit to be protected is less, then both protections will formally work as intended, but when used in paral-

lel, the external one will have no function as the first voltage rooftop will be reached by the internal supply. Again true, like a tsunami, the external device will do something, but only when it gets triggered in time at its trigger voltage before the internal clamping circuit takes over.

Taking the clamping voltage data from the internal and external protection devices or circuits doesn't make sense, see Figure 2. Taking the triggering voltage of both devices neither. From both devices, I/V data versus time are required to find out which one takes the burden. As such, taking the I/V data after 70% of the TLP edge doesn't make sense as the whole transition versus time contains the crucial information, see Figure 3. As TLP systems generate pulses with rise times in the order of 100 ps or even less ( $\approx 3$  GHz bandwidth), the sampling time for the current and voltage data has to be taken even faster considering Nyquist. Furthermore, the two: current and voltage, have to be taken simultaneously with sufficient bandwidth, both for the scope used, as for the sensors, see Figure 4.

As testing by using (vf-)TLP is artificial w.r.t the real ESD phenomena, it is still debatable on whether the data: I/V versus time, found is practically suitable enough to enable SEED prediction. Again, true ... only by having the entire I/V versus time data base will enable a correct input for analogue circuit simulations. Even the inclusion of specific discretized and extracted 3D-layout information of the PCB and IC-packages into this equation is possible.

## CDM

The use of the device charging plate with CDM test method which is not RF-wise defined decoupled to the 1 sense resistor reference plane doesn't make sense, see Figure 5. Theoretically, the max. di/dt will be the charged voltage to the device (towards the sense resistor reference plane, not the charging plate) divided by 1 . In reality, by the commercially CDM test systems offered, the di/dt will be immediately limited by the length of the test (pogo) pin used. As a CDM standard update is in progress between ANSI/JEDEC and ESDA, the critical factors for testing i.e. qualification and quantification shall be identified and restrictions to those parameters shall be given. Otherwise the whole CDM test reduces to a unified test method which, as long as everyone is making the same

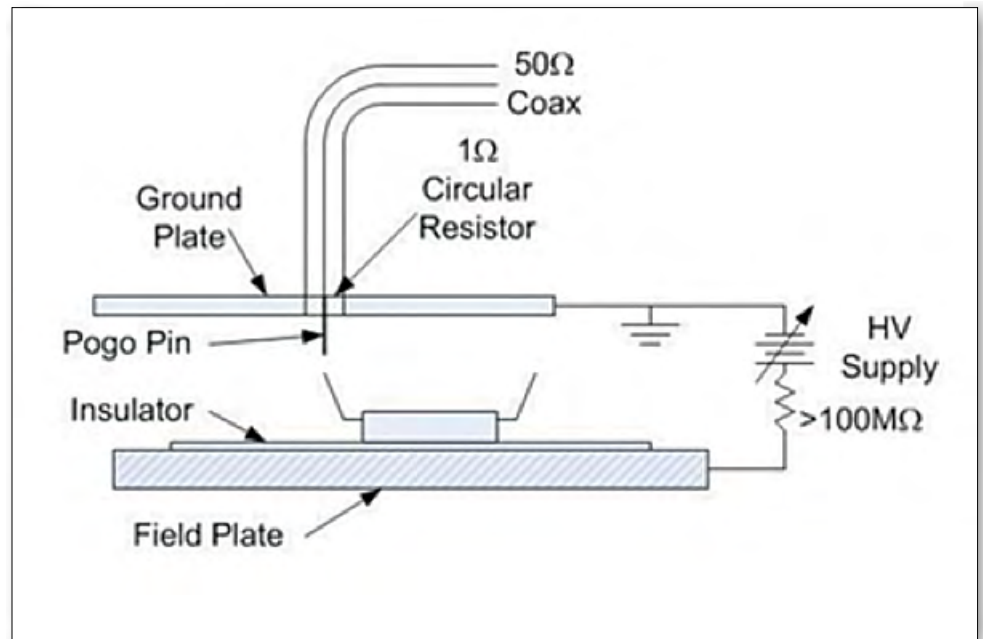


Figure 5: Simplified CDM test setup.

mistakes, is providing a common relative reference test method rather than an absolute one.

## CONCLUSIONS

Before one can start to harvest SEED, the seeding and breeding has to take place, which will not occur overnight. But to harvest the right SEED parameters, one needs to adapt the way of measurement and characterization first. The ingredients for artificial ESD measurement by the TLP method are there, but the right application to gather the SEED data correctly is lacking.

The SEED approach doesn't only apply between ICs and external protection devices but also between on-chip circuits and the I/O and supply ESD protection circuits. When split grounds are used; VSSA, VSSD, VSSX, etc., also here the SEED approach shall be adopted to guarantee ESD safe operation.

Only dV/dt triggered ESD protection circuits are very likely to fail in combination with their real application.

Reaching SEED carries more constraints in the application than putting the external and on-chip ESD protection circuits in parallel. The signal/supply-ground references taken are crucial w.r.t. the performances reached

Not only the (vf-)TLP test method needs to be adapted but also the CDM test method requires an update to become a more unambiguous test method rather than a relative test.

The ultimate ESD requirements will be based on the end-user environment which is unlikely to change. As such, the IEC 61000-4-2 or ISO 10605 for an automotive environment have to be adhered.



# Calendar

## EDI CON 2015

April 14 – 16, 2015, Beijing, China

The 3rd annual Electronic Design Innovation Conference (EDI CON) is now accepting papers related to all aspects of RF, microwave, EMI/EMC and high speed digital design for presentation during this premier three day event. Authors are requested to submit a draft paper or comprehensive abstract that provides sufficient detail about the proposed paper.

<http://www.ediconchina.com>

## EMC BY YOUR DESIGN

April 14 – 16, 2015, Northbrook, Illinois

An EMC Practical Applications Seminar and Workshop by Donald L. Sweeney, Roger Swanberg & Tim Lusha. Using Latest EMC Textbook "Controlling Radiated Emissions by Design" published in 2014 by Michel Mardiguian, contributed to and edited by Donald L. Sweeney.

<http://dlsemc.com/emc-class/emc-seminar>

## EMC LIVE 2015

April 28 – 30, 2015, Online Event

EMC Live 2015 is a unique 3-day event, featuring live webinar presentations, with practical solutions to electromagnetic interference (EMI) challenges. Various electromagnetic compatibility (EMC) topics will be covered including shielding, grounding, filtering, standards, pre-compliance and testing; and will be applicable to electronics, design and test engineers working in all industries.

<http://emclive2015.com>

## 2015 IEW WORKSHOP

May 03 – 07, 2015, Lake Tahoe, California

9th Annual International Electrostatic Workshop (IEW). The IEW provides a unique environment for envisioning, developing, and sharing robust design and test of ESD protection for state-of-the-art integrated circuits as well as advanced semiconductor system on chip (SOC) and system in package (SIP) applications.

<http://www.esda.org/IEW>

## ESD DEVICE DESIGN ESSENTIALS SEMINAR

May 07 – 08, 2015, Reno, Nevada

This two-day seminar consists of concentrated versions of twelve ESDA tutorials which comprise the ESDA Device Design Certification Program. Increased device performance has created sensitivity to ESD events. Learn how design sensitivity trends affect ESD control practices.

<http://www.esda.org>

## 2015 WIRELESS & EMC EUROPE TRAINING TOUR

May 20 – 21, 2015, Helsinki, Finland

June 16 – 17, 2015, Como, Italy

Comprehensive instruction for Wireless, RF, Regulatory and Testing

<http://abcert.com/seminars/2015-Seminar-email/2015-Training.html>

## ASIA-PACIFIC INTERNATIONAL SYMPOSIUM ON ELECTROMAGNETIC COMPATIBILITY (APEMC) 2015

May 26 – 29, 2015, Taipei, Taiwan

APEMC 2015 will cover all aspects of EMC in the Asia-Pacific region, including EMC standards, test and measurement; power system EMC and the smart grid; system-level EMI protection; automotive and aerospace EMC; antenna and wave propagation; electronic packaging; SI/PI and more. Attendees are invited to participate in technical panels and workshops and attend the products and services exhibition.

<http://www.apemc2015.org>

## INNOVATIVE SMART GRID TECHNOLOGIES (ISGT) EUROPE 2015

Oct. 21 – 24, 2015, Warsaw, Poland

The 6th European Innovative Smart Grid Technologies (ISGT) Conference will provide participants from industry and academia with the opportunity to discuss the cutting-edge development of smart grid technologies and the associated solutions related to increased penetration of renewables and distributed energy resources in the power system.

<http://www.ieee-pes.org/meetings-and-conferences/>

## Need an *EMI Filter*?



Do you need help meeting your EMI/EMC requirements? Did you just fail your EMI test? Is physical size a limitation?

**IT'S TIME TO GET WHAT YOU NEED.**

- ▶ Custom filters in any shape/size/configuration
- ▶ Any voltage/frequency/current/power
- ▶ Prototypes through production

Visit Us Online!  
[www.captorcorp.com](http://www.captorcorp.com)

For over 40 years, Captor's superior engineering and design has meant quality, economy, and outstanding service. Call now for more details.



Quality. Expertise. Solutions.



**CAPTOR CORPORATION**

5040 S. County Rd., Tipp City, Ohio 45371 • Phone: (937) 667-8484 • Fax: (937) 667-5133  
www.captorcorp.com © 2007 Captor Corporation

**THE PHYSICS OF ELECTROMAGNETIC COMPATIBILITY MEASUREMENTS**

June 02, 2015, Madison, Wisconsin

This one-day course reviews test equipment, settings, and set-up parameters that affect EMC measurements. The primary EMC tests covered include Conducted and Radiated Emissions, Radiated Immunity, Bulk Current Injection, Electrical Fast Transient testing and Electrostatic Discharge testing. Students completing this course will be familiar with EMC test procedures and have a better understanding of the physics involved.

<http://www.learnemc.com>

**ELECTRONIC SYSTEMS DESIGN FOR EMC COMPLIANCE**

June 03–04, 2015, Madison, Wisconsin

This two-day course introduces fundamental electromagnetic compatibility concepts for electronic system designers. The focus of the course is on providing students with the knowledge and tools required to develop products that comply with all EMC requirements. Students completing this course will be able to systematically review their designs to find problems before the first hardware is built and tested.

<http://www.learnemc.com>

**15TH IEEE CONFERENCE ON ENVIRONMENTAL AND ELECTRICAL ENGINEERING (EEEIC 2015)**

June 10 – 13, 2015, Rome, Italy

EEEIC 2015 is the 15th annual conference, making it the Europe's one of the largest, longest-running, professional networking and educational event of its kind. EEEIC is an annual energy and environment conference held in 2015 in Rome, Italy, where the delegates make presentations and discuss various issues including clean and renewable energy solutions for protection of our environment. In 2015, for the first time, the conference is fully sponsored by IEEE.

<http://eeeic.eu>

**EMC LIVE 2015 TEST BOOTCAMP**

November 12, 2015, Online Event

The EMC Live 2015 Test Bootcamp is a highly focused 1-day event for engineers involved in the development, pre-compliance, testing and certification of electronic products, systems and assemblies. Electromagnetic interference (EMI) challenges, and electromagnetic compatibility (EMC) solutions will be addressed across a wide range of applications, covering the latest in standards, test equipment, setups and techniques.

<http://emclive2015.com>

**WANT TO KNOW MORE?**

To learn more about any EMC topic, including testing, design, shielding, military, aerospace and more, visit [www.interferencetechnology.com](http://www.interferencetechnology.com).

# Consultant Services

**Don HEIRMAN Consultants, L.L.C.**

Donald N. Heirman, NCE  
President

143 Jumping Brook Road +1 732-741-7723 (Voice)  
Lincroft, NJ 07738-1442 USA +1 732-530-5695 (FAX)  
d.heirman@ieee.org  
<http://www.DonHEIRMAN.com>



Electromagnetic Compatibility and Product Safety



**Mark I. Montrose**

Low Cost Professional EMC Services

- Consulting
- Training
- Testing
- Troubleshooting

ISO 17025 Assessed Laboratory-CE Approval

2353 Mission Glen Drive  
Santa Clara, CA 95051

and FAX: +1 (408) 247-5715  
[mark@montrosecpliance.com](mailto:mark@montrosecpliance.com)

973-992-1793

FAX 973-533-1442

**HENRY OTT CONSULTANTS**

EMC CONSULTING & TRAINING  
[www.hotconsultants.com](http://www.hotconsultants.com)

48 BAKER RD.  
LIVINGSTON, NJ 07039

[h.ott@verizon.net](mailto:h.ott@verizon.net)  
**HOC**  
ELECTROMAGNETIC  
COMPATIBILITY

**KIMMEL GERKE ASSOCIATES, LTD.**



Consulting Engineers

**EMI DESIGN & TROUBLESHOOTING**

- **EMI Design and Systems Consulting**  
– Regulations – Emissions – RFI – ESD – Power Disturbances
- **EMI Seminars**  
– Design – Systems – Custom – Public and Private
- **EMI Design Reviews**  
– Circuit Boards – Cables – Power – Grounding – Shielding
- **EMI - Toolkit®** – An EMI Software "Reference Handbook"

**Daryl Gerke, PE**  
2256 W. Lindner #31  
Mesa, AZ 85202

**William Kimmel, PE**  
628 LeVander Way  
S. St. Paul, MN 55075

[www.emiguru.com](http://www.emiguru.com) • 1-888-EMI-GURU



# Standards Review

**Compliance with standards** makes or breaks the marketing of any new product. This section recaps new and revised national and international EMC standards. The information below has been featured in our weekly Interference Technology eNews. Just go to [InterferenceTechnology.com](http://InterferenceTechnology.com), subscribe to the eNews, and you'll be updated on important changes in EMC standards weekly.

## INTERNATIONAL ELECTROTECHNICAL COMMISSION WEBSTORE

01/02/2014

### IEC 62586-2:2013: Power Quality Measurement in Power Supply Systems – Part 2: Functional Tests and Uncertainty Requirements

IEC 62586-2:2013 specifies functional tests and uncertainty requirements for instruments whose functions include measuring, recording, and possibly monitoring power quality parameters in power supply systems, and whose measuring methods (class A or class S) are defined in IEC 61000-4-30. This standard applies to power quality instruments complying with IEC 62586-1. This standard may also be referred to by other product standards (e.g. digital fault recorders, revenue meters, MV or HV protection relays) specifying devices embedding class A or class S power quality functions according to IEC 61000-4-30. These requirements are applicable in single, dual- (split phase) and 3-phase a.c. power supply systems at 50 Hz or 60 Hz.

01/22/2014

### IEC 60794-1-20 ed1.0: Optical Fiber Cables – Part 1-20: Generic Specification – Basic Optical Cable Test Procedures – General and Definitions

IEC 60794-1-20:2014 applies to optical fiber cables for use with telecommunication equipment and devices employing similar techniques, and to cables having a combination of both optical fibers and electrical conductors. The object of this standard is to define test procedures to be used in establishing uniform requirements for the geometrical, transmission, material, mechanical, aging (environmental exposure) and climatic properties of optical fiber cables, and electrical requirements where appropriate. Throughout this standard the wording "optical cable" may also include optical fiber units, microduct fiber units, etc.

01/29/2014

### IEC TS 62153-4-1:2014(E): Metallic Communication Cable Test Methods – Part 4-1: EMC – Introduction to Electromagnetic Screening Measurements

IEC TS 62153-4-1:2014(E) deals with screening measurements. Screening (or shielding) is one basic way of achieving electromagnetic compatibility (EMC). However, a confusingly large number of methods and concepts are available to test for the screening quality of cables and related components, and for defining their quality. This technical specification gives a brief introduction to basic concepts and terms trying to reveal the common features of apparently different test methods. It is intended to assist in correct interpretation of test data, and in the better understanding of screening (or shielding) and related specifications and standards.

This technical specification cancels and replaces the second edition of the technical report IEC/TR 62153-4-1 published in 2010.

0

2/05/2014

### IEC/TR 61869-102:2014(E): Instrument Transformers – Part 102: Ferroresonance Oscillations in Substations with Inductive Voltage Transformers

IEC/TR 61869-102:2014(E) provides technical information for understanding the undesirable phenomenon of ferroresonance oscillations in medium voltage and high voltage networks in connection with inductive voltage transformers. Ferroresonance can cause considerable damage to voltage transformers and other equipment. Ferroresonance oscillations may also occur with other non-linear inductive components.

02/11/2014

### IEC 60974-10:2014: Arc Welding Equipment – Part 10: Electromagnetic Compatibility (EMC) Requirements

IEC 60974-10:2014 specifies:

- applicable standards and test methods for radio-frequency (RF) emissions
- applicable standards and test methods for harmonic current emission, voltage fluctuations and flicker
- immunity requirements and test methods for continuous and transient, conducted and radiated disturbances including electrostatic discharges.

This standard is applicable to equipment for arc welding and allied processes, including power sources and ancillary equipment, for example wire feeders, liquid cooling systems and arc striking and stabilizing devices.

This third edition cancels and replaces the second edition published in 2007 and constitutes a technical revision. This edition includes the following significant technical changes with respect to the previous edition:

- inclusion of optional use of a decoupling network and a load outside the test chamber
- inclusion of an alternative test setup for portable equipment
- inclusion of test conditions for complex controls, liquid cooling systems and arc striking and stabilizing devices
- update of the applicable limits related to the updated reference to CISPR 11
- exclusion of the use of narrow band relaxations for RF emission limits
- update of the applicable limits for harmonics and flicker and inclusion of flow-charts related to the updated reference to IEC 61000-3-11 and IEC 61000-3-12
- update of the requirements for voltage dips related to the updated reference to IEC 61000-4-11 and IEC 61000-4-34
- update of the informative annex for installation and use
- inclusion of symbols to indicate the RF equipment class and restrictions for use.

02/25/2014

### IEC 62761:2014: Guidelines for the Measurement Method of Nonlinearity for Surface Acoustic Wave (SAW) and Bulk Acoustic Wave (BAW) Devices in Radio Frequency (RF)

IEC 62761:2014-02(en-fr) gives the measurement method for non-linear signals generated in the radio frequency (RF) surface acoustic wave (SAW) and bulk acoustic wave (BAW) devices such as filters and duplexers, which are used in telecommunications, measuring equipment, radar systems and consumer products. It includes basic properties of non-linearity, and guidelines to setup the measurement system and to establish the measurement procedure of nonlinear signals generated in SAW/BAW devices.

03/04/2014

**IEC 60601-1-2:2014: Medical Electrical Equipment – Part 1-2: General Requirements for Basic Safety and Essential Performance – Collateral Standard: Electromagnetic Disturbances – Requirements and Tests)**

IEC 60601-1-2:2014 applies to the basic safety and essential performance of medical equipment (ME) equipment and ME systems in the presence of electromagnetic disturbances and to electromagnetic disturbances emitted by ME equipment and ME systems. This collateral standard to IEC 60601-1 specifies general requirements and tests for basic safety and essential performance with regard to electromagnetic disturbances and for electromagnetic emissions of ME equipment and ME systems. They are in addition to the requirements of the general standard IEC 60601-1 and serve as the basis for particular standards.

This fourth edition cancels and replaces the third edition of IEC 60601-1-2 and constitutes a technical revision. The most significant changes with respect to the previous edition include the following modifications:

- specification of immunity test levels according to the environments of intended use, categorized according to locations that are harmonized with IEC 60601-1-11: the professional healthcare facility environment, the home healthcare environment and special environments
- specification of tests and test levels to improve the safety of medical electrical equipment and medical electrical systems when portable RF communications equipment is used closer to the medical electrical equipment than was recommended based on the immunity test levels that were specified in the third edition
- specification of immunity tests and immunity test levels according to the ports of the medical electrical equipment or medical electrical system
- specification of immunity test levels based on the reasonably foreseeable maximum level of electromagnetic disturbances in the environments of intended use, resulting in some immunity test levels that are higher than in the previous edition
- better harmonization with the risk concepts of basic safety and essential performance, including deletion of the defined term “life-supporting”. This new edition includes the following main additions
- guidance for determination of immunity test levels for special environments
- guidance for adjustment of immunity test levels when special considerations of mitigations or intended use are applicable
- guidance on risk management for basic safety and essential performance with regard to electromagnetic disturbances
- guidance on identification of immunity pass/fail criteria.

04/16/2014

**IEC 61558-2-10:2014 – Safety of Transformers, Reactors, Power Supply Units and Combinations Thereof – Part 2-10: Particular Requirements and Tests for Separating Transformers with High Insulation Level and Separating Transformers with Output Voltages Exceeding 1,000V**

IEC 61558-2-10:2014 deals with the safety of separating transformers with high insulation level and separating transformers with output voltages exceeding 1 000 V. Transformers incorporating electronic circuits are also covered by this standard. This first edition cancels and replaces Chapter II Section Three of IEC 60989 published in 1991. It constitutes a technical revision.

The main changes consist of:

1. updating this part in accordance with IEC 61558-1:2005
2. adding power supply units to the scope.

04/30/2014

**IEC 62149-8:2014: Fiber Optic Active Components and Devices – Performance Standards – Part 8: Seeded Reflective Semiconductor Optical Amplifier Devices**

IEC 62149-8:2014 covers the performance specification for seeded reflective semiconductor optical amplifier (RSOA) devices used for fiber optic telecommunication and optical data transmission applications. The performance standard contains a definition of the product performance requirements together with a series of sets of tests and measurements with clearly defined conditions, severities, and pass/fail criteria. The tests are intended to be run on a “once-off” basis to prove any product’s ability to satisfy the performance standard’s requirements. A product that has been shown to meet all the requirements of a performance standard can be declared as complying with the performance standard, but should then be controlled by a quality assurance/quality conformance program.

05/13/2014

**IEC 61000-4-19:2014 – Electromagnetic Compatibility (EMC) – Part 4-19: Testing and Measurement Techniques – Test for Immunity to Conducted, Differential Mode Disturbances and Signalling in the Frequency Range 2 kHz to 150 kHz at A.C. Power Ports**

IEC 61000-4-19:2014 relates to the immunity requirements and test methods for electrical and electronic equipment to conducted, differential mode disturbances and signalling in the range 2 kHz up to 150 kHz at a.c. power ports. The object of this standard is to establish a common and reproducible basis for testing electrical and electronic equipment with the application of differential mode disturbances and signalling to a.c. power ports. This standard defines:

- test waveforms
- range of test levels
- test equipment
- test setup
- test procedures
- verification procedures

These tests are intended to demonstrate the immunity of electrical and electronic equipment operating at a mains supply voltage up to 280 V (from phase to neutral or phase to earth, if no neutral is used) and a frequency of 50 Hz or 60 Hz when subjected to conducted, differential mode disturbances such as those originating from power electronics and power line communication systems. The immunity to harmonics and interharmonics, including mains signalling, on a.c. power ports up to 2 kHz in differential mode is covered by IEC 61000-4-13. Emissions in the frequency range 2 kHz to 150 kHz often have both differential mode and common mode components. This standard provides immunity tests only for differential mode disturbances and signalling. It is recommended to perform common mode tests as well, which are covered by IEC 61000-4-16.

05/20/2014

**IEC 61000-4-5:2014 – Electromagnetic Compatibility (EMC) – Part 4-5: Testing and Measurement Techniques – Surge Immunity Test**

IEC 61000-4-5:2014 relates to the immunity requirements, test methods and range of recommended test levels for equipment with regard to unidirectional surges caused by over-voltages from switching and lightning transients. Several test levels are defined which relate to different environment and installation conditions. These requirements are developed for and are applicable to electrical and electronic equipment. The object of this standard is to establish a common reference



for evaluating the immunity of electrical and electronic equipment when subjected to surges.

The test method documented describes a consistent method to assess the immunity of an equipment or system against a defined phenomenon. This standard defines a range of:

- test levels
- test equipment
- test setups and
- test procedures.

The task of the described laboratory test is to find the reaction of the equipment under test (EUT) under specified operational conditions to surge voltages caused by switching and lightning effects. It is not intended to test the capability of the EUT's insulation to withstand high-voltage stress. Direct injections of lightning currents, i.e. direct lightning strikes, are not considered in this standard.

This third edition cancels and replaces the second edition published in 2005, and constitutes a technical revision which includes the following significant technical changes with respect to the previous edition:

- a new Annex E on mathematical modelling of surge waveforms
- a new Annex F on measurement uncertainty
- a new Annex G on method of calibration of impulse measuring systems and
- a new Annex H on coupling/decoupling surges to lines rated above 200 A.

Moreover, while surge test for ports connected to outside telecommunication lines was addressed in 6.2 of the second edition (IEC 61000-4-5:2005), in this third edition (IEC 61000-4-5:2014) the normative Annex A is fully dedicated to this topic. In particular, it gives the specifications of the 10/700  $\mu$ s combined wave generator.

**05/28/2014**

**IEC 61000-3-2:2014 – Electromagnetic Compatibility (EMC) – Part 3-2: Limits – Limits for Harmonic Current Emissions (Equipment Input Current  $\leq$  16 A Per Phase)**

IEC 61000-3-2:2014 deals with the limitation of harmonic currents injected into the public supply system. It specifies limits of harmonic components of the input current which may be produced by equipment tested under specified conditions. It is applicable to electrical and electronic equipment having an input current up to and including 16 A per phase, and intended to be connected to public low voltage distribution systems. Arc welding equipment which is not professional equipment, with input current up to and including 16 A per phase, is included in this standard. Arc welding equipment intended for professional use, as specified in IEC 60974-1, is excluded from this standard and may be subject to installation restrictions as indicated in IEC/TR 61000-3-4 or IEC 61000-3-12. The tests according to this standard are type tests. Test conditions for particular equipment are given in Annex C. For systems with nominal voltages less than 220 V (line-to-neutral), the limits have not yet been considered.

This fourth edition cancels and replaces the third edition published in 2005, Amendment 1:2008, Amendment 2:2009 and Corrigendum of August 2009. This edition includes the following significant technical changes with respect to the previous edition:

- a clarification of the repeatability and reproducibility of measurements

- a more accurate specification of the general test conditions for information technology equipment
- the addition of optional test conditions for information technology equipment with external power supplies or battery chargers
- the addition of a simplified test method for equipment that undergoes minor changes or updates
- an update of the test conditions for washing machines
- a clarification of the requirements for Class C equipment with active input power  $\leq$  25 W
- an update of the test conditions for audio amplifiers
- a clarification of the test conditions for lamps
- an update of the test conditions for vacuum cleaners
- the addition of test conditions for high pressure cleaners
- an update of the test conditions for arc welding equipment
- the reclassification of refrigerators and freezers with variable-speed drives into Class D
- and the addition of test conditions for refrigerators and freezers.

**06/11/2014**

**IEC 61290-10-5:2014 – Optical Amplifiers – Test Methods – Part 10-5: Multichannel Parameters – Distributed Raman Amplifier Gain and Noise Figure**

IEC 61290-10-5:2014 applies to distributed Raman amplifiers (DRAs). DRAs are based on the process whereby Raman pump power is introduced into the transmission fibre, leading to signal amplification within the transmission fibre through stimulated Raman scattering. A detailed overview of the technology and applications of DRAs can be found in IEC TR 61292-6.

The object of this standard is to establish uniform requirements for accurate and reliable measurements, using an optical spectrum analyser (OSA), of the following DRA parameters:

- channel on-off gain
- pump unit insertion loss
- channel net gain
- channel signal-spontaneous noise figure. Keywords: Raman amplifiers (DRAs), optical spectrum analyser (OSA)

**06/18/2014**

**IEC 61169-45:2014 – Radio-frequency Connectors – Part 45: Sectional Specification for SQMA Series Quick Lock RF Coaxial Connectors**

IEC 61169-45:2014, which is a sectional specification (SS), provides information and rules for the preparation of detail specifications (DS) for type SQMA quick lock RF coaxial connectors. The connectors are normally used with 50 Ohms in microwave, telecommunication, wireless and other fields, connecting with RF cables or micro-strips. The operating frequency limit is up to 18 GHz. It describes the interface dimensions for general purpose connectors grade 2 and standard test connectors – grade 0 with gauging information and the mandatory tests selected from IEC 61169-1, applicable to all detail specifications relative to type SQMA connectors.

This specification indicates the recommended performance characteristics to be considered when writing a DS and covers all tests schedules and inspection requirements for assessment levels M and H.

06/25/2014

**IEC 61300-2-43:2014 – Fiber Optic Interconnecting Devices and Passive Components – Basic Test and Measurement Procedures – Part 2-43: Tests – Screen Testing of Return Loss of Single-Mode PC Optical Fiber Connectors**

IEC 61300-2-43:2014 aims at screening single-mode physical contact (PC) optical fibre connectors of an optical fibre cord or an optical fibre pigtail in terms of return loss, thus ensuring minimum return loss when the connectors, which have been screen tested by this method, are randomly mated with each other in the field. This second edition of IEC 61300-2-43 cancels and replaces the first edition published in 1999 and constitutes a technical revision.

This edition includes the following significant technical changes with respect to the previous edition:

- revision of the scope
- revision of the procedure
- addition of measurement uncertainty into the 'Details to be specified'
- addition of a bibliography.

07/09/2014

**IEC 61280-4-2: 2014 – Fiber-Optic Communication Subsystem Test Procedures – Part 4-2: Installed Cable Plant – Single-Mode Attenuation and Optical Return Loss Measurement**

IEC 61280-4-2: 2014 is applicable to the measurement of attenuation and optical return loss of installed optical fibre cable plant using single-mode fibre. This cable plant can include single-mode optical fibres, connectors, adapters, splices and other passive devices. The cabling may be installed in a variety of environments including residential, commercial, industrial and data centre premises, as well as outside plant environments. This standard may be applied to all single-mode fibre types including those designated by IEC 60793-2-50 as Class B fibres. The principles of this standard may be applied to cable plants containing branching devices (splitters) and at specific wavelength ranges in situations where passive wavelength selective components are deployed, such as WDMs, CWDM and DWDM devices. This standard is not intended to apply to cable plant that includes active devices such as fibre amplifiers or dynamic channel equalizers.

This second edition cancels and replaces the first edition, published in 1999, and constitutes a technical revision. The main changes with respect to the previous edition are listed below: revision of optical time-domain reflectometer (OTDR) measurements; addition of optical return loss (ORL) measurements; addition of informative annexes on measurement uncertainties, OTDR configuration, test cord attenuation verification and spectral attenuation measurement.

07/16/2014

**IEC 61196-1-111:2014 – Coaxial Communication Cables – Part 1-111: Electrical Test Methods – Stability of Phase Test Methods**

IEC 61196-1-111:2014 applies to coaxial communication cables. It specifies methods for determining the stability of phase of coaxial communication cables, [including];

- phase variation with temperature
- phase constant variation with temperature

- phase stability with bending
- phase stability with twisting

This second edition cancels and replaces the first edition published in 2005. This edition constitutes a technical revision. This edition includes the following significant technical changes with respect to the previous edition:

- a revised clause on phase variation with temperature
- a revised clause on phase stability with bending
- a revised clause on phase stability with twisting.

08/19/2014

**IEC/TR 62681:2014 – Electromagnetic Performance of High Voltage Direct Current (HVDC) Overhead Transmission Lines**

IEC/TR 62681:2014 provides general guidance on the electromagnetic environment issues of HVDC transmission lines. It concerns the major parameters adopted to describe the electromagnetic environment of a High-Voltage Direct Current (HVDC) transmission line, including electric fields, ion current, magnetic fields radio interference and audible noise generated as a consequence of such effects. Engineers in different countries can refer to this Technical Report to ensure the safe operation of HVDC transmission lines, limit the influence on the environment within acceptable ranges, and optimize engineering costs.

08/28/2014

**IEC TS 61967-3:2014 – Integrated Circuits – Measurement of Electromagnetic Emissions – Part 3: Measurement of Radiated Emissions – Surface Scan Method**

IEC TS 61967-3:2014 provides a test procedure which defines an evaluation method for the near electric, magnetic or electromagnetic field components at or near the surface of an integrated circuit (IC). This diagnostic procedure is intended for IC architectural analysis such as floor planning and power distribution optimization. This test procedure is applicable to measurements on an IC mounted on any circuit board that is accessible to the scanning probe. In some cases, it is useful to scan not only the IC but also its environment. For comparison of surface scan emissions between different ICs, the standardized test board defined in IEC 61967-1 should be used.

This measurement method provides a mapping of the electric or magnetic near-field emissions over the IC. The resolution of the measurement is determined by the capability of the measurement probe and the precision of the probe-positioning system.

This method is intended for use up to 6 GHz. Extending the upper limit of frequency is possible with existing probe technology but is beyond the scope of this specification. Measurements may be carried out in the frequency domain or in the time domain.

This edition includes the following significant technical changes with respect to the previous edition:

1. Removal of: Clause 9.4 Data analysis and Annex D Analysing the data from near-field surface scanning
2. Addition of: Introduction, Clause 9.4 Measurement data, Clause 9.5 Post-processing, Clause 9.6 Data exchange and Annex D Co-ordinate systems
3. Expansion of: Clause 8.4 Test technique and Annex A Calibration of near-field probes.



09/03/2014

### Electrical Installations in Ships – Part 350: General Construction and Test Methods of Power, Control and Instrumentation Cables for Shipboard and Offshore Applications

The following types of cables are not included:

- optical fibre
- sub-sea and umbilical cables
- data and communication cables
- coaxial cables

This edition includes the following significant technical changes with respect to the previous edition:

- a) reference to IEC 60092-360 for both the insulating and sheathing compounds
- b) partial discharge tests have been transferred from IEC 60092-354 to align it with IEC 60092-353
- c) requirements for oil and drilling-fluid resistance (former Annexes F and G) have been transferred to IEC 60092-360
- d) requirements for cold bending and shocks have been improved
- e) the document reflects the changes of material types that have been introduced during the development of IEC 60092-353 and IEC 60092-360.

09/23/2014

### IEC 60127-2 ed3.0: Miniature fuses – Part 2: Cartridge fuse-links

IEC 60127-2:2014 relates to special requirements applicable to cartridge fuse-links for miniature fuses with dimensions measuring 5 mm x 20 mm and 6,3 mm x 32 mm for the protection of electric appliances, electronic equipment and component parts thereof, normally intended for use indoors. It does not apply to cartridge fuse-links for appliances intended to be used under special conditions, such as in corrosive or explosive atmospheres. This standard applies in addition to the requirements of IEC 60127-1. The object of this standard is to define special and additional test methods for cartridge fuse-links applying in addition to the requirements of IEC 60127-1. This third edition of IEC 60127-2 cancels and replaces the second edition published in 2010. This edition includes the following significant technical changes with respect to the previous edition: add 4 new standard sheets 7 up to 10. Keywords: cartridge fuse-links for miniature fuses, protection of electric appliances, electronic equipment and component.

09/26/2014

### IEC 61010-2-010 ed3.0: Safety requirements for electrical equipment for measurement, control and laboratory use – Part 2-010: Particular requirements for laboratory equipment for the heating of materials

IEC 61010-2-010:2014 specifies safety requirements for electrically powered laboratory equipment for the heating of materials, where the heating of materials is one of the functions of the equipment. This third edition cancels and replaces the second edition published in 2003. It constitutes a technical revision and includes the following significant changes from the second edition, as well as numerous other changes:

- added a definition for HEAT TRANSFER MEDIUM to Clause 3
- added a symbol for FLAMMABLE LIQUID to Table 1 in Clause 5
- added a requirement for instructions pertaining to ventilation in Clause 5
- modified the requirements for humidity preconditioning in Clause 6
- added requirements for equipment containing or using flammable liquids to Clause 9
- added requirements for over-temperature protection devices to Clause 10

It has the status of a group safety publication in accordance with IEC Guide 104.

10/07/2014

### IEC 62489-2 ed2.0: Electroacoustics – Audio-frequency induction loop systems for assisted hearing – Part 2: Methods of calculating and measuring the low-frequency magnetic field emissions from the loop for assessing conformity with guidelines on limits for human exposure

IEC 62489-2:2014 applies to audio-frequency induction-loop systems for assisted hearing. It may also be applied to such systems used for other purposes, as far as it is applicable. The standard is intended for assessment of human exposure to low-frequency magnetic fields produced by the system, by calculation and by in-situ testing. This standard does not deal with other aspects of safety, for which IEC 60065 applies, or with EMC. This second edition cancels and replaces the first edition published in 2011. This edition constitutes a technical revision which includes significant technical changes to reflect several updates to the ICNIRP Guide (Guidelines for limiting exposure to time-varying electric, magnetic, and electromagnetic fields) to which it makes frequent reference. The most significant change is that the underlying metric in the Guide has been changed from tissue current density to induced electric field. Keywords: hearing aid, accessibility, surdity, deafness.

10/22/2014

### IEC 61000-6-7 ed1.0: Electromagnetic compatibility (EMC) – Part 6-7: Generic standards – Immunity requirements for equipment intended to perform functions in a safety-related system (functional safety) in industrial locations

IEC 61000-6-7:2014 is intended to be used by suppliers when making claims for the immunity of equipment intended for use in safety-related systems against electromagnetic disturbances. This standard should also be used by designers, integrators, installers, and assessors of safety-related systems to assess the claims made by suppliers. It provides guidance to product committees. This part of IEC 61000 applies to electrical and electronic equipment intended for use in safety-related systems and that is:

- intended to comply with the requirements of IEC 61508 and/or other sector-specific functional safety standards
- and intended to be operated in industrial locations as described in 3.1.15. The object of this standard is to define immunity test requirements for equipment in relation to continuous and transient, conducted and radiated disturbances, including electrostatic discharge. These requirements apply only to functions intended for use in functional safety applications. Test requirements are specified for each port considered.

10/29/2014

### IEC 60071-5 ed1.0: Insulation co-ordination – Part 5: Procedures for high-voltage direct current (HVDC) converter stations

IEC 60071-5:2014 provides guidance on the procedures for insulation co-ordination of high-voltage direct current (HVDC) converter stations, without prescribing standardized insulation levels. This standard applies only for HVDC applications in high-voltage a.c. power systems and not for industrial conversion equipment. Principles and guidance given are for insulation co-ordination purposes only. The requirements for human safety are not covered by this standard. This International Standard cancels and replaces IEC TS 60071-5 published in 2002. On the basis of technical experience gained since the Technical Specification was published, sufficient consensus has emerged for transformation of the Technical Specification into an International Standard. The technical content is essentially the same as that contained in the Technical Specification with amendments mainly for user convenience. The structure of

the document has been changed to allow division and subdivision into complete integral parts to facilitate comprehension and ease of referencing. In addition to the high level revisions above, the following main technical changes have been made with respect to the previous edition:

- arresters have been added to several locations to reflect some recent 800 kV HVDC scheme practice, along with their justifications, expected voltages, overvoltages and arrester stresses in service
- significant changes have been made in Clause 8 – all subclauses on the characteristics, schemes, stresses and specification of arresters have been consolidated into a single entity, Clause 8
- the implications of a smoothing reactor and of a neutral blocking filter located on the neutral bus (as on some recent 800 kV schemes), on coordination of arresters connected to the neutral end have been added
- possible use of sacrificial arresters on the neutral bus is introduced to cater for excessive arrester energy in the rather unlikely event of a particular rare fault
- all subclauses dealing with study tools and modelling details have been consolidated into Clause 10
- creepage distances and clearances have been consolidated into Clauses 11 and 12, respectively, with more details added.

**11/10/2014**

**IEC 60115-8-1 ed2.0: Fixed resistors for use in electronic equipment – Part 8-1: Blank detail specification: Fixed surface mount (SMD) low power film resistors for general electronic equipment, classification level G**

IEC 60115-8-1:2014 is applicable to the drafting of detail specifications for fixed surface mount (SMD) low-power film resistors in rectangular chip shape (styles RR) or in cylindrical MELF shape (styles RC) classified to level G, which is defined in IEC 60115-8:2009, 1.5 for general electronic equipment, typically operated under benign or moderate environmental conditions, where the major requirement is function. Examples for level G include consumer products and telecommunication user terminals. This edition includes the following significant technical changes with respect to the previous edition:

- It includes minor revisions related to tables, figures and references
- Dedication to resistors of product classification level G, which is for general electronic equipment, typically operated under benign or moderate environmental conditions, like e.g. consumer products, or telecommunication user terminals
- Implementation of the zero defect policy with the application of the single assessment level EZ in all test schedules
- Substitution of the temperature coefficient of resistance (TCR), specified over the full defined temperature range, for the inferior and less significant temperature characteristic
- Addition of a test for the immunity against electrostatic discharge
- Implementation of the concept of stability classes with coordinated requirements to the performance at all prescribed tests
- Addition of information relevant for the component user in his assembly process
- Addition of an Annex providing special provisions for 0 resistors (jumpers), which may be part of a range of products covered by a detail specification derived from this blank detail specification.

**11/18/2014**

**IEC 61000-4-36 ed1.0: Electromagnetic compatibility (EMC) – Part 4-36: Testing and measurement techniques – IEMI immunity test methods for equipment and systems**

IEC 61000-4-36:2014(E) provides methods to determine test levels for the assessment of the immunity of equipment and systems to intentional electromagnetic interference (IEMI) sources. It introduces the general IEMI problem, IEMI source parameters, derivation of test limits and

summarises practical test methods. Keywords: EMC, electromagnetic compatibility.

**01/21/2015**

**IEC 62320-1 ed2.0: Maritime Navigation and Radiocommunication Equipment and Systems – Automatic Identification System (AIS) – Part 1: AIS Base Stations – Minimum Operational and Performance Requirements, Methods of Testing and Required Test Results**

IEC 62320-1:2015(E) specifies the minimum operational and performance requirements, methods of testing and required test results for AIS Base Stations, compatible with the performance standards adopted by IMO Resolution MSC.74 (69), Annex 3, Universal AIS. It incorporates the technical characteristics of non-shipborne, fixed station AIS equipment, included in recommendation ITU-R M.1371 and IALA Recommendation A-124. Where applicable, it also takes into account the ITU Radio Regulations. This standard takes into account other associated IEC international standards and existing national standards, as applicable. This standard is applicable for AIS Base Stations. It does not include specifications for the display of AIS data on shore. This second edition cancels and replaces the first edition published in 2007 and its Amendment 1:2008. This edition constitutes a technical revision.

This edition includes the following significant technical changes with respect to the previous edition:

- incorporation of the technical characteristics included in Recommendation ITU R M.1371 5
- the BCE, BCF and CAB sentences replaced with BCG, BCL and RST
- comment blocks replaced with TAG blocks
- scheduled broadcast of Message 26 added
- Message 27 control added
- transmitter intermodulation attenuation harmonised with ITU;
- 12,5 kHz channel operation removed
- transmission of Message 24A, Message 25 and Message 26 added
- 90 % channel load test with VSI and TAG blocks enabled added.

**02/11/2015**

**IEC 61169-51 ed1.0: Radio-frequency connectors – Part 51: Sectional specification for RF coaxial connectors with inner diameter of outer conductors 13,5 mm with bayonet lock – Characteristic impedance 50 Ω (type QLI)**

IEC 61169-51:2015 provides information and rules for the preparation of detail specifications (DS) for type QLI R.F. coaxial connectors with quick lock. The connectors are normally used with 50 Ohms corrugated cable and flexible cables for middle power applications in an operating range up to 6 GHz. It describes the interface dimensions for general purpose connectors with gauging information and the mandatory tests selected from IEC 61169-1 applicable to all detail specifications relative to type QLI connectors. This specification indicates the recommended performance characteristics to be considered when writing a DS and covers all tests schedules and inspection requirements.

**02/25/2015**

**IEC 61290-1-3 ed3.0: Optical amplifiers – Test methods – Part 1-3: Power and gain parameters – Optical power meter method**

IEC 61290-1-3:2015 applies to all commercially available optical amplifiers (OA) and optically amplified subsystems. It applies to OA using optically pumped fibres (OPA based on either rare-earth doped fibres or on the Raman effect), semiconductors (SOA), and waveguides (POWA). The object of this part of IEC 61290-1 is to establish uniform requirements for accurate and reliable measurements, by means of the optical power meter test method, of the following OA parameters, as defined in IEC 61291-1:

- nominal output signal power



- gain
- polarization-dependent gain
- maximum output signal power
- maximum total output power. All numerical values followed by (±) are suggested values for which the measurement is assured. Other values may be acceptable but should be verified. This part of IEC 61290-1 applies to single-channel amplifiers. For multichannel amplifiers, the IEC 61290-10 series applies. This third edition cancels and replaces the second edition published in 2005. This edition constitutes a technical revision. This edition includes the following significant technical changes with respect to the previous edition
- Detail description of most parameters has been described in IEC 61290-1 and removed from this part
- Description of maximum output signal power and maximum total output power are added. Keywords: optical amplifiers (OA), single-channel amplifiers, optical power meter test method.

#### INTERNATIONAL SPECIAL COMMITTEE ON RADIO INTERFERENCE (CISPR)

03/26/2014

##### **CISPR 16-1-2:2014: Specification for Radio Disturbance and Immunity Measuring Apparatus and Methods – Part 1-2: Radio Disturbance and Immunity Measuring Apparatus – Coupling Devices for Conducted Disturbance Measurements**

CISPR 16-1-2:2014 specifies the characteristics and performance of equipment for the measurement of radio disturbance voltages and currents in the frequency range 9 kHz to 1 GHz. It has the status of a basic EMC publication. Specifications for ancillary apparatus are included for artificial mains networks, current and voltage probes and coupling units for current injection on cables. It is intended that the requirements of this publication are fulfilled at all frequencies and for all levels of radio disturbance voltages and currents within the CISPR indicating range of the measuring equipment. Methods of measurement are covered in the CISPR 16-2 series, and further information on radio disturbance is given in CISPR 16-3, while uncertainties, statistics and limit modelling are covered in the CISPR 16-4 series.

This second edition cancels and replaces the first edition published in 2003 and its Amendment 1 (2004) and Amendment 2 (2006). This edition constitutes a technical revision which includes the following significant technical changes with respect to the previous edition:

- requirements from CISPR 22 for the AAN have been copied to this standard
- and the CDNE for measurement of disturbance voltage in the frequency range 30 MHz to 300 MHz is added.

07/02/2014

##### **CISPR 16-1-1+A2:2014 – Specification for Radio Disturbance and Immunity Measuring Apparatus and Methods – Part 1-1: Radio Disturbance and Immunity Measuring Apparatus – Measuring Apparatus**

CISPR 16-1-1:2010+A1:2010+A2:2014 specifies the characteristics and performance of equipment for the measurement of radio disturbance in the frequency range 9 kHz to 18 GHz. In addition, requirements are provided for specialized equipment for discontinuous disturbance measurements. The specifications in this standard apply to EMI receivers and spectrum analyzers.

This third edition cancels and replaces the second edition published in 2006, and its Amendments 1 (2006) and 2 (2007). It is a technical revision. This main technical change with respect to the previous edition consists of the addition of new provisions for the use of spectrum analyzers for compliance measurements. CISPR 16-1-1:2009 has the status of a basic EMC publication in accordance with IEC Guide 107, Electromagnetic compatibility – Guide to the drafting of electromagnetic compatibility

publications. The contents of the corrigendum of October 2010 have been included in this copy.

12/23/2014

##### **CISPR 16-1-5 ed2.0: Specification for radio disturbance and immunity measuring apparatus and methods – Part 1-5: Radio disturbance and immunity measuring apparatus – Antenna calibration sites and reference test sites for 5 MHz to 18 GHz**

CISPR 16-1-5:2014 specifies the requirements for calibration sites in the frequency range 5 MHz to 18 GHz used to perform antenna calibrations according to CISPR 16-1-6. It also specifies the requirements for reference test sites that are used for the validation of compliance test sites in the frequency range 30 MHz to 1 000 MHz according to CISPR 16-1-4. It has the status of a basic EMC standard in accordance with IEC Guide 107. Measurement instrumentation specifications are given in CISPR 16-1-1 and CISPR 16-1-4. Further information and background on uncertainties in general is given in CISPR 16-4, which can also be helpful in establishing uncertainty estimates for the calibration processes of antennas and site validation measurements. This second edition cancels and replaces the first edition published in 2003, and its Amendment 1 (2012). It constitutes a technical revision which includes the following significant technical changes with respect to the previous edition:

- site validation methods for other sites covered in CISPR 16-1-6 are added
- smaller step sizes are specified for swept frequency measurements;
- the minimum ground plane size is increased
- and other miscellaneous technical and editorial refinements are included. Keywords: electromagnetic compatibility.

02/04/2015

##### **CISPR 13 ed5.1 Consol. with am1: Sound and television broadcast receivers and associated equipment – Radio disturbance characteristics – Limits and methods of measurement**

CISPR 13:2009+A1:2015 applies to the generation of electromagnetic energy from sound and television receivers for the reception of broadcast and similar transmissions and from associated equipment. CISPR 13:2009 describes the methods of measurement applicable to sound and television receivers or associated equipment and specifies limits for the control of disturbance from such equipment. The frequency range covered extends from 9 kHz to 400 GHz. This edition constitutes the introduction of the RMS-average detector as an alternative to quasi-peak and average detector for conducted and radiated emission measurements. This consolidated version consists of the fifth edition (2009) and its amendment 1 (2015). Therefore, no need to order amendment in addition to this publication.

03/03/2015

##### **CISPR 14-2 ed2.0: Electromagnetic Compatibility – Requirements for Household Appliances, Electric Tools and Similar Apparatus – Part 2: Immunity – Product Family Standard**

CISPR 14-2:2015 is available as IEC Standards+ CISPR 14-2:2015 which contains the International Standard and its Redline version, showing all changes of the technical content compared to the previous edition.

CISPR 14-2:2015 deals with the electromagnetic immunity of appliances and similar apparatus for household and similar purposes that use electricity, as well as electric toys and electric tools, the rated voltage of the apparatus being not more than 250 V for single-phase apparatus to be connected to phase and neutral, and 480 V for other apparatus. Apparatus may incorporate motors, heating elements or their combination, may contain electric or electronic circuitry, and may be powered by the mains, by transformer, by batteries, or by any other electrical power source. Apparatus not intended for household use, but which nevertheless may require the immunity level, such as apparatus intended to be used by laymen in shops, in light industry and on farms, are within the scope

of this standard, as far as they are included in CISPR 14-1. In addition, the following are also included in the scope of this standard:

- microwave ovens for domestic use and catering
- cooking hobs and cooking ovens, heated by means of r.f. energy
- (single- and multiple-zone) induction cooking appliances
- appliances for personal care equipped with radiators in the range from UV to IR, inclusive (this includes visible light)
- power supplies and battery chargers provided with or intended for apparatus within the scope of this standard.

This second edition cancels and replaces the first edition published in 1997, Amendment 1:2001 and Amendment 2:2008. It constitutes a technical revision. This edition includes the following significant technical changes with respect to the previous edition:

- 5.1: For ESD tests on contacts of plugs and sockets the note (“The 4 kV contact discharge shall be applied to conductive accessible parts. Metallic contacts, such as in battery compartments or in socket outlets, are excluded from this requirement.”) saying that no test on contacts is necessary has been removed. The IEC 61000-4-2 includes a detailed description how to deal with ESD on contacts and other surfaces. Also discharge on HCP and VCP is required by the basic standard IEC 61000-4-2
- 5.3 and 5.4: The tables for tests at D.C. power ports according IEC 61000-4-6 are aligned with the generic standards and are the same for 5.3 and 5.4
- 5.3 and 5.4: For EUT with single mains cable and not other cable, the test set-up as shown in Figure 2 shall be used. The set-up as described in Annex F of IEC 61000-4-6:2013 shall not be used
- 5.5: The IEC 61000-4-22 has been introduced as alternative method for testing radiated immunity
- 5.6: No line-to-earth surges are applied to products which do not have provision for connection to earth.”

## EUROPEAN UNION (EU)

03/18/2014

### EU Radio Equipment Directive to Require Universal Phone Charger

According to EU officials, the new Radio Equipment Directive aims to keep up with the growing number of “radio equipment devices” and ensure they do not interfere with each other by setting common standards. The new directive also includes requirements for the creation of a universal charger for “certain categories of radio equipment” such as mobile phones, in order to simplify use and reduce extraneous electronic waste and costs. The European Commission will reportedly decide which specific types of radio equipment will have to meet this requirement.

“The modernized Radio Equipment Directive is an efficient tool to prevent interference between different radio equipment devices. I am especially pleased that we agreed on the introduction of a common charger. This serves the interests both of consumers and the environment. It will put an end to charger clutter and 51,000 tons of electronic waste annually,” said rapporteur Barbara Weiler (S&D, DE).

The new Radio Equipment Directive also includes provisions that would give authorities “additional market surveillance tools to detect radio equipment products that fail to comply with the new safety rules.”

The draft directive was approved 550 to 12 with eight abstentions, and has already been informally agreed upon by the Council of Ministers, with formal approval expected in the near future. Member states will have two years to adopt the new rules and manufacturers will have an additional year to comply.

04/08/2014

### New EU EMC Directive Published

The European Union has published the new EMC Directive 2014/30/EU of the European Parliament and of the Council of 25 February 2014 on the harmonization of the laws of the Member States relating to

electromagnetic compatibility (recast). The new directive serves as an update to the EMC Directive 2004/108/EC and will be applicable starting April 20, 2016.

The primary objective of the Directive 2004/108/EC and, now, the Directive 2014/30/EU, is “to regulate the compatibility of equipment regarding EMC”:

- equipment (apparatus and fixed installations) needs to comply with EMC requirements when it is placed on the market and/or taken into service
- the application of good engineering practice is required for fixed installations, with the possibility for the competent authorities of Member States to impose measures if non-compliance is established.

The EMC Directive first limits electromagnetic emissions of equipment in order to ensure that, when used as intended, such equipment does not disturb radio and telecommunication as well as other equipment. The Directive also governs the immunity of such equipment to interference and seeks to ensure that this equipment is not disturbed by radio emissions when used as intended.

## EUROPEAN COMMITTEE FOR STANDARDIZATION (CEN)

01/08/2014

### EN 12016:2013: EMC – Product Family Standard for Lifts, Escalators and Moving Walks – Immunity

This European Standard specifies the immunity performance criteria and test levels for apparatus used in lifts, escalators and moving walks which are intended to be permanently installed in buildings including the basic safety requirements in regard to their electromagnetic environment. These levels represent essential EMC requirements. The standard refers to EM conditions as existing in residential, office and industrial buildings. This standard addresses commonly known EMC related hazards and hazardous situations relevant to lifts, escalators and moving walks when they are used as intended and under the conditions foreseen by the lift installer or escalator and/or moving walk manufacturer.

However, performance criteria and test levels for apparatus/assembly of apparatus used in general function circuits do not cover situations with an extremely low probability of occurrence [and] this standard does not apply to other apparatus already proven to be in conformity to the EMC Directive, and not related to the safety of the lift, escalator or moving walk, such as lighting apparatus, communication apparatus, etc.

This European Standard does not apply to electromagnetic environments such as radio-transmitter stations, railways and metros, heavy industrial plants and electricity power stations, which need additional investigation.

This standard is not applicable to apparatuses that were manufactured before the date of its publication as EN 12016.

## ACCREDITED STANDARDS COMMITTEE ON ELECTROMAGNETIC COMPATIBILITY

12/18/2014

### C63.14-2014 – American National Standard Dictionary of Electromagnetic Compatibility (EMC) including Electromagnetic Environmental Effects (E3)

Description: Terms associated with electromagnetic compatibility (EMC) and electromagnetic environmental effects (E3) are defined including electromagnetic pulse (EMP) and electrostatic discharge (ESD) terms. Quantities, units, multiplying factors, symbols, and abbreviations are covered.



# Professional Societies

## IEEE ELECTROMAGNETIC COMPATIBILITY SOCIETY (S-27)

**IEEE Operations Center**  
**445 Hoes Lane, P.O. Box 6804**  
**Piscataway, NJ 08855-1331**  
**Phone: 732-981-0060**  
**Website: [www.emcs.org](http://www.emcs.org)**

The Institute of Electrical & Electronics Engineers (IEEE), the world's largest professional engineering society, is a global organization of individuals dedicated to improving the understanding of electrical and electronics engineering and its applications to the needs of society. The parent organization has over 360,000 members, approximately 70 percent of whom belong to technical groups such as the EMC Society.

The EMC Society, which enjoys a membership of over 5000, functions through a Board of Directors elected by the Society membership. The Board includes 20 members-at-large who serve staggered 3-year terms. The Executive Board consists of the President, President-Elect, Immediate Past President, Secretary, Treasurer, and five Vice Presidents, who oversee the activities of standing and technical committees. The officers are elected by the Board of Directors. The annual IEEE International Symposium on Electromagnetic Compatibility is sponsored by the Board of Directors, which also coordinates activities of standing technical and ad hoc committees.

EMC Society publications include Transactions on EMC, a quarterly journal which features state-of-the-art papers on interference technology and EMC, and the EMC Society Newsletter, a quarterly newsletter of society activities, industry developments, practical papers, and notices of meetings, regulations, and new publications.

The EMC Society also has a group of distinguished lecturers who are available to present talks to IEEE and other organizations. The society subsidizes the lecturers' expenses, and organizations are encouraged to contact the society for further details.

The IEEE Symposium on Electromagnetic Compatibility - US was held March 15-20, 2015 in Silicon Valley, Calif., USA. The IEEE Symposium on Electromagnetic Compatibility - Germany will be held in Dresden, Germany August 16-22, 2015. Visit the Symposium website at [www.emc2015.org](http://www.emc2015.org).

The EMC Society has published a number of standards. For information on EMC Society and other IEEE standards, contact the IEEE Operations Center.

## IEEE PRODUCT SAFETY ENGINEERING SOCIETY

While product safety had been addressed in various committees over the years, there was never a professional society or symposium solely devoted to product safety engineering as a discipline until recently. The IEEE Product Safety Engineering Society (PSES) began operation on 1 January 2004.

The field of interest of the Society is the theory, design, development and implementation of product safety engineering for electronic and electro-mechanical equipment and devices. This includes the theoretical study and practical application of analysis techniques, testing methodologies, conformity assessments, and hazard evaluations.

The society's mission is to strive for the advancement of the theory and practice of applied electrical and electronic engineering as applied to product safety and of the allied arts and sciences.

The society provides a focus for cooperative activities, both internal and external to IEEE, including the promotion and coordination of product safety engineering activities among IEEE entities. In addition, the Society will provide a forum for product safety engineering professionals and design engineers to discuss and disseminate technical information, to enhance personal product safety engineering skills, and to provide product safety engineering outreach to engineers, students

and others with an interest in the field. The Society is accepting members at any time during the calendar year, both full IEEE members and affiliate members. Membership is available at [www.ieee.org/services/join/](http://www.ieee.org/services/join/).

The IEEE Product Safety Engineering Society works closely with various IEEE Societies and Councils that also include product safety engineering as a technical specialty.

Every year, the PSES hosts a Symposium on Product Compliance Engineering. The next conference will be in Chicago, Illinois, USA on May 18-20, 2015. The Symposium will consist of Technical Sessions, Workshops, Tutorials and Demonstrations specifically targeted to the compliance engineering professional. Attendees will have the opportunity to discuss problems with vendors displaying the latest regulatory compliance products and services. For more information, visit [www.psessymposium.org](http://www.psessymposium.org). Past papers from the Symposia are available in IEEE Xplore or on CD (for a fee).

In addition to hosting an annual conference, the PSES provides the opportunity for product safety engineers to publish technical papers in a newsletter. See <http://www.ieee-pses.org/newsletters.html>.

**For further information visit [www.ieee-pses.org](http://www.ieee-pses.org).**

## dB SOCIETY

**22117 NE 10th Place**  
**Sammamish, WA 98074**  
**Fax: 425-868-0547**  
**Email: [j.n.oneil@ieee.org](mailto:j.n.oneil@ieee.org)**

This unique, interesting, and exclusive fraternity of EMC engineers was founded in 1975 by 10 eminent EMC engineers. The purpose of the dB Society is to open doors within the EMC community. Its primary objectives are to greet and to welcome new engineers, suppliers, vendors, and manufacturers to the EMC community and to assist them in establishing contacts in the EMC field.

The following membership requirements are unique and rigidly enforced:

- Ten years of service to the EMC community,
- Five years of service to a recognized professional, EMC organization,
- Sponsorship by two Duo-Decade members,
- Favorable recommendations by three other recognized individuals in the EMC community, and
- Acceptance by the Admissions Board.

Business meetings and informal, relaxed get-togethers take place during major EMC functions. A formal evening social function is the highlight of each year and is usually conducted during the IEEE EMC Symposium. All meetings are for members only.

U.S. membership is limited to 100 EMC engineers. There are society affiliates in the United Kingdom, India, and Israel.

## ESD ASSOCIATION

**ESD Association**  
**7900 Turin Road, Building 3**  
**Rome, NY 13440-2069**  
**Phone: 315-339-6937**  
**Fax: 315-339-6793**  
**Email: [info@esda.org](mailto:info@esda.org)**  
**Website: [www.esda.org](http://www.esda.org)**

Founded in 1982, the ESD Association is a professional voluntary association dedicated to advancing the theory and practice of electrostatic discharge (ESD) avoidance. From fewer than 100 members, the Association has grown to more than 2,000 members throughout the world. From an initial emphasis on the effects of ESD on electronic components, the association has broadened its horizons to include areas such as textiles, plastics, web processing, cleanrooms, and graphic arts. To meet the needs of a continually changing environment, the Association is chartered to expand ESD awareness through standards development, educational programs, local chapters, publications, tutorials, certification, and symposia.

EXHIBITION - CONFERENCES - ANIMATIONS

4th  
edition

# Microwave & RF

The Trade show  
of radiofrequencies,  
microwaves, wireless, EMC  
and optical fibre.

**April 1 & 2, 2015**

**CNIT  
Paris la Défense**

**[www.microwave-rf.com](http://www.microwave-rf.com)**

Organization





**ELECTROSTATIC DISCHARGE (ESD) TECHNOLOGY ROADMAP**

In the late 1970s, electrostatic discharge, or ESD, became a problem in the electronics industry. Low-level ESD events from people were causing device failures and yield losses. As the industry learned about this phenomenon, both device design improvements and process changes were made to make the devices more robust and processes more capable of handling these devices. With devices becoming more sensitive through the year 2010, it is imperative that companies begin to determine the ESD capabilities of their handling processes. The ESD Technology Roadmap can be downloaded at: [www.esda.org](http://www.esda.org)

**ANSI/ESD S20.20 CONTROL PROGRAM STANDARD AND CERTIFICATION**

A primary direction for the association is the continued implementation of a facility certification program in conjunction with ISO registrars. With the association's ESD control program standard, ANSI/ESD S20.20: Protection of Electrical and Electronic Parts, Assemblies and Equipment (Excluding Electrically Initiated Explosive Devices), the Association offers a means of independently assessing a company's ESD control program and of issuing a formal ANSI/ESD S20.20 certification.

The ANSI/ESD S20.20 standard covers the requirements necessary to design, establish, implement, and maintain an ESD control program to protect electrical or electronic parts, assemblies and equipment susceptible to ESD damage from Human Body Model (HBM) discharges greater than or equal to 100 volts. Developed in response to the Military Standardization Reform Act, ANSI/ESD S20.20 has been formally adopted for use by the U.S. Department of Defense.

**SYMPOSIA, TUTORIALS, AND PUBLICATIONS**

As part of its commitment to education and technology, the association holds the annual EOS/ESD Symposium, which places major emphasis on providing the knowledge and tools needed to meet the challenges of ESD. Scheduled for June 30-July 3, 2015, at the Conference Center, COEX in Seoul, KOREA, the annual Symposium attracts attendees and contributors from around the world. Technical sessions, workshops, authors' corners, seminars, tutorials, and technical exhibits provide a myriad of opportunities for attendees to expand their knowledge of ESD.

In addition to tutorials and seminars, the association offers a number of publications and reference materials for sale. These range from proceedings of past EOS/ESD Symposia to textbooks written by experts in the field of ESD.

**TECHAMERICA ELECTROMAGNETIC COMPATIBILITY COMMITTEE**

1401 Wilson Blvd., Suite 1100  
Arlington, VA 22209  
Phone: 703-284-5344  
Website: [www.geia.org](http://www.geia.org)

TechAmerica is the association that was created by the merger of AeA and ITAA. Earlier in 2008, ITAA and GEIA merged. The result of these mergers is an organization that is the leading voice for the U.S. technology industry, which is the driving force behind productivity growth and jobs creation in the United States. TechAmerica is the technology industry's only grassroots-to-global advocacy network. With nearly 1200 member companies, 20 regional councils and offices in Beijing and Brussels, the association represents the full spectrum of the technology industry.

TechAmerica is the technology industry's only grassroots-to-global advocacy network. The organization has expanded initiatives in areas such as information Assurance / Information Security, Identity Management, Cloud Computing, Global Sourcing / Globalization, Intelligence agencies, Department of Defense & NASA, and State & Local programs and public policy advocacy.

TechAmerica provides programs for business development, networking and market intelligence in the Federal arena, dealing with government entities such as Department of Defense, Homeland Security, Federal Communications Commission, Federal Trade Commission, Congress, as well as with state and local governments.

TechAmerica has a team of public policy professionals at state, federal and international levels that allow the organization to successfully influence legislative and regulatory issues that affect member companies.

In addition, TechAmerica offers an active standards development program to provide industry with proven solutions to business process challenges. The program is nationally and internationally recognized for its leadership and expertise in the development of standards. Configuration Management, Systems Engineering, Systems Safety, Earned Value Management, Logistics, Reliability and Electromagnetic Compatibility (EMC) area where TechAmerica is involved in standard.

The Electromagnetic Compatibility (EMC) Committee (formally known as G-46) deals with the system-oriented discipline that ensures electromagnetic compatibility in electronics design. The Committee develops technical criteria and procedures to guide the design engineer. Its work also includes spectrum management and conservation; secure communications; and electromagnetic emissions, susceptibility, control, and characterization.

The EMC Committee was established to provide an industry/user position on government specifications, regulations, and standards. Participation has expanded to include G-46 representation on the various committees drafting government specifications and standards. For example, G-46 participated on the working committees for MIL-STD-464A and MIL-STD-461E and provided update recommendations to MIL-STD-461F. The scope of G-46 activities has expanded to foster and facilitate the EMC discipline for the benefit of TechAmerica member companies.

Additional information on TechAmerica and the EMC Committee (G-46) can be obtained at (703) 284-5315, [phyllis.call@techamerica.org](mailto:phyllis.call@techamerica.org), or via the GEIA website at <http://www.geia.org>.

**SOCIETY OF AUTOMOTIVE ENGINEERS**

400 Commonwealth Drive  
Warrendale, PA 15096-0001  
Phone: 724-776-4841

SAE International is a professional society of engineers dedicated to a broad spectrum of engineering disciplines within the aerospace and automotive fields. Under the SAE Aerospace Council, technical standards committees address disciplines ranging from electrical power to multiplex signal characteristics — and from fiber optic data transmission to electromagnetic compatibility. The many elements of EMC are handled by SAE Committee AE-4, Electromagnetic Compatibility, which was organized in 1942 under the Aerospace Council. The committee is composed of technically qualified members, liaison members, and consultants — all of whom are responsible for writing standards on electromagnetic compatibility.

Committee AE-4 provides assistance to the technical community through standardization, improved design and testing methodology, and technical forums for the resolution of mutual problems. Engineering standards, specifications, and technical reports are developed by the Committee and are issued by the Society for industry and governments worldwide. Objectives of Committee AE-4 are to advance the state of technology, to stabilize existing technology, to obtain a uniformity of EMC requirements among government agencies, and to further the interests of the EMC technical community. The theme of "design before the fact" for EMC is a guiding concept. Special attention is given to maintenance of EMI control requirements consistent with the rapidly advancing state-of-the-art.

The following is a partial list of documents that have been issued to assist in implementing SAE objectives. For a complete list, visit the SAE website at [www.sae.org](http://www.sae.org) or call SAE Customer Service at 724-776-4841.

**AEROSPACE RECOMMENDED PRACTICES (ARPS)**

<b>ARP</b>	<b>935A</b>	Control Plan/Technical Construction File
<b>ARP</b>	<b>936A</b>	Capacitor, 10 mF for EMI Measurements
<b>ARP</b>	<b>958C</b>	Electromagnetic Interference Measurement Antennas, Standard Calibration Method
<b>ARP</b>	<b>958D</b>	Electromagnetic Interference Measurement Antennas, Standard Calibration Method
<b>ARP</b>	<b>1172</b>	Filters, Conventional, EMI Reduction, Specifications
<b>ARP</b>	<b>1173</b>	Test Methods for EMI Gasketing
<b>ARP</b>	<b>1267</b>	EMI Measurement of Impulse Generators, Standard Calibration Requirements and Techniques

- ARP 1481A** Corrosion Control and Electrical Conductivity in Enclosure Design
- ARP 1705** Coaxial Test Procedure to Measure the RF Shielding Characteristics of EMC Gasket Materials
- ARP 1870** Aerospace Systems Electrical Bonding and Grounding for Electromagnetic Compatibility and Safety
- ARP 1972** Recommended Practices and Procedures for EMC Testing
- ARP 4043A** Flightline Bonding and Grounding of Aircraft
- ARP 4242** Electromagnetic Compatibility Control Requirements, Systems
- ARP 4244** Recommended Insertion Loss Test Methods for EMI Power Line Filters
- ARP 5416A** Aircraft Lightning Test Methods

**AEROSPACE INFORMATION REPORTS (AIRS)**

- AIR 1147** EMI on Aircraft from Jet Engine Charging
- AIR 1209** Construction and Calibration of Parallel-Plate Transmission Lines for EMI Susceptibility Testing
- AIR 1221** EMC System Design Checklist
- AIR 1255** Spectrum Analyzers for EMI Measurements
- AIR 1394A** Cabling Guidelines for Electromagnetic Compatibility
- AIR 1404** DC Resistivity vs. RF Impedance of EMI Gaskets
- AIR 1423** EMC on Gas Turbine Engines for Aircraft Propulsion
- AIR 1425A** Methods of Achieving EMC of Gas Turbine Engine Accessories, for Self-Propelled Vehicles
- AIR 1499** Recommendations for Commercial EMC Susceptibility Requirements
- AIR 1662** Minimization of Electrostatic Hazards in Aircraft Fuel Systems
- AIR 1700A** Upper Frequency Measurement Boundary for Evaluation of Shielding Effectiveness in Cylindrical Systems
- AIR 4079** Procedure for Digitized Method of Spark Energy Measurement

**SAE AE-4 ELECTROMAGNETIC ENVIRONMENTAL EFFECTS (E3 OR EMC) COMMITTEE**

The SAE AE-4 E3 Committee provides a technical, coordinating, and advisory function in the field of E3. The focus is on problem areas in which committee expertise can be effectively applied at the national and international levels. Electrical and electronic accessories are studied for compatibility within systems and with various communications media. Engineering standards, specifications, and technical reports are developed and are issued for the general information of industry and government.

In the past, subcommittees have included AE-4R, Aircraft Radiated Environments, and AE-4H, High Power RF Simulators and Effects. AE-4 E3 holds national meetings in conjunction with the IEEE EMC Society Symposium, usually held in August at various locations. Additional information about meetings or more specific information on the activities of the committee can be obtained by contacting the world headquarters at 1-724-776-4841. Visit the SAE's Technical Standards Committee Forum website at <http://forums@sae.org>.

**iNARTE**

**Ste. 301, 600 N. Plankinton Ave.  
Milwaukee, WI 53201  
Phone: 888-722-2440  
Fax 414-765-8661  
Email: [service@inarte.us](mailto:service@inarte.us)  
Website: [www.inarte.org](http://www.inarte.org)**

iNARTE, Inc. (The International Association for Radio, and Telecommunications and Electromagnetics, Inc.) was founded as a non-profit membership/certification organization in 1982. With the advent of deregulation and the Federal Communications Commission's "encouragement/urging" private industry to establish certification standards to fill the licensing void, iNARTE initiated and developed a comprehensive certification program for telecommunications engineers and technicians.

In 1988, a Command of the United States Navy, seeking a credible and respected certification entity, selected iNARTE as the administrative agent for the certification of engineers and technicians in the field of electromagnetic compatibility (EMC).

**ACIL—THE AMERICAN COUNCIL OF INDEPENDENT LABORATORIES**

**1875 I Street, NW, Suite 500  
Washington, DC 20006  
Phone: 202-887-5872  
Fax: 202-887-0021  
Email: [Info@acil.org](mailto:Info@acil.org)  
Website: [www.acil.org](http://www.acil.org)**

The American Council of Independent Laboratories (ACIL) is the trade association representing independent, commercial engineering, and scientific laboratory, testing, consulting, product certifying and R&D firms; manufacturers' laboratories; related non-profit organizations; and consultants and suppliers to the industry. The organization was founded in 1937. All ACIL activities focus on its mission: to enhance members' success by providing advocacy, education, services, and mutual support and by promoting ethics, objectivity, independence, and free enterprise.

ACIL is a voluntary, non-profit membership organization. Programs are determined by members, administered by an elected Board of Directors, and supported by a professional staff operating from headquarters in Washington, D.C.

**ACIL'S CONFORMITY ASSESSMENT SECTION**

ACIL's Conformity Assessment Section consists of firms with wide and varied interests, all performing testing, listing, or labeling in accordance with applicable safety and performance standards, and/or materials testing and resolution of product and structural problems. Several committees have evolved within the Section to meet the needs of its diverse membership, including the EMC Committee, the U.S. Council of EMC Laboratories, and the Third-Party Product Certifiers Committee. In January 2005, the section sponsored a booth at the Consumer Electronics Show that advocated the advantages of independent third-party testing and the capabilities of ACIL member EMC laboratories.

**ACIL'S EMC COMMITTEE**

ACIL's EMC Committee was established in 1996 to address the common concerns of the ACIL EMC community. The Committee sponsors educational sessions at ACIL meetings that include both technical and policy issues such as mutual recognition agreements (MRAs). The Committee updates members on the latest developments, upcoming requirements, and activities in the field—both domestic and international.

In January 2002, ACIL published a 143-page document, Technical Criteria for the Accreditation of Electromagnetic Compatibility (EMC) and Radio Testing Laboratories, a checklist to assist both assessors and laboratories.

The Committee also formed the U.S. Council of EMC Laboratories (USCEL) in an effort to aid U.S. laboratories in addressing technical issues arising from the U.S./EU MRA and other global concerns. As the USCEL Secretariat, ACIL provides staff and supports volunteers active in this important area.

**U.S. PRODUCT CERTIFIERS**

Key U.S. product certifiers are ACIL members and are reaping many benefits, such as participation in the ACIL Third-Party Product Certifiers Committee (3P<sup>2</sup>C<sup>2</sup>). This Committee provides a forum for members to discuss and to act upon various issues of common interest. This committee formed the American Council for Electrical Safety to serve as a forum among testing laboratories, regulators, and electrical inspectors.



# Government Directory

The following is a list of the principal government personnel involved in EMC/EMI. This list is based upon best available data at the time of publication. Additions, deletions and corrections for any facility may be updated at any time by e-mailing your changes to [bstas@interferencetechnology.com](mailto:bstas@interferencetechnology.com).

## DEPARTMENT OF DEFENSE

### Defense Spectrum Organization

DSO Director: Stuart F. Timerman ..... 703-325-2567  
DSO Dep Dir: Mr. Ralph Puckett ..... 703-325-2874

### Strategic Planning Office (SPO)

SPO Director ..... 703-325-0435  
Internat'l Team Lead: Mr. Chris Hofer ..... 703-325-2876  
EST Team Lead: Ms. Mary Lin ..... 703-325-0136  
National Team Lead: Mr. Dan O'Neill ..... 703-325-2606

### Joint Spectrum Center (JSC)

2004 Turbot Landing, Annapolis, MD 21402-5064  
Tel: 410-293-4957, Fax: 410- 293-2631  
Commander, JSC (J00):  
COL John J. Hickey Jr., USA ..... 410- 293-2450  
Technical Director (J01):  
Mr. Mike Williams ..... 410- 293-2457  
Executive Officer (J02):  
CDR Robert "Jeff" Lamont, USN ..... 410- 293-2452

### Operations Division (J3)

Chief: LTC Kevin T. Laughlin ..... 410-293-9813  
Senior Engineer: Mr. Robert Lynch ..... 410-293-9816  
RD&A Division (J5):  
Mr. Robert Schneider ..... 410-293-4958  
Senior Engineer: Mr. Marcus Shellman ..... 410-293-4959  
Team Lead: Mr. Matthew Grenis ..... 410-293-9264  
R&D Team Lead: Mr. Serey Thai ..... 410-293-9263

### Spectrum Management Information Technology Division (J6)

Acting Chief: Mr. Joseph Whitworth ..... 410-293-9822  
Plans and Resources Division (J7):  
Chief: Mrs. Joanne F. Sykes ..... 410-293-2356  
Applied Engineering Division (J8):  
Chief: Aaron Leong, Lt Col, USAF ..... 410- 293-2682  
Senior Engineer: Mr. Irving Mager ..... 410- 293-2103  
Chief, DSRMA: Mr. Ted Grove ..... 410- 293-2222

### Joint Frequency Management and Spectrum Engineering Office, Atlantic (JFMO LANT)

Director JFMO LANT (USJFCOM/J63)  
1562 Mitscher Ave., Ste. 200  
Norfolk, VA 23551-2488  
Tel.: 757-836-8006 Fax: 757-836-8022

## UNITED STATES AIR FORCE

### Aeronautical Systems Center (ASC) ASC / ENAC

2145 Monahan Way  
Wright-Patterson Air Force Base, OH 45433-7101  
Fax: 937-255-5305  
E3 Technical Advisor  
Mr. Manny Rodriguez ..... 937-255-6957  
EMI/EMC Tech Expert  
Mr. Joseph M. DeBoy, ..... 937-255-6995  
EMI/EMC Engineer  
Mr. Brian M. Lezanic ..... 937-255-9051

### Aeronautical Systems Center (ASC) ASC / ENAC

2145 Monahan Way  
Wright-Patterson Air Force Base, OH 45433-7017  
Fax: 937-255-5305  
Electromagnetic Environmental Effects (E3) Engineer  
Mr. Jose Pabon Soto ..... 937-255-7676

### Aeronautical Systems Center (ASC) ASC / WKE

2590 Loop Rd. West  
Wright-Patterson Air Force base, OH 45433-7142  
Fax: 937-255-7749  
Electromagnetic Environmental Effects (E3) Engineer  
Ms. Natalia Bartholomew ..... 937-255-3451

### Air Force Research Laboratory, 711 Human Performance Wing

711 HPW/HP  
2510 Fifth Street, Bldg 840  
Wright-Patterson AFB, OH 45433  
Mr. Joseph Harrington ..... 937-938-3474  
Aeronautical Systems Center (ASC)  
312/326 AE SW (Fighter Bomber Wing)  
702 AE SG (B-2)  
2690 C St., B556  
Wright-Patterson AFB, OH 45433-7424  
Dr. Phil Beccue ..... 937-255-6881

### Aeronautical Systems Center (ASC)

312/326 AE SW (Fighter Bomber Wing)  
651 AE SS (B-52)  
2690 C St., B556  
Wright-Patterson AFB, OH 45433-7424  
FAX (937) 656-4621  
Mr. Jeremy Burns ..... (937) 255-7025

### HQ Air Force Material Command (AFMC) AFMC / EN P

Bldg. 262/Rm N145/Post116D  
Wright-Patterson AFB, Ohio 45433  
Fax: 937-656-4183  
Mr. John S. Welch ..... 937-255-0651

### Aeronautical Systems Center (ASC)

516 AE SW (Mobility)  
836 AE SG (Tankers)  
2530 Loop Road West,  
Wright-Patterson AFB, Ohio 45433  
Mr. Robert Rosengarten ..... (937) 255-3451

### Air Force Research Laboratory, Sensors Directorate AFRL/RVWD

2241 Avionics Circle  
Bldg 620, Rm 1D6106  
Wright-Patterson Air Force Base, OH 45433  
EMI Laboratory  
Fax: 937-656-9047  
Mr. Steven Coffman ..... 937-528-8673  
Mr. John Zentner ..... 937-528-8677

### Aeronautical Systems Center Reconnaissance Systems Wing

303 AE SG (Global Hawk)  
2640 Loop Road West  
Wright-Patterson Air Force Base, OH 45433-7106  
Mr. Dave Osborn ..... 937-255-7437

### Air Force Space Command (AFSPC)

85th Engineering Installation Squadron  
85 EIS/SCYM  
670 Maltby Hall Drive, Ste.234  
Keesler AFB, MS 39534-2633  
Specialized Engineering Flight:  
Mr. George R. McNeer, SCY ..... 228-377-1037  
Electromagnetics Section Chief:  
Mr. Frederick G. Blache, SCYM ..... 228-377-3926  
E3 Engineers:  
Mr. Randal Blanchard, SCYT ..... 228-377-1068  
Mr. William D. Boxx, II ..... 228-377-1078  
Mr. Edward Crum, SCYM ..... 228-377-1096  
Mr. Stephen L. Dabney ..... 228-377-1074  
Mr. Justin L. Johnston ..... 228-377-3041  
Mr. Carlton L. Jones ..... 228-377-1088  
Mr. James W Laycock ..... 288-377-1035  
Mr. Tom Lipski ..... 228-377-1084  
Mr. Alton J. Richards III ..... 228-377-1079  
Mr. Gregory P. Smith ..... 228- 377-1083  
Mr. Ronald E. Smith, III ..... 228-377-1278  
Mr. Phi D. Tran ..... 228- 377-1062  
Mr. Truong X. Vu ..... 228- 377-1866  
Mr. Brandon Walker ..... 228- 377-1048  
Sr. Electronics Engineer:  
Mr. Robert (Nick) Wilson ..... 228- 377-1047

**UNITED STATES ARMY**

**U. S. Army Research, Development and Engineering Command (RDECOM)**

Attn.: AMSRD-AAR-AEP-F  
 Bldg. 3208  
 Picatinny Arsenal, NJ 07806-5000  
 Fax: (73-724-3025)  
 Mr. Tom Crowley, Supvr. . . . . 973-724-5678  
 Mr. Daniel Gutierrez, Sr. Proj. Engr. . . . . 973-724-4667  
 Mr. Paul Lee, Proj. Engr. . . . . 973-724-4584

**Army Research, Development, and Engineering Command (RDECOM)**

Attn: RDMR-AES-E3  
 Building 4488  
 Redstone Arsenal, AL 35898-5000  
 Fax: 256-313-3194  
 E3 for Army Aircraft Airworthiness  
 E3 Branch Chief:  
 Mr. Dave Lewey . . . . . 256-313-8464  
 E3 Team Lead, Attack/Recon/Cargo Team:  
 Ms. Karen Compton . . . . . 256-313-8437  
 E3 Team Lead, Utility/Fixed Wing/SOA Team:  
 Mr. Duane Driver . . . . . 256-313-8447  
 Mr. Dale Heber . . . . . 256-313-2229  
 Mr. Bruce Hildebrandt . . . . . 256-313-8457

Mr. Elliot Croom . . . . . 256-842-5387  
 Mr. Abner Merriweather. . . . . 256-313-8470  
 Mr. Brian Smith,iNCE, iNCT . . . . . 256-313-8484  
 Mr. John Trp . . . . .  
 256-313-3148  
 Mr. Mike Dreyer . . . . . 256-313-6384  
 Mr. Dan Hinton . . . . . 256-313-8497  
 Mr. David Alan Landrith. . . . . 256-313-9102  
 Mr. Roy Lawson . . . . . 256-313-8454  
 Mr. Chris Myers . . . . . 256-842-3197  
 Mr. Thad Paone. . . . . 256-842-1387  
 Attn.: AMSAM-RD-MG-SD

**Army Test and Evaluation Command (ATEC)  
 United States Army Aberdeen Test Center (ATC) Electromagnetic Interference Test Facility (EMITF)**

Attn.: TEDT-AT-C4  
 400 Colleran Road, Building 456  
 Aberdeen Proving Ground, MD 21005-5059  
 Fax: 410-278-0579  
 EMITF Supervisor:  
 Mr. Michael C. Geiger . . . . . 410-278-2598  
 Senior Electrical Engineer:  
 Mr. Clinton Sienkiewicz . . . . . 410-306-1334  
 Electronic Technicians:

Mr. Duane Buono . . . . . 410-278-3005  
 Mr. Emmanuel Hammett. . . . . 410-278-3161  
 Mr. Mark Connor. . . . . 410-278-3189  
 JR Gildeleon . . . . . 410-278-3008  
 Mr. Todd Holman . . . . . 410-278-3022  
 Mr. Harry Giles . . . . . 410-278-3232  
 Mr. Nate Reyerson. . . . . 410-278-3176

**Army Center for Health Promotion & Preventive Medicine (CDR USACHPPM)**

Radiofrequency/Ultrasound Program  
 Attn.: MCHB-TS-ORF  
 5158 Blackhawk Road  
 Aberdeen Proving Ground, MD 21010-5403  
 Mr. John J. DeFrank. . . . . 410-436-3353

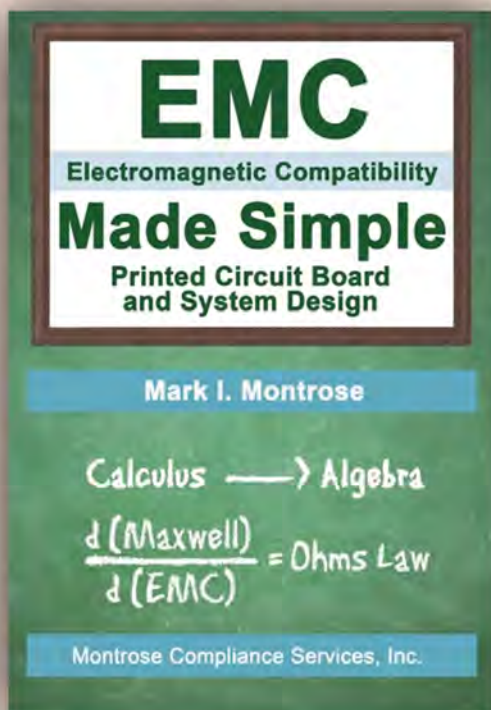
**Bureau of Medicine and Surgery (M3F72)**

2300 E. St., N.W.  
 Washington, DC 20372-5300  
 Fax: 202-762-0931

**Army Engineer Research and Development Center - Construction Engineering Research Laboratory**

Attn.: CEERD-CF-F  
 P.O. Box 9005  
 Champaign, IL 61826-9005  
 Dr. William J. Croisant. . . . . 217-373-3496

# A New Book by Mark Montrose



This book simplifies the complex field of electromagnetic compatibility into easy concepts without the need for complicated math or extensive computational analysis.

Learn how to design printed circuit boards and systems quickly with just five easy algebraic equations.

Electromagnetic compatibility requirements are easily achieved with the author's unique approach by transforming Maxwell's Equations (calculus) into Ohm's Law (algebra) in a visual, or conceptual manner.

Everyone, regardless of experience, will benefit from learning a new way of solving complex field problems using an oscilloscope instead of a spectrum analyzer based on simplified transmission line theory.

**Available from Amazon and major retailers  
[www.montrosecompliance.com](http://www.montrosecompliance.com)**



**Army Electronic Proving Ground Test Engineering Directorate**

Laboratory Division  
 Attn.: TEDT-EP-TEL  
 Fort Huachuca, AZ 85613-7110  
 Div. Chief Mr. Rafael Anton ..... 520-538-4916

**E3 Test Facility/Blacktail Canyon**

Mr. James Smith ..... 520-538-5188  
 Ms. Rachel Blake ..... 520-538-2818  
 Mr. David Seitz ..... 520-533-5819

**Antenna Test Facility**

Technical Lead: Mr. Doug Kremer ..... 520-533-8170

**Army Intelligence and Security Command G-4, Technical Support Division**

Attn.: IALO-T  
 8825 Beulah St.  
 Ft. Belvoir, VA 22060-5246  
 Tel.: 703-428-4479 (DSN: 328-4479)  
 Fax: 703-428-4911 (DSN: 328-4911)  
 Ms. Anne Bilgihan

**Army Nuclear and Chemical Agency (USANCA)**

7150 Heller Loop, Ste. 101  
 Springfield, VA 22150-3198  
 Mr. R. Pfeffer ..... 703-806-7862

**Army Research Laboratory (ARL)**

Survivability/Lethality Analysis Directorate (SLAD)  
 Bldg 1628, AMSRD-ARL-SL-ES WSMR, NM 88002  
 575-678-7650

**White Sands Test Center  
Survivability, Vulnerability and Assessment Directorate**

21225 Headquarters Avenue  
 WSMR, NM 88002  
 Fax: 575-678-2480  
 Chief, EMR Branch: Ms. Stephanie Jesson . . . 575-678-6107  
 Ms. Janet Danneman ..... 575-678-6307  
 Mr. Gustavo Sierra ..... 575-678-2038  
 Mr. John Chavarria ..... 575-678-1993

**Army Test and Evaluation Command (ATEC United States Army Electronic Proving Ground (EPG) Enterprise Test Services Directorate Electromagnetic Environmental Effects/TEMPEST and Antenna Division**

ATTN: TEDT-EP-SEA  
 2000 Arizona Street  
 Fort Huachuca, AZ 85613-7063  
 E3/TEMPEST  
 Test Officers  
 Mr. James A. Smith ..... 520-538-5188  
 Mr. Thomas Q. Markham ..... 520-538-1802  
 Mr. Fulton K. Woo ..... 520-533-8266  
 Mr. David L. Seitz ..... 520-533-7529  
 Mr. Garrett V. Rude ..... 520-538-5623

Antenna Technical Lead  
 Mr. Douglas P. Kremer ..... 520-533-8170  
 Test Officer  
 Mr. Anthony C. Sanchez ..... 520-533-9874  
 Ms. Rachel M. Blake ..... 520-538-0726

**UNITED STATES MARINE CORPS****Marine Corps Operational Test and Evaluation Activity (MCOTEA)**

3035 Barnett Ave., Quantico, VA 22134, Chief of Test (703)  
 432-0927, Marine Corps Systems Command (MCSC),  
 Attn.: Mr. Praful Bharucha (C4II/ACENG), 2000 Lester  
 Street, Quantico, VA 22134-5010  
 E3 Control Program Sponsor  
 Mr. Praful Bharucha ..... 703-432-3806

**UNITED STATES NAVY****MID-LANT Area Frequency Coordination Office; Naval Air Warfare Center Aircraft Division**

Code 5.2.2.2  
 23013 Cedar Point Road, Unit 4, Building 2118  
 Patuxent River, MD 20670-1183  
 Fax: 301-342-1200

**Naval Air Warfare Center Aircraft Division**

Electromagnetic Compatibility Branch, 5.4.4.5  
 Patuxent River, MD, Fax: 301-342-6982

**Naval Air Warfare Center Training Systems Division (NAWCTSD)**

Code 6.7.2.3  
 12350 Research Parkway, Orlando, FL 32826-3275

**Space and Naval Warfare Systems Center, Charleston (SPAWAR SYSCEN, Charleston)**

P.O. Box 190022  
 North Charleston, SC 29419-9022  
 Fax: 843-218-4238

**Electromagnetic Environmental Effects (E3) Branch, Code 5610**

Branch Hd.: Mr. Wayne Lutzen ..... 843-218-5723  
 E3 Engineers  
 Reco Baker ..... 843-218-3988  
 Mr. Frederic Duffy ..... 843-218-4363  
 Mr. Michael Hanna ..... 843-218-4039  
 Mr. Guillermo Leiva ..... 843-218-7129  
 Mr. Thomas Sessions ..... 843-218-6331

**Space and Naval Warfare Systems Center Pacific, Pacific C4ISR Department**

(SSC PAC, PAC C4ISR DEPT)  
 2293 Victor Wharf Access Road, Pearl City, HI 96782-3356  
 Fax: (808) 474-5511  
 Ms. Candice Saka ..... 808-471-4028  
 Mr. Jack Munechika ..... 808-471-1976  
 Mr. Randy Yamada ..... 808-474-6061  
 Mr. Lloyd Hayashida ..... 808-474-1967  
 Mr. Laine Murakami ..... 808-471-0366

**SPAWAR Systems Center - Pacific (SSC-Pacific)**

53560 Hull St., San Diego, CA 92152-5001  
 Fax: 619-553-3791

**Applied Electromagnetics Branch, Code 5541**

Branch Hd.: Dr. John Meloling ..... 619-553-2134  
 Mr. Jeffrey C. Allen ..... 619-553-6566  
 Ms. Carol Becker ..... 619-553-1033  
 Mr. David C. Dawson ..... 619-553-4075  
 Mr. Lance Koyama ..... 619-553-3784  
 Mr. Ahn Lee ..... 619-553-3426  
 Mr. P. Michael McGinnis ..... 619-553-5092  
 Ms. Nazia Mozaffar ..... 619-553-2593  
 Mr. Rick Nielsen ..... 619-553-6015  
 Ms. Jeanne Rockway ..... 619-553-3886  
 Mr. Kianoush Rouzbehani ..... 619-553-3134  
 Raquel Sanchez-Karem ..... 619-553-5876  
 Ricardo Santoyo-Mejia ..... 619-553-6139  
 Anirudha Siripuram ..... 619-553-8749  
 Ron Thompson ..... 619-553-0457

**Electromagnetics Technology Branch, Code 5542**

Branch Head: Matt Osburn ..... 619-553-5941  
 Dr. Rich Adams ..... 619-553-4313  
 Mr. Jim Birkett ..... 619-553-3586  
 Mr. Jose L. Chavez ..... 619-553-5075  
 Dr. Will Cronyn ..... 619-553-5084  
 Mr. Chris Dilay ..... 619-553-3794  
 Mr. Vincent V. Dinh ..... 619-553-7255  
 Ms. Silvia Goodman, Secretary ..... 619-226-5953  
 Mr. David Hilton ..... 619-553-2666  
 Mr. Carl P. Kugel ..... 619-553-3066  
 Ms. Wendy Massey ..... 619-553-9711  
 Mr. Daniel Meeks ..... 619-553-6753  
 Dr. John D. Rockway ..... 619-553-5438  
 Mr. Alberto Rodriguez ..... 619-553-5697

**Advanced Electromagnetic Technology Branch, Code 5546**

Branch Hd.: Jodi McGee ..... 619-553-3778  
 Diana Arceo ..... 619-553-6344  
 Lam T. Bui ..... 619-553-6038  
 Jennifer Edwards ..... 619-553-5428  
 Daniel R. Gaytan ..... 619-553-7461  
 John L. Hunter ..... 619-553-5086  
 Lillie Jackson, Secretary ..... 619-553-5076  
 Dr. Burt Markham ..... 619-553-6082  
 Mr. Marcus Maurer ..... 619-553-3797  
 Mr. Aldo Monges ..... 619-553-6129  
 Mr. Filemon Peralta ..... 619-553-3043  
 Mr. Hoa Phan ..... 619-553-0148  
 Mr. Randall Reeves ..... 619-553-1032  
 Mr. Anthony Ton ..... 619-553-5428  
 Mr. Daryl W. Von Mueller ..... 619-553-6527  
 Mr. Benton Wong ..... 619-553-3043  
 Chief of Naval Operations  
 Code NC-1, PT-5451, N6F13  
 2000-Navy Pentagon, Washington, DC 20350-2000  
 Fax: (703) 601-1323  
 Spectrum Electromagnetic Environmental Effects (E3) & EMP Policy & Programs

# emv



International Exhibition with Workshops  
on Electromagnetic Compatibility (EMC)  
Stuttgart, Germany, 24 – 26 March 2015

Take the chance to step into the European market!  
Save the date and come to Germany to be part of  
Europe's marketplace for electromagnetic compatibility.

Further information:  
web: [e-emc.com](http://e-emc.com)  
phone: +49 711 61946 63  
email: [emv@mesago.com](mailto:emv@mesago.com)

**mesago**  
Messe Frankfurt Group



Head: Mr. Dave D. Harris . . . . . (703) 601-3968  
 Naval Ordnance Safety and Security Activity (NOSSA)  
 NAVORDSAFSECACT INDIAN HEAD  
 Electrical Explosives Safety  
 Code N84  
 Farragut Hall, Bldg. D323, 23 Strauss Ave.  
 Indian Head, MD 20640-5035, Fax: 301-744-6088  
 Weapons Assessment (N8)  
 Director: Charles Denham . . . . . 301-744-4447

### Naval Research Laboratory

Code 5348  
 4555 Overlook Ave., S.W., Washington, D.C. 20375-5320  
 Tel.: 202-404-7726, Mr. Larry Cohen  
 Naval SeaSystems Command (NAVSEA)

### Force Electromagnetic Environmental Effects (E3) and Spectrum Management Warfare Systems

Engineering Directorate (SEA 06)  
 1333 Isaac Hull Ave., S.E., Stop 5011, Washington Navy  
 Yard, DC 20376-5011, Fax: (202) 781-4568

### Force E3 and Spectrum Management Branch

Branch Head: Mr. J. Don Pierce . . . . . 202-781-4214

### Naval Surface Warfare Center, Crane Division (NSWC Crane)

Code GX5  
 300 Highway 361, Bldg. 3287E, Crane, IN 47522  
 Fax: 812-854-3589  
 Mr. Larry McKibben . . . . . 812-854-5107

### Naval Surface Warfare Center, Dahlgren Division (NSWC Dahlgren)

5493 Marple Road, Suite 156, Dahlgren, VA 22448-5153

### Electromagnetic Effects Division, Code Q50

Electromagnetic Effects Division  
 Chief Engineer:  
 Mr. Jason Bardine . . . . . 540-653-7450  
 NAVSEA E3 Technical Warrant Holder:  
 Mr. Kurt Mikoleit . . . . . 540-653-3425

### E3 Spectrum Supportability Branch, Code Q51

Branch Head:  
 Mr. Mike Workman . . . . . 540-653-4646

### E3 Spectrum Supportability Branch, Code Q51

Operations and Spectrum Support Group Lead:  
 Mr. Mark Flenner . . . . . 540-653-7892

### E3 Spectrum Supportability Branch, Code Q51

Spectrum Engineering Group Lead:  
 Ms. Margaret Neel . . . . . 540-653-8021

### E3 Spectrum Supportability Branch, Code Q51

Electromagnetic Pulse Group Lead:  
 Mr. Blaise Corbett . . . . . 540-653-2104

### E3 Assessment & Evaluation Branch (Q52)

Branch Head:  
 Mr. William T. Lenzi . . . . . 540-653-3444

### E3 Assessment & Evaluation Branch (Q52)

EMC/EMV Evaluation Group Lead:  
 Mr. James McGinniss . . . . . 540-653-0489

### E3 Assessment & Evaluation Branch (Q52)

RADHAZ Program Manager:  
 Mr. Richard Magrogan . . . . . 540-653-3445

### E3 Assessment & Evaluation Branch (Q52)

Weapons System E3 Group Lead:  
 Mr. Michael Miller . . . . . 540-653-3460

### E3 Assessment & Evaluation Branch (Q52)

EMI/461 Lab Group Lead:  
 Mr. Carl Hager . . . . . 540-653-9501

### E3 Assessment & Evaluation Branch (Q52)

Test Operations Group Lead:  
 Mr. Matthew Curtis . . . . . 540-653-3439

### E3 Assessment & Evaluation Branch (Q52)

Chief Engineer:  
 Mr. Michael Slocum . . . . . 540-653-2212

### E3 Assessment & Evaluation Branch (Q52)

RADHAZ Environment Characterization Group Lead:  
 Ms. Tamera Hay . . . . . 540-653-1419

### E3 Assessment & Evaluation Branch (Q52)

Surface Maritime Sensors Group Lead:  
 Mr. Michael Workman . . . . . 540-653-4646

### E3 Platform Integration Branch (Q53)

Branch Head:  
 Mr. Kenneth D. Larsen . . . . . 540-653-3476

### E3 Platform Integration Branch (Q53)

Senior Scientist:  
 Dr. Greg Balchin . . . . . 540-653-6037

### E3 Platform Integration Branch (Q53)

MAAC Group Lead:  
 Mr. Greg Brobjorg . . . . . 540-653-7075

### E3 Platform Integration Branch (Q53)

Combatant Group Lead:  
 Mr. Reza Biazaran . . . . . 540-284-0595

### E3 Platform Integration Branch (Q53)

CVN Group Lead:  
 Mr. Tim Baseler . . . . . 540-653-0741

### E3 Platform Integration Branch (Q53)

Computational Electromagnetics Group Lead:  
 Mr. Bryan Wagaman . . . . . 540-653-3430

### E3 Systems Interoperability Branch, Code Q54

Branch Head:  
 Mr. Rich Link . . . . . 540-653-8907

### E3 Systems Interoperability Branch, Code Q54

Shipboard EMC Improvement Program Lead:  
 Mr. Mark Hamer . . . . . 540-284-0711

### E3 Systems Interoperability Branch, Code Q54

Force E3 Interoperability Group Lead:  
 Mr. John "Bart" Barbee . . . . . 540-653-3483

### E3 Systems Interoperability Branch, Code Q54

Communication Systems E3 Interoperability Group Lead:  
 Mr. Cris Lake . . . . . 540-653-5087

### E3 Systems Interoperability Branch, Code Q54

Radar Systems E3 Interoperability Group Lead:  
 Mr. Al Pitts . . . . . 540-653-6268

### E3 Systems Interoperability Branch, Code Q54

Electronic Warfare Systems E3 Interoperability Group  
 Lead:  
 Mr. Brad Conner . . . . . 540-653-0610

### Naval Undersea Warfare Center (NUWC)

1176 Howell St.  
 Newport, RI 02841-1708  
 Submarine Electromagnetic Environmental Effects (E3)  
 Branch, Code 3431  
 Branch Head, 401-832-5542  
 Branch Head: Mr. Craig F. Derewiany . . . . . 401-832-5542  
 Mr. Scott Albert . . . . . 401-832-4122  
 Mr. Jon Bond . . . . . 401-832-6480  
 Mr. Michael J. Carpenter . . . . . 401-832-5540  
 Mr. Douglas L. DeAngelis . . . . . 401-832-5872  
 Mr. Jamie A. Donais . . . . . 401-832-3603  
 Mr. Anthony Francis . . . . . 401-832-5493  
 Mr. Edward R. Javor . . . . . 401-832-5546  
 Mr. Alan T. McHale . . . . . 401-832-5635  
 Mr. Michael P. Martin . . . . . 401-832-5630  
 Mr. Paul D. Opperman . . . . . 401-832-4092  
 Mr. Fredric A. Stawarz . . . . . 401-832-5550  
 Mr. John L. Thibeault . . . . . 401-832-5551  
 Mr. Richard L. Thibeault . . . . . 401-832-5552  
 Mr. Oleg Volchansky . . . . . 401-832-5399  
 Mr. Oscar R. Zelaya . . . . . 401-832-5597  
 EMC Laboratory . . . . . 401-832-5554  
 OPNAV N2N6F1221

### Spectrum Management and Electromagnetic Environmental Effects Office Net-Centric Capabilities/Strategic and Tactical Communications Branch Information Dominance Directorate

2511 Jefferson Davis Highway, Arlington, VA 22244-0001,  
 Tel: 703-601-1414; Fax: 703-601-1323  
 Director: Mr. D. Mark Johnson . . . . . 703-601-1414

### OTHER UNITED STATES AGENCIES

### Dept. of Health & Human Services - Food and Drug Administration

Center for Devices and Radiological Health  
 12725 Twinbrook Pkwy. (HFZ 133), Rockville, MD 20852  
 Tel.: 301-827-4944  
 Electrophysics Branch, Div. Physical Sciences  
 Mr. Howard I. Bassen, Chief  
 Mr. Paul S. Ruggera  
 Mr. Donald Witters

**U.S. Environmental Protection Agency (EPA)**

Office of Radiation and Indoor Air (ORIA)  
 Radiation Protection Division (6608J)  
 1200 Pennsylvania Ave., N.W., Washington, DC 20460  
 Fax: 202-343-3204  
 Director: Mr. Jonathan Edwards ..... 202-343-9437  
 Mr. Norbert Hankin ..... 202-343-9235

**Federal Aviation Administration  
 Headquarters- ATC Spectrum Engineering  
 Services, AJW-6**

800 Independence Avenue, S.W.  
 Washington, DC 20591  
 Spectrum Assignment & Engineering Office, AJW-1C2  
 Manager: Mr. Timothy Pawlowitz ..... 202-267-9720  
 Spectrum Planning & International Office, AJW-1C3  
 Manager: Mr. Robert A. Frazier ..... 202-267-9722

**Federal Aviation Administration  
 FAA Aviation Safety (AMN-110N)**

1601 Lind Ave. S.W., Renton, WA 98057  
 Fax: 425-917-6590  
 Chief Scientific & Technical Advisor - Aircraft EMC:  
 Mr. David Walen ..... 425-917-6586

**Federal Communications Commission**

445 12th Street, SW, Washington, DC 20554, Office of  
 Engineering & Technology, Tel.: 202-418-2470  
 Chief: Julius P. Knapp  
 Deputy Chiefs.: Mr. Ira Keltz, Ronald Repasi, Alan Stillwell;  
 Associate Chief: Bruce Romano

**Policy & Rules Division**

Tel.: 202-418-2472  
 Chief: Geraldine Matise  
 Deputy Chief: Mark Settle

**Spectrum Policy Branch**

Chief: Mr. Jamison Prime  
 Technical Rules Branch  
 Chief: Ms. Karen Ansari

**Spectrum Coordination Branch**

Chief: John Kennedy

**Electromagnetic Compatibility Division**

Tel: 202-418-2475  
 Chief: Walter Johnston  
 Technical Analysis Branch  
 Chief: Mr. Robert Weller

**Experimental Licensing Branch**

Chief: Mr. James Burtle

**Federal Communications Commission  
 Laboratory**

7435 Oakland Mills Rd., Columbia, MD 21046  
 FCC Laboratory Division  
 Dr. Rashmi Doshi, Chief ..... 301-362-3011  
 Mr. Jim Szeliga ..... 301-362-3051  
 Mrs. Pat Wright ..... 301-362-3001

**Equipment Authorization Branch**

Mr. Joe Dichosco, Chief. .... 301-362-3024  
 Ms. Evelyn Cherry ..... 301-362-3022  
 Mr. Steve Dayhoff ..... 301-362-3027  
 Mr. Tim Harrington ..... 301-362-3039  
 Mr. Andrew Leimer ..... 301-362-3049  
 Mr. Stanley Lyles ..... 301-362-3047  
 Ms. Diane Poole ..... 301-362-3034

**Audits and Compliance Branch**

Mr. Raymond Laforge, Chief. .... 301-362-3041  
 Mr. David Galosky ..... 301-362-3290  
 Ms. Katie Hawkins ..... 301-362-3030  
 Ms. Phyllis Parrish ..... 301-362-3045  
 Mr. Martin Perrine ..... 301-362-3025  
 Mr. Richard Tseng ..... 301-362-3054  
 Mr. Samuel Uganzenwoko ..... 301-362-3033

**Technical Research Branch**

Mr. William Hurst, Chief ..... 301-362-3031  
 Mr. Kwok Chan ..... 301-362-3055  
 Mr. James Drasher ..... 301-362-3047  
 Mr. Steve Jones ..... 301-362-3056  
 Mr. Steve Martin ..... 301-362-3052  
 Mr. Tom Phillips ..... 301-362-3044  
 Mr. George Tannahill ..... 301-362-3026

**Customer Service Branch**

Mrs. Sandy Haase, Chief. .... 301-362-3013  
 Ms. Bessie Bordenave ..... 301-362-3046  
 Ms. Linda Elliott ..... 301-362-3032  
 Mr. Tim Jamerson ..... 301-362-3014  
 Mr. Ken Reitzel ..... 301-362-3015  
 Ms. Bette Taube ..... 301-362-3028  
 Mrs. Joycelyn Walls ..... 301-362-3017

**Goddard Space Flight Center**

Greenbelt, MD 20771  
 Code 565 Electrical Systems Branch  
 Code 549.0, Electromagnetic Systems Engineering  
 Mr. Todd Bonalsky, PhD, lead engineer. .... 301-286-1008

**National Aeronautics and Space  
 Administration - Kennedy Space Center**

Kennedy Space Center, FL 32899  
 EMC Engineers  
 Team Lead: Ms. Dawn Trout (VA-F3), ..... 321-867-5366  
 Mr. Ron Brewer (Analex) ..... 321-867-5329  
 Ms. Janessa Burford (VA-H3) ..... 321-867-5333  
 Mr. Tung Doan ..... 321-867-5330  
 Mr. Paul Edwards ..... 321-867-8927  
 Mr. Gabriel Vazquez Ramos, (VAH3) ..... 321-867-3374  
 Mr. Noel Sargent (Analex) ..... 216-433-3395  
 Mr. James Stanley ..... 321-867-1991  
 Mr. Jarek Tracz ..... 321-867-2780  
 EMC Test Engineer Manager:  
 Pete Aragona (NEE10) ..... 321-867-1027

**National Aeronautics and Space  
 Administration - Langley Research Center**

5 North Dryden St., Bldg. 1202, Hampton, VA 23665  
 Fax: 757-864-9884

**EMC Test Facility (MS 130)**

Ms. Courtney Rollins ..... 757-864-7814

**HIRF Laboratory (MS 130)**

Mr. Jay J. Ely ..... 757-864-1868  
 Mr. Truong X. Nguyen ..... 757-864-7528

**EMI/EMC Analysis and Troubleshooting (MS 488)**

Dr. Arthur T. Bradley ..... 757-864-7343

**National Aeronautics and Space  
 Administration - John H. Glenn Research  
 Center**

21000 Brookpark Road, Cleveland, OH 44135

**National Aeronautics and Space  
 Administration - Lyndon B. Johnson  
 Space Center**

2101 NASA Parkway, Houston, TX 77058-3696

**Electronic Design & Manufacturing Branch**

Branch Chf: Ms. Darilyn Peddie ..... 281-483-8279  
 Deputy Branch Chf: Ms. Denise Romero ..... 281-483-8056  
 E3 Group Lead: Dr. Robert Scully ..... 281-483-1499  
 EMC Test Facility Lab Mgr: Mr. Rick Deppisch 281-483-0475

**National Aeronautics and Space  
 Administration - George C. Marshall Space  
 Flight Center**

Marshall Space Flight Center, AL 35812  
 Spectrum Manager: Terry Luttrell ..... 256-544-0130  
 EMC Engineers (M/S ES42/4708)  
 Branch Chief: Mr. Jeff Wesley ..... 256-544-3393  
 Mr. Tony Clark ..... 256-544-2394  
 Mr. Michael Crane (ERC) ..... 256-544-7259  
 Mr. Ross Evans (Dynetics) ..... 256-961-2305  
 Ms. Tammy Flowers ..... 256-961-0508  
 Mr. Truman Glasscock (Triumph) ..... 256-544-5318  
 Mr. Kenneth Gonzalez (Qualis) ..... 256-544-1658  
 Mr. Steve R Jones ..... 256-544-4373  
 Mr. Mark Krome ..... 256-544-5635  
 Mr. Steve Linthicum (Dynetics) ..... 256-544-5312  
 Mr. Jonathan Mack ..... 256-544-3599  
 Mr. Matthew McCollum ..... 256-544-2351  
 Mr. Matthew McGrath (Dynetics) ..... 256-544-3051  
 Mr. Tom Perry (Jacobs) ..... 256-544-0744  
 EMI Test Facility ..... 256-544-8121

**National Institute of Standards  
 and Technology**

**RF Technology, 672, Boulder, CO 80305**

Div. Chief: Dr. Michael H. Kelley ..... 303-497-4736  
 Secretary: Ms. Mary Filla ..... (303) 497-3132

**RF Fields Group**

Group Leader: Dr. Perry F. Wilson ..... 303-497-3406  
 Secretary: Chris Carson ..... 303-497-3321



**Antenna Parameters**

Mr. Jeffrey Guerrieri ..... 303-497-3863

**Wireless Systems**

Dr. Kate Remley ..... 303-497-3652

**Field Parameters and EMC Applications**

Galen Koepke ..... 303-497-5766

**Quantum Measurement Division, 684**

Gaithersburg, MD 20899

Div. Chief: Dr. Carl Williams ..... 301-975-3531

**National Telecommunications and Information Administration (NTIA)**

U.S. Department of Commerce

1401 Constitution Ave., N.W., Washington, DC 20230

202-482-1850

Emergency Planning Subcommittee Chairman

Chief: Mr. Stephen R. Veadar ..... 202-482-4417

Spectrum Planning Subcommittee Chairman

Chief: Mr. Stephen Butcher ..... 202-482-4163

**Institute for Telecommunications Sciences (ITS)**

325 Broadway, Boulder, CO 80305-3328

Exec. Officer: Mr. Brian Lane ..... 303-497-3484

Director: Mr. Al Vincent ..... 303-497-3500

**Spectrum & Propagation Measurements Division**

Mr. Eric D. Nelson ..... 303-497-7410

**Telecommunications Engineering, Analysis & Modeling Division**

Ms. Patricia Raush ..... 303-497-3568

**Telecommunications Theory Division**

Mr. Frank Sanders ..... 303-497-7600

**TEMPEST CONTACTS****Army Electronic Proving Ground Enterprise Test Services Directorate**

Mr. Alan Morris, Director

Attn.: TEDT-EP-SE

2000 Arizona Street, Fort Huachuca, AZ 85613-7110

520-533-8275

**Electromagnetic Environmental Effects/ TEMPEST & Antenna Division**

Attn.: TEDT-EP-SEA

2000 Arizona Street, Fort Huachuca, AZ 85613-7110

E3 Test Facility/Blacktail Canyon

Mr. James A. Smith ..... 520-538-5188

Mr. David Seitz ..... 520-533-5819

Mr. Garrett Rude ..... 520-533-9874

Mr. Fulton Woo ..... 520-533-5819

**Antenna Test Facility**

Technical Lead: Mr. Doug Kremer ..... 520-533-8170

Mr. Anthony Sanchez ..... 520-533-9874

Mr. Jeremy Wendte ..... 520-538-2457

**BELGIUM****Belgian Naval Headquarters**

Project Office, Kwartier Koningin Elisabeth

1 Everestraat, 1140 Brussels, Belgium

Tel.: +32-2-7013334, Fax: +32-2-7014786

**CANADA****Aerospace Engineering Test Establishment (DND)**

PO Box 6550, Cold Lake, AB T9M 2C6, Canada

Tel.: 780-840-8000

Mr. Serge Couture ext. 7511

**DENMARK****Naval Materiel Command Denmark**

Danneskiold-Sasoees Alle 1 Copenhagen K 1434 Denmark

Tel.: +45-32-663266

FAX: +45-32-663299

<http://smk.svn.dk>**GERMANY****Bundesministerium der Verteidigung**

Arbeitsbereich 2

Stauffenbergstr. 18

10785 Berlin

Tel: +49 (0) 18 88 -242424

Fax: 49 (0) 18 88-248520

**Wehrtechnische Dienststelle für Fernmeldewesen und Elektronik (WTD 81)**

Center of Competence EMC

91171 Greding

Germany

Tel: +49-8463-652-0

Fax: +49-8463-652-607

[www.bwb.org/wtd81](http://www.bwb.org/wtd81)**GREECE****Ministry of National Defence**

Hellenic Navy Research

229 Messogion Ave.

Cholargos, Athens 15561

Greece

Tel.: +30-210-6598100-200

**ITALY****Ministry of Defense**

Centro Interforze Studi per le Applicazioni Militari (CISAM)

Via della Bigattiera 10, San Piero a Grado, 56122 San Piero a Grado (Pisa), Italy

Fax: +39 050-961001

Director:

Amm. Isp. Giordano Cottini ..... +39 050-964200

**MARITELERADAR - Istituto per le Telecomunicazioni e l'Electronica della Marina Militare**

"Giancarlo Vallauri", Viale Italia, 72-57126 Livorno, Italy

EMC Dept.

Ric. Ing. Giancarlo Misuri ..... +00-39-0586-238208

EMC Section/Laboratory

Cdr. Roberto Desideri ..... +00-39-0586-238153

C.T.E.R. Salvatore Trovato ..... +00-39-0586-238153

**NETHERLANDS****Royal Netherlands Navy**

Division Special Product/Consultancy

P.O. Box 20701

2500 ES The Hague

The Netherlands

Tel.: +31-223-656124

Fax: +31-223-656467

**Ministry of Defense - Directorate of Materials RNI Navy, Department of Naval Architecture & Marine Engineering**

P.O. Box 20702

2500 ES The Hague

The Netherlands

Tel.: +31 70 3162335

Fax: +31 70 3163131

**UNITED KINGDOM****Defence Science & Technology Laboratory**

Headquarters

Porton Down

Salisbury, Wiltshire

SP4 0JQ

Tel.: +44 (0) 1980 613000

**NEED MORE INFO?**

Visit our EMC military channel at [www.interferencetechnology.com](http://www.interferencetechnology.com) for more information.



# EMC 2015

DRESDEN, AUGUST 16-22



*"Where Baroque  
meets High-Tech..."*

## EMC 2015: Joint IEEE International Symposium on Electromagnetic Compatibility and EMC Europe

The Joint IEEE International Symposium on Electromagnetic Compatibility and EMC Europe will be held from 16 to 22 August 2015 in Dresden, Germany. With an outstanding technical program, an accompanying technology and innovation exhibition and expected 1,500 participants from the global EMC community, EMC 2015 is the most important international event for Electromagnetic Compatibility this year.

### TECHNICAL PROGRAM

- **Technical Papers:** Over 400 papers were submitted!
- **Workshops and Tutorials:** Twenty-seven half-day workshops and tutorials will be scheduled from Monday to Friday of the symposium week.
- **Special Sessions:** Will address the emerging technologies of Smart Grid EMC, Wireless EMC and Automotive EMC.
- **Global University:** Professor Flavio Canavero will chair the highly rated Clayton R. Paul Global EMC University.



The EMC Symposium provides decision-makers and experts from industry and academia an excellent platform for information, communication and presentation. In particular, professionals from the electromagnetic (EM) industry will appreciate papers presented on:

- EM Management – Measurements – Environment – Interference
- Computational Electromagnetics
- Signal Integrity → (see website for all topics)

FREE access  
to the exhibition of  
over 120 companies  
showing the latest in EMC  
products and services



### WHY COME TO DRESDEN?

Dresden, located in the heart of Europe, is the gateway to the emerging markets of Central and Eastern Europe. In addition, Germany is the world's fifth largest economy.

### NETWORKING

Do you want to learn more about EMC standards and interact directly with experts in the global EMC community? Consider attending the standards and many technical committee meetings that will be held in conjunction with the Symposium. The annual EMC Society awards ceremony will take place in Dresden. Leaders will be recognized for their significant technical and professional contributions to the EMC community. Together with the social program planned, these activities provide excellent networking opportunities.

### THE VENUE

The terrace-style International Congress Center Dresden (ICC) benefits from both state of the art design and enviable location. The facility is considered one of Europe's most modern congress centers. The host hotel is located just next to the ICC and connected to the convention center by a covered walkway.



[www.emc2015.org](http://www.emc2015.org)

### GENEROUSLY SUPPORTED BY

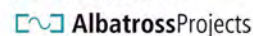
#### Platinum Sponsors



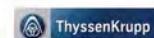
#### Gold Sponsors



#### Silver Sponsors



#### Bronze Sponsors





# 2015 EMC SUPPLIER QUICK GUIDE

## FOR 2015, WE HAVE CHANGED

the location of our full supplier directory from this print edition to our online directory at [buyersguide.interferencetechnology.com](http://buyersguide.interferencetechnology.com) - where information on products and contacts is now updated daily. In this section, we provide a quick guide to some of the top suppliers in each EMC category - test equipment, components, materials, services, and more. To find a product that meets your needs for applications, frequencies, standards requirements, etc., please search these individual supplier websites for the latest information and availability. If you have trouble finding a particular product or solution, email [gkilshaw@item-media.net](mailto:gkilshaw@item-media.net) for further suppliers and contacts.

### AMPLIFIERS



#### AE Techron Inc.

Sales offices: [www.aetechron.com](http://www.aetechron.com)  
Phone number: 574-295-9495



#### AR RF / Microwave Instrumentation

Sales offices: [www.arworld.com](http://www.arworld.com)  
Phone number: 215-723-8181



satcom division

#### Communications & Power Industries (CPI)

Sales offices: [www.cpii.com](http://www.cpii.com)  
Phone number: 650-846-2900



#### Empower RF Systems, Inc.

Sales offices: [www.empowerrf.com](http://www.empowerrf.com)  
Phone number: 310-412-8100



#### a TESEQ Company

#### Instruments for Industry

Sales offices: <http://ifi.com>  
Phone number: 631-913-1434

### AMPLIFIERS (continued)



#### RF/Microwave Amplifiers

#### Milmega

Sales offices: [www.milmega.co.uk](http://www.milmega.co.uk)  
Phone number: +44 (0) 1983 618000



#### R&K Company Limited

Sales offices: [www.rk-microwave.com](http://www.rk-microwave.com)  
Phone number: +81-545-31-2600

### ANTENNAS



#### A.H. Systems, Inc.

Sales offices: [www.ahsystems.com](http://www.ahsystems.com)  
Phone number: 818-998-0223

### MEDIA



#### Interference Technology

Website: [www.interferencetechnology.com](http://www.interferencetechnology.com)  
Phone number: 484-688-0300

### CABLES & CONNECTORS



#### API Technologies

Sales offices: [www.apitech.com](http://www.apitech.com)  
Phone number: 855-294-3800



#### Schurter

Sales offices: [www.schurter.com](http://www.schurter.com)  
Phone number: 707-636-3000

### CERTIFICATION SERVICES

#### EM TEST USA

iNARTE  
National Technical Systems

### HELPFUL HINT

Need more information on amplifiers, antennas, filters or any of our other featured categories? Visit Interference Technology online and click on the channels on the left sidebar. There you will find news, articles, standards, products and more, relating to each topic! Visit [interferencetechnology.com](http://interferencetechnology.com) and bookmark the ones you use the most.

## CONSULTANTS

Cherry Clough Consultants, Ltd.  
 Don Heirman Consultants  
 Henry Ott Consultants  
 Interference Technology  
 Leader Tech, Inc.  
 Montrose Compliance Services  
 Wyatt Technical Services

## COMPONENTS

**Curtis Industries**

Sales offices: [www.curtisind.com](http://www.curtisind.com)  
 Phone number: 414-649-4200

**ETS-Lindgren**

Sales offices: [www.ets-lindgren.com](http://www.ets-lindgren.com)  
 Phone number: 512-531-6400

**TDK EPC Corporation**

Sales offices: [www.tdk-epc.us](http://www.tdk-epc.us)  
 Phone number: 516-535-2600

## FILTERS / FERRITES

**Astrodyne**

Sales offices: [www.astrodyne.com](http://www.astrodyne.com)  
 Phone number: 508-964-6300

**Delta Electronics**

Sales offices: [www.delta.com.tw](http://www.delta.com.tw)  
 Phone number: 978-927-1060

## FILTERS / FERRITES (continued)

**Fair-Rite Products Corp.**

Sales offices: [www.fair-rite.com](http://www.fair-rite.com)  
 Phone number: 845-895-2055

**TRI-MAG, a Curtis Industries Company**

Sales offices: [www.tri-mag.com](http://www.tri-mag.com)  
 Phone number: 559-651-2222

## LIGHTNING AND SURGE

Advanced Test Equipment Rentals  
 EM TEST USA  
 HV Technologies Inc.  
 Retlif Testing Laboratories  
 TESEQ, Inc.

## SHIELDING

**Fotofab**

Sales offices: [www.fotofab.com](http://www.fotofab.com)  
 Phone number: 773-463-6211

**Ja-Bar**

Sales offices: <http://ja-bar.com>  
 Phone number: 973-786-5000

**Kemtron**

Sales offices: [www.kemtron.co.uk](http://www.kemtron.co.uk)  
 Phone number: +44 (0)1376 348115

## SHIELDING (continued)

**Nolato**

Sales offices: [www.nolato.com](http://www.nolato.com)  
 Phone number: +46 (0) 582 889 00

**Orbel**

Sales offices: [www.orbel.com](http://www.orbel.com)  
 Phone number: 610-829-5000

**Parker Chomerics**

Sales offices: [www.chomerics.com](http://www.chomerics.com)  
 Phone number: 856-825-8900

**United Western**

Sales offices: [www.uweinc.com](http://www.uweinc.com)  
 Phone number: 805-389-1077

## DID YOU KNOW?

Interference Technology has a brand new *EMC Resources* section online. This features free downloads and whitepapers on shielding, filtering, design, testing, and more.

Visit [interferencetechnology.com](http://interferencetechnology.com) to check out our *Resources*. Or, simply sign up for our newsletter to get *Resources* delivered straight to your inbox!



SOFTWARE



**CST of America, Inc.**  
Sales offices: [www.cst.com](http://www.cst.com)  
Phone number: 508-665 4400



**Remcom**  
Sales offices: [www.remcom.com](http://www.remcom.com)  
Phone number: 814-861-1299

TEST EQUIPMENT



**Advanced Test Equipment Rentals**  
Sales offices: [www.atecorp.com](http://www.atecorp.com)  
Phone number: 888-404-2832



**AMETEK**  
Sales offices: [www.ametek.com](http://www.ametek.com)  
Phone number: 610-647-2121



**EM TEST USA.**  
Sales offices: [www.emtest.com](http://www.emtest.com)  
Phone number: 732-417-0501

TEST EQUIPMENT (continued)



**HV Technologies Inc.**  
Sales offices: [www.hvtechnologies.com](http://www.hvtechnologies.com)  
Phone number: 703-365-2330



**Keysight Technologies**  
Sales offices: [www.keysight.com](http://www.keysight.com)  
Phone number: 800-829-4444



**Prana**  
Sales offices: [www.hvtechnologies.com](http://www.hvtechnologies.com)  
Phone number: 703-365-2330



**Rohde & Schwarz, Inc.**  
Sales offices: [www.rohde-schwarz-usa.com](http://www.rohde-schwarz-usa.com)  
Phone number: 410-910-7800



Advanced Test Solutions for EMC

**TESEQ, Inc.**  
Sales offices: [www.teseq.us](http://www.teseq.us)  
Phone number: 732-417-0501

TEST EQUIPMENT (continued)

A.H. Systems, Inc.  
Advanced Test Equipment Rentals  
AR RF / Microwave Instrumentation  
Empower RF Sytems, Inc.  
ETS-Lindgren  
Rohde & Schwarz, Inc.  
TESEQ, Inc.  
Retlif Testing Laboratories

TESTING LABORATORIES



**Retlif Testing Laboratories**  
Sales offices: [www.retlif.com](http://www.retlif.com)  
Phone number: 215-256-4133



**Washington Laboratories, Ltd.**  
Website: [www.wll.com](http://www.wll.com)  
Phone number: 301-216-1500

TRAINING, SEMINARS, & WORKSHOPS

CST of America, Inc.  
EM TEST USA.  
Interference Technology  
TESEQ, Inc.

LEARN MORE WITH US

If you would like to learn more about EMI test and design solutions, please join Interference Technology each April as we host the annual **EMC Live** event.

**EMC Live 2015** is an online 3-day event, featuring live webinar presentations and roundtables, with practical solutions to EMI challenges. Various EMC topics, including shielding, grounding, filtering, standards, pre-compliance and testing will be covered.

Visit [www.emclive2015.com](http://www.emclive2015.com) for more information and to register today!



# Puzzled about EMI?

**interference**  
technology

Home | Buyers' Guide | Articles | Digital Magazines | Europe | 中国 | 日本 | About Us

**Markets**

- Aerospace
- Automotive
- Consumer Electronics
- Medical
- Military
- Telecom

**Technologies**

- Amplifiers
- Antennas
- Cable & Connectors
- Conductive Materials
- Filters / Ferrites
- Lightning & Surge
- Shielding
- Software
- Test Instrumentation
- Testing

**Health Concerns Over Electromagnetic Radiation in India**  
India's Department of Telecommunications has issued new rules for radiation emissions from towers, e...

**We Got You Covered.**  
STM

**EMC ZONE - LATEST BLOG POSTS**  
Comment from Blog Reader Plus Test Fil...  
Before launching into calculating the power re... to create the test fields

**SUBSCRIBE TO OUR WEEKLY NEWSLETTER**  
CLICK TO SIGN UP TODAY!

Find Solutions at  
[interferencetechnology.com](http://interferencetechnology.com)

**interference**<sup>ITEM™</sup>  
THE INTERNATIONAL JOURNAL OF  
ELECTROMAGNETIC COMPATIBILITY | **technology**

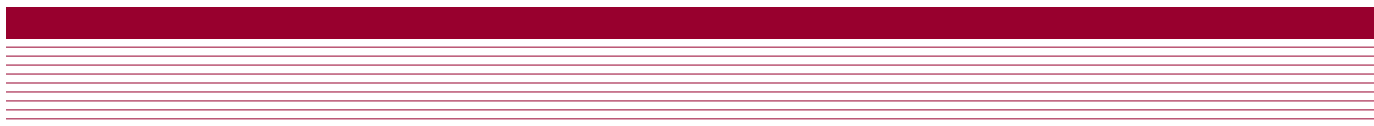


# Index of Advertisers

**REQUEST INFORMATION FROM OUR ADVERTISERS**

When you contact our advertisers, please remember to tell them you saw their ad in *Interference Technology*.

ADVANCED TEST EQUIPMENT RENTALS .....	24
AH SYSTEMS, INC. ....	INSIDE FRONT COVER
AR RF/MICROWAVE INSTRUMENTATION .....	5, 37
API TECHNOLOGIES.....	55
ASTRODYNE .....	59
CAPTOR CORPORATION.....	86
CPI - COMMUNICATIONS AND POWER INDUSTRIES. ....	15
CST - COMPUTER SIMULATION TECHNOLOGY.....	67
CUMING LEHMAN CHAMBERS .....	33
CURTIS INDUSTRIES.....	42
DELTA ELECTRONICS.....	47
DEXMET .....	64
DON HEIRMAN CONSULTANTS .....	87
EMC LIVE.....	10
EM TEST USA.....	23
ELECTRONICS COOLING.....	35
ETS - LINDGREN .....	BACK COVER, 31
FAIR-RITE PRODUCTS CORP. ....	51
FOTOFAB CORP .....	63
HAEFELY EMC DIVISION.....	26
HENRY OTT CONSULTANTS .....	87
HV TECHNOLOGIES, INC. ....	29
IFI.....	19
INTERFERENCE TECHNOLOGY .....	27, 35, 111
KEYSIGHT .....	39
KIMMEL GERKE .....	87
MESAGO MESSE FRANKFURT GMBH .....	103
MICROWAVE AND RF SHOW .....	97
MILMEGA.....	25
MONTROSE COMPLIANCE SERVICES, INC .....	87, 101
OPHIR RF.....	26
ORBEL CORPORATION .....	9
PARKER HANNIFIN CORP. - CHOMERICS .....	61
PRANA.....	7
R&K COMPANY LIMITED .....	17
RADIOMETRICS .....	34
RETLIF TESTING LABORATORIES.....	41
ROHDE & SCHWARZ .....	3
SCHURTER INC.....	45
SPIRA MFG. CORP.....	1
SWIFT TEXTILE METALIZING .....	INSERT
TECH-ETCH, INC. ....	57
TESEQ .....	21
THERMAL LIVE 2015.....	INSIDE BACK COVER





# THERMAL LIVE **2015**

A BRAND NEW EVENT FEATURING  
PRACTICAL THERMAL MANAGEMENT  
TECHNIQUES & TOPICS

FREE TO ATTEND  
FROM THE COMFORT OF YOUR OWN CHAIR

**OCTOBER 6-8, 2015**

[thermallive2015.com](http://thermallive2015.com)



# SOLUTIONS. SIMPLIFIED.



**Keeping things simple makes you more productive.** You get things done more quickly and with less effort when you have tools that are easy to use.

That's exactly how our solutions for RF test are designed – easy for operators to use, and requiring a lot less of your effort to design and implement.

We make it simple by providing test solutions that adapt to change, accept a choice of instrumentation, and operate with equal ease by engineers and lab technicians alike.

At project level, our in-house capabilities smooth the way with RF, mechanical and architectural engineering (including BIM), site surveys, local permitting (MEP), project management, system performance verification, operator training, assistance with agency certification, and ongoing support.

With us, you work with a single accountable partner with a proven track record of delivering on our promises, and a knack for making things simple.





## Breathable, Durable Shielding & Conductive Fabric



Swift Textile Metalizing's non-woven fabrics are made from point-bonded non-woven nylon. Non-woven fabrics are a breathable alternative to tightly woven fabrics. Point bonding adds strength, stability and durability beyond what a knit product can offer. Available in silver only and silver-nickel coating options for added conductivity, shielding and corrosion resistance.

### Non-Woven Product Features

- Silver or nickel-silver coating
- Weights range from 1.3 to 2.6 oz/sq yard
- Widths range from 0.5 up to 36 inches
- Point bonding provides superior strength, stability and durability
- Offers a more breathable alternative to woven fabrics
- Nickel coating provides resistance to corrosion
- Available with EMI maximum resistance as low as 0.1 Ohms/sq
- Available with EMI shielding effectiveness as high as 75 dB at 1 GHz

### Non-Woven Fabric Product Details

#### Nickel-Silver Coated Heavy Non-Woven SMS-0112

Heavy duty, point bonded silver & nickel coated fabric delivers excellent conductivity and our best non-woven shielding option.

**Applications:** EMI/RFI shielding gaskets; shielded enclosures, containers, and bags; architectural shield; anti-static and grounding materials

#### Nickel-Silver Coated Light Non-Woven SMS-0112

A lightweight, non-woven fabric that offers excellent conductivity, shielding and durability.

**Applications:** EMI/RFI shielding gaskets; shielded enclosures, containers, and bags; architectural shield; anti-static and grounding materials.

#### Silver Coated Non-Woven SMS-0141

A lightweight, non-woven fabric without nickel for improved biocompatibility and reduced skin contact irritation with good conductivity and shielding characteristics.

**Applications:** Medical applications; bacterial mitigation products.



Since 1955, **Swift Textile Metalizing** has offered conductive fabrics for customers in a wide range of industries including Aerospace, Telecommunications, Medical Equipment manufacturing, Commercial and Consumer Electronics, Defense and Mobile Forensics. Our specialized services include research and development, design, prototyping, and testing of custom products for a wide range of applications.

Swift also provides a variety of value-added services designed to save our customers time and money. Swift's value-added capabilities include tape slitting, laminating, sewing, ultrasonic cutting, ultrasonic bonding, and dimensional cutting, along with printing, calendaring and the installation of fasteners and grommets. An onsite specialty production shop handles prototype to high volume production runs, with flexible turnaround times. Swift Textile Metalizing maintains a culture of quality, upholding stringent industry standards. Swift Textile Metalizing maintains ISO 9001:2008 certified status. As a defense contractor, Swift complies with ITAR, International Traffic in Arms Regulations.

**Swift Textile Metalizing LLC**  
P.O. Box 66, 23 Britton Drive, Bloomfield, CT 06002-0066  
Phone: 860.243.1122 Fax: 860.243.0848  
Email: [sales@swift-textile.com](mailto:sales@swift-textile.com)  
Website: [www.swift-textile.com](http://www.swift-textile.com)



## Electrically Conductive and Reflective Metalized Fabrics

Protecting People and Equipment from Electromagnetic Interference (EMI), Radio Frequency Interference (RFI) and Static Discharge





# Electrically Conductive and Reflective Metalized Fabrics

Protecting People and Equipment from Electromagnetic Interference (EMI), Radio Frequency Interference (RFI) and Static Discharge

Swift Textile Metalizing LLC is a U.S. manufacturing company that specializes in the design, development and production of a wide range of electrically conductive and reflective metalized fabrics used in products that provide protection to people and equipment from Electromagnetic Interference (EMI), Radio Frequency Interference (RFI) and Static Discharge.

## Fabric Options



STM's line of conductive and reflective materials includes flexible, lightweight Woven, Non-Woven and Knit fabrics, typically utilizing a durable nylon base. The base is coated with layers of highly conductive metals designed to meet a wide range of EMI and RFI shielding applications, such as shielded gaskets, tapes (including hook & loop), cable wrap, towed arrays, curtains, doors, tents, enclosures, grounding straps and more. Swift Textile Metalizing utilizes proprietary technologies to produce silver, nickel and copper coated fabrics. STM product width dimensions range from 0.5 inches for tape products up to a maximum of 80 inches for rolled fabrics. STM produces products with electrical resistivity of up to a maximum of 1.8 Ohms/sq.

All Swift Textile Metalizing fabrics offer flexibility, durability, electromagnetic reflection, and resistance to corrosion, as well as anti-static, anti-bacterial, and ultra low out gassing properties.

# Woven Fabrics

## Light Weight, Durable Shielding & Conductive Fabric



Swift Textile Metalizing woven fabrics are lightweight and extremely durable. They deliver the highest standard of performance in shielding and conductivity. STM's proprietary metalizing process applies a thin layer of metal to each fiber. The result is a textile product with the feel, durability and flexibility of a woven fabric and the conductivity and shielding effectiveness of a metal foil.

### Woven Fabric Product Features

- Silver, nickel, or copper coatings
- Rip stop or taffeta weaves
- Weights ranging from 1.1 to 2.8 oz/sq yd
- Widths from 0.5 up to 60 inches
- Non-conductive, conductive, or fire retardant adhesives
- Available with maximum resistivity as low as 0.05 Ohms/sq
- Available with EMI shielding effectiveness as high as 80 dB at 1 GHz
- Available in single or multi-ply versions

### Woven Fabric Product Details

#### Nickel-Silver Coated Rip Stop SMS-0115

Lightweight and highly durable. Nickel top coat enhances durability and protects against corrosion.

**Applications:** EMI/RFI shielding gaskets; shielded enclosures, containers, and bags; architectural shielding; conductive and shielding tapes.

#### Silver Coated Rip Stop SMS-0116

Lightweight and highly durable. No Nickel improves biocompatibility for direct skin contact applications.

**Applications:** Pressure sensors; medical products and sensors; conductive ground planes; conductive gaskets and tapes; bacterial mitigation products.

#### Silver Coated Heavy Rip Stop SMS-0117

A heavier version of standard rip stop for improved durability and performance in harsh environments or severe conditions.

**Applications:** Pressure sensors; medical products and sensors; conductive ground planes; conductive gaskets and tapes.

#### Nickel-Silver Coated Taffeta SMS-0118

Tighter weave and high thread count for low permeability and excellent shielding.

**Applications:** EMI/RFI shielding gaskets; shielded enclosures, containers, and bags; architectural shield; conductive and shielding tapes.

# Knit Fabrics

## Stretchable, Flexible, Shielding & Conductive Fabric



Swift Textile Metalizing knit fabrics are the best choice for applications that require stretching and flexing characteristics. The unique bond of silver to the nylon fabric allows for superior endurance, conductivity and shielding performance, especially for repeated loading and unloading applications. Precision knit fabrics used for the base material provide excellent product elasticity.

### Knit Fabric Product Features

- Silver coating
- Mesh, scrim, tricot, jersey knit and continuous loop fabric options
- Weights range from 0.4 to 5.2 oz/sq yd
- Widths range from 1 up to 80 inches
- Available in mesh counts from 338 to 2200 cells/sq in
- Available with maximum resistivity as low as 0.5 Ohms/sq
- Available with EMI shielding effectiveness as high as 50 dB at 1 GHz
- Available with removable carrier film.

### Knit Fabric Product Details

#### Silver Coated Tricot SMS-0107

Offers lightweight and breathability characteristics without sacrificing strength in a durable knit fabric.

**Applications:** Medical products and sensors; EMI/RFI shielding; conductive ground planes; radar reflection; bacterial mitigation products.

#### Silver Coated Scrim SMS-0105

Maintains a high degree of shielding and conductivity performance in an open and stretchable structure.

**Applications:** Conductive ground planes; radar reflection.

#### Silver Coated Mesh SMS-0109

Our lightest weight metal coated material offers an open structure & a high degree of stretchability.

**Applications:** Radar reflection; shielding covers and enclosures; bacterial mitigation products.

#### Silver Coated Continuous Loop SMS-0104

Silver coated napped nylon knit provides conductivity with compatible hook fastener.

**Applications:** Shielding covers; bacterial mitigation products; anti-static applications.

#### Silver Coated Jersey Knit SMS-0108

STM's heaviest knit fabric delivers excellent stretch and unparalleled durability. Provides conductivity, shielding and superior biocompatibility in medical skin contact applications.

**Applications:** Medical, shielding covers, pressure sensors.