

M-14500 1

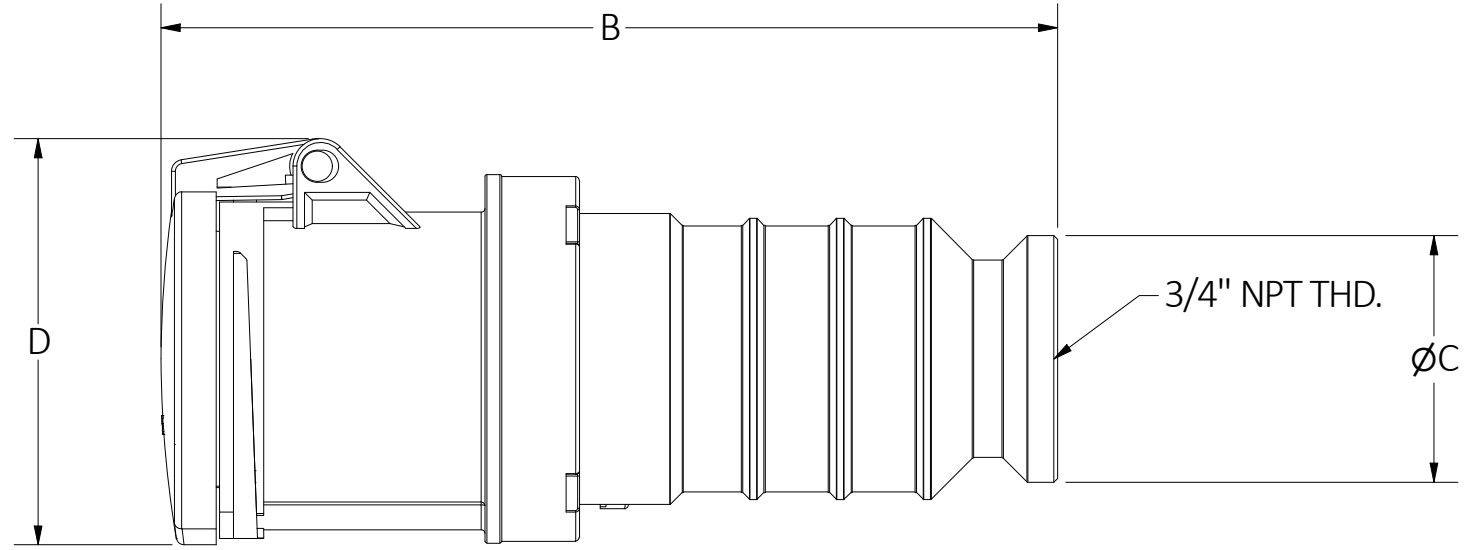

KEY	60A					
	3 WIRE		4 WIRE		5 WIRE	
	IN.	MM	IN.	MM	IN.	MM
ØA	3.84	97,5	3.84	97,5	3.84	97,5
B	9.56	243	9.56	243	9.56	243
ØC	2.57	65	2.57	65	2.57	65
D	4.25	107,5	4.25	107,5	4.25	107,5

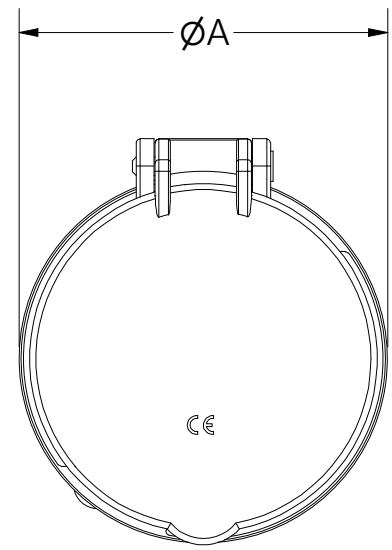
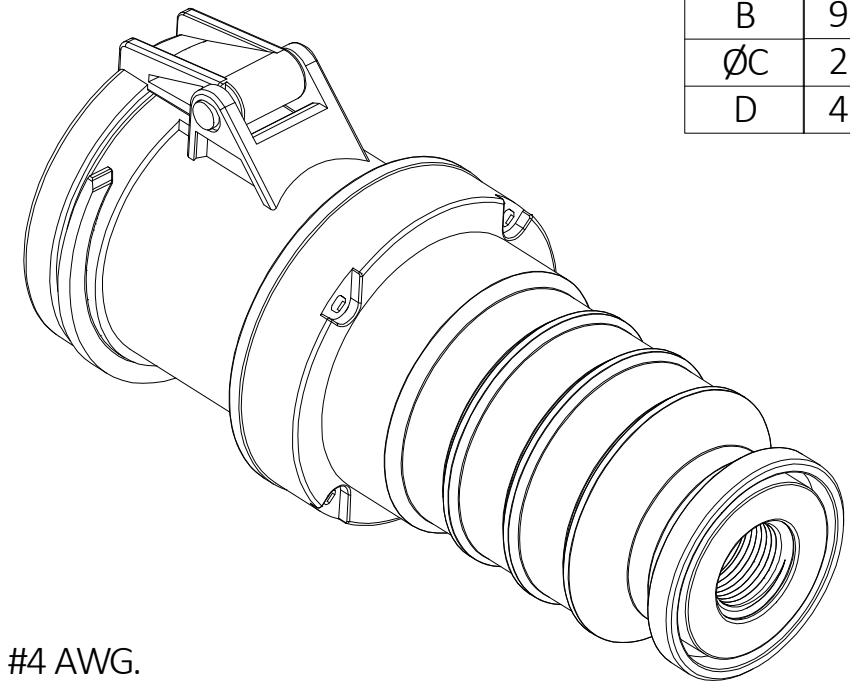

NOTES:

1. UNITS ARE INCHES [mm].
2. UL LISTED. ENV. RATING IP44.
3. WIRE TERMINATION RANGE #8 TO #4 AWG.
4. USES SCREW TERMINATIONS.
5. ACCEPTS STANDARD UL LISTED 3/4" TRADE SIZE LIQUID TIGHT FITTINGS BOTH METALLIC & NON METALLIC.

LIST OF PARTS		
DESCRIPTION	MATERIAL	FINISH
HOUSING	PBT/PC	
INTERIOR	NYLON GF	
SLEEVES	COPPER ALLOY	
COVER	PBT/PC	
GASKET	TPE/EPDM	
HINGE ARM	PBT/PC	
HINGE PIN	COPPER ALLOY	NICKEL PL.
HINGE SPRING	ST. STEEL	
ASSY. SCREWS	ST. STEEL	

DIMENSION SHEET FOR CAT. NO. SEE TABLE

LIQUID TIGHT CAT NO.'S	
CATALOG NO.	TRADE SIZE
C560C5SLT34	3/4 IN.
C560C6SLT34	3/4 IN.
C560C7SLT34	3/4 IN.
C560C9SLT34	3/4 IN.
C360C4SLT34	3/4 IN.
C360C6SLT34	3/4 IN.
C360C7SLT34	3/4 IN.
C460C5SLT34	3/4 IN.
C460C6SLT34	3/4 IN.
C460C7SLT34	3/4 IN.
C460C9SLT34	3/4 IN.

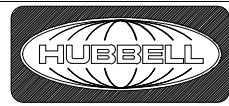
SUB.	REVISIONS
1	01/24/22 NEW RELEASE PER DCN 220124016287 CAC
THE DESIGN AND DIMENSIONS OF THE PRODUCT SHOWN ON THIS DRAWING ARE SUBJECT TO CHANGE WITHOUT NOTICE. DIMENSIONS ARE IN INCHES [mm].	
TITLE 60A PIN AND SLEEVE HUBBELL PRO SLT IP44 LIQUID TIGHT CONNECTOR	
 WIRING DEVICE-KELLEMS HUBBELL INCORPORATED SHELTON, CT	
TOLERANCES UNLESS OTHERWISE SPECIFIED -XX = ±.01 -XXX = ±.005 ANGLE TOL. ±2'	DR. BY CAC SCALE 1/2 CHK. BY DATE 01/13/22

B M-14500 1