

PROFESSIONAL FOODSERVICE PRODUCTS



COMPARTMENT SINK
WORK TABLE
STORAGE SHELF
CABINET
SERVICE CART
EXHAUST HOOD
WET-BATH TABLE

TABLE OF CONTENTS

COMPARTMENT SINK	1
BAR SINK & UNI-SERV BAR	6
BLENDER STATION & TRASH BIN	7
ICE BIN	8
BUDGET SINK	9
CLEAN & SOLID DISH TABLE	10
MOP & HAND SINK	11
GREASE TRAP & FLOOR TROUGH	13
WORK TABLE	14
EQUIPMENT STAND	18
WALL SHELF	19
STORAGE SHELF	23
OVER SHELF	24
DRAWER	25
FLOOR MOUNTED CABINET	26
WALL MOUNTED CABINET	29
PAN RACK	30
SERVICE CART	31
WET-BATH TABLE	32
EXHAUST HOOD	33
MODULAR BAR SOLUTION	34
SPARE PARTS	35





Sinks

Stainless Steel Sinks



Features

- Welded construction for consistent metal gauge thickness throughout
- 12" (304.8 mm) or 14" (355mm) deep tub with 3/4" (19.1 mm) coved radius tub corners
- 9" (228 mm) Back Splash with tile ledge for easy installation.
- Raised 1-5/8" (41.3 mm) diameter rolled edge
- 3-1/2" (88.9 mm) drain size.
- 1-2/3" (42.5 mm) legs with 1" (25.4 mm) adjustable feet .

Materials

- **Top:** 16 Ga. or 18Ga. 300 series stainless steel .
- **Legs:** All sinks furnished with 1-2/3" (42.5 mm) diameter heavy gauge tubing with leg gussets and high impact corrosion resistant fully adjustable 1" (25.4 mm) feet.

Mechanical

- 1-1/8" (28.6mm) faucet holes on 8" (203.2mm) centers.
- 3-1/2" (88.9mm) waste drain opening.



1 Compartment - 12" Series Sinks

300 series stainless steel top, Galvanized or stainless steel legs, 12" Deep Bowls, 3/4" coved corners, 9" back splash, 2-1/2" edge rim, 3-1/2" drain. 1-2/3" legs with adjustable feet. Drainboards are dipped and the bowls are seamlessly welded together. 6 PCS /1 pallet. Pallet covered with protecting film, bubble paper and carton corners.

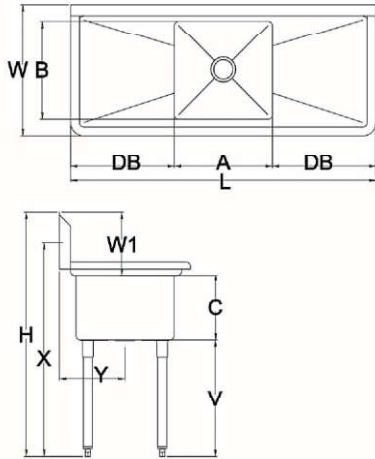

Optional Upgrade: Model SS (STAINLESS STEEL LEGS)
For Example: CS3-1-2016LRSS-18

Model Number	Drainboard	O.A.Dims - in.				Bowl Dims - in.			Installation Dims - in.				CBM
		L	W	H	DB	A	B	C	V	W1	X	Y	
CS3-1-2016	NO	22	26	45	-	16	20	12	21-1/2	11-1/2	39-1/2	13	0.146
CS3-1-201612L-18	Left	37	26	45	18	16	20	12	21-1/2	11-1/2	39-1/2	13	0.242
CS3-1-201612R-18	Right	37	26	45	18	16	20	12	21-1/2	11-1/2	39-1/2	13	0.242
CS3-1-201612RL-18	Double	52	26	45	18	16	20	12	21-1/2	11-1/2	39-1/2	13	0.338
CS3-1-1818	NO	24	24	45	-	18	18	12	21-1/2	11-1/2	39-1/2	12	0.147
CS3-1-1818L-18	Left	39	24	45	18	18	18	12	21-1/2	11-1/2	39-1/2	12	0.235
CS3-1-1818R-18	Right	39	24	45	18	18	18	12	21-1/2	11-1/2	39-1/2	12	0.235
CS3-1-1818RL-18	Double	54	24	45	18	18	18	12	21-1/2	11-1/2	39-1/2	12	0.324
CS3-1-2418	NO	24	30	45	-	18	24	12	21-1/2	11-1/2	39-1/2	15	0.182
CS3-1-2418L-18	Left	39	30	45	18	18	24	12	21-1/2	11-1/2	39-1/2	15	0.292
CS3-1-2418R-18	Right	39	30	45	18	18	24	12	21-1/2	11-1/2	39-1/2	15	0.292
CS3-1-2418RL-18	Double	54	30	45	18	18	24	12	21-1/2	11-1/2	39-1/2	15	0.337
CS3-1-2418L-24	Left	45	30	45	24	18	24	12	21-1/2	11-1/2	39-1/2	15	0.337
CS3-1-2418R-24	Right	45	30	45	24	18	24	12	21-1/2	11-1/2	39-1/2	15	0.337
CS3-1-2418RL-24	Double	66	30	45	24	18	24	12	21-1/2	11-1/2	39-1/2	15	0.491
CS3-1-2020	NO	26	26	45	-	20	20	12	21-1/2	11-1/2	39-1/2	13	0.171
CS3-1-2020L-20	Left	43	26	45	20	20	20	12	21-1/2	11-1/2	39-1/2	13	0.280
CS3-1-2020R-20	Right	43	26	45	20	20	20	12	21-1/2	11-1/2	39-1/2	13	0.280
CS3-1-2020RL-20	Double	60	26	45	20	20	20	12	21-1/2	11-1/2	39-1/2	13	0.389
CS3-1-2222	NO	28	28	45	-	22	22	12	21-1/2	11-1/2	39-1/2	14	0.198
CS3-1-2424	NO	30	30	45	-	24	24	12	21-1/2	11-1/2	39-1/2	15	0.226
CS3-1-2424L-24	Left	51	30	45	24	24	24	12	21-1/2	11-1/2	39-1/2	15	0.381
CS3-1-2424R-24	Right	51	30	45	24	24	24	12	21-1/2	11-1/2	39-1/2	15	0.381
CS3-1-2424RL-24	Double	72	30	45	24	24	24	12	21-1/2	11-1/2	39-1/2	15	0.520



2 Compartments - 12" Series Sinks

300 series stainless steel top, Galvanized or stainless steel legs, 12" Deep Bowls, 3/4" covered corners, 9" back splash, 2-1/2" edge rim, 3-1/2" drain. 1-2/3" legs with adjustable feet. Drainboards are dipped and the bowls are seamlessly welded together. 6 PCS / 1 pallet. Pallet covered with protecting film, bubble paper and carton corners.

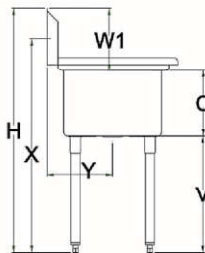
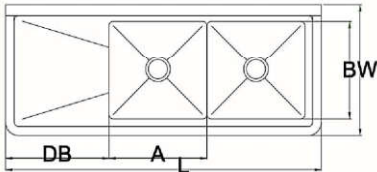

Optional Upgrade: Model SS (STAINLESS STEEL LEGS)
For Example: CS3-2-2016LRSS-18

Model Number	Drainboard	O.A.Dims - in.				Bowl Dims - in.			Installation Dims - in.				CBM
		L	W	H	DB	A	B	C	V	W1	X	Y	
CS3-2-2016	NO	38	26	45	-	16	20	12	21-1/2	11-1/2	39-1/2	13	0.248
CS3-2-2016L-18	Left	53	26	45	18	16	20	12	21-1/2	11-1/2	39-1/2	13	0.344
CS3-2-2016R-18	Right	53	26	45	18	16	20	12	21-1/2	11-1/2	39-1/2	13	0.344
CS3-2-2016RL-18	Double	68	26	45	18	16	20	12	21-1/2	11-1/2	39-1/2	13	0.248
CS3-2-1818	NO	42	24	45	-	18	18	12	21-1/2	11-1/2	39-1/2	12	0.253
CS3-2-1818L-18	Left	57	24	45	18	18	18	12	21-1/2	11-1/2	39-1/2	12	0.342
CS3-2-1818R-18	Right	57	24	45	18	18	18	12	21-1/2	11-1/2	39-1/2	12	0.342
CS3-2-1818RL-18	Double	72	24	45	18	18	18	12	21-1/2	11-1/2	39-1/2	12	0.431
CS3-2-2418	NO	42	30	45	-	18	24	12	21-1/2	11-1/2	39-1/2	15	0.314
CS3-2-2418L-18	Left	57	30	45	18	18	24	12	21-1/2	11-1/2	39-1/2	15	0.425
CS3-2-2418R-18	Right	57	30	45	18	18	24	12	21-1/2	11-1/2	39-1/2	15	0.425
CS3-2-2418RL-18	Double	72	30	45	18	18	24	12	21-1/2	11-1/2	39-1/2	15	0.535
CS3-2-2418L-24	Left	63	30	45	24	18	24	12	21-1/2	11-1/2	39-1/2	15	0.461
CS3-2-2418R-24	Right	63	30	45	24	18	24	12	21-1/2	11-1/2	39-1/2	15	0.461
CS3-2-2418LR-24	Double	84	30	45	24	18	24	12	21-1/2	11-1/2	39-1/2	15	0.623
CS3-2-2020	NO	46	26	45	-	20	20	12	21-1/2	11-1/2	39-1/2	13	0.299
CS3-2-2020L-20	Left	63	26	45	20	20	20	12	21-1/2	11-1/2	39-1/2	13	0.408
CS3-2-2020R-20	Right	63	26	45	20	20	20	12	21-1/2	11-1/2	39-1/2	13	0.408
CS3-2-2020RL-20	Double	80	26	45	20	20	20	12	21-1/2	11-1/2	39-1/2	13	0.517
CS3-2-2222	NO	50	28	45	-	22	22	12	21-1/2	11-1/2	39-1/2	14	0.349
CS3-2-2424	NO	54	30	45	-	24	24	12	21-1/2	11-1/2	39-1/2	15	0.403
CS3-2-2424L-24	Left	75	30	45	24	24	24	12	21-1/2	11-1/2	39-1/2	15	0.557
CS3-2-2424R-24	Right	75	30	45	24	24	24	12	21-1/2	11-1/2	39-1/2	15	0.557
CS3-2-2424RL-24	Double	96	30	45	24	24	24	12	21-1/2	11-1/2	39-1/2	15	0.711



3 Compartments- 12" Series Sinks

300 series stainless steel top, Galvanized or stainless steel legs, 12" Deep Bowls, 3/4" covered corners, 9" back splash, 2-1/2" edge rim, 3-1/2" drain. 1-2/3" legs with adjustable feet. Drainboards are dipped and the bowls are seamlessly welded together. 6 PCS / 1 pallet. Pallet covered with protecting film, bubble paper and carton corners.

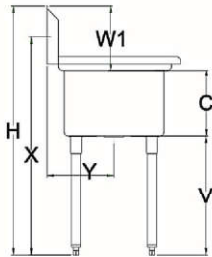
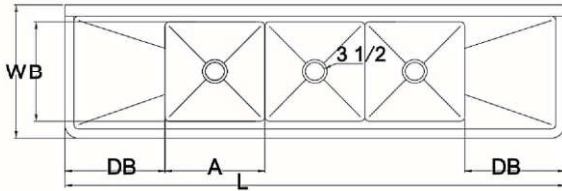

Optional Upgrade: Model SS (STAINLESS STEEL LEGS)
For Example: CS3-3-2016LRSS-18

Model Number	Drainboard	O.A.Dims - in.				Bowl Dims - in.			Installation Dims - in.				CBM
		L	W	H	DB	A	B	C	V	W1	X	Y	
CS3-3-2016	NO	54	26	45	-	16	20	12	21-1/2	11-1/2	39-1/2	13	0.350
CS3-3-2016L-18	Left	69	26	45	18	16	20	12	21-1/2	11-1/2	39-1/2	13	0.446
CS3-3-2016R-18	Right	69	26	45	18	16	20	12	21-1/2	11-1/2	39-1/2	13	0.446
CS3-3-2016RL-18	Double	84	26	45	18	16	20	12	21-1/2	11-1/2	39-1/2	13	0.542
CS3-3-1818	NO	60	24	45	-	18	18	12	21-1/2	11-1/2	39-1/2	12	0.360
CS3-3-1818L-18	Left	75	24	45	18	18	18	12	21-1/2	11-1/2	39-1/2	12	0.443
CS3-3-1818R-18	Right	75	24	45	18	18	18	12	21-1/2	11-1/2	39-1/2	12	0.443
CS3-3-1818RL-18	Double	90	24	45	18	18	18	12	21-1/2	11-1/2	39-1/2	12	0.537
CS3-3-2418	NO	60	30	45	-	18	24	12	21-1/2	11-1/2	39-1/2	15	0.447
CS3-3-2418L-18	Left	75	30	45	18	18	24	12	21-1/2	11-1/2	39-1/2	15	0.557
CS3-3-2418R-18	Right	75	30	45	18	18	24	12	21-1/2	11-1/2	39-1/2	15	0.557
CS3-3-2418RL-18	Double	90	30	45	18	18	24	12	21-1/2	11-1/2	39-1/2	15	0.667
CS3-3-2418L-24	Left	81	30	45	24	18	24	12	21-1/2	11-1/2	39-1/2	15	0.601
CS3-3-2418R-24	Right	81	30	45	24	18	24	12	21-1/2	11-1/2	39-1/2	15	0.601
CS3-3-2418RL-24	Double	102	30	45	24	18	24	12	21-1/2	11-1/2	39-1/2	15	0.755
CS3-3-2020	NO	66	26	45	-	20	20	12	21-1/2	11-1/2	39-1/2	13	0.427
CS3-3-2020L-20	Left	83	26	45	20	20	20	12	21-1/2	11-1/2	39-1/2	13	0.536
CS3-3-2020R-20	Right	83	26	45	20	20	20	12	21-1/2	11-1/2	39-1/2	13	0.536
CS3-3-2020RL-20	Double	100	26	45	20	20	20	12	21-1/2	11-1/2	39-1/2	13	0.644
CS3-3-2222	NO	72	28	45	-	22	22	12	21-1/2	11-1/2	39-1/2	14	0.500
CS3-3-2424	NO	78	30	45	-	24	24	12	21-1/2	11-1/2	39-1/2	15	0.579
CS3-3-2424L-24	Left	99	30	45	24	24	24	12	21-1/2	11-1/2	39-1/2	15	0.733
CS3-3-2424R-24	Right	99	30	45	24	24	24	12	21-1/2	11-1/2	39-1/2	15	0.733
CS3-3-2424RL-24	Double	120	30	45	24	24	24	12	21-1/2	11-1/2	39-1/2	15	0.888



Deli Line - 3 Compartments - 10" Deep Bowls

300 series stainless steel top, Galvanized or stainless steel legs, 10" Deep Bowls, 3/4" covered corners, 9" back splash, 2-1/2" edge rim, 3-1/2" drain. 1-2/3" legs with adjustable feet. Drainboards are dipped and the bowls are seamlessly welded together. 6 PCS / 1 pallet. Pallet covered with protecting film, bubble paper and carton corners.

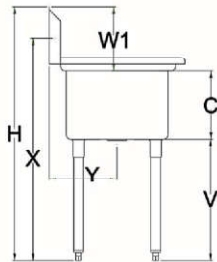
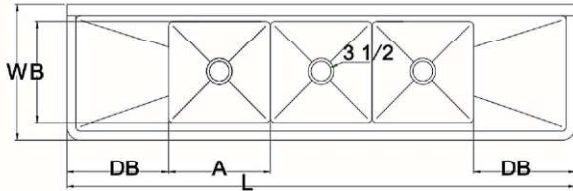

Optional Upgrade: Model SS (STAINLESS STEEL LEGS)
For Example: CS3-3-1410LRSS-12

Model Number	Drainboard	O.A.Dims - in.				Bowl Dims - in.			Installation Dims - in.				CBM
		L	W	H	DB	A	B	C	V	W1	X	Y	
CS3-3-1410	NO	36	20	45	-	10	14	10	23-1/2	11-1/2	39-1/2	10	0.207
CS3-3-1410L-12	Left	45	20	45	12	10	14	10	23-1/2	11-1/2	39-1/2	10	0.258
CS3-3-1410R-12	Right	45	20	45	12	10	14	10	23-1/2	11-1/2	39-1/2	10	0.258
CS3-3-1410RL-12	Double	54	20	45	12	10	14	10	23-1/2	11-1/2	39-1/2	10	0.309
CS3-3-1410L-16	Left	49	20	45	16	10	14	10	23-1/2	11-1/2	39-1/2	10	0.281
CS3-3-1410R-16	Right	49	20	45	16	10	14	10	23-1/2	11-1/2	39-1/2	10	0.281
CS3-3-1410RL-16	Double	62	20	45	16	10	14	10	23-1/2	11-1/2	39-1/2	10	0.354
CS3-3-1612	NO	42	22	45	-	12	16	10	23-1/2	11-1/2	39-1/2	11	0.263
CS3-3-1612RL-12	Double	60	22	45	12	12	16	10	23-1/2	11-1/2	39-1/2	11	0.374
CS3-3-1612RL-16	Double	68	22	45	16	12	16	10	23-1/2	11-1/2	39-1/2	11	0.423

Work Table with Sink

16Ga. 300 series stainless steel table top and bowl, 18Ga. 400 series stainless steel under shelf, stainless steel legs, bowl size: 16"x20"x12", with 5" back splash, rolled edge, 4" O.C..



Model Number	Bowl location	O.A.Dims - in.			Packing Dims - mm			Qty/ Pallet	CBM
		L	W	H	L	W	H		
KMS-11B-305R	Right	60	30	40-1/2	1560	800	470	5	0.587
KMS-11B-305L	Left	60	30	40-1/2	1560	800	470	5	0.587



Bar Sink

18-1/2" from front to back dimension, 4" high back splash, 10"x14"x10" sink bowls, S/S H-frame legs with adjustable bullet feet, 20 Ga. 300 series stainless steel bowl and 400 series skirt. 4" faucet, 1.5" drainer and overflow pipe included.

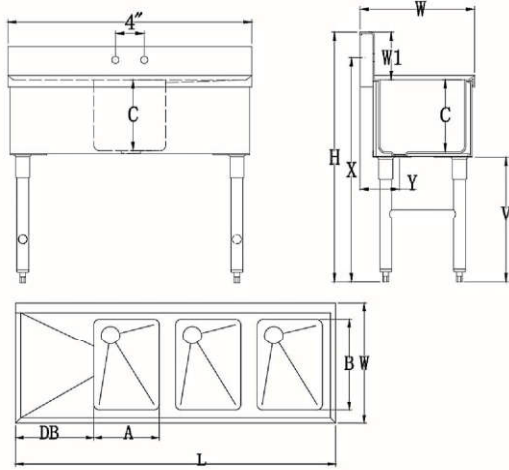

Model Number	Drainboard	O.A.Dims - in.				Bowl Dims - in.			Installation Dims - in.				CBM
		L	W	H	DB	A	B	C	V	W1	X	Y	
BS3-22	No	24	18-1/2	33	-	10	14	10	18.4	4.6	31.15	5	0.152
BS3-42C	Double	47	18-1/2	33	12	10	14	10	18.4	4.6	31.15	5	0.298
BS3-33	No	35	18-1/2	33	-	10	14	10	18.4	4.6	31.15	5	0.227
BS3-43R	Right	47	18-1/2	33	12	10	14	10	18.4	4.6	31.15	5	0.298
BS3-53C	Double	59	18-1/2	33	12	10	14	10	18.4	4.6	31.15	5	0.378
BS3-63C	Double	71	18-1/2	33	18	10	14	10	18.4	4.6	31.15	5	0.451

Uni-serv Speed Bar

4" Backsplash
 300 series stainless steel
 29" Insulated Ice Bin, 29" Speed Rail in front of ice bin optional
 Dump Sink size 10"x14"x6"
 Include 4" O.C. Deck Mounted Swing Spout Faucet
 Recessed Drainboard for Glassware
 Dual Blender/Mixer Recess
 120V duplex outlet in front of blender station optional
 Stainless steel H-frame legs
 The R/L in the model number denotes drainboard location

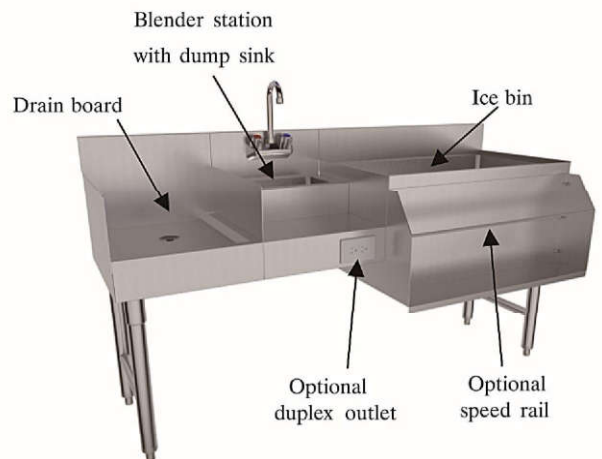

	Model Number	O.A.Dims - in.			Packing Dims - mm			Qty/ Pallet	CBM
		L	W	H	L	W	H		
Without speed rail and outlet	SLU-60L	59	18-1/2	33	1550	520	570	4	0.459
	SLU-60R	59	18-1/2	33	1550	520	570	4	0.459
With speed rail and outlet	SLU-60L-OSR	59	23-1/2	33	1550	520	570	4	0.459
	SLU-60R-OSR	59	23-1/2	33	1550	520	570	4	0.459



Blender Station with Dump Sink

Features:

- 4" backsplash
- 20Ga. 300 stainless steel top and dump sink, dump sink size: 10"x14"x6"
- Includes 4" faucet and 1.5" drainer
- Recess step with grommet hole for blender power cords.
- 120V duplex outlet hidden beneath shelf.
- S/S H-Frame legs with adjustable bullet feet

Material:

- Sink Bowl: 20Ga, 300 stainless steel
- Recess Step & Backsplash: 22Ga. 300 stainless steel
- Sides: 16Ga., 400 stainless steel



Model Number	O.A.Dims - in.			Packing Dims - mm			Qty/ Pallet	CBM
	L	W	H	L	W	H		
BLS3-2318	18	23	33	500	630	445	6	0.140

Trash Bin Cover

- 4" backsplash
- 20Ga, 300 stainless steel
- Top sliding cover shown in open position
- Knock-down structure
- Optional waste basket shown for clarity only



Model Number	O.A.Dims - in.			Packing Dims - mm			Qty/ Pallet	CBM
	L	W	H	L	W	H		
TB3-2412	12	23-13/16	18	650	350	125	21	0.028



Standard Line Ice Bin

18-1/2" or 21-1/2" from front to back dimension, 4" high backsplash. Poly foam insulation, S/S H-Frame legs with adjustable bullet feet, 20Ga. 300 series sink top and bowl, 400 series skirt.

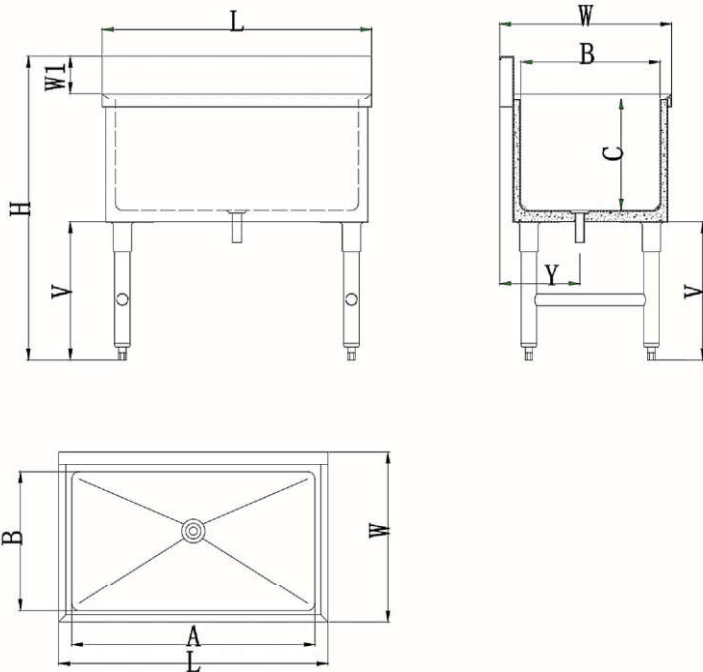

Model Number	Drainboard	O.A.Dims - in.			Bowl Dims - in.			Installation Dims - in.			CBM
		L	W	H	A	B	C	V	W1	Y	
SIB3-12	NO	12	18-1/2	33	9	15	12	15	4	8-5/8	0.090
SIB3-23	NO	23	18-1/2	33	20	15	12	15	4	8-5/8	0.136
SIB3-29	NO	29	18-1/2	33	26	15	12	15	4	8-5/8	0.170
SIB3-35	NO	35	18-1/2	33	32	15	12	15	4	8-5/8	0.204
SIB3-41	NO	41	18-1/2	33	38	15	12	15	4	8-5/8	0.238
SIB3-47	NO	47	18-1/2	33	44	15	12	15	4	8-5/8	0.272
SIB3-12 (21W)	NO	12	21-1/2	33	9	15	12	15	4	11-3/8	0.104
SIB3-23 (21W)	NO	23	21-1/2	33	20	15	12	15	4	11-3/8	0.157
SIB3-29 (21W)	NO	29	21-1/2	33	26	15	12	15	4	11-3/8	0.196
SIB3-35 (21W)	NO	35	21-1/2	33	32	15	12	15	4	11-3/8	0.236
SIB3-41 (21W)	NO	41	21-1/2	33	38	15	12	15	4	11-3/8	0.274
SIB3-47 (21W)	NO	47	21-1/2	33	44	15	12	15	4	11-3/8	0.314
SIB3-23 (16D)	NO	23	18-1/2	33	20	15	16	11	4	8-5/8	0.136
SIB3-29 (16D)	NO	29	18-1/2	33	26	15	16	11	4	8-5/8	0.170
SIB3-35 (16D)	NO	35	18-1/2	33	32	15	16	11	4	8-5/8	0.204
SIB3-23 (21W16D)	NO	23	21-1/2	33	20	15	16	11	4	11-3/8	0.157
SIB3-29 (21W16D)	NO	29	21-1/2	33	26	15	16	11	4	11-3/8	0.196
SIB3-35 (21W16D)	NO	35	21-1/2	33	32	15	16	11	4	11-3/8	0.236



Budget Sink - 12" Deep Bowl - 400 Series S/S

legs with adjustable feet, all welded, welded areas blended to match adjacent surfaces and to a satin finish, faucet holes on 8" O.C., waste drains are 1 1/2" IPS basket type, 12" deep, 400 series stainless steel.

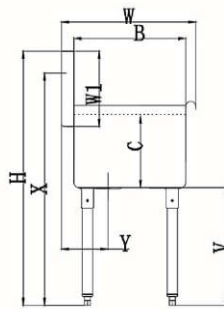
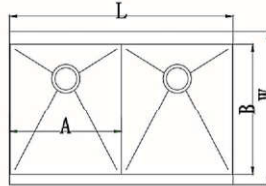

Upgrade Drainboard:

- DB3-1818 (For 18" width bowl)
- DB3-2118 (For 21" width bowl)
- DB3-2418 (For 24" width bowl)



Drainboard Assembled
300 series stainless steel

Optional Upgrade: Model SS (STAINLESS STEEL LEGS)
For Example: ES4-1-1818-SS

Model Number	Drainboard	O.A.Dims - in.			Bowl Dims - in.			Installation Dims - in.				CBM
		L	W	H	A	B	C	V	W1	X	Y	
ES4-1-1818	NO	18	21-3/5	41	18	18	12	19	12	37-1/2	7-1/2	0.102
ES4-1-2118	NO	18	24-3/5	41	18	21	12	19	12	37-1/2	7-1/2	0.116
ES4-1-2124	NO	24	24-3/5	41	24	21	12	19	12	37-1/2	7-1/2	0.153
ES4-1-2136	NO	36	24-3/5	41	36	21	12	19	12	37-1/2	7-1/2	0.226
ES4-1-2424	NO	24	27-3/5	41	24	24	12	19	12	37-1/2	7-1/2	0.170
ES4-1-2436	NO	36	27-3/5	41	36	24	12	19	12	37-1/2	7-1/2	0.253
ES4-2-2118	NO	36	24-3/5	41	18	21	12	19	12	37-1/2	7-1/2	0.226
ES4-2-2124	NO	48	24-3/5	41	24	21	12	19	12	37-1/2	7-1/2	0.300
ES4-2-2130	NO	60	24-3/5	41	30	21	12	19	12	37-1/2	7-1/2	0.374
ES4-2-2424	NO	48	27-3/5	41	24	24	12	19	12	37-1/2	7-1/2	0.335
ES4-2-2430	NO	60	27-3/5	41	30	24	12	19	12	37-1/2	7-1/2	0.418
ES4-3-2112	NO	36	24-3/5	41	12	21	12	19	12	37-1/2	7-1/2	0.226
ES4-3-2116	NO	48	24-3/5	41	16	21	12	19	12	37-1/2	7-1/2	0.300
ES4-3-2118	NO	54	24-3/5	41	18	21	12	19	12	37-1/2	7-1/2	0.337
ES4-3-2124	NO	72	24-3/5	41	24	21	12	19	12	37-1/2	7-1/2	0.448
ES4-3-2420	NO	60	27-3/5	41	20	24	12	19	12	37-1/2	7-1/2	0.418
ES4-3-2424	NO	72	27-3/5	41	24	24	12	19	12	37-1/2	7-1/2	0.500
ES4-4-2112	NO	48	24-3/5	41	12	21	12	19	12	37-1/2	7-1/2	0.300
ES4-4-2115	NO	60	24-3/5	41	15	21	12	19	12	37-1/2	7-1/2	0.374
ES4-4-2118	NO	72	24-3/5	41	18	21	12	19	12	37-1/2	7-1/2	0.448

Clean Dish Table

Clean Dish Table, straight design, right-to-left operation, 9" high back splash with 2" return, stainless steel 300 series top, Galvanized legs with adjustable bullet feet.

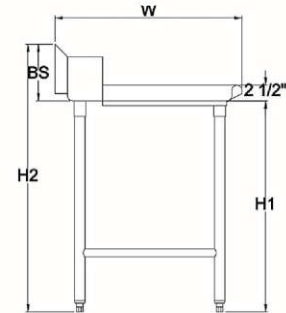
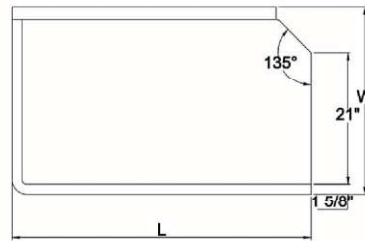

Optional Upgrade: Model SS (STAINLESS STEEL LEGS)

Model Number	O.A.Dims - in.					Packing Dims - mm			Qty/Pallet	CBM
	L	W	H1	H2	BS	L	W	H		
CDTA3-3024L/R	24	30	34	43	9	910	800	290	9	0.215
CDTA3-3030L/R	30	30	34	43	9	910	800	290	9	0.215
CDTA3-3036L/R	36	30	34	43	9	950	800	290	9	0.224
CDTA3-3048L/R	48	30	34	43	9	1250	800	290	9	0.295
CDTA3-3060L/R	60	30	34	43	9	1560	800	290	9	0.368
CDTA3-3072L/R	72	30	34	43	9	2170	800	290	9	0.440
CDTA3-3084L/R	84	30	34	43	9	1865	800	290	9	0.512
CDTA3-3096L/R	96	30	34	43	9	2475	800	290	9	0.584

Soiled Dish Table

Soiled Dish Table, straight design, 9" high back splash with 2" return, bowl size: 20"x20"x8", stainless steel 300 series top and bowl, Galvanized legs with adjustable bullet feet.



Dish Rack (SDR-2022)

Full welded, flat steel bar is 1-1/4 x 1/8 , 300 series stainless steel

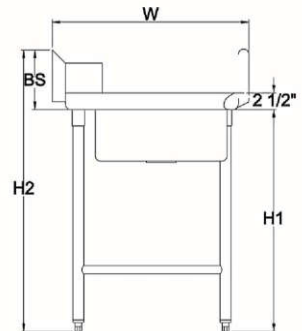
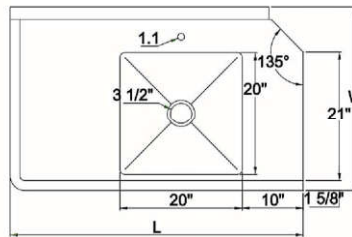

Optional Upgrade: Model SS (STAINLESS STEEL LEGS)

Model Number	O.A.Dims - in.					Packing Dims - mm			Qty/Pallet	CBM
	L	W	H1	H2	BS	L	W	H		
SDTA3-3036L/R	36	30	34	43	9	940	790	465	5	0.345
SDTA3-3048L/R	48	30	34	43	9	1245	790	465	5	0.456
SDTA3-3060L/R	60	30	34	43	9	1550	790	465	5	0.569
SDTA3-3072L/R	72	30	34	43	9	1855	790	465	5	0.681

Floor Mop Sink

Welded construction for consistent metal gauge thickness throughout , 300 series stainless steel, 3-1/2" (88.9 mm) drain.

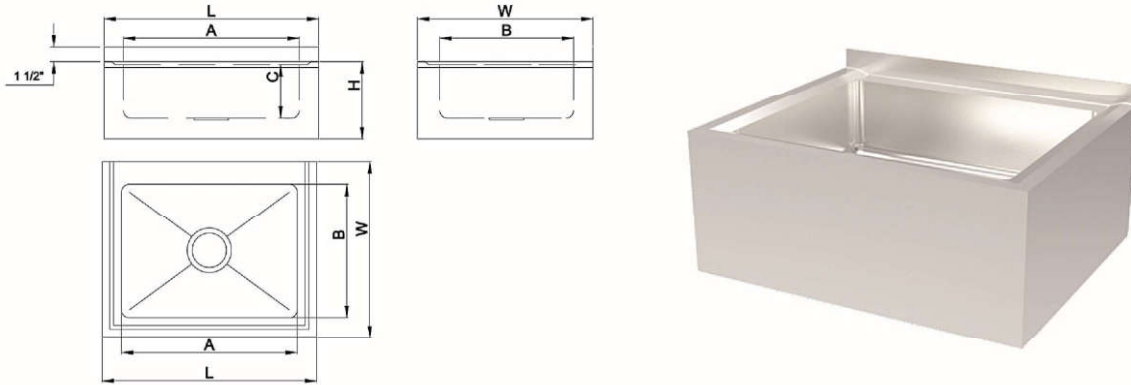

Model Number	Drainboard	O.A.Dims - in.			Bowl Dims - in.			Packing Dims - mm			Qty/ Pallet	CBM
		L	W	H	A	B	C	L	W	H		
MS3-06-1620	NO	24	20	10	20	16	6	630	530	310	8	0.103
MS3-06-2820	NO	24	32	10	20	28	6	630	835	310	8	0.163
MS3-12-1620	NO	24	20	16	20	16	12	630	530	460	5	0.154
MS3-12-2820	NO	24	32	16	20	28	12	630	835	460	5	0.242

Hand Sink

20 Gauge, 300 series stainless steel, 6" Back splash with 2" return, Goose neck faucet and basket drain supplied with sink, SB model include left and right side splashes, 1-1/2" Drain opening, Z-clip mounting bracket

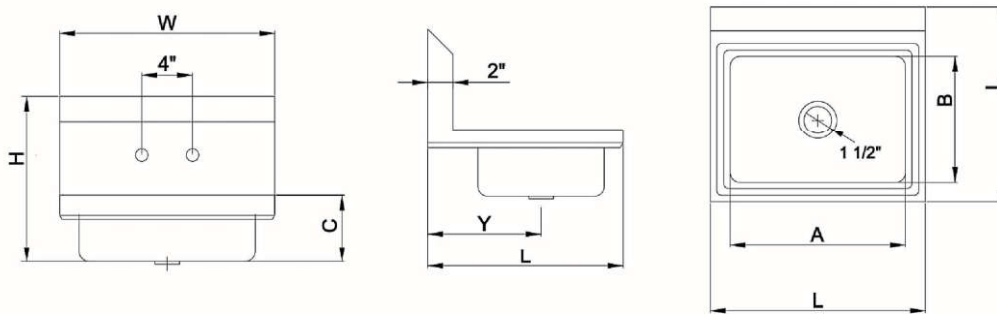

SB Model

Model Number	Drainboard	O.A.Dims - in.			Bowl Dims - in.			Packing Dims - mm			Qty/ Pallet	CBM
		L	W	H	A	B	C	L	W	H		
HS3-101406	NO	17	15	14	14	10	6	445	395	370	14	0.050
HS3-101406SB	NO	17	15	14	14	10	6	445	395	370	7	0.084



Pedal Hand Sink

6" backsplash with 2" return
 20Ga. 300 stainless steel top and hand sink, hand sink size:
 10"x14"x6"
 22Ga. 300 stainless steel enclosure
 Z-clip mounting bracket
 Includes foot pedal valve, outlet water pipe, faucet and 1.5" drainer
 Easily removable front panel to access hidden plumbing



Model Number	O.A.Dims - in.			Packing Dims - mm			Qty/ Pallet	CBM
	L	W	H	L	W	H		
HS3PD-101406-FAB	17	15	42	1120	485	420	6	0.228

Pedal Hand Sink with Trash Bin

6" backsplash with 2" return
 20Ga. 300 stainless steel top and hand sink, hand sink size: 10"x14"x6"
 22Ga. 300 stainless steel enclosure
 Z-clip mounting bracket
 Includes foot pedal valve, outlet water pipe, faucet, 1.5" drainer and plastic trash bin
 Easily removable front panel to access hidden plumbing



Model Number	O.A.Dims - in.			Packing Dims - mm			Qty/ Pallet	CBM
	L	W	H	L	W	H		
HS3PD-101406-FAB-TB	17	15	42	1120	485	420	6	0.228

Knee Valve Hand Sink

12-1/4" backsplash by knock-down structure, 400 stainless steel
 300 series stainless steel sink bowl and top, hand sink size: 13-5/8"x10"x4-3/4"
 Includes Knee operated valve, outlet and inlet water pipe, faucet and 1.5" drainer



Model Number	O.A.Dims - in.			Packing Dims - mm			Qty/ Pallet	CBM
	L	W	H	L	W	H		
HS3KN-101405-FAB	17-3/8	12-3/4	19-1/2	1120	485	420	6	0.228



Stainless Steel Grease Trap

20 Ga. 300 series stainless steel

Floor mounted.

Removable stainless steel cover and perforated waste basket.

Include 2" diameter Inlet and outlet pipe. No hub connections (standard).

Prevent 90% greasy substances



Model Number	O.A.Dims - in.			Flow rate GPM	Capacity LBS	Inlet H A	Outlet H B	Packing Dims - mm			Qty/ Pallet	CBM
	L	W	H					L	W	H		
GTSS-8	16	10	11	8	16	3	4.3	460	305	290	9	0.041
GTSS-12	18	13	12	12	23	3	4.3	515	340	365	7	0.064
GTSS-15	21-3/4	14	12	15	30	3	4.3	605	340	390	6	0.080
GTSS-16	22	15	14	16	33	3	4.3	615	390	415	6	0.100
GTSS-19	24	15-3/4	15	19	38	3	4.3	665	415	435	5	0.120
GTSS-21	26	16-1/2	16-1/2	21	42	3	4.3	720	455	455	5	0.149
GTSS-27	30	18	19	27	54	3	4.3	820	520	495	5	0.211
GTSS-35	32	22	21-1/2	35	70	3	4.3	870	580	595	4	0.300

Stainless Steel Floor Trough

Features:

Waste receptacle will accommodate up to a 4" waste pipe.

Includes 4" O.D. - 3" Long Plumbing Sleeve.

Removable perforated stainless steel strainer basket with handle provided.

Pitched towards waste.

Includes "Subway Style" grating from 3/16" x 1" solid "304" stainless steel bar.

Grating is spaced 9/16" (Inside clearance) between bars to prevent casters from getting trapped.

Troughs 96" or larger in length made with two (2) drains.

Material:

14 Ga. 300 series stainless steel

Polished 300 series stainless steel grating.



Model Number	O.A.Dims - in.			Installation Dims-in		Packing Dims - mm			Qty/ Pallet	CBM
	L	W	H	A	B	L	W	H		
SS3FT-1224	26	14	4	24	12	705	400	200	13	0.056
SS3FT-1230	32	14	4	30	12	855	400	200	13	0.068
SS3FT-1236	38	14	4	36	12	1010	400	200	13	0.081
SS3FT-1242	44	14	4	44	12	1160	400	200	13	0.093
SS3FT-1248	50	14	4	48	12	1315	400	200	13	0.105
SS3FT-1254	56	14	4	54	12	1465	400	200	13	0.117
SS3FT-1260	62	14	4	60	12	1620	400	200	13	0.130
SS3FT-1272	74	14	4	72	12	1925	400	200	13	0.154
SS3FT-1284	86	14	4	84	12	2230	400	200	13	0.178
SS3FT-1296	98	14	4	96	12	2535	400	200	13	0.203



Work Table - 1-1/2" Backsplash

18 Ga., 400 series top, Galvanized adjustable under shelf, 1-2/3" (42.5mm) Galvanized legs with adjustable bullet feet

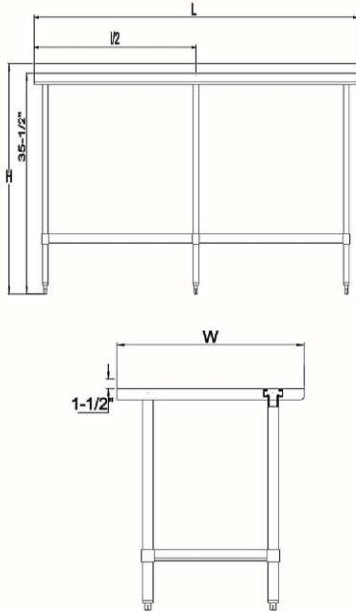

Optional upgrade: Model TSS3
 300 series top, 400 series under shelf, stainless steel legs
 For example: TSS3-2412B1.5

Model Number	O.A.Dims - in.			Packing Dims - mm			Qty/Pallet	CBM
	L	W	H	L	W	H		
TSG4-2412B1.5	12	24	36.5	950	645	145	18	0.089
TSG4-2418B1.5	18	24	36.5	950	645	145	18	0.089
TSG4-2424B1.5	24	24	36.5	950	645	145	18	0.089
TSG4-2430B1.5	30	24	36.5	950	645	145	18	0.089
TSG4-2436B1.5	36	24	36.5	950	645	145	18	0.089
TSG4-2448B1.5	48	24	36.5	1255	645	145	18	0.117
TSG4-2460B1.5	60	24	36.5	1560	645	145	18	0.146
TSG4-2472B1.5	72	24	36.5	1865	645	145	18	0.174
TSG4-2484B1.5	84	24	36.5	2170	645	145	18	0.203
TSG4-2496B1.5	96	24	36.5	2475	645	145	18	0.232
TSG4-3012B1.5	12	30	36.5	950	800	145	18	0.110
TSG4-3018B1.5	18	30	36.5	950	800	145	18	0.110
TSG4-3024B1.5	24	30	36.5	950	800	145	18	0.110
TSG4-3030B1.5	30	30	36.5	950	800	145	18	0.110
TSG4-3036B1.5	36	30	36.5	950	800	145	18	0.110
TSG4-3048B1.5	48	30	36.5	1255	800	145	18	0.146
TSG4-3060B1.5	60	30	36.5	1560	800	145	18	0.181
TSG4-3072B1.5	72	30	36.5	1865	800	145	18	0.216
TSG4-3084B1.5	84	30	36.5	2170	800	145	18	0.252
TSG4-3096B1.5	96	30	36.5	2475	800	145	18	0.287



Supersave Line Work Table - 5" Backsplash

18 Ga., 400 series top, Galvanized adjustable under shelf, 1-2/3" (42.5mm) Galvanized legs with adjustable bullet feet

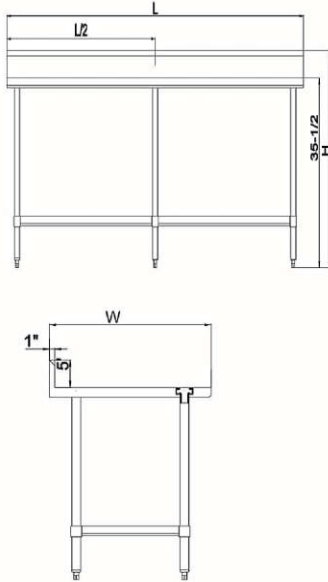

Optional upgrade: Model TSS3
300 series top, 400 series under shelf, stainless steel legs
For example: TSS3-2412B5

Model Number	O.A.Dims - in.			Packing Dims - mm			Qty/Pallet	CBM
	L	W	H	L	W	H		
TSG4-2412B5	12	24	40	950	845	230	25	0.092
TSG4-2418B5	18	24	40	950	845	230	25	0.092
TSG4-2424B5	24	24	40	950	845	230	25	0.092
TSG4-2430B5	30	24	40	950	845	230	25	0.092
TSG4-2436B5	36	24	40	950	845	230	25	0.092
TSG4-2448B5	48	24	40	1255	745	230	25	0.108
TSG4-2460B5	60	24	40	1560	745	230	25	0.134
TSG4-2472B5	72	24	40	1865	745	230	25	0.160
TSG4-2484B5	84	24	40	2170	745	230	25	0.186
TSG4-2496B5	96	24	40	2475	745	230	25	0.212
TSG4-3012B5	12	30	40	950	1000	230	25	0.109
TSG4-3018B5	18	30	40	950	1000	230	25	0.109
TSG4-3024B5	24	30	40	950	1000	230	25	0.109
TSG4-3030B5	30	30	40	950	1000	230	25	0.109
TSG4-3036B5	36	30	40	950	1000	230	25	0.109
TSG4-3048B5	48	30	40	1255	900	230	25	0.130
TSG4-3060B5	60	30	40	1560	900	230	25	0.161
TSG4-3072B5	72	30	40	1865	900	230	25	0.193
TSG4-3084B5	84	30	40	2170	900	230	25	0.225
TSG4-3096B5	96	30	40	2475	900	230	25	0.256



Work Table - Flat Top

18 Ga., 400 series top, Galvanized adjustable under shelf, 1-2/3" (42.5mm) Galvanized legs with adjustable bullet feet

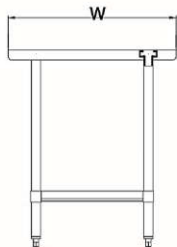
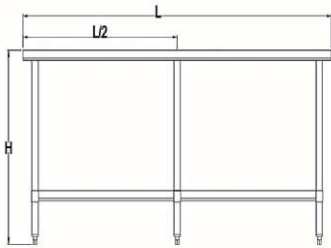

Optional upgrade: Model TSS3
300 series top, 400 series under shelf, stainless steel legs
For example: TSS3-2412

Model Number	O.A.Dims - in.			Packing Dims - mm			Qty/Pallet	CBM
	L	W	H	L	W	H		
TSG4-2412	12	24	35	940	735	105	25	0.073
TSG4-2418	18	24	35	940	735	105	25	0.073
TSG4-2424	24	24	35	940	735	105	25	0.073
TSG4-2430	30	24	35	940	735	105	25	0.073
TSG4-2436	36	24	35	940	735	105	25	0.073
TSG4-2448	48	24	35	1245	635	105	25	0.083
TSG4-2460	60	24	35	1550	635	105	25	0.103
TSG4-2472	72	24	35	1855	635	105	25	0.124
TSG4-2484	84	24	35	2160	635	105	25	0.144
TSG4-2496	96	24	35	2465	635	105	25	0.164
TSG4-3012	12	30	35	940	890	105	25	0.088
TSG4-3018	18	30	35	940	890	105	25	0.088
TSG4-3024	24	30	35	940	890	105	25	0.088
TSG4-3030	30	30	35	940	890	105	25	0.088
TSG4-3036	36	30	35	940	890	105	25	0.088
TSG4-3048	48	30	35	1245	790	105	25	0.103
TSG4-3060	60	30	35	1550	790	105	25	0.129
TSG4-3072	72	30	35	1855	790	105	25	0.154
TSG4-3084	84	30	35	2160	790	105	25	0.179
TSG4-3096	96	30	35	2465	790	105	25	0.205



Work Table with Open Base

1.5" backsplash

18Ga. 300 series table top, stainless steel leg

Stainless steel rails connected by aluminum connector



Model Number	O.A.Dims - in.			Packing Dims - mm			Qty/ Pallet	CBM
	L	W	H	L	W	H		
TFS3-3018	18	30	36.5	910	590	135	18	0.072

Poly Top Work Table

Features:

Flat high density polyethylene (HDPE) top working surface with welded stainless steel angle frame and die-formed flush tabs

Removeable high density polyethylene (HDPE) top for easy reversable and replacement

Material:

16Ga. 400 series top frame, with 18Ga. 400 series undershelf

1" thick high density polyethylene (HDPE) top



Model Number	O.A.Dims - in.			Packing Dims - mm			Qty/ Pallet	CBM
	L	W	H	L	W	H		
PTTS4-2424	24	24	35	755	905	115	23	0.079
PTTS4-2436	36	24	35	960	755	115	23	0.083
PTTS4-2448	48	24	35	1265	655	115	23	0.095
PTTS4-2460	60	24	35	1570	655	115	23	0.118
PTTS4-2472	72	24	35	1875	655	115	23	0.141
PTTS4-3030	30	30	35	905	905	115	23	0.094
PTTS4-3036	36	30	35	960	905	115	23	0.1
PTTS4-3048	48	30	35	1265	810	115	23	0.118
PTTS4-3060	60	30	35	1570	810	115	23	0.146
PTTS4-3072	72	30	35	1875	810	115	23	0.175



Equipment Stands

Features

- Top is furnished with 1.5" hemmed edge splash on rear and both sides.
- Under shelf is adjustable.

Material:

- Top is 400 series stainless steel.
- Galvanized under shelf.
- Galvanized legs are 1-2/3" (42.5mm) diameter with adjustable feet.

Construction:

- All TIG welded. Exposed welding areas finished to match adjacent surfaces.
- Entire Top is mechanically polished to a satin finish and is sound deadened.
- Hat channels are secured to top by means of structural adhesive and weld studs.
- Gussets die-stamped and welded to support hat sections.



Optional upgrade:

300 series top, 400 series under shelf, Stainless steel legs

For example: EQS3-2424-SS

300 series top, Galvanized under shelf, Galvanized legs

For example: EQS3-2424

Model Number	O.A.Dims - in.			Packing Dims - mm			Qty/Pallet	CBM
	L	W	H	L	W	H		
EQS4-2424	24	24	26	645	645	150	17	0.062
EQS4-2430	30	24	26	800	645	150	17	0.077
EQS4-2436	36	24	26	950	645	150	17	0.092
EQS4-2448	48	24	26	1255	645	150	17	0.121
EQS4-2460	60	24	26	1560	645	150	17	0.151
EQS4-2472	72	24	26	1865	645	150	17	0.180
EQS4-2484	84	24	26	2170	645	150	17	0.210
EQS4-2496	96	24	26	2475	645	150	17	0.239
EQS4-3024	24	30	26	645	800	150	17	0.077
EQS4-3030	30	30	26	800	797	150	17	0.096
EQS4-3036	36	30	26	950	797	150	17	0.114
EQS4-3048	48	30	26	1255	797	150	17	0.150
EQS4-3060	60	30	26	1560	797	150	17	0.186
EQS4-3072	72	30	26	1865	797	150	17	0.223
EQS4-3084	84	30	26	2170	797	150	17	0.259
EQS4-3096	96	30	26	2475	797	150	17	0.296

Note: 12" and 18" length available. Please contact our sales.



K.D. Style Wall Shelf

400 series stainless steel, wall mounting brackets included, Knocked-down structure, does not include mounting hardware, carries NSF certification for food service application. Unit is easily assembled employing the slip-fit TAB-LOK design.



Construction:

Shelf and brackets are die stamped and die formed.

Requirements of NSF installation:

1. Install at least 60” above floor.
2. Limit to dry storage.
3. Avoid contact with liquids.

Model Number	O.A.Dims - in.			Packing Dims - mm			Qty/Pallet	CBM
	L	W	H	L	W	H		
WS4-1224	24	12	12	645	340	100	27	0.022
WS4-1230	30	12	12	800	340	100	27	0.027
WS4-1236	36	12	12	950	340	100	27	0.032
WS4-1248	48	12	12	1255	340	100	27	0.043
WS4-1260	60	12	12	1560	340	100	27	0.053
WS4-1272	72	12	12	1865	340	100	27	0.063
WS4-1284	84	12	12	2170	340	100	27	0.074
WS4-1296	96	12	12	2475	340	100	27	0.084
WS4-1424	24	14	12	645	390	100	27	0.025
WS4-1430	30	14	12	800	390	100	27	0.031
WS4-1436	36	14	12	950	390	100	27	0.037
WS4-1448	48	14	12	1255	390	100	27	0.049
WS4-1460	60	14	12	1560	390	100	27	0.061
WS4-1472	72	14	12	1865	390	100	27	0.073
WS4-1484	84	14	12	2170	390	100	27	0.085
WS4-1496	96	14	12	2475	390	100	27	0.097
WS4-1624	24	16	12	645	440	100	27	0.028
WS4-1630	30	16	12	800	440	100	27	0.035
WS4-1636	36	16	12	950	440	100	27	0.042
WS4-1648	48	16	12	1255	440	100	27	0.055
WS4-1660	60	16	12	1560	440	100	27	0.069
WS4-1672	72	16	12	1865	440	100	27	0.082
WS4-1684	84	16	12	2170	440	100	27	0.095
WS4-1696	96	16	12	2475	440	100	27	0.109

Note: 18" Wall Shelf available. Please contact with our sales about your inquiry.

Microwave Shelf -One piece

Stainless steel, one piece structure, does not include mounting hardware



MATERIAL:
18-gauge 300 series stainless steel.
400 series available.

Model Number	O.A.Dims - in.			Packing Dims - mm			Qty/Pallet	CBM
	L	W	H	L	W	H		
MS3ADV-1824	24	18	12-1/2	620	465	325	8	0.047
MS3ADV-2424	24	24	12-1/2	620	620	325	8	0.062

Microwave Shelf-Knock-down

18Ga. 300 series stainless steel, knock down side brackets, does not include mounting hardware,



Model Number	O.A.Dims - in.			Packing Dims - mm			Qty/Pallet	CBM
	L	W	H	L	W	H		
MS3-1824	24	18	12-1/2	645	495	100	27	0.032
MS3-2424	24	24	12-1/2	645	645	100	27	0.042

Ceiling Mounted Pot Rack

Ceiling suspension with chain hangers
 Flat steel bar is 2" x 1/4", 300 series stainless steel
 Hooks not included
 All welded stainless steel units are blended to a satin finish.

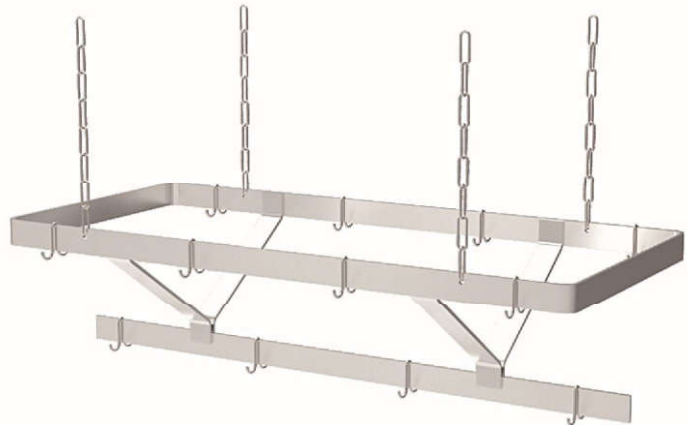

Model Number	O.A.Dims - in.			Packing Dims - mm			Qty/Pallet	CBM
	L	W	H	L	W	H		
SC-48	48	22	12	1219	559	305	8	0.240
SC-60	60	22	12	1524	559	305	8	0.301
SC-72	72	22	12	1829	559	305	8	0.361

Wall Mounted Pot Rack

Secured to wall by means of bolts through welded brackets.
 (Hardware not provided)
 Flat steel bar is 2" x 1/4", 300 series stainless steel.
 Include plated pot hooks.
 All welded stainless steel units are blended to a satin finish.

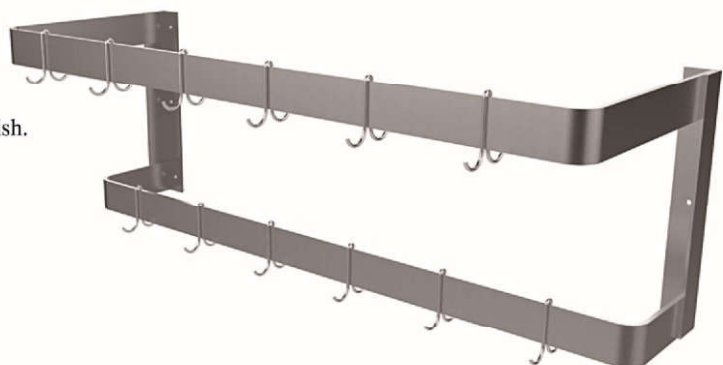

Model Number	O.A.Dims - in.			Hook Qty	Packing Dims - mm			Qty/Pallet	CBM
	L	W	H		L	W	H		
DWPR-36	36	12	12	12	935	325	325	16	0.099
DWPR-48	48	12	12	18	1240	325	325	16	0.131
DWPR-60	60	12	12	18	1545	325	325	16	0.163



Wall Shelf with Pot Rack

18Ga. 400 series shelf and bracket

Flat stainless steel bar is 2" x 1/4".

Pot hooks are plated.

All welded stainless steel units are blended to a satin finish.



Model Number	O.A.Dims - in.			Hook Qty	Packing Dims - mm			Qty/Pallet	CBM
	L	W	H		L	W	H		
PS-1248	48	12	12	6	1255	355	90	28	0.041
PS-1260	60	12	12	9	1560	355	90	28	0.050
PS-1272	72	12	12	9	1865	355	90	28	0.060

Dish Slant Shelf

400 series stainless steel, 3/4" drain on left or right side, wall brackets included, Knocked-down structure, does not include mounting hardware.

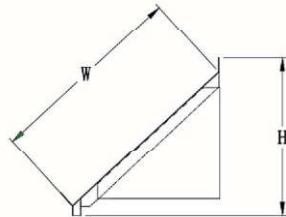
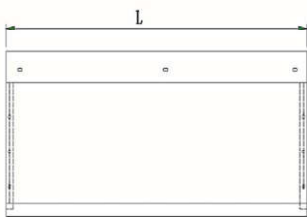

Model Number	O.A.Dims - in.			Packing Dims - mm			Qty/Pallet	CBM
	L	W	H	L	W	H		
DWS4-2221R	21	22	15-1/2	570	595	90	29	0.031
DWS4-2242R	42	22	15-1/2	1110	595	90	29	0.031
DWS4-2263R	63	22	15-1/2	1635	595	90	29	0.088
DWS4-2284R	84	22	15-1/2	2170	595	90	29	0.116
DWS4-2221L	21	22	15-1/2	570	595	90	29	0.031
DWS4-2242L	42	22	15-1/2	1110	595	90	29	0.031
DWS4-2263L	63	22	15-1/2	1635	595	90	29	0.088
DWS4-2284L	84	22	15-1/2	2170	595	90	29	0.116



Oil Filtering Shelf

300 series stainless steel top, filtering board, front panel and brackets, Knocked-down structure, does not include mounting hardware

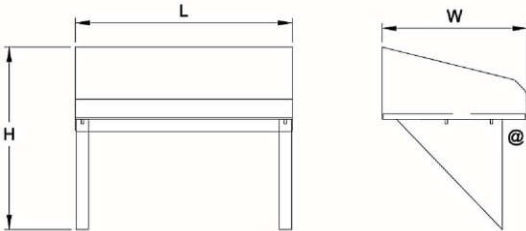

Note: Area-@ will mounted on the edge of fryer.

Model Number	O.A.Dims - in.			Packing Dims - mm			Qty/Pallet	CBM
	L	W	H	L	W	H		
FWS3-1218	18	12	15	495	345	185	14	0.030

Storage Shelf

- 18Ga. 400 series stainless steel shelves
- Stainless steel posts with adjustable feet
- Extra shelves available for extending larger storage space
- Square edge with safely-use care
- Legs pack in individual box



	Model Number	O.A.Dims - in.			Packing Dims - mm			Qty/Pallet	CBM
		L	W	H	L	W	H		
Four levels	ST4S4-1836	36	18	71	960	500	180	23	0.086
	ST4S4-1848	48	18	71	1265	500	180	23	0.114
	ST4S4-1860	60	18	71	1570	500	180	23	0.141
	ST4S4-1872	72	18	71	1875	500	180	23	0.169
Five levels	ST5S4-1836	36	18	71	960	500	220	23	0.106
	ST5S4-1848	48	18	71	1265	500	220	23	0.139
	ST5S4-1860	60	18	71	1570	500	220	23	0.173
	ST5S4-1872	72	18	71	1875	500	220	23	0.206



Stainless Steel Over Shelf for Existing Table

400 series stainless steel, All Shelves are stainless steel. Surface Mount(Top) or Edge Mount(Side) Available. The height of second shelf is adjustable(DOS models).

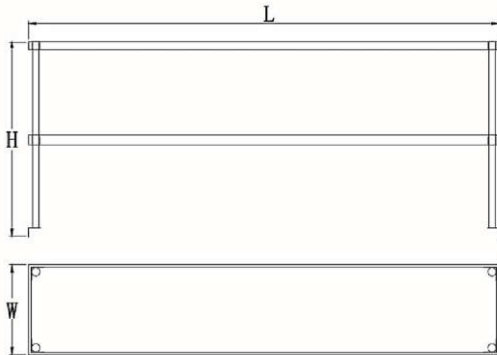

Single Over Shelf

Model Number	O.A.Dims - in.			Packing Dims - mm			Qty/Pallet	CBM
	L	W	H	L	W	H		
SOSA4-1236	36	12	18	950	340	80	33	0.026
SOSA4-1248	48	12	18	1255	340	80	33	0.034
SOSA4-1260	60	12	18	1560	340	80	33	0.042
SOSA4-1272	72	12	18	1865	340	80	33	0.051
SOSA4-1436	36	14	18	950	390	80	33	0.030
SOSA4-1448	48	14	18	1255	390	80	33	0.039
SOSA4-1460	60	14	18	1560	390	80	33	0.049
SOSA4-1472	72	14	18	1865	390	80	33	0.058
SOSA4-1636	36	16	18	950	440	80	33	0.033
SOSA4-1648	48	16	18	1255	440	80	33	0.044
SOSA4-1660	60	16	18	1560	440	80	33	0.055
SOSA4-1672	72	16	18	1865	440	80	33	0.066

Double Over Shelf

Model Number	O.A.Dims - in.			Packing Dims - mm			Qty/Pallet	CBM
	L	W	H	L	W	H		
DOSA4-1236	36	12	30	950	340	100	27	0.032
DOSA4-1248	48	12	30	1255	340	100	27	0.043
DOSA4-1260	60	12	30	1560	340	100	27	0.053
DOSA4-1272	72	12	30	1865	340	100	27	0.063
DOSA4-1436	36	14	30	950	390	100	27	0.037
DOSA4-1448	48	14	30	1255	390	100	27	0.049
DOSA4-1460	60	14	30	1560	390	100	27	0.061
DOSA4-1472	72	14	30	1865	390	100	27	0.073
DOSA4-1636	36	16	30	950	440	100	27	0.042
DOSA4-1648	48	16	30	1255	440	100	27	0.055
DOSA4-1660	60	16	30	1560	440	100	27	0.069
DOSA4-1672	72	16	30	1865	440	100	27	0.082

Drawers

22 GA 400 series stainless steel, offer roller bearing drawers, included stainless liner, compatible with our Work Tables.

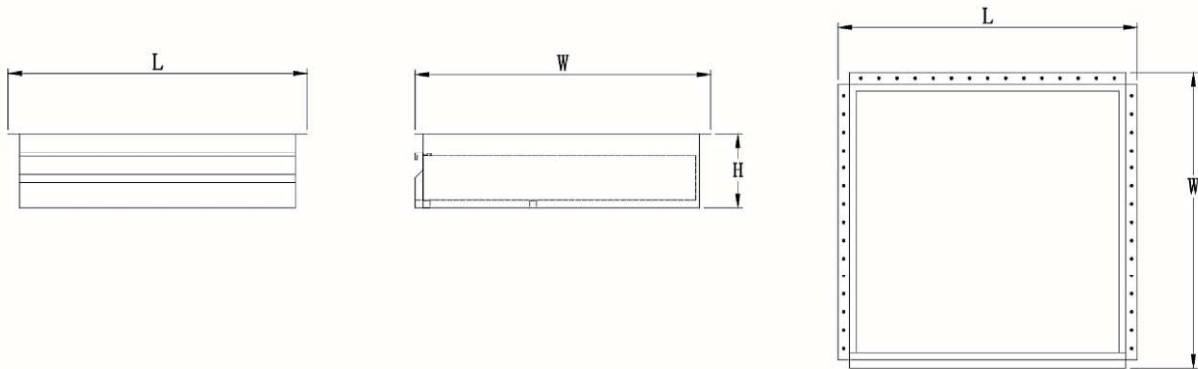

Standard Model



With Locks

Drawers without Lock

Model Number	O.A.Dims - in.			Packing Dims - mm			Qty/Pallet	CBM
	L	W	H	L	W	H		
DRA4-18-24	20	20	6-1/2	585	575	245	10	0.082
DRA4-24-30	26	26	6-1/2	735	730	245	10	0.131
DRA4-24-24	20	26	6-1/2	585	730	245	10	0.105
DRA4-18-30	26	20	6-1/2	735	575	245	10	0.104
DRA4-18-24DOUBLE	20	20	11-1/2	585	575	365	7	0.123
DRA4-24-24DOUBLE	20	26	11-1/2	585	730	365	7	0.156

Drawers with Lock

Model Number	O.A.Dims - in.			Packing Dims - mm			Qty/Pallet	CBM
	L	W	H	L	W	H		
DRA4-18-24-L	20	20	6-1/2	585	575	245	10	0.082
DRA4-24-30-L	26	26	6-1/2	735	730	245	10	0.131
DRA4-24-24-L	20	26	6-1/2	585	730	245	10	0.105
DRA4-18-30-L	26	20	6-1/2	735	575	245	10	0.104
DRA4-18-24DOUBLE-L	20	20	11-1/2	585	575	365	7	0.123
DRA4-24-24DOUBLE-L	20	26	11-1/2	585	730	365	7	0.156

K.D. Cabinet With Sliding Door

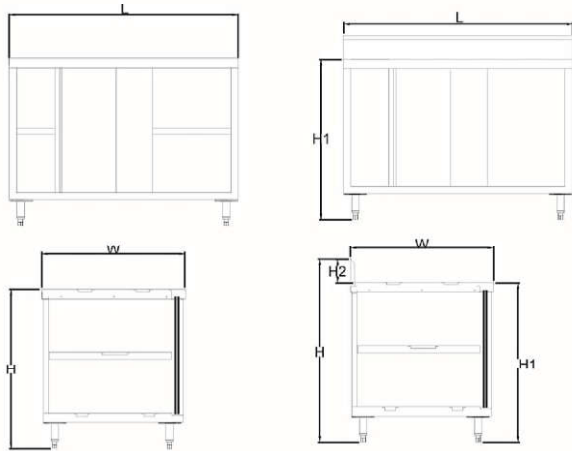

Optional Upgrade: Model SC3
(300 series materia)
For example:SC3-2448B5

Features

- FLAT TOP is furnished with square bend edges on the 4 sides.
- 1 ½” SPLASH is furnished square bend edges on the 3 sides and a 1-1/2” splash of single metal thickness on the rear side.
- 5” SPLASH is furnished with square bend edges on the 3 sides and a 5” splash with return on the rear side.
- SLIDING DOORS have recessed handles for ease in opening and closing.
- Knock-Down structure for saving half freight and storage cost.
- Exporting carton box with wooden pallet.

Construction

- All TIG welded. Exposed areas finished to match adjacent surfaces.
- Entire Top is mechanically polished to a satin finish and is sound deadened.
- Hat section secured to Top reinforces and maintains level working surface.
- Heavy gauged material welded on the bottom for fixing adjustable feet or wheels.

Materials

- TOP is 18 gauge stainless steel type 400 series with galvanized understructure.
- BODY is 22 gauge stainless steel type 400 series.

Model Number	O.A.Dims - in.			Packing Dims - mm			Qty/Pallet	CBM
	L	W	H	L	W	H		
SC4-2448	48	24	35	1265	770	340	7	0.331
SC4-2460	60	24	35	1570	770	340	7	0.411
SC4-2472	72	24	35	1875	770	340	7	0.491
SC4-3048	48	30	35	1265	840	390	7	0.414
SC4-3060	60	30	35	1570	840	390	7	0.514
SC4-3072	72	30	35	1875	840	390	7	0.614
SC4-2448B1.5	48	24	36-1/2	1265	770	340	7	0.331
SC4-2460B1.5	60	24	36-1/2	1570	770	340	7	0.411
SC4-2472B1.5	72	24	36-1/2	1875	770	340	7	0.491
SC4-3048B1.5	48	30	36-1/2	1265	840	390	7	0.414
SC4-3060B1.5	60	30	36-1/2	1570	840	390	7	0.514
SC4-3072B1.5	72	30	36-1/2	1875	840	390	7	0.614
SC4-2448B5	48	24	40	1265	770	340	7	0.331
SC4-2460B5	60	24	40	1570	770	340	7	0.411
SC4-2472B5	72	24	40	1875	770	340	7	0.491
SC4-3048B5	48	30	40	1265	840	390	7	0.414
SC4-3060B5	60	30	40	1570	840	390	7	0.514
SC4-3072B5	72	30	40	1875	840	390	7	0.614

Supersave Cabinet With Drawers

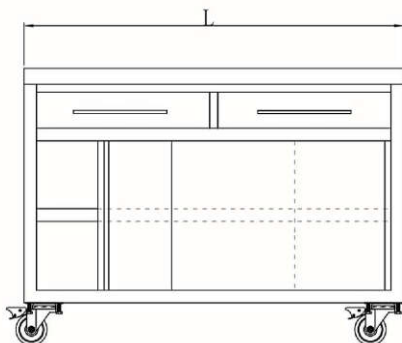
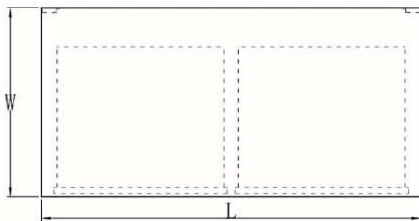
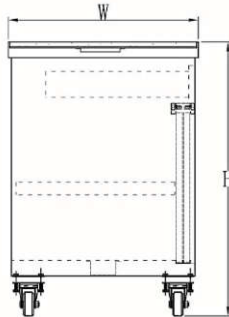

Features

- 400 series stainless steel.
- Flat top model is furnished with square bend edges on the 4 sides.
- 5" splash model is furnished with square bend edges on the 3 sides and a 5" splash with return on the rear side.
- Sliding doors have recessed handles for ease in opening and closing.
- Seamless welded drawers with high quality sliding rails and recessed handles.
- Exporting carton box with wooden pallet.

Construction

- All TIG welded. Exposed areas finished to match adjacent surfaces.
- Entire Top is mechanically polished to a satin finish and is sound deadened.
- Hat section secured to Top reinforces and maintains level working surface.
- Heavy gauged material welded on the bottom for fixing wheels, adjustable feet is available

Model Number	O.A.Dims - in.			Packing Dims - mm			Qty/Pallet	CBM
	L	W	H	L	W	H		
SC4-2436D	36	24	35	924	620	777	3	0.445
SC4-2448D	48	24	35	1229	620	777	3	0.592
SC4-2460D	60	24	35	1534	620	777	3	0.739
SC4-3036D	36	30	35	924	772	777	3	0.462
SC4-3048D	48	30	35	1153	772	777	3	0.691
SC4-3060D	60	30	35	1534	772	777	3	0.920
SC4-2436DB5	36	24	40	924	620	777	3	0.445
SC4-2448DB5	48	24	40	1229	620	777	3	0.592
SC4-2460DB5	60	24	40	1534	620	777	3	0.739
SC4-3036DB5	36	30	40	924	772	777	3	0.462
SC4-3048DB5	48	30	40	1229	772	777	3	0.691
SC4-3060DB5	60	30	40	1534	772	777	3	0.920



Beverage Cabinet

Beverage Cabinet with 5" backsplash, with 16"x18"x12" sink, with 4"OC, with urn trough 5" wide with no splash drain plate, 18Ga. 300 series stainless steel top with no drip counter top edge, 20Ga. Enclosed s/s base with bottom & intermediate under shelves

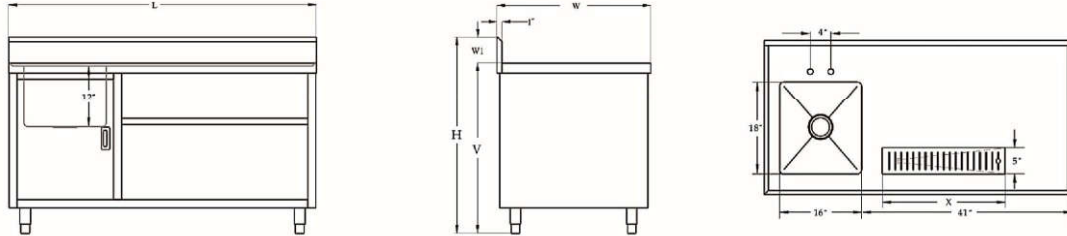

Optional:
With slides in middle(R)
For example:
SBC3-3048B5R

Model Number	O.A.Dims - in.				Installation Dims-in			CBM
	L	W	H	DB	V	w1	X	
SBC3-3048B5	48	30	40	29	35	5	18	0.930
SBC3-3060B5	60	30	40	41	35	5	24	1.157
SBC3-3072B5	72	30	40	53	35	5	36	1.384
SBC3-3084B5	84	30	40	65	35	5	48	1.611
SBC3-3096B5	96	30	40	77	35	5	60	1.837

Dish Cabinet

Dish Cabinet, 15" wide, 35" high, 16Ga 300. series stainless steel top, 20Ga 400. series body, open base with intermediate shelf, with adjustable feet
18" width model available



Model Number	O.A.Dims - in.			Packing Dims - mm			Qty/Pallet	CBM
	L	W	H	L	W	H		
SDC3-1548	48	15	35	1229	391	777	3	0.373
SDC3-1560	60	15	35	1534	391	777	3	0.466
SDC3-1572	72	15	35	1839	391	777	3	0.558
SDC3-1584	84	15	35	2144	391	777	3	0.651
SDC3-1596	96	15	35	2448	391	777	3	0.744

Supersave Wall Cabinet

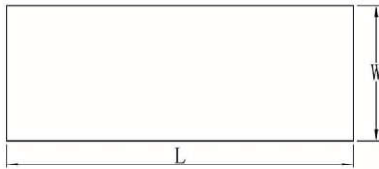
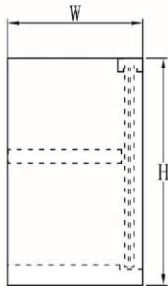

Features:

- Wall hung cabinet with intermediate shelf.
- Recessed handles.

Construction:

- All TIG welded.
- Welded seams finished to match adjacent surfaces. Unit polished to a satin finish.

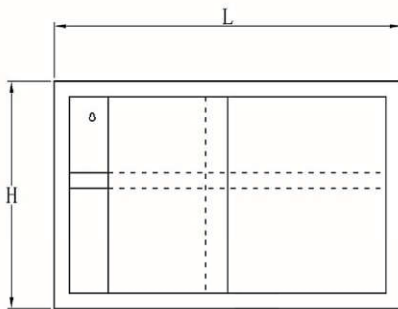

Material:

- 20 gauge type 400 series stainless steel top and 22 gauge other parts. Mounting hardware is not supplied.

Model Number	O.A.Dims - in.			Packing Dims - mm			Qty/Pallet	CBM
	L	W	H	L	W	H		
WC4-123624	36	12	24	935	325	630	4	0.191
WC4-124824	48	12	24	1240	325	630	4	0.254
WC4-126024	60	12	24	1545	325	630	4	0.316
WC4-143624	36	14	24	935	375	630	4	0.221
WC4-144824	48	14	24	1240	375	630	4	0.293
WC4-146024	60	14	24	1545	375	630	4	0.365



Stainless Steel Bun Pan Rack

Features:

200 series stainless steel.
 Fully welded 1" square tubing ladder assembly.
 Six support bars provide strength and durability.
 Plastic end caps, 1-1/8" angles, heavy duty 5" stem bolted swivel casters and two with brake.
 Support 18" X 26" pans.
 Or double quantity of 18" X 13" pans.
 500lb. Capacity.
 Knocked-down structure.



	Model Number	Load Position	Pan Capacity	Overall Size - in.				Packing Dims - mm			Qty/Pallet	CBM
				A	L	W	H	L	W	H		
STANDARD	SPR-10-1826-KDA	Front Load	10 Full Size	3	26	20-1/4	40	1020	730	100	26	0.075
	SPR-12-1826-KDA	Front Load	12 Full Size	5	26	20-1/4	71	1810	730	100	26	0.132
	SPR-18-1826-KDA	Front Load	18 Full Size	3	26	20-1/4	71	1810	730	100	26	0.132
	SPR-20-1826-KDA	Front Load	20 Full Size	3	26	20-1/4	71	1810	730	100	26	0.132
	SPR-30-1826-KDA	Front Load	30 Full Size	2	26	20-1/4	71	1810	730	100	26	0.132
	SPR-18-2618-KDA	Side Load	18 Full Size	3	18	28-1/4	71	1810	530	100	26	0.132
	SPR-20-2618-KDA	Side Load	20 Full Size	3	18	28-1/4	71	1810	530	100	26	0.096

Aluminum Bun Pan Rack

Features:

6000 series extruded aluminum angles, upright tubing, and support pieces.
 Curved top design.
 Fully welded 1" square tubing ladder assembly.
 Six support bars provide strength and durability.
 3" or 3.5" shelf spacing.
 Plastic end caps, 1-1/8" angles, heavy duty 5" stem bolted swivel casters.
 Support 18" X 26" pans. Or double quantity of 18" X 13" pans.
 500lb. Capacity. Knocked-down structure.



Model Number	Load Position	Pan Capacity	Overall Size - in.				Packing Dims - mm			Qty/Pallet	CBM
			A	L	W	H	L	W	H		
ALPR-17-1826-KDA	Front Load	17 Full Size	3-1/2	26	20-1/4	69-3/4	1810	695	105	25	0.132
ALPR-18-1826-KDA	Front Load	18 Full Size	3	26	20-1/4	69-3/4	1810	695	105	25	0.132

Stainless Steel Utility Carts

Features:

- ABS plastic handle and inserts
- 20 gauge 400 series stainless steel
- TIG welded shelf with one side open edge for cleaning easier
- 4" swivel casters and two with brake
- Knocked-down structure.

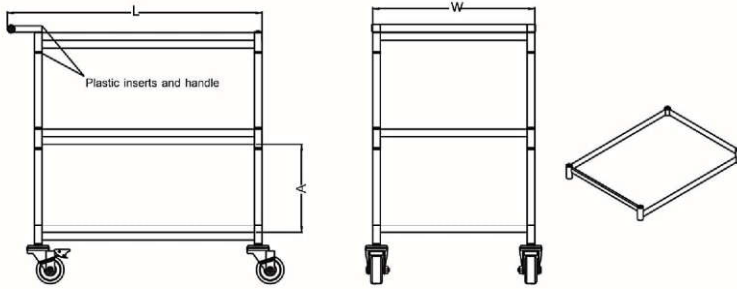

Model Number	With/WO Brakes	Pan Capacity	Overall Size - in.				Packing Dims - mm			Qty/ Pallet	CBM
			A	L	W	H	L	W	H		
BC4-2-1524	2/2	2	24	24	15	33-1/2	650	420	145	18	0.041
BC4-2-1828	2/2	2	24	28	18	33-1/2	745	490	145	18	0.053
BC4-2-2133	2/2	2	24	33	21	33-1/2	875	570	145	18	0.072
BC4-3-1524	2/2	3	11	24	15	33-1/2	650	420	205	13	0.056
BC4-3-1828	2/2	3	11	28	18	33-1/2	745	490	205	13	0.075
BC4-3-2133	2/2	3	11	33	21	33-1/2	875	570	205	13	0.102

Stainless Steel Service Cart

Features:

- 22 gauge 400 series stainless steel
- Die-formed shelves
- 3" swivel casters and two with brake
- Knocked-down structure.

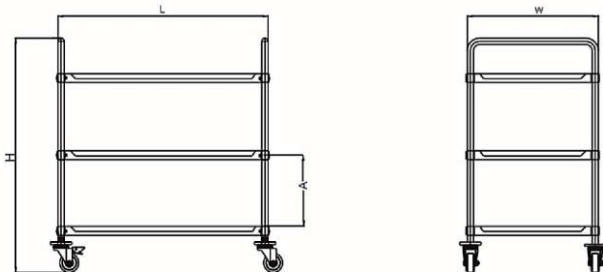

Model Number	With/WO Brakes	Pan Capacity	Overall Size - in.				Packing Dims - mm			Qty/ Pallet	CBM
			A	L	W	H	L	W	H		
BC3-2-2133	2/2	2	23	33	21	37-1/2	920	590	120	22	0.065
BC3-3-2133	2/2	3	11	33	21	37-1/2	920	590	145	18	0.079



**STAINLESS STEEL WET-BATH TABLE
K.D. STYLE ENCLOSED TABLE**

NOTE:

SNG- Sneeze guards are 200 series SS tubing with tempered Glass. Heat Bulbs not included. Shipped Knocked down. See the SNG models below.



FEATURES:

- 15,000 BTU'S / 2&3 compartments
- 25,000 BTU'S / 4&5&6 compartments
- Single control knob with 3 settings Pilot indicator openings
- Stainless steel dish shelf & under shelf
- 1" thick poly cutting board (8" wide)
- Wet Gas units are perfect for prepared food. It maintains food temperature with hot steam. Add 1-2" of water to the wet bath unit to achieve the correct amount of hot moisture.

OPTIONAL:

Open base under structure available.

MATERIAL:

- TOP: 20 gauge 300 series stainless steel
- BODY: 22 gauge 400 series stainless steel
- Sneeze Guards Frame: 18 gauge, 200 series stainless steel

GAS:

- Available for Natural or Bottled Gas
- 1/2" female NPT connection to regulator
- Infinite Control knobs Indicator lights
- Note: External pressure regulator is required.
- 4" WC pressure in for Natural Gas and
- 10" WC pressure in for LP.

Base Model	Wells	Gas Type	Overall Size			CBM	Sneeze Guards	Light Socket	Overall Size			CBM
			L	W	H				L	W	H	
WB-2GC-LP	2	Bottled Gas	32	32	34	0.283	SNG-2G	2	32	22	20	0.199
WB-3GC-LP	3	Bottled Gas	48	32	34	0.422	SNG-3G	2	48	22	20	0.286
WB-4GC-LP	4	Bottled Gas	60	32	34	0.526	SNG-4G	3	60	22	20	0.352
WB-5GC-LP	5	Bottled Gas	72	32	34	0.630	SNG-5G	4	72	22	20	0.418
WB-6GC-LP	6	Bottled Gas	84	32	34	0.735	SNG-6G	4	84	22	20	0.483



STAINLESS STEEL EXHAUST HOOD



Wall Canopy Hood for use over 450°F, 600°F and 700°F cooking surface temperatures. The aerodynamic design includes a baffle for exceptional capture and containment.

FEATURES:

- All fabricated with 400 series stainless steel.
- Superior exhaust flow rates. Available in single or back-to-back configurations.
- Insulated, double-wall rigid front has aerodynamic design that reduces radiant heat into kitchen, prevents condensation and provides exceptional capture and containment of cooking vapors.
- Incandescent light fixtures and globes shall be installed and pre-wired to a junction box. The light fixtures shall be installed with a maximum of 36" spacing on center.
- Polished stainless steel on the interior and exterior of the front enhance aesthetics.
- All hoods come standard with stainless steel filters and a deep grease trough which allows for easy cleaning. Grease drain system with removable cup for easy cleaning.
- Standard built in 3" rear standoff to meet NFPA 96 requirements, when installed in a wall application.

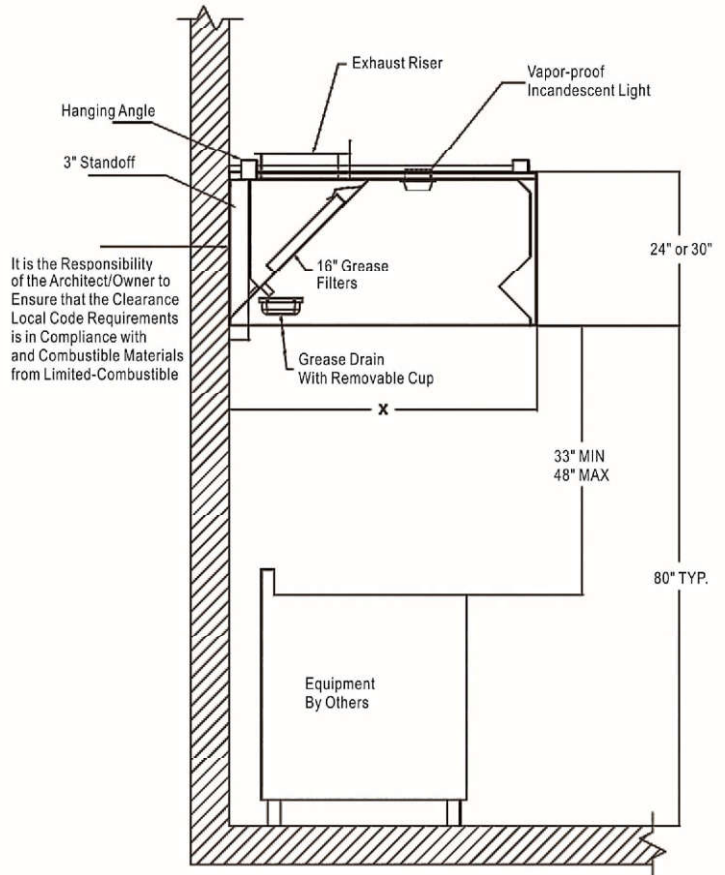

It is the Responsibility of the Architect/Owner to Ensure that the Clearance Local Code Requirements is in Compliance with and Combustible Materials from Limited-Combustible

Model	Overall Size-in			Packing Size-mm			Filter Size-mm			Filter Qty.	Light Bulb	Cup Qty.	CBM
	L	W	H	L	W	H	L	W	H				
EHWM4-4	48	42	24	1270	720	1200	500	400	45	2	1	1	1.166
EHWM4-6	72	42	24	1880	720	1200	500	400	45	4	1	1	1.727
EHWM4-8	96	42	24	2490	720	1200	500	400	45	5	2	2	2.287
EHWM4-10	120	42	24	3100	720	1200	500	400	45	7	3	2	2.847

Note: Other sizes available.

Module Bar Solution

We may change design according to your feedback. This page just for reference now. We need your floor plan for bar section. Hope you can send your information to us. Many thanks.

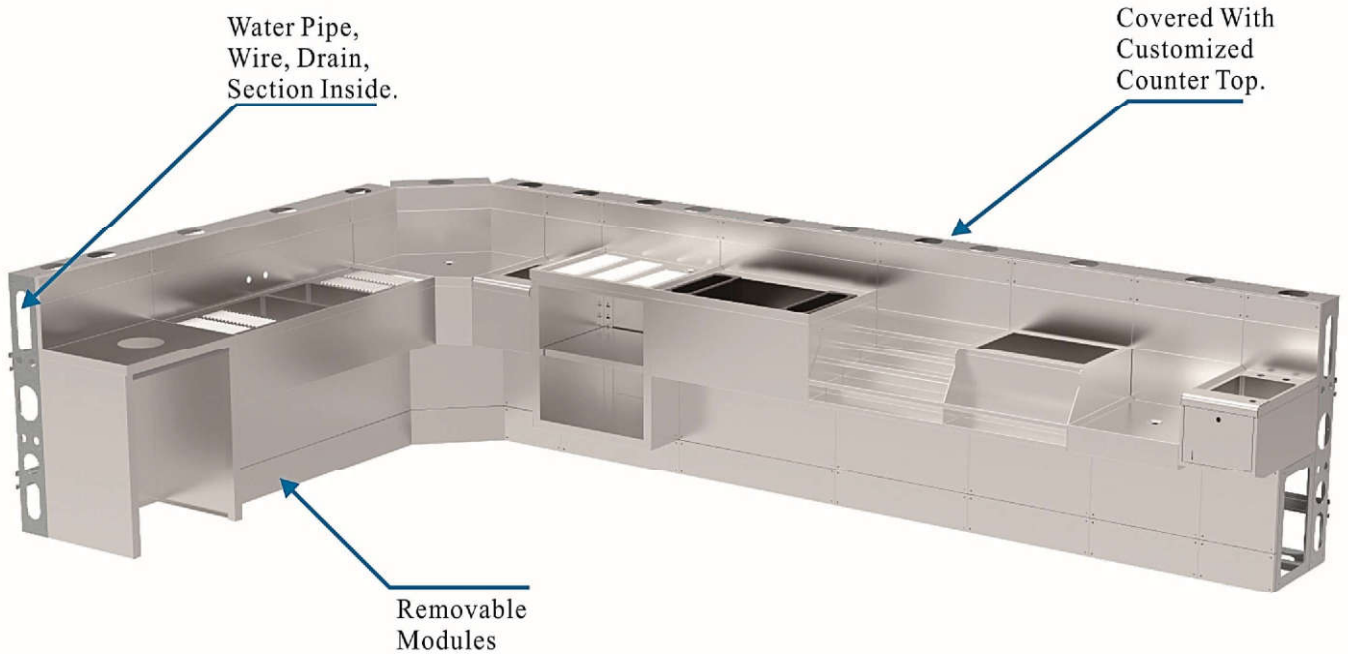

Features:

- Removable modules.
- Easier assembly with different modules according to your idea.
- Top and wall sides can be assembled with your customized material like stone, wood etc.
- Standard wall and connected with screws.
- Removable cover board on the bottom.

Material:

- 18ga. 300 series stainless steel.
- Or 18ga. 300 series stainless steel top and 400 series bottom cover.
- 16 ga. Galvanized standard wall.

Function:

- Standard wall will suite for electrical conduit, beer/soda line, plumbing lines, drain conduit.

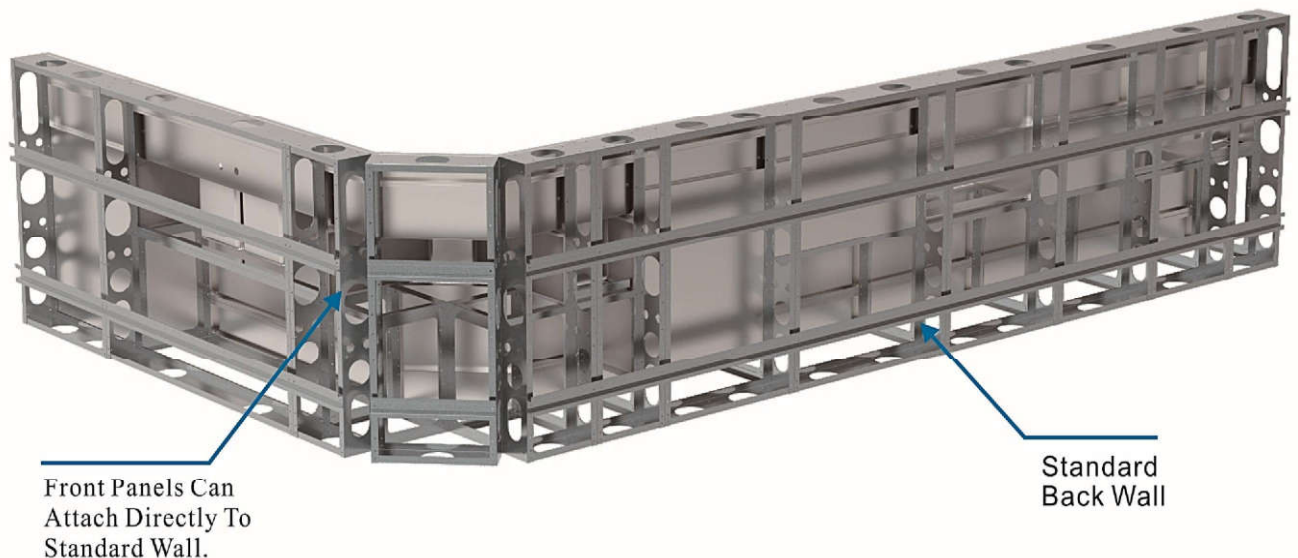

Spare parts



FAU-4C12S-BS

Wall mounted 4" faucet
With swing spout



FAU-4C12S

Wall mounted 4" faucet
With swivel gooseneck spout



Wall mounted 8" faucet

FAU-8C-12S

With 12" spout

FAU-8C-14S

With 14" spout



Leg with castor



1-1/2" drainer

3-1/2" drainer

What Is Stainless Steel?

Unlike iron or steel that readily corrodes, stainless steel contains additional metals like chromium and nickel. Don't confuse stainless steel with galvanized steel--galvanized steel is plain steel with a layer of zinc deposited on the surface.

While there are many different "series" (different compositions) of stainless steel, two of the most common ones you'll see in the food service industry are 400 series and 300 series.

- ★ 400 Series stainless steel contains chromium
- ★ 300 Series stainless steel contains both chromium and nickel

Without getting too technical, adding these metals in specific percentages to the steel itself change its makeup all the way down at the atomic level, and form an invisible film on the surface, which protects the metal against corrosion.

Because this film is only millionths of an inch thick, it can be damaged if abused. Three basic things can damage this protective layer and allow corrosion to take hold:

1. Mechanical Abrasion--Anything that can scratch the steel's surface including steel wool, wire brushes, and scrapers
2. Deposits & Water- -Hard water left sitting on the surface will leave water spots and can break down the layer of protection, as well as food deposits
3. Chlorides--Found in water, food, table salt, but mainly found in many household and industrial cleaners

Care & Cleaning Tips for Work Tables, Sinks, and Equipment Is Stainless Steel?

1. Use the right cleaning tools: Soft cloths, microfiber, sponges, or plastic scouring pads are best. The microfiber buying guide shows the best cleaning methods and products to ensure your stainless steel maintains its appearance. Avoid using scrapers, wire brushes, steel wool, or anything else that might scratch the surface.
2. Clean with the polish lines: Stainless steel usually has a "grain" that you can see running in one direction or another. If you can see the lines, it's always best to scrub or wipe parallel to them. This is especially important if you do have to use something more abrasive than a cloth or wiper.
3. Use the right cleaning chemicals: The best cleaner for stainless steel will contain alkaline, alkaline chlorinated, or non-chloride chemicals. Noble Chemical offers a variety of stainless steel cleaners and polishes specifically designed for stainless steel.
 - ★ Excel is a water-based aerosol cleaner / polish that won't attract dirt like an oil-based cleaner can. It's great for commercial kitchen equipment!
 - ★ Spiffy Shine is an oil-based liquid stainless steel cleaner. While it will give the most brilliant shine of these three products, it is not the best for use in your commercial kitchen. We don't recommend it for use around heavy grease areas like near a fryer, because it will actually attract grease and dust. Also, you should thoroughly wash any food-contact surfaces after using it on them.



They not only clean and shine, but also help enhance the protective film. It's also a good idea to clean and sanitize frequently, using chemicals at the required strength. Noble's QuikSan is a ready-to-use sanitizer that won't damage stainless steel and is great for sanitizing work tables, and other surfaces around your commercial kitchen. Cleaning stainless steel regularly also prevents dirt or spills from drying onto the surface so you won't have to work as hard to clean anyway!

For other types of cleaners including citrus-based cleaners, bleach, and deliming agents, the key is to rinse them off thoroughly after use.

4. Minimize the impact of hard water: If you have hard water, having a water softening system is probably the best option, but may not be practical in every situation. If you have hard water and aren't able to treat it throughout your entire facility, it's a good idea to not let water stand on your stainless steel surfaces for extended periods.



Heavy Duty Stainless

New York, NY10001

Tel:212.924.6920

Fax:212.627.1759

sales@heavydutystainless.com