



Atmospheric Vented Gas Water Heaters

Proven technology. Exceptional reliability. Peace-of-mind.

FVIR water heaters are designed to keep burning vapours inside the combustion chamber until they burn out. A sensor inside the water heater will detect if it has ignited a flammable vapour from outside of the water heater and shut off the flow of gas to the burner and pilot light.

Flame Guard® patented technology prevents the ignition of flammable vapours from products such as gasoline, paint thinner and solvents. Subjected to over 1,000 tests including lint, dust and oil, butane and endurance burn, the Flame Guard® system is the safest and most proven technology available today.

PRODUCT FEATURES:

- Same footprint as existing heaters making them perfect for replacement
- Turbulator™ dip tube for self-cleaning, reducing sediment at the bottom of the tank and increasing hot water output by as much as 8%
- Over 20% more foam insulation and a higher EF for energy and cost savings

BENEFITS OF THE FLAME GUARD® SYSTEM

Servicing made simple – saves you time and money

- Combustion chamber is easy to access
- T&P valve is conveniently located at the side of the tank to facilitate piping to a drain or outside the building
- Piezoelectric ignitor allows for lighting of the pilot without matches
- Dependable three-leg design for better leveling and access to flame trap

Long-lasting dependability means years of assurance

- Glass-lined inner flue prevents scaling
- Top-mounted heavy duty anode rod for added tank protection
- Robust 1/4" pilot tubing

NEW “Series 10” VESTA GAS VALVE on 40 and 50 USG Natural Gas models - features include:

- Thermopile design provides robust pilot to withstand down drafts and environmental conditions
- LED indicator light
 - gives visual identification that pilot is on by flashing continuously
 - provides diagnostics and troubleshooting
- Easy temperature adjustments



GSW Atmospheric Vented Gas Water Heaters

WARRANTY	MODELS	RATED CAPACITY		INPUT BTU PER HR.	RECOVERY @ (100°F/55°C)		ENERGY FACTOR	A	B	APPROX. SHIP WT. lb/kg	FLAME GUARD®
		US GAL	LITRES		USG/h	LITRE/H		JACKET DIA. in/cm	TOP OF VENT in/cm		
NATURAL GAS											
6	SS19NA-FV-04	19	72	22,000	18	69	0.58	18/46	37/95	81/36.8	YES
6	G630S27-FV-04	30	113	27,000	22.9	86.7	0.61	19/48.3	49.8/126.5	108/47	YES
6	6G40S38ES Series 10	40	151	38,000	32.2	121.8	0.62	21/53.34	53/134.6	136/64	YES
6	6G40T40ES Series 10	40	151	40,000	32.2	121.8	0.62	19/48.3	63.3/161	136/64	YES
6	6G50S40ES Series 10	50	189	40,000	33.9	128.2	0.62	22.5/57.2	54.5/138	160/75	YES
6	6G50T40ES Series 10	50	189	40,000	33.9	128.2	0.62	21/53.34	62/157	155/70	YES
6	6G60NA-FV-07	60	227	47,000	52.2	197.62	0.56	22.5/57.2	62.5/160	181/85	YES
6	6G-75-3NC-04*	75	284	76,000	66.6	252.13	0.53	26/66	66/168	268/121	
PROPANE											
Sea Level (0-2,000 ft.)											
6	GP630S30FV-05	30	113	30,000	25	96	0.61	19/48.3	49.8/126.5	113/51	YES
6	GP640S38FV-05	40	151	38,000	32.2	121.8	0.59	21/53.34	53/134.6	136/64	YES
6	GP640T40FV-05	40	151	40,000	33.9	128.2	0.60	19/48.3	63.3/161	136/64	YES
6	GP650S40FV-05	50	189	40,000	33.9	128.2	0.58	22.5/57.2	54.5/138	160/74.8	YES
6	GP650T40FV-05	50	189	40,000	33.9	128.2	0.58	21/53.34	62/157	168/76	YES
All Altitude (0-4,500 ft.)											
6	GP630S27FV-06	30	113	27,000	23	87	0.61	19/48.3	49.8/126.5	113/51	YES
6	GP640S34FV-06	40	151	34,000	32.2	121.8	0.59	21/53.34	53/134.6	136/64	YES
6	GP640T36FV-06	40	151	36,000	30.5	115.4	0.60	19/48.3	63.3/161	136/64	YES
6	GP650S36FV-06	50	189	36,000	33.9	128.2	0.58	22.5/57.2	54.5/138	160/74.8	YES
6	GP650T36FV-06	50	189	36,000	30.5	115.4	0.58	21/53.34	62/157	168/76	YES
6	6G-75-3PC-06*	75	284	68,400	58	219	0.53	26/66	66/168	268/121	

*Inputs are based on sea level (0-2,000 ft.) models. All altitude (0-4,500 ft.) models are de-rated by 10% as per CSA.

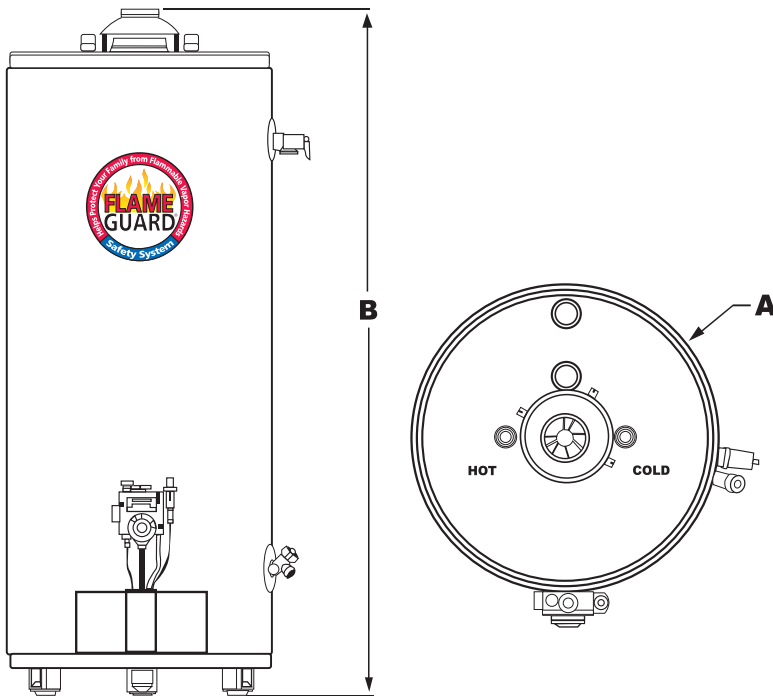

GSW Warranty:

All GSW Water Heaters will be replaced free of charge in the case of tank leakage within 6 years from the date of installation in domestic applications, and one year in commercial applications. All parts supplied are warranted for one year. Warranty does not include labour. Consult owner's manual for complete details.

GSW Water Heating HEAD OFFICE:

599 Hill Street West
Fergus, ON, Canada N1M 2X1
Tel: 888-599-2837
Fax: 519-787-5500
E-mail: gswinfo@gsw-wh.com
www.gsw-wh.com

