

SERIES "F" GEAR OPERATED BALL VALVE DIM. DATA

VALVE SIZE	ANSI CLASS	WORKING PRESSURE	PORT SIZE	A		B
				RF	RTJ	
4"	600	1500	F/P	17"	17 1/8"	9 9/16"
6"	600	1500	R/P	22"	22 1/8"	9 9/16"
6"	600	1500	F/P	22"	22 1/8"	8 5/8"

VALVE SIZE	C	D	E	F	G	WT.
4"	6"	9"	12"	8"	10 1/2"	262
6"	6"	9"	12"	8"	10 1/2"	358
6"	9"	10 1/2"	18"	12"	12 1/4"	465



**GATORVALVE**

**GVI**

"F" series  
ball valves  
sizes 2" through 6"  
pressure: 150, 300, 600



43,000 SQUARE FEET OF MANUFACTURING AND WAREHOUSING TO BETTER SERVE OUR CUSTOMERS.

## FEATURES:

- Body material ASTM A216 grade WCC
- 316 stainless steel trim "standard"
- Grease fitting in stem for lubrication
- Locking device "standard"
- Viton seal kits "standard"
- Nylon seat seals "standard"
- Available in full or regular port
- Mounting pad for actuation
- Fire-safe design
- Every valve hydro-tested

## GVI/BETTIS SHUT DOWN VALVE



## BILL OF MATERIALS

NUMBER	NAME OF PART	MATERIAL
1	END ADAPTER	ASTM A216 GR. WCC
2	BODY SECTION	ASTM A216 GR. WCC
3	STEM	316 STAINLESS STEEL
4	BALL	ASTM A351 CF8M (316) ENC
5	SEAT	NYLON/TFE
6	STOP PLATE	ALLOY STEEL
7	BODY STUDS	ASTM A-193 GR. B7
8	BODY NUTS	ASTM A-194 GR. 2H
9	STOP PIN	GR. 8 ALLEN HEAD CAP SCREWS
10	HANDLE	DUCTILE IRON
11	SNAP RING	ALLOY STEEL
12	O-RINGS	VITON - V 75
13	WEATHER SEAL	URETHANE
14	THRUST WASHER	TEFLON
	NAME PLATE	STAINLESS STEEL

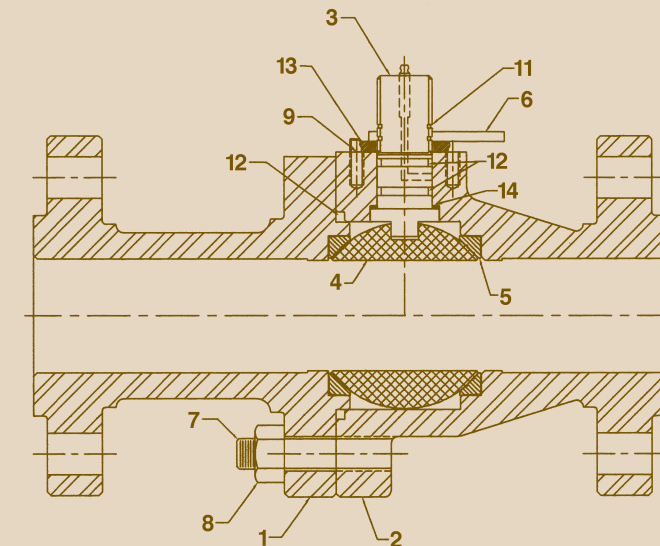

# SERIES "F" BALL VALVES

## SERIES "F" HANDLE OPERATED BALL VALVE DIM. DATA

VALVE SIZE	ANSI CLASS	WORKING PRESSURE	PORT SIZE	A		B	C	D	E	WT.
				RF	RTJ					
2"	150	290	R/P	7"	—	3 5/8"	5 1/4"	8 11/16"	6"	23
2"	150	290	F/P	7"	—	4 5/16"	5 19/32"	10 5/1"	6"	30
2"	300	750	R/P	8 1/2"	—	3 5/8"	5 1/4"	8 11/16"	6 1/2"	30
2"	300	750	F/P	8 1/2"	—	4 5/16"	5 19/32"	10 5/16"	6 1/2"	37
2"	600	1500	F/P	11 1/2"	11 5/8"	4 5/16"	5 19/32"	10 5/16"	6 1/2"	48
2"	600	1500	R/P	11 1/2"	11 5/8"	3 5/8"	5 1/4"	8 11/16"	6 1/2"	37
3"	150	290	R/P	8"	—	4 3/8"	5 3/4"	10 5/16"	7 1/2"	42
3"	150	290	F/P	8"	—	5 11/16"	7 1/16"	17 13/16"	7 1/2"	54
3"	300	750	R/P	11 1/8"	—	4 3/8"	5 3/4"	10 5/16"	8 1/4"	56
3"	300	750	F/P	11 1/8"	—	5 11/16"	7 1/16"	17 13/16"	8 1/4"	84
3"	600	1500	R/P	14"	14 1/8"	4 3/8"	5 3/4"	10 5/16"	8 1/4"	73
3"	600	1500	F/P	14"	14 1/8"	5 11/16"	7 1/16"	17 13/16"	8 1/4"	95
4"	150	290	R/P	9"	—	5 9/16"	6 5/16"	17 3/16"	9"	71
4"	150	290	F/P	9"	—	6 13/16"	8 3/16"	17 13/16"	9"	89
4"	300	750	R/P	12"	—	5 9/16"	6 5/16"	17 3/16"	10"	103
4"	300	750	F/P	12"	—	6 13/16"	8 3/16"	17 13/16"	10"	126
4"	600	1500	R/P	17"	17 1/8"	5 9/16"	6 5/16"	17 3/16"	10 3/4"	152
4"	600	1500	F/P	17"	17 1/8"	5 7/16"	9 3/16"	25 3/8"	10 3/4"	211
6"	150	290	R/P	10 1/2"	—	7 1/8"	8 1/4"	17 3/16"	11"	130
6"	600	1500	R/P	22"	22 1/8"	9 7/16"	9 3/16"	25 3/8"	14"	307

